



Pediatrics & Neonatology Journals  
[Ahmed Manfy] on **TELEGRAM** 

*Nelson*

# TEXTBOOK OF PEDIATRICS

Robert M. Kliegman  
Joseph W. St Geme III

NATHAN J. BLUM  
ROBERT C. TASKER  
KAREN M. WILSON  
ABIGAIL M. SCHUH  
CARA L. MACK

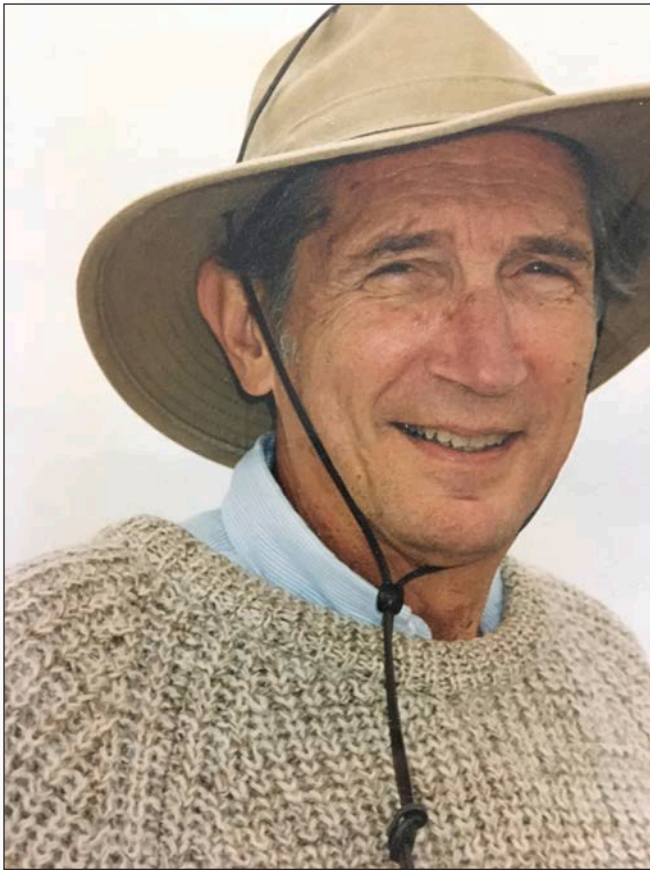
EDITION

**22**



**Volume 1**





## *In Memory*

**DR. RICHARD BEHRMAN** successfully served as editor of the *Nelson Textbook of Pediatrics* for 9 editions spanning over 3 decades. But more than that and without question, he excelled as an educator, a mentor, an exemplary leader in the field of pediatrics, and a role model as an investigator, clinician, department chair, dean, and director of the Packard Foundation Center for the Future of Children. Dick's career exemplifies the responsibility and critical role academic physicians must provide as child advocates by combining scholarly pursuits to advance knowledge, while seeking justice and equality for all children.

Dick always searched for expert contributors to the textbook who believed in the value of caring for all children; he recruited leading authors knowing that their approach to clinical pediatrics and to social justice would have a deeper impact and broader reach by contributing to the textbook. Because of this, *Nelson's* persists as an up-to-date authoritative global resource in not only presenting the clinical diagnosis and treatment of childhood diseases but also in identifying issues of social justice and providing solutions to improve access to health care and health outcomes. Dick's approachable intellect and intuitive nature fostered countless students, residents, and faculty allowing them to discover and nurture the best version of themselves as physicians and human beings.

Although Dick is no longer with us, his legacy persists in his selection of chapter topics and his meticulous editing of the previous chapters along with his unyielding philosophy that *Nelson* must continue to evolve while remaining a book for all children for generations to come. For those of us who know Dick as "REB" we will miss you but never forget you.



EDITION  
**22**

*Nelson*

# TEXTBOOK OF PEDIATRICS

## **Robert M. Kliegman, MD**

Professor and Chair Emeritus  
Department of Pediatrics  
Medical College of Wisconsin  
Children's Wisconsin  
Milwaukee, Wisconsin

## **NATHAN J. BLUM, MD**

W.T. Grant Professor of Pediatrics  
University of Pennsylvania Perelman School of Medicine  
Chief, Division of Developmental and Behavioral Pediatrics  
Children's Hospital of Philadelphia  
Philadelphia, Pennsylvania

## **ROBERT C. TASKER, MBBS, MD**

Professor of Anesthesia (Pediatrics, Harvard Medical School)  
Founding Chair in NeuroCritical Care  
Department of Anesthesiology  
Critical Care and Pain Medicine  
Boston Children's Hospital  
Boston, Massachusetts

## **KAREN M. WILSON, MD, MPH**

Ruth A. Lawrence Professor of Pediatrics  
Vice-Chair for Clinical and Translational Research  
Department of Pediatrics  
University of Rochester School of Medicine and Dentistry  
Co-Director, Clinical and Translational Science Institute  
Chief Research Officer, UR Medicine  
Golisano Children's Hospital  
Rochester, New York



ELSEVIER

## **Joseph W. St Geme III, MD**

Professor of Pediatrics and Microbiology  
Chair, Department of Pediatrics  
University of Pennsylvania Perelman School of Medicine  
Physician-in-Chief  
Leonard and Madlyn Abramson Endowed Chair in Pediatrics  
Children's Hospital of Philadelphia  
Philadelphia, Pennsylvania

## **ABIGAIL M. SCHUH, MD, MMHPE**

Associate Professor of Pediatrics  
Division of Pediatric Emergency Medicine  
Medical College of Wisconsin  
Children's Wisconsin  
Milwaukee, Wisconsin

## **CARA L. MACK, MD**

Professor of Pediatrics  
Chief, Division of Pediatric Gastroenterology, Hepatology, and  
Nutrition  
Medical College of Wisconsin  
Children's Wisconsin  
Milwaukee, Wisconsin

*With the assistance of*

## **MATTHEW A. DEARDORFF, MD, PhD**

Director of Translational Genomics  
Division of Genomic Medicine  
Department of Pathology and Laboratory Medicine  
Director of Personalized Care  
Children's Hospital Los Angeles  
Professor of Clinical Pathology and Pediatrics  
Keck School of Medicine of the University of Southern  
California  
Los Angeles, California



*To the Child's Health Care Provider  
who through their expressed confidence in past editions of this book  
have provided the stimulus for this revision.  
May we continue to be a resource of helpful information  
for clinicians who care for all of our children.*

**R.M. Kliegman**



# Contributors

## **Mark J. Abzug, MD**

Professor of Pediatrics  
Vice Chair for Academic Affairs  
University of Colorado School of Medicine  
Section of Pediatric Infectious Diseases  
Children's Hospital Colorado  
Aurora, Colorado  
297. *Nonpolio Enteroviruses*

## **Krishna K. Acharya, MD**

Associate Professor of Pediatrics  
Medical College of Wisconsin  
Division of Neonatal-Perinatal Medicine  
Children's Wisconsin  
Milwaukee, Wisconsin  
117. *The Fetus*  
122. *Nervous System Disorders*  
124. *Transition to Newborn Pulmonary Respiration*  
125. *Apnea*  
126. *Respiratory Distress Syndrome (Hyaline Membrane Disease)*  
127. *Bronchopulmonary Dysplasia*  
128. *Transient Tachypnea of the Newborn*  
129. *Aspiration of Foreign Material (Meconium Aspiration Syndrome, Aspiration Pneumonia)*  
130. *Persistent Pulmonary Hypertension of the Newborn (Persistent Fetal Circulation)*  
131. *Diaphragmatic Hernia*  
132. *Pulmonary Air Leaks: Pneumothorax, Pneumomediastinum, Pulmonary Interstitial Emphysema, Pneumopericardium*  
133. *Pulmonary Hemorrhage*

## **Denise M. Adams, MD**

Professor of Pediatrics  
Alan R. Cohen Endowed Chair in Pediatrics  
University of Pennsylvania Perelman School of Medicine  
Director, Complex Vascular Anomalies Program  
Children's Hospital of Philadelphia  
Philadelphia, Pennsylvania  
554. *Complex Vascular Anomalies*

## **Stewart Adelson, MD**

Clinical Associate Professor  
Weill Cornell Medical College  
Adjunct Associate Clinical Professor  
Columbia University Vagelos College of Physicians and Surgeons  
New York, New York;  
Senior Visiting Fellow  
Yale Law School  
New Haven, Connecticut  
154. *Gay, Lesbian, and Bisexual Adolescents*

## **Molly C. Adrian, PhD**

Associate Professor of Psychiatry and Behavioral Sciences  
University of Washington School of Medicine  
Attending Psychologist  
Seattle Children's Hospital  
Seattle, Washington  
46. *Self-Injurious Behavior*

## **Shawn K. Ahlfeld, MD**

Assistant Professor of Pediatrics  
University of Cincinnati College of Medicine  
Division of Neonatology  
Cincinnati Children's Hospital Medical Center  
Cincinnati, Ohio  
131.2. *Paraesophageal Hernia*

## **John J. Aiken, MD, FACS, FAAP**

Professor of Surgery  
Medical College of Wisconsin  
Division of Pediatric General and Thoracic Surgery  
Children's Wisconsin  
Milwaukee, Wisconsin  
391. *Acute Appendicitis*  
394. *Inguinal Hernias*  
420. *Epigastric Hernia*

## **Cezmi A. Akdis, MD**

Professor of Immunology  
University of Zurich Faculty of Medicine  
Director, Swiss Institute of Allergy and Asthma Research  
Zurich, Switzerland;  
Christine Kühne Center for Allergy Research and Education  
Davos, Switzerland  
182. *Allergy and the Immunologic Basis of Atopic Disease*

## **Daniah Albokhari, MBBS**

Department of Pediatrics  
Division of Human Genetics  
Section of Metabolism  
The Children's Hospital of Philadelphia  
Philadelphia, Pennsylvania;  
Department of Pediatrics  
Taibah University College of Medicine  
Medina, Saudi Arabia  
735. *General Considerations in Skeletal Dysplasias*  
736. *Disorders Involving Cartilage Matrix Proteins*  
737. *Disorders Involving Transmembrane Receptors*  
738. *Disorders Involving Ion Transporters*  
739. *Disorders Involving Transcription Factors*  
740. *Osteopetrosis and Other Disorders Involving Defective Bone Resorption*  
741. *Other Inherited Disorders of Skeletal Development*

## **Elizabeth M. Alderman, MD**

Professor of Pediatrics  
Professor of Obstetrics & Gynecology and Women's Health  
Albert Einstein College of Medicine  
Chief, Division of Adolescent Medicine  
Children's Hospital at Montefiore  
Bronx, New York  
160. *Contraception*

## **Omar Ali, MD**

Pediatric Endocrinologist  
Division of Pediatric Endocrinology  
Valley Children's Hospital  
Madera, California  
598. *Hyperpituitarism*  
623. *Hypofunction of the Testes*  
624. *Pseudoprecocity Resulting From Tumors of the Testes*  
625. *Gynecomastia*

## **Wendy A. Allen-Rhoades, MD, PhD**

Assistant Professor  
Division of Pediatric Hematology-Oncology  
Mayo Clinic  
Rochester, Minnesota  
549. *Soft Tissue Sarcomas*  
550.1. *Malignant Tumors of Bone*

## **Nourah N. Almutlaq, MBBS**

Division of Pediatric Endocrinology  
Indiana University School of Medicine  
Riley Hospital for Children  
Indianapolis, Indiana  
747. *Hypophosphatasia*  
748. *Hyperphosphatasia*

## **Louella B. Amos, MD**

Associate Professor of Pediatrics  
Medical College of Wisconsin  
Division of Pulmonary and Sleep Medicine  
Children's Wisconsin  
Milwaukee, Wisconsin  
450. *E-Cigarette or Vaping Product Use-Associated Lung Injury (EVALI)*

## **Jason B. Anari, MD**

Assistant Professor of Orthopedic Surgery  
University of Pennsylvania Perelman School of Medicine  
Division of Pediatric Orthopedics  
Children's Hospital of Philadelphia  
Philadelphia, Pennsylvania  
724. *Common Fractures*

## **Karl E. Anderson, MD, FACP**

Professor of Internal Medicine  
Director, Porphyria Laboratory and Center  
University of Texas Medical Branch  
Galveston, Texas  
112. *The Porphyrrias*

## **Sudha A. Anupindi, MD, FSAR**

Professor of Radiology  
Kenneth E. Fellows Endowed Chair in Radiology Quality and Safety  
Associate Radiologist-in-Chief  
Director of the Section of Gastrointestinal and Hepatic Imaging  
Children's Hospital of Philadelphia  
Philadelphia, Pennsylvania  
382. *Inflammatory Bowel Disease*

## **Brian S. Appleby, MD**

Professor of Neurology, Psychiatry, and Pathology  
Case Western Reserve University School of Medicine  
Director, National Prion Disease Pathology Surveillance Center  
University Hospitals Cleveland Medical Center  
Cleveland, Ohio  
324. *Transmissible Spongiform Encephalopathies*



**Stacy P. Ardoin, MD, MHS**

Professor of Clinical Medicine  
Division of Adult and Pediatric Rheumatology  
The Ohio State University Wener Medical  
Center  
Chief, Division of Pediatric Rheumatology  
Nationwide Children's Hospital  
Columbus, Ohio  
199. *Systemic Lupus Erythematosus*  
210. *Vasculitis Syndromes*

**Alexandre Arkader, MD**

Attending Surgeon  
Department of Orthopaedics  
Division of Oncology  
Children's Hospital of Philadelphia  
Philadelphia, Pennsylvania  
724. *Common Fractures*

**Thaïs Armangué, MD, PhD**

Head of the Pediatric Neuroimmunology Unit,  
Service of Neurology  
Sant Joan de Déu Children's Hospital  
Principal Investigator at Neuroimmunology  
Program  
IDIBAPS-Hospital Clinic  
University of Barcelona  
Barcelona, Spain  
638.4. *Autoimmune Encephalitis*

**Carola A.S. Arndt, MD**

Professor of Pediatrics  
Division of Pediatric Hematology-Oncology  
Mayo Clinic  
Rochester, Minnesota  
549. *Soft Tissue Sarcomas*  
550. *Neoplasms of Bone*

**Danielle E. Arnold, MD**

Assistant Research Physician  
Immune Deficiency Cellular Therapy Program  
Center for Cancer Research  
National Cancer Institute  
National Institutes of Health  
Bethesda, Maryland  
174. *Immune Dysregulation*

**Adrienne R. Artis, MD**

Assistant Professor of Pediatrics  
The George Washington University School of  
Medicine and Health Sciences  
Child and Adolescent Protection Center  
Children's National Hospital  
Washington, DC  
162. *Adolescent Sexual Assault*

**David M. Asher, MD**

Former Supervisory Medical Officer and Chief  
Laboratory of Bacterial and Transmissible  
Spongiform Encephalopathy Agents (Retired)  
Division of Emerging and Transfusion Transmitted  
Diseases  
US Food and Drug Administration  
Silver Spring, Maryland  
324. *Transmissible Spongiform Encephalopathies*

**Barbara L. Asselin, MD**

Professor of Pediatrics and Oncology  
University of Rochester School of Medicine and  
Dentistry  
Department of Pediatrics  
Golisano Children's Hospital and  
Wilmut Cancer Institute  
Rochester, New York  
540. *Epidemiology of Childhood and Adolescent  
Cancer*

**Christina M. Astley, MD, ScD**

Assistant Professor of Pediatrics  
Harvard Medical School  
Attending Physician  
Division of Endocrinology  
Boston Children's Hospital  
Boston, Massachusetts  
608. *Autoimmune Polyglandular Syndromes*

**Norrell K. Atkinson, MD, FAAP**

Assistant Professor of Pediatrics  
Drexel University College of Medicine  
Child Protection Program  
St. Christopher's Hospital for Children  
Philadelphia, Pennsylvania  
162. *Adolescent Sexual Assault*

**Erika F. Augustine, MD, MS**

Associate Chief Science Officer  
Kennedy Krieger Institute  
Baltimore, Maryland  
637.4. *Dystonia*

**Marilyn C. Augustyn, MD**

Professor of Pediatrics  
Boston University Aram V. Chobanian & Edward  
Avedisian School of Medicine  
Division Director, Developmental-Behavioral  
Pediatrics  
Boston Medical Center  
Boston, Massachusetts  
15. *Impact of Violence Exposure on Children*

**Leonard B. Bacharier, MD, FAAAAI**

Janie Robinson and John Moore Lee Chair in  
Pediatrics  
Professor of Pediatrics and Allergy, Immunology,  
and Pulmonary Medicine  
Scientific Director  
Center for Clinical and Translational Research  
Vanderbilt University School of Medicine  
Attending Physician  
Division of Pediatric Allergy and Immunology  
Monroe Carell Jr. Children's Hospital at Vanderbilt  
Nashville, Tennessee  
185. *Childhood Asthma*

**Carlos A. Bacino, MD**

Professor and Vice Chair of Clinical Affairs  
Department of Molecular and Human Genetics  
Medical Director, Baylor Genetics, Cytogenetics  
Laboratory  
Baylor College of Medicine  
Director, Pediatrics Genetics Clinic  
Texas Children's  
Houston, Texas  
99. *Chromosome Disorders*

**Zinzi D. Bailey, ScD, MSPH**

Social Epidemiologist and Research Assistant  
Professor  
University of Miami Miller School of Medicine  
Managing Director  
Health Equity Research Solutions, LLC  
Miami, Florida  
2.1. *Racism and Child Health*

**Frances B. Balamuth, MD, PhD, MSCE**

Associate Professor of Pediatrics  
University of Pennsylvania Perelman School of  
Medicine  
Director of Research  
Division of Emergency Medicine  
Co-Director, Pediatric Sepsis Program  
Children's Hospital of Philadelphia  
Philadelphia, Pennsylvania  
78. *Triage of the Acutely Ill Child*

**Robert N. Baldassano, MD**

Professor of Pediatrics  
Colman Family Chair in Pediatric Inflammatory  
Bowel Disease  
University of Pennsylvania Perelman School of  
Medicine  
Co-Director, Center for Pediatric Inflammatory  
Bowel Disease  
Director, CHOP Microbiome Center  
Children's Hospital of Philadelphia  
Philadelphia, Pennsylvania  
382. *Inflammatory Bowel Disease*  
383. *Eosinophilic Gastroenteritis*

**Keith D. Baldwin, MD, MSPT, MPH**

Associate Professor of Orthopaedic Surgery  
University of Pennsylvania Perelman School of  
Medicine  
Attending Orthopaedic Surgeon  
Director, Orthopedic Trauma  
Children's Hospital of Philadelphia  
Philadelphia, Pennsylvania  
720. *The Spine*  
721. *The Neck*

**Christina B. Bales, MD**

Associate Professor of Clinical Pediatrics  
University of Pennsylvania Perelman School of  
Medicine  
Attending Physician  
Division of Gastroenterology, Hepatology, and  
Nutrition  
Medical Director, Intestinal Rehabilitation Program  
Children's Hospital of Philadelphia  
Philadelphia, Pennsylvania  
376. *Intestinal Atresia, Stenosis, and Malrotation*

**William F. Balistreri, MD**

Dorothy M. M. Kersten Professor of Pediatrics  
University of Cincinnati College of Medicine  
Director Emeritus, Pediatric Liver Care Center  
Medical Director Emeritus, Liver Transplantation  
Division of Pediatric Gastroenterology,  
Hepatology, and Nutrition  
Cincinnati Children's Hospital Medical Center  
Cincinnati, Ohio  
402. *Morphogenesis of the Liver and Biliary System*  
403. *Manifestations of Liver Disease*  
404. *Cholestasis*  
405. *Metabolic Diseases of the Liver*  
406. *Viral Hepatitis*  
408. *Liver Disease Associated with Systemic  
Disorders*  
409. *Mitochondrial Hepatopathies*

**Manisha Balwani, MD, MS, FACMG**

Professor and Chief  
Division of Medical Genetics and Genomics  
Icahn School of Medicine at Mount Sinai  
Department of Genetics and Genomic Sciences  
New York, New York  
112. *The Porphyrias*

**Vaneeta Bamba, MD**

Professor of Clinical Pediatrics  
Division of Endocrinology  
University of Pennsylvania Perelman School of  
Medicine  
Medical Director, Diagnostic and Research Growth  
Center  
Children's Hospital of Philadelphia  
Philadelphia, Pennsylvania  
27. *Assessment of Growth*

**Aleena Banerji, MD**

Associate Professor of Medicine  
Drug and Vaccine Allergy Center of Excellence  
Director of Clinical Care  
Clinical Director, Allergy and Immunology Unit  
Massachusetts General Hospital  
Boston, Massachusetts  
189. *Urticaria (Hives) and Angioedema*

**Janet Y. Bang, PhD**

Assistant Professor of Child and Adolescent  
Development  
San Jose State University  
Connie L. Lurie College of Education  
San Jose, California  
53. *Language Development and Communication  
Disorders*

**Nikita Barai, MD**

Assistant Professor of Medicine  
Icahn School of Medicine at Mount Sinai  
New York, New York  
152. *Transitioning to Adult Care*

**Katherine Baranowski, MD**

Assistant Professor of Pediatrics  
Chief, Division of Pediatric Emergency Medicine  
Rutgers University New Jersey Medical School  
Newark, New Jersey  
762. *Nonbacterial Food Poisoning*

**Sarah F. Barclay, PhD**

Lead Genome Analyst  
TIGeR: Translational Implementation of Genomics  
for Rare Diseases  
University of Calgary and Alberta Precision Labs  
Cumming School of Medicine at University of  
Calgary  
Calgary, Alberta, Canada  
468.3. *Rapid-Onset Obesity with Hypothalamic  
Dysfunction, Hypoventilation, and Autonomic  
Dysregulation*

**Elizabeth Barkoudah, MD**

Instructor in Neurology  
Harvard Medical School  
Co-Director, Cerebral Palsy and Spasticity Center  
Director, Neurodevelopmental Disabilities  
Residency Training Program  
Boston Children's Hospital  
Boston, Massachusetts  
638. *Encephalopathies*  
638.1. *Cerebral Palsy*

**Alejandra Barrero-Castillero, MD, MPH**

Instructor in Pediatrics  
Harvard Medical School  
Division of Newborn Medicine  
Boston Children's Hospital  
Boston, Massachusetts  
114. *Overview of Morbidity and Mortality*

**Katherine J. Barrett, PhD**

Postdoctoral Fellow  
University of Colorado School of Medicine  
Section of Pediatric Nutrition  
Aurora, Colorado  
61. *Feeding Healthy Infants, Children, and  
Adolescents*

**Karyl S. Barron, MD**

Deputy Director, Division of Intramural Research  
National Institute of Allergy and Infectious  
Diseases  
National Institutes of Health  
Bethesda, Maryland  
206. *Amyloidosis*

**Donald Basel, MBBCh**

Professor of Pediatrics  
Chief, Division of Medical Genetics  
Medical College of Wisconsin  
Milwaukee, Wisconsin  
744. *Ehlers-Danlos Syndrome*

**Dorsey M. Bass, MD**

Associate Professor of Pediatrics Emeritus  
Stanford University School of Medicine  
Division of Pediatric Gastroenterology  
Lucile Salter Packard Children's Hospital  
Palo Alto, California  
312. *Rotaviruses, Caliciviruses, and Astroviruses*

**Mary T. Bassett, MD, MPH**

Commissioner, New York State Department of  
Health  
Albany, New York;  
FXB Professor and Director  
FXB Center for Health and Human Rights  
Harvard T.H. Chan School of Public Health  
Boston, Massachusetts;  
Associate Professor of Clinical Epidemiology  
Columbia University Mailman School of Public  
Health  
New York, New York  
2.1. *Racism and Child Health*

**Hamid Bassiri, MD, PhD**

Assistant Professor of Pediatrics  
University of Pennsylvania Perelman School of  
Medicine  
Attending Physician and Fellowship Program  
Director  
Division of Infectious Diseases  
Co-Director, Immune Dysregulation Program  
Children's Hospital of Philadelphia  
Philadelphia, Pennsylvania  
235. *Actinomyces*

**Rebecca A. Baum, MD**

Clinical Professor of Pediatrics  
Division of General Pediatrics and Adolescent  
Medicine  
Section of Development, Behavior, and Learning  
University of North Carolina School of Medicine  
Chapel Hill, North Carolina  
20. *Positive Parenting and Support*

**Edward M. Behrens, MD**

Associate Professor of Pediatrics  
Joseph Lee Hollander Chair in Pediatric  
Rheumatology  
University of Pennsylvania Perelman School of  
Medicine  
Chief, Division of Rheumatology  
Children's Hospital of Philadelphia  
Philadelphia, Pennsylvania  
207. *Macrophage Activation Syndrome*

**Michael J. Bell, MD**

Professor, Pediatrics and Critical Care Medicine  
Chief, Critical Care Medicine  
Children's National Medical Center  
The George Washington University School of  
Medicine  
Washington, DC  
82. *Neurologic Emergencies and Stabilization*

**Daniel K. Benjamin Jr., MD, PhD, MPH**

Kiser-Arena Professor of Pediatrics  
Duke Clinical Research Institute  
Duke University Medical Center  
Durham, North Carolina  
280. *Candida*

**Amanda E. Bennett, MD, MPH**

Associate Professor of Clinical Pediatrics  
University of Pennsylvania Perelman School of  
Medicine  
Associate Chief, Division of Developmental and  
Behavioral Pediatrics  
Children's Hospital of Philadelphia  
Philadelphia, Pennsylvania  
59. *Fragile X Syndromes*

**Jenna R.E. Bergerson, MD, MPH**

Director, Allergy Immunology Consult Service  
Associate Program Director, Allergy and  
Immunology Fellowship Training Program  
Primary Immunodeficiency Clinic  
Laboratory of Clinical Immunology and  
Microbiology  
National Institute of Allergy and Infectious  
Diseases  
National Institutes of Health  
Bethesda, Maryland  
175. *Defects of Innate Immunity*

**Daniel Bernstein, MD**

Alfred Woodley Salter and Mabel G. Salter  
Endowed Professor of Pediatrics  
Division of Pediatric Cardiology  
Associate Dean for Curriculum and Scholarship  
Stanford University School of Medicine  
Palo Alto, California  
469. *Cardiac Development*  
470. *The Fetal to Neonatal Circulatory Transition*  
471. *History and Physical Examination in Cardiac  
Evaluation*  
472. *Laboratory Cardiac Evaluation*  
473. *Epidemiology and Genetic Basis of Congenital  
Heart Disease*  
474. *Evaluation and Screening of the Infant or Child  
With Congenital Heart Disease*  
475. *Acyanotic Congenital Heart Disease: Left-to-  
Right Shunt Lesions*  
476. *Acyanotic Congenital Heart Disease:  
Obstructive Lesions*  
477. *Acyanotic Congenital Heart Disease:  
Regurgitant Lesions*  
478. *Cyanotic Congenital Heart Disease: Evaluation  
of the Critically Ill Neonate With Cyanosis and  
Respiratory Distress*  
479. *Cyanotic Congenital Heart Disease: Lesions  
Associated With Decreased Pulmonary Blood  
Flow*  
480. *Cyanotic Congenital Heart Disease: Lesions  
Associated With Increased Pulmonary Blood Flow*  
481. *Other Congenital Heart and Vascular  
Malformations*  
482. *Pulmonary Hypertension*  
483. *General Principles of Treatment of Congenital  
Heart Disease*  
493.1. *Aneurysms*  
493.2. *Arteriovenous Fistulas*

**Henry H. Bernstein, DO, MHCM, FAAP**

Professor of Pediatrics  
Zucker School of Medicine at Hofstra/Northwell  
Cohen Children's Medical Center  
New Hyde Park, New York  
215. *Immunization Practices*

**Brittany J. Bice-Urbach, PhD**

Assistant Professor of Pediatrics  
Medical College of Wisconsin  
Child Development Center  
Children's Wisconsin  
Milwaukee, Wisconsin  
52. *Math and Writing Disabilities*



**Brett P. Bielory, MD**

Medical Director  
Department of Ophthalmology  
OPTUM Tri-State (NJ)  
Rutherford, New Jersey;  
Adjunct Clinical Surgeon  
Department of Ophthalmology  
New York Eye and Ear Infirmary  
Mount Sinai School of Medicine  
New York, New York;  
Associate Professor  
Department of Ophthalmology  
Hackensack Meridian School of Medicine  
Nutley, New Jersey  
188. *Ocular Allergies*

**Leonard Bielory, MD**

Professor of Medicine, Allergy, Immunology, and  
Ophthalmology  
Hackensack Meridian School of Medicine  
Nutley, New Jersey  
188. *Ocular Allergies*

**Samra S. Blanchard, MD**

Associate Professor of Pediatrics  
Division Chief, Pediatric Gastroenterology  
University of Maryland School of Medicine  
Baltimore, Maryland  
381. *Peptic Ulcer Disease in Children*

**Eliza Blanchette, MD**

Assistant Professor of Pediatrics  
Renal Section, Department of Pediatrics  
University of Colorado School of Medicine  
Aurora, Colorado  
568. *Tubular Function*

**Joshua A. Blatter, MD, MPH**

Associate Professor of Pediatrics, Allergy,  
Immunology, and Pulmonary Medicine  
Researcher, Patient Oriented Research Unit  
Washington University School of Medicine  
in St. Louis  
Associate Director, Pediatric Lung Transplantation  
Center  
St. Louis Children's Hospital  
St. Louis, Missouri  
444. *Congenital Disorders of the Lung*

**Archie Bleyer, MD, FRCP (Glasg)**

Clinical Research Professor  
Knight Cancer Center  
Oregon Health & Science University  
Chair, Institutional Review Board for St. Charles  
Health System  
Portland, Oregon;  
Professor of Pediatrics  
University of Texas MD Anderson Cancer Center  
Houston, Texas  
543. *Principles of Cancer Treatment*  
544. *The Leukemias*

**Steven R. Boas, MD, FAAP, FACS**

Clinical Professor of Pediatrics  
Northwestern University Feinberg School of  
Medicine  
Chicago, Illinois;  
Director, The Cystic Fibrosis Center of Chicago  
Glenview, Illinois;  
Director, Illinois Sports Science Institute  
President and CEO, The Cystic Fibrosis Institute  
Northfield, Illinois  
441. *Emphysema and Overinflation*  
442.  *$\alpha$ 1-Antitrypsin Deficiency and Emphysema*  
443. *Other Distal Airway Diseases*  
467. *Skeletal Diseases Influencing Pulmonary  
Function*

**Margret E. Bock, MD, MS**

Associate Professor of Pediatrics  
Renal Section, Department of Pediatrics  
University of Colorado School of Medicine  
Aurora, Colorado  
570. *Nephrogenic Diabetes Insipidus*

**Sarah R. Boggs, MD**

Associate Professor of Pediatrics  
University of Virginia School of Medicine  
Charlottesville, Virginia  
429. *Sinusitis*  
432. *Retropharyngeal Abscess, Lateral Pharyngeal  
(Parapharyngeal) Abscess, and Peritonsillar  
Cellulitis/Abscess*

**Michael J. Boivin, PhD, MPH**

University Distinguished Professor of Psychiatry,  
Neurology, and Ophthalmology  
Director, Psychiatry Research Program  
Michigan State University College of Human  
Medicine  
East Lansing, Michigan  
633.10. *Nodding Syndrome*

**Julie Bonn, MD**

Assistant Professor of Pediatrics  
University of Cincinnati College of Medicine  
Division of Pediatric Gastroenterology,  
Hepatology, and Nutrition  
Cincinnati Children's Hospital Medical Center  
Cincinnati, Ohio  
405. *Metabolic Diseases of the Liver*

**Daniel J. Bonthius, MD, PhD**

Clinical Professor of Neurology  
Wake Forest University School of Medicine  
Winston-Salem, North Carolina;  
Medical Director, Pediatric Neurology  
Levine Children's Hospital  
Charlotte, North Carolina  
318. *Lymphocytic Choriomeningitis Virus*

**Suresh B. Boppana, MD**

Hugh Dillon Professor of Pediatrics  
Professor of Microbiology  
University of Alabama Heersink School of  
Medicine  
Birmingham, Alabama  
302. *Cytomegalovirus*

**Brett J. Bordini, MD, FAAP**

Associate Professor of Pediatrics  
Section of Hospital Medicine  
Nelson Service for Undiagnosed and Rare Diseases  
Medical College of Wisconsin  
Milwaukee, Wisconsin  
440. *Plastic Bronchitis*

**Alexandra J. Borst, MD**

Clinical Assistant Professor of Pediatrics  
University of Pennsylvania Perelman School of  
Medicine  
Attending Physician  
Division of Hematology  
Children's Hospital of Philadelphia  
Philadelphia, Pennsylvania  
554. *Complex Vascular Anomalies*

**Kristopher R. Bosse, MD**

Assistant Professor of Pediatrics  
University of Pennsylvania Perelman School of  
Medicine  
Attending Physician  
Division of Pediatric Oncology  
Children's Hospital of Philadelphia  
Philadelphia, Pennsylvania  
541. *Molecular and Cellular Biology of Cancer*

**Kenneth M. Boyer, MD**

Professor and Woman's Board Chair Emeritus  
Department of Pediatrics  
Rush University Medical Center  
Chicago, Illinois  
336. *Toxoplasmosis (Toxoplasma gondii)*

**Patrick W. Brady, MD, MSc**

Professor of Pediatrics  
University of Cincinnati College of Medicine  
Research Director, Division of Hospital Medicine  
James M. Anderson Center for Health Services  
Excellence  
Cincinnati Children's Hospital Medical Center  
Cincinnati, Ohio  
5. *Safety in Healthcare for Children*

**Rebecca C. Brady, MD**

Professor of Pediatrics  
University of Cincinnati College of Medicine  
Director, Adult Clinical Studies  
Vaccine Research Center  
Cincinnati Children's Hospital Medical Center  
Cincinnati, Ohio  
286. *Coccidioidomycosis (Coccidioides Species)*

**Samuel L. Brady, MS PhD, FAAPM**

Associate Professor of Radiology  
University of Cincinnati College of Medicine  
Section Chief Clinical Medical Physicist  
Cincinnati Children's Hospital Medical Center  
Cincinnati, Ohio  
758. *Biologic Effects of Ionizing Radiation on  
Children*

**Brian R. Branchford, MD**

Associate Professor of Pediatrics  
Medical College of Wisconsin  
Division of Hematology/Oncology  
Children's Wisconsin  
Associate Medical Director  
Versiti Medical Sciences Institute  
Associate Investigator  
Versiti Blood Research Institute  
Milwaukee, Wisconsin  
524. *Hemostasis*  
525. *Hereditary Clotting Factor Deficiencies  
(Bleeding Disorders)*  
526. *Von Willebrand Disease*  
528. *Thrombotic Disorders in Children*  
529. *Postneonatal Vitamin K Deficiency*  
530. *Coagulopathy in Liver Disease*  
531. *Acquired Inhibitors of Coagulation*  
533. *Platelet and Blood Vessel Disorders*

**Amanda M. Brandow, DO, MS**

Professor of Pediatrics  
Section of Hematology/Oncology/Bone Marrow  
Transplantation  
Medical College of Wisconsin  
Milwaukee, Wisconsin  
512. *Enzymatic Defects*  
513. *Hemolytic Anemias Resulting from  
Extracellular Factors—Immune Hemolytic  
Anemias*  
514. *Hemolytic Anemias Secondary to Other  
Extracellular Factors*  
515. *Polycythemia*  
516. *Nonclonal Polycythemia*  
534. *Anatomy and Function of the Spleen*  
535. *Splenomegaly*  
536. *Hyposplenism, Splenic Trauma, and  
Splenectomy*

**Erik Brandsma, MD**

Associate Professor of Clinical Pediatrics  
University of Pennsylvania Perelman School of  
Medicine  
Attending Neonatologist  
Medical Director of Medicine and Transport  
Medical Director of the Infant Breathing Disorder  
Center  
Newborn/Infant Intensive Care Unit  
Children's Hospital of Philadelphia  
Philadelphia, Pennsylvania  
119. *The High-Risk Infant*

**David T. Breault, MD, PhD**

Associate Professor of Pediatrics  
Harvard Medical School  
Division of Endocrinology  
Boston Children's Hospital  
Boston, Massachusetts  
596. *Diabetes Insipidus*  
597. *Other Abnormalities of Arginine Vasopressin  
Metabolism and Action*

**Cora Collette Breuner, MD, MPH, FAAP**

Professor of Pediatrics  
Adjunct Professor of Orthopedics and Sports  
Medicine  
University of Washington School of Medicine  
Division of Adolescent Medicine  
Department of Orthopedics and Sports Medicine  
Seattle Children's Hospital  
Seattle, Washington  
157. *Substance Use Disorder*  
161. *Adolescent Pregnancy*

**Carolyn F. Bridgemohan, MD**

Associate Professor of Pediatrics  
Harvard Medical School  
Co-Director Autism Spectrum Center  
Division of Developmental Medicine  
Boston Children's Hospital  
Boston, Massachusetts  
58. *Autism Spectrum Disorder*

**William J. Britt, MD**

Charles A. Alford Professor of Pediatrics  
Professor of Microbiology  
University of Alabama Heersink School of  
Medicine  
Birmingham, Alabama  
302. *Cytomegalovirus*

**Laura Brower, MD, MSc**

Associate Professor of Pediatrics  
University of Cincinnati College of Medicine  
Attending Physician  
Division of Hospital Medicine  
Cincinnati Children's Hospital Medical Center  
Cincinnati, Ohio  
220. *Fever Without a Focus in the Neonate and  
Young Infant*  
221. *Fever in the Older Child*

**Maria D. Brown, MD, MA**

Assistant Professor of Pediatrics  
The Ohio State University College of Medicine  
Attending Physician  
Section of Adolescent Medicine  
Nationwide Children's Hospital  
Columbus, Ohio  
150. *Adolescent Physical and Social Development*

**Jefferson N. Brownell, MD, MS**

Assistant Professor of Pediatrics  
University of Pennsylvania Perelman School of  
Medicine  
Division of Gastroenterology, Hepatology and  
Nutrition  
Children's Hospital of Philadelphia  
Philadelphia, Pennsylvania  
389. *Disorders of Brain-Gut Interaction (Functional  
Gastrointestinal Disorders)*

**Meghen B. Browning, MD**

Associate Professor of Pediatrics  
Medical College of Wisconsin  
Division of Pediatric Hematology-Oncology  
Children's Wisconsin  
Milwaukee, Wisconsin  
401. *Pancreatic Tumors*

**Nicola Brunetti-Pierrri, MD**

Professor of Medical Genetics  
University of Naples Federico II  
Naples, Italy;  
Principal Investigator  
Telethon Institute of Genetics and Medicine  
(TIGEM)  
Pozzuoli, Italy  
98. *Integration of Genetics into Pediatric Practice*

**Supinda Bunyavanich, MD, MPH, MPhil**

Professor of Pediatrics  
Professor of Genetics & Genomic Sciences  
Mount Sinai Endowed Professor in Allergy and  
Systems Biology  
Deputy Director, Jaffe Food Allergy Institute  
Icahn School of Medicine at Mount Sinai  
New York, New York  
183. *Diagnosis of Allergic Disease*

**Danielle S. Burstein, MD**

Assistant Professor of Pediatrics  
University of Pennsylvania Perelman School of  
Medicine  
Attending Physician  
Division of Pediatric Cardiology  
Children's Hospital of Philadelphia  
Philadelphia, Pennsylvania  
491. *Heart Failure*  
492. *Pediatric Heart and Heart-Lung  
Transplantation*

**Amaya L. Bustinduy, MD, PhD, MPH**

Professor of Global Paediatric and Adolescent  
Infectious Diseases  
Chair, Global Paediatric and Adolescent Infectious  
Diseases  
Department of Clinical Research  
London School of Hygiene and Tropical Medicine  
London, United Kingdom  
346. *Schistosomiasis (Schistosoma)*  
347. *Flukes (Liver, Lung, and Intestinal)*

**Jill P. Buyon, MD**

Sir Deryck and Lady Va Maughan Professor of  
Rheumatology  
New York University Grossman School of Medicine  
Co-Director, Colton Center for Autoimmunity,  
Director, Division of Rheumatology, Director,  
Lupus Center  
NYU Langone Health  
New York, New York  
199.1. *Neonatal Lupus*

**Miguel M. Cabada, MD, MSc**

Associate Professor of Medicine  
Division of Infectious Diseases  
The University of Texas Medical Branch at  
Galveston  
Galveston, Texas  
349. *Cysticercosis*  
350. *Echinococcosis (Echinococcus granulosus sensu  
lato and Echinococcus multilocularis)*

**Michaela Cada, MD, FRCPC, FAAP, MPH**

Associate Professor of Paediatrics  
University of Toronto Faculty of Medicine  
Division of Hematology/Oncology  
The Hospital for Sick Children  
Toronto, Ontario  
517. *Inherited Bone Marrow Failure Syndromes  
With Pancytopenia*

**Mitchell S. Cairo, MD**

Professor of Pediatrics, Medicine, Pathology,  
Microbiology & Immunology and Cell Biology  
& Anatomy  
Chief, Pediatric Hematology, Oncology, and Stem  
Cell Transplantation  
Director, WMC Cancer Center  
Medical and Scientific Director, WMC Cellular and  
Tissue Engineering Laboratory  
Medical Director, WMC Hematology Program  
Vice Chairman, Department of Pediatrics  
Maria Fareri Children's Hospital  
Westchester Medical Center  
New York Medical College  
Valhalla, New York  
545. *Lymphoma*

**Diane P. Calello, MD**

Professor of Emergency Medicine  
Executive Director, Center for Emerging and Re-  
Emerging Pathogens  
Rutgers University New Jersey Medical School  
Executive and Medical Director  
New Jersey Poison Information and Education  
System  
Newark, New Jersey  
762. *Nonbacterial Food Poisoning*

**Lindsay H. Cameron, MD, MPH**

Pediatrician, Pediatric Infectious Diseases  
Texas Children's  
Houston, Texas  
261. *Tuberculosis (Mycobacterium tuberculosis)*

**Angela J.P. Campbell, MD, MPH**

Medical Officer  
Epidemiology and Prevention Branch, Influenza  
Division  
National Center for Immunization and Respiratory  
Diseases  
Centers for Disease Control and Prevention  
Atlanta, Georgia  
306. *Parainfluenza Viruses*

**Margo Candelaria, PhD**

Research Assistant Professor and Research Director  
Co-Director, Parent Infant Early Childhood (PIEC)  
Institute for Innovation and Implementation  
University of Maryland School of Social Work  
Baltimore, Maryland  
19. *Developmental and Behavioral Theories*

**Laura Cannon, MD**

Assistant Professor of Pediatrics  
Division of Pediatric Rheumatology  
University of North Carolina at Chapel Hill  
Chapel Hill, North Carolina  
209. *Sarcoidosis*

**Rebecca F. Carlin, MD**

Assistant Professor of Pediatrics  
Columbia University Vagelos College of Physicians  
and Surgeons  
Division of Hospital Medicine  
Columbia University Irving Medical Center  
New York, New York  
423. *Sudden Infant Death Syndrome*

**James G. Carlucci, MD, MPH**

Assistant Professor of Pediatrics  
Ryan White Center for Pediatric Infectious  
Diseases and Global Health  
Indiana University School of Medicine  
Indianapolis, Indiana  
218. *Health Advice for Children Traveling  
Internationally*

**Michael R. Carr, MD**

Associate Professor of Pediatrics  
Northwestern University Feinberg School of  
Medicine  
Division of Cardiology  
Ann & Robert H. Lurie Children's Hospital of  
Chicago  
Chicago, Illinois  
487. *Rheumatic Heart Disease*

**Robert B. Carrigan, MD**

Associate Professor of Clinical Orthopedic Surgery  
University of Pennsylvania Perelman School of  
Medicine  
Attending Hand and Upper Extremity Surgeon  
Attending Surgeon, Hand Transplantation Program  
Children's Hospital of Philadelphia  
Philadelphia, Pennsylvania  
722. *The Upper Limb*

**Rebecca G. Carter, MD**

Assistant Professor of Pediatrics  
University of Maryland School of Medicine  
Baltimore, Maryland  
24. *The Second Year*  
25. *The Preschool Years*

**Gail V. Carter-Hamilton, MSN, RN, CSN**

Chief Racial Equity Officer  
Philadelphia Department of Public Health  
Philadelphia, Pennsylvania  
217. *Childcare and Communicable Diseases*

**Abigail Case, MD**

Assistant Professor of Clinical Pediatrics and  
Physical Medicine and Rehabilitation  
Associate Fellowship Director  
Attending Physician  
Division of Rehabilitation Medicine  
Department of Pediatrics  
Children's Hospital of Philadelphia  
Philadelphia, Pennsylvania  
751. *Spinal Cord Injury and Autonomic Dysreflexia  
Management*  
755. *Upper and Lower Extremity Assistive Devices*

**Pearl W. Chang, MD**

Assistant Professor of Pediatrics  
University of Washington School of Medicine  
Division of Hospital Medicine  
Seattle Children's Hospital  
Seattle, Washington  
575. *Urinary Tract Infections*

**Gisela G. Chelimsky, MD**

Professor of Pediatrics  
Division of Pediatric Gastroenterology  
Children's Hospital of Richmond and Virginia  
Commonwealth University  
Richmond, Virginia  
84.1. *Postural Tachycardia Syndrome*  
212. *Chronic Overlapping Pain Conditions*

**Thomas Chelimsky, MD**

Professor of Neurology  
Virginia Commonwealth University  
Richmond, Virginia  
84.1. *Postural Tachycardia Syndrome*  
212. *Chronic Overlapping Pain Conditions*

**Wassim Chemaitilly, MD**

Professor of Pediatrics  
University of Pittsburgh School of Medicine  
Clinical Director  
Division of Pediatric Endocrinology  
UPMC Children's Hospital of Pittsburgh  
Pittsburgh, Pennsylvania  
599. *Physiology of Puberty*  
600. *Disorders of Pubertal Development*

**Kathleen Chiotos, MD, MSCE**

Assistant Professor of Anesthesiology, Critical  
Care, and Pediatrics  
University of Pennsylvania Perelman School of  
Medicine  
Attending Physician  
Divisions of Critical Care Medicine and Infectious  
Diseases  
Children's Hospital of Philadelphia  
Philadelphia, Pennsylvania  
226. *Antimicrobial Stewardship*

**Yvonne E. Chiu, MD**

Vice Chair and Professor of Dermatology  
Division of Pediatric Dermatology  
Professor of Pediatrics  
Medical College of Wisconsin  
Children's Wisconsin  
Milwaukee, Wisconsin  
686. *Morphology of the Skin*  
686. *Dermatologic Evaluation of the Patient*  
696. *Eczematous Disorders*  
697. *Photosensitivity*  
698. *Diseases of the Epidermis*  
700. *Diseases of the Dermis*  
701. *Diseases of Subcutaneous Tissue*

**Hey Jin Chong, MD, PhD**

Associate Professor of Pediatrics  
University of Pittsburgh School of Medicine  
Chief, Division of Pediatric Allergy and  
Immunology  
Director, Immune Dysregulation Diagnosis and  
Treatment Program  
UPMC Children's Hospital of Pittsburgh  
Pittsburgh, Pennsylvania  
223. *Infections in Immunocompromised Persons*

**Stella T. Chou, MD**

Associate Professor of Pediatrics  
University of Pennsylvania Perelman School of  
Medicine  
Chief, Division of Transfusion Medicine  
Attending Physician, Division of Hematology  
Children's Hospital of Philadelphia  
Philadelphia, Pennsylvania  
495. *Development of the Hematopoietic System*

**Lori A. Christ, MD**

Associate Professor of Clinical Pediatrics  
University of Pennsylvania Perelman School of  
Medicine  
Attending Neonatologist  
Children's Hospital of Philadelphia  
Medical Director of Intensive Care Nursery  
Hospital of the University of Pennsylvania  
Philadelphia, Pennsylvania  
119. *The High-Risk Infant*

**John C. Christenson, MD, FAAP, FIDSA, FPIDS**

Professor of Clinical Pediatrics  
Ryan White Center for Pediatric Infectious  
Diseases and Global Health  
Indiana University School of Medicine  
Indianapolis, Indiana  
218. *Health Advice for Children Traveling  
Internationally*

**Ankur A. Chugh, MD**

Associate Professor of Pediatrics  
Medical College of Wisconsin  
Division of Pediatric Gastroenterology  
Children's Wisconsin  
Milwaukee, Wisconsin  
384. *Celiac Disease*

**Theodore J. Cieslak, MD, MPH, FAAP, FIDSA**

Professor of Epidemiology and Pediatrics  
Co-Medical Director, Nebraska Biocontainment  
Unit  
University of Nebraska Medical Center  
Omaha, Nebraska  
763. *Biological and Chemical Terrorism*

**Donna J. Claes, MD, MS**

Associate Professor of Pediatrics  
University of Cincinnati College of Medicine  
Division of Pediatric Nephrology  
Cincinnati Children's Hospital Medical Center  
Cincinnati, Ohio  
572.2. *Chronic Kidney Disease*  
572.3. *End-Stage Kidney Disease*

**Thomas D. Coates, MD**

Section Head, Hematology  
Cancer and Blood Disease Institute  
Professor of Pediatrics and Pathology  
University of Southern California Keck School of  
Medicine  
Children's Hospital Los Angeles  
Los Angeles, California  
168. *Neutrophils*  
170. *Disorders of Phagocyte Function*

**María I. Sánchez Códez, MD**

Departamento de Pediatría  
Unidad de Infectología Pediátrica  
Hospital Universitario Puerta del Mar  
Cádiz, Spain  
270. *Genital Mycoplasmas (Mycoplasma hominis,  
Mycoplasma genitalium, and Ureaplasma  
urealyticum)*

**Susan E. Coffin, MD, MPH**

Professor of Pediatrics  
University of Pennsylvania Perelman School of  
Medicine  
Attending Physician  
Division of Infectious Diseases  
Distinguished Chair in the Department of Pediatrics  
Associate Hospital Epidemiologist  
Children's Hospital of Philadelphia  
Philadelphia, Pennsylvania  
217. *Childcare and Communicable Diseases*



**Mitchell B. Cohen, MD**

Katharine Reynolds Ireland Endowed Chair in Pediatrics  
 Professor and Chair, Department of Pediatrics  
 University of Alabama at Birmingham School of Medicine  
 Physician-in-Chief  
 Children's of Alabama  
 Birmingham, Alabama  
 258. *Clostridioides difficile* Infection

**Susan S. Cohen, MD**

Associate Professor of Pediatrics  
 Medical College of Wisconsin  
 Division of Neonatal-Perinatal Medicine  
 Children's Wisconsin  
 Milwaukee, Wisconsin  
 117. *The Fetus*  
 122. *Nervous System Disorders*  
 124. *Transition to Newborn Pulmonary Respiration*  
 125. *Apnea*  
 126. *Respiratory Distress Syndrome (Hyaline Membrane Disease)*  
 127. *Bronchopulmonary Dysplasia*  
 128. *Transient Tachypnea of the Newborn*  
 129. *Aspiration of Foreign Material (Meconium Aspiration Syndrome, Aspiration Pneumonia)*  
 130. *Persistent Pulmonary Hypertension of the Newborn (Persistent Fetal Circulation)*  
 131. *Diaphragmatic Hernia*  
 132. *Pulmonary Air Leaks: Pneumothorax, Pneumomediastinum, Pulmonary Interstitial Emphysema, Pneumopericardium*  
 133. *Pulmonary Hemorrhage*

**F. Sessions Cole III, MD**

Assistant Vice-Chancellor for Children's Health  
 Park J. White Professor of Pediatrics  
 Professor of Cell Biology and Physiology  
 Washington University School of Medicine in St. Louis  
 Chief Medical Officer  
 Vice-Chairman, Department of Pediatrics  
 Director of Newborn Medicine  
 St. Louis Children's Hospital  
 St. Louis, Missouri  
 456. *Diffuse Lung Diseases in Childhood*

**J. Michael Collaco, MD, MS, MBA, MPH, PhD**

Associate Professor of Pediatrics  
 Eudowood Division of Pediatric Respiratory Sciences  
 Johns Hopkins University School of Medicine  
 Baltimore, Maryland  
 466. *Bronchopulmonary Dysplasia*

**James W. Collins Jr., MD, MPH**

Professor of Pediatrics (Neonatology)  
 Northwestern University Feinberg School of Medicine  
 Medical Director, Neonatal Intensive Care Unit  
 Ann & Robert H. Lurie Children's Hospital of Chicago  
 Chicago, Illinois  
 114.1. *Race, Class, and Birth Outcomes*

**Joseph A. Congeni, MD**

Director, Sports Medicine Center  
 Akron Children's Hospital  
 Akron, Ohio;  
 Professor of Pediatrics  
 Northeast Ohio Medical University  
 Rootstown, Ohio;  
 Clinical Associate Professor of Pediatrics and Sports Medicine  
 Ohio University College of Osteopathic Medicine  
 Athens, Ohio  
 730. *Cervical Spine Injuries*

**Máire A. Conrad, MD, MS**

Assistant Professor of Pediatrics  
 Division of Gastroenterology, Hepatology, and Nutrition  
 University of Pennsylvania Perelman School of Medicine  
 Children's Hospital of Philadelphia  
 Philadelphia, Pennsylvania  
 377. *Intestinal Duplications, Meckel Diverticulum, and Other Remnants of the Omphalomesenteric Duct*

**Justin N. Corcoran, MD**

Assistant Professor of Emergency Medicine  
 Medical College of Wisconsin  
 Medical Toxicologist  
 Wisconsin Poison Center  
 Milwaukee, Wisconsin  
 94. *Poisoning*

**Alexandra M.S. Corley, MD, MPH**

Assistant Professor of Pediatrics  
 University of Cincinnati College of Medicine  
 Attending Physician, Division of General and Community Pediatrics  
 Cincinnati Children's Hospital Medical Center  
 Cincinnati, Ohio  
 12. *Cultural Issues in Pediatric Care*

**Amanda L. Cox, MD**

Associate Professor of Pediatrics  
 Icahn School of Medicine at Mount Sinai  
 Division of Pediatric Allergy and Immunology  
 Mount Sinai Kravis Children's Hospital  
 New York, New York  
 192. *Food Allergy and Adverse Reactions to Foods*

**Anne M. Coyle, MD**

Lewis Katz School of Medicine at Temple University  
 Philadelphia, Pennsylvania  
 718. *The Knee*

**Tamera Coyne-Beasley, MD, MPH, FAAP, FSAHM**

Professor of Pediatrics and Internal Medicine  
 Derrol Dawkins MD Endowed Chair in Adolescent Medicine  
 Vice Chair, Pediatrics for Community Engagement  
 Children's of Alabama  
 The University of Alabama at Birmingham  
 Birmingham, Alabama  
 151. *Delivery of Healthcare to Adolescents*  
 155. *The Epidemiology of Adolescent Health Problems*  
 163. *Sexually Transmitted Infections*

**Sansanee S. Craig, MD**

Assistant Professor of Clinical Pediatrics  
 University of Pennsylvania Perelman School of Medicine  
 Attending Physician, Division of General Pediatrics  
 Department of Biomedical and Health Informatics  
 Children's Hospital of Philadelphia  
 Philadelphia, Pennsylvania  
 3. *Global Child Health*

**Sarah M. Creighton, MD, FRCOG**

Consultant Gynaecologist and Honorary Clinical Professor  
 Department of Women's Health  
 University College London Hospitals  
 London, United Kingdom  
 593. *Female Genital Mutilation*

**Chad B. Crigger, MD, MPH**

Division of Pediatric Urology  
 Johns Hopkins University Medical Center  
 Baltimore, Maryland  
 574. *Congenital Anomalies and Dysgenesis of the Kidneys*  
 576. *Vesicoureteral Reflux*  
 577. *Obstruction of the Urinary Tract*  
 578. *Anomalies of the Bladder*  
 579. *Neuropathic Bladder*  
 580. *Enuresis and Voiding Dysfunction*  
 581. *Anomalies of the Penis and Urethra*  
 582. *Disorders and Anomalies of the Scrotal Contents*  
 583. *Trauma to the Genitourinary Tract*  
 584. *Urinary Lithiasis*

**James E. Crowe Jr., MD**

Professor Pediatrics and Pathology, Microbiology and Immunology  
 Vanderbilt University School of Medicine  
 Director, Vanderbilt Vaccine Center  
 Ann Scott Carell Chair  
 Vanderbilt University Medical Center  
 Nashville, Tennessee  
 307. *Respiratory Syncytial Virus*  
 308. *Human Metapneumovirus*

**Gabriel Culbert, PhD, RN**

Associate Professor of Nursing  
 Department of Population Health Nursing Science  
 University of Illinois at Chicago College of Nursing  
 Chicago, Illinois  
 114.1. *Race, Class, and Birth Outcomes*

**Steven J. Czinn, MD**

Drs. Rouben and Violet Jiji Endowed Professor Chair, Department of Pediatrics  
 University of Maryland School of Medicine  
 Director, University of Maryland Children's Hospital  
 Baltimore, Maryland  
 381. *Peptic Ulcer Disease in Children*

**Aarti S. Dalal, DO, CEPS-P**

Assistant Professor of Pediatrics  
 Vanderbilt University School of Medicine  
 Associate Director, Pediatric Electrophysiology  
 Division of Cardiology  
 Monroe Carell Jr. Children's Hospital at Vanderbilt  
 Nashville, Tennessee  
 84. *Syncope*  
 484. *Disturbances of Rate and Rhythm of the Heart*  
 485. *Sudden Death*

**Josep Dalmau, MD, PhD**

Research Professor ICREA-IDIBAPS  
 Service of Neurology  
 Hospital Clinic  
 University of Barcelona  
 Barcelona, Spain;  
 Adjunct Professor of Neurology  
 University of Pennsylvania Perelman School of Medicine  
 Philadelphia, Pennsylvania  
 638.4. *Autoimmune Encephalitis*

**Lynn A. D'Andrea, MD**

Professor of Pediatrics  
 Medical College of Wisconsin  
 Chief, Division of Pulmonary and Sleep Medicine  
 Children's Wisconsin  
 Milwaukee, Wisconsin  
 450. *E-Cigarette or Vaping Product Use-Associated Lung Injury (EVALI)*

**Lara A. Danziger-Isakov, MD, MPH**

Professor of Pediatrics  
University of Cincinnati College of Medicine  
Director, Immunocompromised Host Infectious  
Disease  
Cincinnati Children's Hospital Medical Center  
Cincinnati, Ohio  
284. *Histoplasmosis (Histoplasma capsulatum)*

**Toni Darville, MD**

Distinguished Professor of Pediatrics and  
Microbiology and Immunology  
University of North Carolina School of Medicine at  
Chapel Hill  
Chief, Division of Infectious Diseases  
Vice-Chair of Pediatric Research  
Department of Pediatrics  
Scientific Director, Children's Research Institute  
North Carolina Children's Hospital  
Chapel Hill, North Carolina  
238. *Neisseria gonorrhoeae (Gonococcus)*

**Richard J. David, MD**

Professor of Pediatrics  
University of Illinois at Chicago College of  
Medicine  
Co-Director, Neonatal Intensive Care Unit (retired)  
Stroger Hospital of Cook County  
Chicago, Illinois  
114.1. *Race, Class, and Birth Outcomes*

**Katharine Davidoff, MD**

Attending Physician, Pediatric Palliative Care  
Massachusetts General Hospital for Children  
(MGHfC)  
Boston, Massachusetts  
8. *Pediatric Palliative Care*

**Loren T. Davidson, MD**

Health Sciences Clinical Professor of Physical  
Medicine and Rehabilitation  
UC Davis School of Medicine  
Director, Spinal Cord Injury  
Shriners Hospital for Children  
Sacramento, California  
752. *Spasticity*

**Richard S. Davidson, MD**

Professor of Orthopaedic Surgery  
University of Pennsylvania Perelman School of  
Medicine  
Children's Hospital of Philadelphia Endowed Chair  
in Pediatric Orthopaedic Surgery  
Attending Orthopaedic Surgeon  
Children's Hospital of Philadelphia  
Philadelphia, Pennsylvania  
715. *The Foot and Toes*  
717. *Leg-Length Discrepancy*  
723. *Arthrogryposis*

**H. Dele Davies, MD, MS, MHCM**

Senior Vice Chancellor for Academic Affairs  
Dean for Graduate Studies  
University of Nebraska Medical Center  
Omaha, Nebraska  
241. *Chancroid (Haemophilus ducreyi)*  
264. *Syphilis (Treponema pallidum)*  
265. *Nonvenereal Treponemal Infections*  
266. *Leptospira*  
267. *Relapsing Fever (Borrelia)*

**Stephanie D. Davis, MD**

Edward C. Curnen Jr Distinguished Professor and  
Chair  
Department of Pediatrics  
The University of North Carolina at Chapel Hill  
School of Medicine  
Physician-in-Chief  
UNC Children's Hospital  
Chapel Hill, North Carolina  
448.1. *Hypersensitivity Pneumonia*  
448.2. *Occupational and Environmental Lung  
Disease*  
448.3. *Granulomatous Lung Disease*  
448.4. *Eosinophilic Lung Disease*  
448.5. *Interstitial Lung Disease*

**Christina Davis-Kankanamge, MD**

Assistant Professor of Obstetrics and Gynecology  
Baylor College of Medicine  
Department of Pediatric and Adolescent  
Gynecology  
Texas Children's  
Houston, Texas  
587. *Vaginal Bleeding in the Prepubertal Child*

**Najat C. Daw, MD**

Professor of Pediatrics  
University of Texas MD Anderson Cancer Center  
Houston, Texas  
548. *Neoplasms of the Kidney*

**Shannon L. Dean, MD, PhD**

Assistant Professor of Neurology  
Johns Hopkins University School of Medicine  
Kennedy Krieger Institute  
Baltimore, Maryland  
637.4. *Dystonia*

**Roberta L. DeBiasi, MD, MS**

Professor of Pediatrics and Microbiology,  
Immunology and Tropical Medicine  
The George Washington University School of  
Medicine  
Chief, Division of Pediatric Infectious Diseases  
Robert H. Parrott Professor of Pediatric Research  
Children's National Hospital and Research Institute  
Washington, DC  
311. *Coronaviruses*

**Shirley Delair, MD, MPH**

Associate Professor of Pediatrics  
Chief, Division of Pediatric Infectious Diseases  
Associate Dean of Diversity, Equity and Inclusion  
University of Nebraska Medical Center  
Omaha, Nebraska  
241. *Chancroid (Haemophilus ducreyi)*

**Amy M. DeLaroche, MD**

Assistant Professor of Pediatrics  
Central Michigan University College of Medicine  
Division of Emergency Medicine  
Children's Hospital of Michigan  
Detroit, Michigan  
424. *Brief Resolved Unexplained Events and Other  
Acute Events in Infants*

**Diva D. De León-Crutchlow, MD, MSCE**

Professor of Pediatrics  
University of Pennsylvania Perelman School of  
Medicine  
Chief, Division of Endocrinology and Diabetes  
Director, Congenital Hyperinsulinism Center  
Children's Hospital of Philadelphia  
Philadelphia, Pennsylvania  
113. *Hypoglycemia*

**Helen M. Oquendo Del Toro, MD**

Clinical Assistant Professor of Obstetrics and  
Gynecology  
Division of Pediatric and Adolescent Gynecology  
University of New Mexico School of Medicine  
Albuquerque, New Mexico  
586. *Vulvovaginitis*

**Coralee Del Valle Mojica, MD, MPH**

Assistant Professor of Clinical Pediatrics  
University of Pennsylvania Perelman School of  
Medicine  
Attending Physician  
Division of Infectious Diseases  
Children's Hospital of Philadelphia  
Philadelphia, Pennsylvania  
236. *Nocardia*

**David R. DeMaso, MD**

George P. Gardner and Olga E. Monks Professor of  
Child Psychiatry  
Professor of Pediatrics  
Department of Psychiatry  
Harvard Medical School  
Chair of Psychiatry  
Department of Psychiatry and Behavioral Sciences  
Boston Children's Hospital  
Boston, Massachusetts  
33. *Psychopharmacology*  
34. *Psychotherapy*  
35. *Somatic Symptom and Related Disorders*  
36. *Rumination and Pica*  
37. *Motor Disorders and Habits*  
42. *Disruptive, Impulse-Control, and Conduct  
Disorders*  
43. *Tantrums and Breath-Holding Spells*  
44. *Lying, Stealing, and Truancy*  
45. *Aggression*

**Melina L. Dendinos, MD**

Assistant Professor of Obstetrics and Gynecology  
University of Michigan Medical School  
Ann Arbor, Michigan  
592. *Gynecologic Care for Adolescents with Special  
Needs*

**Arlene E. Dent, MD, PhD**

Associate Professor of Pediatrics  
Center for Global Health and Diseases  
Case Western Reserve University School of  
Medicine  
Cleveland, Ohio  
337. *Ascariasis (Ascaris lumbricoides)*  
339. *Trichuriasis (Trichuris trichiura)*  
340. *Enterobiasis (Enterobius vermicularis)*  
341. *Strongyloidiasis (Strongyloides stercoralis)*  
342. *Lymphatic Filariasis (Brugia malayi, Brugia  
timori, and Wuchereria bancrofti)*  
343. *Other Tissue Nematodes*  
344. *Toxocariasis (Visceral and Ocular Larva  
Migrans)*  
345. *Trichinellosis (Trichinella spiralis)*

**Robert J. Desnick, MD, PhD**

Dean for Genetic and Genomic Medicine Emeritus  
Professor and Chairman Emeritus  
Department of Genetics and Genomic Sciences  
Icahn School of Medicine at Mount Sinai  
New York, New York  
106.4. *Lipidoses (Lysosomal Storage Disorders)*  
106.5. *Mucopolidoses*  
107.6. *Disorders of Glycoprotein Degradation and  
Structure*  
112. *The Porphyrias*

**Robin R. Deterding, MD**

Professor of Pediatrics  
University of Colorado School of Medicine  
Aurora, Colorado  
448.7. Fibrotic Lung Disease

**Prasad Devarajan, MD, FAAP, FASN**

Louise M. Williams Endowed Chair  
Professor of Pediatrics and Developmental Biology  
University of Cincinnati College of Medicine  
Director of Nephrology and Hypertension  
Director and CEO, Dialysis Unit and ESRD Program  
Director, Biomarker Laboratory  
Cincinnati Children's Hospital Medical Center  
Cincinnati, Ohio  
560. Multisystem Disease Associated With Hematuria  
561. Tubulointerstitial Disease Associated With Hematuria  
562. Vascular Diseases Associated with Hematuria  
563. Anatomic Abnormalities Associated With Hematuria  
564. Lower Urinary Tract Causes of Hematuria  
572.1. Acute Kidney Injury

**Gabrielle A. deVeber, MD, MHSc**

Professor of Pediatrics  
University of Toronto Faculty of Medicine  
Children's Stroke Program  
Division of Neurology  
Senior Scientist Emeritus, Research Institute  
Hospital for Sick Children  
Toronto, Ontario, Canada  
641. Pediatric Stroke

**Vineet K. Dhar, BDS, MDS, PhD**

Assistant Dean, Postgraduate and Professional Studies in Dentistry  
Clinical Professor and Chairman, Orthodontics and Pediatric Dentistry  
Diplomate, American Board of Pediatric Dentistry  
University of Maryland School of Dentistry  
Baltimore, Maryland  
353. Development and Developmental Anomalies of the Teeth  
354. Disorders of the Oral Cavity Associated with Other Conditions  
355. Malocclusion  
356. Cleft Lip and Palate  
357. Syndromes With Oral Manifestations  
358. Dental Caries  
359. Periodontal Diseases  
360. Dental Trauma  
361. Common Lesions of the Oral Soft Tissues  
362. Diseases of the Salivary Glands and Jaws  
363. Diagnostic Radiology in Dental Assessment

**Julie M. Dhossche, MD**

Assistant Professor of Dermatology  
Oregon Health & Science University  
Portland, Oregon  
685. Morphology of the Skin  
686. Dermatologic Evaluation of the Patient  
696. Eczematous Disorders  
697. Photosensitivity  
698. Diseases of the Epidermis

**Liliane K. Diab, MD**

Assistant Professor of Pediatrics  
University of Colorado School of Medicine  
Section of Pediatric Nutrition  
Children's Hospital Colorado  
Aurora, Colorado  
64. Malnutrition in High-Resource Settings

**Heather N. Di Carlo, MD**

Assistant Professor of Urology  
Director, Pediatric Urology Research  
Johns Hopkins University Medical Center  
Baltimore, Maryland  
574. Congenital Anomalies and Dysgenesis of the Kidneys  
576. Vesicoureteral Reflux  
577. Obstruction of the Urinary Tract  
578. Anomalies of the Bladder  
579. Neuropathic Bladder  
580. Enuresis and Voiding Dysfunction  
581. Anomalies of the Penis and Urethra  
582. Disorders and Anomalies of the Scrotal Contents  
583. Trauma to the Genitourinary Tract  
584. Urinary Lithiasis

**Harry C. Dietz III, MD**

Victor A. McKusick Professor of Medicine and Genetics  
Departments of Pediatrics, Medicine, and Molecular Biology and Genetics  
Institute of Genetic Medicine  
Johns Hopkins University School of Medicine  
Investigator, Howard Hughes Medical Institute  
Baltimore, Maryland  
743. Marfan Syndrome

**Megan L. Dietze-Fiedler, MD**

Pediatric and Adult Plastic Surgery  
Prevea Health  
Green Bay, Wisconsin  
632. Deformational Plagiocephaly

**Linda A. DiMeglio, MD, MPH**

Professor of Pediatrics  
Chief, Division of Pediatric Endocrinology  
Indiana University School of Medicine  
Riley Hospital for Children  
Indianapolis, Indiana  
747. Hypophosphatasia  
748. Hyperphosphatasia

**Bradley P. Dixon, MD, FASN**

Associate Professor of Pediatrics and Medicine  
Renal Section, Department of Pediatrics  
University of Colorado School of Medicine  
Aurora, Colorado  
568. Tubular Function  
569. Renal Tubular Acidosis  
570. Nephrogenic Diabetes Insipidus  
571. Inherited Tubular Transport Abnormalities

**Amy D. DiVasta, MD, MMSc**

Associate Professor of Pediatrics  
Harvard Medical School  
Attending Physician  
Division of Adolescent/Young Adult Medicine  
Director, Young Women's Health Research  
Boston Children's Hospital  
Boston, Massachusetts  
588. Breast Health

**Nomazulu Dlamini, MBBS, PhD**

Associate Professor of Pediatrics  
University of Toronto Faculty of Medicine  
Staff Physician in Neurology  
Director, Children's Stroke Program  
Hospital for Sick Children  
Toronto, Ontario, Canada  
641. Pediatric Stroke

**Katherine R. Dobbs, MD**

Assistant Professor of Pediatrics  
Center for Global Health and Diseases  
Case Western Reserve University School of Medicine  
Cleveland, Ohio  
337. Ascariasis (*Ascaris lumbricoides*)  
339. Trichuriasis (*Trichuris trichiura*)  
340. Enterobiasis (*Enterobius vermicularis*)  
341. Strongyloidiasis (*Strongyloides stercoralis*)  
342. Lymphatic Filariasis (*Brugia malayi*, *Brugia timori*, and *Wuchereria bancrofti*)  
343. Other Tissue Nematodes  
344. Toxocariasis (Visceral and Ocular Larva Migrants)  
345. Trichinellosis (*Trichinella spiralis*)

**Sonam N. Dodhia, MD**

Department of Otolaryngology – Head and Neck Surgery  
Columbia University Vagelos College of Physicians and Surgeons  
NewYork-Presbyterian Hospital  
Columbia University Irving Medical Center  
New York, New York  
426. Acquired Disorders of the Nose

**Katja Doerholt, MD**

Paediatric Infectious Diseases Consultant  
St George's University Hospital  
Honorary Clinical Lecturer  
University College London Faculty of Population Health Sciences  
London, United Kingdom  
346. Schistosomiasis (*Schistosoma*)  
347. Flukes (Liver, Lung, and Intestinal)

**Cara D. Dolin, MD, MPH**

Assistant Professor of Obstetrics and Gynecology  
University of Pennsylvania Perelman School of Medicine  
Division of Maternal-Fetal Medicine  
Philadelphia, Pennsylvania  
116. High-Risk Pregnancies

**Samuel R. Dominguez, MD, PhD**

Professor of Pediatrics  
University of Colorado School of Medicine  
Division of Pediatric Infectious Diseases  
Children's Hospital Colorado  
Aurora, Colorado  
311. Coronaviruses

**Patricia A. Donohoue, MD**

Professor and Chief, Emerita  
Pediatric Endocrinology  
Medical College of Wisconsin  
Former Medical Director of Endocrinology  
Children's Wisconsin  
Milwaukee, Wisconsin  
622. Development and Function of the Gonads  
623. Hypofunction of the Testes  
624. Pseudoprecocity Resulting From Tumors of the Testes  
625. Gynecomastia  
626. Hypofunction of the Ovaries  
627. Pseudoprecocity Resulting From Lesions of the Ovary  
628. Disorders of Sex Development



**Jennifer Dow, MD, MHA, FACEP, FAWM, DiMM**

Medical Director, Denali National Park and Preserve  
 Medical Director, National Park Service, Alaska Region  
 Attending Physician  
 Department of Emergency Medicine  
 Alaska Regional Hospital  
 Anchorage, Alaska;  
 Adjunct Assistant Professor of Emergency Medicine  
 University of Utah School of Medicine  
 Salt Lake City, Utah  
 90. *Cold Injuries*

**Kevin J. Downes, MD**

Assistant Professor of Pediatrics  
 University of Pennsylvania Perelman School of Medicine  
 Attending Physician  
 Division of Infectious Diseases  
 Children's Hospital of Philadelphia  
 Philadelphia, Pennsylvania  
 252. *Tularemia (Francisella tularensis)*  
 253. *Brucella*

**Daniel A. Doyle, MD**

Associate Professor of Pediatrics  
 Sidney Kimmel Medical College of Thomas Jefferson University  
 Philadelphia, Pennsylvania;  
 Chief, Division of Pediatric Endocrinology  
 Nemours Alfred I. duPont Hospital for Children  
 Wilmington, Delaware  
 610. *Hormones and Peptides of Calcium Homeostasis and Bone Metabolism*  
 611. *Hypoparathyroidism*  
 612. *Pseudohypoparathyroidism*  
 613. *Hyperparathyroidism*

**Jefferson J. Doyle, MBBChir, PhD, MHS**

Assistant Professor of Ophthalmology and Genetic Medicine  
 Dracopoulos Finkelstein Rising Professor in Ophthalmology  
 Wilmer Eye Institute  
 Johns Hopkins Hospital  
 Department of Genetic Medicine  
 Johns Hopkins School of Medicine  
 Baltimore, Maryland  
 743. *Marfan Syndrome*

**Yigal Dror, MD, FRCPC**

Professor of Paediatrics  
 University of Toronto Faculty of Medicine  
 Director, Marrow Failure and Myelodysplasia  
 Division of Hematology/Oncology  
 The Hospital for Sick Children  
 Senior Scientist  
 Program in Genetics and Genome Biology  
 Research Institute  
 Toronto, Ontario  
 517. *Inherited Bone Marrow Failure Syndromes with Pancytopenia*

**Howard Dubowitz, MD, MS, FAAP**

Professor of Pediatrics  
 Head, Division of Child Protection  
 Director, Center for Families  
 Department of Pediatrics  
 University of Maryland School of Medicine  
 Baltimore, Maryland  
 17. *Abused and Neglected Children*

**J. Stephen Dumler, MD**

Professor and Chair  
 Department of Pathology  
 Uniformed Services University of the Health Sciences  
 Walter Reed National Military Medical Center  
 Bethesda, Maryland  
 274. *Spotted Fever Group Rickettsioses*  
 275. *Scrub Typhus (Orientia tsutsugamushi)*  
 276. *Typhus Group Rickettsioses*  
 277. *Ehrlichiosis and Anaplasmosis*  
 278. *Q Fever (Coxiella burnetii)*

**Andrea F. Duncan, MD, MSClinRes**

Associate Professor of Pediatrics  
 University of Pennsylvania Perelman School of Medicine  
 Distinguished Endowed Chair in the Department of Pediatrics  
 Associate Chair, Diversity and Equity, Department of Pediatrics  
 Medical Director, Neonatal Follow-up Program  
 Clinic at Buerger  
 Attending Neonatologist  
 Children's Hospital of Philadelphia  
 Philadelphia, Pennsylvania  
 119. *The High-Risk Infant*

**Nefertiti H. Durant, MD, MPH**

Associate Professor of Pediatrics  
 The University of Alabama at Birmingham  
 Division of Adolescent Medicine  
 Children's of Alabama  
 Birmingham, Alabama  
 163. *Sexually Transmitted Infections*

**Jeffrey A. Dvergsten, MD**

Associate Professor of Pediatrics  
 Duke University School of Medicine  
 Division of Pediatric Rheumatology  
 Duke University Health System  
 Durham, North Carolina  
 195. *Treatment of Rheumatic Diseases*  
 200. *Juvenile Dermatomyositis*

**Michael G. Earing, MD, MS**

Professor of Internal Medicine and Pediatrics  
 Chief of Pediatric Cardiology  
 The University of Chicago Pritzker School of Medicine  
 Section Chief and Co-director Advocate Children's Hospital Heart Institute  
 Medical Director  
 Chicago Alliance for Adult Congenital Heart Disease Care  
 Chicago, Illinois  
 483.1. *Congenital Heart Disease in Adults*

**Col. Matthew D. Eberly, MD**

Associate Professor of Pediatrics  
 Uniformed Services University of the Health Sciences  
 Bethesda, Maryland  
 326. *Primary Amebic Meningoencephalitis*

**Marie E. Egan, MD**

Professor of Pediatrics (Respiratory) and Cellular and Molecular Physiology  
 Director, Cystic Fibrosis Center  
 Vice Chair for Research  
 Department of Pediatrics  
 Yale School of Medicine  
 New Haven, Connecticut  
 454. *Cystic Fibrosis*

**Eric C. Eichenwald, MD**

Professor of Pediatrics  
 University of Pennsylvania Perelman School of Medicine  
 Chief of the Division of Neonatology  
 Thomas Frederick McNair Scott Endowed Chair  
 Children's Hospital of Philadelphia  
 Philadelphia, Pennsylvania  
 121. *Clinical Manifestations of Diseases in the Newborn Period*  
 135. *Meconium Ileus, Peritonitis, Intestinal Obstruction, and Gastroschisis*  
 144. *The Umbilicus*

**Abdul-Aziz K. Elkadri, MD**

Associate Professor of Pediatrics  
 Medical College of Wisconsin  
 Division of Pediatric Gastroenterology, Hepatology and Nutrition  
 Children's Wisconsin  
 Milwaukee, Wisconsin  
 385. *Disorders of Malabsorption*

**Elizabeth Englander, PhD**

Professor of Psychology  
 Bridgewater State University  
 Founder and Executive Director  
 Massachusetts Aggression Reduction Center  
 Bridgewater, Massachusetts  
 15.1. *Bullying, Cyberbullying, and School Violence*

**Jessica E. Ericson, MD, MPH**

Associate Professor of Pediatrics  
 Pennsylvania State University College of Medicine  
 Division of Pediatric Infectious Disease  
 Milton S. Eisenhower Medical Center  
 Hershey, Pennsylvania  
 280. *Candida*

**Elif Erkan, MD, MS**

Professor of Pediatrics  
 University of Cincinnati College of Medicine  
 Division of Pediatric Nephrology  
 Cincinnati Children's Hospital Medical Center  
 Cincinnati, Ohio  
 567. *Nephrotic Syndrome*

**Ruth A. Etzel, MD, PhD**

Adjunct Professor  
 Milken Institute School of Public Health  
 George Washington University  
 Washington, DC  
 757. *Overview of Environmental Health and Children*

**Sarah Helen Evans, MD**

Professor of Clinical Pediatrics and Physical Medicine and Rehabilitation  
 University of Pennsylvania Perelman School of Medicine  
 Chief, Division of Rehabilitation Medicine  
 Department of Pediatrics  
 Children's Hospital of Philadelphia  
 Philadelphia, Pennsylvania  
 755. *Upper and Lower Extremity Assistive Devices*

**Erin Faherty, MD**

Assistant Professor of Clinical Pediatrics  
 Yale School of Medicine  
 Children's Heart Center  
 Division of Pediatric Cardiology  
 Yale New Haven Children's Hospital  
 New Haven, Connecticut  
 486. *Infective Endocarditis*

**Marni J. Falk, MD**

Professor of Pediatrics  
University of Pennsylvania Perelman School of  
Medicine  
Executive Director, Mitochondrial Medicine  
Frontier Program  
Division of Human Genetics, Department of  
Pediatrics  
Children's Hospital of Philadelphia  
Philadelphia, Pennsylvania  
108. *Mitochondrial Disease Diagnosis*

**Itziar Familiar-Lopez, MD, PhD, MPH**

Assistant Professor of Psychiatry  
Michigan State University College of Human  
Medicine  
East Lansing, Michigan  
633.10. *Nodding Syndrome*

**John H. Fargo, DO**

Assistant Professor of Pediatrics  
Northeast Ohio Medical University  
Rootstown, Ohio;  
Director, Hemostasis and Thrombosis Center  
Director, Divisional Quality Improvement  
Division of Pediatric Hematology/Oncology  
Showers Family Center for Childhood Cancer and  
Blood Disorders  
Akron Children's Hospital  
Akron, Ohio  
518. *Acquired Pancytopenias*

**Kristen A. Feemster, MD, MPH, MSPHR, FAAP**

Director of Research  
Vaccine Education Center  
Children's Hospital of Philadelphia  
Adjunct Associate Professor of Pediatrics  
University of Pennsylvania Perelman School of  
Medicine  
Philadelphia, Pennsylvania  
313. *Human Papillomaviruses*

**Katie P. Fehnel, MD**

Assistant Professor of Neurosurgery  
Harvard Medical School  
Director, Spinal Cord Tumor Program  
Boston Children's Hospital  
Dana Farber Cancer Institute  
Boston, Massachusetts  
81. *Spinal Cord Injuries in Children*  
646. *Spinal Cord Disorders*

**Susan Feigelman, MD**

Professor of Pediatrics  
University of Maryland School of Medicine  
Baltimore, Maryland  
19. *Developmental and Behavioral Theories*  
21. *Assessment of Fetal Growth and Development*  
23. *The First Year*  
24. *The Second Year*  
25. *The Preschool Years*  
26. *Middle Childhood*

**Amy G. Feldman, MD, MSCS**

Associate Professor of Pediatrics  
University of Colorado School of Medicine  
Program Director, Liver Transplant Fellowship  
Children's Hospital Colorado  
Aurora, Colorado  
410. *Autoimmune Hepatitis*  
411. *Drug- and Toxin-Induced Liver Injury*  
412. *Acute Hepatic Failure*  
413. *Cystic Diseases of the Biliary Tract and Liver*  
414. *Diseases of the Gallbladder*  
415. *Portal Hypertension and Varices*

**Heidi M. Feldman, MD, PhD**

Ballinger-Swindells Professor and Division Chief  
Developmental and Behavioral Pediatrics  
Stanford University School of Medicine  
Service Chief, Developmental and Behavioral  
Pediatric Programs  
Stanford Medicine Children's Health  
Palo Alto, California  
53. *Language Development and Communication  
Disorders*

**Edward C. Fels, MD**

Clinical Assistant Professor of Medicine  
Tufts University School of Medicine  
Boston, Massachusetts;  
Rheumatology Associates  
Portland, Maine  
210. *Vasculitis Syndromes*

**Eric I. Felner, MD, MSCR**

Professor of Pediatrics  
Division of Pediatric Endocrinology  
Emory University School of Medicine  
Atlanta, Georgia  
594. *Hormones of the Hypothalamus and Pituitary*  
595. *Hypopituitarism*

**Sing-Yi Feng, MD, FAAP, FACMT**

Professor of Pediatrics  
University of Texas Southwestern Medical Center  
at Dallas  
Associate Pediatric Emergency Medicine  
Fellowship Director  
Division of Emergency Medicine, Department of  
Pediatrics  
Children's Medical Center of Dallas  
Medical Toxicologist  
North Texas Poison Center  
Parkland Memorial Hospital  
Dallas, Texas  
768. *Envenomations*

**Thomas W. Ferkol Jr., MD**

Professor of Pediatrics  
Chief, Division of Pediatric Pulmonology  
University of North Carolina at Chapel Hill School  
of Medicine  
Chapel Hill, North Carolina  
455. *Primary Ciliary Dyskinesia (Immotile Cilia  
Syndrome, Kartagener Syndrome)*

**Karin E. Finberg, MD, PhD**

Associate Professor of Pathology  
Yale School of Medicine  
New Haven, Connecticut  
504.1. *Iron-Refractory Iron Deficiency Anemia*

**Jonathan D. Finder, MD**

Professor of Pediatrics  
The University of Tennessee Health Science Center  
Attending Physician  
Division of Pediatric Pulmonology  
Le Bonheur Children's Hospital  
Memphis, Tennessee  
437. *Bronchomalacia and Tracheomalacia*  
444. *Congenital Disorders of the Lung*

**Kristin N. Fiorino, MD**

Global Development Medical Director  
AstraZeneca  
Bethesda, Maryland  
378. *Motility Disorders and Hirschsprung Disease*

**Philip R. Fischer, MD**

Professor of Pediatrics  
Department of Pediatric and Adolescent Medicine  
Mayo Clinic  
Rochester, Minnesota  
348. *Adult Tapeworm Infections*  
349. *Cysticercosis*  
350. *Echinococcosis (Echinococcus granulosus sensu  
latu and Echinococcus multilocularis)*

**Anne M. Fitzpatrick, PhD, APRN**

Professor of Pediatrics  
Emory University School of Medicine  
Atlanta, Georgia  
185. *Childhood Asthma*

**Dustin D. Flannery, DO, MSCE**

Assistant Professor of Pediatrics  
University of Pennsylvania Perelman School of  
Medicine  
Attending Neonatologist  
Children's Hospital of Philadelphia  
Philadelphia, Pennsylvania  
148. *Epidemiology of Infections*

**Nicholas L. Fleming, DO**

Department of Pediatric Physical Medicine &  
Rehabilitation  
Logan Health Children's Hospital  
Kalispell, Montana  
753. *Birth Brachial Plexus Palsy*

**Veronica H. Flood, MD**

Professor of Pediatrics  
Medical College of Wisconsin  
Interim Chief, Division of Pediatric Hematology/  
Oncology  
Children's Wisconsin  
Associate Medical Director and Investigator  
Comprehensive Center for Bleeding Disorders  
Versiti Blood Center of Wisconsin  
Milwaukee, Wisconsin  
524. *Hemostasis*  
525. *Hereditary Clotting Factor Deficiencies  
(Bleeding Disorders)*  
526. *Von Willebrand Disease*  
529. *Postneonatal Vitamin K Deficiency*  
530. *Coagulopathy in Liver Disease*  
531. *Acquired Inhibitors of Coagulation*  
533. *Platelet and Blood Vessel Disorders*

**Francisco X. Flores, MD**

Associate Professor of Pediatrics  
University of Cincinnati College of Medicine  
Medical Director, Clinical Services and MARS  
Program  
Division of Nephrology and Hypertension  
Cincinnati Children's Hospital Medical Center  
Cincinnati, Ohio  
558. *Clinical Evaluation of the Child With  
Hematuria*  
559. *Isolated Glomerular Diseases Associated With  
Recurrent Gross Hematuria*  
565. *Clinical Evaluation of the Child With  
Proteinuria*  
566. *Conditions Associated With Proteinuria*

**Joseph T. Flynn, MD, MS**

Professor of Pediatrics  
University of Washington School of Medicine  
Chief, Division of Nephrology  
Seattle Children's Hospital  
Seattle, Washington  
494. *Systemic Hypertension*

**Patricia M. Flynn, MD**

Senior Vice President and Medical Director  
Quality and Patient Care  
Deputy Clinical Director and Member  
Department of Infectious Diseases  
Arthur Ashe Chair in Pediatric AIDS Research  
St. Jude Children's Research Hospital  
Memphis, Tennessee  
329. *Cryptosporidium*, *Cystoisospora*, *Cyclospora*,  
and *Microsporidia*

**Elizabeth E. Foglia, MD, MA, MSCE**

Associate Professor of Pediatrics  
University of Pennsylvania Perelman School of  
Medicine  
Attending Neonatologist  
Children's Hospital of Philadelphia  
Philadelphia, Pennsylvania  
123. *Neonatal Resuscitation and Delivery Room  
Emergencies*

**Heather C. Forkey, MD**

Professor of Pediatrics  
University of Massachusetts Chan Medical School  
Chief, Child Protection Program (CPP)  
Director, Foster Children Evaluation Service  
(FaCES)  
Medical Director, Lifeline4Kids  
UMass Memorial Children's Medical Center  
Worcester, Massachusetts  
10. *Foster and Kinship Care*

**Joel A. Forman, MD**

Professor of Pediatrics, Medical Education, and  
Environmental Medicine and Public Health  
Icahn School of Medicine at Mount Sinai  
Vice-Chair for Education  
Interim Chief and Medical Director  
Division of Pediatric Hospital Medicine  
Kravis Children's Hospital  
New York, New York  
759. *Chemical Pollutants*

**Alexandra F. Freeman, MD**

Director, Primary Immune Deficiency Clinic  
Laboratory of Clinical Immunology and  
Microbiology  
National Institute of Allergy and Infectious  
Diseases  
National Institutes of Health  
Bethesda, Maryland  
175. *Defects of Innate Immunity*

**Deborah M. Friedman, MD**

Professor Emerita of Pediatrics  
New York Medical College  
Valhalla, New York  
199.1. *Neonatal Lupus*

**Susan A. Friedman, MD**

Clinical Professor of Pediatrics  
University of Pennsylvania Perelman School of  
Medicine  
Medical Director, International Adoption Health  
Program  
Attending Physician, Neonatal Follow Up Program  
Attending Physician, Fostering Health Program  
Children's Hospital of Philadelphia  
Philadelphia, Pennsylvania  
146. *Fetal Alcohol Spectrum Disorder*

**Erika D. Friehling, MD, MS**

Associate Professor of Pediatrics  
Associate Vice Chair of Faculty Development  
Department of Pediatrics  
University of Pittsburgh School of Medicine  
Division of Pediatric Hematology/Oncology  
UPMC Children's Hospital of Pittsburgh  
Pittsburgh, Pennsylvania  
542. *Principles of Cancer Diagnosis*  
543. *Principles of Cancer Treatment*  
544. *The Leukemias*

**Stephanie A. Fritz, MD, MSCI**

Professor of Pediatrics  
University of Washington School of Medicine in  
St. Louis  
Division of Infectious Diseases  
St. Louis Children's Hospital  
St. Louis, Missouri  
227. *Staphylococcus*  
233. *Diphtheria (Corynebacterium diphtheriae)*

**Donald P. Frush, MD, FACR, FAAP, FSAB**

John Strohhahn Professor of Radiology  
Associate Faculty, Duke Medical Physics Graduate  
Program  
Duke University Medical Center  
Durham, North Carolina  
758. *Biologic Effects of Ionizing Radiation on  
Children*

**Ramsay L. Fuleihan, MD**

Professor of Pediatrics  
Columbia University Vagelos College of Physicians  
and Surgeons  
Clinical Director, Division of Pediatric Allergy,  
Immunology and Rheumatology  
Columbia University Medical Center  
New York, New York  
165. *T-Cell and Combined Deficiencies*

**Sheila Gahagan, MD, MPH**

Professor of Clinical Pediatrics  
Chief, Division of Academic General Pediatrics,  
Child Development, and Community Health  
Martin Stein Endowed Chair, Developmental-  
Behavioral Pediatrics  
UC San Diego School of Medicine  
La Jolla, California  
65. *Overweight and Obesity*

**Patrick G. Gallagher, MD**

Professor of Pediatrics, Physiology and Cell Biology  
Ohio State University  
Attending Physician  
Nationwide Children's Hospital  
Columbus, Ohio  
506. *Definitions and Classification of Hemolytic  
Anemias*  
507. *Hereditary Spherocytosis*  
508. *Hereditary Elliptocytosis, Hereditary  
Pyropoikilocytosis and Related Disorders*  
509. *Hereditary Stomatocytosis Syndromes*  
510. *Paroxysmal Nocturnal Hemoglobinuria and  
Acanthocytosis*

**David P. Galloway, MD**

Associate Professor of Pediatrics  
University of Alabama at Birmingham School of  
Medicine  
Medical Director, Center of Advanced Intestinal  
Rehabilitation  
Division of Pediatric Gastroenterology, Hepatology,  
and Nutrition  
Children's of Alabama  
Birmingham, Alabama  
258. *Clostridioides difficile Infection*

**Hayley A. Gans, MD**

Clinical Professor of Pediatrics  
Stanford University School of Medicine  
Co-Director, Pediatric Infectious Diseases Program  
for Immunocompromised Hosts  
Division of Pediatric Infectious Diseases  
Children's Hospital at Stanford  
Stanford, California  
293. *Measles*  
294. *Rubella*  
295. *Mumps*

**Andrea K. Garber, PhD, RD**

Professor of Pediatrics  
Division of Adolescent and Young Adult Medicine  
Chief Nutritionist, Eating Disorders Program  
UC San Francisco School of Medicine  
San Francisco, California  
63. *Refeeding Syndrome*

**Paula M. Gardiner, MD, MPH**

Associate Professor and Associate Director of  
Research  
Department of Family Medicine and Community  
Health  
University of Massachusetts Chan Medical School  
Worcester, Massachusetts  
7. *Complementary Therapies and Integrative  
Medicine*

**Luigi R. Garibaldi, MD**

Professor of Pediatrics  
University of Pittsburgh School of Medicine  
Clinical Director  
Division of Pediatric Endocrinology  
UPMC Children's Hospital of Pittsburgh  
Pittsburgh, Pennsylvania  
599. *Physiology of Puberty*  
600. *Disorders of Pubertal Development*

**Gregory M. Gauthier, MD, MS**

Associate Professor of Medicine  
Division of Infectious Diseases  
University of Wisconsin School of Medicine and  
Public Health  
Madison, Wisconsin  
285. *Blastomycosis*

**Jeffrey S. Gerber, MD, PhD**

Associate Professor of Pediatrics and Epidemiology  
University of Pennsylvania Perelman School of  
Medicine  
Division of Infectious Diseases  
Children's Hospital of Philadelphia  
Philadelphia, Pennsylvania  
226. *Antimicrobial Stewardship*  
254. *Legionella*

**Anne A. Gershon, MD**

Professor of Pediatrics  
Columbia University Vagelos College of Physicians  
and Surgeons  
Division of Pediatric Infectious Diseases  
NewYork-Presbyterian Morgan Stanley Children's  
Hospital  
New York, New York  
300. *Varicella-Zoster Virus*

**Saied Ghadersohi, MD**

Assistant Professor of Otolaryngology - Head and  
Neck Surgery  
Northwestern University Feinberg School of  
Medicine  
Ann & Robert H. Lurie Children's Hospital of  
Chicago  
Chicago, Illinois  
438. *Neoplasms of the Larynx, Trachea, and Bronchi*



**Kathleen A. Gibbs, MD**

Associate Professor of Clinical Pediatrics  
University of Pennsylvania Perelman School of  
Medicine  
Attending Neonatologist  
Medical Director, Newborn and Infant Chronic  
Lung Disease Program  
Medical Director, Quality Improvement and  
Patient Safety, N/IICU  
Children's Hospital of Philadelphia  
Philadelphia, Pennsylvania  
121. *Clinical Manifestations of Diseases in the  
Newborn Period*

**Mark Gibson, MD**

Professor (Clinical) Emeritus  
Department of Obstetrics and Gynecology  
Division Chief, Utah Center for Reproductive  
Medicine  
University of Utah School of Medicine  
Salt Lake City, Utah  
589. *Polycystic Ovary Syndrome and Hirsutism*

**Joseph Gigante, MD**

Professor of General Pediatrics  
Director of Education  
Office of Faculty Development  
Department of Pediatrics  
Vanderbilt University Medical Center  
Monroe Carell Jr. Children's Hospital at Vanderbilt  
Nashville, Tennessee  
430. *Acute Pharyngitis*

**Francis Gigliotti, MD**

Professor of Pediatrics  
University of Rochester Medical Center School of  
Medicine and Dentistry  
Department of Pediatric Infectious Diseases  
Golisano Children's Hospital  
Rochester, New York  
290. *Pneumocystis jirovecii*

**Stephanie P. Gilley, MD, PhD**

Assistant Professor in Pediatrics  
University of Colorado School of Medicine  
Section of Pediatric Nutrition  
Children's Hospital Colorado  
Aurora, Colorado  
61. *Feeding Healthy Infants, Children, and  
Adolescents*  
64. *Malnutrition in High-Resource Settings*

**Walter S. Gilliam, PhD**

Executive Director  
Richard D. Holland Presidential Chair in Early  
Childhood Development  
Buffett Early Childhood Institute  
University of Nebraska  
Omaha, Nebraska  
29. *Child Care*

**Salil Ginde, MD, MPH**

Associate Professor of Internal Medicine and  
Pediatrics  
Medical College of Wisconsin  
Section of Pediatric Cardiology  
Children's Wisconsin  
Milwaukee, Wisconsin  
483.1. *Congenital Heart Disease in Adults*

**John A. Giroto, MD, MBA, FAAP, FACS**

Professor of Surgery  
Michigan State College of Human Medicine  
Chief, Pediatric Plastic Surgery  
Helen DeVos Children's Hospital  
Grand Rapids, Michigan  
632. *Deformational Plagiocephaly*

**Samuel B. Goldfarb, MD**

Professor of Pediatrics  
Annalisa Marzotto Endowed Chair in Cystic  
Fibrosis Care  
Director, Pediatric Cystic Fibrosis Program  
Co-Director, University of Minnesota Cystic  
Fibrosis Center  
Division of Pediatric Pulmonary and Sleep  
Medicine  
University of Minnesota  
Minneapolis, Minnesota  
492.2. *Heart-Lung and Lung Transplantation*

**David L. Goldman, MD**

Associate Professor of Pediatrics and Microbiology  
and Immunology  
Albert Einstein College of Medicine  
Division of Pediatric Infectious Disease  
The Children's Hospital at Montefiore  
Bronx, New York  
281. *Cryptococcus neoformans and Cryptococcus  
gattii*

**Stanton C. Goldman, MD**

Principal Investigator  
Children's Oncology Group  
Chief Medical Officer  
Medical City Children's Hospital  
Texas Oncology, PA  
Dallas, Texas  
545. *Lymphoma*

**Oscar G. Gómez-Duarte, MD, PhD**

Associate Professor of Pediatrics  
Jacobs School of Medicine and Biomedical Sciences  
University at  
Buffalo State University of New York  
Buffalo, New York  
242. *Moraxella catarrhalis*

**Misty Good, MD, MS, FAAP**

Associate Professor of Pediatrics  
Chief, Division of Neonatal-Perinatal Medicine  
University of North Carolina at Chapel Hill School  
of Medicine  
Chapel Hill, North Carolina  
136. *Necrotizing Enterocolitis*

**Christine M. Goodbody, MD, MBE**

Assistant Professor of Orthopedic Surgery  
University of Pennsylvania Perelman School of  
Medicine  
Attending Orthopedic Surgeon  
Children's Hospital of Philadelphia  
Philadelphia, Pennsylvania  
715. *The Foot and Toes*  
717. *Leg-Length Discrepancy*  
723. *Arthrogyposis*

**Denise M. Goodman, MD, MS**

Professor of Pediatrics  
Northwestern University Feinberg School of  
Medicine  
Attending Physician, Division of Critical Care  
Medicine  
Ann & Robert H. Lurie Children's Hospital of  
Chicago  
Chicago, Illinois  
468.1. *Chronic Respiratory Failure and Long-Term  
Mechanical Ventilation*

**Tracey Goodman, MA**

Team Lead, Life Course & Integration  
EPI Unit  
Department of Vaccines and Biologicals  
World Health Organization  
Geneva, Switzerland  
215.1. *International Immunization Practices*

**William R. Goodyer, MD, PhD**

Assistant Professor of Pediatrics  
Division of Pediatric Cardiology  
Stanford University School of Medicine  
Palo Alto, California  
469. *Cardiac Development*

**Catherine M. Gordon, MD, MS**

Senior Faculty, USDA/ARS Children's Nutrition  
Research Center  
Professor of Pediatrics  
Baylor College of Medicine  
Houston, Texas  
746. *Bone Structure, Growth, and Hormonal Regulation*  
749. *Osteoporosis*

**Leslie B. Gordon, MD, PhD**

Professor of Pediatrics Research  
Warren Alpert Medical School of Brown University  
Hasbro Children's Hospital  
Providence, Rhode Island;  
Department of Anesthesiology, Critical Care, and  
Pain Medicine  
Harvard Medical School  
Boston Children's Hospital  
Boston, Massachusetts;  
Medical Director, The Progeria Research Foundation  
Peabody, Massachusetts  
111. *Hutchinson-Gilford Progeria Syndrome (Progeria)*

**Rebecca J. Gordon, MD**

Instructor in Pediatrics  
Harvard Medical School  
Attending Physician  
Division of Endocrinology  
Boston Children's Hospital  
Boston, Massachusetts  
746. *Bone Structure, Growth, and Hormonal  
Regulation*  
749. *Osteoporosis*

**Eliza Gordon-Lipkin, MD**

Assistant Research Physician  
Metabolism, Infection and Immunity Section  
National Institutes of Health  
Bethesda, Maryland  
28. *Developmental and Behavioral Surveillance and  
Screening*

**Michael Gorelik, MD**

Assistant Professor  
Division of Pediatric Otolaryngology  
Children's Wisconsin  
Medical College of Wisconsin  
Madison, Wisconsin  
434. *Congenital Anomalies of the Larynx, Trachea,  
and Bronchi*  
435. *Foreign Bodies in the Airway*

**W. Adam Gower, MD, MS**

Associate Professor of Pediatrics  
Division of Pediatric Pulmonology  
The University of North Carolina at Chapel Hill  
School of Medicine  
Chapel Hill, North Carolina  
448.6. *Neuroendocrine Cell Hyperplasia of Infancy*

**Evan G. Graber, DO**

Clinical Associate Professor of Pediatrics  
Sidney Kimmel Medical College of  
Thomas Jefferson University  
Philadelphia, Pennsylvania;  
Pediatric Endocrinologist  
Nemours Children's Hospital-Delaware  
Wilmington, Delaware  
610. *Hormones and Peptides of Calcium  
Homeostasis and Bone Metabolism*  
613. *Hyperparathyroidism*

**Zachary T. Graff, MD**

Assistant Professor of Pediatrics  
Medical College of Wisconsin  
Pediatric Leukemia and Lymphoma Program  
Division of Pediatric Hematology/Oncology  
Children's Wisconsin  
Milwaukee, Wisconsin  
539. *Lymphadenopathy*

**Robert J. Graham, MD**

Associate Professor of Anesthesiology  
Harvard Medical School  
Senior Associate in Critical Care Medicine  
Department of Anesthesiology, Critical Care and  
Pain Medicine  
Boston Children's Hospital  
Boston, Massachusetts  
468.4. *Long-term Ventilation and Technology  
Support: Indications, Principles, Decision-  
Making, Pragmatics and Home Provision*

**Cori M. Green, MD, MSc**

Assistant Professor of Clinical Pediatrics  
Director of Behavioral Health Education and  
Integration in Pediatrics  
Weill Cornell Medicine  
Associate Attending Pediatrician  
NewYork-Presbyterian Phyllis and David  
Komansky Children's Hospital at Weill Cornell  
Medical Center  
New York, New York  
18. *Strategies for Health Behavior Change*

**Michael Green, MD, MPH**

Professor of Pediatrics, Surgery, and Clinical and  
Translational Science  
University of Pittsburgh School of Medicine  
Division of Infectious Diseases  
Director, Antimicrobial Stewardship and Infection  
Prevention  
Co-Director, Pediatric Transplant Infectious  
Diseases  
UPMC Children's Hospital of Pittsburgh  
Pittsburgh, Pennsylvania  
223. *Infections in Immunocompromised Persons*

**Larry A. Greenbaum, MD, PhD**

Bernard Marcus Professor of Pediatrics  
Director, Division of Pediatric Nephrology  
Emory University School of Medicine  
Executive Clinical Director  
Children's Healthcare of Atlanta  
Atlanta, Georgia  
69. *Vitamin D Deficiency (Rickets) and Excess*  
70. *Vitamin E Deficiency*  
71. *Vitamin K Deficiency*  
72. *Micronutrient Mineral Deficiencies*  
73. *Electrolyte and Acid-Base Disorders*  
74. *Maintenance and Replacement Therapy*  
75. *Deficit Therapy*

**V. Jordan Greenbaum, MD**

Medical Director  
International Centre for Missing and Exploited  
Children  
Alexandria, Virginia  
16. *Child Trafficking for Sex and Labor*

**Mary V. Greiner, MD, MS**

Associate Professor of Pediatrics  
University of Cincinnati College of Medicine  
Medical Director, CHECK Foster Care Center  
Cincinnati Children's Hospital Medical Center  
Cincinnati, Ohio  
10. *Foster and Kinship Care*

**Anne G. Griffiths, MD**

Pediatric Pulmonologist  
Director, Primary Ciliary Dyskinesia Center  
Children's Minnesota  
Children's Respiratory & Critical Care Specialists  
Minneapolis, Minnesota  
422. *Chronic or Recurrent Respiratory Symptoms*

**Kenneth L. Grizzle, PhD**

Associate Professor of Pediatrics  
Medical College of Wisconsin  
Child Development Center  
Children's Wisconsin  
Milwaukee, Wisconsin  
52. *Math and Writing Disabilities*  
53.1. *Childhood-Onset Fluency Disorder*

**Judith A. Groner, MD, FAAP**

Professor of Clinical Pediatrics  
The Ohio State University of Medicine  
Division of Primary Care Pediatrics  
Nationwide Children's Hospital  
Columbus, Ohio  
759. *Chemical Pollutants*

**Anete Sevciovic Grumach, MD, PhD**

Clinical Immunology  
University Center Faculty of Medicine ABC  
(CEUFMABC)  
Santo Andre, SP, Brazil  
173. *Complement System*

**Seyni Gueye-Ndiaye, MD**

Research Fellow in Sleep Medicine  
Brigham and Women's Hospital  
Boston Children's Hospital  
Harvard Medical School  
Boston, Massachusetts  
31. *Sleep Medicine*

**Anat Guz-Mark, MD**

Attending Physician  
Institute of Gastroenterology, Nutrition and Liver  
Disease  
Schneider Children's Medical Center of Israel  
Petah Tikva, Israel;  
Sackler Faculty of Medicine  
Tel Aviv University  
Tel Aviv, Israel  
388. *Chronic Diarrhea*

**Fareeda Haamid, DO**

Associate Professor of Pediatrics  
The Ohio State University College of Medicine  
Division of Adolescent Medicine  
Nationwide Children's Hospital  
Columbus, Ohio  
159. *Menstruation-Related Disorders*

**Gabriel G. Haddad, MD**

Distinguished Professor of Pediatrics and  
Neuroscience  
Chairman, Department of Pediatrics  
University of California San Diego School of  
Medicine  
Physician-in-Chief and Chief Scientific Officer  
Rady Children's Hospital-San Diego  
San Diego, California  
421. *Diagnostic Approach to Respiratory Disease*

**Joseph Haddad Jr., MD**

Lawrence Savetsky Professor Emeritus  
Columbia University Irving Medical Center  
New York, New York  
425. *Congenital Disorders of the Nose*  
426. *Acquired Disorders of the Nose*  
427. *Nasal Polyps*  
676. *General Considerations and Evaluation of the  
Ear*  
677. *Hearing Loss*  
678. *Congenital Malformations of the Ear*  
679. *External Otitis (Otitis Externa)*  
682. *The Inner Ear and Diseases of the Bony  
Labyrinth*  
683. *Traumatic Injuries of the Ear and Temporal  
Bone*  
684. *Tumors of the Ear and Temporal Bone*

**Matthew A. Haemer, MD**

Associate Professor of Pediatrics  
University of Colorado School of Medicine  
Section of Pediatric Nutrition  
Children's Hospital Colorado  
Aurora, Colorado  
61. *Feeding Healthy Infants, Children, and  
Adolescents*

**Joseph F. Hagan Jr., MD, FAAP**

Clinical Professor of Pediatrics  
The Robert Larner, MD College of Medicine at the  
University of Vermont  
Lakeside Pediatrics, PLLC  
Burlington, Vermont  
13. *Maximizing Children's Health: Screening,  
Anticipatory Guidance, and Counseling*

**Suraiya K. Haider, MD**

Sleep Physician  
Inova Children's Sleep Center  
Fairfax, Virginia  
451. *Pleurisy, Pleural Effusions, and Empyema*  
461. *Pneumothorax*  
462. *Pneumomediastinum*  
463. *Hydrothorax*  
464. *Hemothorax*  
465. *Chylothorax*

**Hana Hakim, MD, MS**

Member  
Department of Infectious Diseases  
St. Jude Children's Research Hospital  
Memphis, Tennessee  
224. *Infection Associated With Medical Devices*

**Chad R. Haldeman-Englert, MD, FACMG**

Clinical Geneticist  
Fullerton Genetics Center  
Asheville, North Carolina  
101. *Signaling Pathway Disorders*

**Scott B. Halstead, MD**

Adjunct Professor of Preventive Medicine and  
Biostatistics  
Uniformed Services University of the Health  
Sciences  
Bethesda, Maryland  
314. *Arboviral Infections*  
315. *Dengue Fever, Dengue Hemorrhagic Fever, and  
Severe Dengue*  
316. *Yellow Fever*  
317. *Ebola and Other Viral Hemorrhagic Fevers*  
319. *Hantavirus Pulmonary Syndrome*

**Lamiaa Hamie, MD, MS**

Instructor in Dermatology  
Medical College of Wisconsin  
Children's Wisconsin  
Milwaukee, Wisconsin  
708. *Cutaneous Viral Infections*  
709. *Arthropod Bites and Infestations*

**Margaret R. Hammerschlag, MD**

Professor of Pediatrics and Medicine  
Director, Pediatric Infectious Diseases Fellowship  
Training Program  
Vice-Chair for Faculty Development  
Department of Pediatrics  
SUNY Downstate Health Sciences University  
Brooklyn, New York  
271. *Chlamydia pneumoniae*  
272. *Chlamydia trachomatis*  
273. *Psittacosis (Chlamydia psittaci)*

**E. Adrienne Hammershaimb, MD**

Instructor in Pediatrics  
Division of Infectious Disease and Tropical  
Pediatrics  
Center for Vaccine Development and Global  
Health  
University of Maryland School of Medicine  
Baltimore, Maryland  
387. *Acute Gastroenteritis in Children*

**Elisa Hampton, MD**

Assistant Professor of Pediatrics  
Medical Director, Well Newborn Service  
University of Virginia School of Medicine  
Charlottesville, Virginia  
22. *The Newborn*

**Aaron Hamvas, MD**

Raymond and Hazel Speck Barry Professor of  
Neonatology  
Department of Pediatrics  
Northwestern University Feinberg School of  
Medicine  
Head, Division of Neonatology  
Ann & Robert H. Lurie Children's Hospital of  
Chicago  
Chicago, Illinois  
456. *Diffuse Lung Diseases in Childhood*

**Neil A. Hanchard, MBBS, Dphil**

Senior Investigator  
Center for Precision Health Research  
National Human Genome Research Institute  
National Institutes of Health  
Bethesda, Maryland  
103. *Genetics of Common Disorders*

**Patrick C. Hanley, MD, MSHQS**

Assistant Professor of Pediatrics  
Sidney Kimmel Medical College of  
Thomas Jefferson University  
Philadelphia, Pennsylvania;  
Pediatric Endocrinologist  
Nemours Alfred I. duPont Hospital for Children  
Wilmington, Delaware  
611. *Hypoparathyroidism*  
612. *Pseudohypoparathyroidism*

**Melisha G. Hanna, MD, MS**

Associate Professor of Pediatrics  
Renal Section, Department of Pediatrics  
University of Colorado School of Medicine  
Aurora, Colorado  
569. *Renal Tubular Acidosis*

**Pooja D. Harijan, MBCHB (Leics),  
MRCPCH, MD (Leics)**

Consultant in Pediatric Neurology  
Addenbrooke's Hospital  
Cambridge, United Kingdom  
645. *Idiopathic Intracranial Hypertension  
(Pseudotumor Cerebri)*

**Douglas J. Harrison, MD**

Associate Professor of Pediatrics  
University of Texas MD Anderson Cancer Center  
Houston, Texas  
547. *Neuroblastoma*

**Elizabeth B. Harstad, MD, MPH**

Assistant Professor of Pediatrics  
Harvard Medical School  
Attending Physician  
Division of Developmental Medicine  
Boston Children's Hospital  
Boston, Massachusetts  
50. *Attention-Deficit/Hyperactivity Disorder*

**David B. Haslam, MD**

Professor of Pediatrics  
University of Cincinnati College of Medicine  
Director, Antimicrobial Stewardship Program  
Director, Microbial Genomics and Metagenomics  
Laboratory  
Cincinnati Children's Hospital Medical Center  
Cincinnati, Ohio  
231. *Non-Group A or B Streptococci*  
232. *Enterococcus*

**Fern R. Hauck, MD, MS**

Spencer P. Bass, MD Twenty-First Century  
Professor of Family Medicine  
Professor of Public Health Sciences  
Departments of Family Medicine and Public  
Health Sciences  
University of Virginia School of Medicine  
Charlottesville, Virginia  
423. *Sudden Infant Death Syndrome*

**Fiona P. Havers, MD, MHS**

Medical Epidemiologist  
Epidemiology and Prevention Branch, Influenza  
Division  
National Center for Immunization and Respiratory  
Diseases  
Centers for Disease Control and Prevention  
Atlanta, Georgia  
306. *Parainfluenza Viruses*

**Ericka V. Hayes, MD**

Professor of Clinical Pediatrics  
University of Pennsylvania Perelman School of  
Medicine  
Attending Physician  
Division of Infectious Diseases  
Senior Medical Director of Infection Prevention  
and Control  
Children's Hospital of Philadelphia  
Philadelphia, Pennsylvania  
248. *Campylobacter*  
249. *Yersinia*  
263. *Nontuberculous Mycobacteria*  
322. *Human Immunodeficiency Virus and Acquired  
Immunodeficiency Syndrome*

**Nia J. Heard-Garris, MD, MSc**

Division of Advanced General Pediatrics and  
Primary Care  
Mary Ann & J. Milburn Smith Child Health  
Outreach, Research, and Evaluation Center  
Ann & Robert H. Lurie Children's Hospital of  
Chicago  
Department of Pediatrics, Northwestern University  
Feinberg School of Medicine  
Chicago, Illinois  
1. *Overview of Pediatrics*

**Holly L. Hedrick, MD**

Professor of Surgery  
University of Pennsylvania Perelman School of  
Medicine  
Attending Pediatric and Fetal Surgeon  
Louise Schnauffer Endowed Chair in Pediatric  
Surgery  
Division of Pediatric General, Thoracic and Fetal  
Surgery  
Surgical Director, Neonatal Surgical Service  
Co-Director, Neonatal Surgical Team  
Director, Pulmonary Hypoplasia Program  
Children's Hospital of Philadelphia  
Philadelphia, Pennsylvania  
118. *Fetal Intervention and Surgery*

**Cheryl Hemingway, MBChB, MMed,  
PhD, FRCPC(UK), FCPaed(SA)**

Honorary Senior Lecturer  
Imperial College London  
Paediatric Neurology Consultant  
Great Ormond Street Hospital for Children  
London, United Kingdom  
638.3. *Other Encephalopathies*  
640. *Demyelinating Disorders of the Central Nervous  
System*

**Chelsea Heneghan, MSN, CPNP-  
PC/AC**

Nurse Practitioner  
Division of Pediatric Palliative Care  
Boston Children's Hospital  
Boston, Massachusetts  
8. *Pediatric Palliative Care*

**Michelle L. Hernandez, MD**

Professor of Pediatrics  
Division of Allergy & Immunology  
The University of North Carolina at Chapel Hill  
School of Medicine  
Chapel Hill, North Carolina  
448.1. *Hypersensitivity Pneumonia*  
448.2. *Occupational and Environmental Lung  
Disease*

**Vivian P. Hernandez-Trujillo, MD**

Clinical Professor of Pediatrics  
Florida International University Herbert Wertheim  
School of Medicine  
Director, Division of Allergy & Immunology  
Nicklaus Children's Hospital  
Allergy and Immunology Care Center of South  
Florida  
Miami Lakes, Florida  
166. *B-Cell and Antibody Deficiencies*

**Fiorela N. Hernandez Tejada, MD**

Assistant Professor of Pediatrics  
University of Texas MD Anderson Cancer Center  
Houston, Texas  
547. *Neuroblastoma*  
553. *Neoplasms of the Liver*



**Heidi M. Herrick, MD, MSCE**

Assistant Professor  
University of Pennsylvania Perelman School of  
Medicine  
Attending Neonatologist  
Children's Hospital of Philadelphia  
Philadelphia, Pennsylvania  
123. *Neonatal Resuscitation and Delivery Room  
Emergencies*

**Andrew D. Hershey, MD, PhD,  
FAAN, FAHS**

Endowed Chair and Director of Neurology  
Professor of Pediatrics and Neurology  
University of Cincinnati College of Medicine  
Cincinnati Children's Hospital Medical Center  
Cincinnati, Ohio  
635. *Headaches*

**Cynthia E. Herzog, MD**

Professor of Pediatrics  
Deputy Head, Division of Pediatrics  
University of Texas MD Anderson Cancer Center  
Houston, Texas  
551. *Retinoblastoma*  
552. *Gonadal and Germ Cell Neoplasms*  
553. *Neoplasms of the Liver*  
555.2. *Nasopharyngeal Carcinoma*  
555.3. *Adenocarcinoma of the Colon and Rectum*  
555.5. *Desmoplastic Small Round Cell Tumor*

**Sarah M. Heston, MD**

Assistant Professor of Pediatrics  
Duke University School of Medicine  
Division of Infectious Diseases  
Duke Children's Hospital and Health Center  
Durham, North Carolina  
329. *Cryptosporidium, Cystoisospora, Cyclospora,  
and Microsporidia*

**Ghada Hijazi, MD, MRCPCH,  
FCCMG**

Postdoctoral Research Associate  
Department of Pediatrics  
Division of Medical Genetics  
Duke University Medical Center  
Durham, North Carolina  
107. *Defects in Metabolism of Carbohydrates*

**Samantha V. Hill, MD, MPH**

Assistant Professor of Pediatrics  
The University of Alabama at Birmingham  
Division of Adolescent Medicine  
Children's of Alabama  
Birmingham, Alabama  
151. *Delivery of Healthcare to Adolescents*  
155. *The Epidemiology of Adolescent Health  
Problems*  
163. *Sexually Transmitted Infections*

**Jessica Hochberg, MD**

Associate Professor of Pediatrics  
New York Medical College  
Director, Hematologic Malignancy Program  
Division of Pediatric Hematology, Oncology, and  
Stem Cell Transplant  
Maria Fareri Children's Hospital at Westchester  
Medical Center  
Valhalla, New York  
545. *Lymphoma*

**Deborah Hodes, MBBS, BSc,  
DRCOG, FRCPC**

Consultant Community Paediatrician  
Honorary Consultant Community Paediatrician  
University College London Hospitals  
London, United Kingdom  
593. *Female Genital Mutilation*

**Holly R. Hoefgen, MD**

Assistant Professor of Obstetrics and Gynecology  
Washington University School of Medicine in  
St. Louis  
Attending Physician  
Division of Adolescent and Pediatric Gynecology  
Co-Director, Integrated Care and Fertility  
Preservation Program  
St. Louis Children's Hospital  
Barnes-Jewish Hospital  
St. Louis, Missouri  
586. *Vulvovaginitis*

**Lauren D. Holinger, MD, FAAP,  
FACS**

Paul H. Holinger MD Professor of Otolaryngology –  
Head and Neck Surgery  
Northwestern University Feinberg School of  
Medicine  
Ann & Robert H. Lurie Children's Hospital of  
Chicago  
Chicago, Illinois  
438. *Neoplasms of the Larynx, Trachea, and Bronchi*

**Cynthia M. Holland-Hall, MD, MPH**

Professor of Pediatrics  
The Ohio State University College of Medicine  
Attending Physician  
Section of Adolescent Medicine  
Nationwide Children's Hospital  
Columbus, Ohio  
150. *Adolescent Physical and Social Development*  
158. *The Breast*

**Laura L. Hollenbach, MD**

Assistant Professor of Obstetrics and Gynecology  
University of Arkansas for Medical Sciences  
Director, Division of Pediatric and Adolescent  
Gynecology  
Arkansas Children's Hospital  
Little Rock, Arkansas  
591. *Vulvovaginal and Müllerian Anomalies*

**Yolanda F. Holler-Managan, MD**

Associate Professor of Pediatrics (Neurology)  
Northwestern University Feinberg School of  
Medicine  
Attending Physician  
Division of Pediatric Neurology  
Ann & Robert H. Lurie Children's Hospital of  
Chicago  
Chicago, Illinois  
630. *Neurologic Evaluation*

**David K. Hooper, MD, MS**

Professor of Pediatrics  
University of Cincinnati College of Medicine  
Medical Director of Kidney Transplantation  
Cincinnati Children's Hospital Medical Center  
Cincinnati, Ohio  
573. *Renal Transplantation*

**Thomas A. Hooven, MD**

Assistant Professor of Pediatrics  
University of Pittsburgh School of Medicine  
Scholar, Richard King Mellon Foundation Institute  
for Pediatric Research  
UPMC Children's Hospital of Pittsburgh  
Pittsburgh, Pennsylvania  
230. *Group B Streptococcus*

**Julie E. Hoover-Fong, MD, PhD**

Professor of Genetic Medicine and Pediatrics  
McKusick-Nathans Institute of Genetic Medicine  
Director, Greenberg Center for Skeletal Dysplasias  
Johns Hopkins University School of Medicine  
Baltimore, Maryland  
735. *General Considerations in Skeletal Dysplasias*  
736. *Disorders Involving Cartilage Matrix Proteins*  
737. *Disorders Involving Transmembrane Receptors*  
738. *Disorders Involving Ion Transporters*  
739. *Disorders Involving Transcription Factors*  
740. *Osteopetrosis and Other Disorders Involving  
Defective Bone Resorption*  
741. *Other Inherited Disorders of Skeletal  
Development*

**Rachel K. Hopper, MD**

Clinical Associate Professor of Pediatrics  
Division of Pediatric Cardiology  
Stanford University School of Medicine  
Palo Alto, California  
482. *Pulmonary Hypertension*

**Jeffrey D. Hord, MD**

Professor of Pediatrics  
Northeast Ohio Medical University  
Rootstown, Ohio;  
The LOPE Charities and Mawaka Family Chair,  
Division of Pediatric Hematology/Oncology  
Showers Family Center for Childhood Cancer and  
Blood Disorders  
Akron Children's Hospital  
Akron, Ohio  
518. *Acquired Pancytopenias*

**B. David Horn, MD**

Professor of Clinical Orthopaedic Surgery  
University of Pennsylvania Perelman School of  
Medicine  
Attending Orthopaedic Surgeon  
Children's Hospital of Philadelphia  
Philadelphia, Pennsylvania  
719. *The Hip*

**Helen M. Horstmann, MD**

Associate Professor of Orthopaedic Surgery  
University of Pennsylvania Perelman School of  
Medicine  
Attending Orthopaedic Surgeon  
Children's Hospital of Philadelphia  
Philadelphia, Pennsylvania  
723. *Arthrogyposis*

**Peter J. Hotez, MD, PhD**

Professor, Pediatrics and Molecular Virology and  
Microbiology  
Texas Children's Endowed Chair of Tropical  
Pediatrics  
Dean, National School of Tropical Medicine  
Baylor College of Medicine  
Houston, Texas  
338. *Hookworms (Necator americanus and  
Ancylostoma spp)*

**Samantha A. House, DO, MPH**

Associate Professor of Pediatrics  
Geisel School of Medicine at Dartmouth  
Associate Professor of The Dartmouth Institute  
Chief, Section of Pediatric Hospital Medicine  
Dartmouth Health Children's  
Lebanon, New Hampshire  
439. *Wheezing, Bronchiolitis, and Bronchitis*

**Ashley C. Howard, DO, FAAP**

Assistant Professor of Pediatrics  
University of Connecticut School of Medicine  
Division of Infectious Diseases and Immunology  
Connecticut Children's Medical Center  
Hartford, Connecticut  
234. *Listeria monocytogenes*  
251. *Pseudomonas, Burkholderia, and Stenotrophomonas*

**Mary Beth Howard, MD, MSc**

Assistant Professor of Pediatrics  
Johns Hopkins University School of Medicine  
Baltimore, Maryland  
77.1. *Interfacility Transport of the Seriously Ill or Injured Pediatric Patient*

**Evelyn K. Hsu, MD**

Professor of Pediatrics  
University of Washington School of Medicine  
Chief, Division of Gastroenterology and Hepatology  
Seattle Children's Hospital  
Seattle, Washington  
416. *Liver Transplantation*

**Katherine Hsu, MD, MPH**

Professor of Pediatrics  
Section of Pediatric Infectious Diseases  
Boston University Medical Center  
Medical Director, Division of STD Prevention  
Bureau of Infectious Disease and Laboratory Sciences  
Massachusetts Department of Public Health  
Boston, Massachusetts  
238. *Neisseria gonorrhoeae (Gonococcus)*

**Heather G. Huddleston, MD**

Professor of Obstetrics, Gynecology, and Reproductive Sciences  
UC San Francisco School of Medicine  
San Francisco, California  
589. *Polycystic Ovary Syndrome and Hirsutism*

**Winston W. Huh, MD**

Associate Professor of Clinical Pediatrics  
Keck School of Medicine of USC  
University of Southern California  
Children's Hospital of Los Angeles  
Los Angeles, California  
552. *Gonadal and Germ Cell Neoplasms*  
555.3. *Adenocarcinoma of the Colon and Rectum*

**Stephen R. Humphrey, MD**

Associate Professor of Dermatology and Pediatrics  
Medical College of Wisconsin  
Children's Wisconsin  
Milwaukee, Wisconsin  
687. *Principles of Dermatologic Therapy*  
706. *Cutaneous Bacterial Infections*  
707. *Cutaneous Fungal Infections*  
708. *Cutaneous Viral Infections*  
709. *Arthropod Bites and Infestations*

**David A. Hunstad, MD**

Professor of Pediatrics and Molecular Microbiology  
Washington University School of Medicine in St. Louis  
St. Louis, Missouri  
643. *Central Nervous System Infections*  
644. *Brain Abscess*  
765. *Animal and Human Bites*  
766. *Rat Bite Fever*  
767. *Mpox (Monkeypox)*

**Stephen P. Hunger, MD**

Professor and Jeffrey E. Perelman Distinguished Chair  
Department of Pediatrics  
University of Pennsylvania Perelman School of Medicine  
Chief, Division of Pediatric Oncology  
Director, Center for Childhood Cancer Research  
Children's Hospital of Philadelphia  
Philadelphia, Pennsylvania  
541. *Molecular and Cellular Biology of Cancer*

**Carl E. Hunt, MD**

Research Professor of Pediatrics  
Uniformed Services University of the Health Sciences  
Division of Neonatology  
Walter Reed National Military Medical Center  
Bethesda, Maryland;  
Adjunct Professor of Pediatrics  
George Washington University School of Medicine and Health Sciences  
Washington, DC  
423. *Sudden Infant Death Syndrome*

**Stacey S. Huppert, PhD**

Associate Professor of Pediatrics  
University of Cincinnati College of Medicine  
Division of Gastroenterology, Hepatology, and Nutrition  
Division of Developmental Biology  
Cincinnati Children's Hospital Medical Center  
Cincinnati, Ohio  
402. *Morphogenesis of the Liver and Biliary System*

**Anna R. Huppler, MD**

Associate Professor of Pediatrics  
Medical College of Wisconsin  
Division of Pediatric Infectious Diseases  
Children's Wisconsin  
Milwaukee, Wisconsin  
180. *Infectious Complications of Hematopoietic Stem Cell Transplantation*

**Hallam Hurt, MD**

Professor of Pediatrics  
University of Pennsylvania Perelman School of Medicine  
Attending Neonatologist  
Education Director, Neonatal Follow-up Program at Buerger Center  
Children's Hospital of Philadelphia  
Philadelphia, Pennsylvania  
146. *Fetal Alcohol Spectrum Disorder*

**Kosuke Izumi, MD, PhD**

Assistant Professor of Pediatrics  
Division of Genetics and Metabolism  
Department of Pediatrics  
University of Texas Southwestern Medical Center  
Dallas, Texas  
102. *Chromatin Regulatory Disorders*

**Allison M. Jackson, MD, MPH, FAAP**

Division Chief, Child & Adolescent Protection Center  
Washington Children's Foundation  
Endowed Professor of Child & Adolescent Protection  
Children's National Hospital  
Associate Professor of Pediatrics  
The George Washington University School of Medicine and Health Sciences  
Washington, DC  
162. *Adolescent Sexual Assault*

**Mary Anne Jackson, MD, FAAP, FPIDS, FIDSA**

Dean and Clinical Professor of Pediatrics  
University of Missouri–Kansas City School of Medicine  
Department of Pediatric Infectious Diseases  
Children's Mercy Hospitals and Clinics  
Kansas City, Missouri  
674. *Orbital Infections*

**Ashlee M. Jaffe, MD, MEd**

Associate Professor of Clinical Pediatrics and Physical Medicine & Rehabilitation  
University of Pennsylvania Perelman School of Medicine  
Attending Physician  
Division of Pediatric Physical Medicine & Rehabilitation  
Children's Hospital of Philadelphia  
Philadelphia, Pennsylvania  
751. *Spinal Cord Injury and Autonomic Dysreflexia Management*

**Kiera M. James, PhD**

Postdoctoral Scholar  
Department of Psychology  
University of Pittsburgh  
Pittsburgh, Pennsylvania  
46. *Self-Injurious Behavior*

**Andrew B. Janowski, MD, MSCI**

Assistant Professor of Pediatrics and Molecular Microbiology  
Washington University School of Medicine in St. Louis  
St. Louis, Missouri  
643. *Central Nervous System Infections*  
644. *Brain Abscess*

**Brian P. Janssen, MD, MSHP**

Assistant Professor of Pediatrics  
University of Pennsylvania Perelman School of Medicine  
Attending Physician  
Division of General Pediatrics  
Children's Hospital of Philadelphia  
Philadelphia, Pennsylvania  
157.2. *Tobacco, E-Cigarettes, and Other Tobacco Products*

**H.A. Jinnah, MD, PhD**

Professor  
Departments of Neurology, Human Genetics, and Pediatrics  
Emory University School of Medicine  
Atlanta, University  
110. *Disorders of Purine and Pyrimidine Metabolism*

**Chandy C. John, MD, MS**

Ryan White Professor of Pediatrics  
Director, Ryan White Center for Pediatric Infectious Diseases and Global Health  
Indiana University School of Medicine  
Indianapolis, Indiana  
328. *Giardiasis and Balantidiasis*  
334. *Malaria (Plasmodium)*

**Kari Johansen, MD, PhD**

Senior Consultant in Vaccine-Preventable Diseases  
Public Health Agency of Sweden  
Stockholm, Sweden  
215.1. *International Immunization Practices*

**Susan L. Johnson, PhD**

Professor of Pediatrics  
University of Colorado School of Medicine  
Section of Pediatric Nutrition  
Children's Hospital Colorado  
Aurora, Colorado  
61. *Feeding Healthy Infants, Children, and Adolescents*

**Brian D. Johnston, MD, MPH**

Professor of Pediatrics  
Adjunct Professor of Health Systems and Population Health  
University of Washington School of Medicine  
Chief of Service, Department of Pediatrics  
Harborview Medical Center  
Seattle, Washington  
14. *Injury Control*

**Artemio M. Jongco III, MD, PhD, MPH, FACP, FACA, FAAAAI**

Clinical Associate Professor  
Departments of Medicine, Pediatrics and Science Education  
Donald and Barbara Zucker School of Medicine at Hofstra/Northwell  
Hempstead, New York;  
Adjunct Assistant Professor  
Institute of Molecular Medicine  
Feinstein Institutes for Medical Research  
Manhasset, New York  
176. *Approaches to Treatment of Primary Immune Deficiency Diseases*

**Cassandra D. Josephson, MD**

Director, Cancer and Blood Disorders Institute  
Director, Blood Bank, Transfusion, and Apheresis Service  
Johns Hopkins All Children's Hospital  
St. Petersburg, Florida;  
Professor (PAR), Oncology and Pediatrics  
Johns Hopkins University School of Medicine  
Baltimore, Maryland  
519. *Red Blood Cell Transfusions and Erythropoietin Therapy*  
520. *Platelet Transfusions*  
522. *Neutrophil (Granulocyte) Transfusions*  
522. *Plasma Transfusions*  
523. *Risks of Blood Transfusions*

**Joel C. Joyce, MD**

Section Chief, Pediatric Dermatology  
NorthShore University Health System  
Skokie, Illinois;  
Clinical Assistant Professor of Dermatology  
University of Chicago Pritzker School of Medicine  
Chicago, Illinois  
693. *Hyperpigmented Lesions*  
694. *Hypopigmented Lesions*  
695. *Vesiculobullous Disorders*  
712. *Nutritional Dermatoses*

**Soma Jyonouchi, MD**

Associate Professor of Clinical Pediatrics  
University of Pennsylvania Perelman School of Medicine  
Attending Physician  
Division of Allergy and Immunology  
Children's Hospital of Philadelphia  
Philadelphia, Pennsylvania  
164. *Orientation to the Consideration of Inborn Errors of Immunity*

**Mohammad Nasser Kabbany, MD**

Assistant Professor of Pediatrics  
Cleveland Clinic Lerner College of Medicine of Case Western Reserve University  
Department of Pediatric Gastroenterology, Hepatology, and Nutrition  
Cleveland Clinic Children's  
Cleveland, Ohio  
393. *Tumors of the Digestive Tract*

**Marielle Kabbouche, MD, FAAN, FAHS**

Professor of Pediatrics  
University of Cincinnati College of Medicine  
Division of Pediatric Neurology  
Director, Headache Center  
Cincinnati Children's Hospital Medical Center  
Cincinnati, Ohio  
635. *Headaches*

**Joanne Kacperski, MD, FAHS**

Associate Professor of Pediatrics  
University of Cincinnati College of Medicine  
Division of Pediatric Neurology  
Cincinnati Children's Hospital Medical Center  
Cincinnati, Ohio  
635. *Headaches*

**Nadia A. Kadry, PhD**

Biologist  
US Food and Drug Administration  
Center for Devices and Radiological Health  
Silver Spring, Maryland  
240. *Haemophilus influenzae*

**Batul Kaj-Carbaidwala, MD**

Assistant Professor of Pediatrics  
Northwestern University Feinberg School of Medicine  
Attending Physician  
Department of Gastroenterology, Hepatology & Nutrition  
Ann & Robert H. Lurie Children's Hospital of Chicago  
Chicago, Illinois  
408. *Liver Disease Associated with Systemic Disorders*

**Jennifer M. Kalish, MD, PhD**

Assistant Professor of Pediatrics and Genetics  
University of Pennsylvania Perelman School of Medicine  
Attending Physician  
Division of Human Genetics  
Lorenzo "Turtle" Sartini Jr. Endowed Chair in Beckwith-Wiedemann Syndrome Research  
Children's Hospital of Philadelphia  
Philadelphia, Pennsylvania  
598.1. *Overgrowth Syndromes*

**Deepak Kamat, MD, PhD, FAAP**

Professor of Pediatrics  
Vice Chair for Academic Affairs  
Chair, Promotion and Tenure Committee  
Department of Pediatrics  
Joe R and Teresa Lozano Long School of Medicine  
UT Health San Antonio  
San Antonio, Texas  
219. *Fever*

**Alvina R. Kansra, MD**

Associate Medical Director  
AbbVie  
North Chicago, Illinois  
626. *Hypofunction of the Ovaries*  
627. *Pseudoprecocity Resulting From Lesions of the Ovary*

**David M. Kanter, MD**

Assistant Professor of Physical Medicine and Rehabilitation  
State University of New York  
SUNY Upstate Medical University  
Syracuse, New York  
756. *Health and Wellness for Children With Disabilities*

**Carol M. Kao, MD**

Associate Professor of Pediatrics  
Washington University School of Medicine in St. Louis  
Division of Pediatric Infectious Diseases  
St. Louis Children's Hospital  
St. Louis, Missouri  
227. *Staphylococcus*

**Prasanna K. Kapavarapu, MD**

Assistant Professor of Clinical Pediatrics  
University of Pennsylvania Perelman School of Medicine  
Attending Physician  
Division of Gastroenterology, Hepatology, and Nutrition  
Children's Hospital of Philadelphia  
Philadelphia, Pennsylvania  
378. *Motility Disorders and Hirschsprung Disease*  
390. *Cyclic Vomiting Syndrome*

**Jacob Kattan, MD, MSCR**

Assistant Professor of Pediatrics, Allergy and Immunology  
Jack and Lucy Clark Department of Pediatrics  
Jaffe Food Allergy Institute  
Icahn School of Medicine at Mount Sinai  
Mount Sinai Kravis Children's Hospital  
New York, New York  
183. *Diagnosis of Allergic Disease*

**Andrea Kelly, MD, MSCE**

Professor of Pediatrics  
University of Pennsylvania Perelman School of Medicine  
Attending Physician  
Children's Hospital of Philadelphia  
Philadelphia, Pennsylvania  
27. *Assessment of Growth*

**Desmond P. Kelly, MD**

Professor of Pediatrics  
University of South Carolina School of Medicine Greenville  
Interim Chief Academic Executive Officer  
Prisma Health  
Greenville, South Carolina;  
Clinical Professor  
Clemson University School of Health Research  
Clemson, South Carolina  
49. *Neurodevelopmental and Executive Function and Dysfunction*

**Matthew S. Kelly, MD, MPH**

Associate Professor of Pediatrics  
Associate Research Professor of Global Health and Molecular Genetics & Microbiology  
Duke University School of Medicine  
Durham, North Carolina  
449. *Community-Acquired Pneumonia*

**Michael E. Kelly, MD, PhD**

Clinical Professor of Pediatrics  
Cleveland Clinic Lerner College of Medicine of Case Western Reserve University  
Cleveland, Ohio  
537. *Anatomy and Function of the Lymphatic System*  
538. *Abnormalities of Lymphatic Vessels*



**Sadiqa Kendi, MD, MPH, CPST**

Associate Professor of Pediatrics  
Boston University Chobanian & Avedisian School  
of Medicine  
Division Chief, Pediatric Emergency Medicine  
Boston Medical Center  
Boston, Massachusetts  
14. *Injury Control*

**Eitan Kerem, MD**

Professor of Pediatrics  
Hadassah University Medical Center  
Jerusalem, Israel  
15.3. *Effects of War on Children*

**Julie M. Kerr, MD**

Sports Medicine Center  
Akron Children's Hospital  
Medical Director  
University of Akron Health Services  
Team Physician  
Department of Intercollegiate Athletics  
University of Akron  
Akron, Ohio;  
Clinical Associate Professor of Pediatrics  
Northeast Ohio Medical University  
Rootstown, Ohio  
730. *Cervical Spine Injuries*

**David A. Khan, MD**

Professor of Internal Medicine and Pediatrics  
University of Texas Southwestern Medical Center  
Dallas, Texas  
189. *Urticaria (Hives) and Angioedema*

**Seema Khan, MD**

Clinical Associate Professor of Pediatrics  
Division of Pediatric Gastroenterology, Hepatology  
& Nutrition  
Stanford University School of Medicine  
The Lucile Packard Children's Hospital  
Palo Alto, California  
364. *Embryology, Anatomy, and Function of the  
Esophagus*  
365. *Congenital Anomalies*  
366. *Obstructing Disorders of the Esophagus*  
367. *Dysmotility*  
368. *Hiatal Hernia*  
369. *Gastroesophageal Reflux Disease*  
370. *Eosinophilic Esophagitis, Pill Esophagitis, and  
Infective Esophagitis*  
371. *Esophageal Perforation*  
372. *Esophageal Varices*  
373. *Ingestions*

**Ameneh Khatami, BHB, MBChB, MD**

Senior Lecturer, Discipline of Child and Adolescent  
Health  
University of Sydney  
Department of Infectious Diseases and  
Microbiology  
The Children's Hospital at Westmead  
Sydney, Australia  
250. *Aeromonas and Plesiomonas*

**Ilya Khaytin, MD, PhD**

Assistant Professor of Pediatrics  
Northwestern University Feinberg School of  
Medicine  
Attending Physician, Divisions of Autonomic  
Medicine and Sleep Medicine  
Ann & Robert H. Lurie Children's Hospital of Chicago  
and Stanley Manne Children's Research Institute  
Chicago, Illinois  
468.3. *Rapid-Onset Obesity with Hypothalamic  
Dysfunction, Hypoventilation, and Autonomic  
Dysregulation*

**Catherine Kier, MD, FAAP, FCCP,  
DABSM, AE-C, ATSF**

Professor of Pediatrics  
Renaissance School of Medicine at Stony Brook  
University  
Division of Pulmonology  
Stony Brook Children's Hospital  
Stony Brook, New York  
443. *Other Distal Airway Diseases*

**Alexandra Kilinsky, DO, MS-HPPL**

Assistant Professor of Pediatrics  
University of Colorado School of Medicine  
Division of Pediatric Hospital Medicine  
Children's Hospital Colorado  
Aurora, Colorado  
215. *Immunization Practices*

**Chong-Tae Kim, MD, PhD**

Professor of Pediatrics  
University of Pennsylvania Perelman School of  
Medicine  
Division of Rehabilitation Medicine  
Children's Hospital of Philadelphia  
Philadelphia, Pennsylvania  
750. *Rehabilitation for Traumatic Brain Injury*

**Jung Won Kim, MD**

Assistant Professor of Psychiatry  
Department of Psychiatry  
Harvard Medical School  
Attending Psychiatrist  
Department of Psychiatry & Behavioral Sciences  
Boston Children's Hospital  
Boston, Massachusetts  
37. *Motor Disorders and Habits*

**Rosa K. Kim, MD**

Assistant Professor of Psychiatry and Behavioral  
Medicine  
Division of Child and Adolescent Psychiatry  
Medical Director, Wisconsin Child Psychiatry  
Consultation Program (WI CPCR)  
Medical College of Wisconsin  
Milwaukee, Wisconsin  
38. *Anxiety Disorders, Obsessive-Compulsive  
Disorder, and Posttraumatic Stress Disorder*  
39. *Mood Disorders*  
40. *Suicide and Attempted Suicide*  
47. *Childhood Psychoses*  
48. *Delirium*

**J. Michael King, MD, MEd**

Attending Physician  
Division of Rehabilitation Medicine  
Associate Director, Trauma Center  
Children's Hospital of Philadelphia  
Philadelphia, Pennsylvania  
750. *Rehabilitation for Traumatic Brain Injury*

**Matthew P. Kirschen, MD, PhD**

Assistant Professor  
Associate Director, Pediatric Neurocritical Care  
Department of Anesthesia and Critical Care  
Medicine  
Departments of Pediatrics and Neurology  
University of Pennsylvania Perelman School of  
Medicine  
Children's Hospital of Philadelphia  
Philadelphia, Pennsylvania  
83. *Brain Death: Death by Neurologic Criteria*

**Priya S. Kishnani, MD**

C.L. and Su Chen Professor of Pediatrics  
Chief, Division of Medical Genetics  
Duke University Medical Center  
Durham, North Carolina  
107. *Defects in Metabolism of Carbohydrates*

**Meghan A. Klawonn, MD**

Clinical Assistant Professor of Physical Medicine  
and Rehabilitation  
State University of New York  
SUNY Upstate Medical University  
Syracuse, New York  
756. *Health and Wellness for Children With  
Disabilities*

**Bruce L. Klein, MD**

Associate Professor of Pediatrics  
Johns Hopkins University School of Medicine  
Director, Transport Services  
Johns Hopkins Bloomberg Children's Center  
Baltimore, Maryland  
77.1. *Interfacility Transport of the Seriously Ill or  
Injured Pediatric Patient*  
80. *Acute Care of Multiple Trauma*

**Bruce S. Klein, MD**

Professor of Pediatrics, Internal Medicine, and  
Medical Microbiology and Immunology  
Chief, Division of Pediatric Infectious Disease  
University of Wisconsin School of Medicine and  
Public Health  
Madison, Wisconsin  
285. *Blastomycosis*

**Alison S. Kliegman, MPH**

Public Health Clinic Operations Director  
City of Milwaukee Health Department  
Milwaukee, Wisconsin  
161.1. *Abortion*

**Robert M. Kliegman, MD**

Professor of Pediatrics  
Nelson Service for Undiagnosed and Rare Diseases  
Medical College of Wisconsin  
Milwaukee, Wisconsin  
134. *Digestive System Disorders*  
137. *Jaundice and Hyperbilirubinemia in the  
Newborn*  
161.1. *Abortion*  
493.3. *Generalized Arterial Calcification of Infancy  
(Idiopathic Infantile Arterial Calcification)*  
493.4. *Arterial Tortuosity*

**Martin C.J. Kneyber, MD, PhD,  
FCCM**

Consultant in Paediatric Intensive Care  
University of Groningen Faculty of Medical  
Sciences  
Chief, Division of Paediatric Critical Care Medicine  
Beatrix Children's Hospital  
Medical President-Elect, European Society for  
Paediatric and Neonatal Intensive Care  
Groningen, Netherlands  
86. *Acute Care of Respiratory Distress and Failure*

**William C. Koch, MD**

Professor of Pediatrics  
Virginia Commonwealth University School of  
Medicine  
Division of Pediatric Infectious Diseases  
Children's Hospital of Richmond at VCU  
Richmond, Virginia  
298. *Parvoviruses*

**Patrick M. Kochanek, MD, MCCM**

Distinguished Professor of Critical Care Medicine  
Ake N. Grenvik Professor of Critical Care Medicine  
Vice Chair, Department of Critical Care Medicine  
Professor of Anesthesiology, Pediatrics,  
Bioengineering, and Clinical and Translational  
Science

University of Pittsburgh School of Medicine  
Director, Safar Center for Resuscitation Research  
UPMC Children's Hospital of Pittsburgh  
John G. Rangos Research Center  
Pittsburgh, Pennsylvania  
82. *Neurologic Emergencies and Stabilization*

**Eric Kodish, MD**

Professor of Pediatrics, Oncology and Bioethics  
Cleveland Clinic Lerner College of Medicine  
Case Western Reserve University  
Vice-Chair, Professional Staff Affairs and Faculty  
Development  
Pediatric Institute  
Cleveland Clinic  
Cleveland, Ohio  
6. *Ethics in Pediatric Care*

**Stephan A. Kohlhoff, MD**

Associate Professor of Pediatrics and Medicine  
Chief, Division of Pediatric Infectious Diseases  
SUNY Downstate Health Sciences University  
Brooklyn, New York  
271. *Chlamydia pneumoniae*  
273. *Psittacosis (Chlamydia psittaci)*

**Mark G. Kortepeter, MD, MPH, FACP, FIDSA, FASTMH**

Vice President for Research  
Professor of Medicine and Preventive Medicine  
Uniformed Services University of the Health  
Sciences  
Bethesda, Maryland  
763. *Biological and Chemical Terrorism*

**Karen L. Kotloff, MD**

Professor of Pediatrics  
Head, Division of Infectious Disease and Tropical  
Pediatrics  
Center for Vaccine Development and Global  
Health  
University of Maryland School of Medicine  
Baltimore, Maryland  
387. *Acute Gastroenteritis in Children*

**Anastassios C. Koumbourlis, MD, MPH**

Professor of Pediatrics  
George Washington University School of Medicine  
and Health Sciences  
Chief, Division of Pulmonary and Sleep Medicine  
Director, Cystic Fibrosis Center  
Children's National Medical Center  
Washington, DC  
446. *Acute Aspiration*  
447. *Chronic Recurrent Aspiration*

**Peter J. Krause, MD**

Senior Research Scientist in Epidemiology  
(Microbial Diseases), Medicine (Infectious  
Diseases), and Pediatrics (Infectious Diseases)  
Affiliated Faculty, Yale Institute for Global Health  
Yale School of Public Health  
New Haven, Connecticut  
335. *Babesiosis (Babesia)*

**Nancy F. Krebs, MD, MS**

Professor and Associate Vice Chair, Academic  
Affairs  
Department of Pediatrics  
University of Colorado School of Medicine  
Head, Section of Pediatric Nutrition  
Children's Hospital Colorado  
Aurora, Colorado  
60. *Nutritional Requirements*  
61. *Feeding Healthy Infants, Children, and  
Adolescents*  
64. *Malnutrition in High-Resource Settings*

**Richard E. Kreipe, MD, FAAAP, FSAHM, FAED**

Professor Emeritus of Pediatrics  
University of Rochester School of Medicine and  
Dentistry  
Division of Adolescent Medicine  
Golisano Children's Hospital  
Rochester, New York  
41. *Eating Disorders*

**Steven E. Krug, MD**

Professor of Pediatrics  
Northwestern University Feinberg School of  
Medicine  
Former Head, Division of Pediatric Emergency  
Medicine  
Ann & Robert H. Lurie Children's Hospital of  
Chicago  
Chicago, Illinois  
77. *Emergency Medical Services for Children*

**Janet L. Kwiatkowski, MD, MSCE**

Professor of Pediatrics  
University of Pennsylvania Perelman School of  
Medicine  
Attending Physician  
Division of Hematology  
Director, Thalassemia Program  
Children's Hospital of Philadelphia  
Philadelphia, Pennsylvania  
511. *Hemoglobinopathies*

**Jennifer M. Kwon, MD**

Professor of Child Neurology  
University of Wisconsin School of Medicine and  
Public Health  
Madison, Wisconsin  
639. *Neurodegenerative Disorders of Childhood*

**Stephan Ladisch, MD**

Professor  
Departments of Pediatrics and Biochemistry and  
Molecular Biology  
George Washington University School of Medicine  
Center for Cancer and Immunology Research  
Center for Cancer and Blood Disorders  
Children's Research Institute  
Children's National Medical Center  
Washington, DC  
556. *Histiocytosis Syndromes of Childhood*

**Oren J. Lakser, MD**

Master Clinician  
Division of Pulmonary and Sleep Medicine  
Ann & Robert H. Lurie Children's Hospital of  
Chicago  
Assistant Professor of Pediatrics  
Northwestern University Feinberg School of  
Medicine  
Chicago, Illinois  
452. *Bronchiectasis*  
453. *Pulmonary Abscess*

**Leah Lalor, MD**

Associate Professor of Dermatology and Pediatrics  
Medical College of Wisconsin  
Department of Dermatology  
Division of Pediatric Dermatology  
Milwaukee, Wisconsin  
701.2. *Lipodystrophy*  
705. *Disorders of the Mucous Membranes*  
710. *Acne*  
745. *Cutis Laxa*

**Simon Lam, MD, FRCPC**

Clinical Assistant Professor of Pediatrics  
University of Calgary Cummings School of  
Medicine  
Section of Pediatric Gastroenterology, Hepatology  
& Nutrition  
Alberta Children's Hospital  
Calgary, Alberta  
404. *Cholestasis*

**Michele P. Lambert, MD, MSTR**

Associate Professor of Pediatrics  
University of Pennsylvania Perelman School of  
Medicine  
Medical Director, Special Coagulation Laboratory  
Associate Clinical Director, Frontier Program in  
Immune Dysregulation  
Division of Hematology  
Children's Hospital of Philadelphia  
Philadelphia, Pennsylvania  
138. *Blood Disorders*  
139. *Anemia in the Newborn Infant*  
140. *Hemolytic Disease of the Fetus and Newborn*  
141. *Neonatal Polycythemia*  
142. *Hemorrhage in the Newborn Infant*

**Christina Lampe, MD**

Senior Physician  
Center for Rare Diseases Giessen (ZSEGI)  
Department of Pediatric Neurology, Social  
Pediatrics, and Epileptology  
Center for Pediatrics and Adolescent Medicine  
University Hospital of Giessen  
Giessen, Germany  
109. *Mucopolysaccharidoses*

**Gregory L. Landry, MD**

Professor Emeritus  
Department of Pediatrics  
University of Wisconsin – Madison  
School of Medicine and Public Health  
Madison, Wisconsin  
727. *Prevention of Injuries*  
728. *Management of Musculoskeletal Injury*  
731. *Heat Injuries*  
732. *Nutrition and Endocrine Conditions in Athletes*  
733. *Performance-Enhancing Aids*  
734. *Specific Sports and Associated Injuries*

**Wendy G. Lane, MD, MPH, FAAP**

Clinical Associate Professor  
Departments of Epidemiology and Public Health  
and Pediatrics  
University of Maryland School of Medicine  
Baltimore, Maryland  
17. *Abused and Neglected Children*

**A. Noelle Larson, MD**

Professor of Orthopedics  
Chair, Division of Community Orthopedics  
Mayo Clinic  
Rochester, Minnesota  
550.2. *Benign Tumors and Tumor-Like Processes of  
Bone*

**Phillip S. LaRussa, MD**

Professor of Pediatrics  
Columbia University Vagelos College of Physicians  
and Surgeons  
Division of Pediatric Infectious Diseases  
NewYork-Presbyterian Morgan Stanley Children's  
Hospital  
New York, New York  
300. *Varicella-Zoster Virus*

**J. Todd R. Lawrence, MD, PhD**

Professor of Orthopaedic Surgery  
University of Pennsylvania Perelman School of  
Medicine  
Attending Orthopaedic Surgeon  
Children's Hospital of Philadelphia  
Philadelphia, Pennsylvania  
718. *The Knee*

**Brendan Lee, MD, PhD**

Robert and Janice McNair Endowed Chair in  
Molecular and Human Genetics  
Professor and Chairman  
Department of Molecular and Human Genetics  
Baylor College of Medicine  
Houston, Texas  
95. *Genetics in Pediatric Medicine*  
96. *Principles of Human Genetics*  
97. *Patterns of Genetic Transmission*  
98. *Integration of Genetics into Pediatric Practice*  
99. *Chromosome Disorders*  
103. *Genetics of Common Disorders*

**Erica H. Lee, PhD**

Assistant Professor of Psychology in Psychiatry  
Harvard Medical School  
Attending Psychologist  
Department of Psychiatry and Behavioral Sciences  
Attending Psychologist  
Department of Psychiatry and Behavioral Sciences  
Boston Children's Hospital  
Boston, Massachusetts  
34. *Psychotherapy*  
42. *Disruptive, Impulse-Control, and Conduct  
Disorders*  
43. *Tantrums and Breath-Holding Spells*  
44. *Lying, Stealing, and Truancy*  
45. *Aggression*

**Jennifer W. Leiding, MD**

Adjunct Associate Professor  
Johns Hopkins University  
Baltimore, Maryland;  
Institute for Clinical and Translational Research  
Johns Hopkins All Children's Hospital  
St. Petersburg, Florida  
174. *Immune Dysregulation*

**Monica E. Lemmon, MD**

Associate Professor of Pediatrics and Population  
Health Sciences  
Medical Director, Children's Clinical Research Unit  
Duke University Medical Center  
Durham, North Carolina  
633.7. *Neonatal Seizures*

**Daniel J. Lesser, MD**

Clinical Professor of Pediatrics  
University of California San Diego School of  
Medicine  
Division of Respiratory Medicine  
Rady Children's Hospital—San Diego  
San Diego, California  
421. *Diagnostic Approach to Respiratory Disease*

**Steven O. Lestrud, MD**

Assistant Professor of Pediatrics  
Northwestern University Feinberg School of  
Medicine  
Medical Director, Respiratory Care  
Ann & Robert H. Lurie Children's Hospital of  
Chicago  
Chicago, Illinois  
468.1. *Chronic Respiratory Failure and Long-Term  
Mechanical Ventilation*

**Donald Y. M. Leung, MD, PhD**

Professor of Pediatrics  
University of Colorado School of Medicine  
Edelstein Family Chair of Pediatric Allergy-  
Immunology  
National Jewish Health  
Denver, Colorado  
186. *Atopic Dermatitis (Atopic Eczema)*

**Michael N. Levas, MD, MS**

Associate Professor of Pediatrics  
Medical College of Wisconsin  
Director of Social Medicine  
Division of Pediatric Emergency Medicine  
Medical Director, Project Ujima  
Associate Director, Comprehensive Injury Center  
Children's Wisconsin  
Milwaukee, Wisconsin  
156. *Violent Behavior*

**Chris A. Liacouras, MD**

Professor of Pediatrics  
University of Pennsylvania Perelman School of  
Medicine  
Director, Clinical Laboratory  
Medical Director, CHOP Exton Satellite  
Co-Director, Center for Pediatric Eosinophilic  
Disorders  
Children's Hospital of Philadelphia  
Philadelphia, Pennsylvania  
351. *Normal Digestive Tract Phenomena*  
352. *Major Symptoms and Signs of Digestive Tract  
Disorders*  
374. *Normal Development, Structure, and Function  
of the Stomach and Intestines*  
375. *Pyloric Stenosis and Other Congenital  
Anomalies of the Stomach*  
376. *Intestinal Atresia, Stenosis, and Malrotation*  
377. *Intestinal Duplications, Meckel Diverticulum,  
and Other Remnants of the Omphalomesenteric  
Duct*  
378. *Motility Disorders and Hirschsprung Disease*  
379. *Ileus, Adhesions, Intussusception, and Closed-  
Loop Obstructions*  
380. *Foreign Bodies and Bezoars*  
389. *Disorders of Brain-Gut Interaction (Functional  
Gastrointestinal Disorders)*  
390. *Cyclic Vomiting Syndrome*  
417. *Peritoneal Malformations*  
418. *Ascites*  
419. *Peritonitis*

**Paul H. Lipkin, MD**

Professor of Pediatrics  
Kennedy Krieger Institute  
Johns Hopkins University School of Medicine  
Baltimore, Maryland  
28. *Developmental and Behavioral Surveillance and  
Screening*

**Deborah R. Liptzin, MD, MS**

Associate Clinical Professor of Pediatrics  
University of Colorado School of Medicine  
Aurora, Colorado  
448.7. *Fibrotic Lung Disease*

**Andrew H. Liu, MD**

Professor of Pediatrics  
Section of Pediatric Pulmonary and Sleep Medicine  
Children's Hospital Colorado  
University of Colorado School of Medicine  
Aurora, Colorado  
185. *Childhood Asthma*

**Mindy S. Lo, MD, PhD**

Assistant Professor of Pediatrics  
Harvard Medical School  
Director, Rheumatology Fellowship Training  
Program  
Boston Children's Hospital  
Boston, Massachusetts  
208. *Kawasaki Disease*

**Stanley F. Lo, PhD**

Professor of Pathology  
Medical College of Wisconsin  
Technical Director, Clinical Chemistry and Point of  
Care Testing  
Director, Reference Standards Library  
Co-Director, Biochemical Genetics Laboratory  
Associate Director, Clinical Pathology  
Children's Wisconsin  
Milwaukee, Wisconsin  
769. *Laboratory Testing in Infants and Children*  
770. *Reference Intervals for Laboratory Tests and  
Procedures*

**Sarah S. Long, MD**

Professor of Pediatrics  
Drexel University College of Medicine  
Chief Emeritus  
Section of Infectious Diseases  
St. Christopher's Hospital for Children  
Philadelphia, Pennsylvania  
243. *Pertussis (Bordetella pertussis and Bordetella  
parapertussis)*

**Katherine Lord, MD**

Associate Professor of Pediatrics  
University of Pennsylvania Perelman School of  
Medicine  
Director, Inpatient Endocrinology Service  
Children's Hospital of Philadelphia  
Philadelphia, Pennsylvania  
113. *Hypoglycemia*

**Charles G. Macias, MD, MPH**

Associate Professor of Pediatrics  
Case Western Reserve University School of  
Medicine  
Division Chief, Pediatric Emergency Medicine  
Executive Director, EMS for Children Innovation  
and Improvement Center  
Chief Quality Officer/Vice Chair Quality & Safety  
University Hospitals Rainbow Babies & Children's  
Hospital  
Cleveland, Ohio  
77. *Emergency Medical Services for Children*

**Michelle M. Macias, MD**

Professor of Pediatrics  
Director, SC Leadership Education in  
Neurodevelopmental and Related Disabilities  
Program  
Division of Developmental-Behavioral Pediatrics  
Department of Pediatrics  
Medical University of South Carolina  
Charleston, South Carolina  
54. *Augmentative and Alternative Communication*



**Ian R. Macumber, MD**

Clinical Assistant Professor of Pediatrics  
Keck School of Medicine of USC  
University of Southern California  
Attending Physician  
Division of Nephrology  
Children's Hospital Los Angeles  
Los Angeles, California  
494. *Systemic Hypertension*

**Mark R. Magnusson, MD, PhD**

Medical Director, Diagnostic and Complex  
Care Center; Spina Bifida Program; Inpatient  
Rehabilitation Unit; Acquired Autonomic  
Dysfunction Program and Clinic; Children's  
Hospital Home Care  
Children's Hospital of Philadelphia  
Philadelphia, Pennsylvania  
212.1. *Chronic Fatigue Syndrome*

**Pilar L. Magoulas, MS, CGC**

Associate Professor  
Department of Molecular and Human Genetics  
Baylor College of Medicine  
Houston, Texas  
98.1. *Genetic Counseling*

**Kathleen J. Maguire, MD**

Attending Orthopaedic Surgeon  
Sports Medicine and Performance Center  
Children's Hospital of Philadelphia  
Philadelphia, Pennsylvania  
714. *Orthopedic Evaluation of the Child*

**Prashant V. Mahajan, MD, MPH, MBA**

Professor of Emergency Medicine and Pediatrics  
Vice-Chair, Department of Emergency Medicine  
Division Chief, Pediatric Emergency Medicine  
C.S. Mott Children's Hospital  
University of Michigan Medical School  
Ann Arbor, Michigan  
760. *Heavy Metal Intoxication*

**Joseph A. Majzoub, MD**

Thomas Morgan Rotch Professor of Pediatrics  
Harvard Medical School  
Vice Chair for Research  
Department of Pediatrics  
Division of Endocrinology  
Boston Children's Hospital  
Boston, Massachusetts  
596. *Diabetes Insipidus*  
597. *Other Abnormalities of Arginine Vasopressin  
Metabolism and Action*

**Petar Mamula, MD**

Professor and Distinguished Endowed Chair  
Department of Pediatrics  
University of Pennsylvania Perelman School of  
Medicine  
Director, Kohl's GI Nutrition and Diagnostic  
Center  
Co-Director, Center for Digestive, Liver and  
Pancreatic Medicine  
Children's Hospital of Philadelphia  
Philadelphia, Pennsylvania  
380. *Foreign Bodies and Bezoars*

**Colleen K. Manak, MD**

Assistant Professor of Psychiatry and Behavioral  
Medicine  
Medical College of Wisconsin  
Wisconsin Child Psychiatric Consultation Program  
(WI CPCP)  
Division of Child and Adolescent Psychiatry  
Children's Wisconsin  
Milwaukee, Wisconsin  
39. *Mood Disorders*  
48. *Delirium*

**Courtney W. Mangus, MD**

Assistant Professor of Pediatrics and Emergency  
Medicine  
University of Michigan Medical School  
Ann Arbor, Michigan  
80. *Acute Care of Multiple Trauma*

**Irin Manoli, MD, PhD**

Clinician Associate Investigator  
National Human Genome Research Institute  
National Institutes of Health  
Bethesda, Maryland  
105.6. *Isoleucine, Leucine, Valine, and Related  
Organic Acidemias*

**Adnan Y. Manzur, MD, FRCPC**

Consultant Paediatric Neurologist  
Dubowitz Neuromuscular Centre (DNC)  
Great Ormond Street Hospital for Children  
London, United Kingdom  
647. *Evaluation and Investigation of Neuromuscular  
Disorders*  
648. *Developmental Disorders of Muscle*  
649. *Muscular Dystrophies*  
650. *Endocrine and Toxic Myopathies*  
651. *Metabolic Myopathies and Channelopathies*  
652. *Disorders of Neuromuscular Transmission and  
of Motor Neurons*  
653. *Hereditary Motor-Sensory Neuropathies*  
654. *Toxic Neuropathies*

**Asim Maqbool, MD**

Professor of Clinical Pediatrics  
University of Pennsylvania Perelman School of  
Medicine  
Attending Physician  
Division of Gastroenterology, Hepatology, and  
Nutrition  
Director, Center for Pancreatic Disorders  
Children's Hospital of Philadelphia  
Philadelphia, Pennsylvania  
351. *Normal Digestive Tract Phenomena*  
352. *Major Symptoms and Signs of Digestive Tract  
Disorders*  
374. *Normal Development, Structure, and Function  
of the Stomach and Intestines*  
389. *Disorders of Brain-Gut Interaction (Functional  
Gastrointestinal Disorders)*  
390. *Cyclic Vomiting Syndrome*

**Col. Ashley M. Maranich, MD, MHPE, FAAP, FIDSA**

Assistant Dean for Clinical Sciences  
Associate Professor of Pediatrics  
Uniformed Services University of the Health Sciences  
Bethesda, Maryland  
282. *Malassezia*

**Miranda Margetts, PhD**

Assistant Research Professor  
Center for American Indian and Rural Health  
Equity  
Montana State University  
Bozeman, Montana  
591. *Vulvovaginal and Müllerian Anomalies*

**David Margolis, MD**

Professor of Pediatrics  
Medical College of Wisconsin  
Program Director, Bone Marrow Transplantation  
Children's Wisconsin  
Milwaukee, Wisconsin  
177. *Principles and Clinical Indications of  
Hematopoietic Stem Cell Transplantation*  
178. *Hematopoietic Stem Cell Transplantation from  
Alternative Sources and Donors*  
179. *Graft-Versus-Host Disease, Rejection, and  
Venoocclusive Disease*  
181. *Late Effects of Hematopoietic Stem Cell  
Transplantation*

**Mona Marin, MD**

Division of Viral Diseases  
National Center for Immunization and Respiratory  
Diseases  
Centers for Disease Control and Prevention  
Atlanta, Georgia  
300. *Varicella-Zoster Virus*

**Joan C. Marini, MD, PhD**

Scientist Emeritus, Section on Heritable Disorders  
of Bone and Extracellular Matrix  
National Institute for Child Health and  
Development  
National Institutes of Health  
Bethesda, Maryland  
742. *Osteogenesis Imperfecta*

**Morri Markowitz, MD**

Professor of Pediatrics and Medicine  
Albert Einstein College of Medicine  
Director, Lead Poisoning Prevention and  
Treatment Program  
The Children's Hospital at Montefiore  
Bronx, New York  
761. *Lead Poisoning*

**Stacene R. Maroushek, MD, PhD, MPH**

Assistant Professor of Pediatrics  
University of Minnesota Medical School  
Divisions of Pediatric Infectious Diseases and  
General Pediatrics  
Hennepin County Medical Center  
Minneapolis, Minnesota  
11. *Medical Evaluation of the Foreign-Born Child*  
260. *Principles of Antimycobacterial Therapy*

**Justin D. Marsh, MD**

Eye Physicians of Central Florida  
Maitland, Florida  
658. *Growth and Development of the Eye*  
659. *Examination of the Eye*  
660. *Abnormalities of Refraction and  
Accommodation*  
661. *Disorders of Vision*  
662. *Abnormalities of Pupil and Iris*  
663. *Disorders of Eye Movement and Alignment*  
664. *Abnormalities of the Lids*  
665. *Disorders of the Lacrimal System*  
666. *Disorders of the Conjunctiva*  
667. *Abnormalities of the Cornea*  
668. *Abnormalities of the Lens*  
669. *Disorders of the Uveal Tract*  
670. *Disorders of the Retina and Vitreous*  
671. *Abnormalities of the Optic Nerve*  
672. *Childhood Glaucoma*  
673. *Orbital Abnormalities*  
674. *Orbital Infections*  
675. *Injuries to the Eye*

**Trisha L. Marshall, MD, MSc**

Assistant Professor of Pediatrics  
University of Cincinnati College of Medicine  
Division of Hospital Medicine  
Cincinnati Children's Hospital Medical Center  
Cincinnati, Ohio  
4. *Quality and Value in Healthcare for Children*

**Kari L. Martin, MD**

Associate Professor of Dermatology and Child Health  
Co-Medical Director, Dermatology Clinics  
University of Missouri School of Medicine  
Columbia, Missouri  
688. *Dermatologic Diseases of the Neonate*  
689. *Cutaneous Defects*  
690. *Ectodermal Dysplasias*  
691. *Vascular Anomalies*  
692. *Cutaneous Nevi*  
699. *Disorders of Keratinization*  
702. *Disorders of the Sweat Glands*  
703. *Disorders of Hair*  
704. *Disorders of the Nails*  
711. *Tumors of the Skin*

**Vicki K. Masson, MD**

Assistant Professor of Pediatrics  
Renaissance School of Medicine at Stony Brook University  
Division of Pulmonology  
Stony Brook Children's Hospital  
Stony Brook, New York  
441. *Emphysema and Overinflation*  
442.  *$\alpha$ 1-Antitrypsin Deficiency and Emphysema*

**Dena R. Matalon, MD**

Clinical Associate Professor of Pediatrics and Medical Genetics  
Stanford University School of Medicine  
Palo Alto, California  
105.15. *N-Acetylaspartic Acid (Canavan Disease)*

**†Reuben K. Matalon, MD, PhD**

Professor of Pediatrics and Genetics  
University of Texas Medical Branch  
Texas Children's  
Galveston, Texas  
105.15. *N-Acetylaspartic Acid (Canavan Disease)*

**Irene M.J. Mathijssen, MD, PhD, MBA-H**

Professor and Head  
Department of Plastic and Reconstructive Surgery  
Head, Craniofacial Research  
Erasmus Medical Center  
Rotterdam, The Netherlands  
631.10 *Craniosynostosis*

**Sravan Kumar Reddy Matta, MD**

Medical Director  
Medical Safety and Pharmacovigilance  
Intercept Pharmaceutical  
Morristown, New Jersey  
364. *Embryology, Anatomy, and Function of the Esophagus*  
365. *Congenital Anomalies*  
366. *Obstructing Disorders of the Esophagus*  
367. *Dysmotility*  
368. *Hiatal Hernia*  
369. *Gastroesophageal Reflux Disease*

**Elizabeth C. Maxwell, MD, MS**

Assistant Professor of Pediatrics  
University of Pennsylvania Perelman School of Medicine  
Division of Gastroenterology, Hepatology and Nutrition  
Children's Hospital of Philadelphia  
Philadelphia, Pennsylvania  
379. *Ileus, Adhesions, Intussusception, and Closed-Loop Obstructions*

**Aletha Maybank, MD, MPH**

Chief Health Equity Officer and Senior Vice President  
American Medical Association  
New York, New York  
2.1. *Racism and Child Health*

**Megan E. McCabe, MD, FAAP**

Vice Chair for Education  
Associate Professor of Pediatrics  
Hackensack Meridian School of Medicine  
Joseph Sanzari Children's Hospital  
Hackensack, New Jersey  
30. *Loss, Separation, and Bereavement*

**Darla H. McCain, MD, MA, FAAP, NCSP**

Clinical Assistant Professor of Pediatrics  
University of South Carolina School of Medicine Greenville  
Division of Developmental Pediatrics  
Prisma Health Children's Hospital – Upstate  
Greenville, South Carolina  
49. *Neurodevelopmental and Executive Function and Dysfunction*

**Susanna A. McColley, MD**

Professor of Pediatrics  
Northwestern University Feinberg School of Medicine  
Scientific Director, Interdisciplinary Research Partnerships  
Stanley Manne Children's Research Institute  
Ann & Robert H. Lurie Children's Hospital of Chicago  
Chicago, Illinois  
422.1. *Extrapulmonary Diseases With Pulmonary Manifestations*  
460. *Pulmonary Tumors*

**Neena McConico, PhD**

Assistant Professor of Pediatrics  
Boston University Aram V. Chobanian & Edward Avedisian School of Medicine  
Executive Director, Child Witness to Violence Program  
Boston, Massachusetts  
15. *Impact of Violence Exposure on Children*

**Elizabeth M. McCormick, MS, LCGC**

Senior Genetic Counselor  
Research Coordinator, Mitochondrial Medicine Frontier Program  
Division of Human Genetics, Department of Pediatrics  
Children's Hospital of Philadelphia  
Philadelphia, Pennsylvania  
108. *Mitochondrial Disease Diagnosis*

**Christine M. McDonald, ScD, MS**

Assistant Professor of Pediatrics  
The Benioff Center for Microbiome Medicine  
UC San Francisco School of Medicine  
San Francisco, California  
62. *Nutrition, Food Security, and Health*

**Margaret M. McGovern, MD, PhD**

Deputy Dean for Clinical Affairs  
Yale School of Medicine  
CEO, Yale Medicine  
New Haven, Connecticut  
106.4. *Lipidoses (Lysosomal Storage Disorders)*  
106.5. *Mucopolidoses*  
107.6. *Disorders of Glycoprotein Degradation and Structure*

**Sharon A. McGrath-Morrow, MD, MBA**

Professor of Pediatrics  
Robert Gerard Morse Endowed Chair in Pediatric Pulmonary Medicine  
University of Pennsylvania Perelman School of Medicine  
Associate Chief  
Division of Pulmonary and Sleep Medicine  
Children's Hospital of Philadelphia  
Philadelphia, Pennsylvania  
466. *Bronchopulmonary Dysplasia*

**Alissa McInerney, MD, FAAP**

Summit Health Allergy & Immunology  
New York, New York  
176. *Approaches to Treatment of Primary Immune Deficiency Diseases*

**Jeffrey S. McKinney, MD, PhD**

Professor of Pediatrics  
Vice Chair for Education  
Harry W. Bass Jr. Professorship in Pediatric Education  
Distinguished Teaching Professor  
Division of Pediatric Infectious Diseases  
UT Southwestern Medical Center  
Dallas, Texas  
244. *Salmonella*

**Rima McLeod, MD**

Professor of Ophthalmology and Visual Science and Pediatrics  
Medical Director, Toxoplasmosis Center  
University of Chicago Pritzker School of Medicine  
Chicago, Illinois  
336. *Toxoplasmosis (Toxoplasma gondii)*

**Marcene R. McVay-Gillam, MD, FACS, FAAP**

Associate Professor of Surgery  
University of Arkansas for Medical Sciences  
Little Rock, Arkansas;  
Medical Director, Trauma Program  
Medical Director, Surgery  
Arkansas Children's Northwest  
Springdale, Arkansas  
588. *Breast Health*

**Julia C. Meade, MD**

Assistant Professor of Pediatrics  
University of Pittsburgh School of Medicine  
Director, Pediatric Cancer Predisposition Program  
UPMC Children's Hospital of Pittsburgh  
Pittsburgh, Pennsylvania  
542. *Principles of Cancer Diagnosis*  
543. *Principles of Cancer Treatment*  
544. *The Leukemias*

**William P. Meehan III, MD**

Associate Professor of Pediatrics and Orthopedics  
Harvard Medical School  
Director, The Micheli Center for Sports Injury Prevention  
Director, Clinical Effectiveness Research Center  
Director of Research  
Division of Sports Medicine  
Boston Children's Hospital  
Boston, Massachusetts  
729. *Sports-Related Traumatic Brain Injury (Concussion)*

**Asuncion Mejias, MD, PhD, MSCS**

Professor of Pediatrics  
 Pediatric Infectious Diseases Physician  
 Member, St Jude Faculty  
 Department of Infectious Diseases  
 St Jude Children's Research Hospital  
 Memphis, Tennessee  
 262. *Hansen Disease (Mycobacterium leprae)*  
 269. *Mycoplasma pneumoniae*  
 270. *Genital Mycoplasmas (Mycoplasma hominis, Mycoplasma genitalium, and Ureaplasma urealyticum)*

**Peter C. Melby, MD**

Professor of Internal Medicine (Infectious Diseases),  
 Microbiology and Immunology, and Pathology  
 Director, Division of Infectious Diseases  
 Director, Center for Tropical Diseases  
 University of Texas Medical Branch (UTMB)  
 Galveston, Texas  
 331. *Leishmaniasis (Leishmania)*

**Marlene D. Melzer-Lange, MD**

Professor of Pediatrics  
 Medical College of Wisconsin  
 Program Director, Project Ujima  
 Children's Wisconsin  
 Milwaukee, Wisconsin  
 156. *Violent Behavior*

**Jamie F. Merves, MD**

Assistant Professor of Clinical Pediatrics  
 University of Pennsylvania Perelman School of  
 Medicine  
 Attending Physician  
 Division of Gastroenterology, Hepatology and  
 Nutrition  
 Children's Hospital of Philadelphia  
 Philadelphia, Pennsylvania  
 417. *Peritoneal Malformations*

**Kevin B. Messacar, MD, PhD**

Associate Professor of Pediatrics  
 University of Colorado School of Medicine  
 Section of Pediatric Infectious Diseases  
 Section of Hospital Medicine  
 Children's Hospital Colorado  
 Aurora, Colorado  
 297. *Nonpolio Enteroviruses*

**Marian G. Michaels, MD, MPH**

Professor of Pediatrics and Surgery  
 University of Pittsburgh School of Medicine  
 Director, Pediatric HIV Center  
 Co-Director, Pediatric Transplant Infectious  
 Diseases  
 UPMC Children's Hospital of Pittsburgh  
 Pittsburgh, Pennsylvania  
 223. *Infections in Immunocompromised Persons*

**Thomas F. Michniacki, MD**

Clinical Assistant Professor of Pediatrics  
 University of Michigan Medical School  
 Division of Pediatric Hematology/Oncology  
 C. S. Mott Children's Hospital  
 Ann Arbor, Michigan  
 171. *Leukopenia*  
 172. *Leukocytosis*

**Mohamad A. Mikati, MD**

Wilburt C. Davison Professor of Pediatrics  
 Professor of Neurobiology  
 Chief, Division of Pediatric Neurology and  
 Developmental Medicine  
 Duke University Medical Center  
 Durham, North Carolina  
 633. *Seizures in Childhood*  
 634. *Conditions That Mimic Seizures*

**Hilary E. Miller-Handley, MD**

Instructor in Pediatrics and Internal Medicine  
 Division of Infectious Diseases  
 University of Cincinnati College of Medicine  
 Cincinnati Children's Hospital Medical Center  
 Cincinnati, Ohio  
 407. *Liver Abscess*

**Jonathan W. Mink, MD, PhD, FAAN, FANA, FAAP**

Frederick A. Horner MD Distinguished Professor  
 in Pediatric Neurology  
 Professor of Neurology, Neuroscience, and  
 Pediatrics  
 University of Rochester School of Medicine and  
 Dentistry  
 Chief, Division of Child Neurology  
 Vice Chair, Department of Neurology  
 Director, University of Rochester Batten Center  
 University of Rochester Medical Center  
 Rochester, New York  
 637. *Movement Disorders*  
 764. *Mass Psychogenic Illness*

**Karolyn Mirasola, MS**

Speech and Language Pathologist  
 Child Development Center  
 Children's Wisconsin  
 Milwaukee, Wisconsin  
 53.1. *Childhood-Onset Fluency Disorder*

**R. Justin Mistovich, MD, MBA**

Associate Professor of Orthopaedic Surgery  
 Case Western Reserve University School of  
 Medicine  
 Attending Physician  
 Director, Division of Pediatric Orthopaedic  
 Surgery  
 MetroHealth Medical Center University Hospitals  
 Rainbow and Babies Children's Hospital  
 Cleveland, Ohio  
 720. *The Spine*  
 721. *The Neck*

**Emma L. Mohr, MD, PhD**

Assistant Professor  
 Department of Pediatrics  
 University of Wisconsin School of Medicine and  
 Public Health  
 Madison, Wisconsin  
 149. *Congenital and Perinatal Infections*

**Diana Montoya-Williams, MD, MSHP**

Assistant Professor of Pediatrics  
 University of Pennsylvania Perelman School of  
 Medicine  
 Division of Neonatology  
 Children's Hospital of Philadelphia  
 Philadelphia, Pennsylvania  
 114. *Overview of Morbidity and Mortality*

**Rachel Y. Moon, MD**

Harrison Distinguished Teaching Professor of  
 Pediatrics  
 University of Virginia School of Medicine  
 Charlottesville, Virginia  
 423. *Sudden Infant Death Syndrome*

**Eva Morava, MD, PhD**

Professor and Consultant  
 Departments of Clinical Genomics and Laboratory  
 Medicine and Pathology  
 Mayo Clinic  
 Rochester, Minnesota  
 107.7. *Congenital Disorders of Glycosylation*

**Megan A. Moreno, MD, MEd, MPH**

Professor and Vice Chair of Academic Affairs  
 Department of Pediatrics  
 Division Chief, General Pediatrics and Adolescent  
 Medicine  
 University of Wisconsin School of Medicine and  
 Public Health  
 Madison, Wisconsin  
 15.1. *Bullying, Cyberbullying, and School Violence*  
 15.2. *Media Violence*

**Ryan W. Morgan, MD, MTR**

Assistant Professor of Anesthesiology, Critical  
 Care, and Pediatrics  
 University of Pennsylvania Perelman School of  
 Medicine  
 Attending Physician  
 Department of Anesthesiology and Critical Care  
 Children's Hospital of Philadelphia  
 Philadelphia, Pennsylvania  
 79. *Pediatric Cardiorespiratory Emergencies and  
 Resuscitation*

**Peter E. Morrison, DO**

Assistant Professor of Neurology  
 University of Rochester School of Medicine and  
 Dentistry  
 Co-Director, Tourette Association of America  
 (TAA) Center of Excellence  
 University of Rochester Medical Center  
 Rochester, New York  
 637.1. *Ataxias*

**Wynne Morrison, MD, MBE**

Professor of Anesthesiology and Critical Care and  
 Pediatrics  
 University of Pennsylvania Perelman School of  
 Medicine  
 Director, Justin Michael Ingerman Center for  
 Palliative Care  
 Justin Michael Ingerman Endowed Chair for  
 Palliative Care  
 Children's Hospital of Philadelphia  
 Philadelphia, Pennsylvania  
 83. *Brain Death: Death by Neurologic Criteria*

**Sagori Mukhopadhyay, MD, MMSc**

Assistant Professor of Pediatrics  
 University of Pennsylvania Perelman School of  
 Medicine  
 Attending Neonatologist  
 Children's Hospital of Philadelphia  
 Philadelphia, Pennsylvania  
 136. *Necrotizing Enterocolitis*

**Flor M. Munoz, MD**

Associate Professor of Pediatrics  
 Baylor College of Medicine  
 Director, Transplant Infectious Diseases  
 Texas Children's  
 Houston, Texas  
 305. *Influenza Viruses*

**David A. Munson, MD**

Professor of Clinical Pediatrics  
 University of Pennsylvania Perelman School of  
 Medicine  
 Medical Director, Newborn/Infant Intensive Care  
 Unit  
 Children's Hospital of Philadelphia  
 Philadelphia, Pennsylvania  
 120. *Transport of the Critically Ill Newborn*



**Timothy F. Murphy, MD**

SUNY Distinguished Professor of Medicine  
Senior Associate Dean for Clinical and  
Translational Research  
Director, Clinical and Translational Science  
Institute  
Director, Community Health Equity Research  
Institute  
Jacobs School of Medicine and Biomedical Sciences  
Buffalo State University of New York  
Buffalo, New York  
242. *Moraxella catarrhalis*

**Karen F. Murray, MD**

Professor of Pediatrics  
Cleveland Clinic Lerner College of Medicine of  
Case Western Reserve University  
Chair, Pediatrics Institute  
Physician-in-Chief, Cleveland Clinic Children's  
President, Cleveland Clinic Children's Hospital for  
Rehabilitation  
Cleveland, Ohio  
393. *Tumors of the Digestive Tract*

**Thomas S. Murray, MD, PhD**

Professor of Pediatrics, Infectious Disease and  
Global Health  
Yale School of Medicine  
Associate Medical Director, Infection Prevention  
Yale New Haven Children's Hospital  
New Haven, Connecticut  
234. *Listeria monocytogenes*  
251. *Pseudomonas, Burkholderia, and*  
*Stenotrophomonas*  
486. *Infective Endocarditis*

**Levent Mutlu, MD**

Clinical Fellow in Gynecologic Oncology  
Obstetrics, Gynecology, and Reproductive Sciences  
Yale School of Medicine  
New Haven, Connecticut  
590. *Gynecologic Neoplasms and Prevention*  
*Methods for Human Papillomavirus Infections in*  
*Adolescents*

**Jason M. Nagata, MD, MSc**

Assistant Professor of Pediatrics  
Division of Adolescent and Young Adult Medicine  
UC San Francisco School of Medicine  
San Francisco, California  
62. *Nutrition, Food Security, and Health*  
63. *Refeeding Syndrome*

**Sona Narula, MD**

Associate Professor of Clinical Neurology  
University of Pennsylvania Perelman School of  
Medicine  
Attending Physician  
Division of Pediatric Neurology  
Children's Hospital of Philadelphia  
Philadelphia, Pennsylvania  
642. *Central Nervous System Vasculitis*

**James P. Nataro, MD, PhD, MBA**

Professor and Chair  
Department of Pediatrics  
University of Virginia School of Medicine  
Physician-in-Chief  
UVA Children's Hospital  
Charlottesville, Virginia  
247. *Cholera*

**Dipesh Navsaria, MD, MPH, MSLIS, FAAP**

Associate Professor of Pediatrics  
University of Wisconsin School of Medicine and  
Public Health  
Clinical Associate Professor of Human  
Development and Family Studies  
University of Wisconsin School of Human Ecology  
Madison, Wisconsin  
13. *Maximizing Children's Health: Screening,*  
*Anticipatory Guidance, and Counseling*

**Ruth W. Nduati, MBChB, MMED, MPH**

Professor of Pediatrics and Child Health  
University of Nairobi Faculty of Health Sciences  
Consultant Pediatrician Kenyatta National Hospital  
Nairobi, Kenya  
3. *Global Child Health*

**Edward J. Nehus, MD, MS**

Associate Professor of Pediatrics  
Marshall University Joan C. Edwards School of  
Medicine  
Division of Pediatric Nephrology  
Hoops Family Children's Hospital at  
Cabell Huntington Hospital  
Huntington, West Virginia  
557. *Introduction to Glomerular Diseases*

**Maureen R. Nelson, MD**

Professor of Physical Medicine & Rehabilitation  
and of Pediatrics  
Baylor College of Medicine  
Medical Director, Physical Medicine &  
Rehabilitation  
Texas Children's  
Austin, Texas  
753. *Birth Brachial Plexus Palsy*

**Caitlin M. Neri, MD, MPH**

Assistant Professor of Pediatrics  
Boston University School of Medicine  
Attending Physician  
Division of Pediatric Hematology and Oncology  
Medical Director, Pediatric Pain Clinic  
Boston Medical Center  
Boston, Massachusetts  
7. *Complementary Therapies and Integrative*  
*Medicine*

**Mary A. Nevin, MD, FAAP, FCCP**

Associate Professor of Pediatrics  
University of Chicago Medicine  
Chicago, Illinois  
457. *Pulmonary Hemosiderosis*  
458. *Pulmonary Embolism, Infarction, and*  
*Hemorrhage*

**Jane W. Newburger, MD**

Commonwealth Professor of Pediatrics Harvard  
Medical School  
Commonwealth Chair of Pediatrics  
Associate Cardiologist-in-Chief, Academic Affairs  
Boston Children's Hospital  
Boston, Massachusetts  
208. *Kawasaki Disease*

**Jonathan Newmark, MD, MM, FAAN**

Senior Medical Advisor  
Office of Biodefense Research and Surety  
National Institute of Allergy and Infectious Diseases  
National Institutes of Health  
Rockville, Maryland;  
Staff Neurologist  
Washington DC VA Medical Center  
Adjunct Assistant Professor of Neurology and  
Rehabilitation Medicine  
George Washington University School of Medicine  
and Health Sciences  
Washington, DC;  
Adjunct Professor of Neurology  
F. Edward Hebert School of Medicine  
Uniformed Services University of the Health  
Sciences  
Bethesda, Maryland  
763. *Biological and Chemical Terrorism*

**Linda S. Nield, MD, FAAP**

Associate Dean for Admissions  
Professor of Medical Education and Pediatrics  
West Virginia University School of Medicine  
Morgantown, West Virginia  
219. *Fever*

**Susan Niermeyer, MD, MPH**

Professor Emerita of Pediatrics and Epidemiology  
University of Colorado School of Medicine and  
Colorado School of Public Health  
Aurora, Colorado  
87. *Altitude-Associated Illness in Children*

**James J. Nocton, MD**

Professor of Pediatrics  
Section of Pediatric Rheumatology  
Medical College of Wisconsin  
Milwaukee, Wisconsin  
90.1. *Cold-Induced Autoinflammatory and Other*  
*Genetic Disorders*  
211. *Musculoskeletal Pain Syndromes*  
700.1. *Mast Cell Activation Syndrome*

**Lawrence M. Noguee, MD**

Professor of Pediatrics  
Eudowood Neonatal Pulmonary Division  
Johns Hopkins University School of Medicine  
Baltimore, Maryland  
456. *Diffuse Lung Diseases in Childhood*

**Corina Noje, MD**

Associate Professor of Clinical Anesthesiology and  
Critical Care Medicine  
Johns Hopkins University School of Medicine  
Medical Director, Pediatric Transport  
Johns Hopkins Bloomberg Children's Center  
Baltimore, Maryland  
77.1. *Interfacility Transport of the Seriously Ill or*  
*Injured Pediatric Patient*

**Anna H. Nowak-Wegrzyn, MD, PhD**

Professor of Pediatrics  
New York University Grossman School of Medicine  
Director, Division of Pediatric Allergy and  
Immunology  
Hassenfeld Children's Hospital at NYU Langone  
New York, New York  
191. *Serum Sickness*  
192. *Food Allergy and Adverse Reactions to Foods*

**Stephen K. Obaro, MD, PhD**

Helen and Robert Whitley Endowed Chair of  
Pediatric Infectious Diseases  
HSOM Assistant Dean for Global Health  
University of Alabama, Birmingham  
Birmingham, Alabama  
265. *Nonvenereal Treponemal Infections*  
267. *Relapsing Fever (Borrelia)*

**Makram M. Obeid, MD**

Assistant Professor of Neurology  
Indiana University School of Medicine  
Division of Pediatric Neurology  
Riley Children's Health  
Indianapolis, Indiana  
634. *Conditions That Mimic Seizures*

**Kevin P. O'Callaghan, MB BCh, BAO**

Instructor of Pediatrics  
University of Pennsylvania Perelman School of  
Medicine  
Attending Physician  
Division of Infectious Diseases  
Children's Hospital of Philadelphia  
Philadelphia, Pennsylvania  
214. *Public Health Approach to Pandemics*  
216. *Infection Prevention and Control*

**Joyce L. Oleszek, MD**

Professor of Physical Medicine and Rehabilitation  
University of Colorado School of Medicine  
Children's Hospital Colorado  
Denver, Colorado  
752. *Spasticity*

**Scott E. Olitsky, MD, MBA**

Professor Emeritus of Ophthalmology  
University of Missouri – Kansas City School of  
Medicine  
Kansas City, Missouri  
658. *Growth and Development of the Eye*  
659. *Examination of the Eye*  
660. *Abnormalities of Refraction and  
Accommodation*  
661. *Disorders of Vision*  
662. *Abnormalities of Pupil and Iris*  
663. *Disorders of Eye Movement and Alignment*  
664. *Abnormalities of the Lids*  
665. *Disorders of the Lacrimal System*  
666. *Disorders of the Conjunctiva*  
667. *Abnormalities of the Cornea*  
668. *Abnormalities of the Lens*  
669. *Disorders of the Uveal Tract*  
670. *Disorders of the Retina and Vitreous*  
671. *Abnormalities of the Optic Nerve*  
672. *Childhood Glaucoma*  
673. *Orbital Abnormalities*  
674. *Orbital Infections*  
675. *Injuries to the Eye*

**John M. Olsson, MD, CPE**

Professor of Pediatrics  
Division of General Pediatrics  
University of Virginia School of Medicine  
Charlottesville, Virginia  
22. *The Newborn*

**Meghan E. O'Neill, MD**

Assistant Professor of Pediatrics  
Northwestern University Feinberg School of  
Medicine  
Division of Developmental Behavioral Pediatrics  
Ann & Robert H. Lurie Children's Hospital of  
Chicago  
Chicago, Illinois  
56. *Developmental Delay and Intellectual Disability*

**Mutiati T. Onigbanjo, MD**

Assistant Professor of Pediatrics  
University of Maryland School of Medicine  
Baltimore, Maryland  
23. *The First Year*  
26. *Middle Childhood*

**Robert O. Opoka, MD, PhD**

Associate Dean  
Undergraduate Medical Education  
The Aga Khan University Medical College  
Kampala, Uganda;  
Adjunct Associate Professor of Pediatrics  
Indiana University School of Medicine  
Indianapolis, Indiana  
334. *Malaria (Plasmodium)*

**Helen M. Oquendo Del Toro, MD**

Clinical Assistant Professor of Obstetrics and  
Gynecology  
Division of Pediatric and Adolescent Gynecology  
University of New Mexico School of Medicine  
Albuquerque, New Mexico  
586. *Vulvovaginitis*

**Walter A. Orenstein, MD, DSc (Hon)**

Professor Emeritus of Medicine, Pediatrics, and  
Global Health  
Emory University  
Associate Director, Emory Vaccines Center  
Atlanta, Georgia;  
Former Deputy Director for Immunization  
Programs  
Bill & Melinda Gates Foundation  
Seattle, Washington;  
Former Director, National Immunization  
Program  
Centers for Disease Control and Prevention  
Atlanta, Georgia  
215. *Immunization Practices*

**Sarah H. Orkin, MD**

Assistant Professor of Pediatrics  
University of Cincinnati College of Medicine  
Attending Physician  
Division of Gastroenterology, Hepatology and  
Nutrition  
Cincinnati Children's Hospital Medical Center  
Cincinnati, Ohio  
408.1. *Nonalcoholic Fatty Liver Disease*

**Rachel C. Orscheml, MD**

Professor of Pediatrics  
Director, Clinical Services  
Washington University School of Medicine in St  
Louis  
Medical Director, Ambulatory Pediatric Infectious  
Diseases  
St. Louis Children's Hospital  
St. Louis, Missouri  
255. *Bartonella*

**Camile Ortega, DO**

Allergy and Immunology Care Center of South  
Florida  
Miami Lakes, Florida  
166. *B-Cell and Antibody Deficiencies*

**Timothy R. O'Toole, BS**

Division of Critical Care Medicine  
Department of Anesthesiology, Critical Care and  
Pain Medicine  
Boston Children's Hospital  
Boston, Massachusetts  
111. *Hutchinson-Gilford Progeria Syndrome  
(Progeria)*

**Judith A. Owens, MD, MPH**

Professor of Neurology  
Harvard Medical School  
Director of Sleep Medicine  
Boston Children's Hospital  
Boston, Massachusetts  
31. *Sleep Medicine*

**Seza Ozen, MD**

Professor of Pediatrics  
Department of Pediatric Rheumatology  
Hacettepe University  
Ankara, Turkey  
202. *Behçet Disease*

**Sophie Pach, MB BCHir**

Research Fellow  
London School of Hygiene and Tropical Medicine  
London, United Kingdom  
346. *Schistosomiasis (Schistosoma)*  
347. *Flukes (Liver, Lung, and Intestinal)*

**Lee M. Pachter, DO**

Professor of Pediatrics and Population Health  
Sidney Kimmel Medical College and Jefferson  
College of Population Health  
Thomas Jefferson University  
Philadelphia, Pennsylvania;  
Senior Physician Scientist  
Director, Mentorship and Professional  
Development  
Institute for Research on Equity and Community  
Health (iREACH)  
Christiana Care Health System  
Wilmington, Delaware  
1. *Overview of Pediatrics*  
2. *Child Health Disparities*  
12. *Cultural Issues in Pediatric Care*

**Amruta Padhye, MD**

Associate Professor of Pediatrics  
Division of Pediatric Infectious Diseases  
University of Missouri School of Medicine  
Columbia, Missouri  
233. *Diphtheria (Corynebacterium diphtheriae)*

**Sindhu Pandurangi, MD, MSc**

Assistant Professor of Pediatrics  
Pediatric Gastroenterology, Hepatology and  
Nutrition  
University of Texas Southwestern Medical Center  
Dallas, Texas  
409. *Mitochondrial Hepatopathies*

**Suzinne Pak-Gorstein, MD, PhD, MPH**

Associate Professor of Pediatrics  
Adjunct Associate Professor of Global Health  
University of Washington School of Medicine  
Seattle, Washington  
3. *Global Child Health*

**John Palla, MD**

Assistant Professor of Pediatrics  
Northwestern University Feinberg School of  
Medicine  
Attending Physician  
Division of Pulmonary and Sleep Medicine  
Ann & Robert H. Lurie Children's Hospital of  
Chicago  
Chicago, Illinois  
422.1. *Extrapulmonary Diseases With Pulmonary  
Manifestations*  
460. *Pulmonary Tumors*

**Tina L. Palmieri, MD, FACS, MCCM**

Professor of Surgery  
Chief, Division of Burn Surgery  
Director, Firefighters Burn Institute  
UC Davis School of Medicine  
Assistant Chief of Burns  
Shriners Hospital for Children Northern California  
Sacramento, California  
89. *Burn Injuries*

**Jessica M. Palmieri, DO**

Department of Pediatrics  
Baylor College of Medicine  
Section of Immunology, Allergy, and Retrovirology  
Texas Children's  
Houston, Texas  
167. *Natural Killer Cells*

**Diane E. Pappas, MD, JD**

Professor of Pediatrics  
Director of Child Advocacy  
University of Virginia School of Medicine  
Charlottesville, Virginia  
429. *Sinusitis*  
432. *Retropharyngeal Abscess, Lateral Pharyngeal (Parapharyngeal) Abscess, and Peritonsillar Cellulitis/Abscess*

**John J. Parent, MD, MSCR**

Associate Professor of Clinical Pediatrics  
Indiana University School of Medicine  
Section of Cardiology  
Riley Hospital for Children at Indiana University  
Health  
Indianapolis, Indiana  
488. *Diseases of the Myocardium*  
489. *Diseases of the Pericardium*  
490. *Tumors of the Heart*

**Joanna J. Parga-Belinkie, MD**

Assistant Professor of Clinical Pediatrics  
University of Pennsylvania Perelman School of  
Medicine  
Attending Neonatologist  
Hospital of the University of Pennsylvania and  
Children's Hospital of Philadelphia  
Philadelphia, Pennsylvania  
115. *The Newborn Infant*

**Bijal A. Parikh, MD, PhD**

Assistant Professor of Pathology and Immunology  
Division of Laboratory and Genomic Medicine  
Washington University School of Medicine  
Director, Molecular Diagnostics Laboratory  
Director, Molecular Genetic Pathology Fellowship  
Barnes-Jewish Hospital  
St. Louis, Missouri  
321. *Polyomaviruses*

**Alasdair P.J. Parker, MBBS (Lond), MRCP, MD, MA (Camb)**

Consultant in Pediatric Neurology  
Addenbrooke's Hospital  
Associate Lecturer  
University of Cambridge School of Clinical  
Medicine  
Cambridge, United Kingdom  
645. *Idiopathic Intracranial Hypertension (Pseudotumor Cerebri)*

**Emily A. Partridge, MD, PhD, MHS**

Assistant Professor of Surgery  
University of Pennsylvania Perelman School of  
Medicine  
Attending Pediatric and Fetal Surgeon  
Division of Pediatric General, Thoracic and Fetal  
Surgery  
Children's Hospital of Philadelphia  
Philadelphia, Pennsylvania  
118. *Fetal Intervention and Surgery*

**Ami B. Patel, MD, MPH**

Assistant Professor of Pediatrics  
Northwestern University Feinberg School of  
Medicine  
Associate Medical Director, Infection Prevention  
and Control  
Division of Pediatric Infectious Diseases  
Ann & Robert H. Lurie Children's Hospital of  
Chicago  
Chicago, Illinois  
229. *Group A Streptococcus*

**Trusha Patel, MD**

Assistant Professor of Pediatrics  
University of Pennsylvania Perelman School of  
Medicine  
Attending Physician  
Division of Gastroenterology, Hepatology and  
Nutrition  
Children's Hospital of Philadelphia  
Philadelphia, Pennsylvania  
380. *Foreign Bodies and Bezoars*

**Stephen W. Patrick, MD, MPH, MS, FAAP**

Associate Professor of Pediatrics and Health Policy  
Director, Center for Child Health Policy  
Vanderbilt University School of Medicine  
Attending Neonatologist  
Monroe Carell Jr. Children's Hospital at Vanderbilt  
Nashville, Tennessee  
145. *Neonatal Abstinence Syndrome*

**Briana C. Patterson, MD, MSCR**

Associate Professor of Pediatrics  
Emory University School of Medicine  
Division of Pediatric Endocrinology  
Director, Pediatric Endocrine Fellowship Program  
Aflac Cancer & Blood Disorders Center of  
Children's Healthcare of Atlanta  
Atlanta, Georgia  
594. *Hormones of the Hypothalamus and Pituitary*  
595. *Hypopituitarism*

**Emanuele Pelosi, PhD**

Assistant Research Professor  
Department of Biochemistry and Molecular  
Biology School of Medicine  
Indiana University–Purdue University Indianapolis  
Indianapolis, Indiana  
591. *Vulvovaginal and Müllerian Anomalies*

**Sallie R. Permar, MD, PhD**

Nancy C. Paduano Professor and Chair  
Department of Pediatrics  
Weill Cornell Medical College of Cornell  
University  
Pediatrician-in-Chief  
New York-Presbyterian Hospital  
New York, New York  
149. *Congenital and Perinatal Infections*

**Michael Perry, MD, MRes, BA**

PhD Candidate in Neuroimmunology  
Cambridge Centre for Myelin Repair  
University of Cambridge  
Cambridge, United Kingdom;  
Honorary Clinical Research Fellow in Paediatric  
Neurology  
Great Ormond Street Hospital for Children  
London, United Kingdom  
638.3. *Other Encephalopathies*  
640. *Demyelinating Disorders of the Central Nervous System*

**Tamara T. Perry, MD, FAAP, FAAAAI**

Professor of Pediatrics  
Dr. & Mrs. Leeman King Endowed Chair in  
Pediatric Allergy  
University of Arkansas for Medical Sciences  
Chief of Allergy and Immunology  
Arkansas Children's Hospital  
Little Rock, Arkansas  
184. *Allergic Rhinitis*

**Mark J. Peters, MBChB, DPhil**

Professor of Paediatric Intensive Care  
Infection, Immunity & Inflammation Department  
University College London – Great Ormond Street  
Institute of Child Health  
London, United Kingdom  
85. *Shock*

**Timothy R. Peters, MD**

Professor of Pediatrics  
Wake Forest School of Medicine  
Section of Pediatric Infectious Diseases  
Wake Forest Baptist Medical Center  
Winston-Salem, North Carolina  
228. *Streptococcus pneumoniae (Pneumococcus)*

**Stacy J.B. Peterson, MD**

Associate Professor of Anesthesiology  
Medical College of Wisconsin  
Division of Pediatric Anesthesiology  
Jane B. Pettit Pain and Headache Center  
Children's Wisconsin  
Milwaukee, Wisconsin  
93. *Pediatric Pain Management*

**Rachel A. Phelan, MD, MPH**

Associate Professor of Pediatrics  
Medical College of Wisconsin  
Division of Hematology/Oncology/BMT  
Children's Wisconsin  
Milwaukee, Wisconsin  
177. *Principles and Clinical Indications of Hematopoietic Stem Cell Transplantation*  
178. *Hematopoietic Stem Cell Transplantation from Alternative Sources and Donors*  
179. *Graft-Versus-Host Disease, Rejection, and Venoocclusive Disease*  
181. *Late Effects of Hematopoietic Stem Cell Transplantation*

**Anna L. Pinto, MD, PhD**

Assistant Professor of Neurology  
Harvard Medical School  
Director, Sturge Weber Clinic  
Boston Children's Hospital  
Boston, Massachusetts  
636. *Neurocutaneous Syndromes*  
636.3. *Sturge-Weber Syndrome*

**Mary Pipan, MD**

Director, Trisomy 21 Program  
Division of Behavioral Pediatrics  
Children's Hospital of Philadelphia  
Philadelphia, Pennsylvania  
57. *Down Syndrome and other Abnormalities of Chromosome Number*

**Brittany Player, DO, MS**

Division of Infectious Diseases  
Medical College of Wisconsin  
Children's Wisconsin  
Milwaukee, Wisconsin  
680. *Otitis Media*  
681. *Acute Mastoiditis*



**William Benjamin Prince, MD**

Clinical Assistant Professor of Pediatrics  
and Emergency Medicine  
University of Washington School of Medicine  
Division of Emergency Medicine  
Seattle Children's Hospital  
Seattle, Washington  
88. *Drowning and Submersion Injury*

**Mark R. Proctor, MD**

Franco D. Ingraham Professor of Neurosurgery  
Harvard Medical School  
Neurosurgeon-in-Chief  
Boston Children's Hospital  
Boston, Massachusetts  
81. *Spinal Cord Injuries in Children*  
646. *Spinal Cord Disorders*  
729. *Sports-Related Traumatic Brain Injury*  
(*Concussion*)

**Stephanie Prozora, MD**

Assistant Professor of Clinical Pediatrics  
Division of Pediatric Hematology/Oncology  
Pediatric Medical Director  
Yale Hemophilia Treatment Center  
Yale School of Medicine  
New Haven, Connecticut  
506. *Definitions and Classification of Hemolytic Anemias*  
507. *Hereditary Spherocytosis*  
508. *Hereditary Elliptocytosis, Hereditary Pyropoikilocytosis and Related Disorders*  
509. *Hereditary Stomatocytosis Syndromes*  
510. *Paroxysmal Nocturnal Hemoglobinuria and Acanthocytosis*

**Howard I. Pryor II, MD**

Associate Professor of Surgery  
Baylor College of Medicine  
Trauma Medical Director  
Texas Children's  
Houston, Texas;  
Associate Professor of Surgery  
Uniformed Services University of the Health Sciences  
Walter Reed National Military Medical Center  
Washington, DC  
80. *Acute Care of Multiple Trauma*

**Lee A. Pyles, MD, MS**

Professor of Pediatrics  
Pediatric Vice-Chair for Research  
Director, Preventive Pediatric Cardiology  
Division of Pediatric Cardiology  
West Virginia University School of Medicine  
Morgantown, West Virginia  
106.3. *Disorders of Lipoprotein Metabolism and Transport*

**Molly M. Quinn, MD**

Assistant Professor of Clinical Obstetrics and Gynecology  
Keck School of Medicine  
University of Southern California  
Los Angeles, California  
589. *Polycystic Ovary Syndrome and Hirsutism*

**Elisabeth H. Quint, MD**

Professor of Obstetrics and Gynecology  
University of Michigan Medical School  
Ann Arbor, Michigan  
592. *Gynecologic Care for Adolescents with Special Needs*

**C. Eglia Rabinovich, MD, MPH**

Professor of Pediatrics  
Duke University School of Medicine  
Durham, North Carolina  
194. *Evaluation of Suspected Rheumatic Disease*  
195. *Treatment of Rheumatic Diseases*  
196. *Juvenile Idiopathic Arthritis*  
201. *Scleroderma and Raynaud Phenomenon*  
203. *Sjögren Syndrome*  
213. *Miscellaneous Conditions Associated With Arthritis*

**Leslie J. Raffini, MD**

Professor of Pediatrics  
University of Pennsylvania Perelman School of Medicine  
Medical Director, Hemostasis and Thrombosis Center  
Attending Physician  
Division of Hematology  
Children's Hospital of Philadelphia  
Philadelphia, Pennsylvania  
524. *Hemostasis*  
527. *Hereditary Predisposition to Thrombosis*  
528. *Thrombotic Disorders in Children*  
532. *Disseminated Intravascular Coagulation*

**Dristhi S. Ragoonanan, MBBS**

Assistant Professor of Pediatrics  
University of Texas MD Anderson Cancer Center  
Houston, Texas  
548. *Neoplasms of the Kidney*

**Shamima Rahman, MA, BMBCh, FRCP, FRCPCH, PhD**

Professor of Paediatric Metabolic Medicine  
UCL Great Ormond Street Institute of Child Health  
London, United Kingdom  
638.2. *Mitochondrial Encephalomyopathies*

**Shawn L. Ralston, MD, MS**

Professor of Pediatrics  
University of Washington School of Medicine  
Chief, Division of Hospital Medicine  
Seattle Children's Hospital  
Seattle, Washington  
439. *Wheezing, Bronchiolitis, and Bronchitis*

**Sanjay Ram, MBBS**

Professor of Medicine  
University of Massachusetts Chan Medical School  
Division of Infectious Diseases and Immunology  
University of Massachusetts Memorial Medical Center  
Worcester, Massachusetts  
238. *Neisseria gonorrhoeae (Gonococcus)*

**Octavio Ramilo, MD**

Professor of Pediatrics  
Chair, Department of Infectious Diseases  
St Jude Children's Research Hospital  
Memphis, Tennessee  
269. *Mycoplasma pneumoniae*

**Kacy A. Ramirez, MD**

Associate Professor of Pediatrics  
Wake Forest School of Medicine  
Section of Pediatric Infectious Diseases  
Wake Forest Baptist Medical Center  
Winston-Salem, North Carolina  
228. *Streptococcus pneumoniae (Pneumococcus)*

**Casey M. Rand, MSDS**

Research Manager and Data Scientist  
Division of Autonomic Medicine  
Center for Autonomic Medicine in Pediatrics  
Ann & Robert H. Lurie Children's Hospital of Chicago  
and Stanley Manne Children's Research Institute  
Chicago, Illinois  
468.2. *Congenital Central Hypoventilation Syndrome*  
468.3. *Rapid-Onset Obesity with Hypothalamic Dysfunction, Hypoventilation, and Autonomic Dysregulation*

**Sonja A. Rasmussen, MD, MS**

Professor of Genetic Medicine  
Johns Hopkins School of Medicine  
Baltimore, Maryland  
117.4. *Medications and Teratogenic Exposures*

**Kevin M. Rathke, MD**

Clinical Associate  
Department of Pediatrics  
Duke University Medical Center  
Durham, North Carolina  
633. *Seizures in Childhood*

**Adam J. Ratner, MD, MPH**

Professor of Pediatrics and Microbiology  
New York University Grossman School of Medicine  
Director, Division of Pediatric Infectious Diseases  
Hassenfeld Children's Hospital  
New York, New York  
250. *Aeromonas and Plesiomonas*

**Lee Ratner, MD, PhD**

Professor of Medicine  
Professor of Molecular Microbiology and of Pathology and Immunology  
Washington University School of Medicine in St. Louis  
St. Louis, Missouri  
323. *Human T-Cell Leukemia Viruses (1 and 2)*

**Ann M. Reed, MD**

Samuel L. Katz Distinguished Professor of Pediatrics  
Chair, Department of Pediatrics  
Duke University Medical Center  
Physician-in-Chief  
Duke Children's  
Durham, North Carolina  
200. *Juvenile Dermatomyositis*

**Patrick J. Reich, MD, MSCI**

Associate Professor of Pediatrics  
Washington University School of Medicine in St. Louis  
Division of Pediatric Infectious Diseases  
Medical Director, Infection Prevention  
St. Louis Children's Hospital  
St. Louis, Missouri  
227. *Staphylococcus*

**Shimon Reif, MD**

Chairman, Department of Pediatrics  
Hadassah Medical Center  
Hebrew University  
Jerusalem, Israel  
388.1. *Diarrhea from Neuroendocrine Tumors*

**Megan E. Reller, MD, PhD, MPH**

Associate Professor of Medicine  
Duke University Medical Center  
Durham North Carolina  
274. *Spotted Fever Group Rickettsioses*  
275. *Scrub Typhus (Orientia tsutsugamushi)*  
276. *Typhus Group Rickettsioses*  
277. *Ehrlichiosis and Anaplasmosis*  
278. *Q Fever (Coxiella burnetii)*

**Katherine E. Remick, MD, FAAP, FACEP, FAEMS**

Associate Professor, Departments of Pediatrics and Surgery  
Associate Chair for Quality, Innovation, and Outreach  
Co-Director, National EMS for Children Innovation and Improvement Center  
Medical Director, San Marcos Hays County EMS System  
Executive Director, National Pediatric Readiness Quality Initiative  
EMS Director, Pediatric Emergency Medicine Fellowship  
The University of Texas at Austin Dell Medical School  
Austin, Texas  
77. *Emergency Medical Services for Children*

**Allison S. Remiker, MD**

Assistant Professor of Pediatrics  
Section of Hematology/Oncology/Bone Marrow Transplant  
Immunohematology Program Director  
Medical College of Wisconsin  
Attending Physician  
Children's Wisconsin  
Milwaukee, Wisconsin  
512. *Enzymatic Defects*  
513. *Hemolytic Anemias Resulting from Extracellular Factors—Immune Hemolytic Anemias*  
514. *Hemolytic Anemias Secondary to Other Extracellular Factors*  
515. *Polycythemia*  
516. *Nonclonal Polycythemia*  
534. *Anatomy and Function of the Spleen*  
535. *Splenomegaly*  
536. *Hyposplenism, Splenic Trauma, and Splenectomy*

**Jorge D. Reyes, MD**

Professor and Roger K. Giesecke Distinguished Chair  
Department of Surgery  
University of Washington School of Medicine  
Chief, Division of Transplant Surgery  
Seattle Children's Hospital  
Seattle, Washington  
386. *Intestinal Transplantation in Children with Intestinal Failure*  
416. *Liver Transplantation*

**Katherine M. Richardson, MD**

Clinical Assistant Professor of Pediatrics  
University of South Carolina School of Medicine Greenville  
Division of Pediatric Infectious Diseases  
Shriner's Hospital  
Greenville, South Carolina  
310. *Rhinoviruses*  
428. *The Common Cold*

**Natalie E. Rintoul, MD**

Professor of Clinical Pediatrics  
University of Pennsylvania Perelman School of Medicine  
Attending Neonatologist  
Co-Director, Neonatal Surgical Team  
Medical Director, Neonatal Surgical Service  
Children's Hospital of Philadelphia  
Philadelphia, Pennsylvania  
118. *Fetal Intervention and Surgery*

**A. Kim Ritchey, MD**

Professor and Vice-Chair of International Affairs  
Department of Pediatrics  
University of Pittsburgh School of Medicine  
Division of Hematology/Oncology  
UPMC Children's Hospital of Pittsburgh  
Pittsburgh, Pennsylvania  
542. *Principles of Cancer Diagnosis*  
543. *Principles of Cancer Treatment*  
544. *The Leukemias*

**Angela Byun Robinson, MD, MPH**

Associate Professor of Pediatrics  
Cleveland Clinic Lerner College of Medicine  
Center for Pediatric Rheumatology and Immunology  
Cleveland Clinic  
Cleveland, Ohio  
213. *Miscellaneous Conditions Associated With Arthritis*

**Kristine Knuti Rodrigues, MD, MPH**

Associate Professor of Pediatrics  
University of Colorado School of Medicine  
Department of Pediatrics  
Denver Health Medical Center  
Denver, Colorado  
433. *Acute Inflammatory Upper Airway Obstruction (Croup, Epiglottitis, Laryngitis, and Bacterial Tracheitis)*

**Michael E. Rogers, DO, MPH**

Assistant Professor of Pediatrics  
University of Cincinnati College of Medicine  
Division of Pediatric Gastroenterology, Hepatology, and Nutrition  
Cincinnati Children's Hospital Medical Center  
Cincinnati, Ohio  
406. *Viral Hepatitis*

**Mary E. Romano, MD, MPH**

Associate Professor of Pediatrics  
Division of Adolescent and Young Adult Health  
Department of Pediatrics  
Monroe Carell Jr. Children's Hospital at Vanderbilt  
Vanderbilt University Medical Center  
Nashville, Tennessee  
160. *Contraception*

**Genie E. Roosevelt, MD, MPH**

Professor of Emergency Medicine  
University of Colorado School of Medicine  
Department of Emergency Medicine  
Denver Health Medical Center  
Denver, Colorado  
433. *Acute Inflammatory Upper Airway Obstruction (Croup, Epiglottitis, Laryngitis, and Bacterial Tracheitis)*

**Stephen M. Roper, PhD**

Associate Professor of Pathology and Immunology  
Division of Laboratory and Genomic Medicine  
Washington University School of Medicine in St. Louis  
St. Louis, Missouri  
769. *Laboratory Testing in Infants and Children*  
770. *Reference Intervals for Laboratory Tests and Procedures*

**Stephen M. Rosenthal, MD**

Professor of Pediatrics  
University of California San Francisco School of Medicine  
Medical Director, Child and Adolescent Gender Center  
Division of Pediatric Endocrinology  
UCSF Benioff Children's Hospitals  
San Francisco, California  
153. *Gender Identity and Transgender Care*

**A. Catharine Ross, PhD**

Professor of Nutrition  
Department of Nutrition and Institute for Advancing Health Through Agriculture  
College of Agriculture and Life Sciences  
Texas A&M University  
College Station, Texas  
66. *Vitamin A Deficiencies and Excess*

**Joseph W. Rossano, MD, MS**

Associate Professor of Pediatrics  
University of Pennsylvania Perelman School of Medicine  
Chief, Division of Cardiology  
Co-Executive Director, The Cardiac Center  
Jennifer Terker Endowed Chair in Pediatric Cardiology  
Children's Hospital of Philadelphia  
Philadelphia, Pennsylvania  
491. *Heart Failure*  
492. *Pediatric Heart and Heart-Lung Transplantation*

**Jennifer A. Rothman, MD**

Professor of Pediatrics  
Director, Pediatric Comprehensive Sickle Cell Center  
Division of Pediatric Hematology and Oncology  
Duke University Medical Center  
Durham, North Carolina  
504. *Iron-Deficiency Anemia*  
505. *Other Microcytic Anemias*

**Alexandre T. Rotta, MD, FCCM**

Professor of Pediatrics  
Chief, Division of Pediatric Critical Care Medicine  
Duke University Medical Center  
Durham, North Carolina  
86. *Acute Care of Respiratory Distress and Failure*

**Ranna A. Rozenfeld, MD, FAAP, FCCM**

Professor of Pediatrics  
The Warren Alpert Medical School of Brown University  
Division Director, Pediatric Critical Care Medicine  
Medical Director, LifePACT Pediatric Critical Care Transport Team  
Attending Physician, PICU  
Hasbro Children's Hospital  
Providence, Rhode Island  
459. *Atelectasis*

**Michael E. Russo, MD**

Assistant Professor of Clinical Pediatrics  
University of Pennsylvania Perelman School of Medicine  
Attending Physician  
Division of Infectious Diseases  
Children's Hospital of Philadelphia  
Philadelphia, Pennsylvania  
259. *Other Anaerobic Infections*

**Kelsey S. Ryan, MD**

Assistant Professor of Pediatrics  
Division of Neonatology  
Medical College of Wisconsin  
Milwaukee, Wisconsin  
137. *Jaundice and Hyperbilirubinemia in the Newborn*

**Monique M. Ryan, MMed, FRACP**

Formerly of University of Melbourne  
Formerly of Royal Children's Hospital, Melbourne  
Parkville, Victoria, Australia  
655. *Autonomic Neuropathies*  
656. *Guillain-Barré Syndrome*  
657. *Bell Palsy*

**Julie Ryu, MD**

Professor of Pediatrics  
University of California San Diego School of  
Medicine  
Interim Chief, Division of Respiratory Medicine  
Chief Research Informatics Officer  
Department of Pediatrics  
Rady Children's Hospital–San Diego  
San Diego, California  
421. *Diagnostic Approach to Respiratory Disease*

**Sara E. Sabbagh, DO**

Assistant Professor of Pediatrics  
Medical College of Wisconsin  
Division of Pediatric Rheumatology  
Children's Wisconsin  
Milwaukee, Wisconsin  
205. *Interferonopathies*

**H.P.S. Sachdev, MD, FIAP, FAMS, FRCPC**

Senior Consultant  
Departments of Pediatrics and Clinical  
Epidemiology  
Sitaram Bharti Institute of Science and Research  
New Delhi, India  
67. *Vitamin B Complex Deficiencies and Excess*  
68. *Vitamin C (Ascorbic Acid) Deficiency and Excess*

**Manish Sadarangani, BM BCh, FRCPC, DPhil**

Associate Professor of Pediatrics  
Division of Infectious Diseases  
University of British Columbia Faculty of Medicine  
Sauder Family Chair in Pediatric Infectious  
Diseases  
Director, Vaccine Evaluation Center  
Physician Lead, Family Immunization Clinic  
British Columbia Children's Hospital  
Vancouver, British Columbia, Canada  
237. *Neisseria meningitidis (Meningococcus)*

**Rebecca E. Sadun, MD, PhD**

Assistant Professor of Rheumatology  
Departments of Medicine and Pediatrics  
Duke University School of Medicine  
Durham, North Carolina  
199. *Systemic Lupus Erythematosus*

**Mustafa Sahin, MD, PhD**

Professor of Neurology  
Harvard Medical School  
Director, Rosamund Stone Zander Translational  
Neuroscience Center  
Boston Children's Hospital  
Boston, Massachusetts  
636. *Neurocutaneous Syndromes*

**Martine Saint-Cyr, MD**

Assistant Professor of Pediatrics  
Division of Gastroenterology, Hepatology and  
Nutrition  
Washington University School of Medicine in St.  
Louis  
St. Louis, Missouri  
60. *Nutritional Requirements*

**Robert A. Salata, MD**

Professor and Chairman  
Department of Medicine  
STERIS Chair of Excellence in Medicine  
Founding Director, Infectious Diseases and  
Immunology Institute  
Case Western Reserve University School of  
Medicine  
Physician-in-Chief  
University Hospitals Case Medical Center  
Cleveland, Ohio  
327. *Amebiasis*  
330. *Trichomoniasis (Trichomonas vaginalis)*  
332. *African Trypanosomiasis (Sleeping Sickness; Trypanosoma brucei Complex)*  
333. *American Trypanosomiasis (Chagas Disease; Trypanosoma cruzi)*

**José H. Salazar, MD, PhD**

Assistant Professor of Surgery  
Medical College of Wisconsin  
Division of Pediatric General and Thoracic Surgery  
Children's Wisconsin  
Milwaukee, Wisconsin  
391. *Acute Appendicitis*  
394. *Inguinal Hernias*

**Edsel Maurice T. Salvana, MD**

Clinical Associate Professor of Medicine  
University of the Philippines College of Medicine  
Director, Institute of Molecular Biology and  
Biotechnology  
National Institutes of Health  
Manila, The Philippines;  
Adjunct Professor of Global Health  
University of Pittsburgh School of Medicine  
Pittsburgh, Pennsylvania  
327. *Amebiasis*  
330. *Trichomoniasis (Trichomonas vaginalis)*  
332. *African Trypanosomiasis (Sleeping Sickness; Trypanosoma brucei Complex)*  
333. *American Trypanosomiasis (Chagas Disease; Trypanosoma cruzi)*

**Benjamin J. Samelson-Jones, MD, PhD**

Assistant Professor of Pediatrics  
University of Pennsylvania Perelman School of  
Medicine  
Attending Physician  
Division of Hematology  
Children's Hospital of Philadelphia  
Philadelphia, Pennsylvania  
524. *Hemostasis*  
525. *Hereditary Clotting Factor Deficiencies (Bleeding Disorders)*  
527. *Hereditary Predisposition to Thrombosis*  
529. *Postneonatal Vitamin K Deficiency*  
532. *Disseminated Intravascular Coagulation*  
533. *Platelet and Blood Vessel Disorders*

**Julia S. Sammons, MD, MSCE**

Associate Professor of Clinical Pediatrics  
University of Pennsylvania Perelman School of  
Medicine  
Assistant Vice President  
Office of Preparedness, Prevention and Response  
Attending Physician  
Division of Infectious Diseases  
Children's Hospital of Philadelphia  
Philadelphia, Pennsylvania  
216. *Infection Prevention and Control*

**Hugh A. Sampson, MD**

Kurt Hirschhorn Professor of Pediatrics  
Director Emeritus, Jaffe Food Allergy Institute  
Icahn School of Medicine at Mount Sinai  
Division of Pediatric Allergy  
Mount Sinai Kravis Children's Hospital  
New York, New York  
190. *Anaphylaxis*  
192. *Food Allergy and Adverse Reactions to Foods*

**Chase B. Samsel, MD**

Assistant Professor of Psychiatry  
Department of Psychiatry  
Harvard Medical School  
Attending Psychiatrist  
Department of Psychiatry and Behavioral Sciences  
Boston Children's Hospital  
Boston, Massachusetts  
36. *Rumination and Pica*

**Thomas J. Sandora, MD, MPH**

Associate Professor of Pediatrics  
Harvard Medical School  
Senior Associate Physician in Pediatrics  
Division of Infectious Diseases  
Hospital Epidemiologist  
Medical Director, Infection Control  
Boston Children's Hospital  
Boston, Massachusetts  
449. *Community-Acquired Pneumonia*

**Wudbhav N. Sankar, MD**

Professor of Orthopaedic Surgery  
University of Pennsylvania Perelman School of  
Medicine  
Attending Orthopaedic Surgeon  
Director, Young Adult Hip Preservation Program  
Children's Hospital of Philadelphia  
Philadelphia, Pennsylvania  
719. *The Hip*

**Ashok P. Sarnaik, MD**

Professor and Former Interim Chair  
Department of Pediatrics  
Wayne State University School of Medicine  
Former Pediatrician-in-Chief  
Children's Hospital of Michigan  
Detroit, Michigan  
86. *Acute Care of Respiratory Distress and Failure*

**Alice I. Sato, MD, PhD**

Associate Professor of Pediatrics  
Division of Infectious Diseases  
University of Nebraska College of Medicine  
Hospital Epidemiologist  
Children's Nebraska  
Omaha, Nebraska  
264. *Syphilis (Treponema pallidum)*

**Lisa Forbes Satter, MD**

Associate Professor of Pediatrics  
Baylor College of Medicine  
Section of Immunology, Allergy, and Retrovirology  
William T. Shearer Center for Human  
Immunobiology  
Texas Children's  
Houston, Texas  
167. *Natural Killer Cells*

**Felicia A. Scaggs Huang, MD, MS**

Assistant Professor of Pediatrics  
University of Cincinnati College of Medicine  
Associate Director, Infection Prevention and  
Control  
Division of Infectious Diseases  
Cincinnati Children's Hospital Medical Center  
Cincinnati, Ohio  
286. *Coccidioidomycosis (Coccidioides Species)*



**Joshua K. Schaffzin, MD, PhD**

Associate Professor of Clinical Pediatrics  
University of Ottawa Faculty of Medicine  
Staff Physician, Division of Infectious Diseases,  
Immunology, & Allergy  
Children's Hospital of Eastern Ontario  
Ottawa, Ontario  
407. *Liver Abscess*

**Michael S. Schechter, MD, MPH**

Professor of Pediatrics  
Virginia Commonwealth University School of  
Medicine  
Chief, Division of Pulmonary Medicine  
Director, Cystic Fibrosis Center  
Director, UCAN Community Asthma Program  
Children's Hospital of Richmond at VCU  
Richmond, Virginia  
454. *Cystic Fibrosis*

**Samantha Schilling, MD, MSHP**

Clinical Associate Professor of Pediatrics  
Division of General Pediatrics and Adolescent  
Medicine  
University of North Carolina School of Medicine  
North Carolina Children's Hospital  
Chapel Hill, North Carolina  
20. *Positive Parenting and Support*

**Mark R. Schleiss, MD**

Professor of Pediatrics  
American Legion and Auxiliary Heart Research  
Foundation Endowed Chair  
Division of Pediatric Infectious Diseases and  
Immunology  
University of Minnesota Medical School  
Minneapolis, Minnesota  
225. *Principles of Antibacterial Therapy*  
256. *Botulism (Clostridium botulinum)*  
257. *Tetanus (Clostridium tetani)*  
292. *Principles of Antiviral Therapy*

**W. William Schluter, MD, MSPH**

Director, CDC China Country Office  
US Centers for Disease Control and Prevention  
Beijing, China  
215.1. *International Immunization Practices*

**Amanda C. Schondelmeyer, MD, MSC**

Associate Professor of Pediatrics  
University of Cincinnati College of Medicine  
Attending Physician, Division of Hospital Medicine  
Cincinnati Children's Hospital Medical Center  
Cincinnati, Ohio  
4. *Quality and Value in Healthcare for Children*

**James W. Schroeder Jr., MD, FACS, FAAP**

Professor of Otolaryngology – Head and Neck  
Surgery and Medical Education  
Northwestern University Feinberg School of  
Medicine  
Vice Chair, Department of Surgery  
Ann & Robert H. Lurie Children's Hospital of  
Chicago  
Chicago, Illinois  
434. *Congenital Anomalies of the Larynx, Trachea,  
and Bronchi*  
435. *Foreign Bodies in the Airway*  
436. *Laryngotracheal Stenosis and Subglottic  
Stenosis*  
438. *Neoplasms of the Larynx, Trachea, and Bronchi*

**Elaine E. Schulte, MD, MPH, BCC**

Professor of Pediatrics  
Albert Einstein College of Medicine  
Vice Chair, Academic Affairs and Faculty  
Development  
Co-Director, Leadership, Engagement, Advocacy,  
and Diversity (L.E.A.D.) Program  
Division of Academic General Pediatrics  
Children's Hospital at Montefiore  
Bronx, New York  
9. *Domestic and International Adoption*

**Jennifer E. Schuster, MD, MSCI**

Associate Professor of Pediatrics  
University of Missouri-Kansas City School of  
Medicine  
Division of Pediatric Infectious Diseases  
Children's Mercy Kansas City  
Kansas City, Missouri  
310. *Rhinoviruses*  
428. *The Common Cold*

**Marcy Schuster, PsyD**

Clinic Coordinator  
Elwyn Fragile X Center  
Elwyn, Pennsylvania  
59. *Fragile X Syndromes*

**Mark A. Schuster, MD, PhD**

Founding Dean and CEO  
Professor of Health Systems Science  
Kaiser Permanente Bernard J. Tyson School of  
Medicine  
Pasadena, California  
154. *Gay, Lesbian, and Bisexual Adolescents*

**Daryl A. Scott, MD, PhD**

Professor of Molecular and Human Genetics  
Director, Medical Research Pathway  
Baylor College of Medicine  
Houston, Texas  
95. *Genetics in Pediatric Medicine*  
96. *Principles of Human Genetics*  
97. *Patterns of Genetic Transmission*

**John P. Scott, MD**

Professor of Anesthesiology and Pediatrics  
Medical College of Wisconsin  
Divisions of Pediatric Anesthesiology and Pediatric  
Critical Care  
Children's Wisconsin  
Milwaukee, Wisconsin  
91. *Anesthesia and Perioperative Care*  
92. *Procedural Sedation*

**Kristin A. Seaborg, MD**

Assistant Professor of Neurology  
University of Wisconsin School of Medicine and  
Public Health  
Madison, Wisconsin  
639. *Neurodegenerative Disorders of Childhood*

**Patrick C. Seed, MD, PhD, FAAP, FIDSA**

Professor of Pediatrics, Microbiology and  
Immunology  
Children's Research Fund Chair in Basic Science  
Northwestern University Feinberg School of  
Medicine  
Associate Chief Research Officer of Basic Science  
Stanley Manne Children's Research Institute  
Director, Host-Microbial Interactions,  
Inflammation, and Immunity (HMI3) Program  
Ann & Robert H. Lurie Children's Hospital  
Chicago, Illinois  
245. *Shigella*  
246. *Escherichia coli*

**Janet R. Serwint, MD**

Professor of Pediatrics  
Johns Hopkins University School of Medicine  
Baltimore, Maryland  
30. *Loss, Separation, and Bereavement*

**Dheeraj Shah, MD, FIAP, FAMS**

Director-Professor  
Department of Pediatrics  
University College of Medical Sciences  
Guru Teg Bahadur Hospital  
New Delhi, India  
67. *Vitamin B Complex Deficiencies and Excess*  
68. *Vitamin C (Ascorbic Acid) Deficiency and Excess*

**Samir S. Shah, MD, MSCE, MHM**

Vice Chair, Clinical Affairs and Education  
James M. Ewell Endowed Chair  
Attending Physician, Divisions of Hospital  
Medicine and Infectious Diseases  
Cincinnati Children's Hospital Medical Center  
Professor, Department of Pediatrics  
University of Cincinnati College of Medicine  
Cincinnati, Ohio  
220. *Fever Without a Focus in the Neonate and  
Young Infant*  
221. *Fever in the Older Child*  
725. *Osteomyelitis*  
726. *Septic Arthritis*

**Shivang S. Shah, MD**

Assistant Professor of Pediatrics  
Columbia University Vagelos College of Physicians  
and Surgeons  
Division of Pediatric Infectious Diseases  
NewYork-Presbyterian Morgan Stanley Children's  
Hospital  
New York, New York  
300. *Varicella-Zoster Virus*

**Raanan Shamir, MD**

Professor of Pediatrics  
Director, Institute of Gastroenterology, Nutrition  
and Liver Diseases  
Schneider Children's Medical Center  
Chair, Eduarda and Dr. Moshe Ishay Institute for  
the Study of the Effects of Natural Food on  
Quality of Life and Human Health  
Lea and Arieh Pickel Chair for Pediatric Research  
Faculty of Medicine  
Tel Aviv University  
Tel Aviv, Israel  
388. *Chronic Diarrhea*

**Christina M. Shanti, MD**

Assistant Professor of Surgery  
Wayne State University School of Medicine  
Arvin I. Philippart MD Endowed Chair in Pediatric  
Surgical Research  
Chief, Division of Pediatric Surgery  
Children's Hospital of Michigan  
Detroit, Michigan  
392. *Surgical Conditions of the Anus and Rectum*

**Bruce K. Shapiro, MD**

Professor of Pediatrics  
The Arnold J. Capute MD, MPH Chair in  
Neurodevelopmental Disabilities  
Johns Hopkins University School of Medicine  
Emeritus Vice President of Training  
Kennedy Krieger Institute  
Baltimore, Maryland  
56. *Developmental Delay and Intellectual Disability*

**Bennett A. Shaywitz, MD**

Charles and Helen Schwab Professor in Dyslexia and Learning Development  
Co-Director, Center for Dyslexia & Creativity  
Chief, Child Neurology  
Yale School of Medicine  
New Haven, Connecticut  
51. *Dyslexia*

**Sally E. Shaywitz, MD**

Audrey G. Ratner Professor in Learning Development  
Co-Director, Center for Dyslexia & Creativity  
Department of Pediatrics  
Yale School of Medicine  
New Haven, Connecticut  
51. *Dyslexia*

**Oleg A. Shchelochkov, MD**

Director of Residency and Fellowship Programs  
Medical Genomics and Metabolic Genetics Branch  
National Human Genome Research Institute  
National Institutes of Health  
Bethesda, Maryland  
104. *An Approach to Inborn Errors of Metabolism*  
105. *Defects in Metabolism of Amino Acids*

**Stanford T. Shulman, MD**

Emeritus Professor of Infectious Disease  
Northwestern University Feinberg School of Medicine  
Ann & Robert H. Lurie Children's Hospital of Chicago  
Chicago, Illinois  
229. *Group A Streptococcus*  
487. *Rheumatic Heart Disease*

**Scott H. Sicherer, MD**

Elliot and Roslyn Jaffe Professor of Pediatrics, Allergy and Immunology  
Director, Jaffe Food Allergy Institute  
Medical Director, Clinical Research Unit  
Jack and Lucy Clark Department of Pediatrics  
Icahn School of Medicine at Mount Sinai  
Division Chief, Pediatric Allergy  
Mount Sinai Kravis Children's Hospital  
New York, New York  
182. *Allergy and the Immunologic Basis of Atopic Disease*  
183. *Diagnosis of Allergic Disease*  
184. *Allergic Rhinitis*  
185. *Childhood Asthma*  
186. *Atopic Dermatitis (Atopic Eczema)*  
187. *Insect Allergy*  
188. *Ocular Allergies*  
189. *Urticaria (Hives) and Angioedema*  
190. *Anaphylaxis*  
191. *Serum Sickness*  
192. *Food Allergy and Adverse Reactions to Foods*  
193. *Adverse and Allergic Reactions to Drugs*

**Jeffrey M. Simmons, MD, MSc**

Chief Value Officer, VP Value and Clinical Excellence  
Children's Minnesota  
Minneapolis, Minnesota  
4. *Quality and Value in Healthcare for Children*  
5. *Safety in Healthcare for Children*

**Eric A.F. Simões, MBBS, DCH, MD**

Professor of Pediatrics  
University of Colorado School of Medicine  
Division of Pediatric Infectious Diseases  
Children's Hospital Colorado  
Aurora, Colorado  
296. *Polioviruses*

**Kari A. Simonsen, MD**

Professor of Pediatrics  
Division of Pediatric Infectious Disease  
University of Nebraska Medical Center  
Omaha, Nebraska  
266. *Leptospira*

**Tess S. Simpson, PhD**

Assistant Professor of Physical Medicine and Rehabilitation  
University of Colorado School of Medicine  
Children's Hospital Colorado  
Denver, Colorado  
754. *Meningomyelocele (Spina Bifida)*

**Keneisha R. Sinclair-McBride, PhD**

Assistant Professor of Psychology in Psychiatry  
Harvard Medical School  
Attending Psychologist  
Department of Psychiatry and Behavioral Sciences  
Boston Children's Hospital  
Boston, Massachusetts  
34. *Psychotherapy*  
42. *Disruptive, Impulse-Control, and Conduct Disorders*  
43. *Tantrums and Breath-Holding Spells*  
44. *Lying, Stealing, and Truancy*  
45. *Aggression*

**Arunjot Singh, MD, MPH**

Assistant Professor of Pediatrics  
University of Pennsylvania Perelman School of Medicine  
Division of Gastroenterology, Hepatology, and Nutrition  
Co-Director, Center for Celiac Disease  
Children's Hospital of Philadelphia  
Philadelphia, Pennsylvania  
375. *Pyloric Stenosis and Other Congenital Anomalies of the Stomach*

**Jacquelyn R. Sink, MD**

Dermatologist  
Northwestern Medicine Regional Medical Group  
Naperville, Illinois  
700. *Diseases of the Dermis*  
701. *Diseases of Subcutaneous Tissue*

**Bryan A. Sisk, MD, MSCI**

Assistant Professor of Pediatrics, Hematology and Oncology, and General Medical Sciences  
Director of Research, Bioethics Research Center  
Washington University School of Medicine in St. Louis  
St. Louis, Missouri  
6. *Ethics in Pediatric Care*

**Vidya Sivaraman, MD**

Clinical Associate Professor of Pediatrics  
Division of Pediatric Rheumatology  
Nationwide Children's Hospital  
Columbus, Ohio  
210. *Vasculitis Syndromes*

**Susan M. Slattery, MD, HSOR**

Assistant Professor of Pediatrics  
Northwestern University Feinberg School of Medicine  
Attending Physician, Divisions of Autonomic Medicine and Neonatology  
Ann & Robert H. Lurie Children's Hospital of Chicago and Stanley Manne Children's Research Institute  
Chicago, Illinois  
468.2. *Congenital Central Hypoventilation Syndrome*

**Anne M. Slavotinek, MBBS, PhD**

Professor of Pediatrics  
University of Cincinnati College of Medicine  
Director, Division of Human Genetics  
Cincinnati Children's Hospital Medical Center  
Cincinnati, Ohio  
100. *Dysmorphology, Phenotyping and Sequences*  
101. *Signaling Pathway Disorders*

**Jessica R. Smith, MD**

Assistant Professor of Pediatrics  
Harvard Medical School  
Associate Medical Director, Thyroid Center  
Boston Children's Hospital  
Boston, Massachusetts  
601. *Thyroid Development and Physiology*  
602. *Disorders of Thyroxine-Binding Globulin*  
603. *Hypothyroidism*  
604. *Thyroiditis*  
605. *Goiter*  
606. *Thyrotoxicosis*  
607. *Carcinoma of the Thyroid*  
608. *Autoimmune Polyglandular Syndromes*  
609. *Multiple Endocrine Neoplasia Syndromes*

**Kim Smith-Whitley, MD**

Executive Vice President  
Head of Research and Development  
Global Blood Therapeutics, Inc.  
San Francisco, California  
511. *Hemoglobinopathies*

**Roland Solensky, MD**

Division of Allergy & Immunology  
The Corvallis Clinic  
Corvallis, Oregon  
193. *Adverse and Allergic Reactions to Drugs*

**Mary Beth F. Son, MD**

Associate Professor of Pediatrics  
Harvard Medical School  
Section Chief, Rheumatology Program Director, Services and Outreach  
Boston Children's Hospital  
Boston, Massachusetts  
208. *Kawasaki Disease*

**Danielle E. Soranno, MD**

Associate Professor of Pediatrics  
Indiana University School of Medicine  
Division of Pediatric Nephrology  
Riley Hospital for Children  
Indianapolis, Indiana  
571. *Inherited Tubular Transport Abnormalities*

**Tina K. Sosa, MD, MSc**

Assistant Professor of Pediatrics  
University of Rochester Medical Center School of Medicine and Dentistry  
Associate Chief Quality Officer  
Division of Pediatric Hospital Medicine  
Golisano Children's Hospital  
Rochester, New York  
5. *Safety in Healthcare for Children*

**Carmen L. Soto-Rivera, MD**

Instructor in Pediatrics  
Harvard Medical School  
Director, Neuroendocrine and Growth Programs  
Division of Endocrinology  
Boston Children's Hospital  
Boston, Massachusetts  
596. *Diabetes Insipidus*  
597. *Other Abnormalities of Arginine Vasopressin Metabolism and Action*

**Laura Stout Sosinsky, PhD**

Research Scientist  
Research and Evaluation Group  
Public Health Management Corporation  
Philadelphia, Pennsylvania  
29. *Child Care*

**Emily E. Souder, MD**

Attending Physician  
Section of Infectious Diseases  
St. Christopher's Hospital for Children  
Philadelphia, Pennsylvania  
243. *Pertussis (Bordetella pertussis and Bordetella parapertussis)*

**Cristina Tomatis Souverbielle, MD**

Assistant Professor  
The Ohio State University College of Medicine  
Division of Infectious Diseases  
Nationwide Children's Hospital  
Columbus, Ohio  
262. *Hansen Disease (Mycobacterium leprae)*

**Paul Spearman, MD**

Albert B. Sabin Professor of Pediatrics  
University of Cincinnati College of Medicine  
Director, Division of Infectious Diseases  
Cincinnati Children's Hospital Medical Center  
Cincinnati, Ohio  
323. *Human T-Cell Leukemia Viruses (1 and 2)*

**David A. Spiegel, MD**

Professor of Orthopaedic Surgery  
University of Pennsylvania Perelman School of  
Medicine  
Attending Orthopaedic Surgeon  
Children's Hospital of Philadelphia  
Philadelphia, Pennsylvania  
720. *The Spine*  
721. *The Neck*

**Adiaha I.A. Spinks-Franklin, MD, MPH**

Clinical Associate Professor of Pediatrics  
Baylor College of Medicine  
Division of Developmental-Behavioral Pediatrics  
Texas Children's  
Houston, Texas  
2. *Child Health Disparities*

**Alicia J. Sprecher, MD**

Assistant Professor of Pediatrics  
Medical College of Wisconsin  
Division of Neonatal-Perinatal Medicine  
Children's Wisconsin  
Milwaukee, Wisconsin  
117. *The Fetus*  
122. *Nervous System Disorders*  
124. *Transition to Newborn Pulmonary Respiration*  
125. *Apnea*  
126. *Respiratory Distress Syndrome (Hyaline Membrane Disease)*  
127. *Bronchopulmonary Dysplasia*  
128. *Transient Tachypnea of the Newborn*  
129. *Aspiration of Foreign Material (Meconium Aspiration Syndrome, Aspiration Pneumonia)*  
130. *Persistent Pulmonary Hypertension of the Newborn (Persistent Fetal Circulation)*  
131. *Diaphragmatic Hernia*  
132. *Pulmonary Air Leaks: Pneumothorax, Pneumomediastinum, Pulmonary Interstitial Emphysema, Pneumopericardium*  
133. *Pulmonary Hemorrhage*

**James E. Squires, MD, MS**

Associate Professor of Pediatrics  
Director, Pediatric Transplant Hepatology  
Fellowship Program  
University of Pittsburgh School of Medicine  
Associate Director of Hepatology  
Division of Gastroenterology, Hepatology and  
Nutrition  
Children's Hospital of Pittsburgh  
Pittsburgh, Pennsylvania  
403. *Manifestations of Liver Disease*

**Siddharth Srivastava, MD, PhD**

Assistant Professor of Neurology  
Harvard Medical School  
Boston Children's Hospital  
Boston, Massachusetts  
636. *Neurocutaneous Syndromes*

**Joseph W. St. Geme III, MD**

Professor of Pediatrics and Microbiology and Chair  
of the Department of Pediatrics  
University of Pennsylvania Perelman School of  
Medicine  
Chair of the Department of Pediatrics and  
Physician-in-Chief  
Leonard and Madlyn Abramson Endowed Chair in  
Pediatrics  
Children's Hospital of Philadelphia  
Philadelphia, Pennsylvania  
240. *Haemophilus influenzae*

**Rachel D. St. John, MD, NCC, FAAP**

Professor of Otolaryngology—Head & Neck Surgery  
University of Texas Southwestern Medical Center  
Director, Family-Focused Center for Deaf and  
Hard of Hearing Children  
Children's Health Medical Center  
Dallas, Texas  
55. *Outcomes Among Infants and Children Who Are Deaf/Hard of Hearing*

**Kathryn C. Stambough, MD**

Assistant Professor of Obstetrics and Gynecology  
University of Arkansas for Medical Sciences  
Chief, Division of Pediatric and Adolescent  
Gynecology  
Arkansas Children's Hospital  
Little Rock, Arkansas  
585. *Gynecologic History and Physical Examination*  
587. *Vaginal Bleeding in the Prepubertal Child*

**Lawrence R. Stanberry, MD, PhD**

Professor of Pediatrics  
Associate Dean for International Programs  
Director of the Programs in Global Health  
Vagelos College of Physicians and Surgeons  
Columbia University  
New York, New York  
299. *Herpes Simplex Virus*

**Jeffrey R. Starke, MD**

Professor of Pediatrics  
Faculty Senator  
Baylor College of Medicine  
Pediatric Infectious Diseases  
Texas Children's  
Houston, Texas  
261. *Tuberculosis (Mycobacterium tuberculosis)*

**Taylor B. Starr, DO, MPH**

Associate Professor of Pediatrics  
University of Rochester School of Medicine and  
Dentistry  
Division of Adolescent Medicine  
Golisano Children's Hospital  
Rochester, New York  
41. *Eating Disorders*

**Andrew P. Steenhoff, MBBCh, DCHFAAP**

Associate Professor of Pediatrics  
University of Pennsylvania Perelman School of  
Medicine  
Attending Physician  
Division of Infectious Diseases  
Medical Director, Global Health Center  
Children's Hospital of Philadelphia  
Philadelphia, Pennsylvania  
222. *Fever of Unknown Origin*  
287. *Paracoccidioides brasiliensis*  
288. *Sporotrichosis (Sporothrix schenckii)*

**Ronen E. Stein, MD**

Assistant Professor of Clinical Pediatrics  
University of Pennsylvania Perelman School of  
Medicine  
Division of Gastroenterology, Hepatology, and  
Nutrition  
Children's Hospital of Philadelphia  
Philadelphia, Pennsylvania  
382. *Inflammatory Bowel Disease*  
383. *Eosinophilic Gastroenteritis*

**William J. Steinbach, MD**

Robert H. Fiser Jr. MD, Endowed Chair in Pediatrics  
Chair, Department of Pediatrics  
Associate Dean for Child Health  
College of Medicine, University of Arkansas for  
Medical Sciences  
Pediatrician-in-Chief, Arkansas Children's  
Little Rock, Arkansas  
279. *Principles of Antifungal Therapy*  
283. *Aspergillus*  
289. *Mucormycosis*  
291. *Other Pathogenic Fungi*

**Terri L. Stillwell, MD**

Clinical Associate Professor of Pediatrics  
University of Michigan Medical School  
Division of Pediatric Infectious Diseases  
C. S. Mott Children's Hospital  
Ann Arbor, Michigan  
301. *Epstein-Barr Virus*  
309. *Adenoviruses*

**Deborah L. Stone, MD**

National Human Genome Research Institute  
National Institutes of Health  
Bethesda, Maryland  
206. *Amyloidosis*

**Stefani Su, MD**

Potomac Allergy & Asthma, P.C.  
Alexandria, Virginia  
176. *Approaches to Treatment of Primary Immune Deficiency Diseases*

**Gina S. Sucato, MD, MPH**

Director, Adolescent Center  
Washington Permanente Medical Group  
Adjunct Investigator, Kaiser Permanente  
Washington Health Research Institute  
Seattle, Washington  
159. *Menstruation-Related Disorders*

**Frederick J. Suchy, MD**

Professor of Pediatrics  
University of Colorado School of Medicine  
Children's Hospital Colorado  
Aurora, Colorado  
410. *Autoimmune Hepatitis*  
411. *Drug- and Toxin-Induced Liver Injury*  
412. *Acute Hepatic Failure*  
413. *Cystic Diseases of the Biliary Tract and Liver*  
414. *Diseases of the Gallbladder*  
415. *Portal Hypertension and Varices*



**Kathleen E. Sullivan, MD, PhD**

Professor of Pediatrics  
University of Pennsylvania Perelman School of  
Medicine  
Chief, Division of Allergy and Immunology  
Frank R. Wallace Endowed Chair in Infectious  
Diseases  
Children's Hospital of Philadelphia  
Philadelphia, Pennsylvania  
164. *Orientation to the Consideration of Inborn  
Errors of Immunity*

**Sanjeev K. Swami, MD**

Associate Professor of Clinical Pediatrics  
University of Pennsylvania Perelman School of  
Medicine  
Attending Physician  
Division of Infectious Diseases  
Director, Outpatient Infectious Diseases Clinic  
Children's Hospital of Philadelphia  
Philadelphia, Pennsylvania  
268. *Lyme Disease (Borrelia burgdorferi)*

**Vibha A. Szafron, MD**

Department of Pediatrics  
Baylor College of Medicine  
Section of Immunology, Allergy, and Retrovirology  
Texas Children's  
Houston, Texas  
167. *Natural Killer Cells*

**Maira Szilagyi, MD, PhD**

Professor of Pediatrics  
David Geffen School of Medicine at UCLA  
Interim Division Chief, General Pediatrics  
Section Chief, Developmental/Behavioral  
Pediatrics  
UCLA Mattel Children's Hospital  
Los Angeles, California  
10. *Foster and Kinship Care*

**Dalal Taha, DO**

Associate Professor of Clinical Pediatrics  
University of Pennsylvania Perelman School of  
Medicine  
Attending Neonatologist  
Children's Hospital of Philadelphia  
Philadelphia, Pennsylvania  
143. *Nonimmune Hydrops*

**Libo Tan, PhD**

Associate Professor  
Department of Human Nutrition  
College of Human Environmental Sciences  
University of Alabama  
Tuscaloosa, Alabama  
66. *Vitamin A Deficiencies and Excess*

**Kelan G. Tantisira, MD, MPH**

Professor of Pediatrics  
University of California San Diego School of  
Medicine  
Chief, Division of Respiratory Medicine  
Rady Children's Hospital—San Diego  
San Diego, California  
421. *Diagnostic Approach to Respiratory Disease*

**Alex M. Taylor, PsyD**

Assistant Professor of Psychology  
Department of Psychiatry  
Harvard Medical School  
Director of Neuropsychology  
Brain Injury Center  
Boston Children's Hospital  
Boston, Massachusetts  
729. *Sports-Related Traumatic Brain Injury  
(Concussion)*

**Dmitry Tchapyjnikov, MD**

Adjunct Assistant Professor of Pediatrics  
Duke University Medical Center  
Durham, North Carolina  
633. *Seizures in Childhood*

**Brenda L. Tesini, MD**

Assistant Professor of Medicine and Pediatrics  
University of Rochester Medical Center School of  
Medicine and Dentistry  
Department of Pediatric Infectious Diseases  
Golisano Children's Hospital  
Rochester, New York  
303. *Roseola (Human Herpesviruses 6 and 7)*  
304. *Human Herpesvirus 8*

**Jillian L. Theobald, MD, PhD**

Associate Professor of Emergency Medicine  
Medical College of Wisconsin  
Associate Medical Director, Wisconsin Poison  
Center  
Milwaukee, Wisconsin  
94. *Poisoning*

**Beth K. Thielen, MD, PhD**

Assistant Professor of Pediatrics  
Division of Pediatric Infectious Diseases  
University of Minnesota Medical School  
Minneapolis, Minnesota  
325. *Principles of Antiparasitic Therapy*

**Christopher S. Thom, MD, PhD**

Assistant Professor of Pediatrics  
University of Pennsylvania Perelman School of  
Medicine  
Attending Neonatologist  
Children's Hospital of Philadelphia  
Philadelphia, Pennsylvania  
138. *Blood Disorders*  
139. *Anemia in the Newborn Infant*  
140. *Hemolytic Disease of the Fetus and Newborn*  
141. *Neonatal Polycythemia*  
142. *Hemorrhage in the Newborn Infant*

**Courtney D. Thornburg, MD, MS**

Professor of Clinical Pediatrics  
UC San Diego School of Medicine  
La Jolla, California;  
Medical Director, Hemophilia and Thrombosis  
Treatment Center  
Rady Children's Hospital, San Diego  
San Diego, California  
496. *Anemias*  
497. *Congenital Hypoplastic Anemia (Diamond-  
Blackfan Anemia)*  
498. *Pearson Syndrome*  
499. *Acquired Pure Red Blood Cell Anemia*  
500. *Anemia of Chronic Disease and Renal Disease*  
501. *Congenital Dyserythropoietic Anemias*  
502. *Physiologic Anemia of Infancy*  
503. *Megaloblastic Anemias*

**Joel S. Tieder, MD, MPH**

Professor of Pediatrics  
University of Washington School of Medicine  
Division of Hospital Medicine  
Seattle Children's Hospital  
Seattle, Washington  
424. *Brief Resolved Unexplained Events and Other  
Acute Events in Infants*

**Pierre Tissières, MD, PhD**

Professor of Pediatrics  
Director of Pediatric Intensive Care, Neonatal  
Medicine, and Pediatric Emergency Department  
AP-HP Paris Saclay University, Bicetre Hospital  
Le Kremlin-Bicetre, France  
85. *Shock*

**Victorio R. Tolentino Jr., JD, MPH, NP**

Healthcare Consultant  
Jackson Heights, New York;  
Psychiatric Nurse Practitioner  
Counseling and Wellness Services, Student Health  
Center  
New York University  
New York, New York  
77.3. *Principles Applicable to the Developing World*

**Alexis A. Topjian, MD, MSCE**

Professor of Anesthesiology, Critical Care, and  
Pediatrics  
University of Pennsylvania Perelman School of  
Medicine  
Attending Physician  
Department of Anesthesiology and Critical Care  
Children's Hospital of Philadelphia  
Philadelphia, Pennsylvania  
79. *Pediatric Cardiorespiratory Emergencies and  
Resuscitation*

**Richard L. Tower, MD, MS**

Professor of Pediatrics  
Medical College of Wisconsin  
Division of Pediatric Hematology/Oncology  
Children's Wisconsin  
Milwaukee, Wisconsin  
537. *Anatomy and Function of the Lymphatic System*  
538. *Abnormalities of Lymphatic Vessels*  
539. *Lymphadenopathy*

**Rebecca Trachtman, MD, MS**

Assistant Professor of Pediatrics  
Icahn School of Medicine at Mount Sinai  
Division of Pediatric Rheumatology  
Mount Sinai Kravis Children's Hospital  
New York, New York  
207. *Macrophage Activation Syndrome*

**Jourdan E. Triebwasser, MD, MA**

Clinical Assistant Professor of Obstetrics and  
Gynecology  
Division of Maternal-Fetal Medicine  
University of Michigan Medical School  
Ann Arbor, Michigan  
116. *High-Risk Pregnancies*

**Sara K. Trowbridge, MD**

Instructor in Neurology  
Harvard Medical School  
Boston Children's Hospital  
Boston, Massachusetts  
631. *Congenital Anomalies of the Central Nervous  
System*

**Joseph M. Truglio, MD, MPH**

Associate Professor of Medicine, Pediatrics, and  
Medical Education  
Icahn School of Medicine at Mount Sinai  
New York, New York  
152. *Transitioning to Adult Care*

**David G. Tubergen, MD**

Medical Director, Host Program  
MD Anderson Physicians Network  
Houston, Texas  
544. *The Leukemias*

**Margaret A. Turk, MD**

SUNY Distinguished Service Professor  
 Departments of Physical Medicine &  
 Rehabilitation, Pediatrics, Public Health &  
 Preventive Medicine  
 Vice-Chairman, Physical Medicine &  
 Rehabilitation  
 State University of New York  
 SUNY Upstate Medical University  
 Syracuse, New York  
 756. *Health and Wellness for Children With  
 Disabilities*

**Joan R. Tymon-Rosario, MD**

Assistant Professor  
 Division of Gynecologic Oncology  
 Department of Obstetrics and Gynecology  
 Zucker School of Medicine  
 Uniondale, New York;  
 Northwell Health Cancer Institute  
 Hyde Park, New York  
 590. *Gynecologic Neoplasms and Prevention  
 Methods for Human Papillomavirus Infections in  
 Adolescents*

**Paul J. Ufberg, DO, MBA**

Medical Director, Global Medical Affairs  
 The Janssen Pharmaceutical Companies of  
 Johnson & Johnson  
 Horsham, Pennsylvania  
 389. *Disorders of Brain-Gut Interaction (Functional  
 Gastrointestinal Disorders)*

**Christina Ullrich, MD, PhD, MPH**

Assistant Professor of Pediatrics  
 Harvard Medical School  
 Senior Physician and Clinical Director  
 Pediatric Advanced Care Team, Psychosocial  
 Oncology and Palliative Care  
 Dana-Farber Cancer Institute  
 Interim Director, Pediatric Palliative Care  
 Division of Pediatric Hematology/Oncology  
 Boston Children's Hospital  
 Boston, Massachusetts  
 8. *Pediatric Palliative Care*

**Nicole Ullrich, MD, PhD**

Professor of Neurology  
 Harvard Medical School  
 Director, Neurologic Neuro-Oncology  
 Associate Director, Clinical Trials  
 Neurofibromatosis Program  
 Boston Children's Hospital  
 Boston, Massachusetts  
 636.1. *Neurofibromatosis*

**Taher S. Valika, MD**

Assistant Professor of Otolaryngology – Head and  
 Neck Surgery  
 Northwestern University Feinberg School of  
 Medicine  
 Attending Physician  
 Division of Otorhinolaryngology – Head and Neck  
 Surgery  
 Medical Director, Aerodigestive Program  
 Director, Upper Airway Surgery  
 Ann & Robert H. Lurie Children's Hospital of  
 Chicago  
 Chicago, Illinois  
 436. *Laryngotracheal Stenosis and Subglottic  
 Stenosis*

**George F. Van Hare, MD**

Professor of Pediatrics  
 Washington University School of Medicine in St Louis  
 Division of Pediatric Cardiology  
 St Louis Children's Hospital  
 St. Louis, Missouri  
 84. *Syncope*  
 484. *Disturbances of Rate and Rhythm of the Heart*  
 485. *Sudden Death*

**Heather A. Van Mater, MD, MS**

Associate Professor of Pediatrics  
 Duke University School of Medicine  
 Chief, Division of Pediatric Rheumatology  
 Duke University Health System  
 Durham, North Carolina  
 201. *Scleroderma and Raynaud Phenomenon*

**Charles D. Varnell Jr., MD, MS**

Assistant Professor of Pediatrics  
 University of Cincinnati College of Medicine  
 Division of Nephrology and Hypertension  
 Cincinnati Children's Hospital Medical Center  
 Cincinnati, Ohio  
 573. *Renal Transplantation*

**Alla Vash-Margita, MD**

Associate Professor of Obstetrics, Gynecology and  
 Reproductive Sciences  
 Yale School of Medicine  
 Chief, Division of Pediatric and Adolescent  
 Gynecology  
 Yale New Haven Children's Hospital  
 New Haven, Connecticut  
 585. *Gynecologic History and Physical Examination*  
 590. *Gynecologic Neoplasms and Prevention Methods  
 for Human Papillomavirus Infections in Adolescents*  
 591. *Vulvovaginal and Müllerian Anomalies*

**Timothy J. Vece, MD**

Professor of Pediatrics  
 Division of Pediatric Pulmonology  
 The University of North Carolina at Chapel Hill  
 School of Medicine  
 Medical Director  
 NC Children's Airway Center  
 Chapel Hill, North Carolina  
 448.3. *Granulomatous Lung Disease*  
 448.4. *Eosinophilic Lung Disease*  
 448.5. *Interstitial Lung Disease*

**Aarthi P. Vemana, MD**

Pediatric Sleep Physician  
 Inova Children's Sleep Center  
 Fairfax, Virginia  
 451. *Pleurisy, Pleural Effusions, and Empyema*  
 461. *Pneumothorax*  
 462. *Pneumomediastinum*  
 463. *Hydrothorax*  
 464. *Hemothorax*  
 465. *Chylothorax*

**Charles P. Venditti, MD, PhD**

Head, Organic Acid Research Section  
 Senior Investigator, National Human Genome  
 Research Institute  
 National Institutes of Health  
 Bethesda, Maryland  
 104. *An Approach to Inborn Errors of Metabolism*  
 105. *Defects in Metabolism of Amino Acids*

**Sarah Vepraskas, MD**

Associate Professor of Pediatrics  
 Section of Hospital Medicine  
 Medical College of Wisconsin  
 Milwaukee, Wisconsin  
 423.1. *Sudden Unexpected Postnatal Collapse/  
 Sudden Unexpected Early Neonatal Death*

**James W. Verbsky, MD, PhD**

Professor of Pediatrics  
 Medical College of Wisconsin  
 Division of Pediatric Rheumatology  
 Children's Wisconsin  
 Milwaukee, Wisconsin  
 90.1. *Cold-Induced Autoinflammatory and Other  
 Genetic Disorders*  
 204. *Hereditary Periodic Fever Syndromes and Other  
 Systemic Autoinflammatory Diseases*  
 205. *Interferonopathies*

**Jennifer A. Vermilion, MD**

Assistant Professor of Neurology and Pediatrics  
 University of Rochester School of Medicine and  
 Dentistry  
 Rochester, New York  
 637.2. *Chorea, Athetosis, and Tremor*

**Brian P. Vickery, MD**

Associate Professor of Pediatrics  
 Section Chief, Allergy/Immunology  
 Emory University School of Medicine  
 Director, Food Allergy Center  
 Emory + Children's Healthcare of Atlanta  
 Atlanta, Georgia  
 169. *Eosinophils*

**Jerry Vockley, MD, PhD**

Cleveland Family Endowed Chair in Pediatric  
 Research  
 Professor of Human Genetics  
 University of Pittsburgh School of Medicine  
 Chief, Division of Genetic and Genomic Medicine  
 Director, Center for Rare Disease Therapy  
 UPMC Children's Hospital of Pittsburgh  
 Pittsburgh, Pennsylvania  
 106.1. *Disorders of Mitochondrial Fatty Acid  $\beta$ -  
 Oxidation*

**Judith A. Voynow, MD**

Professor of Pediatrics  
 Virginia Commonwealth University School of  
 Medicine  
 Edwin L. Kendig Jr. Professor of Pediatric  
 Pulmonology  
 Children's Hospital of Richmond at VCU  
 Richmond, Virginia  
 454. *Cystic Fibrosis*

**Abby Walch, MD**

Assistant Professor of Pediatrics  
 University of California San Francisco School of  
 Medicine  
 Division of Pediatric Endocrinology  
 UCSF Benioff Children's Hospitals  
 San Francisco, California  
 153. *Gender Identity and Transgender Care*

**Stephanie W. Waldrop, MD**

Instructor in Pediatrics  
 University of Colorado School of Medicine  
 Section of Pediatric Nutrition  
 Children's Hospital Colorado  
 Aurora, Colorado  
 60. *Nutritional Requirements*

**David M. Walker, MD**

Associate Professor of Pediatrics  
 Hackensack University Medical Center  
 Chief, Pediatric Emergency Medicine  
 Joseph M. Sanarzi Children's Hospital  
 Hackensack, New Jersey  
 77.3. *Principles Applicable to the Developing World*

**Kelly J. Walkovich, MD**

Clinical Associate Professor of Pediatrics and Communicable Diseases  
Division of Pediatric Hematology/Oncology  
University of Michigan Medical School  
Ann Arbor, Michigan  
171. *Leukopenia*  
172. *Leukocytosis*

**Heather J. Walter, MD, MPH**

Professor of Psychiatry  
Department of Psychiatry  
Harvard Medical School  
Senior Attending Psychiatrist  
Department of Psychiatry and Behavioral Sciences  
Boston Children's Hospital  
Boston, Massachusetts  
32. *Psychosocial Assessment and Psychiatric Diagnostic Evaluation*  
33. *Psychopharmacology*  
34. *Psychotherapy*  
36. *Rumination and Pica*  
37. *Motor Disorders and Habits*  
42. *Disruptive, Impulse-Control, and Conduct Disorders*  
43. *Tantrums and Breath-Holding Spells*  
44. *Lying, Stealing, and Truancy*  
45. *Aggression*

**Jennifer A. Wambach, MD**

Associate Professor of Pediatrics  
Washington University School of Medicine in St. Louis  
Division of Newborn Medicine  
St. Louis Children's Hospital  
St. Louis, Missouri  
456. *Diffuse Lung Diseases in Childhood*

**Susan Wamithi, MD, MMed**

Consultant Developmental Paediatrician  
Department of Paediatrics, Child and Adolescent Health  
Aga Khan University Hospital  
Nairobi, Kenya  
3. *Global Child Health*

**Julie Wang, MD**

Professor of Pediatrics  
Jaffe Food Allergy Institute  
Icahn School of Medicine at Mount Sinai  
Division of Pediatric Allergy  
Mount Sinai Kravis Children's Hospital  
New York, New York  
187. *Insect Allergy*  
190. *Anaphylaxis*

**Marie E. Wang, MD, MPH**

Clinical Associate Professor of Pediatrics  
Stanford University School of Medicine  
Palo Alto, California  
575. *Urinary Tract Infections*

**Michael F. Wangler, MD**

Associate Professor of Molecular and Human Genetics  
Baylor College of Medicine  
Jan and Dan Duncan Neurological Research Institute  
Texas Children's  
Houston, Texas  
106.2. *Disorders of Very-Long-Chain Fatty Acids and Other Peroxisomal Functions*

**Stephanie M. Ware, MD, PhD, FACMG**

Professor of Pediatrics  
Professor and Interim Chair  
Department of Medical and Molecular Genetics  
Director, Cardiovascular Genetics  
Herman B Wells Center for Pediatric Research  
Indiana University School of Medicine  
Indianapolis, Indiana  
488. *Diseases of the Myocardium*  
489. *Diseases of the Pericardium*  
490. *Tumors of the Heart*

**Matthew C. Washam, MD, MPH**

Assistant Professor of Pediatrics  
The Ohio State University College of Medicine  
Nationwide Children's Hospital  
Columbus, Ohio  
284. *Histoplasmosis (Histoplasma capsulatum)*

**Jonathan D. Wasserman, MD, PhD**

Associate Professor of Paediatrics  
University of Toronto—Faculty of Medicine  
Staff Physician  
Division of Endocrinology  
The Hospital for Sick Children  
Toronto, Ontario, Canada  
555.1. *Thyroid Tumors*  
555.4. *Adrenal Tumors*

**Ari J. Wassner, MD**

Associate Professor of Pediatrics  
Harvard Medical School  
Medical Director, Thyroid Center  
Boston Children's Hospital  
Boston, Massachusetts  
601. *Thyroid Development and Physiology*  
602. *Disorders of Thyroxine-Binding Globulin*  
603. *Hypothyroidism*  
604. *Thyroiditis*  
605. *Goiter*  
606. *Thyrototoxicosis*  
607. *Carcinoma of the Thyroid*  
608. *Autoimmune Polyglandular Syndromes*  
609. *Multiple Endocrine Neoplasia Syndromes*

**Andrew M. Watson, MD**

Assistant Professor of Orthopedics and Rehabilitation  
Division of Sports Medicine  
Team Physician  
Division of Intercollegiate Athletics  
University of Wisconsin – Madison  
School of Medicine and Public Health  
Madison, Wisconsin  
727. *Prevention of Injuries*  
728. *Management of Musculoskeletal Injury*  
731. *Heat Injuries*  
732. *Nutrition and Endocrine Conditions in Athletes*  
733. *Performance-Enhancing Aids*  
734. *Specific Sports and Associated Injuries*

**Rachel L. Wattier, MD, MHS**

Associate Professor of Clinical Pediatrics  
UC San Francisco School of Medicine  
Medical Director, Pediatric Antimicrobial Stewardship Program  
UCSF Benioff Children's Hospital  
San Francisco, California  
289. *Mucormycosis*

**David R. Weber, MD, MSCE**

Assistant Professor of Pediatrics  
University of Pennsylvania Perelman School of Medicine  
Attending Physician  
Division of Endocrinology and Diabetes  
Medical Director, Center for Bone Health  
Children's Hospital of Philadelphia  
Philadelphia, Pennsylvania  
629. *Diabetes Mellitus*

**Jennifer Webster, DO, MSHP**

Assistant Professor of Clinical Pediatrics  
University of Pennsylvania Perelman School of Medicine  
Attending Physician  
Division of Gastroenterology, Hepatology and Nutrition  
Children's Hospital of Philadelphia  
Philadelphia, Pennsylvania  
378. *Motility Disorders and Hirschsprung Disease*

**Debra E. Weese-Mayer, MD**

Beatrice Cummings Mayer Professor of Pediatrics and Pediatric Autonomic Medicine  
Northwestern University Feinberg School of Medicine  
Chief, Division of Pediatric Autonomic Medicine  
Ann & Robert H. Lurie Children's Hospital of Chicago and Stanley Manne Children's Research Institute  
Chicago, Illinois  
468.2. *Congenital Central Hypoventilation Syndrome*  
468.3. *Rapid-Onset Obesity with Hypothalamic Dysfunction, Hypoventilation, and Autonomic Dysregulation*

**Jason B. Weinberg, MD**

Associate Professor of Pediatrics and Microbiology and Immunology  
University of Michigan Medical School  
Division of Pediatric Infectious Diseases  
C. S. Mott Children's Hospital  
Ann Arbor, Michigan  
301. *Epstein-Barr Virus*  
309. *Adenoviruses*

**Jason P. Weinman, MD**

Associate Professor of Radiology  
University of Colorado School of Medicine  
Aurora, Colorado  
448.7. *Fibrotic Lung Disease*

**Steven J. Weisman, MD**

Professor of Anesthesiology and Pediatrics  
Medical College of Wisconsin  
Jane B. Pettit Chair in Pain Management  
Children's Wisconsin  
Milwaukee, Wisconsin  
93. *Pediatric Pain Management*

**Anna K. Weiss, MD, MSEd**

Assistant Professor of Clinical Pediatrics  
University of Pennsylvania Perelman School of Medicine  
Associate Director for Medical Education  
Division of Emergency Medicine  
Children's Hospital of Philadelphia  
Philadelphia, Pennsylvania  
77.2. *Risk Adjustment and Outcomes Measurement of Pediatric Emergency Medical Services*  
78. *Triage of the Acutely Ill Child*



**Scott L. Weiss, MD, MSCE, FCCM**

Associate Professor of Pediatrics and Pathology,  
Anatomy, and Cell Biology  
Sidney Kimmel Medical College at Thomas  
Jefferson University  
Division Chief, Critical Care Medicine  
Nemours Children's Health  
Wilmington, Delaware  
85. *Shock*

**Pamela F. Weiss, MD, MSCE**

Associate Professor of Pediatrics and Epidemiology  
University of Pennsylvania Perelman School of  
Medicine  
Attending Physician and Clinical Research Director  
Division of Rheumatology  
Children's Hospital of Philadelphia  
Philadelphia, Pennsylvania  
197. *Ankylosing Spondylitis and Other  
Spondyloarthritides*  
198. *Reactive and Postinfectious Arthritis*

**Carol C. Weitzman, MD**

Co-Director Autism Spectrum Center  
Boston Children's Hospital  
Associate Professor, Harvard Medical School  
Professor Emeritus, Yale School of Medicine  
Boston, Massachusetts  
58. *Autism Spectrum Disorder*

**Lawrence Wells, MD**

Associate Professor of Orthopaedic Surgery  
University of Pennsylvania Perelman School of  
Medicine  
Attending Orthopaedic Surgeon  
Associate Director, Sports Medicine and  
Performance Center  
Children's Hospital of Philadelphia  
Philadelphia, Pennsylvania  
713. *Orthopedic Growth and Development*  
714. *Orthopedic Evaluation of the Child*  
716. *Torsional and Angular Deformities of the Limb*  
719. *The Hip*  
724. *Common Fractures*

**Jessica W. Wen, MD**

Associate Professor of Clinical Pediatrics  
University of Pennsylvania Perelman School of  
Medicine  
Director, Viral Hepatitis Treatment Program  
Attending Physician  
Division of Gastroenterology, Hepatology and  
Nutrition  
Children's Hospital of Philadelphia  
Philadelphia, Pennsylvania  
418. *Ascites*  
419. *Peritonitis*

**Danielle R. Wendel, MD**

Associate Professor of Pediatrics  
University of Washington School of Medicine  
Medical Director, Intestinal Transplant Service  
Division of Gastroenterology and Hepatology  
Seattle Children's Hospital  
Seattle, Washington  
386. *Intestinal Transplantation in Children with  
Intestinal Failure*

**Steven L. Werlin, MD**

Professor Emeritus of Pediatrics  
Medical College of Wisconsin  
Milwaukee, Wisconsin  
395. *Embryology, Anatomy, and Physiology of the  
Pancreas*  
396. *Pancreatic Function Tests*  
397. *Disorders of the Exocrine Pancreas*  
398. *Treatment of Pancreatic Insufficiency*  
399. *Pancreatitis*  
400. *Pancreatic Fluid Collections*  
401. *Pancreatic Tumors*

**Isaiah D. Wexler, MD, PhD**

Associate Professor of Pediatrics  
Hadassah Medical School  
Attending Physician, Department of Pediatrics  
Hadassah University Medical Center  
Jerusalem, Israel  
15.3. *Effects of War on Children*

**Alexander S. Whitaker, MD**

Instructor in Pediatrics  
University of Maryland School of Medicine  
Baltimore, Maryland  
21. *Assessment of Fetal Growth and Development*

**A. Clinton White Jr., MD**

Professor of Medicine  
Division of Infectious Diseases  
The University of Texas Medical Branch at  
Galveston  
Galveston, Texas  
348. *Adult Tapeworm Infections*  
349. *Cysticercosis*  
350. *Echinococcosis (Echinococcus granulosus sensu  
lato and Echinococcus multilocularis)*

**Perrin C. White, MD**

Professor of Pediatrics  
Chief, Division of Pediatric Endocrinology  
Audre Newman Rapoport Distinguished Chair in  
Pediatric Endocrinology  
University of Texas Southwestern Medical Center  
Dallas, Texas  
614. *Physiology of the Adrenal Gland*  
615. *Adrenocortical Insufficiency and Altered  
Sensitivity to Corticosteroids*  
616. *Congenital Adrenal Hyperplasia and Related  
Disorders*  
617. *Adrenocortical Tumors and Masses*  
618. *Virilizing and Feminizing Adrenal Tumors*  
619. *Cushing Syndrome*  
620. *Primary Aldosteronism*  
621. *Pheochromocytoma*

**Rodney E. Willoughby Jr., MD**

Professor of Pediatrics  
Medical College of Wisconsin  
Division of Pediatric Infectious Diseases  
Children's Wisconsin  
Milwaukee, Wisconsin  
320. *Rabies*

**Michael Wilschanski, MD**

Professor of Pediatrics  
Hebrew University Hadassah School of Medicine  
Director, Pediatric Gastroenterology Unit  
Hadassah University Hospitals  
Jerusalem, Israel  
395. *Embryology, Anatomy, and Physiology of the  
Pancreas*  
396. *Pancreatic Function Tests*  
397. *Disorders of the Exocrine Pancreas*  
398. *Treatment of Pancreatic Insufficiency*  
399. *Pancreatitis*  
400. *Pancreatic Fluid Collections*  
401. *Pancreatic Tumors*

**Susan E. Wiley, MD, FAAP**

Professor of Pediatrics  
University of Cincinnati College of Medicine  
Cincinnati Children's Hospital Medical Center  
Cincinnati, Ohio  
55. *Outcomes Among Infants and Children Who Are  
Deaf/Hard of Hearing*

**Brendan A. Williams, MD**

Assistant Professor of Orthopaedic Surgery  
University of Pennsylvania Perelman School of  
Medicine  
Attending Orthopaedic Surgeon  
Sports Medicine and Performance Center  
Children's Hospital of Philadelphia  
Philadelphia, Pennsylvania  
713. *Orthopedic Growth and Development*  
716. *Torsional and Angular Deformities of the Limb*

**Karen M. Wilson, MD, MPH**

Ruth A. Lawrence Professor of Pediatrics  
Vice-Chair for Clinical and Translational Research  
Department of Pediatrics  
University of Rochester School of Medicine and  
Dentistry  
Strategic Director, Research Services Branch  
Clinical and Translational Science Institute  
Chief Research Officer, UR Medicine  
Golisano Children's Hospital  
Rochester, New York  
759.2. *Marijuana Smoke Exposure*

**Pamela E. Wilson, MD**

Associate Professor of Physical Medicine and  
Rehabilitation  
University of Colorado School of Medicine  
Children's Hospital Colorado  
Denver, Colorado  
754. *Meningomyelocele (Spina Bifida)*

**Jennifer J. Winell, MD**

Attending Orthopaedic Surgeon  
Children's Hospital of Philadelphia  
Philadelphia, Pennsylvania  
715. *The Foot and Toes*  
716. *Torsional and Angular Deformities of the Limb*  
719. *The Hip*

**Peter Witters, MD, PhD**

Assistant Professor of Pediatrics  
Center for Metabolic Diseases  
University Hospitals Leuven  
Department of Development and Regeneration  
Katholieke Universiteit Leuven  
Leuven, Belgium  
107.7. *Congenital Disorders of Glycosylation*

**Joshua Wolf, PhD, MBBS**

Associate Member  
Department of Infectious Diseases  
St. Jude Children's Research Hospital  
Memphis, Tennessee  
224. *Infection Associated With Medical Devices*

**Joanne Wolfe, MD, MPH**

Professor of Pediatrics  
Harvard Medical School  
Chief, Division of Pediatric Palliative Care  
Department of Psychosocial Oncology and  
Palliative Care  
Faculty Vice President for Faculty Development  
Dana-Farber Cancer Institute  
Director, Pediatric Palliative Care  
Boston Children's Hospital  
Boston, Massachusetts  
8. *Pediatric Palliative Care*

**Peter M. Wolfram, MD**

Associate Professor of Pediatrics  
Medical College of Wisconsin  
Division of Pediatric Endocrinology  
Children's Wisconsin  
Milwaukee, Wisconsin  
600.1. *Delayed or Absent Puberty*

**Brandon T. Woods, MD, MS**

Division of Critical Care Medicine  
Department of Pediatrics  
University of Washington School of Medicine  
Seattle Children's Hospital  
Seattle, Washington  
445. *Pulmonary Edema*

**Benjamin L. Wright, MD**

Associate Professor of Medicine  
Division of Allergy, Asthma, and Clinical  
Immunology  
Mayo Clinic  
Scottsdale, Arizona;  
Phoenix Children's Hospital  
Phoenix, Arizona  
169. *Eosinophils*

**Terry W. Wright, PhD**

Associate Professor of Pediatrics  
Professor of Microbiology and Immunology  
University of Rochester Medical Center School of  
Medicine and Dentistry  
Department of Pediatric Infectious Diseases  
Golisano Children's Hospital  
Rochester, New York  
290. *Pneumocystis jirovecii*

**Eveline Y. Wu, MD, MSCR**

Associate Professor of Pediatrics  
Division Chief, Pediatric Rheumatology  
University of North Carolina at Chapel Hill  
Chapel Hill, North Carolina  
196. *Juvenile Idiopathic Arthritis*  
209. *Sarcoidosis*  
448.3 *Granulomatous Lung Disease*

**Pablo Yagupsky, MD**

Professor of Pediatrics and Clinical Microbiology  
(Emeritus)  
Ben-Gurion University of the Negev  
Department of Pediatrics  
Soroka Medical Center  
Beer-Sheva, Israel  
239. *Kingella kingae*

**Edward Yang, MD, PhD**

Assistant Professor of Radiology  
Harvard Medical School  
Attending Physician  
Department of Radiology  
Boston Children's Hospital  
Boston, Massachusetts  
631. *Congenital Anomalies of the Central Nervous  
System*

**Kesi C. Yang, MD**

Assistant Professor of Clinical Pediatrics  
University of Pennsylvania Perelman School of  
Medicine  
Philadelphia, Pennsylvania  
147. *Infants of Diabetic Mothers*

**Ming Yang, MD**

Assistant Professor of Pediatrics  
Division of Pediatric Endocrinology  
University of Texas Southwestern Medical Center  
Dallas, Texas  
616. *Congenital Adrenal Hyperplasia and Related  
Disorders*

**Michael Yaron, MD**

Clinical Professor of Emergency Medicine  
University of Colorado School of Medicine  
Aurora, Colorado  
87. *Altitude-Associated Illness in Children*

**Sarah B. Younger, MD**

Assistant Professor of Clinical Child Health  
Medical Director, Palliative Care  
University of Missouri School of Medicine  
Columbia, Missouri  
688. *Dermatologic Diseases of the Neonate*

**Christopher J. Yuskaitis, MD, PhD**

Assistant Professor of Neurology  
Harvard Medical School  
Co-Director, Infantile Spasms Program  
Division of Pediatric Neurology  
Boston Children's Hospital  
Boston, Massachusetts  
631. *Congenital Anomalies of the Central Nervous  
System*

**Philip Zachariah, MD**

Associate Director  
Vaccine Research and Development  
Pfizer, Inc  
Pearl River, New York  
299. *Herpes Simplex Virus*

**Muhammad S. Zafar, MBBS**

Associate Professor of Pediatrics and Neurology  
Duke University Medical Center  
Durham, North Carolina  
633.5. *Mechanisms of Seizures*  
633.6. *Treatment of Seizures and Epilepsy*

**Stacey G. Zahler, DO, MS**

Assistant Professor of Pediatrics  
Cleveland Clinic Lerner College of Medicine of  
Case Western Reserve University  
Department of Pediatric Hematology, Oncology,  
and Bone Marrow Transplantation  
Cleveland Clinic Children's  
Cleveland, Ohio  
393. *Tumors of the Digestive Tract*

**Lauren M. Zajac, MD, MPH**

Associate Professor of Environmental Medicine  
and Public Health and Pediatrics  
Icahn School of Medicine at Mount Sinai  
New York, New York  
759. *Chemical Pollutants*

**Wafik Zaky, MD**

Associate Professor of Pediatrics  
University of Texas MD Anderson Cancer Center  
Houston, Texas  
546. *Central Nervous System Tumors in Childhood*

**Jennifer A. Zaspel, MD**

Assistant Professor of Psychiatry and Behavioral  
Medicine  
Medical College of Wisconsin  
Division of Child and Adolescent Psychiatry  
Children's Wisconsin  
Milwaukee, Wisconsin  
40. *Suicide and Attempted Suicide*  
47. *Childhood Psychoses*

**Patricia E. Zerra, MD**

Assistant Professor of Pathology/Laboratory  
Medicine and Pediatrics  
Center for Transfusion Medicine and Cellular  
Therapies  
Department of Laboratory Medicine and Pathology  
Aflac Cancer and Blood Disorders Center  
Children's Healthcare of Atlanta  
Department of Pediatrics  
Emory University  
Atlanta, Georgia  
519. *Red Blood Cell Transfusions and Erythropoietin  
Therapy*  
520. *Platelet Transfusions*  
521. *Neutrophil (Granulocyte) Transfusions*  
522. *Plasma Transfusions*  
523. *Risks of Blood Transfusions*

**Amy Zhou, BA**

Clinical Research Coordinator  
Division of Autonomic Medicine  
Center for Autonomic Medicine in Pediatrics  
Ann & Robert H. Lurie Children's Hospital of  
Chicago and Stanley Manne Children's Research  
Institute  
Chicago, Illinois  
468.2. *Congenital Central Hypoventilation  
Syndrome*  
468.3. *Rapid-Onset Obesity with Hypothalamic  
Dysfunction, Hypoventilation, and Autonomic  
Dysregulation*

**Barry S. Zuckerman, MD**

Professor and Chair Emeritus, Pediatrics  
Boston University Aram V. Chobanian & Edward  
Avedisian School of Medicine  
Boston, Massachusetts  
15. *Impact of Violence Exposure on Children*

**Karen B. Zur, MD**

Professor of Otorhinolaryngology – Head & Neck  
Surgery  
University of Pennsylvania Perelman School of  
Medicine  
Chief, Division of Otolaryngology  
E. Mortimer Newlin Endowed Chair in Pediatric  
Otolaryngology & Human Communication  
Director, Pediatric Voice Program  
Children's Hospital of Philadelphia  
Philadelphia, Pennsylvania  
431. *Tonsils and Adenoids*

# Preface

*Whoever saves one life, it is considered as if they saved an entire world.*

— Babylonian Talmud

The 22nd edition of *Nelson Textbook of Pediatrics* continues its tradition as an essential resource for general pediatric providers as well as pediatric subspecialists as they rely on the most current and modern approaches to diagnose and treat infants, children, and adolescents throughout the world. The 22nd edition has been thoroughly revised and updated by expert contributors and experienced editors to help the reader keep up with the huge advances in clinical care derived from basic, clinical, and population-based research. The promise that translational medicine will improve the lives of children has become a daily reality for most but not all children. Knowledge of human development, behavior, and diseases from the molecular to sociologic levels has led to greater understanding of health and illness in children and to substantial improvements in health quality for those who have access to health care. These exciting scientific advances also provide hope to effectively address prevention and treatment of new and emerging diseases threatening children and their families.

The field of pediatrics encompasses advocacy for all children throughout the world and must address societal inequalities of important resources required for normal development, as well as protection from natural and man-made disasters. Unfortunately, many children throughout the world have not benefited from the significant advances in the prevention and treatment of health-related problems. For medical advances to benefit all children and youth, good clinical practice must always be coupled with effective advocacy to overcome unconscious and systemic biases, lack of political will, and misplaced priorities.

This new edition of *Nelson Textbook of Pediatrics* attempts to provide the essential information that primary care and medical specialists, house staff, medical students, and all other care providers involved in pediatric health care throughout the world need to understand to effectively address the enormous range of biologic, psychologic, and social problems that our children and youth face. Pediatric subspecialists will benefit from the details of coexisting disorders often seen in their patients. Our goal is to be comprehensive yet concise and reader friendly, embracing both new advances in clinical science and the time-honored art of pediatric practice.

The 22nd edition is reorganized and revised from the previous edition. There are many additional chapters of new diseases, as well as substantial expansion or significant modification of others. In addition, many more tables, photographs, imaging studies, and illustrative figures, as well as up-to-date references, have been added.

This new edition has greatly benefited from the addition of two new associate editors with an extremely broad base of clinical experience: Dr. Cara Mack, Professor of Pediatrics, Gastroenterology Division

Chief at the Medical College of Wisconsin, and Dr. Abigail Schuh, Associate Professor of Pediatrics, Director of Education, Section of Pediatric Emergency Medicine at the Medical College of Wisconsin.

Although, to an ill child and their family and health care provider, even the rarest disorder is of central importance, all health problems cannot possibly be covered with the same degree of detail in one general textbook of pediatrics. Thus, leading articles and subspecialty texts are referenced and should be consulted when more information is desired. In addition, as new recommendations or policies are developed, they will be updated on our website.

The outstanding value of the 22nd edition of the textbook is due to its many expert and authoritative contributors. We are all indebted to these dedicated authors for their hard work, knowledge, thoughtfulness, and outstanding judgment.

Our sincere appreciation also goes to Jennifer Shreiner, John Casey, and Sarah Barth at Elsevier and to Carolyn Redman in the Pediatric Department of the Medical College of Wisconsin. Ms. Shreiner and Ms. Redman have worked harmoniously together on five editions and are actually the editors behind the editors in maintaining the book's excellence. We also wish to thank Ms. Hayley Severson, the Clinical Services Librarian at Children's Wisconsin who has been an outstanding asset in keeping the content as well as the references as current as possible. We have all worked together to produce an edition that will be helpful to those who provide care for children and youth and to those desiring to know more about children's health worldwide.

In this edition we have had informal assistance from many faculty and house staff of the department of pediatrics at the Medical College of Wisconsin, the Perelman School of Medicine at the University of Pennsylvania, Harvard Medical School, and the University of Rochester School of Medicine and Dentistry. The help of these individuals and of the many practicing pediatricians from around the world who have taken the time to offer thoughtful feedback and suggestions is always greatly appreciated and helpful.

Last and certainly not least, we especially wish to thank our families for their patience and understanding about the great time commitment we as editors have spent reading and editing this edition.

*Robert M. Kliegman, MD  
Joseph W. St. Geme III, MD  
Nathan J. Blum, MD  
Robert C. Tasker, MBBS, MD  
Karen M. Wilson, MD, MPH  
Abigail M. Schuh, MD, MMHPE  
Cara L. Mack, MD*



## Chapter 1

# Overview of Pediatrics

Lee M. Pachter and Nia J. Heard-Garris

Since the late 19th century, pediatrics has been the only discipline dedicated to all aspects of the care and well-being of infants, children, and adolescents, including their health—their physical, mental, social, and psychologic growth and development—and their ability to achieve full potential as adults. The importance of scientific inquiry and research discovery in pediatrics and related subspecialties was cemented by the creation of the National Institute for Child Health and Development (NICHD) in 1962. As the earliest pediatricians focused on social and environmental issues that affected health (e.g., housing, sanitation, and poverty), so too are today's pediatricians (e.g., racism, poverty, and other socioenvironmental influences). In 1959 the United Nations (UN) issued the **Declaration of the Rights of the Child**, articulating the universal presumption that children have fundamental needs and rights. However, the United States is the only UN member that has not yet ratified these rights.

The pediatrician's purpose is to advance the well-being of children, and thus pediatricians must be concerned with specific organ systems, genetics, and biologic processes and also with environmental, psychosocial, cultural, and political influences, all of which affect the health and well-being of children and their families. Pediatricians must be advocates for the individual child, their families, and communities because children cannot advocate wholly for themselves. Pediatricians must serve as advocates of all children irrespective of culture, religion, gender/gender identity, sexual orientation, race or ethnicity, ability, place of birth, or geographic boundaries. The more politically, economically, or socially disenfranchised a population is, the greater the need for advocacy for its children and for those who support children. Youth are often the most vulnerable persons in society, and thus their needs require special attention. As boundaries between nations blur through advances in media, transportation, technology, communication, and economics, a *global*, rather than a national or local, perspective for the field of pediatrics becomes both a reality and a necessity.

The interconnectedness of health issues across the world has achieved widespread recognition in the wake of new and emerging illnesses, such as COVID-19, Zika, Ebola, and severe acute respiratory syndrome (SARS), as well as familiar and persistent illnesses, such as malaria, tuberculosis, HIV/AIDS, and vaccine-preventable illness. Additionally, health issues transcend communicable disease and are influenced by global events, such as war, ethnic wars, mass shootings, bioterrorism, the burning of the Amazon rainforest, and the growing severity of wildfires, storms, drought, and hurricanes brought about by climate change to very specific events, such as the earthquake in Haiti in 2010; the displacement of families during the Syrian refugee crisis in 2016–2018; the White supremacist attack on a mosque in Christchurch, New Zealand, livestreamed in 2019; and George Floyd's and Breonna Taylor's murders in 2020.

## VITAL STATISTICS ABOUT CHILDREN'S HEALTH GLOBALLY

From 1990 to 2020, the world population grew at an annual rate of 1% per year, down from 1.3% during the prior 20 years, to reach a population of nearly 8 billion people. The population growth rate continues to decline. The Pew Research Center projects the population to reach 10.9 billion people in 2100 with a growth rate of less than 0.1% at that time

because of the fall in fertility rates. Africa is the only continental region that is predicted to continue to have strong population growth, as the 20 countries with the highest birthrates currently are all located in Africa. By 2100, the countries of India, China, and Nigeria are estimated to be the largest. In 2019, the average birthrate in the world was 17.9 births per 1,000 population, with a range from 46/1,000 in Niger to 6.0/1,000 in Monaco. The most populous countries—China (18.5% of the world population), India (17.7%), and the United States (4.3%)—have birthrates of 11, 18, and 11 per 1,000 population, respectively, which were all trending down from previous years. Worldwide, there are roughly 2.5 billion youth under 19 years old, which accounts for approximately one third (32%) of the world's population. The African region boasts the largest share of youth under 15 at 40% compared with 26% globally.

Despite global interconnectedness, the health of children and youth varies widely between and within regions and nations, depending on several interrelated factors. These include (1) economic conditions, (2) educational, social, and cultural considerations, (3) health and social welfare infrastructure, (4) climate and geography, (5) agricultural resources and practices, which account for nutritional resources, (6) stage of industrialization and urbanization, (7) gene frequencies for certain disorders, (8) the ecology of infectious agents and their hosts, (9) social stability, and (10) political focus and stability. Although genetics, biology, and access to affordable and quality healthcare are important determinants, social and structural influences on health outcomes—the physical environment, political and economic conditions, and social, cultural, and behavioral considerations—play as great a role, if not greater.

To ensure that the needs of children and adults worldwide were not obscured by local needs, in 2000 the international community established eight Millennium Development Goals (MDGs) slated to be achieved by 2015. Although all eight MDGs affect child well-being, MDG 4 was exclusively focused on children: to reduce the under-5 mortality rate (U5MR) by two thirds between 1990 and 2015. It was estimated that poor nutrition contributed to more than one third of the deaths worldwide in children <5 years old, so many of the efforts to reach this goal centered on increasing household food security. There has been significant progress toward this goal; the worldwide U5MR decreased by 60% between 1990 and 2021, from 93 deaths per 1,000 live births in 1990 to 38 in 2021. However, the World Health Organization (WHO) cites that between 5.2 and 5.4 million children died worldwide from preventable or treatable causes. Infants younger than 28 days account for over half the deaths, followed by children age 1–11 months, and then by children age 1–4 years old. Children in sub-Saharan Africa are 9 times more likely to die before age 5 than children in the developed areas of the world (see Fig. 3.1). School children (ages 5–9 years old) also experienced a large decline in mortality since the year 1990 related to lower prevalence of infectious diseases.

The infant mortality rate globally (2023) is 27.4 deaths per 1,000 live births, with female infants having a lower rate than male infants. The child death rates in the first year of life were highest in Afghanistan (106.8), Somalia (88.0), and Central African Republic (84.2) per 1,000 live births. In the least developed countries, as classified by the UN, this rate was 45 per 1,000, and the rate was 4 per 1,000 for high-income countries. The causes of infant and under-5 mortality differ greatly between developed and developing nations. The leading causes of under-5 mortality are preterm birth and birth-related asphyxia/trauma, pneumonia, diarrhea, and malaria (Fig. 1.1). As compared with higher-resourced countries, more children less than 5 years old in lower-resourced countries die from non-birth-related causes (see Fig. 3.4).

In developing countries, over half of the deaths in children less than 5 years old resulted from infectious and parasitic diseases, including diarrheal disease (10% of deaths) and pneumonia (15%). Neonatal

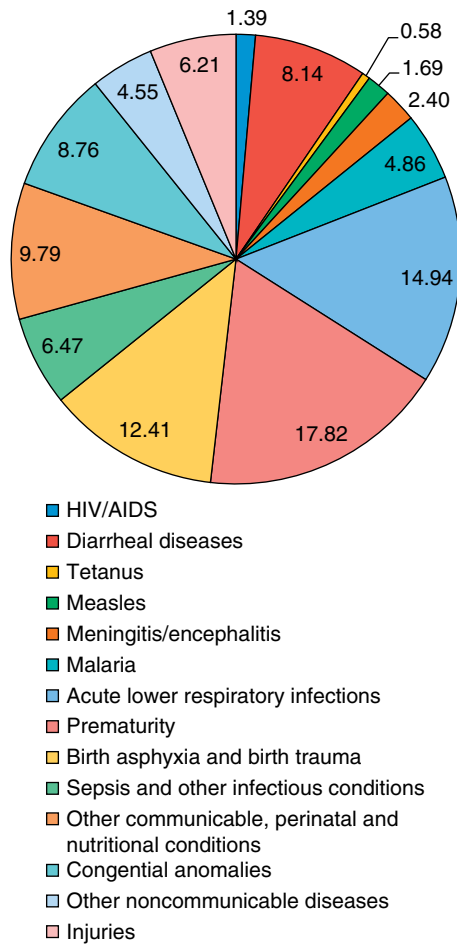


Fig. 1.1 Global causes of death under the age of 5 years.

causes contributed 12%, congenital defects 9%, and malaria, AIDS, and measles accounted for the other causes of death. In the United States, pneumonia and influenza accounted for only 2% of under-5 deaths, with only negligible contributions from diarrheal diseases and malaria (Table 1.1). Although unintentional injuries in developing countries are a proportionately less important cause of mortality than in developed countries, the absolute rates and contributions of these injuries to morbidity are substantially greater. In the United States, the top causes of unintentional injury include unintentional suffocation, drowning, motor vehicle collision, and fire. Other causes accounted for <5% of total mortality within this age-group (Tables 1.2). Violence is a significant contributor to injury-related mortality in all child age-groups (Tables 1.2 and 1.3). Globally (2023), the life expectancy at birth is 73.2 years old, with females at 76 years and males at 70.8 years.

### THE CHANGING PEDIATRIC WORLD

A profound improvement in child health within industrialized nations occurred in the 20th century with the introduction of vaccines, antibiotic agents, improved hygienic practices, and attention to scientific clinical practice. Efforts to control infectious diseases were complemented by better understanding of the role of nutrition in preventing illness and maintaining health. In the United States, Canada, and parts of Europe, new and continuing discoveries in these areas led to establishment of publicly funded well-child clinics for low-income families. Although the timing of infectious disease control was uneven around the globe, this focus on control was accompanied by significant decreases in morbidity and mortality in all countries.

Later in the 20th century, with improved control of infectious diseases through more effective prevention and treatment (including the eradication of polio in the Western hemisphere), pediatric medicine in industrialized nations increasingly turned its attention to a broad spectrum of

Table 1.1 Ten Leading Causes of Death by Age Group, United States – 2018

10 leading causes of death by age group, United States – 2018					
Rank	Age groups				
	<1	1–4	5–9	10–14	15–24
1	Congenital anomalies 4,473	Unintentional injury 1,226	Unintentional injury 734	Unintentional injury 692	Unintentional injury 12,044
2	Short gestation 3,679	Congenital anomalies 384	Malignant neoplasms 393	Suicide 596	Suicide 6,211
3	Maternal pregnancy comp. 1,358	Homicide 353	Congenital anomalies 201	Malignant neoplasms 450	Homicide 4,607
4	SIDS 1,334	Malignant neoplasms 326	Homicide 121	Congenital anomalies 172	Malignant neoplasms 1,371
5	Unintentional injury 1,168	Influenza and pneumonia 122	Influenza and pneumonia 71	Homicide 168	Heart disease 905
6	Placenta cord membranes 724	Heart disease 115	Chronic lower respiratory disease 68	Heart disease 101	Congenital anomalies 354
7	Bacterial sepsis 579	Perinatal period 62	Heart disease 68	Chronic lower respiratory disease 64	Diabetes mellitus 246
8	Circulatory system disease 428	Septicemia 54	Cerebrovascular 34	Cerebrovascular 54	Influenza and pneumonia 200
9	Respiratory distress 390	Chronic lower respiratory disease 50	Septicemia 34	Influenza and pneumonia 51	Chronic lower respiratory disease 165
10	Neonatal hemorrhage 375	Cerebrovascular 43	Benign neoplasms 19	Benign neoplasms 30	Complicated pregnancy 151

Courtesy Centers for Disease Control and Prevention, [https://www.cdc.gov/injury/wisqars/pdf/leading\\_causes\\_of\\_death\\_by\\_age\\_group\\_2018-508.pdf](https://www.cdc.gov/injury/wisqars/pdf/leading_causes_of_death_by_age_group_2018-508.pdf).

noninfectious acute and chronic conditions. These included potentially lethal conditions in addition to temporarily or permanently disabling conditions. Advances occurred in the diagnosis, care, and treatment of leukemia and other neoplasms, cystic fibrosis, sickle cell disease, diseases of the newborn infant, congenital heart disease, genetic defects, rheumatic diseases, renal diseases, and metabolic and endocrine disorders.

Until the 1970s and early 1980s, children affected with sickle cell disease often died within the first 3 years of life, often from overwhelming sepsis caused by encapsulated bacteria. In the 1980s a multicenter study showed that early initiation of penicillin prophylaxis led to an 84% risk reduction for pneumococcal sepsis. Life expectancy for those with sickle cell disease increased when penicillin prophylaxis was initiated early in life. The use of prophylactic penicillin became the standard of care, increasing the importance of early detection of sickle cell disease (which led to expanding universal newborn screening) and paving the way for advances in the chronic management of the disease, including transfusion therapy, radiographic screening for silent cerebral infarctions, hydroxyurea as a disease-modifying therapy, and now, gene-altering therapies. The success of penicillin prophylaxis likely led to a more rapid rate of innovation in the diagnosis and management of the disease as a result of increased life expectancy. Today 95% of individuals born with sickle cell disease will live to their 18th birthday, and most will survive until their fifth decade.

Similarly, the treatment of acute lymphoblastic leukemia (ALL), the most common pediatric malignancy, has also shown amazing

**Table 1.2** Ten Leading Causes of Injury Deaths by Age Group Highlighting Unintentional Injury Deaths, United States – 2018

10 leading causes of injury deaths by age group highlighting unintentional injury deaths, United States – 2018					
Rank	Age groups				
	<1	1–4	5–9	10–14	15–24
1	Unintentional suffocation 977	Unintentional drowning 443	Unintentional MV traffic 341	Suicide suffocation 361	Unintentional MV traffic 6,308
2	Homicide unspecified 125	Unintentional MV traffic 292	Unintentional drowning 130	Unintentional MV traffic 360	Unintentional poisoning 4,245
3	Unintentional MV traffic 80	Homicide unspecified 152	Unintentional fire/burn 99	Suicide firearm 202	Homicide firearm 4,107
4	Homicide other spec., classifiable 68	Unintentional fire/burn 123	Homicide firearm 57	Homicide firearm 134	Suicide firearm 2,995
5	Undetermined suffocation 45	Unintentional suffocation 112	Unintentional suffocation 30	Unintentional drowning 86	Suicide suffocation 2,237
6	Unintentional drowning 39	Unintentional pedestrian, other 70	Unintentional other land transport 20	Unintentional fire/burn 52	Suicide poisoning 454
7	Homicide suffocation 30	Homicide other spec., classifiable 66	Homicide unspecified 17	Unintentional suffocation 43	Unintentional drowning 431
8	Undetermined unspecified 30	Homicide firearm 54	Adverse effects 16	Unintentional other land transport 37	Homicide cut/pierce 256
9	Unintentional natural/environment 22	Unintentional natural/environment 38	Unintentional pedestrian, other 15	Unintentional poisoning 23	Undetermined poisoning 224
10	Two tied 18	Unintentional firearm 30	Homicide other spec., NEC <sup>N</sup> 14	Suicide poisoning 20	Suicide fall 205



Courtesy Centers for Disease Control and Prevention, [https://www.cdc.gov/injury/wisqars/pdf/leading\\_causes\\_of\\_injury\\_deaths\\_highlighting\\_unintentional\\_2018-508.pdf](https://www.cdc.gov/injury/wisqars/pdf/leading_causes_of_injury_deaths_highlighting_unintentional_2018-508.pdf).

advances. Five-year survival rates have increased from <10% in the 1960s to >90% in 2023. Cystic fibrosis has shown improvements in survival as well. In the 1960s, most children with cystic fibrosis did not live to school age. With advances in pulmonary and nutritional therapies, as well as earlier initiation of these therapies secondary to earlier identification through newborn screening, a child born with cystic fibrosis in 2010 has a projected life expectancy of 39–56 years.

These major advances in the management of chronic diseases of childhood were accomplished when significant improvement occurred in the prevention and treatment of acute infectious diseases, at least in industrial countries. This allowed human and economic resources to shift toward addressing chronic disease. However, infectious diseases continue to cause significant morbidity and mortality throughout the world. In the fall of 2021, the WHO recommended the use of the RTS,S/AS01 malaria vaccine for children in areas of moderate and high levels of transmission of *Plasmodium falciparum*, which is the most prevalent cause of malaria in Africa. This historic declaration holds great promise for improving children's health, as more than 250,000 African children under 5 die from malaria each year. The coronavirus disease 2019 (COVID-19) pandemic has proved to be an unremitting global health challenge that has not only affected health but also changed and influenced the socioeconomic lives of people throughout the world.

**Table 1.3** Ten Leading Causes of Injury Deaths by Age Group Highlighting Violence-Related Injury Deaths, United States – 2018

10 leading causes of injury deaths by age group highlighting violence-related injury deaths, United States – 2018					
Rank	Age groups				
	<1	1–4	5–9	10–14	15–24
1	Unintentional suffocation 977	Unintentional drowning 443	Unintentional MV traffic 341	Suicide suffocation 361	Unintentional MV traffic 6,308
2	Homicide unspecified 125	Unintentional MV traffic 292	Unintentional drowning 130	Unintentional MV traffic 360	Unintentional poisoning 4,245
3	Unintentional MV traffic 80	Homicide unspecified 152	Unintentional fire/burn 99	Suicide firearm 202	Homicide firearm 4,107
4	Homicide other spec., classifiable 68	Unintentional fire/burn 123	Homicide firearm 57	Homicide firearm 134	Suicide firearm 2,995
5	Undetermined suffocation 45	Unintentional suffocation 112	Unintentional suffocation 30	Unintentional drowning 86	Suicide suffocation 2,237
6	Unintentional drowning 39	Unintentional pedestrian, other 70	Unintentional other land transport 20	Unintentional fire/burn 52	Suicide poisoning 454
7	Homicide suffocation 30	Homicide other spec., classifiable 66	Homicide unspecified 17	Unintentional suffocation 43	Unintentional drowning 431
8	Undetermined unspecified 30	Homicide firearm 54	Adverse effects 16	Unintentional other land transport 37	Homicide cut/pierce 256
9	Unintentional natural/environment 22	Unintentional natural/environment 38	Unintentional pedestrian, other 15	Unintentional poisoning 23	Undetermined poisoning 224
10	Two tied 18	Unintentional firearm 30	Homicide other spec., NEC <sup>N</sup> 14	Suicide poisoning 20	Suicide fall 205



Courtesy Centers for Disease Control and Prevention, [https://www.cdc.gov/injury/wisqars/pdf/leading\\_causes\\_of\\_injury\\_deaths\\_highlighting\\_violence\\_2018-508.pdf](https://www.cdc.gov/injury/wisqars/pdf/leading_causes_of_injury_deaths_highlighting_violence_2018-508.pdf).

### THE NEW NORMAL: PANDEMICS

Since COVID-19 was first reported and identified in Wuhan, China, in 2019, it has radically and fundamentally affected both the public health and global health landscapes (see Chapters 311 and 449.1). The identification of COVID-19 and development of a vaccine unfolded over the course of 1 year, which was a testament to the importance and critical need for scientific research and rapid clinical implementation. We learned that children could present with or without symptoms and were important factors in community-based viral transmission.

Whereas many children experienced minor illnesses, others experienced more severe illnesses, which were related to underlying chronic conditions, such as asthma or the use of medical devices for children with special healthcare needs, and around 1% of children would go on to develop multiinflammatory syndrome (MIS-C). This condition could be lethal, but most children who received timely care improved. As of spring 2023, there were over 766 million cases and nearly 6.9 million deaths from COVID-19, and the United States had the highest number of cases and deaths throughout the world. Children in the United States accounted for 6 million COVID-19–positive cases, with 0.1–2.0% of children hospitalized and 0.03% leading to child deaths.

Although children were less affected by COVID-19–related illnesses than their adult counterparts, they experienced significant mental health and psychosocial challenges, grief, and loss. Over 1.5 billion



children living through the pandemic faced unprecedented learning challenges because of widespread school closures and dependence on electronic devices and stable internet connections and widening educational disparities, especially for those in poverty, children of frontline workers and single parents, and those already marginalized. Additionally, children who received nutritional support in school or received in-school or in-home services to support their learning and/or developmental needs (e.g., speech therapy, specialized teaching, or other ancillary therapies) also faced disruptions. These disruptions and stress contributed to an increase in mental and emotional health burdens, such as depression, anxiety, isolation, and fear; however, these burdens were unable to be matched with a sufficient number of mental health-care professionals to provide needed care.

The pandemic also disproportionately affected poor families and families of color in other ways. Children in these families faced increased risk of economic hardship and instability, loss of caregivers, and other challenges. Additionally, concerns about all children’s safety and welfare continued and were highlighted, as noncustodial adults had less access and exposure to children who may have experienced physical, sexual, or emotional abuse. Finally, children with special healthcare needs experienced insurmountable challenges throughout the pandemic, such as not receiving essential medicines, medical supplies, and nursing or home healthcare services because of supply chain disruptions and staffing shortages. So although children largely were spared from the illness severity, there were undoubtedly victims of the sequelae that the pandemic brought forth. Now, in partnership with parents, communities, schools, and governments, pediatricians will need to continue to advocate for and support children to mitigate COVID-19’s effects on children.

**THE NEW MORBIDITIES**

Given the advances in public health in decreasing morbidity and mortality in infectious diseases (immunization, hygiene, antibiotics), along with technologic advances in clinical care that improved survival for many chronic illnesses, attention was given to what was described in the 1980s and 1990s as the “new morbidities”—behavioral, developmental, psychosocial conditions, and societal inequities, which have been shown to be increasingly associated with suboptimal health outcomes and quality of life. The prevention, early detection, and management of these types of child health problems should be a central focus of the field of pediatrics and require an expansion in the knowledge base regarding (1) physical and environmental factors affecting behavior, (2) normal child behavior and development, (3) health behaviors as they pertain to child health, and (4) mild, moderate, and severe behavioral and developmental disorders. Accomplishing this would require reconceptualizing professional training, improving clinical communication and interviewing skills, expanding mental health resources for children, and shifting time allocation during child health supervision

visits to address these concerns. In 2001 this issue was revisited and reemphasized the need to address environmental and social aspects in addition to developmental and behavioral issues (Table 1.4). This included violence, firearms, substance use, food insecurity, and school problems, as well as poverty, unhoused (homelessness), single-parent families, divorce, social media, incarceration, and childcare. Although at first glance this list seems daunting and beyond the scope of what pediatricians typically address (i.e., physical health and development), many of these behavioral, environmental, and psychosocial problems (which all fall under what was termed the “social determinants of health” but are better characterized as the “**social and structural influences on health**”) account for a large proportion of variance in health outcomes in children and youth. The role of pediatrics and the boundaries of clinical practice needed to change in order to address these salient contributors to child health and well-being. Newer models of clinical care that rely on close collaboration and coordination with other professionals committed to child welfare (e.g., social workers, psychologists, mental health providers, educators) were developed. As this model expanded, so did the role of the family, in particular the child’s caregiver, from a passive recipient of professional services to a more equitable and inclusive partner in identifying the issues that needed to be addressed, as well as helping decide which therapeutic options had the “best fit” with the child, the family, and the condition.

The framing of salient child health issues under the “new morbidity” concept acknowledges that the influences on health are heterogeneous but interconnected. Biology, genetics, healthcare, behaviors, social conditions, and environmental influences should not be viewed as mutually exclusive determinants; they exert their influences through complex interactions on multiple levels. For example, epigenetic changes that result from specific social and environmental conditions illustrate the influence of context on gene expression.

Studies have demonstrated that while each of these interrelated influences are important for optimal health, development, and well-being, the greatest contributions to health outcomes occur in the behavioral, social, and environmental domains—the social and structural influences on health. From 40% to 70% of the relative variation in certain health outcomes are caused by social and economic conditions, health behaviors, and environmental factors, as well as structural inequality in the healthcare domain. Whereas traditional medical education and clinical practice emphasized the biologic and genetic determinants of health, the recognition of the new morbidities as a focus of child healthcare provision reinforced the need to address social and structural influences as a key component of pediatric care, training, and research.

**The “New” New Morbidities**

The new morbidities concept brought into perspective the importance of addressing the social determinants of health, as well as the increasing

Table 1.4 A Development History of the New Morbidities in Child Health*		
THE NEW MORBIDITIES (1982–1993)	THE NEW MORBIDITIES REVISITED (2001)	THE “NEW” NEW MORBIDITIES (2010 TO PRESENT)
Behavioral disorders/mental health	School problems	Adverse childhood experiences (ACEs)
Family crisis	Mood and anxiety disorders	Toxic stress
Abuse and neglect	Adolescent suicide/homicide	Allostatic load
Long-term disease	Firearms in home	Chronic illnesses of lifestyle (e.g., obesity, type 2 diabetes, hypertension)
Substance abuse	School violence	Behavioral conditions (autism, ADHD, depression, anxiety)
School difficulties	Drug and alcohol abuse	Food insecurity
	HIV	Oral health
	Effects of media	Witnessing community/interpersonal violence
	Poverty	Peer victimization/bullying
	Homelessness	Discrimination
	Single-parent families	
	Effects of divorce	
	Struggle of working parents	
	Child care quality and policy	

\*Each column adds further categories and refinements to prior columns.

prevalence and salience of chronic physical and behavioral health conditions in pediatric healthcare. Since then, advances in epidemiology, physiology, and epigenetics have expanded the scope of inquiry into the effects of a broad range of health influences and provided more sophisticated explanatory models for the mechanisms that explain their effects (see Table 1.4).

### Racism

Although racism is known as “America’s Original Sin,” **racism and racial discrimination** is a worldwide problem (see Chapter 2.1). Racism can occur at the systemic/structural, interpersonal, and internal/psychologic levels. Structural racism is the hierarchical grouping of people based on physical attributes, including skin color, which assigns value to those groups and then allocates certain resources, privileges, and power to the dominant or in-group. Structural racism built on White supremacy and hegemony has been a persistent and plaguing problem for over 400 years. It is racism and racist ideology that have created and perpetuated pediatric health disparities by race (see Chapters 2 and 2.1). In the aftermath of the state-sanctioned violence against Black people, there are calls for the end of racism, police actions, and White supremacy ideology throughout the world. The field of pediatrics did not go untouched in these discussions, and numerous articles were presented about how to dismantle structural racism and equip pediatricians with the tools to do so. Importantly, pediatricians have been called to examine areas in which racism and harm are perpetuated through healthcare, through policies, practices, beliefs, and ideals. Racism along with adverse childhood experiences are some of the pressing challenges for the modern-day pediatrician in promoting equitable health access and outcomes.

The issue of racism is even more relevant by understanding that of the ~73,000,000 children in the United States, ~50% are non-White, non-Hispanic (~26% Hispanic, ~14% Black, 5% Asian, ~5% other), 20% speak a language other than English at home, and ~25% are immigrants or children of immigrants.

### Adverse Childhood Experiences

Adverse childhood experiences (ACEs) are stressful events experienced during childhood that can have profound health consequences both in childhood and throughout the life course into adulthood. ACEs were initially defined as abuse (physical, emotional, sexual), neglect (physical and emotional), and household challenges/family dysfunction (parental spousal abuse, mental illness in household, household substance abuse, incarceration of household member, parental separation or divorce). Retrospective studies have shown a graded dose-response effect of ACEs on future adult health of those who experience the adverse event in childhood. For example, more childhood adversity is associated with significantly increased risk in later life of ischemic heart disease, chronic obstructive pulmonary disease, liver disease, depression, obesity, and cancer. People who suffer ≥6 ACEs die almost 20 years earlier than those who had not experienced ACEs.

Although the original conceptualization of ACEs included family-level psychosocial trauma, recent attempts have been made to expand the concept to include “macro” level stressors, such as those encountered in the neighborhood and community (Table 1.5). These include witnessing violence in the community, poverty, bullying and peer victimization, peer isolation, living in unsafe neighborhoods, low neighborhood social capital, living in foster care, and experiencing discrimination or racism.

ACEs and other psychosocial traumas may influence health through a number of mechanisms. ACEs are associated with adoption of risky behaviors such as substance use and early initiation of sexual activity, which in turn may increase the risk of chronic diseases such as lung cancer, liver disease, obesity, human papillomavirus (HPV) infection and cervical cancer, chronic lung disease, and premature mortality. Childhood trauma can also disrupt neurodevelopment during critical stages of brain development and contribute to social, emotional, and cognitive impairment. Finally, ACEs can result in toxic stress and lead to the dysregulation of normal physiologic processes (see Toxic Stress and Allostatic Load later).

**Table 1.5** Adverse Childhood Experiences

CATEGORY	ITEMS
Abuse and neglect	Physical abuse* Physical neglect* Emotional abuse* Emotional neglect* Sexual abuse*
Family dysfunction	Intimate partner violence* Substance use in household* Mental illness in household* Parental separation or divorce* Family member incarcerated* Parental discord
Community-level adversity	Witnessing community violence  Neighborhood safety Lack of neighborhood connectedness/trust Experiencing discrimination
Others	Being bullied/peer victimization Living in foster care Social isolation Low socioeconomic status/poverty

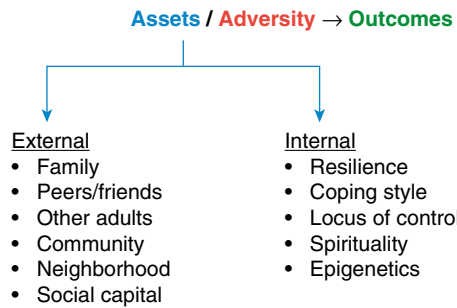
\*Items included in original Kaiser ACE study.

The documentation of cumulative ACE “scores” has value from a population-based epidemiologic perspective but has *limited clinical utility*. An ACE score gives no information regarding specific adversities and traumas, nor information regarding which interventions may be required. Although ACE screening may not be the optimal approach to incorporating a trauma lens into individual clinical care, a discussion around ACEs can help the clinician to begin collaborative communication with patients and families on the importance of psychosocial stress and adversity in health and well-being in childhood and throughout the life course.

Furthermore, it becomes important to understand that individuals are not merely a sum of their traumas. Although the recognition of the importance of ACEs and **trauma-informed care** has resulted in the reframing of the question “what’s wrong with you” to “what’s happened to you,” this needs to be seen as a transition step toward the goal of **healing-centered care**, which includes an emphasis not only on adversity but also on **assets** (Fig. 1.2). Those assets may be external (e.g., family, community, peers, mentors) or internal (e.g., resilience, positive coping strategies, locus of control). In a healing-centered model of care, the evolution of the question “what’s wrong with you” to “what happened to you” gets further refined to include “what’s right or positive about you.”

### Toxic Stress and Allostatic Load

The effects of stress are moderated by the intensity of the stress, the biologic response to the stress, and the social and physical environment in which the stress is experienced. **Toxic stress** occurs when a child experiences stressful events that are chronic, intense, or prolonged and are inadequately buffered by the child’s social support system (most importantly, parents and adult caregivers). Toxic psychosocial stress influences physical health by producing allostatic load, or pathophysiologic dysregulation of normal regulatory systems. **Allostatic load** is the “wear and tear” that the body and its regulatory mechanisms experience in response to chronic, unbuffered stress. The systems that can be affected through allostatic load include the neuroendocrine, cardiovascular, immune, and metabolic systems. Dysregulation of stress hormones in the hypothalamic-pituitary-adrenal (HPA) and sympathetic-adrenal-medullary (SAM) systems, inflammatory cytokines, hormones (e.g., insulin), immune factors (e.g., fibrinogen, C-reactive protein), and



**Fig. 1.2** Healing-centered care. Well-being and outcomes are a function of an individual's assets and adversities.

cardiovascular biomarkers (e.g., blood pressure) can occur from chronic stress and result in pathophysiologic conditions associated with chronic diseases. Chronic stress can also have effects at the genetic level. Studies of cellular aging have shown that chronic stress decreases telomere length, a determinant of aging on the cellular level. Epigenetic changes, including differential immune system DNA methylation, may occur after child abuse and posttraumatic stress disorder (PTSD) potentially contributing to inflammatory and immune dysregulation.\*

Pediatrics, developmental psychology, basic sciences, and public health have contributed significant advances to the study of the behavioral, developmental, and social influences on child health. The influence of psychosocial stress brought about by environmental challenges, although always acknowledged as important, has taken on a new level of salience as epidemiologists have linked its occurrence to significant morbidities throughout the life course and as basic and clinical neuroscience has provided a multilevel framework for understanding how behavioral and psychosocial issues “get under the skin” to cause physiologic dysfunction and dysregulation. Such a framework can also be seen as a mechanism underlying health disparities (see [Chapter 2](#)).

### Ecobiodevelopmental Framework

An **ecobiodevelopmental framework** has been proposed to integrate the overlapping influences of environmental (ecologic), biologic, and developmental factors into a model of health and illness. This model posits that ecology (or the social and physical environment) affects biology through physiologic disruptions and adaptations secondary to allostatic load mechanisms. The environment also influences development through life course science, which includes the effects of toxic exposures and childhood adversity on learning, cognitive, behavioral, and physical health throughout the life course. Stress-induced biologic responses to adversity may negatively affect development and biologic health. Biology influences development through brain maturation and neuroplasticity, which in turn are also affected by inputs from the social and physical environment. The ecobiodevelopmental framework is consistent with the biopsychosocial model while adding a longitudinal life course developmental dimension.

### CHRONIC ILLNESS AND CHILDREN WITH SPECIAL HEALTHCARE NEEDS

The care of children with chronic conditions has become an increasingly larger part of clinical pediatrics for both the pediatric subspecialist and the general pediatrician. **Children and youth with special healthcare needs (CSHCN)** are defined by the U.S. Maternal and Child Health Bureau as “those who have or are at increased risk for a chronic physical, developmental, behavioral, or emotional condition and who also require health and related services of a type or amount beyond that required by children generally.” According to the 2018–2019 National Survey of Children's Health (NSCH), >14.1 million, or 19% of U.S. children, have a special health need. The 2009–2010 National Survey of Children with Special Health Care Needs (NS-CSHCN) reports that almost one quarter (23%) of U.S. households with children have a child with a special need. The conditions these children have are extremely heterogeneous, as shown in [Table 1.6](#). Most of these children need specialty care in addition

**Table 1.6** Children with Special Healthcare Needs (CSHCN)\*

#### HEALTH CONDITIONS

Attention-deficit/hyperactivity disorder  
 Depression  
 Anxiety problems  
 Behavioral or conduct problems  
 Autism spectrum disorder  
 Developmental delay  
 Intellectual disability  
 Communication disorder  
 Asthma  
 Diabetes  
 Epilepsy or seizure disorder  
 Migraines or frequent headaches  
 Head injury, traumatic brain injury  
 Heart problems, including congenital heart disease  
 Blood problems, including anemia or sickle cell disease  
 Cystic fibrosis  
 Cerebral palsy  
 Muscular dystrophy  
 Down syndrome  
 Arthritis or joint problems  
 Allergies

\*List is not comprehensive and does not include all conditions that CSHCN may have. Adapted from Child and Adolescent Health Measurement Initiative. “2009/10 NS-CSHCN: Health Conditions and Functional Difficulties.” Data Resource Center, supported by Cooperative Agreement 1-U59-MC06980-01 from the U.S. Department of Health and Human Services, Health Resources and Services Administration (HRSA). *Maternal and Child Health Bureau (MCHB)*. 2012. Available at [www.childhealthdata.org](http://www.childhealthdata.org). Revised 01/27/2012.

to primary care. In the United States, 0.4–0.7% of children fall into the category of “highest medical complexity”; these children account for 15–33% of all healthcare spending for children. Children with medical complexity account for >70% of hospital readmissions.

Nine of 10 CSHCN have functional difficulties in the sensory, cognitive, movement, emotional, or behavioral domains ([Table 1.7](#)). More than 65% (7.2 million) of CSHCN have conditions that affect their daily activities, and >2.3 million families experience financial difficulties because of their children's special health needs. The fact that 25% of family members of CSHCN cut back work hours or stop working because of their child's special needs highlights the social and economic impact of child chronic illness at both the individual and the national economic level.

Pediatricians are typically the “point persons” in the professional care of these children and provide data and expert opinion to procure needed services and resources to the child in the clinic, home, schools, and community. Such demands require an efficient model of chronic care.

### SYSTEMS OF CARE

#### Population Health Approach

Because pediatric practice is increasingly spent working with patients and families who have chronic issues and conditions, new approaches to healthcare services delivery have been proposed. Whereas traditional practice models concentrate efforts toward the preventive and therapeutic needs of those patients who present for care, a **population health approach** to care refocuses efforts to emphasize the need to address health from a community- or population-level perspective, with emphasis on identifying and addressing the needs of individuals and families who do not seek regular care or whose care is episodic and suboptimal from a prevention or management standpoint. Effectiveness of such a system improves with greater collaboration between healthcare providers and payers (insurance companies) to identify gaps in care, with data surveillance systems and **electronic health records (EHRs)** and with an expanded cadre of healthcare personnel such as care coordinators, nurse practitioners, physician assistants, social workers, health navigators, and **community health workers**. Healthcare reimbursement modifications, such as incorporating value-based

\*Editor Note: Community members and some healthcare workers refer to this disorder as “hood disease.”



**Table 1.7** Functional Difficulties in Children with Special Healthcare Needs (CSHCN)\*

Experiencing difficulty with...
Breathing or respiratory problem
Swallowing, digesting food, or metabolism
Blood circulation
Repeated or chronic physical pain, including headaches
Seeing even when wearing glasses or contact lenses
Hearing even when using a hearing aid or other device
Taking care of self, such as eating, dressing, or bathing
Coordination or moving around
Using his or her hands
Learning, understanding, or paying attention
Speaking, communicating, or being understood
Feeling anxious or depressed
Behavior problems such as acting out, fighting, bullying, or arguing
Making and keeping friends

\*List is not comprehensive and does not include all functional difficulties that CSHCN may have.

From Child and Adolescent Health Measurement Initiative. "2009/10 NS-CSHCN: Health Conditions and Functional Difficulties." Data Resource Center, supported by Cooperative Agreement 1-U59-MC06980-01 from the U.S. Department of Health and Human Services, Health Resources and Services Administration (HRSA), Maternal and Child Health Bureau (MCHB). 2012. Available at [www.childhealthdata.org](http://www.childhealthdata.org). Revised 01/27/2012.

and quality-of-care-based models, if implemented correctly, may further advance a population health approach to care.

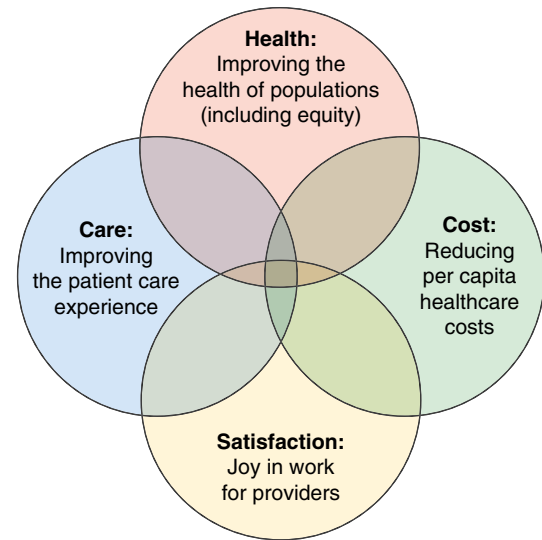
### Medical Home

The concept of the **patient and family-centered medical home (PFCMH)** approach to providing care is defined as a medical home that provides care that is accessible, continuous, comprehensive, family-centered, coordinated, compassionate, and culturally effective. Patients and family members are key active participants, working with clinicians to identify priorities for and approaches to care (**shared decision-making**; see [Chapter 18](#)). A key aspect of the PFCMH is **care coordination**. Care coordination "addresses interrelated medical, social, developmental, behavioral, educational and financial needs to achieve optimal health and wellness outcomes." A care coordinator is the "point person" on the team who prospectively identifies the patient's and family's needs, concerns, and priorities for the healthcare visit, gathers pertinent information (lab results, consultations, educational plans, screening/testing results), communicates with subspecialists, and relays all important information to the clinical team before the patient/family visit. After a healthcare visit, the care coordinator works with the family to address any ongoing concerns, directs efforts to schedule follow-up appointments and referrals, and communicates information to all necessary parties. The care coordinator typically is not a physician. The intended result of care coordination is an efficient and comprehensive interaction between the pediatric team and the family, between primary care and specialty care, between ambulatory and inpatient care teams, and between the pediatric care team and the community-based supports on which the patient and family depend.

Provision of care consistent with the elements of a medical home has been associated with more accurate and early diagnosis, fewer emergency department visits and inpatient hospitalizations, lower costs, fewer unmet needs, lower out-of-pocket medical costs, less impact on parental employment, fewer school absences, and better patient satisfaction. According to the 2016 NSCH, 43% of U.S. CSHCN and 50% of U.S. children without a SHCN received coordinated, comprehensive care within a medical home.

### Medical and Health Neighborhood

Although the medical home concept relates to practice transformation specific to primary care, a broadening of this concept has been proposed along two separate dimensions. The **medical neighborhood** expands the medical home concept and refers to coordinated and efficient integration between primary care pediatricians and the subspecialists, including integrated EHRs, efficient coordinated appointment



**Fig. 1.3** The quadruple aim for healthcare. (Data from Bodenheimer T, Sinsky C. From triple to quadruple aim: care of the patient requires care of the provider. *Ann Fam Med*. 2014;12:573–576.)

scheduling, and enhanced communication. Such a system has the potential to provide a less stressful patient and family experience and could also lead to cost reduction and a decrease in medical errors.

Another expansion and modification of the medical home is the **health neighborhood** concept. The health neighborhood is based on the recognition of the importance of coordination with community-based and nonmedical providers to address comprehensively and efficiently the social and structural influences on health. Health neighborhoods include the healthcare providers (consistent with the medical home and neighborhood) but also involve services such as early intervention programs, the education system, childcare, community-based behavioral and mental health services, legal services, nutritional support services, and other clinical and community-based services that the patient and family need to access. The health neighborhood team helps families identify the needs of the patient, assists with referrals to appropriate agencies outside the healthcare system, and coordinates care.

Some nonmedical services may be co-located at the medical office. **Medical-legal partnerships (MLPs)** are collaborations between the healthcare and legal systems and embed legal aid personnel in the medical clinic. These lawyers and legal paraprofessionals can provide direct services to patients and families who have legal issues that may be affecting the child's health (e.g., housing code violations, utility shutoff, food insecurity, immigration issues, educational accommodations, guardianship). In addition to providing direct services, MLPs train healthcare personnel in the legal, social, and structural influences on health and work with physicians and others to advocate for policy change. Other nonmedical health neighborhood services that could be co-located in the medical center include supplemental nutrition assistance programs, parenting programs, behavioral health services, and family financial counseling.

Many, if not most, other services are located in the community. The health neighborhood model links families to these services and provides efficient ongoing coordination and communication. Community health workers or health navigators are paraprofessional team members who are community and culturally informed and serve as a coordinating link between the family, the medical home, and needed community services. Community health workers and health navigators can also provide patient and family education.

Expanded care models such as these have the potential to achieve what the Institute for Healthcare Improvement calls the "**quadruple aim**" for healthcare: focusing on **care** (improving the patient experience with healthcare, quality care, and satisfaction), **health** (improving the health of populations, including emphasis on equity), provider **satisfaction** ("joy in work"), and **cost** (reducing per-capita healthcare costs) ([Fig. 1.3](#)).

Visit Elsevier eBooks+ at [eBooks.Elsevier.com](http://eBooks.Elsevier.com) for Bibliography.

## Chapter 2

## Child Health Disparities

Lee M. Pachter and Adiaha I.A. Spinks-Franklin

Health and illness are not distributed equally among all members in most societies. Differences exist in historical roots, risk factors, prevalence and incidence, manifestations, severity, and outcome of health conditions, as well as in the availability and quality of healthcare. When these differences are modifiable and avoidable, they are referred to as **disparities** or **inequities**. The U.S. Department of Health and Human Services (DHHS) *Healthy People 2030* report defines *health disparity* as “a particular type of health difference that is closely linked with social, economic, and/or environmental disadvantage. Health disparities adversely affect groups of people who have systematically experienced greater obstacles to health based on their racial or ethnic group; religion; socioeconomic status; gender; age; mental health; cognitive, sensory, or physical disability; sexual orientation or gender identity; geographic location; or other characteristics historically linked to discrimination or exclusion.” The U.S. Centers for Disease Control and Prevention (CDC) define *health disparities* as “preventable differences in the burden of disease, injury, violence, or in opportunities to achieve optimal health experienced by socially disadvantaged racial, ethnic, and other population groups, and communities.” *Healthy People 2030* defines health equity as “the attainment of the highest level of health for all people. Achieving health equity requires valuing everyone equally with focused and ongoing societal efforts to address avoidable inequalities, historical and contemporary injustices, and the elimination of health and health care disparities.” Health and healthcare disparities occur because of unequal distribution of resources that are inherent in societies that exhibit *social stratification*, which occurs in social systems that rank and categorize people into a hierarchy of unequal status and power.

### ROOT HISTORICAL CAUSES OF STRUCTURAL DETERMINANTS OF HEALTH AND HEALTH DISPARITIES

Figure 2.1 displays a categorization of the multiple determinants of health and well-being. Applying this categorization to health disparities, conceptualizations of the root causes of health disparities

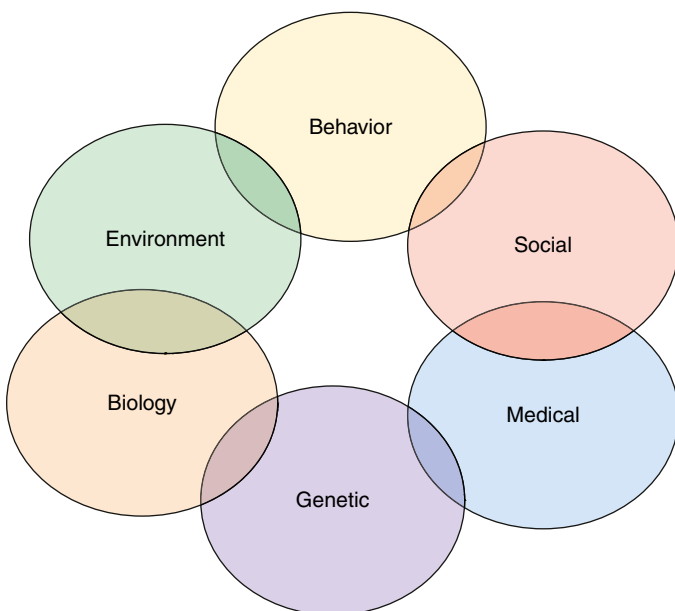


Fig. 2.1 Determinants of health.

emphasize the most modifiable determinants of health: the physical and social environment, psychology and health behaviors, socioeconomic position and status, and access to and quality of healthcare (and the policies that place marginalized groups at greater risk based on these determinants). Differential access to these resources results in differences in *material* resources (e.g., money, education, healthcare) or *psychosocial* factors (e.g., locus of control, adaptive or risky behaviors, stress, social connectedness) that may contribute to differences in health status. This section will explore several historical social and structural root contributors to health disparities (see also Chapter 2.1).

### Federal Policies and Economic Outcomes Redlining (1933–1960)

A federally backed homeowner mortgage banking system, the Homeowners Loan Corporation (HOLC), was created in the 1930s and graded neighborhoods on credit risk for investment and mortgage lending into four color-coded levels that were outlined on city maps. The four color-coded levels were based primarily on racial and ethnic demographics rather than economic factors, with the 2 most desirable codes being for more affluent White neighborhoods. Neighborhoods defined as “Definitely Declining” were marked in yellow and were older neighborhoods with mixed ethnic makeup, including lower-income White residents and European immigrant residents, but no Black residents. Residents in these communities were allowed to get homeowner mortgages, but there was less overall economic development. Neighborhoods defined as “Hazardous” were marked in red (hence the term *redlined communities*) and were where Blacks lived, including affluent Blacks. Residents in these neighborhoods were denied homeowner mortgages and were systematically disinvested by local, state, and federal government policies.

The Federal Housing Authority (FHA), created in 1934 to be the government entity that would federally secure homeowner mortgages, created underwriting manuals for banks with rules regarding lending practices that included denying loans to Black applicants and devaluing properties in redlined neighborhoods. Therefore from the 1930s to 1960s, 98% of FHA homeowner mortgage loans were given to White Americans. This led to decades of residential housing segregation. Redlining was officially outlawed by the Fair Housing Act of 1968; however, the impact of redlining continues.

### Urban Renewal (1949–1974)

After World War II, city officials and city planners across the United States described urban areas as “slums,” full of poor people and in blight. At the same time, the Great Migration (1916–1970) changed the racial makeup for northern cities, when millions of rural southern Black farm workers, domestic workers, laborers, and their families left the harsh Jim Crow segregated conditions of the South and migrated to northern cities seeking a better life and improved economic conditions and opportunities. The leaders in northern destination cities sought to control and contain these southern Black Americans. The federal government passed the Housing Act of 1949 to provide funding to cities across the country to clear and redevelop the slums (called “slum clearance”). City leaders and planners used the funds to revitalize their downtown areas to woo suburban Whites for shopping and entertainment and simultaneously target redlined communities to demolish old buildings and houses and move poor Black and brown residents into public housing facilities (called “housing projects”). In 1956, the Eisenhower administration passed the Federal-Aid Highway Act of 1956 that created the national interstate system. Redlined communities were targeted for placement of these interstate highways that displaced Black and brown residents into segregated housing projects. All of these federal policies led to the following consequences affecting public health:

- **Residential housing segregation:** Fifty-plus years of discriminatory homeowner lending practices, real estate practices, and economic disinvestment have led to *hypersegregation* of neighborhoods and resources. Black and Latinx residents are more likely to live in neighborhoods where the majority of residents have incomes below the federal poverty level, which is referred to as *concentrated poverty*. Residents living in formerly redlined neighborhoods have poorer

health outcomes, including higher rates of asthma, cancer, heart disease, and premature birth and shorter life expectancies. They are at higher risk of being exposed to environmental toxins, including lead, mold, exhaust pollutants and greenhouse gases, that all contribute to poor health. Residential housing segregation has other significant health consequences for Black and Latinx American children, including living in food deserts (having few grocery stores in neighborhoods), digital deserts (lack of access to reliable high-speed internet), having fewer green spaces, and few pharmacies.

- Economic disparities, racial wealth gap, and concentrated poverty:** Federal policies during the 1930s and 1940s created the foundation for racial wealth gaps. The Social Security Administration and the Servicemen's Readjustment Act of 1944 (the GI Bill) were established to create a middle class. The Social Security system was created to provide income to older adults. However, farmworkers and domestic workers were not included among the professionals that would pay into the Social Security system. *These occupations employed predominantly Black laborers, who did not benefit from the initial Social Security policy.* The GI Bill provided former World War II military soldiers with low-interest home, farm, and business loans; funds to pay for higher education; and unemployment assistance. White and Japanese American soldiers were granted the financial benefits from the GI Bill to buy homes and attend college. However, millions of Black soldiers were denied the GI Bill. First American (i.e., Indigenous Nations peoples) WWII veterans used the GI Bill to pay for a college education, but could not use the GI Bill to buy homes on reservations because reservation land was excluded from the GI Bill. Mexican American soldiers did not have full access to the benefits of the GI Bill for homeownership, but some were able to benefit from job training. Therefore millions of Black, Indigenous Nations peoples, and Mexican American WWII veterans did not receive all the financial and educational benefits of the GI Bill. White Americans have accumulated 10 times the wealth of Black Americans, which has transgenerational implications. Discriminatory hiring and firing practices place minoritized workers at higher risk of chronic underemployment and unemployment. Additionally, there is an ongoing racial and gendered racial pay gap between White American men and women and men and women who are Black, Asian American, Latinx American, and Indigenous Nations peoples. In 2021, for every dollar a White American man made, Asian American women made 85 cents, Black women made 63 cents, Indigenous Nations women made 60 cents, and Latina American women made 57 cents.
- School segregation and educational underfunding:** Public schools are funded by property taxes. In hypersegregated communities with concentrated poverty, schools are underfunded, with a 2019 study reporting a \$23 billion funding gap between school districts with predominantly White students and school districts with predominantly Black, Latinx, and Indigenous Nations students. This funding gap leads to schools with less qualified teachers, less rigorous

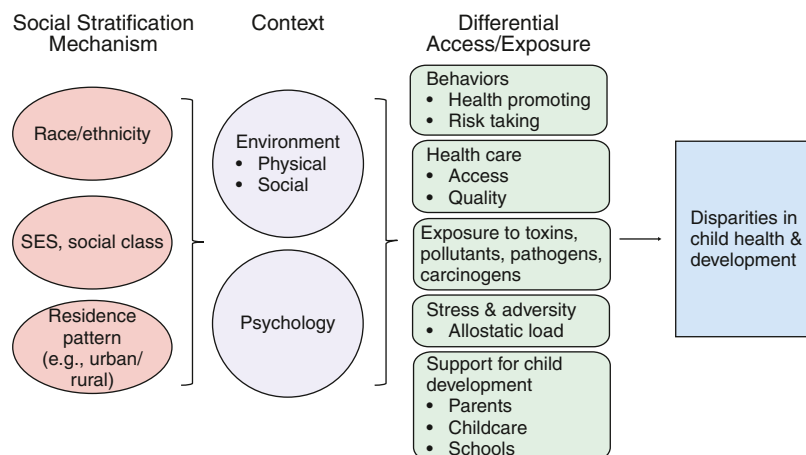
curricula, and fewer extracurricular activities. Black, Latinx, and Indigenous Nations students have overpolicing and harsher school punishment practices, as discussed further in Chapter 2.1. Schools are not teaching BIPOC students self-discipline; they are overpunishing and criminalizing these students.

- Environmental injustice:** There are racial disparities in who suffers the health consequences of climate change. Residential housing segregation and environmental policies have contributed to unequal exposure to environmental toxins. White Americans produce the majority of greenhouse gas emissions but experience less of the negative health effects of such emissions such as asthma, other chronic lung disease, cancer, and cardiovascular disease. Black and Latinx American children in hypersegregated neighborhoods are also more likely to be exposed to lead poisoning compared with their White American counterparts. Lead exposure increases the risk of health problems, including anemia, attention regulation problems, and learning problems. Increased exposure to mold and other major asthma triggers contributes to disparities in asthma outcomes among children of color and poor children. Residential housing segregation also places communities of color at risk for poor water quality and the health consequences.

Figure 2.2 illustrates the complex relations among multileveled factors and health outcomes. Historical **social stratification** factors, such as socioeconomic status (SES), race, and gender, have profound influences on environmental resources available to individuals and groups, including neighborhood factors (e.g., safety, environmental toxins, grocery stores, transportation, healthy spaces), social connectedness and support, work opportunities, and family environment. Much of the differential access to these resources results from historical discrimination on a systematic, institutional, and interpersonal level (see Chapter 2.1). Discriminatory policies place historically subordinated groups at greater risk of poorer health outcomes and psychologic functioning, including sense of control over one's life, expectations, resiliency, negative affect, and perceptions of and response to discrimination. Environmental and psychologic context then have influence over more proximal determinants of health, including health-promoting or risk-promoting behaviors; access to and quality of healthcare and health education; exposure to pathogens, toxins, and carcinogens; pathophysiological responses to stress; and the resources available to support optimal child development.

### Psychosocial Stress and Allostatic Load

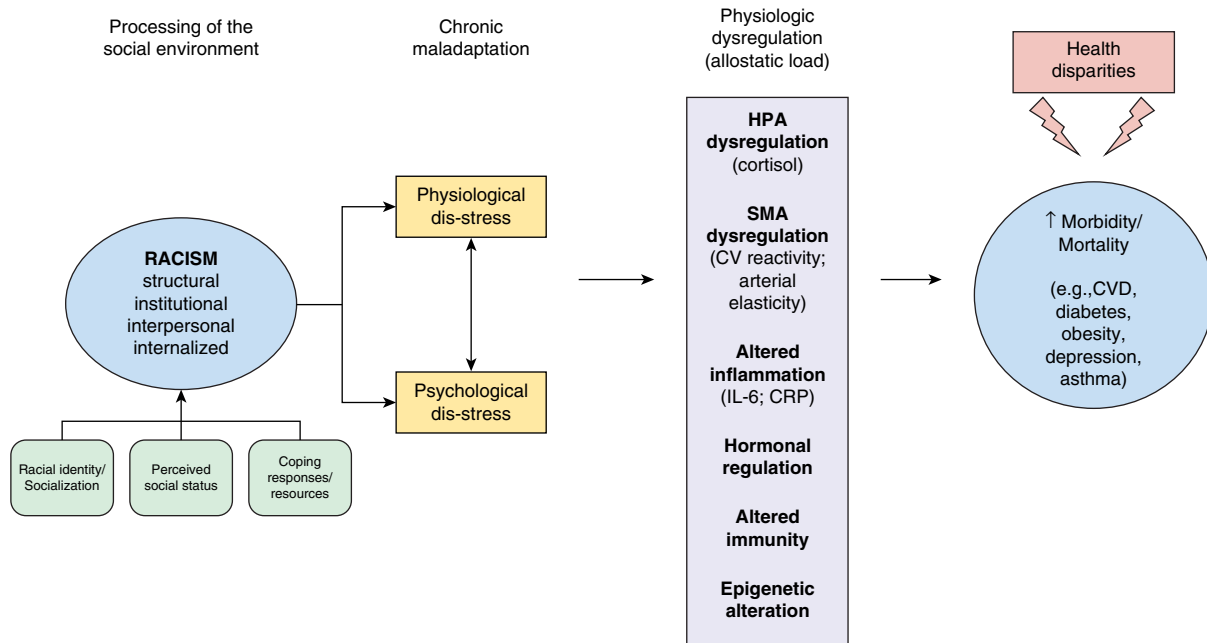
An understanding of allostatic load helps explain how psychosocial stress influences disease, health outcomes, and health disparities (Fig. 2.3 and Chapter 1). *Allostasis* refers to the normal physiologic changes that occur when individuals experience a stressful event, including activation of the stress-response systems, changes in levels of inflammatory and immune mediators, cardiovascular reactivity, and metabolic and hormone activation. These are normal and adaptive responses to



**Fig. 2.2** Child health disparities. SES, Socioeconomic status. (Data from Adler NE, Stewart J. Health disparities across the lifespan: Meaning, methods, and mechanisms. *Ann NY Acad Sci.* 2010;1186[1]:5–23.)



## Conceptual model for how racism increases disease risk and health disparities



**Fig. 2.3** Mechanism through which racism leads to health disparities.

stress and result in physiologic stability in the face of an external challenge. After an acute external stress or challenge, these systems revert to normal baseline states.

However, when the stressor becomes chronic and unbuffered by social supports, dysregulation of these systems may occur, resulting in pathophysiologic alterations to these responses, such as hyperactivation of the allostatic systems, or *burnout*. Over time this dysregulation contributes to increased risk of disease and dysfunction. This pathophysiologic response is called *allostatic load*.

Allostatic load may contribute to increased incidence of chronic diseases such as cardiovascular disease, stroke, diabetes, obesity, asthma, and depression. It is notable that these specific chronic diseases have increased prevalence in racial and ethnic minority groups because of long-standing historical and current discrimination and oppression that have contributed to increased psychologic distress that in turn contributes to allostatic load and the resultant disparities in these chronic diseases. Many of these conditions are noted to occur in adulthood, demonstrating the life course consequences of chronic psychosocial stress and adversity that begins in childhood. **Figure 2.3** shows a model through which racism as a toxic psychosocial stressor “gets under the skin” to cause physiologic dysregulation (allostatic load), which over time leads to chronic illnesses that are known to have higher prevalence in minoritized populations (health disparities).

The allostatic load model provides a pathophysiologic mechanism through which negative structural and social determinants of health contribute to health disparities. It complements other mechanisms noted in **Figure 2.2**, such as differential access to healthcare; increase in health risk behaviors; and increased exposure to pathogens, toxins, and other unhealthy agents.

### The Healthy Immigrant Paradox

The Healthy Immigrant Paradox refers to the epidemiologic finding that first-generation immigrants have better health than native-born counterparts regardless of age, sex, economic status, or ethnic category, but their health status declines and converges with the native-born population over time. Studies in the United States and Europe have found that most immigrants have better physical and psychologic health status than native-born people of similar ethnicity in their receiving country. There are a variety of possible explanations for this health difference, including

self-selection bias among people who emigrate: being younger, more educated, and physically healthier than those in the country of origin who do not emigrate. In addition, immigrants may bring healthier cultural beliefs and practices that may contribute to better health outcomes. However, the health status of immigrant populations declines in the decades after initial migration because of a variety of complex socio-political and economic reasons, including denial of access to healthcare services (e.g., laws that prohibit immigrants from having access to preventive health services), having jobs with unsafe work conditions, adopting poorer health habits, and the psychologic stress of adapting to a new society (i.e., acculturation stress) (see **Fig. 12.1**).

The Healthy Immigrant Paradox is not universal and has been called into question by some. Many studies of the Healthy Immigrant Paradox use self-report of health status, which may be prone to bias. Not all first-generation immigrants demonstrate better health than their U.S.-born counterparts. Immigrant health status can be influenced by country-of-origin factors (e.g., war, famine), health beliefs (e.g., perceiving obesity to be a sign of wealth rather than of poor health), and racialized immigration policies in the receiving country that favor immigrants from some countries over others. Many studies of the Healthy Immigrant Paradox do not include temporary immigrant workers who often do not have the same access to resources as do longer-term immigrants.

Approximately 18.4 million, or 25% of children in the United States under age 12 years, have at least one immigrant parent. Children of immigrant parents have better health and academic outcomes compared with their U.S.-born counterparts. For example, Latinx and Asian children who are born to immigrant parents (second generation) and those brought to the United States as children (1.5 generation) have better study habits and better academic outcomes compared with third-generation U.S.-born Latinx and Asian American counterparts. Behavioral health outcomes also vary among immigrant children and their U.S.-born counterparts, where third-generation and subsequent generation children engage in more risky health behaviors.

### DISPARITIES IN CHILD HEALTH AND HEALTHCARE

**Tables 2.1 and 2.2** display some of the known disparities in child health and healthcare. Many health disparities may occur as a result of historical oppression and marginalization of people with policies targeting groups

<b>Table 2.1   Child Health Disparities</b>			
<b>HEALTH INDICATOR</b>	<b>RACE/ETHNICITY</b>	<b>FAMILY INCOME</b>	<b>RESIDENCE</b>
Child health status fair or poor	Black and Hispanic > White and Asian	Poor > Not Poor	
Children with special healthcare needs (CSHCN)	Black > White > Hispanic	Poor > Not Poor	
One or more chronic health conditions	Black > White > Hispanic > Asian	Poor > Not Poor	
Asthma	Mainland Puerto Rican > Black > White and Mexican American	Poor > Not Poor	Urban > Rural
Obesity	Hispanic and Black > White and Asian	Poor > Not Poor	Rural > Urban
Infant mortality	Black > Hispanic > White	Poor > Not Poor	
Low birthweight (<2,500 g)	Black > White, Hispanic, American Indian/ Native Alaskan, Asian/Pacific Islander Mainland Puerto Rican > Mexican American	Poor > Not Poor	
Preterm birth (<37 wk)	Black > American Indian/Native Alaskan, Hispanic, White, Asian/Pacific Islander Mainland Puerto Rican > Mexican American	Poor > Not Poor	
Seizure disorder, epilepsy	Black > White, Hispanic	Poor > Not Poor	
Bone, joint, or muscle problem	White > Black, Hispanic	Poor > Not Poor	
Ever breastfed	White, Hispanic, Asian > Black	Not Poor > Poor	Urban > Rural
No physical activity in the past week	Hispanic > Black, Asian > White	Poor > Not Poor	
Hearing problem		Poor > Not Poor	
Vision problem		Poor > Not Poor	
Oral health problems (including caries and untreated caries)	Hispanic > Black > White, Asian	Poor > Not Poor	Rural > Urban
Attention-deficit/hyperactivity disorder (ADHD)	White, Black > Hispanic	Poor > Not Poor	Rural > Urban
Have ADHD but not taking medication	Hispanic, Black > White		
Anxiety problems	White > Black, Hispanic	Poor > Not Poor	
Depression		Poor > Not Poor	Rural > Urban
Behavior or conduct problem (ODD, conduct disorder)	Black > White, Hispanic	Poor > Not Poor	
Autism spectrum disorder	White > Black > Hispanic	Poor > Not Poor	
Learning disability	Black > White, Hispanic	Poor > Not Poor	Rural > Urban
Developmental delay	Black > White > Hispanic, Asian	Poor > Not Poor	
Risk of developmental delay by parental concern	Hispanic > Black and White	Poor > Not Poor	
Speech or language problems		Poor > Not Poor	
Adolescent suicide attempts (consider, attempt, needed medical attention for an attempt)	Girls: Hispanic > Black and White Boys: Hispanic and Black > White		
Adolescent suicide rate	Girls: American Indian > White, Asian/Pacific Islander, Hispanic, Black Boys: American Indian and White > Hispanic, Black, Asian/Pacific Islander		
Child maltreatment (reported)	Black, American Indian/Alaskan Native, Multiracial > White, Hispanic, Asian, Pacific Islander	Poor > Not Poor	
Flourishing	Asian American > White > Other Non-Hispanic > Black > Hispanic	Not Poor > Poor	
AIDS (adolescents)	Black > Hispanic > White		

AIDS, Acquired immunodeficiency syndrome; ODD, oppositional defiant disorder.

HEALTHCARE INDICATOR	RACE/ETHNICITY	FAMILY INCOME	RESIDENCE
Did not receive any type of medical care in past 12 mo	Hispanic, Black, Asian > White	Poor > Not Poor	Rural > Urban
No well-child checkup or preventive visit in past 12 mo	Hispanic > White and Black	Poor > Not Poor	Rural > Urban
Delay in medical care	Hispanic > Black > White	Poor > Not Poor	
Unmet need in healthcare due to cost	Black > Hispanic > White > Asian	Poor > Not Poor	
No coordinated, comprehensive, or ongoing care in a medical home	Hispanic > Black and Asian > White	Poor > Not Poor	Rural > Urban
Problem accessing specialist care when needed	Hispanic and Black > White	Poor > Not Poor	
No preventative dental care visit in past 12 mo	Hispanic and Asian > Black > White	Poor > Not Poor	Rural > Urban
No vision screening in past 2 yr	Hispanic and Asian > Black and White	Poor > Not Poor	
Did not receive needed mental health treatment or counseling in past 12 mo	Black and Hispanic > White	Poor > Not Poor	
Not receiving a physician recommendation for HPV vaccination among 13- to 17-yr-old girls	Black and Hispanic > White		
Immunization rates: adolescent HPV vaccine	Girls: white > Black and Hispanic Boys: Black and Hispanic > White		

HPV, Human papillomavirus.

that are deemed to be socially, politically, geographically, and economically inferior. As a result of these targeted policies, we tend to see health disparities of people based upon racial/ethnic group, socioeconomic status (often operationalized through family income, sometimes using insurance status as a proxy), and residency patterns, such as urban and rural locale. Other stratification factors, such as ability/disability status, may also contribute to health and healthcare inequality

### Child Health Disparities

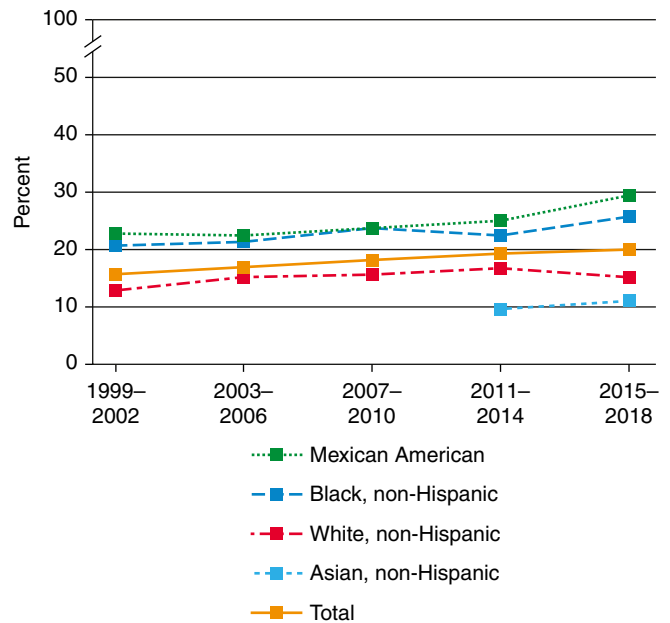
#### Asthma

Disparities in asthma prevalence are seen by racial/ethnic group and SES. According to the CDC’s 2019 National Health Interview Survey (NHIS) data, the national mean prevalence of asthma among children (<18 years old) was 7.0%. Compared with the mean, the children with the highest prevalence of asthma were Black (18.0%), Indigenous Nation/Alaskan Native (17.8%), and Hispanic (12.5%). Asthma prevalence for Asian American children was 8.2%. There are also significant regional and SES differences in asthma prevalence, with children who live below the federal poverty level having a 14.5% prevalence.

Exposure to environmental pollutants is one factor explaining these disparities in asthma prevalence. Although non-Hispanic White Americans consume the most goods and services that produce greenhouse gases (e.g., fine particulate matter), Black and Hispanic Americans have higher exposure to greenhouse gases that are associated with poor health outcomes, including asthma. Residential hypersegregation results in higher exposure to air pollution and other respiratory toxins for Black and Hispanic Americans, increasing their risk of asthma. In addition, evidence shows a correlation between exposure to traffic pollutants and having fewer local pharmacies and healthcare providers. This “triple jeopardy” is more common with Black and Hispanic children.

#### Obesity

In 2018, the National Center for Health Statistics found that 19.3% of all U.S. children and adolescents (ages 6-17 years) have obesity (Fig. 2.4). Obesity prevalence was highest among Hispanic children (25.6%) and non-Hispanic Black children (24.2%). The prevalence of obesity was 16.1% among non-Hispanic White children and 8.7% among non-Hispanic Asian children. The obesity prevalence among Indigenous Nation/Alaskan Native adolescents is 11.0% and among Native Hawaiian/Pacific Islanders is 26.7%. There are complex interplays between social, environmental, and behavioral influences on health that contribute to obesity disparities in the United States. Studies



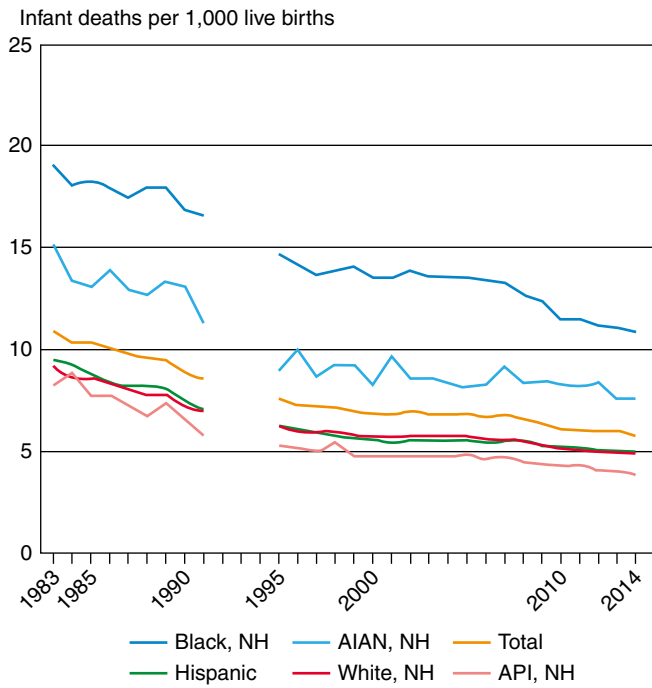
**Fig. 2.4** Percentage of children ages 6-17 with obesity by race and Hispanic origin, selected years 1999–2002 through 2015–2018. (From National Center for Health Statistics. National Health and Nutrition Examination Survey. <https://www.childstats.gov/americaschildren/surveys/2.asp#nhnes>.)

have found that obesity prevalence is higher in communities with high rates of poverty and communities with a majority Black population because of lack of access to grocery stores and farmers markets (food deserts), overabundance of fast-food restaurants, less access to parks and outdoor recreation areas, food marketing targeting, and higher healthy food prices. In addition, dietary patterns, access to nutritious foods, and differing cultural norms regarding body habitus may account for some of these differences.

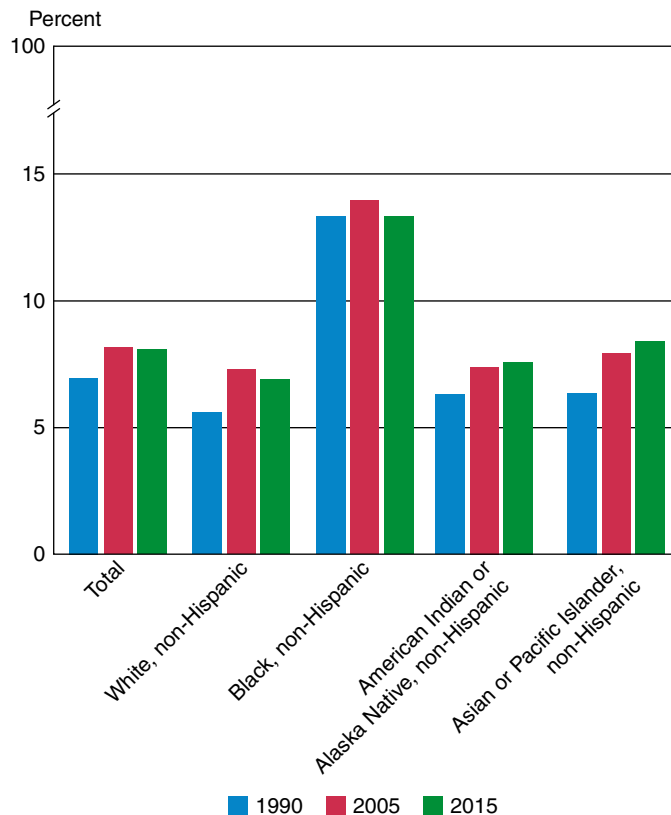
#### Pregnancy Outcomes, Preterm Birth, and Infant Mortality

The highest rates of infant mortality are seen in non-Hispanic Black infants (Figs. 2.5 and 2.6). According to data from the CDC, the overall





**Fig. 2.5** Death rates among infants by race and Hispanic origin of mother, 1983–1991 and 1995–2014. AIAN, American Indian or Alaska Native; API, Asian or Pacific Islander; NH, non-Hispanic. (From National Center for Health Statistics. National Vital Statistics System. [https://www.childstats.gov/americaschildren/health\\_fig.asp#health2](https://www.childstats.gov/americaschildren/health_fig.asp#health2). Accessed July 2018.)



**Fig. 2.6** Percentage of infants born with low birthweight by race and Hispanic origin of mother, 1990, 2005, and 2015. (From National Center for Health Statistics. National Vital Statistics System. [https://www.childstats.gov/americaschildren/health\\_fig.asp#health1b](https://www.childstats.gov/americaschildren/health_fig.asp#health1b). Accessed July 2018.)

infant mortality rate was 5.7 infants per 1,000 live births. For Black infants, the mortality rate was 10.8 infants per 1,000 live births. The top 5 causes of mortality (in order of frequency) among Black infants were low birthweight, congenital malformations, maternal complications, sudden infant death syndrome (SIDS), and unintended injuries. Black American infant mortality remains high compared with other populations, regardless of maternal education, insurance status, maternal age, and income.

Chronic experiences with structural, institutional, and interpersonal racism contribute to elevated biomarkers for stress and allostatic load, which is referred to as *weathering*—the accumulative effect of adversity on the health of individuals (see Chapter 2.1). Weathering of Black women has been associated with a risk of preterm birth and infant mortality. When examining the life-course perspective, studies suggest that early life exposure to adversity, including systemic racism, increases the risk of poor birth outcomes (see Chapter 2.1). Having a racially concordant physician significantly reduces the risk of infant mortality by 39% among Black newborns.

Infant mortality rates among Indigenous Nation/Alaskan Native populations was 8.2 infants per 1,000 live births, with the leading causes of infant death (in order of frequency) being low birthweight, congenital malformations, and maternal complications. Asian American infants had the lowest infant mortality rates, at 3.8 infants per 1,000 live births, with the leading causes of death (in order of frequency) being congenital malformations, low birthweight, maternal complications, and unintended injuries. The Asian American population was not disaggregated by country of origin, so granular details regarding this heterogeneous American population were not available. Overall Hispanic infant mortality was 4.9 infants per 1,000 live births, but mortality rates varied significantly based upon country of origin from 3.8 to 5.6 per 1,000 live births. Leading causes of death among all Hispanic infants (in order of frequency) were congenital malformations, low birthweight, maternal complications, SIDS, and unintended injuries. The White American infant mortality rate was 4.6 infants per 1,000 live births, with the leading causes of infant mortality (in order of frequency) being congenital malformations, low birthweight, SIDS, unintended injuries, and maternal complications (see Chapters 114 and 114.1).

Infant mortality among the Native Hawaiian/Pacific Islander population was 9.4 infants per 1,000 live births overall. Infant mortality rates varied in the Native Hawaiian/Pacific Islander population when the data were disaggregated by country of origin from 10.1 to 22.5 per 1,000 live births. In 2017, the World Health Organization (WHO), UNICEF, and United Nations (UN) highlighted some of the social and environmental risk factors for such high infant mortality among Pacific Islanders, which include prematurity, birth complications, and severe infections (specifically, pneumonia and diarrheal illnesses). Infant mortality among Native Hawaiians was 9.4 infants per 1,000 live births, and the leading causes of infant mortality were preterm birth and low birthweight, sudden unexplained infant death, congenital anomalies, infection, and injury.

Many of the causes of infant mortality disparities can be mitigated through public policy, public health measures, and healthcare interventions that specifically target populations at highest risk, such as increased access to quality prenatal care, reducing air pollution exposure, and improving physician training to reduce implicit bias and improve communication skills.

### Oral Health

Significant differences exist in oral health status and in preventive oral healthcare according to race/ethnicity, SES, and residency locale. The 2019–2020 National Survey of Children’s Health (NSCH) found the prevalence of oral health problems among children (ages 1–17 years) to be 17.7% for Hispanic Americans, 16.2% for Black Americans, 15.8% for Asian Americans, 12.1% for White Americans, and 13.2% for other non-Hispanic Americans. The prevalence of oral health problems in this 2019–2020 NSCH were found to be highest among children who live in households with incomes below the federal poverty level (20.3%) compared with children who live in households making >400% of the federal poverty level (8.7%).

Data from the CDC demonstrated that overall prevalence of dental caries decreased for children age 6–11 years: from 21% in the 1994–2004 NHANES survey to 17% in the 2011–2016 survey. The children in the survey who did not show improvements in the prevalence of dental caries were younger children (ages 6–8 years), poor children (both near-poor and children living below the federal poverty level), and non-Hispanic Black children. Preventive oral healthcare may improve rates of caries and treat caries before further impairment ensues. Data from the 2014 Medical Expenditure Panel Survey revealed that being poor and lacking health insurance were the main reasons for not receiving preventive dental care.

### Hearing Care

No data suggest that the prevalence of hearing loss (either congenital or acquired) is different among racial/ethnic or SES categories, but follow-up care after diagnosis of a hearing problem has been shown to be poorer in certain groups. Delays in diagnosis and treatment of hearing loss are found among children who lack health insurance, live farther away from diagnostic health centers, are poor, live in areas with specialists' shortages, live in rural areas, and have primary care providers with limited experience in caring for children with hearing loss. Much of this disparity is reduced when families have access to specialists.

### Vision Problems

The parent-reported 2019–2020 NSCH found that vision problems were reported in 3.1% of Hispanic children, 1.2% of White children, 2.1% of Black children, 1.0% of Asian children, and 1.6% of children in other racial categories. Vision problems were more commonly reported among children who lived in households with an income that was less than the federal poverty level (3.4%) compared with children living in households with an income greater than 400% of the federal poverty level (0.8%). Vision problems were more commonly reported among children who did not have a medical home (2.6%) compared with children with a medical home (1.0%). Reports of vision problems in children also varied by insurance coverage type, with 0.9% of children with private health insurance, 3.0% of children with public health insurance, 3.0% of children with both public and private health insurance, and 4.1% among uninsured children.

### Immunization

Disparities in immunization rates had been noted with household income status, insurance status, and residential location. In response to these socioeconomic disparities and to higher rates of measles cases in the 1980s, a number of interventions were initiated, including the creation of the **Vaccines for Children program (VFC)**, which eliminated the financial barrier to immunization by providing free immunizations to at-risk groups (Medicaid-eligible, uninsured, Indigenous Nation/Alaskan Native, or underinsured and vaccinated at a federally qualified health center or rural health clinic). Although vaccination rates have improved, the 2018–2020 CDC National Immunization Survey—Child study found income, geographic, and racial disparities in infant vaccination rates. Vaccination rates were lower among infants living in households with an income below the federal poverty level and infants who lacked health insurance. Vaccination rates varied widely by state and region of the United States.

Although rates of initial *primary* vaccine series demonstrate no or decreasing disparities, other vaccination rates do show differences. Black and Hispanic adolescent females have lower human papillomavirus (HPV) vaccination rates than do Whites. Reasons for this disparity include parental concerns about safety and providers not recommending the vaccine. Of interest, Black and Hispanic male adolescents have higher rates of HPV vaccine coverage than do Whites.

### Adolescent Suicide

In 2019, the CDC Youth Behavior Risk Surveillance System of 9th–12th graders reported suicide attempts by racial category, sex, and sexual orientation. The highest rate of suicide attempts was among Indigenous Nations/Alaskan Native teens (25.5%), followed by Native Hawaiian/Pacific Islanders (18.4%), multiracial teens (12.9%), Blacks (11.8%),

Latinx Americans (8.9%), White Americans (7.9%), and Asian Americans (7.7%). Suicide attempts were higher among adolescent females (11.0%) than among adolescent males (6.6%). Suicide attempts vary when stratified by sexual orientation status, with the highest prevalence among bisexual teens (24.5%), followed by gay male teens (19.5%) and heterosexual teens (6.4%). Risk factors for suicide ideations and attempts include sexual assault, being bullied, substance abuse, depression, and experiences with interpersonal racial discrimination (see [Chapter 40](#)).

### Child Maltreatment

In 2014, *reports* of child abuse and neglect were higher in Black (15.3 per 1,000 children), Indigenous Nation/Alaskan Native (13.4/1,000), and multiracial (10.6/1,000) children, compared with Hispanic (8.8/1,000), Pacific Islander (8.6/1,000), White (8.4/1,000), and Asian (1.7/1,000) children. Poverty, measured at the family and at the community level, is also a significant risk factor for maltreatment. Counties with high poverty concentration had >3 times the rate of child abuse deaths than counties with the lowest concentration of poverty. Additionally, it is the “criminalization” of poverty that increases the risk of poor people being reported for abuse and neglect compared to their more affluent counterparts. However, despite the fact that Black children are overrepresented in the child welfare system in the United States, race itself *should not be a marker* for child abuse or neglect. *Studies have found that Black parents are overreported for child abuse and maltreatment compared with White parents who engage in the same behavior because of historical systemic racism and implicit racial bias among those who report and caseworkers.* Latinx children's representation in the child welfare system varies by state and region, where they are overrepresented in some states, but underrepresented in other states. Indigenous Nation/Alaskan Native youth are underrepresented in the child welfare system in most states, but Alaska is the state with the highest overrepresentation of Indigenous children reported to the child welfare system. White American children are not overrepresented in the child welfare system and are often underrepresented.

### Behavioral Health Disparities

#### Attention-Deficit/Hyperactivity Disorder (ADHD)

The 2019–2020 NSCH found the overall prevalence of ADHD among children age 3–17 years to be 8.9%. White and Black children are more often diagnosed with ADHD (10.2% and 10.5%, respectively) than are Hispanic children (6.9%), Asian American children (2.7%), and children of other non-Hispanic groups (8.5%). Other studies have shown that both Black and Hispanic children have lower odds of having an ADHD diagnosis than White children. Children reared in homes with a household income below the federal poverty level are diagnosed more often (10.9%) than those at or above the federal poverty level (8.3%). Children with two or more adverse childhood experiences (ACEs) are almost 3 times as likely to be diagnosed with ADHD (17.1%) compared with children with no ACEs (5.8%). Children without a medical home are more likely to be diagnosed with ADHD (9.7%) compared with children who have a medical home (8.0%).

Children diagnosed with ADHD have different treatment experiences. After being diagnosed with ADHD, White children, when compared with Black and Hispanic children, were more likely to be diagnosed with a coexisting anxiety disorder. Within the first year of treatment for ADHD, White children were most likely to be treated with medication or behavior therapy and Asian American children were the least likely to receive any type of treatment for ADHD.

#### Depression and Anxiety Disorders

According to the 2020 National Survey of Drug Use and Health, from 2004 to 2019, the reported prevalence of major depression episodes increased among all U.S. adolescents. In 2019, those with the highest reported prevalence of a major depression episode were 16- to 17-year-olds (20.2%), adolescent girls (23.0%), adolescents of two or more races (20.9%), and teens living in households with incomes above the federal poverty level (16.1%).

When stratifying by racial group, a major depression episode was found in 17.3% of Hispanic teens, 15.9% of White teens, 15.1% of Asian American teens, 12.2% of Indigenous Nation/Alaska Native teens, and

11.4% of Black teens. Differences in reported rates of depression based upon racial group may be the result of differences in the manifestation of depression symptoms, clinician treatment bias, and limited access to adequate mental healthcare.

### Autism Spectrum Disorder (ASD)

Compared with White children, Black and Hispanic children are less likely to be diagnosed with ASD, and when diagnosed, are typically diagnosed at a later age and with more severe symptoms. Nonetheless, Blacks and Hispanics are typically diagnosed at a later age and with more severe symptoms. Disparities in diagnosis and timing of diagnosis are concerning given that early diagnosis provides access to therapeutic services that are most effective when initiated early. Reasons for these disparities may include differences in cultural behavioral norms, stigma, differences in parental knowledge of typical and atypical child development, poorer access to quality healthcare, and differences in the quality of provider-patient communication along with trust in providers. Recent CDC data suggest that racial and ethnic disparities in ASD diagnosis are decreasing.

### Behavioral or Conduct Problems

According to the 2011–2012 NSCH, Black children age 2–17 years have higher rates of oppositional defiant disorder (ODD) or conduct disorder than do White and Hispanic children. Evidence suggests that the *overdiagnosis* of Black children with these disorders is linked to the pervasive criminalization and adultification of Black child behavior. Adults often view Black children as older, less innocent, and in less need of protection than same-age peers of other racial groups. In fact, studies have found that physicians with negative implicit racial bias are more likely to overpathologize Black child behavior and overdiagnose Black children with ODD, conduct disorder, and ADHD. The pathologizing of Black child behavior can have severe consequences, including excessive school punishment, school expulsion, and early contact with the legal system.

### Developmental Delay

The 2019–2020 NSCH found that Black children age 3–17 years had higher reported rates of developmental delay (7.4%) than Hispanic children (5.3%), White children (5.4%), and other non-Hispanic children (5.4%). Children living in households with incomes below the federal poverty level were more likely to be diagnosed with a developmental delay (8.7%) than children living in households with an income at 400% of the federal poverty level (3.6%). Children experiencing two or more ACEs have a higher prevalence of developmental delay than do children with no ACEs (10.8% vs 3.8%). ACEs increase the child's allostatic load and impede neurologic development, thus placing them at increased risk of developmental delays. Evidence also suggests that physicians with negative implicit racial biases are less likely to ask Black parents and parents who speak English less fluently about their concerns regarding developmental delays and are less likely to refer the children to early intervention, and these children are less likely to receive appropriate developmental evaluations by early intervention providers.

### Flourishing

In the 2019–2020 NSCH, parents reported rates of flourishing, which is overall good mental health in their children and teens. Flourishing was measured by three behaviors: learning, resilience, and self-regulation. Overall, 63.3% of parents reported their child met all three flourishing criteria. Females (66.8%) were reported as having higher flourishing than males (59.9%). The highest level of flourishing was reported among Asian American youth (73.0%), followed by White (64.8%), other non-Hispanic children (62.1%), Black (61.8%), and Hispanic (59.7%). Flourishing rates were lowest among youth who live in households with incomes lower than the federal poverty level (55.6%) and highest among youth living in families with incomes higher than 400% of the federal poverty level (70.0%).

### Child Healthcare Disparities

In almost all areas, Black, Hispanic, and Indigenous Nation/Alaskan Native children have been identified as having worse access to needed

healthcare, including receipt of any type of medical care within the past 12 months, well-child or preventive visits, delay in care, having an unmet need because of healthcare cost, lack of care in a medical home, problems accessing specialist care when needed, lack of preventive dental care, vision screening, mental health counseling, and recommendations for adolescent immunizations (see Table 2.2). In addition, many of these healthcare indicators are found to be worse for children living in poverty and for those living in a rural area. Disparities in access to and quality of healthcare among children of color and poor children are linked to long-standing structural barriers, systemic racist policies and practices, environmental policies, social and structural determinants of health, and healthcare provider negative implicit racial biases that influence healthcare delivery and patient-physician communication and relationships.

### APPROACHES TO ERADICATING DISPARITIES: INTERVENTIONS

An example of a successful intervention that closed the disparity gap is the implementation of the VFC program, which significantly decreased the disparity in immunization rates noted among racial/ethnic groups and poor/underinsured children. This is an example of a **public health policy** approach to intervention.

Interventions need to occur at the **clinical** level as well. The almost-universal use of electronic health records (EHRs) provides a unique opportunity for collecting vital clinical and demographic data that can be helpful in identifying disparities and monitoring the success of interventions. All EHR platforms should use a standardized approach to gathering information on patient race/ethnicity, SES, primary language preferences, and health literacy. The Institute of Medicine's 2009 report *Race, Ethnicity, and Language Data: Standardization for Health Care Quality Improvement* provides best practices information about capturing these data in the health record.

The advancing science of **clinical quality improvement** can also provide a framework for identifying clinical strategies to reduce disparities in care. Use of **PDSA** (Plan-Do-Study-Act) cycles targeting specific clinical issues where health disparities exist can result in practice transformation and help reduce differential outcomes.

Another practice-level intervention that has the potential to reduce disparities in care and outcomes is the **medical home** model, providing care that is accessible, family centered, continuous, comprehensive, compassionate, coordinated, and culturally effective. The use of care coordinators and using community-based health navigators are effective tools in helping to break down the multiple social and health system barriers that contribute to disparities.

**Community engagement** is an essential requirement for lessening health and healthcare inequities. Health systems, practices, providers, public health, researchers, and payers need to include community voice and representation in all aspects of quality improvement, data interpretation, program design and development, and dissemination. To do less would be “working *on* people” instead of “working *with* people.” To use a phrase from the disability advocacy community: “*Nothing about us without us.*” Many potential interventions seem appropriate and demonstrate efficacy under ideal circumstances. However, if the intervention does not address the concerns of the end users—patients and communities—or fit the social or cultural context, it will likely be ineffective in the “real world.” Only by involving the community from the beginning, including defining the issues and problems, can the likelihood of success be optimized.

At the provider level, there are opportunities for training in implicit bias and communication skills, as discussed in Chapter 2.1. *Shared decision-making* has been found to improve physician-patient relationships and health outcomes. Another strategy to address cognitive biases in physician clinical decision-making is to identify heuristic and other cognitive errors (see Tables 5.3–5.5) and use the diagnostic time-out (see Table 5.6) when a diagnosis does not fit the clinical presentation.

**Population health** strategies have the advantage of addressing the determinants of disparities at both the clinic and community levels. Techniques such as hotspotting, cold-casing (finding



patients and families lost to follow-up and not receiving care), and geocoding; collaborating with communities and community-based organizations; and periodic community health needs assessments identify the structural, systemic, environmental, and social factors that contribute to disparities and help guide interventions that are tailored to the local setting.

Health disparities are a consequence of social and structural determinants of health that often have developed based on historically racist policies and other practices and traditions that led to the social stratification mechanisms inherent in many modern societies. Health disparities mirror other societal disparities in education, policing, employment opportunities, and living conditions. While society grapples with the broader issues contributing to disparities, healthcare and public health can work to understand the multiple causes of these disparities and develop interventions that address the structural, clinical, and social root causes of these inequities.

Visit Elsevier eBooks+ at [eBooks.Elsevier.com](https://eBooks.Elsevier.com) for Bibliography.

## 2.1 Racism and Child Health

Mary T. Bassett, Zinzi D. Bailey, and Aletha Maybank

### RACISM AS A SOCIAL DETERMINANT OF HEALTH AND HEALTH INEQUITIES

An emerging body of evidence supports the role of racism in a range of adverse physical, behavioral, developmental, and mental health outcomes. Racial/ethnic inequity in health outcomes in the United States is long-standing, apparent from the first collection of vital statistics in the colonial period. However, the extensive data that document racial disparities have not settled the question of why groups of people, particularly of African and Indigenous Nations peoples ancestry, face increased odds of shorter lives and poorer health (see [Tables 2.1, 2.2, and 2.3](#)). The role of societal factors is well recognized in determining population health, but often omits racism among social determinants of health. This oversight occurs in the face of a long history of racial and ethnic subjugation in the United States that has been justified both explicitly and implicitly by racism. From the early 18th century, colonial America established racial categories that enshrined White supremacy, conferring rights specifically on White men, while denying these rights to others. This “racial” designation was social and not based on genetics. Similar, perhaps less explicit, discrimination has continued through the centuries and remains a primary contributor to racial/ethnic inequities in children’s health. Current lifelong exposure to interpersonal, structural, and institutional racial discrimination and subordination has a significant impact on Black health outcomes.

For generations, racial/ethnic disparities have been documented beginning at birth and extending across life. In 2018, life expectancy at birth for Blacks was almost 4 years shorter than life expectancy of non-Hispanic Whites, influenced heavily by disparities starting at birth ([Table 2.3](#)). The **infant mortality rate** (IMR), arguably the most important measure of national health, has shown a persistent Black-White gap despite a substantial decline in U.S. IMR for all racial/ethnic groups (see [Fig. 2.5](#)). NCHS data in 2022 showed a double-digit IMR *only* among non-Hispanic Blacks, with 10.38 deaths per 1,000 live births, compared to 4.4/1,000 for non-Hispanic Whites. A troubling stagnation in IMR, with no recent decline, is found among Alaska Natives and Indigenous Nations peoples. The 2022 IMR among non-Hispanic Indigenous Nation peoples or Alaskan Native individuals, 7.68 deaths/1,000 live births, has remained essentially unchanged for almost 2 decades.

Exposures that affect infant survival occur before birth. Much of the maternal and child health literature emphasizes a higher prevalence of maternal obesity, diabetes, and substance/alcohol use before conception among Black women as individualized risk factors leading to disparities in birth outcomes ([Chapter 114.1](#)). A California study of maternal obesity found that 22.3% of pregnant Black women and

20.3% of Latina women had a body mass index (BMI) of 30-40, compared with 14.9% of White and 5.6% of Asian women. BMI >40 was more than twice as prevalent in Black (5.7%) than in White (2.6%) women. Further, in a nationally representative study of over 7 million singleton live births from the 2016 and 2017 U.S. National Vital Statistics System, although maternal prepregnancy obesity was associated with the risk of preterm birth in the general population, risk varied by maternal age and race/ethnicity. Maternal obesity among non-Hispanic Black women was inversely associated with risk of preterm birth among those younger than 30 years, but positively associated among those age 30 and older. Similar relationships were shown for non-Hispanic White and Hispanic women. Although individual risk factors such as obesity contribute to differences in birth and health outcomes, individual risk factors alone do not sufficiently explain these differences. Further, a focus on individual risk factors may contribute to a narrative that places blame on the individual without acknowledging the structural and social conditions of patients’ lives influencing the prevalence of these risk factors. Proximal factors such as maternal obesity do not capture the root causes of early childhood health inequities, **social determinants of health**, which present intervention points for achieving health equity.

Achieving health equity requires examining equity in outcomes *and* also equity in process. Causes and interventions to address health inequities can be conceptualized as occurring upstream, downstream, or somewhere in between ([Fig. 2.7](#)). Downstream determinants occur on individual levels, including individual biology and specific risk factors and behaviors. In [Figure 2.7](#), measures of health and health inequities, like life expectancy, IMR, maternal obesity, and maternal age, are at the far right and are considered downstream factors. Clinical interventions focused on downstream factors may help individuals, but do not address factors upstream that drive inequities in population health outcomes.

These upstream factors include the physical, social, work, and service environments in which people are born, grow, live, work, and age that lead to downstream outcomes. If a child lives in public housing that is systematically underresourced to eliminate common pests, that child is more likely to encounter asthma triggers, experience asthma attacks, and require emergency department care or hospitalization. Interventions could include remediating one apartment or home or increasing access to insurance; however, this is not getting at systematic mechanisms by which public housing becomes a social determinant of health. Moreover, these interventions do not address the reasons that families need public housing in the first place or why these living conditions are more prevalent among certain communities compared with others.

The distribution of these living conditions is patterned by institutional inequities in the public and private sectors and in our laws and regulations, which represent a wider set of forces and systems shaping the conditions of daily life. Social inequities, like racism, sexism, classism, heterosexism, and ableism, represent upstream social determinants of health that affect access to resources and healthy living conditions and are inequitably distributed across preexisting hierarchies of power. Resource allocation for public housing and the absence of universal access to a living wage might drive the living conditions within public housing. Focusing solely on downstream results of larger inequitable structures seldom yields sustainable change and ignores the roots of health inequities while tending to blame individuals structurally constrained by centuries of inequitable systems.

Prenatal maternal exposures to pesticides, lead, and other environmental toxins vary by race. This inequitable distribution is largely driven by racist policies and practices affecting exposures to small- and large-scale environmental hazards (see [Chapter 2](#)). The effects of persistent racism are stressful and toxic to the body, with the experience of discrimination across leading to biologic changes that persist the life span, especially for pregnant women and their children. Thus racism is an essential social determinant of racial/ethnic inequities in maternal and child health. Racism can increase cortisol levels and lead to a cascade of effects, including impaired cell function, altered fat metabolism, increased blood glucose and blood pressure, and decreased bone formation (see [Chapter 1](#) and [Fig. 2.3](#)). This can affect a growing fetus,

**Table 2.3** New Social and Health Inequities in the United States

	TOTAL	WHITE NON- HISPANIC	ASIAN*	HISPANIC OR LATINO	BLACK NON- HISPANIC†	NATIVE AMERICAN OR ALASKA NATIVE
Wealth: median household assets (2019)	\$118,200	\$187,300	\$206,400	\$31,700	\$14,100	NR
Poverty: proportion living below poverty level, all ages (2019)	12.3%	9.0%	9.7%	17.2%	21.2%	24.2%
Poverty: proportion living below poverty level, children <18 yr (2019)	16.0%	10.0%	9.0% for Asians only; 18.0% for Pacific Islanders	23.0%	30.0%	30.0%
Unemployment rate (2021)	5.2%	4.6%	4.7%	6.2%	8.4%	NR
Incarceration: male inmates per 100,000 (2010)	733	450	115 for Asians only; 1,017 for Native Hawaiians and other Pacific Islanders	831	2,306	1,291
Proportion with no health insurance, age <65yr (2018)	11.0%	7.8%	7.4%	20.1%	12.1%	28.6%
Infant mortality per 1,000 live births (2018)	5.7	4.6	3.9 for Asians only; 9.4 for Native Hawaiian and other Pacific Islander	4.9	10.8	8.2
Preterm Birth: proportion of singleton births before 37 wk gestation (2018)	8.2%	7.2%	7.1%	8.4%	11.9%	10.2%
Maternal mortality, deaths per 100,000 live births (2018)	17.4	14.9	NR	11.8	37.3	NR
Proportion of children <18 yr reporting current asthma (2018)	7.5%	5.6%	3.6%	8.0%	14.3%	NR
Self-assessed health status (age-adjusted): proportion with fair or poor health (2018)	9.0%	7.6%	8.2%	12.3%	13.5%	18.6%
Potential life lost: person-years per 100,000 before age 75yr (2016)	7,431.7	7,021.0	3,176.8	4,926.0	10,505.2	7,360.2
Proportion reporting serious psychologic distress‡ in past 30 days, age ≥18yr, age-adjusted (2015–2016)	3.6%	3.7%	2.1%	3.7%	3.6%	9.2%
Life expectancy at birth (2018), yr	78.7	78.6	NR	81.8	74.7	NR
Diabetes-related mortality: age-adjusted mortality per 100,000 (2018)	21.4	18.9	15.4 for Asians only; 48.1 for Native Hawaiians and other Pacific Islander	24.6	39.3	32.1
Mortality related to heart disease: age-adjusted mortality per 100,000 (2018)	163.6	168.1	82.0 for Asian alone; 161.4 for Native Hawaiian and other Pacific Islander	112.3	212.0	109.6

\*Economic data and data on self-reported health and psychologic distress are for Asians only; all other health data reported combine Asians and Pacific Islanders, unless otherwise noted.

†Wealth, poverty, and potential life lost before age 75 yr are reported for the Black population only; all other data are for the Black non-Hispanic population.

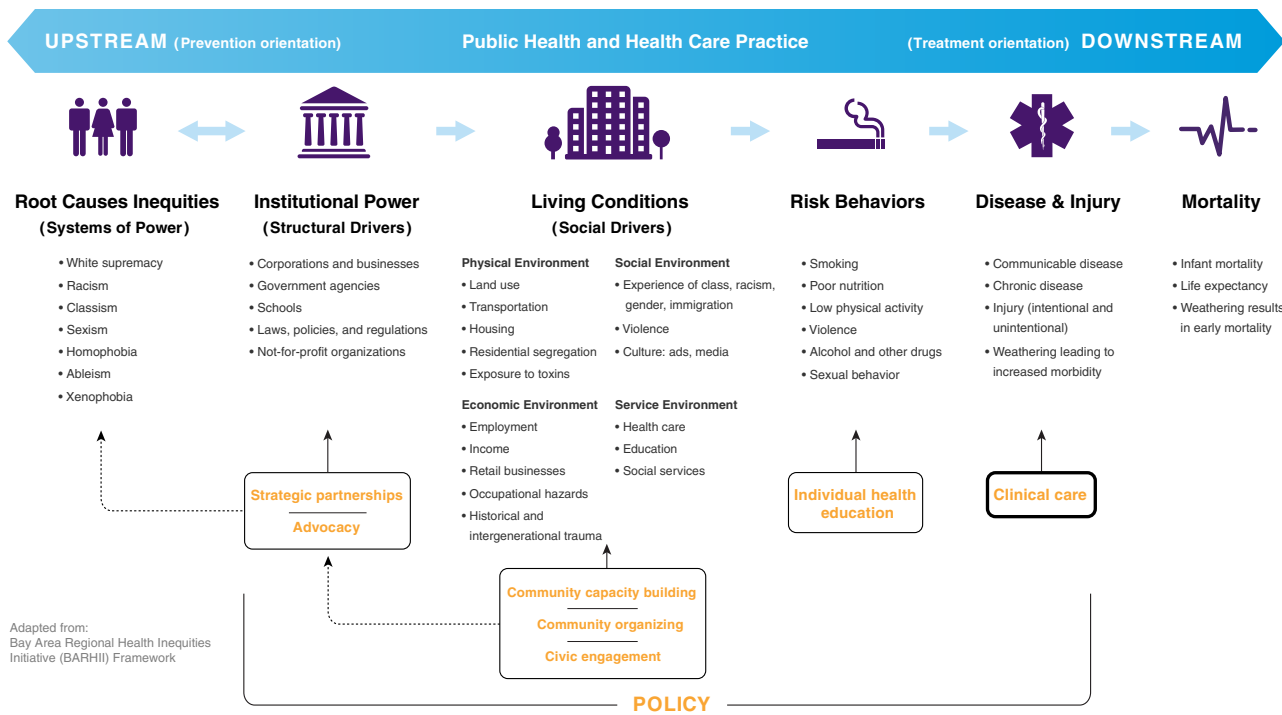
‡Serious psychologic distress in the past 30 days among adults 18 yr and older is measured using the Kessler 6 scale (range: 0–24; serious psychologic distress ≥13). NR, Not reported.

Sources: Wealth data taken from the U.S. Census; poverty data for adults taken from the Kaiser Family Foundation, and poverty data for children taken from the National Center for Education Statistics; unemployment data taken from the U.S. Bureau of Labor Statistics; incarceration data taken from the Prison Policy Initiative using U.S. Census Bureau data; data on uninsured individuals, infant mortality, self-assessed health status, potential life lost, serious psychologic distress, current asthma, preterm birth, life expectancy, diabetes-related mortality, and mortality related to heart disease taken from the National Center for Health Statistics.

leading to increased infant cortisol levels, lower birthweight (LBW), and prematurity. In New York City, White women had lower rates of adverse birth outcomes: 1.3% had preeclampsia, less than half the rate for Black women (2.9%).

Although infant deaths occur more frequently among low-income groups of all races/ethnicities, these birth outcome disparities by race/ethnicity are found also in Blacks with higher SES. College-educated Black women are more likely than White high school-educated women to have a LBW infant, a principal risk factor for infant

death. Another study examined California birth certificates of pregnant Arab American women after the September 11, 2001, terrorist attacks and found that those who experienced discrimination immediately after the 9/11 attacks had a higher relative risk of giving birth to an LBW infant in the following 6 months than seen in births before this date. A similar association between exposures to discrimination-based violence and Latina mothers giving birth to LBW infants was found after the largest federal immigration incident in U.S. history in Postville, Iowa, with infants having a 24% greater risk of being LBW



\* Upstream refers to acknowledging and addressing the structural, societal, community and individual-level factors that influence health. Whereas downstream refers to the dominant approach of treating individual-level factors and/or contributors without wholly addressing structural, societal, and community factors.

**Fig. 2.7** What creates health framework. (From American Medical Association. Organizational Strategic Plan to Embed Racial Justice and Advance Health Equity, 2021–2023; adapted from the Bay Area Regional Health Inequities Initiative [BARHII] Framework.)

at birth. These findings reinforce the critical role the physician has in explicitly asking families about potential exposures to racialized stressors and trauma.

The increased risk of disease for populations of color continues from infancy into childhood (see Table 2.1); racial/ethnic disparities are seen across almost all health indicators, with most relative gaps remaining stagnant or worsening over the past two decades. Compared with White children, Black children are about twice as likely to be diagnosed with **asthma**, more likely to be hospitalized for its treatment, and more likely to have fatal attacks. The Black-White disparity in asthma has grown steadily over time. Indigenous Nations children and youth (≤19 years) also experience negative health outcomes, with the highest rates of **unintentional injury** and mortality rates at least twice as high as for other racial/ethnic groups. Additionally, according to a 2017 NCHS brief, Latino youth age 2-19 have the highest rates of **obesity** in the 2000 CDC sex-/age-specific growth charts. The NCHS data show that 25.8% of Latino (followed by Black) children qualified as obese from 2015 to 2016. Black children are more likely to be exposed to witnessed, personal, or family **violence** (an example of an **adverse childhood experience**), and exposure to these stressful life experiences is associated with academic, behavioral, and health problems. Notably, children with more stressful life experiences have a higher likelihood of experiencing ear infections, acute respiratory infections, obesity, eczema, viral infections, and teen pregnancy.

### EXPLAINING RACIAL DISPARITIES: A TAXONOMY OF RACISM

Explanations of these ubiquitous racial gaps have focused on individual factors, including variation in individual genetic constitution, behavioral risks, poverty, and access to (and use of) healthcare

services. Scientists agree that “race” is a social construct that is not based on biology, despite the persistence of the idea that racial categories reflect a racially distinctive genetic makeup that has a bearing on health. In fact, the genetic variation between individuals within a particular racial/ethnic group is far greater than the variability between “races.” Further, biologic ancestry is distinct and separate from the social construct of race. Despite the genetic data, many groups have been “racialized” over time. Notably, the U.S. Census Bureau’s demographic classifications reflect this process. In the mid-to-late 1800s the census counted “mulattos,” those of White and Black ancestry, as another race.

Starting in the late 19th century, Eastern European immigrants and Jews were considered different races. As early as 1961, the U.S. Census identified Mexicans and Puerto Ricans as “White” even as racial classification varied by geography. All states collected birth records by 1919, but there was little uniformity on how race was collected, if at all, across states. It was not until 1989, when the National Center for Health Statistics (NCHS) recommended assigning “infant race” as that of the mother and that standard guidance and categories were issued for states on collecting racial data at birth. Existing categories were changed and continue to change based on the economic, cultural, or political utility of the time, rather than actual genetic distinction.

### Defining Racism

Racism has consistently structured U.S. society and is based on “White supremacy,” a hierarchical idea that Whites, the *dominant* group, are intrinsically superior to other groups who are not classified as “White” No single definition of racism exists, but one useful description is *racial prejudice backed by power and resources*. This conceptualization asserts that not only must there be prejudice but



**Table 2.4** Pathways Between Racism and Health and Examples**Economic injustice and social deprivation**

Residential, educational, and occupational segregation to lower-quality neighborhoods, schools, and jobs (both historical de jure discrimination and contemporary de facto discrimination)  
 Lower salary for same work  
 Lower promotion rate despite comparable evaluations

**Environmental and occupational health inequities**

Placement of bus garages and toxic waste sites  
 Selective government failure to prevent lead in drinking water (per Flint, Michigan, 2015–2016)  
 Disproportionate exposure of workers of color to occupational hazards

**Psychosocial trauma**

Interpersonal racial discrimination, including microaggressions\*  
 Exposure to racist media, including social media

**Targeted marketing of health-harming substances**

Legal: cigarettes; sugar sweetened beverages  
 Illegal: heroin; illicit opioids

**Inadequate healthcare**

Inadequate access to health insurance and healthcare facilities  
 Inadequate treatment caused by implicit or explicit racial bias

**State-sanctioned violence and alienation from property and traditional lands**

Police violence  
 Forced urban “renewal” (use of eminent domain to force relocation of urban communities of color)  
 Genocide and forced removal of Native Americans

**Political exclusion**

Voter restrictions (e.g., for ex-felons, ID requirements)

**Maladaptive coping behaviors**

Increased tobacco and alcohol consumption

**Stereotype threat**

Stigma of inferiority leading to physiologic arousal  
 Impaired patient-provider relationship

\*Small, often unintentional racial slights/insults (e.g., a judge asking a Black defense attorney, “Can you wait outside until your attorney gets here?”)  
 From Bailey ZD, Krieger N, Agénor M, et al. Structural racism and health inequities in the USA: Evidence and interventions. *Lancet*. 2017;389:1453–1463. Panel 2.

also an interlocking system of institutions to produce and reproduce inequities in access to and use of resources and decision-making power. Even when considering variations in health behavior, lifestyles, economic status, and healthcare use, individual-level behavioral factors do not capture how broader shared social experiences shape outcomes. **Racial domination** or racism contributes to variation in the population’s access to resources and exposure to disease and to the group experience of fair treatment and opportunity. Although many groups in the United States may encounter discrimination based on race/ethnicity, most of the modest literature on health effects of racism has focused on people of African descent, leaving a need to better understand the impact of racism on people of color. [Table 2.4](#) and [Figure 2.3](#) describe various pathways through which racism affects health.

Although the empirical data on disparities for non-Black populations of color deserve greater research, useful frameworks exist to understand the disparities that public health has documented to date. A useful taxonomy of how racism operates in society has four categories: internalized racism, interpersonal racism, institutional racism, and structural racism. Each is relevant in considering the impact of racism on child health.

**Internalized Racism**

When the larger society characterizes marginalized racialized groups as “inferior,” these negative assessments may be accepted by members of those groups themselves, either consciously or unconsciously. The result is *devaluation* of personal abilities and intrinsic worth, in addition to the capacity, of others also classified as being a part of a marginalized racialized group. The best-known documentation of *internalized racism* comes from the study of Kenneth and Mamie Clark known as the **doll experiment**, conducted in the 1940s. Black children, both males and females, were asked to choose between a Black doll and a White doll according to attributes described by the interviewer. In response to positive attributes (e.g., *pretty, good, smart*), most children chose the White doll. The Clarks interpreted this finding to mean that Black children had internalized the societal views of Black inferiority and White superiority, even at the expense of their personal self-image. Repeated by a New York City high school student several decades later, the findings were much the same, with 15 of 21 children endorsing positive attributes to light-skinned dolls. Multiple studies confirm that racial identity is established in young children, both Black and White, along with negative views of blackness. Developmentally, however, youth of color often explore racial identity earlier than their White counterparts. In terms of health outcomes, depending on perceived inferiority or superiority of the group, racial identification is associated with self-esteem, mastery, and depressive symptoms. Low self-esteem is independently implicated in mental health disorders and may contribute to the phenomenon of **stereotype threat**, in which personal *expectation of underperformance* correlates with prevailing social stereotypes and adversely affects actual performance.

**Interpersonal Racism**

How racial beliefs affect interactions between individuals has been the most-studied aspect of racism. *Interpersonal racism* refers to situations where one person from society’s privileged racial group acts in a discriminatory manner that adversely affects another person or group of people. Such actions may be based on *explicit* beliefs or on *implicit* beliefs of which the perpetrating individual is not consciously aware. The experience of unfair and prejudicial treatment has *biologic* consequences, reflected in measurable increases in stress responses.

Such effects of interpersonal racism are best documented for **mental health**, where perceived unfair treatment serves as psychosocial stressors, and are less robust for physical health outcomes. A 2021 study of 10,354 U.S. children age 10 and 11 years found only 2.8% of Whites, 5.4% of Latinos, 6.2% of Asian and Pacific Islanders, 6.5% of Indigenous Nations peoples, and 10% of Blacks self-reported enduring racial discrimination. Furthermore, discriminatory experiences have been strongly and consistently linked to greater risk for anxiety, depression, conduct disorder, psychologic distress, ADHD, ODD, low self-esteem or self-worth, and challenges to psychologic adaptation and adjustment (see [Chapter 2](#)). Perceived racial discrimination can affect behavioral, mental, and physical health outcomes and is associated with increased alcohol and drug use among Indigenous Nations peoples (age 9–16 years), increased tobacco smoking for Black youth (11–19 years), higher depressive symptoms among Puerto Rican children, and insulin resistance among young females.

Understanding the enduring impact of childhood experience on adult health has increased with the study of ACEs (see [Chapter 1](#)). ACEs have well-documented cumulative negative health effects that occur across the life span and are patterned by race/ethnicity. Early experience of racism is a proxy measure for **toxic stress**. The question, “Was [child’s name] ever treated or judged unfairly because of their race or ethnic group?” is included in the U.S. Census Bureau’s NSCH, a random sample of over 90,000 households to assess the

health of children up to 17 years old. Children of color from low-income households, especially Latino children, were reported to have the lowest level of health. However, higher SES did not protect children exposed to racism from experiencing relatively poorer health. Children exposed to racism were also more likely (by 3.2%) to have a diagnosis of ADHD and were 2 times more likely to experience anxiety and depression.

Toxic stress increases cortisol levels in the body, increasing the risk of chronic disease. One study revealed that adolescents who reported average or high levels of perceived discrimination experienced exaggerated cortisol output in response to negative affect, whereas those reporting low levels of perceived discrimination did not experience significant reactivity to negative affect, after controlling for other stressors. Adolescents who experience racism with no support have been shown to have higher levels of blood pressure and obesity than those with emotional support, which can be protective.

Medical practice has not been exempted from occurrences of interpersonal racism. Using variation in adherence to established clinical standards in diagnostic and treatment decisions across racialized groups, researchers have been assessing interpersonal racism in physician-patient interactions. The most comprehensive review of such bias in clinical care remains the study by the U.S. Institute of Medicine, in which the discriminatory treatment was inferred from examination of clinical decision-making rather than from directly observed interactions. For virtually every condition studied, Black patients were less likely to receive recommended care. Such racial bias has been most extensively established in adults but also extends to children. A study conducted in an emergency department found pediatric patients (<21 years) were less likely to receive medically indicated pain medication if they were Black, mirroring the historical misconception of reduced pain sensitivity among Blacks. Within this context, it is unsurprising that perceived interpersonal racism has been linked to healthcare use, including delays in seeking care or filling prescriptions and distrust of the health system. When Black patients receive **concordant care** from Black healthcare providers, their communications, health outcomes, and care are improved when compared with care from White providers.

Perceived and experienced discrimination can be measured by at least six instruments (scales). Questions such as “Are you treated with less respect or courtesy than other people,” “Do people act as if they are afraid of you,” “Do people act as if they think you are not smart,” and “Do you receive poorer service than other people,” can be quantified with responses that range from *Almost everyday* to *Never*. High scores have been associated with preterm birth (see Chapter 114.1)

### Institutional Racism

Interpersonal racism clearly inflicts harms, but even if completely eliminated, racial inequities would persist because of institutional and structural racism. Broadly, *institutional racism* refers to patterns of discrimination based on policy, culture, or practice and carried

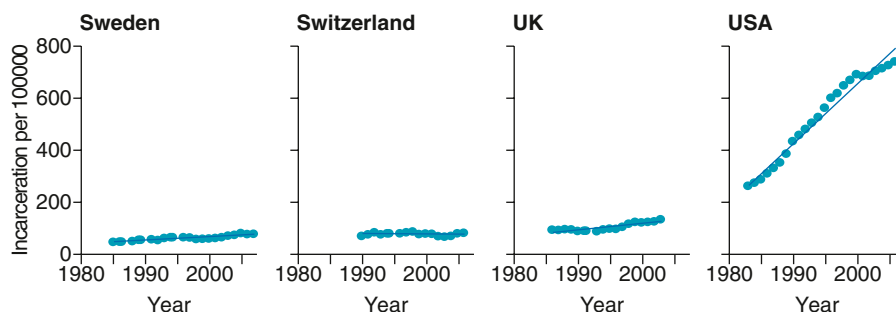
out by state and nonstate institutions (e.g., corporations, universities, legal systems, cultural institutions) within various sectors (e.g., housing, education, criminal justice). Key to current residential segregation are banking practices dating to the post-Depression era. As an institution, the education system has been another tragic case of how racism affects children’s health. In addition, mass incarceration by the criminal justice system has dramatically increased in the United States while remaining relatively flat in other developed countries (Fig. 2.8). Over a lifetime, approximately 30% of Black men have been imprisoned.

In school, children of color can experience not only individual racism but also institutional racism, as documented by higher rates of disciplinary actions such as suspensions, and at younger ages than White children. According to a 2016 U.S. Department of Education civil rights survey, Black children, who represent only 19% of national preschool students, account for a staggering 47% of out-of-school suspensions. Black preschoolers are 3.6 times more likely to be suspended than their White peers. Black females, representing 20% of the female preschool population, account for 54% of out-of-school suspensions. Many schools have a “zero tolerance” policy for childhood behaviors, which criminalizes minor school infractions.

Unfortunately, this disparity persists as children continue through the school system: for kindergarten to grade 12 (K-12) students, Black children are 3.8 times more likely to face out-of-school suspension than White peers. This inequity is particularly harmful because the educational system feeds into the criminal justice system (school to prison pipeline). Black students are 2.2 times more likely to have either school-related arrests or law enforcement referrals than their White peers. The U.S. Department of Education survey also reveals racial inequities among children with disabilities. For K-12 children with disabilities covered under the Individuals with Disability Education Act, 21% of multiracial females were issued at least one out-of-school suspension, compared with 5% of White females.

Racial disparities in school discipline for minor infractions, disruptive behavior, or disobedience is linked to the concept of **adultification**. In this harmful, often unrecognized racial bias and social stereotype, adults and especially police view Black children (as young as 5-10 year) as older, less innocent, and more culpable than White students of the same age. Black male children are perceived as older, bigger, and more physically threatening than White peers. Black female children are viewed with similar characteristics plus a perception that Black female youth need less nurturing or protection, are more independent, and less innocent.

In addition to the threat to educational and employment prospects, school suspensions also affect children’s health. A 2016 brief from the Yale Child Study Center states that early suspensions and expulsions of children harm behavioral and social-emotional development, weakening a child’s overall development. Furthermore, these forms of punishment may prevent the treatment of underlying health issues, such as mental health issues or disabilities, and cause increased stress for the entire family.



**Fig. 2.8** Trends in incarceration prevalence in developed democracies, 1981–2007. (Adapted from Wilderman C, Wang EA. Mass incarceration, public health, and widening inequality in the USA. *Lancet*. 2017;389:1464–1472, Fig 1.)

Institutional racism can function without apparent individual involvement and has powerful repercussions that persist centuries later. Both medical professional organizations and educational institutions have legacies of racial discrimination rooted in *scientific racism*. In 2008 the American Medical Association (AMA) issued a formal apology for its long history, dating to the 1870s, of endorsing explicitly racist practices, including exclusion of Black physicians, silence on civil rights, and refusal to make any public statement on federally sponsored hospital segregation. In 2020, the American Academy of Pediatrics' (AAP) board of directors published an acknowledgement and apology, *Truth, Reconciliation, and Transformation: Continuing on the Path for Equity*, for the institutionalized racist and exclusionary treatment of two Black physicians, Drs. Alonzo deGrate Smith and Roland Boyd Scott, dating back to 1939 and spanning until 1945 when they were finally admitted to the AAP as the first Black members. Exclusion from medical associations also meant exclusion from gaining privileges to work at the majority of hospitals. Despite a focus on medical school desegregation in the 1960s and 1970s, the presence of Black students in medical schools is actually declining. Low enrollment has become especially critical for Black men, who in 2014 accounted for about 500 of the 20,000 medical students nationwide. If physicians hold stereotyped views about race that affect their clinical decision-making, the declining diversity of medical student bodies may well have consequences for the quality of medical care. This history of institutional racism on people of color contributes to the mistrust, apprehension, and fear projected toward the entire medical establishment.

### Structural Racism

The institutional racism within medical institutions reinforces institutional racism in other sectors, creating a larger system of discrimination, *structural racism*. Structural racism can be described as “the totality of ways in which societies foster racial discrimination via mutually reinforcing systems of housing, education, employment, earnings, benefits, credit, media, healthcare, and criminal justice. These patterns and practices in turn reinforce discriminatory beliefs, values, and distribution of resources, which together affect risk of adverse health outcomes.” Institutional racism and structural racism are sometimes used interchangeably, but structural racism refers to overarching patterns beyond a single institution, or even a collection of institutions. Historically, government policies and practices have been largely responsible for the creation of these structures.

De facto and de jure urban residential segregation serves as a case study for how the mechanisms of structural racism operate across multiple sectors and can affect child health and development across the life course. As described in [Chapter 2](#) urban residential racial segregation was reinforced by the practice of **redlining** initiated by the U.S. Federal Housing Administration in 1934. This now illegal (but still covert) practice demarcated urban neighborhoods to be made ineligible for home loans based primarily on the racial composition of the neighborhood. Thus Black neighborhoods were excluded from the federally financed, post-Depression home ownership boom and remained segregated. Through this segregation, existing resources were systematically removed (*disinvestment*) and led to further impoverished communities of color.

The effects of residential segregation were not restricted to the banking or housing sectors. **Residential segregation** ties together multiple systems, driving children's access to and quality of healthcare, education, and justice, as follows:

- *Residential segregation and the healthcare system.* Healthcare institutions were explicitly racially segregated by law and inequitably resourced until passage of the 1964 Civil Rights Act. Vestiges of this segregation continue in hospital-level segregation and racial composition by hospital. In addition, institutions that provide mainly for uninsured or underserved residents are often financially unstable, leading to higher risk of closure in disinvested neighborhoods of color. On the provider level, fewer primary care and specialty physicians practice in disinvested, segregated neighborhoods, and

those who are present are less likely to participate in Medicaid.

- *Residential segregation and the education system.* Schools have a similar history of racial segregation and, after a brief respite of integration peaking in 1980, the level of segregation now resembles pre-civil rights levels. School segregation is related to high-risk health behaviors. Within these schools and in their neighborhoods, Black children experience disproportionate penalization and criminalization in the educational and criminal justice systems, reinforcing institutional racism in other sectors and other forms of racism. A low-income Black child is much more likely than a low-income White child to live in a segregated neighborhood. The result is that the Black child will face not only the cumulative disadvantage in both family and neighborhood resources and experiences over time but also the initiation of chains of disadvantage during sensitive periods of childhood key for development and adult transition (e.g., early childhood, adolescence).
- *Residential segregation and the criminal justice system.* Incarceration is concentrated in overpoliced and criminalized Black communities. In the NCHS, almost 13% of Black children had a parent imprisoned during their childhood (to age 17 years), compared with about 6% of White children. Parental incarceration—which may start with a traumatic arrest in the home and later disrupt caregiving, create social stigma, deepen financial disadvantage, disconnect parents emotionally from children, and disrupt children's psychologic development—has been independently associated with a higher risk of children's antisocial behavior.

Most notably, experiences directly related to institutional and structural racism, operating through residential segregation (including financial hardship, parental imprisonment, and neighborhood violence), result in higher levels of ACEs for Blacks and Latinos than for Whites. There has been growing, consistent evidence of the lifelong association between ACEs and a range of negative physical and mental health outcomes across the life course.

Structural racism, shown here with the example of residential segregation, affects child health through various direct and indirect, overlapping pathways, including the concentration of dilapidated housing, inferior quality of the social and built environment, exposure to pollutants and toxins, limited access to high-quality primary and secondary education, few well-paying jobs, overpolicing and criminalization, adverse experiences, and limited access to quality healthcare.

### OPPORTUNITIES TO ADDRESS RACISM

Racism as a determinant of health has strong empirical support, and there is promising evidence for community-wide approaches to its mitigation. Less is known about effective interventions in clinical settings. Most medical schools and subsequent training will not have prepared practitioners to examine the role of racism in their patients' lives or clinical care settings. Nonetheless, it is reasonable to expect that pediatricians can help address racism and promote racial justice in at least three ways: during individual patient encounters and at their practice sites, as members of institutions that provide medical care and training, and as respected community members.

### Clinical Settings

A first step in understanding that racism affects everyone is personally assessing **implicit bias**. Such biases reflect reflexive patterns of thinking, often using racial stereotypes stemming from living in a racially stratified society. The **Project Implicit Race Implicit Association Test** (<https://implicit.harvard.edu/implicit/takeatest.html>) is available online, and its results are confidential. The purpose of such tests is to create awareness, not apportion blame. Nonetheless, results are usually jarring for all participants, no matter their racial identity, many of whom will uncover negative racial biases of which they were unaware. Such individual assessments may contribute to addressing interpersonal racism as it triggers self-reflection. Further, a growing number of organizations offer training in understanding common behaviors associated with implicit bias, including microaggressions (see later)



and inequitable hiring practices. Recognizing and undoing personal biases as pediatricians requires training to challenge existing thought processes and actions that are often difficult to see. Seeing and undoing personal biases are lifelong endeavors, and progress should be tracked over time.

Pediatricians and other health workers have an entrusted role in families that requires a partnership. Recognizing the strengths of families and valuing their lived experiences of internalized and interpersonal racism as expertise fosters a more collaborative clinical interaction and relationship. This expertise cannot be readily captured by pedagogy or acquired by a pediatrician in training or clinical practice. Such an approach emphasizes respect for the expertise that caregivers bring to raising their child and begins with the presumption that caregivers want to do what is best for the child. By doing this, physicians can form a collaborative relationship, rather than one based on racial stereotypes and blame. Cultural competence is a widespread concept, recognizing that *other cultures* exist that the dominant culture must learn to decode. In contrast, the concept of **cultural humility**, for which training is increasingly available, considers equality among cultures and a partnership approach to differences.

During clinical encounters with children and families, healthcare workers can use their authority to acknowledge racism. Although there is still a gap in evidence on how, when, and what, pediatricians can consider having “The Talk” with their patients who are Black, young adolescent, and male. “The Talk” is the conversation that Black parents typically initiate with their children regarding interactions with police. In doing so, the pediatrician affirms the need for such conversations to promote safety and may provide opportunities to connect families to community resources. For all young children and youth of color, pediatricians should ask patients if they have they been treated unfairly because of their race, recognizing this can be a form of **bullying**. The experience of racism at all levels can be traumatic. Trauma consists of experiences or situations that are emotionally painful and distressing and that overwhelm people’s ability to cope, leaving them powerless. Pediatricians must consider adopting trauma-informed care practices that shift the paradigm from, “What is wrong with you?” to “What has happened to you?”

In addition, healthcare providers must strive for **structural competency**, which is the “trained ability to discern how a host of issues defined clinically as symptoms, attitudes, or diseases also represent the downstream implications of a number of upstream decisions,” according to Johnathan M. Metz and Helena Hansen. Consequently, it is helpful to ensure that clinical practices are aware of other social services that may enhance health and engagement with clinical care, such as a need for legal counsel to address standard housing, counter landlord harassment, or negotiate threatened evictions (<http://medical-legalpartnership.org/>), or the support of literacy by prescribing or distributing children’s books in order to encourage parents to read to children (<http://www.reachoutandread.org/>).

### Institutional Settings

The healthcare institution more broadly is also a setting where racial dynamics occur. Introducing conversations about race may uncover experiences that would not otherwise be apparent. A common outcome of implicit racial bias is **microaggressions**, actions and attitudes that may seem trivial or unimportant to the perpetrators but create a cumulative burden for those who perceive them. A physician of color might be asked for identification on entering a hospital, whereas White colleagues are not so queried. These microaggressions occur in interactions among staff and with patients and may contribute to an unspoken and uncomfortable racial climate. Although such interactions rarely would violate federal discrimination standards, interaction between coworkers shapes an entire practice and can be perceived by families.

Encouraging institutions to assess the impact of race among patients and staff is a first step. Healthcare delivery institutional settings can use both data and patient accounts to examine racial effects

in the practice and experience by routinely disaggregating assessment measures by race/ethnicity. Patient-reported satisfaction or quality of care might be disaggregated by race. In addition, it is important to consider racial equity within the practice’s employment structure: Are there discrepancies in hiring, retention, and salaries by race? Are there proper supervision and grievance procedures, particularly around issues related to racial microaggressions? Also, consider the images and language used to discuss and represent both patients and staff, particularly when alluding to race/ethnicity. Organizations such as **Race Forward** (<https://www.raceforward.org>) and organizational assessment tools developed by the **Race Matters Institute** can help guide institutional assessments and internal change processes. Several local health departments have already incorporated antiracism training into staff professional development and introduced internal reforms to drive organizational change. Because institutional reform is closely associated with other models of productive practices, including quality improvement, collective impact, community engagement, and community mobilization, application of an antiracism lens should be judged by its contributions to organizational effectiveness and on its moral merits.

Education or training institutions have a special role in ensuring a workforce that is both diverse and informed. Patterns of student admissions should be scrutinized, as should the curriculum. The recruitment of Black healthcare workers will enhance the benefits of racially concordant care between Black providers and patients.

Although many medical schools now include diversity training and provide instruction on cultural competency, such instruction is often brief (and sometimes delivered online). By contrast, approaches based on structural competency, cultural humility (see [Chapter 12](#)), and **cultural safety** have been implemented in health professionals’ training in such countries as Canada and New Zealand. These approaches emphasize the value of gaining knowledge about structural racism, internalized scripts of racial superiority and inferiority, and the cultural and power contexts of health professionals and their patients or clients. Health professionals benefit from the scholarship of diverse disciplines about the origins and perpetuation of, and remedies to counter, racism. Finding class time for these topics encounters a *biomedical bias* that is widespread in medical education, although arguably successful medical practice also requires a host of skills in addition to a firm grounding in pathophysiology and recommended treatments. Racism results in damaging disparities that cause ill health and shorten lives, which justifies the teaching hours committed to its understanding.

### Pediatricians as Advocates for Antiracist Practices and Systems

Physicians are respected members of communities and wield the power, privilege, and responsibility for dismantling structural racism. A conceptual review of structural racism highlights the promise of place-based interventions that target geographically defined communities, to engage residents and a range of institutions (across sectors) in order to ensure equitable access to resources and services, remediating the processes set in motion decades earlier. Clinicians play a role in advocating with the halls of medicine in linking patients to services, programming, and other resources and advocating for responsiveness in addressing gaps. Over time, concentrated efforts across sectors in targeted areas have shown improvement in a host of social outcomes, including health outcomes. Similarly, providing access to higher-quality housing, either with housing vouchers or housing lotteries, had unexpected positive health impacts. These findings are encouraging, as are the social policy interventions and systemic change, including legislation such as the Civil Rights Act, the advent of Medicare and Medicaid, and tenement regulations, associated with the narrowing of racial gaps.

Visit Elsevier eBooks+ at [eBooks.Health.Elsevier.com](http://eBooks.Health.Elsevier.com) for Bibliography.

Chapter 3

# Global Child Health

Suzinne Pak-Gorstein, Ruth W. Nduati, Sansanee S. Craig, and Susan Wamithi

## GLOBAL BURDEN AND TRENDS IN CHILD HEALTH

The **under-5 mortality rate (U5MR)**, also known as the **child mortality rate**, serves as a reliable gauge of child well-being. It measures the outcome of a country's health system and reflects a nation's social and economic development. The global U5MR fell by 61% between the years 1990 and 2020. Despite these gains, in 2019 an estimated 5.3 million children under 5 years of age died worldwide, which is equivalent to 37.1 deaths per 1,000 live births, or nearly 13,700 child deaths each day. The burden of the world's child mortality disproportionately falls upon low- and middle-income populations of Africa and Asia (Fig. 3.1), with 82% of all child deaths in the world occurring in just two regions: sub-Saharan Africa (55%) and South Asia (27%), compared to the less than 1% of child deaths occurring in high-income countries (HICs). Consequently, a child born in sub-Saharan Africa is over 15 times more likely to die by age 5 years compared to a child born in an HIC.

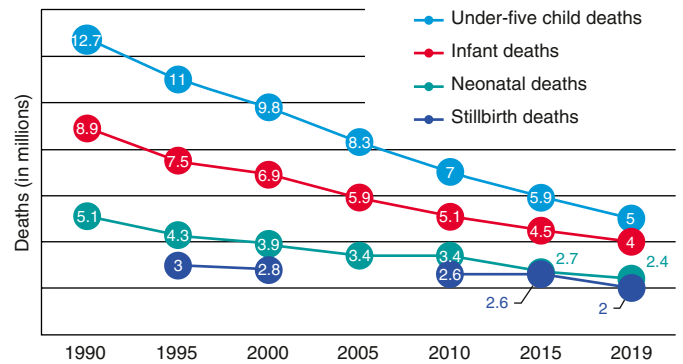
Improvements in child mortality have been uneven globally, regionally, and nationally. Significant disparities in child mortality persist and are concentrated in specific regions of Africa and Asia. The countries with the highest child mortality gap between the richest and the poorest in 2019 were Nigeria, Guinea, and the Central African Republic. In Nigeria in 2019 while the national rate of child mortality was 117 deaths per 1,000 live births, at the sub-national level, the rates ranged from 58 to 261 deaths per 1,000 live births.

Although the number of child deaths has decreased dramatically over the past 3 decades, the early years of life remain one of a child's

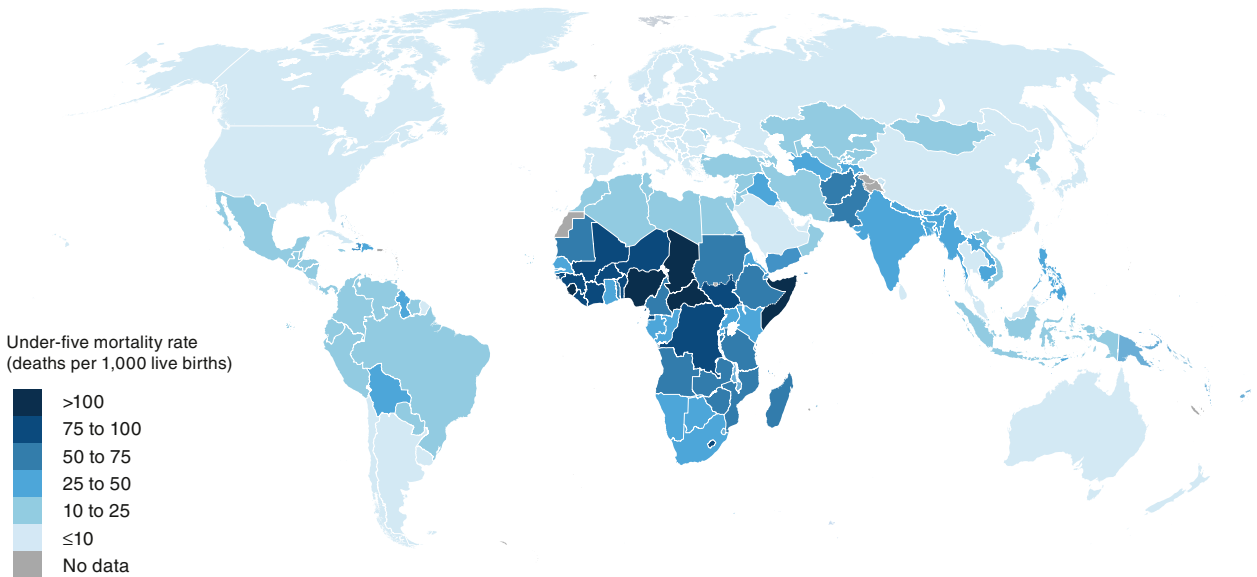
most vulnerable periods. Among the under-5 child deaths, nearly half occurred within their first month of life (2.4 million deaths in 2019). This estimate of **neonatal deaths** (<1 month of age) translates into 17.9 per 1,000 live births. Declines in neonatal mortality occurred at slower rates, so that in 2019 the neonatal deaths made up 48% of all under-5 deaths (Fig. 3.2).

Neonatal deaths account for a smaller percentage of child mortality in low- and middle-income countries (LMICs) compared to HICs (Fig. 3.3), but the absolute risk of death remains significantly higher. A child in sub-Saharan Africa or in Southern Asia is nine times more likely to die in the first month of life than a child born in an HIC.

An estimated 2 million **stillborn** deaths (≥28 completed weeks' gestation) burden families worldwide every year, which correlates to 13.9 deaths per 1,000 births. This translates into a stillborn baby



**Fig. 3.2** Deaths for under-5 children, infants, neonates, and stillbirths between 1990 and 2019. (Data from United Nations Inter-agency Group for Child Mortality Estimation – UN IGME 2020; Stillbirth estimates for 1995 and 2009 from Cousens 2011 [2010 rate is from 2009]; year 2000 rates from Lawn 2012, and 2015 rate of 2.6 million is from Blencowe 2016.)



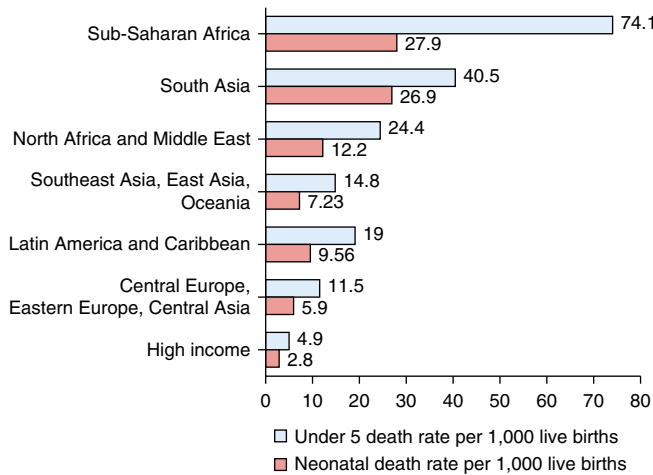
**Fig. 3.1** Under-5 mortality rate (probability of dying by age 5 per 1,000 live births) by country, 2019. Note: The classification is based on unrounded numbers. This map does not reflect a position by UN IGME agencies on the legal status of any country or territory or the delimitation of any frontiers. (From United Nations Inter-agency Group for Child Mortality Estimation [UN IGME]. *Levels & Trends in Child Mortality: Report 2020*, Estimates developed by the United Nations Inter-agency Group for Child Mortality Estimation. New York: United Nations Children's Fund, 2020. [https://www.un.org/development/desa/pd/sites/www.un.org.development.desa/pd/files/unpd\\_2020\\_levels-and-trends-in-child-mortality-igme-.pdf](https://www.un.org/development/desa/pd/sites/www.un.org.development.desa/pd/files/unpd_2020_levels-and-trends-in-child-mortality-igme-.pdf).)

for every 72 births, or one every 16 seconds. These figures are likely an underestimate because stillbirths are underreported, reflecting the low prioritization of this vulnerable age group. Before 2006, no organization published global, regional, or country-specific

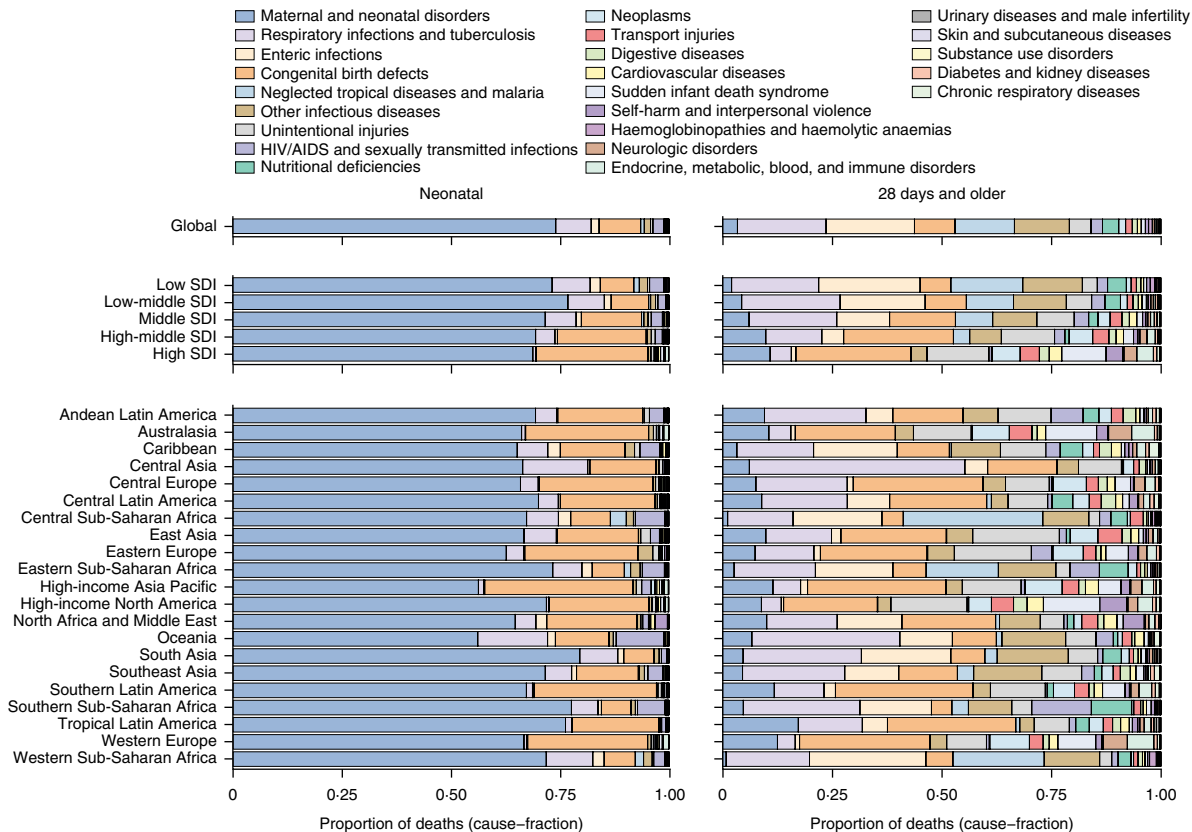
stillbirth rates. Progress to reduce stillbirths has been slow, with the annual rate of reduction estimated to be half that for neonatal deaths between 2000 and 2019. Almost all stillbirths occur in LMICs (98%), with three-quarters in sub-Saharan Africa and South Asia.

Most childhood deaths are caused by conditions that could be prevented or managed through improved access to simple, low-cost interventions. The **most common causes of child death** are pre-term birth complications, intrapartum-related events, pneumonia, and diarrhea (Fig. 3.4). Of all under-5 child deaths, 2.61 million were the result of infectious diseases and 21.7% of all child deaths were vaccine-preventable. **Neonatal disorders** accounted for an estimated 46% of the deaths in children younger than the age of 5 years. In contrast, child deaths from infections in developed countries are less common, where injuries and congenital malformations account for higher proportions of under-5 deaths. **Undernutrition**, including fetal growth restriction, stunting and wasting, and micronutrient deficiencies, contributes up to 45% of under-5 deaths and poor childhood development in LMICs. Undernutrition has an enormous impact on child mortality because of the vicious cycle between nutrition and infection whereby lowered immunity and mucosal damage from inadequate dietary intake lead to increased susceptibility to pathogen invasion, while recurrent illnesses impair the child's appetite and ability to absorb adequate calories and nutrients. In addition, undernutrition early in life can have long-lasting consequences, including impaired cognitive ability and reduced school and work performance.

Infants who start out life with a **low birthweight** are at high risk of death, contributing 60–80% of all neonatal deaths. Most of these



**Fig. 3.3** Under-5 child and neonatal death rates per 1,000 live births, 2019. (Data from GBD 2019 Under-5 Mortality Collaborators. *Global, regional, and national progress towards Sustainable Development Goal 3.2 for neonatal and child health: All-cause and cause-specific mortality findings from the Global Burden of Disease Study 2019.* Lancet. 2021;398:870–905.)



**Fig. 3.4** Neonatal and remaining under-5 cause-specific mortality by region and SDI. Values presented are cause fractions: the proportion of total age-specific deaths with a particular underlying cause of death. Causes are presented at Level 2 in the hierarchy, with other noncommunicable diseases disaggregated to include congenital birth defects, sudden infant death syndrome, hemoglobinopathies and hemolytic anaemias, endocrine, metabolic, blood, and immune disorders, and urinary diseases and male infertility separately. Total under-5 mortality is split at 28 days to include neonatal (<28 days) separately from children between 28 days and 5 years of age. SDI, Sociodemographic Index. (From GBD 2019 Under-5 Mortality Collaborators. *Global, regional, and national progress towards Sustainable Development Goal 3.2 for neonatal and child health: All-cause and cause-specific mortality findings from the Global Burden of Disease Study 2019.* Lancet 2021;398:870–905. Fig. 3, p. 887.)



infants are premature (born before 37 weeks of pregnancy) or suffered from fetal growth restriction. About half of stillbirths take place during labor, ranging from 10% in developed regions to 59.3% in South Asia, which reflects the role that timely, high-quality care around delivery can play to prevent many deaths.

Mortality among older children age 5–14 is low compared with the younger cohort, although 1 million children in this age group died in 2016, which is equivalent to 3,000 children dying every day. Infectious diseases play a smaller role in deaths among these older children, with injuries from causes such as drowning and road traffic trauma accounting for more than a quarter of the deaths and noncommunicable diseases for about another quarter.

Child health should not be assessed based on mortality rates alone. Children surviving illness are often left with lifelong disabilities, burdening their families and affecting their economic productivity. Approximately 1 in 10 children are born with or acquire a disability, and 80% of these disabled children live in LMICs. Neonatal disorders, infectious diseases, protein-energy and micronutrient deficiencies, hemoglobinopathies, and injuries are leading causes of disability in children. Child deaths can also lead to disability in the surviving mother. For example, a woman who has a stillbirth is at risk of an obstetric fistula or death, with an estimated 78–98% of women with obstetric fistula having had a stillbirth. Also, perinatal loss and child death is a psychological trauma. Stillbirth, neonatal death, and child loss can lead to posttraumatic stress disorder, depression, anxiety, guilt, and in some settings shame and social stigma, particularly in the mother, with significant impact on the health and well-being of the family.

Adolescents age 10–19 years who have benefited from the gains in child survival grow up to find themselves in social settings where less attention and fewer resources are devoted to their well-being compared to their earlier years of growth. The paucity of support during this time of transition into adulthood diminishes the impact that child survival can have on their lives. *Adolescents made up 18% of the world's population, approximately 1.8 billion individuals, in 2010, and the adolescent population is expected to increase to over 2 billion in the year 2050.* The vast majority of adolescents, 88%, live in LMICs. In 2050, sub-Saharan Africa is projected to have more adolescents than any other region. Although adolescent mortality rates are far lower than their younger age cohorts, in low-income countries adolescents face a lack of educational and employment opportunities and increased risk of injuries and violence, HIV and AIDS, mental health problems, adolescent marriage, and teenage pregnancy—preventing them from attaining their potential as they transition into adulthood. The decade of adolescence is a critical period when poverty and inequity frequently transfer to the next generation. *The intergenerational transmission of poverty is most apparent among undereducated adolescent females.* In many parts of the world poor teenage females are likely to be married early, risking premature childbearing, higher rates of maternal mortality, and contributing to infant and child undernutrition.

## THE SOCIAL DETERMINANTS OF CHILD HEALTH AND THE COVID-19 PANDEMIC

The gross national income level accounts for much of the differences in child mortality rates observed between countries; however, other significant factors affect child health. For example, although the wealth of the United States places it in the 7th position with respect to gross domestic product (GDP) per capita (2022) in the world, the U.S. child mortality rate is ranked 47th in the world, at 6.5 deaths out of 1,000 live births, which is higher than Cuba (5.1), Canada (4.9), the UK (4.3), the Czech Republic (3.2), and Japan (2.5). In addition, *national estimates of mortality mask differences in health status among subpopulations within the same country.* In Burkina Faso, the child mortality rate is 43.7 per 1,000 live births among children born to mothers with no education, whereas it is 16.7 per 1,000 among children born to mothers with at least secondary education. Similarly, in 2016 the child mortality rate in Bolivia was 18.6 per 1,000 live births for children in the highest wealth quintile, whereas it was 55.1 per 1,000 for children living in the lowest quintile.

Child health is influenced by socioeconomic factors that operate at multiple levels of society. Disparities in these socioeconomic factors translate into child health inequities as reflected by high rates of disease, poor nutrition, and disability. The immediate, underlying, and basic structural determinants of disease, malnutrition, and disability are outlined in Figure 3.5. Preventive and curative medical interventions focus on the immediate causes of poor health; however, inequities in child mortality and morbidity will persist unless the basic and underlying determinants of health are addressed.

### Socioeconomic and Political Roots of Disparities in Global Health

The root influences on a child's health often lie in the economic and political environments in which the child is born (see Figs. 3.4 and 3.5). Growth of economies during the first half of the 20th century was associated with dramatic health improvements, with falling mortality rates and rising life expectancy across all regions. However, the second half of the 20th century was characterized by growing disparities in global economies and health between and within many countries. According to the **World Inequality Report** (<http://wir2018.wid.world/>) between 1980 and 2016 the richest 1% of the world reaped twice as much of the world's income as the poorest 50% of the world (27% of income growth compared with 12%). Although almost all countries report population-level income inequalities, a few such as the United States have seen income disparities at historical proportions. For example, since 1980 the bottom half of Americans captured only 3% of the total growth. Growing income inequalities translate into greater differences in health outcomes, such as life expectancy, between the rich and poor in the United States (Fig. 3.6). More aggressive redistribution of wealth through taxes and transfers, labor protections, and

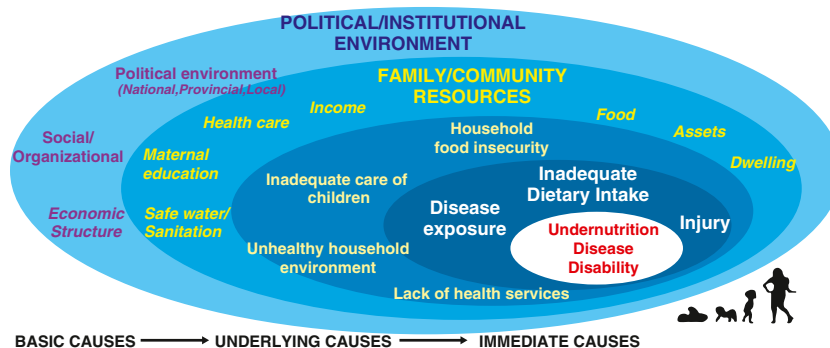


Fig. 3.5 Socioecologic model – Basic, underlying, and immediate determinants of child health.

universal access to education and health care contribute to Europe’s significantly lower levels of income disparities.

Evidence supports the notion that inequalities are not just a human rights issue, but are detrimental to economic growth. Wealthier households spend a smaller percentage of their own income, thereby dampening demand and slowing down economies. Poorer households face greater challenges to invest in health and educational opportunities, translating into less human capital and obstacles to be productive and contribute to the economy. In extreme cases, inequalities can threaten social unrest, which further undermines economic activity.

Global disparities have grown between many wealthy and low-income countries, in large part because of **austerity measures**, including structural adjustment programs, imposed on many postcolonial countries by the International Monetary Fund (IMF) and World Bank. To receive loans and pay off their debt, many of these countries were required to take on austerity measures that transformed their economies to produce cash crops and export natural resources to HICs, rather than supporting local industries and investing in human capital and social services. The focus on cash economies rather than

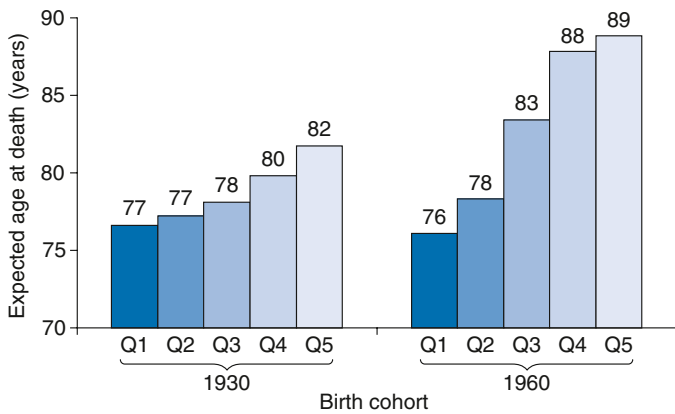
health and social service systems limited their ability to provide services to their growing poor population and further hindered responses to the spread of communicable diseases such as HIV/AIDS and the growing prevalence of noncommunicable diseases.

**The COVID-19 Pandemic**

The emergence of the severe acute respiratory syndrome coronavirus-2 (SARS-CoV-2) leading to the global pandemic of coronavirus disease 2019 (COVID-19) resulted in over 6 million deaths from COVID-19 and over 499 million cases of COVID-19 infection in the world (see Chapter 311). Children and adolescents tend to experience less severe illness and fewer deaths from SARS-CoV-2 compared to adults, which may lead to lower rates of testing among children and contribute to transmission.

Childhood COVID-19 infections have not affected countries equally, with early evidence showing pediatric deaths from COVID-19 to be significantly greater in LMICs compared to HICs. One study estimated 2.77 pediatric deaths/1 million children in LMICs compared to 1.32/million children in HICs and higher rates of death among infants <1 year of age, at 0.07%, in HICs versus 1.30% in LMICs. Although some LMICs’ settings are protected from COVID-19 infection by having a younger demographic profile, lower prevalence of the chronic conditions predisposing to severe infection, and less international transport especially in remote, low-income regions, they also suffer from limited personal protective equipment, poor ventilation of indoor spaces, and inequitable distribution of COVID-19 vaccines. Marginalized groups in these nations who are infected face inadequate medical support and supplies, which can greatly elevate their risk of death and disability. Furthermore, poor availability of testing leads to a large number of deaths and infections being underreported.

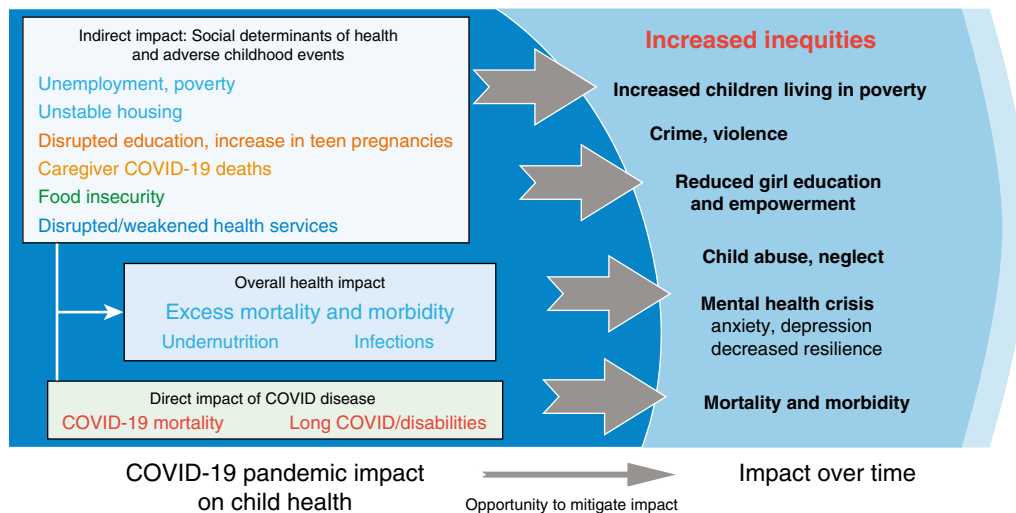
The pandemic has significantly strained the already weak health and public health systems in LMICs, raising grave concerns about the risk for youth with chronic conditions. COVID-19 impact has led to disruptions in routine childhood vaccinations, lack of medical supplies, shortages of a health workforce, and reduced delivery of lifesaving services such as cardiac surgery. One estimate showed that 90% of countries report disruptions in essential health services such as essential medicines, routine childhood immunizations, and diagnostics, although some mitigation efforts are in place.



**Fig. 3.6** Projected life expectancy for U.S. men at age 50 for 1930 and 1960 birth cohorts by income quintile – Q1 (poorest) to Q5 (richest). (From Bor J, Cohen GH, Galea S. Population health in an era of rising income inequality: USA, 1980–2015, *Lancet*. 2017;389:1475–1490, Fig. 5b; with data from National Academies of Sciences, Engineering, and Medicine. The Growing Gap in Life Expectancy by Income: Implications for Federal Programs and Policy Responses. Washington, DC: National Academies Press;2015.)

**COVID-19 and Social Determinants of Health**

COVID-19 affects child and adolescent health indirectly through the rippling effects on the world’s economies and disruption of national systems in public health, healthcare, food, and education, all which are feared to be more of a threat than the pandemic itself (Fig. 3.7).



**Fig. 3.7** Direct and indirect effects of the COVID-19 pandemic on child and adolescent health over time.

The economic crisis precipitated by the COVID pandemic lockdown and supply chain disruptions places the greatest strain on low-income communities, increasing the proportion of children who live in extreme poverty and face housing instability. An estimated additional 100 million children are estimated to have fallen into extreme poverty worldwide, which is the first increase in this indicator in 20 years. Pre-existing disparities have widened during the pandemic both within countries and globally between LMICs and HICs.

The COVID pandemic has stressed the social fabric of communities around the world so that the most marginalized and vulnerable bear the brunt of its full impact. Many racial and ethnic minority groups are unequally affected by COVID-19, with significantly higher rates of illness and death from COVID-19. Vulnerable communities that existed before the pandemic living in poverty, those employed in the informal sectors (e.g., street vendors), living within close proximity to others, unable to afford being able to stay safe at home, lacking protective gear at work, and without access to healthcare and health insurance are all at greater risk for COVID-19 infections.

Children in LMICs are particularly vulnerable because of the prolonged shutdown of schools, resulting in loss of education without access to technologic online solutions to engage in the educational curriculum. The loss of safe school environments has also been attributed to further widening gender inequities, and several countries reported a surge in adolescent pregnancies, domestic violence, and child abuse after closures.

Furthermore, the number of children affected by COVID-19-associated orphanhood and caregiver death has been estimated to have increased by 90%. The loss of a mother is associated with increased child mortality, especially when maternal death occurs in the first year of the child's life. In regions where rates of maternal death were already high, the impact of COVID-19 leading to loss of a mother or another caregiver can have devastating impact on the lives of children in the short and long term.

An epidemic of poor mental health has followed the COVID-19 pandemic for parents and their children; as the pandemic has progressed, the prevalence of depression and anxiety symptoms among adolescents has escalated. The impact on mental health is not surprising because of the extraordinary disruption of routines, recreation, family income, peer interaction, and school support. The pandemic further halted mental health services in 93% of countries worldwide as the demand for mental health services increased in settings where online mental health services are not an option.

### Sustainable Development Goals

The prioritization and planning of global development and international aid has been guided by international goals. In 2015, world leaders agreed to 17 goals, the **Sustainability Development Goals (SDGs)**, to improve global well-being by 2030 (Fig. 3.8). The SDGs were built on the eight **Millennium Development Goals (MDGs)**, which were concrete, specific, and measurable targets set by the United Nations in 2000 to eradicate poverty, hunger, illiteracy, and disease by 2015.

The SDGs have become even more critical to countries planning for ways to mitigate the future impact of the COVID-19 pandemic on child health, particularly among marginalized communities and LMICs. The SDGs highlight recommended interventions for countries to meet their goals in the setting of the challenges created by the COVID-19 pandemic such as optimizing digital centers to increase access to public services, with an emphasis on targeting solutions for communities with low internet connectivity. There have been setbacks in progress towards meeting the 17 SDGs because of the COVID pandemic, highlighting the need to prioritize programs such as routine immunization services, malaria bed net distribution, family planning, and antenatal care services to prevent further negative impacts on child health.

## SUSTAINABLE DEVELOPMENT GOALS



**Fig. 3.8** Sustainable development goals. (Courtesy United Nations Department of Public Information, 2016. United Nations Sustainable Development Goals website: <https://www.un.org/sustainabledevelopment/>. The content of this publication has not been approved by the United Nations and does not reflect the views of the United Nations or its officials or Member States.)



SDG-3 is to ensure healthy lives and promote well-being for all at all ages. It includes health-related subtargets, including to reduce U5MR to 25 deaths per 1,000 live births and neonatal mortality rate to 12 deaths per 1,000 live births by 2030. The other 16 SDGs focus mainly on social and economic determinants and the environment. This reflects an important shift to broaden the global targets to include upstream determinants of health, including health systems, and socioeconomic, gender-based, political, and environmental factors. As a social movement to support sustainable development, the SDGs were founded on the recognition that the world's environment, economic and social development, and human health are interconnected and dependent. The SDGs were formulated with core principles and values for economic development, environmental sustainability, and social inclusion for all.

The **Global Strategy for Women's, Children's and Adolescent's Health 2016–2030** maps out the strategies to achieve the SDGs by centering on the goal of health for all women, children, and adolescents using evidence-based approaches, backed by innovative and sustainable financing mechanisms. An important component of the Global Strategy is the inclusion of adolescents as central to the 2030 Agenda for Sustainable Development. In alignment with the SDGs, the Global Strategy focuses on three pillars of action: (1) **ending preventable deaths** among women, children, and adolescents, (2) **ensuring their**

**health and well-being** by ending malnutrition and ensuring access to family planning, reducing exposure to pollution, and achieving universal health coverage, and (3) **expanding enabling environments** by efforts such as eradicating extreme poverty, ensuring good-quality education, eliminating violence against females, enhancing research and technologic capabilities, and encouraging innovation.

In addition to being much broader in scope, the Global Strategy focuses on equity in that the strategy is meant to apply to all people, including the marginalized and difficult-to-reach populations, in all situations, including during crisis. Health insurance coverage would not be assessed based simply on the national average of coverage but also by how well the increases in coverage benefit all population groups regardless of income or educational level.

### EVIDENCE-BASED INTERVENTIONS AND INNOVATIONS TO ADDRESS CHILD HEALTH INEQUITIES

Estimates suggest that most of the 5.6 million annual deaths in children younger than 5 could be averted by increasing implementation of proven low-cost interventions (Table 3.1). Childhood deaths from diarrheal illness and pneumonia can be prevented by simple

**Table 3.1** Essential Interventions Across the Continuum of Care to Improve Child Survival

#### HEALTH AND MULTISECTOR ACTIONS

- Ensuring food security for the family (or mother and child)
- Maternal education
- Safe drinking water and sanitation
- Handwashing with soap
- Reduced household air pollution
- Health education in schools

#### AGE-SPECIFIC ACTIONS

##### PREVENTION

##### TREATMENT

#### Adolescence and Pre-Pregnancy

- Family planning
- Preconception care

#### Pregnancy

- Appropriate care for normal and high-risk pregnancies (maternal tetanus vaccination)
- Antenatal steroids for premature births
- Intermittent preventive treatment for malaria

#### Childbirth

- Maternal intrapartum care and monitoring
- Skilled delivery
  - Thermal care for all newborns
  - Clean cord and skin care
  - Early initiation and exclusive breastfeeding within the first hour
- Newborn resuscitation (e.g., Healthy Babies Breathe)
- Premature: Surfactant administration, continuous positive airway pressure (CPAP), treatment of jaundice, feeding support for small/preterm infants
- Kangaroo mother care

#### Postnatal Period

- Appropriate postnatal visits
- Extra care for small and sick babies (kangaroo mother care, treatment of infection, support for feeding, and management of respiratory complications)
- Antibiotics for newborns at risk and for treatment of bacterial infections (PROM, sepsis, meningitis, pneumonia)

#### Infancy and Childhood

- Exclusive breastfeeding for 6 mo and continued breastfeeding up to at least 2 yr with appropriate complementary feeding from 6 mo
- Monitoring and care for child growth and development
- Routine immunization for childhood diseases
- Micronutrient supplementation, including vitamin A, from 6 mo
- Prevention of childhood diseases
  - Malaria (insecticide-treated bed nets)
  - Pneumonia
  - Diarrhea (rotavirus immunization)
  - Meningitis (meningococcal/Hib/pneumococcal vaccine)
  - Measles (vaccine)
- Prevention of mother-to-child transmission
- Case management of severe acute malnutrition
- Management of childhood diseases
  - Malaria (antimalarials)
  - Pneumonia (case management, antibiotics)
  - Diarrhea (ORS, zinc supplement, continued feeding)
  - Meningitis (case management, antibiotics)
  - Measles (vitamin A supplement)
- Comprehensive care of children exposed to or infected with HIV (highly active antiretroviral therapy [HAART])

measures such as vaccinations and exclusive breastfeeding until 6 months of age. Deaths related to undernutrition, which predisposes children to infectious diseases, may be prevented by proper infant and young child feeding practices, micronutrient supplementation, and community-based screening and management of malnutrition.

Addressing the SDGs to improve the health of mothers, children, and adolescents takes a **life-course approach**. Figure 3.9 displays estimates of coverage for essential interventions across the continuum of care, indicating the wide range of coverage rates within countries that will need to be addressed if SDGs are to be attained.

### Vaccine-Preventable Diseases

Vaccines prevent an estimated 2.5 million deaths per year among children under 5 years of age. One study predicted a reduction in 120 million deaths among children born between 2000 and 2030 with vaccination programs. Yet in 2019 an estimated 1.15 million under-5 deaths were the result of vaccine-preventable diseases, with 99% of these children who died living in LMICs. Top contributors were *Streptococcus pneumoniae* and rotavirus, followed by *Bordetella pertussis*, measles virus, *Haemophilus influenzae* B (Hib), and influenza virus.

The WHO Expanded Program on Immunization (EPI) has resulted in a dramatic reduction in deaths, illness, and disability from many of these diseases, in addition to the near elimination of poliomyelitis. Recommendations for routine immunizations have continued to grow with the development of new vaccines that have demonstrated significant lifesaving potential in industrialized countries (Table 3.2). The vulnerability of these programs was demonstrated during the pandemic as global vaccine coverage dropped from 86% in 2019 to 83% in 2020, with an estimated 23 million under the age of 1 year who did not receive basic vaccines in 2020—the highest number since 2009.

In 2015, 86% of the world's infants were vaccinated with 3 doses of DTP. Although vaccines are very effective in improving child survival, rates of coverage are low in many countries. In 2016, a total of 19.5 million did not receive all routine lifesaving vaccinations, and 90,000 deaths were reported due to measles alone. Lifesaving vaccines are still not available in many countries, but progress has been made to expand availability to new countries every year. The

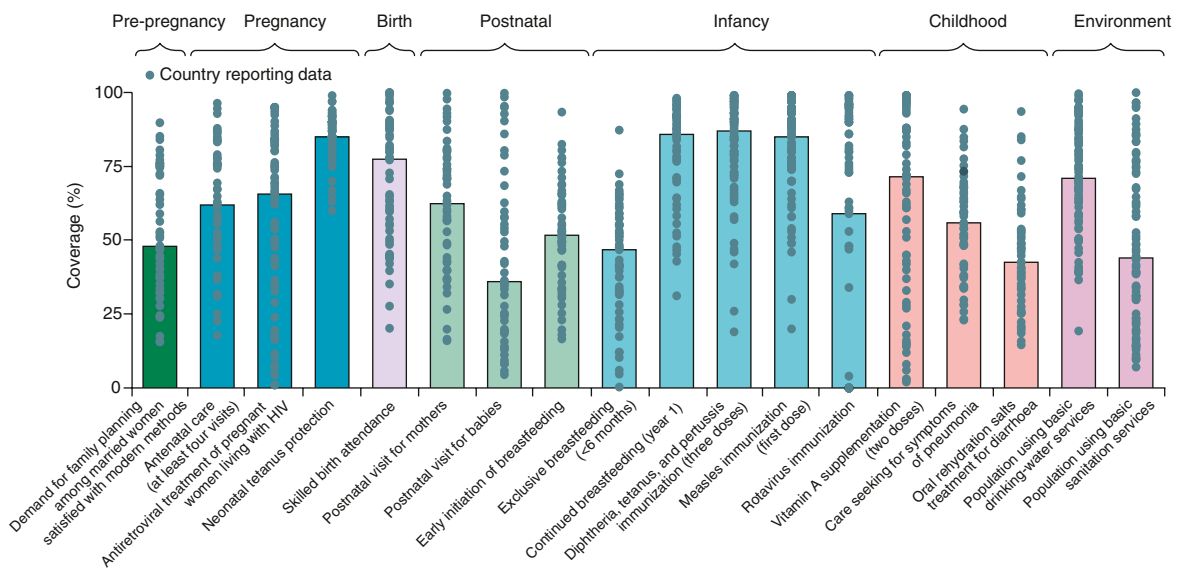
lowest number of wild poliovirus cases were reported in 2016 (37 cases). The significant declines in immunization coverage caused by the COVID-19 pandemic have increased the risk for a resurgence of these vaccine-preventable infections amidst weakened healthcare systems.

### Reaching Every Child, Everywhere

Global vaccine organizations aim for universal coverage of immunizations but face challenges within countries to attain this goal. Other lifesaving interventions have met barriers to attaining universal coverage. Oral rehydration therapy has been the evidence-based intervention to prevent dehydration from diarrheal disease since the 1970s, yet only 2 in 5 children under 5 with diarrheal illness receive this treatment. The determinants of whether or not a child receives a lifesaving intervention are multifactorial. Characteristics of a healthcare system, the social attitudes and practices, and political climate affect whether universal coverage can be reached for evidence-based essential interventions. Innovations to strengthen vaccine coverage to reach every child in every district of a country range from programs such as **Reaching Every Child through Quality Improvement (REC-QI)**, using community mapping techniques, to the integration of service delivery mechanisms and strengthening the health system with improved surveillance.

### Effective Delivery Strategies: Integrated Management of Childhood Illness

Weak health systems impede the ability of countries to deliver cost-effective interventions and lifesaving health messages for children. Such systems are characterized by insufficient numbers of health workers, low-quality training and supervision, and poorly functioning supply chains. The provision of child health services may focus on a single level such as the health facility, but effective and lasting improvements can only be achieved with the integration of delivery at all levels, such as adequate referrals and follow-up between community, clinic, and health facility. As countries resume health services after the COVID-19 pandemic, an important component will be community-based, lifesaving outreach services such as mass immunization, vitamin A campaigns, and community-based health promotion activities (Fig. 3.10).



**Fig. 3.9** Coverage of interventions across the continuum of care based on the most recent data since 2012 in countdown countries. Bars show median national coverage of interventions, whereas the dots show country-specific data. (From Countdown to 2030 Collaboration. Countdown to 2030: Tracking progress towards universal coverage for reproductive, maternal, newborn, and child health. Lancet. 2018;391:1538–1548. Fig. 1.)

**Table 3.2** Routine Childhood Immunizations Recommended by the World Health Organization (2021)\*

ANTIGEN	AGE OF 1ST DOSE	DOSES IN PRIMARY SERIES	INTERVAL BETWEEN DOSES		BOOSTER DOSE	CONSIDERATIONS
			1ST TO 2ND	2ND TO 3RD		
<b>BCG</b>	As soon as possible after birth	1				Birth dose and HIV; universal vs selective vaccination; co-administration; vaccination of older age groups; pregnancy
<b>Hepatitis B</b>	Option 1	As soon as possible after birth (<24hr)	3	4 wk (min) with DTCPV1	4 wk (min) with DTCPV2	Premature and low birth weight; co-administration and combination vaccine; high risk groups
	Option 2	As soon as possible after birth High risk groups	4	4 wk (min) with DTCPV1	4 wk (min) with DTCPV2	
<b>Polio</b>	bOPV + IPV "Preferred schedule" (fractional Salk-IPV permitted)	bOPV 6 wk IPV 14 wk	5 (3 bOPV and 2 IPV)	bOPV 4 wk (min) (e.g. with DTCPV2) IPV ≥ 4 mo (min) (e.g. with MCV)	bOPV 4 wk (min) (e.g. with DTCPV3)	bOPV birth dose; type of vaccine; fractional dose IPV; transmission and importation risk; local epidemiology, programmatic implications and feasibility for "early" option
	bOPV+IPV "Early option" (full dose IPV only)	bOPV 6 wk IPV 6 wk	5 (3 bOPV and 2 IPV)	bOPV 4 wk (min) (e.g. with DTCPV2) IPV 14 wk (min) (e.g. with DTCPV3)	bOPV 4 wk (min) (e.g. with DTCPV3)	
	IPV / bOPV Sequential	8 wk (IPV 1st) bOPV (4–8 wk after 2nd IPV)	4 (2 IPV followed by ≥ 2 bOPV)	IPV (4–8 wk)	bOPV (4–8 wk) <sup>†</sup>	
	IPV-only	6–8 wk	3	4–8 wk	4–8 wk	
	Alternative IPV-only (fractional permitted)	≥14 wk	2	≥ 4 mo (e.g. with MCV)		Only for countries in polio-free regions with a very low risk of importation and sustained high routine immunization coverage (DTP3> 90%)



ANTIGEN	AGE OF 1ST DOSE	DOSES IN PRIMARY SERIES	INTERVAL BETWEEN DOSES		BOOSTER DOSE	CONSIDERATIONS
			1ST TO 2ND	2ND TO 3RD		
<b>DTP-containing vaccine</b>	6 wk (min)	3	4 wk (min) – 8 wk	4 wk (min) – 8 wk	3 boosters 12–23 mo (DTP containing vaccine); 4–7 yr (Td/DT containing vaccine); and 9–15 yr (Td)	Delayed/ interrupted schedule Combination vaccine; Maternal immunization
<b>Haemophilus influenzae type b</b>	Option 1	6 wk (min) 59 mo (max)	3	4 wk (min) with DTPCV2	4 wk (min) with DTPCV3	Single dose if >12 mo of age; not recommended for children > 5 yr; delayed/interrupted schedule; co-administration and combination vaccine
	Option 2		2–3	8 wk (min) if only 2 doses 4 wk (min) if 3 doses	4 wk (min) if 3 doses	
<b>Pneumococcal (conjugate)</b>	Option 1 3p+0	6 wk (min)	3	4 wk (min)	4 wk	Schedule options (3p+0 vs 2p+1); vaccine options; HIV+ and preterm neonate booster; vaccination in older adults
	Option 2 2p+1	6 wk (min)	2	8 wk (min)		
<b>Rotavirus</b>	6 wk (min) with DTP1	2 or 3 depending on product		4 wk (min) with DTPCV2	For three dose series – 4 week (min) with DTPCV3	Not recommended if >24 mo
<b>Measles</b>	9 or 12 mo (6 mo min)	2		4 wk (min)		Co-administration live vaccines; combination vaccine; HIV early vaccination; pregnancy
<b>Rubella</b>	9 or 12 mo with measles containing vaccine	1				Achieve and sustain 80% coverage; co-administration and combination vaccine; pregnancy
<b>HPV</b>	As soon as possible from 9 yr (females only)	1–2		6–12 mo		Target 9–14 yr old females; off-label 1 dose schedule; MACs with intro; pregnancy; HIV and immunocompromised

\*Please see WHO reference for specific vaccine recommendations for children residing in certain regions and in high-risk populations and more detailed footnotes. [https://cdn.who.int/media/docs/default-source/immunization/immunization\\_schedules/table\\_2\\_feb\\_2023\\_english.pdf?sfvrsn=3e27ab48\\_11&download=true](https://cdn.who.int/media/docs/default-source/immunization/immunization_schedules/table_2_feb_2023_english.pdf?sfvrsn=3e27ab48_11&download=true).

<sup>†</sup>Interval between 3rd and 4th, bOPV (4–8 wk).

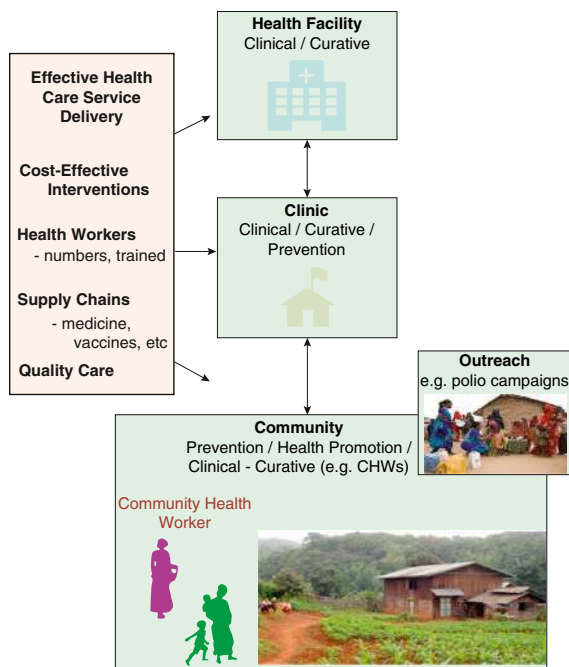


Fig. 3.10 Health services delivery systems.

**Community-based interventions** are effective in extending health-care delivery, are low cost, improve healthcare-seeking behavior, and can reduce infant and child mortality and morbidity. They may include **community health workers (CHWs)**, who are members of a community without formal medical training chosen to provide basic health and medical care to their community, as discussed in more detail later.

The lack of integration of programs that deliver individual interventions results in missed opportunities. Children may receive immunizations from one health worker at one encounter, but go somewhere else to obtain oral rehydration solution (ORS) for diarrheal illness and yet elsewhere for treatment of malnutrition. Past programs focused on a single disease and set of interventions, whereas most children present with overlapping signs and symptoms to community-level health facilities with limited diagnostic tools such as laboratories or radiography.

The **Integrated Management of Childhood Illnesses (IMCI)** was launched in the mid-1990s by UNICEF and the World Health Organization (WHO) as an approach to reduce child death, illness, and disability and to promote improved growth and development in countries struggling with high child mortality rates. The IMCI was designed to increase coverage of evidence-based, high-impact interventions that tackle the top causes of child mortality by integrating health promotion, illness prevention, and disease treatment.

The IMCI contains both preventive and curative elements that are set forth through a series of clinical algorithms and guidelines for case management (Fig. 3.11 provides an example) and implemented by families, communities, and providers at health facilities. One key component of the IMCI strategy is to train CHWs to use the algorithms to identify signs of common childhood illness and to decide when a child needs referral to a health facility. IMCI trains CHWs to instruct parents on home management of ill children, including ORS and zinc for diarrhea, antimalarial medicine for febrile children who test positive for malaria, and antibiotics for children with signs of pneumonia. CHWs can schedule follow-up

visits for ill children. They also promote use of bed nets, hand-washing, and proper infant and young child feeding. In 2003, the IMCI guidelines underwent minor transitions, including the addition of newborn care under 1 week of age, so that it was renamed Integrated Management of Newborn and Childhood Illnesses (IMNCI).

Over 100 countries have adopted the IMNCI and implement some or all of its components that include not only improving health workers' skills but also strengthening health systems and improving family and community practices. After 20 years of implementation, a recent review of the IMNCI strategy noted that it was associated with a 15% reduction in child mortality when activities were properly implemented in health facilities and communities. However, the implementation of IMNCI was found to be uneven between and within countries. In many countries the resources for CHW training and supervision, supply of medications, and referrals were limited or absent. The IMNCI was only successful in those countries with strong government leadership and a commitment to implement IMNCI in partnership with support from groups such as UNICEF and the WHO. The success of IMNCI required an adequate health system and a systematic approach to planning and implementation.

### Social Protection Programs: Conditional and Unconditional Cash Transfers

Financial incentives are widely used to improve healthcare coverage, alleviate poverty, and improve access to child health services. In industrialized countries, cash transfers are a common mechanism for ensuring that the poorest, most marginalized subgroups of the population, particularly with children, receive adequate support to meet their basic needs. Before the COVID-19 pandemic, cash transfer schemes were increasingly being used in LMICs to support population needs, and COVID-19 led to an enormous elevation of social protection efforts as a critical response to mitigate the far-reaching impact of the pandemic on vulnerable communities. Many lessons have been learned during this escalation of social protection programs, which provides hope for continued support of families in need, in addition to an expansion of services to mitigate the projected increases in children living in extreme poverty.

Out-of-pocket expenses by households form the major share of total health expenditure in most LMICs. Many social protection programs serve a dual purpose of reducing financial barriers and strengthening service delivery. Financial incentives may include cash transfers, microcredit, vouchers, and user fee removal and health insurances. **Financial incentive programs may be unconditional**, provided to eligible families without any requirements or expectations, based on the belief that families will use this type of financial support for their children's best interests. **Other incentives are conditional on health promotion behavior targeting child health**, such as the provision of cash or vouchers only to those families who participate in mother groups to learn about breastfeeding practices, visiting clinics for child vaccinations and growth monitoring, engaging in deworming, and ensuring that their children receive vitamin A and iron supplementation. Some social protection programs are also directed towards educational improvement by making cash transfers conditional on child school enrollment, attendance, and occasionally on some measure of academic performance.

Expansions of innovations that have been scaled up quickly during the pandemic protected millions of families such as through mobile cash transfer programs that take advantage of data and technology to better target those in need. Certain countries with a large proportion of children at risk are projected to have a protracted recovery period. Efforts have been taken to identify and provide international support for these countries and communities (Fig. 3.12).

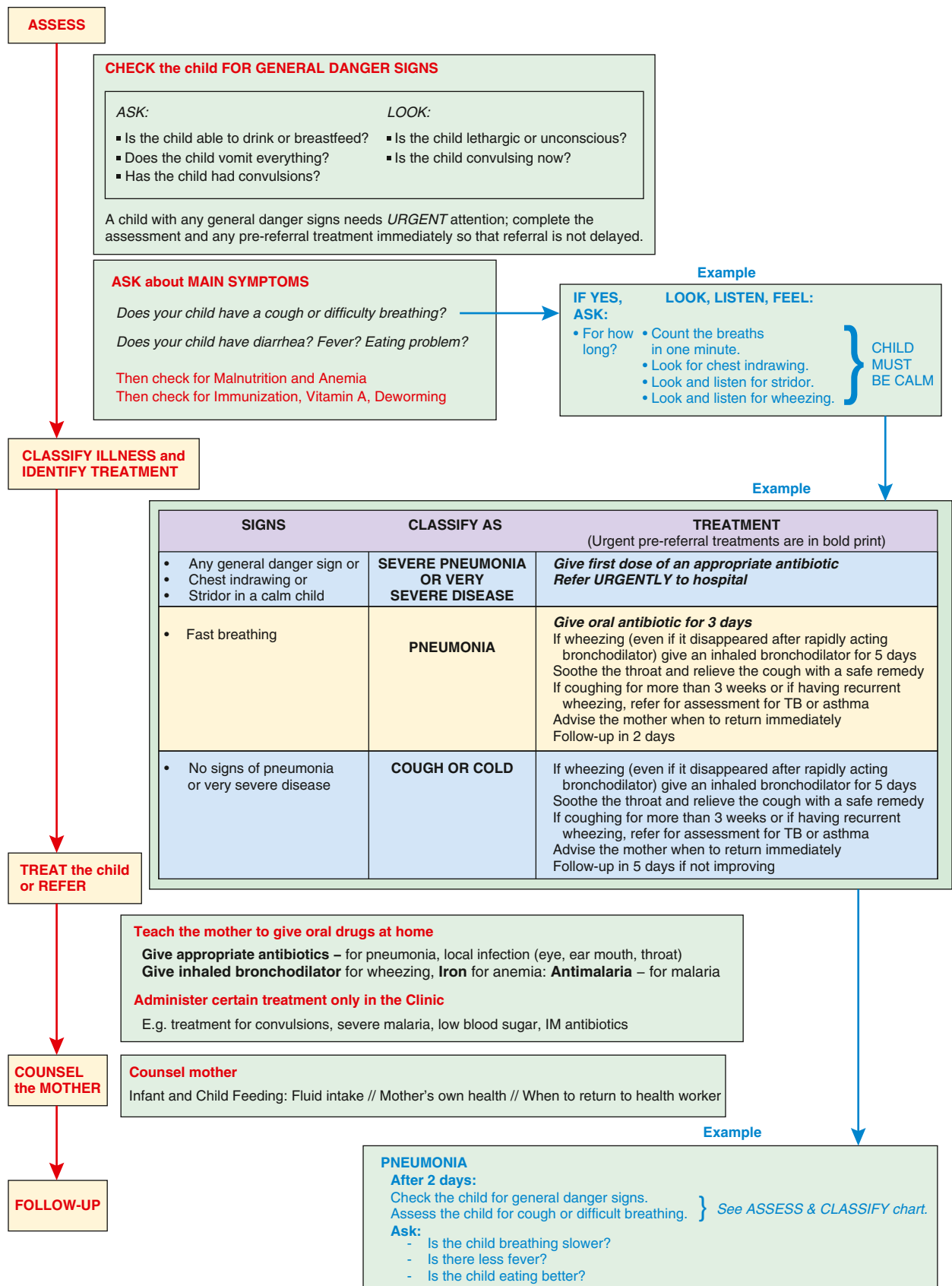
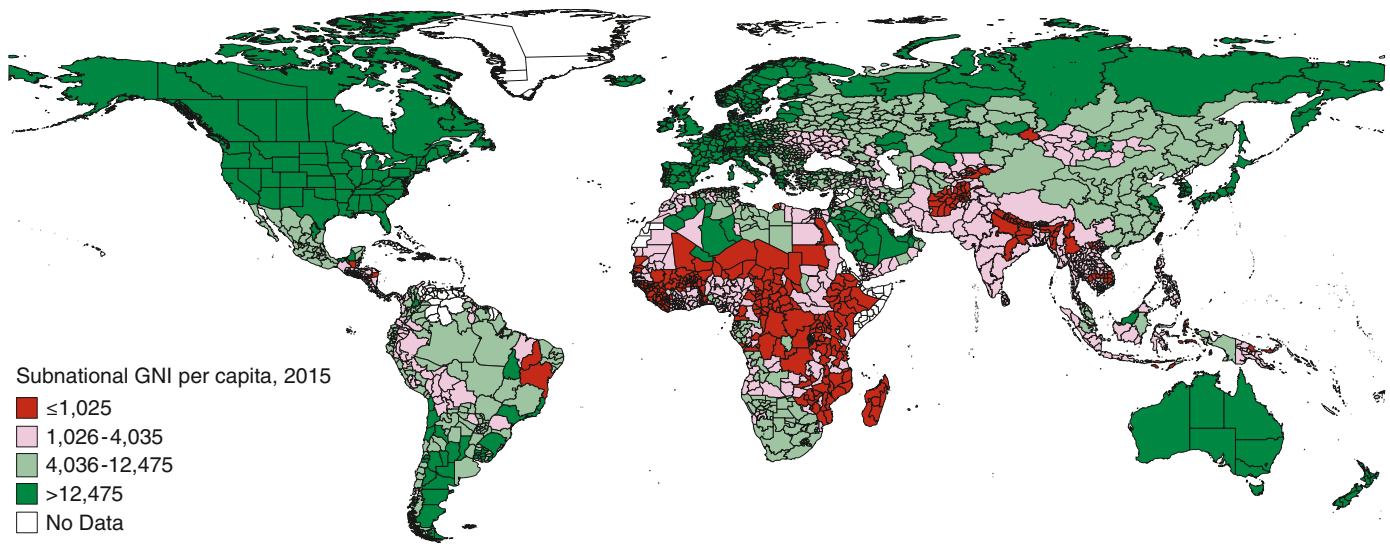
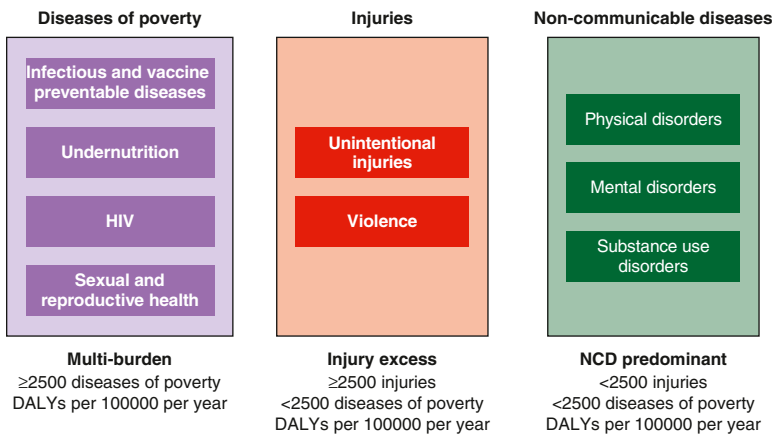


Fig. 3.11 Integrated management of childhood illnesses (IMCI) Generic IMCI table for appraisal of respiratory symptoms, with each algorithm tailored to the specific country context before implementation.



**Fig. 3.12** Subnational poverty “hotspots” for extreme poverty (2015), based on GNI per capita. (From Desai R, Kharas H, Ozdogan S. Poverty hotspots and the correlates of subnational development. Brookings Institution. Dec. 2020. Global working paper #149. [https://www.brookings.edu/wp-content/uploads/2020/12/Poverty-hotspots\\_final.pdf](https://www.brookings.edu/wp-content/uploads/2020/12/Poverty-hotspots_final.pdf).)



**Fig. 3.13** Country categorization based on adolescent burden of disease. Categorization into 3 groups according to adolescent burden of disease and reflecting passage through epidemiologic transition. DALYs, Disability-adjusted life-years; NCD, noncommunicable diseases. (From Patton GC, Sawyer SM, Santelli JS, et al. Our future: A Lancet commission on adolescent health and wellbeing. *Lancet*. 2016;387:2423–2478, Fig. 7.)

### CHALLENGES IN GLOBAL HEALTH

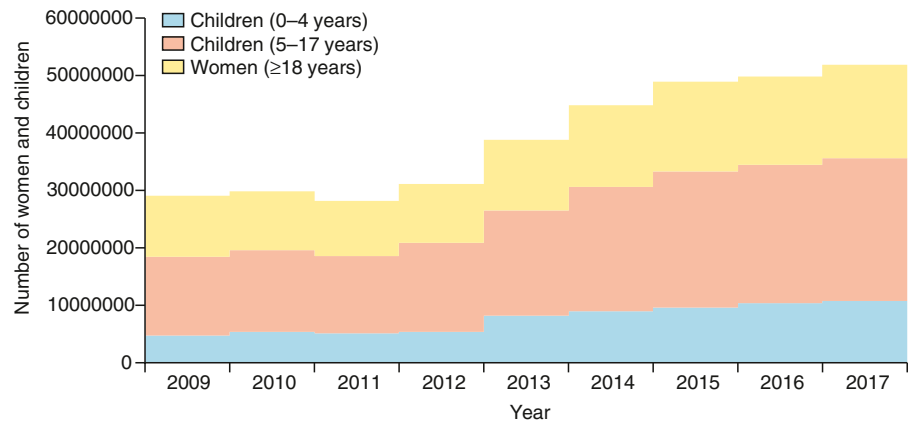
**Adolescent health.** The Global Strategy, which directs countries to attain their SDGs, has called upon countries to focus efforts to support adolescent health given the potential role in breaking the intergenerational cycle of poverty. One challenge to attaining these health goals will be to effectively advocate for governments to invest in this age group as a means to improve national productivity and the economy. Considerable gaps in data on adolescents pose one of the biggest challenges to promoting their health and their rights. Data on early adolescents age 10-14 is relatively scarce, thus limiting the knowledge of this crucial period. Efforts to promote youth participation in delineating their health priorities are essential to the design of effective interventions.

One critical strategy to support adolescents is to improve completion of secondary school education, particularly among girls. The development of adolescents’ capacities and values through education can empower an entire generation to become economically independent, to become positive contributors to society, and to break out of the cycle of poverty.

Other threats to adolescent health include mental health, substance abuse, sexual and reproductive health, and noncommunicable diseases (NCDs) such as obesity, which vary depending on country (Fig. 3.13). The surge in adolescent pregnancies that has been reported in several countries during the COVID-19 pandemic places particular emphasis on the need to strengthen youth access to sexual and reproductive education and services.

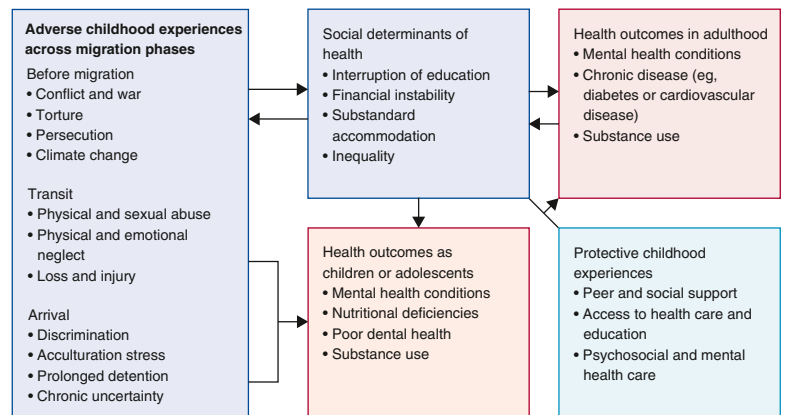
A common theme for these threats is that interventions to combat these issues must attempt to influence individual behavior and attitudes while promoting healthy lifestyles. It is estimated that around 20% of the world’s adolescents have a mental health or behavioral problem, and this has only increased since the COVID-19 pandemic. Depression is the single largest contributor to the global burden of disease for people age 15-19, and suicide is one of the three leading causes of mortality among people age 15-35. Efforts to tackle these problems will require an interdisciplinary approach, with more research needed to identify and evaluate interventions to effectively influence adolescent behavior in LMIC settings.





**Fig. 3.14** Estimated number of children and women displaced by conflict, 2009–2017. (From Bendavid E, Boerma T, Akseer N, et al. *The effects of armed conflict on the health of women and children*. *Lancet*. 2021;397:522–530, Fig. 2, p. 524.)

**Fig. 3.15** Intersection between adverse childhood experiences during migration and social determinants of health and their long-term effects. Protective childhood experiences can act as a buffer so that adverse health conditions of childhood and adolescence are less prolonged and less severe in adulthood. (From Maioli SC, Bhabha J, Wickramage K, et al. *International migration of unaccompanied minors: Trends, health risks, and legal protection*. *Lancet Child Adolescent*. 2021;5:882–895.)



**Climate change.** Climate change is the most urgent and alarming long-term threat to child health and well-being in this century. Contributing to environmental degradation, the loss of natural resources and change in climate undermine food and water sources. Climate change and an increased frequency and severity of humanitarian crises have already adversely affected children's health and nutrition. Advocacy at local, national, and international levels to reduce greenhouse gas emissions are needed.

**Conflict, emergency situations, and migration.** During times of crisis, children, adolescents, and women are most vulnerable (Fig. 3.14). Although the youngest are the most likely to perish because of disease or injuries, all children suffer as a result of food shortages, poor water and sanitation, interrupted education, and family separation or displacement. Approximately 281 million migrants live outside their countries of birth, which includes 35 million young children and adolescents under the age of 20 who have migrated either with their parents or are unaccompanied. Many other children are affected by migration through parental separation because of deportation or emigration.

Children and adolescents crossing borders are often not entitled to the same protections and rights as those who reside in a given country, leaving them at greater risk of discrimination and exploitation. A rights-based approach to migration is required to reinforce the steady buildup of support and attention to migration issues at the international and national levels. This approach must also address the long-term social and health consequences and the root causes of migration (e.g., instability, inequality, discrimination, poverty) in the country of origin and should incorporate policies

specifically targeted for young children, adolescents, young women, and vulnerable populations, including those left behind when family members migrate away (Fig. 3.15).

**Health information and communications technology.** The widespread proliferation of health information and communications technology (HICT) has transformed health care. Social media and mobile apps can be used to raise awareness and build skills, especially in LMICs, where other channels of public health messages may not be readily accessible.

The dissemination of HICT has not been equitable. The majority of LMICs are still in the early stages of adoption. Many healthcare settings in LMICs rely exclusively on paper-based records or simple electronic data-capture tools such as spreadsheets for disease surveillance, reporting, and research. Barriers to implementing HICT in LMICs include lack of health data infrastructures, reliable internet and electricity, workforce training, tools that fit local healthcare needs and culture, and sustainable funding. A further challenge is the need to ensure privacy and security while standardizing the format in which health data are captured to permit sharing of health information across facilities to reduce costly inefficiencies and to improve quality of care. Balanced partnerships between health care and technology communities across low-, middle-, and high-income countries are needed to share knowledge, foster innovation, and strengthen health information systems to advance equitable health outcomes.

Visit Elsevier eBooks+ at [eBooks.Elsevier.com](https://eBooks.Elsevier.com) for Bibliography.

## Chapter 4

# Quality and Value in Healthcare for Children

Trisha L. Marshall, Amanda C. Schondelmeyer,  
and Jeffrey M. Simmons

## THE NEED FOR IMPROVEMENT IN QUALITY AND VALUE

Adults and children receive recommended evidence-based care only about half the time. The gap between knowledge and practice widens to a *chasm* in part because of variations in practice and disparities in care from doctor to doctor, institution to institution, geographic region to geographic region, and socioeconomic group to socioeconomic group. Furthermore, it is estimated that it routinely takes more than a decade for new knowledge to be adopted into clinical practice.

In addition to appropriate care that patients do not receive, the U.S. healthcare systems also deliver much care that is unnecessary and waste many resources in doing so. This overuse or waste is one **key driver** of the disproportionate costs of care in the United States compared with other developed countries' delivery systems (in 2016, the United States spent about twice as much per capita, adjusting for gross domestic product [GDP], on healthcare compared to the average of peer wealthy nations). It is estimated that more than one quarter of all U.S. healthcare spending is waste. Gaps in appropriate care, combined with overuse and high costs, have driven conversations about the need to improve the value of care, which would mean better quality at lower overall costs. **Choosing Wisely**, an initiative initially sponsored by the American Board of Internal Medicine Foundation and subsequently endorsed by the American Academy of Pediatrics (AAP), asked medical societies to identify overused practices that clinicians could then make collective efforts to address.

## WHAT ARE QUALITY AND VALUE?

The National Academy of Medicine (NAM) defines *quality* of healthcare as "the degree to which healthcare services for individuals and populations increases the likelihood of desired health outcomes and are consistent with current professional knowledge." To measure healthcare quality, they identified *Six Dimensions of Quality*: **effectiveness, efficiency, equity, timeliness, patient safety, and patient-centered care**. Healthcare services need to be *effective*, which means that they should result in benefits and be grounded in evidence whenever possible. Healthcare services also need to be *efficient*, which incorporates the idea of avoiding waste and improving system cost efficiencies, and the services should be *safe* for patients. Healthcare services must be *timely*, thus incorporating the need for appropriate access to care (see [Chapter 5](#)). Healthcare services should be *equitable*, which highlights the importance of minimizing variations as a result of race, ethnicity, gender, geographic location, and socioeconomic status (SES). Healthcare quality should be *patient centered*, which underscores the importance of identifying and incorporating individual patient needs, preferences, and values in clinical decision-making. In pediatrics, the patient-centered dimension extends to family-centeredness, so that the needs, preferences, and values of parents and other child caregivers are considered in care decisions and system design.

This framework emphasizes the concept that all Six Dimensions of Quality need to be met for the provision of *high-quality* healthcare. Collectively, the Six Dimensions of Quality represent *quality* in the overall *value* proposition of quality per cost. Value remains a critical concept, though difficult to measure accurately.

The evolving healthcare system requires physicians, healthcare providers, hospitals, and healthcare organizations to partner together and with patients to define, measure, and improve the overall quality and value of care delivered. Concrete examples of the evolving U.S. perspective include the widespread adoption of **Maintenance of Certification (MOC)** requirements by medical-certifying bodies, which require providers to engage in activities that improve care in their practices, and the core quality measurement features and population health incentives of the **Patient Protection and Affordable Care Act (ACA)** of 2010. The ACA also established the **Patient-Centered Outcomes Research Institute (PCORI)** to develop a portfolio of effectiveness and implementation research that requires direct engagement of patients and families to partner in setting research priorities, formulating research questions, and designing studies that will directly affect the needs of patients to improve the value of the research.

Although significant progress has been made along many dimensions of quality, a notable gap is the lack of progress on addressing inequities in healthcare. Disparities in healthcare based on racial or ethnic background, SES, and for patients and families with limited English proficiency are well documented and include inequities in access to care, treatment of pain, and in number of adverse events experienced during acute hospitalizations (see [Chapter 2](#)).

## FRAMEWORKS FOR QUALITY IMPROVEMENT

**Quality improvement (QI)** science is a predominant method used to close gaps and improve value. Initially focused on improving performance and reliability in care processes, more recently, in part inspired by the Institute for Healthcare Improvement's **Triple Aim** approach, QI is also being used to improve value for *populations* of patients by focusing more on *outcomes* defined by patients' needs. The Triple Aim included (1) improving the patient experience of care, (2) improving the health of populations, and (3) reducing per capita cost of healthcare. The **Quadruple Aim** approach adds the fourth dimension of healthcare worker experience, or *joy in work*, to focus delivery systems on the need to consider the resilience and safety of the clinical workforce in order to maintain the delivery of high-value care.

Quality is broader in scope than QI. Many quality measurement systems have attempted to be more transparent with clinicians and patients about costs of care. Because more direct costs have been shifted to patients and families through widespread adoption of high-deductible insurance plans (i.e., families experience lower up-front insurance coverage costs but pay for certain acute healthcare expenses out-of-pocket until the preset deductible is met), better awareness of costs has become a more important driver of improvement in value, in part by reducing overuse.

The applied science of QI currently in use in healthcare is also firmly grounded in the classic scientific method of observation, hypothesis, and planned experimentation. There are four key features of the applied science of QI: appreciation of systems, understanding variation, knowledge theory, and psychology of change. In addition to this theoretical framework, statistical analytic techniques have evolved to better evaluate variable systems over time. Although each derives key features from this applied scientific foundation, multiple QI methodologies are currently in use in healthcare. At their most parsimonious level, each method can be described as a three-step model: *Data* → *Information* → *Improvement*. Quality needs to be measured. Data obtained from measurement needs to be converted into meaningful information that can be analyzed, compared, and reported. Information must then be *actionable* to achieve improvements in clinical practice and health systems' processes. Some common approaches to conducting QI in healthcare, many of which originated in manufacturing, include Model for Improvement, Six Sigma, and Lean methodologies. These approaches are not mutually exclusive and share common features and tools. The Model for Improvement is an overarching framework

for improvement. Six Sigma focuses largely on reducing variation in processes, and Lean focuses on eliminating waste.

**Model for Improvement**

The Model for Improvement is structured around three key questions: (1) What are we trying to accomplish? (2) How will we know that a change is an improvement? and (3) What change can we make that will result in improvement? Clarifying the first question, the *goal*, is critical and is often a step skipped by clinicians, who typically already have change ideas in mind. The second question is about defining measures, with an emphasis on practicality and efficiency. The third question is about defining testable ideas for improvement, which are subsequently tested using a framework of rapid cycle improvement, also known as the **plan-do-study-act (PDSA) cycle** (Fig. 4.1A). The PDSA cycle is typically aimed at testing small care process changes in iterative, rapid cycles. After discrete testing periods, results are analyzed, and the next cycle of change testing is planned and implemented (i.e., multiple PDSA cycles, often called a PDSA *ramp*, build on previous learning from PDSAs; see Fig. 4.1B). Valuable information can be obtained from PDSA cycles that are successful, and those that are not, to help plan the next iteration of the PDSA cycle. The PDSA cycle specifically requires that improvements be data driven. Many clinicians attempt to make changes for improvement in their practice based on clinical intuition rather than on interpretation of empirical data. Data can be either quantitative or qualitative in nature.

One successful QI collaborative using the Model for Improvement in the outpatient setting is related to improvements in remission rates and reduction in systemic corticosteroid use among children with inflammatory bowel disease (IBD, Crohn disease, or ulcerative

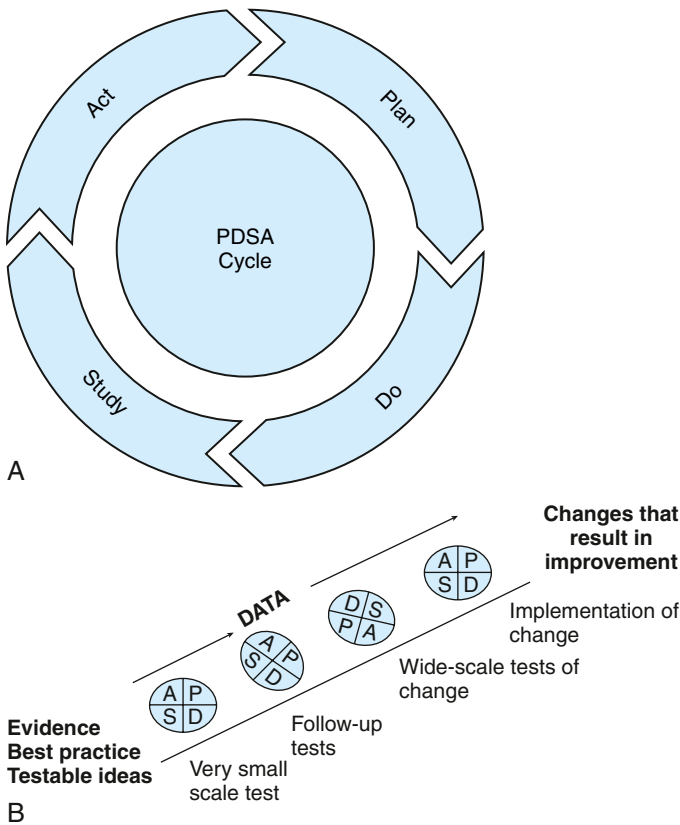
colitis). This work was supported by the **ImproveCareNow Network** (<https://improvecarenow.org/>), a learning health system. A *learning health system* is a collaborative endeavor organized around communities of patients, clinicians, and researchers working together to integrate research with QI (i.e., knowledge dissemination and implementation) to improve care delivery while advancing clinical research. For the IBD network, outpatient gastroenterology practices standardized treatment approaches to align with existing evidence through QI interventions adapted to local circumstances. Therapeutic decisions for individual patients remained at the discretion of physicians and their patients.

**Six Sigma**

Six Sigma is related to the reduction in *undesirable variation in processes*. Six Sigma attempts to provide a structured approach to unwanted variations in healthcare processes. Six Sigma approaches have been successfully used in healthcare to improve processes in both clinical and nonclinical settings.

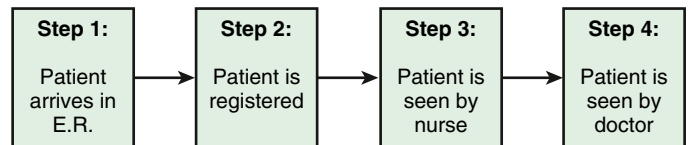
**Lean Methodology**

Lean methodology focuses on reducing waste within a process in a system. Figure 4.2A illustrates the steps in the process of a patient coming to the emergency department (ED). After the initial registration, the patient is seen by a nurse and then the physician. In a busy ED, a patient may need to wait for hours before registration is complete and the patient is placed in the examination room. This wait time is a waste from the perspective of the patient and the family. Incorporating the registration process after placing the patient in the physician examination room can save time and minimize waste (see Fig. 4.2B). Lean methods have been successfully used in several outpatient and inpatient settings with resulting improvements in efficiency. Lean principles have also been adopted as a core strategy for many children’s hospitals and health systems with the goal of improving efficiencies, including access, while reducing waste. These efforts can improve aspects of quality while also

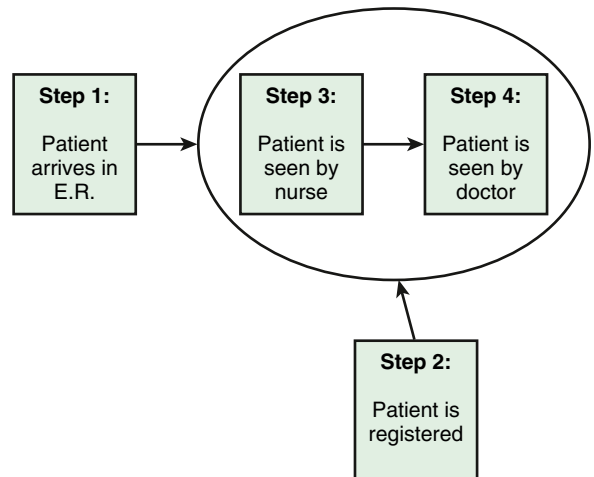


**Fig. 4.1** A, The plan-do-study-act (PDSA) cycle. B, Use of PDSA cycles: a ramp. (From Langley GJ. *The Improvement Guide: A Practical Guide to Enhancing Organizational Performance*. San Francisco: Jossey-Bass;1996. Copyright 1996 by Gerald J. Langley, Kevin M. Nolan, Thomas W. Nolan, L. Norman, and Lloyd P. Provost.)

**A. Original Process**



**B. Lean Implementation Reduces “Waste” by Incorporating Step 2 into Steps 3 or 4**



**Fig. 4.2** A and B, Lean methodology—waste reduction.

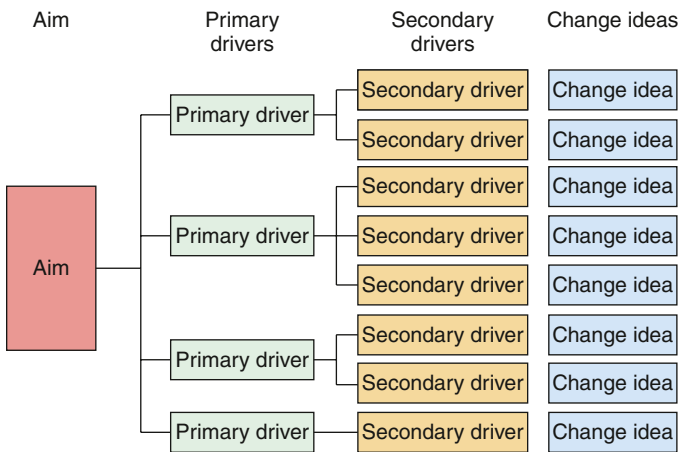


Fig. 4.3 Key driver diagram: theory of how to achieve an aim.

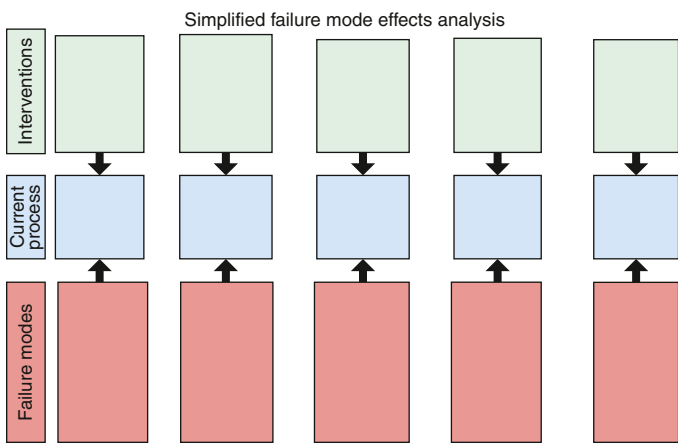


Fig. 4.4 Failure modes and effects analysis (FMEA).

typically reducing costs. Another key principle of Lean methods is the empowerment of the workforce and frontline leaders to make changes that reduce hassles for them and for patients.

### Tools for Organizing Quality Improvement Theory and Execution

QI efforts need to be organized around a theory of how the desired changes in outcome will be achieved. Multiple tools are available to help organize a QI team's thinking and execution. These tools typically help teams organize work into discrete projects or phases, and some of them also help teams develop change ideas.

**Key driver diagrams (KDDs)** are a tool to organize the theory of learning that underpins a QI project (Fig. 4.3), using the Model for Improvement. Important aspects of a KDD include a statement of the specific aim or improvement goal; a list of the key themes, or drivers, that are theorized to require improvement in order to achieve the aim; and lastly a list of the discrete change ideas or initiatives to be tested to determine whether or not they affect discrete drivers, and therefore the overall aim. Because most system outcomes are driven by multiple factors, a KDD allows a QI team to depict a theory that addresses multiple factors. Similarly, Lean and Six Sigma projects use a tool called an A3 that, in addition to organizing the theory of a project, also prompts teams to assess the current state and consider timelines and personnel for planned change (examples are available at <https://www.lean.org/common/display>).

There are additional QI tools to help assess the current state of a system to better understand how to improve it. One, the **failure**

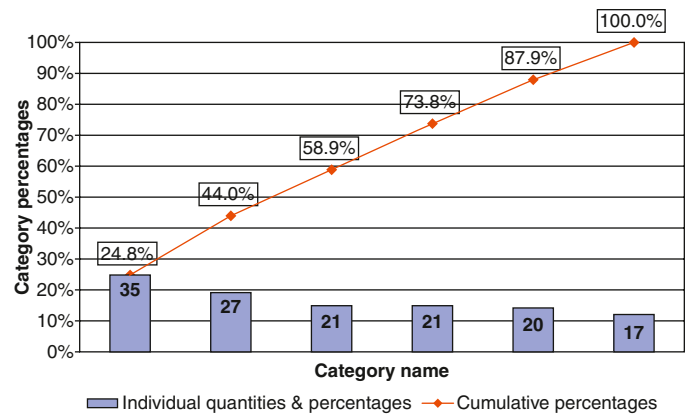


Fig. 4.5 Pareto chart.

Table 4.1 Properties of Robust Quality Measures

ATTRIBUTE	RELEVANCE
Validity	Indicator accurately captures the concept being measured.
Reliability	Measure is reproducible.
Feasibility	Data can be collected using paper or electronic records.
Usability	Measure is useful in clinical practice.

**modes and effects analysis (FMEA)**, also helps teams develop change ideas (Fig. 4.4). Starting with a map of the processes in the current system, FMEA then asks teams to investigate and brainstorm the many ways discrete processes can go wrong—the *failure modes*. Once failure modes are identified, teams begin to develop discrete interventions or countermeasures to address the failures (see Chapter 5). A similar tool, the **fishbone** or **cause-and-effect** diagram, is organized around key components in a system (e.g., people, material, machines) and helps a team catalog how deficiencies in each component can affect the overall outcome of a system.

Another tool to help teams prioritize action is a **Pareto chart**, which organizes system deficiencies in terms of their prevalence (Fig. 4.5). A Pareto chart typically displays the individual prevalence of discrete problems, determined by baseline analysis of data, as well as the cumulative prevalence, helping teams see which problems should be addressed first to maximize impact on the overall outcome.

### MEASURING QUALITY

Robust quality indicators should have clinical and statistical relevance. **Clinical relevance** ensures that the indicators are meaningful to patient care from the standpoint of patients and clinicians. **Statistical relevance** ensures that the indicators have measurement properties to allow an acceptable level of accuracy and precision. These concepts are captured in the national recommendations that quality measures must meet the criteria of being valid, reliable, feasible, and usable (Table 4.1). **Validity** of quality measures refers to the measure being an estimate of the true concept of interest. **Reliability** refers to the measure being reproducible and providing the same result if retested. It is important that quality measures are **feasible** in practice, with an emphasis on how the data supporting the measures are collected. Quality measures must be **usable**, which means that they should be clinically meaningful. The Agency for Healthcare Research and Quality (AHRQ) and the National Quality Forum have provided specific criteria to be considered when developing quality measures.



Several categories of quality measures can be used to measure the performance of healthcare systems: structure, process, outcome, and balancing. **Structure** refers to the *organizational characteristics* in healthcare delivery. Examples of organizational characteristics are the number of physicians and nurses in an acute care setting and the availability and use of systems such as electronic health records (EHRs). **Process** measures estimate how services are provided; examples are the percentage of families of children with asthma who receive an asthma action plan as part of their office visit and the percentage of hospitalized children who have documentation of pain assessments as part of their care. **Outcome** measures refer to the final health status of the child; examples are risk-adjusted survival in an intensive care unit setting, birthweight-adjusted survival in the neonatal intensive care unit (NICU) setting, and the functional status of children with chronic conditions such as cystic fibrosis. **Balancing measures** are often used to ensure changes in processes or systems do not have unintended consequence. If a healthcare system is actively working to reduce hospital length of stay for common conditions, it would be beneficial to ensure that hospital readmission rates are not increasing.

It is important to distinguish between measures for accountability and measures for improvement. Measures, particularly measures for accountability that may be linked to attribution and payment, must be based on a rigorous process (Fig. 4.6). This can be resource-intensive and time-consuming. In contrast, measures for improvement serve a different purpose—to track incremental improvements linked to specific QI efforts. These may not undergo rigorous testing, and they often have limited applicability beyond the specific QI setting.

Quality data can be quantitative and qualitative. *Quantitative* data includes numerical data, which can be *continuous* (patient satisfaction scores represented as a percentage, with higher numbers indicating better satisfaction) or *categorical* (patient satisfaction scores from a survey using a Likert scale indicating satisfactory, unsatisfactory, good, or superior care). Data can also be *qualitative* in nature, which includes nonnumerical data. Examples of qualitative data can include results from open-ended surveys related to the experience of care in a clinic or hospital setting.

Data measuring quality of care can be obtained from a variety of sources, which include chart reviews, patient surveys, existing administrative data sources (i.e., billing data), disease and specialty databases, and patient registries, which track individual patients over time. Sources of data vary in terms of reliability and accuracy, which will influence *rigor* and therefore appropriate-use cases for the data; many national databases invest significant resources in implementing processes to improve data reliability and accuracy. Data quality can become a significant impediment when using data from secondary sources, which can adversely affect the overall quality evaluation.

Health information technology (HIT) is a critical component in the effort to improve quality. EHRs have resulted in an unprecedented rise in available healthcare data, including traditional, structured data fields such as patient demographic and billing diagnosis codes, as well as unstructured data such as written clinician documentation in notes and imaging studies. The 21st Century Cures Act aims to facilitate the exchange and use of electronic health information “without special effort” on the part of the user. The Cures Act was designed to address concerns about interoperability and usability of electronic health systems, which can be barriers to care, improvement, and research.

The potential applications of big data in quality improvement are far reaching and include advancements in clinical informatics designed to better predict, manage, and treat common illnesses and provide effective, evidence-based, real-time, clinical decision-making support. For example, the Hospital for Sick Children at the University of Toronto is using a real-time data gathering and analysis framework to detect subtle changes on infant heart monitors that may predict potential cases of late-onset neonatal sepsis.

## ANALYZING QUALITY DATA

The classic statistical approach from a research paradigm has been applied to quality data for comparing trends over time and differences before and after an intervention. Another approach from an improvement science paradigm uses techniques such as run charts and statistical process control (SPC) charts to track data longitudinally to assess for changes in a system over time. There are several advantages to using run or SPC charts when analyzing quality

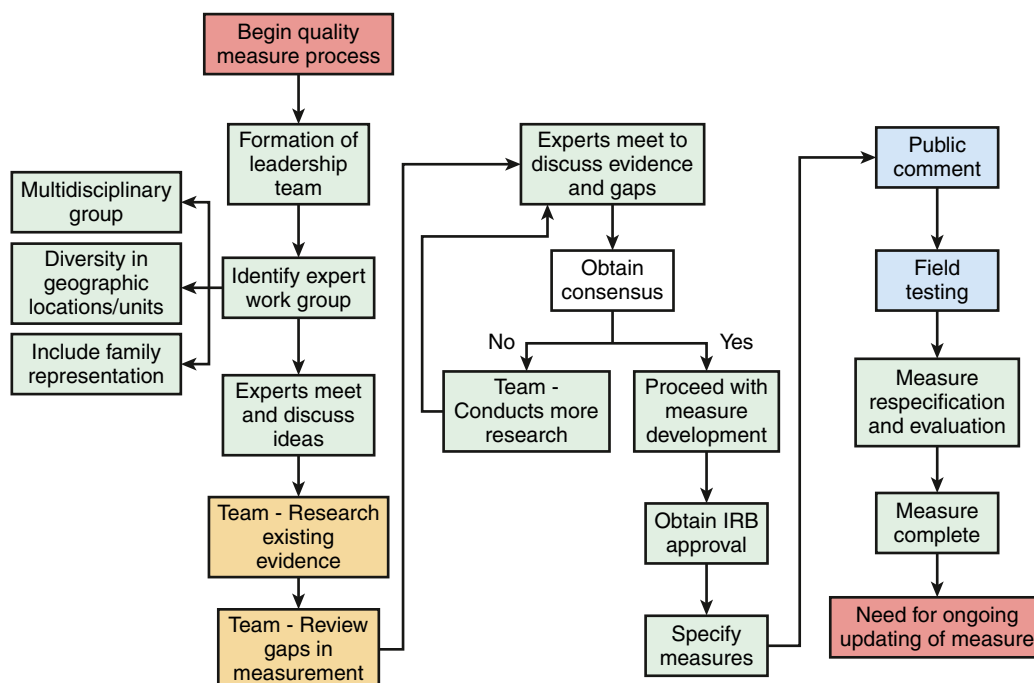
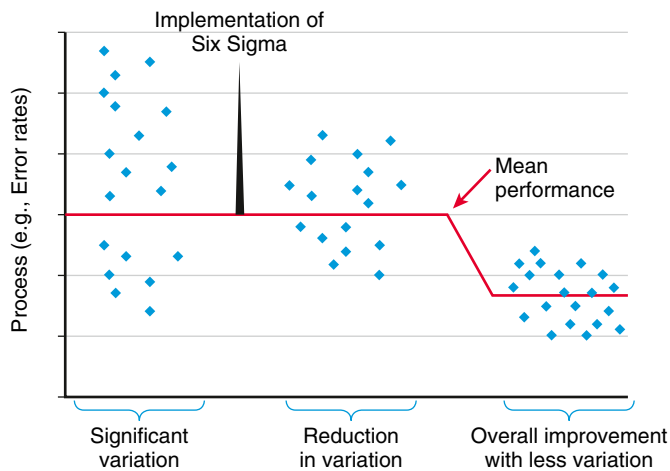


Fig. 4.6 Development of a rigorous quality measure.



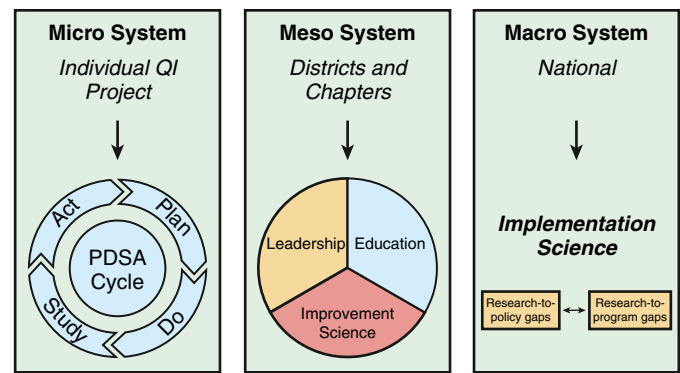
**Fig 4.7** Run or SPC chart with common cause and special cause variation.

data—for example, these tools allow evaluation of the effectiveness of various interventions in near real time. Additionally, when using an SPC chart QI teams can also more clearly assess how variation in a process or system is changing over time. Two types of variations are important to distinguish between. **Random variation**, also called *common cause variation*, refers to the variation that is inherent in a process and is expected in any system. In contrast, **special cause variation** refers to nonrandom variation that can affect a process and implies something in the system has been perturbed. When tracking infection rates in a nursery, for example, a sudden increase in the infection rates may be secondary to a planned or unexpected change in a product or supply critical to infection prevention. This would represent a special cause variation; once the supply issue is resolved or mitigated, the system perturbation is resolved, and the infection rates will likely go back to the baseline level. Alternatively, improvement ideas are intended to perturb the system positively such that outcomes improve, ideally without exacerbating the variation in the system (Fig. 4.7). Both run and SPC charts have established rules to assess for special cause variation or a statistically significant change in a process or system over time.

### EXPANDING INDIVIDUAL QUALITY IMPROVEMENT INITIATIVES TO SCALE

Despite the success of individual QI projects, the overall progress to achieve large-scale improvements to reach all children across the spectrum of geographic location and SES remains limited. This contributes to the health disparities that persist for children, with significant differences in access and quality of care. A potential factor that limits the full impact of QI is the lack of strategic alignment of improvement efforts with hospitals, health systems, and across states.

This challenge can be viewed from a system standpoint in being able to conduct and expand QI from a micro level (individual projects), to the meso level (regional), to the macro level (national and international). The learning from individual QI projects for addressing specific challenges can be expanded to the regional level by ensuring that there is optimal leadership, opportunity for education, and adoption of improvement science (Fig. 4.8). To further expand the learning to a national and international level, it is important to leverage implementation science to allow a strategic approach to the identification of the key factors that influence success. To leverage fully the synergies in order to impact the quality of care delivered to children, it is important for national and international healthcare organizations to collaborate effectively from a knowledge management and improvement standpoint (Table 4.2).



**Fig. 4.8** Progressing from small scale to large scale quality improvement.

### COMPARING AND REPORTING QUALITY

At the health system level, there is an increasing emphasis on quality reporting in healthcare in the United States. Many states have mandatory policies for the reporting of quality data. This reporting may be tied to reimbursement using the approach of pay-for-performance (P4P), which implies that reimbursements by insurers to hospitals and physicians will be partially based on the quality metrics. An extension of the P4P concept relates to the implementation of the policy of **nonreimbursable hospital-acquired conditions**, formerly called *never events* by the Centers for Medicare and Medicaid Services (CMS). CMS has identified a list of hospital-acquired conditions, which are specific quality events that will result in no payment for subsequent care provided to patients, such as wrong-site surgery, central line-associated bloodstream infections (CLA-BSIs), and pressure ulcers. This approach has not yet been widely implemented for pediatric patients.

There are growing, internet-based, commercial platforms for sharing information about patient and family experiences of care with specific clinical sites and specific providers. Many children's hospitals have also developed their own websites for voluntarily reporting their quality information, including ratings of care experiences. Although greater transparency may provide a competitive advantage to institutions, the underlying policy goal of transparency is to improve the quality of care being delivered and for families to be able to make informed choices in selecting hospitals and providers for their children.

When comparing quality measures across clinical settings, it is important to perform risk adjustments. **Risk adjustment** is the statistical concept that uses measures of underlying severity or risk so that the outcomes can be compared in a meaningful manner. The importance of risk adjustment was highlighted in the pediatric intensive care unit (PICU) setting many years ago. The unadjusted mortality rate for large tertiary care centers was significantly higher than that for smaller hospital settings. However, after **severity of illness** risk adjustment, it was subsequently shown that the risks in tertiary-care, large PICUs were higher because patients had, in general, greater severity of illness. Although this concept is intuitive for most clinicians, the use of severity of illness models allows mathematical estimates of patient severity using physiologic and laboratory data and permits meaningful comparisons of the outcomes across institutions, which may care for patient populations varying in complexity and acuity.

At the individual physician level, quality measures may also be used for purposes of certification as part of the MOC process. In the past, specialty and subspecialty certification in medicine, including pediatrics, was largely based on demonstrating a core fund of knowledge by being successful on an examination. Further, no specific evidence of competency in actual practice needed to be demonstrated beyond successful completion of a training program. However, significant variation in practice patterns among

**Table 4.2** National Organizations Involved in Pediatric Quality Improvement (QI)

ORGANIZATION	ROLE	ACTIVITIES
American Academy of Pediatrics (AAP)	Represents more than 60,000 pediatricians and pediatric subspecialists worldwide	Resources for QI to improve health for all children, best practices, advocacy, policy, research and practice, and medical home
American Board of Pediatrics (ABP)	Certifying board for pediatrics and pediatric subspecialties	Certification policies and resources for activities such as Maintenance of Certification (MOC)
American Medical Association (AMA)	Physician member association	Physician Consortium for Performance Improvement (PCPI)—physician-led initiative
Children's Hospital Association (CHA)	Formerly the National Association of Children's Hospitals and Related Institutions and the Child Health Corporation of America	Databases, QI collaboratives, and policy
Institute for Healthcare Improvement (IHI)	QI organization for adult and pediatric care	QI collaboratives, QI educational workshops and materials
National Initiative for Child Health Quality (NICHQ)	QI organization for pediatric care	QI training, improvement networks
The Joint Commission (TJC)	Hospital accreditation organization	Unannounced surveys to evaluate quality of care in hospitals
National Committee for Quality Assurance (NCQA)	QI organization	Healthcare Effectiveness Data and Information Set (HEDIS) and quality measures for improvement
National Quality Forum (NQF)	Multidisciplinary group including healthcare providers, purchasers, consumers, and accrediting bodies	Endorsing national quality measures, convening expert groups, and setting national priorities

physicians who are board certified has demonstrated how medical knowledge is important, but not sufficient, for the delivery of high-quality care. In response, the American Board of Medical Specialties, including its member board, the American Board of Pediatrics, implemented the MOC process in 2010. Within the MOC process, there is a specific requirement (Part IV) for the physician to demonstrate the assessment of their quality of care and implementation of improvement strategies as part of recertification in pediatrics and pediatric subspecialties. Lifelong learning and the translation of learning into practice are the basis for the MOC process and an essential competency for physicians' professionalism. This concept has also filtered in to graduate medical education, as demonstrated by the Accreditation Council for Graduate Medical Education requirement for residency programs to incorporate QI curriculum to ensure that systems-based practice and QI are part of the overall competencies within accredited graduate medical training programs.

### IMPLICATIONS OF THE U.S. HEALTHCARE REFORM FOR QUALITY

Regarding quality of healthcare for children, healthcare reform efforts had three key implications. First, expanded insurance coverage optimized access and include expanded coverage for young adults to age 26 years. Second, various initiatives related to quality, safety, patient-centered outcomes research, and innovation were implemented and funded. For example, the AHRQ funded a national effort to establish 7 centers of excellence through the **Pediatric Quality Measurement Program (PQMP)** to improve existing pediatric quality measures and create new measures that can be used by states and in a variety of other settings to evaluate quality of care for children. Third, reform advocated a paradigm

shift in the existing model of healthcare delivery from vertical integration toward a model of *horizontal* integration. This has led to the creation and rapid growth of integrated delivery systems and risk-sharing relationships through **accountable care organizations (ACOs)**. Population health outcomes from these changes remain uncertain, although it appears healthcare cost inflation may have slowed somewhat.

Another area of increasing emphasis is **population health**. This is important because it expands the traditional role of physicians to improve quality of care for individual patients to also improve the quality of care for larger populations. Populations can be defined by geographic constraints or disease/patient condition. Efforts to link payment and reimbursement for care delivery by physicians and health systems are being increasingly tied to measurable improvements in population health and demonstration of improved value. To achieve a meaningful improvement in population outcome, physician practices will need to embrace the emerging paradigm of practice transformation, whose many facets include the adoption of a **medical home**, the seamless connectivity across the primary care and subspecialty continuum, and a strong connection between the medical and social determinants of healthcare delivery. To implement successful practice transformation, health systems are increasingly striving to evolve to serve children across the entire range of the care continuum, including preventive and primary care and acute hospital care, and to partner with community organizations for enhancing social supports. In addition, new risk-sharing payment models are being developed, such as value-based purchasing, which represent a financial risk-sharing model across primary and subspecialty care and hospitals.

Visit Elsevier eBooks+ at [eBooks.Health.Elsevier.com](http://eBooks.Health.Elsevier.com) for Bibliography.

## Chapter 5

## Safety in Healthcare for Children

Patrick W. Brady, Tina K. Sosa, and  
Jeffrey M. Simmons

Children may be harmed by the healthcare that aims to make them better. Such harms include central line–associated bloodstream infections (CLA-BSIs) and medication errors. In 1991 the Harvard Medical Practice Study reviewed adult medical records from New York State and found that adverse events occurred in an estimated 3.7% of hospitalizations. Most events gave rise to serious disability, and 13.6% led to death. The National Academy of Medicine estimated that as many as 98,000 Americans per year die in the hospital from medical errors.

Although fewer data are available for children, it is evident that children experience substantial healthcare-related harm. Nationally, hospitalized children experience approximately 1,700 CLA-BSIs and 84,000 adverse drug events each year. Although the evidence is less robust, and not without controversy, substantial progress has been reported, particularly in **healthcare-associated conditions (HACs)**. Less strong epidemiologic estimates are available for adverse events in the ambulatory environment, but these events are likely more common than reported.

The **Solutions for Patient Safety (SPS)** collaborative includes >145 children's hospitals across the United States and Canada (<http://www.solutionsforpatientsafety.org>) and uses a learning network model to pursue the aim of eliminating serious harm across all children's hospitals. In addition, healthcare has recognized the high rates of healthcare worker injury and the critical role that the safety of healthcare providers plays in outcomes, burnout, and safe patient care.

### ERROR VS HARM

Clinical leaders, improvers, and researchers often employ measures of error and harm to understand and improve safety, but the differences between these two measures can lead to confusion. **Errors** occur when a member of the healthcare team does the wrong thing (*error of commission*) or fails to do the right thing (*error of omission*); errors of omission (e.g., not arriving at the right diagnosis) are considerably more difficult to measure. **Harm**, as defined by the Institute for Healthcare Improvement, is “unintended physical injury resulting from or contributed to by medical care (including the absence of indicated medical treatment), that requires additional monitoring, treatment, or hospitalization, or that results in death.” Most errors in healthcare do not lead to harm; harm may be both preventable and nonpreventable (Fig. 5.1). A physician may erroneously fail to add a decimal point in a medication order for an aminoglycoside antibiotic, ordering a dose of 25 mg/kg rather than the intended dose of 2.5 mg/kg. If this error is caught by the computerized order entry system or the pharmacist, this would be an error with no resultant harm. If this error was not caught and reached the patient, who suffered acute kidney injury, this would be *preventable* harm since evidence shows that pharmacist review can reduce the risk of these errors 10-fold. Alternatively, if a patient received a first lifetime dose of amoxicillin and had anaphylaxis requiring hospital admission, this harm would be considered *non-preventable* since no valid predictive tests are available for antibiotic allergy. Furthermore, the concept of **latent risk**, independent of any actual error, is inherent in any system where patients can be harmed. Among errors that do not lead to harm, **near misses** that

do not reach patients—or high-risk situations that do not lead to harm because of good fortune or mitigation—are important learning opportunities about safety threats.

Several classification systems exist to rate harm severity, including the National Coordinating Council for Medication Error Reporting and Prevention (NCC-MERP) Index for medication-related harm and the severity scales for all-cause harm. **Serious safety events (SSEs)** are deviations from expected practice followed by death or severe harm. The SPS collaborative has SSE elimination as its primary goal. **Sentinel events** or **never events**, such as a wrong-site surgery, are also targets of external reporting and for elimination through quality improvement (QI) initiatives (see Chapter 4). Increasingly, health systems are using a *composite serious harm index*, which combines a variety of preventable HACs (e.g., CLA-BSIs) to examine system safety performance over time across various patient populations and sites of care.

### SAFETY FRAMEWORKS

Safety frameworks are conceptual models and tools to help clinicians, improvers, and researchers understand the myriad contributors to safe healthcare and safety events. Healthcare is delivered in a complex system with many care providers and technologies, such as electronic health records and continuous physiologic monitors. The Donabedian framework, which links structure, process, and outcome, can be a very useful tool. The **Systems Engineering Initiative for Patient Safety (SEIPS)** model, developed by human factors engineers, cognitive psychologists, and physicians, provides more detailed tools to understand the work system and the complex interactions between people (including the patient and family) and task work and technology and the environment. The SEIPS 3.0 model uses the concept of the “patient journey” to describe a patient's interactions with multiple complex and separate care settings over time. Other available safety frameworks include those from the Institute for Healthcare Improvement. The “Swiss cheese” model illustrates how multiple components of an organization's defenses prevent failures from leading to harm, but harm may occur when multiple defenses fail at the same time (Fig. 5.2).

Traditionally, safety science and improvement have focused on identifying *what went wrong* (near misses, errors, and harm) and then tried to understand and improve the system of care that led to these events (Safety-I framework). There is increasing focus on *what goes right*. This framework, called *Safety-II*, brings focus on the much greater number of things that go right and how people act every day to create safety in complex and unpredictable systems. Safety-II seeks to learn from people, the greatest source of system resilience, particularly in the midst of high levels of risk and stress, as often seen in healthcare.

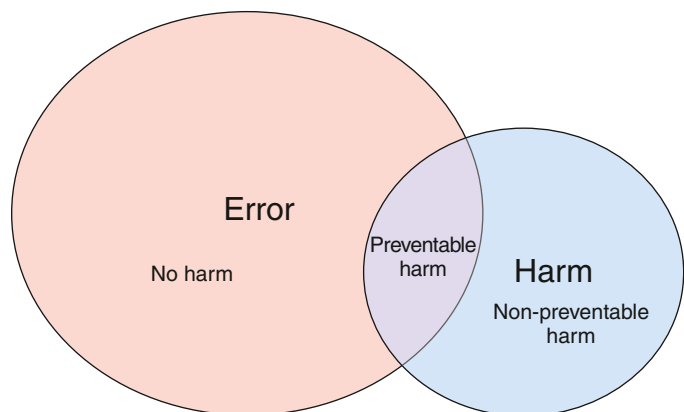
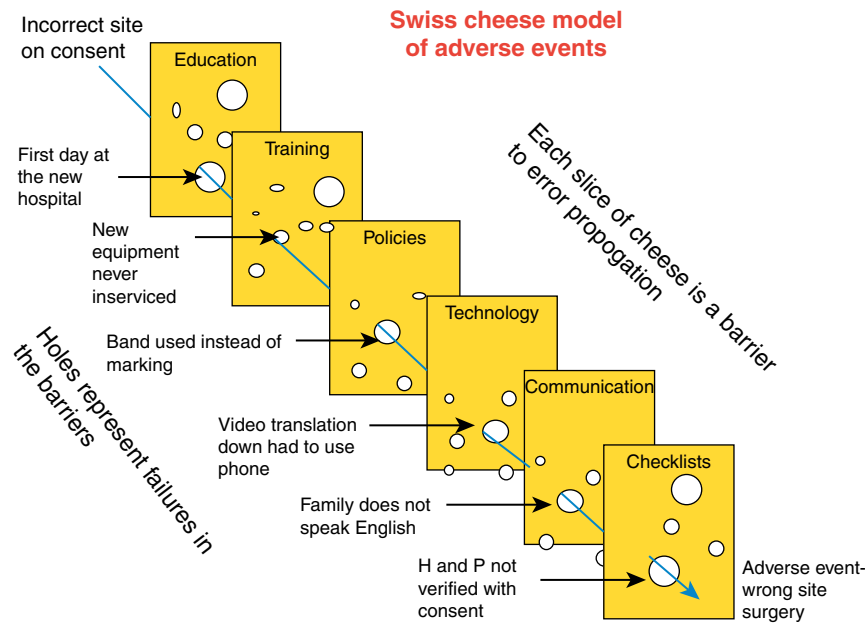


Fig. 5.1 Overlap between error and harm.





**Fig. 5.2** The Swiss cheese model of adverse events. (From Stein JE, Heiss K. *The Swiss cheese model of adverse event occurrence—Closing the holes*. *Semin Pediatr Surg.* 2015;24(6):278–282.)

## IDENTIFYING AND ANALYZING HARM, ERRORS, AND LATENT THREATS

Health systems use a toolbox of processes to discover, understand, and mitigate unsafe conditions.

### Incident Reporting Systems

Many health systems and hospitals offer employees access to a system to report errors, harms, or near misses. Most frequently, these are anonymous so that healthcare workers feel safe to submit an event in which they may have been involved or when the harm involved someone in a position of authority. Ideally, these systems facilitate smooth and efficient entry of enough information for further review but avoid excessive burden of time or cognitive load on the reporter. **Incident reporting** systems likely work best in the presence of a strong safety culture and when employees have some confidence that the event will be reviewed and actions taken. The chief limitation of incident reporting systems is that incident reports dramatically *underreport* safety events. Thus other mechanisms must also be in place to learn about safety. **Trigger tool** systems use *triggers*, such as the need for an antidote to an opioid overdose or the transfer of a patient to higher-level care, to facilitate targeted medical record review by trained nurses and physicians to elucidate any errors or system risks.

### Simulation

Simulation is an excellent tool to better understand system and latent threats. *High-fidelity simulation*, which involves the use of a manikin that can reproduce or mimic human anatomy and physiology, can allow clinicians to practice technical skills such as intubation in a safe environment. Perhaps more importantly, simulation can help clinical teams improve nontechnical skills such as using closed-loop communication and sharing a mental model (e.g., a team leader states, “I believe this patient has septic shock. We are rapidly infusing fluids and giving antibiotics. Blood pressure is normal for age. What other thoughts does the team have?”). It is often easier and more feasible to give feedback in a simulated scenario versus a real event.

*Low-fidelity simulation* does not require costly simulated patients and may have advantages in identifying latent threats in the hospital or clinic. For example, a simulated scenario on a medical-surgical unit might identify that nurses do not know where to find a mask

for continuous positive airway pressure (CPAP) to support an infant with respiratory failure. Identifying—and then mitigating—this latent threat in a simulated environment is preferable to doing so in an acutely deteriorating child.

### Event Analysis

Several types of event analysis, including root cause analysis, apparent cause analysis, and common cause analysis, can help teams understand—and later mitigate—the causes of adverse events. Each model has its own strengths and weaknesses. **Root cause analysis (RCA)** is a robust and time-intensive process to ascertain the most fundamental, or *root*, causes of a safety event. The Joint Commission requires the use of RCA on sentinel events. Most health systems reserve this methodology primarily for sentinel events, because RCAs can take months to complete and require convening a multidisciplinary team of experts. The safety event and its antecedents are reviewed in detail with a focus not on human behavior, but instead on systems, hazards, and latent errors. The RCA team works to go beyond the event (e.g., enteral formula feeds connected to and administered through a central line) to the proximal causes (e.g., “feeding tube and intravenous tubing are visually identical and are easily attached”) and root cause (e.g., “organization lacks a system to assess human factors risks as new equipment is procured and put into practice”). When root causes are identified and tied to robust improvement action plans, safety can be substantially improved (e.g., “we will design feeding tubing and intravenous tubing to be distinct and incompatible”). In addition to the time-intensive nature of RCAs, *hindsight bias* is a risk and needs to be managed carefully by the team. Additional challenges with RCAs include the potential to *overfit solutions*—designing protocols or procedures that may have reduced the risk of the specific safety event reviewed but also introduce new problems and increase the probability of other safety threats—as well as difficulties in spreading solutions to different care areas that often have different needs, processes, and goals.

Apparent cause analysis, common cause analysis, and failure modes and effects analysis are complementary learning methods. **Apparent cause analysis** is performed by a smaller multidisciplinary team to look primarily for proximal causes, making it feasible for events that occur often (e.g., the wrong medication is sent from the pharmacy). Importantly, in each analysis the team works to determine how likely it is that such an event will occur in the

future and how widespread the proximate causes are in the micro-system. **Common cause analysis** seeks to aggregate learning across multiple events. A similar common cause, such as poor handoff procedures, may lead to different safety events (e.g., a missed laboratory check and a delayed diagnosis); common cause analysis aids leaders in determining this. **Failure mode and effects analysis (FMEA)** is a powerful tool that clinicians use to describe a process and identify *failure modes*, or ways in which each step might fail. A more robust and quantitative form of FMEA rates potential failure modes in three categories: probability of event occurring, its severity, and its ability to be detected. The product of these, called the *risk priority number*, can help a team identify which failure modes may lead to the greatest harm and thus which to target first.

## SAFETY CULTURE

A broad and supportive safety culture likely drives both patient and employee safety outcomes. An organization with a mature safety culture fosters a culture of learning and treats errors as opportunities to improve the system, rather than as the personal failures of individual clinicians. *Just culture* differentiates the mistakes and wrong decisions that a clinician makes commensurate with their training and experience from willful violations and gross or repeated patterns of negligence. A safety culture prioritizes clear and consistent communication and teamwork and aims to ease authority gradients (described later). Several tools are available to measure safety culture, including the Safety Attitudes Questionnaire and the Agency for Healthcare Research and Quality (AHRQ) surveys on Patient Safety Culture. A strong safety culture supports transfer of responsibility within disciplines at handoffs and across disciplines (e.g., when a nurse is calling a physician with a new concern). Structured communication tools such as the **Situation-Background-Assessment-Recommendation (SBAR)** approach are valued in a safety culture, as are safety behaviors such as “repeat back or write back,” when a critical laboratory result is shared and repeated back by the receiving clinician.

*Authority gradients* are quite real in healthcare. In a culture of safety, both junior and senior clinicians work together across disciplines to speak up when concerns are identified, to ask questions, and not to proceed if there is uncertainty about safe patient care. Health system leaders have a critical role in supporting this culture, orienting new employees to its importance, and stepping in if authority gradients or disruptive behaviors contribute to safety events or unsafe conditions. To address the adverse impact of the healthcare hierarchy on providing safe care, recent efforts have focused on *psychologic safety*. Psychologic safety is defined as the ability to raise concerns and ask questions without the fear of negative consequences for self-image, status, or career. This concept is critical for multiple aspects of safety culture, including establishing a shared mental model, event reviews and debriefs, addressing professionalism concerns, and effectively partnering with patients and families to pursue safety goals.

## RELIABILITY SCIENCE, HUMAN FACTORS ENGINEERING, AND HIGH-RELIABILITY ORGANIZATIONS

*Reliability* in healthcare is defined as the measurable capability of a process, procedure, or health service to perform its intended function in the required time under commonly occurring conditions. Most processes in healthcare organizations currently perform at **Level 1** reliability, meaning a success rate of only 80–90%. To achieve **Level 2** performance ( $\leq 5$  failures/100 opportunities), processes must be *intentionally designed* with tools and concepts based on the principles of **human factors engineering** and **reliability science**. These processes include creating intentional redundancy, such as independent verification on high-risk medication dosing, and making the default action the desired action based on evidence, such as a default to an influenza vaccination for high-risk patients

with asthma. Performance at **Level 3** ( $\leq 5$  failures/1,000 opportunities) requires a well-designed system with low variation and cooperative relationships and a state of “mindfulness,” with attention to processes, structure, and their relationship to outcomes.

Healthcare can learn important safety lessons from disciplines such as human factors engineering and cognitive psychology. Industries that better leverage learnings from these disciplines—and robustly identify and mitigate threats and use simulation—include commercial aviation and nuclear power, termed *high-reliability organizations*. These organizations achieve exemplary safety records under dynamic and high-risk conditions through consistent application of five tenets: (1) a preoccupation with failure—surprises and errors are thought of as learning opportunities, and learnings spread quickly through the organization, (2) reluctance to simplify interpretations—serious safety events receive an RCA, (3) sensitivity to operations—proactive assessments and huddles target risks to patients and the organization, (4) a commitment to resilience—errors do not disable, and high-risk, uncommon scenarios are negotiated, and (5) deference to expertise—leaders defer to frontline experts when their knowledge is required.

## SERIOUS HARM EVENTS AND HEALTHCARE-ASSOCIATED CONDITIONS

Substantial improvement in patient safety has occurred through improvement teams targeting *serious harm* events. The **serious harm event rate** is a composite metric that groups preventable HACs into one number (usually a rate per at-risk patient-days), so that an organization or collaborative can track progress on a variety of conditions with one metric and chart. [Table 5.1](#) lists frequently targeted HACs. Commonalities among successful improvement teams targeting these HACs include multidisciplinary team membership, clear outcome definitions and measurement, learning systems around each HAC, and attention to both process and outcome measures. Many of the successes with CLA-BSIs were associated with targeted improvements to reliably adhere to a line insertion bundle and a line maintenance bundle. [Figure 5.3](#) illustrates coincident improvements in process measures and outcomes measure in a hypothetical CLA-BSI project. In this case, after improvement interventions targeted two process measures known to be important in CLA-BSI risk—the line insertion and the line maintenance bundles—the QI team saw improvement in both measures and coincident reduction in CLA-BSIs.

A safety culture and experienced improvement teams are consistent drivers of success. A **learning network model**, as used in SPS, is effective in bringing project teams together from different hospitals to discuss lessons learned and common barriers faced and negotiated.

## SAFETY OPPORTUNITIES AND GAPS

In addition to HACs, several other safety events are the targets of active study and improvement. Unrecognized clinical deterioration in hospitalized children, diagnostic error, poor handoffs across multiple stakeholders, and alarm/alert fatigue lead to substantial and preventable harm. There are also important considerations for improving safety in unique sites of care, including the surgical and ambulatory environments. Additionally, it is increasingly clear that patient safety improvements might be limited if the field does not also target improved occupational safety of those who provide care.

### Clinical Deterioration

The deterioration of hospitalized patients is rarely a sudden and unpredictable event; rather, it is often preceded by abnormal vital signs and concerns from patients, families, and clinicians. **Rapid response systems** are designed to detect deterioration and then deploy teams with critical care expertise to provide treatment or escalate care to an intensive care unit (ICU). Although variation remains in how these teams

**Table 5.1** Common Healthcare-Associated Conditions (HACs) Targeted in Quality Improvement Efforts with Interventions

HAC	DEFINITION	COST PER EVENT	POTENTIALLY EFFECTIVE INTERVENTIONS
Central line–associated bloodstream infections	Laboratory-confirmed bloodstream infection with central line in place at time of or 48 hr before onset of event (details at <a href="https://www.cdc.gov/nhsn">https://www.cdc.gov/nhsn</a> )	\$55,646	Line insurance bundle (e.g., handwashing, chlorhexidine scrub), maintenance bundle (catheter care, change dressing, discuss daily if catheter is needed)
Catheter-associated urinary tract infections	Urinary tract infection where an indwelling urinary catheter was in place >2 days on day of event (details at <a href="https://www.cdc.gov/nhsn">https://www.cdc.gov/nhsn</a> )	\$7,200	Protocols for reviewing and removing catheters daily, clear indications for inserting catheters, physician champions, audit and feedback of data
Adverse drug events	Harm associated with any dose of a drug (details at <a href="http://www.nccmerp.org/types-medication-errors">http://www.nccmerp.org/types-medication-errors</a> )	\$3,659	Pharmacist review of medication order, computerized physician order entry, co-ordering of laxatives in patients on opiates
Peripheral IV infiltrates	Moderate or serious harm (e.g., diminished pulses, >30% swelling) associated with a peripheral IV infiltrate (details at <a href="http://www.solutionsforpatientsafety.org">http://www.solutionsforpatientsafety.org</a> )	—	Hourly reviews of IV status, limitations on use of desiccants through peripheral IVs, remove IVs when no longer needed
Pressure injuries	Localized damage to skin and/or underlying soft tissue usually over a bony prominence or related to a device (details at <a href="http://www.solutionsforpatientsafety.org">http://www.solutionsforpatientsafety.org</a> )	—	Screening of high-risk patients (e.g., Braden Q Scale), regular turning of low-mobility patients, regular inspection and skin care; specialized device padding
Surgical site infections	Infection of incision or deep tissue space after operative procedure (details at <a href="https://www.cdc.gov/nhsn">https://www.cdc.gov/nhsn</a> )	—	Surgical checklist, antimicrobial prophylaxis within 60 min before incision, preoperative baths, postoperative antibiotic redosing
Venous thromboembolism	Blood clot in deep vein, stratified as central line–associated vs not (details at <a href="https://www.cdc.gov/nhsn">https://www.cdc.gov/nhsn</a> )	\$27,686	Screening for high-risk patients, removal of central line catheters when no longer needed, targeted prophylaxis

are activated and staffed, all U.S. children’s hospitals have some version of a rapid response system. The initiation of rapid response teams is associated with a significant reduction in codes outside the ICU and in-hospital mortality.

**Pediatric early warning scores (PEWS)** are used in many large children’s hospitals to identify deteriorating patients by assigning scores based on the degree of abnormalities in different body systems. Different versions of PEWS are often employed, but all include scores driven by age-based vital signs and nursing assessments in areas such as mental status and perfusion. Importantly, PEWS take these diverse exam elements and combine them into a single score, which when coupled with clear, expected actions (e.g., evaluation by physician at score of 5, evaluation by rapid response team at score of 7) may better detect deterioration and improve safety outcomes.

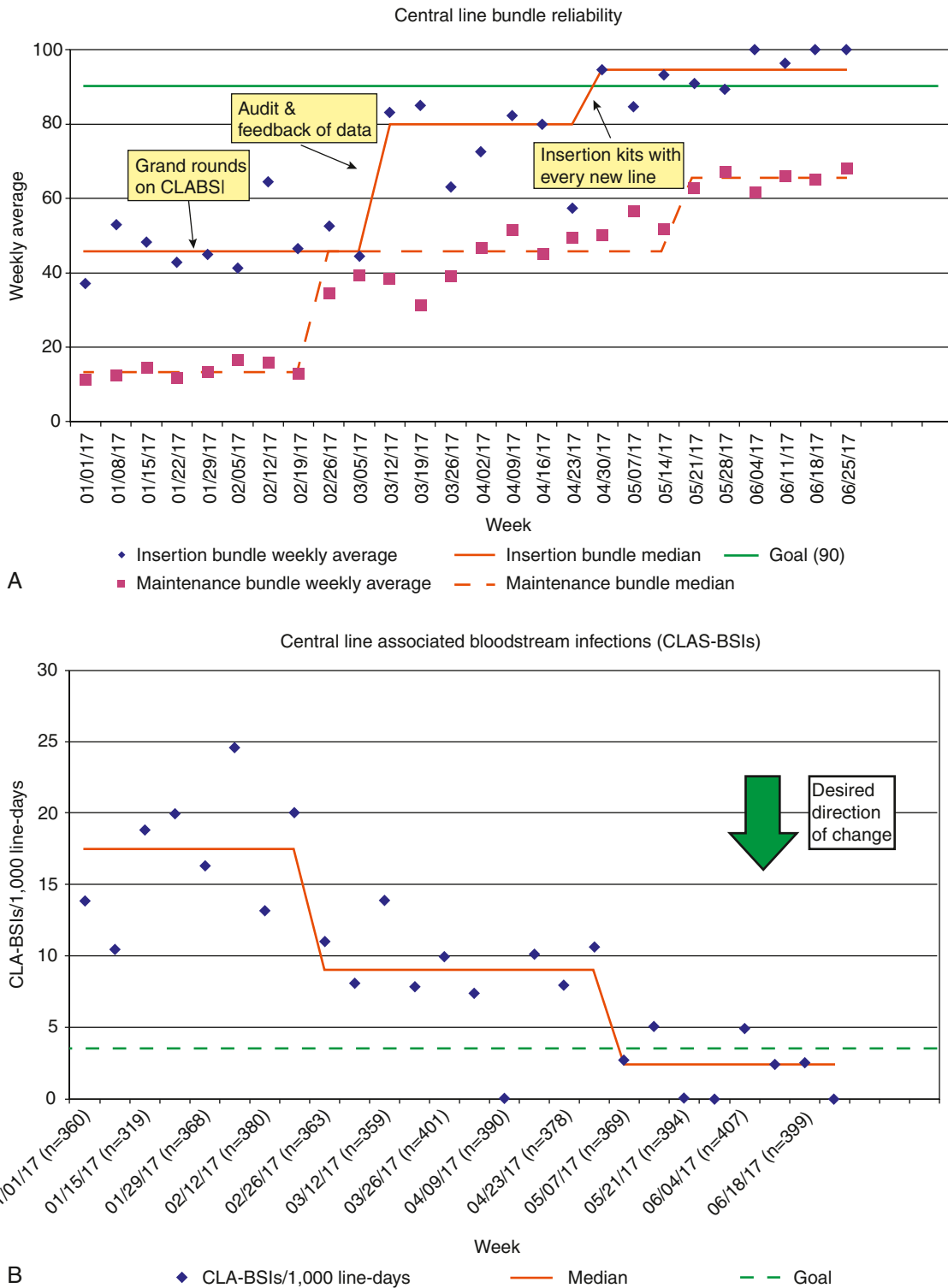
PEWS are one method of improving a clinician’s *situation awareness*—the sense of what is going on around the clinician, the notion of what is important, and the anticipation of future consequences. Maintaining situation awareness can be challenging in dynamic, high-risk environments such as healthcare. Work at several children’s hospitals to improve situation awareness has been associated with sustained and significant reductions in unrecognized clinical deterioration. This improvement work first designed systematic and proactive identification of *watcher* patients, or those a nurse, physician, or patient family felt were close to the edge of deterioration. These high-risk patients are discussed at multidisciplinary bedside “huddles,” and specific treatment plans and predictions are outlined. Concerns are more fully addressed through the rapid response team and at hospital-wide safety huddles and safety rounds. To gain a better sense of organization safety and performance threats, many hospitals in the SPS collaborative employ a daily safety or operations brief, where leaders from a variety of service lines (e.g., inpatient, pharmacy, perioperative care) can discuss unexpected events and rapidly develop solutions and follow-up plans to mitigate emerging threats that cross disciplines. Event debriefs and reviews

are particularly relevant for instances of clinical deterioration. They serve multiple purposes, including the emotional processing of an event, a discussion of the process of care and team performance, and the development of action plans to improve care in the future. The Pediatric Resuscitation Quality Collaborative (pediRES-Q: <https://www.pedires-q.org/>) classifies debriefs into two types: (1) “hot” debriefs, which occur minutes to hours after the event and allow for emotional processing and educational discussion, and (2) “cold” debriefs, which occur days to weeks after the event and allow for a comprehensive, multidisciplinary review of all data and feedback. Current research and improvement efforts in this area are focused on developing successful frameworks to guide discussions and action plan development, such as formal processes for classifying and reviewing cardiac arrest events in the pediatric ICU.

Cardiopulmonary arrest rates outside of the ICU are useful metrics to evaluate the performance of rapid response systems in adult patients. Given that these events are quite rare in pediatrics, and increasingly so since the implementation of rapid response systems, the identification of valid, more frequent proximal metrics is a focus of research efforts. [Table 5.2](#) describes proximal metrics to arrest and the types of code events used to identify risk factors for unrecognized deterioration and evaluate rapid response system effectiveness in pediatrics.

### Diagnostic Error

Diagnostic error is recognized as an increasingly common and impactful event, with 10–15% of diagnoses estimated to be incorrect. There are two systems of clinical decision-making. **System 1** is fast, instinctual, and largely unconscious. **System 2** is slow, effortful, cognitive, and calculating. System 1 and its *heuristics* or *biases* allow for quick—almost automatic—decision-making, often by associating new information with existing patterns or beliefs (e.g., that red object on the right side of the road is a stop sign; I should stop). However, system 1 thinking can be dangerous in diagnosis, particularly when new data are unconsciously made to fit the preconceived pattern and



**Fig. 5.3** Quality improvement interventions targeted process improvement in the A, line insertion bundle, where performance improved from 46% to 95%, and B, line maintenance bundle, where performance improved from 13% to 66%. Coincident with the improved bundle performance, the rate of CLA-BSIs fell from 17.6 to 2.5 per 1,000 line-days.

are not seen as disconfirming. Research in this area aims to better understand how well-described cognitive biases (e.g., premature closure, availability bias) play out in clinical care and what system-based strategies can mitigate their effects (Tables 5.3 to 5.5). There are ongoing efforts to move clinicians from system 1 to system 2 thinking, such as being explicit on uncertainty (e.g., patients admitted from the emergency department [ED] as “uncertain diagnosis”) or using

decision aids to prompt revisiting provisional diagnoses such as the diagnostic time-out or team-based (collective intelligence) thinking (Tables 5.6 and 5.7). Safety culture is critical to both the open acknowledgment of diagnostic uncertainty and the willingness to discuss and learn from diagnostic error when it occurs.

The 2015 National Academy of Medicine (NAM) report entitled *Improving Diagnosis in Health Care* emphasized the centrality of



**Table 5.2** Metrics to Identify Risk Factors for Unrecognized Deterioration Outside of the ICU and Evaluate Rapid Response System Performance

METRIC	REFERENCE	DEFINITION	STRENGTHS	LIMITATIONS
Unplanned ICU transfer	Baker 2009 Reese 2015	All patients unexpectedly admitted to the ICU from a lower level of care in the hospital Transfer to the ICU from the inpatient ward that was not expected or previously coordinated (such as a planned ICU admission postoperatively)	More common than code events and other proximal metrics to arrest High sensitivity for unrecognized deterioration	Low specificity for unrecognized deterioration Often requires time-intensive manual review of ICU transfers Site-specific parameters, including definition adjustments, and the acuity of patients cared for outside of the ICU
Critical deterioration event	Bonafide 2012	Noninvasive ventilation, intubation, or vasopressor initiation within 12 hr after ICU transfer	More common than emergency transfers and code events High sensitivity for unrecognized deterioration Increased specificity as compared with unplanned ICU transfers Objective criteria facilitating use in multicenter studies and collaboratives	Less specific than emergency transfers; may include patients with promptly recognized deterioration Often requires time-intensive manual review of ICU transfers
Emergency transfer	Brady 2013	Intubation, inotropic support, or 3 or more fluid boluses in the first hour after arrival or before ICU transfer	More common than code events High specificity for unrecognized deterioration Objective criteria facilitating use in multicenter studies and collaboratives Feasible to track in near-real time	Less common than critical deterioration events and unplanned ICU transfers
Significant clinical deterioration event	Parshuram 2018	Death, cardiopulmonary resuscitation, tracheal intubation, vasoactive medications, or $\geq 60$ mL/kg fluid boluses in the 12 hr before transfer, or death, cardiopulmonary resuscitation, tracheal intubation, or ECMO initiation within 1 hr after ICU transfer	More common than code events Objective criteria facilitating use in multicenter studies and collaboratives	Complex definition not inclusive of all interventions and outcomes associated with acute deterioration events Often requires time-intensive manual review of ICU transfers
Code event: Cardiopulmonary arrests (CPAs)	Children's Hospital Association	Pulselessness or pulse with inadequate perfusion necessitating chest compressions and/or electric shock	High specificity for unrecognized deterioration Objective criteria facilitating use in multicenter studies and collaboratives Feasible to track in near-real time	Less common than proximal metrics to arrest Low sensitivity for inadequately recognized, subacute cases of deterioration
Code event: Acute respiratory compromise (ARC)	Children's Hospital Association	Respiratory insufficiency with bag-valve mask or invasive airway interventions, followed by a transfer to a higher level of care for sustained airway support	High specificity for unrecognized deterioration Objective criteria facilitating use in multicenter studies and collaboratives Feasible to track in near-real time	Less common than proximal metrics to arrest Low sensitivity for inadequately recognized, subacute cases of deterioration Not inclusive of all nonrespiratory etiologies of deterioration

communication to patients and families in the diagnostic process while introducing a diagnostic process model with several important outcomes (Fig. 5.4). The diagnostic process occurs with iterative cycles of information gathering, its integration and interpretation, and the formulation of a working diagnosis. The NAM report brought particular emphasis to the diagnostic team, which includes doctors and nurses in different practice contexts (e.g., the ED and primary care), as well as pharmacists, respiratory therapists, patients, and families. Strategies that aim to leverage the diagnostic team, as opposed to simply the cognition of busy individuals, may be particularly well poised to improved patient-level and system-diagnostic outcomes.

### Handoffs/I-PASS

There is a growing evidence base on the consequences of poor handoffs and on complex interventions to improve handoffs and resultant

safety outcomes. The best-studied handoff is resident-to-resident shift handoff in teaching hospitals. Use of the **I-PASS** mnemonic—*illness severity, patient summary, action list, situation awareness and contingency planning, and synthesis by receiver*—and the surrounding educational quality improvement curriculum was associated with a significant 23% reduction in medical errors and 30% reduction in adverse events in a nine-hospital study. Related work has described improved communication by targeting ICU-to-floor, operating room-to-ICU, and inpatient medical team-to-primary care handoffs.

### Alarm/Alert Fatigue

**Alarm fatigue**, when a healthcare provider is subject to so many interruptions that a potentially relevant alarm is not heard, is also an area of active research and improvement. In the hospital, many physiologic monitor alarms occur each day (up to 400 per patient

**Table 5.3** Cognitive Biases Related to Heuristic Failure

BIASES	DEFINITION
Anchoring	Locking into a diagnosis based on initial presenting features, failing to adjust diagnostic impressions when new information becomes available
Confirmation bias	Looking for and accepting only evidence that confirms a diagnostic impression, rejecting or not seeking contradictory evidence
Diagnostic momentum	Perpetuating a diagnostic label over time, usually by multiple providers both within and across healthcare systems, despite the label being incomplete or inaccurate
Expertise bias/yin-yang out	Believing that a patient who has already undergone an extensive evaluation will have nothing more to gain from further investigations, despite the possibility that the disease process or diagnostic techniques may have evolved so as to allow for appropriate diagnosis
Overconfidence bias	Believing one knows more than one does, acting on incomplete information or hunches, and prioritizing opinion or authority, as opposed to evidence
Premature closure	Accepting the first plausible diagnosis before obtaining confirmatory evidence or considering all available evidence: "When the diagnosis is made, thinking stops"
Unpacking principle	Failing to explore primary evidence or data in its entirety and subsequently failing to uncover important facts or findings, such as accepting a biopsy report or imaging study report without reviewing the actual specimen or image; especially important in undiagnosed and rare diseases

From Bordini BJ, Stephany A, Kliegman R. Overcoming diagnostic errors in medical practice. *J Pediatr.* 2017;185:19–25, Table I.

**Table 5.4** Cognitive Biases Related to Errors of Attribution

BIASES	DEFINITION
Affective bias	Allowing emotions to interfere with a diagnosis, either positively or negatively; dislikes of patient types ("frequent flyers").
Appeal to authority	Deferring to authoritative recommendations from senior, supervising, or "expert" clinicians, independent of the evidentiary support for such recommendations.
Ascertainment bias	Maintaining preconceived expectations based on patient or disease stereotypes.
Attribution error	Placing undue importance on the perceived internal characteristics or motivations of others, whether they are the patient, the patient's family, or other members of the evaluation team.
Countertransference	Being influenced by positive or negative subjective feelings toward a specific patient.
Outcome bias	Minimizing or overemphasizing the significance of a finding or result, often based on subjective feelings about a patient, a desired outcome, or personal confidence in one's own clinical skills. The use of "slightly" to describe abnormal results.
Psych-out bias	Maintaining biases about people with presumed mental illness.

From Bordini BJ, Stephany A, Kliegman R. Overcoming diagnostic errors in medical practice. *J Pediatr.* 2017;185:19–25, Table II.

**Table 5.5** Cognitive Biases Related to Errors of Context

BIASES	DEFINITION
Availability bias	Basing decisions on the most recent patient with similar symptoms, preferentially recalling recent and more common diseases.
Base-rate neglect	Prioritizing specific information (e.g., a laboratory value) pertaining to a case while ignoring general base rate information about the prevalence of disease in populations (pretest probability).
Framing effect	Being influenced by how or by whom a problem is described or by the context in which the evaluation takes place.
Frequency bias	Believing that common things happen commonly and usually are benign in general practice.
Hindsight bias	Reinforcing diagnostic errors once a diagnosis is discovered despite these errors. May lead to a clinician overestimating the efficacy of his or her clinical reasoning and may reinforce ineffective techniques.
Posterior probability error	Considering the likelihood of a particular diagnosis in light of a patient's chronic illness. New headaches in a patient with a history of migraines may in fact be a tumor.
Representative bias	Basing decisions on an expected typical presentation. Not effective for atypical presentations. Overemphasis on disease-diagnostic criteria or "classic" presentations. "Looks like a duck, quacks like a duck."
Sutton's slip	Ignoring alternative explanations for "obvious" diagnoses (Sutton's law is that one should first consider the obvious).
Thinking in silo	Restricting diagnostic considerations to a particular specialty or organ system. Each discipline has a set of diseases within its comfort zone, which reduces diagnostic flexibility or team-based communication.
Zebra retreat	Lacking conviction to pursue rare disorders even when suggested by evidence.

From Bordini BJ, Stephany A, Kliegman R. Overcoming diagnostic errors in medical practice. *J Pediatr.* 2017;185:19–25, Table III.

in some environments), and nurses exposed to a high volume of alarms respond more slowly to them. Interventions currently being studied include removing monitors from patients unlikely to benefit from them, designing smart alarms that alert only when certain scenarios occur (e.g., bradycardia in the context of hypoxia), and using advanced communication technology to safely escalate true alarms while ignoring nonactionable alarms. **Alert fatigue** is related to alarm fatigue but refers to clinicians not processing an alert, such as a medication interaction from the electronic health record, when receiving a large burden of alerts often regarded as nonactionable.

**Table 5.6** Diagnostic Time-Out

- Identify the clinical issues, dilemmas, or concerns needing a time-out.
- Remove all previous diagnoses and reexamine all laboratory studies, imaging, and other information, including the history and physical exam.
- Did we consider the risks of heuristic (intuitive) thinking?
- Do we have biases?
- What are the diseases we must not miss?

From Bordini BJ, Basel D. Disease mimics: An approach to undiagnosed diseases. In: Kliegman RM, Toth H, Bordini BJ, Basel D. (eds). *Nelson Pediatric Symptom-Based Diagnosis*. 2nd ed. Philadelphia: Elsevier; 2023: Table 1.6.

**Table 5.7** Solutions to Avoid Diagnostic Errors

<p>1. Enhancing foundational knowledge in medical education</p> <ul style="list-style-type: none"> <li>• Teach symptoms and their differential pathophysiology, not just diseases.</li> <li>• Emphasize red flags and must-not-miss diagnoses.</li> </ul> <p>2. Minimizing errors related to heuristic failure</p> <ul style="list-style-type: none"> <li>• Build understanding of system 1 and system 2 thought processes and the risks of heuristic failure.</li> <li>• Actively model and encourage counterfactual reasoning and hypothesis generation to enhance system 2 skills.</li> </ul> <p>3. Mitigating errors of attribution</p> <ul style="list-style-type: none"> <li>• Increase awareness of biases toward specific patients by promoting self-reflection.</li> <li>• Use a team-based approach and diagnostic strategies that actively dispel biases.</li> </ul> <p>4. Avoiding errors of context</p> <ul style="list-style-type: none"> <li>• Solicit input across a variety of specialties when appropriate.</li> <li>• Consciously acknowledge the risk of thinking in silo and actively seek explanations outside of one's specialty.</li> </ul> <p>5. Optimizing data gathering, analysis, and hypothesis generation</p> <ul style="list-style-type: none"> <li>• Develop differential diagnoses based on pathophysiology; consider alternatives and competing options.</li> <li>• Realize that diagnostic criteria for certain diseases do not account for atypical disease manifestations.</li> <li>• Rely on objective individual data, not just disease prevalence rates, when considering the pretest likelihood of a particular diagnosis.</li> <li>• Avoid diagnostic momentum and question-accumulated diagnostic labels, regardless of who applied the label.</li> </ul> <p>6. Improving hypothesis testing</p> <ul style="list-style-type: none"> <li>• Know the limitations of laboratory tests (i.e., false positives and negatives).</li> <li>• Do not be so quick to "rule out" a diagnosis: consider the posttest likelihood of a disease in terms of a probabilistic analysis that applies specifically to the patient.</li> </ul>	<ul style="list-style-type: none"> <li>• Acknowledge that the initial "working" diagnosis may not always be the final diagnosis.</li> <li>• Rely on evidence-based data and avoid authority- or overconfidence-based errors.</li> <li>• Recognize that a diagnosis is an iterative and interactive process that should not be bounded by premature closure or anchoring. Be open to both confirmatory and nonconfirmatory data.</li> <li>• Both know and accept what you do not know.</li> </ul> <p>7. Critical solutions for complex and undiagnosed and rare-disease patients</p> <ul style="list-style-type: none"> <li>• Maintain healthy skepticism, especially with patients who come prediagnosed.</li> <li>• Analyze historical diagnostic data methodically and thoroughly and unpack all data completely. Examine actual studies, such as tissue specimens and imaging investigations, and do not rely on written reports.</li> <li>• Question the working diagnosis when findings or the clinical course does not fit.</li> <li>• Realize that patients can have more than one disease process.</li> <li>• Incorporate all data and avoid minimizing the significance of abnormal results. Do not ignore contradictory clinical, laboratory, or imaging data.</li> <li>• Never say "never" or "it cannot be."</li> <li>• Use a systematic team-based approach to enhance debiasing, broaden the collective knowledge base, and minimize context-related errors.</li> <li>• Be aware that patients with undiagnosed and rare diseases may have an atypical or rare manifestation of a recognizable common disease or may have a rare disease.</li> <li>• Use extensive literature review and search strategies based on the patient's phenotype and individual findings and hypotheses.</li> </ul>
--	--

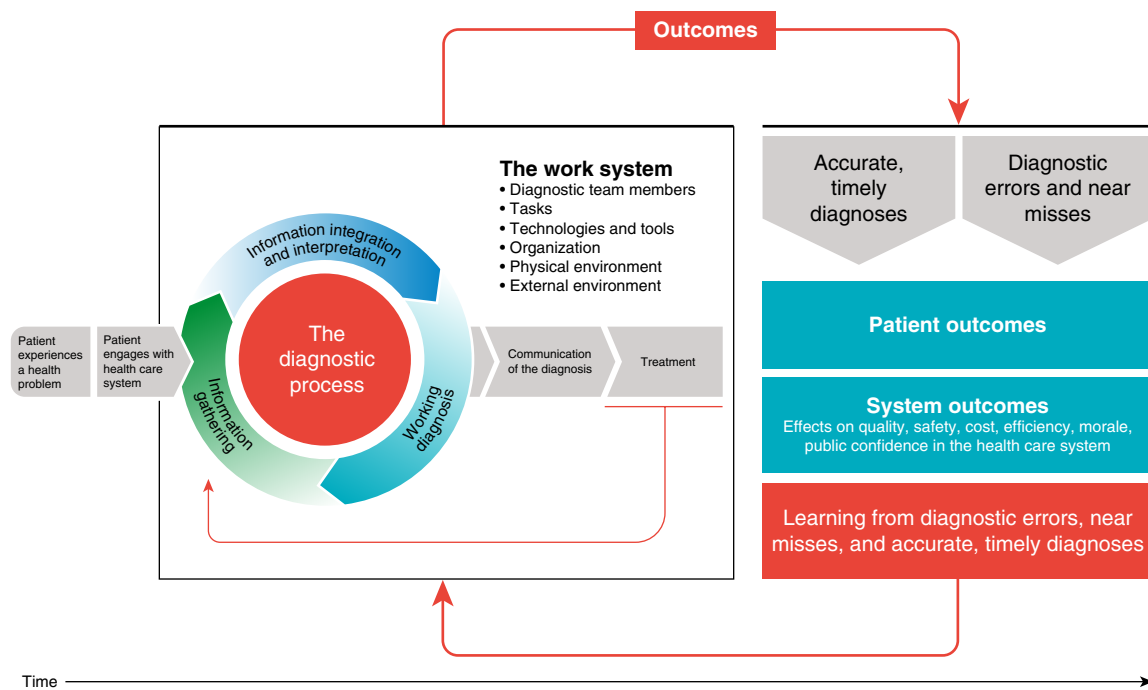
From Bordini BJ, Stephany A, Kliegman R. Overcoming diagnostic errors in medical practice. *J Pediatr*. 2017;185:19–25, Table V.

## Surgical Safety

Initially, in response to the problem of wrong-patient or wrong-site surgeries, perioperative leaders developed a set of safety strategies often termed the *tenets of surgical safety*, which are endorsed by the World Health Organization (<https://www.who.int/patientsafety/safe-surgery/en/>). The tenets are implemented as several discrete checklists at key points, or "time-outs," in the workflow around a procedure or surgery. Several studies have demonstrated reduced harm to patients, and surgical checklists are adopted widely throughout surgical and procedural environments. Typically, checklists are used at three key times during a procedure: before induction of anesthesia, before skin incision or insertion of a device into any body cavity or orifice, and before a patient leaves the procedural area or operating room. Key aspects of the impact of this approach include multidisciplinary active participation, visual display of the checklist or other key tools as references, and attention to hierarchies and team-based communication. An evolving area of surgical and procedural safety is the use of simulation and video-based procedure review to improve surgical technique and perioperative team function and to identify latent threats.

## Ambulatory Safety

Adverse drug events and medication dosing errors are the best-studied safety events in the outpatient environment. A study of children receiving chemotherapy used direct observation by a trained nurse at home and found approximately 70 errors per 100 patients, many of which were serious or significant. Families often make dosing errors



**Fig. 5.4** Outcomes from the diagnostic process. (From National Academies of Sciences, Engineering, and Medicine. 2015. *Improving Diagnosis in Health Care* <https://doi.org/10.17226/21794>.)

in administering liquid medications, particularly when using kitchen spoons rather than dosing syringes. A health literacy-informed pictogram reduces the rates of these errors. Additional ambulatory safety threats include delays in diagnosis or treatment caused by mishandling of laboratory or imaging results and failures in care coordination.

### Occupational Safety

The provision of healthcare can be a dangerous profession, with injury rates that surpass those of coal miners. The magnitude of this challenge and efforts to improve workplace safety have gained considerable attention over the past several years. Nurses and physicians still typically view a needlestick injury or back strain from lifting a patient as simply “part of the job.” A culture of safety should include employee safety, and health systems should have mechanisms for employees to report injuries, near misses, and threats. Focused improvement efforts might include the roll-out of safer needle systems, education on safe processes, and easy access to lifts for larger children with limited mobility. Violence and patient interaction injuries, often from children with psychiatric disease or developmental disabilities, are a growing source of harm to clinicians. Education for clinicians on de-escalation techniques, behavioral specialist engagement in bedside care, and implementation of standardized behavior response teams are active areas of improvement and study as we consider how to best support patients with behavioral needs admitted to the medical unit.

## EMERGING AREAS OF SAFETY RESEARCH AND IMPROVEMENT

### Safe and Equitable Care

The authors of *Crossing the Quality Chasm* stated that healthcare should target 6 aims for improvement: safety, effectiveness, patient-centeredness, timeliness, efficiency, and equity. These aims are not independent, and we are just beginning to critically examine the relationship between safety and equity. Existing evidence suggests that there are disparities in safety for several groups of pediatric patients, including Black and Latino children, for children whose families do not primarily speak English, and for children on public

insurance. In pediatric surgery, one study found that Black children had over three times the odds of dying in the postoperative period, nearly 20% relative greater odds of postoperative complications, and 7% relative higher odds of developing serious adverse events as compared to White children, even while controlling for multiple variables, including racial variation in preoperative morbidity. A systematic review of the evidence in pediatric appendicitis found that social, racial, and economic inequities exist in the rate of misdiagnosis, laparoscopic versus open approach, length of stay, and appendiceal perforation rate. In pediatric severe sepsis, a recent large retrospective study found evidence of an increased odds of death for Black children as compared to White children, particularly in the Western and Southern United States. This study also described longer hospital stays for Hispanic and Black children as compared to White children. Disparities also affect adverse events for hospitalized children, with one multicenter study reporting that hospitalized Latino children experience higher rates of adverse events as compared to non-Latino White children, and publicly insured children experience higher rates of preventable adverse events as compared to those who are privately insured. The Institute for Healthcare Improvement notes that “there can be no quality without equity,” and the field of pediatric patient safety is increasingly focused on health equity as a critical and essential outcome measure.

### Learning from Patient and Family Partnerships

Another important area of current and growing research involves how healthcare providers can partner with patients and families to improve the safety of care. Families often identify a wide number of errors and safety events that clinicians fail to report. More important than families simply reporting mistakes are early efforts to engage families more broadly and deeply to co-produce healthcare that is efficient, effective, and safe. This is particularly important for the growing population of children with complex chronic disease, for whom family caregivers are critical in identifying deviations from baseline in their children.

Visit Elsevier eBooks+ at [eBooks.Health.Elsevier.com](https://www.elsevier.com/ebooks/health) for Bibliography.



## Chapter 6

## Ethics in Pediatric Care

Eric Kodish and Bryan A. Sisk

Pediatric ethics is the branch of bioethics that analyzes moral aspects of decisions made relating to the healthcare of children. In general terms, the **autonomy**-driven framework of adult medical ethics is replaced by a **beneficent** paternalism in pediatrics. Pediatric ethics is distinctive because the pediatric clinician has an independent fiduciary obligation to act in a younger child's **best interest** that takes moral precedence over the wishes of the child's parent(s). For older children, the concept of **assent** suggests that the voice of the patient must be heard. These factors create the possibility of conflict among child, parent, and clinician. The approach to the ethical issues that arise in pediatric practice *must* include respect for parental responsibility and authority balanced with a child's developing capacity and autonomy. Heterogeneity of social, cultural, and religious views about the role of children adds complexity.

Additional features of ethical decision-making include **nonmaleficence** (do no harm) and **justice** (treating patients with the same condition equally).

### ASSENT AND PARENTAL PERMISSION

The doctrine of *informed consent* has limited direct application to children and adolescents who lack decisional capacity. The capacity for informed decision-making in healthcare involves the ability to understand and communicate, to reason and deliberate, and to analyze conflicting elements of a decision using a set of personal values. The age at which a competent patient may legally exercise voluntary and informed consent for medical care varies from state to state, and there may be exceptions related to specific conditions (sexually transmitted infections, family planning, drug or alcohol abuse).

In contrast to decisions about one's own care, a parent's right to direct a child's medical care is more limited. For this reason, the term *parental consent* is misleading. The concept of parental permission (rather than consent) reflects a *surrogate* or *proxy* decision made by a parent on behalf of a child. It is constrained by the child's best interest, even if this places the clinician in conflict with the parent. In any given instance, the decision of what is or is not in a child's best interest may be difficult, especially given the diverse views of acceptable child rearing and child welfare. Parents are (and should be) granted wide discretion in raising their children. In cases involving a substantial risk of harm, the moral focus should be on avoiding or preventing harm to the child, not on a parental right to decide. Although the term *best interests* may be too high of a threshold requirement, a minimum standard of *basic interests* is ethically obligatory.

Respect for children must account for both a child's vulnerability and developing capacity. This respect encompasses both the protective role of parental permission and the developmental role of **child assent** (the child's affirmative agreement). Understanding the concept of assent is one of the major conceptual challenges in pediatric ethics. The **dissent** (or disagreement) of a child is the opposite of assent and is also morally relevant. Pediatric ethics *requires* clinicians and parents to override a child's dissent when a proposed intervention is essential to the child's welfare. Otherwise, assent should be solicited and dissent honored. In seeking younger children's assent, a clinician should help them understand their condition, tell them what they can expect, assess their understanding and whether they feel pressured to assent, and solicit their willingness to proceed. All efforts must be made to delineate situations in which the test or procedure will be done regardless of the child's assent/dissent, and in such cases the charade of soliciting assent should be avoided. There is an important distinction between soliciting assent and respectfully informing a child that a test or procedure will take place regardless of the child's decision. Optimally, an educational process can transpire (if time allows) to gain the trust and assent of the

child-patient. When this cannot occur, pediatric ethics requires that clinicians apologize to a child for acting to override dissent.

Older children or adolescents (<18 years) may have the cognitive and emotional capacity to participate fully in healthcare decisions. If so, the adolescent should be provided with the same information given to an adult patient. In such situations the patient may be able to provide informed consent ethically but not legally. The adolescent's parent(s) remain in a guiding and protective role. The process of communication and negotiation will be more complex should disagreement arise between the parent and adolescent. Pediatricians can be effective intercessors when these situations arise, making use of communication skills in a respectful way that uses an ethical framework.

### TREATMENT OF CRITICALLY ILL CHILDREN

Infants, children, and adolescents who become critically ill may recover fully, may die, or may survive with new or increased limitations of function. Uncertainty about outcomes can make planning goals of care difficult or, if misunderstandings among patient, families, and medical staff occur, may drive conflict over treatment proposals. *Ethical issues* that arise during critical illness include balancing benefits, burdens, and harms of therapy in the face of uncertainty; maintaining a helpful degree of transparency and communication about medical standards of care at an institution; understanding and respecting religious and cultural differences that affect requests for or refusal of treatments; defining limits of therapy based on assessments of medical futility; recognizing the moral equivalence of not starting an ineffective treatment and stopping (although the two acts may seem very different to families and even to clinicians); and controversies such as withholding medically administered nutrition and hydration.

### Transitioning the Goals of Care

Most acutely ill children who die in an intensive care unit do so after a decision has been made to forgo or withdraw **life-sustaining medical treatment (LSMT)**, and the same may apply in the chronically ill population. LSMT is justified when the anticipated benefit outweighs the burdens to the patient; it is important to note that the availability of technology does not in and of itself obligate its use. Decisions to use, limit, or withdraw LSMT should be made after careful consideration of all pertinent factors recognizable by both family and medical staff, including medical likelihood of particular outcomes, burdens on the patient and family, religious and cultural decision-making frameworks, and input by the patient when possible (Table 6.1). Although fear of legal repercussions may sometimes drive treatment and medical advice, ultimately decisions should be based on what is thought to be best for the patient.

The concept of **futility** has been used to support unilateral forgoing of LSMT against the wishes of patients and families by holding that clinicians should not provide futile (or useless) interventions. If *medical futility* is defined narrowly as the impossibility of achieving a desired physiologic outcome, forgoing a particular intervention is ethically justified. However, this approach may not adequately engage professionals and families in understanding facts and values that might allow the same therapy to reach other goals and may leave medical and family stakeholders in permanent conflict. Guidance from critical care groups recommend restricting use of the word *futility* to situations of strict physiologic futility, and instead use process guidelines to evaluate and manage situations of *potentially inappropriate treatment*. If agreement cannot be reached through clear and compassionate communication efforts, further input should be sought from an ethics consultant or committee.

**Communication** about life-threatening or life-altering illness is challenging and requires skills learned through both modeling and practice. These *skills* include choosing a setting conducive to what may become one or more long conversations; listening carefully to children's and families' hopes, fears, understanding, and expectations; explaining medical information and uncertainties simply and clearly without complicated terms and concepts; conveying concern and openness to discussion; and being willing to share the burdens of decision-making with families by giving clear recommendations. Discussing difficult topics with children requires an understanding of child development and can be aided by professionals such as child psychologists or child life specialists. Such conversations and their outcomes have a major impact on the future care of the patient, on

**Table 6.1** Approach to Termination of Medical Treatments for Adults (≥18 yr) and Children

CONSIDERATION	DISCUSSION
Is there a legal right to refuse medical interventions?	<b>YES.</b> The U.S. Supreme Court declared that competent patients ≥18 yr have a constitutionally protected right to refuse unwanted medical treatments. <b>NO.</b> In neonates and children, if the treatment is in the best interest of the child, the family cannot refuse beneficial treatments (see later).
What interventions can be legally and ethically terminated?	Any and all interventions (including respirators, antibiotics, pacemakers, ECMO, intravenous or enteral nutrition and hydration) can be legally and ethically terminated.
Is there a difference between withholding life-sustaining interventions and withdrawing them?	<b>NO.</b> The consensus is that there is no legal or ethical difference between withholding and withdrawing medical interventions. Stopping a treatment once begun is just as ethical as never having started it.
Whose view about terminating life-sustaining interventions prevails if there is a conflict between the family and physician?	If continued treatment is not beneficial (futile), there is no obligation to continue such care. At times, involvement of an ethics committee or the courts is necessary. In most circumstances, the parents agree with the healthcare team (shared decision-making).
Are advance care directives legally enforceable?	<b>YES.</b> As a clear expression of the patient's wishes, they are a constitutionally protected method for patients to exercise their right to refuse medical treatments. In almost all states, clear and explicit oral statements are legally and ethically sufficient for decisions about withholding or withdrawing medical interventions. This is true for patients over 18 yr old. Mature, competent adolescents (≥16 yr) may provide assent and consent to refuse care, but this is not universally accepted.

ECMO, Extracorporeal membrane oxygenation.

Modified from Emanuel EJ. Bioethics in the practice of medicine. In: Goldman L, Schafer AI (eds). *Goldman-Cecil Medicine*. 26th ed. Philadelphia: Elsevier; 2020: Table 2.2.

families, and on medical staff. For this reason, ongoing evaluation of goals and communication about them is needed with families and within complex medical teams as the course of the illness unfolds.

Experts recognize that good medical care involves providing for communication, symptom management, and a range of supportive services from the onset of acute illness. In this way, if an illness proves to be life-limiting despite intensive therapies, the elements of palliative care are already in place. This concept has had difficulty gaining traction, especially in critical care settings, because of the mistaken conflation of broadly defined palliative measures with hospice care. **Palliative care** interventions focus on the relief of symptoms and conditions that may detract from quality of life regardless of the impact on a child's underlying disease process, and as such are important whether care is focused on cure or on transitioning to end-of-life care (see [Chapter 8](#)). Some interventions regarded as life-sustaining, such as chemotherapy, may be ethically acceptable in the end-of-life setting if their use decreases pain and suffering.

### Withholding and Withdrawing Life-Sustaining Treatment

Limitation of interventions or withdrawal of existing therapies is ethically permissible if congruent with a plan of care focused on **comfort** and **improved quality** at the end of life rather than cure. The prevailing view in Western medical ethics is that there is no moral distinction between withholding or withdrawing interventions that are not medically indicated (see [Table 6.1](#)). Uncertainty in predicting a child's response to treatment may drive the initiation and continuation of interventions that are subsequently determined to be no longer aligned with the goals of care. It is important to continually evaluate the results of these treatments and the evolution of the illness to recognize whether such interventions continue to be the best medical and moral choices. Maintaining the focus on the child rather than on the interests of parents or medical staff should be the primary driver of decision-making.

The decision about whether to attempt **cardiopulmonary resuscitation** (CPR) may become an issue to discuss with parents of children living with life-threatening or terminal conditions. All elements of end-of-life care approaches, including resuscitation status, should be supportive of agreed-on goals of care. It is imperative that decisions and plans are effectively communicated to all caregivers in order to avoid denying medically effective interventions and measures to ensure comfort. Orders about resuscitation status should clarify the plan regarding intubation and mechanical ventilation, the use of cardiac medications, chest compressions, cardioversion,

blood products, antibiotics, and dialysis. Because goals of care may change over time, a medical order regarding resuscitation is not irrevocable. Clinicians may assume that the absence of a **do-not-attempt-resuscitation (DNAR)** order obligates them to perform CPR. This action may not be ethically obligatory if resuscitative efforts will not achieve the desired physiologic end-point. In all cases, treatments should be tailored to the child's clinical condition, balancing benefits and burdens to the patient. Resuscitation should not be performed solely to mollify parental distress at the tragic time of the loss of their child.

### Artificial Hydration and Nutrition

Issues surrounding withholding or withdrawing artificial hydration and nutrition are controversial, and interpretations are affected by parental religious and medical beliefs. Any adult or child who is fully dependent on the care of others will die as a result of not receiving hydration and nutrition. Case law has supported the withholding of artificially administered nutrition and hydration in the setting of adult vegetative or permanently unconscious patients who can be shown to have previously expressed a wish not to be maintained in such a state. This requires a valid advance directive or for a surrogate decision maker to speak on behalf of the patient's known wishes. Because infants and many children have not reached a developmental stage in which such discussions would have been possible, decisions about stopping artificially administered nutrition and hydration as a limitation of treatment are more problematic. These decisions should be based on what families and caregivers decide best support comfort. In the child who is imminently dying, unaware of hunger, does not tolerate enteral feedings, and in whom family and staff agree that IV nutrition and hydration only prolong the dying process, it may be ethically permissible to withhold or withdraw these treatments based on a benefit-burden analysis.

### The Doctrine of Double Effect

Treatment decisions at the end of life may include limitations of certain LSMT or may involve the use of analgesic or sedative medications that some fear may shorten life, thereby causing death. The doctrine of double effect (**DDE**) holds that an action with both good and bad effects is morally justifiable if the good effect is the only one intended and the bad effect is foreseen and accepted, but not desired. In pediatrics, DDE is most commonly applied in end-of-life cases when upward titration of medication (opiates) necessary to relieve pain, anxiety, or air hunger can be expected to result in a degree of respiratory depression. In such cases, meeting a clinician's obligation to relieve suffering is the intended effect, and this

obligation to the patient outweighs the acknowledged but unavoidable side effect. Choosing medications that adequately relieve symptoms with minimal adverse effects would be ethically preferable, but absent these options, the obligation to provide comfort at the end of life outweighs the foreseeable occurrence of unavoidable side effects. Hastening death as a primary intention is not considered to be morally acceptable.

Providing pain medication guided by the DDE should not be confused with active euthanasia. The distinction is clear:

- In **active euthanasia**, causing death is chosen as a means of relieving the symptoms that cause suffering.
- Under DDE, adequate management of pain, anxiety, or air hunger is recognized as an obligation to dying patients and is provided by careful titration of medications in response to symptoms. If death occurs sooner as a result, this is accepted.

In both cases the patient dies, and in both cases suffering ends, but immediate death is the intended consequence only in the case of euthanasia. Codes of ethics and legislation in many states support the obligation to provide pain and symptom relief at the end of life, even if this requires increasing doses of medication.

## NEONATAL ETHICS

As neonatal care has evolved, the limits of viability of extremely premature infants are continuing to change. This introduces new elements of uncertainty to decision-making, often in emotionally fraught circumstances such as a precipitous premature delivery. In cases of uncertain prognosis, parental desires should determine the decision-making, while clinicians should help parents recognize when treatments are inappropriate; this should result in a shared decision-making approach to developing plans of care.

The federal **Child Abuse Prevention and Treatment Act of 1984 (CAPTA)**, which became known as “Baby Doe Regulations,” required state child protective services agencies to develop and implement mechanisms to report to a specific government agency treatment that the reporter believed was withheld from infants on the basis of disability. Exceptions were (1) an infant is chronically and irreversibly comatose; (2) if providing a treatment would merely prolong dying, would not be effective in ameliorating or correcting all the infant’s life-threatening conditions, or would be futile in terms of the infant’s survival; and (3) if the treatment would be virtually futile and inhumane. This legislation pertains *only* to infants and is intended to prevent discrimination on the basis of disability alone. One consequence of the legislation was a shift from potential undertreatment to widespread overtreatment (LSMT that does not serve the interests of the child) of severely disabled newborns. As parental involvement in decision-making is again taking a more central role, and as palliative care approaches in infants have become more available and skilled, balanced approaches to valuing the lives of disabled infants should be considered. Understanding institutional, regional, state, and national regulations related to care of infants is important in order to practice within regulatory frameworks while respecting the values of the family and pursuing the interests of the patient.

Active euthanasia of severely suffering disabled newborns has been legalized in The Netherlands and Belgium, using protocols designed to minimize the risk of abuse and maximize transparency. It is currently illegal in the United States, and although controversy surrounds the subject, the predominant view is that active euthanasia is not ethically acceptable in the care of infants and children, instead favoring palliative treatment (including pain management) and limiting escalation of treatment (see [Chapter 8](#)).

## DECLARING DEATH AND ORGAN DONATION

Donation of solid organs necessary to support life can occur after a patient is declared dead based on either irreversible cessation of function of the brain and brainstem (death by neurologic criteria, or *brain death*) or a predetermined period of cardiac asystole called *circulatory death* (see [Chapter 83](#)). To avoid a potential conflict of interest by surgeons or others caring for a potential organ recipient, the request for organ donation should be separated from the clinical discussion of either brain death or withdrawal of LSMT. Although clinicians may be the first to enter discussion about death and organ donation with family members during conversations

about outcomes and options, detailed discussion of organ donation should be done by other individuals who are specifically trained for this purpose. This decoupling of clinical decision-making from a request for organ donation by trained individuals, perhaps by providing families with expert information without a perceived conflict of interest, has been associated with improved donation rates.

## Death by Neurologic Criteria

Death by neurologic criteria (**DNC**), commonly referred to as brain death (**BD**), may be difficult for families to understand when the child appears to be breathing (although on a ventilator), pink, and warm to the touch and when language such as “life support” is used at the bedside by staff. Studies also document clinician misunderstanding of the diagnosis of **BD/DNC**. For these reasons, strict criteria adhering to nationally accepted guidelines must be used to determine when irreversible cessation of brain and brainstem function (coma, brainstem areflexia, apnea) has occurred and adequately document these findings (see [Chapter 83](#)).

## RELIGIOUS OR CULTURAL OBJECTIONS TO TREATMENT

Differences in religious beliefs or cultural norms may lead to conflict among patients, families, and medical caregivers over the approach to medical care. Pediatricians need to remain sensitive to and maintain an attitude of respect for these differences yet recognize that an independent obligation exists to provide safe and effective medical treatment to the child. An adult with decision-making capacity is recognized as having the right to refuse treatment on religious or cultural grounds, but children who have not yet developed this capacity are considered a vulnerable population with a right to treatment. In situations that threaten the life of the child or that may result in substantial harm, legal intervention should be sought if reasonable efforts toward collaborative decision-making are ineffective. If a child’s life is imminently threatened, medical intervention is ethically justified despite parental objections.

## PEDIATRIC ETHICS COMMITTEES AND ETHICS CONSULTATION

Most hospitals have *institutional ethics committees* to assist with policy development, education, and case consultation. When these committees serve institutions caring for children, they may be referred to as *pediatric ethics committees*. Because of the important differences in approach between adult and pediatric ethics, member expertise on this committee should include those with special insight into the unique ethical issues arising in the care of children. Such committees generally provide ethics consultation advice without mandating action or being determinative. For the vast majority of decisions involving the medical treatment of children (including forgoing LSMT), pediatric clinicians and parents are in agreement about the desirability of the proposed intervention. Because of the ethical importance of assent, the views of older children should also be given considerable weight.

Pediatric ethics committees typically perform at least three different functions: (1) the drafting and review of institutional policy on such issues as DNAR orders and forgoing LSMT, (2) the education of healthcare professionals, patients, and families about ethical issues in healthcare, and (3) case consultation and conflict resolution. Although the process of *case consultation* may vary, ideally the committee (or consultant) should adopt a collaborative approach that uncovers all the readily available and relevant facts, considers the values of those involved, and balances the relevant interests, while arriving at a recommendation based on a consistent ethical analysis. One helpful approach involves consideration of the 4 following elements: (1) medical indications, (2) patient preferences, (3) quality of life, and (4) contextual features. Another framework based on principles would suggest attention to respect for persons, beneficence/nonmaleficence, and justice.

Pediatric ethics committees often play a constructive role when parents and medical staff cannot agree on the proper course of action. Over the past several decades, these committees have acquired considerable influence and are increasingly recognized by state courts as an important aid in decision-making. The membership, policies, and procedures of a pediatric ethics committee should conform to accepted professional standards.



## NEWBORN SCREENING

The *Oxford Dictionary of Public Health* defines screening as “the identification of a previously unrecognized disease or disease precursor, using procedures or tests that can be conducted rapidly and economically on large numbers of people with the aim of sorting them into those who may have the condition(s) ... and those who are free from evidence of the condition(s).” Several programs, such as newborn screening for inborn errors of metabolism (see Chapter 104; e.g., phenylketonuria and hypothyroidism), are rightly counted among the triumphs of contemporary pediatrics. The success of such programs sometimes obscures serious ethical issues that continue to arise in proposals to screen for other conditions for which the benefits, risks, and costs have not been clearly established. Advances in genetics and technology have led to exponential growth in the number of conditions for which screening programs might be considered, with insufficient opportunity to study each proposed testing program (see Chapter 95).

The introduction of screening efforts should be done in a carefully controlled manner that allows for the evaluation of the costs (financial, medical, and psychologic) and benefits of screening, including the effectiveness of follow-up and treatment protocols. New programs should be considered *experimental* until the risks and benefits can be carefully evaluated. Screening tests that identify candidates for treatment must have demonstrated sensitivity, specificity, and high predictive value, lest individuals be falsely labeled and subject to possibly toxic treatments or to psychosocial risks. As newborn screening tests are being developed, parents should be given the opportunity to exercise informed parental permission or refusal. However, once a particular screening test has been clearly demonstrated to benefit the individual or public health, a formal, active parental permission process may not be ethically obligatory.

A persistent ethical issue is whether screening should be (1) voluntary (“opt in”), (2) routine, with the ability to “opt out” or refuse, or (3) mandatory. A **voluntary** approach entails an informed decision by parents before screening. Concern is often expressed that seeking parental permission is ethically misguided for tests of clear benefit, such as phenylketonuria screening, because refusal would constitute neglect. **Routine** testing with an opt-out approach requires an explicit refusal of screening by parents who object to this intervention. The principal ethical justification for **mandatory** screening is the claim that society’s obligation to promote child welfare through early detection and treatment of selected conditions supersedes any parental right to refuse this simple and low-risk medical intervention. Parental permission is clearly required when there is a research agenda (i.e., for incorporating experimental tests into established screening programs).

## GENETICS, GENOMICS, AND PRECISION MEDICINE

**Genetics** refers to the study of particular genes, and **genomics** describes the entirety of an individual’s genetic material. Genomics has been made possible by technologic advances that allowed the rapid and inexpensive sequencing now used in clinical care. The development of **precision medicine** is in large part predicated on genomic science and may have a major impact on the practice of pediatrics in the future. Efforts to undertake whole-genome sequencing of newborns may yield actionable information to benefit the child, but also carry the risk of stigmatization, false positives, and unwanted information that could lead to anxiety and psychologic distress.

Genetic testing of young children for late-onset disorders such as the *BRCA1* and *BRCA2* breast cancer risk genes has also been the subject of some ethical controversy. Knowledge of increased risk status may lead to lifestyle changes that can reduce morbidity and the risk of mortality or may precipitate adverse emotional and psychologic responses and discrimination. Because many adults choose not to be tested for late-onset disorders, one cannot assume that a child would want or will benefit from similar testing. Genetic testing of young children for late-onset disorders is generally inappropriate unless such testing will result in interventions that have been shown to reduce morbidity and mortality when initiated in childhood. Otherwise, such testing should be deferred until the child has the capacity to make an informed and voluntary choice.

Precision medicine promises to enhance treatment and public health outcomes in the future. Yet the success of precision medicine will depend on whose data are used to develop and refine artificial intelligence algorithms that will inform care. A large body of literature has begun to explore racial and ethnic disparities in precision medicine, with the goal of ensuring advances will benefit all people. However, children represent another group that is at risk of exclusion from these benefits. Historically, the rarity of many childhood illnesses, protective regulations, and financial disincentives have limited the development of effective treatments for many childhood diseases. Legislation such as the “Research to Accelerate Cures and Equity for Children Act” (RACE Act) has begun to mandate greater representation of children in clinical trials. If similar steps are not taken in pediatric precision medicine, we run the risk of creating a new generation of therapeutic orphans.

## ADOLESCENT HEALTHCARE

### Adolescent Assent and Consent

Many adolescents are more like adults than children in their capacity to understand healthcare issues and to relate them to their life goals (see Chapter 150). Teenagers may lack legally defined competency, yet they may have developed the capacity to meet the elements of informed consent for many aspects of medical care (see Chapter 151). There are also public health reasons for allowing adolescents to consent to their own healthcare with regard to reproductive decisions, such as contraception, abortion, and treatment of sexually transmitted infections. Strict requirements for parental permission may deter adolescents from seeking healthcare, with serious implications for their health and other community interests.

Counterbalancing these arguments are legitimate parental interests to maintain responsibility and authority for child rearing, including the opportunity to influence the sexual attitudes and practices of their children. Others claim that access to treatment such as contraception, abortion, or needle exchange programs implicitly endorses sexual activity or drug use during adolescence. Pediatricians should not impose their own moral beliefs in these disputes. Rather, they should provide unbiased evidence-based information and nonjudgmental support. One guiding principle should be encouragement of children and adolescents to begin taking responsibility, with guidance, for their own health. This requires some input from parents or guardians but also some privacy during decision-making as adolescents achieve developmentally anticipated separation from parental control.

### Communication, Privacy, and Confidentiality

Exchanging information is a core function of communication in pediatric and adolescent care. As adolescents mature, their need to exchange information about sensitive topics can increase, complicating the triadic clinician-parent-child relationship. For example, adolescents might wish to start oral contraception or seek treatment for a sexually transmitted infection without their parents’ knowledge. The confidentiality of conversations about reproductive health and sexually transmitted infections between adolescents and clinicians is often protected by state laws, although the scope of protections in these laws varies widely. A recent federal law that mandates increased transparency in medical care will further complicate this sensitive communication.

The 21st Century Cures Act included a rule that requires healthcare organizations to provide electronic health information (EHI) to patients in easily accessible platforms. This mandate went into effect in April 2021. As a result of this law, adolescents now have access to their EHI. For preadolescent patients, healthcare organizations provide proxy access to parents. When children reach adolescence, approaches to provision of EHI access vary greatly. Some sites allow parental access to adolescent EHI that has been filtered for confidential information. Other sites revoke parental access, but allow adolescents the option of permitting proxy consent. Still other sites permanently revoke parental access once a child has reached adolescence. This new transparency will likely provide benefits, but could also generate new ethical risks to preserving the confidentiality of adolescent patients. Pediatricians must be cognizant of this tension when creating clinical documentation that might be visible to parents and adolescent patients.



### Chronic Illness

The normal process of adolescent development involves gradually separating from parents, establishing self-confidence, asserting individuality, developing strong peer relationships, solidifying an ability to function independently outside the family, and taking on increasing autonomy in health-care decisions. Most developmentally typical children older than age 14 years understand the implications of well-explained medical options as well as the average adult, and their input into their own care should be respected. For children living with chronic illness, the ability to make medical decisions for themselves may either occur earlier than for those who have been previously healthy or may occur later if, because of illness, they have not been able to achieve normal developmental milestones or psychologic maturity. The clinician's role involves assessment of the individual adolescent patient's ability to understand the medical situation, to support the patient's efforts to express wishes regarding medical treatment, to value and encourage parental support and involvement, and to foster cooperation and mutual understanding. This may be difficult in situations in which parents and adolescents disagree about life-sustaining treatments such as organ transplantation or chemotherapy, but many such conflicts may be resolved by exploring the reasons for the disagreement. Overriding an adolescent's wishes should be done very infrequently and only after careful consideration of the potential consequences of unwanted interventions.

### Decisions in Terminally Ill Adolescents

Most adolescents share end-of-life decision-making with family members, although communication may be challenging because of a growing sense of independence. Open communication and flexibility about treatment preferences may help teens cope with fears and uncertainties. Development of an age-appropriate advance directive may support the patient's emerging autonomy by clarifying the adolescent's wishes while fostering a collaborative process among the patient, family, and medical caregivers. From the time of diagnosis of a life-threatening condition through the end-of-life phase, children should be included in a developmentally tailored process of communication and shared decision-making that builds a foundation of mutual respect and trust. Some experts believe that most adolescents are not yet fully capable of making a decision to forgo life-sustaining treatment. Careful case-by-case evaluation is required to make this determination, and assistance from developmental psychologists and ethics consultants may be helpful.

### RESEARCH

The central ethical challenge of pediatric research is the need to balance protection of children from research risk against the ethical imperative of conducting studies to better the lives of future children. *Research* is defined in the federal regulations as "a systematic investigation designed to develop or contribute to generalizable knowledge." For any research to be performed, the risks should be minimized and reasonable with respect to any anticipated benefits to the participants and the importance of the resulting knowledge. That some children derive a direct benefit from participation in research must also be considered, making it important to distinguish research with the prospect of direct benefit from nontherapeutic pediatric research. *Because children are a vulnerable population, there are restrictions on the research risks to which a child may be exposed*, in contrast to the risk level acceptable for research with consenting adults. These restrictions function by limiting the type of research that institutional review boards (IRBs) are permitted to approve and by specifying the conditions under which parents have the moral and legal authority to permit a child to participate in research.

**Nontherapeutic research** in children is the most ethically controversial because it holds no expected direct benefit for the individual. The prohibition against using a person (especially a child) solely as a means to an end has led some to argue that children should *never* be used in nontherapeutic research. The more widely held opinion is that children may be exposed to a limited degree of risk with IRB approval, parental permission, and assent if the child is capable. The federal regulations allow healthy children to participate in minimal-risk research regardless of the potential benefit to the child. More controversially, the regulations also state that children with a disorder or condition may be exposed to slightly more than minimal risk in nontherapeutic research if the child's experience is similar to everyday life with the condition and

the anticipated knowledge is of vital importance for understanding the condition.

In pediatric research with the prospect of direct benefit, the risks must be justified by the anticipated benefit to the child, and the balance of anticipated benefit to the risk should be at least as favorable as that presented by available alternatives. *In our opinion, the welfare of an individual child must always come before the scientific goals of the research study.*

U.S. regulations for the protection of human research participants rest on two foundations: (1) independent review of the ethics and science of the research by an IRB **before** (2) voluntary and informed consent of the participant. Although it is not amenable to regulation, the *integrity* of the investigator is probably the most important element contributing to the protection of human research participants. The standard for informed consent in a research setting is higher than for clinical care because the risks and benefits are typically less clear, the investigator has a conflict of interest, and humans have historically been subjected to unauthorized risks when strict requirements for consent were not respected.

Adolescents who are competent may sometimes consent to be research participants. Younger children may participate in a process of assent, but this does not imply that a child's signature on an assent document is necessarily a legal or ethical requirement. Children should be given the opportunity to dissent, particularly for nontherapeutic research, when there cannot be a claim that participation is in the child's interest. In the United States, national regulations require that reasonable efforts be made at least to inform children who are capable of understanding that participation is *not* part of their care, and therefore they are free to refuse to participate. In the rare case that the research offers a direct benefit to the child that would not otherwise be available, the regulations do not require child assent but only parental permission.

In addition to the protection that informed consent or parental permission is intended to provide, virtually all research involving humans in the United States is reviewed by an IRB, as required by federal regulations for institutions receiving federal research funds and for drug research regulated by the U.S. Food and Drug Administration. For research that carries more than a minor increase over minimal risk without prospect of benefit to the child such that a local IRB cannot provide approval, there is a process for federal review of research that "presents a reasonable opportunity to further the understanding, prevention, or alleviation of a serious problem affecting the health or welfare of children." Ultimately, the U.S. Secretary of Health and Human Services has the authority to approve such research.

### JUSTICE AND PEDIATRIC ETHICS

The most serious ethical problem in U.S. healthcare may be *inequality* in access to healthcare. Children are particularly vulnerable to this disparity, and pediatricians have a moral obligation to advocate for children as a class. Because children do not vote and do not have financial resources at their disposal, they are subject to a greater risk of being uninsured or underinsured. This lack of adequate and affordable healthcare has serious consequences in terms of death, disability, and suffering. The per capita proportion of healthcare funding spent on adults greatly exceeds that spent on children, and Medicare is available to all adults who turn 65 years old, whereas Medicaid is limited to those beneath a specific income level. Pediatricians should be familiar with policy issues around the economics of child healthcare so that they will be better able to advocate for their own patients.

Beyond access to healthcare, structural social inequalities also have profound impacts on child health and well-being. Systemic racism and structural disadvantages can affect every aspect of pediatric care, from infant mortality and neonatal care delivery to asthma outcomes and surgical complications. Furthermore, social inequality and adverse childhood experiences (ACEs) have been linked to greater incidence of chronic diseases, substance abuse, increased encounters with the justice system, and lower executive functioning. Pediatricians should take active steps to acknowledge and attempt to mitigate the effect of these inequalities on their patients through individual, local, and national advocacy efforts.

Visit Elsevier eBooks+ at [eBooks.Health.Elsevier.com](http://eBooks.Health.Elsevier.com) for Bibliography.

## Chapter 7

## Complementary Therapies and Integrative Medicine

Paula M. Gardiner and Caitlin M. Neri

**Integrative medicine** focuses on promoting physical, mental, emotional, spiritual, social, and educational well-being in the context of a medical home in a healthy family and community. The foundations of integrative medicine are health-promoting practices such as optimal nutrition and dietary supplements to prevent deficiencies, avoidance of addictive substances (e.g., nicotine, illicit drugs), physical activity, adequate sleep, a healthy environment, and supportive social relationships. Evidence-based **complementary therapies** such as dietary supplements, massage, chiropractic, other forms of bodywork, yoga, meditation practices, hypnosis, guided imagery, biofeedback, and acupuncture may also be used.

Not including multivitamins and mineral supplements such as iron and calcium, an estimated 10–40% of healthy children and >50% of children with chronic conditions use integrative medicine in the United States. The prevalence could be even higher because these treatments usually occur without disclosure to the children's primary care physician. Common therapies include dietary supplements, deep breathing, guided imagery, meditation, biofeedback, hypnosis, yoga, acupuncture, massage, and aromatherapy.

Use of complementary therapies is most common among youth with chronic, incurable, or recurrent conditions such as cancer, depression and other mental health conditions, asthma, autism, headaches, abdominal pain, and other chronic painful conditions. In a 2017 study of freestanding children's hospitals, 92% offered complementary services, 38% had a specific complementary center on-site, and 60% had policies related to supplement use during hospitalization. Integrative therapies are being used in pediatric cancer symptom management and chronic pain clinics. Practice often includes supplements (e.g., probiotics) and mind-body techniques (e.g., hypnotherapy, biofeedback) with traditional medical management for these common pediatric conditions.

## DIETARY SUPPLEMENTS

Under the 1994 U.S. Dietary Supplement Health and Education Act, a **dietary supplement** is a product taken by mouth that contains a *dietary ingredient* intended to supplement the diet. These may include vitamins, minerals, herbs or other botanical, amino acids, and substances such as enzymes, organ tissues, glands, and metabolites. Dietary supplements are the most frequently used complementary therapies for children and adolescents (Table 7.1). Some uses are common and recommended, such as vitamin D supplements for breastfed infants and probiotics to prevent antibiotic-associated diarrhea, whereas other uses are more controversial, such as using herbal products to treat otitis media.

In the United States, dietary supplements do not undergo the same stringent evaluation and postmarketing surveillance as prescription medications. Although they may not claim to prevent or treat specific medical conditions, product labels may make *structure-function* claims. A label may claim that a product "promotes a healthy immune system," but it may not claim to cure the common cold.

According to the 2017–2018 National Health and Nutrition Examination Survey (NHANES), 34% of children and adolescents used any dietary supplement in the past 30 days, with multivitamin-mineral products the most common (24%). Use of dietary supplements is most common among children whose families have higher income and education and whose parents use supplements, among older children, and among those with chronic conditions.

Despite this widespread use, many patients and their parents who use dietary supplements do not talk with their physician about their

use. Several guidelines have called for more complete dietary supplement history taking by healthcare professionals. The Joint Commission recommends that this information be included in the medication reconciliation process.

## DIETARY SUPPLEMENT SAFETY

Dietary supplements may have safety issues in children, but toxicity is much less common with nonprescription dietary supplements than with prescription medications. Toxicity depends on dose, use of other therapies, and the child's underlying medical condition (see Table 94.20). Current use of a dietary supplement (e.g., ephedra for weight loss) may not reflect its traditional use (e.g., ephedra as a component of a traditional Chinese medicine tea in small doses to improve allergic or respiratory symptoms). Moreover, herbs that are apparently safe for most adults may be more hazardous in specific conditions (e.g., newborns, patients with impaired renal or hepatic function), under special circumstances (e.g., after organ transplantation or other surgery), or when combined with prescription medications. Some natural products are toxic in and of themselves. Even when a product is safe when used correctly, it can cause mild or severe toxicity when used incorrectly. Although peppermint is a commonly used and usually benign gastrointestinal spasmolytic included in after-dinner mints, it can exacerbate gastroesophageal reflux.

**Table 7.1** Commonly Used Dietary Supplements in Pediatrics

PRODUCT	USES
<b>VITAMINS</b>	
B <sub>2</sub> (riboflavin)	Migraine headache prophylaxis
B <sub>6</sub> (pyridoxine)	Pyridoxine-dependent epilepsy; neuropathy; nausea associated with pregnancy
B <sub>9</sub> (folate)	Prevention of neural tube defects
D	Prevention of rickets; treatment of vitamin D deficiencies
Multivitamins	General health promotion
<b>MINERALS</b>	
Iodine (salt)	Prevent goiter and intellectual disability
Iron	Prevent and treat iron-deficiency anemia
Magnesium	Constipation, asthma, migraine prevention
Zinc	Diarrhea in nutrient-poor populations
<b>HERBS*</b>	
Aloe vera	Mild burns
Chamomile	Mild sedative, dyspepsia
Echinacea	Prevention of upper respiratory infections
Ginger	Nausea
Lavender (aromatherapy)	Mild sedative
Peppermint	Irritable bowel syndrome
Tea tree oil	Antibacterial (acne remedies), pediculicide (lice)
<b>OTHER</b>	
Melatonin	Insomnia
Omega-3 fatty acids	ADHD, allergies, inflammation, anxiety and mood disorders
Probiotics	Antibiotic-associated diarrhea; <i>Clostridium difficile</i> -associated diarrhea; constipation; irritable bowel syndrome; pouchitis; inflammatory bowel disorders

ADHD, Attention-deficit/hyperactivity disorder.

\*See text; potentially useful evidence base not established for many herbs.

Although there are good manufacturing practices for dietary supplements in the United States, dietary supplement labels might not accurately reflect the contents or concentrations of ingredients. Because of natural variability, variations of 10-fold to 1,000-fold have been reported for several popular herbs, even across lots produced by the same manufacturer. Herbal products may be contaminated with pesticides or microbial agents or toxins, or the wrong herb may be misidentified during harvesting. Products from some countries (e.g., Ayurvedic products from South Asia) might contain toxic levels of mercury, cadmium, arsenic, or lead, either from unintentional contamination during manufacturing or from intentional additions by producers who believe that these metals have therapeutic value. Approximately 30–40% of Asian patent medicines include potent pharmaceuticals, such as analgesics, antibiotics, hypoglycemic agents, or corticosteroids; typically the labels for these products are not written in English and do not note the inclusion of pharmaceutical agents. Even conventional mineral supplements, such as calcium, have been contaminated with lead or had significant problems with product variability.

Many families use supplements concurrently with medications, posing hazards of interactions (Table 7.2). Using the same principles of drug-drug interactions can help determine if a supplement-drug interaction is a concern. For example, St. John's wort induces CYP3A4 activity of the cytochrome P450 enzyme system and thus can enhance elimination of most drugs that use this pathway, including digoxin, cyclosporine, protease inhibitors, oral contraceptives, and numerous antibiotics, leading to subtherapeutic serum levels.

### DIETARY SUPPLEMENT EFFICACY

Evidence about the effectiveness of dietary supplements to prevent or treat pediatric problems is mixed, depending on the product used and condition treated. Some herbal products may be helpful adjunctive treatments for common childhood problems; some herbs have proved helpful for colic (fennel and the combination of chamomile, fennel, vervain, licorice, and balm mint), nausea (ginger), irritable bowel syndrome (peppermint), and diarrhea (probiotics).

### MASSAGE AND CHIROPRACTIC

Massage is usually provided at home by parents and in clinical settings by professional massage therapists, physical therapists, and nurses. **Infant massage** is routinely provided in many neonatal intensive care units to promote growth and development in preterm infants. Massage also has been demonstrated to be beneficial for pediatric patients with asthma, insomnia, colic, cystic fibrosis, or juvenile arthritis and patients undergoing cancer therapy. **Massage therapy** is generally safe. Professional massage practice is regulated by state government and may be in the form of a

license, registration, or certification. More than 44 states license massage therapists, with licensure being the strictest form of regulation, making it illegal for any nonlicensed professional to practice massage therapy.

**Chiropractic healthcare** deals with the diagnosis, treatment, and prevention of disorders of the neuromusculoskeletal system and their effects on general health. Currently, >70,000 chiropractors have licensure in the United States, with licensure in all 50 states. Most medical insurance companies cover chiropractic care. Children and families seek chiropractic care for common childhood conditions such as asthma, infantile colic, nocturnal enuresis, constipation, and headache. A consensus update on chiropractic care in children found no evidence for the effectiveness of chiropractic care for such common childhood conditions. With respect to safety, the evidence is also limited; however, published cases of serious adverse events in infants and children receiving chiropractic care are rare. Unfortunately, although rare, complications of cervical manipulation include vertebrobasilar dissection with resultant stroke and rupture of a syringomyelia with resultant paralysis. If children and families are seeking chiropractic care, it is appropriately done following consultation with the child's pediatric primary care provider to ensure patient safety. In addition, chiropractors often give medical advice beyond their expertise; up to 30% believe vaccines have significant side effects.

### MIND-BODY THERAPIES

Mind-body therapies such as slow, deep breathing, meditation, guided imagery, biofeedback, hypnosis, tai chi, and yoga are also frequently used complementary therapies in pediatrics. These practices can be learned informally through books, online videos, compact discs, digital video discs, smartphone apps, or classes and in therapeutic sessions with health professionals, such as psychologists and social workers (Table 7.3). Substantial research suggests that such practices can aid in reducing anxiety, insomnia, and stress-related conditions, including migraine headaches and functional abdominal pain. These therapies can also help patients struggling with chronic pain.

### ACUPUNCTURE

Modern acupuncture incorporates treatment traditions from China, Japan, Korea, France, and other countries. In the United States, acupuncturists are licensed to practice in 47 states. Acupuncture can be delivered to pediatric patients in hospital and clinic settings to treat a variety of ailments. Acupuncture is particularly useful for children experiencing pain, and acupuncture services are offered alongside conventional medicine and psychology by >50% of North American academic pediatric chronic pain programs. The technique that has undergone the most scientific study involves penetrating the skin

**Table 7.2** Common Herbal Dietary Supplement (HDS)–Drug Interactions

HDS	DRUGS	POTENTIAL CONSEQUENCES/REACTIONS
Aloe vera	Glibenclamide (glyburide)	↑ Oral aloe vera gel can cause additive glycemic-lowering effects when taken concurrently with a hypoglycemic agent
Bitter orange	Phenelzine	↑ Risk of hypertensive crisis
Garlic	Ritonavir	↓ Effect of ritonavir
	Saquinavir	↓ Effect of saquinavir
Licorice	Warfarin	↑ Risk of bleeding
Grapefruit	Calcium channel blockers	Grapefruit juice has been found to increase the bioavailability of certain drugs by inhibition of the cytochrome P450 (CYP) 3A4 isozyme in the liver and gut wall
Melatonin	Zolpidem	↑ Sedative effects
Valerian	Alprazolam, phenobarbital	↑ Central nervous system depression
Goldenseal	Inhibition of CYP2D6 and CYP3A4	May affect approximately 50% of common pharmaceutical agents
St. John's wort	Cyclosporine, tacrolimus, warfarin, protease inhibitors, digoxin, theophylline, venlafaxine, oral contraceptives	May decrease drug effectiveness

↓, Decreasing; ↑, increasing.



**Table 7.3** Commonly Used Mind-Body Practices in Pediatrics

PRACTICE	USES
Biofeedback	Preventing migraine headaches; reducing stress and anxiety; encopresis/constipation treatment; treatment of stress incontinence; neurofeedback is adjunctive for ADHD
Deep breathing	Relaxation; stress management
Guided imagery	Stress management; anxiety reduction; pain relief
Hypnosis	Correcting habit disorders; preventing headaches; managing pain
Meditation	Stress management; improving concentration
Tai chi	Improving balance, coordination, concentration, and discipline
Yoga	Improving balance, coordination, and concentration

ADHD, Attention-deficit/hyperactivity disorder.

with thin, solid, metallic needles manipulated by hand or by electrical stimulation. Variants include rubbing (**shiatsu**), heat (**moxibustion**), lasers, magnets, pressure (**acupressure**), or electrical currents.

Although pediatric patients may be averse to needles, when approached in a developmentally appropriate way by an acupuncturist trained in pediatrics, children are often amenable to acupuncture and report that it is helpful. Acupuncture can offer significant benefits in the treatment of recurrent headache, anxiety, back and other types of pain, depression, abdominal pain, and nausea. Infections and bleeding are rare but can occur, and more serious complications, such as pneumothorax, occur in <1 in 30,000 treatments.

## CANNABIS

Because marijuana has been legalized in many states for both recreational (adult) use and medical use, caregivers and families may inquire about the potential health benefits of cannabis for both children and adults. There are significant safety concerns in adolescents and young adults, because detrimental effects of marijuana on the developing brain have been documented. One systematic review of 90 studies, including 9,441 adolescents and young adults, provided preliminary evidence for functional and structural alterations in frontoparietal, frontolimbic, frontostriatal, and cerebellar regions among adolescent cannabis users.

It is important to note that in some children with severe refractory epilepsy, oral cannabidiol, a nonpsychoactive component in marijuana, improves seizure control. Outside of prescription cannabidiol, the purity and regulation of marijuana and its commercially available component products are variable. Most of the pediatric literature on cannabis describes an increase in accidental ingestions in young children, presumably in association with the increase in products now available for adult use; this is an additional safety risk for pediatricians to consider.

## INTERNET RESOURCES

American Academy of Pediatrics Section on Integrative Medicine: <https://www.aap.org/en/community/aap-sections/integrative-medicine/about-soim/>

Academic Consortium Integrative Medicine and Health: <http://www.imconsortium.org/>

National Institutes of Health, National Center for Complementary and Integrative Health: <https://nccih.nih.gov/>

Visit Elsevier eBooks+ at [eBooks.Elsevier.com](https://eBooks.Elsevier.com) for Bibliography.

## Chapter 8

# Pediatric Palliative Care

*Katharine Davidoff, Chelsea Heneghan, Joanne Wolfe, and Christina Ullrich*

According to the World Health Organization (WHO), “Palliative care for children is the active total care of the child’s body, mind and spirit and also involves giving support to the family. Optimally, this care begins when a life-threatening illness or condition is diagnosed and continues regardless of whether or not a child receives treatment directed at the underlying illness.” Provision of palliative care applies to children with a wide variety of serious illnesses, including cancer, cystic fibrosis, complex or severe cardiac disease, neurodegenerative disorders, severe malformations, and trauma with life-threatening sequelae (Table 8.1). Many children who benefit from integration of palliative care approaches have **complex chronic conditions and are supported by advanced medical technology that allows them to live longer**. These children, who often survive health crises followed by the renewed need for rehabilitative and life-prolonging treatments, are best served by a system that is flexible and responsive to changing needs and blended goals of care.

Although often mistakenly understood as synonymous with *end-of-life care*, **the scope and potential benefits of palliative care are applicable throughout the illness trajectory**. Palliative care emphasizes ascertaining and aligning with goals of care, which may be congruent with maximal treatment aimed at sustaining or prolonging life, optimization of quality of life, communication, and symptom control.

The mandate of pediatric clinicians to attend to children’s physical, mental, and emotional health and development includes the provision of palliative care for those who live with a significant possibility of death before adulthood (Fig. 8.1). As such, all pediatric clinicians benefit from using basic (primary) palliative care principles when approaching the care of children living with serious illness. At the same time, such comprehensive physical, psychological, social, and spiritual care benefits from an interdisciplinary approach.

The philosophy of palliative care can be successfully integrated into any hospital setting, including the ICU, when the focus of care also includes the prevention or amelioration of suffering and improving comfort and quality of life. All interventions that affect the child and family need to be assessed in relationship to these goals. This proactive approach asks the question, “What can we offer that will improve the quality of this child’s life and provide the most meaning and sense of control and choice for their family?” instead of, “What therapies are we no longer going to offer this patient?” Staff may benefit from education, support, and guidance on the basic principles of pediatric palliative care, while using specialty-trained pediatric palliative care providers when available for additional support and expertise. *Regardless of the care setting, comprehensive palliative care requires an interdisciplinary approach that may include nurses, physicians, psychologists, psychiatrists, social workers, chaplains/clergy, child life specialists, and trained volunteers.*

## GOALS OF CARE AND DECISION-MAKING

In the course of a child’s serious illness, a series of important decisions may arise in relation to location of care, medications with risks and benefits, not starting or discontinuing life-prolonging treatments, experimental treatments in research protocols, and use of integrative therapies. Guided discussions around **goals of care** for the child provide opportunities to support decision-making. This is often accomplished



**Table 7.3** Commonly Used Mind-Body Practices in Pediatrics

PRACTICE	USES
Biofeedback	Preventing migraine headaches; reducing stress and anxiety; encopresis/constipation treatment; treatment of stress incontinence; neurofeedback is adjunctive for ADHD
Deep breathing	Relaxation; stress management
Guided imagery	Stress management; anxiety reduction; pain relief
Hypnosis	Correcting habit disorders; preventing headaches; managing pain
Meditation	Stress management; improving concentration
Tai chi	Improving balance, coordination, concentration, and discipline
Yoga	Improving balance, coordination, and concentration

ADHD, Attention-deficit/hyperactivity disorder.

with thin, solid, metallic needles manipulated by hand or by electrical stimulation. Variants include rubbing (**shiatsu**), heat (**moxibustion**), lasers, magnets, pressure (**acupressure**), or electrical currents.

Although pediatric patients may be averse to needles, when approached in a developmentally appropriate way by an acupuncturist trained in pediatrics, children are often amenable to acupuncture and report that it is helpful. Acupuncture can offer significant benefits in the treatment of recurrent headache, anxiety, back and other types of pain, depression, abdominal pain, and nausea. Infections and bleeding are rare but can occur, and more serious complications, such as pneumothorax, occur in <1 in 30,000 treatments.

## CANNABIS

Because marijuana has been legalized in many states for both recreational (adult) use and medical use, caregivers and families may inquire about the potential health benefits of cannabis for both children and adults. There are significant safety concerns in adolescents and young adults, because detrimental effects of marijuana on the developing brain have been documented. One systematic review of 90 studies, including 9,441 adolescents and young adults, provided preliminary evidence for functional and structural alterations in frontoparietal, frontolimbic, frontostriatal, and cerebellar regions among adolescent cannabis users.

It is important to note that in some children with severe refractory epilepsy, oral cannabidiol, a nonpsychoactive component in marijuana, improves seizure control. Outside of prescription cannabidiol, the purity and regulation of marijuana and its commercially available component products are variable. Most of the pediatric literature on cannabis describes an increase in accidental ingestions in young children, presumably in association with the increase in products now available for adult use; this is an additional safety risk for pediatricians to consider.

## INTERNET RESOURCES

American Academy of Pediatrics Section on Integrative Medicine: <https://www.aap.org/en/community/aap-sections/integrative-medicine/about-soim/>

Academic Consortium Integrative Medicine and Health: <http://www.imconsortium.org/>

National Institutes of Health, National Center for Complementary and Integrative Health: <https://nccih.nih.gov/>

Visit Elsevier eBooks+ at [eBooks.Elsevier.com](https://eBooks.Elsevier.com) for Bibliography.

## Chapter 8

# Pediatric Palliative Care

*Katharine Davidoff, Chelsea Heneghan, Joanne Wolfe, and Christina Ullrich*

According to the World Health Organization (WHO), “Palliative care for children is the active total care of the child’s body, mind and spirit and also involves giving support to the family. Optimally, this care begins when a life-threatening illness or condition is diagnosed and continues regardless of whether or not a child receives treatment directed at the underlying illness.” Provision of palliative care applies to children with a wide variety of serious illnesses, including cancer, cystic fibrosis, complex or severe cardiac disease, neurodegenerative disorders, severe malformations, and trauma with life-threatening sequelae (Table 8.1). Many children who benefit from integration of palliative care approaches have **complex chronic conditions and are supported by advanced medical technology that allows them to live longer**. These children, who often survive health crises followed by the renewed need for rehabilitative and life-prolonging treatments, are best served by a system that is flexible and responsive to changing needs and blended goals of care.

Although often mistakenly understood as synonymous with *end-of-life care*, **the scope and potential benefits of palliative care are applicable throughout the illness trajectory**. Palliative care emphasizes ascertaining and aligning with goals of care, which may be congruent with maximal treatment aimed at sustaining or prolonging life, optimization of quality of life, communication, and symptom control.

The mandate of pediatric clinicians to attend to children’s physical, mental, and emotional health and development includes the provision of palliative care for those who live with a significant possibility of death before adulthood (Fig. 8.1). As such, all pediatric clinicians benefit from using basic (primary) palliative care principles when approaching the care of children living with serious illness. At the same time, such comprehensive physical, psychological, social, and spiritual care benefits from an interdisciplinary approach.

The philosophy of palliative care can be successfully integrated into any hospital setting, including the ICU, when the focus of care also includes the prevention or amelioration of suffering and improving comfort and quality of life. All interventions that affect the child and family need to be assessed in relationship to these goals. This proactive approach asks the question, “What can we offer that will improve the quality of this child’s life and provide the most meaning and sense of control and choice for their family?” instead of, “What therapies are we no longer going to offer this patient?” Staff may benefit from education, support, and guidance on the basic principles of pediatric palliative care, while using specialty-trained pediatric palliative care providers when available for additional support and expertise. *Regardless of the care setting, comprehensive palliative care requires an interdisciplinary approach that may include nurses, physicians, psychologists, psychiatrists, social workers, chaplains/clergy, child life specialists, and trained volunteers.*

## GOALS OF CARE AND DECISION-MAKING

In the course of a child’s serious illness, a series of important decisions may arise in relation to location of care, medications with risks and benefits, not starting or discontinuing life-prolonging treatments, experimental treatments in research protocols, and use of integrative therapies. Guided discussions around **goals of care** for the child provide opportunities to support decision-making. This is often accomplished

**Table 8.1** Conditions Appropriate for Pediatric Palliative Care

**CONDITIONS FOR WHICH CURATIVE TREATMENT IS POSSIBLE BUT MAY NOT SUCCEED**

Advanced or progressive cancer or cancer with a poor prognosis  
Complex and severe congenital or acquired heart disease

**CONDITIONS FOR WHICH THERE IS INTENSIVE LONG-TERM TREATMENT AIMED AT PROLONGING LIFE AND MAINTAINING QUALITY OF LIFE, BUT PREMATURE DEATH IS STILL POSSIBLE**

Cystic fibrosis  
Severe immunodeficiency  
High-risk solid-organ transplant candidates and/or recipients (e.g., lung, multivisceral)  
Chronic or severe respiratory failure  
Muscular dystrophy  
Complex multiple congenital malformation syndromes  
Primary pulmonary hypertension  
Severe chromosomal disorders (aneuploidy, deletions, duplications)

**PROGRESSIVE CONDITIONS FOR WHICH THERE IS NO CURATIVE OPTION AND IN WHICH TREATMENT IS ALMOST EXCLUSIVELY PALLIATIVE AFTER DIAGNOSIS**

Progressive metabolic disorders (Tay-Sachs disease)  
Batten disease  
Severe forms of osteogenesis imperfecta

**CONDITIONS INVOLVING SEVERE, NONPROGRESSIVE DISABILITY, CAUSING EXTREME VULNERABILITY TO HEALTH COMPLICATIONS**

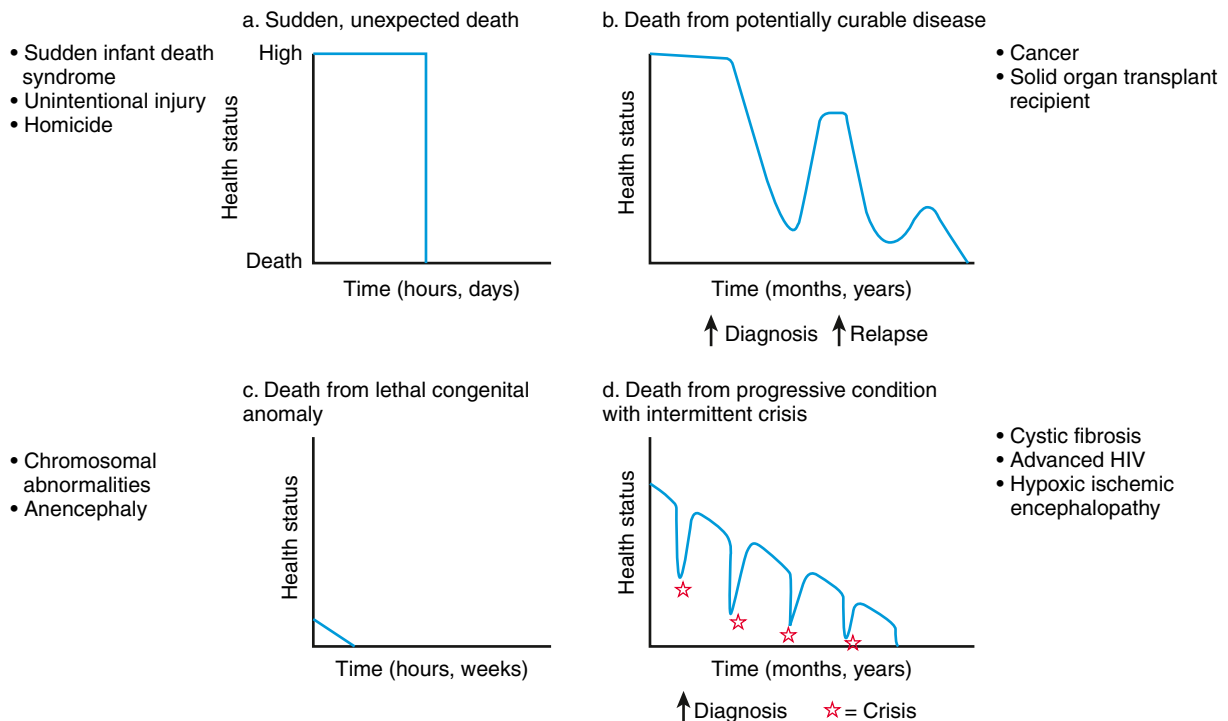
Severe cerebral palsy with recurrent infection or difficult-to-control symptoms  
Severe neurologic sequelae of infectious disease  
Hypoxic or anoxic brain injury  
Brain malformations (e.g., holoprosencephaly, lissencephaly)

Adapted from The Together for Short Lives (formerly the Association for Children's Palliative Care [ACT]) Life-limiting/Life-threatening Condition Categories. [http://www.togetherforshortlives.org.uk/professionals/childrens\\_palliative\\_care\\_essentials/approach](http://www.togetherforshortlives.org.uk/professionals/childrens_palliative_care_essentials/approach).

by eliciting parent (and child) understanding of the child's condition and asking open-ended questions that explore the parent's and child's hopes, worries, and family values. Goals-of-care conversations include what is most important for them as a family, considerations of their child's clinical condition, and their values and beliefs, including cultural, religious, and spiritual considerations (see Chapters 2 and 12). Table 8.2 presents specific questions that can effectively guide these discussions, and Figure 8.2 provides a basic framework illustrating a palliative-minded approach to care, anchored by eliciting goals of care and aligning care with those goals. The conversation should also include a review of previous discussions, active listening to concerns and issues as they are raised, opportunities to repeat back elements of the discussion to ensure clarity, and provision of honest, factual answers even in areas of uncertainty. As a provider, it is imperative to consider one's own views and implicit biases before entering into discussions with families who may identify with different cultures, races, or other social determinants (see Chapters 2, 3, and 12).

**Decision-making should be focused on the goals of care, as opposed to limitations of care:** "This is what we can offer," instead of, "There is nothing more we can do." Rather than meeting specifically to discuss discontinuing life-prolonging therapies or a do-not-resuscitate (DNR) order, a more general discussion centered on the goals of care will naturally lead to considering which interventions are in the child's best interests and can present an opportunity for the clinicians to make recommendations based on these goals. By offering medical recommendations based on family goals and the clinical reality, the team can decrease the burden of responsibility for decision-making that parents carry.

Conflicts in decision-making can occur within families, within healthcare teams, between the child and family, and between the family and care team (see Chapter 6). For children who are developmentally unable to provide guidance in decision-making (neonates, very young children, or children with severe cognitive impairment), parents and healthcare professionals may come to different conclusions as to what is in the child's best interests. Decision-making around the care of adolescents presents specific challenges, given the shifting boundary that separates childhood from adulthood. In some families and cultures, open disclosure and



**Fig. 8.1** Typical illness trajectories for children with life-threatening illness. (From Field M, Behrman R [eds]. *When Children Die: Improving Palliative and End-of-Life Care for Children and Their Families*. Washington, DC: National Academies Press;2003: 74.)

autonomy are secondary to maintaining the integrity of the family (see Chapter 12). Although frequently encountered, differences in opinion are often manageable for all involved when lines of communication are kept open, team and family meetings are held, and the goals of care are clear.

**ADVANCE CARE PLANNING**

Although accurate prognostication is a particular challenge in pediatrics, the medical team often recognizes a poor prognosis before the prognosis is understood by parents or the child. This delay may impede informed decision-making about how the child lives at the end of life. Given the inherent prognostic uncertainty of a serious, life-threatening diagnosis, discussions concerning resuscitation, symptom control, and end-of-life care planning should be initiated when the physician recognizes that a significant possibility of patient mortality exists. Having these conversations in the midst of a crisis is not ideal. Whenever possible, they should

occur well in advance of the crisis or when the patient has recovered from a crisis but is at high risk for others.

Patients and families are most comfortable being cared for by physicians and other care providers with whom they have an established relationship. Even in the face of long-standing and highly connected relationships, clinicians often hold assumptions about parent prognostic awareness, as well as parent readiness and willingness to have such discussions. In an attempt to protect families, clinicians may avoid conversations they perceive as promoting distress or hopelessness. However, parents greatly value honesty, and in fact such conversations can promote parent hopefulness and trust and connection with the care team. At times, a consultative specialty palliative care team provides the family with an opportunity to engage in sensitive conversations that may not as readily occur with the primary team, at least initially.

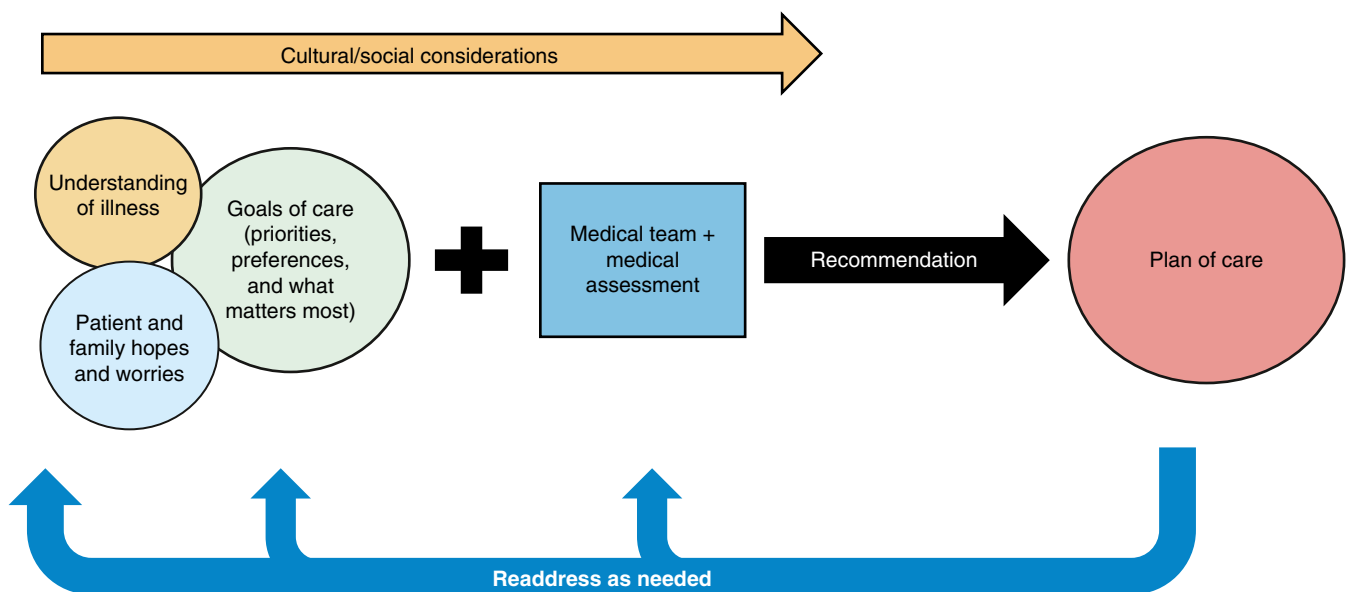
The population of individuals who die before reaching adulthood includes a disproportionate number of nonverbal and preverbal children and adolescents who are developmentally unable to make autonomous care decisions. Although parents are usually the primary decision-makers, these youth should be as fully involved in discussions and decisions about their care as appropriate for their developmental status. Using communication experts, child life therapists, chaplains, social workers, psychologists, and psychiatrists to allow children to express themselves through art, play, music, talk, and writing will enhance the provider’s knowledge of the child’s understanding and hopes. Tools such as **Five Wishes** (for adults), **Voicing My Choices** (for adolescents), and **My Wishes** (for school-age children) have in practice been useful in helping to introduce advance care planning to children, adolescents, and their families ([www.agingwithdignity.org/index.php](http://www.agingwithdignity.org/index.php)).

**Table 8.2** Five Basic Questions to Guide the “Goals of Care” Conversation

PHRASING FOR ADULT OR OLDER ADOLESCENT	PHRASING FOR CHILD
Tell us about your child as a person. What does your child enjoy?	Tell me about yourself before you got sick.
What is your understanding of your child’s illness/condition?	Why are you in the hospital? What do you understand about your illness?
In light of your understanding, what is most important to you regarding your child’s care?	What do you want others to know or do for you when taking care of you?
What are you hoping for? What are your worries?	I wonder if there is anything that is worrying you or that is keeping you up at night. Is there anything you wish you could talk about?
What gives you strength in the face of your child’s illness/condition?	What helps you get through the day? What helps you feel good?

**Resuscitation Status**

Many parents do not understand the legal mandate requiring attempted resuscitation for cardiorespiratory arrest unless a written DNR order is in place. In broaching this topic, rather than asking parents if they want to forgo cardiopulmonary resuscitation (CPR) for their child (and placing the burden of decision-making on them), discuss whether or not resuscitative interventions are likely to benefit the child. It is important to make recommendations based on overall goals of care and medical knowledge of potential benefit and/or harm of these interventions. Once the goals of therapy are agreed on, the physician is required to write a formal order. Out-of-hospital DNR verification forms are available which, if completed on behalf of the child, affirm that rather than initiating resuscitative efforts, emergency response teams are obligated to provide appropriate symptom management intended to support



**Fig. 8.2** A framework for creating plans of care with a palliative-minded approach, anchored by patient/family goals of care.

comfort and relief of suffering with appropriate interventions when called to the scene.

All states have implemented the **physician orders for life treatment (POLST) system**. A POLST order is completed for children with life-threatening illness, creating actionable orders for interventions to pursue versus avoid based on the expressed parent's and/or child's wishes ([polst.org](http://polst.org)). It is usually helpful to frame discussions about POLST as ways for parents to maintain some control by communicating their goals and care preferences so their wishes may be honored, irrespective of the setting. It may also be beneficial to write a letter that delineates decisions regarding resuscitation interventions and supportive care measures to be undertaken for the child, particularly if POLST are not available. The letter should be as detailed as possible, including recommendations for comfort medications and contact information for the care team best known to the patient. Such a letter, given to the parents, with copies to the involved care team and institutions, can be a useful communication aid, especially in times of crisis. In any case, if a child dies in the home setting and the parents opt to use an out-of-hospital DNR verification form or POLST, plans to pronounce the child and provide support for the family must be in place. If the child has been referred to hospice, the hospice usually fulfills those responsibilities.

## CARE SETTINGS

Pediatric palliative care should be provided across settings, including hospital, outpatient, and home, as well as pediatric nursing facilities and sometimes inpatient hospice locations. **Home care** for the child with a life-threatening illness requires 24 hour/day access to experts in pediatric palliative care, a team approach, and an identified coordinator who serves as a link among hospitals, the community, and specialists and who may assist in preventing or arranging for hospital admissions, respite care, and increased home care support as needed based on the child's clinical condition and goals of care. Adequate home care support and respite care, although sorely needed, is often not readily available, given gaps in staffing or the high-tech skills required to care for these children. Furthermore, families may view using respite care as a personal failure, or they may worry that others cannot adequately care for their child's special needs or potential rapid escalation of symptoms.

In the United States, the healthcare and reimbursement structure, combined with frequent use of medical technology (e.g., home ventilatory support) or continuous home nursing, historically precluded formal enrollment of children on the hospice benefit when they were otherwise eligible (i.e., had estimated prognosis of  $\leq 6$  months). Section 2302 of the Patient Protection and Affordable Care Act (ACA), the Concurrent Care for Children Requirement (CCCR), eliminated the requirement that Medicaid patients <21 years old forgo curative or life-prolonging therapies to be eligible for hospice. Although Medicaid programs in every state are required to provide concurrent curative/life-prolonging treatment and hospice services for hospice-eligible children, development of systems to make such concurrent care a reality has been slow. A limitation of the CCCR is that it does not expand access to hospice for children with life-threatening illness who do not meet hospice eligibility criteria (i.e., have a prognosis that cannot be estimated to be <6 months) or those not receiving Medicaid.

A number of state-based pediatric palliative care coalitions have formed to improve access to home-based pediatric hospice/palliative care services, using strategies such as Medicaid waivers or state plan amendments to increase coverage for hospice services. A growing number of home care agencies have also developed palliative care programs that serve as a bridge to hospice services for children not yet meeting hospice eligibility criteria. Some hospices have adopted an **open hospice** model with more flexible eligibility criteria. However, provision of hospice or palliative care for children is often also limited by the availability of clinicians who have training or experience in caring for seriously ill children. Furthermore, there are only a few inpatient facilities in existence within the United States that provide end-of-life care exclusively to pediatric patients.

At the end of life, children and families may need intensive support. About half of pediatric deaths occur in acute care hospitals, and end-of-life care may otherwise be provided in the home, pediatric nursing

facility, or hospice house. Families need to feel safe and well cared for and given permission, if possible, to choose the location of care. In tertiary care hospitals, most children die in the neonatal and pediatric ICUs. In some instances, when death at home for a child in the ICU is preferred, transport and even extubation at home may be possible, if clinical and logistical circumstances permit it and support it.

## COMMUNICATION AND ANTICIPATORY GUIDANCE Parents

For parents (parents defined as any primary caregivers for children), **compassionate communication** with medical providers who understand their child's illness, treatment options, and family beliefs and goals is the cornerstone of caring for children with serious illness. During this time, one of the most significant relationships is that with the child's primary care clinician, who often has an enduring relationship with the child and family, including healthy siblings. Although a family's goals may change with the child's evolving clinical condition and other variable factors, *parents need to know that their child's primary care clinician will not abandon them as the goals of care evolve*. A flexible approach rooted in ongoing communication and guidance that incorporates understanding of the family's values, goals, and religious, cultural, spiritual, and personal beliefs is of paramount importance.

Pediatricians should recognize the important role they have in continuing to care for the child and family, because the primary goal of treatment may simultaneously be prolongation of life as well as comfort, relief of suffering, and promoting quality of life. Regular meetings between the care team and the family are essential to reassess and manage symptoms, explore the impact of illness on immediate family members, and provide anticipatory guidance. At these meetings, important issues with lifelong implications for parents and their child may be discussed. Such discussions should be planned with care, ensuring that adequate time for in-depth conversation is allotted; a private, physical setting is arranged; devices are silenced; and both parents and others who might be identified by the family as primary supports are present. Strategies for facilitating conversations related to goals of care and decision-making are detailed later.

Families may look to their pediatrician for assurance that all treatment options have been explored. Assisting a patient's family to arrange a second opinion may be helpful. Listening to families and children speak about the future even in the face of a poor prognosis may help keep the focus on living even while the child may be dying. Hoping for a miracle can coexist for parents even as they are facing and accepting the reality of death.

Parents also need to know about the availability of home care, respite services, web-based support (e.g., [www.courageousparentsnetwork.org](http://www.courageousparentsnetwork.org)), educational materials, and support groups. Responding to parental requests or need for counseling referrals for themselves, other children, or the family is essential. Also, attending to the concrete needs of families (e.g., financial, insurance, housing) can be paramount in freeing them from worries that might interfere or compete with their ability to be fully present in their child's care.

When closer to the patient's end of life, although broaching the topic may seem daunting, exploration of how parents envision their child's death, addressing their previous loss experiences (most often with death of an adult relative) and any misconceptions, is often a great relief. *Learning about cultural, spiritual, and family values regarding pain management, suffering, and the preferred place of end-of-life care is essential* (see Chapters 2 and 12). Even mentioning funeral arrangements, possible autopsy, and organ/tissue donation pre-emptively can be helpful to give parents choices and know that these considerations can be discussed without fear. A major worry of many parents is how to involve and communicate with siblings, as well as the child, about the likelihood of impending death.

Ratings of "high satisfaction" with physician care have been directly correlated with receiving **clear communication** around end-of-life issues, delivered with sensitivity and caring; such communication included speaking directly to the child when appropriate. Communication may be complicated by **mutual protection** in which the child



wants to protect his or her parents, and likewise the parents want to protect their child, from painful information, sadness, or fear. Honoring the uniqueness of the child and understanding and respecting the family's communication style, values, spirituality, and culture are critical in these highly sensitive conversations. Evidence shows that parents who have open conversations with their child about death and dying do not regret having done so, whereas many parents who do not engage in these conversations regret avoiding them.

In communications with the child and family, the physician should avoid giving specific estimates of survival length, even when the child or family explicitly asks for them. These predictions are invariably inaccurate because population-based statistics do not predict the course for individual patients. A more honest approach may be to explore *ranges of time in general terms* (days to weeks, weeks to months, months to years) while recognizing that children with serious illness are also susceptible to acute events that cause rapid deterioration. The physician can also ask parents what they might do differently if they knew how long their child would live, then assist them in thinking through the options relating to their specific concerns (e.g., suggest celebrating upcoming holidays or important events earlier to take advantage of times when the child may be feeling better). It is generally wise to suggest that relatives who wish to visit might do so earlier rather than later, given the unpredictable trajectory of many conditions.

**For the child and family, the integration of “bad news” is a process, not an event**, and when done sensitively, does not take away hope or alter the relationship between the family and physician. The physician should expect that some issues previously discussed may not be fully resolved for the child and parents (e.g., DNR orders, artificial nutrition or hydration) and may need to be revisited over time. Parents of a child with a chronic illness may reject the reality of an impending death because past predictions may not have been accurate. Whether they are parents of a child with a chronic illness or a child whose death is the result of an accident or sudden catastrophic illness, they may experience great anxiety, guilt, or despair.

### The Child

Truthful communication that takes into account the child's developmental stage and unique lived experience can help to address the fear and anxiety commonly experienced among children with serious illness. Responding in a developmentally appropriate fashion (Table 8.3) to a child's questions about death (e.g., “What's happening to me?” or “Am I dying?”) requires a careful exploration of what is already known by the child, what is really being asked (*the question behind the question*), and why the question is being asked at this particular time and in this setting. It may signal a need to be with someone who is comfortable listening to such unanswerable questions. Many children find nonverbal expression much easier than talking; art, play therapy, and storytelling may be more helpful than direct conversation.

A child's perception of death depends on his or her conceptual understanding of *universality* (that all things inevitably die), *irreversibility* (that dead people cannot come back to life), *nonfunctionality* (that being dead means that all biologic functions cease), and *causality* (that there are objective causes of death).

**Very young children** may struggle with the concepts of irreversibility and nonfunctionality. For young school-age children, who are beginning to understand the finality of death, worries may include *magical thinking* in which their thoughts, wishes, or bad behavior might be the underlying cause for their illness. Older children seek more factual information to gain some control over the situation.

**Children's** fears of death are often centered on the concrete fear of being separated from parents and other loved ones and what will happen to their parents rather than themselves. This can be true for teens and young adults as well. This fear may be responded to in different ways: some families may give reassurance that loving relatives will be waiting, and others use religious concepts to refer to an eternal spiritual connection.

**Adolescents** may have a conceptual understanding of death similar to that of adults, but working with the adolescent with life-threatening illness presents unique concerns and issues. The developmental work

of adolescence includes separating from their parents, developing strong peer relationships, and moving toward independent adulthood. For this population, the teenager's developmental need to separate is complicated by the increasing dependence both physically and emotionally on their parents. Providing space for these conversations and communicating openly and honestly supports independence while also meeting the adolescent's individual need.

In addition to developmental considerations, understanding related to the child's life experiences, the length of the child's illness, the understanding of the nature and prognosis of the illness, the child's role in the family, and the complex relationship between the child and their parents as primary caretakers should be considered in communication with children.

The question of whether and when to involve adolescents in decision-making arises particularly often. There is no one answer to this question. Instead, numerous considerations should be taken into account, including the adolescent's chronological age, developmental stage, adolescent preference with regard to such participation, and the family's preferred approach to communication and decision-making.

Parents have an instinctive and strong desire to protect their children from harm. When facing the death of their child, many parents attempt to keep the reality of impending death hidden from their child, hoping the child can be protected from the harsh reality. Although it is important to respect parental wishes, it is also true that most children already have a sense of what is happening to their bodies, even when it has been purposely left unspoken. Children may blame themselves for their illness and the resulting hardships for their loved ones. *Perpetuating the myth that “everything is going to be all right” takes away the chance to explore fears and provide reassurance.* Assisting parents to understand that the key to honest communication is not telling a child he or she is dying, but opening the door to conversation and validating what the child *already knows*. Honest communication also allows opportunities for memory and legacy making and saying goodbye.

**School** is the work of childhood and adolescence and is important in optimizing quality of life for a child seeking normalcy in the face of illness. Finding ways to help children and their families to maintain these connections through modification of the school day and exploring options to promote educational and social connections into the home or into the hospital room can be meaningful in the event that a child is not well enough to attend school. Video conferencing can be readily arranged from almost any setting.

### The Siblings

Siblings are at special risk both during their sibling's illness and after the death. Because of the extraordinary demands placed on parents to meet the needs of their ill child, healthy siblings may feel their own needs are not being acknowledged or fulfilled. These feelings of neglect may then trigger guilt about their own good health and resentment toward their parents and ill sibling. Younger siblings may react to the stress by becoming seemingly oblivious to the turmoil around them. Some younger siblings may feel guilty for wishing the affected child would die so they could get their parents back (magical thinking). Parents need to know that these are normal responses, and siblings should be encouraged to maintain the typical routines of daily living. Siblings who are most involved with their sick sibling before death usually adjust better both at the time of and after the death. Acknowledging and validating sibling feelings, being honest and open, and appropriately involving them in the life of their sick sibling provide a good foundation for the grief process. It is often helpful to identify a person in the family (e.g., caring aunt) or school (e.g., counselor) to offer confidential and supportive opportunities for the sibling to reflect on their family experience, particularly as parents may be too overwhelmed to provide this at crucial times.

### The Staff

Inadequate support for the staff providing palliative care can result in depression, emotional withdrawal, and other symptoms. Offering educational opportunities and emotional support in the form of both

**Table 8.3** Developmental Questions, Thoughts, and Concepts of Dying, with Responsive Strategies

TYPICAL QUESTIONS AND STATEMENTS ABOUT DYING	THOUGHTS THAT GUIDE BEHAVIOR	DEVELOPMENTAL UNDERSTANDING OF DEATH	STRATEGIES AND RESPONSES
<p><b>MONTHS TO 3 YR OF AGE</b></p> <p>"Mommy, don't cry." "Daddy, will you still tickle me when I'm dead?"</p>	<p>Child has limited understanding of events, future and past, and of the difference between living and nonliving.</p>	<p>Child may have "sense" that something is wrong. Death is often viewed as continuous with life (analogous to being awake and being asleep).</p>	<p>Optimize comfort and consistency; familiar persons, objects, routines. Use soothing songs, words, and touch. "I will always love you." "I will always take care of you." "I will tickle you forever."</p>
<p><b>AGE 3-5 YR</b></p> <p>"I did something bad and so I will die." "Can I eat anything I want in heaven?"</p>	<p>Concepts are simple and reversible. Variations between reality and fantasy.</p>	<p>Child may see death as temporary and reversible and not universal. Child may feel responsible for illness. Death may be perceived as an external force that can get you.</p>	<p>Assure child that illness is not their fault. Provide a consistent care team. Promote honest, simple language. Use books to explain the life cycle and promote questions and answers. "You did not do anything to cause this." "You are so special to us, and we will always love you." "We know (God, Jesus, Grandma, Grandpa) are waiting to see you."</p>
<p><b>AGE 5-10 YR</b></p> <p>"How will I die?" "Will it hurt?" "Is dying scary?"</p>	<p>Child begins to demonstrate organized, logical thought. Thinking becomes less esoteric. Child begins to problem-solve concretely, reason logically, and organize thoughts coherently. However, child has limited abstract reasoning.</p>	<p>Child begins to understand death as real and permanent. Death means that your heart stops, your blood does not circulate, and you do not breathe. It may be viewed as a violent event. Child may not accept death could happen to himself or herself or to anyone he or she knows, but starts to realize that people they know will die.</p>	<p>"Tell me why you are asking." Be honest and provide specific details if they are requested. Help and support the child's need for control. Permit and encourage the child's participation in decision-making. "We will work together to help you feel comfortable. It is very important that you let us know how you are feeling and what you need. We will always be with you, so you do not need to be afraid."</p>
<p><b>AGE 10-18 YR</b></p> <p>"I'm afraid if I die my mom will just break down." "I'm too young to die. I want to get married and have children." "Why is God letting this happen?"</p>	<p>Abstract thoughts and logic possible. Body image is important. Child needs peer relationships for support and for validation. Child expresses altruistic values, such as staying alive for family (parents, siblings) and donating organs/tissue. Disbelief that they are dying.</p>	<p>Understand death as irreversible, inevitable, and universal. Child needs reassurance of continued care and love. Search for meaning and purpose of life.</p>	<p>Reinforce child's/adolescent's self-esteem, sense of worth, and self-respect. Allow need for privacy, independence, access to friends and peers. Tolerate expression of strong emotions and permit participation in decision-making. "I can't imagine how you must be feeling. Despite it all, you are doing an incredible job. I wonder how I can help?" "What's most important to you now?" "What are your hopes ... your worries?" "You have taught me so much; I will always remember you."</p>

Adapted from Hurwitz C, Duncan J, Wolfe J. Caring for the child with cancer at the close of life, *JAMA*. 2003;292:2141–2149.

informal opportunities to express emotions or formal debriefs/check-ins for staff at various stages of caring for a child with life-threatening illness can be helpful in bettering patient/family care and preventing staff from experiencing compassion fatigue, burnout, and long-term repercussions, including leaving the field.

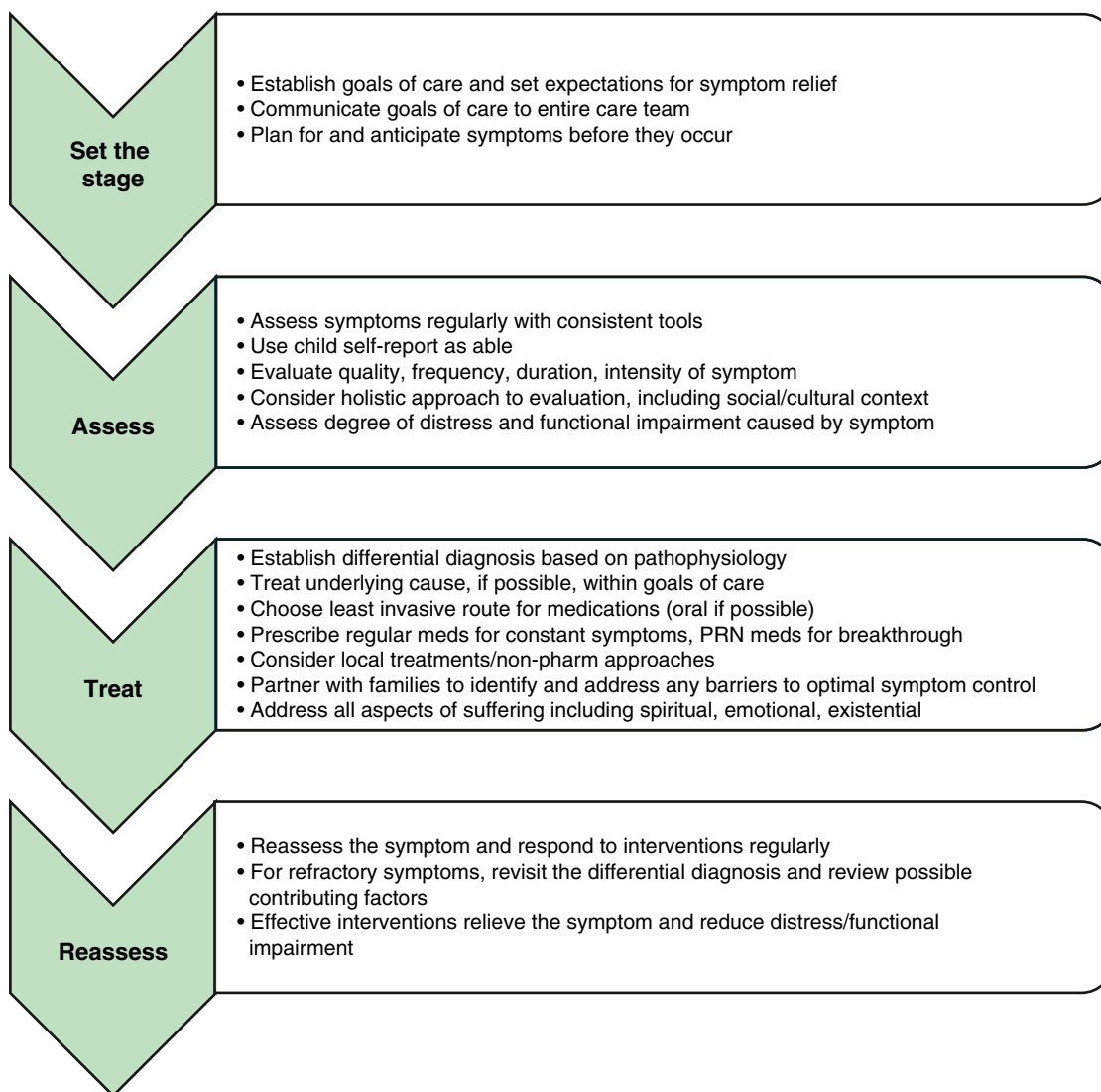
### The Pediatric Clinician

Although optimal palliative care for children entails an interdisciplinary care team approach, pediatric clinicians are well positioned to support children and their families, particularly when they have a long-standing relationship with multiple family members. A primary care clinician who has cared for a family over time may already know and care for other family members, understand pre-existing stressors for the family, and be familiar with coping strategies used by family members. For this reason, trusted primary care clinicians may be best suited to explore goals of care, provide difficult news in a compassionate manner, and support families throughout the trajectory of illness. Specialty training is not needed

to provide expert primary palliative care; rather, a motivation to guide decisions based on family goals and values and understanding of the community supports available are a sufficient starting point. Pediatric clinicians are familiar with the process of eliciting concerns and providing anticipatory guidance for parents, as well as developmentally appropriate explanations for children. Those interested in developing skillful communication techniques surrounding serious illness have many resources available, including VitalTalk ([vitaltalk.org](http://vitaltalk.org)).

### Symptom Management

Intensive symptom management is another cornerstone of pediatric palliative care. Alleviation of symptoms reduces suffering of the child and family and allows them to focus on other concerns and participate in meaningful experiences. Despite increasing attention to symptoms and pharmacologic and technical advances in medicine, children often suffer from multiple symptoms. [Figure 8.3](#) provides key elements and general approaches to managing symptoms.



**Fig. 8.3** Key elements of effective symptom management.

**Pain** is a complex sensation triggered by actual or potential tissue damage and influenced by cognitive, behavioral, emotional, social, and cultural factors. Effective pain relief is essential to prevent *central sensitization*, a central hyperexcitation response that may lead to hypersensitivity and escalating pain, and to diminish a stress response that may have a variety of physiologic effects. Assessment tools include self-report tools for children who can communicate their pain verbally and tools based on behavioral cues for children who are unable to do so because of their age, medical condition, or a neurodevelopmental disorder. [Figure 8.4](#) and [Tables 8.4 and 8.5](#) address management of pain (see also Chapter 93).

Many children with life-threatening illness experience pain that requires **opioids** for adequate relief at some point in their illness trajectory. The WHO pain guidelines recommend the first step for mild pain and the second step for moderate to severe pain ([Fig. 8.4](#)). Prescribing *codeine* should be avoided because of its side effect profile and lack of superiority over nonopioid analgesics. Furthermore, relatively common genetic polymorphisms in the *CYP2D6* gene lead to wide variation in codeine metabolism. Specifically, 10–40% of individuals carry polymorphisms causing them to be *poor metabolizers* who cannot convert codeine to its active form, *morphine*, and therefore are at risk for inadequate pain control. Others are *ultrametabolizers* who may even experience respiratory depression

from rapid generation of morphine from codeine. It is therefore preferable to use a known amount of the active agent, morphine. Federal and state health agencies in the United States have put forth considerable effort in establishing guidelines for opioid prescribing. Before prescribing opioids, create an opioid agreement with patients and families, check the state's electronic prescription monitoring program, and limit opioid prescription for minors to 7 days or less for *initial* opioid prescription.

It is important to explore with families and members of the care team misconceptions that they may have regarding opioids, such as respiratory depression, addiction, dependence, the symbolic meaning of starting an opioid such as methadone or morphine and/or a morphine drip, and the potential for opioids to hasten death. *There is no association between administration or escalation of opioids and length of survival.* In fact, evidence supports longer survival in individuals with symptoms that are well controlled. Collaboration with specialty palliative care and/or hospice care teams can help guide complex symptom management.

Children with serious illness and medical complexity often experience a multitude of nonpain symptoms. A combination of both pharmacologic (see [Table 8.4](#)) and nonpharmacologic (see [Table 8.5](#)) interventions is often optimal. **Fatigue** is one of the most common symptoms in children with advanced illness. Children

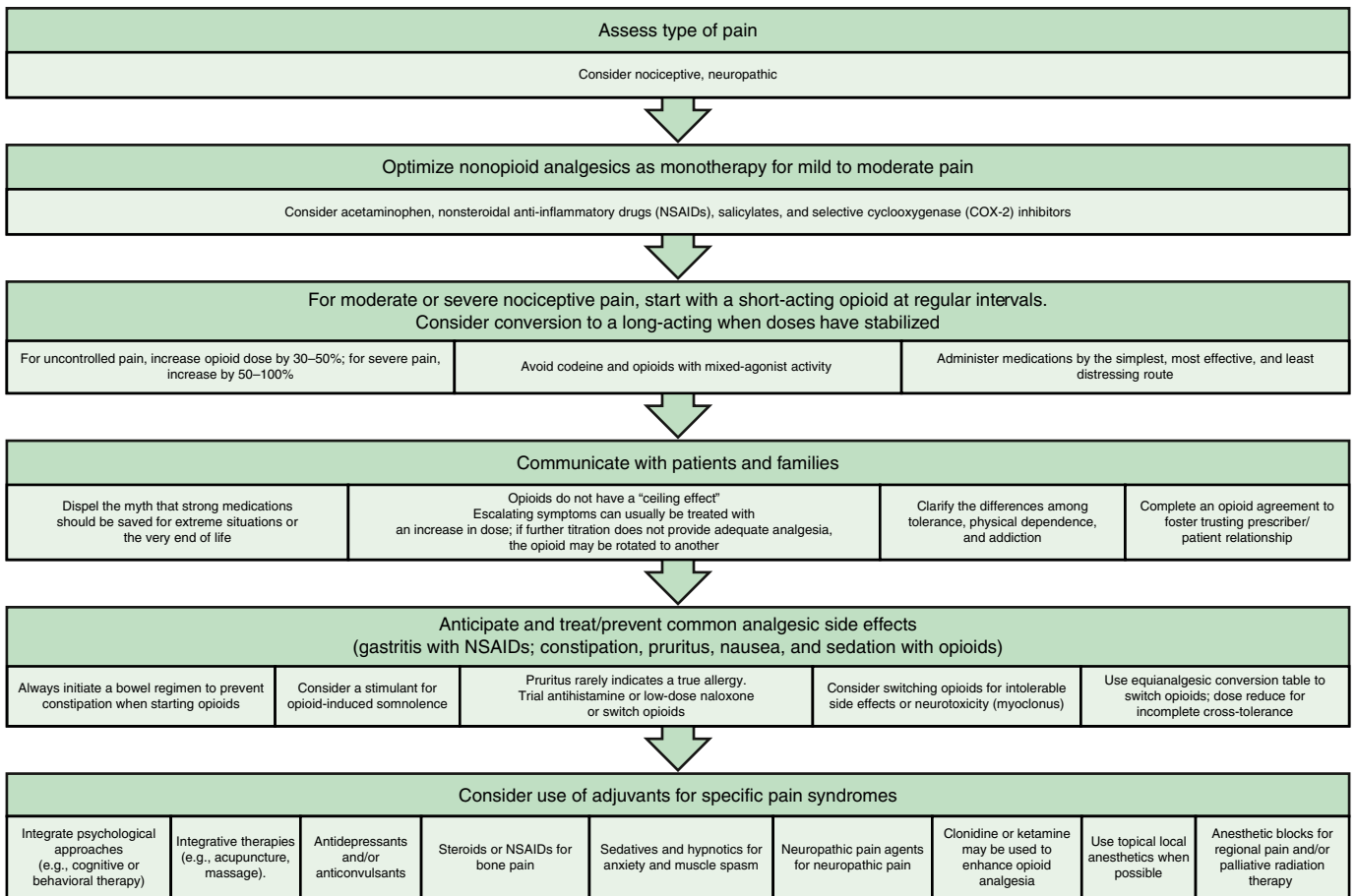


Fig. 8.4 Guidelines for pain management related to life-threatening illness.

Table 8.4 Pharmacologic Approach to Symptoms Commonly Experienced by Children with Life-Threatening Illness			
SYMPTOM	MEDICATION	STARTING DOSE	COMMENTS
Pain—mild	Acetaminophen	15 mg/kg PO q4h, max 3 g/day or 40 mg/kg/day	Available PO (including liquid), PR, or IV PO (including liquid) only; avoid if risk of bleeding; use only in infants ≥6 mo. Use with caution in congestive heart failure. Chewable tablets contain phenylalanine. Avoid if risk of bleeding; may cause nephrotoxicity. Selective cyclooxygenase (COX-2) inhibitor has low risk of gastritis and low antiplatelet activity. Do not use longer than 5 days; may cause nephrotoxicity.
	Ibuprofen	10 mg/kg PO q6h	
	Naproxen	5 mg/kg PO q12h	
	Celecoxib	1-2 mg/kg (max 100-200 mg) PO q12-24h	
Pain—moderate/severe	Ketorolac	0.5 mg/kg (15-30 mg) IV q6h, max 24h dose 120 mg	Also available in IV/SC formulation. Reduce dose in renal/hepatic impairment. †§
	Morphine immediate release (i.e., MSIR)	0.3 mg/kg PO q4h if <50 kg 15 mg PO q4h if >50 kg*† 0.05-0.1 mg/kg IV q2-4h	
	Oxycodone	0.1 mg/kg PO q4h if <50 kg 5-10 mg PO q4h if >50 kg*†	
	Hydromorphone	0.05 mg/kg PO q4h if <50 kg 2-4 mg PO q4h if >50 kg*† 0.015 mg/kg IV q2-4h	
	Fentanyl	0.5-1.5 µg/kg IV/SC q30min*†	

Continued



**Table 8.4** Pharmacologic Approach to Symptoms Commonly Experienced by Children with Life-Threatening Illness—cont'd

SYMPTOM	MEDICATION	STARTING DOSE	COMMENTS
Pain— sustained- release formulations	MS Contin Kadian (contains sustained- release pellets) Oramorph Oxycontin Transdermal fentanyl patch	Total daily dose of MSIR divided bid-tid  Total daily dose of oxycodone divided bid-tid Divide total 24hr PO morphine dose by 2 to determine starting dose of transdermal fentanyl. No data exist on the equianalgesic conversion from transdermal fentanyl to any oral opioid.	Do not crush MS Contin. For those unable to swallow pills, Kadian capsules may be opened and contents mixed with food, but <i>cannot be chewed</i> . Kadian contents may be mixed in 10mL water and given via 16-French G-tube. Larger-dose formulation may not be suitable for small children.§  Do not crush.§ Smallest patch size may be too high for small children. Patches are for children >2yr. Apply to upper back in young children. Patch may <b>not</b> be cut. Typically for patients taking at least 60mg morphine/day or its equivalent. Not appropriate when dosage changes are frequent or for opioid-naïve patients. Fever >40°C results in higher serum concentrations.§
	Methadone	Starting dose 0.1-0.2mg/kg PO bid. May give tid if needed. Recommend consultation with experienced clinician for equivalence dosing from other opioids.*†	Only opioid with immediate and prolonged effect; available as a liquid; do not adjust dose more often than every 72hr because prolonged biologic half-life is greater than therapeutic half-life. Knowledge of methadone pharmacokinetics is needed for converting to and from doses of other opioids. Also available IV/ SC. May cause QT interval prolongation (consider ECG), especially in adults on >200mg/day or in those at risk for QT prolongation. Interacts with several antiretroviral, antiepileptic agents.§
	Gabapentin  Nortriptyline  Pregabalin  Methadone	Start at 5mg/kg/day at bedtime and gradually increase to 10-15mg/kg/day divided tid; titrate up by 5mg/kg/day q3-4 days as needed, but not to exceed 50-75mg/kg/day (3,600mg/day)  0.5mg/kg PO at bedtime (max 150mg/day). Begin at lower dose and titrate every 3-4 days until therapeutic effect or max dose.  Start at 1 mg/kg/dose PO at bedtime for 3 days, then increase to 1 mg/kg/dose bid. Increase every 3 days to 3 mg/kg/dose PO bid (max 6 mg/kg/dose).  See previous listing	May cause neuropsychiatric events in children (aggression, emotional lability, hyperkinesia), usually mild but may require discontinuation of gabapentin. May cause dizziness, drowsiness, tremor, nystagmus, ataxia, and swelling.  Fewer anticholinergic side effects than amitriptyline. May cause constipation, sedation, postural hypotension, and dry mouth. May cause QT interval prolongation (consider ECG). At higher doses, monitor ECG and plasma levels.  See gabapentin.  See previous listing.
Dyspnea	Morphine, immediate release (i.e., MSIR)  Lorazepam	0.1 mg/kg PO q4h prn*†  0.025-0.05 mg/kg IV/PO q6h, up to 2 mg/dose	All opioids may relieve dyspnea. For dyspnea, the starting dose is 25–35% of the dose that would be administered for pain.§  See previous listing For anxiety contributing to dyspnea
	Scopolamine patch  Glycopyrrrolate  Hyoscyamine sulfate  Atropine	1.5 mg patch, change q72h (for children >8-12yr old)  0.04-0.1 mg/kg PO q4-8h  PO/SL: 2-12 yr: 0.0625-0.125 mg q4h as needed; max daily dosage 0.75 mg or timed release 0.375 mg q12h; max daily dosage 0.75 mg >12 yr-adult: 0.125-0.25 mg q4h as needed; max daily dosage 1.5 mg or timed release 0.375- 0.75 mg q12h; max daily dosage 1.5 mg  1-2 gtt SL q4-6h prn	Excessive drying of secretions can cause mucus plugging of airways. Good for motion-induced nausea and vomiting. Handling patch and contacting eye may cause anisocoria and blurry vision. May fold patches, but do not cut them. Anticholinergic side effects possible.  Powerful antisialagogue. Excessive drying of secretions can cause mucus plugging of airways. Anticholinergic side effects possible. Quaternary ammonium structure limits its ability to cross lipid membranes, such as the blood-brain barrier (in contrast to atropine, scopolamine, and hyoscyamine sulfate), so may exert fewer central anticholinergic effects.  Anticholinergic side effects possible, including sedation. May be given sublingually.  Give 0.5% ophthalmic drops sublingually.

<b>Table 8.4 Pharmacologic Approach to Symptoms Commonly Experienced by Children with Life-Threatening Illness—cont'd</b>			
<b>SYMPTOM</b>	<b>MEDICATION</b>	<b>STARTING DOSE</b>	<b>COMMENTS</b>
Nausea	Metoclopramide	0.1-0.2mg/kg/dose q6h, up to 10 mg/dose (prokinetic and mild nausea dosing). For chemotherapy-associated nausea, 0.5-1 mg/kg q6h prn PO/IV/SC; give with diphenhydramine and continue diphenhydramine for 24 hr after last dose of high-dose metoclopramide to prevent extrapyramidal reaction.	Helpful when dysmotility is an issue; may cause extrapyramidal reactions, particularly in children after IV administration of high doses. Contraindicated in complete bowel obstruction or pheochromocytoma. Avoid concomitant use with olanzapine.
	Ondansetron	0.15 mg/kg dose IV/PO q8h prn. No single IV dose should exceed 16 mg because of risk of QT prolongation.	Significant experience in pediatrics. Good empirical therapy for nausea in palliative care population. Oral dissolving tablet contains phenylalanine. Higher doses used with chemotherapy, although single 32 mg IV dose is no longer available (risk for QT prolongation). Consider ECG monitoring in patients with electrolyte abnormalities, congestive heart failure, bradyarrhythmias, or in patients taking other medications with the potential to cause QT prolongation. May cause constipation.
	Dexamethasone	0.1 mg/kg/dose tid PO/IV; max dose 10 mg/day	Also helpful with hepatic capsular distension, bowel wall edema, anorexia, increased ICP. May cause mood swings or psychosis.
	Lorazepam	See previous listing.	Helpful for anticipatory nausea
	Dronabinol	<6 yr: No dosing information; use with caution 6-12 yr: 2.5-5 mg/dose PO q6h prn or scheduled >12 years: 5-7.5 mg/dose PO q6h prn or scheduled; max dosage (escalating): 5 mg 4 times/day (20 mg/day)	Available in 2.5 and 5 mg capsules and 5 mg/mL liquid. May remove liquid contents from capsules for children who cannot swallow capsules. Avoid in patients with sesame oil hypersensitivity or history of schizophrenia. May cause euphoria, dysphoria, strange dreams, or other mood changes. Tolerance to CNS side effects usually develops in 1-3 days of continuous use. Avoid in patients with depression or mania.
	Scopolamine patch Olanzapine	See previous listing 4-6yr: 1.25mg PO daily 6-12 yr: 2.5 mg PO daily ≥12 yr: 5 mg daily; doses may be titrated to max of 10 mg/day	See previous listing Little evidence to guide antiemetic dosing. Ranges largely derived from olanzapine dosing for other purposes. Avoid concomitant use with metoclopramide.
Anxiety	Lorazepam	See previous listing	See previous listing
Agitation/ delirium	Haloperidol	0.01 mg/kg PO tid prn for acute onset: 0.025-0.050 mg/kg PO, may repeat 0.025 mg/kg in 1 hr prn	May cause extrapyramidal reactions, which can be reversed with diphenhydramine or Cogentin. Safety not established in children <3yr.
Sleep disturbance/ insomnia	Trazodone	Children 6-18yr: 0.75-1 mg/kg/dose, given bid-tid if needed If >18 yr, start at 25-50 mg/dose, given bid-tid if needed Max dose 150 mg/dose	Potentially arrhythmogenic
Fatigue	Methylphenidate	0.3 mg/kg/dose (2.5-5 mg) titrated as needed, up to 60mg/day	Rapid antidepressant effect; also improves cognition. Administer before meals to avoid appetite suppression. Use with caution in children at risk for cardiac arrhythmia. Available as liquid and chewable tablet and transdermal patch.
Pruritus	Diphenhydramine	0.5-1 mg/kg q6h IV/PO (100mg max per day)	Indicated for histamine-mediated itch. May reverse phenothiazine-induced dystonic reactions. Topical formulation on large areas of the skin or open area may cause toxic reactions. May cause paradoxical reaction in young children. Typically ineffective for opioid-associated pruritus.
	Hydroxyzine	0.5-1 mg/kg q6h IV/PO (600mg max per day)	Low-dose continuous infusion indicated for opioid-induced itch
	Naloxone	0.25-2 mcg/kg/hr continuous IV infusion	For opioid-induced itch
Constipation	Nalbuphine	0.02 mg/kg (1.5 mg) IV q6h PRN	Stool softener available as liquid or capsule
	Docusate	40-150mg/day PO in 1-4 divided doses	

Continued

Table 8.4 Pharmacologic Approach to Symptoms Commonly Experienced by Children with Life-Threatening Illness—cont'd			
SYMPTOM	MEDICATION	STARTING DOSE	COMMENTS
	MiraLAX	<10 kg: ¼ scoop (4.25 g) daily <5yr: 1/2 scoop (8.5g) in 4 oz water daily >5 yr: 1 scoop (17 g) in 8 oz water daily	Tasteless powder may be mixed in beverage of choice. Now available over the counter.
	Lactulose	5-10 mL PO up to q2h until bowel movement or 15-30 mL PO bid	Bowel stimulant; dosing q2h may cause cramping.
	Senna	2.5-5mL PO daily (for children >27 kg)	Bowel stimulant; available as granules
	Dulcolax (bisacodyl)	3-12yr: 5-10 mg PO daily >12 yr 5-15 mg PO daily	Available in oral or rectal formulation
	Pediatric Fleets Enema	2-4 yr: Administer one half contents of one 2.25 oz pediatric enema 5-11 yr: Administer contents of one 2.25 oz pediatric enema ≥12 yr and adolescents: Administer contents of one 4.5 oz enema as single dose	May repeat ×1 if needed. Do not use in neutropenic patients.
	Methylnaltrexone	10 mg/dose 10-20 kg: 2 mg SC 21-33 kg: 4 mg SC 34-46 kg: 6 mg SC 47-62 kg: 8 mg SC 63-114 kg: 12 mg SC ≥115 kg: 0.15 mg/kg SC Administer 1 dose every other day as needed; max 1 dose/24 hr	Peripherally acting opioid antagonist for opioid-induced constipation. Usually works within 30-60 min of administration. May cause cramping.
Muscle spasm	Diazepam	Oral/IM/IV: <50 kg: 0.05 mg/kg q6h (titrate to 0.2 mg/kg/dose max) >50 kg: 2.5 mg q6h (titrate to 10 mg/dose max)	May be irritating if given by peripheral IV line.
	Baclofen	5 mg PO tid, increase by 5 mg/dose as needed. Max 80 mg/day.	Helpful with neuropathic pain and spasticity; abrupt withdrawal may result in hallucinations and seizures; not for children <10 yr
Seizures	Lorazepam Diazepam	0.1 mg/kg IV/PO/SL/PR repeat q10min × 2 0.1 mg/kg IV/PO q6h (max 5 mg/dose if <5yr; max 10 mg/dose if >5yr)	May be given PR as Diastat (0.2 mg/kg/dose q15min × 3 doses)
Neuroirritability	Gabapentin Clonidine	See previous listing Oral or transdermal patch: Initial dosing: 5 mcg/kg/day; divide daily dose into q8-12h for enteral dosing, or round daily dose to nearest ¼ patch size for transdermal dosing (max initial dose 100 mcg/day) Increase gradually if needed by 2.5 mcg/kg/day; max dose 25 mcg/kg/day (up to max 0.6 mg/day). May switch from oral to transdermal route once optimal oral dose is established. Transdermal dose is equivalent to the total oral daily dose (e.g., if total oral dose is 0.1 mg/day, apply 1 patch [delivers 0.1 mg/day]). Change patch every 7 days.	Transdermal patch may contain metal (e.g., aluminum) that may cause burns if worn during MRI scan. Remove patch before MRI. Patch may be cut into 1/4 or 1/2 fractions based on dose needed.
	Clonazepam	<10yr or <30kg: initial dose 0.01-0.03 mg/kg/day divided tid ≥10 yr (≥30 kg): initial dose up to 0.25 mg PO tid; may increase by 0.5-1 mg/day every 3 days Maintenance dose: 0.05-0.2 mg/kg/day up to 20 mg/day	
Appetite stimulation	Dronabinol Cyproheptadine	See previous listing Children ≥2yr and adolescents: 0.08 mg/kg PO q8h; if no benefit in 5 days, increase dose by 0.04-0.08 mg/kg/dose Max daily dose: ≤6 yr: 12 mg/day; 7-14 yr: 16 mg/day; ≥15 yr: 32 mg/day	See previous listing Potent antihistamine and serotonin antagonist

\*Infants <6 mo should receive 25–30% of the usual opioid starting dose.

†Although the usual opioid starting dose is presented, the dose may be titrated as needed. There is no ceiling/maximum dose for opioids.

‡Breakthrough dose is 10% of 24 hr dose. See Chapter 76 for information regarding titration of opioids.

§Side effects from opioids include constipation, respiratory depression, pruritus, nausea, urinary retention, and physical dependence.

Note: Some medications or dosing may not apply to infants (≤12 mo). Verify suitability and dosing of all medications before administering to neonates.

IV, Intravenous(ly); PO, by mouth; PR, rectally; prn, as needed; gtt, drops; SC, subcutaneously; bid, twice daily; tid, 3 times daily; q4h, every 4 hours; q30min, every 30 minutes; CNS, central nervous system; ECG, electrocardiogram; ICP, intracranial pressure.

Adapted from Ullrich C, Wolfe J. Pediatric pain and symptom control. In Walsh TD, Caraceni AT, Fainsinger R, et al (eds): *Palliative Medicine*. Philadelphia: Saunders, 2008.

**Table 8.5** Nonpharmacologic Approach to Symptoms Commonly Experienced by Children with Life-Threatening Illness

SYMPTOM	APPROACH TO MANAGEMENT
Pain	Prevent pain when possible by limiting unnecessary painful procedures, providing sedation, and giving preemptive analgesia before a procedure (e.g., including sucrose for procedures in neonates). Address coincident depression, anxiety, sense of fear, or lack of control. Consider guided imagery, relaxation, hypnosis, art/pet/play therapy, acupuncture/acupressure, cognitive behavioral therapy (CBT), physical therapy, biofeedback, massage, heat/cold, yoga, transcutaneous electric nerve stimulation, and distraction.
Dyspnea or air hunger	Wipe and/or suction oral secretions if present; positioning; comfortable loose clothing; fan to provide cool, blowing air. Limit volume of intravenous fluids; consider diuretics if fluid overload/pulmonary edema present. Behavioral strategies, including breathing exercises, guided imagery, relaxation, music, and distraction.
Fatigue	Sleep hygiene (establish a routine, promote habits for restorative sleep). Regular, gentle exercise; prioritize or modify activities. Address potentially contributing factors (e.g., anemia, depression, side effects of medications). Aromatherapy*: peppermint, rosemary, basil.
Nausea/vomiting	Consider dietary modifications (bland, soft, adjust timing/volume of foods or feeds). Aromatherapy*: ginger, peppermint, lavender, acupuncture/acupressure.
Constipation	Increase fiber in diet, encourage fluids, ambulation (if possible).
Oral lesions/ dysphagia	Oral hygiene and appropriate liquid, solid, and oral medication formulation (texture, taste, fluidity). Treat infections, complications (mucositis, pharyngitis, dental abscess, esophagitis).  Oropharyngeal motility study and speech (feeding team) consultation.
Anorexia/cachexia	Manage treatable lesions causing oral pain, dysphagia, or anorexia. Support caloric intake during phase of illness when anorexia is reversible. Acknowledge that anorexia/cachexia is intrinsic to the dying process and may not be reversible. Prevent/treat coexisting constipation.
Pruritus	Moisturize skin. Trim child's nails to prevent excoriation. Try specialized anti-itch lotions. Apply cold packs. Counterstimulation, distraction, relaxation.
Diarrhea	Evaluate/treat if obstipation. Assess and treat infection. Dietary modification.
Depression	Psychotherapy, behavioral techniques, setting attainable daily goals. Aromatherapy*: bergamot, lavender.
Anxiety	Psychotherapy (individual and family), behavioral techniques. Aromatherapy*: clary sage, angelica, mandarin, lavender.
Agitation/terminal restlessness	Evaluate for organic or drug causes. Educate family. Orient and reassure child; provide calm, nonstimulating environment; use familiar music, verse, voice, touch. Aromatherapy*: frankincense, ylang.

\*Best if aromatherapy is administered by a practitioner trained in aromatherapy use and safety and if child has choice of essential oil aroma that stimulates positive response. From Sourkes B, Frankel L, Brown M, et al. Food, toys, and love: Pediatric palliative care. *Curr Probl Pediatr Adolesc Health Care*. 2005;35:345–392.

may experience fatigue as a physical symptom (e.g., weakness or somnolence), a decline in cognition (e.g., diminished attention or concentration), and impaired emotional function (e.g., depressed mood or decreased motivation). Because of its multidimensional and incapacitating nature, fatigue can prevent children from participating in meaningful or pleasurable activities, thereby impairing quality of life. Fatigue is usually multifactorial in etiology. A careful history may reveal contributing physical factors (uncontrolled symptoms, medication side effects), psychologic factors (anxiety, depression), spiritual distress, or sleep disturbance. It is important to explore a patient's sleep history and encourage behavioral interventions such as optimizing sleep hygiene (e.g., instituting a regular bedtime routine, limiting screens and physical activity before bed), and sticking to regular sleep and wake times as much as feasible. If biobehavioral approaches remain ineffective, pharmacologic approaches such as trazodone may be considered. Interventions to reduce fatigue include treatment of contributing factors, exercise,

behavior modification strategies, and pharmacologic agents. Challenges to effectively addressing fatigue include the common belief that fatigue is inevitable, lack of communication between families and care teams about it, and limited awareness of potential interventions for fatigue.

**Dyspnea** (the *subjective* sensation of shortness of breath) results from a mismatch between afferent sensory input to the brain and the outgoing motor signal from the brain. It may stem from respiratory causes (e.g., airway secretions, obstruction, infection) or other factors (e.g., cardiac) and may also be influenced by psychologic factors (e.g., anxiety). Respiratory parameters such as respiratory rate and oxygen saturation correlate unreliably with the degree of dyspnea. Therefore giving oxygen to a cyanotic or hypoxic child who is otherwise quiet and relaxed may relieve staff discomfort while having no impact on patient distress and may also add burden if the child cannot tolerate the mask or cannula. *Dyspnea can be relieved with the use of regularly scheduled plus as-needed doses of*



*opioids*. Opioids work *directly* on the brainstem to reduce the sensation of respiratory distress, as opposed to relieving dyspnea by sedation. The dose of opioid needed to reduce dyspnea is as little as 25% of the amount that would be given for analgesia. Nonpharmacologic interventions, including guided imagery or hypnosis to reduce anxiety, or cool, flowing air, aimed toward the face, are also frequently helpful in alleviating dyspnea. Although oxygen may relieve hypoxemia-related headaches, it is no more effective than blowing room air in reducing the distressing sensation of shortness of breath.

As death approaches, a buildup of secretions may result in noisy respiration sometimes referred to with the outdated term “death rattle.” Patients at this stage are usually unconscious, and noisy respirations are often more distressing for others than for the child. It is often helpful to discuss this anticipated phenomenon with families in advance, and if it occurs, to point out the child’s lack of distress from it. Nonpharmacologic interventions include positional changes, and if treatment is needed, an anticholinergic medication, such as glycopyrrolate, may reduce secretions.

Neurologic symptoms include **seizures** that are often part of the antecedent illness but may increase in frequency and severity toward the end of life. A plan for managing seizures should be made in advance, and anticonvulsants should be readily available in the event of seizure. Parents can be taught to use rectal diazepam at home. Increased **neuroirritability** accompanies some neurodegenerative disorders; it may be particularly disruptive because of the resultant break in normal sleep–wake patterns and the difficulty in finding respite facilities for children who have prolonged crying or difficulty consoling. Such neuroirritability may respond to gabapentin. Judicious use of sedatives, benzodiazepines, clonidine, nortriptyline, or methadone may also reduce irritability without inducing excessive sedation; such treatment can dramatically improve the quality of life for both child and caregivers. **Increased intracranial pressure** and **spinal cord compression** are most often encountered in children with brain tumors or metastatic and solid tumors. Depending on the clinical situation and the goals of care, radiation therapy, surgical interventions, and steroids are potential therapeutic options.

**Delirium** is an underrecognized brain disorder characterized by waxing and waning attention, confusion, and disorientation. Agitation may occur along with features of hypomania. Although delirium as a whole is often not diagnosed, the hypomanic form is particularly underrecognized. Delirium has a range of causes, including electrolyte imbalances, organ dysfunction, sleep–wake cycle disturbances, and results of medications such as anticholinergics and benzodiazepines. Environmental strategies to calm and orient the child while addressing potentially contributing factors are helpful. In some patients, antipsychotic/neuroleptic medications are indicated (see Chapters 33 and 47).

**Feeding and hydration** issues can raise ethical questions that evoke intense emotions in families and medical caregivers alike. Options that may be considered to artificially support nutrition and hydration in a child who can no longer feed by mouth include nasogastric and gastrostomy feedings or intravenous nutrition or hydration (see Chapter 60). These complex decisions require evaluating the risks and benefits of artificial feedings and taking into consideration the child’s functional level and prognosis. At times, it may be appropriate to initiate a trial of tube feedings, with the understanding that they may be discontinued at a later stage of the illness. A commonly held but unsubstantiated belief is that artificial nutrition and hydration are comfort measures, without which a child may suffer from starvation or thirst. The sensation of thirst may be alleviated by careful efforts to keep the mouth moist and clean. There are also deleterious side effects to artificial hydration in the form of increased secretions, need for frequent urination, edema, and exacerbation of dyspnea. For these reasons, it is important to educate families about anticipated decreases in appetite/

thirst and therefore little need for nutrition and hydration as the child approaches death. In addition, exploring the meaning that provision of nutrition and hydration may hold for families, as well as helping families anticipate the changes in their child’s appearance and exploring alternative ways that they may love and nurture their child, may ease distress around this issue.

**Nausea and vomiting** may be caused by medications or toxins, irritation to or obstruction of the gastrointestinal tract, motion, and emotions. Drugs such as metoclopramide, 5-hydroxytryptamine antagonists, corticosteroids, olanzapine, and aprepitant may be used and should be chosen depending on the underlying pathophysiology and neurotransmitters involved. Vomiting may accompany nausea but may also occur without nausea, as with increased intracranial pressure. **Constipation** is commonly encountered in children with neurologic impairment or children receiving medications that impair gastrointestinal motility (most notably opioids). Stool frequency and quantity should be evaluated in the context of the child’s diet and usual bowel pattern. Children using scheduled opioids should routinely be placed on an osmotic laxative (polyethylene glycol) in addition to a stimulant laxative agent (e.g., senna). For some patients, parenteral methylalantrexone is also helpful in relieving opioid-induced constipation. **Diarrhea** may be particularly difficult for the child and family and may be treated with loperamide (an opioid that does not cross the blood–brain barrier), and in some cases, cholestyramine or octreotide may be indicated. Paradoxical diarrhea, a result of overflow resulting from constipation, should also be included in the differential diagnosis.

**Hematologic issues** include consideration of anemia and thrombocytopenia or bleeding. If the child has symptomatic anemia (weakness, dizziness, shortness of breath, tachycardia), red blood cell transfusions may be considered. Platelet transfusions may be an option if the child has symptoms of bleeding. Teabags on the gums and topical agents such as Amicar may be used for mucosal bleeding. It is important to provide anticipatory education that although distressing to see, bleeding is not painful. Life-ending hemorrhage is disturbing for all concerned, and a plan involving environment intervention such as dark sheets and the use of fast-acting sedatives should be prepared in advance if such an event is a possibility.

**Skin care issues** include primary prevention of problems by ongoing and timely assessment (including observation of indwelling lines and tubes) and frequent turning and repositioning and alleviating pressure wherever possible (e.g., elevating heels off the bed with pillows). Pruritus may be secondary to systemic disorders or drug therapy. Treatment includes avoiding excessive use of drying soaps, using moisturizers, trimming fingernails, and wearing loose-fitting clothing, in addition to administering topical or systemic corticosteroids. Oral antihistamines and other specific therapies may also be indicated (e.g., cholestyramine in biliary disease). Opioids can cause histamine release from mast cells, but this does not account for most of the pruritus caused by opioids. Given that opioid-induced pruritus is generally not histamine-mediated, the mainstay of treatment includes rotating opioids or instituting a low dose of opioid antagonist (nalbuphine or naloxone) rather than an antihistamine.

Children with life-threatening illness may experience psychologic symptoms such as **anxiety** and **depression**. Such symptoms are frequently multifactorial and sometimes interrelated with uncontrolled symptoms such as pain and fatigue. Diagnosing depression in the context of serious illness may pose challenges because neurovegetative symptoms may not be reliable indicators. Instead, expressions of hopelessness, helplessness, worthlessness, and guilt may be more useful. Interventions and opportunities for children to explore worries, hopes, and concerns in an open, supportive, and nonjudgmental setting are equally, if not more, important approaches to psychologic distress. Skilled members from a variety of disciplines, including psychology, social work, chaplaincy, child life, and expressive therapy, may help children and their families in this regard. Such opportunities may

create positive moments in which meaning, connection, and new definitions of hope are found. Pharmacologic agents such as antidepressants may be helpful, although their effect is often preceded by a significant lag phase. Because of its immediate and positive effect on mood, *methylphenidate* may be an effective antidepressant for children at the end of life, when there may not be time for a traditional antidepressant to take effect.

Discussions with adolescent patients, or with the parents of any ill child, about possible therapies or interventions should include **integrative therapies** such as massage therapy, Reiki, acupuncture, clinical aromatherapy, prayer, and nutritional supplements. Many families use integrative therapy but do not bring it up with their physician unless explicitly asked (see Chapter 7). Although largely unproven, some of these therapies are inexpensive and provide relief to individual patients. Other therapies may be expensive, painful, intrusive, and even toxic. By initiating a conversation and inviting discussion in a nonjudgmental way, the clinician can offer advice on the safety of different therapies and may help avoid expensive, dangerous, or burdensome interventions. Medical marijuana (**cannabis**) for pediatric use has been legalized by some states, and pediatricians are increasingly asked about it. In such cases, it is most helpful to use this opportunity to engage in a broader conversation about symptoms and symptom management, even in states where use of cannabis for pediatric medicinal purposes is legal.

### Intensive Symptom Management

At the end of life, when intensive efforts to relieve the symptom have been exhausted, or when efforts to address suffering are incapable of providing relief with acceptable toxicity/morbidity or in an acceptable time frame, **palliative sedation** may be considered. Palliative sedation may relieve suffering from refractory symptoms by reducing a child's level of consciousness. It is most often used for intractable pain, dyspnea, or agitation, but is not limited to these distressing indications. It is imperative that parents, staff, and primary clinicians discuss the indications and goals for sedation before initiation of this therapy, as well as questions or concerns about this therapy, and to engage in ongoing discussions after initiation of sedation.

The doctrine of double effect (DDE) is often invoked to justify escalation of symptom-relieving medications or palliative sedation for uncontrolled symptoms at the end of life. Use of DDE emphasizes the risk of hastening death posed by escalating opioids or sedation, which is theoretical and unproven (see Chapter 6). There is mounting evidence that patients with well-controlled symptoms live longer.

### Approaching End of Life and Bereavement

As death seems imminent, the major task of the physician and team is to help the child have as many good days as possible and not suffer. If patient and family preference is to remain at home and clinical status and community supports allow this, if not already in place, a referral **for hospice care** (usually provided in the *home*, rather than a hospice facility) may provide the most comprehensive care for the child and family. Gently preparing the family for what to expect and offering choices, when possible, will allow them a sense of control in the midst of tragic circumstances. Before death, it can be very helpful to discuss the following:

- ♦ Support of siblings or other family members
- ♦ Resuscitation status
- ♦ Limiting technology when no longer beneficial to the child
- ♦ Cultural, spiritual, or religious needs
- ♦ Location of death
  - Who will pronounce if death occurs at home
- ♦ Funeral arrangements

- Offering siblings choice and appropriate support to attend
  - ♦ Autopsy and/or tissue/organ donation
    - Builds a legacy, benefits others, and informs science and family
- Offered the opportunity, families will often tolerate thinking and speaking about their hopes and fears regarding their child's end of life, and some even express relief when the door to such a conversation is opened by the care team. It may help to let the family know these conversations are not about *whether* the child will die, but *how* the child may die.

Families gain tremendous support from having a physician and team who will continue to stay involved in the child's care. If the child is at home or hospitalized, regular phone calls or visits, assisting with symptom management, and offering emotional support is invaluable for families.

In an intensive care setting, where technology can be overwhelming and put distance between the child and parent, the physician can offer discontinuation of that which is no longer benefiting the child or adding to quality of life. Less invasive ways to control symptoms, such as subcutaneous infusions or topical applications, may be helpful. Parents may be afraid to ask about holding their child or sleeping next to their child. They may need reassurance and assistance in holding, touching, and speaking with their child, despite tubes and technology, even if the child appears unresponsive.

It is believed that hearing and the ability to sense touch are often present until death; all family members should be encouraged to continue interacting with their loved one through the dying process as they feel comfortable. Parents may be afraid to leave the bedside so that their child will not die alone. Offering parents other supports such as chaplaincy/clergy, social work, and extended family members may be helpful. In most instances the moment of death cannot be predicted. Some propose that children wait to die until their parents are ready, an important event has passed, or they are given permission. The care team need not dispute this, nor the hope for a miracle often held by families until the child takes the last breath.

For the family, the moment of death is an event that is recalled in detail for years to come, and thus enhancing opportunity for dignity and limited suffering is essential. Research suggests that improved symptom control and easing of difficult moments at the time of death may lessen the long-term distress of bereaved parents. Clinical experience has shown that families often find solace in clinician presence, whether at home or in the hospital. After death, families should be given the option of remaining with their child for as long as they would like and should be prepared for changes in the child's body. During this time, physicians and other professionals may ask permission to say goodbye. The family may be invited to bathe and dress the body as a final act of caring for the child.

The clinician's decision to attend the funeral is a personal one. Participation may serve the dual purpose of showing respect and helping the provider cope with a personal sense of loss. If unable to attend services, families report highly valuing the importance of receiving a call, card, or note from the physician. To know that their child made a difference and will not be forgotten is often very important to families in their bereavement. Furthermore, bereaved parents cite ongoing support from their child's healthcare teams and medical institutions after the death of their child as essential sources of support during their grief journeys. Many families benefit from community-based bereavement support groups, which are often offered through hospice organizations, or individual grief counseling.

Visit Elsevier eBooks+ at [eBooks.Health.Elsevier.com](http://eBooks.Health.Elsevier.com) for Bibliography.

## Chapter 9

# Domestic and International Adoption

Elaine E. Schulte

Adoption is a social, emotional, and legal process that provides a new family for a child when the family of origin is unable or unwilling to parent. In the United States, about 1.5 million children <18 years of age are adopted; 2–4% of American families have adopted. In the United States, approximately 135,000 children are adopted every year. Of these, 59% are from the child welfare (foster) system, 25% are from other countries, and 15% are voluntarily relinquished American babies. The remaining numbers are from private agencies, American Indigenous Nations, stepparent, or other forms of kinship care. Because of changing policies toward adoption and social change in several of the sending countries, the number of international adoptions has decreased dramatically over the last 15 years. Public agencies support approximately 50% of total annual adoptions in the United States, private agencies facilitate 25% of adoptions, and independent practitioners (e.g., lawyers) handle 15% of adoptions. Compared to 19% of the general population, approximately 39% of adopted children have special healthcare needs.

## DOMESTIC ADOPTION

The **Adoption and Safe Families Act** (P.L. 105-89) requires children in foster care to be placed with adoptive families if they cannot be safely returned to their families within a reasonable time. In fiscal year (FY) 2020 there were an estimated 407,000 children in foster care and 117,000 waiting for adoption. Of the 224,000 who exited foster care, 48% were reunited with parent(s) or primary caretaker(s) and 25% were adopted. Of the 53,500 children who were adopted in 2021, 55% were adopted by their foster parent(s) and 34% were adopted by relatives (see Chapter 10).

Many children awaiting adoption are less likely to be adopted because they are of school age, are part of a sibling group, are members of historically oppressed racial/ethnic groups, or have considerable physical, emotional, or developmental needs. A number of policy efforts are aimed at increasing adoption opportunities for these children, including federal adoption subsidies, tax credits, recruitment efforts to identify ethnically diverse adults willing to adopt, increased preplacement services, and expanding adoption opportunities to single adults, older couples, and gay/lesbian partners.

**Same-sex couple adoption** is legal in more than a dozen countries worldwide. Although legislation regarding same-sex couple adoption varies by state, increasing numbers of gay and lesbian partners have been able to adopt. Current estimates suggest that over 2 million children, including 5% of all adopted children, are raised by gay or lesbian parents. Adopted children include those adopted domestically, those from foster care, and internationally adopted children. There is good evidence that children raised by same-sex couples are as physically or psychologically healthy, capable, and successful as those raised by opposite-sex couples. Pediatricians can advocate for adopted children by supporting gay and lesbian parents.

**Open adoption**, usually through an agency or privately, occurs when the birth mother arranges to continue to be involved, although in a limited manner, with the legally adopted family. This may occur through surrogacy or, more often, in an unplanned pregnancy.

## INTERCOUNTRY ADOPTION

Along with foster care adoptions, **international adoptions** are a way of providing stable, long-term care to vulnerable children

throughout the world. There is concern that in some countries of origin, the rapid growth of international adoption has outpaced regulation and oversight to protect vulnerable children and families. Opportunities for financial gain have led to abuses, including the sale and abduction of children, bribery, and financial coercion of families, but the extent and scope of the potential concern are difficult to ascertain. Increasing global efforts, such as the **Hague Convention on Protection of Children and Co-operation in Respect of Intercountry Adoption**, have promoted political cooperation between nations and established international law to reduce the potential for child abduction and child trafficking and to ensure that the best interests of the child are paramount in decision-making. Participating nations, including the United States, are working to address the myriad of sociopolitical conditions that create the need for out-of-family care and are working to support children within their nation's borders. International adoption is increasingly considered a measure of last resort if the child cannot be cared for within his or her family of origin (including extended relatives), the immediate community, or the larger national culture. As a result, children adopted internationally into the United States are more likely to enter their families at older ages or with complex medical, developmental, or social-emotional needs.

In 2021, US families adopted 1,785 children from other countries (compared to a peak of 22,884 in 2004). Children from Bulgaria, Columbia, India, Nigeria, South Korea, and Ukraine represented 65% of children adopted internationally into the United States; 2021 marked the first year since 1984 where no children were adopted from China. Although individual experiences vary, most children placed for international adoption have some history of poverty and social hardship in their home countries, and most are adopted from orphanages or institutional settings. Many young infants are placed into **orphanage care** shortly after birth. Some older children have experienced family disruption resulting from parental illness, war, or natural disasters. Still others enter orphanage care after determination of significant abuse or neglect within their biologic families. The effects of **institutionalization** and other life stresses may affect all areas of growth and development. As a result, many children require specialized support and understanding to overcome the impact of stress and early adversity and to reach their full potential.

## ROLE OF PEDIATRICIANS

### Preadoption Medical Record Reviews

Preadoption medical record reviews are important for both domestic and international adoptions. Adoption agencies are making increased efforts to obtain biologic family health information and genetic histories to share with adoptive families before adoption. Such information often becomes increasingly relevant as the child ages. The unique medical and developmental needs of adopted children have led to the creation of specialty clinics throughout the United States, which may be a valuable resource for adoptive families at all stages in the adoption process and throughout the adopted child's life. When available, adoption medicine pediatricians can help prospective adoptive parents understand the health and developmental history of a child and available background information from birth families in order to assess actual and potential medical and psychosocial risk factors to support adult decision-making about the family's ability to parent the waiting child.

Under the Hague Convention, U.S. agencies that arrange international adoptions must make efforts to obtain accurate and complete health histories on children awaiting adoption. The nature and quality of medical and genetic information, when available, vary greatly. Incongruous translation and use of medical terminology and medications that are unfamiliar to U.S.-trained physicians are common. Results of specific diagnostic studies and laboratory tests performed outside the United States should not be relied on and *should be repeated* once the child arrives in the United States. Paradoxically, review of the child's medical records may raise more questions than provide answers. Each medical diagnosis should be considered carefully before being rejected or accepted. Country-specific growth curves should be avoided because they do not reflect the demographic of institutionalized



**Table 9.1** Recommended Screening Tests for International Adoptees on U.S. Arrival

SCREENING TESTS
Complete blood cell count, including eosinophil count
Thick and thin smear for malaria if from endemic area
Vitamin D level
TSH, T <sub>4</sub>
Iron, ferritin
Blood lead level
Newborn universal screening (age ≤6 mo)
Vision and hearing screening
Dental screening
Developmental testing
Immunization records or titers (alternative plan: revaccinate)
OTHER SCREENING TESTS TO CONSIDER BASED ON CLINICAL FINDINGS AND AGE OF CHILD
Stool cultures or NAAT for bacterial pathogens in the presence of diarrhea and fever
Glucose-6-phosphate dehydrogenase deficiency (based on heritage)
Sickle cell test or hemoglobin electrophoresis (based on heritage)
Urine pregnancy test
INFECTIOUS DISEASE SCREENING
(see Table 9.2)

NAAT, Nucleic acid amplification test; TSH, thyroid-stimulating hormone.

children. Instead, *serial growth* data should be plotted on U.S. standard growth curves; this may reveal a pattern of poor growth because of malnutrition or other chronic illness. Photographs or video files may provide the only objective information from which medical status can be determined. Full-face photographs may reveal dysmorphic features consistent with fetal alcohol syndrome (see Chapter 146) or findings suggestive of other congenital disorders.

Frank interpretations of available information should be shared with the prospective adoptive parents. The role of the healthcare provider is not to comment on the advisability of an adoption, but to inform the prospective parents of any significant medical, developmental, and behavioral health needs identified now or anticipated in the future.

### Postadoption Medical Care Arrival Visit: International Adoption

All internationally adopted children should have a thorough medical evaluation shortly after arriving in the United States. Many children may have acute or chronic medical problems that are not always immediately evident, including malnutrition, growth deficiencies, stool pathogens, anemia, elevated blood lead, dental decay, strabismus, birth defects, developmental delay, feeding and sensory difficulty, and social-emotional concerns. *All children who are adopted from other countries should undergo comprehensive screening for infectious diseases and disorders of growth, development, vision, and hearing (Tables 9.1 and 9.2).* Regardless of test results before arrival, all children should be screened for tuberculosis with either a tuberculin skin test (TST) or interferon- $\gamma$  release assay (IGRA). If the child's purified protein derivative (PPD) skin test is negative, it should be repeated in 4-6 months; children may have false-negative tests because of poor nutrition. Additional tests (e.g., malaria) should be ordered depending on the prevalence of disease in the child's country of origin (see Chapter 11). **Immunization records** should be carefully reviewed. Internationally adopted children frequently have incomplete records or have been vaccinated using alternative schedules. Pediatricians may choose to check titers to determine which vaccines need to be given, or they can *choose to reimmunize* the child.

### Growth Delays

Physical growth delays are common in internationally adopted children and may represent the combined result of many factors, such as unknown/untreated medical conditions, malnutrition, and psychologic

**Table 9.2** Infectious Disease Screening for Internationally Adopted Children

CONDITION OR TEST	INTERNATIONALLY ADOPTED CHILDREN
<b>HEPATITIS A VIRUS (ACUTE INFECTION)</b>	
Hepatitis A IgM antibody	All
<b>HEPATITIS B VIRUS</b>	
Hepatitis B surface antigen (HBsAg)	All <sup>a</sup>
Hepatitis B surface antibody (anti-HBs)	All <sup>a</sup>
Hepatitis B core antibody (anti-HBc)	All <sup>a</sup>
<b>HEPATITIS C VIRUS</b>	
Hepatitis C antibody	All <sup>a</sup>
<b>SYPHILIS</b>	
Nontreponemal test (RPR, VDRL, or ART)	All
Treponemal test (TPPA, MHA-TP, or FTA-ABS)	All
<b>HUMAN IMMUNODEFICIENCY VIRUS</b>	
Human immunodeficiency virus 1 and 2 antibody	All <sup>a</sup>
<b>TUBERCULOSIS</b>	
Tuberculin skin test (TST)	All <sup>a</sup>
or	
Interferon- $\gamma$ release assay	≥2 yr
<b>INTESTINAL PARASITES</b>	
Microscopic evaluation of stool for ova and parasites	All (3 specimens)
<i>Giardia intestinalis</i> and <i>Cryptosporidium</i> antigen	All (1 specimen)
<b>BACTERIAL ENTERIC INFECTION</b>	
In children with diarrhea: bacterial stool culture	All
<b>CHAGAS (ENDEMIC AREAS)</b>	
<i>Trypanosoma cruzi</i> serologic testing	All
Complete blood count	All
<b>EOSINOPHILIA WITH NEGATIVE STOOL OVA AND PARASITE FOR HELMINTHS</b>	
<i>Strongyloides</i> serologic testing	All
<i>Schistosoma</i> serologic testing (endemic countries) <sup>b</sup>	
<b>LYMPHATIC FILARIASIS (ENDEMIC AREAS)</b>	
<i>Filariasis</i> serology	≥2 yr
<b>CHAGAS (ENDEMIC AREAS)</b>	
<i>Trypanosoma cruzi</i> serologic testing	All
<b>MALARIA SCREENING (ENDEMIC AREAS)</b>	
Malaria polymerase chain reaction	Not recommended
<b>HEMATURIA (SCHISTOSOMIASIS)</b>	
Urinalysis	Not recommended

<sup>a</sup>Consider reassessing 6 months after arrival.

<sup>b</sup>Some experts recommend serologic testing regardless of whether eosinophilia is present. ART, Automated reagent test; FTA-ABS, fluorescent treponemal antibody absorption; MHA-TP, microhemagglutination-*Treponema pallidum*; RPR, rapid plasma reagin; TPPA, *Treponema pallidum* particle agglutination; VDRL, Venereal Disease Research Laboratory.

<https://wwwnc.cdc.gov/travel/yellowbook/2020/family-travel/international-adoption>.

deprivation. It is more important to monitor growth over time, including preplacement measurements, because trend data may provide a more objective assessment of the child's nutritional and medical status. Children who present with low height for age (**growth stunting**) may have a history of inadequate nutrition and chronic adversity. Although most children experience a significant catch-up in physical growth after adoption, many remain shorter than their peers who did not experience early adversity.



## Developmental Delays

Many children adopted internationally exhibit delays in at least one area of development, but most exhibit significant gains within the first 12 months after adoption. Children adopted at older ages are likely to have more variable outcomes. In the immediate postadoption period, it may be impossible to determine with any certainty whether developmental delays will be transient or long-lasting. Careful monitoring of development within the first years of adoption can identify a **developmental trend** over time that may be more predictive of long-term functioning than assessment at any specific point in time. When in doubt, it is better to *refer early* for developmental intervention, rather than wait to see if the children will catch up (see Chapter 28).

## Language Development

For both domestic and international adoptees, genetic or biologic risk factors for poor language development may be identified pre-adoptively, but it is unlikely that international adoptees will have had these delays identified before adoption. These children typically have not had an assessment in their native language and have had little exposure to English. If assessment in their native language is not available, it may not be possible to fully assess their language abilities until they have had a chance to learn English. Regardless of the age at adoption, most internationally adopted children will reach age-expected language skills over time.

If a child has language delays, referral to early intervention or the school district should be made. Clinicians may need to work with these groups to help them understand the unique circumstances surrounding an adopted child's language development. For example, English language acquisition in internationally adopted children depends on the age of adoption and native language skills. Placing the recently adopted, school-age child in an English as a second language class may not be sufficient if the child's language development in the primary language has been atypical.

## Eating Concerns

Initial concerns about eating, sleep regulation, and repetitive (e.g., self-stimulating or self-soothing) behaviors are common, especially among children adopted after a high degree of neglect or developmental trauma. Feeding behaviors of international adoptees may be linked to orphanage feeding practices or limited exposure to textured or solid foods during later infancy/toddlerhood. Children who have experienced chronic lack of food may not have developed an awareness of *satiety cues*, leading to hoarding or frequent vomiting. **Feeding concerns** often subside gradually with introduction of age-appropriate foods and parental support for positive feeding practices. Many children who were adopted after significant malnutrition may eat an excessive amount of food. Unless the child is eating to the point of vomiting (which would indicate little awareness of satiety cues), it is generally best to allow them to eat until satiation. Typically, within several months, the child will regulate food intake appropriately. Occasionally, additional support from a speech pathologist or feeding specialist is warranted to address possible sensory, physical, or psychological issues around proper feeding.

## Sleep Concerns

Sleep is often disrupted as the child reacts to changes in routines and environments. Efforts to create continuity between the preadoption and postadoption environment can be helpful. Within the first 3-6 months, as the child's emotional self-regulation improves, many sleep concerns subside. Similarly, stereotypical behaviors, such as rocking or head banging, often diminish within the first few months after adoption.

## Social and Emotional Development

Dyadic interactions between child and caretaker are a critical component to later regulatory functioning and social-emotional development. The amount and quality of individualized caretaking that children have received before their adoption, whether international, domestic, or through the foster care system, is usually unknown. In many cases,

entry into a secure, stable home setting with consistent childcare routines is sufficient to support the child's emerging social-emotional development. Pediatricians can help parents remember that adoption is part of the child's identity. Throughout one's childhood, prior experiences or biologic disposition may result in behavior that is confusing to the adoptive parents. The child's reactions may be subtle or difficult to interpret, interfering with the parents' ability to respond in a sensitive manner. In these circumstances, additional behavioral health support may be helpful to foster the emerging relationships and behavioral regulation in the newly formed family.

## Racial Identity Development

**Transracial adoption** (where the racial background of the child differs from that of the parent/parents) accounts for a significant percentage of adoptions each year in the United States. In most of these adoptive placements, children of color have been adopted by White parents. Racial identity development, including ways to understand and respond to discrimination, is increasingly recognized as important in the overall development of children. Surveys of adults adopted transracially indicate that racial identity is of central importance at many ages and tends to increase in significance during young adulthood. Integrating race/ethnicity into identity can be a complex process for all children, but it may be especially complicated when they are raised in a family where racial differences are noted. Adults raised within interracial families have noted the value of attending racially diverse schools and of having adult role models (e.g., teachers, doctors, coaches) who share their racial background. Parents who adopt transracially are often encouraged to support interactions within diverse communities and to discuss race (and associated discrimination) often within the family. Black children raised by White families in White communities may have been sheltered from overt racism but need to be taught that many others (including law enforcement officers) will regard them as Black with all the intense biases associated with race (see Chapter 2.1).

Adoption culture camps are another option for transracial Black children to experience their racial heritage and meet children with similar experiences. In addition, there are Asian (Chinese, Korean) heritage camps that provide a similar cultural experience for internationally adopted children.

## Toxic Stress

The cumulative amount of unsupported early adversity (e.g., numerous years within international orphanage care, extensive abuse/neglect before removal from the biologic family, or multiple foster care placements) experienced by a child before adoption, referred to as *toxic stress*, can affect both immediate placement stability and long-term physical health and emotional well-being (see Chapter 2). The degree of presumed toxic stress may be helpful in interpreting a child's behavior and supporting family functioning.\*

## Family Support

The unique aspects to adoptive family formation can create familial stress and affect child and family functioning. Some adoptive families may have to address infertility, creation of a multiracial family, disclosure of adoptive status, concerns and questions the child may have about their preadoptive experiences and biologic origins, and ongoing scrutiny by adoption agencies. With gay/lesbian parents, there are often additional psychosocial stressors, including continued barriers to legal recognition of both parents in a gay/lesbian partnership that can negatively affect family functioning. Although most families acclimate well to adoption-related stressors, some parents experience postadoption depression and may benefit from additional mental health support to ease the family's transition.

## Adoption Narrative

Families are encouraged to speak openly and repeatedly about adoption with their child, beginning in the toddler years and continuing through adolescence. Creating a *lifebook* for the adopted child provides a way to support family communication about the child's

\* See video at <https://www.youtube.com/watch?v=rVwFkcOZHJw>

history and significant relationships (including members of the family of origin) and to document the child's important life transitions (e.g., through foster care or immigration to the United States). It is common, and normal, for children to have questions about adoption and their preadoptive experiences and biologic family throughout their development. An increase in cognitive understanding between ages 7 and 10 years can sometimes increase adoption-related questions and distress. Youth who have questions about biologic family members are increasingly able to access information via social media and web-based searching, raising the importance of ongoing open communication about adoption. Pediatricians may need to respond to increased concerns and questions when the adoptee's health and genetic history is incomplete or unknown. It is important to remember that, at any time, concerns about development, behavior, and social-emotional functioning may or may not be related to the child's adoption history.

The vast majority of adopted children and families adjust well and lead healthy, productive lives. Adoptions infrequently disrupt; disruption rates are higher among children adopted from foster care, which research associates with their age at adoption and a history of multiple placements before adoption. With increased understanding of the needs of families who adopt children from foster care, agencies are placing greater emphasis on the preparation of adoptive parents and ensuring the availability of a full range of postadoption services, including physical health, mental health, and developmental services for their adopted children.

Visit Elsevier eBooks+ at [eBooks.Health.Elsevier.com](https://eBooks.Health.Elsevier.com) for Bibliography.

## Chapter 10

# Foster and Kinship Care

Mary V. Greiner, Heather C. Forkey, and Moira Szilagyi

The placement of children in out-of-home care has served the needs of children in many societies worldwide throughout history. The institution of foster care was developed in the United States as a temporary resource for children during times of family crisis and is rooted in the principle that children fare best when raised in family settings. The mission of foster care is to provide for the safety, permanency, and well-being of children while assisting their families with services to promote reunification.

### EPIDEMIOLOGY

The number of children in foster care worldwide is unknown, although it has been estimated that 8 million may be in foster and **congregate care**. On September 30, 2021, approximately 391,098 children in the United States resided in foster care, down from a high of 511,318 in care in 2005. Early in the millennium, foster care numbers decreased despite an increase in maltreatment reports, as child welfare offered families more preventive services and placement with relatives (**kinship care**) or nonrelative caregivers as an alternative to court-ordered removal. Higher rates of children in care, reaching 437,337 in 2018, appear to be related to the opioid epidemic. Over the last 10 years, reunification rates and adoption of children from foster care have increased. Nationally, approximately 44% of children live with a nonrelative foster caregiver, 35% of children are in placement with a relative, 9% are in congregate (group) care, and 2% are in supervised independent living.

Approximately 37% of children in foster care in the United States are younger than 5 years, and 28% are older than 12 years. Most children are White (44%), 22% are Black, 22% are Hispanic of any race, and 8% are identified as 2 or more races. Child welfare agencies have been attending to the drivers of disparities rooted in implicit bias and structural racism for nearly 2 decades. Despite efforts to address disparities, Black, Latinx, and Indigenous children are overrepresented in foster care compared with their representation in the population at large. The average length of stay in foster care continues to decline (median in 2021, 14.9 months), though 33% of children spend >2 years in care as of 2021. Approximately half of children achieve reunification, and 25% are adopted and 9% reside with relatives. Among the remaining children, 8% emancipate between ages 18 and 21. There were 368 deaths reported in foster care in FY 2021.

**Placement instability** (multiple placements) is associated with poor outcomes for children in foster care, including poor educational outcomes and increased behavioral and mental health issues as well as delayed permanency (i.e., reunification, adoption). The majority of children in foster care for longer than 2 years have three or more placements. Important predictors of multiple placements include older age, longer time in custody, history of sexual or physical abuse, and behavioral and physical health challenges.

Youth who emancipate (e.g., age out) from foster care face additional challenges. Approximately 75% have graduated from high school or obtained a GED. By age 24, only 5% have graduated from any 2- or 4-year college and only half are employed. 39% have experienced homelessness or "couch surfing." 81% of males and 57% of females have been arrested. Two thirds of females and one half of males report they have had at least one child. Extended foster care to age 21 benefits youth in foster care, although it does not eliminate all risks.

### LEGISLATION IN THE UNITED STATES

In the United States, the **Adoption and Safe Families Act** (P.L. 105-89) requires that a permanency plan be made for each child no later than 12 months after entry into foster care and that a petition to terminate parental rights typically be filed when a child has been in foster care for at least 15 of the previous 22 months. The **Fostering Connections and Promoting Adoptions Act** of 2009 (P.L. 110-351) focused on incentives for guardianship and adoption, supports for young adults at the age of emancipation, and rights of U.S. Indigenous Nation children to caregiving within their tribe. This act also contained a clause requiring states to develop and coordinate healthcare systems for children in foster care in collaboration with Medicaid and pediatricians. In 2018 the **Family First Prevention Services Act** was signed into law. This legislation emphasizes providing evidence-based mental health and substance abuse services for families whose children are at imminent risk of entering foster care, addresses the need for children in care to be provided with appropriate evidence-based mental health services, and has incentives to move children in care from congregate to family settings.

### EARLY CHILDHOOD TRAUMA LEADS TO POOR HEALTH OUTCOMES

Children in foster care have high rates of **early childhood trauma** and adversity. More than 60% are placed in foster care for neglect, 12% for physical abuse, 4% for sexual abuse, and 5% are abandoned. Parental alcohol and other **substance use** is a known factor in 42% of removals and are likely underestimated. Parental alcohol and substance use also contributes to prenatal substance exposures for their children. **Violence** in the home is common, with many children having experienced intimate partner and/or community violence.

Removal from the family of origin may compound prior trauma experiences, although some children experience relief at removal from a chaotic, abusive, or dangerous home. No matter the circumstances of removal, most children miss their family, worry about their family, and long for reunification. Separation, loss and grief, unpredictable contact with family of origin, placement changes, the process of terminating parental rights, and the sheer uncertainty of foster care may further erode a child's well-being.

Childhood trauma is correlated with poor developmental, behavioral, and health outcomes. Early trauma and chronic stress adversely affect the neurobiology of the developing brain, especially those areas involved in attention, emotional regulation, memory, executive function, and cognition. As a result, shortened attention span, hyperactivity or dissociation, poorer cognitive function, aggression, and memory issues are problems encountered frequently among children in foster care. Evidence-based mental health trauma treatment is recommended for children who are symptomatic. Additionally, evidence shows that foster care–specific interventions, such as specially trained foster caregivers and mentoring for adolescents in foster care, can improve outcomes, although replication and dissemination of these evidence-based interventions is limited.

## HEALTH ISSUES

Experiencing multiple childhood adversities and receiving fragmented and inadequate health services before placement into foster care mean that children enter foster care with a high prevalence of chronic medical, mental health, developmental, dental, and educational problems. Thus they are defined as *children with special healthcare needs* (CSHCN). The greatest single healthcare need of this population is for high-quality, evidence-based, **trauma-informed** mental health services to address the impacts of prior and ongoing trauma, loss, and unpredictability. In addition, children in foster care have higher rates of asthma, growth failure, obesity, vertically transmitted infections, hearing and vision loss, dental decay, and neurologic conditions than the general pediatric population. Adolescents need access to reproductive health and substance use services. Up to 60% of children <5 years old have a developmental delay in at least one domain, and >40% of school-age children qualify for special education services. Unfortunately, educational difficulties persist despite improvements in school attendance and performance after placement in foster care. Each placement change that is accompanied by a change in school sets children back academically by about 4 months. Federal legislation requires child welfare to maintain children in their school of origin when possible, even if child welfare has to provide transportation to ensure this.

Although children in foster care are CSHCN, they often lack access to the services they need. Most public and private child welfare agencies do not have formal arrangements for accessing the needed array of health services and rely on local physicians and health clinics funded by Medicaid. Health histories are often sparse at admission because many have lacked regular care, or their family of origin may not be available, and information sharing between medical and child welfare settings is often very limited. Once children enter foster care, there is often a diffusion of responsibility for obtaining healthcare services across caregivers and child welfare. Foster caregivers usually receive little information about a child's healthcare needs, but they are typically expected to decide when and where children receive medical treatment. Child welfare professionals are responsible for ensuring that a child's health needs are addressed, but coordination across multiple healthcare providers can be daunting. Although child welfare can consent to routine care and even some procedures, the child's parents or family of origin may retain some medical decision-making rights unless parental rights have been terminated. Complexity in legal responsibility for making healthcare treatment decisions and access to health information may delay or result in the denial of healthcare services.

## HEALTHCARE FOR CHILDREN AND ADOLESCENTS IN FOSTER CARE

The American Academy of Pediatrics (AAP) has published detailed healthcare standards for children in foster care, available on the *Healthy Foster Care America* website. The AAP recommends that

children receive healthcare services in a medical home setting, where comprehensive healthcare is continuous over time. Compassionate, culturally competent healthcare that is trauma-informed means that health staff should understand, recognize, and respond to symptoms and risk factors of traumatic stress and provide an environment that offers physical, emotional, and psychologic safety for children and caregivers. In foster care, attention must be paid to the effects of past trauma and the impact of ongoing uncertainty and loss on a child's health and well-being, as well as that of their birth and foster/kinship caregivers.

The **trauma-informed office** is one in which symptoms such as dysregulation of sleep, behavioral problems, developmental delays, poor school function, and somatic complaints are recognized as potential effects of childhood trauma. Understanding the child's psychosocial context and history, as well as that of the caregiver, and exploring their strengths, assets, and challenges are the foundation of a trauma-informed approach. The office should have resources for education of families and child welfare professionals and ideally the ability to make warm hand-offs to community resources. Integrated trauma-informed pediatric mental health services are ideal, with referrals to community mental health services when needed, in collaboration with caregivers, child welfare, and educators. **Continuity of care** is very important for the child in foster care and includes ongoing monitoring and management of progress and care.

Several recommendations are specific to the care of children and youth in foster care (Table 10.1). Children should be seen early and often when they first enter a new placement to identify all their health issues and to support the child and caregivers through a major transition that involves considerable loss and adjustment, including the development of an attachment relationship with a new caregiver and the promotion of the child and family of origin relationship.

It is recommended that every child in foster care have comprehensive medical, dental, developmental, and mental health assessments within 30 days of entering foster care. Almost every child in foster care deserves a full mental health evaluation to assess for the impact of trauma and loss on emotional well-being. *Psychotropic medication* should only be considered, after a thorough, high-quality, trauma-informed mental health evaluation by a pediatric-trained mental health professional. The healthcare provider should remember that the impact of trauma on the developing brain can mimic other mental health disorders, including attention-deficit/hyperactivity disorder, anxiety, and depression (see Chapters 38, 39, and 50). Childhood trauma may impair cognition, executive function, and memory (see Chapter 49), so that children <6 years of age benefit from a comprehensive developmental assessment, whereas older children often benefit from a comprehensive psychoeducational assessment. The child welfare professional should provide consents for healthcare and any available health history and encourage the appropriate involvement of the family of origin. This can be facilitated with electronic medical records, though multiple sources of information may need to be identified, as most children have experienced fragmented care. The primary care provider can help child welfare professionals and caregivers by obtaining and interpreting the results of these assessments. Pediatricians, caregivers, and child welfare professionals should share information to ensure the best healthcare delivery.

**Foster/kinship caregivers** are the major therapeutic intervention of the foster care system, and pediatricians are in a unique position to provide them with appropriate education and support. Important topics include positive parenting strategies, supporting children through transitions, providing a consistent and nurturing environment, and helping children heal from past trauma and adversity (Table 10.2). All caregivers may need extensive education

**Table 10.1** Healthcare Needs and Guidance for Pediatricians Caring for Children in Foster Care

HEALTH NEED	HEALTHCARE RISKS	GUIDANCE FOR PEDIATRICIANS
Health supervision Physical health and growth Nutrition Vision/hearing Immunizations Anticipatory guidance	Food insecurity and malnutrition, leading to poor growth (failure to thrive) or obesity Vision/hearing deficits Behind on immunizations or overvaccinated with poor records Increased lead exposures Increased communicable diseases	See early and often with entry into foster care and placement changes, screening within the first week, and comprehensive evaluation within 1 mo After stabilization, visits every month for first 6 mo of age; every 3 mo from 6 mo to 2 yr; twice yearly after age 2 Support child, caregivers at placement, and family of origin Communicate and collaborate with child welfare professionals and legal professionals Maintain a comprehensive medical record despite changes in placement
Evaluation and monitoring for abuse/neglect	History of abuse and neglect at entry into foster care Abuse/neglect during out-of-home placement	Examine and document full physical examination, including skin, joint range of motion, and genital examination Laboratory testing for sexually transmitted infections (STIs), pregnancy, consideration of history of commercial sexual exploitation
Oral health	Poor dental hygiene Untreated dental disease	Examine teeth, apply fluoride when applicable, teach oral hygiene Connect with dental services by first birthday or first tooth, whichever comes first
Developmental delay/academic concern	Early adversity and environmental exposures with decreased supports lead to decreased rates of kindergarten readiness, literacy, and high school graduation School disruptions with placement changes	Developmental screening with low threshold for referral to early intervention and developmental therapies Recommend preschool programming (i.e., Head Start) and early education programs Clarification of ability to stay in school of origin (best interests determination), role of foster caregiver or education surrogate with role in requesting and approving educational plan Support child in obtaining IEP/504 plans for learning and/or behavior when needed
Mental health concerns	Placement into foster care is a trauma on top of whatever trauma that child has already experienced Placement disruptions cause further trauma Increased rates of mental health diagnoses Overlap/overrepresentation with juvenile justice	Maintain a trauma-informed medical office: Understand and educate children, families, and other healthcare professionals on the impact of early childhood adversities, trauma, and ongoing uncertainties of foster care on the developing child All children in foster care should have mental health evaluations, including screening for trauma symptoms Integrate pediatric care with behavioral health when possible Close psychiatric medication monitoring to prevent overuse; any medication should be accompanied by trauma-informed therapy Immediate referral for psychiatric emergency (i.e., suicide or violent behavior)
Medical complexity	Face challenges with chronic disease management caused by disruptions in care May be dependent on medical technologies Information sharing with foster caregiver and child welfare can improve care, follow-up	Need medical home to serve as hub for involved specialties Education required for child welfare professional to understand needs Extra care must be taken with placement changes to ensure appropriate medications, supplies, technology, etc., move with child and new caregivers are trained and prepared to meet needs; information sharing and transfer of medical information to be considered Assist with supports (e.g., SSI, special education)
Transition to adulthood	Adolescents more likely to be in nonfamilial settings, such as group homes and independent living with less adult support Sexual health risks, including earlier sexual debut and earlier transition to parenting Substance use risks, earlier initiation At risk for disengagement with healthcare system	Identify supports, such as mentors and educational/employment opportunities (i.e., Job Corps) Regular STI screening to include contraception and safe sex counseling with support for LGBTQ+ individuals Screen for intimate partner violence Regular substance use screening with brief intervention and/or referral to treatment when appropriate Partner with adolescent medicine and transition medicine when available Support youth in foster care who are parents Warm handoff to adult healthcare providers to avoid disruptions



**Table 10.2** Trauma-Informed Anticipatory Guidance for Children in Foster Care

SITUATION	ANTICIPATORY GUIDANCE FOR FOSTER CAREGIVERS
Preparing for visits with family of origin	Educate foster/kinship caregivers about impact of visitation on children and ways to improve the experience for children Create standard routines before visit Send familiar object with child to visit Have child draw picture or card to give family of origin Reassure child that foster/kinship caregiver will be there when child returns from visits Advise all caregivers to minimize conflict with and negativity toward each other Ideally, visits with family of origin are coached by trained professionals
Returning from visits and other transitions	Greet child warmly and help with unpacking Reassure safety with welcoming words, creating safe spaces in home (tent in the child's room, child's own special chair, lovey object) Establish reentry rituals, such as quiet play, reading together, active play, having a healthy snack
Relationship with family of origin	Encourage child welfare professional to have family of origin keep child's rituals and routines consistent with those in foster/kinship home (vice versa when appropriate) Focus on family of origin's positive qualities; maintain a neutral or positive affect
Affirming and building on child's strengths	Encourage participation in child-directed play Time-in with child Encourage participation in normalizing activities (e.g., hobbies, sports) "Catch the child being good," praising positive behaviors Give specific praise Practice attentive listening Provide child with words for emotions Ignore negative behavior or redirect unless there is a safety issue
Preparing for court dates	Foster/kinship caregiver, child welfare professional or law guardian should explain purpose of court hearings to child in simple terms Anticipate that court outcomes may disrupt child and reassure safety; return to routines as quickly as possible
School	If changing schools, visit school together a few times and meet teacher Check in regularly (weekly or monthly depending on need) with child's teacher Address need for any additional evaluation and supports, including IEP or specialized setting
Adolescence	Identify what issues demand firm limits and guidelines (e.g., curfews, no smoking, party at a friend's house), what issues are not important and can be left up to teen (e.g., hair length and color), and what issues are ideal for negotiation (e.g., transportation to school function, style of dress) Encourage responsible decision-making by recognizing and complimenting it Encourage and support after-school activities Teach driving when age and developmentally appropriate Encourage teen to seek employment and teach job skills Support skills in financial awareness and money management Help teen to identify mentors and focus on the future

about behavioral and emotional problems within the context of the child's trauma history to remove blame and promote healing. Minimizing conflict among parents/caregivers is extremely important because children ideally have affection and loyalty for all their caregivers. Clinicians can promote resilience by focusing on child, caregiver, and family of origin strengths. For teens and young adults in foster care, the pediatrician can provide anticipatory guidance around education, identity formation in the face of past trauma, independent decision-making, health promotion including reproductive health, healthy relationships, and developing the skills and competencies needed for a successful future life. The pediatrician can advocate for placement stability in a nurturing and responsive family setting where caregivers possess the appropriate skills to help children and youth heal.

Visit Elsevier eBooks+ at [eBooks.Health.Elsevier.com](http://eBooks.Health.Elsevier.com) for Bibliography.

## Chapter 11

# Medical Evaluation of the Foreign-Born Child

*Stacene R. Maroushek*

More than 210,000 foreign-born children (≤16 years old) enter the United States each year as asylees (asylum seekers), refugees, and immigrants, including international adoptees (see [Chapter 9](#)). This number does not include undocumented children living and working in the United States, the U.S.-born children of foreign-born parents, or the approximately 2.7

million nonimmigrant visitors ≤16 years old who legally enter the United States annually with temporary visas. With the exception of internationally adopted children, pediatric guidelines for screening these newly arrived children are sparse. The diverse countries of origin and patterns of infectious disease, the possibility of previous high-risk living circumstances (e.g., refugee camps, orphanages, foster care, rural/urban poor), the limited availability of reliable healthcare in many economically developing countries, the generally unknown past medical histories, and interactions with parents who may have limited English proficiency and/or varied educational and economic experiences make the medical evaluation of immigrant children a challenging but important task.

Before admission into the United States, all immigrant children are required to have a medical examination performed by a physician designated by the U.S. Department of State in their **country of origin**. This examination is limited to completing legal requirements for screening for certain communicable diseases and examination for serious physical or mental problems that would prevent issuing a permanent residency visa. This evaluation is *not* a comprehensive assessment of the child's health, and except in limited circumstances, laboratory or radiographic screening for infectious diseases is *not required* for children <15 years old. After entry into the United States, health screenings of refugees, but not other immigrants, are recommended to be done by the resettlement state. There is limited tracking of refugees as they move to different cities or states. Thus many foreign-born children have had minimal prearrival or postarrival screening for infectious diseases or other health issues.

**Immunization** requirements and records also vary depending on entry status. Internationally adopted children who are younger than 10 years are exempt from Immigration and Nationality Act regulations pertaining to immunization of immigrants before arrival in the United States. Adoptive parents are required to sign a waiver indicating their intention to comply with U.S.-recommended immunizations, whereas older immigrants need only show evidence of up-to-date, not necessarily complete, immunizations before application for permanent resident (green card) status after arrival in the United States.

**Infectious diseases** are among the most common medical diagnoses identified in immigrant children after arrival. Children may be asymptomatic; therefore diagnoses must be made by screening tests in addition to history and physical examination. Because of inconsistent perinatal screening for hepatitis B and hepatitis C viruses, syphilis, and HIV and the high prevalence of certain intestinal parasites and tuberculosis, all foreign-born children should be screened for these infections on arrival in the United States. [Table 9.2](#) and [Table 11.1](#) list suggested screening tests for infectious diseases for international adoptees or immigrants/refugees, respectively. [Table 11.2](#) lists incubation periods of common internationally acquired diseases. In addition to these infections, other medical and developmental issues, including hearing, vision, dental, and mental health assessments; evaluation of growth and development; nutritional assessment; lead exposure risk; complete blood cell count with red blood cell indices; microscopic urinalysis; newborn screening (this could also be done in nonneonates) and/or measurement of thyroid-stimulating hormone concentration; and examination for congenital anomalies (including fetal alcohol syndrome) should be considered as part of the initial evaluation of any immigrant child.\*

Children should be examined within 1 month of arrival in the United States, or earlier if there are immediate health concerns, but foreign-born parents may not access the healthcare system with their children unless prompted by illness, school vaccination, or other legal requirements. *It is important to assess the completeness of previous medical screenings at any first visit with a foreign-born child.*

Clinicians should be aware of potential diseases in high-risk immigrant children and their clinical manifestations. Some diseases, such as central nervous system cysticercosis, may have incubation periods as long as several years and thus may not be detected during initial screening. On the basis of findings at the initial evaluation, consideration

\*For the most up-to-date guidelines based on country of origin/birth, see: <https://www.cdc.gov/immigrantrefugeehealth/guidelines/domestic/domestic-guidelines.html>.

**Table 11.1** Infectious Disease Screening for Refugee Children

CONDITION OR TEST	REFUGEE CHILDREN
<b>HEPATITIS A VIRUS (ACUTE INFECTION)</b>	
Hepatitis A IgM antibody	Not recommended
<b>HEPATITIS B VIRUS</b>	
Hepatitis B surface antigen (HBsAg)	All
Hepatitis B surface antibody (anti-HBs)	All
Hepatitis B core antibody (anti-HBc)	All
<b>HEPATITIS C VIRUS</b>	
Hepatitis C antibody	Some
<b>SYPHILIS</b>	
Nontreponemal test (RPR, VDRL, or ART)	≥15 yr
Treponemal test (TPPA, MHA-TP, or FTA-ABS)	Not recommended
<b>HUMAN IMMUNODEFICIENCY VIRUS</b>	
Human immunodeficiency virus 1 and 2 antibody	≥13 yr
Recommended	<13 yr
<b>TUBERCULOSIS</b>	
Tuberculin skin test (TST)	All
or	
Interferon-γ release assay	≥2 yr
<b>INTESTINAL PARASITES</b>	
Microscopic evaluation of stool for ova and parasites	All (two specimens)*
<i>Giardia intestinalis</i> and <i>Cryptosporidium</i> antigen	All (one specimen)*
<b>BACTERIAL ENTERIC INFECTION</b>	
In children with diarrhea: bacterial stool culture	All
<b>CHAGAS (ENDEMIC AREAS)</b>	
<i>Trypanosoma cruzi</i> serologic testing	All
Complete blood count	All
<b>EOSINOPHILIA WITH NEGATIVE STOOL OVA AND PARASITE FOR HELMINTHS</b>	
<i>Strongyloides</i> serologic testing	All
<i>Schistosoma</i> serologic testing (endemic countries)*	
<b>LYMPHATIC FILARIASIS (ENDEMIC AREAS)</b>	
<i>Filari</i> serology	All
<b>CHAGAS (ENDEMIC AREAS)W</b>	
<i>Trypanosoma cruzi</i> serologic testing	All
<b>MALARIA SCREENING (ENDEMIC AREAS)</b>	
Malaria polymerase chain reaction	All without pretreatment
<b>HEMATURIA (SCHISTOSOMIASIS)</b>	
Urinalysis	All

\*Some experts recommend serologic testing regardless of whether eosinophilia is present.

ART, Automated reagent test; FTA-ABS, fluorescent treponemal antibody absorption; MHA-TP, microhemagglutination-*Treponema pallidum*; RPR, rapid plasma reagin; TPPA, *Treponema pallidum* particle agglutination; VDRL, Venereal Disease Research Laboratory.

Modified from Staat MA. Infectious disease considerations in international adoptees and refugees. In: Cherry JD, Harrison GJ, Kaplan SL, et al. (eds): *Feigin and Cherry's Textbook of Pediatric Infectious Diseases*. 8th ed. Philadelphia: Elsevier; 2019: Table 233.1, p. 2310.

should be given to a repeat evaluation 6 months after arrival. In most cases, the longer the interval from arrival to development of a clinical syndrome, the less likely the syndrome can be attributed to a pathogen acquired in the country of origin.

**Table 11.2** Incubation Periods of Common Travel-Related Infections\*

SHORT INCUBATION (<10 DAYS)	MEDIUM INCUBATION (10-21 DAYS)	LONG INCUBATION (>21 DAYS)
Malaria	Malaria	Malaria
Arboviruses including dengue, yellow fever, Japanese encephalitis, Zika, chikungunya	Flaviviruses: tick-borne encephalitis and Japanese encephalitis	Schistosomiasis
Hemorrhagic fevers: Lassa, Ebola, South American arenaviruses	Hemorrhagic fevers: Lassa, Ebola, Crimean-Congo	Tuberculosis
Respiratory viruses including severe acute respiratory syndrome	Acute HIV infection	Acute HIV infection
Typhoid and paratyphoid	Typhoid and paratyphoid	Viral hepatitis
Bacterial enteritis	<i>Giardia</i>	Filariasis
<i>Rickettsia</i> : spotted fever group—Rocky Mountain spotted fever, African tick typhus, Mediterranean spotted fever, scrub typhus, Q fever	<i>Rickettsia</i> : flea-borne, louse-borne, and scrub typhus, Q fever, spotted fevers (rare)	<i>Rickettsia</i> : Q fever
Bacterial pneumonia including <i>Legionella</i>	Cytomegalovirus	Secondary syphilis
Relapsing fever	<i>Toxoplasma</i>	Epstein-Barr virus including mononucleosis
Amoebic dysentery	Amoebic dysentery	Amoebic liver disease
Meningococemia	Histoplasmosis	Leishmaniasis
<i>Brucella</i> (rarely)	<i>Brucella</i>	<i>Brucella</i>
Leptospirosis	Leptospirosis	Bartonellosis (chronic)
Fascioliasis	Babesiosis	Babesiosis
Rabies (rarely)	Rabies	Rabies
African trypanosomiasis (acute), East African (rarely)	East African trypanosomiasis (acute)	West African trypanosomiasis (chronic)
	Hepatitis A (rarely)	Cytomegalovirus
	Measles	

\*Diseases that commonly have variable incubation periods are shown more than once. However, most diseases may rarely have an atypical incubation period, and this is not shown here.

HIV, Human immunodeficiency virus.

From Freedman DO. Infections in returning travelers. In: Bennett JE, Blaser MJ, Dolin R, et al (eds): *Mandell, Douglas, and Bennett's Principles and Practice of Infectious Diseases*, 8th ed. Philadelphia: Saunders;2015: Table 324-2.

## COMMONLY ENCOUNTERED INFECTIONS

### Hepatitis B

See also Chapter 406.

The prevalence of hepatitis B surface antigen (HBsAg) in refugee children ranges from 4% to 14%, depending on the country of origin, age, and year studied. Prevalence of markers of past hepatitis B virus (HBV) infection is higher. HBV infection is most prevalent in immigrants from Asia, Africa, and some countries in Central and Eastern Europe, as well as the former Soviet Union (e.g., Bulgaria, Romania, Russia, Ukraine), but also occurs in immigrants born in other countries. All immigrant children, even if previously vaccinated, coming from high-risk countries (HBsAg seropositivity >2%) should undergo serologic testing for HBV infection, including both HBsAg and antibody to HBsAg (anti-HBs), to identify current or chronic infection, past resolved infection, or evidence of previous immunization. Because HBV has a long incubation period (6 weeks to 6 months), the child may have become infected at or near the time of migration, and initial testing might be falsely negative. Therefore strong consideration should be given to a repeated evaluation 6 months after arrival for all children, especially those from highly endemic countries. Chronic HBV infection is indicated by persistence of HBsAg for >6 months. Children with HBsAg-positive test results should be evaluated to identify the presence of chronic HBV infection, which occurs in >90% of infants infected at birth or in the first year of life and in 30% of children exposed at ages 1-5 years. Once identified as being infected, additional testing should be done to assess for biochemical evidence of severe or chronic liver disease or liver cancer.

### Hepatitis A

See Chapter 406.

### Hepatitis C

See also Chapter 406.

The decision to screen children should depend on history (e.g., receipt of blood products; traditional percutaneous procedures such as tattooing, body piercing, circumcisions, or other exposures to reused, unsterile medical devices) and the prevalence of hepatitis C virus (HCV) infection in the child's country of origin. Children from Eastern Mediterranean and Western Pacific countries, Africa, China, and

Southeast Asia should be considered for HCV infection screening. All children coming from Egypt, which has the highest known HCV seroprevalence (12% nationally and 40% in some villages), should be tested for hepatitis C.

### Intestinal Pathogens

Fecal examinations for ova and parasites (O&P) by an experienced laboratory will identify a pathogen in 8–86% of immigrants and refugees. The prevalence of intestinal parasites varies by country of origin, time period when studied, previous living conditions (including water quality, sanitation, and access to footwear), and age, with toddler/young school-aged children being the most affected. If documented predeparture treatment was given, an eosinophil count should be performed. An absolute eosinophil count of >400 cells/μL, if persistently elevated for 3-6 months after arrival, should prompt further investigation for tissue-invasive parasites such as *Strongyloides* (see Chapter 341) and *Schistosoma* (see Chapter 346) species (if no predeparture ivermectin or praziquantel was given). If no documented predeparture treatment was given and screening eosinophils are >400 cells/μL, two stool O&P specimens obtained from separate morning stools should be examined by the concentration method or empiric ivermectin and praziquantel given. If the child is symptomatic, including evidence of poor physical growth, but no eosinophilia is present, a single stool specimen should also be sent for *Giardia lamblia* (see Chapter 328.1) and *Cryptosporidium parvum* (see Chapter 329) antigen detection. All potentially pathogenic parasites found should be treated appropriately. All nonpregnant refugees >2 years of age coming from sub-Saharan Africa and Southeast Asia should be presumptively treated with predeparture albendazole.

### Tuberculosis

See also Chapter 261.

Tuberculosis (TB) commonly is encountered in immigrants from all countries because *Mycobacterium tuberculosis* infects approximately 30% of the world's population. Latent TB infection rates can be up to 60% in populations of refugee children from some regions of North Africa and the Middle East. Since 2007, TB *Technical Instructions for Medical Evaluation of Aliens* have required that children ages 2-14 years undergo a TB skin test or interferon-γ release assay if they are medically screened

in countries where the TB rate is  $\geq 20$  cases per 100,000 population. If the testing is positive, a chest radiograph is required. If the chest film suggests TB, cultures and three sputum smears are required, all before arrival in the United States. Check with the Centers for Disease Control and Prevention, Division of Global Migration and Quarantine, for the latest information ([www.cdc.gov/ncidod/dq/technica.htm](http://www.cdc.gov/ncidod/dq/technica.htm)).

### Congenital Syphilis

See Chapter 264.

### HIV Infection

See Chapter 322.

## IMMUNIZATIONS

See Chapter 215.

Immigrant children and adolescents should receive immunizations according to the recommended schedules in the United States for healthy children and adolescents. Some immigrants will have written documentation of immunizations received in their birth or home country. Although immunizations such as bacille Calmette-Guérin (BCG), diphtheria and tetanus toxoids and pertussis (DTP), poliovirus, measles, and HBV vaccines often are documented, other immunizations, such as *Haemophilus influenzae* type b, mumps, and rubella vaccines, are given less frequently, and *Streptococcus pneumoniae*, human papillomavirus, meningococcal, and varicella vaccines are given rarely. When doubt exists, an equally acceptable alternative is to reimmunize the child. Because the rate of more serious local reactions after DTP vaccine increases with the number of doses administered, serologic testing for antibody to tetanus and diphtheria toxins before reimmunizing, or if a serious reaction occurs, can decrease risk.

In children older than 6 months with or without written documentation of immunization, testing for antibodies to diphtheria and tetanus toxoid may be considered to determine whether the child has protective antibody concentrations. If the child has protective concentrations, the immunization series should be completed as appropriate for that child's age. In children older than 12 months, measles, mumps, rubella, and varicella antibody concentrations may be measured to determine whether the child is immune; these antibody tests should not be performed in children younger than 12 months because of the potential presence of maternal antibody.

Visit Elsevier eBooks+ at [eBooks.Health.Elsevier.com](http://eBooks.Health.Elsevier.com) for Bibliography.

## Chapter 12

# Cultural Issues in Pediatric Care

Lee M. Pachter and Alexandra M.S. Corley

Pediatricians live and work in a multicultural world. Among the world's nearly 8 billion people residing in over 200 countries, more than 6,000 languages are spoken. As the global population becomes more mobile, population diversity increases in all countries. In the United States, sources of ethnic and cultural diversity come from indigenous groups, such as Indigenous Nation peoples and Alaskan and Hawaiian natives, groups from U.S. territories such as Puerto Rico, recent immigrant groups, those whose heritage originates from the African diaspora and arrived to U.S. soil forcibly via the middle passage of the transatlantic slave trade, and others whose

families and communities migrated to the United States from Europe and Asia generations ago but who have retained cultural identification. U.S. census estimates suggest that in 2020, nearly 40% of the U.S. population self-identified as belonging to an ethnic group other than non-Hispanic white. Immigrants comprise 15.4% of the U.S. population. Based on recent estimates, 25% of children in the United States are either new immigrants or first-generation US citizens. Immigrants from China and India account for the largest groups coming to the United States, followed by those from Mexico and Latin America. This national and international diversity allows for a heterogeneity of experience that enriches the lives of everyone. Much of this diversity is based on varied cultural orientation.

## WHAT IS CULTURE?

The concept of *culture* does not refer exclusively to ethnic categorizations. A common definition of **cultural group** is *a collective that shares common heritage, worldviews, beliefs, values, attitudes, behaviors, practices, and identity*. Cultural groups can be based on identities such as gender (cis, trans, nonbinary), sexual orientation (gay, lesbian, straight, bisexual), age (teen culture), being deaf or hearing impaired (deaf culture; see Chapter 55), and having neurodevelopmental differences (neurodiversity). Those who identify in such groups, to a certain extent, may share common worldviews, attitudes, beliefs, values, practices, and identities with others in the group.

As a part of their shared experiences, many cultural groups face oppression, which can affect their health. Therefore these cultural groups require focused consideration from healthcare providers, and we must critically examine societal factors like racism, sexism, ableism, and other forms of discrimination at the structural (institutional), interpersonal, and psychologic levels as root causes of health disparities (see Chapters 2 and 2.1). These premises are particularly relevant in a white supremacy and hegemony-based society such as the United States and previously colonized nations.

Medical professionals can also be considered as belonging to a specific cultural group. Those who identify with the **culture of medicine** share common theories of well-being and disease, acceptance of the biomedical and biopsychosocial models of health, and common practices and rituals. As with other cultural groups, physicians and other healthcare professionals have a distinct language and share a common history, including experiencing similar preparatory courses that must be mastered for entrance into training for the profession (a rite of passage) and a degree of socioeconomic privilege. Medical professionals subscribe to common norms in medical practice. Young physicians learn a way to describe health and illness that requires a new common vocabulary and an accepted structure for communicating a patient's history. These common beliefs, orientations, and practices are often not shared by those outside of medicine. Therefore *any clinical interaction between a healthcare provider and a patient can be a potential cross-cultural interaction*—between the culture of medicine and the culture of the patient—regardless of the ethnicity or socioeconomic status of the participants. A culturally informed and sensitized approach to clinical communication is a fundamental skill required of *all* medical professionals, regardless of the demographic makeup of one's patient population.

## Culture, Identity, and Intersectionality

We are all members of multiple cultural groups. Our identification with different groups can be dynamic. How we identify may depend on the context in which we find ourselves and may change over time. A gay Latino physician may feel, at different times and in different situations, greatest affinity with Latino culture, the culture of medicine, the “minority” culture in the United States, or his gay identity. An immigrant from India may initially feel great connection with her Indian culture and heritage, which may wane during periods of assimilation into American cultural life, then increase again at other points in life. Alternatively, there may be identities that are not as flexible; a dark-skinned person will never be able to “pass” as White. An obese person will not have the “thin privilege” of their underweight counterpart. In addition, multiple cultural identities can intersect. **Intersectionality** is a concept that expresses the *interconnected nature of the different social categorizations an individual may be connected to and how those identities interact to create systems*



of disadvantage and/or privilege. Considering intersectionality helps to understand how people who are members of multiple disenfranchised groups may experience harm as a result of either identity or both simultaneously. For example, a Black woman's experience with navigating both racism and sexism might differ from how her White female colleague deals with sexism alone. Culturally informed clinicians should never assume to understand the cultural identity or experiences of a person based solely on their perception of ethnic, racial, or group affiliation.

### Intracultural Variability

There can be significantly different beliefs, values, and behaviors among members of the same cultural group. There is as much variability *within* cultures as there is *between* cultures. The sources of this variability include differences in personal psychology and philosophy, family beliefs and practices, social context, and other demographic differences, as well as **acculturation**, defined as the changes in beliefs and practices resulting from continuous interactions with another culture. The literature on acculturation and health outcomes shows varied effects of cultural change on health and well-being. These differences are in part caused by overly simplistic ways of measuring acculturation in public health and health services research. The use of *acculturation proxies* such as generational status (recent immigration, first generation) and socioeconomic status as measures of acculturation do not allow for an understanding of the complex behavioral changes that occur during shifts in cultural orientation. Often, acculturation is seen as a linear process where individuals move from unacculturated to acculturated or assimilated into the host culture. This simplistic view does not consider the reality that acculturation is *multidimensional* and includes the degree to which an individual continues to identify with her original culture-of-origin identity, the degree to which the host cultural orientation is adopted, and how inviting and welcoming the host culture is. These are separate and independent processes (Fig. 12.1). One can become *bicultural* (adopting the host culture while retaining aspects of the original culture), *assimilated* (host culture is adopted, but original culture is not retained), *separated* (original cultural orientation is retained, but host culture is not greatly adopted), or *marginalized* (does not adopt host culture and does not retain original culture). These variations in the acculturation process are determined not only by the individual going through the cultural change process but also by the degree of acceptance of diversity in the host culture. In theory, individuals who best adapt to the multicultural society are those who are **bicultural** because they retain the strengths and assets of their heritage culture while being able to positively adjust to host cultural norms. However, historically and in the present day, people from various cultural groups have taken on acculturation in a variety of ways for different reasons (e.g., survival, safety, wealth attainment). The acculturative process can be a source of stress and may have a negative impact on health and contribute to health disparities. It is worth noting that the acculturation process is one that the majority culture often has little awareness of or participation in. Members of the majority culture should strive for cultural awareness as a foundation for a culturally informed practice.

	Original culture retained	Original culture not retained
Host culture adopted	<b>Bicultural</b>	<b>Assimilated</b>
Host culture not adopted	<b>Separated</b>	<b>Marginalized</b>

**Fig. 12.1** Multidimensional model of acculturation. (Adapted from Berry J. *Immigration, acculturation, and adaptation*. *Appl Psychol* 1997;46:5–68.)

### CULTURALLY INFORMED CARE

Physicians and patients bring to their interactions diverse orientations from multiple cultural systems. These different belief systems and practices could have significant implications for the delivery of healthcare and the receipt of health information. Consequently, physician cultural awareness, sensitivity, and humility are critical to successful patient-provider interaction.

The culturally informed physician (1) attempts to understand and respect the beliefs, values, attitudes, and lifestyles of all patients; (2) understands that health and illness are influenced by beliefs and practices originating from cultural orientation, linguistic considerations, religious and spiritual beliefs, and other socially constructed affiliations; (3) has insight into their own cultural biases and does not see cultural issues as something that only affects the patient; (4) is sensitive to how differences in power and privilege may affect the quality of the clinical encounter; (5) recognizes that in addition to the physiologic aspects of disease, the culturally and psychologically constructed meaning of illness and health is a central clinical issue; and (6) is sensitive to the role of intersectionality and intragroup variations in beliefs and practices and avoids stereotyping based on group affiliation. These core components of culturally informed care are important for interactions with *all* patients, regardless of socioeconomic status or ethnicity.

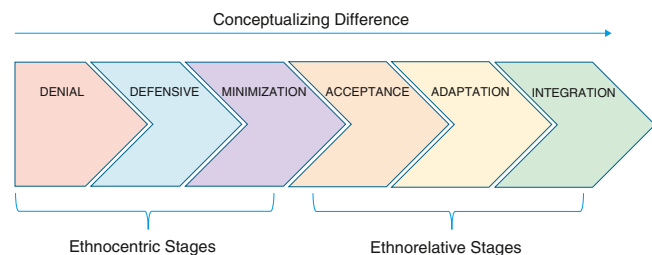
Becoming culturally informed is a developmental process. Figure 12.2 displays a framework that includes a continuum of perceptions and orientations to cultural awareness. Individuals in the *denial* stage perceive their own cultural orientation as the true one, with other cultures either undifferentiated or unnoticed. In the *defensive* stage, other cultures are acknowledged but regarded as inferior to one's own culture. The *minimization* stage is characterized by beliefs that fundamental similarities among people outweigh any differences and downplays the role of culture as a source of human variation. The mistaken idea that one should be "color blind" is an example of a common belief of individuals in the minimization stage and ignores the important historical adverse sociopolitical events faced by Black or other minoritized peoples.

As one moves to the *acceptance* stage, cultural differences are acknowledged. Further expansion and understanding lead to *adaptation*, where one not only acknowledges differences but can shift frames of reference and have a level of comfort outside one's own cultural frame. This eventually leads to further comfort with different worldviews seen at the *integration* stage, where individuals respect cultural differences and can comfortably interact across cultures with humility and respect.

### Understanding Culture in the Context of Healthcare

Cultural orientation is just one of many different perspectives that individuals draw on as they make health and healthcare decisions. Individual psychology, past experiences (including racism), religious and spiritual views, social position, socioeconomic status (poverty), and family norms all can contribute to a person's health beliefs and practices as well as trust in the healthcare system.

Trust is essential to the patient–healthcare provider relationship. However, because of historical or current experiences, many cultures do not trust the healthcare system. In the past, Black people have been subjected to involuntary sterilization and not being treated for syphilis (the notorious Tuskegee study). Currently, Black people have received unequal pain relief and have experienced episodes of implicit and explicit racism in our healthcare system. These experiences create mistrust.



**Fig. 12.2** Development of intercultural awareness. (Adapted from Bennett MJ. *A developmental approach to training for intercultural sensitivity*. *Int J Intercultural Relations*. 1986;10:179–196.)

The concept of intersectionality also contributes to the variability of beliefs and practices any individual subscribes to. These beliefs and practices can also change over time and may be expressed differently in different situations and circumstances. Because of the significant variability in health beliefs and behaviors seen among members of the same cultural group, an approach to cultural competency that emphasizes a “knowledge set” of specific cultural health practices in different cultural groups could lead to false assumptions and stereotyping. Knowledge is important, but it only goes so far. *Instead, an approach that focuses on the healthcare provider acquiring skills and attitudes relating to open and effective communication is a preferable approach to culturally effective and informed care.* Such an approach does not rely on rote knowledge of facts that may be stereotypical or outdated. Instead, it provides a toolbox that can be used in all circumstances. The following skills can lead to a culturally informed approach to care:

1. *Don't assume.* Presupposing that a particular patient may have certain beliefs or may act in a particular way based on stereotypic cultural group affiliation could lead to incorrect assumptions. Sources of intracultural diversity are varied. Multiple cultural identities can intersect and can contribute to a diversity of experiences.
2. *Practice humility.* Cultural humility has been described as “the ability to maintain an interpersonal stance that is ‘other’-oriented (or open to the other) in relation to aspects of cultural identity.” Cultural humility goes beyond cultural competency in that it requires the clinician to self-reflect and acknowledge that one’s own cultural orientation enters any transaction with a patient. Cultural humility aims to address power imbalances between the dominant (hospital-medical) privileged culture and the patient. It incorporates the patient’s life experiences. It creates a collaborative partnership between practitioner and patient. It also pushes the provider to critically examine their own biases and presuppositions. *Cultural competency* is an approach that typically focuses on the patient’s culture, whereas cultural humility acknowledges that both physicians and patients have cultural orientations and that a successful relationship requires give and take among those differing perspectives. Cultural humility also includes an understanding that differences in social power, which are inherent in the physician-patient relationship, need to be understood and addressed so that open communication can occur.
3. *Understand and address privilege.* Members of the majority culture have certain privileges and benefits that are often unrecognized and unacknowledged. For example, they are more likely to be positively represented in media such as movies and television. Compared with minoritized groups, those in the majority culture have less chance of being followed by security guards at stores, stopped by the police, or having their bags checked. They have a greater chance of having a positive reception in a new neighborhood or of finding food in the supermarket that is consistent with their heritage. They have a lower likelihood of having to deal with the burden of racism and the acculturation process. These privileges typically go unnoticed by members of the majority culture, but their absence is painfully recognized by members of oppressed cultural groups. The culturally informed physician should try to be mindful of these privileges and power differentials and how they may influence their interactions with patients. Addressing such privilege might involve proactively centering traditionally silenced voices.
4. *Be inquisitive.* Because of the significant amount of intracultural diversity of beliefs and practices noted earlier, the only way to know a particular patient’s approach to health and illness is through direct and effective communication. Asking about the patient’s/family’s perspective in an inquisitive and respectful manner will usually be met with open and honest responses, as long as the patient does not feel looked down on and the questions are asked in genuine interest. Obtaining a **health beliefs history** on *all* patients is an effective way of understanding clinical issues from the patient’s and family’s perspective (Table 12.1). The health beliefs history gathers information on the patient’s views on the identification of health problems, causes, susceptibility, signs and symptoms, concerns, treatment, and expectations. Responses gathered from the health beliefs history can be helpful in guiding care plans and health education interventions.

**Table 12.1** The Health Beliefs History

- What do you think is wrong with your child?
- Why do you think your child has gotten it (the illness)?
- What do you think caused it?
- Why do you think it started when it did?
- What do you think is happening inside the body?
- What are the symptoms that make you know your child has this illness?
- What problems does this illness cause your child?
- What are you most worried about with this illness?
- How long do you think it will last?
- How do you treat it?
- What will happen if it is not treated?
- What do you expect from the treatments?

Data from Kleinman A, Eisenberg L, Good B. Culture, illness and care: Clinical lessons from anthropologic and cross-cultural research. *Ann Intern Med.* 1978;88:251–258.

5. *Be flexible.* As members of the culture of medicine, clinicians have been educated and acculturated to the biomedical model as the optimal approach to health and illness. Patients and families may have health beliefs and practices that do not fully fit the biomedical model. Traditional beliefs and practices may be used in tandem with biomedical approaches without posing harm. An individual’s approach to health rarely is exclusively biomedical or traditional and is often a combination of multiple approaches. The health beliefs history provides clinicians with information regarding nonbiomedical beliefs and practices that may be held by the patient. Culturally informed physicians should be flexible and find ways of integrating nonharmful traditional beliefs and practices into the medical care plan to make that plan fit the patient’s needs and worldview, while still reaching the desired health outcome. This will likely result in better adherence to treatment and prevention. Obtaining a health beliefs history for a child with asthma, for example, may reveal that the family uses an **alternative remedy** when the symptoms first occur. If the symptoms do not resolve after giving the remedy, the family administers standard medical care. In this case, if the alternative remedy is safe and has no significant likelihood of causing adverse effects, the culturally informed physician might say, “I’m not sure if the remedy you’re using is helpful or not, but I can say that if used as you described, it’s not likely to be harmful. So, if you think it may work, feel free to try it. But instead of waiting to give the prescription medicine until after you see if the remedy works, why don’t you give it at the same time you give the remedy? Maybe they’ll work well together.” This approach shows respect for the family-held beliefs and practices while increasing timely adherence to the biomedical therapy. At times, an alternative therapy may be contraindicated or may have adverse effects. In this case it is advisable to recommend against the therapy, but whenever possible, one should attempt to replace the therapy with another, safer, culturally acceptable treatment. If a parent is giving a child tea containing harmful ingredients to treat a cold, the culturally informed physician could recommend stopping the practice and explain the concerns, but then recommend replacing the harmful tea with something safer that fits the family’s cultural belief system, such as an herbal tea with no harmful ingredients. This requires an awareness and background knowledge of the cultural belief system, and this approach increases the chances that the family will follow through on the recommendation and feel that their beliefs are respected.

### Awareness-Assessment-Negotiation Model

Providing care in the multicultural context can be challenging, but it offers opportunities for creativity and can result in improved long-term physician-patient relationships, which will ultimately improve the quality and outcomes of healthcare. Culturally informed care combines knowledge with effective communication skills, an open attitude, and the qualities of flexibility and humility.

The culturally informed physician should first become **aware** of common health beliefs, practices, and communication styles

of patients in the practice. Reading literature on particular groups could increase awareness, but with the caution that such information may be biased, outdated, or not specific to the local context. The best approach to becoming aware of specific health beliefs and practices is to ask—enter into conversations with patients, families, and community members. One might say, “Other families have shared with me that there are ways of treating this illness [or staying healthy] that work for them, but doctors do not know about them. Sometimes they are recommended by grandparents or others in the community. They may be effective. Have you heard of any of these?” This approach shows genuine interest and openness, is not based on presumptions, and does not ask about behaviors or practices, only if the patient has heard of these practices. If the question elicits a positive response, the conversation can then continue, including asking whether the patient has personally tried any of the therapies, under what circumstances, and if they thought it was helpful. This approach shows respect for the patient as an individual and avoids stereotyping all members of a particular group as monolithic in their cultural beliefs and practices.

The information obtained should be seen only as common ways that members of a community *may* interpret health-related issues. Assuming that all members subscribe to similar beliefs and practices would be incorrect and potentially damaging by promoting stereotypes. Because the unit of measurement in clinical care is the individual patient and family, clinicians must **assess** to what extent a specific patient may act on these general beliefs and under what circumstances. The health beliefs history can help the physician become aware of the specific beliefs and practices that a patient holds and allow one to tailor the care to the individual patient.

Once the patient’s explanatory model is elicited and understood, the clinician should be able to assess the congruity of this model and the biomedical model, finding similarities. Then the process of **negotiating** can occur. Integrating patient-held approaches to health with evidence-based biomedical standards of care will help place care within the lifestyle and worldview of patients, leading to increased adherence to medical care plans, better physician-patient communication, enhanced long-term therapeutic relationships, better health outcomes, and improved patient (and physician) satisfaction. When there is a needed behavioral change, counseling for a patient or family should follow motivational interviewing best practices (see [Chapter 18](#)).

Visit Elsevier eBooks+ at [eBooks.Health.Elsevier.com](http://eBooks.Health.Elsevier.com) for Bibliography.

## Chapter 13

# Maximizing Children’s Health: Screening, Anticipatory Guidance, and Counseling

Joseph F. Hagan Jr. and Dipesh Navsaria

Health supervision visits from birth to age 21 are the platform for a young person’s healthcare. Routine, scheduled care of well infants, children, and adolescents is an essential prevention effort for children and youth worldwide. The provision of **well care** in the medical home fosters strong relationships between the clinic or practice and the child and family, enabling the provision of appropriate surveillance, screening, and sick care.

To ensure the optimal health of the developing child, pediatric care in the United States and other countries evolved into regularly scheduled visits to ensure adequate nutrition, to detect and immunize against infectious diseases, and to observe the child’s development. To foster optimal child healthy development, it is also wise to assess the child’s or adolescent’s emotional-behavioral health, their parents’ mental health, their relational health, and their social determinants of health.

Well-child care focuses on the health and well-being of the child, but as children live in families of many varieties, it must also address that context by evaluating the needs, strengths, opportunities, and challenges of the identified family, including parents and other adults. Answering parents’ questions while creating an environment where parents feel comfortable asking is an important feature of the well-child visit. Promoting family-centered care and partnership with parents increases the ability to elicit parental concerns, especially about their child’s development, learning, behavior, and social needs. Addressing of needs may be as straightforward as supportive listening, or may include validation, and referral to an appropriate resource whether in the community or the adult’s own medical home. Such two-generation approaches benefit both the parent and the child.

Ever-present and lying just beneath the surface of arguably every pediatric encounter is the phenomenon of *relational health*. What is the health of the relationships within the family unit? Is the child surrounded by safe, stable, nurturing relationships? Or are they subject to unbuffered threats to their well-being? Are caregivers confident of their caregiving abilities? Do they have the capacity to do it well? This assessment followed by efforts to bolster relational health within families will act as a strong support to child development that has significant implications for the life course.

Contemporary analysis of changes in the population’s health, coupled with the recognition that early life experiences and social factors affect health along the entire life course, call for a supportive environment providing positive childhood experiences that enhance the trajectory for child development and health. But stressful circumstances impair development, and **adverse childhood experiences** (ACEs) early in life increase the risk of disease (see [Chapter 1](#)). Adults who experienced abuse, violence, or other stressors as children have an increased risk for depression, heart disease, and other morbidities. Biology informs us that **unbuffered stress** leads to increased heart rate and blood pressure and increased levels of inflammatory cytokines, cortisol, and other stress hormones, all of which impair brain activity, immune status, and cardiovascular function. These impacts of stress present causal models of how ACEs, including those that could have been prevented, increase health risk and negatively affect the life course.

**Preventive care** for children, youth, and families offers great opportunity for health cost savings as a component of contemporary U.S. health reform activities. A thriving society and economy requires educated and healthy citizens and workers. For children to have a successful, meaningful, and useful educational experience, they must have physical, cognitive, and emotional health. Educational success in particular is tied to early childhood developmental competence. Well-child care plays a vital role in promoting adult health, a concept endorsed by business leaders as essential to building the human infrastructure of the U.S. economy and society.

## THE PERIODICITY SCHEDULE AND GUIDELINES

The frequency and content for well-child care activities are derived from evidence-based practice and research. In addition, federal agencies and professional organizations, such as the American Academy of Pediatrics (AAP), have developed evidence-informed, expert consensus guidelines for care. The *Recommendations for Preventive Pediatric Health Care*, or **Periodicity Schedule**, is a compilation of



recommendations listed by age-based visits (Fig. 13.1). It is intended to guide practitioners of pediatric primary care to perform certain services and intentionally make observations at age-specific visits; it designates the standard for *preventive services* for U.S. children and youth and is referred to as such in some legislation. It is updated annually and is available online.

Comprehensive guides for care of well infants, children, and adolescents have been developed based on the Periodicity Schedule to expand and further recommend how practitioners might accomplish the tasks outlined. The current guideline standard is *The Bright Futures Guidelines for Health Supervision of Infants, Children, and Adolescents*, fourth edition (<https://brightfutures.aap.org/Pages/default.aspx>). These guidelines were developed by the AAP under the leadership of the Maternal Child Health Bureau of the U.S. Department of Health and Human Services, in collaboration with the National Association of Pediatric Nurse Practitioners, American Academy of Family Physicians, American Medical Association, American Academy of Pediatric Dentistry, Family Voices, and others.

### TASKS OF WELL-CHILD CARE

The well-child encounter aims to promote the physical and emotional well-being of children and youth. Child health professionals, including pediatricians, family medicine physicians, nurse practitioners, and physician assistants, take advantage of the opportunity well-child visits provide to elicit parental questions and concerns, gather relevant family and individual health information, perform a physical examination, and initiate screening tests. The tasks of each well-child visit include the following:

1. Disease detection
2. Disease prevention
3. Health promotion
4. Anticipatory guidance

To achieve these outcomes, healthcare professionals employ techniques to screen for disease—or for the risk of disease—and provide advice about healthy behaviors. These activities lead to the formulation of appropriate anticipatory guidance and health advice.

Clinical detection of disease in the well-child encounter is accomplished by a careful physical examination and both surveillance and screening. In well-child care, **surveillance** occurs in every health encounter and is enhanced by repeated visits and observations with advancing developmental stages. It relies on the experience of a skilled clinician performing intentional observation over time facilitated and informed by the observations offered by parents. **Screening** is a more formal process using a validated assessment tool that has known sensitivity and specificity. For example, anemia *surveillance* is accomplished through taking a dietary history and seeking signs of anemia in the physical examination. Anemia *screening* is done by hematocrit or hemoglobin tests. Developmental *surveillance* relies on the observations of parents and the assessment of clinicians in pediatric healthcare who are knowledgeable about child development. Table 13.1 shows the age at which 75% or more of children would be expected to achieve a developmental milestone across multiple streams of development. Developmental *screening* involves trained personnel scoring and interpreting a structured developmental screening tool completed by parents (see Chapter 28).

The second essential action of the well-child encounter, **disease prevention**, may include both *primary prevention* activities applied to a whole population and *secondary prevention* activities aimed at patients with specific risk factors. For example, counseling about reducing fat intake is appropriate for all children and families. However, counseling is intensified for overweight and obese youth or in the presence of a family history of hyperlipidemia and its sequelae. The child and adolescent healthcare professional needs to individualize disease prevention strategies to the specific patient, family, and community.

**Health promotion** and **anticipatory guidance** activities distinguish the well-child health supervision visit from all other encounters with the healthcare system. Disease detection and disease prevention activities are germane to all interactions of children with physicians

and other healthcare clinicians, but health promotion and anticipatory guidance shift the focus to wellness and to the strengths of the family (e.g., what is being done well and how this might be improved). This approach is an opportunity to help the family address relationship issues; broach important safety topics; access needed services; and engage with extended family, school, neighborhood, and community and spiritual organizations. This is a prime area for relational health to be conceptually housed in the mind of the skilled clinician.

It is not possible to cover all the topics suggested by comprehensive guidelines such as *Bright Futures* in the average 18-minute well-child visit. Child health professionals must prioritize the most important topics to cover. Consideration should be given to a discussion of the following:

- First and foremost, the agenda the parent or child brings to the health supervision visit.
- The topics where evidence suggests counseling is effective in behavioral change.
- The topics where there is a clear rationale for the issue's critical importance to health, such as sleep environment to prevent sudden unexpected infant death (SUID) or attention to diet and physical activity.
- A summary of the child's progress in emotional, cognitive, and social development; physical growth; and strengths.
- Issues that address the questions, concerns, or specific health problems relevant to the individual family.
- Community-specific problems that could significantly affect the child's health (e.g., neighborhood violence from which children need protection or the absence of bike paths that would promote activity).

### INFANCY AND EARLY CHILDHOOD

Nutrition, physical activity, sleep, safety, and emotional, social, and physical growth, along with parental well-being, are critical for all children. For each well-child visit, there are topics specific to individual children based on their age, family situation, chronic health condition, or a parental concern, such as sleep environment to prevent SUID, activities to promote healthy weight, and fences around swimming pools. Attention should also be focused on the family milieu and other social determinants of health, including screening for parental depression (especially maternal postpartum depression) and other mental illness, family violence, substance abuse, nutritional inadequacy, and lack of housing. It is equally important to identify, acknowledge, and empower family strengths. These issues are essential to the care of young children.

Evidence-based approaches such as early literacy assessment and promotion (e.g., Reach Out and Read) provide a structure for enquiry, surveillance, and parent coaching efficiently within the health supervision visit.

It is important to identify children with developmental disorders as early as possible. Developmental surveillance at every visit combined with a structured developmental screening, neuromuscular screening, and autism screening at certain visits enhances early diagnosis, especially for mild to moderate delays or autism spectrum disorders for which early intervention is believed to be associated with reduced morbidity.

### MIDDLE CHILDHOOD AND ADOLESCENCE

As the child enters school-age years, additional considerations emerge. Attention to their developing autonomy requires fostering a clinician-patient relationship that begins to separate from the clinician-child-family relationship, with increasing needs for privacy and confidentiality as the child ages. As gender awareness develops, supportive and nonjudgmental care that is inclusive of the array of gender identities and sexual orientations found in youth is essential, particularly for LGBTQ+ youth.

The six health behaviors that most significantly affect adolescent and adult morbidity and mortality are inadequate physical activity, poor nutrition, sexuality-related behaviors, substance use and abuse (including tobacco and vaporized nicotine), unintentional injury-related behaviors, and intentional injury-related behaviors. New morbidities related to social media affect all contemporary youth, starting at remarkably young ages. Children are particularly





1. If a child comes under care for the first time at any point on the schedule, or if any items are not accomplished at the suggested age, the schedule should be brought up to date at the earliest possible time.
2. A prenatal visit is recommended for parents who are at high risk, for first-time parents, and for those who request a conference. The prenatal visit should include anticipatory guidance, pertinent medical history, and a discussion of benefits of breastfeeding and planned method of feeding, per "The Prenatal Visit" (<https://doi.org/10.1542/peds.2018-1218>).
3. Newborns should have an evaluation after birth, and breastfeeding should be encouraged (and instruction and support should be offered).
4. Newborns should have an evaluation within 3 to 5 days of birth and within 48 to 72 hours after discharge from the hospital to include evaluation for feeding and jaundice. Breastfeeding newborns should receive formal breastfeeding evaluation, and their mothers should receive encouragement and instruction, as recommended in "Breastfeeding and the Use of Human Milk" (<https://doi.org/10.1542/peds.2011-3552>). Newborns discharged less than 48 hours after delivery must be examined within 48 hours of discharge, per "Hospital Stay for Healthy Term Newborn Infants" (<https://doi.org/10.1542/peds.2015-0699>).
5. Screen, per "Expert Committee Recommendations Regarding the Prevention, Assessment, and Treatment of Child and Adolescent Overweight and Obesity: Summary Report" (<https://doi.org/10.1542/peds.2007-2329C>).
6. Screening should occur per "Clinical Practice Guideline for Screening and Management of High Blood Pressure in Children and Adolescents" (<https://doi.org/10.1542/peds.2017-1904>). Blood pressure measurement in infants and children with specific risk conditions should be performed at visits before age 3 years.
7. A visual acuity screen is recommended at ages 4 and 5 years, as well as in cooperative 3-year-olds. Instrument-based screening may be used to assess risk at ages 12 and 24 months, in addition to the well visits at 3 through 5 years of age. See "Visual System Assessment in Infants, Children, and Young Adults by Pediatricians" (<https://doi.org/10.1542/peds.2015-3596>) and "Procedures for the Evaluation of the Visual System by Pediatricians" (<https://doi.org/10.1542/peds.2015-3597>).
8. Confirm initial screen was completed, verify results, and follow up, as appropriate. Newborns should be screened, per "Year 2007 Position Statement: Principles and Guidelines for Early Hearing Detection and Intervention Programs" (<https://doi.org/10.1542/peds.2007-2333>).
9. Verify results as soon as possible, and follow up, as appropriate.
10. Screen with audiometry including 6,000 and 8,000 Hz high frequencies once between 11 and 14 years, once between 15 and 17 years, and once between 18 and 21 years. See "The Sensitivity of Adolescent Hearing Screens Significantly Improves by Adding High Frequencies" (<https://www.sciencedirect.com/science/article/abs/pii/S1054139X16000483>).
11. Screening should occur per "Incorporating Recognition and Management of Perinatal Depression Into Pediatric Practice" (<https://doi.org/10.1542/peds.2018-3259>).
12. Screening should occur per "Promoting Optimal Development: Identifying Infants and Young Children With Developmental Disorders Through Developmental Surveillance and Screening" (<https://doi.org/10.1542/peds.2019-3449>).
13. Screening should occur per "Identification, Evaluation, and Management of Children With Autism Spectrum Disorder" (<https://doi.org/10.1542/peds.2019-3447>).
14. Screen for behavioral and social-emotional problems per "Promoting Optimal Development: Screening for Behavioral and Emotional Problems" (<https://doi.org/10.1542/peds.2014-3716>), "Mental Health Competencies for Pediatric Practice" (<https://doi.org/10.1542/peds.2019-2757>), "Clinical Practice Guideline for the Assessment and Treatment of Children and Adolescents With Anxiety Disorders" (<https://pubmed.ncbi.nlm.nih.gov/32439401>), and "Screening for Anxiety in Adolescent and Adult Women: A Recommendation From the Women's Preventive Services Initiative" (<https://pubmed.ncbi.nlm.nih.gov/32510990>). The screening should be family centered and may include asking about caregiver emotional and mental health concerns and social determinants of health, racism, poverty, and relational health. See "Poverty and Child Health in the United States" (<https://doi.org/10.1542/peds.2016-0339>), "The Impact of Racism on Child and Adolescent Health" (<https://doi.org/10.1542/peds.2019-1765>), and "Preventing Childhood Toxic Stress: Partnering With Families and Communities to Promote Relational Health" (<https://doi.org/10.1542/peds.2021-052582>).
15. A recommended assessment tool is available at <http://craftt.org>.
16. Screen adolescents for depression and suicide risk, making every effort to preserve confidentiality of the adolescent. See "Guidelines for Adolescent Depression in Primary Care (GLAD-PC): Part I. Practice Preparation, Identification, Assessment, and Initial Management" (<https://doi.org/10.1542/peds.2017-4081>), "Mental Health Competencies for Pediatric Practice" (<https://doi.org/10.1542/peds.2019-2757>), "Suicide and Suicide Attempts in Adolescents" (<https://doi.org/10.1542/peds.2016-1420>), and "The 21st Century Cures Act & Adolescent Confidentiality" ([https://www.adolescenthealth.org/Advocacy/Advocacy-Activities/2019-\(1\)/NASPAG-SAHM-Statement.aspx](https://www.adolescenthealth.org/Advocacy/Advocacy-Activities/2019-(1)/NASPAG-SAHM-Statement.aspx)).
17. At each visit, age-appropriate physical examination is essential, with infant totally unclothed and older children undressed and suitably draped. See "Use of Chaperones During the Physical Examination of the Pediatric Patient" (<https://doi.org/10.1542/peds.2011-0322>).
18. These may be modified, depending on entry point into schedule and individual need.
19. Confirm initial screen was accomplished, verify results, and follow up, as appropriate. The Recommended Uniform Screening Panel (<https://www.hrsa.gov/advisory-committees/heritable-disorders/rusp/index.html>), as determined by The Secretary's Advisory Committee on Heritable Disorders in Newborns and Children, and state newborn screening laws/regulations (<https://www.babysfirsttest.org/>) establish the criteria for and coverage of newborn screening procedures and programs.
20. Verify results as soon as possible, and follow up, as appropriate.
21. Confirm initial screening was accomplished, verify results, and follow up, as appropriate. See "Hyperbilirubinemia in the Newborn Infant  $\geq 35$  Weeks' Gestation: An Update With Clarifications" (<https://doi.org/10.1542/peds.2009-0329>).
22. Screening for critical congenital heart disease using pulse oximetry should be performed in newborns, after 24 hours of age, before discharge from the hospital, per "Endorsing of Health and Human Services Recommendation for Pulse Oximetry Screening for Critical Congenital Heart Disease" (<https://doi.org/10.1542/peds.2011-3211>).
23. Schedules, per the AAP Committee on Infectious Diseases, are available at <https://publications.aap.org/redbook/pages/immunization-schedules>. Every visit should be an opportunity to update and complete a child's immunizations.
24. Perform risk assessment or screening, as appropriate, per recommendations in the current edition of the AAP *Pediatric Nutrition: Policy of the American Academy of Pediatrics* (Iron chapter).
25. For children at risk of lead exposure, see "Prevention of Childhood Lead Toxicity" (<https://doi.org/10.1542/peds.2016-1493>) and "Low Level Lead Exposure Harms Children: A Renewed Call for Primary Prevention" ([https://www.cdc.gov/nceh/lead/docs/final\\_document\\_030712.pdf](https://www.cdc.gov/nceh/lead/docs/final_document_030712.pdf)).
26. Perform risk assessments or screenings as appropriate, based on universal screening requirements for patients with Medicaid or in high prevalence areas.
27. Tuberculosis testing per recommendations of the AAP Committee on Infectious Diseases, published in the current edition of the AAP *Red Book: Report of the Committee on Infectious Diseases*. Testing should be performed on recognition of high-risk factors.
28. See "Integrated Guidelines for Cardiovascular Health and Risk Reduction in Children and Adolescents" ([http://www.nhlbi.nih.gov/guidelines/cvd\\_ped/index.htm](http://www.nhlbi.nih.gov/guidelines/cvd_ped/index.htm)).
29. Adolescents should be screened for sexually transmitted infections (STIs) per recommendations in the current edition of the AAP *Red Book: Report of the Committee on Infectious Diseases*.
30. Screen adolescents for HIV at least once between the ages of 15 and 21, making every effort to preserve confidentiality of the adolescent, as per "Human Immunodeficiency Virus (HIV) Infection: Screening" (<https://www.uspreventiveservicestaskforce.org/uspstf/recommendation/human-immunodeficiency-virus-hiv-infection-screening>); after initial screening, youth at increased risk of HIV infection should be retested annually or more frequently, as per "Adolescents and Young Adults: The Pediatrician's Role in HIV Testing and Pre- and Postexposure HIV Prophylaxis" (<https://doi.org/10.1542/peds.2021-055207>).
31. Perform a risk assessment for hepatitis B virus (HBV) infection according to recommendations per the USPSTF (<https://www.uspreventiveservicestaskforce.org/uspstf/recommendation/hepatitis-b-virus-infection-screening>) and in the 2021–2024 edition of the AAP *Red Book: Report of the Committee on Infectious Diseases*, making every effort to preserve confidentiality of the patient.
32. All individuals should be screened for hepatitis C virus (HCV) infection according to the USPSTF (<https://www.uspreventiveservicestaskforce.org/uspstf/recommendation/hepatitis-c-screening>) and Centers for Disease Control and Prevention (CDC) recommendations (<https://www.cdc.gov/mmwr/volumes/69/rr/rr6902a1.htm>) at least once between the ages of 18 and 79. Those at increased risk of HCV infection, including those who are persons with past or current injection drug use, should be tested for HCV infection and reassessed annually.
33. Perform a risk assessment, as appropriate, per "Sudden Death in the Young: Information for the Primary Care Provider" (<https://doi.org/10.1542/peds.2021-052044>).
34. See USPSTF recommendations (<https://www.uspreventiveservicestaskforce.org/uspstf/recommendation/cervical-cancer-screening>). Indications for pelvic examinations prior to age 21 are noted in "Gynecologic Examination for Adolescents in the Pediatric Office Setting" (<https://doi.org/10.1542/peds.2010-1564>).
35. Assess whether the child has a dental home. If no dental home is identified, perform a risk assessment (<https://www.aap.org/en/patient-care/oral-health/oral-health-practice-tools/>) and refer to a dental home. Recommend brushing with fluoride toothpaste in the proper dosage for age. See "Maintaining and Improving the Oral Health of Young Children" (<https://doi.org/10.1542/peds.2014-2984>).
36. Perform a risk assessment (<https://www.aap.org/en/patient-care/oral-health/oral-health-practice-tools/>). See "Maintaining and Improving the Oral Health of Young Children" (<https://doi.org/10.1542/peds.2014-2984>).
37. The USPSTF recommends that primary care clinicians apply fluoride varnish to the primary teeth of all infants and children starting at the age of primary tooth eruption (<https://www.uspreventiveservicestaskforce.org/uspstf/recommendation/prevention-of-dental-caries-in-children-younger-than-age-5-years-screening-and-interventions1>). Once teeth are present, apply fluoride varnish to all children every 3 to 6 months in the primary care or dental office based on caries risk. Indications for fluoride use are noted in "Fluoride Use in Caries Prevention in the Primary Care Setting" (<https://doi.org/10.1542/peds.2020-034637>).
38. If primary water source is deficient in fluoride, consider oral fluoride supplementation. See "Fluoride Use in Caries Prevention in the Primary Care Setting" (<https://doi.org/10.1542/peds.2020-034637>).

Fig. 13.1 cont'd

**Table 13.1** Developmental Milestones Across Streams of Development

AGE	STREAMS OF DEVELOPMENT			
	LANGUAGE	COGNITIVE	MOTOR	SOCIAL EMOTIONAL
2 mo	<ul style="list-style-type: none"> <li>Makes sounds other than crying</li> <li>Reacts to loud sounds</li> </ul>	<ul style="list-style-type: none"> <li>Watches you as you move</li> <li>Looks at a toy for several seconds</li> </ul>	<ul style="list-style-type: none"> <li>Holds head up when on tummy</li> <li>Opens hands briefly</li> </ul>	<ul style="list-style-type: none"> <li>Calms when spoken to or picked up</li> <li>Looks at face</li> <li>Seems happy to see parent</li> <li>Smiles when parent talks to them</li> </ul>
4 mo	<ul style="list-style-type: none"> <li>Makes cooing sounds</li> <li>Makes sounds back when talked to</li> <li>Turns head towards sound of parent's voice</li> </ul>	<ul style="list-style-type: none"> <li>If hungry, opens mouth when sees breast or bottle</li> <li>Looks at hands with interest</li> </ul>	<ul style="list-style-type: none"> <li>Holds head steady without support when being held</li> <li>Uses arms to swing at toys</li> <li>Brings hands to mouth</li> <li>Pushes up onto elbows/forearms when on tummy</li> </ul>	<ul style="list-style-type: none"> <li>Smiles to get parent's attention</li> <li>Chuckles responsively</li> <li>Attempts to get parent's attention using eye contact, movement, or sounds</li> </ul>
6 mo	<ul style="list-style-type: none"> <li>Takes turns making sounds</li> <li>Sticks tongue out and blows (e.g., raspberries)</li> <li>Makes squealing noises</li> </ul>	<ul style="list-style-type: none"> <li>Puts things in mouth to explore them</li> <li>Reaches to grab a toy</li> <li>Closes lips when does not want more food</li> </ul>	<ul style="list-style-type: none"> <li>Rolls from tummy to back</li> <li>Pushes up with straight arms when on tummy</li> <li>Leans on hands for support when sitting</li> </ul>	<ul style="list-style-type: none"> <li>Knows familiar people</li> <li>Likes to look at self in a mirror</li> <li>Laughs</li> </ul>
9 mo	<ul style="list-style-type: none"> <li>Makes babbling sounds</li> <li>Lifts arms up to be picked up</li> </ul>	<ul style="list-style-type: none"> <li>Looks for objects when dropped out of sight</li> <li>Bangs 2 things together</li> </ul>	<ul style="list-style-type: none"> <li>Gets to a sitting position on one's own</li> <li>Transfers things between hands</li> <li>Uses fingers to "rake" food</li> <li>Sits without support</li> </ul>	<ul style="list-style-type: none"> <li>Is shy or clingy around strangers</li> <li>Makes several facial expressions like happy, sad, angry, or surprised</li> <li>Looks when you call name</li> <li>Smiles or laughs when playing peek-a-boo</li> </ul>
12 mo	<ul style="list-style-type: none"> <li>Waves "bye-bye"</li> <li>Has name for parent such as "mama" or "dada"</li> <li>Understands "no" (not just tone of voice)</li> </ul>	<ul style="list-style-type: none"> <li>Puts something in a container, like a block in a cup</li> <li>Looks for things they see you hide</li> </ul>	<ul style="list-style-type: none"> <li>Pulls up to stand</li> <li>Walks holding on to furniture</li> <li>Drinks from a cup without a lid as parent holds it</li> <li>Picks things up between thumb and pointer finger</li> </ul>	<ul style="list-style-type: none"> <li>Plays games with parent, like pat-a-cake</li> </ul>
15 mo	<ul style="list-style-type: none"> <li>Approximates saying 1 or 2 words besides "mama" or "dada"</li> <li>Looks at a familiar object when named</li> <li>Follows directions given with gesture</li> <li>Points to request object or help (e.g., proto-imperative pointing)</li> </ul>	<ul style="list-style-type: none"> <li>Tries to use things the right way, like a phone, cup, or book</li> <li>Stacks at least 2 small objects, like blocks</li> </ul>	<ul style="list-style-type: none"> <li>Takes a few steps on own</li> <li>Able to finger feed</li> </ul>	<ul style="list-style-type: none"> <li>Copies other children playing</li> <li>Shows parent an object they like</li> <li>Claps when excited</li> <li>Hugs stuffed doll or other toy</li> <li>Shows parent affection</li> </ul>
18 mo	<ul style="list-style-type: none"> <li>Says 3 or more words besides "mama" or "dada"</li> <li>Follows 1-step directions without a gesture</li> <li>Points to show interest (e.g., proto-declarative pointing)</li> </ul>	<ul style="list-style-type: none"> <li>Copies parent doing chores</li> <li>Plays with toys in a simple way, like pushing a toy car</li> </ul>	<ul style="list-style-type: none"> <li>Walks on own</li> <li>Scribbles</li> <li>Drinks from a cup without a lid, may spill sometimes</li> <li>Tries to use a spoon</li> <li>Climbs on and off a couch or chair without help</li> </ul>	<ul style="list-style-type: none"> <li>Checks in when moving away from parent</li> <li>Puts hands out to be washed</li> <li>Looks at a book with parent</li> <li>Helps with dressing by pushing arm through sleeve or lifting up foot</li> </ul>
2 yr	<ul style="list-style-type: none"> <li>Points to pictures in book on request</li> <li>Says at least 2 words together (e.g., more milk)</li> <li>Points to 2 or more body parts on request</li> <li>Uses more gestures than just waving and pointing (e.g., blowing a kiss, nodding yes)</li> </ul>	<ul style="list-style-type: none"> <li>Holds something while using the other hand (e.g., holding container and taking lid off)</li> <li>Tries to use knobs, switches, or buttons on toys</li> <li>Plays with more than 1 toy at the same time (e.g., putting toy food on toy plate)</li> </ul>	<ul style="list-style-type: none"> <li>Kicks a ball</li> <li>Runs</li> <li>Walks (not climbs) up a few stairs with or without help</li> <li>Eats with a spoon</li> </ul>	<ul style="list-style-type: none"> <li>Notices when others are hurt or upset, like pausing or looking sad when someone is crying</li> <li>Looks at parent's face to see how to react in a new situation</li> </ul>
2½ yr	<ul style="list-style-type: none"> <li>Says about 50 words</li> <li>Says 2 or more words, with 1 action word (e.g., doggie run)</li> <li>Names things in a book when you point and ask, "What is this?"</li> <li>Says words like "I," "me," or "we"</li> </ul>	<ul style="list-style-type: none"> <li>Engages in pretend play</li> <li>Shows simple problem-solving skills (e.g., using a stool to reach something)</li> <li>Follows 2-step instructions</li> <li>Knows at least 1 color</li> </ul>	<ul style="list-style-type: none"> <li>Uses hands to twist things (e.g., turning doorknobs or lids)</li> <li>Takes off some clothes on own</li> <li>Jumps off the ground with both feet</li> <li>Turns book pages, 1 at a time, when read to</li> </ul>	<ul style="list-style-type: none"> <li>Plays next to other children and at times with them</li> <li>Shows what he or she can do by saying, "Look at me!"</li> <li>Follows simple routines when told (e.g., clean-up time)</li> </ul>

Table 13.1		Developmental Milestones Across Streams of Development—cont’d			
AGE	STREAMS OF DEVELOPMENT				
3 yr	<ul style="list-style-type: none"> <li>Has conversation using at least 2 back-and-forth exchanges</li> <li>Asks “who,” “what,” “where,” or “why” questions</li> <li>Says what action is happening in a picture or book (e.g., running, eating)</li> <li>Says first name when asked</li> <li>Talks well enough for others to understand most of the time</li> </ul>	<ul style="list-style-type: none"> <li>Imitates drawing a circle</li> <li>Avoids touching hot objects, like a stove, when warned</li> </ul>	<ul style="list-style-type: none"> <li>Strings items together, like large beads or macaroni</li> <li>Puts on some clothes on own</li> <li>Uses a fork</li> </ul>	<ul style="list-style-type: none"> <li>Calms down within 10 min after parent leaves (e.g., at childcare drop-off)</li> <li>Notifies other children and joins them to play</li> </ul>	
4 yr	<ul style="list-style-type: none"> <li>Says sentences with 4 or more words</li> <li>Talks about at least 1 thing that happened during the day</li> <li>Answers simple questions (e.g., what is a coat for?)</li> </ul>	<ul style="list-style-type: none"> <li>Names a few colors</li> <li>Tells what comes next in a well-known story</li> <li>Draws a person with 3 or more body parts</li> </ul>	<ul style="list-style-type: none"> <li>Catches a large ball most of the time</li> <li>Serves themselves food or pours water, with adult supervision</li> <li>Unbuttons some buttons</li> <li>Holds crayon or pencil between fingers and thumb (not a fist)</li> </ul>	<ul style="list-style-type: none"> <li>Pretends to be something else during play (e.g., teacher, dog)</li> <li>Asks to play with children</li> <li>Comforts others who are hurt or sad</li> <li>Likes to be a “helper”</li> <li>Changes behavior based on location (e.g., library, playground)</li> </ul>	
5 yr	<ul style="list-style-type: none"> <li>Tells a story they heard or made up with at least 2 events</li> <li>Answers simple questions about a book or story</li> <li>Keeps a conversation going with more than 3 back-and-forth exchanges</li> <li>Uses or recognizes simple rhymes (e.g., bat-cat, ball-tall)</li> </ul>	<ul style="list-style-type: none"> <li>Counts to 10</li> <li>Names some numbers between 1 and 5 when you point to them</li> <li>Uses words about time, like yesterday, tomorrow, morning, or night</li> <li>Pays attention for 5 to 10 min during activities</li> <li>Writes some letters in name</li> <li>Names some letters when they are pointed to</li> </ul>	<ul style="list-style-type: none"> <li>Buttons some buttons</li> <li>Hops on 1 foot</li> </ul>	<ul style="list-style-type: none"> <li>Follows rules or takes turns when playing games with other children</li> <li>Sings, dances, or acts</li> <li>Does simple chores at home</li> </ul>	

Adapted from Centers for Disease Control Developmental Milestones: <https://www.cdc.gov/ncbddd/actearly/milestones/index.html>. Accessed March 19, 2022.

vulnerable to advertising of unhealthy products and behaviors because of immature skills in critical thinking and impulse control. Emotional well-being and early diagnosis and treatment of mental health problems are crucially important, with attention to the developmental tasks of adolescence: competence at school and other activities, connection to friends and family, autonomy, empathy, and a sense of self-worth.

**Children and Youth with Special Healthcare Needs**

This set of frameworks must be directed at *all children*, including children and youth with special healthcare needs (CYSHCN). CYSHCN are no different from other children in their need for guidance about healthy nutrition, physical activity, progress in school, connection with friends, a healthy sense of self-efficacy, and avoidance of risk-taking behaviors. The existence of frequent visits to the medical home or specialists to address the special health needs sometimes masks the lack of general health supervision care. The coordination of specialty consultation, medication monitoring, and functional assessment, which should occur in their periodic visits, needs to be balanced with a discussion of the child’s unique ways of accomplishing the emotional, social, and developmental tasks of childhood and adolescence. Comprehensive, integrated care planning for CYSHCN should support partnerships between family-centered medical homes and families and youth through goal setting and negotiating next steps. In this process,

chronic condition management and health surveillance (including adolescent engagement and planning for transition to adult care) occur within an effective patient care relationship, partnering to improve health outcomes and efficiencies of current and future care provision.

**OFFICE INTERVENTION FOR BEHAVIORAL AND MENTAL HEALTH ISSUES**

One fifth of primary care encounters with children are for a behavioral or mental health problem or sickness visits complicated by a mental health issue. Pediatricians and other primary care clinicians seeing children must have reasonable comfort with and knowledge for diagnosis, treatment, and referral criteria for attention-deficit/hyperactivity disorder (see Chapter 50), depression and other mood disorders (see Chapter 39), anxiety (see Chapter 38), and conduct disorder (see Chapter 42), as well as an understanding of the pharmacology of the frequently prescribed psychotropic medications. Familiarity with available local mental health services and clinicians and knowledge of the types of services indicated are important for effective consultation or referral. With new understanding of the impact of lifestyle on mood disorders and anxiety, encouragement of behavioral change to implement regular exercise, a healthy diet, avoidance of substances, and judicious use of media has become an important responsibility of the primary care clinician. **Motivational interviewing** (see Chapter 18) provides a structured approach that has been designed to help patients and parents identify the discrepancy between their desire for health and



the outcomes of their current behavioral choices. It also allows the clinician to use proven strategies that lead to a patient-initiated plan for change.

### Strength-Based Approaches and Framework

Questions about school or extracurricular accomplishments or competent personal characteristics should be integrated into the content of the well child visit. Such inquiries set a positive context for the visit, deepen the partnership with the family, acknowledge the child's healthy development, and facilitate discussing social-emotional development with children and their parents. There is a strong relationship between appropriate social-emotional development (e.g., children's strong connection to their family, social friends, and mentors; competence; empathy; appropriate autonomy) and decreased participation in all the risk behaviors of adolescence (related to drugs, sex, and violence). An organized approach to the identification and encouragement of a child's strengths during health supervision visits provides both the child and the parent with an understanding of how to promote healthy achievement of the developmental tasks of childhood and adolescence. It also provides an opportunity to assess and comment on the relational health in the family. CYSHCN often have a different timetable, but they have an equal need to be encouraged to develop strong family and peer connections, competence in a variety of arenas, ways to do things for others, and appropriate independent decision-making.

### Family Support Programs

Family support can range from the informal, to the highly formalized, to the referral to other agencies. Informal supports can be incorporated easily into existing assessment or anticipatory guidance. More formalized programs incorporate clinician and clinic staff training and guidance for the family while still operating within the existing framework of the well-child visit, such as Reach Out and Read. Even more structured are programs such as HealthySteps or Video Interaction Project, which address deeper needs for support through additional personnel and time. Finally, agencies external to the medical home, like evidence-based home visiting, can offer even greater intensity or flexibility of service.

This continuum of offerings allows a clinician to “tune” the intensity of services to meet the needs of a family while maintaining the support and connection of the medical home in the face of the reality of families who have needs far beyond what can be addressed immediately. Family support programs should be selected and offered based on available evidence and strong elements of reproducibility, scalability, and clarity. Advocacy for funding for family support programs is also imperative.

### Office System Change for Quality Improvement

To facilitate the effective delivery of preventive services for children and youth, screening schedules and parent handouts, flow sheets, registries, and parent and youth previsit questionnaires are available in *The Bright Futures Guidelines Toolkit*. These efforts are part of a larger national effort that is built on a coordinated team approach in the office setting and the use of continuous measurement for improvement.

## EVIDENCE

Available evidence should be used in developing health-promotion and disease-detection recommendations. Revisions to the AAP Periodicity Schedule undergo rigorous evidence assessment; however, many highly valued well-child care activities have not been evaluated for efficacy. Lack of evidence is most often related to absence of systematic study and does not necessarily mean lack of benefit. Thus the clinical encounter with the well child is also guideline and recommendation driven and requires the integration of clinician goals, family needs, and community realities in seeking better health for the child. The evidence and rationale for recommendations in the Periodicity Schedule (see Fig. 13.1) and *Bright Futures Guidelines* regarding well-child care activities are a balance of evidence from research, clinical practice guidelines, professional recommendations, expert opinion, experience, and knowledge of the needs of the patient

population in the context of community assets and challenges. Clinical or counseling decisions and recommendations may also be based on local legislation (e.g., seat belts), on commonsense measures not likely to be studied experimentally (e.g., lowering water heater temperatures, use of car seats), or on the basis of relational evidence (e.g., television watching associated with violent behavior in young children). Most importantly, sound clinical and counseling decisions are responsive to family needs and desires and support patient-centered decision-making.

## CARING FOR THE CHILD AND YOUTH IN THE CONTEXT OF THE FAMILY AND COMMUNITY

A successful primary care practice for children incorporates families, is family centered, and embraces the concept of the medical home. To be considered a **medical home**, a primary care practice must certify that their care is accessible, continuous, comprehensive, family centered, coordinated, compassionate, and culturally effective. In a medical home, a clinician works in partnership with the family and patient to ensure that all medical and nonmedical needs of the child are met. Through this partnership, the child healthcare professional helps the family/patient access and coordinate specialty care, educational services, out-of-home care, family support, and other public and private community services that are important to the overall health of the child and family.

Health promotion activities occur not only in the medical home but also through community members and other health and education professionals. To be most effective, communication and coordination around providing accurate, consistent information is key, with a clear understanding of the important role that the community plays in supporting healthy behaviors among families. Communities where children and families feel safe and valued and have access to positive activities and relationships provide the important base that the healthcare professional can build on and refer to for needed services that support health but are outside the realm of the healthcare system or primary care medical home. It is important for the medical home and community agencies to identify mutual resources, communicate well with families and each other, and partner in designing service delivery systems. This interaction is the practice of **community pediatrics**, whose unique feature is its concern for all the population: those who remain well but need preventive services, those who have symptoms but do not receive effective care, and those who do seek medical care in a physician's office or hospital.

Contemporary and future health supervision of children and adolescents must evolve to improve the delivery of this comprehensive care, which is critical to the healthy development of every child, their family, and their community. Relevant practice models for delivery of health supervision care will continue to evolve to provide comprehensive care and partnership with medical and community services to serve their patients and families. Such models will appropriately broaden the sphere of primary care pediatrics and foster partnerships in community care. Pediatric clinicians should also advocate not only for individual patients but also for system change for the betterment of this and future generations.

Health reform is key to this work to assure that an evidence-based, comprehensive system of health supervision is supported. Payment modalities might vary, but payment must recognize that the work of healthcare and the essential work of those providing preventive care to children is poorly recognized, supported, and remunerated by most existing payment systems. The success of accountable care organizations and any other current or future healthcare system can and should require strengthening and broadening primary care preventive services. This reform must acknowledge and embrace the already existing reality that preventive care is so much more than merely height, weight, and immunizations.

Visit Elsevier eBooks+ at [eBooks.Health.Elsevier.com](http://eBooks.Health.Elsevier.com) for Bibliography.

## Chapter 14

## Injury Control

Brian D. Johnston and Sadiqa Kendi

In all high-income countries of the world, and increasingly in many low- and middle-income countries, injuries are the most common cause of death during childhood and adolescence beyond the first few months of life (Table 14.1 and Fig. 14.1). Injuries represent one of the most important causes of preventable pediatric morbidity and mortality in the United States. Identification of risk factors for injuries has led to the development of successful programs for prevention and control. Strategies for injury prevention and control should be pursued by the pediatrician in the office, emergency department (ED), hospital, and community setting.

Injuries have identifiable risk and protective factors that can be used to define prevention strategies. The term *accident* implies a chance event occurring without pattern or predictability. In fact, most injuries occur under predictable circumstances to children and families known to be at risk. *Most injuries are preventable.*

Reduction of morbidity and mortality from injuries can be accomplished not only through *primary* prevention (averting the event or injury) but also through *secondary* and *tertiary* prevention. The latter two approaches include appropriate **emergency medical services** (EMS) for injured children; **regionalized trauma care** for the child with multiple injuries, severe burns, or traumatic brain injury; and **specialized pediatric rehabilitation** services to optimize functional recovery after injury.

Injury control also encompasses *intentional injuries* (assaults and self-inflicted injuries). These injuries are important in adolescents and young adults, and in some populations, these rank first or second as causes of death in these age-groups. Many of the same principles of injury control can be applied to these problems; for example, limiting access to firearms may reduce unintentional shootings and also homicides and suicides.

## SCOPE OF THE PROBLEM

### Mortality

In the United States, injuries cause 41% of deaths among 1- to 4-year-old children and 3.2 times more deaths than the next leading cause, congenital anomalies. For the rest of childhood and adolescence up to age 19 years, 65% of deaths are a result of injuries, more than all other causes combined. In 2019, injuries caused 13,384 deaths (16.4 deaths per 100,000 population) among individuals  $\leq 19$  years old in the United States, resulting in more years of potential life lost than any other cause. **Unintentional injuries** remained the leading cause of death among those  $< 24$  years old in 2019 (see Table 14.1).

**Motor vehicle injuries** lead the list of injury deaths among school-age children and adolescents and are the second leading cause of injury death for those age 1-4 years. In children and adults, motor vehicle *occupant* injuries account for most of these deaths. During adolescence, occupant injuries are the leading cause of injury death, accounting for  $> 50\%$  of unintentional trauma mortality in this age-group.

**Drowning** ranks second overall as a cause of unintentional injury deaths among those age 1-19 years, with peaks in the preschool and later teenage years (see Chapter 88). In some areas of the United States, drowning is the leading cause of injury death for preschool-age children. The causes of drowning deaths vary with age and geographic area. In young children, bathtub and swimming pool drowning predominates, whereas in older children and adolescents, drowning occurs in natural bodies of water while swimming or boating.

**Fire- and burn-related deaths** account for 3% of all unintentional trauma deaths, with the highest rates among those  $< 5$  years of age (see Chapter 89). Most deaths are a result of house fires and are caused by

smoke inhalation or asphyxiation rather than severe burns. Children and elderly persons are at greatest risk for these deaths when they cannot independently escape from burning buildings.

**Suffocation** represents approximately 87% of all unintentional deaths in children  $< 1$  year old. Some cases result from choking on food items, such as hot dogs, candy, grapes, and nuts. Nonfood items that can cause choking include undersized infant pacifiers, small balls, and latex balloons. An increasing number of infant suffocation deaths represent sleep-related mortality in the presence of unsafe bedding or crib bumpers, or when co-sleeping with an impaired adult. In previous years these might have been classified as sudden infant death syndrome (see Chapter 423).

**Homicide** is the third leading cause of injury death in children 1-4 years old and in adolescents (15-19 years old) (Fig. 14.2). Homicide in the pediatric age-group falls into two patterns: infant (child) and adolescent. Child homicide involves children  $< 5$  years old and represents child abuse (see Chapter 17). The perpetrator is usually a caretaker; death is generally the result of blunt trauma to the head and/or abdomen. The adolescent pattern of homicide involves peers and acquaintances and is caused by firearms in 77.6% of cases. The majority of these deaths involve handguns. Children between these two age-groups experience homicides of both types.

**Suicide** is rare in children  $< 10$  years old; however, the rate increases greatly after age 10 years, with the result that suicide is now the second leading cause of death for 10- to 19-year-olds. Approximately 50.6% of teenage suicides involve firearms (see Chapter 40).

There has been a sharp and substantial increase in unintentional **poisoning** deaths among teens and young adults. In 2019, unintentional poisonings were the second leading cause of injury deaths among 15- to 24-year-olds. Many of these were from prescription analgesic and opioid medications such as fentanyl.

### Nonfatal Injuries

Most childhood injuries do not result in death. Approximately 12% of children and adolescents receive medical care for an injury each year in hospital EDs, and at least as many are treated in physicians' offices. Of these, 2% require inpatient care, and 55% have at least short-term disability because of their injuries.

The distribution of nonfatal injuries is very different from that of fatal trauma (Fig. 14.3). **Falls** are the leading cause of both ED visits and hospitalizations. **Bicycle-related trauma** is the most common type of sports and recreational injury, accounting for approximately 300,000 ED visits annually. **Nonfatal injuries** may be associated with severe morbidity such as anoxic encephalopathy from near-drowning, scarring and disfigurement from burns, and persistent neurologic deficits from head injury, leading to substantial changes in the quality of life for victims and their families. In 2010, nonfatal injuries to U.S. children  $< 19$  years old resulted in  $> \$32$  billion in direct medical and lifetime work-loss costs.

### Global Child Injuries

Child injuries are a global public health issue, and prevention efforts are necessary in low-, middle-, and high-income countries. Between 1990 and 2010 there was a 53% decrease in mortality of people of all ages from communicable, maternal, neonatal, and nutritional disorders, whereas injury mortality decreased by only 16% (Fig. 14.4).

Worldwide, almost 1 million children and adolescents die from injuries and violence each year, and  $> 90\%$  of these deaths are in low- and middle-income countries. As child mortality undergoes an epidemiologic transition because of better control of infectious diseases and malnutrition, injury increasingly becomes a leading cause of death for children in the developing world, as it now is in all industrialized countries. Drowning is the fifth most common cause of death for 5- to 9-year-old children globally, and in some countries, such as Bangladesh, it is the leading cause of death among children 1-4 years old, with a rate over 50 times greater than that in the United States.

An estimated 1 billion people do not currently have immediate access to roads; as industrialization and motorization spread, the incidence of motor vehicle crashes, injuries, and fatalities will climb.

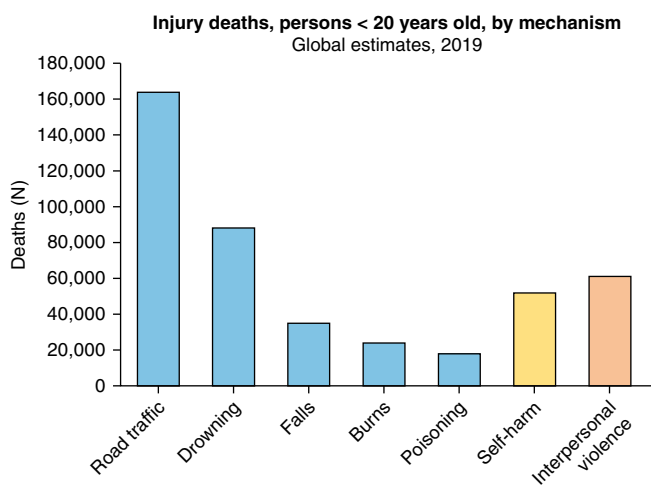
**Table 14.1** Injury Deaths in the United States, 2019 (N [rate per 100,000])

CAUSE OF DEATH	<1 YEAR	1-4 YEARS	5-9 YEARS	10-14 YEARS	15-19 YEARS	0-19 YEARS
All causes	20,921 (553.0)	3,676 (23.3)	2,333 (11.6)	3,164 (15.2)	10,258 (48.7)	40,352 (49.4)
All injuries	1,645 (43.48)	1,494 (9.46)	915 (4.53)	1,536 (7.39)	7,794 (37.02)	13,384 (16.40)
All unintentional	1,266 (33.47)	1,149 (7.28)	714 (3.54)	778 (3.74)	3,537 (16.80)	7,444 (9.12)
Motor vehicle occupant	16 (0.42)	67 (0.42)	91 (0.45)	106 (0.51)	654 (3.11)	934 (1.14)
Pedestrian	7 (0.19)	158 (1.00)	78 (0.39)	94 (0.45)	225 (1.07)	562 (0.69)
Drowning	34 (0.90)	378 (2.39)	133 (0.66)	100 (0.48)	216 (1.03)	861 (1.05)
Fire and burn	8 (0.21)	76 (0.48)	71 (0.35)	40 (0.19)	35 (0.17)	230 (0.28)
Poisoning	14 (0.37)	27 (0.17)	12 (0.06)	21 (0.10)	692 (3.29)	766 (0.94)
Pedal cyclist	0 (0.00)	4 (0.03)	13 (0.06)	26 (0.13)	53 (0.25)	96 (0.12)
Firearm	2 (0.05)	24 (0.15)	9 (0.04)	16 (0.08)	66 (0.31)	117 (0.14)
Fall	7 (0.19)	23 (0.15)	14 (0.07)	14 (0.07)	55 (0.26)	113 (0.14)
Suffocation	1,095 (28.94)	139 (0.88)	33 (0.16)	28 (0.13)	40 (0.19)	1,335 (1.64)
All intentional	263 (6.95)	284 (1.80)	167 (0.83)	725 (3.49)	4,123 (19.58)	562 (6.81)
Suicide	0 (0.00)	0 (0.00)	12 (0.06)	534 (2.57)	2,210 (10.50)	2,756 (3.38)
Firearm suicide	0 (0.00)	0 (0.00)	0 (0.00)	172 (0.83)	995 (4.73)	1,167 (1.43)
Homicide	263 (6.95)	284 (1.80)	155 (0.77)	191 (0.92)	1,877 (8.91)	2,770 (3.39)
Firearm homicide	10 (0.26)	47 (0.30)	68 (0.34)	144 (0.69)	1,754 (8.33)	2,023 (2.48)
Undetermined intent	116 (3.07)	61 (0.39)	34 (0.17)	33 (0.16)	134 (0.64)	378 (0.46)

Injury data from Centers for Disease Control and Prevention (CDC): Web-based Injury Statistics Query and Reporting System (WISQARS) (website). National Center for Injury Prevention and Control, CDC (producer). <https://www.cdc.gov/injury/wisqars/>.

All cause mortality data from Centers for Disease Control and Prevention, National Center for Health Statistics.

Underlying Cause of Death 1999-2019 on CDC WONDER Online Database, released in 2020. Data are from the Multiple Cause of Death Files, 1999-2019, as compiled from data provided by the 57 vital statistics jurisdictions through the Vital Statistics Cooperative Program. <http://wonder.cdc.gov/ucd-icd10.html>. Accessed June 4, 2021.



**Fig. 14.1** Global injury deaths, persons <20 years old, by mechanism, in 2019. (From Global Burden of Disease Collaborative Network, *Global Burden of Disease Study 2019 [GBD 2019] Results*. Seattle, United States: Institute for Health Metrics and Evaluation [IHME], 2020. Available from <http://ghdx.healthdata.org/gbd-results-tool>.)

The rate of child injury death in low- and middle-income countries is threefold higher than that in high-income countries and reflects both a higher incidence of many types of injuries and a much higher case fatality rate in those injured because of a lack of access to emergency and surgical care. As in high-income countries, prevention of

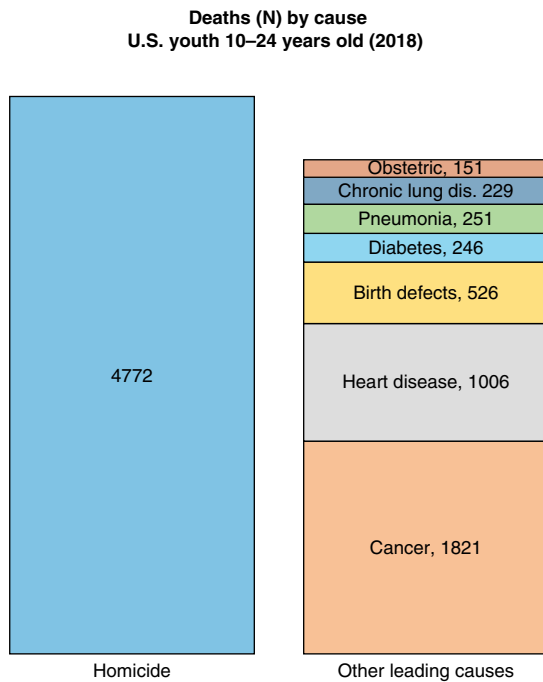
child injuries and consequent morbidity and mortality is feasible with multifaceted approaches, many of which are low cost and of proven effectiveness.

## PRINCIPLES OF INJURY CONTROL

Injury prevention once centered on attempts to pinpoint the innate characteristics of a child that result in greater frequency of injury. Most now discount the theory of the “accident-prone child.” For example, although longitudinal studies have demonstrated an association between attention-deficit/hyperactivity disorder (ADHD; see [Chapter 50](#)) and increased rates of injury, the sensitivity and specificity of these traits as a test to identify individuals at high risk for injury are extremely low. The concept of *accident proneness* is counterproductive in that it shifts attention away from more modifiable factors, such as product design or the built environment. It is more appropriate to examine the physical and social environment of children with frequent rates of injury than to try to identify personality traits or temperaments, which are difficult to modify.

Efforts to control injuries include education or persuasion, changes in product design, and modification of the social and physical environment. Efforts to persuade individuals, particularly parents, to change their behaviors have constituted the greater part of injury control efforts. Speaking with parents specifically about using child car seat restraints and bicycle helmets, installing smoke detectors, and checking the tap water temperature is likely to be more successful than offering well-meaning but too-general advice about supervising the child closely, being careful, and childproofing the home. This **information should be geared to the developmental stage of the child and presented in moderate doses in the form of anticipatory guidance** at well-child visits. [Table 14.2](#) lists topics to discuss at each developmental

stage. It is important to acknowledge that there are many barriers to prevention adherence beyond simple knowledge acquisition; pediatricians should be familiar with low-cost sources for safety equipment such as bicycle helmets, smoke detectors, trigger locks, and car seats in their community.



**Fig. 14.2** Chart showing third leading cause of death (homicide) among persons aged 10–24 years compared with fourth through tenth leading causes of death in the same age-group in the United States in 2018. Does not include the two leading causes of death among persons aged 10–24 years in 2018: unintentional injuries (12,736 deaths) and suicide (6,807). (Data from Centers for Disease Control and Prevention, National Center for Injury Prevention and Control. ([https://www.cdc.gov/injury/wisqars/LeadingCauses\\_images.html](https://www.cdc.gov/injury/wisqars/LeadingCauses_images.html)). Accessed July 12, 2021.)

The most successful injury prevention strategies generally are those involving **changes in product design**. These passive interventions protect all individuals in the population, regardless of cooperation or level of skill, and are likely to be more successful than measures that require repeated behavioral actions by the parent or child. The most important and effective product changes have been in motor vehicles, in which protection of the passenger compartment, use of airbags, and development of crash avoidance and driving support technologies have had large effects on injury risk. Reducing the factory-set water heater temperature, installing smoke detectors, and using child-resistant caps on medicines and household products are other examples of effective product modifications. Many interventions require both active and passive measures: smoke detectors provide passive protection when fully functional, but behavior change is required to ensure periodic battery changes and proper testing.

**Modification of the environment** often requires greater changes than individual product modification but may be very effective in reducing injuries. Safe roadway design, decreased traffic volume and speed limits in neighborhoods, and elimination or safe storage of guns in households are examples of such interventions. Included in this concept are changes in the social environment through legislation, such as laws mandating child seat restraint and seatbelt use, zero-tolerance laws for alcohol-impaired driving, and graduated driver's licensing laws.

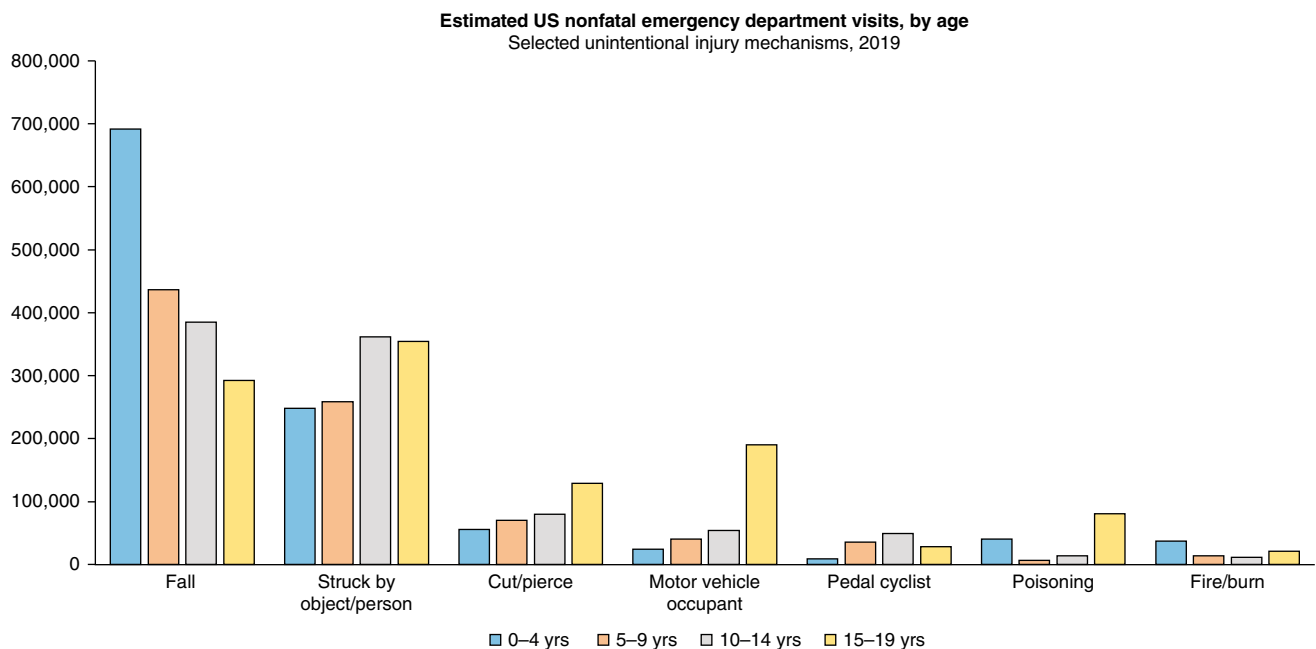
Prevention campaigns combining two or more of these approaches have been particularly effective in reducing injuries. The classic example is the combination of legislation and education to increase child seat restraint and seatbelt use; other examples are programs to promote bike helmet use among school-aged children and improvements in occupant protection in motor vehicles.

### RISK FACTORS FOR CHILDHOOD INJURIES

Major factors associated with an increased risk of injuries to children include age, sex, socioeconomic status, rural-urban location, and the environment.

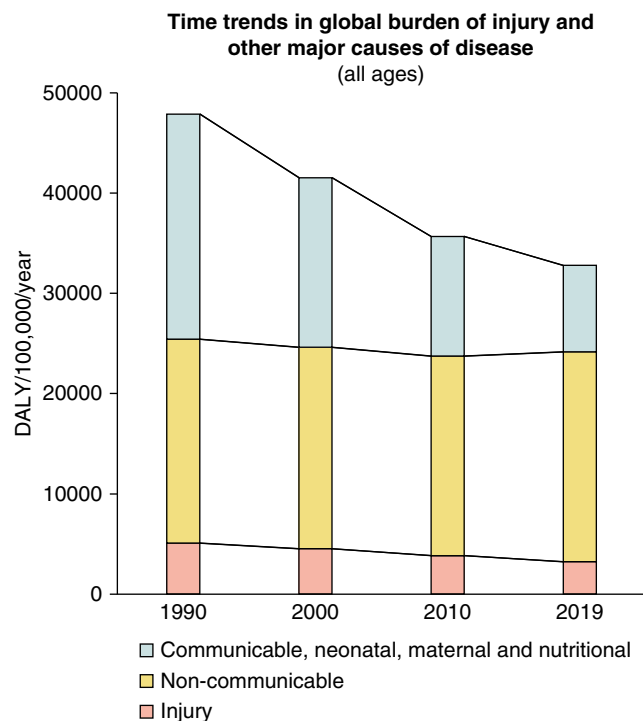
#### Age

Infants are especially vulnerable to sleep-related suffocation and to abusive head trauma. Toddlers are at the greatest risk for burns, drowning, and falling. Poisonings become another risk as these



**Fig. 14.3** Estimated U.S. nonfatal emergency department visits, by age for selected unintentional injury mechanisms, 2019. (Injury data from Centers for Disease Control and Prevention [CDC]. Web-based Injury Statistics Query and Reporting System (WISQARS) (website); National Center for Injury Prevention and Control, CDC (producer). <https://www.cdc.gov/injury/wisqars/nonfatal.html>. Accessed July 12, 2021.)





**Fig. 14.4** Rates of disability-adjusted life-years (DALYs) lost per 100,000 per year by major grouping of cause. (Data from Institute for Health Metrics and Evaluation; GBD data visualization site, <https://vizhub.healthdata.org/gbd-compare/>. Accessed July 14, 2021.)

children acquire mobility and exploratory behavior. Young school-age children are at greatest risk for pedestrian injuries, bicycle-related injuries (the most serious of which usually involve motor vehicles), motor vehicle occupant injuries, burns, and drowning. During the teen years, there is a greatly increased risk from motor vehicle occupant trauma, a continued risk from drowning and burns, and the new risk of intentional trauma. Sports- and recreation-related injuries, including concussion, become more common, and more serious, as children age. Work-related injuries associated with child labor, especially for 14- to 16-year-olds, are an additional risk.

Injuries occurring at a particular age represent a period of vulnerability during which a child or an adolescent encounters a new task or hazard that they may not have developed the cognitive, socio-emotional, or physical skills to handle successfully. Toddlers do not have the judgment to know that medications can be poisonous or that some houseplants are not to be eaten; they do not understand the hazard presented by a swimming pool or an open second-story window. For young children, parents may inadvertently set up this mismatch between the skills of the child and the demands of the task. Many parents expect young school-age children to walk home from school, the playground, or the local convenience store, tasks for which most children are not developmentally ready. Likewise, the lack of skills and experience to handle many tasks during the teenage years contributes to an increased risk of injuries, particularly motor vehicle injuries. The high rate of motor vehicle crashes among 15- to 17-year-olds is caused primarily by inexperience, but also reflects their level of cognitive development and emotional maturity. Alcohol, other drugs, and distraction from mobile phone use substantially add to these limitations.

Age also influences the severity of injury and the risk of long-term disability. Young school-age children have an incompletely developed pelvis. In a motor vehicle crash, a seatbelt does not anchor onto the pelvis but rides up onto the abdomen, resulting in the risk of serious abdominal injury. Proper restraint for 4- to 8-year-old children requires the use of booster seats. Children <2 years old have much poorer outcomes from traumatic brain injuries than older children

**Table 14.2** Injury Prevention Topics for Anticipatory Guidance by the Pediatrician

#### NEWBORN

- Car seats
- Tap water temperature
- Smoke detectors
- Sleep safety

#### INFANT

- Car seats
- Tap water temperature
- Bath safety
- Choking prevention

#### TODDLER AND PRESCHOOLER

- Car seats and booster seats
- Water safety
- Poison prevention
- Fall prevention

#### PRIMARY SCHOOL CHILD

- Pedestrian skills training
- Water skills training
- Booster seats and seat belts
- Bicycle and sports helmets

#### MIDDLE SCHOOL CHILD

- Pedestrian skills training
- Seatbelts
- Safe storage of firearms in the home
- Water skills training

#### HIGH SCHOOL AND OLDER ADOLESCENT

- Seatbelts
- Alcohol and drug use, especially while driving and swimming
- Driving risks and readiness
- Safe storage of firearms
- Sports safety and concussion prevention
- Occupational injuries

and adolescents, partly related to the unique severity of abusive head trauma.

### Gender

Beginning at 1-2 years of age and continuing throughout the life span, males have higher rates of fatal injury than do females. During childhood, this does *not* appear to be primarily a result of developmental differences between the genders, differences in coordination, or differences in muscle strength. Variation in *exposure* to risk may account for the male predominance in some types of injuries. Although males in all age-groups have higher rates of bicycle-related injuries, adjusting for exposure reduces this excess risk. Gender differences in rates of pedestrian injuries do *not* appear to be caused by differences in the amount of walking but rather reflect differences in *behavior* between young females and males; whether these are genetic or the result of gender socialization is uncertain. Greater risk-taking behavior, combined with greater frequency of alcohol use, may lead to the disproportionately high rate of motor vehicle crashes among teenage males. The rate of violence-related injuries is higher among males because of their higher rates of aggression and risk-taking behaviors.

### Socioeconomic Status

**Poverty** is one of the most important risk factors for childhood injury. Mortality from fires, motor vehicle crashes, and drowning is 2-4 times higher in poor children. Death rates have an inverse relationship to income level: the higher the income level, the lower the death rate. Many other identified injury risk factors, such as single-parent families,

teenage parents, multiple care providers, family stress, and having multiple siblings, are also mediated primarily through their strong association with poverty.

### Rural-Urban Location

Injury rates are generally higher in rural than in urban areas. Homicide rates are higher in urban areas, as is violent crime in general. However, suicide among adolescents is higher in rural than in urban areas. Case fatality from injury is generally twice as high in rural areas than in urban areas, reflecting both the increased severity of some injuries (e.g., motor vehicle crashes occurring at higher speeds) and poorer access to EMS and definitive trauma care. Some injuries are unique to rural areas, such as agricultural injuries to children and adolescents.

### Environment

Poverty increases the risk of injury to children at least in part through its effect on the environment. Children who are poor are at increased risk for injury because they are exposed to more hazards in their living environments. They may live in poor housing, which is more likely to be dilapidated and less likely to be protected by smoke detectors. The roads in their neighborhoods are more likely to be major thoroughfares. Their neighborhoods are more likely to experience higher levels of violence, and they are more likely to be victims of assault than children and adolescents living in the suburbs. The focus on the environment is also important because it directs attention away from relatively immutable factors, such as family dynamics, child temperament, and race and directs efforts toward factors that can be changed through interventions.

### Ethnic Disparities

In the United States, Indigenous Nation children have the highest death rate from unintentional injuries, followed by Black, Hispanic, and White children. These discrepancies are even more pronounced for some injuries. The homicide rate for Black children aged 15-19 years was 34.86 per 100,000 population in 2019 compared with 7.67/100,000 for Indigenous Nations and Alaskan Natives and 3.86/100,000 for Whites and 2.72/100,000 for Asians. The suicide rate for Indigenous Nation youth was 2.1 times the rate for Whites

and 3.2 times the rate for Blacks. Disparities in fatal drowning rates vary by age, with highest rates in the 1- to 4-year-old age group in Indigenous Nation and Alaskan Native children (4.1/100,000) and in the 5- to 9- and 10- to 14-year-old age-groups in Black children (1.5/100,000 and 1.6/100,000, respectively). Indigenous Nation teenagers 15-19 years old are at the highest risk for suicide, followed by White males; Black females have the lowest rate of suicide in this age-group.

It is important to acknowledge racial disparities in injury rates and recognize that the underlying risk factors are racism and social determinants of health (such as socioeconomic status, the educational status of parents, natural and built environment conditions, and access to timely high-quality trauma care), rather than race itself.

## MECHANISMS OF INJURY

### Motor Vehicle Injuries

Motor vehicle injuries are the leading cause of serious and fatal injuries for children and adolescents. Large and sustained reductions in motor vehicle crash injuries can be accomplished by identifiable interventions.

### Occupants

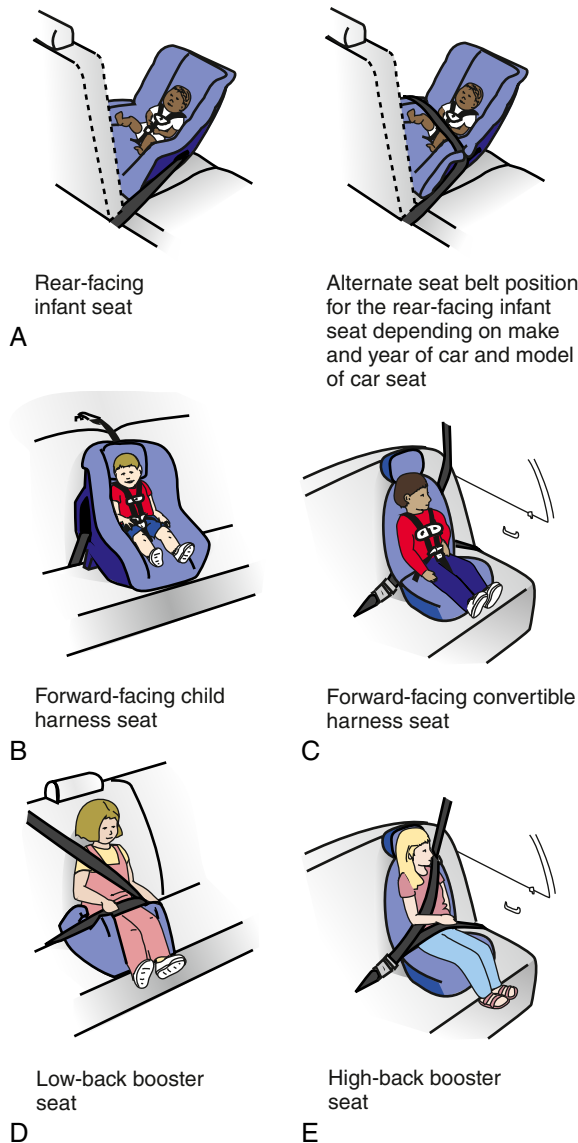
Injuries to passenger vehicle occupants are the predominant cause of motor vehicle deaths among children and adolescents. The peak injury and death rate for both males and females in the pediatric age-group occurs between 15 and 19 years (see Table 14.1). Proper restraint use in vehicles is one of the most effective methods for preventing serious or fatal injury in children involved in motor vehicle crashes. Table 14.3 shows the recommended restraints at different ages. Figure 14.5 provides examples of car safety seats.

Much attention has been given to child occupants <8 years old. Use of child-restraint devices, infant car seats, and booster seats can be expected to reduce fatalities by 71% and the risk of serious injuries by 67% in this age-group. All 50 states and the District of Columbia have laws mandating their use, although the upper age limit for booster seat requirements varies by state. Physician reinforcement of the positive benefits of child seat restraints has been successful in improving parent acceptance.

**Table 14.3** Recommended Child-Restraint Methods

	INFANTS	TODDLERS (1-3)	YOUNG CHILDREN
Recommended age/weight requirements	Birth to 1 yr or below weight limit of seat.	Older than 1 yr and weight 20-40 lb.	Weight 40-80 lb and height under 4 ft 9 in; generally, between 4 and 8 yr of age.
Type of seat	Infant-only or Rear-facing convertible.	Convertible or Forward-facing harness seat.	Forward-facing car seat with harness and tether until height or weight limit allowed by manufacturer. Then, belt-positioning booster seat.
Seat position	Rear-facing only. Place in back seat of vehicle.	Rear-facing as long as possible, until height or weight limit allowed by manufacturer. Then forward facing. Place in back seat of vehicle.	Forward-facing. Always in back seat of vehicle.
Notes	Children should use rear-facing seat until at least 1 yr and at least 20 lb. Harness straps should be at or below shoulder level.	Harness straps should be at or above shoulder level. Most seats require top strap for forward-facing use.	Belt-positioning booster seats must be used with both lap and shoulder belts. Make sure that lap belt fits low and tightly across lap/upper thigh area and that shoulder belt fits snugly, crossing chest and shoulder to avoid abdominal injuries.

Data from the National Highway Traffic Safety Administration, <https://www.nhtsa.gov/equipment/car-seats-and-booster-seats>.



**Fig. 14.5** Car safety seats. A, Rear-facing infant seat. B, Forward-facing child harness seat. C, Forward-facing convertible harness seat. D, Low-back booster seat. E, High-back booster seat. (From Ebel BE, Grossman DC. *Crash proof kids? An overview of current motor vehicle child occupant safety strategies.* *Curr Probl Pediatr Adolesc Health Care.* 2003;33:33–64. Source: NHTSA.)

A detailed guide and list of acceptable devices is available from the American Academy of Pediatrics (AAP)\* and the National Highway Traffic Safety Administration (NHTSA).† Infants may use an infant seat within the height and weight guidelines of the seat or may be placed in a convertible infant-toddler child-restraint device. Infants and toddlers should remain rear facing until at least 2 years old and up to the weight and height limits of their seat. Once toddlers outgrow the rear-facing limits of their seat, they can be placed in a forward-facing child harness seat until it is outgrown. Emphasis must be placed on the correct use of these seats, including placing the seat in the right direction, routing the belt properly, and ensuring that the child is buckled into the rear seat of the car correctly. Government regulations specific to automobile and product design, including the Lower Anchors and Tethers for Children (LATCH) system, have made the fit between car seats and the car easier, quicker, and less prone to error.

\* <http://www.healthychildren.org/english/safety-prevention/on-the-go/pages/car-safety-seats-information-for-families.aspx>.

† <https://www.nhtsa.gov/equipment/car-seats-and-booster-seats>.

Older children are often not adequately restrained. Many ride in the rear seat restrained with lap belts only. **Booster seats** have been shown to decrease the risk of injury by 59% and should be used by children once they outgrow their forward-facing child harness seat until at least 8 years of age and 4 ft 9 in (145 cm) tall. Many states have extended their car seat laws to include children of booster seat age as well. Shoulder straps placed behind the child or under the arm do not provide adequate crash protection and may increase the risk of serious injury. The use of lap belts alone has been associated with an increased risk of seatbelt-related injuries, especially fractures of the lumbar spine and hollow-viscus injuries of the abdomen. These flexion-distraction injuries of the spine are often accompanied by injuries to the abdominal organs.

The rear seat is clearly much safer than the front seat for both children and adults. One study of children <15 years old found that the risk of injury in a crash was 70% lower for children in the rear seat compared with those sitting in the front seat. Frontal **airbags** present a risk of serious or fatal injury from the airbag itself for children <13 years. Side airbags also pose a risk for children who are in the front seat and are leaning against the door at the time of a crash. **The safest place for children is in the rear middle seat, properly restrained for their age and size.** Educational and legislative interventions to increase the number of children traveling in the rear seat have been successful.

Children riding in the rear bed of pickup trucks are at special risk for injury because of the possibility of ejection from the truck and resultant serious injury. Preschool or younger children riding in a **school bus** should use a proper child restraint system. Older children (usually >65 lb) can ride safely in a large (>16 passenger) school bus because of compartmentalization of the bus. Smaller buses require child restraint systems with seat belts, and seat belts are recommended for all new school buses.

Transportation of **premature infants** presents special challenges. The possibility of oxygen desaturation, sometimes associated with bradycardia, among premature infants while in child seat restraints has led the American Association of Pediatrics (AAP) to recommend an observed trial of infants born at <37 weeks of gestational age in the seat before discharge and the use of oxygen or alternative restraints for infants who experience desaturation or bradycardia, such as seats that can be reclined and used as a car bed.

### Teenage Drivers

Drivers 15–17 years old have more than twice the rate of collisions compared with motorists 18 years and older. Formal driver education courses for young drivers appear to be ineffective as a primary means of decreasing the number of collisions. The risk of serious injury and mortality is directly related to the speed at the time of the crash and inversely related to the size of the vehicle. Small, fast cars greatly increase the risk of a fatal outcome in the event of a crash.

The number of passengers traveling with teen drivers influences the risk of a crash. The risk of death for 17-year-old drivers is 50% greater when driving with one passenger compared with driving alone; this risk is 2.6-fold higher with two passengers and 3-fold higher with three or more passengers.

Teens driving at night are overrepresented in crashes and fatal crashes, with nighttime crashes accounting for >33% of teen motor vehicle fatalities. Almost 50% of fatal crashes involving drivers <18 years old occur in the 4 hours before or after midnight. Teens are 5–10 times more likely to be in a fatal crash while driving at night compared with driving during the day. The difficulty of driving at night combined with the inexperience of teen drivers appears to be a deadly combination.

Another risk factor for motor vehicle crashes for people of all ages, including teens, is **distracted driving**. Distracting events can include *visual* distraction (taking eyes from the forward roadway), *manual* distraction (removing hands from vehicle controls), or *cognitive* distraction (taking attention from navigating the vehicle or responding to critical events). **Electronic devices** present all three modes of distraction in combination and are increasingly recognized as a major threat to driver safety, especially among teens. The recent uptick in motor vehicle fatality rates per vehicle mile driven is generally believed to be caused by distracted driving.



In 2017, 39.2% of teen drivers reported they had texted or emailed while driving in the last 30 days. Dialing on a cell phone increases the risk of a crash almost threefold, and texting may increase the risk as much as sixfold. Although most states have banned text messaging for all drivers, the effect of state laws on prohibiting such behavior while driving is unknown. Parents should set limits on the use of these devices by their teens; technologic interventions that can block cell phone signals in a moving vehicle are also available and should be considered by parents for their teens.

Newer vehicles are increasingly equipped with driver assistance technology, electronic stability control, and automated crash avoidance systems. Despite the potential to reduce road traffic crashes and injury, these technologies are not yet prevalent in the vehicular fleet. In addition, there is evidence that many drivers do not understand the use, or limitations, of these technologies.

**Graduated driver's licensing (GDL) programs** consist of a series of steps over a designated period before a teen can receive full, unrestricted driving privileges. In a three-stage graduated license, the student driver must first pass vision and knowledge-based tests, followed by obtaining a learner's permit, and once a specific age has been achieved and driving skills advanced, the student driver is eligible to take the driving test. Once given a provisional license, the new driver will have a specified time to do low-risk driving. GDL usually places initial restrictions on the number of passengers (especially teens) allowed in the vehicle and limits driving at night. The number of crashes decreases 10–30% among the youngest drivers in states with a GDL system. The characteristics of GDL programs vary substantially across states. Optimal safety benefits depend on parent monitoring and engagement with teens around driving restrictions and responsibilities. Parent–teen driving contracts are available and help to facilitate these discussions.

**Alcohol use** is a major cause of motor vehicle trauma among adolescents. The combination of inexperience in driving and inexperience with alcohol is particularly dangerous. Approximately 20% of all deaths from motor vehicle crashes in this age-group are the result of alcohol intoxication, with impairment of driving seen at blood alcohol concentrations (BACs) as low as 0.05 g/dL. In 2019, approximately 16.7% of adolescents reported riding with a driver who had been drinking, and 5.4% reported driving after drinking. All states have adopted a *zero-tolerance policy* to adolescent drinking while driving, which defines any measurable alcohol content as legal intoxication. All adolescent motor vehicle injury victims should have their BAC measured in the ED and should be screened for high-risk alcohol use with a validated screening test (e.g., CRAFFT (<https://craft.org/>); Alcohol Use Disorders Identification Test [AUDIT]) to identify those with alcohol abuse problems (see Chapter 157.1). Individuals who have evidence of alcohol abuse should not leave the ED or hospital without plans for appropriate alcohol abuse treatment. Interventions for problem drinking can be effective in decreasing the risk of subsequent motor vehicle crashes. Even brief interventions in the ED using motivational interviewing can be successful in decreasing adolescent problem drinking.

Another cause of impaired driving is **marijuana use**. In 2017, nearly 20% of high school students reported using marijuana in the prior 30 days, and 50% of current teen users reported driving after use. Marijuana is currently legal (2021) for adult use in 19 U.S. states and for medical use in 27 states, while being considered in many others; the effects of this on adolescent injury remain to be determined. Marijuana is often co-ingested with alcohol or other drugs, and blood thresholds for biologic impairment have not been standardized. It is therefore difficult to estimate the independent effect of marijuana on crash risk.

### All-Terrain Vehicles

All-terrain vehicles (ATVs) in many parts of the United States are an important cause of injuries to children and adolescents. These vehicles can attain high speeds, especially with low-weight children, and are prone to rollover because of their high center of gravity. Orthopedic and head injuries are the most common serious injuries seen among children involved in ATV crashes. Helmets can significantly decrease the risk and severity of head injuries among ATV riders, but current use is very low. Voluntary industry efforts to decrease the risk of injuries appear to have had little effect in making ATVs safer. The AAP recommends that children <16 years old should not ride or drive ATVs.

### Bicycle Injuries

Each year in the United States, approximately 122,000 children and adolescents are treated in EDs for bicycle-related injuries, making this one of the most common reasons that children with trauma visit EDs. The majority of severe and fatal bicycle injuries involve **head trauma**. A logical step in the prevention of these head injuries is the use of helmets. **Helmets** are very effective, reducing the risk of all head injury by 85% and the risk of traumatic brain injury by 88%. Helmets also reduce injuries to the mid and upper face by as much as 65%. Pediatricians can be effective advocates for the use of bicycle helmets and should incorporate this advice into their anticipatory guidance schedules for parents and children. Appropriate helmets are those with a firm polystyrene liner that fits properly on the child's head. Parents should avoid buying a larger helmet to give the child "growing room." If a crash occurs and the helmet is struck, it should be replaced.

Promotion of helmet use can and should be extended beyond the pediatrician's office. Community education programs spearheaded by coalitions of physicians, educators, bicycle clubs, and community service organizations have been successful in promoting the use of bicycle helmets to children across the socioeconomic spectrum, resulting in helmet use rates of  $\geq 70\%$  with a concomitant reduction in the number of head injuries. Passage of bicycle helmet laws also leads to increased helmet use.

Consideration should also be given to other types of preventive activities, although the evidence supporting their effectiveness is limited. Bicycle paths are a logical method for separating bicycles and motor vehicles.

### Ski- and Snowboard-Related Head Injuries

The increasing use of helmets in snow sports, such as skiing and snowboarding, is encouraging because head injuries are the most common cause of death in these sports, and helmets reduce the risk of head injury by  $\geq 50\%$ . Use of helmets does not result in skiers or snowboarders taking more risks and should be encouraged in all snow sports at all ages, not just for young children.

### Pedestrian Injuries

Pedestrian injuries are a major cause of traumatic death for children and adolescents in the United States and in most high-income countries. In low-income countries, a much higher proportion of road traffic fatalities are pedestrians, especially among 5- to 14-year-olds. Although case fatality rates are <5%, serious nonfatal injuries constitute a much larger problem, resulting in 29,233 ED visits in 2019 for children and adolescents. Pedestrian injuries are the most important cause of traumatic coma in children and a frequent cause of serious lower-extremity fractures, particularly in school-age children.

Most pedestrian injuries occur during the day, with a peak in the after-school period; thus improved lighting or reflective clothing would be expected to prevent few injuries. Surprisingly, approximately 30% of pedestrian injuries occur while the individual is in a marked crosswalk, reflecting a false sense of security and decreased vigilance in these areas. The risk of pedestrian injury is greater in neighborhoods with high traffic volumes, speeds >25 miles/hr, absence of play space adjacent to the home, household crowding, and low socioeconomic status.

One important risk factor for childhood pedestrian injuries is the developmental level of the child. Children <5 years old are at risk for being run over in the driveway. Few children <9 or 10 years of age have the developmental skills to successfully negotiate traffic under all circumstances. Young children have poor ability to judge the distance and speed of traffic and are easily distracted by playmates or other factors in the environment. Many parents are not aware of this mismatch between the abilities of the young school-age child and the skills needed to cross streets safely. The use of mobile phones and devices has become increasingly common while walking and can increase the risk of being struck by a motor vehicle.

Prevention of pedestrian injuries is difficult but should consist of a multifaceted approach. Education of the child in pedestrian safety should be initiated at an early age by the parents and continue into the school-age years. Younger children should be taught never to cross streets when alone; older children should be taught (and practice how) to negotiate quiet streets with little traffic. Major streets should not be crossed alone until the child is at least 10 years of age and has been observed to follow safe practices.



Legislation and police enforcement are important components of any campaign to reduce pedestrian injuries. Right-turn-on-red laws increase the hazard to pedestrians. In many cities, few drivers stop for pedestrians in crosswalks, a special hazard for young children. Engineering changes in roadway design are extremely important as passive prevention measures. Most important are measures to slow the speed of traffic and to route traffic away from schools and residential areas; these efforts are endorsed by parents and can decrease the risk of injuries and death by 10–35%. Other modifications include networks of one-way streets, proper placement of transit or school bus stops, sidewalks in urban and suburban areas, striping in rural areas to delineate the edge of the road, “road diets” to reduce lanes of traffic pedestrians must cross, and curb parking regulations. Comprehensive traffic “calming” schemes using these strategies have been very successful in reducing child pedestrian injuries in Sweden, the Netherlands, Germany, and increasingly, the United States.

### Falls

Falls are the leading cause of **nonfatal injury** in children and adolescents. Altogether, there were 1.8 million falls that led to ED visits in 2019 for children and adolescents; approximately 2.9% of these visits led to a hospitalization or transfer. There have been relatively few in-depth analytic studies of falls, except in particular circumstances, such as playground injuries. Strategies to prevent falls depend on the environmental circumstances and social context in which they occur. *Window falls* have been successfully prevented with the use of devices that prevent egress, and injuries from *playground falls* can be mitigated through the use of proper surfacing, such as woodchips or other soft, energy-absorbing materials. Alcohol may also contribute to falls among teenagers, and these injuries can be reduced by general strategies to reduce teen alcohol use.

### Fire- and Burn-Related Injuries

See Chapter 89.

### Poisoning

See Chapter 94.

### Drowning

See Chapter 88.

### Traumatic Brain Injury

See Chapter 82.

### Firearm Injuries

Injuries to children and adolescents involving firearms occur in three different situations: unintentional injury, suicide attempt, and assault. The injury may be fatal or may result in permanent sequelae.

Firearm related deaths (all causes) for youths (1–19 years) in 2020 was ~5.62 per 100,000 population. The rate was 17.4 for Black youths, compared to 3.4 for White youths. Firearm homicides represent 60% of firearm-related deaths in youths. In 2020, firearm-related deaths exceeded motor vehicle collisions as the leading cause of death for children and adolescents. **Unintentional firearm injuries** and deaths have continued to decrease and accounted for 426 deaths to children 0–18 years old in 2019, representing only a very small fraction of all firearm injuries among children and adolescents. The majority of these deaths occur to teens during hunting or recreational activities.

**Suicide** is the second most common cause of death from all causes in both males and females aged 10–19 years. During the 1950s to 1970, suicide rates for children and adolescents more than doubled; firearm suicide rates peaked in 1994 and decreased by 59% from this peak by 2010 before gradually increasing, paralleling increases in the overall suicide rate. The difference in the rate of suicide death between males and females is related to the differences in method used during attempts. Females die less often in suicide attempts because they use less lethal means (mainly drugs) and perhaps have a lower degree of intent. The use of firearms in a suicidal act results in an approximately 90% case fatality rate.

**Homicides** are third only to motor vehicle crashes and suicide among causes of death in teenagers >15 years old. In 2019, 2,023 adolescents aged 15–19 years were homicide victims; Black teenagers accounted for 64% of the total, making homicides the most common cause of death among this group. Over 85% of homicides among teenage males involved firearms, mostly handguns.

In the United States, approximately 32% of adults reported owning a gun in 2020, including 36% of adults who had children under 18 in the household. Home ownership of guns increases the risk of adolescent suicide 3- to 10-fold and the risk of adolescent homicide up to 4-fold. In homes with guns, the risk to the occupants is far greater than the chance that the gun will be used against an intruder; for every death occurring in self-defense, there may be 1.3 unintentional deaths, 4.6 homicides, and 37 suicides.

Handguns account for approximately 30% of the firearms in use today, yet they are involved in 80% of criminal and other firearm misuse. Of all firearms, **handguns** pose the greatest risk to children and adolescents. Access to handguns by adolescents is surprisingly common and is not restricted to those involved in gang or criminal activity. Stricter policies to reduce youth access to handguns, rather than all firearms, would appear to be the most appropriate focus of efforts to reduce shooting injuries in children and adolescents (Fig. 14.6).

Locking and unloading guns and storing ammunition locked in a different location substantially reduce the risk of a suicide or unintentional firearm injury among youth by up to 73%. Because up to 30% of handgun-owning households have at least one firearm stored unsafely, one potential approach to reducing these injuries could focus on improving household firearm storage practices where children and youth reside or visit. The evidence regarding the effectiveness of office-based counseling to influence firearm storage practice is mixed; the most effective programs are those in which safe storage devices are dispensed along with advice.

Adolescents with mental health conditions and alcoholism are at particularly high risk for firearm injury. In the absence of conclusive evidence, physicians should continue to work with families to eliminate access to guns in these households.

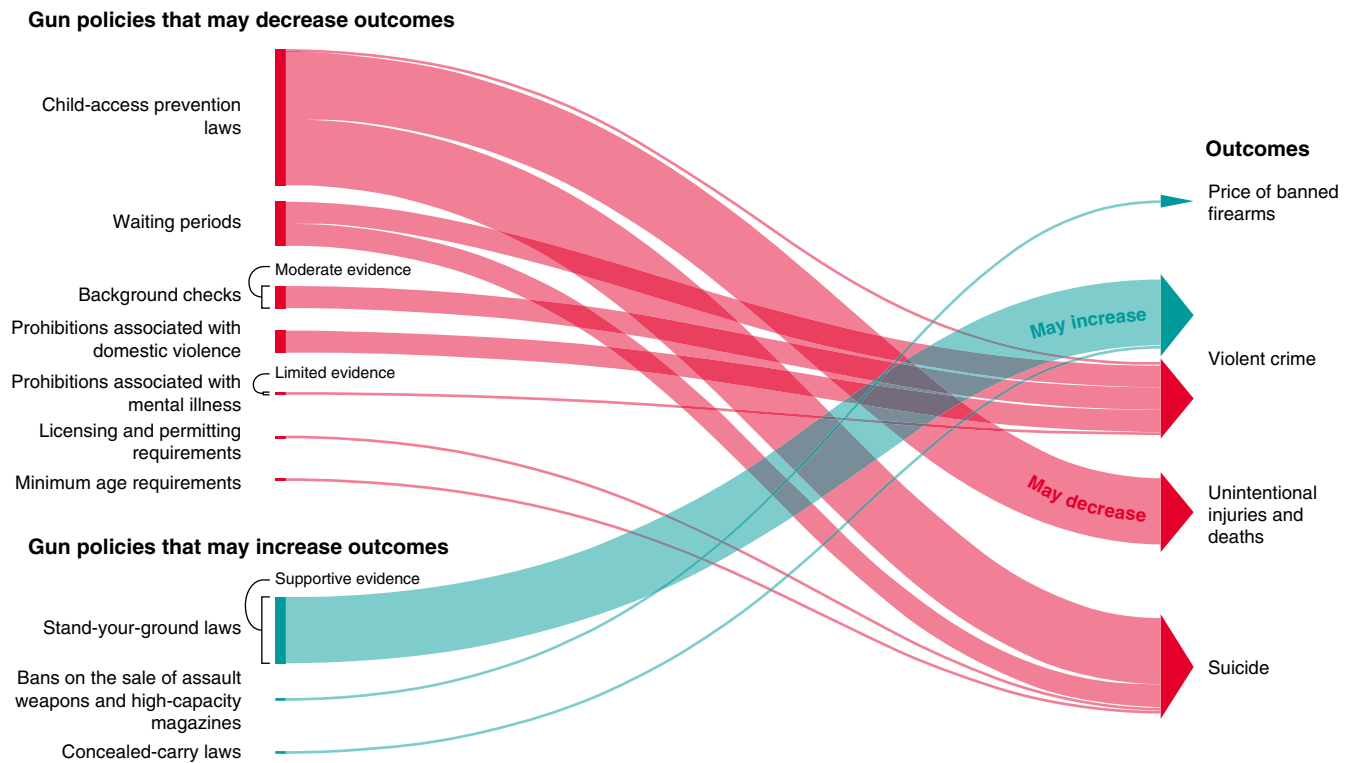
### Violent Behavior and Aggression

Although the current rates of homicide are much lower than at their peak in the late 1980s and early 1990s, the problem of violence and assault remains large. The origins of adult and teen violence occur during childhood. Almost all adults who commit violent acts have a history of violent behavior during childhood or adolescence. Longitudinal studies following groups of individuals from birth have found that aggression occurs early and that most children learn to control this aggression in childhood. Children who later become violent adolescents and adults do not learn to control this aggressive behavior.

The most successful interventions for violence target young children and their families. These include home visits by nurses and paraprofessionals beginning in the prenatal period and continuing for the first few years of life to provide support and guidance to parents, especially parents without other resources. Enrollment in early childhood education programs (e.g., Head Start) beginning at age 3 years has been shown to be effective in improving school success, keeping children in school, and decreasing the chance that the child will experience delinquency in adolescence. School-based interventions, including curricula to increase the social skills of children and improve the parenting skills of caregivers, have long-term effects on violence and risk-taking behavior. Early identification of behavior problems by primary care pediatricians can best be accomplished through the routine use of formal screening tools. Interventions in adolescence, such as family therapy, multisystemic therapy, and therapeutic foster care, can decrease problem behavior and a subsequent decline into delinquency and violence.

### PSYCHOSOCIAL CONSEQUENCES OF INJURIES

Many children and their parents have substantial psychosocial sequelae from trauma. Studies in adults indicate that 10–40% of hospitalized injured patients will have **posttraumatic stress disorder** (PTSD; see Chapter 38). Among injured children involved in motor vehicle



**Fig. 14.6** Gun policy–based outcomes. (Adapted from *Gun Policy in America*/RAND. <https://www.rand.org/research/gun-policy.html>.)

crashes, 90% of families will have symptoms of **acute stress disorder** after the crash, although the diagnosis of acute stress disorder is poorly predictive of later PTSD. Standardized questionnaires that collect data from the child, the parents, and the medical record at the time of initial injury can serve as useful screening tests for later development of PTSD. Early mental health intervention, with close follow-up, is important for the treatment of PTSD and for minimizing its effect on the child and family.

Visit Elsevier eBooks+ at [eBooks.Health.Elsevier.com](https://www.elsevier.com/ebooksplus) for Bibliography.

## Chapter 15

# Impact of Violence Exposure on Children

Marilyn C. Augustyn, Neena McConnico, and Barry S. Zuckerman

The reach of violence—whether as the victim, perpetrator, or witness, whether in person or through the media—is far, deep, and long-standing across the globe. In the home, it is estimated that 80–95% of children and youth witness such aggression. In general, the types of violence children are exposed to increases in severity as children grow older. *Exposure to violence* disrupts the healthy development of children in a myriad of ways. Pediatric clinicians must be aware of violence exposure and competent to address its impact on children and families under their care (**trauma-informed care**). Trauma-informed care gives

pediatric clinicians the tools to assess childhood trauma and adversity experiences as well as practical guidance, resources, and interventions. Clinicians also have a wider responsibility to advocate on local, state, national, and international levels for safer environments in which all children can grow and thrive (see Fig. 14.6).

We know that many traumatic events during childhood can have immediate and long-term impact (**adverse childhood experiences**; see Chapter 1). Adversity in the first years of life may deleteriously affect the course of human development throughout the life span, and **witnessing violence** is one such adversity. Because bystanders who witness violence can have permanent emotional and behavioral effects due to neurophysiologic alterations, healthcare providers may not fully appreciate their distress and thereby miss an opportunity to provide needed interventions. For children not living in war zones, the source of first exposure to violence is often **intimate partner violence (IPV)**. In the United States alone, >1 in 15 children witness IPV each year, and worldwide approximately 275 million children are exposed to IPV yearly. Exposure to IPV in infancy and toddlerhood affects attachment relationships, and school-aged youth who witness IPV have difficulties in developing and maintaining friendships, have difficulty in school, may abuse drugs and alcohol, and may develop mental health problems.

Another source of witnessed violence is **community violence**, a serious problem in the United States that disproportionately affects children from low-income areas. Approximately 22% of children witness violence in their family or in their community each year; *witnessed violence* includes assaults and bullying, sexual victimization, maltreatment by a caregiver, and theft or vandalism. Almost 60% of children will experience or witness violence during childhood. Witnessing acts of violence may be a significant stressor in children's lives. Witnessed community violence is related to internalizing problems such as depression and posttraumatic stress disorder (PTSD), as well as externalizing problems, including delinquent behavior, aggression, and substance abuse.

The most ubiquitous source of witnessing violence for U.S. children is **media violence**, sometimes referred to as **virtual violence**. This form

of violence is not experienced physically; rather it is experienced in realistic ways through technology and ever more intense and realistic games. There is an ever-widening array of screens that are part of children's everyday lives, including computers, tablets, and cell phones, in addition to long-standing platforms, such as televisions and movies. Tragic events, including mass shootings and acts of terrorism, have increased the specter of fear among children as these events are reenacted for them on the multiple screens they encounter. Although exposure to media/virtual violence cannot be equated to exposure to real-life violence, many studies confirm that media/virtual violence *desensitizes* youth to the meaning and impact of violent behavior. Violent video game exposure may be associated with increased aggressive behavior; increased aggressive cognitions; increased aggressive affect, increased desensitization, and decreased empathy; and increased physiologic arousal. Violent video game use is a risk factor for adverse outcomes; however, insufficient data exist to examine any potential link between violent video game use and delinquency or criminal behavior. [Table 15.1](#) lists interventions to reduce exposure to media violence.

## IMPACTS OF VIOLENCE

All types of violence have a profound impact on health and development, physiologically, psychologically, and behaviorally potentially leading to the challenges mentioned earlier. It may influence how children view the world and their place in it. Children can come to see the world as a dangerous and unpredictable place. This fear may thwart their exploration of the environment, which is essential to learning in childhood. Youth may experience overwhelming terror, helplessness, and fear, even if they are not immediately in danger. Young children are most vulnerable to threats that involve the safety (or perceived safety)

of their caretakers. Chronic exposure to violence predisposes children to subsequent mental health problems and can have a deleterious effect on learning and neurodevelopment. High exposure to violence in older youth correlates with poorer performance in school, symptoms of anxiety and depression, and lower self-esteem. Violence, particularly IPV, can also teach youth especially powerful early lessons about the role of violence in relationships. Violence may change the way that children view their future; they may believe that they could die at an early age and thus take more risks, such as drinking alcohol, abusing drugs, not wearing a seatbelt, and not taking prescribed medication. Violence exposure is an important childhood adversity that is known to increase the risk for poor health in adults.

Some children exposed to severe and/or chronic violence may suffer from PTSD, exhibiting constricted emotions, difficulty concentrating, autonomic disturbances, and reenactment of the trauma through play or action (see [Chapter 38](#)). Based on the *Diagnostic and Statistical Manual of Mental Disorders, Fifth Edition* (DSM-5) criteria for PTSD in children  $\leq 6$  years old,  $>50\%$  of preschoolers may experience clinically significant symptoms of PTSD after exposure to IPV. Although young children may not fully meet these criteria, certain behavioral changes are associated with exposure to trauma, such as sleep disturbances, aggressive behavior, new fears, and increased anxiety about separations (clinginess). A challenge in treating and diagnosing pediatric PTSD is that a child's caregiver exposed to the same trauma may be suffering from it as well.

## Diagnosis and Follow-Up

The simplest way to recognize whether violence exposure has affected a family is to screen both the caregivers and the youth (after approximately 8 years of age) on a regular basis. This practice is particularly important during pregnancy and the immediate postpartum period, when women may be at highest risk for being abused. It is important to assure families that they are not being singled out, but that all families are asked about their exposure to violence. In the case of IPV, it is important to ask the caregivers separately to maintain safety and mitigate risk for the caregiver who is being abused.

A direct approach may be useful: "Violence is a major problem in our world today and one that impacts everyone in our society. So I ask all my patients and families about violence that they experienced growing up as well as now. . . ." This can take the form of a three-generation family history of violence exposure. In other cases, beginning with general questions and then moving to the specific may be helpful: "Do you feel safe in your home and neighborhood? Has anyone ever hurt you or your child?" When violence has affected the child, it is important to gather details about symptoms, behaviors, and protective factors that support resilience.

The pediatric clinician can effectively counsel many parents and children who have been exposed to violence. Regardless of the type of violence to which the child has been exposed, the following components are part of the guidance: (1) careful review of the facts and details of the event, (2) referring to support services, (3) providing information about the symptoms and behaviors common in youth exposed to violence, (4) assistance in restoring a sense of stability to the family in order to enhance the youth's feelings of safety, and (5) helping caregivers talk to their children about the event. Families should be referred to a mental health professional when (1) the violence is significant, (2) symptoms are chronic ( $>6$  months) or not improving, (3) if the violent event involved the death or departure of a parent, (4) if the caregivers are unable to empathize with the child, or (5) if the ongoing safety of the child is a concern.

Visit Elsevier Ebooks+ at [eBooks.Health.Elsevier.com](http://eBooks.Health.Elsevier.com) to read this chapter.

**Table 15.1** Public Health Recommendations to Reduce Effects of Media Violence on Children and Adolescents

### 1. Parents should:

- Be made aware of the risks associated with children viewing violent imagery, as it promotes aggressive attitudes, antisocial behavior, fear, and desensitization.
- Review the nature, extent, and context of violence in media available to their children before children view it.
- Assist children's understanding of violent imagery appropriate to their developmental level.
- Be aware and monitor social media access/use of youth

### 2. Professionals should:

- Offer support and advice to parents who allow their children unsupervised access to extreme violent imagery, as this could be seen as a form of emotional abuse and neglect.
- Educate all young people in critical film appraisal in terms of realism, justification, and consequences.
- Exercise greater control over access to inappropriate violent media entertainment by young people in secure institutions.
- Use violent film material in anger management programs under guidance.

### 3. Media producers should:

- Reduce violent content and promote antiviolence themes and publicity campaigns.
- Ensure that when violence is presented, it is in context and associated with remorse, criticism, and penalty.
- Ensure that violent action is not justified or its consequences understated.

### 4. Policymakers should:

- Monitor the nature, extent, and context of violence in all forms of media and implement appropriate guidelines, standards, and penalties.
- Ensure that education in media awareness is a priority and a part of school curricula.

From Browne KD, Hamilton-Giachritsis C. The influence of violent media on children and adolescents: A public-health approach. *Lancet*. 2005;365:702-710.



## 15.1 Bullying, Cyberbullying, and School Violence

Megan A. Moreno and Elizabeth Englander

### BULLYING AND CYBERBULLYING

Bullying behavior affects people throughout the life span, but much of the focus has been on children and adolescents. In the past, bullying was sometimes considered a rite of passage or was written off as “kids being kids.” However, it is well recognized that bullying can have profound short- and long-term negative consequences on all those involved, including perpetrators, targets, and bystanders. The consequences of bullying can affect a child’s social experiences, academic progress, and health.

**Bullying** is defined as any unwanted aggressive behavior by another youth or group of youths that involves an actual or perceived power imbalance and is repeated multiple times or is highly likely to be repeated. Generally, sibling aggression and dating violence are excluded, but research has associated these problems with *peer bullying*. Digital technology was initially viewed as a context in which bullying can occur. **Cyberbullying** is not merely bullying that occurs through electronic communications, but rather a type of bullying with distinct elements, such as the potential for a single event to “go viral” and the use of technology as a tool to achieve power imbalance.

It is thought that bullying and cyberbullying are more alike than dissimilar and that surveillance efforts, as well as prevention and intervention approaches, should address both types of bullying.

### Bullying Roles and Nomenclature

Bullying represents a dynamic social interaction in which an individual may play different roles at different stages. A child can be a perpetrator of bullying, a target of bullying, a witness or bystander, or simply a child whose environment is affected by pervasive bullying. In any bullying experience, the roles that each child plays may be fluid, such that a target of bullying may then become a perpetrator, or vice versa. Thus common nomenclature has evolved to refer to children as *perpetrators* of bullying or *targets* of bullying to represent a present state, rather than labeling a child as a bully or a victim, which suggests a static role and may affect that child’s self-image.

### Epidemiology

Bullying is a widespread problem during childhood and adolescence. Current estimates suggest that school-based bullying likely affects 18–31% of children and youth and that cyberbullying affects 7–15% of youth. Apparent rates of bullying are influenced by the questions that are asked; the word “bully” is stigmatized, and absent that label, youth are more willing to acknowledge having engaged in activities that can be categorized as bullying. Estimates of bullying prevalence are typically based on self-reported victimization (not perpetration), but here too, language can influence results. Targets of other types of social conflict may overestimate or underestimate their bullying victimization unless precise language is used during assessment.

### Risk Factors

Certain groups are more vulnerable to bullying, including youth who are lesbian, gay, bisexual, transgender, and questioning (LGBTQ+); immigrant and ethnic/racial minoritized youth; obese youth; and youth with disabilities. However, it is important to recognize that although these individual risk factors exist, the context and situation can also present unique risk factors. Some studies have found that Black children are bullied more often than Latinos, whereas other studies have found no group differences. Contextual factors, such as the school climate or prevalence of a particular ethnic group in a school setting, may be important factors in a given bullying situation. The 2019 Youth Risk Behavior Survey found that White teens were much more likely than Black teens to report experiencing any bullying. Thus it is important to

recognize that any individual being bullied is embedded within a situation that is within a larger social context. This *person by situation by context* approach is useful to consider in identifying why bullying takes place in some situations but not others.

Bullying may occur with other high-risk behaviors. Students who carry weapons, smoke, and drink alcohol are at higher risk for engaging in bullying. Negative parenting behavior is related to a moderately increased risk of becoming a *bully/victim* (youth who are both perpetrators and targets) and small to moderate effects on being targeted for bullying at school.

Some risk factors may be specific to cyberbullying. Among pre-adolescent children, more access to technology (e.g., cell phone ownership) predicts cyberbullying behaviors and some types of digital victimization. Also, communications through digital technology can be misperceived as hostility, and those misperceptions can in turn increase electronic forms of bullying.

### Consequences of Bullying

Involvement in any type of bullying is associated with poorer psychosocial adjustment; perpetrators, targets, and those both perpetrator and target report greater health problems and poorer emotional and social adjustment. Consequences of both traditional and cyber forms of bullying are particularly significant in the areas of physical health, mental health, and academic achievement. Being the target of bullying is typically viewed as particularly stressful. The impact of this stress has been shown to affect the developing brain and to be associated with changes to the stress response system, which confers an increased risk for future health and academic difficulties. The long-term consequences of being bullied as a child include increased risk for depression, poor self-esteem, and abusive relationships. Negative outcomes for perpetrating bullying include higher risks of depression and substance abuse. Mental health consequences for both perpetrator and target include, across types of bullying, increased risks of depression, poor self-esteem, increased suicidality, and anxiety. Academic difficulties include increased risk of poor school performance, school failure, and dropping out.

## SCHOOL VIOLENCE

### Epidemiology

School violence is a significant problem in the United States. Almost 40% of U.S. schools report a least one violent incident to police, with >600,000 victims of violent crime per year. Among 9th to 12th graders, 8% were threatened or injured on school property in the last 12 months, and 14% were involved in a physical fight over the last year. Still, school-associated violent deaths are rare. Seventeen homicides of children aged 5–18 years occurred at school during the 2009–2010 school year. Of all youth homicides, <2% occur at school. Although urban schools experience more episodes of violence, the rare rampage gun violence that happens in rural and suburban schools demonstrates that no region is immune to lethal violence.

### Risk Factors

Bullying and weapon carrying may be important precursors to more serious school violence. Among perpetrators of violent deaths at school, 20% had been bullying victims, and 6% carried a weapon to school in the last 30 days. Nonlethal violence, mental health problems, racial tensions, student attacks on teachers, and the effects of rapid economic change in communities can all lead to school violence. Individual risk factors for violence include prior history of violence, drug, alcohol, or tobacco use, association with delinquent peers, poor family functioning, poor grades in school, and poverty in the community.

Family risk factors include early childbearing, low parental attachment and involvement, authoritarian or permissive parenting styles (see Chapter 20), and poverty. There is more school violence in areas with higher crime rates and more street gangs, which take away students’ ability to learn in a safe environment and leave many children with traumatic stress and grief reactions.



## TREATMENT AND PREVENTION OF BULLYING AND SCHOOL VIOLENCE

Pediatric providers are in a unique position to screen, treat, and advocate for reducing the impact of bullying and school violence by assisting those affected and seeking to prevent further occurrences.

### Signs and Symptoms

Signs of a child being involved in bullying or exposed to school violence include physical complaints such as insomnia, stomachaches, headaches, and new-onset enuresis. **Psychologic symptoms**, such as depression (see Chapter 39), loneliness, anxiety (see Chapter 38), and suicidal ideation, may occur. **Behavioral changes**, such as irritability, poor concentration, school avoidance, and substance abuse, are common. **School problems**, such as academic failure, social problems, and lack of friends, can also occur. Additional vigilance is warranted for those children who represent vulnerable groups for bullying and aggression, including youth with disabilities; obesity; or minority, immigrant, or LGBTQ+ status.

### Screening for Bullying

Assessing bullying and cyberbullying involvement is an important part of pediatric visits. Several tools can be helpful for clinicians, including the *Bright Futures Guidelines*, which recommend screening at each well-child visit. In these discussions, begin by normalizing the conversation; for example, practitioners can let the patient know that bullying is a topic they discuss with all their patients. It is advisable to define bullying based on the uniform definition but using readily understandable and developmentally appropriate language. Physicians can ask patients if they have had experiences where there was repeated cruelty or “mean actions” between peers, either as a target of that cruelty or seeing the cruelty, or even being angry or mean toward others. Asking a patient if he or she is a bully is not likely to generate either trust or an honest answer. Asking about exposures to peer victimization or school violence is also important. Throughout these discussions, it is critical to provide support and empathy while engaging a patient.

One tool to help providers begin and navigate these discussions is a *Practice Enhancement Tool* developed by the **Massachusetts Aggression Reduction Center** (MARC) and Children’s Hospital Boston (Fig. 15.1). It begins by defining bullying in readily understandable language and then asks, “Is there any one kid, or a bunch of kids, that pick on you or make you feel bad over and over again?” The tool also guides the practitioner in asking about problematic digital experiences and asks whom the child has spoken to about the problem and whether that has helped. Finally, it guides the practitioner through emphasizing the usefulness of talking about social problems and discusses how the physician can assist the patient.

Children who are aggressive, overly confident, lacking in empathy, or have persistent conduct problems may need careful screening. It is important to bear in mind that bullying is a dynamic process, and a child may be involved as both a perpetrator and a target at different time points. The physical, behavioral, psychologic, and academic symptoms of bullying may overlap with other conditions, such as medical illness, learning problems, and psychologic disorders. Thus labeling the behavior as *bullying* rather than the child as a “bully” is recommended.

Management of bullying and school violence involves several steps. First, ensure that all parties understand the relevant information (the patient, parents, and school). Second, assess a child’s need for specialized counseling or social skills interventions. Extracurricular activities (e.g., drama clubs, mentoring programs, sports) can be discussed as avenues to help increase the child’s social skills and self-esteem. Third, ensure that the patient has adequate support, including at home and at school. Peers are a particularly effective source of support, and patients can be encouraged to spend time with friends, but parents and educators are also important sources of emotional support. Many children benefit from planning their actions in unstructured settings (e.g., discussing where they could sit during lunch), whereas some benefit from role-playing. Finally, the clinician should identify safety issues, such as suicidal ideation and plans, substance abuse, and other high-risk behaviors.

When bullying or cyberbullying is suspected or confirmed, the parents and child should be offered education and resources. Some resources include the government-supported website [www.stopbullying.gov](http://www.stopbullying.gov), as well as MARC. Both provide free downloadable literature that can be offered to parents and families.

Addressing cases of bullying or exposure to violence in clinic often requires a cross-disciplinary approach. Involving teachers or school counselors, as well as outside referrals to psychologists, social workers, or counselors, may be warranted. Parental mental health and resource risk factors should also be addressed.

### Prevention

Pediatric clinicians can reasonably expect their patients’ schools to provide violence and bullying prevention programs. Rather than focusing on only changing a target of bullying, successful interventions use whole-school approaches that involve multiple stakeholders. **School climate** has been shown to have significant effects on bullying prevalence, so these approaches are essential to primary prevention. These broad-based programs simultaneously include school-wide rules and sanctions, teacher training, classroom curriculum, and high levels of student engagement. Addressing access to firearms, involving community organizations and parents, and supporting youth mental health are important in creating a safe school climate.

Prevention programs for cyberbullying are at a nascent stage, reflecting uncertainty about the prevalence of the practice, who is perpetrating it and from where, and how students respond when they are victimized. Many schools have established cyberbullying policies and are increasingly involved with teaching youth about guidelines for appropriate online interactions and monitoring for cyberbullying problems. As of 2016, 23 states included cyberbullying in their state antibullying laws, and 48 states included “electronic harassment.” Although legal remedies are frequently not the most productive answer to bullying and cyberbullying incidents, pediatric clinicians should be aware of local laws and be prepared to refer parents to more information about these laws when necessary. Studies suggest that preventive interventions designed to address bullying have effects on cyberbullying, and vice versa.

The American Academy of Pediatrics (AAP) provides a free online **Family Media Use Plan** that allows families to develop rules for digital media use and prompts for discussions about safety and online relationships with the goal of preventing negative consequences of online behavior and interactions. The tool is designed for ongoing discussions with family members about online experiences and family rules and values.

Visit Elsevier eBooks+ at [eBooks.Health.Elsevier.com](http://eBooks.Health.Elsevier.com) for Bibliography.

## 15.2 Media Violence

Megan A. Moreno

Today’s youth are growing up in a media-rich environment of both traditional and digital media. *Traditional* media includes television (TV), radio, and periodicals; *digital* media includes online content that promotes interactive and social engagement. The online world allows youth instant access to entertainment, information, and knowledge; social contact; and marketing. Social and interactive media allow users to act as both creators and consumers of content. Examples include applications (apps), social media, multiplayer video games, YouTube videos, and video blogs (vlogs).

One of the earliest studies that has been linked to media effects on aggression and violence was the “bobo doll” experiment in which children who observed an aggressive adult model were more likely to be aggressive toward a doll afterward. It has been widely accepted that media exposure can affect behavior; the advertising industry is grounded in the concept that media exposure can change purchasing behavior. Exposure to sexual content in media has been linked to earlier sexual initiation; exposure to pro-alcohol content

# MARC/BACPAC Pediatric Questionnaire: Bullying & Cyberbullying



Date of office visit: \_\_\_\_\_

Child's name: _____	Gender: <input type="checkbox"/> Male <input type="checkbox"/> Female	Parent present during interview? <input type="checkbox"/> Yes <input type="checkbox"/> No
Child's grade: _____	Child's age: _____ years _____ months	Subjective complaints (eg, H/A, tics, sleep): _____
IEP? <input type="checkbox"/> Yes <input type="checkbox"/> No	Neurodev / Psych Dx (if established): _____	_____

**BEGIN BY STATING:**

“You probably know that grownups today are very worried about bullying. I’d like to ask you a little bit about that, but I want to make sure you understand what I mean. When I ask about bullying, I mean another kid (or group of kids) who picks on someone or is mean to them on purpose, over and over again – not just one time.”

**1. Do you see bullying happen at your school?**

Yes  No

**2. Is there any one kid or a bunch of kids that pick on you or make you feel bad over and over again?**

Yes (inquire as to the frequency):

( \_\_\_\_\_ times daily; \_\_\_\_\_ times a week; \_\_\_\_\_ times a month; \_\_\_\_\_ times a year).

**IF NO, SKIP TO #3**

**If YES:**

**Where does this happen? (check all that apply):**

- classroom  lunchroom  hallways
- stairwell  bathroom  locker-room
- playground  bus  other: \_\_\_\_\_

**What did he or she do to you? (check all that apply):**

- made fun of me  kids laughed  name-calling
- rumors  made up lies  got me in trouble
- pushed, shoved, hit, threw stuff  other: \_\_\_\_\_

**3. How about on the computer at home? Has anyone been mean to you or made fun of you on the internet?**

Yes (Details):

\_\_\_\_\_

\_\_\_\_\_

**If NO to both #2 and #3, END HERE. Otherwise, continue.**

Copyright ©2013: Peter C. Raffalli, MD, Elizabeth Englander, PhD

**Fig. 15.1** MARC/BACPAC\* pediatric questionnaire on bullying and cyberbullying. \*Massachusetts Aggression Reduction Center and Bullying and Cyberbullying Prevention and Advocacy Collaborative. (Copyright 2013 Peter C. Raffalli, MD, and Elizabeth Englander, PhD.)

Continued

## MARC/BACPAC Pediatric Questionnaire: Bullying & Cyberbullying



4. It's very important that you understand that if you are being bullied that it is never your fault. Bullying is wrong and people should never bully others. Have you told any adults about the kids that are bothering you?

**Yes (Who have you told?)**

Parent

Teacher

Other: \_\_\_\_\_

If Yes..... Were the adults able to stop the bullying?

Yes  No

If Yes..... Did talking about it make you feel better?

Yes  No ("That's ok. Sometimes talking does help though.")

5. "Sometimes it feels good just to talk about things. I wish you and I had more time to talk about it today. Would you like to have a chance to talk about it sometime soon?"

**Yes (if YES, refer to):**

\_\_\_\_\_

\_\_\_\_\_

**No**

**IF NO...**

..."Would you like me to try to help? As your doctor, I can talk with the school officials and try to make sure that the bullying stops. While I cannot promise that everything will be better, I know that if we do nothing the bullying will likely continue and probably get worse. I want you to be happy and safe at school — is it okay with you if I talk to your school about this?"

**Yes**

(Who would you like me to talk to? Principal / Nurse / Counselor / Teacher / Other: \_\_\_\_\_)

**No**

Copyright ©2013: Peter C. Raffalli, MD, Elizabeth Englander, PhD

Fig. 15.1 cont'd

## MARC/BACPAC Pediatric Questionnaire: Bullying & Cyberbullying



### Guide to the bullying/cyberbullying checklist/interview

**“Warm up” questions: briefly acknowledge these but do not discuss at length. No need to note the child’s answers.**

- › Are the kids in your school friendly?
- › Tell me about one child at your school who you like.
- › Tell me about one child at your school who is not friendly.

**(Brief acknowledgement, e.g.: “Ok” or “that’s good.”)**

*Note: It’s fine to skip the warm-up questions if you have already chatted with the child.*

### Websites for parents/ teachers/students:

The Massachusetts Aggression Reduction Center (MARC): [MARCcenter.org](http://MARCcenter.org)

Bullying And Cyberbullying Prevention and Advocacy Collaborative (BACPAC) at Boston Children’s Hospital: [bostonchildrens.org/BACPAC](http://bostonchildrens.org/BACPAC)

Stop Bullying Now from the U.S. government: [stopbullying.gov](http://stopbullying.gov)

### When a child is being bullied

**There are three venues through which you can help this child:**

- 1. BY GIVING THEM A “SAFE ADULT” AT SCHOOL THEY CAN ALWAYS SPEAK WITH (EG, THE SCHOOL NURSE, THE SCHOOL ADJUSTMENT COUNSELOR);**
- 2. BY GIVING THEIR PARENTS GUIDANCE ABOUT HOW TO COPE (THROUGH HANDOUTS, WEBSITES); AND**
- 3. BY OFFERING THEM SUPPORT FROM YOURSELF.**

If child consents to your involvement, seek written parental consent to share information with the school in writing. The more details the child can provide as to who, what, where, how, the more power the school will have to act. Explain this to the child/parent and do your best to gently get details for your letter to the school. If child or parent will not consent to communication with school, provide advice / handouts ([MARCcenter.org](http://MARCcenter.org)) to help the parent advocate themselves for their child with the school. Always document in your note the conversation in the office.

Copyright ©2013: Peter C. Raffalli, MD, Elizabeth Englander, PhD

Fig. 15.1 cont’d



has been linked to earlier alcohol initiation. However, applying these same constructs to media violence has been controversial. Some suggest that other concepts may be important to consider, such as “dose-response” effects of media or gene-environment interactions.

There are three main types of media in which children may be exposed to violence: video games, traditional media, and social media. **Violent video game** exposure is associated with several outcomes, including increases in composite aggression score, aggressive behavior, aggressive cognitions, aggressive affect, and desensitization; decreased empathy; and increased physiologic arousal. Several mechanisms for these outcomes have been studied. These have included evaluating links between video game violence and the limbic or reward areas of the brain, as well as through other cognitive processes, including skill acquisition, cognitive control, and attention.

**Traditional media** such as movies and TV often model violent behavior for the purposes of entertainment. Media violence does not always portray the real human cost or suffering caused by violence. Special effects can make virtual violence more believable and appealing than in the real world. For some children, exposure to media violence can lead to anxiety, depression, posttraumatic stress disorder, or sleep disorders and nightmares. Repeated exposure to the behavioral scripts provided by entertainment media can lead to increased feelings of hostility, expectations for aggression, desensitization to violence, and increased likelihood of interacting and responding to others with violence.

**Social media** presents similar risks of exposure to virtual violence, but because of the interactive nature of the medium, this content can feel more personal, relevant, or targeted. Social media combines peer and media effects and thereby represents a powerful motivator of behavior, whether content created by adolescents themselves or content they find and share with peers. The Facebook Influence Model describes 13 distinct constructs in which social media may influence users, such as establishing *social norms* and connection to identity. Thus exposure to violent content on social media may have an influence in promoting a social norm or connecting this type of content to one’s own identity.

## SCREENING

It is important for pediatricians to screen and counsel patients and families about media use and exposure to violent content. Both the quantity and the quality of media are critical factors in media effects on children. When heavy media use by a child is identified, pediatricians should evaluate the child for aggressive behaviors, fears, or sleep disturbances and intervene appropriately.

## RECOMMENDATIONS (SEE TABLE 15.1)

Pediatricians can counsel parents to help their children **avoid exposure to any form of media violence under age 8 years**. These younger children do not have the capacity to distinguish fantasy from reality.

Parents should **select and co-view media with their children**, including playing video games with them, watching movies together, and co-viewing social media content. Parents can then assess these games and shows in regard to what they are teaching about communication and interactions with others.

Parents should **feel empowered to place restrictions** on games or shows that reward shooting, killing, or harming other people. Media are powerful teachers, and parents can make choices about how much violence they want their children to learn. Parents can use industry ratings, such as from the Motion Picture Association of America and the Entertainment Software Ratings Board for movies and TV, as well as resources such as Commonsense Media (which also includes video game reviews), to guide media selections.

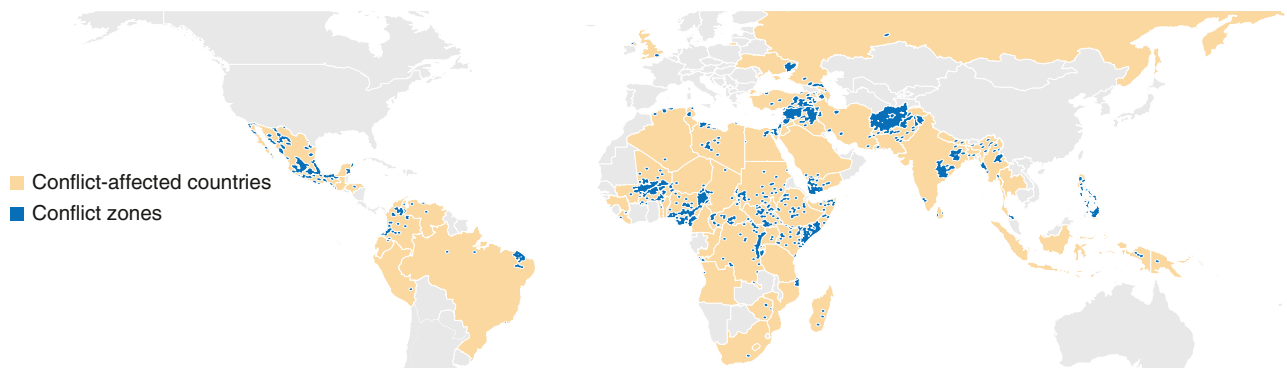
Visit Elsevier Ebooks+ at [eBooks.Health.Elsevier.com](https://eBooks.Health.Elsevier.com) to read this chapter.

## 15.3 Effects of War on Children

Isaiah D. Wexler and Eitan Kerem

The adverse consequences of war on children are devastating and long-lasting—death, injury, loss of family members, conflict-associated sexual violence, food insecurity, forced relocation (prejudice and discrimination in the receiving country), coercive conscription, child abduction, and psychologic trauma. Human rights organizations and the Secretary General of the United Nations annually detail the extent and impact of war on children. These reports clearly establish that war is a global phenomenon associated with a staggering intensity of human rights violations involving children. Approximately 426 million live in a conflict zone, and ~1.6 billion children (0-18 years) live in a conflict-affected country (Fig. 15.2). The recent onset of large-scale hostilities between Russia and Ukraine in 2022 has had a significant impact on children, especially displacement.

During the last decade, there has been an increase in armed conflict-associated exploitation in the form of **human trafficking**, slavery, forced marriages, prostitution, and child labor. **Displacement** and forced relocation are on the rise as a result of the increasing number of intrastate conflicts, especially in the Middle East and Africa. In 2020, UNHCR (**Office of the United Nations High Commissioner for Refugees**) reported the



**Fig. 15.2** Conflict-affected countries and conflict zones, 2019. Overlays of the conflict-affected countries with the conflict zones where actual fighting took place in 2019. Conflicts are usually concentrated in limited geographical areas within countries. (From Østby G, Rustad SA, Tollefsen AF. Children affected by armed conflict, 1990–2019. *Conflict Trends*, vol 6. Oslo: PRIO;2020: Figure 1. <https://www.prio.org/publications/12527>.)

astounding statistic of 82.4 million people forcibly displaced worldwide, with most of the refugees being sheltered in developing countries that lack adequate resources to deal with large-scale humanitarian crises. In Ukraine, the United Nations Office for the Coordination of Humanitarian Affairs reported that 2 million children had been internally displaced at the end of 2022. Reemergence of polio or cholera and the increased virulence of tuberculosis have been associated with conflict-affected regions and large population displacements. The COVID-19 pandemic that began in 2020 has worsened the existing situation, with widespread disruption of health and educational services provided by domestic healthcare systems and humanitarian organizations.

Mortality and morbidity related to the long-term effects of war and civil strife are as significant as those occurring during actual fighting. War and violence are rarely listed as leading causes of childhood mortality, but the regions with the highest levels of child mortality, especially among children <5 years of age, are the same locations involved in military conflicts. Nations experiencing conflict often devote substantial portions of their budgets to military expenditures at the expense of the healthcare infrastructure; a substantial proportion of deaths attributed to malnutrition, environmentally related infectious disease, or inadequate immunization are related to the effects of war. Children experiencing the trauma of wartime violence are at risk for long-term health sequelae, with greater risk for obesity, hypertension, stroke, and cardiovascular disease.

During wartime, customary patterns of behavior are forced to change, overcrowding is frequent, and essential resources, such as water and food staples, may be polluted or contaminated. There is a growing understanding that war and climate change are linked. Armed conflict can worsen the impact of spreading desertification, and competition for scarce resources can serve as a stimulus for war.

The morbidity of children exposed to conflicts is significant and long-term (Table 15.2). Many more children are physically harmed than killed. Children bear the psychologic scars of war resulting from exposure to violent events, loss of primary caregivers, and forced removal from their homes. Impressment of children into service as **soldiers** is a form of *exploitation* associated with long-term problems of adjustment. Child soldiers often lack the appropriate education and socialization, and thus their moral compass is often misaligned. They are often incapable of understanding the sources of conflict or why they have been targeted. Their thought processes are more concrete; it is easier for them to dehumanize their adversaries. Children, who themselves are exposed to violence and cruelty, frequently become the worst perpetrators of atrocities.

After cessation of hostilities, children are still at risk for life-endangering injuries from **landmines**, unexploded ordinance, and other explosive remnants of war. Before the signing of the international treaty to ban landmines in 1997, an estimated 20,000–25,000 casualties occurred annually from landmines. Despite the ban, there are still a significant amount of casualties reported, with over 7,000 casualties in 2020 according to *Landmine and Cluster Munition Monitor*, a nongovernmental organization monitoring adherence to the international treaty. Approximately 30% of these casualties occur in children, with a predominance of males. The continued proliferation of small arms and light weapons, which are easily handled by children, also continues to take its toll on human life and hinders stabilization in post conflict societies.

### SUSCEPTIBILITY OF CHILDREN IN TIMES OF WAR

Children do not have the physical or intellectual capabilities to defend themselves. It is easier for adults to victimize children than other adults. Older children's curiosity, desire for adventure, and imperfect assessment of risk often lead them to participate in dangerous behavior. Younger children, because of their small size and immature physiology, are more susceptible to disease and starvation and are more likely to sustain fatal injuries from ballistic projectiles and explosive devices such as mines. **Blast injuries**, a common cause of violence-related injuries, have a more devastating impact on children than on adults. Specific types of military engagement can have

**Table 15.2** Impact of War on Children

<b>PHYSICAL</b>
Death
Sexual violence (pregnancy, genital trauma, STIs)
Amputations and fractures
Head trauma
Ballistic wounds
Blast injuries
Burns
Chemical- and biologic-induced respiratory disease
Malnutrition and starvation
Infectious disease
Toxicity from polluted natural resources
Torture
<b>PSYCHOSOCIAL</b>
Abduction
Displacement
Loss of caregivers and family members (orphaned)
Child assuming adult roles (labor, parenting sibling)
Separation from community
Lack of education
Inappropriate socialization
Acute stress reaction
Posttraumatic stress disorder
Depression
Maladaptive behavior
<b>EXPLOITATION</b>
Conscription as soldiers
Coerced involvement in terrorist activities
Prostitution
Slavery
Forced adoption

STI, Sexually transmitted infection.

a disproportionate effect on children. In a survey of war-related mortality in Iraq from 2003 to 2008, it was found that approximately 10% of the violence-related fatalities were children. Most children succumbed to either small arms gunfire or suicide bombs (35%). Data collected during the Syrian civil war from 2011 to 2016 showed that 17% of the approximately 100,000 fatal civilian casualties were children, with over 70% of male children succumbing as a result of artillery shelling or aerial bombardments.

During times of war, there is a breakdown of social inhibitions and cultural norms. Exploitation of children, such as forced marriages or involuntary conscription, are rationalized as being beneficial for the greater cause. Aberrant behavior such as rape, torture, and pillaging, which would be inconceivable in times of peace, is common during war. Children may be attacked, kidnapped, or used as human shields.

The changing nature of war has adversely affected children. Conventional warfare in which armies of professional soldiers representing different countries battle each other has become less common since World War II, with the notable exception of the Russia-Ukraine war **Intrastate conflicts** in the form of civil war or insurgency predominate. In 2020, there were over 50 active intrastate armed conflicts in the world, as documented by the *Uppsala Conflict Data Program* (UCDP). These conflicts are often rooted in factious ethnic, political, or religious ideologies, and the participants are frequently nonprofessional irregulars who lack discipline and accountability to higher echelons and are directed by those who do not acknowledge or respect international accords governing warfare. Often the military resources of the antagonists are disproportionate, leading the weaker protagonist to develop compensatory

tactics that can include guerrilla, paramilitary, and terrorist activities, while the stronger side often resorts to the disproportionate use of force. Low-intensity conflicts have become more common. These types of conflicts are often characterized by military activities targeting civilian populations with the goal of disrupting normal routines and generating publicity for the perpetrators. Sites of violence can be remote from the battleground when one or both parties to a conflict resort to terrorist activities.

**Terrorism** and organized urban-based **gang warfare** have become prevalent. Violence perpetrated by terrorist groups or gangs is designed to coerce and intimidate both individuals and entire societies. Children are often intended victims of political- or religious-motivated violence because this serves to maximize the impact of terrorism. The destruction of the New York City World Trade Center Towers in 2001 and the nearly 3,000 fatalities showed that highly organized and motivated terrorists have few inhibitions and can strike anywhere. **Biologic** and **chemical** weapons of mass destruction have been employed, with the most recent example being the use of poisonous gases in the Syrian civil war. Children are more susceptible to chemical and biologic toxins because of their higher respiratory rates, more permeable skin, and other developmental vulnerabilities (see Chapter 763).

The media and the internet have had a significant role in exacerbating the effects of war on children. Media coverage of war and terrorist events is extensive and visual, and social media promulgated via the internet is a convenient tool for disseminating **propaganda** and graphic video material designed to recruit volunteers and shock opponents. Children, more impressionable than adults, often view this material uncontrolled. Uncensored pictures of victims, unbridled violence, people in shock, or family members searching through ruins for relatives may traumatize children and even encourage inappropriate behavior. Overt broadcast propaganda glorifying war and violence may sway children to participate in militaristic or antisocial activities (see Chapter 15.2).

### PSYCHOLOGIC IMPACT OF WAR

Exposure to war and violence can have a significant impact on a child's psychosocial development. Displacement, loss of caregivers, physical suffering, and the lack of appropriate socialization all contribute to abnormal child development. Often the reactions are age specific (Table 15.3). Preschoolers may have an increase in somatic complaints and sleep disturbances and display acting-out behaviors such as tantrums or excessively clinging behavior. School-aged children may show regressive behavior such as enuresis and thumb sucking. They, too, have an increase in somatic complaints; there is often a negative impact on school performance. For teenagers, psychologic withdrawal and depression are common. Adolescents often exhibit trauma-stimulated acting-out behavior. Motivated by the desire for revenge, they may be quick to join in the violence and contribute to the continuation of conflict.

There is an increased incidence of both **acute stress reactions** and **posttraumatic stress disorder** (PTSD; see Chapter 38). The true incidence is difficult to assess because of the heterogeneous nature of war, degree of exposure to violence, and methodologic challenges related to the precise characterization of PTSD. Risk factors for having a more serious psychologic response to a violent event include severity of the incident, personal involvement (physical injury, proximity, loss of a relative), prior history of exposure to traumatic events, female gender, and a dysfunctional parental response to the same event. Children may develop PTSD many years after the traumatic event. Children do not have to be directly exposed to violent activity, and media coverage of terrorist events may be sufficient to trigger PTSD-like symptomatology.

The trauma experienced by children during war can have lifelong effects. Studies on children imprisoned in concentration camps or evacuated from their homes in London during the Battle of Britain show that these individuals were at greater risk for PTSD, anxiety

**Table 15.3** Manifestations of Stress Reactions in Children and Adolescents Exposed to Armed Conflict

#### CHILDREN ≤6 YR

- Excessive fear of separation
- Clinging behavior
- Uncontrollable crying or screaming
- Freezing (persistent immobility)
- Sleep disorders
- Terrified affect
- Regressive behavior
- Expressions of helplessness and passivity

#### CHILDREN 7-11 YR

- Decline in school performance
- Truancy
- Sleep disorders
- Somatization
- Depressive affect
- Abnormally aggressive or violent behavior
- Irrational fears
- Regressive and childish behavior
- Expressions of fearfulness, withdrawal, and worry

#### ADOLESCENTS 12-17 YR

- Decline in school performance
- Sleep disturbances
- Flashbacks
- Emotional numbness
- Antisocial behavior
- Substance abuse
- Revenge fantasies
- Suicidal ideation
- Withdrawal

disorders, and a higher level of dissatisfaction with life when surveyed decades after the traumatic events. Depression is often a comorbid condition associated with PTSD among children exposed to armed conflict. Trauma may have a **transgenerational effect**, with biologic stress responses and environmental influences causing children of PTSD victims to display a wide variety of psychologic disorders. On the positive side, children are more resilient than adults. With appropriate support from family and community, together with timely and intensive psychologic intervention, children can recover and lead normal, productive lives despite the searing trauma that they may have experienced.

### EFFORTS TO PROTECT CHILDREN FROM THE EFFECTS OF WAR

#### International Conventions

War and terror violate the human rights of children, including the right to life, the right to be nurtured and protected, the right to develop appropriately, the right to be with family and community, and the right to a healthy existence. Several international treaties and conventions have been ratified, beginning with the **Fourth Geneva Convention** (1949) that set forth guidelines regarding appropriate treatment of children in times of war. The **United Nations Convention on the Rights of the Child** (1990) delineated specific human rights inherent to every child (defined as any individual younger than 18 years) and the subsequent **First Optional Protocol** (2000), which prohibits conscripting or recruiting children for military activities. The **Third Optional Protocol** in 2014 established methods for communicating complaints of human rights violations involving children to the United Nations Committee on the Rights of the Child and sets up procedures by which the committee can



conduct inquiries into alleged human rights violations among signatory nations. The **Rome Statute of the International Criminal Court** enacted in 2002 declared that the conscription or enlistment of children younger than 15 years is a prosecutable war crime. Despite these conventions and better documentation, human rights violations have not abated. In the past decade there has even been an upswing in the recruitment of child soldiers as combatants by nonstate armed groups (NSAGs).

Although these treaties and conventions define the extent of protection afforded to children, the means of enforcement available to the international community is limited. Individuals, motivated by religious fervor, nationalistic zeal, or ethnic xenophobia, are unlikely to curb their activities because of fear of prosecution. These treaties better serve in heightening awareness regarding the protected status of children in wartime, and perhaps deter high-ranking leaders who fear being held accountable for war crimes.

### Humanitarian Efforts

Several organizations, either nongovernmental or under UN auspices, are involved in mitigating the effects of war on children. The International Red Cross, UNICEF, UNHCR, International Rescue Committee, World Health Organization (WHO), and Médecins Sans Frontières (Doctors Without Borders) have had a significant impact on reducing violence-related casualties in war-torn regions. During the Russia-Ukraine war, many countries sent medical teams including pediatricians to Ukraine and neighboring countries hosting refugees to provide assistance. The infusion of humanitarian aid into developing countries often improves overall mortality and morbidity by increasing the level of medical and social services available to the general population. Other organizations, such as Amnesty International, Stockholm International Peace Research Institute, and Physicians for Human Rights, actively monitor human rights abuses involving children and other civilian groups. In 2005 the UN Security Council approved the establishment of a monitoring and reporting system designed to protect children exposed to war. UN-led task forces conduct active surveillance in war-stricken regions reporting on the **six grave violations against children during armed conflict**: the killing or injuring of children, recruitment of child soldiers, attacks directed against schools or hospitals, sexual violence against children, abduction of children, and denial of humanitarian access for children.

### ROLE OF PEDIATRICIANS AND ALLIED HEALTH PROFESSIONALS

War is a chronic condition, and health providers need to be prepared to treat childhood casualties resulting from military or terrorist activity, as well as caring for children suffering from the aftermath of war or related violence. Community and hospital pediatricians need to be involved in community disaster planning. General disaster planning should not ignore the unique needs and requirements of children; in planning for a possible chemical attack, appropriate resuscitation equipment suitable for children needs to be stockpiled. The signs of biologic infection, chemical intoxication, or radiation injury are different for children, and pediatricians and emergency personnel need to be aware of these differences (see Chapters 758 and 763). Surveys of pediatricians and other healthcare providers indicate that many feel unprepared for bioterrorism attacks. Professional organizations (e.g., WHO, American Academy of Pediatricians [AAP], Centers for Disease Control and Prevention [CDC]) have published position papers, and the AAP *Red Book* presents guidelines for treating specific pathogens likely to be used in **biologic warfare**. In regions

where violent terrorist activity is likely, pediatricians, nurses, and rescue personnel should obtain certification provided by Red Cross Basic and Advanced Trauma Life Support programs. The U.S. Department of Health and Human Services sponsors a *Technical Resources, Assistance Center, and Information Exchange* (TRACIE) website that includes information for health service providers related to disaster management and preparedness for incidents involving children ([asprtracie.hhs.gov](http://asprtracie.hhs.gov)).

Pediatricians need to be aware of the potential effects of war and terror on parents and children. Loss or separation from parents or caregivers has a devastating impact on children (see Chapter 30). Parents, who themselves are under tremendous strain, may not be sensitive to the effects that the same stressors have on their children. Parents and caregivers must be made cognizant of the effect that media coverage can have on their children and their role in the intermediation of the repetitive broadcast of real-time acts of violence and incendiary communications designed to enlist support for specific causes. Pediatricians should draw out both parents and children and encourage them to talk freely about their feelings. Child healthcare providers can be instrumental in educating parents to be more aware of inappropriate responses by children to war and violence. When necessary, pediatricians can serve their families by referring them to appropriate support services.

Just as it is important to administer first aid for physical trauma, it is also critical to provide psychologic first aid to victims of trauma. An excellent source of online information for both providers and caregivers is the **U.S. government-sponsored National Child Traumatic Stress Network** ([nctsn.org](http://nctsn.org)). In day-to-day patient interactions, a pediatrician is most likely to confront situations related to stress reactions such as PTSD or depressive disorders. Recognition of PTSD is essential so that early treatment can be initiated. The *Diagnostic and Statistical Manual of Mental Disorders, Fifth Edition* (DSM-5) stipulates that for a diagnosis of PTSD, there has to be manifestations from each of four symptom clusters: *intrusion, avoidance, negative alterations in cognitions and mood*, and *alterations in arousal and reactivity*. DSM-5 also established a special preschool subtype of PTSD that has the same four symptom clusters but with specific manifestations typical of preschoolers exposed to trauma. Clues to the presence of PTSD and acute anxiety reactions include changes in behavior, school performance, affect, and sleep patterns and an increase in somatic complaints. Even when the triggering event is neither temporally nor physically proximate, it should not dissuade the pediatrician from making an appropriate referral to mental health professionals who are expert in childhood stress disorders.

Medical professional standards demand that the physician treat all patients equitably without regard to their background. Both international law and professional medical societies ban physicians from actively participating in **torture** or other activities that infringe on human rights, including those of children. It is difficult to countenance any situation in which a health professional, even acting as a representative of their country, might directly or indirectly injure a minor. On the positive side, many pediatricians and other physicians have treated children during war either as members of the armed services or volunteers, often under adverse conditions, refusing to abandon their patients even when it has put their own lives at risk. Pediatricians and pediatric organizations have been at the forefront in advocating for peaceful coexistence, assisting in relief efforts, and attempting to alleviate the disparities in healthcare resulting from war.

Visit Elsevier eBooks+ at [eBooks.Elsevier.com](http://eBooks.Elsevier.com) for Bibliography.



## Chapter 16

## Child Trafficking for Sex and Labor

V. Jordan Greenbaum

**Human trafficking** violates the fundamental human rights of affected children, adolescents, and adults and affects families, communities, and societies. Trafficked persons originate from countries worldwide and may belong to any racial, ethnic, religious, socioeconomic, or cultural group. They may be of any gender. According to the United Nations *Protocol to Prevent, Suppress and Punish Trafficking in Persons*, **child trafficking** refers to the “recruitment, transportation, transfer, harboring or receipt of a person” under 18 years old for purposes of exploitation. Two major types of trafficking involve **forced labor** and **sexual exploitation** (Table 16.1). Whereas adult sex trafficking requires demonstration of force, fraud, coercion, deception, or the abuse of power as a means of exploitation, these are *not* required for persons younger than 18 years. Interpretation of the international protocol varies across the globe; U.S. law does not require movement of a victim to qualify as human trafficking. In addition, minors who “consent” to commercial sex in the absence of a third party (trafficker) are victims of commercial sexual exploitation, because their age precludes true informed consent.

Child trafficking may occur within the confines of the child’s home country (*domestic* trafficking) or may cross national borders (*international*, or *transnational*, trafficking). Globally, individuals tend to be trafficked within their own country or to a country in the same region. In the United States, most identified children and adolescents experiencing *sex trafficking* are U.S. citizens or legal residents; few statistical data exist on minors who are trafficked for labor. Variations in definitions of terms, problems with data collection, and underrecognition of affected individuals complicate estimates of the prevalence of human trafficking, but the International Labour Organization estimates that

approximately 3.3 million children and adolescents across the globe experienced forced labor in 2021, of whom approximately 1.7 million were subjected to commercial sexual exploitation. In a global study of officially identified trafficked persons, the United Nations Office on Drugs and Crime estimated that approximately 19% were girls and 15% boys. However, laws that define sexual exploitation in terms of females and women, as well as cultural views regarding gender roles, lead to underreporting of males, especially as victims of sex trafficking, so their numbers may be higher than estimated.

Factors creating vulnerability to human trafficking exist at the individual, relationship, community, and societal levels (Table 16.2). **Age** is an important risk factor for adolescents because they are at a stage in their development at which they have limited life experience, a desire to demonstrate their independence from parental control, and a level of brain maturation that favors risk-taking and impulsive behaviors over careful situational analysis and other executive functions. They are also very interested in social media and are savvy at internet use, which render them susceptible to online recruitment and solicitation.

Recruitment of children and adolescents for labor or sex trafficking often involves false promises of romance, job opportunities, or a better life. Individuals may remain in their exploitative situation for a number of reasons, including **fear of violence** to themselves or their loved ones should they attempt to leave their situation; **guilt and shame** for believing the fraudulent recruitment scheme or engaging in illegal and/or socially condemned activities; **humiliation** and fear of criticism by authorities; **debt bondage** (believing they owe the trafficker exorbitant amounts of money and cannot leave until the debt is paid); and fear of **arrest** and/or **deportation**. Many children and adolescents do not view their situation as exploitative. Females who believe their trafficker is a boyfriend may view their commercial sexual activities as demonstrations of their love; males engaging in commercial sex to obtain shelter or food while living on the street may feel they are exploiting buyers rather than being victimized themselves. Traffickers may use violence, economic manipulation, and psychologic manipulation to control individuals.

### CLINICAL PRESENTATION

Children and adolescents who experience trafficking may seek medical care for any of the myriad physical and emotional conditions associated with exploitation. They may present with traumatic injuries inflicted by traffickers, buyers, or others or injuries related to unsafe working conditions. They may present with a history of sexual assault or symptoms/signs of sexually transmitted infections (STIs) and infections related to overcrowded, unsanitary conditions. They may request testing for HIV or complain of signs/symptoms of HIV or infections endemic to their home country (e.g., malaria, schistosomiasis, tuberculosis). Other clinical presentations may involve pregnancy and complications of pregnancy or abortion; malnutrition and/or dehydration; exhaustion; conditions related to exposure to toxins, chemicals, and dust; and signs and symptoms of posttraumatic stress disorder (PTSD), major depression, suicidality, behavioral problems including aggression, and somatization. Some children and adolescents may have preexisting chronic medical conditions that have been inadequately treated before or during the exploitation (e.g., diabetes, seizure disorder, asthma). Individuals who are trafficked may also seek medical care for their children.

Many of the same factors that prevent children and adolescents from leaving their exploitative conditions also preclude them from disclosing their situation to others. Most affected individuals presenting for medical care at clinics, hospitals, and emergency departments do not spontaneously self-identify as trafficked persons. Consequently, it is incumbent on the medical professional to be aware of risk factors so that those being trafficked and those at risk may be recognized and offered services. A trafficked individual may present to a medical facility alone, in the company of a parent/guardian (who may or may not be aware of the trafficking situation), a friend or other person not involved in the trafficking, a person working for the trafficker (who may pose as a friend or relative),

**Table 16.1** Types of Exploitation Included in Child Trafficking

<b>Sexual Exploitation</b>
Prostitution of a child
Production of child sexual exploitation materials (child pornography)
Exploitation in context of travel and tourism
Having a minor perform sex acts in a sexual venue (e.g., strip club)
Child marriage or forced marriage
Live online sexual abuse
<b>Labor Exploitation</b>
Agriculture, manufacturing, textiles, food/hospitality services
Domestic work
Construction
Magazine sales
Health and beauty
Cleaning services
<b>Forced Begging</b>
<b>Forced Criminality</b>
<b>Forced Engagement in Armed Conflict</b>
<b>Illegal Adoption</b>

**Table 16.2** Risk Factors for Child Trafficking**INDIVIDUAL**

Member of marginalized group (e.g., racial, ethnic, sexual minority, caste)  
 History of sexual/physical abuse or neglect  
 Limited education  
 Unaccompanied immigrant status  
 Substance misuse  
 Homeless/runaway status; told to leave home  
 History of child welfare and/or juvenile justice involvement (U.S., sex trafficking)  
 Untreated mental or behavioral health condition

**RELATIONSHIP**

Family poverty  
 Family violence, substance misuse, or other dysfunction  
 Forced migration  
 Family/peers involved in trafficking  
 Intolerance of LGBTQ+ status  
 Significantly older intimate partner

**COMMUNITY**

Limited resources (economic, educational, social support)  
 Tolerance of trafficking/exploitation  
 Natural disaster  
 Community violence  
 Limited knowledge of trafficking/exploitation  
 Increased tourism, travel to area

**SOCIETAL**

Cultural beliefs about roles and rights of children  
 Gender bias/discrimination  
 Cultural beliefs and practices that marginalize and disempower groups (e.g., transphobia, xenophobia)  
 Tolerance of exploitation  
 Systemic racism and discrimination  
 Tolerance of violence  
 Societal/economic/health inequity and inequality  
 Social or political upheaval  
 Inadequate laws regarding trafficking; corruption

LGBTQ+, Lesbian, gay, bisexual, transgender, queer/questioning, and other.

or the trafficker. Traffickers may be male or female, adult or juvenile, and they may be family members, acquaintances, friends, or strangers. On occasion, children and adolescents are brought in by law enforcement or child protective services because of concerns of trafficking. Table 16.3 lists potential “red flags” for labor or sex trafficking. In some cases, the red flag may be the **chief complaint**, which may involve a condition frequently associated with trafficking (e.g., STI symptoms/signs, especially with history of prior STI, and a preventable work-related injury such as a toxic exposure). The practitioner may become concerned about possible trafficking on recognizing the presence of one or more **risk factors** (e.g., runaway status, recent migration and current work in a sector known for labor trafficking).

### APPROACH TO THE PATIENT AT RISK FOR TRAFFICKING

When interacting with a patient who may have experienced labor or sex trafficking, the medical provider should use a **trauma-informed, human rights-based, culturally appropriate, and gender-sensitive approach** (Table 16.4). This involves an awareness that trauma experienced by a young person may influence the child’s thoughts about themselves and others, their beliefs and perceptions of the world, and their behavior.

**Table 16.3** Potential “Red Flags” for Child Trafficking**RED FLAGS AT PRESENTATION**

Chief complaint of acute physical or sexual assault  
 Chief complaint of suicide attempt or ideation  
 Patient accompanied by unrelated adult or juvenile  
 Patient or parent accompanied by domineering person who appears in hurry to leave  
 Patient or parent appears intimidated or fearful  
 Patient or accompanying person provides inconsistent or unlikely history of events  
 Patient unfamiliar with city/town, cannot provide address where staying

**PHYSICAL FINDINGS**

Patient withdrawn and with flat affect, fearful, very anxious, intoxicated, or with inappropriate affect  
 Evidence of remote or acute inflicted injury (suspicious burns, bruising, signs of strangulation, fractures, closed head injury, thoracoabdominal trauma)  
 Evidence of preventable work injury, toxic exposure, overuse injury, or untreated injury  
 Malnutrition with or without dehydration  
 Poor dentition and/or dental trauma  
 Late presentation of illness/injury

Hostility, withdrawal, or distrust may be reactions to trauma and should be met with a sensitive, nonjudgmental, empathic response by the provider. Physical safety of the patient and staff are critical, and protocols should be in place to address security issues that may arise if the trafficker is on the premises. Psychologic safety of the patient may be facilitated by separating them from any accompanying person when obtaining the medical history, conducting the visit in a warm, child-friendly environment, and taking adequate time to build rapport and begin to establish trust. When interpretation is needed, a professional interpreter should be used. This person needs to be trained in trauma-informed care and should not be from the same community as the patient. When possible, the patient’s preference for gender of clinician and interpreter should be respected.

Respect for the **patient’s rights** is essential, including the right to an explanation regarding the purpose of the questions being asked and the reasons for, and elements of, the examination and diagnostic evaluation. Informed assent by the patient for all steps of the process should be obtained whenever possible. Every attempt should be made to understand and respect cultural, gender-based, and religious factors that may affect the individual’s views of their bodies, their condition, and their desired treatment.

The limits of confidentiality should be explained in a way the patient understands so that they are able to choose what information to disclose. This should occur before asking sensitive questions. As appropriate to developmental stage and the context of the visit, the provider should discuss how sensitive information is to be documented in the individual’s medical record and work collaboratively to honor the patient’s preferences and desire for privacy and confidentiality (within the bounds of laws, policies, and the need to ensure appropriate continuity of care).

Currently, there are limited child trafficking screening tools designed for the healthcare setting. The Short Screen for Child Sex Trafficking (SSCST) is validated for youth 11-17 years who present to emergency departments, child abuse clinics, and teen clinics; this tool screens for risk factors associated with sex trafficking; a positive screen indicates a child is at risk, and additional follow-up questions are needed to assess the level of risk and to determine next steps (e.g., specific service referrals, mandatory reporting). It does not screen for labor trafficking. The Quick Youth Indicators of Trafficking (QYIT) is a short screen designed for young adults

**Table 16.4** Elements of a Human Rights–Based, Trauma-Informed Approach to Patient Care**BASIC RIGHTS**

- Best interest of the child to be primary concern in all actions involving the child
- Protection from discrimination because of gender, race, ethnicity, culture, socioeconomic status, disability, religion, language, country of origin, or other status
- Right to express views and be heard appropriate to the child's age and development
- Right to obtain information relevant to the child to be given in a way that the child can understand
- Right to privacy and confidentiality
- Right to the highest attainable standard of health and to access healthcare services
- Right to dignity and self-respect
- Right to consideration of special needs (e.g., age, disability)
- Right to respect of cultural and religious beliefs and practices

**TRAUMA-INFORMED CARE**

- A strength-based approach that facilitates patient resilience and empowerment.
- Obtain medical history in a private, safe place, outside the presence of persons accompanying the patient to the visit.
- Explain all processes in way the patient understands, and obtain assent for each step; discuss the limits of confidentiality and mandated reporting.
- Encourage the patient to express views and to participate in decision-making regarding referrals and care.
- Foster the patient's sense of control during the evaluation.
- Ask only the questions needed to assess safety, health, and well-being. Avoid asking irrelevant questions about trauma to avoid unnecessarily triggering anxiety and distress.
- Minimize retraumatization during history, examination, and diagnostic testing (avoid triggers of stress when possible).
- Monitor for signs of distress, both verbal and nonverbal.
- Allow the patient to choose the gender of the provider, if feasible.
- Have trained personnel present during the examination to assist with providing support and reassurance.
- Avoid making promises the provider cannot fulfill.
- Put information gathered to good use.
- Work with the child to conduct a safety assessment and create a plan.
- Be prepared to make referrals and offer resources.

(18–25) seeking services at a homeless shelter; it screens for both labor and sex trafficking.

When a provider is speaking with a child at perceived risk for trafficking, additional questions may be asked once trust has been established. These should be asked using a trauma-informed approach. For example,

- “Many children who are living on the street have a hard time getting money for food and shelter. Sometimes they have to exchange sex to get what they need. Has this ever happened to you or anyone you know?”
- When asking about sexual history: “Has anyone ever asked you or forced you to have sex with another person? Do you feel comfortable telling me about it?”
- “If you feel comfortable, can you tell me a little bit about your job? Is the work you do what you expected when you agreed to the job? Are you allowed to keep all of the money you earn or send it home? Where, and with whom, do you live? When you are not working, are you allowed to come and go from the place you stay?”

Such questions may open the door to a discussion of exploitation and facilitate the provider identifying appropriate resources and referrals.

All elements of the medical history and review of systems are important, but special attention should be paid to reproductive history (including sexual orientation and gender identity, prior history of sex partners, STIs, pregnancy and terminations, and condom use); injury history; substance use/misuse; and mental health history and current symptoms. Rates of substance misuse, PTSD, depression, and suicidality are very high among individuals experiencing human trafficking, and questioning may highlight the need for emergency care or nonurgent referrals. It also provides an opportunity for anticipatory guidance aimed at harm reduction: a discussion of condom use, STIs, HIV/AIDS, and substance use may prove invaluable, because many youth lack accurate information on these topics. It is important to identify any chronic conditions, especially if untreated, and to assess vaccination status. Many individuals who have experienced trafficking have had very poor healthcare in the past and lack basic primary care. It is important to ask questions about signs/symptoms of infections endemic to the child's home country or to countries in which the child has been trafficked (e.g., tuberculosis, dengue, malaria; see [Chapter 11](#)).

**EXAMINATION AND DIAGNOSTIC TESTING**

A thorough physical examination allows the provider to assess and treat acute and chronic medical conditions, collect forensic evidence (as appropriate), assess nutritional and developmental status, and document recent and remote injuries. Diagnostic testing may identify pregnancy, STIs, HIV seroconversion, nonsexually transmitted infections, vitamin and mineral deficiencies, anemia, toxic exposures, and drug or alcohol use. A sexual assault evidence kit may reveal trace evidence or DNA from offenders. Informed assent for the exam, assault kit, and diagnostic tests is important, as is careful explanation of each step during the process and monitoring of the patient for signs of distress and anxiety. Those who have been sex-trafficked may experience particular distress during the anogenital examination, the oral exam, and when injuries are photographed. A trauma-trained chaperone is very helpful in providing comfort and support to the patient. The examination should be conducted outside the presence of anyone suspected of being involved in the trafficking situation. After the exam the provider should explain the results, ask the patient if they have any questions about the exam, and give them the opportunity to discuss concerns about their bodies. Individuals who experience trafficking may harbor anxiety about a variety of issues, including possible infertility, future health, or possible permanent damage from work-related injuries and toxic conditions.

Providers may follow U.S. Centers for Disease Control and Prevention (CDC) guidelines on STI testing and prophylaxis. Additional resources on laboratory testing for sexually and nonsexually transmitted diseases may be obtained from the CDC (<https://www.cdc.gov/>) or World Health Organization (WHO) websites (<http://www.who.int/en/>). In general, STIs of greatest relevance include *Neisseria gonorrhoeae*, *Chlamydia trachomatis*, *Trichomonas vaginalis*, HIV, syphilis, and hepatitis B and C viruses. Methods of testing and decisions to treat (e.g., positive test results vs prophylaxis vs syndromic treatment) will depend on national guidelines and on medical resources, which may be limited in some countries or regions. However, consideration should be given to the high likelihood that the patient may be lost to follow-up after the visit, so the decision to delay treatment until test results are available may lead to lack of needed medication. Testing and treatment decisions need to be outlined in a protocol. Emergency contraception and other methods of birth control (especially long-acting reversible contraception) should be discussed with the patient as feasible.

Many individuals who have been trafficked (and children of trafficked adults) have experienced nutritional deprivation, lack of immunizations, and general poor health, especially if they are from low-resource countries or are born into the trafficking situation. Guidance on **medical screening** and care for immigrant children (see [Chapter 11](#)) also may be obtained from the CDC (<https://www.cdc.gov/immigrantrefugeehealth/guidelines/refugee-guidelines.html>) or American Academy of Pediatrics



(AAP) *Red Book or Immigrant Child Health Toolkit* (<https://aapca1.org/resource/aap-immigrant-child-health-toolkit/>). Consideration should be given to vaccine-preventable diseases (including tetanus if there are open wounds) and common diseases in the patient's home country. Trafficked individuals may have iron deficiency, hemoglobinopathies, vitamin D deficiency, and undiagnosed vision or hearing problems. Crowded, unhygienic living conditions during the trafficking period raise the risks of tuberculosis, scabies, and diarrheal illnesses. Toxic levels of lead or chemicals may be present, and vitamin/mineral deficiencies should be considered. A **developmental or educational assessment** is important, given the high likelihood of poor primary care in the past and possible harsh living conditions.

Documentation of overall health and identified injuries is extremely important and should be detailed and accurate. Body diagrams and photographs (if not traumatizing to the patient) are helpful, as are written descriptions of injury location, type (e.g., contusion, laceration), size, shape, and color. All photographs should include patient identifiers and a measuring instrument when possible. Distance photographs to establish injury location may be supplemented with close-up photographs from various angles. Physical signs of untreated illness, malnutrition, and other conditions need to be documented carefully. When documenting the medical history, direct quotes should be used when possible (quotes of provider and of patient statements). Records, including written, video, audio, and photographic records, should be stored in a secure health information system, with limited access and password protection. Strict protocols for patient confidentiality and privacy should be established and followed.

## REFERRALS AND RESOURCES

Before discharge, the provider should ensure the patient understands the results of the evaluation and has the opportunity to ask questions. A **risk assessment** should be done by the provider or other qualified staff, to include a discussion with the individual of safety concerns (involving current risks and perceived risks after discharge). The provider should engage the patient in establishing a **treatment plan** as developmentally appropriate. Transparency and shared decision-making are key elements of a trauma-informed approach. Healthcare providers must comply with mandatory reporting laws in their state or country, but in doing so, should make every effort to avoid causing harm to the patient or their family. If a mandatory report is necessary, this should be discussed with the patient before making the call to authorities, so the individual is aware of actions being taken. For nonmandated referrals, patient permission is needed.

For those practicing within the United States, assistance on interpreting laws, working with individuals who may have been trafficked, making reports to authorities, and identifying local referral sources may be obtained by contacting the **National Human Trafficking Hotline** (1-888-373-7888). The hotline has trained staff to assist trafficked persons and professionals alike, including interpreters for over 200 languages. Additional assistance may be obtained by contacting state or local law enforcement and antitrafficking task forces or local child advocacy centers (free-standing or hospital-based facilities that provide services for children and families who have experienced child abuse and/or neglect). In other countries, "helplines" and "hotlines" may be used to seek assistance for those who are being trafficked and those at risk. It is important for the healthcare provider to be aware of local, state, and national resources for individuals experiencing human trafficking.

Affected patients have numerous needs that extend beyond the range of the healthcare provider's ability to respond. A multidisciplinary team approach is needed to ensure the child is provided with necessary food, shelter, crisis management, language interpretation, immigration assistance, mental health and medical care, educational needs, and other services. Such a team may include local victim service providers, shelter

**Table 16.5** Potential Health Referrals for Trafficked Persons

Behavioral health assessment and treatment (emergent or nonurgent): trauma-focused, preferably conducted by a professional trained in trauma therapies*
Substance use assessment/treatment
Obstetrician/gynecologist
Specialized medical service
Primary medical home (for immunizations including HPV; HIV PrEP; periodic STI testing; monitoring of growth and development; family planning and reproductive health; anticipatory guidance; and nutrition/hygiene counseling)
Physical therapy, occupational therapy
Developmental assessment
Dentist
Optometrist or audiologist
Resources for LGBTQ+ individuals
HIV clinic
Child advocacy center (for second opinion on anogenital exam; forensic interview, behavioral health services)

\*Appropriate therapy may differ with victims from varied cultures; there is a limited evidence base for the effectiveness of behavioral health therapy for children experiencing trafficking. However, in the United States, therapies with an evidence base for child sexual assault/abuse are often adapted for use.

HPV, Human papillomavirus; HIV PrEP: human immunodeficiency virus pre-exposure prophylaxis; STI, sexually transmitted infection; LGBTQ+, lesbian, gay, bisexual, transgender, queer/questioning, and other.

staff, behavioral health professionals, child protective services (CPS) workers, law enforcement, child advocacy center staff, representatives of sexual assault crisis centers, and victim advocates. Potential health-related referrals may be found in **Table 16.5**. To increase the likelihood that the patient and family will obtain the services they desire, it is helpful for the provider to make a "warm handoff" to a referral agency, either contacting agency staff directly or allowing the patient/trusted caregiver to make the call to the agency before leaving the health facility.

Children and adolescents who experience trafficking may face considerable **discrimination** and **social stigma** from the public and from professionals. They may be viewed as "consenting" participants, "illegal immigrants" who somehow "deserve" maltreatment, or "bad" youth who are responsible for their own actions. They may face discrimination related to risk factors such as poverty, gender identity, or systemic racism. In some countries, laws on sexual exploitation do not include boys, and cultural beliefs foster the attitude that males cannot be victimized. This complicates service provision and support for male patients who have experienced trafficking. Variations in the age of consent may result in a child being considered an adult in one country and a child in another, the former condition limiting access to adequate support or increasing the likelihood of being viewed as a criminal offender. For these reasons and others, it is important for the healthcare provider to advocate for the patient's best interests when interacting with other professionals and emphasize the need for comprehensive, sustained, trauma-informed services.

If responsible for long-term care of the patient, the provider should consider that treatment needs change over time, so treatment plans must be reevaluated periodically. Continuity of care is important but can be challenging when the individual is moved to another city, is transported back to the home country, or is re-trafficked. Ongoing communication with external agencies and other healthcare providers can be extremely helpful, along with assignment of a case manager to help ensure referrals are in place in destination towns or villages.

Visit Elsevier eBooks+ at [eBooks.Elsevier.com](http://eBooks.Elsevier.com) for Bibliography.



## Chapter 17

## Abused and Neglected Children

Howard Dubowitz and Wendy G. Lane

The abuse and neglect (maltreatment) of children are pervasive problems worldwide, with short- and long-term physical and mental health, cognitive, social, and economic consequences. Primary care professionals (PCPs) serving children have an important role in helping address this problem. In addition to their responsibility to identify maltreated children and help ensure their protection, health, and well-being, PCPs can also play vital roles related to prevention, treatment, and advocacy. While securing a child's safety is a priority, the child welfare system also aims to improve families' functioning and enable them to adequately care for their children.

**DEFINITIONS**

Abuse is defined as acts of commission, neglect as acts of omission. The U.S. government offers a minimal definition of child abuse as "any recent act or failure to act on the part of a parent or caretaker, which results in death, serious physical or emotional harm, sexual abuse or exploitation, or an act or failure to act which presents an imminent risk of serious harm." Many states include other household members and a broader set of circumstances. Children may face situations in which no actual harm has occurred and no imminent risk of serious harm is evident, yet potential harm is a concern. Many states include *potential harm* in their child abuse laws. This is critical to preventing maltreatment, although predicting harm is inherently difficult. Two aspects should be considered: the likelihood and the severity of the potential harm.

Physical abuse includes beating, shaking, burning, drowning, suffocating, and biting. Physical punishment remains controversial, although it is increasingly being prohibited. The Global Initiative to End All Physical Punishment of Children reported that 62 countries have banned physical punishment in all settings, including the home; 135 have done so for schools, and governments in 27 other countries have committed to full prohibition. In the United States, physical punishment in the home remains lawful in all states, and 20 still permit it in schools.

The threshold for when physical punishment should be considered as abuse is unclear. One can consider any injury beyond transient redness such as from a slap as abuse. Proponents of physical punishment suggest that if parents spank a child, it should be limited to the buttocks, be over clothing, and should never involve the head and neck. When parents use objects other than a hand, the potential for serious harm increases. Acts of serious violence (e.g., throwing a hard object, slapping an infant's face) should be seen as abusive even if no injury ensues; significant potential harm exists. Although some PCPs think that hitting is acceptable under limited conditions, almost all prefer more constructive approaches to discipline. The American Academy of Pediatrics issued a policy statement clearly opposing the use of physical punishment. Although many agree that hitting a child should never be accepted, and research has amply documented the potential harm, there remains a reluctance in the United States to label hitting as abuse—unless there is an injury. Clearly the emotional impact of being hit may leave the most worrisome and lasting scars, long after the bruises fade and the fractures heal.

Neglect refers to omissions in care resulting in actual or potential harm. Omissions include inadequate healthcare, education,

supervision, or protection from hazards in the environment and unmet physical needs (e.g., clothing, food) and inadequate emotional support. A preferable alternative to focusing on caregiver omissions is to instead consider the *basic needs* (or rights) of children (e.g., adequate food, clothing, shelter, healthcare, education, nurturance). Neglect occurs when a need is not adequately met and results in actual or potential harm, whatever the reasons. A broad definition concerned with children's needs fosters a more comprehensive understanding of what contributes to neglect in addition to the potential parental role. A child-focused definition also offers a more constructive approach to ensure a child's needs are adequately met in contrast to one that narrowly focuses on and blames parents. A child whose health is jeopardized or harmed by not receiving necessary care experiences medical neglect. This view enables professionals to approach the problem in terms of what the child needs, rather than focusing on what parents did badly. Not all such situations necessarily require a referral to child protective services (CPS); less intrusive initial efforts may be appropriate.

Psychologic abuse includes verbal abuse and humiliation and acts that scare or terrorize a child. Although this form of abuse may be extremely harmful to children, resulting in problems such as depression, anxiety, poor self-esteem, and lack of empathy, CPS seldom becomes involved because of the difficulty in proving such allegations. PCPs should still carefully consider this form of maltreatment, even if the concern fails to reach a legal or agency threshold for referral. These children and families can still benefit from counseling and other services. Many children experience more than one form of maltreatment; CPS is more likely to address psychologic abuse in the context of other forms of maltreatment.

**INCIDENCE AND PREVALENCE**

Abuse and neglect mostly occur behind closed doors and often remain a dark, well-kept secret. Rates of maltreatment are thus difficult to estimate. Nevertheless, the problem is globally prevalent.

**Global Situation**

The World Health Organization (WHO) estimates that nearly 3 in 4 children, or 300 million children aged 2-4 years, regularly suffer physical punishment and/or psychologic violence at the hands of parents. In addition, as many as 1 in 5 women and 1 in 13 men report having been sexually abused as a child. Less international research has been done on child neglect. Nevertheless, neglect too is clearly a global problem. For example, a large study (n = 41,194) of Balkan countries found lifetime rates of neglect ranging from 23% in Romania to 48% in Bosnia. Among Hong Kong adults, 45% reported a history of childhood neglect. Rates as high as 94% of children for emotional neglect and 89% for physical neglect were found in Burundi, a country severely affected by civil war and political violence. Varying definitions, policies, and practices concerning child maltreatment preclude comparing rates across countries.

**United States**

There were 4.4 million reports to CPS involving 7.9 million children in the United States in 2019. Of the 656,000 children with substantiated reports (8.9 per 1,000 children), 75% experienced neglect (including 2.3% medical neglect), 17.5% physical abuse, 9.3% sexual abuse, and 6.8% psychologic maltreatment. Neglect is by far the most common form of maltreatment referred to CPS, involving 7 per 1,000 children. Although there had been a welcome decline in rates beginning in the early 1990s, rates increased in 2014 and 2015 and stayed stable until the COVID-19 pandemic, when reports of physical abuse increased. Medical personnel made 11% of all reports. Sources other than official CPS statistics indicate that the incidence of maltreatment is far greater than what gets reported to CPS. In a community survey, for example, 3% of parents reported using very severe violence (e.g., hitting with fist, burning, using gun or knife) toward their child in the prior year.

## ETIOLOGY

Child maltreatment seldom has a single cause; rather, multiple and interacting biopsychosocial risk factors at four levels usually interact and contribute to the problem. At the individual level, a child's disability or behavioral challenges or a parent's depression or substance use predispose a child to maltreatment. At the familial level, intimate partner (or domestic) violence jeopardizes children's health and development. Influential community factors include stressors such as dangerous neighborhoods with few supports or recreational facilities. Professional inaction may contribute to neglect, such as when the treatment plan is not clearly communicated or risk factors are ignored. Broad societal factors, such as poverty and its many associated burdens, also contribute significantly to maltreatment. The WHO estimates the rate of child homicide is approximately twofold higher in low-income compared to high-income countries (2.58 vs 1.21 per 100,000 population). Nevertheless, children at all income levels can be maltreated, and PCPs need to guard against biases concerning minoritized and low-income families.

In contrast, protective factors, such as family supports or a parent's concern for their child, may buffer risk factors and protect children from maltreatment. Deliberately identifying and incorporating protective factors is vital to intervening effectively. One can say to a parent who did not fill a prescription, for example, "I can see how much you love [child's name]. What can we do to keep them out of the hospital?" In sum, child maltreatment results from a complex interplay among risk and protective factors. A single parent who has a colicky baby and who recently lost their job has multiple risk factors, but a loving grandparent may be protective. A good assessment and understanding of both risk and protective factors guide an appropriate response.

## OUTCOMES

All forms of child maltreatment jeopardize children's physical and emotional health and their cognitive and social development, manifesting in a wide array of possible problems—in the short and the long term. Problems in adolescence and adulthood include health risk behaviors (e.g., smoking, alcohol, and substance use), mental health problems (e.g., anxiety, depression, suicide attempt), and physical health problems (e.g., heart disease, cancer). Maltreated children are also at risk for becoming maltreating parents. The impact of neuroendocrine stress responses to child abuse and neglect on the developing brain may partly explain some of these sequelae.

Some maltreated children appear to be resilient and function relatively well, perhaps owing to protective factors or interventions. Still, PCPs and parents need to be sensitive to the possibility of later problems ("sleeper effects"). The benefits of intervention have been found in even the most severely neglected children, such as those rescued from Romanian orphanages in the early 1990s, who were adopted—the earlier, the better. That said, resilience is a relative concept, and few severely maltreated children escape unscathed.

## CLINICAL MANIFESTATIONS

Child abuse and neglect can manifest in a myriad of ways (Table 17.1). A critical element of physical abuse is the lack of a plausible history other than inflicted trauma. The onus is on the clinician to carefully consider the differential diagnosis and not jump to conclusions.

Bruises are the most common manifestation of physical abuse. Features suggestive of abuse include (1) bruising in a preambulatory infant (occurring in just 2% of such infants), (2) bruising of padded and less exposed areas (buttocks, cheeks, ears, neck, genitalia), (3) patterned bruising conforming to the shape of an object (Fig. 17.1), and (4) multiple bruises, especially if clearly of different ages. Earlier suggestions for estimating the age of bruises, however, have long been discredited. It is very difficult to precisely age bruises. The **TEN-4 FACESp** mnemonic is useful for when to suspect abuse in children under 4 years of age: torso, ear, neck, frenulum, angle of jaw, cheeks [fleshy], eyelids, subconjunctivae, and patterned, as well as *any* bruise

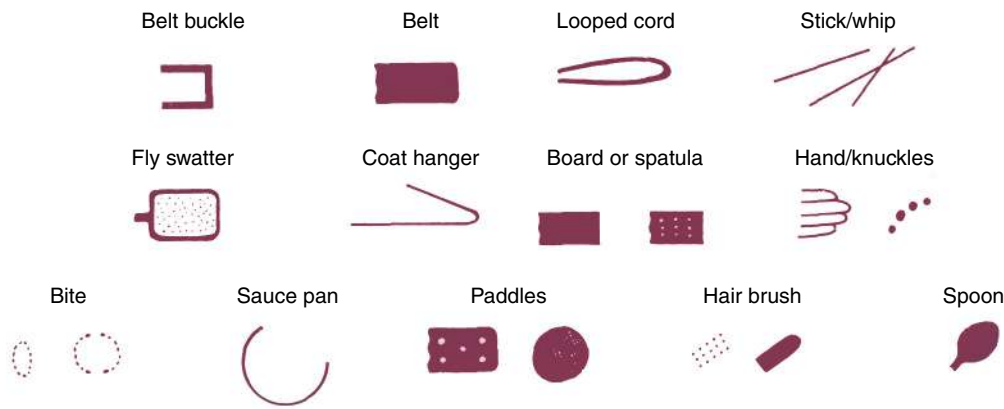
**Table 17.1** Injury Patterns

METHOD OF INJURY/IMPLEMENT	PATTERN OBSERVED
Grip/grab	Relatively round marks that correspond to fingertips and/or thumb
Closed-fist punch	Series of round bruises that correspond to the knuckles of the hand
Slap	Parallel, linear bruises (usually petechial) separated by areas of central sparing
Belt/electrical cord	Loop marks or parallel lines of petechiae (the width of the belt/cord) with central sparing, may see triangular marks from the end of the belt, small circular lesions caused by the holes in the tongue of the belt, and/or a buckle pattern
Rope	Areas of bruising interspersed with areas of abrasion
Other objects/ household implements	Injury in shape of object/implement (e.g., rods, switches, and wires cause linear bruising)
Human bite	Two arches forming a circular or oval shape, may cause bruising and/or abrasion
Strangulation	Petechiae of the head and/or neck, including mucous membranes; may see subconjunctival hemorrhages
Binding/ligature	Marks around the wrists, ankles, or neck; sometimes accompanied by petechiae or edema distal to the ligature mark
Punishment by kneeling on salt or other rough substance	Abrasions/burns, especially to knees
Hair pulling	Traumatic alopecia; may see petechiae on underlying scalp or swelling or tenderness of the scalp (from subgaleal hematoma)
Tattooing or intentional scarring	Abusive cases have been described but can also be a cultural phenomenon (e.g., Māori body ornamentation); may also be a symbol of ownership in a youth being sexually trafficked

in children under 4 months, helps identify suspicious bruises. This prediction rule is 95.6% sensitive and 87.1% specific for identifying abuse.

In nonmobile infants, bruises are considered a **sentinel injury** because of the low likelihood of noninflicted injury. Bruises are the most common injury to be missed or misdiagnosed among children who later present with fatal or near-fatal injuries. Other sentinel injuries include oropharyngeal injuries in children <6 months of age and subconjunctival hemorrhage in healthy children under 4 years of age.

Conditions such as birthmarks, including slate gray nevus (congenital dermal melanocytosis or Mongolian spots), can be confused with bruises and abuse. Other mimics are noted in Table 17.2. These skin markings are not tender and do not rapidly change color or size. An underlying medical explanation for bruises may exist, such as blood dyscrasias (hemophilia) or connective tissue disorders (Ehlers-Danlos syndrome). The history or examination usually provides clues to these conditions. Hemorrhagic edema of infancy and IgA vasculitis (Henoch-Schönlein purpura) is the most common vasculitis in young

**MARKS from INSTRUMENTS**

**Fig. 17.1** A variety of instruments may be used to inflict injury on a child. Often the choice of an instrument is a matter of convenience. Marks tend to silhouette or outline the shape of the instrument. The possibility of intentional trauma should prompt a high degree of suspicion when injuries to a child are geometric, paired, mirrored, of various ages or types, or on relatively protected parts of the body. Early recognition of intentional trauma is important to provide therapy and prevent escalation to more serious injury.

children, and may be confused with abuse. The pattern and location of bruises caused by abuse are usually different from those caused by a coagulopathy. Noninflicted bruises are characteristically anterior and over bony prominences, such as shins and foreheads. However, the presence of a medical disorder does not preclude abuse.

Cultural practices can cause bruising. Cao gio, or coining, is a Southeast Asian folkloric therapy. A hard object is vigorously rubbed on the skin, causing petechiae or purpura. *Cupping* is another approach, popular in the Middle East. A heated glass is applied to the skin, often on the back. As it cools, a vacuum forms, leading to perfectly circular bruises. The context here is important, and such circumstances should not be considered abusive (see [Chapter 12](#)).

A careful history of bleeding problems in the patient and first-degree relatives is needed. If a bleeding disorder is suspected, a complete blood count, including platelet count, prothrombin time, and partial thromboplastin time, should be obtained. More extensive testing, such as for factors VIII, IX, and XIII activity and von Willebrand disease, should be considered in consultation with a hematologist.

Bites have a characteristic pattern of one or two opposing arches with multiple bruises. They can be inflicted by an adult, another child, an animal, or the patient. Forensic odontologists developed guidelines for distinguishing adult from child and human from animal bites. However, several recent studies have identified problems with the accuracy and consistency of bite mark analysis.

Burns may be inflicted, noninflicted, or the result of inadequate supervision. Scalding burns may result from immersion or splash. *Immersion burns*, when a child is forcibly held in hot water, show a clear delineation between the burned and healthy skin and uniform depth ([Fig. 17.2](#)). They may have a sock or glove distribution. Splash marks are usually absent, unlike when a child inadvertently encounters hot water. Symmetric burns are strongly suggestive of abuse, as are burns of the buttocks and perineum. Although most often noninflicted, splash burns may also result from abuse. Burns from hot objects such as curling irons, radiators, steam irons, metal grids, hot knives, and cigarettes leave patterns indicating the object ([Fig. 17.3](#)). A child is likely to try to rapidly escape from a hot object; thus burns that are extensive and deep reflect more than fleeting contact and suggest abuse.

Several conditions mimic abusive burns, such as brushing against a hot radiator, car seat burns, congenital insensitivity to pain syndromes, and folk remedies such as moxibustion. Impetigo may resemble cigarette burns. Cigarette burns are usually 7–10 mm across, whereas impetigo has lesions of varying size. Noninflicted cigarette burns are usually oval and superficial.

Neglect frequently contributes to childhood burns. Children left home alone may be burned in house fires. A parent taking drugs

may cause a fire and be unable to protect a child. Exploring children left unattended may pull hot liquids onto themselves. Liquids cool as they flow downward so that the burn is most severe and broad proximally, often in an inverted triangle pattern. If the child is wearing a diaper or clothing, the fabric may absorb the hot water and cause burns worse than otherwise expected. Burns through clothing tend to have an irregular pattern. Some circumstances are difficult to foresee, and a single burn resulting from a momentary lapse in supervision should not automatically be construed as neglect.

Concluding whether a burn was inflicted depends on the history, burn pattern, and the child's capabilities. A delay in seeking healthcare may result from the burn initially appearing minor, before blistering or becoming infected. This circumstance may represent reasonable behavior and should not be automatically deemed neglectful. A scene investigation by law enforcement is often valuable (e.g., testing the water temperature).

Fractures that strongly suggest abuse include those of the posterior ribs, scapula, sternum, and spinous processes and classic metaphyseal lesions—especially in young children ([Table 17.3](#)). These fractures all require more force than would be expected from a minor fall or routine handling and activities of a child. Rib and sternal fractures rarely result from cardiopulmonary resuscitation, even when performed by untrained adults. The recommended two-finger or two-thumb technique for infants may, however, produce anterolateral rib fractures. Most common in abused infants are rib ([Fig. 17.4](#)), metaphyseal ([Fig. 17.5](#)), and skull fractures. Femoral and humeral fractures in nonambulatory infants are also very worrisome for abuse. In contrast, with increasing mobility and running, toddlers can fall with enough rotational force to cause a spiral, femoral fracture. Multiple fractures in various stages of healing are suggestive of abuse. In some circumstances, such as when there are multiple or repeated fractures or a family history of such, underlying medical conditions need to be considered. Clavicular, femoral, supracondylar humeral, and distal extremity fractures in children older than 2 years are most likely noninflicted unless they are multiple or accompanied by other signs of abuse. Few fractures are pathognomonic of abuse; all must be considered together with the history and child's development.

The differential diagnosis includes conditions that increase susceptibility to fractures, such as osteopenia and osteogenesis imperfecta, metabolic and nutritional disorders (e.g., scurvy, rickets), renal osteodystrophy, osteomyelitis, congenital syphilis, and neoplasia (see [Table 17.2](#)). Some have pointed to possible rickets and low but subclinical levels of vitamin D as being responsible for fractures thought to be due to abuse. The evidence, however, refutes this supposition. Features of congenital or metabolic conditions



**Table 17.2** Mimics of Nonaccidental Trauma**CUTANEOUS LESIONS**

Accidental trauma  
 Congenital coagulation defects (hemophilia, von Willebrand disease)  
 Acquired coagulation defects (aplastic anemia, ITP, leukemia, vitamin K deficiency)  
 Ehlers-Danlos syndrome  
 Vitamin C deficiency  
 Impetigo  
 Vasculitis (IgA vasculitis: Henoch-Schönlein purpura)  
 Dermal melanocytosis (Mongolian spots)  
 Cupping  
 Coining  
 Spooning

**SKELETAL LESIONS**

Osteogenesis imperfecta  
 Obstetric trauma  
 Caffey disease  
 Rickets (not just low 25-hydroxy-vitamin D levels)  
 Hyper-IgE syndrome  
 Recurrent multifocal osteomyelitis  
 Skeletal dysplasias

**HEAD TRAUMA**

Birth trauma  
 Hemophilia  
 Factor XIII deficiency  
 Vitamin K deficiency (malabsorption)  
 Cobalamin C defect  
 Osteogenesis imperfecta  
 Ehlers-Danlos syndrome  
 Glutaric aciduria type I  
 Menkes syndrome  
 Vasculitis (primary CNS, systemic)  
 Benign enlargement of subarachnoid spaces

ITP, Immune thrombocytopenic purpura; IgA, immunoglobulin A; IgE, immunoglobulin E; CNS, central nervous system.

associated with noninflicted fractures include family history of recurrent fractures after minor trauma, abnormally shaped cranium, dentinogenesis imperfecta, blue sclera, impaired hearing, craniotabes, ligamentous laxity, bowed legs, hernia, and translucent skin. *Subperiosteal new bone formation* is a nonspecific finding seen in infectious, traumatic, and metabolic disorders. In young infants, new bone formation may be a normal physiologic finding; it is usually bilateral, symmetric, and less than 2 mm in depth.

The evaluation of a fracture should include a skeletal survey in children less than 24 months of age when abuse seems possible (Table 17.4). Multiple radiographs with different views are needed; “babygrams” (one or two films of the entire body) should be avoided. If a fracture is found or when the survey is normal but concern for an occult injury remains, a follow-up survey should be completed 2 weeks later, as it may reveal fractures not apparent initially. Omission of skull, spine, and pelvis films on repeat survey reduces radiation exposure while still capturing most occult fractures.

In corroborating the history and the injury, the age of a fracture can be crudely estimated (Table 17.5). Soft tissue swelling subsides in 2-21 days. Subperiosteal new bone is visible within 4-21 days. Loss of definition of the fracture line and visible soft callus formation occur on a similar timeline. Hard callus is visible between 14 and 90 days. These ranges are shorter in infancy and longer in children with poor nutritional status or a chronic underlying disease. Fractures of flat bones such as the skull do not form a callus and cannot be aged, although soft tissue swelling indicates recency (i.e., within the prior week).

Abusive head trauma (AHT) results in significant morbidity and mortality. Abusive injury may be caused by direct impact, asphyxia, shaking, or a combination. Subdural hematomas (Fig. 17.6); retinal hemorrhages, especially when extensive and involving multiple layers; brain parenchymal injury; and fractures (often rib and classic metaphyseal lesions) strongly suggest AHT, especially when they occur together. Infants’ poor neck muscle tone and relatively large heads make them vulnerable to acceleration-deceleration forces if severely shaken, leading to AHT. Children may lack external signs of injury, even with serious intracranial trauma. The clinical presentation varies, ranging from nonspecific lethargy, to vomiting (without diarrhea), changing neurologic status or seizures, or coma. In all preverbal children, the possibility of AHT should be considered when children present with these signs or symptoms.

Acute intracranial trauma is best evaluated via CT. CT helps identify bone and soft tissue injury. Some centers use fast-sequence MRI to reduce radiation exposure, but the sensitivity may not be as good as CT. MRIs are helpful in differentiating extraaxial fluid, determining the approximate time of injuries, assessing parenchymal injury, and identifying vascular anomalies. Neck imaging may identify spinal subdural blood and ligamentous, spinal cord, and nerve root injuries. MRIs are best obtained 5-7 days after an acute injury. Other causes of subdural hemorrhage in infants include arteriovenous malformations, coagulopathies, birth trauma, tumor, and infections (see Table 17.2). Glutaric aciduria type 1 can present with intracranial bleeding and should be considered. When AHT is suspected, possible injuries elsewhere—especially skeletal and abdominal—should be ruled out.

Retinal hemorrhages are an important marker of AHT (Fig. 17.7). Whenever AHT is being considered, a dilated indirect eye examination by a pediatric ophthalmologist should be performed. Although retinal hemorrhages can be found in other conditions, hemorrhages that are multiple, involve more than one retinal layer, and extend to the periphery are very suspicious for abuse. The mechanism is likely repeated acceleration-deceleration caused by shaking. Traumatic retinoschisis points strongly to abuse.

With other causes of retinal hemorrhages, the pattern is usually different from that seen in child abuse. After birth, many newborns have them, but they disappear by 2-6 weeks. Coagulopathies (particularly leukemia), retinal diseases, carbon monoxide poisoning, and glutaric aciduria may be responsible. Severe noninflicted direct crush injury to the head can rarely cause an extensive hemorrhagic retinopathy. Cardiopulmonary resuscitation rarely, if ever, causes retinal hemorrhages in infants and children; if present, there are only a few hemorrhages in the posterior pole. Hemoglobinopathies, diabetes mellitus, routine play, minor noninflicted head trauma, and vaccinations do not appear to cause retinal hemorrhage in children. Severe coughing or seizures rarely cause retinal hemorrhages that could be confused with AHT.

The dilemma frequently posed is whether minor, everyday forces can explain the findings seen in AHT. Simple linear skull fractures in the absence of other suggestive evidence can be explained by a short fall, although even that is unusual (1-2%); underlying brain injury from short falls is exceedingly rare. Timing of brain injuries in cases of abuse is not precise. In fatal cases, however, the trauma most likely occurred very soon before the child became symptomatic.

Other manifestations of AHT may be seen. *Raccoon eyes* are associated with subgaleal hematomas after traction on the anterior hair and scalp or a blow to the forehead. Neuroblastoma can present similarly. Bruises from attempted strangulation may be visible on the neck. Choking or suffocation can cause hypoxic brain injury, often with no external signs.

**Oral lesions** may present as bruised lips, bleeding, torn frenulum, and dental trauma or multiple caries (neglect).

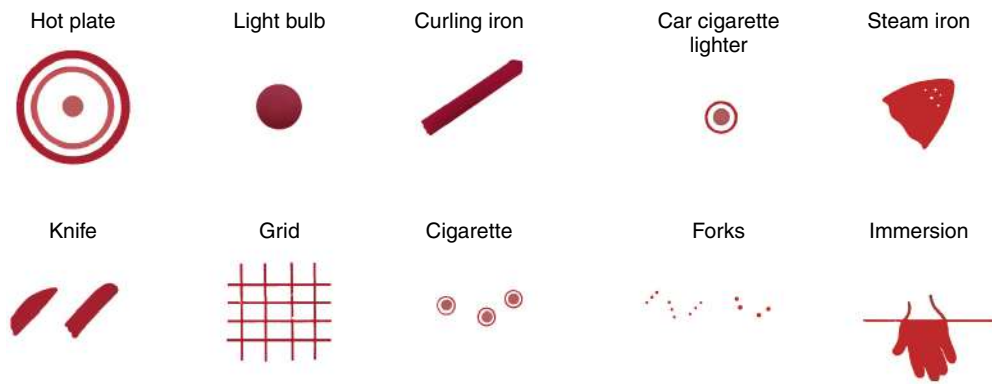
Abdominal trauma also accounts for significant morbidity and mortality in abused children. Young children are especially vulnerable because of their relatively large abdomens and lax abdominal musculature. A forceful blow or kick can cause hematomas of solid organs (liver, spleen, kidney) from compression against the spine, as well as hematomas (duodenal) or rupture (stomach) of hollow organs. Intra-abdominal bleeding may result from trauma to an organ or from





**Fig. 17.2** Immersion injury patterns. A, Sparing of flexural creases. B, Immersion “sock” burn. C, Immersion “glove” burn. D, Immersion buttocks burn. (From Jenny C. *Child abuse and neglect: diagnosis, treatment, and evidence*. Philadelphia: Saunders;2011: Fig. 28-3, p. 225.)

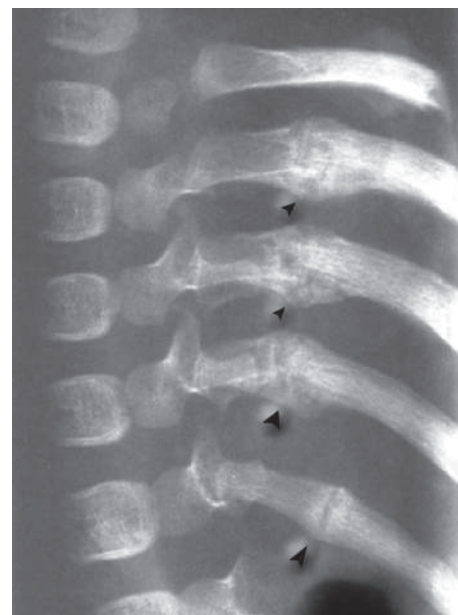
**BURN MARKS**



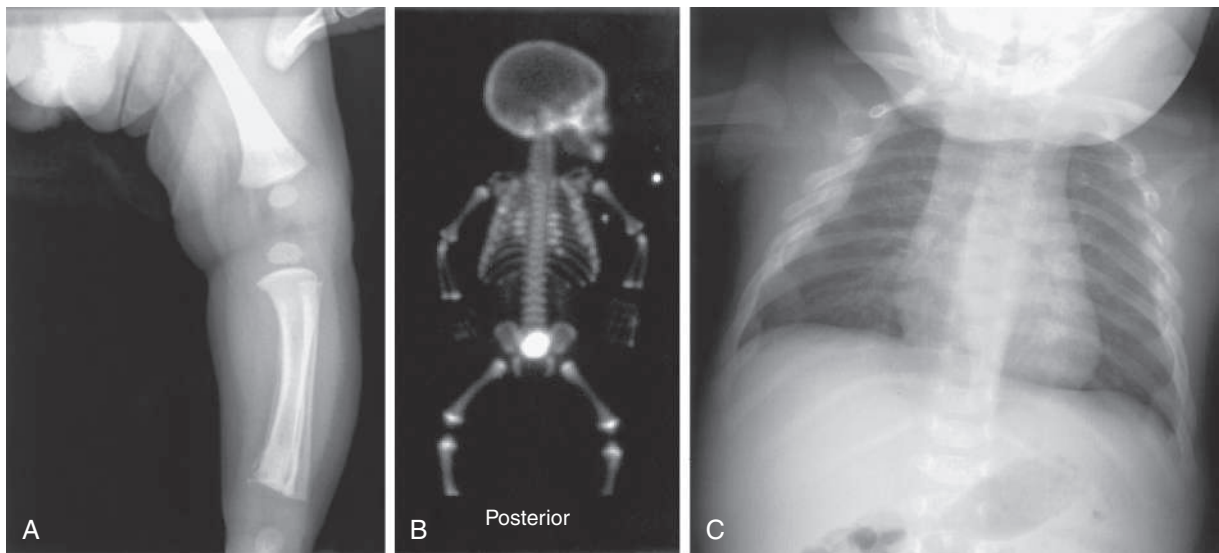
**Fig. 17.3** Marks from heated objects cause burns in a pattern that duplicates that of the object. Familiarity with the common heated objects that are used to traumatize children facilitates recognition of possible intentional injuries. The location of the burn is important in determining its cause. Children tend to explore surfaces with the palmar surface of the hand and rarely touch a heated object repeatedly or for a long time.

Table 17.3	Specificity of Radiologic Findings
<b>HIGH SPECIFICITY*</b>	
Classic metaphyseal lesions	
Rib fractures, especially posteromedial	
Scapular fractures	
Spinous process fractures	
Sternal fractures	
<b>MODERATE SPECIFICITY</b>	
Multiple fractures, especially bilateral	
Fractures of different ages	
Epiphyseal separations	
Vertebral body fractures and subluxations	
Digital fractures	
Complex skull fractures	
Pelvic fractures	
<b>COMMON BUT LOW SPECIFICITY</b>	
Subperiosteal new bone formation	
Clavicular fractures	
Long bone shaft fractures	
Linear skull fractures	

\*Highest specificity applies in infants  
 From Kleinman PK. *Diagnostic imaging of child abuse*, 3rd ed. Cambridge, UK: Cambridge University Press;2015: 24.



**Fig. 17.4** High detail oblique view of the ribs of a 6-month-old infant shows multiple healing posteromedial rib fractures (arrowheads). The level of detail in the image is far greater than what would be present on a standard chest radiograph. (From Dwek JR. *The radiographic approach to child abuse*. *Clin Orthop Relat Res*. 2011;469:776–789, Fig. 4.)



**Fig. 17.5** A, Metaphyseal fracture of the distal tibia in a 3-month-old infant admitted to the hospital with severe head injury. There is also periosteal new bone formation of the tibia, perhaps from previous injury. B, Bone scan of the same infant. The initial chest x-ray showed a single fracture of the right posterior fourth rib. A radionuclide bone scan performed 2 days later revealed multiple previously unrecognized fractures of the posterior and lateral ribs. C, Follow-up radiograph 2 weeks later showed multiple healing rib fractures. This pattern of fractures is highly specific for child abuse. The mechanism of these injuries is usually violent squeezing of the chest.

**Table 17.4** Radiologic Skeletal Survey for Infants and Children under 2 Years of Age\*

- Anteroposterior (AP) and lateral views of skull (Townes view optional; add if any fracture seen)
- Lateral spine (cervical spine [C-spine] may be included on skull radiographs; AP spine is included on AP chest and AP pelvis views to include entire spine)
- AP view, right posterior oblique, left posterior oblique view of chest-rib technique
- AP pelvis
- AP view of each femur
- AP view of each leg
- AP view of each humerus
- AP view of each forearm
- Posteroanterior (PA) view of each hand
- AP (dorsoventral) view of each foot

\*Images are checked by a radiologist before the patient leaves. Poorly positioned or otherwise suboptimal images should be repeated. Lateral views are added for positive or equivocal findings in the extremities. Coned views of positive or equivocal findings (i.e., at ends of long bones, ribs) may be obtained.

Adapted from Coley BD. *Caffey's pediatric diagnostic imaging*, 12th ed. Philadelphia: Mosby;2013: Box 144-1, p. 1588.

shearing of a vessel. More than one organ may be affected. Children may present with cardiovascular failure or an acute abdomen, often after a delay in care. Bilious vomiting without fever or peritoneal irritation suggests a duodenal hematoma, often the result of abuse.

The manifestations of abdominal trauma are often subtle, even with severe injuries. Bruising of the abdominal wall is unusual, and symptoms may evolve slowly. Delayed perforation may occur days after the injury; bowel strictures or a pancreatic pseudocyst can develop weeks or months later. PCPs should consider screening for occult abdominal trauma when other evidence of physical abuse exists. Screening should include liver and pancreatic enzyme levels and testing urine for blood. When results indicate possible injury or if there is concern about possible splenic, adrenal, or hepatic injury, an abdominal CT is indicated.

Neglect is the most prevalent form of child maltreatment, with potentially severe and lasting sequelae. It may manifest in many ways, depending on which basic needs are not adequately met. Nonadherence

**Table 17.5** Timetable of Radiologic Changes in Children's Fractures\*

CATEGORY	EARLY	PEAK	LATE
1. SPNBF	4-10 days	10-14 days	14-21 days
2. Loss of fracture line definition, days		10-14 days	14-21 days
3. Soft callus		10-14 days	14-21 days
4. Hard callus	14-21 days	21-42 days	42-90 days

The time points tend to increase from early infancy into childhood.

\*Repetitive injuries may prolong all categories.

SPNBF, Subperiosteal new bone formation.

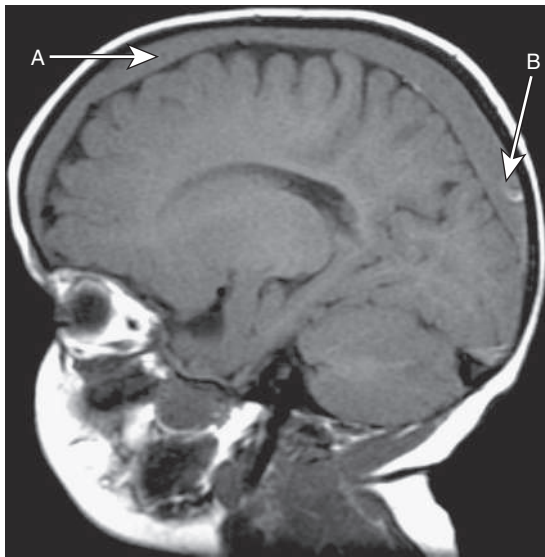
From Kleinman PK. *Diagnostic imaging of child abuse*, 3rd ed. Cambridge, UK: Cambridge University Press;2015: p. 215.

to medical treatment, for example, may aggravate the condition, as may a delay in seeking healthcare. Inadequate food may manifest as impaired growth; inattention to obesity is also a problem. Poor hygiene may contribute to infected cuts or lesions. Inadequate supervision contributes to injuries and ingestions. Children's needs for mental healthcare, dental care, and other healthcare may be inadequately met, manifesting as neglect. Educational needs, particularly for children with learning disabilities, are often not adequately met.

## GENERAL PRINCIPLES FOR ASSESSING POSSIBLE PHYSICAL ABUSE AND NEGLECT

The heterogeneity of circumstances in situations of child maltreatment precludes specific detailing of varied assessments. The following are useful general principles:

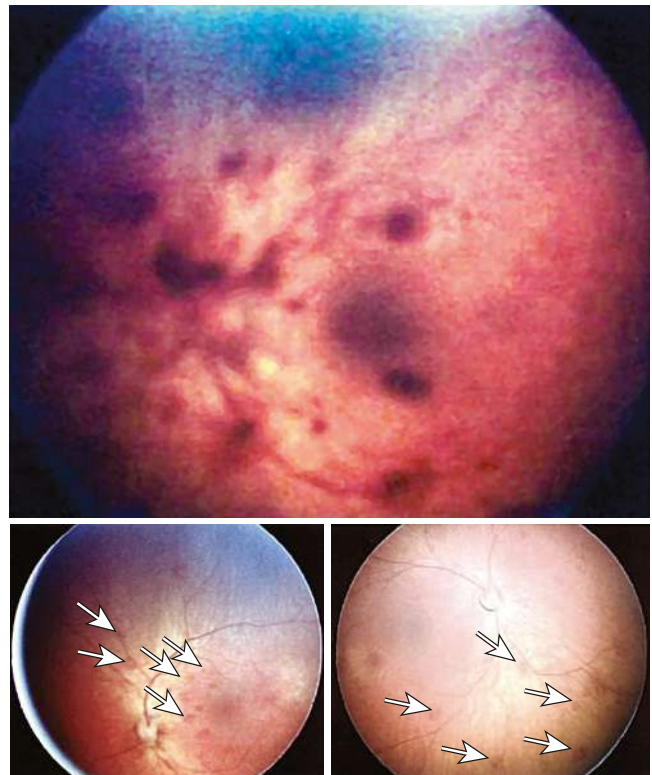
- Given the complexity and possible ramifications of determining child maltreatment, an **interdisciplinary assessment** is optimal, with input from all involved professionals. Consultation with a physician expert in child abuse pediatrics is recommended.
- A thorough **history** should be obtained from the parent(s), optimally via separate interviews.
- Verbal children should be interviewed separately in a developmentally appropriate manner. **Open-ended questions** (e.g., "Tell me what happened") are best. Some children need more directed



**Fig. 17.6** CT scan indicating intracranial bleeding. A, Older blood. B, New blood.

questioning (e.g., “How did you get that bruise?”); others need multiple-choice questions. Leading questions must be avoided (e.g., “Did your daddy hit you?”).

- A thorough **physical examination** is necessary.
- Careful **documentation** of the history and physical is essential. Verbatim quotes are valuable, including the question that prompted the response. Photographs are helpful.
- For **abuse**, the assessment should answer these questions: What is the evidence for concluding abuse? Have other diagnoses been ruled out? What is the likely mechanism of the injury? When did the injury likely occur?
- For **neglect**, the assessment should answer these questions: Do the circumstances indicate that the child’s needs have not been adequately met? Is there evidence of actual harm? Is there evidence of potential harm and on what basis? Suboptimal treatment adherence may not be ideal but lead to few or no consequences. What is the nature of the neglect? Is there a pattern of neglect?
- It may be **difficult to be certain** regarding the likelihood of abuse or neglect. The use of “possible” or “probable” is recommended when uncertain. Inadequacies in the care children receive naturally fall along a continuum, requiring a range of responses tailored to the individual family’s situation. Legal considerations or CPS practice may discourage PCPs from labeling many circumstances as neglect. Even if neglect does not meet a threshold for referring to CPS, professionals can still help ensure children’s needs are adequately met.
- Are there indications of **other forms of maltreatment**? Has there been prior CPS involvement?
- A child’s **safety** is a paramount concern. What is the risk of imminent harm and of what severity?
- What is contributing to the maltreatment? Consider the categories described in the section on etiology.
- What **strengths/resources** are there? This is as important as identifying problems.
- What **treatment or services** do the child and family need? What interventions have been tried and with what results? Knowing the nature of these interventions can be useful, especially from the parent’s perspective.
- What is the **prognosis**? Is the family motivated to improve the circumstances and accept help, or are they resistant? Are needed resources, formal and informal, available?
- Are there **other children** in the home who should be assessed for maltreatment?



**Fig. 17.7** Retinal hemorrhages. Arrows point to hemorrhages of varying sizes.

## GENERAL PRINCIPLES FOR ADDRESSING PHYSICAL ABUSE AND NEGLECT

The heterogeneity of circumstances also precludes specific details regarding how to address different types of maltreatment. The following are general principles:

- Treat any medical problems.
- Help ensure the child’s safety, often in conjunction with CPS; this is a priority. In some instances, hospitalization is the prudent approach.
- Convey concerns of maltreatment to parents, kindly but forthrightly. Avoid blaming. It is natural to feel anger towards parents of maltreated children, but they need support and deserve respect.
- Have a means of addressing the difficult emotions child maltreatment can evoke in us. Self-care is important.
- Be empathic and state interest in helping or suggest another health-care professional.
- Know the laws and/or local CPS policies on referring child maltreatment. In the United States, the legal threshold for referring is typically “reason to believe” (or “reason to suspect”); one does not need to be certain. Physical abuse and moderate to severe neglect warrant a referral. In less severe neglect, less intrusive interventions may be an appropriate initial response. For example, if an infant’s mild failure to gain sufficient weight is caused by an error in mixing the formula, parent education and perhaps a visiting nurse should be tried. In contrast, severe growth faltering may require hospitalization, and, if the contributing factors are particularly serious (e.g., a psychotic mother), out-of-home placement may be needed. CPS can assess the home environment and provide valuable insights.
- Referring child maltreatment to public agencies is never easy. Parental inadequacy or culpability is at least implicit, and parents may become angry. PCPs should supportively inform families directly of the referral to CPS; it can be explained constructively as an effort to clarify the situation and provide help, as well as a professional (and legal) responsibility. Words matter, and “referral” avoids the stigma of “report,” and it is what we commonly



do in healthcare. Explaining what the ensuing process is likely to entail (e.g., a visit from a CPS worker and sometimes a police officer) may ease a parent's anxiety. Parents are frequently concerned that they might lose their child. PCPs can cautiously reassure parents that CPS is responsible for helping children and families and that, in most instances, children remain with their parents. When CPS does not accept a referral or when it is not substantiated, they may still facilitate supportive services such as food, shelter, parenting resources, and childcare. PCPs can be a useful liaison between the family and the public agencies and should try to remain involved after referring to CPS.

- Help address contributory factors, prioritizing those that are most important to the family and amenable to being remedied. Concrete needs should not be overlooked; accessing food programs, obtaining health insurance, enrolling children in preschool, and help finding housing can make a valuable difference. Parents may need their own problems addressed to enable them to adequately care for their children.
- Establish specific objectives (e.g., no hitting, diabetes will be adequately controlled), with measurable outcomes (e.g., urine dipsticks, hemoglobin A<sub>1c</sub>). Similarly, advice should be specific and limited to a few reasonable steps. A written (and perhaps signed) contract can help establish the agreed-upon plan and help ensure it pans out.
- Engage the family in developing the plan—solicit their input and agreement. Motivational interviewing (MI) offers a fundamentally different approach to working with parents (and older children and teens), forging a partnership, and understanding their perceptions of an issue and how they think they can address it. Knowledge and skills regarding MI can enhance the effectiveness of PCPs (see Chapter 18).
- Deliberately identify protective factors or strengths—within and outside the family; there are always some. Incorporating these in one's approach is a valuable way to engage parents and ensure plans get implemented.
- Encourage informal supports (e.g., family, friends; invite fathers to office visits). This is where most people get their support, not from professionals. Consider support available through a family's religious affiliation.
- Consider children's specific needs. Too often, maltreated children do not receive needed services.
- Be knowledgeable about community resources and facilitate appropriate referrals. Consider how to help ensure referrals pan out.
- Provide support, follow-up, and review of progress, and adjust the plan if needed.
- Recognize that maltreatment often requires long-term intervention with ongoing support and monitoring.

### PREVENTION OF PHYSICAL ABUSE AND NEGLECT

An important aspect of prevention is that many of the efforts to strengthen families and support parents should promote children's health, development, well-being, and safety and prevent maltreatment. Medical responses to child maltreatment have typically occurred after the fact; preventing the problem is preferable. PCPs can help in several ways. An ongoing relationship offers opportunities to develop trust and knowledge of a family's circumstances. Astute observation of parent-child interactions can reveal useful information.

Parent and child education regarding medical conditions helps to ensure implementation of the treatment plan and to prevent neglect. Possible barriers to treatment should be addressed. Practical strategies such as writing down the plan can help. In addition, anticipatory guidance helps with positive parenting (see Chapter 20), diminishing the risk of maltreatment. Hospital-based programs that educate parents about caring for a crying infant and the risks of shaking may help prevent AHT.

Screening for and addressing major psychosocial risk factors for maltreatment such as parental depression, substance use, intimate partner violence, major stress, and helping address identified problems, often via referrals, can help prevent maltreatment. Primary care offers excellent opportunities to screen briefly for psychosocial problems. The traditional organ system-focused review of systems can be expanded to probe areas such as feelings about the child, the parent's own functioning, the relationship, possible depression, disciplinary approaches, stressors, and supports. The Safe Environment for Every Kid (SEEK) model offers an evidence-informed approach for pediatric primary care to identify and help address prevalent adverse childhood experiences (ACEs) (e.g., exposure to intimate partner violence, parental depression, or substance use) or social determinants of health (e.g., food insecurity, severe parental stress) that are also risk factors for child maltreatment. This approach should incorporate working with protective factors and use of MI principles in developing a plan jointly with the family.

Obtaining information directly from children or youth is also important, especially given that separate interviews with teens have become the norm. Any concerns identified on such screens require at least a brief assessment and initial management, which may lead to a referral for further evaluation and treatment. More frequent office visits can be scheduled for support and counseling while monitoring the situation. Other key family members (e.g., father, a grandparent) might be invited to participate, thereby encouraging informal support. Some practices arrange parent groups through which problems and solutions are shared. PCPs also need to recognize their limitations and facilitate referrals to other community resources.

### ADVOCACY

PCPs can assist in understanding what contributed to a child's maltreatment. When advocating for the best interest of the child and family, addressing contributory factors at the individual, family, and community levels is optimal. At the individual level, an example of advocating on behalf of a child is explaining to a parent that an active toddler is behaving normally and not intentionally annoying the parent. Encouraging a parent to seek help dealing with a violent spouse, saying, for example, "You and your life are very important"; asking about substance use; and helping parents obtain health insurance for their children are all forms of advocacy.

Efforts to improve family functioning, such as encouraging fathers' involvement in the lives of their children, are also examples of advocacy. Remaining involved after a referral to CPS and helping ensure needed services are provided is advocacy as well. In the community, PCPs can be influential advocates for improving resources devoted to children and families. These include parenting programs, services for abused women and children, and recreational facilities. They can be strong advocates for policies and programs at the local, state, and national levels to benefit children and families. The problems underpinning child maltreatment, such as poverty, parental stress, substance use, and limited child-rearing resources, require policies and programs that enhance families' abilities to care for their children at least adequately. Examples in the United States include Medicaid, the Supplemental Nutrition Assistance Program (SNAP), the Women, Infants, and Children (WIC) program, paid family and medical leave, the Earned Income Tax Credit (EITC), and childcare subsidies.

Child maltreatment is a complex problem without simple solutions. Through partnerships with parents and colleagues in child protection, mental health, education, and law enforcement, PCPs can make an enormous difference in the lives of many children and families.

Visit Elsevier eBooks+ at [eBooks.Elsevier.com](https://www.elsevier.com/ebooksplus) for Bibliography.



## 17.1 Sexual Abuse

Wendy G. Lane and Howard Dubowitz

See also Chapter 162.

Approximately 18% of females and 7% of males in the United States are sexually abused at some point during childhood. Primary care professionals (PCPs) serving children can play several roles in addressing sexual abuse, including identification, referring to child protective services (CPS) and/or law enforcement, testing for and treating sexually transmitted infections, providing support and reassurance, and providing guidance to prevent future sexual abuse. In many jurisdictions throughout the United States, PCPs play a mostly triage role, with the definitive medical evaluation conducted by a child abuse specialist.

### DEFINITION

**Sexual abuse** has been defined as “the involvement of dependent, developmentally immature children and adolescents in sexual activities which they do not fully comprehend, to which they are unable to give consent, or that violate the social taboos of family roles.” Sexual abuse includes exposure to sexually explicit materials, oral-genital contact, genital-to-genital contact, genital-to-anal contact, and genital fondling. Any touching of “private parts” by parents or caregivers in a context other than necessary care is inappropriate. It is important to note that sexual abuse does not have to involve direct touching or physical contact by the perpetrator. Showing pornography to a child, filming or photographing a child in sexually explicit poses, and encouraging or forcing a child to perform sex acts on another all constitute sexual abuse. When these acts occur for financial gain or in exchange for something of value, it is considered sexual exploitation. Recruiting, enticing, harboring, transporting, providing, obtaining, and/or maintaining a minor for the purpose of engaging in sexual acts are forms of sex trafficking (see [Chapter 16](#)), a subset of sexual exploitation.

Some legal definitions distinguish sexual abuse from sexual assault; the former being committed by a parent or caregiver or household member, and the latter being committed by someone without a custodial or any relationship to the child. For this chapter, the term *sexual abuse* encompasses abuse, assault, and exploitation.

### PRESENTATION OF SEXUAL ABUSE

Because physical findings are uncommon and behavioral findings are often nonspecific, a more reliable means of identifying sexual abuse is through a child's history. Some children provide a clear, spontaneous description of abuse to a trusted adult. Other children provide less clear histories, such as not wanting to visit a particular person's home or vaguely saying “something bad happened.” Preschool-aged children and those with limited language skills may be developmentally unable to provide details about sexual acts or timing. Such lack of detail may unfortunately dissuade adults from trusting the account and referring. Because PCPs are mandated reporters, they should have a low threshold for referring young children.

Sexual abuse may be discovered when another person witnesses the abuse or discovers evidence such as sexually explicit photographs or videos. There are also children, with and without symptoms, who will not be identified at any point during their childhood, and perhaps never.

Behavioral changes may be the first indication of possible abuse. Children may exhibit **sexually explicit behavior** outside the norm for their age and developmental level. It can be tricky to distinguish normal from concerning behavior, especially given children's increasing and prevalent exposure to sexual material and information over recent decades. For preschool- and school-age children, behavior thought to be normal includes curiosity about their own body and differences between boys and girls. Touching their own genitals, masturbation, and undressing in front of others are also

common. Worrisome sexual behavior includes compulsive masturbation (i.e., continuing in public areas even after being told to stop), attempting to perform sex acts on adults or other children, or asking adults or children to perform sex acts on them. Teen sexual behavior thought to be normal includes interest in media with sexual themes, looking up sexual information on the internet, demanding more privacy, masturbation, and sexual contact with teens of the same or opposite sex. Worrisome teenage behaviors include sexual promiscuity, engaging in prostitution, and engaging in sexual acts with younger children or with animals. Sexting has become common among teenagers and requires a discussion between parents and teens about its risks. Sexting that involves extortion or trafficking is very concerning; in many states trafficking requires mandated reporting to CPS.

It is important to recognize that in addition to sexual abuse, some sexualized behavior could also result from other exposure (e.g., a child who enters their parents' bedroom at night to find their parents having sex), from neglect (e.g., parents watching pornographic movies where a child can see them), from exposure to sexual behavior by other children who may have been abused or exposed to inappropriate sexual behavior or materials, or from information discussed and shared by peers.

A number of other behavior changes, although not specific for sexual abuse, are common among children who have been sexually abused. These include social withdrawal, acting out, increased clinginess or fearfulness, distractibility, learning difficulties, and behavioral regression such as secondary enuresis. Teenagers may become depressed, experiment with drugs or alcohol, or run away from home. Therefore sexual abuse should usually be considered when addressing a wide variety of child behavior and mental health problems.

Physical signs of sexual abuse are uncommon and are seen in only about 5% of children who undergo medical examination, usually soon after the abuse occurred. The absence of physical findings can often be explained by the type and timing of sexual contact. Abusive acts such as fondling or even digital penetration may not cause any injury. In addition, many children do not disclose abuse until days, weeks, months, or even years after the abuse occurred. Because genital injuries usually heal within days, injuries are generally not seen by the time a child presents for medical evaluation. Clearly, a normal genital exam does not rule out the possibility or probability of abuse and should not influence the decision to refer to CPS. Physical findings that may indicate sexual abuse include genital or anal pain, anogenital bleeding, or discharge. Sexually transmitted infections (STIs), including gonorrhea, chlamydia, and trichomonas beyond the neonatal period, are highly suspicious for abuse. Pregnancy, too, may be the result of abuse. Rarely, there are physical signs of healed trauma, such as a complete hymenal transection (i.e., part of the posterior hymen is missing).

All 50 U.S. states mandate that professionals refer suspected sexual abuse to CPS, and many require reporting of sex trafficking. The specific criteria or threshold for “reason to suspect” is generally not defined by state law. Clearly, referrals do not require certainty that abuse occurred. Therefore it may be appropriate to refer a child with worrisome sexual behavior when no alternative explanation is plausible and the child does not clearly confirm or deny abuse.

### THE ROLE OF THE PCP IN ASSESSING AND ADDRESSING POSSIBLE SEXUAL ABUSE

**Speaking with parents about possible abuse:** When a parent raises concern for sexual abuse, PCPs should have the child leave the room before obtaining additional information from the parent alone to avoid influencing the child. The child healthcare professional should gather details regarding the parent's concern to help discriminate between possible sexual abuse and other behavioral or health issues. For example, parents may be worried about a child's normal sexual behavior, or they may assume that a nonspecific finding such as vulvar irritation is the result of abuse. In these situations, reassurance and treatment

of the medical issue may suffice. PCPs should document the parental concerns, clearly indicating the source of the information. If a child reported abuse to a parent, documentation should include what questions the parent asked to elicit the disclosure or what triggered it. Additional evaluation should include a review of systems for behavioral and urogenital problems. Parents should be asked whether there are other children in the home, school, or childcare who may have been exposed to the alleged offender; this information should be shared with CPS, as these children may benefit from a precautionary interview or exam at the local child advocacy center (CAC). Parents who have experienced sexual abuse themselves may disclose this information to the child healthcare professional, and they may have a heightened concern about abuse of their children and the sequelae. In these situations, the PCP should discuss mental health services for the parent. Some states require reporting of sexual abuse even when the survivor is an adult.

**Speaking with children about possible abuse:** Children with suspected sexual abuse may present to the PCP's office with a clear history of abuse or more subtle indicators. A private, brief conversation between PCP and child provides an opportunity for the child to speak in their own words. Doing this may be especially important when the parent does not believe or support the child. Telling parents that a private conversation is standard in such circumstances can be reassuring.

When speaking with a child, it is essential to **first establish rapport**, starting with general and open-ended questions; for example: "Tell me about school" and "What are your favorite things to do?" It helps to explain the purpose of the evaluation and why it is being done. For example, "Your mom is worried that someone may have hurt you and we want to make sure you're healthy and safe." Questions about sexual abuse should focus on a **minimally adequate history** (i.e., gathering enough information to determine if sexual abuse may have happened and whether there is a need to refer to CPS). If a referral is made to CPS, a multidisciplinary investigation will likely be initiated, including an extensive forensic interview. Questions should also be nonleading (e.g., avoid asking questions such as "who touched you there?"). It helps to explain that sometimes children are hurt or bothered by others and that one wonders whether that might have happened to the child. Open-ended questions, such as "Can you tell me more about that?" allow the child to add information and clarification in their own words. The PCP should document the child's statements in quotation marks and the source. Documenting the questions that elicited the child's response should clarify whether questions were leading or not. Very young children and those with developmental delay may lack the verbal skills to describe what happened. In this situation, the parent's history may provide enough information to warrant a CPS referral without interviewing the child.

**Medical referral:** Because delayed disclosure is common, most children do not need an urgent expert medical evaluation (Fig. 17.8). Indications for one include recent abuse (i.e., within the past 3-5 days), current pain or bleeding, and severe child or parental emotional distress. It is optimal for children suspected of having been sexually abused to be evaluated in a child-friendly setting and by professionals skilled in this field. Because emergency departments may not have a child abuse expert and can be busy, noisy, and lacking in privacy, examination at an alternative location such as a CAC or outpatient clinic is preferable, when possible. If the exam is not urgent, it is best that the evaluation be done at a time when the child is not tired and cranky.

Referring PCPs should be familiar with the triage procedures in their communities, including the referral sites for both acute and nonacute evaluations, timeframes for when an evaluation is considered acute, and whether there are different referral sites for prepubertal and postpubertal children. Depending on the jurisdiction, the site may be an emergency department, a CAC, or an outpatient clinic. For the *prepubertal child*, if abuse is thought to have occurred in the previous 72 hours and history suggests direct contact, forensic evidence collection (e.g., external genital, vaginal, anal, and oral swabs, sometimes referred to as a *rape kit*) may be indicated, and the

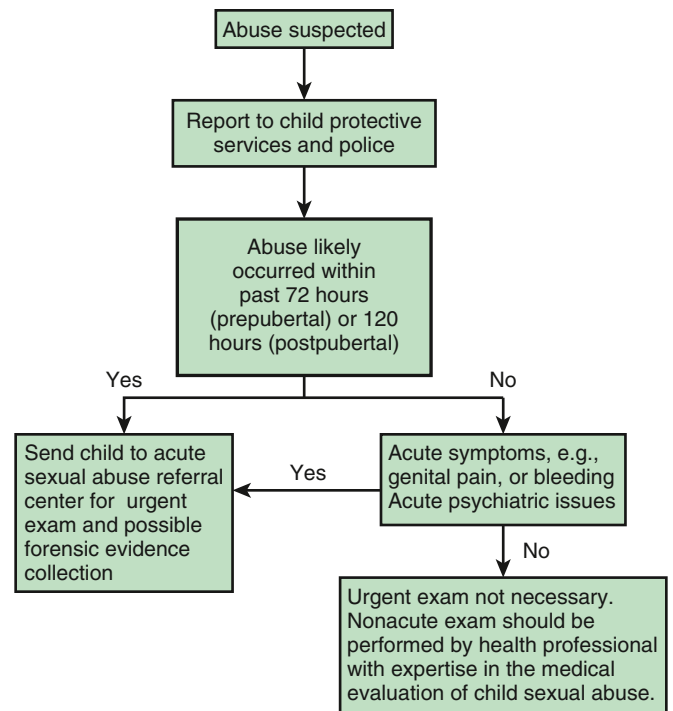
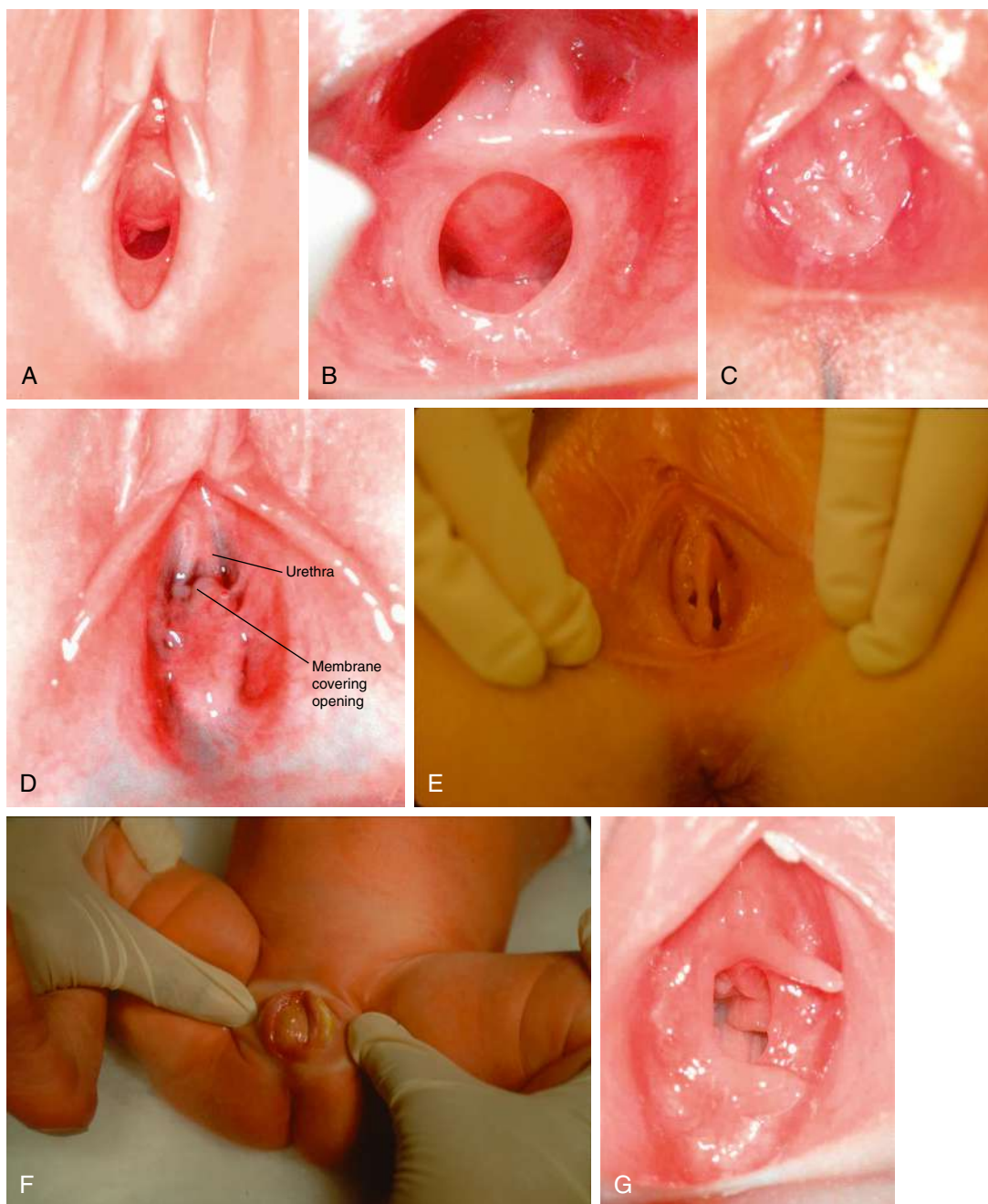


Fig. 17.8 Triage protocol for children with suspected sexual abuse.

child should be referred to a site equipped to do this. Some centers may have shorter or longer cutoffs (e.g., 24 hours or 5 days). If the last suspected incident of abuse occurred more than 72 hours prior, the likelihood of recovering forensic evidence is extremely low, making forensic evidence collection unnecessary. For *postpubertal females*, it is recommended that forensic evidence be collected up to 120 hours after the abuse—as for adult women. The extended timeframe relates to semen possibly remaining in the postpubertal vaginal vault for more than 72 hours. Some jurisdictions extend the time for collecting forensic evidence up to 10-15 days if there has been penetration and possible ejaculation. The National Institute of Justice suggests considering a 9-day time frame based on one study.

**Physical examination of the child with suspected sexual abuse:** Children suspected of having been sexually abused may benefit from a brief evaluation and examination of their anogenital area to determine whether and when an expert medical evaluation is needed. Unfortunately, many physicians are unfamiliar with genital anatomy, particularly in the prepubertal girl (Figs. 17.9 and 17.10). Nevertheless, signs of trauma such as bruising, abrasions, and bleeding or of infection may be apparent. Because about 95% of children who undergo a medical evaluation after sexual abuse have normal exams, the role of the PCP is often simply to be able to distinguish a normal exam from findings indicative of common medical concerns (e.g., diaper dermatitis) or trauma, or to reassure a parent whose preschooler is touching himself. Unsuspected injuries or medical problems such as labial adhesions, imperforate hymen, or urethral prolapse may be identified. In addition, reassurance about the child's physical health may often allay anxiety for the child and family.

When concerns about sexual abuse arise because of genital findings or complaints, it is important to assess for and rule out medical problems that can be confused with abuse. Several genital findings may raise concern about abuse but often have alternative explanations. For example, genital redness in a prepubertal child is usually caused by nonspecific vulvovaginitis, diaper dermatitis, or infection with a nonsexually transmitted organism such as staphylococcus or

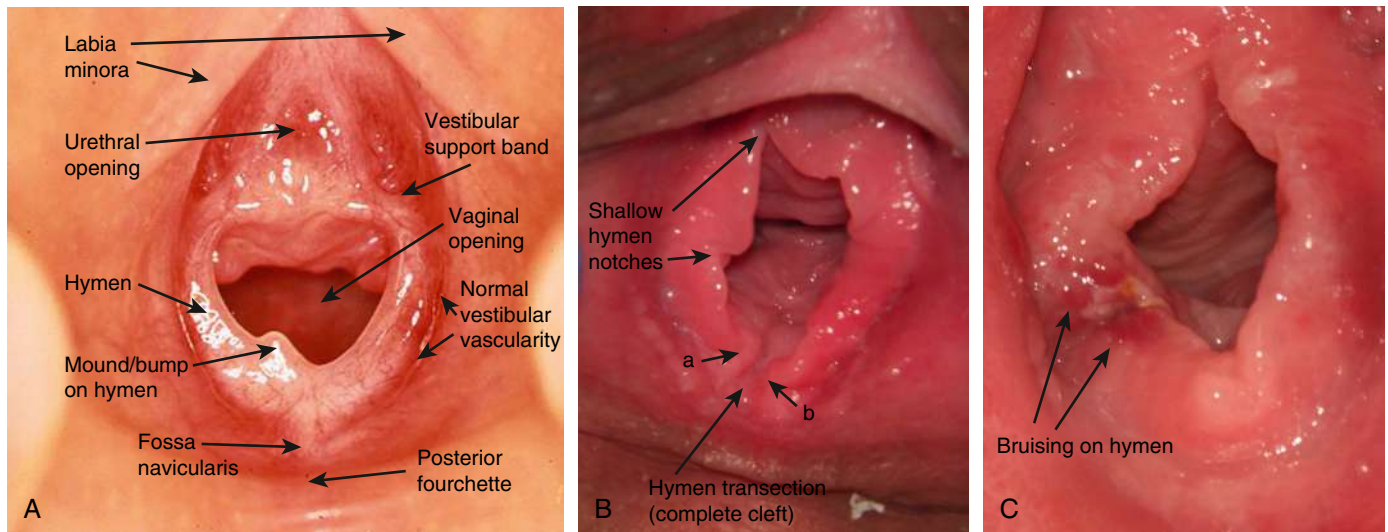


**Fig. 17.9** Types of hymens. A, Crescentic. B, Annular. C, Redundant. D, Microperforate. E, Septated. F, Imperforate. G, Hymeneal tags. (A-D and G from McCann JJ, Kerns DL. *The Anatomy of Child and Adolescent Sexual Abuse*. St. Louis: InterCorp, 1999; E and F from Perlman SE, Nakajima ST, Hertweck SP. *Clinical Protocols in Pediatric and Adolescent Gynecology*. London: Parthenon Publishing Group, 2004. Figs. 25.5 and 25.9.)

group A streptococcus. It is often apparent that the diffuse redness is unlikely to be the result of trauma. Lichen sclerosus is an uncommon cause of redness and usually presents with vulvar and/or perianal atrophy and hypopigmentation, often in a figure 8 pattern. Vaginal discharge can be caused by STIs, but also by poor hygiene, foreign body, the onset of puberty, or infection with *Salmonella*, *Shigella*, or *Yersinia*. Genital ulcers can be caused by herpes simplex virus (HSV) and syphilis, but also by Epstein-Barr virus, varicella-zoster, Crohn's disease, and Behçet's disease. Genital bleeding can be caused by urethral prolapse, vaginal foreign body, or noninlicted trauma.

The medical exam should begin with a general exam of the child. Doing so enables the child to become comfortable with the exam process before the genital exam and may identify other evidence of maltreatment or health problems. For prepubertal children, the parent should be present to provide comfort and reassurance. Older children should be given the option of having a parent present. The American Academy of Pediatrics (AAP) recommends that whenever "private" parts are examined (i.e., genitals, breast, anus), a chaperone should be present. In prepubertal children, this can be a parent. For adolescents, the chaperone should be a clinical staff member, unless the teen objects. If so, the PCP may have a parent be present if all three





**Fig. 17.10** **A**, Photograph taken with a camera attached to colposcope at 10× magnification. Note the increased vascularity and redness in the vestibule adjacent to the hymen on the right and left. This is a normal finding and not to be mistaken for signs of trauma. **B**, Photograph taken with a camera attached to colposcope at 10× magnification shows the appearance of the hymen in an adolescent. Shallow notches in the hymen are evident at the 9 and 11 o'clock positions, as well as hymen transection at approximately 7 o'clock. There is no hymen tissue between arrow *a* and arrow *b*, confirming that the defect extends all the way through the hymen tissue. **C**, Photograph taken with a camera attached to a colposcope shows bruising of the hymen at the 7 to 8 o'clock position and the suggestion of a possible hymen laceration. Examination of additional positions and other examination techniques would be required to determine if a hymen laceration is also present at this location. (From Adams JA, Kellog ND, Moles R. Medical care for children who may have been sexually abused: an update for 2016. *J Pediatr Adolesc Gynecol.* 2015;17(4):255–263. Figs. 1, 2, and 4.)

are amenable. The PCP may decline to do an exam if the teen refuses a chaperone.

The female genital exam is done with the child in the frog-leg supine position or the adolescent in the lithotomy position. Labial separation and labial traction, with gentle tugging apart and down of the labia majora, provide a view of the hymen. Any suspected abnormalities should be confirmed by also examining the child in the prone knee-chest position. Supine knee-chest is the best way to examine the anus. Internal vaginal and anal exams are rarely needed. If there is significant bleeding or a persistent discharge, a referral to an expert in child abuse is recommended.

**Referral to a child abuse specialist:** Referral to a child abuse specialist will help ensure that findings indicative or suggestive of abuse are appropriately identified and documented. It is considered the standard of care to use a colposcope or camera for the genital exam to magnify the genital and anal tissues for improved visualization and to take photographs or video as potential evidence and for peer review. Child abuse experts can identify mimics of sexual abuse, test for and treat STIs, and address child or parental concerns.

**Testing for STIs:** Testing for STIs is not indicated for most children but is warranted in certain situations (Table 17.6). Culture was considered the gold standard for diagnosing vaginal gonorrhea (Chapter 238) and chlamydia (Chapter 272) infections in children. Nucleic acid amplification testing (NAAT) for gonorrhea and chlamydia by either vaginal swab or urine in prepubertal girls is as, or more, sensitive than culture. Guidelines from the Centers for Disease Control and Prevention (CDC) allow for such NAAT testing as an alternative to culture. Because obtaining vaginal swabs can be uncomfortable, particularly for prepubertal girls, urine testing is preferable, using a Food and Drug Administration (FDA)-approved assay. Although the FDA has not approved NAATs for the diagnosis of gonorrhea or chlamydia infections of the throat or anus, they may be used if the laboratory has performed internal validation with reference standards. Although little data on the use of urine NAAT testing in prepubertal boys are available, the CDC has indicated that there is no reason to suspect that test performance in children and youth would be different from adults. Thus urine testing of them too appears adequate.

**Table 17.6** Indications for STI Screening in Children with Suspected Sexual Abuse

1. The child has experienced penetration or has evidence of recent or healed penetrative injury to the genitals, anus, or oropharynx.
2. The child has been abused by a stranger.
3. The child has been abused by an assailant known to be infected with an STI or at high risk for STIs (e.g., injecting drug user, men who have sex with men, persons with multiple sexual partners, or person with a history of STIs).
4. The child has a sibling, other relative, or another person in the household with an STI.
5. The child lives in an area with a high rate of STIs in the community.
6. The child has signs or symptoms of STIs (e.g., vaginal discharge or pain, genital itching or odor, urinary symptoms, or genital lesions or ulcers).
7. The child or parent requests STI testing.
8. The child is unable to verbalize details of the assault.

STI, Sexually transmitted infection.

From Workowski KA, Bachmann LH, Chan PA, et al. Sexually transmitted infections treatment guidelines, 2021. *MMWR Recomm Rep.* 2021;70(4):1–184.

For all NAAT testing in females and males, the child should *not* receive presumptive treatment at the time of testing. Instead, a positive NAAT test should be confirmed by repeating the test on the original sample or on a new sample. Whereas the CDC previously recommended confirmatory testing with a different FDA-approved assay, the 2021 Sexually Transmitted Infection Treatment Guidelines no longer require this. Gonorrhea and chlamydia in prepubertal children rarely cause ascending infection; thus waiting for a definitive diagnosis before treatment holds little risk for pelvic inflammatory disease.

Testing for *Trichomonas vaginalis* is by culture, NAAT, or wet mount. Wet mount requires the presence of vaginal secretions, viewing must be immediate for optimal results, and sensitivity is only



**Table 17.7** Implications of Commonly Encountered Sexually Transmitted or Sexually Associated Infections for Diagnosis and Reporting of Sexual Abuse Among Infants and Prepubertal Children

INFECTION	EVIDENCE FOR SEXUAL ABUSE	SUGGESTED ACTION
Gonorrhea*	Diagnostic†	Report†
Syphilis*	Diagnostic	Report†
HIV§	Diagnostic	Report†
<i>Chlamydia trachomatis</i> *	Diagnostic†	Report†
<i>Trichomonas vaginalis</i> *	Diagnostic	Report†
Anogenital herpes	Suspicious	Consider report†,¶
Condylomata acuminata (anogenital warts)*	Suspicious	Consider report†,¶,**
Anogenital molluscum contagiosum	Inconclusive	Medical follow-up
Bacterial vaginosis	Inconclusive	Medical follow-up

\*If unlikely to be perinatally acquired and vertical transmission, which is rare, is excluded.

†Reports should be made to the local or state agency mandated to receive reports of suspected child abuse or neglect.

§If unlikely to have been acquired perinatally or through transfusion.

¶Unless a clear history of autoinoculation exists.

\*\*Report if evidence exists to suspect abuse, including history, physical examination, or other identified infections. Lesions appearing for the first time in a child aged >5 yr are more likely to have been caused by sexual transmission.

From Workowski KA, Bachmann LH, Chan PA, et al. Sexually transmitted infections treatment guidelines, 2021. *MMWR Recomm Rep*. 2021;70(4):1–184. Adapted from Kellogg N, American Academy of Pediatrics Committee on Child Abuse and Neglect. The evaluation of sexual abuse in children. *Pediatrics*. 2005;116:506–512; Adams JA, Farst KJ, Kellogg ND. Interpretation of medical findings in suspected child abuse: An update for 2018. *J Pediatr Adolesc Gynecol*. 2018;31:225–231.

44–68%; therefore false-negative tests are common. NAAT tests for *Trichomonas* should only be performed using FDA-approved products. Positive tests should be confirmed using the same sample or a repeat collection. Point-of-care tests for *Trichomonas*, done at the PCP's office, have not been validated for prepubertal children and should not be used.

Obtaining a blood sample for HIV, syphilis, and hepatitis B testing should be considered, particularly if there has been vaginal or anal penetration with pain, bleeding, or ejaculation. To limit painful procedures, some experts begin with genital, anal, and/or throat testing and do the blood testing if the earlier testing is positive. Because HIV testing identifies antibodies to the virus, it may take several months for seroconversion—repeat testing at 6 weeks and 3 months after the last suspected exposure is indicated. Repeat testing for syphilis and hepatitis B is also recommended at the same intervals.

## INTERPRETATION OF FINDINGS

**History:** A clear disclosure of abuse by a child or adolescent, particularly with details that can be corroborated, is strong evidence that abuse has occurred. A strong denial could indicate that abuse did not occur, but could also be the result of fear, threats from the perpetrator, or pressure from family members to remain silent. Limited language skills or a long length of time since the abuse occurred may limit the specificity of the disclosure. Alternatively, a vague disclosure may lead a parent to assume abuse when none has occurred. Infrequently, a child may be coached by a parent to describe abuse, sometimes in the context of a custody dispute. More commonly, an abusive parent will allege coaching to protect themselves and enable ongoing access to the child.

**Findings indicative of trauma:** Abrasions, lacerations, and bruising of the labia, vulva, penis, scrotum, perianal tissues, or perineum indicate recent trauma. Hymenal bruising and lacerations and deep perianal lacerations (vs superficial fissures) indicate penetrating trauma. Anogenital scars indicate older trauma. Hymenal scars often appear as changes in the usual anatomy and pallor. It is noteworthy that such findings that are exactly midline are likely normal embryonic remnants. A complete transection of the hymen all the way to

the base below 3 and 9 o'clock in the supine position (i.e., absence or gap of hymenal tissue posteriorly) is considered diagnostic for penetrating trauma (see Fig. 17.10). For all these findings, the cause of injury must be elucidated through the child and parent history, as trauma may also be the result of a noninjured injury or consensual sexual activity. If there is any concern that the finding may be the result of sexual abuse, CPS should be notified, and a medical evaluation should be performed by a medical specialist with expertise in child sexual abuse.

**STIs:** A number of STIs raise serious concern for abuse (Table 17.7). In a prepubertal child, **gonorrhea**, **trichomonas**, or **syphilis** beyond the neonatal period indicates that the child had contact with infected genital secretions, almost always as a result of sexual abuse. There is some evidence to indicate that **chlamydia** in children up to 3 years of age may be perinatally acquired. Chlamydia in children older than 3 years is diagnostic of contact with infected genital secretions almost always because of abuse. **HIV** is diagnostic for sexual abuse if other means of transmission have been excluded. Because of the potential for human papillomavirus (HPV) transmission, either perinatally or through nonsexual contact, the presence of **genital warts** has a low specificity for sexual abuse. Nevertheless, the possibility of abuse should be briefly probed with the family, especially in children whose warts first appear beyond 5 years of age. **Type 1 or 2 herpes simplex virus (HSV)** in the anogenital area is concerning for sexual abuse, but not diagnostic given other possible routes of transmission. PCPs should consider referring patients with HPV and HSV to CPS.

## Integration of Information

Because most sexually abused children have normal exams, it is often not possible to make a diagnosis of sexual abuse by the exam alone. Ideally, the determination of abuse should be made as part of a multidisciplinary team process, where information from interviews, medical evaluation, forensic kit, and laboratory test results are integrated. Determinations by CPS as to whether abuse occurred may not align directly with a decision to prosecute alleged offenders because criminal cases require a higher level of proof (beyond a reasonable doubt) than do CPS cases, which rely on the preponderance of evidence (i.e., more likely than not).

### Recommendations for Children and Families

At the conclusion of the medical evaluation, the PCP should let the child and parent know that the child is physically healthy but should also explain to them why a normal exam does not rule out abuse. It is often helpful to reinforce that in most cases, what is most important in determining whether sexual abuse occurred is what the child has said. When there are findings indicative of abuse, these should also be clearly explained. Of note, injuries to the anogenital area typically heal without complications, and most STIs respond well to treatment. Thus comforting and reassuring children and families is generally appropriate, even when injuries and/or infection occurs. PCPs should tell children that the abuse was not their fault and encourage parents to be supportive of their child. Although most children will not need medical follow-up, a visit with their PCP can be helpful to monitor psychosocial progress and to support the child and family. Some will need repeat HIV, syphilis, and hepatitis B testing. Hepatitis B and HPV vaccination (for children  $\geq 9$  years) should be given if the child has not been adequately vaccinated. Most children and their parents benefit from therapy or counseling. A mental health evaluation for other children in the home should be considered; the stress of coping with abuse and its ramifications can be difficult for the entire family. Parents are often very stressed by the sexual abuse of their child, even when it is uncertain what happened. This is compounded by the legal processes and implications. If emotional or behavior problems arise later, the PCP should try to refer the child to a mental health professional with experience in addressing trauma.

### SEXUAL ABUSE PREVENTION

PCPs can play a role in the prevention of sexual abuse by educating parents and children about sexual safety at well-child visits. During the genital exam the PCP can inform the child that only the doctor and select adult caregivers should be permitted to see their “private parts” and that a trusted adult should be told if anyone else attempts to do so. Parents and children should be encouraged to use correct terms (vagina, vulva, penis, breasts) to demystify the genitals. The pediatrician can teach parents, children, and youth how to minimize the opportunity for perpetrators to access children, for example, by limiting one-adult/one-child situations outside the home (e.g., in daycare or school) and being sensitive to another adult’s unusual interest in young children. In addition, PCPs can model for parents talking with children about what to do if confronted with a potentially abusive situation. Some examples include telling children to say “no,” to leave, and to tell a parent and/or another trusted adult. Conversations with children of all ages can include a discussion of consent before touching another person. Conversations with teens can include information about statutory rape and electronic dissemination of sexual photos, along with their risks. Finally, PCPs can encourage open communication between parents and children; children need to hear that their parent is there to protect them and will not be angry with them if they hear something bad. Instead, they need to know.

Visit Elsevier eBooks+ at [eBooks.Health.Elsevier.com](http://eBooks.Health.Elsevier.com) for Bibliography.

## 17.2 Factitious Disorder Imposed on Another: Medical Child Abuse (Munchausen Syndrome by Proxy)

Howard Dubowitz and Wendy G. Lane

*Munchausen syndrome* describes situations in which adults falsify their own symptoms to obtain healthcare. In *Munchausen syndrome by proxy*, a parent, typically a mother, simulates or causes signs and/or symptoms in her child, resulting in unnecessary healthcare. Several terms describing this phenomenon focus on the abuse or

neglect experienced by a child, including *pediatric condition falsification*, *caregiver-fabricated illness in a child*, and **medical child abuse (MCA)**. **Factitious disorder imposed on another (FDIA)** is a *Diagnostic and Statistical Manual of Mental Disorders, Fifth Edition* (DSM-5) psychiatric diagnosis focused on the psychopathology in the responsible parent attempting to meet their own psychologic needs. FDIA may encompass all other titles. In some instances, such as partial suffocation, “child abuse” may be most appropriate.

Because milder forms of MCA often go undetected, its incidence is unclear, although 0.5-2 per 100,000 children is commonly cited, and it appears to be a global problem. The core dynamic is that a parent falsely presents a child for healthcare. This may be via fabricating a history, such as reporting seizures or apnea that never occurred. A parent may directly cause a child’s illness, for example, by exposing a child to a toxin, medication, or infectious agent (e.g., injecting stool into an intravenous line) or smothering a child. Signs or symptoms may also be manufactured, such as when a parent withholds medication or alters laboratory samples or temperature measurements. Parents may also withhold information about normal procedures or testing done elsewhere. Verbal children are usually involved, although older children may be convinced by parents that they have a particular problem and become dependent on the increased attention; this may lead to feigning symptoms. They may also be coached to corroborate false histories. Each of these actions may lead clinicians to suspect a health problem and thus to provide unnecessary healthcare, including intrusive tests and surgeries.

**When to suspect FDIA/MCA?** Consideration of MCA may be triggered when the described symptoms, their course, test results, or response to standard treatment is incompatible with any known disease or condition. The reported symptoms may be repeatedly noted by only one parent or occur only when one caregiver is alone with the child. Other risk indicators include parents who appear to need a lot of attention from physicians or who insist that the child cannot cope without them. They may refuse to leave the bedside for days.

Parents with experience in a medical field may be adept at constructing plausible presentations, although the internet provides other parents with easy access to medical information. A convincing seizure history may be offered, as a normal electroencephalogram cannot fully rule out the possibility of a seizure disorder. Even after extensive testing fails to lead to a diagnosis or treatment proves ineffective, clinicians may think they are confronting a new or rare disease and may unwittingly contribute to unnecessary testing and to a parent’s belief that a real problem exists. Efforts to carefully pursue a diagnosis along with difficulty accepting uncertainty may lead clinicians to persist with testing. Clinicians generally rely on and trust parents to provide an accurate history. As with other forms of child maltreatment, accurate diagnosis of MCA requires that professionals maintain a healthy skepticism under certain circumstances; this can be difficult. Clinicians, including mental health experts, may think that they are skilled at detecting deception. Most do poorly when attempting to do so during a clinical interview.

At a systems level, limited communication among treating professionals may delay the diagnosis of MCA. The “problems” often recur repeatedly over several years. The time from first presentation until the diagnosis is made averages about 2 years. Ultimately, a diagnosis of MCA rests on clear evidence of a child repeatedly being subjected to unnecessary tests and treatment, primarily stemming from a parent’s exaggeration, fabrication, or induction of symptoms or signs suggesting an illness or condition.

### CLINICAL MANIFESTATIONS

Mothers are the most frequent perpetrators of MCA. They may present as devoted or even model parents who form close relationships with members of the healthcare team. Although appearing very interested in their child’s condition, they may be distant emotionally. Negative test results may meet with disappointment, and they may insist on further evaluation. They may have a history

of Munchausen syndrome, though not necessarily diagnosed as such.

MCA varies in nature and severity. Males and females are equally involved. Most of the victims are infants and toddlers, but approximately 25% of cases occur in children over 6 years of age. Siblings are commonly affected. Approximately 6–9% of cases are fatal, with fatalities most often the result of poisoning or suffocation. It is important to note that children who really do have health problems can also be victims of MCA; up to 30% of patients with MCA have been found to have a medical problem. Many medical or behavioral conditions can be falsified. The following are examples of relatively common ways MCA presents:

**Bleeding** may be caused by adding dyes to samples, adding blood (e.g., from the mother) to the child's sample, or giving the child an anticoagulant (e.g., warfarin). Blood group testing may be needed.

**Seizures** are easy to fabricate and difficult to rule out. A parent may report that another physician diagnosed seizures, and the myth may be perpetuated if there is no effort to confirm the original "diagnosis." Alternatively, seizures may be induced by toxins, medications (e.g., insulin), water, or salt. Clinicians need to be familiar with the substances available to families and their risks.

**Apnea** may be falsified or created by partial suffocation. A history of a sibling with the same problem, perhaps dying from it, should raise concern. Parents of children hospitalized for a brief resolved unexplained event (BRUE) have been videotaped attempting to suffocate their child while in the hospital.

**Gastrointestinal** problems such as vomiting and diarrhea are common. Forced ingestion of medications such as ipecac may induce chronic vomiting, or laxatives may cause diarrhea. Toxicology testing is indicated in such circumstances.

**Allergies** may be fabricated. Sometimes, allergies may be diagnosed or considered, and a parent persists in viewing this as a problem even after it has subsequently been ruled out.

**Urinary tract infections and hematuria** account for about 25% of cases.

**Behavior problems** such as self-harm or harming others, learning disabilities, hyperactivity, or autism may be falsely described.

## EVALUATION AND DIAGNOSIS

It is critical that clinicians consider the possibility of MCA in their differential diagnosis when facing the previously noted presentations. Further, it helps to focus on the actual or potential harm to a child, rather than the parent's possible motivation. Once MCA is suspected, gathering and critically reviewing **all** the child's medical records from all sources is an onerous but critical first step, best done by someone knowledgeable about MCA. Child protective services (CPS) can help gather the records, and a hospital-based child protection team might be able to review the case. Important documentation at each health contact includes date, location, reason for contact, reported signs/symptoms as stated by the caregiver, objective observations documented by the physician, conclusions/diagnosis made, treatment provided, effectiveness of treatment, and other comments or observations. It is important to confer with other treating physicians about what specifically was conveyed to the family; they may have been reluctant to document concerns in the child's record. A parent may report that a certain test was done at the insistence of a physician, when they, in fact, had demanded it. It is also sometimes necessary to confirm the exact basis for a given diagnosis, rather than simply accepting a parent's account (e.g., seizure).

Depending on the nature of the presenting problem, hospitalization may be needed. Verbal children should be interviewed alone, and the family history should probe for unusual and frequent illnesses. Close observation of a child can be valuable. There may be

a history of poor appetite and vomiting, yet the child is observed to eat well without problems. Symptoms may only be described when the parent is present and otherwise noted to be absent. In some instances, such as BRUEs, covert video surveillance accompanied by monitoring (to rapidly intervene if a parent attempts to suffocate a child) can be valuable. In addition to helping clarify the diagnosis, video surveillance can identify a true medical problem. It is prudent to consult with risk management and hospital legal staff before initiating surveillance. Specimens should be carefully collected, with no opportunity for tampering with them. Similarly, temperature measurements should be closely observed.

Coordination among treating professionals is essential, especially as some may side with the parent and resent even the possibility of MCA being raised. Ideally, parents should not be informed of the evaluation for MCA until the diagnosis is made. Doing so could influence their behavior and jeopardize establishing the diagnosis. In summarizing the review of health records and gathering additional information, careful and chronologic documentation is important. This includes who witnessed symptoms, direct information from other clinicians who made diagnoses, what guidance was given to the family, whether a parent insisted on testing or treatment, and suspected tampering with equipment or records as well as other concerning behavior. It may be necessary to block parents at least temporarily from accessing part of the electronic health record.

The diagnosis of MCA hinges on a child receiving unnecessary healthcare that is actually or potentially harmful and that is instigated by a parent or caregiver. Three questions to be answered in considering MCA include:

1. Are the history, signs, and symptoms credible?
2. Is the child receiving unnecessary and harmful or potentially harmful medical care?
3. If so, who is instigating the evaluations or treatments?

Comprehensive practice guidelines regarding MCA are available from the American Academy of Pediatrics (AAP) and the American Professional Society on the Abuse of Children (APSAC). In addition, consultation with a board-certified child abuse pediatrician is strongly recommended.

**Related circumstances:** In assessing possible MCA, several other circumstances should be considered in addition to a true health problem. Some parents may be extremely anxious and genuinely concerned about a possible problem. There may be many reasons underpinning the vulnerable child syndrome, such as the death of neighbor's child or something read on the internet. Alternatively, parents may believe something told to them by a trusted clinician despite subsequent evidence to the contrary and efforts to correct the earlier misdiagnosis (e.g., persistent belief that the child has multiple food allergies). Secondary gain, such as qualifying for a disability benefit, may be the impetus for malingering. A child's anxiety, especially in the context of complex medical conditions, may lead to psychosomatic symptoms and consideration of MCA. In addition, parents of such children may be extremely stressed, and this may contribute to an approach that is overly medicalized (e.g., reluctance to wean a child off medication). There is also a need to discern commonly used hyperbole (e.g., exaggerating the height of a fever) to evoke concern and perhaps justify a clinic visit. Whatever the possible underlying dynamics, children who receive unnecessary healthcare as a result of parental actions can be diagnosed with MCA.

## TREATMENT

MCA is a form of child abuse or neglect and needs to be referred to CPS even when one is less than certain of the diagnosis; law enforcement may also need to be involved. CPS staff often lack knowledge of and experience with MCA and may need to be educated regarding this condition. Once the diagnosis of MCA is



established, the medical team and CPS should determine the treatment and safety plan, which may require out-of-home placement and should include mental healthcare for the offending parent; psychiatric decompensation and maternal suicide have been reported. Further medical care should be carefully coordinated through one primary care professional. CPS should be encouraged to meet with the family only after the medical team has informed the offending parent of the diagnosis, together with the other parent or another supportive adult if possible. Direct CPS involvement with the family during the assessment may jeopardize clarifying the diagnosis. If the plan is to place the child out-of-home, it is optimal that CPS plan the necessary steps in advance. Parents often respond with resistance, denial, and threats. It may be prudent to have hospital security in the vicinity in case of physical aggression or an attempt to remove the child from the hospital against medical advice. CPS should assess the safety of other children in the home. All family members may be affected by an MCA diagnosis; mental healthcare is recommended specifically for the parent involved with FDIA.

Assessing and addressing MCA can be time intensive and challenging. Clinicians may face the dilemma of when to accept that all plausible diagnoses have been reasonably ruled out, the circumstances fit MCA, and when testing and treatment should cease. The likelihood of MCA must be balanced with concerns about possibly missing an important diagnosis. Consultation with a child abuse pediatrician is recommended for making the diagnosis and for helping plan ongoing healthcare if the child remains in or returns to the home. Good communication among treating clinicians is needed to adequately monitor the situation; long-term monitoring may be needed.

## OUTCOMES

There may be lasting physical harms associated with unnecessary and sometimes invasive evaluations and interventions, including scarring, surgical complications, brain damage, and death. There are also potentially serious and lasting social and psychologic sequelae as a result of missing school and extracurricular activities and viewing themselves as disabled. Victims of MCA may be overly compliant or aggressive and may develop poor self-esteem, posttraumatic stress disorder, and eating problems. Indirectly, other family members and friends, professionals, and even community members may be affected. Recidivism has been reported in 17–50% of cases. Successful treatment of the abusive parent appears rare and hinges on acknowledging their role and being willing and able to change their behavior.

Visit Elsevier eBooks+ at [eBooks.Health.Elsevier.com](http://eBooks.Health.Elsevier.com) for Bibliography.

## Chapter 18

# Strategies for Health Behavior Change

Cori M. Green

To improve the health of children, pediatricians often ask patients and caregivers to make behavioral changes. These may be lifestyle changes to manage a chronic condition (e.g., obesity, asthma), adherence with the recommended timing and frequency of medications, or recommendations to seek assistance from other health providers (e.g., dietitians; mental health providers; physical,

occupational, or speech therapists). However, change is difficult and can cause distress, and families often express reluctance or ambivalence to change because of perceived barriers. When families do not believe change is needed or possible, pediatricians may become discouraged or uncomfortable in providing care. This can make it difficult for clinicians to form an alliance with families, which is central to finding a solution to most problems identified in the medical setting.

Many healthcare problems may require complex, multifaceted interventions, but the first step is always to engage the family in identifying the healthcare problem driving the need for behavior change. Once a problem is identified and agreed on, clinicians and families need to set an achievable goal and identify specific behaviors that can help families reach their goal. It is important to be specific and precise about the actual behavior and not simply identify the *category* of the behavior. When counseling a patient on weight loss for obesity, for example, one might discuss three possible approaches: making dietary changes, increasing exercise, and decreasing screen time. The choice of which behavior to focus on should come from the patient but needs to be specific. It is not enough for the patient to state he or she will exercise more. Instead, the clinician should help the patient identify a more specific goal, such as playing basketball with friends 3 times a week at the park near home. This takes into account the action, context, setting, and time of the new behavioral goal. Specific examples of problems that would necessitate a behavior change to improve outcomes are used throughout the chapter.

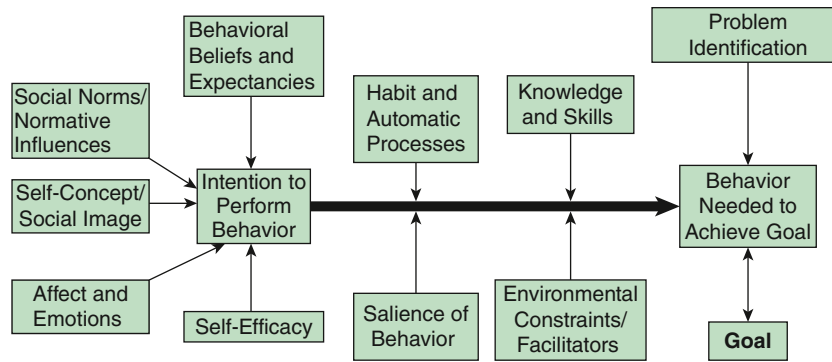
## UNIFIED THEORY OF BEHAVIOR CHANGE

There are several theories of health-related behavior change. Each highlights a different concept, but frameworks that unite these theories suggest that the factor most predictive of whether one will perform a behavior is the *intention* to do so. The **unified theory of behavior change** examines behavior along two dimensions: influences on intent and moderators of the intention-behavior relationship (Fig. 18.1). Five main factors that influence one's decision to perform a behavior are expectancies, social norms/normative influences, self-concept/self-image, emotions, and self-efficacy. Table 18.1 provides specific examples on how to explore influences of intent when guiding families in decision-making, such as deciding to start a stimulant medication for a child diagnosed with attention-deficit/hyperactivity disorder (ADHD). It is not necessary to ask about each influence, but these principles are particularly useful when guiding patients who may be resistant to change.

Once a decision to make a change is made, four factors determine whether an intention leads to carrying out the behavior: knowledge and skills, environmental facilitators and constraints, salience of the behavior, and habits. The pediatrician can help ensure intent leads to behavior change by addressing these factors during the visit. In the ADHD example, the clinician can help the family build their knowledge by providing handouts on stimulants, nutritional pamphlets on how to minimize the appetite-suppressant effects of the medication on weight, and information on how the family can explain to others the need for medication. Asking about morning routines will help identify potential barriers in remembering to take the medication. Lastly, clinicians can help families think about cues for remembering to give the medication in the morning, because their morning routines, or habits, will have to be adjusted to adhere to this medication.

By using these principles of behavior change, clinicians can guide their patients toward change during an encounter by ensuring they leave with (1) a strong positive intention to perform the behavior; (2) the perception that they have the skills to accomplish it; (3) a belief that the behavior is socially acceptable and consistent with their self-image; (4) a positive feeling about the behavior; (5) specific strategies in overcoming potential barriers in performing the behavior; and (6) a set of identified cues and enablers to help build new habits.





**Fig. 18.1** The five constructs that influence one’s intent to perform a behavior and the four influences that determine whether an intent will lead to performing the behavior. Problem identification (box at upper right) is where the process of thinking about health behavior changes begins. A clinician can then help the patient decide which behavior can help them meet the health goal. Once this is decided, to help with behavior change, clinicians should think about intent, influences of intent, and the factors that may facilitate or impede intent from leading to action.

Table 18.1 Influences of Intent and Possible Use During a Patient Encounter (Specifically, Starting a Stimulant for ADHD)		
INFLUENCE OF INTENT	STRATEGIES TO ENGAGE FAMILIES USING INFLUENCES OF INTENT	POSSIBLE FACTORS INFLUENCING THE DECISION*
<b>Beliefs and expectancies</b> Perceived advantages and disadvantages of performing a behavior.	Ask questions about their beliefs and experiences. “What do you already know about stimulants?” “Have you heard about other children’s experiences taking stimulants?” “What do you expect will happen if your child takes a stimulant?” Ask permission to give information addressing their prior beliefs or experiences. “Is it all right if I give you some information addressing your concerns?”	“I know that stimulants helped my nephew do better in school.” “I heard stimulants stunt children’s growth.”
<b>Social norms</b> Pressures to (or not) perform a behavior because of what is standard among social groups.	Share information about the normative nature of the behavior and ways to cope if performing a behavior that is not the social norm. “I have a lot of patients who have improved in school after starting a stimulant.”	“Do other parents give their children stimulants if they are diagnosed with ADHD?” “What would my mother think if she found out my child was taking a stimulant?”
<b>Self-concept/self-image</b> Overall sense of self and whether behavior is congruent with that and with the image they want to project to others.	Interact with family in a partnering, supportive, respectful manner. Identify strengths. Reframe any negative images they foresee may happen with the behavior. “I am sure your in-laws will be so happy when your child is doing better in school.”	“Am I a good parent if I give my child medications that affect their brain?” “What will other parents at school think if I allow my child to start a stimulant? What will my in-laws think?”
<b>Emotions</b> Emotional reactions to performing behaviors in terms of intensity and direction (positive or negative).	Allow patients to express their feelings. Suggest ways to manage negative or avoidant feelings. “Many parents are scared to start stimulants at first. However, once their child is succeeding in school, they realize the benefits outweighed the risks. Let’s talk more about your fears.”	“I am so nervous about my child starting to take a stimulant.” “I am so upset with how my child is doing in school and really do not know what to do next.” “I am so relieved that there is a medication that may help improve my child’s grades and chance of going to college.”
<b>Self-efficacy</b> Perceived confidence they can perform the behavior.	Provide information, model the behavior, encourage success, and teach skills. Explore what obstacles they foresee and how confident they are they can overcome obstacles. Help strategize ways to overcome obstacles. “Do you feel confident you will be able to get your child to take the medication?” “Let’s brainstorm how we can prevent any of the side effects.” “Many of my patients have a large breakfast before taking the medication. Can I help you figure out how to fit that into your schedule?”	“Will I be able to remember to give my child this medication every day?” “Will I be able to make sure my child has a large breakfast in the morning before taking the medication?”

ADHD, Attention-deficit/hyperactivity disorder.

\*Statements and questions are examples of what caregivers may be thinking.

**Table 18.2** Stages of Change and Strategies for Counseling\*

STAGE/DEFINITION	GOAL AND STRATEGY	SPECIFIC EXAMPLES
<b>Precontemplation</b> Not considering change. May be unaware that a problem exists.	Establish a therapeutic relationship. Increase awareness of need to change.	"I understand you are only here because you are worried and that you don't feel that smoking marijuana is a big deal." "Can I ask if smoking marijuana has created any problems for you now? I know your parents were worried about your grades." "It's up to you to decide if and when you are ready to cut back on smoking marijuana." "Is it okay if I give you some information about marijuana use?" "I know it can be hard to change a habit when you feel under pressure. It is totally up to you to decide if cutting back is right for you. Is it okay if I ask you about this during our next visit?"
<b>Contemplation</b> Beginning to consider making a change, but still feeling ambivalent about making a change.	Identify ambivalence. Help develop discrepancy between goals and current behaviors. Ask about pros and cons of changing problem behavior. Support patient toward making a change.	"I'm hearing that you do agree that sometimes your marijuana use does get in the way, especially with school. However, it helps relax you and it would be hard to make a change right now." "What would be one benefit of cutting back? What would be a drawback to cutting back? Do you think your smoking will cause problems in the future?" "After talking about this, if you feel you want to cut back, the next step would be to think about how to best do that. We wouldn't need to jump right into a plan. Why don't you think about what we discussed, and we can meet next week if you are ready to make a plan?"
<b>Preparation</b> Preparing for action. Reduced ambivalence and exploration of options for change.	Help patient set a goal and prepare a concrete plan. Offer a menu of choices. Identify supports and barriers.	"It's great that you are thinking about ways to cut back on your smoking. I understand your initial goal is to stop smoking during the week." "I can give you some other options of how to relax and reduce stress during the week." "We need to figure out how to react to your friends after school who you normally smoke with." "Do you have other friends who you can see after school instead, who would support this decision?"
<b>Action</b> Taking action; actively implementing plan.	Provide positive feedback. Identify unexpected barriers and create coping strategies.	"Congratulations on cutting back. Have you noticed any differences in your schoolwork? I'm so happy to hear your grades improved." "Has it been difficult to not see your friends after school? How have you reacted when they get annoyed you don't want to smoke with them?" "Let's continue to track your progress."
<b>Maintenance</b> Continues to change behavior and maintains healthier lifestyle.	Reinforce commitment and affirm ability to change. Create coping plans when relapse does occur. Manage triggers.	"You really are committed to going to a good college and improving your grades. I'm so happy the hard work has paid off." "I understand that it was hard to say no to smoking with your friends last week when it was someone's birthday. How did you feel after? Are there triggers that we can think about preventing in the future?"

\*This table uses an example of an adolescent who is initially resistant to cutting back on smoking marijuana. His parents caught him smoking in his room and arranged for him to see the pediatrician.

Adapted from *Implementing Mental Health Priorities in Practice: Substance Use*, American Academy of Pediatrics. <https://www.aap.org/en-us/advocacy-and-policy/aap-health-initiatives/Mental-Health/Pages/substance-use.aspx>.

## TRANSTHEORETICAL MODEL OF HEALTH BEHAVIOR CHANGE

It is difficult to counsel families to change a behavior when they may not agree there is a problem or when they are not ready to build an intention to change. The **transtheoretical model of health behavior change** places an individual's motivation and readiness to change on a continuum. The premise of this model is that behavior change is a process, and as someone attempts to change, they move through five stages (although not always in a linear fashion): *precontemplation* (no current intention of making a change), *contemplation* (considering change), *preparation* (creating an intention, planning, and committing to change), *action* (has changed behavior for a short time), and *maintenance* (sustaining long-term change). Assessing a patient's stage of change and then targeting counseling toward that stage can help build a *therapeutic alliance*, in contrast to counseling a patient to do something she or he is not ready for, which can disrupt the therapeutic alliance and lead to resistance. **Table 18.2** further describes stages of change and gives examples for counseling that target the adolescent's stage of change in reducing marijuana smoking.

## COMMON FACTORS APPROACH

Conversations around behavior change are most effective when they take place in a context of a trusting, mutually respectful relationship. The traditional medical model assumes that patients and their families come with questions and needs and that the pediatrician's job is to offer specific advice and advocate for its acceptance. This approach fails when families are reluctant, ambivalent, demoralized, or unfamiliar with the healthcare system or the treatment choices offered. A context more supportive of behavior change can be developed when clinicians use communication strategies that facilitate collaboration and building a therapeutic alliance.

The **common factors approach** is an evidence-based communication strategy that is effective in facilitating behavior change. The skills central to a common factors approach are consistent across multiple forms of psychotherapy and therefore can be considered transdiagnostic. Common factors and processes can be viewed as generic aspects of treatment that can be used across a wide range of symptoms to build a therapeutic alliance between the physician and patient. This alliance predicts outcomes of counseling more than the specific modality of treatment. The common factors approach has been implemented and

**Table 18.3** Hope, Empathy, Language, Loyalty, Permission, Partnership, Plan (HEL<sup>2</sup>P<sup>3</sup>)\*

SKILL	EXAMPLES
<b>Hope</b> for improvement: Develop strengths.	"I have seen other children like you with similar feelings of sadness, and they have gotten better."
<b>Empathy:</b> Listen attentively.	"It must be hard for you that you no longer get pleasure in playing soccer."
<b>Language:</b> Use family's language. Check understanding.	"Let me make sure I understand what you are saying. You no longer feel like doing things that made you happy in the past?"
<b>Loyalty:</b> Express support and commitment.	"You are free to talk to me about anything while we work through this."
<b>Permission:</b> Ask permission to explore sensitive subjects. Offer advice.	"I would like to ask more questions that you may find more sensitive, is that okay?" "Is it okay with you if I give you my opinion on what may be the problem here?"
<b>Partnership:</b> Identify and overcome barriers.	"Can we discuss together possible solutions to overcoming your discomfort in getting therapy?"
<b>Plan:</b> Establish a plan, or at least a first step the family can take.	"If we work together, maybe we can think through solutions for the problems you identified."

\*This table illustrates the interpersonal skills highlighted in the common factors approach. In this example the clinician is responding to an adolescent struggling with depression and resistant to seeking help.

Adapted with data from Foy JM, Kelleher KJ, Laraque D. American Academy of Pediatrics Task Force on Mental Health. Enhancing pediatric mental health care: Strategies for preparing a primary care practice. *Pediatrics*. 2010;125 Suppl 3:S87–S108.

studied in pediatric primary care for children with mental health problems. Children who were treated by pediatricians trained in the common factors approach had improved functioning compared to those who saw pediatricians without this training.

A common factors approach distinguishes between the impact of the patient-provider alliance and the pediatrician's use of skills that influence patient behavior change across a broad range of conditions. Interpersonal skills that help build alliances with patients include showing empathy, warmth, and positive regard. Skills that influence behavior change include a clinician's ability to provide optimism, facilitate treatment engagement, and maintain the focus on achievable goals. This can be done by clearly explaining the condition and treatment approaches while keeping the discussion focused on immediate and practical concerns.

### Interpersonal Skills: HEL<sup>2</sup>P<sup>3</sup>

The interpersonal skills that facilitate an effective bond between the patient and clinician can be remembered by the HEL<sup>2</sup>P<sup>3</sup> mnemonic (Table 18.3). These skills include providing **hope**, **empathy**, and **loyalty**; using the patient's **language**; **partnering** with the family; asking **permission** to raise more sensitive questions or to give advice; and creating a **plan** that is initiated by the family. These interpersonal skills should help operationalize the common factors approach by increasing a patient's optimism, feelings of well-being, and willingness to work toward improved health, while also targeting feelings of anger, ambivalence, and hopelessness.

Structuring a patient encounter using common factors to facilitate behavior change uses these steps: eliciting concerns while setting an agenda and agreeing on the nature of the problem; establishing a plan; and responding to anger and demoralization and emphasizing hope.

### Elicit Concerns: Set the Agenda and Agree on the Problem

The first step of the visit is to elicit both the child's and the parent's concerns and agree on the focus for the visit. This can be accomplished by using open-ended questions and asking "anything else?" until nothing else is disclosed. It is important to show you have time and are interested in their concerns by making eye contact, listening attentively, minimizing distractions, and responding with empathy and interest. Engage both the child and the parent by taking turns eliciting their concerns. It is helpful to summarize their story to reassure them you have heard and understand what they are saying. Keep the session organized, and manage rambling by gently interrupting, paraphrasing, asking for additional concerns, and refocusing the conversation. These same principles apply for telehealth visits. Make sure you are looking into the camera and use exaggerated responses. It is particularly helpful to frequently summarize the child's and parents' concerns, voice observations, and use reflective statements during telehealth visits so the family does see that you are listening to them.

By the end of this step in the visit, all parties should feel reassured that their problems were heard and accurately described. The next step is to agree on the problem to be addressed during that visit. If the parent and child do not agree on the issue, try to find a common thread that will address the concerns of both.

### Establish a Plan

Once a problem is agreed on, the clinician can partner with families to develop acceptable and achievable plans for treatment or further evaluation. Families should take the lead in developing goals and the strategies to attain them, and information should be given in response to patients' expressed needs. Pediatricians can involve families by offering choices and asking for feedback. Advice should be given only after asking a family's permission to do so. If the family asks for advice, the clinician should respond by considering principles of behavior change, as described earlier. Advice should be tailored toward the family's willingness to act, concerns for barriers, and attitudes and should be as specific and practical as possible. Once an initial plan is established, it is important to partner in monitoring responses and to provide continued support.

### Respond to Anger and Demoralization and Emphasize Hope

The common factors approach is particularly helpful in engaging families in situations where anger and demoralization could prevent patients from being able to use the clinician's advice. Focusing the conversation on goals for the future and how to achieve them is more productive than discussing how problems began. This "solution-focused therapy" approach grew out of the need for clinicians to help people in a brief encounter. Hopelessness can be relieved by pediatricians helping patients to identify and build on strengths and past success, reframing events and feelings, and breaking down overwhelming goals into small, concrete steps that are more readily accomplished. In general, pediatricians can use the **elicit-provide-elicited model**. After eliciting a concern or hearing about patients' goals, ask if they want to hear your thoughts about the situation. Provide guidance in a neutral way, and then ask the family what they think about what you just stated.

Table 18.4 provides an example of how to use common factors in practice using a scenario of an adolescent female who has been teased for using albuterol before physical education class for her exercise-induced asthma. The clinician in the scenario attempts to address both the patient's and her mother's concerns.

**Table 18.4** Common Factors Approach in Practice\*

GOAL	SPECIFIC SKILLS	EXAMPLES
Elicit child's and parents' concerns.	Use open-ended questions and ask, "What else?" until nothing else is listed, while engaging both parties and demonstrating empathy.	"Hi, Jacqueline and Mrs. Smith. How have things been since last time? What are your biggest concerns for today?" "What else do you think we should put on the agenda for today?" "I am sorry to hear that you have had more asthma symptoms around gym time, Jacqueline. I'd like to ask you a few more questions to get a better understanding of what has changed, if that's okay with you." "I understand this is upsetting you, Mrs. Smith, and that you worry that Jacqueline is not going to the nurse before gym to use her inhaler pump anymore. Let's hear from Jacqueline."
	Agree on the problem.	"Can we all agree that managing the asthma symptoms around gym time is the most pressing issue for today? Should we focus on that today?"
	Manage rambling.	"What you're saying is really important, but I want to be sure we have time to talk about controlling your daughter's asthma symptoms during gym. Is it okay if we go back to that topic?"
Partner with families to find acceptable forms of treatment.	Develop acceptable plans for treatment of further diagnoses.	"I believe we can develop a plan to help deal with this. Is it okay to start talking about next steps?" "I am happy to give suggestions on how to more easily use your inhaler before gym, without the other kids noticing. But what were you thinking, Jacqueline?" "Let's brainstorm how you would respond to your classmates if they see you using your inhaler."
	Address barriers to treatment.	"Is there anything that makes you worry that this may not work?"
Increase expectations that treatment will be helpful.	Respond to hopelessness, anger, and frustration.	"I realize it wasn't your choice to come here, Jacqueline, but I'm interested in hearing how you feel about this issue." "It must be really hard for you, Jacqueline, when the kids tease you about your inhaler. Discussing this with your mom and me was very brave, and now we can help you." "It must be frustrating for the school nurse to call you in the middle of the day at work, Mrs. Smith." "I would be angry, too, if I felt my mom didn't understand how it felt when I got teased for going to the nurse's office."
	Emphasize hope.	"We've managed difficult things before. Remember when Jacqueline kept getting admitted for her asthma when she was younger? We have come a long way since then, and I'm sure we can manage this as well."

\*Jacqueline is an adolescent female who has had asthma since she was an infant. Despite multiple hospitalizations as an infant, her asthma had been under control except for during exercise, including physical education (PE) class. She had been going to the nurse's office to take albuterol before PE class, but recently she had been teased for having to take medication before PE. She has begun to skip treatments to avoid the teasing. However, her mother has now been called a few times to pick her up from school because of her asthma symptoms. Jacqueline's caregiver is a single parent who cannot miss work and is very frustrated. She was not aware of the bullying Jacqueline has undergone. This scenario is adapted from the American Academy of Pediatrics curricula on common factors. <https://www.aap.org/en-us/advocacy-and-policy/aap-health-initiatives/Mental-Health/Pages/Module-1-Brief-Intervention.aspx>.

## MOTIVATIONAL INTERVIEWING

Motivational interviewing (MI) is a goal-oriented, supportive counseling style that complements the HEL<sup>2</sup>P<sup>3</sup> framework and is useful when patients or families remain ambivalent about making health-related behavior changes. MI is designed to enhance intrinsic motivation in patients by exploring their perspectives and ambivalence. It is also aligned with the transtheoretical model's continuum of change, where the clinician not only tailors counseling to a patient's stage of change but does so with the goal of moving the patient toward the next stage. It is particularly effective for those not interested in change or not ready to make a commitment. MI has been shown to be an effective intervention strategy for decreasing high-risk behaviors, improving chronic disease control, and increasing adherence to preventive health measures.

MI is a collaborative approach in which the pediatrician respects patients' perspectives and treats them as the "expert" on their values, beliefs, and goals. *Collaboration*, *acceptance*, *compassion*, and *evocation* are the foundation of MI and are referred to as the "spirit" of the approach. The clinician is a "guide," respecting patients' autonomy

and their ability to make their own decision to change. The pediatrician expresses genuine concern and demonstrates that he or she understands and validates the patient's or family's struggle. Using open-ended questions, the pediatrician evokes the patient's own motivation for change.

*Expressing empathy* facilitates behavior change by accepting the patient's beliefs and behaviors. This contrasts with *direct persuasion*, which often leads to resistance. The pediatrician must reinforce that ambivalence is normal and use skillful reflective listening, showing the patient an understanding of the situation.

*Developing a discrepancy* between current behaviors (or treatment choices) and treatment goals motivates change and helps move the patient from the precontemplative stage to the contemplative stage or from the contemplative stage to preparation, as described in the transtheoretical model. Through MI the clinician can guide patients in understanding that their current behaviors may not be consistent with their stated goals and values.

*Rolling with resistance*, or not pushing back when suggestions are declined, is a strategy again to align with the patient. Resistance is



**Table 18.5** Counseling for Obesity Using a Motivational Interviewing (MI) Approach

ACTION	SPECIFIC SKILLS	EXAMPLES
Engagement*	Open-ended questions	"Now that we have finished the majority of the visit, I'd like to talk about your weight. Is that okay? How do you feel about your size?" "How do you feel about Jimmy's weight?" (directed toward caregiver)
	Affirmations	"You definitely have shown how strong you are having dealt with kids teasing you about your size." "Remember when you were having difficulties with your schoolwork? You were able to make a few changes, and now you are doing well. I am confident we can do the same with your weight."
	Reflective listening	"You are feeling like your son is the same size as everyone in your family, and you aren't concerned right now." "I hear that as a working parent, watching TV before bed really works for your family." "You're not terribly excited about having to think of ways to cook differently."
	Summary statements	"So far, we have discussed how challenging it would be to lose weight and make changes for the whole family, but you are willing to consider some simple changes."
Focusing	Set the agenda.	"We could talk about increasing the amount of exercise Jimmy has every week, reducing screen time, or making a dietary change. What do you think would work best?" "Great, so we will talk about soda. What do you like about it? How many times a week do you drink it?"
Evocation	Reinforce any change talk.	"Those are great reasons for thinking about cutting back on soda."
	Change ruler.	"On a scale of 1 to 10, how confident are you (or how important is it) that you can cut back on soda?" "A 5. Why didn't you answer a 3?" "What would it take to bring it to a 7?"
Planning	Focus on how to make the change, not "why" anymore. Be concrete.	"Maybe completely eliminating soda is too difficult right now. Do you want to think of a couple of times during the week where you can reward yourself with a soda?" "What will you drink after school instead of soda?"

\*OARS is used to engage the patient and build rapport.

Adapted from *Changing the Conversation About Childhood Obesity*, American Academy of Pediatrics, Institute for Healthy Childhood Weight. <https://www.aap.org/en-us/about-the-aap/aap-press-room/pages/Changing-the-conversation-about-Childhood-Obesity.aspx>.

usually a sign that a different approach is needed. As necessary, the clinician can ask permission to give new perspectives.

*Self-efficacy*, or a patient's belief in her or his ability to perform the behavior, is a key element for change and a powerful motivator. Clinicians can express confidence in the patient's ability to achieve change and support the patient's self-efficacy.

The process by which MI is used in a patient encounter involves the following four parts:

1. *Engagement* is the rapport-building part of the encounter. In addition to using the skills presented in the HEL<sup>2</sup>P<sup>3</sup> framework, the MI approach highlights the use of open-ended questions, affirmations, reflective listening, and summaries (OARS). **Open-ended questions** should be inviting and probing, enabling the patient to think through and come to a better understanding of the problem and elicit their internal motivation. **Affirmations** provide positive feedback, express appreciation about a patient's strengths, and can reinforce autonomy and self-efficacy. **Reflective listening** demonstrates that the clinician understands the patient's thoughts and feelings without judgement or interruption. It should be done frequently and can encourage the patient to be more open. **Summarizing** the conversation in a succinct way reinforces that you are listening, pulls together all information, and allows the patient to hear his or her own motivations and ambivalence.
2. *Focusing* the visit is done to clarify the patient's priorities and stage of readiness and to identify the problem where there is ambivalence. If a patient remains resistant to change, ask permission to give information or share ideas and then ask for feedback on what they think about what you said. In the **elicited-ask-elicited model**, a clinician can deliver information about an unhealthy behavior or lifestyle decision in a nonpaternalistic manner.
3. *Evocation* is when the clinician assesses their patients' reasons for change and helps them to explore advantages, disadvantages, and barriers to change. It is important to reinforce the patient's **change**

**talk**. Examples of change talk include an expression of desire ("I want to..."), ability ("I can..."), reasons ("There are good reasons to..."), or a need for change ("I need to..."). Clinicians can use "readiness rulers" by asking their patients to rate on a scale from 1 to 10 how important and confident they are in making a change. The clinician should then respond by asking why the patient did not choose a lower number and should follow up by asking what it would take to bring it to a higher number.

4. The *planning* stage is similar to that described in the discussion of a common factors approach and occurs once a patient is in the preparation stage on the continuum of change. A clinician can guide their patient through this stage by having them write down responses to statements such as, "The changes I want to make are...", "The most important reasons to make this change are...", "Some people who can support me are..." and "They can help me by..." A concrete plan should include specific actions and a way to factor in accountability and rewards. **Table 18.5** uses a visit for counseling about obesity to demonstrate the process of MI.

## SHARED DECISION-MAKING

Shared decision-making (SDM) has many similarities to the processes previously described in that it emphasizes moving clinicians away from a paternalistic approach in dictating treatment to one where patients and clinicians collaborate in making a medical decision, particularly when multiple evidence-based treatment options exist. The overall goal is to approach medical decisions using patient-centered strategies that are based on the best evidence available while aligning with family values. By definition, (1) SDM must involve two parties (clinician and patient/family); (2) information must be exchanged in both directions; (3) both parties must be aware of all treatment options; and (4) the clinician and patient/family must both bring their own knowledge and values equally into the decision-making

process. This approach is only possible when there is more than one management strategy and SDM does not put a patient at risk.

SDM is often facilitated by using evidence-based decision aids such as pamphlets, videos, web-based tools, or educational workshops. Condition-specific or more generic decision aids have been created and facilitate the process of SDM. Studies in adults show that such aids improve knowledge and satisfaction, reduce decisional conflict, and increase the alignment between patient preferences and treatment options. Although SDM is widely used and has been studied in

adult populations, it is more complicated in pediatric settings because the caregiver (a surrogate for the patient) is also involved in decision-making. It is important to involve the child or adolescent in SDM, as the more they are involved in SDM, the better their outcomes may be. Options must be explained in a developmentally appropriate way. Then both the parent and clinician need to assess how much the patient truly understands regarding their stated preference.

*Visit Elsevier eBooks+ at [eBooks.Health.Elsevier.com](http://eBooks.Health.Elsevier.com) for Bibliography.*

## Chapter 19

# Developmental and Behavioral Theories

Margo Candelaria and Susan Feigelman

The field of pediatrics is dedicated to optimizing the growth and development of each child. Pediatricians require knowledge of normal growth, development, and behavior to effectively monitor children's progress, identify delays or abnormalities in development, help obtain needed services, and counsel parents and caretakers. To alter factors that increase or decrease risk and resilience, pediatricians need to understand how biologic and social forces interact within the parent-child relationship, within the family, and between the family and the larger society. Growth is an indicator of overall well-being, status of chronic disease, and interpersonal and psychologic stress. By monitoring children and families over time, pediatricians are uniquely situated to observe the interrelationships between physical growth and cognitive, motor, and emotional development. Observation is enhanced by familiarity with developmental and behavioral theories that inform one about typical patterns of development and provide guidance for prevention or intervention for behavior problems. Familiarity with theories of health behavior may assist clinicians in guiding patients and families in disease management and wellness care.

### BIOPSYCHOSOCIAL MODEL AND ECOBIODEVELOPMENTAL FRAMEWORK: MODELS OF DEVELOPMENT

The **medical model** presumes that a patient presents with signs and symptoms and a physician focuses on diagnosing and treating diseases of the body. This model neglects the social and psychologic aspect of a person who exists in the larger realm of the family and society. In the **biopsychosocial model**, societal and community systems are simultaneously considered along with more proximal systems that make up the person and the person's environment (Fig. 19.1). A patient's symptoms are examined and explained in the context of the patient's existence. This multidimensional model can be used to understand health and both acute and chronic disease, and this model has been increasingly used to develop care models over the past few decades.

With the advances in neurology, genomics (including epigenetics), molecular biology, and the social sciences, a broader model, the **ecobiodevelopmental framework**, has emerged. This framework emphasizes how the ecology of childhood (social and physical environments) interacts with biologic processes to determine outcomes and life trajectories. Early influences, particularly those producing **toxic levels of stress**, affect the individual through their impact on the body's stress response systems, brain development, and modification of gene expression. Epigenetic changes, such as DNA methylation and histone acetylation, may be influenced by early life experiences (the environment) and impact gene expression without changing the DNA sequence. These changes can produce long-lasting effects on the health and well-being of the individual and may be passed on to future generations (Fig. 19.2).

Critical to learning and remembering (and therefore development) is **neuronal plasticity**, which permits the central nervous system to reorganize neuronal networks in response to environmental stimulation, both positive and negative. An overproduction of neuronal precursors eventually leads to about 100 billion neurons in the adult brain.

Each neuron develops on average 15,000 synapses by 3 years of age. During early childhood, synapses in frequently used pathways are preserved, whereas less-used ones atrophy, a process termed *pruning*. Changes in the strength and number of synapses and reorganization of neuronal circuits also play important roles in brain plasticity. Increases or decreases in synaptic activity result in persistent increases or decreases in synaptic strength. Thus experience (**environment**) has a direct effect on the physical and therefore functional properties of the brain. Children with different talents and temperaments (already a combination of genetics and environment) further elicit different stimuli from their varying environments.

Periods of rapid development generally correlate with periods of great changes in synaptic numbers in relevant areas of the brain. Accordingly, sensory deprivation during the time when synaptic changes should be occurring has profound effects. The effects of strabismus leading to amblyopia occur quickly during early childhood; patching the eye with good vision to reverse amblyopia is less effective in late childhood (see Chapter 663). Early experience is particularly important because learning proceeds more efficiently along established synaptic pathways. However, some plasticity of the brain continues into adolescence, with further development of the prefrontal cortex, which is important in decision-making, future planning, and emotional control; neurogenesis persists in adulthood in certain areas of the brain.

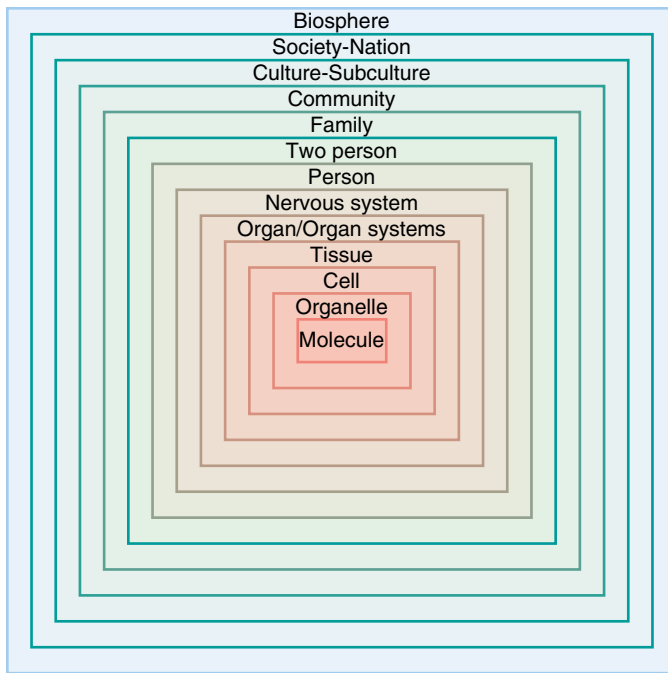
Early traumatic experiences modify the expression of stress mediators (in particular the hypothalamic-pituitary-adrenal axis) and neurotransmitters, leading to changes in brain connectivity and function. These effects may be persistent, leading to alterations and dysfunction in the stress response throughout life. Chronic stress has negative effects on cognitive functions, including memory and emotional regulation. Positive and negative experiences do not determine the ultimate outcome but shift the probabilities by influencing the child's ability to respond adaptively to future stimuli.

There is increasing evidence that positive experiences and relationships can buffer the impact of negative or traumatic experience and toxic stress. In fact, there is a recent call for pediatrics to recognize and promote relational health as a protective factor. By promoting positive relationships, labeled safe, stable, and nurturing relationships (SSNRs) within primary care, healthcare providers can work with families to build relational health, thereby combatting the deleterious effects of toxic stress and promoting resilience. Pediatric care can do this by employing a public health approach, partnering with families and communities, to build healthy relationships by connecting to and integrating with primary, secondary, and tertiary prevention programs. This can include embedding interventions within primary care and creating robust referral networks to connect families to needed services.

### Biologic Influences

Biologic influences on development include genetics, in utero exposure to teratogens, the long-term negative effects of low birthweight (neonatal morbidities plus increased rates of subsequent adult-onset obesity, coronary heart disease, stroke, hypertension, and type 2 diabetes), postnatal illnesses, exposure to hazardous substances, and maturation. Adoption and twin studies consistently show that heredity accounts for approximately 40% of the variance in IQ and in other personality traits, such as sociability and desire for novelty, whereas shared environment accounts for another 50%. The negative effects on development of prenatal exposure to teratogens, such as mercury and alcohol, and of postnatal insults, such as meningitis and traumatic brain injury, have been extensively studied (see Chapters 117, 122, and 146). Any chronic illness can affect growth and development, either directly or through changes in factors such as nutrition, parenting, school attendance, peer interactions, or self-esteem.

Most children follow similar motor developmental sequences despite great variability in child-rearing practices. The attainment of skills such as the use of complex sentences is less tightly bound to a



**Fig. 19.1** Continuum and hierarchy of natural systems in the biopsychosocial model. (From Engel GL. *The clinical application of the biopsychosocial model*. *Am J Psychiatry*. 1980;137:535–544.)

maturational schedule. Maturational changes also generate behavioral challenges at predictable times. Decrements in growth rate and sleep requirements around 2 years of age often generate concern about poor appetite and refusal to nap. Although it is possible to accelerate many developmental milestones (toilet training a 12 month old or teaching a 3 year old to read), *the long-term benefits of such precocious accomplishments are questionable*.

In addition to physical changes in size, body proportions, and strength, maturation brings about hormonal changes. Sexual differentiation, both somatic and neurologic, begins in utero. Both stress and reproductive hormones affect brain development as well as behavior throughout development. Steroid production by the fetal gonads leads to differences in brain structures between males and females.

**Temperament** describes the stable, early-appearing individual variations in behavioral dimensions, including emotionality (crying, laughing, sulking), activity level, attention, sociability, and persistence. The classic theory proposes nine dimensions of temperament (Table 19.1). These characteristics lead to three common constellations: (1) the easy, highly adaptable child, who has regular biologic cycles; (2) the difficult child, who is inflexible, moody, and easily frustrated; and (3) the slow-to-warm-up child, who needs extra time to adapt to new circumstances. Various combinations of these clusters also occur. Temperament has long been described as biologic or “inherited.” Monozygotic twins are rated by their parents as temperamentally similar more often than are dizygotic twins. Estimates of heritability suggest that genetic differences account for 20–60% of the variability of temperament within a population. The remainder of the variance is attributed to the child’s environment. Maternal prenatal stress and anxiety is associated with child temperament, possibly through stress hormones. However, certain polymorphisms of specific genes moderate the influence of maternal stress on infant temperament. Children who are easily frustrated, fearful, or irritable may elicit negative parental reactions, making these children even more susceptible to negative parenting behaviors and to poor adjustment to adversity. Longitudinal twin studies of adult personality indicate that changes in personality over time largely result from dissimilar environmental influences, whereas stability of temperament appears to result from genetic factors.

The concept of temperament can help parents understand and accept the characteristics of their children without feeling responsible for having caused them. Children who have difficulty adjusting to change

may have behavior problems when a new baby arrives or at the time of school entry. In addition, pointing out the child’s temperament may allow for adjustment in parenting styles. Behavioral and emotional problems may develop when the temperamental characteristics of children and parents are in conflict. If parents who keep an irregular schedule have a child who is not readily adaptable, behavioral difficulties are more likely than if the child has parents who have predictable routines.

### Psychologic Influences: Attachment and Contingency

The influence of the child-rearing environment dominates most current models of development. Infants in hospitals and orphanages, devoid of opportunities for attachment, have severe developmental deficits. **Attachment** refers to a biologically determined tendency of a young child to seek proximity to the parent during times of stress and to the relationship that allows securely attached children to use their parents to reestablish a sense of well-being after a stressful experience. Insecure attachment may be predictive of later behavioral and learning problems.

At all stages of development, children progress optimally when they have adult caregivers who pay attention to their verbal and nonverbal cues and respond accordingly. In early infancy, such contingent responsiveness to signs of overarousal or underarousal helps maintain infants in a state of quiet alertness and fosters autonomic self-regulation. **Consistent contingent responses** (reinforcement depending on the behavior of the other) to nonverbal gestures create the groundwork for the shared attention and reciprocity that are critical for later language and social development.

### Social Factors: Family Systems and the Ecologic Model

Contemporary models of child development recognize the critical importance of influences outside the mother–child dyad. Fathers play critical roles, both in their direct relationships with their children and in supporting mothers. As traditional nuclear families become less dominant, the influence of other family members and caregivers (grandparents, foster and adoptive parents, same-sex partners) becomes increasingly important. Furthermore, the presence of nurturing and stable caregivers, in or out of the nuclear family, can help to buffer the impact of a parent who may struggle with mental illness, substance use, or other afflictions. As children grow within their larger ecosystem, it is important to recognize and include all relevant caregivers in the child’s care.

Families function as systems, with internal and external boundaries, subsystems, roles, and rules for interaction. In families with rigidly defined parental subsystems, children may be denied any decision-making, exacerbating rebelliousness. In families with poorly defined parent–child boundaries, children may be required to take on responsibilities beyond their years or may be recruited to play a spousal role.

**Family systems theory** recognizes that individuals within systems adopt implicit roles. Although birth order does not have long-term effects on personality development, within families the members take on different roles. One child may be the troublemaker, whereas another is the negotiator and another is quiet. Changes in one person’s behavior affects every other member of the system; roles shift until a new equilibrium is found. The birth of a new child, attainment of developmental milestones such as independent walking, the onset of nighttime fears, diagnosis of a chronic illness, or death of a family member are all changes that require renegotiation of roles within the family and have the potential for healthy adaptation or dysfunction.

The family system, in turn, functions within the larger systems of extended family, subculture, culture, and society. Bronfenbrenner’s ecologic model depicts these relationships as concentric circles, with the parent–child dyad at the center (with associated risks and protective factors) and the larger society at the periphery. Changes at any level are reflected in the levels above and below. Furthermore, these systems and their interactions change over time, with some influences being persistent and chronic and others being temporary. The shift from an industrial economy to one based on service and information and the influence of systemic racism are examples of how society has profound effects on families and children. Understanding the child’s greater ecosystem is important to understand their family and the context of their



An Ecobiodevelopmental Framework for Early Childhood Policies and Programs

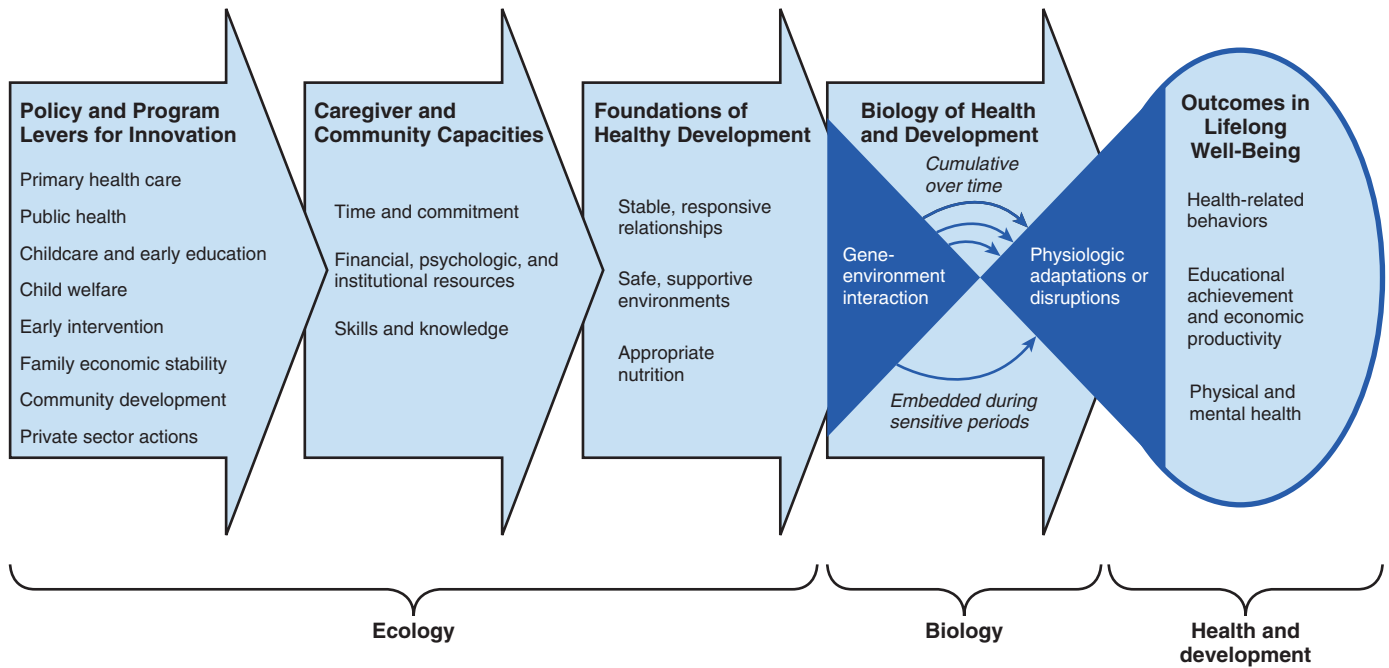


Fig. 19.2 Ecobiodevelopmental framework for early childhood policies and programs. (Adapted from Center on the Developing Child. The foundations of lifelong health are built in early childhood. 2010; Available at: <http://www.developingchild.harvard.edu>.)

Table 19.1 Temperamental Characteristics: Descriptions and Examples		
CHARACTERISTIC	DESCRIPTION	EXAMPLES*
Activity level	Amount of gross motor movement	"She's constantly on the move." "He would rather sit still than run around."
Rhythmicity	Regularity of biologic cycles	"He's never hungry at the same time each day." "You could set a watch by her nap."
Approach and withdrawal	Initial response to new stimuli	"She rejects every new food at first." "He sleeps well in any place."
Adaptability	Ease of adaptation to novel stimulus	"Changes upset him." "She adjusts to new people quickly."
Threshold of responsiveness	Intensity of stimuli needed to evoke a response (e.g., touch, sound, light)	"He notices all the lumps in his food and objects to them." "She will eat anything, wear anything, do anything."
Intensity of reaction	Energy level of response	"She shouts when she is happy and wails when she is sad." "He never cries much."
Quality of mood	Usual disposition (e.g., pleasant, glum)	"He does not laugh much." "It seems like she is always happy."
Distractibility	How easily diverted from ongoing activity	"She is distracted at mealtime when other children are nearby." "He doesn't even hear me when he is playing."
Attention span and persistence	How long a child pays attention and sticks with difficult tasks	"He goes from toy to toy every minute." "She will keep at a puzzle until she has mastered it."

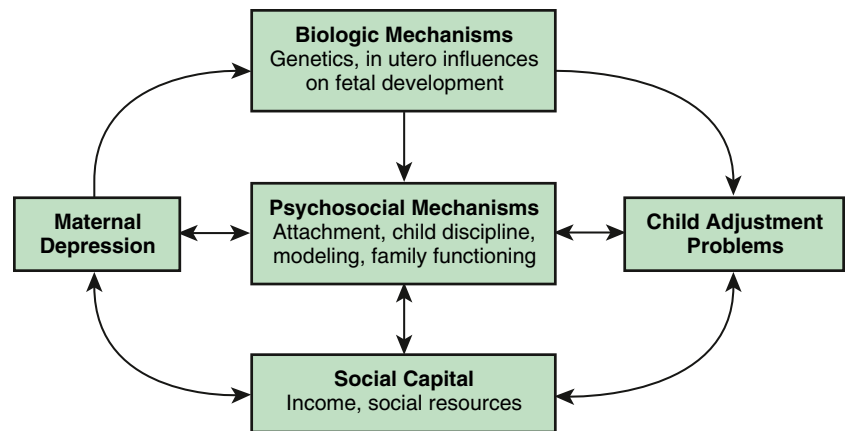
\*Typical statements of parents, reflecting the range for each characteristic from very little to very much. Based on data from Chess S, Thomas A. *Temperament in Clinical Practice*. New York: Guilford; 1986.

growth. Factors such as poverty, systemic racism, access to education, transportation, food, housing, parental employment, and local support systems are influential factors in a child's well-being. Whenever possible, identifying community supports and assets for families can help promote health and development.

**Unifying Concepts: The Transactional Model, Risk, and Resilience**

The **transactional model** proposes that a child's status at any point in time is a function of the interaction between biologic and social influences. The influences are bidirectional: biologic factors, such

as temperament and health status, affect the child-rearing environment and are affected by it. A premature infant may cry little and sleep for long periods; the infant's depressed parent may welcome this behavior, setting up a cycle that leads to poor nutrition and inadequate growth. The child's failure to thrive may reinforce the parent's sense of failure as a parent. At a later stage, impulsivity and inattention associated with early, prolonged undernutrition may lead to aggressive behavior. The cause of the aggression in this case is not the prematurity, the undernutrition, or the maternal depression, but the interaction of all these factors (Fig. 19.3). Conversely, children with biologic risk factors may nevertheless do



**Fig. 19.3** Theoretical model of mutual influences on maternal depression and child adjustment. (From Elgar FJ, McGrath PJ, Waschbusch DA, et al. *Mutual influences on maternal depression and child adjustment problems*, *Clin Psychol Rev* 2004;24:441–459.)

well developmentally if the child-rearing environment is supportive. Premature infants with electroencephalographic evidence of neurologic immaturity may be at increased risk for cognitive delay. When parent–child interactions are optimal, risk of developmental disability is reduced.

An estimate of developmental risk can begin with risk factors, such as low income, low literacy, and lack of neighborhood resources. Stress and anxiety in pregnancy are associated with cognitive, behavioral, and emotional problems in the child. Early stress may have effects on aging mediated by shortening of telomere length, a link to health disparities. Risk for negative outcomes over time increases exponentially as a result of declining plasticity and accumulation of risk factors (both behavioral and environmental). Interventions are most effective in young children; over time, risk increases as the ability to change decreases.

Children growing up in poverty experience multiple levels of developmental risk: increased exposure to biologic risk factors, such as environmental lead and inadequate nutrition; lack of stimulation in the home; and decreased access to interventional education and therapeutic experiences. As they respond by withdrawal or acting out, they further discourage positive stimulation from those around them. Children of adolescent mothers are also at risk. When early intervention programs provide timely, intensive, comprehensive, and prolonged services, at-risk children show marked and sustained upswings in their developmental trajectory. Early identification of children at developmental risk, along with early intervention to support parenting, is critically important (see [Chapter 20](#)). Promoting relational health and identifying supportive community resources and interventions can buffer the negative impact of environmental risk factors.

Children can have appropriate developmental trajectories despite childhood trauma. **Resilience** is the ability to withstand, adapt to, and recover from adversities. There are several modifiable resilience factors: a positive appraisal or outlook and good executive functioning (see [Chapter 49](#)); nurturing parenting; good maternal mental health, self-care skills, and consistent household routines; and an understanding of trauma. The personal histories of children who overcome poverty often include at least one trusted adult (parent, grandparent, teacher) with whom the child has a special, supportive, close relationship. Pediatric providers are positioned to target and bolster resilience in their patients and families.

### Developmental Domains and Theories of Emotion and Cognition

Child development can also be tracked by the child’s developmental progress in particular domains, such as gross motor, fine motor, social, emotional, language, and cognition. Within each of these categories are *developmental* sequences of changes leading up to particular attainments. Development in the gross motor domain, from rolling

to creeping to independent walking, are clear. Others, such as the line leading to the development of conscience, are subtler.

The concept of a developmental line implies that a child passes through successive stages. Several developmental theories are based on stages as qualitatively different epochs in the development of emotion and cognition ([Table 19.2](#)). In contrast, behavioral theories rely less on qualitative change and more on the gradual modification of behavior and accumulation of competence.

### Psychoanalytic Theories

At the core of **Freudian theory** is the idea of body-centered (or broadly, “sexual”) drives; the emotional health of both the child and the adult depends on adequate resolution of conflicts brought about by these drives. Although Freudian ideas have been challenged, they opened the door to subsequent theories of development.

**Erikson** recast Freud’s stages in terms of the emerging personality (see [Table 19.2](#)). The child’s sense of basic trust develops through the successful negotiation of infantile needs. As children progress through these psychosocial stages, different issues become salient. It is predictable that a toddler will be preoccupied with establishing a sense of autonomy, whereas a late adolescent may be more focused on establishing meaningful relationships and an occupational identity. Erikson recognized that these stages arise in the context of Western European societal expectations; in other cultures, the salient issues may be quite different.

Erikson’s work calls attention to the intrapersonal challenges facing children at different ages in a way that facilitates professional intervention. Knowing that the salient issue for school-age children is industry vs inferiority, pediatricians inquire about a child’s experiences of mastery and failure and (if necessary) suggest ways to ensure adequate successes.

### Cognitive Theories

Cognitive development is best understood through the work of **Piaget**. A central tenet of Piaget’s work is that cognition changes in *quality*, not just quantity (see [Table 19.2](#)). During the sensorimotor stage, an infant’s thinking is tied to immediate sensations and a child’s ability to manipulate objects. The concept of “in” is embodied in a child’s act of putting a block into a cup. With the arrival of language, the nature of thinking changes dramatically; symbols increasingly take the place of objects and actions. Piaget described how children actively construct knowledge for themselves through the linked processes of **assimilation** (taking in new experiences according to existing schemata) and **accommodation** (creating new patterns of understanding to adapt to new information). In this way, children are continually and actively reorganizing cognitive processes.

There have been challenges to some of the Piaget’s basic concepts. Children may reach the stages at variable ages. Of undeniable

**Table 19.2** Classic Developmental Stage Theories

	INFANCY (0-1 YR)	TODDLERHOOD (2-3 YR)	PRESCHOOL (3-6 YR)	SCHOOL AGE (6-12 YR)	ADOLESCENCE (12-20 YR)
Freud: psychosexual	Oral	Anal	Phallic/oedipal	Latency	Genital
Erikson: psychosocial	Basic trust vs mistrust	Autonomy vs shame and doubt	Initiative vs guilt	Industry vs inferiority	Identity vs role diffusion
Piaget: cognitive	Sensorimotor	Sensorimotor	Preoperational	Concrete operations	Formal operations
Kohlberg: moral	—	Preconventional: avoid punishment/obtain rewards (stages 1 and 2)	Conventional: conformity (stage 3)	Conventional: law and order (stage 4)	Postconventional: moral principles

importance is Piaget's focus on cognition as a subject of empirical study, the universality of the progression of cognitive stages, and the image of a child as actively and creatively interpreting the world. Piaget's work is of special importance to pediatricians for three reasons: (1) Piaget's observations provide insight into many puzzling behaviors of infancy, such as the common exacerbation of sleep problems at 9 and 18 months of age; (2) Piaget's observations often lend themselves to quick replication in the office, with little special equipment; and (3) open-ended questioning, based on Piaget's work, can provide insights into children's understanding of illness and hospitalization.

However, other studies have found that even young children and infants are "natural scientists" and able to integrate new information through experimentation. Young children's learning is highly similar to the scientific thought process, including inductive reasoning, making predictions, and hypothesis testing. Hypotheses and conclusions about the world are constantly being revised based on the child's experience. When children are faced with evidence that conflicts with expected outcomes (**expectancy violation**), they are motivated to explore and resolve ambiguities. Children can alter their beliefs when given new evidence. That children utilize probabilistic models and exploration to resolve unexpected outcomes has strong implications for the advancement of educational theory.

Based on cognitive development, **Kohlberg** developed a theory of moral development in six stages, from early childhood through adulthood. Preschoolers' earliest sense of right and wrong is egocentric, motivated by externally applied controls. In later stages, children perceive equality, fairness, and reciprocity in their understanding of interpersonal interactions through perspective taking. Most youth will reach stage 4, conventional morality, by mid-to late adolescence. The basic theory has been modified to distinguish morality from social conventions. Whereas moral thinking considers interpersonal interactions, justice, and human welfare, social conventions are the agreed-on standards of behavior particular to a social or cultural group. Within each stage of development, children are guided by the basic precepts of moral behavior, but they also may take into account local standards, such as dress code, classroom behavior, and dating expectations. There is a broader understanding of moral development of even young infants and children theorizing an innate capacity to relate to others. Moral development can be found in very young infants, toddlers, and preschoolers who have a concept of self in relation to others, empathy and caring for others, and may incorporate their cultural context in a way that influences how and when moral development occurs.

### Behavioral Theory

This theoretical perspective distinguishes itself by its lack of concern with a child's inner experience. Its focus is on observable behaviors and measurable factors that either increase or decrease the frequency with which these behaviors occur. No stages are

implied; children, adults, and indeed animals all respond in the same way. In its simplest form, the behaviorist orientation asserts that behaviors that are reinforced occur more frequently; behaviors that are punished or ignored occur less frequently. Reinforcement may be further divided into *positive* reinforcement, when a reward or attention increases the chance of a behavior occurring, and *negative* reinforcement, when removal of an aversive stimulus increases the frequency of the behavior. A teacher who allows students who complete the homework Monday through Thursday not to have an assignment on Friday is using negative reinforcement to motivate homework completion during the week.

The strengths of behavioral theory are its simplicity, wide applicability, and conduciveness to scientific verification. A behavioral approach lends itself to interventions for various common problems, such as temper tantrums, aggressive preschool behavior, and eating disorders, in which behaviors are broken down into discrete units. In cognitively limited children and children with autism spectrum disorder, behavioral interventions using **applied behavior analysis** approaches have demonstrated the ability to teach new, complex behaviors. Applied behavior analysis has been particularly useful in the treatment of early-diagnosed autism spectrum disorder (see [Chapter 58](#)). However, when misbehavior is symptomatic of an underlying emotional, perceptual, or family problem, an exclusive reliance on behavior therapy risks leaving the cause untreated. Behavioral approaches can be taught to parents for application at home.

### Theories Used in Behavioral Interventions

An increasing number of programs or interventions (within and outside the physician's office) are designed to influence health behaviors; some of these models are based on behavioral or cognitive theory or may have attributes of both. The most commonly employed models are the Health Belief Model, Theory of Reasoned Action, Theory of Planned Behavior, Social Cognitive Theory, and Transtheoretical Model, also known as Stages of Change Theory (see [Chapter 18](#)). Pediatricians should be aware of these models and their similarities and differences ([Table 19.3](#)). Interventions based on these theories have been designed for children and adolescents in community, clinic, and hospital-based settings.

**Motivational interviewing (MI)** is a technique often used in clinical settings to bring about behavior change ([Chapter 18](#)). Briefly, the goal is to enhance an individual's motivation to change behavior by exploring and overcoming ambivalence. The therapist is a partner rather than an authority figure and recognizes that, ultimately, the patient has control over his or her choices. Pediatric providers can learn brief MI techniques.

### Statistics Used in Describing Growth and Development

See [Chapter 27](#).

In everyday use, the term *normal* is synonymous with *healthy*. In a statistical sense, *normal* means that a set of values generates a

**Table 19.3** Similar or Identical Elements Within Six Theories of Health Behavior

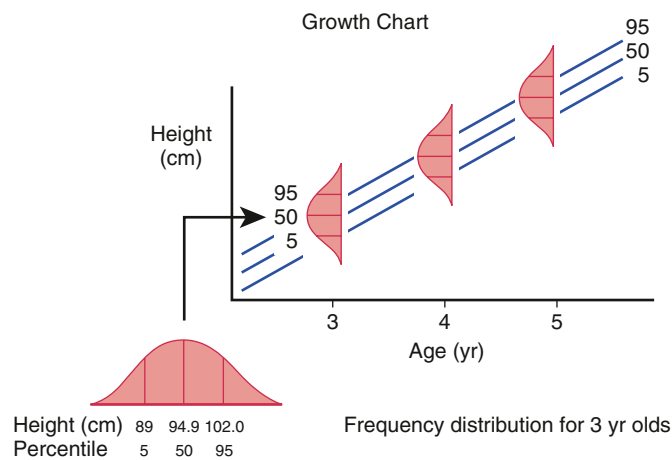
CONCEPT	GENERAL TENET OF "ENGAGING IN THE BEHAVIOR IS LIKELY IF..."	HEALTH BELIEF MODEL	THEORY OF REASONED ACTION	THEORY OF PLANNED BEHAVIOR	SOCIAL COGNITIVE THEORY	TRANS-THEORETICAL MODEL (STAGES OF CHANGE)	SOCIAL NORMS THEORY
<b>ATTITUDINAL BELIEFS</b>							
Appraisal of positive/negative aspects of the behavior and expected outcome	Positive aspects outweigh negative aspects	Benefits vs. barriers; health motive	Behavioral beliefs and evaluation of those beliefs (attitudes)		Outcome expectation; expectancies	Pros, cons (decision balance)	Perceptions of peer attitudes and behaviors
<b>SELF-EFFICACY/BELIEF ABOUT CONTROL OVER THE BEHAVIOR</b>							
Belief in one's ability to perform the behavior; confidence	Belief that one can perform the behavior	Self-efficacy	—	Perceived behavioral control	Self-efficacy	Self-efficacy/temptation	—
<b>NORMATIVE AND NORM-RELATED BELIEFS AND ACTIVITIES</b>							
Belief that others are supportive of the behavior	Belief that others support the behavior change	Cues from media, friends	Normative beliefs and motivation to comply (subjective norms)		Social support	Helping relationships (process of change)	Misperceptions of actual vs. perceived norms
Belief that others are engaging in the behavior	Other people are engaging in the behavior	—	—	—	Social environment; modeling	Social liberation (process of change)	Misperceptions of actual vs. perceived norms
Responses that increase or decrease the likelihood of engaging in the behavior; reminders	Receives positive reinforcement	Cues to action	—	—	Reinforcement	Reinforcement management/stimulus control	Change in perceptions through media; social messaging
<b>RISK-RELATED BELIEFS AND EMOTIONAL RESPONSES</b>							
Belief that one is at risk if not engaging in the behavior; consequences may be severe	Belief that one is at risk for negative outcome or disease	Perceived susceptibility/severity (perceived threat)	—	—	Emotional coping responses/expectancies about environmental cues	Dramatic relief (process of change)	—
<b>INTENTION/COMMITMENT/PLANNING</b>							
Intending or planning to perform the behavior/setting goals	Forms strong intentions to engage in the behavior/makes a commitment	—	Behavioral intentions		Self-control/self-regulation	Contemplation/preparation/self-liberation (process of change)	Understanding actual norms leads to change

Adapted from Noar SM, Zimmerman RS. Health behavior theory and cumulative knowledge regarding health behaviors: are we moving in the right direction? Health Educ Res. 2005; 20:275-290, Table 1.

**Table 19.4** Relationship Between Standard Deviation (SD) and Normal Range for Normally Distributed Quantities

OBSERVATIONS INCLUDED IN THE NORMAL RANGE		PROBABILITY OF A "NORMAL" MEASUREMENT DEVIATING FROM THE MEAN BY THIS AMOUNT	
SD	%	SD	%
±1	68.3	≥1	16.0
±2	95.4	≥2	2.3
±3	99.7	≥3	0.13





**Fig. 19.4** Relationship between percentile lines on the growth curve and frequency distributions of height at different ages.

normal (bell-shaped or gaussian) distribution. This is the case with anthropometric quantities, such as height and weight, and with many developmental measures, such as IQ. For a **normally distributed measurement**, a histogram with the quantity (height, age) on the  $x$  axis and the frequency (the number of children of that height, or the number who stand on their own at that age) on the  $y$  axis generates a bell-shaped curve. In an ideal bell-shaped curve, the peak corresponds to the arithmetic **mean** (average) of the sample, as well as to the median and the mode. The **median** is the value above and below which 50% of the observations lie; the **mode** is the value with the highest number of observations. Distributions are termed *skewed* if the mean, median, and mode are not the same number.

The extent to which observed values cluster near the mean determines the width of the bell and can be described mathematically by the **standard deviation (SD)**. In the ideal normal curve, a range of values extending from 1 SD below the mean to 1 SD above the mean includes approximately 68% of the values, and each “tail” above and below that range contains 16% of the values. A range encompassing  $\pm 2$  SD includes 95% of the values (with the upper and lower tails each comprising approximately 2.5% of the values), and  $\pm 3$  SD encompasses 99.7% of the values (Table 19.4 and Fig. 19.4).

For any single measurement, its distance away from the mean can be expressed in terms of the number of SDs (also called a  **$z$  score**); one can then consult a table of the normal distribution to find out what percentage of measurements fall within that distance from the mean. Software to convert anthropometric data into  $z$  scores for epidemiologic purposes is available. A measurement that falls “outside the normal range” (arbitrarily defined as 2, or sometimes 3, SDs on either side of the mean) is atypical, but not necessarily indicative of illness. The further a measurement (height, weight, IQ) falls from the mean, the greater is the probability that it represents not simply normal variation, but rather a different, potentially pathologic condition.

Another way of relating an individual to a group uses percentiles. The **percentile** is the percentage of individuals in the group who have achieved a certain measured quantity (e.g., height of 95 cm) or a developmental milestone (e.g., walking independently). For anthropometric data, the percentile cutoffs can be calculated from the mean and SD. The 5th, 10th, and 25th percentiles correspond to  $-1.65$  SD,  $-1.3$  SD, and  $-0.7$  SD, respectively. Figure 19.4 demonstrates how frequency distributions of a particular parameter (height) at different ages relate to the percentile lines on the growth curve.

Visit Elsevier eBooks+ at [eBooks.Elsevier.com](http://eBooks.Elsevier.com) for Bibliography.

## Chapter 20

# Positive Parenting and Support

Rebecca A. Baum and Samantha Schilling

No single force may be more important to a child’s development than the environment in which they are raised. Many factors, both positive and negative, contribute to this environment. Parenting practices provide a foundation to promote healthy child development, protect against adverse outcomes, and foster resilience. The term **positive parenting** describes an approach to parenting that achieves these goals.

### THE IMPORTANCE OF PARENTING

Interactions between parents and their children provide stimulation that promotes the development of language, early cognitive skills, and school readiness. Less frequent participation in interactive parenting practices, such as reading aloud to children, eating family meals, and participating in family outings, predicts an increased risk of developmental delay in low-income families. Interventions that increase parents’ reading to children promote positive developmental outcomes such as early language and literacy development.

The affective nature of the parent–child interaction is important for both cognitive and social emotional development. Persistent maternal depression has been linked to decreases in child IQ scores at school entry. Early exposure to positive parenting has been associated with lower rates of childhood depression, risky behavior, delinquency, injuries, behavior problems, and bullying, and with increased likelihood of empathy and prosocial behavior. The beneficial effects of early maternal sensitivity on social competence have been found to persist into adulthood, contributing to the growing evidence that early parent–child interactions have a long-term impact.

Positive parenting practices, such as using a warm, supportive approach during conflict, and negative practices, such as maternal aggression, have been associated with MRI changes in adolescent brain development in males. Animal models have been used to demonstrate the detrimental effects of stressful early life experiences. Offspring raised in these environments were more likely to exhibit fearful behavior and had differences in brain architecture and in epigenetic changes that alter gene expression. Importantly in these animal models, increased maternal nurturing could protect against these changes.

### THE ROLE OF THE FAMILY

Parenting occurs in the context of the family, and yet a “one size fits all” approach to understanding families does not suffice. To understand the influence of the family environment on parenting practices, it is important to appreciate the evolving diversity among U.S. families with respect to culture, race/ethnicity, and family makeup. The U.S. population continues to become more racially/ethnically diverse (61.1% in 2020 vs 54.9% in 2010). Over the last several decades, the percentage of children raised in single-parent homes has continued to grow to nearly 25% in 2020, up from 9% in 1960. It is also important to appreciate that many families face disparities in health and developmental outcomes related to racism and other forms of discrimination that may occur on the basis of religion, sexuality/gender, disability, and socioeconomic status among other factors. For many children these factors interact to further increase risk for disparities in outcomes. Children living in single-parent homes experience poverty at a higher rate than those living in two-parent homes.

Chronic stress and adverse experiences in childhood can have far-reaching consequences that negatively affect health and developmental outcomes (see [Chapters 1 and 2](#)). However, parenting—in the form of safe, stable, and nurturing relationships (SSNRs)—has been suggested as one of a number of strategies that can promote resilience and buffer adversity and turn potentially toxic stress responses into tolerable or positive responses.

## PARENTING STYLES

Parenting practices are significantly influenced by culture, defined as a pattern of social norms, values, language, and behavior shared by a group of individuals. Approaches to self-regulation, for example, vary across cultures with respect to promoting attention, compliance, delayed gratification, executive function, and effortful control. In examining parent practices, it is important to recognize the role of structural racism and bias on the design and interpretation of parenting research.

Three styles of parenting have been described: authoritative, authoritarian, and permissive. Each style has varying approaches to parental control and responsiveness. A fourth style, neglectful parenting, has also been suggested. **Authoritative parenting** describes a parenting style that is warm, responsive, and accepting but that also sets expectations for behavior and achievement. Differences are approached with reasoning and discussion rather than by exerting control. **Authoritarian parenting** is characterized by a high degree of parental control in which obedience is expected. Punishment is often employed to foster compliance rather than verbal discussion. **Permissive parenting** refers to an approach characterized by warmth and acceptance with the child's autonomy being highly valued, but with few rules or expectations. This contrasts with **neglectful parenting**, similarly characterized by few rules or expectations but also by limited parental warmth or responsiveness.

An authoritative parenting style is most likely to be associated with positive child outcomes across multiple domains, including educational achievement and social-emotional competence. Parental supervision, consistency, and open communication reduce risky behaviors in adolescents. Harsh, inconsistent, and coercive discipline and physical punishment have been associated with increases in emotional and behavioral problems. Child physical abuse is often preceded by corporal punishment. In addition to a higher rate of aggression and behavioral problems, children who have experienced physical punishment have been found to have lower IQs and smaller prefrontal cortexes compared to those who have not. Much of the initial research on parenting styles was based on select U.S. populations (White middle-class families).

## CHILD TEMPERAMENT

As evidenced by the effects of family structure, culture/ethnicity, and economics, parenting does not occur in isolation. The child also brings to the parent-child relationship their own personality, or **temperament**, a collection of traits that stay relatively constant over time (see [Chapter 19](#)). The initial temperament research identified nine traits: activity level, predictability of behavior, reaction to new environments, adaptability, intensity, mood, distractibility, persistence, and sensitivity. Most infants (65%) fit into one of three groups, easy (40%), difficult (10%), and slow to warm up (15%), and these patterns are relatively stable over time. Although variations in temperament traits are part of normal human variations, certain behavioral difficulties have been associated with certain temperament types. For example, a difficult temperament has been associated with the development of externalizing behavior (e.g., acting out, disruptive, and aggressive behavior) and, not surprisingly, a slow-to-warm-up temperament with internalizing behavior (e.g., anxious and moody behavior).

Temperament traits are relatively stable, but how the child functions is affected by the environment, especially by parenting and the “goodness of fit” between the parent and child. Children with difficult temperament characteristics respond more negatively to neglectful parenting, and children of all temperament groups

respond positively to responsive and sensitive parenting. Moreover, childhood traits such as low adaptability, impulsivity, and low frustration tolerance may lead some parents to engage in more negative parenting practices. These findings illustrate the interactive nature between parent and child, with parental behavior shaping child behavior, and vice versa.

## CHILD BEHAVIORAL PROBLEMS

Emotional and behavioral problems are common in childhood. Early behavioral problems impact at least one in five children under age 5 in the United States and are associated with impairments in multiple domains, including family, academic, and social functioning, which often continue into adulthood. Emotional and behavioral problems have been associated with single-parent households and poverty. Children in underserved populations experience life circumstances and structural barriers to care that place them at greater risk of behavior problems and unmet needs. High rates of socioeconomic disadvantage, inadequate social infrastructure, neighborhood exposure to violence, repetitive experiences of discrimination, and chronic exposure to racism among minoritized children can have significant adverse effects on children's physical and mental health. Although negative parenting may contribute to and exacerbate such problems, positive parenting practices have been shown to buffer against poor outcome for children growing up in such adversity.

Other risk factors for the development of challenging behavior include trauma and developmental problems. **Adverse childhood experiences (ACEs)**, defined as abuse and neglect, caregiver substance use, caregiver mental health problems, and domestic violence or criminality, are often present during childhood (see [Chapter 1](#)). In the National Survey of Child and Adolescent Well-Being there was a cumulative relationship between emotional and behavioral problems and ACE exposure, with children exposed to four or more ACEs being almost five times more likely to have internalizing problems than children not exposed to ACEs. A similar relationship was found for externalizing problems. Studies involving children with developmental disabilities suggest emotional and behavioral problems occur more frequently in this group than in typically developing children. These children may have delays in self-regulation and communication skills as well as increased family stress, which contribute to the increased likelihood of behavioral challenges.

## DEFINING POSITIVE PARENTING

The precise definition of the components of positive parenting is lacking. Positive parenting must ensure the child's safety, health, and nutrition as well as developmental promotion. Common attributes of positive parenting include caring, leading, providing, teaching, and communicating with the child in a consistent and unconditional manner. To account for the long-term goals of successful parenting in promoting optimal emotional, behavioral, and developmental outcomes, some suggest the term **purposeful parenting** and related characteristics ([Table 20.1](#)). The characterization of an ideal approach to parenting will evolve with ever-changing societal norms, but key components such as those in [Table 20.1](#) will likely remain fundamental.

## PARENTING AS AN INTERVENTION

The influence of parenting practices on child behavior, development, and overall adjustment has led to efforts to teach parenting as a method of primary prevention. The Video Interaction Project (VIP) uses a coaching and education model with recorded parent-child interactions to foster positive parenting behavior. These parenting behaviors range from reading aloud to encouraging interactive play. In an urban, low-income, primary care setting, parent and child outcomes for the VIP group were compared to those from a lower-intensity intervention (parent mailings encouraging positive parenting behaviors) and a control group. VIP produced the most robust impacts on socioemotional outcomes, including decreased distress with separation, hyperactivity, and externalizing behavior in toddlers.

ATTRIBUTE	DEFINING ACTIONS
Protective	Ensure the child's emotional, developmental, and physiologic needs are met. Provide a safe environment. Balance the need for safety with the child's need for exploration and independence.
Personal	Show unconditional love and acceptance. Be kind and gentle. Avoid name-calling and harsh language. Label emotions and behaviors to help children understand their feelings. Teach and model helpful behavior rather than just saying "no."
Progressive	Adapt parenting skills and discipline to meet the child's developmental needs. Learn about child development to know what to expect. Notice and praise new skills and desirable behaviors.
Positive	Be warm, supportive, and optimistic, even during times of misbehavior. Avoid harsh or physical punishments. Provide encouragement and reward effort, not just a positive result.
Playful	Enjoy child-led time together to encourage exploration, foster creativity, and learn new skills. Read together.
Purposeful	Take care of your needs as a parent. Keep the long-term goals of parenting in mind. Preferentially use teaching instead of punishment to encourage desirable behavior. Be consistent with routines and expectations. Try to understand the reason behind the child's behavior.

Adapted from the work of Andrew Garner and the Ohio Chapter, American Academy of Pediatrics. [http://ohioaap.org/wp-content/uploads/2013/07/BPoM\\_PurposefulParenting.pdf](http://ohioaap.org/wp-content/uploads/2013/07/BPoM_PurposefulParenting.pdf).

Positive parenting as a public health intervention has resulted in decreased rates of substantiated child maltreatment cases, out-of-home placements, and child maltreatment injuries. Other effective public health approaches include home-visiting programs, which have been deployed to at-risk families in an effort to improve maternal and child outcomes. The Maternal, Infant and Early Childhood Home Visiting Program, authorized as part of the Affordable Care Act of 2010 and again in 2015, is part of the Medicare Access and Children's Health Insurance Program (CHIP) Reauthorization Act. A key component of home-visiting programs is the promotion of positive parenting behavior to foster child developmental and school readiness. Group parenting programs have been deployed as primary prevention to promote emotional and behavioral adjustment in young children. There is moderate-quality evidence that group-based parenting programs may improve parent-child interactions. These programs typically employ praise, encouragement, and affection and have been associated with improved self-esteem and social and academic competence.

Parenting behaviors have also been employed as an *intervention* to treat emotional and behavioral problems in young children. Parenting interventions such as Incredible Years, Triple P Positive Parenting Program, New Forrest Parenting Program, and Child Adult Relationship Enhancement in Primary Care are effective for at least short-term improvements in child conduct problems, parental mental health, and parenting practices. Also called *parent training programs*, most teach the importance of play, rewards, praise, and consistent discipline and allow parents to practice new skills. This active-learning component distinguishes parent training programs

COMPONENT	ACTIVITIES
Knowledge about child development and behavior	Providing developmentally appropriate environment Learning about child development Promoting positive emotional development
Positive parent-child interactions	Learning the importance of positive, non-discipline-focused interactions Using skills that promote positive interactions Providing frequent positive attention
Responsiveness and warmth	Responding sensitively to the child's emotional needs Providing appropriate physical contact and affection
Emotional communication	Using active listening to foster communication Helping children identify and express emotion
Disciplinary communication	Setting clear, appropriate, and consistent expectations Establishing limits and rules Choosing and following through with appropriate consequences
Discipline and behavior management	Understanding child misbehavior Understanding appropriate discipline strategies Using safe and appropriate monitoring and supervision practices Using reinforcement techniques Using problem solving for challenging behavior Being consistent
Promoting children's social skills and prosocial behavior	Teaching children to share, cooperate, and get along with others Using good manners
Promoting children's cognitive or academic skills	Fostering language and literacy development Promoting school readiness

Adapted from U.S. Centers for Disease Control and Prevention: *Parent training programs: insight for practitioners*, Atlanta, CDC;2009.

from educational programs, which have been shown to be less effective.

Teaching emotional communication skills and positive parent-child interaction skills are associated with parent training programs that demonstrate a greater increase in parenting skills (Table 20.2). Several components are associated with programs that show greater improvements in child externalizing behavior including teaching parents to interact positively and respond consistently to their children as well as to use time-out correctly. All successful programs require parents to practice parenting skills during the program.

Parents have been found to benefit from participation in parenting programs. Before their participation, parents experienced a loss of control, self-blame, social isolation, and difficulty dealing with their child's emotional and behavioral problems, all of which improved after participation. The few studies that have assessed the long-term efficacy of parent-training programs suggest overall positive child outcomes but also periods of relapse during which the use of positive parenting skills decreased. Use of social supports is associated with positive child outcomes and may be an important program component when considering long-term success.

## THE ROLE OF THE PEDIATRICIAN

Pediatricians and other pediatric practitioners have a primary responsibility to support the needs of parents and their children. Numerous programs and interventions have been developed to be delivered effectively and efficiently in the primary care setting.



The American Academy of Pediatrics (AAP) publishes Bright Futures and the associated Guidelines for Preventive Care to standardize child health promotion and prevention in primary care. A substantial amount of the content in Bright Futures maps to the positive-parenting domains of safety, feeding, developmental promotion, and protection. Implementing Bright Futures guidelines in health supervision visits is an important way for pediatric practitioners to support the promotion of positive parenting in practice. The AAP's policy statement titled Preventing Childhood Toxic Stress: Partnering with Families and Communities to Promote Relational Health describes the importance of the parent-child relationship in building the foundation for healthy child development as well as buffering the effects of more significant stressors.

Reading aloud to children is a powerful strategy to promote language development, early literacy, and positive parent-child interaction. The Reach Out and Read program is a primary care-based intervention that trains practitioners to encourage parents to read with their child and provides books to at-risk families. In the absence of a formal partnership with Reach Out and Read, practitioners should promote the benefits of reading aloud to children and support parents in their efforts to develop habits that incorporate reading into daily routines.

In addition to VIP described earlier, other primary care models to promote parenting have been studied. The Healthy Steps for Young Children program is a strengths-based approach delivered in the primary care setting from infancy to age 3 years. Healthy Steps promotes changes in parents' knowledge, beliefs, and psychologic health and changes in parenting behaviors using a variety of methods delivered in the office setting by the practitioner and Healthy Steps specialists and through home visits. Extensive evaluations have shown improvements in parental well-being, parenting practices, and parent-child attachment and decreased child behavior problems. Another promising approach uses community health workers and nurses to provide parenting education and allow mothers to practice parenting skills outside the office setting.

If participation in a formal parenting program is not possible, pediatric practitioners can still implement a systematic approach to support the needs of parents and their children. Practitioners can take advantage of materials in the public domain from national organizations devoted to child and family health, such as ZERO TO THREE (<https://www.zerotothree.org/>) and AAP (<https://www.aap.org/>). The U.S. Centers for Disease Control and Prevention (CDC) also provides evidenced-based parenting resources (<https://www.cdc.gov/parents/essentials/index.html>). Additional components include early identification of parents' concerns, addressing concerns in a supportive and nonjudgmental way, and providing linkage to treatment services when appropriate.

Parents want more information about child development, but parents of children with behavior problems often feel stigmatized and isolated. Practitioners are encouraged to be supportive and optimistic in their interactions with families and to develop a partnership aimed at promoting parent and child health (see [Chapter 18](#)). Practitioners may also encourage parents to practice new skills briefly in the office setting before trying a new skill at home. Active modeling by the practitioner using "teachable moments" may also be effective.

## DISCIPLINE/PUNISHMENT

**Discipline** is meant to teach children to learn good behavior and thus enhance child development. There are many positive parenting approaches to discipline that help avoid confrontations and to also correct behavior without conflict or physical punishment ([Tables 20.3 and 20.4](#)) (see [Chapters 25 and 26](#)). In addition, parents should teach by example; rather than prompting a child to say thank you,

**Table 20.3** UNICEF Approach to Positive Discipline

- Create one-on-one times for engagement
- Praise good behavior
- Set clear and realistic expectations
- Distract to a more positive activity
- Calm (not shouting) realistic consequences (if/then)

Data from United Nations Children's Fund (UNICEF). *How to discipline your child the smart and healthy way.* <https://www.unicef.org/parenting/child-care/how-discipline-your-child-smart-and-healthy-way>.

**Table 20.4** CDC Time-Out Steps

1. Identify behavior and give warning
2. Explain why time-out
3. Go to time-out space
  - No talking
  - No playing
  - No lecturing
  - No scolding
  - No excuses from child
  - Ignore protesting or promise to be good
  - Time for both parent and child to calm down
4. End time-out
5. Explain why there was a time-out
6. Praise next positive behavior

Time-out duration rule is ~1 minute per child age in years

Adapted from U.S. Centers for Disease Control and Prevention (CDC). *Using discipline and consequences.* <https://www.cdc.gov/parents/essentials/consequences/index.html>. Accessed 14 March 2022.

the parents saying thank you is a behavior that an imitating child will follow. Furthermore, when possible, give the child a choice between positive activities, thus enhancing autonomy and preventing conflict. In verbal children, it is helpful to engage the child in problem solving by asking "how can *we* make this better?"

Corporal (physical) punishment is viewed as a violation of the child's right of protection by the United Nations Convention on the Rights of Children. It is viewed by the CDC as a form of child abuse. Corporal punishment is the use of force to produce harm, pain, or discomfort in a dependent child for the purpose of correcting behavior or showing disapproval. It may be manifest by hitting, striking, smacking, slapping, whapping, pinching, kicking, shaking, burning/scalding, pulling hair, washing the mouth with soap or other harmful substances, forcing the child to assume a painful or prolonged posture/position, or using an object to inflict harm. Parents who use corporal punishment may have experienced this punishment as a child. Use of corporal punishment is also associated with adults who misuse drugs, are depressed, or experience intimate partner violence.

The consequences of corporal punishment to the child include worsening behavioral problems including aggression and adverse effects on cognitive development and mental health (anxiety, depression). In addition, corporal punishment does not correct the behavior. Furthermore, there may be a dose-response relationship between the frequency of corporal punishment and adverse child behaviors and development.

For age-related approaches to discipline see [Chapters 24, 25, and 26](#).

Visit Elsevier eBooks+ at [eBooks.Elsevier.com](https://eBooks.Elsevier.com) for Bibliography.



## Chapter 21

# Assessment of Fetal Growth and Development

Alexander S. Whitaker and Susan Feigelman

The developing fetus is affected by social and environmental influences, including maternal nutritional status, substance use (both legal and illicit), and psychologic trauma. Correspondingly, the psychologic alterations experienced by the parents during the gestation profoundly impact the lives of all members of the family. The complex interplay among these forces and the somatic and neurologic transformations occurring in the fetus influence growth and behavior at birth, through infancy, and potentially throughout the individual's life.

## SOMATIC DEVELOPMENT

### Embryonic Period

Table 21.1 lists milestones of prenatal development. By 6 days post-conception age, as implantation begins, the embryo consists of a spherical mass of cells with a central cavity (the *blastocyst*). By 2 weeks, implantation is complete and the uteroplacental circulation has begun; the embryo has two distinct layers, *endoderm* and *ectoderm*, and the amnion has started to form. By 3 weeks, the third primary germ layer (*mesoderm*) has appeared, along with a primitive neural tube and blood vessels. Paired heart tubes have begun to pump.

During weeks 4-8, lateral folding of the embryologic plate, followed by growth at the cranial and caudal ends and the budding of arms and legs, produces a human-like shape. Precursors of skeletal muscle and vertebrae (somites) appear, along with the branchial arches that will form the mandible, maxilla, palate, external ear, and other head and neck structures. Lens placodes appear, marking the site of future eyes; the brain grows rapidly. By the end of week 8, as the embryonic period closes, the rudiments of all major organ systems have developed; the crown-rump length is 3 cm.

### Fetal Period

From the ninth week on (fetal period), somatic changes consist of rapid body growth as well as differentiation of tissues, organs, and organ systems. Figure 21.1 depicts changes in body proportion. By week 10, the face is recognizably human. The midgut returns to the abdomen from the umbilical cord, rotating counterclockwise to bring the stomach, small intestine, and large intestine into their normal positions. By week 12, the gender of the external genitals becomes clearly distinguishable. Lung development proceeds, with the budding of bronchi, bronchioles, and successively smaller divisions. By weeks 20-24, primitive alveoli have formed and surfactant production has begun; before that time, the absence of alveoli renders the lungs useless as organs of gas exchange.

During the third trimester, weight triples and length doubles as body stores of protein, fat, iron, and calcium increase.

## NEUROLOGIC DEVELOPMENT

During the third week, a neural plate appears on the ectodermal surface of the trilaminar embryo. Infolding produces a neural tube that will become the central nervous system and a neural crest that will become the peripheral nervous system. Neuroectodermal cells differentiate into neurons, astrocytes, oligodendrocytes, and ependymal cells, whereas microglial cells are derived from mesoderm. By the fifth week, the three main subdivisions of forebrain, midbrain, and hindbrain are evident. The dorsal and ventral horns of the spinal cord have begun to form, along with the peripheral motor and sensory nerves. Myelination begins at midgestation and continues for years.

By the end of the embryonic period (week 8), the gross structure of the nervous system has been established. On a cellular level, neurons migrate outward to form the six cortical layers. Migration is complete by the sixth month, but differentiation continues. Axons and dendrites form synaptic connections at a rapid pace, making the central nervous system vulnerable to teratogenic or hypoxic influences throughout gestation. Figure 21.2 shows rates of increase in DNA (a marker of cell number), overall brain weight, and cholesterol (a marker of myelination). Epigenetic modifications are made in the presence of fetal gonadal steroids, directing masculinization of the male brain. The prenatal and postnatal peaks of DNA probably represent rapid growth of neurons and glia, respectively. The glial cells are important in shaping the brain and neuronal circuits. The various types of glial cells are needed for the formation of axonal myelin sheaths, a range of functions in the formation and maintenance of neural pathways, and removal of waste (the brain has no lymphoid system for this task).

By the time of birth, the structure of the brain is complete. However, many cells will undergo *apoptosis* (cell death). Synapses will be pruned back substantially, and new connections will be made, largely as a result of experience. Many psychiatric and developmental disorders are thought to result at least in part from disruptions in the **functional connectivity** of brain networks. Disorders of connectivity may begin during fetal life; MRI studies provide a developmental timetable for such connections that lend support to the possible role of disruptions in the establishment of such connections.

## BEHAVIORAL DEVELOPMENT

No behavioral evidence of neural function is detectable until the third month. Reflexive responses to tactile stimulation develop in a cranio-caudal sequence. By weeks 13-14, breathing and swallowing motions appear. The grasp reflex appears at 17 weeks and is well developed by 27 weeks. Eye opening occurs around 26-28 weeks. By midgestation, the full range of neonatal movements can be observed.

During the third trimester, fetuses respond to external stimuli with heart rate elevation and body movements, which can be observed with ultrasound (see Chapter 117). Reactivity to auditory (vibroacoustic) and visual (bright light) stimuli vary, depending on their behavioral state, which can be characterized as quiet sleep, active sleep, or awake. Individual differences in the level of fetal activity are usually noted by mothers. Fetuses will preferentially turn to light patterns in the configuration of the human face. Fetal movement is affected by maternal medications and diet, increasing after ingestion of caffeine. Behavior may be entrained to the mother's diurnal rhythms: asleep during the day, active at night. Abnormal fetal movement patterns are found in neonates with subsequent muscular or neurologic abnormalities.

Fetal movement increases in response to a sudden auditory tone but decreases after several repetitions. This demonstrates **habituation**, a basic form of learning in which repeated stimulation results in a response decrement. If the tone changes in pitch, the movement increases again, which is evidence that the fetus distinguishes between a familiar, repeated tone and a novel tone. Habituation improves in older fetuses and decreases in neurologically impaired or physically stressed fetuses. Similar responses to visual and tactile stimuli have been observed.

## PSYCHOLOGIC CHANGES IN PARENTS

Many psychologic changes occur during pregnancy. An unplanned pregnancy may be met with anger, denial, or depression. Ambivalent feelings are common, whether or not the pregnancy was planned. Elation at the thought of producing a baby and the wish to be the perfect parent compete with fears of inadequacy and of the lifestyle changes that parenting will impose. Parents of an existing child may feel protective of the child, worried that the child may feel less valued. Old conflicts may resurface as a woman psychologically identifies with her own mother and with herself as a child. The father-to-be faces similar mixed feelings, and problems in the parental relationship may intensify.

Tangible evidence that a fetus exists as a separate being, whether as a result of ultrasonic visualization or awareness of fetal movements known as *quickening* (at 16-20 weeks), often heightens a

woman's feelings. Parents worry about the fetus's healthy development and mentally rehearse what they will do if the child is malformed, including their response to evidence of abnormality through ultrasound, amniocentesis, or other fetal laboratory tests. Toward the end of pregnancy, a woman becomes aware of patterns of fetal activity and reactivity and begins to ascribe to her fetus an individual personality and an ability to survive independently. Appreciation of the psychologic vulnerability of the expectant parents and of the powerful contribution of fetal behavior facilitates supportive clinical intervention.

**Table 21.1** Milestones of Prenatal Development

WK	DEVELOPMENTAL EVENTS
1	Fertilization and implantation; beginning of <i>embryonic</i> period
2	Endoderm and ectoderm appear (bilaminar embryo)
3	First missed menstrual period; mesoderm appears (trilaminar embryo); somites begin to form
4	Neural folds fuse; folding of embryo into human-like shape; arm and leg buds appear; crown-rump length 4-5 mm
5	Lens placodes, primitive mouth, digital rays on hands
6	Primitive nose, philtrum, primary palate
7	Eyelids begin; crown-rump length 2 cm
8	Ovaries and testes distinguishable
9	<i>Fetal</i> period begins; crown-rump length 5 cm; weight 8 g
12	External genitals distinguishable
20	Usual lower limit of viability; weight 460 g; length 19 cm
25	Third trimester begins; weight 900 g; length 24 cm
28	Eyes open; fetus turns head down; weight 1,000-1,300 g
38	Term

## THREATS TO FETAL DEVELOPMENT

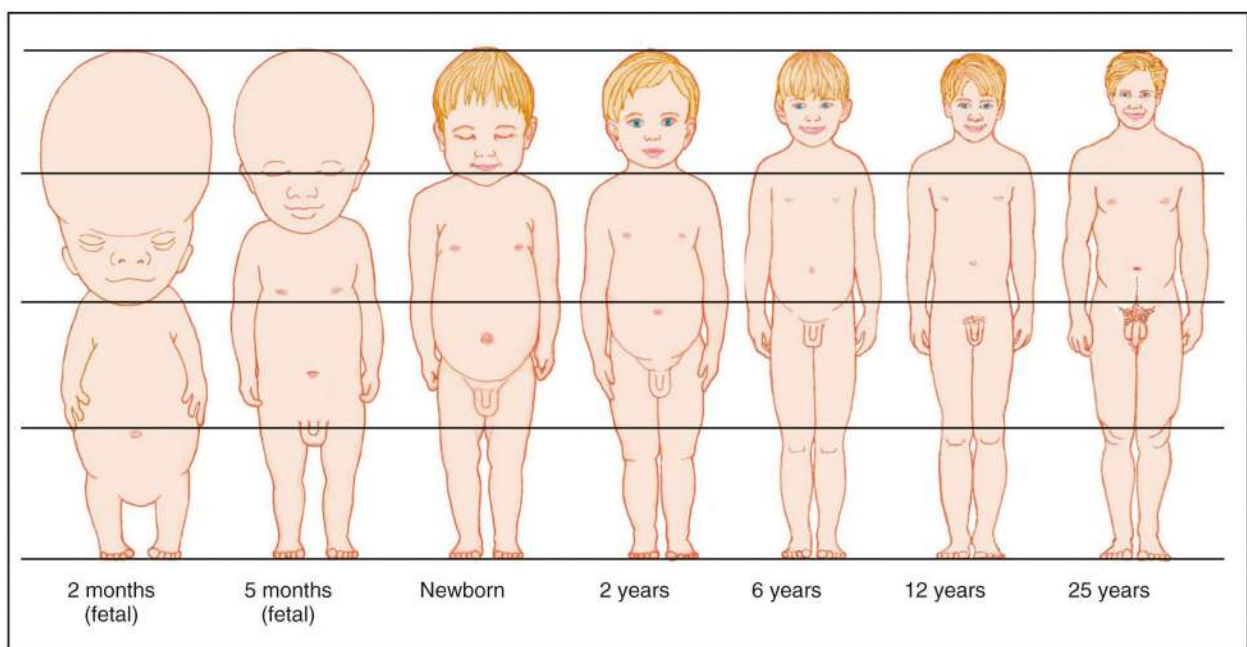
Mortality and morbidity are highest during the prenatal period (see Chapter 114). An estimated 50% of all pregnancies end in spontaneous abortion, including 10–15% of all clinically recognized pregnancies. The majority occur in the first trimester. Many spontaneous abortions occur as a result of chromosomal abnormalities, most commonly aneuploidies.

Teratogens associated with gross physical and mental abnormalities include various infectious agents (e.g., toxoplasmosis, rubella, syphilis, Zika virus), chemical agents (e.g., mercury, thalidomide, antiepileptic medications, retinoids, ethanol), high temperature, and radiation (see Chapters 117 and 758).

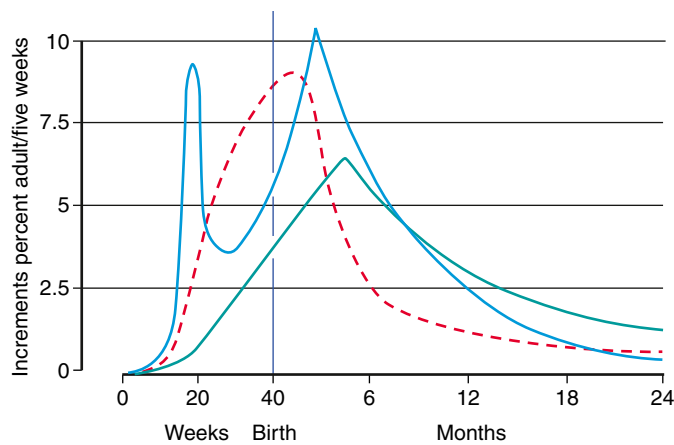
Teratogenic effects may also result in decreased growth and cognitive or behavioral deficits that only become apparent later in life. Nicotine has vasoconstrictor properties and may disrupt dopaminergic and serotonergic pathways. Prenatal exposure to cigarette smoke is associated with lower birthweight, stunting, and smaller head circumference. It is also associated with changes in neonatal neurodevelopmental assessments; later, these children are at increased risk for learning problems, attention and behavior disorders, and other long-term health effects. Alcohol is a common teratogen affecting physical development, cognition, and behavior (see Chapter 146). Prenatal exposure to opiates can result in neonatal abstinence syndrome (NAS) characterized by irritability, poor feeding, tremors and temperature instability in newborn infants. Affected infants may require treatment with low-dose opiates to abate the symptoms. School-age children with a history of NAS are significantly more likely to have educational disabilities, even when controlling for external factors such as maternal educational attainment and gestational age.

The effects of prenatal exposure to cocaine, also occurring through alternations in placental blood flow and in direct toxic effects to the developing brain, have been followed in several cohorts and are less dramatic than previously believed. Exposed adolescents show small but significant effects in behavior and functioning but may not show cognitive impairment. Associated risk factors including alcohol and tobacco use, and postnatal environments frequently characterized by toxic stress, may explain some of the observed negative developmental outcomes. (see Chapters 1, 15, and 17).

The association between an inadequate nutrient supply to the fetus and low birthweight has been recognized for decades; this adaptation



**Fig. 21.1** Changes in body proportions. Approximate changes in body proportions from fetal life through adulthood. (From Leifer G. *Introduction to Maternity & Pediatric Nursing*. Philadelphia: WB Saunders;2011: pp 347–385, Fig. 15-2.)



**Fig. 21.2** Velocity curves of the various components of human brain growth. Blue line, DNA; red line, brain weight; green line, cholesterol. From Brasel JA, Gruen RK. In Falkner F, Tanner JM, eds: *Human Growth: a comprehensive treatise*. New York: Plenum Press; 1986: pp 78–95.

on the part of the fetus presumably increases the likelihood that the fetus will survive until birth. For any potential fetal insult, the extent and nature of its effects are determined by characteristics of the host as well as the dose and timing of the exposure. Inherited differences in the metabolism of ethanol, timing of exposure, and the mother's diet may explain the variability in fetal alcohol effects. Organ systems are most vulnerable during periods of maximum growth and differentiation, generally during the first trimester (**organogenesis**) (<http://www.epa.gov/children/children-are-not-little-adults> details critical periods and specific developmental abnormalities).

Fetal adaptations or responses to an adverse situation in utero, termed **fetal programming** or **developmental plasticity**, have life-long implications. Fetal programming may prepare the fetus for an environment that matches that experienced in utero. Fetal programming in response to some environmental and nutritional signals in utero increases the risk of cardiovascular disease, diabetes, and obesity in later life. These adverse long-term effects appear to represent a mismatch between environmental conditions faced by a fetus or neonate and the conditions that the individual will confront later in life. A fetus deprived of adequate calories may or may not face famine as a child or adolescent. One proposed mechanism for fetal programming is epigenetic imprinting, in which one of two alleles is turned off through environmentally induced epigenetic modification (see **Chapter 97**). Many environmental factors have been found to play a role in producing epigenetic modifications that are both transgenerational (direct effect on the developing fetus) and intergenerational (changes in the germ cells that will affect future generations).

Just as the fetal adaptations to the in utero environment may increase the likelihood of later metabolic conditions, the fetus adapts to the mother's psychologic distress. In response to the stressful environment, physiologic changes involving the hypothalamic-pituitary-adrenal axis and the autonomic nervous system occur. Dysregulation of these systems may explain the associations observed in some but not all studies between maternal distress and negative infant outcomes. These negative outcomes include low birthweight, spontaneous abortion, prematurity, and decreased head circumference. In addition, children born to mothers experiencing high stress levels have been found to have higher rates of inattention, impulsivity, conduct disorders, and negative cognitive changes. Although these changes may have been adaptive in primitive cultures, they are maladaptive in modern societies, leading to psychopathology. Genetic variability, timing of stress during sensitive periods, and the quality of postnatal parenting can attenuate or exacerbate these associations.

Visit Elsevier eBooks+ at [eBooks.Health.Elsevier.com](http://eBooks.Health.Elsevier.com) for Bibliography.

## Chapter 22

# The Newborn

Elisa Hampton and John M. Olsson

See also Chapter 115.

Regardless of gestational age, the newborn (neonatal) period begins at birth and includes the first month of life. During this time, marked physiologic transitions occur in all organ systems, and the infant learns to respond to many forms of external stimuli. Because infants thrive physically and psychologically only in the context of their social relationships, any description of the newborn's developmental status has to include consideration of the parents' role as well.

### PARENTAL ROLE IN PARENT-INFANT ATTACHMENT

Parenting a newborn infant requires dedication because a newborn's needs are urgent, continuous, and often unclear. Parents must attend to an infant's signals and respond empathically. Many factors influence parents' ability to assume this role.

### Prenatal Factors

Pregnancy is a period of psychologic preparation for the profound demands of parenting. Expectant parents may experience ambivalence, particularly (but not exclusively) if the pregnancy was unplanned. Financial concerns, physical illness, prior miscarriages or stillbirths, or other crises may interfere with future bonding. For adolescent parents, the demand that they relinquish their own developmental agenda, such as an active social life, may be especially burdensome.

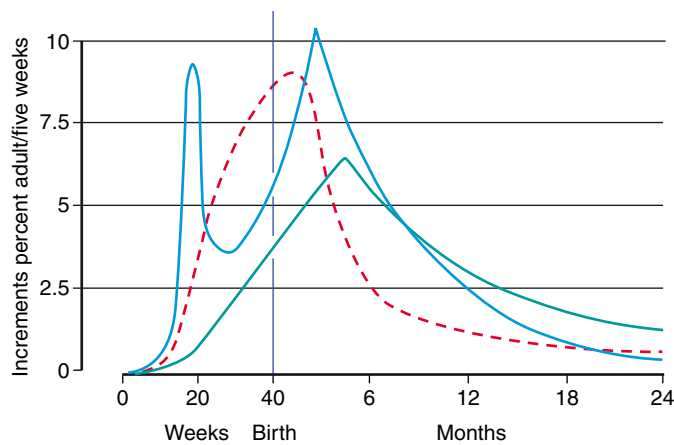
The transition to parenthood is a unique developmental phase, and a stressful one. Lifetime experiences of parents, particularly traumatic ones, may affect their approaches to developing a nurturing relationship with their infant (**Table 22.1**). It has been shown that an increasing number of adverse childhood experiences (ACEs) may be associated with increased parental stress, a more authoritarian style of parenting, increased risk for child abuse, and greater insecurity in parent-child attachment (bonding). Identifying parental ACEs and addressing them with community resources, including parenting classes, parent aides, and parent support groups may help provide parents with the resilience to mitigate the effects of ACEs.

**Table 22.1** Prenatal Risk Factors for Attachment

Recent death of a loved one
Previous loss of or serious illness in another child
Prior removal of a child
History of depression or serious mental illness
History of infertility or pregnancy loss
Troubled relationship with parents
Financial stress or job loss
Marital discord or poor relationship with the other parent
Recent move or no community ties
No friends or social network
Unwanted pregnancy
No good parenting model
Experience of poor parenting
Drug and/or alcohol use
Extreme immaturity

From Dixon SD, Stein MT. *Encounters With Children: Pediatric Behavior and Development*. 4th ed. Philadelphia: Mosby, 2006. p 131.





**Fig. 21.2** Velocity curves of the various components of human brain growth. Blue line, DNA; red line, brain weight; green line, cholesterol. From Brasel JA, Gruen RK. In Falkner F, Tanner JM, eds: *Human Growth: a comprehensive treatise*. New York: Plenum Press; 1986: pp 78–95.

on the part of the fetus presumably increases the likelihood that the fetus will survive until birth. For any potential fetal insult, the extent and nature of its effects are determined by characteristics of the host as well as the dose and timing of the exposure. Inherited differences in the metabolism of ethanol, timing of exposure, and the mother's diet may explain the variability in fetal alcohol effects. Organ systems are most vulnerable during periods of maximum growth and differentiation, generally during the first trimester (**organogenesis**) (<http://www.epa.gov/children/children-are-not-little-adults> details critical periods and specific developmental abnormalities).

Fetal adaptations or responses to an adverse situation in utero, termed **fetal programming** or **developmental plasticity**, have life-long implications. Fetal programming may prepare the fetus for an environment that matches that experienced in utero. Fetal programming in response to some environmental and nutritional signals in utero increases the risk of cardiovascular disease, diabetes, and obesity in later life. These adverse long-term effects appear to represent a mismatch between environmental conditions faced by a fetus or neonate and the conditions that the individual will confront later in life. A fetus deprived of adequate calories may or may not face famine as a child or adolescent. One proposed mechanism for fetal programming is epigenetic imprinting, in which one of two alleles is turned off through environmentally induced epigenetic modification (see **Chapter 97**). Many environmental factors have been found to play a role in producing epigenetic modifications that are both transgenerational (direct effect on the developing fetus) and intergenerational (changes in the germ cells that will affect future generations).

Just as the fetal adaptations to the in utero environment may increase the likelihood of later metabolic conditions, the fetus adapts to the mother's psychologic distress. In response to the stressful environment, physiologic changes involving the hypothalamic-pituitary-adrenal axis and the autonomic nervous system occur. Dysregulation of these systems may explain the associations observed in some but not all studies between maternal distress and negative infant outcomes. These negative outcomes include low birthweight, spontaneous abortion, prematurity, and decreased head circumference. In addition, children born to mothers experiencing high stress levels have been found to have higher rates of inattention, impulsivity, conduct disorders, and negative cognitive changes. Although these changes may have been adaptive in primitive cultures, they are maladaptive in modern societies, leading to psychopathology. Genetic variability, timing of stress during sensitive periods, and the quality of postnatal parenting can attenuate or exacerbate these associations.

Visit Elsevier eBooks+ at [eBooks.Health.Elsevier.com](http://eBooks.Health.Elsevier.com) for Bibliography.

## Chapter 22

# The Newborn

Elisa Hampton and John M. Olsson

See also Chapter 115.

Regardless of gestational age, the newborn (neonatal) period begins at birth and includes the first month of life. During this time, marked physiologic transitions occur in all organ systems, and the infant learns to respond to many forms of external stimuli. Because infants thrive physically and psychologically only in the context of their social relationships, any description of the newborn's developmental status has to include consideration of the parents' role as well.

### PARENTAL ROLE IN PARENT-INFANT ATTACHMENT

Parenting a newborn infant requires dedication because a newborn's needs are urgent, continuous, and often unclear. Parents must attend to an infant's signals and respond empathically. Many factors influence parents' ability to assume this role.

#### Prenatal Factors

Pregnancy is a period of psychologic preparation for the profound demands of parenting. Expectant parents may experience ambivalence, particularly (but not exclusively) if the pregnancy was unplanned. Financial concerns, physical illness, prior miscarriages or stillbirths, or other crises may interfere with future bonding. For adolescent parents, the demand that they relinquish their own developmental agenda, such as an active social life, may be especially burdensome.

The transition to parenthood is a unique developmental phase, and a stressful one. Lifetime experiences of parents, particularly traumatic ones, may affect their approaches to developing a nurturing relationship with their infant (**Table 22.1**). It has been shown that an increasing number of adverse childhood experiences (ACEs) may be associated with increased parental stress, a more authoritarian style of parenting, increased risk for child abuse, and greater insecurity in parent-child attachment (bonding). Identifying parental ACEs and addressing them with community resources, including parenting classes, parent aides, and parent support groups may help provide parents with the resilience to mitigate the effects of ACEs.

**Table 22.1** Prenatal Risk Factors for Attachment

Recent death of a loved one
Previous loss of or serious illness in another child
Prior removal of a child
History of depression or serious mental illness
History of infertility or pregnancy loss
Troubled relationship with parents
Financial stress or job loss
Marital discord or poor relationship with the other parent
Recent move or no community ties
No friends or social network
Unwanted pregnancy
No good parenting model
Experience of poor parenting
Drug and/or alcohol use
Extreme immaturity

From Dixon SD, Stein MT. *Encounters With Children: Pediatric Behavior and Development*. 4th ed. Philadelphia: Mosby, 2006. p 131.



**Social support** during pregnancy, particularly support from the partner and close family members, is also important. Family support can promote resilience in the face of ACEs as described earlier.

Many decisions have to be made by parents in anticipation of the birth of their child. One important choice is how the infant will be nourished. Among the important benefits of **breastfeeding** is its promotion of bonding. Providing breastfeeding education for the parents during prenatal pediatric or obstetric care can increase maternal confidence in breastfeeding after delivery, reduce stress during the newborn period, and promote increased breastfeeding rates and duration (see Chapter 61).

### Peripartum and Postpartum Influences

The continuous presence of a support person during labor results in shorter labor and fewer obstetric complications (including cesarean section). These beneficial effects may be even more pronounced when the support person is specially trained and present solely for the purpose of continuous support (a **doula**). Early skin-to-skin contact between mothers and infants immediately after birth is associated with an increased rate and longer duration of breastfeeding. Most new parents value even a brief period of uninterrupted time in which to get to know their new infant, and increased mother–infant contact over the first days of life may improve long-term mother–child interactions. Nonetheless, early separation, although predictably very stressful, does not inevitably impair a mother’s ability to bond with her infant.

**Postpartum mood and anxiety disorder (PMAD)** may occur in the first week or up to 6 months after delivery and can adversely affect neonatal growth and development. Screening tools, such as the **Edinburgh Postnatal Depression Scale (EPDS)**, are available for use during neonatal and infant visits to the pediatric provider. Screening mothers for PMAD is recommended at the 1, 2, 4, and 6 month well child visit. PMAD is also seen in partners of postpartum women, but peaks later at 3–6 months. Pediatric providers should consider screening partners at the 6 month well child visit using the EPDS. A score of 10 or higher, or a positive response to question 10 (suicidal thoughts), in either postpartum women or their partners warrants referral for evaluation (Table 22.2).

## THE INFANT’S ROLE IN PARENT–INFANT ATTACHMENT

The in utero environment contributes greatly but not completely to the future growth and development of the fetus. Abnormalities in maternal-fetal placental circulation and maternal glucose metabolism or the presence of maternal infection can result in abnormal fetal growth. Infants may be small or large for gestational age as a result. These abnormal growth patterns not only predispose infants to an increased requirement for medical intervention, but they also may affect their ability to respond behaviorally to their parents.

### Physical Examination

Examination of the newborn should include an **evaluation of growth** (see Chapter 21) and an **observation of behavior**. The average term newborn weighs approximately 3.4 kg (7.5 lb); boys are slightly heavier than girls. The average length and head circumference are about 50 cm (20 in) and 35 cm (14 in), respectively, in term infants. Each newborn’s growth parameters should be plotted on growth curves specific for that infant’s gestational age to determine the appropriateness of size. Specific growth charts for conditions associated with variations in growth patterns have also been developed. It is important to note that in the United States, significant disparities exist in low birthweight (<2,500 g) rates with higher rates in low socioeconomic status (SES) groups and in minoritized populations.

The infant’s response to being examined may be useful in assessing its vigor, alertness, and tone. Observing how the parents handle

their infant, their comfort, and affection is also important. The order of the physical examination should be from the least to the most intrusive maneuvers. Assessing visual tracking and response to sound and noting changes of tone with level of activity and alertness are very helpful. Performing this examination and sharing impressions with parents is an important opportunity to facilitate bonding (see Chapter 115).

### Interactional Abilities

Soon after birth, neonates are alert and ready to interact and nurse. This first alert-awake period may be affected by maternal analgesics and anesthetics or fetal hypoxia. Neonates are nearsighted, having a fixed focal length of 8–12 inches, approximately the distance from the breast to the mother’s face, as well as an inborn visual preference for faces. Hearing is well developed, and infants preferentially turn toward a female voice. These innate abilities and predilections increase the likelihood that when a mother gazes at her newborn, the baby will gaze back. The initial period of social interaction, usually lasting about 40 minutes, is followed by a period of somnolence. After that, briefer periods of alertness or excitement alternate with sleep. If a mother misses her baby’s first alert-awake period, she may not experience as long a period of social interaction for several days. The hypothalamic-midbrain-limbic-paralimbic-cortical circuits of the parent’s brain together support responses to the infant that are critical for effective parenting (e.g., emotion, attention, motivation, empathy, decision-making).

### Modulation of Arousal

Adaptation to extrauterine life requires rapid and profound physiologic changes, including aeration of the lungs, rerouting of the circulation, and activation of the intestinal tract. The necessary behavioral changes are no less profound. To obtain nourishment, to avoid hypo- and hyperthermia, and to ensure safety, neonates must react appropriately to an expanded range of sensory stimuli. Infants must become aroused in response to stimulation, but not so overaroused that their behavior becomes disorganized. Underaroused infants are not able to feed and interact; overaroused infants show signs of **autonomic instability**, including flushing or mottling, perioral pallor, hiccupping, vomiting, uncontrolled limb movements, and inconsolable crying.

### Behavioral States

The organization of infant behavior into discrete behavioral states may reflect an infant’s inborn ability to regulate arousal. *Six states* have been described: quiet sleep, active sleep, drowsy, alert, fussy, and crying. In the **alert state**, infants visually fixate on objects or faces and follow them horizontally and (within a month) vertically; they also reliably turn toward a novel sound, as if searching for its source. When overstimulated, they may calm themselves by looking away, yawning, or sucking on their lips or hands, thereby increasing parasympathetic activity and reducing sympathetic nervous system activity. The behavioral state determines an infant’s muscle tone, spontaneous movement, electroencephalogram pattern, and response to stimuli. In **active sleep**, an infant may show progressively less reaction to a repeated heelstick (habituation), whereas in the **drowsy state**, the same stimulus may push a child into fussing or crying.

### Mutual Regulation

Parents actively participate in an infant’s state regulation, alternately stimulating and soothing. In turn, they are regulated by the infant’s signals, responding to cries of hunger with a letdown of milk (or with a bottle). Such interactions constitute a system directed toward furthering the infant’s physiologic homeostasis and physical growth. At the same time, they form the basis for the emerging psychologic relationship between parent and child. Infants come to associate the presence of the parent with the pleasurable reduction of tension (as

**Table 22.2** Edinburgh Postnatal Depression Scale**INSTRUCTIONS FOR USERS**

1. The mother is asked to underline the response that comes closest to how she has been feeling in the previous 7 days.
2. All 10 items must be completed.
3. Care should be taken to avoid the possibility of the mother discussing her answers with others.
4. The mother should complete the scale herself, unless she has limited English or has difficulty with reading.
5. The Edinburgh Postnatal Depression Scale may be used at 6-8wk to screen postnatal women. The child health clinic, a postnatal checkup, or a home visit may provide a suitable opportunity for its completion.

**EDINBURGH POSTNATAL DEPRESSION SCALE**

Name:

Address:

Baby's age:

Because you have recently had a baby, we would like to know how you are feeling. Please underline the answer that comes closest to how you have felt in the past 7 days, not just how you feel today.

Here is an example, already completed.

I have felt happy:

Yes, all the time

Yes, most of the time

No, not very often

No, not at all

This would mean: "I have felt happy most of the time" during the past week. Please complete the other questions in the same way.

In the past 7 days:

1. I have been able to laugh and see the funny side of things
  - As much as I always could
  - Not quite so much now
  - Definitely not so much now
  - Not at all
2. I have looked forward with enjoyment to things
  - As much as I ever did
  - Rather less than I used to
  - Definitely less than I used to
  - Hardly at all
- \*3. I have blamed myself unnecessarily when things went wrong
  - Yes, most of the time
  - Yes, some of the time
  - Not very often
  - No, never
4. I have been anxious or worried for no good reason
  - No, not at all
  - Hardly ever
  - Yes, sometimes
  - Yes, very often
- \*5. I have felt scared or panicky for no very good reason
  - Yes, quite a lot
  - Yes, sometimes
  - No, not much
  - No, not at all
- \*6. Things have been getting on top of me
  - Yes, most of the time I haven't been able to cope at all
  - Yes, sometimes I haven't been coping as well as usual
  - No, most of the time I have coped quite well
  - No, I have been coping as well as ever
- \*7. I have been so unhappy that I have had difficulty sleeping
  - Yes, most of the time
  - Yes, sometimes
  - Not very often
  - No, not at all
- \*8. I have felt sad or miserable
  - Yes, most of the time
  - Yes, quite often
  - Not very often
  - No, not at all
- \*9. I have been so unhappy that I have been crying
  - Yes, most of the time
  - Yes, quite often
  - Only occasionally
  - No, never
- \*10. The thought of harming myself has occurred to me
  - Yes, quite often
  - Sometimes
  - Hardly ever
  - Never

Response categories are scored 0, 1, 2, and 3 according to increased severity of the symptom. Items marked with an asterisk (\*) are reverse-scored (i.e., 3, 2, 1, and 0). The total score is calculated by adding the scores for each of the 10 items. Users may reproduce the scale without further permission provided they respect copyright (which remains with the *British Journal of Psychiatry*) by quoting the names of the authors, the title, and the source of the paper in all reproduced copies.

Adapted from Cox JL, Holden JM, Sagovsky R. Detection of postnatal depression. Development of the 10-item Edinburgh Postnatal Depression Scale. *Br J Psychiatry*. 1987;150:782-786; reproduced from Currie ML, Rademacher R. The pediatrician's role in recognizing and intervening in postpartum depression. *Pediatr Clin North Am*. 2004;51(3):785-xi.

in feeding) and show this preference by calming more quickly for their parent than for a stranger. This response in turn strengthens a parent's sense of efficacy and their connection with their baby.

### IMPLICATIONS FOR THE PEDIATRICIAN

The pediatrician can support healthy newborn development in several ways.

#### Optimal Practices

A **prenatal pediatric visit** allows pediatricians to assess both the strengths of the expectant parents and any needs they may have in anticipation of the birth of their infant. This should include assessment of social determinants of health and may consist of addressing needs such as baby supplies, financial assistance, and parental mental health support. **Supportive hospital policies** include the use of birthing rooms rather than operating suites and delivery rooms; encouraging the partner or a trusted relative or friend to remain with the mother during labor or the provision of a professional doula; the practice of giving the newborn infant to the mother immediately after drying and a brief assessment; keeping the newborn with the mother rather than in a central nursery; and avoiding in-hospital distribution of infant formula. Such policies ("Baby Friendly Hospital") have been shown to significantly increase breastfeeding rates (see Chapter 115.3). After discharge, **home visits** by nurses and lactation counselors can reduce early feeding problems and identify emerging medical conditions in either mother or baby. Infants requiring transport to another hospital should be brought to see the mother first, if at all possible. Timing of hospital discharge should be individualized for each maternal–infant dyad based on the mode of delivery, presence or absence of specific risk factors, and any problems identified during the birth hospitalization. Some healthy term newborns may be discharged before 48 hours of life, and these newborns should be evaluated with a follow up visit by 3–5 days after birth and within 48–72 hours after discharge. The timing of the first visit for newborns with a longer initial hospital stay will depend on the newborn's specific issues and identified needs.

#### Assessing Parent–Infant Interactions

During a feeding or when infants are alert and face-to-face with their parents, it is normal for the dyad to appear absorbed in one another. Infants who become overstimulated by the parent's voice or activity may turn away or close their eyes, leading to a premature termination of the encounter. Alternatively, the infant may be ready to interact, but the parent may appear preoccupied. Asking a new mother about her own emotional state, and inquiring specifically about a history of depression, facilitates referral for therapy, which may provide long-term benefits to the child.

#### Teaching About Individual Competencies

The **Newborn Behavior Assessment Scale (NBAS)** provides a formal measure of an infant's neurodevelopmental competencies, including state control, autonomic reactivity, reflexes, habituation, and orientation toward auditory and visual stimuli. This examination can also be used to demonstrate to parents an infant's capabilities and vulnerabilities. Parents might learn that they need to undress their infant to increase the level of arousal or to swaddle the infant to reduce overstimulation by containing random arm movements. The NBAS can be used to support the development of positive early parent–infant relationships. Demonstration of the NBAS to parents in the first week of life has been shown to correlate with improvements in the caretaking environment months later.

Visit Elsevier eBooks+ at [eBooks.Health.Elsevier.com](http://eBooks.Health.Elsevier.com) for Bibliography.

## Chapter 23

# The First Year

Mutiati T. Onigbanjo and Susan Feigelman

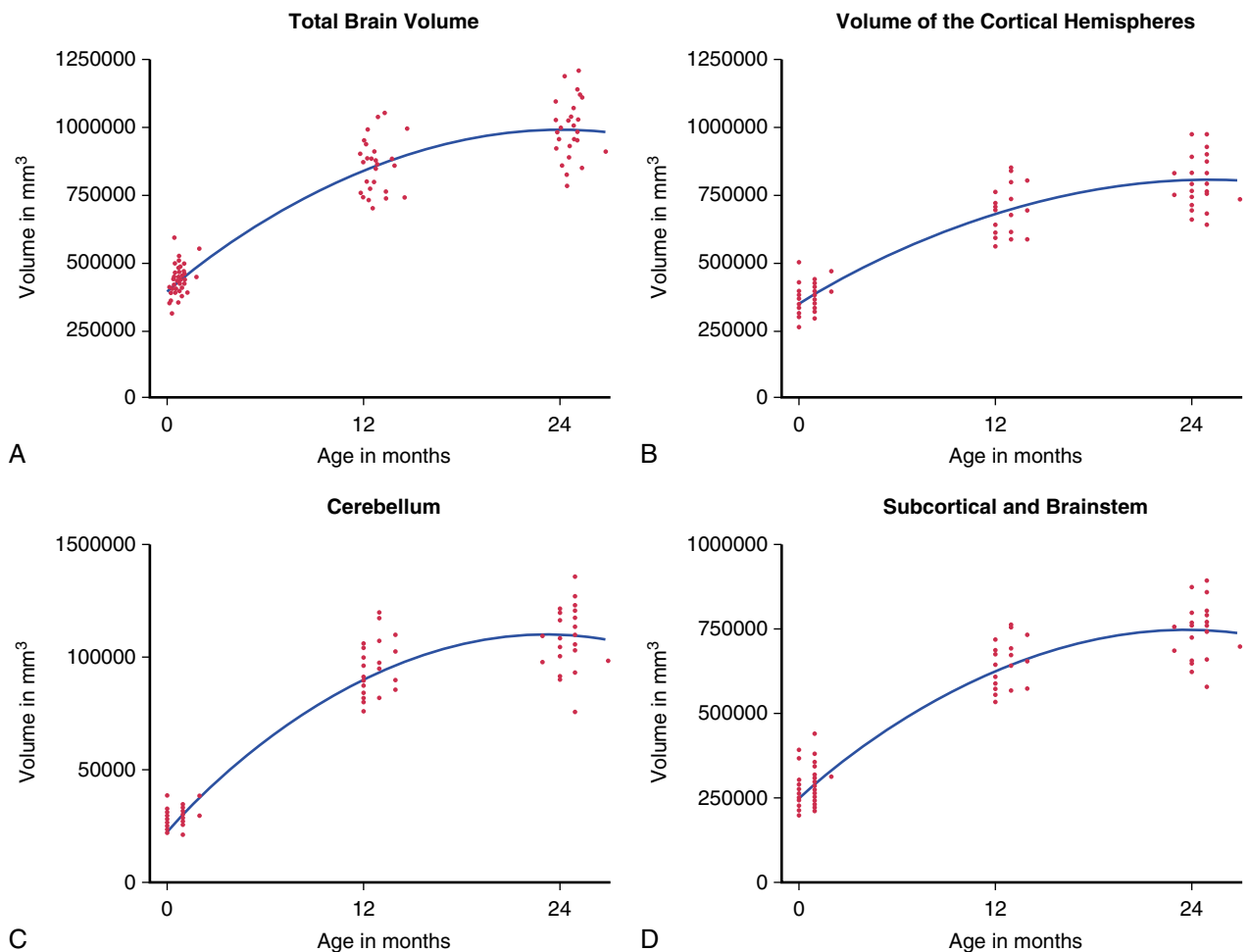
The prenatal period and the first year of life provide the platform for remarkable growth and development, setting the trajectory for a child's life. **Neural plasticity**, the ability of the brain to be shaped by experience, both positive and negative, is at its peak. Total brain volume doubles in the first year of life and increases by an additional 15% over the second year. Total brain volume at age 1 month is approximately 36% of adult volume but by age 1 year is approximately 72% (83% by 2 years) (Fig. 23.1).

The acquisition of seemingly "simple" skills, such as swallowing, reflects a series of intricate and highly coordinated processes involving multiple levels of neural control distributed among several physiologic systems whose nature and relationships mature throughout the first year of life. Substantial learning of the basic tools of language (phonology, word segmentation) occurs during infancy. Speech processing in older individuals requires defined and precise neuronal networks; the infant brain possesses a structural and functional organization similar to that of adults, suggesting that structural neurologic processing of speech may guide infants to discover the properties of their native language. Myelination of the cortex begins at 7–8 months' gestation and continues into adolescence and young adulthood. It proceeds posterior to anterior, allowing progressive maturation of sensory, motor, and finally associative pathways. Given the importance of iron, cholesterol, and other nutrients in myelination, adequate stores throughout infancy are critical (see Chapter 61). Insufficient interactions with caregivers or the wider environment may alter experience-dependent processes that are critical to brain structure development and function during infancy. Although for some processes, subsequent stimulation may allow catch-up; as the periods of plasticity close during the rapid developmental changes occurring in infancy, more permanent deficits may result.

The infant acquires new competences in all developmental domains. The concept of **developmental trajectories** recognizes that complex skills build on simpler ones; it is also important to realize how development in each domain affects functioning in all the others. All growth parameters should be plotted using the World Health Organization charts, which show how children from birth through 72 months "should" grow under optimal circumstances (see Figs. 24.1 and 24.2). Table 23.1 presents an overview of key milestones by domain; Table 23.2 presents similar information arranged by age. Table 23.3 presents age at time of x-ray appearance of centers of ossification. Parents often seek information about "normal development" during this period and should be directed to reliable sources, including the American Academy of Pediatrics website ([www.healthychildren.org](http://www.healthychildren.org)) or the Center for Disease Control website ([www.cdc.gov/ncbddd/actearly/milestones/index.html](http://www.cdc.gov/ncbddd/actearly/milestones/index.html)).

#### AGE 0-2 MONTHS

In the full-term infant, **myelination** is present by the time of birth in the dorsal brainstem, cerebellar peduncles, and posterior limb of the internal capsule. The cerebellar white matter acquires myelin by 1 month of age and is well myelinated by 3 months. The subcortical white matter of the parietal, posterior frontal, temporal, and calcarine cortex is partially myelinated by 3 months of age. In this period the infant experiences tremendous growth. Physiologic changes allow the establishment of effective feeding routines and a predictable sleep–wake cycle. The social interactions that occur as parents and infants accomplish these tasks lay the foundation for cognitive and emotional development.



**Fig. 23.1** Scatterplots showing brain growth in the first 2 years of life. A, Total brain volume by age at scan. B, Cortical hemispheres. C, Cerebellum. D, Subcortical region and brainstem. (From Knickmeyer RC, Gouttard S, Kang C, et al. A structural MRI study of human brain development from birth to 2 years. *J Neurosci.* 2008;28:12176–12182.)

### Physical Development

A newborn's weight may initially decrease 10% (vaginal delivery) to 12% (cesarean section) below birthweight in the first week as a result of excretion of excess extravascular fluid and limited nutritional intake. Nutrition improves as colostrum is replaced by higher-fat content breast milk, infants learn to latch on and suck more efficiently, and mothers become more comfortable with feeding techniques. Infants regain or exceed birthweight by 2 weeks of age and should grow at approximately 30 g (1 oz) per day during the first month (see Table 27.1). This is the period of fastest postnatal growth. Arms are held to the sides. Limb movements consist largely of uncontrolled writhing, with apparently purposeless opening and closing of the hands. Smiling occurs involuntarily. Eye gaze, head turning, and sucking are under better control and thus can be used to demonstrate infant perception and cognition. An infant's preferential turning toward the mother's voice is evidence of recognition memory.

Six **behavioral states** have been described (see Chapter 22). Initially, sleep and wakefulness are evenly distributed throughout the 24 hour day (Fig. 23.2). Neurologic maturation accounts for the consolidation of sleep into blocks of 5 or 6 hours at night, with brief awake, feeding periods. Learning also occurs; infants whose parents are consistently more interactive and stimulating during the day learn to concentrate their sleeping during the night.

### Cognitive Development

Infants can differentiate among patterns, colors, and consonants. They can recognize facial expressions (smiles) as similar, even when they appear on different faces. They also can match abstract properties of stimuli, such as contour, intensity, or temporal pattern, across sensory

modalities. Infants at 2 months of age can discriminate rhythmic patterns in native vs nonnative language. Infants appear to seek stimuli actively, as though satisfying an innate need to make sense of the world. These phenomena point to the integration of sensory inputs in the central nervous system. Caretaking activities provide visual, tactile, olfactory, and auditory stimuli, all of which support the development of cognition. Infants **habituate** to the familiar, attending less to repeated stimuli and increasing their attention to novel stimuli.

### Emotional Development

The infant is dependent on the environment to meet its needs. The consistent availability of a trusted adult to meet the infant's urgent needs creates the conditions for **secure attachment**. Basic **trust vs mistrust**, the first of Erikson's psychosocial stages (see Chapter 19), depends on attachment and reciprocal maternal bonding. Crying occurs in response to stimuli that may be obvious (a soiled diaper) but are often obscure (see Chapter 23.1). Infants who are consistently picked up and held in response to distress cry less at 1 year and show less aggressive behavior at 2 years. Infants of adolescent mothers who are trained to carry their babies demonstrate secure attachment. Infants cry in response to the cry of another infant, which has been interpreted as an early sign of empathy.

### Implications for Parents and Pediatricians

Success or failure in establishing feeding and sleep cycles influences parents' feelings of competence. When things go well, the parents' anxiety and ambivalence, as well as the exhaustion of the early weeks, decrease. Infant issues (e.g., colic) or familial conflict may prevent this from occurring. With physical recovery from delivery and hormonal



**Table 23.1** Developmental Milestones in First 2 Years of Life

MILESTONE	AVERAGE AGE OF ATTAINMENT (MO)	DEVELOPMENTAL IMPLICATIONS
<b>GROSS MOTOR</b>		
Holds head steady while sitting	2	Allows more visual interaction
Pulls to sit, with no head lag	3	Muscle tone
Brings hands together in midline	3	Self-discovery of hands
Asymmetric tonic neck reflex gone	4	Can inspect hands in midline
Sits without support	6	Increasing exploration
Rolls back to stomach	6.5	Truncal flexion, risk of falls
Walks alone	12	Exploration, control of proximity to parents
Runs	16	Supervision more difficult
<b>FINE MOTOR</b>		
Grasps rattle	3.5	Object use
Reaches for objects	4	Visuomotor coordination
Palmar grasp gone	4	Voluntary release
Transfers object hand to hand	5.5	Comparison of objects
Thumb-finger grasp	8	Able to explore small objects
Turns pages of book	12	Increasing autonomy during book time
Scribbles	13	Visuomotor coordination
Builds tower of two cubes	15	Uses objects in combination
Builds tower of six cubes	22	Requires visual, gross, and fine motor coordination
<b>COMMUNICATION AND LANGUAGE</b>		
Smiles in response to face, voice	1.5	More active social participant
Monosyllabic babble	6	Experimentation with sound, tactile sense
Inhibits to “no”	7	Response to tone (nonverbal)
Follows one-step command with gesture	7	Nonverbal communication
Follows one-step command without gesture	10	Verbal receptive language (e.g., “Give it to me”)
Says “mama” or “dada”	10	Expressive language
Points to objects	10	Interactive communication
Speaks first real word	12	Beginning of labeling
Speaks 4-6 words	15	Acquisition of object and personal names
Speaks 10-15 words	18	Acquisition of object and personal names
Speaks two-word sentences (e.g., “Mommy shoe”)	19	Beginning grammaticalization, corresponds with 50-word vocabulary
<b>COGNITIVE</b>		
Stares momentarily at spot where object disappeared	2	Lack of object permanence (out of sight, out of mind; e.g., yarn ball dropped)
Stares at own hand	4	Self-discovery, cause and effect
Bangs two cubes	8	Active comparison of objects
Uncovers toy (after seeing it hidden)	8	Object permanence
Egocentric symbolic play (e.g., pretends to drink from cup)	12	Beginning symbolic thought
Uses stick to reach toy	17	Able to link actions to solve problems
Pretend play with doll (e.g., gives doll bottle)	17	Symbolic thought

normalization, the mild postpartum “blues” that affects many mothers passes. If the mother continues to feel sad, overwhelmed, or anxiety, the possibility of moderate to severe **postpartum depression or anxiety**, found in 20–25% of postpartum women, needs to be considered. Major depression that arises during pregnancy or in the postpartum period threatens the mother–child relationship and is a risk factor for later cognitive and behavioral problems. Postpartum depression is often reported in mothers and can also occur in fathers. It can present over the course of a year with symptoms of depression or irritability. The pediatrician may be the first professional to encounter the depressed parent and should be instrumental in assisting the parent in seeking treatment (see [Chapter 22](#)).

### AGE 2–6 MONTHS

At about age 2 months, the emergence of voluntary (social) smiles and increasing eye contact mark a change in the parent–child relationship, heightening the parents’ sense of being loved reciprocally. During the next months, an infant’s range of motor and social control and cognitive engagement increases dramatically. Mutual regulation takes the form of

complex social interchanges, resulting in strong mutual attachment and enjoyment. Routines are established. Parents are less fatigued.

### Physical Development

Between 3 and 4 months of age, the rate of growth slows to approximately 20 g/day (see [Table 27.1](#) and [Figs. 24.1 and 24.2](#)). By age 4 months, birthweight is doubled. Early reflexes that limited voluntary movement recede (e.g., **primitive reflexes**; see [Chapter 630](#)). Disappearance of the asymmetric tonic neck reflex means that infants can begin to examine objects in the midline and manipulate them with both hands. Waning of the early grasp reflex allows infants both to hold objects and to let them go voluntarily. A novel object may elicit purposeful, although inefficient, reaching. The quality of spontaneous movements also changes, from larger (proximal) writhing to smaller, circular (distal) movements that have been described as “fidgety.” Abnormal or absent fidgety movements may constitute a risk factor for later neurologic abnormalities.

Increasing control of truncal flexion makes intentional rolling possible. Once infants can hold their heads steady while sitting, they can

**Table 23.2** Emerging Patterns of Behavior During the First Year of Life\***NEONATAL PERIOD (0-4 WK)**

Prone:	Lies in flexed attitude; turns head from side to side; head sags on ventral suspension
Supine:	Generally flexed and a little stiff
Visual:	May fixate face on light in line of vision; doll's eye movement (oculocephalic reflex) of eyes on turning of the body
Reflex:	Moro response active; stepping and placing reflexes; grasp reflex active
Social:	Visual preference for human face

**AT 1 MO**

Prone:	Legs more extended; holds chin up; turns head; head lifted momentarily to plane of body on ventral suspension
Supine:	Tonic neck posture predominates; supple and relaxed; head lags when pulled to sitting position
Visual:	Watches person; follows moving object
Social:	Body movements in cadence with voice of other in social contact; beginning to smile

**AT 2 MO**

Prone:	Raises head slightly farther; head sustained in plane of body on ventral suspension
Supine:	Tonic neck posture predominates; head lags when pulled to sitting position
Visual:	Follows moving object 180 degrees
Social:	Smiles on social contact; listens to voice and coos

**AT 3 MO**

Prone:	Lifts head and chest with arms extended; head above plane of body on ventral suspension
Supine:	Tonic neck posture predominates; reaches toward and misses objects; waves at toy
Sitting:	Head lag partially compensated when pulled to sitting position; early head control with bobbing motion; back rounded
Reflex:	Typical Moro response has not persisted; makes defensive movements or selective withdrawal reactions
Social:	Sustained social contact; listens to music; says "aah, ngah"

**AT 4 MO**

Prone:	Lifts head and chest, with head in approximately vertical axis; legs extended
Supine:	Symmetric posture predominates, hands in midline; reaches and grasps objects and brings them to mouth
Sitting:	No head lag when pulled to sitting position; head steady, tipped forward; enjoys sitting with full truncal support
Standing:	When held erect, pushes with feet
Adaptive:	Sees raisin, but makes no move to reach for it
Social:	Laughs out loud; may show displeasure if social contact is broken; excited at sight of food

**AT 7 MO**

Prone:	Rolls over; pivots; crawls or creep-crawls (Knobloch)
Supine:	Lifts head; rolls over; squirms
Sitting:	Sits briefly, with support of pelvis; leans forward on hands; back rounded
Standing:	May support most of weight; bounces actively
Adaptive:	Reaches out for and grasps large object; transfers objects from hand to hand; grasp uses radial palm; rakes at raisin
Language:	Forms polysyllabic vowel sounds
Social:	Prefers mother; babbles; enjoys mirror; responds to changes in emotional content of social contact

**AT 10 MO**

Sitting:	Sits up alone and indefinitely without support, with back straight
Standing:	Pulls to standing position; "cruises" or walks holding on to furniture
Motor:	Creeps or crawls
Adaptive:	Grasps objects with thumb and forefinger; pokes at things with forefinger; picks up pellet with assisted pincer movement; uncovers hidden toy; attempts to retrieve dropped object; releases object grasped by other person
Language:	Repetitive consonant sounds ("mama," "dada")
Social:	Responds to sound of name; plays peek-a-boo or pat-a-cake; waves bye-bye

**AT 1 YR**

Motor:	Walks with one hand held; rises independently, takes several steps (Knobloch)
Adaptive:	Picks up raisin with unassisted pincer movement of forefinger and thumb; releases object to other person on request or gesture
Language:	Says a few words besides "mama," "dada"
Social:	Plays simple ball game; makes postural adjustment to dressing

\*Data are derived from those of Gesell (as revised by Knobloch), Shirley, Provence, Wolf, Bailey, and others. Data from Knobloch H, Stevens F, Malone AF. *Manual of Developmental Diagnosis*. Hagerstown, MD: Harper & Row; 1980.

gaze across at things rather than merely looking up at them, opening up a new visual range. They can begin taking food from a spoon. At the same time, maturation of the visual system allows greater depth perception.

In this period, infants achieve stable state regulation and regular sleep-wake cycles. Total sleep requirements are approximately 14-16 hours per 24 hours, with about 9-10 hours concentrated at night and 2 naps per day. Approximately 70% of infants sleep for a 6-8 hour stretch by age 6 months (see Fig. 23.2). By 4-6 months, the sleep electroencephalogram shows a mature pattern, with demarcation of rapid eye movement and three stages of non-rapid eye movement sleep. The sleep cycle remains shorter than in

adults (50-60 minutes vs approximately 90 minutes). As a result, infants arouse to light sleep or wake frequently during the night, setting the stage for behavioral sleep problems (see Chapter 31).

### Cognitive Development

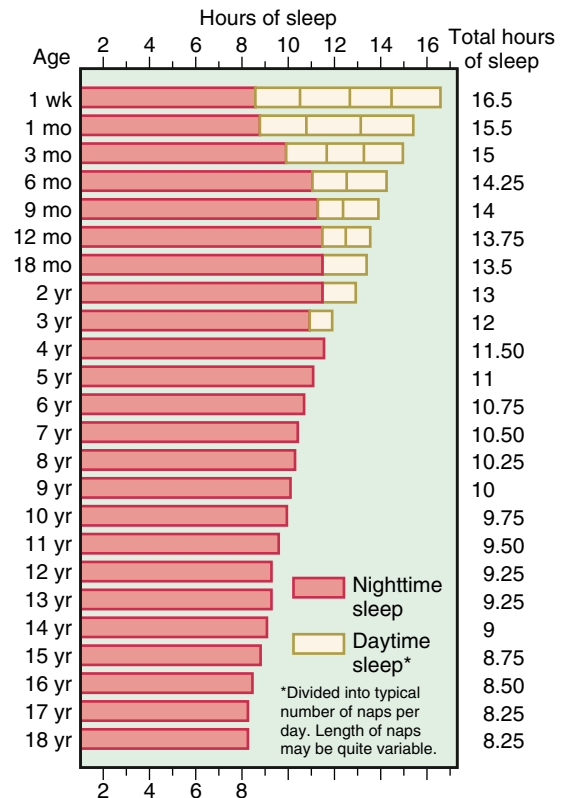
The overall effect of these developments is a qualitative change. At 4 months of age, infants are described as "hatching" socially, becoming interested in a wider world. During feeding, infants no longer focus exclusively on the mother, but become distracted. In the mother's arms, the infant may literally turn around, preferring to face outward.

**Table 23.3** Time of Radiographic Appearance of Centers of Ossification in Infancy and Childhood

MALES: AGE AT APPEARANCE*	BONES AND EPIPHYSEAL CENTERS	FEMALES: AGE AT APPEARANCE*
<b>HUMERUS, HEAD</b>		
3wk		3wk
<b>CARPAL BONES</b>		
2mo ± 2mo	Capitate	2mo ± 2mo
3mo ± 2mo	Hamate	2mo ± 2mo
30mo ± 16mo	Triangular†	21mo ± 14mo
42mo ± 19mo	Lunate†	34mo ± 13mo
67mo ± 19mo	Trapezium†	47mo ± 14mo
69mo ± 15mo	Trapezoid†	49mo ± 12mo
66mo ± 15mo	Scaphoid†	51mo ± 12mo
No standards available	Pisiform†	No standards available
<b>METACARPAL BONES</b>		
18mo ± 5mo	II	12mo ± 3mo
20mo ± 5mo	III	13mo ± 3mo
23mo ± 6mo	IV	15mo ± 4mo
26mo ± 7mo	V	16mo ± 5mo
32mo ± 9mo	I	18mo ± 5mo
<b>FINGERS (EPIPHYSES)</b>		
16mo ± 4mo	Proximal phalanx, 3rd finger	10mo ± 3mo
16mo ± 4mo	Proximal phalanx, 2nd finger	11mo ± 3mo
17mo ± 5mo	Proximal phalanx, 4th finger	11mo ± 3mo
19mo ± 7mo	Distal phalanx, 1st finger	12mo ± 4mo
21mo ± 5mo	Proximal phalanx, 5th finger	14mo ± 4mo
24mo ± 6mo	Middle phalanx, 3rd finger	15mo ± 5mo
24mo ± 6mo	Middle phalanx, 4th finger	15mo ± 5mo
26mo ± 6mo	Middle phalanx, 2nd finger	16mo ± 5mo
28mo ± 6mo	Distal phalanx, 3rd finger	18mo ± 4mo
28mo ± 6mo	Distal phalanx, 4th finger	18mo ± 5mo
32mo ± 7mo	Proximal phalanx, 1st finger	20mo ± 5mo
37mo ± 9mo	Distal phalanx, 5th finger	23mo ± 6mo
37mo ± 8mo	Distal phalanx, 2nd finger	23mo ± 6mo
39mo ± 10mo	Middle phalanx, 5th finger	22mo ± 7mo
152mo ± 18mo	Sesamoid (adductor pollicis)	121mo ± 13mo
<b>HIP AND KNEE</b>		
Usually present at birth	Femur, distal	Usually present at birth
Usually present at birth	Tibia, proximal	Usually present at birth
4mo ± 2mo	Femur, head	4mo ± 2mo
46mo ± 11mo	Patella	29mo ± 7mo
<b>FOOT AND ANKLE‡</b>		

\*To nearest month.  
 †Except for the capitate and hamate bones, the variability of carpal centers is too great to make them very useful clinically.  
 ‡Standards for the foot are available, but normal variation is wide, including some familial variants, so this area is of little clinical use.  
 Values represent mean ± standard deviation, when applicable.  
 The norms present a composite of published data from the Fels Research Institute, Yellow Springs, OH (Pyle SI, Sontag L. *AJR Am J Roentgenol.* 1943, 49:102), and unpublished data from the Brush Foundation, Case Western Reserve University, Cleveland, OH, and the Harvard School of Public Health, Boston, MA. Compiled by Lieb, Buehl, and Pyle.

Infants at this age also explore their own bodies, staring intently at their hands; vocalizing; blowing bubbles; and touching their ears, cheeks, and genitals. These explorations represent an early stage in the understanding of cause and effect as infants learn that voluntary muscle movements generate predictable tactile and visual sensations. Learning and memory involving the hippocampus can be demonstrated at 3 months. These activities have a role in the emergence of a sense of self, separate from the parents. This is the first stage of personality



**Fig. 23.2** Typical sleep requirements in children. (From Ferber R. *Solve Your Child's Sleep Problems*, New York: Simon & Schuster; 1985.)

development. Infants come to associate certain sensations through frequent repetition. The proprioceptive feeling of holding up the hand and wiggling the fingers always accompanies the sight of the fingers moving. Such “self” sensations are consistently linked and reproducible at will. In contrast, sensations that are associated with “other” occur with less regularity and in varying combinations. The sound, smell, and feel of the parent sometimes appear promptly in response to crying, but sometimes do not. The satisfaction that the mother or another loving adult provides continues the process of attachment.

**Emotional Development and Communication**

Babies interact with increasing sophistication and range. They have an innate ability for facial expressions that, over time, become the functional expressions of emotion (anger, joy, interest, fear, disgust, and surprise). Infants can discriminate and imitate facial expressions, when paired with vocalizations, of adults as well as other infants. Initiating games (singing, hand games) increases social development. Such face-to-face behavior reveals the infant’s ability to share emotional states, the first step in the development of communication. Infants of depressed parents show a different pattern, spending less time in coordinated movement with their parents and making fewer efforts to reengage. Rather than anger, they show sadness and a loss of energy when the parents continue to be unavailable.

**Implications for Parents and Pediatricians**

Motor and sensory maturation makes infants at 3-6 months exciting and interactive. Some parents experience their 4-month-old child’s outward turning as a rejection, secretly fearing that their infants no longer love them. For most parents, this is a happy period and they may excitedly report that they can hold conversations with their infants, taking turns vocalizing and listening. Pediatricians share in the enjoyment, as the baby coos, makes eye contact, and moves rhythmically. Infants who do not show this reciprocal language and movements are at risk for autism spectrum disorder or other developmental disabilities (see **Chapters 56 and 58**). If this visit does not feel joyful and relaxed, causes such as social

stress, family dysfunction, parental mental illness, or problems in the infant–parent relationship should be considered. Parents can be reassured that responding to an infant’s emotional needs cannot spoil the infant. Giving vaccines and drawing blood while the child is seated on the parent’s lap or nursing at the breast increases pain tolerance.

### AGE 6–12 MONTHS

With achievement of the sitting position, increased mobility, and new skills to explore the world around them, 6–12 month old infants show advances in cognitive understanding and communication, and new tensions arise in regard to attachment and separation. Infants develop will and intentions, characteristics that most parents welcome but still find challenging to manage.

#### Physical Development

Growth slows more (see Table 27.1 and Figs. 24.1 and 24.2). By the first birthday, birthweight has tripled, length has increased by 50%, and head circumference has increased by 10 cm (4 in). The ability to sit unsupported (6–7 months) and to pivot while sitting (around 9–10 months) provides increasing opportunities to manipulate several objects at a time and to experiment with novel combinations of objects. These explorations are aided by the emergence of a thumb–finger grasp (8–9 months) and a neat pincer grasp by 12 months. Voluntary release emerges at 9 months. Many infants begin crawling and pulling to stand around 8 months, followed by cruising. Some walk by 1 year. Motor achievements correlate with increasing myelination and cerebellar growth. These gross motor skills expand infants’ exploratory range and create new physical dangers, as well as opportunities for learning. Tooth eruption occurs, usually starting with the mandibular central incisors. Tooth development (see Table 353.1) reflects skeletal maturation and bone age, although there is wide individual variation.

#### Cognitive Development

The 6-month-old infant has discovered his hands and will soon learn to manipulate objects. At first, everything is mouthed. In time, novel objects are picked up, inspected, passed from hand to hand, banged, dropped, and then mouthed. Each action represents a nonverbal idea about what things are for (in Piagetian terms, a *schema*; see Chapter 19). The complexity of an infant’s play, how many different schemata are brought to bear, is a useful index of cognitive development at this age. The pleasure, persistence, and energy with which infants tackle these challenges suggest the existence of an intrinsic drive or mastery motivation. Mastery behavior occurs when infants feel secure; those with less secure attachments show limited experimentation and less competence.

A major milestone is the achievement by 9 months of **object permanence (constancy)**, the understanding that objects continue to exist, even when not seen. At 4–7 months of age, infants look down for a yarn ball that has been dropped but quickly give up if it is not seen. With object constancy, older infants persist in searching. They will find objects hidden under a cloth or behind the examiner’s back. Peek-a-boo brings unlimited pleasure as the child magically brings back the other player. Events seem to occur as a result of the child’s own activities.

#### Emotional Development

The advent of object permanence corresponds with qualitative changes in social and communicative development. Infants look back and forth between an approaching stranger and a parent and may cling or cry anxiously, demonstrating **stranger anxiety**. Separations often become more difficult. Infants who have been sleeping through the night for months begin to awaken regularly and cry, as though remembering that the parents are nearby or in the next room (see Chapter 31).

A new demand for **autonomy** also emerges. Poor weight gain at this age often reflects a struggle between an infant’s emerging independence and parent’s control of the feeding situation. Use of the two-spoon method of feeding (one for the child and one for the parent), finger foods, and a high chair with tray table can avert potential problems. Tantrums make their first appearance as the drives for autonomy and mastery come in conflict with parental controls and the infant’s still-limited abilities.

#### Communication

Infants at 7 months of age are adept at nonverbal communication, expressing a range of emotions and responding to vocal tone and facial expressions. At about 9 months of age infants become aware that emotions can be shared between people; they show parents toys as a way of sharing their happy feelings. Between 8 and 10 months of age, babbling takes on a new complexity, with multisyllabic sounds (“ba-da-ma”) called **canonical babbling**. Babies can discriminate between languages. Infants in bilingual homes learn the characteristics and rules that govern two different languages. Social interaction (attentive adults taking turns vocalizing with the infant) profoundly influences the acquisition and production of new sounds. The first true word (i.e., a sound used consistently to refer to a specific object or person) appears in concert with an infant’s discovery of object permanence. Picture books now provide an ideal context for verbal language acquisition. With a familiar book as a shared focus of attention, a parent and child engage in repeated cycles of pointing and labeling, with elaboration and feedback by the parent. Often infants learn a gesture to communicate before they can say the word (e.g., waving bye-bye before saying “bye-bye”), and there is limited evidence that the addition of sign language may support infant development while enhancing parent–infant communication.

#### Implications for Parents and Pediatricians

With the developmental reorganization that occurs around 9 months of age, previously resolved issues of feeding and sleeping reemerge. Pediatricians can prepare parents at the 6 month visit so that these problems can be understood as the result of developmental progress and not regression. Parents should be encouraged to plan ahead for necessary, and inevitable, separations (e.g., babysitter, daycare). Routine preparations may make these separations easier. Dual parent employment has not been consistently found to be harmful or beneficial for long-term cognitive or social-emotional outcomes. Introduction of a **transitional object** may allow the infant to self-comfort in the parents’ absence. The object cannot have any potential for asphyxiation or strangulation.

Infants’ wariness of strangers often makes the 9 month examination difficult, particularly if the infant is temperamentally prone to react negatively to unfamiliar situations. Initially, the pediatrician should avoid direct eye contact with the child. Time spent talking with the parent and introducing the child to a small, washable toy will be rewarded with more cooperation. The examination can be continued on the parent’s lap when feasible. Encourage parents to read, play, and communicate with their infant.

Visit Elsevier eBooks+ at [eBooks.Health.Elsevier.com](http://eBooks.Health.Elsevier.com) for Bibliography.

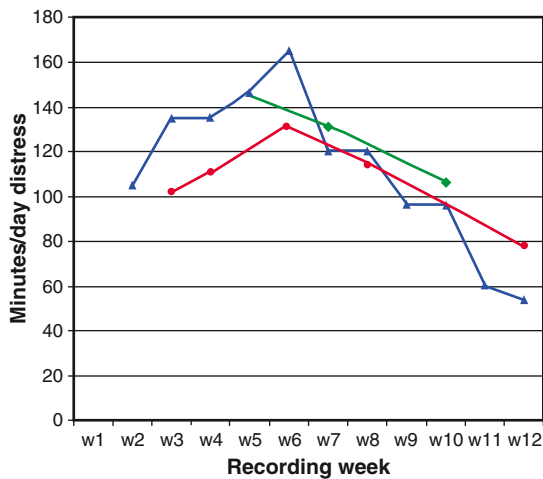
## 23.1 Infant Crying and Colic

Mutiati T. Onigbanjo and Susan Feigelman

Crying or fussiness is present in all babies but reaches medical attention in about 20% of infants younger than 2 months. Although usually a transient and normal infant behavior, crying is often associated with parental concern and distress. On average, babies cry 2 hours per day, peaking at 6 weeks of age. Premature infants will have peak crying at 6 weeks corrected age (Fig. 23.3). Small-for-gestational-age and premature babies may be at higher risk. The peak period of infant crying usually occurs in the evenings and early part of the night. Excessive crying or fussiness persisting longer than 3–5 months may be associated with behavioral problems in an older child (anxiety, aggression, hyperactivity), decreased duration of breastfeeding, or postnatal depression, but it is uncertain which is the cause or effect. Most infants with crying/fussiness do not have gastroesophageal reflux, lactose intolerance, constipation, or cow’s milk protein allergy.

**Acute-onset uncontrollable crying** could be caused by a medical condition. Potentially overlooked conditions to consider include corneal abrasion, tourniquet effect of a hair wrapped around a digit or





**Fig. 23.3** Crying amounts and patterns from three North American studies illustrating similarities in crying pattern. (From Barr RG, Trent RB, Cross J. Age-related incidence curve of hospitalized shaken baby syndrome cases: convergent evidence for crying as a trigger to shaking. *Child Abuse Negl.* 2006;30:7–16.)

penis, occult fracture, urinary tract infection, acute abdomen including inguinal hernia, or anomalous coronary artery. Breastfeeding mothers should be asked about medications, drugs, and diet. Gastrointestinal distress can result from a maternal diet high in cruciferous vegetables. Most of the time, the etiology of a serious problem can be discovered with a careful history and physical examination.

Crying is a normal part of neurobehavioral development. Infants have various signals for their needs and for getting attention from a caregiver. These behaviors progressively increase in intensity in many infants, from changes in breathing and color, to postural and movement changes, and then to calm vocalizations. These precry cues, if not attended to, will eventually lead to active crying. Some infants may go directly to crying, perhaps based on temperament; these infants may be less easily consolable, more intense, or more responsive to sensory stimuli. Management of crying/fussiness should include teaching caregivers about precry cues and responding to the signal for feeding in a calm, relaxed manner. If sensory overstimulation is a factor, creating a nondistracting, calm environment may help, as well as swaddling. When lack of sensory stimulation is present, parent–infant skin-to-skin contact and carrying the infant may be beneficial. In all situations, reassurance that this is both normal and transient, with only 5% of infants persisting beyond 3 months of age, helps the family cope. Teaching families about expectations for normal crying behavior can reduce emergency department visits.

The emotional significance of any experience depends on both the individual child's temperament and the parent's responses (see Table 19.1); differing feeding schedules produce differing reactions. Hunger generates increasing tension; as the urgency peaks, the infant cries, the parent offers the breast or bottle, and the tension dissipates. Infants fed "on demand" consistently experience this link among their distress, the arrival of the parent, and relief from hunger. Most infants fed on a fixed schedule quickly adapt their hunger cycle to the schedule. Those who cannot adapt, because they are temperamentally prone to irregular biologic rhythms, experience periods of unrelieved hunger as well as unwanted feedings when they already feel full. Similarly, infants who are fed at the parents' convenience, with neither attention to the infant's hunger cues nor a fixed schedule, may not consistently experience feeding as the pleasurable reduction of tension. Infants with early dysregulation often show increased irritability and physiologic instability (spitting, diarrhea, poor weight gain) as well as later behavioral problems. Infants with excess crying after 4–6 months may have neurobehavioral dysregulation and may be at higher risk of other behavior problems (sleep, behavior, feeding).

**Colic** is characterized by the "rule of 3." It occurs in a healthy, thriving infant beginning in the second or third week of life with crying that lasts at

least 3 hours per day, occurs at least 3 days per week, lasts for more than 3 weeks, and resolves by 3 or 4 months of age. It is equally common in breastfed and bottle-fed infants, although prevalence is variable (up to 20%). There is no racial, socioeconomic status, or gender risk for colic. Colic is a diagnosis of exclusion following a careful history and physical examination. Few cases will be found to have an organic etiology. Although all babies have crying episodes, colicky babies cry excessively and are difficult to settle. The fussiness is not associated with hunger or any other form of discomfort. Colicky babies may be more reactive to the same stimulus and may cry louder than other babies. Although crying periods are a normal developmental phenomenon, babies with colic can cause parents to become anxious, distraught, frustrated, and sleep deprived. Mothers are at higher risk for postpartum depression if they report inconsolable crying episodes lasting more than 20 minutes. Depression may lead to cessation of breastfeeding. The risk of abuse increases as frustrated parents may use aggressive means in an attempt to quiet the child, resulting in the **shaken baby syndrome**.

There is no specific treatment for colic, but practitioners should provide advice and reassurance to parents. Parents must be counseled about the problem, the importance of implementing a series of calm, systematic steps to soothe the infant, and having a plan for stress relief, such as time-out for parents and substitute caregivers. Parents can be advised that colic is self-limited with no adverse effects on the child. Public health programs, such as the **Period of PURPLE Crying** (<http://purplecrying.info/>) and **Take 5 Safety Plan for Crying**, are invaluable tools for parents. These programs inform parents that all babies go through periods of crying, deflecting parental guilt and self-recrimination. Most importantly, parents are reminded that it is better to allow the baby to cry than engage in shaking that leads to head trauma. Although babies with colic will have inconsolable periods when there is no relief, parents can try some simple steps. Predictable daily schedules may help, ensuring the baby has adequate sleep. Parents should provide appropriate stimulation throughout the day when baby is in an alert/awake period. The sleep environment should be free of stimulation. Swaddling, rocking, white noise, and movement (e.g., stroller, car ride) help some babies settle. Infants who are carried by a parent show different physiologic changes than when held in a sitting position, although there is no evidence that continuous carrying is effective in colic management. A study in a hunter-gatherer society showed that children who are continuously carried by their mothers display similar crying periods as those in Western societies.

Some studies have found differences in **fecal microflora (dysbiosis)** between babies with excess crying and controls. Results include fewer bifidobacteria and lactobacilli and more coliform bacteria such as *Escherichia coli*. None has been conclusive, however, and each study was found to have limitations such as lack of precise inclusion criteria, lack of blinded observers, and variability in outcome measurements.

If the child appears to have gastrointestinal symptoms, breastfeeding mothers may try elimination of milk, beans, and cruciferous vegetables from their diets. In allergic families, mothers may try a stricter elimination of food allergens (milk, egg, wheat, nuts, soy, and fish), although nutritional status should be monitored. For formula-fed infants, changing from milk-based to soy-based or other lactose-free formulas had no effect in most studies. A protein hydrolysate formula may moderately improve symptoms.

The cause of colic is not known, and no medical intervention has been consistently effective. Colic has been described as a "functional gastrointestinal disorder" and has been associated with maternal migraines, as well as later development of **migraine** in the child. Simethicone has not been shown to be better than placebo. Anticholinergic medications should not be used in infants younger than 6 months. Early studies of probiotics look promising, but evidence is insufficient to recommend their routine use. Among various complementary therapies, certain **herbal teas**, sugar solutions, Gripe water (containing herbal supplements), chamomile and fennel extract may have benefit, but the evidence is weak. Baby massage may be helpful, but chiropractic manipulation should not be performed in young children. Acupuncture was effective in one trial and singing while in utero may produce babies who cry less.

Visit Elsevier eBooks+ at [eBooks.Health.Elsevier.com](http://eBooks.Health.Elsevier.com) for Bibliography.

## Chapter 24

## The Second Year

Rebecca G. Carter and Susan Feigelman

The second year of life is a time of rapid growth and development, particularly in the realms of social-emotional and cognitive skills as well as motor development. The toddler's newly found ability to walk allows separation and independence; however, the toddler continues to need secure attachment to the parents. At approximately 18 months of age, the emergence of symbolic thought and language causes a reorganization of behavior, with implications across many developmental domains.

**AGE 12–18 MONTHS****Physical Development**

Although overall rate of growth continues to decline, the toddler continues to experience considerable brain growth and myelination in the second year of life, resulting in an increase in head circumference of 2 cm over the year (Figs. 24.1 and 24.2). Toddlers have relatively short legs and long torsos, with exaggerated lumbar lordosis and protruding abdomens.

Most children begin to walk independently at about 12–15 months of age. Early walking is not associated with advanced development in other domains. Infants initially toddle with a wide-based gait, with the knees bent and the arms flexed at the elbow; the entire torso rotates with each stride; the toes may point in or out, and the feet strike the floor flat. The appearance is that of genu varum (**bowleg**). Subsequent refinement leads to greater steadiness and energy efficiency. After several months of practice, the center of gravity shifts back and the torso stabilizes, while the knees extend and the arms swing at the sides for balance. The feet are held in better alignment, and the child is able to stop, pivot, and stoop without toppling over (see Chapters 713 and 714).

**Cognitive Development**

Exploration of the environment increases in parallel with improved dexterity (reaching, grasping, releasing) and mobility. Learning follows the precepts of Piaget's **sensorimotor stage** (see Chapter 19). Toddlers manipulate objects in novel ways to create interesting effects, such as stacking blocks or filling and dumping buckets. Playthings are also more likely to be used for their intended purposes (combs for hair, cups for drinking). Imitation of parents and older siblings or other children is an important mode of learning. Make-believe play (**symbolic play**) centers on the child's own body, such as pretending to drink from an empty cup (Table 24.1; see also Table 23.1).

**Emotional Development**

Infants who are approaching the developmental milestone of taking their first steps may be irritable. Once they start walking, their predominant mood changes markedly. Toddlers are often elated with their new ability and with the power to control the distance between themselves and their parents. Exploring toddlers will orbit around their trusted adults, moving away and then returning for a reassuring touch before moving away again. A child with **secure attachment** will use the trusted adult as a secure base from which to explore independently. Proud of their accomplishments, the child illustrates Erikson's **stage of autonomy and separation** (see Chapter 19). The toddler who is overly controlled and discouraged from active exploration may feel doubt, shame, anger, and insecurity. All children will experience tantrums, reflecting their inability to delay gratification, suppress or displace anger, or verbally communicate their emotional states. Children may form secure attachments with parents as well as other trusted adults, thereby reinforcing the value of quality childcare if parents are employed out of the home.

**Linguistic Development**

*Receptive* language precedes *expressive* language. By the time infants speak their first words around 12 months of age, they already respond appropriately to several simple statements, such as “no,” “bye-bye,” and

“give me.” By 15 months, the average child points to major body parts and uses four to six words spontaneously and correctly. Toddlers also enjoy **polysyllabic jargon** (see Tables 23.1 and 24.1) and do not seem upset that no one understands. Most communication of wants and ideas continues to be nonverbal (e.g., by pointing, facial expressions).

**Implications for Parents and Pediatricians**

Parents who cannot recall any other milestone tend to remember when their child began to walk, perhaps because of the symbolic significance of walking as an act of independence and because of the new demands that the ambulating toddler places on the parent. All toddlers should be encouraged to explore their environment; however, a child's ability to wander out of sight also increases the risks of injury and the need for supervision, making recommendations regarding **childproofing** an integral focus of physician visits.

Parents must understand the importance of exploration. Rather than limiting movement, parents should place toddlers in safe environments or substitute one activity for another. In the office setting, many toddlers are comfortable exploring the examination room, but cling to the parents under the stress of the examination. Children who become more, not less, distressed in their parents' arms or who avoid their parents at times of stress may be insecurely attached. Young children who, when distressed, turn to strangers rather than parents for comfort are particularly worrisome. Children raised in environments with extreme and/or chronic levels of stress (**toxic stress**) have increased vulnerability to disease that continues into adulthood (see Chapter 1). These effects can be mediated by fostering elements of resiliency including introduction of a supportive or encouraging trusted adult. The conflicts between independence and security manifest in issues of **discipline**, temper tantrums, toilet training, and changing feeding behaviors. Parents should be counseled on these matters within the framework of normal development.

Parents may express concern about poor food intake as growth slows. The growth chart should provide reassurance. Many children still take two daytime naps, although the duration steadily decreases and may start to condense to one longer nap (see Fig. 23.2).

**AGE 18–24 MONTHS****Physical Development**

Motor development during this period is reflected in improvements in balance and agility and the emergence of running and stair climbing. Height and weight increase at a steady rate during this year, with a gain of 5 in and 5 lb. By 24 months, children are about half their ultimate adult height. Head growth slows slightly, with 85% of adult head circumference achieved by age 2 years, leaving only an additional 5 cm (2 in) gain over the next few years (see Fig. 24.1 and Table 27.1).

**Cognitive Development**

At approximately 18 mo of age, several cognitive changes coalesce, marking the conclusion of the sensorimotor period. These can be observed during *self-initiated play*. **Object permanence**, which was first demonstrated around 9 months of age (see Chapter 23), is now firmly established; toddlers anticipate where an object will end up, even though the object was not visible while it was being moved. Cause and effect are better understood, and toddlers demonstrate flexibility in problem solving (e.g., using a stick to obtain a toy that is out of reach, figuring out how to wind a mechanical toy). Symbolic transformations in play are no longer tied to the toddler's own body; thus a doll can be “fed” from an empty plate. As with the reorganization that occurs at 9 months (see Chapter 23), the cognitive changes at 18 months correlate with important changes in the emotional and linguistic domains (see Table 24.1).

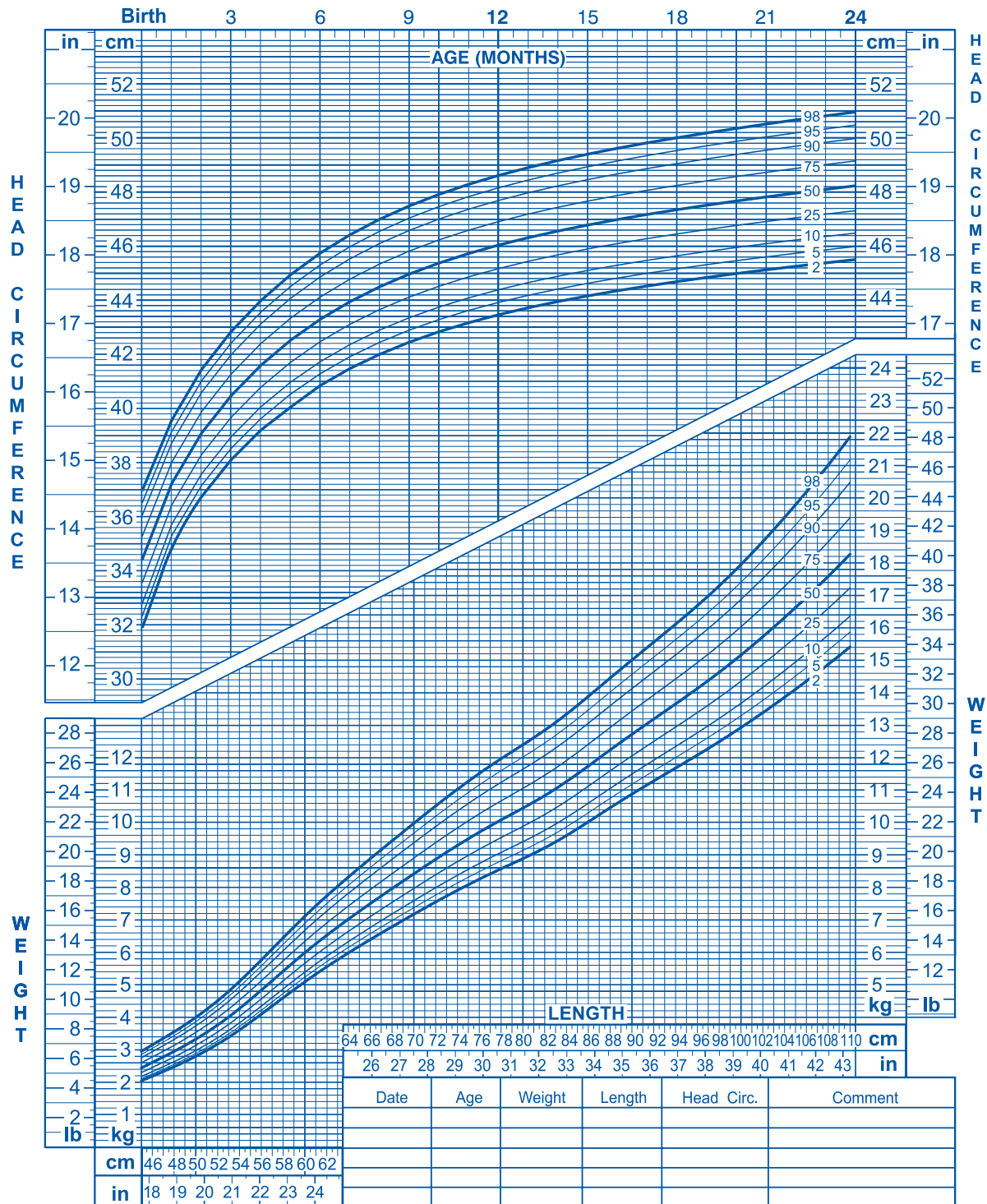
**Emotional Development**

The relative independence of the preceding half-year often gives way to increased clinginess at about 18 months. This stage, described as “*raprochement*,” may be a reaction to growing awareness of the possibility of separation. Many parents report that they cannot go anywhere without having a small child attached to them. **Separation anxiety** will manifest at bedtime. Many children use a special blanket or stuffed toy as a **transitional object**, which functions as a symbol of the absent parent. The transitional object remains important until the transition to symbolic thought

### Birth to 24 months: Boys Head circumference-for-age and Weight-for-length percentiles

NAME \_\_\_\_\_

RECORD # \_\_\_\_\_



Published by the Centers for Disease Control and Prevention, November 1, 2009  
SOURCE: WHO Child Growth Standards (<http://www.who.int/childgrowth/en>)



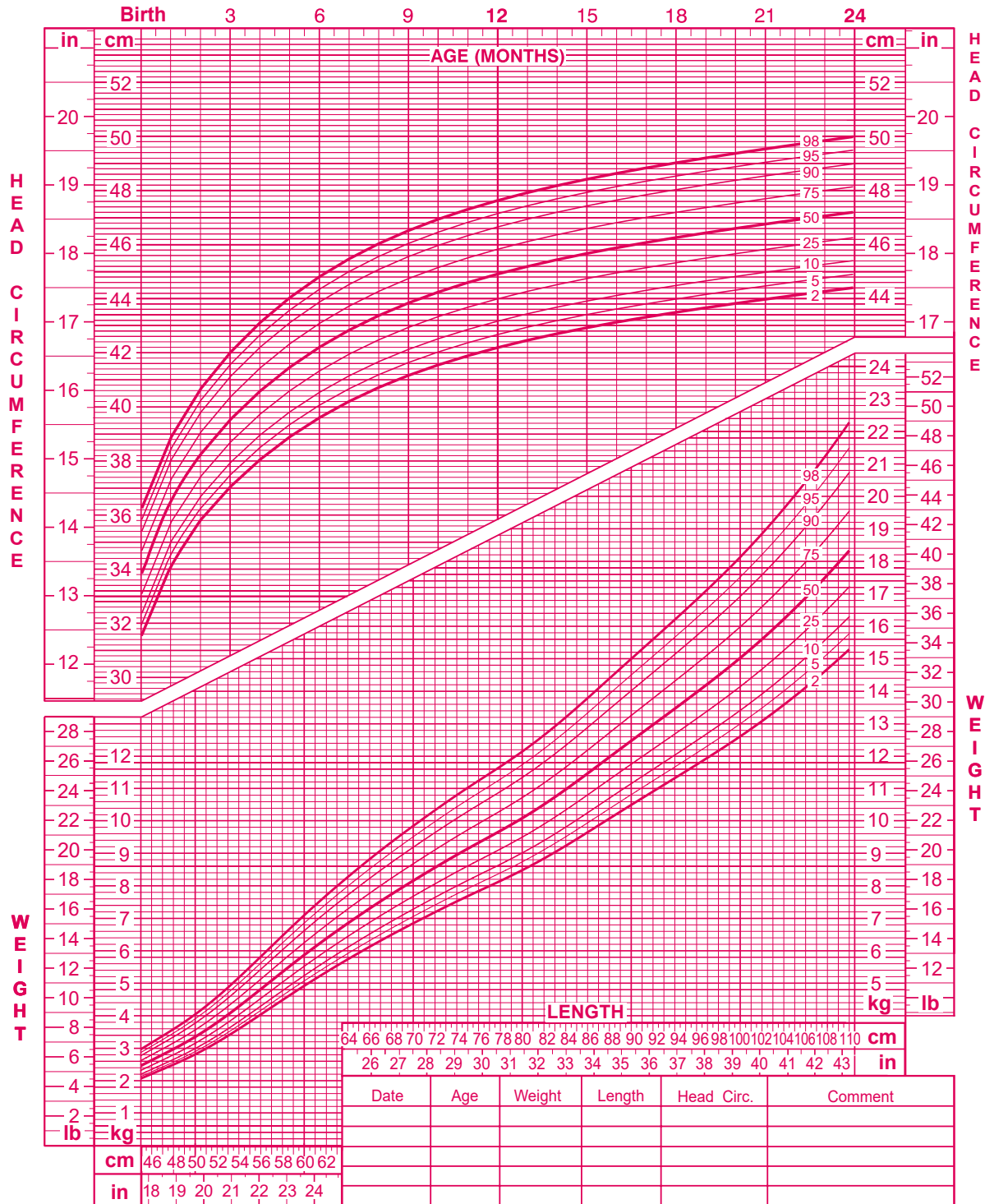
A

Fig. 24.1 World Health Organization growth charts. A, Weight for length and head circumference for age for boys, birth to 24 months. B, Weight for length and head circumference for age for girls, birth to 24 months. (Courtesy World Health Organization: WHO Child Growth Standards, 2021.)

**Birth to 24 months: Girls**  
**Head circumference-for-age and**  
**Weight-for-length percentiles**

NAME \_\_\_\_\_

RECORD # \_\_\_\_\_



Published by the Centers for Disease Control and Prevention, November 1, 2009  
 SOURCE: WHO Child Growth Standards (<http://www.who.int/childgrowth/en>)



B

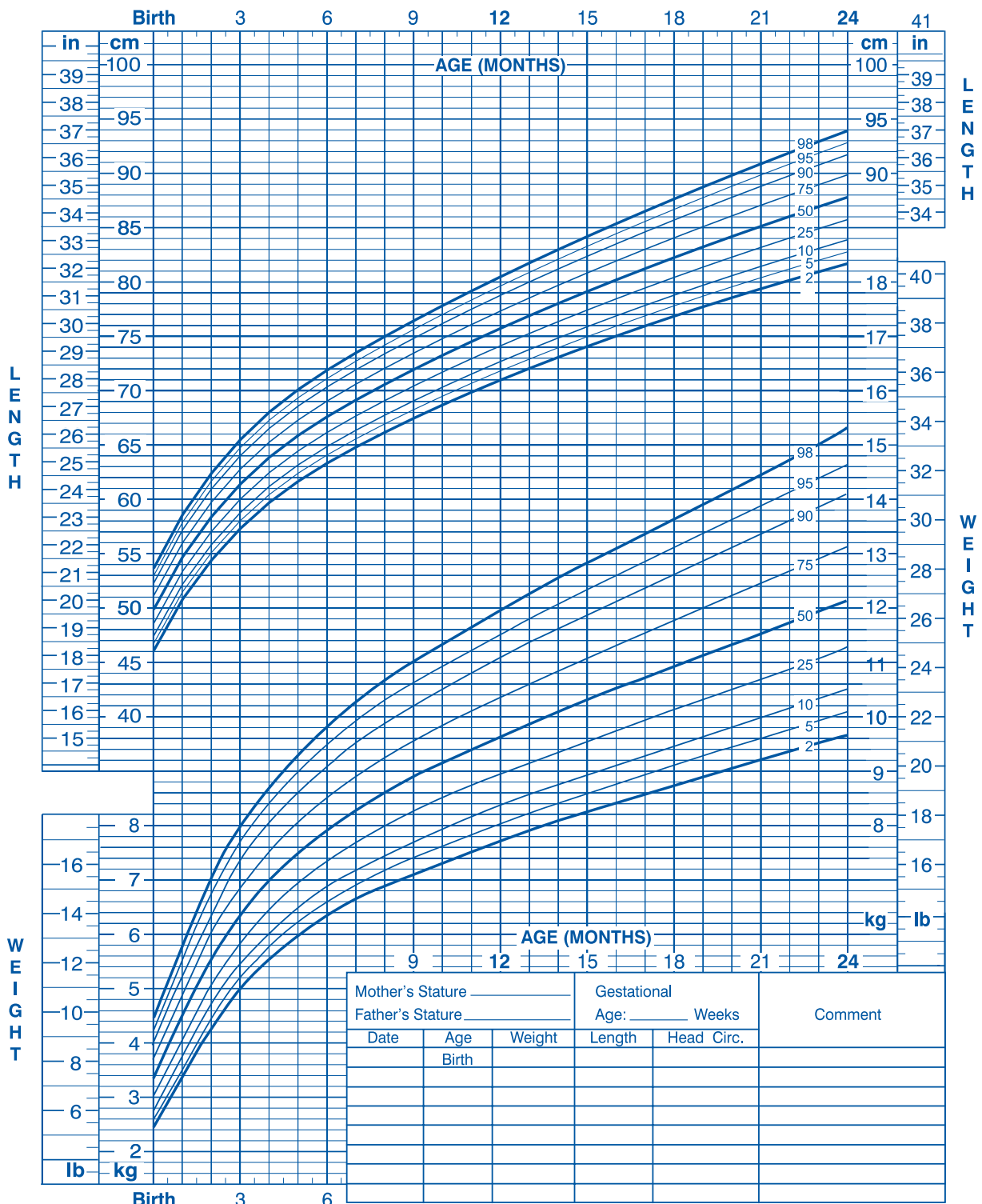
Fig. 24.1, cont'd



**Birth to 24 months: Boys**  
**Length-for-age and Weight-for-age percentiles**

NAME \_\_\_\_\_

RECORD # \_\_\_\_\_



Published by the Centers for Disease Control and Prevention, November 1, 2009  
 SOURCE: WHO Child Growth Standards (<http://www.who.int/childgrowth/en>)

SAFER • HEALTHIER • PEOPLE™



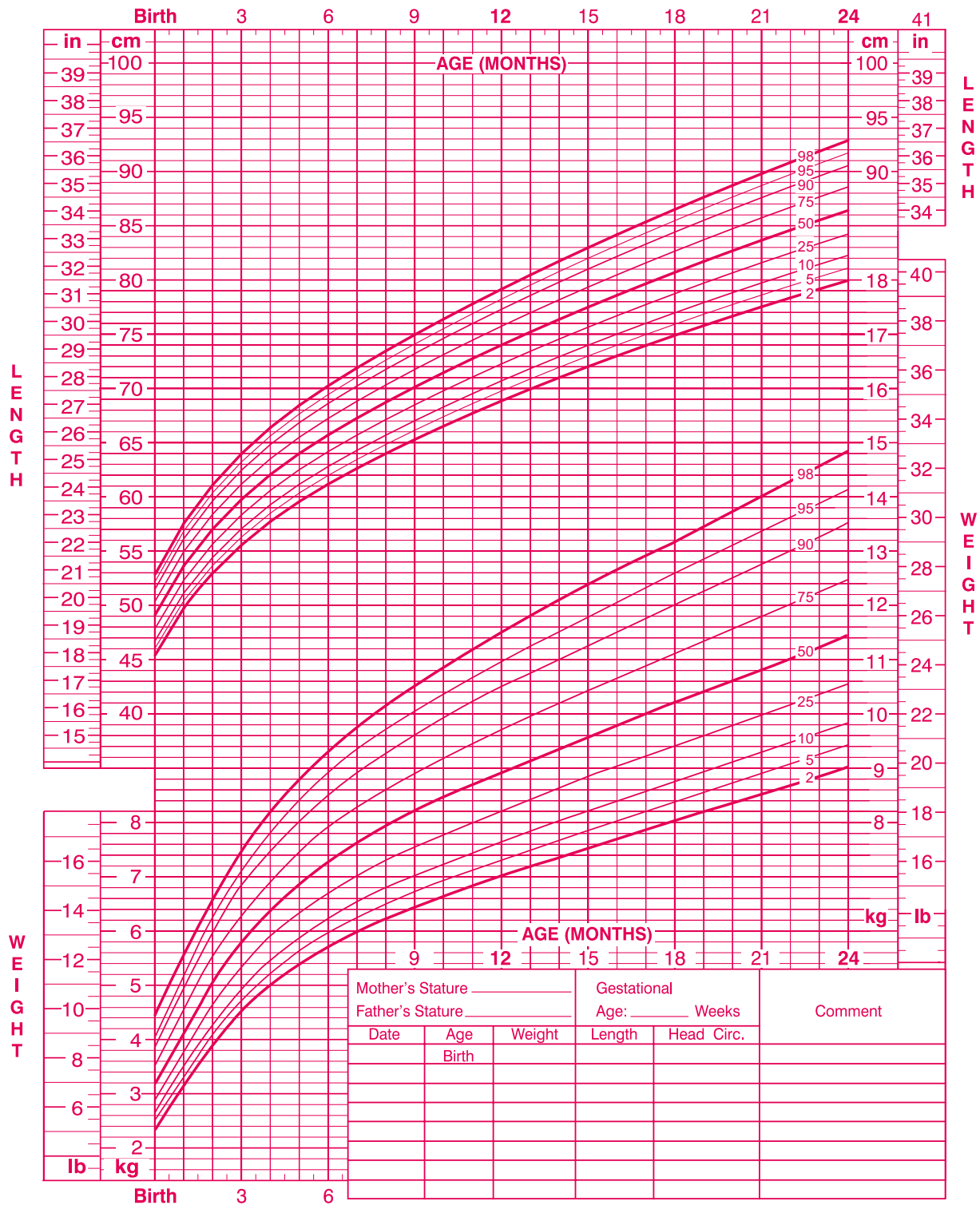
A

**Fig. 24.2** World Health Organization growth charts. A, Length for age and weight for age for boys, birth to 24 months. B, Length for age and weight for age for girls, birth to 24 months. (Courtesy World Health Organization: WHO Child Growth Standards, 2021.)

**Birth to 24 months: Girls**  
**Length-for-age and Weight-for-age percentiles**

NAME \_\_\_\_\_

RECORD # \_\_\_\_\_



Published by the Centers for Disease Control and Prevention, November 1, 2009  
 SOURCE: WHO Child Growth Standards (<http://www.who.int/childgrowth/en>)



B

Fig. 24.2, cont'd

**Table 24.1** Emerging Patterns of Behavior from 1-5 Years of Age

<b>15 MO</b>	
Motor:	Walks alone; crawls up stairs
Adaptive:	Makes tower of 3 cubes; makes a line with crayon; inserts raisin in bottle
Language:	Jargon; follows simple commands; may name a familiar object (e.g., ball); responds to his/her name
Social:	Indicates some desires or needs by pointing; hugs parents
<b>18 MO</b>	
Motor:	Runs stiffly; sits on small chair; walks up stairs with 1 hand held; explores drawers and wastebaskets
Adaptive:	Makes tower of 4 cubes; imitates scribbling; imitates vertical stroke; dumps raisin from bottle
Language:	10 words (average); names pictures; identifies 1 or more parts of body
Social:	Feeds self; seeks help when in trouble; may complain when wet or soiled; kisses parent with pucker
<b>24 MO</b>	
Motor:	Runs well, walks up and down stairs, 1 step at a time; opens doors; climbs on furniture; jumps
Adaptive:	Makes tower of 7 cubes (6 at 21 mo); scribbles in circular pattern; imitates horizontal stroke; folds paper once imitatively
Language:	Puts 3 words together (subject, verb, object)
Social:	Handles spoon well; often tells about immediate experiences; helps to undress; listens to stories when shown pictures
<b>30 MO</b>	
Motor:	Goes up stairs alternating feet
Adaptive:	Makes tower of 9 cubes; makes vertical and horizontal strokes, but generally will not join them to make cross; imitates circular stroke, forming closed figure
Language:	Refers to self by pronoun "I"; knows full name
Social:	Helps put things away; pretends in play
<b>36 MO</b>	
Motor:	Rides tricycle; stands momentarily on 1 foot
Adaptive:	Makes tower of 10 cubes; imitates construction of "bridge" of 3 cubes; copies circle; imitates cross
Language:	Knows age and gender; counts 3 objects correctly; repeats 3 numbers or a sentence of 6 syllables; most of speech intelligible to strangers
Social:	Plays simple games (in "parallel" with other children); helps in dressing (unbuttons clothing and puts on shoes); washes hands
<b>48 MO</b>	
Motor:	Hops on 1 foot; throws ball overhand; uses scissors to cut out pictures; climbs well
Adaptive:	Copies bridge from model; imitates construction of "gate" of 5 cubes; copies cross and square; draws man with 2-4 parts besides head; identifies longer of 2 lines
Language:	Counts 4 pennies accurately; tells story
Social:	Plays with several children, with beginning of social interaction and role-playing; goes to toilet alone
<b>60 MO</b>	
Motor:	Skips
Adaptive:	Draws triangle from copy; names heavier of 2 weights
Language:	Names 4 colors; repeats sentence of 10 syllables; counts 10 pennies correctly
Social:	Dresses and undresses; asks questions about meaning of words; engages in domestic role-playing

Data derived from those of Gesell (as revised by Knobloch), Shirley, Provence, Wolf, Bailey, and others. After 6yr, the Wechsler Intelligence Scales for Children (WISC-IV) and other scales offer the most precise estimates of cognitive development. To have their greatest value, they should be administered only by an experienced and qualified person.

has been completed and the symbolic presence of the parent fully internalized. Despite the attachment to the parent, the child's use of "no" is a way of declaring independence. Individual differences in **temperament**, in both the child and the parents, play a critical role in determining the balance of conflict vs cooperation in the parent-child relationship. As effective language emerges, conflicts often become less frequent.

**Self-conscious awareness** and internalized standards of behavior first appear at this age. Toddlers looking in a mirror will, for the first time, reach for their own face rather than the mirror image if they notice something unusual on their nose. They begin to recognize when toys are broken and may hand them to their parents to fix. Language becomes a means of impulse control, early reasoning, and connection between ideas. When tempted to touch a forbidden object, they may tell themselves "no, no." This is the very beginning of the formation of a conscience. The fact that they often go on to touch the object anyway demonstrates the relative weakness of **internalized inhibitions** at this stage.

### Linguistic Development

Perhaps the most dramatic developments in this period are linguistic. Labeling of objects coincides with the advent of symbolic thought. After the realization occurs that words can stand for objects or ideas, a child's vocabulary grows from 10-15 words at 18 months to between 50 and 100 at 2 years. After acquiring a vocabulary of about 50 words, toddlers begin to combine them to make simple sentences, marking the beginning of grammar. At this stage, toddlers understand **two-step commands**, such as "Give me the ball and then get your shoes." Language also gives the toddler a sense of control over the surroundings, as in "night-night" or "bye-bye." The emergence of verbal language marks the end of the sensorimotor period. As toddlers learn to use symbols to express ideas and solve problems, the need for cognition based on direct sensation and motor manipulation wanes.

### Implications for Parents and Pediatricians

With children's increasing mobility, physical limits on their explorations become less effective; words become increasingly important for behavior control as well as cognition. Children with delayed language acquisition often have greater behavior problems and frustrations due to problems with communication. Language development is facilitated when parents and caregivers use clear, simple sentences; ask questions; pause to allow time to process and generate verbal responses and respond to children's incomplete sentences and gestural communication with the appropriate words. Television and distracted screen-time viewing, as well as television as background noise, decreases parent-child verbal interactions, whereas looking at picture books and engaging the child in two-way conversations stimulates language development. In the world of constant access to tablets, phones, and screens, parents and children have more distractions from direct language engagement. Even educational programming needs to be limited on screens to reinforce face-to-face contact with caregivers during language acquisition; solo media use should be avoided in this age. As an introduction to this topic, the provider can ask "What are your child's favorite activities?" and "What activities do you like to do with your child?"

Performing most of the physical examination in the parent's lap may help allay fears of separation and **stranger anxiety**. Avoid direct eye contact initially and introduce all tools used during the exam such as the otoscope for the patient to explore before use. Save the more invasive portions of the exam to the end (i.e., ears, throat, etc.). Pediatricians can help parents understand the resurgence of problems with separation and the appearance of a transitional object as developmental phenomenon. Methods of **discipline** should be discussed; effective alternatives to corporal punishment will usually be appreciated (see [Chapter 20](#) and [Tables 20.3 and 20.4](#)). Helping parents to understand and adapt to their children's different temperamental styles can constitute an important intervention (see [Table 19.1](#)). Developing daily routines is helpful to all children at this age. Rigidity in those routines reflects a need for mastery over a changing environment. Parents should also institute systems to help prepare their child during times of transition from one activity or setting to another to help foster a sense of trust and communication.

Visit Elsevier eBooks+ at [eBooks.Health.Elsevier.com](http://eBooks.Health.Elsevier.com) for Bibliography.

## Chapter 25

## The Preschool Years

Rebecca G. Carter and Susan Feigelman

The emergence of language and exposure of children to an expanding social sphere represent the critical milestones for children age 2-5 years. As toddlers, children learn to walk away and come back to the secure adult. As preschoolers, they explore emotional separation, alternating between stubborn opposition and cheerful compliance, between bold exploration and clinging dependence. Increasing time spent in classrooms and playgrounds strengthens a child's ability to adapt to new rules and relationships. Emboldened by their growing array of new skills and accomplishments, preschool children also are increasingly cognizant of the constraints imposed on them by the adult world and their own limited abilities.

**STRUCTURAL DEVELOPMENT OF THE BRAIN**

The preschool brain experiences dramatic changes in its anatomic and physiologic characteristics, with increases in cortical area, decreases in cortical thickness, and changing cortical volume. These changes are not uniform across the brain and vary by region. Gray and white matter tissue properties change dramatically, including diffusion properties in the major cerebral fiber tracts. Dramatic increases occur in brain metabolic demands. In general, more brain regions are required in younger than in older children to complete the same cognitive task. This duplication has been interpreted as a form of "scaffolding," which is discarded with increasing age. The preschool brain is characterized by growth and expansion of synapses that will be followed in later years by "pruning."

**PHYSICAL DEVELOPMENT**

Somatic and brain growth slows by the end of the second year of life, with corresponding decreases in nutritional requirements and appetite, and the emergence of "picky" eating habits (see Table 27.1). Increases of approximately 2 kg (4-5 lb) in weight and 7-8 cm (2-3 in) in height per year are expected. Birthweight quadruples by 2.5 years of age. An average 4 year old weighs 40 lb and is 40 in tall. The head will grow only an additional 5-6 cm between ages 3 and 18 years. Current growth charts, with growth parameters, can be found on the U.S. Centers for Disease Control and Prevention website (<http://www.cdc.gov/growthcharts/>) and in Chapter 27. Children with early **adiposity rebound** (increase in body mass index) are at increased risk for adult obesity.

The preschooler has genu valgum (**knock-knees**) and mild pes planus (**flatfoot**). The torso slims as the legs lengthen. Growth of sexual organs is commensurate with somatic growth. Physical energy peaks, and the need for sleep declines to 11-13 hours per 24 hours, with the child eventually dropping the nap (see Fig. 23.2). Visual acuity reaches 20/30 by age 4 years and 20/20 by school age. All 20 primary teeth have erupted by 3 years of age (see Chapter 353).

Most children walk with a mature gait and run steadily before the end of their third year (see Table 24.1). Beyond this basic level, there is wide variation in ability as the range of motor activities expands to include throwing, catching, and kicking balls; riding on bicycles; climbing on playground structures; dancing; and other complex pattern behaviors. Stylistic features of gross motor activity, such as tempo, intensity, and cautiousness, also vary significantly. Although toddlers may walk with different styles, **toe walking** should not persist.

The effects of such individual differences on cognitive and emotional development depend in part on the demands of the social environment and alignment with their caregivers' temperaments. Energetic, coordinated children may thrive emotionally with parents or teachers who encourage physical activity; lower-energy, more cerebral children may thrive with adults who value quiet play.

**Handedness** is usually established by the third year. Frustration may result from inability to properly teach skills based on child's hand

preference. Variations in fine motor development reflect both individual proclivities and different opportunities for learning. Children who are restricted from drawing with crayons, for example, develop a mature pencil grasp later.

**Bowel and bladder control** emerge during this period, with "readiness" for toileting having large individual and cultural variation. Females tend to potty "train" faster and earlier than males. Bed-wetting is common up to age 5 years (see Chapter 580). Many children master toileting with ease, particularly once they are able to verbalize their bodily needs. For others, **toilet training** can involve a protracted power struggle. Refusal to defecate in the toilet or potty is relatively common, associated with constipation, and can lead to parental frustration. Defusing the issue with a temporary cessation of training (and a return to diapers) often allows toilet mastery to proceed. Parents should focus on positive reinforcement and avoid negative reactions during the toilet training process.

**Implications for Parents and Pediatricians**

The normal decrease in appetite at this age may cause parental concern about nutrition; growth charts should reassure parents that the child's intake is adequate. Children normally modulate their food intake to match their somatic needs according to feelings of hunger and satiety. Daily intake fluctuates, at times widely, but intake over a week is relatively stable. Parents should provide a predictable eating schedule, with three meals and two snacks per day, allowing the child to choose how much to eat. This will avoid power struggles and allows the child to respond to satiety cues. However, it is important to obtain thorough diet histories for children at this age to advise parents about healthy choices and encourage physical activity to decrease long-term obesity risks and improve learning and cognitive development.

Highly active children face increased risks of injury, and parents should be counseled about safety precautions. Parental concerns about possible hyperactivity may reflect inappropriate expectations, heightened fears, or true overactivity. Children who engage in ongoing impulsive activity with no apparent regard for personal safety or those harming others on a regular basis should be evaluated further.

Assessment of motor skills must take into account a child's exposure history. Before diagnosing a motor delay based on screening tools, pediatricians should explore any limitations to a child's exposure and encourage parents to seek opportunities to work on these skills. Children should be followed closely at this age; referral to therapies should be pursued when true delays are identified given the proven benefits of early intervention.

**LANGUAGE, COGNITION, AND PLAY**

These three domains all involve **symbolic function**, a mode of dealing with the world that emerges during the preschool period.

**Language**

Our understanding of the acquisition of language is evolving. Preschool children command significant computational skills and understanding of statistical patterns that allow them to learn about both language and causation. The 2- and 3-year-old child employs frequency distributions to identify phonetic units distinguishing words in his or her native language from other languages.

Language development occurs most rapidly between 2 and 5 years of age. Vocabulary increases from 50-100 words to more than 2,000. Sentence structure advances from telegraphic phrases ("baby cry") to sentences incorporating all the major grammatical components (see Chapter 53). As a rule of thumb, between ages 2 and 5 years, the number of words the child puts in a typical sentence should, at a minimum, equal the child's age (2 by age 2 years, 3 by age 3 years, and so on). By 21-24 months, most children are using possessives ("my ball"), progressives (the "-ing" construction, as in "I playing"), questions, and negatives. By age 4 years, most children can count to 4 and use the past tense; by age 5 years, they can use the future tense. Young children do not use figurative speech; they will comprehend only the literal meaning of words. Referring to an object as "light as a feather" may produce a quizzical look on a child.



It is important to distinguish between **speech** (the production of intelligible sounds) and **language**, which refers to the underlying mental act. Language includes both expressive and receptive functions. *Receptive* language (understanding) varies less in its rate of acquisition than does *expressive* language; therefore it has greater prognostic importance (see [Chapters 28 and 53](#)).

Language acquisition depends critically on environmental input. Key determinants include the amount and variety of speech directed toward children and the frequency with which adults ask questions and encourage verbalization. Children raised in poverty typically perform lower on measures of language development than children from economically advantaged families, who tend to be exposed to many more words in the preschool period. Interventions aimed at increasing access to books in the home can temper these differences and improve language and pre-reading skills in the preschool child.

Although experience influences the rate of language development, many linguists believe that the basic mechanism for language learning is “hard-wired” in the brain. Children do not simply imitate adult speech; they abstract the complex rules of grammar from the ambient language, generating implicit hypotheses. Evidence for the existence of such implicit rules comes from analysis of grammatical errors, such as the overgeneralized use of “-s” to signify the plural and “-ed” to signify the past (“We seed lots of mouses.”).

Language is linked to both cognitive and emotional development. Language delays may be the first indication of an intellectual disability, autism spectrum disorder, or child neglect or maltreatment. Language plays a critical part in the regulation of behavior through internalized “private speech” in which a child repeats adult prohibitions, first audibly and then mentally. Language also allows children to express feelings, such as anger or frustration, without acting them out; consequently, language-delayed children may show higher rates of tantrums and other externalizing behaviors.

Preschool language development lays the foundation for later success in school. Approximately 35% of U.S. children may enter school lacking the language skills that are the prerequisites for acquiring literacy. Children from socially and economically disadvantaged backgrounds have an increased risk of school problems, making early detection, along with referral and enrichment in programs such as Head Start, highly crucial for later development. Although children typically learn to read and write in elementary school, critical foundations for literacy are established during the preschool years. Through repeated early exposure to written words, children learn about the uses of writing (telling stories or sending messages) and about its form (left to right, top to bottom). Early errors in writing, like errors in speaking, reveal that literacy acquisition is an active process involving the generation and revision of hypotheses. **Bilingual children** may initially appear to lag behind their monolingual peers in acquiring language. They learn the differing rules governing both languages, and generally have the same number of total words between the languages. Bilingual children do not follow the same course of language development as monolingual children, but rather create a different system of language cues. Several cognitive advantages have been repeatedly demonstrated among bilingual compared to monolingual children.

Picture books have a special role in familiarizing young children with the printed word and in the development of verbal language. Children’s vocabulary and receptive language improve when their parents or caregivers consistently read to them. Reading aloud with a young child is an interactive process in which a parent repeatedly focuses the child’s attention on a particular picture, asks questions, and then gives the child feedback (**dialogic reading**). The elements of shared attention, active participation, immediate feedback, repetition, and graduated difficulty make such routines ideal for language learning. Programs in which physicians provide books to preschool children have shown improvement in language skills among the children (e.g., Reach Out and Read).

The period of rapid language acquisition is also when **developmental dysfluency** and **stuttering** are most likely to emerge (see [Chapter 53.1](#)); these can be traced to activation of the cortical motor, sensory, and cerebellar areas. Common difficulties include pauses and repetitions of

initial sounds. Stress or excitement exacerbates these difficulties, which generally resolve on their own. Although 5% of preschool children will stutter, it will resolve in 80% of those children by age 8 years. Children with stuttering should be referred for evaluation if it is severe, persistent, or associated with anxiety, or if parental concern is elicited. Treatment includes guidance to parents to reduce pressures associated with speaking.

### Cognition

The preschool period corresponds to Piaget’s **preoperational** (pre-logical) **stage**, characterized by magical thinking, egocentrism, and thinking that is dominated by perception, not abstraction (see [Table 19.2](#)). **Magical thinking** includes confusing coincidence with causality, *animism* (attributing motivations to inanimate objects and events), and unrealistic beliefs about the power of wishes. A child might believe that people cause it to rain by carrying umbrellas, that the sun goes down because it is tired, or that feeling resentment toward a sibling can actually make that sibling sick. **Egocentrism** refers to a child’s inability to take another’s point of view and does not connote selfishness. A child might try to comfort an adult who is upset by bringing the adult a favorite stuffed animal. After 2 years of age, the child develops a concept of herself or himself as an individual and senses the need to feel “whole.”

Piaget demonstrated the dominance of **perception** over logic. In one experiment, water is poured back and forth between a tall, thin vase and a low, wide dish, and children are asked which container has more water. Typically, preschool-age children choose the one that looks larger (usually the tall vase), even when the examiner points out that no water has been added or taken away. Such misunderstandings reflect young children’s developing hypotheses about the nature of the world, as well as their difficulty in attending simultaneously to multiple aspects of a situation. Preschool children also are able to understand **causal relationships**; this adds to our understanding of the ability of preschool children to engage in abstract thinking (see [Chapter 19](#)).

**Imitation**, central to the learning experience of preschool children, is a complex act because of differences in the size of the operators (the adult and the child), different levels of dexterity, and even different outcomes. A child who watches an adult unsuccessfully attempt a simple act (unscrew a lid) will imitate the action, but often with the intended outcome and not the demonstrated (failed) outcome. Thus “imitation” goes beyond the mere repetition of observed movements.

By age 3 years, children have self-identified their sex and are actively seeking understanding of the meaning of **gender identification**. There is a developmental progression from rigidity (males and female have strict gender roles) in the early preschool years to a more flexible realistic understanding (males and females can have a variety of interests that are not gender specific). Parents can facilitate this flexibility by eliminating gender-based expectations and expanding play options.

### Play

Play involves learning, physical activity, socialization with peers, and practicing adult roles. Play increases in complexity and imagination, from simple imitation of common experiences, such as shopping and putting baby to bed (2 or 3 years of age), to more extended scenarios involving singular events, such as going to the zoo or going on a trip (3 or 4 years of age), to the creation of scenarios that have only been imagined, such as flying to the moon (4 or 5 years of age). By age 3 years, **cooperative play** is seen in activities such as building a tower of blocks together; later, more structured **role-play activity**, as in playing house, is seen. Play also becomes increasingly governed by rules, from early rules about asking (rather than taking) and sharing (2 or 3 years of age), to rules that change from moment to moment, according to the desires of the players (4 and 5 years of age), to the beginning of the recognition of rules as relatively immutable (5 years of age). Electronic forms of play (games) are best if interactive and educational and should remain limited in duration.

Play also allows for resolution of conflicts and anxiety and for creative outlets. Children can vent anger safely (reprimanding a doll), take on superpowers (dinosaur and superhero play), and obtain things that

are denied in real life (an imaginary friend or stuffed animal). Creativity is particularly apparent in drawing, painting, and other artistic activities. Themes and emotions that emerge in a child's drawings often reflect the emotional issues of greatest importance for the child.

Difficulty distinguishing fantasy from reality colors a child's perception of what the child views in the media, through programming and advertising. Twenty-five percent of young children have a television set or tablet in their bedroom; screen time in the bedroom is associated with more hours of watching. The number of hours that most preschoolers watch screens exceeds guidelines (1 hr/day for 2-5 year olds). Interactive quality educational programming in which children develop social relationships with the characters can increase learning if paired with adult interaction around the storyline. Exposure to commercial programming with violent content is associated with behavior problems, and because children younger than 8 years are not able to comprehend the concept of persuasive intent, they are more vulnerable to advertising.

### Implications for Parents and Pediatricians

The significance of language as a target for assessment and intervention cannot be overestimated, because of its central role as an indicator of cognitive and emotional development and a key factor in behavioral regulation and later school success. As language emerges, parents can support emotional development by using words that describe the child's feeling states ("You sound angry right now") and urging the child to use words to express rather than act out feelings. Active imaginations will come into play when children offer explanations for misbehavior. A parent's best way of dealing with untruths is to address the event, not the child, and have the child participate in "making things right."

Parents should have a regular time each day for reading or looking at books with their children. Programs such as **Reach Out and Read**, in which clinicians give out picture books along with appropriate guidance during primary care visits, have been effective in increasing reading aloud and thereby promoting language development, particularly in lower-income families. TV and similar media should be limited to 1 hr/day of quality programming for children age 2-5 years, and parents should be watching the programs with their children and debriefing their young children afterward. At-risk children, particularly those living in poverty, can better meet future school challenges if they have early high-quality child care and learning experiences (e.g., Head Start).

Preoperational thinking constrains how children understand experiences of illness and treatment. Children begin to understand that bodies have "insides" and "outsides." Children should be given simple, concrete explanations for medical procedures and given some control over procedures if possible. Children should be reassured that they are not to blame when receiving a vaccine or venipuncture, and parents should be discouraged from making threats about needles if their child is not cooperating with the exam. An adhesive bandage will help to make the body "whole" again in a child's mind.

The active imagination that fuels play and the magical, animist thinking characteristic of preoperational cognition can also generate intense fears. More than 80% of parents report at least one fear in their preschool children. Refusal to take baths or to sit on the toilet may arise from the fear of being washed or flushed away, reflecting a child's immature appreciation of relative size. Attempts to demonstrate rationally that there are no monsters in the closet often fail, inasmuch as the fear arises from preoperational thinking. However, this same thinking allows parents to be endowed with magical powers that can banish the monsters with "monster spray" or a night-light. Parents should acknowledge the fears, offer reassurance and a sense of security, and give the child some sense of control over the situation. Use of the **Draw-a-Person**, in which a child is asked to draw the best person the child can, may help elucidate a child's viewpoint.

### Emotional and Moral Development

Emotional challenges facing preschool children include accepting limits while maintaining a sense of self-direction, reigning in aggressive and sexual impulses, and interacting with a widening circle of adults and peers. At 2 years of age, behavioral limits are predominantly

external; by 5 years of age, these controls need to be internalized if a child is to function in a typical classroom. Success in achieving this goal relies on prior emotional development, particularly the ability to use internalized images of trusted adults to provide a secure environment in times of stress. The love a child feels for important adults is the main incentive for the development of self-control.

Children learn what behaviors are acceptable and how much power they wield vis-à-vis important adults by testing limits. **Limit testing** increases when it elicits attention, even though that attention is often negative, and when limits are inconsistent. Testing often arouses parental anger or inappropriate solicitude as a child struggles to separate, and it gives rise to a corresponding parental challenge: letting go. Excessively tight limits can undermine a child's sense of initiative, whereas overly loose limits can provoke anxiety in a child who feels that no one is in control.

**Control** is a central issue. Young children cannot control many aspects of their lives, including where they go, how long they stay, and what they take home from the store. They are also prone to lose internal control, that is, to have **temper tantrums**. Fear, overtiredness, hunger, inconsistent expectations, or physical discomfort can also evoke tantrums. Tantrums normally appear toward the end of the first year of life and peak in prevalence between 2 and 4 years of age. Tantrums lasting more than 15 minutes or regularly occurring more than three times per day may reflect underlying medical, emotional, developmental, or social problems. Parents likely will not be able to reason or teach in the context of an active tantrum, and should offer emotional support during these times, sticking to short and concise explanations ("I can't let you hit"). Lessons about their behavior or discussions about strategies for future challenges should be delayed until the child is calm and able to engage.

Preschool children normally experience complicated feelings toward their parents that can include strong attachment and possessiveness toward the parent of the opposite sex, jealousy and resentment of the other parent, and fear that these negative feelings might lead to abandonment. These emotions, most of which are beyond a child's ability to comprehend or verbalize, often find expression in highly labile moods. The resolution of complicated feelings (a process extending over years) involves a child's unspoken decision to identify with the parents rather than compete with them. Play and language foster the development of emotional controls by allowing children to express emotions and role-play.

Curiosity about genitals and adult sexual organs is normal, as is **masturbation**. Excessive masturbation interfering with normal activity, acting out sexual intercourse, extreme modesty, or mimicry of adult seductive behavior all suggest the possibility of sexual abuse or inappropriate exposure (see [Chapter 17.1](#)). Modesty appears gradually between 4 and 6 years of age, with wide variations among cultures and families. Parents should begin to teach children about "private" body areas before school entry.

**Moral thinking** is constrained by a child's cognitive level and language abilities but develops as the child builds their identity with trusted adults. Beginning before the second birthday, the child's sense of right and wrong stems from the desire to earn adult approval and avoid negative consequences. The child's impulses are tempered by external forces; the child has not yet internalized societal rules or a sense of justice and fairness. Over time, as the child internalizes parental admonitions, words are substituted for aggressive behaviors. Finally, the child accepts personal responsibility. Actions will be viewed by damage caused, not by intent. Empathic responses to others' distress arise during the second year of life, but the ability to consider another child's point of view remains limited throughout this period. In keeping with a child's inability to focus on more than one aspect of a situation at a time, fairness is taken to mean equal treatment, regardless of circumstance. A 4 year old will acknowledge the importance of taking turns but will complain if he or she "didn't get enough time." Rules tend to be absolute, with guilt assigned for bad outcomes, regardless of intentions.

### Implications for Parents and Pediatricians

The importance of the preschooler's sense of control over his or her body and surroundings have implications for practice. Preparing the

patient by letting the child know how the visit will proceed is reassuring. Tell the child what will happen, but do not ask permission unless you are willing to deal with a “no” answer. A brief introduction to “private parts” is warranted before the genital examination.

The visit of the 4 or 5 year old should be entertaining, because of the child’s ability to communicate, as well as the child’s natural curiosity. Physicians should realize that all children are occasionally difficult. Guidance emphasizing appropriate expectations for behavioral and emotional development and acknowledging normal parental feelings of anger, guilt, and confusion should be part of all visits at this time. Parents should be queried about daily routines and their expectations of child behavior. Providing children with **acceptable choices** (all options being acceptable to the parent) and encouraging independence in self-care activities (feeding, dressing, and bathing) will reduce conflicts.

Although some cultures condone the use of physical **punishment** for disciplining of young children, it is not a consistently effective means of behavioral control (Chapter 20). As children habituate to repeated spanking, parents have to spank ever harder to achieve the desired response, increasing the risk of serious injury. Sufficiently harsh punishment may acutely inhibit undesired behaviors, but at great long-term psychologic cost. Children may mimic the physical punishment that they receive; children who are spanked will have more aggressive behaviors later. Whereas spanking is the use of force, externally applied, to produce behavior change, **discipline** is the process that allows the child to internalize controls on behavior. Alternative discipline strategies should be offered, such as the “countdown” for transitions along with consistent limit setting, “time-outs” and “time-ins” (fun activities with caregiver present and interacting), clear communication of rules, and frequent approval with positive reinforcement of productive play and behavior (see Chapter 20 and Tables 20.3 and 20.4). Punishment should be immediate, specific to the behavior, and time limited. *Time-out for approximately 1 minute per year of age is very effective if children are getting sufficient time in.* A kitchen timer or digital phone alarm allows the parent to step back from the situation; the child is free when the timer rings. Although one strategy might not work for all children uniformly, consistency is integral to healthy learning and growth.

Visit Elsevier eBooks+ at [eBooks.Health.Elsevier.com](http://eBooks.Health.Elsevier.com) for Bibliography.

## Chapter 26

# Middle Childhood

Mutiati T. Onigbanjo and Susan Feigelman

Middle childhood (6-11 years of age) is the period in which children increasingly separate from parents and seek acceptance from teachers, other adults, and peers. Children begin to feel under pressure to conform to the style and ideals of the peer group. Self-esteem becomes a central issue, as children develop the cognitive ability to consider their own self-evaluations and their perception of how others see them. For the first time, they are judged according to their ability to produce socially valued outputs, such as getting good grades, playing a musical instrument, or hitting home runs.

### PHYSICAL DEVELOPMENT

Growth occurs *discontinuously*, in three to six irregularly timed spurts each year, but varies both within and among individuals. Growth during the period averages 3-3.5 kg (6.6-7.7 lb) and 6-7 cm (2.4-2.8 in) per year (Fig. 26.1). The head grows only 2 cm in circumference throughout the entire period, reflecting a slowing of brain growth. Myelination continues into adolescence, with peak gray matter at 12-14 years. Body habitus is more erect than previously, with long legs compared with the torso.

Growth of the midface and lower face occurs gradually. Loss of deciduous (baby) teeth is a more dramatic sign of maturation, beginning around 6 years of age. Replacement with adult teeth occurs at a rate of about four per year, so that by age 9 years, children will have eight permanent incisors and four permanent molars. Premolars erupt by 11-12 years of age (see Chapter 353). Lymphoid tissues hypertrophy and reach maximal size, often giving rise to impressive tonsils and adenoids.

Muscular strength, coordination, and stamina increase progressively, as does the ability to perform complex movements, such as dancing or shooting baskets. Such higher-order motor skills are the result of both maturation and training; the degree of accomplishment reflects wide variability in innate skill, interest, and opportunity.

Physical fitness has declined among school-age children. Sedentary habits at this age are associated with increased lifetime risk of obesity, cardiovascular disease, lower academic achievement, and lower self-esteem. The number of overweight children and the degree of overweight have been increasing (see Chapter 65). Only 15% of middle and junior high schools require physical education classes at least three days per week. One quarter of youth do not engage in any free-time physical activity, despite the recommendation for at least 1 hour of physical activity per day.

Perceptions of **body image** develop early during this period; children as young as 5 and 6 years may express dissatisfaction with their body image; by ages 8 and 9 years many of these youth report trying to diet, often using ill-advised regimens. Loss-of-control (binge) eating occurs among approximately 6% of children at this age.

Before puberty the sensitivity of the hypothalamus and pituitary changes, leading to increased gonadotropin synthesis. Interest in gender differences and sexual behavior increases progressively until puberty. Although this is a period when sexual drives are limited, masturbation is common, and children may be interested in differences between genders. Rates of maturation differ by geography, ethnicity, and country. Sexual maturity occurs earlier for both sexes in the United States. Differences in maturation rates have implications for differing expectations of others based on sexual maturation.

### Implications for Parents and Pediatricians

Middle childhood is generally a time of excellent health. However, children have variable sizes, shapes, and abilities. Children of this age compare themselves with others, eliciting feelings about their physical attributes and abilities. Fears of being “abnormal” can lead to avoidance of situations in which physical differences might be revealed, such as gym class or medical examinations. However, all children, including those with disabilities, should participate in gym classes. Those with physical disabilities may face special stresses; medical, social, and psychologic risks tend to occur together.

Children should be asked about risk factors for **obesity**. Participation in physical activity, including organized sports or other organized activities, can foster skill, teamwork, and fitness as well as a sense of accomplishment, but pressure to compete when the activity is no longer enjoyable has negative effects. Counseling on establishing healthy eating habits and limited screen time should be given to all families. Prepubertal children should not engage in high-stress, high-impact sports, such as power lifting or tackle football, because skeletal immaturity increases the risk of injury and concussions may have long-term sequelae (see Chapter 729).

### COGNITIVE DEVELOPMENT

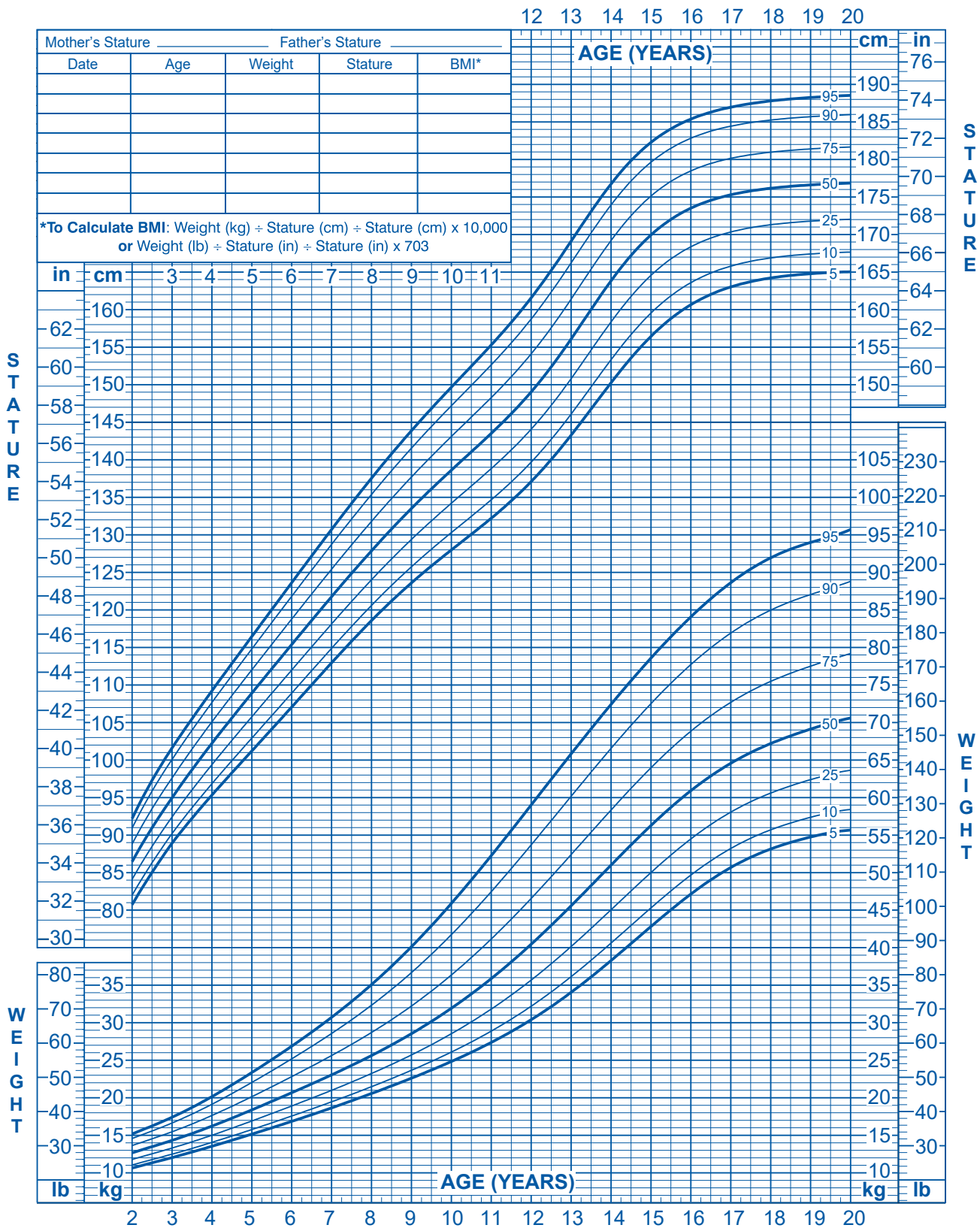
The thinking of early elementary school-age children differs qualitatively from that of preschool children. In place of the magical, ego-centric, and perception-bound cognition of preschool children, school-age children increasingly apply rules based on observable phenomena, factor in multiple dimensions and points of view, and interpret their perceptions using physical laws. Piaget documented this shift from preoperational to **concrete** (logical) **operations** (see Chapter 19). When 5 year olds watch a ball of clay being rolled into a snake, they might insist that the snake has “more” because it is longer. In contrast, 7 year olds typically reply that the ball and the snake must weigh the same because nothing has been added or taken away or because the



## 2 to 20 years: Boys Stature-for-age and Weight-for-age percentiles

NAME \_\_\_\_\_

RECORD # \_\_\_\_\_



Published May 30, 2000 (modified 11/21/00).  
SOURCE: Developed by the National Center for Health Statistics in collaboration with the National Center for Chronic Disease Prevention and Health Promotion (2000).  
<http://www.cdc.gov/growthcharts>



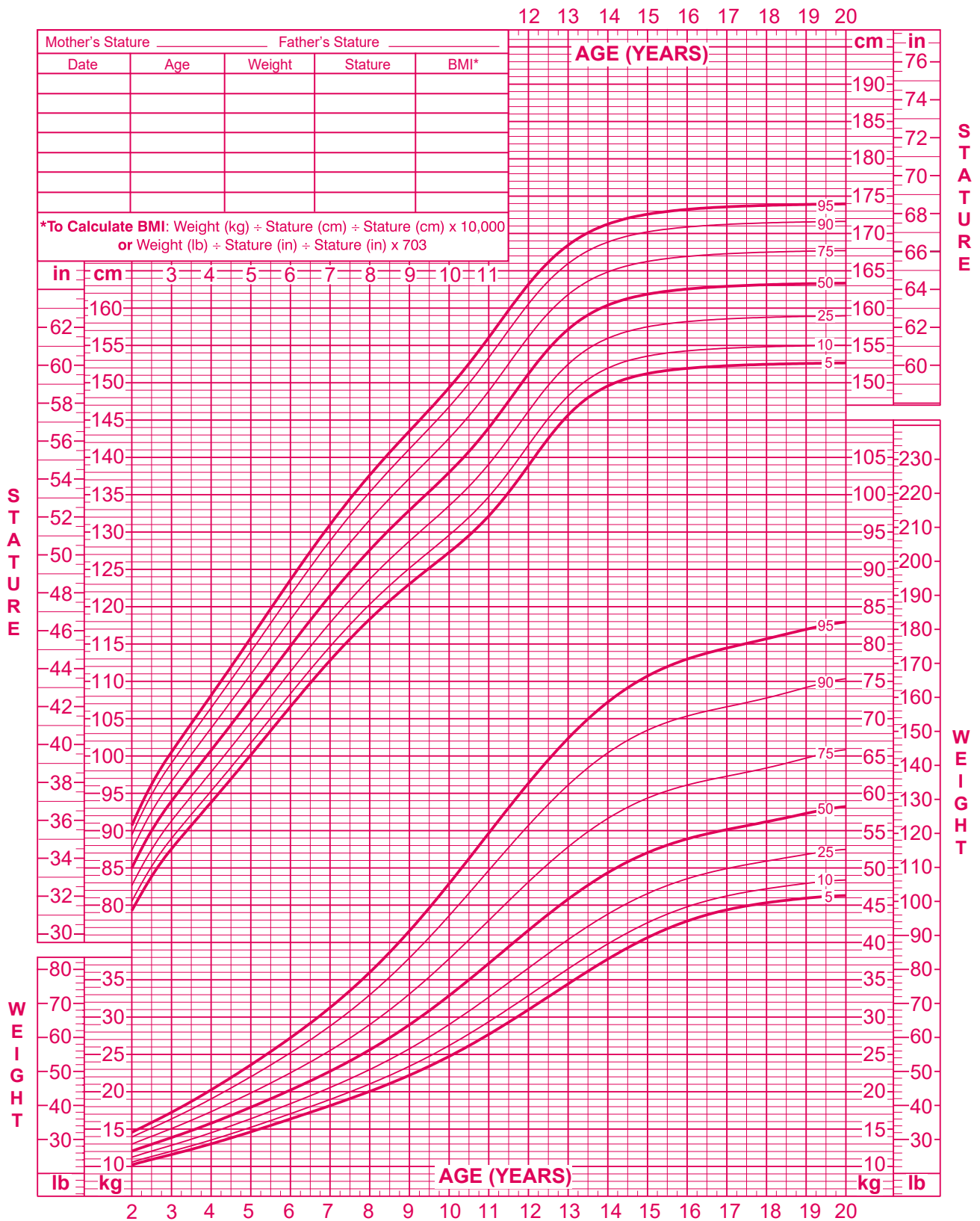
**A** Fig. 26.1 A, Stature (height) for age and weight for boys, age 2-20 years. B, Stature (height) for age and weight for girls, age 2-20 years. (Courtesy National Center for Health Statistics, in collaboration with the National Center for Chronic Disease Prevention and Health Promotion, 2000. <http://www.cdc.gov/growthcharts>.)



**2 to 20 years: Girls**  
**Stature-for-age and Weight-for-age percentiles**

NAME \_\_\_\_\_

RECORD # \_\_\_\_\_



Published May 30, 2000 (modified 11/21/00).  
 SOURCE: Developed by the National Center for Health Statistics in collaboration with  
 the National Center for Chronic Disease Prevention and Health Promotion (2000).  
<http://www.cdc.gov/growthcharts>



SAFER • HEALTHIER • PEOPLE™

Fig. 26.1, cont'd

**Table 26.1** Selected Perceptual, Cognitive, and Language Processes Required for Elementary School Success

PROCESS	DESCRIPTION	ASSOCIATED PROBLEMS
<b>PERCEPTUAL</b>		
Visual analysis	Ability to break a complex figure into components and understand their spatial relationships	Persistent letter confusion (e.g., between <i>b</i> , <i>d</i> , and <i>g</i> ); difficulty with basic reading and writing and limited “sight” vocabulary
Proprioception and motor control	Ability to obtain information about body position by feel and unconsciously program complex movements	Poor handwriting, requiring inordinate effort, often with overly tight pencil grasp; special difficulty with timed tasks
Phonologic processing	Ability to perceive differences between similar-sounding words and to break down words into constituent sounds	Delayed receptive language and reading skill; attention and behavior problems secondary to not understanding directions; delayed acquisition of letter-sound correlations (phonetics)
<b>COGNITIVE</b>		
Long-term memory, both storage and recall	Ability to acquire skills that are “automatic” (i.e., accessible without conscious thought)	Delayed mastery of the alphabet (reading and writing letters); slow handwriting; inability to progress beyond basic mathematics
Selective attention	Ability to attend to important stimuli and ignore distractions	Difficulty following multistep instructions, completing assignments, and behaving well; problems with peer interaction
Sequencing	Ability to remember things in order; facility with time concepts	Difficulty organizing assignments, planning, spelling, and telling time
<b>LANGUAGE</b>		
Receptive language	Ability to comprehend complex constructions, function words (e.g., <i>if</i> , <i>when</i> , <i>only</i> , <i>except</i> ), nuances of speech, and extended blocks of language (e.g., paragraphs)	Difficulty following directions; wandering attention during lessons and stories; problems with reading comprehension; problems with peer relationships
Expressive language	Ability to recall required words effortlessly (word finding), control meanings by varying position and word endings, and construct meaningful paragraphs and stories	Difficulty expressing feelings and using words for self-defense, with resulting frustration and physical acting out; struggling during “circle time” and in language-based subjects (e.g., English)

snake is both longer and thinner. This cognitive reorganization occurs at different rates in different contexts. In the context of social interactions with siblings, young children often demonstrate an ability to understand alternate points of view long before they demonstrate that ability in their thinking about the physical world. Understanding time and space constructs occurs in the later part of this period.

The concept of **school readiness** has evolved. The American Academy of Pediatrics recommends following an “interactional relational” model in which the focus is on the child, the environment, and the resulting interactions. This model explicitly asserts that all children can learn and that the educational process is reciprocal between the child and the school. It is developmentally based, recognizing the importance of early experiences for later development. Rather than delaying school entry, high-quality early-education programs may be the key to ultimate school success.

School makes increasing cognitive demands on the child. Mastery of the elementary curriculum requires that many perceptual, cognitive, and language processes work efficiently (Table 26.1), and children are expected to attend to many inputs at once. The first 2-3 years of elementary school are devoted to acquiring the fundamentals: reading, writing, and basic mathematics skills. By third grade, children need to be able to sustain attention through a 45-minute period, and the curriculum requires more complex tasks. The goal of reading a paragraph is no longer to decode the words, but to understand the content; the goal of writing is no longer spelling or penmanship, but composition. The volume of work increases along with the complexity.

Cognitive abilities interact with a wide array of attitudinal and emotional factors in determining classroom performance. These factors include *external rewards* (eagerness to please adults and approval from peers) and *internal rewards* (competitiveness, willingness to work for a delayed reward, belief in one’s abilities, and ability to risk trying when success is not ensured). Success predisposes to success, whereas failure impacts self-esteem and reduces self-efficacy, diminishing a child’s willingness to take future risks.

Children’s intellectual activity extends beyond the classroom. Beginning in the third or fourth grade, children increasingly enjoy strategy games and wordplay (puns and insults) that exercise their growing cognitive and linguistic mastery. Many become experts on subjects of their own choosing, such as sports trivia, or develop hobbies, such as special card collections. Others become avid readers or take on artistic pursuits. Whereas board and card games were once the usual leisure-time activity of youth, video, computer, and other electronic games currently fill this need.

### Implications for Parents and Pediatricians

Pediatricians have an important role in preparing their patients for school entrance by promoting health through immunizations, adequate nutrition, appropriate recreation, and screening for physical, developmental, and cognitive disorders. The American Academy of Pediatrics recommends that pediatric providers promote the “5 Rs” of early education: (1) reading as a daily family activity; (2) rhyming, playing, and cuddling together; (3) routines and regular times for meals, play, and sleep; (4) reward through praise for successes; and (5) reciprocal nurturing relationships.

Concrete operations allow children to understand simple explanations for illnesses and necessary treatments, although they may revert to prelogical thinking when under stress. A child with pneumonia may be able to explain about white cells fighting the “germs” in the lungs but may still secretly harbor the belief that the sickness is a punishment for disobedience.

As children are faced with more abstract concepts, academic and classroom behavior problems emerge and come to the pediatrician’s attention. Referrals may be made to the school for remediation or to community resources (medical or psychologic) when appropriate. The causes may be one or more of the following: deficits in perception (vision and hearing); specific learning disabilities (see Chapters 51 and 52); global cognitive delay (intellectual disability; Chapter 56); deficits in attention and executive function (Chapters 49 and 50);

and attention deficits secondary to family dysfunction, depression, anxiety, or chronic illness. Children whose learning style does not fit the classroom culture may have academic difficulties and need assessment before failure sets in. Simply having a child repeat a failed grade rarely has any beneficial effect and often seriously undercuts the child's self-esteem. In addition to finding the problem areas, identifying each child's strengths is important. Educational approaches that value a wide range of talents ("multiple intelligences") beyond the traditional reading, writing, and mathematics may allow more children to succeed.

The change in cognition allows the child to understand "if/when" clauses. Increased responsibilities and expectations accompany increased rights and privileges. Discipline strategies should move toward negotiation and a clear understanding of consequences, including removal of privileges for infringements.

## SOCIAL, EMOTIONAL, AND MORAL DEVELOPMENT

### Social and Emotional Development

In middle childhood, energy is directed toward creativity and productivity. Changes occur in three spheres: the home, the school, and the neighborhood. Of these, the home and family remain the most influential. Increasing independence is marked by the first sleepover at a friend's house and the first time at overnight camp. Parents should make demands for effort in school and extracurricular activities, celebrate successes, and offer unconditional acceptance when failures occur. Regular chores, associated with an allowance, provide an opportunity for children to contribute to family functioning and learn the value of money. These responsibilities may be a testing ground for psychologic separation, leading to conflict. Siblings have critical roles as competitors, loyal supporters, and role models.

The beginning of school coincides with a child's further separation from the family and the increasing importance of teacher and peer relationships. Social groups tend to be same-sex, with frequent changing of membership, contributing to a child's growing social development and competence. Popularity, a central ingredient of self-esteem, may be won through possessions (having the latest electronic gadgets or the right clothes), as well as through personal attractiveness, accomplishments, and actual social skills. Children are aware of racial differences and are beginning to form opinions about racial groups that impact their relationships. **Gender identification**, which began in early childhood, continues to evolve and can have significant implications for peer relationships and self-awareness.

Some children conform readily to the peer norms and enjoy easy social success. Those who adopt individualistic styles or have visible differences may be teased or bullied. Children with deficits in social skills may go to extreme lengths to win acceptance, only to meet with repeated failure. Attributions conferred by peers, such as funny, stupid, bad, or fat, may become incorporated into a child's self-image and affect the child's personality, as well as school performance. Parents may have their greatest effect indirectly, through actions that change the peer group (changing the child's school or encouraging involvement in structured after-school activities). Children who identify with a gender different from their sex of birth, or whose manner and dress reflect those more typically seen as "opposite" their birth sex, may be subject to teasing or **bullying** (Chapter 153). This can magnify the confusion for these children, who are formulating their own concept of "self."

In the neighborhood, real dangers, such as busy streets, bullies, violence, and strangers, tax school-age children's common sense and resourcefulness (see Chapter 15). Interactions with peers without close adult supervision call on increasing conflict resolution skills. Media exposure to adult materialism, sexuality, substance use, and violence may be frightening, reinforcing children's feeling of powerlessness in the larger world. Compensatory fantasies of being powerful may fuel the fascination with heroes and superheroes. A balance between fantasy and an appropriate ability to negotiate real-world challenges indicates healthy emotional development.

### Moral Development

Although by age 6 years most children will have a **conscience** (internalized rules of society), they vary greatly in their level of moral development. For younger children, many still subscribe to the notion that rules are established and enforced by an authority figure (parent or teacher), and decision-making is guided by self-interest (avoidance of negative and receipt of positive consequences). The needs of others are not strongly considered in decision-making. As they grow older, most will recognize not only their own needs and desires but also those of others, although personal consequences are still the primary driver of behavior. Social behaviors that are socially undesirable are considered wrong. By age 10-11 years, the combination of peer pressure, a desire to please authority figures, and an understanding of **reciprocity** (treat others as you wish to be treated) shapes the child's behavior.

### Implications for Parents and Pediatricians

Children need unconditional support as well as realistic demands as they venture into a world that is often frightening. A daily query from parents over the dinner table or at bedtime about the good and bad things that happened during the child's day may uncover problems early. Parents may have difficulty allowing the child independence or may exert excessive pressure on their children to achieve academic or competitive success. Children who struggle to meet such expectations may have behavior problems or psychosomatic complaints.

Many children face stressors that exceed the normal challenges of separation and success in school and the neighborhood. Approximately 50% of all marriages in the United States end in divorce. In addition, domestic violence, parental substance abuse, and other adverse childhood experiences (**ACEs**) may also impair a child's ability to use home as a secure base for refueling emotional energies. In many neighborhoods, random violence makes the normal development of independence extremely dangerous. Older children may join gangs as a means of self-protection and a way to attain recognition and to belong to a cohesive group. Children who bully others and those who are victims of bullying should be evaluated, because bullying is associated with mood disorders, family problems, and school adjustment problems. Parents should reduce exposure to hazards where possible. Because of the risk of unintentional firearm injuries to children, parents should be encouraged to ask parents of playmates whether a gun is kept in their home and, if so, how it is secured.

Pediatrician visits are infrequent in this period; therefore each visit is an opportunity to assess children's functioning in all contexts (home, school, neighborhood). Maladaptive behaviors, both internalizing and externalizing, occur when children do not have safe, secure attachments to adults and stress in any of these environments overwhelms the child's coping responses, becoming "toxic stress." Because of continuous exposure and the strong influence of media (programming and advertisements) on children's beliefs and attitudes, parents must be alert to exposures from television and internet. Youth 8-12 years of age spend over 6 hr/day with a variety of media; half have a TV in their bedroom. Parents should be advised to remove the TV from their children's rooms, limit viewing to 2 hr/day, and monitor what programs children watch. Nearly all children have exposure to mobile technology. Some computer screen time may be necessary for schoolwork and virtual learning. However, the widespread use of **social media** may have detrimental effects including risky health behaviors, cyberbullying, targeted advertisements, and low self-esteem. The **Draw-a-Person** (for ages 3-10 years, with instructions to "draw a complete person") and **Kinetic Family Drawing** (beginning at age 5 years, with instructions to "draw a picture of everyone in your family doing something") are useful office tools to assess a child's functioning.

Visit Elsevier eBooks+ at [eBooks.Health.Elsevier.com](http://eBooks.Health.Elsevier.com) for Bibliography.

## Chapter 27

## Assessment of Growth

Vaneeta Bamba and Andrea Kelly

Growth can be considered a vital sign in children, and aberrant growth may be the first sign of an underlying pathologic condition. The most powerful tool in growth assessment is the **growth chart** (Figs. 24.1, 24.2, 26.1, and 27.1), used in combination with accurate measurements of height, weight, head circumference, and calculation of the **body mass index (BMI)**.

## TECHNIQUES TO MEASURE GROWTH

Growth assessment requires accurate and precise measurements. For infants and toddlers age <2 years, weight, length, and head circumference are obtained. **Head circumference** is measured with a flexible tape measure starting at the supraorbital ridge around to the occipital prominence in the back of the head, locating the maximal circumference. **Height** and **weight** measures should be performed with the infant naked, and ideally, repeated measures will be performed on the same equipment. **Recumbent length** is most accurately measured by two examiners (one to position the child). Hair ornaments and hairstyles that interfere with measurements and positioning should be removed. The child's head is positioned against an inflexible measuring board in the **Frankfurt plane**, in which the outer canthi of the eyes are in line with the external auditory meatus and are perpendicular to the long axis of the trunk. Legs should be fully extended, and feet are maintained perpendicular to the plane of the supine infant. For older children (>2 years) who can stand unassisted, standing heights should be obtained without shoes, using a stadiometer with the head in the Frankfurt plane, and the back of the head, thoracic spine, buttocks, and heels approximating the vertical axis of one another and the stadiometer.

Measurements obtained using alternative means, such as marking examination paper at the foot and head of a supine infant or using a tape measure or wall growth chart with a book or ruler on the head can lead to inaccuracy and render the measurement useless.

Measurements for height and weight should be plotted on the age-appropriate growth curve. Comparing measurements with previous growth trends, repeating measures that are inconsistent, and plotting results longitudinally are essential for monitoring growth. Calculation of interim linear height velocity, such as centimeters per year (cm/yr), allows more precise comparison of growth rate to the norm (Table 27.1).

If a child is growing faster or more slowly than expected, measurement of body proportions, which follow a predictable sequence of changes with development, are useful. The head and trunk are relatively large at birth, with progressive lengthening of the limbs throughout development, particularly during puberty. The **upper-to-lower body segment ratio (U/L ratio)** provides an assessment of truncal growth relative to limb growth. The **lower-body segment** is defined as the length from the top of the symphysis pubis to the floor, and the **upper-body segment** is the total height minus the lower-body segment. The U/L ratio equals approximately 1.7 at birth, 1.3 at 3 years, and 1.0 after 7 years. Higher U/L ratios are characteristic of short-limb dwarfism, as occurs with Turner syndrome or bone disorders, whereas lower ratios suggest hypogonadism or Marfan syndrome.

**Arm span** also provides assessment of proportionality and is measured as the distance between the tips of the middle fingers while the patient stands with the back against the wall with arms outstretched horizontally at a 90-degree angle to the trunk. This span should be close to height, although the proportion changes with age.

## GROWTH CURVES

The American Academy of Pediatrics (AAP) and the U.S. Centers for Disease Control and Prevention (CDC) recommend use of the

2006 World Health Organization (WHO) growth curves for children age 0-24 months and the 2000 CDC growth curves for children age 2-19 years (<https://www.cdc.gov/growthcharts>). There are five standard gender-specific charts: (1) weight for age, (2) height (length and stature) for age, (3) head circumference for age, (4) weight for height (length and stature) for infants, and (5) BMI for age (see Fig. 27.1; see also Figs. 24.1, 24.2, and 26.1). Clinicians should confirm that the correct CDC and WHO growth charts are used in electronic medical records to ensure accurate characterization of growth.

The WHO curves describe growth differently than the CDC curves (Fig. 27.2). The WHO curves are **growth standards** that describe how children grow under optimal conditions, whereas the CDC curves are **growth references** that describe how children grew in a specific time and place. The WHO growth curves are based on longitudinal growth studies in which cohorts of newborns were chosen from six countries (Brazil, Ghana, India, Norway, Oman, United States) using specific inclusion and exclusion criteria; all infants were breastfed for at least 12 months and were predominantly breastfed for the first 4 months of life. They were measured regularly from birth to 23 months during 1997-2003. In contrast, the CDC curves are based on cross-sectional data from different studies during different time points. Growth curves for children age 2-59 months were based on the National Health and Nutrition Examination Survey (NHANES), which included a cross section of the U.S. population. These data were supplemented with additional participants in a separate nutrition surveillance study.

Several deficiencies of the older charts have been corrected, such as the overrepresentation of bottle-fed infants and the reliance on a local dataset for the infant charts. The disjunction between length and height when transitioning from the infant curves to those for older children is improved.

Each chart is composed of percentile curves, which indicate the percentage of children at a given age on the x axis whose measured value falls below the corresponding value on the y axis. The 2006 WHO growth curves include values that are 2 standard deviations (SD) above and below median (2nd and 98th percentiles), whereas the 2000 CDC growth curves include 3rd and 97th percentiles. On the WHO weight chart for boys ages 0-24 months (see Fig. 24.2A), the 9 month age line intersects the 25th percentile curve at 8.3 kg, indicating that 25% of 9-month-old males in the WHO cohorts weigh less than 8.3 kg (75% weigh more). Similarly, a 9-month-old male weighing more than 11 kg is heavier than 98% of his peers. The median or 50th percentile is also termed the **standard value**, in the sense that the standard length for a 7-month-old female is 67.3 cm (see Fig. 24.2B). The weight-for-length charts (see Fig. 24.1) are constructed in an analogous fashion, with length or stature in place of age on the x axis; the median or standard weight for a female measuring 100 cm is 15 kg.

Extremes of height or weight can also be expressed in terms of the age for which they would represent the standard or median. For instance, an 18-month-old female who is 74.9 cm (2nd percentile) is at the 50th percentile for a 13 month old. Thus the height age is 13 months. Weight age can similarly be expressed.

In assessing adolescents, caution must be used in applying cross-sectional charts. Growth during adolescence is linked temporally to the onset of puberty, which varies widely. Normal variations in the timing of the growth spurt can lead to misdiagnosis of growth abnormalities. By using cross-sectional data based on chronologic age, the charts combine youth who are at different stages of maturation. Data for 12-year-old males include both earlier-maturing males who are at the peak of their growth spurts and later-maturing ones who are still growing at their prepubertal rate. The net results are an artificially blunted growth peak, and the appearance that adolescents grow more gradually and for a longer duration than in actuality.

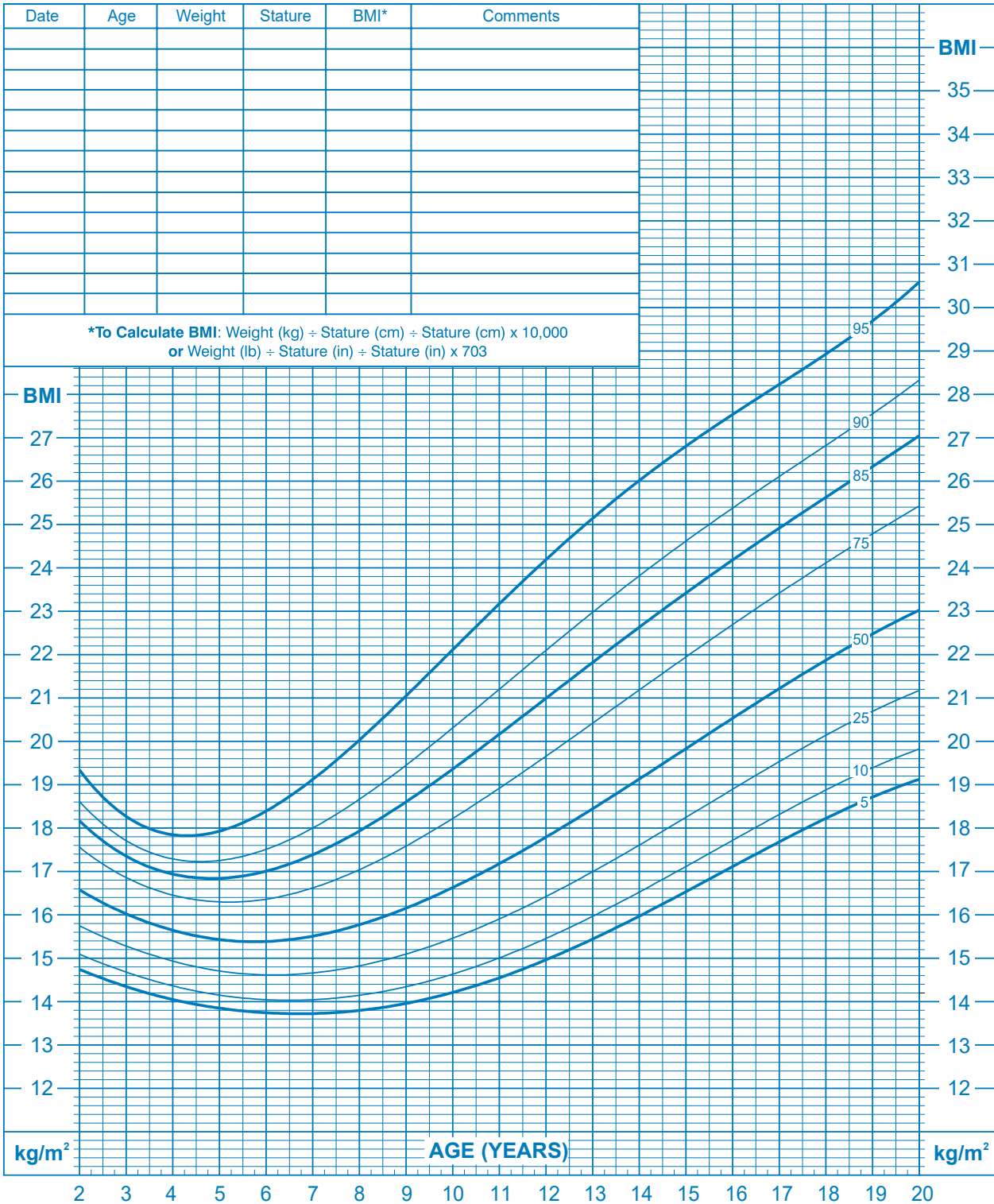
When additional insight is necessary, growth charts derived from longitudinal data, such as the **height velocity charts** of Tanner and colleagues, are recommended. The longitudinal component of these velocity curves is based on British children from the 1950s and 1960s, and cross-sectional data from U.S. children were superimposed. Height velocity curves based on longitudinal data from a multiethnic study conducted at five U.S. sites included SD scores for height velocity for



### 2 to 20 years: Boys Body mass index-for-age percentiles

NAME \_\_\_\_\_

RECORD # \_\_\_\_\_



Published May 30, 2000 (modified 10/16/00).

SOURCE: Developed by the National Center for Health Statistics in collaboration with the National Center for Chronic Disease Prevention and Health Promotion (2000). <http://www.cdc.gov/growthcharts>



SAFER • HEALTHIER • PEOPLE™

A

Fig. 27.1 A, Body mass index (BMI) percentiles for boys, age 2-20 years.

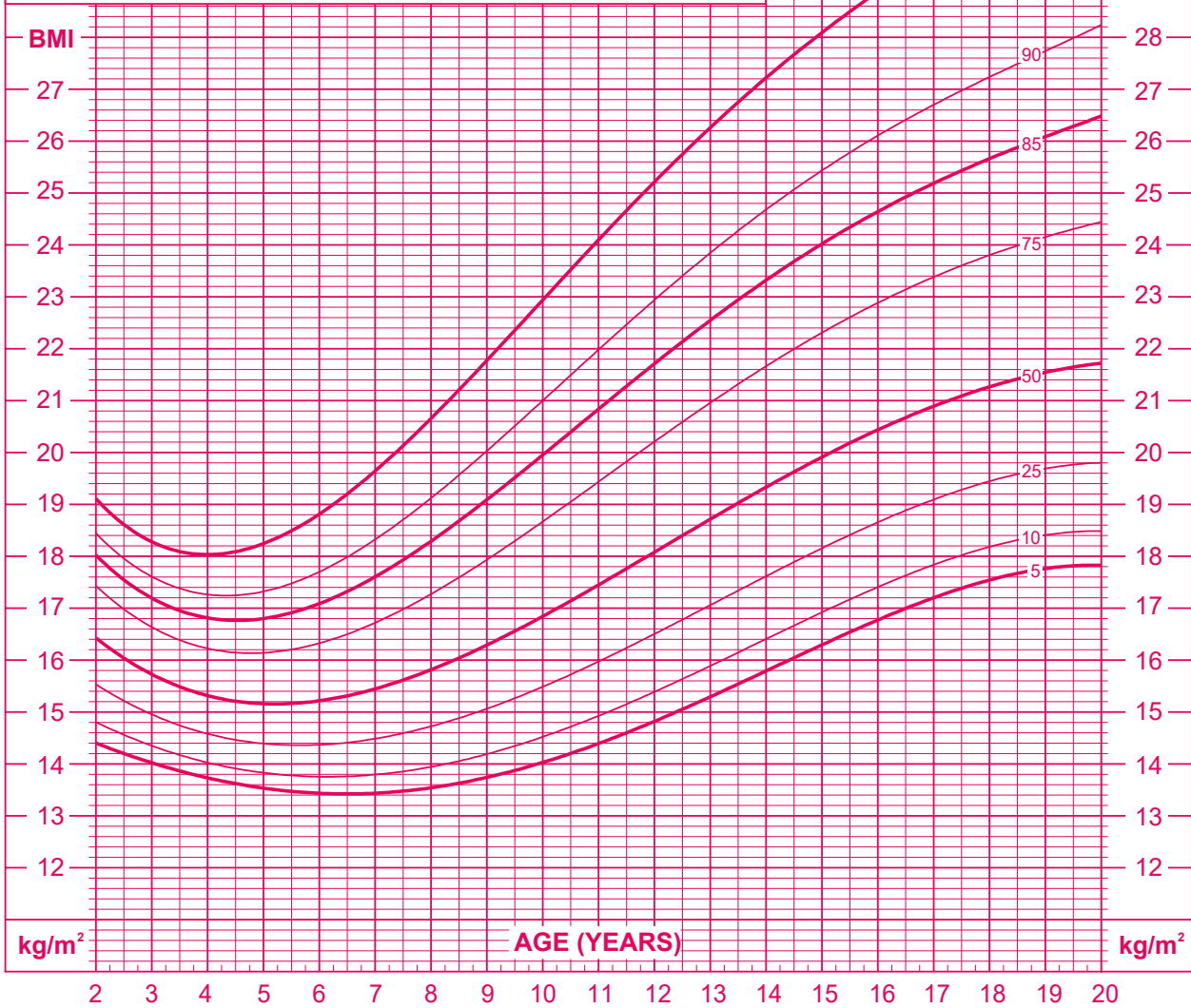
**2 to 20 years: Girls**  
**Body mass index-for-age percentiles**

NAME \_\_\_\_\_

RECORD # \_\_\_\_\_

Date	Age	Weight	Stature	BMI*	Comments

\*To Calculate BMI: Weight (kg) ÷ Stature (cm) ÷ Stature (cm) x 10,000  
 or Weight (lb) ÷ Stature (in) ÷ Stature (in) x 703

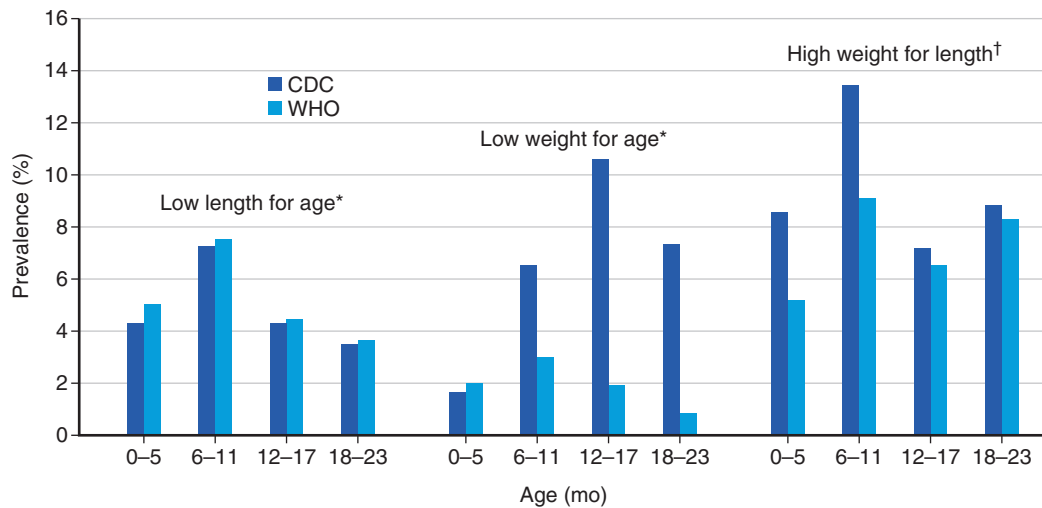


Published May 30, 2000 (modified 10/16/00).  
 SOURCE: Developed by the National Center for Health Statistics in collaboration with  
 the National Center for Chronic Disease Prevention and Health Promotion (2000).  
<http://www.cdc.gov/growthcharts>



SAFER • HEALTHIER • PEOPLE™

**Fig. 27.1 Cont'd B**, BMI percentiles for girls, age 2-20 years. Official Centers for Disease Control and Prevention [CDC] growth charts, as described in this chapter.) The 85th to 95th percentile is at risk for overweight; >95th percentile is overweight; <5th percentile is underweight. Technical information and interpretation and management guides are available at [www.cdc.gov/nchs](http://www.cdc.gov/nchs). Developed by the National Center for Health Statistics in collaboration with the National Center for Chronic Disease Prevention and Health Promotion, 2000 (<http://www.cdc.gov/growthcharts>).



**Fig. 27.2** Comparison of World Health Organization (WHO) and Centers for Disease Control and Prevention (CDC) growth chart prevalence of low length for age, low weight for age, and high weight for length among children age <24 months, United States, 1999–2004. \*, ≤5th percentile on the CDC charts; ≤2.3rd percentile on the WHO charts. †, ≥95th percentile on the CDC charts; ≥97.7th percentile on the WHO charts. (Data from the National Health and Nutrition Examination Survey, 1999–2004; from Grummer-Strawn LM, Reinold C, Krebs NF: Centers for Disease Control and Prevention: Use of World Health Organization and CDC growth charts for children ages 0-59 months in the United States, *MMWR Recomm Rep* 2010;59[RR-9]:1–15.)

Table 27.1 Growth Velocity and Other Growth Characteristics by Age		
INFANCY	CHILDHOOD	ADOLESCENCE
Birth-12 mo: 24 cm/yr 12-24 mo: 10 cm/yr 24-36 mo: 8 cm/yr	6 cm/yr Slowly decelerates before pubertal onset Height typically does not cross percentile lines	Sigmoid-shaped growth Adolescent growth spurt accounts for about 15% of adult height Peak height velocity Girls: 8 cm/yr Boys: 10 cm/yr

earlier- and later-maturing adolescents to facilitate the identification of poor or accelerated linear growth.

**Specialized growth charts** have been developed for U.S. children with various conditions, including very low birthweight (VLBW), small for gestational age, trisomy 21, Turner syndrome, and achondroplasia, and should be used when appropriate.

Facilitating identification of obesity, the charts include curves for plotting BMI for ages 2-20 years rather than weight for height (see Fig. 27.1). Methodologic steps have ensured that the increase in the prevalence of obesity has not unduly raised the upper limits of normal. BMI can be calculated as weight in kilograms/(height in meters)<sup>2</sup> or weight in pounds/(height in inches)<sup>2</sup> × 703, with fractions of pounds and inches expressed as decimals. Because of variable weight and height gains during childhood, BMI must be interpreted relative to age and sex; the BMI percentile provides a more standardized comparison. For example, a 6-year-old girl with a BMI of 19.7 kg/m<sup>2</sup> (97th percentile) is obese, whereas a 15-year-old female with BMI of 19.7 kg/m<sup>2</sup> (50th percentile) is normal weight.

**Normal Growth**

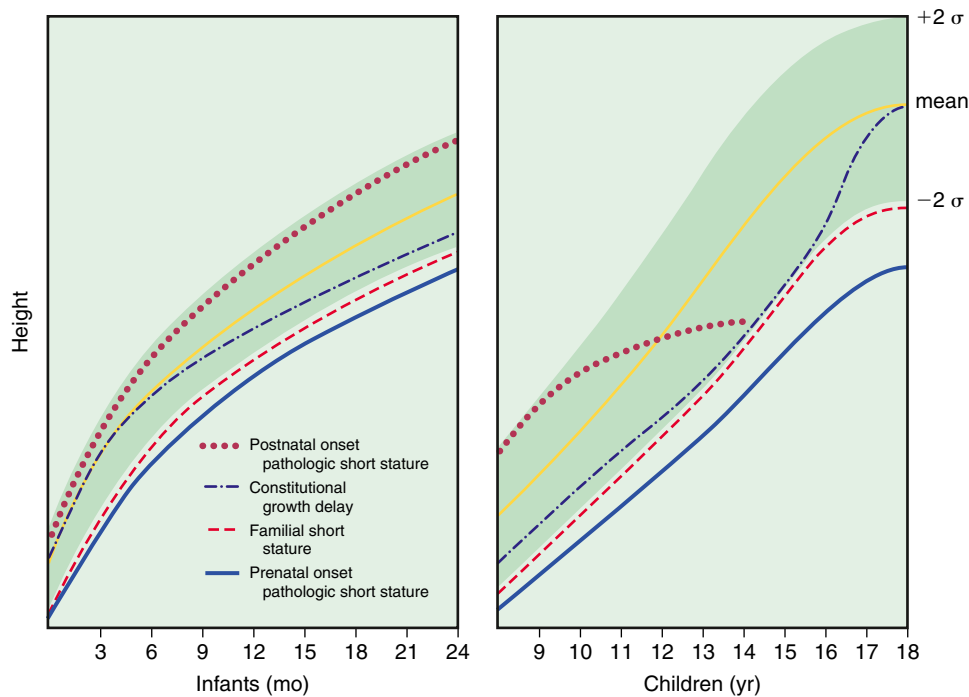
Height is highly correlated with genetics, specifically parental height. Calculation of sex-adjusted **midparental height** is important when assessing growth in a child to avoid misclassification of abnormal growth. The average difference in stature between males and females is 5 inches (13 cm); therefore 5 inches (13 cm) is subtracted from the father’s height before averaging with mother’s height in a female, whereas 5 inches (13 cm) is added to the mother’s height before averaging with the father’s height in a male:

- Males: [(Maternal height + 5 inches) + Paternal height]/2
- Females: [Maternal height + (Paternal height – 5 inches)]/2

Furthermore, generally 4 inches (2 SD) is applied above and below this value to provide a *genetic target height range*. For example, if the mother is 63 inches tall and the father 70 inches tall, the daughter’s sex-adjusted midparental height is 64 inches ± 4 inches, for a target height range of 60-68 inches. The son of these same parents would have a sex-adjusted midparental height of 69 inches, with a range of 65-73 inches. Note that these general guidelines do not address extreme differences between parental heights that may affect individual target height range.

Growth can be divided into four major phases: fetal, infantile, childhood, and adolescence. Growth rate varies by age (see Table 27.1). Different factors are of different importance in each phase, and the various contributors to poor growth may feature more in one phase than another. Long-term height may be permanently compromised if one entire phase is characterized by poor growth. Therefore early detection and prevention are critical. **Fetal growth** is the fastest growth phase, with maternal, placental, fetal, and environmental factors playing key roles. Birthweight does not necessarily correlate with adult height, although factors that inhibit fetal growth may have long-lasting effects, as seen in children with intrauterine growth retardation. **Infantile growth** is particularly sensitive to nutrition as well as congenital conditions. Genetic height gradually becomes influential; indeed, crossing of percentiles in the first 2 years of life is common as children begin to approach their genetic potential. **Childhood growth** is often the most steady and predictable. During this phase the height percentile is fairly consistent in otherwise healthy children.

**Adolescent growth** is associated with a decrease in growth velocity before the onset of puberty; this deceleration tends to be more pronounced in males. During pubertal development, sex hormones



**Fig. 27.3** Height-for-age growth curves of the four general causes of proportional short stature: postnatal onset pathologic short stature, constitutional growth delay, familial short stature, and prenatal onset pathologic short stature. (From Mahoney CP: *Evaluating the child with short stature*, *Pediatr Clin North Am* 1987;34:825.)

(testosterone and estrogen) are the primary drivers of growth and enhance growth hormone secretion, thereby facilitating pubertal growth acceleration. Females typically experience growth acceleration during Tanner stage 3 for breast development, whereas this acceleration occurs during Tanner stage 4 for pubic hair development in males. Males not only achieve greater height velocities than females during puberty, but also grow approximately 2 years longer than females, both of which contribute to the taller average height of adult males compared with adult females.

### Abnormal Growth

Growth is a dynamic process. A child measured at the 5th percentile for stature may be growing normally, may be failing to grow, or may be recovering from growth failure, depending on the trajectory of the growth curve (Fig. 27.3). Growth failure must be distinguished from short stature. **Growth failure** is defined as achievement of height velocity that is less than expected for a child's age and sex (and pubertal development if relevant) or a downward crossing of more than 2 percentile lines for height on the growth chart. **Short stature** is defined as growing either below expected genetic potential or growing below  $-2$  SD for age and sex. For some children, however, growth parameters  $\leq 2$  SD may be normal, and differentiating appropriately small vs. pathologically small is crucial. Midparental height, ethnicity, and other factors that may be inherent in the child's genetic height potential are important considerations in the assessment of growth. For children with particularly tall or short parents, overdiagnosing and underdiagnosing growth disorders are risks if parental heights are not considered. In the setting of familial short stature or tall stature, more specialized charts can help determine whether a child is even shorter or taller than expected for parental heights, to prevent misdiagnosis of growth disorders.

For **premature infants**, overdiagnosis of growth failure can be avoided by using growth charts developed specifically for this population. A cruder method, subtracting the weeks of prematurity from the postnatal age when plotting growth parameters, does not capture the variability in growth velocity that VLBW infants demonstrate. Although VLBW infants may continue to show **catch-up growth** through early school age, most achieve weight catch-up during the

second year and height catch-up by 3-4 years, barring medical complications (see Chapter 119).

Abnormal growth may be caused by a variety of factors, including congenital conditions, systemic disease, endocrine disorders, nutritional deficiency (see Chapter 62), psychosocial conditions, constitutional delay, or familial disorders (Tables 27.2 and 27.3). In congenital pathologic short stature, an infant may or may not be born small, but growth gradually tapers throughout infancy (see Fig. 27.3). Causes include chromosome or genetic abnormalities (Turner syndrome, skeletal dysplasia, trisomy 21; see Chapters 57 and 99), perinatal infection, extreme prematurity, and teratogens (phenytoin, alcohol) (see Chapters 117.4 and 146). Linear growth deceleration with or without changes in weight can occur at the onset or as a result of a systemic illness or chronic inflammation. Medications such as high-dose glucocorticoids may also impact growth. Analysis of growth patterns requires consideration of weight status. Poor linear growth in the setting of decreasing BMI suggests a nutritional or gastrointestinal issue, whereas *poor linear growth* in the context of good or robust BMI may suggest a hormonal condition (hypothyroidism, growth hormone deficiency, cortisol excess).

Not all decreased growth is abnormal; variations of growth include constitutional growth (and pubertal) delay and familial short stature. In **constitutional growth delay**, weight and height decrease near the end of infancy, parallel the norm through middle childhood, and accelerate toward the end of adolescence with achievement of normal adult height. In **familial short stature**, both the infant/child and the parent(s) are small; growth runs parallel to and just below the normal curves.

Although **tall or accelerated growth** may be a variation of normal, unexpected increase in growth may also signal an underlying condition (see Table 27.3). Typically, obese individuals grow more quickly than their peers because of peripheral aromatization of estrogen and effects on bone maturation. Despite early taller stature, obese children are not ultimately taller than anticipated for genetic height. Early onset of puberty, growth hormone excess, and sex steroid exposure can also lead to accelerated growth. Several of these conditions may ultimately lead to short stature in adulthood. Genetic conditions associated with tall stature and overgrowth include Sotos, Klinefelter, and Marfan syndromes (see Chapter 598 and 598.1).



**Table 27.2** Common Causes of Decreased Growth and Short Stature

<b>Variation of normal</b>
Familial short stature
Constitutional delay
Delayed puberty
<b>Nutrition and gastrointestinal conditions</b>
Malnutrition
Celiac disease
Inflammatory bowel disease
<b>Genetic conditions</b>
Turner syndrome
Prader-Willi syndrome
22q deletion syndrome
Trisomy 21
Skeletal dysplasias: achondroplasia, SHOX haploinsufficiency, osteogenesis imperfecta
<b>Endocrine conditions</b>
Hypothyroidism
Growth hormone deficiency
Poorly controlled diabetes mellitus
Poorly controlled diabetes insipidus
Metabolic bone disease: rickets, hypophosphatasia
Glucocorticoid excess
<b>Psychosocial causes</b>
<b>Renal conditions</b>
Renal tubular acidosis
Nephrotic syndrome
<b>Medications</b>
Glucocorticoids
Inappropriate sex steroid exposure
Antiepileptic medications

**Table 27.3** Common Causes of Increased Growth and Tall Stature

<b>Variation of normal</b>
Constitutional tall stature
Familial tall stature
<b>Endocrine conditions</b>
Growth hormone excess
Precocious puberty (ultimate height may be decreased)
Congenital adrenal hyperplasia
<b>Obesity</b>
<b>Genetic conditions</b>
Marfan syndrome
Klinefelter syndrome
Sotos syndrome

### Evaluation of Abnormal Growth

Evaluation of abnormal growth should include confirmation that the data are accurate and plotted correctly. Comparisons should be made with previous measurements. If poor or rapid growth or short or tall stature is a concern, a radiograph of the left hand and wrist to show the **bone age** can provide information about skeletal maturation. Skeletal development represents physiologic rather than chronologic age. Reference standards for bone maturation facilitate estimation of bone age (see Table 23.3). A delayed bone age (skeletal age younger than chronologic age) suggests catch-up potential for linear growth. Advanced bone age suggests a rapid maturation of the skeleton that may lead to earlier cessation of growth. Bone age should be interpreted with the guidance of a pediatric endocrinologist. Skeletal age correlates well with stage of pubertal development and may be helpful in predicting adult height in

early- or late-maturing adolescents. In familial short stature the bone age is normal (comparable to chronologic age), whereas constitutional delay, endocrinologic short stature, and undernutrition may be associated with delay in bone age comparable to the height age.

Laboratory testing is also useful in assessment of growth and may be tailored to suspected etiology based on the patient history and physical examination. Initial assessment includes comprehensive metabolic panel, complete blood count, sedimentation rate, C-reactive protein, thyroid-stimulating hormone, thyroxine, celiac panel, and insulin-like growth factor (IGF)-I and IGF-BP3, which are surrogate markers for growth hormone secretion (see Chapter 595). A karyotype to exclude Turner syndrome is an essential component of the evaluation of short stature in females and should be performed even in the absence of characteristic physical features (see Chapter 626.1). If there is concern for abnormal timing of puberty contributing to growth pattern, gonadotropins (luteinizing hormone, follicle-stimulating hormone), and estradiol or testosterone may also be assessed. A urinalysis can provide additional information about renal function. Evaluation by a pediatric nutritionist for caloric needs assessment may be useful in patients with malnutrition, underweight status, or slow weight gain. Additional testing and referral to specialists should be performed as indicated.

### OTHER GROWTH CONSIDERATIONS

#### Obesity

Obesity affects large numbers of children (see Chapter 65). The CDC defines *obesity* as BMI  $\geq$ 95th percentile for age and sex, and *overweight* as BMI 85th to <95th percentile for age and sex. Although widely accepted as the best clinical measure of underweight and overweight, BMI may not provide an accurate index of adiposity because it does not differentiate lean tissue and bone from fat. In otherwise healthy individuals, lean body mass is largely represented by BMI at lower percentiles. BMI >80–85% largely reflects increased body fat with a nonlinear relationship between BMI and adiposity. In the setting of chronic illness, increased body fat may be present at low BMI, whereas in athletes, high BMI may reflect increased muscle mass. Measurement of the triceps, subscapular, and suprailiac skinfold thickness have been used to estimate adiposity. Other methods of measuring fat, such as hydrodensitometry, bioelectrical impedance, and total body water measurement, are used in research, but not in clinical evaluation, but whole body dual-energy x-ray absorptiometry (DXA) is beginning to emerge as a tool for measuring body fat and lean body mass.

#### Dental Development

Dental development includes mineralization, eruption, and exfoliation (Table 27.4). Initial mineralization begins as early as the second trimester (mean age for central incisors, 14 weeks) and continues through 3 years of age for the primary (deciduous) teeth and 25 years of age for the secondary (permanent) teeth. Mineralization begins at the crown and progresses toward the root. Eruption begins with the central incisors and progresses laterally. Exfoliation begins at about 6 years of age and continues through 12 years. Eruption of the permanent teeth may follow exfoliation immediately or may lag by 4–5 months. The timing of dental development is poorly correlated with other processes of growth and maturation. **Delayed eruption** is usually considered when no teeth have erupted by approximately 13 months of age (mean  $\pm$  3 SD). Common causes include congenital or genetic disorders, endocrine disorders (e.g., hypothyroidism, hypoparathyroidism), familial conditions, and (the most common) idiopathic conditions. Individual teeth may fail to erupt because of mechanical blockage (crowding, gum fibrosis). Causes of **early exfoliation** include hypophosphatasia, histiocytosis X, cyclic neutropenia, leukemia, trauma, and idiopathic factors. Nutritional and metabolic disturbances, prolonged illness, and certain medications (tetracycline) frequently result in discoloration or malformations of the dental enamel. A discrete line of pitting on the enamel suggests a time-limited insult.

Visit Elsevier eBooks+ at eBooks.Health.Elsevier.com for Bibliography.

**Table 27.4** Chronology of Human Dentition of Primary (Deciduous) and Secondary (Permanent) Teeth

	CALCIFICATION		AGE AT ERUPTION		AGE AT SHEDDING	
	BEGINS AT	COMPLETE AT	MAXILLARY	MANDIBULAR	MAXILLARY	MANDIBULAR
<b>PRIMARY TEETH</b>						
Central incisors	5th fetal mo	18-24mo	6-8mo	5-7 mo	7-8yr	6-7yr
Lateral incisors	5th fetal mo	18-24mo	8-11 mo	7-10mo	8-9yr	7-8yr
Cuspids (canines)	6th fetal mo	30-36mo	16-20mo	16-20mo	11-12yr	9-11yr
First molars	5th fetal mo	24-30mo	10-16mo	10-16mo	10-12yr	10-12yr
Second molars	6th fetal mo	36mo	20-30mo	20-30mo	10-12yr	11-13yr
<b>SECONDARY TEETH</b>						
Central incisors	3-4 mo	9-10yr	7-8yr	6-7 yr		
Lateral incisors	Max, 10-12mo Mand, 3-4mo	10-11yr	8-9yr	7-8yr		
Cuspids (canines)	4-5mo	12-15yr	11-12yr	9-11yr		
First premolars (bicuspid)	18-21 mo	12-13yr	10-11 yr	10-12yr		
Second premolars (bicuspid)	24-30mo	12-14yr	10-12yr	11-13yr		
First molars	Birth	9-10yr	6-7 yr	6-7 yr		
Second molars	30-36mo	14-16yr	12-13yr	12-13yr		
Third molars	Max, 7-9yr Mand, 8-10yr	18-25yr	17-22yr	17-22yr		

Mand, Mandibular; max, maxillary.

Adapted from a chart prepared by P.K. Losch, Harvard School of Dental Medicine, who provided the data for this table.

## Chapter 28

# Developmental and Behavioral Surveillance and Screening

Eliza Gordon-Lipkin and Paul H. Lipkin

In healthy development, a child will acquire new skills beginning prenatally and extending into at least young adulthood. The roots of this acquisition of skills lie in the development of the nervous system, with additional influences from the health status of other organ systems and the physical and social environment in which the development occurs. *Development* and its milestones are divided into the “streams” of gross motor, fine motor, language (expressive and receptive), social language, and self-help. *Behavior* can be categorized into observable, spontaneous, and responsive behaviors in the settings of home, school, and community.

Although typical development is associated with wide variability in the age of skill acquisition in each of these streams, specific developmental and behavioral disorders are seen in approximately 1 of 6 children and may affect the health, function, and well-being of the child and family for a lifetime. These disorders include relatively less common conditions that often cause severe impairments, such as cerebral palsy and autism, and relatively common conditions such as attention-deficit/hyperactivity disorder, speech language disorders, and behavioral and emotional disorders that affect as many as 25% of children. The more common conditions are generally perceived as “less severe,” but these too can have major short-term and long-term impact on the child’s health and daily functioning in the home, school, and community and can affect lifelong well-being. Because of their high prevalence in children; their impact on health, social, and economic status; and their effect on the child, the home, and the community, these disorders require the attention of the pediatrician throughout childhood. In addition, both the child and the family benefit from the early identification

and treatment of many of these conditions, including the most severe. It is therefore incumbent on the primary care clinician to conduct regular **developmental surveillance** and periodic **developmental screening** at health supervision visits aimed at early identification and treatment.

Among the many types of developmental or behavioral conditions, the most common include *language problems*, affecting at least 10% of children (see [Chapter 53](#)); *behavior or emotional disorders*, affecting up to 25% of children, with 6% considered serious; *attention-deficit/hyperactivity disorder*, affecting 10% of children ([Chapter 50](#)); and *learning disabilities*, affecting up to 10% ([Chapters 51 and 52](#)). Less common and more disabling are the intellectual disabilities (1–2%; [Chapter 56](#)); autism spectrum disorders (1 in 36 children; [Chapter 58](#)); cerebral palsy and related motor impairments (0.3%, or 1 in 345 children; [Chapter 638.1](#)); hearing impairment, also referred to as deafness, hard-of-hearing, or hearing loss (0.12%; [Chapters 55 and 677](#)); and nonrefractive vision impairment (0.8%; [Chapter 661](#)).

## DEVELOPMENTAL AND BEHAVIORAL SURVEILLANCE

General health surveillance is a critical responsibility of the primary care clinician and is a key component of health supervision visits. Regular developmental and behavioral surveillance should be performed at every health supervision visit from infancy through young adulthood. Surveillance of a child’s development and behavior includes both obtaining historical information on the child and family and making observations at the office visit ([Tables 28.1 and 28.2](#)).

Key historical elements include (1) eliciting and attending to the parents’ or caregivers’ concerns around the child’s development or behavior; (2) obtaining a history of the child’s developmental skills and behavior at home, with peers, in school, and in the community; and (3) identifying the risks, strengths, and protective factors for development and behavior in the child and family, including the social determinants of health. During the office visit, the clinician should make and document direct observations of the child’s developmental skills and behavioral interactions. Skills in all streams of development should be considered along with observations of related neurologic functioning made on physical examination.

With this history and observation, the clinician should create and maintain a longitudinal record of the child’s development and behavior for tracking the child across visits. It is often helpful to obtain information from and share information with other professionals involved

**Table 28.1** Key Components of Developmental and Behavioral Surveillance**HISTORY**

1. Parental developmental concerns
2. Developmental history
  - a. Streams of developmental milestone achievement
    - i. Gross motor
    - ii. Fine motor
    - iii. Verbal speech and language
      - (1) Expressive
      - (2) Receptive
    - iv. Social language and self-help
  - b. Patterns of abnormality
    - i. Delay
    - ii. Dissociation
    - iii. Deviation or deviant development
    - iv. Regression
3. Behavior history
  - a. Interactions
    - i. Familiar settings (e.g., home, school): parents, siblings, other familiar people, peers, other children
    - ii. Interaction in unfamiliar settings (e.g., community): unfamiliar adults and children
  - b. Patterns of abnormality
    - i. Noncompliance, disruption (including tantrums), aggression, impulsivity, increased activity, decreased attention span, decreased social engagement, decreased auditory or visual attention
    - ii. Deviation or atypical behaviors
      - (1) Repetitive play, rituals, perseverative thought or action, self-injury
4. Risk factor identification: medical, family, and social history (including social determinants of health)
5. Protective factor identification (also including social determinants)

**DEVELOPMENTAL OBSERVATION**

1. Movement: gross and fine motor skills
2. Verbal communication: expressive speech and language, language understanding
3. Social engagement and response
4. Behavior: spontaneous and responsive with caregiver and with staff
5. Related neurologic function on physical examination

with the child, including childcare professionals, home visitors, teachers, after-school providers, and developmental therapists. This provides a complete picture of the child's development and behavior and allows collaborative tracking of the child's progress.

### The Developmental and Behavioral Histories

**Developmental surveillance** includes tracking a child's achievement of milestones, which represent key readily recognizable skills that usually occur in a predictable sequence and at predictable age ranges during childhood. The developmental skill areas can be divided into **gross motor**, **fine motor**, **speech and language** (expressive and receptive), **social language**, and **self-help**. Tracking milestones will reveal that most children achieve the milestones in a typical pattern and within typical age ranges. However, the pediatrician or the parent may recognize concerning patterns of development, such as delay, dissociation, deviation, or regression.

*Developmental delay* occurs when development is occurring in its usual sequence but at a slower rate, with milestones achieved later than the normal range (see Chapter 56). Delay can occur in a single area of development or across several streams and can be expressed as a *developmental quotient* (DQ). The DQ is calculated by dividing the age at which the child is functioning developmentally (*developmental age*; DA) by *chronologic age* (CA) and multiplying by 100 ( $DQ = DA/CA \times 100$ ).

**Table 28.2** Red Flags in Developmental Screening and Surveillance

These indicators suggest that development is significantly delayed or disordered and that the child should be referred to a developmental pediatrician or pediatric neurologist. Any delay in achieving a milestone at the 75th percentile may be considered a red flag and merits further evaluation, vigilant surveillance, or repeat screening.

**POSITIVE INDICATORS**

Presence of any of the following:  
 Loss of developmental skills at any age  
 Parental or professional concerns about vision, fixing, or following an object or a confirmed visual impairment at any age (simultaneous referral to pediatric ophthalmology)  
 Hearing loss at any age (simultaneous referral for expert audiologic or ear, nose, and throat assessment)  
 Persistently low muscle tone or floppiness (check creatine kinase)  
 No speech by 15 mo, especially if the child does not try to communicate by other means, such as gestures (simultaneous referral for urgent hearing test)  
 Asymmetry of movements or other features suggestive of cerebral palsy, such as increased muscle tone  
 Persistent toe walking  
 Multiple organ involvement  
 Head circumference above the 99.6th centile or below 0.4th centile; also, if circumference has crossed 2 centiles (up or down) on the appropriate chart or is disproportionate to parental head circumference

**NEGATIVE INDICATORS**

Activities that the child cannot do:  
 Sit unsupported by 12 mo  
 Walk by 18 mo (check creatine kinase)  
 Walk other than on tiptoes  
 Run by 24 mo  
 Hold object placed in hand by 4 mo (corrected for gestation)  
 Reach for objects by 6 mo (corrected for gestation)  
 Points to show you something interesting by 18 months

Adapted from Horridge KA. Assessment and investigation of the child with disordered development. *Arch Dis Child Educ Pract Ed.* 2011;96:9–20; Zubler JM, Wiggins LD, Macias MM, et al. Evidence-informed milestones for developmental surveillance tools. *Pediatrics.* 2022;149(3):e2021052138.

A DQ of 100 indicates that the child is developing at the mean or average rate, whereas a DQ below 70 is associated with delays of 2 or more standard deviations from the mean and suggests a significant delay that requires further evaluation.

*Developmental dissociation* indicates delay in a single stream with typical development in other streams. A child with autism may have delays in verbal or social language but normal motor skills. *Deviation or deviant development* is defined by development occurring out of sequence, as when a child stands before sitting (as in diplegic cerebral palsy) or has better expressive vocabulary than receptive understanding of words (language and autism spectrum disorders). *Regression* refers to a loss of skills. It may also be identified earlier or more subtly by a slowing or lack of advancement in skills. Although regression is uncommon in most developmental disabilities, regression is described in as many as 25% of children with autism and is also seen in rarer neurologic disorders, such as Rett syndrome and Duchenne muscular dystrophy.

**Behavioral surveillance** is conducted by obtaining a history of a child's behavior and interactions across settings, including home, day-care, school, and community, and in situations such as eating, sleeping, and play. In addition, interactions may differ based on who the child is with (parent or guardian, sibling, peers, teachers, strangers). Concerns may include limited engagement or socializing, compliance, tantrums, aggression, destruction, impulsivity, high activity level, decreased auditory or visual attention, and short attention span. Deviations from

**Table 28.3** Standardized Tools for General Developmental Screening

SCREENING TEST*	AGE RANGE	ITEMS (NO.)	ADMIN TIME (MIN)	PUBLICATION INFORMATION
Ages & Stages Questionnaires-3 (ASQ3) <sup>1</sup>	2-66 mo	30	10-15	Paul H. Brookes Publishing <a href="http://www.agesandstages.com">www.agesandstages.com</a>
Parents' Evaluation of Developmental Status (PEDS) <sup>2</sup>	0-8yr	10	2-10	Ellsworth & Vandermeer Press 877-296-9972 <a href="http://www.pedstest.com">www.pedstest.com</a>
Parents' Evaluation of Developmental Status: Developmental Milestones (PEDS:DM) Screening Version <sup>2</sup>	0-8yr	6-8 items at each age level	4-6	Ellsworth & Vandermeer Press 877-296-9972 <a href="http://www.pedstest.com">www.pedstest.com</a>
Survey of Well-Being of Young Children (SWYC) <sup>3-6</sup>	Dev: 1-65 mo Autism: 16-35 mo	Dev: 10 Autism: 7	Dev: <5 Autism: <5	<a href="http://www.theswyc.org">www.theswyc.org</a>

\*Key reference sources:

<sup>1</sup>Squires J, Potter L, Bricker D. *The ASQ User's Guide*, 3rd ed, Baltimore, MD, Paul H. Brookes Publishing, 2009.

<sup>2</sup>Glascoe FP, Marks KP, Poon JK, et al. (eds). *Identifying and addressing developmental-behavioral problems: a practical guide for medical and non-medical professionals, trainees, researchers and advocates*. Nolensville, TN: PEDStest.com, 2013.

<sup>3</sup>Sheldrick RC, Perrin EC. Evidence-based milestones for surveillance of cognitive, language, and motor development. *Acad Pediatr*. 2013; 13(6):577-556.

<sup>4</sup>Smith N, Sheldrick R, Perrin E. An abbreviated screening instrument for autism spectrum disorders. *Infant Ment Health J*. 2012;34(2):149-155.

<sup>5</sup>Salisbury LA, Nyce JD, Hannum CD, et al. Sensitivity and specificity of 2 autism screeners among referred children between 16 and 48 months of age. *J Dev Behav Pediatr*. 2018;39(3):254-258.

<sup>6</sup>Publications and user's manual available at [www.theswyc.org](http://www.theswyc.org).

usual behavior may also occur, including repetitive play, ritualistic behaviors, perseverative thoughts or actions, and self-injury.

### Observation

Observations of the child's developmental skills and behavioral interactions should be made in the examining room, with documentation in the medical record, and combined with the examination of other neurologic functioning, such as muscle tone, reflexes, and posture.

Developmental observations may include a child's gross and fine motor movements, both on the floor and on the examination table. Spoken language and response to others' communications, as well as interactions and engagement with the parent or guardian, should be noted. If siblings are in the room, the interaction between the child and a sibling may also be informative. Impulsivity, attention problems, tantrums, noncompliance, oppositionality, and aggression may be observed along with interactions with the clinician, but one should inquire about whether these behaviors are seen in *other settings*, given the possible unfamiliarity or discomfort of the child with the health-care professional or in healthcare settings.

If inquiring about and observing the child's development and behavior suggests normal or typical patterns of development and behavior, discussions can be held about future milestones and usual behavior management strategies employable at home. If problems or concerns are identified by the parent or clinician, however, formal developmental screening, evaluation, or management should be considered, along with early follow-up and review.

### DEVELOPMENTAL AND BEHAVIORAL SCREENING

Periodic episodic screening for developmental and behavioral conditions should be conducted on every child, as done for other health conditions such as anemia, lead poisoning, hearing, and congenital metabolic disorders. Developmental and behavioral screenings are centered on administration of low-cost, brief, and standardized tests in the primary care setting. These tests can be implemented by health assistants at age-determined visits, with interpretation of the results and referral or treatment initiation by the primary care clinician as indicated.

The American Academy of Pediatrics provides recommendations and guidelines on age-specific developmental screening for implementation in the primary care medical home. Developmental screening using a formal, validated, and standardized test is recommended during health supervision visits at 9, 18, and 30 months. Tests recommended at these ages screen development across all the

streams. In addition, an autism screening test is recommended at the 18 and 24 month visits. [Tables 28.3 and 28.4](#) provide recommended screening tests for general development and for autism. It is also recommended that a child have a screening test administered any time that a parent, guardian, or child health or early childhood professional has concerns identified during developmental surveillance, or through screening performed at early childhood programs. Although routine formal screening before the child's entry into elementary school is not included in current guidelines, the primary care clinician should be vigilant about surveillance regarding development at the 4 or 5 year old visit and perform formal screening if concerns are identified, because of the potential impact on learning and school services.

Each of the screening visits offers special opportunities to identify specific developmental conditions. At the 9 month screening, critical areas of development are vision, hearing, gross motor, fine motor, and receptive language. It is at this age that disabilities may be identified in vision or hearing, as well as cerebral palsy and other neuromotor disorders. At 18 months, expressive language and social language development are particularly important areas. Conditions identified at this age may include those considered at 9 months, although in milder forms, as well as autism spectrum, language, and intellectual disorders. By the 30 month visit, the child's behavioral interactions become an additional area of focus, with problems emerging tied to attention and disruptive behavior disorders. Although universal screening is not recommended at later ages, developmental surveillance may identify children in need of screening or evaluation for problems in learning, attention, and behavior.

Additional screening for *behavioral conditions* should be considered, although there is currently no recommended consensus on the ages at which behavioral screening should occur. One possibility would be to provide behavioral screening at the 30 month, 4 or 5 year, and 8 year visits to identify problems emerging in the toddler, preschool, and early elementary years. For older children, visits during preadolescent or adolescent ages also offer an opportunity for surveillance and possible screening for behavioral and emotional problems meriting professional assistance or intervention. [Table 28.5](#) provides recommended behavior screening tools.

### Evidence-Based Tools

[Tables 28.3, 28.4, and 28.5](#) show a range of measures useful for early identification of developmental and behavioral problems. Because well-child visits are brief and with broad agendas (health



**Table 28.4** Standardized Tools for Language and Autism Screening

SCREENING TEST*	AGE RANGE	ITEMS (NO.)	ADMIN TIME (MIN)	PUBLICATION INFORMATION
Communication and Symbolic Behavior Scales: Developmental Profile (CSBS-DP): Infant Toddler Checklist <sup>1</sup>	6 mo-6 years (for language function 6-24 mo)	24	5-10	Paul H. Brookes Publishing 800-638-3775 <a href="http://www.brookespublishing.com">www.brookespublishing.com</a>
Modified Checklist for Autism in Toddlers, Revised with Follow-up (M-CHAT-R/F) <sup>2</sup>	16-48 mo	20 plus follow-up interview	5-10	<a href="http://www.mchatscreen.com">www.mchatscreen.com</a>
Screening Tool for Autism in Toddlers and Young Children (STAT) <sup>3,4</sup>	24-35 mo	12 (avg)	20-30	<a href="https://stat.vueinnovations.com">https://stat.vueinnovations.com</a>
Social Communication Questionnaire (SCQ) <sup>5,6</sup>	4+ yr	40 (avg)	5-10	Western Psychological Services <a href="http://www.wpspublish.com">www.wpspublish.com</a>

\*Key reference sources:

<sup>1</sup>Wetherby AM, Prizant BM. *Communication and Symbolic Behavior Scales: developmental profile*. Baltimore, MD: Paul H. Brookes Publishing, 2002.

<sup>2</sup>Robins DL, Casagrande K, Barton M, et al. Validation of the Modified Checklist for Autism in Toddlers, Revised with Follow-up (M-CHAT-R/F). *Pediatrics*. 2014;133(1):37-45.

<sup>3</sup>Stone WL, Coonrod EE, Ousley O. Brief report: screening tool for autism in 2-year-olds (STAT): development and preliminary data. *J Autism Dev Disord*. 2000;30:607-612

<sup>4</sup>Stone WL, Coonrod EE, Turner LM, Pozdol SL. Psychometric properties of the STAT for early autism screening. *J Autism Dev Disord*. 2004;34:691-701.

<sup>5</sup>Rutter M, Bailey A, Lord C. *The Social Communication Questionnaire (SCQ) Manual*. Los Angeles; Western Psychological Services, 2003.

<sup>6</sup>Corseello C, Hus V, Pickles A, et al. Between a ROC and a hard place: decision making and making decisions about using the SCQ. *J Child Psychol Psychiatry*. 2007;48(9):932-940.

**Table 28.5** Standardized Tools for General Behavioral Screening

SCREENING TEST*	AGE RANGE	ITEMS (NO.)	ADMIN TIME (MIN)	PUBLICATION INFORMATION
Ages & Stages Questionnaire: Social-Emotional-2 (ASQ:SE-2) (2015) <sup>1,2</sup>	2-72 mo	9 age-specific forms with 19-33 items	10	Paul H. Brookes Publishing 800-638-3775 <a href="http://www.agesandstages.com">www.agesandstages.com</a>
Brief Infant Toddler Social Emotional Assessment (BITSEA) <sup>3</sup>	12-36 mo	42	7-10	Mapi Research Trust <a href="https://eprovide.mapi-trust.org/">https://eprovide.mapi-trust.org/</a>
Pediatric Symptom Checklist-17 items (PSC-17b) <sup>4</sup>	4-16 yr PSC-35 Youth self-report: ≥11 yr	17	<5	Massachusetts General Hospital <a href="https://www.massgeneral.org/psychiatry/treatments-and-services/pediatric-symptom-checklist">https://www.massgeneral.org/psychiatry/treatments-and-services/pediatric-symptom-checklist</a>
Strengths and Difficulties Questionnaire (SDQ) <sup>5</sup>	4-17 yr 3-4 yr old version available Youth self-report 11-16 yr	25; 22 for 3-4 yr olds	5-10	<a href="http://www.sdqinfo.org">www.sdqinfo.org</a>

\*Key reference sources:

<sup>1</sup>Squires J, Bricker DD, Twombly E. *Ages & Stages Questionnaires: Social-Emotional-2 (ASQ:SE-2): a parent-completed, child-monitoring system for social-emotional behaviors*. Baltimore, MD: Paul H. Brookes Publishing, 2016.

<sup>2</sup>Briggs RD, Stettler EM, Johnson Silver E, et al. Social-emotional screening for infants and toddlers in primary care. *Pediatrics*. 2012;129(2):1-8.

<sup>3</sup>Briggs-Gowan MJ, Carter AS, McCarthy K, et al. Clinical validity of a brief measure of early childhood social-emotional/behavioral problems. *J Pediatr Psychol*. 2013;38(5):557-587.

<sup>4</sup>Murphy JM, Stepanian S, Riobueno-Naylor A, et al. Implementation of an electronic approach to psychosocial screening in a network of pediatric practices. *Acad Pediatr*. 2021;21(4):702-709.

<sup>5</sup>Stone LL, Otten R, Engels RC, et al. Psychometric properties of the parent and teacher versions of the Strengths and Difficulties Questionnaire for 4- to 12-year-olds: a review. *Clin Child Fam Psychol Rev*. 2010;13(3):254-274.

surveillance and screening, physical examination, immunization, anticipatory guidance, safety and injury prevention, and developmental promotion), tools relying on parent completion with office staff administration and scoring are well suited for primary care settings. Such tests may be completed in advance of appointments, either online or in writing, whether at home or while waiting for the pediatric visit to begin. If a test is scored in advance of the visit, the pediatric clinician can enter the room with results in hand for review and discussion, including a description of the child's development and behavior compared with peers, general information on child development and behavior, any areas of concern, referrals needed, and information to share with the child's daycare, preschool, or other community providers, when applicable.

### Screening Test Properties

Each of the tests provided in Tables 28.3 to 28.5 meets accepted psychometric test criteria. The test has standardized questions or milestones with norms based on administration to parents of a large sample of

children with typical development. These norms allow comparison of an individual child's performance on the test with that of the large sample of typically developing children. In addition, the tests demonstrate accepted standards of *reliability*, or the ability to produce consistent results; *predictive validity*, or the ability to predict later test performance or development; *sensitivity*, or accuracy in the identification of delayed development or disability; and *specificity*, or accuracy in the identification of children who are not delayed. Some of the screening tests are general, evaluating multiple areas of development or behavior (sometimes referred to as "broad band"). Others are domain specific, evaluating one area of development (e.g., language), or disorder specific, aimed at identifying a specific developmental disorder (sometimes referred to as "narrow band").

### BEYOND SURVEILLANCE AND SCREENING Comprehensive Evaluation

When a developmental or behavioral concern is identified through surveillance or screening, the primary care clinician's role is to

ensure that the child receives an appropriate diagnostic evaluation, related medical testing, and indicated developmental interventions and medical treatment. When a concern is identified, a full diagnostic evaluation should be performed by a professional with appropriate training and experience. In the case of developmental concerns, this may be a pediatric specialist, such as a neurodevelopmental pediatrician/neurologist or a developmental-behavioral pediatrician, or a related developmental professional, depending on resources in the local community. Related professionals may include early childhood educators, psychologists, speech/language pathologists, audiologists, physical therapists, and occupational therapists, many of whom are available through the local early intervention system. Such an evaluation would typically include more detailed standardized developmental testing. The primary care physician should ensure that hearing and vision assessments are completed. For the child with motor concerns, the physician should pay particular attention to the motor and neurologic evaluation. Children with language delays should have hearing, speech, language, and learning skills (e.g., reading, phonics) evaluated.

The primary care clinician should also perform a comprehensive medical evaluation of the child to identify any related health conditions. Physical examination including head circumference should be reviewed to identify growth abnormalities and dysmorphic features. For the child with motor delay and decreased or normal muscle tone, serum creatine kinase and thyroid function testing are recommended to rule out muscular dystrophy and thyroid disease, respectively. When there is increased tone, MRI or referral to a neurologist should be considered. For the child with suspected autism or intellectual disability (or global developmental delay), chromosomal microarray and fragile X testing are recommended (see Chapter 56).

### Referral and Intervention

Children with significant developmental delays or an identified developmental disability are entitled to and usually benefit from early intervention with therapy services directed at delayed or atypical development. The U.S. Individuals with Disabilities Education Act (IDEA) entitles any child with a disability or developmental delay to receive local education and related services, including therapy, from as early as birth, for known or high-risk conditions that lead to such delay or disability, through age 21 years. These interventions enhance the child's development through early intervention and family support as well as individualized public education with the goal of improving long-term functional outcomes and reducing public costs. The pediatric provider should therefore refer every child with developmental concerns to the local early intervention program or agency (ages 0-3 years), public school program ( $\geq 3$  years), and/or local therapy providers. Typical service needs include special education for the child with intellectual or learning concerns, physical or occupational therapy for children with motor delays, speech language therapy for the child with language or social communication difficulties, and behavioral therapy services for the child with social engagement or other behavior problems.

Likewise, the child with specific behavior concerns should be referred to an appropriate pediatric or behavioral health professional who can perform a thorough evaluation and assist the family to alleviate the problems or concerns. Such professionals may include those trained in developmental-behavioral pediatrics, neurodevelopmental disabilities, adolescent medicine, child and adolescent psychiatry, pediatric psychology, psychiatric advanced practice nursing, and social work. Such an evaluation is similar to developmental evaluation in its aim of determining a diagnosis, as well as developing a treatment program that may include psychotherapeutic and medication management. Associated medical or developmental disorders should be considered and further evaluated as needed.

### Ongoing Management

Children with developmental or behavioral disorders should be identified as *children with special healthcare needs* in the medical home, with a program of chronic condition management initiated by the clinical program staff, including its medical and nonmedical staff. In doing so, the clinician and family should work together to outline the child's short- and long-term goals and management plan. This includes a program of regular monitoring and follow-up of the child's development and behavior, referrals, treatment, and surveillance for identification and treatment of related medical, developmental, or behavioral comorbidities that may arise. Some children and families may warrant assignment of a case manager or care navigator either within the medical home or in a related local agency. The pediatric clinician or other medical home staff should participate in care coordination activities as needed and assist the family and other professionals in decision-making on medical care, therapies, and educational services.

The family can be further assisted during the screening and referral phases or later with ongoing care by referral to support service programs, such as respite care, parent-to-parent programs, and advocacy organizations. Some children may qualify for additional state or federal benefit programs, including insurance, supplemental security income, and state programs for children with special healthcare needs. Families often seek out information, support, or connection to other families with similarly affected children and find benefit in local or national networks (e.g., Family Voices, Family to Family Health Information centers) and condition-specific associations.

### Implementation

The principles and professional guidelines for developmental-behavioral surveillance and screening have been solidified to identify children with developmental disabilities, including the specific conditions of intellectual disability, autism spectrum disorder, motor disorders, and behavioral-emotional problems. Specific algorithms are included in these guidelines to assist the clinician with implementation. However, primary care clinicians have reported difficulties in putting these into practice, with obstacles and barriers identified and policy changes made to ensure that screening and referral can be implemented. (See Bibliography online for specific guidelines.)

Implementation projects have identified key factors for successful incorporation of developmental surveillance and screening into practice. Successful office-based screening requires development of a comprehensive office-based system that extends from the child's home to the front office and into the clinic visit, rather than solely centered on the time in the clinic room. This requires utilizing office and medical support staff for scheduling, advance test distribution, and initiation of the surveillance and screening procedures before the health supervision visit. The practice must choose screening tests that are not only valid for screening of the specific condition at the recommended ages, but also appropriate to the population being served (including reading level and language). The tests chosen should be able to be completed by the caregiver in a short time and at low cost. Staff training on billing and coding for these procedures ensures appropriate payment.

Practice systems should also be developed for referral and tracking of children who have problems identified through screening. This should include systems for referral to early intervention, community therapy, developmental professionals, and medical consultants. Office representatives or the clinician should establish working relationships with local community programs and resources to assist the child and family.

Visit Elsevier eBooks+ at [eBooks.Health.Elsevier.com](http://eBooks.Health.Elsevier.com) for Bibliography.

## Chapter 29

## Child Care

Laura Stout Sosinsky and Walter S. Gilliam

Child care impacts the health and development of children and the economic stability of families. For too many young children and their families, affordable high-quality child care is not accessible. Pediatricians have a role in helping children receive safe, enriching care in high-quality early childhood education (ECE) settings that allows parents to be able to work.

As an environment in which children learn, grow, and play, child care is a component of the social determinants of health. The majority of young children regularly spend time in at least one nonparental child care arrangement. Routine exposure to high-quality child care provides an opportunity for early education in language, early literacy, math, and social skills, as well as for teaching children health-promoting behaviors and for identifying early signs of delays or special needs. Inadequate child care supply and poor availability block these opportunities for many children, disproportionately those from low-resourced families. Instead, many young children are exposed to a patchwork of child care arrangements that are unstable, unaffordable, and often poorly resourced, adding stress that harms child and family well-being.

Child care provision is affected by many factors, derived from family demand, child care supply, and child/family policy. With increasing movement of mothers into the workplace across the globe, the prime reason most families use child care is to support employment of both parents. After childbirth, unpaid maternity leave is the typical situation among U.S. mothers. The U.S. federal leave program allows for 12 weeks of unpaid job-protected leave during pregnancy or after childbirth, but only covers approximately 50% of the workforce because companies with <50 employees, with part-time employees, and those working in informal labor markets are exempt. Several states and cities have passed paid family leave laws.

In part because of the financial burden of an unpaid maternity leave, many mothers return to work, and their children may begin child care in the first few weeks after birth. In a 2000 Family and Medical Leave Act survey, only 10% of respondents reported taking more than 60 days for maternity leave. Approximately 44% of mothers in 2005–2007 were working by the time their first child was 3–4 months of age, and approximately 63% of mothers were working by the time their first child was 12 months. Some mothers face work requirements if they are receiving public benefits because of the reforms to welfare passed by the U.S. Congress in 1996. Many mothers feel strong financial motivation or even pressure to work, especially in single-parent households, or have strong incentive to work for short- and long-term financial security. Employment is not the only factor driving child care use; young children of *unemployed* mothers spend on average 21 hours per week in child care. Many parents want their children to have child care experiences for the potential benefits that early learning environments can give to their children. Given these realities, child care quality is of great concern, yet the quality of child care and early education environments varies widely, and the supply of high-quality child care is largely deemed inadequate.

The COVID-19 pandemic revealed the fragility of America's child care system. Relative to adults, young children have been far less likely to suffer severe medical complications from coronavirus infection, and rates of transmission in child care facilities that followed mitigation protocols have been low. However, the downstream effects of the pandemic on young children have been acute. Burdensome child care cost and access barriers became exaggerated. Parents of young children report significant concerns about their children's safety and education during the pandemic and describe significant disruptions and impacts on families' well-being. Estimates indicate that 1 in every 500

U.S. children have experienced COVID-19 orphanhood or the loss of a caregiving grandparent, further highlighting a crisis in early childhood caregiving.

## QUALITY, PROVISION, REGULATION, AND ACCESS

### Child Care Quality

**High-quality child care** is characterized by warm, responsive, and stimulating interactions between children and child care providers. These caregivers express positive feelings toward the children; are emotionally involved, engaged, and aware of the child's needs and sensitive and responsive to their initiations; speak directly with children in a manner that is elaborative and stimulating while being age-appropriate; and ask questions and encourage children's ideas and verbalizations. Structural quality features of the setting, including ratio of children to adults, group size, and caregiver education and training, act indirectly on child outcomes by facilitating high-quality interactions. It would be highly unlikely, if not impossible, for even the most sensitive and stimulating provider to engage in high-quality interactions with each child, if, for example, the provider was the sole caregiver of 10 toddlers.

Poor-quality child care settings and unsafe environments that do not meet children's basic physical and emotional needs can result in developmental delays tied to lack of healthy relationships with adults or developmentally inappropriate activities, toxic stress, neglect, or injury or death from fire, building hazards, disease, and inadequate staff oversight. State regulations put a "floor" on structural quality and basic staff indicators to mitigate risks and safeguard health and safety. Although structural indicators are more easily monitored in licensing, some but not all research suggests only modest relationships of structural indicators with child outcomes. When it comes to process quality, a body of studies demonstrates small-to-modest associations with short-term child development and some evidence of long-term impacts.

The early childhood field is focusing increasingly on effective practices, evidence-based curricula, and programs that are reported to have moderate-to-large effects on child outcomes. Some specific teacher practices are related to gains in academic and social-emotional skills among preschool students. Evidence-informed and evaluated ECE curricula with aligned professional development can have substantial impacts on child outcomes across several developmental domains. Primary caregiving, the practice in infant and toddler classrooms of assigning one teacher the primary responsibility for the care of a small group of children and developing relationships with their families, is consistent with research showing that infants who experience stable, consistent, sensitive and responsive care develop more secure attachment relationships and more positive developmental outcomes. Family engagement, in which early educators partner with families to share their unique knowledge of each child to build positive and goal-oriented relationships, relates to gains in preschool children's social and early academic skills and reduced problem behaviors.

### Integration of Health and Safety Within Quality Practices

The American Academy of Pediatrics (AAP), the American Public Health Association, and the National Resource Center for Health and Safety in Child Care and Early Education provide health and safety guidelines in *Caring for Our Children (CFOC): National Health and Safety Performance Standards; Guidelines for Early Care and Education Programs, 4th ed.* (<https://nrckids.org/CFOC>; 2019). These national standards represent the best evidence on quality practices and address health and safety as an integrated component of early care and education. The intent is for the guidelines to serve as a resource for states and other entities to improve health and safety standards in licensing and quality rating improvement systems. An additional objective is for the various monitoring agencies and mechanisms to work together to collaboratively safeguard children and minimize or eliminate the duplication and burden of complicated and sometimes conflicting procedures and requirements.

The current guidelines include sections in 10 areas (Table 29.1). The National Resource Center also provides updated online resources: (1) up-to-date CFOC Standards Online Database (<https://nrckids.org/CFOC>) and (2) a crosswalk of COVID-19 questions with CFOC



**Table 29.1** *Caring for Our Children Performance Standards: Chapters and Topics*

1. <b>Staffing:</b> Child-staff ratio, group size, minimum age; background checks (criminal history, sex offender registry, and child abuse and neglect registry checks), qualifications, professional development, training
2. <b>Program Activities for Healthy Development:</b> Developmental activities (general and by age), supervision and discipline, parent/guardian relationships, health education
3. <b>Health Promotion and Protection:</b> Health promotion in child care (health checks and supervision, physical activity, limiting screen time, safe sleep, oral health); hygiene (diapering, hand hygiene, exposure to bodily fluids); cleaning, sanitizing, and disinfecting; tobacco and drug use; animals; emergency procedures; child abuse and neglect; sun safety and insect repellent; strangulation hazards; management of illness
4. <b>Nutrition and Food Service:</b> General and by age, meal service, seating, and supervision, nutrition learning experiences for children and for parents/guardians, food safety, and more
5. <b>Facilities, Supplies, Equipment, and Environmental Health:</b> Space per child, exits, ventilation, lighting, noise, furnishings, equipment, and more
6. <b>Play Areas/Playgrounds and Transportation:</b> Playground equipment, water play areas, toys
7. <b>Infectious Diseases:</b> Immunizations, respiratory tract infections, enteric (diarrheal) infections and hepatitis A virus, skin and mucous membrane infections, blood-borne infections, herpes viruses, interaction with state or local health departments, judicious use of antibiotics
8. <b>Children with Special Healthcare Needs and Disabilities:</b> Inclusion, service plans, coordination and documentation, periodic reevaluation, assessment of facilities for children with special needs, additional standards
9. <b>Administration:</b> Governance, policies, human resources, records
10. <b>Licensing and Community Action:</b> Regulatory policy, licensing agency, facility licensing, health department responsibilities and role, caregiver/teacher support, public policy issues and resource development

From the American Academy of Pediatrics, American Public Health Association, National Resource Center for Health and Safety in Child Care and Early Education. *Caring for Our Children: National Health and Safety Performance Standards; Guidelines for Early Care and Education Programs*. 4th ed., Itasca, IL: American Academy of Pediatrics; 2019. (<https://nrckids.org/CFOC/TOC>).

standards (<https://nrckids.org/files/CFOC.Crosswalk.pdf>) to help child care health consultants and providers learn how the CFOC standards address provision of safe and healthy early care and education environments during the COVID-19 pandemic.

### Child Care Settings and Use

Public early education programs (such as Head Start and targeted state-funded prekindergarten programs) have historically been designed as policy mechanisms to close the school readiness gap among children with fewer resources, whereas child care has been seen as necessary when parents (usually mothers) work while their children are young. Despite these historical “silos,” all early care and education settings serve both purposes: they are early learning environments for children and necessary supports for working parents.

Quality of care matters for all child care settings, but there are key differences in the structure and provision of care that influence organizational and business operations, regulatory mandates, and accessibility and affordability for families.

Child care settings vary widely and fall into four broad categories from the least to the most formal:

1. Relative or friend cares for a child in the relative’s or friend’s home or in the child’s home

2. Nonrelative care who comes to the child’s home, such as nannies, babysitters, or au pairs
3. Home-based child care in which an individual runs a child care business in their own home and cares for a few or several children, often including children of mixed ages, siblings, or the provider’s own children
4. Center-based care, provided in nonresidential facilities for children grouped by age, including preschools, prekindergarten programs, Head Start centers, and child care centers.

Child care centers and early education programs are administered by a wide array of businesses and organizations, including for-profit providers or companies, religious organizations, public and private schools including early childhood special education programs, nonprofits and other community organizations, cooperatives, employer-based child care, and public agencies. Increasingly, publicly funded prekindergarten programs contract with existing community-based centers and home-based providers for program delivery. With a few exceptions (such as faith-affiliated child care), center-based child care programs must satisfy state licensing laws for safety practices. For other child care options, governmental oversight for health and safety is rarer; many home-based child care programs are licensed, whereas many others are unknown to regulatory agencies, and family, friend, and nanny care are almost never regulated. Child care licensing and regulation is described in the next section.

Approximately 59% of children 5 years and younger and not yet in kindergarten were in at least 1 weekly nonparental child care arrangement, as reported by their parents in the U.S. Census Bureau’s 2019 National Household Education Surveys Program. Forty-two percent of children less than 1 year of age, 55% of 1-2 year olds, and 74% of 3-5 year olds were in nonparental care. Nearly 60% of those in at least one child care arrangement were in a center-based arrangement, 38% were in relative care, and 20% were in nonrelative care in a private home; children may have been in more than one type of arrangement. Center-based arrangements were most common among preschoolers, whereas relative care arrangements were most common among infants.

### Child Care Closures

The COVID-19 pandemic accelerated a worsening trend of child care closures. In 2012, there were approximately 129,000 center-based programs serving 6.98 million children from birth through age 5. Between 2014 and 2017, the number of licensed child care programs of all types in the United States decreased to approximately 109,000 centers. The number of listed home-based providers (which includes licensed or otherwise regulated providers) decreased by about 25% between 2012 and 2019.

In response to COVID-19, by April 2020 new state public health requirements resulted in closing 70% of U.S. child care centers; more than 35% of child care workers became unemployed. Reasons for this include COVID-19 outbreaks and preventative health protocols such as social distancing with limits in group sizes and child:staff ratios. As the pandemic continued, reasons for new or even permanent closures included staffing shortages as well as business models that cannot support a program’s financial survival at low enrollment rates. However, child masking within the first year of the pandemic was associated with a 13-14% reduction in child care closure rates.

### Licensing, Regulation, Monitoring, and Accreditation

State and territory licensing agencies enumerate which providers are subject to licensing to legally operate and monitor those providers’ compliance with foundational, mandated regulations to protect children’s safety, health, and well-being. Many states and territories also offer systems of child care monitoring that are usually voluntary in nature, such as quality rating and improvement systems (QRIS), and various professional organizations offer voluntary accreditation systems to assess whether providers meet higher-quality standards, often (but not always) requiring licensure as a prerequisite to participation.

### Licensing

Licensing and regulatory requirements establish the minimum requirements necessary to protect the health and safety of children in



child care. Typically, these include basic health and safety standards such as sanitary practices, child and provider vaccinations, access to a healthcare professional, and facilities and equipment hazards and safety, as well as basic structural and caregiver characteristics such as background checks, the ratio of children to staff, group sizes, and minimum caregiver education and training requirements. Most child care centers and preschools and many family child care providers are subject to state licensing and regulation. All states regulate child care centers, as does the District of Columbia, and most states regulate family child care providers.

Pediatricians are encouraged to learn about their own state's child care licensing rules. Large differences between states mean large differences in allowable levels of quality. The most common child:staff ratios are 4:1 for infants, 6:1 for toddlers, and 10:1 for preschoolers. However, some states permit ratios that are 5:1 or 6:1 for infants 9 months of age or younger.

State and territory child care licensing regulations are maintained in a searchable National Database of Child Care Licensing Regulations (<https://childcareta.acf.hhs.gov/licensing>) by the National Center on Early Childhood Quality Assurance (NCECQA). The site provides a tool for searching state and territory licensing regulations and agency contact information. Licensing requirements are frequently updated.

Unlicensed settings and even licensed providers in states with low licensing and regulatory standards may be providing care at quality levels below professional recommendations. Moreover, various types of programs may be exempt from licensure, such as faith-affiliated child care programs, and exemptions are specific to each state; as many as one third of child care centers are legally exempt in some states. Centers are often exempted if care is offered by other organizations such as school districts that provide external oversight. The smallest homes (three or four children in care) are often license-exempt, encompassing relative, friend, and neighbor caregivers as well as babysitters, nannies, and au pairs. Some of these providers and the families who use them may not even think of themselves as providing "child care." The Child Care Development Block Grant (CCDBG) reauthorization in 2014 required states and territories to expand their monitoring of legally exempt providers to protect the health and safety of children receiving subsidized child care. Most states require exempt centers and family child care homes to meet some licensure requirements such as background checks and to receive an annual inspection to receive child care subsidy payments.

### Other Quality Monitoring Systems

Several voluntary public and private initiatives require that child care settings meet their own sets of guidelines and regulations in areas considered critical to effective practice and child outcomes to receive either state or federal funding. These diverse initiatives include those that focus on nutrition (the Child and Adult Care Food Program [CACFP]), inclusion (the Individuals with Disabilities Education Act [IDEA]), and financial assistance to low-income working parents (child care subsidies through the CCDBG). Most states have quality initiatives called QRIS. Publicly funded early education programs, including the federal Head Start and Early Head Start program as well as state and local public prekindergarten have their own program performance standards.

Participating providers benefit in ways that may include technical assistance supports, professional development, and additional funding often tied to the numbers of children served under the program. About 75% of early care and education centers report receiving funds from multiple sources. Providers may also value earning a public-facing "seal of approval" to help families learn about higher-quality programs.

These programs all monitor eligibility and compliance with program standards. For example, Head Start and most of the state prekindergarten programs that restrict enrollment to low-income families require verification of family eligibility (although some states' and cities' prekindergarten programs are universally available to all preschool-age children regardless of family income). Other eligibility standards include verification of parental employment for child care subsidies or verification of nutritious food for low-income families for receipt of

CACFP funds. Other monitoring may cover staffing, meals and snacks, curricula and teaching, and other areas of service delivery. QRIS systems work within the infrastructure of the early care and education system to assess, incentivize, and support higher levels of quality. Examples of incentives and supports include tiered subsidy reimbursement systems in which participating providers who achieve levels of quality beyond basic licensing requirements are entitled to higher subsidy payments, public funding to facilitate accreditation, professional development systems and coaching, and program assessments and technical assistance.

### Accreditation

A smaller portion of providers become accredited by National Association for the Education of Young Children (NAEYC), National Association for Family Child Care (NAFCC), or other organizations by voluntarily meeting high-quality, developmentally appropriate, professionally recommended standards. The accreditation process goes beyond health and safety practices and structural and caregiver characteristics to examine the quality of child-caregiver interactions. Evidence indicates that child care programs that complete voluntary accreditation through NAEYC provide an environment that better facilitates children's overall development, but few providers are accredited. This is partly the result of a lack of knowledge, resources, and incentives for providers to improve quality, but it may also be partly because of expenses providers incur in becoming accredited.

### Child Care Access

As one social determinant of health, access to affordable high-quality child care that supports child development and meets family needs is critical.

Access to child care goes beyond simple "supply" (numbers of available slots) and "demand" (numbers of young children needing extra-familial care). Barriers to access include aspects of affordability, hours of operation, location, transportation, and culturally or linguistically appropriate care. Barriers to access to high-quality child care are pervasive among families in which caregivers work irregular, fluctuating, or nontraditional work schedules, families with infants and toddlers, families for whom English is not the primary language spoken at home, and families with children with disabilities or special needs.

Two thirds of children 5 years of age and younger have both parents in the workforce or in school or training programs. Nearly 30% of low-income mothers of children under 6 years of age work nonstandard hours, but child care supply during nonstandard or irregular hours is extremely limited. Over 30% of parents with children in weekly care report that the arrangement does not cover the hours needed for work very well. Many more report that they are not in the workforce or school, or not working the hours or shifts that they need or want, due to lack of affordable accessible child care.

## SCREENING AND SUPPORT FOR CHILD DEVELOPMENT AND HEALTH

### Child Care and Child Behavior

Before the COVID-19 pandemic, about 192,000 U.S. young children were being expelled or suspended from child care programs annually for concerns rising from developmentally typical crying and temper tantrums to physical aggression to violations of various "zero tolerance policies," such as bringing a water gun to child care. In fact, young children are expelled from child care and preschool programs at a rate more than 3 times that for kindergarten through 12th graders. Young children experiencing any number of adverse childhood events are at significantly increased odds of preschool expulsion, such as exposure to domestic or community violence, family mental illness and substance abuse, poverty, parental divorce, and parental incarceration. These disciplinary exclusions are disproportionately applied to young males and to children of color; implicit biases account for at least some of these disproportionalities. These early disciplinary exclusions predict later negative school attitudes, academic failure and grade retention, and later expulsions and suspensions, as well as a 10-fold increase in high-school dropout rates and an 8-fold increase in later incarceration.

State efforts to reduce early childhood exclusionary discipline include early childhood mental health consultation (ECMHC) models to support child care providers, who are often not well trained in managing child behavior, as well as build capacity to raise child care quality for all children. ECMHC links a mental health professional with an early education and care provider in an ongoing problem-solving and capacity-building relationship. ECMHC has been shown to be effective in statewide randomized controlled trials, and now exist in several states and cities. Because this is a rapidly evolving area of support, clinicians wishing to provide guidance to parents of young children at risk of early disciplinary exclusion should consider inquiring about the existence of an ECMHC system within their state or locality by contacting their state early childhood department and/or state/local child care resource and referral agency. Local regulations may limit or prohibit the exclusion of children in response to behaviors that may be a symptomatic expression of a diagnosed disability or special education need, providing a potential method for safeguarding a child's ability to receive early care and education, as described in the next section.

### Children with Special Needs

Children with cognitive, physical, or emotional disabilities who require special care and instruction often require particular attention when it comes to their participation in most child care settings. Guiding principles of services for children with disabilities advocate supporting children in natural environments, including child care. Furthermore, the Americans with Disabilities Act and Section 504 of the Rehabilitation Act of 1973 prohibit discrimination against children and adults with disabilities by requiring equal access to offered programs and services.

Child care can be, and often is, utilized for delivery of support services to children with special needs and/or for linking families to services such as early intervention. Furthermore, clinicians can draw on child care providers for important evaluative data regarding a child's well-being, as these providers have extensive daily contact with the child and may have broad, professional understanding of normative child development. Child care providers often conduct screenings for developmental milestones and delays using standardized instruments. A child care provider may be the first to identify a child's potential language delay. Child care providers are also necessary and valuable partners in the development and administration of early intervention service plans. However, many child care providers and settings are unprepared to identify or administer services for children with special needs.

Children with special needs may be eligible for special educational services under IDEA. The purpose of this law is to provide "free appropriate public education," regardless of disability or chronic illness, to all eligible children, birth to 21 years of age, in a natural and/or least-restrictive environment. Eligible children include those with mental, physical, or emotional disabilities who, because of their disability or chronic illness, require special instruction to learn. As a part of these services, a formal plan of intervention is to be developed by the service providers, families, and the children's healthcare providers. Federal funds are available to implement a collaborative early intervention system of services for eligible infants and toddlers between the ages of birth and 3 years and their families. These services include screening, assessment, service coordination, and collaborative development of an **individualized family service plan (IFSP)**. The IFSP describes early intervention services for the child's health, therapeutic, and educational needs and supports needed by the family. An understanding of the child's routines and real-life opportunities and activities, such as eating, playing, interacting with others, and working on developmental skills, is crucial to enhancing a child's ability to achieve the functional goals of the IFSP. Therefore it is critical that child care providers be involved in IFSP development or revision, with parental consent. Child care providers should also become familiar with the child's IFSP and understand the providers' role and the resources available to support the family and child care provider. Additionally, IDEA provides support for eligible children 3 years of age and older to receive services through the local school district. This includes development of a written **individualized education program (IEP)**, with implementation

being the responsibility of the local education agency in either a public or private preschool setting. As with IFSPs, child care providers should become familiar with the preschooler's special needs as identified in the IEP and may become involved, with parental consent, in IEP development and review meetings. In cases where children may have or be at risk of developmental delays, a diagnosis is important for obtaining and coordinating services and further evaluation. To this end, clinicians can partner with child care providers to screen and monitor children's behavior and development. Even if a young child is not being provided special educational services, special accommodations may be requested for any child whose access to child care is being adversely impacted by a diagnosable developmental or behavioral disability through Section 504 of the Rehabilitation Act of 1973.

### Sick Children and Control of Infectious Disease

When children are ill, they may be excluded from out-of-home child care and under state licensure child care programs are required to exclude children with certain conditions. Children in child care are of an age that places them at increased risk for acquiring infectious diseases. Participation in group settings elevates exposure, leading to increased infections, especially during the first year of child care exposure and especially with infants. Children enrolled in such settings have a higher incidence of illness (upper respiratory tract infections, otitis media, diarrhea, hepatitis A infections, skin conditions, and asthma) than those cared for at home, especially in the preschool years; these illnesses have no long-term adverse consequences. Child care providers that follow child care licensure guidelines for handwashing, diapering, and food handling, and manage child illness appropriately, can reduce communicable illnesses.

CFOC (2019) and its up-to-date online supplement and the AAP (Table 29.2) offer guidelines and recommendations regarding the conditions under which sick children should and should not be excluded from group programs. State laws typically mirror these guidelines but may be stricter in some states. Although exclusion from child care due to mild illness is often unnecessary, their summary of guidelines states that a child should be excluded temporarily from care if the signs or symptoms of the illness does any of the following:

- ♦ Prevents the child from participating in daycare activities
- ♦ Results in a level of care that is greater than the staff can provide
- ♦ Poses a contagion risk of serious diseases to other children and staff

For COVID-19 exposure or symptoms or recovery go to <https://www.cdc.gov/coronavirus/2019-nCoV/index.html>

Health checks should be performed on each child every day. If symptoms develop during child care but do not require exclusion, written or verbal communication after the daycare is appropriate. Emergencies must be addressed with 911 calls and immediate notification of the family. If nonemergent but requiring exclusion, the parents should be notified to take the child home. Parents should have a backup plan when exclusions occur. *Return to child care is usually permissible without a primary healthcare visit.*

CFOC also provides guidelines for control of infectious disease outbreaks and for exclusion of any child or staff member who is suspected of contributing to transmission of the illness, who is not adequately immunized when there is an outbreak of a vaccine-preventable disease, or when the circulating pathogen poses an increased risk to the individual.

During the first 3 months of the COVID-19 pandemic in the United States, exposure to child care was not associated with an elevated risk of COVID-19 transmission to adult child care providers within the context of the considerable efforts that were employed to reduce transmission. Although enhanced hand hygiene and surface disinfecting were the most common transmission mitigation methods, many child care programs also engaged in daily symptom screening and temperature checks, social distancing efforts, and cohorting (i.e., keeping groups of children separate to help control the speed of transmission). Despite Centers for Disease Control and Prevention (CDC) guidance, masking of adults and children were rarely employed; federal guidance and requirements in several states, child care provider COVID-19 vaccination rates in June 2021 were only 78.2%. COVID-19 modifications and

**Table 29.2** Signs and Symptoms for Consideration of Exclusion or Inclusion in Child Care

SIGN OR SYMPTOM	COMMON CAUSES	COMPLAINTS OR WHAT MIGHT BE SEEN	NOTIFY HEALTH CONSULTANT	NOTIFY PARENT	TEMPORARILY EXCLUDE?	IF EXCLUDED, READMIT WHEN
Cold symptoms	<p>Viruses (early stage of many viruses)</p> <ul style="list-style-type: none"> <li>• Adenovirus</li> <li>• Coronavirus</li> <li>• Enterovirus</li> <li>• Influenza virus</li> <li>• Parainfluenza virus</li> <li>• Respiratory syncytial virus (RSV)</li> <li>• Rhinovirus</li> </ul> <p>Bacteria</p> <ul style="list-style-type: none"> <li>• Mycoplasma</li> <li>• Pertussis</li> </ul>	<ul style="list-style-type: none"> <li>• Coughing</li> <li>• Runny or stuffy nose</li> <li>• Scratchy throat</li> <li>• Sneezing</li> <li>• Fever</li> <li>• Watery eyes</li> </ul>	Not necessary unless epidemics occur (i.e., RSV or vaccine-preventable disease like measles or varicella [chickenpox])	Yes	<p>No, unless</p> <ul style="list-style-type: none"> <li>• Fever accompanied by behavior change.</li> <li>• Child looks or acts very ill.</li> <li>• Child has difficulty breathing.</li> <li>• Child has blood-red or purple rash not associated with injury.</li> <li>• Child meets routine exclusion criteria.</li> </ul>	Exclusion criteria are resolved.
Cough (cough is a body response to something that is irritating tissues in the airway anywhere from the nose to the lungs)	<ul style="list-style-type: none"> <li>• Common cold</li> <li>• Lower respiratory infection (e.g., pneumonia, bronchiolitis)</li> <li>• Croup</li> <li>• Asthma</li> <li>• Sinus infection</li> <li>• Bronchitis</li> <li>• Pertussis</li> <li>• Noninfectious causes like allergies</li> </ul>	<ul style="list-style-type: none"> <li>• Dry or wet cough</li> <li>• Runny nose (clear, white, or yellow-green)</li> <li>• Sore throat</li> <li>• Throat irritation</li> <li>• Hoarse voice, barking cough</li> <li>• Coughing fits</li> </ul>	Not necessary unless the cough is due to a vaccine-preventable disease, such as pertussis	Yes	<p>No, unless</p> <ul style="list-style-type: none"> <li>• Severe cough.</li> <li>• Rapid or difficult breathing.</li> <li>• Wheezing if not already evaluated and treated.</li> <li>• Cyanosis (i.e., blue color of skin or mucous membranes).</li> <li>• Pertussis is diagnosed and not yet treated.</li> <li>• Fever with behavior change.</li> <li>• Child meets routine exclusion criteria.</li> </ul>	Exclusion criteria are resolved.
Diaper rash	<ul style="list-style-type: none"> <li>• Irritation by rubbing of diaper material against skin wet with urine or stool</li> <li>• Infection with yeast or bacteria</li> </ul>	<ul style="list-style-type: none"> <li>• Redness</li> <li>• Scaling</li> <li>• Red bumps</li> <li>• Sores</li> <li>• Cracking of skin in diaper region</li> </ul>	Not necessary	Yes	<p>No, unless</p> <ul style="list-style-type: none"> <li>• Oozing sores that leak body fluids outside the diaper.</li> <li>• Child meets routine exclusion criteria.</li> </ul>	Exclusion criteria are resolved.
Diarrhea	<ul style="list-style-type: none"> <li>• Usually viral, less commonly bacterial or parasitic</li> <li>• Noninfectious causes such as dietary (drinking too much juice), medications, inflammatory bowel disease, or cystic fibrosis</li> </ul>	<ul style="list-style-type: none"> <li>• Frequent loose or watery stools compared with child's normal pattern. (Note that exclusively breastfed infants normally have frequent unformed and somewhat watery stools or may have several days with no stools.)</li> <li>• Abdominal cramps</li> <li>• Fever</li> <li>• Generally not feeling well</li> <li>• Vomiting occasionally present</li> </ul>	Yes, if one or more cases of bloody diarrhea or two or more children in same group with diarrhea within a week	Yes	<p>Yes, if</p> <ul style="list-style-type: none"> <li>• Directed by the local health department as part of outbreak management.</li> <li>• Stool is not contained in the diaper for diapered children.</li> <li>• Diarrhea is causing "accidents" for toilet-trained children.</li> <li>• Stool frequency exceeds 2 stools above normal during the time the child is in the program because this may cause too much work for teachers/caregivers and make it difficult to maintain good sanitation.</li> <li>• Blood/mucus in stool.</li> <li>• Black stools.</li> <li>• No urine output in 8 hours.</li> <li>• Jaundice (i.e., yellow skin or eyes).</li> <li>• Fever with behavior change.</li> <li>• Looks or acts very ill.</li> <li>• Child meets routine exclusion criteria.</li> </ul>	<ul style="list-style-type: none"> <li>• Cleared to return by healthcare provider for all cases of bloody diarrhea and diarrhea caused by Shiga toxin-producing <i>Escherichia coli</i>, <i>Shigella</i>, or <i>Salmonella</i> serotype Typhi until negative stool culture requirement has been met.</li> <li>• Diapered children have their stool contained by the diaper (even if the stools remain loose) and toilet-trained children do not have toileting accidents.</li> <li>• Stool frequency is no more than 2 stools above normal during the time the child is in the program, or what has become normal for that child when the child seems otherwise well.</li> <li>• Exclusion criteria are resolved.</li> </ul>

Continued

**Table 29.2** Signs and Symptoms for Consideration of Exclusion or Inclusion in Child Care—cont'd

SIGN OR SYMPTOM	COMMON CAUSES	COMPLAINTS OR WHAT MIGHT BE SEEN	NOTIFY HEALTH CONSULTANT	NOTIFY PARENT	TEMPORARILY EXCLUDE?	IF EXCLUDED, READMIT WHEN
Difficult or noisy breathing	<ul style="list-style-type: none"> <li>• Common cold</li> <li>• Croup</li> <li>• Epiglottitis</li> <li>• Bronchiolitis</li> <li>• Asthma</li> <li>• Pneumonia</li> <li>• Object stuck in airway</li> <li>• Exposed to a known trigger of asthma symptoms (e.g., animal dander, pollen)</li> </ul>	<ul style="list-style-type: none"> <li>• Common cold: stuffy/runny nose, sore throat, cough, or mild fever</li> <li>• Croup: barking cough, hoarseness, fever, possible chest discomfort (symptoms worse at night), or very noisy breathing, especially when breathing in</li> <li>• Epiglottitis: gasping noisily for breath with mouth wide open, chin pulled down, high fever, or bluish (cyanotic) nails and skin; drooling, unwilling to lie down</li> <li>• Bronchiolitis and asthma: child is working hard to breathe; rapid breathing; space between ribs looks like it is sucked in with each breath (retractions); wheezing; whistling sound with breathing; cold/cough; irritable and unwell. Takes longer to breathe out than to breathe in.</li> <li>• Pneumonia: deep cough, fever, rapid breathing, or space between ribs looks like it is sucked in with each breath (retractions)</li> <li>• Object stuck in airway: symptoms similar to croup (listed previously)</li> <li>• Exposed to a known trigger of asthma symptoms: a known trigger and breathing that sounds or looks different from what is normal for that child</li> </ul>	Not necessary except for epiglottitis	Yes	Yes, if <ul style="list-style-type: none"> <li>• Fever with behavior change.</li> <li>• Child looks or acts very ill.</li> <li>• Child has difficulty breathing.</li> <li>• Rapid or difficult breathing.</li> <li>• Wheezing if not already evaluated and treated.</li> <li>• Cyanosis (i.e., blue color of skin or mucous membranes).</li> <li>• Cough interferes with activities.</li> <li>• Breath sounds can be heard when the child is at rest.</li> <li>• Child has blood-red or purple rash not associated with injury.</li> <li>• Child meets routine exclusion criteria.</li> </ul>	Exclusion criteria are resolved.
Earache	<ul style="list-style-type: none"> <li>• Bacteria</li> <li>• Often occurs in context of common cold virus</li> </ul>	<ul style="list-style-type: none"> <li>• Fever</li> <li>• Pain or irritability</li> <li>• Difficulty hearing</li> <li>• “Blocked ears”</li> <li>• Drainage</li> <li>• Swelling around ear</li> </ul>	Not necessary	Yes	No, unless child meets routine exclusion criteria.	Exclusion criteria are resolved.



**Table 29.2** Signs and Symptoms for Consideration of Exclusion or Inclusion in Child Care—cont'd

SIGN OR SYMPTOM	COMMON CAUSES	COMPLAINTS OR WHAT MIGHT BE SEEN	NOTIFY HEALTH CONSULTANT	NOTIFY PARENT	TEMPORARILY EXCLUDE?	IF EXCLUDED, READMIT WHEN
Eye irritation, pinkeye	<ul style="list-style-type: none"> <li>Bacterial infection of the membrane covering one or both eyes and eyelids (bacterial conjunctivitis)</li> <li>Viral infection of the membrane covering one or both eyes and eyelids (viral conjunctivitis)</li> <li>Allergic irritation of the membrane covering one or both eyes and eyelids (allergic conjunctivitis)</li> <li>Chemical irritation of the membrane covering the eye and eyelid (irritant conjunctivitis) (e.g., swimming in heavily chlorinated water, air pollution, smoke exposure)</li> </ul>	<ul style="list-style-type: none"> <li>Bacterial infection: pink color of the “whites” of eyes and thick yellow/green discharge. Eyelid may be irritated, swollen, or crusted.</li> <li>Viral infection: pinkish/red color of the whites of the eye; irritated, swollen eyelids; watery discharge with or without some crusting around the eyelids; may have associated cold symptoms.</li> <li>Allergic and chemical irritation: red, tearing, itchy, puffy eyelids; runny nose, sneezing; watery/stringy discharge with or without some crusting around the eyelids.</li> </ul>	Yes, if two or more children have red eyes with watery discharge	Yes	<p><i>For bacterial conjunctivitis</i> No. Exclusion is no longer required for this condition. Healthcare providers may vary on whether to treat this condition with antibiotic medication. The role of antibiotics in treatment and preventing spread is unclear. Most children with pinkeye get better after 5 or 6 days without antibiotics.</p> <p><i>For other eye problems</i> No, unless child meets other exclusion criteria.</p> <p><i>Note:</i> One type of viral conjunctivitis spreads rapidly and requires exclusion. If two or more children in the group have watery red eyes without any known chemical irritant exposure, exclusion may be required and health authorities should be notified to determine whether the situation involves the uncommon epidemic conjunctivitis caused by a specific type of adenovirus. Herpes simplex conjunctivitis (red eyes with blistering/vesicles on eyelid) occurs rarely and would also require exclusion if there is eye watering.</p>	<ul style="list-style-type: none"> <li><i>For bacterial conjunctivitis</i>, once parent has discussed with healthcare provider. Antibiotics may or may not be prescribed.</li> <li>Exclusion criteria are resolved.</li> </ul>
Fever	<ul style="list-style-type: none"> <li>Any viral, bacterial, or parasitic infection</li> <li>Vigorous exercise</li> <li>Reaction to medication or vaccine</li> <li>Other noninfectious illnesses (e.g., rheumatoid arthritis, malignancy)</li> </ul>	<p>Flushing, tired, irritable, decreased activity</p> <p><i>Notes:</i></p> <ul style="list-style-type: none"> <li>Fever alone is not harmful. When a child has an infection, raising the body temperature is part of the body's normal defense against germs.</li> <li>Rapid elevation of body temperature sometimes triggers a febrile seizure in young children; this usually is outgrown by age 6 yr. The first time a febrile seizure happens, the child requires medical evaluation. These seizures are frightening but are usually brief (less than 15 minutes) and do not cause the child any long-term harm. Parents should inform their child's healthcare provider every time the child has a seizure, even if the child is known to have febrile seizures.</li> </ul> <p>Warning: <i>Do not</i> give aspirin. It has been linked to an increased risk of Reye syndrome (a rare and serious disease affecting the brain and liver).</p>	Not necessary	Yes	<p>No, unless</p> <ul style="list-style-type: none"> <li>Behavior change or other signs of illness in addition to fever or child meets other routine exclusion criteria.</li> <li>Unable to participate.</li> <li>Care would compromise staff's ability to care for other children.</li> </ul> <p><i>Note:</i> A temperature considered meaningfully elevated above normal, although not necessarily an indication of a significant health problem, for infants and children older than 2 mo is above 101°F (38.3°C) from any site (axillary, oral, or rectal).</p> <p><i>Get medical attention</i> when infants younger than 4 mo have unexplained fever. In any infant younger than 2 mo, a temperature above 100.4°F (38.0°C) is considered meaningfully elevated and requires that the child get medical attention immediately, within an hour if possible. The fever is not harmful; however, the illness causing it may be serious in this age group.</p>	Exclusion criteria are resolved.

Continued

**Table 29.2** Signs and Symptoms for Consideration of Exclusion or Inclusion in Child Care—cont'd

SIGN OR SYMPTOM	COMMON CAUSES	COMPLAINTS OR WHAT MIGHT BE SEEN	NOTIFY HEALTH CONSULTANT	NOTIFY PARENT	TEMPORARILY EXCLUDE?	IF EXCLUDED, READMIT WHEN
Headache	<ul style="list-style-type: none"> <li>Any bacterial/viral infection</li> <li>Other noninfectious causes</li> </ul>	<ul style="list-style-type: none"> <li>Tired and irritable</li> <li>Can occur with or without other symptoms</li> </ul>	Not necessary	Yes	<p>No, unless child meets routine exclusion criteria.</p> <p><i>Note:</i> Notify healthcare provider in case of sudden, severe headache with vomiting or stiff neck that might signal meningitis. It would be concerning if the back of the neck is painful or the child cannot look at his or her belly button (putting chin to chest)—different from soreness in the side of the neck.</p>	Exclusion criteria are resolved.
Itching	<ul style="list-style-type: none"> <li>Ringworm</li> <li>Chickenpox</li> <li>Pinworm</li> <li>Head lice</li> <li>Scabies</li> <li>Allergic or irritant reaction (e.g., poison ivy)</li> <li>Dry skin or eczema</li> <li>Impetigo</li> </ul>	<ul style="list-style-type: none"> <li>Ringworm: itchy ring-shaped patches on skin or bald patches on scalp.</li> <li>Chickenpox: blister-like spots surrounded by red halos on scalp, face, and body; fever; irritable.</li> <li>Pinworm: anal itching.</li> <li>Head lice: small insects or white egg sheaths that look like grains of sand (nits) in hair.</li> <li>Scabies: severely itchy red bumps on warm areas of body, especially between fingers or toes.</li> <li>Allergic or irritant reaction: raised, circular, mobile rash; reddening of the skin; blisters occur with local reactions (poison ivy, contact reaction).</li> <li>Dry skin or eczema: dry areas on body. More often worse on cheeks, in front of elbows, and behind knees. In infants, may be dry areas on face and anywhere on body but not usually in the diaper area. If swollen, red, or oozing, think about infection.</li> <li>Impetigo: areas of crusted yellow, oozing sores. Often around mouth or nasal openings or areas of broken skin (insect bites, scrapes).</li> </ul>	Yes, for infestations such as lice and scabies; if more than one child in group has impetigo or ringworm; for chickenpox	Yes	<p><i>For chickenpox:</i> Yes, until lesions are fully crusted <i>For ringworm, impetigo, scabies, and head lice:</i> Yes, at the end of the day Children should be referred to a healthcare provider at the end of the day for treatment. <i>For pinworm, allergic or irritant reactions like hives, and eczema:</i> No, unless appears infected as a weeping or crusty sore <i>Note:</i> Although exclusion for these conditions is not necessary, families should seek advice from the child's health professional for how to care for these health problems. <i>For any other itching:</i> No, unless the child meets routine exclusion criteria.</p>	<ul style="list-style-type: none"> <li>Exclusion criteria are resolved.</li> <li>On medication or treated as recommended by a healthcare provider if treatment is indicated for the condition. For conditions that require application of antibiotics to lesions or taking antibiotics by mouth, the period of treatment to reduce risk of spread to others is usually 24 hours. For most children with insect infestations or parasites, readmission as soon as the treatment has been given is acceptable.</li> </ul>
Mouth sores	<ul style="list-style-type: none"> <li>Oral thrush (yeast infection)</li> <li>Herpes or coxsackievirus infection</li> <li>Canker sores</li> </ul>	<ul style="list-style-type: none"> <li>Oral thrush: white patches on tongue, gums, and along inner cheeks</li> <li>Herpes or coxsackievirus infection: pain on swallowing; fever; painful, white/red spots in mouth; swollen neck glands; fever blister, cold sore; reddened, swollen, painful lips</li> <li>Canker sores: painful ulcers inside cheeks or on gums</li> </ul>	Not necessary	Yes	<p>No, unless</p> <ul style="list-style-type: none"> <li>Drooling steadily related to mouth sores.</li> <li>Fever with behavior change.</li> <li>Child meets routine exclusion criteria.</li> </ul>	Exclusion criteria are resolved.

**Table 29.2** Signs and Symptoms for Consideration of Exclusion or Inclusion in Child Care—cont'd

SIGN OR SYMPTOM	COMMON CAUSES	COMPLAINTS OR WHAT MIGHT BE SEEN	NOTIFY HEALTH CONSULTANT	NOTIFY PARENT	TEMPORARILY EXCLUDE?	IF EXCLUDED, READMIT WHEN
Rash	<p>Many causes</p> <ul style="list-style-type: none"> <li>Viral: roseola infantum, fifth disease, chickenpox, herpesvirus, molluscum contagiosum, warts, cold sores, shingles (herpes zoster), and others</li> <li>Skin infections and infestations: ringworm (fungus), scabies (parasite), impetigo, abscesses, and cellulitis (bacteria)</li> <li>Scarlet fever (strep infection)</li> <li>Severe bacterial infections: meningococcus, pneumococcus, <i>Staphylococcus</i> (methicillin-susceptible <i>S. aureus</i>; methicillin-resistant <i>S. aureus</i>), <i>Streptococcus</i></li> <li>Noninfectious causes: allergy (hives), eczema, contact (irritant) dermatitis, medication related, poison ivy</li> </ul>	<ul style="list-style-type: none"> <li>Skin may show similar findings with many different causes. Determining cause of rash requires a competent healthcare provider evaluation that takes into account information other than just how rash looks. However, if the child appears well other than the rash, a healthcare provider visit is not necessary.</li> <li>Viral: usually signs of general illness such as runny nose, cough, and fever (except not for warts or molluscum). Some viral rashes have a distinctive appearance.</li> <li>Minor skin infections and infestations: see Itching.</li> <li>More serious skin infections: redness, pain, fever, pus.</li> <li>Severe bacterial infections: rare. These children usually have fever with a rapidly spreading blood-red rash and may be very ill.</li> <li>Allergy may be associated with a raised, itchy, pink rash with bumps that can be as small as a pinpoint or large welts known as hives. See also Itching for what might be seen for allergy or contact (irritant) dermatitis or eczema.</li> </ul>	For outbreaks, such as multiple children with impetigo within a group	Yes	<p>No, unless</p> <ul style="list-style-type: none"> <li>Rash with behavior change or fever.</li> <li>Has oozing/open wound.</li> <li>Has bruising not associated with injury.</li> <li>Has joint pain and rash.</li> <li>Rapidly spreading blood-red rash.</li> <li>Tender, red area of skin, especially if it is increasing in size or tenderness.</li> <li>Child meets routine exclusion criteria.</li> <li>Diagnosed with a vaccine-preventable condition, such as chickenpox.</li> </ul>	<ul style="list-style-type: none"> <li>On antibiotic medication for required period (if indicated).</li> <li>Infestations (lice and scabies) and ringworm can be treated at the end of the day with immediate return the following day.</li> <li>Exclusion criteria are resolved.</li> </ul>
Sore throat (pharyngitis)	<ul style="list-style-type: none"> <li>Viral: common cold viruses that cause upper respiratory infections</li> <li>Strep throat</li> </ul>	<ul style="list-style-type: none"> <li>Viral: verbal children will complain of sore throat; younger children may be irritable with decreased appetite and increased drooling (refusal to swallow). Often see symptoms associated with upper respiratory illness, such as runny nose, cough, and congestion.</li> <li>Strep throat: signs of the body's fight against infection include red tissue with white patches on sides of throat, at back of tongue (tonsil area), and at back wall of throat. Unlike viral pharyngitis, strep throat infections are not accompanied with cough or runny nose in children older than 3 yr.</li> <li>Tonsils may be large, even touching each other. Swollen lymph nodes (sometimes called "swollen glands") occur as body fights off the infection.</li> </ul>	Not necessary	Yes	<p>No, unless</p> <ul style="list-style-type: none"> <li>Inability to swallow.</li> <li>Excessive drooling with breathing difficulty.</li> <li>Fever with behavior change.</li> <li>Child meets routine exclusion criteria.</li> </ul> <p>Note: Most children with red back of throat or tonsils, pus on tonsils, or swollen lymph nodes have viral infections. If strep is present, 12 hours of antibiotics is required before return to care. However, tests for strep infection are not often necessary for children younger than 3 yr because these children do not develop rheumatic heart disease, which is the primary reason for treatment of strep throat.</p>	<ul style="list-style-type: none"> <li>Able to swallow.</li> <li>On medication at least 12 hours (if strep).</li> <li>Exclusion criteria are resolved.</li> </ul>

Continued

**Table 29.2** Signs and Symptoms for Consideration of Exclusion or Inclusion in Child Care—cont'd

SIGN OR SYMPTOM	COMMON CAUSES	COMPLAINTS OR WHAT MIGHT BE SEEN	NOTIFY HEALTH CONSULTANT	NOTIFY PARENT	TEMPORARILY EXCLUDE?	IF EXCLUDED, READMIT WHEN
Stomachache	<ul style="list-style-type: none"> <li>Viral gastroenteritis or strep throat</li> <li>Problems with internal organs of the abdomen such as intestine, colon, liver, bladder</li> <li>Nonspecific, behavioral, and dietary causes</li> <li>If combined with hives, may be associated with a severe allergic reaction</li> </ul>	<ul style="list-style-type: none"> <li>Viral gastroenteritis or strep throat: Vomiting and diarrhea or cramping are signs of a viral infection of the stomach or intestine. Strep throat may cause stomachache with sore throat, headache, and possible fever. In children older than 3 yr, if cough or runny nose is present, strep is very unlikely.</li> <li>Problems with internal organs of the abdomen: persistent severe pain in abdomen.</li> <li>Nonspecific stomachache: vague complaints without vomiting/diarrhea or much change in activity.</li> </ul>	If multiple cases in same group within 1 week	Yes	No, unless <ul style="list-style-type: none"> <li>Severe pain causing child to double over or scream.</li> <li>Abdominal pain after injury.</li> <li>Bloody/black stools.</li> <li>No urine output for 8 hours.</li> <li>Diarrhea (see Diarrhea).</li> <li>Vomiting (see Vomiting).</li> <li>Yellow skin/eyes.</li> <li>Fever with behavior change.</li> <li>Looks or acts very ill.</li> <li>Child meets routine exclusion criteria.</li> </ul>	<ul style="list-style-type: none"> <li>Pain resolves.</li> <li>Able to participate.</li> <li>Exclusion criteria are resolved.</li> </ul>
Swollen glands (properly called swollen lymph nodes)	<ul style="list-style-type: none"> <li>Normal body defense response to viral or bacterial infection in the area where lymph nodes are located (i.e., in the neck for any upper respiratory infection)</li> <li>Bacterial infection of lymph nodes that is more than the normal response to infection near where the lymph nodes are located</li> </ul>	<ul style="list-style-type: none"> <li>Normal lymph node response: swelling at front, sides, and back of the neck and ear; in the armpit or groin; or anywhere else near an area of an infection. Usually, these nodes are less than 1 inch across.</li> <li>Bacterial infection of lymph nodes: swollen, warm lymph nodes with overlying pink skin, tender to the touch, usually located near an area of the body that has been infected. Usually these nodes are larger than 1 inch across.</li> </ul>	Not necessary	Yes	No, unless <ul style="list-style-type: none"> <li>Difficulty breathing or swallowing.</li> <li>Red, tender, warm glands.</li> <li>Fever with behavior change.</li> <li>Child meets routine exclusion criteria.</li> </ul>	<ul style="list-style-type: none"> <li>Child is on antibiotics (if indicated).</li> <li>Exclusion criteria are resolved.</li> </ul>
Vomiting	<ul style="list-style-type: none"> <li>Viral infection of the stomach or intestine (gastroenteritis)</li> <li>Coughing strongly</li> <li>Other viral illness with fever</li> <li>Noninfectious causes: food allergy (vomiting, sometimes with hives), trauma, dietary and medication related, headache</li> </ul>	Diarrhea, vomiting, or cramping for viral gastroenteritis	For outbreak	Yes	Yes, if <ul style="list-style-type: none"> <li>Vomited more than 2 times in 24 hours</li> <li>Vomiting and fever</li> <li>Vomiting with hives</li> <li>Vomit that appears green/bloody</li> <li>No urine output in 8 hours</li> <li>Recent history of head injury</li> <li>Looks or acts very ill</li> <li>Child meets routine exclusion criteria.</li> </ul>	<ul style="list-style-type: none"> <li>Vomiting ends.</li> <li>Able to participate.</li> <li>Exclusion criteria are resolved.</li> </ul>

From Aronson SS, Shope TR, (eds). *Managing Infectious Diseases in Child Care and Schools: a quick reference guide*. 4th ed. Elk Grove Village, IL: American Academy of Pediatrics, 2017.



considerations are itemized in the Crosswalk (<https://nrckids.org/files/CFOC.Crosswalk.pdf>) and include, for example, discussion of daily symptom checks for children as well as daily screening procedures and exclusion criteria for staff.

Most families need to arrange to keep sick children at home necessitating staying home from work or having backup plans with an alternative caregiver. Alternative care arrangements outside the home for sick children are relatively rare but may include either (1) care in the child's own center, if it offers special provisions designed for the care of ill children (sometimes called the **infirmarium model** or **sick daycare**), or (2) care in a center that serves only children with illness or temporary conditions. Although it is important that such arrangements emphasize preventing further spread of disease, one study found no occurrence of additional transmission of communicable disease in children attending a sick center.

### Protection and Promotion of Child Health

Child care has a role in protecting and promoting child health and well-being. Child care providers are often the first to notice signs of child abuse and neglect and are a major source of child welfare referrals. Findings of increased health-related issues in the first year of child care are likely a testament to early detection benefits provided by child care providers.

### Sudden Infant Death Syndrome

A disproportionate number of sudden infant death syndrome (SIDS) deaths occur in child care centers or family-based child care homes. Infants who are back-sleepers at home but are put to sleep on their front in child care settings have a higher risk of SIDS. Providers and parents should be made aware of the importance of placing infants on their backs to sleep.

### Asthma and Respiratory Illness

Children enrolled in prekindergarten may have a greater risk of asthma diagnosis during prekindergarten but a lower risk in the years following prekindergarten, when compared with children who were not exposed to prekindergarten. Enrollment in prekindergarten may increase the early detection of asthma symptoms.

A 10-year follow-up of a birth cohort has found no association between child care attendance and respiratory infections, asthma, allergic rhinitis, or skin-prick test reactivity. Another study found that in the first year of elementary school, children who had attended child care had fewer absences from school, half as many episodes of asthma, and less acute respiratory illness than their peers who had never attended child care. These results are perhaps related to protection against respiratory illness through early exposure or a shift in the age-related peak of illness, although selection of illness-prone children into home care may play a role. Other factors include children in child care potentially being less exposed to passive smoking than children at home.

### Vision and Hearing Problems

Children enrolled in a citywide universal prekindergarten program had higher probability of diagnosis of vision problems, receipt of treatment for hearing or vision problems, and receiving an immunization. These effects were not offset by lower rates in the kindergarten year, suggesting that identification and treatment of these conditions was accelerated by enrollment in universal prekindergarten. As hearing and vision problems could potentially delay learning and cause behavioral problems, early detection and treatment is beneficial for future health and school readiness.

### Obesity and Promotion of Healthy Behaviors

There is insufficient research on longitudinal associations between child care, diet, and physical activity behaviors. Some limited research suggests a negative or mixed association between child care exposure and healthy behaviors, but the strength of these associations, and whether any causal implications exist, are difficult to tease apart. Other research suggests that child care center-based interventions are generally found

to be effective in improving physical activity and may be effective at improving dietary behaviors.

The CDC identifies child care settings as one of the best places to reach young children with obesity prevention efforts. Through their Spectrum of Opportunities framework (<https://www.cdc.gov/obesity/strategies/childcare.html>), they outline how a state's early care and education system can embed recommended standards and support for obesity prevention, including nutrition, infant feeding, physical activity, and screen time.

## ROLE OF PEDIATRIC PROVIDERS

### Consultation, Referrals, and Screening to Improve Access

Many parents are first-time purchasers of child care with little experience and very immediate needs; they may select care in a market that does little to provide them with useful information about child care arrangements. To inform their child care decisions, parents may turn to their child's healthcare provider as the only professional with expertise in child development with whom they have regular and convenient contact. Primary care clinicians should screen for child care just as they do for other social determinants of health, asking about child care arrangements and offering information about resources to help find and pay for child care to reinforce the importance of child care and increase the chances that children are enrolled in high-quality settings.

It is difficult for many parents to find high-quality child care that they can accept and afford. Many parents also worry how their child will fare in child care (e.g., they may worry that their child will feel distressed by the group settings, suffer from separation from the parents, or even be subjected to neglect or abuse). Practical concerns of transportation, scheduling to cover their work or school hours, and reliability are also common. The reliability of the arrangement is often rated as a "very important" selection factor by a higher proportion of parents than any other factor, followed by availability and staff qualifications. Among those who reported difficulty finding child care, cost was most often the primary reason, followed by lack of open slots, quality, then location or other reasons. Worries about finding quality child care are especially likely among parents with greater barriers to child care access and fewer personally accessible family and community resources. With the coronavirus pandemic, parents may be worried about the transmission of COVID-19 and about sporadic disruptions in service caused by quarantines or temporary closures, and unfounded fears about the safety of vaccines or facial masks.

Primary care practices can share information with parents about publicly available sources of information to help them find or pay for child care (Table 29.3). For example, they can

- ♦ Refer low-income parents to Head Start, which serves 3-4 year old children, or Early Head Start programs, which serves low-income expecting families and their children until their child's third birthday
- ♦ Refer low-income working parents to apply for child care subsidies and financial assistance in their state or county
- ♦ Refer parents to their local child care resource and referral agency for help finding and selecting child care; these can be located via the national association, Child Care Aware of America ([www.childcareaware.org/families](http://www.childcareaware.org/families))

Some parents may think of child care only as babysitting focusing mainly on whether the child is safe and warm and may not fully appreciate the potential consequences of unenriched care for their child's cognitive, linguistic, and social development. These parents may be less likely to select a high-quality child care arrangement. Healthcare providers can help parents understand the importance for their child's development of selecting high-quality care by describing how it looks and providing referrals and tips on how to find and select high-quality child care. Families facing socioeconomic challenges accessing high-quality care should be referred to available resources listed previously and in Table 29.3.

When a healthcare provider talks with a parent about a child care arrangement, it also is important to consider the individual child's health concerns, dispositions, and physiologic responses to the environment. Like all environments, child care is experienced differently

**Table 29.3** Child Care Information Resources

ORGANIZATION	SPONSOR	WEBSITE AND CONTACT INFORMATION
All Our Kin		<a href="https://allourkin.org/">https://allourkin.org/</a>
<i>Caring for Our Children</i> : National Resource Center for Health and Safety in Child Care and Early Education (NRC)	American Academy of Pediatrics, the American Public Health Association, and the National Resource Center for Health and Safety in Child Care and Early Education	<i>Caring for Our Children, National Health and Safety Performance Standards</i> <a href="https://nrckids.org/CFOC">https://nrckids.org/CFOC</a>
Child Care Aware of America		<a href="http://www.childcareaware.org">http://www.childcareaware.org</a>
Healthy Child Care America	American Academy of Pediatrics	<a href="http://www.healthychildcare.org">http://www.healthychildcare.org</a>
HealthySteps	Zero to Three	<a href="https://www.healthysteps.org/">https://www.healthysteps.org/</a>
National Association for the Education of Young Children (NAEYC)		<a href="http://www.naeyc.org">http://www.naeyc.org</a>
National Association for Family Child Care		<a href="https://nafcc.org/">https://nafcc.org/</a>
National Black Child Development Institute		<a href="https://www.nbcdi.org/">https://www.nbcdi.org/</a>
National Database of Child Care Licensing Regulations	National Center on Early Childhood Quality Assurance (NCECQA) funded by the U.S. Department of Health and Human Services, Administration for Children and Families.	<a href="https://childcareta.acf.hhs.gov/licensing">https://childcareta.acf.hhs.gov/licensing</a>
National Indian Child Care Association		<a href="https://www.nicca.us/">https://www.nicca.us/</a>
Office of Child Care (OCC)	U.S. Department of Health and Human Services, Administration for Children & Families	<a href="http://www.acf.hhs.gov/programs/occ">http://www.acf.hhs.gov/programs/occ</a>
Office of Child Care Technical Assistance Network (CCTAN)	U.S. Department of Health and Human Services, Administration for Children & Families, Office of Child Care	<a href="https://childcareta.acf.hhs.gov/">https://childcareta.acf.hhs.gov/</a>
UnidosUS		<a href="https://www.unidosus.org/">https://www.unidosus.org/</a>
Zero to Three		<a href="https://www.zerotothree.org/">https://www.zerotothree.org/</a>

by different children. When an environment lacks adequate support for a child's unique needs, healthy development can be compromised. Some children may be more vulnerable to low-quality child care (or particularly responsive to high-quality child care), such as children with difficult or fearful temperaments, especially if their home environments are characterized by more risk factors, such as poverty or high conflict with a parent. Clinicians can help parents determine how to adjust child care arrangements to best meet their child's specific needs (e.g., allergies, eating and sleeping habits, temperament, and stress-regulation capacities).

### Children Who Are Expelled from Child Care

A provider may tell a parent that they will not continue to serve a child because of the child's behaviors. Such expulsions are prohibited in some regulated child care settings, such as Head Start and many state-funded prekindergarten programs. In addition to complete termination of a child's child care arrangement (expulsion), children are sometimes told that they cannot attend for a certain number of days (suspension) or have their hours of care reduced, sent home from care early, or excluded in other ways. Regardless of the form of the exclusion or its stated reason, the result is often extremely stressful for the child and family, and often the child care provider too. Indeed, parents may lose their jobs due to the resulting lack of reliable child care or resort to dangerous alternatives, such as leaving the child unattended or in an unsafe arrangement. Healthcare providers should play an important role during child care expulsions by supporting families' efforts to find alternative care, perhaps through a referral to their local child care resource and referral agency, assessing for any potentially contributory underlying developmental or behavioral concerns, and asking parents about the safety of any alternative care arrangements. (See Standard 2.2.0.8 [Preventing Expulsions, Suspensions, and Other Limitations in Services] of *Caring for Our Children*, as well as the most recent policy statement on this issue by the AAP.)

### Supporting Parents Regarding Children's Health

Parents frequently may ask primary care clinicians about sick children, exposure to and prevention of risks in child care, and support for children with special needs in child care. When children are ill, parents should be advised to follow guidelines for inclusion and temporary exclusion (see CFOE, CDC, and state guidelines) (see Table 29.2). Parents may disagree with child care staff about whether a child meets or does not meet the exclusion criteria, as a substantial amount of work absenteeism is due to a child illness, showing the impact of lost child care on parental employment. However, professional guidelines in CFOE state that if the reason for exclusion relates to the child's ability to participate or the caregiver's ability to provide care for the other children, the caregiver should not be required to accept responsibility for the care of the child.

Primary care clinicians should emphasize that parents of infants ensure that child care providers put infants on their backs to sleep to prevent SIDS and follow vaccination schedules, including COVID-19 vaccination as it is available to children of younger ages. Most states require compliance with scheduled vaccinations for children to participate in licensed group child care settings. As of October 2021, only three states (Connecticut, Illinois, New Jersey, and Washington) plus the District of Columbia required child care providers to be vaccinated against COVID-19 and/or participate in regular testing.

### Helping Families of Children with Special Needs

Healthcare providers should work with parents and communicate with other service providers and early intervention staff to identify problems, remove access barriers, and coordinate service delivery for children with special needs. They should also encourage involvement of parents and child care providers in developing special education plans such as IEPs and IFSPs. Federal law emphasizes the central role of the family in the development of these plans, and the team writing this plan must consist of the parent or legal guardian and other professionals

that may be involved in the provision of these services, including child care providers. Healthcare providers have an important role to play on these IFSP teams and may attend meetings at the request of the family. Many children with developmental or other special needs that would qualify them for early childhood special education services will present with health concerns, making the healthcare professionals an essential part of adequate early education planning. Additionally, healthcare professionals may support a child's civil rights to access public services such as preschool when their access or ability to participate fully in the program are at risk of limitation due to a diagnosable disability, health, or mental health condition. Often this may require writing a letter stating the nature of the medical condition and the types of accommodations that may improve the child's ability to participate more fully in the range of activities offered by the program. By supporting a child's civil rights under Section 504 of the Rehabilitation Act of 1973 and the Americans with Disabilities Act of 1990, clinicians can and should play an integral role for safeguarding the rights of their patients.

### Consulting and Partnering with Child Care Providers

Most state regulations mandate that licensed programs have a formal relationship with a healthcare provider. They can provide consultation to child care providers about measures to protect and maintain the health and safety of children and staff. This may include consultation regarding promoting practices to prevent SIDS; preventing and reducing the spread of communicable disease; reducing allergen, toxin, and parasite exposure; ensuring vaccinations for children and staff; removing environmental hazards; and preventing injuries. In some cases pediatricians have provided ongoing health and mental health consultation to child care programs, such through highly successful programs like HealthySteps (<https://www.healthysteps.org/>) and "Docs for Tots" (<https://docsfortots.org/>).

Visit Elsevier eBooks+ at [eBooks.Health.Elsevier.com](https://ebooks.health.elsevier.com) for Bibliography.

## Chapter 30

# Loss, Separation, and Bereavement

Megan E. McCabe and Janet R. Serwint

All children will experience involuntary separations, whether from illness, death, or other causes, from loved ones at some time in their lives. Relatively brief separations of children from their parents usually produce minor transient effects, but more enduring and frequent separation may cause sequelae. The potential impact of each event must be considered in light of the age, stage of development, and experiences of the child; the particular relationship with the absent person; and the nature of the situation.

### SEPARATION AND LOSS

Separations may be from temporary causes, such as vacations, parental job requirements, natural disasters or civil unrest, or parental or sibling illness requiring hospitalization. More long-term separations occur as a result of divorce, placement in foster care, or immigration, whereas permanent separation may occur because of death. The initial reaction of young children to separation of any duration may involve crying, such as a tantrum type, protesting type, and a quieter, sadder type. Children's behavior may appear subdued, withdrawn, fussy, or moody, or they may demonstrate resistance to authority. Specific problems may

include poor appetite, behavior issues such as acting against caregiver requests, reluctance to go to bed, sleep problems, or regressive behavior, such as requesting a bottle or bed-wetting. School-age children may experience impaired cognitive functioning and poor performance in school. Some children may repeatedly ask for the absent parent and question when the absent parent will return. The child may go to the window or door or out into the neighborhood to look for the absent parent; a few may even leave home or their place of temporary placement to search for their parents. Other children may not refer to the parental absence at all.

A child's response to reunion may surprise or alarm an unprepared parent. A parent who joyfully returns to the family may be met by wary or cautious children. After a brief interchange of affection, children may seem indifferent to the parent's return. This response may indicate anger at being left or wariness that the event will happen again, or the young child may feel, as a result of **magical thinking** (see Chapter 25), as if the child caused the parent's departure. For example, if the parent who frequently says "Stop it, or you'll give me a headache" is hospitalized, the child may feel at fault and guilty. Because of these feelings, children may seem more closely attached to the present parent than to the absent one, or even to the grandparent or babysitter who cared for them during their parent's absence. Some children, particularly younger ones, may become more clinging and dependent than they were before the separation, while continuing any regressive behavior that occurred during the separation. Such behavior may engage the returned parent more closely and help to reestablish the bond that the child felt was broken. Such reactions are usually transient, and within 1-2 weeks, children will have recovered their usual behavior and equilibrium. Recurrent separations may tend to make children wary and guarded about reestablishing the relationship with the repeatedly absent parent, and these traits may affect other personal relationships. Parents should be advised not to try to modify a child's behavior by threatening to leave.

### DIVORCE

More sustained experiences of loss, such as divorce or placement in foster care, can give rise to the same kinds of reactions noted earlier, but they are more intense and possibly more lasting. Currently in the United States, approximately 40% of first marriages end in divorce. Divorce has been found to be associated with negative parent functioning, such as parental depression and feelings of incompetence; negative child behavior, such as noncompliance and whining; and negative parent-child interaction, such as inconsistent discipline, decreased communication, and decreased affection. Greater childhood distress is associated with greater parental distress. Continued parental conflict and loss of contact with the noncustodial parent is common.

Two of the most important factors that contribute to morbidity of the children in a divorce include *parental psychopathology* and *disrupted parenting* before the separation. The year after the divorce is the period when problems are most apparent; these problems tend to dissipate over the next 2 years. Depression may be present up to 5 years later, and educational or occupational decline may occur even 10 years later. It is difficult to sort out all confounding factors. Children may suffer when exposed to parental conflict that continues after divorce and that in some cases may escalate. The degree of *interparental conflict* may be the most important factor associated with child morbidity. A continued relationship with the noncustodial parent when there is minimal interparental conflict is associated with more positive outcomes.

School-age children may become depressed, may seem indifferent, or may be extremely angry. Other children appear to deny or avoid the issue, behaviorally or verbally. Most children cling to the hope that the actual placement or separation is not real and only temporary. The child may experience guilt by feeling that the loss, separation, or placement represents rejection and perhaps punishment for misbehavior. Children may protect a parent and assume guilt, believing that their own "badness" caused the parent to depart. Children who feel that their misbehavior caused their parents to separate may have the fantasy that their own trivial or recurrent behavioral patterns caused their parents to become angry at each other. A child might perceive that outwardly



blaming parents is emotionally risky; parents who discover that a child harbors resentment might punish the child further for these thoughts or feelings. Some children have behavioral or psychosomatic symptoms and unwittingly adopt a “sick” role as a strategy they hope will reunite their parents.

In response to divorce of parents and the subsequent separation and loss, older children and adolescents usually show intense anger. Five years after the breakup, approximately 30% of children report intense unhappiness and dissatisfaction with their life and their reconfigured family; another 30% show clear evidence of a satisfactory adjustment; and the remaining children demonstrate a mixed picture, with good achievement in some areas and faltering achievement in others. After 10 years, approximately 45% do well, but 40% may have academic, social, or emotional problems. As adults, some are reluctant to form intimate relationships, fearful of repeating their parents’ experience.

Parental divorce has a moderate long-term negative impact on the adult mental health status of children, even after controlling for changes in economic status and problems before divorce. Good adjustment of children after a divorce is related to ongoing involvement with two psychologically healthy parents who minimize conflict and to the siblings and other relatives who provide a positive support system. Divorcing parents should be encouraged to avoid adversarial processes and to use a trained mediator to resolve disputes if needed. Joint-custody arrangements may reduce ongoing parental conflict, but children in joint custody may feel overburdened by the demands of maintaining a strong presence in two homes.

When the primary care provider is asked about the effects of divorce, parents should be informed that different children may have different reactions, but that the parents’ behavior and the way they interact will have a major and long-term effect on the child’s adjustment. The continued presence of both parents in the child’s life, with minimal interparental conflict, is most beneficial to the child.

### MOVE/FAMILY RELOCATION

A significant proportion of the U.S. population changes residence each year. The effects of this movement on children and families are frequently overlooked. For children, the move is essentially involuntary and out of their control. When changes in family structure such as divorce or death precipitate moves, children face the stresses created by both the precipitating events and the move itself. Parental sadness surrounding the move may transmit unhappiness to the children. Children who move lose their old friends, the comfort of a familiar bedroom and house, and their ties to school and community. They not only must sever old relationships but also are faced with developing new ones in new neighborhoods and new schools. Children may enter neighborhoods with different customs and values, and because academic standards and curricula vary among communities, children who have performed well in one school may find themselves struggling in a new one. Frequent moves during the school years are likely to have adverse consequences on social and academic performance.

**Migrant children** and children who emigrate from other countries present with special circumstances. These children not only need to adjust to a new house, school, and community, but also need to adjust to a new culture and in many cases a new language. Because children have faster language acquisition than adults, they may function as translators for the adults in their families. This powerful position may lead to role reversal and potential conflict within the family. In the evaluation of migrant children and families, it is important to ask about the circumstances of the migration, including legal status, violence or threat of violence, conflict of loyalties, and moral, ethical, and religious differences.

Parents should prepare children well in advance of any move and allow them to express any unhappy feelings or misgivings. Parents should acknowledge their own mixed feelings and agree that they will miss their old home while looking forward to a new one. Visits to the new home in advance are often useful preludes to the actual move. Transient periods of regressive behavior may be noted in preschool children after moving, and these should be understood and accepted. Parents should assist the entry of their children into the new

community, and whenever possible, exchanges of letters and visits with old friends should be encouraged.

### SEPARATION BECAUSE OF HOSPITALIZATION

Potential challenges for hospitalized children include coping with separation; adapting to the new hospital environment; adjusting to multiple caregivers; seeing very sick children; and sometimes experiencing the disorientation of intensive care, anesthesia, and surgery. To help mitigate potential problems, a preadmission visit to the hospital can help by allowing the child to meet the people who will be offering care and ask questions about what will happen. Parents of children <5-6 years old should room with the child if feasible. Older children may also benefit from parents or other family members staying with them while in the hospital, depending on the severity of their illness. Creative and active recreational or socialization programs with child life specialists, chances to act out feared procedures in play with dolls or mannequins, and liberal visiting hours, including visits from siblings, are all helpful. Sensitive, sympathetic, and accepting attitudes toward children and parents by the hospital staff are very important. Healthcare providers need to remember that parents have the best interest of their children at heart and know their children the best. Whenever possible, school assignments and tutoring for hospitalized children should be available to engage them intellectually and prevent them from falling behind in their scholastic achievements.

The psychologic aspects of illness should be evaluated from the outset, and physicians should act as a model for parents and children by showing interest in a child’s feelings, allowing them a venue for expression, and demonstrating that it is possible and appropriate to communicate about discomfort. Continuity of medical personnel may be reassuring to the child and family.

### MILITARY FAMILIES

More than 2 million children live in military families in the United States, and approximately 50% of them obtain medical care in the community rather than at a military medical facility. Children whose parents are serving in the military may experience loss and separation in multiple ways. These include frequent relocations, relocation to foreign countries, and duty-related separation from parents. The most impactful experiences have been repeated wartime deployments of parents and the death of parents during military service. All branches of the military have increased their focus on preparing and supporting military families for a service member’s deployment to improve family coping. Military families composed of young parents and young children are at risk for child maltreatment in the context of repeated or prolonged deployments.

### PARENTAL/SIBLING DEATH

Approximately 5–8% of U.S. children will experience parental death; rates are much higher in parts of the world more directly affected by war, AIDS, and natural disasters. Anticipated deaths from chronic illness may place a significant strain on a family, with frequent bouts of illness, hospitalization, disruption of normal home life, absence of the ill parent, and perhaps more responsibilities placed on the child. Additional strains include changes in daily routines, financial pressures, and the need to cope with aggressive treatment options.

Children can and should continue to be involved with the sick parent or sibling, but they need to be prepared for what they will see in the home or hospital setting. The stresses that a child will face include visualizing the physical deterioration of the family member, helplessness, and emotional lability. Forewarning the child that the family member may demonstrate physical changes, such as appearing thinner or losing hair, will help the child to adjust. These warnings combined with simple yet specific explanations of the need for equipment, such as a nasogastric tube for nutrition, an oxygen mask, or a ventilator, will help lessen the child’s fear. Children should be honestly informed of what is happening, in language they can understand, allowing them choices, but with parental involvement in decision-making. They should be encouraged, but not forced, to see their ill family member. Parents who are caring for a dying spouse or child may be too emotionally depleted



to be able to tend to their healthy child's needs or to continue regular routines. Children of a dying parent may suffer the loss of security and belief in the world as a safe place, and the surviving parent may be inclined to impose his or her own need for support and comfort onto the child. However, the well parent and caring relatives must keep in mind that children need to be allowed to remain children, with appropriate support and attention. Sudden, unexpected deaths lead to more anxiety and fear because there is no time for preparation, and explanations for the death can cause uncertainty. Examples of this may be death of a parent due to a motor vehicle crash, homicide or suicide, sudden health-related issue such as a myocardial infarction or stroke, or from infection such as the recent COVID pandemic. Providing support to the child is paramount to allow him or her to express sorrow and grief and to have stability in the child's remaining relationships.

## GRIEF AND BEREAVEMENT

**Grief** is a personal, emotional state of bereavement or an anticipated response to loss, such as a death. Common reactions include sadness, anger, guilt, fear, and at times, relief. The normality of these reactions needs to be emphasized. Most bereaved families remain socially connected and expect that life will return to some new, albeit different, sense of normalcy. The pain and suffering imposed by grief should never be automatically deemed “normal” and thus neglected or ignored. In **uncomplicated grief** reactions, the steadfast concern of the pediatrician can help promote the family's sense of well-being. In more distressing reactions, as seen in traumatic grief of sudden death, the pediatrician may be a major, first-line force in helping children and families address their loss.

Participation in the care of a child with a life-threatening or terminal illness is a profound experience. Parents experience much anxiety and worry during the final stages of their child's life. In one study, 45% of children dying from cancer died in the pediatric intensive care unit, and parents report that 89% of their children suffered “a lot” or “a great deal” during the last month of life. Physicians consistently underreport children's symptoms compared with parents' reports. Better ways are needed to provide care for dying children. Providers need to maintain honest and open communication, provide appropriate pain management, and meet the families' wishes as to the preferred location of the child's death, in some cases in their own home. Inclusion of multiple disciplines, such as hospice, clergy, nursing, pain service, child life specialists, social work, and pet therapy, often helps to support patients and families fully during this difficult experience.

The practice of withholding information from children and parents regarding a child's diagnosis and prognosis has generally been abandoned, because physicians have learned that protecting parents and patients from the seriousness of their child's condition does not alleviate concerns and anxieties. Even very young children may have a real understanding of their illness. Children who have serious diseases and are undergoing aggressive treatment and medication regimens, but who are told by their parents that they are okay, are not reassured. These children understand that something serious is happening to them, and they are often forced to suffer in silence and isolation because the message they have been given by their parents is to not discuss it and to maintain a cheerful demeanor. Children have the right to know their diagnosis and should be informed early in their treatment. The content and depth of the discussion needs to be tailored to the child's personality and developmental level of understanding. Parents have choices as to how to orchestrate the disclosure. Parents may want to be the ones to inform the child themselves, may choose for the pediatric healthcare provider to do so, or may do it in partnership with the pediatrician.

A **death**, especially the death of a family member, is the most difficult loss for a child. Many changes in normal patterns of functioning may occur, including loss of love and support from the deceased family member, a change in income, the possible need to relocate, less emotional support from surviving family members, altering of routines, and a possible change in status from sibling to only child. Relationships between family members may become strained, and children may blame themselves or other family members for the death of a parent or sibling. Bereaved children may exhibit many of the emotions discussed

**Table 30.1** Example Items from the Three Grief Measurement Tools Assessed Through Cognitive Interviewing

CORE BEREAVEMENT ITEMS (CBI)	
Do you experience images of the events surrounding your loved one's death? Do thoughts of your loved one make you feel distressed?	
Do you find yourself pining for/yearning for your loved one?	
Do reminders of your loved one such as photos, situations, music, places, etc., cause you to feel loneliness?	
Do reminders of your loved one such as photos, situations, music, places, etc. cause you to cry about your loved one?	
<b>Response options:</b> A lot of the time; Quite a bit of the time; A little bit of the time; Never	
GRIEF COGNITIONS QUESTIONNAIRE FOR CHILDREN (GCQ-C)	
Since my loved one died, I think of myself as a weak person.	
I should have seen to it that he/she would not have died.	
I blame myself for not having cared for him/her better than I did. It is not nice toward him/her, when I will begin to feel less sad. My life is worthless since he/she died.	
<b>Response options:</b> Hardly ever; Sometimes; Always	
INTRUSIVE GRIEF THOUGHTS SCALE (IGTS)	
(During the past 4 wk) How often did you think about the death of your loved one?	
How often did you find yourself thinking how unfair it is that your loved one died, even though you didn't want to think about it?	
How often did you have trouble falling asleep because you were thinking about your loved one's death? How often have you had bad dreams related to your loved one's death?	
How often did you have trouble doing things you like because you were worrying about how you and your family will get along?	
<b>Response options:</b> Several times a day; About once a day; Once or twice a week; Less than once a week; Not at all	

From Taylor TM, Thurman TR, Nogela L. Every time that month comes, I remember: using cognitive interviews to adapt grief measures for use with bereaved adolescents in South Africa. *J Child Adolesc Mental Health*. 2016;28(2):163–174, Table 1, p 166.

earlier as a result of the loss, in addition to behaviors of withdrawal into their own world, sleep disturbances, nightmares, and symptoms such as headache, abdominal pains, or possibly symptoms similar to those of the family member who has died. Children 3–5 years of age who have experienced a family bereavement may show regressive behaviors such as bed-wetting and thumb sucking. School-age children may exhibit nonspecific symptoms, such as headache, abdominal pain, chest pain, fatigue, and lack of energy. Children and adolescents may also demonstrate enhanced anxiety if these symptoms resemble those of the family member who died. Bereavement may be measured by various published scales (Table 30.1). Behavioral patterns of *persistent complex bereavement disorder* are noted in Table 30.2.

The presence of secure and stable adults who can meet the child's needs and who permit discussion about the loss is most important in helping a child to grieve. The pediatrician should help the family understand this necessary presence and encourage the protective functioning of the family unit (Table 30.3). More frequent visits to the healthcare professional may be necessary to address these symptoms and provide reassurance when appropriate. Suggested availability of clergy or mental health providers can provide additional support and strategies to facilitate the transitions after the death.

Death, separation, and loss as a result of **natural catastrophes** and **human-made disasters** have become increasingly common events in children's lives. Exposure to such disasters occurs either directly or indirectly, where the event is experienced through the media. Examples of **indirect exposure** include scenes of earthquakes, hurricanes, tsunamis, tornadoes, and terrorist attacks. Children who experience personal loss in disasters tend to watch more media coverage than children who do not. Children without a personal loss watch as a way of participating in the event and may thus experience repetitive exposure to traumatic scenes and stories. The loss and devastation for a child who personally lives through a disaster are significant; the effect of the simultaneous occurrence of disaster

**Table 30.2** Developmental Manifestations of Persistent Complex Bereavement Disorder in Children and Adolescents: Developmental Considerations and Symptom Manifestation in Youth

CRITERION A	CHILD HAS EXPERIENCED THE DEATH OF A LOVED ONE
<b>CRITERION B</b>	
B1: Expression of persistent yearning or longing for the deceased	Children have an evolving understanding of the permanence of death, particularly among young children; behavioral expressions of separation distress from surviving caregivers are common, as are reunification fantasies (i.e., wanting to die to be reunited with the parent in the afterlife)
B2: Intense sorrow or emotional pain	Children focus on the more salient immediate physical environment rather than their own internal state; young children often have difficulties expressing inner mood; overt expressions of emotional pain might be interspersed within seemingly normal mood, which can lead to others incorrectly assuming they are not grieving
B3: Preoccupation with the person who died	Children might become distressed when separated from the deceased parent's belongings; it is common for youth to seek out physical connections to their parent, including sleeping in the parent's bed, or wearing their clothing or jewelry
B4: Preoccupation with the circumstances of the death	Young children might reenact the death through play, sometimes with alternate (i.e., counterfactual) actions that depict what children feel they or others could have done to prevent the death; reenacting might also take the form of drawing disturbing scenes or aspects of the death
<b>CRITERION C</b>	
C3: Difficulties related to positive reminiscing about the deceased	Children's ability to reminisce matures with development and is often facilitated by surviving caregivers
C4: Bitterness or anger related to the loss	Youth might show overall irritability, oppositional behavior, and problem behavior in the context of bereavement; externalizing behaviors are often precipitated by changes to the youth's daily routine that are a result of the parent's absence (including others assuming the deceased parent's roles)
C5: Maladaptive self-appraisals in relation to the deceased or the death	Youth, particularly adolescents, might become preoccupied by a perceived accountability (e.g., blaming others or oneself for their parent's death); in young children, this might manifest as magical thinking that their own thoughts or actions caused their parents to die
C6: Excessive avoidance of reminders of the loss	Avoidance might not always be under a child's control (e.g., a parent might choose not to bring the child to the gravesite, which prevents the child from confronting that reminder)
C7: Desire not to live so that they can be with the deceased	Children and adolescents often experience suicidal ideation as a means of reunification fantasies, and their reduced understanding of the complexities of death might exacerbate this mindset among young children; suicidal ideation associated with reunification fantasies might not be accompanied by intent or planning; adolescents might engage in risk-taking behaviors (e.g., substance use, reckless driving)
C8: Difficulty trusting other people since the death	Children might have difficulty establishing relationships with new caregivers, which is often reflective of difficulty with new life circumstances, rather than lack of trust; youth might also display overt anger or oppositional and defiant behaviors toward the surviving or new caregiver
C9: Feeling alone or detached from others since the death	Youth often report feelings of alienation from other peers who have not experienced a similar loss, particularly when reminders of this difference are salient (e.g., seeing other classmates' parents coming to a school event); children and adolescents might conceal their own grief reactions to protect their caregivers from additional distress
C10: Feeling that life is meaningless or empty without the deceased or the belief that they cannot function without the deceased	Developmental regressions (e.g., regression in toileting or language among young children; loss of study skills or emotion regulation in adolescents) are common, as are disruptions to sleep and appetite patterns; adolescents can show a lack of engagement in preparations for adulthood (e.g., applying to jobs)
C11: Confusion about their role in life or a diminished sense of their identity	Youth can express sadness over lost opportunities they were planning to experience with their deceased caregiver (e.g., riding a bicycle, walking down the aisle at their wedding); adolescents might show disorganization, lack of direction, or both
The letters and numbers refer to the symptom within each diagnostic criterion (e.g., criterion B, 4th symptom). Persistent complex bereavement disorder symptom criteria and descriptions have been adapted to the context of parental death.	

From Kentor RA, Kaplow JB. Supporting children and adolescents following parental bereavement: guidance for health-care professionals. *Lancet Child Adolesc.* 2020;4:889–898, p 891.

and personal loss complicates the bereavement process as grief reactions become interwoven with posttraumatic stress symptoms (see [Chapter 38](#)). After a death resulting from aggressive or traumatic circumstances, access to expert help may be required. Under conditions of threat and fear, children seek proximity to safe, stable, protective figures.

It is important for parents to grieve with their children. Some parents want to protect their children from their grief, so they put on an outwardly brave front or do not talk about the deceased family member or traumatic event. Instead of the desired protective effect, the child receives the message that demonstrating grief or talking about death is wrong, leading the child to feel isolated, grieve privately, or delay grieving. The child may also conclude that the parents did not really

care about the deceased because they seem to have forgotten the person so easily or demonstrate no emotion. The parents' efforts to avoid talking about the death may cause the parents to isolate themselves from their children at a time when the children most need them. Children need to know that their parents love them and will continue to protect them. Children need opportunities to talk about their relative's death and associated memories. A surviving sibling may feel guilty simply because he or she survived, especially if the death was the result of an accident that involved both children. Siblings' grief, especially when compounded by feelings of guilt, may manifest as regressive behavior or anger. Parents should be informed of this possibility and encouraged to discuss it with their children.

**Table 30.3** Recommendations for Healthcare Professionals for Helping Children After Bereavement

- Help children and families recognize that there is no correct way to grieve and that every child grieves differently
- Help caregivers recognize that child grief is not the same as adult grief, and children express their grief reactions in very different ways
- Help caregivers understand that the circumstances of the death can play a major role in children's grief reactions, and deaths by homicide or suicide might be especially difficult for children (therefore could require more intensive mental healthcare)
- Empower caregivers by explaining they can be instrumental in facilitating adaptive grief in their children by providing empathy, reassurance, and a listening ear, and talking openly about the deceased person with their child
- Help caregivers to use language accessible to children when talking about the death, meaning that they should use simple and straightforward language that is appropriate for the child's developmental stage, and let the child ask questions as opposed to providing a lot of detailed information
- Provide accurate information to children about the cause of death; children can become preoccupied with thoughts about contagion (e.g., "will I catch cancer too?") or worries about the caregiver's level of suffering (e.g., "did it hurt when my dad had a stroke?"), and healthcare professionals can help children understand the circumstances of the death and assist in alleviating some of these concerns
- Never underestimate the importance of simply bearing witness to a child's grief; our society often sends children messages that it is not okay to talk about their own grief, and in allowing them the space to do that, healthcare professionals can help to both normalize and validate their reactions.

From Kentor RA, Kaplow JB. Supporting children and adolescents following parental bereavement: guidance for health-care professionals. *Lancet Child Adolesc.* 2020;4:889–898, p 896.

## DEVELOPMENTAL PERSPECTIVE

Children's responses to death reflect the family's current culture, their past heritage, their experiences, and the sociopolitical environment. Personal experience with terminal illness and dying may also facilitate children's comprehension of death and familiarity with mourning. Developmental differences exist in children's efforts to make sense of and master the concept and reality of death and profoundly influence their grief reactions.

**Children younger than 3 years** have little or no understanding of the concept of death. Despair, separation anxiety, and detachment may occur at the withdrawal of nurturing caretakers. Young children may respond in reaction to observing distress in others, such as a parent or sibling who is crying, withdrawn, or angry. Young children also express signs and symptoms of grief in their emotional states, such as irritability or lethargy, and in severe cases, mutism. If the reaction is severe, failure to thrive may occur.

**Preschool children** are in the preoperational cognitive stage, in which communication takes place through play and fantasy (see Chapter 25). They do not show well-established cause-and-effect reasoning. They may feel that death is reversible, analogous to someone going away. In attempts to master the finality and permanence of death, preschoolers frequently ask unrelenting, repeated questions about when the person who died will be returning. This makes it difficult for parents, who may become frustrated because they do not understand why the child keeps asking and do not like the constant reminders of the person's death. The primary care provider has a very important role in helping families understand the child's struggle to comprehend death. Preschool children typically

express magical explanations of death events, sometimes resulting in guilt and self-blame ("He died because I wouldn't play with him"; "She died because I was mad at her"). Some children have these thoughts but do not express them verbally because of embarrassment or guilt. Parents and primary care providers need to be aware of magical thinking and must reassure preschool children that their thoughts had nothing to do with the outcome. Children of this age are often frightened by prolonged, powerful expressions of grief by others. Children conceptualize events in the context of their own experiential reality, and therefore consider death in terms of sleep, separation, and injury. Young children express grief intermittently and show marked affective shifts over brief periods.

**Younger school-age children** think concretely, recognize that death is irreversible, but believe it will not happen to them or affect them, and begin to understand biologic processes of the human body ("You'll die if your body stops working"). Information gathered from the media, peers, and parents forms lasting impressions. Consequently, they may ask candid questions about death that adults will have difficulty addressing ("He must have been blown to pieces, huh?").

**Children approximately 9 years and older** do understand that death is irreversible and that it may involve them or their families. These children tend to experience more anxiety, overt symptoms of depression, and somatic complaints than do younger children. School-age children are often left with anger focused on the loved one, those who could not save the deceased, or those presumed responsible for the death. Contact with the primary care clinician may provide great reassurance, especially for the child with somatic symptoms, and particularly when the death followed a medical illness. School and learning problems may also occur, often linked to difficulty concentrating or preoccupation with the death. Close collaboration with the child's school may provide important diagnostic information and offer opportunities to mobilize intervention or support.

At **12–14 years of age**, children begin to use symbolic thinking, reason abstractly, and analyze hypothetical, or "what if," scenarios systematically. Death and the end of life become concepts rather than events. Teenagers are often ambivalent about dependence and independence and may withdraw emotionally from surviving family members, only to mourn in isolation. Adolescents begin to understand complex physiologic systems in relationship to death. Because they are often egocentric, they may be more concerned about the impact of the death on themselves than about the deceased or other family members. Fascination with dramatic, sensational, or romantic death sometimes occurs and may find expression in *copycat behavior*, such as cluster suicides, as well as *competitive behavior*, to forge emotional links to the deceased person ("He was my best friend"). Somatic expression of grief may revolve around highly complex syndromes such as eating disorders (see Chapter 41) or conversion reactions (Chapter 35), as well as symptoms limited to the more immediate perceptions (stomachaches). *Quality of life* takes on meaning, and the teenager develops a focus on the future. Depression, resentment, mood swings, rage, and risk-taking behaviors can emerge as the adolescent seeks answers to questions of values, safety, evil, and fairness. Alternately, adolescents may seek philosophic or spiritual explanations ("being at peace") to ease their sense of loss. The death of a peer may be especially traumatic.

Families often struggle with how to inform their children of the death of a family member. The answer depends on the child's developmental level. It is best to avoid misleading euphemisms and metaphor. A child who is told that the relative who died "went to sleep" may become frightened of falling asleep, resulting in sleep problems or nightmares. Children can be told that the person is "no longer living" or "no longer moving or feeling." Using examples of pets that have died sometimes can help children gain a more realistic idea of the meaning of death. Parents who have religious beliefs may comfort their children with explanations, such as, "Your sister's soul is in heaven," or "Grandfather is now with God," provided those beliefs are honestly held. If these are not religious beliefs that the parents share, children will sense the insincerity and experience anxiety rather than



the hoped-for reassurance. Children's books about death can provide an important source of information, and when read together, these books may help the parent to find the right words while addressing the child's needs.

### ROLE OF THE PEDIATRIC HEALTHCARE PROVIDER IN GRIEF

The pediatric healthcare provider who has had a longitudinal relationship with the family will be an important source of support in the disclosure of bad news and in critical decision-making, during both the dying process and the bereavement period (see Table 30.3). The involvement of the healthcare provider may include being present at the time the diagnosis is disclosed, at the hospital or home at the time of death, being available to the family by phone during the bereavement period, sending a sympathy card, attending the funeral, and scheduling a follow-up visit. Attendance at the funeral sends a strong message that the family and their child are important, respected by the healthcare provider, and can also help the pediatric healthcare provider to grieve and reach personal closure about the death. A family meeting 1-3 months later may be helpful because parents may not be able to formulate their questions at the time of death. This meeting allows the family time to ask questions, share concerns, and review autopsy findings (if one was performed), and allows the healthcare provider to determine how the parents and family are adjusting to the death.

Instead of leaving the family feeling abandoned by a healthcare system that they have counted on, this visit allows them to have continued support. This is even more important when the healthcare provider will be continuing to provide care for surviving siblings. The visit can be used to determine how the mourning process is progressing, detect evidence of marital discord, and evaluate how well surviving siblings are coping. This is also an opportunity to evaluate whether referrals to support groups or mental health providers may be of benefit. Continuing to recognize the child who has died is important. Families appreciate the receipt of a card on their child's birthday, around holidays, or the anniversary of their child's death.

The healthcare provider needs to be an *educator* about disease, death, and grief. The pediatrician can offer a safe environment for the family to talk about painful emotions, express fears, and share memories. By giving families permission to talk and modeling how to address children's concerns, the clinician demystifies death. Parents often request practical help. The healthcare provider can offer families resources, such as literature (both fiction and nonfiction), referrals to therapeutic services, and tools to help them learn about illness, loss, and grief. In this way the physician reinforces the sense that other people understand what they are going through and helps to normalize their distressing emotions. The healthcare provider can also facilitate and demystify the grief process by sharing basic tenets of **grief therapy**. There is no single right or wrong way to grieve. Everyone grieves differently; mothers may grieve differently than fathers, and children mourn differently than adults. Helping family members to respect these differences and reach out to support each other is critical. Grief is not something to "get over," but a lifelong process of adapting, readjusting, and reconnecting.

Parents may need help in knowing what constitutes **normal grieving**. Hearing, seeing, or feeling their child's presence may be a normal response. Vivid memories or dreams may occur. The healthcare provider can help parents to learn that, although their pain and sadness may seem intolerable, other parents have survived similar experiences, and their pain will lessen over time.

Healthcare providers are often asked whether children should attend the **funeral** of a parent or sibling. These rituals allow the family to begin their mourning process. Children >4 years old should be given a choice. If the child chooses to attend, the child should have a designated, trusted adult who is not part of the immediate family and who will stay with the child, offer comfort, and be willing to leave with the child if the experience proves to be overwhelming. If the child chooses not to attend, the child should be offered additional opportunities to share in a ritual, go to the cemetery to view the grave, tell stories about

the deceased, or obtain a keepsake object from the deceased family member as a remembrance.

In the era of regionalized tertiary care medicine, the primary care provider and medical home staff may not be informed when one of their patients dies in the hospital. Yet, this communication is critically important. Families assume their primary care provider has been notified and often feel hurt when they do not receive some symbol of condolence. Because of their longitudinal relationship with the family, primary care providers may offer much needed support. There are practical issues, such as the need to cancel previously made appointments and to alert office and nursing staff so that they are prepared should the family return for a follow-up visit or for ongoing health maintenance care with the surviving siblings. Even minor illnesses in the surviving siblings may frighten children. Parents may contribute to this anxiety because their inability to protect the child who has died may leave them with a sense of guilt or helplessness. They may seek medical attention sooner or may be hypervigilant in the care of the siblings because of guilt over the other child's death, concern about their judgment, or the need for continued reassurance. A primary care visit can do much to allay their fears.

Clinicians must remain vigilant for risk factors in each family member and in the family unit as a whole. Primary care providers, who care for families over time, know bereft patients' premorbid functioning and can identify those at current or future risk for physical and psychiatric morbidity. Providers must focus on symptoms that interfere with a patient's normal activities and compromise a child's attainment of developmental tasks. Symptom duration, intensity, and severity, in context with the family's culture, can help identify **complicated grief** reactions in need of therapeutic attention (see Table 30.2). Descriptive words such as "unrelenting," "intense," "intrusive," or "prolonged" should raise concern. Total absence of signs of mourning, specifically an inability to discuss the loss or express sadness, also suggests potential problems.

No specific sign, symptom, or cluster of behaviors identifies the child or family in need of help. Further assessment is indicated if the following occur: (1) persistent somatic or psychosomatic complaints of undetermined origin (headache, stomachache, eating and sleeping disorders, conversion symptoms, symptoms related to the deceased's condition, hypochondriasis); (2) unusual circumstances of death or loss (sudden, violent, or traumatic death; inexplicable, unbelievable, or particularly senseless death; prolonged, complicated illness; unexpected separation); (3) school or work difficulties (declining grades or school performance, social withdrawal, aggression); (4) changes in home or family functioning (multiple family stresses, lack of social support, unavailable or ineffective functioning of caretakers, multiple disruptions in routines, lack of safety); and (5) concerning psychologic factors (persistent guilt or blame, desire to die or talk of suicide, severe separation distress, disturbing hallucinations, self-abuse, risk-taking behaviors, symptoms of trauma such as hyperarousal or severe flashbacks, grief from previous or multiple deaths). Children who are intellectually impaired may require additional support.

### TREATMENT

Suggesting interventions outside the natural support network of family and friends can often prove useful to grieving families. Bereavement counseling should be readily offered if needed or requested by the family. Interventions that enhance or promote attachments and security, as well as give the family a means of expressing and understanding death, help to reduce the likelihood of future or prolonged disturbance, especially in children. Collaboration between pediatric and mental health professionals can help determine the timing and appropriateness of services.

Interventions for children and families who are struggling to cope with a loss in the community include gestures such as sending a card or offering food to the relatives of the deceased and teaching children the etiquette of behaviors and rituals around bereavement and mutual support. Performing community service or joining



charitable organizations, such as fund-raising in memory of the deceased, may be useful. In the wake of a disaster, parents and older siblings can give blood or volunteer in search and recovery efforts. When a loss does not involve an actual death (e.g., parental divorce, geographic relocation), empowering the child to join or start a “divorced kids’ club” in school or planning a “new kids in town” party may help. Participating in a constructive activity moves the family away from a sense of helplessness and hopelessness and helps them find meaning in their loss.

**Psychotherapeutic services** may benefit the entire family or individual members. Many support or self-help groups focus on specific types of losses (sudden infant death syndrome, suicide, widow/widowers, AIDS) and provide an opportunity to talk with other people who have experienced similar losses. Family, couple, sibling, or individual counseling may be useful, depending on the nature of the residual coping issues. Combinations of approaches may work well for children or parents with evolving needs. A child may participate in family therapy to deal with the loss of a sibling and use individual treatment to address issues of personal ambivalence and guilt related to the death.

The question of **pharmacologic intervention** for grief reactions often arises. Explaining that medication does not cure grief and often does not reduce the intensity of some symptoms (separation distress) can help. Although medication can blunt reactions, the psychological work of grieving still must occur. The physician must consider the patient’s premorbid psychiatric vulnerability, current level of functioning, other available supports, and the use of additional therapeutic interventions. Medication as a first line of defense rarely proves useful in normal or uncomplicated grief reactions. In certain situations (severe sleep disruption, incapacitating anxiety, intense hyperarousal), an anxiolytic or antidepressant may help to achieve symptom relief and provide the patient with the emotional energy to mourn. Medication used in conjunction with some form of psychotherapy, and in consultation with a psychopharmacologist, has optimal results.

Children who are **refugees** and may have experienced war, violence, or personal torture, while often resilient, may experience post-traumatic stress disorder if exposures were severe or repeated (see Chapters 15.3 and 38). Sequelae such as depression, anxiety, and grief need to be addressed, and mental health therapy is indicated. Cognitive-behavioral therapy, use of journaling and narratives to bear witness to the experiences, and use of translators may be essential.

## SPIRITUAL ISSUES

Responding to patients’ and families’ spiritual beliefs can help in comforting them during family tragedies. Offering to call members of pastoral care teams or their own spiritual leader can provide needed support and can aid in decision-making. Families have found it important to have their beliefs and their need for hope acknowledged in end-of-life care. The majority of patients report welcoming discussions on spirituality, which may help individual patients cope with illness, disease, dying, and death. In addressing spirituality, physicians need to follow certain guidelines, including maintaining respect for the patient’s beliefs, following the patient’s lead in exploring how spirituality affects the patient’s decision-making, acknowledging the limits of their own expertise and role in spirituality, and maintaining their own integrity by not saying or doing anything that violates their own spiritual or religious views. Healthcare providers should not impose their own religious or non-religious beliefs on patients, but rather should listen respectfully to their patients. By responding to spiritual needs, clinicians may better aid their patients and families in end-of-life care and bereavement and take on the role of healers.

Visit Elsevier eBooks+ at [eBooks.Health.Elsevier.com](http://eBooks.Health.Elsevier.com) for Bibliography.

## Chapter 31

# Sleep Medicine

Judith A. Owens and Seyni Gueye-Ndiaye

## BASICS OF SLEEP AND CHRONOBIOLOGY

Sleep and wakefulness are a highly complex and intricately regulated neurobiologic system that both influences and is influenced by all physiologic systems in the body, as well as by the environment and socio-cultural practices. The concept of **sleep regulation** is based on what is usually referred to as the “two-process model” because it requires the simultaneous operation of two basic, highly coupled processes that govern sleep and wakefulness. The **homeostatic process** (“Process S”), regulates the length and depth of sleep and is thought to be related to the accumulation of adenosine and other sleep-promoting chemicals (“sommogens”), such as cytokines, during prolonged periods of wakefulness. This sleep pressure appears to build more quickly in infants and young children, thus limiting the duration that wakefulness can be sustained during the day and necessitating periods of daytime sleep (i.e., naps). The endogenous **circadian rhythms** (“Process C”) influence the internal organization of sleep and the timing and duration of daily sleep-wake cycles and govern predictable patterns of alertness throughout the 24-hour day.

The “master circadian clock” or “circadian pacemaker” that controls sleep-wake patterns, of which melatonin secretion is the principal biomarker, is located in the suprachiasmatic nucleus in the anterior hypothalamus. In addition, “circadian clocks” are present in virtually every cell in the body, which in turn govern the timing of multiple other physiologic systems (e.g., cardiovascular reactivity, hormone levels, renal and pulmonary functions). Because the human circadian clock is slightly longer than 24 hours, intrinsic circadian rhythms must be synchronized or “entrained” to the 24-hour-day cycle by environmental cues called *zeitgebers*. The **dark-light cycle** is the most powerful of the *zeitgebers*; light signals are transmitted to the suprachiasmatic nucleus via the circadian photoreceptor system within the retina (functionally and anatomically separate from the visual system), which switch the pineal gland’s production of the hormone melatonin off (light) or on (dark). Circadian rhythms are also synchronized by other external time cues, such as timing of meals and clock time.

*Sleep propensity*, the relative level of sleepiness or alertness experienced at any given time during a 24-hour period, is partially determined by the homeostatic *sleep drive*, which in turn depends on the duration and quality of previous sleep and the amount of time awake since the last sleep period. Interacting with this *sleep homeostat* is the 24-hour cyclic pattern or rhythm characterized by clock-dependent periods of maximum sleepiness and maximum alertness. There are two periods of maximum sleepiness, one in the late afternoon (approximately 3:00–5:00 PM) and one toward the end of the night (around 3:00–5:00 AM), and two periods of maximum alertness, one in mid-morning and one in the evening just before the onset of natural sleep, the so-called forbidden zone or second-wind phenomenon, which allows for the maintenance of wakefulness in the face of an accumulated sleep drive.

There are significant health, safety, and performance consequences of failure to meet basic sleep needs, termed *insufficient/inadequate sleep* or **sleep loss**. Sufficient sleep is a biologic imperative, necessary for optimal brain and body functioning. **Slow-wave sleep (SWS)** (i.e., N3, delta, or deep sleep) appears to be the most restorative form of sleep; it is entered relatively quickly after sleep onset, is preserved in the face of reduced total sleep time and increases (rebounds) after a night of restricted sleep. These restorative properties of sleep may be linked to the “glymphatic system,” which increases clearance of metabolic waste

products, including  $\beta$ -amyloid, produced by neural activity in the awake brain. **Rapid eye movement (REM)** sleep (stage R or “dream” sleep) appears to be involved in numerous important brain processes, including completion of vital cognitive functions (e.g., consolidation of memory), promoting the plasticity of the central nervous system (CNS), and protecting the brain from injury. Sufficient amounts of these sleep stages are necessary for optimal cognitive functioning and emotional and behavioral self-regulation.

Partial sleep loss (i.e., sleep restriction) on a chronic basis accumulates in a **sleep debt** and over several days produces deficits equivalent to those seen under conditions of one night of total sleep deprivation. If the sleep debt becomes large enough and is not voluntarily repaid by obtaining sufficient recovery sleep, the body may respond by overriding voluntary control of wakefulness. This results in periods of decreased alertness, dozing off, and unplanned napping, recognized as *excessive daytime sleepiness (EDS)*. The sleep-restricted individual may also experience very brief (several seconds) repeated daytime microsleeps, of which the individual may be completely unaware, but which nonetheless may result in significant lapses in attention and vigilance. There is also a relationship between the amount of sleep restriction and performance on cognitive tasks, particularly those requiring sustained attention and higher-level cognitive skills (*executive functions*; see Chapter 49), with a decay in performance correlating with declines in sleep amounts.

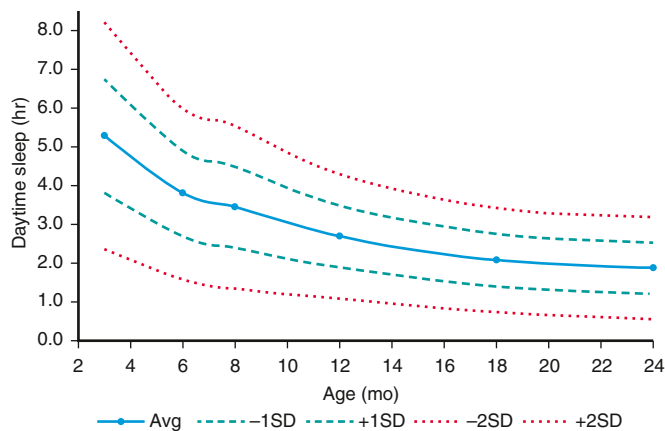
It has also been recognized that what may be globally described as “deficient” sleep involves alterations in both amount and *timing* of sleep. Misalignment of intrinsic circadian rhythms with extrinsic societal demands, such as a shift work and early school start times, is associated with deficits in cognitive function and self-regulation, increased emotional and behavioral problems and risk-taking behaviors, and negative impacts on health, such as increased risk of cardiovascular disease, obesity, and metabolic dysfunction.

Insufficient quantity of sleep, mistimed sleep, and poor-quality sleep frequently result in EDS and decreased daytime alertness levels. Sleepiness in children may be recognizable as drowsiness, yawning, and other classic “sleepy behaviors” as well as resumption of napping in older children and extending sleep when given the opportunity such as on weekends. If a child can sleep more, they need more sleep. EDS can also manifest as mood disturbance, including irritability, emotional lability, low frustration tolerance and depressed or negative mood; fatigue and daytime lethargy, including increased somatic complaints (headaches, gastrointestinal disturbances); cognitive impairment, including problems with memory, attention, concentration, decision-making, and problem solving; daytime behavior problems, including hyperactivity, impulsivity, and noncompliance; and academic problems, including chronic tardiness related to insufficient sleep and school failure. While sleepiness and fatigue may overlap in their clinical presentation, sleepiness is characterized by the propensity to fall asleep, particularly under conditions of low stimulation (e.g., riding in the car), while fatigue is often described as a state of low energy, decreased motivation, and “exhaustion.”

## DEVELOPMENTAL CHANGES IN SLEEP

Sleep disturbances, as well as many characteristics of sleep itself, have some distinctly different features in children from sleep and sleep disorders in adults. Changes in sleep architecture and the evolution of sleep patterns and behaviors reflect the physiologic/chronobiologic, developmental, and social/environmental changes that are occurring across childhood. These trends may be summarized as the gradual assumption of more adult sleep patterns as children mature (Figs. 31.1 and 31.2):

1. Sleep is *the* primary activity of the brain during early development; for example, by age 2 years, the average child has spent 9,500 hours (approximately 13 months) asleep vs 8,000 hours awake, and between 2 and 5 years, the time asleep is equal to the time awake.
2. There is a gradual decline in the average 24-hour sleep duration from infancy through adolescence, which involves a decrease in both diurnal and nocturnal sleep amounts. The decline in daytime sleep (scheduled napping) results in termination of naps typically by age 5 years, although there is clearly considerable variability in the age



**Fig. 31.1** Daytime sleep duration in infants ages 3–24 mo. SD, Standard deviation. (From Paavonen EJ, Saarenpää-Heikkilä O, Morales-Munoz, I, et al. *Normal sleep development in infants: findings from two large birth cohorts*. *Sleep Med*. 2020;69:145–154. Fig. 2, p 149.)

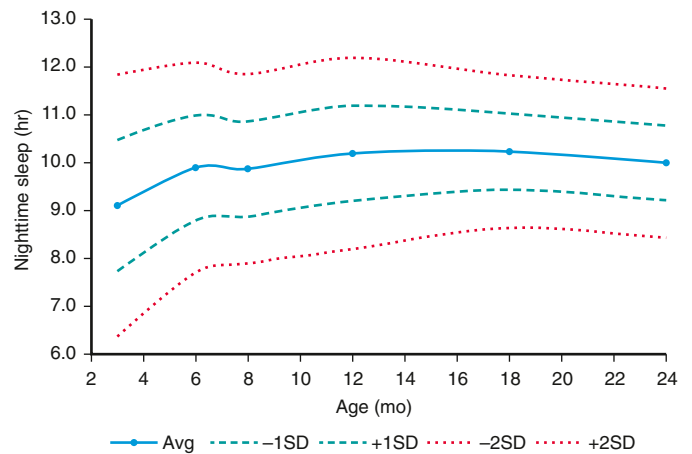
at which children cease napping. There is also a gradual continued decrease in nocturnal sleep amounts into late adolescence; however, adolescents still require 8–10 hours of sleep per night.

3. There is also a decline in the relative percentage of REM sleep from birth (50% of sleep) through early childhood into adulthood (25–30%), and a similar initial predominance of SWS that peaks in early childhood, drops off abruptly after puberty (40–60% decline), and then further decreases over the life span. This SWS preponderance in early life has clinical significance; for example, the high prevalence of partial arousal parasomnias (sleepwalking and sleep terrors) in preschool- and early school-age children is related to the relative increased percentage of SWS in this age-group.
4. The within-sleep *ultradian cycle* lengthens from about 50 minutes in the term infant to 90–110 minutes in the school-age child. This has clinical significance in that typically a brief arousal or awakening occurs during the night at the termination of each ultradian cycle. As the length of the cycles increase, there is a concomitant decrease in the number of these end-of-cycle arousals (night wakings).
5. A gradual shift in the circadian sleep–wake rhythm to a delayed (later) sleep onset and offset time, linked to pubertal stage rather than chronologic age, begins with pubertal onset in middle childhood and accelerates in early to mid-adolescence. This biologic phenomenon often coincides with environmental factors, which further delay bedtime and advance wake time and result in insufficient sleep duration, including exposure to electronic “screens” in the evening, social networking, academic and extracurricular demands, and early (before 8:30 AM) high school start times. In addition, the accumulation of the homeostatic sleep drive across the day slows and both sensitivity and exposure to evening light increases (especially blue spectrum light from electronic devices) during adolescence, conspiring to further delay sleep onset.
6. Increasing irregularity of sleep–wake patterns is typically observed across childhood into adolescence; this is characterized by increasingly larger discrepancies between school night and non-school night bedtimes and wake times, and increased “weekend oversleep” in an attempt to compensate for chronic weekday sleep insufficiency. This phenomenon, often referred to as “social jet lag” not only fails to adequately address performance deficits associated with insufficient sleep on school nights but further exacerbates the normal adolescent phase delay and results in additional circadian disruption (analogous to that experienced by shift workers).

Table 31.1 lists normal developmental changes in children’s sleep.

## COMMON SLEEP DISORDERS

Childhood sleep problems may be conceptualized as resulting from (1) inadequate duration of sleep for age and sleep needs (insufficient sleep quantity); (2) disruption and fragmentation of sleep (poor



**Fig. 31.2** Nighttime sleep duration in infants ages 3–24 mo. SD, Standard deviation. (From Paavonen EJ, Saarenpää-Heikkilä O, Morales-Munoz, I, et al. Normal sleep development in infants: findings from two large birth cohorts. *Sleep Med.* 2020;69:145–154. Fig. 3, p 149.)

sleep quality) as a result of frequent, repetitive, and brief arousals during sleep; (3) misalignment of sleep–wake timing with circadian rhythms; or (4) CNS-mediated **hypersomnia** (EDS and increased sleep needs). Insufficient sleep is usually the result of difficulty initiating (*delayed sleep onset*) or maintaining sleep (*prolonged night wakings*) but, especially in older children and adolescents, may also represent a conscious lifestyle decision to sacrifice sleep in favor of competing priorities, such as homework and social activities. The underlying causes of delayed sleep onset/prolonged night wakings or sleep fragmentation may in turn be related to primarily behavioral factors (e.g., bedtime resistance resulting in shortened sleep duration) or medical causes (e.g., **obstructive sleep apnea [OSA]** causing frequent, brief arousals).

Certain pediatric populations are relatively more vulnerable to acute or chronic sleep problems. These include children with chronic illnesses or pain conditions (e.g., cystic fibrosis, asthma, idiopathic juvenile arthritis) and acute illnesses (e.g., otitis media); children taking stimulants (e.g., psychostimulants, caffeine), sleep-disrupting medications (e.g., corticosteroids), or daytime-sedating medications (some anticonvulsants,  $\alpha$ -agonists); hospitalized children; and children with a variety of psychiatric disorders, including attention-deficit/hyperactivity disorder (ADHD), depression, bipolar disorder, and anxiety disorders. Children with neurodevelopmental disorders such as autism, intellectual disability, blindness, and some chromosomal syndromes (e.g., Smith-Magenis, fragile X) have especially high rates of sleep disturbances for a wide variety of reasons. They may have comorbid medical issues or may be taking sleep-disrupting medications, may be more prone to nocturnal seizures, may be less easily entrained by environmental cues and thus more vulnerable to circadian disruption, and are more likely to have psychiatric and behavioral comorbidities that further predispose them to disrupted sleep. Children from low socioeconomic households or minoritized racial and ethnic groups, as well as children in alternative care such as foster placement, are more likely to experience, are less likely to be diagnosed and treated, and are more vulnerable to the negative impact of sleep disorders resulting in significant sleep health disparities.

### Insomnia of Childhood

**Insomnia** is defined as difficulty initiating and/or maintaining sleep that occurs despite age-appropriate time and opportunity for sleep and results in some degree of impairment in daytime functioning for the child and/or family (ranging from fatigue, irritability, lack of energy, and mild cognitive impairment to effects on mood, school performance, and quality of life). Insomnia may be of a short-term and transient nature (usually related to an acute event) or may be characterized as long-term and chronic. Insomnia is a set of *symptoms* with many possible etiologies (e.g., pain, medication, medical/

psychiatric conditions, learned behaviors). As with many behavioral issues in children, insomnia is often primarily defined by parental concerns rather than by objective criteria and therefore should be viewed in the context of family (maternal depression, stress), child (temperament, developmental level), and environmental (cultural practices, sleeping space) considerations.

While current terminology (*Diagnostic and Statistical Manual of Mental Disorders*, 5th edition, 2015; *International Classification of Sleep Disorders*, 3rd edition, 2014) groups most types of insomnia in both children and adults under a single category of Chronic Insomnia Disorder, the descriptor of Behavioral Insomnia of Childhood and its subtypes (Sleep Onset Association and Limit Setting) remains a useful construct in clinical practice, particularly for young children (0–5 years). One of the most common presentations of insomnia found in infants and toddlers is the **sleep-onset association type**. In this situation the child learns to fall asleep only under certain conditions or associations, which typically require parental presence, such as being rocked or fed, and does not develop the ability to self-soothe. During the night, when the child experiences the type of brief arousal that normally occurs at the end of an ultradian sleep cycle or awakens for other reasons, the child is not able to get back to sleep without those same associations being present. The infant then “signals” the parent by crying (or coming into the parents’ bedroom if the child is ambulatory) until the necessary associations are provided. The presenting complaint is typically one of prolonged night waking requiring caregiver intervention and resulting in insufficient sleep (for both child and caregiver).

Management of **night wakings** should include establishment of a set sleep schedule and bedtime routine and implementation of a behavioral program. The treatment approach typically involves a program of rapid withdrawal (extinction) or more gradual withdrawal (graduated extinction) of parental assistance at sleep onset and during the night. **Extinction** (“cry it out”) involves putting the child to bed at a designated bedtime, “drowsy but awake,” to maximize sleep propensity and then systematically ignoring any protests by the child until a set time the next morning. Although it has considerable empirical support, extinction is often not an acceptable choice for families. **Graduated extinction** (aka “check-ins,” “Ferber method,” “sleep training”) involves gradually weaning the child from dependence on parental presence; typically, the parent leaves the room at “lights out” and then returns or “checks” periodically at fixed or successively longer intervals during the sleep–wake transition to provide *brief* reassurance until the child falls asleep. The exact interval between checks is generally determined by the parents’ tolerance for crying and the child’s temperament; the goal is to allow enough time between checks for the child to fall asleep independently while avoiding extended time intervals that result in continued escalation of protest behaviors such as screaming and

**Table 31.1** Normal Developmental Changes in Children's Sleep

AGE CATEGORY	SLEEP DURATION* AND SLEEP PATTERNS	ADDITIONAL SLEEP ISSUES	SLEEP DISORDERS
Newborn (0-2 mo)	<ul style="list-style-type: none"> <li>Total sleep: 10-19 hr per 24 hr (average, 13-14.5 hr), may be higher in premature babies.</li> <li>Bottle-fed babies generally sleep for longer periods (2-5 hr bouts) than breastfed babies (1-3 hr).</li> <li>Sleep periods are separated by 1-2 hr awake.</li> <li>No established nocturnal-diurnal pattern in first few wk; sleep is evenly distributed throughout the day and night, averaging 8.5 hr at night and 5.75 hr during day.</li> </ul>	<ul style="list-style-type: none"> <li>American Academy of Pediatrics issued a revised recommendation in 2016 advocating against bed-sharing in the first year of life, instead encouraging proximate but separate sleeping surfaces for mother and infant for at least the first 6 mo and preferably first year of life.</li> <li>Safe sleep practices for infants: <ul style="list-style-type: none"> <li>Place baby on his or her back to sleep at night and during nap times.</li> <li>Place baby on a firm mattress with well-fitting sheet in safety-approved crib.</li> <li>Do not use pillows or comforters.</li> <li>Standards require crib bars to be no farther apart than 2 3/8 in.</li> <li>Make sure baby's face and head stay uncovered and clear of blankets and other coverings during sleep.</li> </ul> </li> </ul>	<ul style="list-style-type: none"> <li>Most sleep issues perceived as problematic at this stage represent a discrepancy between parental expectations and developmentally appropriate sleep behaviors.</li> <li>Newborns who are extremely fussy and persistently difficult to console, as noted by parents, are more likely to have underlying medical issues such as colic, gastroesophageal reflux, and formula intolerance.</li> </ul>
Infant (2-12 mo)	<ul style="list-style-type: none"> <li>Recommended sleep duration (4-12 mo) is 12-16 hr (note that there is great individual variability in sleep times during infancy).</li> </ul>	<ul style="list-style-type: none"> <li>Sleep regulation or self-soothing involves the infant's ability to negotiate the sleep-wake transition, both at sleep onset and following normal awakenings throughout the night. The capacity to self-soothe begins to develop in the first 12 wk of life and is a reflection of both neurodevelopmental maturation and learning.</li> <li>Sleep consolidation, or "sleeping through the night," is usually defined by parents as a continuous sleep episode without the need for parental intervention (e.g., feeding, soothing) from the child's bedtime through the early morning. Infants develop the ability to consolidate sleep between 6 wk and 3 mo.</li> </ul>	<ul style="list-style-type: none"> <li>Behavioral insomnia of childhood; sleep-onset association type</li> <li>Sleep-related rhythmic movements (head banging, body rocking)</li> </ul>
Toddler (1-2 yr)	<ul style="list-style-type: none"> <li>Recommended sleep amount is 11-14 hr (including naps).</li> <li>Naps decrease from two to one nap at average age of 18 mo.</li> </ul>	<ul style="list-style-type: none"> <li>Cognitive, motor, social, and language developmental issues impact sleep.</li> <li>Nighttime fears develop; transitional objects and bedtime routines are important.</li> </ul>	<ul style="list-style-type: none"> <li>Behavioral insomnia of childhood, sleep-onset association type</li> <li>Behavioral insomnia of childhood, limit-setting type</li> </ul>
Preschool (3-5 yr)	<ul style="list-style-type: none"> <li>Recommended sleep amount is 10-13 hr (including naps).</li> <li>Overall, 26% of 4 yr olds and just 15% of 5 yr olds nap.</li> </ul>	<ul style="list-style-type: none"> <li>Persistent cosleeping tends to be highly associated with sleep problems in this age-group.</li> <li>Sleep problems may become chronic.</li> </ul>	<ul style="list-style-type: none"> <li>Behavioral insomnia of childhood, limit-setting type</li> <li>Sleepwalking, sleep terrors, nighttime fears/nightmares, obstructive sleep apnea syndrome</li> </ul>
Middle childhood (6-12 yr)	<ul style="list-style-type: none"> <li>Recommended sleep amount is 9-12 hr.</li> </ul>	<ul style="list-style-type: none"> <li>School and behavior problems may be related to sleep problems.</li> <li>Media and electronics, such as television, computer, video games, and the internet, increasingly compete for sleep time.</li> <li>Irregularity of sleep-wake schedules reflects increasing discrepancy between school and non-school night bedtimes and wake times.</li> </ul>	<ul style="list-style-type: none"> <li>Nightmares</li> <li>Obstructive sleep apnea syndrome</li> <li>Insufficient sleep</li> </ul>
Adolescence (13-18 yr)	<ul style="list-style-type: none"> <li>Recommended sleep amount is 8-10 hr.</li> <li>Later bedtimes; increased discrepancy between sleep patterns on weekdays and weekends</li> </ul>	<ul style="list-style-type: none"> <li>Puberty-mediated phase delay (later sleep onset and wake times), relative to sleep-wake cycles in middle childhood</li> <li>Earlier required wake times</li> <li>Environmental competing priorities for sleep</li> </ul>	<ul style="list-style-type: none"> <li>Insufficient sleep</li> <li>Delayed sleep-wake phase disorder</li> <li>Narcolepsy</li> <li>Restless legs syndrome/periodic limb movement disorder</li> </ul>

\*All recommended sleep amounts from Paruthi S, Brooks LJ, D'Ambrosio C, et al. Recommended amount of sleep for pediatric populations: a consensus statement of the American Academy of Sleep Medicine. *J Clin Sleep Med*. 2016;12:785-786.

gagging/vomiting. This allows the infant or child to develop the skills necessary for self-soothing at bedtime and also during the night. Sleep training is typically not instituted until about 6 months of age, but the practice of putting the infant to sleep "drowsy but

awake" starting at 3-4 months to encourage self-soothing may avoid the need for later intervention. In older infants and young children, the introduction of more appropriate sleep associations that will be readily available to the child during the night (transitional



objects, such as a blanket or toy), in addition to positive reinforcement (stickers for remaining in bed), is often beneficial. As healthy, normally growing full-term infants no longer need night feedings from a nutritional standpoint, if the child has become habituated to awaken for nighttime feedings (learned hunger), these feedings should be eliminated (either “cold turkey” or by gradually decreasing volume and the milk:water ratio). Parents must be consistent in applying behavioral interventions to avoid inadvertent, intermittent reinforcement of night wakings. They should also be forewarned that crying behavior often temporarily escalates at the beginning of treatment (*postextinction burst*).

Bedtime problems, including stalling and refusing to go to bed, are more common in preschool-age and older children. This type of insomnia is frequently related to inadequate **limit setting** at bedtime such as an inability or unwillingness to set consistent bedtime rules, and enforce a regular bedtime. In some cases, caregivers have adopted an inconsistent approach to night wakings that involves intermittently allowing the child to share their bed. This type of sleep problem may be associated with parental difficulty in setting limits or managing behavior in general and may be exacerbated by a child’s tendency to engage in oppositional behavior. In some cases, the child’s resistance at bedtime is the result of an underlying problem in falling asleep that is caused by other factors (medical conditions such as asthma or medication use; a sleep disorder such as restless legs syndrome; anxiety) or a mismatch between the child’s intrinsic circadian rhythm (“night owl”) and parental expectations regarding an “appropriate” bedtime.

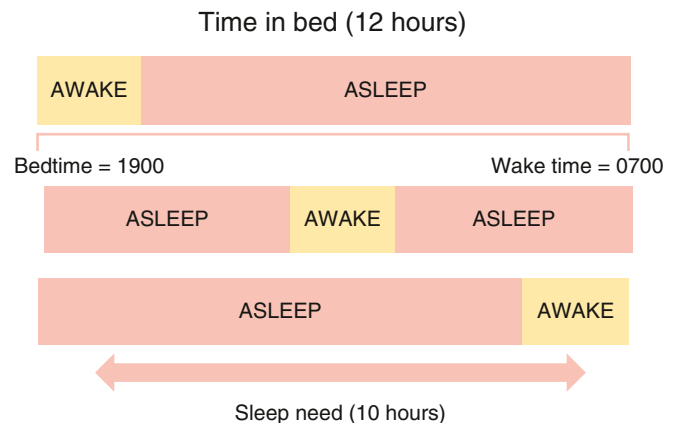
Successful treatment of limit-setting sleep problems generally involves a combination of parent education regarding appropriate limit setting, decreased parental attention for bedtime-delaying behavior, establishment of bedtime routines, and positive reinforcement (sticker charts) for appropriate behavior at bedtime and during the night. For problematic night wakings, it is essential for caregivers to have a consistent response (e.g., returning the child to their bedroom after every night waking). Other behavioral management strategies that have empirical support include **bedtime fading**, or temporarily setting the bedtime closer to the actual sleep-onset time and then gradually advancing the bedtime to an earlier target bedtime. Older children may benefit from being taught relaxation techniques to help themselves fall asleep or back to sleep more readily. Following the principles of healthy sleep practices for children is essential (Table 31.2).

A third type of childhood insomnia is related to a mismatch between parental expectations regarding time in bed and the child’s intrinsic sleep needs. If, as illustrated in Figure 31.3, a child’s typical sleep time is 10 hours but the “sleep window” is set for 12 hours (7 PM to 7 AM), the result is likely to be a prolonged sleep onset of 2 hours, an extended period of wakefulness during the night, or early morning waking (or a combination); these periods are usually characterized by “normal” wakefulness in the child that is not accompanied by excessive distress. This situation is important to recognize because the solution (reducing the time in bed to actual sleep time) is typically simple and effective.

Another form of insomnia that is more common in older children and adolescents has often been referred to as *psychophysiological, primary, or learned insomnia*. **Primary insomnia** occurs mainly in adolescents and is characterized by a combination of learned sleep-preventing associations and heightened physiologic arousal resulting in a complaint of sleeplessness and decreased daytime functioning. A hallmark of primary insomnia is excessive worry about sleep and an exaggerated concern of the potential daytime consequences. The physiologic arousal can be in the form of cognitive **hypervigilance**, such as “racing” thoughts; in many individuals with insomnia, an increased baseline level of arousal is further intensified by this secondary anxiety about sleeplessness. Treatment usually involves educating the adolescent about the principles of healthy sleep practices (Table 31.3), institution of a consistent sleep–wake schedule, avoidance of daytime napping, instructions to use the bed for sleep only and to get out of bed if unable to fall asleep (*stimulus control*), restricting time in bed to the actual time asleep (*sleep restriction*), addressing maladaptive cognitions about sleep, and teaching relaxation techniques to reduce anxiety (cognitive behavioral therapy for insomnia [CBT-I]).

**Table 31.2** Basic Principles of Healthy Sleep for Children

1. Have a set bedtime and bedtime routine for your child.
2. Bedtime and wake-up time should be about the same time on school nights and non-school nights. There should not be more than about 1 hr difference from one day to another.
3. Make the hour before bed shared quiet time. Avoid high-energy activities, such as rough play, and stimulating activities, such as watching television or playing computer games, just before bed.
4. Don’t send your child to bed hungry. A light snack (e.g., milk and cookies) before bed is a good idea. Heavy meals within 1 hr or 2 of bedtime, however, may interfere with sleep.
5. Avoid products containing caffeine for at least several hours before bedtime. These include caffeinated sodas, coffee, tea, and chocolate.
6. Make sure your child spends time outside every day, whenever possible, and is involved in regular exercise.
7. Keep your child’s bedroom quiet and dark. A low-level night light is acceptable for children who find completely dark rooms frightening.
8. Keep your child’s bedroom at a comfortable temperature during the night (<24°C [75°F]).
9. Don’t use your child’s bedroom for time-out or punishment.
10. Keep the television out of your child’s bedroom. Children can easily develop the bad habit of “needing” the television to fall asleep. It is also much more difficult to control your child’s viewing if the set is in the bedroom.



**Fig. 31.3** Mismatch between sleep needs/duration and time in bed, resulting in insomnia.

The keys to successful behavioral sleep interventions involve forming an alliance with the family, negotiating tailored solutions that are more likely to be effective if families can be successful in implementing them, and setting appropriate agreed-on treatment goals with planned follow-up. Behavioral treatments for insomnia, even in young children, appear to be highly effective and well tolerated. Several studies have failed to demonstrate long-term negative effects of behavioral strategies such as “sleep training” on parent–child relationships and attachment, psychosocial-emotional functioning, and chronic stress. It should also be emphasized that, as in adults, behavioral interventions are the *first-line treatment* for insomnia in children, and in general, hypnotic medications or supplements such as melatonin are infrequently needed and should only be used as an adjunct to behavioral therapy to treat insomnia in typically developing and healthy children. If cognitive behavior therapy and sleep hygiene practices are ineffective in children with autism spectrum disorders or ADHD, melatonin may be an additional effective therapy.

**Table 31.3** Basic Principles of Healthy Sleep for Adolescents

1. **Wake up and go to bed at about the same time** every night. Bedtime and wake-up time should not differ from school to non-school nights by more than approximately 1 hr.
2. **Avoid sleeping in on weekends** to “catch up” on sleep. This makes it more likely that you will have problems falling asleep.
3. If you take **naps**, they should be **short** (no more than 1 hr) and **scheduled in the early to mid-afternoon**. However, if you have a problem with falling asleep at night, napping during the day may make it worse and should be avoided.
4. **Spend time outside** every day. Exposure to sunlight helps to keep your body's internal clock on track.
5. **Exercise regularly**. Exercise may help you fall asleep and sleep more deeply.
6. **Use your bed for sleeping only**. Don't study, read, listen to music, or watch television on your bed.
7. **Make the 30-60 min before bedtime a quiet or wind-down time**. Relaxing, calm, enjoyable activities, such as reading a book or listening to calm music, help your body and mind slow down enough to let you get to sleep. Don't study, watch exciting/scary movies, exercise, or get involved in “energizing” activities just before bed.
8. Eat regular meals, and **don't go to bed hungry**. A light snack before bed is a good idea; eating a full meal within 1 hr before bed is not.
9. **Avoid eating or drinking products containing caffeine** from dinnertime to bedtime. These include caffeinated sodas, coffee, tea, and chocolate.
10. **Do not use alcohol**. Alcohol disrupts sleep and may cause you to awaken throughout the night.
11. Smoking (e.g., cigarettes) disturbs sleep. Although you should not smoke at all, if you do, **do not smoke at least 2 hr before bed**.
12. **Do not use sleeping pills, melatonin, or other nonprescription sleep aids** to help you sleep unless specifically recommended by your doctor. These can be dangerous, and the sleep problems often return when you stop taking the medicine.

### Obstructive Sleep Apnea

**Sleep disordered breathing (SDB)** in children encompasses a broad spectrum of respiratory disorders that occur exclusively in sleep or that are exacerbated by sleep, including primary snoring and upper airway resistance syndrome, as well as apnea of prematurity (see Chapter 125) and central apnea (see Chapter 468.2). OSA, the most important clinical entity within the SDB spectrum, is characterized by repeated episodes of prolonged upper airway obstruction during sleep despite continued or increased respiratory effort, resulting in complete (*apnea*) or partial (*hypopnea*;  $\geq 30\%$  reduction in airflow accompanied by  $\geq 3\%$  O<sub>2</sub> desaturation and/or arousal) cessation of airflow at the nose and/or mouth, as well as disrupted sleep. Both intermittent hypoxia and the multiple arousals resulting from these obstructive events likely contribute to significant metabolic, cardiovascular, and neurocognitive-neurobehavioral morbidity.

**Primary snoring** is defined as snoring without associated ventilatory abnormalities on overnight **polysomnogram (PSG)** (e.g., no apneas or hypopneas, hypoxemia, hypercapnia) or respiratory-related arousals and is a manifestation of the vibrations of the oropharyngeal soft tissue walls that occur when an individual attempts to breathe against increased upper airway resistance during sleep. Although generally considered nonpathologic, primary snoring in children may still be associated with subtle breathing abnormalities during sleep, including evidence of increased respiratory effort, which in turn may be associated with adverse neurodevelopmental outcomes that may be similar to those associated with OSA.

### Etiology

OSA results from an anatomically or functionally narrowed upper airway; this typically involves some combination of decreased upper

**Table 31.4** Anatomic Factors That Predispose to Obstructive Sleep Apnea Syndrome and Hypoventilation in Children

#### NOSE

Anterior nasal stenosis  
Choanal stenosis/atresia  
Deviated nasal septum  
Seasonal or perennial rhinitis  
Nasal polyps, foreign body, hematoma, mass lesion

#### NASOPHARYNGEAL AND OROPHARYNGEAL

Adenotonsillar hypertrophy  
Macroglossia  
Cystic hygroma  
Velopharyngeal flap repair  
Cleft palate repair  
Pharyngeal mass lesion

#### CRANIOFACIAL

Micrognathia/retrognathia  
Midface hypoplasia (e.g., trisomy 21, Crouzon disease, Apert syndrome)  
Mandibular hypoplasia (Pierre Robin, Treacher Collins, Cornelia de Lange syndromes)  
Craniofacial trauma  
Skeletal and storage diseases  
Achondroplasia  
Storage diseases (e.g., glycogen; Hunter, Hurler syndromes)

airway patency (upper airway obstruction and/or decreased upper airway diameter), increased upper airway collapsibility (reduced pharyngeal muscle tone), and decreased drive to breathe in the face of reduced upper airway patency (reduced central ventilatory drive) (Table 31.4). Upper airway obstruction varies in degree and level (i.e., nose, nasopharynx/oropharynx, hypopharynx) and is most frequently caused by adenotonsillar hypertrophy, although tonsillar size does not necessarily correlate with degree of obstruction, especially in older children. Other causes of airway obstruction include allergies associated with chronic rhinitis or nasal obstruction; craniofacial abnormalities, including hypoplasia or displacement of the maxilla and mandible; gastroesophageal reflux with resulting pharyngeal reactive edema (see Chapter 369); nasal septal deviation (Chapter 425); and velopharyngeal flap cleft palate repair. Reduced upper airway tone may result from neuromuscular diseases, including hypotonic cerebral palsy and muscular dystrophies (see Chapter 649), or hypothyroidism (Chapter 603). Reduced central ventilatory drive may be present in some children with Arnold-Chiari malformation (see Chapter 631.09); rapid-onset obesity with hypothalamic dysfunction, hypoventilation, and autonomic dysregulation (Chapter 65); and meningomyelocele (Chapter 631.04). In other situations, the etiology is mixed; individuals with Down syndrome (see Chapter 57), because of their facial anatomy, hypotonia, macroglossia, and central adiposity, as well as the increased incidence of hypothyroidism, are at particularly high risk for OSA, with some estimates of prevalence as high as 70%.

Although children with OSA may be of normal weight, a large percentage are overweight or obese, and many of these children are school-age or younger. There is a significant correlation between weight and SDB (e.g., habitual snoring, OSA, sleep-related hypoventilation). Although adenotonsillar hypertrophy also plays an important etiologic role in overweight/obese children with OSA, mechanical factors related to an increase in the amount of adipose tissue in the throat (pharyngeal fat pads), neck (increased neck circumference), and chest wall and abdomen can increase upper airway resistance, worsen gas exchange, and increase the work of breathing, particularly in the supine position and during REM sleep. A component of blunted central ventilatory drive in response to hypoxia/hypercapnia and hypoventilation may occur as well (see Chapter 468.2), particularly in children with morbid or syndrome-based (e.g., Prader-Willi) obesity. Overweight and obese children and adolescents are at particularly high risk for

metabolic and cardiovascular complications of SDB, such as insulin resistance and systemic hypertension. Morbidly obese children are also at increased risk for postoperative complications as well as residual OSA after adenotonsillectomy.

### Epidemiology

Overall prevalence of parent-reported snoring in the pediatric population is approximately 8%; “always” snoring is reported in 1.5–6%, and “often” snoring in 3–15%. When defined by parent-reported symptoms, the prevalence of OSA is 4–11%. The prevalence of pediatric OSA as documented by overnight sleep studies using ventilatory monitoring procedures (e.g., in-lab polysomnography, home studies) is 1–4% overall, with a reported range of 0.1–13%. Prevalence is also affected by the demographic characteristics such as age (increased prevalence between 2 and 8 years), gender (more common in males, especially after puberty), ethnicity (increased prevalence in African American and Asian children), history of prematurity, and family history of OSA.

### Pathogenesis

The upregulation of inflammatory pathways, as indicated by an increase in peripheral markers of inflammation (e.g., C-reactive protein, interleukins), appears to be linked to metabolic dysfunction (e.g., insulin resistance, dyslipidemia, alterations in neurohormone levels such as leptin) in both obese and nonobese children with OSA. Systemic inflammation and arousal-mediated increases in sympathetic autonomic nervous system activity with altered vasomotor tone may be key contributors to increased cardiovascular risk due to alterations in vascular endothelium in both adults and children with OSA. Other potential mechanisms that may mediate cardiovascular sequelae in adults and children with OSA include elevated systemic blood pressure and ventricular dysfunction. Mechanical stress on the upper airway induced by chronic snoring may also result in both local mucosal inflammation of adenotonsillar tissues and subsequent upregulation of inflammatory molecules, most notably leukotrienes.

One of the primary mechanisms by which OSA is believed to exert negative influences on cognitive function appears to involve repeated episodic arousals from sleep leading to sleep fragmentation and sleepiness. Equally important, intermittent hypoxia may lead directly to systemic inflammatory vascular changes in the brain. Levels of inflammatory markers such as C-reactive protein and interleukin-6 are elevated in children with OSA and are also associated with cognitive dysfunction.

### Clinical Manifestations

The clinical manifestations of OSA may be divided into sleep-related and daytime symptoms. The most common nocturnal manifestations of OSA in children and adolescents are loud, frequent, and disruptive snoring; breathing pauses; choking or gasping arousals; restless sleep; and nocturnal diaphoresis. Many children who snore do not have OSA, but few children with OSA do not snore (caregivers may not be aware of snoring in older children and adolescents). Children, like adults, tend to have more frequent and more severe obstructive events in REM sleep and when sleeping in the supine position. Children with OSA may adopt unusual sleeping positions, keeping their necks hyperextended to maintain airway patency. Frequent arousals associated with obstruction may result in nocturnal awakenings but are more likely to cause fragmented sleep.

Daytime symptoms of OSA include mouth breathing and dry mouth, chronic nasal congestion or rhinorrhea, hyponasal speech, morning headaches, difficulty swallowing, and poor appetite. Children with OSA may have *secondary enuresis*, postulated to result from the disruption of the normal nocturnal pattern of atrial natriuretic peptide secretion by changes in intrathoracic pressure associated with OSA. Partial arousal parasomnias (sleepwalking and sleep terrors) may occur more frequently in children with OSA, related to the frequent associated arousals and an increased percentage of SWS.

One of the most important but frequently overlooked sequelae of OSA in children is the effect on mood, behavior, learning, and academic functioning. The neurobehavioral consequences of OSA in

children include daytime sleepiness with drowsiness, difficulty in morning waking, and unplanned napping or dozing off during activities, although evidence of frank hypersomnolence tends to be less common in children compared to adults with OSA (except in very obese children or those with severe disease). Mood changes include increased irritability, mood instability and emotional dysregulation, low frustration tolerance, and depression or anxiety. Behavioral issues include both “internalizing” (i.e., increased somatic complaints and social withdrawal) and “externalizing” behaviors, including aggression, impulsivity, hyperactivity, oppositional behavior, and conduct problems. There is substantial overlap between the clinical impairments associated with OSA and the diagnostic criteria for ADHD, including inattention, poor concentration, and distractibility (see [Chapter 50](#)).

Many of the studies that have looked at changes in behavior and neuropsychologic functioning in children after treatment (usually adenotonsillectomy) for OSA have found significant improvement in outcomes, both short term and long term, including daytime sleepiness, mood, behavior, academics, and quality of life. However, most studies failed to find a dose-dependent relationship between OSA in children and specific neurobehavioral-neurocognitive deficits, suggesting that other factors may influence neurocognitive outcomes, including individual genetic susceptibility, racial/ethnic background, environmental influences (e.g., passive smoking exposure), and comorbid conditions, such as obesity, shortened sleep duration, and other sleep disorders.

### Diagnosis

The 2012 revised American Academy of Pediatrics clinical practice guidelines provide excellent information for the evaluation and management of uncomplicated childhood OSA ([Table 31.5](#)). No physical examination findings are truly pathognomonic for OSA, and most healthy children with OSA appear normal; however, certain physical examination findings may suggest OSA. Growth parameters may be abnormal (obesity, or less frequently, failure to thrive), and there may be evidence of chronic nasal obstruction (hyponasal speech, mouth breathing, septal deviation) and signs of atopic disease (i.e., “allergic shiners”). Oropharyngeal examination may reveal enlarged tonsils, excess soft tissue in the posterior pharynx, and a narrowed posterior pharyngeal space, as well as craniofacial features associated with an increased risk of obstruction including “adenoidal facies” with open mouth posture and long/asymmetric face, midface hypoplasia, retrognathia and micrognathia, forward head posture (best appreciated by inspection of the frontal and lateral facial profile), and teeth crowding, narrow arched palate, and tongue tie (short frenulum). In severe cases the child may have evidence of pulmonary hypertension, right-sided heart failure, and cor pulmonale; systemic hypertension may occur, especially in obese children.

Because no combination of clinical history and physical findings can accurately predict which children with snoring have OSA, the gold standard for diagnosing OSA remains an in-lab overnight **PSG**. Overnight PSG is a technician-supervised, monitored study that documents physiologic variables during sleep; sleep staging, arousal measurement, cardiovascular parameters, and body movements (electroencephalography [EEG], electrooculography, chin and leg electromyography [EMG], electrocardiogram, body position sensors, and video recording), and a combination of breathing monitors (oronasal thermal sensor and nasal air pressure transducer for airflow), chest/abdominal monitors (e.g., inductance plethysmography for respiratory effort, pulse oximeter for O<sub>2</sub> saturation, end-tidal or transcutaneous CO<sub>2</sub> for CO<sub>2</sub> retention, snore microphone). The PSG parameter most often used in evaluating for sleep-disordered breathing is the **apnea-hypopnea index (AHI)**, which indicates the number of apneic and hypopneic (both obstructive and central) events per hour of sleep. There are no universally accepted PSG normal reference values or parameters for diagnosing OSA in children, and it is still unclear which parameters best predict morbidity. Normal preschool- and school-age children generally have a total AHI <1.5 (obstructive AHI <1), and this is the most widely used cutoff value for OSA in children ≤12 years old; in older adolescents the adult cutoff of an AHI ≥5 is generally used. When AHI is between one and five obstructive events per hour, assessment of



**Table 31.5** American Academy of Pediatrics Clinical Practice Guideline: Diagnosis and Management of Childhood Obstructive Sleep Apnea Syndrome**Key Action Statement 1: Screening for OSA**

As part of routine health maintenance visits, clinicians should inquire whether the child or adolescent snores. If the answer is affirmative or if a child or adolescent presents with signs or symptoms of OSA, clinicians should perform a more focused evaluation. (Evidence Quality: Grade B; Recommendation Strength: Recommendation.)

**Key Action Statement 2A: Polysomnography**

If a child or adolescent snores on a regular basis and has any of the complaints or findings of OSA, clinicians should either (1) obtain a polysomnogram (Evidence Quality: Grade A; Recommendation Strength: Recommendation) or (2) refer the patient to a sleep specialist or otolaryngologist for a more extensive evaluation. (Evidence Quality: Grade D; Recommendation Strength: Option.)

**Key Action Statement 2B: Alternative Testing**

If polysomnography is not available, clinicians may order alternative diagnostic tests, such as nocturnal video recording, nocturnal oximetry, daytime nap polysomnography, or ambulatory polysomnography. (Evidence Quality: Grade C; Recommendation Strength: Option.)

**Key Action Statement 3: Adenotonsillectomy**

If a child is determined to have OSA, has a clinical examination consistent with adenotonsillar hypertrophy, and does not have a contraindication to surgery, the clinician should recommend adenotonsillectomy as the first line of treatment. If the child has OSA but does not have adenotonsillar hypertrophy, other treatment should be considered (see Key Action Statement 6). Clinical judgment is required to determine the benefits of adenotonsillectomy compared with other treatments in obese children with varying degrees of adenotonsillar hypertrophy. (Evidence Quality: Grade B; Recommendation Strength: Recommendation.)

**Key Action Statement 4: High-Risk Patients Undergoing Adenotonsillectomy**

Clinicians should monitor high-risk patients undergoing adenotonsillectomy as inpatients postoperatively. (Evidence Quality: Grade B; Recommendation Strength: Recommendation.)

**Key Action Statement 5: Reevaluation**

Clinicians should clinically reassess all patients with OSA for persisting signs and symptoms after therapy to determine whether further treatment is required. (Evidence Quality: Grade B; Recommendation Strength: Recommendation.)

**Key Action Statement 5B: Reevaluation of High-Risk Patients**

Clinicians should reevaluate high-risk patients for persistent OSA after adenotonsillectomy, including those who had a significantly abnormal baseline polysomnogram, have sequelae of OSA, are obese, or remain symptomatic after treatment, with an objective test (see Key Action Statement 2), or refer such patients to a sleep specialist. (Evidence Quality: Grade B; Recommendation Strength: Recommendation.)

**Key Action Statement 6: CPAP**

Clinicians should refer patients for CPAP management if symptoms/signs or objective evidence of OSA persists after adenotonsillectomy or if adenotonsillectomy is not performed. (Evidence Quality: Grade B; Recommendation Strength: Recommendation.)

**Key Action Statement 7: Weight Loss**

Clinicians should recommend weight loss in addition to other therapy if a child/adolescent with OSA is overweight or obese. (Evidence Quality: Grade C; Recommendation Strength: Recommendation.)

**Key Action Statement 8: Intranasal Corticosteroids**

Clinicians may prescribe topical intranasal corticosteroids for children with mild OSA in whom adenotonsillectomy is contraindicated or for children with mild postoperative OSA. (Evidence Quality: Grade B; Recommendation Strength: Option.)

CPAP, Continuous Positive Airway Pressure; OSA, obstructive sleep apnea.

Adapted from Marcus CL, Brooks LJ, Draper KA, et al. Diagnosis and management of childhood obstructive sleep apnea syndrome. *Pediatrics*. 2012;130:576–584.

additional PSG parameters (e.g., elevated CO<sub>2</sub> indicating obstructive hypoventilation, O<sub>2</sub> desaturation, respiratory-related arousals), clinical judgment regarding risk factors for SDB, presence and severity of clinical symptoms, and evidence of daytime sequelae should determine further management.

**Treatment**

No universally accepted guidelines exist regarding the indications for treatment of pediatric SDB, including primary snoring and OSA. Recommendations largely emphasize weighing what is known about the potential cardiovascular, metabolic, and neurocognitive sequelae of SDB in children in combination with the individual healthcare professional's clinical judgment. The decision of whether and how to treat OSA specifically in children depends on several parameters, including severity (nocturnal symptoms, daytime sequelae, sleep study results), duration of disease, and individual patient variables such as age, comorbid conditions, and underlying etiologic factors. In the case of moderate (AHI 5–10) to severe (AHI >10) disease, the decision to treat is usually straightforward, and most pediatric sleep experts recommend that any child with AHI >5 should be treated. However, a large randomized trial of early adenotonsillectomy vs watchful waiting with supportive care demonstrated that 46% of the control group children normalized on PSG (vs 79% of early adenotonsillectomy group) during the 7 month observation period. In addition, it is worth emphasizing that the child with habitual snoring (≥3×/week) but without polysomnographic evidence of OSA may also experience adverse neurobehavioral and neurocognitive outcomes; ongoing studies are examining

whether these children may benefit from more aggressive treatment such as adenotonsillectomy.

In the majority of cases of pediatric OSA, adenotonsillectomy is the first-line treatment in any child with significant adenotonsillar hypertrophy, even in the presence of additional risk factors such as obesity. Adenotonsillectomy (or adenotonsillotomy, which is considered a less invasive procedure and may be indicated in some children) in uncomplicated cases generally (70–90% of children) results in complete resolution of symptoms; regrowth of adenoidal tissue after surgical removal occurs in some cases. Groups considered at high risk include young children (<3 years) as well as those with severe OSA documented by PSG, significant clinical sequelae of OSA (e.g., failure to thrive), or associated medical conditions, such as craniofacial syndromes, morbid obesity, and hypotonia. All patients should be reevaluated postoperatively to determine whether additional evaluation, a repeat PSG, and treatment are required. The American Academy of Sleep Medicine recommends that in high-risk groups (children with obesity, craniofacial anomalies, Down syndrome, or moderate-severe OSA) or in children with continued symptoms of OSA, a follow-up sleep study about 6 weeks after adenotonsillectomy is indicated. Also, a number of studies have suggested that children who are underweight, normal weight, or overweight/obese at baseline all tend to *gain weight* after adenotonsillectomy, and thus clinical vigilance is required during follow-up.

It should be noted that in cases of residual OSA postadenotonsillectomy, additional diagnostic evaluation to identify other sites of obstruction may be necessary to more specifically tailor treatment. An example of this type of advanced diagnostic tool is **drug-induced sleep**



**endoscopy (DISE)**, a powerful method for studying the airway in a sleeping patient in real time. DISE provides direct visualization of the spontaneously breathing airway under light anesthesia and facilitates identification of obstructive lesions. Site of obstruction with potential surgical corrections include lingual (resection) tonsils, tongue base (reductions), turbinate (reduction), and supraglottoplasty.

Additional treatment measures that may be appropriate include weight loss, **positional therapy** (attaching a firm object, such as a tennis ball, to the back of a sleep garment to prevent the child from sleeping in the supine position), and aggressive treatment of additional risk factors when present, such as asthma, seasonal allergies, and gastroesophageal reflux. Evidence suggests that intranasal corticosteroids and leukotriene inhibitors may be helpful in reducing upper airway inflammation in mild OSA. Other surgical procedures (e.g., uvulopharyngopalatoplasty) and maxillofacial surgery (e.g., mandibular distraction osteogenesis) are seldom performed in children. Oral appliances, such as mandibular advancing devices and palatal expanders, may be considered in select cases, particularly in those children with craniofacial risk factors as mentioned earlier, and consultation with a pediatric dentist or orthodontist is recommended. Neuromuscular reeducation or repatterning of the oral and facial muscles with exercises to address abnormal tongue position and low upper airway tone (i.e., **myofunctional therapy**) have been shown to be beneficial in addressing pediatric OSA as well as alleviating chewing and swallowing problems in children able to cooperate with the behavioral program.

**Continuous or bilevel positive airway pressure (CPAP or BiPAP)** is the most common treatment for OSA in adults and can be used successfully in children and adolescents. Positive airway pressure (PAP) may be recommended if removing the adenoids and tonsils is not indicated, if there is residual disease following adenotonsillectomy, or if there are major risk factors not amenable to surgery (obesity, hypotonia). PAP delivers humidified, warmed air through an interface (mask, nasal pillows) that, under pressure, effectively “splints” the upper airway open. Optimal pressure settings (that abolish or significantly reduce obstructive respiratory events without increasing arousals or central apneas) are determined in the sleep lab during a full-night PAP titration. Careful attention should be paid to education of the child and family, and desensitization protocols should usually be implemented to increase the likelihood of adherence. Efficacy studies at the current pressure and retitrations should be conducted periodically with

long-term use (at least annually) or in association with significant weight changes or resurgence of SDB symptoms. High-flow nasal cannula therapy may be another approach. A novel treatment for OSA in adults is hypoglossal nerve stimulation; case series suggest this may be an effective treatment in selected pediatric cases, especially in children with Down syndrome.

### Parasomnias

Parasomnias are episodic nocturnal behaviors that often involve cognitive disorientation and autonomic and skeletal muscle disturbance. Parasomnias may be further characterized as occurring primarily during non-REM sleep (partial arousal parasomnias) or in association with REM sleep, including nightmares, hypnogogic hallucinations, and sleep paralysis; other common parasomnias include sleep-talking and hypnic jerks or “sleep starts.”

### Etiology

**Partial arousal parasomnias** represent a dissociated sleep-wake state, the neurobiology of which remains unclear, although genetic factors and an intrinsic oscillation of subcortical-cortical arousal with sleep have been proposed. These episodic events, which include sleepwalking, sleep terrors, and confusional arousals, are more common in preschool- and school-age children because of the relatively higher percentage of SWS in younger children. Partial arousal parasomnias typically occur when SWS predominates, in the first third of the night. In contrast, **nightmares**, which are much more common than partial arousal parasomnias but are often confused with them, tend to be concentrated in the last third of the night, when REM sleep is most prominent. Any factor associated with an increase in the relative percentage of SWS (certain medications, previous sleep restriction) may increase the frequency of events in a predisposed child. There appears to be a genetic predisposition for both sleepwalking and sleep terrors. Partial arousal parasomnias may also be difficult to distinguish from nocturnal seizures. [Table 31.6](#) summarizes similarities and differences among these nocturnal arousal events.

### Epidemiology

Many children sleepwalk on at least one occasion; the lifetime prevalence by age 10 years is 13%. **Sleepwalking** (somnambulism) may persist into adulthood, with the prevalence in adults of

**Table 31.6** Key Similarities and Differentiating Features Between Non-REM and REM Parasomnias as Well as Nocturnal Seizures

	CONFUSIONAL AROUSALS	SLEEP TERRORS	SLEEPWALKING	NIGHTMARES	NOCTURNAL SEIZURES
Time	Early	Early	Early-mid	Late	Any
Sleep stage	SWA	SWA	SWA	REM	Any
EEG discharges	–	–	–	–	+
Scream	–	++++	–	++	+
Autonomic activation	+	++++	+	+	+
Motor activity	–	+	+++	+	++++
Awakens	–	–	–	+	+
Duration (min)	0.5-10; more gradual offset	1-10; more gradual offset	2-30; more gradual offset	3-20	5-15; abrupt onset and offset
Postevent confusion	+	+	+	–	+
Age	Child	Child	Child	Child, young adult	Adolescent, young adult
Genetics	+	+	+	–	±
Organic CNS lesion	–	–	–	–	++++

CNS, Central nervous system; EEG, electroencephalogram; REM, rapid eye movement; SWA, slow-wave arousal.

From Avidan A, Kaplish N. The parasomnias: epidemiology, clinical features and diagnostic approach. *Clin Chest Med*. 2010;31:353–370.

approximately 4%. The prevalence is approximately 10 times greater in children with a family history of sleepwalking. The peak prevalence of **sleep terrors** (or night terrors) is 34% at age 1-5 years, decreasing to 10% by age 7; the age at onset is usually between 4 and 12 years. Because of the common genetic predisposition, the likelihood of developing sleepwalking after age 5 is almost twofold higher in children with a history of sleep terrors. Although sleep terrors can occur at any age from infancy through adulthood, most individuals outgrow sleep terrors by adolescence. **Confusional arousals** may be accompanied by (and often precede in onset) episodes sleepwalking and sleep terrors; prevalence rates have been estimated at >15% in children age 3-13 years.

### Clinical Manifestations

The partial arousal parasomnias have several features in common. Because they typically occur at the transition out of “deep” sleep or SWS, partial arousal parasomnias have clinical features of both the *awake* (ambulation, vocalizations) and the *sleeping* (high arousal threshold, unresponsiveness to environment) states, usually with amnesia for the events. External (noise) or internal (obstruction) factors may trigger events in some individuals. The duration is typically a few minutes (sleep terrors) up to 30-40 minutes (confusional arousals). Sleep terrors are sudden in onset and characteristically involve a high degree of autonomic arousal (tachycardia, diaphoresis, dilated pupils). Confusional arousals typically arise more gradually from sleep, may involve thrashing around, mumbling, and other vocalizations, but usually not displacement from bed, and are often accompanied by slow mentation, disorientation, and confusion on forced arousal from SWS or on waking in the morning. Sleepwalking may be associated with safety concerns (e.g., falling out of windows, wandering outside). The child’s avoidance of, or increased agitation with, comforting by parents or prolongation of events by attempts at awakening are also common to all partial arousal parasomnias.

### Treatment

Management of partial arousal parasomnias involves some combination of parental education and reassurance, healthy sleep practices, and avoidance of exacerbating factors such as sleep restriction and caffeine. Particularly in the case of sleepwalking, it is important to institute safety precautions such as use of gates in doorways and at the top of staircases, locking of outside doors and windows, and installation of parent notification systems such as bedroom door alarms. **Scheduled awakening** is a behavioral intervention that involves having the parent wake the child 15-30 minutes before the time of night that the first parasomnia episode typically occurs and is most likely to be successful in situations where partial arousal episodes occur on a nightly basis. Pharmacotherapy is rarely necessary but may be indicated in cases of frequent or severe episodes despite nonpharmacologic interventions and absence of treatable underlying sleep disorders exacerbating partial arousal parasomnias such as OSA or **periodic limb movement disorder (PLMD)**, high risk of injury, violent behavior, or serious disruption to the family. The primary pharmacologic agents used are potent SWS suppressants, primarily benzodiazepines and tricyclic antidepressants.

### Sleep-Related Movement Disorders: Restless Legs Syndrome/Periodic Limb Movement Disorder, Restless Sleep Disorder, and Rhythmic Movement Disorder

Although some of these sleep disorders share common features (e.g., movements of specific body parts such as extremities vs whole body movements) and pathogenesis (e.g., iron deficiency), each has a distinctive set of diagnostic criteria, epidemiology and clinical management, and may differ in the degree of disruption to sleep quality and quantity and related daytime consequences.

Although most of these sleep-related movement disorders do not require overnight polysomnographic evaluation for diagnosis (PLMD is a notable exception), a videotaped episode by caregivers in the home

setting can prove very valuable in helping to differentiate sleep-related movements from nocturnal seizures. Such sleep-related seizures usually arise from the frontal and/or temporal lobes. Ambulatory EEG, in-patient video-EEG monitoring and overnight video PSG with chin and leg EMG recording may be necessary to establish a diagnosis of a sleep-related movement disorder.

### Restless Legs Syndrome/Periodic Limb Movement Disorder

**Restless legs syndrome (RLS)**, also termed *Willis-Ekbom disease*, is a primary disorder of the CNS sensorimotor network characterized by an almost irresistible urge to move the legs, often accompanied by uncomfortable sensations in the lower extremities. Both the urge to move and the sensations are usually worse at rest and in the evening and are at least partially relieved by movement, including walking, stretching, and rubbing, but only if the motion continues. RLS is a clinical diagnosis that is based on the presence of these key symptoms (Table 31.7).

PLMD is characterized by periodic, repetitive, brief (0.5-10 seconds), and highly stereotyped limb jerks typically occurring at 20-40 second intervals. These movements occur primarily during sleep, usually occur in the legs, and frequently consist of rhythmic extension of the big toe and dorsiflexion at the ankle. Although there may be clinical complaints of kicking movements in sleep or restless sleep, the diagnosis of **periodic limb movements (PLMs)** requires overnight PSG to document the characteristic limb movements with anterior tibialis EMG leads. However, like adults, children also show considerable individual night-to-night variability of PLMs, and a single-night PSG may not always reflect the true severity.

### Etiology

RLS has a clear genetic component, with a sixfold to sevenfold increase in prevalence in first-degree relatives of RLS patients. The mode of inheritance is complex, and several genetic loci have been identified (*MEIS1*, *BTBD9*, *MAP2K5*). Low serum iron levels (even without anemia) in both adults and children may be an important etiologic factor for the presence and severity of both RLS symptoms and PLMs. As a marker of decreased iron stores, serum ferritin levels in both children and adults with RLS are frequently low (<50 µg/mL). The postulated underlying mechanism is related to the role of iron as a cofactor in tyrosine hydroxylation, a rate-limiting step in dopamine

**Table 31.7** Diagnostic Criteria for Restless Legs Syndrome

- A. An urge to move legs, usually accompanied by or in response to uncomfortable and unpleasant sensations in the legs, characterized by the following:
  1. The urge to move the legs begins or worsens during periods of rest or inactivity.
  2. The urge to move the legs is partially or totally relieved by movement.
  3. The urge to move the legs is worse in the evening or at night than during the day, or occurs only in the evening or at night.
- B. The symptoms in Criterion A occur at least 3 times per week and have persisted for at least 3 mo.
- C. The symptoms in Criterion A are accompanied by significant distress or impairment in social, occupational, educational, academic, behavioral, or other important areas of functioning.
- D. The symptoms in Criterion A are not attributable to another mental disorder or medical condition (e.g., arthritis, leg edema, peripheral ischemia, leg cramps) and are not better explained by a behavioral condition (e.g., positional discomfort, habitual foot tapping).
- E. The symptoms are not attributable to the physiologic effects of a drug or abuse or medication (e.g., akathisia).

synthesis; in turn, dopaminergic dysfunction has been implicated, particularly in the genesis of the sensory component of RLS, as well as in PLMD. Certain medical conditions, including diabetes mellitus, end-stage renal disease, cancer, idiopathic juvenile arthritis, hypothyroidism, and pregnancy, may also be associated with RLS/PLMD, as are specific medications (e.g., antidepressants, including tricyclic antidepressants, and selective serotonin reuptake inhibitors (SSRIs), such as fluoxetine, first-generation sedating antihistamines, and dopamine receptor antagonists, such as Compazine and metoprolamide), as well as caffeine.

### Epidemiology

Survey studies estimate the prevalence rates of RLS in the pediatric population as between 1 and 6%; approximately 2% of 8-17 year olds meet the criteria for “definite” RLS. Prevalence rates of PLMs >5 per hour in clinical populations of children referred for sleep studies range from 5–27%; in survey studies of PLM symptoms, rates are 8–12%. About 40% of adults with RLS have symptoms before age 20 years; 20% report symptoms before age 10. Familial cases usually have a younger age of onset. Several studies in referral populations have found that PLMs occur in as many as 25% of children diagnosed with ADHD.

### Clinical Manifestations

In addition to the urge to move the legs and the sensory component (paresthesia-like, tingling, burning, itching, crawling), most RLS episodes are initiated or exacerbated by rest or inactivity, such as lying in bed to fall asleep or riding in a car for prolonged periods. Children may describe the sensory symptoms as a funny feeling, tickling, hurting, or pain or bugs, spiders, ants, or goosebumps in the legs. Sometimes, the child may draw pins, needles, tiny sand particles, and bugs over his or her legs when asked to depict the symptoms. An “informal” suggested clinical immobilization test (SCIT) (i.e., “If I asked you to lie perfectly still sitting on your bed at bedtime, would you be able to do it?”) can be helpful in eliciting RLS complaints. A unique feature of RLS is that the timing of symptoms also appears to have a circadian component, in that they often peak in the evening hours. Some children may complain of “growing pains,” although this is considered a nonspecific feature. Because RLS symptoms are usually worse in the evening, bedtime struggles and difficulty falling asleep are two of the most common presenting complaints. In contrast to patients with RLS, individuals with PLMs are usually unaware of these movements, but children may complain of morning muscle pain or fatigue; these movements may result in arousals during sleep and consequent significant sleep disruption. Parents of children with RLS/PLMD may report that their child is a restless sleeper and kicks a bed partner.

The differential diagnosis includes growing pains, leg cramps, neuropathy, arthritis, myalgias, nerve compression (“leg fell asleep”), and dopamine antagonist–associated akathisia.

### Treatment

Because of the frequent co-occurrence and overlap in underlying pathophysiology and risk factors for RLS and PLMD, management strategies for both disorders are similar. The clinical decision to treat RLS and PLMs is based on the severity of symptoms, sleep disturbances, and effect on daytime functioning. An acronym that summarizes the management approach for RLS/PLMD in children is AIMS. This includes the following:

- ♦ Avoidance of drugs/substances which may exacerbate RLS/PLMD (including caffeine, nicotine, alcohol)
- ♦ Iron supplementation
- ♦ Muscles: increased physical activity, massage, application of heat/cold, muscle relaxation and biofeedback
- ♦ Sleep: regular and adequate sleep

Treatment with iron supplementation is indicated if serum ferritin is <50 ng/mL. Administration of oral supplements for ferritin levels >75–100 µg/L, at least in adults, are likely ineffective because of low absorption. It should be kept in mind that ferritin is an

acute-phase reactant and thus may be falsely elevated (i.e., normal) in the setting of a concomitant illness. In addition, the ferritin level should be drawn, if possible, in the early morning after avoiding a dinner with a high iron content (e.g., red meat) on the previous evening. A typical iron regimen is ferrous fumarate or sulfate as an oral tablet or liquid: 3–6 mg/kg of elemental iron/day × 3 months with 200 mg vitamin C on an empty stomach while avoiding calcium-containing foods that may slow absorption. Ferritin levels should be repeated after 3 months to assess response and avoid iron overload.

If ferritin levels are very low or levels fail to improve after treatment with iron, these children may require referral to hematology for evaluation of their iron deficiency (e.g., occult blood loss, malabsorption). Although pediatric data regarding IV iron for RLS/PLMD are largely lacking, there are studies examining the role of IV iron therapy (e.g., ferric carboxymaltose, iron dextran) in the treatment of severe iron deficiency or with iron malabsorption in adults. Potential advantages of IV therapy include rapid response and avoidance of malabsorption/tolerance/compliance issues.

Treatment with pharmacologic agents may be indicated in children with moderate-severe RLS symptoms and PLMD, who did not respond to the previously mentioned measures. Currently, there are no Food and Drug Administration (FDA)-approved pharmacologic agents for RLS/PLMD in children. Dopaminergic medication is considered the first line of treatment for RLS in adults. Other classes of medications used to treat RLS/PLMD include  $\alpha$ -agonists, opiates, benzodiazepines, and bupropion.

### Restless Sleep Disorder

Restless sleep disorder (RSD) has both clinical and PSG features *distinct* from RLS and PLMD. Clinical descriptors include a complaint of “restless sleep” typically reported by a parent, caregiver, or bedpartner; the visible body movements, involving *large muscle groups of the whole body, all four limbs, arms, legs, or head* during sleep, may be characterized further as frequent repositioning disruption of the bedsheets, falling out of bed and being found in a completely different position compared to the position in which they fell asleep. Diagnostic criteria also include objective documentation on videography of increased levels of nocturnal activity and gross body movements with a total movement index during sleep that exceeds five per hour of sleep. RSD has also been found to be associated with low serum iron levels with symptomatic improvement following iron supplementation.

**Sleep-related rhythmic movements**, including head banging, body rocking, and head rolling, are characterized by repetitive, stereotyped, and rhythmic movements or behaviors that involve large muscle groups. These behaviors typically occur with the transition to sleep at bedtime, but also at nap times and after nighttime arousals. Children are thought to engage in these behaviors as a means of soothing themselves to (or back to) sleep. These behaviors are very common, with about two thirds of all infants having some type, typically beginning before 12 months and usually disappearing by preschool age. In most cases, rhythmic movement behaviors are benign, because sleep is not significantly disrupted, and associated significant injury is rare; however, these behaviors can potentially affect the sleep of a family member room-sharing and/or caregivers in nearby sleeping spaces. In addition, caregivers are often concerned about these behaviors as potentially being harmful to the child or possibly indicative of an underlying neurologic or neurodevelopmental disorder (e.g., autism). However, these behaviors typically occur in normally developing children and in the majority of cases do not indicate some underlying neurologic or psychologic problem. Usually, the most important aspect in management of sleep-related rhythmic movements is reassurance to the family that this behavior is normal, common, benign, and self-limited. Safety may be an important concern, and appropriate measures such as tightening of crib bolts and guardrails on the bed should be taken to prevent injury; noise dampening measures such as moving the bed away from adjoining walls may be helpful. If there are concerns about an associated sleep disorder, seizure disorder, or risk of injury referral to a sleep specialist may be considered.



### Central Disorders of Hypersomnolence: Narcolepsy type 1, Narcolepsy type 2, Idiopathic Hypersomnia

Hypersomnia is a clinical term that is used to describe a group of disorders characterized by recurrent episodes of EDS, reduced baseline alertness, and/or prolonged nighttime sleep periods that interfere with normal daily functioning (Table 31.8). The many potential causes of EDS can be broadly grouped as “extrinsic” (e.g., secondary to insufficient and/or fragmented sleep) or “intrinsic” (e.g., resulting from an increased need for sleep).

**Table 31.8** Diagnostic Criteria for Narcolepsy

- A. Recurrent periods of an irrepressible need to sleep, lapsing into sleep, or napping occurring within the same day. These must have been occurring at least 3 times per week over the past 3 mo.
- B. The presence of at least one of the following:
1. Episodes of cataplexy, defined as either (a) or (b), occurring at least a few times per month:
    - a. In individuals with long-standing disease, brief (seconds to minutes) episodes of sudden bilateral loss of muscle tone with maintained consciousness that are precipitated by laughter or joking.
    - b. In children or individuals within 6 mo of onset, spontaneous grimaces or jaw-opening episodes with tongue thrusting or a global hypotonia, without any obvious emotional triggers.
  2. Hypocretin deficiency, as measured using CSF hypocretin-1 immunoreactivity values (less than or equal to one third of values obtained in healthy subjects tested using the same assay, or  $\leq 110$  pg/mL). Low CSF levels of hypocretin-1 must not be observed in the context of acute brain injury, inflammation, or infection.
  3. Nocturnal sleep polysomnography showing REM sleep latency  $\leq 15$  min, or a multiple sleep latency test showing a mean sleep latency  $\leq 8$  min and two or more sleep-onset REM periods.

Specify whether:

**Narcolepsy without cataplexy but with hypocretin deficiency:**

Criterion B requirements of low CSF hypocretin-1 levels and positive polysomnography/multiple sleep latency test are met, but no cataplexy is present (Criterion B1 not met).

**Narcolepsy with cataplexy but without hypocretin deficiency:** In this rare subtype (<5% of narcolepsy cases), Criterion B requirements of cataplexy and positive polysomnography/multiple sleep latency test are met, but CSF hypocretin-1 levels are normal (Criterion B2 not met).

**Autosomal dominant cerebellar ataxia, deafness, and narcolepsy:** This subtype is caused by exon 21 DNA (cytosine-5)-methyltransferase-1 mutations and is characterized by late-onset (age 30-40 yr) narcolepsy (with low or intermediate CSF hypocretin-1 levels), deafness, cerebellar ataxia, and eventually dementia.

**Autosomal dominant narcolepsy, obesity, and type 2 diabetes:** Narcolepsy, obesity, and type 2 diabetes are low; CSF hypocretin-1 levels have been described in rare cases and are associated with a mutation in the myelin oligodendrocyte glycoprotein gene.

**Narcolepsy without cataplexy but with hypocretin deficiency:** This subtype is for narcolepsy that develops secondary to medical conditions that cause infectious (e.g., Whipple disease, sarcoidosis), traumatic, or tumoral destruction of hypocretin neurons.

Severity:

**Mild:** Infrequent cataplexy (less than once per week), need for naps only once or twice per day, and less disturbed nocturnal sleep.

**Moderate:** Cataplexy once daily or every few days, disturbed nocturnal sleep and need for multiple naps daily.

**Severe:** Drug-resistant cataplexy with multiple attacks daily, nearly constant sleepiness, and disturbed nocturnal sleep (i.e., movements, insomnia, and vivid dreaming).

### Narcolepsy

Narcolepsy is a chronic, lifelong CNS disorder, typically presenting in adolescence and early adulthood, characterized by profound daytime sleepiness resulting in significant functional impairment. More than half of patients with narcolepsy also present with **cataplexy** (type 1 narcolepsy), defined as the sudden, brief, partial, or complete loss of skeletal muscle tone, typically triggered by strong emotion (e.g., laughter, surprise, anger), with retained consciousness. Other symptoms frequently associated with narcolepsy, including hypnogenic/hypnopompic (immediately before falling asleep/awakening) visual, auditory, or perceptual hallucinations, and sleep paralysis, may be conceptualized as representing the “intrusion” of REM-related phenomena (dream mentation, loss of motor tone) into the waking state. Other REM-related features include observance of eye movements and twitches at sleep onset and vivid dreams. Somewhat paradoxically, increased sleep fragmentation is a common feature. Rapid weight gain, especially near symptom onset, may be observed, and young children with narcolepsy have been reported to develop precocious puberty.

### Etiology

The genesis of narcolepsy with cataplexy (type 1) is thought to be related to a specific deficit in the hypothalamic orexin/hypocretin neurotransmitter system involving the selective loss of cells that secrete hypocretin/orexin in the lateral hypothalamus. *Hypocretin* neurons stimulate a range of wake-promoting neurons in the brainstem, hypothalamus, and cortex and basal forebrain that produce neurochemicals to sustain the wake state and prevent lapses into sleep.

The development of narcolepsy may involve autoimmune mechanisms, possibly triggered by streptococcal, influenza virus, H1N1, and other viral infections, likely in combination with a genetic predisposition and environmental factors. A 12-13-fold increase in narcolepsy type 1 cases, especially in children, was reported in parts of Europe in 2009–2010 following immunization with the AS03 adjuvanted H1N1 influenza vaccine. Human leukocyte antigen testing also shows a strong association with narcolepsy; the majority of individuals with this antigen (~25% of the general population) do not have narcolepsy, but most (>90%) patients with narcolepsy with cataplexy are HLA-DQB1\*0602-positive. Patients with narcolepsy without cataplexy (type 2) are increasingly thought to have a significantly different underlying pathophysiology; they are much less likely to be HLA-DQB1\*0602-positive (4–50%), and cerebrospinal fluid (CSF) hypocretin levels are normal in most patients.

Although most cases of narcolepsy are considered idiopathic (autoimmune), **secondary narcolepsy** can be caused by lesions to the posterior hypothalamus induced by traumatic brain injury, tumor, stroke, and neuroinflammatory processes such as poststreptococcal pediatric autoimmune neuropsychiatric disorder associated with streptococcal infection (PANDAS; see Chapter 229), as well as by neurogenetic diseases such as Prader-Willi syndrome (Chapter 99.7), Niemann-Pick type C (Chapter 106.4), myotonic dystrophy (Chapter 649.6), Angelman syndrome, autosomal dominant cerebellar ataxia-deafness-narcolepsy (ADCA-DN), Moebius syndrome, and Norrie disease.

### Epidemiology

Narcolepsy is a rare disorder with a prevalence of approximately 1 in 2000 with equal sex distribution; however, specific countries (e.g., Japan) appear to have relatively higher prevalence rates. The risk of developing narcolepsy with cataplexy in a first-degree relative of a narcoleptic patient is estimated at 1–2%. This represents an increase of 10-40-fold compared to the general population, but the risk remains very low, reinforcing the likely role for other etiologic factors.

### Clinical Manifestations and Diagnosis

The typical onset of symptoms of narcolepsy is in adolescence and early adulthood, although symptoms may initially present in school-age and even younger children. The early manifestations of narcolepsy are often ignored, misinterpreted, or misdiagnosed as other medical, neurologic, or psychiatric conditions, and the appropriate diagnosis is frequently delayed for years. The onset may be abrupt or slowly progressive.

CSF, Cerebrospinal fluid; REM, rapid eye movement.

From American Psychiatric Association. *Diagnostic and Statistical Manual of Mental Disorders*, 5th ed, Arlington, VA: American Psychiatric Association; 2013. pp 372–373.



The most prominent clinical manifestation of narcolepsy is profound daytime sleepiness, characterized by both an increased baseline level of daytime drowsiness and the repeated occurrence of sudden and unpredictable sleep episodes. These “sleep attacks” are often described as “irresistible,” in that the child or adolescent is unable to stay awake despite considerable effort and occur even in the context of normally stimulating activities (e.g., during meals, in conversation). Very brief (several seconds) sleep attacks may also occur in which the individual may “stare off,” appear unresponsive, or continue to engage in an ongoing activity (*automatic behavior*). EDS may also be manifested by increased nighttime sleep needs and extreme difficulty waking in the morning or after a nap.

Cataplexy is considered virtually pathognomonic for narcolepsy but can develop several years after the onset of EDS. Manifestations are triggered by strong positive (laughing, joy) or negative (fright, anger, frustration) emotions and predominantly include facial slackening, head nodding, jaw dropping, and less often, knees buckling or complete collapse with falling to the ground. The cataplectic attacks are typically brief (seconds to minutes), the patient is awake and aware, and episodes are fully reversible, with complete recovery of normal tone when the episode ends. A form of cataplexy unique to children known as **cataplectic facies** is characterized by prolonged tongue protrusion, ptosis, slack jaw, slurred speech, grimacing, and gait instability. Additionally, children may have positive motor phenomenon similar to dyskinesias or motor tics, with repetitive grimacing and tongue thrusting. The cataplectic attacks are typically brief (seconds to minutes) but in children may last for hours or days (**status cataplecticus**). The differential diagnosis of cataplexy includes syncope, seizures, cataplexy-like episodes in *KCNA1* pathologic variants (ataxia-myokymia syndrome), hyperekplexia, hypo and hyperkalemic periodic paralysis syndromes, and pseudocataplexy.

**Hypnagogic/hypnopompic hallucinations** usually involve vivid visual but also auditory and sometimes tactile sensory experiences during transitions between sleep and wakefulness, either at sleep offset (hypnopompic) or sleep onset (hypnagogic). **Sleep paralysis** is the inability to move or speak for a few seconds or minutes at sleep onset or offset and often accompanies the hallucinations. Other symptoms associated with narcolepsy include disrupted nocturnal sleep, impaired cognition, inattention and ADHD-like symptoms, and behavioral and mood dysregulation.

Several pediatric screening questionnaires for EDS, including the modified Epworth Sleepiness Scale, help to guide the need for further evaluation in clinical practice when faced with the presenting complaint of daytime sleepiness. Physical examination should include a detailed neurologic assessment. Overnight PSG and a multiple sleep latency test (MSLT) are strongly recommended components in the evaluation of a patient with profound unexplained daytime sleepiness or suspected narcolepsy. The purpose of the overnight PSG is to evaluate for primary sleep disorders (e.g., OSA) that may cause EDS. The MSLT involves a series of five opportunities to nap (20 min long), during which patients with narcolepsy demonstrate a pathologically shortened mean sleep-onset latency ( $\leq 8$  minutes, typically  $< 5$  minutes) as well as at least two periods of REM sleep occurring immediately after sleep onset. Alternatively, a diagnosis of type 1 narcolepsy can be made by findings of low CSF hypocretin-1 concentration (typically  $\leq 110$  pg/mL) with a standardized assay.

## Treatment

In general, the management of pediatric narcolepsy is best done in conjunction with a pediatric sleep specialist. An individualized narcolepsy treatment plan usually involves education, good sleep hygiene, behavioral changes, and medication. Scheduled naps during the day are often helpful. Wake-promoting medications such as modafinil or armodafinil may be prescribed to control the EDS, although these are not approved for use in children by the U.S. FDA, and potential side effects include rare reports of Stevens-Johnson syndrome and reduced efficacy of hormone-based contraceptives. Psychostimulants are approved for ADHD in children and can be used for EDS; side effects include appetite suppression, mood lability, and cardiovascular effects. Antidepressants (serotonin reuptake inhibitors, tricyclic antidepressants, venlafaxine)

may be used to reduce cataplexy. Sodium oxybate, which is approved for use in children, is a unique drug that appears to have a positive impact on daytime sleepiness, cataplexy, and nocturnal sleep disruption; reported side effects include dizziness, weight loss, enuresis, exacerbation of OSA, depression, and risk of respiratory depression, especially when combined with CNS depressants, including alcohol. Pitolisant has a novel mechanism as a histamine ( $H_3$ ) receptor agonist and has been shown to improve cataplexy and EDS in adult patients with narcolepsy. Preliminary results in children have been encouraging. Solriamfetol, a norepinephrine-dopamine reuptake inhibitor, is another alertness-enhancing drug recently approved in adults. The goal for the child should be to allow the fullest possible return of normal functioning in school, at home, and in social situations.

## Idiopathic Hypersomnia

Idiopathic hypersomnia (**IH**) is a central sleep disorder, presenting in adolescence and young adults, characterized by chronic and EDS, but without cataplexy or REM sleep intrusions. Patients typically present with prolonged nocturnal sleep duration and severe sleep inertia, making it difficult to arouse from nocturnal sleep or daytime naps. Patients often report transient periods of confusion and “sleep drunkenness” on awakening, sleep paralysis, and hypnagogic hallucinations. Unlike patients with narcolepsy, daytime naps tend to be long (more than 1 hour) and unrefreshing. The prevalence in the general population is not known because of challenges with diagnostic evaluation, but is estimated to be approximately 20–50 cases per million. The pathogenesis also is not well understood; however, some cases were documented to be precipitated by viral illnesses, suggesting a possible autoimmune process. A diagnosis of IH requires daily periods of irrepressible need to sleep or daytime lapses into sleep for at least 3 months, absence of cataplexy, and exclusion of other causes including insufficient sleep. Diagnosis is made by PSG followed by an MSLT showing mean sleep latency of  $< 8$  minutes and less than two sleep-onset REM periods (SOREMPs) on MSLT or no SOREMPs if the REM sleep latency preceding PSG is 15 minutes or less. When the mean sleep latency on the MSLT is  $> 8$  minutes, a 24-hour PSG or 2-week actigraphy to ensure a total 24-hour sleep time  $\geq 660$  minutes is needed. Treatment is mostly derived from experience with medications to treat EDS in narcolepsy. Wakeful promoting medications such as modafinil, armodafinil, methylphenidate, amphetamines, and oxybate are treatment options. Behavior modifications such as scheduled naps are not generally helpful.

**Kleine-Levin syndrome (KLS)** may mimic IH and manifests with recurrent episodes of hypersomnia (Table 31.9). KLS may resolve overnight; some reports support the use of parenteral steroids during an episode.

**Table 31.9** Diagnostic Criteria for Kleine-Levin Syndrome

### CRITERIA A–E MUST BE MET

- A. The patient experiences at least two recurrent episodes of excessive sleepiness and sleep duration, each persisting for 2 days to 5 weeks.
- B. Episodes recur usually more than once a year and at least once every 18 months.
- C. The patient has normal alertness, cognitive function, behavior, and mood between episodes.
- D. The patient must demonstrate at least one of the following during episodes:
  - E. Cognitive dysfunction.
  - F. Altered perception.
  - G. Eating disorder (anorexia or hyperphagia).
  - H. Disinhibited behavior (such as hypersexuality).
- I. The hypersomnolence and related symptoms are not better explained by another sleep disorder, other medical, neurologic, or psychiatric disorder (especially bipolar disorder), or use of drugs or medications.

### Delayed Sleep–Wake Phase Disorder

Delayed sleep–wake phase disorder (DSWPD), a circadian rhythm disorder, involves a significant, persistent, and intractable phase shift in sleep–wake schedule (later sleep onset and wake time) that conflicts with the individual’s normal school, work, and lifestyle demands. DSWPD may occur at any age but is most common in adolescents and young adults.

#### Etiology

Individuals with DSPD may start out as “night owls”; that is, they have an underlying biologic predisposition/circadian-based “eveningness” chronotype that results in a propensity for staying up relatively late at night and sleeping until late in the morning or early afternoon, and in extreme cases, a complete “day–night reversal.” Although these patients struggle to get up in time for school or work, they usually revert to their preferred sleep schedule on weekends, holidays, and summer vacations. The underlying pathophysiology of DSWPD is still unknown, although some theorize that it involves an intrinsic abnormality in the circadian oscillators that govern the timing of the sleep period.

#### Epidemiology

Studies indicate that the prevalence of DSWPD may be as high as 7–16% in adolescents and young adults.

#### Clinical Manifestations

The most common clinical presentation of DSWPD is sleep–initiation insomnia when the individual attempts to fall asleep at a “socially acceptable” desired bedtime and experiences very delayed sleep onset (often after 1–2 AM), accompanied by daytime sleepiness. Patients may also report extreme difficulty arising in the morning even for desired activities, with pronounced confusion on waking (*sleep inertia*), and caregivers often complain of the need for multiple reminders or even the complete failure to awaken the adolescent in time to attend school. Sleep maintenance is generally not problematic, and no sleep-onset insomnia is experienced if bedtime coincides with the preferred sleep-onset time. Patients may also develop “secondary” psychophysiological insomnia as a result of spending prolonged time in bed attempting to fall asleep. School tardiness and frequent absenteeism with a decline in academic performance often occur, and there may be school-related disciplinary action (i.e., suspension, truancy label) or a need to justify home-based schooling/tutoring that motivate families to seek help. It is important to recognize that there may also be issues related to family dynamics and comorbid anxiety, depression, or learning disabilities that provide a motivation to avoid attending school and perpetuate the sleep schedule problems, as well as reducing adherence to interventions.

#### Treatment

The treatment of DSWPD usually has three components, all directed toward the goals of shifting the sleep–wake schedule to an earlier, more desirable time and maintaining the new schedule. The initial step involves shifting the sleep–wake schedule to the desired earlier times, usually with gradual (i.e., in 15–30 minute increments every few days) alternating advancement of rise time in the morning and bedtime in the evening. More significant phase delays (i.e., larger difference between current sleep onset and desired bedtime) may require *chronotherapy*, which involves delaying bedtime and wake time by 2–3 hours every 24 hours “forward around the clock” until the target bedtime is reached. Because melatonin secretion is highly sensitive to light, exposure to light in the morning (either natural light or a “light box,” which typically produces light at around 10,000 lux) and avoidance of evening light exposure (especially from screens emitting predominantly blue light, such as computers and laptops) are often beneficial. Exogenous oral melatonin supplementation may also be used; larger, mildly sedating doses (5 mg) are typically given 30 minutes before bedtime, but some studies have

suggested that physiologic doses of oral melatonin (0.3–0.5 mg) administered in the afternoon or early evening (5–7 hours before the habitual sleep-onset time or 2 hours before the desired bedtime) may be more effective in advancing the sleep phase.

### SLEEP HEALTH SUPERVISION

It is especially important for pediatricians to screen for and recognize sleep disorders in children and adolescents during routine healthcare encounters. The well-child visit is an opportunity to educate parents about normal sleep and to teach strategies to prevent sleep problems from developing (primary prevention) or becoming chronic, if problems already exist (secondary prevention). Developmentally appropriate screening for sleep disturbances should take place in the context of every well-child visit and should include a range of potential sleep problems; Table 31.10 outlines a simple sleep screening algorithm called the “BEARS.” Because parents may not always be aware of sleep problems, especially in older children and adolescents, it is also important to question the child directly about sleep concerns. The recognition and evaluation of sleep problems in children require both an understanding of the association between sleep disturbances and daytime consequences (e.g., irritability, inattention, poor impulse control) knowledge of risk factors for the wide variety of sleep disorders (e.g., obesity, positive family history, medications), and familiarity with the developmentally appropriate differential diagnoses of common presenting sleep complaints (difficulty initiating and maintaining sleep, episodic nocturnal events). An assessment of sleep patterns and possible sleep problems should be part of the initial evaluation of every child presenting with behavioral or academic problems, especially ADHD.

Effective preventive measures include educating parents of newborns about normal sleep amounts and patterns. The ability to regulate sleep begins to develop in the first 8–12 weeks of life. Thus it is important to recommend that parents put their 2–4 month old infants to bed “drowsy but awake” if they want to avoid dependence on parental presence at sleep onset and foster the infant’s ability to self-soothe. Other important sleep issues include discussing the importance of regular bedtimes, bedtime routines, and transitional objects for toddlers, and providing parents and children with basic information about healthy sleep practices, recommended sleep amounts at different ages, and signs that a child is not getting sufficient sleep.

The cultural and family context within which sleep problems in children occur should be considered. For example, bed-sharing of infants and parents is a common and accepted practice in many racial/ethnic groups, and these families may not share the goal of independent self-soothing in young infants. *Anticipatory guidance* needs to balance cultural awareness with the critical importance of “safe sleep” conditions in sudden infant death syndrome prevention (i.e., sleeping in the supine position, avoidance of bed-sharing but encouragement of room-sharing in the first year of life) (see Chapter 423). On the other hand, the institution of cosleeping by parents as an attempt to address a child’s underlying sleep problem (so-called reactive cosleeping), rather than as a conscious family decision, is likely to yield only a temporary respite from the problem and may set the stage for more significant sleep issues.

### EVALUATION OF PEDIATRIC SLEEP PROBLEMS

The clinical evaluation of a child presenting with a sleep problem involves obtaining a careful medical history to assess for potential medical causes of sleep disturbances, such as allergies, concomitant medications, and acute or chronic pain conditions. A developmental history is important because of the increased risk of sleep problems in children with neurodevelopmental disorders. Assessment of the child’s current level of functioning (school, home) is a key part of evaluating possible mood, behavioral, and neurocognitive sequelae of sleep problems. Current sleep patterns, including the usual sleep duration and sleep–wake schedule, are often best assessed with a **sleep diary**, in which a parent (or adolescent) records daily sleep behaviors for an extended period (1–2 weeks). A review of sleep habits, such as bedtime routines, daily caffeine intake, and the

**Table 31.10** BEARS Sleep Screening Algorithm

The BEARS instrument is divided into five major sleep domains, providing a comprehensive screen for the major sleep disorders affecting children 2-18yr old. Each sleep domain has a set of age-appropriate “trigger questions” for use in the clinical interview.

B = Bedtime problems

E = Excessive daytime sleepiness

A = Awakenings during the night

R = Regularity and duration of sleep

S = Snoring

	DEVELOPMENTALLY APPROPRIATE TRIGGER QUESTIONS		
	TODDLER, PRESCHOOL (2-5 YR)	SCHOOL-AGE (6-12 YR)	ADOLESCENT (13-18 YR)
1. Bedtime problems	Does your child have any problems going to bed? Falling asleep?	Does your child have any problems at bedtime? (P) Do you any problems going to bed? (C)	Do you have any problems falling asleep at bedtime? (C)
2. Excessive daytime sleepiness	Does your child seem overtired or sleepy a lot during the day? Does your child still take naps?	Does your child have difficulty waking in the morning, seem sleepy during the day, or take naps? (P) Do you feel tired a lot? (C)	Do you feel sleepy a lot during the day? In school? While driving? (C)
3. Awakenings during the night	Does your child wake up a lot at night?	Does your child seem to wake up a lot at night? Any sleepwalking or nightmares? (P) Do you wake up a lot at night? Do you have trouble getting back to sleep? (C)	Do you wake up a lot at night? Do you have trouble getting back to sleep? (C)
4. Regularity and duration of sleep	Does your child have a regular bedtime and wake time? What are they?	What time does your child go to bed and get up on school days? Weekends? Do you think your child is getting enough sleep? (P)	What time do you usually go to bed on school nights? Weekends? How much sleep do you usually get? (C)
5. Snoring	Does your child snore a lot or have difficulty breathing at night?	Does your child have loud or nightly snoring or any breathing difficulties at night? (P)	Does your teenager snore loudly or nightly? (P)

C, Child; P, parent.

sleeping environment (e.g., temperature, noise level), may reveal environmental factors that contribute to the sleep problems. Nocturnal symptoms that may be indicative of a medically based sleep disorder, such as OSA (loud snoring, choking or gasping, sweating) or PLMs (restless sleep, repetitive kicking movements), should be elicited. Home video recording may be helpful in the evaluation of potential parasomnia episodes and the assessment of snoring and

increased work of breathing in children with OSA. An overnight sleep study (PSG) is not routinely warranted in the evaluation of a child with sleep problems unless there are symptoms suggestive of OSA or PLMs, unusual features of episodic nocturnal events, or unexplained daytime sleepiness.

Visit Elsevier eBooks+ at [eBooks.Health.Elsevier.com](http://eBooks.Health.Elsevier.com) for Bibliography.

## Chapter 32

# Psychosocial Assessment and Psychiatric Diagnostic Evaluation

Heather J. Walter

It is estimated that 20% of children living in the United States experience a mental illness in a given year; mental illness is more prevalent than leukemia, diabetes, and AIDS combined. More money is spent on mental disorders than on any other childhood illness, including asthma, trauma, and infectious diseases. Although nearly one in five youths suffers from a psychiatric disorder, 75–85% do not receive specialty mental health services; rather most services are delivered in nonspecialty sectors (primary care, schools, child welfare, juvenile justice), where mental health expertise may be limited. Untreated or inadequately treated psychiatric disorders persist over decades, become increasingly intractable to treatment, impair adherence to medical treatment regimens, and incur progressively greater social, educational, and economic consequences over time.

### AIMS OF PSYCHOSOCIAL ASSESSMENT IN THE PEDIATRIC SETTING

A psychosocial assessment in the pediatric setting should determine whether there are signs and symptoms of cognitive, developmental, emotional, behavioral, or social difficulties and characterize those signs and symptoms sufficiently to determine their appropriate management. The focus of the assessment varies with the nature of the presenting problem and the clinical setting. Under emergency circumstances, the focus may be limited to an assessment of “dangerousness to self or others” for the purpose of determining the safest level of care. In routine circumstances (well-child visits), the focus may be broader, involving a screen for symptoms, distress, and functional impairment in the major psychosocial domains. The challenge for the pediatric practitioner will be to determine as accurately as possible whether the presenting signs and symptoms are likely to meet criteria for a psychiatric disorder and whether the severity and complexity of the disorder suggest referral to a mental health specialist or management in the primary care setting.

### PRESENTING PROBLEMS

**Infants** may come to clinical attention because of problems with eating and/or sleep regulation, concerns about failure to gain weight, poor social responsiveness, limited vocalization, apathy or disinterest, and response to strangers that is excessively fearful or overly familiar. Psychiatric disorders most commonly diagnosed during this period are rumination and reactive attachment disorders.

**Toddlers** are assessed for concerns about sleep problems, language delay, motor hyperactivity, extreme misbehavior, extreme shyness, inflexible adherence to routines, difficulty separating from parents, struggles over toilet training, dietary issues, and testing limits. Developmental delays and more subtle physiologic, sensory, and motor processing problems can be presented as concerns. Problems with “goodness of fit” between the child’s temperament and the parents’ expectations can create relationship difficulties that also require assessment (see [Chapter 19](#)). Mental health disorders most commonly

diagnosed during this period are developmental delays, autism spectrum disorder (ASD) and reactive attachment disorders.

Presenting problems in **preschoolers** include elimination difficulties, sibling jealousy, difficulty forming friendships, self-destructive impulsiveness, multiple fears, nightmares, refusal to follow directions, rigidity, somatization, speech that is difficult to understand, and temper tantrums. Mental health disorders most commonly diagnosed in this period are ASD, communication, oppositional, attention-deficit/hyperactivity (ADHD), anxiety (separation, selective mutism), reactive attachment, and sleep disorders.

**Older children** are brought to clinical attention because of concerns about angry or sad mood, bed-wetting, overactivity, impulsiveness, distractibility, learning problems, arguing, defiance, nightmares, school refusal, bullying or being bullied, worries and fears, somatization, communication problems, tics, and withdrawal or isolation. Mental health disorders most commonly diagnosed during this period are ADHD, oppositional, anxiety (phobias), elimination, somatic symptom, specific learning, and tic disorders.

**Adolescents** are assessed for concerns about the family situation, experimentation with sexuality and drugs, delinquency and gang involvement, friendship patterns, issues of independence, identity formation, self-esteem, and morality. Mental health disorders most often diagnosed during this period are anxiety (panic, social anxiety), depressive, bipolar, psychotic, obsessive-compulsive, impulse control, conduct, substance-related, and eating disorders.

### GENERAL PRINCIPLES OF THE PSYCHOSOCIAL INTERVIEW

Psychosocial interviewing in the context of a routine pediatric visit requires adequate time and privacy. The purpose of this line of inquiry should be explained to the child and parents (“to make sure things are going OK at home, at school, and with friends”), along with the limits of confidentiality. Thereafter, the first goal of the interview is to build rapport with both the child and the parents (see [Chapters 18 and 34](#) for further discussion of strategies for engaging families).

With the parents, this rapport is grounded in respect for the parents’ knowledge of their child, their role as the central influence in their child’s life, and their desire to make a better life for their child. Parents often feel anxious or guilty because they believe that problems a child is experiencing imply that their parenting skills are inadequate. Parents’ experiences of their own childhood influence the meaning a parent places on a child’s feelings and behavior. A good working alliance allows mutual discovery of the past as it is active in the present and permits potential distortions to be modified more readily. Developmentally appropriate overtures can facilitate rapport with the child. Examples include playing peek-a-boo with an infant, racing toy cars with a preschooler, commenting on sports with a child who is wearing a baseball cap, and discussing music with a teenager who is wearing a rock band T-shirt.

After an overture with the child, it is helpful to begin with **family-centered interviewing**, in which the parent is invited to present any psychosocial concerns (learning, feelings, behavior, peer relationships) about the child. With adolescent patients, it is important to conduct a separate interview to give the adolescent an opportunity to confirm or refute the parent’s presentation and to present the problem from his or her perspective. Following the family’s undirected presentation of the primary problem, it is important to shift to direct questioning to clarify the duration, frequency, and severity of symptoms, associated distress or functional impairment, and the developmental and environmental context in which the symptoms occur.

Because of the high degree of **comorbidity** of psychosocial problems in children, after eliciting the presenting problem, the pediatric practitioner should then briefly screen for problems in all the major



**Table 32.1** Mental Health Action Signs

- Feeling very sad or withdrawn for more than 2 weeks
- Seriously trying to harm or kill yourself, or making plans to do so
- Sudden overwhelming fear for no reason, sometimes with a racing heart or fast breathing
- Involvement in many fights, using a weapon, or wanting to badly hurt others
- Severe out-of-control behavior that can hurt yourself or others
- Not eating, throwing up, or using laxatives to make yourself lose weight
- Intense worries or fears that get in the way of your daily activities
- Extreme difficulty in concentrating or staying still that puts you in physical danger or causes school failure
- Repeated use of drugs or alcohol
- Severe mood swings that cause problems in relationships
- Drastic changes in your behavior or personality

From The Action Signs Project. *Center for the Advancement of Children's Mental Health* at Columbia University.

developmentally appropriate categories of cognitive, developmental, emotional, behavioral, and social disturbance, including problems with mood, anxiety, attention, behavior, substance use, eating, elimination, social relatedness, language, and learning. This can be preceded by a transition statement such as, “Now I'd like to ask about some other issues that I discuss with all parents and kids. Have there been any problems with attention, learning, behavior, sad mood...” etc.

A useful guide for this area of inquiry is provided by the **11 Action Signs** (Table 32.1), designed to give frontline clinicians the tools needed to recognize early symptoms of mental disorders. *Functional impairment* can be assessed by inquiring about symptoms and function in the major life domains, including home and family, school, peers, and community. These domains are included in the **HEADSS** (Home, Education, Activities, Drugs, Sexuality, Suicide/Depression) Interview Guide, often used in the screening of adolescents (Table 32.2).

The nature and severity of the presenting problem(s) can be further characterized through a **standardized self-, parent-, or teacher-informant symptom rating scale**; Table 32.3 lists selected scales in the public domain. A rating scale is a type of measure that provides a relatively rapid assessment of a specific construct with an easily derived numerical score that is readily interpreted. The use of symptom rating scales can ensure efficient, systematic coverage of relevant symptoms, quantify symptom severity, and document a baseline against which treatment effects can be measured. Functional impairment also can be assessed with self- and other-reported rating scales.

Clinical experience and methodologic studies suggest that parents and teachers are more likely than the child to report externalizing problems (disruptive, impulsive, overactive, or antisocial behavior). Children may be more likely to report anxious or depressive feelings, including suicidal thoughts and acts, of which the parents may be unaware. Discrepancies across informants are common and can shed light on whether the symptoms are pervasive or contextual. Although concerns have been raised about children's competence as self-reporters (because of limitations in linguistic skills, self-reflection, emotional awareness, ability to monitor behavior, thoughts, and feelings, tendency toward social desirability), children and adolescents can both be reliable and valid self-reporters.

Pediatric practitioners are encouraged to become familiar with the psychometric characteristics and appropriate use of at least one **general (broad-band) psychosocial screening instrument**, such as the *Strengths and Difficulties Questionnaire* (SDQ)\* or the *Pediatric Symptom Checklist* (PSC)† to identify potential mental health problems. If the clinical interview or broad-band symptom rating scale suggests difficulties in one or more specific symptom areas, the clinician can follow with a psychometrically sound, corresponding **narrow-band**

**Table 32.2** HEADSS Screening Interview for Taking a Rapid Psychosocial History**PARENT INTERVIEW**

## Home

- How well does the family get along with each other?

## Education

- How well does your child do in school?

## Activities

- What does your child like to do?
- Does your child do anything that has you really concerned?
- How does your child get along with peers?

## Drugs

- Has your child used drugs or alcohol?

## Sexuality

- Are there any issues regarding sexuality or sexual activity that are of concern to you?

## Suicide/Depression

- Has your child ever been treated for an emotional problem?
- Has your child ever intentionally tried to hurt him/herself or made threats to others?

**ADOLESCENT INTERVIEW**

## Home

- How do you get along with your parents?

## Education

- How do you like school and your teachers?
- How well do you do in school?

## Activities

- Do you have a best friend or group of good friends?
- What do you like to do?

## Drugs

- Have you used drugs or alcohol?

## Sexuality

- Are there any issues regarding sexuality or sexual activity that are of concern to you?

## Suicide/Depression

- Everyone feels sad or angry some of the time. How about you?
- Did you ever feel so upset that you wished you were not alive or so angry you wanted to hurt someone else badly?

HEADSS, Home, Education, Activities, Drugs, Sexuality, Suicide/Depression.

From Cohen E, MacKenzie RG, Yates GL. HEADSS, a psychosocial risk assessment instrument: implications for designing effective intervention programs for runaway youth. *J Adolesc Health*. 1991;12:539-544.

**instrument**, such as the *Vanderbilt ADHD Diagnostic Rating Scale* or *Swanson Nolan and Pelham (SNAP)-IV-26* for attention and behavior problems; the *Center for Epidemiological Studies Depression Scale for Children* (CES-DC), *Mood and Feelings Questionnaire* (MFQ), or *Patient Health Questionnaire-9* (PHQ-9) for depression; or the *Screen for Child Anxiety Related Emotional Disorders* (SCARED) or the *Generalized Anxiety Disorder-7* (GAD-7) for anxiety.

Children and adolescents scoring above focused symptom rating scale cutpoints in most cases should undergo a mental health assessment, because scores above cutpoints are highly correlated with clinically significant psychiatric disorders. Youths scoring just below or only slightly above cutpoints may be appropriate for preventive intervention (anticipatory guidance) in the pediatric primary care setting. Youths scoring moderately above cutpoints for disorders commonly presenting in pediatric primary care (e.g., anxiety, depression, ADHD) may be appropriate for treatment in primary care. Youths scoring greatly above cutpoints for anxiety, depression, and ADHD, or youths presenting with symptoms of psychiatric disorders nearly always characterized by severity and complexity (e.g., bipolar, psychotic, obsessive-compulsive,

\* <http://www.sdqinfo.org/py/sdqinfo/b0.py>.

† [http://www.brightfutures.org/mentalhealth/pdf/professionals/ped\\_symptom\\_chklst.pdf](http://www.brightfutures.org/mentalhealth/pdf/professionals/ped_symptom_chklst.pdf).

**Table 32.3** Selected List of Mental Health Rating Scales in the Public Domain

INSTRUMENTS	FOR AGES (YR)	INFORMANT: NUMBER OF ITEMS	TIME TO COMPLETE (MIN)	AVAILABLE AT
<b>BROAD-BAND/GENERALIZED</b>				
Pediatric Symptom Checklist (PSC)	4-18	Parent: 35, 17 Youth: 35, 17	5-10	<a href="https://www.massgeneral.org/psychiatry/treatments-and-services/pediatric-symptom-checklist">https://www.massgeneral.org/psychiatry/treatments-and-services/pediatric-symptom-checklist</a>
Strengths and Difficulties Questionnaire (SDQ)	4-18	Parent, Teacher, Child: 25	5	<a href="https://www.sdqinfo.org">https://www.sdqinfo.org</a>
<b>NARROW-BAND/FOCUSED</b>				
<b>Anxiety</b>				
Self-Report for Childhood Anxiety Related Emotional Disorders (SCARED)	8-18	Parent, Child: 41	5	<a href="https://www.pediatricbipolar.pitt.edu/resources/instruments">https://www.pediatricbipolar.pitt.edu/resources/instruments</a>
Generalized Anxiety Disorder-7 (GAD-7)	12-18	Youth: 7	1	<a href="https://www.phqscreeners.com">https://www.phqscreeners.com</a>
<b>Attention and Behavior</b>				
Vanderbilt ADHD Diagnostic Rating Scale	6-12	Parent: 55 Teacher: 43	10	<a href="https://www.nichq.org/resource/nichq-vanderbilt-assessment-scales">https://www.nichq.org/resource/nichq-vanderbilt-assessment-scales</a>
Swanson Nolan and Pelham (SNAP)-IV 26	6-18	Parent and Teacher: 26	5	<a href="http://www.shared-care.ca/files/Scoring_for_SNAP_IV_Guide_26-item.pdf">http://www.shared-care.ca/files/Scoring_for_SNAP_IV_Guide_26-item.pdf</a>
<b>Autism</b>				
Modified Checklist for Autism in Toddlers (M-CHAT)	16-30 mo	Parent: 23	5-10	<a href="https://mchatscreen.com">https://mchatscreen.com</a>
<b>Depression</b>				
Center for Epidemiological Studies Depression Scale for Children (CES-DC)	6-18	Child: 20	5	<a href="https://www.brightfutures.org/mentalhealth/pdf/professionals/bridges/ces_dc.pdf">https://www.brightfutures.org/mentalhealth/pdf/professionals/bridges/ces_dc.pdf</a>
Mood and Feelings Questionnaire (MFQ)	7-18	Parent: 34 Child: 33	<5	<a href="https://devepi.duhs.duke.edu/measures/the-mood-and-feelings-questionnaire-mfq/">https://devepi.duhs.duke.edu/measures/the-mood-and-feelings-questionnaire-mfq/</a>
Patient Health Questionnaire-9 (PHQ-9)	12/13+	9	<5	<a href="https://www.phqscreeners.com">https://www.phqscreeners.com</a>

ADHD, Attention-deficit/hyperactivity disorder.

posttraumatic stress, eating) may be most appropriate for treatment in specialty care.

The **safety** of the child in the context of the home and community is of paramount importance. The interview should sensitively assess whether the child has been exposed to any frightening events, including abuse, neglect, bullying, marital discord, or domestic or community violence; whether the child shows any indication of dangerousness to self or others or a severely altered mental status (psychosis, intoxication, delirium, rage, hopelessness); or whether the child (if age appropriate) has been involved in any **risky behavior**, including running away, staying out without permission, truancy, gang involvement, experimentation with substances, and unprotected sexual encounters. The interview also should assess the capacity of the parents to adequately provide for the child's physical, emotional, and social needs or whether parental capacity has been diminished by psychiatric disorder, family dysfunction, or the sequelae of disadvantaged socioeconomic status. Any indications of threats to the child's safety should be immediately followed by thorough assessment and protective action.

## DIAGNOSIS

There is variability in the level of confidence pediatric practitioners perceive in diagnosing mental health problems in children and adolescents in accordance with *Diagnostic and Statistical Manual of Mental Disorders* (DSM) criteria. Pediatric practitioners who have familiarity with psychiatric diagnostic criteria may feel confident diagnosing certain disorders, particularly the more common neurodevelopmental, elimination, and eating disorders (ADHD, anxiety, autism spectrum, tics, enuresis, encopresis, anorexia). The disorders about which some pediatric practitioners might have less diagnostic confidence include the disruptive/impulse control/conduct,

anxiety, depressive, bipolar, psychotic, obsessive-compulsive, trauma-related, somatic symptom, and substance-related disorders. Pediatric practitioners may prefer to use the "unspecified" diagnosis option in the context of diagnostic uncertainty until clarification is achieved, often through consultation with or referral to a mental health clinician.

While focusing on the specific psychiatric manifestations and their appropriate treatment, the practitioner must also take into consideration secondary etiologies (systemic illnesses, substance and medication use [Tables 32.4 and 32.5]) producing psychiatric symptoms. Disease-specific therapy combined with psychopharmacology is often necessary when a systemic disorder is identified.

## PSYCHIATRIC DIAGNOSTIC EVALUATION

The objectives of the psychiatric diagnostic evaluation of the child and adolescent, generally conducted by a behavioral health specialist, are to determine whether **psychopathology or developmental risk** is present and if so, to establish an explanatory formulation and a differential diagnosis, and to determine whether treatment is indicated and, if so, to develop a treatment plan and facilitate the parents' and child's involvement in the plan. The aims of the diagnostic evaluation are to clarify the reasons for the referral, to obtain an accurate accounting of the child's developmental functioning and the nature and extent of the child's psychosocial difficulties, functional impairment, and subjective distress, and to identify potential individual, family, or environmental factors that might account for, influence, or ameliorate these difficulties. The issues relevant to diagnosis and treatment planning can span genetic, constitutional, and temperamental factors, individual psychodynamics, cognitive, language, and social skills, family patterns of interaction and child-rearing practices, and community, school, and socioeconomic influences.

Table 32.4 Medical (Secondary) and Psychiatric (Primary) Causes of Psychosis and/or Depression			
CATEGORY	DISORDERS	CATEGORY	DISORDERS
Psychiatric	Schizophrenia Schizoaffective Schizophreniform Brief psychotic Major depression Bipolar Postpartum	Inherited metabolic (cont'd)	Mitochondrial neurogastrointestinal encephalopathy (MNGIE) Cerebrotendinous xanthomatosis Homocystinuria Ornithine transcarbamylase deficiency Phenylketonuria
Head trauma	Traumatic brain injury Subdural hematoma	Syndromes	Williams Prader-Willi Marfan Fragile X Deletion 22q11.2 Rapid-onset obesity with hypothalamic dysfunction, hypoventilation, autonomic dysregulation (ROHHAD) Klinefelter
Infectious	Viral infections/encephalitides (HIV infection/encephalopathy, herpes encephalitis, cytomegalovirus, Epstein-Barr virus, COVID-19) Lyme disease Cerebral malaria Endocarditis Neurosyphilis Whipple disease	Epilepsy	Ictal Interictal Postictal Postepilepsy surgery Lafora progressive myoclonic epilepsy Complex partial (temporal lobe)
Inflammatory	Autoimmune encephalitis: NMDAR, limbic, others (see Table 32.5) Systemic lupus erythematosus Sjögren syndrome Hashimoto encephalopathy (steroid-responsive encephalopathy associated with autoimmune thyroiditis [SREAT]) Sydenham chorea Sarcoidosis Celiac disease	Substance induced (medications)	Analgesics Acyclovir Androgens (anabolic steroids) Antiarrhythmics Anticonvulsants Anticholinergics Antihypertensives Antineoplastic agents β-Blocking agents Cefepime Clarithromycin Cyclosporine Dextromethorphan Dopamine agonists Ketamine Fluoroquinolones Metronidazole Sulfamethoxazole-trimethoprim Oral contraceptives Sedatives/hypnotics Selective serotonin reuptake inhibitors (SSRIs) (serotonin syndrome) Steroids
Neoplastic	Primary or secondary cerebral neoplasm Paraneoplastic encephalitis: ovarian teratoma-associated autoimmune encephalitis Systemic neoplasm Pheochromocytoma	Substance induced	Alcohol Amphetamines Cocaine LSD Marijuana and synthetic cannabinoids Methylenedioxymethamphetamine (MDMA, Ecstasy) Phencyclidine Mescaline Psilocybins (mushrooms)
Endocrine or acquired metabolic	Hepatic encephalopathy Uremic encephalopathy Hypo/hyperparathyroidism Hypo/hyperthyroidism Addison disease Cushing disease Vitamin deficiency: vitamin B <sub>12</sub> , folate, niacin, vitamin C, thiamine Gastric bypass-associated nutritional deficiencies Hypoglycemia Hyponatremia	Drug withdrawal syndromes	Alcohol Barbiturates Benzodiazepines Amphetamines SSRIs
Vascular	Cerebral autosomal dominant arteriopathy with subcortical infarcts and leukoencephalopathy (CADASIL) Other vasculitis syndromes Stroke	Toxins	Heavy metals: lead, mercury, arsenic Carbon monoxide Inhalants Organophosphates St. John's wort
Degenerative	Idiopathic basal ganglia calcifications, Fahr disease Neuroacanthocytosis Neurodegeneration with brain iron accumulation (NBIA) Tuberous sclerosis Huntington disease Corticobasal ganglionic degeneration Multisystem atrophy, striatonigral degeneration, olivopontocerebellar atrophy	Other	Normal-pressure hydrocephalus Ionizing radiation Decompression sickness Narcolepsy
Demyelinating, dysmyelinating	Multiple sclerosis Acute disseminated encephalomyelitis Adrenoleukodystrophy Metachromatic leukodystrophy		
Inherited metabolic	Wilson disease Posterior horn syndrome Tay-Sachs disease (adult onset) Neuronal ceroid lipofuscinosis Niemann-Pick disease type C Acute intermittent porphyria Mitochondrial encephalopathy, lactic acidosis, and stroke-like episodes (MELAS)		

**Table 32.5** Antigenic Targets in Autoimmune Encephalitis with Associated Psychiatric Features

COMMONLY TARGETED ANTIGENS	ANTIGEN DESCRIPTION OR EPITOPE	MAIN ENCEPHALOPATHY SYNDROME AND PSYCHIATRIC FEATURES	OTHER ASSOCIATED NEUROLOGIC DISORDERS	MAIN PSYCHIATRIC FEATURES
NMDAR	Ligand-gated ion channel	Encephalopathy (frequently extralimbic manifestation)	Post-herpes simplex encephalitis relapse with chorea; pediatric dyskinetic encephalitis lethargica; idiopathic epilepsy; immunotherapy-responsive dementia	Anxiety, agitation, bizarre behavior, catatonia, delusional or paranoid thoughts, and visual or auditory hallucinations; also movement disorder, seizures, autonomic instability
LGI1	VGKC-associated and AMPAR-associated secreted molecule	Limbic encephalitis with or without faciobrachial dystonic seizures; prominent hyponatremia	Morvan syndrome, neuromyotonia, epilepsy, REM sleep behavior disorder; rarely isolated movement disorder (parkinsonism, dystonia, chorea)	Confusion, hallucinations, depression
CASPR2	VGKC-associated adhesion molecule	Morvan syndrome: peripheral nerve hyperexcitability, autonomic instability, encephalopathy	Limbic encephalitis, neuromyotonia, epilepsy; rarely isolated movement disorder (chorea, myoclonus)	Confusion, hallucinations, agitation, delusions
AMPA	Ligand-gated ion channel	Limbic encephalitis	NA	Personality change, psychosis, apathy, agitation, confabulation
GABA <sub>A</sub> R	Ligand-gated ion channel	Limbic encephalitis with refractory seizures	Varied presentations	Confusion, anxiety, affective changes (including depression), hallucinations, catatonia
GABA <sub>B</sub> R	Ligand-gated ion channel	Limbic encephalitis with refractory status epilepticus	Opsoclonus-myoclonus; cerebellar ataxia; PERM	Psychosis, agitation, catatonia
Hu	Intracellular RNA-binding protein	Limbic encephalitis or limbic encephalomyelitis occurring with small cell lung cancer	Painful sensory neuropathy; cerebellar ataxia	Confusion, depression, less commonly hallucinations
Ma2	Intracellular protein involved in mRNA processing or biogenesis	Limbic encephalitis occurring with testicular germ cell tumors; REM sleep disorder is common; frequent short-term memory problems	Visual dysfunction, gait disturbance, hypokinesia	Confusion and anxiety, including obsessions and compulsions
D2R	Metabotropic receptor	So-called basal ganglia encephalitis with prominent movement disorder (i.e., dystonia, parkinsonism, chorea, tics)	Sydenham chorea, PANDAS	Agitation, depression, psychosis, emotional lability
DPPX	Auxiliary subunit of Kv4.2 potassium channels	Limbic encephalitis with enteropathy	PERM	Amnesia, delirium, psychosis, depression
MGlur5	Metabotropic glutamate receptor	So-called Ophelia syndrome: limbic encephalitis in association with Hodgkin lymphoma	Paraneoplastic limbic encephalitis without lymphoma, or nonparaneoplastic limbic encephalitis; immunotherapy-responsive prosopagnosia	Depression, anxiety, delusions, visual and auditory hallucinations, personality change, anterograde amnesia
GFAP	Intracellular (cytosolic) glial intermediate filament protein	Corticosteroid-responsive meningoencephalitis or encephalitis, with or without myelitis; presents with subacute onset of memory loss and confusion	NA	Occurred in 29% in one study but not described in detail; psychosis and behavioral changes reported

AMPA,  $\alpha$ -Amino-3-hydroxy-5-methyl-4-isoxazolepropionic acid receptor; CASPR2, contactin-associated protein-like 2; D2R, dopamine receptor D2; DPPX, dipeptidyl-peptidase-like protein-6; GABA<sub>A</sub>R,  $\gamma$ -aminobutyric acid type A receptor; GABA<sub>B</sub>R,  $\gamma$ -aminobutyric acid type B receptor; GFAP, glial fibrillary acidic protein; LGI1, leucine-rich glioma-inactivated 1; MGlur5, metabotropic glutamate receptor 5; NA, not applicable; NMDAR, N-methyl-D-aspartate receptor; PANDAS, pediatric autoimmune neuropsychiatric disorders associated with streptococcal infections; PERM, progressive encephalomyelitis with rigidity and myoclonus; REM, rapid eye movement; VGKC, voltage-gated potassium channel.

Modified from Pollak TA, Lennox BR, Muller S, et al. Autoimmune psychosis: an international consensus on an approach to the diagnosis and management of psychosis of suspected autoimmune origin. *Lancet Psychiatry*. 2020;7(1):93-108.



The focus of the evaluation is developmental; it seeks to describe the child's functioning in various realms and to assess the child's adaptation in these areas relative to that expected for the child's age and phase of development. The developmental perspective extends beyond current difficulties to vulnerabilities that can affect future development and as such are important targets for preventive intervention. Vulnerabilities may include **subthreshold or subsyndromal difficulties** that, especially when manifold, often are accompanied by significant distress or impairment and as such are important as potential harbingers of future problems.

Throughout the assessment, the clinician focuses on identifying a realistic balance of vulnerabilities and strengths in the child, in the parents, and in the parent-child interactions. From this strength-based approach, over time a hopeful family narrative is co-constructed to frame the child's current developmental progress and predict the child's ongoing progress within the scope of current risk and protective factors.

As described earlier a **psychiatric** assessment conducted by a pediatric primary care practitioner generally will be a brief **psychosocial** assessment focused on obtaining sufficient information to triage the case to the appropriate level of care. A brief assessment can comprise both administration of a focused (narrow-band) symptom rating scale to assess symptom severity and a focused clinical interview. The focused clinical interview can comprise four dimensions: **history** (onset, duration, response to prior treatment, family history), **severity** (as derived from the focused rating scale and verbal query about the degree of distress and/or impairment associated with the symptom[s]), **complexity** (brief review of psychiatric comorbidities and medical or social complexities), and **safety** (ascertainment of imminent and substantial risk of harm). With this information, the pediatrician can provisionally diagnose the case and triage the case to primary care (for preventive intervention or treatment of mild to moderate presentations of common disorders [e.g., ADHD, anxiety, depression]), or to specialty behavioral healthcare (for severe presentations of these disorders or for other psychiatric disorders nearly always characterized by severity and complexity).

In the specialty care setting, although the scope of the evaluation will vary with the clinical setting (e.g., emergency room vs medical floor vs psychiatric clinic), a **comprehensive psychiatric diagnostic evaluation** typically has 12 major components:

- ♦ Presenting problem(s) and the context in which they occur
- ♦ Review of psychiatric symptoms
- ♦ History of psychiatric treatment
- ♦ Medical history
- ♦ Developmental history
- ♦ Educational history
- ♦ Family history
- ♦ Mental status examination
- ♦ Biopsychosocial clinical formulation
- ♦ *DSM, Fifth Edition* (DSM-5) diagnosis
- ♦ Risk assessment
- ♦ Treatment plan

For infants and young children, the presenting problem and historical information is derived from parents and other informants. As children mature, they become increasingly important contributors to the information base, and they become the primary source of information in later adolescence. Information relevant to formulation and differential diagnosis is derived in multiple ways, including directive and nondirective questioning, interactive play, and observation of the child alone and together with the caregiver(s).

The **explication of the presenting problem(s)** includes information about onset, duration, frequency, setting, and severity of symptoms, associated distress and/or functional impairment, and predisposing, precipitating, and ameliorating contextual factors. The **symptom review** assesses potential comorbidity in the major domains of child and adolescent psychopathology. The

**history of psychiatric treatment** includes gathering information about prior emergency mental health assessments, psychiatric hospitalizations, day treatment, psychotherapy, pharmacotherapy, and nontraditional treatments.

The **medical history** includes information about the source of primary care, the frequency of health supervision, past and current medical illnesses and treatments, and the youth and family's history of adherence to medical treatment. A systematic review of organ or functional systems facilitates the identification of abnormalities that require investigation or monitoring by the pediatric practitioner, as well as the identification of cautionary factors related to the prescription of psychotropic medication. The **developmental history** includes information about the circumstances of conception, pregnancy, or adoption, pre-, peri-, or postnatal insults, attachment and temperament, cognitive, motor, linguistic, emotional, social, and moral development, health habits, sexuality, substance use (as age appropriate), coping and defensive structure, future orientation, and perceived strengths. The **educational history** includes schools attended, typical grades, attendance, behavior, classroom accommodations, special education services, disciplinary actions, social relationships, extracurricular activities, and barriers to learning. The **family history** assesses family composition, sociodemographic and neighborhood characteristics, domiciliary arrangements, parenting capacities, family function, medical/psychiatric histories of family members, and cultural/religious affiliations.

The **mental status examination** assesses appearance, relatedness, cognition, communication, mood, affective expression, behavior, memory, orientation, and perception.

The comprehensive psychiatric evaluation culminates in a biopsychosocial formulation, diagnosis, and risk assessment. The **biopsychosocial formulation** is derived from an assessment of *vulnerabilities* and *strengths* in the biologic, psychologic, and social domains and serves to identify targets for intervention and treatment. In the *biologic* domain, major vulnerabilities include a family history of psychiatric disorder as well as a personal history of pre-, peri-, or postnatal insults, cognitive or linguistic impairments, chronic physical illness, and a difficult temperament. In the *psychologic* domain, major vulnerabilities include failure to achieve developmental tasks, unresolved unconscious conflicts, and maladaptive coping and defensive styles. In the *social* domain, major vulnerabilities include parental incapacity, unskilled parenting, family dysfunction, social isolation, inadequate school setting, absence of supportive community structures, and sociodemographic disadvantage. Major strengths include cognitive and linguistic capability, physical health and vigor, stable, moderate temperamental characteristics, and stable supportive parenting, family, peer, and community structures. The biopsychosocial formulation can be organized to reflect *predisposing, precipitating, perpetuating, and protective (ameliorating) factors (the "4 Ps")* influencing the development of the observed psychopathology.

The **diagnosis** is made in accordance with the nomenclature in DSM-5. This nomenclature categorizes cross-sectional phenomenology into discrete clinical syndromes and seeks to improve diagnostic accuracy at the expense of theories of causation. By DSM-5 convention, if diagnostic criteria are met, the diagnosis is given (except where hierarchical rules apply); consequently, psychiatric comorbidity is a common occurrence. The **risk assessment** includes a careful assessment of risk status, including suicidality, homicidality, assaultiveness, self-injuriousness, acute mental status changes, and involvement in risky behavior or situations.

The comprehensive psychiatric diagnostic evaluation culminates in a **treatment plan** that brings the broad array of targeted interventions to the service of the child. Diagnoses drive the choice of evidence-based psychotherapeutic and psychopharmacologic treatments. The formulation drives the selection of interventions targeted at biologic, psychologic, and social vulnerabilities and strengths. Many of these treatments and interventions are described in the succeeding chapters.

## SPECIAL CONSIDERATIONS IN THE DIAGNOSTIC EVALUATION OF INFANTS AND YOUNG CHILDREN

Evaluation of infants and young children with challenging behaviors includes the domains of physiology, temperament, language and motor development, affective behavior, social behavior, and communication. Although much of the information in these domains will be derived from parent report, much also can be gleaned from nonverbal behavior and observation of the parent–child interaction. Observations should include predominant affective tone of parent and child (positive, negative, apathetic), involvement in the situation (curiosity, disinterest), social responsiveness (mutuality of gaze, auditory responsiveness), and reactions to transitions (including separation).

A screen for maternal depression\* is critical at this stage, as is an assessment of the mother's (or other caregiver's) ability to respond rapidly on a contingent basis to the child's expressed needs, regulate the child's rapid shifts of emotion and behavior, and provide a stimulus shelter to prevent the child from being overwhelmed.

Standardized screening instruments (Ages and Stages Questionnaires, Brief Infant-Toddler Social & Emotional Assessment, Early Childhood Screening Assessment, Modified Checklist for Autism in Toddlers, Parents' Evaluation of Developmental Status, and Survey of Well-being of Young Children) designed for this age-group can be helpful in systematizing the evaluation. In addition, the Infant, Toddler and Preschool Mental Status Exam (ITP-MSE) is a reference tool that describes how traditional categories of the mental status examination can be adapted to observations of young children. Additional categories, including sensory and state regulation, have been added that reflect important areas of development in young children.

Diagnostic systems that are more age appropriate than DSM-5 have been developed for infants and young children. These systems include the *Research Diagnostic Criteria–Preschool Age* (RDC-PA) and *Zero to Three Diagnostic Classification of Mental Health and Developmental Disorders of Infancy and Early Childhood-Revised* (DC: 0-3R). The DC: 0-3R includes a relationship classification that assesses the range of interactional adaptation in each parent–child relationship and regulation disorders of sensory processing that identify a range of constitutionally and maturationally based sensory reactivity patterns, motor patterns, and behavior patterns that together can dysregulate a child internally and impact the child's interactions with caregivers.

Visit Elsevier eBooks+ at [eBooks.Health.Elsevier.com](http://eBooks.Health.Elsevier.com) for Bibliography.

\* See <http://www.medicalhomeportal.org/clinical-practice/screening-and-prevention/maternal-depression> for several examples.

## Chapter 33

# Psychopharmacology

David R. DeMaso and Heather J. Walter

Psychopharmacology is the first-line treatment for several child and adolescent mental health disorders (e.g., attention-deficit/hyperactivity [ADHD], schizophrenia spectrum, and bipolar disorders) and is used adjunctively with psychosocial treatments for other disorders (or comorbid conditions), including anxiety, depressive, autism spectrum, trauma-related, and obsessive-compulsive disorders. Before prescribing a psychotropic medication, primary care practitioners (PCPs) should review full prescribing information for each medication (in package inserts or at reliable websites such as the National Institutes of Health *DailyMed*\*) to obtain complete and up-to-date information about indications, contraindications, warnings, interactions, and precautions.

\* <https://dailymed.nlm.nih.gov/dailymed/index.cfm>.

It is helpful for PCPs to be guided by principles for effective use of psychotropic medications in their medication assessment and management (Table 33.1). These principles involve a series of interconnected steps, including conducting a focused behavioral health assessment, **establishing target symptom(s)** and appropriate level of care, deciding on a medication and a monitoring plan, obtaining treatment assent/consent, and implementing treatment. In following this approach, PCPs are well positioned to provide safe and effective first-line psychopharmacology for common mental health conditions (e.g., ADHD, anxiety, depression) with moderate symptom presentations. Severe/complex presentations likely are better served through consultation with and/or referral to a behavioral health specialist.

Questions remain about the quality of the evidence supporting the use of many psychotropic medications in children and adolescents. In general, cognitive, emotional, and behavioral symptoms are targets for medication treatment when (1) there is no or insufficient response to available evidence-based psychosocial interventions, (2) the patient's symptoms are severe and the patient is experiencing significant distress or functional impairment, and/or (3) the patient's symptoms convey significant risk of harm. Common target symptoms include agitation, aggression, anxiety, depression, mania, hyperactivity, inattention, impulsivity, obsessions, compulsions, and psychosis (Table 33.2). All these symptoms can be quantitatively measured with standardized rating scales to establish baseline symptom severity and facilitate "treating to target."

## STIMULANTS AND OTHER ADHD MEDICATIONS

Stimulants are sympathomimetic drugs that act both in the central nervous system (CNS) and peripherally by enhancing dopaminergic and noradrenergic transmission (Table 33.3). Strong evidence (approximate effect size 1.00, large) exists for the effectiveness of these medications for the treatment of ADHD (Chapter 50); stimulants also are effective for the management of aggression. In some cases, stimulants have been used as monotherapy for fatigue or malaise associated with chronic physical illnesses.

No major differences in efficacy or tolerability have been found between different classes of stimulants, and no consistent patient profile identifies those who will respond preferentially to one class over another. The most common (generally dose-dependent) side effects of stimulants include headache, stomachache, appetite suppression, weight loss, blood pressure (BP) and heart rate increases, and delayed sleep onset. Less common side effects include irritability (more prominent in younger children), aggression, social withdrawal, and rarely, hallucinations (visual or tactile).

Stimulants have been associated with elevations in mean BP (<5 mm Hg) and pulse (<10 beats/min); a subset of individuals (5–10%) may have greater increases. The rate of sudden death in pediatric patients taking stimulants is comparable to children in the general population; the hazard ratio for serious cardiovascular (CV) events is 0.75 (although up to a twofold increase in risk could not be ruled out). Moreover, a case series analysis of children with a CV incident and treatment with methylphenidate demonstrated an increased risk of arrhythmia (incidence rate ratio, 1.61) that was highest in the presence of congenital heart disease. The U.S. Food and Drug Administration (FDA) recommends that stimulants should be avoided in the presence of structural cardiac abnormalities (e.g., postoperative tetralogy of Fallot, coronary artery abnormalities, subaortic stenosis, hypertrophic cardiomyopathy) and patient symptoms (syncope, palpitations, arrhythmias) or family history (e.g., unexplained sudden death) suggestive of CV disease. In these circumstances, cardiology consultation is recommended before prescribing. Routine electrocardiograms (ECGs) are not recommended in the absence of cardiac risk factors.

The  $\alpha$ -adrenergic agents **clonidine** and **guanfacine** are presynaptic adrenergic agonists that appear to stimulate inhibitory presynaptic autoreceptors in the CNS (see Table 33.3). The extended release formulations of both agents have FDA approval for ADHD. The extended-release formulation of guanfacine has strong evidence (approximate effect size 0.80, large) for the monotherapy of ADHD. Extended-release guanfacine also has moderate evidence for effective treatment

**Table 33.1** Principles for Effective Use of Psychotropic Medications

- Identify potential target symptoms using broad mental health screening instruments (e.g., Pediatric Symptom Checklist [PSC-17])
- Conduct focused behavioral health (BH) assessment to establish target symptoms and appropriate level of care
  - Focused symptom rating scales, e.g.,
    - Patient Health Questionnaire-9 (PHQ-9)
    - Mood and Feelings Questionnaire (MFQ)
    - Screen for Child Anxiety Related Disorders (SCARED)
    - Generalized Anxiety Disorder-7 (GAD-7)
    - Vanderbilt ADHD Diagnostic Rating Scales
    - Swanson Nolan and Pelham-IV-26 (SNAP-IV-26)
  - Focused clinical interview to determine symptom history, severity (from focused rating scale score), complexity (psychiatric comorbidities, medical or psychosocial complexity), and safety (imminent risk of substantial harm)
    - If insufficient information is available to render a precise diagnosis for a symptom cluster, consider applying Unspecified Diagnostic and Statistical Manual of Mental Disorders-5 (DSM-5) psychiatric diagnosis
  - Rule out alternative explanations (medical, medication, substance, or developmental “masqueraders”) for target symptoms (may require specialty referral)
- Establish appropriate level of care based upon findings from focused BH assessment
  - Subclinical to mild presentation: triage to brief preventive intervention (e.g., anticipatory guidance)
  - Moderate presentation: triage to primary care for basic psychopharmacology and/or brief psychosocial intervention
  - Severe presentation: triage to specialty behavioral healthcare for comprehensive diagnostic evaluation, advanced psychopharmacology, and/or specialized psychotherapy
- Rule out relative or absolute contraindications to medication use, e.g.,
  - Medical conditions
  - Drug interactions
  - Inability to monitor (e.g., unreliable parent/guardian, patient residing out of town)
  - Concern about drug diversion in the context of substance abuse or antisocial behavior
- Counsel about factors potentially contributing to symptom presentation or affecting response to medication
  - Inadequate nutrition, physical activity, sleep, recreation, stress management; substance use
- Consider response to previous medication trials
  - Favorable and adverse effects
- Develop comprehensive treatment plan as indicated
  - Psychotherapy and/or medication
  - Home and/or school interventions
- Obtain informed consent from parent/guardian and assent from patient
  - Nature of the condition needing treatment
  - Nature and purpose of proposed treatment and the probability that it will succeed
  - Risks and benefits of the proposed treatment
  - Alternatives to the proposed treatment, and their attendant risks and benefits
  - Prognosis with and without the proposed treatment
- Select evidence-based medication and prescribe an adequate dose for an adequate duration; whenever possible, U.S. Food and Drug Administration (FDA)-approved medications for the given indication should be prioritized
  - Titrate to effective tolerated dose within established dosage range
  - Consider the period of time needed for each medication to achieve maximum effect
  - “Start low, go slow”
- Explain details of medication management
  - Name of medication
  - When to administer
  - Who should administer (e.g., parent, older teen)
  - How to administer (e.g., with food, swallowed whole)
  - Time to onset
  - Duration of action
  - How to store medication
  - Review of side effects and what to do if each should occur
  - How response to medication will be monitored (e.g., focused symptom rating scales, height/weight, pulse/blood pressure, side effect checks)
  - Special safety instructions (e.g., suicidal thoughts, severe agitation)
  - What the next step will be if medication is ineffective or not tolerated
  - How long medication likely will need to be taken if effective
  - Consider providing parent with standardized Medication Guide, such as those found at <https://dailymed.nlm.nih.gov/dailymed/index.cfm>
- Monitor medication compliance and physical/laboratory parameters as indicated
- Monitor response to treatment
  - Periodic readministration of focused symptom rating scale(s); adjust dose as indicated to achieve remission
- Taper and discontinue ineffective medication before substituting alternative medication, or have clear rationale for using medication combinations
- Plan for medication discontinuation after symptom-free and high-functioning interval

of ADHD with comorbid oppositional defiant disorder (ODD), favorably affecting both symptom clusters, as well as for the treatment of agitation in autism.

Sedation, somnolence, headache, abdominal pain, hypotension, bradycardia, cardiac conduction abnormalities, dry mouth, depression, and confusion are potential side effects of clonidine and guanfacine. Abrupt withdrawal can result in rebound hypertension; overdose can result in bradycardia and hypotension leading to hospitalization or death.

**Atomoxetine** is a selective inhibitor of presynaptic norepinephrine reuptake that increases dopamine and norepinephrine in the prefrontal cortex (see Table 33.3). It is less effective for the treatment of ADHD (approximate effect size 0.60, medium) than stimulants, but atomoxetine has a longer duration of action (approximately 24 hours). Atomoxetine can have an onset of action within 1-2 weeks of starting treatment, but there is an incrementally increasing response for up to 4-6 weeks or longer. Common side effects include nausea, headache, abdominal pain, insomnia, somnolence, erectile dysfunction, irritability, fatigue,



**Table 33.2** Target Symptom Approach to Psychopharmacologic Management

TARGET SYMPTOM	MEDICATION CONSIDERATIONS
Aggression	Stimulant α-Agonist Antipsychotic (only if aggression is severe or dangerous)
Agitation	Antipsychotic (only if agitation is severe or dangerous) Anxiolytic
Anxiety	Antidepressant Anxiolytic (only for acute situational anxiety)
Depression	Antidepressant
Hyperactivity, inattention, impulsivity	Stimulant α-Agonist Selective norepinephrine reuptake inhibitor
Mania	Antipsychotic Lithium
Obsessions, compulsions	Antidepressant
Psychosis	Antipsychotic
Tics	α-Agonist Antipsychotic (only if tics are severe/disabling)

Adapted from Shaw RJ, DeMaso DR. *Clinical Manual of Pediatric Consultation-Liaison Psychiatry*. Washington, DC: American Psychiatric Press, 2020: 443.

decreased appetite, weight loss, and dizziness, along with nonclinical increases in heart rate and BP. Potential serious neuropsychiatric reactions include psychosis, mania, panic attacks, aggressive behavior, depression, seizures, and suicidal thinking. Atomoxetine carries an FDA warning regarding the risk of suicidal thinking and the need to monitor this closely. Atomoxetine also has been associated with rare hepatotoxicity and should be discontinued in patients with jaundice or laboratory evidence of liver injury, and should not be restarted. Because of the risk of sudden death, atomoxetine generally should be avoided in youth with known serious structural cardiac abnormalities, cardiomyopathy, heart rhythm abnormalities, or other serious cardiac problems.

**Viloxazine** is a second selective norepinephrine reuptake inhibitor that was approved for ADHD by the FDA in 2021. It has once daily dosing, reaches steady state by day 2, and has a similar side effect profile to atomoxetine (including FDA warnings on suicidality and increases in heart rate and blood pressure).

## ANTIDEPRESSANTS

Antidepressant drugs act on presynaptic and postsynaptic receptors affecting the release and reuptake of brain neurotransmitters, including norepinephrine, serotonin, and dopamine (Table 33.4). There is moderate evidence for the effectiveness of antidepressant medications in the treatment of anxiety and obsessive-compulsive disorders (approximate effect size 0.70, medium) and weaker evidence for the treatment of depressive disorders (approximate effect size 0.30, small). Suicidal thoughts have been reported during treatment with all antidepressants. The overall risk difference of suicidal thoughts/behaviors across randomized controlled trials (RCTs) of all antidepressants and all indications has been reported as 0.7%, corresponding to a *number needed to harm* of 143. All antidepressants carry an FDA warning for suicidality; careful monitoring is recommended during the initial stages of treatment and following dose adjustments.

The **selective serotonin reuptake inhibitor (SSRI)** fluoxetine outperforms all other antidepressants (both SSRI and non-SSRI) studied and is the only SSRI separating from placebo in studies of depressed *preadolescents*. Side effects to SSRIs generally manifest in the first few weeks of treatment, and many will resolve with time. More common

side effects include nausea, irritability, insomnia, appetite changes, weight loss/gain, headaches, dry mouth, dizziness, bruxism, diaphoresis, tremors, akathisia, and restlessness. A small proportion of youth taking SSRIs, particularly younger children, develop **behavioral activation** (motor or mental restlessness, increased impulsivity, disinhibited behavior, talkativeness, insomnia) that can be confused with mania, but the activation symptoms typically resolve when the dose is decreased or the medication discontinued. Because the likelihood of activation events has been associated with higher antidepressant plasma levels, slow up-titration and close monitoring (particularly in younger children) is warranted and underscores the importance of educating parents/guardians and patients in advance about this potential side effect.

Sexual side effects are common, including decreased libido, anorgasmia, and erectile dysfunction. There is an increased risk of bleeding, especially when used with aspirin or nonsteroidal antiinflammatory drugs (NSAIDs).

SSRIs can be associated with abnormal heart rhythms, and citalopram causes dose-dependent QT interval prolongation, contraindicating doses >40 mg/day. Patients with diabetes may experience hypoglycemia during SSRI treatment and hyperglycemia on discontinuation. **Discontinuation symptoms** (e.g., dysphoric mood, irritability, agitation, dizziness, sensory disturbances, anxiety, confusion, headache, lethargy, emotional lability, insomnia, hypomania) are common with short-acting SSRIs (sertraline, citalopram, escitalopram), leading to a recommendation for divided doses if these medications are used at higher doses and graduated reduction if discontinued.

**Serotonin syndrome** results from excessive agonism of the CNS and peripheral nervous system serotonergic receptors and can be caused by prescribing multiple serotonergic medications concomitantly (Chapter 94). Symptoms can arise within 24-48 hours and are characterized by *mental status changes* (confusion, agitation, anxiety), *neuromuscular hyperactivity* (tremors, clonus, hyperreflexia, muscle rigidity), and *autonomic hyperactivity* (hypertension, tachycardia, arrhythmias, tachypnea, diaphoresis, shivering, vomiting, diarrhea). Advanced symptoms include fever, seizures, arrhythmias, and unconsciousness, which can lead to fatalities. Treatment is hospital based and includes discontinuation of all serotonergic agents and supportive care with continuous cardiac monitoring. Monoamine oxidase inhibitors (MAOIs) play a role in most cases of serotonin syndrome and should be avoided in combination with any other serotonergic drug, including another MAOI. Moreover, caution should be exercised when combining two or more non-MAOI serotonergic drugs, including antidepressants, opioids and other pain medications, stimulants, cough/cold/allergy medications, and other over-the-counter products. Caution entails starting the second non-MAOI serotonergic drug at a low dose, increasing the dose slowly, and monitoring for symptoms, especially in the first 24-48 hours after dosage changes. Adolescents should be informed that certain recreational drugs (e.g., dextromethorphan, “ecstasy”) are highly serotonergic and can cause serious interactions with antidepressants.

The **non-SSRI antidepressants** include duloxetine, venlafaxine, bupropion, and mirtazapine (see Table 33.4). These medications all lack rigorous evidence to support their effectiveness in children and adolescents and as such should not be considered first-line options.

Duloxetine and venlafaxine are **serotonin-norepinephrine reuptake inhibitors (SNRIs)**. *Duloxetine* has FDA approval for treatment of generalized anxiety disorder in children and adolescents but typically is not as effective for anxiety as the SSRIs. Studies of duloxetine for depression in youth have been negative. There is some evidence in adults that duloxetine can be useful for fibromyalgia and chronic musculoskeletal pain, an effect that has also been observed in children and adolescents. Common side effects of duloxetine include nausea, diarrhea, decreased weight, and dizziness. Increases in heart rate and BP have been noted; BP should be monitored at each visit and with each dosage change. In addition, there have been reports of hepatic failure, sometimes fatal; duloxetine should be discontinued and not resumed in patients who develop jaundice or other evidence of liver dysfunction. Duloxetine also has been associated with severe skin reactions (erythema multiforme and Stevens-Johnson syndrome).



**Table 33.3** Select Medications for Attention-Deficit/Hyperactivity Disorder Symptoms

GENERIC [BRAND] (HOW SUPPLIED) DURATION OF ACTION	FDA APPROVED (AGE RANGE IN YEARS)	TARGET SYMPTOMS	SUGGESTED DAILY STARTING DOSE (MG)	USUAL DAILY THERAPEUTIC DOSAGE RANGE (MG)*
Methylphenidate [Concerta] (18, 27, 36, 54 mg caps) 12 hr	ADHD (6+)	Inattention Hyperactivity Impulsivity	18	Age 6-12: 18-54; Age >12: 18-72
Dexmethylphenidate [Focalin XR] <sup>†</sup> (5, 10, 15, 20 mg caps) 10-12 hr	ADHD (6+)	Inattention Hyperactivity Impulsivity	5	5-30
Serdexmethylphenidate/ dexmethylphenidate [Azstarys] <sup>†</sup> (26.1 mg/5.2 mg, 39.2 mg/7.8 mg, 52.3 mg/10.4 mg) 12 hr	ADHD (6+)	Inattention Hyperactivity Impulsivity	26.1 /5.2	26.1 /5.2-52.3/10.4
Methylphenidate suspension, extended release [Quillivant XR] (25 mg/5 mL) 12 hr	ADHD (6+)	Inattention Hyperactivity Impulsivity	10	10-60
Dextroamphetamine/ amphetamine [Adderall XR] <sup>†</sup> (5, 10, 15, 20, 25, 30 mg caps) 12 hr	ADHD (6+)	Inattention Hyperactivity Impulsivity	2.5-5	5-30
Lisdexamfetamine [Vyvanse] <sup>†</sup> (10, 20, 30, 40, 50, 60, 70 mg caps; 10, 20, 30, 40, 50, 60 mg chewable tabs) 12-14 hr	ADHD (6+)	Inattention Hyperactivity Impulsivity	10	10-70
Amphetamine suspension extended release [Dyanavel XR] (2.5/mL) 13 hr	ADHD (6+)	Inattention Hyperactivity Impulsivity	2.5-5	2.5-20
Methylphenidate [Metadate CD] <sup>†</sup> (10, 20, 30, 40, 60 mg caps) 8 hr	ADHD (6+)	Inattention Hyperactivity Impulsivity	10	10-60
Methylphenidate [Ritalin LA] <sup>†</sup> (10, 20, 30, 40 mg caps) 8 hr	ADHD (6+)	Inattention Hyperactivity Impulsivity	10	10-60
Dextroamphetamine [Dexedrine Spansule] <sup>†</sup> (5, 10, 15 mg spansules) 6-8 hr	ADHD (6+)	Inattention Hyperactivity Impulsivity	5	5-40
Dexmethylphenidate [Focalin] (2.5, 5, 10 mg tabs) 4-5 hr	ADHD (6+)	Inattention Hyperactivity Impulsivity	2.5-5	5-20
Methylphenidate [Ritalin] (5, 10, 20 mg tabs) 4 hr	ADHD (6+)	Inattention Hyperactivity Impulsivity	2.5-5	5-60
Methylphenidate [Methylin] (5 mg/5 mL, 10 mg/5 mL) 4 hr	ADHD (6+)	Inattention Hyperactivity Impulsivity	2.5-5	5-60
Dextroamphetamine/ amphetamine [Adderall] (5, 10, 15, 20, 30 mg tabs) 4-5 hr	ADHD (3+)	Inattention Hyperactivity Impulsivity	Age 3-5: 2.5 Age ≥6: 5	Age 6-12: 5-30; Age >12: 5-40

Continued

**Table 33.3** Select Medications for Attention-Deficit/Hyperactivity Disorder Symptoms—cont'd

GENERIC [BRAND] (HOW SUPPLIED) DURATION OF ACTION	FDA APPROVED (AGE RANGE IN YEARS)	TARGET SYMPTOMS	SUGGESTED DAILY STARTING DOSE (MG)	USUAL DAILY THERAPEUTIC DOSAGE RANGE (MG)*
Dextroamphetamine [Dexedrine] (5, 10, 15, mg caps) 4 hr	ADHD (3+)	Inattention Hyperactivity Impulsivity	Age 3-5: 2.5 Age ≥6: 5	5-40
Atomoxetine [Strattera] <sup>†</sup> (10, 18, 25, 40, 60, 80, 100 mg caps) 24 hr	ADHD (6+)	Inattention Hyperactivity Impulsivity	<70 kg: 0.5 mg/kg/day >70 kg: 40	<70 kg: 0.5-1.2 mg/kg/day >70 kg: 40-100
Viloxazine [Qelbree] <sup>†</sup> (100, 150, 200 mg ER caps) 24 hr	ADHD (6+)	Inattention Hyperactivity Impulsivity	Age 6-11: 100 Age ≥12: 200	Age 6-11: 100-400 Age ≥11: 200-400
Clonidine [Kapvay] (0.1 mg tabs) 12 hr	ADHD (6+)	Inattention Hyperactivity Impulsivity	0.05	25-40kg: 0.05-0.2 41-45kg: 0.05-0.3 >45kg: 0.05-0.4
Guanfacine [Intuniv] (1, 2, 3, 4 mg tabs) 24 hr	ADHD (6+)	Inattention Hyperactivity Impulsivity	1	25-40kg: 1-2 41-45kg: 1-3 >45kg: 1-4
Clonidine [Catapres] (0.1, 0.2, 0.3 mg tabs) 4 hr	None	Inattention Hyperactivity Impulsivity	0.05	25-40 kg: 0.05-0.2 41-45 kg: 0.05-0.3 >45 kg: 0.05-0.4
Guanfacine [Tenex] (1, 2 mg tabs) 6 hr	None	Inattention Hyperactivity Impulsivity	0.5	25-40kg: 0.5-2mg 41-45 kg: 0.5-3 mg >45 kg: 0.5-4 mg

\*Doses shown in table may exceed maximum recommended dose for some children.

<sup>†</sup>Capsule contents may be sprinkled on soft food.

ADHD, Attention-deficit/hyperactivity disorder; FDA, U.S. Food and Drug Administration.

*Bupropion*, a **norepinephrine-dopamine reuptake inhibitor (NDRI)**, appears to have an indirect mixed-agonist effect on norepinephrine and dopamine transmission. No rigorous studies of bupropion for anxiety or depression have been conducted with children or adolescents, although some evidence suggests that bupropion may be effective for smoking cessation and ADHD in youth. Common side effects include irritability, nausea, anorexia, headache, and insomnia. Dose-related seizures (0.1% risk at 300 mg/day and 0.4% risk at 400 mg/day) have occurred with bupropion, so it is contraindicated in those with epilepsy, eating disorders, or at risk for seizures.

*Venlafaxine* has only negative trials for the treatment of depression in children and adolescents but does have some favorable evidence for the treatment of anxiety. Side effects are similar to SSRIs, including hypertension, irritability, insomnia, headaches, anorexia, nervousness, and dizziness, and dropout rates are high in clinical trials of venlafaxine. BP should be monitored at each visit and with each dosage change. Discontinuation symptoms are more pronounced with venlafaxine than the other non-SSRI antidepressants. In addition, suicidal thinking and agitation may be more common with venlafaxine than with other antidepressants, requiring close monitoring. In light of the substantial adverse effects, venlafaxine likely should be considered to be a third-line medication.

*Mirtazapine* is both a noradrenergic and a specific serotonergic antidepressant. Mirtazapine has only negative trials for the treatment of depression in youth and has no rigorous evidence of effectiveness for any other child or adolescent psychiatric disorder. Mirtazapine is associated with a risk for substantial weight gain and, more rarely, hypotension, elevated liver enzymes, agranulocytosis, and QT prolongation. Although its sedating properties have led to its adjunctive use for insomnia in adults with depressive/anxiety disorders, there is no evidence for use of mirtazapine in childhood sleep disorders.

The **tricyclic antidepressants (TCAs)** have mixed mechanisms of action; for example, clomipramine is primarily serotonergic, and imipramine is both noradrenergic and serotonergic. With the advent of the SSRIs, the lack of efficacy studies, particularly in depression, and more serious side effects, the use of TCAs in children and adolescents has substantially declined. *Clomipramine* has been used in the treatment of obsessive-compulsive disorder (see [Table 33.4](#)). TCAs also have been used for neuropathic pain. TCAs cause both blood pressure and heart rate increases and are class I antiarrhythmics with quinidine-like properties that are potentially fatal in overdose. Anticholinergic symptoms (e.g., dry mouth, blurred vision, constipation) are the most common side effects.

**Anxiolytic agents**, including lorazepam, clonazepam, and hydroxyzine, have been effectively used for the *short-term* relief of the symptoms of *acute* anxiety (see [Table 33.4](#)). They are less effective as chronic (>4 months) anxiolytic medications, particularly when used as monotherapy. Chronic use carries a significant risk of physical and psychological dependence.

## ANTIpsychOTICS

Based on their mechanism of action, antipsychotic medications can be divided into first-generation (blocking dopamine D<sub>2</sub> receptors) and second-generation (mixed dopaminergic and serotonergic antagonists) agents ([Table 33.5](#)).

The **second-generation antipsychotics (SGAs)** have relatively strong antagonistic interactions with 5-HT<sub>2</sub> receptors and perhaps more variable activity at central adrenergic, cholinergic, and histaminic sites, which might account for the varying side effects, particularly metabolic, noted among these agents. The SGAs have moderate evidence for the treatment of agitation in autism and for the treatment of schizophrenia, bipolar disorder, and aggression. Haloperidol is a

**Table 33.4** Select Medications for Depression and Anxiety in Children and Adolescents

GENERIC [BRAND] (HOW SUPPLIED)	FDA APPROVED (AGE RANGE IN YEARS)	TARGET SYMPTOMS	SUGGESTED DAILY STARTING DOSE (MG)	USUAL DAILY THERAPEUTIC DOSAGE RANGE (MG)*
Citalopram [Celexa] (10, 20, 40 mg tabs)	None	Depression Anxiety Obsessions Compulsions	Age 6-12: 10 Age 13-17: 20	10-40
Escitalopram [Lexapro] (5, 10, 20 mg tabs)	Depression (12-17) Anxiety (7-17)	Depression Anxiety Obsessions Compulsions	10	5-20
Fluoxetine [Prozac] (10, 20, 40, 60 mg tabs)	Depression (8-17) OCD (7-17)	Depression Anxiety Obsessions Compulsions	Age 6-12: 10 Age 13-17: 20	Depression: 10-20 Anxiety, OCD: 10-60
Sertraline [Zoloft] (25, 50, 100 mg tabs)	OCD (6-17)	Depression Anxiety Obsessions Compulsions	Age 6-12: 12.5-25 Age 13-17: 25-50	25-200
Duloxetine [Cymbalta] (20, 30, 60 mg tabs)	Anxiety (7-17)	Depression Anxiety	30	30-60
Venlafaxine [Effexor XR] (37.5, 75, 150 mg caps)	None	Depression Anxiety	37.5	37.5-225
Bupropion [Wellbutrin XL] (150, 300 mg tabs)	None	Depression	150	150-300
Mirtazapine [Remeron] (15, 30, 45 mg tabs)	None	Depression	7.5	7.5-45
Clomipramine [Anafranil] (25, 50, 75 mg caps)	OCD (10-17)	Obsessions Compulsions	25	25-200
Lorazepam [Ativan] (0.5, 1, 2 mg tabs)	None	Acute anxiety	0.5	0.5-2
Clonazepam [Klonopin] (0.5, 1, 2 mg tabs)	None	Panic	0.5	0.5-1
Hydroxyzine [Vistaril] (25, 50 mg caps)	Anxiety	Acute anxiety	Age <12: 12.5-25 Age >12: 25-50	Age <12: 25-50 Age >12: 50-100

\*Doses shown in table may exceed maximum recommended dose for some children.

high-potency **first-generation antipsychotic** that is most commonly used in treatment of agitation and schizophrenia.

The antipsychotic agents have significant side effects, including sedation, extrapyramidal symptoms, hyperprolactinemia, anticholinergic, orthostatic, orthostasis, CV effects, weight gain, hyperlipidemia, metabolic syndrome, glucose abnormalities, hematologic effects (e.g., leukopenia, neutropenia), and elevated liver transaminases (Table 33.6). They have an FDA warning for increased risk of diabetes. Youth appear to be more sensitive to sedation, extrapyramidal side effects (except akathisia), withdrawal dyskinesia, prolactin abnormalities, weight gain, hepatotoxicity, and metabolic abnormalities. The development of diabetes or tardive dyskinesia appears less prevalent than in adults, although this may be a function of short follow-up periods because these side effects may not emerge until adulthood.

The management of adverse effects should be proactive with baseline assessment and ongoing monitoring (Table 33.7). Abnormal movements (dystonia, akathisia, tardive dyskinesia) need periodic assessment using a standardized instrument such as the *Abnormal Involuntary Movement Scale* (AIMS). The need for antiparkinsonian agents may be a consideration, particularly for patients at risk for acute dystonia or who have a previous history of dystonic reactions. CV effects include prolongation of the QTc interval, tachycardia,

orthostatic hypertension, and pericarditis. In patients with a personal or family history of cardiac abnormalities, including syncope, palpitations, arrhythmias, or sudden unexplained death, a baseline ECG with subsequent monitoring should be considered, along with cardiology consultation before prescribing. Alternative pharmacology should be considered if the resting heart rate exceeds 130 beats/min, or the PR, QRS, and QTc exceed 200, 120, and 460 msec, respectively.

The **cytochrome P450 (CYP)** enzymes metabolize the antipsychotics and as such necessitate that the PCP and psychiatrist are alert for potential drug-drug interactions that may impact the serum levels of all patient medications. CYP3A4 is mainly relevant to lurasidone, quetiapine, olanzapine, and haloperidol, whereas CYP2D6 predominately clears aripiprazole and risperidone. Asenapine is metabolized by CYP1A2 as well as direct glucuronidation by UGT1A4. Because <10% of paliperidone undergoes CYP first-pass metabolism, there is a lower likelihood of drug-drug interactions.

Primary prevention strategies to manage weight and metabolic dysfunction include educating the youth and family about healthy lifestyle behaviors and selecting an agent that has the lowest likelihood of impacting metabolic status. Secondary strategies would include intensifying healthy lifestyle instructions, consideration of switching agents, and a weight loss treatment program. Consideration

**Table 33.5** Select Medications for Psychosis, Mania, Irritability, Agitation, Aggression, and Tourette Disorder in Children and Adolescents

GENERIC (BRAND)	FDA APPROVED (AGE RANGE IN YEARS)	TARGET SYMPTOMS	SUGGESTED DAILY STARTING DOSE	USUAL DAILY THERAPEUTIC DOSAGE RANGE (MG)*
Aripiprazole [Abilify]	Bipolar (10-17) Schizophrenia (13-17) Irritability in autism (6-17) Tourette (6-17)	Mania Psychosis Irritability Aggression Agitation Vocal/motor tics	Bipolar, schizophrenia: 2 Autism: 2 Tourette: 2	Bipolar, schizophrenia: 10-30 Autism: 5-15 Tourette: 5-20
Olanzapine [Zyprexa] Available in dissolvable and IM prep	Bipolar (13-17) Schizophrenia (13-17)	Mania Psychosis Agitation	2.5	2.5-20
Quetiapine [Seroquel]	Bipolar (10-17) Schizophrenia (13-17)	Mania Psychosis Agitation	25mg bid	Bipolar: 400-600 Schizophrenia: 400-800
Risperidone [Risperdal] Available in liquid and dissolvable prep	Bipolar (10-17) Schizophrenia (13-17) Irritability in autism (5-17)	Mania Psychosis Irritability Aggression Agitation	Bipolar, schizophrenia: 0.5 Autism: <20 kg: 0.25 ≥20 kg: 0.5	Bipolar, schizophrenia: 1-6 Autism: 0.5-3
Paliperidone [Invega] Available in IM prep	Schizophrenia (12-17)	Psychosis	3	<51 kg: 3-6 ≥51 kg: 3-12
Lurasidone [Latuda]	Schizophrenia (13-17) Depressive episodes with Bipolar (13-17)	Psychosis	Schizophrenia: 40 Bipolar: 20	Schizophrenia: 40-80 Bipolar: 20-80
Asenapine [Saphris]	Bipolar (10-17)	Mania Psychosis	2.5 twice daily	5-20
Haloperidol [Haldol] Available in liquid and IM prep	Psychosis Severe behavioral disorders Agitation (3-17) Tourette disorder	Mania Psychosis Irritability Aggression Agitation Vocal/motor tics	0.05mg/kg/day	0.05-0.15mg/kg/day
Lithium carbonate Available in liquid prep	Bipolar (12-17)	Mania	Acute mania: 1800mg/day Target level: 1.0-1.5 mEq/L	Long-term control: 900-1200mg/day Target level: 0.6-1.2 mEq/L

\*Doses shown in table may exceed maximum recommended dose for some children.

of weight management interventions and increased monitoring of blood glucose and lipid levels should be implemented if weight gain exceeds the 90th percentile of body mass index (BMI) for age, or a change of 5 BMI units in youth who were obese at the initiation of treatment. Tertiary strategies, where diabetes, hypertension, obesity, or another metabolic abnormality has occurred, require more intensive weight reduction interventions, changing medication, and consultation with a medical subspecialist. Metformin has been found to be an effective treatment for antipsychotic-induced weight gain in children with autism spectrum disorder. Extrapyramidal adverse effects are generally dose- and titration rate-dependent and may respond to dose or titration rate reductions. More disabling effects may benefit from adjunctive treatment (e.g., anticholinergics, antihistamines).

**Neuroleptic malignant syndrome** is a rare, potentially fatal reaction that can occur during antipsychotic therapy (see Chapter 94). The syndrome generally manifests with fever, muscle rigidity, autonomic instability, and delirium. It is associated with elevated serum creatine phosphokinase levels, a metabolic acidosis, and high end-tidal CO<sub>2</sub> excretion. It has been estimated to occur in 0.2–1% of patients treated with dopamine-blocking agents. Malnutrition

and dehydration in the context of an organic brain syndrome and simultaneous treatment with lithium and antipsychotic agents (particularly haloperidol) can increase the risk. Mortality rates may be as high as 20–30% as a result of dehydration, aspiration, kidney failure, and respiratory collapse. Differential diagnosis of neuroleptic malignant syndrome includes infections, heat stroke, malignant hyperthermia, lethal catatonia, agitated delirium, thyrotoxicosis, serotonin syndrome, drug withdrawal, and anticholinergic or amphetamine, ecstasy, and salicylate toxicity.

### MOOD STABILIZERS

Because of their limited evidence of effectiveness and concerns about safety, mood-stabilizing medications (see Table 33.5) have limited use in the treatment of child and adolescent psychiatric disorders. For the treatment of bipolar mania in adolescents, antipsychotics are considered first-line therapy.

Of the mood stabilizers, **lithium** alone has rigorous support for the treatment of bipolar mania. Lithium's mechanism of action is not well understood; proposed theories relate to neurotransmission, endocrine effects, circadian rhythm, and cellular processes. Common side effects include polyuria and polydipsia, hypothyroidism,



**Table 33.6** Relative Side Effects for Select Antipsychotic Medications

ADVERSE EFFECT	ARIPRAZOLE [ABILIFY]	OLANZAPINE [ZYPREXA]	QUETIAPINE [SEROQUEL]	RISPERIDONE [RISPERDAL]	PALIPERIDONE [INVEGA]	LURASIDONE [LATUDA]	HALOPERIDOL [HALDOL]
Akathisia	++	++	+	++	++	++	+++
Parkinsonism	+	++	+	++	++	++	+++
Dystonia	+	+	+	++	++	++	+++
Tardive dyskinesia	+	+	+	++	++	++	+++
Hyperprolactinemia	+	++	+	+++	+++	+	+++
Anticholinergic	+	++	+ / +++	++	+	+	+
Seizures	+	++	++	+	+	+	+
Orthostasis	+	++	++	++	++	+	+
QT interval	+	++	+	+	+	+	++
Weight gain	+	+++	++	++	++	+	+
Hyperlipidemia	+	+++	++	+++	++	++	+
Glucose abnormalities	+	+++	++	++	+	+	+
Sedation	+	++	++	+	+	++	+

+ = Seldom; ++ = sometimes; +++ = often.

Adapted from Keepers GA, Fochtmann LJ, Anzia JM, et al. The American Psychiatric Association Practice Guideline for the Treatment of Patients With Schizophrenia. *Am J Psychiatry*. 2020;177(9):868–872.

**Table 33.7** Metabolic Monitoring Parameters Based on ADA/APA Consensus Guidelines

	BASELINE	WEEK 4	WEEK 8	WEEK 12	EVERY 3 MO THEREAFTER	ANNUALLY
Medical history*	X			X		X
Body mass index	X	X	X	X	X	X
Waist circumference	X			X		X
Blood pressure	X			X		X
Fasting glucose and Hemoglobin A <sub>1c</sub>	X			X		X
Fasting lipid panel	X			X		X

\*Personal/family history of obesity, hypertension, and cardiovascular disease.

From American Diabetes Association. American Psychiatric Association; American Association of Clinical Endocrinologists; North American Association for the Study of Obesity. Consensus development conference on antipsychotic drugs and obesity and diabetes. *Diabetes Care*. 2004;27(2):596–601.

hyperparathyroidism, weight gain, nausea, abdominal pain, diarrhea, acne, and CNS symptoms (sedation, tremor, somnolence, memory impairment). Periodic monitoring of lithium levels along with thyroid and renal function is needed. Lithium serum levels of 0.8–1.2 mEq/L are targeted for acute episodes, and levels of 0.6–0.9 mEq/L are targeted for maintenance therapy. Acute overdose (level >1.5 mEq/L) manifests with neurologic symptoms (e.g., tremor, ataxia, nystagmus, hyperreflexia, myoclonus, slurred speech, delirium, coma, seizures) and altered renal function. Toxicity is enhanced when dehydrated or with drugs that affect renal function, such as NSAIDs or angiotensin-converting enzyme (ACE) inhibitors. Neuroleptic malignant syndrome has been reported in patients concurrently taking antipsychotic drugs and lithium.

### MEDICATION USE IN PHYSICAL ILLNESS

There are special considerations in the use of psychotropic medications with physically ill children. Between 80% and 95% of most psychotropic medications are protein bound; the exceptions are lithium (0%), methylphenidate (10–30%), and venlafaxine (25–30%). As a result, psychotropic levels may be directly affected because albumin binding is reduced in many physical illnesses. Metabolism is primarily through the liver and gastrointestinal (GI) tract, with excretion via the kidney. Therefore dosages may need to be adjusted in children with hepatic or renal impairment.

### Hepatic Disease

In general, it is necessary to use lower doses of medications for patients with hepatic disease. Initial dosing of medications should

be reduced, and titration should proceed slowly. In acute hepatitis, there is generally no need to modify dosing because metabolism is only minimally altered. In chronic hepatitis and cirrhosis, hepatocytes are destroyed, and doses may need to be modified.

In steady-state situations, changes in protein binding can result in elevated unbound medication, resulting in increased drug action even in the presence of normal serum drug concentrations. Albumin and  $\alpha_1$  glycoproteins produced in the liver may be reduced with infectious and inflammatory hepatic disease, whereas surgery, trauma, and cirrhosis may result in elevated protein levels. Because it is often difficult to predict changes in protein binding, it is important to maintain attention to the clinical effects of psychotropic medications and not rely exclusively on serum drug concentrations.

Medications with high baseline rates of liver clearance (e.g., haloperidol, sertraline, venlafaxine) are significantly affected by hepatic disease. For drugs that have significant hepatic metabolism, intravenous (IV) administration may be preferred because parenteral administration avoids first-pass liver metabolic effects, and the dosing and action of parenteral medications are similar to those in patients with normal hepatic function.

### Gastrointestinal Disease

GI disease primarily affects drug absorption. Examples that impact absorption include conditions affecting GI motility, surgical alterations of the GI tract, short bowel syndrome, or celiac disease. Any condition that diverts blood away from the GI tract (e.g., congestive heart failure, shock) may also reduce absorption.

Psychotropic medications have the potential to cause GI side effects. Medications with anticholinergic side effects can slow GI motility, affecting absorption and causing constipation. SSRIs increase gastric motility and can cause diarrhea. SSRIs can increase the risk of GI bleeding, especially when administered with NSAIDs. Extended-release or controlled-release preparations of medications can reduce GI side effects, particularly where gastric distress is related to rapid increases in plasma drug concentrations. Using extended-release medication preparations may reduce these side effects.

### Renal Disease

In general, initial dosages of medication should be reduced or dosing intervals lengthened in renal failure. The rule of two thirds is that dosages should be reduced by one third of the normal dosage for a patient with renal insufficiency. However, most psychotropic medications, with the exceptions of lithium and gabapentin, do not require significant dosing adjustments in kidney failure. It is important to monitor serum concentrations in renal insufficiency, particularly for medications with a narrow therapeutic index. Cyclosporine can elevate serum lithium levels by decreasing lithium excretion. Although TCAs have been largely supplanted by SSRIs, patients with kidney failure and those on dialysis appear to be more sensitive to their side effects, possibly because of the accumulation of hydroxylated tricyclic metabolites.

Because most psychotropic medications are highly protein bound, they are not significantly cleared by dialysis. Lithium is essentially completely removed by dialysis, and the common practice is to administer lithium after dialysis. Patients on dialysis often have significant fluid shifts and are at risk for dehydration, with neuroleptic malignant syndrome more likely in these situations.

### Cardiac Disease

Antipsychotics, TCAs, and citalopram (>40 mg/day) can lead to prolongation of the QTc interval, with increased risk of ventricular tachycardia and ventricular fibrillation, particularly in patients with

structural heart disease. Patients with a baseline QTc interval of >440 msec should be particularly considered at risk. The normal QTc value in children is 400 msec ( $\pm 25$ -30 msec). A QTc value that exceeds 2 standard deviations (SDs; >450-460 msec) is considered too long and may be associated with increased mortality. An increase in the QTc from a baseline of >60 msec is also associated with increased mortality.

There is increased risk of morbidity and mortality in patients with preexisting cardiac conduction problems. Patients with Wolff-Parkinson-White syndrome who have a short PR interval (<0.12 sec) and widened QRS interval associated with paroxysmal tachycardia are at high risk for life-threatening ventricular tachycardia that may be exacerbated by the use of antipsychotics, TCAs, and citalopram.

### Respiratory Disease

Anxiolytic agents can increase the risk of respiratory suppression in patients with pulmonary disease. SSRIs are the first-line medications to consider in treating disabling anxiety. Possible airway compromise caused by acute laryngospasm should be considered when dopamine-blocking antipsychotic agents are used.

### Neurologic Disease

Psychotropic medications can be used safely with epilepsy following consideration of potential interactions among the medication, the seizure disorder, and the anticonvulsant. Any behavioral toxicity of anticonvulsants used either alone or in combination should be considered before proceeding with psychotropic treatment. Simplification of combination anticonvulsant therapy or a change to another agent can result in a reduction of behavioral or emotional symptoms and obviate the need for psychotropic intervention. Clomipramine and bupropion possess significant seizure-inducing properties and should be avoided when the risk of seizures is present.

### Principles for Psychotropic Prescribing in Primary Care

In the context of a severe and prolonged shortage of child and adolescent psychiatrists (CAPs), PCPs are increasingly managing behavioral health conditions in primary care. The principles for effective use of psychotropic medications outlined in the beginning of this chapter can be used by PCPs to guide their medication assessment and management (see [Table 33.1](#)). This approach emphasizes **baseline assessment with standardized symptom rating scales** to identify target symptoms and their level of severity, **prioritizing FDA-approved medications** for the target symptom and patient age range, adherence to recommendations regarding therapeutic dosage ranges, using a **follow-up symptom rating scale assessment** to monitor medication response, continuing the medication trial for sufficient duration, and switching to an alternative FDA-approved medication if the first medication trial is ineffective.

PCPs can access support for psychotropic prescribing through the development of collaborative relationships with CAPs who can provide timely consultation for questions/advice; interim management until stable; and ongoing care for patients with severe, complex, unsafe, or treatment-refractory conditions. Ideally, consultation with a CAP should occur if one is considering using psychotropic medications with very young children, multiple psychotropic medications, medication doses outside of therapeutic range, or non-FDA-approved medications.

Visit Elsevier eBooks+ at [eBooks.Health.Elsevier.com](http://eBooks.Health.Elsevier.com) for Bibliography.

## Chapter 34

## Psychotherapy

Erica H. Lee, Keneisha R. Sinclair-McBride,  
David R. DeMaso, and Heather J. Walter

## PSYCHOTHERAPY

Psychotherapy is the first-line treatment for many child and adolescent psychiatric disorders (e.g., posttraumatic stress disorder [PTSD], depression, anxiety, behavior, substance-related) because for these disorders, psychotherapy produces outcomes greater than or equal to pharmacotherapy, with less risk of harm. Even with disorders (e.g., schizophrenia, bipolar disorder, attention-deficit/hyperactivity disorder [ADHD]) for which medication is typically the first-line treatment, adjunctive psychotherapy can convey additional benefit.

Psychotherapy is moderately effective in reducing psychiatric symptomatology and achieving remission of illness. In a 2017 multilevel meta-analysis of almost 500 randomized trials over 5 decades, there was a 63% probability that a youth receiving psychotherapy fared better than a youth in a control condition. Effects varied across multiple moderators. The mean posttreatment and follow-up effect sizes were highest for anxiety, followed by behavior/conduct, ADHD, and depression, and lowest for multiple concurrent comorbidities. Effect sizes varied according to outcome measure informant, with youth and parents generally reporting larger effects than teachers.

A variety of psychotherapeutic modalities have been developed, with varying levels of effectiveness (Table 34.1). Differences between therapeutic approaches may be less pronounced in practice than in theory. The quality of the therapist-patient alliance is consistently one of the most important predictors of treatment outcome. A positive working relationship, expecting change to occur, facing problems assertively, increasing mastery, and attributing change to the participation in the therapy have all been associated with effective therapy, irrespective of the specific psychotherapeutic modality.

All psychotherapy interventions involve a series of interconnected steps, including performing an assessment, constructing working diagnoses and an explanatory formulation, deciding on treatment and a monitoring plan, obtaining treatment assent/consent, implementing treatment, terminating treatment, and following for symptom recurrence. Psychotherapists ideally develop a treatment plan by combining evidence-based therapies with clinical judgment and patient/family preference to collaboratively arrive at a specific intervention plan for the individual patient.

## Behavior Therapy

Behavior therapy is based on both classic (Pavlovian) and operant (Skinnerian) conditioning. Both approaches address the **antecedent stimuli** and **consequent outcomes** of problematic thoughts or behaviors. The treatment begins with a behavioral assessment along with a functional analysis of the setting, immediately preceding events, and real-world outcomes of the behavior to identify the settings in which the behavior occurs and/or the reason the child engages in the behavior. Often the function of problematic behavior is to **gain access to attention** or a **tangible item** the child wants or to **avoid a task or stressful situation**. The goal is to teach the child a more adaptive response using tools such as positive and negative reinforcement; social and tangible rewards; response cost/consequences; shaping, modeling, and prompting; systematic desensitization; and aversive conditioning.

Behavior therapy has shown particular effectiveness with oppositional behavior, obsessive-compulsive, autism spectrum disorder, and substance use disorders, and ADHD.

## Cognitive-Behavioral Therapy

Cognitive-behavioral therapy (CBT) is based on social and cognitive learning theories and extends behavior therapy to address the influence

of cognitive processes on behavior. CBT is a short-term, problem- and goal-oriented treatment centered on correcting problematic patterns in thinking and behavior that lead to emotional difficulties and functional impairments. The CBT therapist seeks to help the patient identify and change cognitive distortions (e.g., learned helplessness, irrational fears); identify and incrementally approach aversive situations; and identify and practice distress-reducing behavior. **Self-monitoring** (daily thought records), **self-instruction** (brief sentences asserting thoughts that are comforting and adaptive), and **self-reinforcement** (rewarding oneself for adaptive behaviors) are key tools used to facilitate achievement of the CBT goals.

CBT has good-quality evidence for the treatment of anxiety, obsessive-compulsive disorder (OCD), behavior disorders, substance abuse, and insomnia, and fair evidence for the treatment of depression. For many childhood psychiatric disorders, CBT alone provides outcomes comparable to psychotropic medication alone, and the combination of both may convey additional benefit in symptom and harm reduction. Modified versions of CBT have shown applicability to the treatment of other disorders.

## Trauma-Focused Cognitive-Behavioral Therapy

Trauma-focused cognitive-behavioral therapy (TF-CBT) is designed to process and master the psychologic, behavioral, and physiologic consequences of a specific traumatic experience. It involves a combination of education about the broad effects of trauma exposure; teaching effective relaxation, affective modulation, and cognitive coping and processing skills; creating a trauma narrative to foster understanding; mastering trauma reminders; enhancing future safety and development; and teaching parents how to support youth with trauma exposure. TF-CBT is considered the first-line treatment for PTSD.

## Dialectical Behavioral Therapy

Dialectical behavioral therapy (DBT) is a modality targeted at emotional and behavioral dysregulation by synthesizing or integrating the seemingly opposite strategies of acceptance and change. *Dialectic conflicts* (wanting to die vs wanting to live) often exist in the same patient. **The four skills modules—mindfulness (the practice of being fully aware and present in the moment), distress tolerance (how to tolerate emotional pain), interpersonal effectiveness (how to maintain self-respect and effective communication in relationships with others), and emotion regulation (how to manage complex emotions)—are balanced in terms of acceptance and change.** The treatment targets, in order of priority within a given session, are life-threatening behaviors, such as suicidal and self-injurious behaviors or communications; therapy-interfering behaviors, such as coming late to sessions, canceling appointments, and being uncollaborative in working toward treatment goals; quality-of-life behaviors, including relationship and occupational problems and financial crises; and skills acquisition to help patients achieve their goals. DBT has good-quality evidence for self-injurious thoughts and behaviors and has shown promise for the treatment of bipolar disorder and other manifestations of emotional-behavioral dysregulation.

## Interpersonal Psychotherapy

Interpersonal psychotherapy (IPT) focuses on resolving interpersonal difficulties that lead to psychologic distress and maladaptive behaviors. Patients are viewed as having strengths and vulnerabilities that determine the manner in which they cope with or respond to an interpersonal crisis (stressor). The main goals of IPT include expanding social support, decreasing interpersonal stress, enhancing the processing of emotions, and improving social functioning within significant relationships. The interpersonal inventory, a detailed review of the patient's significant relationships, both current and past, with their emotional valence, leads to a formulation linking the interpersonal situations to the emotional/behavior symptoms. Various techniques (linking emotions/behaviors to interpersonal events, communication and problem-solving training, perspective-taking, role adaptation) are utilized to resolve interpersonal difficulties. IPT is a well-established treatment for adolescent depression.

**Table 34.1** Effective Psychotherapies for Specific Behavioral Health Disorders

DISORDER	WELL-ESTABLISHED*	PROBABLY EFFICACIOUS†
Anorexia	Family therapy: behavioral	Family therapy: systemic Individual psychodynamic psychotherapy
Anxiety, children under 8	Family-based CBT	Group parent CBT ± group child CBT
Anxiety	CBT ± parent component ± medication	Family psychoeducation Parent/child CBT Relaxation, assertiveness training
Attention-deficit/hyperactivity	BPT Behavioral classroom management Behavioral peer interventions Organization (executive function) training	Combined training interventions
Autism	Individual, comprehensive ABA Teacher-implemented focused ABA + DSP	Individual, focused (communication) ABA ± DSP Focused DSP parent training
Behavior, child	Group BPT Individual BPT with child component	Modifications of Group BPT‡ Individual BPT alone or with other modifications Self-directed parent behavior therapy Group child behavior therapy ± teacher training Individual child behavior therapy ± parent component Group/individual child-centered play therapy
Behavior, adolescent	Behavioral therapy + CBT + family therapy	CBT
Bipolar	Family skill building + psychoeducation	DBT
Depression, child	None	None
Depression, adolescent	Individual/group CBT Individual IPT	Group IPT
Obsessive-compulsive	Family-focused CBT	Individual CBT
Posttraumatic stress	Individual/group trauma-focused CBT ± parent component	Group CBT + parent component EMDR
Substance use	Individual/group/family CBT ± MET Family-based treatment, ecologic ± CBT ± MET	Family-based treatment, behavioral Motivational interviewing/MET Family-based treatment, ecologic + contingency management Family-based treatment, behavioral, ecologic, contingency management + MET MET + CBT + contingency management
Self-injurious thoughts and behaviors	DBT-adolescents (deliberate self-harm, suicidal ideation)	DBT—adolescents (nonsuicidal self-injury, suicide attempt) Individual/family CBT (suicide attempt) Family therapy (suicide attempt) Interpersonal therapy—adolescents (suicidal ideation) Individual psychodynamic therapy (deliberate self-harm) Parent training (self-injurious thoughts and behaviors (suicidal and nonsuicidal))

\*Two or more consistent randomized controlled trials demonstrating superiority of treatment over control groups; conducted by independent investigators working at different research settings.

†Same as in the previous footnote, but lacking independent investigator criterion.

‡Modifications of Group Behavioral Parent Training that are probably efficacious include adding child components or family problem-solving strategies

CBT, Cognitive-behavioral therapy; BPT, behavioral parent training; ABA, applied behavioral analysis; DSP, developmental social-pragmatic; DBT, dialectical behavioral therapy; IPT, interpersonal psychotherapy; EMDR, eye movement desensitization and reprocessing; MET, motivational enhancement treatment.

Adapted from Society of Clinical Child and Adolescent Psychology. Concerns, symptoms and disorders. <https://effectivechildtherapy.org/concerns-symptoms-disorders/>. Accessed July 13, 2021.

Criteria derived from Southam-Gerow MA, Prinstein MJ. Evidence base updates: The evolution of the evaluation of psychological treatments for children and adolescents. *J Clin Child Adol Psychol*. 2014;43(1):1–6.

### Psychodynamic Psychotherapy

At the core of psychodynamic psychotherapy lies a dynamic interaction between different dimensions of the mind, conscious and unconscious. This approach is based on the belief that much of one's mental activity occurs outside one's awareness. The patient is often unaware of internal conflicts because threatening or painful emotions, impulses, and memories are repressed to avoid experiencing psychological pain. Behavior is then controlled by what the patient does not know about himself or herself. Therapy objectives are to increase self-understanding and acceptance of painful conflicting feelings, and to develop realistic

relationships between self and others. A fundamental difference of this modality is its nondirective approach to allow a patient's characteristic patterns of thinking and behavior to emerge over time. The relationship between the patient and the therapist can play a key role in identifying these patterns, as they are recapitulated in the therapeutic environment. The therapist can then analyze and interpret the manifest pattern so that self-understanding and a corrective emotional experience can be fostered.

Psychodynamic psychotherapy has shown applicability for the treatment of self-injurious thoughts and behaviors as well as anxiety,



depression, and maladaptive aspects of personality. Brief, time-limited psychodynamic psychotherapy can be appropriate for youth who are in acute situational distress. Long-term therapy can be appropriate when the biologic or social factors destabilizing the child's adaptation and development are chronic, or the psychological difficulties are complex, or if entrenched conflicts and developmental interferences are present.

### Supportive Psychotherapy

Supportive psychotherapy aims to minimize levels of emotional distress through the provision of individual and contextual support. The goal is to reduce symptoms, and treatment is focused on the “here and now.” The therapist is active and helpful in providing the patient with symptomatic relief by helping the patient to contain and manage anxiety, sadness, and anger. The therapist provides support and encouragement (“coaching”) to bolster a patient's existing coping mechanisms, facilitates problem solving, and provides social and instrumental support for ameliorating or lessening contextual precipitants. CBT-informed techniques are often combined with supportive psychotherapy. Probably the most common psychotherapy employed by therapists, supportive psychotherapy has shown comparable results to CBT in a number of research studies, particularly those targeting depression.

### Family Therapy

The core premise in family therapy is that **dysfunctional family** interaction patterns precipitate and/or perpetuate an individual's emotional or behavioral difficulties. Family dysfunction can take a variety of forms, including enmeshment, disengagement, role-reversal or confusion, and maladaptive communication patterns. Family therapy begins with an assessment of the family system, including observing patterns of interaction; assessing family beliefs and the meanings attached to behaviors; defining social and cultural contexts; exploring the presenting problem in the context of individual and family development; assessing the family's style of dealing with problems; and identifying family strengths and weaknesses.

Family therapy techniques are drawn from two major theoretical models: structural and behavioral. **Structural family therapy** develops structures believed to foster well-functioning families, including clear and flexible boundaries between individuals, well-defined roles, and an appropriate balance between closeness and independence. **Behavioral family therapy** focuses on behavioral sequences that occur in daily life and attempts to interrupt unhelpful behavioral patterns and strengthen positive behavioral patterns through effective communication and problem solving.

Family therapy has shown established applicability in anorexia nervosa, behavior problems, and substance use and may be a promising treatment for depression and bipolar disorder.

### Parenting Interventions

See [Chapters 20 and 42](#) for more details.

Parenting interventions seek to improve both the parent–child relationship and parenting skills using the principles of behavior therapy previously described. These interventions can be provided in individual or group therapy formats. Core relationship recommendations include spending quality time with the child to foster a strong parent–child bond, increasing positive verbal interaction, showing physical affection, and engaging in child-directed play. Core parenting skills include increasing reinforcement of positive behaviors; decreasing reinforcement of negative behaviors; ignoring merely annoying behaviors; applying logical consequences for dangerous/destructive behaviors; and making parental responses predictable, contingent, and immediate. Parenting interventions have shown applicability for behavior disorders and ADHD.

### Common Elements of Evidence-Based Psychotherapies

A major challenge for the practitioner is selecting the “right intervention” for the “right person” in the “right setting,” and delivering the intervention in the “right way” (to meet the needs of patients and families). This challenge has led to an interest in identifying **common**

**practice elements** across efficacious evidence-based therapies that could be “matched” in a flexible way to patients of a certain age, gender, and race/ethnicity who have certain psychiatric disorders. [Table 34.2](#) provides the major practice elements for three of the most common child and adolescent psychiatric disorders: anxiety, depression, and disruptive behaviors. These practice elements, when made available to patients with psychiatric disorders in a system of care, are estimated to be relevant to approximately two thirds of the patients. Six of the practice elements—psychoeducation of the parent, problem-solving skills, relaxation skills, self-monitoring, cognitive/coping skills, and psychoeducation of the child—are applicable to all three disorders and as such could be considered “**core competencies**” for both mental health specialists as well as primary care practitioners (PCPs) interested in delivering brief psychotherapeutic interventions in the context of anticipatory guidance (see Discussion of Common Factors in [Chapter 18](#)).

Psychoeducation is the education of the parent and child about the cause, course, prognosis, and treatment of the disorder. Problem solving includes techniques, discussions, or activities designed to bring about solutions to targeted problems, with the intention of imparting skills for how to approach and solve future problems in a similar manner. Relaxation includes techniques designed to create and maintain the physiologic relaxation response. Self-monitoring is the repeated measurement of a target emotional or behavioral metric by the child or parent to establish goals for treatment and monitor progress toward mastery. Cognitive/coping skills consist of techniques designed to alter interpretations of events through examination of the child's reported thoughts, accompanied by exercises designed to test the validity of the reported thoughts.

### Modular Therapy Packages

Of considerable importance to day-to-day clinical work is the manner in which common therapy practice elements are selected, sequenced, repeated, or selectively applied. This **coordination of psychotherapeutic elements** is particularly relevant for patients presenting with multiple concurrent psychiatric disorders whose primary concern may shift between sessions. The *Modular Approach to Therapy for Children (MATCH)* is a multi-disorder intervention system that incorporates treatment procedures (practice elements) and treatment logic (coordination) corresponding to efficacious interventions for childhood anxiety, depression, traumatic stress, and behavior problems, with modifications to allow the system to operate as a single protocol. Compared with standard manualized treatments for individual disorders and with usual care, the modular package outperformed both comparators on multiple clinical and service outcome measures when assessed over a 2-year period, although additional, independently derived evidence is needed to determine the conditions under which it is most effective and categorize this treatment approach as well established.

### Treatment Engagement Interventions

Treatment engagement is conceptualized as a multidimensional construct targeting cognitive, attendance, and adherence domains. Research has identified several key factors addressing these domains that are associated with treatment engagement: accessibility promotion, psychoeducation about services, appointment reminders, assessment of treatment barriers, patient assessment, setting of positive expectations, modeling, homework assignments, rapport building, cultural acknowledgement, and goal setting ([Table 34.3](#)). To promote treatment engagement, the first 10 of these factors can be addressed by the PCP and the medical home team as soon as a mental health problem is identified that would benefit from treatment (see [Chapter 18](#) for further discussion).

### Psychotherapy in the Medical Home

Recognizing that up to one half of visits to PCPs involve a mental health problem and that an estimated one fifth of pediatric patients have a functionally impairing psychiatric disorder, in the context of limited access to specialty mental health services in community or hospital settings a number of models have been developed to deliver

**Table 34.2** Practice Elements in Interventions for Three Common Child and Adolescent Psychiatric Disorders

	ANXIETY DISORDERS	DEPRESSION	DISRUPTIVE BEHAVIOR
Directed play			X
Limit setting			X
Time-out			X
Cost response			X
Activity scheduling		X	
Maintenance		X	X
Skill building		X	
Social skills training		X	X
Therapist praise/rewards			X
Natural and logical consequences	X		X
Communication skills	X		X
Assertiveness training	X		
Parent monitoring	X		X
Modeling	X		
Ignoring	X		X
Parent praise	X		X
Problem solving	X	X	X
Parent coping	X		X
Psychoeducation, parent	X	X	X
Relaxation	X	X	X
Tangible rewards	X		X
Self-monitoring	X	X	X
Cognitive/coping	X	X	X
Psychoeducation, child	X	X	X
Exposure	X		

Adapted from Chorpita BF, Daleiden EL, Weisz JR. Identifying and selecting the common elements of evidence based interventions: a distillation and matching model. *Ment Health Serv Res.* 2005;7(1):5–20.

psychotherapy in primary care. Two prominent models, both originally developed for adult populations, are collaborative care and primary care behavioral health.

**Collaborative care**, which spans a spectrum ranging from coordinated to co-located to integrated, provides mental healthcare for patients through a collaboration between mental health specialists and PCPs. In integrated collaborative care, patients' mental health problems are managed in the medical home setting by an interdisciplinary care team of PCPs, mental health clinicians, and care coordinators supported by a consulting psychiatrist. The PCP is the "team captain"; the mental health clinician maintains a population registry, provides brief, focused psychosocial interventions, and monitors treatment response; the care coordinator facilitates external referrals; and the consulting psychiatrist provides input regarding evidence-based psychiatric diagnosis and treatment. The four critical elements of integrated collaborative care are that it is team-driven, population-focused, measurement-guided, and evidence-based. These elements guide a treatment approach in which the patient perceives a seamless integration of medical and mental healthcare.

In children and adolescents, randomized controlled trials (RCTs) have shown that integrated collaborative care for child behavior problems, adolescent depression, and adolescent substance use is associated with more favorable treatment adherence, symptom reduction,

disorder remission, and consumer satisfaction outcomes than usual care, with or without specialty referral. In a meta-analysis of collaborative care RCTs, larger effects were observed for treatment trials targeting diagnoses and elevated symptoms relative to prevention trials and for mental health diagnoses relative to substance-related diagnosis, as well as for integrated models relative to other types of collaborative mental healthcare.

**Primary care behavioral health** employs a mental health clinician (psychologist, social worker, mental health counselor) in the primary care setting to provide focused assessment of patients with mental health, health behavior, and substance use problems, and short-term therapy as well as health/mental health promotion and prevention interventions. Mental health clinicians typically collaborate with PCPs to develop treatment plans, monitor patient progress, and flexibly provide care to meet patients' changing needs. The model uses a "wide net" approach aimed at serving the entire primary care population, with emphasis on brief, focused interventions.

The results of **brief interventions**, particularly applicable to the fast-paced medical home setting, are encouraging. Interventions lasting only one session, particularly those utilizing CBT techniques, can be effective for mild presentations of multiple child psychiatric disorders, particularly anxiety and behavior problems in children (vs adolescents). These interventions can greatly expand capacity to

**Table 34.3** Selected Psychotherapy Engagement Elements

ELEMENT	DEFINITION
Accessibility promotion	Any strategy used to make services convenient and accessible to proactively encourage and increase participation in treatment; e.g., hiring a co-located therapist or referring to a local community-based therapist with whom the practice has an ongoing collaborative relationship
Psychoeducation about services	Provision of information about services or the service delivery system; e.g., type of therapy being recommended, information about the therapist, session frequency and duration
Appointment reminders	Providing information about the day, time, and location of the therapy office for the initial appointment via mail, text, phone, email, etc., to increase session attendance
Assessment of treatment barriers	Discussion to elicit and identify barriers that hinder participation in treatment; e.g., transportation, scheduling, childcare, previous experiences with therapy, stigma
Assessment	Measurement of the patient's strengths/needs through a variety of methods; e.g., mental health screening instruments, interviews, recorded reviews during which the referring practitioner can motivate treatment engagement
Modeling	Demonstration of a desired behavior to promote imitation and performance of that behavior by client
Expectation setting	Instillation of hope regarding the efficacy of therapy and the patient's ability to participate successfully in treatment
Homework assignment	Therapeutic tasks given to the patient to complete outside the therapy session to reinforce or facilitate knowledge or skills that are consistent with the treatment plan
Goal setting	Selection of a therapeutic goal for the purpose of making a plan to achieve that goal
Rapport building	Strategies used to strengthen the relationship between therapist and patient
Cultural acknowledgment	Exploration of an individual's culture; e.g., race/ethnicity, age, sexual orientation, gender identity

Adapted from Lindsey MA, Brandt NE, Becker KD, et al. Identifying the common elements of treatment engagement interventions in children's mental health services. *Clin Child Fam Psychol Rev*. 2014;17(3):283–298; Becker KD, Lee BR, Daleiden EL, Lindsey M, Brandt NE, Chorpita BF. The common elements of engagement in children's mental health services: which elements for which outcomes?. *J Clin Child Adolesc Psychol*. 2015;44(1):30–43; and Becker KD, Boustani M, Gellatly R, Chorpita BF. Forty Years of Engagement Research in Children's Mental Health Services: Multidimensional Measurement and Practice Elements. *J Clin Child Adolesc Psychol*. 2018;47(1):1–23.

provide mental health support to those patients with emerging mild mental health problems, with the goal of preventing escalation into full-blown psychiatric disorders if problems are left untreated.

Visit Elsevier eBooks+ at [eBooks.Health.Elsevier.com](http://eBooks.Health.Elsevier.com) for Bibliography.

## Chapter 35

## Somatic Symptom and Related Disorders

David R. DeMaso

Medically unexplained physical symptoms are common in children and adolescents. Although frequently chronic and disabling, these symptoms do not often result in referrals for mental health assessment and treatment (see Chapter 212). The *Diagnostic and Statistical Manual of Mental Disorders, Fifth Edition* (DSM-5) somatic symptom and related disorders (SSRDs) are those conditions in which the physical symptoms are unexplained or for which the patient's response to the underlying medical condition is disproportionate and debilitating.

The SSRDs include somatic symptom disorder (Table 35.1), conversion disorder (Table 35.2), factitious disorders (Table 35.3), illness anxiety disorder (Table 35.4), and other specified/unspecified somatic symptom disorders (Table 35.5), as well as psychologic factors affecting other medical conditions (Table 35.6). With the exception of illness anxiety disorder (with high level of anxiety about health in the absence of significant somatic symptoms) and psychologic factors affecting other medical conditions (with psychologic and/or behavioral factors adversely affect a pediatric condition), SSRDs are classified on the basis of physical symptoms associated with clinically significant distress and impairment, with or without the presence of a diagnosed medical condition.

Most patients with SSRDs are seen by primary care practitioners or by pediatric subspecialists, who may make specialty-specific diagnoses such as visceral hyperalgesia, chronic fatigue syndrome, psychogenic syncope, or noncardiac chest pain. Even within psychiatry, SSRDs are variously referred to as functional or psychosomatic disorders or as medically unexplained symptoms. The nosologic heterogeneity across the pediatric subspecialties contributes to the varying diagnostic labels. There is a significant overlap in the symptoms and presentation of patients with somatic symptoms who have received different diagnoses from different specialties. Moreover, SSRDs share similarities

**Table 35.1** DSM-5 Diagnostic Criteria for Somatic Symptom Disorder

- A. One or more somatic symptoms that are distressing or result in significant disruption of daily life.
- B. Excessive thoughts, feelings, or behaviors related to the somatic symptoms or associated health concerns, as manifested by at least one of the following:
  1. Disproportionate and persistent thoughts about the seriousness of one's symptoms.
  2. Persistent high level of anxiety about health and symptoms.
  3. Excessive time and energy devoted to these symptoms or health concerns.
- C. Although any one somatic symptom may not be continuously present, the state of being symptomatic is persistent (typically >6 mo).

Specify if:

**With predominant pain** (previously known as "pain disorder" in DSM IV-TR): for individuals whose somatic symptoms predominantly involve pain.

**Persistent:** A persistent course is characterized by severe symptoms, marked impairment, and long duration (>6 mo).

From the *Diagnostic and Statistical Manual of Mental Disorders*, 5th ed. p 311. Copyright 2013. American Psychiatric Association.

**Table 35.2** DSM-5 Diagnostic Criteria for Conversion Disorder or Functional Neurologic Symptom Disorder

- A. One or more symptoms of altered voluntary motor or sensory function.
  - B. Clinical findings provide evidence of incompatibility between the symptom and recognized neurologic or medical conditions.
  - C. The symptom is not better explained by another medical or mental disorder.
  - D. The symptom causes clinically significant distress or impairment in social, occupational, or other important areas of functioning or warrants medical evaluation.
- Specify symptom type: weakness or paralysis, abnormal movements, swallowing symptoms, speech symptom, attacks/seizures, anesthesia/sensory loss, special sensory symptom (e.g., visual, olfactory, hearing), or mixed symptoms.

From the *Diagnostic and Statistical Manual of Mental Disorders*, 5th ed. p 318. Copyright 2013. American Psychiatric Association.

**Table 35.3** DSM-5 Diagnostic Criteria for Factitious Disorders**FACTITIOUS DISORDER IMPOSED ON SELF**

- A. Falsification of physical or psychologic signs or symptoms, or induction of injury or disease, associated with identified deception.
- B. The individual presents himself or herself to others as ill, impaired, or injured.
- C. The deceptive behavior is evident even in the absence of obvious external rewards.
- D. The behavior is not better explained by another mental disorder, such as delusional disorder or another psychotic disorder.

Specify if: single episode or recurrent episodes.

**FACTITIOUS DISORDER IMPOSED ON ANOTHER (PREVIOUSLY "FACTITIOUS DISORDER BY PROXY")**

- A. Falsification of physical or psychologic signs or symptoms, or induction of injury or disease, in another, associated with identified deception.
- B. The individual presents another individual (victim) to others as ill, impaired, or injured.
- C. The deceptive behavior is evident even in the absence of obvious external rewards.
- D. The behavior is not better explained by another mental disorder, such as delusional disorder or another psychotic disorder.

Note: The perpetrator, not the victim, receives this diagnosis.

Specify if: single episode or recurrent episodes.

From the *Diagnostic and Statistical Manual of Mental Disorders*, 5th ed. p 324. Copyright 2013. American Psychiatric Association.

in etiology, pathophysiology, neurobiology, psychologic mechanisms, patient characteristics, and management and treatment response, which is indicative of a single spectrum of somatic disorders.

It is helpful for all healthcare providers to avoid the dichotomy of approaching illness using a medical model in which diseases are considered physically or psychologically based. In contrast, a developmental biopsychosocial continuum of disease better characterizes these illnesses as occurring across a spectrum ranging from a predominantly biologic to a predominantly psychosocial etiology. Indeed, there is a neurobiologic component to the related **functional neurologic disorders**, especially related to pain symptoms (see Chapters 212 and 389).

**SOMATIZATION**

The term *somatization* is defined as a pattern of seeking medical help for physical symptoms that cannot be fully explained by pathophysiologic mechanisms but are nevertheless attributed to physical disease by the sufferer. It has been described as the propensity to express

**Table 35.4** DSM-5 Diagnostic Criteria for Illness Anxiety Disorder

- A. Preoccupation with having or acquiring a serious illness.
- B. Somatic symptoms are not present, or, if present, are only mild in intensity. If another medical condition is present or there is a high risk for developing a medical condition (e.g., strong family history is present), the preoccupation is clearly excessive or disproportionate.
- C. There is a high level of anxiety about health, and the individual is easily alarmed about personal health status.
- D. The individual performs excessive health-related behaviors (e.g., repeatedly checks his or her body for signs of illness) or exhibits maladaptive avoidance (e.g., avoids doctor appointments and hospitals).
- E. Illness preoccupation has been present for at least 6 months, but the specific illness that is feared may change over that time.
- F. The illness-related preoccupation is not better explained by another mental disorder.

Specify whether: care-seeking type or care-avoidant type.

From the *Diagnostic and Statistical Manual of Mental Disorders*, 5th ed. p 315. Copyright 2013. American Psychiatric Association.

**Table 35.5** DSM-5 Diagnostic Criteria for Other Specified/Unspecified Somatic Symptom and Related Disorders**OTHER SPECIFIED**

This category applies to presentations in which symptoms characteristic of a somatic symptom and related disorder that cause clinically significant distress or impairment in social, occupational, or other important areas of functioning predominate but do not meet full criteria for any of the disorders in the *somatic symptom and related disorders diagnostic class*.

Examples of presentations that can be specified using the "other specified" designation include the following:

1. Brief somatic symptom disorder: duration of symptoms is <6 mo.
2. Brief illness anxiety disorder: duration of symptoms is <6 mo.
3. Illness anxiety disorder without excessive health-related behaviors: Criterion D for illness anxiety disorder is not met (see Table 35.4).
4. Pseudocyesis: a false belief of being pregnant that is associated with objective signs and reported symptoms of pregnancy.

**UNSPECIFIED**

This category applies to presentations in which symptoms characteristic of a somatic symptom and related disorder that cause clinically significant distress or impairment in functioning predominate but do not meet criteria for any of the other disorders in the *somatic symptom and related disorders diagnostic class*.

From the *Diagnostic and Statistical Manual of Mental Disorders*, 5th ed. p 327. Copyright 2013. American Psychiatric Association.

psychologic distress through somatic complaints. It is thought to occur universally in young children (but occurs in every age group) who have not yet developed the cognitive and a linguistic skill needed to comprehend and communicate their feelings.

Between 10% and 30% of children worldwide experience physical symptoms that are seemingly unexplained by a physical illness, with recurrent somatic complaints generally falling into cardiovascular, gastrointestinal, pain, and pseudoneurologic symptom clusters (Chapter 212). The prevalence of somatization is roughly equal among school-age males and females with a rise in adolescence, at which point somatic complaints in females are five times greater than those in males. Youth with a history of somatization are more likely to experience emotional/behavioral difficulties, be absent from school, and perform poorly academically. There are high rates of anxiety and depressive disorders in youth with SSRDs. Youth with conversion disorder, specifically



**Table 35.6** DSM-5 Diagnostic Criteria for Psychologic Factors Affecting Other Medical Conditions

- A. A medical symptom or condition (other than a mental disorder) is present.
- B. Psychologic or behavioral factors adversely affect the medical condition in one of the following ways:
1. The factors have influenced the course of the medical condition, as shown by a close temporal association between the psychologic factors and the development or exacerbation of, or delayed recovery from, the medical condition.
  2. The factors interfere with the treatment of the medical condition (e.g., poor adherence).
  3. The factors constitute additional well-established health risks for the individual.
  4. The factors influence the underlying pathophysiology, precipitating or exacerbating symptoms or necessitating medical attention.
- C. The psychologic and behavioral factors in Criterion B are not better explained by another mental disorder (e.g., panic disorder, major depressive disorder, posttraumatic stress disorder).
- Specify if: mild, moderate, severe, or extreme.

From the *Diagnostic and Statistical Manual of Mental Disorders*, 5th ed. p 322. Copyright 2013. American Psychiatric Association.

nonepileptic seizures, have increased rates of comorbid psychopathology including internalizing disorders and posttraumatic stress disorders. Somatization is common in cultures that accept physical illness but not psychologic symptoms as a reason for disability.

### RISK FACTORS FOR SOMATIZATION

Genetic and biologic factors, stressful life events, personality traits and coping styles, cognitive and learning difficulties, learned complaints, family factors, and sociocultural background are potential risk factors that have been associated with pediatric somatization.

#### Genetic and Biologic Factors

Somatization clusters in families with increased rates in first-degree relatives of patients with SSRDs. The concordance rates for somatization approximate 29% in monozygotic twin studies. Genetic factors have been hypothesized to contribute to the development of personality traits that may predispose to somatization when combined with environmental factors. Neuroimaging studies have found neuronal areas (premotor and supplementary motor cortices, the middle frontal gyrus, the anterior cingulate cortex, the insula, and the posterior cingulate cortex) to differ between patients with SSRDs.

#### Stressful Life Events

Stressful life events, including childhood trauma, physical/sexual abuse, bullying, and exposure to natural disasters have all been associated with somatization. Youth with SSRDs have shown high rates of comorbid anxiety, suicidal histories, family psychiatric histories, bullying, learning difficulties, and significant life events.

#### Personality Traits and Coping Styles

Somatization has been postulated to occur in patients who are unable to verbalize emotional distress and instead use physical symptoms as a means of expression. Physical symptoms have been called a form of body language for children who have difficulty expressing emotions verbally. Examples include individuals who have difficulties with disclosing traumatic events and high-achieving children who cannot admit they are under too much pressure. *Alexithymia* has been used to describe individuals with somatic concerns who do not have a verbal vocabulary to describe their feelings. Somatic complaints have also been linked to *somatosensory amplification*, which is the tendency to experience normal somatic sensations as “intense, noxious and disturbing.” When present, patients are hypervigilant to their own bodily sensations, overreact to these sensations, and interpret them as indicating physical illness.

### Cognitive and Learning Difficulties

Children with difficulties learning and using academic skills, particularly in the context of high parental expectations, are associated with increased rates of somatization. Compared with unaffected siblings, youth with “functional” neurologic disorders have been found to score lower on tests of full-scale IQ, vocabulary level, and mathematics as well as to have more learning difficulties. Between 40% and 60% of patients with psychogenic nonepileptic seizures are reported to have learning and subtle language problems.

### Learned Complaints

In operant conditioning learning, attention and sympathy from others and/or decrease in responsibilities (*secondary gain*) can reinforce somatic complaints. If somatic symptoms are reinforced (i.e., increased parental attention and/or avoidance of unpleasant school pressures) early in the course of an SSRD the likelihood increases that the somatic complaints will become more ingrained and less amenable to change. Social learning theory suggests that somatic symptoms may be a result of “modeling” or “observational learning” within the family. Family members with similar physical complaints (*symptom model*) are commonly found in SSRDs.

### Family Factors

In family systems theory, somatization can serve the function of drawing attention away from other areas of tension with a family. It has been suggested that children in families with significant conflict may develop somatic complaints as a mechanism to avoid any emotional expression that may exacerbate family conflict.

### Sociocultural Background

SSRDs have been reported to be more common in rural areas and among individuals of lower socioeconomic status. Spells or visions are common aspects of culturally sanctioned religious and healing rituals, and falling down with loss or alteration in consciousness is a feature in a variety of culture-specific syndromes.

### ASSESSMENT

The diagnosis of SSRD must be based on the presence of somatic symptoms that are distressing and/or result in significant impairment of daily life. These somatic symptoms must be accompanied by excessive thoughts, feelings, and behaviors related to these symptoms and/or associated health concerns. SSRDs are not diagnoses of exclusion; the mere absence of a medical explanation is insufficient to make the diagnosis.

The assessment of suspected SSRDs should include an assessment of biologic, psychologic, social, and developmental realms, both separately and in relation to each other. A collaborative healthcare approach between pediatric practitioners and mental health clinicians is indicated to ensure that all realms are considered in the assessment of medically unexplained physical symptoms ([Table 35.7](#))

### Medical Assessment

A comprehensive medical workup to rule out serious physical illness is necessary, but must be carefully balanced with efforts to avoid unnecessary and potentially harmful tests and procedures. Certain medical conditions are notoriously overlooked and should be carefully considered as part of the diagnostic workup for problematic somatic symptoms ([Table 35.8](#)).

The presence of a medical condition does not exclude the possibility of somatization playing an important role in the presentation. Somatic symptoms early in a disease course that can be directly attributed to a specific physical illness (e.g., acute respiratory illness) may evolve into psychologically based symptoms, particularly in situations where the patient may experience benefit from adopting the sick role. Symptoms may not follow known physiologic principles or anatomic patterns and may respond to suggestion or placebo. Physical findings may occur secondary to the effects of the SSRD, especially when chronic or severe (e.g., deconditioning, disuse atrophy from prolonged immobilization, nutritional deficiency, gastroparesis and constipation from chronic poor oral intake).

**Table 35.7** Key Elements to Consider in the Psychiatric Assessment of Somatic Symptoms and Related Disorders in Children and Adolescents**MEDICAL FINDINGS SUGGESTIVE OF SSRDS**

- Absence of findings despite thorough medical workup
  - Lack of electrical evidence on video-electroencephalographic monitoring
- Inconsistent findings on examination
  - Sensory changes inconsistent with anatomic distribution (e.g., splitting at the midline, loss of sensation of entire face but not scalp, discrepancy between pain and temperature sensation, absence of Romberg sign)
  - Absence of functional impairment despite claims of profound weakness (e.g., impairment of fine motor function on testing, yet able to dress and undress)
  - Face-hand test (deflecting falling arm from face)
  - Hoover sign (patient pushes down with “paretic” leg when attempting to raise unaffected leg and fails to press down with unaffected leg when raising “paretic” leg)
  - Astasia-abasia (staggering gait, momentarily balancing, but never actually falling)
  - Dragging a “weak” leg as though it were a totally lifeless object instead of circumduction of the leg
  - Psychogenic deafness responding to unexpected words or noises
  - Tunnel vision
  - Movement disorder with normal concurrent electroencephalogram
  - Symptoms suggestive of conversion seizures (see [Table 634.3](#)).
  - Increased symptoms in the presence of family or medical staff
  - Periods of normal function when distracted
- Temporal relationship between onset of symptom and psychosocial stressor

**PSYCHIATRIC FINDINGS SUGGESTIVE OF SSRDS**

- Excessive thoughts, feelings, or behaviors related to the somatic symptoms or associated health concerns
- Co-occurring psychiatric disorder
- Learning difficulties and academic failure
- Stressful life events (including childhood trauma and bullying)
- Symptom model(s)

**FAMILY BELIEFS REGARDING SOMATIC SYMPTOMS**

- Belief in a single undiagnosed primary medical cause
  - Investment in further medical workup
  - Fear about serious medical illness
- Belief in the role of environmental triggers
- Belief in the role of psychologic factors
- Beliefs regarding symptom management
  - Awareness of nonpharmacologic approaches
  - Belief that the child should rest and be excused from usual responsibilities

**FAMILY MEDICAL HISTORY**

- Family history of unexplained somatic symptoms
- Pattern of reinforcement of illness behavior in the family

**IMPACT OF SOMATIC SYMPTOMS**

- Emotional (e.g., depression/anxiety vs la belle indifférence)
- Family (e.g., disruption of work schedule, impact on marital relationship, impact on distraction from family conflict)
- Social and peer relationships
- Academic (e.g., absenteeism, placement in home teaching)

**REINFORCEMENT OF SOMATIC SYMPTOMS**

- Reinforcement by parents
  - Medical journals and diaries of symptoms kept by parents
  - Parent home from work
- Increased attention from family/friends
- Increased attention from medical providers
- Avoidance of school, social, or athletic stressor

**Table 35.8** Selected Medical Conditions to Consider in the Differential Diagnosis of Youth Presenting with Disabling Somatic Symptoms

AIDS	Hyperparathyroidism
Acquired myopathies	Hyperthyroidism
Acute intermittent porphyria	Juvenile idiopathic arthritis
Angina	Lyme disease
Autoinflammatory (recurrent fever) syndromes	Migraine headaches
Basal ganglia disease	Mitochondrial disorders
Brain tumors	Multiple sclerosis
Cardiac arrhythmias	Myasthenia gravis
Chronic systemic infections	Narcolepsy
Ehlers-Danlos syndrome	Optic neuritis
Fabry disease	Periodic paralysis
Gaucher disease	Postural orthostatic hypertension syndrome
Guillain-Barré syndrome	Polymyositis
Hereditary neuropathies	Seizure disorders
Hereditary angioedema	Small fiber neuropathy
	Superior mesenteric artery syndrome
	Systemic lupus erythematosus

Modified from Shaw RJ, DeMaso DR. *Clinical Manual of Pediatric Consultation-Liaison Psychiatry*. American Psychiatric Press; 2020:248.

**Psychosocial Assessment**

If somatization is suspected, a mental health consultation should be included early in the diagnostic workup. This can be a difficult step for many families given their belief that there is a medical cause for their child's problem. A common response is for the family to react adversely and think that their child's symptoms are not being taken seriously. It is helpful for the pediatric practitioner to frame the consultation as a routine part of the medical workup as well as an opportunity to assess the level of stress connected with the current physical symptoms. The practitioner can communicate that the mental health consultation will be used to gain a more complete understanding of the origins of their child's distress, what perpetuates it, and which treatments are likely to be most effective.

The mental health assessment should include a careful assessment of psychosocial stressors, comorbid depression or anxiety disorders, individual and family histories of somatization, the presence of a model of illness behavior, and evidence of secondary gain resulting from the symptoms. The assessment should provide the pediatric practitioner(s) with a biopsychosocial explanation of the child's symptoms (diagnosis and formulation), which will inform the development of a comprehensive biopsychosocial management plan.

**Differential Diagnoses**

The primary differential diagnosis is between an SSRD and a physical illness. *Importantly, however, these disorders are not mutually exclusive and often coexist.* Depressive and anxiety disorders frequently include the presence of physical symptoms, which tend to remit with treatment of the primary depressive or anxiety symptoms, and which appear distinct from physical complaints seen in SSRDs. Distinguishing features of other physical complaint disorders are noted in [Table 35.9](#). Chronic pain syndromes may be caused by fibromyalgia and small fiber autonomic neuropathy and complex regional pain syndrome (see Chapter 211).

**MANAGEMENT**

Effective management of SSRDs begins with the development of a positive working relationship between the patient, family, pediatric practitioner, and mental health clinician based on a shared understanding of the diagnosis, formulation, and a management plan that generally incorporates a number of different treatment modalities.

*The formulation of the problem is the crucial first step.* Patients and their families routinely present with the belief that their symptoms are caused by a medical illness alone. This view needs to be reframed from this narrow medical model view to a comprehensive biopsychosocial understanding. With the completion of medical and psychosocial assessments, a joint meeting of the pediatric practitioner(s) and

**Table 35.9** Features of Conditions Characterized by Patient's Physical Complaints

	ILLNESS ANXIETY DISORDER	SOMATIC SYMPTOM DISORDER	CONVERSION DISORDER FUNCTIONAL NEUROLOGIC DISORDER
Presenting complaint	Primary concern is the development of a serious illness—does not require specific symptoms	Primary concern is a specific symptom; generally presents with a more specific physical complaint There are no objective physical findings other than those related to deconditioning	Presents with new-onset neurologic or physical symptom; patient may or may not be concerned about this new symptom
Medical correlation to complaint	Generally present with more vague complaints than a specific symptom; not usually explained by medical workup In the presence of a known disease, the complaint does not correlate to the natural history of the disorder in severity, duration, or dysfunction	Patient can have a medical explanation for their symptom; however, the worry about the seriousness of the symptom is disproportionate or excessive	Physical and neurologic findings do not correlate with patient's presentation Neurologic manifestations involve aspects of CNS where voluntary control is exercised
Course of disease	Often associated with other anxiety disorders; can be chronic	Chronic; rarely remits	Generally acute onset; can recur with same or different presenting symptom(s)

CNS, Central nervous system

Modified from Byrne R, Elsner G, Beattie A. Emotional and behavioral symptoms. In: Kliegman RM, Toth H, Bordini BJ, Basel D, eds. *Nelson Pediatric Symptom-Based Diagnosis: Common Diseases and their Mimics*. 2nd ed. Elsevier; 2023:Table 31.14, p. 530.

mental health clinician (as well as any involved pediatric specialists) should be arranged to reach and ensure a consensus on the diagnosis and treatment plan and facilitate adequate and consistent communication among all providers.

The next step is an “informing conference or meeting” that includes both the managing pediatric practitioner and the family. It is important in this meeting that this practitioner present the medical and psychosocial findings together to the patient and the family in a supportive and nonjudgmental manner. If patients and their families believe that the practitioner understands and empathizes with the degree of distress the somatic symptoms have produced, then they are more likely to be active participants in treatment. Depending on the comfort and expertise of the pediatric practitioner and the severity of the SSRD, the mental health clinician may or may not elect to attend this meeting.

After complete medical investigations yield no unifying results, labeling the symptoms as “psychiatric” may be problematic because it can shift the search for the cause onto family functioning, resulting in children and parents feeling blamed for the symptoms. The goal is to avoid such labeling and instead help the family move toward an understanding of the *mind-body connection and to shift their approach from searching for the cause of the symptoms to increasing child functioning*. Providing mind-body examples, such as facial flushing when embarrassed, hand shaking when frightened, or phantom limb pain, will help the patient and family understand how the brain may produce physical symptoms.

### Treatment

With child and family acceptance of a biopsychosocial understanding, an integrated medical and psychosocial treatment approach focused on the development and implementation a treatment plan to improve the patient's functioning, and not a continued search for a cause of the presenting symptoms, can be implemented. It is helpful to establish realistic goals that emphasize improvements in *functioning* rather than the illusion that the symptoms can be completely removed. Those patients with mild-moderate presentations can be treated effectively in the primary or specialty pediatric care setting with appropriate mental health follow-up, whereas those with severe presentations and high complexity are better managed in the psychiatry specialty care setting.

### Role of the Pediatric Practitioner

The pediatric practitioner serves an important role in providing ongoing monitoring and treatment for possible physical illness in addition to the

recommended mental health interventions. Frequent, brief, and ongoing pediatric visits can be scheduled as a means of helping avoid unnecessary medical investigations and procedures. This arrangement permits the patient to receive attention from their pediatric practitioner without having to develop somatic symptoms. Furthermore it may reassure the family that the team is continuing to monitor for symptoms that would require further evaluation and helps ensure that any further medical evaluation is directed by a clinician knowledgeable about the previous symptoms and evaluations. It is generally more helpful for the practitioner to attend to a patient's *anxiety* in relation to their physical symptoms rather than the symptoms themselves. This approach has been shown to reduce overall healthcare utilization and to improve patient satisfaction.

### Using Rehabilitation Approach

A rehabilitative approach *acknowledges* the reality of the symptoms, *emphasizes* the necessary involvement of mind and body in the recovery process, and *shifts the focus* from “cure” to “return to normal functioning” while allowing youth to “save face” through the promotion of physical recovery as the primary goal. A rehabilitative approach includes the use of intensive physical and occupational therapy that emphasizes the recovery of function. This approach can be combined with a behavioral modification program, with incentives for improvements in functioning, while removing secondary gain for illness behavior.

In severely disabled patients, it may be preferable to recommend admission to an inpatient medical-psychiatric treatment program that specializes in SSRDs. Another useful option to consider is that of day treatment or partial hospitalization programs. Multidisciplinary inpatient rehabilitation programs have much to offer these patients because they are designed to support both physical and psychologic recovery. Families are generally reassured that multidisciplinary staff can continue to monitor physical symptoms, thus ensuring that any missed diagnoses will be recognized quickly.

Youth with a high level of impairment often miss a significant amount of school. Communication with the school is often crucial in coordinating a successful reintegration. In addition to discussions with the school guidance counselor and/or nurse, a letter for the school providing education and recommended approaches for the patient's symptoms can be beneficial. These interventions can be formalized by having the school work with the family to develop either a 504 plan for accommodations needed in regular education settings, or an individualized educational plan (IEP) if the child needs special education services. Ongoing communication between the school and the pediatric practitioner for monitoring of further symptoms is recommended.



## Psychotherapy and Psychopharmacology

Meta-analyses have shown that psychologic treatments improve symptom load, disability, and school attendance in youth suffering from various somatic symptoms including functional abdominal symptoms, fatigue, tension-type headache, and musculoskeletal pain. **Cognitive-behavioral therapy (CBT)** interventions modify symptom experience and restore central nervous system abnormalities associated with functional impairment. CBT techniques (e.g., relaxation training, biofeedback, hypnosis) can be used to teach patients the control they can have over certain physiologic processes, such as autonomic system activity. Cognitive restructuring is effective in addressing and altering dysfunctional thoughts regarding symptoms and their implications for functioning. Treatments that encourage active coping strategies and emotional expression and modulation are helpful in reducing symptoms and improving functioning. Modifying parental response patterns that are overprotective and potentially reinforcing (e.g., allowing the child to sleep late or to stay home from school in response to symptoms) help to decrease disability.

Psychopharmacologic treatment may be considered when psychiatric comorbidities are present, specifically, depressive and anxiety disorders. A combination of pharmacotherapy, physical therapy, and psychologic interventions in multicomponent management programs has been shown to be effective.

Visit Elsevier eBooks+ at [eBooks.Health.Elsevier.com](http://eBooks.Health.Elsevier.com) for Bibliography.

## Chapter 36

# Rumination and Pica

Chase B. Samsel, Heather J. Walter, and David R. DeMaso

## 36.1 Rumination Disorder

Chase B. Samsel, Heather J. Walter, and David R. DeMaso

Rumination disorder is the repeated regurgitation of food, in which the regurgitated food may be rechewed, reswallowed, or spit out, for a period of at least 1 month following a period of normal functioning. Regurgitation is typically frequent and daily; it does not occur during sleep. It is not caused by an associated gastrointestinal illness or other medical conditions (e.g., gastroesophageal reflux, pyloric stenosis). It does not occur exclusively during the course of anorexia nervosa, bulimia nervosa, binge-eating disorder, or avoidant/restrictive food intake disorder. If the symptoms occur in the context of an intellectual or other neurodevelopmental disorder, the symptoms must be sufficiently severe to warrant additional clinical attention.

Weight loss and failure to make expected weight are common features in infants with rumination disorder. Infants may display a characteristic position of straining and arching the back with the head held back while making sucking movements with their tongue. In infants and older individuals with intellectual disability, the rumination behavior may appear to have a self-soothing or self-stimulating function. Malnutrition may occur in older children and adults,

particularly when the regurgitation is associated with restricted food intake (which may be designed to avoid regurgitation in front of others). They may attempt to hide the regurgitation behavior or avoid eating among others.

## EPIDEMIOLOGY

Originally thought of as a disorder predominantly seen in infants and those with intellectual disability, rumination disorder has also been recognized in healthy individuals across the life span and can be overlooked in adolescents. In otherwise healthy children, rumination disorder typically appears in the first year of life, generally between ages 3 and 12 months. The disorder can have an episodic course or can occur continuously until treatment is initiated. In infants the disorder frequently remits spontaneously but can be protracted with problematic and even life-threatening malnutrition. Additional complications related to the secondary effects of malnutrition include growth delay and negative effects on development and learning potential.

## ETIOLOGY AND DIFFERENTIAL DIAGNOSIS

Risk factors for rumination disorder in infants and young children include a disturbed relationship with primary caregivers, lack of an appropriately stimulating environment, neglect, stressful life situations, learned behavior reinforced by pleasurable sensations, distraction from negative emotions, and inadvertent reinforcement (attention) from primary caregivers. Risk factors for rumination disorder in adolescents include similar early childhood factors along with female gender and comorbid anxiety and depression. The differential diagnosis includes congenital gastrointestinal system anomalies, pyloric stenosis, Sandifer syndrome, gastroparesis, hiatal hernia, increased intracranial pressure, diencephalic tumors, adrenal insufficiency, and inborn errors of metabolism. Older children and adults with anorexia nervosa or bulimia nervosa may also engage in regurgitation because of concerns about weight gain. The diagnosis of rumination disorder is appropriate only when the severity of the disturbance exceeds that routinely associated with a concurrent physical illness or mental disorder.

## TREATMENT

The first step in treatment begins with a behavioral analysis to determine whether the disorder serves a self-stimulation purpose and/or is socially motivated. The behavior may begin as self-stimulation, but it subsequently becomes reinforced and maintained by the social attention given to the behavior. The central focus of behavioral treatment is to reinforce correct eating behavior while minimizing attention to rumination. Diaphragmatic breathing and postprandial gum chewing, when used as a competing response, have been shown to be helpful. Aversive conditioning techniques (e.g., withdrawal of positive attention, introducing bitter/sour flavors when regurgitating) are considered when a child's health is jeopardized but can be more reasonable and useful in adolescents. Additional techniques shown to be useful in adolescents include reswallowing all regurgitation, use of paradoxical intention, and guided progressive food trials.

Successful behavioral treatment requires the child's primary caregivers to be involved in the intervention. The caretakers need education and counseling on responding adaptively to the child's behavior as well as altering any maladaptive responses. No current evidence supports a psychopharmacologic intervention for rumination disorder. In more severe or intractable cases (e.g., severe dehydration, malnutrition), an intensive integrated medical-behavioral treatment program on a medical or medical-psychiatric unit may be necessary.

Visit Elsevier eBooks+ at [eBooks.Health.Elsevier.com](http://eBooks.Health.Elsevier.com) for Bibliography.



## 36.2 Pica

Chase B. Samsel, Heather J. Walter, and  
David R. DeMaso

Pica involves the persistent eating of nonnutritive, nonfood substances (e.g., paper, soap, plaster, charcoal, clay, wool, ashes, paint, earth) over a period of at least 1 month. The eating behavior is inappropriate to the developmental level (e.g., the normal mouthing and tasting of objects in infants and toddlers), and therefore a minimum age of 2 years is suggested. The eating behavior is not part of a culturally supported or socially normative practice. A diagnosis of pica may be assigned in the presence of any other feeding and eating disorder.

### EPIDEMIOLOGY

Pica can occur throughout life but occurs most frequently in childhood. It is more common in those with intellectual disability and autism spectrum disorders, and to a lesser degree in obsessive-compulsive and schizophrenic disorders. The prevalence of pica is unclear, although it appears to increase with the severity of an intellectual disability. It usually remits in childhood but can continue into adolescence and adulthood. **Geophagia** (eating earth) is associated with pregnancy and is not seen as abnormal in some cultures (e.g., rural or preindustrial societies in parts of Africa and India). Children with pica are at increased risk for lead poisoning, iron-deficiency anemia, mechanical bowel problems, intestinal obstruction, intestinal perforations, dental injury, and parasitic infections. Pica can be fatal based on substances ingested.

### ETIOLOGY AND DIFFERENTIAL DIAGNOSIS

Numerous etiologies have been proposed but not proved, ranging from psychosocial causes to physical ones. They include nutritional deficiencies (e.g., iron, zinc, calcium), low socioeconomic factors (e.g., lead paint exposure), child abuse and neglect, family disorganization (e.g., poor supervision), mental disorder, learned behavior, underlying (but undetermined) biochemical disorder, and cultural and familial factors. The differential diagnosis includes anorexia nervosa, factitious disorder, and nonsuicidal self-injury. A separate diagnosis of pica should be made only if the eating behavior is sufficiently severe enough to warrant additional clinical attention.

### TREATMENT

Combined behavioral, social, and medical approaches are generally indicated for pica. Assessment for neglect and family supervision combined with psychiatric assessment for concurrent mental disorders and developmental delay are important in developing an effective intervention strategy for pica. Behavioral interventions, particularly applied behavioral analysis in patients with intellectual disability or autism spectrum disorders, are increasingly found to be helpful. The sequelae related to an ingested item can require specific treatment (e.g., lead toxicity, iron-deficiency anemia, parasitic infestation). Ingestion of hair can require medical or surgical intervention for a gastric bezoar.

Visit Elsevier eBooks+ at [eBooks.Health.Elsevier.com](http://eBooks.Health.Elsevier.com) for Bibliography.

## Chapter 37

# Motor Disorders and Habits

Jung Won Kim, Heather J. Walter, and  
David R. DeMaso

**Motor disorders** are interrelated sets of psychiatric symptoms characterized by abnormal motor movements and associated phenomena. In the *Diagnostic and Statistical Manual of Mental Disorders, Fifth Edition* (DSM-5), they include tic, stereotypic movement, and developmental coordination disorders. **Tic disorders** (Tourette, persistent motor or vocal tic, provisional tic, other specified/unspecified tic) and **stereotypic movement disorders** (SMDs) are addressed in this chapter. **Habits** present as repetitive and often problematic motor behaviors (e.g., thumb sucking, nail biting, teeth grinding). When the problems cause significant distress or impairment they are discussed as **body-focused repetitive behavior disorder** in the Obsessive Compulsive and Related Disorders section of DSM-5.

## 37.1 Tic Disorders

Jung Won Kim, Heather J. Walter, and  
David R. DeMaso

**Tourette disorder (TD), persistent (chronic) motor or vocal tic disorder (PTD), and provisional tic disorders** are characterized by involuntary, rapid, repetitive, and single or multiple motor and/or vocal/phonic tics that wax and wane in frequency but have persisted for >1 year since the first tic onset (<1 year for provisional tic disorder) (Table 37.1). PTD is differentiated from TD in that PTD is limited to either motor or vocal tics (not both), whereas TD has both motor and vocal tics at some point in the illness (although not necessarily concurrently). The tic disorders are hierarchical in order (i.e., TD followed by PTD followed by provisional tic disorder), such that once a tic disorder at one level of the hierarchy is diagnosed, a lower-hierarchy diagnosis cannot be made. **Other specified/unspecified tic disorders** are presentations in which symptoms characteristic of a tic disorder that cause significant distress or impairment predominate but do not meet the full criteria for a tic or other neurodevelopmental disorder.

### DESCRIPTION

**Tics** are sudden, rapid, recurrent, nonrhythmic motor movements or vocalizations. *Simple motor tics* (e.g., eye blinking, neck jerking, shoulder shrugging, extension of the extremities) are fast, brief movements involving one or a few muscle groups. *Complex motor tics* involve sequentially and/or simultaneously produced, relatively coordinated movements that can seem purposeful (e.g., brushing back one's hair bangs, tapping the foot, imitating someone else's movement [**echopraxia**], or making a sexual or obscene gesture [**copropraxia**]). *Simple vocal tics* (e.g., throat clearing, sniffing, coughing) are solitary, meaningless sounds and noises. *Complex vocal tics* involve recognizable word or utterances (e.g., partial words [syllables], words out of context, obscenities or slurs [**coprolalia**], repeating one's own sounds or words [**palilalia**], or repeating the last heard word or phrase [**echolalia**]).

**Table 37.1** DSM-5 Diagnostic Criteria for Tic Disorders**TOURETTE DISORDER**

- A. Both multiple motor and one or more vocal tics have been present at some time during the illness, although not necessarily concurrently.
- B. The tics may wax and wane in frequency but have persisted for >1 year since first tic onset.
- C. Onset is before age 18 years.
- D. The disturbance is not attributable to the physiologic effects of a substance (e.g., cocaine) or another medical condition (e.g., Huntington disease, postviral encephalitis).

**PERSISTENT (CHRONIC) MOTOR OR VOCAL TIC DISORDER**

- A. Single or multiple motor or vocal tics have been present during the illness, but not both motor and vocal.
- B. The tics may wax and wane in frequency but have persisted for >1 year since first tic onset.
- C. Onset is before age 18 years.
- D. The disturbance is not attributable to the physiologic effects of a substance (e.g., cocaine) or another medical condition (e.g., Huntington disease, postviral encephalitis).
- E. Criteria have never been met for Tourette disorder.

Specify if:

With motor tics only

With vocal tics only

**PROVISIONAL TIC DISORDER**

- A. Single or multiple motor and/or vocal tics.
- B. The tics have been present for <1 year since first tic onset.
- C. Onset is before age 18 years.
- D. The disturbance is not attributable to the physiologic effects of a substance (e.g., cocaine) or another medical condition (e.g., Huntington disease, postviral encephalitis).
- E. Criteria have never been met for Tourette disorder or persistent (chronic) motor or vocal tic disorder.

Note: A tic is a sudden, rapid, recurrent, nonrhythmic motor movement or vocalization. Reprinted with permission from the *Diagnostic and Statistical Manual of Mental Disorders*, 5th ed. p 81. Copyright ©2013. American Psychiatric Association. All Rights Reserved.

Sensory phenomena (premonitory urges) that precede and trigger the urge to tic have been described. Individuals with tics can suppress them for varying periods of time, particularly when external demands exert their influence, when deeply engaged in a focused task or activity, or during sleep. Tics are often suggestible and are worsened by anxiety, excitement, or exhaustion. Parents have described increasing frequency of tics at the end of the day.

**CLINICAL COURSE**

Onset of tics is typically between ages 4 and 6 years. The frequency of tics tends to wax and wane with peak tic severity between ages 10 and 12 years and marked attenuation of tic severity in most individuals (65%) by age 18–20 years. A small percentage will have worsening tics into adulthood. New onset of tics in adulthood is very rare and most often is associated with exposure to drugs or insults to the central nervous system. Tics manifest similarly in all age groups, with changes in affected muscle groups and vocalizations that occur over time. Some individuals may have tic-free periods of weeks to months.

**EPIDEMIOLOGY**

Prevalence rates for all tics range from 6–18% for males and 3–11% for females, with the rate of TD alone estimated as 0.8%. In general, PTD/TD has a male preponderance with a gender ratio varying from 2:1 to 4:1.

**DIFFERENTIAL DIAGNOSIS**

The differential diagnosis includes other repetitive movements of childhood (Table 37.2). Tics may be difficult to differentiate from stereotypies. Although stereotypies may resemble tics, **stereotypies** are

typically rhythmic movements and do not demonstrate the change in body location or movement type over time that is typical of tics. **Compulsions** may be difficult to differentiate from tics when tics have premonitory urges. Tics should be differentiated from a variety of developmental and benign movement disorders (e.g., benign paroxysmal torticollis, Sandifer syndrome, benign jitteriness of newborns, shuddering attacks). Although tics may present in various neurologic illnesses (e.g., Wilson disease, neuroacanthocytosis, Huntington syndrome, various frontal-subcortical brain lesions), it is rare for tics to be the only manifestation of these disorders (Table 37.3).

Individuals presenting with tics in the context of declining motor or cognitive function should be referred for neurologic assessment. Substances/medications that are reported to worsen tics include selective serotonin reuptake inhibitors (SSRIs), lamotrigine, and cocaine. If tics develop in close temporal relationship to the use of a substance or medication and then remit when use of the substance is discontinued, a causal relationship is possible. Stimulants do not commonly increase tics.

**COMORBIDITIES**

Comorbid psychiatric disorders are common, often with both patient and family viewing the accompanying condition as more problematic than the tics. There is a bidirectional association between PTD/TD (especially TD) and obsessive-compulsive disorder (OCD), with 20–60% of TD patients meeting OCD criteria and 20–40% of OCD patients reporting tics (Fig. 37.1). Attention-deficit/hyperactivity disorder (ADHD) occurs in approximately 50% of all childhood PTD/TD, but estimates in clinically referred patients suggest much higher rates (60–80%). PTD/TD is often accompanied by behavior problems, including poor frustration tolerance, temper outbursts, and oppositionality. Learning disabilities have been found in >20% of these patients. Concurrent anxiety and depression have also been observed. Some patients with PTD/TD will display symptoms of autism spectrum disorder (ASD); careful assessment is required to determine which disorder is primary.

**ETIOLOGY**

Tics are proposed to be the result of dysfunctional corticostriatal-thalamocortical motor pathways in the basal ganglia, striatum, and frontal lobes associated with abnormalities in the dopamine, serotonin, and norepinephrine neurotransmitter systems. Male predominance in PTD/TD may be attributable to influences of sex hormones on the neurodevelopment of these motor pathways, as reflected by the effects of antiandrogens in the treatment of TD.

Family studies suggest a 10–100-fold increased risk of PTD/TD among first-degree relatives compared to rates in the general population. Twin studies also support a genetic link, with approximately 80% of monozygotic twins and 30% of dizygotic twins showing concordance for PTD/TD. Candidate-gene association and nonparametric linkage studies have not identified specific susceptibility genes for PTD/TD.

Autoimmune-mediated mechanisms have been hypothesized as having a potential etiologic role in some tic disorders. The **pediatric autoimmune neuropsychiatric disorder associated with streptococcal infection (PANDAS)** designation describes cases of acute childhood onset of OCD and/or tics following a streptococcal infection. Pediatric acute-onset neuropsychiatric syndrome (PANS) describes a subtype of acute childhood-onset OCD (tics are not a required feature) in which a link to a prior streptococcal infection is not evident, suggesting that other infectious agents may be responsible. In addition to a diagnosis of OCD and tics, children with PANS/PANDAS may potentially have separation anxiety, nightmares, personality change, oppositional behaviors, and deterioration in math skills and handwriting. Although some studies suggest a prior history of infections may increase the risk for developing tic disorder, this remains controversial.

Premorbid stress has been hypothesized to act as a sensitizing agent in the pathogenesis of TD among susceptible individuals by affecting stress-responsive biologic systems such as the hypothalamic-pituitary-adrenal axis.

**Table 37.2** Repetitive Movements of Childhood

MOVEMENT	DESCRIPTION	TYPICAL DISORDERS WHERE PRESENT
Tics	Sudden rapid, recurrent, nonrhythmic, stereotyped, vocalization or motor movement	Transient tics, Tourette disorder, persistent tic disorder
Dystonia	Involuntary, sustained, or intermittent muscle contractions that cause twisting and repetitive movements, abnormal postures, or both	<i>DYT1</i> gene, Wilson disease, myoclonic dystonia, extrapyramidal symptoms caused by dopamine-blocking agents
Chorea	Involuntary, random, quick, jerking movements, most often of the proximal extremities, that flow from joint to joint. Movements are abrupt, nonrepetitive, and arrhythmic and have variable frequency and intensity	Sydenham chorea, Huntington chorea
Stereotypies	Stereotyped, rhythmic, repetitive movements or patterns of speech, with lack of variation over time	Autism, stereotypic movement disorder, intellectual disability
Compulsions	A repetitive, excessive, meaningless activity or mental exercise that a person performs in an attempt to avoid distress or worry	Obsessive-compulsive disorder, anorexia, body dysmorphic disorder, trichotillomania, excoriation disorder
Myoclonus	Shocklike involuntary muscle jerk that may affect a single body region, one side of the body, or the entire body; may occur as a single jerk or repetitive jerks	Hiccups, hypnic jerks, Lennox-Gastaut syndrome, juvenile myoclonic epilepsy, mitochondrial encephalopathies, metabolic disorders
Akathisia	Unpleasant sensations of “inner” restlessness, often prompting movements in an effort to reduce the sensations	Extrapyramidal adverse effects from dopamine-blocking agents; anxiety
Volitional behaviors	Behavior that may be impulsive or caused by boredom, such as tapping peers or making sounds (animal noises)	Attention-deficit/hyperactivity disorder, oppositional defiant disorder, sensory integration disorders

Adapted from Murphy TK, Lewin AB, Storch EA, Stock S. American Academy of Child and Adolescent Psychiatry (AACAP) Committee on Quality Issues (CQI). Practice parameter for the assessment and treatment of children and adolescents with tic disorders. *J Am Acad Child Adolesc Psychiatry*. 2013;52(12):1341–1359.

## SEQUELAE

Many individuals with mild to moderate tics express minimal to no distress or functional impairment and may even be unaware of their tics. Even individuals with moderate to severe tics can experience minimal functional impairment, but psychologic distress may occur. Infrequently, the presence of tics can lead to social isolation, social victimization, inability to work or attend school, or impaired quality of life. TD/PTD is associated with increased risk of suicide. Suicidal behavior should be monitored, particularly in those with persistent tics, history of suicide attempts, and psychiatric comorbidities.

## SCREENING

Pediatric practitioners should routinely screen for unusual movements (e.g., sudden twitches or jerks, eye blinking, neck twisting, muscle tightening, shoulder shrugging, or involuntary gestures) or vocalizations (e.g., utter involuntary sounds, like grunts, yelps, squeaks, or throat clears). Often families are unaware that frequent sniffing, coughing, or blinking may be indicative of tics, attributing these behaviors to medical problems (e.g., allergies, visual problems). A careful assessment of the timing, triggers, and specific characteristics may differentiate tics from other medical problems. If differentiation is difficult, a referral to a pediatric specialist in the affected system is warranted.

## ASSESSMENT

If the screening suggests the presence of a tic disorder, a more comprehensive evaluation should ensue, including the age of onset, types of tics, tic frequency, alleviating and aggravating factors, and a family history of tics. Parent rating scales specific for tics (e.g., the *Motor Tic, Obsessions and Compulsions, Vocal Tic Evaluation Survey* [MOVES] and *Autism-Tics, ADHD and other Comorbidities inventory* (A-TAC) can supplement the assessment. For clinician-rated tic severity, the most comprehensive, reliable, and valid instrument is the *Yale Global Tic Severity Scale* (YGTSS), though its relatively long administration makes routine use in clinical practice problematic

(<https://candapediatricmedicalhomes.files.wordpress.com/2017/02/yale-global-tic-severity-scale.pdf>).

A medical workup should be considered for new-onset tics, particularly for presentations characterized by sudden onset, atypicality, or mental status abnormalities. Basic laboratory measures (hemogram, renal/hepatic function panel, thyroid panel, and ferritin, along with urine drug screen for adolescents) should be considered. For new, sudden onset, or severe symptom exacerbation, pediatric practitioners may assess for concurrent acute infection (e.g., culture, rapid viral tests). Electroencephalography and brain imaging are not routinely recommended for isolated tics and should be reserved for patients with other neurologic findings that might suggest an autoimmune encephalitis syndrome (limbic encephalitis). Comorbid psychiatric disorders (e.g., OCD, ADHD, ASD) should be investigated.

## TREATMENT

The decision to treat tics is made with the child and family based on the level of impairment and distress caused by the tics. If tics are mild in severity, the pediatric practitioner can provide the family with education, often with no need for further intervention.

Patient and family education should include common symptom presentations, implications of concurrent conditions, course and prognosis, and treatment options (including no treatment). The patient's typical exacerbating and alleviating factors should be outlined. Pediatric practitioners can also direct the patient and family to informational websites, including the Tourette Association of America ([www.tourette.org](http://www.tourette.org)).

Almost 75% of children with TD/PTD receive some form of classroom accommodation (e.g., directions to ignore tics and permission to leave the room as needed). The accommodations may need to be formalized in an individualized education plan (IEP) if a child needs special education services or a 504 plan if the child just needs accommodations in the regular classroom.

**Table 37.3** Etiology of Tics**PRIMARY CAUSES****Sporadic**

Transient motor or phonic (<1 year), chronic motor or phonic tics (>1 year), adult-onset recurrent) tics, Tourette disorder, primary dystonia

**Inherited**

Tourette disorder, Huntington disease, primary dystonia, neuroacanthocytosis syndromes, neurodegeneration with brain iron accumulation (type 1) (pantothenate kinase associated neurodegeneration), tuberous sclerosis, Wilson disease, Duchenne muscular dystrophy

**SECONDARY CAUSES****Infections**

Encephalitis, Creutzfeldt-Jakob disease, neurosyphilis, Sydenham chorea, PANS

**Drugs**

Amphetamines, methylphenidate, levodopa, cocaine, carbamazepine, phenytoin, phenobarbital, lamotrigine, antipsychotics, and other dopamine receptor-blocking drugs

**Toxins**

Carbon monoxide, wasp venom

**Developmental**

Static encephalopathy, intellectual disability syndromes, chromosomal abnormalities, autistic spectrum disorders

**Chromosomal Disorders**

Down syndrome, Klinefelter syndrome, XYY karyotype, fragile X, triple X, and 9p mosaicism, partial trisomy 16, 9p monosomy, citrullinemia, Beckwith-Wiedemann syndrome

**Other Causes**

Head trauma, stroke, cardiopulmonary bypass with hypothermia, neurocutaneous syndromes, schizophrenia, neurodegenerative diseases

**RELATED DISORDERS**

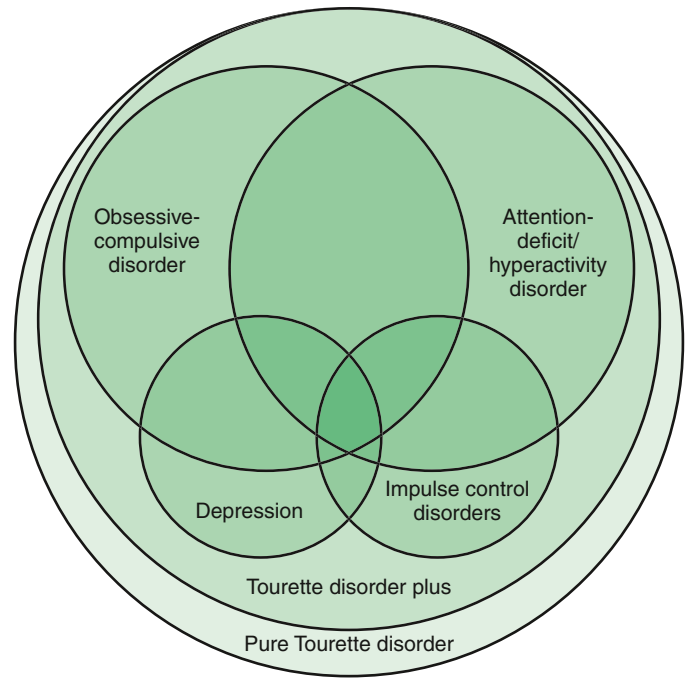
- Stereotypies/habits/mannerisms
- Self-injurious behaviors
- Motor restlessness
- Akathisia
- Compulsions
- Hyperekplexia
- Jumping Frenchman (startle response)

PANS, Pediatric acute neuropsychiatric syndrome.

Modified from Jankovic J. Differential diagnosis and etiology of tics. In: Cohen DJ, Goetz CG, Jankovic J, eds. Tourette Syndrome. Lippincott Williams & Wilkins, 2001:Table 2.2, p. 18.

Referral to a *behavioral treatment specialist* should be considered when tics are distressing or functionally impairing. The behavioral interventions with the strongest empirical support are habit reversal therapy (HRT) and comprehensive behavioral intervention for tics (CBIT). The basic components of HRT include premonitory urge awareness training and building a competing response to the urge to tic (Table 37.4). Based on HRT, CBIT additionally includes relaxation training and a functional intervention designed to mitigate against tic-generating situations. A course of HRT/CBIT treatment typically takes several months or 8-10 sessions. CBIT has been found to reduce significantly the severity of tics compared to education and supportive therapy.

Medications should be considered when the tics are causing severe impairment in the quality of life or when psychiatric comorbidities are present. The only U.S. Food and Drug Administration (FDA)-approved medications to treat TD in children and adolescents are



**Fig. 37.1** Schematic representation of the behavioral spectrum in Tourette disorder. The size of each area is proportional to the estimated prevalence of the symptoms; the background color intensity is proportional to the complexity of the clinical presentation. (From Cavanna AE, Seri S. Tourette's syndrome. *BMJ*. 2013;347:f4964.)

two first-generation antipsychotics (haloperidol, pimozide) and one second-generation antipsychotic (aripiprazole).  $\alpha$ -Agonists (clonidine, guanfacine) are also considered as first-line agents because of their more favorable side effect profile compared with the antipsychotic medications (see Chapter 33).

Youths with tic disorders may benefit from SSRIs for the treatment of comorbid obsessive-compulsive, anxiety, or depressive disorders. Augmentation of SSRIs with an atypical antipsychotic has been a consideration in patients with concurrent tic disorders and OCD responding poorly to an SSRI alone. The presence of tics does not preclude the use of stimulants to address comorbid ADHD. Treatment of tics and comorbid ADHD with a combination of  $\alpha$ -agonists and stimulants (e.g., clonidine with methylphenidate) decreases tics. Close clinical monitoring is required for possible exacerbation of tics during stimulant treatment. Anger and rage outbursts are common particularly among youth with severe tics (up to 80% in clinically referred samples). Behavioral therapies (cognitive-behavioral therapy [CBT], parent management training; see Chapter 34) that address anger management may be useful.

A systematic review indicated high confidence of efficacy for CBIT; moderate confidence for medications, such as haloperidol, risperidone, aripiprazole, clonidine; and low confidence for medications, such as ziprasidone, guanfacine, and topiramate. No evidence exists to differentiate the effectiveness of HRT/CBIT alone vs combined with pharmacotherapy as tic disorder treatment options. There is no rigorous scientific evidence to support the use of deep brain stimulation, repetitive magnetic stimulation, or dietary supplements in the treatment of TD or PTD.

In severe presentations, pediatric practitioners should consider seeking consultations from and/or making referrals to pediatric tic disorder specialists (i.e., behavioral psychologist, pediatric neurologist, developmental-behavioral pediatrician, or child and adolescent psychiatrist) in determining a treatment regimen.



## 37.2 Stereotypic Movement Disorder

Jung Won Kim, Heather J. Walter, and David R. DeMaso

Stereotypic movement disorder (SMD) is defined in DSM-5 as a neurodevelopmental disorder characterized by repetitive, seemingly driven, and apparently purposeless motor behavior (*stereotypy*) that interferes with social, academic, or other activities and may result in self-injury. The onset of SMD is the early developmental period (often before age 3 years), and the symptoms are not attributable to the physiologic effects of a substance or neurologic condition and are not better explained by another neurodevelopmental or mental disorder. The disorder is considered *mild* if symptoms are easily suppressed by sensory stimulation or distraction, and *severe* if continuous monitoring and protective measures are required to prevent serious injury, with *moderate* falling between mild and severe.

### DESCRIPTION

Examples of stereotypic movements include hand shaking or waving, body rocking, head banging, self-biting, and hitting one's own body. The presentation depends on the nature of the stereotypic movement and level of the child's awareness of the behavior. Among typically developing children, the repetitive movements may be stopped when attention is directed to the movements or when the child is distracted from performing them. Among youth with intellectual disability, the behaviors may be less responsive to such efforts. Each individual presents with their own uniquely patterned behavior. Stereotypic movements may occur many times during a day, lasting a few seconds to several minutes or longer. The behaviors may occur in multiple contexts, including when the individual is excited, stressed, fatigued, or bored.

### CLINICAL COURSE

Stereotypic movements typically begin before age 3 years. In those who develop complex motor stereotypies, the great majority exhibit these symptoms before 24 months. In most typically developing youth, these movements resolve over time. Among those with intellectual disability, the stereotyped behaviors may persist for years, although the pattern may change over time.

### EPIDEMIOLOGY

*Simple* stereotypic movements are common in typically developing young children. Some children may bang their head on their mattress as they are falling asleep or may sit and rock when bored or overstimulated. Self-injurious habits, such as self-biting or head banging, can occur in up to 25% of typically developing toddlers (often during tantrums), but they are *almost invariably* associated with developmental delay in youth older than 5 years. *Complex* stereotypic movements are much less common (approximately 3–4%). Between 4% and 16% of patients with intellectual disability engage in stereotypic movements.

### COMORBIDITY

Stereotypic movements are a common manifestation of a variety of neurogenetic disorders, such as Lesch-Nyhan, Rett, fragile X, Cornelia de Lange, and Smith-Magenis syndromes.

### DIFFERENTIAL DIAGNOSIS

According to DSM-5, stereotypic movements must be differentiated from normal development, ASDs, tic disorders, OCDs, and other neurologic/medical conditions. Simple stereotypic movements occurring in the context of typical development usually resolve with age. Stereotypic movements may be a presenting symptom of ASD, but SMD does not include the deficits in the social communication characteristic of ASD. When ASD is present, SMD is diagnosed only

when there is self-injury or when the stereotypic behaviors are sufficiently severe to become a focus of treatment. Typically, SMD has an earlier age of onset than the tic disorders. SMD is distinguished from OCD by the absence of obsessions as well as the nature of the repetitive behaviors, which in OCD are purposeful (e.g., in response to obsessions). The diagnosis of stereotypic movements requires the exclusion of mannerisms, paroxysmal dyskinesias, and benign hereditary chorea. A neurologic history and examination are required to assess features suggestive of other disorders, such as myoclonus, dystonia, and chorea.

### ETIOLOGY

There is a possible evolutionary link between repetitive abnormal grooming-like behaviors and early human experience with adversity. Brain regions implicated in this model (e.g., amygdala, hippocampus) are those involved in navigating human experience through unpredictable, anxiety-provoked emotional states, as well as regions (e.g., nucleus accumbens) related to pleasure and reward seeking. The latter involves the hypothesis that individuals experience some level of gratification from performing the stereotypic behavior.

Social isolation with insufficient stimulation (e.g., severe neglect) is a risk factor for self-stimulation that may progress into stereotypies, particularly repetitive rocking or spinning. Environmental stress may trigger stereotypic behaviors. Repetitive self-injurious behavior may be a behavioral phenotype in neurogenetic syndromes (e.g., Lesch-Nyhan, Rett, and Cornelia de Lange syndromes). Lower cognitive functioning is also linked to greater risk of stereotypic behaviors.

### TREATMENT

The initial approach to mild stereotypy is for the primary caretakers to ignore the undesired behavior, encourage substitute behavior, and not convey worry to their child. These behaviors may disappear with time and elimination of attention in young children. However, in children with intellectual disability or ASDs, stereotypies may be more refractory to treatment than in typically developing children and may necessitate referral to a behavioral psychologist, developmental-behavioral pediatrician, or child and adolescent psychiatrist for behavioral and/or psychopharmacologic management. The pediatric practitioner should consider and rule out neglect of the child, which can be associated with repetitive rocking, spinning, or other stereotypic movements.

Behavior therapy is the mainstay of treatment, using a variety of strategies, including habit reversal, relaxation training, self-monitoring, contingency management, competing responses, and negative practice. The environment should also be modified to reduce risk of injury to those engaging in self-injurious behavior.

Atypical antipsychotic medications may be helpful in reducing stereotypic movements in youth with ASD. Patients with anxiety and obsessive-compulsive behaviors treated with SSRIs may show improvement in their stereotypic movements.

### HABITS

Habits involve an action or pattern of behavior that is repeated often. Habits are common in childhood and range from usually benign and transient behaviors (e.g., thumb sucking, nail biting) to more problematic (e.g., trichotillomania, bruxism). In DSM-5, habits are not included as a diagnostic category because they are not viewed as disorders causing clinically significant distress or impairment in functioning. When they do cause distress or impairment or are associated with repeated attempts by the individual to stop the behavior they are discussed as body-focused repetitive behavior disorder. HRT has been effective as a first-line treatment approach (see Table 37.4).

**Table 37.4** Components of Habit Reversal Training**INCREASE INDIVIDUAL'S AWARENESS OF HABIT**

Response description—have individual describe behavior to therapist in detail while reenacting the behavior and looking in a mirror.

Response detection—inform individual of each occurrence of the behavior until each occurrence is detected without assistance.

Early warning—have individual practice identifying earliest signs of the target behavior.

Situation awareness—have individual describe all situations in which the target behavior is likely to occur.

**TEACH COMPETING RESPONSE TO HABIT**

The competing response must result in isometric contraction of muscles involved in the habit, be capable of being maintained for 3 min, and be socially inconspicuous and compatible with normal ongoing activities but incompatible with the habit (e.g., clenching one's fist, grasping and clenching an object). For vocal tics and stuttering, deep relaxed breathing with a slight exhale before speech has been used as the competing response.

**SUSTAIN COMPLIANCE**

Habit inconvenience review—have individual review in detail all problems associated with target behavior.

Social support procedure—family members and friends provide high levels of praise when a habit-free period is noted.

Public display—individual demonstrates to others that he or she can control the target behavior in situations in which the behavior occurred in the past.

**FACILITATE GENERALIZATION—SYMBOLIC REHEARSAL PROCEDURE**

For each situation identified in situation awareness procedure, individual imagines himself or herself beginning the target behavior but stopping and engaging in the competing response.

From Carey WB, Crocker AC, Coleman WL, et al., eds. *Developmental-Behavioral Pediatrics*. 4th ed. Philadelphia: Saunders; 2009:639.

**Thumb Sucking**

Thumb sucking is common in infancy and occurring in as many as 25% of children age 2 years and 15% of children age 5 years. Thumb sucking beyond 5 years of age may be associated with sequelae (e.g., paronychia, anterior open bite). As with other rhythmic patterns of behavior, thumb sucking is self-soothing. Basic behavioral management, including encouraging parents to ignore thumb sucking and instead focus on praising the child for substitute behaviors, is often an effective treatment. Simple reminders and reinforcers can also be considered; giving the child a sticker or other reward for each block of time that they do not thumb suck. In rare cases, mechanical devices placed on the thumb or in the mouth to prevent thumb sucking or noxious agents (bitter salves) placed on the thumb may be part of the treatment plan.

**Bruxism**

Bruxism or teeth grinding is common (5–30% of children), can begin in the first 5 years of life, and may be associated with daytime anxiety. Persistent bruxism can manifest as muscular or temporomandibular joint pain. Untreated bruxism can cause problems with dental occlusion. Helping the child find ways to reduce anxiety might relieve the problem; bedtime can be made more relaxing by reading or talking with the child and allowing the child to discuss fears. Praise and other emotional support are useful. Persistent bruxism requires referral to a dentist given the risk for dental occlusion.

Visit Elsevier eBooks+ at [eBooks.Health.Elsevier.com](http://eBooks.Health.Elsevier.com) for Bibliography.

## Chapter 38

**Anxiety Disorders,  
Obsessive-Compulsive  
Disorder, and Post-  
traumatic Stress Disorder**

Rosa K. Kim

Anxiety is not necessarily pathologic, is seen across the life span, and can be adaptive (e.g., the anxiety one might feel during life-threatening situations). It has both a cognitive-behavioral component, expressed in worrying and wariness, and a physiologic component, mediated by the autonomic nervous system. Anxiety is characterized as *pathologic* (e.g., a disorder) when it becomes disabling, interferes with social interactions, or derails normal development.

Anxiety disorders are some of the most common psychiatric disorders in childhood. The point prevalence worldwide is nearly 7%, and the estimated lifetime prevalence in the United States is approximately 20–30%. Anxiety disorders are often comorbid with other psychiatric and medical disorders, and they can have physical manifestations, such as weight loss, palpitations, tremors, muscle cramps, paresthesias, hyper-reflexia, and abdominal distress (Table 38.1). Although onset can be acute, the course is generally chronic with periods of fluctuating severity. The potential consequences of untreated anxiety include impairments in social, educational, and overall functioning. Because anxiety is both a normal phenomenon and, when highly activated, strongly associated with impairment, the clinician is tasked with differentiating between normal anxiety and abnormal anxiety across development (Fig. 38.1).

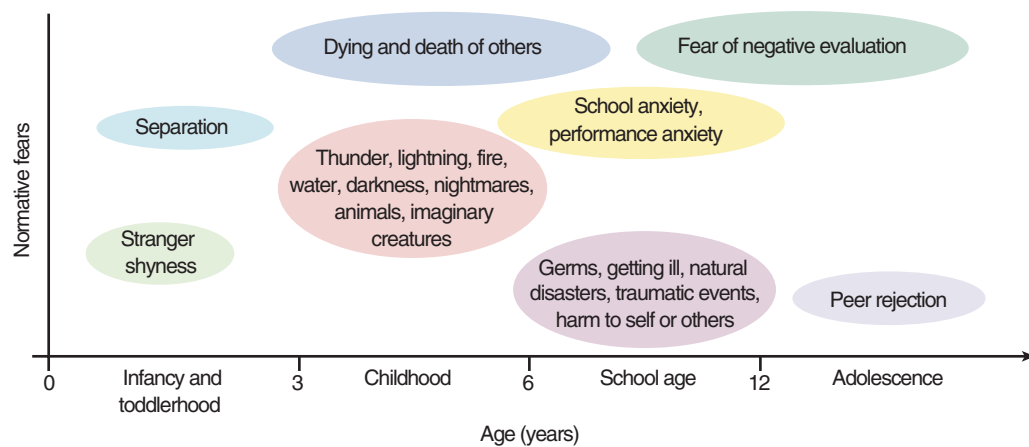
The median age of onset is 11 years. However, there are known periods of typical onset during specific developmental phases for both normal and pathologic anxiety. Normal stranger anxiety begins around 7–9 months of age. Preschoolers typically have specific fears related to the dark, animals, and imaginary situations. **Separation anxiety** can occur during the preschool years. Although most school-aged children abandon the imaginary fears of early childhood, some replace them with fears of bodily harm or other worries, reaching the level of a **specific phobia** (Table 38.2). Some characteristics of obsessive-compulsive disorder (OCD) can be considered typical in early school-ages, but OCD often has its onset in the mid-school-aged years (Table 38.3). **Social anxiety** occurs in later grade-school ages and early adolescence (Table 38.4) as the value of peer relationships increases. **Generalized anxiety, panic, and agoraphobia** tend to occur during the teen and young adult years (Tables 38.5 to 38.7).

Genetic or temperamental factors contribute more to the development of some anxiety disorders, whereas environmental factors are closely linked to the cause of others. Specifically, behavioral inhibition (sensitivity to novel stimuli) appears to be a heritable tendency and is linked with social phobia, generalized anxiety, and selective mutism. OCD and other disorders associated with OCD-like behaviors, such as Tourette syndrome and other tic disorders, tend to have high genetic risk as well (see Chapter 37.1). Environmental factors, such as parent-infant attachment and exposure to trauma, contribute more to **separation anxiety disorder** and posttraumatic stress disorder (PTSD) (Table 38.8). Parental anxiety disorder is associated with an increased risk of anxiety disorder in offspring.

**Table 38.1** Mental and Somatic Disorders that are Frequently Comorbid or Difficult to Distinguish in Anxiety Disorder

EXAMPLES OF OVERLAPPING SYMPTOMS		KEY CLINICAL INSIGHTS TO RECOGNIZE
<b>MENTAL DISORDERS</b>		
Major depressive disorder	Fatigue, anxiety, worry, or agitation	Major depressive disorder is the highest comorbidity in anxiety disorder and associated with higher severity, suicidality, disability and chronicity; clinicians must comprehensively assess because major depressive disorder comorbidity requires more intensive pharmacologic treatment and a different form of psychotherapy treatment (e.g., cognitive-behavioral therapy for depression rather than for anxiety disorder)
Bipolar disorder	Agitation, irritability, or racing thoughts	Anxiety is often present in bipolar disorder and is associated with rapid cycling; targeting anxiety could aid in mood stabilization; bipolar disorder requires focus on mood stabilization and considerate use of medication, which could induce mania (especially antidepressants)
Obsessive-compulsive disorder*	Extreme worry or inability to relax	People who have obsessive-compulsive disorder engage in ritualistic, repetitive behavior to deal with their fears, which is absent in anxiety disorder; these people often realize that their behavior is irrational and inappropriate
Posttraumatic stress disorder*	Avoidance, hyperarousal, or anxiety-laden intrusive memories	The intense experience of anxiety in posttraumatic stress disorder is specifically in response to a psychologic trauma (e.g., abuse, war, or accident); specific psychotherapies focused on the trauma associated with the posttraumatic stress disorder should be used
Health anxiety* (hypochondriasis)	Anxiety or worry from bodily responses	Anxiety is specifically related to preoccupation with having or acquiring a serious, undiagnosed medical illness
Substance use (e.g., illicit drugs, alcohol, or benzodiazepines) disorder	Tremor, sweating, palpitations, or panic attacks (during withdrawal or in some cases intoxication)	When suspected, clinicians should conduct a psychiatric interview of substance use disorders, with potential breath, urine, or plasma drug screening; comorbidity of alcohol or benzodiazepine abuse with anxiety disorder is considerable
<b>SOMATIC DISORDERS</b>		
Cardiac disease	Chest pain or palpitations (which is also common in panic disorder)	Clinical evaluation, including electrocardiogram, assessment of plasma troponin concentration, or Holter monitoring
Thyroid disease (e.g., hyperthyroidism)	Palpitations, tremor, panic attacks, or persistent anxiety	Laboratory assessment of plasma thyroid-stimulating hormone
Respiratory disease (e.g., asthma)	Shortness of breath	Clinical evaluation with a pulmonary function test
Pheochromocytoma or other disorders that result in sudden blood pressure increase	Panic attacks or bodily sensations	Blood pressure monitoring over 24 hr or hormone assessment (e.g., in blood or urine)
Epilepsy	Anxiety symptoms as part of aura or start of seizure	Clinical evaluation or neurologic referral when the causes of symptoms are unclear

\*In previous classifications of the *Diagnostic and Statistical Manual of Mental Disorders* and *International Classification of Diseases*, these disorders were included in the classification of anxiety disorders. In current classifications (e.g., the fifth edition of the *Diagnostic and Statistical Manual of Mental Disorders* and the 11th edition of the *International Classification of Diseases*), they are integrated in different classifications.  
 From Penninx BWJH, Pine DS, Holmes EA, Reif A. Anxiety disorders. *Lancet*. 2021;397:914–926:Table 2, p. 917.



**Fig. 38.1** Normative fears throughout childhood and adolescence. (From Craske MG, Stein MB. *Anxiety*. *Lancet*. 2016;388[10063]:3048–3059.)

**Table 38.2** DSM-5 Diagnostic Criteria for Specific Phobia

- A. Marked fear or anxiety about a specific object or situation (e.g., flying, heights, animals, receiving an injection, seeing blood).  
*Note:* In children, the fear or anxiety may be expressed by crying, tantrums, freezing, or clinging.
- B. The phobic object or situation almost always provokes immediate fear or anxiety.
- C. The phobic object or situation is actively avoided or endured with intense fear or anxiety.
- D. The fear or anxiety is out of proportion to the actual danger posed by the specific object or situation and to the sociocultural context.
- E. The fear, anxiety, or avoidance is persistent, typically lasting for 6 mo or more.
- F. The fear, anxiety, or avoidance causes clinically significant distress or impairment in social, occupational, or other important areas of functioning.
- G. The disturbance is not better explained by the symptoms of another mental disorder, including fear, anxiety, and avoidance or situations associated with panic-like symptoms or other incapacitating symptoms (as in agoraphobia); objects or situations related to obsessions (as in obsessive-compulsive disorder); reminders of traumatic events (as in posttraumatic stress disorder); separation from home or attachment figures (as in separation anxiety disorder); or social situations (as in social anxiety disorder).

Specify if:

Code based on the phobic stimulus:

- Animal** (e.g., spiders, insects, dogs).
- Natural environment** (e.g., heights, storms, water).
- Blood-injection-injury** (e.g., needles, invasive medical procedures).
- Situational** (e.g., airplanes, elevators, enclosed places).
- Other** (e.g., situations that may lead to choking or vomiting; in children, e.g., loud sounds or costumed characters).

From the *Diagnostic and Statistical Manual of Mental Disorders*, 5th ed. pp 197–198. Copyright 2013. American Psychiatric Association.

**Table 38.4** DSM-5 Diagnostic Criteria for Social Anxiety Disorder (Social Phobia)

- A. Marked fear or anxiety about one or more social situations in which the individual is exposed to possible scrutiny by others. Examples include social interactions (e.g., having a conversation, meeting unfamiliar people), being observed (e.g., eating or drinking), and performing in front of others (e.g., giving a speech).
- B. The individual fears that he or she will act in a way or show anxiety symptoms that will be negatively evaluated (i.e., will be humiliating or embarrassing; will lead to rejection or offend others).
- C. The social situations almost always provoke fear or anxiety.  
*Note:* In children, the fear or anxiety may be expressed by crying, tantrums, freezing, clinging, shrinking, or failing to speak in social situations.
- D. The social situations are avoided or endured with intense fear or anxiety.
- E. The fear or anxiety is out of proportion to the actual threat posed by the social situation and to the sociocultural context.
- F. The fear, anxiety, or avoidance is persistent, typically lasting for 6 mo or more.
- G. The fear, anxiety, or avoidance causes clinically significant distress or impairment in social, occupational, or other important areas of functioning.
- H. The fear, anxiety, or avoidance is not attributable to the physiologic effects of a substance (e.g., a drug of abuse, a medication) or another medical condition.
- I. The fear, anxiety, or avoidance is not better explained by the symptoms of another mental disorder, such as panic disorder, body dysmorphic disorder, or autism spectrum disorder.
- J. If another medical condition (e.g., Parkinson disease, obesity, disfigurement from burns or injury) is present, the anxiety or avoidance is clearly unrelated or is excessive.

Specify if:

**Performance only:** If the fear is restricted to speaking or performing in public.

From the *Diagnostic and Statistical Manual of Mental Disorders*, 5th ed. pp 202–203. Copyright 2013. American Psychiatric Association.

**Table 38.3** DSM-5 Diagnostic Criteria for Obsessive-Compulsive Disorder

- A. Presence of obsessions, compulsions, or both:  
 Obsessions are defined by (1) and (2):
1. Recurrent and persistent thoughts, urges, or images that are experienced, at some time during the disturbance, as intrusive and unwanted, and that in most individuals cause marked anxiety or distress.
  2. The individual attempts to ignore or suppress such thoughts, urges, or images, or to neutralize them with some other thought or action (i.e., by performing a compulsion).
- Compulsions are defined by (1) and (2):
1. Repetitive behaviors (e.g., handwashing, ordering, checking) or mental acts (e.g., praying, counting, repeating words silently) that the individual feels driven to perform in response to an obsession or according to rules that must be applied rigidly.
  2. The behaviors or mental acts are aimed at preventing or reducing anxiety or distress, or preventing some dreaded event or situation; however, these behaviors or mental acts are not connected in a realistic way with what they are designed to neutralize or prevent, or are clearly excessive.
- B. The obsessions or compulsions are time-consuming (e.g., take more than 1 hr/day) or cause clinically significant distress or impairment in social, occupational, or other important areas of functioning.
- C. The obsessive-compulsive symptoms are not attributable to the physiologic effects of a substance (e.g., a drug of abuse, a medication) or another medical condition.
- D. The disturbance is not better explained by the symptoms of another mental disorder (e.g., excessive worries, as in generalized anxiety disorder; preoccupation with appearance, as in body dysmorphic disorder; difficulty discarding or parting with possessions, as in hoarding disorder; hair pulling, as in trichotillomania [hair-pulling disorder]; skin picking, as in excoriation [skin-picking] disorder; stereotypies, as in stereotypic movement disorder; ritualized eating disorder, as in eating disorders; preoccupation with substances or gambling, as in substance-related and addictive disorders; preoccupation with having an illness, as in illness anxiety disorder; sexual urges or fantasies, as in paraphilic disorders; impulses, as in disruptive, impulse-control, and conduct disorders; guilty ruminations, as in schizophrenia spectrum and other psychotic disorders; or repetitive patterns of behavior, as in autism spectrum disorder).

Specify if:

**With good or fair insight:** The individual recognizes that obsessive-compulsive disorder beliefs are definitely or probably not true or that they may or may not be true.

**With poor insight:** The individual thinks obsessive-compulsive disorder beliefs are probably true.

**With absent insight/delusional beliefs:** The individual is completely convinced that obsessive-compulsive disorder beliefs are true.

Specify if:

**Tic-related:** The individual has a current or past history of a tic disorder.

From the *Diagnostic and Statistical Manual of Mental Disorders*, 5th ed. p 237. Copyright 2013. American Psychiatric Association.



**Table 38.5** DSM-5 Diagnostic Criteria for Generalized Anxiety Disorder

- A. Excessive anxiety and worry (apprehensive expectation), occurring more days than not for at least 6 mo, about a number of events or activities (such as work or school performance).
- B. The individual finds it difficult to control the worry.
- C. The anxiety and worry are associated with three (or more) of the following six symptoms (with at least some symptoms having been present for more days than not for the past 6 mo):
- Note: Only one item is required in children.
1. Restlessness or feeling keyed up or on edge.
  2. Being easily fatigued.
  3. Difficulty concentrating or mind going blank.
  4. Irritability.
  5. Muscle tension.
  6. Sleep disturbance (difficulty falling or staying asleep, or restless, unsatisfying sleep).
- D. The anxiety, worry, or physical symptoms cause clinically significant distress or impairment in social, occupational, or other important areas of functioning.
- E. The disturbance is not attributable to the physiologic effects of a substance (e.g., a drug of abuse, a medication) or other medical condition (e.g., hyperthyroidism).
- F. The disturbance is not better explained by another mental disorder (e.g., anxiety or worry about having panic attacks in panic disorder, negative evaluation in social anxiety disorder [social phobia], contamination or other obsessions in obsessive-compulsive disorder, separation from attachment figures in separation anxiety disorder, reminders of traumatic events in posttraumatic stress disorder, gaining weight in anorexia nervosa, physical complaints in somatic symptom disorder, perceived appearance flaws in body dysmorphic disorder, having a serious illness in illness anxiety disorder, or the content of delusional beliefs in schizophrenia or delusional disorder).

From the *Diagnostic and Statistical Manual of Mental Disorders*, 5th ed. p 222. Copyright 2013. American Psychiatric Association.

## ASSESSMENT

There is no recommendation for routine screening of children and adolescents for anxiety disorders. Freely available general screening instruments such as the Pediatric Symptom Checklist and Strengths and Difficulties Questionnaire can be used to identify anxiety concerns in primary care and school settings. Rating scales can be used to support diagnosis and to follow response to treatment, but they are not diagnostic on their own. Commonly used anxiety rating scales include the Screen for Child Anxiety Related Emotional Disorders (SCARED), the Spence Children's Anxiety Scale (SCAS), the Preschool Anxiety Scale, the Generalized Anxiety Disorder-7 (GAD-7), and the Patient Reported Outcomes Measurement Information System (PROMIS) Pediatric Short Form-Anxiety-8a.

Symptoms of anxiety are typically identified through the clinical interview by asking questions about “worries,” “fears,” and “stress” or by the patient and family's spontaneous report. The interview must be developmentally sensitive, and further discussions with the family may reveal environmental reinforcements, including the caregiver's parenting style and enabling of avoidance behaviors.

Because some degree of anxiety is considered normal, it is important to clarify when the symptom severity reaches the point of being pathologic and to differentiate between the subtypes (Table 38.9). The *Diagnostic and Statistical Manual of Mental Disorders, Fifth Edition* (DSM-5) has specific criteria for each type of anxiety with requirements for frequency, duration, and extent of functional impairment.

## DIFFERENTIAL DIAGNOSIS AND COMORBIDITIES

In addition to determining whether diagnostic criteria are met for a specific anxiety disorder, it is also crucial to rule out alternative explanations. The differential diagnosis includes numerous medical

**Table 38.6** DSM-5 Diagnostic Criteria for Panic Disorder

- A. Recurrent unexpected panic attacks. A panic attack is an abrupt surge of intense fear or intense discomfort that reaches a peak within minutes, and during which time four (or more) of the following symptoms occur:
- Note: The abrupt surge can occur from a calm state or an anxious state.
1. Palpitations, pounding heart, or accelerated heart rate.
  2. Sweating.
  3. Trembling or shaking.
  4. Sensations of shortness of breath or smothering.
  5. Feelings of choking.
  6. Chest pain or discomfort.
  7. Nausea or abdominal distress.
  8. Feeling dizzy, unsteady, light-headed, or faint.
  9. Chills or heat sensations.
  10. Paresthesias (numbness or tingling sensations).
  11. Derealizations (feeling or unreality) or depersonalization (being detached from oneself).
  12. Fear of losing control or “going crazy.”
  13. Fear of dying.
- Note: Culture-specific symptoms (e.g., tinnitus, neck soreness, headache, uncontrollable screaming or crying) may be seen. Such symptoms should not count as one of the four required symptoms.
- B. At least one of the attacks has been followed by 1 mo (or more) of one or both of the following:
1. Persistent concern or worry about additional panic attacks or their consequences (e.g., losing control, having a heart attack, “going crazy”).
  2. A significant maladaptive change in behavior related to the attacks (e.g., behaviors designed to avoid having panic attacks, such as avoidance of exercise or unfamiliar situations).
- C. The disturbance is not attributable to the physiologic effects of a substance (e.g., a drug of abuse, a medication) or another medical condition (e.g., hyperthyroidism, cardiopulmonary disorders).
- D. The disturbance is not better explained by another mental disorder (e.g., the panic attacks do not occur only in response to feared social situations, as in social anxiety disorder; in response to circumscribed phobic objects or situations, as in specific phobia; in response to obsessions, as in obsessive-compulsive disorder; or in response to reminders of traumatic events, as in posttraumatic stress disorder; or in response to separation from attachment figures, as in separation anxiety disorder).

From the *Diagnostic and Statistical Manual of Mental Disorders*, 5th ed. pp 208-209. Copyright 2013. American Psychiatric Association.

conditions and medication-induced anxiety (Table 38.10). Anxiety disorders also frequently occur with not just other anxiety subtypes but also other psychiatric comorbidities, notably depression and substance use disorders (Table 38.11; see Table 38.1).

## TREATMENT OF ANXIETY

### Cognitive-Behavioral Therapy (CBT)

**Cognitive-behavioral therapy (CBT)** is a therapy that targets the cognitions, behaviors, and physiologic symptoms of anxiety, with a particular focus on the interconnections between the three. Its framework typically involves homework assignments for practicing the skills in real-life environments. The goal is to achieve functional improvement within approximately 18 sessions. Because it is a skills-based treatment, CBT is thought to be a durable treatment, an important consideration when treating children and adolescents. It is specifically recommended to patients 6-18 years old with social anxiety, generalized anxiety, separation anxiety, specific phobia, and panic disorder.

Specialized training and experience are paramount to the effective delivery of this treatment modality, and it is worth taking the time to ensure that patients identify therapists with the training and experience to provide rigorous CBT. CBT typically should incorporate graduated exposure, in which stepwise mastery of a hierarchy of fearful stimuli results in desensitization.

**Table 38.7** DSM-5 Diagnostic Criteria for Agoraphobia

- A. Marked fear or anxiety about two (or more) of the following five situations:
1. Using public transportation (e.g., automobiles, buses, trains, ships, planes).
  2. Being in open spaces (e.g., parking lots, marketplaces, bridges).
  3. Being in enclosed places (e.g., shops, theaters, cinemas).
  4. Standing in line or being in a crowd.
  5. Being outside of the home alone.
- B. The individual fears or avoids these situations because of thoughts that escape might be difficult or help might not be available in the event of a developing panic-like symptoms or other incapacitating or embarrassing symptoms (e.g., fear or falling in the elderly, fear of incontinence).
- C. The agoraphobic situations almost always provoke fear or anxiety.
- D. The agoraphobic situations are actively avoided, require the presence of a companion, or are endured with intense fear or anxiety.
- E. The fear or anxiety is out of proportion to the actual danger posed by the agoraphobic situations and to the sociocultural context.
- F. The fear, anxiety, or avoidance is persistent, typically lasting for 6 mo or more.
- G. The fear, anxiety, or avoidance causes clinically significant distress or impairment in social, occupational, or other important area of functioning.
- H. If another medical condition (e.g., inflammatory bowel disease, Parkinson disease) is present, the fear, anxiety, or avoidance is clearly excessive.
- I. The fear, anxiety, or avoidance is not better explained by the symptoms or another mental disorder—for example, the symptoms are not confined to specific phobia or situational type; do not involve only social situations (as in social anxiety disorder); and are not related exclusively to obsessions (as in obsessive-compulsive disorder), reminders or traumatic events (as in posttraumatic stress disorder), or fear of separation (as in separation anxiety disorder).

Note: Agoraphobia is diagnosed irrespective of the presence of panic disorder. If an individual's presentation meets criteria for panic disorder and agoraphobia, both diagnoses should be assigned.

From the *Diagnostic and Statistical Manual of Mental Disorders*, 5th ed. pp 217-218. Copyright 2013. American Psychiatric Association.

**Table 38.8** DSM-5 Diagnostic Criteria for Posttraumatic Stress Disorder

#### POSTTRAUMATIC STRESS DISORDER

Note: The following criteria apply to adults, adolescents, and children older than 6 yr. For children 6 yr and younger, see corresponding criteria below.

- A. Exposure to actual or threatened death, serious injury, or sexual violence in one (or more) of the following ways:
1. Directly experiencing the traumatic event(s).
  2. Witnessing, in person, the event(s) as it occurred to others.
  3. Learning that the traumatic event(s) occurred to a close family member or close friend. In cases of actual or threatened death of a family member or friend, the event(s) must have been violent or accidental.
  4. Experiencing repeated or extreme exposure to aversive details of the traumatic event(s) (e.g., first responders collecting human remains; police officers repeatedly exposed to details of child abuse).

Note: Criterion A4 does not apply to exposure through electronic media, television, movies, or pictures, unless this exposure is work related.

- B. Presence of one (or more) of the following intrusion symptoms associated with the traumatic event(s), beginning after the traumatic event(s) occurred:

1. Recurrent, involuntary, and intrusive distressing memories of the traumatic event(s).

Note: In children older than 6 yr, repetitive play may occur in which themes or aspects of the traumatic event(s) are expressed.

2. Recurrent distressing dreams in which the content and/or effect of the dream are related to the traumatic event(s).

Note: In children, there may be frightening dreams without recognizable content.

3. Dissociative reactions (e.g., flashbacks) in which the individual feels or acts as if the traumatic event(s) were recurring. (Such reactions may occur on a continuum, with the more extreme expression being a complete loss or awareness of present surroundings.)

Note: In children, trauma-specific reenactment may occur in play.

4. Intense or prolonged psychological distress at exposure to internal or external cues that symbolize or resemble an aspect of the traumatic event(s).
5. Marked physiologic reactions to internal or external cues that symbolize or resemble an aspect of the traumatic event(s).

- C. Persistent avoidance of stimuli associated with the traumatic event(s), beginning after the traumatic event(s) occurred, as evidenced by one or both of the following:

1. Avoidance of or efforts to avoid distressing memories, thoughts, or feelings about or closely associated with the traumatic event(s).
2. Avoidance of or efforts to avoid external reminders (people, places, conversations, activities, objects, situations) that arouse distressing memories, thoughts, or feelings about or closely associated with the traumatic event(s).

- D. Negative alterations in cognitions and mood associated with the traumatic event(s), beginning or worsening after the traumatic event(s) occurred, as evidenced by two (or more) of the following:

1. Inability to remember an important aspect of the traumatic event(s) (typically due to dissociative amnesia and not to other factors such as head injury, alcohol, or drugs).
2. Persistent and exaggerated negative beliefs or expectations about oneself, others, or the world (e.g., "I am bad," "No one can be trusted," "The world is completely dangerous," "My whole nervous system is permanently ruined").
3. Persistent, distorted cognitions about the cause or consequences of the traumatic event(s) that lead the individual to blame himself/herself or others.
4. Persistent negative emotional state (e.g., fear, horror, anger, guilt, or shame).
5. Markedly diminished interest or participation in significant activities.

**Table 38.8** DSM-5 Diagnostic Criteria for Posttraumatic Stress Disorder—cont'd

- 6. Feelings of detachment or estrangement from others.
  - 7. Persistent inability to experience positive emotions (e.g., inability to experience happiness, satisfaction, or loving feelings).
  - E. Marked alterations in arousal and reactivity associated with the traumatic event(s), beginning or worsening after the traumatic event(s) occurred, as evidenced by two (or more) of the following:
    - 1. Irritable behavior and angry outbursts (with little or no provocation) typically expressed by verbal or physical aggression toward people or objects.
    - 2. Reckless or self-destructive behavior.
    - 3. Hypervigilance.
    - 4. Exaggerated startle response.
    - 5. Problems with concentration.
    - 6. Sleep disturbance (e.g., difficulty falling or staying asleep or restless sleep).
  - F. Duration of the disturbance (Criteria B, C, D, and E) is more than 1 mo.
  - G. The disturbance causes clinically significant distress or impairment in social, occupational, or other important areas of functioning.
  - H. The disturbance is not attributable to the physiologic effects of a substance (e.g., medication, alcohol) or another medical condition.
- Specify whether:
- With dissociative symptoms:** The individual's symptoms meet the criteria for posttraumatic stress disorder, and in addition, in response to the stressor, the individual experiences persistent or recurrent symptoms of either of the following:
- 1. **Depersonalization:** Persistent or recurrent experiences of feeling detached from, and as if one were an outside observer of, one's mental processes or body (e.g., feeling as though one were in a dream; feeling a sense of unreality of self or body or of time moving slowly).
  - 2. **Derealization:** Persistent or recurrent experiences of unreality of surroundings (e.g., the world around the individual is experienced as unreal, dreamlike, distant, or distorted).
- Note: To use this subtype, the dissociative symptoms must not be attributable to the physiologic effects of a substance (e.g., blackouts, behavior during alcohol intoxication) or another medical condition (e.g., complex partial seizures).
- Specify if:
- With delayed expression:** If the full diagnostic criteria are not met until at least 6 mo after the event (although the onset and expression of some symptoms may be immediate).

**POSTTRAUMATIC STRESS DISORDER FOR CHILDREN 6 YEARS AND YOUNGER**

- A. In children 6 yr and younger, exposure to actual or threatened death, serious injury, or sexual violence in one (or more) of the following ways:
  - 1. Directly experiencing the traumatic event(s).
  - 2. Witnessing, in person, the event(s) as it occurred to others, especially primary caregivers.

Note: Witnessing does not include events that are only in electronic media, television, movies, or pictures.

  - 3. Learning that the traumatic event(s) occurred to a parent or caregiving figure.
- B. Presence of one (or more) of the following intrusion symptoms associated with the traumatic event(s), beginning after the traumatic event(s) occurred:
  - 1. Recurrent, involuntary, and intrusive distressing memories of the traumatic event(s).

Note: Spontaneous and intrusive memories may not necessarily appear distressing and may be expressed as play reenactment.

  - 2. Recurrent distressing dreams in which the content and/or effect of the dream is related to the traumatic event(s).

Note: It may not be possible to ascertain that the frightening content is related to the traumatic event.

  - 3. Dissociative reactions (e.g., flashbacks) in which the child feels or acts as if the traumatic event(s) were recurring. (Such reactions may occur on a continuum, with the most extreme expression being a complete loss of awareness of present surroundings.) Such trauma-specific reenactment may occur in play.
  - 4. Intense or prolonged psychological distress at exposure to internal or external cues that symbolize or resemble an aspect of the traumatic event(s).
- C. One (or more) of the following symptoms, representing either persistent avoidance of stimuli associated with the traumatic event(s) or negative alterations in cognitions and mood associated with the traumatic event(s), must be present, beginning after the event(s) or worsening after the event(s):

**PERSISTENT AVOIDANCE OF STIMULI**

- 1. Avoidance of or efforts to avoid activities, places, or physical reminders that arouse recollections or the traumatic event(s).
- 2. Avoidance of or efforts to avoid people, conversations, or interpersonal situations around recollections of the traumatic event(s).

**NEGATIVE ALTERATIONS IN COGNITIONS**

- 3. Substantially increased frequency of negative emotional states (e.g., fear, guilt, sadness, shame, confusion).
- 4. Markedly diminished interest or participation in significant activities, including constriction of play.
- 5. Socially withdrawn behavior.
- 6. Persistent reduction in expression of positive emotions.
- D. Alterations in arousal and reactivity associated with the traumatic event(s), beginning or worsening after the traumatic event(s) occurred, as evidenced by two (or more) of the following:
  - 1. Irritable behavior and angry outbursts (with little or no provocation), typically expressed as verbal and physical aggression toward people or objects (including extreme temper tantrums).
  - 2. Hypervigilance.
  - 3. Exaggerated startle response.
  - 4. Problems with concentration.
  - 5. Sleep disturbance (e.g., difficulty falling asleep or staying asleep or restless sleep).
- E. The duration of the disturbance is more than 1 mo.
- F. The disturbance causes clinically significant distress or impairment in relationships with parents, siblings, peers, or other caregivers or with school behavior.
- G. The disturbance is not attributable to the physiologic effects of a substance (e.g., medication or alcohol) or another medical condition.

Continued

**Table 38.8** DSM-5 Diagnostic Criteria for Posttraumatic Stress Disorder—cont'd

Specify whether:

**With dissociative symptoms:** The individual's symptoms meet the criteria for posttraumatic stress disorder, and the individual experiences persistent or recurrent symptoms of either of the following:

1. **Depersonalization:** Persistent or recurrent experiences of feeling detached from, and as if one were an outside observer of, one's mental processes or body (e.g., feeling as though one were in a dream; feeling a sense of unreality of self or body or of time moving slowly).
2. **Derealization:** Persistent or recurrent experiences of unreality of surroundings (e.g., the world around the individual is experienced as unreal, dreamlike, distant, or distorted).

**Note:** To use this subtype, the dissociative symptoms must not be attributable to the physiologic effects of a substance (e.g., blackouts, behavior during alcohol intoxication) or another medical condition (e.g., complex partial seizures).

Specify if:

**With delayed expression:** If the full diagnostic criteria are not met until at least 6 mo after the event (although the onset and expression of some symptoms may be immediate).

From the *Diagnostic and Statistical Manual of Mental Disorders*, 5th ed. pp 271-274. Copyright 2013. American Psychiatric Association.

**Table 38.9** Core Diagnostic Features and Characteristics for Anxiety Disorders

	<b>SELECTIVE MUTISM</b>	<b>SEPARATION ANXIETY</b>	<b>SPECIFIC PHOBIA</b>	<b>SOCIAL ANXIETY DISORDER</b>	<b>AGORAPHOBIA</b>	<b>PANIC DISORDER</b>	<b>GENERALIZED ANXIETY DISORDER</b>
Core emotions or cognitions	Consistent failure to speak in situations for which there is an expectation to speak, despite language competence	Unrealistic, persistent fear or anxiety about separation from, or loss of, attachment figure, or adverse events occurring to them	Marked, excessive, and unreasonable fear or anxiety of circumscribed objects or situations (e.g., animals, natural forces, blood injection, or places)	Marked, excessive, and unreasonable fear or anxiety of scrutiny or negative judgement by other people	Marked, excessive, and concerning fear of leaving home, entering closed or open public places, crowds, or transportation	Recurrent, unexpected panic attacks with sustained mental (e.g., fear, fear of losing control, or feeling of alienation) manifestations	Marked, uncontrollable, and anxious worry and fears about everyday events and problems
Physical symptoms	No physical symptoms	Nightmares and symptoms of distress	No physical symptoms	Blushing, fear of vomiting, urgency or fear of micturition or defecation	No physical symptoms	Multiple symptoms (e.g., palpitations, dyspnea, diaphoresis, chest pain, dizziness, paresthesia, or nausea)	Restlessness, fatigue, irritability, difficulty concentrating, muscle tension, sleep disturbance, or autonomic arousal
Behavior	Disturbance interferes with (educational) achievement or social communication	Reluctance to leave attachment figure; disturbance impairs social, school, or other functioning	Avoidance of circumscribed objects or situations; disturbance impairs social, school, work, or other functioning	Avoidance of social interactions and situations; disturbance impairs social, school, work, or other functioning	Avoidance of fear-inducing situations; disturbance impairs social, school, work, or other functioning	Changed behavior in maladaptive ways related to the attacks; disturbance impairs social, school, work or other functioning	Disturbance impairs social, school, work, or other functioning
Required symptom duration	>1 month (beyond first school month)	>1 mo (childhood; 4-18 yr); >6 months (adulthood; 18 yr or older)	>6 mo	>6 mo	>6 mo	>1 mo	>6 mo
Median age of onset	Childhood (<5 yr)	Childhood (around 6 yr)	Childhood (around 8 yr)	Early adolescence (around 13 yr)	Late adolescence (around 20 yr)	Adulthood (around 25 yr)	Adulthood (around 30 yr)

For OCD see Table 38.3; for PTSD see Table 38.8.

Characteristics and features for anxiety disorders were based on criteria from the *Diagnostic and Statistical Manual of Mental Disorders (Fifth Edition)* and *International Classification of Diseases (11th Edition)*.

From Penninx BWJH, Pine DS, Holmes EA, Reif A. Anxiety disorders. *Lancet*. 2021;397:914-926. Table 1, p. 915.



**Table 38.10** Differential Diagnosis of Anxiety Disorders

GENERAL	PSYCHIATRIC	MEDICAL
Shyness	Substance use (including caffeine) Substance use withdrawal Body dysmorphic disorder ADHD (distractibility, restlessness) ASD (social withdrawal, social skills deficits, distractibility) MDD (distractibility, insomnia, somatic symptoms) Bipolar disorder Delusional disorder Learning disorders (worry about school performance) ODD (refusal to do activity)	Antihistamines Bronchodilators Nasal decongestants Steroids Dietary supplements Stimulants Hyperthyroidism Allergic reactions Asthma Cardiac conditions Autoimmune encephalitis Chronic pain Headaches CNS disease Diabetes Dysmenorrhea Lead intoxication Hypoglycemia Hypoxia Pheochromocytoma Mast cell disorders Carcinoid syndrome Hereditary angioedema Systemic lupus erythematosus

**Table 38.11** Psychiatry and Medical Comorbidities of Anxiety

PSYCHIATRIC	MEDICAL
Depression	Somatic symptoms
ADHD	Headaches
Bipolar disorder	GI disorders
Eating disorder	Asthma
Learning disorder	Allergies
Language disorder	
Substance-related disorders	

component of treatment, and specific plans for anxiety management can be included in a child's 504 plan or individualized education plan (IEP).

The therapy with the most evidence for PTSD is a subtype of CBT called trauma-focused CBT (TF-CBT). Given that standard anxiety medications are less effective in PTSD, it is particularly crucial that clinicians refer these patients to trauma-focused therapy. In TF-CBT, the therapist amplifies stress management techniques in preparation for exposure-based interventions with the goal of achieving mastery over trauma triggers. In small adult trials, ketamine- or 3,4-methylenedioxymethamphetamine (MDMA)-assisted therapy have shown benefit. There is insufficient evidence to currently recommend either therapy.

### Selective Serotonin Reuptake Inhibitors

**Selective serotonin reuptake inhibitors (SSRIs)** as a class are effective in treating anxiety. The available options include citalopram, escitalopram, fluoxetine, fluvoxamine, paroxetine, sertraline, and vilazodone. Despite randomized clinical trials (RCTs) providing support for the safety and effectiveness of this medication class, no specific SSRIs are U.S. Food and Drug Administration (FDA)-approved for anxiety in children. SSRIs are generally well tolerated, with the most common side effects involving xerostomia, gastrointestinal upset, headache, somnolence or insomnia, dizziness, fatigue, and changes in appetite (see [Chapter 33](#)).

RCTs in children and adolescents with PTSD found no significant difference between SSRI and placebo. SSRIs may be considered in pediatric patients with PTSD who have comorbid conditions responsive to SSRIs, including depression, affective numbing, and anxiety (see [Table 33.5](#)).

All of the SSRIs carry a “black box” warning for suicidal thinking and behavior through age 24 years, and this specific risk must be discussed with the patient and caregiver and documented before initiation. Other potential adverse effects include behavioral activation, hypomanic or manic symptoms, and serotonin syndrome (see [Chapter 33](#)).

### Combination Treatment

The combination of CBT and an SSRI is generally thought to be better than either treatment alone for moderate to severe anxiety. It is important to continue recommending CBT even after the decision has been made to start pharmacologic treatment.

### Serotonin-Norepinephrine Reuptake Inhibitors

Duloxetine is a serotonin-norepinephrine reuptake inhibitor (SNRI) and has an FDA indication for the treatment of generalized anxiety disorder in children ages 7-17. However, it is still considered a second-line treatment as SSRIs tend to be more effective. The other SNRI options are venlafaxine and desvenlafaxine. Potential side effects of duloxetine include xerostomia, diaphoresis, abdominal discomfort, gastrointestinal distress, headache, tremor, sedation or insomnia, decreased appetite, and weight loss. Of note, it is less likely to cause behavioral activation than the SSRIs.

### α-Agonists

Clonidine and guanfacine are α-agonists and may be helpful for PTSD by targeting sleep disturbances like nightmares, persistent physiologic arousal, and exaggerated startle response.

### OBSESSIVE-COMPULSIVE DISORDER AND PEDIATRIC ACUTE-ONSET NEUROPSYCHIATRIC SYNDROME

Obsessive-compulsive symptoms can be effectively treated with SSRIs (sertraline, fluoxetine). If the patient's symptoms prove to be treatment-refractory to the standard options, then one might consider fluvoxamine and/or clomipramine, which is a heterocyclic antidepressant. These are indicated when a patient has failed two or more SSRI trials. Habit reversal training is an important nonpharmacologic treatment modality for OCD as well.

A proportion of *abrupt-onset OCD* cases are attributed to an immune response that targets the brain (pediatric acute-onset neuropsychiatric syndrome [PANS]). The immune response may be brought about by

**Table 38.12** Diagnostic Criteria for Pediatric Acute-Onset Neuropsychiatric Syndrome**CRITERION 1**

Abrupt, dramatic onset of obsessive-compulsive disorder or severely restricted food intake.

**CRITERION 2**

Concurrent presence of additional neuropsychiatric symptoms with similarly severe and acute onset from at least two of the following seven categories:

1. Anxiety.
2. Emotional lability or depression.
3. Irritability, aggression, or severely oppositional behaviors.
4. Behavioral (developmental) regression.
5. Deterioration in school performance.
6. Sensory or motor abnormalities.
7. Somatic signs and symptoms, including sleep disturbances, enuresis, or urinary frequency.

**CRITERION 3**

Symptoms are not better explained by a known neurologic or medical disorder, such as Sydenham chorea, systemic lupus erythematosus, Tourette disorder, autoimmune encephalitis, or others. The diagnostic workup of patients with suspected PANS must be comprehensive enough to rule out these and other relevant disorders. The nature of the co-occurring symptoms will dictate the necessary assessments, which may include MRI scans, lumbar puncture, electroencephalograms, or other diagnostic tests.

PANS, Pediatric acute-onset neuropsychiatric syndrome.

Modified from Johnson M, Fernell E, Preda I, et al. Paediatric acute-onset neuropsychiatric syndrome in children and adolescents: an observational cohort study. *Lancet Child Adolesc Health*. 2019;3(3):175–180.

infections (commonly, but not exclusively, streptococcal infections) or other mechanisms that activate the immune system.

There are no DSM-5 diagnostic criteria for PANS. One suggested approach to PANS diagnostic criteria is noted in Table 38.12. Of note is the *abrupt-sudden onset* of OCD, the presence of additional psychiatric disorders (e.g., anxiety, depression, emotional lability), and the requirement to rule out other disorders like Sydenham chorea.

If PANS is suspected, a comprehensive evaluation is warranted primarily to rule out neurologic and medical conditions (see Table 38.12). Children with an abrupt onset of psychiatric and neurologic findings should be evaluated with MRI, electroencephalogram (EEG), and blood plus cerebrospinal fluid (CSF) autoimmune encephalitis antibody testing. Children with a sudden onset of only psychiatric symptoms (OCD, tics, anxiety) do not require extensive testing except for testing for a group A streptococcus, unless they have severe and disabling psychiatric features. The latter group should be evaluated to rule out the disorders noted in Table 38.12. Once diagnosed, clinicians should prioritize the target symptoms of the individual patient and select treatments accordingly. The three realms of PANS treatment are psychotherapeutic, antimicrobial, and immunomodulatory. Because behavioral interventions take time to work, psychiatric interventions should begin expeditiously for symptomatic relief. Antibiotics may eliminate the underlying source of neuroinflammation, and immunomodulatory options can help treat immune system disturbances.

**SPECIFIC PHOBIAS**

Specific phobias may not typically require treatment with an SSRI and may be better targeted with *exposure response prevention* therapies and with *premedicating* with a  $\beta$  blocker before an anticipated exposure. The exception to this is needle phobia; premedication with a  $\beta$  blocker is not indicated in this instance because of the risk of exacerbating the vasovagal response. Physical maneuvers, such as crossing the legs and tensing the muscles, may be effective in needle phobia.

Visit Elsevier eBooks+ at [eBooks.Health.Elsevier.com](http://eBooks.Health.Elsevier.com) for Bibliography.

## Chapter 39

**Mood Disorders**

Colleen K. Manak and Rosa K. Kim

Mood disorders encompass several different entities on the spectrum between depression and mania. Mood disorders are interrelated sets of psychiatric symptoms characterized by a core deficit in emotional self-regulation. Classically, the mood disorders have been divided into depressive and bipolar disorders, representing the two emotional polarities, *dysphoric* (“low”) and *euphoric* (“high”) mood. Mood disorders in children and adolescents are highly prevalent and are the most common psychiatric illnesses seen after attention-deficit/hyperactivity disorder (ADHD) and anxiety. Primary care is often their first point of contact when seeking treatment.

**39.1 Depressive Disorders**

Colleen K. Manak and Rosa K. Kim

Depressive disorders include major depressive, persistent depressive, disruptive mood dysregulation, other specified/unspecified depressive, premenstrual dysphoric, and substance/medication-induced disorders, as well as depressive disorder caused by another medical condition (Fig. 39.1).

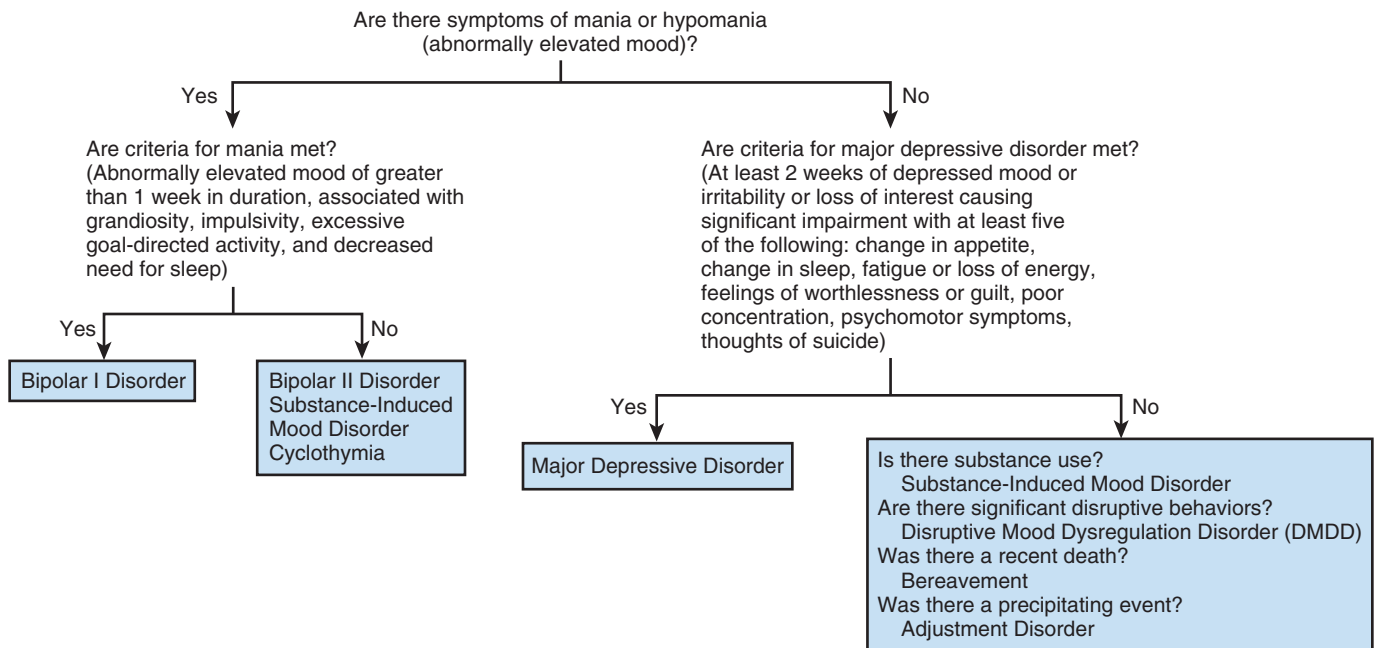
**DESCRIPTION**

**Major depressive disorder (MDD)** is characterized by a distinct period of at least 2 weeks (an *episode*) in which there is a depressed or irritable mood and/or loss of interest or pleasure in almost all activities that is present for most of the day, nearly every day (Table 39.1 and Fig. 39.2). Major depression is associated with characteristic vegetative and cognitive symptoms, including disturbances in appetite, sleep, energy, and activity level; impaired concentration; thoughts of worthlessness or guilt; and suicidal thoughts or actions. Major depression is considered *mild* if few or no symptoms in excess of those required to make the diagnosis are present, and the symptoms are mildly distressing, manageable, and result in minor functional impairment. Major depression is considered *severe* if symptoms substantially in excess of those required to make the diagnosis are present, and the symptoms are highly distressing, unmanageable, and markedly impair function. *Moderate* major depression is intermediate in severity (Fig. 39.3).

**Persistent depressive disorder** is characterized by depressed or irritable mood for more days than not, for at least 1 year (in children and adolescents). This chronic form of depression is associated with characteristic vegetative and cognitive symptoms; however, the cognitive symptoms of persistent depression are less severe (e.g., low self-esteem rather than worthlessness, hopelessness rather than suicidality). Persistent depressive disorder is characterized as mild, moderate, or severe (Table 39.2).

Overall, the clinical presentation of major and persistent depressive disorders in children and adolescents is similar to that in adults. The prominence of the symptoms can change with age: irritability and somatic complaints may be more common in children, and energy, activity level, appetite, and sleep disturbances may be more common in adolescents. Because of the cognitive and linguistic immaturity of young children, symptoms of depression in that age group may be more likely to be observed than self-reported.

The core feature of **disruptive mood dysregulation disorder (DMDD)** is severe, persistent irritability evident most of the day, nearly every day, for at least 12 months in multiple settings (at home, at school, with peers). The irritable mood is interspersed



**Fig. 39.1** Evaluation of mood disorders. (From Kliegman RM, Lye, PS, Bordini BJ, et al., eds. *Nelson Pediatric Symptom-Based Diagnosis*. Elsevier, 2018; Fig, 27.2, p. 426.)

**Table 39.1** DSM-5 Diagnostic Criteria for Major Depressive Episode

<p>A. Five (or more) of the following symptoms have been present during the same 2-wk period and represent a change from previous functioning; at least one of the symptoms is either (1) depressed mood or (2) loss of interest or pleasure.</p> <ol style="list-style-type: none"> <li>1. Depressed most of the day, nearly every day, as indicated by either subjective report (e.g., feels sad, empty, hopeless) or observation made by others (e.g., appears tearful).</li> </ol> <p>Note: In children and adolescents, can be irritable mood.</p> <ol style="list-style-type: none"> <li>1. Markedly diminished interest or pleasure in all, or almost all, activities most of the day, nearly every day (as indicated by either subjective account or observation).</li> <li>2. Significant weight loss when not dieting or weight gain (e.g., a change of more than 5% of body weight in a month), or decrease or increase in appetite nearly every day.</li> </ol> <p>Note: In children, consider failure to make expected weight gain.</p> <ol style="list-style-type: none"> <li>1. Insomnia or hypersomnia nearly every day.</li> <li>2. Psychomotor agitation or retardation nearly every day (observable by others, not merely subjective feelings of restlessness or being slowed down).</li> <li>3. Fatigue or loss of energy nearly every day.</li> </ol>	<ol style="list-style-type: none"> <li>4. Feelings of worthlessness or excessive or inappropriate guilt (which may be delusional) nearly every day (not merely self-reproach or guilt about being sick).</li> <li>5. Diminished ability to think or concentrate, or indecisiveness, nearly every day (either by subjective account or as observed by others).</li> <li>6. Recurrent thoughts of death (not just fear of dying), recurrent suicidal ideation without a specific plan, or a suicide attempt or a specific plan for committing suicide.</li> </ol> <p>B. The symptoms cause clinically significant distress or impairment in social, occupational, or other important areas of functioning.</p> <p>C. The episode is not attributable to the physiologic effects of a substance or to another medical condition.</p> <p>Note: Criteria A-C represent a major depressive episode.</p> <p>D. The occurrence of the major depressive episode is not better explained by schizoaffective disorder, schizophrenia, schizophreniform disorder, delusional disorder, or other specified and unspecified schizophrenia spectrum and other psychotic disorders.</p> <p>E. There has never been a manic episode or a hypomanic episode.</p>
--	--

From the *Diagnostic and Statistical Manual of Mental Disorders*, 5th ed. pp. 125–126. Copyright 2013. American Psychiatric Association.

with frequent ( $\geq 3$  times/week) and severe temper outbursts (verbal rages, physical aggression; Table 39.3). This diagnosis is intended to characterize more accurately the extreme irritability, which some investigators had considered a *developmental* presentation of bipolar disorder, and to distinguish extreme irritability from the milder presentations characteristic of oppositional defiant disorder (ODD) and intermittent explosive disorder. Table 39.4 highlights some of the similarities and differences between the various mood disorders and also factors that distinguish mood disorders from grief experienced in response to loss.

**Other specified/unspecified depressive disorder** (subsyndromal depressive disorder) applies to presentations in which symptoms characteristic of a depressive disorder are present and cause clinically significant distress or functional impairment but do not meet the full criteria for any of the disorders in this diagnostic class.

## EPIDEMIOLOGY

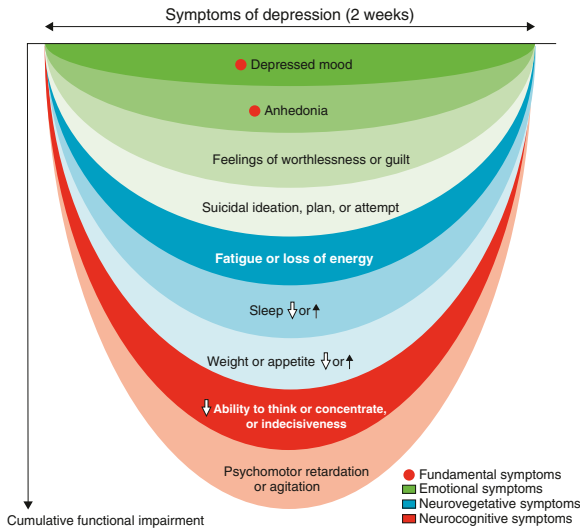
The current prevalence of depressive disorder in the United States among 3–17 year olds is approximately 3.2%; the lifetime prevalence rates increase to 4.9% for ages 6–17 and to 12.8% for 12–17 year olds. The male:female ratio (excluding DMDD) is approximately 1:1 during childhood and beginning in early adolescence rises to 1:1.5–3.0 by adulthood.

Based on rates of chronic and severe persistent irritability, which is the core feature of DMDD, the overall 6 month to 1 year prevalence has been estimated in the 2–5% range. In three community samples, the 3-month prevalence rate of DMDD ranged from 0.8–3.3%, with the highest rates occurring in preschoolers (although *Diagnostic and Statistical Manual of Mental Disorders, Fifth Edition* [DSM-5] does not permit this diagnosis until age 6 years). Approximately 5–10% of children and adolescents are estimated to have subsyndromal (unspecified) depression.

**ETIOLOGY AND RISK FACTORS**

Models of vulnerability to depressive disorders are grounded in genetic and environmental pathways. Genetic studies have demonstrated the heritability of depressive disorders, with monozygotic twin studies finding concordance rates of 40–65%. In families, both bottom-up (children to parents) and top-down (parents to children) studies have shown a two- to four-fold bidirectional increase in depression among first-degree relatives. Cerebral variations in structure and function (particularly serotonergic), the function of the hypothalamic-pituitary-adrenal axis, difficult temperament/personality (i.e., negative affectivity), and

ruminative, self-devaluating cognitive style have been implicated as components of biologic vulnerability. The great majority of depressive disorders arise in youth with long-standing psychosocial difficulties, among the most predictive of which are physical/sexual abuse, neglect, chronic illness, school difficulties (bullying, academic failure), social isolation, family or marital disharmony, divorce/separation, parental psychopathology, and domestic violence. Longitudinal studies demonstrate the greater importance of environmental influences in children who become depressed than in adults who become depressed. Factors shown to be protective against the development of depression include better family function, a prosocial peer group, higher IQ, greater educational aspirations, a positive relationship with a caregiver, and closer caregiver supervision, monitoring, and involvement.



**Fig. 39.2** Defining major depressive disorder. Key symptoms of *Diagnostic and Statistical Manual of Mental Disorders, Fifth Edition (DSM)-5* for major depressive disorder. For a diagnosis of major depressive disorder, the individual needs to present with five or more of any of the symptoms nearly every day during the same 2-week period, provided at least one of these symptoms is a fundamental one. The clinical symptoms of major depressive disorder are usually accompanied by functional impairment. The greater the number and severity of symptoms (as opposed to particular symptoms), the greater the probability of the functional impairment they are likely to confer. The symptoms of depression can be grouped into emotional, neurovegetative, and neurocognitive domains. Importantly sleep, weight, and appetite are usually diminished in depression but can also be increased, and suicidal ideation, plans, or an attempt should be documented whenever depression is suspected. (From Malhi GS, Mann JJ. *Depression*. *Lancet*. 2018;392[10161]:2299–2312:Fig. 1, p. 2300.)

**SCREENING AND DIAGNOSIS**

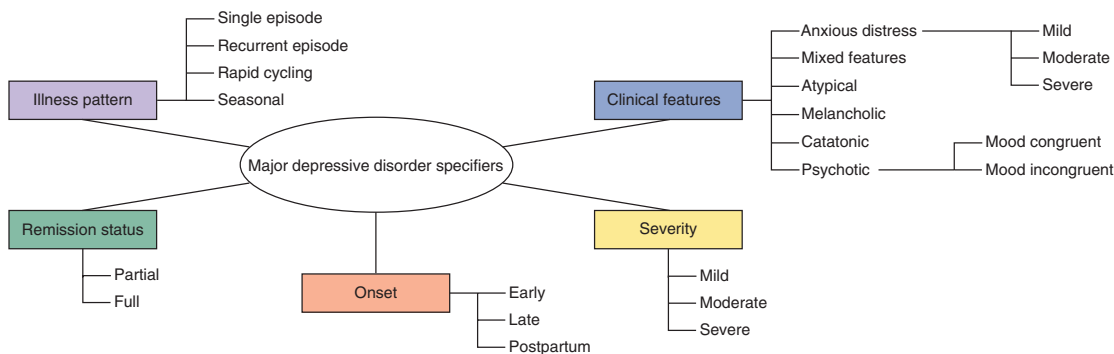
**Screening**

Adolescents presenting in the primary care setting should be queried, along with their caregiver(s), about depressed mood as part of the routine clinical interview. A typical screening question would be, “Everyone feels sad or angry some of the time; how about you (or your teen)?” The caregivers of younger children can be queried about overt signs of depression, such as tearfulness, irritability, boredom, or social isolation. A number of standardized screening instruments widely used in the primary care setting (e.g., *Pediatric Symptom Checklist*, *Strengths and Difficulties Questionnaire*, *Vanderbilt ADHD Diagnostic Rating Scales*) have items specific to sad mood and as such can be used to focus the interview. Additionally, screening tools specific to depression, such as the *Patient Health Questionnaire-9 (PHQ-9)* and *Beck Depression Inventory*, can be utilized as part of routine screening (Table 39.5).

The role of universal depression screening using standardized depression-specific instruments is unclear. A Cochrane review found that the use of depression screening in primary care has little or no impact on the recognition, management, or outcome of depression. Nonetheless, the U.S. Preventive Services Task Force (USPSTF) recommends the universal use of depression screening instruments, but only among adolescents and only when systems are in place to ensure adequate follow-up. Targeted screening of known high-risk groups (e.g., youth who are homeless, refugees, attracted to the same sex, involved with child welfare or juvenile justice), or youth experiencing known psychosocial adversities or self-reporting a dysphoric mood, may be a higher-yield case-finding strategy than universal screening.

**Assessment**

Youth (and/or their caregivers) presenting in the primary care setting who self-report, or respond affirmatively to queries about a distressing life experience or a depressed or irritable mood should be offered the opportunity to talk about the situation with the pediatric practitioner (separately with the older youth). By engaging in active listening (e.g.,



**Fig. 39.3** Major depressive disorder specifiers. Episodes of major depression can be described in greater depth by specifiers (outlined in *Diagnostic and Statistical Manual of Mental Disorders, Fifth Edition [DSM-5]*) that provide additional information regarding the pattern of the illness and its clinical features. Specifiers can also indicate the severity of the episode, when it first emerged (onset), and whether it has remitted (status). For example, in clinical practice, a typical episode of depression can be described as suffering from a recurrence of depression that is moderately severe with melancholic features and has partly remitted in response to initial treatment. (From Malhi GS, Mann JJ. *Depression*. *Lancet*. 2018;392[10161]:2299–2312:Fig. 2, p. 2301.)



**Table 39.2** DSM-5 Diagnostic Criteria for Persistent Depressive Disorder

- A. Depressed mood for most of the day, for more days than not, as indicated either by subjective account or observation by others, for at least 2 yr.
- Note: In children and adolescents, mood can be irritable and duration must be at least 1 yr.
- B. Presence, while depressed, of two (or more) of the following:
- Poor appetite or overeating.
  - Insomnia or hypersomnia.
  - Low energy or fatigue.
  - Low self-esteem.
  - Poor concentration or difficulty making decisions.
  - Feelings of hopelessness.
- C. During the 2 yr period (1 yr for children or adolescents) of the disturbance, the individual has never been without the symptoms in Criteria A and B for more than 2 mo at a time.
- D. Criteria for a major depressive disorder may be continuously present for 2 yr.
- E. There has never been a manic episode or a hypomanic episode, and criteria have never been met for cyclothymic disorder.
- F. The disturbance is not better explained by a persistent schizoaffective disorder, schizophrenia, delusional disorder, or other specified or unspecified schizophrenia spectrum and other psychotic disorder.
- G. The symptoms are not attributable to the physiologic effects of a substance (e.g., a drug of abuse, a medication) or another medical condition (e.g., hypothyroidism).
- H. The symptoms cause clinically significant distress or impairment in social, occupational, or other important areas of functioning.
- Note: Because the criteria for a major depressive episode include four symptoms that are absent from the symptom list for persistent depressive disorder (dysthymia), a very limited number of individuals will have depressive symptoms that have persisted longer than 2 yr but will not meet criteria for persistent depressive disorder. If full criteria for a major depressive episode have been met at some point during the current episode of illness, they should be given a diagnosis of major depressive disorder. Otherwise, a diagnosis of other specified depressive disorder or unspecified depressive disorder is warranted.

From the *Diagnostic and Statistical Manual of Mental Disorders*, 5th ed. pp. 168–169. Copyright 2013. American Psychiatric Association.

“I hear how upset you have been feeling; tell me more about what happened to make you feel that way”), the clinician can begin to assess the onset, duration, context, and severity of the symptoms and associated dangerousness, distress, and functional impairment. In the absence of acute dangerousness (e.g., suicidality, psychosis, substance abuse) and significant distress or functional impairment, the pediatric practitioner can schedule a follow-up appointment within 1–2 weeks to conduct a depression assessment. At this follow-up visit, to assist with decision-making about appropriate level of care, a depression-specific screening or standardized rating scale can be administered to assess symptom severity (see Table 39.5), and additional risk factors can be explored.

### DIFFERENTIAL DIAGNOSIS

A number of psychiatric disorders, general medical conditions, and medications can generate symptoms of depression or irritability and must be distinguished from the depressive disorders. The psychiatric disorders include autism spectrum disorder (ASD), ADHD, and bipolar, anxiety, trauma- and stressor-related, disruptive/impulse control/conduct, and substance-related disorders. Medical conditions include neurologic disorders (including autoimmune encephalitis), endocrine disorders (including hypothyroidism and Addison disease), infectious diseases, tumors, anemia, uremia, failure to thrive, chronic fatigue disorder, and pain disorder. Medications include narcotics, chemotherapy agents,  $\beta$  blockers, corticosteroids, and contraceptives. The diagnosis

**Table 39.3** DSM-5 Diagnostic Criteria for Disruptive Mood Dysregulation Disorder

- A. Severe recurrent temper outbursts manifested verbally (e.g., verbal rages) and/or behaviorally (e.g., physical aggression toward people or property) that are grossly out of proportion in intensity or duration to the situation or provocation.
- B. The temper outbursts are inconsistent with developmental level.
- C. The temper outbursts occur, on average, three or more times per week.
- D. The mood between temper outbursts is persistently irritable or angry most of the day, nearly every day, and is observable by others (e.g., parents, teachers, peers).
- E. Criteria A–D have been present for 12 or more months. Throughout that time, the individual has not had a period lasting 3 or more consecutive months without all of the symptoms in Criteria A–D.
- F. Criteria A and D are present in at least two of three settings (i.e., at home, at school, with peers) and are severe in at least one of these.
- G. The diagnosis should not be made for the first time before age 6 yr or after age 18 yr.
- H. By history or observation, the age at onset of Criteria A–E is before 10 yr.
- I. There has never been a distinct period lasting more than 1 day during which the full symptom criteria, except duration, for a manic or hypomanic episode have been met.
- Note: Developmentally appropriate mood elevation, such as occurs in the context of a highly positive event or its anticipation, should not be considered as a symptom of mania or hypomania.
- J. The behaviors do not occur exclusively during an episode of major depressive disorder and are not better explained by another mental disorder (e.g., autism spectrum disorder, posttraumatic stress disorder, separation anxiety disorder, persistent depressive disorder [dysthymia]).
- Note: The diagnosis cannot coexist with oppositional defiant disorder, intermittent explosive disorder, or bipolar disorder, though it can coexist with others, including major depressive disorder, attention-deficit/hyperactivity disorder, conduct disorder, and substance use disorders. Individuals whose symptoms meet criteria for both disruptive mood dysregulation disorder and oppositional defiant disorder should only be given the diagnosis of disruptive mood dysregulation disorder. If an individual has ever experienced a manic or hypomanic episode, the diagnosis of disruptive mood dysregulation disorder should not be assigned.
- K. The symptoms are not attributable to the physiologic effects of a substance or to another medical or neurologic condition.

From the *Diagnostic and Statistical Manual of Mental Disorders*, 5th ed. p. 156. Copyright 2013. American Psychiatric Association.

of a depressive disorder should be made after these and other potential explanations for the observed symptoms have been ruled out.

### COMORBIDITY

Major and persistent depressive disorders often co-occur with other psychiatric disorders. Depending on the setting and source of referral, 40–90% of youths with a depressive disorder have other psychiatric disorders, and up to 50% have two or more comorbid diagnoses. The most common comorbid diagnosis is an **anxiety disorder** and as such may reflect a common diathesis; other common comorbidities include ADHD and disruptive behavior, eating, and substance use disorders. The development of depressive disorders can both lead to and follow the development of comorbid disorders.

DMDD may occur with other psychiatric disorders, including other depressive disorders, ADHD, conduct disorder, and substance use disorders. Because the symptoms of DMDD overlap in part with symptoms of bipolar disorder, ODD, and intermittent explosive disorder, by DSM-5 convention, hierarchical diagnostic rules apply. Thus bipolar disorder takes precedence over DMDD if a manic/hypomanic episode

**Table 39.4** A Comparison of Features of Depression, Persistent Depressive Disorder, Disruptive Mood Dysregulation Disorder, and Grief in Children with Developmental Considerations

	MAJOR DEPRESSIVE DISORDER	PERSISTENT DEPRESSIVE DISORDER	DISRUPTIVE MOOD DYSREGULATION DISORDER	GRIEF
Core feature(s)	Sadness, irritability, anhedonia	Sadness, irritability, anhedonia	Irritability and anger with behavioral outbursts (verbal, physical)	Sadness in response to the loss/death of a loved one
Duration	2 weeks with symptoms nearly every day	1 year with symptoms more days than not	1 year with outbursts at least three times/week	Ongoing, can continue/recur indefinitely (e.g., around anniversaries, birthdays, holidays)
Associated symptoms	Changes in appetite, sleep, energy and activity level; impaired concentration; hopelessness, worthlessness and guilt; suicidal ideations/actions	Changes in appetite, sleep, energy and activity level; impaired concentration; hopelessness, worthlessness and guilt; suicidal ideations/actions	Persistent irritability between episodes	Anger; guilt; regret; anxiety; intrusive images; overwhelmed; lonely
Age considerations	Younger children may be irritable and complain of somatic symptoms		Cannot be diagnosed before age 6 or after age 18	Developmental level and understanding of death can influence grief symptoms

**Table 39.5** Depression-Specific Rating Scales

NAME OF INSTRUMENT	INFORMANT(S)	AGE RANGE (YR)	ITEMS (NO.)
Beck Depression Inventory	Youth	13+	21
Beck Depression Inventory for Youth	Youth	7-14	20
Center for Epidemiologic Studies-Depression-Children	Youth	6-18	20
Children's Depression Rating Scale-Revised	Youth, Parent, Clinician	6-18	47
Children's Depression Inventory, Second Edition	Youth, Parent, Teacher	7-17	28/17/12
Depression Self-Rating Scale	Youth	7-13	18
Mood and Feelings Questionnaire	Youth, Parent	7-18	33-34
Patient Health Questionnaire-9	Youth	12/13+	9
Preschool Feelings Checklist	Parent	3-5.6	20
PROMIS Emotional Distress-Depressive Symptoms	Youth, Parent	8-17 (youth report) or 5-17 (parent report)	8/6
Reynolds Child Depression Scale	Youth	8-13	30
Reynolds Adolescent Depression Scale, Second Edition	Youth	11-20	30

has ever occurred, and DMDD takes precedence over ODD and intermittent explosive disorder if full criteria for DMDD are met.

## TREATMENT

Treatment decisions should be guided by the understanding that depression in youth is highly responsive to placebo (50–60%) or brief nonspecific intervention (15–30%). The goal of treatment is **remission**, defined as a period of at least 2 weeks with no or very few depressive symptoms, and ultimately **recovery**, defined as a period of at least 2 months with no or very few depressive symptoms. Assessment of remission and recovery can be aided using the depression-specific standardized rating scales, in which remission is defined as scores below the scale-specific clinical cut point.

For *mild symptoms* (manageable and not functionally impairing) and in the absence of major risk factors (e.g., suicidality; psychosis; substance use; history of depression, mania, or traumatic exposures; parental psychopathology, particularly depression; severe family dysfunction), **guided self-help** (anticipatory guidance) with watchful waiting and scheduled follow-up may suffice. Guided self-help

can include provision of educational materials (e.g., pamphlets, books, workbooks, apps, internet sites) that provide information to the youth about coping adaptively with stressful situations, as well as advice to caregivers about strengthening the caregiver-child relationship and modifying triggering exposures (e.g., taking action against bullying, increasing opportunities for social interaction and support, protecting child from exposure to marital discord). Additional self-help activities that have shown promise in improving mild depressive symptoms include behavioral activation (e.g., physical exercise, social engagement, participation in a hobby), mindfulness (e.g., yoga, meditation), and a regular sleep schedule.

For youths who *continue* to have mild depression after a few weeks of guided self-help, supportive therapy by a mental health professional may be an appropriate subsequent step. For youths who have not responded to approximately 4–8 weeks of supportive psychotherapy, or who from the outset exhibit moderate to severe, comorbid, or recurrent depression or suicidality, or who have a history of mania, traumatic exposures, or severe family dysfunction or psychopathology,

assessment and treatment by a child-trained mental health clinician should be obtained.

For *moderate to severe depression*, specific manualized psychotherapies, antidepressant medication, or a combination of both should be considered. There is insufficient evidence on which to base definitive conclusions about the relative effectiveness of these treatments.

### Psychotherapies

Clinical trials of acute treatments have generated support for the efficacy of cognitive-behavioral therapy (CBT)/behavioral activation therapy and interpersonal therapy as monotherapies in depressed youth, but overall effect sizes are modest. CBT focuses on identifying and correcting cognitive distortions that may lead to depressed mood and teaches problem-solving, behavior activation, social communication, and emotional regulation skills to combat depression. Interpersonal therapy focuses on enhancing interpersonal problem solving and social communication to decrease interpersonal conflicts. Each of these therapies typically involves 8-12 weekly visits. Limited evidence suggests that family therapy may be more effective than no treatment in decreasing depression and improving family functioning. Manualized CBT treatment as well as alternative therapy modalities such as play therapy are also available for younger children.

### Pharmacologic Treatment

Two selective serotonin reuptake inhibitors (SSRIs), fluoxetine and escitalopram, are the only antidepressants approved by the U.S. Food and Drug Administration (FDA) for the treatment of depression in youth; fluoxetine alone is approved for preadolescents. Other SSRIs, with the exception of paroxetine, which has been shown to be ineffective in children, are frequently used off-label and may be considered for use in depressed children and teens despite the lack of FDA approval.

There are several considerations to keep in mind when starting an SSRI, including family history of response to SSRIs, comorbid medical conditions, and other concurrent medications. Fluoxetine should be given in the morning, given its propensity to be activating for some patients; escitalopram is preferentially dosed in the evening as it can be sedating. Sertraline has the advantage of a very wide dosing range, which can be helpful when small dosing changes are preferred.

All SSRIs carry a “black box” warning for increased suicidal thinking in patients under age 25 that must be discussed with all patients and caregivers before starting an SSRI. The risk for this side effect is highest when initiating treatment and when making dose adjustments. All SSRIs can cause *akathisia*, an uncomfortable feeling of internal restlessness; this side effect is more common in children than it is in adults. Gastrointestinal upset and headaches are among the most common side effects; they typically self-resolve after a few weeks. However, they may recur when dose increases are made. Education around the expected course and resolution of these side effects can be helpful when providing informed consent and may lead to improved adherence in the early phase of treatment. Sexual side effects of SSRIs, including decreased libido and difficulty reaching orgasm, are also important considerations and should be addressed with patients before treatment initiation.

If the first trial of an SSRI is unsuccessful, a trial of a second SSRI should be considered. An adequate trial of an SSRI requires that a sufficient dose be achieved and that it be continued for a reasonable amount of time. Given the length of time it takes for SSRIs to take full effect, an adequate trial would be at least 6-8 weeks at a target dose. Trials may end early if patients experience intolerable side effects. For patients who do not respond to two adequate trials of an SSRI, it is appropriate to consider referral to a psychiatrist for further management.

Clinical severity, comorbidity, family conflict, low drug concentration, nonadherence, anhedonia, sleep difficulties, subsyndromal manic symptoms, and child maltreatment have all been related to treatment resistance. Approximately 50% of depressed youth failing to respond to the first SSRI respond after switching to a second antidepressant plus CBT, vs approximately 40% who respond to a second medication alone. For youth with psychotic depression, augmenting the antidepressant with an atypical antipsychotic medication should be considered, while monitoring closely for side effects.

Because of the high rate of recurrence, successful treatment should continue for 6-12 months. The findings from one trial suggested that the addition of relapse-prevention CBT to ongoing medication management reduces the risk of relapse more than medication management alone, even after the end of treatment. When treatment concludes, all antidepressants (except possibly fluoxetine because of its long half-life) should be discontinued gradually to avoid withdrawal symptoms (gastrointestinal upset, disequilibrium, sleep disruption, flu-like symptoms, sensory disturbances). Patients with recurrent (two or more episodes), chronic, or severe major depression may require treatment beyond 12 months.

Ketamine or esketamine, glutamatergic *N*-methyl-D-aspartate (NMDA) receptor antagonists have demonstrated efficacy in treating treatment resistant depression in adults.

There are no rigorous studies evaluating the effectiveness of pharmacologic or psychosocial treatment approaches to persistent depressive disorder or DMDD. The aforementioned treatments for MDD may prove helpful in persistent depressive disorder. In suspected cases of DMDD, child and adolescent psychiatry consultation may be helpful to clarify diagnosis and suggest treatment approaches.

### LEVEL OF CARE

Most children and adolescents with mild to moderate depressive disorders can be safely and effectively treated as outpatients, provided that a clinically appropriate schedule of visits can be maintained through the phases of treatment. Inpatient treatment should be considered for youth who present with a substantial risk of suicide, serious self-harm, or self-neglect, or when the family is not able to provide an appropriate level of supervision or follow-up with outpatient treatment recommendations, or when comprehensive assessment for diagnostic clarity is needed. When considering inpatient admission for a young person with depression, the benefits of inpatient treatment need to be balanced against potential detrimental effects, such as separation from family and community support.

### CLINICAL COURSE

Major depression may first appear at any age, but the likelihood of onset greatly increases with puberty. Incidence appears to peak in the 20s. The median duration of a major depressive episode is about 5-8 months for clinically referred youth and 3-6 months for community samples. The course is quite variable in that some individuals rarely or never experience remission, whereas others experience many years with few or no symptoms between episodes. Persistent depressive disorder often has an early and insidious onset and, by definition, a chronic course (average untreated duration in both clinical and community samples: 3.5 years).

Depressed children appear to be more likely to develop nondepressive psychiatric disorders in adulthood than depressive disorders. However, depression in adolescents has a probability of recurrence reaching 50-70% after 5 years. The persistence of even mild depressive symptoms during remission is a powerful predictor of recurrence; other negative prognostic factors include more severe symptoms, longer time to remission, history of maltreatment, and comorbid psychiatric disorders. Up to 20% of depressed adolescents develop a bipolar disorder; the risk is higher among adolescents who have a high genetic risk for bipolar disorder, who have psychotic depression, or who have had pharmacologically induced mania.

### SEQUELAE

Approximately 60% of youths with MDD report thinking about suicide; 30% attempt suicide. Youths with depressive disorders are also at high risk of substance abuse, impaired family and peer relationships, early pregnancy, legal problems, educational and occupational underachievement, and poor adjustment to life stressors, including physical illness.

Children with DMDD have displayed elevated rates of social impairments, school suspension, and service use. Irritability in adolescence has predicted the development of major depressive and dysthymic disorders and generalized anxiety disorder (but not bipolar disorder) 20 years later, as well as lower educational attainment and income.

## PREVENTION

Experimental trials have sought to demonstrate the effectiveness of psychologic or educational strategies in preventing the onset of depressive disorders in children and adolescents. These programs generally have provided information about the link between depressed mood, thoughts, and behaviors, as well as training in skills intended to modify these thoughts and behaviors. A Cochrane review found small effects of these programs on depression symptoms when implemented universally vs no intervention, with selective programs targeted at high-risk groups performing better than universal programs; however, the effect of prevention programs was null compared with attention controls.

Visit Elsevier eBooks+ at [eBooks.Health.Elsevier.com](http://eBooks.Health.Elsevier.com) for Bibliography.

## 39.2 Bipolar Disorders

Colleen K. Manak and Rosa K. Kim

The bipolar and related disorders include bipolar I, bipolar II, cyclothymic, and other specified/unspecified bipolar and related disorders, as well as bipolar and related disorder caused by another medical condition.

A **manic episode** is characterized by a distinct period of at least 1 week in which there is an abnormally and persistently elevated, expansive, or irritable mood and abnormally and persistently increased goal-directed activity or energy that is present for most of the day, nearly every day (or any duration if hospitalization is necessary). The episode is associated with characteristic cognitive and behavioral symptoms, including disturbances in self-regard, speech, attention, thought, activity, impulsivity, and sleep (Table 39.6). To diagnose **bipolar I disorder**, criteria must be met for at least one manic episode, and the episode must not be better explained by a psychotic disorder. The manic episode may be preceded and may be followed by hypomanic or major depressive episodes. Bipolar I disorder is rated as mild, moderate, or severe in the same way as the depressive disorders.

To diagnose **bipolar II disorder**, criteria must be met for at least one hypomanic episode and at least one major depressive episode. A **hypomanic episode** is similar to a manic episode but is briefer (at least 4 days) and less severe (causes less impairment in functioning, is not associated with psychosis, and would not require hospitalization) (Table 39.7). In bipolar II disorder, there must never have been a manic disorder, the episodes must not be better explained by a psychotic disorder, and the symptoms of depression or the unpredictability caused by frequent alternation between periods of depression and hypomania must cause clinically significant distress or functional impairment. Bipolar II disorder is also rated as mild, moderate, or severe.

**Cyclothymic disorder** is characterized by a period of at least 1 year (in children and adolescents) in which there are numerous periods with hypomanic and depressive symptoms that do not meet criteria for a hypomanic episode or a major depressive episode, respectively (Table 39.8).

## EPIDEMIOLOGY

The lifetime prevalence of bipolar disorder I among adults in the United States varies from 0.8–1.6%, and bipolar II carries a lifetime prevalence of around 1.1%. Bipolar I disorder affects males and females equally, whereas bipolar II disorder is more common in females. Lifetime rates of mania among youth have ranged from 0.1–1.7%. The estimated annual number of U.S. office-based visits of youth with a diagnosis of bipolar disorder increased from 25 per 100,000 population in 1994–1995 to 1,003/100,000 in 2002–2003. U.S. hospital discharge diagnoses increased from 1.4 to 7.3/10,000 in 9–13-year-old children and from 5.1 to 20.4 per 10,000 in 14–19 year olds. These increases were not found in U.K. diagnoses or hospital discharges, raising questions about whether bipolar disorder was being over-diagnosed in the

**Table 39.6** DSM-5 Diagnostic Criteria for a Manic Episode

- A. A distinct period of abnormally and persistently elevated, expansive, or irritable mood and abnormally and persistently increased goal-directed activity or energy, lasting at least 1 wk and present most of the day, nearly every day (or any duration if hospitalization is necessary).
- B. During the period of mood disturbance and increased energy or activity, three (or more) of the following symptoms (four if the mood is only irritable) are present to a significant degree and represent a noticeable change from usual behavior:
  1. Inflated self-esteem or grandiosity.
  2. Decreased need for sleep (e.g., feels rested after only 3 hr of sleep).
  3. More talkative than usual or pressure to keep talking.
  4. Flight of ideas or subjective experience that thoughts are racing.
  5. Distractibility (i.e., attention too easily drawn to unimportant or irrelevant external stimuli), as reported or observed.
  6. Increase in goal-directed activity (either socially, at work or school, or sexually) or psychomotor agitation (i.e., purposeless non-goal-directed activity).
  7. Excessive involvement in activities that have a high potential for painful consequences (e.g., engaging in unrestrained buying sprees, sexual indiscretions, or foolish business investments).
- C. The mood disturbance is sufficiently severe to cause marked impairment in social or occupational functioning or to necessitate hospitalization to prevent harm to self or others, or there are psychotic features.
- D. The episode is not attributable to the physiologic effects of a substance (e.g., a drug of abuse, a medication, other treatment) or to another medical condition.

Note: A full manic episode that emerges during antidepressant treatment (e.g., medication, electroconvulsive therapy) but persists at a fully syndromal level beyond the physiologic effect of that treatment is sufficient evidence for a manic episode and, therefore, a bipolar I diagnosis.

Note: Criteria A–D constitute a manic episode. At least one lifetime manic episode is required for the diagnosis of bipolar I disorder.

From the *Diagnostic and Statistical Manual of Mental Disorders*, 5th ed. p. 124. Copyright 2013. American Psychiatric Association.

United States, with resultant increases in prescribing of antipsychotic and mood-stabilizing medications.

## ETIOLOGY AND RISK FACTORS

Twin studies suggest the heritability of bipolar disorder may be 60–90%; shared and unique environmental factors may account for 30–40% and 10–20%, respectively. Offspring of parents with bipolar disorders are at high risk for early-onset bipolar disorders as well as anxiety and behavioral disorders and mood dysregulation. There is an average 10-fold increased risk among adult relatives of individuals with bipolar disorder, with the magnitude of risk increasing with the degree of kinship. Bipolar disorder and schizophrenia likely share a common genetic origin, reflected in familial co-aggregation of the two disorders.

Studies to date suggest key roles for the amygdala, anterior paralimbic cortices, and their connections in the emotional dysregulation of bipolar disorder. Some of these abnormalities are apparent by adolescence, whereas others appear to progress over adolescence into young adulthood.

*Dysthymic* (sad), *cyclothymic* (labile), or *hyperthymic* (irritable) temperaments may presage eventual bipolar disorder. Premorbid anxiety and dysphoria also are common. Environmental factors such as irritable and negative parenting styles, physical and sexual abuse, poor social support, and prenatal alcohol exposure may interact with genetic vulnerability to produce early onset of bipolar illness as well as negative prognostic indicators. *Affective lability*, in particular, has been associated with high levels of childhood trauma, and gradual sensitization to stressors has been linked to episode recurrence.



## SCREENING

Cardinal manic symptoms of elation, increased energy, and grandiosity occurring in adolescents as a discrete episode representing an unequivocal and uncharacteristic change in functioning should alert pediatric practitioners to the possibility of bipolar disorder. High scores on

**Table 39.7** DSM-5 Diagnostic Criteria for a Hypomanic Episode

- A. A distinct period of abnormally and persistently elevated, expansive, or irritable mood and abnormally and persistently increased goal-directed activity or energy, lasting at least four consecutive days and present most of the day, nearly every day.
- B. During the period of mood disturbance and increased energy or activity, three (or more) of the following symptoms (four if the mood is only irritable) have persisted, represent a noticeable change from usual behavior, and have been present to a significant degree:
1. Inflated self-esteem or grandiosity.
  2. Decreased need for sleep (e.g., feels rested after only 3 hr of sleep).
  3. More talkative than usual or pressure to keep talking.
  4. Flight of ideas or subjective experience that thoughts are racing.
  5. Distractibility (i.e., attention too easily drawn to unimportant or irrelevant external stimuli), as reported or observed.
  6. Increase in goal-directed activity (either socially, at work or school, or sexually) or psychomotor agitation (i.e., purposeless non-goal-directed activity).
  7. Excessive involvement in activities that have a high potential for painful consequences (e.g., engaging in unrestrained buying sprees, sexual indiscretions, or foolish business investments).
- C. The episode is associated with an unequivocal change in functioning that is uncharacteristic of the individual when not symptomatic.
- D. The disturbance in mood and the change in functioning are observable by others.
- E. The disturbance is not severe enough to cause marked impairment in social or occupational functioning or to necessitate hospitalization. If there are psychotic features, the episode is, by definition, manic.
- F. The episode is not attributable to the physiologic effects of a substance (e.g., a drug of abuse, a medication, other treatment) or to another medical condition.

Note: A full hypomanic episode that emerges during antidepressant treatment (e.g., medication, electroconvulsive therapy) but persists at a fully syndromal level beyond the physiologic effect of that treatment is sufficient evidence for a hypomanic episode diagnosis. However, caution is indicated so that one or two symptoms (particularly increased irritability, edginess, or agitation following antidepressant use) are not taken as sufficient for diagnosis of a hypomanic episode, nor necessarily indicative of a bipolar diathesis.

Note: Criteria A-F constitute a hypomanic episode. Hypomanic episodes are common in bipolar I disorder but are not required for the diagnosis of bipolar I disorder.

From the *Diagnostic and Statistical Manual of Mental Disorders*, 5th ed. p. 124. Copyright 2013. American Psychiatric Association.

parent-completed versions of mania-specific rating scales (e.g., *General Behavior Inventory*, *Child Mania Rating Scale*, *Young Mania Rating Scale*) have been associated with increased likelihood of a bipolar diagnosis. However, screening tools for bipolar disorder have suboptimal psychometric properties when applied to young people. Because of the complexity of diagnosing and treating bipolar disorders, any suspected cases should be referred to the specialty mental health setting for comprehensive assessment and treatment.

## PRESENTATION

In adolescents, the clinical manifestations of mania are similar to those in adults; psychosis (delusions, hallucinations) often is an associated symptom (see Chapter 47). Mood in a manic episode is often described as euphoric, excessively cheerful, high, or “feeling on top of the world.” During the episode, the adolescent may engage in multiple new projects that are initiated with little knowledge of the topic and often at unusual hours (middle of the night). Inflated self-esteem is usually present, ranging from uncritical self-confidence to marked grandiosity, and may reach delusional proportions. The adolescent may sleep little, if at all, for days and still feel rested and full of energy. Speech can be rapid, pressured, and loud and characterized by jokes, puns, amusing irrelevancies, and theatricality. Frequently there is a “flight of ideas,” evidenced by an almost continuous flow of accelerated speech, with abrupt shifts from one topic to another. Distractibility is evidenced by an inability to censor irrelevant extraneous stimuli, which often prevents an individual with mania from engaging in a rational conversation. The expansive mood, grandiosity, and poor judgment often lead to reckless involvement in activities with high potential for personal harm.

*Controversy surrounds the applicability of the diagnostic criteria for mania to prepubertal children.* It may be developmentally normal for children to be elated, expansive, grandiose, or talkative, reducing the specificity of these symptoms to this disorder. In addition, the distractibility, overactivity, impulsivity, and irritability formerly ascribed to bipolar disorder by some investigators may be better explained by a diagnosis of ADHD, with or without comorbid ODD. The presentation of severe and pervasive irritability formerly diagnosed as “bipolar disorder” may be better captured by the diagnosis of DMDD.

## DIFFERENTIAL DIAGNOSIS

Numerous psychiatric disorders, general medical conditions, and medications can generate manic-like symptoms and must be distinguished from the bipolar and related disorders. The psychiatric disorders include ADHD, ODD, and intermittent explosive, posttraumatic stress, depressive, anxiety, substance abuse, and borderline personality disorders. Medical conditions include neurologic disorders, endocrine disorders, infectious diseases, tumors, anemia, uremia, and vitamin deficiencies. Medications include androgens, bronchodilators, cardiovascular medications, corticosteroids, chemotherapy agents, thyroid preparations, and certain psychiatric medications (benzodiazepines, antidepressants, stimulants). The diagnosis of a bipolar disorder should be made after these other explanations for the observed symptoms have been ruled out. Substance-induced mood disorder should also be considered and ruled out in patients presenting with mania.

**Table 39.8** A Comparison of Bipolar I and II and Cyclothymia in Children and Adolescents

	BIPOLAR I	BIPOLAR II	CYCLOTHYMIA
Core feature(s)	One manic episode	One hypomanic episode AND one major depressive episode	Symptoms of hypomania and depression, without meeting full criteria for a manic, hypomanic or depressive episode
Duration	Mania: 7 days	Hypomania: 4 days Depressive episode: 14 days	1 year
Associated symptoms	Depressive episodes, hypomanic episodes, psychosis		Chronic disruption in mood patterns

For bipolar II disorder, the main differential is unipolar depression (MDD) or cyclothymic disorder, which are ruled out by the lack of a hypomanic episode and by not meeting full criteria for either a major depressive or hypomanic episode, respectively.

## COMORBIDITY

The most common simultaneous comorbidities (ADHD, ODD, conduct disorder, anxiety) may be difficult to distinguish from mania because of considerable symptom overlap. Substance use also is a common comorbidity in adolescents, and presentations that appear to be manic may remit when the substances of abuse are discontinued.

## TREATMENT

### Pharmacologic Treatment

Medication is the primary treatment for mania (Table 39.9). Studies have demonstrated the superiority of antipsychotics over mood stabilizers in the treatment of mania. Risperidone and olanzapine are the most efficacious agents; quetiapine, risperidone, and olanzapine ranked as the most tolerable agents. The choice of antipsychotic medication is based on factors such as side effect profiles, comorbidities, adherence, and positive response of a family member.

Among traditional mood stabilizers, only lithium is FDA approved for the treatment of bipolar disorder from age 12 years; its efficacy and tolerability compared to placebo has been demonstrated in randomized controlled trials (RCTs). There also is evidence that lithium reduces the risk of suicide and total deaths in patients with both unipolar and bipolar depressive disorder.

Given the co-occurrence of sleep disturbance with bipolar disorders, the use of medications to help regulate sleep can have a significant benefit on mood and functioning. Medications to promote sleep, including benzodiazepines, benzodiazepine receptor agonists, and melatonin receptor agonists have some evidence for the treatment of sleep in bipolar disorder in adults. When treating children and adolescents, it is important to monitor for paradoxical activation/disinhibition when using benzodiazepines.

Medication trials should be systematic and their duration sufficient (generally 6-8 weeks) to determine effectiveness. Care should be taken to avoid unnecessary polypharmacy, in part by discontinuing agents that have not demonstrated significant benefit. Because these medications are associated with significant side effects, careful monitoring of baseline and follow-up indices is imperative (see Chapter 33).

The regimen needed to stabilize acute mania should be maintained for 12-24 months. Maintenance therapy is often needed for adolescents with bipolar I disorder, and some patients need lifelong medication. Any attempts to discontinue prophylactic medication should be done gradually while closely monitoring the patient for relapse.

Antidepressants *alone* should not be prescribed for depressive symptoms in confirmed cases of bipolar I disorder because of the risk of manic switch. For treatment of depression in bipolar II, antidepressant

medication may be used cautiously. Comorbid ADHD can be treated with a stimulant once a mood stabilizer has been initiated.

## Psychotherapies

Psychotherapy is a potentially important adjunctive treatment for bipolar disorders. Therapies with some evidence of efficacy, primarily as adjunctive to pharmacotherapy, include multifamily psychoeducational psychotherapy and family-focused treatment, child and family-focused CBT, dialectical behavioral therapy, and interpersonal and social rhythm therapy. Active components of these therapies include family involvement and psychoeducation, along with self-regulation, cognitive restructuring, communication, problem-solving, and emotion regulation skills. Factors that adversely influence response to therapy include high-conflict families and sleep impairment, suggesting the importance of targeting these factors in treatment. Sleep hygiene is an important factor in the treatment of mania, and there is support for the use of CBT in treating insomnia related to bipolar disorder. Ensuring patients get adequate rest will help with recovery and the prevention of future episodes of mania.

## LEVEL OF CARE

Most youths with bipolar disorders can be safely and effectively treated as outpatients, provided that an appropriate schedule of visits and laboratory monitoring can be maintained through the course of treatment. Youths who are suicidal, homicidal, psychotic, or present an intentional danger to themselves or others typically require inpatient care.

## Clinical Course and Prognosis

The mean age of onset of the first manic episode is approximately 18 years old for bipolar I disorder. Premorbid problems are common in bipolar disorder, especially temperamental difficulties with mood and behavioral regulation. Premorbid anxiety also is common. The early course of adolescent-onset bipolar I disorder appears to be more chronic and refractory to treatment than adult-onset bipolar disorder. Comorbidity predicts functional impairment, and age at onset predicts duration of episodes. Sleep impairment and family conflict are inversely related to favorable treatment response, suggesting important targets for treatment. The bipolar disorders are highly recurrent, and 70-80% of bipolar I patients will have additional mood episodes. Recurrent episodes can approximate 4 in 10 years, with the inter-episode interval shortening as the patient ages. Although the majority of patients with bipolar I return to a fully functional level between episodes, approximately 30% continue to be symptomatic and functionally impaired between episodes.

The initial presentation of bipolar I disorder is often a major depressive episode. Switching from a depressive episode to a manic episode by adulthood may occur in 10-20% of youth, both spontaneously and during depression treatment. Factors that predict the eventual development of mania in depressed youth include a depressive episode characterized by rapid onset, psychomotor retardation, and psychotic features; a family history of affective disorders, especially bipolar disorder; and a history of mania or hypomania after antidepressant therapy.

The mean age of onset of bipolar II disorder is 20 years old. The illness most often begins with a depressive episode and is not recognized as bipolar II disorder until a hypomanic episode occurs, in about 12% of individuals with the initial diagnosis of major depression. Many individuals experience several episodes of major depression before experiencing the first recognized hypomanic episode. Anxiety, substance misuse, or eating disorders may also precede the onset of bipolar II, complicating its detection. About 5-15% of individuals with bipolar II disorder will ultimately develop a manic episode, which changes the diagnosis to bipolar I disorder.

Depression in bipolar I or II usually has an earlier age of onset, more frequent episodes of shorter duration, an abrupt onset and offset, is linked to comorbid substance misuse, and is triggered by stressors. Atypical symptoms such as hypersomnia, lability, and weight instability are also common in bipolar depression, reported in up to 90% of cases vs 50% in unipolar depression. Psychosis, psychomotor retardation, and catatonia are also more characteristic of bipolar depression,

**Table 39.9** U.S. Food and Drug Administration–Approved Treatments for Bipolar Disorder in Youth

MEDICATION	INDICATION (APPROVED AGES)
Aripiprazole	Mania (10-17 yr)
Asenapine	Mania/mixed episode (10-17 yr)
Lithium	Acute mania/bipolar maintenance (7-17 yr)
Lurasidone	Bipolar depression (10-17 yr)
Olanzapine	Mania/mixed episode (13-17 yr)
Quetiapine	Mania (10-17 yr)
Risperidone	Mania/mixed episode (10-17 yr)

whereas somatic complaints are more frequent in unipolar depression. A family history of mania is also a relevant discriminating factor.

Provision of clinical services is poor for youth with bipolar disorder. In one healthcare system study spanning 2-year follow-up after diagnosis, despite complex drug regimens, medication appointments were infrequent, averaging one visit every 2 months. More than 50% of patients needed one or more hospitalizations, and almost half had psychiatric emergency department visits. In a national study, 38% of youths diagnosed with bipolar disorder had received no treatment at all.

## SEQUELAE

Bipolar disorder has one of the higher rates of suicide among mental health diagnoses, with a lifetime risk of suicide in individuals with bipolar disorder estimated to be at least 15 times that of the general population. Factors associated with suicide attempts include female gender, young age at illness onset, depressive polarity of first illness episode or current or most recent episode, comorbid anxiety disorder, any comorbid substance use disorder, borderline personality disorder, and first-degree family history of suicide. In contrast, completed suicides are associated with male sex and a first-degree family history of suicide. Despite patients with bipolar disorder having normal or even superior cognition before diagnosis, bipolar disorder has been associated with decrements in executive function and verbal memory. Youths with bipolar disorder are also at high risk for substance abuse, antisocial behavior, impaired academic performance, impaired family and peer relationships, and poor adjustment to life stressors.

## PREVENTION

Although empirical support is sparse, one study demonstrated the effectiveness of family-focused treatment vs an educational control in hastening and sustaining recovery from mood symptoms in a high-familial-risk cohort of youths with subsyndromal symptoms of mania. Family-focused treatment is a manualized psychoeducational intervention designed to reduce family stress, conflict, and affective arousal by enhancing communication and problem solving between youths and their caregivers. Pharmacologic interventions for subsyndromal mania have produced equivocal results.

Visit Elsevier eBooks+ at [eBooks.Health.Elsevier.com](https://eBooks.Health.Elsevier.com) for Bibliography.

## Chapter 40

# Suicide and Attempted Suicide

Jennifer A. Zaspel and Rosa K. Kim

Youth suicide is a major public health concern. In 2021, suicide was the second leading cause of death in adolescents and young adults (aged 10-24 years) and the tenth leading cause of death for all ages. The rates of emergency department (ED) visits for psychiatric chief complaints have also increased over time, with a 2.5-fold increase in suicide-related visits in adolescents. There are numerous genetic, psychiatric, social, cultural, and environmental risk factors for suicidal behavior (Fig. 40.1). There are also many protective factors and interventions that can reduce rates of self-injury and suicide. Knowledge of these risk factors and protective factors may facilitate identification and treatment in youths at highest risk for intentional harm to themselves.

## EPIDEMIOLOGY

Suicide rates for children and adolescents have been increasing over time, with the overall suicide rates increasing by 35% since 1999. It is estimated that 46% of people who die by suicide were diagnosed with a psychiatric condition at the time of their death. Linear trends in suicide attempts from 2009–2019 have also increased and specifically among certain demographic groups. A better understanding of which groups are at risk for suicide and parasuicidal behavior can help pediatricians identify and support those who are at risk (Table 40.1).

## Suicidal Ideation and Attempts

More than 30% of 9th-12th grade students in the United States felt so sad or hopeless almost every day for 2 or more weeks in a row during the previous year that they stopped doing usual activities. During that same period, 18.8% of the students reported that they had seriously considered attempting suicide, and 8.9% reported that they had attempted suicide one or more times. A suicide attempt in the previous year that resulted in an injury, poisoning, or overdose that had to be treated by a physician or nurse was reported by 2.5% of students.

Ingestion is the most common method of attempted suicide. The 15–19-year-old age-group is the most likely to intentionally harm themselves by ingestion, receive treatment in the ED, and survive. Attempts are more common in adolescent females than males and in Hispanic females than their non-Hispanic counterparts. LGBTQ+ and bullied youths also have disproportionately high rates of suicidal ideation and suicide attempts (see Chapter 154). Prior self-harm (self-injury) from poisoning, drowning, firearms, fires, asphyxiation (hanging), and traffic injury are risk factors for suicide. Repeated episodes of self-harm are a higher risk factor than a single episode (see Chapter 46). Attempters who have made prior suicide attempts, who used a method other than ingestion, who have a plan, who have no regret, and who still want to die are at increased risk for completed suicide. Nonetheless, a significant number of children and adolescents who have completed suicide had no previous attempts.

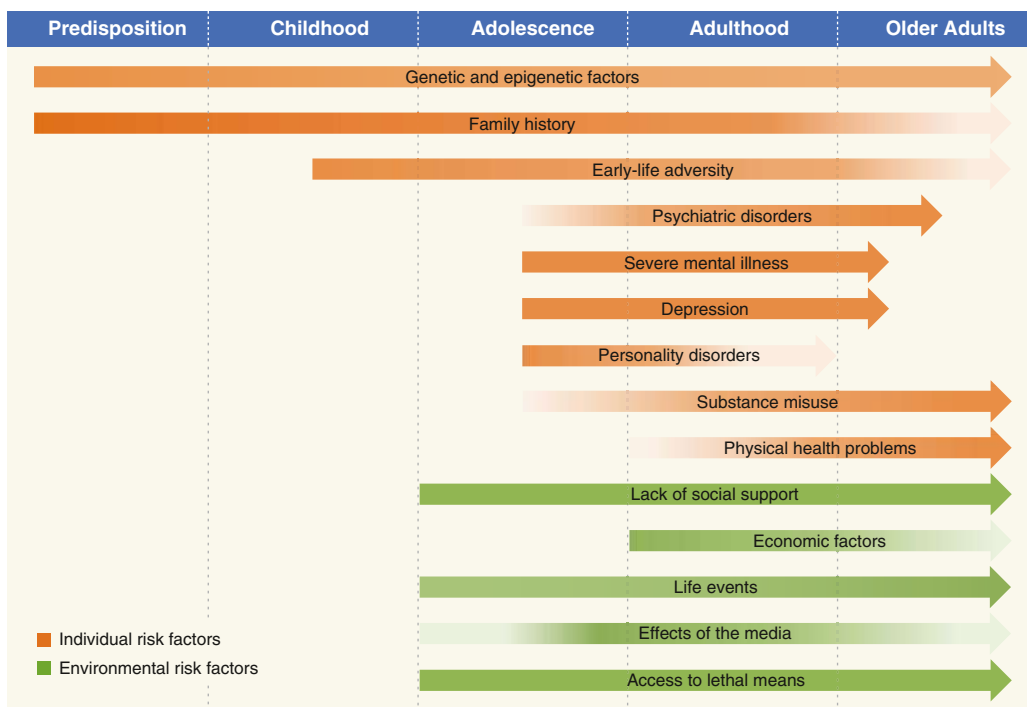
## Suicide Completions

In the United States, completed suicide is very rare before age 10. Rates of completed suicide increase steadily across adolescence into young adulthood, peaking in the early 20s. The male-to-female ratio for completed suicide rises with age from 3:1 in children to approximately 4:1 in those aged 15-24 and greater than 6:1 among those ages 20-24. Although exact rates have changed over time, firearms, suffocation, and poisoning remain the most common methods of suicide (Fig. 40.2).

For both male and female youth ages 15-24, suicide rates remain highest among Indigenous American and Indigenous Alaskan youth and White youth relative to Black, Asian or Pacific Islander, and Hispanic youth. However, rates have been rising for both Black and Asian or Pacific Islander youth, with the rates in Black males increasing 47% between 2013 and 2019 (12.2/100,000 to 17.9/100,000 individuals) and Asian or Pacific Islander males increasing 40% between 2013 and 2019 (12.0/100,000 to 16.8/100,000 individuals). Similar increases have also been seen in female youth in these groups in this time, with a rate increase of 59% among Black female youth (2.7 to 4.3/100,000) and 42% among Asian or Pacific Islander (3.6 to 5.1/100,000). In 2021, the combined (male and female, age 10-24) suicide rates among Indigenous youths increased ~16% (over 2018 rates); Increases were also noted among Black youths (~36%) and Hispanic youths (~8%).

## RISK FACTORS

Multiple risk factors predispose youth to suicide (see Fig. 40.1, Table 40.1). Dynamic risk factors are those that change over time and are most amenable to risk mitigation through treatment, resources, and support. Static risk factors are those that increase an individual's risk of suicide attempt and completion but are not amenable to direct intervention. They include genetic factors, demographic information, an individual's past psychiatric history, family psychiatric history, and history of suicidal and parasuicidal behavior. The risk associated with each factor varies, with the highest risk associated with a personal



**Fig. 40.1** Risk factors for suicide and the strength of the association throughout life. The strength of the association between each risk factor and suicide is indicated by the shading (darker shading indicates a stronger association). (From Fazel S, Runeson B. Suicide [published correction appears in. *N Engl J Med*. 2020 Mar 12;382:1078]; *N Engl J Med*. 2020;382:266–274:Fig. 1, p 267.)

history of a suicide attempt. Risk is also cumulative, with childhood adversity leading to an increased lifetime risk of suicide.

### Access to Firearms

Firearms are the most lethal method of suicide completion; the death rate with respect to firearms is approximately 80–90%, whereas the death rate is only 1.5–4% for drug overdoses. Firearms have long been the most common method of completed suicide across all ages and genders and have become the most common method of suicide completion for adolescent males (see Fig. 40.2). Limiting access to lethal means, in particular firearms, reduces rates of completed suicide.

### Suicide Contagion

Suicide attempts may also be precipitated by exposure to news of another person's suicide or by reading about or viewing a suicide portrayed in a romantic light in the media. Media coverage of suicide is linked to fluctuating incidence rates of suicides, particularly among adolescents. Glorification of suicide whether in news or in fictional media has been associated with an increase in suicides. When media coverage includes a detailed description of specific means used, the use of that particular method may increase in the overall population.

### Preexisting Psychiatric Illness

Approximately 90% of youths who complete suicide have a preexisting psychiatric illness, most often major depression. Among females, chronic anxiety, especially panic disorder, also is associated with suicide attempts and completion. Among males, conduct disorder and substance use confer increased risk. Comorbidity of a substance use disorder, a depressive disorder, and/or conduct disorder are linked to suicide by firearm. Schizophrenia spectrum disorders are linked to suicide attempts and completions (see Chapter 47.1).

### Suicidal and Parasuicidal Behavior

History of a previous suicide attempt is recognized as the strongest predictive risk factor for future suicidal behavior. Individual definitions of suicide attempts can vary; therefore parasuicidal behavior should be explored when considering past attempts. Some patients may not consider an aborted attempt or interrupted attempt an actual suicide attempt, but these behaviors carry considerable risk, as do researching

suicide methods, preparatory acts, rehearsals, giving away possessions, and making arrangements for responsibilities (e.g., finding someone else to care for a pet or family member in their planned absence).

**Nonsuicidal self-injury (NSSI)** is the direct and deliberate destruction of one's own body tissue with the *absence of intent to die* (see Chapter 46). The most common self-harm behavior is cutting or carving, but other behaviors include scratching, burning, punching or hitting oneself, biting, and others. NSSI is common among adolescents, especially females. Up to 47.4% of youth with a diagnosis of depression engage in NSSI, and lifetime prevalence rates of NSSI are between 17% and 60%. Although the intent of these behaviors may not be to cause death, they are important to note, as they are strong predictors of future suicidality if left untreated. Seventy percent of adolescents who engaged in NSSI report a lifetime suicide attempt, and 55% reported multiple attempts. Individuals who are most likely to engage in NSSI are those who have a family member or close friend who have engaged in self-harm and those who believe that peers engage in self-harm.

### Protective Factors

Protective factors (Table 40.2) can provide a counterbalance for those contemplating suicide. Internal protective factors are those that are inherent to the individual. External protective factors are typically dependent on relationships and interactions with others. Protective factors, even if present, may not counteract significant acute risk.

## ASSESSMENT AND INTERVENTION

All suicidal ideation (including planning) and suicide attempts should be taken seriously and require a thorough assessment by a child-trained mental health clinician to evaluate the youth's current state of mind, ongoing risk of harm, and next best steps in treatment. Emergency mental health assessment is needed for immediate threat to self (i.e., active suicidal ideation with plan and intent); urgent mental health assessment (48–72 hours) is needed for severe psychiatric symptoms, significant change in overall functioning, and suicidal ideation without intent or plan. Routine mental health assessment is appropriate for mild to moderate psychiatric symptoms without suicidal ideation.

Pediatric practitioners should expect the mental health clinician to evaluate the presence and degree of suicidality and underlying risk factors. The reliability and validity of child interviewing are affected by



**Table 40.1** Dynamic and Static Risk Factors for Suicide in Children and Adolescents

DYNAMIC RISK FACTORS	
Psychiatric symptoms	Anhedonia Feelings of hopelessness, helplessness, or worthlessness Impulsivity Insomnia Command hallucinations Agitation Anxiety or panic Poor coping
Changes in psychiatric treatment	Recent discharge from a psychiatric hospital Change in treatment plan Change in treatment team
Psychosocial stressors or precipitants	Events that can cause humiliation, shame, or despair (e.g., loss of a relationship, death of a loved one, housing insecurity, academic problems, newly diagnosed medical condition) Ongoing medical illness Substance intoxication Family turmoil/chaos/conflict Social isolation Bullying or being bullied Pending legal situation Suicide in the community (contagion)
STATIC RISK FACTORS	
Demographics	Age: 14-25 Sex: male Race: White, Indigenous American, and Native Alaskan LGBTQ+ identification
Preexisting and/or current psychiatric illness	Mood disorder Psychotic disorder Substance abuse disorder ADHD Eating disorder Posttraumatic stress disorder Cluster B personality traits/disorders Conduct disorder or behaviors (antisocial behavior, aggression) History of trauma, abuse, or neglect
Past suicidal and parasuicidal behavior	Previous suicide attempts Aborted or interrupted suicide attempts Nonsuicidal self-injury (self-harm) thoughts and/or action
Family history	Psychiatric illness Psychiatric hospitalization Suicide attempts and completions

ADHD, Attention-deficit/hyperactivity disorder.

children's level of cognitive development as well as their understanding of the relationship between their emotions and behavior. Confirmation of the youth's suicidal behavior can be obtained from information gathered by interviewing others who know the child or adolescent. A discrepancy between patient and parent reports is not unusual, with both children and adolescents more likely to disclose suicidal ideation and suicidal actions than their parents.

### Suicide Inquiry

In the mental health assessment, suicidal ideation is assessed by explicit questions posed in a nonjudgmental, noncondescending, matter-of-fact approach. The clinician should explore all aspects of

suicidal ideation (i.e., frequency, intensity), suicide plan, parasuicidal behaviors like preparatory acts or writing notes, and intent associated with their thoughts. The assessment of a suicide attempt should also include a detailed exploration of the hours immediately preceding an attempt to identify precipitants as well as the circumstances of the attempt itself to better understand the patient's intent and potential lethality. It is important to recognize that suicidal ideation is dynamic in nature and should be considered on an individual basis; a patient should be compared to their own baseline when assessing for risk of harm to self.

### Children Under 12 Years

Although suicidal ideation and attempts are less frequent in children under 12 than older teens and adults, they do occur. A developmental approach must be taken, as children vary in their understanding of death, moral reasoning, and cognitive reasoning based on age and whether they are following a typical developmental trajectory. A young child may not recognize that their means are not lethal, but that fact should not discount their intent.

Unlike adolescents, Black male *children* are most likely to complete suicide, most often by hanging or strangulation. Children who are at risk of suicide may be less likely to demonstrate classical symptoms of depression than teens and are more likely to attempt at home. Children who die by suicide have higher rates of attention-deficit/hyperactivity disorder (ADHD), emphasizing the importance of impulsivity in suicide attempts. Relationship problems are the most common precipitating circumstance, but the specific relationship differs along developmental lines. Younger adolescents are more likely to have had relationship problems with peers or a significant other, whereas children are more likely to have had relationship problems with family.

### Determining Risk

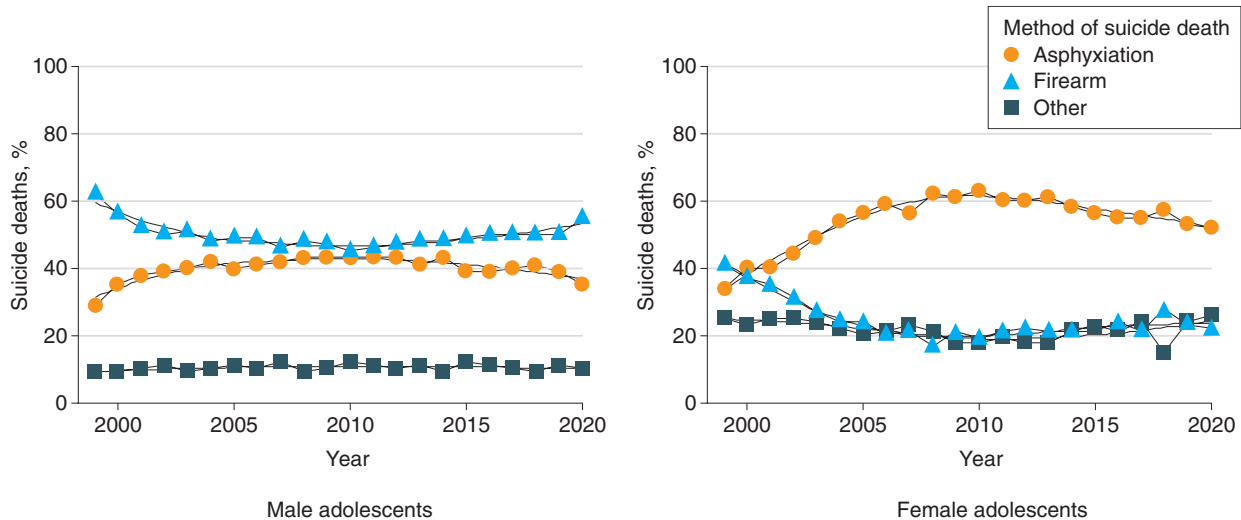
The calculation of the level of risk of harm to self is complex, requiring a determination across a spectrum of risk. At the low end of the risk spectrum are youth with thoughts of death or wanting to die but without suicidal thoughts, intent, or plan. Those with specific suicide plans, preparatory acts or suicide rehearsals, low probability of being found during an attempt, and clearly articulated intent are at the high end. A history of suicide attempts, presently impaired judgment, and poor social support further exacerbates the heightened risk. Among adolescents who consider self-harm, those who carry out self-injury are more likely to have family or friends who have engaged in self-harm. When considering all aspects of a suicide risk assessment, positive responses to a suicide inquiry carry more weight and concern than risk factors alone.

### Levels of Psychiatric Care

For youth who are an imminent danger to themselves (i.e., have active thoughts of killing themselves with plan and intent), inpatient level of psychiatric care is necessary to ensure safety, clarify diagnoses, and plan comprehensive treatment. These patients can be hospitalized voluntarily or involuntarily. It is helpful for the pediatric practitioner to have an office protocol to follow in these situations. This protocol should take into consideration state laws regarding involuntary hospitalization, transportation options, nearest emergency assessment site, necessary forms for hospitalization, and available emergency mental health consultants.

For those youth suitable for treatment in the outpatient setting (e.g., suicidal ideation without plan or intent, intact mental status, few or no other risk factors for suicidality, willing and able to participate in outpatient treatment; has caregivers able to provide emotional support, supervision, safeguarding, and adherence to follow-up), an appointment should be scheduled within a few days with a mental health clinician. Ideally, this appointment should be scheduled before leaving the assessment venue. A procedure should be in place to contact the family to encourage mental health follow-up and provide additional support or resources, if needed. Some

Percentage of Suicide Deaths by Method Among Male and Female Adolescents Age 10 to 19 Years, 1999-2020



**Fig. 40.2** Percentage of suicide deaths by method among male and female adolescents, age 10 to 19 years, 1999-2020. Locally estimated scatterplot smoothing regression estimated percentages of suicide deaths by method with 95% CIs. *Asphyxiation* includes suicide deaths involving hanging, strangulation, and suffocation; *Firearm* includes suicide deaths involving firearm use; and *Other* includes suicide deaths involving poisoning, drowning, fall, fire, and cuts. (Data from Centers for Disease Control and Prevention. Multiple cause of death: 1999-2020 request form. Updated July 27, 2022. Accessed July 11, 2022. <https://wonder.cdc.gov/wonder/help/mcd.html>.)

Table 40.2 Protective Factors Against Suicide in Children and Adolescents	
<b>PROTECTIVE FACTORS</b>	
Internal protective factors	Positive coping skills Frustration tolerance Religious faith Fear of consequences of an attempt (e.g., disfigurement, hospitalization, effects on family/friends) Future oriented thinking Fear of lost opportunities
External protective factors	Responsibilities for others (e.g., other children in the home, pets) Positive therapeutic or mentoring relationships (e.g., physician, therapist, teacher, coach) Social supports Living with others

evidence suggests that quick and consistent follow-up with a team approach, including both primary care and mental health, can be helpful in enhancing treatment plan engagement among patients who are suicidal.

**Safety Planning**

Safety planning is a brief psychosocial intervention that has been shown to reduce suicidal behavior and increase engagement in treatment. Safety plan development consists of working ideally with both the patient and their caregivers to identify individual warning signs and symptoms related to self-harm and suicidal behavior, outlining healthy coping skills and people or places that can provide distraction, identifying loved ones and professionals who can be contacted during a crisis, and agreeing on ways to make the home environment safe (e.g., removing firearms, locking up medications). *Studies have repeatedly refuted the efficacy of safety or suicide contracts in mitigating risk of completing suicide, and some have shown them to be harmful to the therapeutic relationship.*

Table 40.3 Warning Signs of Suicide	
Seek help as soon as possible by contacting a mental health professional or by calling the National Suicide Prevention Lifeline at 1-800-273-TALK if you or someone you know exhibits any of the following signs:	
<ul style="list-style-type: none"> <li>• Threatening to hurt or kill oneself or talking about wanting to hurt or kill oneself.</li> <li>• Looking for ways to kill oneself by seeking access to firearms, available pills, or other means.</li> <li>• Talking or writing about death, dying, or suicide when these actions are out of the ordinary for the person.</li> <li>• Feeling hopeless.</li> <li>• Feeling rage or uncontrolled anger or seeking revenge.</li> <li>• Acting reckless or engaging in risky activities, seemingly without thinking.</li> <li>• Feeling trapped, “like there’s no way out.”</li> <li>• Increasing alcohol or drug use.</li> <li>• Withdrawing from friends, family, and society.</li> <li>• Feeling anxious, agitated, or unable to sleep, or sleeping all the time.</li> <li>• Experiencing dramatic mood changes.</li> <li>• Seeing no reason for living, or having no sense of purpose in life.</li> </ul>	

Developed by the U.S. Department of Health and Human Services, Substance Abuse and Mental Health Services Administration (SAMHSA). <https://www.nimh.nih.gov/health/publications/warning-signs-of-suicide>

**PREVENTION**

The previously mentioned risk factors associated with suicide are relatively common and individually not strong predictors of suicide. The assessment is complicated by patients who may attempt to conceal their suicide thoughts and by those who express suicidal thoughts without serious intent. Suicide screening has been challenging because most screening instruments have variable sensitivity and specificity. In addition, the follow-up mental health evaluations for those who screen positive has been poor.

Prevention strategies in the pediatric medical home include training staff to recognize and respond to the warning signs of suicide (Table 40.3), screening for and treating depression, educating

patients/parents about warning signs for suicide, and restricting access to lethal means. Pediatric practitioners should consider counseling parents to remove firearms from the home entirely or securely lock guns and ammunition in separate locations. Anecdotal evidence suggests youths frequently know where guns and keys to gun cabinets are kept, even though parents may think they do not. The same recommendation applies to restricting access to potentially lethal prescription and nonprescription medications (e.g., containers of >25 acetaminophen tablets) and alcohol. These approaches emphasize the importance of restriction of access to means of suicide to prevent self-harm.

## SCREENING AND EARLY TREATMENT

In 2022, the U.S. Preventive Services Task Force (USPSTF) concluded that there is insufficient evidence to recommend universal suicide screening in the primary care setting for children and adolescents. The American Academy of Pediatrics does recommend universal suicide screening for all children  $\geq 12$  years old. In addition, in 2018 the American Academy of Pediatrics and the USPSTF (2022) recommended annual universal depression screening for youths 12 and older, which often includes suicide screening as part of validated tools. Pediatric practitioners should also consider suicide potential and the need for mental health assessment in the



NIMH TOOLKIT

### Suicide Risk Screening Tool

#### Ask Suicide-Screening Questions

#### Ask the patient:

1. In the past few weeks, have you wished you were dead?  Yes  No
2. In the past few weeks, have you felt that you or your family would be better off if you were dead?  Yes  No
3. In the past week, have you been having thoughts about killing yourself?  Yes  No
4. Have you ever tried to kill yourself?  Yes  No  
If yes, how? \_\_\_\_\_  
\_\_\_\_\_  
\_\_\_\_\_  
When? \_\_\_\_\_  
\_\_\_\_\_

If the patient answers **Yes** to any of the above, ask the following acuity question:

5. Are you having thoughts of killing yourself right now?  Yes  No  
If yes, please describe: \_\_\_\_\_

#### Next steps:

- If patient answers “No” to all questions 1 through 4, screening is complete (not necessary to ask question #5). No intervention is necessary (\*Note: Clinical judgment can always override a negative screen).
- If patient answers “Yes” to any of questions 1 through 4, or refuses to answer, they are considered a **positive screen**. Ask question #5 to assess acuity:
  - “Yes” to question #5 = **acute positive screen** (imminent risk identified)
    - Patient requires a **STAT safety/full mental health evaluation**.
    - Patient **cannot leave until evaluated for safety**.
    - Keep patient in sight. Remove all dangerous objects from room. Alert physician or clinician responsible for patient’s care.
  - “No” to question #5 = **non-acute positive screen** (potential risk identified)
    - Patient requires a **brief suicide safety assessment to determine if a full mental health evaluation is needed**. Patient **cannot leave until evaluated for safety**.
    - Alert physician or clinician responsible for patient’s care.

#### Provide resources to all patients

- 24/7 National Suicide Prevention Lifeline 1-800-273-TALK (8255) En Español: 1-888-628-9454
- 24/7 Crisis Text Line: Text “HOME” to 741-741

asQ Suicide Risk Screening Toolkit

NATIONAL INSTITUTE OF MENTAL HEALTH (NIMH)

7/1/2020

**Fig. 40.3** Ask Suicide-Screening Questions—Suicide Risk Screening Tool. (ASQ Tool courtesy National Institute of Mental Health. National Institutes of Health, Bethesda, Maryland. Accessed at <https://www.nimh.nih.gov/research/research-conducted-at-nimh/asq-toolkit-materials>, May 9, 2022.)

**Table 40.4** Columbia Suicide Severity Rating Scale Screener

1. Have you wished you were dead or wished you could go to sleep and not wake up?
2. Have you actually had any thoughts about killing yourself?  
If “Yes” to 2, answer questions 3, 4, 5, and 6.  
If “No” to 2, go directly to question 6.
3. Have you thought about how you might do this?
4. Have you had any intention of acting on these thoughts of killing yourself, as opposed to you having the thoughts but you definitely would not act on them?
5. Have you started to work out or worked out the details of how to kill yourself? Do you intend to carry out this plan?
6. Have you done anything, started to do anything, or prepared to do anything to end your life?

**RESPONSE PROTOCOL TO SCREENING (BASED ON LAST ITEM ANSWERED “YES”)**

- Item 1—Mental Health Referral at discharge
- Item 2—Mental Health Referral at discharge
- Item 3—Care Team Consultation (Psychiatric Nurse) and Patient Safety Monitor/Procedures
- Item 4—Psychiatric Consultation and Patient Safety Monitor/Procedures
- Item 5—Psychiatric Consultation and Patient Safety Monitor/Procedures
- Item 6—If over 3 months ago, Mental Health Referral at discharge

If 3 months ago or less, Psychiatric Consultation and Patient Safety Monitor

From Posner K. Columbia Lighthouse Project. The Columbia-Suicide Severity Rating Scale (C-SSRS) Screener—Recent. <https://cssrs.columbia.edu/the-columbia-scale-c-srs/risk-identification/>

context of concerning information elicited in child/parent psychosocial histories (e.g., HEADSS Psychosocial Risk Assessment; see Chapter 32, Table 32.2), general screening measure scores out of the normal range (e.g., Pediatric Symptom Checklist Internalizing Sub-Scale; see Table 28.5), or self-reported statements or behaviors from patients and parents. The Ask Suicide-Screening Questionnaire (ASQ) is a validated four-item measure shown in the ED setting to have high sensitivity and negative predictive value in identifying youth at risk for suicide ideation and behavior (Fig. 40.3). Other common screening tools are the Columbia Suicide Severity Rating Scale (C-SSRS) Screener (Table 40.4) and the Patient Health Questionnaire (PHQ-2/PHQ-9). These scales have also been used in the emergency room setting.

Through follow-up office visits, pediatric practitioners can help support and facilitate the implementation of psychotherapies that target the *specific psychiatric disorders* and the emotional dysphoria or behavioral dysregulation that accompany suicidal ideation or behavior. In conjunction with a child and adolescent psychiatrist, psychotropic medications may be used as indicated to treat underlying psychiatric disorders. Both dialectical behavioral therapy and cognitive behavioral therapy are effective in reducing harm but must be combined with appropriate psychopharmacology of an underlying disorder. Pediatric practitioners also can encourage social connectedness to peers and to community organizations, as well as promote help-seeking (e.g., talking to a trusted adult when distressed) and wellness behaviors. In the event of a completed suicide, pediatricians can offer support to the family, particularly by monitoring for pathologic bereavement responses in siblings and parents.

### SCHOOL RESOURCES

Screening for suicide in schools is also fraught with problems related to low specificity of screening instruments, paucity of referral sites, and variable acceptability among school administrators. Gatekeeper (e.g., student support personnel) training appears effective in improving skills among school personnel and is highly acceptable to administrators but has not been shown to prevent suicide. School curricula (e.g., Signs of Suicide) have shown some preventive potential by teaching students to recognize the signs of depression and suicide in themselves and others and providing them with specific action steps necessary for responding to these signs. Peer helpers have not generally been shown to be efficacious.

Visit Elsevier eBooks+ at [eBooks.Elsevier.com](http://eBooks.Elsevier.com) for Bibliography.

## Chapter 41

# Eating Disorders

Taylor B. Starr and Richard E. Kreipe

Eating disorders (EDs) are characterized by body dissatisfaction related to overvaluation of a thin body ideal, associated with dysfunctional patterns of cognition and weight control behaviors that result in significant biologic, psychologic, and social complications. EDs can develop in individuals of any age, gender, sexual orientation, ethnicity, or cultural background. Early intervention in EDs improves outcome.

### DEFINITIONS

**Anorexia nervosa (AN)** involves significant overestimation of body size and shape, with a relentless pursuit of thinness that, in the **restrictive** subtype, typically combines excessive dieting and compulsive exercising. In the **binge-purge** subtype, patients might intermittently overeat and then attempt to rid themselves of calories by vomiting or taking laxatives, still with a strong drive for thinness (Table 41.1).

**Bulimia nervosa (BN)** is characterized by episodes of eating large amounts of food in a brief period, followed by compensatory vomiting, laxative use, exercise, or fasting to rid the body of the effects of overeating in an effort to avoid obesity (Table 41.2).

Children and adolescents with EDs may not fulfill criteria for AN or BN in the *Diagnostic and Statistical Manual of Mental Disorders, Fifth Edition* (DSM-5) and may fall into a subcategory of **Other Specified Feeding and Eating Disorders (OSFED)**. Youth with these subthreshold conditions merit close monitoring over time because they may be early in the course of an illness.

**Avoidant/restrictive food intake disorder (ARFID)** involves limiting food intake based on the subjective qualities of food (e.g., appearance, color, smell, taste, texture or consistency), fear of adverse consequences of eating (e.g., choking, gagging or vomiting), or lack of interest in eating, but without concern about body image, weight, shape, or size. However, significant unintended weight loss or nutritional deficiencies and problems with social interactions can occur as a result (Table 41.3).

**Binge eating disorder (BED)**, in which binge eating is not followed regularly by any compensatory behaviors (vomiting, laxatives), is a stand-alone category in DSM-5 but shares many features with obesity (see Chapter 65).



**Table 41.1** DSM-5 Diagnostic Criteria for Anorexia Nervosa

- A. Restriction of energy intake relative to requirements, leading to a significantly low body weight in the context of age, sex, developmental trajectory, and physical health. Significantly low weight is defined as a weight that is less than minimally normal or, for children and adolescents, less than that minimally expected.
- B. Intense fear of gaining weight or of becoming fat, or persistent behavior that interferes with weight gain, even though at a significantly low weight.
- C. Disturbance in the way in which one's body weight or shape is experienced, undue influence of body weight or shape on self-evaluation, or persistent lack of recognition of the seriousness of the current low body weight.

Specify whether:

**Restricting type** (ICD-10-CM code F50.01): During the last 3 mo, the individual has not engaged in recurrent episodes of binge eating or purging behavior (i.e., self-induced vomiting or the misuse of laxatives, diuretics, or enemas). This subtype describes presentations in which weight loss is accomplished primarily through dieting, fasting, and/or excessive exercise.

**Binge-eating/purging type** (ICD-10-CM code F50.02): During the last 3 mo, the individual has engaged in recurrent episodes of binge eating or purging behavior (i.e., self-induced vomiting or the misuse of laxatives, diuretics, or enemas).

Specify if:

**In partial remission:** After full criteria for anorexia nervosa were previously met, Criterion A (low body weight) has not been met for a sustained period, but either Criterion B (intense fear of gaining weight or becoming fat or behavior that interferes with weight gain) or Criterion C (disturbances in self-perception of weight and shape) is still met.

**In full remission:** After full criteria for anorexia nervosa were previously met, none of the criteria has been met for a sustained period of time.

Specify current severity:

The minimum level of severity is based, for adults, on current BMI (see the following) or, for children and adolescents, on BMI percentile. **The ranges below are derived from World Health Organization categories for thinness in adults; for children and adolescents, corresponding BMI percentiles should be used.** The level of severity may be increased to reflect clinical symptoms, the degree of functional disability, and the need for supervision.

**Mild:** BMI  $\geq 17$  kg/m<sup>2</sup>  
**Moderate:** BMI 16–16.99 kg/m<sup>2</sup>  
**Severe:** BMI 15–15.99 kg/m<sup>2</sup>  
**Extreme:** BMI  $< 15$  kg/m<sup>2</sup>

From the *Diagnostic and Statistical Manual of Mental Disorders*, 5th ed. pp. 338–339. Copyright 2013. American Psychiatric Association.

## EPIDEMIOLOGY

The classic presentation of AN is an early to middle adolescent female of above-average intelligence and socioeconomic status who is a conflict-avoidant, risk-averse perfectionist and is struggling with disturbances of anxiety and/or mood. BN tends to emerge in later adolescence, sometimes evolving from AN, and is typified by impulsivity and features of borderline personality disorder associated with depression and mood swings. ARFID typically presents in late childhood, is more common in males, and more often co-occurs with anxiety disorders and autism spectrum disorder. The 0.5–1% and 3–5% incidence rates among younger and older adolescent females for AN and BN, respectively, probably reflect ascertainment bias in sampling and underdiagnosis in cases not fitting the common profile. The same may be true of

**Table 41.2** DSM-5 Diagnostic Criteria for Bulimia Nervosa

- A. Recurrent episodes of binge eating. An episode of binge eating is characterized by both of the following:
1. Eating, in a discrete period of time (e.g., within any 2 hr period), an amount of food that is definitely larger than what most individuals would eat in a similar period of time under similar circumstances.
  2. A sense of lack of control over eating during the episode (e.g., a feeling that one cannot stop eating or control what or how much one is eating).

B. Recurrent inappropriate compensatory behaviors to prevent weight gain, such as self-induced vomiting; misuse of laxatives, diuretics, or other medications; fasting; or excessive exercise.

C. The binge eating and inappropriate compensatory behaviors both occur, on average, at least once a week for 3 mo.

D. Self-evaluation is unduly influenced by body shape and weight.

E. The disturbance does not occur exclusively during episodes of anorexia nervosa.

Specify if:

**In partial remission:** After full criteria for bulimia nervosa were previously met, some, but not all, of the criteria have been met for a sustained period of time.

**In full remission:** After full criteria for bulimia nervosa were previously met, none of the criteria has been met for a sustained period of time.

Specify current severity:

The minimum level of severity is based on the frequency of inappropriate compensatory behaviors (see the following). The level of severity may be increased to reflect other symptoms and the degree of functional disability.

**Mild:** An average of 1–3 episodes of inappropriate compensatory behaviors per week.

**Moderate:** An average of 4–7 episodes of inappropriate compensatory behaviors per week.

**Severe:** An average of 8–13 episodes of inappropriate compensatory behaviors per week.

**Extreme:** An average of 14 or more episodes of inappropriate compensatory behaviors per week.

From the *Diagnostic and Statistical Manual of Mental Disorders*, 5th ed. p. 345. Copyright 2013. American Psychiatric Association.

the significant gender disparity, in which female patients account for approximately 85% of patients with diagnosed EDs.

No single factor causes the development of an ED; sociocultural studies indicate a complex interplay of culture, ethnicity, gender, peers, and family. The gender dimorphism is presumably related to females having a stronger relationship between body image and self-evaluation, as well as the influence of the Western culture's thin body ideal. Ethnicity appears to moderate the association between risk factors and disordered eating, with African American and Caribbean females reporting lower body dissatisfaction and less dieting than Hispanic and non-Hispanic White females. Because peer acceptance is central to healthy adolescent growth and development, especially in early adolescence, when AN tends to have its initial prevalence peak, the potential influence of peers on EDs is significant, as are the relationships among peers, body image, and eating. Teasing by peers or by family members (especially males) may be a contributing factor for overweight females.

**Table 41.3** DSM-5 Diagnostic Criteria for AVOIDANT/Restrictive Food Intake Disorder

A. An eating or feeding disturbance (e.g., apparent lack of interest in eating or food; avoidance based on the sensory characteristics of food; concern about aversive consequences of eating) as manifested by persistent failure to meet appropriate nutritional and/or energy needs associated with one (or more) of the following: <ol style="list-style-type: none"> <li>1. Significant weight loss (or failure to achieve expected weight gain or faltering growth in children).</li> <li>2. Significant nutritional deficiency.</li> <li>3. Dependence on enteral feeding or oral nutritional supplements.</li> <li>4. Marked interference with psychosocial functioning.</li> </ol>
B. The disturbance is not better explained by lack of available food or by an associated culturally sanctioned practice.
C. The eating disturbance does not occur exclusively during the course of anorexia nervosa or bulimia nervosa, and there is no evidence of a disturbance in the way in which one's body weight or shape is experienced.
D. The eating disturbance is not attributable to a concurrent medical condition or not better explained by another mental disorder. When the eating disturbance occurs in the context of another condition or disorder, the severity of the eating disturbance exceeds that routinely associated with the condition or disorder and warrants additional clinical attention.
Specify if:
In remission: After full criteria for avoidant/restrictive food intake disorder were previously met, the criteria have not been met for a sustained period of time.

From the *Diagnostic and Statistical Manual of Mental Disorders*, 5th ed. p. 334. Copyright 2013. American Psychiatric Association.

**Family** influence in the development of EDs is even more complex because of the interplay of environmental and genetic factors; shared elements of the family environment and immutable genetic factors account for approximately equal amounts of the variance in disordered eating. There are associations between parents' and children's eating behaviors; dieting and physical activity levels suggest parental reinforcement of body-related societal messages. The influence of inherited genetic factors on the emergence of EDs during adolescence is also significant, but not directly. Rather, the risk for developing an ED appears to be mediated through a genetic predisposition to *anxiety* (see [Chapter 38](#)), *depression* (see [Chapter 39](#)), or *obsessive-compulsive traits* that may be modulated through the internal milieu of puberty. There is no evidence to support the outdated notion that parents or family dynamics cause an ED; rather, the family dynamics may represent responses to having a family member with a potentially life-threatening condition. The supportive influence on recovery of parents as nurturing caregivers cannot be overestimated.

## **PATHOLOGY AND PATHOGENESIS**

The emergence of EDs coinciding with the processes of adolescence (e.g., puberty, identity, autonomy, cognition) indicates the central role of development. EDs may be viewed as a final common pathway, with a number of *predisposing* factors that increase the risk of developing an ED, *precipitating* factors often related to developmental processes of adolescence triggering the emergence of the ED, and *perpetuating* factors that cause an ED to persist. A history of sexual trauma is more common in children with BN, and when present with any ED makes recovery more difficult. EDs often begin with dieting but gradually progress to unhealthy habits that lessen the negative impact of associated psychosocial problems to which the affected person is vulnerable because of premorbid biologic and psychologic characteristics, family interactions, and social climate. When persistent, the biologic effects of starvation and malnutrition (e.g., true loss of appetite, hypothermia, gastric atony, amenorrhea, sleep disturbance, fatigue, weakness, depression), combined with

the psychologic rewards of increased sense of mastery and reduced emotional reactivity, actually maintain and reward pathologic ED behaviors.

This positive reinforcement of behaviors and consequences, generally viewed by parents and others as negative, helps to explain why persons with an ED characteristically deny that a problem exists and resist treatment. With significantly low caloric intake, patients initially exhibit extreme irritability, but over time experience emotional “numbness,” which reinforces continued caloric restriction. Although noxious, purging can be reinforcing because of a reduction in anxiety triggered by overeating; purging also can result in short-term, but reinforcing, improvement in mood related to changes in neurotransmitters. In addition to an imbalance in neurotransmitters, most notably serotonin and dopamine, alterations in functional anatomy also support the concept of EDs as brain disorders. The cause-and-effect relationship in central nervous system (CNS) alterations in EDs is not clear, nor is their reversibility.

## **CLINICAL MANIFESTATIONS**

Except for ARFID, in which weight loss is *unintentional*, a central feature of EDs is the overestimation of body size, shape, or parts (e.g., abdomen, thighs) leading to intentional weight control practices to reduce weight (AN) or prevent weight gain (BN). Associated practices include severe restriction of caloric intake and behaviors intended to reduce the effect of calories ingested, such as compulsive exercising or purging by inducing vomiting or taking laxatives. Eating and weight loss habits commonly found in EDs can result in a wide range of energy intake and output, the balance of which leads to a wide range in weight, from extreme loss of weight in AN to fluctuation around a normal to moderately high weight in BN. Reported eating and weight control habits thus inform the initial primary care approach ([Table 41.4](#)).

Although weight control patterns guide the initial pediatric approach, an assessment of common symptoms and findings on physical examination is essential to identify targets for intervention. When reported symptoms of excessive weight loss (feeling tired and cold; lacking energy; orthostasis; difficulty concentrating) are explicitly linked by the clinician to their associated physical signs (hypothermia with acrocyanosis and slow capillary refill; loss of muscle mass; bradycardia with orthostasis), it becomes more difficult for the patient to deny that a problem exists. Furthermore, awareness that bothersome symptoms can be eliminated by healthier eating and activity patterns can increase a patient's motivation to engage in treatment. [Tables 41.5](#) and [41.6](#) detail common symptoms and signs that should be addressed in a pediatric assessment of a suspected ED.

## **DIFFERENTIAL DIAGNOSIS**

In addition to identifying symptoms and signs that deserve targeted intervention for patients who have an ED, a comprehensive history and physical examination are required to rule out other conditions in the differential diagnosis. Weight loss can occur in any condition with increased *catabolism* (e.g., hyperthyroidism, malignancy, occult chronic infection) or *malabsorption* (e.g., **celiac disease**) or in other disorders (Addison disease, type 1 diabetes mellitus, stimulant abuse), but these illnesses are generally associated with other findings and are not usually associated with decreased caloric intake. Patients with **inflammatory bowel disease** can reduce intake to minimize abdominal cramping; eating can cause abdominal discomfort and early satiety in AN because of gastric atony associated with significant weight loss, not malabsorption. Likewise, signs of weight loss in AN might include hypothermia, acrocyanosis with slow capillary refill, and neutropenia similar to some features of sepsis, but the overall picture in EDs is one of relative cardiovascular stability compared with sepsis. **Endocrinopathies** are also in the differential of EDs. With BN, voracious appetite in the face of weight loss might suggest diabetes mellitus, but blood glucose levels are normal or low in EDs. Adrenal insufficiency mimics many physical symptoms and signs found in restrictive AN but is associated with elevated potassium levels and hyperpigmentation. Thyroid disorders may be considered, because of changes in weight, but the overall presentation of AN includes symptoms of both underactive and

**Table 41.4** Eating and Weight Control Habits Commonly Found in Children and Adolescents with an Eating Disorder (ED)

HABIT	PROMINENT FEATURE		CLINICAL COMMENTS REGARDING ED HABITS	
	ANOREXIA NERVOSA	BULIMIA NERVOSA	ANOREXIA NERVOSA	BULIMIA NERVOSA
Overall intake	Inadequate energy (calories), although volume of food and beverages may be high because of very low caloric density of intake as a result of “diet” and nonfat choices	Variable, but calories normal to high; intake in binges is often “forbidden” food or drink that differs from intake at meals	Consistent inadequate caloric intake leading to wasting of the body is an essential feature of diagnosis	Inconsistent balance of intake, exercise, and vomiting, but severe caloric restriction is short-lived
Food	Counts and limits calories, especially from fat; emphasis on “healthy food choices” with reduced caloric density Monotonous, limited “good” food choices, often leading to vegetarian or vegan diet Strong feelings of guilt after eating more than planned leads to exercise and renewed dieting	Aware of calories and fat, but less regimented in avoidance than AN Frequent dieting interspersed with overeating, often triggered by depression, isolation, or anger	Obsessive-compulsive attention to nutritional data on food labels and may have “logical” reasons for food choices in highly regimented pattern, such as sports participation or family history of lipid disorder	Choices less structured, with more frequent diets
Beverages	Water or other low- or no-calorie drinks; nonfat milk	Variable, diet soda common; may drink alcohol to excess	Fluids often restricted to avoid weight gain	Fluids ingested to aid vomiting or replace losses
Meals	Consistent schedule and structure to meal plan Reduced or eliminated caloric content, often starting with breakfast, then lunch, then dinner Volume can increase with fresh fruits, vegetables, and salads as primary food sources	Meals less regimented and planned than in AN; more likely impulsive and unregulated, often eliminated following a binge-purge episode	Rigid adherence to “rules” governing eating leads to sense of control, confidence, and mastery	Elimination of a meal following a binge-purge only reinforces the drive for binge later in the day
Snacks	Reduced or eliminated from meal plan	Often avoided in meal plans, but then impulsively eaten	Snack foods removed early because “unhealthy”	Snack “comfort foods” can trigger a binge
Dieting	Initial habit that becomes progressively restrictive, although often appearing superficially “healthy” Beliefs and “rules” about the patient’s idiosyncratic nutritional requirements and response to foods are strongly held	Initial dieting gives way to chaotic eating, often interpreted by the patient as evidence of being “weak” or “lazy”	Distinguishing between healthy meal planning with reduced calories and dieting in ED may be difficult	Dieting tends to be impulsive and short-lived, with “diets” often resulting in unintended weight gain
Binge eating	None in restrictive subtype, but an essential feature in binge-purge subtype	Essential feature, often secretive Shame and guilt prominent afterward	Often “subjective” (more than planned but not large)	Relieves emotional distress, may be planned
Exercise	Characteristically obsessive-compulsive, ritualistic, and progressive May excel in dance, long-distance running	Less predictable May be athletic, or may avoid exercise entirely	May be difficult to distinguish active thin vs ED	Males often use exercise as means of “purging”
Vomiting	Characteristic of binge-purge subtype May chew, then spit out, rather than swallow, food as a variant	Most common habit intended to reduce effects of overeating Can occur after meal as well as a binge	Physiologic and emotional instability prominent	Strongly “addictive” and self-punishing, but does not eliminate calories ingested—many still absorbed
Laxatives	If used, generally to relieve constipation in restrictive subtype, but as a cathartic in binge-purge subtype	Second most common habit used to reduce or avoid weight gain, often used in increasing doses for cathartic effect	Physiologic and emotional instability prominent	Strongly “addictive,” self-punishing, but ineffective means to reduce weight (calories are absorbed in small intestine, but laxatives work in colon)
Diet pills	Very rare, if used; more common in binge-purge subtype	Used to either reduce appetite or increase metabolism	Use of diet pills implies inability to control eating	Control over eating may be sought by any means

AN, Anorexia nervosa; BN, bulimia nervosa.

**Table 41.5** Symptoms Commonly Reported by Patients with an Eating Disorder (ED)

SYMPTOMS	DIAGNOSIS		CLINICAL COMMENTS REGARDING ED SYMPTOMS
	ANOREXIA NERVOSA	BULIMIA NERVOSA	
Body image	Feels fat, even with extreme emaciation, often with specific body distortions (e.g., stomach, thighs); strong drive for thinness, with self-efficacy closely tied to appraisal of body shape, size, and/or weight	Variable body image distortion and dissatisfaction, but drive for thinness is less than desire to avoid gaining weight	Challenging patient's body image is both ineffective and countertherapeutic clinically Accepting patient's expressed body image but noting its discrepancy with symptoms and signs reinforces concept that patient can "feel" fat but also "be" too thin and unhealthy
Metabolism	Hypometabolic symptoms include feeling cold, tired, and weak and lacking energy May be both bothersome and reinforcing	Variable, depending on balance of intake and output and hydration	Symptoms are evidence of body's "shutting down" in an attempt to conserve calories with an inadequate diet Emphasizing reversibility of symptoms with healthy eating and weight gain can motivate patients to cooperate with treatment
Skin	Dry skin, delayed healing, easy bruising, gooseflesh Orange-yellow skin on hands	No characteristic symptom; self-injurious behavior may be seen	Skin lacks good blood flow and ability to heal in low weight Carotenemia with large intake of $\beta$ -carotene foods; reversible
Hair	Lanugo-type hair growth on face and upper body Slow growth and increased loss of scalp hair	No characteristic symptom	Body hair growth conserves energy Scalp hair loss can worsen during refeeding "telogen effluvium" (resting hair is replaced by growing hair) Reversible with continued healthy eating
Eyes	No characteristic symptom	Subconjunctival hemorrhage	Caused by increased intrathoracic pressure during vomiting
Teeth	No characteristic symptom	Erosion of dental enamel Decay, fracture, and loss of teeth	Intraoral stomach acid resulting from vomiting etches dental enamel, exposing softer dental elements
Salivary glands	No characteristic symptom	Enlargement (no to mild tenderness)	Caused by chronic binge eating and induced vomiting, with parotid enlargement more prominent than submandibular; reversible
Heart	Dizziness, fainting in restrictive subtype Palpitations more common in binge-purge subtype	Dizziness, fainting, palpitations	Dizziness and fainting due to postural orthostatic tachycardia and dysregulation at hypothalamic and cardiac level with weight loss, as a result of hypovolemia with binge-purge Palpitations and arrhythmias often caused by electrolyte disturbance Symptoms reverse with weight gain and/or cessation of binge-purge
Abdomen	Early fullness and discomfort with eating Constipation Perceives contour as "fat," often preferring well-defined abdominal musculature	Discomfort after a binge Cramps and diarrhea with laxative abuse	Weight loss is associated with reduced volume and tone of GI tract musculature, especially the stomach Laxatives may be used to relieve constipation or as a cathartic Symptom reduction with healthy eating can take weeks to occur
Extremities and musculoskeletal	Cold, blue hands and feet	No characteristic symptoms Self-cutting or burning on wrists or arms	Energy-conserving low body temperature with slow blood flow most notable peripherally Quickly reversed with healthy eating
Nervous system	No characteristic symptom	No characteristic symptom	Neurologic symptoms suggest diagnosis other than ED
Mental status	Depression, anxiety, obsessive-compulsive symptoms, alone or in combination	Depression; PTSD; borderline personality disorder traits	Underlying mood disturbances can worsen with dysfunctional weight control practices and can improve with healthy eating AN patients might report emotional "numbness" with starvation preferable to emotionality associated with healthy eating

AN, Anorexia nervosa; ED, eating disorder; GI, gastrointestinal; PTSD, posttraumatic stress disorder.



**Table 41.6** Signs Commonly Found in Patients with Eating Disorder Relative to Prominent Feature of Weight Control

PHYSICAL SIGN	PROMINENT FEATURE		CLINICAL COMMENTS RELATED TO ED SIGNS
	RESTRICTIVE INTAKE	BINGE EATING/PURGING	
General appearance	Thin to cachectic, depending on balance of intake and output Might wear bulky clothing to hide thinness and might resist being examined	Thin to overweight, depending on the balance of intake and output through various means	Examine in hospital gown Weight loss more rapid with reduced intake and excessive exercise Binge eating can result in large weight gain, regardless of purging behavior Appearance depends on balance of intake and output and overall weight control habits
Weight	Low and falling (if previously overweight, may be normal or high); may be falsely elevated if patient drinks fluids or adds weights to body before being weighed	Highly variable, depending on balance of intake and output and state of hydration Falsification of weight is unusual	Weigh in hospital gown with no underwear, after voiding (measure urine SG) Remain in gown until physical exam completed to identify possible fluid loading (low urine SG, palpable bladder) or adding weights to body
Metabolism	Hypothermia: temp <35.5°C (95.9°F), pulse <60 beats/min Slowed psychomotor response with very low core temperature Hypoglycemia Hypokalemia Amenorrhea Delayed puberty	Variable, but hypometabolic state is less common than in AN	Hypometabolism related to disruption of hypothalamic control mechanisms as a result of weight loss Signs of hypometabolism (cold skin, slow capillary refill, acrocyanosis) most evident in hands and feet, where energy conservation is most active Metabolic acidosis or alkalosis
Skin	Dry, scaly Increased prominence of hair follicles Orange or yellow hands Hair loss	Calluses over proximal knuckle joints of hand (Russell sign)	Carotenemia with large intake of $\beta$ -carotene foods Russell sign: maxillary incisors abrasion develops into callus with chronic digital pharyngeal stimulation, usually on dominant hand
Hair	Lanugo-type hair growth on face and upper body Scalp hair loss, especially prominent in parietal region	No characteristic sign	Body hair growth conserves energy Scalp hair loss “telogen effluvium” can worsen weeks after refeeding begins, as hair in resting phase is replaced by growing hair
Eyes	No characteristic sign	Subconjunctival hemorrhage	Increased intrathoracic pressure during vomiting
Teeth	Caries	Eroded dental enamel and decayed, fractured, missing teeth	Perimolysis (dental erosions) worse on lingual surfaces of maxillary teeth, is intensified by brushing teeth without preceding water rinse
Salivary glands	No characteristic sign	Enlargement, relatively nontender	Parotid > submandibular involvement with frequent and chronic binge eating and induced vomiting
Throat	No characteristic sign	Absent gag reflex	Extinction of gag response with repeated pharyngeal stimulation
Heart	Bradycardia, hypotension, and orthostatic pulse differential >25 beats/min	Hypovolemia if dehydrated	Changes in AN resulting from central hypothalamic and intrinsic cardiac function Orthostatic changes less prominent if athletic, more prominent if associated with purging
Abdomen	Scaphoid, organs may be palpable but not enlarged, stool-filled left lower quadrant Constipation Transaminitis	Increased bowel sounds if recent laxative use	Presence of organomegaly requires investigation to determine cause Constipation prominent with weight loss Pancreatitis Esophageal or gastric ulceration or perforation
Extremities and musculoskeletal system	Cold, acrocyanosis, slow capillary refill Edema of feet Loss of muscle, subcutaneous, and fat tissue Osteopenia	No characteristic sign, but may have rebound edema after stopping chronic laxative use	Signs of hypometabolism (cold) and cardiovascular dysfunction (slow capillary refill and acrocyanosis) in hands and feet Edema, caused by capillary fragility more than hypoproteinemia in AN, can worsen in early phase of refeeding
Nervous system	No characteristic sign Peripheral neuropathy	No characteristic sign	Water loading before weigh-ins can cause acute hyponatremia
Mental status	Anxiety about body image, irritability, depressed mood, oppositional to change	Depression, evidence of PTSD, more likely suicidal than AN	Mental status often improves with healthier eating and weight; SSRIs only shown to be effective for BN

AN, Anorexia nervosa; BN, bulimia nervosa; ED, eating disorder; PTSD, posttraumatic stress disorder; SG, specific gravity; SSRIs, selective serotonin reuptake inhibitors.

overactive thyroid, such as hypothermia, bradycardia, and constipation, as well as weight loss and excessive physical activity, respectively.

In the CNS, craniopharyngiomas and Rathke pouch tumors can mimic some of the findings of AN, such as weight loss and growth failure, and even some body image disturbances, but the latter are less fixed than in typical EDs and are associated with other findings, including evidence of increased intracranial pressure. **Mitochondrial neurogastrointestinal encephalomyopathy**, caused by a mutation in the *TYMP* gene, presents with gastrointestinal dysmotility, cachexia, ptosis, peripheral neuropathy, ophthalmoplegia, and leukoencephalopathy. Symptoms begin during the second decade of life and are often initially diagnosed as AN. Early satiety, vomiting, cramps, constipation, and pseudoobstruction result in weight loss often before the neurologic features are noticed (see Chapter 638.2). Acute or chronic oromotor dysfunction and obsessive-compulsive disorder may mimic an ED. Fear of choking may lead to **avoidance-restrictive food intake disorder**.

Any patient with an atypical presentation of an ED, based on age, sex, or other factors not typical for AN or BN, deserves a scrupulous search for an alternative explanation. In ARFID, disturbance in the neurosensory processes associated with eating, not weight loss, is the central concern and must be recognized for appropriate treatment. Patients can have both an underlying illness and an ED. The core features of dysfunctional eating habits (body image disturbance and change in weight) can co-occur with conditions such as diabetes mellitus, where patients might manipulate their insulin dosing to lose weight.

### LABORATORY FINDINGS

Because the diagnosis of an ED is made clinically, there is no confirmatory laboratory test. Laboratory abnormalities, when found, are the result of malnutrition secondary to weight control behaviors or medical complications; studies should be chosen based on history and physical examination. A routine screening battery typically includes complete blood count, erythrocyte sedimentation rate (should be normal), and biochemical profile. Common abnormalities in ED include low white blood cell count with normal hemoglobin and differential; hypokalemic, hypochloremic metabolic alkalosis from severe vomiting; mildly elevated liver enzymes, cholesterol, and cortisol levels; low gonadotropins and blood glucose with marked weight loss; and generally normal total protein, albumin, and renal function. An electrocardiogram (ECG) may be useful when profound bradycardia or arrhythmia is detected; the ECG usually has low voltage, with nonspecific ST or T-wave changes. Although prolonged QTc has been reported, prospective studies have not found an increased risk for this. Nonetheless, when a prolonged QTc is present in a patient with ED, it may increase the risk for ventricular dysrhythmias.

### COMPLICATIONS

No organ is spared the harmful effects of dysfunctional weight control behaviors, but the most concerning targets of medical complications are the heart, brain, gonads, and bones. Some **cardiac** findings in EDs (e.g., sinus bradycardia, hypotension) are *physiologic* adaptations to starvation that conserve calories and reduce afterload. Cold, blue hands and feet with slow capillary refill that can result in tissue perfusion insufficient to meet demands also represent energy-conserving responses associated with inadequate intake. All these acute changes are reversible with restoration of nutrition and weight. Significant orthostatic pulse changes, ventricular dysrhythmias, or reduced myocardial contractility reflect myocardial impairment that can be lethal. In addition, with extremely low weight, **refeeding syndrome** (a result of the rapid drop in serum phosphorus, magnesium, and potassium with excessive reintroduction of calories, specifically carbohydrates), is associated with acute tachycardia and heart failure and neurologic symptoms (see Chapter 63). With long-term malnutrition, the myocardium appears to be more prone to tachyarrhythmias, the second most common cause of death in these patients after suicide. In BN, dysrhythmias can also be related to electrolyte imbalance.

Clinically, the primary CNS area affected acutely in EDs, especially with weight loss, is the **hypothalamus**. Hypothalamic dysfunction is reflected in problems with thermoregulation (warming and cooling), satiety, sleep, autonomic cardioregulatory imbalance (orthostasis), and endocrine function (reduced gonadal and excessive adrenal cortex stimulation), all of which are reversible. Anatomic studies of the brain in ED have focused on AN, with the most common finding being increased ventricular and sulcal volumes that normalize with weight restoration. Persistent gray matter deficits following recovery, related to the degree of weight loss, have been reported. Elevated medial temporal lobe cerebral blood flow on positron emission tomography, similar to that found in psychotic patients, suggests that these changes may be related to body image distortion. Also, visualizing high-calorie foods is associated with exaggerated responses in the visual association cortex that are similar to those seen in patients with specific phobias. Patients with AN might have an imbalance between serotonin and dopamine pathways related to neurocircuits in which dietary restraint reduces anxiety.

Reduced **gonadal** function occurs in male and female patients; it is clinically manifested in AN as amenorrhea in female patients and erectile dysfunction in males. It is related to understimulation from the hypothalamus as well as cortical suppression related to physical and emotional stress. Amenorrhea precedes significant dieting and weight loss in up to 30% of females with AN, and most adolescents with EDs perceive the absence of menses positively. The primary health concern is the negative effect of decreased ovarian function and estrogen on **bones**. Decreased bone mineral density (BMD) with osteopenia or the more severe osteoporosis is a significant complication of EDs (more pronounced in AN than BN). Data do not support the use of sex hormone replacement therapy because this alone does not improve other causes of low BMD (low body weight, lean body mass, low insulin-like growth factor-1, high cortisol).

### TREATMENT

#### Principles Guiding Primary Care Treatment

The approach in primary care should facilitate the acceptance by the ED patient (and parents) of the diagnosis and initial treatment recommendations. A **nurturant-authoritative** approach using the biopsychosocial model is useful. A pediatrician who explicitly acknowledges that the patient may disagree with the diagnosis and treatment recommendations and may be ambivalent about changing eating habits, while also acknowledging that recovery requires strength, courage, willpower, and determination, demonstrates *nurturance*. Parents also find it easier to be nurturing once they learn that the development of an ED is neither a willful decision by the patient nor a reflection of poor parenting. Framing the ED as a “maladaptive coping mechanism” for a complex variety of issues with both positive and negative aspects avoids blame or guilt and can prepare the family for professional help that will focus on strengths and restoring health, rather than on the deficits in the adolescent or the family.

The *authoritative* aspect of a physician’s role comes from expertise in health, growth, and physical development. A goal of primary care treatment should be attaining and maintaining health, not merely weight gain, although weight gain is a means to the goal of wellness. Providers who frame themselves as consultants to the patient with authoritative knowledge about health can avoid a countertherapeutic authoritarian stance. Primary care health-focused activities include monitoring the patient’s physical status, setting limits on behaviors that threaten the patient’s health, involving specialists with expertise in EDs on the treatment team, and continuing to provide primary care for health maintenance, acute illness, or injury.

The **biopsychosocial model** uses a broad ecologic framework, starting with the biologic impairments of physical health related to dysfunctional weight control practices, evidenced by symptoms and signs. Explicitly linking ED behaviors to symptoms and signs can increase motivation to change. In addition, there are usually unresolved psychosocial conflicts in both the intrapersonal (self-esteem, self-efficacy) and the interpersonal (family, peers, school)

domains. Weight control practices initiated as coping mechanisms become reinforced because of positive feedback. That is, external rewards (e.g., compliments about improved physical appearance) and internal rewards (e.g., perceived mastery over what is eaten or what is done to minimize the effects of overeating through exercise or purging) are more powerful to maintain behavior than negative feedback (e.g., conflict with parents, peers, and others about eating) is to change it. Thus, when definitive treatment is initiated, more productive alternative means of coping must be developed.

### Nutrition and Physical Activity

The primary care provider generally begins the process of prescribing nutrition, although a dietitian should be involved eventually in the meal planning and nutritional education of patients with AN or BN. Framing food as fuel for the body and the source of energy for daily activities emphasizes the health goal of increasing the patient's energy level, endurance, and strength. For patients with AN and low weight, the nutrition prescription should work toward gradually increasing weight at the rate of about 0.5-1 lb/week, by increasing energy intake by 100-200 kcal increments every few days, toward a target of approximately 90% of average body weight for sex, height, and age. Weight gain will not occur until intake exceeds output, and eventual intake for continued weight gain can exceed 4,000 kcal/day, especially for patients who are anxious and have high levels of thermogenesis from nonexercise activity. Stabilizing intake is the goal for patients with BN, with a gradual introduction of "forbidden" foods while also limiting foods that might trigger a binge.

When initiating treatment of an ED in a primary care setting, the clinician should be aware of common cognitive patterns. Patients with AN typically have all-or-none thinking (related to perfectionism) with a tendency to overgeneralize and jump to catastrophic conclusions, while assuming that their body is governed by rules that do not apply to others. These tendencies lead to the dichotomization of foods into good or bad categories, having a day ruined because of one unexpected event, or choosing foods based on rigid self-imposed restrictions. These thoughts may be related to neurocircuitry and neurotransmitter abnormalities associated with executive function and rewards. Weight loss in the absence of body shape, size, or weight concerns should raise suspicion about ARFID, because the emotional distress associated with "forced" eating is not associated with gaining weight, but with the neurosensory experience of eating.

A standard nutritional balance of 15–20% calories from protein, 50–55% from carbohydrate, and 25–30% from fat is appropriate. The fat content may need to be lowered to 15–20% early in the treatment of AN because of continued fat phobia. With the risk of low BMD in patients with AN, calcium and vitamin D supplements are often needed to attain the recommended 1,300 mg/day intake of calcium. Refeeding can be accomplished with frequent small meals and snacks consisting of a variety of foods and beverages (with minimal diet or fat-free products), rather than fewer high-volume high-calorie meals. Some patients find it easier to take in part of the additional nutrition as canned supplements (medicine) rather than food. Regardless of the source of energy intake, the risk for refeeding syndrome (e.g., see the previous section on "Complications") increases with the degree of weight loss and the rapidity of caloric increases (see Chapter 63). Therefore, if the weight has fallen below 80% of expected weight for height, refeeding should proceed carefully (not necessarily slowly) and possibly in the hospital (Table 41.7).

Patients with AN tend to have a highly structured day with restrictive intake, in contrast to BN, which is characterized by a lack of structure, resulting in chaotic eating patterns and binge-purge episodes. All patients with AN, BN, or ED-NOS benefit from a daily structure for healthy eating that includes three meals and at least one snack a day, distributed evenly over the day, based on balanced meal planning. Breakfast deserves special emphasis because it is often the

**Table 41.7** Potential Indications for Inpatient Medical Hospitalization of Patients with Anorexia Nervosa

#### PHYSICAL AND LABORATORY

Heart rate <50 beats/min  
Other cardiac rhythm disturbances  
Blood pressure <80/50 mm Hg  
Postural hypotension resulting in >10 mm Hg decrease or >25 beats/min increase  
Hypokalemia  
Hypophosphatemia  
Hypoglycemia  
Dehydration  
Body temperature <36.1°C (97°F)  
<80% healthy body weight  
Hepatic, cardiac, or renal compromise

#### PSYCHIATRIC

Suicidal intent and plan  
Very poor motivation to recover (in family and patient)  
Preoccupation with ego-syntonic thoughts  
Coexisting psychiatric disorders

#### MISCELLANEOUS

Requires supervision after meals and while using the restroom  
Failed day treatment

first meal eliminated in AN and is often avoided the morning after a binge-purge episode in BN. In addition to structuring meals and snacks, patients should plan structure in their activities. Although overexercising is common in AN, completely prohibiting exercise can lead to further restriction of intake or to surreptitious exercise; inactivity should be limited to situations in which weight loss is dramatic or there is physiologic instability. Also, healthy exercise (once a day, for no more than 30 min, at no more than moderate intensity) can improve mood and make increasing calories more acceptable. Because patients with AN often are unaware of their level of activity and tend toward progressively increasing their output, exercising without either a partner or supervision is not recommended.

### Primary Care Treatment

Follow-up primary care visits are essential in the management of EDs. Close monitoring of the response of the patient and the family to suggested interventions is required to determine which patients can remain in primary care treatment (patients with early, mildly disordered eating), which patients need to be referred to individual specialists for co-management (mildly progressive disordered eating), and which patients need to be referred for interdisciplinary team management (EDs). Between the initial and subsequent visits, the patient can record daily caloric intake (food, drink, amount, time, location), physical activity (type, duration, intensity), and emotional state (e.g., angry, sad, worried) in a journal that is reviewed jointly with the patient in follow-up. Focusing on the recorded data helps the clinician to identify dietary and activity deficiencies and excesses, as well as behavioral and mental health patterns, and helps the patient to become objectively aware of the relevant issues to address in recovery.

Given the tendency of patients with AN to overestimate their caloric intake and underestimate their activity level, before reviewing the journal record it is important at each visit to measure weight, without underwear, in a hospital gown after voiding; urine specific gravity; temperature; and blood pressure and pulse in supine, sitting, and standing positions as objective data. In addition, a targeted physical examination focused on hypometabolism, cardiovascular stability, and mental status, as well as any related symptoms, should occur at each visit to monitor progress (or regression).

### Referral to Mental Health Services

In addition to referral to a registered dietitian, mental health and other services are important elements of treatment of ED patients. Depending on availability and experience, these services can be provided by a psychiatric social worker, psychologist, or psychiatrist, who should team with the primary care provider. ARFID presents the challenge of working with patients' negative experiences of eating, or fear of trauma such as vomiting or choking, while also addressing inadequate nutritional needs. Although patients with AN often are prescribed a selective serotonin reuptake inhibitor (SSRI) because of depressive symptoms, there is no evidence of efficacy for patients at low weight; food remains the initial treatment of choice to treat depression in AN. SSRIs, very effective in reducing binge-purge behaviors regardless of depression, are considered a standard element of therapy in BN. SSRI dosage in BN, however, may need to increase to an equivalent of >60 mg of fluoxetine to maintain effectiveness.

**Cognitive-behavioral therapy**, which focuses on restructuring "thinking errors" and establishing adaptive patterns of behavior, is more effective than interpersonal or psychoanalytic approaches in ED patients. **Dialectical behavioral therapy**, in which distorted thoughts and emotional responses are challenged, analyzed, and replaced with healthier ones, with an emphasis on "mindfulness," requires adult thinking skills and is useful for older patients with BN. **Group therapy** can provide much needed support, but it requires a skilled clinician. Combining patients at various levels of recovery who experience variable reinforcement from dysfunctional coping behaviors can be challenging if group therapy patients compete with each other to be "thinner" or take up new behaviors such as vomiting.

The younger the patient, the more intimately the parents need to be involved in therapy. The only treatment approach with evidence-based effectiveness in the treatment of AN in children and adolescents is **family-based treatment**, exemplified by the Maudsley approach. This three-phase intensive outpatient model helps parents play a positive role in restoring their child's eating and weight to normal, then returns control of eating to the child, who has demonstrated the ability to maintain healthy weight, and then encourages healthy progression in the other domains of adolescent development. Features of effective family treatment include (1) an agnostic approach in which the cause of the disease is unknown and irrelevant to weight gain, emphasizing that parents are *not* to blame for EDs; (2) parents being actively nurturing and supportive of their child's healthy eating while reinforcing limits on dysfunctional habits, rather than an authoritarian "food police" or complete hands-off approach; and (3) reinforcement of parents as the best resource for recovery for almost all patients, with professionals serving as consultants and advisors to help parents address challenges.

### Referral to an Interdisciplinary Eating Disorder Team

The treatment of a child or adolescent diagnosed with an ED is ideally provided by an interdisciplinary team (physician, nurse, dietitian, mental health provider) with expertise treating pediatric patients. Because such teams, often led by specialists in adolescent medicine at medical centers, are not widely available, the primary care provider might need to convene such a team. Adolescent medicine-based programs report encouraging treatment outcomes, possibly related to patients entering earlier into care and the stigma that some patients and parents may associate with psychiatry-based programs. Specialty centers focused on treating EDs are generally based in psychiatry and often have separate tracks for younger and adult patients. The elements of treatment noted earlier (cognitive-behavioral, dialectical behavioral, family-based), as well as individual and group treatment, should all be available as part of interdisciplinary team treatment. Comprehensive services ideally include intensive outpatient and partial hospitalization as well as inpatient treatment. Regardless of the intensity, type, or location of the treatment services, the patient, parents, and primary care provider are essential members of the treatment team. A recurring theme in effective treatment is helping patients and families reestablish connections that are disrupted by the ED.

**Inpatient** medical treatment of EDs is generally limited to patients with AN to stabilize and treat life-threatening starvation and to provide supportive mental health services. Inpatient medical care may be required to avoid refeeding syndrome in severely malnourished patients, provide nasogastric tube feeding for patients unable or unwilling to eat, or initiate mental health services, especially family-based treatment, if this has not occurred on an outpatient basis (see Table 41.7). Admission to a general pediatric unit is advised only for short-term stabilization in preparation for transfer to a medical unit with expertise in treating pediatric EDs. Inpatient psychiatric care of EDs should be provided on a unit with expertise in managing often challenging behaviors (e.g., hiding or discarding food, vomiting, surreptitious exercise) and emotional problems (e.g., depression, anxiety). Suicidal risk is small, but patients with AN might threaten suicide if made to eat or gain weight in an effort to "get their parents to back off."

An ED **partial hospital program** offers outpatient services that are less intensive than round-the-clock inpatient care. Generally held 4-5 days/week for 6 to 9 hours each session, partial hospital program services typically are group based and include eating at least two meals as well as opportunities to address issues in a setting that more closely approximates "real life" than inpatient treatment. That is, patients sleep at home and are free-living on weekends, exposing them to challenges that can be processed during the 25-40 hours each week in program, as well as sharing group and family experiences.

### Supportive Care

In relation to pediatric EDs, support groups are primarily designed for parents. Because their daughter or son with an ED often resists the diagnosis and treatment, parents often feel helpless and hopeless. Because of the historical precedent of blaming parents for causing EDs, parents often express feelings of shame and isolation ([www.maudsleyparents.org](http://www.maudsleyparents.org)). Support groups and multifamily therapy sessions bring parents together with other parents whose families are at various stages of recovery from an ED in ways that are educational and encouraging. Patients often benefit from support groups after intensive treatment or at the end of treatment because of residual body image or other issues after eating and weight have normalized.

### PROGNOSIS

With early diagnosis and effective treatment, ≥80% of youth with AN recover: They develop normal eating and weight control habits, resume menses, maintain average weight for height, and function in school, work, and relationships, although some still have poor body image. With weight restoration, fertility returns as well, although the weight for resumption of menses (approximately 92% of average body weight for height) may be lower than the weight for ovulation. The prognosis for BN is less well established, but outcome improves with multidimensional treatment that includes SSRIs and attention to mood, past trauma, impulsivity, and any existing psychopathology. Since the diagnosis of ARFID was only established in 2013, little is known about its long-term prognosis, although anecdotal evidence suggests that weight restoration is not actively resisted as it is in AN.

### PREVENTION

Given the complexity of the pathogenesis of EDs, prevention is difficult. Targeted preventive interventions can reduce risk factors in older adolescents and college-age women. Universal prevention efforts to promote healthy weight regulation and discourage unhealthy dieting have not shown effectiveness in middle school students. Programs that include recovered patients or focus on the problems associated with EDs can inadvertently normalize or even glamorize EDs and should be discouraged.

Visit Elsevier eBooks+ at [eBooks.Health.Elsevier.com](http://eBooks.Health.Elsevier.com) for Bibliography.



## Chapter 42

# Disruptive, Impulse-Control, and Conduct Disorders

Erica H. Lee, Keneisha R. Sinclair-McBride,  
David R. DeMaso, and Heather J. Walter

The disruptive, impulse-control, and conduct disorders (CDs) are interrelated sets of psychiatric symptoms characterized by a core deficit in self-regulation of anger, aggression, defiance, and antisocial behaviors that typically begin in childhood or adolescence. These disorders include oppositional defiant, intermittent explosive, conduct, and other specified/unspecified disruptive/impulse-control/CDs, as well as pyromania, kleptomania, and antisocial personality disorder. Although all involve difficulty with both emotional and behavioral self-regulation, the disorders vary by the relative intensity of problems with emotional regulation (e.g., anger outbursts) vs behavioral regulation (e.g., defiance, aggression, violating the rights of others or societal norms).

## DESCRIPTION

**Oppositional defiant disorder (ODD)** is characterized by a persistent pattern lasting at least 6 months of **angry/irritable mood, argumentative/defiant behavior, and/or vindictiveness** exhibited during interaction with at least one individual who is not a sibling (Table 42.1). For preschool children, the behavior must occur on most days, whereas in school-age children, the behavior must occur at least once a week. The severity of the disorder is considered *mild* if symptoms are confined to only one setting (e.g., at home, at school, at work, with peers), *moderate* if symptoms are present in at least two settings, and *severe* if symptoms are present in three or more settings.

**Intermittent explosive disorder (IED)** is characterized by **recurrent verbal or physical aggression** that is grossly disproportionate to the provocation or to any precipitating psychosocial stressors (Table 42.2). The outbursts, which are impulsive and/or anger-based rather than premeditated and/or instrumental, typically onset rapidly, last <30 minutes, and frequently occur in response to a minor provocation by a close intimate.

CD is characterized by a repetitive and persistent pattern over at least 12 months of **serious aggressive, destructive, and/or rule-violating behavior** in which the basic rights of others or major age-appropriate societal norms or rules are violated (Table 42.3). The symptoms of CD are divided into four major categories: aggression to people and animals, destruction of property, deceitfulness or theft, and serious rule violations (e.g., truancy, running away). Three subtypes of CD (which have different prognostic significance) are based on the age of onset: childhood-onset type, adolescent-onset type, and unspecified. A small proportion of individuals with CD exhibit characteristics (lack of remorse/guilt, callous/lack of empathy, unconcerned about performance, shallow/deficient affect) that qualify for the “with limited prosocial emotions” specifier. CD is classified as *mild* when few if any symptoms over those required for the diagnosis are present, and the symptoms cause relatively minor harm to others. CD is classified as *severe* if many symptoms over those required for the diagnosis are present, and the symptoms cause considerable harm to others. *Moderate* severity is intermediate between mild and severe.

**Other specified/unspecified disruptive/impulse-control/CD (subsyndromal disorder)** applies to presentations in which symptoms characteristic of the disorders in this class are present and cause clinically significant distress or functional impairment, but do not meet full diagnostic criteria for any of the disorders in this class.

## EPIDEMIOLOGY

The prevalence of ODD is approximately 3%, and in preadolescents is more common in males than females (1.4:1). One-year prevalence rates for IED and CD approximate 3% and 4%, respectively. For CD, prevalence rates rise from childhood to adolescence and are higher among males than females.

## CLINICAL COURSE

Oppositional behavior can occur in all children and adolescents at times, particularly during the toddler and early teenage periods when autonomy and independence are normative developmental tasks. Oppositional behavior becomes a concern when it is frequent, intense, persistent, and pervasive and when it affects the child's social, family, and/or academic life. Some of the earliest manifestations of oppositionality are stubbornness (3 years), defiance and temper tantrums (4-5 years), and argumentativeness (6 years). Approximately 65% of children with ODD exit from the diagnosis after a 3-year follow-up; earlier age at onset of oppositional symptoms conveys a poorer prognosis. ODD often precedes the development of CD and there is an approximately 30% higher likelihood of CD when ODD is comorbid with attention-deficit/hyperactivity disorder (ADHD). ODD also increases the risk for the development of depressive and anxiety disorders. The defiant, argumentative, and vindictive symptoms carry most of the risk for CD, whereas the angry, irritable mood symptoms carry most of the risk for depression and anxiety.

IED usually begins in late childhood or adolescence and appears to follow a persistent course over many years, with recurrent periods of impulsive and aggressive outbursts.

The onset of CD may occur as early as the preschool years, but the first significant symptoms usually emerge during the period from middle childhood through middle adolescence; onset is rare after age 16 years. Symptoms of CD vary with age as the individual develops increased physical strength, cognitive abilities, and sexual maturity. Symptoms that emerge first tend to be less serious (e.g., lying), while those emerging later tend to be more severe (e.g., sexual or physical assault). Severe behaviors emerging at an early age convey a poor prognosis. In the majority of individuals, the disorder remits by adulthood; in a substantial fraction, antisocial personality disorder develops. Individuals with CD also are at risk for the later development of mood, anxiety, posttraumatic stress, impulse-control, psychotic, somatic symptom, and substance-related disorders.

## DIFFERENTIAL DIAGNOSIS

The disorders in this diagnostic class share a number of characteristics with each other as well as with disorders from other classes, and as such must be carefully differentiated. ODD can be distinguished from CD by the absence of physical aggression and destructiveness and by the presence of angry, irritable mood. ODD can be distinguished from IED by the lack of serious aggression toward others (e.g., physical assault). IED can be distinguished from CD by the lack of predatory aggression and other, nonaggressive symptoms of CD.

The oppositionality seen in ODD, the explosivity seen in IED, and the aggression/destructiveness seen in CD must be distinguished from those symptoms occurring in the context of other psychiatric disorders, particularly ADHD, depression, and bipolar, substance-related, autism spectrum, or psychotic disorders.

## COMORBIDITY

Rates of ODD are much higher in children with ADHD, which suggests shared temperamental risk factors. Depressive, anxiety, and substance-related disorders are most often comorbid with IED. ADHD and ODD are both common in individuals with CD, and this comorbid presentation predicts worse outcomes. CD may also occur with anxiety, depressive, bipolar, learning, language, and substance-related disorders.

## SEQUELAE

The disruptive, impulse-control, and CDs are associated with a wide range of psychiatric disorders in adulthood and with many other adverse outcomes, such as suicidal behavior, physical injury,

**Table 42.1** DSM-5 Diagnostic Criteria for Oppositional Defiant Disorder

A. A pattern of angry/irritable mood, argumentative/defiant behavior, or vindictiveness lasting at least 6 mo as evidenced by at least four symptoms from any of the following categories, and exhibited during interaction with at least one individual who is not a sibling:

**ANGRY/IRRITABLE MOOD**

1. Often loses temper.
2. Is often touchy or easily annoyed.
3. Is often angry and resentful.

**ARGUMENTATIVE/DEFIANT BEHAVIOR**

4. Often argues with authority figures or, for children and adolescents, with adults.
5. Often actively defies or refuses to comply with requests from authority figures or with rules.
6. Often deliberately annoys others.
7. Often blames others for his or her mistakes or misbehavior.

**VINDICTIVENESS**

8. Has been spiteful or vindictive at least twice within the past 6 mo.

Note: The persistence and frequency of these behaviors should be used to distinguish a behavior that is within normal limits from a behavior that is symptomatic. For children younger than 5 yr, the behavior should occur on most days for a period of at least 6 mo unless otherwise noted (Criterion A8). For individuals 5 yr or older, the behavior should occur at least once per week for at least 6 mo, unless otherwise noted (Criterion A8). Although these frequency criteria provide guidance on a minimal level of frequency to define symptoms, other factors should be considered, such as whether the frequency and intensity of the behaviors are outside a range that is normative for the individual's developmental level, gender, and culture.

B. The disturbance in behavior is associated with distress in the individual or others in his or her immediate social context (e.g., family, peer group, work colleagues), or it impacts negatively on social, educational, occupational, or other important areas of functioning.

C. The behaviors do not occur exclusively during the course of a psychotic, substance use, depressive, or bipolar disorder. Also, the criteria are not met for disruptive mood dysregulation disorder.

From the *Diagnostic and Statistical Manual of Mental Disorders*, 5th ed. pp. 462–463. Copyright 2013. American Psychiatric Association.

delinquency and criminality, legal problems, substance use, unplanned pregnancy, social instability, marital failure, and academic and occupational underachievement.

## ETIOLOGY AND RISK FACTORS

At the individual level, a number of neurobiologic markers (lower heart rate and skin conductance reactivity, reduced basal cortisol reactivity, abnormalities in the prefrontal cortex and amygdala, serotonergic abnormalities) have been variously associated with aggressive behavior disorders. Other biologic risk factors include pre-, peri-, and postnatal insults; cognitive and linguistic impairment, particularly language-based learning deficits; difficult temperamental characteristics, particularly negative affectivity, emotional reactivity, poor frustration tolerance, and impulsivity; certain personality characteristics (novelty seeking, reduced harm avoidance, and reward dependence); and certain cognitive characteristics (cognitive rigidity, hostile attributions for ambiguous social cues).

At the family level, a consistently demonstrated risk factor is ineffective parenting. Parents of behaviorally disordered children are more inconsistent in their use of rules, issue more and unclear commands, are more likely to respond to their child based on their own mood rather than the child's behavior, are more likely to utilize a harsh or neglectful parenting style, are less likely to monitor their children's whereabouts, and are relatively unresponsive to their children's prosocial behavior. Complicating this association is the consistent finding that temperamentally difficult children

**Table 42.2** DSM-5 Diagnostic Criteria for Intermittent Explosive Disorder

A. Recurrent behavioral outbursts representing a failure to control aggressive impulses as manifested by either of the following:

1. Verbal aggression (e.g., temper tantrums, tirades, verbal arguments or fights) or physical aggression toward property, animals, or other individuals, occurring twice weekly, on average, for a period of 3 mo. The physical aggression does not result in damage or destruction of property and does not result in physical injury to animals or other individuals.
2. Three behavioral outbursts involving damage or destruction of property and/or physical assault involving physical injury against animals or other individuals occurring with a 12 mo period.

B. The magnitude of aggressiveness expressed during the recurrent outbursts is grossly out of proportion to the provocation or to any precipitating psychosocial stressors.

C. The recurrent aggressive outbursts are not premeditated (i.e., they are impulsive and/or anger-based) and are not committed to achieve some tangible objective (e.g., money, power, intimidation).

D. The recurrent aggressive outbursts cause either marked distress in the individual or impairment in occupational or interpersonal functioning, or as associated with financial or legal consequences.

E. Chronologic age is at least 6 yr (or equivalent developmental level).

F. The recurrent aggressive outbursts are not better explained by another mental disorder (e.g., major depressive disorder, bipolar disorder, disruptive mood dysregulation disorder, a psychotic disorder, antisocial personality disorder, borderline personality disorder) and are not attributable to another medical condition (e.g., head trauma, Alzheimer disease) or to the physiologic effects of a substance (e.g., a drug of abuse, a medication). For children ages 6–18 yr, aggressive behavior that occurs as part of an adjustment disorder should not be considered for this diagnosis.

Note: This diagnosis can be made in addition to the diagnosis of attention-deficit/hyperactivity disorder, conduct disorder, oppositional defiant disorder, or autism spectrum disorder when recurrent impulsive aggressive outbursts are in excess of those usually seen in these disorders and warrant clinical attention.

From the *Diagnostic and Statistical Manual of Mental Disorders*, 5th ed. p. 466. Copyright 2013. American Psychiatric Association.

are more likely to elicit negative parenting responses, including physical punishment, which can exacerbate anger and oppositionality in the child. Other important family-level influences include impaired parent–child attachment, child maltreatment (physical and sexual abuse, neglect), exposure to marital conflict and domestic violence, family poverty and crime, frequent changes in caregivers, and family genetic liability (family history of the disorders in this class along with substance use, depressive, bipolar, schizophrenic, somatization, and personality disorders, as well as ADHD, have all been shown to be associated with the development of behavior disorders).

Peer-level influence on the development of behavior problems includes peer rejection in childhood and antisocial peer groups. Neighborhood influences include social processes such as collective efficacy, social control, and exposure to violence. Culturally, it is helpful to consider the context in which undesirable behaviors occur to better understand their function.

## PREVENTION

An effective conduct problem prevention program was *Fast Track*, a multicomponent school-based intervention comprising a classroom curriculum targeted at conflict resolution and interpersonal skills, parent training, and interventions targeted at the school environment. Implemented in grades 1 through 10, former program participants at age 25 had a lower prevalence of any externalizing, internalizing, or substance

**Table 42.3** DSM-5 Diagnostic Criteria for Conduct Disorder

A. A repetitive and persistent pattern of behavior in which the basic rights of others or major age-appropriate societal norms or rules are violated, as manifested by the presence of at least 3 of the following 15 criteria in the past 12 mo from any of the following categories, with at least one criterion present in the past 6 mo:

**AGGRESSION TO PEOPLE AND ANIMALS**

1. Often bullies, threatens, or intimidates others.
2. Often initiates physical fights.
3. Has used a weapon that can cause serious physical harm to others (e.g., a bat, brick, broken bottle, knife, gun).
4. Has been physically cruel to people.
5. Has been physically cruel to animals.
6. Has stolen while confronting a victim (e.g., mugging, purse snatching, extortion, armed robbery).
7. Has forced someone into sexual activity.

**DESTRUCTION OF PROPERTY**

8. Has deliberately engaged in fire setting with the intention of causing serious damage.
9. Has deliberately destroyed others' property (other than by fire setting).

**DECEITFULNESS OR THEFT**

10. Has broken into someone else's house, building, or car.
11. Often lies to obtain good or favors or to avoid obligations (i.e., "cons" others).
12. Has stolen items of nontrivial value without confronting a victim (e.g., shoplifting, but without breaking and entering; forgery).

**SERIOUS VIOLATIONS OF RULES**

13. Often stays out at night despite parental prohibitions, beginning before age 13 yr.
14. Has run away from home overnight at least twice while living in the parental or parental surrogate home, or once without returning for a lengthy period.
15. Is often truant from school, beginning before age 13 yr.

B. The disturbance in behavior causes clinically significant impairment in social, academic, or occupational functioning.

C. If the individual is age 18 yr or older, criteria are not met for antisocial personality disorder.

From the *Diagnostic and Statistical Manual of Mental Disorders*, 5th ed. pp. 469–471. Copyright 2013. American Psychiatric Association.

abuse problem than program nonparticipants. Program participants also had lower violent and drug crime conviction scores, lower risky sexual behavior scores, and higher well-being scores. Another useful prevention program, the *Seattle Social Development Project*, was also a multicomponent school-based intervention with teacher, parent, and student components targeting classroom management, interpersonal problem solving, child behavior management, and academic support skills. Implemented in grades 1 through 6, outcomes at age 19 years demonstrated that the intervention decreased lifetime drug use and delinquency for participant males compared with males in comparator communities but had no significant effects on females.

## SCREENING/CASE FINDING

The parents of children presenting in the primary care setting should be queried about angry mood or aggressive, defiant, or antisocial behavior as part of the routine clinical interview. A typical screening question would be, "Does [name] have a lot of trouble controlling [his/her] anger or behavior?" A number of standardized broad-band screening instruments widely used in the primary care setting (e.g., *Pediatric Symptom Checklist*, *Strengths and Difficulties Questionnaire*) have items specific to angry mood and aggressive behavior, and as such can also be used to identify problems in this domain.

## EARLY INTERVENTION

Youth (and/or their parents) presenting in the primary care setting who self-report or respond affirmatively to queries about difficulties managing angry mood or aggressive or antisocial behavior should be afforded the opportunity to talk about the situation with the pediatric practitioner (separately with older youth as indicated). By engaging in **active listening** (e.g., "I hear how you have been feeling. Tell me more about what happened to make you feel that way"), the pediatric practitioner can establish therapeutic rapport and begin to assess the onset, duration, context, severity, and complexity of the symptoms, and associated dangerousness, distress, and functional impairment. In the absence of acute dangerousness (e.g., homicidality, assaultiveness, psychosis, substance abuse) and significant distress or functional impairment, the pediatric practitioner can schedule a follow-up appointment within a few weeks to conduct a behavior assessment. At this follow-up visit, to assist with decision-making about appropriate level of care, a focused symptom rating scale can be administered (Table 42.4) and additional risk factors explored (e.g., see the previous section on "Etiology and Risk Factors").

For mild symptoms (manageable by the parent and not functionally impairing) and in the absence of major risk factors, guided self-help (anticipatory guidance) and monitoring with a scheduled follow-up may suffice. Guided self-help can include provision of educational materials (pamphlets, books, videos, workbooks, internet sites) that provide information to the youth about dealing with anger-provoking situations, and advice to parents about strengthening the parent-child relationship, effective parenting strategies, and the effects of adverse environmental exposures on the development of behavior problems. In a Cochrane review, media-based parenting interventions had a moderate positive effect on child behavior problems, either alone or as an adjunct to medication. An example of a self-help program for parents is the *Positive Parenting Program* (*Triple P*; <http://www.triplep-parenting.com>), online version, in which parents can purchase 6-8 modules of instruction addressing techniques for positive parenting and strategies for encouraging good behavior, teaching new emotional and behavioral skills, and managing misbehavior with youth from toddlers to teens (see Chapter 20).

If a mental health clinician has been **co-located or integrated into the primary care setting**, all parents of young children (universal prevention), as well as the parents of youth with mild behavior problems (indicated prevention), could be provided with a brief version of **behavioral parent training**. For example, *Incredible Years* (<http://www.incredibleyears.com>) has a 4-8 session universal prevention version to help parents promote their 2-6-year-old children's emotional regulation, social competence, problem solving, and reading readiness. A randomized trial in pediatric practices found that *Incredible Years* significantly improved parenting practices and 2-4-year-olds' disruptive behaviors compared to a wait-list control. *Incredible Years'* positive effects on parenting and child behavior have been found for populations diverse in race, cultural background, and socioeconomic status. Similarly, the *Triple P* program has seminar (three, 90 minute sessions), brief (15-30 min consultations), and primary care (four, 20-30 minute consultations) versions for the parents of youth from birth to the teenage years, specifically designed for implementation in the primary care setting. The *Triple P* interventions, supported by an extensive evidence base, focus on strengthening the parent-child relationship, identifying and monitoring the frequency of a problem behavior, and implementing and reviewing the effects of a targeted behavior plan. Meta-analyses have found that gains from *Triple P* are maintained over time.

## TREATMENT

For youth who continue to have mild to moderate behavior problems after several weeks of guided self-help or a brief course of behavioral parent training, or who from the outset exhibit moderate to severe symptoms, or who have a history of maltreatment or severe family dysfunction or psychopathology, assessment and treatment in the specialty mental health setting by a child-trained mental health clinician should be provided.

The youth's problem behavior may predominantly occur at home, at school, with peers, or in the community, or it may be pervasive. If possible, interventions need to address each context specifically, rather than assuming generalizability of treatment. Thus, for behaviors mostly manifested in the home setting, behavioral parent training would be the treatment of



**Table 42.4** Selected Anger/Aggression Rating Scales

NAME OF INSTRUMENT	INFORMANT(S)	AGE RANGE (YR)	NO. OF ITEMS
Children's Aggression Scale	Parent, Teacher	5-18	33 (P), 23 (T)
Eyberg Child Behavior Inventory	Parent	2-16	36
Outburst Monitoring Scale	Parent	12-17	20
Sutter-Eyberg Student Behavior Inventory-Revised	Teacher	2-16	38
Vanderbilt ADHD Diagnostic Rating Scales	Parent, Teacher	6-12	55 (P), 43 (T)

choice, whereas for behaviors manifested mostly at school, consultation with the teacher regarding an assessment for a 504 plan or individualized education plan (IEP) can be useful. School-based services can include a functional behavioral analysis to determine the function of the problematic behavior for the child, and development of a behavioral intervention plan to direct the child toward alternative positive behaviors that can achieve the same goal. School-based services should be considered whenever a child is subjected to repeated disciplinary action in school or suspensions for misbehavior. When there are pervasive problems, including aggression toward peers, **cognitive-behavioral therapy (CBT)** with the child/teen can be employed in addition to the other interventions.

**Behavioral parent training** has been extensively studied for the treatment of youth problem behavior. These programs work by reshaping negative family patterns that may trigger or reinforce problem behaviors. They are typically 10-15 weeks in duration and focus on some combination of the following components: understanding social learning principles, developing a warm supportive relationship with the child, encouraging child-directed interaction and play, providing a predictable structured household environment, setting clear and simple household rules, consistently praising and materially or socially rewarding positive behavior, consistently ignoring annoying behavior (followed by praise when the annoying behavior ceases), giving effective commands, and consistently giving consequences (e.g., time-out, loss of privileges) for dangerous or destructive behavior. Other important targets for parenting training include understanding developmentally appropriate moods and behavior, managing difficult temperamental characteristics, fostering the child's social and emotional development, and protecting the child from traumatic exposures. Parent training can be implemented with families in individual or group formats. Specific parent training programs include *Incredible Years* and *Triple P*, described earlier, and *Parent-Child Interaction Therapy, Helping the Noncompliant Child*, and *Parent Management Training Oregon*. Predictors of nonresponse to these interventions have included greater initial symptom severity as well as involvement of the parent with child protection services.

Difficulty with adherence to the complete treatment regimen has limited the effectiveness of parent training programs. Estimates of premature termination are as high as 50-60%, and termination within five treatment sessions is not uncommon. Predictors of premature termination have included single-parent status, low family income, low parental education levels, young maternal age, minority group status, and life stresses.

CBT for youth with disruptive behavior also has been extensively studied. Common CBT techniques for disruptive behavior include identifying the antecedents and consequences of disruptive or aggressive behavior, learning strategies for recognizing and regulating anger expression, problem-solving and cognitive restructuring (perspective-taking) techniques, and modeling and rehearsing socially appropriate behaviors that could replace angry or aggressive reactions. Programs typically are delivered in 16-20 weekly sessions.

Multicomponent treatments for serious behavior disorders such as CD target the broader social context. **Multidimensional Treatment Foster Care**, delivered in a foster care setting for 6-9 months, typically includes foster parent training and support; family therapy for biologic parents; youth anger management, social skills, and problem-solving training; school-based behavioral interventions and academic support; and

psychiatric consultation and medication management, when needed. **Multisystemic Therapy**, typically lasting 3-5 months, generally includes social competence training, parent and family skills training, medications, academic engagement and skills building, school interventions and peer mediation, mentoring and after-school programs, and involvement of child-serving agencies. Due to the strength of the supporting evidence, these multicomponent programs have been designated "well-established" treatments for adolescents involved in the juvenile justice system. Predictors of nonresponse to multicomponent treatments have included higher frequency of rule-breaking behavior and predatory aggression, higher psychopathy scores, and comorbid mood disorders.

Psychosocial interventions should be considered the first-line intervention; pharmacotherapy may provide benefit, particularly if psychosocial treatment has not led to adequate improvement. Three classes of medication, stimulants,  $\alpha_2$ -adrenergic agonists, and atypical antipsychotics, have evidence for the management of impulsive, anger-driven aggressive behavior, although none is approved by the U.S. Food and Drug Administration (FDA) for this indication, except irritability/aggression in autism. Resource limitations may necessitate provision of pharmacotherapy in the primary care setting; the safety and efficacy of this practice can be enhanced by regular consultation with a child and adolescent psychiatrist or developmental-behavioral pediatrician.

There are favorable effects of stimulants on oppositional behavior, anger outbursts, and aggression in youths, with or without comorbid ADHD. The doses of stimulants used for aggression are similar to those used for ADHD. An extended-release  $\alpha_2$ -adrenergic agonist (guanfacine) is efficacious for oppositionality comorbid with ADHD, with a dose of 1-4 mg/day, dosed according to weight. There is evidence for efficacy of risperidone in reducing aggression and conduct problems in children age 5-18 years. The suggested usual daily dose of risperidone for severe aggression is 1.5-2 mg for children and 2-4 mg for adolescents, titrating up as needed and tolerated from starting doses of 0.25 mg (children) or 0.5 mg (adolescents). The use of this class of medication should be reserved for severe presentations in which the safety of self and/or others is compromised.

Medication trials should be systematic, and the duration of trials should be sufficient (generally 6-8 weeks for atypical antipsychotics; shorter for stimulants and  $\alpha$ -agonists) to determine the agent's effectiveness. The short-term goal of medication treatment is to achieve at least a 50% reduction in aggressive symptoms, as assessed by a focused symptom rating scale (see Table 42.4); the ultimate goal is to achieve symptom remission (below clinical cutpoint on the rating scale). A second medication of the same class can be considered if there is insufficient evidence of response to the maximal tolerated dose. Care should be taken to avoid unnecessary polypharmacy, in part by discontinuing agents that have not demonstrated significant benefit. Discontinuation of the medication should be considered after a symptom-free interval.

#### LEVEL OF CARE

Most children and adolescents with a behavior disorder can be safely and effectively treated in the outpatient setting. Youths with intractable CD may benefit from residential or specialized foster care treatment, where more intensive treatments can be provided.

Visit Elsevier eBooks+ at [eBooks.Health.Elsevier.com](http://eBooks.Health.Elsevier.com) for Bibliography.



## Chapter 43

# Tantrums and Breath-Holding Spells

*Keneisha R. Sinclair-McBride, Erica H. Lee,  
David R. DeMaso, and Heather J. Walter*

**Temper tantrums** are common during early childhood. They are typically developmentally normative expressions of children's frustration with their own limitations or anger about not being able to get their way. It is important for parents to recognize the different triggers for tantrums to determine the best course of action to prevent or manage this behavior as it arises. Dealing with tantrum behavior can become very frustrating for parents and these feelings should be validated, while also helping make sure parents are aware that many tantrums can be averted by awareness or attunement to certain cues given by their child. In particular, parents should be aware that when a child is tired, hungry, or has to make a transition, it can be expected that the child will be more likely to have a tantrum because limit setting or unmet expectations may feel particularly overwhelming in these circumstances. In this case, it is advised that parents plan ahead and take a preventive stance by being aware of triggers and minimizing the potential for a tantrum. Parents should not make a tired or hungry child accompany them on an extended outing unless absolutely necessary. Additionally, depending on the child's developmental level, it is helpful to have a clear discussion ahead of time about the expectations in certain scenarios. An example of setting expectations to help prevent a tantrum is: "When we go into the store I need you to (1) stay with me, (2) keep your hands to yourself, and (3) not whine for treats. If you can do these three things, we can pick one treat to bring home." When children are able to demonstrate good control, their behavior should be acknowledged, praised, and rewarded when appropriate. This will increase the likelihood that they will engage in the desired response more often, even in situations they find frustrating.

When children tantrum as an expression of anger or sadness in not getting their way, parents may feel inclined to give in or respond to the negative behavior with yelling or threats. Unfortunately, these responses can reinforce and even escalate the oppositional behavior. Parents should attempt to avert defiance by giving the child choices (e.g., you can walk to the car on your own two feet or I can carry you). Active ignoring can be used for mild tantrum behaviors because paying attention, even negative attention, can be reinforcing. If a child is tantruming in a way that is unsafe, they can be removed from the unsafe situation and given a consequence by being placed in time-out. If the tantrum was to avoid a task, the child should be required to complete the task once time-out is over.

**Breath-holding spells** occasionally occur during a tantrum and can be frightening to parents. These are reflexive events in which the crying child becomes apneic, pale, or cyanotic, may lose consciousness, and occasionally will have a brief seizure. Parents are best advised to ignore

breath holding during a tantrum once it has started. Without reinforcement, breath-holding generally disappears.

Subtypes of breath-holding spells include cyanotic, pallid, or mixed episodes. Cyanotic spells are the dominant type. Pallid spells may be similar to vasovagal-related syncopal events in older children and may be initiated by similar stimuli. Iron deficiency with or without anemia may be present, and some children with breath-holding spells respond to iron therapy. There is no increased risk of seizure disorders in children who have had a short seizure during a breath-holding spell. Medical conditions to rule-out in breath-holding spells (usually pallid) include seizures, Chiari crisis, familial dysautonomia, cardiac arrhythmias, cataplexy, hereditary hyperekplexia, and other central nervous system lesions.

The first key to the management of temper tantrums and breath-holding spells is to help parents intervene before the child is highly distressed. The parent can be instructed to calmly remind the child of the expected behavior and the potential consequence if the expected behavior does not occur. In addition, distraction to another activity or conversation may help. If the child does not comply, he or she should be placed in time-out for a period approximating 1 min for each year of age. Parents should state the reason the child is being placed in time-out beforehand in a calm and neutral tone, but they should not discuss the reasons during time-out. Once the time-out is over and the child is calm, it may be helpful for parents to discuss with the child the reasons for the child's frustration and their expectations for how the child will respond in the future.

Time-out can be effectively used in children up to approximately 10 years of age. Parents should also be advised to be mindful of their own reactions to their child's tantrum behavior to avoid an escalation of the child's behavior caused by an angry parental response.

If behavioral measures such as time-out fail, pediatricians must assess other aspects of parent-child interactions, such as the frequency of positive interactions, the consistency of parental responses to child behavior, and the ways that parents handle anger, before making further recommendations. In the absence of frequent positive parent-child interactions, time-out may not be effective, and inconsistent responding to problem behavior increases the likelihood of the negative behavior continuing. Children can be frightened by the intensity of their own angry feelings and by angry feelings they arouse in their parents. Parents should model the anger control that they want their children to exhibit. Some parents are unable to see that if they lose control themselves, their own angry behavior does not help their children to behave differently. Advising parents to calmly provide simple choices will help the child to feel more in control and to develop a sense of autonomy. Providing the child with options also typically helps reduce the child's feelings of anger and shame, which can later have adverse effects on social and emotional development. Providing choice also reduces power struggles between the parent and child and can aid in enhancing the parent-child relationship and building problem-solving skills.

When tantrum behavior, including breath holding, does not respond to parent coaching or is accompanied by head banging or high levels of aggression, referral for a mental health evaluation is indicated. Further evaluation is also recommended if tantrum behavior persists into the latency period and preteen years.

Visit Elsevier eBooks+ at [eBooks.Health.Elsevier.com](http://eBooks.Health.Elsevier.com) for Bibliography.

## Chapter 44

## Lying, Stealing, and Truancy

Keneisha R. Sinclair-McBride, Erica H. Lee,  
David R. DeMaso, and Heather J. Walter

*Young children* lie for a multitude of reasons. Lies for this age group can be considered developmentally normative attempts at understanding language, communication, rules, and expectations. In early childhood, lying often occurs as a child experiments with language. By observing the reactions of parents, preschoolers learn about expectations for honesty in communication. Lying can also be a form of fantasy for children, who often describe things as they wish them to be rather than as they are. To avoid an unpleasant confrontation, a child who has not followed a rule or met an expectation may lie. At this stage, children often do not understand that lying only postpones a confrontation. Parents should keep in mind that lying behavior in this age group is rarely malicious or premeditated.

In *older children*, lying is generally an effort to cover up actions that do not fit into the child's conceptualization of themselves. Children in this age group may lie as an attempt to maintain self-esteem. Of course, lying is also often used to avoid a negative consequence for misbehavior. Older children are also more likely to intentionally leave out critical parts of a story in an attempt to deceive or avoid a negative consequence. Lying can also be promoted by poor adult modeling. Many children and adolescents lie to avoid adults' disapproval. If children and teens are responded to in harsh and punitive ways, they may lie to avoid this. Alternatively, lying may be used as a method of rebellion, especially in adolescence. Lying about forbidden activities, social media use, or other behaviors may be an attempt to continue to break the rules without detection. Chronic lying can occur in combination with several other antisocial behaviors and is a sign of underlying psychopathology or family dysfunction.

Parents should address lying by giving the child a clear message of what is acceptable. Sensitivity and support combined with limit setting are necessary for a successful intervention. Although habitual lying can become frustrating for parents, they should be discouraged from making accusations or focusing on catching their child in a lie and instead should work toward creating an atmosphere that makes it easier for their child to tell the truth. Parents should let the child know that telling the truth about a difficult situation will allow the parents to help them better problem-solve the issue at hand. Should a situation arise where a child has lied and the parents are aware of the true details, the lie should be confronted while providing the facts of what is known and also stating the desired or expected behavior. This should be done in a calm, neutral manner. For example, if a parent is aware that a child played video games instead of doing homework and the child denies it, the parent can state, "I notice that your homework is incomplete and that you are playing without permission. Our rule is that you complete homework first. There will be no more video games for the rest of the week." This response reminds the child how he can meet his goals in an acceptable way and an appropriate consequence can then be given. Parents should be encouraged to address the expectations for their home and children in a family meeting or in regular discussions with their child outside the context of the child's lying.

Regardless of age or developmental level, when lying becomes a common way of managing conflict, intervention is warranted. If this behavior cannot be resolved through the parents' understanding of the situation and the child's understanding that lying is not a reasonable alternative, a mental health evaluation is indicated.

### STEALING

Many children steal something at some point in their lives. Often, when very *young children* steal, the behavior is an impulsive action to acquire something they want. A common example is the child who takes candy or a toy from the store shelf. If a parent notices this behavior, they can

use the situation as a teaching opportunity to explain that community and family expectations are that we have to pay for things at the store and not take them without permission. It should not be expected that a very young child will be aware of all the rules around shopping or stealing. It may also be difficult for a child who has been used to being able to freely take whatever she wants to be aware of all the expected behaviors across different settings. When preschoolers and school-age children begin to steal frequently even after they have been told not to, the behavior may be a response to stressful environmental circumstances and requires further exploration and evaluation.

For some *older children*, stealing can be an expression of anger or revenge for perceived frustrations with parents or other authority figures. In such instances, stealing becomes one way the child and adolescent can manipulate and attempt to control their world. Stealing can also be learned from adults. Some children will report that the behavior is "exciting" for them, and they may also engage in the behavior for peer approval. In some cases, youth living in poverty may engage in the behavior as a survival mechanism.

**Kleptomania**, an impulse-control disorder, may begin in adolescence and is characterized by an intense impulse to steal objects that may not be rationally needed by the patient. There are often comorbid disorders such as anxiety, eating disorders, substance misuse, and depression. Treatment includes cognitive-behavioral therapy (CBT) in addition to various drugs such as lithium, naltrexone, and selective serotonin reuptake inhibitors (SSRIs).

Parents should work with their children to rectify stealing through restitution. Parents should require that their child return stolen items or pay for them with their own money (i.e., allowance or gift money). When this is not possible, another reasonable consequence should be given, such as losing a privilege or completing additional chores. When stealing is part of a pattern of broader conduct problems, referral for a mental health evaluation is warranted.

### TRUANCY

Truancy and running away are never developmentally appropriate. Truancy may represent an unsafe environment of disorganization within the home including lack of appropriate supervision or older children being required to caretake for younger siblings. Truancy can also be a sign of developing conduct problems or behavioral health problems including depression or anxiety. When truancy occurs in younger children, there are usually psychosocial concerns with the parents or adult caretakers in the home that prevent them from following through with the required demands of getting their children to school each day. Families struggling with housing and food insecurity may have difficulties having their children attend school regularly. Parents with intellectual disability or their own mental health or substance abuse problems may become overwhelmed with managing the home and caring for their children; thus they might not consistently ensure their child gets to school. In addition, children might decide to remain at home to take care of parents who are impaired.

Truancy is more common in *preteens and adolescents* and can be a function of multiple factors, including but not limited to learning difficulties, social anxiety, depression, traumatic exposure, bullying, peer pressure, and substance use. In any of these cases, the child should be referred for further evaluation to assess the barriers to returning to school. Best practices for dealing with truancy resulting from school avoidance and anxiety include addressing the underlying psychologic symptoms causing the school avoidance and empowering parents, children, and school staff to work on a consistent plan for a return to school.

Younger children may threaten running away out of frustration or a desire to "get back at" parents. Older children who run away are almost always expressing a serious underlying problem within themselves or their family, including violence, abuse, and neglect. Adolescent runaways are at high risk for substance abuse and other risk-taking behaviors as well as at risk for being victims of abuse (e.g., sexual exploitation).

Youth exhibiting truancy or running away should be referred for a mental health evaluation.

Visit Elsevier eBooks+ at [eBooks.Health.Elsevier.com](http://eBooks.Health.Elsevier.com) for Bibliography.

## Chapter 45

## Aggression

*Keneisha R. Sinclair-McBride, Erica H. Lee,  
David R. DeMaso, and Heather J. Walter*

Aggressive behavior is a serious symptom associated with significant morbidity and mortality. Early intervention is indicated for persistent aggressive behavior given that children may not simply “grow out of” this pattern of behavior. Aggressive tendencies are heritable, although environmental factors can promote aggression in susceptible children. Both enduring and temporary stressors affecting a family can increase aggressive behavior in children. Aggression in childhood is correlated with both poverty and chaotic family situations, including chronic unemployment, family discord, and exposure to community and domestic violence, criminality, and psychiatric disorders. Children born to teenage mothers and parents with limited resources and support are also at risk. Males are reported to be more aggressive than females. A difficult temperament and later aggressiveness are related. When children with temperament difficulties are responded to with punitive discipline strategies within the family environment, it can set up a cycle of increasing aggression. Aggressive children often misinterpret social cues in such a way that they perceive hostile intent in ambiguous or benign interactions, and then may react with verbal or physical aggression toward peers and parents.

It is important to differentiate the causes and motives for childhood aggression. Intentional aggression may be primarily instrumental (i.e., to achieve an end), primarily hostile (i.e., to inflict physical or psychologic pain), or primarily impulsive. Impulsive aggression can often be effectively managed with simple behavioral interventions at home. Children who are callous, not empathetic, and more consistently aggressive require intervention in the specialty mental health setting (see [Chapter 42](#)). These children are at high risk for suspension from school and eventual school failure. Because learning disorders are common in this population, aggressive children should be referred for screening. Aggressive behavior is often present in a variety of other psychologic conditions, including attention-deficit/hyperactivity and oppositional defiant, intermittent explosive, conduct, and disruptive mood dysregulation disorders (see [Chapters 39 and 42](#)).

Aggressive behavior in males is relatively consistent from the pre-school period through adolescence. Without effective intervention, a male with a high level of aggressive behavior between 3 and 6 years of age has a high probability of carrying this behavior into adolescence. The developmental progression of aggression among females is less well studied. Fewer females show physically aggressive behavior in early childhood. However, interpersonal coercive behavior, especially in peer relationships, is seen in females. This behavior may be related to the development of physical aggression for females in adolescence (e.g., fighting) or other conduct problems (e.g., stealing).

Children exposed to aggressive models on television, in video games, or in play have more aggressive behavior compared with children not exposed to these models. Parents’ anger and aggressive or harsh punishment can model behavior that children may imitate when they are physically or psychologically hurt. Parents’ abuse may be transmitted to the next generation by several modes: children imitate aggression

that they have witnessed; abuse can cause neurologic damage, which itself predisposes the child to violence; and internalized rage often results from abuse.

Aggressive behavior in youth is often oriented toward peers through bullying (see [Chapter 15.1](#)). Although it is developmentally normative for children to engage in some teasing behavior, bullying has a more serious tone. Bullying is defined as unwanted aggressive behavior in which there is a real or perceived imbalance of power or strength between the bully and the victim. Typically, it involves a pattern of behavior repeated over time. Although most often perceived as physical aggression, bullying can take on a variety of forms, including relational bullying, the most common form engaged in by females. Cyberbullying is a particular risk during the middle and high school years because of increased exposure and access to multiple social media platforms at this developmental stage. Parents should be advised to closely monitor their child’s social media and maintain open communication with their children. Children may bully others because of impulse-control and social skills deficits, strong need for power and negative dominance, satisfaction in causing harm to others, or psychologic or material rewards. Children who bully are at risk for a variety of negative school and psychologic outcomes.

Victims of bullying are particularly at risk for negative outcomes, especially if the behavior is not addressed by adults. Victimization experiences are associated with school avoidance and school dropout, social isolation, somatic symptoms, and increased psychologic problems such as depression and anxiety. There have been numerous cases of suicide in children who reported a prior history of being bullied. Should a concern arise around bullying in the school setting, parents should be advised to reach out to their child’s teacher, school counselor, and school administrative staff to have the bullying behavior addressed. Many schools also have a bullying intervention protocol that can be implemented, and state departments of education have antibullying policies with formal protocols to address concerns. Given the significant psychologic risks for both victims and perpetrators of bullying, it is essential that all children who are persistently involved in these incidents be referred for mental health evaluation.

Visit Elsevier eBooks+ at [eBooks.Health.Elsevier.com](http://eBooks.Health.Elsevier.com) for Bibliography.

## Chapter 46

## Self-Injurious Behavior

*Kiera M. James and Molly C. Adrian*

Self-injurious behaviors, or deliberate engagement in self-inflicted harm, comprise both **suicidal behaviors** and **nonsuicidal self-injury (NSSI)** (see [Chapter 40](#)). NSSI, specifically, involves intentional self-inflicted damage to bodily tissue without the intent to die, though it can unintentionally result in significant harm or even death.

Suicidal behaviors and NSSI are both transdiagnostic behaviors occurring in the context of numerous psychiatry disorders as well as in the absence of any diagnosis at all. Nonetheless, the vast majority of youth who engage in NSSI meet diagnostic criteria for a psychiatry disorder. Self-injurious behavior may also be associated with developmental disabilities often as a manifestation of stereotypic movement disorder ([Chapter 37.2](#)).



## Chapter 45

## Aggression

Keneisha R. Sinclair-McBride, Erica H. Lee,  
David R. DeMaso, and Heather J. Walter

Aggressive behavior is a serious symptom associated with significant morbidity and mortality. Early intervention is indicated for persistent aggressive behavior given that children may not simply “grow out of” this pattern of behavior. Aggressive tendencies are heritable, although environmental factors can promote aggression in susceptible children. Both enduring and temporary stressors affecting a family can increase aggressive behavior in children. Aggression in childhood is correlated with both poverty and chaotic family situations, including chronic unemployment, family discord, and exposure to community and domestic violence, criminality, and psychiatric disorders. Children born to teenage mothers and parents with limited resources and support are also at risk. Males are reported to be more aggressive than females. A difficult temperament and later aggressiveness are related. When children with temperament difficulties are responded to with punitive discipline strategies within the family environment, it can set up a cycle of increasing aggression. Aggressive children often misinterpret social cues in such a way that they perceive hostile intent in ambiguous or benign interactions, and then may react with verbal or physical aggression toward peers and parents.

It is important to differentiate the causes and motives for childhood aggression. Intentional aggression may be primarily instrumental (i.e., to achieve an end), primarily hostile (i.e., to inflict physical or psychologic pain), or primarily impulsive. Impulsive aggression can often be effectively managed with simple behavioral interventions at home. Children who are callous, not empathetic, and more consistently aggressive require intervention in the specialty mental health setting (see [Chapter 42](#)). These children are at high risk for suspension from school and eventual school failure. Because learning disorders are common in this population, aggressive children should be referred for screening. Aggressive behavior is often present in a variety of other psychologic conditions, including attention-deficit/hyperactivity and oppositional defiant, intermittent explosive, conduct, and disruptive mood dysregulation disorders (see [Chapters 39 and 42](#)).

Aggressive behavior in males is relatively consistent from the pre-school period through adolescence. Without effective intervention, a male with a high level of aggressive behavior between 3 and 6 years of age has a high probability of carrying this behavior into adolescence. The developmental progression of aggression among females is less well studied. Fewer females show physically aggressive behavior in early childhood. However, interpersonal coercive behavior, especially in peer relationships, is seen in females. This behavior may be related to the development of physical aggression for females in adolescence (e.g., fighting) or other conduct problems (e.g., stealing).

Children exposed to aggressive models on television, in video games, or in play have more aggressive behavior compared with children not exposed to these models. Parents’ anger and aggressive or harsh punishment can model behavior that children may imitate when they are physically or psychologically hurt. Parents’ abuse may be transmitted to the next generation by several modes: children imitate aggression

that they have witnessed; abuse can cause neurologic damage, which itself predisposes the child to violence; and internalized rage often results from abuse.

Aggressive behavior in youth is often oriented toward peers through bullying (see [Chapter 15.1](#)). Although it is developmentally normative for children to engage in some teasing behavior, bullying has a more serious tone. Bullying is defined as unwanted aggressive behavior in which there is a real or perceived imbalance of power or strength between the bully and the victim. Typically, it involves a pattern of behavior repeated over time. Although most often perceived as physical aggression, bullying can take on a variety of forms, including relational bullying, the most common form engaged in by females. Cyberbullying is a particular risk during the middle and high school years because of increased exposure and access to multiple social media platforms at this developmental stage. Parents should be advised to closely monitor their child’s social media and maintain open communication with their children. Children may bully others because of impulse-control and social skills deficits, strong need for power and negative dominance, satisfaction in causing harm to others, or psychologic or material rewards. Children who bully are at risk for a variety of negative school and psychologic outcomes.

Victims of bullying are particularly at risk for negative outcomes, especially if the behavior is not addressed by adults. Victimization experiences are associated with school avoidance and school dropout, social isolation, somatic symptoms, and increased psychologic problems such as depression and anxiety. There have been numerous cases of suicide in children who reported a prior history of being bullied. Should a concern arise around bullying in the school setting, parents should be advised to reach out to their child’s teacher, school counselor, and school administrative staff to have the bullying behavior addressed. Many schools also have a bullying intervention protocol that can be implemented, and state departments of education have antibullying policies with formal protocols to address concerns. Given the significant psychologic risks for both victims and perpetrators of bullying, it is essential that all children who are persistently involved in these incidents be referred for mental health evaluation.

Visit Elsevier eBooks+ at [eBooks.Health.Elsevier.com](http://eBooks.Health.Elsevier.com) for Bibliography.

## Chapter 46

## Self-Injurious Behavior

Kiera M. James and Molly C. Adrian

Self-injurious behaviors, or deliberate engagement in self-inflicted harm, comprise both **suicidal behaviors** and **nonsuicidal self-injury (NSSI)** (see [Chapter 40](#)). NSSI, specifically, involves intentional self-inflicted damage to bodily tissue without the intent to die, though it can unintentionally result in significant harm or even death.

Suicidal behaviors and NSSI are both transdiagnostic behaviors occurring in the context of numerous psychiatry disorders as well as in the absence of any diagnosis at all. Nonetheless, the vast majority of youth who engage in NSSI meet diagnostic criteria for a psychiatry disorder. Self-injurious behavior may also be associated with developmental disabilities often as a manifestation of stereotypic movement disorder ([Chapter 37.2](#)).



Although NSSI and suicidal behavior are distinct constructs based on the *intent* of the behavior, they are also highly comorbid. Research exploring the attitudes of youth who have engaged in NSSI indicates that there is a strong identification with suicide and death for this population, which makes NSSI a significant clinical issue and risk factor that cannot be ignored or minimized. Although some youth engage in repeated NSSI without ever attempting suicide, studies suggest that 50–75% of adolescents who have a history of NSSI will make a suicide attempt at some point.

NSSI has been documented in children as young as 7 years of age, with rates increasing from childhood (~8%) to adolescents (~18%), and decreasing during adulthood (~5.5%). Although traditionally thought to be more prevalent in females than males, NSSI occurs in both sexes. Emerging research suggests that, if present at all, gender differences in rates of NSSI are more likely in clinical than community populations. Notably, however, rates of NSSI are particularly high among transgender and gender nonconforming teens with up to 55% reporting past-year engagement in NSSI. There are no significant ethnicity or class differences among youth who engage in NSSI. Youth identified as those with the highest risk include females ages 15–19 and males 20–24.

Cutting is the most commonly reported form of NSSI. For those youth who engage in NSSI for the first time, approximately 20% will repeat the behavior within the same year; cutting is the most commonly repeated method of NSSI. Other methods of NSSI include scratching, burning, carving, piercing, hitting or punching, biting, picking at wounds, and digging nails into the skin. The most common areas of injury are the arms, legs, and torso, though NSSI may also occur on other parts of the body (e.g., breasts, genitals, groin, neck). Objects used in cutting include razors, scissors, broken glass, hard plastic, knives, staples, paper clips, or any other objects sharp enough to cause injury. Importantly, there are gender differences in methods such that females are more likely to engage in cutting, scratching, biting, hair pulling, and wound picking whereas males are more likely to engage in burning and self-battery, including hitting and head banging.

Youth often report exposure to NSSI before engaging in the behavior. Some youth report that they have friends who self-injure (e.g., cut) to attempt to alleviate negative emotions. Others may view stories of their peers' engagement in NSSI on websites and social media. Impressionable youth have also reported learning about NSSI for the first time from celebrities who have engaged in the behavior.

NSSI is associated with depression, anxiety, peer (bullying) victimization, social isolation, low self-esteem, substance abuse, eating disorders, impulsivity, poor school performance, delinquency, and neglectful or highly punitive parenting practices, as well as trauma, including a history of physical or sexual abuse. The behavior may begin as an impulsive response to internal distress for younger children, but for those who are older, the behavior can take on a self-reinforcing function. Youth may feel a sense of *relief* or *mastery* over negative emotions once the behavior has been completed. Some youth report that they engage in NSSI when feeling intense negative emotions, overwhelmed, or panicked to regulate their emotions. Others engage in the behavior when they are feeling numb, to “feel something” again. NSSI may also serve as a *distraction* from emotional pain, provide a sense of *control* over the body, or be used as a form of *self-punishment* for a perceived wrongdoing. NSSI may also function to *communicate* distress or strength or provide peer group *affiliation*. Youth often report that they are unable to resist the urge to engage in the behavior and will continue to feel increasing levels of distress until they engage in NSSI. Others plan or schedule the behavior, building it into their routine. Youth who view NSSI as an effective, private, and necessary coping strategy tend to have more dependence on the behavior and more resistance to stopping it.

Some adolescents and young adults engage in repeated NSSI for years without disclosing the behavior. Due to the shame associated

with this stigmatized behavior, youth will often go to great lengths to keep it a secret. Some wear bracelets to cover scars on their arms or wear long sleeves in summer to hide the scarring. They report feeling ashamed of the behavior and fear rejection or disappointment from family and friends should they find out. At times, fear of being rejected or a disappointment to others can increase feelings of depression and anxiety and can serve to perpetuate the behavior. In contrast, others are more open about showing their scars and sharing their behavior with others. In either case, the behavior is a way to communicate or manage some level of *distress*. Many youth who engage in NSSI may never be seen in a hospital emergency department or by a mental health professional. Factors that protect against engagement in NSSI include a lack of awareness of, or exposure to, NSSI; an aversion to physical pain; an aversion to NSSI-related stimuli (e.g., blood); a positive view of the self; the use of other more adaptive emotion regulation strategies; and social norms. *Youth with repetitive NSSI should be referred to behavioral health services.* Effective treatment strategies include conducting a functional analysis around NSSI behavior, identifying and teaching alternative emotion regulation strategies, and reducing access to means to harm oneself. Reduction of NSSI has been observed with dialectical behavior therapy for adolescents, cognitive-behavioral therapy, cognitive analytic therapy, and mentalization-based therapy for adolescents. There are no psychopharmacologic treatments that have demonstrated efficacy; thus behavioral approaches should be prioritized.

Parents should be advised to monitor youth social media access and be aware of their peer group. Maintaining open communication can assist parents in recognizing an increase in concerning behaviors or patterns of behaviors. Parents should talk with their child about strategies for managing strong emotions and provide emotion coaching to support their child through experiences of distress. They should also be encouraged to talk with their child about their use of and exposure to drugs and alcohol as substance use can be associated with NSSI. Learning that their child has been engaging in self-injury can be frightening for parents because they are unsure of what to do or why their child is engaging in this behavior. It is important that parents receive psychoeducation about NSSI to reduce common misconceptions that make it difficult to understand their child's engagement in NSSI and respond effectively. Such information should be digestible and accurate, including written suggestions and examples. Parents should also seek mental health services for their child. *It is recommended that the child receive a full assessment for risk of suicide when NSSI is a concern.*

The *Diagnostic and Statistical Manual of Mental Disorders, Fifth Edition* (DSM-5) has classified NSSI as a condition requiring further study before consideration for possible placement in forthcoming editions of DSM. Proposed diagnostic criteria include self-inflicted injury without suicidal intent occurring on 5 or more days in the past year, with lack of suicidal intent either stated by the individual or inferred by the individual's repeated engagement in a behavior not likely to result in death. The individual expects that the self-injurious behavior will relieve a negative feeling or thought, resolve an interpersonal difficulty, or induce a positive feeling state. The self-injurious behavior is associated with interpersonal difficulties or negative feelings or thoughts, preoccupation with the intended behavior that is difficult to control, or frequent thoughts about the intended behavior. The proposed criteria also specify that the behavior is not socially sanctioned (e.g., body piercing, tattooing) and is not restricted to skin picking or nail biting. The behavior must be associated with significant *distress* or functional impairment.

Visit Elsevier eBooks+ at [eBooks.Health.Elsevier.com](http://eBooks.Health.Elsevier.com) for Bibliography.

## Chapter 47

## Childhood Psychoses

Jennifer A. Zaspel and Rosa K. Kim

Psychosis is a severe disruption of thought, perception, and behavior resulting in *loss of reality testing*. Psychosis can occur as part of a mood disorder, such as major depressive disorder or bipolar I disorder; between mood disorder episodes, as in schizoaffective disorder; or without mood disorder episodes, as in schizophrenia. Transient psychotic episodes can arise during times of psychologic or physiologic stress in patients who are vulnerable because of personality, developmental, or genetic disorders. **Positive symptoms**, including delusions, hallucinations, disorganized thinking, and grossly disorganized behavior, are key features that define psychoses across disorders, likely because of shared pathophysiologic mechanisms. **Negative symptoms**, on the other hand, are most typical of schizophrenia.

**Delusions** are fixed, unchangeable, false beliefs held despite conflicting evidence. They may include a variety of themes, including persecutory, referential (the belief that irrelevant events or details in the world are related directly to oneself), somatic, religious, and grandiose. Delusions are considered bizarre if they are clearly implausible. **Hallucinations** are vivid, clear, perceptual disturbances that occur without external stimulus and have the full force and impact of normal perceptions. They may occur in any sensory modality; auditory hallucinations are the most common associated with psychosis. **Disorganized thinking** is inferred from an individual's speech by examining their thought process and thought content and is typically severe enough to impair one's ability to communicate. **Grossly disorganized behavior** may range from childlike silliness to unpredictable agitation to catatonic behavior. **Negative symptoms** include diminished emotional expression, avolition (decreased drive to perform purposeful tasks), alogia (lack of speech), anhedonia, and social withdrawal. Negative symptoms account for a substantial portion of the long-term morbidity associated with schizophrenia.

Given the centrality of hallucinations and delusions in making a diagnosis of a psychotic illness, their differentiation from developmentally normal fantasy is essential. When children are imagining, they control the fantasy and do not have the perceptual experience of seeing and hearing. When children are hallucinating, they do not control the hallucination. Almost two thirds of children will endorse at least one psychotic-like experience, most often a hallucination. When not persistent or accompanied by distress, these experiences are not usually a cause for concern. The largest population-based study to date evaluating psychotic symptoms and neurocognition in youth 11-21 years old found that those who endorsed more psychotic-like experiences than is typical for their age had reduced accuracy across neurocognitive domains, reduced global functioning, and increased risk of depression, anxiety, behavioral disorders, substance use, and suicidal ideation. Thus psychotic-like symptoms that are frequent, distressing, and cause impairment signal a need for further evaluation and monitoring; however, only a small minority of these children will develop persisting psychotic illnesses.

## 47.1 Schizophrenia Spectrum Disorders

Jennifer A. Zaspel and Rosa K. Kim

Schizophrenia spectrum and other psychotic disorders as described in the *Diagnostic and Statistical Manual of Mental Disorders, Fifth Edition* (DSM-5) include brief psychotic disorder, schizophreniform disorder, schizophrenia, schizoaffective disorder, substance/

medication-induced psychotic disorder, psychotic disorder caused by another medical condition, catatonia associated with another mental disorder, catatonic disorder due to another medical condition, unspecified catatonia, delusional disorder, schizotypal personality disorder, and other specified/unspecified schizophrenia spectrum and other psychotic disorders.

## DESCRIPTION

The **schizophrenia spectrum** and other psychotic disorders are primarily characterized by the presence of symptoms of psychosis, specifically delusions, hallucinations, disorganized speech, or grossly disorganized or catatonic behavior, and negative symptoms. **Brief psychotic disorder** is characterized by the duration of one or more of these symptoms for at least 1 day but less than 1 month followed by complete resolution. Emergence of symptoms may or may not be preceded by an identifiable stressor (Table 47.1). Although brief, the level of impairment in this disorder may be severe enough that supervision is required to ensure that basic needs are met and that the individual is protected from the consequences of poor judgment and cognitive impairment.

If two or more psychotic symptoms persist for between 1 and 6 months, the condition is called **schizophreniform disorder** (Table 47.2). To meet DSM-5 criteria for **schizophrenia**, two or more psychotic symptoms must have been present for a significant portion of time for at least 1 month (unless suppressed by treatment), and the level of psychosocial functioning must either be markedly below the level achieved before the onset or there is failure to achieve the expected level of functioning. In addition, there must be continuous signs of the disturbance for at least 6 months (Table 47.3).

Individuals with schizophrenia can display inappropriate affect, dysphoric mood, disturbed sleep patterns, and lack of interest in eating, or food refusal. Depersonalization, derealization, somatic concerns, and anxiety and phobias are common. Cognitive deficits are observed, including decrements in declarative memory, working memory, language function, and other executive functions, as well as slower processing speed. These individuals may have no

**Table 47.1** DSM-5 Diagnostic Criteria for Brief Psychotic Disorder

- A. Presence of one (or more) of the following symptoms. At least one of these must be (1), (2), or (3):
1. Delusions
  2. Hallucinations
  3. Disorganized speech (e.g., frequent derailment or incoherence)
  4. Grossly disorganized or catatonic behavior

Note: Do not include a symptom if it is a culturally sanctioned response.

- B. Duration of an episode of the disturbance is at least 1 day but less than 1 mo, with eventual full return to premorbid level of functioning.
- C. The disturbance is not better explained by major depressive or bipolar disorder with psychotic features or another psychotic disorder such as schizophrenia or catatonia, and is not attributable to the physiologic effects of a substance (e.g., a drug of abuse, a medication) or another medical condition.

Specify if:

**With marked stressor(s)** (brief reactive psychosis): If symptoms occur in response to events that, singly or together, would be markedly stressful to almost anyone in similar circumstances in the individual's culture.

**Without marked stressor(s)**: If the symptoms do not occur in response to events that, singly or together, would be markedly stressful to almost anyone in similar circumstances in the individual's culture.

**With postpartum onset**: If onset is during pregnancy or within 4 wk postpartum.

**Table 47.2** DSM-5 Diagnostic Criteria for Schizophreniform Disorder

- A. Two (or more) of the following, each present for a significant portion of time during a 1 mo period (or less if successfully treated). At least one of these must be (1), (2), or (3):
1. Delusions
  2. Hallucinations
  3. Disorganized speech (e.g., frequent derailment or incoherence)
  4. Grossly disorganized or catatonic behavior
  5. Negative symptoms (i.e., diminished emotional expression or avolition)
- B. An episode of the disorder lasts at least 1 mo but less than 6 mo. When the diagnosis must be made without waiting for recovery, it should be qualified as “provisional.”
- C. Schizoaffective disorder and depressive or bipolar disorder with psychotic features have been ruled out because either (1) no major depressive or manic episodes have occurred concurrently with the active-phase symptoms or (2) if mood episodes have occurred during active-phase symptoms, they have been present for a minority of the total duration of the active and residual periods of the illness.
- D. The disturbance is not attributable to the physiologic effects of a substance (e.g., a drug of abuse, a medication) or another medical condition.

Specify if:

**With good prognostic features:** This specifier requires the presence of at least two of the following features: onset of prominent psychotic symptoms within 4 wk of the first noticeable change in usual behavior or functioning; confusion or perplexity; good premorbid social and occupational functioning; and absence of blunted or flat affect.

**Without good prognostic features:** This specifier is applied if two or more of the previous features have not been present.

From the *Diagnostic and Statistical Manual of Mental Disorders*, 5th ed. pp 96–97. Copyright 2013. American Psychiatric Association.

insight or awareness of their disorder, which is a predictor of non-adherence to treatment, higher relapse rates, and poorer prognosis. Hostility and aggression can be associated with schizophrenia, although spontaneous or random assault is uncommon. Aggression is more frequent for younger males and for individuals with a history of violence, nonadherence with treatment, substance abuse, and impulsivity.

The essential features of schizophrenia are the same in childhood as in adulthood, but it is more difficult to make the diagnosis. In children, delusions and hallucinations may be less elaborate, visual hallucinations may be more common, and disorganized speech may be better attributed to an autism spectrum or communication disorder. In youth with schizophrenia, the most frequent psychotic symptoms are auditory hallucinations (82%), delusions (78%), thought disorder (66%), disorganized or bizarre behavior (53%), and negative symptoms (50%). Childhood-onset schizophrenia tends to represent a more severe form of the disorder spectrum, with more genetic risk factors, more brain abnormalities, and more prominent prepsychotic developmental disorders.

## EPIDEMIOLOGY

Brief psychotic disorder is reported to account for 9% of first-onset psychosis in the United States and is more common in females than males. The incidence of schizophreniform disorders in the United States appears as much as fivefold less than that of schizophrenia. The lifetime prevalence of schizophrenia is approximately 0.3–0.7%, although variations are reported by race/ethnicity, across countries, and by geographic origin for immigrants. The male-to-female ratio is approximately 1.4:1. Males generally have poorer premorbid adjustment, lower educational achievement, more prominent negative symptoms, and more cognitive impairment than females.

**Table 47.3** DSM-5 Diagnostic Criteria for Schizophrenia

- A. Two (or more) of the following, each present for a significant portion of time during a 1 mo period (or less if successfully treated). At least one of these must be (1), (2), or (3):
1. Delusions
  2. Hallucinations
  3. Disorganized speech (e.g., frequent derailment or incoherence)
  4. Grossly disorganized or catatonic behavior
  5. Negative symptoms (i.e., diminished emotional expression or avolition)
- B. For a significant portion of the time since the onset of the disturbance, level of functioning in one or more major areas, such as work, interpersonal relations, or self-care, is markedly below the level achieved before the onset (or when the onset is in childhood or adolescence, there is failure to achieve expected level of interpersonal, academic, or occupational functioning).
- C. Continuous signs of the disturbance persist for at least 6 mo. This 6 mo period must include at least 1 mo of symptoms (or less if successfully treated) that meet Criterion A (i.e., active-phase symptoms) and may include periods of prodromal or residual symptoms. During these prodromal or residual periods, the signs of the disturbance may be manifested by only negative symptoms or by two or more symptoms listed in Criterion A present in an attenuated form (e.g., odd beliefs, unusual perceptual experiences).
- D. Schizoaffective disorder and depressive or bipolar disorder with psychotic features have been ruled out because either (1) no major depressive or manic episodes have occurred concurrently with the active-phase symptoms or (2) if mood episodes have occurred during active-phase symptoms, they have been present for a minority of the total duration of the active and residual periods of the illness.
- E. The disturbance is not attributable to the physiologic effects of a substance (e.g., a drug of abuse, a medication) or another medical condition.
- F. If there is a history of autism spectrum disorder or a communication disorder of childhood onset, the additional diagnosis of schizophrenia is made only if prominent delusions or hallucinations, in addition to the other required symptoms of schizophrenia, are also present for at least a month (or less if successfully treated).

From the *Diagnostic and Statistical Manual of Mental Disorders*, 5th ed. pp 99–100. Copyright 2013. American Psychiatric Association.

Childhood (preadolescent)-onset is exceedingly rare, with an incidence of less than 0.04%, and 2:1 ratio in males versus females.

## CLINICAL COURSE

Brief psychotic disorder most often appears in adolescence or early adulthood, with the average age of onset in the mid-30s but can occur throughout the life span. A diagnosis of brief psychotic disorder requires *full remission* within 1 month of onset and gradual return to premorbid level of function. The age of onset of schizophreniform disorder is similar to that of schizophrenia. Recovery from an episode of the disorder is within 6 months; however, about 65% of patients relapse and eventually receive a diagnosis of schizophrenia or schizoaffective disorder. Abrupt onset, confusion, absence of blunted affect, and good premorbid functioning predict a better outcome in schizophreniform disorder.

Schizophrenia typically develops between the late teens and the mid-30s; onset before adolescence is rare. The peak age at onset for the first psychotic episode is in the early to mid-20s for males and in the late 20s for females. The onset may be abrupt or insidious, but most individuals manifest a slow and gradual development of symptoms, with about 50% of individuals complaining of depressive symptoms. The predictors of course and outcome are largely unexplained. The course is favorable in approximately 20% of cases; a small number of individuals are reported to recover completely. However, many remain chronically ill, with exacerbations and remissions of active symptoms, whereas others experience

progressive deterioration. Most individuals diagnosed with schizophrenia require some form of daily living support. Positive symptoms tend to diminish over time, and negative symptoms are the most persistent, along with cognitive deficits.

It is important to recognize hallmark phases in the assessment and management of schizophrenia. In the **prodrome phase**, most patients experience functional deterioration over the course of months (e.g., social withdrawal, idiosyncratic preoccupations, unusual behaviors, academic failure, deteriorating self-care skills, and/or dysphoria) before the onset of overt psychotic symptoms. The **acute phase** is characterized by prominent positive symptoms and deterioration in functioning and is the phase in which most patients present for care. During the **recovery phase**, negative symptoms and disorganization may persist as active psychosis remits. The **residual phase** has minimal to no positive symptoms, although negative symptoms may cause continued impairment. Some patients will experience **chronic impairment** despite adequate treatment.

## DIFFERENTIAL DIAGNOSIS

The differential diagnosis for the psychotic disorders is broad and includes reactions to substances/medications (dextromethorphan, LSD, hallucinogenic mushrooms, psilocybin, peyote, cannabis, stimulants, inhalants, corticosteroids, anesthetics, anticholinergics, antihistamines, amphetamines); medical conditions causing psychotic-like symptoms (Table 47.4; see Table 32.4); and other psychiatric disorders (depressive, bipolar, obsessive-compulsive, factitious, body dysmorphic, posttraumatic stress, autism spectrum,

communication, personality). The differential diagnosis can be difficult because many conditions that can be mistaken for psychosis also increase the risk for it.

There are many indications that suggest psychotic symptoms may be related to a physical illness rather than a primarily psychiatric illness (Table 47.5). When psychotic symptoms are caused by identifiable medical conditions, there are often impairments in attention, orientation, recent memory, and intellectual function. Hallucinations associated with medical illness are more often tactile or visual, whereas auditory hallucinations are more common in primary psychotic disorders. Patients whose hallucinations are caused by medical illness are more likely to recognize that they do represent reality. A positive family or prior personal history of psychosis or other serious psychiatric illnesses is less likely to be present.

**Autoimmune encephalitis** caused by anti-*N*-methyl-*D*-aspartate (NMDA) receptor or other autoantibodies may manifest with psychosis, anxiety, depression, agitation, aggression, delusions, catatonia, visual or auditory hallucinations, disorientation, and paranoia in combination with sleep disturbances, autonomic dysfunction, dyskinesias, movement disorders, seizures, memory loss, and a depressed level of consciousness (Fig. 47.1; see Table 32.5). The cerebrospinal fluid (CSF) and MRI are usually, but not always, abnormal. The constellation of a relatively rapid onset psychosis and encephalitic features should suggest the diagnosis, although at presentation, behavioral problems may be the dominant feature (see Chapter 638.4; Table 47.6). A small number of patients present with purely psychiatric symptoms without other neurologic findings.

Determining when identifiable medical conditions are causing delirium with prominent psychotic symptoms may be difficult

**Table 47.4** Possible Causes of Secondary Psychosis

	EXAMPLES	INVESTIGATIONS
Trauma	Traumatic head injury	CT, MRI
Autoimmune disorders	Systemic lupus erythematosus, NMDA receptor encephalitis and others	Autoantibody titers
Cytogenetic/congenital disorders	Velocardiofacial syndrome, agenesis of corpus callosum	Karyotyping, MRI
Toxic/substance-induced disorders	PCP, MDMA, LSD, cannabis, alcohol, cocaine, synthetic cannabinoids (bath salts) Lead, mercury or arsenic poisoning, ginseng, St. John's Wort, ma huang	Careful medication history; urine screen for drugs, heavy metal screen; trial off the offending agent
Iatrogenic disorders	Antimalarials, steroids, isoniazid	Careful medication history; trial off the offending agent
Cerebrovascular disorders	Stroke, subdural hematomas	CT, MRI
Space-occupying disorders	Cerebral tumors	CT, MRI
Metabolic disorders	Pheochromocytoma, metachromatic leukodystrophy, Wilson disease, adult Tay-Sachs disease, acute intermittent porphyria	Urinary catecholamines; arylsulfatase-A levels, copper and ceruloplasmin levels
Dietary disorders	Pellagra, B <sub>12</sub> deficiency; thiamine deficiency	B <sub>12</sub> , folate, thiamine levels
Sepsis/infectious disorders	Neurosyphilis, toxoplasmosis, HIV disease, encephalitis	RPR to rule out syphilis; HIV antibody titers; glucose, protein in CSF
Unknown cause/degenerative/demyelinating disorders	Lewy body dementia, Parkinson disease, Huntington disease, multiple sclerosis, Friedreich ataxia	MRI, CT, EEG, evoked potentials
Seizure disorders	Partial complex seizures, temporal lobe epilepsy	EEG, including sleep deprivation; telemetric EEG as indicated
Endocrine disorders	Hyperthyroidism, hypothyroidism, hyperparathyroidism	Serum calcium, thyroid/parathyroid hormone levels

CSF, Cerebrospinal fluid; EEG, electroencephalography; LSD, lysergic acid diethylamide; MDMA, 3,4-methylenedioxy-*N*-methylamphetamine; NMDA, *N*-methyl-*D*-aspartate; PCP, phencyclidine; RPR, rapid plasma reagin.

Modified from Keshavan MS, Kaneko Y. Secondary psychoses: An update. *World Psychiatry*. 2013;12(1):4–15:Table 1, p 5.



**Table 47.5** Red Flags and Features Suggesting Secondary Etiologies of Psychosis**ATYPICAL FEATURES**

- Normal before event
- Very early ( $\leq 13$  yr) age of onset
- Acute or subacute onset (days,  $\leq 1$  mo)
- Catatonia
- Dyskinesias
- Isolated misidentification delusion (Capgras syndrome)
- Depressed level of consciousness; disorientation; somnolence
- Cognitive and recent memory decline
- Poor orientation
- Intractability despite adequate therapy
- Rapidly progressive and/or fluctuating (polymorphic) symptoms
- Multimodal hallucinations: visual, auditory, olfactory, gustatory
- Poor response to antipsychotics

**HISTORY**

- Infectious prodrome (fever)
- New or worsening headache; change in headache pattern
- Paresthesias
- Past, current substance misuse
- Recent onset incontinence
- Anorexia/weight loss
- Risk factors for cerebrovascular disease or central nervous system infections
- Malignancy
- Immunocompromised status
- Head trauma
- Seizures
- Hepatobiliary disorders
- Systemic lupus erythematosus/other autoimmune diseases
- Biologic relatives with similar medical complaints
- Aphasia, mutism, dysarthria

**PHYSICAL EXAMINATION**

- Autonomic hyperactivity: tachycardia, hypertension, mydriasis, sleep disturbance
- Incoordination, or gait difficulty; nystagmus
- Toxidrome
- Abnormal neurologic exam: upper and lower motor neuron focal findings
- Movement disorder
- Neuroendocrine changes

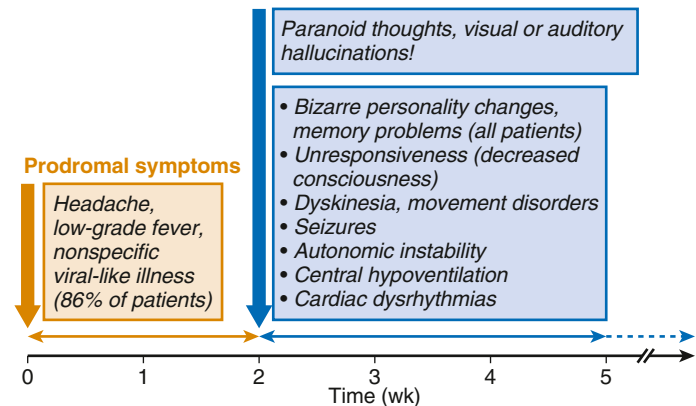
**DIAGNOSTIC ABNORMALITIES**

- Abnormal electroencephalogram (extreme delta brush, diffuse slowing)
- Abnormal cerebrospinal fluid (pleocytosis: greater than 5 lymphocytes)
- Positive urine toxicology
- Screening laboratory tests including *N*-methyl-D-aspartate receptor and other antibodies
- Abnormal neuroimaging studies (unilateral or bilateral hippocampal/medial temporal lobe hyperdensities: limbic encephalitis)
- Hyponatremia

Modified from Kliegman RM, Toth H, Bordini BJ, Basel D, eds. *Nelson Pediatric Symptom-Based Diagnosis*. 2nd ed. Elsevier, 2023: Table 31.9, p 526

and is more fully explored in [Chapter 48](#). In general, **delirium** is hallmarked by fluctuating levels of consciousness and is often associated with abnormalities in the neurologic exam and vital signs. Psychosis may be present in patients with delirium, but it will be accompanied by clear signs and symptoms of physical illness.

The diagnosis of a psychotic disorder should be made only after other explanations for the observed symptoms have been thoroughly considered. Mistakenly diagnosing psychosis when it is not present can lead to inappropriate use of antipsychotics with their attendant risks. The persistence, frequency, and form of possible psychotic symptoms, as well as the degree of accompanying distress and functional regression, need to be considered in determining the likelihood of an underlying psychotic pathophysiology.

**Symptom presentation/hospital admission (77% psychiatric, 23% neuropsychiatric)**

**Fig. 47.1** Clinical characteristics of patients with anti-NMDA-receptor encephalitis. (Modified from Wandinger KP, Saschenbrecker S, Stoecker W, Dalmau J. Anti-NMDA-receptor encephalitis: A severe, multi-stage, treatable disorder presenting with psychosis. *J Neuroimmunol*. 2011;231:86–91. Fig 2.)

**Table 47.6** Proposed Diagnostic Criteria for Autoimmune Psychosis**For a diagnosis of possible autoimmune psychosis:**

The patient must have current psychotic symptoms of abrupt onset (rapid progression of  $<3$  months) with at least one of the following:

- Currently or recently diagnosed with a tumor
- Movement disorder (catatonia or dyskinesia)
- Adverse response to antipsychotics, raising suspicion of neuroleptic malignant syndrome (rigidity, hyperthermia, or raised creatine kinase)
- Severe or disproportionate cognitive dysfunction
- A decreased level of consciousness
- The occurrence of seizures that are not explained by a previously known seizure disorder
- A clinically significant autonomic dysfunction (abnormal or unexpectedly fluctuant blood pressure, temperature, or heart rate)

If a patient has possible autoimmune psychosis, they should be investigated as per section 5 ("Consensus multimodal approach to the systematic investigation of patients with suspected autoimmune psychosis"), including electroencephalography, MRI, serum autoantibodies, and CSF analysis (including CSF autoantibodies). The results should lead to a diagnosis of non-autoimmune psychosis or probable/definite autoimmune psychosis.

**For a diagnosis of probable autoimmune psychosis:**

The patient must have current psychotic symptoms of abrupt onset (rapid progression of  $<3$  mo) with at least one of the seven clinical criteria listed previously for possible autoimmune psychosis and at least one of the following:

- CSF pleocytosis of  $>5$  white blood cells/ $\mu\text{L}$
- Bilateral brain abnormalities on T2 weighted fluid-attenuated inversion recovery MRI highly restricted to the medial temporal lobes

Or two of the following:

- Electroencephalogram encephalopathic changes (i.e., spikes, spike-wave activity, or rhythmic slowing [intermittent rhythmic delta or theta activity] focal changes, or extreme delta brush)
- CSF oligoclonal bands or increased IgG index
- The presence of a serum antineuronal antibody detected by cell-based assay

After exclusion of alternative diagnoses.

**For a diagnosis of definite autoimmune psychosis:**

The patient must meet the criteria for probable autoimmune psychosis with IgG class antineuronal antibodies in CSF.

Note that these criteria do not exclude a diagnosis being made in a patient with an acute onset ( $<3$  mo) of psychosis, even if that patient has had a previous psychotic, other psychiatric, or encephalopathic episode that resolved.

From Pollak TA, Lennox BR, Müller S, et al. Autoimmune psychosis: an international consensus on an approach to the diagnosis and management of psychosis of suspected autoimmune origin [published correction appears in *Lancet Psychiatry*. 2019 Dec;6(12):e31]. *Lancet Psychiatry*. 2020;7(1):93–108: Panel 1, p 100.

## COMORBIDITY

Among youth with schizophrenia, rates of comorbidity are approximately 34% for posttraumatic stress disorder, 34% for attention-deficit/hyperactivity and/or disruptive behavior disorders, and 32% for substance abuse/dependence. At least 10–20% of children diagnosed with schizophrenia have intellectual delays; it is unclear if this is related to the impact of the illness on cognitive testing. Children with schizophrenia also demonstrate impairments in language, communication, and information processing. Co-occurring rates of schizophrenia and autism spectrum disorder (ASD) are higher than would be expected in general populations; childhood-onset schizophrenia has been linked to ASD, with an estimated 30–50% of cases preceded by a diagnosis of an ASD.

## SEQUELAE

Follow-up studies of early-onset schizophrenia suggest moderate to severe impairment across the life span. Poor outcome is predicted by low pre-morbid functioning, insidious onset, higher rates of negative symptoms, childhood onset, and low intellectual functioning. When followed into adulthood, youth with schizophrenia demonstrated greater social deficits, lower levels of employment, and lower likelihood of independent living, relative to those with other childhood psychotic disorders.

Approximately 5–10% of individuals with schizophrenia die by suicide or accidental death directly related to behaviors caused by psychotic thinking, approximately 20% attempt suicide on one or more occasions, and many more have suicidal ideation. Life expectancy is reduced in individuals with schizophrenia because of associated medical conditions; a shared vulnerability for psychosis and medical disorders may explain some of the medical comorbidity of schizophrenia.

## ETIOLOGY AND RISK FACTORS

Etiologic evidence for schizophrenia supports a neurodevelopmental and neurodegenerative model, with multiple genetic and environmental risks having important roles. It has been hypothesized that although psychotic disorders have their origins in early development, it is not until youth are in their mid-teens that the underlying neural structures manifest the disabling functional deficits and resultant psychotic symptoms.

### Genetic Factors

The lifetime risk of developing schizophrenia is 5–20 times higher in first-degree relatives of affected probands than the general population. Concordance rates of 40–60% and 5–15% have been reported in monozygotic and dizygotic twins, respectively. Genome-wide association studies have implicated variants in >100 different genes that are statistically significant but individually only demonstrate small increases in the risk for schizophrenia. The risk for schizophrenia increases with increasing burden of these risk alleles; approximately 30% of the risk is attributable to common genetic variants. Rare variants of larger effect have also been implicated as increasing risk. Some rare copy number variants, where segments of the genome encompassing many genes are either duplicated or deleted, increase the risk of schizophrenia more markedly, with odds ratios of 2–25. Although these copy number variants may be responsible for 0.5–1.0% of typical adolescent/adult-onset schizophrenia, data indicate that they are responsible for about 12% of schizophrenia cases with onset before age 13 years.

### Environmental Factors

In utero exposure to maternal famine, advanced paternal age, prenatal infections, obstetric complications, marijuana use, and immigration have been hypothesized to contribute to the development of schizophrenia. Cannabis use in teens is associated with a higher risk of eventually developing psychosis, but it is difficult to determine whether this is related to drug effects or an unmasking of underlying

disease potential. Environmental exposures may mediate disease risk through direct neurologic damage, gene-environment interactions, epigenetic effects, or de novo mutations. There is no evidence that psychologic or social factors alone cause schizophrenia. Rather, environmental factors potentially interact with biologic risk factors to mediate the timing of onset, course, and severity of an acute episode. Expressed emotion within the family setting can influence the onset and exacerbation of acute episodes and relapse rates.

## NEUROANATOMIC ABNORMALITIES

Increased lateral ventricle volumes, along with reductions in hippocampus, thalamus, and frontal lobe volumes, have been reported in schizophrenia. Youth with schizophrenia have reductions in gray matter volumes and reduced cortical folding. Neurotransmitter systems, particularly central nervous system dopamine circuits, are hypothesized to have a key role in the pathophysiology of schizophrenia. The dopamine hypothesis is derived in part from the identification of D<sub>2</sub> receptor blockade as the mechanism for the action of antipsychotic medications. On neurologic exam, those with schizophrenia are often found to have deficits in smooth-pursuit eye movements and autonomic responsiveness.

## PREVENTION

There has been significant interest in prospectively identifying youth at risk for schizophrenia spectrum and other psychotic disorders to provide early intervention before the development of a chronic psychotic disorder. Those considered to be at clinically high risk may express a variety of unusual or odd beliefs. They may have unusual perceptual experiences, including frank hallucinations, but retain insight into their unreality. Their speech and behavior may be unusual, but not overtly disorganized. Individuals who had been socially active may become withdrawn. The symptoms are described as present at least once per week for the past month and have begun or worsened over the past year. Although the symptoms are less severe and more transient than in a psychotic disorder, 20–40% of patients with these attenuated symptoms appear to go on to a psychotic disorder within several years of symptom presentation. There is evidence that premorbid lower cognitive and social skills as well as a history of substance abuse contribute to the risk of developing a schizophrenia spectrum disorder.

Some evidence indicates that antipsychotic medication may delay conversion to a psychotic disorder and ameliorate attenuated symptoms in active treatment, yet there appear to be no lasting effects after the medication is withdrawn. Additionally, the known adverse effects of antipsychotics argue against their being used broadly to prevent psychosis in these patients, given that about 65% do not go on to develop a psychotic disorder.

Antidepressants have been associated with symptomatic improvement in adolescents who are at risk of developing a schizophrenia spectrum disorder. Psychologic interventions, including social skills, cognitive, and interaction training programs, as well as educational family interventions and cognitive-behavioral therapy (CBT), are reported to improve symptoms and psychosocial functioning in youth with early symptoms and decrease the rate of conversion to psychosis.

Despite improvements in diagnostic predictive validity, significant concern remains regarding a high false-positive rate that may cause individuals to be stigmatized or exposed to unnecessary treatment. In this context, youth with early symptoms suggestive of psychosis should be referred to a child and adolescent psychiatrist or other qualified mental health specialist.

## SCREENING

There are no validated tools for screening for schizophrenia spectrum disorders in children or adolescents. A widely accepted premorbid phenotype for childhood-onset schizophrenia has yet to be established.

Of children with childhood-onset schizophrenia, 67% show disturbances in social, motor, and language functioning, as well as learning disabilities. Many meet criteria for comorbid ASDs, mood disorders, and anxiety disorders.

Pediatric practitioners can make general inquiries of youth and their parents regarding problems with thinking or perceptions, including hallucinations and delusions. For younger children, the clinician must ensure that the child understands the questions. True psychotic symptoms are generally confusing to the individual. Highly descriptive, detailed, organized, and situation-specific reports are less likely to represent true psychosis. Overt evidence of psychosis is not always present on mental status examination, but in the absence of this, the validity of symptom reports should be scrutinized. Given the strong genetic component of schizophrenia spectrum disorders, a thorough family history is key in supporting the workup of psychosis in children. Youth presenting with possible psychosis warrant assessment and treatment by a child and adolescent psychiatrist or other qualified mental health specialist.

## ASSESSMENT

The diagnostic assessment of schizophrenia in youth is uniquely complicated; misdiagnosis is common. Most children who report hallucinations do not meet criteria for schizophrenia, and many do not have a psychotic illness. The persistence, frequency, and form of possible psychotic symptoms; the presence of distress; functional impairment; and insight need to be considered in arriving at a diagnosis. Expertise in childhood psychopathology and experience in assessing reports of psychotic symptoms in youth are important prerequisite skills for clinicians evaluating youth for psychosis. Comprehensive diagnostic assessments, which reconcile mental status findings with the rigorous application of diagnostic criteria, help improve accuracy.

All children who present with psychotic symptoms should receive a thorough pediatric and neurologic evaluation to focus on ruling out nonpsychiatric causes of psychosis (see [Tables 47.4](#) and [32.4](#)). There is no neuroimaging or laboratory test that establishes a diagnosis of schizophrenia spectrum disorders; these diagnostic tests are instead used to further assist with the medical evaluation while also establishing baseline laboratory parameters for monitoring medication therapy. Routine laboratory testing typically includes blood counts; basic metabolic panel; and assessment of liver, renal, and thyroid function. More extensive evaluation is indicated for atypical presentations, such as a gross deterioration in cognitive and motor abilities, focal neurologic symptoms, or delirium (see [Table 47.5](#)). Neuroimaging may be indicated when neurologic deficits are present, or EEG may be indicated for a clinical history suggestive of seizures or encephalopathy. Toxicology screens are indicated for acute onset or exacerbations of psychosis when exposure to drugs of abuse cannot be ruled out. Genetic testing is indicated if there are associated dysmorphic or syndromic features. Tests to rule out specific syndromes or diseases are indicated for clinical presentations suggestive of a specific syndrome (e.g., amino acid screens for inborn errors of metabolism, ceruloplasmin for Wilson disease, porphobilinogen for acute intermittent porphyria, neuronal antibodies for autoimmune encephalitis). Neuropsychologic testing cannot establish the diagnosis but may be important for documenting cognitive deficits for academic planning.

## TREATMENT

Treatment goals include decreasing psychotic symptomatology, directing the child toward a developmentally typical trajectory, and reintegrating the child into the home and community. Children and families facing schizophrenia spectrum disorders require an array of mental health services to address their psychologic, social, educational, and

cultural needs. Given the insidious onset and chronic course of these disorders, the patient must be followed longitudinally, with periodic reassessment to hone diagnostic accuracy and tailor services to meet the patient's and family's needs. Integrated psychopharmacologic, psychotherapeutic, psychoeducational, and case management services are often necessary.

**Psychoeducation** about the illness with an assessment of the potential role of stigma in treatment participation is critical for improving adherence with treatment recommendations. Assessing a child's strengths and vulnerabilities as well as available environmental resources is critical in devising an effective treatment plan. School and community liaison work to develop and maintain a day-to-day schedule for the patient is important. Specialized educational programs should be considered within the school system. Cognitive remediation has led to some promising gains in planning ability and cognitive flexibility. Effective and collaborative communication among the family, the pediatrician, a child and adolescent psychiatrist, and other mental health providers increases the potential for the patient's optimal functioning.

## Pharmacotherapy

First-generation (typical) and second-generation (atypical) antipsychotic medications are effective in reducing psychotic symptoms. Antipsychotics appear to outperform placebo and to have approximately equal effectiveness, except for ziprasidone and clozapine, which may be less and more effective than the others, respectively. Risperidone, aripiprazole, quetiapine, olanzapine, and lurasidone are FDA-approved second-generation antipsychotics for treating schizophrenia in patients 13 years and older, and paliperidone for those 12 years and older. Several first-generation antipsychotics are also FDA-approved for children and adolescents. The choice of which agent to use first is typically based on FDA approval status, side effect profile, patient and family preference, clinician familiarity, and cost. Although clozapine is effective in treating both positive and negative symptoms, it has a risk for agranulocytosis and seizures, which limits its use to those patients with *treatment-resistant* disorders. Ziprasidone and paliperidone are associated with QT prolongation; this finding along with the inferior effectiveness of ziprasidone limits its use with children and adolescents. All antipsychotics carry some degree of risk of sedation, weight gain, and extrapyramidal symptoms (see [Chapter 33](#)).

Most patients require long-term treatment and are at significant risk of relapse if their medication is discontinued. However, more than 75% of youth with schizophrenia discontinue their medication within 6 months. Common reasons for discontinuation include lack of efficacy, intolerable side effects, and general lack of adherence with treatment plan. Many patients will continue to experience some degree of positive or negative symptoms, requiring ongoing treatment. Patients should maintain regular physician contact to monitor symptom course, side effects, and adherence. Depot or long-acting injectable antipsychotics have not been studied well in pediatric age groups and have inherent risks with long-term exposure to adverse side effects. They are typically only considered when there is a well-documented history of psychotic symptoms as well as poor medication adherence.

## Electroconvulsive Therapy

Electroconvulsive therapy (ECT) may be used with severely impaired adolescents if medications are either not helpful or cannot be tolerated. It has not been systematically studied in children, but its use is supported in adults with schizophrenia, typically in combination with antipsychotic therapy.

Visit Elsevier eBooks+ at [eBooks.Health.Elsevier.com](http://eBooks.Health.Elsevier.com) for Bibliography.



## 47.2 Non-Schizophrenia Spectrum Psychotic Disorders

Jennifer A. Zaspel and Rosa K. Kim

Beyond the schizophrenia spectrum of psychotic disorders, substance/medication-induced psychotic disorder (Table 47.7) and psychotic disorder due to another medical condition (Table 47.8) can be seen in pediatric populations.

The hallmark features of **substance/medication-induced psychosis** are delusions and hallucinations that develop within the context of substance exposure: typically a drug of abuse, a medication, or a toxin exposure (see Tables 47.4 and 32.4 for a brief list). Synthetic cannabinoids (bath salts) are a common drug producing psychotic effects. A substance-induced psychosis is distinguished from a primary psychotic disorder by examining the onset and course of symptoms; the onset of a primary psychosis may precede substance exposure and may occur during periods of sustained abstinence. Once they arise, psychotic symptoms may be present as long as substance exposure is continued. Although the prevalence of substance/medication-induced psychotic disorder in the general

population is unknown, it is estimated that 7–25% of individuals presenting with a first episode of psychosis meet criteria for this diagnosis. Symptoms can be managed with antipsychotics until they remit, which often happens shortly after the offending substance is removed. Patients can develop a schizophrenia spectrum disorder following substance exposure, but this tends to occur in individuals who are at high risk for developing a primary psychotic disorder regardless of substance exposure.

Psychosis due to **another medical condition** (see Table 47.8) is also characterized by prominent hallucinations or delusions, but history, physical exam, and laboratory findings support a direct pathophysiologic connection between these symptoms and another medical condition (see Tables 32.4, 47.4, 47.5, and 47.8). Any sensory modality can be affected by hallucinations. The hallucinations vary in complexity depending on their etiology, and their description may be highly suggestive of a particular diagnosis, like olfactory hallucinations in temporal lobe epilepsy. Associations between delusions and medical conditions tend to be less specific. The list of medical conditions that can cause psychosis is long, and includes epilepsy, strokes, neoplasms, endocrine disorders, genetic syndromes like velocardiofacial syndrome, autoimmune disorders, and the permanent sequelae of toxic exposures (see Tables 32.4 and 47.4). Notably, delirium is excluded from psychosis due to another medical condition. When narrowing the differential between schizophrenia spectrum disorders, psychosis due to another medical condition, and any other etiology, it is important to consider the timeline of symptoms, the presence of features that are atypical for a primary psychosis, and the possibility of substance or medication exposure. Treatment of the underlying medical condition may or may not require adjunctive antipsychotic treatment for management of psychosis, and the course and prognosis of the psychosis will likely depend on the etiology.

A notable example of psychosis due to another medical condition is **psychosis associated with epilepsy**. The disorder manifests with delusions or hallucinations associated with poor insight, and can be further differentiated into ictal, interictal, and postictal psychosis. Ictal-induced psychosis is a form of **nonconvulsive status epilepticus**, usually a complex partial status that can last for hours to days and is associated with periods of impaired consciousness. Brief interictal psychosis can last days to weeks and is associated with paranoia, delusions, and auditory hallucinations. Chronic interictal psychosis resembles schizophrenia and manifests with paranoia, visual hallucinations, and catatonia. Postictal psychosis is the most common type (observed in 2–7% of patients with epilepsy) and lasts up to 1 week and then spontaneously remits. The diagnosis requires a strong index of suspicion and EEG monitoring. Treatment requires appropriate anticonvulsant drugs and, if the psychosis persists, initiating low-dose antipsychotic medication.

Visit Elsevier eBooks+ at [eBooks.Health.Elsevier.com](http://eBooks.Health.Elsevier.com) for Bibliography.

**Table 47.7** DSM-5 Diagnostic Criteria for Substance/Medication Induced Psychotic Disorder

- A. Presence of one or both of the following symptoms:
    1. Delusions
    2. Hallucinations
  - B. There is evidence from the history, physical examination, or laboratory findings of both (1) and (2):
    1. The symptoms of Criterion A developed during or soon after substance intoxication or withdrawal or after exposure to a medication.
    2. The involved substance/medication is capable of producing the symptoms in Criterion A.
  - C. The disturbance is not better explained by a psychotic disorder that is not substance/medication induced.
  - D. The disturbance does not occur exclusively during the course of a delirium.
  - E. The disturbance causes clinically significant distress or impairment in social, occupational, or other important areas of functioning.
- Specify if:
- With onset during intoxication:** If the criteria are met for intoxication with the substance and the symptoms develop during intoxication.
- With onset during withdrawal:** If the criteria are met for withdrawal from the substance and the symptoms develop during, or shortly after, withdrawal.

From the *Diagnostic and Statistical Manual of Mental Disorders*, 5th ed. pp 110–115. Copyright 2013. American Psychiatric Association. .

**Table 47.8** DSM-5 Diagnostic Criteria for Psychotic Disorder Due to Another Medical Condition

- A. Prominent hallucinations or delusions.
  - B. There is evidence from the history, physical examination, or laboratory findings that the disturbance is the direct pathophysiologic consequence of another medical condition.
  - C. The disturbance is not better explained by another mental disorder.
  - D. The disturbance does not occur exclusively during the course of a delirium.
  - E. The disturbance causes clinically significant distress or impairment in social, occupational, or other important areas of functioning.
- Specify whether:
- With delusions:** If delusions are the predominant symptom.
- With hallucinations:** If hallucinations are the predominant symptom.

From the *Diagnostic and Statistical Manual of Mental Disorders*, 5th ed. pp 115–116. Copyright 2013. American Psychiatric Association. .

## 47.3 Catatonia in Children and Adolescents

Jennifer A. Zaspel and Rosa K. Kim

Catatonia is a constellation or syndrome of psychomotor features, the most notable of which are decreased purposeful motor activity, decreased engagement in interviews and physical exams, or excessive and peculiar motor activity. The most characteristic symptoms are waxy flexibility and bizarre poses, but these may or may not be present (Table 47.9). Diagnosis can be challenging, as psychomotor disturbances can range from unresponsiveness to agitation. Catatonia has been associated with a broad array of conditions affecting children, adolescents, and adults, including psychotic, affective, drug-related, autoimmune, encephalitic, and neurodevelopmental conditions (Table 47.10). Autoimmune encephalitis may be the most common etiology in childhood. In addition, catatonia (*autism shut down syndrome*) may complicate ASD (Chapter 58).



**Table 47.9** Catatonia

**Excitement:** Extreme hyperactivity; constant motor unrest, which is apparently nonpurposeful

**Immobility/stupor:** Extreme hypoactivity, immobility; minimally responsive to stimuli

**Mutism:** Verbally unresponsive or minimally responsive

**Staring:** Fixed gaze, little or no visual scanning of environment, decreased blinking

**Posturing/catalepsy:** Maintains posture(s), including mundane (e.g., sitting or standing for hours without reacting)

**Grimacing:** Maintenance of odd facial expressions

**Echopraxia/echolalia:** Mimics of examiner's movements/speech

**Stereotypy:** Repetitive, non-goal-directed motor activity (e.g., finger play; repeatedly touching, patting, or rubbing self)

**Mannerisms:** Odd, purposeful movements (hopping or walking tiptoe, saluting passersby, exaggerated caricatures of mundane movements)

**Verbigeration:** Repetition of phrases or sentences

**Rigidity:** Maintenance of a rigid posture despite efforts to be moved

**Negativism:** Apparently motiveless resistance to instructions or to attempts to move/examine the patient; contrary behavior does the opposite of the instruction

**Waxy flexibility:** During repositioning of the patient, offers initial resistance before allowing themselves to be repositioned (similar to that of bending a warm candle)

**Withdrawal:** Refusal to eat, drink, or make eye contact

**Impulsivity:** Suddenly engaging in inappropriate behavior (e.g., runs down the hallway, starts screaming, or takes off clothes) without provocation; afterward, cannot explain

**Automatic obedience:** Exaggerated cooperation with examiner's request, or repeated movements that are requested once

**Passive obedience (mitgehen):** Raising arm in response to light pressure of finger, despite instructions to the contrary

**Negativism (gegenhalten):** Resistance to passive movement that is proportional to strength of the stimulus; response seems automatic rather than willful

**Ambitendency:** Appears stuck in indecisive, hesitant motor movements

**Grasp reflex:** Striking the patient's open palm with two extended fingers of the examiner's hand results in automatic closure of the patient's hand

**Perseveration:** Repeatedly returns to the same topic or persists with the same movements

**Combativeness:** Belligerence or aggression, usually in an undirected manner, without explanation

**Autonomic abnormality:** Abnormality of body temperature (fever), blood pressure, pulse rate, respiratory rate, inappropriate sweating

From Dhossche DM, Wachtel LE. Catatonia is hidden in plain sight among different pediatric disorders: A review article. *Pediatr Neurol*. 2010;43:307–315.

**Table 47.10** Conditions Associated with Catatonia

Psychotic Disorders

- Paranoid schizophrenia, catatonic schizophrenia, psychosis, autism, Prader-Willi syndrome, intellectual impairment

Mood Disorders

- Bipolar disorder: manic or mixed episodes

Major Depressive Disorder

Medical Conditions

- Hyper-hypothyroidism, euthyroid autoimmune thyroiditis, Addison disease, infections, electrolyte imbalances, pathogenic variants in *SCN2A* gene, systemic lupus erythematosus

Neurologic Conditions

- Epilepsy, strokes, traumatic brain injury, multiple sclerosis, infectious and autoimmune encephalitis, acute disseminated encephalomyelitis, neuromyelitis optica spectrum

Drugs

- Withdrawal: benzodiazepines, L-dopa, gabapentin
- Overdose: LSD, PCP, cocaine, MDMA (Ecstasy), disulfiram, levetiracetam

LSD, Lysergic acid; MDMA, 3,4-methylenedioxy-N-methylamphetamine; PCP, phencyclidine. Adapted from Weder ND, Muralee S, Penland H, Tampi RR. Catatonia: A review. *Ann Clin Psychiatry*. 2008;20(2):97–107:Table 2.

**Table 47.11** DSM-5 Criteria for Catatonia Due to Another Medical Condition

- A. The clinical picture is dominated by three (or more) of the following symptoms:
- Stupor (i.e., no psychomotor activity; not actively relating to environment).
  - Catalepsy (i.e., passive induction of a posture held against gravity).
  - Waxy flexibility (i.e., slight, even resistance to positioning by examiner).
  - Mutism (i.e., no, or very little, verbal response [Note: not applicable if there is an established aphasia]).
  - Negativism (i.e., opposing or not responding to instructions or external stimuli).
  - Posturing (i.e., spontaneous and active maintenance of a posture against gravity).
  - Mannerism (i.e., odd, circumstantial caricature of normal actions).
  - Stereotypy (i.e., repetitive, abnormally frequent, non-goal-directed movements).
  - Agitation, not influenced by external stimuli.
  - Grimacing.
  - Echolalia (i.e., mimicking another's speech).
  - Echopraxia (i.e., mimicking another's movements).
- B. There is evidence from the history, physical examination, or laboratory findings that the disturbance is the direct pathophysiologic consequence of another medical condition.
- C. The disturbance is not better explained by another mental disorder (e.g., a manic episode).
- D. The disturbance does not occur exclusively during the course of a delirium.
- E. The disturbance causes clinically significant distress or impairment in social, occupational, or other areas of functioning.

**Coding note:** Include the name of the medical condition in the name of the mental disorder (e.g., F06.1 catatonic disorder due to hepatic encephalopathy). The other medical condition should be coded and listed separately immediately before the catatonic disorder due to the medical condition (e.g., K71.90 hepatic encephalopathy; F06.1 catatonic disorder due to hepatic encephalopathy)

Adapted from Weder ND, Muralee S, Penland H, Tampi RR. Catatonia: A review. *Ann Clin Psychiatry*. 2008;20(2):97–107:Table 2.

The exact pathophysiology of catatonia is unknown, but neuroanatomic, neuroendocrine, immunologic, and neurotransmitter-based theories have all been proposed based on the various underlying etiologies of catatonia. Morbidity and mortality are high in adults who have experienced catatonia and are presumed to be high in pediatric populations based on limited data primarily because of the severity of an underlying illness that could cause catatonia. Patients with schizophrenia spectrum disorders and catatonia tend to be more impaired than those who do not experience catatonia, and suicide rates are estimated to be 500-fold higher than in the general population.

Catatonia is defined as 3 or more of the 12 symptoms listed in Table 47.11 and can be described by both etiology and presentation. The DSM-5 broadly splits etiology into presentations related to mental disorders and presentations related to another medical condition, the diagnosis of which must be supported by the patient's history, physical exam, and any accompanying laboratory findings. Pediatric prevalence rates range from 0.6–17% in child psychiatric inpatients and up to 17% in medically hospitalized children, but rates are difficult to determine due to underdiagnosis of the condition. Catatonia can be further subdivided into three presentation categories: stuporous, excited, and malignant. **Stuporous** presentations are characterized by immobility, mutism, staring, and rigidity, whereas **excited** presentations include prolonged periods of psychomotor agitation. **Malignant catatonia** is an emergent condition, presenting with hyperthermia, hypertension, rhabdomyolysis, and psychomotor agitation in addition to the psychiatric and motor

**Table 47.12** Standard Examination of Catatonia

The method described here is used to complete the 23-item Bush-Francis Catatonia Rating Scale (BFCRS) and the 14-item Bush-Francis Catatonia Screening Instrument (BFCSI). Item definitions on the two scales are the same. The BFCSI measures only the presence or absence of the first 14 signs.

Ratings are based solely on observed behaviors during the examination, with the exception of completing the items for “withdrawal” and “autonomic abnormality,” which may be based on directly observed behavior or chart documentation.

As a general rule, only items that are clearly present should be rated. If the examiner is uncertain as to the presence of an item, rate the item as “0.”

**PROCEDURE**

1. Observe the patient while trying to engage in a conversation.
2. The examiner should scratch his or her head in an exaggerated manner.
3. The arm should be examined for cogwheeling. Attempt to reposition and instruct the patient to “keep your arm loose.” Move the arm with alternating lighter and heavier force.
4. Ask the patient to extend his or her arm. Place one finger beneath his or her hand and try to raise it slowly after stating, “Do not let me raise your arm.”
5. Extend the hand stating, “Do not shake my hand.”
6. Reach into your pocket and state, “Stick out your tongue. I want to stick a pin in it.”
7. Check for grasp reflex.
8. Check the chart for reports from the previous 24-hour period. Check for oral intake, vital signs, and any incidents.
9. Observe the patient indirectly, at least for a brief period each day, regarding the following:
  - Activity level
  - Abnormal movements
  - Abnormal speech
  - Echopraxia
  - Rigidity
  - Negativism
  - Waxy flexibility
  - Gegenhalten
  - Mitgehen
  - Ambitendency
  - Automatic obedience
  - Grasp reflex

*Gegenhalten*, Resistance to movements that is equal and opposite to the pressure exerted by examiner; *mitgehen*, extreme *mitmachen* where even slightest pressure moves limb; *mitmachen*, passive movement of extremity despite instruction not to move.

From Bush G, Fink M, Petrides G, Dowling F, Francis A. Catatonia. I. Rating scale and standardized examination. *Acta Psychiatr Scand.* 1996;93(2):129–136.

symptoms seen in catatonia. The differential diagnosis for this type includes neuroleptic malignant syndrome or serotonin syndrome (see Chapter 33). Most children will present with a stuporous clinical picture, whereas the remaining cases present as excited or malignant, 19% and 5%, respectively. The severity of symptoms can be measured and tracked using the Bush-Francis Catatonia Rating Scale, a validated tool that accompanies a standardized physical examination and observation of patient behavior (Table 47.12). The diagnostic approach is driven by the search for the underlying cause for catatonia and the monitoring of its potentially dangerous effects on the body.

Beyond supportive care and discontinuation of any precipitating agents, treatment of catatonia should be expeditious to reduce the medical sequelae of prolonged symptoms. Benzodiazepines, in particular lorazepam, are typically first-line pharmacologic treatment

for catatonia. Low-dose lorazepam is often trialed as a confirmatory “challenge” for patients with suspected catatonia, where a positive result is improvement or even resolution of symptoms within hours of administration of the medication. If the initial challenge test does reverse symptoms, increasing doses of lorazepam are indicated, with careful monitoring to avoid side effects (Fig. 47.2). Rapid withdrawal of benzodiazepines can, in turn, precipitate catatonia in those who are susceptible. The use of antipsychotics in catatonia is controversial, as they have been associated with an increased incidence of malignant catatonia or neuroleptic malignant syndrome. ECT has also been used in both adults and children, though it is underutilized due to caretaker and ethical concerns. Its use is typically recommended when other viable treatment options have either not been successful or cannot be safely administered. It has been successful in treating refractory catatonia in children with autism.

Visit Elsevier eBooks+ at [eBooks.Health.Elsevier.com](http://eBooks.Health.Elsevier.com) for Bibliography.

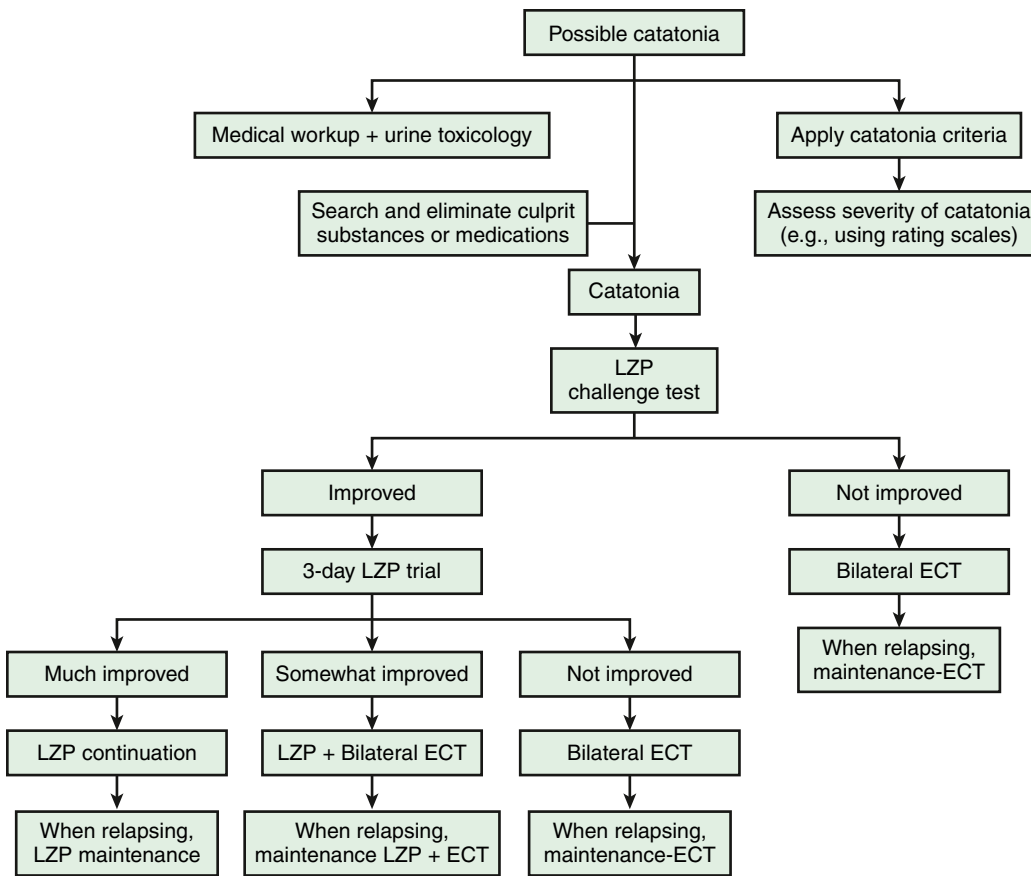
## 47.4 Hallucinations of Childhood

Jennifer A. Zaspel and Rosa K. Kim

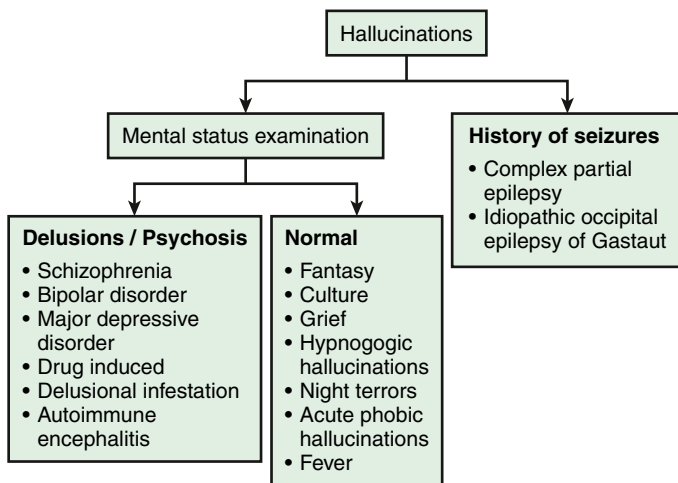
Hallucinations are perceptions that occur in the absence of identifiable external stimuli. Nondiagnostic hallucinations are those that fall within the realm of normal human experience, such as hearing footsteps, knocking, or one’s name being called. **Hypnagogic** and **hypnopompic** hallucinations are experienced as one transitions into and out of sleep, respectively, and on their own carry no psychopathologic implications. In younger children, reported hallucinations can reflect a developmentally appropriate blurring between fantasy and reality, especially regarding dreams and imaginary friends. Children are also more susceptible to perceptual distortions or **illusions** (misinterpretations of external stimuli) but may communicate these phenomena to adults in a way that most would interpret as hallucinations. The first clinical task in evaluating youth who report hallucinations is to sort out those associated with severe mental illness from those derived from other causes (Fig. 47.3).

**Acute phobic hallucinations** are benign, common, and typically occur in otherwise healthy preschool children. The hallucinations are often visual or tactile, last 10–60 minutes, and most often occur at night. The children are quite frightened and might complain that bugs or snakes are crawling over themselves and attempt to remove them. The child’s fear is not alleviated by reassurance by the parents or physician, and the child is not amenable to reason. Findings on physical and mental status examinations are otherwise normal, and the cause is unknown. Symptoms can persist for 1–3 days, slowly abating over 1–2 weeks.

In children with nonpsychotic hallucinations, all other symptoms of psychosis are absent. Nonpsychotic hallucinations typically occur in the context of severe traumatic stress, developmental difficulties, social and emotional deprivation, parents whose own psychopathology promotes a breakdown in the child’s sense of reality, cultural beliefs in mysticism, and unresolved mourning. Auditory hallucinations of voices telling the child to do “bad things” may be associated with disruptive behavior disorders in an unconscious attempt to distance oneself from undesirable behaviors. Hearing a voice invoking suicide is often associated with depression. Trauma-related hallucinations are commonly associated with posttraumatic stress disorder and are likely a representation of flashbacks. Auditory and visual hallucinations may similarly be endorsed in complex bereavement. The content of the hallucinations is often relevant in understanding the underlying psychopathology and developmental issues.



**Fig. 47.2** Algorithm for the evaluation, diagnosis, and treatment of catatonia in children and adolescents. ECT, Electroconvulsive therapy; LZP, lorazepam. (From Dhossche DM, Wilson C, Wachtel LE. Catatonia in childhood and adolescents: Implications for the DSM-5. *Prim Psychiatry*. 2010;17:23–26.)



**Fig. 47.3** Algorithm for the evaluation of hallucinations.

The evaluation of the underlying condition directs the type of treatment needed. Diagnostic nonpsychotic hallucinations suggest the need for disorder-specific psychotherapy and adjunctive medication, if indicated. CBT focused on helping the youth understand the origin of the hallucinations and on developing coping strategies for stressful situations may be helpful for older children and adolescents.

Visit Elsevier eBooks+ at [eBooks.Health.Elsevier.com](http://eBooks.Health.Elsevier.com) for Bibliography.

## Chapter 48

# Delirium

Colleen K. Manak and Rosa K. Kim

Delirium is defined as a disorder of **awareness** and **attention** and is characterized by its waxing and waning nature. It is not a primary psychiatric diagnosis and instead occurs secondary to an underlying medical condition, though at the time of initial presentation the underlying cause is often unknown. The symptoms of delirium are similar between adults and children. Delirium in children carries risks of adverse outcomes, including death, if it is not treated. Untreated delirium can serve to prolong the recovery course of comorbid and underlying conditions; the clinical features of delirium, including agitation, aggression, and confusion, can often interfere with necessary medical care. Delirium in children and adolescents is associated with a 12.5–29% mortality rate. Quick recognition, diagnosis, and treatment of delirium and its underlying cause is essential in ensuring the best outcome for patients.

### DIAGNOSIS

Criteria for the diagnosis of delirium are included in the DSM-5 under Neurocognitive Disorders (Table 48.1). Delirium presents with an **acute onset**, developing quickly over the course of hours to days and symptoms tend to **wax and wane**. This fluctuation of symptoms can be dramatic over the course of a day, with a patient appearing

**Table 48.1** DSM-5 Diagnostic Criteria for Delirium

- A. A disturbance in attention (i.e., reduced ability to direct, focus, sustain, and shift attention) and awareness (reduced orientation to the environment).
- B. The disturbance develops over a short period of time (usually hours to a few days), represents a change from baseline attention and awareness, and tends to fluctuate in severity during the course of a day.
- C. An additional disturbance in cognition (e.g., memory deficit, disorientation, language, visuospatial ability, or perception).
- D. The disturbances in Criteria A and C are not explained by another preexisting, established, or evolving neurocognitive disorder and do not occur in the context of a severely reduced level of arousal, such as coma.
- E. There is evidence from the history, physical examination, or laboratory findings that the disturbance is a direct physiologic consequence of another medical condition, substance intoxication or withdrawal (i.e., due to a drug of abuse or to a medication), or exposure to a toxin, or is due to multiple etiologies.

From the *Diagnostic and Statistical Manual of Mental Disorders*, 5th ed. p. 596. Copyright 2013. American Psychiatric Association.

**Table 48.2** DSM-5 Delirium Subtypes

Hyperactive delirium	<p><b>Increased psychomotor activity and mood lability</b></p> <ul style="list-style-type: none"> <li>• Confusion</li> <li>• Psychosis</li> <li>• Disorientation</li> <li>• Agitation</li> <li>• Hypervigilance</li> <li>• Hyper-alertness</li> <li>• Combativeness</li> <li>• Loud, pressured speech</li> <li>• Behavioral dysregulation</li> <li>• Pulling at lines/catheters</li> </ul>
Hypoactive delirium	<p><b>Decreased psychomotor activity</b></p> <ul style="list-style-type: none"> <li>• Sluggishness</li> <li>• Lethargy</li> <li>• Stupor</li> <li>• Confusion</li> <li>• Apathy</li> </ul>
Mixed delirium	<p><b>Normal level of psychomotor activity</b></p> <ul style="list-style-type: none"> <li>• Poor attention</li> <li>• Decreased awareness</li> <li>• Rapid fluctuation of activity level</li> </ul>

Adapted from Meagher D, Moran M, Raju B, et al. A new data-based motor subtype schema for delirium. *J Neuropsychiatry Clin Neurosci*. 2008;20(2):185–193:Fig 1.

relatively well from a cognitive perspective during one assessment, and then seeming acutely altered at the next. At the core of delirium is an alteration in attention and awareness, and a disturbance in cognition. Patients with delirium will struggle to focus and sustain attention. They are often disoriented, showing confusion about where they are, poor orientation to time, and sometimes disorientation to self. In addition to these core features, delirium often presents with symptoms that have the potential to be mistaken for psychosis or mania. People with delirium may hallucinate, engage in bizarre or purposeless movements, and show alterations in their sleep–wake cycles.

Delirium can be further categorized into subtypes (Table 48.2). The **hyperactive** subtype is characterized by increased motor activity, loss of control of activity, restlessness, and wandering. The **hypoactive**

subtype presents with reduction in activity, speed of actions, awareness of surroundings, quantity and speed of speech, and alertness. It is possible for patients to present with both hyperactive and hypoactive symptoms over the course of 24 hours, classified as having a **mixed motor subtype**. There has been emerging evidence of a fourth group, identified as the **no motor subtype**, in which they do not show characteristics of either hyper- or hypoactive subtypes.

Although these subtypes are often seen in both pediatric and adult delirium, diagnosing delirium in children can pose challenges not present in adult populations. Developmental differences, especially in young children, necessitate alternative approaches to assessing and diagnosing delirium. Bedside staff and caregivers can provide helpful insight into behaviors and cognitive changes, such as changes in attention, increased fussiness over baseline, and difficulty soothing, which might be missed by clinicians who are unable to evaluate symptoms of delirium using traditional methods (Fig. 48.1).

## EPIDEMIOLOGY

The prevalence rate of pediatric delirium is an estimated to be 13–44% among *hospitalized* children, with higher rates seen in patients who are admitted to the intensive care unit (ICU) and/or those being mechanically ventilated. Increased risk for delirium may be associated with the underlying medical condition, prolonged hospitalization (especially ICU admission), young age, neurocognitive and developmental disorders, and a personal history of delirium. Potentially modifiable risk factors include polypharmacy, deep sedation, the use of benzodiazepines and anticholinergic medications, disrupted sleep, pain, sensory deprivation, and lack of familiar environment or caregivers. Delirium can occur at any age and has been observed in infants in the NICU.

## ETIOLOGY

Although nearly any medical condition that requires hospitalization can lead to delirium, there are diagnoses that are more commonly associated with delirium (Table 48.3). Similarly, there are several drugs that are associated with the development of delirium in children including benzodiazepines, anticholinergic medications, sedatives, opiates, steroids, and some illicit substances (synthetic cathinone, synthetic cannabinoids).

## ASSESSMENT

A thorough review of the medical record helps to identify predisposing and precipitating factors including exposures, changes in behavior, recent illness, and surgeries. If a reasonable cause is unable to be found on history, a further medical work-up is usually indicated.

It is possible for children with known psychiatric illnesses to develop delirium in response to medical stress. Having a comorbid psychiatric diagnosis should not delay the diagnosis of delirium. Psychiatric illnesses that can be confused with delirium include psychosis, mania, depression, and catatonia (Table 48.4). Key factors to look for in the history of patients with delirium are an acute onset without prodrome or other previous concern for worsening behavioral functioning, variable symptoms from moment to moment, and deficits in attention and orientation.

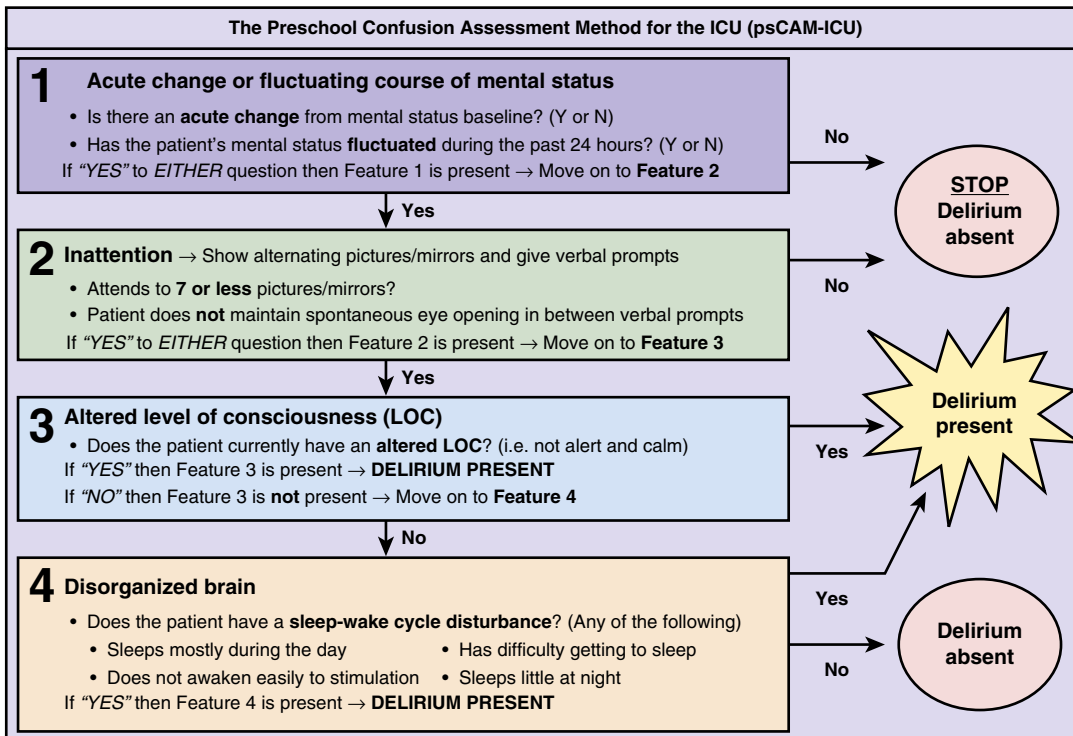
One of the factors that complicates assessment of delirium in children is the developmental level of the child. A young child will be unable to answer some of the standard assessment questions (e.g., questions about orientation), which means that a fair amount of the assessment will come from the bedside staff and the child's primary caregivers. More standard assessment strategies can be utilized in older children and adolescents.

In the patient interview, a good assessment will strive to evaluate affect, thought process, thought content, attention, and orientation to make the diagnosis of delirium. Because the nature of delirium is waxing and waning, it would not be atypical to have a seemingly normal exam in a patient one suspects to have delirium. Performing multiple assessments over the course of time is important to making an accurate diagnosis. In delirium, patients can have a disruption in their normal affect and may appear restricted or dysthymic.



Cornell Assessment of Pediatric Delirium (CAPD)						
RASS score _____ (if -4 or -5 do not proceed)						
Please answer the following questions based on your interactions with the patient over the course of your shift:						
	Never	Rarely	Sometimes	Often	Always	Score
	4	3	2	1	0	
1. Does the child make eye contact with the caregiver?						
2. Are the child's actions purposeful?						
3. Is the child aware of his/her surroundings?						
4. Does the child communicate needs and wants?						
	Never	Rarely	Sometimes	Often	Always	
	0	1	2	3	4	
5. Is the child restless?						
6. Is the child inconsolable?						
7. Is the child underactive—very little movement while awake?						
8. Does it take the child a long time to respond to interactions?						
<b>TOTAL</b>						

A



B

**Fig. 48.1** Screening tools for the assessment of delirium. **A**, Cornell Assessment of Pediatric Delirium (CAPD). **B**, The Preschool Confusion Assessment Method for the ICU (psCAM-ICU). The short-form (clinical) psCAM-ICU is used to assess for delirium in infants and children who are at least responsive to voice. RASS, Richmond Agitation and Sedation Scale. (A from Traube C, Silver G, Kearney J, et al. *Cornell Assessment of Pediatric Delirium: A valid, rapid, observational tool for screening delirium in the PICU\**. *Crit Care Med*. 2014;42:656–663; B from Smith HA, Gangopadhyay M, Goben CM, et al. *The Preschool Confusion Assessment Method for the ICU: Valid and Reliable Delirium Monitoring for Critically Ill Infants and Children*. *Crit Care Med*. 2016;44:592–600:Fig. 2.)

<b>Table 48.3</b> Etiologies of Pediatric Delirium (CRITICAL CARE mnemonic)	
Cardiovascular	Anemia, shock, vasculitis, hypertensive encephalopathy
Respiratory	Respiratory insufficiency, respiratory failure, pneumothorax
Infection	Sepsis, encephalitis, urinary tract infection, meningitis, fever, pneumonia, tracheitis, cellulitis, surgical site infection, COVID-19
Toxins	Polypharmacy, heavy metals, drug:drug interactions
Inflammatory process	Autoimmune and rheumatologic disease
CNS pathology	Stroke, seizure, head trauma, intracranial bleed, tumor, anoxic brain injury
Abuse, withdrawal, sedation	Alcohol, benzodiazepines, opioids, barbiturates, prolonged/excessive sedation
Liver	Liver insufficiency, hepatic failure, hyperammonemia
Catheters, central line infections	Invasive device or procedure complications
Alimentation	Electrolyte imbalance, nutritional deficiencies, dehydration
Renal	Renal insufficiency or failure
Endocrinopathies	Glycemic disturbance, thyroid disease, parathyroid disease, adrenal disease

Adapted from Malas N, Brahmabhatt K, McDermott C, Smith A, Ortiz-Aguayo R, Turkel S. Pediatric delirium: Evaluation, management, and special considerations. *Curr Psychiatry Rep.* 2017;19(9):65.

Thought processes are often disorganized, tangential, or circumstantial and may seem loosely associated with, or not at all related to, the reality of what is going on in the moment. Patient with delirium may also be perseverative in their thought content, with difficulty moving away from a subject or becoming highly fixated on, or preoccupied with, one thing. They may have altered thought content, with hallucinations. Visual hallucinations especially are one of the hallmark alterations of thought content associated with delirium. Attention is frequently impacted in delirium, with patients demonstrating decreased attention, with an impaired ability to attend to a conversation or a situation. Orientation in people with delirium is often altered, especially with regards to orientation to place and time. Although all of these changes are observed to wax and wane during the course of delirium, changes in orientation can be the most striking, with patients sometimes going from being fully oriented to quite confused in the span of hours.

### RATING SCALES

There are multiple rating scales that have been created to help to screen for delirium, particularly in critical care or intensive care setting (see Fig. 48.1). The Cornell Assessment for Pediatric Delirium (CAPD), Pediatric Confusion Assessment Method for the Intensive Care Unit (pCAM-ICU), Preschool Confusion Assessment Method for the ICU (psCAM-ICU), and Richmond Agitation Sedation Scale (RASS) are all scales that are frequently used to help monitor for delirium. The CAPD, pCAM-ICU, and psCAM-ICU have all been validated for use in the pediatric population. Rating scales are not diagnostic on their own but can be useful for identifying patients at risk for delirium and for following response to treatment.

### MEDICAL EVALUATION

Delirium is a clinical diagnosis and can be made with history and physical exam alone. There are no tests that are routinely recommended in

<b>Table 48.4</b> Differential Diagnosis of Delirium				
CLINICAL FEATURE	DELIRIUM	PSYCHOSIS	DEPRESSION	CATATONIA
Course	Acute onset, hours, days or more	Insidious onset over many months, prodrome	Insidious onset, at least 2 wk, often over months	Onset variable
Attention	Markedly impaired attention and arousal	Normal to mild impairment	Mild impairment	Variable difficulty with attention and arousal
Fluctuation	Characterized by a waxing and waning course; disturbed day/night cycle	Absent	Absent	Less likely to fluctuate, motor signs may show more fluctuation
Perception	Misperceptions; hallucinations (visual, fleeting); paramnesia	Hallucinations, auditory with personal reference	May have mood-congruent hallucinations	May have hallucinations, especially if secondary to primary psychosis
Speech and language	Abnormal clarity, speed and coherence; disjointed and dysarthric; misnaming; characteristic dysgraphia	Disorganized with bizarre theme	Decreased amount of speech	Mutism; echolalia
Other cognition	Disorientation to time, place; recent memory and visuospatial abnormalities	Disorientation to person; concrete interpretations	Mental slowing; indecisiveness; memory retrieval difficulty	Global disorientation
Behavior	Lethargy; nonsystematized delusions; emotional lability	Systematized delusions; paranoia; bizarre behavior	Depressed mood; anhedonia; lack of energy; sleep and appetite disturbance	Stupor; catalepsy; negativism; posturing; stereotypy; agitation not influenced by external stimuli; grimacing; echopraxia
Electroencephalogram	Diffuse slowing; low voltage fast activity; specific patterns	Normal	Normal	Normal, focal abnormalities or generalized slowing

the evaluation for delirium, rather clinicians should be guided by the history and medical concerns. There are times when laboratory, imaging, and other testing modalities can be helpful particularly in patients with suspected delirium when the underlying medical etiology of delirium is unknown.

Central nervous system imaging may be recommended to help identify underlying processes that may be contributing to delirium; brain imaging on its own is not a tool that can diagnose delirium and is not recommended for the sole purpose of diagnosis.

Electroencephalogram (EEG) is one of the few tools that can be used to help confirm a delirium diagnosis if there is diagnostic ambiguity or uncertainty. Various studies have found 65–86% of children with delirium have *abnormal* EEGs. Findings associated with delirium typically include some degree of diffuse background slowing and disorganization. This EEG finding has been shown to effectively discriminate between children with delirium and healthy controls. However, these EEG findings are nonspecific and are not sufficient to diagnose delirium. Another caveat when utilizing EEG in the evaluation of delirium is the reality that several of the underlying causes of delirium, including metabolic derangement, seizures, infections, and intoxication, can also lead to EEG changes in the absence of delirium (see Table 48.3).

## DIFFERENTIAL DIAGNOSIS

Both medical and psychiatric disorders may share or mimic some of the symptoms of delirium and can sometimes lead to complications when trying to make the diagnosis. **Catatonia**, **depression**, and **psychosis** are some of the more frequently occurring diagnoses that can be confused for delirium in children and especially adolescents (see Table 48.4; see Chapter 47). In particular, catatonia can be difficult to separate from delirium, especially because the two can co-occur. It is important to attempt to clarify the diagnosis because treatment of delirium and catatonia is different; the treatment for one can exacerbate the other. To help distinguish between the two, it is often helpful to assess for motor signs seen in catatonia that are not typically present in delirium (see Chapter 47.3). Additionally, catatonia is less likely to present with a waxing and waning course. The Bush-Francis Rating Scale can be used to help diagnose catatonia (see Table 47.12).

Delirium can also mimic psychosis, frequently presenting with hallucinations and sometimes delusions. One of the most profound differences between the two is the onset; delirium has an acute onset compared with the prodromal nature of a first episode of psychosis. It would be unusual for primary psychosis to develop over the course of days. However, this is characteristic of delirium. Hallucinations in delirium are often visual, whereas primary psychotic illnesses typically present with predominantly auditory hallucinations. Delusional thought content in delirium often lacks any internal structure or interconnectedness, while delusions in primary psychotic disorders are frequently structured around a common theme.

Patients with depression may have some characteristics of delirium. The course and onset can help to distinguish depression from delirium; with depression the timing of onset is often closer to that of delirium. Depression does not demonstrate a waxing and waning course, and while cognition can be affected, it is often slowed with some memory problems, whereas orientation remains intact.

## TREATMENT

### Nonpharmacologic Interventions

Nonpharmacologic interventions are a mainstay in both delirium treatment and prevention. The goal behind these interventions is to provide a supportive environment and to provide sensory and environmental modifications to help offset the challenges posed by the need for hospital-based care and treatment. Strategies such as frequent reorientation, adherence to normal routines, clustering care, and maintaining a normal sleep–wake cycle are all frequently implemented to prevent or manage delirium (Table 48.5)

### Pharmacologic Treatment

Pharmacologic management of delirium focuses on both utilizing medications to help manage the symptoms of delirium while the

**Table 48.5** Nonpharmacologic Management of Delirium

Environmental modifications	<ul style="list-style-type: none"> <li>• Maintain lighting consistent with the time of day</li> <li>• Minimize noise</li> <li>• Familiar objects</li> <li>• Visible clock, calendar</li> </ul>
Sensory modifications	<ul style="list-style-type: none"> <li>• Have appropriate sensory aides available (glasses, hearing aids)</li> <li>• Soft, calming music</li> <li>• Minimize lines, catheters, restraints</li> <li>• Maintain comfortable position and body alignment</li> </ul>
Caregiver interventions	<ul style="list-style-type: none"> <li>• Frequent reorientation</li> <li>• Fewer care team providers/different faces</li> <li>• Cluster cares to minimize interruptions</li> <li>• Promote normal sleep/wake schedule</li> <li>• Presence of familiar caregivers</li> </ul>

underlying process is being treated and removing medications that may precipitate or worsen delirium.

## Antipsychotics

Medications for the behavioral symptoms of delirium target disruptive behaviors that pose a danger to the patient and caregivers and interfere with necessary medical care. Although these medications do not treat the underlying cause of delirium, they can help to decrease distress and lead to a shorter overall course. Antipsychotic medications are the mainstay of treatment for the behavioral and psychiatric symptoms of delirium. Both first- and second-generation antipsychotics are effective, and the choice of medication is based on what other medical needs are co-occurring. It is recommended to “start low and go slow” to arrive at an effective dose. Although typically used only for a short course (days to weeks), it remains important to consider adverse effects of antipsychotic medications (see Chapter 33). All antipsychotics can cause QTc prolongation; thus it is recommended that electrocardiogram (ECG) monitoring be considered at the onset of and throughout the treatment. For a patient who is unable to take medications by mouth, intramuscular (IM) or intravenous (IV) haloperidol can be used. IV haloperidol is more potent than IM or oral haloperidol; switching between formulations and modes of administration must be done carefully. For patients who can take medications by mouth, second-generation antipsychotics are typically the preferred choice. Risperidone, quetiapine, and olanzapine have all been shown to be effective in treating children and adolescents with delirium. Risperidone and olanzapine are available in an oral disintegrating tablet, and quetiapine is available in a liquid solution, which makes them easy to administer for patients who are dependent on a nasogastric tube for nutrition. Choice of medication is often dependent on what is available in the treatment setting, and the preferred route of administration. In chronically ill medical patients, inquiring about a past history of delirium and treatment can be helpful in guiding medication choices.

## Other Medications

Melatonin has some utility in the management of delirium as it can help to promote a normal circadian rhythm and the return to a healthy sleep–wake cycle. Trazodone has also been shown to have some benefit for patients who are struggling with nocturnal sleep maintenance.

## Medications to Avoid

In addition to adding medications for the treatment of delirium, eliminating unnecessary or potentially deliriogenic medications is equally important. *Benzodiazepines worsen delirium and should be avoided as much as possible in patients at risk of developing delirium.* They should not be used to treat agitation in delirious patients. Anticholinergic medications are also known to potentiate delirium and should also be avoided. Minimizing polypharmacy to the extent possible can help to

eliminate potentially deliriogenic medications and aid in the *prevention of delirium*.

### **Pain Medications**

Opiate pain medications can be associated with worsening delirium and should be used with care in patients at risk for delirium. Complicating this is the reality that untreated or undertreated pain can also be associated with the development and perpetuation of delirium, so ensuring adequate pain control will help to manage, and in some cases, prevent delirium.

### **Course and Sequelae**

#### **Course**

The resolution of delirium can be variable. Some patients improve quickly once the underlying cause is identified and treated, while

others may take weeks to months to show full resolution of symptoms. Patients who have delirium related to complex medical issues, such as autoimmune encephalitis, or prolonged hospital stays, may have longer lasting delirium. When symptoms improve, antipsychotic medications can be weaned; patients do not need to be on them long term.

#### **Sequelae**

Patients who have delirium are more likely to have subsequent episodes of delirium. There is evidence that patients with delirium go on to have impaired cognitive functioning compared to patients who have never had an episode of delirium.

Visit Elsevier eBooks+ at [eBooks.Health.Elsevier.com](http://eBooks.Health.Elsevier.com) for Bibliography.



## Chapter 49

# Neurodevelopmental and Executive Function and Dysfunction

Desmond P. Kelly and Darla H. McCain

### TERMINOLOGY AND EPIDEMIOLOGY

A **neurodevelopmental function** is a basic brain process needed for learning and productivity and involves the following core neurodevelopmental domains: sensory, motor, language, visual-spatial/visual-perceptual, intellectual, memory, social cognition, and executive function. **Executive function (EF)** is a broad term used to describe specific neurocognitive processes involved in the regulating, guiding, organizing, and monitoring of thoughts and actions to achieve a specific goal. Processes considered to be “executive” in nature include inhibition/impulse control, cognitive/mental flexibility, emotional control, initiation skills, planning, organization, working memory, and self-monitoring.

**Neurodevelopmental variation** refers to differences in neurodevelopmental functioning. Wide variations in these functions exist within and between individuals. These differences can change over time and need not represent pathology or abnormality.

**Neurodevelopmental and/or executive dysfunctions** reflect any disruptions or weaknesses in these processes, which may result from neuroanatomic disturbance or neuropsychologic malfunctioning.

Neurodevelopmental and/or executive dysfunction places a child at risk for developmental, cognitive, emotional, behavioral, psychosocial, and adaptive challenges. Preschool-age children with neurodevelopmental or executive dysfunction may manifest delays in developmental domains such as language, motor, self-help, or social-emotional development and self-regulation. For the school-age child, an area of particular focus is academic skill development. It is at this age that disorders of learning are often diagnosed. The *Diagnostic and Statistical Manual of Mental Disorder, Fifth Edition (DSM-5)* classifies disorders of learning within the group of neurodevelopmental disorders as **specific learning disorder (SLD)**, with separate specifiers recognizing impairments in reading, written expression, and mathematics. In the *International Classification of Diseases, Tenth Edition (ICD-10)*, neurodevelopmental disorders include **specific developmental disorders of scholastic skills** with specific reading disorder, mathematics disorder, and disorder of written expression. **Dyslexia** is a term used more frequently by neurologists and by some advocacy groups to describe reading disorders. **Disorders of EF** have traditionally been viewed as a component of **attention-deficit/hyperactivity disorder (ADHD)**, which is also classified in DSM-5 as a neurodevelopmental disorder. **Frontal lobe and executive function deficit** is a recognized diagnostic term used primarily by neuropsychologists.

There are no prevalence estimates specifically for neurodevelopmental dysfunction, but overall estimates for learning disorders range from 5% to 10% or more with a similar range reported for ADHD. These disorders frequently co-occur. The range in prevalence is related to differences in criteria used for classification and diagnosis, the overlap and interaction of neurodevelopmental variations, and differing methods of assessment.

### ETIOLOGY AND PATHOGENESIS

Neurodevelopmental and executive dysfunction may result from a broad range of etiologic factors, including genetic, medical, psychologic, environmental, and sociocultural influences.

A high degree of **heritability** is reported in learning and attention disorders, with estimates ranging from 45% to 80%, but identification of specific gene associations is elusive. Neurodevelopmental dysfunctions generally fall along a continuum of traits with disorders becoming evident at extremes of dimensions or thresholds of dysfunction. The same genetic and early environmental risk factors that are associated with a disorder such as ADHD also predict trait levels in the general population. Specific genes have been identified as associated with reading disorders, including the *DYX2* locus on chromosome 6p22 and the *DYX3* locus on 2p12. Neuroimaging studies have confirmed links between gene variations and variations in cortical thickness in areas of the brain known to be associated with learning and academic performance, such as the temporal regions. Chromosomal abnormalities can lead to unique patterns of dysfunction, such as visual-spatial deficits in females diagnosed with Turner syndrome (see Chapter 99.4) or executive and language deficits in children with fragile X syndrome (see Chapter 99.6). Chromosome 22q11.2 deletion syndrome (see Chapter 99.3) has been associated with predictable patterns of neurodevelopmental and executive dysfunction that can be progressive, including a higher prevalence of intellectual disability and deficits in visual-spatial processing, attention, **working memory** (e.g., the ability to hold and manipulate information over short periods), verbal learning, arithmetic, and language.

**Perinatal** factors, including very low birthweight, severe intrauterine growth restriction, perinatal hypoxic-ischemic encephalopathy, and prenatal exposure to substances such as alcohol and drugs or infections, may independently disrupt neurodevelopment or exacerbate genetic vulnerabilities. Increased risk of neurodevelopmental and executive dysfunction has also been associated with environmental toxins, including lead (see Chapter 761); drugs such as cocaine; infections such as meningitis, HIV, and Zika; and brain injury associated with intraventricular hemorrhage, periventricular leukomalacia, or head trauma. The negative academic impact of concussion in children and adolescents, although usually temporary, has been well characterized, including impaired concentration and slowed processing speed. Repeated injuries have a much higher likelihood of long-term negative neurocognitive effects.

Early **psychologic trauma** may result in both structural and neurochemical changes in the developing brain, which may contribute to neurodevelopmental and executive dysfunction. Exposure to trauma, abuse, or other adverse experiences in early childhood in the absence of positive experiences—primarily safe, stable, and nurturing relationships—can lead to diminished regulatory influences mediated by key brain regions (hippocampus and prefrontal cortex) and may influence right hemisphere function with associated risk for problems with information processing, memory, focus, and self-regulation. Environmental and sociocultural deprivation can also lead to, or potentiate, neurodevelopmental and executive dysfunction, and numerous studies have indicated that parent/caregiver executive functioning affects the development of EFs in children.

Investigations of neuroanatomic substrates have yielded important information about the underlying **pathogenesis** in neurodevelopmental and executive dysfunction. Differences have been demonstrated in the left parietotemporal and left occipitotemporal brain regions of individuals with dyslexia compared to those without reading difficulties (see Chapter 51). Studies have also described the neural circuitry, primarily in the parietal cortex, underlying mathematical competencies such as the processing of numerical magnitude and mental arithmetic. The associations between executive dysfunction and the *prefrontal/frontal cortex* have been established, and injury to the frontal lobe regions often

result in dysfunction of executive abilities (e.g., poor inhibitory control). Although the prefrontal/frontal cortex may be the primary control region for EFs, there is considerable interconnectivity between the brain's frontal regions and other areas, such as *arousal systems* (reticular activating system), *motivational and emotional systems* (limbic system), *cortical association systems* (posterior/anterior; left/right hemispheres), and *input/output systems* (frontal motor/posterior sensory areas).

## CORE NEURODEVELOPMENTAL FUNCTIONS

The neurodevelopmental processes that are critical to a child's successful functioning may best be understood as falling within **core neurodevelopmental domains** that are highly integrated.

### Sensory and Motor Function

**Sensory** development begins well before birth in the primary visual, auditory, and somatosensory cortical regions along with the olfactory and gustatory cortices. This neurodevelopmental process is crucial in helping children experience, understand, and manipulate their environments. Sensory development progresses in association with environmental exposure and with the development of other cognitive processes, such as motor development. Through sensory experiences, children's brains mature as new neuronal pathways are created and existing pathways are strengthened.

There are three distinct, yet related, forms of **neuromotor** ability: fine motor, graphomotor, and gross motor coordination. **Fine motor function** reflects the ability to control the muscles that produce small, exact movements. Deficits in fine motor function can disrupt the ability to communicate in written form and to excel in artistic and crafts activities and can interfere with learning a musical instrument or mastering a computer keyboard.

**Graphomotor function** refers to the specific motor aspects of written output. Several subtypes of graphomotor dysfunction can significantly impede writing. Children who harbor weaknesses of visualization during writing have trouble picturing the configurations of letters and words as they write (orthographics), with poorly legible written output and inconsistent spacing between words. Others have weaknesses in orthographic memory and may labor over individual letters and prefer printing (manuscript) to cursive writing. Some exhibit signs of finger agnosia and have trouble localizing their fingers while they write, needing to keep their eyes very close to the page and applying excessive pressure to the pencil. Others struggle to produce the highly coordinated motor sequences needed for writing. It is important to emphasize that a child may show excellent fine motor dexterity (as revealed in mechanical or artistic domains) but very poor graphomotor fluency (with labored or poorly legible writing).

**Gross motor function** refers to control of large muscles. Children with gross motor incoordination often have problems in processing "outer spatial" information to guide gross motor actions. Affected children may be inept at catching or throwing a ball because they cannot form accurate judgments about trajectories in space. Others demonstrate diminished body position sense. They do not efficiently receive or interpret proprioceptive and kinesthetic feedback from peripheral joints and muscles. They are likely to evidence difficulties when activities demand balance and tracking of body position and movement. Others are unable to meet the motor planning demands of complex motor procedures such as those needed for dancing, gymnastics, or swimming.

The term **dyspraxia** relates to difficulty in developing an ideomotor plan and activating coordinated and integrated visual-motor actions to complete a task or solve a motor problem, such as assembling a model or learning a new movement.

**Developmental coordination disorder** is categorized in DSM-5 as a motor disorder where the learning and execution of coordinated motor skills is below age level given the child's opportunity for skill learning, and the motor difficulties significantly interfere with activities of daily living, academic productivity, and play.

### Language

Language is one of the most critical and complex cognitive functions and can be broadly divided into **receptive** (auditory comprehension/

understanding) and **expressive** (speech and language production and/or communication) functions (see Chapter 53). Children who primarily experience receptive language problems may have difficulty understanding verbal information, following instructions and explanations, and interpreting what they hear. Expressive language weaknesses can result from problems with speech production and/or problems with higher-level language development. **Speech production difficulties** include oromotor problems affecting articulation, verbal fluency, and naming. Some children have trouble with sound sequencing within words. Others find it difficult to regulate the rhythm or prosody of their verbal output. Their speech may be dysfluent, hesitant, and inappropriate in tone. Problems with **word retrieval** can result in difficulty finding exact words when needed (as in a class discussion) or substituting definitions for words (circumlocution).

The basic components of language include **phonology** (ability to process and integrate the individual sounds in words), **semantics** (understanding the meaning of words), **syntax** (mastery of word order and grammatical rules), **discourse** (processing and producing paragraphs and passages), **metalinguistics** (ability to think about and analyze how language works and draw inferences), and **pragmatics** (social understanding and application of language). Children who evidence higher-level expressive language impediments have trouble formulating sentences, using grammar appropriately, and organizing spoken (and possibly written) narratives.

To one degree or another, all academic skills are taught largely through language, and thus it is not surprising that children who experience language dysfunction often experience problems with academic performance. In fact, some studies suggest that up to 80% of children who present with a specific learning disorder also experience language-based weaknesses. Additionally, the role of language in executive functioning cannot be understated, because language serves to guide cognition and behavior.

### Visual-Spatial/Visual-Perceptual Function

Important structures involved in the development and function of the visual system include the retina, the optic nerves, the brainstem (control of automatic responses, e.g., pupil dilation), the thalamus (e.g., lateral geniculate nucleus for form, motion, color), and the primary (visual space and orientation) and secondary (color perception) visual processing regions located in and around the occipital lobe. Other brain areas, although considered to be outside of the primary visual system, are also important to visual function, helping to process *what* is seen (temporal lobe) and *where* it is located in space (parietal lobe).

Critical aspects of visual processing development in the child include appreciation of **spatial relations** (ability to perceive objects accurately in space in relation to other objects), visual discrimination (ability to differentiate and identify objects based on their individual attributes, e.g., size, shape, color, form, position), and visual closure (ability to recognize or identify an object when the entire object cannot be seen). Visual-spatial processing dysfunctions are rarely the cause of reading disorders, but some investigations have established that deficits in orthographic coding (visual-spatial analysis of character-based systems) can contribute to reading disorders. Spelling and writing can emerge as a weakness because children with visual processing problems usually have trouble with the precise visual configurations of words. In mathematics, these children often have difficulty with visual-spatial orientation, with resultant difficulty aligning digits in columns when performing calculations and difficulty managing geometric material. In the social realm, intact visual processing allows a child to make use of visual or physical cues when communicating and interpreting the paralinguistic aspects of language. Secure visual functions are also necessary to process proprioceptive and kinesthetic feedback and to coordinate movements during physical activities.

### Intellectual Function

A useful definition of **intellectual function** is the capacity to think in the abstract, reason, problem-solve, and comprehend. Intelligence is viewed as a global construct composed of more specific cognitive

functions (e.g., auditory and visual-perceptual processing, spatial abilities, processing speed, and working memory).

The expression of intellect is mediated by many factors, including language development, sensorimotor abilities, genetics, heredity, environment, and neurodevelopmental function. When an individual's measured intelligence is  $>2$  standard deviations below the mean (a standard score of  $<70$  on most IQ tests) and accompanied by significant weaknesses in adaptive skills, the diagnosis of **intellectual disability** may be warranted (see Chapter 56). Functionally, some common characteristics distinguish children with intellectual disability from those with average or above-average abilities. Typically, those at the lowest end of the spectrum (e.g., profound or severe intellectual disability) are incapable of independent function and require a highly structured environment with constant aid and supervision. At the other end of the spectrum are those with unusually well-developed intellect ("gifted"). Stronger intellect has been associated with better-developed concept formation, critical thinking, problem solving, understanding and formulation of rules, brainstorming and creativity, and *metacognition* (ability to "think about thinking"). Although high levels of intellectual functioning offer many opportunities, they can also be associated with functional challenges related to socialization, learning, and communication style.

Individuals whose intellect falls in the below-average range (sometimes referred to as the "borderline" or "slow learner" range) tend to experience greater difficulty processing and managing information that is abstract, making connections between concepts and ideas, and generalizing information (e.g., may be able to comprehend a concept in one setting but be unable to carry it over and apply it in different situations). In general, these individuals tend to do better when information is presented in more concrete and explicit terms (with repetition) and when working with rote information (e.g., memorizing specific material).

### Memory

Memory is a term used to describe the complex, cognitive mechanism by which information is acquired, retained, and recalled. Major brain areas involved in memory processing include the hippocampus, fornix, temporal lobes, and cerebellum, with connections in and between most brain regions. Memory consists of multiple distinct and interconnected subsystems that are categorized based on the length of time information is stored (e.g., short-term memory, long-term memory), type of information stored (e.g., events, facts, procedures, emotional associations, conditioned reflexes), modality of the information (e.g., visual, auditory, olfactory), and whether memories are consciously recalled (**explicit memory**) or unconsciously recalled (**implicit memory**). Information processing models also include **working memory** as a distinct component.

Memory formation begins with sensory input (e.g., auditory, visual, tactile) that is identified, or **registered**, and subsequently **encoded**. Encoding is a mental process that transforms perceptual input into a representational code for the memory system. Information in **short-term memory** is transferred into **long-term memory** through the process of **consolidation** and **storage**. Information capacity in short-term memory is limited and brief, lasting for seconds to minutes, whereas information in long-term memory is potentially unlimited in terms of capacity and can be available for hours or as long as a life span.

Once information finds its way into long-term memory, it must be accessed. In general, information can be retrieved spontaneously (a process known as **free recall**) or with the aid of cues (**cued or recognition recall**). With deliberate, repeated practice, children can develop **automaticity**, the ability to instantaneously and effortlessly access information that has been learned in the past. Automaticity frees cognitive resources to process other information and promote learning. For example, automaticity in decoding words allows a child to focus on the meaning of the text.

### Social Cognition

The development of effective social skills is heavily dependent on secure **social cognition**, which consists of mental processes that allow

an individual to understand and interact with the social environment. Although some evidence shows that social cognition exists as a discrete area of neurodevelopmental function, multiple cognitive processes are involved with social cognition. These include the ability to recognize, interpret, and make sense of the thoughts, communications (verbal and nonverbal), and actions of others; the ability to understand that others' perceptions, perspectives, and intentions might differ from one's own (commonly referred to as "theory of mind"); the ability to use language to communicate with others socially (pragmatic language); and the ability to make inferences about others and the environment based on contextual information. It can also be argued that social cognition involves processes associated with memory and EFs, such as flexibility and shifting. Children with autism spectrum disorder harbor deficits in social cognition (see Chapter 58).

### Executive Function

EF involves multiple skills (Table 49.1) that begin development early in life (early indications of inhibitory control and even working memory have been found in infancy), mature significantly during the preschool years, and continue to develop through adolescence and well into adulthood. Some studies suggest that secure EF may be more important than intellectual ability for academic success and have revealed that a child's ability to delay gratification early in life predicts competency, attention, self-regulation, frustration tolerance, aptitude, physical and mental health, and even risk for substance dependency in adolescence and adulthood. Conversely, deficits in other areas of neurodevelopment, such as language development, affect EF.

**Attention** is far from a unitary, independent, or specific brain function. This may be best illustrated through the phenotype associated with ADHD (see Chapter 50). Disordered attention can result from faulty mechanisms in and across subdomains of attention. These subdomains include *selective* attention (ability to focus attention on a particular stimulus and to discriminate relevant from irrelevant information), *divided* attention (ability to orient to more than one stimulus at a given time), *sustained* attention (ability to maintain one's focus), and *alternating* attention (capacity to shift focus between stimuli).

Attention problems in children can manifest at any point, from arousal through output. Children with diminished alertness and

**Table 49.1** Symptom Expression of Executive Dysfunction

EXECUTIVE FUNCTION DEFICIT	SYMPTOM EXPRESSION
Inhibitory control	Impulsivity/poor behavioral regulation Interrupts "Blurts things out"
Shifting	Problems with transitioning from one task/activity to another Unable to adjust to unexpected change Repeats unsuccessful problem-solving approaches
Initiation	Difficulty independently beginning tasks/activities Lacks initiative Difficulty developing ideas or making decisions
Working memory	Challenges following multistep instruction (e.g., only completes one of three steps) Forgetfulness
Organization and planning	Fails to plan ahead Work is often disorganized Procrastinates and does not complete tasks "Messy" child
Self-monitoring	Fails to recognize errors and check work Does not appreciate impact of actions on others Poor self-awareness
Emotional control	Experiences behavioral and emotional outbursts (e.g., tantrums) Easily upset/frustrated Frequent mood changes



arousal can exhibit signs of mental fatigue in a classroom or when engaged in any activity requiring sustained focus. They are apt to have difficulty directing and sustaining their concentration, and their efforts may be erratic and unpredictable, with extreme performance inconsistency. Weaknesses in determining saliency often result in allocating cognitive resources to the wrong stimuli, at home, in school, and socially, and missing important information. **Distractibility** can take the form of listening to extraneous noises instead of a teacher, staring out the window, or constantly thinking about the future. Attention dysfunction can affect the output of work, behavior, and social activity. It is important to appreciate that most children with attentional dysfunction also have other forms of neurodevelopmental dysfunction that can be associated with academic disorders (with some estimates suggesting up to 60% comorbidity).

**Inhibitory control (IC)** can be described as one's ability to restrain, resist, and not act (cognitively or behaviorally/emotionally) on a thought. IC may also be seen as one's ability to stop thoughts or ongoing actions. Deficits in this behavioral/impulse regulation mechanism are a core feature of the **combined or hyperactive impulsive** presentation of ADHD and have a significant adverse impact on a child's overall functioning. In everyday settings, children with weak IC may exhibit difficulties with self-control and self-monitoring of their behavior and output (e.g., impulsivity), may not recognize their own errors or mistakes, and often act prematurely and without consideration of the potential consequences of their actions. In the social context, disinhibited children may interrupt others and demonstrate other impulsive behaviors that often interfere with interpersonal relationships. The indirect consequences of poor IC can include challenges with behavior, emotional regulation, and academic functioning and have adverse impacts on social interactions and safety.

**Shifting** is the ability to transition from one activity, topic, or aspect of a problem to another when needed. Effective shifting allows a child to flexibly move through their day, tolerating changes in schedule and routine. Additionally, shifting allows a child to change strategies when working a problem and adjust to changes in topics when conversing with others. Children with difficulties in shifting can become quickly upset in novel situations (e.g., when presented with a substitute teacher) and show marked resistance to change in routine. They can get stuck on one problem-solving strategy, which compromises their work efficiency. Socially, problems with shifting can result in one-sided conversations, negatively affecting a child's ability to build and maintain friendships.

**Initiation** refers to the ability to independently begin an activity, a task, or thought process (e.g., problem-solve). Children who present with initiation difficulties often have trouble "getting started." This can be exhibited behaviorally, such that the child struggles to start on physical activities like getting out of bed or beginning chores. Cognitively, weaknesses in initiation may manifest as difficulty coming up with ideas or generating plans. In school, children who have poor initiation abilities may be slow or unable to start homework assignments or tests. In social situations, initiation challenges may cause a child to have difficulty beginning conversations, calling on friends, or going out with friends.

Deficits in "primary" initiation are relatively rare and are often associated with significant neurologic conditions and treatments (e.g., traumatic brain injury, anoxia, effects of radiation treatment in childhood cancer). More often, initiation deficits are secondary to other executive problems (e.g., disorganization) or behavioral (e.g., oppositional/defiant behaviors), developmental (e.g., autism spectrum disorder), or emotional (e.g., depression, anxiety) disorders.

**Working memory (WM)** can be defined as the ability to hold, manipulate, and store information for short periods. In its simplest form, WM involves the interaction of short-term verbal and visual processes (e.g., memory, phonologic awareness, and spatial skills) with a centralized control mechanism that is responsible for coordinating all the cognitive processes involved (e.g., temporarily suspending information in memory while manipulating it). Ultimately, this function enables new information arriving in short-term memory to be linked to prior knowledge or procedures held in long-term memory. As such, working memory is critical to be able to complete multistep problems

and more complex instructions and tasks. WM capacity can double or triple between the preschool years and adolescence. In the classroom, a child with a weakness in working memory might appear inattentive or careless when completing their work. When doing math, a child with WM dysfunction might have difficulty carrying a number and following the expected procedure. When reading a paragraph, a child might not recall key facts or be able to integrate information when reading, particularly long paragraphs. For writing tasks, a child might leave out ideas they intended to express while they are recalling grammar rules, such as placing a comma, and working on spelling a word correctly.

**Planning** refers to the ability to effectively generate, sequence, and put into motion the steps and procedures necessary to realize a specific goal. In real-world settings, children who struggle with planning are typically described by caregivers and teachers as being inept at independently gathering what is required to solve a problem or as unable to complete more weighty assignments. These children commonly exhibit poor time management skills.

**Organization** is an ability that represents a child's proficiency in arranging, ordering, classifying, and categorizing information. Planning and organizing depend on **discrimination** ability, which refers to the child's ability to determine what is and is not valuable when trying to problem-solve or organize. Common daily life challenges associated with organizational difficulties in childhood include problems with gathering and managing materials or items. When children struggle with organization, indirect consequences may include becoming overwhelmed with information and being unable to complete a task or activity. Effective organization is a vital component in learning (more specifically, in memory/retention); many studies, along with clinical experience, have shown that poor organization significantly affects how well a child recalls information.

**Self-monitoring** involves awareness and assessment of one's actions, whether it be a work product (e.g., writing an essay) or social interaction with another. This EF allows one to evaluate and make necessary corrections. Children with difficulty in self-monitoring fail to recognize errors in their work and struggle with editing. When interacting with others, they may not realize how their verbal and nonverbal behaviors are being perceived, ultimately missing opportunities to correct their behavior and resulting in poor social interactions.

**Emotional control** is the ability to regulate emotions in order to realize goals and direct one's behavior, thoughts, and actions. It has been well established that affective/emotional states have an impact on many aspects of functioning. Conversely, executive function or dysfunction often contributes to modulation of affect. Although emotional control is highly interrelated with different EFs (e.g., disinhibition, self-monitoring), separating it conceptually facilitates an appreciation for and recognition of the often-overlooked role that a child's emotional state plays in cognitive and behavioral functioning. Children with weak emotional control may exhibit explosive outbursts, poor temper/anger control, and oversensitivity. Understanding a child's emotional state is vital to understanding its impact not only on executive functioning but also on functioning as a whole (e.g., socially, mentally, behaviorally, academically).

Any discussion involving emotional control should also recognize **motivation**. *Motivation/effort* may be defined as the reason or reasons one acts or behaves in a certain way. Less motivated children are less likely to engage and utilize all their abilities. Such a disposition not only interferes with application of executive skills but also results in less-than-optimal performance and functioning. The less success a child feels, the less likely the child is to put forth effort and to persevere when things become more challenging. If a child's initial efforts are met with a negative reaction, the likelihood that the child will continue putting forth adequate effort diminishes. If left unchecked, a child's overall level of functioning will likely be compromised. More importantly, the child's sense of personal efficacy (e.g., self-esteem) and competence may suffer.

## CLINICAL MANIFESTATIONS

The symptoms and clinical manifestations of neurodevelopmental and executive dysfunction differ with age. **Preschool-age children**



might present with delayed language development, including problems with articulation, vocabulary development, word finding, and rhyming. They often experience early challenges with learning colors, shapes, letters, numbers, the alphabet, and days of the week. Children with visual processing deficits may have difficulty learning to draw and write and have problems with art activities. These children might also have trouble discriminating between left and right. They might encounter problems recognizing letters and words. Difficulty following instructions, overactivity, and distractibility may be early symptoms of emerging executive dysfunction. Difficulties with fine motor development (e.g., grasping crayons/pencils, coloring, drawing) and social interaction may develop. These manifestations should be considered as potential “red flags” for future learning challenges (see “Assessment and Diagnosis”).

**School-age children** with neurodevelopmental and executive dysfunctions can vary widely in clinical presentations. Their specific patterns of academic performance and behavior represent final common pathways of neurodevelopmental strengths and deficits interacting with environmental, social, or cultural factors; temperament; educational experience; and intrinsic resilience (Table 49.2). Children with language weaknesses might have problems integrating and associating letters and sounds, decoding words, deriving meaning, and being able to comprehend passages. Children with early signs of a mathematics weakness might have difficulty with concepts of quantity or with adding or subtracting without using concrete representation (e.g., their fingers when calculating). Difficulty learning time concepts and confusion with directions (right/left) might also be observed. Poor fine motor control and coordination and poor planning can lead to writing problems. Attention and behavioral regulation weaknesses observed earlier can continue, and together with other EF weaknesses (e.g., organization, initiation skills), further complicate the child’s ability to acquire and generalize new knowledge. Children with weaknesses in WM may struggle to remember the steps necessary to complete an activity or problem-solve. In social settings, these children often have difficulty keeping up with more complex conversations.

**Table 49.2** Neurodevelopmental Dysfunction Underlying Academic Disorders\*

ACADEMIC DISORDER	POTENTIAL UNDERLYING NEURODEVELOPMENTAL DYSFUNCTION
Reading	Language <ul style="list-style-type: none"> <li>• Phonologic processing</li> <li>• Verbal fluency</li> <li>• Syntactic and semantic skills</li> </ul> Memory <ul style="list-style-type: none"> <li>• Working memory</li> </ul> Sequencing Visual-spatial Attention
Written expression, spelling	Language <ul style="list-style-type: none"> <li>• Phonologic processing</li> <li>• Syntactic and semantic skills</li> </ul> Graphomotor Visual-spatial Memory <ul style="list-style-type: none"> <li>• Working memory</li> </ul> Sequencing Attention
Mathematics	Visual-spatial Memory <ul style="list-style-type: none"> <li>• Working memory</li> </ul> Language Sequencing Graphomotor Attention

\*Isolated neurodevelopmental dysfunction can lead to a specific academic disorder, but more often there is a combination of factors underlying weak academic performance. In addition to the dysfunction in neurodevelopmental domains as listed in the table, the clinician must also consider the possibility of limitations of intellectual and cognitive abilities or associated social and emotional problems.

In **middle school children** the substantial increase in cognitive, academic, and regulatory demands can cause further difficulties for those with existing neurodevelopmental and executive challenges. In reading and writing, middle school children might present with transposition and sequencing errors; might struggle with root words, prefixes, and suffixes; might have difficulty with written expression; and might avoid reading and writing altogether. Challenges completing word problems in math are common. Difficulty with recall of information might also be experienced. Although observable in both lower and more advanced grades, behavioral, emotional, and social difficulties tend to become more salient in middle school children who experience cognitive or academic problems.

**High school students** can present with deficient reading comprehension, written expression, and slower processing efficiency. Difficulty in answering open-ended questions, dealing with abstract information, and deploying executive control (e.g., self-monitoring, organization, planning, self-starting) is often reported.

### Academic Problems

**Reading disorders** (see Chapter 51) can stem from a number of neurodevelopmental dysfunctions, as described earlier (see Table 49.2). Most often, language and auditory processing weaknesses are present, as evidenced by poor phonologic processing that results in deficiencies at the level of decoding individual words and, consequently, a delay in *automaticity* (e.g., acquiring a repertoire of words readers can identify instantly) that causes reading to be slow, laborious, and frustrating. Deficits in other core neurodevelopmental domains might also be present. Weak WM might make it difficult for a child to hold sounds and symbols in mind while breaking down words into their component sounds, or might cause reading comprehension problems. Some children experience temporal-ordering weaknesses and struggle with reblending phonemes into correct sequences. Memory dysfunction can cause problems with recall and summarization of what was read. Some children with higher-order cognitive deficiencies have trouble understanding what they read because they lack a strong grasp of the concepts in a text. Although rare as a cause of reading difficulty, problems with visual-spatial functions (e.g., visual perception) can cause children difficulty in recognizing letters. It is not unusual for children with reading problems to avoid reading practice, and a delay in reading proficiency becomes increasingly pronounced and difficult to remediate.

**Spelling and writing impairments** share many related underlying processing deficits with reading, so it is not surprising that the two disorders often occur simultaneously in school-age children (see Table 49.2). Core neurodevelopmental weaknesses that underlie *spelling difficulties* include phonologic and decoding difficulties, orthographic problems (coding letters and words into memory), and morphologic deficits (use of suffixes, prefixes, and root words). Problems in these areas can manifest as phonetically poor, yet visually comparable, approximations to the actual word (*faght* for *fight*), spelling that is phonetically correct but visually incorrect (*fite* for *fight*), and inadequate spelling patterns (*plade* for *played*). Children with memory disorders might misspell words because of coding weaknesses. Others misspell because of poor auditory WM that interferes with their ability to process letters. Sequencing weaknesses often result in transposition errors when spelling.

*Writing difficulties* have been classified as **disorder of written expression**, or **dysgraphia** (see Table 49.2). Although many of the same dysfunctions described for reading and spelling can contribute to problems with writing, written expression is the most complex of the language arts, requiring synthesis of many neurodevelopmental functions (e.g., auditory, visual-spatial, memory, executive; see Chapter 52.2). Weaknesses in these functions can result in written output that is difficult to comprehend, disjointed, and poorly organized. The child with WM challenges can lose track of what the child intended to write. Attention deficits can make it difficult for a child to mobilize and sustain the mental effort, pacing, and self-monitoring demands necessary for writing. In many cases, writing is laborious because of an underlying *graphomotor dysfunction* (e.g., fluency does not keep pace

with ideation and language production). Thoughts may also be forgotten or underdeveloped during writing because the mechanical effort is so taxing.

*Weaknesses in mathematical ability*, known as **mathematics disorder** or **dyscalculia**, involve the assimilation of both procedural knowledge (e.g., calculations) and higher-order cognitive processes (e.g., WM) (see Table 49.2). There are many reasons why children struggle with mathematics (see Chapter 52.1). It may be difficult for some to grasp and apply math concepts effectively and systematically; good mathematicians are able to use both verbal and perceptual conceptualization to understand such concepts as fractions, percentages, equations, and proportion. Children with language dysfunctions have difficulty in mathematics because they have trouble understanding their teachers' verbal explanations of quantitative concepts and operations and are likely to experience frustration in solving word problems and in processing the vast network of technical vocabulary in math. Mathematics also relies on visualization. Children who have difficulty forming and recalling visual imagery may be at a disadvantage. They might experience problems writing numbers correctly, placing value locations, and processing geometric shapes or fractions. Children with executive dysfunction may be unable to focus on fine detail (e.g., operational signs), might take an impulsive approach to problem solving, engage in little or no self-monitoring, forget components of the problem, or commit careless errors. When a child's memory system is weak, the child might have difficulty recalling appropriate procedures and automatizing mathematical facts (e.g., multiplication tables). Moreover, children with mathematical disabilities can have superimposed mathematics **phobias**; anxiety over mathematics can be especially debilitating.

### Nonacademic Problems

The impulsivity and lack of effective self-monitoring of children with executive dysfunction can lead to unacceptable actions that were unintentional. Children struggling with neurodevelopmental dysfunction can experience excessive performance anxiety, sadness, or clinical depression; declining self-esteem; and chronic fatigue. Some children may lose motivation and feel no need to exert effort and develop future goals. These children may be easily led toward dysfunctional interpersonal relationships, detrimental behaviors (e.g., delinquency, substance abuse), and the development of mental health disorders, such as mood disorders (see Chapter 39) or conduct disorder (see Chapter 42).

### ASSESSMENT AND DIAGNOSIS

Pediatricians have a critical role in identifying and treating the child with neurodevelopmental or executive dysfunction (Fig. 49.1). They have knowledge of the child's medical and family history and social-environmental circumstances and have the benefit of longitudinal contact over the course of routine health visits. Focused **surveillance and screening** will facilitate early identification of developmental-behavioral and preacademic difficulties and interventions to facilitate optimal outcomes.

A **family history** of a parent who still struggles with reading or time management or an older sibling who has failed at school should spur an increased level of monitoring. **Risk factors** in the medical history, such as extreme prematurity or chronic medical conditions, should likewise be flagged. Children with low birthweight and those born prematurely who appear to have been spared more serious neurologic problems might only manifest academic problems later in their school career. **Nonspecific physical complaints** or unexpected **changes in behavior** might be presenting symptoms. Warning signs might be subtle or absent, and parents might have concerns about their child's learning progress but may be reluctant to share these with the pediatrician unless prompted, such as through completion of **standardized developmental screening questionnaires** or direct questioning regarding possible concerns. Concerns voiced to parents or caregivers by daycare, preschool, or early elementary teachers might be the first indicators of neurodevelopmental dysfunctions. There should be a low threshold for initiating further school performance screening and assessment if there are any concerns or "red flags" (see "Clinical Manifestations").

In elementary school, review of **school report cards** and teacher comments can provide very useful information. In addition to patterns of grades in the various academic skill areas, it is also important to review ratings of classroom behavior and work habits. Group-administered **standardized tests** provide further information, although interpretation is required because poor scores could result from a learning disorder, ADHD, emotional problems, lack of motivation, or some combination. Conversely, a discrepancy between above-average scores on standardized tests and unsatisfactory classroom performance could signal motivation, adjustment issues, or instructional mismatches. Challenges related to **homework**, such as excessive time to complete, can provide further insight regarding EFs, academic skill, and behavioral factors or factors related to the home environment.

Underlying or associated medical problems should be ruled out. Any suspicion of sensory difficulty should warrant referral for **vision or hearing testing**. The influence of chronic medical problems or potential side effects of medications should be considered. **Sleep deprivation** is increasingly being recognized as a contributor to academic problems, especially in middle and high school. **Substance use** must always be a consideration as well, especially in the adolescent previously achieving well who has shown a rapid decline in academic performance.

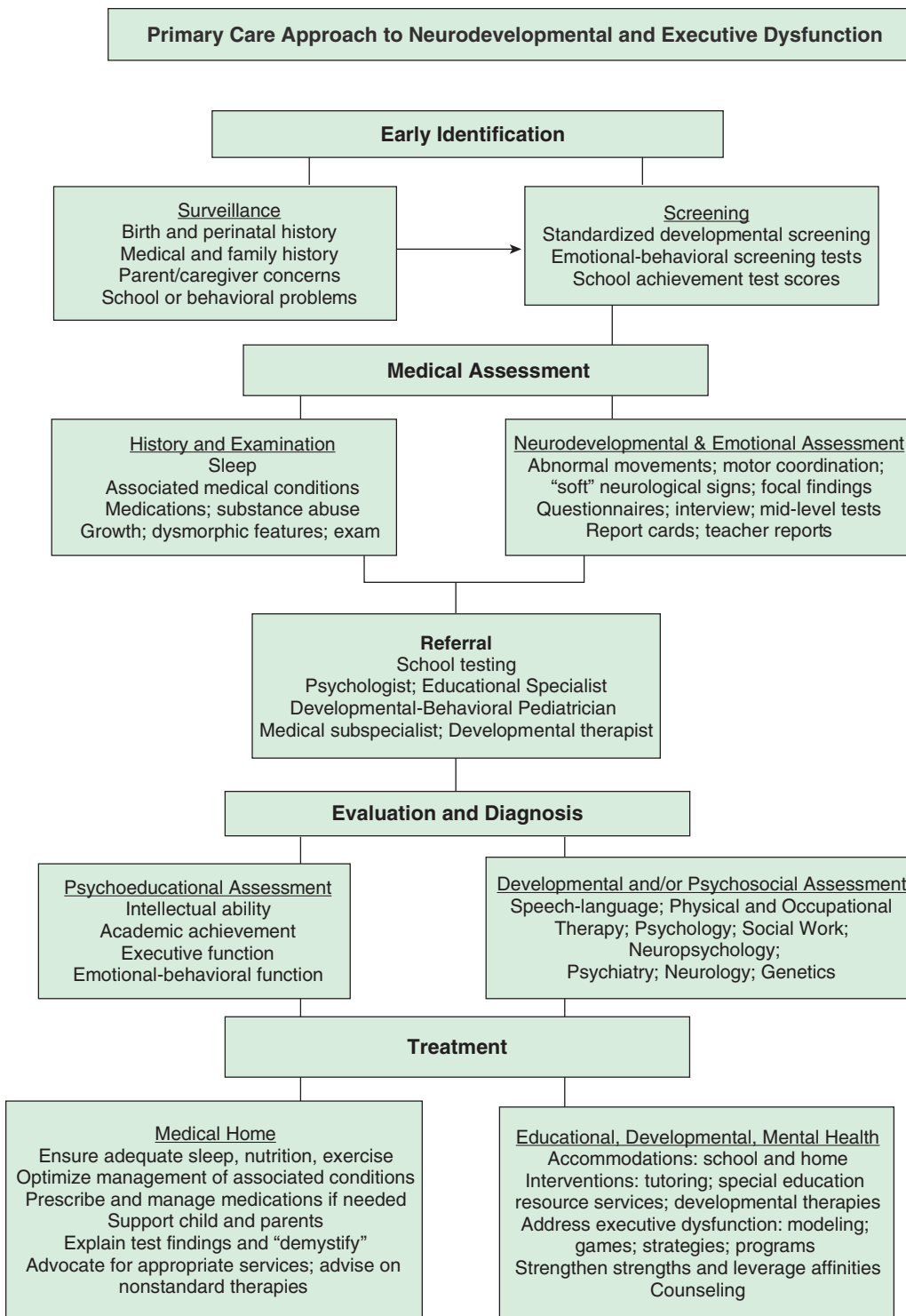
The physician should be alert for **dysmorphic physical features**, minor congenital anomalies, or constellations of physical findings (e.g., cardiac and palatal anomalies in 22q11.2 deletion syndrome) and should perform a detailed **neurologic examination**, including an assessment of fine and gross motor coordination and any involuntary movements or soft neurologic signs. Genetic testing is often recommended for children with intellectual disability or autism spectrum disorder; electroencephalogram and brain MRI are generally not indicated in the absence of specific medical findings or a family history.

Early signs of **executive dysfunction** can also be subtle and easily overlooked or misinterpreted. Informal inquiry might include questions about how children complete schoolwork or tasks, how organized or disorganized they are, how much guidance they need, whether they think through problems or respond and react too quickly, what circumstances or individuals affect their ability to employ EFs, how easily they begin tasks and activities, and how well they plan, manage belongings, and control their emotions.

Pediatricians who are interested in performing further assessment before referral, or who are practicing in areas where psychologic testing resources are limited, can use **standardized rating scales and inventories** or brief, individually administered tests to narrow potential diagnoses and guide next steps in diagnosis and treatment. Such instruments, completed by the parents, teachers, and the child (if old enough), can provide information about emotions and behavior, patterns of academic performance, and traits associated with specific neurodevelopmental dysfunctions (see Chapter 32). Screening instruments such as the *Pediatric Symptom Checklist* and behavioral questionnaires such as the *Child Behavior Checklist* (CBCL) and *Behavior Assessment System for Children, Third Edition* (BASC-3) can aid in evaluation.

EFs can be further assessed by instruments such as the *Behavior Rating Inventory of Executive Function, Second Edition* (BRIEF-2), which provides a comprehensive measure of real-world behaviors that are closely tied to executive functioning in children age 5-18 years. Tests that can be directly administered to gauge intellectual and language functioning include the *Kaufman Brief Intelligence Test, Second Edition* (KBIT-2) and *Peabody Picture Vocabulary Test, Fifth Edition* (PPVT 5; assessing receptive vocabulary). A relatively brief test of academic skills is the *Wide Range Achievement Test5* (WRAT5). It should be recognized that these are midlevel tests that can provide descriptive estimates of function but are not diagnostic.

Children who are struggling academically are entitled to evaluations in school. Such assessments are guaranteed in the United States under Public Law 101-476, the **Individuals with Disabilities Education Act (IDEA)**. One increasingly common type of evaluation model supported by IDEA is referred to as a **Response to Intervention (RtI)** model (see Chapter 52.1). In this model, students who are struggling with academic skills are initially provided research-based instruction. If a child does not respond to this instruction, an individualized



**Fig. 49.1** Algorithm showing components of a primary care approach to identification, diagnosis, and comprehensive multidisciplinary management of neurodevelopmental and executive dysfunction.

evaluation by a multidisciplinary team is conducted. Children found to have attentional dysfunction and other disorders might qualify for educational accommodations in the regular classroom under Section 504 of the Rehabilitation Act of 1973 (**504 Plan**) or might qualify for an **individualized education program (IEP)**.

The pediatrician should advise and support parents regarding steps to request evaluations by the school. Multidisciplinary evaluations are focused primarily on determining whether a student meets the eligibility criteria for special education services and to assist in developing an IEP for those eligible for these services. **Independent evaluations** can provide second opinions outside the school setting.

The multidisciplinary team should include a psychologist and preferably an educational diagnostician who can undertake a detailed analysis of academic skills and subskills to pinpoint where breakdowns are occurring in the processes of reading, spelling, writing, and mathematics. Other professionals should become involved, as needed, such as a speech-language pathologist, occupational therapist, and social worker. A mental health specialist can be valuable in identifying family-based issues or psychiatric disorders that may be complicating or aggravating neurodevelopmental dysfunctions.

In some cases, more in-depth examination of a child's **neurocognitive status** is warranted. This is particularly true for children who



present with developmental or cognitive difficulties in the presence of a medical condition (e.g., epilepsy, traumatic brain injury, childhood cancers/brain tumors, genetic conditions). A **neuropsychologic evaluation** involves comprehensive assessment to understand brain functions across domains. Neuropsychologic data are often analyzed together with other tests, such as MRI, to look for supporting evidence of any areas of difficulty (e.g., memory weaknesses associated with temporal lobe anomalies). Neuropsychologists can also provide more in-depth evaluation of EFs. Assessment of EFs is typically completed in an examination setting using tools specifically designed to identify any weaknesses in these functions. Although few tools are currently available to assess EF in preschool-age children, the assessment of school-age children is better established. Problems with EFs should be evaluated across measures and in different settings, particularly within the context of the child's daily demands.

## TREATMENT

Treatment for neurodevelopmental and executive dysfunction involves a **multimodal, multidisciplinary “cross-sector” approach to foster optimal outcomes**. This process begins with **demystification**, which involves educating the child and family about the nature of the child's delay or dysfunction while also identifying a child's strengths. The explanation of the dysfunction should be provided in nontechnical language, communicating a sense of optimism for improvement with appropriate intervention. Children need to have their affinities, potentials, and talents identified clearly and emphasized as an integral component of the long-term treatment plan. It is as important to **augment strengths** as it is to attempt to **remedy deficiencies**. Athletic skills, artistic inclinations, creative talents, and mechanical abilities are among the potential assets of certain students who are underachieving academically. Parents and school personnel need to create opportunities for such students to build on these assets. These well-developed personal assets can ultimately have implications for the transition into young adulthood, including career or college selection.

In the clinic setting, the pediatrician plays an important role as a **consultant and advocate** in overseeing and monitoring the implementation of a comprehensive multidisciplinary management plan for children with neurodevelopmental dysfunctions. The primary care provider should **identify and treat any underlying or associated medical problems** that might contribute to neurodevelopmental and EF dysfunction, such as iron deficiency, elevated lead levels, and sleep problems, including inadequate sleep related to poor sleep hygiene or poor quality of sleep (e.g., obstructive sleep apnea). Additionally, the pediatrician will need to monitor for **conditions that often co-occur** with neurodevelopmental delays and executive dysfunction or that may develop over time, including anxiety, depression, and substance use disorder.

### Bypass Strategies (Accommodations)

Numerous techniques can enable a child to circumvent neurodevelopmental dysfunctions. Such strategies are typically used in the regular classroom and can be incorporated into a 504 Plan or IEP. Accommodations change *how* the child learns, allowing them to access material and meet the same expectations as their peers. Examples of accommodations include using large print for those with visual impairment and using a frequency modulation (FM) system for students with hearing impairment. For children with learning disorders, accommodations may include using a calculator while solving mathematical problems, writing essays with a word processor and use of spellcheck, or presenting oral instead of written reports. Children with executive dysfunction might benefit from being seated near the teacher to minimize distractions and taking tests untimed. These bypass strategies do not cure neurodevelopmental dysfunctions, but they minimize their academic and nonacademic effects and can provide a scaffold for more successful academic achievement.

### Curriculum Modifications

Many children with neurodevelopmental dysfunctions require alterations in the school curriculum to succeed, especially as they progress

through secondary school. A modification changes *what* the child is taught or expected to learn. Modifications include a student learning different material (e.g., continuing to work on addition and subtraction facts while peers move on to fractions) and instructors assigning grades using a different standard. In high school and college, students with memory weaknesses might need to work with an advisor to select courses that avoid an inordinate cumulative memory load in any single semester. For adolescents with learning disorders, the timing of foreign language learning and the selection of mathematics and science courses are critical to their academic success.

### Remediation/Targeted Intervention

Interventions can be implemented at home and in school to strengthen academic skills. **Early identification** is critical so that appropriate instructional interventions can be introduced to minimize the long-term effects of academic disorders. Any interventions should be empirically supported (e.g., phonologically based reading intervention has been shown to significantly improve reading skills in school-age children). **Remediation** may take place in a resource room or learning center at school and is usually limited to children who have met the educational criteria for special education services described earlier. Reading specialists, mathematics tutors, and other professionals can use diagnostic data to select techniques that use a student's neurodevelopmental strengths to improve decoding skills, writing ability, or mathematical computation skills. Remediation need not focus exclusively on specific academic areas. Many students need assistance in acquiring study skills, cognitive strategies, and productive organizational habits.

**Speech-language pathologists** offer intervention for children with various forms of language disability. **Occupational therapists** focus on sensorimotor skills, including the motor skills of students with writing problems, and **physical therapists** address gross motor incoordination.

### Treatment of Executive Dysfunction

Interventions to strengthen EFs can be implemented throughout childhood but are most effective if started at a young age. Preschool-age children first learn EFs by way of the **modeling, boundaries, and rules** observed and put in place by their parents/caregivers, and this modeled behavior must gradually become “internalized” by the child. Early **play** has been shown to be effective in promoting executive skills in younger children with games such as peek-a-boo (WM); pat-a-cake (WM and IC); follow the leader, Simon Says, and “Ring Around the Rosie” (self-control); imitation activities (attention and impulse control); matching and sorting games (organization and attention); and imaginary play (attention, WM, IC, self-monitoring, cognitive flexibility).

In school-age children it is crucial to establish consistent **cognitive and behavioral routines** that foster and maximize independent, goal-oriented problem solving and performance through mechanisms that include modification of the child's environment, modeling and guidance with the child, and positive reinforcement strategies. Interventions should promote **generalization** (teaching executive routines in the context of a problem, not as a separate skill) and should move from the external to the internal (from “external support” with active and directive modeling to an “internal process”). An intervention could proceed from external modeling of multistep problem-solving routines and external guidance in developing and implementing everyday routines, to practicing application and use of routines in everyday situations, to a gradual fading of external support and cueing of internal generation and use of executive skills. Such approaches should make the child a part of intervention planning, should avoid labeling, reward effort not outcomes, make interventions positive, and hold the child responsible for his or her efforts. Studies have consistently shown that a **combination of medication and behavioral treatments** are most effective, although evidence for long-term efficacy is lacking. It is important that any treatment plans aimed at bolstering attention and EF also include interventions that address the specific deficits associated with any comorbid diagnoses.

In addition to behavioral approaches, **cognitive training**, both computerized and noncomputerized, has been shown to strengthen the cognitive skills on which one is trained. Some computerized training



programs show lasting improvements in WM skills in children, though benefits are narrow and limited only to the aspects of WM specifically trained. Recently, game-based digital therapy has been shown to improve attention in children with ADHD-inattentive type and combined type. Noncomputerized cognitive training has shown greater improvements in EF than any type of computerized cognitive training. This may be the result of instructor-trainee interaction. Also evidencing positive outcomes are curriculum-based **classroom programs**, such as the *Tools of the Mind* (Tools) and *Promoting Alternative Thinking Strategies* (PATHS), which have been shown to improve IC.

Emerging evidence suggests **physical activity** can improve EF. Children who are more physically active and have better aerobic fitness have been shown to have better EF than children who are sedentary. Although plain aerobic exercise (e.g., walking, running) has not been found to improve EF, encouraging findings have been noted when an activity involves aerobic exercise and is also cognitively demanding. Basketball and dance, for example, are high in physical exertion while also requiring cognitive engagement through motor coordination and planning. In contrast, resistance training has not been shown to improve EF.

Approaches that use **mindfulness techniques** are also gaining prominence. Mindfulness practices incorporating movement (e.g., tai chi) improve EF better than those performed in a seated position. **Martial arts** such as taekwondo, which stresses discipline and self-regulation, have demonstrated improvements that generalize in many aspects of EFs and attention (e.g., sustained focus).

### COUNSELING AND PARENT TRAINING PROGRAMS

The pediatrician is often in a close, trusting relationship with families and is well-positioned to identify adverse home factors that may require additional supports, including counseling and parent training.

When academic difficulties are complicated by family problems or identifiable psychiatric disorders, **psychotherapy** may be indicated. Mental health professionals may offer long-term or short-term therapy. Such intervention may involve the child alone or the entire family. **Cognitive-behavioral therapy** is especially effective for mood and anxiety disorders. It is essential that the therapist have a firm understanding of the nature of a child's neurodevelopmental dysfunctions. Formal **parenting interventions** have also demonstrated strong evidence for effectiveness. Four programs that have the most empirical support are the *Triple P*, *Parent-Child Interaction Therapy* (PCIT), *Incredible Years*, and *New Forest Parenting Programme*.

Table 49.3 outlines interventions to target the specific components of EF. Although interventions may target each component separately, success will be determined by how well treatments can be integrated across settings and generalized to other areas of function. Whenever possible, working with more than one EF simultaneously is encouraged as a means of scaffolding intervention and building on previously mastered skills.

### Medication

Psychopharmacologic agents may be helpful in lessening the toll of some neurodevelopmental dysfunctions. Most often, **stimulants** are used in the treatment of children with attention deficits. Although most children with attention deficits have other associated dysfunctions, such as language disorders, memory problems, motor weaknesses, or social skill deficits, medications such as methylphenidate, dextroamphetamine, lisdexamfetamine, and mixed amphetamine salts, as well as nonstimulants such as  $\alpha_2$ -**adrenergic agonists** and **atomoxetine**, can be important adjuncts to treatment by helping some children focus more selectively and control their impulsivity. When depression or excessive anxiety is a significant component of the clinical picture,

**Table 49.3** Executive Function Categories: Presenting Symptoms, Suggested Dysfunction, and Potential Interventions

SYMPTOM/PRESENTING COMPLAINT	SUSPECTED AREA OF DYSFUNCTION	POSSIBLE "REAL-WORLD" INTERVENTIONS
Acts before thinking Interrupts Poor behavioral and/or emotional control	Inhibitory control	Increase structure in environment to set limits for inhibition problems. Make behavior and work expectations clear and explicit; review with child. Post rules in view; point to them when child breaks rule. Teach response-delay techniques (e.g., counting to 10 before acting).
Cannot follow multistep instructions Forgetful	Working memory	Repeat instructions as needed. Keep instructions clear and concise. Provide concrete references.
Struggles starting assignments/tasks Lacks initiative/motivation Has trouble developing ideas/strategies	Initiation	Increase structure of tasks. Establish and rely on routine. Break tasks into smaller, manageable steps. Place child with partner or group for modeling and cueing from peers.
Does not plan ahead Uses trial-and-error approach	Planning	Practice with tasks with only a few steps first. Teach simple flow charting as a planning tool. Practice with planning tasks (e.g., mazes). Ask child to verbalize plan before beginning work. Ask child to verbalize second plan if first does not work. Ask child to verbalize possible consequences of actions before beginning. Review incidents of poor planning/anticipation with child.
Work/belongings is/are "messy" Random/haphazard problem solving Procrastinates/does not complete tasks	Organization	Increase organization of classroom and activities to serve as model, and help child grasp structure of new information. Present framework of new information to be learned at the outset, and review again at the end of a lesson. Begin with tasks with only a few steps and increase gradually.
Gets "stuck" Trouble transitioning Does not adapt to change	Flexibility/shifting	Increase routine to the day. Make schedule clear and public. Forewarn of any changes in schedule. Give "2-minute warning" of time to change. Make changes from one task to the next or one topic to the next, clear and explicit. Shifting may be a problem of inhibiting, so apply strategies for inhibition problems.

antidepressants or anxiolytics may be helpful. Other medications may improve behavioral control (see Chapter 33). Children receiving medication need regular follow-up visits that include a history to check for side effects, a review of current behavioral checklists, a complete physical examination, and appropriate modifications of the medication dose. Periodic trials off medication are recommended to establish whether the medication is still necessary.

### Nonstandard Therapies

Pediatricians should be aware of nonstandard therapies that purport to treat neurodevelopmental and executive dysfunction or components therein. A variety of treatment methods for neurodevelopmental dysfunctions have been proposed that currently have little to no known scientific evidence of efficacy. This list includes dietary interventions (vitamins, elimination of food additives or potential allergens), neuro-motor programs or medications to address vestibular dysfunction, eye exercises, filters, tinted lenses, and various technologic devices. Parents should be cautioned against expending the excessive amounts of time and financial resources usually demanded by these remedies. In many cases, it is difficult to distinguish the nonspecific beneficial effects of increased support and attention paid to the child from the purported target effects of the interventions.

Visit Elsevier eBooks+ at eBooks.Health.Elsevier.com for Bibliography.

## Chapter 50

# Attention-Deficit/ Hyperactivity Disorder

Elizabeth B. Harstad

Attention-deficit/hyperactivity disorder (ADHD) is one of the most common and extensively studied neurobehavioral disorders of childhood and is among the most prevalent chronic health conditions affecting school-age children. ADHD is characterized by inattention, including increased distractibility and difficulty sustaining attention; poor impulse control and decreased self-inhibitory capacity; and motor overactivity and restlessness (Table 50.1, Fig. 50.1). Definitions vary in different countries. In the International Classification of Diseases (ICD) 2022 update from ICD-10 to ICD-11, hyperkinetic disorder was replaced with ADHD, which aligns with *Diagnostic and Statistical Manual of Mental Disorders, Fifth Edition* (DSM-5) terminology. Under ICD-11, the essential features of ADHD are described, but without giving age of onset, duration, or minimum number of symptoms needed for the diagnosis as specified in DSM-5 (Table 50.2). Children with ADHD may experience academic underachievement, problems with interpersonal relationships with family members and peers, and low self-esteem. ADHD often coexists with other emotional, behavioral, language, and learning disorders. Evidence also suggests that for many people, the disorder continues, with varying manifestations across the life cycle, leading to significant underemployment and unemployment, social dysfunction, and increased risk of antisocial behaviors (e.g., substance abuse), difficulty maintaining relationships, encounters with the law, and death from suicide or accidents (Figs. 50.2 and 50.3).

## EPIDEMIOLOGY

Studies of the prevalence of ADHD worldwide have generally reported that 5–10% of school-age children are affected, although rates vary considerably by country, perhaps in part because of differing sampling and testing techniques and a varying symptom threshold for diagnosis. ADHD is more common in males than in females (male to female ratio 4:1 for the predominantly hyperactive-impulsive presentation and 2:1 for the predominantly inattentive presentation). Many children with ADHD will have coexisting diagnoses, including learning disabilities, mood disorders, and/or language disorders. Children with high intellectual quotient (IQ) are just as likely to have ADHD as those with average IQ, but children with below-average IQ have increased risk of having coexisting ADHD.

## ETIOLOGY

There is no single etiology identified for ADHD; many factors play a role in its development. A genetic contribution to the etiology of ADHD is well established. Twin studies show 70–80% heritability, and there is a 5- to 10-fold increased risk for ADHD among first-degree relatives of those with ADHD. However, there are many ways in which genetic variants contribute to ADHD; it is thought that ADHD is a polygenic disorder in which multiple common genetic variants act together to increase the risk for ADHD.

Structural and functional abnormalities of the brain have been identified in children with ADHD. These include dysregulation of the frontal subcortical circuits; small cortical volumes in this region or more widespread throughout the brain; and abnormalities of the cerebellum, particularly midline/vermian elements. There is a median of a 3-year delay in attainment of peak cortical thickness in prefrontal regions of the brain in those with ADHD. Although neuroimaging studies have advanced knowledge related to ADHD, neuroimaging does not typically have a role in the clinical diagnosis or inform ongoing management.

Brain catecholamine metabolism, specifically for dopamine and norepinephrine, appears to play a role in the pathophysiology of ADHD. Animal studies suggest that an imbalance between these systems (specifically a decrease in inhibitory dopamine activity and increase in norepinephrine activity) contributes to ADHD. These findings are supported by human studies showing that individuals with ADHD have an increase in dopamine transporter density (which clears away dopamine too quickly) compared to non-ADHD controls. Additionally, studies showing that stimulant medications work to treat ADHD by increasing the amount of available dopamine and norepinephrine at the synapse support a role for catecholamine metabolism in the etiology of ADHD.

Some environmental factors also may contribute to the pathogenesis of ADHD. Prenatal exposure to tobacco smoke or alcohol is associated with increased risk for ADHD. Prematurity, including even late-preterm birth, is also associated with increased risk for ADHD. Maternal mental illness increases the risk for ADHD in offspring, and research indicates underlying maternal mental illness itself, rather than treatment of the mental illness, is the associated risk factor. Diet is not thought to play a role in the pathogenesis of ADHD for most children with the condition. A small subset of children with ADHD may be uniquely sensitive to certain foods, sugars, or additives, but this remains controversial, as studies reporting these findings are typically small and often not rigorously designed.

## CLINICAL MANIFESTATIONS

Development of the DSM-5 criteria for ADHD has occurred mainly in field trials with children 5–12 years of age (see Table 50.1). The DSM-5 criteria state that the inattentive or hyperactive-impulsive behaviors must be developmentally inappropriate (substantially different from that of other children of the same age and developmental level), must begin before age 12 years, must be present for at least 6 months, must be present in two or more settings, and must not be secondary to another disorder. To meet criteria for ADHD, the symptoms must interfere with social, academic, or occupational functioning.

antidepressants or anxiolytics may be helpful. Other medications may improve behavioral control (see Chapter 33). Children receiving medication need regular follow-up visits that include a history to check for side effects, a review of current behavioral checklists, a complete physical examination, and appropriate modifications of the medication dose. Periodic trials off medication are recommended to establish whether the medication is still necessary.

### Nonstandard Therapies

Pediatricians should be aware of nonstandard therapies that purport to treat neurodevelopmental and executive dysfunction or components therein. A variety of treatment methods for neurodevelopmental dysfunctions have been proposed that currently have little to no known scientific evidence of efficacy. This list includes dietary interventions (vitamins, elimination of food additives or potential allergens), neuro-motor programs or medications to address vestibular dysfunction, eye exercises, filters, tinted lenses, and various technologic devices. Parents should be cautioned against expending the excessive amounts of time and financial resources usually demanded by these remedies. In many cases, it is difficult to distinguish the nonspecific beneficial effects of increased support and attention paid to the child from the purported target effects of the interventions.

Visit Elsevier eBooks+ at eBooks.Health.Elsevier.com for Bibliography.

## Chapter 50

# Attention-Deficit/ Hyperactivity Disorder

Elizabeth B. Harstad

Attention-deficit/hyperactivity disorder (ADHD) is one of the most common and extensively studied neurobehavioral disorders of childhood and is among the most prevalent chronic health conditions affecting school-age children. ADHD is characterized by inattention, including increased distractibility and difficulty sustaining attention; poor impulse control and decreased self-inhibitory capacity; and motor overactivity and restlessness (Table 50.1, Fig. 50.1). Definitions vary in different countries. In the International Classification of Diseases (ICD) 2022 update from ICD-10 to ICD-11, hyperkinetic disorder was replaced with ADHD, which aligns with *Diagnostic and Statistical Manual of Mental Disorders, Fifth Edition* (DSM-5) terminology. Under ICD-11, the essential features of ADHD are described, but without giving age of onset, duration, or minimum number of symptoms needed for the diagnosis as specified in DSM-5 (Table 50.2). Children with ADHD may experience academic underachievement, problems with interpersonal relationships with family members and peers, and low self-esteem. ADHD often coexists with other emotional, behavioral, language, and learning disorders. Evidence also suggests that for many people, the disorder continues, with varying manifestations across the life cycle, leading to significant underemployment and unemployment, social dysfunction, and increased risk of antisocial behaviors (e.g., substance abuse), difficulty maintaining relationships, encounters with the law, and death from suicide or accidents (Figs. 50.2 and 50.3).

## EPIDEMIOLOGY

Studies of the prevalence of ADHD worldwide have generally reported that 5–10% of school-age children are affected, although rates vary considerably by country, perhaps in part because of differing sampling and testing techniques and a varying symptom threshold for diagnosis. ADHD is more common in males than in females (male to female ratio 4:1 for the predominantly hyperactive-impulsive presentation and 2:1 for the predominantly inattentive presentation). Many children with ADHD will have coexisting diagnoses, including learning disabilities, mood disorders, and/or language disorders. Children with high intellectual quotient (IQ) are just as likely to have ADHD as those with average IQ, but children with below-average IQ have increased risk of having coexisting ADHD.

## ETIOLOGY

There is no single etiology identified for ADHD; many factors play a role in its development. A genetic contribution to the etiology of ADHD is well established. Twin studies show 70–80% heritability, and there is a 5- to 10-fold increased risk for ADHD among first-degree relatives of those with ADHD. However, there are many ways in which genetic variants contribute to ADHD; it is thought that ADHD is a polygenic disorder in which multiple common genetic variants act together to increase the risk for ADHD.

Structural and functional abnormalities of the brain have been identified in children with ADHD. These include dysregulation of the frontal subcortical circuits; small cortical volumes in this region or more widespread throughout the brain; and abnormalities of the cerebellum, particularly midline/vermian elements. There is a median of a 3-year delay in attainment of peak cortical thickness in prefrontal regions of the brain in those with ADHD. Although neuroimaging studies have advanced knowledge related to ADHD, neuroimaging does not typically have a role in the clinical diagnosis or inform ongoing management.

Brain catecholamine metabolism, specifically for dopamine and norepinephrine, appears to play a role in the pathophysiology of ADHD. Animal studies suggest that an imbalance between these systems (specifically a decrease in inhibitory dopamine activity and increase in norepinephrine activity) contributes to ADHD. These findings are supported by human studies showing that individuals with ADHD have an increase in dopamine transporter density (which clears away dopamine too quickly) compared to non-ADHD controls. Additionally, studies showing that stimulant medications work to treat ADHD by increasing the amount of available dopamine and norepinephrine at the synapse support a role for catecholamine metabolism in the etiology of ADHD.

Some environmental factors also may contribute to the pathogenesis of ADHD. Prenatal exposure to tobacco smoke or alcohol is associated with increased risk for ADHD. Prematurity, including even late-preterm birth, is also associated with increased risk for ADHD. Maternal mental illness increases the risk for ADHD in offspring, and research indicates underlying maternal mental illness itself, rather than treatment of the mental illness, is the associated risk factor. Diet is not thought to play a role in the pathogenesis of ADHD for most children with the condition. A small subset of children with ADHD may be uniquely sensitive to certain foods, sugars, or additives, but this remains controversial, as studies reporting these findings are typically small and often not rigorously designed.

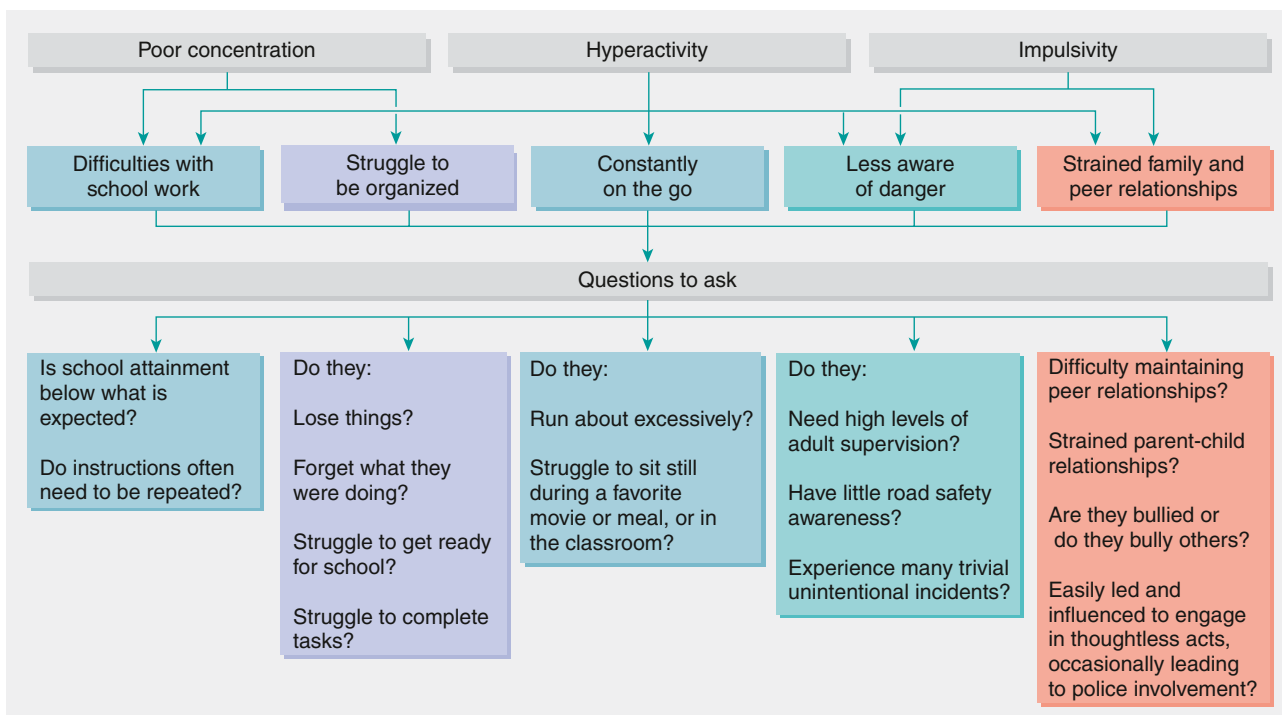
## CLINICAL MANIFESTATIONS

Development of the DSM-5 criteria for ADHD has occurred mainly in field trials with children 5–12 years of age (see Table 50.1). The DSM-5 criteria state that the inattentive or hyperactive-impulsive behaviors must be developmentally inappropriate (substantially different from that of other children of the same age and developmental level), must begin before age 12 years, must be present for at least 6 months, must be present in two or more settings, and must not be secondary to another disorder. To meet criteria for ADHD, the symptoms must interfere with social, academic, or occupational functioning.

**Table 50.1** DSM-5 Diagnostic Criteria for ADHD

<p>A. A persistent pattern of inattention and/or hyperactivity/impulsivity that interferes with functioning or development, as characterized by (1) and/or (2):</p> <ol style="list-style-type: none"> <li><b>Inattention:</b> Six (or more) of the following symptoms of inattention have persisted for <math>\geq 6</math> mo to a degree that is inconsistent with development level and that negatively affects directly on social and academic/occupational activities:             <ol style="list-style-type: none"> <li>Often fails to give close attention to details or makes careless mistakes in schoolwork, at work, or during other activities (e.g., overlooks or misses details, work is inaccurate).</li> <li>Often has difficulty sustaining attention in tasks or play activities.</li> <li>Often does not seem to listen when spoken to directly.</li> <li>Often does not follow through on instructions and fails to finish schoolwork, chores, or duties in the workplace (not the result of oppositional behavior or failure to understand instructions).</li> <li>Often has difficulty organizing tasks and activities.</li> <li>Often avoids, dislikes, or is reluctant to engage in tasks that require sustained mental effort (e.g., schoolwork, homework).</li> <li>Often loses things necessary for tasks or activities (e.g., toys, school assignments, pencils, books, tools).</li> <li>Is often easily distracted by extraneous stimuli.</li> <li>Is often forgetful in daily activities.</li> </ol> </li> <li><b>Hyperactivity/impulsivity:</b> Six (or more) of the following symptoms of inattention have persisted for <math>\geq 6</math> mo to a degree that is inconsistent with development level and that negatively affects directly on social and academic/occupational activities.             <ol style="list-style-type: none"> <li>Often fidgets with hands or feet or squirms in seat.</li> <li>Often leaves seat in classroom or in other situations in which remaining seated is expected.</li> <li>Often runs about or climbs excessively in situations in which it is inappropriate (in adolescents or adults, may be limited to subjective feelings of restlessness).</li> <li>Often has difficulty playing or engaging in leisure activities quietly.</li> <li>Is often "on the go" or often acts as if "driven by a motor."</li> </ol> </li> </ol>	<ol style="list-style-type: none"> <li>Often talks excessively. Impulsivity.</li> <li>Often blurts out answers before questions have been completed.</li> <li>Often has difficulty awaiting turn.</li> <li>Often interrupts or intrudes on others (e.g., butts into conversations or games).</li> </ol> <p>B. Several inattentive or hyperactive/impulsive symptoms were present before 12 yr of age.</p> <p>C. Several inattentive or hyperactive/impulsive symptoms are present in two or more settings (e.g., at school [or work] or at home) and are documented independently.</p> <p>D. There is clear evidence of clinically significant impairment in social, academic, or occupational functioning.</p> <p>E. Symptoms do not occur exclusively during the course of schizophrenia, or another psychotic disorder, and are not better accounted for by another mental disorder (e.g., mood disorder, anxiety disorder, dissociative disorder, personality disorder, substance intoxication or withdrawal).</p> <p><b>CODE BASED ON TYPE</b></p> <p>314.01 Attention-deficit/hyperactivity disorder, combined presentation: if both Criteria A1 and A2 are met for the past 6 mo.</p> <p>314.00 Attention-deficit/hyperactivity disorder, predominantly inattentive presentation: if Criterion A1 is met but Criterion A2 is not met for the past 6 mo.</p> <p>314.01 Attention-deficit/hyperactivity disorder, predominantly hyperactive-impulsive presentation: if Criterion A2 is met but Criterion A1 is not met for the past 6 mo.</p> <p>Specify if:</p> <p><b>Mild:</b> Few, if any, symptoms in excess of those required to make the diagnosis are present, and if the symptoms result in no more than minor impairments in social and occupational functioning.</p> <p><b>Moderate:</b> Symptoms or functional impairment between "mild" and "severe" are present.</p> <p><b>Severe:</b> Many symptoms in excess of those required to make the diagnosis, or several symptoms that are particularly severe, are present, or the symptoms result in marked impairment in social or occupational functioning.</p>
---	---

From American Psychiatric Association. *Diagnostic and Statistical Manual of Mental Disorders*, 4th ed, Text Revision, Washington, DC: American Psychiatric Association; 2000, and *Fifth Edition* (Copyright 2013 American Psychiatric Association).



**Fig. 50.1** How to assess children for attention-deficit/hyperactivity disorder. (From Verkuijl N, Perkins M, Fazel M. *Childhood attention-deficit/hyperactivity disorder*. *BMJ*. 2015;350:h2168, Fig. 2, p. 146.)



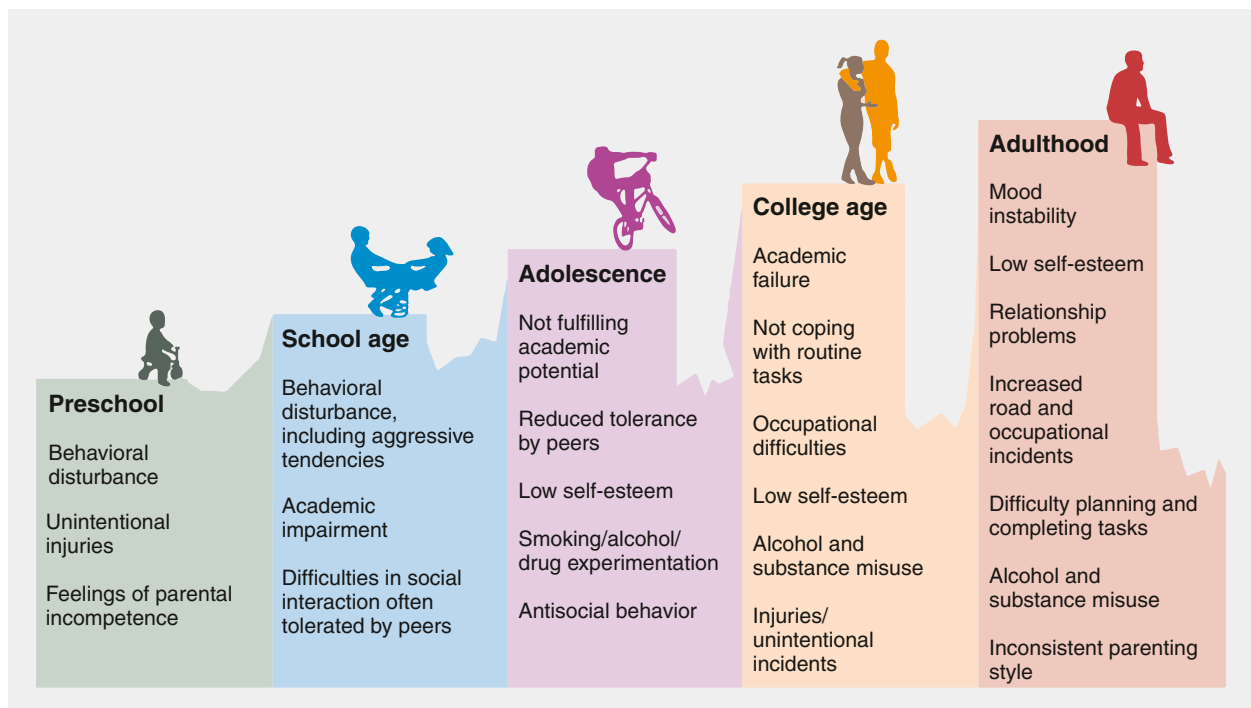
**Table 50.2** Differences Between U.S. and European Criteria for ADHD or HKD

DSM-5 ADHD	ICD-10 HKD	ICD-11 ADHD*
<b>SYMPTOMS</b>		
<p><i>Either or both of the following:</i></p> <ul style="list-style-type: none"> <li>At least 6 of 9 inattentive symptoms</li> <li>At least 6 of 9 hyperactive or impulsive symptoms</li> </ul>	<p><i>All of the following:</i></p> <ul style="list-style-type: none"> <li>At least 6 of 8 inattentive symptoms</li> <li>At least 3 of 5 hyperactive symptoms</li> <li>At least 1 of 4 impulsive symptoms</li> </ul>	<p><i>No minimum numbers of symptoms but must have:</i></p> <ul style="list-style-type: none"> <li>Persistent pattern (≥6 mo) of inattention and/or hyperactivity-impulsivity that has a direct negative impact on academic, occupational, or social functioning</li> </ul>
<b>PERVASIVENESS</b>		
Some impairment from symptoms is present in one or more settings	Criteria are met for one or more settings	Symptoms must be evident across multiple situations or settings but are likely to vary according to the structure and demands of the setting

\*ICD-11 went into effect on January 1, 2022.

ADHD, Attention-deficit/hyperactivity disorder; HKD, hyperkinetic disorder; DSM-5, Diagnostic and Statistical Manual of Mental Disorders, Fifth Edition; ICD-10, International Classification of Diseases, Tenth Edition.

Modified from Biederman J, Faraone S. Attention-deficit hyperactivity disorder. *Lancet*. 2005;366:237–248.



**Fig. 50.2** Possible developmental impacts of attention-deficit/hyperactivity disorder. (From Verkuil N, Perkins M, Fazel M. Childhood attention-deficit/hyperactivity disorder. *BMJ*. 2015;350:h2168, Fig. 1, p. 145.)

DSM-5 identifies three presentations of ADHD: the inattentive presentation, hyperactive-impulsive presentation, and combined presentation. Clinical manifestations of ADHD may change with age; thus the specific ADHD presentation for an individual may not be stable over time but describes current symptomatology (see Fig. 50.2). The symptoms may vary from motor restlessness and aggressive and disruptive behavior, which are common in preschool children, to disorganized, distractible, and inattentive symptoms, which are more typical in older adolescents and adults. Although hyperactivity generally decreases in late childhood and adolescence, symptoms of impulsivity and inattention often persist. Females with ADHD are relatively more likely than males to be diagnosed with the inattentive presentation, and this presentation is more commonly associated with internalizing symptoms (anxiety and low mood).

## DIAGNOSIS

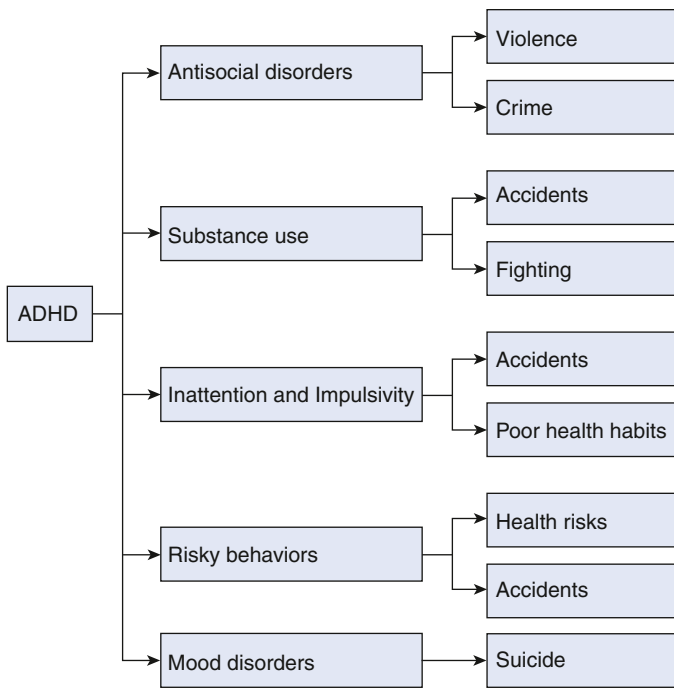
An evaluation for ADHD should be initiated in any child ≥4 years of age with symptoms of inattention, hyperactivity, and/or impulsivity (Fig. 50.4). This evaluation includes a careful history and

clinical interview to rule in ADHD or to identify other causes or contributing factors, completion of behavior rating scales by different observers from at least two settings (e.g., teacher and parent), and a physical examination. It is important to systematically gather and evaluate information from a variety of sources, including the child, parents, teachers, and, when appropriate, other caretakers or professionals involved in the child's care.

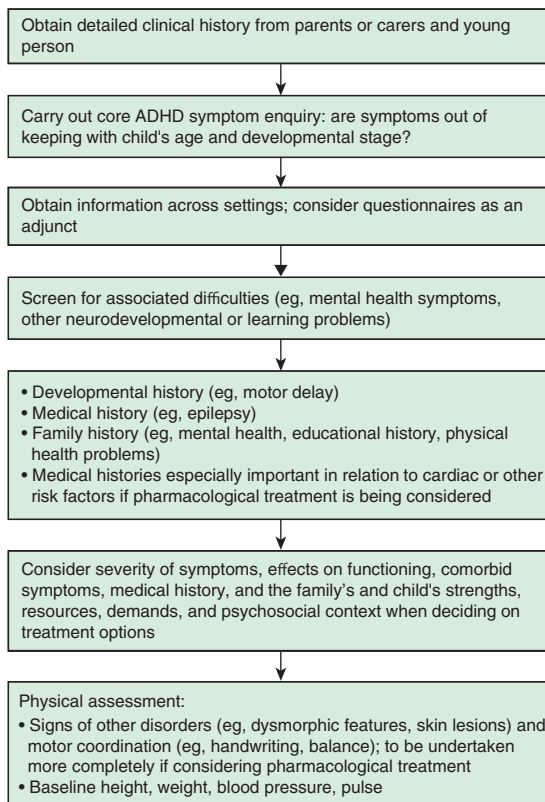
The evaluation for ADHD may require several office visits. A thorough assessment should be conducted at the time of initial diagnosis, and reevaluation should occur if there are worsening or new symptoms, given the common occurrence of coexisting conditions.

## Clinical Interview and History

The clinical interview allows a comprehensive understanding of whether the symptoms meet the diagnostic criteria for ADHD and to assess for coexisting conditions. The interview should collect information about the history and duration of presenting problems, the child's attainment of developmental milestones, school performance, social skills, mood, sleep, medical illnesses, sensory impairments, or



**Fig. 50.3** Pathways to premature death in persons with attention-deficit/hyperactivity disorder (ADHD). (From Faraone SV. Attention deficit hyperactivity disorder and premature death. *Lancet*. 2015;385:2132–2133.)



**Fig. 50.4** Summary of the clinical assessment process for ADHD. ADHD, Attention-deficit/hyperactivity disorder. (From Thapar A, Cooper M. Attention deficit hyperactivity disorder. *Lancet*. 2016;387[10024]:1240–1250, Fig. 2.)

medication use that might affect the child's functioning. Disruptive social factors, such as family discord, situational stress, and abuse or neglect, can result in hyperactive or anxious behaviors. A family history of first-degree relatives with ADHD, mood or anxiety disorders, learning disability, antisocial disorder, or alcohol or substance abuse might indicate an increased risk of ADHD and coexisting conditions.

### Behavior Rating Scales

Behavior rating scales can help to elicit information about ADHD symptoms across contexts (i.e., home and school). The *Vanderbilt ADHD Rating Scale* (which has parent and teacher versions) is a commonly used screening measure for ADHD in primary care. It has specific questions about inattention and hyperactivity/impulsivity that correspond directly with the DSM-5 ADHD diagnostic criteria and questions about overall performance to assess for functional impairment, as well as subscales for some common coexisting conditions (anxiety/depression and oppositional behaviors/conduct disorder). Additional ADHD-specific rating scales include the *Conners 3 ADHD Index* and *ADHD Rating Scale 5*, among others that can be used. Broadband rating scales (such as *Achenbach Child Behavior Checklist [CBCL]* or *Behavioral Assessment Scale for Children [BASC]* or *Conners 3 Full Length Forms*) can be useful in assessing for coexisting conditions. Electronic capture of rating scale information is increasingly available and may facilitate completion and scoring. Rating scales provide information about the type, frequency, and severity of ADHD or other behavioral/mood symptoms, but interpretation requires clinical judgement. Contextual factors (such as triggers for a certain behavior, responses to a behavior that may inadvertently reinforce it) should be considered when interpreting rating scales. When there are discrepancies between results of rating scales for parents and teachers, the context and level of support provided in each setting should be assessed. ADHD rating scales can help with both the initial diagnostic assessment and with monitoring treatment response over time. Although there is no universal standard to use as a criterion for a positive response to treatment in terms of rating scale results, a decrease in ADHD symptom scores by 25% or more is generally considered significant improvement. However, improvement in functional outcomes may be more important to consider than changes in symptom scores. For children on medication, it is important to consider if the medication was "active" when the child was observed (i.e., stimulant medication may work to reduce ADHD symptoms during the school day, but the symptoms may return as the medication wears off in the afternoon/evening when the child is home).

### Physical Examination, Laboratory, and Other Assessments

Most children with ADHD will have a normal physical exam, but one should be conducted as part of the diagnostic evaluation. Particular attention should be paid to cardiac and neurologic evaluations, thyroid, hearing and vision, and assessment for dysmorphic features that may signify an underlying condition, such as fetal alcohol syndrome. A child's behavior in the clinic visit may not represent the child's usual behaviors, as some children may be able to remain focused or calm for brief periods and others may exhibit more impulsivity or high activity level when nervous in the context of a clinic visit. Laboratory tests and brain imaging are not routinely recommended as part of an ADHD assessment. The presence of hypertension, ataxia, or asymmetric neurologic examination or symptoms of a sleep, seizure, or thyroid disorder may prompt further diagnostic tests. Lead levels could be considered if there are other factors associated with risk for lead toxicity. The clinician should identify possible vision or hearing problems. Computerized attentional tasks and quantitative electroencephalographic assessments are not needed to make the diagnosis. They are subject to high rates of false-positive and false-negative results and thus are of limited utility in the diagnostic assessment.

Educational testing should be considered if there are concerns about academic progress, as specific learning disabilities in reading,

mathematics, or written expression often coexist with ADHD (see Chapters 51 and 52). If there has been slow attainment of developmental milestones, intelligence or developmental testing should be conducted. If there are concerns about a child's social communication skills combined with restricted, repetitive behaviors or interests, a clinical assessment for autism spectrum disorder may be indicated (see Chapter 58).

### Differential Diagnosis and Coexisting Conditions

Given that the symptoms of ADHD can overlap with other conditions, a broad differential diagnosis should be considered. For ease of presentation, the differential diagnosis for ADHD can be grouped into specific categories of developmental, psychiatric, medical, and psychosocial (Table 50.3). Children at either end of the developmental/cognitive level (i.e., with significant cognitive delays or with superior intelligence) can appear inattentive and/or distracted and sometimes also disruptive if the material in school or expectations at home are not appropriate for their developmental level. In differentiating impulsivity and challenging behaviors associated with ADHD versus an externalizing disorder (oppositional defiant disorder [ODD] or conduct disorder), consider whether the child “acts without thinking” and/or is more reactive (easily upset over demands for sustained attention or other small triggers), which would be more consistent with ADHD, versus proactively looks to aggress, fight, and challenge authority, which may be indicative of an externalizing disorder. Tic disorders can both present with some symptoms similar to ADHD (e.g., fidgeting, squirming, making sounds that seem impulsive) and also commonly coexist with ADHD. For cases in which ADHD symptoms are reported in one setting but not another, psychosocial causes should be considered, such as unrealistic classroom expectations, distress at home, or untoward parenting strategies. However, clinicians should be aware that inappropriate parenting strategies may be the result of the child's ADHD, as parents try anything (often unsuccessfully) to help their child. These parents are in need of parenting and behavioral supports, without feeling blamed for their child's symptoms.

**Sleep disorders**, including those secondary to chronic upper airway obstruction from enlarged tonsils and adenoids, often result in

behavioral and emotional symptoms that can resemble or exacerbate ADHD (see Chapter 31). Periodic leg movements of sleep/restless legs syndrome have been associated with symptoms of inattention, and inquiry regarding this should be made during the history. Behavioral and emotional disorders can cause disrupted sleep patterns as well.

**Mental health disorders:** Depression and anxiety disorders can cause many of the same symptoms as ADHD (inattention, restlessness, inability to focus and concentrate on work, poor organization, forgetfulness) but can also coexist with ADHD (see Chapters 38 and 39). Obsessive-compulsive disorder can mimic ADHD, particularly when recurrent and persistent thoughts, impulses, or images are intrusive, interfering with normal daily activities. Adjustment disorders secondary to major life stresses (death of a close family member, parents' divorce, family violence, parents' substance abuse, or a move) or parent-child relationship disorders involving conflicts over discipline, overt child abuse and/or neglect, or overprotection can result in symptoms similar to those of ADHD.

When considering a new diagnosis in an adolescent patient, there should be an opportunity to interview the adolescent privately, and the adolescent should be specifically asked about mood symptoms and psychosocial stressors; frequent digital media use; and screened for use of alcohol, marijuana, and illicit substances.

## TREATMENT

### Overall Treatment Approach

ADHD is considered a chronic condition and should be managed as such, with education about ADHD at the time of diagnosis and regular follow-up visits to monitor and treat symptoms. Parent support groups with appropriate professional consultation to such groups can be very helpful. Treatment of ADHD should be multimodal and involve behavioral therapy, school-based supports, and/or medications. The treatment plan should be developed in collaboration with the child (if developmentally appropriate) and family. The recommended initial treatments for ADHD vary by age.

**Preschool-age children:** For children up until 6 years of age, the recommended first-line treatment is evidence-based parent- and/or teacher-administered behavior therapy. If behavior interventions do not provide significant improvements and there is moderate to severe impairment in the child's functioning as a result of ADHD symptoms, medication should be considered. If behavioral interventions are not available, the risks of medication should be compared with risks of not treating ADHD symptoms.

**School-age children and adolescents:** For children ages 6 years old and older, ADHD medications should be considered first-line treatment, along with behavior and educational interventions. Organizational skills training, coaching, or cognitive-behavioral therapy may be helpful for adolescents and adults.

### Behaviorally Oriented Treatments

Behavioral interventions should be an integral part of the treatment plan for all children with ADHD. Behavioral interventions involve modifying the environment and empowering caregivers with strategies to promote positive behaviors and minimize negative behaviors. Behavioral strategies typically focus on promoting a limited number of well-defined appropriate behaviors, using positive reinforcement with increased adult attention, tangible rewards, or access to privileges. A token economy in which a child earns (or loses) tokens that can be exchanged for rewards may be used. Any rules should be clearly defined and consistently enforced. Behavioral parent training, also known as *parent training in behavioral management*, is a well-established combination of behavioral interventions shown to reduce problematic behaviors and improve adaptive skills for children with ADHD. It involves teaching parents how to use behavior modification strategies to address specific behaviors, with a strong emphasis on positive reinforcement (described earlier) while ignoring or, if necessary, systematically implementing appropriate consequences for maladaptive behaviors. Treatments geared toward behavioral management for ADHD often occur in the time frame of 8-12 sessions but may sometimes require more sessions.

**Table 50.3** Differential Diagnosis of Attention-Deficit/Hyperactivity Disorder (ADHD)

GENERAL CATEGORY	SPECIFIC CONDITIONS, CAUSES
Developmental	Low developmental level/cognitive abilities Very high cognitive abilities Specific learning disabilities in reading, mathematics, or written expression Communication or language disorder Autism spectrum disorder Fetal alcohol syndrome
Psychiatric	Anxiety/depression Oppositional defiant disorder/conduct disorder Bipolar disorder/disruptive mood dysregulation disorder Substance use disorder Posttraumatic stress disorder/adjustment disorder
Medical	Sleep disorder, obstructive sleep apnea Hearing or vision impairment Specific medications, such as some antiepileptics or high-dose steroids Thyroid disorders Tic disorders Posttraumatic head injury or encephalitis Genetic conditions, such as fragile X, Klinefelter syndrome, Turner syndrome, tuberous sclerosis, and neurofibromatosis
Psychosocial	Response to abuse, neglect Response to distress in home, inappropriate expectations or parenting practices Response to inappropriate classroom setting

Although there is much less research published on psychosocial treatments for adolescents with ADHD, behavioral parent training can be modified to focus on improving communication between parents and adolescents with ADHD, developing a behavioral contract, and problem-solving around challenging situations. For children and adolescents with ADHD and coexisting anxiety disorders and/or depression, cognitive-behavioral therapy may help address anxiety or low mood.

At least 60 minutes of moderate to vigorous exercise is recommended for the general health of all children  $\geq 6$  years old, and some studies indicate exercise may reduce ADHD symptoms in children; thus encouraging regular exercise is reasonable. Interventions including cognitive training, electroencephalogram (EEG) biofeedback, and diet modification do not have the level of evidence needed to recommend them for most children.

### Educational Supports and Accommodations

Behavioral classroom management strategies can be used by teachers to implement strategies within the whole classroom that will help children with ADHD. These include clear expectations and consistency in follow-through, positive reinforcement for work completion and on-task behaviors, and appropriate consequences when rules are not followed. Additionally, children with ADHD may benefit from individualized educational supports and accommodations, such as preferential seating near the source of instruction and away from distractions, motor breaks as needed, frequent teacher check-ins, being able to take tests in a less distracting environment, and an individualized positive behavior plan. A daily report card or communication log can be used to facilitate regular communication between the parents and teachers. A daily report card is individually designed for each child to include target problem behaviors in academic and/or social domains in the classroom (e.g., following directions, turning in work, getting along with others). The teacher provides a rating for each behavior on the report card, which is sent home daily, and the child is given home-based rewards for meeting goals set for the ratings from school.

Children with ADHD often need explicit instruction in organization and executive functioning skills and may not develop these skills at the same pace as non-ADHD peers. The use of an agenda book to record assignments, color coding for different classes, and teacher check-ins regularly to help with organization may be helpful for some children, and others may require a higher level of more individualized instruction in the executive functioning domains of staying organized, planning, initiating tasks, shifting gears, and self-monitoring.

Children with ADHD and coexisting learning disorders, communication or developmental delays, significant mental health or oppositional challenges, or autism spectrum disorder often need more specialized educational supports than those that can be provided through accommodations in a general classroom. In the United States, these children would qualify to have an individualized educational plan (IEP) developed through the public school system.

### Medications

Before medication initiation, a history and physical examination and an assessment for baseline sleep, eating, and mood should be conducted because these need to be monitored for a child on medication. Children with ADHD and their families should be educated on the benefits, risks, and side effects of medication, with a discussion about goals and expectations for medication treatment. It is common for a child to need to try several trials of different medications or doses to find the optimal ADHD pharmacologic treatment that both reduces core ADHD symptoms and is well tolerated. ADHD rating scales can be used to assess for medication effectiveness and side effects, both at initiation and during medication maintenance, and should be collected from parents and teachers when possible.

The types of medications used to treat ADHD fall into one of the following three categories: stimulants, norepinephrine reuptake

inhibitors, and  $\alpha_2$ -adrenergic agonists. Stimulants are the most commonly used medications to treat ADHD and have been used to treat this condition since the 1930s. Stimulant medications have a slightly larger treatment effect size (standardized mean difference) than nonstimulants (approximately 1.0 for stimulants versus approximately 0.7 for both norepinephrine reuptake inhibitors and  $\alpha_2$ -adrenergic agonists). Although stimulants are generally recommended as the first-line ADHD medication, nonstimulant medications may be considered in the context of active substance use disorder for an adolescent with ADHD or household family member or if there is a strong family desire for a nonstimulant medication. Stimulants have been found to have relatively high rates of adverse effects (particularly moodiness and irritability) in preschool-age children and in children with intellectual disability or autism spectrum disorder, leading some physicians to choose nonstimulant medication in these situations, as described later.

When starting a stimulant, the clinician can select either a methylphenidate-based or an amphetamine-based medication. The decision about which stimulant medication to use for a specific child or adolescent with ADHD is often based on factors such as duration of action (short, intermediate, long acting), preparation (pills, capsules that can be swallowed whole or whose contents can be “sprinkled” into food, chewable tablets, and liquids), and clinician preference or insurance company formularies. Stimulant medications have a rapid onset of action (ranging from about 20 minutes to up to an hour, depending on the formulation), and most leave the system within 3-12 hours, depending on if they are short, intermediate, or long acting. A child who responds poorly to one stimulant medication may do well with a different medication in that class or the other class (methylphenidate versus amphetamine). Stimulant medications should be initiated at the lowest available dose and titrated upward, assessing for both effectiveness and side effects, until reaching a dose that reduces ADHD symptoms and has minimal to no side effects. Common side effects of stimulant medication include decreased appetite, headaches, stomachaches, and difficulty falling asleep. If mood lability occurs, it should be noted whether this is while the stimulant medication is active (which may indicate that a different medication should be tried instead) or as the medication is wearing off (also called *rebound* and may indicate that a short-acting preparation should be replaced by a longer-acting preparation or a low dose of a short-acting preparation should be added about 30 minutes before the onset of the rebound symptoms).

Height, weight, pulse, and blood pressure should be periodically monitored. Stimulants may be associated with a slight reduction in linear growth, although studies of the impact of stimulants on adult height range from findings of a slight impact to no significant difference. Children with decreased appetite from stimulants and difficulty with weight gain can be counseled to increase caloric intake later in the day when the appetite returns. Significant reductions (i.e., crossing two lines on the growth curve) in either height or weight for a child on stimulant medication may prompt changing to a different ADHD medication.

Before starting stimulants, children should be screened for symptoms or signs suggestive of a cardiomyopathy, coronary artery disease, cardiac arrhythmias, or a family history of cardiac arrhythmias or sudden death under 50 years of age, and if these symptoms are present, an electrocardiogram and/or evaluation by a cardiologist to determine if it is safe to start these medications is recommended. Most children with tics can be treated with stimulant medication, but occasionally these medications may exacerbate tics. In these cases, the risks and benefits of continuing versus changing or stopping the medication should be considered.

Treatment of ADHD with stimulant medication is associated with reduced substance use risks. However, stimulant medications themselves are controlled substances with potential for misuse, diversion, and abuse. Therefore clinicians should regularly counsel adolescent patients about this risk, the importance of taking the medication only as prescribed, and about safe medication storage practices (e.g., keeping medication in a secure location).



Two types of selective norepinephrine reuptake inhibitors are approved by the U.S. Food and Drug Administration (FDA) for the treatment of ADHD in children and adolescents: atomoxetine and viloxazine. These medications take up to 4 weeks to achieve effectiveness and should be taken consistently to be effective. Both atomoxetine and viloxazine have common side effects of fatigue, decreased appetite, nausea, vomiting, and irritability and a rare potential for suicidal thinking and behaviors for which the child must be monitored.

$\alpha_2$ -Adrenergic agonist medications include guanfacine and clonidine. Long-acting preparations of both have U.S. FDA approval for the treatment of ADHD in children  $\geq 6$  years old either as monotherapy or an adjunctive therapy with stimulant medication. Short-acting preparations are sometimes used off-label to treat young (<6-year-old) children with ADHD (especially those with coexisting autism spectrum disorder or sleep disorders).  $\alpha_2$ -Adrenergic agonists may take up to 2 weeks to achieve an initial response. These medications can also treat motor and vocal tics and so may be a reasonable choice in a child with a coexisting tic disorder. Common side effects of  $\alpha_2$ -adrenergic agonists can include sedation, headaches, and hypotension, and they should be stopped gradually because abrupt discontinuation could result in rapid increase in blood pressure.

Medication alone may not be sufficient to treat ADHD in children, particularly when children have additional psychiatric disorders, developmental disabilities, or significant psychosocial challenges. When children do not respond to medication, it may be appropriate to refer them to a mental health specialist. Consultation with a child psychiatrist, developmental-behavioral pediatrician, or psychologist can be beneficial to determine the next steps for treatment, including adding other components and supports to the overall treatment program. Evidence suggests that children who receive careful medication management, accompanied by frequent treatment follow-up, all within the context of an educational, supportive relationship with the primary care provider, are likely to experience behavioral gains.

## PROGNOSIS

More than half of individuals with a childhood diagnosis of ADHD will manifest a mental health condition (e.g., anxiety, depression, substance use disorders) in adulthood. Approximately one third to two thirds of those diagnosed with ADHD in childhood will continue to manifest significant symptoms of ADHD in adulthood. In children with ADHD, a reduction in hyperactive behavior often occurs with age. Other symptoms associated with ADHD can become more prominent with age, such as inattention, impulsivity, and disorganization, and these exact a heavy toll on adolescent and young adult functioning. Adolescents and young adults with ADHD have an increased likelihood of risk-taking behaviors (early sexual activity, delinquent behaviors, motor vehicle accidents, substance use), seizures, psychosis, educational underachievement or employment difficulties, and relationship difficulties. With proper treatment, the risks associated with ADHD, including injuries, can be significantly reduced. Consistent treatment with medication and adjuvant therapies appears to lower the risk of adverse outcomes, such as substance abuse.

## SECONDARY PREVENTION

Parent training can lead to significant improvements in ADHD symptoms and oppositional behaviors in preschool and school-age children with ADHD. To the extent that parents, teachers, physicians, and policymakers support efforts for earlier detection, diagnosis, and treatment, prevention of long-term adverse effects of ADHD on affected children's functioning can be considered within the lens of secondary prevention of the long-term effects of untreated or ineffectively treated ADHD on children and youth.

Visit Elsevier eBooks+ at [eBooks.Health.Elsevier.com](https://eBooks.Health.Elsevier.com) for Bibliography.

## Chapter 51

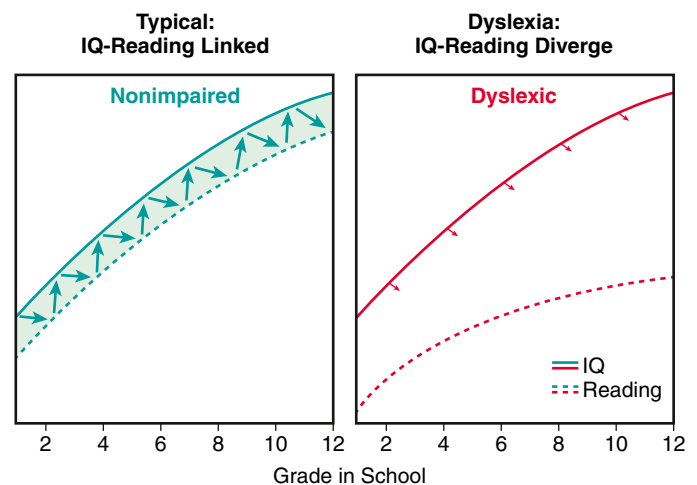
# Dyslexia

Sally E. Shaywitz and Bennett A. Shaywitz

## DEFINITION

Dyslexia has always been defined as an unexpected difficulty in reading, which has been codified in U.S. Federal law (First Step Act of 2018, PL: 115–391) as the most up-to-date, evidence-based definition of dyslexia: “The term *dyslexia* means an unexpected difficulty in reading for an individual who has the intelligence to be a much better reader, most commonly caused by a difficulty in the phonological processing (the appreciation of the individual sounds of spoken language), which affects the ability of an individual to speak, read, and spell.” In typical readers, development of reading and intelligence quotient (IQ) are dynamically linked over time. In dyslexic readers, however, a developmental uncoupling occurs between reading and IQ (Fig. 51.1), such that reading achievement is significantly below what would be expected given the individual's IQ.

The uncoupling between reading achievement and IQ provides the long-sought empirical evidence for the seeming paradox between cognition and reading in individuals with developmental dyslexia, and this discrepancy is recognized in the federal definition as unexpected difficulty in reading. However, clinicians may see other approaches to diagnosis. The *Diagnostic and Statistical Manual of Mental Disorders*, Fifth Edition (DSM-5) describes specific learning disorder with impairment in reading for children with reading skills significantly below those expected for the child's age where the deficits are not explained by intellectual disability, sensory deficits, neurologic disorders, or psychosocial adversity. This definition can be problematic in failing to differentiate primary problems with reading comprehension from the reading problems experienced by children with dyslexia despite strong evidence that the two are distinct. Further, excluding children with psychosocial adversity is concerning because children who struggle with reading due to psychosocial adversity suffer similar adverse long-term consequences and have been shown to benefit from interventions designed to help children with dyslexia.



**Fig. 51.1** Uncoupling of reading and IQ over time: empirical evidence for a definition of dyslexia. *Left*, In typical readers, reading and IQ development are dynamically linked over time. *Right*, In contrast, reading and IQ development are dissociated in dyslexic readers, and one does not influence the other. (Copyright Sally Shaywitz, MD. Adapted from Shaywitz S, Shaywitz J. *Overcoming Dyslexia*, 2nd ed. New York: Vintage Books;2020: 103.)

## EPIDEMIOLOGY

Dyslexia is the most common of the learning disabilities, affecting 80–90% of children identified as having a learning disability. Dyslexia may be the most common neurobehavioral disorder affecting children, with prevalence rates ranging from 20% in unselected population-based samples to much lower rates in school-identified samples. The low prevalence rate in school-identified samples may reflect the reluctance of schools to screen, assess, and identify dyslexia. Dyslexia occurs with equal frequency in males and females in survey samples in which *all* children are assessed. Despite such well-documented findings, schools continue to identify more males than females, probably reflecting the more rambunctious behavior of males who come to the teacher's attention because of misbehavior, whereas females with reading difficulty, who are less likely to be misbehaving, are also less likely to be noticed and identified by the schools. Dyslexia fits a dimensional model in which reading ability and disability occur along a *continuum*.

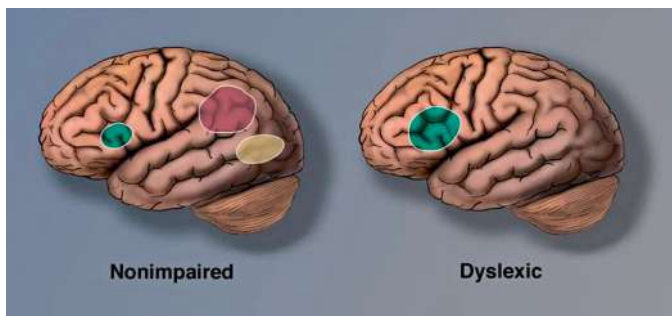
## PATHOGENESIS

Evidence from a number of lines of investigation indicates that dyslexia reflects deficits within the language system, and more specifically, within the **phonologic component** of the language system engaged in processing the sounds of speech. Individuals with dyslexia have difficulty developing an awareness that spoken words can be segmented into smaller elemental units of sound (phonemes), an essential ability given that reading requires that the reader map or link printed symbols to their sounds. Increasing evidence indicates that disruption of attentional mechanisms may also play an important role in reading difficulties.

Functional brain imaging in both children and adults with dyslexia demonstrates an inefficient functioning of left hemisphere posterior brain systems, a pattern referred to as the *neural signature of dyslexia* (Fig. 51.2). These differences can be observed before the start of formal reading instruction, suggesting they represent a biologic predisposition to reading difficulties as opposed to a result of inadequate instruction. Although functional magnetic resonance imaging (fMRI) consistently demonstrates differences between *groups* of dyslexic compared to typical readers, brain imaging is not able to reliably differentiate an *individual* case of a dyslexic reader from a typical reader and thus is not useful in diagnosing dyslexia.

## CLINICAL MANIFESTATIONS

Reflecting the underlying phonologic weakness, children and adults with dyslexia manifest problems in both spoken and written language. Spoken language difficulties are typically manifest by



**Fig. 51.2** A neural signature for dyslexia. Image on left shows left hemisphere brain systems in typical (nonimpaired) readers. The three systems for reading are an anterior system in the region of the inferior frontal gyrus (Broca's area), serving articulation and word analysis, and two posterior systems: one in the occipitotemporal region serving word analysis and a second in the occipitotemporal region (the word-form area) serving the rapid, automatic, fluent identification of words. In dyslexic readers (*right* image), the two posterior systems are functioning inefficiently and appear underactivated. This pattern of underactivation in left posterior reading systems is referred to as the neural signature for dyslexia. (Copyright Sally Shaywitz, MD. Adapted from Shaywitz S. Shaywitz J. *Overcoming Dyslexia*, 2nd ed. New York: Vintage Books;2020: 78.)

mispronunciations, lack of glibness, speech that lacks fluency with many pauses or hesitations and “ums,” word-finding difficulties with the need for time to summon an oral response, and the inability to come up with a verbal response quickly when questioned; these reflect *sound-based*, not semantic or knowledge-based, difficulties.

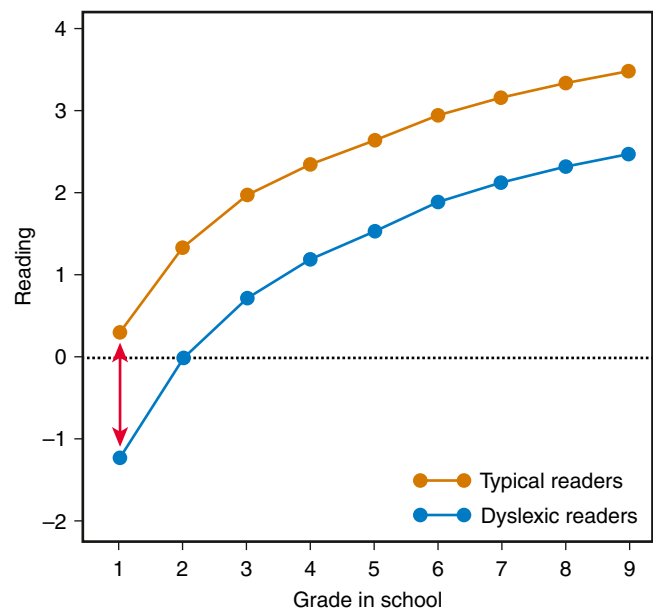
Struggles in decoding and word recognition can vary according to age and developmental level. The cardinal signs of dyslexia observed in school-age children and adults are a labored, effortful approach to reading involving decoding, word recognition, and text reading. Listening comprehension is typically robust. Older children improve reading accuracy over time, but without commensurate gains in reading fluency; they remain slow readers. Difficulties in spelling typically reflect the phonologically based difficulties observed in oral reading. Handwriting is often affected as well.

History often reveals early subtle language difficulties in dyslexic children. During the preschool and kindergarten years, at-risk children display difficulties playing rhyming games and learning the names for letters and numbers. Kindergarten assessments of these language skills can help identify children at risk for dyslexia. Although a dyslexic child enjoys and benefits from being read to, the child might avoid reading aloud to the parent or reading independently.

Dyslexia may coexist with attention-deficit/hyperactivity disorder (see Chapter 50); this comorbidity has been documented in both referred samples (40% comorbidity) and nonreferred samples (15% comorbidity).

## DIAGNOSIS

A large achievement gap between typical and dyslexic readers is evident as early as first grade and persists (Fig. 51.3). These findings provide strong evidence and impetus for early screening and identification of and early intervention for young children at risk for dyslexia. One source of potentially powerful and highly accessible screening information is their teacher's judgment about the child's reading and reading-related skills. Evidence-based screening can be carried out as early as kindergarten, and also in grades 1–3, by the child's teacher. Their teachers' responses to a small set of questions (10–12 questions) predict a pool of children who are at risk for dyslexia with a high degree of accuracy. This evidence-based screening takes less than 10 minutes, is completed on a tablet, and is extremely efficient and economical. Children



**Fig. 51.3** Reading from grades 1 through 9 in typical and dyslexic readers. The achievement gap between typical and dyslexic readers is evident as early as first grade and persists through adolescence. (Copyright Sally Shaywitz, MD. Adapted from Shaywitz S. Shaywitz J. *Overcoming Dyslexia*, 2nd ed. New York: Vintage Books;2020: 56.)

found to be at risk will then have further assessment and, if diagnosed as dyslexic, should receive evidence-based intervention.

Dyslexia is a clinical diagnosis, and history is especially critical. The clinician seeks to determine through history, observation, and psychometric assessment if there are unexpected difficulties in reading (based on the person's intelligence, chronologic/grade, level of education, or professional status) and associated linguistic problems at the level of phonologic processing. No single test score is pathognomonic of dyslexia. The diagnosis of dyslexia should reflect a thoughtful synthesis of all clinical data available.

Dyslexia is distinguished from other disorders that can prominently feature reading difficulties by the unique, circumscribed nature of the *phonologic deficit*, one that does not intrude into other linguistic or cognitive domains. A core assessment for the diagnosis of dyslexia in children includes tests of language, particularly phonology; reading, including real and pseudowords; reading fluency; spelling; and tests of intellectual ability. Additional tests of memory, general language skills, and mathematics may be administered as part of a more comprehensive evaluation of cognitive, linguistic, and academic function.

For informal screening, in addition to a careful history, the primary care physician in an office setting can listen to the child read aloud from the child's own grade-level reader. Keeping a set of graded readers available in the office serves the same purpose and eliminates the need for the child to bring in schoolbooks. **Oral reading** is a sensitive measure of reading accuracy and fluency. The most consistent and telling sign of a reading disability in an accomplished young adult is slow and laborious reading and writing. In attempting to read aloud, most children and adults with dyslexia display an effortful approach to decoding and recognizing single words, an approach in children characterized by hesitations, mispronunciations, and repeated attempts to sound out unfamiliar words. In contrast to the difficulties they experience in decoding single words, persons with dyslexia typically possess the vocabulary, syntax, and other higher-level abilities involved in comprehension.

**Fluency** forms the bridge between decoding, that is, reading a word accurately, and comprehension, understanding what is read. Fluent reading is reading accurately and rapidly, with good intonation (prosody) indicating an understanding of the text. The failure either to recognize or to measure the lack of fluency in reading is perhaps the most common error in the diagnosis of dyslexia, especially in older children and accomplished young adults. Simple word identification tasks will not detect dyslexia in a person who is accomplished enough to be in honors high school classes or to graduate from college or obtain a graduate degree. Tests relying on the accuracy of word identification alone are inappropriate to use to diagnose dyslexia because they show little to nothing of the *struggle* to read. Because they assess reading accuracy but not automaticity or prosody, the types of reading tests used for school-age children might provide misleading data on bright adolescents and young adults. Among the most critical tests are those that are *timed*; they are the most sensitive in detecting dyslexia in a bright adult. Few standardized tests for young adult readers are administered under timed and untimed conditions; the *Nelson-Denny Reading Test* is an exception. The helpful *Test of Word Reading Efficiency* (TOWRE) examines simple word reading under timed conditions, and the Achievement Improvement Monitoring System (AIMSweb) and Dynamic Indicators of Basic Early Literacy Skills (DIBELS) measure reading connected text under timed conditions. Any scores obtained on testing must be considered relative to peers with the same degree of education or professional training.

### IS FAMILY HISTORY HELPFUL IN DIAGNOSING DYSLEXIA?

Although dyslexia is familial, family history is not effective as a screening measure for dyslexia and does not improve the classification accuracy provided by an evidence-based early screening measure.

Genome-wide association studies (GWASs) in children with dyslexia have demonstrated that a large number of genes are involved, each producing a small effect. Complex traits such as reading are the work of thousands of genetic variants working in concert (see Chapter 103). Thus pediatricians should be wary of recommending any genetic test to their patients that purports to diagnose dyslexia in infancy or before language and reading have even emerged. It is unlikely that a single gene or even a few genes will reliably identify people with dyslexia. Rather, dyslexia is best explained by multiple genes, each contributing a small amount toward the expression of dyslexia.

### MANAGEMENT

The management of dyslexia demands a life-span perspective. Early in life the focus is on **remediation** of the reading problem. Applying knowledge of the importance of early language, including phonologic skills and vocabulary, leads to significant improvements in children's reading accuracy, even in predisposed children. As a child matures and enters the more time-demanding setting of middle and then high school, the emphasis shifts to the important role of providing accommodations. Based on the work of the National Reading Panel, evidence-based reading intervention methods and programs are identified. Effective intervention programs provide systematic instruction in five key areas: phonemic awareness, phonics, fluency, vocabulary, and comprehension strategies. These programs also provide ample opportunities for writing, reading, and discussing literature.

Taking each component of the reading process in turn, effective interventions improve phonemic awareness: the ability to focus on and manipulate phonemes (speech sounds) in spoken syllables and words. The elements found to be most effective in enhancing **phonemic awareness**, reading, and spelling skills include teaching children to manipulate phonemes with letters, focusing the instruction on one or two types of phoneme manipulations rather than multiple types, and teaching children in small groups. Providing instruction in phonemic awareness is necessary, but not sufficient, to teach children to read. Effective intervention programs include teaching **phonics**, or making sure that the beginning reader understands how letters are linked to sounds (phonemes) to form letter-sound correspondences and spelling patterns. The instruction should be explicit and systematic; phonics instruction enhances children's success in learning to read, and systematic phonics instruction is more effective than instruction that teaches little or no phonics or that teaches phonics casually or haphazardly. Important but often overlooked is starting children on reading connected text early on, optimally at or near the beginning of reading instruction. Reading connected text is critical in building vocabulary and increasing background knowledge—both important in improving reading comprehension.

**Fluency** is of critical importance because it allows the automatic, rapid recognition of words. Although it is generally recognized that fluency is an important component of skilled reading, it is often overlooked in teaching. One approach is to have a child practice oral reading with a teacher or parent providing positive and helpful feedback. Here practice is critical. Interventions for vocabulary development and reading comprehension are not as well established. The most effective methods to teach reading comprehension involve teaching vocabulary and strategies that encourage active interaction between the reader and the text. Emerging science indicates that it is not only teacher content knowledge but the teacher's skill in engaging the student and focusing the student's attention on the reading task at hand that is required for effective instruction.

The interventions described here can be provided in multiple settings, but specialized schools for children with dyslexia that provide intensive intervention over 4 years or more have been very effective. Typically, these schools are costly, although increasingly offering scholarships. Some school districts are considering developing public schools specializing in educating children with dyslexia.



For those in high school, college, and graduate school, provision of **accommodations** most often represents a highly effective approach to dyslexia. Imaging studies now provide neurobiologic evidence of the need for extra time for dyslexic students; accordingly, college students with a childhood history of dyslexia require extra time in reading and writing assignments and in examinations. Many adolescent and adult students have been able to improve their reading accuracy, but without commensurate gains in reading speed. The accommodation of extra time reconciles the individual's often high cognitive ability and slow reading, so that the exam is a measure of that person's ability rather than disability. Another important accommodation is helping the student access text-to-speech programs. Excellent text-to-speech programs and apps are available for Apple and Android systems and the PC and include Voice Dream Reader, Immersive Reader (available for free in all Microsoft Office programs, including Word, OneNote, and PowerPoint), Kurzweil Firefly, Read & Write Gold, Read: OutLoud, and Natural Reader. Voice-to-text programs are also helpful, often part of the suite of programs, as well as the popular Dragon Dictate. Voice-to-text is found on many smartphones. Other helpful accommodations include the use of laptop computers with spelling checkers, access to lecture notes, tutorial services, and a separate quiet room for taking tests.

In addition, the impact of the primary phonologic weakness in dyslexia mandates special consideration during oral examinations so that students are not graded on their lack of glibness or speech hesitations, but on their content knowledge. Unfortunately, speech hesitations or difficulties in word retrieval often are wrongly confused with insecure content knowledge. The major difficulty in dyslexia—reflecting problems accessing the sound system of spoken language—causes great difficulty learning a second language. As a result, an often-necessary accommodation is a waiver or partial waiver of the foreign language requirement; the dyslexic student may enroll in a course taught in English on the history or culture of a non-English-speaking country.

### PROGNOSIS

Application of evidence-based methods to young children, when provided with sufficient intensity and duration, can result in improvements in reading accuracy and, to a much lesser extent, fluency. Improvements in fluency can be effected with frequent practice in reading aloud with the helpful input of a teacher or parent. As noted earlier, accommodations are critical in allowing the dyslexic child to demonstrate his or her knowledge.

A person who is dyslexic experiences through life aligns with our Sea of Strengths model of dyslexia (Fig. 51.4). This model indicates that in dyslexia there is a weakness in decoding reflecting the difficulties connecting letters to sounds, a weakness that is very visible early on when learning to read. At the same, this weakness is surrounded by a sea of strengths in higher-level cognitive, big-picture thinking, including reasoning, problem solving, vocabulary, empathy, concept formation, and critical thinking. It is this sea of strengths that comes to the fore and supports a positive future as a person with dyslexia matures. The sea of strengths was very “visible” in a recent report examining the academic and social experiences in college and outcomes in the workplace 5 or more years after graduation in Yale graduates with dyslexia compared with a matched group of Yale graduates who were typical readers. Dyslexic college graduates did not differ from typical graduates either in college or in the workplace. Parents of dyslexic children often ask about their child's future. These findings should reassure those pediatricians and parents that dyslexic students can succeed all along the developmental pathway throughout school, and now through college and the workplace. With proper support, dyslexic children can succeed in a range of future occupations that might seem out of their reach, including medicine, law, journalism, and writing.

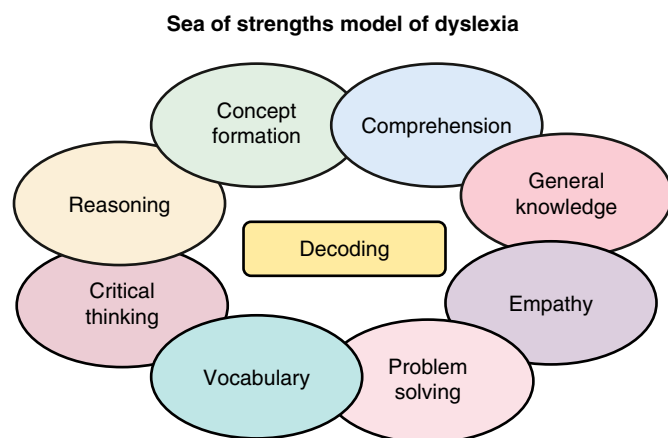
Visit Elsevier eBooks+ at [eBooks.Health.Elsevier.com](https://www.elsevier.com/ebooksplus) for Bibliography.

## Chapter 52

# Math and Writing Disabilities

### 52.1 Math Disabilities

Kenneth L. Grizzle and Brittany J. Bice-Urbach



**Fig. 51.4** Sea of strengths model of dyslexia. In dyslexia, a circumscribed, encapsulated weakness in decoding is surrounded by a sea of strengths in higher-level thinking and reasoning. The weakness in decoding masks what are often excellent thinking and comprehension skills. (Copyright Sally Shaywitz, MD. Adapted from Shaywitz S. Shaywitz J. *Overcoming Dyslexia*, 2nd ed. New York: Vintage Books;2020: 141.)

Data from the U.S. National Center for Educational Statistics for 2009 showed that 69% of U.S. high school graduates had taken algebra 1, 88% geometry, 76% algebra 2/trigonometry, and 35% precalculus. These percentages are considerably higher than those from 20 years earlier. However, concerns remain about the limited mathematics literacy level for children, adolescents, and those entering the workforce; poor math skills predict numerous social, employment, and emotional challenges. The need for number and math literacy extends beyond the workplace and into daily lives, and weaknesses can negatively affect daily functioning. Research into the etiology and treatment of **math disabilities** falls behind the study of reading disabilities (see [Chapter 51](#)), and yet the database needed to effectively identify, treat, and minimize the impact of math challenges on daily functioning and education is growing.

### MATH LEARNING DISABILITY DEFINED

Understanding learning challenges associated with mathematics requires a basic appreciation of domain-specific terminology and operations. The *Diagnostic and Statistical Manual for Mental Disorders, Fifth Edition* (DSM-5) has published diagnostic criteria for learning disorders. Specific types of learning challenges are subsumed under the broad term of **specific learning disorder (SLD)**. The DSM-5 identifies



the following features of a SLD with an **impairment in math**: difficulties mastering number sense, number facts, or fluent calculation and difficulties with math reasoning. Symptoms must be present for a minimum of 6 months and persist despite interventions to address the learning challenges. **Number sense** refers to a basic understanding of quantity, number, and operations and is represented as nonverbal and symbolic. Examples of number sense include an understanding that each number is 1 more or 1 less than the previous or following number, knowledge of number words and symbols, and the ability to compare the relative magnitude of numbers and perform simple arithmetic calculations.

The DSM-5 definition can be contrasted with an **education-defined learning disability in mathematics**. Two math-related areas are identified as part of the **Individuals with Disabilities Education Act (IDEA)**: mathematics calculation and mathematics problem solving. Operationally, this is reflected in age-level competency in arithmetic and math calculation, word problems, interpreting graphs, understanding money and time concepts, and applying math concepts to solve quantitative problems. The federal government allows states to choose the way a *learning disability (LD)* is identified if the procedure is “research based.” Referred to specifically in the IDEA as methods for identifying an LD are a **discrepancy model** and “use of a process based on the child’s response to scientific, research-based intervention.” The former refers to identifying an LD based on a pronounced discrepancy between intellectual functioning and academic achievement. The latter, referred to as a **response to intervention (RTI)** model, requires school systems to screen for a disability, intervene using evidence-based treatments for the identified disability, closely monitor progress, and make necessary adjustments to the intervention as needed. If a child is not responding adequately, a multidisciplinary team is created, and an evaluation is then completed to determine whether the child qualifies for special education programming. Not responding to the interventions alone does not result in automatic qualification for services outside of regular education. Rather, it is a three-step process: lack of adequate progress to the interventions, an evaluation of the area(s) of concern, and then determination by the team if an **individualized educational plan (IEP)** is needed. The IEP team typically consists of teachers, special education teacher, school psychologist, school district representative, parents, and, depending on their age, the student.

It is important that primary care providers understand the RTI process because many states require or encourage this approach to identifying LDs. Confusion can be avoided by helping concerned parents understand that a school may review their child’s records, screen the skills of concern, and provide intervention with close progress monitoring before initiating the process for an IEP. Traditional psychoeducation testing (IQ and achievement) may only be completed if a child has not responded well to specific interventions. The RTI approach is a valuable, empirically supported way to approach and identify a potential LD but is very different from a medical approach to diagnosis and treatment. First and foremost, this allows for early intervention, which has been shown repeatedly to decrease the likelihood of a later identified LD. Intervening early also allows educators to avoid the “wait to fail” model that all too often waited for children to enter third or fourth grade before receiving needed services.

### Terminology

The term **dyscalculia**, often used in medicine and research but seldom used by educators, is reserved for children with a SLD in math when there is a pattern of deficits in learning arithmetic facts and accurate, fluent calculations. The term **math learning disability (MLD)** is used generically here, with dyscalculia used when limiting the discussion to children with deficient math calculation skills. A distinction is also made between children with a MLD and those who are **low achieving (LA) in math**; both groups have received considerable research focus. Although not included in either definition provided earlier, research into math deficits often require that individuals identified with MLD have math achievement scores below the 10th percentile across multiple grade levels. These children start out poorly in math and continue poor performance across grades, despite interventions. LA math

students consistently score below the 25th percentile on math achievement tests across grades, often showing the same weak math-related characteristics as those with MLD but with less severity. Complicating the identification of MLD and its differentiation from LA math students is the variability in relative complexity of math concepts that may result in short-lived math difficulties.

## EPIDEMIOLOGY

### Prevalence

Depending on how MLD is defined and assessed, the prevalence varies. Based on findings from multiple studies, approximately 7% of children will show a MLD profile before high school graduation. An additional 10% of students will be identified as LA. Because research in the area typically requires that individuals show deficits for consecutive years, the respective prevalence estimates are lower than the 10th percentile cutoff for being identified as having an MLD or the 25th percentile cutoff for being identified as LA. It is not unusual for children to score below the criterion one year and then above the criterion in subsequent years. Males are at greater risk to experience MLD.

### Risk Factors Genetics

The heritability of math skills is estimated to be approximately 0.50. The heritability or genetic influence on math skills is consistent across the continuum from high to low math skills. This research emphasizes that although math skills are learned across time, the stability of math performance is the result of genetic influences. Math heritability appears to be the product of multiple genetic markers, each having a small effect.

### Medical/Genetic Conditions

Numerous genetic syndromes are associated with math problems. Although most children with **fragile X syndrome** have an *intellectual disability (ID)*, approximately 50% of females with the condition do not. Of those without an ID,  $\geq 75\%$  have a math disability by the end of third grade and are already scoring below average in mathematics in kindergarten and first grade. For females with fragile X MLD, weak working memory seems to play an important role. The frequency of MLD in **Turner syndrome (TS)** is the same as that found in females with fragile X syndrome. A consistent finding is females with TS complete math calculations at significantly slower speed than typically developing students. Although females with TS have weak calculation skills, their ability to complete math problems not requiring explicit calculation is similar to that of their peers. The percentage of children with **22q11.2 deletion syndrome (22q11.2ds)** with MLD is not clear. Younger children with this genetic condition (6–10 years old) showed similar number sense and calculation skills as typically developing children but weaker math problem solving. Older children with 22q11.2ds showed slower speed in their general number sense and calculations, but accuracy was maintained. Weak counting skills and magnitude comparison have been found in this group of children, suggesting weak visual-spatial processing. Children with **myelomeningocele** are at greater risk for math difficulties than their unaffected peers. Almost 30% of these children have MLD without an additional diagnosed learning disorder, and  $>50\%$  have both math and reading learning disorders. Although broad, deficits are most pronounced in speed of math calculation and written computation.

### Comorbidities

It is estimated that 30–70% of those with MLD will also have a reading disability. This is especially important because children with MLD are less likely to be referred for additional educational assistance and intervention than students with reading problems. Unfortunately, children identified with both learning challenges perform poorer across psychosocial and academic measures than children with MLD alone. Having a MLD places a child at greater risk for not only other learning challenges but also psychiatric disorders, including attention-deficit/hyperactivity disorder (ADHD), oppositional defiant disorder, conduct disorder, generalized anxiety disorder, and major depressive disorder.

Individuals with MLD have been found to have increased social isolation and difficulties developing social relationships in general.

## CAUSES OF MATH LEARNING DISABILITY

There is a consensus that individuals with MLD are a heterogeneous group, with multiple potential broad and specific deficits contributing to their learning difficulties. Research into the causes of MLD has focused on math-specific processes and broad cognitive deficits, with an appreciation that these two factors are not always independent.

### Broad Cognitive Processes Intelligence

Intelligence affects learning, but if intellectual functioning were the primary driver of poor math performance, the math skills of low-IQ children would be similar or worse than individuals with MLD. On the contrary, children with MLD have significantly poorer math achievement than children with low IQ. Children with MLD have severe deficits in math not accounted for by their cognitive functioning. Individuals with lower cognition may have difficulty learning mathematics, but their math skills are likely to be commensurate with their intelligence.

### Memory

Working memory (WM) refers to the ability to keep information in mind while using the information in other mental processes. WM is composed of three core systems: the central executive, the language-related phonologic loop, and the visual-based sketch pad. The central executive coordinates the functioning of the other two systems. All three play a role in various aspects of learning and in the development and application of math skills in particular; children with MLD have shown deficits in each area.

Committing math facts to and/or retrieving facts from memory has consistently been found to be problematic for children with MLD. This is not necessarily limited to inaccurate retrieval of facts but also speed of retrieval, independent of broader speed of processing deficits. Unfortunately, unlike some typically developing peers who may be slower but accurate in their fact retrieval, students with MLD are often slow and inaccurate. Weak fact encoding or retrieval alone do not determine an MLD diagnosis. Many math curricula in the United States do not include development of math facts as a part of the instructional process, resulting in children not knowing basic facts.

### Processing Speed

Individuals with MLD are often slower to complete math problems than their typically developing peers, a result in part of their poor fact retrieval rather than broader speed of processing deficits. However, young children later identified with a MLD when beginning school have numerical-processing speed that is considerably slower than same-age same-grade peers. This is reflected in the time required to recognize numbers, correctly order fractions, and complete word problems.

### Problem Solving

Not only do children with MLD struggle to quickly and accurately engage in numerical-related activities, in part because of these difficulties, they commonly rely on less efficient and laborious problem-solving practices. This is seen in children relying on finger counting beyond second grade, use of repeated adding for multiplication facts, pronounced difficulty moving beyond reliance on manipulatives, and drawing objects to help with calculation. Difficulties with math processes across multiple levels can result in math being a time-intensive and time-consuming process for kids with MLD.

### Executive Skills

Difficulties with executive functioning (EF) can lead to challenges in multiple areas of a child's life, academic and nonacademic (see [Chapter 49](#)). Performance in math is but one example. EF refers to skills including but not limited to sustained attention, managing impulses, cognitive and behavioral flexibility, and WM. Anyone who has worked with children diagnosed with ADHD, a group of kids notorious for having EF challenges, can appreciate the impact these behaviors could

potentially have on math. Deficits in WM, auditory and visual, can negatively affect a child's development of math skills. A child approaching a word problem exemplifies the impact of various executive skills on math. The child must keep in memory the content read and integrate it with what they know about the topic and possible operation to apply, all the while not responding to the irrelevant information contained within the passage. Creating a mental representation of the problem requires use of the visual sketch pad (visual WM).

### Math-Specific Processes Number Sense

The term *number sense* has been defined in different ways, though the general agreement is that the concept refers to an intuitive preverbal ability to identify an approximation of items within a set that precedes formal math instruction. This is seen in the ability to recognize and manipulate nonsymbolic properties without having to apply a name to the process—for example, recognizing that a box of three dots is fewer than a box containing five dots. Unlike their peers, children with MLD are more likely to count the number of items within the comparison rather than recognizing the apparent difference.

Math is a symbolic process and cannot be efficiently learned and mastered without understanding this numerical skill. There is considerable evidence that young children who struggle to develop symbolic numerical representation, in contrast to number sense, are at considerable risk to have difficulty developing higher-level math skills. Examples of symbolic representations range from recognizing that the numeral 4 and word *four* reflect a quantity and quickly recognizing the larger (or smaller) of two numbers, all the way to understanding fractions and more complex notations.

### Procedural Errors

The type of errors made by children with a MLD are typical for any child, the difference being that children with a LD show a 2- to 3-year lag in understanding the concept. An example of a common error a first-grade child with a MLD might make when “counting on” is to undercount: “ $6 + 2 = ?$ ”; “6, 7” rather than starting at 6 and counting an additional two numbers. As children with math deficits get older, it is common to subtract a larger number from a smaller number. For example, in the problem “ $63 - 29 = 46$ ,” the child makes the mistake of subtracting 3 from 9. Another common error is not decreasing the number in the 10s column when borrowing: “ $64 - 39 = 35$ .” For both adding and subtracting, there is a lack of understanding of the commutative property of numbers and a tendency to use repeated addition rather than fact retrieval. It is not that children with an MLD do not develop these skills, it is that they develop them much later than their peers, thereby making the transition to complicated math concepts much more challenging.

Unlike dyslexia, in which deficits have been isolated and identified as causal (see [Chapter 51](#)), factors involved in the development of a MLD are much more heterogeneous. Alone, none of the processes previously outlined fully account for MLD, although all have been implicated as problematic for those struggling with math.

## TREATMENT AND INTERVENTIONS

The most effective interventions for MLD are those that include explicit instruction on solving specific types of problems and that take place over several weeks to several months. Skill-based instruction is a critical component; general math problem solving will not carry over across various math skills unless the skill is part of a more complex math concept. Clear, comprehensive guidelines for effective interventions for students struggling with math have been provided by the U.S. Department of Education in the form of a *Practice Guide* released through the What Works Clearinghouse. This document gives excellent direction in the identification and treatment of children with math difficulties in the educational system. Although not intended for medical personnel or parents, the guide is available free of charge and can be helpful for parents when talking to teachers about their child's learning. [Table 52.1](#) lists additional resources for parents concerned about their young child's development of math facts.

**Table 52.1** Parent Resources for the Child with Math Learning Disability

*Let's Talk About Math.* Available from <http://www.zerotothree.org/parenting-resources/early-math-video-series>. Accessed September 19, 2021.

*Mixing in Math.* Available from <https://www.terc.edu/mixinginmath/>. Accessed September 19, 2021.

PBS Parents. Math resources available to parents through the Public Broadcasting Service website. Accessed September 19, 2021.  
<http://www.pbs.org/parents/earlymath/index.html>  
<http://www.pbs.org/parents/education/math/>

*Understood: Math.* Available from <https://www.understood.org/topics/en/math>.

U.S. Department of Education. *Helping your child learn mathematics.* Available from <https://www2.ed.gov/parents/academic/help/math/index.html>. Accessed September 19, 2021.

**Table 52.2** Risk Factors for a Specific Learning Disability Involving Mathematics

The child is at or below the 20th percentile in any math area, as reflected by standardized testing or ongoing measures of progress monitoring.

The teacher expresses concerns about the child's ability to "take the next step" in math.

There is a positive family history for math learning disability (this alone will not initiate an intervention).

Parents think they have to "reteach" math concepts to their child.

Awareness that most public school systems have implemented some form of an RtI model to identify LDs allows the primary care physician to encourage parents to return to the school seeking an intervention to address their child's concern. Receiving special education services in the form of an IEP may be necessary for some children. However, the current approach to identifying children with an LD allows school systems to intervene earlier, when problems arise, and potentially avoid the need for an IEP. Pediatricians with patients whose parents have received feedback from school with any of the risk factors outlined in [Table 52.2](#) should encourage the parents to discuss an intervention plan with the child's teacher.

Visit Elsevier eBooks+ at [eBooks.Health.Elsevier.com](http://eBooks.Health.Elsevier.com) for Bibliography.

## 52.2 Writing Disabilities

Kenneth L. Grizzle and Brittany J. Bice-Urbach

*Oral language* is a complex process that typically develops in the absence of formal instruction. In contrast, *written language* requires instruction in acquisition (word reading), understanding (reading comprehension), and expression (spelling and composition). Unfortunately, despite reasonable pedagogy, a subset of children struggle with development in one or several of these areas. The disordered output of written language is currently referred to within the *Diagnostic and Statistical Manual for Mental Disorders, Fifth Edition* (DSM-5) as a **specific learning disorder with impairment in written expression** ([Table 52.3](#)).

Various terminology has been used when referring to individuals with writing deficits; this subchapter uses the term **impairment in written expression (IWE)** rather than "writing disorder" or "disorder of written expression." **Dysgraphia** is often used when referring to children with writing problems, sometimes synonymously with IWE, though the two are related but distinct conditions. Dysgraphia

**Table 52.3** DSM-5 Diagnostic Criteria for Specific Learning Disability with Impairment in Written Expression

- A. Difficulties learning and using academic skills that have persisted for at least 6 months, despite the provision of interventions that target those difficulties.  
Difficulties with written expression (e.g., makes multiple grammatical or punctuation errors within sentences; employs poor paragraph organization; written expression of ideas lacks clarity).
- B. The affected academic skills are substantially and quantifiably below those expected for the individual's chronologic age and cause significant interference with academic or occupational performance or with activities of daily living, as confirmed by individually administered standardized achievement measures and comprehensive clinical assessment. For individuals age 17 years and older, a documented history of impairing learning difficulties may be substituted for the standardized assessment.
- C. The learning difficulties begin during school-age years but may not become fully manifest until the demands for those affected academic skills exceed the individual's limited capacities (e.g., as in timed tests, reading or writing lengthy complex reports for a tight deadline, excessively heavy academic loads).
- D. The learning difficulties are not better accounted for by intellectual disabilities, uncorrected visual or auditory acuity, other mental or neurologic disorders, psychosocial adversity, lack of proficiency in the language of academic instruction, or inadequate educational instruction.
- 315.2 (F81.81) With impairment in written expression:  
Spelling accuracy  
Grammar and punctuation accuracy  
Clarity or organization of written expression  
Specify current severity:  
**Mild:** Some difficulties learning skills in one or two academic domains, but of mild enough severity that the individual may be able to compensate or function well when provided with appropriate accommodations or support services, especially during the school years.  
**Moderate:** Marked difficulties learning skills in one or more academic domains, so that the individual is unlikely to become proficient without some intervals of intensive and specialized teaching during the school years. Some accommodations or supportive services at least part of the day at school, in the workplace, or at home may be needed to complete activities accurately and efficiently.  
**Severe:** Severe difficulties learning skills, affecting several academic domains, so that the individual is unlikely to learn those skills without ongoing intensive individualized and specialized teaching for most of the school years. Even with an array of appropriate accommodations or services at home, at school, or in the workplace, the individual may not be able to complete all activities efficiently.

From the *Diagnostic and Statistical Manual of Mental Disorders*, 5th ed. Washington, DC: American Psychiatric Association; 2013:66–67.

is primarily a deficit in motor output (paper/pencil skills), and IWE is a conceptual weakness in developing, organizing, and elaborating on ideas in writing.

The diagnoses of IWE and dysgraphia are made largely based on phenotypical presentation; spelling, punctuation, grammar, clarity, and organization are factors to consider with IWE concerns. Aside from these potentially weak writing characteristics, however, no other guidelines are offered. Based on clinical experience and research into the features of writing samples of children with disordered writing skills, one would expect to see limited output, poor organization, repetition of content, and weak sentence structure and spelling despite the child taking considerable time to produce a small amount of content. For those with comorbid dysgraphia, the legibility of their writing product will also be poor, sometimes illegible.



## EPIDEMIOLOGY

The incidence of IWE is estimated at 6.9–14.7%, with the relative risk for IWE ~2.5 times higher for males than for females. The risk for writing problems is much greater among select populations; >50% of children with oral language disorders reportedly have IWE. The relationship between attention-deficit/hyperactivity disorder (ADHD) and learning disorders in general is well established, including IWE estimates in the 60% range for the combined and inattentive presentations of ADHD. Because of the importance of working memory (WM) and other executive functions in the writing process, any child with weakness in these areas will likely find the writing process difficult (see Chapter 49).

## SKILL DEFICITS ASSOCIATED WITH IMPAIRED WRITING

Written language, much like reading, occurs along a developmental trajectory that can be seamless as children master skills critical to the next step in the process. Mastery of motor control that allows a child to produce letters and letter sequences frees up cognitive energy to devote to spelling words and eventually stringing words into sentences, paragraphs, and complex composition. Early in the development of each individual skill, considerable cognitive effort is required, although ideally the lower-level skills of motor production, spelling, punctuation, and capitalization (referred to as **writing mechanics** or **writing conventions**) will gradually become automatic and require progressively less mental effort. This effort can then be devoted to higher-level skills, such as planning, organization, application of knowledge, and use of varied vocabulary. For children with writing deficits, breakdowns can occur at one, some, or every stage.

### Transcription

Among preschool and primary grade children, there is a wide range of what is considered “developmentally typical” as it relates to letter production and spelling. However, evidence indicates that poor writers in later grades are slow to produce letters and write their name in preschool and kindergarten. Weak early spelling and reading skills (letter identification and phonologic awareness; see Chapter 51) and weak oral language have also been found to predict weak writing skills in later elementary grades. Children struggling to master early **transcription** skills tend to write slowly, or when writing at reasonable speed, the legibility of their writing degrades. Output in quantity and variety is limited, and vocabulary use in poor spellers is often restricted to words they can spell.

As children progress into upper elementary school and beyond, a new set of challenges arises. They are now expected to have mastered lower-level transcription skills, and the focus turns to the application of these skills to more complex text generation. In addition to transcription, this next step requires the integration of additional cognitive skills that have yet to be tapped by young learners.

### Oral Language

Language, though not speech, has been found to be related to writing skills. Writing difficulties are associated with deficits in both expression and comprehension of oral language. Writing characteristics of children with **specific language impairment (SLI)** can differ from their unimpaired peers early in the school experience and persist through high school (see Chapter 53). In preschool and kindergarten, as a group, children with language disorders show poorer letter production and ability to print their name. Poor spelling and weak vocabulary also contribute to the poor writing skills. Beyond primary grades, the written narratives of SLI children tend to be evaluated as “lower quality with poor organization” and weaker use of varied vocabulary.

Pragmatic language and higher-level language deficits also negatively affect writing skills. **Pragmatic language** refers to the social

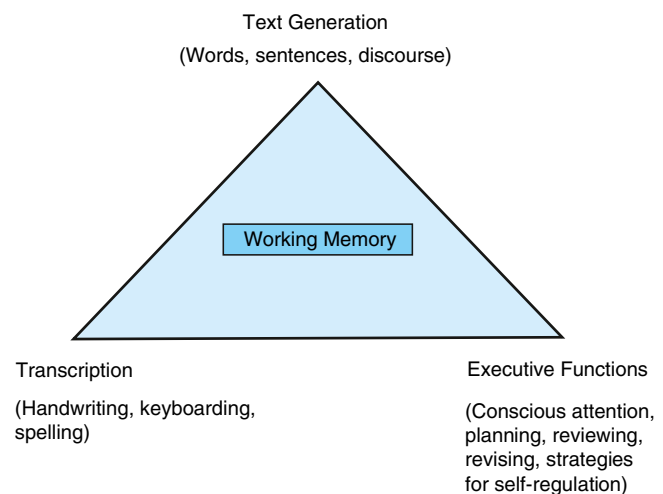
use of language, including though not limited to greeting and making requests, adjustments to language used to meet the need of the situation or listener, and following conversation rules verbally and nonverbally. Higher-level language goes beyond basic vocabulary, word form, and grammatical skills and includes making inferences, understanding and appropriately using figurative language, and making cause-and-effect judgments. Weaknesses in these areas, with or without intact foundational language, can present challenges for students in all academic areas that require writing. For example, whether producing an analytic or narrative piece, the writer must understand the extent of the reader’s background knowledge and in turn what information to include and omit, make an argument for a cause-and-effect relationship, and use content-specific vocabulary or vocabulary rich in imagery and nonliteral interpretation.

### Executive Functions

Writing is a complicated process and, when done well, requires the effective integration of multiple processes. Executive functions (EFs) are a set of skills that include planning, problem solving, monitoring, and adjusting as needed (see Chapter 49). Three recursive processes have consistently been reported as involved in the writing process: *translation* of thought into written output, *planning*, and *reviewing*. Coming up with ideas, although challenging for many, is simply the first step when writing a narrative (story). Once an idea has emerged, the concept must be developed to include a plot, characters, and storyline and then coordinated into a coherent whole that is well organized and flows from beginning to end. Even if one develops ideas and begins to write them down, *persistence* is required to complete the task, which requires *self-regulation*. Effective writers rely heavily on EFs, and children with IWE struggle with this set of skills. Poor writers seldom engage in the necessary planning and struggle to self-monitor and revise effectively.

### Working Memory

WM refers to the ability to hold, manipulate, and store information for short periods. The more space available, the more memory can be devoted to problem solving and thinking tasks. Nevertheless, there is limited space in which information can be held, and the more effort devoted to one task, the less space is available to devote to other tasks. WM has consistently been shown to play an important role in the writing process, because weak WM limits the



**Fig. 52.1** Simple view of writing. (From Berninger VW. *Preventing written expression disabilities through early and continuing assessment and intervention for handwriting and/or spelling problems: Research into practice*. In: Swanson HL, Harris KR, Graham S [eds]. *Handbook of Learning Disabilities*. New York: The Guilford Press;2003.)



space available. Further, when writing skills that are expected to be *automatic* continue to require effort, precious memory is required, taking away what would otherwise be available for higher-level language.

The **Simple View of Writing** is an approach that integrates each of the four ideas just outlined to describe the writing process (Fig. 52.1). At the base of the triangle are transcription and EFs, which support, within WM, the ability to produce text. Breakdowns in any of these areas can lead to poor writing, and identifying where the deficit(s) are occurring is essential when deciding to treat the writing problem. For example, children with weak **graphomotor** skills (e.g., dysgraphia) must devote considerable effort to the accurate production of written language, thereby increasing WM use devoted to lower-level transcription and limiting memory that can be used for developing discourse. The result might be painfully slow production of a legible story or a passage that is largely illegible. If, on the other hand, a child's penmanship and spelling have developed well but their ability to persist with challenging tasks or to organize their thoughts and develop a coordinated plan for their paper is limited, one might see very little information written on the paper despite considerable time devoted to the task. Lastly, even when skills residing at the base of this triangle are in place, students with a language disorder will likely produce text that is more consistent with their language functioning than their chronological grade or age.

## TREATMENT

Poor writing skills can improve with effective treatment. Weak graphomotor skills may not necessarily require intervention from an **occupational therapist (OT)**, although *Handwriting Without Tears* is a curriculum frequently used by OTs when working with children with poor penmanship. An empirically supported writing program has been developed by Berninger, but it is not widely used inside or outside school systems (*PAL Research-Based Reading and Writing Lessons*). Her research suggests that for children with dysgraphia, lower-level transcription skills should be emphasized to the point of becoming automatic. The connection between transcription skills and composition should be included in the instructional process; that is, children need to see how their work at letter production is related to broader components of writing. Further, because of WM constraints that frequently affect the instructional process for students with learning disorders, all components of writing should be taught within the same lesson. Building upon Berninger's sequencing of skills, Otaiba, Gillespie-Rouse, and Baker summarized features of effective handwriting instruction for kids who struggle: direct instruction on letter formation that is modeled and followed using verbal and visual instruction; retrieving letters from memory using such strategies as a child viewing the letter, covering, and reproducing the letter; children identifying their own errors; newly learned letters are integrated into word and sentence context and then into a child's own writing product; integration of multisensory strategies; and handwriting interventions included practice, occurred regularly, and were relatively brief but meaningful (children learned that writing had a purpose beyond accurately producing letters).

Explicit instruction of writing composition strategies combined with implementation and coaching in self-regulation will likely produce the greatest gains for students with writing deficits beyond

transcription. Emphasis will vary depending on the deficit specific to the child. A well-researched and well-supported intervention for poor writers is **self-regulated strategy development (SRSD)**. The six stages in this model include developing and activating a child's background knowledge, introducing and discussing the strategy that is being taught, modeling the strategy for the student, assisting the child in memorization of the strategy, supporting the child's use of the strategy during implementation, and independent use of the strategy. SRSD can be applied across various writing situations and is supported until the student has developed mastery. The model can emphasize the areas most needed by the child.

An additional excellent resource is entitled *Teaching Elementary School Students to Be Effective Writers* and is found within the What Works Clearinghouse maintained by the U.S. Department of Education's Institute of Education Science.

## Educational Resources

Children with identified learning disorders can potentially qualify for formal education programming through special education or a Section 504 plan. **Special education** is guided on a federal level by the **Individual with Disabilities Education Act (IDEA)** and includes development of an **individual education plan (IEP)** (see Chapter 49). The processes involved in pursuing an IEP are somewhat complex and outlined in the chapter on math learning disability (MLD). A **504 plan** provides accommodations to help children succeed in the regular classroom. Accommodations that might be provided to a child with IWE, through an IEP or a 504 plan, include dictation to a scribe when confronted with lengthy writing tasks; additional time to complete exams that require writing; and use of technology such as keyboarding, speech-to-text software, and writing devices that record teacher instruction.

Speech-to-text capability is available on most smartphones, which can be helpful for students from a functional standpoint. Educational resources that can be accessed inside and outside the classroom are often readily available for all children but may need to be included as an accommodation for a child with dysgraphia. Examples of easily available software include Voice Dictation in Google Docs and Dictation in Microsoft Word, both available at no cost. More sophisticated apps that can be purchased include Co:Writer for Chrome, Read & Write, and Kurzweil 3000. Kurzweil 3000 is a comprehensive assistive technology device that, in addition to speech-to-text and text-to-speech, offers multiple valuable resources for students with any type of literacy-based learning disability. Editing is a critical component of the writing process and, for children struggling with written expression, can present quite a challenge. Microsoft Word has built-in spelling and grammar correction suggestions, as do other word processing programs such as Pages and Google Docs. Apps for use when using the internet are also available to help with spelling, grammar, and writing mechanics. One example—though there are others—is Grammarly. When recommending that parents pursue assistive technology for their child as a potential accommodation, the physician should emphasize the importance of instruction to mastery of the device being used. Learning to use technology effectively requires considerable time and is initially likely to require additional effort, which can result in frustration and avoidance.

Visit Elsevier eBooks+ at [eBooks.Elsevier.com](https://www.elsevier.com/ebooksplus) for Bibliography.

## Chapter 53

# Language Development and Communication Disorders

Janet Y. Bang and Heidi M. Feldman

There are over 6,000 languages in the world, each with a distinct set of symbols, defined as words or signs that signify objects, actions, ideas, or relationships. By combining symbols in novel ways, humans can create an infinite number of meanings. Human communication (Table 53.1) encompasses language, speech, nonverbal gestures, and written language. Typically developing children learn language skills seemingly without effort or explicit education early in the course of development. However, there is wide variation in how and when children learn and use language, speech, and communication. Globally, families differ in the specific languages and number of languages they speak and in the ways in which they communicate to convey their beliefs, values, and circumstances. Children vary in their rates of learning language and the highest level of skills they attain. Milestones within each domain (language, speech, communication) signify the unfolding steps by which new structures and skills come into children's language abilities (Table 53.2 and Fig. 53.1). Some children require explicit education or clinical support to learn language or to make their speech easily interpretable.

## TYPICAL DEVELOPMENT

### Development of Phonology

Every language is made up of an inventory of **speech sounds** or **phonemes** (see Table 53.1), and the number of speech sounds varies across languages (e.g., Hawaiian = 13, Cantonese = more than 36, English = 46). **Speech perception** depends on the physical structures of the ear and the auditory processing system. Fetuses detect sound as early as 28 weeks' gestation, and within 5 days after birth, infants can demonstrate the ability to discriminate vowel sounds (i.e., English vs Swedish) and show preferences for their own prenatal monolingual or bilingual language environments (i.e., English vs Tagalog-English). Infants develop their speech sound perception, built on the ability to track the statistical probabilities of sound combinations (e.g.,  $b + a$  is more prevalent in language than  $b + d$ ), segment sounds and words from a stream of speech, and become attuned to the speech sounds in their respective language or languages. Older children or adults learning a new language need to learn a new speech sound inventory.

**Speech production** involves activating the physical structures of the respiratory tract and oral cavity, such as the lips, tongue, and vocal cords, all of which work in concert. Infants begin producing nonspeech **cooing** sounds at 4-6 weeks. By 6-8 months, many infants engage in canonical **babbling** (e.g., *bababa*) followed by variegated babbling (e.g., *badadeda*). Infants who are exposed to **sign language** from birth demonstrate manual babbles at around the same time as hearing infants begin vocal babbles. These skills lay the stage for infants' first words and subsequent word combinations. Speech production continues to develop throughout early childhood, with easier consonant sounds maturing early, around age 3 (e.g., in English *p, b, m, h, w*) and difficult sounds (e.g., in English *l, s, r, v, ch, th*) maturing late, typically by around age 7.

### Development of the Lexicon, Morphology, and Syntax

It is difficult to pinpoint when in development children typically understand their first word, but many children may say their first words by around 1 year; English-speaking families in the United States

report first words appearing as young as 7 and as late as 15 months. Children's first words mark their expressive skills in their **lexicon** (see Table 53.1), and first words may come from a variety of categories (e.g., people, objects, and greetings). Many children recognize their own name between 7 and 15 months old. Initial word learning is typically very slow, but the rate of acquisition of new words gradually accelerates. Expressive lexical errors are common at this age and can include overextensions (e.g., all edible objects are "*apples*") or underextensions (e.g., only one specific spoon is labeled "*spoon*"). Between 1 and 2 years, children build a lexicon of over 50 words. The **vocabulary spurt** is rapid acceleration in word learning, usually after children reach 50 words in expressive language and coincident with the beginning of two-word phrases.

By approximately 2 years, children begin to demonstrate their developing understanding of **morphology** and **syntax** (see Table 53.1). Morphology and syntax rules differ by language. Children's receptive syntax skills are evident when they can follow simple directions or answer *wh-* questions. Notable expressive morphologic milestones in English include the use of the present progressive tense (e.g., "*go-ing*") and the plural *-s* (e.g., *dog-s*). Expressive syntax skills are evident via children's early creative word combinations, starting with two-word combinations, which are likely to vary from adult models (e.g., in English "*me down!*" or "*ick eggs!*"). By 3 years, children begin to produce sentences as long as five words and with increasingly complex grammar, such as negation (e.g., in English "*I no want to*") and questions (e.g., "*What he do?*"). As in these examples, lexical, morphologic, and/or syntax errors in understanding and production are common during this early phase of syntactic development. Morphologic or syntax errors in production may consist of overgeneralizations (e.g., in English, generalizing the "*-ed*" ending to all verbs such as "*runned*" rather than "*ran*"; in Spanish, Italian, or French, using the masculine articles with feminine nouns). By 4-5 years, children are able to use sentences with adult-like grammar (e.g., in English "*I fell because I was running too fast.*"), although they may still make mistakes (e.g., in English "*I gots 1 game and he got 3 games.*"). Children also engage in longer, coherent, connected discourse, such as telling or retelling stories and recounting the steps of a familiar activity, such as taking a bath.

### Development of Pragmatics

Pragmatic skills begin in infancy. The ability to attend to and follow another's **eye gaze** develops as early as 3-4 months old. As young as 3 months old, children can engage in **protoconversations**, turn-taking patterns with caregivers that resemble early conversations. Responsive, contingent interactions between caregivers and children provide infants the opportunity to experience, imitate, and practice the timing, rhythm, and rate of nonverbal pragmatic skills, such as facial expressions, body language, and intonation. By 6 months, many infants can passively follow the adult's line of visual regard, resulting in a joint reference to the same objects and events in the environment. The ability to share the same experience is critical to the development of further language, social, and cognitive skills as infants "map" specific meanings onto their experiences. By 10-13 months, many infants can actively show, give, and point to objects. Children vary widely in when these skills first appear; English-speaking families have reported pointing skills as early as 6 months and as late as 16 months.

An important facet of typical communication development and a building block of conversational turn-taking skills includes establishing a **joint focus of attention**, a sharing of the topic of conversation with a communicative partner, both in comprehension (e.g., infants turn their heads to the object an adult is pointing at) and in production (e.g., a child saying "look at that dog over there," then looking back at their caregiver and expressing a desire for a dog). Conversation skills are important for forming relationships and especially strong social bonds and friendships. As children reach school age and adolescence, they develop **nonliteral** or **figurative language skills** (see Table 53.1), including hints, idioms, metaphors, hyperbole, humor, and sarcasm. In lexical development, understanding often occurs before production; in children's humor development, children's production may precede full understanding of their meaning. Another notable milestone of

**Table 53.1** Definitions of Basic Terms in Communication, Language, and Speech

TERM	DEFINITION	EXAMPLES
Communication	<ul style="list-style-type: none"> <li>Broad umbrella term that encompasses understanding and producing language, speech, nonverbal communicative gestures, and written language</li> </ul>	<ul style="list-style-type: none"> <li>Humans share ideas using verbal or signed speech and language</li> <li>Nonverbal communicative gestures include nodding one's head up and down to convey "yes" in some cultures</li> </ul>
Language	<ul style="list-style-type: none"> <li>Verbal, signed, written, or other systems that use arbitrary but conventional, rule-governed symbols to communicate about objects, events, and ideas in the past, present, and future</li> </ul>	<ul style="list-style-type: none"> <li>Verbal symbols include words (e.g., <i>apple</i> in English or <i>manzana</i> in Spanish, both of which represent a red, tasty fruit)</li> <li>Signed symbols include the word <i>apple</i> in American Sign Language, produced by the twist of the knuckle of the index finger on the cheek</li> </ul>
Speech	<ul style="list-style-type: none"> <li>Perception of the meaningful units of sounds that comprise verbal language and production of these sounds by coordinating the mouth, tongue, airflow, and vibration of the vocal folds</li> </ul>	<ul style="list-style-type: none"> <li>Speech sounds or phonemes make a difference in meaning (e.g., <i>b</i>, <i>p</i>, <i>a</i>, <i>i</i>, and <i>t</i> affect the meaning of <i>bat</i>, <i>bit</i>, <i>pat</i>, and <i>pit</i>)</li> <li>Speech does not include all vocal sounds, such as coughs or throat clearing</li> <li>Phonemes in sign language are based on spatial, temporal features, such as hand shape</li> </ul>
Receptive language	<ul style="list-style-type: none"> <li>Hearing and understanding verbal or sign language</li> </ul>	<ul style="list-style-type: none"> <li>Recognizing own name</li> <li>Following two-step directions</li> </ul>
Expressive language	<ul style="list-style-type: none"> <li>Speaking using verbal or sign language</li> </ul>	<ul style="list-style-type: none"> <li>Speaking first words or signs in a sign language</li> <li>Telling stories</li> </ul>
Phonology	<ul style="list-style-type: none"> <li>The system of relationships among speech sounds or phonemes that constitute a fundamental component of language</li> </ul>	<ul style="list-style-type: none"> <li>Understanding <i>seetheredball</i> can be segmented into <i>see the red ball</i></li> <li>Babbling, consonant-vowel combinations that use phonemes</li> </ul>
Lexicon	<ul style="list-style-type: none"> <li>All of the words or vocabulary of a person or a language</li> </ul>	<ul style="list-style-type: none"> <li>The lexicon of the mathematician may vary from the lexicon of the lawyer</li> </ul>
Morphology	<ul style="list-style-type: none"> <li>Units of meaning that can be combined to form vocabulary</li> </ul>	<ul style="list-style-type: none"> <li>In English <i>dogs</i> is made of two morphemes, <i>dog</i> and the plural <i>-s</i>; <i>untie</i> is made of <i>un-</i> and <i>tie</i></li> </ul>
Syntax	<ul style="list-style-type: none"> <li>Grammar and word order to make sentences</li> </ul>	<ul style="list-style-type: none"> <li>In English word order, <i>the dog chases the cat</i>, while in Hindi word order, <i>the cat the dog chases</i></li> </ul>
Pragmatics	<ul style="list-style-type: none"> <li>Verbal and nonverbal communication skills that govern how language and communication are used in context</li> <li>Includes intonation, facial expression, and body language</li> </ul>	<ul style="list-style-type: none"> <li>Use of eye contact and gestures to make a point forcefully</li> <li>The timing and responsiveness between communication partners (e.g., engaging, responding, and maintaining reciprocal exchanges)</li> </ul>
Nonliteral or figurative language skill	<ul style="list-style-type: none"> <li>Meaning of a word or phrase that is not literal but understood in context</li> </ul>	<ul style="list-style-type: none"> <li>Hints (e.g., a teacher saying, "<i>I think I hear children talking</i>")</li> <li>Idioms (e.g., "<i>Give me a hand</i>")</li> <li>Metaphor (e.g., "<i>You are my sunshine</i>")</li> <li>Hyperbole (e.g., "<i>That's the biggest thing I've ever seen!</i>")</li> </ul>
Advanced language skills	<ul style="list-style-type: none"> <li>Ability to listen, speak, read, write, and reason using language</li> </ul>	<ul style="list-style-type: none"> <li>Academic language</li> <li>Ability to debate and deliver speeches</li> </ul>
Literacy skills	<ul style="list-style-type: none"> <li>Skills required for reading and writing</li> </ul>	<ul style="list-style-type: none"> <li>Reading an alphabetic language requires awareness of the sounds of language, print, and the relationship between letters and sounds</li> <li>Spelling is a literacy skill</li> </ul>
Bilingualism and multilingualism	<ul style="list-style-type: none"> <li>Ability to speak and/or sign two or more languages</li> </ul>	<ul style="list-style-type: none"> <li>Ability to communicate verbally in Chinese and English</li> <li>Ability to communicate verbally in English and to use American Sign Language</li> <li>Ability to use Chinese, English, and American Sign Language</li> </ul>
Biliteracy and multiliteracy	<ul style="list-style-type: none"> <li>Ability to read and write in two or more languages</li> </ul>	<ul style="list-style-type: none"> <li>Ability to read and write Chinese, Spanish, and English</li> </ul>
Phonologic processes	<ul style="list-style-type: none"> <li>Errors in speech production that affect more than a single sound and are based on violations of predictable, rule-based features</li> </ul>	<ul style="list-style-type: none"> <li>Fronting, when a sound that should be made in the back of the mouth (<i>cat</i>) is made in the front of the mouth (<i>tat</i>)</li> <li>Cluster reduction, when a consonant cluster (<i>as in stop</i>) is reduced to a single consonant (<i>top</i>)</li> </ul>

**Table 53.2** Speech, Language, and Communication Milestones from Birth to 5 Years, Based on Typically Developing Children Acquiring a Single Verbal Language

HEARING AND UNDERSTANDING	SPEAKING
<b>BIRTH TO 3 MO</b>	
<ul style="list-style-type: none"> <li>Startles at loud sounds</li> <li>Recognizes voices and quiets if crying</li> <li>Turns head toward sounds</li> <li>Watches faces</li> <li>Quiets or smiles when spoken to</li> </ul>	<ul style="list-style-type: none"> <li>Makes pleasure sounds (cooing, gooing)</li> <li>Cries differently for different needs</li> </ul>
<b>4-6 MO</b>	
<ul style="list-style-type: none"> <li>Moves eyes in direction of sounds</li> <li>Responds to changes in tone of voice</li> <li>Notices music and sounds</li> <li>Recognizes familiar people and things at a distance</li> </ul>	<ul style="list-style-type: none"> <li>Vocalizes differently to show excitement, being tired, or in pain</li> <li>Makes sounds when alone and when playing</li> <li>Makes babbling sounds that are speechlike and uses consonant sounds, such as <i>p</i>, <i>b</i>, and <i>m</i></li> <li>Reaches for toys or objects</li> <li>Engages in turn-taking and protoconversations</li> </ul>
<b>7-12 MO</b>	
<ul style="list-style-type: none"> <li>Listens when spoken to</li> <li>Turns and looks in direction of sounds</li> <li>Enjoys social games, such as peek-a-boo and pat-a-cake</li> <li>Responds to own name</li> <li>Recognizes words for common items, such as <i>cup</i>, <i>shoe</i>, and <i>juice</i></li> <li>Begins to respond to simple requests (<i>Come here</i>; <i>Want more?</i>) or <i>No</i></li> <li>Looks when an adult points at something</li> </ul>	<ul style="list-style-type: none"> <li>Uses speech sounds or gestures to get and keep attention and to respond to others</li> <li>Imitates different speech sounds and gestures</li> <li>Babbles with long and short groups of sounds, such as <i>bababa upup bibi</i>, and mixes different syllables, such as <i>badadeda</i></li> <li>Says one or two words (<i>bye-bye</i>, <i>dada</i>, <i>mama</i>)</li> <li>Points to or shows things to spontaneously share interest with familiar people</li> <li>Uses gestures such as waving for <i>hi</i> and <i>bye</i> or shaking head for <i>no</i></li> </ul>
<b>1-2 YR</b>	
<ul style="list-style-type: none"> <li>Listens to simple stories, songs, and rhymes</li> <li>Follows simple commands and understands simple questions (<i>Roll the ball</i>; <i>Kiss the baby</i>; <i>Where's your shoe?</i>)</li> <li>Points to things when asked or when named such as body parts and objects</li> </ul>	<ul style="list-style-type: none"> <li>Learns to say more words every month</li> <li>Uses some one- and two-word questions (<i>Where kitty?</i> <i>Go bye-bye?</i> <i>What's that?</i>)</li> <li>Combines two words in their own ways (<i>more cookie</i>, <i>no juice</i>, <i>mommy book</i>)</li> <li>Uses consonant sounds such as <i>p</i>, <i>b</i>, <i>m</i>, <i>h</i>, and <i>w</i> in English</li> </ul>
<b>2-3 YR</b>	
<ul style="list-style-type: none"> <li>Understands differences in meaning (e.g., go-stop, in-on, big-little, up-down)</li> <li>Follows two-step requests (<i>Get the book and put it on the table.</i>)</li> </ul>	<ul style="list-style-type: none"> <li>Often asks for or directs attention to objects by naming them</li> <li>Has a word for almost everything</li> <li>Uses prepositions like <i>in</i>, <i>on</i>, and <i>under</i></li> <li>Often uses two- to three-word "sentences"</li> <li>Speech is mostly understood by familiar listeners</li> <li>Uses consonant sounds such as <i>k</i>, <i>g</i>, <i>f</i>, <i>t</i>, <i>d</i>, and <i>n</i> in English</li> </ul>
<b>3-4 YR</b>	
<ul style="list-style-type: none"> <li>Understands simple <i>who</i>, <i>what</i>, <i>where</i>, and <i>why</i> questions</li> <li>Understands words for colors like <i>red</i>, <i>blue</i>, or <i>green</i> and shapes like <i>circle</i> or <i>square</i></li> <li>Responds when you call from another room</li> </ul>	<ul style="list-style-type: none"> <li>Uses pronouns like <i>I</i>, <i>you</i>, <i>me</i>, <i>we</i>, and <i>they</i></li> <li>Uses sentences that have four or more words with more complex grammar such as negative (<i>I no want to</i>) and questions</li> <li>Talks about activities outside the home</li> <li>Usually understood by people outside the family</li> </ul>
<b>4-5 YR</b>	
<ul style="list-style-type: none"> <li>Hears and understands most of what is said at home and in school</li> <li>Pays attention to a short story and answers simple questions about it</li> <li>Understands words for time like <i>yesterday</i>, <i>today</i>, and <i>tomorrow</i></li> <li>Understands words for order like <i>first</i>, <i>next</i>, and <i>last</i></li> <li>Follows longer directions such as (<i>Find an animal you like, draw a circle around it, and bring the paper to me</i>)</li> </ul>	<ul style="list-style-type: none"> <li>Uses sentences that include details (<i>I like to read my books</i>) and different action words like <i>jump</i> or <i>play</i>; may still make some grammar mistakes (<i>I gots one game and he got three games</i>)</li> <li>Tells simple stories using mostly full sentences</li> <li>Communicates easily with other children and adults</li> <li>Says most sounds correctly except a few that are harder to say, such as <i>l</i>, <i>s</i>, <i>r</i>, <i>v</i>, <i>z</i>, <i>ch</i>, <i>sh</i>, and <i>th</i> in English</li> </ul>

Milestones may not apply to bilingual children, children exposed to sign languages, children learning a second language, and children with language and learning disorders. For Spanish translations and more information, including activities for families:

- American Speech-Language-Hearing Association: <http://www.asha.org/public/speech/development/chart.htm>
- The American Academy of Pediatrics: <https://healthychildren.org/English/Pages/default.aspx>
- Centers for Disease Control and Prevention Milestones checklist: <https://www.cdc.gov/ncbddd/actearly/milestones/index.html>

Adapted from the American Speech-Language-Hearing Association (2021), the American Academy of Pediatrics (2009), and the Centers for Disease Control and Prevention Milestones checklist (2021).

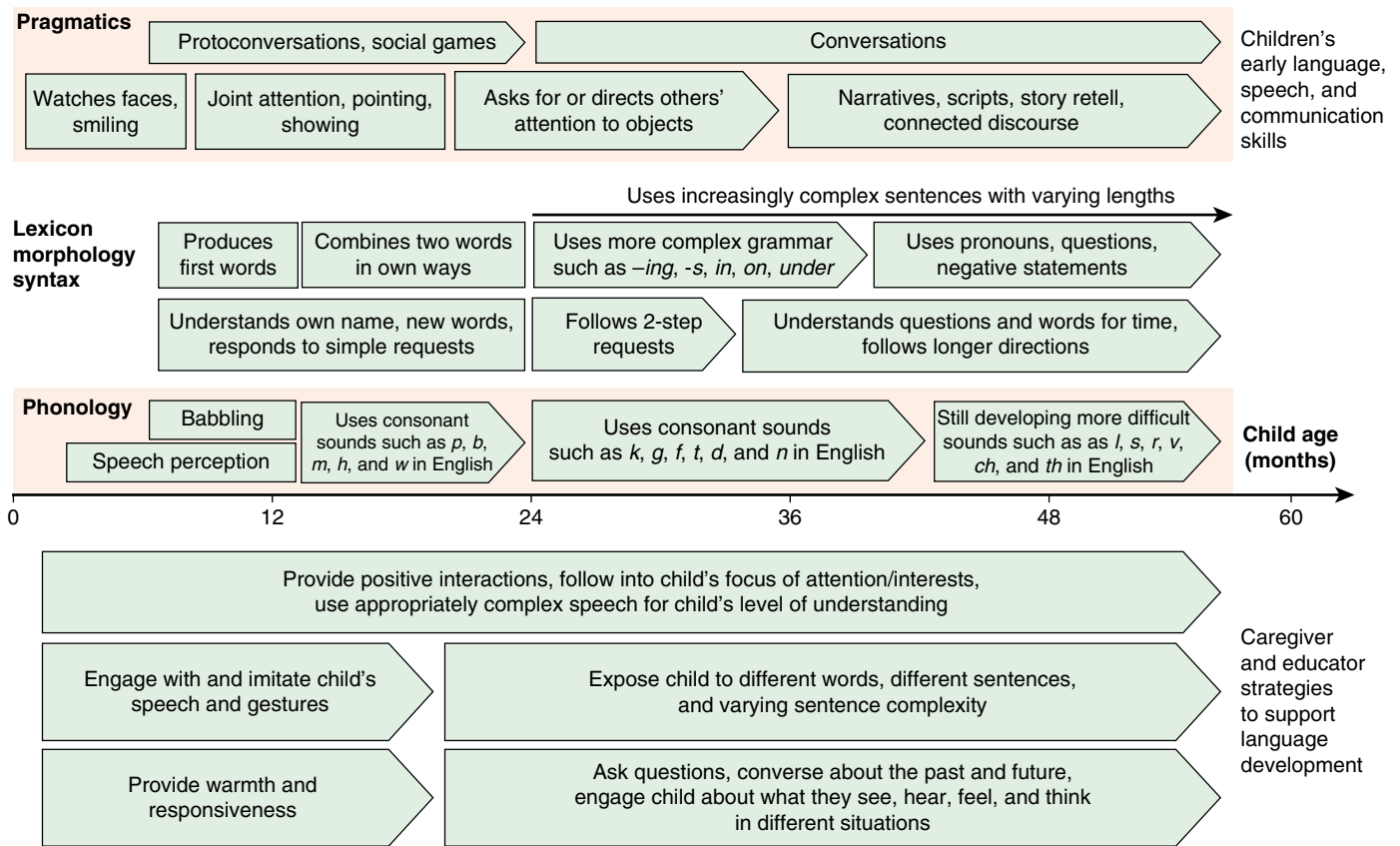
pragmatic skills is the ability to adapt how to narrate events or stories for different audiences (e.g., friends vs teachers).

### Advanced Language Skills

Once children enter school, they continue to develop new vocabulary and use increasingly complex sentence constructions to communicate about abstract, hypothetical, and imaginary topics. By adolescence, many students in Westernized school systems are required to deliver

expository speeches or to debate. Formal schooling also affords new situations to communicate with a broader network of individuals, including teachers, coaches, and supervisors. The diversity of the situations requires nuanced attention to social rules and conventions and increases exposure to diverse forms of nonliteral language use, though proficiency in the use of nonliteral language varies by the language and culture of the speaker and addressee. Finally, the introduction of formal schooling presents children with the demands of acquiring





**Fig. 53.1** Timeline of children's early language, speech, and communication skills and caregivers' and educators' strategies to support that development. The timing and width of boxes for the child skills are adapted from milestones from the American Speech-Language-Hearing Association, The American Academy of Pediatrics, and the Centers for Disease Control and Prevention. More information on milestones can also be seen in [Table 53.1](#). Caregivers and educators should be encouraged to engage with the child using the language with which they are most comfortable because children, even children with delays, are capable of becoming bilingual. Specific child skills and caregiver/educator strategies may vary according to language and cultural practices.

**literacy skills** (see [Table 53.1](#)), those skills required for reading and writing. Early oral language skills are a robust predictor of children's early reading skills, and early oral language and reading skills are in turn predictors of children's writing skills (see [Chapters 51](#) and [52.2](#)). Language skills become critical to support high-level school- and work-related literacy skills.

### BILINGUALISM AND MULTILINGUALISM

Worldwide, learning more than one language is more common than learning just one; many regions and countries in the world are home to individuals who routinely speak two or more languages. The timing of exposure, balance between languages, and level of skill in each language in dual-language or multilingual learners varies across situations. **Simultaneous bilinguals** refers to those regularly exposed to both languages prenatally or from birth. **Sequential bilinguals** refers to those exposed to the second language after the first language, often when they enter school, though the timing of when the second language is introduced varies. Once children learn two languages, the balance in skill level between them may vary. For example, a child who was born in Nigeria, exposed to Igbo, and then immigrated to Greece at age 5 years will initially be more proficient in Igbo than in Greek. As the child attends school in Greece, Greek proficiency will improve (likely also supported through the introduction of reading and writing in a Greek monolingual school environment), and thus the balance will shift and the child may become more proficient in Greek over Igbo. A high level of skill across all domains of phonology, lexicon, syntax, and pragmatics is considered an ideal picture of bilingualism, but this ideal is not always the case or necessary for many bilingual learners. Bilingual learners often demonstrate

**code-switching**, that is, alternating between languages, or **code-mixing**, mixing their languages together, especially when speaking with other bilingual speakers. A distinction between **conversational** and **academic** language skills may be made in reference to bilinguals. Bilingual speakers may master conversational language, the language used to communicate casually with family or friends, but remain less skilled in academic language, the complex, technical, and specialized vocabulary and syntax required in academic or work settings, particularly when school is presented in a language different from the language of the home. Some bilingual learners may experience **language attrition**, a reduction in the proficiency in one language over time. Factors within the child, family (e.g., one caregiver/one language, caregivers speaking both languages), community (e.g., availability of bilingual schooling, minority vs majority language of the community, perceived prestige of a language), and policy (e.g., national acknowledgement of multiple languages or requirements of accessibility of documents in school or business sectors) contribute to proficiency in both languages.

Bilingualism or multilingualism is typical language development for many children and not an adequate explanation for language delays as long as the child's skills in both languages are assessed. Even children with language and developmental disorders, such as intellectual disability and autism spectrum disorder, may be successful bilingual or multilingual learners. It is difficult to predict developmental trajectories in bilingual development because of the wide variety of factors associated with the level of skill in different domains. *Children in homes with two or more languages who show delays in language development (considering the accumulated accomplishments in all languages) should be promptly referred for evaluation.*

## DRIVERS OF VARIATION IN TYPICAL LANGUAGE DEVELOPMENT

### Genetic

Similarities in language abilities across members of the same family suggest that genetic factors contribute to individual differences in language abilities. Genetic factors have been studied more often in the context of disorders of language learning than in the context of normal variation (see below).

### Environment

Interactions between young children and their caregivers that are positive, responsive, and warm allow children to practice their early word learning (e.g., social games, routines). Living in stable home environments is better for language development than living in an unstable condition. The Bucharest Early Intervention Project conducted a randomized controlled trial to examine the role of being raised in a home (foster care) versus in institutionalized care in Romanian orphanages that were providing infants with low levels of responsive interactions. Children taken from the orphanages and placed in foster care by age 15 months had language skills that were similar to typically developing peers at 30 and 42 months in the same Romanian community living with their biologic families; children placed in foster care after 24 months had persistent expressive language delays.

The role of caregivers specifically is one of the few levers available to influence language outcomes in clinical practice and public programs. Positive links have been found between variability in socioeconomic backgrounds and children's later language skills; caregivers have been shown to mediate this link. Caregivers' **child-directed speech** refers to changes to caregivers' prosody (intonation patterns), phonology, grammar, and lexicon when engaging with young children. This child-directed speech has been measured across a wide variety of features, which can be broadly categorized into measures of quantity (e.g., total number of words spoken), quality (e.g., number of different words spoken), and interaction (e.g., warmth and responsiveness). Taken together, these factors constitute **language nutrition**, which, like dietary nutrition, is associated with rates of growth. However, the causal links between caregivers' child-directed speech and children's language outcomes are still unclear in children with typical development or language delays or disorders. Meta-analyses of interventions targeting improved language nutrition to date have generally reported either null effects or small to moderate positive effects on children's language skills. The specific role of book-sharing interventions to support children's language development is also mixed among different meta-analyses. Wide heterogeneity across intervention studies, including the method of delivery (e.g., one-on-one coaching vs caregiver groups), intensity (e.g., 1 hour per week for 12 weeks vs two 45-minute visits), measures of caregiver-child interaction, and child language outcomes, may contribute to differences in results. Caregivers' mental health has been found to be an important mediator of child outcomes; higher caregiver depression has been linked to poorer children's language outcomes.

Greater amounts of screen time and early age of screen time are negatively related to children's early language skills. However, high-quality screen-time practices (e.g., co-viewing, educational programs) are positively related to children's language skills; effect sizes are small to moderate.

### Misattributions of Language Delay

Several common conditions have been erroneously implicated as an adequate explanation for language delays and disorders. Typically developing twins learn to talk at the same age as typically developing single-born children. Birth-order effects on language development have not been consistently found. **Ankyloglossia** (tongue-tie), an extremely tight lingual frenulum, does not prevent the acquisition of speech, but ankyloglossia may be the result of abnormalities associated with disorders of speech, such as neural injury and cerebral palsy. Frequent ear infections and serous otitis media in early childhood *do not* result in persisting language disorder. Prompt placement of tympanostomy tubes for chronic serous otitis media *does not* lead to better

skills than watchful waiting. Biologic sex differences have been found in many studies of language development. Though males are generally slower to develop than females, the differences do not usually rise to the level of being clinically apparent. However, males are more likely to develop language disorders than females. Based on these findings, *children with moderate to severe delays in the development of language and speech deserve a prompt evaluation, even if they are males, non-first born children, twins, tongue-tied toddlers, and/or children with chronic otitis media.*

## LANGUAGE, SPEECH, AND COMMUNICATION DISORDERS

Impairment in language, speech, and communication may occur in isolation or may be associated with other conditions.

### Isolated Language Disorders with or Without Accompanying Speech Disorders

#### Clinical Presentation

**Primary disorders** of speech and language development are significant difficulties found in the absence of major cognitive, sensory, or motor dysfunction. The literature uses the term **specific language impairment** (SLI) or **language impairment**, the term we use here, also called *developmental language disorder* or *developmental dysphasia*. Children with language impairment typically perform >1.25-1.5 standard deviations below the mean on standardized language assessments. The *Diagnostic and Statistical Manual for Mental Disorders, Fifth Edition* (DSM-5) criteria for a language disorder are provided in [Table 53.3](#). Many children with language impairment eventually become competent language users, though they may show persistent and subtle difficulties with skills related to phonology, lexicon, and/or syntax. As adolescents and adults, compared to peers, they are generally less proficient at producing stories, descriptions, and scripts of everyday events, collectively known as **oral narratives**. Their narratives tend to be shorter, including fewer prepositions, main story ideas, and devices fostering cohesion. Children with language impairment may have significant difficulty in higher-level language skills (see [Table 53.1](#)), reasoning skills (e.g., drawing correct inferences and conclusions), the ability to take another person's perspective, and the ability to paraphrase and rephrase. Some children with language impairment show difficulties with social interaction because social interactions are often mediated by verbal language. Young children with language impairment may interact more successfully with older children or adults, who can adapt their communication to match the child's level of function, than with peers.

#### Epidemiology

Over 15% of 2-year-olds may not produce a vocabulary of 50 words or two-word utterances; estimates may vary for children exposed to two or more languages. Almost half of preschool-age children, age 3-5 years old, who qualify for special education meet eligibility based only on speech-language impairment. By age 5, approximately 6% of children are identified as having a speech impairment alone, 5% as having both speech and language impairment, and 8% as having language impairment alone. Males are nearly twice as likely to have an identified speech or language impairment as females.

#### Etiology

Genetic factors appear to play a major role in influencing how children learn to talk. A family history may identify current or past speech or language problems in up to 30% of first-degree relatives of proband children. Concordance rate for low language test scores and/or a history of speech therapy within twin pairs is about 50% in dizygotic pairs and 90% in monozygotic pairs. Consistent pathogenic genetic variations have not been identified. Instead, multiple genetic regions and epigenetic changes may result in heterogeneous genetic pathways causing language disorders. Several single-nucleotide polymorphisms (SNPs) involving noncoding regulatory genes, including *CNTNAP2* (contactin-associated-protein-like-2) and *KIAA0319*, are strongly associated with early language acquisition and are also thought to

affect early neuronal structural development. Several chromosomal **copy number variants** (see Chapter 96) have also been associated with abnormalities of language and speech; these variants may be associated with distinctive physical features (e.g., tall stature in Klinefelter syndrome) or neurobehavioral conditions (e.g., autistic features). Environmental, hormonal, and nutritional factors may exert **epigenetic** influences by dysregulating gene expression. These forces result in aberrant sequencing of the onset, growth, and timing of language development.

All of the family, community, and sociopolitical factors that appear to contribute to variation in typical language learning may contribute to the rate of learning in children with disorders. Improving the quality of the verbal environment, and in particular the quantity and quality of child-directed speech (see above), may moderate the impact of genetic and epigenetic factors.

### Pathogenesis

Language functioning is widely distributed across the brain through interconnected neural networks. Frank neurologic injury is typically absent in children with language impairment. Language disorders have been attributed to a fundamental difficulty in the brain's capacity to process complex information rapidly. Limitations in the amount of information that can be stored in verbal working memory (see Chapter 49) may also limit the rate at which language information is processed. Electrophysiologic studies show abnormal latency in the early phase of auditory processing in children with language impairment. Neuroimaging studies identify an array of anatomic abnormalities, implicated in language processing. MRI scans in children with language impairment may reveal white matter lesions and volume loss, ventricular enlargement, focal gray matter heterotopia within the right and left parietotemporal white matter, abnormal morphology of the inferior frontal gyrus, atypical patterns of asymmetry of language cortex, or increased thickness of the corpus callosum in a minority of affected children. Postmortem studies of children with language disorders found evidence of atypical symmetry in the plana temporale and cortical dysplasia in the region of the sylvian fissure. A high rate of atypical perisylvian asymmetries has been documented in the parents of children with language impairment.

### Language Disorders Associated with Cognitive Impairment and Intellectual Disability

Speech and language impairment may be the first indication of a global neurodevelopmental disorder. **Global developmental delay** or **early developmental impairment** is defined as delays in two or more domains. Children with substantial delays in adaptive function and scores 2 or more standard deviations below the mean on intelligence testing may meet criteria for **intellectual disability** (see Chapter 56). Most children with a mild intellectual disability learn to communicate adequately, though they are likely to encounter difficulties with higher-level language skills (see Table 53.1). Children with an IQ as low as 25 may eventually acquire a small lexicon and ability to combine words. Specific genetic syndromes have distinctive language profiles: in Down syndrome, verbal skills are more impaired than nonverbal skills; in William syndrome, language skills may be relatively preserved compared to nonverbal skills; in fragile X syndrome, unusual word or sound repetition may be present.

### Autism Spectrum Disorder

A disordered pattern of language, speech, and communication development characterizes autism spectrum disorder (ASD) (see Chapter 58). The core characteristics of ASD are persistent difficulties in social communication and social interaction relative to age expectations and restricted, repetitive patterns of behavior, interests, or activities. Children with ASD show a wide range of language and communication abilities. At the severe end, language and speech may be extremely limited (nonverbal). Approximately 30–50% of children with ASD also meet criteria for intellectual disability, which contributes to the challenges of developing communication skills. Parents report regression

in language and social skills (**autistic regression**) in approximately 20–25% of children with ASD, usually between 12 and 36 months of age. The cause of the regression is not known; it is associated with an increased risk for intellectual disability and severe ASD. Individuals with ASD who are high functioning may have large vocabularies and use grammatically correct sentences but have unusual or impaired social-pragmatic features, such as odd intonation patterns, off-topic comments, and atypical conversational skills. For example, they may engage in long monologues about a topic of special interest, without considering the interest of their conversational partner. Some individuals with ASD have highly specialized, isolated, “savant” skills, such as calendar calculations or **hyperlexia** (the precocious ability to recognize written words beyond expectation based on general intellectual ability).

DSM-5 identified **social (pragmatic) communication disorder (SPCD)** as a category of communication disorder distinct from ASD (see Table 53.3). Symptoms of SPCD include extreme literalness and inappropriate verbal and social interactions. Socially appropriate use and understanding of figurative language (see Table 53.1) depends on correct interpretation of the meaning and the context of language and the ability to draw proper inferences, skills limited in SPCD. SPCD has been recognized as a symptom of a wide range of disorders, including right-hemisphere brain injury and nonverbal learning disabilities.

### Hearing Impairment

Hearing loss may be caused by a sensorineural loss, a conductive loss, or a mixed picture in one or both ears. Although it is not possible to accurately predict the impact of hearing loss on a child's verbal language development, the type, degree, and laterality of hearing loss; the age of onset; and the duration of the auditory impairment before amplification play important roles (see Chapter 55). Newborn screening programs are designed to identify congenital hearing loss but fail to identify children with progressive or acquired hearing loss or deafness after birth. *Any child who shows a speech or language problem should have a hearing assessment by an audiologist, even if they passed their newborn hearing screen.*

**Conductive hearing loss** occurs when sounds cannot get through the outer and middle ear to stimulate the auditory nerve. In children, the most common cause of conductive hearing loss is **acute or chronic serous otitis media**. Otitis media is typically transient and may increase the sound threshold at which children can detect tones or understand language. Persistent fluid in the middle ear may be treated with **tympanostomy or ventilation tubes**. However, treatment of chronic serous otitis media with tympanostomy tubes does not improve outcomes in the domains of speech and language, cognition, academic skills, or psychosocial functioning from preschool years through middle childhood.

### Neurologic Conditions Epilepsy Syndromes

Children with Landau-Kleffner syndrome or verbal auditory agnosia have a history of typical language development until they experience a regression in their ability to comprehend spoken language—verbal auditory agnosia—along with the development of seizures, usually between 3 and 7 years of age. Expressive language skills also typically deteriorate. An electroencephalogram (EEG) may show a distinct pattern of status epilepticus in sleep (continuous spike wave in slow-wave sleep), and up to 80% of children with Landau-Kleffner syndrome eventually exhibit clinical seizures. Use of antiepileptic medication, corticosteroids, and intravenous gamma globulin has led to varying results. The prognosis for return of typical language ability is uncertain, even if seizures resolve.

Epileptic interictal discharges are more frequently found on EEGs of children with language impairments than EEGs of otherwise typically developing children. The discharges are likely a manifestation of an underlying disorder of brain, distinct from the language impairment. Only when seizure symptoms or regression in language ability is present is a routine EEG recommended in the evaluation for a child with speech and/or language impairment.



**Table 53.3** DSM-5 Diagnostic Criteria for Communication Disorders**LANGUAGE DISORDER**

- A. Persistent difficulties in the acquisition and use of language across modalities (i.e., spoken, written, sign language, or other) due to deficits in comprehension or production that include the following:
1. Reduced vocabulary (word knowledge and use).
  2. Limited sentence structure (ability to put words and word endings together to form sentences based on the rules of grammar and morphology).
  3. Impairments in discourse (ability to use vocabulary and connect sentences to explain or describe a topic or series of events or have a conversation).
- B. Language abilities are substantially and quantifiably below those expected for age, resulting in functional limitations in effective communication, social participation, academic achievement, or occupational performance, individually or in any combination.
- C. Onset of symptoms is in the early developmental period.
- D. The difficulties are not attributable to hearing or other sensory impairment, motor dysfunction, or another medical or neurologic condition and are not better explained by intellectual disability (intellectual developmental disorder) or global developmental delay.

**SPEECH SOUND DISORDER**

- A. Persistent difficulty with speech sound production that interferes with speech intelligibility or prevents verbal communication of messages.
- B. The disturbance causes limitations in effective communication that interfere with social participation, academic achievement, or occupational performance, individually or in any combination.
- C. Onset of symptoms is in the early developmental period.
- D. The difficulties are not attributable to congenital or acquired conditions, such as cerebral palsy, cleft palate, deafness or hearing loss, traumatic brain injury, or other medical or neurologic conditions.

**SOCIAL (PRAGMATIC) COMMUNICATION DISORDER**

- A. Persistent difficulties in the social use of verbal and nonverbal communication as manifested by all of the following:
1. Deficits in using communication for social purposes, such as greeting and sharing information, in a manner that is appropriate for the social context.
  2. Impairment of the ability to change communication to match context or the needs of the listener, such as speaking differently in a classroom than on a playground, talking differently to a child than to an adult, and avoiding use of overly formal language.
  3. Difficulties following rules for conversation and storytelling, such as taking turns in conversation, rephrasing when misunderstood, and knowing how to use verbal and nonverbal signals to regulate interaction.
  4. Difficulties understanding what is not explicitly stated (e.g., making inferences) and nonliteral or ambiguous meanings of language (e.g., idioms, humor, metaphors, multiple meanings that depend on the context for interpretation).
- B. The deficits result in functional limitations in effective communication, social participation, social relationships, academic achievement, or occupational performance, individually or in combination.
- C. The onset of the symptoms is in the early developmental period (but deficits may not become fully manifest until social communication demands exceed limited capacities).
- D. The symptoms are not attributable to another medical or neurologic condition or to low abilities in the domains of word structure and grammar and are not better explained by autism spectrum disorder, intellectual disability (intellectual developmental disorder), global developmental delay, or another mental disorder.

From the *Diagnostic and Statistical Manual of Mental Disorders, 5th ed.* Washington, DC: American Psychiatric Association; 2013:42, 44, 47–48.

**Cerebellar Mutism Syndrome**

In the aftermath of operations for tumors in the posterior fossa, such as **medulloblastoma**, many children lose the ability to speak. Fortunately, though the presentation is initially profound, most children recover the ability to use language. **Cerebellar mutism syndrome** demonstrates that the cerebellum probably plays a fundamental role in language and communication. The syndrome is thought to result from damage to the superior cerebellar peduncle that connects the cerebellum to language centers in the frontal lobes.

**Stroke**

**Strokes** in childhood can occur prenatally, in the perinatal period, or at any time in childhood. As in adults, a brain territory frequently affected is supplied by the middle cerebral artery resulting in damage to the **left frontal and temporal lobes** that are associated with language function in adults. However, young children with stroke show greater plasticity of language function than do adults with similar brain injuries. Many children with left hemisphere stroke go on to demonstrate typical or near-typical language functions. Functional imaging studies document that these children activate uninjured regions of the left hemisphere around the stroke or homologous regions in the right hemisphere. This demonstrates that though under usual circumstances the left hemisphere serves language, alternative networks can substitute in the case of early injury. The quality of the home language environment is strongly associated with the language skills of children with strokes.

**Metabolic and Neurodegenerative Disorders (see Part IX and Chapter 639)**

Regression of language development may accompany loss of neuromotor function at the outset of a number of metabolic diseases, including lysosomal storage disorders (metachromatic leukodystrophy),

peroxisomal disorders (adrenal leukodystrophy), ceroid lipofuscinosis (Batten disease), and mucopolysaccharidosis (Hunter disease, Hurler disease). A creatine transporter deficiency was identified as an X-linked disorder that manifests with language delay in males and with mild learning disability in female carriers.

**Hydrocephalus (see Chapter 631.11)**

Children with hydrocephalus may be described as having cocktail-party syndrome. In this syndrome, children may use sophisticated words, but their comprehension of abstract concepts is limited, pragmatic conversational skills are weak, their analyses are superficial, and/or they appear to be carrying on a monologue.

**Language in the Context of Psychologic or Mental Health Conditions**  
**Selective Mutism**

In **selective mutism**, children do not speak in specific social situations, such as school or other settings outside the home, though they speak normally in certain settings, such as within their home or when they are alone with their parents. Other symptoms include excessive shyness, withdrawal, dependency on parents, and oppositional behavior. Most cases of selective mutism are the manifestation of a chronic pattern of **anxiety**. Children with selective mutism often report that they want to speak in social settings but are too afraid, worried, or distressed to do so. The family history is often positive for anxiety symptoms. Children with selective mutism may also have a language or speech impairment, contributing to their sense of distress in speaking. Treatment of selective mutism generally uses evidence-based approaches to reducing general anxiety, including cognitive-behavioral therapy and/or selective serotonin reuptake inhibitors in conjunction with speech-language therapy.



## Schizophrenia

A characteristic of schizophrenia is abnormal communication, including highly disorganized language that is difficult to follow and frequent changes in topic (see Chapter 47.1). This communication challenge accompanies the thought disturbance that is the hallmark of schizophrenia. Schizophrenia usually presents in individuals in adolescence or young adulthood. The communication disorder is linked to other features of schizophrenia, including slower processing speed, poorer cognitive control, and weaker working memory relative to typically developing peers.

## Adverse Psychosocial Conditions Orphanages

An estimated 8 million children worldwide are living in residential care or orphanages, despite recognition of the severe adverse impacts of institutionalization on children's health and development. Children in orphanages have poor receptive and expressive language skills, most likely the result of limited language exposure and lack of consistent warm relationships with caring adults. Children from orphanages may be adopted. In an international adoption, the children typically face a new challenge: learning a different language (see Chapter 9). Outcomes for internationally adopted children are mixed; meta-analyses suggest trends for stronger language outcomes when children are adopted before the age of 1 year than after 1 year. However, findings were not statistically significant, likely because of the wide variety of challenges that the children face and difficulty identifying appropriate comparison groups.

## Foster Care

Approximately 30–75% of the children 6 years of age or younger in foster care are delayed, and therefore **assessing language skills for them is imperative** (see Chapter 10). An important contribution to the language delay in many children in foster care, like that of children in orphanages, is the lack of consistently warm, responsive parenting that is fundamental to language nutrition. Encouraging foster parents to increase language nutrition may positively affect the language skills of children in foster care.

## High-Stress, Low-Verbal Environments

Children from homes where they may experience stressors, such as food insecurity, housing insecurity, poor childcare facilities, and high levels of community violence, are at risk for slower language development relative to peers in stable environments. All of these factors may contribute to initial delays in physical and cognitive development, with language development being one of the most noticeable to track developmental progress. If language delays persist, the chances that the children will catch up with others from more resourced environments, even if their circumstance change, are limited. Thus, what begins as a delay may end up as a disorder. Referral of children from stressed, low-verbal environments to public and community-based prevention programs designed to provide stability and to enhance language input may improve the children's outcomes.

## SPEECH DISORDERS

### Structural Anomalies of the Organs of Speech Cleft Lip and Palate

**Cleft lip** is a split in the formation of the lip. **Cleft palate** is a split in the hard and/or soft palate (see Chapter 356). These conditions often occur together but may occur separately. Cleft lip or palate is the most common structural abnormality at birth in the United States. The cleft is often easy to see but may be subtle if isolated to the soft palate. A child with isolated cleft lip may have minimal speech problems. A child with cleft palate is likely to have speech difficulties, including **hypernasal speech** in which air escapes through the nose, making it difficult to produce consonants that need pressure to build in the mouth for proper execution (e.g., *b*, *k*, and *s*). In addition, children with cleft palate may have severe and persistent serous otitis media, leading to moderate to severe conductive hearing loss beyond the frequency and complications of children with an intact palate. Therefore most children with

cleft palate need long-term therapy with a speech-language pathologist (SLP). Cleft palate may occur in isolation, called **nonsyndromic cleft palate**, or in conjunction with other malformations, called **syndromic cleft palate**. **Velocardiofacial syndrome (VCFS)** is an autosomal dominant condition that results from a deletion on the long arm of chromosome 22 (deletion22q11) and may include cleft palate. Many different phenotypes are associated with this deletion, demonstrating the complex relationship of genes, anatomic structure, and function. The prognosis for speech and language in such cases is dependent on the specific syndrome associated with the cleft palate.

## Velopharyngeal Insufficiency

Velopharyngeal insufficiency (VPI) is an abnormality of the soft palate, such that the soft palate cannot regulate the flow of air between the mouth and nose in speech. It may occur as part of cleft palate or may be an isolated finding. VPI may not be apparent in early development when the adenoids are large and bolster the soft palate. As the adenoids regress, it may become clear that the soft palate is not closing off the passage to the nose, creating hypernasal speech. Evaluation of the intactness of the soft palate is important before adenoidectomy because removal of the adenoids can bring on VPI suddenly. Surgery or use of prosthetic devices may be required for individuals who cannot be helped by speech therapy.

## Speech Sound Disorders

**Speech sound disorders** is an umbrella term that refers to difficulties with perception, motor production, or phonologic representation of speech sounds and/or speech segments (see Table 53.3). Speech sound disorders may be organic in origin, including neurologic conditions, structural conditions, or sensory conditions. Speech sound disorders are considered **functional** when no known cause can be identified. Speech sound disorders may be accompanied by subtle difficulties in speech perception.

## Phonologic Disorders

Phonologic disorders are functional speech sound disorders that affect linguistic aspects of speech. **Phonologic processes** (see Table 53.1) are errors in speech production based on violations of predictable, rule-based features of speech. These phonologic processes are typical at young ages and resolve at specific ages. Phonologic processes become disorders when they persist to older ages and impair intelligibility.

## Articulation Disorders

**Articulation disorders** focus on errors (such as distortions and substitutions) in production of individual speech sounds regardless of where in a word or phrase the sound occurs. Articulation errors are not the result of neuromotor impairment, but rather seem to reflect an inability to correctly process the words they hear. As a result, they lack understanding of how to fit sounds together properly to create words. Children with articulation or other speech sound disorders are at risk for later reading and learning disability.

## Childhood Apraxia of Speech

In childhood apraxia of speech (CAS), difficulty in planning and coordinating movements for speech sound production results in inconsistent distortions or errors of speech sounds, even vowel sounds. The same word may be pronounced differently each time, making intelligibility poor. Intelligibility also tends to decline as the length and complexity of the child's speech increase. Consonants may be deleted and sounds transposed. As they try to talk spontaneously or imitate others' speech, children with CAS may display oral groping or struggling. Children with CAS frequently have a history of early feeding difficulty, limited sound production as infants, and/or delayed onset of spoken words. They may point, grunt, or develop an elaborate gestural communication system in an attempt to overcome their verbal difficulty. Apraxia may be limited to verbal motor skills, may extend to oral-motor function, or may be a more generalized problem affecting fine and/or gross motor coordination. Childhood apraxia of speech may co-occur with disorders of language and learning.

## Dysarthria

This motor speech disorder often originates from neuromotor disorders, such as cerebral palsy, muscular dystrophy, myopathy, and facial palsy. Dysarthria is characterized by lack of strength and muscular control and manifests as slurring of words and distorting vowels. Speech patterns are often slow and labored. Feeding difficulty, drooling, open-mouth posture, and protruding tongue may accompany the dysarthric speech.

## Disorders of Fluency, Voice, and Resonance Stuttering

Under normal circumstances, most people do not speak smoothly all the time, but rather repeat words or sounds, hesitate to find a word, pause, add “uh” or “you know” to the flow of speech, or repeat a sound or word more than once. These disruptions are called **dysfluencies** and are discussed further in Chapter 53.1. **Stuttering** in children over age 4 that lasts longer than 6 months, includes repetition of individual sounds, and/or creates emotional distress should be evaluated by a speech and language pathologist.

## Voice

A **voice disorder** is an abnormality in voice quality, pitch, and loudness that is unexpected or inappropriate for an individual’s age, gender, cultural background, or geographic location. Voice disorders can be subdivided into organic and functional. **Organic voice disorders** are physiologic in nature and result from alterations in respiratory, laryngeal, or vocal tract mechanisms. **Aerodigestive disorders** cover congenital or acquired conditions of the aerodigestive tract; they include abnormalities of the **airway** (pharynx and larynx), **pulmonary tract** (trachea, bronchi, and lungs), and **upper digestive tract** (esophagus). These structural problems may affect respiratory and swallowing functions and speech, especially voice. **Functional voice disorders** result from improper or inefficient use of the vocal mechanism in the context of normal physical structure. Psychologic stress can also lead to habitual and maladaptive voice quality, known as **psychogenic voice disorders**. These categories may overlap. Vocal nodules result from behavioral voice misuse that leads to repeated trauma to the vocal folds and structural changes to the vocal fold tissue.

## ASSESSMENT OF LANGUAGE AND SPEECH DISORDERS

### Screening

Developmental surveillance at each well-child visit should include specific questions about typical language developmental milestones and observations of the child’s behavior. Clinical judgment, defined as eliciting and responding to parents’ concerns, can detect many children with speech and language challenges. The American Academy of Pediatricians (AAP) recommends clinicians employ standardized developmental screening questionnaires and observation checklists at select well-child visits (see Chapter 28). However, the U.S. Preventive Services Task Force reviewed screening for language impairment in young children in primary care settings and found inadequate evidence to support screening in the absence of parental or clinician concern about children’s speech, language, hearing, or development. At present, when parents, other caregivers, or physicians are concerned about speech or language development, the child should be referred for a diagnostic evaluation and intervention.

### Diagnostic Evaluation

A developmental delay indicates abnormally slow timing relative to same-age peers in the development of the skill. A language delay becomes a language disorder when it persists to school age; is functionally impactful in terms of communication, social skills, or learning and cognition; or is qualitatively different from normal patterns or sequences of development. Language and communication skills should be interpreted within the context of that child’s overall cognitive, social, and physical abilities. A multidisciplinary evaluation of a child with language delay or disorder is often warranted. At a minimum, the diagnostic evaluation should include psychologic or neurodevelopmental

evaluation, including an assessment of social skills, a speech-language evaluation, an audiologic assessment, and a pediatric examination.

## Psychologic or Neurodevelopmental Evaluation

The two main goals for the psychologic evaluation of a young child with a communication disorder are to assess nonverbal cognitive ability and social skills. A broad-based cognitive assessment is important to determine the breadth and severity of developmental difficulties. At a minimum, the child should have an assessment of both verbal and nonverbal skills. As children reach school age, they may be assessed with an intelligence test and an assessment of adaptive function to determine if they meet criteria for intellectual disability (see Chapter 56). If the child has findings of global developmental delay or intellectually disability, their language and speech skills should be evaluated within that context. Language and speech disorders may coexist with other conditions, so that the psychologic evaluation at all ages should consider mental health conditions, such as anxiety, mood disorder, and attention-deficit/hyperactivity disorder (ADHD) and, at older ages, learning challenges.

A child’s social behaviors must be assessed to determine whether the child meets diagnostic criteria for ASD (see Chapter 58). Children with language impairment may display an interest in social interaction, even if they may have difficulty socializing because of limitations in communication skills, such as difficulties initiating conversation or taking turns. Children with ASD do not display social interest in typical ways. However, the distinction may be challenging in the context of a clinical evaluation when the child needs to interact only with professional adults and not with peers. Observational tests include specific maneuvers, such as calling the child’s name, making exaggerated gestures, and attempting to engage the child in a reciprocal interaction around blowing bubbles, to make this distinction.

## Speech and Language Evaluation

A certified SLP should perform a speech and language evaluation on a child with delays or difficulties in language and speech. A typical evaluation includes assessment of language, speech, and the physical mechanisms associated with speech production. Both expressive and receptive language (see Table 53.1) are assessed, using a combination of standardized measures, informal interactions, and pertinent observations. All components of language are assessed, including phonology, lexicon, morphology, syntax, and pragmatics (see Table 53.1). Speech assessment similarly uses a combination of standardized measures and informal observations and includes assessment of speech sounds, fluency, voice, and resonance. Assessment of physical structures includes oral structures and function, respiratory function, and vocal quality.

## Audiologic Assessment (see Chapter 677)

In many settings, an SLP works in conjunction with an audiologist, who can do an appropriate hearing evaluation of the child. If an audiologist is not available in that setting, a separate referral should be made. No child is too young for a hearing evaluation. Passive methods can be used in children who are young or unable to cooperate with testing. Repeat assessment with an active assessment can be accomplished at older ages. A referral for full hearing evaluation is appropriate whenever there is suspicion of language or speech impairment.

## Pediatric Evaluation

History and physical examination should focus on the identification of potential contributors to the child’s language and communication difficulties. A family history of delay in talking, need for speech and language therapy, or academic difficulty can suggest a genetic predisposition to language disorders. Pregnancy history might reveal risk factors for prenatal developmental anomalies, such as polyhydramnios or decreased fetal movement patterns. Small size for gestational age at birth, symptoms of neonatal encephalopathy, or early and persistent oral-motor feeding difficulty may presage speech and language difficulty. Developmental history should focus on the age when various language skills were mastered and the sequences and patterns of milestone acquisition. *Regression or loss of acquired skills should raise immediate concern.*

Physical examination should include measurement of height (length), weight, and head circumference, even in children over age 2 years. The skin should be examined for lesions consistent with phakomatosis (see Chapter 636). Anomalies of the head and neck, such as white forelock and hypertelorism (Waardenburg syndrome), ear malformations (Goldenhar syndrome), facial and cardiac anomalies (Williams syndrome, VCFS), retrognathism of the chin (Pierre Robin anomaly), or cleft lip/palate, are associated with hearing and speech abnormalities. Neurologic examination might reveal muscular hypertonia or hypotonia, both of which can affect neuromuscular control of speech. Generalized muscular hypotonia, with increased range of motion of the joints, is frequently seen in children with language impairment. The reason for this association is not clear, but it might account for the fine and gross motor clumsiness often seen in these children. However, mild hypotonia is not a sufficient explanation for the impairment of receptive and expressive language. Language impairment may be a component of a syndrome or other recognizable condition. The physical examination gathers information to make other diagnoses.

No routine diagnostic studies are indicated for isolated language disorders with the exception of the hearing assessment. When language delay is a part of a generalized cognitive or physical disorder, referral for further genetic evaluation, genetic testing (e.g., fragile X testing, microarray, whole exome or whole genome sequencing), neuroimaging studies, and EEG should be considered.

### Treatment of Language and Speech Disorders

Disorders of language and speech are often treated by SLPs working alone or as part of a multidisciplinary team with others, such as early intervention specialists or occupational therapists. SLPs may work in hospital in-patient and out-patient settings. More commonly, they work in schools and early intervention programs. The nature and intensity of treatment are predicated on the nature and cause of the language or speech disorder and the explicit objectives of treatment. **Childhood apraxia of speech** typically requires that the child participate in four or five short sessions per week to achieve intelligible speech, whereas language impairment disorder may require once- or twice-weekly therapy in a peer-group setting to increase communicative attempts. Speech-language therapy for young children is typically play-based. Even drills are couched in naturally occurring, enjoyable, or fun activities. Group therapy with other young children is often well suited to children with language and communication disorders because children practice their emerging skills with peers in naturalistic settings. A strong family component to therapy is important to leverage the limited time that therapists can spend with children. Caregivers can be taught to use effective techniques designed to meet the objectives of the treatment program. For children who do not develop useful verbal language, the SLP may consider the use of assistive and augmentative communication (AAC; see Chapter 54), which may use high-technology devices, such as voice-generating computer programs, or low-technology solutions, such as sign language or picture exchanges. The use of AAC allows the nonverbal child to communicate within the human community. Several systematic reviews and meta-analyses provide compelling data that speech-language therapy is effective for improving many aspects of language and speech. Therefore a timely referral for treatment with an SLP is recommended over watchful waiting for many children with delays and disorders of language and speech.

Visit Elsevier eBooks+ at [eBooks.Health.Elsevier.com](http://eBooks.Health.Elsevier.com) for Bibliography.

## 53.1 Childhood-Onset Fluency Disorder

Kenneth L. Grizzle and Karolyn Mirasola

Dysfluent speech describes speech, language, and voice behaviors that interrupt the production and fluency of sounds, words, and thoughts. All speakers produce dysfluent speech, but not all dysfluent speech is stuttering. The words *stuttering*, *stammering*, and *dysfluency* are often used interchangeably. *Stutter* is used informally, particularly in the

United States, to describe when an individual is struggling to express themselves and may speak in a halting manner. *Stammering* is used in the United Kingdom in place of stuttering (Table 53.4). It is important for clinicians to have a general understanding about what stuttering is and when to counsel and refer families to speech-language pathologists (SLPs). It is important to distinguish between stuttered and nonstuttered dysfluencies and other fluency disorders and to identify concomitant symptoms.

### DIAGNOSIS

In the *Diagnostic and Statistical Manual for Mental Disorders, Fifth Edition* (DSM-5), the term *stuttering* has been removed from the diagnostic classification, and the disorder is referred to as **childhood-onset fluency disorder** (Table 53.5). Note that impact on functional behavior is a component of the psychiatric diagnosis. In contrast, communication disorder specialists would consider anxiety and avoidance of various activities as concomitant symptoms, but not necessarily a requirement for the diagnosis of stuttering.

**Child-onset stuttering (formerly known as developmental stuttering)** is a speech disorder that often begins in the preschool period

**Table 53.4** Terminology Related to Childhood-Onset Fluency Disorder

TERM	DEFINITION
Stuttering	A speech disorder manifested through abnormal speech patterns referred to as <i>dysfluencies</i>
Childhood-onset fluency disorder	Term used in DSM-5 that is synonymous with <i>stuttering</i>
Stammering	The clinical term used in the United Kingdom rather than stuttering; stammering also used informally to describe halting speech
Cluttering	A speech disorder characterized by an excessively rapid and irregular rate of speech
Dysfluency	Speech disruptions that can occur in normal or disordered speech

**Table 53.5** DSM-5 Diagnostic Criteria for Childhood-Onset Fluency Disorder

- A. Disturbances in the normal fluency and time patterning of speech that are inappropriate for the individual's age and language skills, persist over time, and are characterized by frequent and marked occurrences of one (or more) of the following:
  1. Sound and syllable repetitions.
  2. Sound prolongations of consonants and vowels.
  3. Broken words (e.g., pauses within a word).
  4. Audible or silent blocking (filled or unfilled pauses in speech).
  5. Circumlocutions (word substitutions to avoid problematic words).
  6. Words produced with an excess of physical tension.
  7. Monosyllabic whole-word repetitions (e.g., "I-I-I-I see him").
- B. The disturbance causes anxiety about speaking or limitations in effective communication, social participation, or academic or occupational performance, individually or in any combination.
- C. The onset of symptoms is in the early developmental period.  
Note: Later-onset cases are diagnosed as 307.0 [F98.5] adult-onset fluency disorder.
- D. The disturbance is not attributable to a speech-motor or sensory deficit, dysfluency associated with neurologic insult (e.g., stroke, tumor, trauma), or another medical condition and is not better explained by another mental disorder.



and is not associated with stroke, traumatic brain injury, or other possible medical conditions. Stuttering behaviors can occur in typically developing children who do not have a speech disorder and in this situation are more accurately referred to as *developmental dysfluencies*. During the toddler and preschool years, children often produce repetition of sounds, syllables, or words, particularly at the beginning of sentences (normal dysfluencies). These developmental dysfluencies occur between the ages of 2.5 and 4 years old when the language, motor, and emotional systems are developing. These dysfluencies may occur as the child struggles to try to express more complex ideas in a rapid and precise manner.

Child-onset stuttering disorder also typically begins between 2 and 4 years of age. Onset of symptoms varies from pronounced stuttering within a few days to gradual worsening of symptoms across months. Symptoms may ebb and flow, including disappearing for weeks before returning, especially among young children. From 40% to 75% of young children who stutter will stop spontaneously, typically within months of starting. Although predicting which child will stop stuttering is difficult, risk factors for persisting include stuttering for >1 year, continued stuttering after age 6 years, and experiencing other speech or language problems. Additionally, certain types of dysfluencies are typically seen only in child-onset stuttering disorder.

### Types of Dysfluencies

Dysfluencies interrupt the normal flow of speech through repeated or prolonged sounds, syllables, or words. Types of dysfluency that are *not* exclusive to children who stutter include *interjections* (“well, uh, umm”), hesitations (pause), *revisions* (“I thought . . . I mean”), and *phrase repetitions* (“Did you say—Did you say”). In addition, the perspective of the speaker and cause of the dysfluency differ between true stuttering disorders and other types of dysfluency. The dysfluencies might sound the same but occur for different reasons. For example, a typically developing child with dysfluency may talk around a word or use a completely different word because of issues with word retrieval, complex thought formulation, or distractibility. But for children who stutter, they may talk around a word or retrieve a completely different word because even though they know exactly what they want to say, they are unable to produce or “get” the sounds out. This highlights the notion that stuttering is about more than what the listener observes. The “moment of stuttering” is different because something occurs that only the person who stutters can perceive.

Dysfluencies that occur in child-onset stuttering vary in type, frequency, and longevity. Specifically, children who stutter show greater part-word repetition (“b-b-b-but”), single-syllable word repetition (“My, my, my”), sound prolongation (“MMMMM-an”), and in more severe cases, blocking. Blocking is a dysfluent behavior that is identified by a fleeting or sometimes lengthy blockage of the flow of air at the level of the vocal folds or articulators (tongue, teeth, and lips). Typically, the child has initiated an articulatory posture (tongue is in the position to produce “k”), but she is unable to release any air and/or phonation (i.e., voice). Often in response to this inability to produce sounds or words, the child will develop secondary behaviors that recruit movement from other parts of the body that the child feels they have more “control” over.

These types of behaviors and movements exist only within child-onset stuttering disorder. They are referred to as *secondary characteristics*, or physical concomitants that often occur as a response to stuttering. Common secondary characteristics include movements of the head (head turning or jerking), face (eye blinking/squinting, grimacing, opening or tightly closing the jaw), neck (tightening), and limbs (stomping feet, slapping hand); an increase in body tension; and irregular patterns of inhalations and exhalations.

### Emotional Symptoms and Stuttering

Fear and anxiety are **emotional symptoms** associated with stuttering. Many people experience some level of fear and anxiety related to speaking in front of a group, but children who stutter often experience high levels of fear and anxiety related to all speaking situations,

especially ones that occur with newer or unfamiliar people (e.g., ordering at a restaurant, calling a store to ask about store hours, introducing oneself). Along with their own feelings interfering with speech production, the reactions of those around them may also increase the anxiety of children who stutter. Negative interactions or comments may inhibit a child’s future attempts to interact verbally with another person or in a group setting. Consider also the potential **social challenges** associated with entering a classroom for the first time, transitioning to middle/high school/college, beginning a job, dating, and so on. Not surprisingly, just as avoiding production of a perceived sound or word is common, *avoidance* of situations and people is a common way of coping with the anxiety created by the fear of stuttering. These avoidance behaviors indicate a need for intervention.

### Differential Diagnosis

Although many dysfluencies are often referred to as stuttering, it is important to recognize that there are different types of fluency disorders. Cluttering is a fluency disorder that may occur with or separate from stuttering but is different in form and cause. Stuttering and cluttering have been identified to exist on a continuum. Unlike stuttering, for which distinct episodes can be identified and even counted, **cluttering** affects the entire speech output and is often diagnosed around age 7 years or later. In addition to elevated repetitions of partial words (as in stuttering), whole words, and phrases, those who clutter show speech bursts that are often choppy, and articulation can be slurred and imprecise. In addition, there is often an increase in disorganization of their language, unusual prosody, and listener perception of a fast rate of talking. The level of awareness of how their speech affects those listening, unlike children who stutter, is minimal for those who clutter. In fact, children with a cluttering disorder often experience a decrease in their dysfluent behaviors when they are speaking in front of a group because of an increased focus on their speech, whereas the impact for children who stutter is exactly the opposite.

In addition to cluttering, neurogenic (result of a stroke, head trauma, or other neurologic damage) and psychogenic (associated with psychological trauma) stuttering also exist, though they rarely occur in childhood. Stuttering can also be confused with dysfluent speech that occurs for other neurologic reasons (e.g., Tourette syndrome, cerebral palsy, spasmodic dysphonia).

### Epidemiology

Approximately 5% of children experience stuttering, with the highest rates among young children. Seldom does a child begin stuttering before 2 years of age or after 12 years; in fact, the mean age of onset is 2–4 years, and most children stop stuttering within 4 years of onset. Symptoms will disappear within 4 weeks for a minority of children. Stuttering is more common in males than in females, and the magnitude of the difference increases as children get older. The ratio among children <5 years is approximately 2:1 and jumps to 4:1 among adolescents and young adults.

### Genetics

There is convergent evidence of a genetic link for childhood-onset fluency disorder. Concordance rates among monozygotic twins range from 20% to 83%, and for dizygotic twins, 4–19%. Family aggregation studies suggest increased incidence of approximately 15% among first-degree relatives of those affected, three times higher than the 5% rate for the general population. The variance in risk for stuttering attributed to genetic effects is high, ranging from 70% to 85%. Although evidence is limited, stuttering appears to be a polygenic condition, and several genes increase susceptibility.

### Brain Structure and Function

Brain structure and function abnormalities found among individuals who stutter include deficits in white matter in the left hemisphere, overactivity in the right cortical region, and underactivity in the auditory cortex. Abnormal basal ganglia activation has also been identified.



## EVALUATION

### Comorbidities

Despite the widely held belief in a high degree of comorbidity between childhood-onset fluency disorder and other communication disorders, research to date does not necessarily support this association. SLPs consistently report high rates of comorbidity, although this would be expected in clinical samples. Speech sound (phonologic) disorders are the most commonly reported comorbidities, occurring in 30–40% of children seen by SLPs. However, studies have not found greater incidence of phonologic disorders among those who stutter compared to a control group. Similarly, SLPs report a much higher percentage of children with language disorders among their patients who stutter than the approximately 7% expected in the population at large, yet studies find the language functioning among individuals who stutter is no different than in the general population. The same pattern holds for learning disorders (LDs).

Children who stutter seem to experience more anxiety than their nonstuttering peers, although research is limited. The frequency of reported anxiety increases with age. Social anxiety and generalized anxiety disorder are common among adolescents who stutter. Although one should not assume that an individual who stutters will have an increased risk for any specific psychiatric disorder, assessing for anxiety is important, as children who stutter frequently avoid situations that demand speaking, as discussed earlier in the chapter.

Children who stutter have consistently been found to be bullied more than peers. In one study, these children were almost four times more likely to be bullied than their nonstuttering counterparts. About 45% of children who stuttered reported having been the victim of bullying.

### Referral to Speech and Language Pathology

In deciding who to refer to an SLP, it is important to distinguish developmental dysfluencies from stuttering. In addition to the risks noted in Table 52.5, indications for referral include three or more dysfluencies per 100 syllables (b-b-but; th-th-the; you, you, you), secondary characteristics denoting escape or avoidance behaviors (pauses, head nod, blinking), discomfort or anxiety while speaking, family history of stuttering or other speech-language disorders, and suspicion of an associated neurologic or psychotic disorder. Most children with persistent stuttering after age 4 years should be evaluated by an SLP.

As a part of the evaluation, the SLPs will be able to address the many pressing concerns and worries of a parent whose child is stuttering. The outcome of a speech-language evaluation for stuttering should accomplish the following:

1. Obtain a strong family history related to the existence of speech and language disorders in general and more specifically related to stuttering and dysfluencies.
2. Interview the parent or child about the child's stress when speaking in various situations.
3. Record a speech sample to analyze the type, frequency, and complexity of the dysfluent behaviors and secondary characteristics that the child is producing.
4. Differentiate between developmental dysfluency behaviors, other causes of dysfluent behaviors, and a child-onset dysfluency disorder (aka stuttering).
5. Develop a plan with the family that involves a combination of direct and indirect speech and language therapy, parent education, and home programming.

## TREATMENT

A true stuttering disorder is a lifelong condition. To date, no evidence supports the use of a pharmacologic agent to treat stuttering in children and adolescents, and there is no cure for stuttering. However, treatment in preschool-age children has been shown to improve stuttering. In fact, speech-language therapy is most effective when initiated during the preschool period. The broad focus of therapy allows for minimizing the adverse effects of the condition.

Based on the child's age, types and frequency of stuttered behaviors, severity of secondary characteristics, and impact on the child's quality of life, the SLP will decide if a less direct or more direct therapeutic intervention is recommended.

Less direct therapy focuses on manipulating the situation and environment while allowing the child to experience increased fluency. Most preschool children respond to interventions taught by SLPs that are accompanied by behavioral feedback strategies implemented by parents and teachers. It is important to recognize that parental pressure or speaking pressure does not cause stuttering. A less direct therapy approach involves working with the caregiver to accomplish the following:

1. Limit situations and expectations that cause increased dysfluencies and stress
2. Demonstrate and model how to adjust speaking rate and complexity of language rather than reprimanding children for their speech errors or asking them to slow down
3. Increase opportunities for the child to experience fluent communication

More direct therapy is recommended and implemented when less direct therapy did not have an impact on the stuttering behaviors, the child has increasing worries related to stuttering, the child has a high risk of continuing to stutter, or the child is older and has been stuttering for some time. One of the overarching goals of the therapy implemented by an SLP is to help the child experience increased fluency and strategies to learn how to "stutter" better.

Therapy that is more direct adds the following elements:

1. Awareness and education: Recognizing and accepting that their speech is different, identifying and naming types of speech, nonjudgmentally noting episodes of stuttering using selected words and phrases (which are often accompanied by pictures) that were developed with and practiced by the child ("That was a bit bumpy"), appreciating others' reaction to the child when stuttering, managing secondary behaviors, admitting they are a person who stutters, and addressing avoidance behaviors as a result of the stress and anxiety they are experiencing.
2. Fluency-shaping behaviors: Regulating rate of speech and breathing and helping the child gradually progress from the fluent production of syllables to more complex sentences. The child should be involved in opportunities to identify speech dysfluencies, implement self-correction, and respond to requests ("Can you say that again?").

Because stuttering rarely disappears, the thrust of therapy is often to "improve" the type of stuttering, decrease the occurrences of stuttering, and develop strategies for coping with the fear and anxiety that will continue to occur in various speaking opportunities.

Appreciating that dysfluency is a broad term and stuttering can be one of the causes for this behavior allows pediatricians to have a more accurate understanding of the symptoms, causes, and treatments associated with dysfluencies. Being armed with this information allows the provider to include in their referral to an SLP an accurate description of symptomology, which will be beneficial in the planning and execution of their initial evaluation.

Visit Elsevier eBooks+ at [eBooks.Health.Elsevier.com](http://eBooks.Health.Elsevier.com) for Bibliography.

## Chapter 54

# Augmentative and Alternative Communication

Michelle M. Macias

Children must develop communicative competence to interact with others, to influence their environment, and to participate fully in society. If children are not able to effectively communicate, they will have minimal means to express what they need, exchange information with others, and develop social skills and relationships. Some children are unable to communicate effectively through natural means, including speech, gestures, or writing (see Chapter 53). These children with **complex communication needs (CCNs)** have more independent function through **augmentative and alternative communication (AAC)** methods to meet their communication needs and to avoid significant restrictions on their participation in all aspects of life.

AAC interventions have been helpful for individuals with no speech, limited speech, and those at risk for speech-language disorders; this includes individuals who rely on speech but need augmentation to enhance speech, those recovering from a traumatic brain injury, and those who may have temporary conditions affecting communication. AAC has changed from an emphasis on providing the means to express needs and wants to the recognition that communication must also foster exchange of information, development of social relationships, and participation in social routines. In addition, there is recognition that communication needs extend beyond face-to-face interactions and also include written communication in the school setting and even social media in peer communities.

## DEFINITIONS

According to the American Speech-Language-Hearing Association (ASHA), AAC is “an area of clinical practice that addresses the needs of individuals with significant and complex communication disorders characterized by impairments in speech-language production and/or comprehension, including spoken and written modes of communication.” AAC encompasses the communication methods used to supplement or replace speech or writing for those with impairments in the production or comprehension of spoken or written language. In pediatrics, AAC is used by youth with a wide range of speech and language impairments, including cerebral palsy (CP), traumatic brain injury, intellectual disabilities, autism spectrum disorder (ASD), and apraxia of speech. In addition, children and adolescents hospitalized in intensive care units can benefit from AAC.

AAC is **augmentative** when used to supplement existing speech and **alternative** when used in place of speech that is absent or not functional. AAC uses a wide variety of electronic and nonelectronic techniques from low technology to high technology, including manual signs, gestures, tangible objects, line drawings, picture communication boards and letter boards, and speech-generating devices. The term **assistive technology (AT)** is a more general term describing systems and devices that alleviate the effects of a disability and improve function, for example, bracing for a child with a neuromotor impairment as well as AAC.

## Prevalence

Across countries, the overall prevalence of AAC use ranges from approximately 1.2% to 1.5% of the population; worldwide up to 0.6% of the school-age population has a severe speech impairment. A national survey of U.S. special educators reported that approximately 18% of students served in special education use a form of AAC for communication, with 7% using gestural modes, 6.5% using pictorial supports, and 4.8% using a speech-generating device (SGD). However, not all

U.S. children with developmental disabilities or children with special healthcare needs have their communication needs met. The more severe a child’s communication deficit, the more likely the child would benefit from AAC support.

Across particular pediatric populations, it has been estimated that 25–50% of children with ASD have limited speech and would benefit from AAC. Up to 45% of children with CP use AAC either exclusively or to supplement speech. Several studies have found that in intensive care units ~30% of patients had communication breakdowns and met AAC candidacy criteria, although alternative communication modes were rarely used.

## Goals of Communicative Interactions and AAC Interventions

The ultimate goal of AAC is to enable individuals to effectively engage in interactions and participate in activities of their choosing. Broadly speaking, the goals of AAC interventions are to assist individuals with meeting their current communication needs and prepare them to meet their future communication needs. Communicative interactions can be said to fulfill four purposes: (1) communicate needs/wants, (2) transfer information, (3) social closeness, and (4) social etiquette. It is important to remember that adequacy of communication depends on the personal goals of the person using AAC, and the definition of success may vary by the professionals involved.

Most children with complex communication needs demonstrate some ability to communicate using speech, although some are entirely nonverbal. The effectiveness of natural speech for communication can be divided into 10 levels (Meaningful Use of Speech Scale; Robbins & Osberger):

1. Makes vocal sounds in communicative exchanges
2. Gets another person’s attention using speech
3. Uses various vocal sounds depending on the intention and content of messages

*Uses speech for communication about:*

1. Known topics with familiar people
2. Known topics with unfamiliar people
3. New topics with familiar people
4. New topics with unfamiliar people
5. Messages that are understood by familiar people
6. Messages that are understood by unfamiliar people
7. Clarification messages as needed when communication breakdown occurs

## AAC Systems

An “**AAC system**” refers to the integrated group of components used to support and enhance communication. These components include the specific forms of AAC, selection techniques, and strategies for use.

Individuals with complex communication needs must have access to a wide range of means to enhance their communication and participate fully within social and educational contexts. This may include **unaided AAC**, which does not require an external tool and requires some degree of motor control (e.g., gestures, sign language, finger spelling, speech approximations), or **aided AAC**, which requires either an electronic or a nonelectronic tool. Nonelectronic aided forms are referred to as **low-tech aided AAC** and include options such as communication boards/books, picture-exchange communication systems (PE or PECS, pictures, photographs), or visual schedules. Electronic forms are referred to as **mid-tech or high-tech AAC** systems and include traditional speech-generating devices (SGDs) or voice output communication aids (VOCAs), recordable devices, and computer/tablet options and applications (“apps”). SGDs/VOCAs include multiple options. **Single-level devices** have pictures/words on a single-level display, whereas **multilevel devices** can have vocabulary programmed on more than one level. **Static display devices** keep the same display, and the user can sequence symbols or words to generate a message. **Dynamic display devices** are usually those with a touch screen for the display in which pages can change using navigation keys and link buttons. **Text-to-speech devices** enable the user to spell messages that convert to synthesized speech. Some dynamic display devices include text-to-speech

**Table 54.1** Types of Augmentative and Alternative Communication

	LOW TECH	MID-HIGH TECH
Unaided	<ul style="list-style-type: none"> <li>• Sign language</li> <li>• Gestures</li> </ul>	—
Aided	<ul style="list-style-type: none"> <li>• Communication boards/books</li> <li>• Picture exchange systems</li> <li>• Visual schedules</li> <li>• Eye-gaze picture board</li> <li>• Simple single-message speech output devices</li> </ul>	<ul style="list-style-type: none"> <li>• Voice output communication aids (VOCAs)/speech-generating devices (SGDs) with prestored recordings of natural speech or computer-generated speech</li> <li>• Specialized software on electronic tablet, smartphone</li> <li>• Spelling and/or symbol systems to represent language</li> </ul>

Unaided systems: Do not require special materials or equipment; rely on user's body to convey messages.

Aided systems: Require the use of tools or equipment; can require power or no power.

and use symbols as well as text. Table 54.1 provides examples of the range of AAC systems.

Mobile technology (e.g., iPad) and greater use of social media tools have increased acceptance of AAC and reduced attitudinal barriers to AAC use. However, the increased diversity of communication tools also means increased operational demands, given that each tool is designed with different representations, organizations, and layouts of information as well as different access techniques (e.g., swiping, tapping). Each design may reflect different motor, cognitive, perceptual, and linguistic learning demands. A combination of gestures/signs, low-technology systems, mobile technology devices, and SGDs can provide AAC users with the most effective communication options to suit their needs.

### AAC Teams

AAC teams serving individuals with CCNs are the groups of people that guide the AAC intervention decision-making process and implement communication supports. Team members include the children and adolescents with CCN themselves, parents/caregivers, and professionals playing a variety of roles.

**Children with CCN.** The most important member of the team is the individual relying on AAC techniques. The role may change in response to the individual's maturation and capability, but to the extent possible, the child or adolescent should participate in the decision-making process regarding goals, social relationships, and support options related to the AAC system and interventions.

**AAC facilitators.** The term *facilitator* refers to parents/family members, friends, professionals, and frequent communication partners who assume some responsibility for keeping the AAC system operational and/or supporting the person with CCN to use it effectively. They support communication interactions by coaching, serving as interpreters, and/or helping resolve communication breakdowns. Importantly, the role of facilitator is to support independent communication by the individual with CCN, not to communicate *for* the individual.

**AAC specialists.** AAC specialists provide direct AAC intervention services by instructing and educating about AAC and designing and implementing AAC interventions. AAC specialists work with clinicians and educators, such as speech-language pathologists, occupational therapists, teachers, and pediatric healthcare providers who provide clinical and educational services to youth with CCN.

### AAC Assessment

AAC assessment involves gathering information so that informed decisions can be made about the adequacy of current communication, the communication needs, the AAC techniques that are most appropriate, how to provide instruction in AAC techniques, and how to evaluate outcomes. Proper evaluation and support for the use of AAC devices are of paramount importance.

Studies comparing acquisition of communication skills reveal few differences in terms of how quickly many children can learn to use some of the available AAC options. For example, PEC and sign language comparison studies vary—some show PECs were acquired more easily than signing, and others suggest both PECs and signing were

acquired at an equal pace. Studies comparing PECs with SGDs similarly vary in terms of effectiveness of device use.

Physicians, therapists, and other professionals who prescribe AAC must make sure the child (and family) receives training and monitoring for using the device and that the device is accessible across settings in which the child functions (e.g., home, school, community activities). A substantial number of AAC devices are abandoned shortly after implementation without support for their use. AAC assessment and intervention is a dynamic process, and usually ongoing, as often the children and adolescents requiring the AAC system are unable to speak or write because of physical, cognitive, language, and/or sensory impairments. Assessment generally consists of four phases as outlined here:

**Phase 1: Referral.** The “finder” role is an important role for pediatric healthcare providers. They may be the impetus for recognizing that a child has a CCN and that an AAC intervention may be helpful. They then assist the patient and their family by initiating a referral to an appropriate resource. The pediatric provider can support the AAC funding application by certifying a medical diagnosis and signing a prescription for the recommended service. Although the role is episodic, it is nonetheless a key role in the AAC assessment and treatment process.

**Phase 2: Initial Assessment.** The goal of this phase is to gather information to design an AAC intervention to match the child's existing needs and capabilities. The AAC specialist(s) assesses the child's current communication interaction needs and his or her physical, cognitive, language, and sensory abilities. This typically focuses on enabling communicative interactions between the child and familiar AAC facilitators. The intervention is refined as the child learns about the operational requirements of the AAC system and the AAC team gathers information on how well the system works for the child. Demonstrations and simulators are available to help with training before the actual equipment is ordered.

**Phase 3: Assessment for Other Settings.** The goal is to develop a solid communication system that supports the child with CCN in a variety of environments, including home, school, and recreational environments. A child must have access to a system that allows educational and social participation.

**Phase 4: Follow-Up Assessment.** This involves maintaining a comprehensive AAC system that accommodates the child's changing capabilities. The communication equipment must be examined regularly to assess the needs of new communication partners, detect replacement/repair needs, and reassess the child's capabilities as they change.

### Specific Assessment Details

**Assess Current Communication.** The initial step is to assess the effectiveness of the child's current communication system. The assessment of communication access focuses on the operational and social aspects of communicative competence. A child with spastic quadriplegia, for example, may be unable to use eye gaze consistently and therefore operationally unable to use an eye-gaze AAC system. On the other hand, a minimally verbal adolescent with ASD may be able to operate an electronic AAC device but never use it to initiate a social interaction.



Some questions to ask regarding current communication behaviors in children with CCN include the following:

- ♦ What are the various methods your child uses to communicate? Examples: words/speech, vocalizations, gestures, signing, communication board, eye gaze, typing, and so on.
- ♦ What body part is used for each technique (e.g., left/right hand, eyes)?
- ♦ On a scale of 1 to 5, how accurately and efficiently is your child able to use this technique?
- ♦ On a scale of 1 to 5, how well is your child able to use this technique in an interactive, socially appropriate manner?

**Screening Tools.** Various screening instruments exist that help document communication behaviors. These include the Communication Matrix; the Inventory of Potential Communicative Acts (IPCA); and the Social Communication, Emotional Regulation, Transactional Support (SCERTS) Model Assessment, among others. The Communication Matrix focuses on individuals using any form of communication (presymbolic or AAC), and the IPCA focuses primarily on presymbolic communicators with physical and/or developmental disabilities. The SCERTS Model Assessment focuses on communication and social regulation behaviors in verbal and nonverbal children with ASD.

**Assess Potential to Use or Increase Speech.** A key issue in AAC assessment for children with CCN is whether AAC is needed to augment insufficient speech or serve as a replacement for speech. Parents are often concerned that using an AAC device will negatively affect speech development, as the child will have access to an “easier” alternative. The use of AAC techniques does not inhibit natural speech; conversely, AAC may enhance spoken language by supporting the development of communicative competence and language skills.

**Assess Potential for Environmental Adaptations.** Modifications of physical spaces or structures may be relatively straightforward or more complex, depending on the specific situation. For example, at home, furniture rearrangement or renovations to adapt the home to accommodate AAC devices may be necessary. In the school, desks/tables may need to be raised/lowered or a vertical workspace may need to be created with a slanted board.

### Specific Issues Regarding AAC for Children with Disabilities Cerebral Palsy

Communication impairments are commonly seen in children with CP, both related to impaired (motor) speech intelligibility and language disorders (see Chapter 638.1). The incidence of dysarthria varies depending on the type of CP and degree of motor impairment. Language impairments are associated with intellectual functioning and hearing loss, if present.

More than any other disability, communication interventions for children with CP require a multidisciplinary team approach. The wide variety of motor impairments entails the involvement of occupational and physical therapists, orthotics specialists, rehabilitation engineers, and speech-language pathologists. Positioning and seating adaptations may need to be developed for optimum stability and to allow efficient movement to access the AAC system. The team must consider the wide range of options available and what is necessary to optimally match the child with the system being used. Although up to half of children with CP may be able to access the AAC device through use of a finger, others will need alternative access techniques, including chin pointers, joysticks, optical indicators, or switches.

Emphasis on AAC needs to be balanced with other developmental interventions, including speech-language therapy, motor development training, and academic instruction. Some will require extensive motor training to be able to use alternative access methods such as eye tracker, head mouse, or a switch for scanning. Although speech, gestures, and facial expressions may be affected as a result of motor impairment, patients should still be encouraged in using these natural modes for communication. A balanced approach supports the use of multimodal systems, which can vary according to the situation. A child with CP may be able to communicate effectively with family members using

natural speech and gestures but may need to rely on AAC techniques with unfamiliar partners.

Long-term planning for adulthood is essential, given the need to rely on AAC devices and techniques that can accommodate the range of demands that are communicative in nature, including interpersonal, academic, and employment demands. Without advance planning, AAC systems are unlikely to meet all these demands, or the individual will not have all the skills required to use the systems.

### Intellectual Disability

As defined by the American Association on Intellectual and Developmental Disabilities (AAIDD), intellectual disability (ID; see [Chapter 57](#)) is characterized by “significant limitations both in intellectual functioning and adaptive behavior as expressed in conceptual, social, and practical skills.” Appropriate supports, including AAC supports, can have a significant impact on the ability of individuals with ID to live and learn successfully in inclusive environments typical of their same-age peers. At least 30% of school-age individuals requiring AAC supports have an ID. One of the main barriers that exists for children with ID is simply recognizing that the use of AAC can be beneficial and that AAC use should be generalized across settings and not just used in highly structured settings such as school.

Although most youth with ID do not engage in socially inappropriate behaviors, problem behaviors occur more frequently in this population compared to those without ID. Many individuals with ID do not use speech as their primary mode of communication, and problem behaviors can be exacerbated by difficulty communicating. Many of the strategies used to support individuals with ID involve AAC strategies such as visual schedules or those used to teach choice making and functional communication training.

The nature of interventions directed at both natural speech development and AAC varies considerably given the diversity of syndromes and conditions that result in ID. Many individuals with ID may have multiple diagnoses that affect the nature of their intervention needs.

### Autism Spectrum Disorder

ASD (see [Chapter 58](#)) is a highly variable disorder; individuals with ASD experience a wide range of complex issues related to language and communication, which presents challenges regarding speech-based and AAC interventions. Individuals with ASD and ID may require more extensive educational, behavioral, and community supports compared with those without ID, but those without ID still require supports in the core area of social communication. **Language forms** are the language structures and vocabulary (e.g., grammar, syntax). **Language function** refers to what individuals do with language as they engage and interact with others. Because ASD affects the nature of communication as a social mediator, it is important that AAC interventions emphasize the function, or pragmatic aspects of communication, as well as the communication aspects related to the form of language.

Interventions must start at the individual’s level of social, communicative, and cognitive development and build skills in a natural developmental progression. The development of dynamic, interactive communication is critical, and the child with ASD needs to learn to use communication skills related to functional activities in daily life. The developmental profiles of youth with ASD are often characterized by an uneven distribution of skills. Children with ASD often perform much better with object permanence and tool use (causality) than those areas requiring interpersonal interaction, such as gestural or vocal imitation, symbolic understanding, or language comprehension. Therefore AAC interventions must be geared to the child’s social and linguistic abilities rather than the child’s object abilities (e.g., fine motor skills or object manipulation skills). Manual sign or pictorial systems (PECS) are often recommended for nonverbal children with ASD. This often presumes that the problem is only one of output and that communicative intent is intact; however, the child may not have the language or the social base on which communication must be built. Therefore interventions should initially build imitation, joint attention, and natural gestural communication skills before initiating formal language-based AAC or speech approaches.



SGDs and other speech-output technologies can be used effectively in children with ASD to teach both communication and literacy skills. SGDs can act as a “social bridge” to familiar and unfamiliar communicative partners. They can be programmed with whole messages (e.g., “do you want to play”) in addition to single words and phrases and thereby increase communicative efficiency and decrease potential communication breakdowns. These output devices are available via touch-screen tablet and mobile devices.

### Childhood Apraxia of Speech

ASHA defines childhood apraxia of speech (CAS) as a neurologic speech-sound disorder “in which the precision and consistency of movements underlying speech are impaired in the absence of neuromuscular deficits.” Given consensus on diagnostic criteria is lacking, ASHA recommends that the term “suspected CAS” be used. There is consensus on motor speech behaviors in three areas: (1) inconsistent errors on consonants and vowels in repeated syllables or words; (2) lengthened, disrupted transitions between sounds and syllables; and (3) inappropriate prosody of speech (see Chapter 53).

Given CAS is primarily a motor speech disorder, AAC is usually a secondary intervention, with the primary intervention focused on improving natural speech production. Because children with CAS often evidence significant language delays related to the inability to practice language, it is important to provide them with AAC modalities early on. The use of AAC will not inhibit speech development and production, and generally use of AAC supports result in increased mean length of utterances for the child.

Children with suspected CAS who benefit from traditional AAC are those who primarily speak in single words, have largely unintelligible speech, and are not able to effectively communicate with family members, peers, and teachers. The children benefit from a wide range of AAC, from unaided techniques including gestures and signs and aided techniques such as PECS communication books and/or SGD. It is important that the AAC device facilitates both language development and social competence. The AAC system should be designed so that the child learns to create longer and more complex messages that are grammatically accurate.

Children with suspected CAS who can produce single-word utterances but struggle with multiword speech often benefit from AAC speech supplementation. This supplementation may be in the form of key symbol supplementation, in which they point to key symbols in conjunction with speech. This can help with topic setting—when the child introduces a new topic of conversation, they point to a symbol, which helps narrow the range of possibilities for the communication partner. Often children with suspected CAS prefer to use natural speech and unaided approaches, using aided AAC techniques only when communication breakdown occurs.

### Special Considerations

**Reimbursement and Funding.** The AAC specialist (usually a speech-language pathologist) should be familiar with public and private funding options. Funding can come from schools, third-party payers (private or public insurance companies), or philanthropic sources. Low-tech AAC systems are usually developed by a speech-language pathologist and do not usually require additional funding. SGDs are considered durable medical equipment (DME), and funding can vary immensely. Coverage will need to be verified based on the patient’s specific needs and insurance. Pediatric care providers are often asked to sign prescriptions and/or write letters of medical necessity for an AAC device. This should be done only after conferring with the AAC team members, especially the speech-language pathologist. The letter should include that the pediatric provider received the evaluation reports, reviewed the recommendations, and agrees that the recommended AAC devices are medically necessary for treatment of the child’s CCN associated with the specific diagnosis. SGD vendors are often able to assist with funding questions.

**The Assistive Technology Act.** The Assistive Technology Act of 2004 provides all U.S. states and territories with federal funding to increase access to AT devices and services. This information can be found at the National Assistive Technology Act Technical Assistance and training (AT3) Center (<https://www.at3center.net/stateprogram>).

Visit Elsevier eBooks+ at [eBooks.Health.Elsevier.com](https://eBooks.Health.Elsevier.com) for Bibliography.

## Chapter 55

# Outcomes Among Infants and Children Who Are Deaf/Hard of Hearing

Susan E. Wiley and Rachel D. St. John

See also Chapter 677.

Approximately 3 in every 1,000 infants in the United States are *born* deaf or hard of hearing (D/HH). Additionally, for infants who pass the newborn hearing screening, there are a number of risk factors for developing *delayed-onset* hearing loss at any time during infancy and childhood. Given that the large majority of deaf infants are born to hearing parents, there is the potential for a developmental crisis when an infant or child does not have an accessible shared language in common with their parents.

Acquisition of one’s first language is a phenomenon of early development (see Chapter 53). The first months and years of a child’s life are critical to developing an intact native language. When the process of language acquisition is delayed or fragmented, as can happen with an infant who is D/HH, it can have a significant and permanent effect on overall lifetime cognitive development. Timely identification and support of infants and children who are D/HH, including the provision of early access to language, is critical to the lifetime trajectory of outcomes, including language, pragmatics, academic success, executive functioning, and psychosocial well-being.

### DEAF CULTURE

It is important to recognize that we as authors do not speak for Deaf individuals or parents of D/HH children but seek to bring awareness of some fundamental norms as a starting point for increasing familiarity and collaboration with these groups. Readers are encouraged to explore the resources cited in this chapter, as well as information provided by Deaf individuals and parents of D/HH children themselves.

Among individuals in America who are D/HH, there is a subset who self-designate as culturally Deaf (intentionally spelled with an uppercase D) who share American Sign Language (ASL) as their primary means of communication and a set of beliefs and traditions that are transmitted across generations. In the United States, the National Association of the Deaf is the organizational body that supports and represents this cultural Deaf community, with a mission “to preserve, protect and promote the civil, human and linguistic rights of deaf and hard of hearing people in the United States of America.”

There is a potential conflict between the “hearing” medical community and the culturally Deaf community, with the medical community traditionally operating from a pathology model (identify and fix the problem) and the Deaf community operating from a sociocultural one (there is no problem in need of fixing). Hearing parents and professionals whose societal existence is grounded in listening and spoken language often view being D/HH as a limitation to interpersonal connection, education, and vocation. Deaf individuals, who achieve virtually all the same milestones as hearing individuals do by using a visual language medium, do not view being D/HH as a loss. Among culturally Deaf individuals, the terms “hearing loss” and “hearing impaired” are often viewed as inaccurate and potentially offensive. For those who were born deaf, the experience of hearing is something they never had and therefore have never missed. It is not something that holds them back, but instead is a source of maintaining a positive self-identity and pride in one’s culture and community.

Hearing clinicians caring for deaf infants and children or members of the Deaf community must practice with the cultural humility necessary to appreciate the perspectives of the Deaf community (see Chapter 2).

**Table 55.1** Common False Assumption About Deaf or Hard of Hearing (D/HH) Infants and Children

FALSE ASSUMPTION	ALTERNATIVE APPROACH
Being D/HH causes language delay.	Often, the parent and deaf infant do not share a common language, creating a language barrier leading to delays. Early identification (by 1-3 mo of age) and intervention by 6 mo of age are critical for language development.
Passing newborn hearing screening tests means one does not need to be concerned about hearing.	Many factors can cause delayed-onset hearing loss. A full audiologic evaluation is indicated for any caregiver concern about hearing or for delays in language development—a “wait and see” approach is never indicated.
All behavioral symptoms or developmental delays are caused by the hearing loss.	Young neurotypical deaf children with adequate access to language through amplification and spoken language, sign language, or both should not be expected to have challenges in development, behavior, or social engagement. Referral for evaluation is essential if these symptoms are present.
Sign language is a last resort for communication for D/HH infants or children.	American Sign Language (ASL) is a full and complex language with a clear syntax and grammar structure. Learning sign language can promote language development when children cannot access spoken language during a period when this input is critical for cortical brain development.

Including access to Deaf individuals as part of healthcare teams involved in the care of D/HH infants and children is an important first step in including this cultural perspective in health service delivery and decision-making.

It is also important to recognize the concept of **intersectionality** (the interconnected nature of social categorizations such as race, ethnicity, class, and gender), which plays a role in the Deaf community. Being Deaf and Black is not just the sum of the experiences of Deaf individuals and Black individuals—the two constructs existing simultaneously in the same person makes for a unique life experience. Intersectionality is recognized within the context of the **Deaf Plus** community because those individuals do not simply experience life as a Deaf person who also happens to have an additional condition. The interplay of these aspects of individuals is a critical part of identity formation, self-esteem, cultural engagement, potential experiences of disadvantage/discrimination, and personhood in general.

### EARLY DETECTION AND LANGUAGE DEVELOPMENT

Deaf children who are born to deaf/signing parents are natively exposed to sign language from the first day of life and subsequently can be expected to acquire sign language milestones in a predictable manner similar to typically developing hearing children acquiring spoken language milestones. Deaf children of signing parents achieve their first signs, vocabulary expansion, combining of two discrete sign concepts, progression to more complex phrases and sentences, and other language-related milestones at expected ages if assessed in sign language. However, more than 90% of deaf infants are born to hearing parents who most often do not sign fluently. This creates an immediate and significant loss of a shared intact language. Families will turn to professionals for advice on making decisions regarding language, education, amplification technology, and social engagement. Sometimes these clinicians make false assumptions that delay detection or intervention for children who are D/HH (Table 55.1).

Clinicians should be aware that although language delay may be a presenting symptom in a D/HH child, being deaf in and of itself does not inherently cause delayed language development. Rather, the inability for a parent and an infant to share a common accessible language creates a barrier to the development of language. This is why early identification and support are critical for D/HH infants to support language access, whether to spoken language through amplification and therapy or access to sign language (or both). Even children who have passed their newborn hearing screening who have language delays must have a full audiologic evaluation, as a substantial number of factors can contribute to delayed-onset hearing loss (DOHL) at any time during early, middle, or late childhood. Parental concern about language delay or responsiveness of their child is a sensitive, but not specific, indicator of possible hearing loss. It is important to respond to parental concerns of hearing or language with referrals for hearing assessment, language evaluation, and age-appropriate therapeutic support systems.

Clinicians should also consider the possibility of hearing loss in young children with other behavioral changes. An older child may report a sudden dramatic hearing loss. However, younger children may not have the linguistic capacity or awareness to describe loss of hearing and may present instead with changes in behavior (being upset, aggressive, withdrawn). Some children with a progressive or sudden change in hearing status may appear to have a behavioral condition such as attention-deficit/hyperactivity disorder (ADHD) or may be described as defiant. Children with unidentified hearing changes and children with ADHD can share behaviors—they are perceived as not paying attention, they often are not aware of what is happening in the moment, they may not respond as expected when being addressed, and they may not focus on the things that are being discussed.

Another problematic issue known as **diagnostic overshadowing** can occur when all developmental or behavioral challenges are attributed to one cause (in this case, hearing status) when the symptoms should suggest the possibility of another disorder. For example young neurotypical D/HH children who have adequate access to language (through amplification technology and spoken language, sign language, or a combination of both) should not automatically be expected to have substantial challenges with language development, behavior, and social engagement. If clinicians reflexively attribute delays in social and language development to the fact that the child is D/HH, they may miss the diagnosis of a developmental disorder when they would not have missed the diagnosis in a hearing child.

Sign language has many benefits for D/HH infants and children and should not be regarded as an inferior last resort only to be used if spoken language efforts are not successful. ASL is a full and complex language. Much of the grammatical structure and concept complexity in ASL is conveyed through spatial placement of signs and body movements. Body movements can include body lean and eyebrow shift to indicate a question, frowning of the brow and pursing of lips to convey negation, and shifting of body position in space to define multiple individuals involved in conversation, to name a few.

The active discouragement of using visual language with any D/HH child is a developmental disservice, particularly so with the profoundly deaf infant whose hearing level is too low to benefit from traditional hearing aids. For these infants, a cochlear implant is likely the only potential route for accessing spoken language input, and the earliest that the Food and Drug Administration (FDA) currently approves cochlear implantation is 9 months of age. There remains a number of children who are not achieving such early ages of cochlear implantation. Lack of access to sign language can mean up to a year or more of complete lack of accessible linguistic input during a period of cortical development when language input is critical; that lack of language input can in turn affect infant bonding with parents. Even after cochlear implantation, it takes a substantial amount of therapy (auditory-verbal/listening and speech-language therapy) to build spoken language skills.

## INTERVENTIONS

Supporting children who are D/HH requires a combination of a proactive approach to care, ongoing monitoring for delays in all developmental domains, and timely recognition and intervention of gaps that can occur because of the impact of hearing status on language and overall development.

There is a tendency, especially for those who are not familiar with D/HH children, to assume that a child who does not hear will have reduced developmental outcomes compared to their hearing peers. There is robust evidence supporting the importance of early identification and intervention for long-term outcomes in children who are D/HH. A child's developmental and learning potential should not be defined by their hearing; clinicians should encourage and support families' high expectations for a child's development regardless of hearing status.

The medical home can fill a critical role in supporting a family's journey, though often primary care providers have relatively few children who are D/HH in their practice and may not be well-versed in how to monitor the medical and psychosocial needs of a D/HH child. This prompts the need to seek out information from a variety of sources and link families with reputable information. Because D/HH is a low-incidence condition, it is challenging for one setting (early intervention-based, school-based, clinical-based) to include a variety of children and match appropriate communication approaches. Interventions can be categorized in a variety of ways. A framework for various communication approaches is commonly used for understanding how to support language development in children who are D/HH (Table 55.2), including technology and environmental modifications.

### Communication Approaches

Often different approaches to communication are presented as a choice to make during the early years of critical language growth. Many communication approaches have passionate national organizations advocating for a specific approach (Table 55.3). The educational philosophy known as total communication is often misunderstood to mean using both signing and spoken language; however, it refers to incorporating an array of communication modalities (formal signs and fingerspelling, gestures, body language, lip reading, speaking, listening), with the goal of optimizing language development that is tailored to be most effective for the individual child.

We have chosen to refer to the national organizations and the Centers for Disease Control and Prevention (CDC) to guide definitions

of communication approaches (see Table 55.2). Each approach has specific components needed for successful implementation and language outcomes. The overall goal to support communication development can be an unfolding journey. Choices and strategies that worked well for a child in early childhood may not be as effective as the child matures, particularly as social engagement and academic demands evolve with age and advancement in school. Thus it is important for families to recognize that communication needs can change over time, prompting a shift from a prior decision to an alternative approach.

### Technology Hearing Aids

Hearing aid technology is very refined. Hearing aids are essentially mini-computers that take sound from the environment and are programmed to adjust how this sound is processed and delivered to the ear. Hearing aids have a number of different features that can augment the quality of sound a child will hear. Hearing aids can analyze the sounds coming into the device and preferentially reduce background noise. They can compress sound waves to preferentially make soft sounds louder and try to avoid distortion of loud sounds (wide dynamic range compression). Hearing aids can have microphones that can receive sound from many directions or focus primarily on sounds coming from in front of a child. A hearing aid can also carry a variety of programs for different listening settings. This allows a child to have a different program for a quiet environment compared to a noisy environment. Technology can also include Bluetooth to link to other devices. There are a number of apps to help monitor battery life and adjust the program for the setting through the app. Follow-up care with audiology is important to ensure continued supports for any amplification used and to monitor for changes in hearing. For children with conductive hearing changes, **bone conduction aids** may be indicated. These devices bypass the outer and middle ear, conducting sound through the skull directly to the cochlea and auditory nerve. When children are 5 years or older, they can be considered for a surgically implanted bone conduction aid called a *bone-anchored hearing aid* (BAHA). These devices also have the capacity to link to a frequency modulation (FM) system.

It is helpful to remember that even with advancements in technology, what children hear with hearing aids is not the same as what people hear with a typically functioning auditory system. It is equally important to consider environmental supports to optimize

**Table 55.2** Communication Approaches for Children Who Are Deaf and Hard of Hearing (D/HH)

COMMUNICATION MODALITY	DESCRIPTION	CITATION/ORGANIZATION
American Sign Language (ASL)	ASL is the recognized sign language of the deaf community in the United States. ASL conforms to linguistic principles and is distinct from English.	National Association of the Deaf ( <a href="https://www.nad.org/about-us/position-statements/position-statement-on-american-sign-language">https://www.nad.org/about-us/position-statements/position-statement-on-american-sign-language</a> )
Conceptually Accurate Signed English (CASE)	Using conventional ASL signs in an English word order.	<a href="https://www.cdc.gov/ncbddd/hearingloss/parentsguide/building/case.html">https://www.cdc.gov/ncbddd/hearingloss/parentsguide/building/case.html</a>
Manually coded English	Signing Exact English is an example of a manually coded English. It is a sign system that matches signs with the English language and includes manual representation of all components of the English language.	<a href="http://www.signingexactenglish.com">www.signingexactenglish.com</a>
Fingerspelling/Rochester method	The Rochester method was intended to support English literacy and uses fingerspelling for all words.	
Cued Speech	Cued Speech is a visual communication system that uses eight handshapes in four different placements near the face in combination with the mouth movements of speech to make the sounds of spoken language look different from each other.	National Cued Speech Association ( <a href="https://www.mdaap.org/pdf/CuedSpeech.pdf">https://www.mdaap.org/pdf/CuedSpeech.pdf</a> )
Spoken language and listening	Children learn to listen and talk with the support of hearing technology such as hearing aids, assistive listening devices (such as an FM system), or cochlear implants. Auditory-oral approaches include gestures, listening, speech/lip reading, and spoken speech. Auditory-verbal relies on listening and spoken speech.	Communication Options ( <a href="https://www.agbell.org/Families/Communication-Options">https://www.agbell.org/Families/Communication-Options</a> ) Centers for Disease Control and Prevention: How People with Hearing Loss Learn Language ( <a href="https://www.cdc.gov/ncbddd/hearingloss/language.html">https://www.cdc.gov/ncbddd/hearingloss/language.html</a> )

**Table 55.3** Resources for Families and Professionals

NATIONAL ORGANIZATIONS: FAMILY SUPPORT	
Hand and Voices ( <a href="http://www.handsandvoices.org">www.handsandvoices.org</a> )	Supports families and children without a platform providing a specific mode of communication.
National Association for the Deaf	Advocates for use of American Sign Language and represents the culturally Deaf community.
Alexander Graham Bell Association for the Deaf and Hard of Hearing ( <a href="http://www.agbell.org">www.agbell.org</a> )	Advocates for people who are D/HH to hear and use spoken language.
Beginnings ( <a href="http://www.ncbegin.org">www.ncbegin.org</a> )	Promotes language accessibility through cued speech (see Table 55.2).
American Society for Deaf Children ( <a href="http://www.deafchildren.org">www.deafchildren.org</a> )	
DEAF HISTORY AND CULTURE	
The National Association of the Deaf	<a href="https://www.nad.org/about-us/">https://www.nad.org/about-us/</a>
<i>Deaf Heritage: A Narrative History of Deaf America</i>	This 1981 book by Jack Gannon, a Deaf author and historian, is often referred to as a canon of Deaf culture in the United States. The book covers a number of events throughout history, including the establishment of schools for the deaf and the inception of the National Association of the Deaf and explores topics such as American Sign Language, Deaf artists, Deaf sports, and seminal Deaf publications.
<i>Through Deaf Eyes</i>	A 2007 documentary covering close to 200 years of being Deaf in the United States in a 2-hour run time through a diversity of interviews, movie shorts, and stories that capture the events that have affected Deaf lives throughout American history ( <a href="https://www.youtube.com/watch?v=PL5d8kyZUQk">https://www.youtube.com/watch?v=PL5d8kyZUQk</a> ).
DEAF MENTORS	
The National Center for Hearing Assessment and Management	Houses a directory of D/HH adult involvement programs by state ( <a href="https://www.infanthearing.org/dhhadultinvolvement/states/index.html">https://www.infanthearing.org/dhhadultinvolvement/states/index.html</a> )
SKI HI Deaf Mentor Program	Curriculum for infants and young children who are D/HH ( <a href="http://www.deaf-mentor.skihi.org">http://www.deaf-mentor.skihi.org</a> )
Hand and Voices Deaf and HH Mentor/Guide/ Role Model Programs	<a href="https://handsandvoices.org/fl3/topics/dhh-involvement/programs.html">https://handsandvoices.org/fl3/topics/dhh-involvement/programs.html</a>
American Society for Deaf Children: Deaf ASL Ambassadors Program	<a href="https://deafchildren.org/knowledge-center/asl-resources/sign-on/">https://deafchildren.org/knowledge-center/asl-resources/sign-on/</a>
PRACTICE GUIDELINES	
American Academy of Pediatrics Early Hearing Detection and Intervention Program	<a href="https://www.aap.org/en/patient-care-pages-in-progress/early-hearing-detection-and-intervention/">https://www.aap.org/en/patient-care-pages-in-progress/early-hearing-detection-and-intervention/</a>
EHDI National Technical Resource Center	<a href="https://www.infanthearing.org">https://www.infanthearing.org</a>
The Joint Committee on Infant Hearing	<a href="http://www.jcih.org">www.jcih.org</a>

listening environments. Contralateral routing of signal aids (CROS) can be helpful for children with unilateral profound deafness. This amplification system uses a transmitter at the ear that does not hear and routes it to a receiver on the typically hearing ear. Assisted listening devices such as FM systems are used to help address problems hearing in background noise and when speakers are farther away. This system has a small transmitter with a microphone. The speaker wears the transmitter, and this then links directly into headphones or a personal amplification system (hearing aid or cochlear implant). FM systems are traditionally used in the classroom setting, although they may be employed in other settings that tend to have competing background noise such as restaurants or when the focus on a particular individual speaking is important. The teacher may also use a transmitter with microphone that links to a number of speakers around the room (**soundfield system**). In this way, the accommodation is available to all students in the classroom, may benefit children easily distracted by background noise as well as the D/HH student, and does not single out the D/HH child alone.

### Cochlear Implants

Cochlear implants are surgically implanted devices that bring direct electrical stimulation to the cochlea. These devices are FDA-approved for children 9 months and older with profound sensorineural hearing loss and in lesser degrees of hearing changes (70 dB or more) when children are not receiving adequate benefit from

traditional amplification. A period of hearing aid trial is recommended before implantation. In children with hearing loss caused by meningitis, it is important to monitor for bony changes in the cochlea via imaging. Early signs of ossification would prompt earlier cochlear implantation to ensure the electrodes are in an optimal position to stimulate the auditory nerve. Even for children who are bilaterally profoundly deaf, there can be reasons that a cochlear implant is not appropriate. For example, absence of an auditory nerve would preclude pursuing an implant.

Often pediatric cochlear implant centers use a multidisciplinary approach to determining cochlear implant candidacy and to ensure strong follow-up support. In the past, children with developmental disabilities were deemed not appropriate for cochlear implantation, as results were thought to be limited. Although outcomes can vary in this group of children, a developmental disability alone does not preclude receiving benefit from the device. Ensuring global developmental supports, addressing potential expectations and outcomes, and linking children and families to resources can help children gain benefit from access to sound.

Coordination of care and follow-up is essential in all children with cochlear implants. They initially will see audiologists at frequent intervals to program the implant, and speech therapy is a critical and ongoing component of fostering success with an implant. At the age of 2 years, they should receive the 23-valent pneumococcal vaccine to ameliorate the increased risk of meningitis. The



medical home can play an important role in managing this additional immunization, as well as in monitoring medical issues and developmental progress.

Early implantation has been associated with better hearing, speech perception, and spoken language outcomes, as it ensures early stimulation of the auditory cortex necessary for the development of spoken language. Although FDA approval is for children 9 months and older, there are situations where earlier implantation is indicated, and many in the field of pediatric audiology and pediatric otology are advocating for earlier implantation. Unilateral deafness is another emerging indication for cochlear implantation in children.

### Other Supports and Factors Influencing Amplification Decisions

The cost of amplification devices can be quite high. Many insurance plans do not cover hearing aids, though more cover costs associated with BAHAs and cochlear implants. Services and coverages vary by state and insurance plan. Families often need to obtain insurance or additional coverage to cover replacement costs associated with damage or loss of the device. Technology updates can also add further expenses.

There are also many day-to-day factors that affect a child's acceptance of amplification. In early childhood there is rapid growth of the skull and ear canal. With hearing aids, children often need to return to audiology frequently to resize the ear molds to ensure a good fit. Children also can become very adept at removing their hearing aids. Young children in daycare are particularly vulnerable to potentially losing their amplification when rolling, crawling, or playing or when naturally curious peers and playmates attempt to take them. Parents, caregivers, and teachers routinely checking on hearing aids/cochlear implants is a critical support to using amplification technology successfully in young children.

A number of environmental supports can be helpful. For families seeking a spoken language approach, it is helpful to decrease background sounds. Turning off TVs and devices can help children be able to listen and hear what is said. Children often struggle hearing speakers from a distance. This affects incidental learning, as they have fewer opportunities to "overhear" peripheral conversations. Families are often coached in ways to optimize their child's listening environment and ways to highlight spoken language and concepts.

Technologic support can include captioning on the television, video-relay with sign language interpreters, texting, speech-to-text, visual fire alarms, and vibrating alarms. These types of technologies are often not covered through insurance, although some state agencies have programs to help defray costs. Other accommodations for communication access can include sign language interpreters, cued speech interpreters, and open captioning. The Americans with Disabilities Act ensures children, adolescents, and adults have the legal right to communication access. This is particularly important in medical settings. Family members should not be asked to serve as interpreters for the child, as this limits the ability for the parent to listen and be part of the conversation or may limit the child's access to the conversation at hand.

### LANGUAGE LEARNING

Language is a critical component of the human condition and allows connection with others. The United Nations has recognized communication as a human right. Communication happens in many ways that can include behavior, nonverbal communication, tone, facial expressions, words, and sentences. These aspects of communication are universal irrespective of mode of communication.

Promoting language development needs to focus on far more than the ear and hearing. As in typical children, the quality and quantity of communication are important (see [Chapter 53](#)). Additionally, children who are D/HH are at high risk of missing learning via "the unwritten curriculum": social and cultural learning that occurs incidentally and passively. Hearing children repeatedly overhear conversations that do not directly include them but are related to them, such as when their parents talk to the pediatrician about their care or how the parents interface with office

staff when they schedule the next appointment. D/HH children are vulnerable to missing years, if not decades, of incidental learning regarding everyday interactions. Direct teaching of incidental information, or making the implicit explicit, is a tenet of supporting the language development of children and youth who are D/HH. In the medical setting, this can be addressed for the signing D/HH child by having a sign language interpreter present to ensure the child can build an understanding of their own health history and expand health literacy, even if they may be too young to engage in the conversation directly. Although it may feel more comfortable and efficient to get information directly from parents, it is critical for the provider to engage the child directly as much as possible to maximize their involvement in their own plan of care. Addressing incidental learning for children who are D/HH should occur regardless of mode of communication.

As families hold an important role in their child's language development, building and empowering families in the development of skills and strategies is an important component of early intervention. Within the field of early intervention, coaching parents on how to engage and interact with their child to promote optimal development has been noted to be effective for a number of populations of children. Communication is interactional, and coaching puts the family in the position of providing the intervention and thus builds skills to support their child.

### When a Child Is Not Progressing

If a child's language development is not progressing, it is necessary to reevaluate factors that could contribute to language development. Factors to consider include problems with devices that have not been fully optimized, aspects of access to language, and coexisting medical, developmental, or behavioral conditions impacting learning.

In evaluating a child's access to language, consider how the child is learning, the language environment, and whether a child is getting a quality language model for learning. If a communication modality is pursued that cannot be supported across the environments the child is in (e.g., school, home, community-based organizations), the D/HH child can lag behind their peers. Overt problematic scenarios include a deaf child without good acoustic access attempting to learn spoken language or a child learning sign language but with limited sign language proficiency in their home, community, and school environments. Regression of language should prompt reevaluation of hearing and consideration of brain-centered as opposed to hearing-centered problems with learning.

A child's response to a communication approach may be affected by broader developmental issues. A child may have a unique learning profile and benefit from alternative approaches to language-based learning. Whereas children who are D/HH often have strong visual problem-solving skills, some children who are D/HH are stronger in the auditory domain. Although it should not be automatically assumed that a D/HH child will have developmental delay, up to 40% also have a developmental disability or condition that can affect progress. Early recognition of a child's broader needs can help ensure children receive effective interventions for all of their needs.

### ACADEMIC CONSIDERATIONS

The Individuals with Disabilities Education Act (IDEA) ensures a free, appropriate public education for all students with disabilities, including those who are D/HH. This law recognizes the right to be educated within the least restrictive environment (LRE), or to the maximum extent that is appropriate, education with their peers who do not have disabilities. This must be balanced with the individual student's communication, linguistic, academic, social, emotional, and cultural needs. Because of the varied settings and range of communication support needs, as well as the diversity of individual student strengths, endorsing one specific educational setting is not possible or appropriate.

Reading and literacy skills are associated with language fluency levels and tend to be improved by early age of identification and intervention. Standardized achievement testing from the early

2000s demonstrated that only half of D/HH high school graduates were reading above a fourth-grade level. However, these data are old and do not control for varying factors across students such as coexisting medical or developmental conditions, delays in identification and early language access, and varying teaching methodologies. Academic outcomes are likely to be optimized with early identification and support of language in infants who are D/HH and with the prompt recognition of, and support for, other developmental or behavioral challenges that may interfere with learning.

### PSYCHOSOCIAL WELL-BEING

An important consideration for any individual is psychosocial well-being. Because the population of D/HH individuals is heterogeneous, it is difficult to make overarching statements regarding mental health and wellness. Hearing loss in the elderly has been associated with depression. This is due—at least in part—to the loss of connection and communication with others. Similar effects can be seen across the life span for deaf individuals who did not develop enough formal language to communicate effectively. Studies have linked a lack of language proficiency with in-patient psychiatric care in adults and psychosocial difficulties in children. A large-scale study in Taiwan spanning over a decade estimated an 11.1% lifetime prevalence of clinically diagnosed unspecified anxiety disorder in the D/HH group, which was twice the incidence in the hearing control group.

A phenomenon described by some D/HH individuals, **deaf anxiety**, is related to interpersonal challenges a D/HH individual can experience when interfacing with a largely hearing society. Although advances in technology with hearing aids and cochlear implants continue to improve access to audiologic input, it is important to consider that these are tools with inherent limitations—they are not an equivalent “replacement” for natural hearing. D/HH adults have described fears such as missing/misunderstanding information, concern with appearing not to be interested in or not paying attention to someone speaking, disproportionately increased difficulty when dealing with noisy environments, and worry about missing significant information in nonaccessible environments such as being unaware that a fire alarm has gone off if there is no visual indicator in addition to the sound alarm.

The experiences of a deaf person in a predominantly hearing world contribute to the critical journey of identity formation for D/HH children as they become young adults. Deaf children, regardless of their success with technology, are still deaf. When a child takes off their hearing aids or cochlear implants to take a bath, swim, or rest, they are deaf. The technology does not change who they are fundamentally. Supporting families in their efforts to understand, accept, and value their child as a deaf individual can provide resilience for identity formation in adolescence. There also needs to be recognition that families are necessarily thrust into a position of making decisions for their young D/HH child with the knowledge they have at the time and may have concerns about how their child as an emerging adult may feel later on about those decisions. Families can benefit tremendously from access to programs that can connect them with other deaf children, deaf adults, and community resources that support a variety of ways to exist as a successful deaf individual.

### DEAF PLUS

It is helpful to recognize that some of the risks associated with being D/HH are also risks for other conditions that impact functioning in children who are D/HH (Table 55.4). It is important to look beyond hearing status as the reason for delays so as not to miss other factors contributing to a child’s slow rate of progress. Delayed

**Table 55.4** Rates and Types of Disabilities Among Children Who Are D/HH and Within the General Population

TYPE OF DISABILITY	D/HH (%)	GENERAL POPULATION (%)
No developmental disability	60	83
Cognitive/intellectual disability	8.3	1
Cerebral palsy	8	0.3
Blindness and vision impairment	5.5	0.3
Attention-deficit/hyperactivity disorder	5.4	9
Specific learning disability	8	7
Autism spectrum disorders	7	1.7

recognition of these factors causes delays in accessing effective intervention strategies. Conversely, the presence of specific coexisting conditions should not be assumed to predict functioning or decisions about communication. A child who is deaf and also has cerebral palsy should not be assumed to be unable to use sign language because of impact on hand/arm movements, as these children may use sign language receptively for language understanding quite well. The need for individually tailored care and education plans is particularly critical in children who are Deaf Plus.

Children who are D/HH have vision changes at nearly twice the rates compared to the general population. Vision differences are important to detect, as children who are D/HH often rely on their vision for accessing information. Even among children who receive effective amplification and good acoustic access to information, some reliance on lip reading and visual attention to the speaker can enhance a child’s ability to process information. There are no specific standards regarding the timing and frequency of ophthalmologic evaluations and monitoring intervals, but it is important for all children who are D/HH to have regular monitoring of vision and eye health with a pediatric eye care specialist.

For children who have both hearing and vision changes (**Deaf-Blind**), intervention strategies can be increasingly complex. IDEA specifically defines DeafBlindness as “concomitant hearing and visual impairments, the combination of which causes such severe communication and other developmental and educational needs that they cannot be accommodated in special education programs solely for children with deafness or children with blindness.” When the two conditions are present simultaneously, there are additional challenges to be considered regarding language access and acquisition. Each state has a federally funded DeafBlind project that provides resources and technical assistance to support children identified as DeafBlind. For children who are DeafBlind, many are advocating for interveners. Intervenors are more than interpreters: they facilitate communication and inclusion and address social and emotional needs within educational settings.

### FAMILY JOURNEY

Each family has a unique narrative to their overall family experience, as well as a specific pathway to supporting the growth and development of their D/HH child. Some families experience profound grief around the loss of an expected parenting story. Many families speak of being overwhelmed initially by an immense amount of information and pressured to make crucial decisions in a timely manner. Others move into an advocacy model and have their own unique take on the parenting journey. One

**Table 55.5** Approaches in the Medical Home to Support the Family Journey

FAMILY JOURNEY THEMES	CONSIDERATIONS AND STRATEGIES
Family-centered decision-making: Ensure families are central in decision-making	Before the visit: <ul style="list-style-type: none"> <li>Physician reflection on their own knowledge, expertise, and biases</li> </ul> At the visit: <ul style="list-style-type: none"> <li>Listen to family concerns actively and address concerns, referring to others when outside provider expertise is necessary</li> </ul>
Families' need for informed choice	Before the visit: <ul style="list-style-type: none"> <li>Recognize that each family and child are unique and decisions may vary across families</li> <li>Recognize that decisions may change over the life span of the child</li> <li>Recognize the passion across communication modalities, which drive potential biases in information and guidance</li> </ul> At the visit: <ul style="list-style-type: none"> <li>Listen actively to understand the family's values and intended goals and outcomes</li> <li>Collaboratively seek information from a variety of reputable sources and discuss potential biases across various "experts" in the field (see resource list)</li> <li>Incorporate the family's values in an action plan together</li> <li>Refer to experts as appropriate</li> </ul>
Family-to-family support: Because having a child who is D/HH can feel isolating and professionals do not carry the same day-to-day experiences, family-to-family connection is an important component of support	Before the visit: <ul style="list-style-type: none"> <li>Recognize the importance of family-to-family support</li> <li>Identify resources to link families with other families (see resources)</li> </ul> During the visit: <ul style="list-style-type: none"> <li>Discuss the possible isolation families face</li> <li>Determine interest and readiness for family networking</li> <li>Share resources that they can rely on when ready to reach out</li> </ul>
Access to D/HH adults: To support the family's recognition of what success can be and to provide children with a conceptual framework for D/HH individuals as adults	Before the visit: <ul style="list-style-type: none"> <li>Recognize families may be experiencing grief over the loss of their child's expected future and that experiences with other individuals who are D/HH may be limited or nonexistent</li> <li>Identify resources to link families with Deaf adults and Deaf mentoring programs (see <a href="#">Table 55.3</a>)</li> </ul> During the visit: <ul style="list-style-type: none"> <li>Discuss family's hopes and fears</li> <li>Highlight the importance of high expectations for their child</li> <li>Discuss ways to promote identity, connection, and independence for their child</li> </ul>
Child interactions and supports	Before the visit: <ul style="list-style-type: none"> <li>Recognize the variability and uniqueness of children who are D/HH in terms of capabilities, skills, and opportunities</li> </ul> At the visit: <ul style="list-style-type: none"> <li>Engage D/HH children directly rather than rely solely on family members for interpreting communication; for children who use sign language, access to an interpreter is a right under the Americans with Disabilities Act</li> <li>Recognize children's strengths and resilience</li> <li>Ensure children have access to their own health information (at their developmental level) and have the opportunity for inclusion in decisions as appropriate</li> <li>Advocate with children and families to have high expectations for skills, recognizing that often medical and educational settings use a deficit model (the child must be behind) to access supports</li> </ul>

simply has to take a look at some of the family stories that are available in the public realm to appreciate the diversity of the family experience in raising a D/HH child.

A number of parent support organizations are available to families, some of which are organized around specific communication philosophies (see [Table 55.3](#)).

The pediatrician may be the first medical professional that families turn to if there is concern about language development and/or hearing. Although these physician/family relationships are often just as diverse as the families themselves, some universal concepts start to emerge when listening to parent stories ([Table 55.5](#)). Recognizing these themes

and identifying ways to partner and support families is a critical role of the medical home.

### ACKNOWLEDGMENTS

The authors extend their gratitude to Chris Moreland, MD, and Robert Nutt, MD, for their input from the deaf adult/deaf professional perspective, and to Lauren Tyra, PhD, for her input from the perspective of a parent of a deaf child.

Visit Elsevier eBooks+ at [eBooks.Health.Elsevier.com](http://eBooks.Health.Elsevier.com) for Bibliography.

## Chapter 56

## Developmental Delay and Intellectual Disability

Meghan E. O'Neill and Bruce K. Shapiro

**Intellectual disability (ID)** refers to a heterogeneous group of disorders that have in common deficits of adaptive and intellectual function and an age of onset before maturity is reached. In Europe, the term *learning disability* is often used to describe ID.

**DEFINITION**

Contemporary conceptualizations of ID emphasize adaptive functioning and social interaction rather than test scores in isolation. The definition of ID requires significant impairment in general intellectual function (reasoning, memory, learning, problem solving) and adaptive behavior, with severity defined by limitations in adaptive functioning or levels of needed support. This focus encourages the development of individual treatment plans characterizing the supports needed to enhance functioning. Consistent across these definitions is onset of symptoms before adulthood (18-22 years of age). Children with ID have a nonprogressive disorder; loss of developmental milestones or progressive symptoms with a downward developmental trajectory suggest another disorder.

*Significant impairment in adaptive behavior* reflects the degree to which cognitive dysfunction directly contributes to impairments in daily functioning at home, at school and work, and in the community. **Adaptive behavior** refers to the skills required for people to function in their everyday lives, and individuals with deficits require more support than same-age peers for optimal participation. The American Association on Intellectual and Developmental Disabilities (AAIDD) and *Diagnostic and Statistical Manual of Mental Disorders, Fifth Edition* (DSM-5) classifications of adaptive behavior address three broad sets of skills: conceptual, social, and practical. **Conceptual skills** include language, reading, writing, time, number concepts, and self-direction. **Social skills** include interpersonal skills, personal and social responsibility, self-esteem, gullibility, naiveté, and ability to follow rules, obey laws, and avoid victimization. Representative **practical skills** involve performance of activities of daily living (dressing, feeding, toileting/bathing, mobility), instrumental activities of daily living (e.g., housework, managing money, taking medication, shopping, preparing meals, using phone and mail systems), occupational skills, and maintenance of a safe environment. For a deficit in adaptive behavior to be present, a significant delay in at least one of the three skill areas must be present. The rationale for requiring only one area is the empirically derived finding that people with ID can have varying patterns of ability and may not have deficits in all three areas.

The requirement for adaptive behavior deficits is the most controversial aspect of the diagnostic formulation. The controversy centers on two broad areas: whether impairments in adaptive behavior are necessary for the construct of ID and what to measure. The adaptive behavior criterion may be irrelevant for many children; adaptive behavior is impaired in virtually all children who have IQ scores <50. The major utility of the adaptive behavior criterion is to confirm ID in children with IQ scores in the 60-75 range, especially considering the historical overdiagnosis of ID among individuals of color with typical adaptive functioning and biased IQ testing results. It should be noted that deficits in adaptive behavior are often found in disorders such as autism spectrum disorder (ASD; see Chapter 58) and attention-deficit/hyperactivity disorder (ADHD; see Chapter 50) in the presence of typical intellectual function, often mediated by significant difficulties with executive functioning, self-directedness, or maladaptive behaviors. In contrast, deficits of adaptive functioning in ID are primarily attributable to the individual's overall cognitive limitations.

The issues of measurement are important as well. The independence of the three domains of adaptive behavior has not been validated. The relationship between adaptive behavior and IQ performance is

insufficiently explored. Many adults with IQ scores in the 60-75 range do not have significant impairments in practical skills. Adaptive behavior deficits also must be distinguished from *maladaptive behavior* (e.g., aggression, self-injury, inappropriate sexual behavior).

*Significant impairment in general intellectual function* refers to performance on an individually administered test of intelligence that is approximately 2 standard deviations (SDs) below the mean. Generally, these tests provide a standard score that has a mean of 100 and SD of 15 points, so that IQ scores <70 would meet these criteria. If the standard error of measurement is considered, the upper limits of significantly impaired intellectual function may extend to an IQ of 75. Using a score of 75 to delineate ID might double the number of children with this diagnosis, but the requirement for impairment of adaptive skills limits the false positives. Children with ID often show a variable pattern of strengths and weaknesses. Not all their subtest scores on IQ tests fall into the significantly impaired range.

*Onset before age 22 years or adulthood* distinguishes dysfunctions that originate during the developmental period from those that begin in adulthood. The diagnosis of ID may be made after 22 years of age, but the cognitive and adaptive dysfunction must have been manifested before age 22 years. Age of onset may be relevant to qualification for certain benefits programs that require a diagnosis of ID.

**Intellectual disability as nonprogressive.** Individuals with ID will acquire new developmental milestones over time, although at a slower rate than unaffected children. A slowing trajectory is not uncommon as individuals with ID get older. This should be distinguished from *regression* of milestones, which involves true loss of previously acquired skills and demands additional and often more extensive etiologic workup. Sometimes regression is seen in the context of the child's larger medical picture, such as loss of mobility with increasing spasticity and contractures in children with comorbid cerebral palsy (CP) or loss of language skills in the setting of new seizures. Alternatively, regression could suggest a **progressive encephalopathy** caused by an *inborn error of metabolism* or a *neurodegenerative disorder* (see Chapters 104 and 639). Prompt identification is essential, as some of these conditions are treatable or modifiable and some necessitate conversations about future reproductive risk.

**Global developmental delay (GDD)** is a term often used to describe young children with delays across multiple domains of development that have not yet resulted in a diagnosis of ID. In DSM-5, GDD is a diagnosis given to children <5 years of age who display significant delay (>2 SDs) in acquiring early childhood developmental milestones in two or more domains of development. These domains include receptive and expressive language; gross and fine motor function; cognition, social and personal development; and activities of daily living. Typically, it is assumed that delay in two domains will be associated with delay across all domains evaluated, including cognitive and intellectual abilities. Longitudinal studies following outcomes of children with GDD are sparse but suggest that that upwards of 80% of children with early global delays continue to experience development challenges through the school-age years. However, not all children who meet criteria for a GDD diagnosis at a young age go on to meet criteria for ID later in childhood. Reasons for the lack of concordance between GDD and later diagnosis of ID include lower reliability and predictive validity of developmental testing in children under 5-6 years of age; a positive change in developmental trajectory with maturation or possibly with intervention; reclassification to a different disability category (autism, ADHD, developmental coordination disorder); or imprecise use of the GDD diagnosis initially. Conversely, in patients with more severe early delays, the GDD term is often used beyond the point when the child could be reclassified as having ID, such as when a child has persistently and markedly low developmental quotients on multiple assessments and despite intervention during the first few years of life.

It is important to distinguish the medical diagnosis of GDD from the federal disability classification of "developmental delay" that may be used by education agencies under the Individuals with Disabilities Education Act (IDEA). This classification requires that a child have delays in only one domain of development with subsequent need for special education. Each state determines its own precise definition and terms of eligibility under the broader definition outlined by IDEA, and many states use the label for children up to 9 years of age.



**Table 56.1** Genetic Testing Guidelines for ID/GDD and/or ASD

ORGANIZATION	RECOMMENDATION(S) FOR GENETIC TESTING
Autism and Intellectual Disability Committee of the American Academy of Child and Adolescent Psychiatry (AACAP)	<ul style="list-style-type: none"> <li>• CMA in all individuals with ID/GDD and/or ASD</li> <li>• FMR1 repeat analysis in males and females with ID or a family history of ID</li> <li>• Depending on history and physical examination, consider: <ul style="list-style-type: none"> <li>• PTEN testing if head circumference (HCM) is more than 2.5 SD above the mean for age in a child with ID/GDD and/or ASD</li> <li>• MECP2 testing for Rett syndrome in females with severe ID</li> <li>• Karyotype if a chromosomal syndrome is suspected</li> </ul> </li> <li>• If other investigations do not provide an etiology and there are unresolved clinical findings, consider ES and mitochondrial DNA testing</li> </ul>
American Academy of Pediatrics (AAP)	<ul style="list-style-type: none"> <li>• If a comprehensive history and exam are indicative of a specific syndrome or disorder, proceed with specific testing in patients with ASD and/or ID/GDD</li> <li>• In all individuals with ASD and ID/GDD without specific findings, consider CMA and FMR1 CGG repeat analysis</li> <li>• In females with ASD and/or ID/GDD without specific findings, consider MECP2 testing</li> <li>• In males with ID/GDD without specific findings, consider an X-linked ID panel (XLID)</li> <li>• If an etiology is not identified, consider a referral to genetics for additional workup, including possible ES</li> </ul>
International Standard Cytogenomic Array (ISCA) Consortium	<ul style="list-style-type: none"> <li>• CMA is the first-tier genetic test in patients with GDD/ID, ASD, and/or multiple congenital anomalies</li> </ul>
American College of Medical Genetics (ACMG)	<ul style="list-style-type: none"> <li>• After a detailed family history and physical examination, proceed with specific testing for patients with ASD if a syndrome is suspected or if features are suggestive of a mitochondrial or metabolic condition</li> <li>• If family history and physical exam are not suggestive of a specific diagnosis, metabolic, or mitochondrial condition, proceed with CMA for all patients with ASD and FMR1 repeat analysis for all males with ASD</li> <li>• If CMA (in males and females) and FMR1 repeat analysis (in males) are not diagnostic, consider: <ul style="list-style-type: none"> <li>• MECP2 sequencing in all females with ASD <ul style="list-style-type: none"> <li>• MECP2 duplication testing in males with ASD if phenotype is suggestive</li> </ul> </li> <li>• PTEN testing in patients with ASD if HCM is more than 2.5 SD above the mean for age</li> <li>• FMR1 repeat analysis in females with ASD and additional features suggestive of fragile X (e.g., family history and phenotype)</li> </ul> </li> </ul>
American College of Medical Genetics (ACMG)	<ul style="list-style-type: none"> <li>• CMA is the first-tier genetic test in patients with multiple congenital anomalies that are not indicative of a specific genetic syndrome and those with nonsyndromic ID/GDD and ASD</li> </ul>
Multidisciplinary Expert Consensus Panel	<ul style="list-style-type: none"> <li>• ES in all individuals with ID and/or ASD</li> <li>• If ES is nondiagnostic and does not include copy number variant analysis, proceed with CMA</li> <li>• If ES (and CMA if needed) is nondiagnostic, reanalysis of data from testing should be undertaken periodically</li> </ul>
American Academy of Neurology (AAN) and Child Neurology Society (CNS)	<ul style="list-style-type: none"> <li>• High-resolution karyotype and FMR1 repeat analysis for patients with ASD that also have ID, family history of fragile X and/or ID, or dysmorphic features</li> <li>• After obtaining a detailed medical, developmental, and family history for patients with ID/GDD, if a specific etiology is considered, perform appropriate testing such as single gene testing, metabolic testing, or XLID panel</li> <li>• If a specific etiology is not suspected, perform CMA (or, if not possible, karyotype and subtelomeric FISH) for all individuals with ID/GDD, MECP2 testing for females with moderate to severe ID/GDD, and FMR1 repeat analysis in all individuals with mild ID/GDD</li> <li>• If these and other etiologic workups are negative, consider a referral to genetics</li> </ul>

From Savatt JM, Myers SM. Genetic testing in neurodevelopmental disorders. *Front Pediatr*. 2021;9:526779, Table 3.

## ETIOLOGY

Numerous identified causes of ID may occur prenatally, during delivery, postnatally, or later in childhood. These include infection, trauma, prematurity, hypoxia-ischemia, toxic exposures, metabolic dysfunction, endocrine abnormalities, malnutrition, and genetic abnormalities. Most people with ID will not have a readily identifiable underlying diagnosis based on prenatal or perinatal history or dysmorphology, meriting further medical and genetic evaluation. Practice guidelines recommend that an etiologic workup be pursued in all children with ID or GDD when there is not a readily apparent explanation for the child's presentation (Tables 56.1 and 56.2). It is anticipated that these diagnostic guidelines change because genome sequencing studies have identified severe monogenic etiologies in previously difficult to diagnose developmental disorders despite extensive previous recommended evaluations.

Among children with milder GDD, yield of etiologic workup will likely be lower in comparison to children with more significant delays or disability. With increases in etiologic testing among all children with ID and advancement of technologic capabilities of testing, the number of identified biologic and genetic causes of ID is continuing to increase rapidly. There are slightly over 100 disorders (all of which are metabolic in nature) for which treatment may ameliorate the core symptoms of ID (see <https://www.treatable-id.org/>), but these conditions account for a relatively small percentage of children with ID (Table 56.3). However, there are several reasons beyond disease modification that should prompt providers

to seek etiologic answers in patients with ID. These include insight into possible associated medical or behavioral comorbidities; information on prognosis and life expectancy; estimation of recurrence risk for family planning counseling, potential validation, and closure for the family; increased access to services or specific supports; and better understanding of underlying pathology with the hope for new treatment options. When surveyed, families of children with ID with no identified underlying etiology almost universally report that they would want to know of an etiologic diagnosis if given the choice. Expanded testing will contribute to the growing pathophysiologic understanding of how ID occurs mechanistically and serves as an opportunity for future targeted treatment opportunities and clinical trial development.

Mild and more severe forms of ID have different but overlapping risk factors and etiologies. Nongenetic risk factors that are often associated with mild ID include low socioeconomic status, low maternal education levels, residence in a developing country, malnutrition, and poor access to healthcare. The most common biologic causes of, or risk factors for, mild ID include intrauterine growth restriction; prematurity; perinatal insults; intrauterine exposure to drugs of abuse (including alcohol); postnatal exposure to neurotoxic substances (including lead); some sex chromosomal abnormalities; and some genetic syndromes with multiple, major, or minor congenital anomalies (e.g., 22q11 deletion syndrome, sex chromosomal abnormalities, Noonan syndrome). Familial clustering is common.

**Table 56.2** Genetic Tests Commonly Used in Evaluation of Neurodevelopmental Disorders

TEST	RESULTS/VARIANTS DETECTED	DETECTION LIMITATIONS
Chromosomal microarray (CMA)	<ul style="list-style-type: none"> <li>• Copy number variants (CNV) (generally &gt;250 kb but could be smaller if region is specifically targeted)</li> <li>• Regions of homozygosity*</li> </ul>	<ul style="list-style-type: none"> <li>• Repetitive DNA sequences, including trinucleotide repeat expansions (e.g., <i>FMR1</i> repeat expansion)</li> <li>• Balanced chromosomal rearrangements</li> <li>• Sequence-level variants in the exome/genome</li> <li>• Mitochondrial variants</li> <li>• Epigenetics alterations (e.g., methylation abnormalities, uniparental heterodisomy)</li> <li>• Low-level mosaicism</li> </ul>
Exome sequencing (ES)	<ul style="list-style-type: none"> <li>• Sequence-level variants in the coding region (exome)</li> <li>• Copy number variants**</li> </ul>	<ul style="list-style-type: none"> <li>• Repetitive DNA sequences, including trinucleotide repeat expansions (e.g., <i>FMR1</i> repeat expansion)</li> <li>• Balanced chromosomal rearrangements</li> <li>• Smaller copy number variants, including deletions/duplications involving one to two exons</li> <li>• Mitochondrial variants</li> <li>• Epigenetics alterations (e.g., methylation abnormalities)</li> <li>• Intronic/noncoding variants</li> <li>• Variants in regions of the exome that are not well-covered by sequencing</li> </ul>
<i>FMR1</i> CGG repeat testing	<ul style="list-style-type: none"> <li>• CGG repeat number in the <i>FMR1</i> gene</li> </ul>	<ul style="list-style-type: none"> <li>• Sequence-level variants in <i>FMR1</i> or elsewhere in the exome/genome</li> <li>• Copy number variants</li> <li>• Balanced chromosomal rearrangements</li> <li>• Exon-level deletions/duplications</li> <li>• Mitochondrial variants</li> <li>• Epigenetics alterations (e.g., methylation abnormalities)</li> </ul>

\*Single-nucleotide polymorphism–based chromosomal microarray (SNP-CMA)

\*\*Several laboratories are now calling CNVs as a routine part of ES, and this trend will continue to expand.

From Savatt JM, Myers SM. Genetic testing in neurodevelopmental disorders. *Front Pediatr.* 2021;9:526779, Table 2.

**Table 56.3** Conditions in Which Early Treatment May Significantly Improve the Course of the Disease

CONDITION	TREATMENT	CONDITION	TREATMENT
Galactosemia	Lactose-free diet	Creatine disorders	Creatine monohydrate
Fructosemia	Fructose-free diet	Vitamin B <sub>12</sub> deficiency	Vitamin B <sub>12</sub>
Phenylketonuria	Phenylalanine-free diet	Cerebral glucose transporter defect	Ketogenic diet
Maternal phenylketonuria	Phenylalanine-free diet during pregnancy	Metachromatic leukodystrophy	BMT
Maple syrup urine disease	Diet restricted in branched-chain amino acids + dialysis or exchange transfusion	Niemann-Pick disease	BMT, liver transplantation, implanted amniotic epithelial cells
Hypoglycemia from any cause	Prevent hypoglycemia and/or provide glucose	Adrenoleukodystrophy	BMT
Lead intoxication	Separate child from source of lead; chelation therapy	Glycogen storage disease type IV	Liver transplantation
Hypothyroidism	Thyroid replacement	Menkes disease	Parenteral copper histidinate
Recurrent otitis media	Antibiotic prophylaxis, pressure-equalizing tubes	Lesch-Nyhan syndrome	Allopurinol + BMT
Malnutrition	Adequate nutrition	Krabbe disease	BMT
Increased intracranial pressure (e.g., hydrocephalus, neoplasm)	Shunt ventricles or cystic structure	α-Mannosidosis	ERT: velmanase alfa
Congenital HIV infection	Prenatal/postnatal treatment with AZT (zidovudine)	Aspartylglucosaminuria	BMT
Congenital toxoplasmosis	Prenatal treatment with spiramycin, pyrimethamine, and sulfonamide	Gaucher disease type III	ERT: Ceredase; SRT: Cerdelga; PCT: Mucosolvan
Dopa-responsive dystonia	Responds to levodopa; may be misdiagnosed as cerebral palsy	Hunter syndrome (MPS II)	ERT: Elaprase
Biotinidase deficiency	Oral biotin	Hurler syndrome (MPS I)	ERT: Aldurazyme
Biotin-thiamine–responsive basal ganglia disease	Biotin, thiamine	Sanfilippo syndrome A (MPS IIIa)	SRT: Genistein
Wilson disease	Copper chelation; liver transplant	Sanfilippo syndrome B (MPS IIIb)	SRT: Genistein
Cerebral folate disorder	Folinic acid	Sanfilippo syndrome C (MPS IIIc)	SRT: Genistein
		Sanfilippo syndrome D (MPS IIId)	SRT: Genistein
		Sly syndrome (MPS VII)	ERT: Mepsevii
		Neuronal ceroid lipofuscinosis type II	ERT: Brineura

BMT, Bone marrow transplant; ERT, enzyme replacement therapy; MPS, mucopolysaccharidosis; PCT, pharmacologic chaperone therapy; SRT, substrate reduction therapy.

From Muriello M. Neurocognitive and developmental regression. In: Kliegman RM, Toth H, Bordini BJ, Basel D (eds). *Nelson Pediatric Symptom-Based Diagnosis*, 2nd ed. Philadelphia: Elsevier; 2023: Table 28.10, p. 481.

**Table 56.4** Identification of Causes in Children with Significant Intellectual Disability

CAUSE	EXAMPLES	% OF TOTAL
Chromosomal disorder	Trisomies 21, 18, 13 Deletions 1p36, 4p, 5p, 11p, 12q, 17p, others Microdeletions Klinefelter, 47,XXX, and Turner syndromes	~20
Genetic syndrome	Fragile X, Prader-Willi, Angelman, and Rett syndromes	~20
Nonsyndromic autosomal mutations	Variations in copy number; de novo mutations in <i>SYNGAP1</i> , <i>GRIK2</i> , <i>TUSC3</i> , oligosaccharyl transferase, and others	~10
Developmental brain abnormality	Hydrocephalus ± meningomyelocele; schizencephaly, lissencephaly	~8
Inborn errors of metabolism or neurodegenerative disorder	Phenylketonuria, ceroid lipofuscinosis, Tay-Sachs disease, other storage diseases	~7
Congenital infections	HIV, toxoplasmosis, rubella, cytomegalovirus, syphilis, herpes simplex, Zika virus	~3
Familial intellectual disability	Environment, syndromic, or genetic	~5
Perinatal causes	Hypoxic-ischemic encephalopathy, meningitis, intraventricular hemorrhage, periventricular leukomalacia, fetal alcohol syndrome	4
Postnatal causes	Trauma (abuse), meningitis, nutritional deficiencies, hypothyroidism	~4
Unknown		20

Adapted from Stromme P, Hayberg G. Aetiology in severe and mild mental retardation: A population-based study of Norwegian children. *Dev Med Child Neurol.* 2000;42:76–86.

In children with more severe ID, a biologic cause (usually with prenatal onset) can be identified in about three fourths of all cases. Causes include chromosomal (e.g., Down, Wolf-Hirschhorn, and deletion 1p36 syndromes) and other genetic and epigenetic disorders (e.g., fragile X, Rett, and Angelman syndromes), abnormalities of brain development (e.g., lissencephaly), and inborn errors of metabolism and mitochondrial disorders (e.g., mucopolysaccharidoses, mitochondrial respiratory chain complex disorders) (Table 56.4). *Nonsyndromic* severe ID may be a result of inherited or de novo gene mutations, as well as microdeletions or microduplications. Currently, >1,300 single genes have been associated with ID. Inherited genetic abnormalities may be mendelian (autosomal dominant de novo, autosomal recessive, X-linked) or non-mendelian (imprinting, methylation, mitochondrial defects; see Chapter 97). De novo mutations may also cause other phenotypic features such as seizures or autism; the presence of these features suggests more pleiotropic manifestations of genetic mutations. Consistent with the finding that disorders altering early embryogenesis are the most common and severe, the earlier the problem occurs in development, the more severe its consequences tend to be.

## EPIDEMIOLOGY

ID is one of the most common causes of disability in children globally. The prevalence of ID depends on the definition, method of ascertainment, and population studied, both in terms of geography and age. According to the statistics of a normal distribution, 2.5% of the population should have ID (based on IQ alone), and 75% of these individuals should fall into the mild to moderate range. Variability in rates across populations likely results from the heavy influence of external environmental factors and definitional differences on the prevalence of mild ID. The prevalence of severe ID is relatively stable. Globally, the prevalence of ID has been estimated to be approximately 16.4 per 1,000 persons in low-income countries, approximately 15.9/1,000 for middle-income countries, and approximately 9.2/1,000 in high-income countries. A meta-analysis of worldwide studies from 1980 to 2009 yielded an overall prevalence of 10.4/1,000. ID occurs more in boys than in girls, at 2:1 in

mild ID and 1.5:1 in severe ID. In part this may be a consequence of the many X-linked disorders associated with ID, the most common being fragile X syndrome (see Chapter 59).

In the United States the prevalence of ID in school-age children ranges from 1.1% to 1.8%. There are several reasons why fewer children are identified as having mild ID than predicted from statistics. Professionals might miss or defer the diagnosis and “give the benefit of the doubt” to the child and await repeated confirmatory testing over time because it is more challenging to diagnose mild ID than the more severe forms. Other reasons that contribute to the discrepancy between predicted and observed prevalence are use of instruments that underidentify young children with mild ID, children diagnosed as having ASD without their ID being recognized or addressed, misdiagnosis as a language disorder or specific learning disability, and a disinclination to make the diagnosis in minoritized students because of concern about biased assessments that historically led to overdiagnosis. In some cases, behavioral disorders may divert the focus from the cognitive dysfunction.

Beyond potential under diagnosis of mild ID, the number of children with mild ID may be decreasing because of public health and education measures to prevent prematurity and provide early intervention and Head Start programs. However, although the number of school children who receive services under a federal disability classification of ID has decreased since 1999, when *developmental delay* is included in analysis of the data, the numbers have not changed appreciably.

The prevalence of *severe ID* has not changed significantly since the 1940s, accounting for 0.3–0.5% of the population. Many of the causes of severe ID involve genetic or congenital brain malformations that can neither be anticipated nor treated at present, though trends toward more expanded prenatal screening (and subsequent termination) may alter this balance, as seen with the decreasing incidence of Down syndrome. Additionally, expanded newborn screening with early treatment has virtually eliminated ID caused by phenylketonuria and congenital hypothyroidism. However, continued high prevalence of fetal exposure to alcohol and illicit drugs, improved survival of very low birthweight premature infants, and increasing overall maternal age during pregnancy (contributing to increased rates of genetic abnormalities) have counterbalanced this effect.

## PATHOLOGY AND PATHOGENESIS

The limitations in our knowledge of the neuropathology of ID are demonstrated by the finding that 10–20% of brains of persons with severe ID appear normal on standard neuropathologic study. Many of the brains that appear abnormal show only mild, nonspecific changes that correlate poorly with the degree of ID, including microcephaly, gray matter heterotopias in the subcortical white matter, unusually regular columnar arrangement of the cortex, and neurons that are more tightly packed than usual. Only a minority of the brains show more specific changes in dendritic and synaptic organization, with dysgenesis of dendritic spines or cortical pyramidal neurons or impaired growth of dendritic trees. CNS maturation is defined by genetic, molecular, autocrine, paracrine, and endocrine influences. Receptors, signaling molecules, and genes are critical to brain development.

As the ability to identify genetic aberrations that correspond to particular phenotypes expands through the use of next-generation sequencing, more will be elucidated about the pathogenesis of ID at a genetic and molecular level. This expanding pathophysiologic knowledge base may serve as a framework with which to develop targeted therapies to bypass or correct newly identified defects. For example, use of histone deacetylase (HDAC) inhibitors has been shown to rescue structural and functional neural deficits in mouse models of Kabuki syndrome, a disorder of histone methylation that leads to variable levels of ID and characteristic facial features. Similarly, there is growing interest in the role of mammalian target of rapamycin (mTOR) inhibitor use

preventing seizures, neurodevelopmental disabilities, retinal tumors, cutaneous tumors, and other manifestations seen in tuberous sclerosis (see Chapter 636.2).

## CLINICAL MANIFESTATIONS

Early diagnosis of ID facilitates earlier intervention, identification of abilities, realistic goal setting, monitoring for potential comorbid conditions, easing of parental anxiety, and greater inclusion of the child in the community. Children with ID may first come to the pediatrician's attention because of dysmorphism (often in infancy), associated developmental disabilities, or failure to meet age-appropriate developmental milestones (Tables 56.5 and 56.6). Physical exam findings are nonspecific, but constellations of dysmorphism may be consistent with certain genetic syndromes. With the advent of more sophisticated genetic testing, the limitations of dysmorphology have become more apparent given the phenotypic variability seen with many genetic causes of ID.

Most children with ID lag behind peers in their acquisition of developmental skills. In early infancy, failure to meet age-appropriate expectations can include a lack of visual or auditory responsiveness, unusual muscle tone (hypotonia or hypertonia), or posture and feeding difficulties. Between 6 and 18 months of age, gross motor delay (lack of sitting, crawling, walking) is the most common concern. Language delay and behavior problems are common concerns after 18 months of age (see Table 56.6). For some children with mild ID, the diagnosis remains

**Table 56.5** Physical Examination of a Child with Suspected Developmental Disabilities

ITEM	POSSIBLE SIGNIFICANCE
General appearance	May indicate significant delay in development or obvious syndrome
<b>STATURE</b>	
Short stature	Malnutrition, many genetic syndromes are associated with short stature (e.g., Turner, Noonan)
Obesity	Prader-Willi syndrome
Large stature	Sotos syndrome, Sotos-like syndromes
<b>HEAD</b>	
Shape	Flat occiput: Down syndrome, Zellweger syndrome; prominent occiput: trisomy 18 Delayed closure of sutures: hypothyroidism, hydrocephalus Craniosynostosis: Crouzon syndrome, Pfeiffer syndrome Delayed fontanel closure: hypothyroidism, Down syndrome, hydrocephalus, skeletal dysplasia
Macrocephaly	Alexander syndrome, Canavan disease, Sotos syndrome, gangliosidosis, hydrocephalus, mucopolysaccharidosis, subdural effusion
Microcephaly	Virtually any condition that can restrict brain growth (e.g., malnutrition, Angelman syndrome, Cornelia de Lange syndrome, fetal alcohol effects)
<b>FACE</b>	
Specific measurements may provide clues to inherited, metabolic, or other diseases	Midface hypoplasia: fetal alcohol syndrome, Down syndrome Triangular facies: Russell-Silver syndrome, Turner syndrome Coarse facies: mucopolysaccharidoses, Sotos syndrome Prominent nose and chin: fragile X syndrome Flat facies: Apert syndrome, Stickler syndrome Round facies: Prader-Willi syndrome Hypotelorism or hypertelorism; slanted or short palpebral fissure; unusual nose, maxilla, and mandible
Nose	Anteverted nares/synophrys: Cornelia de Lange syndrome Broad nasal bridge: fetal drug effects, fragile X syndrome Low nasal bridge: achondroplasia, Down syndrome Prominent nose: Rubenstein Taybi, Coffin-Lowry syndrome, Smith-Lemli-Opitz syndrome
Mouth	Long philtrum/thin vermilion border: fetal alcohol effects Cleft lip and palate: isolated or part of a syndrome Micrognathia: Pierre Robin sequence, trisomies, Stickler syndrome Macroglossia: hypothyroidism, Beckwith-Wiedemann syndrome
Teeth	Anodontia: ectodermal dysplasia Notched incisors: congenital syphilis Late dental eruption: Hunter syndrome, hypothyroidism Talon cusps: Rubinstein-Taybi syndrome Wide-spaced teeth: Cornelia de Lange syndrome, Angelman syndrome



**Table 56.5** Physical Examination of a Child with Suspected Developmental Disabilities—cont'd

ITEM	POSSIBLE SIGNIFICANCE
<b>EYES</b>	
Set	Hypertelorism: fetal hydantoin syndrome, Waardenburg syndrome Hypotelorism: holoprosencephaly sequence, maternal phenylketonuria effect
Prominent	Crouzon, Seckel, Apert syndrome; Beckwith-Wiedemann syndrome and fragile X syndromes
Iris/sclera	Brushfield spots: Down syndrome Lisch nodules: neurofibromatosis Blue sclera: osteogenesis imperfecta, Turner syndrome, hereditary connective tissue disorders
Cataract	Galactosemia, Lowe syndrome, prenatal rubella, hypothyroidism
Cherry-red spot in macula	Gangliosidosis (GM <sub>1</sub> ), metachromatic leukodystrophy, mucopolipidosis, Tay-Sachs disease, Niemann-Pick disease, Farber lipogranulomatosis, sialidosis type III
Chorioretinitis	Congenital infection with cytomegalovirus, toxoplasmosis, Zika virus, or rubella
Corneal cloudiness	Mucopolysaccharidosis types I and II, Lowe syndrome, congenital syphilis
<b>EARS</b>	
Low-set or malformed pinnae	Trisomies such as Down syndrome, Rubinstein-Taybi syndrome, CHARGE syndrome, cerebrooculofacioskeletal syndrome, Treacher Collins syndrome, fetal phenytoin effects
Hearing	Loss of acuity in mucopolysaccharidosis; hyperacusis in many encephalopathies
<b>HEART</b>	
Structural anomaly or hypertrophy	CHARGE syndrome, velocardiofacial syndrome, glycogenosis type II, fetal alcohol effects, mucopolysaccharidosis type I; chromosomal anomalies such as Down syndrome; maternal PKU; chronic cyanosis may impair cognitive development
<b>LIVER</b>	
Hepatomegaly	Fructose intolerance, galactosemia, glycogenosis types I-IV, mucopolysaccharidosis types I and II, Niemann-Pick disease, Tay-Sachs disease, Zellweger syndrome, Gaucher disease, ceroid lipofuscinosis, gangliosidosis
<b>GENITALIA</b>	
Macroorchidism	Fragile X syndrome
Hypogenitalism	Prader-Willi, Klinefelter, and CHARGE syndromes
<b>EXTREMITIES</b>	
Hands, feet; dermatoglyphics, creases	May indicate a specific entity such as Rubinstein-Taybi syndrome or may be associated with chromosomal anomaly Short limbs: achondroplasia, rhizomelic chondrodysplasia Small hands: Prader-Willi syndrome Clinodactyly: trisomies, including Down syndrome Polydactyly: trisomy 13, ciliopathies Broad thumb: Rubinstein-Taybi syndrome Syndactyly: de Lange syndrome Smith Lemli Opitz Transverse palmar crease: Down syndrome Joint laxity: Down syndrome, fragile X syndrome, Ehlers-Danlos syndrome Phocomelia: Cornelia de Lange syndrome
Joint contractures	Signs of muscle imbalance around the joints (e.g., with meningomyelocele, cerebral palsy, arthrogryposis, muscular dystrophy; also occurs with cartilaginous problems such as mucopolysaccharidosis) Williams syndrome
<b>SKIN</b>	
Café-au-lait spots	Neurofibromatosis, Legius syndrome, tuberous sclerosis, chromosomal aneuploidy, ataxia-telangiectasia, multiple endocrine neoplasia type 2b Fanconi anemia, Gaucher disease Syndromes: basal cell nevus; McCune-Albright, Silver-Russell, Bloom, Chediak-Higashi, Hunter, Bannayan-Riley-Ruvalcaba, Maffucci syndromes
Seborrheic or eczematoid rash	PKU, histiocytosis
Hemangiomas and telangiectasia	Sturge-Weber syndrome, Bloom syndrome, ataxia-telangiectasia; Klippel Trenaunay Weber
Hypopigmented macules, streaks, adenoma sebaceum	Tuberous sclerosis, hypomelanosis of Ito
Hair	Hirsutism: De Lange syndrome, mucopolysaccharidosis, fetal phenytoin effects, cerebrooculofacioskeletal syndrome, trisomy 18, Hurler syndrome Low hairline: Klippel-Feil sequence, Turner syndrome Sparse hair: Menkes disease, argininosuccinic acidemia, biotin deficiency Abnormal hair whorls/posterior whorl: chromosomal aneuploidy (e.g., Down syndrome) Hypertrichosis cubiti (elbows): Wiedemann-Steiner, MacDermot-Patton-Williams syndromes Abnormal eyebrow patterning: Cornelia de Lange syndrome

Continued

**Table 56.5** Physical Examination of a Child with Suspected Developmental Disabilities—cont'd

ITEM	POSSIBLE SIGNIFICANCE
Nails	Hypoplastic or dysplastic: fetal alcohol, trisomies, Coffin Siris syndrome
<b>NEUROLOGIC</b>	
Asymmetry of strength and tone	Focal lesion, hemiplegic cerebral palsy
Hypotonia	Prader-Willi, Down, and Angelman syndromes; gangliosidosis; early cerebral palsy; muscle disorders (dystrophy or myopathy)
Hypertonia	Neurodegenerative conditions involving white matter, cerebral palsy, trisomy 18
Ataxia	Ataxia-telangiectasia, metachromatic leukodystrophy, Angelman syndrome
Spine	Sacral dimple/hairy patch: spina bifida
<b>OTHER</b>	
Neck	Webbed neck/low posterior hairline: Turner syndrome, Noonan syndrome
Chest	Shield-shaped chest: Turner syndrome Inverted nipples; congenital disorders of glycosylation

CHARGE, Coloboma, heart defects, atresia choanae, retarded growth, genital anomalies, ear anomalies (deafness); CATCH-22, cardiac defects, abnormal face, thymic hypoplasia, cleft palate, hypocalcemia, defects on chromosome 22; PKU, phenylketonuria.

Modified from Simms M. Intellectual and developmental disability. In: Kliegman RM, Lye PS, Bordini BJ, et al, (eds). *Nelson Pediatric Symptom-Based Diagnosis*. Philadelphia: Elsevier; 2018: Table 24.11, p. 376.

**Table 56.6** Common Presentations of Intellectual Disability by Age

AGE	AREA OF CONCERN
Newborn	Dysmorphic syndromes, (multiple congenital anomalies), microcephaly Major organ system dysfunction (e.g., feeding, breathing)
Early infancy (2-4 mo)	Failure to interact with the environment Concerns about vision and hearing impairments
Later infancy (6-18 mo)	Gross motor delay
Toddlers (2-3 yr)	Language delays or difficulties
Preschool (3-5 yr)	Language difficulties or delays Behavior difficulties, including play Delays in fine motor skills: cutting, coloring, drawing
School age (>5 yr)	Academic underachievement Behavior difficulties (e.g., attention, anxiety, mood, conduct)

uncertain during the early years and becomes clearer as the demands of the school setting increase.

With increasing expectations for independence at home and socially, limitations among those with mild ID become more salient. Older school-age children and adolescents with mild ID are typically up to date on current trends and are conversant as to “who,” “what,” and “where.” It is not until the “why” and “how” questions are asked that their limitations become apparent. If allowed to interact at a superficial level, their mild ID might not be appreciated, even by professionals such as healthcare providers. Because of the stigma associated with ID, adolescents may refer to themselves as learning disabled, dyslexic, language disordered, or slow learners. Some people with ID emulate their social milieu to be accepted. Adolescents with mild ID are both at high risk of being bullied and of being taken advantage of from a social perspective.

## ETIOLOGIC EVALUATION

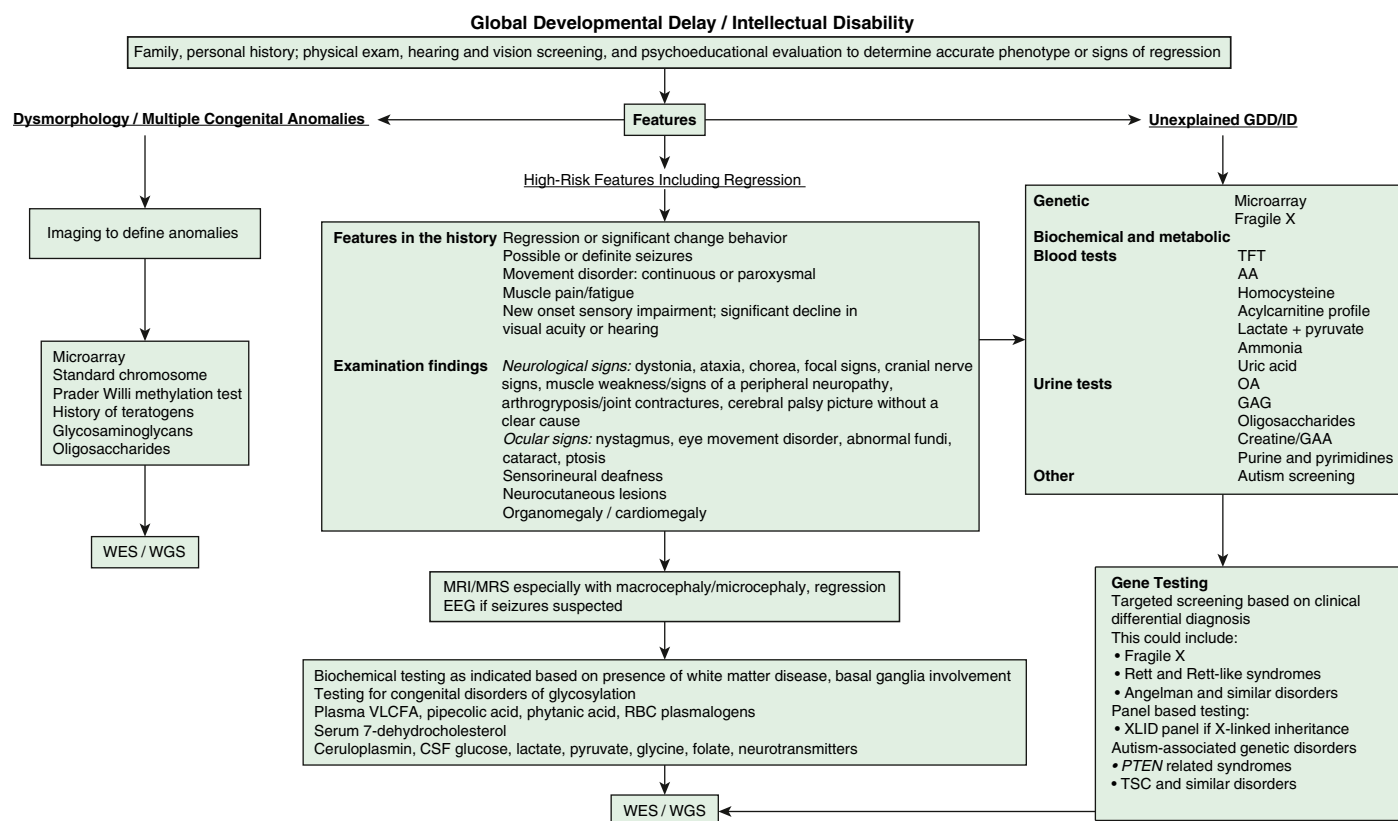
ID is one of the most frequent reasons for referral to pediatric genetic providers, with separate but similar etiologic evaluation guidelines (see Table 56.1). ID is a diagnosis of great clinical heterogeneity, with only a subset of syndromic etiologies identifiable through classic dysmorphism. If diagnosis is not made after conducting an appropriate

history and physical examination, chromosomal microarray and testing for fragile X syndrome are often the recommended first steps in the etiologic evaluation of ID. Other testing to consider in the etiologic evaluation include exome or whole genome sequencing, neuroimaging, metabolic testing, and electroencephalography (Fig. 56.1).

Decisions to pursue an etiologic diagnosis should be based on the medical and family history, physical examination, and the family's wishes. Table 56.7 summarizes clinical practice guidelines and the yields of testing to assist in decisions about evaluating the child with GDD or ID. Yield of testing tends to increase with worsening severity of delays (see also Tables 56.1 and 56.2).

**Microarray analysis** has replaced a karyotype as first-tier testing, given that it discerns abnormalities that are far below the resolution of a karyotype. Microarray analysis will detect copy number variations but may result in identification of variants of unknown significance or benign variants and therefore should be used in conjunction with a genetic consultation. Karyotyping has a role when concerns for trisomy, inversions, balanced insertions, and reciprocal translocations are present. If microarray analysis is not diagnostic, whole exome sequencing (WES) increases the diagnostic yield in children with nonsyndromic severe ID, especially when associated conditions such as autism, epilepsy, or movement disorders are present. WES will identify nucleotide sequence variants within the coding region of genes which affect protein function, missing structural and noncoding variants, and trinucleotide repeat disorders. *Starting with WES may be more cost-effective and may substantially reduce time to diagnosis with higher ultimate yields compared with the traditional diagnostic pathway.* Whole genome sequencing, which identifies variants within both exons and introns, represents the most comprehensive sequencing option, providing roughly 3,000 times more data than a microarray. Multimodal genome-wide analysis has identified monogenic etiologies in difficult to diagnose patients when previous testing did not reveal a diagnosis.

Molecular genetic testing for fragile X syndrome is currently recommended, although a relatively low diagnostic yield has led some to suggest that this should not be considered a first-line test for all children with ID or GDD. Yields are highest in males with moderate ID, unusual physical features, and/or a family history of ID or for females with more subtle cognitive deficits associated with severe shyness and a relevant family history, including premature ovarian failure or later-onset tremor-ataxia symptoms (see Chapter 59). For children with a strong history of X-linked ID, specific testing of genes or the entire chromosome may be revealing. Testing for Rett syndrome (methyl CpG-binding protein 2 [MECP2]) should be considered in females with moderate to severe disability, though WES may supplant this.



**Fig. 56.1** Algorithm for the evaluation of the child with unexplained global developmental delay (GDD) or intellectual disability (ID). AA, Amino acids; ASD, autistic spectrum disorder; CK, creatine kinase; CSF, cerebrospinal fluid; FBC, full blood count; GAA, guanidinoacetic acid; GAG, glycosaminoglycans; LFT, liver function test; OA, organic acids; TFT, thyroid function tests; TSC, tuberous sclerosis complex; U&E, urea and electrolytes; VLCFA, very long-chain fatty acids; WES, whole exome sequencing; WGS, whole genome sequencing; XLID, X-linked intellectual disability genes.

A child with a **progressive neurologic disorder, developmental regression, or acute behavioral changes** needs metabolic investigation, as shown in [Figure 56.1](#). Some advocate for metabolic testing to be done more frequently in children with ID because of the possibility of detecting a condition that could be treatable ([Fig. 56.2](#), [Tables 56.3 and 56.8](#)), though with expanded newborn screening many of these conditions can be identified at birth. This is most relevant for children born in countries without widespread newborn screening initiatives, especially when there is a history of consanguinity. In the absence of a specific indication, an **electroencephalogram (EEG)** is typically of low diagnostic utility and should be reserved for evaluation of clinical events that may represent seizures or when significant language regression occurs, which may be concerning for Landau-Kleffner syndrome. **MRI of the brain** may provide useful information in directing the care of a child with microcephaly or macrocephaly, change in head growth trajectory, asymmetric head shape, new or focal neurologic findings, or seizures. MRI can detect a significant number of subtle markers of cerebral dysgenesis in children with ID, but these markers do not usually suggest a specific etiologic diagnosis, and the risk of anesthesia may outweigh the potential benefits in young children without any additional concerning signs or symptoms.

Some children with subtle physical or neurologic findings can also have determinable biologic causes of their ID (see [Tables 56.5 and 56.6](#)). How intensively one investigates the cause of a child's ID is based on the following factors:

- ♦ What is the degree of delay, and what is the age of the child? If milder or less pervasive delays are present, especially in a younger child, etiologic yield is likely to be lower.
- ♦ Is the medical history, family history, or physical exam suggestive

of a specific disorder, increasing the likelihood that a diagnosis will be made? Are the parents planning on having additional children, and does the patient have siblings? If so, one may be more likely to intensively seek disorders for which prenatal diagnosis or a specific early treatment option is available.

- ♦ Is there a potentially treatable disorder?
- ♦ What are the parents' wishes? Some parents have little interest in searching for the cause of the ID, whereas others become so focused on obtaining a diagnosis that they have difficulty following through on interventions until a cause has been found. The entire spectrum of responses must be respected, and supportive guidance should be provided.

## DIFFERENTIAL DIAGNOSIS

One of the important roles of pediatricians is the early recognition and diagnosis of cognitive deficits. Developmental surveillance should be multifaceted. Parents' concerns and observations about their child's development should be listened to carefully. Medical, genetic, and environmental risk factors should be recognized. Infants at high risk (prematurity, maternal substance abuse, perinatal insult) should be registered in newborn follow-up programs in which they are evaluated periodically for developmental lags in the first 2 years of life; they should be referred to early intervention programs as appropriate. Developmental milestones should be recorded routinely during healthcare maintenance visits. The American Academy of Pediatrics (AAP) has formulated a schema for developmental surveillance and screening at 9, 18, 24, and 30 months of age, including general developmental and autism screens (see [Chapter 28](#)).

**Table 56.7** Suggested Evaluation of the Child with Intellectual Disability (ID) or Global Developmental Delay (GDD)

TEST	COMMENT
In-depth history	Includes prenatal, perinatal, and postnatal events (including seizures); developmental attainments; and three-generation pedigree in family history (focusing on neurologic or developmental abnormalities, miscarriages, consanguinity, etc.)
Physical examination	Particular attention to minor or subtle dysmorphisms; growth issues; neurocutaneous findings; eye and skull abnormalities; hepatosplenomegaly; and neurologic examination for focality Behavioral phenotype
Vision and hearing evaluation	Essential to detect and treat; can mask as developmental delay
Gene microarray analysis	A ~15% yield overall Better resolution than with karyotype; may identify up to twice as many abnormalities as karyotyping Often included in exome testing
Karyotype	No longer a first-line test Reserve use when concerned for trisomic/monosomic conditions, inversions and balanced insertions, or reciprocal translocations
Fragile X screen	Combined yield of 2%, preselection on clinical grounds can increase yield to 7.6%
Next-generation gene sequencing	Detects inherited and de novo point mutations, especially in nonsyndromic severe intellectual disability Whole exome sequencing gives an additional yield of about 30–40% Pilot studies of whole genome sequencing (WGS) reveal additional yield of about 15%
Neuroimaging	MRI preferred; positive findings increased by abnormalities of skull contour or microcephaly and macrocephaly or focal neurologic examination (30–40% if indicated, 10–14% if screening) Identification of specific etiologies is rare; most conditions that are found do not alter the treatment plan; need to weigh risk of sedation against possible yield
Thyroid (T <sub>4</sub> , TSH)	Near 0% in settings with universal newborn screening program
Serum lead	If there are identifiable risk factors for excessive environmental lead exposure (e.g., low socioeconomic status, home built before 1950)
Metabolic testing	Yield of 0.2–4.6% based on clinical indicators and tests performed Urine organic acids, plasma amino acids, ammonia, lactate, and capillary blood gas Focused testing based on clinical findings is warranted if lack of newborn screen results or suggestive history/exam (e.g., regression, consanguinity, hepatosplenomegaly, course facies) Tandem mass spectrometry newborn screening has allowed for identification of many disorders in the perinatal period and has decreased yield in older children; other disorders have emerged, such as congenital disorders of glycosylation (yield 1.4%) and disorders of creatine synthesis and transport (yield 2.8%)
MECP2 for Rett syndrome	1.5% of females with criteria suggestive of Rett (e.g., acquired microcephaly, loss of skills) 0.5% of males
EEG	May be deferred in absence of history of seizures or significant language regression
Repeated history and physical examination	Can give time for maturation of physical and behavioral phenotype; new technology may be available for evaluation

EEG, Electroencephalogram; CGH, comparative genomic hybridization; MECP2, methyl CpG-binding protein 2; T<sub>4</sub>, thyroxine; TSH, thyroid-stimulating hormone.  
Data from Michelson DJ, Shevell MI, Sheer EH, et al. Evidence report. Genetic and metabolic testing on children with global developmental delay: Report of the Quality Standards Subcommittee of the American Academy of Neurology and the Practice Committee of Child Neurology. *Neurology*. 2011;77:1629–1635; Curry CJ, Stevenson RE, Aughton D, et al. Evaluation of mental retardation: Recommendations of a Consensus Conference: American College of Medical Genetics. *Am J Med Genet*. 1997;12:72:468–477; Shapiro BK, Batshaw ML. Mental retardation. In: Burg FD et al: *Gellis and Kagan's Current Pediatric Therapy*, 18th ed, Philadelphia: Saunders; 2005; and Shevell M, Ashwal S, Donley D, et al. Practice parameter: Evaluation of the child with global developmental delay. *Neurology*. 2003;60:367–380.

Before making the diagnosis of ID, other disorders that affect cognitive abilities and adaptive behavior should be considered. These include conditions that mimic ID and others that involve ID as an associated impairment. Sensory deficits (severe hearing and vision loss), communication disorders, refractory seizure disorders, poorly controlled mood disorders, or unmanaged severe attention deficits can mimic ID; certain progressive neurologic disorders can appear as ID before regression is appreciated. Approximately half of children with **cerebral palsy** (see Chapter 638.1) and one third of children with **autism spectrum disorder** (see Chapter 58) also have ID. Differentiation of isolated CP from ID relies on motor skills being more affected than cognitive skills and on the presence of pathologic reflexes and tone changes. Importantly, cognitive testing may be limited because of motor and communication impairments in CP such that an accurate

diagnostic assessment often hinges on evaluation by a professional with experience with this population.

In ASD, social communication and social adaptive skills are more affected than nonverbal reasoning skills, whereas in ID, there are usually more equivalent deficits in social, fine motor, adaptive, and cognitive skills. The discrepancy between social communication abilities and overall developmental abilities and the presence, severity, and intensity of restricted and repetitive behaviors differentiates whether an individual has ID alone or a comorbid diagnosis of ASD. Among toddlers with ASD, those with lower verbal and nonverbal cognitive test scores in conjunction with poor adaptive skills have an 85–90% chance of being classified as having ID in adulthood. However, across all levels of cognition in ASD, there is a significant trend toward much lower adaptive functioning than would be expected otherwise.



<u>Urine Tests</u>	<ul style="list-style-type: none"> <li>▶ β-Ketothiolase Deficiency</li> <li>▶ Cobalamin A Deficiency</li> <li>▶ Cobalamin B Deficiency</li> <li>▶ Cobalamin C Deficiency (&amp;tHcy)</li> <li>▶ Cobalamin D Deficiency (&amp;tHcy)</li> <li>▶ Cobalamin F Deficiency (&amp;tHcy)</li> <li>▶ Ethylmalonic Encephalopathy (&amp;ACP)</li> <li>▶ Glutaric Acidemia type I</li> <li>▶ Glutaric Acidemia type II</li> <li>▶ HMG-CoA Lyase Deficiency</li> <li>▶ Holocarboxylase Synthetase Deficiency</li> <li>▶ Homocystinuria</li> <li>▶ I.o. Isovaleric Acidemia (&amp;ACP)</li> <li>▶ 3-Methylcrotonyl Glycinuria (&amp;ACP)</li> <li>▶ 3-Methylglutaconic Aciduria</li> <li>▶ I.o. Methylmalonic Acidemia (&amp;ACP)</li> <li>▶ MHBD Deficiency</li> <li>▶ mHMG-CoA Synthase Deficiency</li> <li>▶ I.o. Propionic Acidemia (&amp;ACP)</li> <li>▶ SCOT Deficiency</li> <li>▶ SSADH Deficiency</li> <li>▶ Tyrosinemia type II (&amp;PAA)</li> </ul>
Urine Organic Acids (n=22)	
Urine Glycosaminoglycans (n=7)	<ul style="list-style-type: none"> <li>▶ Hunter syndrome (MPS II)</li> <li>▶ Hurler syndrome (MPS I)</li> <li>▶ Sanfilippo syndrome (type a, b, c, d)</li> <li>▶ Sly syndrome (MPS VI)</li> </ul>
Urine Creatine Metabolites (n=3)	<ul style="list-style-type: none"> <li>▶ AGAT deficiency</li> <li>▶ GAMT deficiency</li> <li>▶ Creatine Transporter Defect</li> </ul>
Urine Oligosaccharides (n=2)	<ul style="list-style-type: none"> <li>▶ α-Mannosidosis</li> <li>▶ Aspartylglucosaminuria</li> </ul>
Urine Purines & Pyrimidines (n=2)	<ul style="list-style-type: none"> <li>▶ Pyrimidine 5' nucleotidase superactivity</li> <li>▶ Molybdenum Cofactor Type A deficiency</li> </ul>
<u>Blood Tests</u>	
Plasma Amino-Acids (n=13)	<ul style="list-style-type: none"> <li>▶ I.o. Argininosuccinic Aciduria</li> <li>▶ I.o. Citrullinemia</li> <li>▶ I.o. Citrullinemia Type II</li> <li>▶ I.o. CPS Deficiency</li> <li>▶ I.o. Argininemia</li> <li>▶ HHH syndrome</li> <li>▶ Maple Syrup Urine Disease (Variant)</li> <li>▶ I.o. MTHFR Deficiency (&amp;tHcy)</li> <li>▶ I.o. NAGS Deficiency</li> <li>▶ I.o. OTC Deficiency</li> <li>▶ Phenylketonuria</li> <li>▶ PDH Complex Deficiency</li> <li>▶ Tyrosinemia type II (&amp;UOA)</li> </ul>
Plasma Total Homocysteine (n=9)	<ul style="list-style-type: none"> <li>▶ Homocystinuria (&amp;UOA)</li> <li>▶ I.o. MTHFR Deficiency (&amp;PAA)</li> <li>▶ Cobalamin C Deficiency (&amp;UOA)</li> <li>▶ Cobalamin D Deficiency (&amp;UOA)</li> <li>▶ Cobalamin E Deficiency</li> <li>▶ Cobalamin F Deficiency (&amp;UOA)</li> <li>▶ Cobalamin G Deficiency</li> </ul>

**Fig. 56.2** Summary of treatable inherent errors of metabolism (IEM) that can be detected by metabolic tests in affected children, each of which is affordable and accessible and has the potential to identify at least 2 IEM (and up to 22). Each bar represents the yield of the specific screening test and lists the number and types of treatable IEM it can identify. PAA, Plasma amino acids; tHcy, total homocysteine; ACP, plasma acylcarnitine profile; UOA, urine organic acids. (From van Karnebeek CD, Stockler S. Treatable inborn errors of metabolism causing intellectual disability: A systematic literature review. *Mol Genet Metab.* 2012;105:368–381, Fig. 1, p. 374.)

<b>Table 56.8</b> Treatable Intellectual Disability Endeavor (TIDE) Diagnostic Protocol	
<b>TIER 1: NONTARGETED METABOLIC SCREENING TO IDENTIFY 54 (60%) TREATABLE IEM</b>	
Blood	Plasma amino acids, total homocysteine, acylcarnitine profile, copper, ceruloplasmin
Urine	Organic acids, purine and pyrimidines, creatine metabolites, oligosaccharides, glycosaminoglycans, amino acids (when indicated)
<b>TIER 2: CURRENT PRACTICE ADHERING TO INTERNATIONAL GUIDELINES* (ONE OR MORE OF THE FOLLOWING)</b>	
Blood	Cytogenetic testing (array CGH), thyroid studies, complete blood count, lead, metabolic testing, fragile X, targeted gene sequencing/molecular panel
Diagnostics	Brain MRI and 1H spectroscopy (where available)
Referrals	Audiology, ophthalmology
<b>TIER 3: TARGETED WORKUP TO IDENTIFY 35 (40%) TREATABLE IEM REQUIRING SPECIFIC TESTING</b>	
According to patient's symptomatology and clinician's expertise Use of digital tools ( <a href="http://www.treatable-id.org">www.treatable-id.org</a> )	
Blood	Plasma cholestanol, 7-dehydroxycholesterol:cholesterol ratio, pipercolic acid and urine α-amino adipic semialdehyde (AASA), very-long-chain fatty acids Plasma vitamin B <sub>12</sub> and folate, serum lactate to pyruvate ratio, whole blood manganese
CSF	Lactate to pyruvate ratio, amino acids, neurotransmitters, CSF to plasma glucose ratio
Urine	Urine deoxyipyridinoline
Other	Enzyme activities (leukocytes): arylsulfatase A, biotinidase, glucocerebrosidase, fatty aldehyde dehydrogenase CoQ measurement: fibroblasts Molecular analysis: <i>CASA, NPC1, NPC2, SC4MOL, SLC18A2, SLC19A3, SLC30A10, SLC52A2, SLC52A3, PDHA1, DLAT, PDHX, SPR, TH</i> genes

\*Low threshold for ordering tests.  
IEM, Inborn errors of metabolism; CSF, cerebrospinal fluid; CGH, comparative genomic hybridization; CoQ, coenzyme Q (ubiquinone).  
Adapted from Van Karnebeek CD, Stockler-Ipsiroglu S. Early identification of treatable inborn errors of metabolism in children with intellectual disability: The Treatable Intellectual Disability Endeavor protocol in British Columbia. *Paediatr Child Health.* 2014;19(9):469–471.

## DIAGNOSTIC PSYCHOLOGIC TESTING

The formal diagnosis of ID requires the administration of individual tests of intelligence and adaptive functioning.

The *Bayley Scales of Infant and Toddler Development, Fourth Edition* (BSID-4), the most used infant intelligence test, provides an assessment of cognitive, language, motor, behavior, social-emotional, and general adaptive abilities between 16 days and 42 months of age. The BSID-4 correlates more strongly with other standardized tests of cognition and motor development than did prior versions of the test and permits the differentiation of infants with severe ID from typically developing infants, but it is less helpful in distinguishing between a typical child and one with mild ID.

The most used intelligence tests for children older than 3 years are the Wechsler Scales, although others are also used. The *Wechsler Preschool and Primary Scale of Intelligence, Fourth Edition* (WPPSI-IV) is used for children with mental ages of 2.5-7.6 years. The *Wechsler Intelligence Scale for Children, Fifth Edition* (WISC-V) is used for children who function above a 6-year-old mental age. Both scales contain numerous subtests in the areas of verbal and performance skills. Although children with ID usually score low on all subscales, they occasionally score in the average range in one or more performance areas. Among children who have marked language or verbal limitations, tests like the *Differential Ability Scales-II* (DAS-II) or the *Leiter International Performance Scale, Third Edition* (Leiter-3) may be used to optimally capture nonverbal performance skills.

Several normative scales are used in practice to evaluate adaptive functioning, often through questionnaire or interview formats, with information being attained from caregivers and educators in multiple different environments when possible (home, school, work). For example, the *Vineland Adaptive Behavior Scale* (VABS-3) uses semi-structured interviews with parents and caregivers/teachers to assess adaptive behavior in four domains: communication, daily living skills, socialization, and motor skills. Other tests of adaptive behavior include the *Adaptive Behavior Assessment System* (ABAS-3), the *Woodcock-Johnson Scales of Independent Behavior-Revised*, and the *AAIDD Diagnostic Adaptive Behavior Scale* (DABS). There is usually (but not always) a good correlation between scores on the intelligence and adaptive scales in ID. However, it is important to recognize that adaptive behavior can be influenced by environmentally based opportunities and by family or cultural expectations. Basic practical adaptive skills (feeding, dressing, hygiene) are more responsive to remedial efforts than is the IQ score itself. The trajectory of adaptive skill acquisition may not be consistent over time because of the underlying condition, response to interventions, and environmental expectations.

## COMPLICATIONS AND ASSOCIATED CONDITIONS

Children with ID have higher rates of vision, hearing, neurologic, orthopedic, and behavioral or emotional disorders than typically developing children (Table 56.9). These problems are often detected later in children with ID. If untreated, the associated impairments may adversely affect the individual's outcome more than the ID itself.

The more severe the ID, the greater the number and severity of associated impairments. Knowing the cause of the ID can help predict which associated impairments are most likely to occur. For example, fragile X syndrome (see Chapter 59) and fetal alcohol syndrome (see Chapter 146) are associated with a high rate of behavioral disorders and may be amenable to certain treatments. Children with fetal alcohol syndrome may have a less robust response to stimulant use, whereas preliminary data suggest that children with fragile X syndrome may see behavioral improvements with the use of metformin. Other genetic conditions may have well-established medical comorbidities that should be screened for throughout the life span. For example, Down syndrome (see Chapter 57) has many

**Table 56.9** Conditions Associated with ID

MEDICAL/PHYSICAL CONDITIONS	DEVELOPMENTAL/PSYCHIATRIC CONDITIONS
Cerebral palsy/severe motor impairment	Attention-deficit/hyperactivity disorder
Seizures	Emotional disorders (anxiety, mood disorders, posttraumatic stress disorder)
Endocrine abnormalities (e.g., hypothyroidism, short stature)	Obsessive-compulsive disorder
GI issues (constipation, reflux)	Behavioral disorders (self-injurious behavior, aggression, adjustment disorder, disruptive behavior)
Dysphagia	Autism spectrum disorder
Other organ system anomalies (e.g., congenital heart disease, malformations)	Eating and feeding disorders
Hearing loss	Psychotic disorders
Vision impairment (refractive error, cataracts, strabismus)	Movement disorders (tics, stereotypies,)
Dental caries	Developmental coordination disorder
Lead poisoning from associated pica	Learning disabilities (difficulties not explained by cognition alone)
Sleep disorders (OSA, behavioral sleep dysfunction)	Substance abuse
Obesity	Victimization (bullying, sexual abuse, physical abuse)

GI, Gastrointestinal; OSA, obstructive sleep apnea.

medical complications (hypothyroidism, hearing and vision impairments, obstructive sleep apnea, congenital heart disease, atlantoaxial subluxation). Such associated impairments can require ongoing physical therapy, occupational therapy, speech-language therapy, behavioral therapy, adaptive and mobility equipment, glasses, hearing aids, and medication or other medical management. Failure to identify and treat these impairments can hinder successful habilitation and result in difficulties in the school, home, and neighborhood environment.

Special attention should be given to screening for accidental injury, neglect, and abuse. Children with ID have a greater risk of preventable death from accidental injury. They are more likely to be victims of frequent, continual abuse at the hands of multiple abusers and are more frequently abused by unrelated or unfamiliar perpetrators compared to typically developing peers. Up to 15–30% of children with ID are victims of sexual abuse, with female teens with ID being at highest risk. Abuse may precipitate the onset of maladaptive behaviors and changes in mood. As such, a high index of suspicion must be maintained, with the knowledge that even individuals with severe ID may be able to reliably disclose victimization and abuse.

## PREVENTION

Examples of primary programs to prevent ID include the following:

- ♦ Increasing the public's awareness of the adverse effects of alcohol and other drugs of abuse on the fetus (the most common preventable cause of ID in the Western world is fetal alcohol exposure).
- ♦ Encouraging safe sexual practices, preventing teen pregnancy, and promoting early prenatal care with a focus on preventive programs to limit transmission of diseases that may cause congenital infection (syphilis, toxoplasmosis, cytomegalovirus, HIV).
- ♦ Preventing traumatic injury by encouraging the use of safety technologies (car seats, window locks, helmets, gun locks).
- ♦ Preventing poisonings by teaching parents about securing medications and potential poisons.

- ♦ Implementing immunization programs to reduce the risk of ID caused by encephalitis, meningitis, and congenital infection.

**Presymptomatic detection** of certain disorders can result in treatment that prevents adverse consequences. State newborn screening by tandem mass spectrometry (now detecting >60 rare genetic disorders in most states), newborn hearing screening, and preschool lead poisoning prevention programs are examples. Additionally, screening for comorbid conditions can help to limit the extent of disability and maximize the level of functioning in certain populations. Annual thyroid, vision, and hearing screening in a child with Down syndrome is an example of presymptomatic testing in a disorder associated with ID.

## TREATMENT

Although the core symptoms of ID can be prevented in some conditions, they are generally not treatable once ID is diagnosed. Many associated impairments are amenable to intervention and therefore benefit from early identification. Most children with an ID do not have a behavioral or emotional disorder as an associated impairment, but challenging behaviors (aggression, self-injury, oppositional defiant behavior) and internalizing disorders (mood and anxiety disorders) occur with greater frequency in this population than among children with typical intelligence. These behavioral and emotional disorders are the primary cause for out-of-home placements, increased family stress, reduced employment prospects, and decreased opportunities for social inclusion. Some behavioral and emotional disorders are difficult to diagnose in children with more severe ID because of the child's limited abilities to understand, communicate, interpret, or generalize. Other disorders are masked by the ID. The detection of ADHD (see Chapter 50) in the presence of moderate to severe ID may be difficult, as may be discerning a thought disorder (psychosis) in someone with autism and ID.

**Behavioral disorders** in ID often result from a mismatch between the child's abilities and the demands of the situation, organic problems, and family difficulties. These behaviors may represent attempts by the child to communicate, gain attention, gain access to desired tangibles, escape certain demands, exert control, or avoid frustration. Determining the antecedents, functions, and consequences of behavior can help in developing an effective behavior intervention plan. The most formal iteration of this is a functional behavioral assessment carried out by a well-trained behavior analyst. In assessing the challenging behavior, one must also consider whether it is inappropriate for the child's *mental or developmental age*, rather than the *chronological age*. However, if the behavior is dangerous to the individual or the external world, intervention is required regardless of whether it is "appropriate" for their developmental age. When intervention is needed, an environmental change, such as a more appropriate classroom setting, may improve certain behavior problems. Behavior management techniques and parent training are valuable; psychopharmacologic agents may be appropriate in certain situations, such as aggression or self-injurious behaviors with high levels of intensity and frequency.

No medication has been found that improves the core symptoms of ID. However, several agents are being tested in specific disorders with known biologic mechanisms (e.g., mTOR inhibitors in tuberous sclerosis and PTEN disorder), with the hope for future pharmacologic options that could alter the natural course of cognitive impairment seen in patients with these disorders. Medication is most useful in the treatment of associated behavioral and psychiatric disorders that do not respond to initial behavioral approaches and environmental manipulation. Additionally, underlying medical disorders and abuse/neglect should be considered as part of the differential before medication initiation in patients with self-injury, aggression, irritability, or significant disruptive behaviors.

Medications used among individuals with ID generally target specific associated symptom complexes, including inattention, impulsivity, and hyperactivity (stimulant medications and alpha-agonists); self-injurious behavior and aggression (antipsychotics); anxiety, obsessive-compulsive disorder, and depression (selective serotonin

reuptake inhibitors); and sleep-related dysfunction (melatonin, alpha-agonists, gabapentin, trazodone). Even if a medication proves successful, its use should be reevaluated at least yearly to assess the need for continued treatment of the target behaviors and improvements in functional goals. Generally, medications should be started at a low dose and increased slowly, with frequent assessments of whether benefits outweigh any adverse effects. Adverse effects and idiosyncratic responses to medications may be more common in this population.

## PRIMARY CARE, SUPPORTIVE CARE, AND MANAGEMENT

Each child with ID needs a medical home with a primary care clinician who is readily accessible to the family to answer questions, help coordinate care, and discuss concerns. Healthcare clinicians can have effects on patients and their families that are still felt decades later. The role of primary care includes involvement in prevention efforts, early diagnosis, identification and management of associated deficits, longitudinal developmental surveillance and screening, referral for appropriate diagnostic and therapeutic services, interdisciplinary management, provision of anticipatory guidance (see Chapter 13), and advocacy for the child and family. The management strategies for children with an ID should be multimodal, with efforts directed at all aspects of the child's life: health, education, social and recreational activities, behavior problems, and associated impairments. Support for parents and siblings should also be provided (Table 56.10). A strengths-based approach focusing on optimizing participation in all aspects of life tends to be more beneficial than an exclusive focus on cognitive or academic skill attainment. Goals of overall care should include maximizing the individual's independent functioning, identifying effective communication strategies, preserving and enhancing physical fitness and well-being, supporting positive relationship building, and ensuring opportunities for the individual to participate fully in the community and find purpose and enjoyment in life activities. Goals should be individualized, flexible, appropriate, and attainable.

The AAP has published a series of guidelines and/or toolkits for health supervision of children with specific disorders associated with ID (Down syndrome, fragile X syndrome, Williams syndrome, fetal alcohol spectrum disorder). Another source for disorder-specific information can be found at <https://www.medicalhomeportal.org/diagnoses-and-conditions>.

Goals should be considered and programs adjusted as needed during the primary care visit. Decisions should also be made about what additional information is required for future planning or to explain why the child is not meeting expectations. Other evaluations, such as formal neuropsychologic or educational testing, can be helpful for diagnostic clarification, attaining more appropriate school-based supports, understanding strengths and challenges, or assisting with the process of transition at various time points.

## Interdisciplinary Management

The primary care clinician has the responsibility for consulting with other disciplines to make the diagnosis of ID and coordinate treatment services. Consultant services may include speech-language pathology, physical therapy, occupational therapy, psychology, audiology, nutrition, nursing, and social work, as well as medical specialties such as neurodevelopmental disabilities, neurology, genetics, physical medicine and rehabilitation, psychiatry, developmental-behavioral pediatrics, and surgical specialties. Contact with early intervention and school personnel is equally important to help prepare and assess the adequacy of the child's individual family service plan or individual education plan. The family should be an integral part of the planning and direction of this process. Care should be family centered and culturally sensitive; for older children, their participation in planning and decision-making should be promoted to whatever extent possible. Goal setting should be appropriate, individualized, and achievable.

**Table 56.10** Resource List for Families by Category

Advocacy	Consortium for Citizens with Disabilities	<a href="http://www.c-c-d.org/">http://www.c-c-d.org/</a>
	The Arc	<a href="https://thearc.org/">https://thearc.org/</a>
	American Association on Intellectual and Developmental Disabilities	<a href="https://www.aaid.org/">https://www.aaid.org/</a>
	Council for Exceptional Children	<a href="https://exceptionalchildren.org/">https://exceptionalchildren.org/</a>
	The National Disability Rights Network	<a href="https://www.ndrn.org/">https://www.ndrn.org/</a>
	Ollibean	<a href="https://ollibean.com/">https://ollibean.com/</a>
	TASH	<a href="https://tash.org/">https://tash.org/</a>
	National Association for Councils on Developmental Disabilities	<a href="https://www.nacdd.org/">https://www.nacdd.org/</a>
Assistive Technology	Rehabilitation Engineering and Assistive Technology Society of North America	<a href="http://www.resna.org">www.resna.org</a>
	AT Network	<a href="http://www.atnet.org">www.atnet.org</a>
	Association of Assistive Technology Act Programs (ATAP)	<a href="http://www.atap.org">www.atap.org</a>
	Guide to Software Accessibility for the Disabled	<a href="http://ithare.com/guide-to-software-accessibility-for-the-disabled/">ithare.com/guide-to-software-accessibility-for-the-disabled/</a>
Behavior and Mental Health	National Association for the Dually Diagnosed (NADD)	<a href="http://www.thenadd.org">www.thenadd.org</a>
	Behavior Analyst Certification Board	<a href="http://www.bacb.com">www.bacb.com</a>
	Challenging behaviors in I/DD informational article	<a href="https://milnepublishing.geneseo.edu/instruction-in-functional-assessment/chapter/chapter-1-challenging-behaviors-of-individuals-with-developmental-disabilities/">https://milnepublishing.geneseo.edu/instruction-in-functional-assessment/chapter/chapter-1-challenging-behaviors-of-individuals-with-developmental-disabilities/</a>
	Challenging Behaviors Toolkit	<a href="https://www.autismspeaks.org/sites/default/files/2018-08/Challenging%20Behaviors%20Tool%20Kit.pdf">https://www.autismspeaks.org/sites/default/files/2018-08/Challenging%20Behaviors%20Tool%20Kit.pdf</a>
Early Intervention	Zero to Three	<a href="http://www.zerotothree.org/">www.zerotothree.org/</a>
	Pathways.org	<a href="https://pathways.org/">https://pathways.org/</a>
	First Signs Campaign	<a href="http://www.firstsigns.org/">http://www.firstsigns.org/</a>
	Early intervention overview	<a href="https://www.parentcenterhub.org/ei-overview/">https://www.parentcenterhub.org/ei-overview/</a>
	CDC Early intervention information	<a href="https://www.cdc.gov/ncbddd/actearly/parents/states.html">https://www.cdc.gov/ncbddd/actearly/parents/states.html</a>
	CDC developmental milestones	<a href="https://www.cdc.gov/ncbddd/actearly/milestones/index.html">https://www.cdc.gov/ncbddd/actearly/milestones/index.html</a>
Special Education and Inclusion	Parent Training and Information Centers (PTIs)	<a href="https://www.parentcenterhub.org/find-your-center/">https://www.parentcenterhub.org/find-your-center/</a>
	Iris Center (Inclusion)	<a href="https://iris.peabody.vanderbilt.edu/">https://iris.peabody.vanderbilt.edu/</a>
	Understood.org	<a href="https://www.understood.org/pages/en/learning-thinking-differences/">https://www.understood.org/pages/en/learning-thinking-differences/</a>
	WrightsLaw.com	<a href="http://www.wrightslaw.com/advoc/ltrs/inclusion_right_suzanne.htm">http://www.wrightslaw.com/advoc/ltrs/inclusion_right_suzanne.htm</a>
	Institute for Community Inclusion	<a href="http://www.communityinclusion.org">http://www.communityinclusion.org</a>
	Kids Included Together	<a href="https://www.kit.org/what-we-do/inclusion-resources/">https://www.kit.org/what-we-do/inclusion-resources/</a>
	Kidstogether.org	<a href="http://www.kidstogether.org/">http://www.kidstogether.org/</a>
Postsecondary Education	PACER Center	<a href="http://www.PACER.org/transition">www.PACER.org/transition</a>
	National Center for College Students with Disabilities	<a href="https://www.nccsdonline.org/">https://www.nccsdonline.org/</a>
	DREAM: Disability Rights, Education, Activism, and Mentoring	<a href="https://www.dreamcollegedisability.org/">https://www.dreamcollegedisability.org/</a>
	Guide to Paying for College for People with Disabilities	<a href="https://lendedu.com/blog/paying-for-college-for-people-with-disabilities/">https://lendedu.com/blog/paying-for-college-for-people-with-disabilities/</a>
	Affordable Colleges Online College Resources for Students with Disabilities	<a href="https://www.affordablecollegesonline.org/college-resource-center/resources-for-students-with-disabilities/">https://www.affordablecollegesonline.org/college-resource-center/resources-for-students-with-disabilities/</a>



**Table 56.10** Resource List for Families by Category—cont'd

Transition, Vocational Training, Employment, and Community Participation	The Arc	<a href="https://thearc.org/">https://thearc.org/</a>
	Best Buddies International	<a href="https://www.bestbuddies.org/">https://www.bestbuddies.org/</a>
	Easter Seals	<a href="https://www.easterseals.com/EasterSeals.com">https://www.easterseals.com/EasterSeals.com</a>
	Got Transition	<a href="https://www.gottransition.org/">https://www.gottransition.org/</a>
	Project SEARCH	<a href="https://www.projectsearch.us/Project%20SEARCH">https://www.projectsearch.us/Project SEARCH</a>
	Recruit Disability job listings	<a href="https://www.recruitdisability.org/">https://www.recruitdisability.org/</a>
	Rehabilitation Services Administration	<a href="https://rsa.ed.gov/">https://rsa.ed.gov/</a>
	Work Incentives Planning and Assistance Project Fact Sheet	<a href="https://www.ssa.gov/disabilityresearch/wi/generalinfo.htm">https://www.ssa.gov/disabilityresearch/wi/generalinfo.htm</a>
	Respectability	<a href="https://www.respectability.org/resources/Job-Seekers-Disabilities/">https://www.respectability.org/resources/Job-Seekers-Disabilities/</a>
	Employer assistance and Resource Network on Disability Inclusion	<a href="https://askearn.org/">https://askearn.org/</a>
What Can You Do? Resources for Employers	<a href="https://www.whatcanyoudocampaign.org/where-to-learn-more/resources-for-employers/">https://www.whatcanyoudocampaign.org/where-to-learn-more/resources-for-employers/</a>	
Recreation	Special Olympics	<a href="https://www.specialolympics.org/">https://www.specialolympics.org/</a>
	Summer camp locator	<a href="https://www.veryspecialcamps.com/">https://www.veryspecialcamps.com/</a>
Parent and Family Resources	Family Voices	<a href="https://familyvoices.org/lfpp/f2fs/">https://familyvoices.org/lfpp/f2fs/</a>
	Parents Helping Parents	<a href="https://www.php.com/">https://www.php.com/</a>
	Eparent.com	<a href="http://www.eparent.com">http://www.eparent.com</a>
	Community Parent Resource Centers (CPRCs)	<a href="https://www.parentcenterhub.org/find-your-center/">https://www.parentcenterhub.org/find-your-center/</a>
	Summer camp options for siblings of children with I/DD	<a href="https://www.veryspecialcamps.com/summer/siblings-camps/">https://www.veryspecialcamps.com/summer/siblings-camps/</a>
Government Initiatives and Services	Policy information on SSI for children with disabilities	<a href="https://www.cbpp.org/research/social-security/ssi-a-lifeline-for-children-with-disabilities">https://www.cbpp.org/research/social-security/ssi-a-lifeline-for-children-with-disabilities</a>
	Supplemental security income and social security disability insurance – beneficiaries with I/DD	<a href="https://www.ssa.gov/policy/docs/ssb/v77n1/v77n1p17.html">https://www.ssa.gov/policy/docs/ssb/v77n1/v77n1p17.html</a>
	Centers for Medicare and Medicaid Services	<a href="http://www.cms.gov">http://www.cms.gov</a>
	Home- and community-based waiver programs	<a href="https://www.medicaid.gov/medicaid/home-community-based-services/index.html">https://www.medicaid.gov/medicaid/home-community-based-services/index.html</a>
	Achieving a Better Life Experience (ABLE) Accounts – ABLE national resource center	<a href="https://www.ssa.gov/ssi/spotlights/spot-able.html">https://www.ssa.gov/ssi/spotlights/spot-able.html</a> <a href="https://www.ssa.gov/ssi/spotlights/spot-able.html">https://www.ssa.gov/ssi/spotlights/spot-able.html</a> <a href="https://www.ablencr.org/">https://www.ablencr.org/</a>
	Association of University Centers on Disabilities	<a href="http://www.aucd.org/directory/directory.cfm">http://www.aucd.org/directory/directory.cfm</a>
	Administration for Community Living	<a href="https://acl.gov/www.acl.gov/programs/aidd/index.aspx">https://acl.gov/www.acl.gov/programs/aidd/index.aspx</a>
	Division on Developmental Disabilities (DDD)	<a href="http://daddcec.org/Home.aspx">http://daddcec.org/Home.aspx</a> <a href="http://www.acl.gov/programs/aidd/index.aspx">www.acl.gov/programs/aidd/index.aspx</a>
	National Association of States Directors of Developmental Disabilities Services (NASDDDS)	<a href="http://www.nasddd.org">http://www.nasddd.org</a> <a href="http://daddcec.org/Home.aspx">http://daddcec.org/Home.aspx</a>
	Division on Developmental Disabilities (DDD)	Individual state websites
Disorder-Specific Groups	Epilepsy	<a href="http://www.epilepsyfoundation.org">http://www.epilepsyfoundation.org</a>
	Autism	<a href="http://www.autismspeaks.org">www.autismspeaks.org</a> <a href="http://www.autism-society.org">www.autism-society.org</a>
	Cerebral Palsy	<a href="https://www.yourcpf.org/">https://www.yourcpf.org/</a>
	There are other disorder-specific groups that are too numerous to list here, which include large national networks for more common syndromes such as Down syndrome (e.g., <a href="http://www.ndss.org">http://www.ndss.org</a> , <a href="https://www.ndscenter.org/">https://www.ndscenter.org/</a> ) or fragile X syndrome ( <a href="http://www.fragilex.org">http://www.fragilex.org</a> ) and smaller support groups for more rare disorders (many of which can be located through the unique website at <a href="https://rarechromo.org/">https://rarechromo.org/</a> ).	

Continued

**Table 56.11** Severity of Intellectual Disability and Adult-Age Functioning

LEVEL	SUPPORT LEVEL	FUNCTIONAL AGE EQUIVALENT AS ADULT	ADULT ADAPTATION
Mild	Intermittent	9-11 yr	Reads at fourth- to fifth-grade level; simple multiplication and division; can write a simple list or letter; completes job application; basic independent job skills (arrive on time, stay at task, interact with coworkers); uses public transportation, might qualify for driver's license; keeps house, cooks using recipes; challenges with planning and money management; at risk of being manipulated by others; may need support for making decisions in healthcare, shopping, finances, and raising a family.
Moderate	Limited	6-8 yr	Sight-word reading; copies information (e.g., address from card to job application); matches written number to number of items; recognizes time on clock; communicates; some independence in self-care; housekeeping with supervision or cue cards; meal preparation, can follow picture recipe cards; job skills learned with much repetition; employment in a supported environment; use of public transportation with some supervision; successful friendships attained, but social judgment and life decisions require support.
Severe	Extensive	3-5 yr	Little understanding of written language or number, time, and money concepts; needs extensive supports for problem solving; trainable in some basic activities of daily living, but needs some level of continuous support and supervision for most activities; might communicate wants and needs with use of basic words, phrases, gestures, or with the use of augmentative and alternative communication techniques; trainable in some basic activities of daily living.
Profound	Pervasive	<3 yr	Dependent for self-care, continence, communication needs with supports required for all activities of everyday living; co-occurring physical and sensory limitations are common; may use objects in a goal-directed fashion for recreation or self-care; limited understanding of symbolic communication, but may understand some gestures and emotional cues; uses nonverbal expressions; might need complete custodial or nursing care.

Data from World Health Organization. International Statistical Classification of Diseases and Related Health Problems, 10th revision. Geneva: WHO; 2011 and American Psychiatric Association. Diagnostic and Statistical Manual of Mental Disorders, 5th ed. Washington, DC: American Psychiatric Association.

### Periodic Reevaluation

The child's abilities and the family's needs change over time. As the child grows, more information must be provided to the child and family, goals must be reassessed, and programming needs should be adjusted. A periodic review should include information about the child's health status and the child's functioning at home, at school, and in other community settings. Other information, such as psychologic or educational testing, may be helpful. Reevaluation should be undertaken at routine intervals (every 6-12 months during early childhood), at any time the child is not meeting expectations, or when the child is moving from one service delivery system to another. This is especially true during the transition to adulthood, beginning at age 16, as mandated by the IDEA Amendments of 2004, and lasting through age 21, when care should be transitioned to adult-based systems and providers (see Chapter 152).

### Federal and Education Services

Education is the single most important discipline involved in the treatment of children with an ID. In the United States, the IDEA, Part B, mandates a free and appropriate public education (FAPE) in the least restrictive environment (LRE) for all school-age children (3-21 years of age). Additionally, Part C mandates early intervention services from birth through 36 months of age to be delivered in a natural environment (usually home) for all qualifying infants and toddlers. The developmental and educational program for children with GDD or ID must be relevant to the child's unique needs and address the child's individual strengths and challenges. The child's

developmental level, requirements for support, and goals for independence provide a basis for early intervention services to establish an **individualized family service plan (IFSP)**, which focuses on the family's needs to help them optimize the development of their child. For children over 36 months of age, the school system develops an **individualized education program (IEP)**, which focuses on the child's educational needs. Inclusive education seeks to support the right of every child, regardless of ability, to participate in a broad range of activities and contexts as full members of families, communities, and societies with an effort to maximize access, participation, and supports. Research on inclusion reveals benefits for individuals with disabilities and for typically developing children. As such, to the maximum extent appropriate, children with disabilities should be educated with children who do not have disabilities. In general, removal from the regular educational environment should occur only when the nature or severity of the child's disability is such that education in regular classes with the use of supplementary aids and services cannot be achieved satisfactorily, not simply because significant curriculum modifications are needed. Children who are educated in more inclusive settings, regardless of overall developmental level, tend to have higher rates of community participation as adults. Behavioral challenges are the most limiting factor in terms of full inclusion, both in school and within the community, emphasizing the importance of implementing early and consistent behavior management strategies.

Beyond education services, families of children with ID often are eligible for federal or state-provided social services. All states offer developmental disabilities programs that provide home and

community-based services to eligible children and adults, potentially including in-home supports, care coordination services, residential living arrangements, vocational and employment support programs, and additional therapeutic options. A variety of Medicaid waiver programs are also offered for children with disabilities within each state. Children with ID who live in low-income-status households can qualify to receive supplemental security income (SSI), but many of these families do not receive the benefits to which they are eligible.

### Leisure and Recreational Activities

The child's social and recreational needs should be addressed. Although young children with ID are generally included in play activities with children who have typical development, adolescents with ID often do not have opportunities for enriching social interactions. Community participation among adults with ID is much lower than that of the typical population even though these individuals tend to have the same preferences and wishes for leisure activities as their nondisabled peers. Individuals with ID experience high rates of marginalization, especially from involvement in formal recreational programs, often because of insufficient resources to accommodate participation, difficulties with expenses and transportation, and so forth. To reduce isolation, ideas for inclusion in leisure activities should be explored with families, including church group involvement, Boy and Girl Scout chapters, 4H clubs, local park district programs, and musical opportunities like choir and instrumental lessons. Participation in sports should be encouraged (even if the child is not competitive) because it offers many benefits, including weight management, development of physical coordination, maintenance of cardiovascular fitness, and improvement of self-image. Inclusion in class trips, dances, dating, and other social events should be encouraged. International programs such as Special Olympics and Best Buddies International seek to enhance inclusion and visibility of individuals with disabilities and can be a valuable resource.

### Family Counseling

Many families adapt well to having a child with ID, but some have emotional or social difficulties. The risks of parental depression and child abuse and neglect are higher in this group of children than in the general population. The factors associated with good family coping and parenting skills include stability of the marriage, good parental self-esteem, limited number of siblings, higher socioeconomic status, lower degree of disability or associated impairments (especially behavioral), parents' appropriate expectations and acceptance of the diagnosis, supportive extended family members, and availability of community programs and respite care services. In families in whom the emotional burden of having a child with ID is great, family counseling, parent support groups, sibling support groups and camps, respite care, and home health services should be an integral part of the treatment plan.

### Transition to Adulthood

The transition to adulthood can present a stressful and chaotic time for the adolescent with ID and their family (see Chapter 152). A successful transition correlates with better quality of life but requires significant advanced planning. The transition process for those with ID extends beyond medical care and needs to include education and employment, health and well-being, finances and independence, and social and community life. Specific issues include:

- ♦ Decision-making (supported decision-making, guardianship, power of attorney)
- ♦ Accessing and securing social benefits for which the person is eligible (e.g., SSI, Medicaid)
- ♦ The choice of living arrangements and necessary supports (inde-

pendent living, shared living arrangements, or living with parents; community-integrated living arrangements; group homes)

- ♦ Estate planning for the parents (ABLE accounts, special needs trust)
- ♦ Postsecondary training (vocational choices, postsecondary education – [pacer.org](http://pacer.org))
- ♦ Community participation and involvement in leisure activities (e.g., community service and volunteering activities, religious groups, Special Olympics, Best Buddies, local clubs)

Successful transition is difficult to achieve because of policies, systems, and services that are not comprehensive or coordinated. In moving from child to adult care, families tend to find that services are less readily available, more fragmented, and more difficult to navigate across multiple agencies and jurisdictions.

Transition planning is a required element of the IEP process by age 16 years, and options for continued education or entry into the workforce after high school should be thoroughly considered, with the greater goal of ultimate community-based employment. Postsecondary education possibilities might involve community college or vocational training. In 2008, the U.S. Higher Education Opportunity Act (HEOA) granted students with ID access to federal financial aid to attend colleges with **Comprehensive Transition Programs (CTPs)**, which are designed for postsecondary students with ID to continue academic, career and technical, and independent living instruction to prepare for employment. As of 2019, more than 265 nondegree postsecondary programs for students with ID exist nationwide in the United States.

Although employment is a critical element of life adaptation for persons with ID, only 15% are estimated to have jobs, with significant gaps in pay and compensation compared to workers without disability. Employment selection should be “customized” to the individual's interests and abilities. Options may include participation in competitive employment, supported employment, high school-to-work transition programs, job-coaching programs, and consumer-directed voucher programs.

### Self-Advocacy

The self-advocacy movement represents an important effort by persons with ID and other disabilities to advocate for maximal autonomy and self-determination in all aspects of life. This movement is a part of the greater disabilities rights movement and represents a resistance to historical systemic injustices experienced by individuals with ID, including neglect, abuse, nonautonomy, marginalization, incarceration, sterilization, and isolation. Self-advocacy stresses that individuals with ID should be able to speak for themselves, should be involved maximally in decision-making, should be treated as equal and fully included in society, and should be given as much control over their own self-direction as possible. This movement emphasizes the tenet of “nothing about us without us” and has led to nationwide changes in terms of policy and medical and legal nomenclature. Above all, the self-advocacy movement has sought to redefine the approach to disability, moving toward a social model of acceptance, equality, accommodation, and inclusion, putting the onus on society to change its attitudes and practices rather than calling on the individual with ID to change.

### OUTCOMES

In children with severe ID or ID requiring significant supports, the prognosis is often evident by early childhood. Mild ID might not always be a lifelong disorder. Children might meet criteria for GDD at an early age, but later the disability can evolve into a more specific developmental disorder (language disorder, autism, ADHD, specific learning disability, or borderline intelligence). Others with a diagnosis of mild ID during their school years may develop sufficient adaptive behavior skills that they no longer fit the diagnosis as adolescents or young adults, or the effects of maturation and plasticity may result in children moving from one diagnostic category to another (from

moderate to mild ID). Conversely, some children who have a diagnosis of a specific learning disability or communication disorder might not maintain their rate of cognitive growth and may fall into the range of ID over time.

The apparent higher prevalence of ID in low- and middle-income countries is of concern, given the limitations in available resources. **Community-based rehabilitation (CBR)** is an effort promoted by the World Health Organization (WHO) over the past 4 decades as a means of making use of existing community resources for persons with disabilities in low-income countries, with the goal of increasing inclusion and participation within the community. CBR is now being implemented in >90 countries, although the efficacy of such programs has not been established.

The long-term outcome of persons with ID depends on the underlying cause; degree of cognitive and adaptive deficits; presence of associated medical, developmental, and behavioral impairments; capabilities of the families and schools; and availability of community supports, services, and training provided to the child and family (see [Table 56.10](#)). As adults, many persons with mild ID can gain economic and social independence with functional literacy, but they may need periodic support or supervision (especially when under social, economic, or health-related stress). Most live successfully in the community, either independently or in supervised settings. Many will marry, some will have children, and meaningful and long-lasting relationships can be expected.

For persons with moderate ID, the goals of education are to enhance adaptive abilities and “survival” academic and vocational skills, so they are better able to live and function in the adult world ([Table 56.11](#)). The concept of supported employment has been very beneficial to these individuals; the person is trained by a coach to do a specific job in the setting where the person is to work, bypassing the need for a “sheltered workshop” experience and resulting in successful work adaptation in the community and meaningful inclusion. These persons generally live at home with family or in a supervised setting in the community, such as a **community integrated living arrangement (CILA)** where different levels of supervision and support are provided depending on the needs of the individuals. There has been a strong movement away from institutionalized living, defined as residence in a facility of four or more people who did not choose to live together.

As adults, people with severe to profound ID usually require extensive to pervasive supports (see [Table 56.11](#)). These individuals often have associated impairments, such as CP, behavioral disorders, epilepsy, or sensory impairments, that further limit their adaptive functioning. They can perform simple tasks in supervised settings. Most people with this level of ID can live in the community with appropriate supports, though some may require a higher level of “institutional care” that is best provided though smaller community-run group home settings.

The life expectancy of people with mild ID is similar to the general population, with a mean age at death in the early 70s. However, persons with severe and profound ID have a decreased life expectancy at all ages, presumably from associated serious neurologic or medical disorders, with a mean age at death in the mid-50s. Given that persons with ID are living longer and have high rates of comorbid health conditions in adulthood (e.g., obesity, hypertension, diabetes), ID is now one of the costliest ICD-10 diagnoses, with an average lifetime cost of 1-2 million dollars per person. Thus the priorities for pediatric primary care are to improve healthcare delivery systems during childhood; facilitate the transition of care to adult providers; and ensure high-quality, integrated, community-based services for all persons with ID.

Visit Elsevier eBooks+ at [eBooks.Health.Elsevier.com](http://eBooks.Health.Elsevier.com) for Bibliography.

## Chapter 57

# Down Syndrome and Other Abnormalities of Chromosome Number

Mary Pipan

### PRINCIPLES OF CARING FOR CHILDREN WITH COMPLEX GENETIC DISORDERS

Down syndrome (trisomy 21) is the most common genetic cause of intellectual disability, with an incidence of 1 in 700 live births in the United States. Many of the principles of care for individuals with Down syndrome generalize to other complex genetic disorders. Genetic disorders generally affect all cells in the body, and hence tend to be multisystemic disorders. Trisomy 21's multisystem effects require monitoring of all organ systems for potential related issues.

Chromosome 21 is the smallest human autosome, which likely accounts for the relatively high fetal survival rate in trisomy 21. The clinical manifestations of *other* trisomies and aneuploidies are shown in [Tables 57.1 and 57.2](#) and [Figs. 57.1, 57.2, and 57.3](#). Fetuses with other

**Table 57.1** Chromosomal Trisomies (13, 18) and Their Clinical Findings

TRISOMY 13	TRISOMY 18
<b>HEAD AND FACE</b>	
Scalp defects (e.g., cutis aplasia)	Small and premature appearance
Microphthalmia, corneal abnormalities	Tight palpebral fissures
Cleft lip and palate in 60–80% of cases	Narrow nose and hypoplastic nasal alae
Microcephaly	Narrow bifrontal diameter
Microphthalmia	Prominent occiput
Sloping forehead	Micrognathia
Holoprosencephaly (arrhinencephaly)	Cleft lip or palate
Capillary hemangiomas	Microcephaly
Deafness	
<b>CHEST</b>	
Congenital heart disease (e.g., VSD, PDA, ASD) in 80% of cases	Congenital heart disease (e.g., VSD, PDA, ASD)
Thin posterior ribs (missing ribs)	Short sternum, small nipples
<b>EXTREMITIES</b>	
Overlapping of fingers and toes (clinodactyly)	Limited hip abduction
Polydactyly	Clinodactyly and overlapping fingers; index over third, fifth over fourth; closed fist
Hypoplastic nails, hyperconvex nails	Rocker-bottom feet
	Hypoplastic nails
<b>GENERAL</b>	
Severe developmental delays and prenatal and postnatal growth restriction	Severe developmental delays and prenatal and postnatal growth restriction
Renal abnormalities	Premature birth, polyhydramnios
1-year survival <10%	Inguinal or abdominal hernias
	1-year survival <10%

ASD, Atrial septal defect; PDA, patent ductus arteriosus; VSD, ventricular septal defect. From Behrman RE, Kliegman RM. *Nelson Essentials of Pediatrics*, 4th ed. Philadelphia: Saunders;2002: 142.



Table 57.2 Other Rare Aneuploidies and Partial Autosomal Aneuploidies		
DISORDER	KARYOTYPE	CLINICAL MANIFESTATIONS
Trisomy 8	47,XX/XY,+8	Growth and mental deficiency are variable. The majority of patients are mosaics. Deep palmar and plantar furrows are characteristic. Joint contractures are present.
Trisomy 9	47,XX/XY,+9	The majority of patients are mosaics. Clinical features include craniofacial (high forehead, microphthalmia, low-set malformed ears, bulbous nose) and skeletal (joint contractures) malformations and heart defects (60%).
Trisomy 16	47,XX/XY,+16	The most commonly observed autosomal aneuploidy in spontaneous abortion; the recurrence risk is negligible.
Tetrasomy 12p	46,XX[12]/46,XX, +i(12p) [8] (mosaicism for an isochromosome 12p)	Known as Pallister-Killian syndrome Sparse anterior scalp hair (more so temporal region), eyebrows, and eyelashes; prominent forehead; chubby cheeks; long philtrum with thin upper lip and cupid-bow configuration; polydactyly; streaks of hyperpigmentation and hypopigmentation



**Fig. 57.1** Several physical manifestations of trisomy 18. **A**, Typical profile reveals prominent occiput and low-set, posteriorly rotated malformed auricles. **B**, Clenched hand showing typical pattern of overlapping fingers. **C**, Rocker-bottom feet. (Courtesy Kenneth Garver, MD, Pittsburgh, PA.)



**Fig. 57.2** Trisomy 13 syndrome. Note sloping forehead with variable defect in facial development. (From Jones KL, Jones MC, Del Campo M. *Smith's Recognizable Patterns of Human Malformation*, 8th ed. Philadelphia: Elsevier; 2022: Fig. 1 A-C, p. 16.)



**Fig. 57.3** Trisomy 13. A and B, Note hyperconvex nails and postaxial polydactyly. C, Aplasia cutis congenita over posterior occiput. D, Scrotalization of the phallus. (From Jones KL, Jones MC, Del Campo M. *Smith's Recognizable Patterns of Human Malformation*, 8th ed. Philadelphia: Elsevier; 2022: Fig. 2, p. 17.)

full autosomal trisomies are not always viable, but partial trisomy and quatrismy (trisomy or quatrismy of only part of the chromosome) or mosaic trisomy (only part of the cell lines contain the aneuploidy) can be viable.

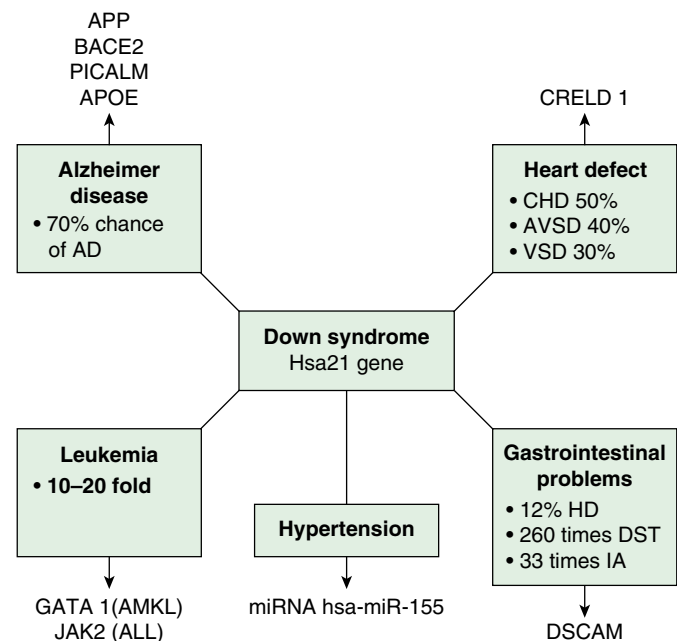
The Down syndrome phenotype can occur as a result of full trisomy 21 (95%), partial trisomy 21 (part of the 21st chromosome in triplicate), mosaic trisomy 21, or translocation. Maternal nondisjunction in meiosis is the most common cause of trisomy 21. Paternal origin accounts for less than 10%.

Chromosome abnormalities affect not only the product and function of that particular group of genes but can have upstream and downstream effects on other gene products in linked pathways. The over 314 triplicate genes in Down syndrome are known to affect the products and metabolic activity of genes from every other chromosome. Possible phenotype (condition) gene relationships in trisomy 21 are noted in Figure 57.4.

The link between children's physical health, development, and behavior becomes obvious when caring for children with complex genetic disorders. Children with developmental disabilities often cannot adequately communicate the symptoms of illness. Challenging behaviors can also interfere with adequate assessment and intervention. Too often, sources of distress, developmental challenges, and behavioral issues are attributed to the genetic disorder and dismissed by family, medical, and educational caregivers. Providing care for genetically complex children requires health and other providers to consider a range of potential differential diagnoses when presented with a change in behavior, a plateau or regression in development, or a new physical complaint.

Trisomy 21 affects brain development across the life span, leading to differences in brain anatomy, neurotransmission, and connectivity that affect processing, glial cell function, infrastructure support, energy metabolism, and in adults, the formation of amyloid plaques leading to high risk for early Alzheimer disease. Alterations in brain development and functioning affect learning, behavior, and emotions, leading to an increased incidence of neurobehavioral and psychiatric disorders such as autism spectrum disorders (ASDs), attention-deficit/hyperactivity disorder (ADHD), anxiety disorders, and depression.

It is important for the clinician to understand that children with genetic disorders are genetically more closely related to their biologic family than they are to other children with similar disorders. Children with Down syndrome will have similar patterns of familial heritability for heritable traits and medical conditions as their biologic siblings. Individuals with genetic disorders need to be seen as children/persons first who happen to have a genetic disorder. Using person-first language (child with Down syndrome, *not* Downs child) helps everyone focus on this principle.



**Fig. 57.4** Various conditions associated with Down syndrome with its causative genes. DST, Duodenal stenosis; IA, imperforate anus; HD, Hirschsprung disease; CHD, congenital heart disease; AVSD, atrioventricular septal defects; VSD, ventricular septal defect; AD, Alzheimer disease. (From Asim A, Kumar A, Muthuswamy S, et al. *Down syndrome: An insight of the disease*. *J Biomed Sci*. 2015;22:41, Fig. 1.)

## CLINICAL CHARACTERISTICS

Children with Down syndrome are at increased risk for a variety of congenital anomalies and comorbid medical conditions. Typically, they have a characteristic facial appearance and other physical characteristics that allow clinical recognition of trisomy 21 in the newborn period (Figs. 57.5 and 57.6 and Table 57.3).

The increased risk for a variety of medical conditions continues throughout the life span (Table 57.4). The American Academy of Pediatrics (AAP) has developed Down Syndrome Health Supervision Guidelines for clinicians caring for children with trisomy 21 (Table 57.5). Individuals with Down syndrome often have significant communication deficits, which can result in difficulty reporting pain and discomfort; clinicians need to pay attention to the caregiver's observation of changes in behavior when evaluating the level of pain or illness. Paying close attention to subtle cues on exam





**Fig. 57.5** Down syndrome in the neonatal period. A, Brushfield spots. B, Loose nuchal skin. C, Wide space between toes 1 and 2. D, Poor tone. E and F, Accentuation of typical face when crying. (From Jones KL, Jones MC, Del Campo M. *Smith's Recognizable Patterns of Human Malformation*, 8th ed. Philadelphia: Elsevier; 2022: Fig. 3, p. 7.)



**Fig. 57.6** Appearance of two 2-year-old children with trisomy 21. The facial appearance of children with trisomy 21 is often characterized by a low nasal bridge, small nose, small ears, up-slanting almond-shaped eyes, and epicanthal folds. (Photos courtesy of Children's Hospital of Philadelphia.)

**Table 57.3** Clinical Features of Trisomy 21 in the Neonatal Period

<p><b>CENTRAL NERVOUS SYSTEM</b> Hypotonia* Developmental delay Poor Moro reflex*</p> <p><b>CRANIOFACIAL</b> Brachycephaly with flat occiput Flat face* Upward slanted palpebral fissures* Epicanthal folds Speckled irises (Brushfield spots) Three fontanelles Delayed fontanel closure Frontal sinus and midfacial hypoplasia Mild microcephaly Short, hard palate Small nose, flat nasal bridge Protruding tongue, open mouth Small dysplastic ears*</p> <p><b>CARDIOVASCULAR</b> Endocardial cushion defects Ventricular septal defect Atrial septal defect Patent ductus arteriosus Aberrant subclavian artery Pulmonary hypertension</p>	<p><b>MUSCULOSKELETAL</b> Joint hyperflexibility* Short neck, redundant skin* Short metacarpals and phalanges Short fifth digit with clinodactyly* Single transverse palmar creases* Wide gap between first and second toes Pelvic dysplasia* Short sternum Two sternal manubrium ossification centers</p> <p><b>GASTROINTESTINAL</b> Duodenal atresia Annular pancreas Tracheoesophageal fistula Hirschsprung disease Imperforate anus Neonatal cholestasis</p> <p><b>CUTANEOUS</b> Cutis marmorata</p>
---	--

\*Hall's criteria to aid in diagnosis.

**Table 57.4** Frequency of Medical Conditions in Trisomy 21

SYSTEM	CONDITION	ESTIMATED FREQUENCY (IF KNOWN)
EYE	Cataracts (birth/after)	1.4%/5–37%
	Glaucoma	1%
	Nystagmus	18–30%
	Strabismus	19–34%
	Refractive errors	80%
	Astigmatism	67–74%
	Nasolacrimal duct obstruction	11–30%
ENT	Stenotic ear canals	50%
	Choanal atresia	
	Bifid uvula/mucosal cleft	5%
	Laryngomalacia	
	Middle ear effusions	50–90%
	Adeno/tonsillar hypertrophy Hearing loss	37–78%
DENTAL	Tooth agenesis	54–58%
	Malocclusion	>70%
	Periodontal disease	~100% under 30 years
ENDOCRINE	Congenital hypothyroidism	1:113 to 1:141 live births
	Acquired hypothyroidism	13–34%
	Subclinical hypothyroidism	7–40%
	Hyperthyroidism	6.5%
	Type 1 diabetes mellitus	0.3–1%
CARDIAC	Congenital heart disease	44–54%
	AV canal defects	42% (of CHD)
	VSD	22–35%
	ASD	8–16%
	Tetralogy of Fallot	2–4%
	Acquired mitral, tricuspid, or aortic regurgitation PDA	5–7%



**Table 57.4** Frequency of Medical Conditions in Trisomy 21—cont'd

SYSTEM	CONDITION	ESTIMATED FREQUENCY (IF KNOWN)
PULMONARY	Pulmonary hypertension	1–5%
	Subglottic stenosis	6%
	Tracheo/laryngomalacia	33% (of ENT-referred population)
	Tracheal bronchus	
	Obstructive sleep apnea	~50%
GASTROINTESTINAL	Esophageal atresia	0.5–0.9%
	Duodenal malformations	4%
	Rectoanal malformations	1%
	Hirschsprung disease	3%
	Celiac disease	5–9.8%
	GERD	14–40%
	Constipation	30–49%
GENITOURINARY	Renal/urinary tract findings	Up to 25%
HEMATOLOGY/ONCOLOGY	Transient myeloproliferative disease (TMD)	5–10%
	Acute megakaryoblastic leukemia (AMKL)	10–20% with TMD, first 4 years of life
	Acute lymphocytic leukemia	0.1–0.2%
ORTHOPEDECS	Atlantoaxial instability (AAI)	9–27%
	Symptomatic AAI	1–2%
	Recurrent joint dislocations (shoulder, knee, elbow, thumb)	1–7%
	Pes planus	91%
	Juvenile idiopathic arthritis	~1%
DERMATOLOGY	Alopecia/vitiligo	1–11%
	Hidradenitis suppurativa	2%
	Xerosis/eczema	
	Seborrheic dermatitis	
	Psoriasis	0.5–8%
NEUROLOGY	Infantile spasms	2–5%
	Seizure disorders	8% (lifetime)
	Strokes and moyamoya	
	Autism spectrum disorder	7–16%
	Early onset Alzheimer disease	~50% >50 yr
	Down syndrome disintegrative disorder	<1%

ENT, Ear/nose/throat; AV, atrioventricular; CHD, congenital heart disease; VSD, ventricular septal defect; ASD, atrial septal defect; PDA, patent ductus arteriosus; GERD, gastroesophageal reflux disease.

and asking direct questions about specific areas of pain or discomfort can be helpful (e.g., “Does your throat hurt?” while pointing to or touching their throat).

### Ophthalmology

The red reflex should be evaluated in the newborn period with a thorough ophthalmologic exam in the first 6 months of life and then annually until age 5, then every 2–3 years thereafter. Children with DS are at higher risk for cataracts, glaucoma, nystagmus, strabismus, astigmatism, refractive error, accommodative error, blepharitis, and keratoconus. Visual acuity and visual processing are foundational for development.

### Ear, Nose, and Throat

The pinna and external ear canals are often small with a predisposition to cerumen impaction. Middle ear effusion occurs in the majority of children, starting in infancy, and may require referral to an ear/nose/throat (ENT) specialist for better visualization because of stenotic ear canals. Chronic nasal congestion, choanal atresia, adenotonsillar hypertrophy, laryngo/tracheomalacia, subglottic stenosis,

and laryngeal cleft all can affect feeding and breathing, including contributing to sleep apnea. Most children with DS require regular ENT follow-up.

Many children with DS have some degree of hearing loss (HL). Most commonly this is conductive HL associated with middle ear effusion. Smaller numbers have mixed or sensorineural HL. Hearing is foundational for speech development. Hearing should be screened in the newborn period and with audiologic assessment between 6 and 9 months and every 6 months thereafter until an accurate ear-specific audiologic evaluation is obtained, then annually. Hearing assessment through auditory brainstem responses (requiring sedation) may be needed if audiologic evaluation is inconclusive. Lack of parental concern about hearing should not preclude obtaining audiologic assessment. Aggressive treatment of otitis media and middle ear effusion reduces the frequency of hearing loss.

### Dental

Children with DS often have delayed tooth eruption, malformed teeth, microdontia, permanent tooth agenesis, tooth impaction, malocclusion, and supernumerary teeth. Periodontal disease is

Action	Pre-natal	Birth up to 1 mo	1 mo up to 1 yr	1 yr up to 5 yr	5 yr up to 12 yr	12 yr up to 21 yr
1. Confirm DS diagnosis with either CVS or amniocentesis prenatally or karyotype postnatally						
2. Review recurrence risk and offer the family referral to a clinical geneticist or genetic counselor.						
3. Offer parent-to-parent and support group information to the family.						
4. Use CDC DS-specific growth charts to monitor weight, length, weight-for-length, head circumference, or BMI. Use standard charts for BMI after age 10 years.		All healthcare visits				
5. Order an echo, to be read by a pediatric cardiologist.						
6. Feeding assessment or video study if any: marked hypotonia, underweight (<5th %ile weight-for-length or BMI), slow feeding or choking with feeds, recurrent or persistent abnormal respiratory symptoms, desaturations with feeds		Any visit				
7. Obtain objective hearing assessment (may be in NBS protocols) and follow EHDI protocols.			Up to 6 mo			
8. If TM can't be visualized, refer to otolaryngologist for exam with microscope until reliable TM and tympanometry exams are possible		Every 3-6 mo				
9. Car safety seat evaluation before hospital discharge.						
10. CBC with differential		By day 3				
11. If TAM, make caregivers aware of risk/signs of leukemia (e.g., easy bruising/bleeding, recurrent fevers, bone pain)						
12. TSH		At birth (if not in NBS)	Every 5-7 mo	Annually, and every 6 mo if antithyroid antibodies ever detected		
13. RSV prophylaxis based on AAP guidelines.		Annually		Through 2 yr		
14. Discuss cervical spine-positioning for procedures and atlantoaxial stability precautions.		All HMV		Biennially		
15. Assess for CAM use, discourage any unsafe CAM practices.		All HMV				
16. Refer children to early intervention for speech, fine motor or gross motor therapy.		Any visit	Up to 3 yr			
17. If middle ear disease occurs, obtain developmentally-appropriate hearing evaluation.			When ear clear	After treatment		
18. Rescreen hearing with developmentally-appropriate methodology (BAER, behavioral, ear-specific).			Start at 6mo, every 6 mo until established normal bilaterally by ear-specific testing, then annually			
19. Refer to ophthalmologist with experience and expertise in children with disabilities.			By 6 mo			
20. CBC with differential if easy bruising or bleeding, recurrent fevers, or bone pain			Any visit			
21. Assess for sleep-disordered breathing; if present, refer to physician with expertise in pediatric sleep disorders.			At least once by 6 mo, then all subsequent HMV thereafter			
22. Ensure child is receiving developmental therapies, and family understands and is following therapy plan at home.		All HMV				
23. CBC with differential and either (1) a combination of ferritin and CRP, or (2) a combination of serum iron and Total Iron Binding Capacity				Annually		
24. If a child has sleep problems and a ferritin less than 50 mcg/L, the pediatrician may prescribe iron supplement.				Any visit		
25. Vision screening			All HMV, use developmentally-appropriate criteria	Photoscreen (all HMV); if unable, refer to ophthalmologist annually	Photoscreen (all HMV); if unable, refer to ophthalmologist biennially	Visual acuity or photoscreening at all HMV, or ophthalmology-determined schedule
26. If a child has myelopathic symptoms, obtain neutral C-spine plain films (see text for details).				Any visit		
27. Obtain polysomnogram.				Between 3-5 yr		
28. Prepare family for transition from early intervention to preschool.				At 30 mo		
29. Discuss sexual exploitation risks.				At least once	At least once	At least once
30. Make developmentally-appropriate plans for menarche, contraception (advocate/offer LARC), and STI prevention.					As developmentally-appropriate, then all subsequent HMV	
31. Discuss risk of DS if patient were to become pregnant.					At least once	At least once
32. Assess for any developmental regression.			All HMV			
33. Discuss and facilitate transitions: education, work, finance, guardianship, medical care, independent living					All HMV starting at 10 yr	

	Do once at this age		Abbreviations: DS, Down syndrome; CVS, Chorionic villus sampling; HMV, Health Maintenance Visit; BMI, Body mass index; CDC, Centers for Disease Control; EHDI, Early Hearing Detection and Intervention; NBS, Newborn screen; CAM, Complementary and alternative medicine; BAER, Brainstem auditory evoked response; TM, Tympanic membrane; TAM: transient abnormal myelopoiesis
	Do if not done previously		
	Repeat at indicated intervals		
(border)	See report for end point		

From Bull MJ, Trotter T, Santoro SL, et al. Health supervision for children and adolescents with Down syndrome. *Pediatrics*. 2022;149(5):e2022057010.

seen in the majority of individuals with DS. Starting oral health preventive programs young, close supervision and support of dental hygiene and chemical adjuvants improve outcomes. Children with DS should first see a pediatric dentist at age 1 year and follow up at least every 6 months. For children who do not tolerate dental examinations or procedures, sedated examinations may be necessary, preferably in a hospital with anesthesiologists familiar with caring for patients with DS.

### Endocrine

Children with DS are at risk for congenital and acquired hypothyroidism (HT) and hyperthyroidism (Graves disease [GD]). Thyroid testing should be done at birth as part of newborn screening. Acquired HT and GD are autoimmune disorders with elevated thyroid antibodies. Thyroid-stimulating hormone (TSH) testing can detect both HT and hyperthyroidism and should be checked by 6 months, at 1 year, and then annually thereafter. Most cases of thyroid disorders are asymptomatic and would be missed without screening. Compensated HT refers to mild elevations in TSH with normal  $T_4$ , requiring continued monitoring. Low TSH can indicate Graves disease. Children with DS who have GD can develop HT, and those with HT can develop GD. Thyroid disorder should be considered as part of the differential diagnoses with mood or behavior changes, slowing of growth, exophthalmos, high blood pressure, or tachycardia.

Type 1 diabetes mellitus (DM) is more common in children with DS. Screening for type 2 DM, especially in obese individuals, should follow similar guidelines to the typically developing (TD) population.

### Cardiac

Congenital heart disease (CHD) affects about half of all children with DS, including atrioventricular (AV) canal defects, atrial septal defect (ASD), ventricular septal defect (VSD), tetralogy of Fallot (TOF), patent ductus arteriosus (PDA), and patent foramen ovale (PFO). All children with DS should have an infant echocardiogram even with a normal physical examination. Cardiology follow-up will be based on echocardiogram findings. Signs of heart failure such as failure to thrive, tachypnea, easy fatigue, or sweating with feeds require expedited referral back to cardiology. Pulmonary hypertension can also occur in children with DS related to congenital heart defects or to respiratory illness. Later in adolescence and adulthood, clinicians should be aware of the increased risk for valvular heart disease and endocarditis.

### Pulmonary

Respiratory infections are the most common cause for hospital admission of children with DS without CHD and are a common cause of mortality in children with CHD. Respiratory compromise may present with subtle signs of respiratory distress such as tachypnea, intercostal retraction, shortness of breath, and easy fatigue with exertion. The lack of overt distress may lead clinicians to underestimate the level of respiratory compromise. Both anatomy and immunodeficiency associated with DS can lead to increased risk for upper and lower respiratory infections. Macro and micro pulmonary structural anomalies have been reported. Gastroesophageal reflux disease, swallowing dysfunction, and upper airway differences (including transesophageal [TE] fistula) increase the risk of aspiration.

### Sleep

The estimated prevalence of obstructive sleep apnea (OSA) ranges from 31% to 79%, and onset occurs from infancy through adulthood. A sleep study before the age of 4 years is recommended. Clinicians should consider ordering a sleep study at any age, with chronic signs of respiratory compromise when awake or asleep or daytime symptoms of nonrestorative sleep. There is some evidence that OSA causes difficulties in cognitive, behavioral, and adaptive

functioning in children with DS. Obesity increases the risks for OSA in many children with DS.

### Neurology

Children with DS ages 6-18 months are at increased risk for infantile spasms (IS). The outcome is often better with treatment than the non-DS population with ID but is variable, ranging from no obvious sequelae to ongoing seizure disorders, ASD, and more severe intellectual disability. In addition to the classic signs of IS, change in mental status in an infant or toddler or a plateau or regression in development should lead to prompt neurologic evaluation, including an electroencephalogram (EEG). Children with trisomy 21 are at increased risk for other seizure disorders. There is an increased risk for strokes possibly related to CHD, vascular malformations (including moyamoya syndrome), and other risk factors.

### Gastrointestinal

Most children with DS have structural or functional gastrointestinal (GI) comorbidities, many of which can affect individuals across the life span. There is evidence of abnormalities in enteric nerves affecting microanatomy and nerve function. Congenital anomalies include esophageal atresia, TE fistula and duodenal atresia, stenosis, and webs, Hirschsprung disease, and anorectal malformations. Constipation and gastroesophageal reflux disease (GERD) are frequent causes of irritability, GI discomfort, feeding issues, toileting refusal, and incontinence. There appears to be a strong association between GERD, pneumonia, and OSA. Children with DS are also at higher risk of celiac disease, which can cause GI, nutritional, and behavioral issues. The AAP guidelines do not recommend routine celiac screening, but rather to maintain a high index of suspicion with GI complaints, growth faltering, or behavioral concerns. Many others, however, have performed routine screening because many patients with DS who have celiac disease are asymptomatic; there may be a lag of 2-3 years before symptoms appear.

### Nutrition/Obesity

In infancy and early childhood, dysphagia, GI conditions, cardiac, and respiratory complications may cause failure to thrive. Weight faltering can continue for older children because of the same issues but may be more intermittent. Because of the high rates of dysphagia in infants with DS, video swallow studies should be considered when there is any sign of weight faltering, aspiration, feeding difficulties, or recurrent respiratory infections. Thickened formulas, low-flow bottles/nipples, or slower paced feeding may be required. Nasogastric (NG) or gastric tube (GT) supplementation to assure adequate nutrition may be needed. Many babies with DS can successfully breastfeed, and clinicians need to be encouraging but watchful for growth faltering.

Obesity becomes more prominent in early childhood and extending into adulthood. In school-age children with DS, those at 50% or greater on DS-specific BMI charts are in the obese range. Thus to gauge the level of overweight for children with DS, the Centers for Disease Control and Prevention (CDC) curves for BMI should be used. When children with DS gain more autonomy in feeding, overeating can become a problem. Many do not appear to satiate and will continue to eat as long as food is presented or will seek food. Caregivers therefore cannot rely on the child's satiety to determine caloric sufficiency. Decreased basal metabolic rates (reduced caloric needs) and lower physical activity can also contribute to obesity. Anticipatory guidance regarding healthy nutritional practices, meal and snack limits, and active lifestyle choices should be part of well-child visits from a young age.

### Genitourinary

Renal and urinary tract abnormalities, including ureteropelvic junction obstruction, vesicoureteral reflux, renal hypoplasia, obstructive uropathy and posterior urethral valves, hypospadias,

**Table 57.6** Neurodevelopmental, Neurobehavioral, and Psychiatric Characteristics of Trisomy 21

<b>MOTOR SKILLS</b>	
Gross motor skills	0-24 mo: Mild delays initially which widen with age At 2 years 25% walking
Oromotor	Dysphagia 0-6 mo: 50% Self-feeding delays: 70%
Fine motor skill	Early skills delays: ~75% Bimanual skill delays: 100%
<b>SPEECH AND LANGUAGE</b>	
Intelligibility	Frequently unintelligible (parent report): 5-21 yr: 54–57% Motor speech impairment: Delay: 27% Articulation: 60% Apraxia: 33% Dysfluency: Stuttering: 10–45% Cluttering (abnormally rapid or irregular pace or both): 80%
Language	Receptive: Similar to mental age–matched controls Expressive: More delayed relative to mental age–matched controls Syntax: More impaired than expressive vocabulary Pragmatics: Same variety of language functions as mental age–matched peers; may be less likely to ask for clarification
<b>SOCIAL AND EMOTIONAL DEVELOPMENT</b>	
	High sociability Joint attention compared with mental age–matched peers Strong imitation skills Pro-social empathetic responses to others in distress Underexpression of emotional distress Less frequent and shorter social referencing Reduced ability to read facial expressions More restricted repetitive behaviors and interests Average social motivation but lower social cognition
<b>COGNITION</b>	
	Intellectual disability: Mild: ~25% Moderate: ~50% Severe: ~25% Decline in IQ throughout childhood (slowing in developmental progress relative to same-age peers) Strengths: Implicit memory, visual spatial sequencing, visual spatial construction, and nonverbal memory Weaknesses: Working memory capacity, explicit memory, verbal processing, auditory short-term memory, complex visual spatial skills, executive functioning
Oppositional behaviors	70%
Aggression	4–15%
Self-injurious behavior	18%
Autism spectrum disorders	15–20%
ADHD	14–40%
Anxiety disorders	10–22%
Obsessive-compulsive disorders	0.5–4.5%
Depression	5–11%
Catatonia/Down syndrome disintegrative disorder	Multiple case series and case reports

IQ, Intelligence quotient; ADHD, attention-deficit/hyperactivity disorder.

asymptomatic renal pelvic dilatation, kidney ectopia, proteinuria and hematuria, immunoglobulin A (IgA) nephropathy, and focal segmental glomerulosclerosis, occur more frequently than in the general population. There are no current guidelines for regular surveillance, but clinicians need to maintain a high index of suspicion.

### Sexuality and Reproductive Health

Males and females with DS undergo puberty at similar ages to peers. In males, after puberty, testicular volume decreases and gonadal dysfunction worsens with age. Males are infertile, with few exceptions. Females

with DS are fertile, having a 33% chance of having a child with DS. Menstrual problems, including irregular periods, and premenstrual irritability are common reasons for use of oral contraceptives. Most females manage menstrual periods well, but there may be difficulties with hygiene. Menopause tends to occur early.

Individuals with DS are at increased risk for sexual abuse, and caregivers should discuss appropriate and inappropriate contact and relationships from an early age. Sexuality education should be included in their educational curriculum. Clinicians should discuss sexuality, birth control, and reproductive issues at health maintenance visits.



### Hematology-Oncology

AAP guidelines recommend a complete blood cell count (CBC) with differential for all newborns with DS. Neonates with DS commonly have hematologic abnormalities, including peripheral blasts, neutrophilia, thrombocytopenia, or polycythemia. Five to ten percent of neonates with DS have transient myeloproliferative disorder (TMD) (also called *transient abnormal myelopoiesis* [TAM]), which is associated with pathologic variants in *GATA1*. Typically, this resolves spontaneously within the first 1-3 months of life, but 10–20% will develop acute megakaryocytic leukemia (AMKL) in the first 4 years of life. AMKL is sensitive to treatment in most cases and has a good prognosis.

Children with DS are ~20 times more likely to get acute lymphoblastic leukemia (ALL) (1 in 900-1,000) than the typical population, which is associated with pathologic variants in *JAK2*. Treatment trials show lower response rates, higher recurrence rate, and higher treatment-related mortality.

Annual hemoglobin screening for anemia is recommended throughout childhood with additional testing for ferritin and C-reactive protein (CRP) when iron deficiency is suspected. The incidence of anemia in DS may be similar or increased compared with the general population. Other common CBC findings include macrocytosis, low white blood cell (WBC) count, and polycythemia, the clinical significance of which is unknown.

### Immunology/Allergy

Individuals with DS are more susceptible to infections because of mild to moderate T- and B-cell lymphopenia, with a decrease in naive lymphocytes, impaired mitogen-induced T-cell proliferation, reduced specific antibody responses to immunizations, and defects of neutrophil chemotaxis. Nonimmunologic anatomic factors also contribute to the increased risk of respiratory infections. Children with DS with significant numbers of serious infections or difficulty clearing infections need further immunologic evaluation.

Autoimmune disorders are also more common, including thyroid disorders, celiac disease, alopecia areata, vitiligo, type 1 DM, juvenile idiopathic arthritis, and systemic lupus erythematosus.

### Musculoskeletal

Individuals with DS have short stature across the life span and stop growing sooner than typical peers, the mechanism of which is unclear. Growth hormone is rarely deficient. Ligamentous laxity is common, especially in the ankles and feet. Inflammatory arthritis is underrecognized, and scoliosis is more common. Joint instability is most apparent in the neck (atlantoaxial instability [AAI]), hips, and knees. Joint pain and impaired mobility can contribute to motor skills deficits, impede independence, and add to behavioral difficulties.

Radiographic screening for AAI is not recommended because flexion/extension neck x-rays are not predictive for future neurologic risk. Signs and symptoms of AAI occur because of compression of the spinal cord from slippage of the C1 or C2 vertebrae, which can occur after an injury or anesthesia but can also be seen spontaneously. Neck pain, stiffness, and/or myelopathic signs and symptoms (e.g., change in gait, bowel, or bladder pattern or weakness) should prompt referral to orthopedics or neurosurgery. Universal neck precautions are recommended for all children with DS, assuming that all are at risk for injury from AAI, including limited participation in any activities that would be associated with forcible neck movement such as contact sports, diving, and universal cervical precautions with intubation procedures/surgery. Children with DS should be secured in rear-facing car seats until 40 pounds and may need harness-style car restraints over 40 pounds.

Hip instability resulting in recurrent (often painless and voluntary) hip dislocation and patellar instability can impair ambulation and may require surgical interventions.

### Dermatology

Although causing minor morbidity, dermatologic problems can be highly distressing to patients and families due to appearance (e.g., alopecia), discomfort (e.g., eczema, hidradenitis), or intractability (e.g., onychomycosis). Common conditions include folliculitis, hidradenitis suppurativa, eczematous and seborrheic dermatitis, autoimmune alopecia and vitiligo, fungal infections including tinea pedis and onychomycosis, angular cheilitis, and hyperkeratosis.

### DEVELOPMENTAL AND BEHAVIORAL CHARACTERISTICS

Development and behavior concerns are almost universal. Some concerns are easily explained and remediated and are responsive to appropriate therapeutic or behavioral interventions, but others may indicate an underlying neurobehavioral disorder such as autism, ADHD, depression, or anxiety (Table 57.6). Thinking through the categories that follow will help clinicians understand this complexity and direct families to appropriate resources.

#### Motor Skills

Children with DS often have marked delays in motor skills in early development related to hypotonia, ligamentous laxity, and lack of coordination.

Acquisition of early gross motor skills is foundational for postural control, feeding, visual motor development, socialization, and communication. Without stimulation and support, infants with DS may persist in lax postural control, further adding to motor delays. Through toddler and childhood many gradually improve but have persistent deficits in motor control and coordination and more difficulty with speed and complex postural changes, as well as persistent hypotonia. **Physical therapy** in the first years of life concentrates on core strengthening and ensuring acquisition of adaptive motor planning that supports effective ambulation. Gait abnormalities and persistent low core strength often require ongoing physical therapy. Developing physical literacy in recreational fitness activities, such as swimming, and community sports can also support health and well-being in school-age and adult years.

Oromotor skills are often delayed, with dysphagia in half of infants, requiring feeding therapy, thickening of formula, low-flow nipples, pacing between swallows, and sometimes supplemental enteral feeding. **Feeding therapy** helps young children learn to handle food boluses, chew, and drink from a cup.

Fine motor skills are also delayed, although they seem to be acquired in the same sequence as typically developing peers, but with a wider age range of acquisition. Most unaffected children are able to write their name between 60 and 72 months, but in children with DS, this usually occurs between 120 and 216 months. **Occupational therapy** often helps remediate or compensate for motor difficulties interfering with independence in activities of daily living.

#### Speech and Language Skills

Individuals with DS often have difficulty speaking clearly enough to be readily comprehensible to listeners across the life span resulting in communication breakdowns, which can be frustrating to both parties. Typical children are 90–100% intelligible by age 4 years. In individuals with DS over 50% of parents reported frequent difficulties in intelligibility over the age of 5 years into adulthood, and almost all qualify for a diagnosis of a motor speech disorder. Differences in voice quality, articulation, phonology, fluency, prosody, and motor coordination (apraxia) all contribute to making speech hard to understand (see Chapter 53). The complexity of speech impairments in children with DS requires **speech therapy** evaluation with targeted interventions for each individual.

Children with DS relative to children matched for nonverbal skills show similar abilities in receptive vocabulary but impairments in expressive vocabulary, syntax, grammar, and verbal short-term

memory indicative of a specific language impairment (SLI). The frequency of such impairments requires comprehensive language assessment for all children with DS. The language impairment may be associated with decreased ability to express thoughts and feelings verbally and use of fewer words in answer to questions or to carry on a conversation.

Misunderstandings may occur if the individual refers to past events in the present tense or thinks that something described as a future event will happen immediately. Verbal short-term memory deficits affect comprehension of more complex language (e.g., multistep instructions, complex sentences, conversation, and narrative) and reading comprehension. Visual, contextual, and multisensory supports incorporated into both receptive and expressive language can be helpful.

Speech and language intervention has been shown to be effective, especially when of higher intensity; focused on individual needs and targeted skills; and when taking into account the individual's age, interests, and motivators. Use of **applied behavior analysis** to teach communication skills improves outcomes. Incorporating interventions across contexts (classroom, home, and community settings) and into pragmatic language situations outside of structured learning settings (e.g., peer interaction, conversation) supports generalization of skills learned in therapy. For some individuals with DS, speech and language intervention will be required through school and possibly into adulthood.

### Social and Emotional Development

Social and emotional development occurs as a complex transactional process between the child and their social partners. Children with developmental delays will likely also have delays in their social interactions, social communication, and play. Children with DS often have a strong orientation toward sociability. From early infancy, mutual gaze in babies with DS emerges more slowly but once established tends to last longer, with sometimes strong preferences for looking at people as opposed to toys and other objects. Development of joint attention is commensurate with developmental age-matched peers and may be a relative strength. Strong imitation skills are noted in children with DS. Children with DS show stronger pro-social empathetic responses to others' distress, but their own expression of distress tends to be dampened (often described as high pain tolerance or, in older children, a perceived reluctance to acknowledge feelings of distress).

There are relative weaknesses in social development, which can help explain some of the social difficulties caregivers encounter. Children with DS have been shown to socially reference less frequently, with shorter glances toward others, and some have more difficulty interpreting the facial expressions of others. Older children with DS have more restricted repetitive behaviors and interests, including rigidity and insistence on sameness. Despite typical social motivation, they may have difficulties with social cognition and difficulty gaining and maintaining friendships. Having friends has been associated with improved quality of life in children with DS. Most adolescents are happy with their level of friendships, but friends may include helpers and adult companions. Leisure time is often spent at home with family or by themselves, and socializing with same-age peer-friends occurs predominantly in the context of common educational or community activities. Building healthy sustained friendships with both TD peers and those with developmental disabilities often requires active ongoing caregiver and community support to prevent social isolation and loneliness as children transition to adulthood.

### Cognition

Individuals with DS have varied degrees of intellectual and learning disabilities. Intelligence quotient (IQ) scores of adults with DS are mostly in the 40s-60s, and tests of adaptive functioning typically have standard scores in the low 50s. In children with DS, IQ scores tend to decline with age because progress is slower than same-age

peers, and deficits are more marked in higher-level thinking. Thus the gap between children with DS and same-age peers widens with age. An actual plateau in functioning before mid-adolescence or a decline at any age is not typical and should prompt thorough etiologic evaluation.

IQ scores are of limited value for intervention planning, as they provide limited information about relative strengths and weaknesses. Children with DS often have relative strengths in areas of imitation, implicit memory, visual spatial sequencing, visual spatial construction, and nonverbal memory. Relative weaknesses tend to occur in working memory capacity, explicit memory, verbal processing, auditory short-term memory, more complex visual spatial skills (mental rotation, closure, wayfinding), and executive functioning (see [Chapter 49](#)). Recognizing a child's individual learning profile and building on strengths while supporting weaknesses will help caregivers, teachers, and therapists work together to teach children effectively to their potential.

Children's reading skills are generally commensurate with their nonverbal mental age. Many children with DS can learn to read, some phonologically, some orthographically. Reading comprehension largely relies on language comprehension skills and is often more difficult.

Mathematics is much more difficult because of weak working memory, language deficits, and fine motor skills. Math interventions generally include direct instruction, modeling, guided and repeated practice, and use of concrete materials.

### Neurobehavioral Challenges and Disorders Autism Spectrum Disorder

Due to the sociability associated with children with DS, ASDs have been underrecognized in the past but are estimated to occur in 15–20% of children with DS. Studies also have shown that autism symptoms are not attributable to the degree of developmental disability and that individuals with DS and ASD are distinct from those with DS alone. *Children with DS who show high levels of repetitive behavior, maladaptive behaviors (e.g., aggression, self-injury, destructive behaviors), social isolation, or difficulty with reciprocal social interaction should be referred for further evaluation, even when overtly sociable.* Children with ASD require specialized behavioral and educational interventions with an emphasis on functional communication, social and play skills development, and sensory-based supports (see [Chapter 58](#)).

### ADHD

The reported incidence of ADHD in children with DS varies greatly, from 14% to 44%. Inattention, impulsivity, and hyperactivity, the core symptoms of ADHD, are nonspecific, and it can be difficult to differentiate all the factors contributing to these symptoms in children with DS (see [Chapter 50](#)). From a clinical perspective, the diagnosis of ADHD relies on reports of ADHD symptoms from two different settings (usually parent and teacher) and dysfunction caused by the ADHD symptoms in areas such as learning, socialization, and safety. Medication use in ADHD has been shown to be effective in children with DS, but the response rates are lower than in typical peers with ADHD. Further, there are higher rates of significant side effects, with some children showing decline in behavior and cognitive performance on medication.

### Aggression and Self-Injurious Behaviors

Aggressive behavior is more common in children with many genetic disorders, including DS. The estimated incidence in DS is 4–15%, which is higher than the general population but less than many other genetic syndromes. Aggression disproportionately affects quality of life for the individual and family members and may result in the use of medications and more restrictive educational placements. These behaviors occur more often in males and in individuals with ASD, ADHD, or poor communication skills. Self-injurious behavior (SIB) occurs in

~18%. Individuals with DS who engage in SIB are likely to have lower cognitive and communication ability (may be nonverbal), more repetitive behaviors, higher levels of activity and impulsivity, and fewer social interactions. Assessment of aggression or SIB should include a functional behavioral analysis (FBA) along with overall skills assessment with emphasis on communication. New onset or escalation of aggression or SIB should also include careful assessment for potential sources of pain or discomfort that may exacerbate these behaviors. Behavioral interventions designed based on the results of the FBA should be the initial intervention. Medications may be needed to address symptoms of ADHD, irritability, mood, or anxiety.

### Oppositional Behaviors

Disobedience and stubbornness are common. In some cases, this behavior may relate, at least in part, to differences in cognitive processing. Children with DS have difficulty shifting attention or disengaging from activities. They often desire sameness and resist changes to routine or to the way they think things should be done. Difficulties with language comprehension or frustration with a task or trying to express oneself may result in behaviors that are seen as oppositional. When combined with difficulty problem solving, low frustration tolerance, and emotional dysregulation, disruptive or sometimes verbally or physically aggressive behaviors may result. Before diagnosing a child as having oppositional defiant disorder (see Chapter 42), clinicians should try to understand potential comprehension or skill deficits that may be contributing to the behavior. If the child has difficulty with transitions, interventions to help them shift activities more easily such as transition routines, warnings, or countdowns may be most helpful. Visual schedules can also be helpful to prepare the child for what is next, as can providing some additional time for the transition. Simplifying language can help avert communication frustration.

### Anxiety

There is an increased prevalence of anxiety disorder in children with DS compared with typical peers. Generally, anxiety disorders are diagnosed based on verbal descriptions of fear or worry and the impact of the fear or worrying on functioning or individual distress. Whereas some individuals with DS have the language skills to describe these experiences, others do not. Clinicians often need to rely on the history from caregivers and contextual cues. Behavioral reactions to anxiety can result in flight-or-fight responses. Thus anxiety could manifest with aggressive or escape/avoidance behaviors. Cognitive-behavioral therapy or exposure therapies can be helpful, and medication management is sometimes needed when anxiety is overwhelming or affects sleep or daytime functioning. Evidence for effectiveness of intervention in DS specifically is sparse.

### Obsessive-Compulsive or Perseverative Behaviors

Children and adults with DS often need specific things to be a certain way or may have repetitive patterns of behavior that can seem obsessive or compulsive. They may spend many minutes arranging pillows on their bed, need all doors in the house to be shut, make long lists, or perseveratively ask about upcoming events. These behaviors can be associated with anxiety, and the possibility of increased anxiety should be investigated if there are sudden increases in intensity or frequency of these behaviors.

### Depression

The prevalence of depression in DS ranges from 4% to 11%, with most studies being done in adults. This may be an underestimation, as depression in individuals with intellectual disability can be difficult to diagnose because of limited abilities to self-report internal mood states. Behavioral symptoms can include anxiety, increases in obsessive-compulsive behaviors, depressed affect, crying for no reason, lack of emotion, social isolation, anhedonia, irritability with

increases in outbursts or aggression, sleep disturbance, psychomotor retardation, low self-esteem, catatonia, and psychosis. Clinicians need to consider potential contributing factors, including medical factors, recent life stressors, trauma, and family history. Anecdotally, interventions that involve reengagement in previously enjoyed activities and treatment with selective serotonin reuptake inhibitors (SSRIs) can be effective.

### Catatonia (Also Known as Down Syndrome Disintegrative Disorder or Down Syndrome Regression Disorder)

Older children and young adults can experience a sudden regression in communication, socialization, and daily living skills associated with psychomotor retardation, negative mood or mood lability, refusal to participate in activities, social withdrawal, and insomnia with signs and symptoms of catatonia on the Bush Frances Catatonia Scale (see Chapter 47.3). Patients should undergo a medical evaluation for mental status change. Contributing etiologic factors include stressful events, depression, anxiety, or high physiologic stress. Treatment consists of addressing the underlying suspected cause and may include a trial of Ativan and then electroconvulsive therapy (ECT) if Ativan is unsuccessful.

Visit Elsevier eBooks+ at [eBooks.Health.Elsevier.com](http://eBooks.Health.Elsevier.com) for Bibliography.

## Chapter 58

# Autism Spectrum Disorder

Carolyn F. Bridgemohan and  
Carol C. Weitzman

### DEFINITION

Autism spectrum disorder (ASD) is a neurobiologic disorder with onset in early childhood. The key features are impairment in social communication and social interaction and restricted and repetitive behaviors. The presentation of ASD can vary significantly from one individual to another, as well as over the course of development for a particular child. There is currently no diagnostic biomarker for ASD. Accurate diagnosis therefore requires careful review of the history and direct observation of the child's behavior.

### DIAGNOSTIC CRITERIA AND SYMPTOMS

The diagnostic criteria in the *Diagnostic and Statistical Manual, Fifth Edition* (DSM-5) focus on symptoms in two primary domains: (1) social communication and social interaction and (2) restricted interests and repetitive behaviors (Table 58.1). To meet criteria for ASD, the symptoms need to have been present since the early developmental period, significantly affect functioning, and not be better explained by the diagnosis of intellectual disability (ID) or global developmental delay (GDD; Chapter 56). Table 58.2 provides associated features not included in the DSM-5 criteria.

Symptoms can present in infancy, with reduced response to name and unusual use of objects being strong predictors for risk of ASD. However, symptoms before age 12 months are not as reliably predictive of later diagnosis. Individuals with milder severity may not present



**Table 58.1** DSM-5 Diagnostic Criteria for Autism Spectrum Disorder

- A. Persistent deficits in social communication and social interaction across multiple contexts, as manifested by the following, currently or by history:
  1. Deficits in social-emotional reciprocity.
  2. Deficits in nonverbal communicative behaviors used for social interaction.
  3. Deficits in developing, maintaining, and understanding relationships.
- B. Restricted, repetitive patterns of behavior, interests, or activities, as manifested by at least two of the following, currently or by history:
  1. Stereotyped or repetitive motor movements, use of objects, or speech.
  2. Insistence on sameness, inflexible adherence to routines, or ritualized patterns of verbal or nonverbal behavior.
  3. Highly restricted, fixated interests that are abnormal in intensity or focus.
  4. Hyperreactivity or hyporeactivity to sensory input or unusual interest in sensory aspects of the environment.
- C. Symptoms must be present in the early developmental period (may not become fully manifest until social demands exceed limited capacities, or may be masked by learned strategies in later life).
- D. Symptoms cause clinically significant impairment in social, occupational, or other important areas of current functioning.
- E. These disturbances are not better explained by intellectual disability (intellectual developmental disorder) or global developmental delay.

From the *Diagnostic and Statistical Manual of Mental Disorders, Fifth Edition*. (Copyright 2013). American Psychiatric Association, pp. 50–51.

**Table 58.2** Associated Features of Autism Not in DSM-5 Criteria

- Atypical language development and abilities
- Age <6 yr: frequently disordered and delayed in comprehension; two thirds have difficulty with expressive phonology and grammar
  - Age ≥6 yr: disordered pragmatics, semantics, and morphology, with relatively intact articulation and syntax (i.e., early difficulties are resolved)
- Motor abnormalities: motor delay; hypotonia; catatonia; deficits in coordination, movement preparation and planning, praxis, gait, and balance

For version with full references, see American Psychiatric Association. *Diagnostic and Statistical Manual of Mental Disorders, Fifth Edition*. Washington DC: American Psychiatric Association; 2013. Adapted from Lai MC, Lombardo MV, Baron-Cohen S. Autism. *Lancet*. 2014;383:896–910.

until preschool or school age, when the social demands for peer interaction and group participation are higher.

### Social Communication and Social Interaction

Individuals with ASD have difficulty understanding and engaging in social relationships. The problems are pervasive and affect three major areas: social-emotional reciprocity, nonverbal communication, and understanding of social relationships. The presentation can vary with severity and developmental functioning. A diagnosis of ASD requires the presence of symptoms from all three categories (Table 58.3).

#### Social-Emotional Reciprocity

Reduced social interactions in ASD may range from active avoidance or reduced social response to having an interest in, but lacking ability to initiate or sustain, an interaction with peers or adults. A young child with ASD may not respond when their name is called, may exhibit limited showing and sharing behaviors, and may prefer solitary play. In

addition, the child may avoid attempts by others to play and may not participate in activities that require taking turns, such as peek-a-boo and ball play. An older child with ASD may have an interest in peers but may not know how to initiate or join in play. The child may have trouble understanding the rules of conversation and may either talk at length about an area of interest or abruptly exit the interaction. Younger children often have limited capacity for imaginative or pretend play. Older children may engage in play and conversation but lack flexibility and may be highly directive to peers. Some children with ASD interact well with adults but struggle to interact with same-age peers.

#### Nonverbal Communicative Behavior

Difficulties with nonverbal communication may manifest as reduced or overly intense use of eye contact and gestures such as pointing. Children may also show reduced awareness or response to the eye gaze or pointing of others. They may use eye contact only when communicating a highly preferred request or may have difficulty coordinating the use of nonverbal with verbal communication. Children with ASD may have limited range of facial social-communicative expression or expressed emotion.

#### Developing, Maintaining, and Understanding Relationships

Children with ASD have limited insight regarding social relationships. They may have difficulty understanding the difference between a true friend and a casual acquaintance, and even when the definitions are well understood, there may still be difficulty in developing and maintaining more intimate relationships. They have trouble picking up on the nuances of social interactions and understanding social expectations for polite behavior. They may have reduced understanding of personal boundaries and may stand too close to others. In addition, they can have trouble understanding and inferring others' emotions and are less likely to share emotion or enjoyment with others. Adolescents and young adults have difficulty engaging in group interactions and navigating romantic relationships.

#### Restrictive and Repetitive Behavior

A diagnosis of ASD requires the presence of two of the four symptoms of restrictive and repetitive patterns of behavior discussed next.

#### Stereotyped Motor Movements or Speech

Stereotyped (or stereotypic) movements and repetitive behaviors may include hand flapping, finger movements, body rocking and lunging, jumping, running and spinning, and repetitive speech such as echoing words immediately after they are said. Repetitive patterns of play may be present, such as lining up objects, repetitively turning light switches on and off or opening and closing doors, spinning objects, or arranging toys in a specific manner. These repetitive patterns may not be seen in very young toddlers but may develop as they get older. Stereotyped movements can change over time and in older children are seen more often in individuals with lower cognitive functioning.

#### Insistence on Sameness

Children with ASD have difficulty tolerating transitions or change. They may insist on certain routines or schedules and can become very distressed with unexpected events or new situations. They may repeat scripts from shows or movies or watch the same portion of a video repeatedly. Intolerance for change can cause significant impairment and irritability and have an effect on child and family function.

#### Restricted Interests

This symptom may manifest as interests that seem of greater intensity when compared to same-age peers. Younger children may play with a limited range of toys or may insist on retaining a small object in each hand. Older children may have a strong preference for a particular story or movie. The area of interest may be shared by peers (e.g., Disney movies, Legos, Thomas the Train) but *unusual* in its intensity. Other affected children may have interests that are both intense and



**Table 58.3** Signs and Symptoms of Possible Autism in Preschool Children (or Equivalent Mental Age)

<p><b>Spoken Language</b> Language delay (in babbling or using words; e.g., using &lt;10 words by age 2 yr). Regression in, or loss of, use of speech. Spoken language (if present) may include unusual features, such as vocalizations that are not speechlike; odd or flat intonation; frequent repetition of set words and phrases (echolalia); reference to self by name or “you” or “she” or “he” beyond age 3 yr. Reduced and/or infrequent use of language for communication (e.g., use of single words, although able to speak in sentences).</p>	<p><b>Eye Contact, Pointing, and Other Gestures</b> Reduced or absent use of gestures and facial expressions to communicate (although may place an adult’s hand on objects). Reduced and poorly integrated gestures, facial expressions, body orientation, eye contact (looking at people’s eyes when speaking), and speech used in social communication. Reduced or absent social use of eye contact (assuming adequate vision). Reduced or absent “joint attention” (when one person alerts another to something by means of gazing, finger pointing, or other verbal or nonverbal indication for the purpose of sharing interest). This would be evident in the child from lack of: Gaze switching Following a point (looking where the other person points to—may look at hand) Using pointing at or showing objects to share interest</p>
<p><b>Responding to Others</b> Absent or delayed response to name being called, despite normal hearing. Reduced or absent responsive social smiling. Reduced or absent responsiveness to other people’s facial expressions or feelings. Unusually negative response to the requests of others (“demand avoidance” behavior). Rejection of cuddles initiated by parent or caregiver, although the child may initiate cuddles.</p>	<p><b>Ideas and Imagination</b> Reduced or absent imagination and variety of pretend play.</p>
<p><b>Interacting with Others</b> Reduced or absent awareness of personal space, or unusually intolerant of people entering their personal space. Reduced or absent social interest in others, including children of own age—may reject others; if interested in others, child may approach others inappropriately, seeming to be aggressive or disruptive. Reduced or absent imitation of others’ actions. Reduced or absent initiation of social play with others; plays alone. Reduced or absent enjoyment of situations that most children like (e.g., birthday parties). Reduced or absent sharing of enjoyment.</p>	<p><b>Unusual or Restricted Interests and/or Rigid and Repetitive Behaviors</b> Repetitive “stereotypic” movements such as hand flapping, body rocking while standing, spinning, and finger flicking. Repetitive or stereotyped play (e.g., opening and closing doors). Overfocused or unusual interests. Excessive insistence on following own agenda. Extremes of emotional reactivity to change or new situations; insistence on things being “the same.” Overreaction or underreaction to sensory stimuli, such as textures, sounds, or smells. Excessive reaction to the taste, smell, texture, or appearance of food, or having extreme food fads.</p>

Adapted from Baird G, Douglas HR, Murphy MS. Recognizing and diagnosing autism in children and young people: Summary of NICE guidance. *BMJ*. 2011;343:d6360, Box 1, p. 901.

unusual, such as an interest in brands of vehicles, license plate numbers, or fans and heating systems. These interests interfere with social interactions; a child may only want to talk about their area of interest or may insist that peers act out a particular story in a rigid and inflexible manner.

### Hyporeactivity or Hyperreactivity to Sensory Input

Children with ASD may be overly sensitive to sensory input, such as noise, smells, or texture. Children may scream or react strongly when they hear a siren or vacuum and may gag and choke with certain foods or odors. They may refuse to wear certain clothing or may become very distressed with bathing or with cutting nails and hair. Conversely, some affected children seem to crave sensory input. They may engage in repetitive jumping or hugging and may smell or lick objects or people. Young children may inappropriately touch the face or hair of others.

Diagnosing ASD with DSM-5 criteria can be challenging in very young children because of reduced expression of repetitive behaviors, particularly stereotyped behavior and intense interests. Studies monitoring development in high-risk young children who have an older sibling with ASD indicate these additional symptoms may emerge over time. This creates a dilemma for specialty clinicians evaluating very young children for ASD, because they may not be able to endorse sufficient symptoms to make an early diagnosis and access specialized intervention services.

### Severity Levels Defined in DSM-5

Severity levels in ASD are based on the level of support the individual requires in each of the major domains impacted—social communication and restricted interests and repetitive behavior. Levels range from “needing support” (level 1), to “needing substantial support” (level 2), to “needing very substantial support” (level 3) (Table 58.4).

### Specifiers Defined in DSM-5

A formal diagnosis of ASD also includes documenting associated conditions, including whether the individual has cognitive and/or language impairment; any related medical, genetic, or environmental factors; and any other neurodevelopmental or behavioral health conditions, including catatonia (Table 58.5). This process helps to better characterize the presentation in an individual child and ensures that the diagnosis has been made by considering the symptoms in the context of the child’s current cognitive and language abilities.

### EPIDEMIOLOGY

The prevalence of ASD is estimated at 1 in 36 persons by the U.S. Centers for Disease Control and Prevention (CDC). This information comes from prevalence data of 8-year-olds derived from 11 sites participating in the Autism and Developmental Disabilities Network (ADDN) and shows a greater than 300% increase in prevalence since systematic surveillance began in the year 2000. The increased prevalence relates, at least in part, to improved diagnosis and case finding, as well as inclusion of less severe presentations within the autism spectrum. There is a 4:1 male predominance, although new emerging information suggests that the prevalence in females may be higher than previously believed. Females with ASD often use “camouflaging,” which is intentionally or unconsciously hiding social communication difficulties by mimicking the facial expressions of others, having more effective compensatory behaviors, and displaying less clearly unusual preoccupying interests. All of these things, including clinician bias, may decrease girls with ASD being diagnosed. The prevalence is increased in siblings (up to 18% recurrence rate) and particularly in identical twins. There are no racial or ethnic differences in prevalence. Individuals from racial minorities and lower socioeconomic status are at risk for later

**Table 58.4** DSM-5 Severity Levels for Autism Spectrum Disorder

SEVERITY LEVEL	SOCIAL COMMUNICATION	RESTRICTED, REPETITIVE BEHAVIORS
Level 3 “Requiring very substantial support”	Severe deficits in verbal and nonverbal social communication skills cause severe impairments in functioning, very limited initiation of social interactions, and minimal response to social overtures from others. <i>For example</i> , a person with few words of intelligible speech who rarely initiates interaction and, when he or she does, makes unusual approaches to meet needs only and responds to only very direct social approaches.	Inflexibility of behavior, extreme difficulty coping with change, or other restricted/repetitive behaviors markedly interfere with functioning in all spheres. Great distress/difficulty changing focus or action.
Level 2 “Requiring substantial support”	Marked deficits in verbal and nonverbal social communication skills; social impairments apparent even with supports in place; limited initiation of social interactions; and reduced or abnormal responses to social overtures from others. <i>For example</i> , a person who speaks simple sentences, whose interaction is limited to narrow special interests, and who has markedly odd nonverbal communication.	Inflexibility of behavior, difficulty coping with change, or other restricted/repetitive behaviors appear frequently enough to be obvious to the casual observer and interfere with functioning in a variety of contexts. Distress and/or difficulty changing focus or action.
Level 1 “Requiring support”	Without supports in place, deficits in social communication cause noticeable impairments. Difficulty initiating social interactions, and clear examples of atypical or unsuccessful responses to social overtures of others. May appear to have decreased interest in social interactions. <i>For example</i> , a person who is able to speak in full sentences and engages in communication but whose to-and-fro conversation with others fails and whose attempts to make friends are odd and typically unsuccessful.	Inflexibility of behavior causes significant interference with functioning in one or more contexts. Difficulty switching between activities. Problems of organization and planning hamper independence.

From the Diagnostic and Statistical Manual of Mental Disorders, 5th ed (Copyright 2013). American Psychiatric Association, p. 52.

diagnosis, although the most recent prevalence data suggest that this gap is closing.

## ETIOLOGY

The etiology of ASD is thought to result from disrupted neural connectivity and is primarily impacted by genetic variations affecting early brain development. Animal models and studies of individuals with ASD indicate changes in brain volume and neural cell density in the limbic system, cerebellum, and frontotemporal regions. One study documented changes in early brain development, characterized as “hyperexpansion of cortical surface area,” at age 6–12 months on brain MRI, which correlated with later development of impaired social skills. Functional studies show abnormalities of processing information, particularly related to foundational social skills such as facial recognition. The disruptions in early brain development likely are responsive to treatment. Early developmental therapies in young children with ASD have demonstrated the capacity for normalization of electrophysiologic response to visual stimuli, including faces.

Numerous genes involved in brain development and synaptic function have been associated with ASD. Pathogenic variants that include large genetic deletions or duplications and small sequencing changes have been implicated; these can be inherited or occur *de novo*. Heterozygous mutations in genes, such as present in deletion or duplication of 15q11.2 or 16p11.2, may have variable expression within a family. Rare recessive mutations have been implicated in some populations with high levels of consanguinity. Patients with a number of genetic syndromes (e.g., fragile X, Down, Smith-Lemli-Opitz, Rett, Angelman, Timothy, Joubert), as well as disorders of metabolism and mitochondrial function have higher rates of ASD than the general population (Tables 58.5, 58.6, and 58.7).

There is also possible evidence for environmental contributions to ASD. Older maternal or paternal age may increase the risk of ASD. In addition, factors influencing the intrauterine environment, such as maternal obesity or overweight, short interval from prior pregnancy, premature birth, and certain prenatal infections (e.g., rubella, cytomegalovirus), are associated with ASD. Population-level associations have been investigated for environmental toxins such as organophosphates, pesticides, air pollution, and volatile organic compounds. An epigenetic model is considered one explanation for the etiology; individuals with genetic vulnerability may be more sensitive to environmental factors influencing early brain development.

Despite frequent concerns from families that vaccines or the preservatives in vaccines lead to ASD, *there is no evidence to support this claim*. Multiple research studies and meta-analyses have failed to show an association of vaccines with ASD.

No biomarkers are available yet, but there is emerging evidence from neuroimaging findings, electrophysiologic testing, and eye tracking that hold the promise for presymptomatic detection along with accurate clinical diagnosis and prognostic assessment.

## DIFFERENTIAL DIAGNOSIS

The differential diagnosis of ASD is complex because many conditions in the differential can also occur with ASD. The most important conditions to consider in young children are language disorder (see Chapter 53), ID or GDD (Chapter 56), and hearing loss (Chapter 55). Children with **language disorder** may have impairments in social communication and play; their social and play skills, however, are typically on par with their language level. In addition, they do not have associated restricted and repetitive behavior or atypical use of language, such as scripting. The diagnosis of **social communication disorder** is also distinguished from ASD by the lack of restrictive and repetitive behaviors. Children with **ID** or **GDD** may have delays in social and communication skills as well as stereotyped behavior. However, social and communication skills are typically commensurate with their cognitive and adaptive functioning. Children with **hearing loss** may present with some “red flags” for ASD, such as poor response to name. However, they typically develop nonverbal communication and play skills as expected and do not have stereotyped or restricted behavior patterns.

In older children, disorders of attention, learning, and mood regulation must be considered in the differential diagnosis of ASD. Children with **attention-deficit/hyperactivity disorder (ADHD)** may present with reduced eye contact and response to name caused by poor attention rather than lack of social awareness. Children with ADHD, however, do not have associated impairments in shared enjoyment and social reciprocity or repetitive behaviors. Children with **social anxiety** or other anxiety disorders may present with some symptoms suggestive of ASD. Shy children may have reduced eye contact and social initiation. Anxious children can be resistant to change and prefer familiar routines. Children with anxiety, however, typically will have preserved social interest and insight and will not exhibit high levels of stereotyped behaviors. **Reactive attachment disorder** can be difficult to distinguish from ASD, particularly in younger children with a history of prolonged

**Table 58.5** Common Co-occurring Conditions in Autism Spectrum Disorder (ASD)

COMORBIDITY	INDIVIDUALS WITH AUTISM AFFECTED	COMMENTS
<b>DEVELOPMENTAL DISORDERS</b>		
Intellectual disability	~45%	Prevalence estimate is affected by the diagnostic boundary and definition of intelligence (e.g., whether verbal ability is used as a criterion). In individuals, discrepant performance between subtests is common.
Language disorders	Variable	An autism-specific language profile (separate from language disorders) exists, but with substantial interindividual variability.
Tic disorders	14–38%	~6.5% have Tourette syndrome.
Motor abnormality	≤79%	See Table 58.2.
<b>GENERAL MEDICAL DISORDERS</b>		
Epilepsy	35–46%	Increased frequency in individuals with intellectual disability or genetic syndromes. Two peaks of onset: early childhood and adolescence. Increases risk of poor outcome.
Gastrointestinal problems	9–70%	Common symptoms include chronic constipation, abdominal pain, chronic diarrhea, cyclic vomiting, and gastroesophageal reflux. Associated disorders include gastritis, esophagitis, gastroesophageal reflux disease, inflammatory bowel disease, celiac disease, Crohn disease, and colitis.
Immune dysregulation	≤38%	Associated with allergic and autoimmune disorders.
Genetic disorders	10–20%	Collectively called <i>syndromic autism</i> . Examples include fragile X syndrome (21–50% of individuals affected have autism), Rett syndrome (most have autistic features but with profiles different from idiopathic autism), tuberous sclerosis complex (24–60%), Down syndrome (5–39%), phenylketonuria (5–20%), CHARGE syndrome* (15–50%), Angelman syndrome (50–81%), Timothy syndrome (60–70%), and Joubert syndrome (~40%).
Sleep disorders	50–80%	Insomnia is the most common.
<b>BEHAVIORAL HEALTH DISORDERS</b>		
Any behavioral health disorder	70–90%	
ADHD	40–70%	
Anxiety	~40%	Common across all age-groups. Most common are social anxiety disorder (13–29% of individuals with autism) and generalized anxiety disorder (13–22%). High-functioning individuals are more susceptible (or symptoms are more detectable).
Catatonia	Unknown	Autism shutdown disorder similar to Down syndrome disintegrative disorder (see Chapters 47.3 and 57).
Depression	12–70%	Common in adults, less common in children. High-functioning adults who are less socially impaired are more susceptible (or symptoms are more detectable).
Obsessive-compulsive disorder (OCD)	7–24%	Shares the repetitive behavior domain with autism that could cut across nosologic categories. Important to distinguish between repetitive behaviors that do not involve intrusive, anxiety-causing thoughts or obsessions (part of autism) and those that do (and are part of OCD).
Psychotic disorders	12–17%	Mainly in adults. Most commonly recurrent hallucinosis. High frequency of autism-like features (even a diagnosis of ASD) preceding adult-onset (52%) and childhood-onset schizophrenia (30–50%).
Substance use disorders	≤16%	Potentially because individual is using substances as self-medication to relieve anxiety.
Oppositional defiant disorder	16–28%	Oppositional behaviors could be a manifestation of anxiety, resistance to change, stubborn belief in the correctness of own point of view, difficulty seeing another's point of view, poor awareness of the effect of own behavior on others, or no interest in social compliance.
Eating disorders	10–21%	Avoidant/restrictive food intake may lead to nutrient deficiencies and poor growth.
<b>PERSONALITY DISORDERS†</b>		
Paranoid personality disorder	0–19%	Could be secondary to difficulty understanding others' intentions and negative interpersonal experiences.
Schizoid personality disorder	21–26%	Partly overlapping diagnostic criteria.
Schizotypal personality disorder	2–13%	Some overlapping criteria, especially those shared with schizoid personality disorder.
Borderline personality disorder	0–9%	Could have similarity in behaviors (e.g., difficulties in interpersonal relationships, misattributing hostile intentions, problems with affect regulation), which requires careful differential diagnosis. Could be a misdiagnosis of autism, particularly in females.
Obsessive-compulsive personality disorder	19–32%	Partly overlapping diagnostic criteria.
Avoidant personality disorder	13–25%	Could be secondary to repeated failure in social experiences.

Continued

**Table 58.5** Common Co-occurring Conditions in Autism Spectrum Disorder (ASD)—cont'd

COMORBIDITY	INDIVIDUALS WITH AUTISM AFFECTED	COMMENTS
<b>BEHAVIORAL DISORDERS</b>		
Aggressive behaviors	≤68%	Often directed toward caregivers rather than noncaregivers. Could be a result of empathy difficulties, anxiety, sensory overload, disruption of routines, and difficulties with communication.
Self-injurious behaviors	≤50%	Associated with impulsivity and hyperactivity, negative affect, and lower levels of ability and speech. Could signal frustration in individuals with reduced communication, as well as anxiety, sensory overload, or disruption of routines. Could also become a repetitive habit.
Pica	~36%	Could cause tissue damage and need for restraint. More likely in individuals with intellectual disability.
Suicidal ideation or attempt	11–14%	Could be a result of a lack of social conformity to cultural categories of what is deemed edible, or sensory exploration, or both. Risks increase with concurrent depression and behavioral problems and after being teased or bullied.

\*Coloboma of the eye; heart defects; atresia of the choanae; retardation of growth and development, or both; genital and urinary abnormalities, or both; and ear abnormalities and deafness.

†Particularly in high-functioning adults.

DSM-IV, Diagnostic and Statistical Manual of Mental Disorders, Fourth Edition; DSM-5, Diagnostic and Statistical Manual of Mental Disorders, Fifth Edition.

Adapted from Lai MC, Lombardo MV, Baron-Cohen S. Autism. *Lancet*. 2014;383:896–910.

**Table 58.6** Syndromes with Autistic-Like Behaviors

CHROMOSOME DELETIONS	OTHER SYNDROMES
1q21	2q37 monosomy
7q11.23	Angelman
16p11.2	Bardet-Biedl
17q12	Cardiofaciocutaneous
2q23.1 ( <i>MBD5</i> *)	CHARGE association
12q24.3	Cohen
Cri-du-chat (5p15.2-p15.33)	Congenital rubella
22q deletion syndrome	Cornelia de Lange
Jacobsen (11q23.2)	Costello
Phelan-McDermid ( <i>SHANK3</i> ; 22q13)	<i>FOXP1</i> variants
Pitt-Hopkins (18q21.2)	Fragile X
	Hypomelanosis of Ito
	Joubert
	Kleefstra ( <i>EHMT1</i> )
<b>CHROMOSOME DUPLICATIONS</b>	Lujan-Fryns
15q11.1-q13.3	Moebius sequence
7q11.23	Muscle-eye brain disease
18q12.2	Myotonic dystrophy
16p11.2	Neurofibromatosis
1q21.1	Nonsyndromic intellectual disability due to <i>SYNGAP1</i> variants
22q11.2	Noonan
Potocki-Lupski (17p11.2)	Oculoauriculovertebral spectrum (including Goldenhar)
<b>EPILEPSY ENCEPHALOPATHIES, EPILEPSY</b>	Partial monosomy 1p36
Cortical dysplasia focal epilepsy	Partial tetrasomy 15
<i>SCN1A</i> -related syndromes (Dravet, Lennox Gastaut, others)	Prader-Willi
Early myoclonic encephalopathies (Ohtahara: <i>STXBP1</i> , <i>ARX</i> , <i>SIK1</i> )	PTEN variants
<i>SCN2A</i> -related syndromes (West, others)	Rett complex (female >> male)
<i>SLC6A1</i> myotonic-ataxic epilepsy	Ring chromosome 14
<i>HCN1</i> -related epilepsies	<i>SETD1B</i> variants
<i>CDKL5</i>	Sex chromosome aneuploidies
<i>SCN8A</i>	Sashi-Pena ( <i>ASXL2</i> )
<i>PCDH19</i>	Smith-Lemli-Opitz
<i>SCL35A2</i> -related disorders	Smith-Magenis
Epilepsy-aphasia spectrum (Landau-Kleffner; <i>GRIN2A</i> ; continuous spike wave during low-wave sleep)	Sotos
Juvenile myoclonic epilepsy ( <i>RING2</i> )	Timothy
	Tolchin-Le Caignec (TOLCAS)
	Trisomy 21
	Tuberous sclerosis
	WAGR
	Wiedemann-Steiner ( <i>KMT2A</i> )
	Williams

\*Italics denoted affected gene

Modified from Kliegman RM, Toth H, Bordini BJ, Basel D, eds. *Nelson Pediatric Symptom-Based Diagnosis*, 2nd ed. Philadelphia: Elsevier; 2023: Table 32.6, p. 537.

**Table 58.7** Inborn Errors of Metabolism with Autistic-Like Behavior

Adenylosuccinate lyase deficiency
Biotinidase deficiency
Cerebral creatinine deficiency
Cerebral folate deficiency
Ceroid lipofuscinosis (infantile)
Cystathionine β-synthase deficiency
Dihydropyrimidinase deficiency
Disorders of creatine transport or metabolism
Homocystinuria
Lesch-Nyhan syndrome
Methylenetetrahydrofolate reductase deficiency
Mitochondrial disorders
Mucopolysaccharidosis
Phenylketonuria (untreated)

Modified from Kliegman RM, Toth H, Bordini BJ, Basel D, eds. *Nelson Pediatric Symptom-Based Diagnosis*, 2nd ed. Philadelphia: Elsevier; 2023: Table 32.8, p. 539.

neglect or trauma. However, social behaviors in these children generally improve with positive caretaking.

The differentiation of ASD from **obsessive-compulsive disorder (OCD)**, tics, and stereotyped behaviors can sometimes be challenging. In general, stereotyped behaviors may be calming or preferred, whereas tics and compulsive routines generally are distressing to the individual. Children with OCD have intense interests, as well as repetitive behaviors and rituals, but do not have impairment in social communication or interaction. Children with **stereotypic movement disorder** will not have impaired social skills or other types of restricted and repetitive behaviors. Children with **Landau Kleffner syndrome (LKS)** present with a loss of skills in language comprehension (auditory verbal agnosia) and verbal expression (aphasia) associated with onset of epileptic seizures during sleep (see [Chapter 53](#)). In contrast to ASD, children with LKS usually present with typical early development followed by loss of language function at age 3–6 years.

### CO-OCCURRING CONDITIONS

Between 35% and 50% of individuals with ASD have ID, ranging in severity from mild to severe (see [Table 58.5](#)). An additional 23% of children have intellectual functioning in the borderline range (IQ = 71–85), and approximately 40% of individuals with ASD are non-verbal. ID is associated with higher rates of both identified genetic conditions and epilepsy. Children with ASD often have associated language impairments, including delays in expressive, receptive, and pragmatic (social) language skills. Language function can range



widely from nonverbal status to age appropriate. Gastrointestinal (GI) problems such as cyclic vomiting, constipation, esophagitis, and gastroesophageal reflux disease (GERD) are reported in up to 70% of children with ASD. Epilepsy occurs in up to 35–46% of children with ASD and presents in two peaks: in early childhood and in adolescence. Children with ID, female gender, and lower gestational age are at higher risk for having seizures.

Overall, between 70% and 90% of children with ASD are identified as having a co-occurring behavioral health condition, with ADHD being the most common, occurring in between 40% and 70% of children with ASD. There are higher rates of anxiety (~40%) and mood disorders in ASD, particularly during adolescence. Children with ASD are also at increased risk for being bullied and may present with secondary irritability, anxiety, or depression. Adolescents may develop gender-nonconforming roles, gender variance, and transgender identities; this may also lead to being bullied. Children with ASD are at high risk for suicidal ideation and attempts. **Catatonia** can also occur, most commonly developing during the teenage years, and may present with changes in activity level, unusual movements, and behavioral regression or loss of skills (Chapter 47.3).

Sleep problems, including delayed sleep onset, frequent night waking, and abnormal sleep architecture, are reported in 50–80% of children with ASD. There is some evidence for baseline abnormalities in melatonin secretion. The use of screen-based activities such as television, computers, or tablets before bedtime can inhibit melatonin secretion.

Children with ASD commonly have high rates of feeding and toileting problems resulting from resistance to change, sensory sensitivity, and repetitive behavior patterns. Many children with ASD have **restrictive feeding patterns** and food selectivity. DSM-5 introduced the diagnosis of avoidant and restrictive food intake disorder (ARFID) that, although not specific to children with ASD, describes a pattern of a severely disturbed eating experience resulting in nutritional deficiency or inadequate weight gain and may affect as many as 21% of children with ASD. Restrictive eating patterns may lead to nutritional deficiencies, such as scurvy, rickets, anemia, or protein malnutrition. Children with ASD also have higher rates of overweight, possibly because of diets higher in carbohydrates, reduced physical activity, use of food rewards to regulate behavior, and side effects from medications used for managing mood and behavior. As many as 25% of preschool-age children with ASD have pica (eating of nonfood items), and this tends to persist in children with co-occurring ID.

Self-injury and aggression are common in ASD patients, but most common in individuals with lower cognitive function and limited language. Sleep deprivation, nutritional deficits, pain, epilepsy, and medication side effects may contribute to these behaviors.

Wandering frequently co-occurs with ASD, with nearly 50% of children between 4 and 10 years of age reported as trying to elope. In children who were missing long enough to call the police, approximately 66% were at risk for traffic-related injury and nearly 30% had near-drowning events, which is the leading cause of death in children who wander.

## SCREENING

The American Academy of Pediatrics recommends screening for ASD for *all* children at age 18 months and 24 months (see Chapter 28). Screening should also occur when there is increased risk for ASD, such as a child with an older sibling who has ASD, or whenever there is concern for possible ASD. Screening can be done by a parent checklist or direct assessment. The most frequently used screening tool is the *Modified Checklist for Autism, Revised/Follow-Up Interview* (MCHAT-R/FU), a 20-item parent report measure, with additional standardized parent interview completed for intermediate scores. The MCHAT-R/FU can be used from age 16-30 months. Children who score  $\geq 8$  or between 3 and 7 after the parent interview are at high risk for a diagnosis of ASD or some developmental delay. The Parent's Observation of Social Interaction (POSI) is another commonly used autism specific screener. It includes seven items.

## ASSESSMENT

Diagnostic assessment optimally should include medical evaluation and assessment of the child's cognitive, language, and adaptive function. Developmental-behavioral pediatricians, neurodevelopmental disability specialists, neurologists, psychiatrists, and psychologists are qualified to make a formal diagnosis of ASD. Other specialists, including speech-language pathologists and occupational therapists, should also be included depending on the child's age and the presenting concerns.

Assessment of ASD includes direct observation of the child to evaluate social-communicative skills and behavior. Informal observation can be supplemented with structured diagnostic tools such as the *Autism Diagnostic Observation Schedule, Second Edition* (ADOS-2) or the Toddler module (ADOS-T). These structured play-based assessments provide social prompts and opportunities to evaluate the frequency and quality of a child's social responsiveness to, initiation, and maintenance of social interactions, the capacity for joint attention and shared enjoyment; the child's behavioral flexibility; and the presence of repetitive patterns of behavior and preoccupying interests. These measures also provide some understanding of a child's insight about social relationships and emotional awareness. The ADOS-2 and ADOS-T are not required for accurate diagnosis and do not stand alone, but rather can be used to augment a careful history and observation. The *Childhood Autism Rating Scale, Second Edition* (CARS-2) is a 15-item direct clinical observation instrument that can assist clinicians in the diagnosis of ASD. The *Autism Diagnostic Interview-Revised* (ADI-R) is a lengthy clinical interview tool that is used primarily in research settings because it takes several hours to administer. Other tools include standardized rating scales, such as the Social Responsiveness Scale or the Social Communication Questionnaire, that parents and teachers can complete to report on the child's social skills and behaviors. There is an emergence of the use of telehealth to assess children with ASD, and preliminary studies have suggested that 80% of children could be determined to have or not have ASD with reasonable certainty.

Medical evaluation should include a thorough history and detailed physical examination of the child, including direct behavioral observations of communication and play. In addition, the examination should include measurement of head circumference, careful evaluation for dysmorphic features, and screening for tuberous sclerosis with Wood lamp exam. Children with ASD should have genetic testing, an audiology examination to rule out hearing loss, and in children with pica, a lead test (Table 58.8).

There are currently several specialty-specific clinical guidelines for genetic evaluation of children diagnosed with ASD. Genetic testing is shown to impact clinical decision-making, but no studies have evaluated the impact of genetic testing on the outcome for the child. The American College of Medical Genetics recommends a tiered approach to genetic testing.

### Initial Etiologic Assessment

All children with ASD should have a **chromosomal microarray (CMA)**. CMA will be positive in 10–15% of individuals with ASD. The rate is increased to almost 30% in individuals who have complex presentations, such as associated microcephaly, dysmorphic features, congenital anomalies, or seizures. CMA technology will identify copy number variants but not DNA sequencing errors, balanced translocations, or abnormalities in trinucleotide repeat length. *Fragile X DNA testing is recommended for all males with ASD*. Fragile X testing should also be considered in females with physical features suggestive of fragile X syndrome or with a family history of fragile X, X-linked pattern of ID, tremor/ataxia, or premature ovarian failure (see Chapter 59).

### Second Tier Etiologic Assessment

Females with ASD should have testing for pathologic variants in the *MeCP2* gene. Males who have hypotonia, drooling, and frequent respiratory infections should have *MeCP2* deletion/duplication testing. All individuals with ASD and a head circumference greater than 2.5

**Table 58.8** Medical and Genetic Evaluation of Children with Autism Spectrum Disorder**PHYSICAL EXAMINATION**

Dysmorphic physical features  
Muscle tone and reflexes  
Head circumference  
Wood lamp examination for tuberous sclerosis

**DIAGNOSTIC TESTING**

Chromosomal microarray (CMA) in all individuals  
Fragile X DNA test in males  
Audiology and vision evaluation  
Lead test in children with pica

**ADDITIONAL TARGETED GENETIC TESTING**

Fragile X DNA test in females with symptoms suggestive of fragile X, family history of X-linked intellectual disability, tremor, ataxia, or premature ovarian failure  
MeCP2 sequencing in females  
PTEN testing if head circumference >2.5 standard deviations (SD) above the mean  
MeCP2 deletion/duplication testing in males with significant developmental regression, drooling, respiratory infections, and hypotonia  
Karyotype if unable to obtain CMA or if balanced translocation suspected

**ADDITIONAL TARGETED DIAGNOSTIC TESTING**

Electroencephalogram (EEG) in children with seizures, staring spells, or developmental regression  
Brain MRI in children with dysmorphology, microcephaly, focal neurologic findings, seizures, severe hypotonia, or developmental regression  
Metabolic testing in children with developmental regression, hypotonia, seizures, food intolerance, cyclic vomiting, lethargy, hearing loss, ataxia, or coarse facial features  
Exome or genome sequencing if atypical features are present (behavioral or dysmorphic) (see Table 56.1)

Data from Schaefer GB, Mendelsohn NJ. Clinical genetics evaluation in identifying the etiology of autism spectrum disorders: 2013 guideline revisions. *Genet Med.* 2013;15(5):399–407 and Lord C, Charman T, Havdahl A, et al. The Lancet Commission on the future of care and clinical research in autism. *Lancet.* 2022;399:271–326.

standard deviations (SD) above the mean should have testing for pathologic variants in the *PTEN* gene because there is a risk for hamartoma tumor disorders (Cowden, Proteus-like, Bannayan-Riley-Ruvakaba syndromes) in these individuals. Cytogenetic testing (karyotype) has a lower yield than CMA. Karyotype is recommended if microarray is not available and in children with suspected balanced translocation, such as history of multiple prior miscarriages.

Further medical diagnostic testing is indicated by the child's history and presentation. Brain imaging (MRI) is indicated in cases of microcephaly, significant developmental regression, seizures, or focal findings on neurologic examination. Because of the high rate (up to 25%) of macrocephaly in ASD, imaging is not indicated for macrocephaly alone. MRI is not recommended for minor language regression (loss of a few words) during the second year of life that is often described in toddlers with ASD. Children with concern for seizures, spells, or developmental regression should have an electroencephalogram (EEG). Metabolic screening is indicated for children with signs of a metabolic or mitochondrial disorder, such as developmental regression, weakness, fatigue, lethargy, cyclic vomiting, or seizures (see Table 58.7 and Chapters 56 and 104).

**Next-Generation Sequencing**

Whole exome sequencing (WES) can identify single-nucleotide variants, including pathogenic loss of function mutations and missense mutations; studies have identified a molecular diagnosis in nearly 30% of individuals tested because of the presence of a neurodevelopmental

disorder. If the initial genetic testing is negative, clinicians should consider ordering this test in conjunction with genetic counseling to aid in understanding results.

**TREATMENT AND MANAGEMENT****Approaches to Intervention**

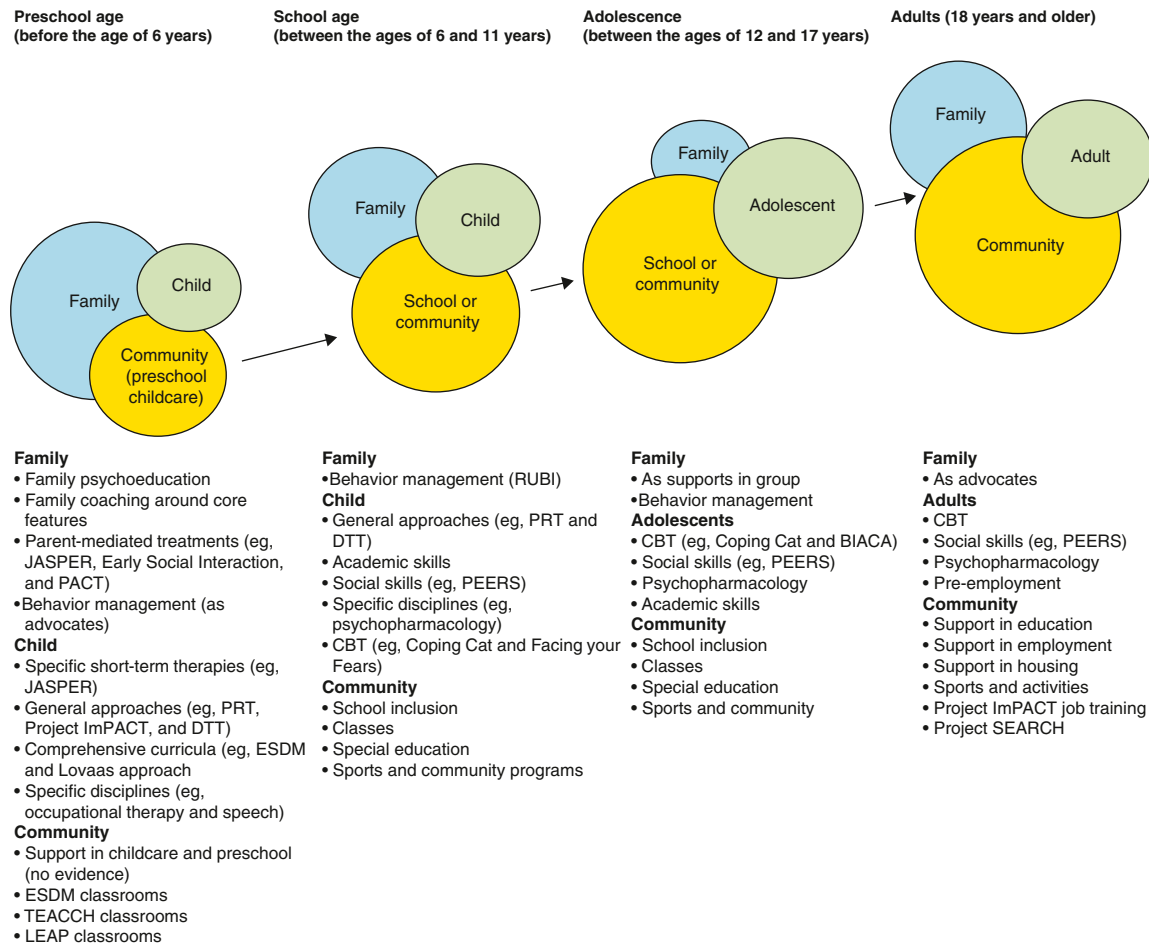
The primary treatment for ASD is done outside the medical setting and includes developmental and educational programming (Fig. 58.1). Numerous resources have been developed that can help families in the complex process of treatment planning (Table 58.9). Intensive behavioral therapies have the strongest evidence to date. Earlier age at initiation of treatment and higher intensity of treatment are associated with better outcomes, although recent studies comparing two different treatments at different levels of intensity (15 vs 25 hr/wk) did not show significant differences between groups in any of the outcomes assessed. Programming must be individualized, and no approach is successful for all children. In addition, research treatments are often conducted with a high level of intensity and fidelity that is difficult to scale up or reproduce in community settings. Higher cognitive, play, and joint attention skills and lower symptom severity at baseline are predictors for better outcomes in core symptoms, intellectual function, and language function.

There are many evidence-based approaches to treating children with ASD, with three main approaches identified. The intervention with the strongest evidence base is **applied behavioral analysis (ABA)**, which is based on the principles of direct incremental teaching of skills within a traditional behavioral framework using reinforcement of desired behavior, careful data collection, and analysis and adjustment of the treatment program based on review of data. The second is **developmental relationship-based intervention (DRBI)**, which includes parent-mediated interventions that focus on building warm, meaningful interaction to improve communication, learning, and problem solving. The best-known approach in this category is **Floortime**. The third approach is the **naturalistic developmental behavioral intervention**, which builds upon ABA to incorporate more choices for children and is implemented in natural situations. Comprehensive models integrating behavioral and developmental approaches that build on key foundational skills, such as joint attention, shared enjoyment, and reciprocal communication, show strong evidence of efficacy for young children, particularly toddlers, with ASD. Examples include the *Early Start Denver Model (ESDM)*, *Joint Attention Symbolic Play Engagement and Regulation (JASPER)*, and *Social Communication/Emotional Regulation/Transactional Support (SCERTS)*.

Educational approaches such as the *Treatment and Education of Autistic and Communication Handicapped Children (TEACCH)* incorporate structured teaching, visual supports, and adjustment of the environment to the individual needs of students with ASD, such as difficulty with communication, understanding time, and need for routine. These approaches have demonstrated efficacy for improved cognitive and adaptive skills. For older children with more severe symptoms, approaches that use behavioral principles in addition to adjusting the environment may be most effective.

Speech and language therapy can help build vocabulary, comprehension, and pragmatic skills. Children with ASD benefit from visual supports for comprehension, understanding expectations, and communicating their needs. **Augmentative communication** approaches using photographs or picture icons can improve comprehension and ability to communicate (see Chapter 54). There are a range of options with varying levels of complexity, flexibility, and technology. Using augmentative communication does not inhibit acquisition of verbal language. On the contrary, supporting a child's language development with augmentative supports can facilitate the development of spoken language, even in older children.

Additional strategies to build social skills are used for school-age children and adolescents and may be administered in the school or community setting by a variety of specialists, including speech therapists, psychologists, and counselors. **Social skills programs** that include training peer mentors have higher rates of efficacy.



**Fig. 58.1** Sources of support and locations of treatment. The size of each ellipse represents the extent of care or intervention received. BIACA, Behavioral Interventions for Anxiety in Children with Autism; CBT, cognitive-behavioral therapy; DTT, discrete trial training; ESDM, Early Start Denver Model; ImPACT, Improving Parents as Communication Teachers; JASPER, Joint Attention, Symbolic Play, Engagement, and Regulation approach; LEAP, Learning Experiences and Alternative Program for Preschoolers and their Parents; PACT, Preschool Autism Communication Trial; PEERS, Program for the Education and Enrichment of Relational Skills; PRT, Pivotal Response Treatment; RUBI, Research Units in Behavioral Intervention; TEACCH, Treatment and Education of Autistic and Related Communication Handicapped Children program. (From Lord C, Charman T, Havdahl A, et al. *The Lancet Commission on the future of care and clinical research in autism. Lancet. 2022;399:271–326, Fig. 6, p. 287.*)

**Table 58.9** Autism Resources for Families

Autism Speaks First 100 Days kit <a href="https://www.autismspeaks.org/family-services/tool-kits/100-day-kit">https://www.autismspeaks.org/family-services/tool-kits/100-day-kit</a>
Autism Speaks Toolkits—dental, transition, guardianship <a href="https://www.autismspeaks.org/family-services/tool-kits">https://www.autismspeaks.org/family-services/tool-kits</a>
AACAP Autism Spectrum Disorder Parent’s Medication Guide <a href="https://www.aacap.org/App_Themes/AACAP/Docs/resource_centers/autism/Autism_Spectrum_Disorder_Parents_Medication_Guide.pdf">https://www.aacap.org/App_Themes/AACAP/Docs/resource_centers/autism/Autism_Spectrum_Disorder_Parents_Medication_Guide.pdf</a>
Sexuality information for individuals with developmental disability <a href="http://vkc.mc.vanderbilt.edu/healthybodies/">http://vkc.mc.vanderbilt.edu/healthybodies/</a>

Occupational and physical therapy may be indicated for individuals with motor delay and difficulty acquiring adaptive skills such as dressing and toileting.

For some high school students with ASD, training in life skills and vocational skills is critical for maximizing independence in adulthood. Training may focus on basic self-care (e.g., dressing, hygiene), functional academics (e.g., money management, banking

skills), learning to fill out a job application, and understanding how to behave with strangers and in work settings. Social skills and job coaching may be needed even for adolescents with strong cognitive and academic function, because they may struggle with social perception and may be vulnerable to exploitation by others.

There continue to be disparities in regard to accessing care, with racially and ethnically minoritized groups and children from low-income families showing less access to acute care and specialized, community and educational services, when compared with higher-income and White families.

### Co-occurring Conditions

Additional medical or behavioral health treatment is often required for the management of co-occurring conditions in ASD. Seizures occur in up to 35% of children with ASD and should be managed with appropriate antiepileptic therapy (see Chapter 633). GI problems (e.g., cyclic vomiting, constipation, esophagitis, GERD) may present with nonspecific irritability, sleep disturbance, self-injury, aggression, and signs of pain or discomfort, such as crying, and can be managed with the same approaches used in typically



**Table 58.10** Common Pharmacologic Treatments in Autism Spectrum Disorder (ASD)

TARGET SYMPTOM	MEDICATION CLASS*	EFFECTS	SIDE EFFECTS	MONITORING
Hyperactivity and/or Inattention	Stimulants	Decreased hyperactivity, impulsivity, improved attention	Activation, irritability, emotional lability, lethargy/social withdrawal, stomach ache, reduced appetite, insomnia, increased stereotypy	Height, weight, BP, HR
	$\alpha_2$ -Agonists	Decreased hyperactivity, impulsivity, improved attention	Drowsiness, irritability, enuresis, decreased appetite, dry mouth, hypotension	Height, weight, BP, HR
	Selective norepinephrine reuptake inhibitor	Decreased hyperactivity, impulsivity, improved attention	Irritability, decreased appetite, fatigue, stomach ache, nausea, vomiting, racing heart rate	Height, weight, BP, HR
Anxiety	Selective serotonin reuptake inhibitors	Decreased anxiety	Activation, hyperactivity, inattention, sedation, change in appetite, insomnia, stomachache, diarrhea Citalopram: prolonged QTc interval	Weight, BP, HR
Irritability	Atypical antipsychotics (risperidone, aripiprazole)	Decreased irritability, aggression, self-injurious behavior, repetitive behavior, hyperactivity	Somnolence, weight gain, extrapyramidal movements, drooling, tremor, dizziness, vomiting, gynecomastia	Weight, BP, HR Monitor CBC, cholesterol, ALT, AST, prolactin, glucose or hemoglobin A <sub>1c</sub>
Insomnia	Melatonin	Shortened sleep onset	Nightmares, enuresis	—

\*Specific medication names are provided in parentheses when there is a Food and Drug Administration (FDA)-approved indication for the use of the medication to treat the symptom in children with ASD. Further information about these medications is available in [Chapter 33](#).  
BP, Blood pressure; HR, heart rate; CBC, complete blood count; ALT, alanine transaminase; AST, aspartate transaminase.

developing children. Children with pica should have lead and iron levels monitored.

Management of co-occurring attention and mood disorders is similar to that for typically developing children. Strategies to increase structure and organization in the environment and use of visual supports (e.g., schedules) can improve attention and reduce anxiety. Some children with ASD benefit from modified cognitive-behavioral therapy to address anxiety and OCD. (see [Chapter 31](#)).

Strategies to promote **sleep hygiene** and use of behavioral approaches, such as structured bedtime routines, can address delayed sleep onset. Other medical problems, such as epilepsy or GERD, can also contribute to poor sleep and should be treated directly. In cases refractory to behavioral approaches, medications may be used.

Structured behavioral approaches for delayed toilet training in concert with treatment to prevent constipation are often needed for children with ASD. For children with highly restrictive diets, nutrition counseling and behaviorally based feeding therapy may be needed to address poor caloric intake or lack of nutritional quality. Because of limited diets, children with ASD may be at risk for low levels of calcium, vitamins C and D, and iron. Children who are overweight may still have poor nutrition as a result of restrictive diets.

**Irritability** is a nonspecific symptom and can be a reflection of pain, anxiety, distress, or lack of sleep. Children with ASD are prone to irritability because of their difficulty tolerating change and their limited communication skills. Management of irritability includes evaluating carefully for medical problems that may be causing pain and for any factors in the child's home or school environment that may be causing distress. Possible causes of distress range from common experiences such as changes in the routine to undisclosed abuse or bullying. Treatment should be targeted first at any underlying cause. Medications are often used to treat irritability in ASD, but should only be used after appropriate behavioral and communication supports have been implemented.

## Pharmacology

There are currently no medications that treat the core symptoms of ASD. Medications can be used to target specific co-occurring conditions or symptoms ([Table 58.10](#); see also [Table 58.5](#)). Families should be cautioned, however, that the effect size may be lower and the rate of medication side effects higher in children with ASD.

Preliminary data suggested that intranasal therapy with neuropeptide oxytocin may improve social functioning in children with ASD, particularly those with low pretreatment oxytocin levels, but a recent randomized trial did not demonstrate any effect of oxytocin on social or cognitive functioning.

There is evidence to support the use of stimulant medications, atomoxetine, and  $\alpha$ -agonists for ADHD in ASD. Selective serotonin reuptake inhibitors (SSRIs) can be used for anxiety and OCD and in adolescents may also be useful for depression. Benzodiazepines may be useful for situational anxiety, for example, triggered by dental and medical procedures or air travel. Medications used to treat ADHD and anxiety may result in activation or irritability in ASD and require careful monitoring.

Melatonin can be used to improve sleep onset but will not address night waking. Clonidine or trazodone may be used for sleep onset and maintenance. No medications are specifically labeled for treatment of insomnia in ASD.

The  $\alpha$ -adrenergic agonists may be helpful in children who present with significant behavioral dysregulation. There are two atypical antipsychotic medications that have U.S. Food and Drug Administration (FDA) recommendation for irritability and aggression in children with ASD. Both risperidone and aripiprazole have several studies documenting efficacy for reducing irritability, aggression, and self-injury. Secondary improvements in attention and repetitive behavior were also noted. Side effects include weight gain and metabolic syndrome, as well as tardive dyskinesia and extrapyramidal movements. Careful laboratory monitoring is recommended. Mood-stabilizing antiepileptic medications have also been used to treat irritability.



### Complementary and Alternative Medicine

Families of children with ASD often use complementary and alternative medicine (CAM) approaches. These treatments can include supplements, dietary changes, and body or physical treatments. There is limited evidence to inform families, who often learn about these treatments from friends and family members, alternative medicine providers, or the internet. For most therapies, evidence is insufficient to show benefit. There is strong evidence that secretin and facilitated communication are not effective. Some therapies, such as hyperbaric oxygen, chelation, and high-dose vitamins, are potentially harmful. For children with restrictive diets, taking a daily multivitamin and 400 IU vitamin D may be indicated, although there is no evidence to support megadoses of vitamins. Similarly, for children with evidence of gluten sensitivity, a trial of a gluten-free diet may be indicated. However, current evidence does not support this as a treatment for all children with ASD. There is an interest in the use of cannabidiol (CBD) to treat core autism symptoms or co-occurring problems such as anxiety, ADHD, or sleep problems, but there is currently no evidence to support this therapy.

When discussing CAM with a family, it is best to use open and collaborative communication, encouraging them to share their current practices and any questions. Specifically ask if they use any herbal treatments, supplements, or other therapies, such as acupuncture, massage, or chiropractic treatment, and what they have observed since trying the treatment. Provide accurate information regarding potential benefit and risk for any treatment. Educate about “red flags” such as treatments that are marketed as a cure for multiple conditions, that report no risk of side effects, or that are marketed by the clinician recommending the treatment. Encourage families to identify a target symptom, “try one thing at a time,” and monitor response carefully.

### Transition

Navigating a successful transition to adult care is a key role for the pediatric provider. This process should ideally start as early as age 12-13 years. Parents are faced with a complex and disconnected system of diverse agencies that they need to navigate. Use of structured-visit templates and care coordinators can help ensure that families and their youth with ASD are able to make appropriate decisions about secondary and postsecondary educational programming, vocational training, guardianship, finances, housing, and medical care. High school educational programming should include individualized and meaningful vocational training, as well as instruction regarding sexuality, relationships, safety—particularly internet safety and abuse prevention—finances, travel training, and general self-advocacy. More than half of young adults with ASD remain unemployed and unenrolled in higher education 2 years after high school graduation. Individuals with ASD who are of average cognitive intellectual functioning will need help accessing supports for college or postsecondary skills training and may benefit from referral to their state vocational rehabilitative services and personal life coaches or counselors. Families who have adult children with more significant cognitive disability need information about the range of adult disability services; how to apply for supplemental security income (SSI); and the process for considering guardianship, medical and financial conservatorship, or supported decision making for their adult child. These decisions are complex and must be individualized for the adult with ASD and the family.

### OUTCOME

ASD is a lifelong condition. Although a minority of individuals no longer meet criteria for the diagnosis, most will make progress but continue to have some impairment in social, behavioral, learning, language, or emotional functioning as adults. Adult outcome studies are sobering, indicating that many adults with ASD are socially isolated, lack gainful employment or independent living, and have higher rates of depression and anxiety. It is not clear if these data

can be extrapolated to younger children currently receiving intensive educational therapies. There is a growing network of adult self-advocates who promote the unique strengths in individuals with ASD. Outcome, as measured by developmental progress and functional independence, is better for individuals who have higher cognitive and language skills and lower ASD severity at initial diagnosis.

Visit Elsevier eBooks+ at [eBooks.Health.Elsevier.com](http://eBooks.Health.Elsevier.com) for Bibliography

## Chapter 59

# Fragile X Syndromes

Amanda E. Bennett and Marcy Schuster

Fragile X syndrome (FXS) is a genetic disorder associated with intellectual, learning, and behavioral symptoms and some specific physical characteristics. In FXS an expansion of >200 CGG repeats on the distal long arm of chromosome Xq27.3 silences the *FMR1* gene, which leads to a deficiency in fragile X mental retardation protein (FMRP) and affects synaptic function throughout much of the brain. It is the most common heritable cause of intellectual disability and has a prevalence rate of approximately 1 in 4,000 males and 1 in 7,000 females. Like many X-linked disorders, males with fragile X tend to present with more features and more significant impairments than females.

On average, unaffected individuals have 30 CGG repeats in the untranslated region of the *FMR1* gene. Those with 55-200 repeats are described as having the premutation. Females with the premutation are at increased risk of expansion of the number of CGG repeats causing FXS in their children (Table 59.1). When males with the premutation alleles pass them to daughters, they typically remain as premutation alleles. Those with premutation alleles may also have clinical manifestations (Tables 59.2 and 59.3).

**Fragile XE syndrome (FRAXE)** resembles FXS and manifests within a variable spectrum of intellectual and learning disabilities. The involved gene (*AFF2*) results in an expansion of CCG trinucleotide repeats and is inherited as an X-linked disorder. Symptoms also include aggressive behaviors, agitation, autistic behaviors, clumsiness, and delayed speech and language development. *This form of FXS will not usually be detected with standard fragile X testing.*

### EVALUATION AND DIAGNOSIS

The phenotype of FXS early in life can be nonspecific with symptoms such as developmental delay, including motor and language delays, and autistic-like behaviors, such as repetitive motor mannerisms, sensory sensitivities, and deficits in eye contact. Manifestations in early to middle childhood often include problems with learning, attention-deficit/hyperactivity disorder (ADHD), anxiety, and aggressive behaviors. The physical features become more pronounced during or after puberty and include macroorchidism, hyperextensible finger joints, and characteristic facial features, including a long face, large ears, and a prominent square jaw (Fig. 59.1). Females affected with FXS show varying degrees of intellectual disability and/or learning disabilities, and they may present with symptoms of ADHD and anxiety as well.

Children with FXS are at increased risk for ophthalmologic, feeding, and orthopedic problems, as well as recurrent otitis media in early childhood. Females are at increased risk for precocious puberty.

Adolescents should be monitored for seizures and heart murmurs, and adults with FXS are at increased risk for mitral valve prolapse. Adults are also at risk for intention tremor and ataxia and premature menopause, which can also occur in those with the premutation. [Table 59.3](#) includes phenotypic features, clinical signs, and their typical age of onset.

### Family History and Premutation Carriers

Collecting a detailed family history can help identify potential risk factors for FXS. Individuals with premutation triplet repeat expansions have been found to have a variety of clinical manifestations. **Fragile X-associated tremor/ataxia syndrome (FXTAS) is a progressive neurodegenerative disorder** that most commonly affects

males over age 50 years. Females are less commonly affected and tend to have mild disease. Symptoms include an intention tremor followed by ataxia that may manifest as needing support when walking or with a wide-based gait. Females with premutation triple repeat expansions are at risk for developing **fragile X-associated premature ovarian insufficiency (FXPOI)**. Women with this condition undergo menopause approximately 5 years earlier than women without the condition, but symptoms are variable, with the most severely affected experiencing irregular or absent menstrual periods before age 40 and often infertility. A variety of neuropsychiatric symptoms, including anxiety, ADHD, social deficits, or autism spectrum disorder (ASD), have also been associated with the premutation. Asking about family members for a history of developmental, behavioral, or learning problems or adult family members with early menopause, fertility challenges, or adult-onset neurologic problems may help to identify risk for a positive fragile X test in a child with developmental or behavioral concerns. Asymptomatic siblings or other family members may benefit from testing to determine premutation status, which can also be associated with the symptoms noted earlier. See [Table 59.3](#) for additional information about clinical symptoms in **premutation carriers**.

**Table 59.1** Risk of Expansion of a Premutation to a Full Mutation in Male Offspring Based on Maternal Number of CGG Triplet Repeats

MATERNAL CGG TRIPLET REPEAT NUMBER	RISK FOR EXPANSION OF PREMUTATION TO FULL MUTATION
59-69	37%
70-79	65%
80-89	70%
90-99	95%
100 or more	100%

CGG triplet repeat, Cytosine-guanine-guanine trinucleotide repeat. From *Fragile X Syndrome. Clinical Overview. Elsevier Point of Care*. [https://www.clinicalkey.com/#!/content/clinical\\_overview/67-s2.0-c9588237-6031-4f21-b273-34970f89cd2e](https://www.clinicalkey.com/#!/content/clinical_overview/67-s2.0-c9588237-6031-4f21-b273-34970f89cd2e). Updated June 14, 2021. Copyright Elsevier. All rights reserved; with data from Hersh JH et al. Health supervision for children with fragile X syndrome. *Pediatrics*. 2011;127(5):994-1006, Table 1; and Saul RA et al. FMR1-related disorders. In: Pagon RA et al, eds. *GeneReviews* [internet]. University of Washington; 1993-2018.

### Diagnostic Testing

A diagnosis of FXS is possible through PCR and Southern blot analysis of a patient's blood. Positive DNA testing shows an expansion of >200 trinucleotide CGG repeats inside an area of the *FMR1* gene on the X chromosome. Diagnostic testing that reports methylation status of the gene region is preferred because methylation status is inversely correlated with cognitive functioning. Because the physical features of FXS are not always apparent in early childhood, diagnostic testing is recommended for any child who presents with global developmental delay, intellectual disability, or ASD (see Chapters 56 and 58). Any positive test for fragile X should include genetic counseling to inform of inheritance risk, phenotypic variability, and medical conditions associated with FXS and premutation status. Specific gene (*AFF2*) testing for FRAXE should be considered if CGG repeat testing is negative.

**Table 59.2** Phenotypic and Genetic Effect of Number of CGG Repeats

VARIATION TYPE	CGG ALLELE SIZE	TYPICAL PHENOTYPE	GENETIC CONSEQUENCES
Full mutation	More than 200 repeats	Males are affected with fragile X syndrome About 50% of females are affected with fragile X syndrome	Repeat expansion and methylation typically result in partial or complete silencing of <i>FMR1</i> Females usually benefit from having two X chromosomes, because usually one of them is unaffected (i.e., no expanded CGG repeats) and X-inactivation does not silence all copies of it
Premutation	About 55-200 repeats	Patients typically have normal intellect, and some may have mild manifestations associated with fragile X syndrome Carriers may be at increased risk for fragile X-associated tremor ataxia syndrome and <i>FMR1</i> -related primary ovarian insufficiency	<i>FMRP</i> expression is usually not significantly impaired; however, larger mutations may have lowered expression Alleles are at risk for CGG expansion during maternal gametogenesis, and offspring are at risk for fragile X syndrome
Intermediate (gray zone)	About 45-54 repeats	Patient does not have fragile X syndrome caused by CGG repeats	A minority of intermediate/gray zone alleles may have minor instability; however, expansion of CGG repeats is unlikely, and if it occurs, it will not reach full mutation number within a single generation
Normal	About 5-44 repeats	Patient does not have fragile X syndrome caused by CGG repeats	No meiotic or mitotic instability is present; alleles are transmitted without any change in repeat number

*FMR1* gene, *FMRP* translational regulator 1; *FMRP*, fragile X mental retardation protein. From *Fragile X Syndrome. Clinical Overview. Elsevier Point of Care*. [https://www.clinicalkey.com/#!/content/clinical\\_overview/67-s2.0-c9588237-6031-4f21-b273-34970f89cd2e](https://www.clinicalkey.com/#!/content/clinical_overview/67-s2.0-c9588237-6031-4f21-b273-34970f89cd2e). Updated June 14, 2021. Copyright Elsevier. All rights reserved; with data from Hersh JH et al. Health supervision for children with fragile X syndrome. *Pediatrics*. 2011;127(5):994-1006, Table 1; and Saul RA et al. FMR1-related disorders. In: Pagon RA et al, eds. *GeneReviews* [internet]. University of Washington; 1993-2018.

**Table 59.3** Clinical Features of Fragile X Syndrome and Premutation Carriers

COGNITIVE, BEHAVIORAL, AND PHYSICAL CHARACTERISTICS	AGE REPORTED
<b>FULL MUTATION FRAGILE X SYNDROME (&gt;200 CGG REPEATS)</b>	
Hypotonia	Infancy
Reflux	Infancy
Poor suck	Infancy
Developmental delay/intellectual disability (96% males, 64% females)	Early childhood
Autism (46% males, 16% females)	Early childhood
Attention problems (84% males, 67% females)	Early childhood
Hyperactivity (66% males, 30% females)	Early childhood
Anxiety (70% males, 56% females)	Early childhood
Aggression (38% males, 14% females)	Early childhood
Self-injurious behaviors (41% males, 10% females)	Early childhood
Depression (12% males, 22% females)	Early childhood
Recurrent otitis media (>60%)	Early childhood
Seizures (18% males, 7% females)	Early childhood
Strabismus (20%)	Early childhood
Sleep disturbances	Early childhood
Flat feet	Early childhood
Low muscle tone	Early childhood
Hyperextensible joints	Early childhood
Large prominent ears	Early/middle childhood
Elongated face	Early/middle childhood
Large testes	Adolescence
Obesity (30%)	Adolescence
Mitral valve prolapse	Adulthood
Cognitive decline/parkinsonism (17%)	Adulthood
Perseveration	Adulthood
<b>PREMUTATION CARRIERS (55-200 CGG REPEATS)</b>	
Attention problems	Early childhood
Autism spectrum disorder	Early childhood
Seizures	Early childhood
Anxiety	Adolescence
Depression	Adulthood
Hypertension	Adulthood
Sleep disturbances	Adulthood
Migraine	Adulthood
Fibromyalgia	Adulthood
Hypothyroidism	Adulthood
Fragile X–associated primary ovarian insufficiency (FXPOI) (~20%)	Adulthood
Fragile X–associated tremor ataxia syndrome (FXTAS) (40% males, 16% females)	Later adulthood

Data from National Center on Birth Defects and Developmental Disabilities, Centers for Disease Control and Prevention. Data and Statistics on Fragile X Syndrome, 2021; Hagerman RJ, Berry-Kravis E, Hazlett HC, et al. Fragile X syndrome. *Nat Rev Dis Primers*. 2017;3:17065; Hersh JH, Saul RA; Committee on Genetics. Health supervision for children with fragile X syndrome. *Pediatrics*. 2011;127(5):994–1006; Wheeler A, Raspa M, Hagerman R, Mailick M, Riley C. Implications of the FMR1 Premutation for Children, Adolescents, Adults, and Their Families. *Pediatrics*. 2017;139(Suppl 3):S172–S182.

## MANAGEMENT OF FRAGILE X SYNDROME

Management of FXS in children often requires a multidisciplinary approach focused on monitoring for and managing developmental and/or behavioral symptoms. In addition to health supervision visits with a primary care clinician, many children with FXS benefit from ongoing care with a medical professional with experience or knowledge of FXS. Families will also benefit from accessing educational and behavioral health resources in the community.

### Educational

Many individuals with FXS will require educational support to meet their needs starting from a young age. **Early intervention** services, including speech therapy, occupational therapy, physical therapy, and special instruction, are often vital components of addressing developmental delays. As a child ages and ongoing assessment occurs, special education support through an **individualized education plan (IEP)** may be warranted (See [Chapter 49](#)). There are interventions shown to be specific to the learning needs of individuals with FXS. Biologic males typically demonstrate strengths in receptive language, verbal labeling, simultaneous processing, imitation, and daily living activities. Biologic females typically demonstrate areas of strength in vocabulary, comprehension, reading, writing, spelling, and short-term visual memory. These advantages should be explored when educational interventions are being developed. Areas often in need of interventions for individuals with FXS include improving complex problem solving, maintaining attention, improving impulse control, understanding spatial relationships, and math concepts.

Environmental modifications and adaptive technologies can be an asset for an individual with FXS. This can include a modified keyboard and/or mouse and touch-screen computer options integrated into classroom lessons. A quiet environment with minimal distractions can help improve focus on tasks. Small group and one-on-one instruction for teaching new tasks can minimize anxiety and improve generalization of skills to the larger classroom. Teaching students to request breaks when feeling overwhelmed can minimize overall frustration. Visual schedules, manipulatives, clutter-free areas, and social stories are all interventions to improve compliance and learning.

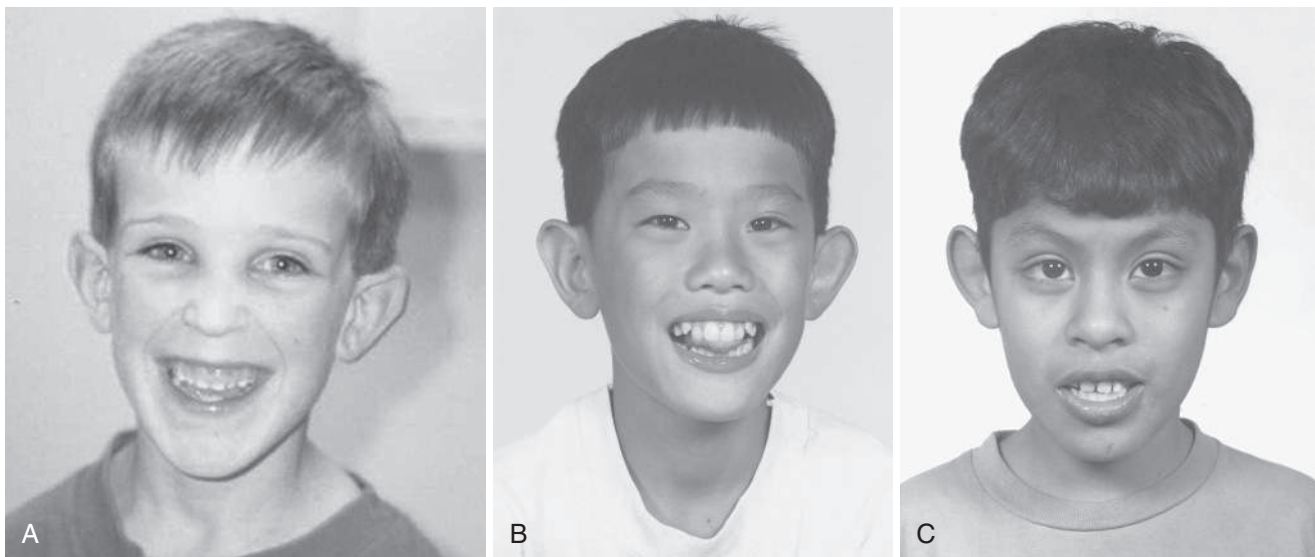
### Behavioral

Individuals with FXS can present with a variety of cognitive and behavioral challenges. ASD is diagnosed in between 50% and 60% of individuals with FXS. ASD is characterized by deficits in communication and social skills along with restricted interests and/or repetitive behaviors that interfere with one's daily life (see [Chapter 58](#)). Individuals with FXS can struggle with making eye contact, engaging in conversations, and expressing wants and needs. Often individuals with FXS want social contact but may avoid it due to anxiety. Hyperarousal is a common behavioral symptom, particularly in social situations where eye contact is expected, suggesting the presence of significant sensory aversions. Behavioral interventions that include skill development and anxiety management can be helpful in addressing social skills deficits. Other sensory-aversive behaviors can be related to auditory, visual, or tactile stimuli. Tantrums, and occasionally aggression, can emerge when children with FXS are overstimulated.

Sensory-seeking behaviors can also be present in individuals with FXS. These may include repetitive movements, narrowed interests, rigid routines, and atypical sensory exploration. Behaviors such as rocking, pacing, and jumping could occur to obtain sensory input. Individuals with FXS can become extremely anxious if a routine is changed or if a preferred activity is interrupted. Teaching coping strategies along with the recognition of triggers for anxiety can be helpful as a behavior management strategy.

Individuals with FXS can present with deficits in attention and focus, impulsivity, and/or hyperactivity, particularly during childhood. This can lead to a diagnosis of ADHD (see [Chapter 50](#)). These deficits can affect learning in school and require specialized





**Fig. 59.1** Boys with fragile X syndrome. Note the long faces, prominent jaws, and large ears and the similar characteristics of children from different ethnic groups: European (A), Asian (B), and Latin American (C). (From Jorde, LB, Carey JC, Bamshad MJ. *Medical Genetics*, 6th ed. Philadelphia: Elsevier; 2020: Fig. 5.20.)

instruction or classroom accommodations to help improve focus and participation.

Individuals with FXS can present with aggressive behavior directed toward themselves and toward others. These behaviors are seen in approximately 50% of males with FXS and tend to increase with age. Individuals who exhibit ongoing aggression also typically present with more significant intellectual impairment, communication delays, and anxiety. Aggression can put a strain on caregivers or lead to injury and therefore often emerges as a primary focus of treatment.

Behavior management techniques vary depending on a child's needs. If an ASD diagnosis is present, applied behavioral analysis (ABA) programs are often integrated into treatment. ABA promotes multiple areas of development, including language, emotion, and cognition. ABA focuses on tracking specific behaviors through observation and data collection, learning their antecedents (the event or environment before the behavior occurred), and managing their consequences (the response others have after the behavior occurs) through a structured approach. Most interventions for unwanted behaviors (e.g., aggression or self-injury) aim to change the antecedents to reduce the likelihood of the behavior occurring or to change the consequence in order to make the behavior less rewarding for the individual. Interventions that aim to increase a desired behavior (e.g., complying with an instruction or toilet training) will incorporate environmental changes to remind and encourage the behavior and identify rewarding consequences that can be delivered after the behavior has occurred. ABA interventions delivered during daily living activities, community participation, and family interactions allow for optimal skill development. Special education programs often include similar behavior management techniques throughout the early childhood for individuals with FXS.

### Medical

In addition to educational and behavioral management, many children with FXS may present with certain medical conditions and may require additional monitoring or care by a specialist (see [Table 59.3](#)). Monitoring in infancy and early childhood should emphasize assessment for orthopedic, growth, and/or feeding concerns. Because young children with FXS are more susceptible to otitis media and may lack communication skills to convey discomfort, a full physical examination, including ear examination, is recommended if a child presents with acute behavior changes. Young children should also be routinely screened for ophthalmologic

problems, such as strabismus or astigmatism, and monitored for symptoms related to connective tissue problems, such as hypermobile joints or inguinal hernias. Seizures are more prevalent in children with FXS; symptoms concerning for any type of seizure should be investigated with electroencephalogram (EEG) when the child is both awake and asleep. Although risk for mitral valve prolapse is not typically increased until adulthood, examination for murmurs, clicks, or changes in blood pressure should be performed regularly. Sleep disturbances commonly reported among children with FXS include delayed sleep onset, frequent night waking, and occasionally obstructive sleep apnea. Screening for sleep concerns should be done at every visit, and parents should be counseled on behavioral strategies to address sleep onset and waking challenges (see [Chapter 31](#)). Concerns for apnea or snoring may require further evaluation by a sleep specialist or with polysomnography. Medications to help address sleep concerns may include melatonin or clonidine, neither of which is currently approved by the Food and Drug Administration (FDA) for use in children with FXS.

There are currently no approved treatments for the core symptoms of FXS, but many individuals will benefit from medication to address some of the commonly co-occurring behavioral symptoms associated with absence of FMRP. If behavioral strategies are not sufficient to address hyperactivity or impulsivity, a young child (<5 years) may benefit from a trial of an  $\alpha_2$ -adrenergic agonist, such as clonidine or guanfacine. School-aged children with FXS often show improvements in hyperactivity, impulsivity, and/or attention problems when treated with a stimulant, but side effects such as irritability or aggression may occur. Selective serotonin reuptake inhibitors (SSRIs) can be safe and effective in reducing anxiety, obsessive-compulsive symptoms, and sometimes aggression in young children with FXS; one trial of sertraline in young children with FXS demonstrated improvements in visual reception and fine motor coordination in 2- to 6-year-olds. Additional analyses demonstrated improvements in expressive language skills for children with FXS and ASD. Treatment with an atypical antipsychotic, such as risperidone or aripiprazole, may be needed in cases of severe anxiety, aggression, or mood instability that have not responded to other medications.

Neurobiologic studies of FXS have identified overactivation of brain glutamate pathways and underactivation of gamma-aminobutyric acid (GABA) pathways leading to studies of



medications targeting these pathways in the hopes that they would improve cognitive outcomes. Although some studies in animal models were encouraging, human trials have yet to demonstrate consistent benefits. Some clinical trials are ongoing.

In addition to continued monitoring for cardiac, seizure, sleep, and behavioral symptoms, health supervision in late childhood

and adolescence should also include discussion of adult transition issues, including vocational training, accessing state-specific adult disability services, and transition to adult medical care.

*Visit Elsevier eBooks+ at [eBooks.Health.Elsevier.com](http://eBooks.Health.Elsevier.com) for Bibliography.*

## Chapter 60

# Nutritional Requirements

Martine Saint-Cyr, Stephanie W. Waldrop,  
and Nancy F. Krebs

Nutrition for infants, children, and adolescents should maintain current weight and support normal growth and development. Growth during infancy is rapid, critical for neurocognitive development, and has the highest energy and nutrient requirements relative to body size compared with any other period of growth. It is followed by growth during childhood, when 60% of total growth occurs, and finally by puberty. Nutrition and growth during the first 3 years of life predict adult stature and some health outcomes. Although the antecedents are numerous and occur earlier, the major risk period for linear **growth faltering or stunting** (length- or height-for-age z score  $\leq -2$ ) is between 6 and 24 months of age. Therefore it is critical to identify nutrient deficiencies promptly and to address them aggressively early in life, because missing them can impart lasting adverse effects on later growth and development.

Dietary intake should meet **energy requirements**, as well as provide the essential macronutrients and micronutrients needed for sustaining the function of multiple vital processes. Nutrient deficiencies can limit growth, impair immune function, affect neurodevelopment, and increase morbidity and mortality. Worldwide, malnutrition and undernutrition are the leading causes of acquired immunodeficiency and a major factor underlying morbidity and mortality in children <5 years of age.

The transition in food supply and the type of nutrition chosen in many developing countries from a traditional to Western diet has resulted in increased life expectancy and adult stature. It is associated with decreases in the incidence of communicable diseases. Unfortunately, the Western diet, characterized by high energy density, more refined grains, and highly processed foods, is also frequently accompanied by decreased physical activity and increases in the incidence and prevalence of noncommunicable diseases such as type 2 diabetes, cardiovascular (CV) disease, obesity, inflammatory bowel disease (IBD), and certain cancers. Consequently, it is important to view the impact of diet and nutrition on health from various perspectives: to prevent deficiency, to promote adequacy, and to prevent or reduce the risk for acquiring diseases associated with excess intakes, such as obesity, diabetes, and CV disease.

Advances in our understanding of the roles of some nutrients such as vitamin D, polyunsaturated fatty acids (PUFAs), and fiber have changed our focus from recommendations about preventing deficiency to recommendations about nutritional intake associated with optimal health. The 2006 World Health Organization (WHO) growth charts, recommended for *all infants and children until age 2 years*, are not only descriptive but also prescriptive on how children with adequate nutrition and healthcare should grow. Identifying and providing appropriate and adequate nutrition in infancy and childhood are critical to supporting normal growth and development, as well as providing the foundation for lifelong health and well-being.

### DIETARY REFERENCE INTAKES

The **dietary reference intakes (DRI)** were established by the Food and Nutrition Board of the U.S. Institute of Medicine (IOM), currently

known as the National Academy of Medicine (NAM), to provide guidance on the nutrient needs for individuals and groups across different life stages and according to gender (Tables 60.1-60.3 and see Tables 60.5 and 60.6).

The DRI represent a series of indicators that are used as a basis for macronutrient and micronutrient intake recommendations for healthy populations within the United States and Canada. The DRI also serve as an estimation of the Dietary Guidelines for Americans 2020-2025 (DGA) Daily Nutritional Goals. DRI indicators include the estimated

**Table 60.1** Equations to Estimate Energy Requirements

INFANTS AND YOUNG CHILDREN: EER (KCAL/DAY) = TEE + ED	
0-3 mo	$EER = (89 \times \text{weight [kg]} - 100) + 175$
4-6 mo	$EER = (89 \times \text{weight [kg]} - 100) + 56$
7-12 mo	$EER = (89 \times \text{weight [kg]} - 100) + 22$
13-36 mo	$EER = (89 \times \text{weight [kg]} - 100) + 20$
CHILDREN AND ADOLESCENTS 3-18 YR: EER (KCAL/DAY) = TEE + ED	
BOYS	
3-8 yr	$EER = 88.5 - (61.9 \times \text{age [yr]} + PA \times [(26.7 \times \text{weight [kg]} + (903 \times \text{height [m]})] + 20$
9-18 yr	$EER = 88.5 - (61.9 \times \text{age [yr]} + PA \times [(26.7 \times \text{weight [kg]} + (903 \times \text{height [m]})] + 25$
GIRLS	
3-8 yr	$EER = 135.3 - (30.8 \times \text{age [yr]} + PA [(10 \times \text{weight [kg]} + (934 \times \text{height [m]})] + 20$
9-18 yr	$EER = 135.3 - (30.8 \times \text{age [yr]} + PA [(10 \times \text{weight [kg]} + (934 \times \text{height [m]})] + 25$

EER, Estimated energy requirement; TEE, total energy expenditure; ED, energy deposition (energy required for growth/new tissue accretion).

PA indicates the physical activity coefficient:

For boys:

PA = 1.00 (sedentary, estimated physical activity level 1.0-1.4); PA = 1.13 (low active, estimated physical activity level 1.4-1.6); PA = 1.26 (active, estimated physical activity level 1.6-1.9); PA = 1.42 (very active, estimated physical activity level 1.9-2.5)

For girls:

PA = 1.00 (sedentary, estimated physical activity level 1.0-1.4); PA = 1.16 (low active, estimated physical activity level 1.4-1.6); PA = 1.31 (active, estimated physical activity level 1.6-1.9); PA = 1.56 (very active, estimated physical activity level 1.9-2.5)

Adapted from Kleinman RE (ed). *Pediatric Nutrition Handbook*, 7th ed. Elk Grove Village, IL: American Academy of Pediatrics; 2013.

**Table 60.2** Acceptable Macronutrient Distribution Ranges

AMDA (% OF ENERGY)		
MACRONUTRIENT	AGE 1-3 YR	AGE 4-18 YR
Fat	30-40	25-35
$\omega 6$ PUFAs (linoleic acid)	5-10	5-10
$\omega 3$ PUFAs ( $\alpha$ -linolenic acid)	0.6-1.2	0.6-1.2
Carbohydrate	45-65	45-65
Protein	5-20	10-30

PUFAs, Polyunsaturated fatty acids.

Adapted from Otten JJ, Hellwig JP, Meyers LD (eds). *Dietary Reference Intakes: The Essential Guide to Nutrient Requirements*. Washington, DC: Institute of Medicine, National Academies Press; 2006.

**Table 60.3** Dietary Reference Intakes: Macronutrients

FUNCTION	LIFE STAGE GROUP	RDA OR AI* (g/day)	SELECTED FOOD SOURCES	ADVERSE EFFECTS OF EXCESSIVE CONSUMPTION
<b>TOTAL DIGESTIBLE CARBOHYDRATE</b>				
RDA based on its role as the primary energy source for the brain AMDR based on its role as a source of kcal to maintain body weight	<i>Infants</i>		Major types: starches and sugars, grains, and vegetables (corn, pasta, rice, potatoes, and breads) are sources of starch. Natural sugars are found in fruits and juices. Sources of added sugars: soft drinks, candy, fruit drinks, desserts, syrups, and sweeteners.†	No defined intake level for potential adverse effects of total digestible carbohydrate is identified, but the upper end of the AMDR was based on decreasing risk of chronic disease and providing adequate intake of other nutrients. It is suggested that the maximal intake of added sugars be limited to providing no more than 10% of energy.
	0-6 mo	60*		
	7-12 mo	95*		
	<i>Children</i>			
	>1 yr	130		
	<i>Pregnancy</i>			
	≤18 yr	175		
	19-30 yr	175		
<b>TOTAL FIBER</b>				
Improves laxation, reduces risk of coronary artery (heart) disease, assists in maintaining normal blood glucose levels	<i>Infants</i>		Includes dietary fiber naturally present in grains (e.g., oats, wheat, unmilled rice) and functional fiber synthesized or isolated from plants or animals and shown to be of benefit to health.	Dietary fiber can have variable compositions; therefore it is difficult to link a specific source of fiber with a particular adverse effect, especially when phytate is also present in the natural fiber source. As part of an overall healthy diet, a high intake of dietary fiber will not produce deleterious effects in healthy persons. Occasional adverse GI symptoms are observed when consuming some isolated or synthetic fibers, but serious chronic adverse effects have not been observed because of the bulky nature of fibers. Excess consumption is likely to be self-limiting; therefore UL was not set for individual functional fibers.
	0-6 mo	ND		
	7-12 mo	ND		
	<i>Children</i>			
	1-3 yr	19*		
	4-8 yr	25*		
	<i>Males</i>			
	9-13 yr	31*		
	14-18 yr	38*		
	19-21 yr	38*		
	<i>Females</i>			
	9-13 yr	26*		
	14-18 yr	26*		
19-21 yr	25*			
	<i>Pregnancy</i>			
	≤18 yr	28*		
	19-21 yr	28*		
<b>TOTAL FAT</b>				
Energy source When found in foods, is a source of ω3 and ω6 PUFAs Facilitates absorption of fat-soluble vitamins	<i>Infants</i>		<i>Infants:</i> Human milk or infant formula <i>Older children:</i> Butter, margarine, vegetable oils, whole milk, visible fat on meat and poultry products, invisible fat in fish, shellfish, some plant products such as seeds and nuts, bakery products.	UL is not set because there is no defined intake of fat at which adverse effects occur. High fat intake will lead to obesity. Upper end of AMDR is also based on reducing risk of chronic disease and providing adequate intake of other nutrients.† Low fat intake (with high carbohydrate) has been shown to increase plasma triacylglycerol concentrations and decrease HDL cholesterol.
	0-6 mo	31*		
	7-12 mo	30*		
	1-18 yr	Insufficient evidence to determine AI or EAR; see AMDR, Table 60.2.		
<b>ω6 POLYUNSATURATED FATTY ACIDS</b>				
Essential component of structural membrane lipids, involved with cell signaling Precursor of eicosanoids Required for normal skin function	<i>Infants</i>		Nuts, seeds; vegetable oils such as soybean, safflower, corn oil.	There is no defined intake of ω6 level at which adverse effects occur. Upper end of AMDR is based on the lack of evidence that demonstrates long-term safety and human in vitro studies that show increased free radical formation and lipid peroxidation with higher amounts of ω6 fatty acids. Lipid peroxidation is thought to be a component of atherosclerotic plaques.
	0-6 mo	4.4*		
	7-12 mo	4.6*		
	<i>Children</i>			
	1-3 yr	7*		
	4-8 yr	10*		
	<i>Males</i>			
	9-13 yr	12*		
	14-18 yr	16*		
	19-21 yr	17*		
	<i>Females</i>			
	9-13 yr	10*		
	14-18 yr	11*		
19-21 yr	12*			
	<i>Pregnancy</i>			
	≤18 yr	13*		
	19-21 yr	13*		
	<i>Lactation</i>			
	≤18 yr	13*		
	19-21 yr	13*		

Continued

**Table 60.3** Dietary Reference Intakes: Macronutrients—cont'd

FUNCTION	LIFE STAGE GROUP	RDA OR AI* (g/day)	SELECTED FOOD SOURCES	ADVERSE EFFECTS OF EXCESSIVE CONSUMPTION
<b>ω3 POLYUNSATURATED FATTY ACIDS</b>				
Involved with neurologic development and growth	<i>Infants</i>		Vegetable oils (e.g., soybean, canola, flaxseed oil); fish oils, fatty fish, walnuts <sup>†</sup> ; smaller amounts in meats and eggs.	No defined intake levels for potential adverse effects of ω3 PUFAs are identified.
	0-6 mo	0.5*		
Precursor of eicosanoids	7-12 mo	0.5*		Upper end of AMDR is based on maintaining appropriate balance with ω6 fatty acids and the lack of evidence that demonstrates long-term safety, along with human in vitro studies that show increased free radical formation and lipid peroxidation with higher amounts of PUFAs. Because the longer-chain <i>n</i> -3 fatty acids, eicosapentaenoic acid (EPA) and docosahexaenoic acid (DHA), are biologically more potent than their precursor, linolenic acid, much of the work on adverse effects of this group of fatty acids has been on DHA and EPA. Lipid peroxidation is thought to be a component in the development of atherosclerotic plaques.
	<i>Children</i>			
1-3 yr	0.7*			
4-8 yr	0.9*			
<i>Males</i>				
9-13 yr	1.2*			
14-18 yr	1.6*			
19-21 yr	1.6*			
<i>Females</i>				
9-13 yr	1.0*			
14-18 yr	1.1*			
19-21 yr	1.1*			
<i>Pregnancy</i>				
≤18 yr	1.4*			
19-21 yr	1.4*			
<i>Lactation</i>				
≤18 yr	1.3*			
19-21 yr	1.3*			
<b>SATURATED AND TRANS FATTY ACIDS</b>				
The body can synthesize its needs for saturated fatty acids from other sources.		No dietary requirement	Saturated fatty acids are present in animal fats (meat fats and butter fat) and coconut and palm kernel oils. Trans fat: stick margarines, foods containing hydrogenated or partially hydrogenated vegetable shortenings	There is an incremental increase in plasma total and LDL cholesterol concentrations with increased intake of saturated or trans fatty acids; therefore saturated fat intake should be limited to <10% with no trans fat. <sup>†‡</sup>
<b>CHOLESTEROL</b>				
		No dietary requirement	Sources: liver, eggs, foods that contain eggs (e.g., cheesecake, custard pie)	
<b>PROTEIN AND AMINO ACIDS<sup>‡</sup></b>				
Major structural component of all cells in the body	<i>Infants</i>		Proteins from animal sources (e.g., meat, poultry, fish, eggs, milk, cheese, yogurt) provide all nine indispensable amino acids in adequate amounts and are considered "complete proteins."	No defined intake levels for potential adverse effects of protein are identified.
	0-6 mo	9.1*		
Functions as enzymes, in membranes, as transport carriers, and as some hormones	7-12 mo	11.0	Protein from plants, legumes, grains, nuts, seeds, and vegetables tend to be deficient in ≥1 of the indispensable amino acids and are called "incomplete proteins." Vegan diets adequate in total protein content can be made "complete" by combining sources of incomplete protein, which lack different indispensable amino acids.	Upper end of AMDR was based on complementing AMDR for carbohydrate and fat for the various age-groups. Lower end of AMDR is set at approximately the RDA.
	<i>Children</i>			
1-3 yr	13			
4-8 yr	19			
<i>Males</i>				
9-13 yr	34			
14-18 yr	52			
≥19 yr	56			
<i>Females</i>				
9-13 yr	34			
≥14 yr	46			
≤18 yr	46			
19-21 yr	46			
<i>Pregnancy and lactation</i>		71		

Note: Starred (\*) numbers are Adequate Intake (AI) **bold** numbers are RDA. RDAs and AIs may both be used as goals for individual intake. RDAs are set to meet the needs of 97–98% of members in a group. For healthy breastfed infants, the AI is the mean intake. The AI for other life stage and gender groups is believed to cover the needs of all members of the group, but lack of data prevents specifying with confidence the percentage covered by this intake.

AMDR is the range of intake for a particular energy source that is associated with reduced risk of chronic disease while providing intakes of essential nutrients. With consumption in excess of the AMDR, there is a potential for increasing the risk of chronic diseases and/or insufficient intakes of essential nutrients.

ND amounts are not determinable because of a lack of data regarding adverse effects in this age-group and concern with regard to a lack of ability to handle excess amounts. Source of intake should be from food only to prevent high levels of intake.

<sup>†</sup>2015–2020 Dietary Guidelines for Americans. U.S. Department of Health and Human Services. <https://health.gov/dietaryguidelines/2015/>.

<sup>‡</sup>Based on 1.5 g/kg/day for infants, 1.1 g/kg/day for 1-3 yr, 0.95 g/kg/day for 4-13 yr, 0.85 g/kg/day for 14-18 yr, 0.8 g/kg/day for adults, and 1.1 g/kg/day for pregnant (using pre-pregnancy weight) and lactating women.

AI, Adequate intake; AMDR, acceptable macronutrient distribution range; EAR, estimated average requirement; GI, gastrointestinal; HDL, high-density lipoprotein; LDL, low-density lipoprotein; ND, not determinable; PUFAs, polyunsaturated fatty acids; RDA, recommended dietary allowance; UL, upper limit of normal.

Institute of Medicine. 2005. Dietary Reference Intakes for Energy, Carbohydrate, Fiber, Fat, Fatty Acids, Cholesterol, Protein, and Amino Acids. <https://doi.org/10.17226/10490>.

Adapted and reproduced with permission from the National Academy of Sciences, Courtesy of the National Academies Press, Washington, DC.



average requirement (EAR), the recommended dietary allowance (RDA), and the tolerable upper limit of intake (UL) (Figs. 60.1 and 60.2). In addition, the concept of the DRI is also applicable to the estimated energy requirement (EER) and the acceptable macronutrient distribution range (AMDR).

The EAR is an estimated average of the daily nutrient intake required to meet the nutritional needs of 50% of the population; it is applied to the assessment of a population's intake. The RDA provides an estimate of the minimum daily average intake for a nutrient that meets the nutritional needs for more than 97% of individuals in a population, and it can be used as a guideline for individuals to avoid deficiency. When an EAR cannot be derived, an RDA cannot be calculated; therefore an **adequate intake (AI)** is developed as a guideline for individuals based on the best available data and scientific consensus. The UL denotes the highest average daily intake with no associated adverse health effects for almost all individuals in a given population. Figure 60.2 shows the relationships among EAR, RDA, and UL.

## ENERGY

Energy balance constitutes both caloric intake, most often derived from food, and metabolic caloric expenditure. An imbalance between energy intake and energy expenditure can lead to undesirable health consequences. *Inadequate* energy intake can lead to weight faltering, catabolism of body tissues (e.g., fat and muscle), diminished immunity, and increased morbidity and mortality. For infants, children, and adolescents, acute or chronic energy deficits can adversely affect

motor, cognitive, and behavioral development. *Excess* energy intake can increase the risk for obesity and obesity-related metabolic disease. Energy balance in adults is associated with maintenance of weight status. Positive energy balance is required in children to support growth. Components of energy expenditure in adults include the *basal metabolic rate (BMR)*, which is primarily determined by lean body mass; the *thermal effect of food* (e.g., energy required for digestion and absorption); *energy* for thermoregulation; and *energy* for physical activity. Energy needs are increased during infancy, childhood, pregnancy, and lactation, necessitating increased energy intakes during these life stages.

The 2020–2025 DGA provides important nutrition and health topics applicable to each life stage, including data on estimates of caloric intake for healthy persons. The exact daily caloric requirement varies according to an individual's age, gender, height, weight, and physical activity, among other factors. Weight loss, weight maintenance, and weight gain depend on calories consumed and calories expended in the context of caloric needs.

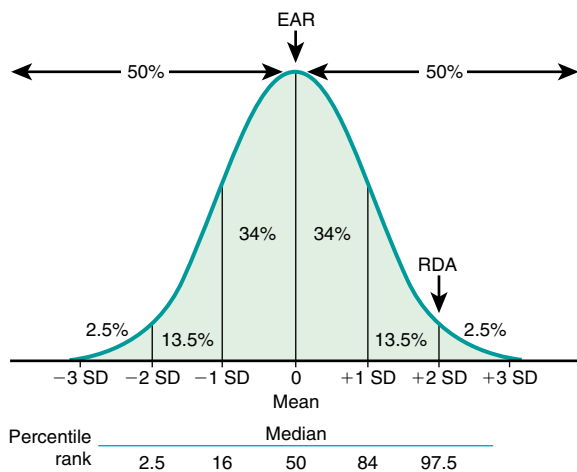
The **estimated energy requirement (EER)** for infants, children, and adolescents is the average dietary energy intake predicted to maintain energy balance, ensure adequate growth and development, and provide for a desirable level of physical activity. It considers age, gender, weight, stature, and level of physical activity (see Table 60.1). The EER was determined based on empirical research in healthy persons at different levels of physical activity and is estimated by equations that account for both *total energy expenditure (TEE)* and *energy deposition (ED)* for healthy growth. EERs for infants, relative to body weight, are approximately twice those for adults because of the increased metabolic rate and energy requirements for weight maintenance and growth.

The EER was not devised for, and does not necessarily apply to, children with acute or chronic diseases who may have altered energy requirements due to chronic infection or inflammation, malabsorption, febrile illnesses, chronic lung disease, congenital heart disease, or other conditions. In these situations, **energy requirements** are typically higher when compared with healthy matched peers. Conversely, in some conditions, individuals may be hypometabolic and thus require less energy than expected (e.g., hypothyroidism, hypothalamic obesity conditions, Down syndrome, and certain syndromic or monogenic obesity disorders). Individual energy needs for healthy persons based on age, gender, height, weight, activity level, pregnancy, or lactation status can be approximated using online tools, such as the DRI Calculator for Healthcare Professionals, available at <https://www.nal.usda.gov/human-nutrition-and-food-safety/dri-calculator>.

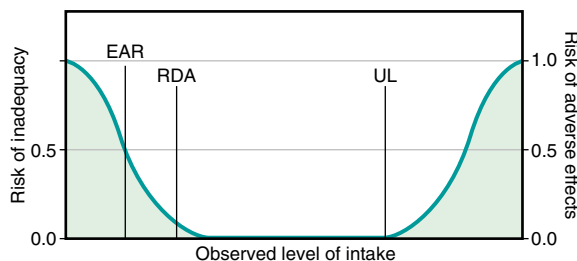
Dietary nutrients that provide energy include *fats* (approximately 9 kcal/g), *carbohydrates* (4 kcal/g), and *protein* (4 kcal/g). These nutrients are called **macronutrients**. If alcohol is consumed, it also contributes to energy intake (7 kcal/g). The EER does not specify the relative energy contributions of macronutrients. Once the minimal intake of each macronutrient is attained (e.g., sufficient protein intake to meet specific amino acid requirements, sufficient fat intake to meet linoleic acid and  $\alpha$ -linolenic acid needs for brain development), the remainder of the intake is used to meet energy requirements, with some degree of freedom and interchangeability among fat, carbohydrate, and protein. This forms the basis for the **acceptable macronutrient distribution ranges (AMDRs)**, expressed as a function of total energy intake (see Table 60.2).

## FAT

Fat is the most calorically dense macronutrient, providing approximately 9 kcal/g. For infants, human milk and formula are the main dietary sources of fat, whereas older children obtain fat from animal products, vegetable oils, margarine, and nuts and seeds. The AMDR for fats is 30–40% of total energy intake for children 1–3 years and 25–35% for children 4–18 years of age. In addition to being energy dense, lipids provide essential fatty acids that have structural and functional roles (e.g., cholesterol moieties are precursors for cell membranes, hormones, and bile acids). Fat intake also facilitates absorption of fat-soluble vitamins (vitamins A, D, E, and K). Both roles are relevant to neurologic and ocular development (see Table 60.3).



**Fig. 60.1** Dietary reference intakes. Normal requirement distribution of hypothetical nutrient showing percentile rank and placement of the estimated average requirement (EAR) and the recommended dietary allowance (RDA) on the distribution; SD, standard deviation.



**Fig. 60.2** Dietary reference intakes: The relationship among the estimated average requirement (EAR), the recommended dietary allowance (RDA), and the tolerable upper limit of intake (UL). This figure shows that the EAR is the intake at which the risk of inadequacy is estimated to be 0.5 (50%). The RDA is the intake at which the risk of inadequacy would be very small, only 0.02–0.03 (2–3%). At intakes between the RDA and the UL, the risk of inadequacy and of excess are estimated to be close to 0.0. At intakes above the UL, the potential risk of adverse effects can increase.

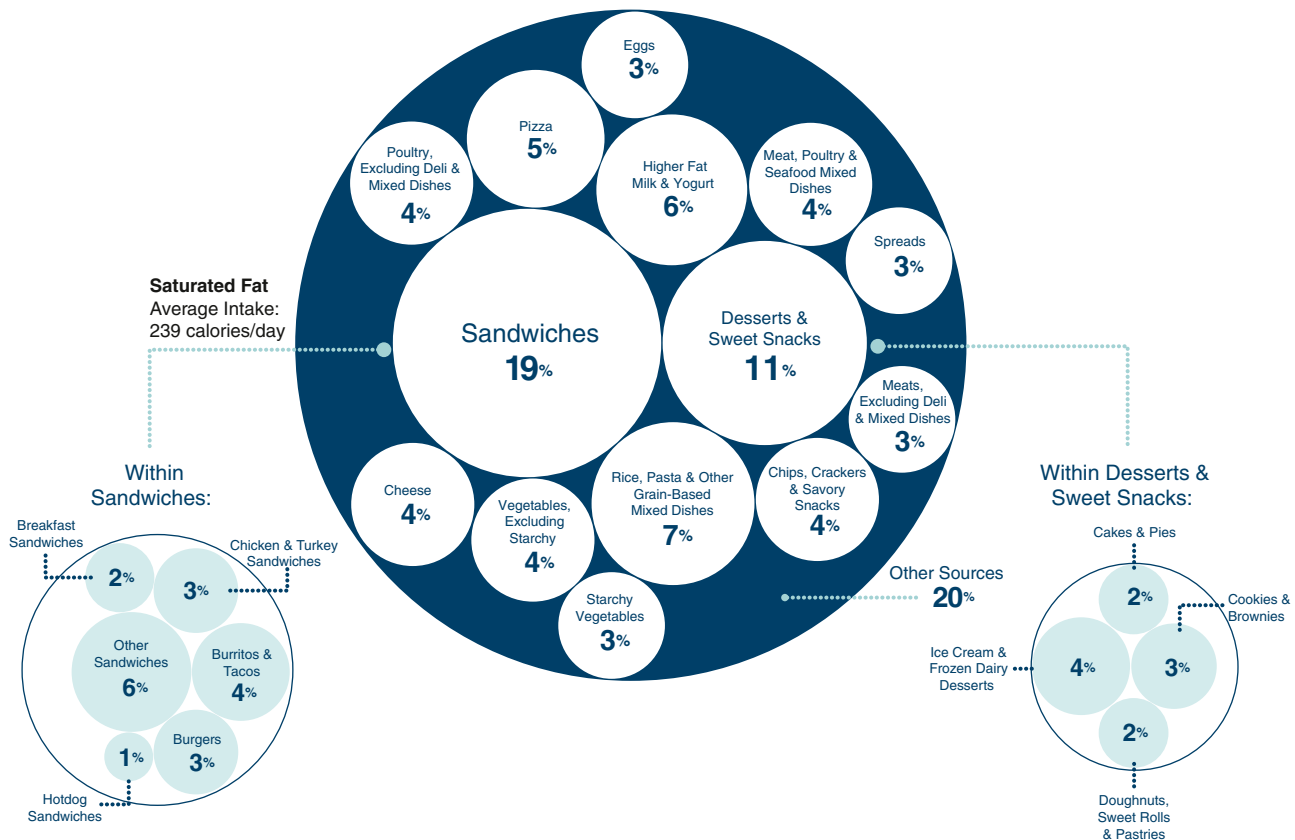
Dietary fats include phospholipids; free fatty acids; monoglycerides, diglycerides, and triglycerides; and sterols. **Triglycerides** are the most common form of dietary fat and are composed of one glycerol molecule with three fatty acids. They are found in both animal and vegetable fats. In addition, simple sugars (i.e., refined grains and high-sugar drinks) can be converted to triglycerides in the liver. In general, dietary fatty acids can be classified as saturated, unsaturated, and more specifically, as monounsaturated or polyunsaturated. Dietary saturated fatty acids, found primarily in animal fat and dairy products as well as some vegetable fats (e.g., coconut and palm oil), can be synthesized endogenously by the body and thus are not required in the diet. **Medium-chain triglycerides (e.g., MCT oil)** are beneficial for those suffering from malabsorptive disorders resulting in steatorrhea because of their direct absorption from the gastrointestinal (GI) tract into the bloodstream via the portal vein, bypassing the need for pancreatic and biliary secretory components. The dietary saturated fatty acids most commonly consumed include myristic (C14), palmitic (C16), and steric acid (C18).

**Trans fatty acids** are a type of unsaturated fat having undergone hydrogenation that alters the configuration of its double bond(s). They are found primarily in processed foods such as margarines and shortenings and are nonessential. A small amount of naturally occurring trans fats can be found in animal products and human breast milk. **Monounsaturated fatty acids** are typically found in certain plants and their derived oils (e.g., avocado oil, olive oil, canola) and in some animal fats. Because monounsaturated fatty acids can be synthesized by the liver, they are considered nonessential to the diet. **Polyunsaturated fatty acids (PUFAs)** are fatty acids not able to be synthesized *de novo* in the body and are necessary for maintenance of growth, skin integrity, aspects of central nervous system development, and other essential physiologic functions such as regulation of gene transcription,

immunity, and inflammation. These dietary essential fatty acids include linoleic (C18:2,W6,9) and linolenic acid (C18:3,W3,6,9), and they are discussed in more detail later.

Neither monounsaturated nor polyunsaturated fatty acids contribute adversely to plasma cholesterol levels. However, dietary saturated fatty acids (found primarily in animal fat and dairy products), trans fats (found in hydrogenated margarines and oils), and **cholesterol** increase the low-density lipoprotein (LDL) fraction of serum cholesterol, which is a risk factor for the development of atherosclerosis. Autopsy studies demonstrate that atherosclerosis begins early in childhood, even in infancy. Therefore dietary advice to optimize CV health should be given starting from age 2 years, when sufficient fat intake to sustain growth and brain development is less of a concern. **It is recommended that saturated fat make up less than 10% of total daily calories in the diet for those age 2 years and above**, with increased focus on consumption of monounsaturated and polyunsaturated fats. **Dietary trans fatty acids are to be avoided**, particularly artificial trans fatty acids in the form of partially hydrogenated oils, which are no longer considered Generally Recognized as Safe (GRAS) by the U.S. Food and Drug Administration (FDA). **Figure 60.3** shows the dietary contributions of saturated fat for those age 1 year and above.

Because saturated and monounsaturated fats can be synthesized endogenously to support adequate structural and physiologic requirements, there is no AI or RDA set for these dietary components. Trans fats, which *have no known health benefits in humans*, also do not have an AI or RDA defined. A UL has not been set for cholesterol, saturated, or trans fats because there is a continuous positive linear association between intake of these fats and increased risk for CV disease, without a threshold level. Diets low in saturated fats without trans fats are therefore preferred. **For optimal CV health in the general population, rather than limiting fat intake, advice should focus in most cases**



**Fig. 60.3** Top sources and average intakes of saturated fat: U.S. population age 1 year and older. Estimates based on 2-day dietary intake data, weighted, from What We Eat in America (WWEIA), National Health and Nutrition Examination Survey (NHANES), 2013-2016. (From *Dietary Guidelines for Americans. 2020-2025, Chapter 1: Nutrition and Health Across the Lifespan. Fig. 1.11. [https://www.dietaryguidelines.gov/sites/default/files/2020-12/Dietary\\_Guidelines\\_for\\_Americans\\_2020-2025.pdf](https://www.dietaryguidelines.gov/sites/default/files/2020-12/Dietary_Guidelines_for_Americans_2020-2025.pdf)*)

**on changing the type of fat consumed.** Because of their high energy density, excessive intake of all types of fatty acids has the potential to increase the risk of obesity.

Humans are incapable of synthesizing the precursor  $\omega 3$  ( $\alpha$ -linolenic acid [ALA]) and  $\omega 6$  (linoleic acid [LA]) long-chain PUFAs and depend on diet for these two essential fatty acids. Walnut, canola, and flaxseed oil are good sources of ALA. Good sources of LA include safflower and sunflower oil. Essential fatty acids are enzymatically elongated and desaturated into longer-chain fatty acids (LC-PUFAs) that serve essential physiologic roles in the body. ALA can be converted to eicosapentaenoic acid (EPA) and docosahexaenoic acid (DHA). LA is converted to arachidonic acid (ARA). The conversion of ALA to EPA and DHA and of LA to ARA is influenced by many factors, including type and amounts of dietary fats and by enzymatic substrate affinity among competing  $\omega 3$ ,  $\omega 6$ ,  $\omega 9$ , saturated, and trans fatty acids. Approximately 0.5% of dietary ALA is converted to DHA, and 5% of ALA intake is converted to EPA; therefore dietary intake of LC-PUFAs is an important determinant of serum and tissue DHA and EPA status.

LC-PUFAs such as DHA and ARA have a variety of cellular structural and functional roles; they influence membrane fluidity and gene expression and modulate the inflammatory response. ARA and DHA are present in breast milk and reflect maternal intake. They are often supplemented in infant formulas and are important for optimal growth and development. DHA is highly concentrated in the retina and is involved in the visual evoked response in infants.

Risk factors for **essential fatty acid deficiency** (i.e., deficiency of ALA and LA) include severe fat malabsorption, prematurity, and administration of fat-free parenteral nutrition. Deficiency can develop within 2-4 weeks of inadequate intake. Essential fatty acid deficiency of LA is associated with desquamating skin rashes, alopecia, thrombocytopenia, impaired immunity, and growth deficits, but is rare in the general population. Deficiency of ALA has been associated with paresthesias, weakness, impaired gait, impaired vision, hemorrhagic folliculitis, and impaired wound healing.

The biologic activity and health benefits of ALA are thought to be derived from its elongation products EPA and DHA. Consistent with the findings of limited conversion of ALA to EPA and DHA, the DRI stipulates that up to 10% of the AI for  $\omega 3$  PUFA (ALA being the major dietary constituent) can be replaced by DHA and EPA to support normal neural development and growth. The ratio of dietary intake of each type of PUFA influences their relative amounts in different tissue compartments. **A dietary  $\omega 6$ : $\omega 3$  PUFA ratio of 4-5:1 may be associated with improved health outcomes, compared with the current 15-30:1 ratio typically observed in U.S. diets.** In general,  $\omega 6$  fatty acids tend to have more proinflammatory effects and  $\omega 3$  fatty acids more anti-inflammatory effects, which have potential implications for adjunctive nutritional management of chronic inflammatory conditions.

## PROTEIN

Protein and amino acids have structural and functional roles in every cell in the body. Dietary protein intake is required to maintain and replenish the turnover of protein and to meet amino acid needs for growth. Dietary protein also provides approximately 4 kcal/g as an energy substrate when intake is in excess of needs or derived from endogenous sources during periods of catabolism. Inadequate energy intake or inadequate protein intake increases catabolism of body protein reservoirs (i.e., lean body mass) for energy and free amino acids required to support normal physiologic function. Without adequate daily dietary protein intake, endogenous sources will be mobilized at the expense of function. Negative energy balance (weight loss) is associated with an obligatory negative nitrogen balance. Nitrogen from protein turnover is primarily excreted in urine and stool.

Increased protein intake of up to 20–30% may be required during hypermetabolic states, as well as in those infants and children recovering from malnutrition. Certain conditions may require a modest increase in protein intake, including conditions with high protein turnover, such as cystic fibrosis, inflammatory conditions, critical illnesses, extensive burn injuries, compensated liver disease, and post-surgical states including bariatric surgery (e.g., laparoscopic sleeve

gastrectomy and Roux-en-Y gastric bypass). Premature infants also require increased protein intakes due to increased needs related to accelerated growth rates. In addition, athletes engaging in resistance, muscle-building training may have increased total protein needs of approximately 1.2-2.0 g/kg/day to prevent loss of lean body mass and to maintain nitrogen balance. Importantly, the increased protein intake in these situations must occur in the context of adequate energy intake in order for protein deposition to occur, thus ensuring that protein is not used or catabolized for energy. Moderate to severe protein-energy malnutrition (PEM), although relatively rare in the non-institutionalized U.S. population, is more common in low-resource settings. Mild PEM occurs more commonly in the United States, leading children not to meet weight targets on growth curves. PEM impairs brain, immune system, and intestinal mucosal functions (see [Chapters 62 and 64](#)).

The DRI for protein is provided in [Table 60.3](#). Numerous factors influence dietary requirements for protein, including gender, age, growth stage, pregnancy, lactation, the presence of illness, the nutritional adequacy of an individual's diet, and genetics. The most important determinant of protein requirements is energy intake because insufficient energy intake will lead to protein catabolism to maintain energy balance, effectively increasing protein intake requirements. The EAR and RDA take into account protein required for growth and maintenance, but the RDA accounts for variation in requirements for a particular population that may exist as a result of differences in maintenance needs, protein accrual rates, and the efficiency of dietary protein accrual. Thus the RDA exceeds the EAR and most protein needs for individuals of a specific group.

The average intake of protein from poultry, meat, eggs, nuts, seeds, and soy products differs by age and gender. According to the 2020–2025 DGA and based on National Health and Nutrition Examination Survey (NHANES) data from 2015 to 2016, the average daily intake of protein for males and females age 2-4 years and 5-8 years is within recommended ranges. In children age 9-13 years, average protein intake barely meets the lower end of recommended intake for both males and females. For adolescents 14 years of age and above, males have average daily protein intakes within the recommended range; that for females falls short of the minimum recommended daily intake. A UL for protein has not been set because of insufficient data; however, excessively high intakes can result in increased urinary calcium excretion that may increase the risk of renal calculi. **Intake of protein or specific amino acids needs to be limited in some health conditions**, such as renal disease, decompensated liver disease, and metabolic diseases such as phenylketonuria and maple syrup urine disease, in which specific amino acids can be toxic. Conclusive evidence for harm in *otherwise healthy* individuals from high protein intakes is lacking. Protein intake necessary to meet micronutrient needs, especially during the first 2 years of postnatal life, will typically exceed recommended protein intakes, thus requiring micronutrient supplementation to prevent insufficiency or deficiency.

The amino acid content of dietary protein is also important. The standard by which a protein's quality is judged is its ability to support adequate growth. Certain amino acids are **indispensable/essential**, and humans depend on dietary sources to meet adequacy and prevent deficiency. Certain amino acids are termed **conditionally indispensable**, meaning they can be endogenously produced but require an exogenous source (i.e., diet) in certain disease conditions or during a certain life stage. An example would be the increased requirements for cysteine, tyrosine, and arginine in newborns because of enzyme immaturity ([Table 60.4](#)). DRI recommendations regarding protein intake assume adequate provision of indispensable amino acids and high digestibility. Human milk contains both the indispensable and conditionally indispensable amino acids and therefore meets the protein requirements for infants. Breast milk is considered the optimal protein source for infants and is the reference amino acid composition by which biologic quality is determined for infants. If a single amino acid in a food protein source is low or absent but is required to support normal metabolism, that specific amino acid becomes the limiting nutrient in that food. Animal protein, unlike plant protein, contains sufficient indispensable



**Table 60.4** Indispensable, Dispensable, and Conditionally Indispensable Amino Acids in the Human Diet

INDISPENSABLE	DISPENSABLE	CONDITIONALLY INDISPENSABLE*	PRECURSORS OF CONDITIONALLY INDISPENSABLE
Histidine†	Alanine	Arginine	Glutamine/glutamate, aspartate
Isoleucine	Aspartic acid	Cysteine	Methionine, serine
Leucine	Asparagine	Glutamine	Glutamic acid/ammonia
Lysine	Glutamic acid	Glycine	Serine, choline
Methionine	Serine	Proline	Glutamate
Phenylalanine		Tyrosine	Phenylalanine
Threonine			
Tryptophan			
Valine			

\*Conditionally indispensable is defined as requiring a dietary source when endogenous synthesis cannot meet metabolic need.

†Although histidine is considered indispensable, unlike the other 8 indispensable amino acids, it does not fulfill the criteria of reducing protein deposition and inducing negative nitrogen balance promptly on removal from the diet.

Adapted from Otten JJ, Hellwig JP, Meyers LD (eds). *Dietary Reference Intakes: The Essential Guide to Nutrient Requirements*. Washington, DC: Institute of Medicine, National Academies Press; 2006.

amino acids and typically is more digestible (>95%) than plant-source proteins (70–80%).

To ensure appropriate growth and to promote satiety, children should consume the recommended amount of protein. Specific recommendations for appropriate dietary protein sources to meet indispensable amino acid requirements are available for groups adopting specific diets, such as vegetarians and vegans. Including mixtures of protein sources (e.g., legumes and corn) and using a variety of food sources to provide all of the required amino acids are strategies advocated for vegetarians and vegans (see [Chapter 61](#)).

## CARBOHYDRATES

Carbohydrates are abundant in many foods, including cereals, grains, fruits, and vegetables, and provide approximately 4 kcal/g of energy. Dietary carbohydrates include *monosaccharides*, which contain one sugar molecule (e.g., glucose, fructose, galactose); *disaccharides*, which contain two sugar molecules (e.g., sucrose, lactose, maltose); *oligosaccharides* or *polysaccharides*, which contain multiple sugar molecules in a chain or complex configuration (e.g., starch, nonstarch polysaccharides like fiber); and *sugar alcohols*. Dietary carbohydrates are absorbed across the intestinal epithelium and converted to glucose in the liver. Glucose serves as the essential energy source for erythrocytes and the central nervous system and is a major energy source for all other cells. The requirements for carbohydrates are based on the average minimum amount of glucose used by the brain. Chronic low carbohydrate intake (e.g., less than 10% of total caloric intake) results in ketosis. Although a UL for carbohydrates has not been set, a maximal intake of <10% of total energy intake from *added* sugars, such as syrups and other caloric *sweeteners*, has been proposed in the 2020–2025 DGA.

Added sugars do not contribute essential nutrients and function to sweeten foods and beverages. Naturally occurring sugars, such as in milk (lactose) or fruits (fructose), are not included. Higher intakes of added sugar can displace other **macronutrients and micronutrients** and increase the risk for nutrient deficiency and excessive energy intake. There is no benefit from consuming added sugars as discretionary calorie intake. The excess calories from added sugars may displace more nutrient-dense foods and make it difficult to meet nutrient needs while remaining within the recommended total caloric intake.

The recommended AMDR for carbohydrates is based on data suggesting a risk for coronary artery disease (CAD) with diets high in refined carbohydrates and low in fat (see [Table 60.2](#)). These diets, compared with diets with higher fat intake, result in high triglyceride levels, low high-density lipoprotein (HDL) cholesterol, and small LDL cholesterol particles and are associated with an increased risk of CAD, especially in sedentary overweight individuals. Diets within the AMDR for carbohydrates and fats minimize the risks of diabetes, obesity, and CAD. Diets with less than the minimum AMDR for carbohydrate most likely do not meet the AI for fiber (see [Table 60.3](#)).

Most carbohydrates are present as starches or sugars in food. Simple sugars (monosaccharides and disaccharides) are often added to foods and beverages during food preparation, processing, and packaging to enhance their palatability and also act as preservatives. Sugar-sweetened beverages, including nondiet soft drinks, juice drinks, iced tea, and sport drinks, are major contributors to added sugars in the diet of U.S. children and adolescents ([Fig. 60.4](#)). Added sugars are associated with increased risk for obesity, diabetes, and dental caries. Fructose is one such added sugar in the form of *high-fructose corn syrup*, which is ubiquitous in the U.S. diet. Added fructose increases HDL and triglyceride production in the liver and serum uric acid, which increases systolic blood pressure and is associated with nonalcoholic fatty liver disease and metabolic syndrome. Excessive fructose intake, such as in the form of fruit juices, may be associated with diarrhea, abdominal pain, and failure to thrive in children. Fructose consumed in whole fruits rarely contributes to these side effects because its systemic absorption and metabolic effects are mitigated by the fact that it is complexed with fiber.

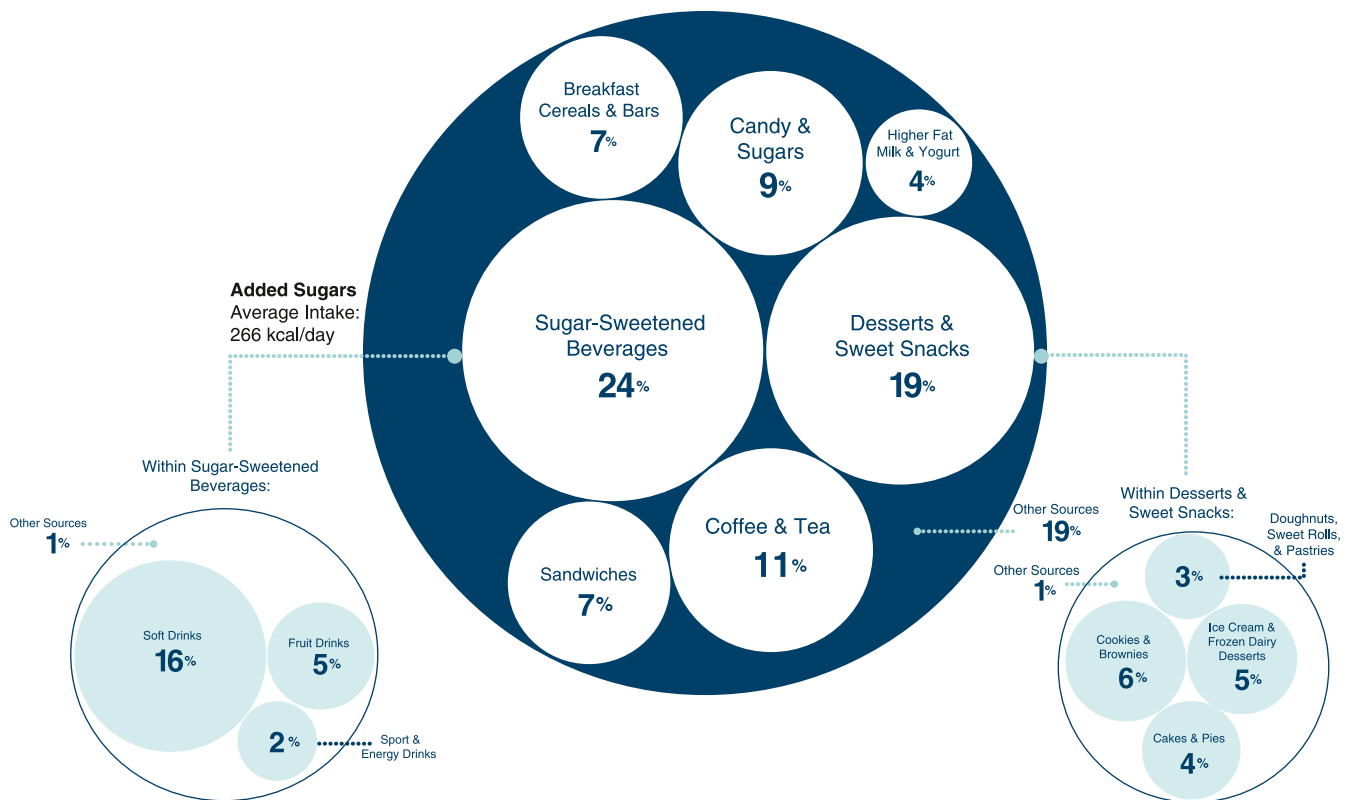
The **glycemic index** is a measure of peak blood glucose concentration 2 hours after ingestion of a given food compared with a reference standard (slice of white bread). The glycemic index has predictable effects on blood glucose, hemoglobin A<sub>1C</sub>, insulin, triglycerides, and HDL cholesterol. *Lower-glycemic-index foods are recommended and may reduce the risk of insulin resistance and CV disease*. Examples of low-glycemic-index foods include oat bran, muesli, barley, carrots, nonstarchy vegetables, and most fruits.

## FIBER

Fiber consists of *nondigestible* carbohydrates (i.e., nonstarch polysaccharides and nonpolysaccharides such as lignins), mostly derived from plant sources, such as whole grains, fruits, and vegetables, that escape digestion and reach the colon almost 100% intact. Fiber can be classified as fermentable and nonfermentable. Fermentable fibers are found in beans, fruits, and products containing oats or psyllium, and nonfermentable fiber is found in whole grains and vegetables. The DRI classification considers total fiber intake to be composed of **dietary fiber** (nondigestible carbohydrates and lignins intrinsic to plants that are fermented by colonic bacteria) and **functional fiber** (nondigestible carbohydrates isolated from plants or manufactured for use as dietary supplements). Although functional fibers may improve constipation and glucose absorption, they do not contain the other beneficial phytochemicals and nutrients of naturally occurring fiber found in whole foods. Functional fibers have been added to cereals, salad dressings, soups, baked goods, and meal replacements with the aim of increasing fiber intake.

Dietary fiber may help reduce intestinal cell dysplasia by diluting toxins, carcinogens, and tumor promoters; decreasing transit time, thereby reducing colonic mucosal exposure; and promoting toxin expulsion in the fecal stream. Dietary fiber that is resistant to colonic





**Fig. 60.4** Top sources and average intakes of added sugars: U.S. population age 1 year and older. Estimates based on 2-day dietary intake data, weighted, from What We Eat in America (WWEIA), NHANES, 2013-2016. (From the *Dietary Guidelines for Americans, 2020-2025, Chapter 1: Nutrition and Health Across the Lifespan*. Fig. 1.10. [https://www.dietaryguidelines.gov/sites/default/files/2020-12/Dietary\\_Guidelines\\_for\\_Americans\\_2020-2025.pdf](https://www.dietaryguidelines.gov/sites/default/files/2020-12/Dietary_Guidelines_for_Americans_2020-2025.pdf).)

degradation may also play a role in maintaining and promoting stool bulk and in regulating intraluminal pressure and colonic wall resistance, disordered colonic motility, or both. Lack of certain types of dietary fiber is associated with constipation and diverticulosis.

All types of dietary fiber slow gastric emptying and promote satiety, and thus may help to regulate appetite. Dietary fiber may decrease the rate of release and absorption of simple sugars and may help regulate blood sugar concentration by lowering postprandial blood glucose levels. Dietary fiber has a low glycemic index and may have a beneficial effect on insulin sensitivity. Fiber also binds luminal cholesterol and reduces absorption and enterohepatic circulation of the cholesterol in bile salts (e.g., with the intake of more viscous forms of dietary fiber, such as pectin). Guar gum, oat products, and pectin (i.e., fermentable/viscous fiber) lower serum cholesterol, whereas nonfermentable/non-viscous fiber (e.g., flax, wheat bran) may reduce serum triglycerides. Fiber such as psyllium, resistant dextrins, and resistant starch may lower both serum LDL cholesterol and triglycerides. Low fiber intake in Western society has been associated with the increasing incidence and prevalence of diabetes, obesity, CV disease, colon cancer, and IBD.

There is a dynamic interplay between the colonic bacterial milieu and the diet. The metabolic fate of fiber is influenced primarily by colonic bacteria, which render it susceptible to fermentation, depending on the structure of the fiber (e.g., pectin, oat bran). Common by-products of colonic fermentation include carbon dioxide, methane (in addition to other gases), **oligofructose** (also known as a *prebiotic*, a substrate that nourishes beneficial commensal GI microbiota), and **short-chain fatty acids (SCFAs)**. The common SCFAs produced by fermentation include acetate, butyrate, and propionate. SCFAs influence colonic physiology by stimulating colonic blood flow and fluid and electrolyte uptake. Butyrate is the preferred fuel for the colonocyte and may have a role in maintaining the normal phenotype in these cells. Good sources of fiber include beans, peas, leafy and cruciferous vegetables, fruits, and whole

grains. The observed benefits of diets rich in fruits and vegetables may be mediated by the fiber they contain and also by the other compounds and micronutrients (e.g., polyphenols, carotenoids) they contain.

Data are insufficient to establish an EAR for dietary fiber. AI for dietary fiber has been established based on the intake levels associated with reducing risk for CV disease and in lowering or normalizing serum cholesterol (see Table 60.3). Several recommendations address dietary fiber intake in children based on body weight or as a proportion of daily calories consumed. The IOM recommends an AI for fiber of 14 g per 1,000 kcal of energy consumed (see Table 60.3), which for younger children may be unrealistic to achieve. *The equation for the range of recommended daily fiber intake in grams = Age (years) + 5 to 10 grams per day.* The recommendations do not specify type of fiber and predate the newer definitions of fiber.

A UL has not been established for fiber, which is not thought to be harmful to human health. Some types of fiber, such as fermentable oligosaccharides, may exert symptoms on the basis of their digestibility, by-product formation, and interactions with GI microbiota. Excessive intake of **fermentable oligosaccharides** (e.g., fructooligosaccharides such as onions), **disaccharides** (e.g., lactose), **monosaccharides** (e.g., fructose), and **polyols** (e.g., sorbitol) (aka **FODMAPs**) is associated with increased risk for GI symptoms along with the functional abdominal pain, functional GI disorders (IBS), and IBD. **Restricted intake or substitution with lower-FODMAP foods may be beneficial.** Substitutions within the same food groups can shift from a high-FODMAP diet to a low-FODMAP diet, which may provide GI symptom relief. For example, substituting cucumber for celery would be exchanging a high-FODMAP food for a low-FODMAP food. Dietary management for some conditions may put certain children at risk of low fiber intake. Gluten-free diets used for celiac disease are often low in fiber. In such cases, gluten-free sources of fiber should be recommended, such as tapioca, flax, corn, rice, sorghum, and quinoa.

## MICRONUTRIENTS

See Chapters 66-72.

Vitamins and minerals, the dietary **micronutrients**, are essential for growth and development and contribute to a host of physiologic functions. Many U.S. children may have suboptimal intake of iron, zinc, potassium, calcium, and vitamins D, E, and K, and excess intake of sodium. Dietary recommendations for micronutrients were originally established to prevent deficiency and currently also include the impact of micronutrients on long-term health outcomes (Table 60.5). Food fortification is an effective strategy to prevent some nutrient deficiencies and has been successfully implemented to prevent iodine, folate, and vitamin D deficiencies.

The DRI for 0-6 months for all micronutrients are AIs, because data are considered to be insufficient to establish an EAR on which an RDA would be based. The AI for the first 6 months of postnatal life is based on the daily mean nutrient intake supplied by human milk for healthy, full-term infants who are exclusively breastfed. For approximately the first 6 months of postnatal life for healthy term infants, an adequately nourished mother produces human milk with adequate amounts of the majority of micronutrients; exceptions are iron and zinc, concentrations of which are unrelated to maternal intake. In the early postnatal months, infants rely on body stores and iron available from the relatively high erythron (especially with delayed cord clamping), and thus the actual dietary requirement for iron is very modest. Infants born prematurely and/or with evidence of fetal growth restriction are likely to have low iron stores at birth and thus may need exogenous iron earlier than 6 months. Zinc concentrations in human milk decline sharply over the first 3-4 months of lactation and are insufficient to meet needs by approximately 6 months. Thus after about 6 months, sources of both iron and zinc are required from complementary foods, such as pureed meats, fortified foods (e.g., infant cereals), or from supplements.

### Iron

Iron requirements are relatively higher during infancy and early childhood than later in life and are higher for menstruating females than for males of similar age-groups (see Chapter 72). Iron from animal protein is more bioavailable than that found in animal-source foods such as milk or plant sources because it is already incorporated into heme moieties in blood and muscle. Iron deficiency is the most common micronutrient deficiency in the world and is associated with iron-deficiency anemia and neurocognitive deficits in some children.

### Zinc

Zinc deficiency is estimated to affect millions of children in low-resource settings and is associated with increased risk for impaired linear growth (stunting), impaired immune function, and increased risk for respiratory and diarrheal diseases. In high-resource settings, mild deficiency may occur in older infants and toddlers if dietary choices do not include meat or fortified products. Whole grains, legumes, and other high-protein plant sources contain good amounts of zinc, but the absorption bioavailability will be lower compared to animal-source foods.

### Vitamin D

Vitamin D insufficiency is more common than previously thought in infants and children. Vitamin D is central to calcium and bone metabolism but is also an important determinant of various nonosseous health outcomes (see Chapter 69). Children of all ages with darker skin and those who do not consume fortified dairy products should be considered for screening for vitamin D deficiency. The DRI for vitamin D is based on its effects on calcium status and bone health. The goal is to achieve serum 25-hydroxyvitamin D levels >50 nmol/L (30 ng/dL). Breast milk is a poor source of vitamin D. The American Academy of Pediatrics (AAP) recommends total vitamin D intake of 400 IU/day for infants (0 to <12 months). A supplement is recommended for all breastfed infants to ensure sufficient intake. The RDA of vitamin D is currently 600 units daily for healthy children 1-18 years of age.

### Calcium

Calcium is key to bone health. Adequacy is determined in part by bone mineral content and bone mineral density (BMD). The main storage organs for calcium are the bones and teeth. Bone mineral accretion occurs primarily during childhood, with peak bone mass being achieved by the second to third decade of life. Calcium recommendations include a change from an AI to RDA, in terms of strength of evidence for recommendations, and increased UL in 9- to 18-year-olds (Table 60.6). There are no adequate biomarkers to assess calcium status in healthy children because serum calcium is tightly regulated (regardless of intake and total body calcium) by changes in parathyroid hormone and calcitriol levels. Maintaining adequate serum calcium level despite inadequate intake could come at the expense of BMD. Therefore in the long term, reduced BMD could serve as a surrogate marker of chronic calcium intake and status. It is important to note other determinants of BMD are age, gender, genetic-ethnic factors, hormonal status, physical activity, and weight. Assessments of calcium status should include calcium intake in the diet. It is also important to educate families on additional and alternative sources of calcium (including calcium supplementation) if calcium intake is determined to be low.

### Electrolytes

Potassium (K<sup>+</sup>) and sodium (Na<sup>+</sup>) are the main intracellular and extracellular cations, respectively, and are involved in transport of fluids and nutrients across the cellular membrane. The AI for potassium is related to its effects in maintaining a healthy blood pressure, reducing risk for nephrolithiasis, and supporting bone health. Moderate potassium deficiency occurs even in the absence of hypokalemia and can result in increased blood pressure, stroke, and other CV disease.

For people at increased risk of hypertension and who are salt sensitive, reducing sodium intake and increasing potassium intake is advised. Leafy green vegetables, vine fruits (e.g., tomatoes, eggplant, zucchini, pumpkin), and root vegetables (e.g., yams, beets) are good sources of potassium (see Table 60.6). People with impaired renal function may need to reduce potassium intake, because hyperkalemia can increase the risk for fatal cardiac arrhythmias among these patients.

Most dietary sodium (i.e., sodium chloride, or table salt) in the United States is found in processed foods, breads, and condiments (Fig. 60.5). Sodium salt (NaCl) is added to foods to serve as a preservative and enhance palatability. Sodium has an AI, but given the risk of table salt-related hypertension, an UL has also been set. The UL threshold may be even lower in certain populations, who on average may be more sodium salt sensitive, and for those with hypertension or preexisting renal disease. Dietary sodium intake also displaces potassium intake. Elevated sodium:potassium ratios can increase the risk for nephrolithiasis. Intakes of <2,300 mg sodium (approximately 1 tsp of table salt) per day are recommended. The average daily salt intake for most people in the United States and Canada exceeds both the AI and UL. *For populations with or at risk of hypertension and renal disease, sodium intake should be decreased to <1,500 mg/day and potassium intake increased to >4,700 mg/day.* For persons with hypertension, additional dietary guidelines are available from the **Dietary Approaches to Stop Hypertension (DASH) eating plan.**

### WATER

The daily water requirement and water content as a proportion of body weight are highest in infants and decrease with age. Water intake is achieved with liquid and food intake, and losses include excretion in the urine and stool, as well as insensible and evaporative losses through the skin and respiratory tract. An AI has been established for water (see Table 60.6). Special considerations are required by life stages and by BMR, physical activity, body proportions (surface area to volume), environment, and underlying medical conditions. Breast milk and infant formula provide adequate water, and additional water or other fluid intake is not required until complementary foods are introduced. Water contains no calories, but the concern is that additional water intake in young infants will decrease breast milk intake and displace the intake of essential nutrients during this phase of rapid rate of growth and high metabolic activity. The relatively higher fluid needs of

**Table 60.5** Dietary Reference Intakes for Vitamins

NUTRIENT	FUNCTION	LIFE STAGE GROUP	RDA OR AI	UL	SELECTED FOOD SOURCES	ADVERSE EFFECTS OF EXCESSIVE CONSUMPTION	SPECIAL CONSIDERATIONS
Biotin (vitamin B <sub>7</sub> )	Coenzyme in synthesis of fat, glycogen, and amino acids	<i>Infants</i> (μg/day)			Liver, smaller amounts in fruits and meats	Limited data to support adverse effects with excess; however, high intakes still should be taken with precaution.	None
		0-6 mo	5*	ND			
		7-12 mo	6*	ND			
		<i>Children</i> (μg/day)					
		1-3 yr	8*	ND			
		4-8 yr	12*	ND			
		<i>Males</i> (μg/day)					
		9-13 yr	20*	ND			
		14-18 yr	25*	ND			
		19-21 yr	30*	ND			
		<i>Females</i> (μg/day)					
		9-13 yr	20*	ND			
		14-18 yr	25*	ND			
		19-21 yr	30*	ND			
		<i>Pregnancy</i> (μg/day)					
		≤18 yr	30*	ND			
		19-21 yr	30*	ND			
<i>Lactation</i> (μg/day)							
≤18 yr	35*	ND					
19-21 yr	35*	ND					
Choline	Precursor for acetylcholine, phospholipids, and betaine	<i>Infants</i> (mg/day)			Milk, liver, eggs, peanuts	Fishy body odor, sweating, salivation, hypotension, hepatotoxicity	Patients with trimethylaminuria, renal disease, liver disease, depression, and Parkinson disease may be at risk for adverse effects with intakes at the UL. AIs have been set for choline, but there are little data to assess whether a dietary supply of choline is needed at all stages of the life cycle because the choline requirement might be met by endogenous synthesis at some of these stages.
		0-6 mo	125*	ND			
		7-12 mo	150*	ND			
		<i>Children</i> (mg/day)					
		1-3 yr	200*	1,000			
		4-8 yr	250*	1,000			
		<i>Males</i> (mg/day)					
		9-13 yr	375*	2,000			
		14-18 yr	550*	3,000			
		19-21 yr	550*	3,500			
		<i>Females</i> (mg/day)					
		9-13 yr	375*	2,000			
		14-18 yr	400*	3,000			
		19-21 yr	425*	3,500			
		<i>Pregnancy</i> (mg/day)					
		≤18 yr	450*	3,000			
		19-21 yr	450*	3,500			
<i>Lactation</i> (mg/day)							
≤18 yr	550*	3,000					
19-21 yr	550*	3,500					

Continued

Table 60.5 Dietary Reference Intakes for Vitamins—cont'd

NUTRIENT	FUNCTION	LIFE STAGE GROUP	RDA OR AI	UL	SELECTED FOOD SOURCES	ADVERSE EFFECTS OF EXCESSIVE CONSUMPTION	SPECIAL CONSIDERATIONS
Folate (folic acid, vitamin B <sub>9</sub> , folacin); pteroyl-polyglutamates given as dietary folate equivalents (DFEs) 1 DFE = 1 μg food folate = 0.6 μg folate from fortified food, or as supplement consumed with food = 0.5 μg of supplement taken on empty stomach	Coenzyme in metabolism of nucleic and amino acids Prevents megaloblastic anemia	<i>Infants</i> (μg/day)			Enriched cereal, grains, dark leafy vegetables, enriched and whole-grain breads and bread products, fortified ready-to-eat cereals	Masks neurologic complications in people with vitamin B <sub>12</sub> deficiency. No adverse effects with folate from food or supplements have been reported; however, high intakes still should be taken with precaution. UL applies to synthetic forms obtained from supplements and/or fortified foods.	Poor intake associated with neural tube defects; therefore all women who can become pregnant should consume, in addition to intake of food folate from a varied diet, 400 μg/day from supplements or fortified foods.
		0-6 mo	65*	ND			
		7-12 mo	80*	ND			
		<i>Children</i> (μg/day)					
		1-3 yr	150	300			
		4-8 yr	200	400			
		<i>Males</i> (μg/day)					
		9-13 yr	300	600			
		14-18 yr	400	800			
		19-21 yr	400	1,000			
		<i>Females</i> (μg/day)					
		9-13 yr	300	600			
		14-18 yr	400	800			
		19-21 yr	400	1,000			
		<i>Pregnancy</i> (μg/day)					
		≤18 yr	600	800			
19-21 yr	600	1,000					
<i>Lactation</i> (μg/day)							
≤18 yr	500	800					
19-21 yr	500	1,000					
Niacin (vitamin B <sub>3</sub> ) Includes nicotinic acid amide, nicotinic acid (pyridine-3 carboxylic acid), and derivatives that exhibit biologic activity of nicotinamide Given as niacin equivalents (NE) 1 mg niacin = 60 mg tryptophan Age 0-6 mo: preformed niacin (not NE).	Coenzyme or cosubstrate in many biologic reduction and oxidation reactions, thus required for energy metabolism	<i>Infants</i> (mg/day)			Meat, fish, poultry, enriched and whole-grain breads and bread products, fortified ready-to-eat cereals	No evidence of adverse effects from consuming naturally occurring niacin in food. Adverse effects from niacin-containing supplements can include flushing and GI distress. UL for niacin applies to synthetic forms obtained from supplements, fortified food, or a combination of these.	Extra niacin may be required by persons treated with hemodialysis or peritoneal dialysis or those with malabsorption syndrome.
		0-6 mo	2*	ND			
		7-12 mo	4*	ND			
		<i>Children</i> (mg/day)					
		1-3 yr	6	10			
		4-8 yr	8	15			
		<i>Males</i> (mg/day)					
		9-13 yr	12	20			
		14-18 yr	16	30			
		19-21 yr	16	35			
		<i>Females</i> (mg/day)					
		9-13 yr	12	20			
		14-18 yr	14	30			
		19-21 yr	14	35			
		<i>Pregnancy</i> (mg/day)					
		≤18 yr	18	30			
19-21 yr	18	35					
<i>Lactation</i> (mg/day)							
≤18 yr	17	30					
19-21 yr	17	35					



**Table 60.5** Dietary Reference Intakes for Vitamins—cont'd

NUTRIENT	FUNCTION	LIFE STAGE GROUP	RDA OR AI	UL	SELECTED FOOD SOURCES	ADVERSE EFFECTS OF EXCESSIVE CONSUMPTION	SPECIAL CONSIDERATIONS
Pantothenic acid (vitamin B <sub>5</sub> )	Coenzyme in fatty acid metabolism	<i>Infants</i> (mg/day)			Chicken, beef, potatoes, oats, cereals, tomato products, liver, kidney, yeast, egg yolk, broccoli, whole grains	Doses greater than 10 mg/day may cause mild diarrhea or mild intestinal distress; therefore high intakes should be taken with precaution.	Doses are age-dependent and if the patient is pregnant or lactating.
		0-6 mo	1.7*	ND			
		7-12 mo	1.8*	ND			
		<i>Children</i> (mg/day)					
		1-3 yr	2*	ND			
		4-8 yr	3*	ND			
		<i>Males</i> (mg/day)					
		9-13 yr	4*	ND			
		14-18 yr	5*	ND			
		19-21 yr	5*	ND			
		<i>Females</i> (mg/day)					
		9-13 yr	4*	ND			
		14-18 yr	5*	ND			
		19-21 yr	5*	ND			
		<i>Pregnancy</i> (mg/day)					
		≤18 yr	6*	ND			
		19-21 yr	6*	ND			
<i>Lactation</i> (mg/day)							
≤18 yr	7*	ND					
19-21 yr	7*	ND					
Riboflavin (vitamin B <sub>2</sub> )	Coenzyme in numerous redox reactions	<i>Infants</i> (mg/day)			Organ meats, milk, bread products, fortified cereals	No adverse effects associated with vitamin B <sub>2</sub> consumption from food or supplements have been reported; however, high intakes still should be taken with precaution.	None
		0-6 mo	0.3*	ND			
		7-12 mo	0.4*	ND			
		<i>Children</i> (mg/day)					
		1-3 yr	0.5	ND			
		4-8 yr	0.6	ND			
		<i>Males</i> (mg/day)					
		9-13 yr	0.9	ND			
		14-18 yr	1.3	ND			
		19-21 yr	1.3	ND			
		<i>Females</i> (mg/day)					
		9-13 yr	0.9	ND			
		14-18 yr	1.0	ND			
		19-21 yr	1.1	ND			
		<i>Pregnancy</i> (mg/day)					
		≤18 yr	1.4	ND			
		19-21 yr	1.4	ND			
<i>Lactation</i> (mg/day)							
≤18 yr	1.6	ND					
19-21 yr	1.6	ND					

Continued

**Table 60.5** Dietary Reference Intakes for Vitamins—cont'd

NUTRIENT	FUNCTION	LIFE STAGE GROUP	RDA OR AI	UL	SELECTED FOOD SOURCES	ADVERSE EFFECTS OF EXCESSIVE CONSUMPTION	SPECIAL CONSIDERATIONS
Thiamin (vitamin B <sub>1</sub> )	Coenzyme in metabolism of carbohydrates and branched-chain amino acids	<i>Infants</i> (mg/day)			Enriched, fortified, or whole-grain products, bread and bread products, mixed foods whose main ingredient is grain, ready-to-eat cereals	No adverse effects associated with vitamin B <sub>1</sub> consumption from food or supplements have been reported; however, high intakes still should be taken with precaution.	Persons being treated with hemodialysis or have a malabsorption syndrome may have increased needs for vitamin B <sub>1</sub> .
		0-6 mo	0.2*	ND			
		7-12 mo	0.3*	ND			
		<i>Children</i> (mg/day)					
		1-3 yr	0.5	ND			
		4-8 yr	0.6	ND			
		<i>Males</i> (mg/day)					
		9-13 yr	0.9	ND			
		14-18 yr	1.2	ND			
		19-21 yr	1.2	ND			
		<i>Females</i> (mg/day)					
		9-13 yr	0.9	ND			
		14-18 yr	1.0	ND			
		19-21 yr	1.1	ND			
		<i>Pregnancy</i> (mg/day)					
		≤18 yr	1.4	ND			
19-21 yr	1.4	ND					
<i>Lactation</i> (mg/day)							
≤18 yr	1.4	ND					
19-21 yr	1.4	ND					
Vitamin A Includes provitamin A carotenoids that are dietary precursors of retinol Given as retinol activity equivalents (RAEs) 1 RAE = 1 μg retinol, 12 μg β-carotene, 24 μg α-carotene, or 24 μg β-cryptoxanthin To calculate RAEs from REs of provitamin A carotenoids in food, divide REs by 2 For preformed vitamin A in food or supplements and for provitamin A carotenoids in supplements, 1 RE = 1 RAE	Required for normal vision, gene expression, reproduction, embryonic development, and immune function	<i>Infants</i> (μg/day)			Liver, dairy products, fish, dark-colored fruit, leafy vegetables	Teratologic effects, liver toxicity (from preformed vitamin A only).	Persons with high alcohol intake, preexisting liver disease, hyperlipidemia, or severe protein malnutrition may be susceptible to the adverse effects of excess preformed vitamin A intake. β-Carotene supplements are advised only to serve as a provitamin A source for persons at risk for vitamin A deficiency.
		0-6 mo	400*	600			
		7-12 mo	500*	600			
		<i>Children</i> (μg/day)					
		1-3 yr	300	600			
		4-8 yr	400	900			
		<i>Males</i> (μg/day)					
		9-13 yr	600	1,700			
		14-18 yr	900	2,800			
		19-21 yr	900	3,000			
		<i>Females</i> (μg/day)					
		9-13 yr	600	1,700			
		14-18 yr	700	2,800			
		19-21 yr	700	3,000			
		<i>Pregnancy</i> (μg/day)					
		≤18 yr	750	2,800			
19-21 yr	770	3,000					
<i>Lactation</i> (μg/day)							
≤18 yr	1,200	2,800					
19-21 yr	1,300	3,000					

**Table 60.5** Dietary Reference Intakes for Vitamins—cont'd

NUTRIENT	FUNCTION	LIFE STAGE GROUP	RDA OR AI	UL	SELECTED FOOD SOURCES	ADVERSE EFFECTS OF EXCESSIVE CONSUMPTION	SPECIAL CONSIDERATIONS
Pyridoxine (vitamin B <sub>6</sub> ) Comprises a group of six related compounds: pyridoxal, pyridoxine, pyridoxamine, and 5'-phosphates (PLP, PNP, PMP)	Coenzyme in metabolism of amino acids, glycogen, and sphingoid bases	<i>Infants</i> (mg/day)			Fortified cereals, organ meats, fortified soy-based meat substitutes	No adverse effects associated with vitamin B <sub>6</sub> from food have been reported; however, high intakes still should be taken with precaution. Sensory neuropathy, ataxia, and nausea have occurred from high intakes (>1,000 mg/day) of supplemental forms.	Deficiencies often occur when other B vitamins in the body are low, particularly vitamin B <sub>12</sub> and folic acid. Risk of developing deficiency is associated with conditions such as kidney disease, celiac disease, inflammatory bowel disease, rheumatoid arthritis, and alcohol use.
		0-6 mo	0.1*	ND			
		7-12 mo	0.3*	ND			
		<i>Children</i> (mg/day)					
		1-3 yr	0.5	30			
		4-8 yr	0.6	40			
		<i>Males</i> (mg/day)					
		9-13 yr	1.0	60			
		14-18 yr	1.3	80			
		19-21 yr	1.3	100			
		<i>Females</i> (mg/day)					
		9-13 yr	1.0	60			
		14-18 yr	1.2	80			
		19-21 yr	1.3	100			
		<i>Pregnancy</i> (mg/day)					
		≤18 yr	1.9	80			
		19-21 yr	1.9	100			
<i>Lactation</i> (mg/day)							
≤18 yr	2.0	80					
19-21 yr	2.0	100					
Cobalamin (vitamin B <sub>12</sub> )	Coenzyme in nucleic acid metabolism Prevents megaloblastic anemia	<i>Infants</i> (μg/day)			Fortified cereals, meat, fish, poultry		Because 10–30% of older people malabsorb food-bound vitamin B <sub>12</sub> , those >50 yr are advised to meet their RDA mainly by consuming foods fortified with vitamin B <sub>12</sub> or a supplement containing vitamin B <sub>12</sub> .
		0-6 mo	0.4*	ND			
		7-12 mo	0.5*	ND			
		<i>Children</i> (μg/day)					
		1-3 yr	0.9	ND			
		4-8 yr	1.2	ND			
		<i>Males</i> (μg/day)					
		9-13 yr	1.8	ND			
		14-18 yr	2.4	ND			
		19-21 yr	2.4	ND			
		<i>Females</i> (μg/day)					
		9-13 yr	1.8	ND			
		14-18 yr	2.4	ND			
		19-21 yr	2.4	ND			
		<i>Pregnancy</i> (μg/day)					
		≤18 yr	2.6	ND			
		19-21 yr	2.6	ND			
<i>Lactation</i> (μg/day)							
≤18 yr	2.8	ND					
19-21 yr	2.8	ND					

Continued

**Table 60.5** Dietary Reference Intakes for Vitamins—cont'd

NUTRIENT	FUNCTION	LIFE STAGE GROUP	RDA OR AI	UL	SELECTED FOOD SOURCES	ADVERSE EFFECTS OF EXCESSIVE CONSUMPTION	SPECIAL CONSIDERATIONS
Vitamin C (ascorbic acid, dehydroascorbic acid)	Cofactor for reactions requiring reduced copper or iron metalloenzyme and as a protective antioxidant	<i>Infants</i> (mg/day)			Citrus fruit, tomatoes, tomato juice, potatoes, brussels sprouts, cauliflower, broccoli, strawberries, cabbage, spinach	GI disturbances, kidney stones, excess iron absorption	Smokers require additional 35 mg/day of vitamin C over that needed by nonsmokers. Nonsmokers regularly exposed to tobacco smoke should ensure they meet the RDA for vitamin C.
		0-6 mo	40*	ND			
		7-12 mo	50*	ND			
		<i>Children</i> (mg/day)					
		1-3 yr	15	400			
		4-8 yr	25	650			
		<i>Males</i> (mg/day)					
		9-13 yr	45	1,200			
		14-18 yr	75	1,800			
		19-21 yr	90	2,000			
		<i>Females</i> (mg/day)					
		9-13 yr	45	1,200			
		14-18 yr	65	1,800			
		19-21 yr	75	2,000			
		<i>Pregnancy</i> (mg/day)					
≤18 yr	80	1,800					
19-21 yr	85	2,000					
<i>Lactation</i> (mg/day)							
≤18 yr	115	1,800					
19-21 yr	120	2,000					
Vitamin E (α-tocopherol) α-tocopherol includes RRR-α-tocopherol, the only form of α-tocopherol that occurs naturally in foods, and the 2R-stereoisomeric forms of α-tocopherol (RRR-, RSR-, RRS-, and RSS-α-tocopherol) that occur in fortified foods and supplements It does not include the 2S-stereoisomeric forms of α-tocopherol (SRR-, SSR-, SRS-, and SSS-α-tocopherol), also found in fortified foods and supplements	A metabolic function has not yet been identified. Vitamin E's major function appears to be as a nonspecific chain-breaking antioxidant.	<i>Infants</i> (mg/day)			Vegetable oil, unprocessed cereal grains, nuts, fruit, vegetables, meat	No evidence of adverse effects from consuming vitamin E naturally occurring in food. Adverse effects from supplements may include hemorrhagic toxicity. UL applies to any form of α-tocopherol obtained from supplements, fortified foods, or a combination of these.	Persons receiving anticoagulant therapy are at risk of excess bleeding when taking vitamin E supplements in doses greater than 1,000 mg/day.
		0-6 mo	4*	ND			
		7-12 mo	5*	ND			
		<i>Children</i> (mg/day)					
		1-3 yr	6	200			
		4-8 yr	7	300			
		<i>Males</i> (mg/day)					
		9-13 yr	11	600			
		14-18 yr	15	800			
		19-21 yr	15	1,000			
		<i>Females</i> (mg/day)					
		9-13 yr	11	600			
		14-18 yr	15	800			
		19-21 yr	15	1,000			
		<i>Pregnancy</i> (mg/day)					
≤18 yr	15	800					
19-21 yr	15	1,000					
<i>Lactation</i> (mg/day)							
≤18 yr	19	800					
19-21 yr	19	1,000					



**Table 60.5** Dietary Reference Intakes for Vitamins—cont'd

NUTRIENT	FUNCTION	LIFE STAGE GROUP	RDA OR AI	UL	SELECTED FOOD SOURCES	ADVERSE EFFECTS OF EXCESSIVE CONSUMPTION	SPECIAL CONSIDERATIONS
Vitamin K	Coenzyme during synthesis of many proteins involved in blood clotting and bone metabolism	<i>Infants</i> (μg/day)			Green vegetables (collards, spinach, salad greens, broccoli), brussels sprouts, cabbage, plant oil, margarine	No adverse effects associated with vitamin K consumption from food or supplements have been reported in humans or animals; however, high intakes still should be taken with precaution.	Patients receiving anticoagulant therapy or taking long-term antibiotics should monitor vitamin K intake.
		0-6 mo	2.0*	ND			
		7-12 mo	2.5*	ND			
		<i>Children</i> (μg/day)					
		1-3 yr	30*	ND			
		4-8 yr	55*	ND			
		<i>Males</i> (μg/day)					
		9-13 yr	60*	ND			
		14-18 yr	75*	ND			
		19-21 yr	120*	ND			
		<i>Females</i> (μg/day)					
		9-13 yr	60*	ND			
		14-18 yr	75*	ND			
		19-21 yr	90*	ND			
		<i>Pregnancy</i> (μg/day)					
		≤18 yr	75*	ND			
19-21 yr	90*	ND					
<i>Lactation</i> (μg/day)							
≤18 yr	75*	ND					
19-21 yr	90*	ND					

Note: Starred (\*) numbers are adequate intake (AI) and bold numbers are RDA. RDAs and AIs may both be used as goals for individual intake. RDAs are set to meet the needs of 97–98% of members in a group. For healthy breastfed infants, the AI is the mean intake. The AI for other life stage and gender groups is believed to cover the needs of all members of the group, but lack of data prevents specifying with confidence the percentage covered by this intake.

UL is the maximum level of daily nutrient intake that is likely to pose no risk of adverse effects. Unless otherwise specified, the UL represents total intake from food, water, and supplements. Because of a lack of suitable data, ULs could not be established for potassium, water, or inorganic sulfate. In the absence of ULs, extra caution may be warranted in consuming levels above recommended intakes.

ND amounts are not determinable because of a lack of data on adverse effects in this age-group and concern with regard to lack of ability to handle excess amounts. Source of intake should be from food only to prevent high levels of intake.

\*RDA for vitamin D in IU/day: 400 if <1 yr age, 600 if >1 yr, lactating, or pregnant.

AI, Adequate intake; GI, gastrointestinal; ND, not determinable; PLP, pyridoxal phosphate; PMP, pyridoxamine phosphate; PNP, pyridoxine phosphate; RDA, recommended dietary allowance; UL, upper limit of normal.

Data from Dietary reference intakes for calcium, phosphorus, magnesium, vitamin D, and fluoride, 1997; Dietary reference intakes for thiamin, riboflavin, niacin, vitamin B<sub>6</sub>, folate, vitamin B<sub>12</sub>, pantothenic acid, biotin, and choline, 1998; Dietary reference intakes for vitamin C, vitamin E, selenium, and carotenoids, 2000; Dietary reference intakes for vitamin A, vitamin K, arsenic, boron, chromium, copper, iodine, iron, manganese, molybdenum, nickel, silicon, vanadium, and zinc, 2001; Dietary reference intakes for energy, carbohydrate, fiber, fat, fatty acids, cholesterol, protein, and amino acids, 2002/2005; Dietary reference intakes for calcium and vitamin D, 2011. These reports may be accessed via

[www.nap.edu](http://www.nap.edu)

**Table 60.6** Dietary Reference Intakes for Select Micronutrients and Water

NUTRIENT	FUNCTION	LIFE STAGE GROUP	AI (mg/day)	UL (mg/day)	SELECTED FOOD SOURCES	ADVERSE EFFECTS OF EXCESSIVE CONSUMPTION	SPECIAL CONSIDERATIONS
Sodium	Maintains fluid volume outside of cells and thus normal cell function	<i>Infants</i>			Processed foods with added sodium chloride (salt), benzoate, phosphate; salted meats, bread, nuts, cold cuts; margarine; butter; salt added to foods in cooking or at the table. Salt is about 40% sodium by weight.	Hypertension, increased risk of cardiovascular disease and stroke	AI is set based on ability to obtain a nutritionally adequate diet for other nutrients and to meet the needs for sweat losses for persons engaged in recommended levels of physical activity. Persons engaged in activity at higher levels or in humid climates resulting in excessive sweating might need more than the AI. UL applies to apparently healthy persons without hypertension; it thus may be too high for persons who already have hypertension.
		0-6 mo	120	ND			
		7-12 mo	370	ND			
		<i>Children</i>					
		1-3 yr	1,000	1,500			
		4-8 yr	1,200	1,900			
		<i>Males</i>					
		9-13 yr	1,500	2,200			
		14-21 yr	1,500	2,300			
		<i>Females</i>					
9-13 yr	1,500	2,200					
13-21 yr	1,500	2,300					
<i>Pregnancy and Lactation</i>							
≥14 yr	1,500	2,300					
Chloride	With sodium, maintains fluid volume outside of cells and thus normal cell function	<i>Infants</i>			Processed foods with added table salt, benzoate, phosphate; salted meats, nuts, cold cuts; margarine; butter; salt added to foods in cooking or at the table. Salt is about 60% chloride by weight.	In concert with sodium, results in hypertension	Chloride is lost, usually with sodium, in sweat and in vomiting and diarrhea. AI and UL are equimolar in amount to sodium because most of sodium in diet comes as table salt.
		0-6 mo	180	ND			
		7-12 mo	570	ND			
		<i>Children</i>					
		1-3 yr	1,500	2,300			
		4-8 yr	1,900	2,900			
		<i>Males</i>					
		9-13 yr	2,300	3,400			
		14-21 yr	2,300	3,600			
		<i>Females</i>					
9-13 yr	2,300	3,400					
13-21 yr	2,300	3,600					
<i>Pregnancy and Lactation</i>							
≥14 yr	2,300	3,600					
Potassium	Maintains fluid volume inside/outside of cells and thus normal cell function; acts to blunt the rise of blood pressure in response to excess sodium intake and decrease markers of bone turnover and recurrence of kidney stones	<i>Infants</i>			Fruits and vegetables, dried peas, dairy products, meats, nuts	None documented from food alone, but potassium from supplements or salt substitutes can result in hyperkalemia and possibly sudden death if excess is consumed by persons with chronic renal insufficiency (kidney disease) or diabetes	Persons taking drugs for cardiovascular disease such as ACE inhibitors, ARBs, or potassium-sparing diuretics should be careful not to consume supplements containing potassium and might need to consume less than the AI.
		0-6 mo	400	None set			
		7-12 mo	700				
		<i>Children</i>					
		1-3 yr	3,000	No UL			
		4-8 yr	3,800				
		<i>Males</i>					
		9-13 yr	4,500				
		14-21 yr	4,700				
		<i>Females</i>					
		9-13 yr	4,500				
		13-21 yr	4,700				
		<i>Pregnancy</i>					
≥14 yr	4,700						
<i>Lactation</i>							
≥14 yr	5,100						

**Table 60.6** Dietary Reference Intakes for Select Micronutrients and Water—cont'd

NUTRIENT	FUNCTION	LIFE STAGE GROUP	AI (mg/day)	UL (mg/day)	SELECTED FOOD SOURCES	ADVERSE EFFECTS OF EXCESSIVE CONSUMPTION	SPECIAL CONSIDERATIONS
Vitamin D (calciferol) 1 µg calciferol = 40 IU vitamin D DRI values are based on absence of adequate exposure to sunlight.	Maintains serum calcium and phosphorus concentrations	<i>Infants (µg/day)*</i>			Fish liver oils, flesh of fatty fish, liver, eggs from hens that have been fed vitamin D, fortified milk products, fortified cereals	Elevated plasma 25(OH)D concentration causing hypercalcemia	Patients receiving glucocorticoid therapy might require additional vitamin D.
		0-6 mo	10	25			
		7-12 mo	10	38			
		<i>Children (µg/day)*</i>					
		1-3 yr	15	63			
		4-8 yr	15	75			
		<i>Males (µg/day)*</i>					
		9-21 yr	15	100			
		<i>Females (µg/day)*</i>					
		9-21 yr	15	100			
		<i>Pregnancy (µg/day)*</i>					
		≤18 yr	15	100			
<i>Lactation (µg/day)</i>							
≤18 yr	15	100					
19-21 yr	15	100					
Calcium	Essential role in blood clotting, muscle contraction, nerve transmission, and bone and tooth formation	<i>Infants</i>			Milk, cheese, yogurt, corn tortillas, calcium-set tofu, Chinese cabbage, kale, broccoli	Kidney stones, hypercalcemia, milk alkali syndrome, renal insufficiency	Amenorrheic women (exercise or anorexia nervosa induced) have reduced net calcium absorption.
		0-6 mo	200	1,000			
		7-12 mo	260	1,500			
		<i>Children</i>					
		1-3 yr	700	2,500			
		4-8 yr	1,000	2,500			
		<i>Males</i>					
		9-18 yr	1,300	3,000			
		19-21 yr	1,000	2,500			
		<i>Females</i>					
		9-18 yr	1,300	3,000			
		19-21 yr					
		<i>Pregnancy</i>					
		≤18 yr	1,300	3,000			
		19-21 yr	1,000	2,500			
<i>Lactation</i>							
≤18 yr	1,300	3,000					
19-21 yr	1,000	2,500					

Continued

**Table 60.6** Dietary Reference Intakes for Select Micronutrients and Water—cont'd

NUTRIENT	FUNCTION	LIFE STAGE GROUP	AI (mg/day)	UL (mg/day)	SELECTED FOOD SOURCES	ADVERSE EFFECTS OF EXCESSIVE CONSUMPTION	SPECIAL CONSIDERATIONS
Iron	Critical component of enzymes, cytochromes, myoglobin, and hemoglobin	<i>Infants</i>			Heme sources: meat, poultry, fish Nonheme sources: dairy, eggs, plant-based foods like whole grains, nuts, seeds, legumes, and leafy greens, breads, cereals, breakfast foods	GI distress	Persons with decreased gastric acidity may be at increased risk for deficiency. Cow's milk is a poor source of bioavailable iron and is not recommended for children <1 yr old. Neurocognitive deficits have been reported in infants with iron deficiency. RDA for females increases with menarche related to increased losses during menstruation. Vegans and vegetarians might require iron supplementation or intake of iron-fortified foods. GI parasites can increase iron losses via GI bleeds. Iron supplements can interfere with zinc absorption, and vice versa; if supplements are being used, the doses should be staggered.
		0-6 mo	0.27	40			
		7-12 mo	11	40			
		<i>Children</i>					
		1-3 yr	7	40			
		4-8 yr	10	40			
		<i>Males</i>					
		9-13 yr	8	40			
		14-18 yr	11	45			
		19-21 yr	8	45			
		<i>Females</i>					
		9-13 yr	8	40			
		14-18 yr	15	45			
		19-21 yr	18	45			
		<i>Pregnancy</i>					
≤18 yr	27	45					
19-21 yr	27	45					
<i>Lactation</i>							
≤18 yr	10	45					
19-21 yr	9	45					
Zinc	Essential for proper growth and development; important catalyst for 100 specific enzymes	<i>Infants</i>			Meats, shellfish, legumes, fortified cereals, whole grains	Acutely, zinc supplements cause GI irritation and headache; chronic effects of zinc supplementation include impaired immune function, changes in lipoprotein and cholesterol levels, and reduced copper status.	Zinc supplements interfere with iron absorption, and vice versa; therefore if supplements are being used, the doses should be staggered. Zinc deficiency can be associated with stunting or impaired linear growth.
		0-6 mo	2	4			
		7-12 mo	3	5			
		<i>Children</i>					
		1-3 yr	3	7			
		4-8 yr	5	12			
		<i>Males</i>					
		9-13 yr	8	23			
		14-18 yr	11	34			
		19-21 yr	11	40			
		<i>Females</i>					
		9-13 yr	8	23			
		14-18 yr	9	34			
		19-21 yr	8	40			
		<i>Pregnancy</i>					
≤18 yr	12	34					
19-21 yr	11	40					
<i>Lactation</i>							
≤18 yr	13	34					
19-21 yr	12	40					



**Table 60.6** Dietary Reference Intakes for Select Micronutrients and Water—cont'd

Water	Maintains homeostasis in the body Allows transport of nutrients to cells and removal and excretion of waste products of metabolism	<i>Infants</i> (L/day)		None set	All beverages, including water Moisture in foods High-moisture foods include watermelon, meats, and soups	No UL because normally functioning kidneys can handle >0.7 L (24 oz) of fluid per hour. Symptoms of water intoxication include hyponatremia, which can result in heart failure, and rhabdomyolysis (skeletal muscle tissue injury), which can lead to kidney failure.	Recommended intakes for water are based on median intakes of generally healthy persons who are adequately hydrated. Persons can be adequately hydrated at levels above or below the AIs provided; AIs provided are for total water in temperate climates. All sources can contribute to total water needs: beverages (tea, coffee, juice, soda, drinking water) and moisture found in foods. Moisture in food accounts for about 20% of total water intake. Thirst and consumption of beverages at meals are adequate to maintain hydration.
		0-6 mo	0.7				
		7-12 mo	0.8				
		<i>Children</i>					
		1-3 yr	1.3				
		4-8 yr	1.7				
		<i>Males</i> (L/day)					
		9-13 yr	2.4				
		14-18 yr	3.3				
		≥19 yr	3.7				
		<i>Females</i> (L/day)					
		9-13 yr	2.1				
		14-18 yr	2.3				
		≥19 yr	2.7				
<i>Pregnancy</i> (L/day)							
≥14 yr	3.0						
<i>Lactation</i> (L/day)							
≥14 yr	3.8						

Note: **Bold** numbers are RDA. RDAs and AIs may both be used as goals for individual intake. RDAs are set to meet the needs of 97–98% of members in a group. For healthy breastfed infants, the AI is the mean intake. The AI for other life stage and gender groups is believed to cover the needs of all members of a group, but lack of data prevents specifying with confidence the percentage covered by this intake.

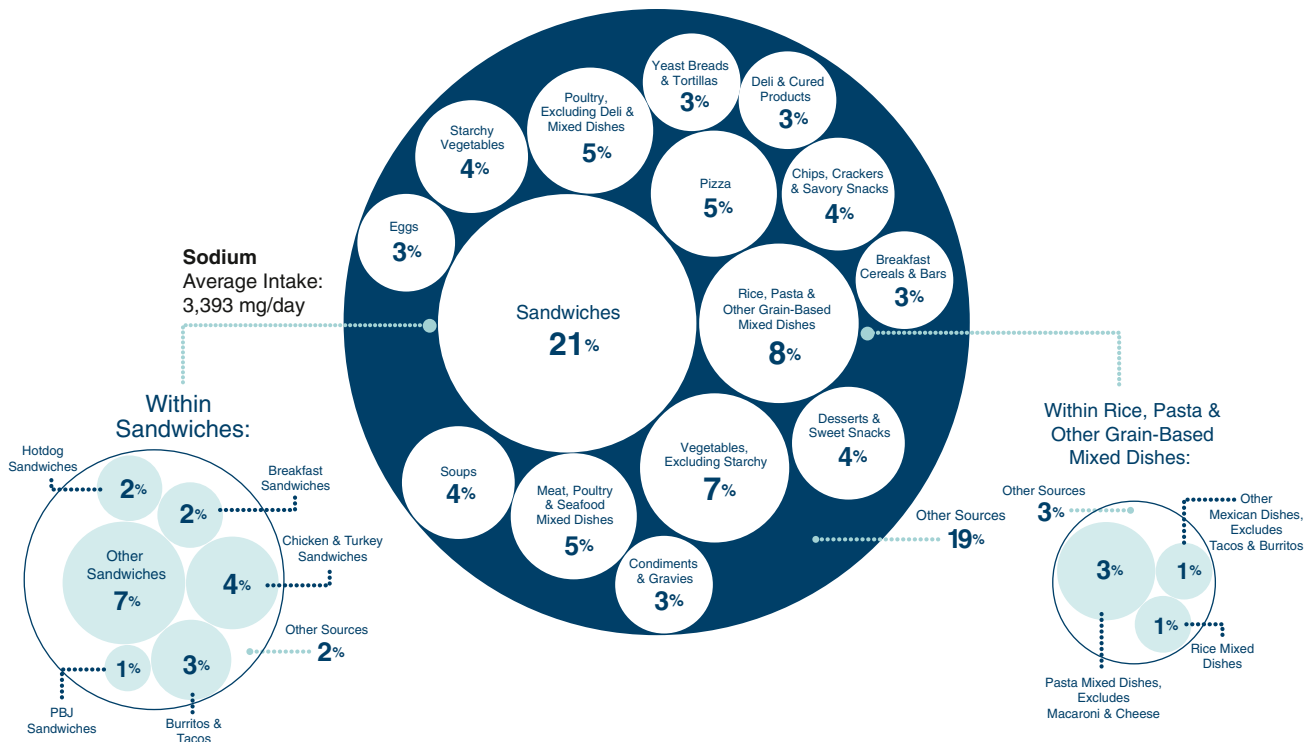
UL is the maximum level of daily nutrient intake that is likely to pose no risk of adverse effects. Unless otherwise specified, the UL represents total intake from food, water, and supplements. Because of a lack of suitable data, ULs could not be established for potassium, water, or inorganic sulfate. In the absence of ULs, extra caution may be warranted in consuming levels above recommended intakes.

ND amounts are not determinable because of a lack of data on adverse effects in this age-group and concern with regard to lack of ability to handle excess amounts. Source of intake should be from food only to prevent high levels of intake.

\*Vitamin D RDA in IU/day: 400 if <1 yr, 600 if >1 yr of age or pregnant or lactating.

ACE, Angiotensin-converting enzyme; AI, adequate intake; ARB, angiotensin receptor blocker; GI, gastrointestinal; ND, not determinable; RDA, recommended dietary allowance; UL, upper limit of normal.

Data from Food and Nutrition Board, U.S. Institute of Medicine. *Dietary Reference Intakes for Water, Potassium, Sodium, Chloride, and Sulfate* ([http://www.nap.edu/openbook.php?record\\_id=10925](http://www.nap.edu/openbook.php?record_id=10925)); and Ross AC, U.S. Institute of Medicine, Committee to Review Dietary Reference Intakes for Vitamin D and Calcium. *Dietary Reference Intakes: Calcium, Vitamin D*. Washington, DC: National Academies Press; 2011: pp. xv, 536



**Fig. 60.5** Top sources and average intakes of sodium: U.S. population age 1 and older. Estimates based on 2-day dietary intake data, weighted, from What We Eat in America (WWEIA), National Health and Nutrition Examination Survey (NHANES), 2013-2016. (From *Dietary Guidelines for Americans. 2020-2025, Chapter 1: Nutrition and Health Across the Lifespan. Fig 1.12.* [https://www.dietaryguidelines.gov/sites/default/files/2020-12/Dietary\\_Guidelines\\_for\\_Americans\\_2020-2025.pdf](https://www.dietaryguidelines.gov/sites/default/files/2020-12/Dietary_Guidelines_for_Americans_2020-2025.pdf).)

GROWTH CHART	AGE RANGE	GROWTH METRICS	INSUFFICIENT GROWTH PERCENTILE	EXCESSIVE GROWTH PERCENTILE	BMI STATUS PERCENTILE
World Health Organization, 2006	Birth to 2 yr	Weight, length, weight-for-length, and head circumference	<2.3rd	>97.7th	—
U.S. Centers for Disease Control and Prevention, 2000	2-20 yr	Weight, height, body mass index (BMI)	<5th	>95th	Under (<5th) Normal (5-85th) Over (85-95th) Obese (>95th) Severe obesity (≥120% of 95th or ≥35 kg/m <sup>2</sup> )

infants and young children can be explained in part by the high ratio of body surface area to volume in infancy, high respiratory rate, and rapid growth.

The consequences of inadequate fluid intake include impaired thermoregulation and heat dissipation, reduced activity tolerance and performance, and reduced intravascular fluid and dehydration. Inadequate fluid intake may be reflected by decreased urine output. These deficits can result in an increased compensatory heart rate, hypotension, and syncope, and if uncorrected, renal injury or nephrolithiasis. “Free water” is defined as water in the body that can be removed by ultrafiltration and in which substances can be dissolved. Excess free water intake is usually better tolerated by healthy adults than by younger children, who are at increased risk for water intoxication. Hyponatremia can result when water and sodium are out of balance, such as excess free water intake coupled with inadequate sodium intake. Fluid intake requirements and restrictions are also influenced by any underlying renal and hormonal disorders, including diabetes, the syndrome of inappropriate antidiuretic hormone secretion (SIADH), and diabetes insipidus.

### MEASURING NUTRITIONAL ADEQUACY

The U.S. Centers for Disease Control and Prevention (CDC) and AAP recommend the use of the WHO charts to monitor growth of all infants and children (human milk-fed and infant formula-fed) from birth to 2 years, and the use of the CDC 2000 growth charts for children 2-20 years (see Chapters 19 and 27). The WHO growth charts are derived from longitudinal and cross-sectional data obtained from a sample of healthy breastfed infants and children (0-2 years) who were receiving adequate nutritional intake and medical care in Brazil, Ghana, India, Norway, Oman, and the United States. Consequently, the WHO/CDC 0-2 year growth charts are considered *standards* and describe the ideal growth of adequately nourished healthy children under best-care practices. The CDC 2-20 year charts are considered *references* and describe the population’s average growth and distribution.

In the clinical setting, the 2.3rd and 97.7th percentiles on the WHO growth charts are used to identify *insufficient* and *excessive* growth from birth to 2 years, respectively. In contrast, the 5th and 95th percentiles are recommended for the equivalent identification in the CDC growth charts from 2 to 20 years (Table 60.7). Note that length, weight, and

weight-for-length are used in the WHO growth charts from birth to 2 years. *Body mass index* (BMI) can be calculated but is not recommended for use in children <2 years. Stature, weight, and BMI are used in the CDC 2000 growth charts from 2 to 20 years of age. These charts can be used to categorize children as *underweight* (<5th BMI percentile), normal weight (5–85th), overweight (85–95th), and obese ( $\geq$ 95th BMI percentile).

*Severe obesity* is defined as BMI  $\geq$ 120% of the 95th percentile or BMI  $\geq$ 35 kg/m<sup>2</sup> (whichever is lower). This assessment corresponds to approximately the 99th percentile or a BMI *z* score  $\geq$ 2.33. Severe obesity that exceeds the 99th percentile is tracked on a specialized percentile curve for obesity. Furthermore, adult classification is used for BMI  $\geq$ 27 kg/m<sup>2</sup> in adolescents over age 18 for consideration of medication and bariatric surgery.

It is important to consider the limitations in the use of WHO and CDC growth charts for certain populations such as premature infants, children with certain genetic disorders (e.g., Turner syndrome, Down syndrome, Wolf-Hirschhorn syndrome, achondroplasia) and children with cerebral palsy. Specific growth charts addressing the unique growth characteristics of these children are available from various resources, including the AAP.

Visit Elsevier eBooks+ at [eBooks.Health.Elsevier.com](http://eBooks.Health.Elsevier.com) for Bibliography.

## Chapter 61

# Feeding Healthy Infants, Children, and Adolescents

Katherine J. Barrett, Stephanie P. Gilley,  
Matthew A. Haemer, Nancy F. Krebs, and  
Susan L. Johnson

Early feeding experiences can support the development of healthy eating habits, optimal growth and development, and prevention of chronic disease throughout the life course. Childhood nutrition is known to play a role in the origin of adult diseases such as type 2 diabetes, hypertension, obesity, and metabolic syndrome. To support development and to prevent chronic disease, appropriate feeding practices are best established in the neonatal period and continued throughout childhood and adolescence to adulthood. Healthful feeding in children requires partnerships between family members, the healthcare system, schools, the community, and policy makers.

## FEEDING DURING THE FIRST YEAR OF LIFE

### Breastfeeding

The American Academy of Pediatrics (AAP) and World Health Organization (WHO) have declared breastfeeding and the administration of human milk to be the ideal practice for infant feeding and nutrition. Breastfeeding has documented short- and long-term medical and neurodevelopmental advantages and rare contraindications (Tables 61.1, 61.2, and 61.3). The AAP and the WHO recommend that infants be exclusively fed human breast milk for approximately 6 months. Breastfeeding ideally should be continued with the introduction of complementary foods until 24 months of age or longer, if mutually desired by the mother and infant. We recognize that there are some lactating individuals who do not identify as women/mothers and may prefer the use of other terms, including the use of chestfeeding in lieu of breastfeeding. This is a consideration that a practitioner may need to make when speaking to a family member who uses these alternative terms. The success of breastfeeding initiation and continuation depends on multiple

**Table 61.1** Selected Beneficial Properties of Human Milk Compared with Infant Formula

FACTOR	ACTION
<b>ANTIBACTERIAL FACTORS</b>	
Secretory IgA	Specific antigen-targeted antiinfective action
Lactoferrin	Immunomodulation, iron chelation, antimicrobial action, antiadhesive, trophic for intestinal growth
$\kappa$ -Casein	Antiadhesive, bacterial flora
Oligosaccharides	Prevention of bacterial attachment
Cytokines	Antiinflammatory, epithelial barrier function
<b>GROWTH FACTORS</b>	
Epidermal growth factor	Luminal surveillance, repair of intestine
Transforming growth factor (TGF)	Promotes epithelial cell growth (TGF- $\beta$ ) Suppresses lymphocyte function (TGF- $\beta$ )
Nerve growth factor	Promotes neural growth
<b>ENZYMES</b>	
Platelet-activating factor (PAF)-acetylhydrolase	Blocks action of PAF
Glutathione peroxidase	Prevents lipid oxidation
Nucleotides	Enhance antibody responses, bacterial flora

Adapted from Hamosh M. Bioactive factors in human milk. *Pediatr Clin North Am.* 2001;48:69–86.

factors, such as education about breastfeeding, hospital breastfeeding practices and policies, routine and timely follow-up care, family and societal support, and the health of the mother (Tables 61.4 and 61.5). Breastfeeding support from both professionals and lay individuals has a positive impact on breastfeeding success, and the importance of such support cannot be overstated.

Feedings are initiated soon after birth unless medical conditions preclude them. Mothers can be encouraged to feed at both breasts at each feeding, starting with the breast offered second at the last feeding. For optimal milk production, it is preferable to fully empty the first breast before moving to the second breast, rather than partially emptying both sides. It is not unusual for an infant to fall asleep after the first breast and refuse the second. Table 61.6 summarizes patterns of milk supply in the first week. Pacifiers may help prevent sudden infant death syndrome in breastfed infants, but it is not recommended to introduce until breastfeeding is well established and should not be used to try to increase time between feeds or in lieu of a feed in a baby showing hunger cues.

Breastfeeding is a learned skill for both mother and infant, and support from a provider knowledgeable in breastfeeding is critical, especially as milk production is established in the first few weeks postpartum. It is helpful to instruct new mothers about infant hunger cues and correct nipple latch, positioning of the infant on the breast, and feeding frequency. It is also suggested that someone trained in lactation observe a feeding to evaluate positioning, latch, milk transfer, maternal responses, and infant satiety. Attention to these issues during the newborn period allows dialog with the mother and family and can prevent problems that could occur with improper technique or knowledge of breastfeeding. Discussions about normal infant feeding, infant elimination patterns, breast engorgement, breast care, and maternal nutrition are important aspects of the hospital discharge process. A follow-up appointment with a lactation specialist is recommended within 24–48 hours after hospital discharge. The AAP recommends that exclusively breastfed infants start supplementation with vitamin D (10 mcg, or 400 IU) by 2 weeks of life.

**Table 61.2** Absolute and Relative Contraindications to Breastfeeding Because of Maternal Health Conditions

MATERNAL HEALTH CONDITION	DEGREE OF RISK
HIV and HTLV infection	In the United States, breastfeeding is contraindicated. In other settings, health risks of not breastfeeding must be weighed against the risk of transmitting the virus to the infant.
Tuberculosis infection	Direct breastfeeding is contraindicated until completion of approximately 2 wk of appropriate maternal therapy.
Varicella-zoster infection	Infant should not have direct contact with active lesions. Infant should receive immune globulin.
Herpes simplex infection	Breastfeeding is contraindicated with active herpetic lesions of the breast.
CMV infection	May be found in milk of mothers who are CMV seropositive. Transmission through human milk causing symptomatic illness in term infants is uncommon.
Hepatitis B infection	Infants routinely receive hepatitis B immune globulin and hepatitis B vaccine if mother is HBsAg positive. No delay in initiation of breastfeeding is required.
Hepatitis C infection	Breastfeeding is not contraindicated.
COVID-19	Maternal infection is not a contraindication for breastfeeding or feeding expressed milk.
Ebola	Confirmed maternal Ebola infection is a contraindication to breastfeeding and expressed milk.
Brucellosis	Active untreated brucellosis is a contraindication to breastfeeding and expressed milk.
Live vaccines	Smallpox and yellow fever live-virus vaccines are contraindicated for breastfeeding mothers.
Alcohol intake	Limit maternal alcohol intake to <0.5 g/kg/day (for a woman of average weight—this is the equivalent of 2 cans of beer, 2 glasses of wine, or 2 oz of liquor).
Cigarette smoking	Discourage cigarette smoking, but smoking is not a contraindication to breastfeeding.
Marijuana usage	Metabolites, including tetrahydrocannabinol, are detectable in breast milk. Marijuana usage is not recommended but is not a strict contraindication to breastfeeding.
Chemotherapy, radio-pharmaceuticals	Breastfeeding is generally contraindicated.

CMV, Cytomegalovirus; HBsAg, hepatitis B surface antigen; HIV, human immunodeficiency virus; HTLV, human T-lymphotropic virus. Adapted from Schanler RJ, Krebs NF, Mass SB (eds). *Breastfeeding Handbook for Physicians*, 2nd ed. Elk Grove Village, IL: American Academy of Pediatrics; 2014: 223–226.

**Nipple pain** is one of the most common complaints of breastfeeding mothers in the immediate postpartum period. Poor infant positioning and improper latch are the most common reasons for nipple pain beyond the mild discomfort felt early in breastfeeding. If the problem persists and the infant refuses to feed, evaluation for **nipple candidiasis** is indicated. If candidiasis is present, the nipples can be treated with an antifungal cream that is wiped off of the breast before feeding, and the infant is treated with an oral antifungal medication.

**Table 61.3** Conditions for Which Human Milk May Have a Protective Effect

INFANT	MOTHER
<ul style="list-style-type: none"> <li>• Diarrhea</li> <li>• Otitis media</li> <li>• Urinary tract infection</li> <li>• Necrotizing enterocolitis</li> <li>• Septicemia</li> <li>• Infant botulism</li> <li>• Insulin-dependent diabetes mellitus</li> <li>• Celiac disease</li> </ul>	<ul style="list-style-type: none"> <li>• Crohn disease</li> <li>• Lymphoma</li> <li>• Leukemia</li> <li>• Recurrent otitis media</li> <li>• Atopy</li> <li>• Hospitalizations for respiratory illness</li> <li>• Sudden infant death syndrome</li> <li>• Obesity</li> </ul>
	<ul style="list-style-type: none"> <li>• Uterine atony</li> <li>• Breast cancer</li> <li>• Ovarian cancer</li> <li>• Cardiovascular disease</li> <li>• Obesity</li> <li>• Type 2 diabetes</li> </ul>

**Table 61.4** Ten Hospital Practices to Encourage and Support Breastfeeding\*†

1. Have a written breastfeeding policy that is routinely communicated to all healthcare staff.
2. Train all healthcare staff in the skills necessary to implement this policy.
3. Inform all pregnant women about the benefits and management of breastfeeding.
4. Help women initiate breastfeeding within 1 hour of birth.
5. Show women how to breastfeed and how to maintain lactation, even if they are separated from their newborns.
6. Give newborns no food or drink other than breast milk unless medically indicated.
7. Practice rooming-in; allow mothers and newborns to remain together 24 hours a day.
8. Encourage breastfeeding on demand.
9. Give no pacifiers or artificial nipples to breastfeeding infants.‡
10. Foster the establishment of breastfeeding support groups and refer to them on discharge from the hospital or birth center.

#### COMPONENTS OF SAFE POSITIONING FOR THE NEWBORN WHILE SKIN-TO-SKIN\*\*

1. Infant's face can be seen.
2. Infant's head is in "sniffing" position.
3. Infant's nose and mouth are not covered.
4. Infant's head is turned to one side.
5. Infant's neck is straight, not bent.
6. Infant's shoulders and chest face mother.
7. Infant's legs are flexed.
8. Infant's back is covered with blankets.
9. Mother-infant dyad is monitored continuously by staff in the delivery environment and regularly on the postpartum unit.
10. When mother wants to sleep, infant is placed in bassinet or with another support person who is awake and alert.

\*The 1994 report of the Healthy Mothers, Healthy Babies National Coalition Expert Work Group recommend that the UNICEF-WHO Baby Friendly Hospital Initiative be adapted for use in the United States as the United States Breastfeeding Health Initiative, using the adapted 10 hospital practices noted.

†Data from Baby-Friendly USA. Guidelines and evaluation criteria for facilities seeking baby-friendly designation. Sandwich, MA: Baby Friendly USA; 2010. Available at <https://www.babyfriendlyusa.org/for-facilities/practice-guidelines/>. Accessed 10 November 2022. From ACOG Committee Opinion. Optimizing support for breastfeeding as part of obstetric practice. *Obstet Gynecol*. 2018;132(4):e187–e195, Boxes 1 and 2, pp. e191–e192.

‡The American Academy of Pediatrics endorsed the UNICEF-WHO Ten Steps to Successful Breastfeeding, but does not support a categorical ban on pacifiers because of their role in reducing the risk of sudden infant death syndrome and their analgesic benefit during painful procedures when breastfeeding cannot provide the analgesia.

\*\*Data from Ludington-Hoe SM, Morgan K. Infant assessment and reduction of sudden unexpected postnatal collapse risk during skin-to-skin contact. *Newborn Infant Nurs Rev*. 2014;14:28–33.

**Tongue-tie (ankyloglossia)** has been associated with nipple pain, poor latching, and poor weight gain in breastfed and bottle-fed infants. Ankyloglossia is defined as a lingual frenulum that attaches close to the anterior tongue tip and is estimated to be present in 4–11% of newborns. *Frenotomy* is a minor surgical procedure with few complications



**Table 61.5** Recommendations on Breastfeeding Management for Healthy Term Infants

- Exclusive breastfeeding for about 6 months
  - Breastfeeding preferred; alternatively, expressed mother's milk or donor breast milk
  - To continue for 2 years or beyond as long as mutually desired by mother and child
  - Complementary foods rich in iron, zinc, and other micronutrients should be introduced at about 6 mo of age
- Peripartum policies and practices that optimize breastfeeding initiation and maintenance should be compatible with the AAP and Academy of Breastfeeding Medicine Model Hospital Policy and include the following:
  - Direct skin-to-skin contact with mothers immediately after delivery until the first feeding is accomplished and encouraged throughout the postpartum period
  - Delay in routine procedures (weighing, measuring, bathing, blood tests, vaccines, and eye prophylaxis) until after the first feeding is completed
  - Delay in administration of intramuscular vitamin K until after the first feeding is completed but within 6 hr of birth
  - Ensure 8-12 feedings at the breast every 24 hr
  - Ensure formal evaluation and documentation of breastfeeding by trained caregivers (including position, latch, milk transfer, examination) at least once for each nursing shift
  - Give no supplements (water, glucose water, commercial infant formula, or other fluids) to breastfeeding newborn infants unless medically indicated using standard evidence-based guidelines for the management of hyperbilirubinemia and hypoglycemia
  - Avoid routine pacifier use in the postpartum period
  - Begin daily oral vitamin D drops (400 IU) at hospital discharge
- All breastfeeding infants should be seen by a pediatrician within 48-72 hr after discharge from the hospital
  - Evaluate hydration and elimination patterns
  - If weight >7% below birthweight or there is additional weight loss on day 5 or later, providers should consider more frequent follow-ups and/or referral to a lactation consultant.
  - Discuss maternal/infant issues
  - Observe feeding
- Mother and infant should sleep in proximity to each other to facilitate breastfeeding
- Pacifier should be offered, while placing infant in back-to-sleep-position, no earlier than 3-4 weeks of age and after breastfeeding has been established

From American Academy of Pediatrics (AAP). Breast-feeding and the use of human milk. *Pediatrics*. 2012;129:e827-e841.

**Table 61.6** Patterns of Milk Supply

DAY OF LIFE	MILK SUPPLY
Day 1	Some milk (~5 mL) may be expressed.
Days 2-4	Lactogenesis; milk production increases.
Day 5	Milk present; fullness and leaking are felt.
Day 6 onward	Breasts should feel "empty" after feeding.

Adapted from Neifert MR. Clinical aspects of lactation: promoting breastfeeding success. *Clin Perinatol*. 1999;26:281-306.

and has been used as a treatment option for ankyloglossia with increasing frequency despite *insufficient evidence* that it improves breastfeeding outcomes, making its use somewhat controversial. Most infants with ankyloglossia have no feeding problems, and most infants with nursing problems do not have ankyloglossia. Providing a feeding evaluation and assessment of latch while monitoring weight over the course of 2-3 weeks may be more valuable than proceeding immediately to frenotomy. During that time many feeding issues resolve, thus avoiding unnecessary frenotomy.

**Engorgement** may occur in the second stage of lactogenesis (typically days 3-10 postpartum) and is characterized by the breasts feeling

firm, overfilled, and sometimes painful. Incomplete removal of milk as a result of ineffective breastfeeding technique or infant illness can cause engorgement. Breastfeeding immediately at signs of infant hunger can prevent this from occurring. To reduce engorgement, breasts may be softened before infant feeding with a combination of hot compresses and manual expression of milk. To reduce inflammation and pain, between feedings mothers can wear a supportive bra, apply cold compresses, and take oral nonsteroidal antiinflammatory drugs (NSAIDs).

**Mastitis** occurs in 2-3% of lactating women and is usually unilateral, manifesting with localized warmth, tenderness, edema, and erythema after the second postdelivery week. Sudden onset of breast pain, myalgia, and fever with fatigue, nausea, vomiting, and headache can also occur. Organisms implicated in mastitis include *Staphylococcus aureus*, *Escherichia coli*, group A streptococcus, *Haemophilus influenzae*, *Klebsiella pneumoniae*, and *Bacteroides* species. Diagnosis is confirmed by physical examination. Treatment is with oral antibiotics (most commonly dicloxacillin or cephalexin) and analgesics, while at the same time promoting breastfeeding or emptying of the affected breast. A **breast abscess** is a much less common complication of mastitis, but it is a more serious infection that requires intravenous antibiotics and incision and drainage, along with continued breast emptying. Washing hands thoroughly before breastfeeding or pumping, especially after changing the baby's diapers, can help minimize risk for breast infections.

**Insufficient milk intake**, dehydration, and jaundice in the infant can occur within the first weeks of life. In fact, retrospective studies suggest higher rates of hospitalization—primarily caused by jaundice and poor weight gain—in the first month of life for breastfed versus formula-fed babies, highlighting the *critical importance of lactation support*. Breastfed neonates feed 8-12 times a day. Signs that milk intake is not adequate include lethargy, delayed stooling, decreased urine output, weight loss >10% of birthweight, hypernatremic dehydration, inconsolable crying, and increased hunger. Insufficient milk intake may be caused by inadequate milk production and/or health conditions in the infant that prevent proper breast stimulation. Careful attention to prenatal history can identify maternal factors associated with low milk production (for example, obesity, type 2 diabetes, postpartum hemorrhage, or failure of breasts to enlarge during pregnancy or within the first few days after delivery). Excess weight loss or failure to return to birthweight by 7-10 days in an exclusively breastfed infant should trigger an evaluation of breastfeeding effectiveness. Direct observation of breastfeeding can help identify improper technique, and test weighs (weighing the infant before and after feeding) may help assess milk transfer. If a large volume of milk is expressed manually after breastfeeding, the infant might not be extracting enough milk, eventually leading to decreased milk output. Late preterm infants (34-36 weeks) are at particular risk for insufficient milk intake because of weak suck, difficulty coordinating suck and swallow patterns, or medical issues.

**Breastfeeding jaundice**, also referred to as *suboptimal intake jaundice*, is related to insufficient fluid intake during the first week of life and is a common reason for hospital readmission of healthy breastfed infants (see Chapter 137). Breastfeeding jaundice is associated with dehydration and hypernatremia. Treatment may require supplementation with expressed maternal breast milk, donor milk, or infant formula. **Breast milk jaundice** is a different disorder that causes persistently high serum indirect bilirubin in thriving, healthy, well-fed infants. Breast milk contains inhibitors of glucuronyl transferase and causes enhanced absorption of bilirubin from the gut. Breast milk jaundice becomes evident later than breastfeeding jaundice and generally declines in the second to third week of life. Infants with severe or persistent jaundice or a direct hyperbilirubinemia need evaluation for other medical causes (see Chapter 137). Persistently high bilirubin levels may require treatment with phototherapy without cessation of breastfeeding or changing from breast milk to infant formula for 24-48 hours if phototherapy is not available or if a rapid reduction in total serum bilirubin is urgently needed. Breastfeeding can resume after the decline in serum bilirubin. Parents can be encouraged to continue collecting breast milk during the period the infant is taking formula.

**Breast milk collection** by pumping is a common practice when the mother and baby are separated and when families wish for other caregivers to engage in infant feeding. Electric breast pumps are generally more efficient and better tolerated by mothers than manual pumps or hand-expression, but not all insurance companies cover electric pumps. Good handwashing and hygiene are important during all steps of pumping. Collection kits should be cleaned with hot soapy water, rinsed, and air-dried after each use. Glass or plastic containers can be used to collect the milk. Fresh milk can be stored at room temperature for up to 4 hours and in the refrigerator for up to 4 days. Expressed breast milk can be frozen and used for up to 6-12 months; frozen milk should be used within 24 hours of thawing. Human milk should never be microwaved. **Paced bottle feeding** helps support breastfeeding during bottle feeds by matching the slower pace of direct breastfeeding.

**Growth of the breastfed infant** differs from that of the formula-fed infant; the infant's risk for excess weight gain during late infancy may be associated with bottle feeding (whether formula or expressed human milk). The WHO growth charts are based on growth patterns of healthy breastfed infants through the first year of life. The infants were selected based on being breastfed, having good healthcare, an absence of socioeconomic constraints, and nonsmoking mothers, so that they reflect the growth pattern of breastfed infants in optimal conditions and can be used as prescriptive standards rather than as normative reference curves. Charts are available for growth monitoring. The Centers for Disease Control and Prevention (CDC) recommends use of the WHO growth charts for infants from birth to 2 years and CDC growth charts for ages 2 to 20 years (see [Chapter 27](#)).

### Formula Feeding

Despite efforts to promote exclusive breastfeeding through 6 months, only ~55% of women in the United States continue any breastfeeding at 6 months. Parental preferences are the most common reason for using infant formula and may relate to return to work, perceived poor milk supply, lack of support, or other factors. Most parents make their infant feeding choices early in pregnancy. However, infant formula is also indicated for infants whose intake of breast milk is contraindicated for infant factors (e.g., inborn errors of metabolism) or maternal factors (see [Table 61.2](#)). In addition, infant formula may be used as a supplement to support inadequate weight gain in breastfed infants, though often formula is used to supplement based upon caregiver perception of benefit rather than medical necessity.

Infant formulas marketed in the United States are safe and nutritionally adequate as the sole source of nutrition for healthy infants for the first 6 months of life. Infant formulas are available in ready-to-feed, concentrated liquid, and powder forms. Ready-to-feed products generally provide 19-20 kcal/30 mL (1 oz) and approximately 64-67 kcal/100 mL. Concentrated liquid products, when diluted according to instructions, and powder formulas, when mixed according to instructions (typically 2 ounces of water plus one scoop of powder), will result in similar caloric density.

Although infant formulas are manufactured in adherence to good manufacturing practices and are regulated by the U.S. Food and Drug Administration (FDA), there are potential safety issues. Ready-to-feed and concentrated liquid formulas are commercially sterile, but powder preparations are not. Although the number of bacterial colony-forming units per gram (CFU/g) of powder formula is generally lower than allowable limits, outbreaks of infections with *Cronobacter sakazakii* (previously *Enterobacter sakazakii*) have been documented, especially in premature infants. The powder preparations can contain other coliform bacteria but have not been linked to disease in healthy term infants. Care must be taken to follow the mixing instructions to avoid overdilution or underdilution, to use clean water, and to use the specific scoops provided by the manufacturer because scoop sizes vary. Water that has been boiled must cool fully to prevent degradation of heat-labile nutrients, specifically vitamin C. Well water should be tested regularly for bacteria and toxin contamination. Testing may also identify high lead concentrations in water flowing through pipes installed before 1986. Municipal water can contain variable concentrations of fluoride, and if the concentrations are higher than 2.0 mg/L,

use of bottled water that is defluoridated is preferred to avoid possible toxicity and tooth discoloration.

Proper handwashing is important before preparing formula for the infant. Formula storage guidelines vary based on preparation. Once opened, ready-to-feed and concentrated liquid containers can be covered and stored in the refrigerator for no longer than 48 hours. Manufacturer guidelines recommend storing powder formula in a cool, dry place but not in the refrigerator; once opened, cans can be covered with the original plastic cap or aluminum foil, and the powdered product used within 4 weeks. The CDC recommends using prepared formula within 24 hours, regardless of type. The CDC further recommends using formula within 2 hours of removal from the refrigerator and within 1 hour from the start of a feed. Prepared formula stored in the refrigerator can be warmed by placing the container in warm water for about 5 minutes. Formula should *never* be heated in a microwave because it can heat unevenly and result in burns, despite appearing to be at the right temperature when tested.

Formula feedings are ideally provided ad libitum, with the goal of achieving growth and development to the child's genetic potential. The usual intake to allow a weight gain of 20-30 g/day in the first 2-3 months of life is approximately 140-180 mL/kg/day, although some may require intake outside this range. The average rate of weight gain declines from 3 to 12 months of age (see [Chapters 27](#) and [64](#)). **Overfeeding** with resultant rapid weight gain increases the risk for developing obesity and is to be prevented. **Paced bottle feeding** may help avoid overfeeding.

### COW'S MILK PROTEIN-BASED FORMULAS

Intact cow's milk protein-based formulas are appropriate for most term infants. There are nutritional differences between formula and breast milk, although the effects of these differences on long-term health are unknown. Formulas contain 10-35 times higher iron compared with breast milk and higher zinc, sodium, and vitamin D. Most formulas in the United States also contain considerably higher protein than in mature breast milk. This concentration is designed to meet the needs of the youngest infants but may lead to excess protein intake for older infants and has been associated with increased risk of obesity. In contrast, breast milk protein content decreases over time to match needs. Protein concentration and composition differences between human milk and cow's milk-based formulas result in different plasma amino acid profiles in infants on different feeding patterns, but clinical significance has not been demonstrated.

Fat provides 40-50% of the energy in cow's milk-based formulas and is primarily from plant and animal oils. Fat blends are better absorbed than dairy fat and provide saturated, monounsaturated, and polyunsaturated fatty acids (PUFAs). All infant formulas are supplemented with long-chain PUFAs, specifically docosahexaenoic acid (DHA) and arachidonic acid (ARA). DHA and ARA are found at varying concentrations in human milk and vary by geographic region and maternal diet. The DHA and ARA added to formulas are derived from single-cell microfungi and microalgae and are classified as "generally recognized as safe" (GRAS) for use in infant formulas at approved concentrations and ratios. Long-term studies are lacking on the relationship between routine supplementation of formula with long-chain PUFAs and physical, neurodevelopmental, or visual outcomes of term infants.

Lactose is the major carbohydrate in breast milk and in standard cow's milk-based formulas for term infants. Formulas for term infants may also contain modified starch or other complex carbohydrates like prebiotic oligosaccharides similar to those in human milk.

### SOY PROTEIN-BASED FORMULAS

Soy protein-based formulas on the market are all free of cow's milk-based protein and lactose. They meet the vitamin, mineral, and electrolyte guidelines from the AAP and the FDA for feeding term infants. In term infants, although soy protein-based formulas have been used to provide nutrition resulting in normal growth patterns, there are few indications for use in place of cow's milk-based formula. Indications for soy formula include galactosemia, preference for a vegetarian diet, and hereditary lactase deficiency, because

soy-based formulas are lactose free. Most healthy infants with acute gastroenteritis can be managed after rehydration with continued use of breast milk or cow's milk–based formulas and do not require a lactose-free formula. However, soy protein–based formulas may be indicated when documented secondary lactose intolerance occurs. Soy protein–based formulas have no advantage over cow's milk protein–based formulas as a supplement for the breastfed infant, unless the infant has one of the indications noted previously. Soy protein–based formulas are *contraindicated for preterm infants* because of concerns about protein quality and aluminum content. The routine use of soy protein–based formula has no proven value in the prevention or management of infantile colic, fussiness, or atopic disease. Infants with documented cow's milk protein–induced enteropathy or enterocolitis often are also sensitive to soy protein and should be fed using an extensively hydrolyzed or amino acid–based formula.

### PROTEIN HYDROLYSATE FORMULAS

Protein hydrolysate formulas may be partially hydrolyzed, containing oligopeptides with a molecular weight of <5,000 daltons (range 3,000–10,000 Da), or extensively hydrolyzed, containing peptides with a molecular weight <3,000 Da. These formulas are lactose free and can include medium-chain triglycerides, making them useful in infants with gastrointestinal malabsorption caused by cystic fibrosis, short bowel syndrome, prolonged diarrhea, or hepatobiliary disease. **Partially hydrolyzed protein** formulas have fat blends similar to cow's milk–based formulas, and carbohydrates are supplied by corn maltodextrin or corn syrup solids. Because the protein is only partially hydrolyzed, these formulas are not appropriate for infants who are allergic to cow's milk protein. There is insufficient evidence to recommend use of hydrolyzed formulas to prevent atopic dermatitis or other atopic diseases in high-risk infants. **Extensively hydrolyzed formulas** are recommended for infants intolerant to cow's milk or soy proteins.

### AMINO ACID FORMULAS

Amino acid (elemental) formulas are peptide-free formulas that contain mixtures of essential and nonessential amino acids. They are designed for infants with cow's milk–based protein allergy who fail to thrive on extensively hydrolyzed protein formulas. The effectiveness of amino acid formulas to prevent atopic disease has not been studied.

### OTHER FLUIDS IN INFANTS AND TODDLERS

Neither breastfed nor formula-fed infants require additional water unless dictated by a specific condition involving excess water loss, such as diabetes insipidus. Vomiting and spitting up are common in healthy infants. When weight gain and general well-being are noted, no change in formula is necessary. Whole cow's milk can impair iron absorption and is not recommended for infants younger than 12 months. Nondairy, very low-protein milks are also inadequate to meet infant nutritional needs. Prune or apple juice may be used in small amounts for treatment of constipation, but juice is not recommended for routine consumption in infants. Infants with vomiting caused by gastroenteritis may need to consume an oral electrolyte solution but will need close monitoring and ideally will consume the solution for less than 24 hours. Goat milk is not an appropriate substitution for formula. Goat milk has been shown to cause significant electrolyte disturbances and anemia because it has low folic acid concentrations. Likewise, homemade formulas, which typically involve a combination of raw cow, raw goat, or plant-based milk, cod liver oil, molasses, and other ingredients, cannot be considered safe for infant feeding. Mixing homemade formula incorrectly can put unnecessary stress on a newborn's kidneys and intestines and may not provide sufficient calories or micronutrients. Infants and young children are also particularly susceptible to infections such as *Escherichia coli*, *Campylobacter*, *Listeria*, *Brucella*, and *Salmonella* found in **raw or unpasteurized milk**.

### COMPLEMENTARY FEEDING

The timely introduction of complementary foods (solid and liquid foods other than breast milk or formula, also called **weaning foods**) during infancy is important for nutritional and developmental reasons (Table 61.7). The AAP recommends exclusive breastfeeding for about the first 6 months, after which nutrient requirements cannot be met by breastfeeding alone. Table 61.7 summarizes the AAP recommendations for introducing complementary foods, though nearly 25% of parents do not adhere to current guidelines (e.g., introducing complementary foods too early or introducing inappropriate foods, such as cow's milk, in children under 12 months).

Complementary foods should be introduced around 6 months and be varied to ensure adequate macronutrient and micronutrient intake. Although there is not currently evidence to promote a recommended order in which to introduce foods, information about important nutrients is included here. Additionally, a wide variety of textures is important for oral motor development, typically starting with pureed or very soft (easy to mash with the gums) foods. This is also a good time to establish consistent eating routines, including providing predictable meal and snack times for solid foods, eating in a safe dedicated space (such as in a highchair at the family table), and eating with family members to the extent possible. Continued breastfeeding up to 24 months of age and use of infant formula until 12 months is encouraged.

Some complementary foods are more nutritionally beneficial than others. *Iron- and zinc-rich foods* (such as fortified infant cereals, age-appropriate meats, eggs, and legumes) are especially important for breastfed infants, whose iron and zinc stores decline over time and are not sufficiently replaced through consumption of breast milk. Yogurt and cheese (including soy-based products) without added sugars are appropriate for infants receiving complementary foods, but full-fat cow's milk as a replacement for infant milk is inappropriate before 12 months. In addition to honey and unpasteurized consumables, foods and beverages with added sugars and those high in sodium are not recommended. Overconsumption of energy-dense complementary foods (e.g., cakes, cookies, fried foods, and sugar-sweetened beverages) can lead to excessive weight gain in infancy, increasing the risk of obesity in childhood.

Early introduction of peanuts and eggs around 4–6 months helps to prevent the development of food allergies. Although data are limited for other highly allergenic foods, the strength of current evidence suggests that introducing other allergenic foods early in complementary

**Table 61.7** Important Principles for Weaning

- Begin around 6 mo of age.
- Introduce one new food at a time.
- Choose foods that provide key nutrients and help meet energy needs.
- Iron-containing foods (meat, iron-supplemented cereals) are required, especially for breastfed infants.
- Zinc intake should be encouraged with foods such as meat, dairy products, and fortified infant cereal.
- Phytate intake should be low to enhance mineral absorption.
- By 7–8 mo infants should be consuming foods from all food groups.
- Between 9 and 12 mo of age, encourage a cup rather than a bottle.
- Fluids other than breast milk, formula, and water should be discouraged.
- Breast milk can continue up to 24 mo of age; cow's milk can be introduced at 12 mo of age and up to 24 oz/day of cow's milk can be consumed if breastfeeding is discontinued.
- Give no more than 4 oz/day of 100% fruit juice; no sugar-sweetened beverages.
- Encourage routine mealtimes and responsive feeding, watching for and responding to the child's hunger and satiety cues.

Adapted from American Academy of Pediatrics. *Pediatric Nutrition Handbook*, 8th ed. Elk Grove Village, IL: American Academy of Pediatrics; 2019.



feeding may prevent IgE-mediated food allergies. The most recent guidelines from the American Academy of Allergy, Asthma, and Immunology recommend early introduction of the top 9 highly allergenic foods (dairy, soy, eggs, peanuts, tree nuts, sesame, wheat, fish, and shellfish) for all children, especially those at higher risk for atopic disease. For more information, see Chapter 192.

### TRANSITION TO MILK

**Whole cow's milk** can be introduced at 12 months, and formula-fed children are transitioned to milk at this time. In children 12-24 months, for whom overweight or obesity is a concern or who have a family history of obesity, dyslipidemia, or cardiovascular disease, the use of reduced-fat milk may be appropriate. Otherwise, whole milk is recommended until age 24 months, after which changing to 1% milk helps reduce overall dietary intake of fat if this is a concern. The Special Supplemental Nutrition Program for Women, Infants, and Children (WIC) does not provide 2% or whole milk for children over 24 months unless authorized by a medical provider. Regardless of the type, all animal milk consumed should be pasteurized because of the infection risk with raw or unpasteurized milk, as discussed earlier.

Nondairy alternatives to milk from plant-based (e.g., soy, hemp, pea, oat, rice) and nut-based (e.g., almond, cashew, peanut) sources are popular. When counseling parents, it is important to emphasize that the overall nutritional content and quality of plant-based milk alternatives is not equivalent to cow's milk. Although most are fortified with vitamin A, vitamin D, and calcium, only some soy-, hemp-, and pea-based milk alternatives have comparable protein content, and all products have inferior protein quality. Many plant-based products have added oils and sugars. No nondairy alternative milks are appropriate substitutions for infant formula or breast milk in infants. Nut-based milks may be suitable for toddlers  $\geq 12$  months of age without allergies who have an otherwise adequate diet. Nondairy (vegan) milks vary between products; a careful assessment of ingredients, including protein and micronutrient fortification, must be determined.

### RESPONSIVE FEEDING

**Responsive feeding** begins in infancy and is associated with desirable growth outcomes. Responsive feeding refers to recognizing and responding to children's signs of hunger and satiety in a timely and developmentally appropriate manner. Parents are encouraged to learn to recognize signs of hunger (e.g., child leans forward or reaches for food, or opens mouth when offered food) and satiety (e.g., child closes mouth or turns away from food) in infants who receive solid foods so that they can respond appropriately.

The period from 6 months to 15 months is characterized by acquisition of self-feeding skills as the infant learns to grasp finger foods, use a spoon, and eat soft foods (Table 61.8). Around 12 months of age, the child learns to drink from a cup, and bottle weaning around 12-15 months is recommended. To prevent dental caries, bedtime bottles should be discouraged, and it is best that cups contain only water outside of mealtimes. Sugar-sweetened beverages and 100% fruit juice are not recommended for infants less than 12 months. Cups without a lid or with a straw rather than a hard spout are preferred.

**Baby-led weaning** (BLW) typically refers to allowing infants to self-feed soft (often well-cooked) solid or table foods from the very beginning of complementary feeding. Presently, many parents are choosing to give their infants finger foods rather than, or in combination with, purees. There is little evidence that BLW leads to improved nutrient status, weight gain, or food acceptance longitudinally. In general, all food textures, including purees, are encouraged to be included in the infant's diet. Parents should be counseled on avoidance of foods that are common choking hazards.

### FEEDING TODDLERS AND PRESCHOOL-AGED CHILDREN

Toddlerhood is a period when eating behaviors and healthful habits can be established, and it is often a confusing and anxiety-generating period for parents. Important goals of early childhood nutrition are to

**Table 61.8** Feeding Skills Birth to 36 Months

AGE (mo)	FEEDING/ORAL SENSORIMOTOR SKILLS
Birth to 4-6	Nipple feeding, breast or bottle Hand on bottle during feeding (2-4 mo) Maintains semiflexed posture during feeding Promotion of infant-parent interaction
6-9 (transition feeding)	Head and neck control Feeding more in upright position Spoon-feeding thin, pureed foods Both hands to hold bottle Finger feeding of easily dissolvable solids introduced Vertical munching of easily dissolvable solids
9-12	Cup drinking Eats lumpy, mashed food Finger feeding for easily dissolvable solids Chewing includes rotary jaw action
12-18	Self-feeding; grasps spoon with whole hand Holds cup with two hands Drinking with four to five consecutive swallows Holding and tipping bottle
>18-24	Swallowing with lip closure Self-feeding predominates Chewing broad range of food Up-down tongue movements
24-36	Circulatory jaw rotations Chewing with lips closed One-handed cup holding and open cup drinking with no spilling Using fingers to fill spoon Eating wide range of solid food Total self-feeding, using fork

Adapted from Arvedson JC. Swallowing and feeding in infants and young children. *GI Motility Online*. 2006. <https://doi.org/10.1038/gimo17>.

offer foods that are developmentally appropriate and to begin to foster healthful eating habits that will last a lifetime. Growth after the first year slows dramatically, appetite decreases, motor activity increases, and children naturally become leaner until they reach an adiposity nadir at 4-6 years. Using growth charts to illustrate adequate growth and provide guidance about typical behavior and eating habits can help allay parents' concerns if they are explained in a way that parents can understand (Table 61.9). Eating behavior can be erratic, and children can appear distracted from eating as they explore the environment. Young children may consume a limited variety of foods, and it is common for children to "like" a particular food for a period and then reject the favored food. It can take many offers before children become familiar with and decide to try a novel food, and it is important to help children learn about food without expectations regarding how much they will eat.

### Recommended Intake and Serving Sizes

Toddlers and preschool-aged children usually eat three healthy meals and one to two snacks daily. Recommended daily amounts for each food group can be found in Table 61.10. Toddlers and preschool children often fail to meet the recommended servings of fruits, vegetables, and fiber, whereas intakes of food with fat and added sugar are excessive. Recommended serving sizes of fruits, vegetables, and grains are approximately the size of the child's fist, and a serving size of protein can be the size of the child's palm. It is important to be mindful that some children become overwhelmed when large portions are offered, fearing that they will be expected to finish the entire portion. If parents are concerned about their children eating enough vegetables, giving vegetables at the beginning of the meal has been shown, in some circumstances, to be an effective strategy for increasing vegetable consumption in preschool children. Milk continues to be an important



**Table 61.9** Suggested Language for Discussing Growth Charts with Families

UNDERWEIGHT	NORMAL WEIGHT	OVERWEIGHT OR OBESE
<ul style="list-style-type: none"> <li>Looking at how your child's weight is matched for their height, only 2 of 100 children are at a weight that is lower at the same height.</li> <li>Your child's weight for their height is lower than what is generally thought to be healthy.</li> <li>BMI looks at the way height and weight are balanced with each other. Currently your child's BMI is too low, which has a higher risk of developing health problems related to weight.</li> </ul>	<ul style="list-style-type: none"> <li>Looking at how your child's weight is matched for their height, 75 of 100 children are at a weight that is lower at the same height.</li> <li>Your child's weight and height are matched for each other in a way that is generally thought to be healthy.</li> <li>If you were to line up 100 children of the same age by weight, your child would be right in the middle.</li> </ul>	<ul style="list-style-type: none"> <li>Looking at how your child's weight is matched for their height, 99 of 100 children are at a weight that is lower at the same height.</li> <li>Your child's weight for their height is heavier than what is generally thought to be healthy.</li> <li>BMI looks at the way height and weight are balanced with each other. Currently your child's BMI is too high, which has a higher risk of developing health problems related to weight.</li> </ul>

**Table 61.10** Recommended Daily Amounts for Children

	TODDLERS AGES 12-23 MO	CHILDREN AGES 2-8 YR	CHILDREN AGES 9 YR AND OLDER
Calories per day*	700-1,000	1,000-1,400	1,600-3,200
Vegetables	2/3-1 cup	1-1½ cups	2-4 cups
Fruits	1/2-1 cup	1-1½ cups	1½-2½ cups
Grains	1¾-3 ounces	3-5 ounces	5-10 ounces
Dairy	1½-2 cups	2-2½ cups	3 cups
Protein foods	2 ounces	2-4 ounces	5-7 ounces
Oils	9-13 grams	15-17 grams	22-51 grams

\*Calorie needs may be higher for children who are active far above typical levels for age. Additionally, calorie needs may change on a daily basis as children experience illness, growth spurts, and variations in activity.

Adapted from the U.S. Department of Agriculture and U.S. Department of Health and Human Services. *Dietary Guidelines for Americans, 2020-2025*, 9th Edition. December 2020. Available at [DietaryGuidelines.gov](https://www.dietaryguidelines.gov).

source of nutrition, particularly protein, fat, calories, and vitamin D, and it is recommended that children consume up to 2-3 cups (16-24 ounces) per day (see [Table 61.10](#)). Sugar-sweetened beverages like soda, sports drinks, sweetened tea, or fruit punch are not recommended. Toddlers ages 12 months and older can be given up to 4 oz/day of 100% fruit juice. Grapefruit juice can affect medications metabolized by CYP3A4 (e.g., antifungals such as fluconazole and ketoconazole, antiretrovirals, erythromycin, clarithromycin, fluoxetine, and amiodarone).

### Feeding Practices

In the second year of life, self-feeding is learned, becomes the norm with time, and provides more opportunities for the family to eat together. Self-feeding also provides the child with the autonomy to self-regulate their intake. Child feeding is an interactive process, especially because children receive cues regarding appropriate eating behaviors from parents. Parents are encouraged to notice and comment on positive and ignore negative eating behaviors unless the behavior jeopardizes the health and safety of the child. Parents should avoid pressuring young children to eat, particularly pressuring them to eat larger, adult-sized portions. Instead, parents are encouraged to focus on acceptance of a wide variety of healthful foods. In addition, parents are encouraged to eat the same foods with their toddlers to model positive eating behaviors such as trying and consuming healthful foods.

The 2-year-old child can progress from small pieces of soft finger foods to prepared table foods with care. They can also learn how to eat with utensils (as culturally appropriate) over the preschooler period. The young child is not capable of completely chewing and swallowing chewy or hard foods, and hard foods present a choking risk. Hard candies, nuts, popcorn, and raw carrots should be avoided before age 4 years. Foods like hot dogs, sausages, and grapes can be sliced lengthwise to avoid choking. Caregivers should always be vigilant and present during feeding, and the child placed in a

highchair or booster seat. The AAP discourages eating in the presence of distractions such as television, tablets, mobile devices, and other screens and eating in a car where an adult cannot adequately observe and assist the child.

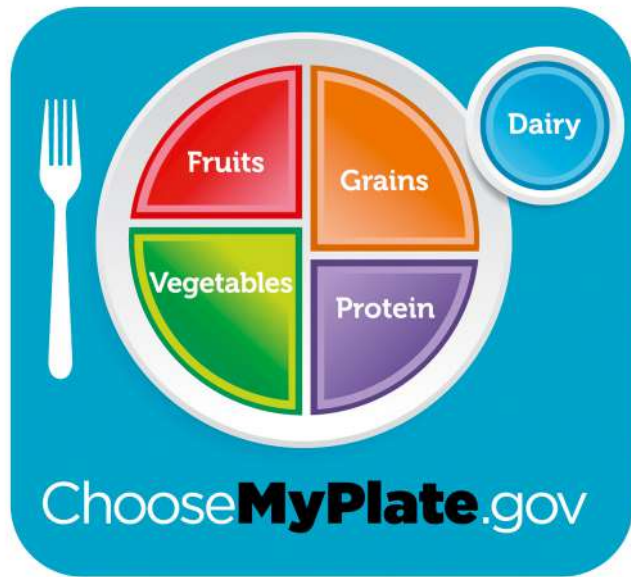
## FEEDING SCHOOL-AGED CHILDREN AND ADOLESCENTS

### MyPlate

The U.S. Department of Agriculture (USDA) MyPlate ([www.myplate.gov](http://www.myplate.gov)) is a basis for building an optimal diet for children and adults ([Fig. 61.1](#)). MyPlate is based on the 2020 **Dietary Guidelines for Americans**. MyPlate provides a visual representation of the different food groups and portion sizes designed for the general public. The website provides recipes, weight management strategies, and tools to track calories and physical activity goals. A personalized eating plan based on these guidelines provides, on average over a few days, all the essential nutrients necessary for health and growth, while limiting nutrients associated with chronic disease development. MyPlate can also be used as an interactive tool for customized recommendations based on age, sex, physical activity, and for some populations, weight and height. Print materials from the USDA are also available for families without internet access.

The MyPlate model emphasizes making half the plate vegetables and fruits, prioritizing whole grains, and eating protein from both animal and plant sources. A separate dairy section is included. Physical activity recommendations to achieve a healthful energy balance are not visually displayed but are provided on the website. MyPlate has removed foods that have low nutritional value, such as sugar-sweetened beverages and sweetened baked goods.

In the United States, the vast majority of children and adolescents do not consume a diet that follows the recommendations of MyPlate. The intake of high-calorie/low-nutrient-density foods is much higher than recommended, with frequent consumption of sugar-sweetened beverages (e.g., soda, juice drinks, iced tea, sport drinks), snack foods,



**Fig. 61.1** MyPlate food guide. (From U.S. Department of Agriculture: <http://www.myplate.gov/>.)

high-fat meat (e.g., bacon, sausage), and high-fat dairy products (e.g., cheese, ice cream). Intake of dark-green and orange vegetables (vs fried white potatoes), whole fruits, reduced-fat dairy products, and whole grains is typically lower than recommended (see Table 61.10 for recommendations). Other common unhealthful eating habits include consuming larger-than-recommended portion sizes; preparing foods with added fat, sugar, or salt; skipping breakfast and/or lunch; grazing; consuming packaged snack foods; and following fad diets. MyPlate offers a helpful and customer-friendly tool to assist pediatricians counseling families on optimal eating plans for short- and long-term health.

Diet quality tends to decline with child age, and ensuring that children and adolescents consume sufficient nutrient-dense foods is a challenge for many parents. The vast majority of children and adolescents consume more than the recommended amounts of added sodium, saturated fats, and added sugars, with ~17% of calorie intake coming from highly processed packaged foods. Frequent snacking and consumption of sugar-sweetened beverages are major contributors to this excess and are valuable targets for dietary counseling. Among adolescents, night eating may be an important source of lower-quality food intake that may be missed during a standard diet recall. In the United States, nearly 85% of adolescents consume caffeinated beverages. Although moderate consumption (up to 2.5 mg/kg/day, equivalent to 6 ounces of coffee for a 30-kg child) is generally considered safe, higher levels of caffeine consumption are associated with impaired sleep and with negative physiologic, emotional, and behavioral outcomes.

## NUTRITION ISSUES OF IMPORTANCE ACROSS PEDIATRIC AGES

### Eating at Home

At home, parents control much of what children and adolescents eat because they typically shop for groceries and monitor which foods are available in the household. Home food availability is associated with child dietary intake: availability of foods such as fruits, vegetables, and dairy has been associated with intake of those foods, whereas availability of foods such as sugar-sweetened beverages is associated with lower diet quality. Parents can help to influence children's healthy food choices by modeling healthful eating behaviors themselves. Dietary counseling includes encouraging parents to make healthier food choices available and attractive at home and part of routine family meals. Improved diet quality for children is associated with regular family meals while sitting at a table (vs eating alone or watching a TV or other screen), perhaps because of increased opportunities for *positive parenting* during meals. Although there are many reasons families may be unable to provide an ideal meal

**Table 61.11** Revised National School Lunch Program and School Breakfast Program Recommendations

1. Portion sizes of food are to be based on age-grade groups.
2. School lunches and breakfasts will have a minimum and maximum calorie level, maximum saturated fat content, and a maximum sodium content.
3. Foods must contain zero grams of trans fat per serving.
4. The inclusion of unsaturated vegetable oils is encouraged within calorie limits.
5. Vegetables and fruits are not interchangeable.
6. Vegetable offerings at lunch must include cup equivalent of the following: dark-green vegetables, bright-orange vegetables, and legumes.
7. No more than half of fruit servings may be in the form of juice.
8. At least one half of bread/grain offered must be whole grain.
9. Milk must be fat free if flavored and either fat free or 1% fat if plain.
10. Students must select a fruit option at breakfast with their meal and either a fruit or a vegetable at lunch for the meal to be reimbursable.

Adapted from the National Academies of Engineering, Science and Medicine. *School Meals: Building Blocks for Healthy Children*. Washington, DC: National Academies Press; 2010.

setting (busy schedules, parents working multiple jobs, no kitchen table), family meals at predictable times are encouraged to the extent families are able.

Another important aspect of *food parenting* is helping children learn to be mindful of and respond to internal cues of hunger and satiety. This can be a challenge for some families who have children with a propensity to overeat or to eat in response to nonhunger signals (such as eating as an emotional response). Parents can support their children to eat at a slower pace and to chew their food properly. Useful strategies when the child is still hungry after a meal include a 15- to 20-minute pause (to allow the child to engage in another activity) before providing a second serving or offering foods that are insufficiently consumed, such as vegetables, whole grains, or fruits.

### Eating in Childcare and School Settings

Many U.S. toddlers and preschool children attend formal or informal childcare and receive meals and snacks in this setting. There is wide variation in the quality of food offered (if food is provided) and level of mealtime supervision. Parents are encouraged to assess the quality of the food and supervision by asking questions, visiting the center, and taking part in parent committees. Free or reduced-price snacks and meals are provided in childcare centers for low- and medium-income communities through the **USDA Child and Adult Care Food Program**. Participating programs are required to provide meals and snacks that meet meal regulations set by the USDA, enabling a certain level of food quality. However, many centers and schools still struggle to provide high-quality meals and snacks due to cost.

The National School Lunch Program and the School Breakfast Program provide low-cost meals to millions of children. Guidelines for meals are taken from the Dietary Guidelines for Americans. Recommendations include the use of age-grade portion sizes and the amounts of vegetables and fruits, grains, and fats (Table 61.11). Among the necessary components of these programs are training and equipment for school food service staff, school community engagement, parent education, and food industry involvement. Parents are encouraged to assist their child with food choices at school. If children bring their lunch from home, lunch should include, at a minimum, a fruit and/or vegetable, a whole grain, and a protein source. Parents can be directed to [www.myplate.gov](http://www.myplate.gov) for healthful lunch ideas. Additionally, parents are encouraged to be aware of school and classroom parties and work with teachers and other parents to ensure children have access to healthy choices.

## Eating Outside the Home

The number of meals eaten outside the home or brought home from takeout restaurants continues to increase among all age-groups in the United States. The increased convenience of this meal pattern is undermined by the generally lower nutritional value of the meals compared with home-cooked meals. Typically, meals from fast-food or casual restaurants are of large portion size; are dense in calories; and contain large amounts of saturated fat, salt, and sugar and low amounts of whole grains, fruits, and vegetables. Although an increasing number of restaurants offer healthier alternatives, the vast majority of what is consumed at restaurants does not fit MyPlate recommendations. Parents are encouraged to evaluate menu labels when available, select the healthiest available options, and consider sharing meals to supplement children's meals, which often comprise highly palatable options with low nutrient density.

With increasing age, more meals and snacks are also consumed during peer social gatherings at friends' houses and parties. When a large part of a child's or adolescent's diet is consumed on these occasions, diet quality can suffer because food offerings are typically of low nutritional value. Parents and pediatricians need to guide children and teens in navigating these occasions while maintaining a healthful diet and enjoying meaningful social interactions. These occasions may also be opportunities for teens to consume alcohol; consequently, adult supervision is important.

## Food Environment

Environmental and social challenges can make it difficult for families to make healthful food choices. Although *taste* is the main determinant of food choice, many other complex factors influence that choice, including cost, availability, accessibility, convenience, and marketing strategies, including shelf placement and special pricing. Recognizing the context of food and lifestyle choices can help providers understand lack of changes or "poor adherence" to dietary recommendations and can decrease the frustration often experienced by the pediatricians who might otherwise "blame the victim" for behavior that is not entirely under their control. Local and national efforts to improve access to fresh and unprocessed foods are ongoing but often struggle to address broader issues such as cost or time to prepare foods at home.

## Responsive Feeding and Contingent Feeding Practices

Responsive feeding entails recognizing and responding to children's hunger and satiety cues in an age-appropriate and developmentally appropriate way across all stages of childhood and adolescence (Table 61.12). It also includes providing routines and structure with clear expectations (e.g., providing meals and snacks at scheduled intervals with a variety of healthy foods to choose from) and a warm emotional context that promotes positive interactions about food and eating. Responsive feeding strategies can include encouraging

children to eat foods that are healthful, teaching them about various foods, and involving them in the selection and preparation of meals. Allowing children to select (within reason) how much to eat of each offered food encourages children to listen to internal cues of hunger and satiety.

It is common for parents to use food as a reward or sometimes withdraw preferred foods as punishment. Most parents use this practice occasionally, and some use it systematically, starting at young ages. The practice is also commonly used in other settings, such as in child-care, school, or even athletics. Although it is a good idea to limit some unhealthful but desirable foods to special occasions, using food as a reward can be problematic. Making access to food contingent on an accomplishment increases the desirability of that food. Conversely, pressuring children to consume some healthful foods renders those foods less desirable. Therefore phrases such as, "Finish your vegetables, and you will get ice cream for dessert" can result in establishing unhealthful eating habits once the child has more autonomy in food choices. Parents are encouraged to choose items other than food as rewards, such as stickers, inexpensive toys or sporting equipment, additional time for a favorite activity, special family events, or collectible items. Similar types of behavior are also seen in schools and extracurricular events, and parents are encouraged to work with teachers and coaches to identify appropriate alternative rewards.

## Cultural Considerations in Nutrition and Feeding

Food choices, food preparation, eating patterns, and infant feeding practices all have very deep cultural roots. Beliefs, attitudes, and practices related to food and eating are some of the most important components of cultural identity (Fig. 61.2). In multicultural societies, high dietary variability can be observed. In a world where global marketing forces tend to reduce geographic differences in the types and brands of food that are available, most families are still influenced by their cultural background, especially during family meals at home. Therefore pediatricians are encouraged to become familiar with the dietary characteristics of various cultures in their community, so that they can identify the potential nutritional benefits and concerns related to their patients' diets and address concerns in a nonjudgmental way.

## Vegetarianism

Vegetarianism is the practice of following a diet that excludes animal flesh foods, including beef, pork, poultry, fish, and shellfish. There are several variations on the vegetarian diet, some of which also exclude eggs and/or some products produced from animal labor, such as dairy products and honey. Another expression used for different varieties of vegetarianism is **plant-based diets**.

It is important to ask parents or adolescents about their diets when they report following a vegetarian, vegan, or plant-based diet, because these terms may mean different restrictions for different families. Vegetarian and vegan diets, with extensive knowledge and forethought, can be safely followed by children. Some people practice diets that are even more restrictive, such as those that exclude foods from the allium family (e.g., onion, garlic, chives) or include only raw foods cooked below a certain temperature. The safety of these *more restrictive diets*, which can be very limited in macronutrients and micronutrients, has not been studied in children, and these more restrictive diets are not recommended. Although being on a vegetarian or vegan diet does not appear to increase the risk of an eating disorder, some teenagers with disordered eating may choose such diets to aid in limiting their caloric intake.

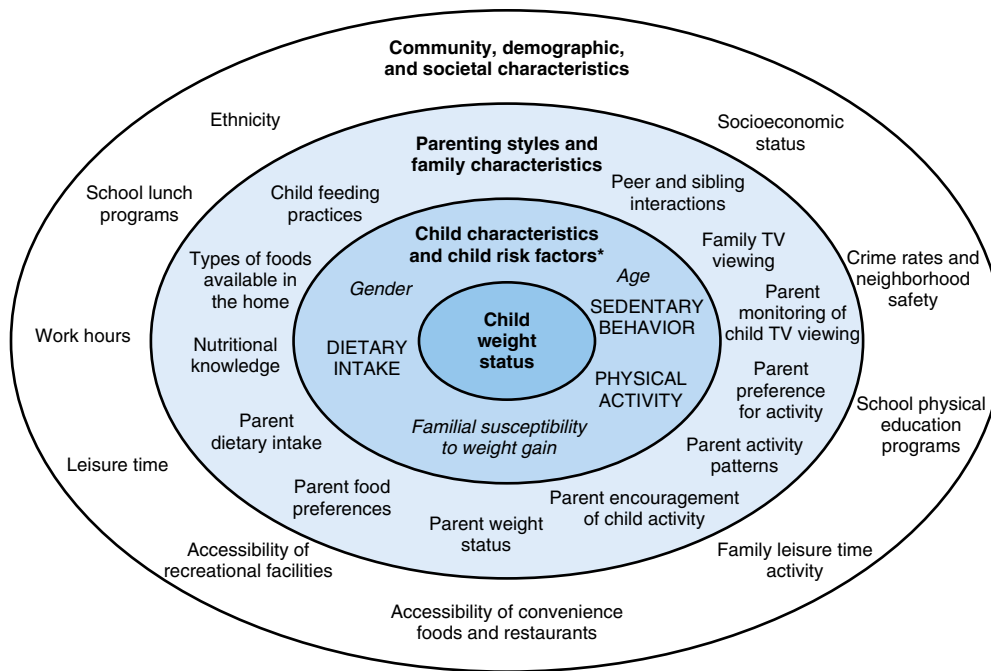
Vegetarianism, or following a plant-based diet, is considered a healthful and viable diet: both the U.S. Academy of Nutrition and Dietetics and the Dietitians of Canada have found that a properly planned and well-balanced vegetarian diet can satisfy the nutritional goals for all stages of life. Recommendations for healthy vegetarian dietary patterns at all ages can be found in the 2020 Dietary Guidelines for Americans. Families may benefit from consultation with a registered dietitian to ensure all nutrient requirements are being met.

Compared with meat-based diets, vegetarian diets tend to have lower intakes of saturated fat, cholesterol, and animal protein and relatively higher levels of complex carbohydrates, fiber, magnesium, potassium,

**Table 61.12** Responsive Feeding Recommendations

WAYS TO PROMOTE RESPONSIVE FEEDING	WHAT TO AVOID
<ul style="list-style-type: none"> <li>• Have set meal and snack times and a consistent place to eat.</li> <li>• Select and provide healthful snack and meal options.</li> <li>• Allow child to decide what to eat and how much.</li> <li>• Sit and eat with the child.</li> <li>• Encourage child to try what is on the plate.</li> <li>• Notice when child attempts to try a food: "You tried your broccoli," or "good job trying your broccoli."</li> </ul>	<ul style="list-style-type: none"> <li>• Allow child to "graze" or eat small bites throughout the day.</li> <li>• Allow child to eat whatever they want.</li> <li>• Make child eat all of the food on their plate.</li> <li>• Leave child to eat by themselves.</li> <li>• Offer the child a (food) reward for eating their food.</li> <li>• Offer person praise to child: "You are a good person for trying your broccoli."</li> </ul>





**Fig. 61.2** A conceptual framework of the context of food and lifestyle choices. Child risk factors (shown in uppercase lettering) refer to child behaviors associated with the development of overweight. Characteristics of the child (shown in italic lettering) interact with child risk factors and contextual factors to influence the development of overweight (i.e., moderator variables). (From Davison KK, Birch LL. *Childhood overweight: a contextual model and recommendations for future research*. *Obes Rev.* 2001;2:159–171. © 2001 The International Association for the Study of Obesity.)

folate, vitamins C and E, and phytochemicals. Vegetarians tend to have a lower body mass index, cholesterol level, and blood pressure and are at decreased risk for cancer and ischemic heart disease. Specific nutrients of concern in vegetarian diets include the following:

- **Iron** (see [Chapter 72](#)): Vegetarian diets may have similar levels of iron intake as nonvegetarian diets, but iron from plant sources has lower bioavailability than iron from meat sources. Additionally, iron absorption may be inhibited by other dietary constituents, such as phytate (found in leafy green vegetables and whole grains). Iron stores are lower in vegetarians and vegans than in nonvegetarians, and iron deficiency is more common in vegetarian and vegan women and children. Plant-based foods rich in iron include iron-fortified cereals, black beans, cashews, kidney beans, lentils, oatmeal, raisins, black-eyed peas, soybeans, sunflower seeds, chickpeas, molasses, chocolate, and tempeh. Iron absorption from plants is increased when consumed with vitamin C-containing foods (e.g., bell peppers, citrus fruits, strawberries, tomatoes, broccoli). Periodic monitoring of iron stores may be valuable in vegan and vegetarian children and adolescents with low iron intake.
- **Vitamin B<sub>12</sub>**: Plants are not a good source of B<sub>12</sub> (see [Chapter 67.7](#)). Vegetarians may consume vitamin B<sub>12</sub> through dairy products and eggs; vegans need fortified foods or supplements. Breastfeeding by B<sub>12</sub>-unsupplemented vegan mothers can place an infant at risk for vitamin B<sub>12</sub> deficiency. Only some infant liquid multivitamins contain B<sub>12</sub>. Vegan children and adolescents may need assessment of vitamin B<sub>12</sub> levels if supplementation is inconsistent.
- **Fatty acids**: Vegetarians and vegans may be at risk for insufficient eicosapentaenoic acid (EPA) and DHA. The inclusion of sources of linolenic acid (a precursor of EPA and DHA), such as walnuts, soy products, flaxseed oil, and canola oil, is recommended.
- **Calcium and vitamin D**: Without supplementation, vegan diets can be low in calcium and vitamin D, putting vegans at risk for impaired bone mineralization (see [Chapter 69](#)). Monitoring serum 25-hydroxyvitamin D levels can identify patients with deficiency (<30 ng/mL) and start supplementation. Calcium sources include leafy greens with low oxalate, such as broccoli, kale, and Chinese cabbage. Calcium and vitamin D are found in some fortified plant-based milks and yogurts and some brands of orange juice.

- **Zinc**: The bioavailability of zinc in plant sources tends to be low because of the presence of phytates and fiber that inhibit zinc absorption (see [Chapter 72](#)). Zinc is found in soy products, legumes, grains, cheese, and nuts.
- **Iodine**: Plant-based diets can be low in iodine, and vegetarians and vegans who do not consume iodized salt or sea vegetables (which have variable iodine content) may be at risk of iodine deficiency. The exclusive use of noniodized salt such as Himalayan, sea, or kosher salts could further increase that risk. Iodized salt is not typically used in processed foods such as crackers, although some bread products are fortified with iodine.

Families may also choose to restrict specific foods in the form of elimination diets to prevent allergies or to treat real or presumed gastrointestinal disorders. [Figure 61.3](#) provides an approach to elimination/restrictive diets.

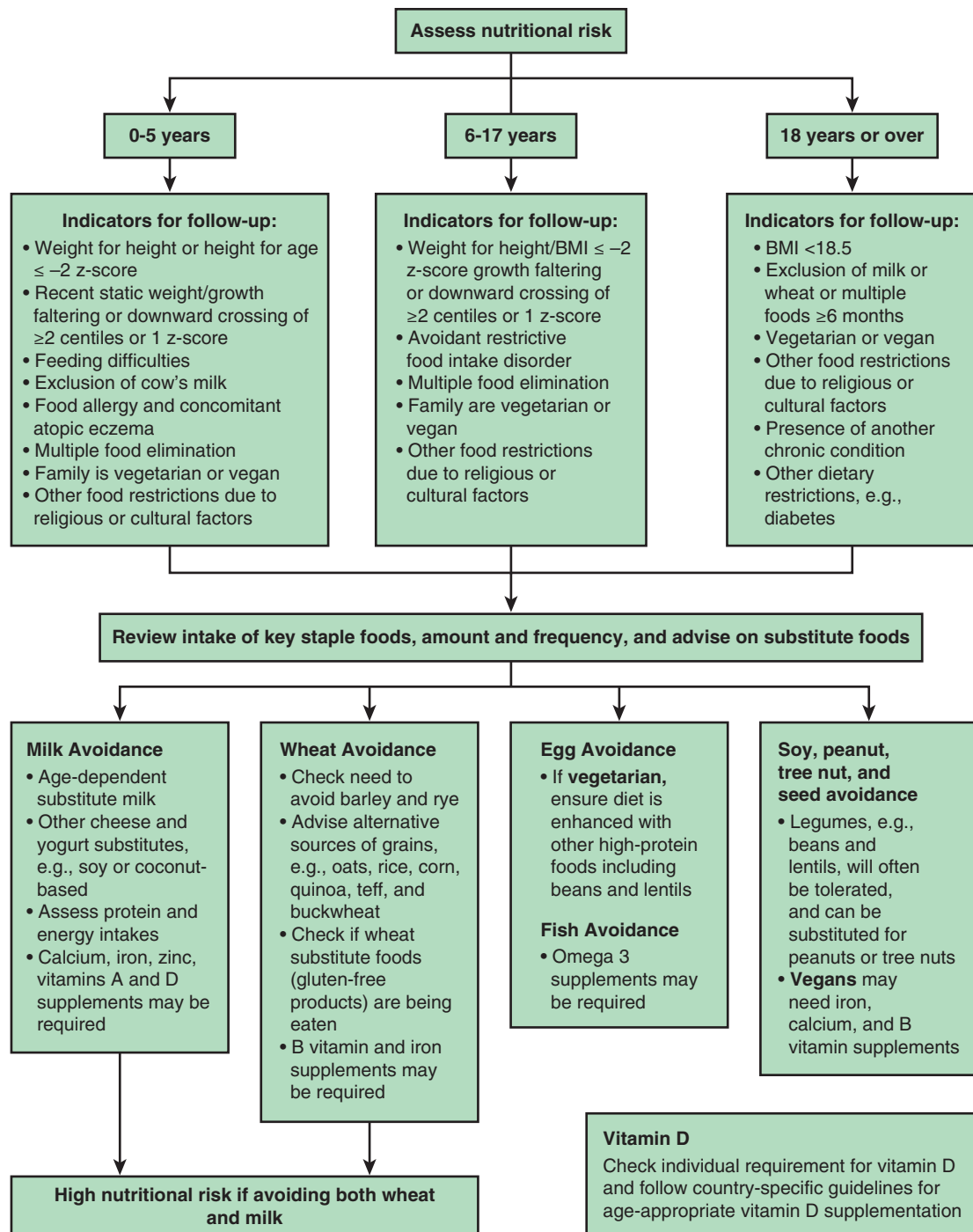
### Organic Food

Organic food is defined as produce and ingredients grown without the use of synthetic pesticides, synthetic fertilizers, sewage sludge, genetically modified organisms, or ionizing radiation. Animals that produce organic meat, poultry, eggs, and dairy products are not given antibiotics or growth hormones. In the United States, certification must be obtained, and USDA regulations must be followed to market food as “organic.”

**Genetically modified organisms (GMOs)** in themselves are not thought to be harmful to consume. However, GMOs are modified to be resistant to the effects of herbicides, including glyphosate and 2,4-dichlorophenoxyacetic acid (2,4-D), which give GMOs a selective growth advantage and facilitate use of these chemicals. Glyphosate and 2,4-D have been designated by the International Agency for Research on Cancer as probable and possible human carcinogens, respectively. Therefore higher concentrations of these chemicals in GMO foods are of concern.

Parents may prefer organic foods to feed children secondary to concerns regarding chemical and hormonal content of animals and produce. Although nutritional differences between organic and conventional foods have been reported (e.g., higher levels of PUFAs,  $\alpha$ -tocopherol, and iron and lower levels of cadmium, selenium, and





**Fig. 61.3** Approach to evaluate risk for adverse elimination diets. BMI, Body mass index. (Modified from Skypala IJ, McKenzie R. Nutritional issues in food allergy. *Clin Rev Allergy Immunol.* 2019;57:166–178, Fig. 1, p. 172.)

iodine), they may not be clinically relevant. Similarly, children consuming organic foods have lower levels of pesticides in their urine compared with those consuming nonorganic foods, but it remains unclear whether such a reduction is clinically meaningful. However, other chemicals in the environment, such as the endocrine disruptors bisphenol-A and phthalates (found in plastics), are best avoided. A high frequency of organic food ingestion has been associated with a lower risk of cancer in adults.

### Nutritional Supplements

The use of nutritional supplements as complementary or alternative medicine is increasing, despite limited data on safety and efficacy, especially in children. Many parents assume that if a food or

supplement is “natural” or “organic,” there is no potential for risk and some potential for benefit. However, adverse effects of some dietary supplements have been documented, and some supplements have been discovered to contain common allergens. In the United States, dietary supplements, including botanical and herbal products, are regulated differently from medications. Manufacturers do not have to prove safety or efficacy before marketing the supplement; the potential for adverse effects, inefficacy, unnecessary cost, and contamination is therefore high. It can be difficult to compete against the aggressive marketing of food supplements. Medical professionals must also compete against advice from people without a scientific background and those with significant conflicts of interest, particularly on the internet.

Pediatricians may be asked whether a child needs to receive a daily multivitamin. Many children do not follow all the guidelines of MyPlate, and parents and pediatricians may be tempted to use multivitamin supplements to fill gaps. The average U.S. diet provides more than a sufficient amount of most nutrients. Therefore multivitamins are recommended only where there is concern for dietary inadequacy, especially when intake of one of the major food groups is very limited or absent (fruits, vegetables, proteins, whole grains, dairy or equivalent). Using vitamin supplements as a support while working to expand dietary variety can help avoid micronutrient deficiencies in cases of dietary restriction whether due to food selectivity or for health, cultural, or religious reasons.

### Food Safety

Food safety issues are an important aspect of feeding infants, children, and adolescents. In addition to choking hazards and food allergies, pediatricians and parents need to be aware of food safety issues related to infectious agents and environmental contaminants. **Food poisoning** with bacteria, viruses, or their toxins is most common with raw or undercooked food, such as meat, poultry, eggs, and seafood, or cooked foods that have not been handled or stored properly. Unwashed fruits and vegetables may also be contaminated. The specific bacteria and viruses involved in food poisoning are described in Chapter 259. Many chemical contaminants, such as heavy metals, pesticides, and organic compounds, are present in various foods, usually in small amounts. Because of concerns regarding their child's neurologic development and cancer risk, many questions arise from parents, especially after media coverage of isolated incidents. A recurring debate is the balance between the benefits of seafood for the growing brain and cardiovascular health and the risk of mercury contamination from consuming large, predatory fish species. The **Food Safety Modernization Act** provides the FDA with authority to have stricter control over food production and distribution, including requirements that manufacturers develop food safety plans. A good source of information for patients and parents can be found at [www.foodsafety.gov](http://www.foodsafety.gov). Other reliable sources of information include the websites of the U.S. Environmental Protection Agency (EPA), FDA, and CDC.

### Preventive Nutrition Counseling in Pediatric Primary Care

An important part of the primary care well child visit focuses on nutrition and growth because most families turn to pediatric health-care providers for guidance on child nutrition. Preventive nutrition is one of the cornerstones of preventive pediatrics and a critical aspect of anticipatory guidance. The first steps of nutrition counseling are nutritional status assessments, primarily achieved through growth monitoring and dietary intake assessment. Although **dietary assessment** is somewhat simple in infants who have a relatively monotonous diet, it is more challenging at older ages. The goals of dietary assessment in the primary care setting need to include an idea of the eating patterns (time, location, and environment) and usual diet. A basic assessment of the child's intake includes evaluating meal routine, dietary diversity (ensuring that a child eats foods from all food groups, namely vegetables, fruits, whole grains, sources of iron and protein, and low-fat or nonfat dairy products), and consumption of sugar-sweetened beverages, including 100% fruit juice. Pediatricians can encourage regularly scheduled meals and one or two healthy snacks (depending on the child's age) with avoidance of grazing, particularly on foods and beverages that are energy dense but of low nutritional value. For more ambitious goals of dietary assessment, referral to a registered dietitian with pediatric experience is recommended.

After understanding the child's usual diet, existing or anticipated nutritional problems can be addressed, such as diet quality, dietary

habits, and portion size. Most nutritional issues, such as overeating or poor food choices, are not solely the result of lack of parents' knowledge but can be the result of access, availability, and economic factors. Therefore nutrition education alone is insufficient in these situations, and pediatricians need to acquire training in behavior-modification techniques such as motivational interviewing (see Chapter 18) or refer to specialists to assist their patients in engaging in healthful feeding and eating behaviors. The physical, cultural, and family environment in which the child lives must be considered so that nutrition counseling is relevant and changes feasible (see Fig. 61.2). The phone app ChangeTalk from the AAP provides free training on motivational interviewing for the prevention and treatment of pediatric obesity.

One important aspect of nutrition counseling is providing families with sources of additional information and behavioral change tools. Although some handouts are available from government agencies, the AAP, and other professional organizations for families without internet access, an increasing number of families rely on the internet to find nutrition information. Therefore pediatricians need to become familiar with common websites so that they can point families to reliable and unbiased sources of information. Perhaps the most useful websites for children are the AAP and USDA MyPlate sites and those of the CDC, FDA, National Institutes of Health, The National Academies, and Food and Nutrition Board for government sources. Other professional resources include the American Heart Association and Academy of Nutrition and Dietetics. Unfortunately, there are websites that provide biased or even dangerous information. Examples include dieting sites, sites that openly promote dietary supplements or other food products, and the sites of "nonprofit" organizations that are mainly sponsored by food companies or that have other social or political agendas.

### Food Security and U.S. Food Assistance Programs

Food insecurity is defined as the state of being without reliable access to a sufficient quantity of affordable, nutritious food. In 2016, minoritized households were 1.5 to almost 2 times more likely to be food insecure than the national average of 12.3%. Children in food-insecure homes are more likely to have medical problems, including asthma and depression, and are more likely to seek emergency medical care. Patients from all backgrounds can experience food insecurity, and selective screening risks reinforcing bias and missing children in need. Answering "often true" or "sometimes true" (versus "never") to the following two-question screen has a sensitivity of 97% and specificity of 83% for identifying food insecurity: For the last 12 months: (1) "We worried whether our food would run out before we got money to buy more." (2) "The food we bought just didn't last, and we didn't have money to get more."

Several programs exist in the United States to help meet the needs of families experiencing food insecurity. One of the most utilized federal programs is the **Special Supplemental Nutrition Program for Women, Infants, and Children (WIC)**. This program provides nutrition supplements to a large proportion of pregnant and postpartum women and children up to their fifth birthday. One of its strengths is that families regularly visit a WIC nutritionist, who can be a useful resource for nutritional counseling. For older children, federal programs provide school lunches, breakfasts, and after-school meals, as well as daycare and summer nutrition. Lower-income families are also eligible for the **Supplemental Nutrition Assistance Program (SNAP)**, formerly known as the Food Stamp Program. This program provides funds directly to families to purchase various food items in regular food stores. **Food insecurity screening should be universal in clinical settings.** Eligibility criteria for both WIC and SNAP can be found on the programs' federal websites.

Visit Elsevier eBooks+ at [eBooks.Health.Elsevier.com](http://eBooks.Health.Elsevier.com) for Bibliography.

## Chapter 62

## Nutrition, Food Security, and Health

Jason M. Nagata and Christine M. McDonald

## MALNUTRITION AS THE INTERSECTION OF FOOD INSECURITY AND HEALTH INSECURITY

**Undernutrition** is usually an outcome of three factors, often in combination: household food supply insecurity, suboptimal childcare practices, and restricted access to or use of health and water/sanitation services. In famine and emergency settings, food shortage is the foremost factor, but in many countries with widespread undernutrition, food production or access to food might not be the most limiting factor. More important causes might be repeated childhood infections, especially diarrheal diseases associated with an unsanitary environment, poor infant and young child feeding practices, or various challenges that may prevent families from using quality maternal and child health services. Figure 62.1 shows some of the many causal factors on the pathway to undernutrition and how they extend from household and community levels to national/international levels. Inequitable distribution of resources because of political, economic, and agricultural policies often denies families their right to adequate land, water, food, healthcare, education, and a safe environment, all of which can influence nutritional status.

Families with few economic resources who know how to care for their children and are enabled to do so can often use available food and health services to produce well-nourished children. If food resources and health services are not available in a community, not used, or not accessible to some families, children might become undernourished. Undernutrition is not confined to low-income countries. It has been noted in chronically ill patients in neonatal and pediatric intensive care units in high-income countries and among patients with burns, human immunodeficiency virus (HIV) infection, tuberculosis, cystic fibrosis, chronic diarrhea syndromes, malignancies, bone marrow

transplantation, and inborn errors of metabolism (see Chapter 64). Severe malnutrition has been reported in affluent communities in infants whose families believe in fad diets and in infants with food allergies fed nutritionally inadequate foods such as rice “milk,” which has a very low protein and micronutrient content (Figs. 62.2 and 62.3; also see Fig. 61.3).

## FOOD SECURITY

Food security exists when all people, at all times, have access to sufficient, safe, nutritious food to maintain a healthy and active life. Four main dimensions of food security can be identified: availability, access, utilization, and stability. **Availability** refers to the *supply* of food, reflecting the level of food production, food stocks, and net trade. **Access** is typically defined at the household level, reflecting purchasing power, household food production, and food/cash transfers received through social “safety net” programs. The **utilization** dimension recognizes that even when a household has access to food, it is not necessarily shared equitably within a household. **Stability** refers to being “food secure” at all times: Examples of situations that affect stability are the “lean seasons” before a harvest, natural disasters, political unrest, and rising food prices. To be food secure, all four dimensions must be met simultaneously.

## Measuring Food Insecurity

The most commonly used measurement of food insecurity is *undernourishment* (chronic hunger), which is the proportion of the population who are unable to meet daily energy requirements for light activities. It is an estimate calculated by the **Food and Agriculture Organization (FAO)** based on country-level food balance sheets. It does not take nutrient adequacy into account, but has the advantage of being available for almost all countries annually (although with a time lag) and assists in monitoring global trends. In addition, FAO measures food access by asking individuals about their experiences over the last 12 months, such as whether they ran out of food or skipped meals. The responses are graded from mild to severe food insecurity. This relatively simple monitoring tool, the **Food Insecurity Experience Scale**, provides timely information to guide decision-making at national and local levels.

In 2020, the FAO estimated that between 720 and 811 million people, or approximately 9.9% of the world’s population, were undernourished. More than half of the world’s undernourished were found in

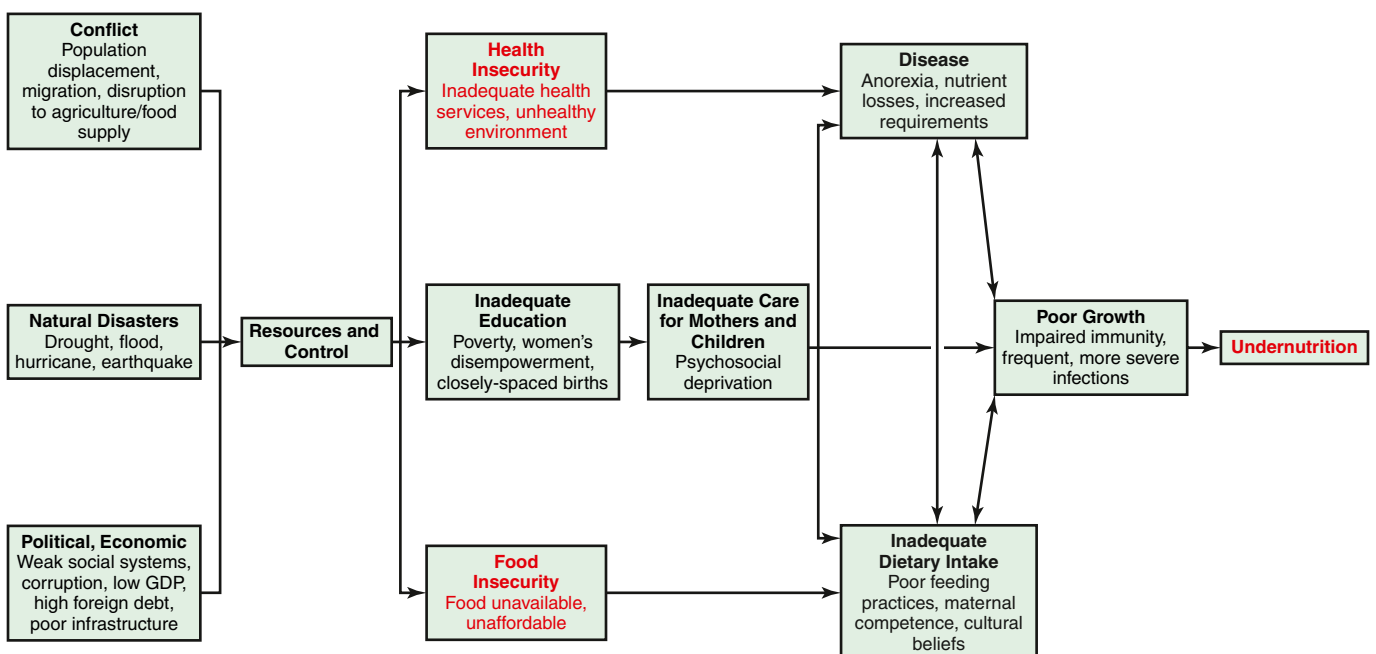


Fig. 62.1 Basic, underlying, and immediate causes of undernutrition.



**Fig. 62.2** A 14-month-old girl with “flaky paint” dermatitis. (From Katz KA, Mahlberg MH, Honig PJ, et al. Rice nightmare: Kwashiorkor in 2 Philadelphia-area infants fed Rice Dream beverage. *J Am Acad Dermatol.* 2005;52:S69–S72.)



**Fig. 62.3** Paired, transverse, homogeneous, and smooth bordered lines noted in all fingernails suggestive of Muehrcke lines in an infant fed diluted cow's milk since birth. Muehrcke lines are an apparent leukonychia most often associated with hypoalbuminemia. (From Williams V, Jayashree M. Muehrcke lines in an infant. *J Pediatr.* 2017;189:234.)

Asia, and more than one third were found in Africa. The majority are rural poor people subsisting on small plots of land or hired as laborers and urban poor people who lack the means to grow or buy food. Alongside the 768 million people who are underfed are 1.9 billion who are overweight or obese, reflecting global inequalities and the “double burden of malnutrition” in low- and middle-income countries.

### Nutrition, Food Security, and Poverty

Household food security tracks income closely. With rising incomes, very poor households first increase their dietary energy intake to avert hunger. If incomes rise further, there is a shift to more expensive staple foods and then to a more varied diet with a greater proportion of energy from animal sources, fruits/vegetables, and fats/sugars and less from cereals, roots, and tubers. National economic growth tends to be accompanied by reductions in stunting, but economic growth can pass by poor persons if they work in unaffected sectors or are unable to take advantage of new opportunities because of lack of education, access to credit, or transportation, or if governments do not channel resources accruing from economic growth to healthcare, education, social protection, and other public services and infrastructure. There is good evidence that economic growth reduces poverty but does not necessarily reduce undernutrition.

**Table 62.1** Global Food Security and Nutrition Targets

ZERO HUNGER CHALLENGE OBJECTIVES	WORLD HEALTH ASSEMBLY GLOBAL NUTRITION TARGETS FOR 2025
1. Access to an adequate and stable food supply for all	1. A 40% reduction in the number of stunted children <5yr
2. Elimination of stunting in children <2 yr, and no malnutrition in pregnancy and early childhood	2. A 50% reduction in anemia in women of reproductive age
3. Sustainable food systems	3. A 30% reduction in low birthweight
4. Doubling of smallholder productivity and income, particularly for women	4. No increase in childhood overweight
5. No loss or waste of food and responsible consumption	5. Increase exclusive breastfeeding rates to at least 50% in the first 6 mo
	6. Reduce and maintain childhood wasting to <5%

### Food Security and Nutrition Targets

The period of the Millennium Development Goals (MDGs) ended in 2015. All developing regions except sub-Saharan Africa achieved the target to halve the proportion of people living in extreme poverty, with the proportion falling from 47% in 1990 to 14% in 2015. Reductions in hunger were broadly consistent with those of poverty reduction, and rates of undernourishment in developing regions fell from 23% in 1990 to 13% in 2015. The prevalence of underweight among children under 5 years (another MDG indicator of “hunger”) fell from 29% in 1990 to 15% in 2015 for the developing regions combined. Rural children are almost twice as likely to be underweight as urban children, and the poorest quintile is almost 3 times as likely to be underweight as the richest quintile.

Eradicating poverty and hunger continue to be core targets of the **Sustainable Development Goals**, as agreed by 193 countries of the United Nations General Assembly in September 2015, and are to be achieved by 2030. In addition, in 2012 the World Health Assembly agreed to six global nutrition targets to be reached by 2025, measured against a 2010 baseline, and the United Nations Secretary-General launched the **Zero Hunger Challenge** with five objectives that “would boost economic growth, reduce poverty and safeguard the environment” and “would foster peace and stability” (Table 62.1).

### Future Food Security

Between now and 2050 the world's population is expected to exceed 9 billion, and an increase in the food supply of 70–100% will be needed to feed this larger, more urban, and more affluent populace. Over this same period, the world's food supply is expected to diminish unless action is taken. Accelerating the decline in fertility rates and reducing overconsumption are basic but difficult actions to bridge the gap between increasing demand and diminishing supply. Equally challenging actions include limiting climate disruption, increasing the efficiency of food production, reducing waste, and reducing the demand for meat and dairy foods. The COVID-19 pandemic significantly disrupted food systems and exacerbated food insecurity globally.

- ♦ **Limit climate disruption.** Drought, floods, and other extreme weather events are becoming more prevalent and destroy crops and livestock, often on a huge scale. Rising sea levels will lead to loss of productive land through inundation and salinization. Acidification of oceans will reduce marine harvests. Because curbing greenhouse gas emissions is essential to minimize climate disruption, the goals are (1) to cut fossil fuel use by at least half of present levels by 2050 so as to reduce carbon dioxide (CO<sub>2</sub>) emissions and (2) change livestock husbandry and agronomic practices to reduce methane and nitrous oxide (N<sub>2</sub>O) emissions.
- ♦ **Increase efficiency of food production.** Expanding the area of agricultural land to any large extent (e.g., by deforestation) is not a sustainable option because of adverse consequences on ecosystems and biodiversity, although some expansion of food production could be



achieved by switching good-quality land away from first-generation biofuels. For example, almost 40% of the U.S. corn harvest in 2016–2017 went to biofuels. Efforts to increase the intensity of production need to be environmentally sustainable. These include optimizing yields by soil and water conservation, removal of technical and financial constraints faced by farmers, and breeding resource-efficient crops and livestock that are also climate resilient and pest/disease resistant.

- ♦ **Reduce waste.** Approximately 30–40% of food is wasted, between harvesting and the market, during retail, at home, and in the food service industry. Better transport and storage facilities in developing countries, less stringent sell-by dates, lower cosmetic standards for fruits and vegetables, and ending supersized portions would help reduce waste.
- ♦ **Change diets.** As wealth increases, so does the demand for processed foods, meat, dairy products, and fish. About one third of global cereal production is fed to animals, so reducing consumption of meat from grain-fed livestock and increasing the proportion derived from the most efficient sources (pigs and poultry) would allow more people to be fed from the same amount of land.

## UNDERNUTRITION

The greatest risk of undernutrition (underweight, stunting, wasting, and micronutrient deficiencies) occurs in the first 1,000 days, from conception to 24 months of age, and this early effect on growth and development can have adverse consequences on health, intellectual ability, school achievement, work productivity, and earnings in later life. Governments and agencies are therefore advised to focus interventions on this critical window of opportunity.

### Measurement of Undernutrition

The term **malnutrition** encompasses both ends of the nutrition spectrum, undernutrition as well as overweight and obesity. Many poor nutritional outcomes begin in utero and are manifest as low birth-weight (LBW, <2,500 g). Preterm birth and fetal growth restriction are the two main causes of LBW, with prematurity relatively more common in richer countries and fetal growth restriction relatively more common in lower-income countries.

Nutritional status is often assessed in terms of anthropometry (Table 62.2). International standards of normal child growth under optimum conditions from birth to 5 years have been established by the World Health Organization (WHO). To compile the standards, longitudinal data from birth to 24 months of healthy, breastfed, term infants were combined with cross-sectional measurements of children ages 18–71 months. The standards allow normalization of anthropometric measures in terms of *z* scores (standard deviation [SD] scores). A *z* score is the child's height (weight) minus the median height (weight) for the child's age and sex divided by the relevant SD. The standards are applicable to all children everywhere, having been derived from a large, multicountry study reflecting diverse ethnic backgrounds and cultural settings.

**Height-for-age** (or length-for-age for children <2 years) is a measure of linear growth, and a deficit represents the cumulative impact of adverse events, usually in the first 1,000 days from conception, that result in *stunting*, or chronic undernutrition. A low height-for-age typically reflects socioeconomic disadvantage. A low **weight-for-height**, or *wasting*, usually indicates acute malnutrition. Conversely, a high weight-for-height indicates *overweight*. **Weight-for-age** is the most commonly used index of nutritional status, although a low value has limited clinical significance because it does not differentiate between wasting and stunting. Weight-for-age has the advantage of being somewhat easier to measure than indices that require height measurements. In humanitarian emergencies and some community or outpatient settings, **mid-upper arm circumference** is used as a screening tool to identify wasted children (Fig. 62.4).

**Body mass index (BMI)** is calculated by dividing weight in kilograms by the square of height in meters. For children, BMI is age and gender specific. **BMI-for-age** can be used from birth to 20 years and is a screening tool for *thinness* (less than  $-2$  SD), *overweight* (between

**Table 62.2** Classification of Undernutrition

CLASSIFICATION	INDEX	GRADING
Gomez (underweight)	90–75% of median weight-for-age	Grade 1 (mild)
	75–60%	Grade 2 (moderate)
	<60%	Grade 3 (severe)
Waterlow (wasting)	90–80% of median weight-for-height	Mild
	80–70%	Moderate
	<70%	Severe
Waterlow (stunting)	95–90% of median height-for-age	Mild
	90–85%	Moderate
	<85%	Severe
WHO (wasting)	< $-2$ to > $-3$ SD weight-for-height	Moderate
	< $-3$	Severe
WHO (stunting)	< $-2$ to > $-3$ SD height-for-age	Moderate
	< $-3$	Severe
WHO (wasting) (for age-group 6–59 mo)	115–125 mm mid-upper arm circumference	Moderate
	<115 mm	Severe

SD, Standard deviation; WHO, World Health Organization.



**Fig. 62.4** Measuring mid-upper arm circumference. (Courtesy Nyani Quarmyne/Panos Pictures.)

+1 SD and +2 SD), and *obesity* (greater than +2 SD). To diagnose obesity, additional measures of adiposity are desirable because a high BMI can result from high muscularity and not only from excess subcutaneous fat.

**Micronutrient deficiencies** are another dimension of undernutrition. Those of particular public health significance are vitamin A, iodine, iron, and zinc deficiencies.

**Vitamin A deficiency** is caused by a low intake of retinol (in animal foods) or its carotenoid precursors, mainly beta-carotene (in orange-colored fruits and vegetables and dark-green leaves) (see Chapter 66). The prevalence of *clinical deficiency* is assessed from symptoms and signs of xerophthalmia (principally night blindness and Bitot spots). *Subclinical deficiency* is defined as serum retinol concentration  $\leq 0.70$   $\mu\text{mol/L}$ . Vitamin A deficiency is the leading cause of preventable blindness in children. It is also associated with a higher morbidity and mortality among young children.

**Iodine deficiency** is the world's leading cause of preventable intellectual impairment (see [Chapter 72](#)). An enlarged thyroid (goiter) is a sign of deficiency. Severe deficiency in pregnancy causes fetal loss and permanent damage to the brain and central nervous system in surviving offspring (cretinism). It can be prevented by iodine supplementation before conception or during the first trimester of pregnancy. Postnatal iodine deficiency is associated with impaired mental function and growth stunting. The median urinary iodine concentration in children age 6-12 years is used to assess the prevalence of deficiency in the general population, and a median of <100 µg/L indicates insufficient iodine intake.

**Iron-deficiency anemia** is common in childhood either from low iron intakes or poor absorption, or as a result of illness or parasite infestation (see [Chapter 72](#)). Women also have relatively high rates of anemia as a result of menstrual blood loss, pregnancy, low iron intake, poor absorption, and illness. Hemoglobin cutoffs to define anemia are 110 g/L for children 6-59 months, 115 g/L for children 5-11 years, and 120 g/L for children 12-14 years. Cutoffs to define anemia are 120 g/L for nonpregnant women, 110 g/L for pregnant women, and 130 g/L for men.

**Zinc deficiency** increases the risk of morbidity and mortality from diarrhea, pneumonia, and possibly other infectious diseases (see [Chapter 72](#)). Zinc deficiency also has an adverse effect on linear growth. Deficiency at the population level is assessed from dietary zinc intakes or serum zinc concentrations. For children under 10 years of age, serum zinc cutoffs of <65 µg/dL and <57 µg/dL are used to define zinc deficiency according to whether the blood sample was obtained in the morning or afternoon, respectively. For females 10 years of age or older, cutoffs of <70 µg/dL, <66 µg/dL, and <59 µg/dL are used depending on whether the blood sample was obtained in the morning in a fasted state, the morning in a nonfasted state, or in the afternoon in a nonfasted state, respectively.

### Prevalence of Undernutrition

It is estimated that approximately 14.6% of births worldwide in 2015 were LBW. Rates of LBW are highest (48%) in southern Asia, which are twice those of sub-Saharan Africa. Globally, in 2015, 14% of children <5 years of age were *underweight* (weight-for-age < -2 SD). The global prevalence of *stunting* (height-for-age < -2 SD) has declined from 33% in 2000 to 22% in 2017, with the greatest reductions occurring in Asia. Stunting prevalence is highest in the African region (30%). *Wasting* (weight-for-height < -2 SD) affects 7% of children <5 years, with minimal change in prevalence over the past 2 decades. These figures represent 149 million stunted children and 50 million wasted children under 5 years of age. Asia carries most of the global burden of underweight children because of the combination of large population size and high prevalence. In 2017, 55% of all stunted children and 69% of all wasted children lived in Asia. Africa carries most of the remaining global burden.

Approximately 29% of children under 5 years of age in low- and middle-income countries (LMICs) suffer from vitamin A deficiency. Nationally representative data on the zinc status of children are sparse, but an estimated 17% of the global population is believed to be at risk of inadequate zinc intake. The estimated prevalence of anemia in children and women of reproductive age in 2016 was 42% and 33%, respectively. Iron deficiency is considered to be the primary cause of anemia in 25-42% and 50-60% of anemia cases among children and women, respectively. Universal salt iodization has made great strides in reducing the global burden of iodine deficiency. However, mild to moderate iodine deficiency remains a public health concern in 25 countries.

### Consequences of Undernutrition

The most profound consequence of undernutrition is premature death ([Table 62.3](#)). Fetal growth restriction together with suboptimal breastfeeding in the first month of life contribute to 19% of all deaths in children <5 years (1.3 million deaths/year). When the effects of stunting, wasting, and deficiencies of vitamin A and zinc are also considered, these six items jointly contribute to 45% of global child deaths (3.1

**Table 62.3** Global Deaths in Children <5 Years Attributed to Nutritional Conditions

CONDITION	ATTRIBUTABLE DEATHS	% OF TOTAL DEATHS <5 YR
(a) Fetal growth restriction (<1 mo)	817,000	11.8
(b) Stunting (1-59 mo)	1,017,000	14.7
(c) Wasting (1-59 mo)	875,000	12.6
(d) Zinc deficiency (12-59 mo)	116,000	1.7
(e) Vitamin A deficiency (6-59 mo)	157,000	2.3
(f) Suboptimal breastfeeding (0-23 mo)	804,000	11.6
Joint effects of (a) + (f)	1,348,000	19.4
Joint effects of all 6 factors	3,097,000	44.7

From Black RE, Victora CG, Walker SP, et al. Maternal and child undernutrition and overweight in low- and middle-income countries. *Lancet*. 2013;382:427-451.

million deaths/year), and many more are disabled or stunted for life. Anemia contributes to over one quarter of maternal deaths.

The risk of child death from infectious diseases increases even with mild undernutrition, and as the severity of undernutrition increases, the risk increases exponentially ([Table 62.4](#)). Undernutrition impairs immune function and other host defenses; consequently, childhood infections are more severe and longer lasting and more likely to be fatal than the same illnesses in well-nourished children. Infections can adversely affect nutritional status, and young children can quickly enter a cycle of repeated infections and ever-worsening malnutrition. Even for the survivors, physical and cognitive damage as a result of undernutrition can affect their future health and economic well-being. For females, the cycle of undernutrition is passed on to the next generation when undernourished women give birth to LBW babies.

Fetal growth restriction and early childhood undernutrition have consequences for adult chronic illness. LBW is associated with an increased risk of hypertension, stroke, and type 2 diabetes in adults. This increased risk is thought to reflect "fetal programming," a process by which fetal undernutrition leads to permanent changes in the structure and metabolism of organs and systems that manifest as disease in later life. The risk is exacerbated by low weight gain during the first 2 years of life. The increased risk of adult chronic disease from undernutrition early in life is a particular challenge to LMICs with rapid economic growth.

Stunting before age 3 years is associated with poorer motor and cognitive development and altered behavior in later years. The developmental quotient (DQ; see [Chapter 28](#)) is reduced by 6-13 points. Iodine and iron deficiencies also lead to loss of cognitive potential. Indications are that children living in areas of chronic iodine deficiency have an average reduction in intelligence quotient (IQ) of 12-13.5 points compared with children in iodine-sufficient areas. Iron deficiency has a detrimental effect on the motor development of children <4 years and on cognition of school-aged children. The estimated deficit is 1.73 IQ points for each 10 g/L decrease in hemoglobin concentration.

Undernutrition can have substantial economic consequences for survivors and their families. The consequences can be quantified in five categories: (1) increased costs of healthcare, either neonatal care for LBW babies or treatment of illness for infants and young children; (2) productivity losses (and thus reduced earnings) associated with smaller stature and muscle mass; (3) productivity losses from reduced cognitive ability and poorer school performance; (4) increased costs of chronic diseases associated with fetal and early child malnutrition; and

**Table 62.4** Hazard Ratios for All-Cause and Cause-Specific Deaths Associated with Stunting, Wasting, and Underweight in Children <5 Years

STANDARD DEVIATION (SD) SCORE	DEATHS				
	ALL	PNEUMONIA	DIARRHEA	MEASLES	OTHER INFECTIONS
<b>HEIGHT/LENGTH-FOR-AGE</b>					
< -3	5.5	6.4	6.3	6.0	3.0
-3 to < -2	2.3	2.2	2.4	2.8	1.9
-2 to < -1	1.5	1.6	1.7	1.3	0.9
≥ -1	1.0	1.0	1.0	1.0	1.0
<b>WEIGHT-FOR-LENGTH</b>					
< -3	11.6	9.7	12.3	9.6	11.2
-3 to < -2	3.4	4.7	3.4	2.6	2.7
-2 to < -1	1.6	1.9	1.6	1.0	1.7
≥ -1	1.0	1.0	1.0	1.0	1.0
<b>WEIGHT-FOR-AGE</b>					
< -3	9.4	10.1	11.6	7.7	8.3
-3 to < -2	2.6	3.1	2.9	3.1	1.6
-2 to < -1	1.5	1.9	1.7	1.0	1.5
≥ -1	1.0	1.0	1.0	1.0	1.0

From Black RE, Victora CG, Walker SP, et al. Maternal and child undernutrition and overweight in low- and middle-income countries. *Lancet*. 2013;382:427–451.

(5) consequences of maternal undernutrition on future generations. The impact of nutrition on earnings appears to be independent of the effects of childhood deprivation.

### Interventions for Undernutrition

Interventions to address child undernutrition can be divided into those that address immediate causes (*nutrition-specific interventions*) and those that address underlying or indirect causes (*nutrition-sensitive interventions*) (Table 62.5). In the short-term, nutrition-specific interventions (e.g., salt iodization) can have substantial impact even in the absence of economic growth, and micronutrient interventions (supplementation and fortification) are consistently ranked as the most cost-effective investment. However, there is increased attention to nutrition-sensitive interventions as the best means of sustainably eliminating malnutrition and to multisectoral policies that harness the synergism between the two types of interventions (e.g., cross-sectoral linkages among agriculture, nutrition, and health).

To reduce the adverse consequences of undernutrition on mortality, morbidity, and cognitive development, interventions must encompass both fetal and postnatal periods. Preventing LBW is essential, with emphasis on prevention of low maternal BMI and anemia, and in the longer term, prevention of low maternal stature. Maternal height is a strong predictor of birth outcomes, and approximately 6.5 million small-for-gestational age (SGA) or preterm births are associated with maternal short stature each year. Other measures include smoking cessation, birth spacing, delaying pregnancy until after 18 years of age, and intermittent preventive treatment of malaria in malaria-endemic areas. In the postnatal period, promotion and support of exclusive breastfeeding is a high priority. Although the Baby Friendly Hospital Initiative has a marked benefit on rates of exclusive breastfeeding in hospitals, postnatal counseling from community workers or volunteers is needed to facilitate continuation of exclusive breastfeeding at home for 6 months (see Chapter 61). Most studies show a lower risk of HIV transmission with exclusive breastfeeding than with mixed breastfeeding. The risk of HIV transmission by breastfeeding is approximately 5–20%

**Table 62.5** Examples of Nutrition-Specific and Nutrition-Sensitive Interventions

NUTRITION-SPECIFIC INTERVENTIONS	NUTRITION-SENSITIVE INTERVENTIONS
<ul style="list-style-type: none"> <li>Promotion and support for exclusive breastfeeding for 6 mo, and continued breastfeeding for at least 2 yr</li> <li>Promotion of adequate, timely, and safe complementary feeding from 6 mo</li> <li>Increased micronutrient intake through dietary diversity</li> <li>Micronutrient supplements for pregnant women (iron/folate) and young children (vitamin A, iron, zinc) in deficient areas</li> <li>Zinc supplements to children during and after diarrhea (10–20 mg/day for 2 wk)</li> <li>Prevention and treatment of severe acute malnutrition</li> <li>Crop biofortification, food fortification, salt iodization</li> <li>Reduced heavy physical activity in pregnancy</li> </ul>	<ul style="list-style-type: none"> <li>Increased access to affordable, nutritious food; smallholder agriculture; credit and microfinance</li> <li>Postharvest food processing and preservation</li> <li>Vaccination against neonatal and childhood illness; access to healthcare</li> <li>Improved water/sanitation and hygiene (e.g., handwashing with soap)</li> <li>Education; women's empowerment; gender equality</li> <li>Social protection (e.g., cash transfers)</li> <li>Malaria prevention (vector control/bednets); intermittent preventive treatment during pregnancy and in children 3–59 mo</li> <li>Birth spacing; delaying pregnancy until after 18 yr of age</li> </ul>

depending on duration, but can be reduced to <2% with antiretroviral drugs. Even without antiretroviral drugs, exclusively breastfed children of HIV-infected mothers in low-income countries have lower mortality than nonbreastfed children, because the latter are at increased risk of death from diarrhea and pneumonia.

Interventions to improve infant feeding must be designed for the local setting and thus require careful formative research during their development. Messages should be few, feasible, and



culturally appropriate. For complementary feeding, the introduction of nutrient-rich energy-dense mixtures of foods at 6 months of age and responsive feeding are often emphasized. Where adequate complementary feeding is difficult to achieve and subclinical deficiencies are common, high-dose vitamin A supplementation every 6 months in children 6–59 months of age reduces all-cause mortality and death caused by diarrhea by 12%, and zinc supplementation can reduce 1- to 4-year mortality by 18%, diarrhea incidence by 13%, and pneumonia by 19%. Monitoring of child growth provides an early alert to a nutrition or health problem but is only worthwhile if accompanied by good counseling and growth promotion activities. The impact of growth monitoring and promotion will depend on coverage, intensity of contact, health worker performance and communication skills, adequacy of resources, and the motivation and ability of families to follow agreed actions.

### Other Nutritional Interventions

Treatment of vitamin and mineral deficiencies is discussed in Chapters 66–72. Treatment of LBW and intrauterine growth restriction is discussed in Chapter 119.

## SEVERE ACUTE MALNUTRITION

Severe acute malnutrition is defined as severe wasting and/or bilateral edema. *Severe wasting* is extreme thinness diagnosed by a weight-for-length (or height)  $< -3$  SD of the WHO Child Growth Standards. In children ages 6–59 months, a mid-upper arm circumference  $< 115$  mm also denotes severe acute malnutrition: a color-banded tape (see Fig. 62.4) is a convenient way of screening children in need of treatment.

*Bilateral edema* is diagnosed by grasping both feet, placing a thumb on top of each, and pressing gently but firmly for 10 seconds. A pit (dent) remaining under each thumb indicates bilateral edema.

This definition of severe acute malnutrition distinguishes wasted/edematous children from those who are stunted because stunted children (although underweight) are not a priority for acute clinical care because their deficits in height and weight cannot be corrected in the short term. The previous name *protein-energy malnutrition* is avoided because it oversimplifies the complex, multifactorial etiology. Other terms are *marasmus* (severe wasting), *kwashiorkor* (characterized by edema), and *marasmic-kwashiorkor* (severe wasting and edema).

Children with severe acute malnutrition have had a diet insufficient in energy and nutrients relative to their needs. The magnitude of the deficits will differ depending on the duration of inadequacy, quantity and diversity of food consumed, presence of antinutrients (e.g., phytate), individual variation in requirements, and number and severity of coexisting infections and their duration. Infections can lead to profound nutrient deficits and imbalances: For example, amino acids are diverted to form acute-phase proteins, potassium, magnesium, vitamin A, and zinc are lost through diarrhea, and losses of glycine and taurine are linked to small bowel bacterial overgrowth. Ingested microbes can cause villous atrophy and loss of nutrients from maldigestion and malabsorption, as well as disruption of gut barrier function leading to microbial translocation, chronic immune activation, and altered gut microbiome (environmental enteric dysfunction). Deficits can also arise from increased nutrient utilization in response to toxins (e.g., cysteine and methionine to detoxify dietary cyanogens).

Children affected by severe acute malnutrition may have different clinical presentations and metabolic disturbances due to variations in the type and extent of deficits and imbalances in their bodies. This heterogeneity is a result of diverse pathways that lead to severe acute malnutrition. Children who develop edematous malnutrition are more likely than nonedematous children to have had exposures that generate oxidative stress and/or to have greater deficits in free radical-scavenging antioxidants (glutathione; vitamins A, C, and E; and essential fatty acids) or cofactors (zinc, copper, selenium).

**Table 62.6** Clinical Signs of Malnutrition

SITE	SIGNS
Face	Moon face (kwashiorkor), simian facies (marasmus)
Eye	Dry eyes, pale conjunctiva, Bitot spots (vitamin A), periorbital edema
Mouth	Angular stomatitis, cheilitis, glossitis, spongy bleeding gums (vitamin C), parotid enlargement
Teeth	Enamel mottling, delayed eruption
Hair	Dull, sparse, brittle hair; hypopigmentation; flag sign (alternating bands of light and normal color); broomstick eyelashes; alopecia
Skin	Loose and wrinkled (marasmus); shiny and edematous (kwashiorkor); dry, follicular hyperkeratosis; patchy hyperpigmentation and hypopigmentation (“crazy paving” or “flaky paint” dermatoses); erosions; poor wound healing
Nails	Koilonychia; thin and soft nail plates, fissures, or ridges
Musculature	Muscle wasting, particularly buttocks and thighs; Chvostek or Trousseau sign (hypocalcemia)
Skeletal	Deformities, usually as a result of calcium, vitamin D, or vitamin C deficiencies
Abdomen	Distended: hepatomegaly with fatty liver; ascites may be present
Cardiovascular	Bradycardia, hypotension, reduced cardiac output, small vessel vasculopathy
Neurologic	Global developmental delay, loss of knee and ankle reflexes, impaired memory
Hematologic	Pallor, petechiae, bleeding diathesis
Behavior	Lethargic, apathetic, irritable on handling
Gastrointestinal tract	Atrophy of small intestine mucosa, lactase deficiency common

Modified from Grover Z, Ee LC. Protein energy malnutrition. *Pediatr Clin North Am.* 2009;56:1055–1068.

### Clinical Manifestations of Severe Acute Malnutrition (Table 62.6)

**Severe wasting** is most visible on the thighs, buttocks, and upper arms and over the ribs and scapulae, where loss of fat and skeletal muscle is greatest (Fig. 62.5). Wasting is preceded by failure to gain weight and then by weight loss. The skin loses turgor and becomes loose as subcutaneous tissues are broken down to provide energy. The face may retain a relatively normal appearance, but eventually becomes wasted and wizened. The eyes may be sunken from loss of retroorbital fat, and lacrimal and salivary glands may atrophy, leading to lack of tears and a dry mouth. Weakened abdominal muscles and gas from bacterial overgrowth of the upper gut may lead to a distended abdomen. Severely wasted children are often fretful and irritable.

In **edematous malnutrition** the edema is most likely to appear first in the feet and then in the lower legs. It can quickly develop into generalized edema affecting also the hands, arms, and face (Fig. 62.6). Skin changes typically occur over the swollen limbs and include dark, crackled peeling patches (“flaky paint” dermatosis) with pale skin underneath that is easily infected (see Figs. 62.2 and 62.6). The hair is sparse, easily pulled out, and may lose its curl. In dark-haired children, the hair may turn pale or reddish. The liver is often enlarged with fat. Children with edema are uncomfortable, irritable and/or apathetic, and often refuse to eat.





Fig. 62.5 Child with severe wasting.



Fig. 62.6 Child with generalized edema.

### Pathophysiology

When a child's intake is insufficient to meet daily needs, physiologic and metabolic changes take place in an orderly progression to conserve energy and prolong life. This process is called *reductive adaptation*. Fat stores are mobilized to provide energy. Later, protein in muscle, skin, and the gastrointestinal tract is mobilized. Energy is conserved by reducing physical activity and growth, reducing basal metabolism and the functional reserve of organs, and reducing inflammatory and immune responses. These changes have important consequences:

- ♦ The liver makes glucose less readily, making the child more prone to hypoglycemia. It produces less albumin, transferrin, and other transport proteins. It is less able to cope with excess dietary protein and to excrete toxins.
- ♦ Heat production is less, making the child more vulnerable to hypothermia.
- ♦ The kidneys are less able to excrete excess fluid and sodium, and fluid easily accumulates in the circulation, increasing the risk of fluid overload.
- ♦ The heart is smaller and weaker and has a reduced output, and fluid overload readily leads to death from cardiac failure.
- ♦ Sodium builds up inside cells because of leaky cell membranes and reduced activity of the sodium-potassium pump, leading to excess body sodium, fluid retention, and edema.
- ♦ Potassium leaks out of cells and is excreted in urine, contributing to electrolyte imbalance, fluid retention, edema, and anorexia.
- ♦ Loss of muscle protein is accompanied by loss of potassium, magnesium, zinc, and copper.
- ♦ The gut produces less gastric acid and enzymes. Motility is reduced, and bacteria may colonize the stomach and small intestine, damaging the mucosa and deconjugating bile salts. Digestion and absorption are impaired.
- ♦ Cell replication and repair are reduced, increasing the risk of bacterial translocation through the gut mucosa.
- ♦ Immune function is impaired, especially cell-mediated immunity. The usual responses to infection may be absent, even in severe illness, increasing the risk of undiagnosed infection.
- ♦ Red blood cell mass is reduced, releasing iron, which requires glucose and amino acids to be converted to ferritin, increasing the risk of hypoglycemia and amino acid imbalances. If conversion to ferritin is incomplete, unbound iron promotes pathogen growth and formation of free radicals.
- ♦ Micronutrient deficiencies limit the body's ability to deactivate free radicals, which cause cell damage. Edema and hair/skin changes are outward signs of cell damage.

When prescribing treatment, it is essential to take these changes in account. Otherwise, organs and systems will be overwhelmed, and death will rapidly ensue.

### Principles of Treatment

Figure 62.7 shows the 10 steps of treatment, which are separated into two phases: stabilization and rehabilitation. These steps apply to all clinical forms and all geographic locations, including North America and Europe. The aim of the **stabilization** phase is to repair cellular function, correct fluid and electrolyte imbalance, restore homeostasis, and prevent death from the interlinked triad of hypoglycemia, hypothermia, and infection. The aim of the **rehabilitation** phase is to restore wasted tissues (i.e., catch-up growth). It is essential that treatment proceeds in an ordered progression and that the metabolic machinery is repaired before any attempt is made to promote weight gain. Pushing ahead too quickly risks inducing the potentially fatal "refeeding syndrome" (see Chapter 63).

Caregivers bring children to health facilities because of illness, rarely because of their malnutrition. A common mistake among healthcare providers is to focus on the illness and treat as for a well-nourished child. This approach ignores the deranged metabolism in malnourished children and can be fatal. Such children should be considered as severely malnourished with a complication, and

	Stabilization		Rehabilitation
	Day 1–2	Day 3–7	Week 2–6
1. Prevent/treat hypoglycemia	→		
2. Prevent/treat hypothermia	→		
3. Treat/prevent dehydration	→		
4. Correct imbalance of electrolytes	→		
5. Treat infections		→	
6. Correct deficiencies of micronutrients	→ no iron	→	with iron →
7. Start cautious feeding		→	
8. Rebuild wasted tissue (catch-up growth)			→
9. Provide loving care and play			→
10. Prepare for follow-up			→

Fig. 62.7 The 10 steps of treatment for severe acute malnutrition and their approximate time frames.

**Table 62.7** Emergency Treatment in Severe Malnutrition

CONDITION	IMMEDIATE ACTION
Shock <ul style="list-style-type: none"> <li>Lethargic or unconscious and</li> <li>Cold hands</li> </ul> Plus either: <ul style="list-style-type: none"> <li>Slow capillary refill (&gt;3 sec) or</li> <li>Weak fast pulse</li> </ul>	1. Give oxygen. 2. Give sterile 10% glucose (5 mL/kg) rapidly by IV injection. 3. Give IV fluid at 15 mL/kg over 1 hr, using: <ul style="list-style-type: none"> <li>Ringer lactate with 5% dextrose or</li> <li>Half-normal saline* with 5% dextrose or</li> <li>Half-strength Darrow solution with 5% dextrose</li> <li>If all these are unavailable, Ringer lactate</li> </ul> 4. Measure and record pulse and respirations at the start and every 10 min. If there are signs of improvement (pulse and respiration rates fall), repeat IV drip, 15 mL/kg for 1 more hr. Then switch to oral or nasogastric rehydration with ReSoMal, 5-10 mL/kg in alternate hr (see Table 62.8 step 3). If there are no signs of improvement, assume septic shock and: <ol style="list-style-type: none"> <li>Give maintenance fluid IV (4 mL/kg/hr) while waiting for blood.</li> <li>Order 10 mL/kg fresh whole blood and transfuse slowly over 3 hr. If signs of heart failure, give 5-7 mL/kg packed cells rather than whole blood.</li> <li>Give furosemide, 1 mg/kg IV at start of transfusion.</li> </ol>
Hypoglycemia Blood glucose <3 mmol/L	See Table 62.8 step 1 for treatment.
Severe dehydration	Do not give IV fluids except in shock. See Table 62.8 step 3 for treatment.
Very severe anemia Hgb <4 g/dL	If very severe anemia (or Hgb 4-6 g/dL and respiratory distress): <ol style="list-style-type: none"> <li>Give whole blood 10 mL/kg slowly over 3 hr. If signs of heart failure, give 5-7 mL/kg packed cells rather than whole blood.</li> <li>Give furosemide 1 mg/kg IV at the start of the transfusion.</li> </ol>
Emergency eye care Corneal ulceration	If corneal ulceration: <ol style="list-style-type: none"> <li>Give vitamin A immediately (age &lt;6 mo: 50,000 IU; 6-12 mo: 100,000 IU; &gt;12 mo: 200,000 IU)</li> <li>Instill 1 drop atropine (1%) into affected eye to relax the eye and prevent the lens from pushing out.</li> </ol>

\*Some would recommend 5% dextrose in normal saline.  
Hgb, Hemoglobin; IV, intravenous(ly).

treatment should follow the 10 steps. *Two other potentially fatal mistakes are to treat edema with a diuretic and to give a high-protein diet in the early phase of treatment.*

**Emergency Treatment**

Table 62.7 summarizes emergency treatment for malnourished children with shock and other emergency conditions. Note that treatment of shock in these children is different (less rapid, smaller volume, different fluid) from treatment of shock in well-nourished children. However, shock from dehydration and shock from sepsis often coexist and are difficult to differentiate on clinical grounds. Thus the physician must be guided by the response to treatment: children with dehydration respond to IV fluid, whereas those with septic shock will not respond. Because severely malnourished children can quickly succumb to fluid overload, they must be monitored closely.

**Stabilization**

Table 62.8 summarizes the therapeutic directives for stabilization steps 1-7 (see Fig. 62.7). Giving broad-spectrum antibiotics (Table 62.9) and feeding frequent small amounts of F75 (a specially formulated low-lactose milk with 75 kcal and 0.9 g protein per 100 mL to which potassium, magnesium, and micronutrients are added) will reestablish metabolic control, treat edema, and restore appetite. The parenteral route should be avoided; children who lack appetite should be fed by nasogastric tube, because nutrients delivered within the gut lumen help in its repair. Table 62.10 provides recipes for preparing the special feeds and their nutrient composition. Of the two recipes for F75, one requires no cooking, and the other is cereal based and has a lower osmolality, which may benefit children with persistent diarrhea. F75 is also commercially available; maltodextrins replace some of the sugar, and potassium, magnesium, minerals, and vitamins are already added.

**Table 62.8** Therapeutic Directives for Stabilization of Malnourished Children

STEP	PREVENTION	TREATMENT
1. Prevent/treat hypoglycemia blood glucose <3mmol/L.	Avoid long gaps without food and minimize need for glucose: <ol style="list-style-type: none"> <li>1. Feed immediately.</li> <li>2. Feed every 3 hr day and night (2 hr if ill).</li> <li>3. Feed on time.</li> <li>4. Keep warm.</li> <li>5. Treat infections (they compete for glucose).</li> </ol> <p>Note: Hypoglycemia and hypothermia often coexist and are signs of severe infection.</p>	<b>If conscious:</b> <ol style="list-style-type: none"> <li>1. Give 10% glucose (50 mL), or a feed (see step 7), or 1 tsp sugar under tongue, whichever is quickest.</li> <li>2. Feed every 2 hr for at least first day. Initially give ¼ of feed every 30 min.</li> <li>3. Keep warm.</li> <li>4. Start broad-spectrum antibiotics.</li> </ol> <b>If unconscious:</b> <ol style="list-style-type: none"> <li>1. Immediately give sterile 10% glucose (5 mL/kg) rapidly by IV.</li> <li>2. Feed every 2 hr for at least first day. Initially give ¼ of feed every 30 min. Use nasogastric (NG) tube if unable to drink.</li> <li>3. Keep warm.</li> <li>4. Start broad-spectrum antibiotics.</li> </ol>
2. Prevent/treat hypothermia axillary <35°C (95°F); rectal <35.5°C (95.9°F).	Keep warm and dry and feed frequently. <ol style="list-style-type: none"> <li>1. Avoid exposure.</li> <li>2. Dress warmly, including head, and cover with blanket.</li> <li>3. Keep room hot; avoid drafts.</li> <li>4. Change wet clothes and bedding.</li> <li>5. Do not bathe if very ill.</li> <li>6. Feed frequently day and night.</li> <li>7. Treat infections.</li> </ol>	Actively rewarm. <ol style="list-style-type: none"> <li>1. Feed.</li> <li>2. Skin-to-skin contact with caregiver (“kangaroo technique”) or dress in warmed clothes, cover head, wrap in warmed blanket, and provide indirect heat (e.g., heater; transwarmer mattress; incandescent lamp).</li> <li>3. Monitor temperature hourly (or every 30 min if using heater).</li> <li>4. Stop rewarming when rectal temperature is 36.5°C (97.7°F).</li> </ol>
3. Prevent/treat dehydration.	Replace stool losses. <ol style="list-style-type: none"> <li>1. Give ReSoMal after each watery stool. ReSoMal (37.5 mmol Na/L) is a low-sodium rehydration solution for malnutrition.</li> </ol>	Do not give IV fluids unless the child is in shock. <ol style="list-style-type: none"> <li>1. Give ReSoMal 5 mL/kg every 30 min for first 2 hr orally or NG tube.</li> <li>2. Then give 5-10 mL/kg in alternate hours for up to 10 hr. Amount depends on stool loss and eagerness to drink. Feed in the other alternate hour.</li> <li>3. Monitor hourly and stop if signs of overload develop (pulse rate increases by 25 beats/min and respiratory rate by 5 breaths/min; increasing edema; engorged jugular veins).</li> <li>4. Stop when rehydrated (≥3 signs of hydration: less thirsty, passing urine, skin pinch less slow, eyes less sunken, moist mouth, tears, less lethargic, improved pulse and respiratory rate).</li> </ol>
4. Correct electrolyte imbalance—deficit of potassium and magnesium, excess sodium.		<ol style="list-style-type: none"> <li>1. Give extra potassium (4 mmol/kg/day) and magnesium (0.6mmol/kg/day) for at least 2wk (see Table 62.12).</li> </ol> <p>Note: Potassium and magnesium are already added in Nutriset F75 and F100 packets.</p>
5. Prevent/treat infections.	Minimize risk of cross-infection. <ol style="list-style-type: none"> <li>1. Avoid overcrowding.</li> <li>2. Wash hands.</li> <li>3. Give measles vaccine to unimmunized children age &gt;6 mo.</li> </ol>	Infections are often silent. Starting on first day, give broad-spectrum antibiotics to all children. <ol style="list-style-type: none"> <li>1. For antibiotic choices/schedule, see Table 62.9.</li> <li>2. Ensure all doses are given, and given on time.</li> <li>3. Cover skin lesions so that they do not become infected. Note: Avoid steroids because they depress immune function.</li> </ol>
6. Correct micronutrient deficiencies.	Note: Folic acid, multivitamins, zinc, copper, and other trace minerals are already added in Nutriset F75 and F100 packets.	Do not give iron in the stabilization phase. <ol style="list-style-type: none"> <li>1. Give vitamin A on day 1 (&lt;6 mo 50,000 units; 6-12 mo 100,000 units; &gt;12 mo 200,000 units) if child has any eye signs of vitamin A deficiency or has had recent measles. Repeat this dose on days 2 and 14.</li> <li>2. Give folic acid, 1 mg (5 mg on day 1).</li> <li>3. Give zinc (2 mg/kg/day) and copper (0.3 mg/kg/day). These are in the electrolyte/mineral solution and Combined Mineral Vitamin mix (CMV) and can be added to feeds and ReSoMal.</li> <li>4. Give multivitamin syrup or CMV.</li> </ol>
7. Start cautious feeding.		<ol style="list-style-type: none"> <li>1. Give 8-12 small feeds of F75 to provide 130mL/kg/day, 100kcal/kg/day, and 1-1.5g protein/kg/day.</li> <li>2. If gross edema, reduce volume to 100 mL/kg/day.</li> <li>3. Keep a 24-hr intake chart. Measure feeds carefully. Record leftovers.</li> <li>4. If child has poor appetite, coax and encourage to finish the feed. If unfinished, reoffer later. Use NG tube if eating ≤80% of the amount offered.</li> <li>5. If breastfed, encourage continued breastfeeding but also give F75.</li> <li>6. Transfer to F100 when appetite returns (usually within 1 wk) and edema has been lost or is reduced.</li> <li>7. Weigh daily and plot weight.</li> </ol>

Dehydration status is easily misdiagnosed in severely wasted children, because the usual signs (e.g., slow skin pinch, sunken eyes) may be present even without dehydration. Rehydration must therefore be closely monitored for signs of fluid overload. Serum electrolyte levels can be misleading because of sodium leaking from the blood into cells and potassium leaking out of cells. Keeping the intake of electrolytes and nutrients constant (see Table 62.8) allows systems to stabilize more quickly than adjusting intake in response to laboratory results.

Table 62.11 provides a recipe for the special rehydration solution used in severe malnutrition (ReSoMal). Therapeutic **Combined**

**Table 62.9** Recommended Antibiotics for Malnourished Children\*

GIVE	
If no complications	Amoxicillin, 25 mg/kg PO twice daily for 5 days
If complications (shock, hypoglycemia, hypothermia, skin lesions, respiratory or urinary tract infections, or lethargy/sickly)	Gentamicin, 7.5 mg/kg IV or IM once daily for 7 days and Ampicillin, 50 mg/kg IV or IM every 6 hr for 2 days, then amoxicillin, 25–40 mg/kg PO every 8 hr for 5 days

If specific infections are identified, add appropriate antibiotics.

For persistent diarrhea or small bowel overgrowth, add metronidazole, 7.5 mg/kg PO every 8 hr for 7 days.

\*Local resistance patterns may require these to be adjusted: Ensure that there is gram-negative coverage.

PO, Orally; IM, intramuscularly; IV, intravenously.

**Mineral Vitamin mix (CMV)** contains electrolytes, minerals, and vitamins and is added to ReSoMal and feeds. If unavailable, potassium, magnesium, zinc, and copper can be added as an electrolyte/mineral stock solution (Table 62.12 provides a recipe), and a multivitamin supplement can be given separately.

### Rehabilitation

The signals for entry to the rehabilitation phase are reduced or minimal edema and return of appetite. A controlled transition over 3 days is recommended to prevent refeeding syndrome (see Chapter 63). After the transition, unlimited amounts should be given of a high-energy, high-protein milk formula such as F100 (100 kcal and 3 g protein per 100 mL), or a **ready-to-use therapeutic food**

**Table 62.11** Recipe for Rehydration Solution for Malnutrition (ReSoMal)

INGREDIENT	AMOUNT
Water	2L
WHO ORS	One 1-L sachet*
Sucrose	50g
Electrolyte/mineral solution†	40mL

ReSoMal contains 37.5 mmol sodium and 40 mmol potassium/L.

\*Sachet contains 2.6 g sodium chloride, 2.9 g trisodium citrate dihydrate, 1.5 g potassium chloride, and 13.5 g glucose.

†See Table 62.12 for recipe, or use commercially available therapeutic Combined Mineral Vitamin mix (CMV).

WHO ORS, World Health Organization Oral Rehydration Solution.

**Table 62.10** Recipes for Milk Formulas F75 and F100

	F75 <sup>B</sup> (STARTER)	F75 <sup>C</sup> (STARTER) (CEREAL-BASED)	F100 <sup>D</sup> (CATCH-UP)
Dried skimmed milk (g)	25	25	80
Sugar (g)	100	70	50
Cereal flour (g)	—	35	—
Vegetable oil (g)	30	30	60
Electrolyte/mineral solution (mL) <sup>a</sup>	20	20	20
Water: make up to (mL)	1000	1000	1000
Content/100mL			
Energy (kcal)	75	75	100
Protein (g)	0.9	1.1	2.9
Lactose (g)	1.3	1.3	4.2
Potassium (mmol)	4.0	4.2	6.3
Sodium (mmol)	0.6	0.6	1.9
Magnesium (mmol)	0.43	0.46	0.73
Zinc (mg)	2.0	2.0	2.3
Copper (mg)	0.25	0.25	0.25
% Energy from protein	5	6	12
% Energy from fat	32	32	53
Osmolality (mOsm/L)	413	334	419

Whisk at high speed to prevent oil from separating out.

<sup>a</sup>See Table 62.12 for recipe, or use commercially available therapeutic Combined Mineral Vitamin mix (CMV).

<sup>b</sup>A comparable F75 can be made from 35 g dried whole milk, 100 g sugar, 20 g oil, 20 mL electrolyte/mineral solution, and water to 1,000 mL or from 300 mL full-cream cow's milk, 100 g sugar, 20 g oil, 20 mL electrolyte/mineral solution, and water to 1,000 mL.

<sup>c</sup>This lower-osmolality formula may be helpful for children with dysentery or persistent diarrhea. Cook for 4 min.

<sup>d</sup>A comparable F100 can be made from 110 g dried whole milk, 50 g sugar, 30 g oil, 20 mL electrolyte/mineral solution, and water to 1000 mL or from 880 mL full-cream cow's milk, 75 g sugar, 20 g oil, 20 mL electrolyte/mineral solution, and water to 1,000 mL.

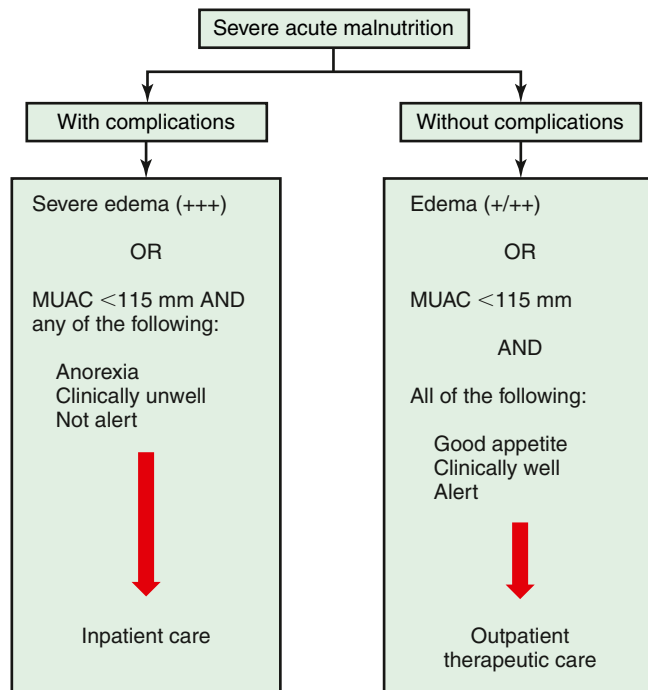


**Table 62.12** Recipe for Concentrated Electrolyte/Mineral Solution\*

INGREDIENT	g	mol/20 mL
Potassium chloride: KCl	224.0	24 mmol
Tripotassium citrate	81.0	2 mmol
Magnesium chloride: MgCl <sub>2</sub> •6H <sub>2</sub> O	76.0	3 mmol
Zinc acetate: Zn acetate•2H <sub>2</sub> O	8.2	300 μmol
Copper (cupric) sulfate: CuSO <sub>4</sub> •5H <sub>2</sub> O	1.4	45 μmol
Water: make up to	2500 mL	

Add 20 mL when preparing 1 L of feed or ReSoMal.

\*Make fresh each month. Use cooled boiled water.



**Fig. 62.8** Flow diagram for inpatient care (left) and outpatient care (right) in the child with severe acute malnutrition. MUAC, Mid-upper arm circumference.

(RUTF), or family foods modified to have comparable energy and protein contents.

To make the transition, for 2 days replace F75 with an equal volume of F100, then increase each successive feed by 10 mL until some feed remains uneaten (usually at about 200 mL/kg/day). After this transition, give 150–220 kcal/kg/day and 4–6 g protein/kg/day and continue to give potassium, magnesium, and micronutrients. Add iron (3 mg/kg/day). If breastfed, encourage continued breastfeeding. Children with severe malnutrition have developmental delays, so loving care, structured play, and sensory stimulation during and after treatment are essential to aid recovery of brain function.

### Community-Based Treatment

Many children with severe acute malnutrition can be identified in their communities before medical complications arise. If these children have a good appetite and are clinically well, they can be rehabilitated at home through community-based management of acute malnutrition, which has the added benefit of reducing their exposure to nosocomial infections and providing continuity of care after recovery. It also reduces the time caregivers spend away from home and their opportunity costs and can be cost-effective for health services.

Figure 62.8 shows the criteria for inpatient and outpatient care. To maximize coverage and compliance, community-based therapeutic care has 4 main elements: community mobilization and sensitization, active case finding, therapeutic care, and follow-up after discharge.

Community-based therapeutic care comprises steps 8–10 (see Fig. 62.7), plus a broad-spectrum antibiotic (step 5). RUTF is usually provided, especially in times of food shortage. RUTF is specially designed for rehabilitating children with severe acute malnutrition at home. It is high in energy and protein and has electrolytes and micronutrients added. The most widely used RUTF is a thick paste that contains milk powder, peanuts, vegetable oil, and sugar. Pathogens cannot grow in it because of its low moisture content. Hospitalized children who have completed steps 1–7 can be transferred to community-based care for completion of their rehabilitation, thereby reducing their hospital stay to about 7–10 days.

Visit Elsevier eBooks+ at [eBooks.Health.Elsevier.com](http://eBooks.Health.Elsevier.com) for Bibliography.

## Chapter 63

# Refeeding Syndrome

Jason M. Nagata and Andrea K. Garber

**Refeeding syndrome** occurs in response to reintroduction of nutrition in the malnourished patient. Rapid electrolyte and fluid shifts in response to the surge of insulin brought on by the presence of nutrients can lead to numerous medical complications shown in Table 63.1 and may progress to life-threatening outcomes, including coma, heart failure, and sudden death. Early accounts of the syndrome were among starved survivors of wartime sieges and concentration camps and among prisoners of war when given sudden access to unlimited food. Refeeding syndrome occurs as a result of oral, enteral, or parenteral (highest risk) feeding of malnourished individuals, especially in the setting of aggressive refeeding. Patient populations at risk for refeeding syndrome include those with anorexia nervosa and other restrictive eating disorders, chronic conditions causing malnutrition (cancer, congenital heart disease), malabsorptive syndromes (inflammatory bowel disease, cystic fibrosis), cerebral palsy, bariatric surgery, and bowel resections (Table 63.2).

In malnourished patients with anorexia nervosa, cases of refeeding syndrome have been documented during refeeding. Risk is greatest within the first 7 days of the start of feeding and is primarily indicated by serum hypophosphatemia (<3.0 ng/dL); hypokalemia (<3.5 mmol/L) and hypomagnesemia (<1.8 mg/dL) are also seen. Studies have identified low weight, but not the caloric load, as the primary risk factor for refeeding syndrome.

An increase in the supply of energy (usually carbohydrates) is accompanied by an increase in sodium pump activity, and too sudden a supply risks causing a rapid release of accumulated sodium from cells, causing expansion of extracellular and plasma volumes. At the same time, there is increased cellular uptake of glucose, potassium, magnesium, and phosphate. Reactivation of metabolic pathways for adenosine triphosphate (ATP) production further depletes serum phosphorus.

For decades, the key to preventing the syndrome was believed to be lower-calorie refeeding with cautious advancement. Diets starting at 1,000–1,200 calories per day were recommended by multiple organizations in the United States. Diets as low as 500 calories per day were recommended in Europe. These cautious approaches are still recommended for patients with extreme malnutrition (<60% of median body mass index for age and sex) and children in developing

**Table 63.1** Clinical Signs and Symptoms of Refeeding Syndrome

HYPOPHOSPHATEMIA	HYPOKALEMIA	HYPOMAGNESEMIA	VITAMIN/THIAMINE DEFICIENCY	SODIUM RETENTION	HYPERGLYCEMIA
<b>Cardiac</b> Hypotension Decreased stroke volume <b>Respiratory</b> Impaired diaphragm contractility Dyspnea Respiratory failure <b>Neurologic</b> Paresthesia Weakness Confusion Disorientation Lethargy Areflexic paralysis Seizures Coma Hematologic Leukocyte dysfunction Hemolysis Thrombocytopenia <b>Other</b> Death	<b>Cardiac</b> Arrhythmias <b>Respiratory</b> Failure <b>Neurologic</b> Weakness Paralysis <b>Gastrointestinal</b> Nausea Vomiting Constipation <b>Muscular</b> Rhabdomyolysis Muscle necrosis <b>Other</b> Death	<b>Cardiac</b> Arrhythmias <b>Neurologic</b> Weakness Tremor Tetany Seizures Altered mental status Coma <b>Gastrointestinal</b> Nausea Vomiting Diarrhea <b>Other</b> Refractory hypokalemia and hypocalcemia Death	Encephalopathy Lactic acidosis Death	Fluid overload Pulmonary edema Cardiac compromise	<b>Cardiac</b> Hypotension <b>Respiratory</b> Hypercapnia Failure <b>Other</b> Ketoacidosis Coma Dehydration Impaired immune function

Data from Kraft MD, Btaiche IF, Sacks GS. Review of RFS. *Nutr Clin Pract.* 2005;20:625–633. From Fuentebella J, Kerner JA. Refeeding syndrome. *Pediatr Clin North Am.* 2009;56:1201–1210.

**Table 63.2** Refeeding Syndrome: National Institutes for Clinical Excellence (NICE) Guidelines for Management of Refeeding Syndrome

PATIENTS AT RISK FOR REFEEDING SYNDROME	
ONE OR MORE OF THE FOLLOWING	—OR— TWO OR MORE OF THE FOLLOWING
• BMI <16 kg/m <sup>2</sup>	• BMI <18.5 kg/m <sup>2</sup>
• Unintentional weight loss of >15% in the previous 3-6 mo	• Unintentional weight loss of >10% in the previous 3-6 mo
• Little or no nutritional intake for >10 days	• Little or no nutritional intake for >5 days
• Low levels of potassium, phosphorus, or magnesium before refeeding	• History of alcohol or drug use, including insulin, chemotherapy, antacids, or diuretics

From Sachs K, Andersen D, Sommer J, Winkelman A, Mehler PS. Avoiding medical complications during the refeeding of patients with anorexia nervosa. *Eat Disord.* 2015;23(5):411–421, Table 1, p. 414.

nations, where the World Health Organization (WHO) guidelines for the treatment of malnutrition are still in place (see [Chapter 62](#)). However, the majority of patients hospitalized in the United States are adolescents with acute, moderate malnutrition. In this patient population, studies have demonstrated the feasibility of higher-calorie refeeding beginning >1,400 calories per day. A randomized clinical trial has demonstrated the efficacy and safety of starting

with 2,000 calories per day in hospitalized adolescents with moderate malnutrition secondary to anorexia nervosa. In the United States, meal-based refeeding is most common, with food served on bedside trays, whereas higher-calorie refeeding by nasogastric tube is reported in Australia. Electrolyte shifts are much lower than expected using these protocols; serum electrolyte levels can be monitored daily in hospital settings and decreased electrolyte levels may be corrected with supplementation.

The following guidance is a suggestion for possible electrolyte repletion for refeeding syndrome in adolescents with eating disorders. For hypophosphatemia: Phos-Na-K 1 packet (250 mg) tid for phosphorous 2.5-2.9 mg/dL; Phos-Na-K 2 packets (500 mg) tid for phosphorous 2.0-2.4 mg/dL; IV Na-K-Phos 0.24 mmol/kg max 15 mmol/dose, and consider intensive care consultation for phosphorous <2.0 mg/dL. For hypokalemia: extended release KCl 20 mEq PO for potassium 3.1-3.4 mmol/L (recheck in 8-12 hours); extended release KCl 40 mEq PO for potassium 2.5-3.0 mmol/L (recheck in 8-12 hours); extended release KCl 40 mEq PO stat for potassium 2.2-2.4 mmol/L; and IV KCl and consider intensive care consultation for potassium <2.2 mmol/L. For hypomagnesemia: Mag-oxide 1 tablet (133-200 mg elemental Mg each) bid for magnesium 1.3-1.7 mg/dL; Mag-oxide 2 tablets (133-200 mg elemental Mg each) bid for magnesium 1.0-1.2 mg/dL; and IV Mg-SO<sub>4</sub> @50 mg/kg; max 2 g/dose and consider intensive care consultation for magnesium <1.0 mg/dL. Declining electrolytes but within the normal range generally do not need to be treated.

Visit Elsevier eBooks+ at [eBooks.Health.Elsevier.com](http://eBooks.Health.Elsevier.com) for Bibliography.

## Chapter 64

# Malnutrition in High-Resource Settings

Liliane K. Diab, Stephanie P. Gilley, and Nancy F. Krebs

See [Chapter 62](#) for malnutrition in low- and middle-income countries. **Malnutrition** refers to **undernutrition** and is defined as an imbalance between nutrient requirements and intake or delivery that then results in deficits—of energy, protein, or micronutrients—that negatively affect growth and development. Malnutrition may be illness related or nonillness related, or both. Illness-related malnutrition may be caused by one or more diseases, infections, or congenital anomalies and by injury or surgery. Nonillness-related causes include environmental, psychosocial, or behavioral factors. Often, one cause may be primary and exacerbated by another. Patients with malnutrition may present with growth deceleration, or actual weight loss, as measured by anthropometric parameters, including weight, length/height, skinfolds, and mid-upper arm circumference (see [Chapter 62](#)). **Wasting** is defined as being too thin for height (weight for length or body mass index [BMI] *z* score less than  $-2$ ). **Stunting** is defined as being too short for age (height or length *z* score less than  $-2$ ).

U.S. data suggest 10% of children seen by primary care physicians are diagnosed with growth faltering. Malnutrition is a primary diagnosis in 1–5% of all hospital admissions. The prevalence of malnutrition in hospitalized patients is ~25%; malnutrition in children can contribute to poor outcomes, especially in intensive care units.

Although **failure to thrive (FTT)** has classically been the term used to describe children who are not meeting weight gain targets based on growth curves, the term *malnutrition* more accurately describes this cohort of children and removes perceived accusations or blame from the diagnosis.

## CLINICAL MANIFESTATIONS

The degree of malnutrition can be assessed by inadequate weight-for-corrected age, failure to gain adequate weight over time (weight gain velocity), height velocity, weight-for-length or BMI depending on age, and developmental outcomes (see [Chapter 62](#)). These growth and anthropometric parameters are measured longitudinally and plotted on growth charts appropriate for the child's sex, age (corrected if premature), and, if known, genetic disorders, such as trisomy 21 or Turner syndrome. The American Academy of Pediatrics (AAP) and the U.S. Centers for Disease Control and Prevention (CDC) recommend the 2006 World Health Organization (WHO) standards for infants up to 2 years of age who are measured supine for length. The CDC 2000 growth references are recommended for children and adolescents (age 2–20 years) when measured with a standing height. The severity of malnutrition (mild, moderate, or severe) may be determined by plotting the *z* score (standard deviation [SD] from the mean) for each of these anthropometric values on the age- and sex-appropriate growth chart ([Table 64.1](#)). Most electronic health records are able to calculate and plot the *z* scores for measured anthropometrics. *Z* scores can also be obtained by entering measurements in electronic applications such as [peditools.org](#). In infants less than 6 months old, a slow or slowing weight gain velocity can indicate malnutrition even if weight/length is preserved. The presence of bilateral pitting edema and low albumin triggers concern for **edematous malnutrition** (kwashiorkor) in the absence of an alternative explanation (such as heart, liver, or renal disease). Edema in the setting of malnutrition automatically classifies as **severe malnutrition** (see [Table 64.1](#)).

## ETIOLOGY AND DIAGNOSIS

The most common mechanisms of pediatric malnutrition are nonillness related and are secondary to insufficient calorie intake, whether the result of low maternal breast milk supply, psychosocial factors such as food insecurity, or feeding difficulties. Picky eating, although common in young children, can occasionally be so restrictive as to result in malnutrition and/or micronutrient deficiencies. **Avoidant restrictive food intake disorder** is one risk factor and is often seen in children with autism, food aversions, or those on elimination diets for fear of food allergies or gluten sensitivity ([Fig. 61.3](#)) ([Table 64.2](#)). The most important illness-related

**Table 64.1** Comprehensive Malnutrition Indicators

INDICATORS*	SEVERE MALNUTRITION	MODERATE MALNUTRITION	MILD MALNUTRITION
Weight-for-length <i>z</i> score	$\leq -3$	$-2.0$ to $-2.99$	$-1.0$ to $-1.99^\dagger$
BMI-for-age <i>z</i> score	$\leq -3$	$-2.0$ to $-2.99$	$-1.0$ to $-1.99^\dagger$
Length <i>z</i> score	$\leq -3$	No data	No data
Mid-upper arm circumference	$\leq -3$	$-2.0$ to $-2.99$	$-1.0$ to $-1.99$
<sup>†</sup> Weight gain velocity (<2 years of age)	<75% of the norm for expected weight gain	<50% of the norm for expected weight gain	<25% of the norm for expected weight gain
<sup>†</sup> Weight loss (2–20yr of age)	>10% of UBW	>7.5% UBW	>5% UBW
<sup>†</sup> Deceleration in weight-for-length/height or BMI-for-age	Deceleration across 3 <i>z</i> score lines	Deceleration across 2 <i>z</i> score lines	Deceleration across 1 <i>z</i> score line
<sup>†</sup> Inadequate nutrient intake	$\leq 25\%$ of estimated energy/protein need	26–50% of estimated energy/protein need	51–75% of estimated energy/protein need
<sup>^</sup> Edema	Present	Absent	Absent

Use clinical judgment when applying these diagnostic criteria.

\*It is recommended that when a child meets more than one malnutrition acuity level, the highest acuity level is used for diagnosis to ensure that appropriate evaluation, monitoring, and treatment are provided.

<sup>^</sup>The presence of bilateral pitting edema and low albumin is diagnostic for kwashiorkor, which is severe malnutrition regardless of any other indicator(s).

<sup>†</sup>Needs additional positive diagnostic criteria to make a malnutrition diagnosis.

BMI, Body mass index; UBW, usual body weight.

Adapted with modifications from Becker PJ, Nieman Carney L, Corkins MR, et al. Consensus statement of the Academy of Nutrition and Dietetics/American Society for Parenteral and Enteral Nutrition: indicators recommended for the identification and documentation of pediatric malnutrition (undernutrition). *J Acad Nutr Diet*. 2014;114(12):1988–2000.

cause of insufficient growth is inability to consume sufficient calories or starvation. The differential diagnosis in this case is broad and includes many health conditions such as cardiac and neurologic diseases. Oral aversion can sometimes be a manifestation of eosinophilic esophagitis or dysphagia. Other causes of malnutrition are (1) increased nutrient losses (e.g., protein-losing enteropathy, chronic diarrhea); (2) increased metabolic demands, as seen in

extensive burn injuries, congenital heart disease, and thyroid disorders; (3) altered nutrient digestion, absorption, or utilization (e.g., cystic fibrosis, short bowel syndrome, celiac disease); and (4) some chromosome abnormalities that can be associated with poor growth such as Russel Silver syndrome. More than one mechanism can exist simultaneously (Fig. 64.1). *Chronic malnutrition* is defined as malnutrition having a duration of  $\geq 3$  months (see Chapter 62).

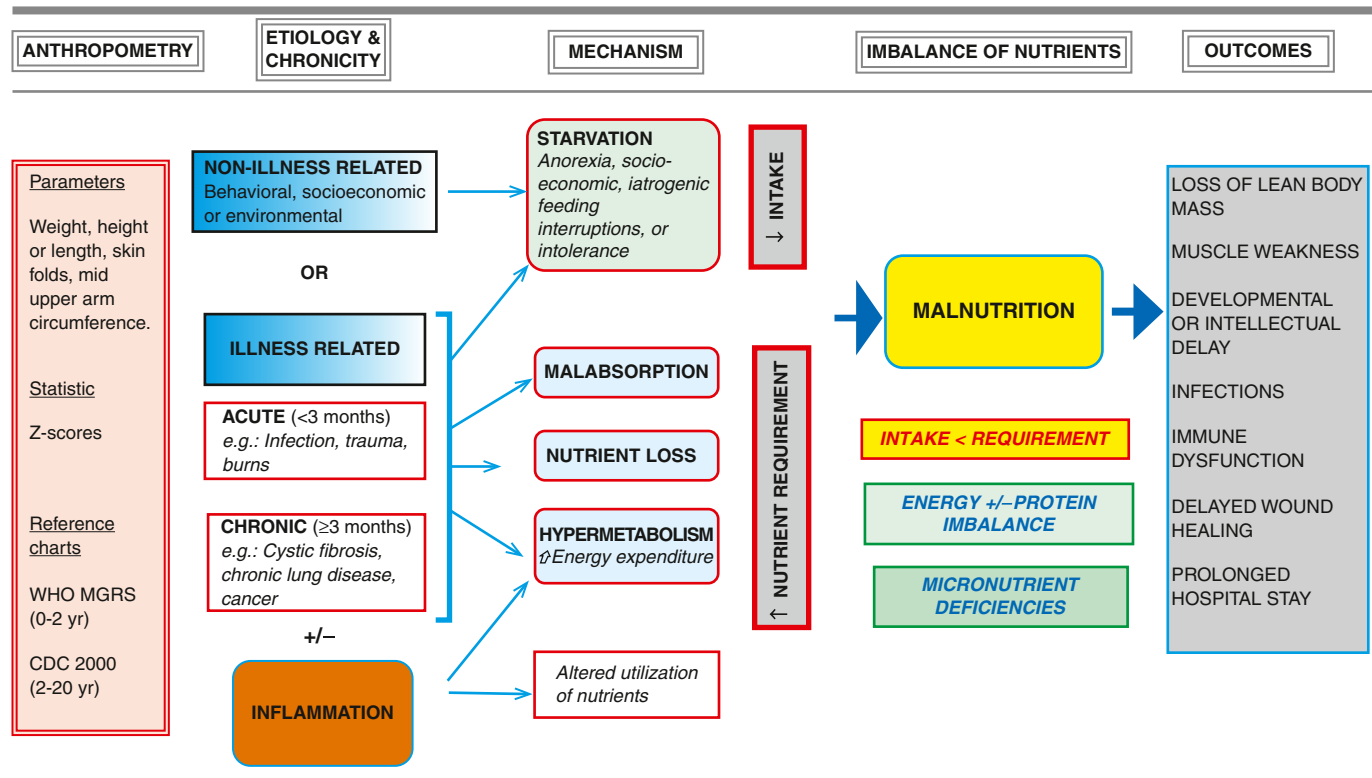
A complete history includes information regarding the onset of the growth faltering, a detailed review of systems, past medical history, and family history including parents' heights and growth patterns. The perinatal history is also important to identify children who are born small for gestational age (SGA). SGA infants who are asymmetric (birthweight is disproportionately more depressed than length or head circumference) have a better prognosis for catch-up growth than do infants who have symmetric intrauterine growth restriction. A detailed nutritional history should include unusual nutritional beliefs and the quantity, quality, and frequency of meals. A comprehensive physical examination can help elucidate possible underlying etiologies and manifestations of micronutrient deficiencies to guide laboratory or imaging evaluation if indicated (Table 64.3 and see Table 62.6). Tanner staging cannot be used as a marker for nutritional status, but it is influenced and often delayed by malnourishment. Puberty will usually resume progression when the malnourished state improves. A reasonable initial screen should include a complete blood count, a comprehensive metabolic panel (CMP), and urinalysis.

Additional measurements that are useful for classifying the severity of malnutrition and following the progress of the acutely malnourished child are mid-upper arm circumference (MUAC) and triceps skin folds (TSF). MUAC can be used as an independent anthropometric tool to screen for and diagnose malnutrition (depletion of subcutaneous fat stores) when obtaining an accurate length or height is difficult. The MUAC is used as a predictor of malnutrition-related mortality by the WHO (increased risk of death from malnutrition if less than 11.5 cm in infants and children 6-64

**Table 64.2** DSM-5 Diagnosis of Avoidant/Restrictive Food Intake Disorder

- A. An eating or feeding disturbance (e.g., apparent lack of interest in eating or food; avoidance based on the sensory characteristics of food; concern about aversive consequences of eating) as manifested by persistent failure to meet appropriate nutritional and/or energy needs associated with one (or more) of the following:
  1. Significant weight loss (or failure to achieve expected weight gain or faltering growth in children).
  2. Significant nutritional deficiency.
  3. Dependence on enteral feeding or oral nutritional supplements.
  4. Marked interference with psychosocial functioning.
- B. The disturbance is not better explained by lack of available food or by associated culturally sanctioned practice.
- C. The eating disturbance does not occur exclusively during the course of anorexia nervosa or bulimia nervosa, and there is no evidence of a disturbance in the way in which one's body weight or shape is experienced.
- D. The eating disturbance is not attributable to a concurrent medical condition or not better explained by another mental disorder. When the eating disturbance occurs in the context of another condition or disorder, the severity of the eating disturbance exceeds that routinely associated with the condition or disorder and warrants additional clinical attention.

From the *Diagnostic and Statistical Manual of Mental Disorders*, 5th ed. p. 947. Copyright 2013. American Psychiatric Association.



**Fig. 64.1** Defining malnutrition in hospitalized children (ASPEN). CDC, Centers for Disease Control and Prevention; MGRS, Multicenter Growth Reference Study; WHO, World Health Organization. (From Mehta NM, Corkins MR, Lyman B, et al. Defining pediatric malnutrition: A paradigm shift toward etiology-related definitions. *J Parenter Enteral Nutr.* 2013;37[4]:460-481.)



**Table 64.3** Approach to Malnutrition Based on Review of Systems

CAUSE	HISTORY AND PHYSICAL EXAMINATION	DIAGNOSTIC CONSIDERATION	WORKUP
Psychosocial	Lack of structure, poor sleep, permissive or intrusive feeding, feeding difficulties and food refusal starting in infancy	Low caloric intake secondary to home feeding environment; in extreme cases need to consider child neglect or abuse Avoidant restrictive food intake disorder (ARFID)	May need blood tests to check for certain micronutrient deficiencies based on diet history
CNS	Developmental delay, poor feeding, vomiting, large head circumference, abnormal neurologic exam	Brain tumor, intracranial bleeding (consider child abuse)	Referral to developmental pediatrics or neurology, MRI, EEG, specific test for neuromuscular function
Gastrointestinal	Chronic vomiting or diarrhea, fatty stool, crying with feedings, nocturnal cough, snoring, history of travel to/from developing countries	Malabsorption, intestinal parasites, milk protein intolerance, pancreatic insufficiency, cystic fibrosis, celiac disease, immunodeficiency, inflammatory bowel disease, small bowel bacterial overgrowth	May need referral to gastroenterology; stool studies (reducing substance, occult blood, fat stain), upper GI with small bowel follow-through; may need endoscopic evaluation
Cardiac	Slow feeding, dyspnea, diaphoresis with feeding, restless sleep, heart murmur	Congenital heart disease, heart failure	Referral to cardiology, ECG, echocardiogram
Genetic	May have a positive family history of developmental delay; often facies typical of a syndrome, skeletal abnormalities, heart murmur; consider in symmetric IUGR.	Noonan syndrome, William syndrome, Turner syndrome, Russel Silver syndrome	Specific genetic testing
Pulmonary	Dyspnea, tachypnea, recurrent wheezing, pulmonary infections	Asthma, aspiration, food allergies, cystic fibrosis, immunodeficiency, neuroendocrine hyperplasia of infancy	Chest x-ray, sweat chloride test; specialty referral
Renal	History of recurrent UTI, abnormal urinalysis, elevated BUN and creatinine	UTI, renal tubular acidosis	General chemistry with BUN and creatinine, urinalysis, urine and serum osmolality
Endocrine	Hypothyroidism is associated with decreased activity level; diabetes is associated with polyuria and polydipsia; growth hormone deficiency is associated with decreased linear growth velocity	Hypothyroidism, type 1 diabetes, growth hormone deficiency	Thyroid function tests, blood glucose and urinalysis, pituitary function tests

BUN, Blood urea nitrogen; CNS, central nervous system; CT, computed tomography; ECG, electrocardiogram; EEG, electroencephalogram; IUGR, intrauterine growth restriction; UTI, urinary tract infection.

Adapted from Carrasco MM, Wolford JE. Child abuse and neglect. In Zitelli BJ, McIntire SC, Nowalk AJ, eds. *Atlas of Pediatric Physical Diagnosis*, 7th ed. Philadelphia: Elsevier; 2018, Table 6.6.

months of age). TSF is a measure of subcutaneous fat and is a sensitive indicator of total body fat. Both MUAC and TSF are especially useful tools for nutrition status assessment in children with altered body composition such as low muscle mass due to cerebral palsy. However, TSF needs to be done by experienced providers to minimize errors. MUAC and TSF charts are available on the WHO website.

## TREATMENT

While an illness-related etiology of malnutrition is being investigated, caloric supplementation can occur simultaneously. Both the medical workup and the initiation of supplemental oral feeds can occur in the outpatient setting with close follow-up. Consider including a speech or occupational therapist for a suck-and-swallow evaluation if the history suggests difficulty with oral feeds. Hospitalization may be indicated for cases of severe malnutrition because of the potential for refeeding syndrome (see Chapter 63), or if a child with mild to moderate malnutrition has not responded after 2-3 months of outpatient management. Hospitalization may include initiation of nasogastric tube feeds, further diagnostic and laboratory evaluation, assessment and observed implementation of adequate nutrition, and evaluation of the parent-child feeding interaction. The type of caloric supplementation is based on the age

of the child, the severity of malnutrition, and the underlying medical condition. Every effort to maximize the breastfeeding relationship in breastfed infants should be made, ideally involving lactation support, expressing breast milk to increase supply if low, and fortification of maternal milk if indicated.

Feeding style is equally important to caloric intake. Parents should be encouraged to respond to the child's cues of hunger and satiety and to have a structured schedule for meals and snacks (every 2-3 hours). A responsive feeding style that respects the toddler's autonomy but retains parental control over food choices helps establish healthy feeding habits (see Chapter 61). Grazing behaviors with frequent small snacks interfere with eating at mealtimes. Commonly used spill-proof and squeezable packaging foster eating "on the go" and has been associated with poor self-regulation of energy intake.

Use of liquid **oral nutritional supplements** resulted in significantly better catch-up growth in children with moderate to severe malnutrition (Tables 64.4 and 64.5). Oral nutritional supplements are most helpful when monitored and balanced with food intake. Start with 30-40 kcal per kg per day and serve them in small amounts simultaneously with meals to allow intake of age-appropriate food. However, children with oral motor difficulties may need to consume a larger proportion of calories in a liquid form.

**Table 64.4** Nutritional Supplements

CATEGORY	BRAND EXAMPLES	FEATURES AND COMMENTS
<b>ORAL SUPPLEMENTS</b>		
Standard, cow's milk protein	Boost Kid Essentials 1.0 or 1.5 (with or without fiber) PediaSure 1.0 or 1.5 (with or without fiber) Nutren Jr 1.0 (with or without fiber) Kate Farms Pediatric Standard 1.2 *EnfaGrow *Nido *Scandishake	May or may not contain lactose.
Semi-elemental	Kate Farms Pediatric Peptide 1.5 PediaSure Peptide 1.0 or 1.5 Peptamen Jr	Used for malabsorption. Contains MCT.
Elemental	EleCare Junior Neocate Splash Neocate Jr Puramino Peptamen Jr	Used for malabsorption or severe protein allergy. Contains MCT.
Soy protein	Bright Beginnings Soy PediSmart Soy	Cow-milk protein free.
Clear liquid	*Boost Breeze *Ensure Clear	Clear liquid, fruit flavored, fat free; cow's milk protein source. For supplemental nutrition <i>only</i> ; none are a complete nutrition supplement.
Wound healing supplement	Juven Arginaid	Arginaid: L-Arginine only. Juven: Arginine glutamine, and betahydroxy-betamethylbutyrate.
<b>TUBE FEEDING</b>		
Standard, cow's milk protein	Boost Kid Essentials 1.0, 1.5 Nutren Junior PediaSure 1.0	Isotonic, most available with or without additional fiber.
High calorie	Boost Kid Essentials 1.5 (1.5 kcal/mL) PediaSure 1.5 (1.5 kcal/mL) Kate Farms Pediatric Peptide 1.5 (1.5 kcal/mL)	For increased caloric needs or fluid restriction.
Food-based formulas	Compleat Pediatric (1.0 kcal/mL) Compleat Pediatric Reduced Calorie (0.6 kcal/mL) Compleat Pediatric Organic Blends (1.2 kcal/mL) PediaSure Harvest (1.0 kcal/mL) Kate Farms Pediatric Standard (1.2 kcal/mL) Nourish (1.13 kcal/mL)	

List of products is not exhaustive and does not imply endorsement. Pediatric formulas are appropriate for children ages 1-11 years and are not appropriate for use in infants. After 11 years, adult formulations (not listed) may be used.

\*Does not provide complete sole source of nutrition.

Adapted from Pediatric Nutrition Handbook/internal guide at Children's Hospital Colorado.

The response to feeding depends on the specific diagnosis, medical treatment, and severity of malnutrition. The same anthropometric measures used to diagnose malnutrition can be used to measure progress and recovery from the malnourished state. Target recovery growth is 150% of the normal rate of weight gain for age (Table 64.6). Many children with malnutrition require empiric micronutrient supplementation with zinc (and thiamine, if concerns about refeeding). Iron deficiency is also common in young children, but supplementation is most effective if initiated after resolution of any acute inflammatory processes (such as infection) and is typically not initiated until after 1-2 weeks of successful weight restoration. Additional supplementation for other micronutrients such as vitamin D and vitamin A can be considered based on symptoms and laboratory evaluation.

Interventions for contributing psychosocial factors are ideally targeted to the underlying issue, such as maternal depression or insufficient funds for food. Some children who develop feeding aversion behaviors will require treatment by a specialized feeding team. If abuse or purposeful neglect is a concern, the family should be referred to the child protective services team.

Kwashiorkor has a specific set of treatment guidelines from the WHO, including empiric antibiotics and avoidance of intravenous fluids and rapid repletion, as this can precipitate heart failure. Treatment of kwashiorkor in a low-resource setting is discussed in more detail in Chapter 62. In a high-resource setting, treatment may involve continuous feeds of a semi-elemental formula through a nasogastric tube to stabilize blood sugars in conjunction with close monitoring of electrolytes.

Table 64.5		Calorie Boosters for Oral and Enteral Feeding	
	Kcal/g	Kcal/Tbsp	FEATURES AND COMMENTS
<b>CARBOHYDRATE (CHO)</b>			
Cornstarch	3.8	33	Can add to formula or water to treat hypoglycemia in glycogen storage disease or other disorders; dose per weight, age, and glucose levels; suggested starting dose of 0.5 g per kg per feed.
Infant rice cereal	—	15	Thickens formula, not human milk; start with 1 teaspoon rice cereal/oz formula (adds 5 kcal/oz, dilutes other nutrients). Not recommended to administer through feeding tube.
<b>FAT</b>			
MCT oil	8.3	116	7.7 kcal/mL; does not mix well, can administer as small bolus.
Heavy whipping cream		50	3.3 kcal/mL can be added to milk or nutritional supplements.
Butter		100	Easy to mix and use in a variety of foods.
<b>PROTEIN</b>			
Beneprotein	3.6	16.7	100% whey protein; 1 packet = 1 scoop = 7 g weight, 6 g protein, 25 kcal; can add to formula, human milk, food, or beverages.
<b>COMBINATION</b>			
Duocal	4.9	42	Hydrolyzed corn starch and fat (35% MCT); can add to formula, human milk, food, or beverages.
MCT Procal	6.6	—	1 packet (16 g) = 105 kcal, 10 g MCT, 2 g protein. For altered fat absorption or metabolism. Contains MCT and milk protein; can add to formula, food, and beverages.
Carnation Instant Breakfast			1 packet (36 g) = 140 kcal

Table 64.6		Weight Gain Velocity (0-2 Years of Age, g/day)	
AGE (MONTHS)	EXPECTED GROWTH (g/DAY)	CATCH-UP GROWTH (g/DAY)	
Preterm infant	30-40		
0-3	20-30	30-45	
3-6	15-20	20-30	
6-9	10-15	15-20	
9-12	10	15	
12-24	6	10	

## PROGNOSIS

Malnutrition, regardless of cause, can potentially have a detrimental effect on physical and intellectual growth and development, especially in infants younger than 2 years old. Early diagnosis and treatment of acute malnutrition may avoid long-term consequences. Multiple studies point to a negative impact of chronic malnutrition and stunting on

intelligence quotient (IQ) later in life. Pediatric medical providers are encouraged to approach nutritional status in children as a controllable factor that can have a profound influence on brain function throughout life.

Visit Elsevier eBooks+ at [eBooks.Health.Elsevier.com](http://eBooks.Health.Elsevier.com) for Bibliography.

## Chapter 65

## Overweight and Obesity

Sheila Gahagan

## EPIDEMIOLOGY

Obesity is an important pediatric public health problem associated with risk of complications in childhood and increased morbidity and mortality throughout adult life. Obesity is linked to more deaths than underweight. In 2016, according to the World Health Organization (WHO), 39% of adults aged 18 years and older were overweight and 13% were obese.

In the United States, child and adolescent obesity prevalence has increased by 300% over the past 40 years. In 2017–2018, the U.S. prevalence of pediatric obesity was 19.3%, affecting about 14.4 million children and adolescents. Obesity prevalence increases by age-group, with 13.4% of 2- to 5-year-olds, 20.3% of 6- to 11-year-olds, and 21.2% of 12- to 19-year-olds affected. Some U.S. populations have higher rates of childhood obesity than others do. Prevalence of obesity in children was 25.6% among Hispanic children, 24.2% among non-Hispanic Black children, 16.1% in non-Hispanic White children, and 8.7% in non-Hispanic Asian children. Higher maternal education confers protection against childhood obesity across all ethnic groups.

The first 1,000 days, the period from conception to age 2 years, are a modifiable period related to risk for childhood obesity. Recommendations for the first 1,000 days include (1) a healthy and nutritious diet during pregnancy; (2) good care for all mothers during pregnancy; (3) exclusive breastfeeding for 6 months; (4) nurturing and responsive care for infants and toddlers; (5) the right foods introduced to babies at the right time; (6) water and other healthy beverages with no added sugars for toddlers; (7) a healthy and nutritious diet for babies and toddlers; (8) the right knowledge and skills for parents and caregivers to properly nourish young children; (9) consistent access to enough nutritious food for families of young children; and (10) societal investments in the well-being of every baby and toddler (for further information see <https://thousanddays.org/resource/nourishing-america-future/>).

Parental obesity correlates with a higher risk for obesity in the children. Prenatal factors, including high preconceptual weight, gestational weight gain, high birthweight, and maternal smoking, are associated with increased risk for later obesity. Paradoxically, intrauterine growth restriction with early infant catch-up growth is associated with the development of central adiposity and adult-onset cardiovascular (CV) risk. Breastfeeding is modestly protective for obesity based on dose and duration. Infants with high levels of negative reactivity (temperament) are more at risk for obesity than those with better self-regulation. The incidence of obesity in children was noted to increase during the COVID-19 pandemic.

## BODY MASS INDEX

Obesity, or increased adiposity, is defined using the **body mass index (BMI)**, an excellent proxy for more direct measurement of body fat.  $BMI = \text{weight in kg}/(\text{height in meters})^2$ . Adults with a BMI  $\geq 30$  meet the criterion for obesity, and those with a BMI 25–30 fall in the overweight range. During childhood, levels of body fat change beginning with high adiposity during infancy. Body fat levels decrease for approximately 5.5 years until the period called *adiposity rebound*, when body fat is typically at the lowest level. Adiposity then increases until early adulthood (Fig. 65.1). Consequently, obesity and overweight are defined using BMI percentiles for children  $\geq 2$  years old and weight/length percentiles for infants  $< 2$  years old. The criterion for **obesity** is BMI  $\geq 95$ th percentile, and for **overweight** is BMI between 85th and 95th percentiles.

## ETIOLOGY

Humans have the capacity to store energy in adipose tissue, allowing improved survival in times of famine. Simplistically, obesity results from an imbalance of caloric intake and energy expenditure. Even incremental but sustained caloric excess results in excess adiposity. Individual adiposity is the result of a complex interplay among genetically determined body habitus, appetite, nutritional intake, **physical activity (PA)**, and energy expenditure. Environmental factors determine levels of available food, preferences for types of foods, levels of PA, and preferences for types of activities. Food preferences play a role in the consumption of energy-dense foods. Humans innately prefer sweet and salty foods and tend initially to reject bitter flavors, common to many vegetables. Repeated exposure to healthy foods promotes their acceptance and liking, especially in early life. This human characteristic to adapt to novel foods can be used to promote healthy food selection.

## Environmental Changes

Over more than 4 decades, the food environment changed dramatically related to urbanization and the food industry as fewer families routinely prepare meals. Foods prepared by a food industry have higher levels of calories, simple carbohydrates, and fat. The price of many foods has declined relative to the family budget. These changes, in combination with marketing pressure, have resulted in larger portion sizes and increased snacking between meals. The increased consumption of high-carbohydrate beverages, including sodas, sport drinks, fruit punch, and juice, adds to these factors.

According to the National Center for Health Statistics, fast food is consumed by 36.3% of 2- to 19-year-old U.S. children each day and by two thirds of children every week. A typical fast-food meal can contain 2,000 kcal and 84 g of fat. Many children consume four servings of high-carbohydrate beverages per day, resulting in an additional 560 kcal of low nutritional value. Sweetened beverages have been linked to increased risk for obesity. The dramatic increase in the use of high-fructose corn syrup to sweeten beverages and prepared foods is another important environmental change, leading to availability of inexpensive calories.

Since World War II, levels of PA in children and adults have declined. According to the 2017 National Health and Nutrition Examination Survey (NHANES) survey, 26.1% of adolescents met PA guidelines of 60 minutes of PA per day. Only 20% met guidelines for aerobic PA and muscle strengthening. The persistence of low levels of PA is related to many factors, including changes in the built environment, more reliance on cars, lower levels of active transportation, safety issues, and increasingly sedentary lifestyles. Many sectors of society do not engage in PA during leisure time. For children, budgetary constraints and pressure for academic performance have led to less time devoted to physical education in schools. Perception of poor neighborhood safety also leads to lower levels of PA. Furthermore, screens (televisions, tablets, smartphones, computers) offer compelling sedentary activities that do not burn calories.

**Sleep** plays a role in the risk for obesity. Over the past 4 decades, children and adults have decreased the amount of time spent sleeping. Reasons for these changes may relate to increased time at work, increased time watching television, and a generally faster pace of life. Chronic partial sleep loss can increase risk for weight gain and obesity, with the impact possibly greater in children than in adults. In studies of young, healthy, lean men, short sleep duration was associated with decreased leptin levels and increased ghrelin levels, along with increased hunger and appetite. *Sleep debt* also results in decreased glucose tolerance and insulin sensitivity related to alterations in glucocorticoids and sympathetic activity. Some effects of sleep debt might relate to *orexins*, peptides synthesized in the lateral hypothalamus that can increase feeding, arousal, sympathetic activity, and neuropeptide Y activity.

## Genetics

Genetic determinants also have a role in individual susceptibility to obesity (Table 65.1). Findings from genome-wide association studies explain a very small portion of interindividual variability in obesity.







**Table 65.1** Endocrine and Genetic Causes of Obesity

DISEASE	SYMPTOMS	LABORATORY
<b>ENDOCRINE</b>		
Cushing syndrome	Central obesity, hirsutism, moon face, hypertension	Dexamethasone suppression test
GH deficiency	Short stature, slow linear growth	Evoked GH response, IGF-1
Hyperinsulinism	Nesidioblastosis, pancreatic adenoma, hypoglycemia, Mauriac syndrome	Insulin level
Hypothyroidism	Short stature, weight gain, fatigue, constipation, cold intolerance, myxedema	TSH, FT <sub>4</sub>
Pseudohypoparathyroidism	Short metacarpals, subcutaneous calcifications, dysmorphic facies, intellectual disability, short stature, hypocalcemia, hyperphosphatemia	Urine cAMP after synthetic PTH infusion
<b>GENETIC/SYNDROMIC</b>		
Albright hereditary osteodystrophy	Short stature, skeletal defects, PTH resistance	<i>GNAS</i> gene, in syndromic but also in isolated nonsyndromic obesity
Alström syndrome	Cognitive impairment, retinitis pigmentosa, insulin-resistant diabetes mellitus, hearing loss, hypogonadism, cardiomyopathy	<i>ALMS1</i> gene
Bardet-Biedl syndrome	Retinitis pigmentosa, renal abnormalities, polydactyly, syndactyly, hypogonadism	~21 different genes
<i>BDNF/TrkB</i> deficiency	Hyperactivity, impaired concentration, limited attention span, impaired short-term memory and pain sensation	<i>BDNF/TrkB</i> gene
Biemond syndrome	Cognitive impairment, iris coloboma, hypogonadism, polydactyly	
Carpenter syndrome	Polydactyly, syndactyly, cranial synostosis, intellectual disability	<i>RAB23</i> gene, located on chromosome 6 in humans
Cohen syndrome	Mid-childhood-onset obesity, short stature, prominent maxillary incisors, hypotonia, intellectual disability, microcephaly, decreased visual activity, neutropenia, joint laxity	<i>VPS13B</i> gene (often called <i>COH1</i> ) at locus 8q22
Deletion 9q34	Early-onset obesity, intellectual disability, brachycephaly, synophrys, prognathism, behavior and sleep disturbances	Deletion 9q34
Down syndrome	Short stature, dysmorphic facies, intellectual disability	Trisomy 21
<i>ENPP1</i> gene	Insulin resistance, childhood obesity	Gene on chromosome 6q
Fragile X	Long facies, large, prominent ears, macroorchidism, autism	<i>FMR1</i> ; CGG repeat expansion >200
Fröhlich syndrome	Hypothalamic tumor	
<i>FTO</i> gene polymorphism, plus upstream regulatory and downstream activation genes	Dysregulation of orexigenic hormone acyl-ghrelin, poor postprandial appetite suppression	Homozygous for <i>FTO</i> AA allele
Kabuki syndrome	Characteristic facies, intellectual disability, visceral and skeletal malformations	<i>KMT2D</i> , <i>MLL2</i> , <i>ALR</i> , <i>KABUK1</i>
Kleefstra syndrome	Intellectual disability, autism-like behavior, hypotonia, cardiac defects	<i>EHMT1</i>
<i>KSR2</i> deficiency	Mild hyperphagia and reduced basal metabolic rate, insulin resistance often with acanthosis nigricans, irregular menses, early development of type 2 diabetes mellitus	<i>KSR2</i> gene
Leptin or leptin receptor gene deficiency	Early-onset severe obesity, infertility (hypogonadotropic hypogonadism), hyperphagia, infections	Leptin
Leptin variant (antagonistic)	Hyperphagia, obesity; treatment with high dose recombinant leptin	High leptin levels
Melanocortin 4 receptor gene mutation	Early-onset severe obesity, increased linear growth, hyperphagia, hyperinsulinemia; <b>most common known genetic cause of obesity</b> ; homozygous worse than heterozygous	<i>MC4R</i> variant
MEHMO	Intellectual disability, epilepsy, hypogonadism, microcephaly, obesity	Xp22.13-p21.1
MORM	Intellectual disability, obesity, retinal dystrophy, micropenis	<i>INPP5E</i>
<i>PCSK1</i> deficiency	Small bowel enteropathy, hypoglycemia, hypothyroidism, ACTH deficiency, diabetes insipidus	<i>PCSK1</i> gene
Prader-Willi syndrome	Neonatal hypotonia, slow infant growth, small hands and feet, intellectual disability, hypogonadism, hyperphagia leading to severe obesity, paradoxically elevated ghrelin	Partial deletion of chromosome 15 or loss of paternally expressed genes: <i>MKRN3</i> , <i>ZNF127</i> , <i>MAGEL2</i> , <i>SNRPN</i>
Proopiomelanocortin (POMC) deficiency	Obesity, red hair, pale skin, adrenal insufficiency due to ACTH deficiency, hyperproinsulinemia, hyperphagia, cholestatic jaundice	Loss-of-function of <i>POMC</i> gene
Rapid-onset obesity with hypothalamic dysfunction, hypoventilation, and autonomic dysregulation (ROHHAD); ROHHADNET (with neuroendocrine tumor)	Often confused with congenital central hypoventilation syndrome (CCHS); presentation ≥1.5yr with weight gain, hyperphagia, hypoventilation, cardiac arrest, central diabetes insipidus, hypothyroidism, GH deficiency, pain insensitivity, hypothermia, precocious puberty, and neural crest tumors	Unknown genes May be a paraneoplastic disorder
Rubinstein-Taylor syndrome	Short stature, visual impairment, scoliosis, dysmorphic facies	<i>CREBBP</i> , <i>EP300</i>
<i>SH2B1</i> deficiency	Hyperphagia, disproportionate hyperinsulinemia, early speech and language delay that often resolves, behavioral problems including aggression	<i>SH2B1</i> gene
<i>SIM1</i> deficiency (Prader-Willi-like)	Hyperphagia with autonomic dysfunction (characterized by low systolic blood pressure), speech and language delay, neurobehavioral abnormalities including autistic-type behaviors	<i>SIM1</i> gene
Smith-Magenis syndrome	Intellectual disability, delayed speech, facial dysmorphology	<i>RAI1</i>
<i>TUB</i> deficiency	Retinal dystrophy, deafness	<i>TUB</i> gene
Turner syndrome	Ovarian dysgenesis, lymphedema, web neck, short stature, cognitive impairment	XO chromosome
WAGRO	Wilms tumor, aniridia, genitourinary anomalies, mental retardation, obesity	<i>BDNF</i>

ACTH, Adrenocorticotropic hormone; cAMP, cyclic adenosine monophosphate; FT<sub>4</sub>, free thyroxine; GH, growth hormone; IGF, insulin-like growth factor; PTH, parathyroid hormone; TSH, thyroid-stimulating hormone.

One important example, the *FTO* gene at 16q12, is associated with adiposity in childhood, probably explained by increased energy intake. Monogenic forms of obesity have also been identified, including **melanocortin-4 receptor (MC4R)** deficiency, associated with early-onset obesity and food-seeking behavior. Pathogenic variants in *MC4R* are a common cause of **monogenetic** obesity but a rare (0.1%) cause of obesity in general. Deficient activation of *MC4R* is also seen in patients with **proopiomelanocortin (POMC)** deficiency, a prohormone precursor of adrenocorticotrophic hormone (ACTH) and melanocyte-stimulating hormone (MSH), resulting in adrenal insufficiency, light skin, red hair, hyperphagia, and obesity. Leptin releases MSH, which can then activate *MC4R*, affecting appetite.

In addition, evidence suggests that appetitive traits are moderately heritable. Some genes associated with appetite also relate to weight, and vice-versa. In addition, there are genetic conditions associated with obesity, such as **Prader-Willi syndrome**, which results from absence of paternally expressed imprinted genes in the 15q11.2-q13 region. Prader-Willi syndrome is characterized by insatiable appetite and food seeking. In the era of genomic medicine, it will be increasingly possible to identify risks according to specific genes and consider gene-environment interactions. Epigenetic environmental modification of genes may have a role in the development of obesity, especially during fetal and early life.

### Endocrine and Neural Physiology

Monitoring of “stored fuels” and short-term control of food intake (appetite and satiety) occurs through neuroendocrine feedback loops linking adipose tissue, the GI tract, and the CNS (Figs. 65.2 and 65.3). GI hormones, including cholecystokinin, glucagon-like peptide 1, peptide YY (PYY), and vagal neuronal feedback, promote satiety. *Ghrelin* stimulates appetite. Adipose tissue provides feedback regarding energy storage levels to the brain through hormonal release of adiponectin and leptin. These hormones act on the arcuate nucleus in the hypothalamus and on the solitary tract nucleus in the brainstem and in turn activate distinct neuronal networks. Adipocytes secrete *adiponectin* into the blood, with reduced levels in response to obesity and increased levels in response to fasting. Reduced adiponectin levels are associated with lower insulin sensitivity and adverse CV outcomes. *Leptin* is directly involved in satiety; low leptin levels stimulate food intake, and high leptin levels inhibit hunger in animal models and in healthy human volunteers. However, the negative feedback loop from leptin to appetite may be more adapted to preventing starvation than excess intake.

Numerous neuropeptides in the brain, including PYY agouti-related peptide, and orexin, appear to affect appetite stimulation, whereas melanocortins and  $\alpha$ -melanocortin-stimulating hormone are involved in satiety (see Fig. 65.3). The neuroendocrine control of appetite and weight involves a negative feedback system, balanced between short-term control of appetite and long-term control of adiposity (including leptin). PYY reduces food intake via the vagal-brainstem-hypothalamic pathway. Developmental changes in PYY are evident, as infants have higher PYY levels than school-aged children and adults. Obese children have lower fasting levels of PYY than adults. Weight loss may restore PYY levels in children, even though this does not happen in adults. In addition, patients homozygous for the *FTO* obesity-risk allele demonstrate poor regulation of the orexigenic hormone acyl-ghrelin and have poor postprandial appetite suppression.

### COMORBIDITIES

Complications of pediatric obesity occur during childhood and adolescence and persist into adulthood. An important reason to prevent and treat pediatric obesity is the increased risk for morbidity and mortality later in life. Males who are overweight during adolescence are twice as likely to die from CV disease as those who have normal weight. More immediate comorbidities include type 2 diabetes, hypertension, hyperlipidemia, and **nonalcoholic fatty liver disease (NAFLD)** (Table 65.2). Insulin resistance increases with increasing adiposity and independently affects lipid metabolism and CV health. **Metabolic syndrome** (central obesity, hypertension, glucose intolerance, and hyperlipidemia) increases the risk for CV morbidity and mortality. NAFLD has

been reported in 34% of patients treated in a pediatric obesity clinic. NAFLD is the most common chronic liver disease in U.S. children and adolescents. It can present with advanced fibrosis or nonalcoholic steatohepatitis and may result in cirrhosis and hepatocellular carcinoma. Insulin resistance is often associated. NAFLD is also independently associated with increased risk of CV disease.

Obesity may also be associated with chronic inflammation. Adiponectin, a peptide with antiinflammatory properties, occurs in reduced levels in obese patients compared with insulin-sensitive, lean persons. Low adiponectin levels correlate with elevated levels of free fatty acids and plasma triglycerides in addition to a high BMI, and high adiponectin levels correlate with peripheral insulin sensitivity. Adipocytes secrete peptides and cytokines into the circulation, and proinflammatory peptides such as interleukin (IL)-6 and tumor necrosis factor (TNF)- $\alpha$  occur in higher levels in obese patients. Specifically, IL-6 stimulates production of CRP in the liver. CRP is a marker of inflammation and might link obesity, coronary disease, and subclinical inflammation.

Some complications of obesity are mechanical, including obstructive sleep apnea and orthopedic complications. Orthopedic complications include Blount disease and slipped femoral capital epiphysis (see Chapters 718 and 719.4).

Mental health problems can coexist with obesity, with the possibility of bidirectional effects. These associations are modified by gender, ethnicity, and socioeconomic status. Self-esteem may be lower in obese adolescent females than in nonobese peers. Some studies have found an association between obesity and adolescent depression. There is considerable interest in the co-occurrence of eating disorders and obesity. Obese youth are also at risk for bullying.

### IDENTIFICATION

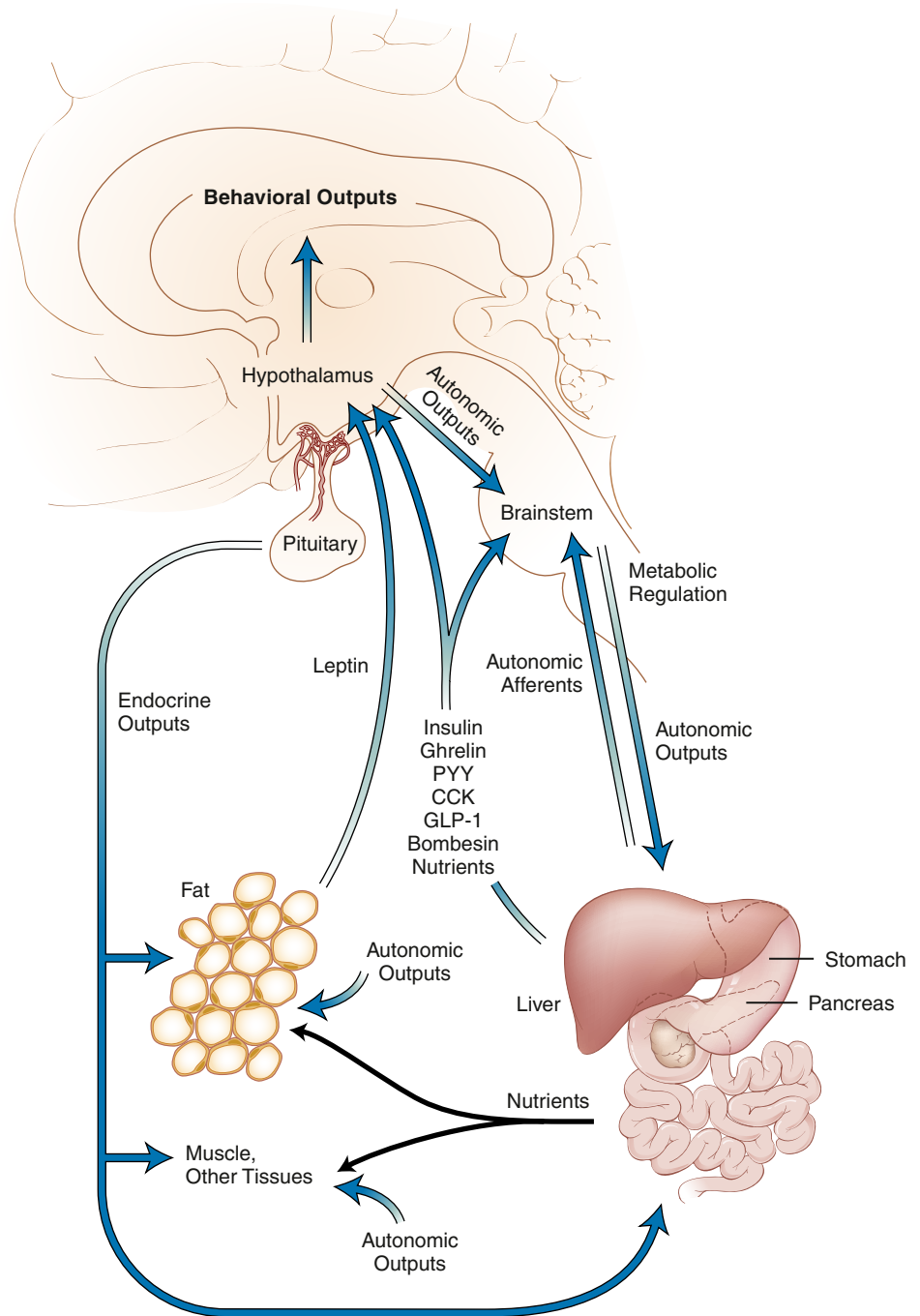
Overweight and obese children are often identified as part of routine medical care. The child and family may be unaware that the child has increased adiposity. They may be unhappy with the medical provider for raising this issue and may respond with denial or apparent lack of concern. It is often necessary to begin by helping the family understand the importance of healthy weight for current and future health. Forging a good therapeutic relationship is important because obesity intervention requires a chronic disease management approach. Intervention and successful resolution of this problem require considerable effort by the family and the child over an extended period in order to change eating and activity behaviors.

### EVALUATION

The evaluation of the overweight or obese child begins with examination of the growth chart for weight, height, and BMI trajectories; consideration of possible medical causes of obesity; and detailed exploration of family eating, nutritional, and activity patterns. A complete pediatric history is used to uncover comorbid disorders. The family history focuses on the adiposity of other family members and the family history of obesity-associated disorders. The physical examination adds data that can lead to important diagnoses. Laboratory testing is guided by the need to identify comorbidities.

Examination of the **growth chart** reveals the severity, duration, and timing of obesity onset. Children who are overweight (BMI in 85th–95th percentile) are less likely to have developed comorbid conditions than those who are obese (BMI  $\geq$ 95th percentile). Those with a BMI  $\geq$ 99th percentile are most likely to have coexisting medical problems. Once obesity severity is determined, the BMI trajectory is examined to elucidate when the child became obese. Several periods during childhood are considered *sensitive* periods, or times of increased risk for developing obesity, including infancy, adiposity rebound (when body fat is lowest at approximately age 5.5 years), and adolescence. An abrupt change in BMI might signal the onset of a medical problem or a period of family or personal stress for the child. Examination of the weight trajectory can further reveal how the problem developed. A young child might exhibit high weight and high height because linear growth can increase early in childhood if a child consumes excess energy. At some point the weight percentile exceeds the height percentile, and the child’s BMI climbs into the obese range. Another example





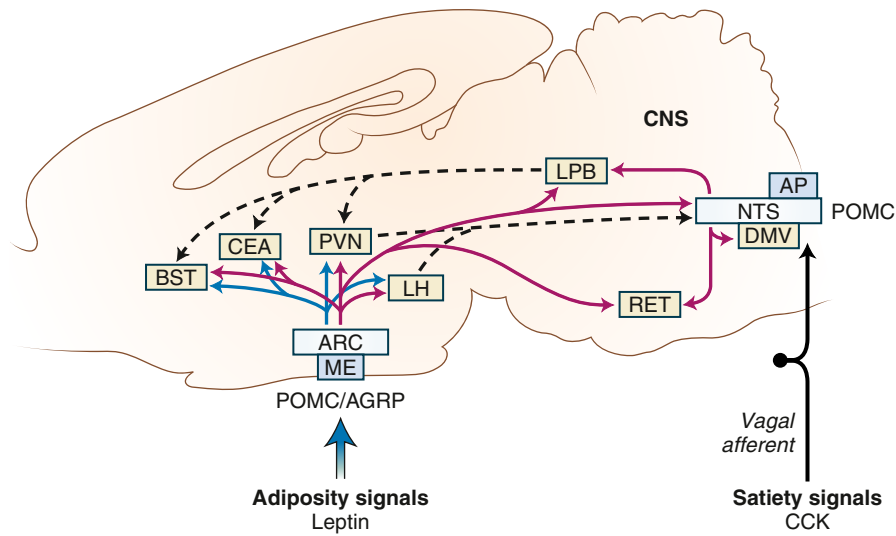
**Fig. 65.2** Regulation of energy homeostasis by the brain-gut-adipose axis. CCK, Cholecystokinin; GLP-1, glucagon-like peptide 1; PYY, peptide YY. (From Melmed S, Polonsky KS, Larsen PR, Kronenberg HM, eds. *Williams Textbook of Endocrinology*, 13th ed. Philadelphia: Elsevier; 2016, p. 1610.)

is a child whose weight rapidly increases when they reduce their activity level and consume more meals away from home. Examination of the height trajectory can reveal endocrine problems, which often occur with slowing of linear growth.

Consideration of possible medical causes of obesity is essential, even though endocrine, syndromic, and monogenetic causes are rare (see [Table 65.1](#)). Growth hormone deficiency, hypothyroidism, and Cushing syndrome are examples of endocrine disorders that can lead to obesity. In general, these disorders manifest with slow linear growth. Because children who consume excessive amounts of calories tend to experience accelerated linear growth, short stature warrants further evaluation. Genetic disorders associated with obesity may manifest extreme hyperphagia, or they can have coexisting dysmorphic features, cognitive impairment, vision and hearing abnormalities, or short stature. In some children with congenital disorders such as myelodysplasia or muscular

dystrophy, lower levels of PA can lead to secondary obesity. Some medications, such as atypical antipsychotics, can cause excessive appetite and hyperphagia, resulting in obesity ([Table 65.3](#)). Rapid weight gain in a child or adolescent taking one of these medications might require its discontinuation. Poor linear growth and rapid changes in weight gain are indications for evaluation of possible medical causes.

Exploration of family eating, nutritional, and activity patterns begins with a description of regular meal and snack times and family habits for walking, bicycle riding, active recreation, and **screen time** (TV, computer, video games). It is useful to request a 24-hour dietary recall with special attention to intake of fruits, vegetables, and water, as well as high-calorie foods and high-carbohydrate beverages. When possible, evaluation by a nutritionist is extremely helpful. This information will form the basis for incremental changes in eating behavior, caloric intake, and PA during the intervention.



**Fig. 65.3** Brain structures involved in energy homeostasis. Receipt of long-term adipostatic signals and acute satiety signals by neurons in arcuate nucleus and brainstem, respectively. Pale-blue boxes indicate nuclei containing proopiomelanocortin (POMC) neurons; tan boxes indicate nuclei containing melanocortin-4 receptor (MC4R) neurons that may serve to integrate adipostatic and satiety signals; and darker-blue boxes show some circumventricular organs involved in energy homeostasis. Magenta arrows designate a subset of projections of POMC neurons; blue arrows show a subset of projections of agouti-related peptide (AGRP) neurons. AP, Area postrema; ARC, arcuate nucleus; BST, bed nucleus of stria terminalis; CCK, cholecystikinin; CEA, central nucleus of amygdala; CNS, central nervous system; DMV, dorsal motor nucleus of vagus; LH, lateral hypothalamic area; LPB, lateral parabrachial nucleus; ME, median eminence; NTS, nucleus tractus solitarius; PVN, paraventricular nucleus of hypothalamus; RET, reticular formation. (Modified from Fan W, Ellacott KL, Halatchev IG, Takahashi K, Yu P, Cone RD. Cholecystikinin-mediated suppression of feeding involves the brainstem melanocortin system. *Nat Neurosci.* 2004;7[4]:335–336.)

Table 65.2 Obesity-Associated Comorbidities		
DISEASE	POSSIBLE SYMPTOMS	LABORATORY CRITERIA
<b>CARDIOVASCULAR</b> Dyslipidemia Hypertension	HDL <40, LDL >130, total cholesterol >200mg/dL SBP >95% for sex, age, height	Fasting total cholesterol, HDL, LDL, triglycerides Serial testing, urinalysis, electrolytes, blood urea nitrogen, creatinine
<b>ENDOCRINE</b> Type 2 diabetes mellitus Metabolic syndrome Polycystic ovary syndrome	Acanthosis nigricans, polyuria, polydipsia Central adiposity, insulin resistance, dyslipidemia, hypertension, glucose intolerance Irregular menses, hirsutism, acne, insulin resistance, hyperandrogenemia	Fasting blood glucose >110, hemoglobin A <sub>1c</sub> , insulin level, C-peptide, oral glucose tolerance test Fasting glucose, LDL and HDL cholesterol Pelvic ultrasound, free testosterone, LH, FSH
<b>GASTROINTESTINAL</b> Gallbladder disease Nonalcoholic fatty liver disease (NAFLD)	Abdominal pain, vomiting, jaundice Hepatomegaly, abdominal pain, dependent edema, ↑ transaminases Can progress to fibrosis, cirrhosis	Ultrasound AST, ALT, ultrasound, CT, or MRI
<b>NEUROLOGIC</b> Pseudotumor cerebri Migraines	Headaches, vision changes, papilledema Hemicrania, headaches	Cerebrospinal fluid opening pressure, CT, MRI None
<b>ORTHOPEDIC</b> Blount disease (tibia vara) Musculoskeletal problems Slipped capital femoral epiphysis	Severe bowing of tibia, knee pain, limp Back pain, joint pain, frequent strains or sprains, limp, hip pain, groin pain, leg bowing Hip pain, knee pain, limp, decreased mobility of hip	Knee radiographs Radiographs Hip radiographs
<b>PSYCHOLOGIC</b> Behavioral complications	Anxiety, depression, low self-esteem, disordered eating, signs of depression, worsening school performance, social isolation, problems with bullying or being bullied	Child Behavior Checklist, Children’s Depression Inventory, Peds QL, Eating Disorder Inventory 2, subjective ratings of stress and depression, Behavior Assessment System for Children, Pediatric Symptom Checklist
<b>PULMONARY</b> Asthma Obstructive sleep apnea	Shortness of breath, wheezing, coughing, exercise intolerance Snoring, apnea, restless sleep, behavioral problems	Pulmonary function tests, peak flow Polysomnography, hypoxia, electrolytes (respiratory acidosis with metabolic alkalosis)

ALT, Alanine transaminase; AST, aspartate transaminase; CT, computed tomography; FSH, follicle-stimulating hormone; HDL, high-density lipoprotein; LDL, low-density lipoprotein; LH, luteinizing hormone; MRI, magnetic resonance imaging; Peds QL, Pediatric Quality of Life Inventory; SBP, systolic blood pressure.

**Table 65.3** Medications Associated with Obesity

Prednisone and other glucocorticoids
Thioridazine
Olanzapine
Clozapine
Quetiapine
Risperidone
Lithium
Amitriptyline and other tricyclic antidepressants
Paroxetine
Valproate
Carbamazepine
Gabapentin
Cyproheptadine
Propranolol and other $\beta$ blockers



**Fig. 65.4** Acanthosis nigricans. From Gahagan S. *Child and adolescent obesity*. *Curr Probl Pediatr Adolesc Health Care*. 2004;34:6–43.

Initial assessment of the overweight or obese child includes a complete review of bodily systems, focusing on the possibility of comorbid conditions (see Table 65.2). Developmental delay and visual and hearing impairment can be associated with genetic disorders. Difficulty sleeping, snoring, or daytime sleepiness suggests sleep apnea. Abdominal pain might suggest NAFLD. Symptoms of polyuria, nocturia, or polydipsia may be the result of type 2 diabetes. Hip or knee pain can be caused by secondary orthopedic problems, including Blount disease and slipped capital femoral epiphysis. Irregular menses may be associated with polycystic ovary syndrome. Acanthosis nigricans can suggest insulin resistance and type 2 diabetes (Fig. 65.4).

The family history begins with identifying other obese family members. Parental obesity is an important risk for child obesity. If all family members are obese, focusing the intervention on the entire family is reasonable. The child may be at increased risk for developing type 2 diabetes if a family history exists. Identification of a family history of hypertension, CV disease, or metabolic syndrome indicates increased risk for developing these obesity-associated conditions. If the clinician helps the family to understand that childhood obesity increases the risk for developing these chronic diseases, this educational intervention might serve as motivation to improve their nutrition and PA.

Physical examination should be thorough, focusing on possible comorbidities (see Table 65.2). Careful screening for hypertension using an appropriately sized blood pressure cuff is important. Systematic examination of the skin can reveal acanthosis nigricans, suggesting insulin resistance, or hirsutism, suggesting polycystic ovary syndrome. Tanner staging can reveal premature adrenarche secondary to advanced sexual maturation in overweight and obese females.

Laboratory testing for fasting plasma glucose, triglycerides, low-density lipoprotein and high-density lipoprotein cholesterol, and liver

**Table 65.4** Normal Laboratory Values for Recommended Tests

LABORATORY TEST	NORMAL VALUE
Glucose	<110mg/dL
Insulin	<15mU/L
Hemoglobin A <sub>1c</sub>	<5.7%
AST (age 2-8yr)	<58U/L
AST (age 9-15yr)	<46U/L
AST (age 15-18yr)	<35U/L
ALT	<35U/L
Total cholesterol	<170mg/dL
LDL	<110mg/dL
HDL	>45mg/dL
Triglycerides (age 0-9yr)	<75mg/dL
Triglycerides (age 10-19yr)	<90mg/dL

AST, Aspartate transaminase; ALT, alanine transaminase; LDL, low-density lipoprotein; HDL, high-density lipoprotein.  
From Children's Hospital of Wisconsin. *The NEW (nutrition, exercise and weight management) kids program*. <http://www.chw.org/display/displayFile.asp?docid=33672&filename=/Groups/NEWKids/NewKidsReferral.PDF>.

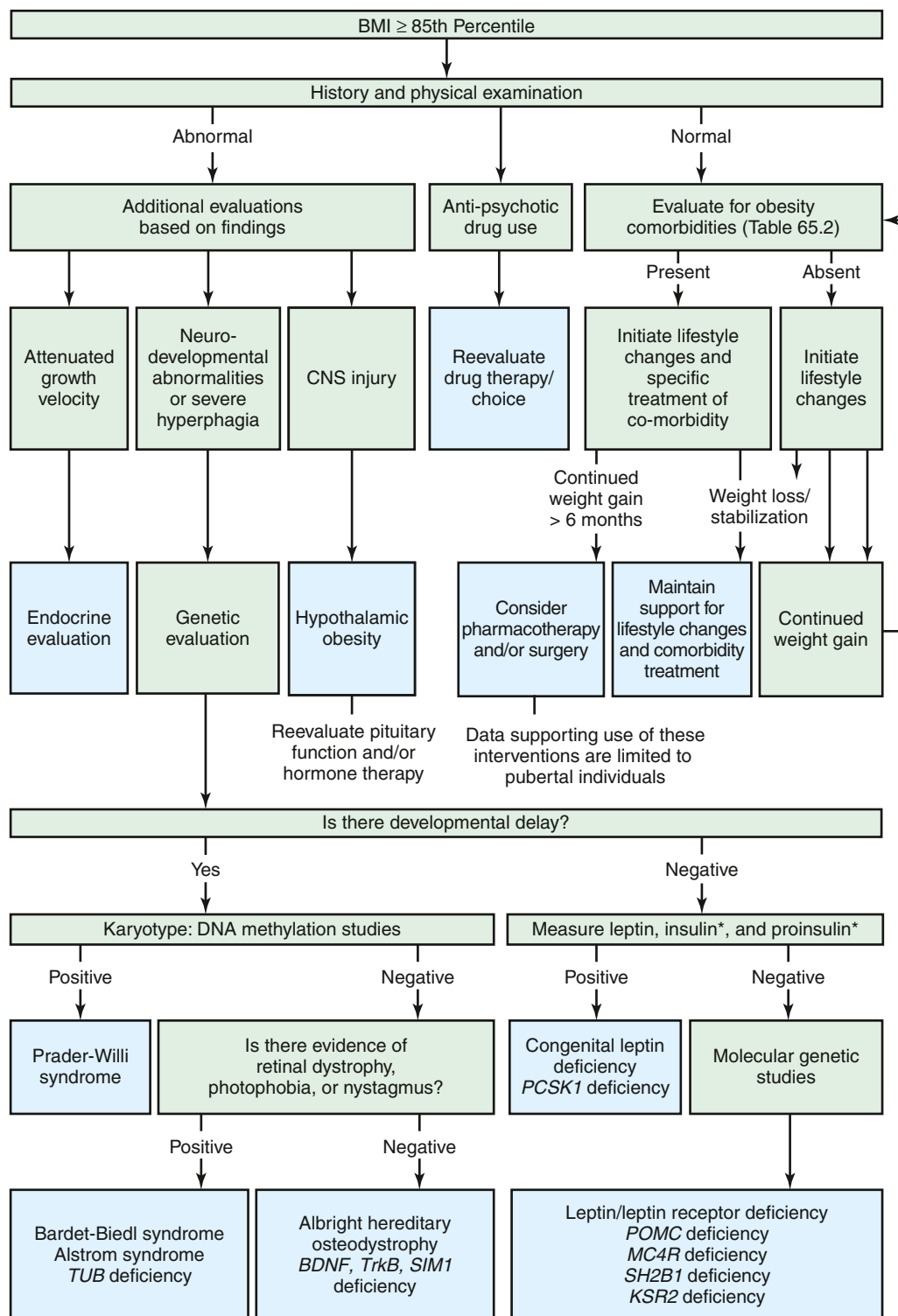
function tests are recommended as part of the initial evaluation for newly identified pediatric obesity (Table 65.4). Overweight children (BMI 85th-95th percentile) who have a family history of diabetes mellitus or signs of insulin resistance should also be evaluated with a fasting plasma glucose test. Other laboratory testing should be guided by history or physical examination findings. Figure 65.5 provides a recommended approach to categorization, evaluation, and treatment.

## INTERVENTION

Evidence shows that some interventions result in modest but significant and sustained improvement in body mass. Based on behavior change theories (see Chapter 18), treatment includes specifying target behaviors, self-monitoring, goal setting, stimulus control, and promotion of self-efficacy and self-management skills. **Behavior changes** associated with improving BMI include drinking lower quantities of sugar-sweetened beverages, consuming higher-quality diets, increasing exercise, decreasing screen time, and self-weighing. Most successful interventions have been *family based* and consider the child's developmental age. "Parent-only" treatment may be as effective as "parent-child" treatment. Because obesity is multifactorial, not all children and adolescents will respond to the same approach. For example, *loss-of-control eating*, associated with weight gain and obesity, predicts poor outcome in response to family-based treatment. Furthermore, clinical treatment programs are expensive and not widely available. Therefore interest has grown in novel approaches such as internet-based treatments and guided self-help.

It is important to begin with clear recommendations about **appropriate caloric intake** for the obese child (Table 65.5). Working with a dietitian is essential. Meals should be based on fruits, vegetables, whole grains, lean meat, fish, and poultry. Prepared foods should be chosen for their nutritional value, with attention to calories and fat. Foods that provide excessive calories and low nutritional value should be reserved for infrequent treats. The World Health Organization recommends avoiding artificial sweeteners (aspartame, sucralose, stevia).

Weight reduction diets in adults generally do not lead to sustained weight loss. Therefore the focus should be on changes that can be maintained for life. Attention to eating patterns is helpful. Families should be encouraged to plan *family meals*, including breakfast. It is almost impossible for a child to make changes in nutritional intake and eating patterns if other family members do not make the same changes.



**Fig. 65.5** Diagnostic and treatment algorithm for the evaluation of the overweight or obese child. \*Measure insulin and proinsulin in patients with clinical features of PCSK1 deficiency. BMI, Body mass index; CNS, central nervous system. (From Farooqi SOR, O’Rahilly S. Genetic obesity syndromes. In Grant S, ed. *The Genetics of Obesity*. New York: Springer; 2014, pp. 23–32; originally adapted from August GP, Caprio S, Fennoy I, et al. Prevention and treatment of pediatric obesity: An Endocrine Society clinical practice guideline based on expert opinion. *J Clin Endocrinol Metab*. 2008;93:4576–4599.)

Dietary needs also change developmentally; adolescents require greatly increased calories during their growth spurts, and adults who lead inactive lives need fewer calories than active, growing children.

Psychologic strategies are helpful. The “**traffic light**” diet groups foods into those that can be consumed without any limitations (green), in moderation (yellow), or reserved for infrequent treats

(red) (Table 65.6). The concrete categories are very helpful to children and families. This approach can be adapted to any ethnic group or regional cuisine. **Motivational interviewing** begins with assessing how ready the patient is to make important behavioral changes. The professional then engages the patient in developing a strategy to take the next step toward the ultimate goal of healthy nutritional intake.



**Table 65.5** Recommended Caloric Intake Designated by Age and Gender

LIFE-STAGE GROUP	AGE (YR)	RELATIVELY SEDENTARY LEVEL OF ACTIVITY (KCAL)	MODERATE LEVEL OF ACTIVITY (KCAL)	ACTIVE (KCAL)
Child	2-3	1,000	1,000-1,400	1,000-1,400
Female	4-8	1,200	1,400-1,600	1,400-1,800
	9-13	1,600	1,600-2,000	1,800-2,200
	14-18	1,800	2,000	2,400
Male	4-8	1,400	1,400-1,600	1,600-2,000
	9-13	1,800	1,800-2,200	2,000-2,600
	14-18	2,200	2,400-2,800	2,800-3,200

Adapted from U.S. Department of Agriculture. Dietary guidelines for Americans, 2005. <http://www.health.gov/DIETARYGUIDELINES/dga2005/document/html/chapter2.htm>.

**Table 65.6** "Traffic Light" Diet Plan

FEATURE	GREEN LIGHT FOODS	YELLOW LIGHT FOODS	RED LIGHT FOODS
Quality	Low-calorie, high-fiber, low-fat, nutrient-dense	Nutrient-dense, but higher in calories and fat	High in calories, sugar, and fat
Types of food	Fruits, vegetables	Lean meats, dairy, starches, grains	Fatty meats, sugar, sugar-sweetened beverages, fried foods
Quantity	Unlimited	Limited	Infrequent or avoided

This method allows the professional to take the role of a coach, helping the child and family reach their goals. Other behavioral approaches include family rules about where food may be consumed (e.g., "not in the bedroom").

Increasing PA without decreasing caloric intake is unlikely to result in weight loss. However, **aerobic exercise** training improves metabolic profiles in obese children and adolescents. Furthermore, it can increase aerobic fitness and decrease percent body fat even without weight loss. Therefore increasing PA can decrease risk for CV disease, improve well-being, and contribute to weight loss. Increased PA can be accomplished by walking to school, engaging in PA during leisure time with family and friends, or enrolling in organized sports. Children are more likely to be active if their parents are active; family PA is recommended. When adults lose significant weight, they may regain that weight despite eating fewer calories. The body may adapt to weight loss by reducing the basal metabolic rate (BMR), thus requiring fewer calories. One approach to this phenomenon is to increase PA.

Active pursuits can replace more sedentary activities. The American Academy of Pediatrics recommends that screen time be restricted to no more than 2 hours/day for children >2 years old and that children <2 years old not watch television. Screen time in general, and TV watching in particular, is often associated with eating and poorer-quality diets, as many highly caloric food products are marketed directly to children during child-oriented television programs.

Pediatric healthcare providers should assist families to develop goals to change nutritional intake and PA. They can also provide the child and family with needed information. The family should not expect immediate lowering of BMI percentile related to behavioral changes, but can instead count on a gradual decrease in the rate of BMI percentile increase until it stabilizes, followed by a gradual decrease. Referral to multidisciplinary, comprehensive pediatric weight management programs is ideal for obese children whenever possible.

**Pharmacotherapy** for weight loss in the pediatric population is understudied. Randomized controlled trials (RCTs) have evaluated

many medications, including metformin, orlistat, sibutramine, and exenatide (Table 65.7). Available medications result in modest weight loss or BMI improvement, even when combined with behavioral interventions. Various classes of drugs are of interest, including those that decrease energy intake or act centrally as **anorexiant**s, those that affect the availability of nutrients through intestinal or renal tubular reabsorption, and those that affect metabolism. One U.S. Food and Drug Administration (FDA)-approved medication for obesity in children <16 years old is *orlistat*, which decreases absorption of fat, resulting in modest weight loss. Complications include flatulence, oily stools, and spotting. This agent offers little benefit to severely obese adolescents.

Saxenda (*liraglutide*) and semaglutide are also FDA approved for chronic weight management among pediatric patients aged 12 and older who are obese. Both drugs are glucagon-like peptide-1 receptor agonists, are approved for children ≥12 years old, and have been effective in reducing weight. In addition, semaglutide improves adverse cardiometabolic features associated with obesity. Adverse reactions include headache, abdominal pain, emesis, and diarrhea. Long-term therapy may increase the risk of medullary thyroid carcinoma and pancreatitis. This class of medication has produced the most significant weight loss of drug-treated obesity.

Because multiple redundant neural mechanisms act to protect body weight, promoting weight loss is extremely difficult. Thus there is considerable interest in combining therapies that simultaneously target multiple weight-regulating pathways. One promising example is the combination of *amylin analogs* (decreases food intake and slows gastric emptying) with *leptin*, which has no anorexigenic effects when given alone. This combination requires injection and is in clinical trials in adults. Another FDA-approved drug for adults is *lorcaserin*, a selective serotonin 2 $\alpha$  receptor agonist. Some medications approved for the treatment of type 2 diabetes, such as other glucagon-like peptide-1 (GLP-1) agonists and sodium-glucose cotransporter-2 (SGLT-2) inhibitors, are being evaluated for treatment of obesity in adults. Establishing long-term safety and tolerability

**Table 65.7** Medications for Weight Management with Mechanism of Action, Availability, and Dosing

MEDICATION	MECHANISM OF ACTION	AVAILABLE FOR CHRONIC USE		MEAN PERCENTAGE WEIGHT LOSS		ADVANTAGES	DISADVANTAGES
		USA	EU	PLACEBO	DRUG		
Phentermine, 15-30mg PO	Sympathomimetic	For short-term use	No	Not stated in label	Not stated in label	Inexpensive	Side effect profile; no long-term data*
Orlistat, 120mg PO tid before meals	Pancreatic lipase inhibitor	Yes	Yes	-2.6%†	-6.1%†	Not absorbed; long-term data*	Modest weight loss; side effect profile
Lorcaserin, 10mg PO bid	5-HT <sub>2c</sub> serotonin agonist with little affinity for other serotonergic receptors	Yes	No	-2.5%	-5.8%	Mild side effects; long-term data*	Expensive; modest weight loss
Phentermine/topiramate ER, 7.5mg/46mg or 15mg/92mg PO indicated as rescue (requires titration)	Sympathomimetic anticonvulsant (GABA receptor modulation, carbonic anhydrase inhibition, glutamate antagonism)	Yes	No	-1.2%	-7.8% (mid-dose) -9.8% (full dose)	Robust weight loss; long-term data*	Expensive; teratogen
Naltrexone SR/bupropion SR, 32mg/360mg PO (requires titration)	Opioid receptor antagonist; dopamine and noradrenaline reuptake inhibitor	Yes	Yes	-1.3%	-5.4%	Reduces food craving; long-term data*	Moderately expensive; side effect profile
Liraglutide, 3.0mg injection (requires titration)	GLP-1 receptor agonist	Yes	Yes	-3%	-7.4% (full dose)	Side effect profile; long-term data*	Expensive; injectable
Semaglutide, 2.4mg once weekly injection	GLP-1 receptor agonist	Yes	Yes	-1%	-10 to -15%	As above	As above

Information is from US product labels, except where noted. The data supporting these tables are derived from the prescribing information labeling approved by the US Food and Drug Administration.

\*Data from randomized controlled trials lasting >52 wk.

†Assuming the average patient in the orlistat and placebo groups weighed 100 kg at baseline.

ER, Extended release; GLP-1, glucagon-like peptide-1; SR, sustained release; PO, orally; bid, twice daily; tid, 3 times daily.

Adapted from Bray GA, Frühbeck G, Ryan DH, Wilding JPH. Management of obesity. *Lancet*. 2016;387:1947-1965, p. 1950.

in children is a challenge because medications of interest have CNS effects or interfere with absorption of nutrients. Teratologic effects must be considered for use in adolescent females. *Setmelanotide*, which binds to and activates *MC4R*, is approved to treat proopiomelanocortin deficiency, leptic receptor deficiency, and proprotein subtilisin/kexin type 1 disorder. **Hormone replacement therapy** is available for patients with leptin deficiency and may become available for patients with POMC deficiency.

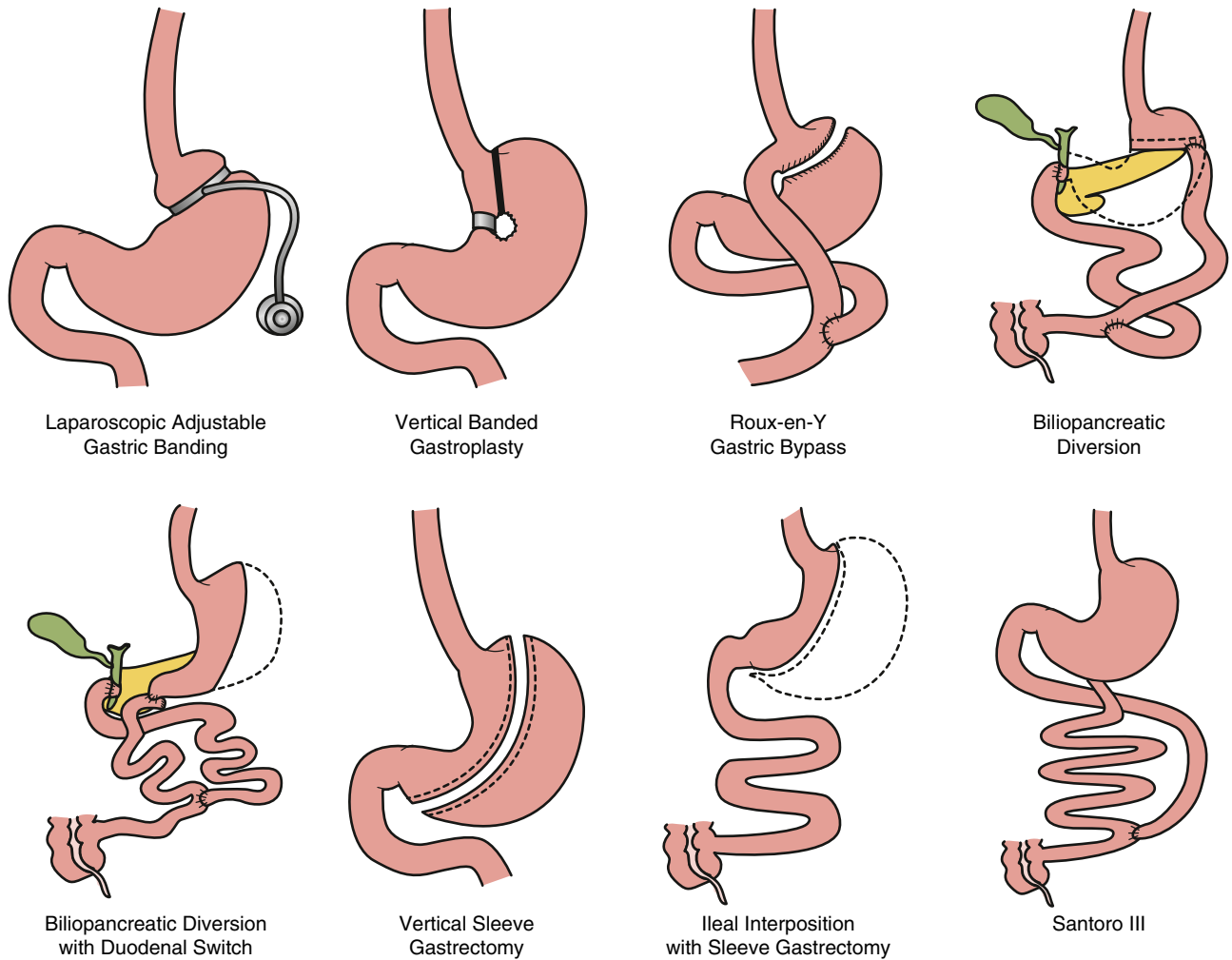
In some cases, it is reasonable to refer adolescents for **bariatric surgery** evaluation. The American Pediatric Surgical Association guidelines recommend that surgery be considered only in children with complete or near-complete skeletal maturity, a BMI  $\geq 40$ , and a medical complication resulting from obesity, *after* they have failed 6 months of a multidisciplinary weight management program. Surgical approaches include the Roux-en-Y and the adjustable gastric band (Fig. 65.6). Endoscopically placed space-occupying fluid or air-filled gastric balloons(s) is approved for adults and may be a nonsurgical intervention. In obese adults, bariatric surgery reduces the risk of developing type 2 diabetes mellitus. In obese adult patients with existing type 2 diabetes, bariatric surgery improves diabetic control. Nutritional complications of bariatric surgery include malabsorption and vitamin (A, B<sub>1</sub>, B<sub>2</sub>, B<sub>6</sub>, B<sub>12</sub>, D, E, K) and mineral (copper, iron) deficiencies that require supplementation.

## PREVENTION

Prevention of child and adolescent obesity is essential for public health in the United States and most other countries (Tables 65.8 and 65.9). Efforts by pediatric providers can supplement national and community

public health programs. The National Institutes of Health (NIH) and U.S. Centers for Disease Control and Prevention (CDC) recommend a variety of initiatives to combat the current obesogenic environment, including promotion of breastfeeding, access to fruits and vegetables, walkable communities, and 60 minutes/day of activity for children. The U.S. Department of Agriculture (USDA) sponsors programs promoting 5.5 cups of fruits and vegetables per day. Incentives for the food industry to promote consumption of healthier foods should be considered. Marketing of unhealthy foods to children is now being regulated. Changes in federal food programs are expected, including commodity foods, the Women, Infant, and Children Supplemental Food Program (WIC), and school lunch programs, to meet the needs of today's children.

Pediatric prevention efforts begin with careful monitoring of weight and BMI percentiles at healthcare maintenance visits. Attention to changes in BMI percentiles can alert the pediatric provider to increasing adiposity before the child becomes overweight or obese. All families should be counseled about healthy nutrition for their children, because the current prevalence of overweight and obesity in adults is 65%. Therefore approximately two thirds of all children can be considered at risk for becoming overweight or obese at some time in their lives. Those who have an obese parent are at increased risk. Prevention efforts begin with promotion of *exclusive breastfeeding for 6 months* and total breastfeeding for 12 months. Introduction of infant foods at 6 months should focus on cereals, fruits, and vegetables. Lean meats, poultry, and fish may be introduced later in the first year of life. Parents should be specifically counseled to *avoid introducing highly sugared beverages and foods in the first*



**Fig. 65.6** Bariatric surgical procedures, including laparoscopic adjustable gastric banding, Roux-en-Y gastric bypass, and vertical sleeve gastrectomy techniques.

year of life. Instead, they should expose their infants and young children to a rich variety of fruits, vegetables, grains, lean meats, poultry, and fish to facilitate acceptance of a diverse and healthy diet. Parenting matters, and authoritative parents are more likely to have children with a healthy weight than those who are authoritarian or permissive. Families who eat regularly scheduled meals together are less likely to have overweight or obese children. Child health professionals can address a child's nutritional status and provide expertise in child growth and development.

Child health professionals can also *promote* PA during regular healthcare maintenance visits. Parents who spend some of their leisure time in PA promote healthy weight in their children. Beginning in infancy, parents should be cognizant of their child's developmental capability and need for PA. Because TV, computer, and video game time can replace health-promoting PA, physicians should counsel parents to limit screen time for their children. Snacking during TV watching should be discouraged. Parents can help their children to understand that television commercials intend to sell a product.

Children can learn that their parents will help them by responsibly choosing healthy foods.

Because obesity is determined by complex multifactorial conditions, prevention will take efforts at multiple levels of social organization. Successful programs include **EPODE** (Ensemble Prévenons l'Obésité Des Enfants), a multilevel prevention strategy that began in France and has been adopted by more than 500 communities in 6 countries. **Shape Up Somerville** is a citywide campaign to increase daily PA and healthy eating in Somerville, Massachusetts, since 2002. The **"Let's Move"** campaign was championed by former First Lady Michelle Obama. Because community and environmental factors are related to pediatric obesity risk, changes in local environments, daycare centers, schools, and recreational settings can have a public health impact. Programs can empower families to adopt practices that promote healthy lifestyles for children and adolescents. The most successful programs are comprehensive and rely on four strategies: political commitment to change, resources to support social

**Table 65.8** Proposed Suggestions for Preventing Obesity**PREGNANCY**

Normalize body mass index (BMI) before pregnancy.  
Do not smoke.  
Maintain moderate exercise as tolerated.  
In women with gestational diabetes, provide meticulous glucose control.  
Monitor gestational weight gain within Institute of Medicine (IOM) recommendations.

**POSTPARTUM AND INFANCY**

Breastfeeding: exclusive for 4-6 mo; continue with other foods for 12 mo.  
Postpone introduction of baby foods to 4-6 mo and juices to 12 mo.

**FAMILIES**

Eat meals as a family in a fixed place and time.  
Do not skip meals, especially breakfast.  
Do not allow television during meals.  
Use small plates and keep serving dishes away from the table.  
Avoid unnecessary sweet or fatty foods and sugar-sweetened drinks.  
Remove televisions from children's bedrooms; restrict times for TV viewing and video games.  
Do not use food as a reward.

**SCHOOLS**

Eliminate candy and cookie sales as fundraisers.  
Review the contents of vending machines and replace with healthier choices; eliminate sodas.  
Avoid financial support for sports teams from beverage and food industries.  
Install water fountains and hydration stations.  
Educate teachers, especially physical education and science faculty, about basic nutrition and the benefits of physical activity (PA).  
Educate children from preschool through high school on appropriate diet and lifestyle.  
Mandate minimum standards for physical education, including 60 min of strenuous exercise 5 times weekly.  
Encourage "the walking school bus": groups of children walking to school with adult supervision.

**COMMUNITIES**

Increase family-friendly exercise and safe play facilities for children of all ages.  
Develop more mixed residential-commercial developments for walkable and bicyclable communities.  
Discourage the use of elevators and moving walkways.  
Provide information on how to shop and prepare healthier versions of culture-specific foods.

**HEALTHCARE PROVIDERS**

Explain the biologic and genetic contributions to obesity.  
Give age-appropriate expectations for body weight in children.  
Work toward classifying obesity as a disease to promote recognition, reimbursement for care, and willingness and ability to provide treatment.

**INDUSTRY**

Mandate age-appropriate nutrition labeling for products aimed at children (e.g., "red light/green light" foods, with portion sizes).  
Encourage marketing of interactive video games in which children must exercise to play.  
Use celebrity advertising directed at children for healthful foods to promote breakfast and regular meals.  
Reduce portion size (drinks and meals).

**GOVERNMENT AND REGULATORY AGENCIES**

Classify childhood obesity as a legitimate disease.  
Find novel ways to fund healthy lifestyle programs (e.g., with revenues from food and drink taxes).  
Subsidize government-sponsored programs to promote the consumption of fresh fruits and vegetables.  
Provide financial incentives to the industry to develop more healthful products and to educate the consumer on product content.  
Provide financial incentives to schools that initiate innovative PA and nutrition programs.  
Allow tax deductions for the cost of weight loss and exercise programs.  
Provide urban planners with funding to establish bicycle, jogging, and walking paths.  
Ban advertising of fast foods, non-nutritious foods, and sugar-sweetened beverages directed at preschool children, and restrict advertising to school-aged children.  
Ban toys as gifts to children for purchasing fast foods.

Adapted from Speiser PW, Rudolf MCJ, Anhalt H, et al. Consensus statement: Childhood obesity. *J Clin Endocrinol Metab.* 2005;90:1871-1887.

**Table 65.9** Anticipatory Guidance: Establishing Healthy Eating Habits in Children

Do not punish a child during mealtimes with regard to eating. The emotional atmosphere of a meal is very important. Interactions during meals should be pleasant and happy.  
Do not use foods as rewards.  
Parents, siblings, and peers should model healthy eating, tasting new foods, and eating a well-balanced meal.  
Children should be exposed to a wide range of foods, tastes, and textures.  
New foods should be offered multiple times. Repeated exposure leads to acceptance and liking.

Forcing a child to eat a certain food will decrease the child's preference for that food. Children's wariness of new foods is normal and should be expected. Offering a variety of foods with low-energy density helps children balance energy intake.  
Parents should control what foods are in the home. Restricting access to foods in the home will increase rather than decrease a child's desire for that food.  
Children tend to be more aware of satiety than adults, so allow children to respond to satiety and stop eating. Do not force children to "clean their plate."

Adapted from Benton D. Role of parents in the determination of food preferences of children and the development of obesity. *Int J Obes Relat Metab Disord.* 2004;28:858-869.

marketing and changes, support services, and evidence-based practices. Community-wide programs are important because neighborhood environmental factors (e.g., poverty) have been associated with obesity in its residents. There is considerable interest in focusing these efforts early in the life cycle. Beginning obesity prevention during

pregnancy and engaging health systems, early childhood programs, and community systems to support healthier life cycles is an approach with great promise.

Visit Elsevier eBooks+ at [eBooks.Health.Elsevier.com](http://eBooks.Health.Elsevier.com) for Bibliography.



## Chapter 66

## Vitamin A Deficiencies and Excess

Libo Tan and A. Catharine Ross

## OVERVIEW OF VITAMIN A

Vitamin A is a fat-soluble micronutrient that cannot be synthesized *de novo* by mammals; thus it is an obligatory dietary factor. The term **vitamin A** is generally used to refer to a group of compounds that possess the biologic activity of all-*trans* retinol (Fig. 66.1). Vitamin A is recognized as being essential for all vertebrates for normal vision, reproduction, cell and tissue differentiation, and immune system functions. Vitamin A plays critical roles in neonatal development. It is required for normal embryonic development, hematopoiesis, and growth and differentiation of many types of cells.

Vitamin A can be obtained from the diet from preformed vitamin A (retinyl esters, such as retinyl palmitate) primarily in foods of animal origin. Organ meats (especially liver and kidney) are very rich in vitamin A, whereas other meats, milk, and cheese contain moderate levels. Other sources of vitamin A include several provitamin A carotenoids, which are found naturally in many fruits and vegetables, especially yellow-orange vegetables (pumpkin, squash, sweet potato) and leafy green vegetables (chard, spinach, broccoli). One of the most abundant carotenoids is  $\beta$ -carotene. Several *cultivars*, or biofortified forms, of sweet potatoes have been introduced to elevate carotene intake in areas of the world where vitamin A deficiency still is prevalent.  $\alpha$ -carotene and oxygenated carotenoids, such as  $\beta$ -cryptoxanthin, found in oranges, also possess vitamin A activity, but at a lower bioactivity. In the body, these precursors are

used for the synthesis of two essential metabolites of vitamin A. **All-*trans* retinoic acid** is the form required for cell differentiation and regulation of gene transcription and is the most bioactive form of vitamin A; **11-*cis* retinal** is the form required for vision as the light-absorbing chromophore of the visual pigments rhodopsin and iodopsin.

## METABOLISM OF VITAMIN A

Vitamin A compounds in foods must first be released through normal digestive processes. Retinyl esters must first be hydrolyzed in the intestinal lumen to liberate unesterified retinol for absorption across the mucosal barrier. Once in the enterocyte, most of the retinol is reesterified, forming new retinyl esters for inclusion in chylomicrons. Approximately 70–90% of dietary preformed vitamin A is absorbed provided there is approximately 10 g of fat in the meal; otherwise, the absorption efficiency is lower. Chronic intestinal disorders or lipid malabsorption can result in vitamin A deficiency. Provitamin-A carotenoids are transported from the intestinal lumen into the enterocytes by specific transporters and then either incorporated intact into chylomicrons or cleaved to form *retinal*, a precursor for retinol;  $\beta$ -carotene becomes retinol through this process. The estimated efficiency of absorption of carotenoids is 20–50%, lower than for preformed vitamin A. Moreover, the efficiency is reduced when the body's vitamin A status is high, and because vitamin A status may vary, there is significant interindividual variability in absorption efficiency. The carotene cleavage enzyme  $\beta$ -carotene monooxygenase, present in the enterocyte and in other tissues at lower levels, exhibits certain single nucleotide polymorphisms (SNPs) that, at least *in vitro*, reduce the efficiency of conversion of  $\beta$ -carotene to retinol. Clinical studies suggest a similar effect *in vivo*.

Once retinol is esterified in the enterocyte, retinyl ester is then packaged into nascent chylomicrons, which are secreted into the lymphatic vessels, enter the systemic circulation, and are then transported to and taken up by various tissues. When vitamin A status is adequate, in most mammals, including humans, the liver

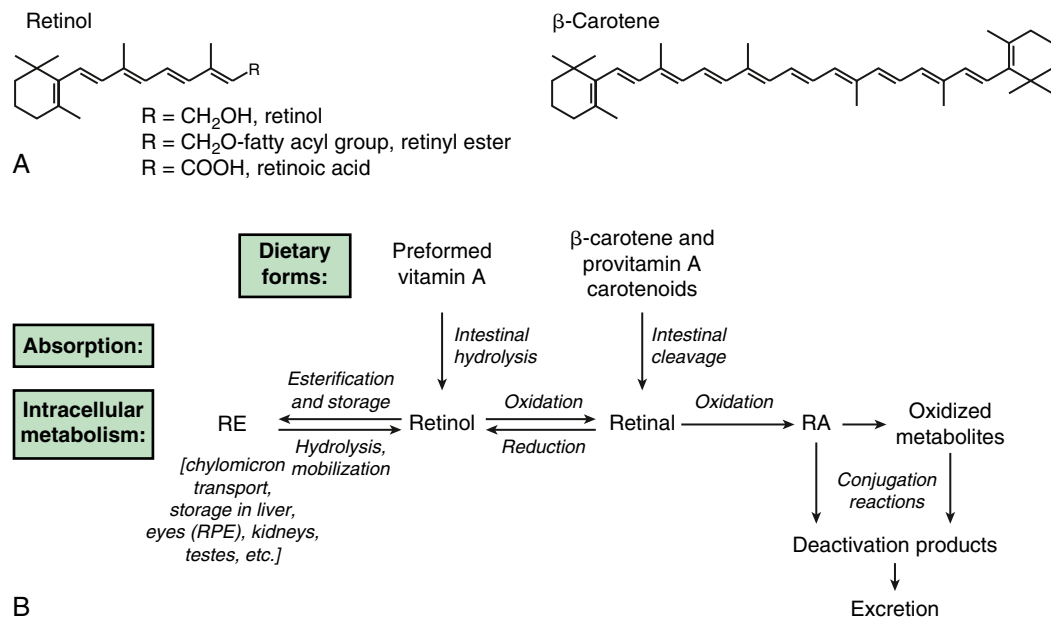


Fig. 66.1 A, Vitamin A structures. B, Overview of vitamin A metabolism. RA, All-*trans* retinoic acid; RE, retinyl ester; RPE, retinal pigment epithelium.

is the major site of chylomicron vitamin A uptake and storage, with potentially high levels of retinyl esters within hepatic stellate cells (HSCs). As vitamin A status deteriorates into the deficient range, vitamin A stores are mobilized from the HSCs, such that the released retinol can be taken up and used by extrahepatic tissues. Circulating retinol is bound to a specific transport protein, retinol-binding protein (RBP), which in turn binds to the thyroid hormone transport protein, transthyretin (TTR); this complex delivers plasma retinol (and the thyroid hormone) to a large number of vitamin A target tissues. The major physiologic mediator of retinol uptake by cells in many tissues is Stra6, a widely expressed multitransmembrane domain protein that functions as a cell surface receptor for retinol bound to RBP. Stra6 is not significantly expressed in the liver, but a homologous receptor may perform the similar function. Within target tissues, retinol is either esterified into retinyl esters for storage or oxidized into retinoic acid for function. In the eye, 11-*cis*-retinal is formed and bound to the protein rhodopsin (rods) or iodopsin (cones), where it functions as a light-sensing receptor.

### Inflammation Causing Low Plasma Retinol

Inflammation is a cause of reduced levels of plasma retinol as a result of reduced synthesis of RBP and TTR. This condition may mimic a lack of vitamin A, but will not be corrected by supplementation. In U.S. adults, those with moderately elevated levels of CRP, indicative of mild inflammation, had lower average plasma retinol levels. The extent to which inflammation is a factor in low plasma retinol in children is uncertain but likely significant in acute infectious diseases such as measles, and possibly in chronic inflammatory conditions such as cystic fibrosis.

## FUNCTIONS OF VITAMIN A AND MECHANISMS OF ACTION

Except for its role in vision, the pleiotropic actions of this micronutrient are mediated by all-*trans*-retinoic acid (RA), which is a ligand for specific nuclear transcription factors, **retinoic acid receptor (RAR)** and **retinoid X receptor (RXR)**, that regulate the expression of several hundred genes. When an RAR is activated by RA, an RAR-RXR complex is formed, which binds to and activates specific DNA sequences present in retinoid-responsive genes, RAREs and RXREs. Genes can be either induced or repressed, depending on additional co-activators or co-repressors recruited to the RAR-RXR complex. Retinoid-regulated genes are involved in several fundamental biologic activities, including regulation of cell division, death, and differentiation. The term *retinoids* is now applied to both natural and synthetic compounds with vitamin A activity, although it is most often used in the context of vitamin A and RA acting at the gene level. Numerous synthetic retinoids have gained clinical acceptance in the treatment of skin disorders and certain cancers.

During embryonic development, RA is among the most important signaling molecules that determine body patterning (morphogenesis). Many physiologic processes are sensitive to a deficiency or excess of vitamin A or RA, including reproduction, growth, bone development, and the functions of the respiratory, gastrointestinal, hematopoietic, and immune systems. Vitamin A supplementation may be particularly important in developing countries, where it reduces morbidity and mortality, presumably by enhancing immune function and host defense, from various infectious diseases, including measles (see Chapter 293).

Vitamin A plays a critical role in vision, mediated by 11-*cis* retinal. The human retina contains two distinct photoreceptor systems: the *rods*, in which rhodopsin senses light of low-intensity, and the *cones*, in which iodopsins detect different colors; 11-*cis*-retinal is the prosthetic group on both these visual proteins. The mechanism of vitamin A action is similar for rods and cones, based on *photoisomerization* of 11-*cis* to all-*trans* retinal (change shape when

exposed to light), which initiates signal transduction via the optic nerve to the brain, resulting in visual sensation. After isomerization (also known as *photobleaching*), a series of reactions serves to regenerate the 11-*cis* retinal for resynthesis of rhodopsin and iodopsin, as is necessary for an efficient visual process. Accessory cells, including retinal pigment epithelium (RPE) cells and Müller cells, are involved in this recycling process.

## VITAMIN A DEFICIENCY

If the growing child has a well-balanced diet and obtains vitamin A from foods rich in vitamin A or provitamin A (Table 66.1), the risk of vitamin A deficiency is small. However, even subclinical vitamin A deficiency can have serious consequences.

Deficiency states in developed countries are rare, except in some impoverished populations (see Chapter 62) or after mistakes in food preparation or with fad diets or restrictive/elimination diets, but are common in many developing countries and often associated with global malnutrition. In the clinical setting, vitamin deficiencies can also occur as complications in children with various chronic disorders or diseases. Information obtained in the medical history related to dietary habits can be important in identifying the risk of such nutritional problems. Except for vitamin A, toxicity from excess intake of vitamins is rare. Table 66.1 summarizes the food sources, functions, and deficiency and excess symptoms of the vitamin.

### Vitamin A Status in Neonates

Neonates begin life with low levels of vitamin A in plasma, liver, and extrahepatic tissues compared with those in adults. Normal plasma levels of retinol are 20-50 µg/dL in infants and increase gradually as children become older. Median serum retinol values are 1.19 µmol/L in both males and females ages 4-8 years; 1.4 and 1.33 µmol/L in males and females, respectively, ages 9-13; and 1.71 and 1.57 µmol/L in males and females, ages 14-18 (for conversion, 1 µmol/L = 28.6 µg/dL). Values of 1.96 and 1.85 µmol/L are found in 19- to 30-year-old adult men and women, respectively. Figure 66.2 shows the distribution of serum retinol concentrations in U.S. children. Few healthy children are severely vitamin A deficient, but the 5th percentile of children 4-8 years and 9-13 years of age, respectively, in the National Health and Examination Survey (NHANES) fell below 1.05 µmol/L, which is interpreted as mild vitamin A deficiency.

Retinol levels are even lower in neonates in developing countries, where vitamin A intakes may be low and vitamin A deficiency is a common nutritional problem. Lower vitamin A stores and plasma retinol concentrations are also seen in low birthweight infants and in preterm newborns, and poor vitamin A status (plasma retinol concentrations <0.35 µmol/L) may contribute to the development of chronic lung disease, such as bronchopulmonary dysplasia (BPD; see Chapter 127).

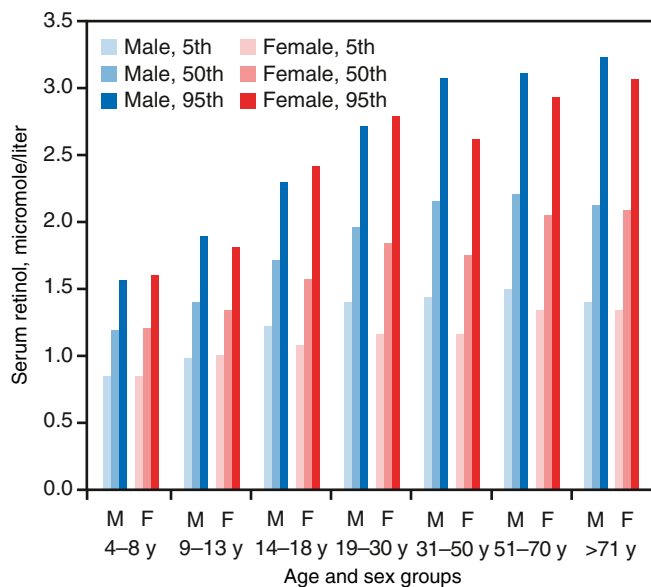
### Clinical Manifestations of Vitamin A Deficiency

The most obvious symptoms of vitamin A deficiency are associated with changes in epithelial cell morphology and functions. In the intestines, mucus-secreting goblet cells are affected, and loss of an effective barrier against pathogens can cause diarrhea or impairment of epithelial barrier function. Similarly, mucus secretion by the epithelium is essential in the respiratory tract for the disposal of inhaled pathogens and toxicants. Characteristic epithelial changes result from vitamin A deficiency, including proliferation of basal cells, hyperkeratosis, and formation of stratified cornified squamous epithelium. Squamous metaplasia of the renal pelvis, ureters, vaginal epithelium, and the pancreatic and salivary ducts can lead to increased infections in these areas. In the urinary bladder,

**Table 66.1** Vitamin A Characteristics

NAMES AND SYNONYMS	CHARACTERISTICS	BIOCHEMICAL ACTION	EFFECTS OF DEFICIENCY	EFFECTS OF EXCESS	SOURCES
Retinol (vitamin A <sub>1</sub> ); 1 μg retinol = 3.3 IU vitamin A = 1 RAE Provitamins A: the plant pigments α-, β-, and γ-carotenes and cryptoxanthin have partial retinol activity: 12 μg β- carotene, or 24 μg other provitamin A carotenoids = 1 μg retinol	Fat-soluble; heat- stable; destroyed by oxidation, drying Bile necessary for absorption Stored in liver Protected by vitamin E	In vision, as retinal, for synthesis of the visual pigments rhodopsin and iodopsin In growth, reproduction, embryonic and fetal development, bone growth, immune and epithelial functions, via retinoic acid as a ligand for specific nuclear transcription factors, regulating genes involved in many fundamental cellular processes	Nyctalopia Photophobia, xerophthalmia, Bitôt spots, conjunctivitis, keratomalacia leading to blindness Faulty epiphyseal bone formation Defective tooth enamel Keratinization of mucous membranes and skin Stunted growth Impaired resistance to infection, anemia, reproductive failure, fetal abnormalities	Anorexia, slow growth, drying and cracking of skin, enlargement of liver and spleen, swelling and pain of long bones, bone fragility, increased intracranial pressure, alopecia, carotenemia Fetal abnormalities	Liver, fish liver oils Dairy products, except skim milk Egg yolk, fortified margarine, fortified skim milk Carotenoids from plants: green vegetables, yellow fruits, and vegetables

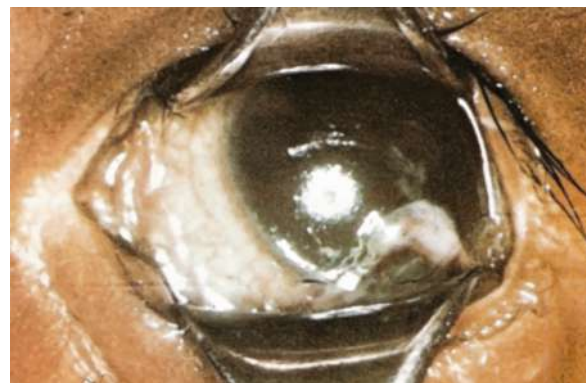
RAE, Retinol activity equivalent.



**Fig. 66.2** Distribution of serum retinol concentrations in U.S. children and adults by age and sex in the National Health and Nutrition Examination Survey (NHANES).

loss of epithelial integrity can result in pyuria and hematuria. In the skin, vitamin A deficiency manifests as dry, scaly, hyperkeratotic patches, typically on the arms, legs, shoulders, and buttocks. The combination of defective epithelial barriers to infection, low immune response, and lowered response to inflammatory stress, all from insufficient vitamin A, can cause poor growth and serious health problems in children.

The most characteristic and specific signs of vitamin A deficiency are *eye lesions*, but these may manifest rather late in the progression of vitamin A deficiency, develop insidiously, and rarely occur before age 2 years. An earlier symptom of vitamin A deficiency is delayed



**Fig. 66.3** Advanced xerophthalmia with an opaque, dull cornea and some damage to the iris in a 1-yr-old boy. (From Oomen HAPC. *Vitamin A deficiency, xerophthalmia and blindness*. *Nutr Rev.* 1974;6:161–166.)

dark adaptation as a result of reduced resynthesis of rhodopsin; this may progress to **night blindness**. Photophobia is a common symptom. The RPE, one of the structural elements of the retina, undergoes keratinization. When the RPE degenerates, the rods and cones have no support and eventually break down, resulting in blindness.

As vitamin A deficiency progresses, the corneal and conjunctival epithelial tissues of the eye become severely altered because of a lack of sufficient RA for normal epithelial cell differentiation. The cornea protects the eye from the environment and is also important in light refraction. Stages in vitamin A deficiency include corneal keratinization and opacity, susceptibility to infection, and formation of dry, scaly layers of cells (**xerophthalmia**) (Figs. 66.3 and 66.4). The conjunctival membrane undergoes keratinization and may develop foamy-appearing plaques (**Bitôt spots**; Fig. 66.5). When lymphocytes infiltrate the cornea in later stages of infection, it degenerates irreversibly (**keratomalacia** and **corneal ulceration**), resulting in irreversible blindness. These eye lesions are primarily diseases of



the young and are a major cause of blindness in developing countries. Although rates of xerophthalmia have fallen, the number of affected children is still too high. Treatment with vitamin A, up to the stage of keratomalacia, is effective in rapidly replenishing the individual and saving vision.

Other clinical signs of vitamin A deficiency include poor overall growth, diarrhea, susceptibility to infections, anemia, apathy, intellectual impairment, and increased intracranial pressure, with wide separation of the cranial bones at the sutures. There may be vision problems



**Fig. 66.4** Recovery from xerophthalmia, showing a permanent eye lesion. (From Bloch CE. Blindness and other disease arising from deficient nutrition [lack of fat soluble A factor]. *Am J Dis Child.* 1924;27:139.)



**Fig. 66.5** Bitôt spots with hyperpigmentation seen in a 10-mo-old Indonesian boy. (From Oomen HAPC. Vitamin A deficiency, xerophthalmia and blindness. *Nutr Rev* 1974;6:161–166.)

as a consequence of bone overgrowth causing pressure on the optic nerve.

**Malnutrition**, particularly protein deficiency, can cause vitamin A deficiency through impaired synthesis of retinol transport protein. In developing countries, subclinical or clinical zinc deficiency can increase the risk of vitamin A deficiency. There is also some evidence of marginal zinc intakes in U.S. children.

### Diagnosis

Dark adaptation tests can be used to assess early-stage vitamin A deficiency. Although Bitôt spots develop relatively early, those related to active vitamin A deficiency are usually confined to preschool-age children. Xerophthalmia is a very characteristic lesion of vitamin A deficiency. For detection of less severe deficiency (marginal vitamin A status), methods include conjunctival impression cytology, relative dose response, and modified relative dose response tests. A diet history is useful in suggesting or ruling out low intake as a cause of symptoms. Marginal vitamin A status is relatively prevalent among pregnant and lactating women in low-resource (and therefore poor dietary intake) areas of the world. Although plasma retinol level is not a completely accurate indicator of vitamin A status, various guidelines have been proposed for categorizing vitamin A status based on serum retinol. In children, plasma retinol <0.35  $\mu\text{mol/L}$  is considered *very deficient*, 0.35–0.7  $\mu\text{mol/L}$  *deficient*, 0.7–1.05  $\mu\text{mol/L}$  *marginal*, and >1.05  $\mu\text{mol/L}$  *adequate*. It has long been thought that a liver vitamin A concentration >20  $\mu\text{g/g}$  is needed to support a normal rate of secretion of retinol-RBP into plasma, and therefore normal delivery of retinol to peripheral tissues.

### Epidemiology and Public Health Issues

Vitamin A deficiency and xerophthalmia still occur throughout much of the developing, income-poor world and are linked to undernourishment and complicated by illness. Various public health programs to provide large doses of vitamin A periodically have been instituted. Vitamin A supplementation is considered part of the strategy of the World Health Organization (WHO) Millennium Development Goals to reduce <5 year mortality. Neonatal supplementation may be most effective in populations with a high incidence of maternal vitamin A deficiency. Other strategies being tested include improving the content of  $\beta$ -carotene in staple foods through plant breeding (biofortification).

### Dietary Reference Intakes for the Healthy Population

Table 66.2 summarizes the dietary reference intakes for infants and children. Dietary reference intake values include the estimated average requirement (EAR), which is the mean biologic requirement for the nutrient for the age/sex-group of interest; the recommended dietary allowance (RDA), which is set to cover the physiologic needs of >97% of the population (thus the needs of many people are more than met by consuming the RDA); and the upper level

**Table 66.2** Dietary Reference Intakes for Vitamin A in Children

AGE RANGE	RECOMMENDED DIETARY ALLOWANCE (RDA)*	UPPER LEVEL (UL)*	COMMENTS
0–6 mo	400	600	The recommended intake for infants is an adequate intake, based on the amount of vitamin A normally present in breast milk.
7–12 mo	500	600	
1–3 yr	300	600	The UL applies only to preformed vitamin A (retinol).
4–8 yr	400	900	
9–13 yr	600	1,700	
14–18 yr	900, male; 700, female	2,800	

\* $\mu\text{g}$  retinol equivalents per day.



of normal (UL), an intake level above which risk of adverse effects may increase; the UL pertains only to chronic consumption of preformed vitamin A. The RDA is expressed as retinol activity equivalents (RAEs; 1 RAE = 1  $\mu\text{g}$  all-*trans* retinol; equivalents for provitamin-A in foods = 12  $\mu\text{g}$   $\beta$ -carotene, 24  $\mu\text{g}$   $\alpha$ -carotene, or 24  $\mu\text{g}$   $\beta$ -cryptoxanthin). From infancy to age 18 years, the RDA increases as a result of increased body size, becoming higher for males than for females during adolescence. During pregnancy the RDA is 750-770  $\mu\text{g}$ , and during lactation it increases to 1,200-1,300  $\mu\text{g}$  to ensure sufficient vitamin A content during breastfeeding.

It is noteworthy that, especially for young children, the UL is only about two times higher than the RDA. This suggests that for children whose diet is good, care should be taken not to overuse dietary supplements (vitamin-mineral supplements) containing preformed vitamin A and/or to avoid excessive consumption of foods that are very rich in vitamin A, such as liver.

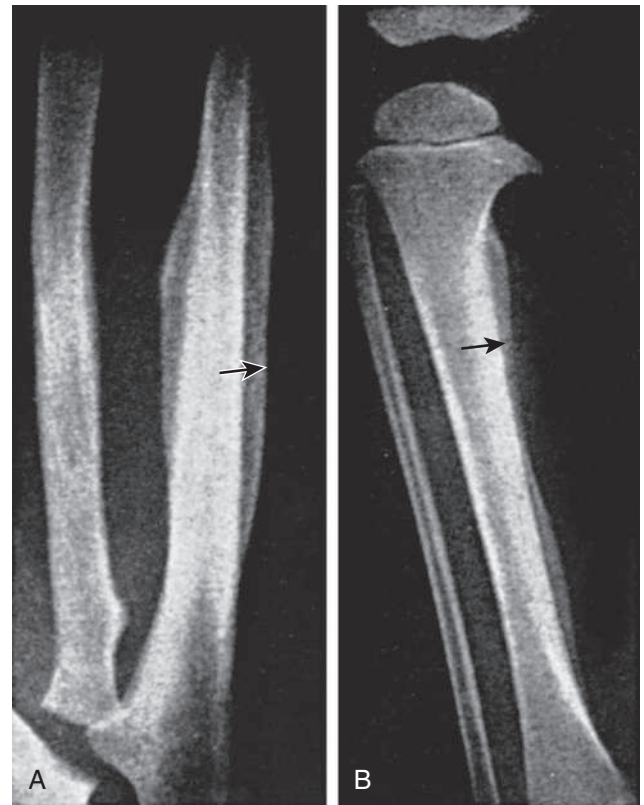
### Vitamin A for Treatment of Deficiency

A daily supplement of 1,500  $\mu\text{g}$  of vitamin A is sufficient for treating latent vitamin A deficiency, after which intake at the RDA level should be the goal. In children without overt signs of vitamin A deficiency but suspected low reserves of vitamin A, rates of morbidity and mortality, as from viral infections such as measles, have been reduced by a weekly dose of vitamin A at the RDA level. More often, higher doses of 30-60 mg of retinol (100,000-200,000 IU/child) are given once or twice, under careful monitoring to avoid toxicity associated with excess vitamin A. Xerophthalmia is treated by giving 1,500  $\mu\text{g}/\text{kg}$  body weight orally for 5 days, followed by intramuscular injection of 7,500  $\mu\text{g}$  of vitamin A in oil, until recovery.

### HYPERVITAMINOSIS A

Chronic hypervitaminosis A results from excessive ingestion of preformed vitamin A (retinol or retinyl ester), generally for several weeks or months. Hypervitaminosis A is most often caused by vitamin A-containing supplements or food faddism, including high intakes of organ meats. Chronic daily intakes of 15,000  $\mu\text{g}$  and 6,000  $\mu\text{g}$  can be toxic in adults and children, respectively. Because there is no antidote for hypervitaminosis A, and vitamin A is readily stored in liver and other tissues, it is most important to prevent toxicity. Symptoms may subside rapidly on withdrawal of the vitamin, but the rate of improvement depends on the amount of vitamin A stored in tissues. Extreme hypervitaminosis A is fatal. Signs of subacute or chronic toxicity can include headache; vomiting (early signs); anorexia; dry, itchy, desquamating skin; and seborrheic cutaneous lesions. With chronic hypervitaminosis A, one may observe fissuring at the corners of the mouth; alopecia and coarsening of the hair; bone abnormalities, including swelling and resorption; enlargement of the liver and spleen; diplopia; increased intracranial pressure; dryness of the mucous membranes; and desquamation of the palms and the soles of the feet. Radiographs may show *hyperostosis* affecting several long bones, especially in the middle of the shafts (Fig. 66.6). Manifestations of hypervitaminosis A may also include nonspecific changes in affect, including severe headache, irritability, stupor, and limited motion. Serum levels of vitamin A are elevated, mostly in the form of retinyl esters carried in lipoproteins, which may result in tissue damage and release of liver enzymes into plasma. Hypercalcemia and/or liver cirrhosis may be present. Hypervitaminosis A is distinct from cortical hyperostosis (see Chapter 741).

In young children, signs of vitamin A toxicity include vomiting and bulging fontanels, neither of which is specific. Combined with anorexia, pruritus, and a lack of weight gain, vitamin A toxicity should be considered. Less common symptoms include diplopia, papilledema,



**Fig. 66.6** Hyperostosis of the ulna and tibia in 21-mo-old infant, resulting from vitamin A poisoning. A, Long, wavy cortical hyperostosis of the ulna (arrow). B, Long, wavy cortical hyperostosis of the right tibia (arrow), with a striking absence of metaphyseal changes. (From Caffey J. *Pediatric X-Ray Diagnosis*, 5th ed. Chicago: Year Book;1967: 994.)

cranial nerve palsies, and other symptoms suggesting **pseudotumor cerebri**.

If high levels of vitamin A or synthetic retinoids are taken early in pregnancy, **severe congenital malformations** may occur in the fetus. **Teratogenicity** has been associated with therapeutic doses (0.5-1.5 mg/kg) of oral 13-*cis*-retinoic acid (e.g., Accutane), generally taken for the treatment of acne or cancer, during the first trimester of pregnancy. A high incidence (>20%) of spontaneous abortions and birth defects, including characteristic craniofacial abnormalities, has prompted the U.S. Food and Drug Administration (FDA) to enact more stringent prescription regulations for such drugs in women of childbearing age to attempt to reduce these birth defects.

Carotenoids, even in high doses, *are not* associated with toxicity but can cause yellowing of the skin (**carotenodermia**), including palms of the hands, and high levels in serum (carotenemia); this relatively benign state disappears slowly when carotene intake is reduced. Children with liver disease, diabetes mellitus, or hypothyroidism are more susceptible. Food faddism, such as excessive consumption of carotene-rich foods and juices, may be a cause of carotenodermia.

Visit Elsevier eBooks+ at [eBooks.Health.Elsevier.com](http://eBooks.Health.Elsevier.com) for Bibliography.

## Chapter 67

# Vitamin B Complex Deficiencies and Excess

H.P.S. Sachdev and Dheeraj Shah

Vitamin B complex includes a number of water-soluble nutrients, including thiamine (vitamin B1), riboflavin (B2), niacin (B3), pyridoxine (B6), folate (B9), cobalamin (B12), biotin (B7), and pantothenic

acid (B5). *Choline* and *inositol* are also considered parts of the B complex and are important for normal body functions, but specific deficiency syndromes have not been attributed to a lack of these factors in the diet (Table 67.1).

B-complex vitamins serve as coenzymes in many metabolic pathways that are functionally closely related. Consequently, a lack of one of the vitamins has the potential to interrupt a chain of chemical processes, including reactions that are dependent on other vitamins, and ultimately can produce diverse clinical manifestations. Because diets deficient in any one of the B-complex vitamins are often poor sources of other B vitamins, manifestations of several vitamin B deficiencies usually can be observed in the same person. *It is therefore a general practice in a patient who has evidence of deficiency of a specific B vitamin to treat with the entire B-complex group of vitamins.*

**Table 67.1** Water-Soluble Vitamins

NAMES AND SYNONYMS	BIOCHEMICAL ACTION	EFFECTS OF DEFICIENCY	TREATMENT OF DEFICIENCY	CAUSES OF DEFICIENCY	DIETARY SOURCES	DIETARY REFERENCE INTAKES BY AGE	
						RDA*	EAR**
Thiamine (vitamin B1)	Coenzyme in carbohydrate metabolism Nucleic acid synthesis Neurotransmitter synthesis	Neurologic (dry beriberi): irritability, peripheral neuritis, muscle tenderness, ataxia Cardiac (wet beriberi): tachycardia, edema, cardiomegaly, cardiac failure	3-5 mg/day PO thiamine for 6 wk	Polished rice-based diets Malabsorptive states Severe malnutrition Malignancies Alcoholism	Meat, especially pork; fish; liver Rice (unmilled), wheat germ; enriched cereals; legumes	0-6 mo: 0.2 mg/day 7-12 mo: 0.3 mg/day 1-3 yr: 0.5 mg/day 4-8 yr: 0.6 mg/day 9-13 yr: 0.9 mg/day 14-18 yr: 1.0 mg/day Males: 1.2 mg/day	1-3 yr: 0.4 mg/day 4-8 yr: 0.5 mg/day 9-13 yr: 0.7 mg/day 14-18 yr: 0.9 mg/day Males: 1.0 mg/day
Riboflavin (vitamin B2)	Constituent of flavoprotein enzymes important in redox reactions: amino acid, fatty acid, and carbohydrate metabolism and cellular respiration	Glossitis, photophobia, lacrimation, corneal vascularization, poor growth, cheilosis	3-10 mg/day PO riboflavin	Severe malnutrition Malabsorptive states Prolonged treatment with phenothiazines, probenecid, or OCPs	Milk, milk products, eggs, fortified cereals, green vegetables	0-6 mo: 0.3 mg/day 7-12 mo: 0.4 mg/day 1-3 yr: 0.5 mg/day 4-8 yr: 0.6 mg/day 9-13 yr: 0.9 mg/day 14-18 yr: 1.0 mg/day Males: 1.3 mg/day	1-3 yr: 0.4 mg/day 4-8 yr: 0.5 mg/day 9-13 yr: 0.8 mg/day 14-18 yr: 0.9 mg/day Males: 1.1 mg/day
Niacin (vitamin B3)	Constituent of NAD and NADP, important in respiratory chain, fatty acid synthesis, cell differentiation, and DNA processing	Pellagra manifesting as diarrhea, symmetric scaly dermatitis in sun-exposed areas, and neurologic symptoms of disorientation and delirium	50-300 mg/day PO niacin	Predominantly maize-based diets Anorexia nervosa Carcinoid syndrome	Meat, fish, poultry Cereals, legumes, green vegetables	0-6 mo: 2 mg/day 7-12 mo: 4 mg/day 1-3 yr: 6 mg/day 4-8 yr: 8 mg/day 9-13 yr: 12 mg/day 14-18 yr: 14 mg/day Males: 16 mg/day	1-3 yr: 5 mg/day 4-8 yr: 6 mg/day 9-13 yr: 9 mg/day 14-18 yr: 11 mg/day Males: 12 mg/day
Pyridoxine (vitamin B6)	Constituent of coenzymes for amino acid and glycogen metabolism, heme synthesis, steroid action, neurotransmitter synthesis	Irritability, convulsions, hypochromic anemia Failure to thrive Oxaluria	5-25 mg/day PO for deficiency states 100 mg IM or IV for pyridoxine-dependent seizures	Prolonged treatment with INH, penicillamine, OCPs	Fortified ready-to-eat cereals, meat, fish, poultry, liver, bananas, rice, potatoes	0-6 mo: 0.1 mg/day 7-12 mo: 0.3 mg/day 1-3 yr: 0.5 mg/day 4-8 yr: 0.6 mg/day 9-13 yr: 1.0 mg/day 14-18 yr: 1.2 mg/day Males: 1.3 mg/day	1-3 yr: 0.4 mg/day 4-8 yr: 0.5 mg/day 9-13 yr: 0.8 mg/day 14-18 yr: 1.0 mg/day Males: 1.1 mg/day

Table 67.1 Water-Soluble Vitamins—cont'd

NAMES AND SYNONYMS	BIOCHEMICAL ACTION	EFFECTS OF DEFICIENCY	TREATMENT OF DEFICIENCY	CAUSES OF DEFICIENCY	DIETARY SOURCES	DIETARY REFERENCE INTAKES BY AGE	
						RDA*	EAR**
Biotin (vitamin B7)	Cofactor for carboxylases, important in gluconeogenesis, fatty acid and amino acid metabolism	Scaly periorificial dermatitis, conjunctivitis, alopecia, lethargy, hypotonia, and withdrawn behavior	1-10 mg/day PO biotin	Consumption of raw eggs for prolonged periods Parenteral nutrition with infusates lacking biotin Valproate therapy	Liver, organ meats, fruits	0-6 mo: 5 µg/day 7-12 mo: 6 µg/day 1-3 yr: 8 µg/day 4-8 yr: 12 µg/day 9-13 yr: 20 µg/day 14-18 yr: 25 µg/day	Not established
Pantothenic acid (vitamin B5)	Component of coenzyme A and acyl carrier protein involved in fatty acid metabolism	Experimentally produced deficiency in humans: irritability, fatigue, numbness, paresthesias (burning feet syndrome), muscle cramps		Isolated deficiency extremely rare in humans	Beef, organ meats, poultry, seafood, egg yolk Yeast, soybeans, mushrooms	0-6 mo: 1.7 mg/day 7-12 mo: 1.8 mg/day 1-3 yr: 2 mg/day 4-8 yr: 3 mg/day 9-13 yr: 4 mg/day 14-18 yr: 5 mg/day	Not established
Folic acid (vitamin B9)	Coenzymes in amino acid and nucleotide metabolism as an acceptor and donor of 1-carbon units	Megaloblastic anemia Growth stunting, glossitis Neural tube defects in progeny	0.5-1 mg/day PO folic acid	Malnutrition Malabsorptive states Malignancies Hemolytic anemias Anticonvulsant therapy	Enriched cereals, beans, leafy vegetables, citrus fruits, papaya	0-6 mo: 65 µg/day 7-12 mo: 80 µg/day 1-3 yr: 150 µg/day 4-8 yr: 200 µg/day 9-13 yr: 300 µg/day 14-18 yr: 400 µg/day	1-3 yr: 120 µg/day 4-8 yr: 160 µg/day 9-13 yr: 250 µg/day 14-18 yr: 330 µg/day
Cobalamin (vitamin B12)	As deoxyadenosylcobalamin, acts as cofactor for lipid and carbohydrate metabolism As methylcobalamin, important for conversion of homocysteine to methionine and folic acid metabolism	Megaloblastic anemia, irritability, developmental delay, developmental regression, involuntary movements, hyperpigmentation	500-1,000 µg IM or oral vitamin B12	Vegan diets Malabsorptive states Crohn disease Intrinsic factor deficiency (pernicious anemia)	Organ meats, seafood, poultry, egg yolk, milk, fortified ready-to-eat cereals	0-6 mo: 0.4 µg/day 7-12 mo: 0.5 µg/day 1-3 yr: 0.9 µg/day 4-8 yr: 1.2 µg/day 9-13 yr: 1.8 µg/day 14-18 yr: 2.4 µg/day	1-3 yr: 0.7 µg/day 4-8 yr: 1.0 µg/day 9-13 yr: 1.5 µg/day 14-18 yr: 2.0 µg/day
Ascorbic acid (vitamin C)	Important for collagen synthesis, metabolism of cholesterol and neurotransmitters Antioxidant functions and nonheme iron absorption	Scurvy manifesting as irritability, tenderness and swelling of legs, bleeding gums, petechiae, ecchymoses, follicular hyperkeratosis, and poor wound healing	100-200 mg/day PO ascorbic acid for up to 3 mo	Predominantly milk-based (non-human milk) diets Severe malnutrition	Citrus fruits and fruit juices, peppers, berries, melons, tomatoes, cauliflower, leafy green vegetables	0-6 mo: 40 mg/day 7-12 mo: 50 mg/day 1-3 yr: 15 mg/day 4-8 yr: 25 mg/day 9-13 yr: 45 mg/day 14-18 yr: Females: 65 mg/day Males: 75 mg/day	1-3 yr: 13 mg/day 4-8 yr: 22 mg/day 9-13 yr: 39 mg/day 14-18 yr: Females: 56 mg/day Males: 63 mg/day

\*For healthy breastfed infants, the values represent adequate intakes (AI), that is, the mean intake of apparently "normal" infants. For biotin and pantothenic acid also, the values represent AI, as the RDA has not been established.

\*\*Values have not been established for infants (0-12 mo).

PO, Orally; IM, intramuscularly; IV, intravenously; INH, isoniazid; NAD, nicotinamide adenine dinucleotide; NADP, nicotinamide adenine dinucleotide phosphate; OCP, oral contraceptive pill; RDA, recommended dietary allowance (average daily nutrient intake level estimated to meet the requirements of nearly all the healthy individuals); EAR, estimated average requirement (average daily nutrient intake level estimated to meet the requirements of 50% of the healthy individuals).

From The National Academies Press. Dietary Reference Intakes for Thiamin, Riboflavin, Niacin, Vitamin B6, Folate, Vitamin B12, Pantothenic Acid, Biotin, and Choline (<https://www.nap.edu/catalog/6015/dietary-reference-intakes-for-thiamin-riboflavin-niacin-vitamin-b6-folate-vitamin-b12-pantothenic-acid-biotin-and-choline>) and Dietary Reference Intakes for Vitamin C, Vitamin E, Selenium, and Carotenoids (<https://www.nap.edu/catalog/9810/dietary-reference-intakes-for-vitamin-c-vitamin-e-selenium-and-carotenoids>)

## 67.1 Thiamine (Vitamin B1)

H.P.S. Sachdev and Dheeraj Shah

Thiamine diphosphate, the active form of thiamine, serves as a cofactor for several enzymes involved in carbohydrate catabolism such as pyruvate dehydrogenase, transketolase, and  $\alpha$ -ketoglutarate. These

enzymes also play a role in the hexose monophosphate shunt that generates nicotinamide adenine dinucleotide phosphate (NADP) and pentose for nucleic acid synthesis. Thiamine is also required for the synthesis of acetylcholine (ACh) and  $\gamma$ -aminobutyric acid (GABA), which have important roles in nerve conduction. Thiamine is absorbed efficiently in the gastrointestinal (GI) tract and

**Table 67.2** Genetic Pathogenic Variants Affecting Thiamine Metabolism

DISEASE	VARIANT	PROTEIN	AGE AT ONSET	CLINICAL SYMPTOMS	MANAGEMENT (DOSE)
TRMA/Rogers syndrome	<i>SLC19A2</i>	THTR1	Birth to adolescence	Megaloblastic anemia, diabetes mellitus, sensorineural deafness, optic atrophy, congenital heart defects, short stature	Thiamine (50-200 mg/day)
Biotin–thiamine-responsive basal ganglia disease	<i>SLC19A3</i>	THTR2	Birth to adolescence	Episodic encephalopathy associated with febrile illness, seizures, external ophthalmoplegia, dysphagia, gait ataxia, bilateral lesions of the basal ganglia	Biotin (5-10 mg/kg/day), thiamine (up to 40 mg/kg/day)
Amish lethal microcephaly/THMD3	<i>SLC25A19</i>	Mitochondrial TPP carrier	Birth	Episodic encephalopathy associated with lactic acidosis and alpha-ketoglutaric aciduria, microcephaly, delayed psychomotor development, seizures, increased urinary lactate	Phenobarbital (for seizures) and physical therapy High-fat diet
Thiamine metabolism dysfunction syndrome 4/THMD4 (progressive polyneuropathy type)	<i>SLC25A19</i>	MTPC	Adolescence	Episodic encephalopathy associated with febrile illness, transient neurologic dysfunction, residual weakness, progressive axonal polyneuropathy, bilateral striatal degeneration	High-dose (600 mg/day) thiamine may prevent acute episodes
Thiamine metabolism dysfunction syndrome 5 (episodic encephalopathy type) THMD5	<i>TPK1</i>	Thiamine phosphokinase 1	Early childhood	Episodic encephalopathy (Leigh-like) associated with high serum and CSF lactate with progressive neurologic and motor dysfunctions (gait disturbances, ataxia, dystonia, and spasticity, which, in some cases, may result in loss of ability to walk) triggered by infections Cognitive function usually preserved; some developmental delay; some patients may recover from some neurologic deficits; in others, the outcome is fatal.	Oral thiamine (100-200 mg/day)

Modified from Dhir S, Tarasenko M, Napoli E, Giulivi C. Neurological, psychiatric, and biochemical aspects of thiamine deficiency in children and adults. *Front Psychiatry*. 2019;10:207, Table 1.

may be deficient in persons with GI or liver disease. The requirement of thiamine is increased when carbohydrates are taken in large amounts and during periods of increased metabolism, such as fever, muscular activity, hyperthyroidism, pregnancy, and lactation. Alcohol affects various aspects of thiamine transport and uptake, contributing to the deficiency in alcoholics.

Pork (especially lean), fish, and poultry are good **dietary sources** of thiamine. Main sources of thiamine for vegetarians are rice, oat, wheat, and legumes. Most ready-to-eat breakfast cereals are enriched with thiamine. Thiamine is water soluble and heat labile; most of the vitamin is lost when the rice is repeatedly washed and the cooking water is discarded. The breast milk of a well-nourished mother provides adequate thiamine; breastfed infants of thiamine-deficient mothers are at risk for deficiency. Thiamine antagonists (coffee, tea, carbonated caffeinated beverages) and thiaminases (fermented fish) may contribute to thiamine deficiency. Most infants and older children consuming a balanced diet obtain an adequate intake of thiamine from food and do not require supplements.

### THIAMINE DEFICIENCY

Deficiency of thiamine is associated with severely malnourished states, including malignancy and after surgery. The disorder (or spectrum of disorders) is classically associated with a diet consisting largely of polished rice (**oriental beriberi**); it can also arise if highly

refined wheat flour forms a major part of the diet, in persons with alcoholic use disorder, and in food faddists (occidental beriberi). Thiamine deficiency has often been reported from inhabitants of refugee camps consuming the polished rice-based monotonous diets and in breastfed infants of mothers on a predominantly polished rice-based diet. Low thiamine concentrations are also noted during critical illnesses.

**Thiamine-responsive megaloblastic anemia (TRMA) syndrome** is a rare autosomal recessive disorder characterized by megaloblastic anemia, diabetes mellitus, and sensorineural hearing loss, responding in varying degrees to thiamine treatment. The syndrome occurs because of pathologic variants of the *SLC19A2* gene, encoding a thiamine transporter protein, leading to abnormal thiamine transportation and cellular vitamin deficiency (Table 67.2). Another dependency state, **biotin-thiamine-responsive basal ganglia disease (BTBGD)**, results from pathologic variants of the *SLC19A3* gene (see Table 67.2). It classically presents in children with recurrent episodes of subacute encephalopathy manifesting as lethargy, dystonia, rigidity, dysphagia, and convulsions and responds to combined treatment with biotin (5-10 mg/kg/day) and thiamine (up to 40 mg/kg/day). An infantile form manifesting with acidosis, lethargy, poor feeding, and infantile spasms is also described. Other genetic disorders are noted in Table 67.2. Thiamine and related vitamins may improve the outcome in children with Leigh encephalomyelopathy.



### Clinical Manifestations

Thiamine deficiency can develop within 2-3 months of a deficient intake. Early symptoms of thiamine deficiency are nonspecific, such as fatigue, apathy, irritability, depression, drowsiness, poor mental concentration, anorexia, nausea, and abdominal discomfort. As the condition progresses, more specific manifestations of **beriberi** develop, such as peripheral neuritis (manifesting as tingling, burning, and paresthesias of the toes and feet), decreased deep tendon reflexes, loss of vibration sense, tenderness and cramping of the leg muscles, heart failure, and psychologic disturbances. Patients can have ptosis of the eyelids and atrophy of the optic nerve. Hoarseness or aphonia caused by paralysis of the laryngeal nerve is a characteristic sign. Muscle atrophy and tenderness of the nerve trunks are followed by ataxia, loss of coordination, and loss of deep sensation. Later signs include increased intracranial pressure, meningismus, and coma. The clinical picture of nutritional thiamine deficiency is usually divided into a dry (**neuritic**) type and a wet (**cardiac**) type. The disease is wet or dry depending on the amount of fluid that accumulates in the body because of cardiac and renal dysfunction, even though the exact cause for this edema is unknown. Many cases of thiamine deficiency show a mixture of both features and are more properly termed **thiamine deficiency with cardiopathy and peripheral neuropathy**. A fulminant form of beriberi (**Shoshin beriberi**) manifesting acutely with severe metabolic acidosis, hypotension, and cardiogenic shock has also been described.

The classic clinical triad of **Wernicke encephalopathy**—mental status changes, ocular signs, and ataxia—is rarely reported in infants and young children with severe deficiency secondary to malignancies or feeding of defective formula. An epidemic of life-threatening thiamine deficiency was seen in infants fed a defective soy-based formula that had undetectable thiamine levels. Manifestations included emesis, lethargy, restlessness, ophthalmoplegia, abdominal distention, developmental delay, failure to thrive (malnutrition), lactic acidosis, nystagmus, diarrhea, apnea, seizures, and auditory neuropathy. An acute presentation with tachycardia, aphonia/hoarse cry, pulmonary hypertension, and severe metabolic acidosis responding to parenteral thiamine has been reported in infants of mothers consuming polished and frequently washed rice.

Death from nutritional thiamine deficiency usually is secondary to cardiac involvement. The initial signs are cyanosis and dyspnea, but tachycardia, enlargement of the liver, loss of consciousness, and convulsions can develop rapidly. The heart, especially the right side, is enlarged. The electrocardiogram (ECG) shows an increased QT interval, inverted T waves, and low voltage. These changes, as well as the cardiomegaly, rapidly revert to normal with treatment, but without prompt treatment, cardiac failure can develop rapidly and result in death. In fatal cases of beriberi, lesions are principally located in the heart, peripheral nerves, subcutaneous tissue, and serous cavities. The heart is dilated, and fatty degeneration of the myocardium is common. Generalized edema or edema of the legs, serous effusions, and venous engorgement are often present. Degeneration of myelin and axon cylinders of the peripheral nerves, with Wallerian degeneration beginning in the distal locations, is also common, particularly in the lower extremities. Lesions in the brain include vascular dilation and hemorrhage.

### Diagnosis

The diagnosis is often suspected based on clinical setting and compatible symptoms. A high index of suspicion in children presenting with unexplained cardiac failure may sometimes be lifesaving. Objective biochemical tests of thiamine status include measurement of erythrocyte transketolase activity and the thiamine pyrophosphate effect. The biochemical diagnostic criteria of thiamine deficiency consist of low erythrocyte transketolase activity and high thiamine pyrophosphate effect (normal range: 0–14%). Urinary excretion of thiamine or its metabolites (thiazole or pyrimidine)

**Table 67.3** Suggested Criteria for the Diagnosis of Inherited Thiamine Defects with Prominent Neurologic Involvement

#### REQUIRED

- Clinical criteria
  - SLC19A3*: Acute or recurrent episodes of encephalopathy (decreased consciousness, irritability) with two or more of the following: (a) dystonia, (b) hypotonia, (c) bulbar dysfunction, (d) ataxia, and (e) seizures. Of note, 16% of patients may have an insidious onset of symptoms (psychomotor regression, clumsy or abnormal gait, and stiff limbs).
  - SLC25A19*: Acute or recurrent episodes of encephalopathy with (a) progressive peripheral neuropathy or (b) severe congenital microcephaly with brain malformations.
  - TPK1*: Acute or recurrent episodes of encephalopathy, with two or more of the following: (a) dystonia, (b) hypotonia, (c) ataxia, (d) seizures, and (e) developmental delay. Of note, some patients may have a nonepisodic early-onset global developmental delay.
- Biochemical criteria
  - Normal total thiamine blood levels
  - Low free-thiamine in CSF and/or fibroblasts (*SLC19A3*)
  - Low TPP in blood, muscle, and/or fibroblasts (*TPK1*)
  - High excretion of alpha-ketoglutaric acid in urine (common in *TPK1* and *SLC25A19*, rare in *SLC19A3*)
- Radiologic criteria
  - MRI pattern compatible with Leigh syndrome (*SLC19A3*, *SLC25A19*, *TPK1*) or Wernicke encephalopathy (*SLC19A3*)
    - SLC19A3*: Symmetric T2W hyperintensity of caudate, putamen, cortico/subcortical areas, and/or ventromedial thalamus. No involvement of mammillary bodies. Diffuse T2W hyperintensity of brain white matter (single adult patient reported).
    - SLC25A19*: Symmetric T2W hyperintensity in the caudate and putamen.
    - TPK1*: Symmetric T2W hyperintensity in basal ganglia and cerebellum (dentate nuclei).
- Therapeutic criteria
  - Clinical improvement after thiamine supplementation

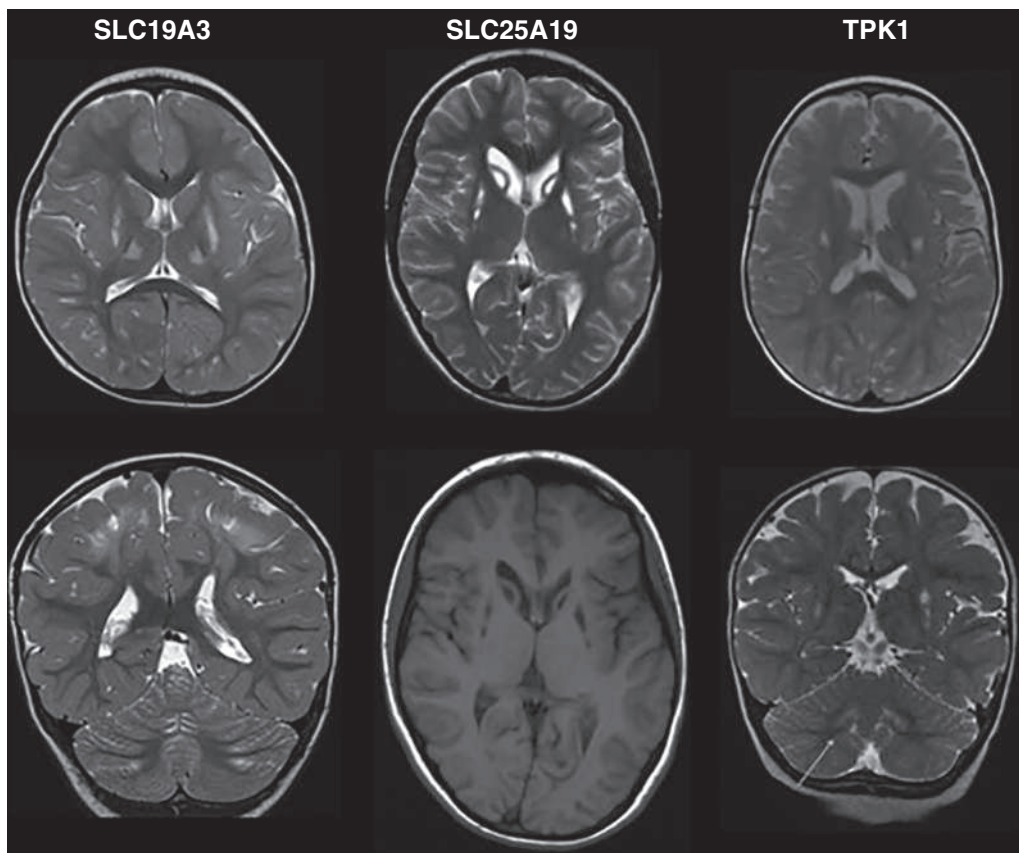
#### SUPPORTIVE

- Consanguinity
- Trigger event (e.g., infection, vaccination, trauma, intense physical activity)
- Absence of predisposing factors of beriberi or Wernicke encephalopathy
- Absence of systemic features of mitochondrial disease (cardiomyopathy, arrhythmia/conduction defects, renal tubulopathy, or dysmorphic features)
- Increased lactate in blood and/or CSF or presence of a lactate peak on MRS
- Normal OXPHOS and PDHc activity in muscle and fibroblast

CSF, Cerebrospinal fluid; MRI, magnetic resonance imaging; OXPHOS, oxidative phosphorylation; PDHc, pyruvate dehydrogenase complex; MRS, magnetic resonance spectroscopy; TPP, thiamine pyrophosphate; T2W, T2-weighted.

From Marcé-Grau A, Martí-Sánchez L, Baide-Mairena H, Ortigoza-Escobar JD, Pérez-Dueñas B. Genetic defects of thiamine transport and metabolism: A review of clinical phenotypes, genetics, and functional studies. *J Inherit Metab Dis*. 2019;42(4):581–597, Table 3, p. 586.

after an oral loading dose of thiamine may also be measured to help identify the deficiency state. A diagnostic approach to genetic thiamine deficiencies is noted in [Table 67.3](#). MRI changes of nutritional and genetic thiamine deficiency in infants are characterized by bilateral symmetric hyperintensities of the basal ganglia and frontal lobe, in addition to the lesions in the mammillary bodies, periaqueductal region, and thalami described in adults ([Fig. 67.1](#)).



**Fig. 67.1** MRI patterns in patients with inherited thiamine defects. *SLC19A3*, Axial and coronal T2-weighted images show bilateral symmetric involvement of the putamen and thalamus along with patchy cortical and subcortical hyperintensities. *SLC25A19*, Axial T2-weighted and T1-weighted images show cystic necrosis of the caudate and putamen. *TPK1*, Axial and coronal T2-weighted spin-echo images show involvement of the posterior putamen and dentate nuclei (gray arrow). (Modified from Ortigoza-Escobar JD, Alfadhel M, Molero-Luis M, et al. Thiamine deficiency in childhood with attention to genetic causes: Survival and outcome predictors. *Ann Neurol.* 2017;82[3]:317-330, Fig. 3, p. 322.)

### Prevention

A maternal diet containing sufficient amounts of thiamine prevents thiamine deficiency in breastfed infants, and infant formulas marketed in all developed countries provide recommended levels of intake. During complementary feeding, adequate thiamine intake can be achieved with a varied diet that includes meat and enriched or whole-grain cereals. When the staple cereal is polished rice, special efforts need to be made to include legumes and/or nuts in the ration. Thiamine and other vitamins can be retained in rice by **parboiling**, a process of steaming the rice in the husk before milling. Improvement in cooking techniques, such as not discarding the water used for cooking, minimal washing of grains, and reduction of cooking time, helps to minimize the thiamine losses during the preparation of food. Thiamine supplementation should be ensured during total parenteral nutrition (TPN).

### Treatment

In the absence of GI disturbances, oral administration of thiamine is effective. Children with cardiac failure, convulsions, or coma should be given 10-50 mg of thiamine intramuscularly (IM) or intravenously (IV) daily for the first week. This treatment should then be followed by 3-5 mg/day of thiamine orally (PO) for at least 6 weeks. The response is dramatic in infants and in those having predominantly cardiovascular manifestations, whereas the neurologic response is slow and often incomplete. Epilepsy, mental disability, and language and auditory problems of varying degrees have been reported in survivors of severe infantile thiamine deficiency.

Patients with beriberi often have other B-complex vitamin deficiencies; therefore all other B-complex vitamins should also be

administered. **Treatment of TRMA syndrome and other genetic pathogenic variants of thiamine metabolism require higher dosages (Table 67.2).** The anemia responds well to thiamine administration, and insulin for associated diabetes mellitus can also be discontinued in many patients with TRMA syndrome. Patients with BTBGD need lifelong supplementation.

### THIAMINE TOXICITY

There are no reports of adverse effects from consumption of excess thiamine by ingestion of food or supplements. A few isolated cases of pruritus and anaphylaxis have been reported in patients after parenteral administration of vitamin B1.

Visit Elsevier eBooks+ at [eBooks.Health.Elsevier.com](http://eBooks.Health.Elsevier.com) for Bibliography.

## 67.2 Riboflavin (Vitamin B2)

H.P.S. Sachdev and Dheeraj Shah

Riboflavin is part of the structure of the coenzymes flavin adenine dinucleotide (FAD) and flavin mononucleotide, which participate in oxidation-reduction (redox) reactions in numerous metabolic pathways and in energy production via the mitochondrial respiratory chain. Specific transporter proteins direct riboflavin intracellularly for these functions. Riboflavin is stable to heat but is destroyed by light. Milk and dairy products, eggs, organ meats, legumes, and mushrooms are rich dietary sources of riboflavin. Most commercial cereals, flours, and breads are enriched with riboflavin.

## RIBOFLAVIN DEFICIENCY

The causes of riboflavin deficiency (**aribo flavinosis**) are mainly related to malnourished and malabsorptive states, including GI infections. Treatment with some drugs, such as probenecid, phenothiazine, doxorubicin, or oral contraceptives (OCs), can also cause the deficiency. Phototherapy for hyperbilirubinemia can contribute to deficiency as the side chain of the vitamin is photochemically destroyed because it is involved in the photosensitized oxidation of bilirubin to more polar excretable compounds.

Brown-Vialotto-Van Laere syndrome (BVVLS) and Fazio-Londe syndrome are clinically overlapping conditions related to **riboflavin transporter deficiency (RTD)**. Pathologic variants (autosomal recessive) of the *SLC52A1* (type 1), *SLC52A2* (type 2), and *SLC52A3* (type 3) genes, which encode intestinal human riboflavin transporter proteins, have been demonstrated in these disorders characterized by *progressive* neurologic deterioration, peripheral neuropathy, hypotonia, ataxia, sensorineural hearing loss (usually the first symptom), optic atrophy, pontobulbar palsy, and respiratory insufficiency. Age of onset is variable; the later the onset, the milder the symptoms. Treatment with high doses (10-80 mg/kg/day) of riboflavin lead to clinical improvement in the majority of cases, especially if treated early in the disease course. Prophylaxis with riboflavin has been demonstrated to be effective in the reduction of frequency of headache in adult migraine; the evidence is insufficient in children and adolescents.

### Clinical Manifestations

Clinical features of nutritional riboflavin deficiency include cheilosis, glossitis, keratitis, conjunctivitis, photophobia, lacrimation, corneal vascularization, and seborrheic dermatitis. Cheilosis begins with pallor at the angles of the mouth and progresses to thinning and maceration of the epithelium, leading to fissures extending radially into the skin (Fig. 67.2). In glossitis the tongue becomes smooth, with loss of papillary structure (Fig. 67.3). Normochromic, normocytic anemia may also be seen because of the impaired erythropoiesis. A low riboflavin content of the maternal diet has been linked to congenital heart defects, but the evidence is weak.

### Diagnosis

Most often, the diagnosis is based on the clinical features of angular cheilosis in a malnourished child, who responds promptly to riboflavin supplementation. A functional test of riboflavin status is done by measuring the activity of erythrocyte glutathione reductase (EGR), with and without the addition of FAD. An EGR activity coefficient (ratio of EGR activity with added FAD to EGR activity without FAD) of >1.4 is used as an indicator of deficiency. Urinary excretion of riboflavin <30 µg/24 hr also suggests low intake.

Riboflavin transporter deficiency may be detected by genetic testing.

### Prevention

Table 67.1 lists the recommended daily allowance of riboflavin for infants, children, and adolescents. Adequate consumption of milk, milk products, and eggs prevents riboflavin deficiency. Fortification of cereal products is helpful for those who follow vegan diets or who are consuming inadequate amounts of milk products for other reasons.

### Treatment

Treatment includes oral administration of 3-10 mg/day of riboflavin, often as an ingredient of a vitamin B-complex mix. The child should also be given a well-balanced diet, including milk and milk products.

## RIBOFLAVIN TOXICITY

No adverse effects associated with riboflavin intake from food or supplements have been reported, and the upper safe limit for consumption has not been established. Although the photosensitizing property of vitamin B2 suggests some potential risks, limited absorption in high-intake situations precludes such concerns.

Visit Elsevier eBooks+ at [eBooks.Health.Elsevier.com](http://eBooks.Health.Elsevier.com) for Bibliography.



Fig. 67.2 Clinical photograph of a child showing angular cheilosis with ulceration and crusting in riboflavin deficiency. (Courtesy National Institute of Nutrition, Indian Council of Medical Research, Hyderabad, India.)



Fig. 67.3 Papillary atrophy, inflammation, and ulceration of the tongue as seen in riboflavin deficiency. (From Zappe HA, Nuss S, Becker K, et al. Riboflavin deficiency in Baltistan. [http://www.rzuser.uni-heidelberg.de/%7Ecn6/baltista/ribofl\\_e.htm](http://www.rzuser.uni-heidelberg.de/%7Ecn6/baltista/ribofl_e.htm).)

## 67.3 Niacin (Vitamin B3)

H.P.S. Sachdev and Dheeraj Shah

Niacin (nicotinamide or nicotinic acid) forms part of two cofactors, nicotinamide adenine dinucleotide (NAD) and nicotinamide adenine dinucleotide phosphate (NADP), which are important in several biologic reactions, including the respiratory chain, fatty acid and steroid synthesis, cell differentiation, and DNA processing. Niacin is rapidly absorbed from the stomach and the intestines and can also be synthesized from tryptophan in the diet.

Major dietary sources of niacin are meat, fish, and poultry for nonvegetarians and cereals, legumes, and green leafy vegetables for vegetarians. Enriched and fortified cereal products and legumes also are major contributors to niacin intake. Milk and eggs contain little niacin but are good sources of tryptophan, which can be converted to NAD (60 mg tryptophan = 1 mg niacin).

### NIACIN DEFICIENCY

**Pellagra**, the classic niacin deficiency disease, occurs chiefly in populations where corn (maize), a poor source of tryptophan, is the major foodstuff. A severe dietary imbalance, such as in anorexia nervosa and in war or famine conditions, also can cause pellagra. Pellagra is rare outside the African subcontinent; however, consumption of a highly restrictive diet, such as in autism, has led to some resurgence in high-income countries. Pellagra can also develop in conditions associated with disturbed tryptophan metabolism, such as carcinoid syndrome and Hartnup disease.





**Fig. 67.4** A, Symmetric, well-demarcated, erythematous, eroded plaques with desquamation over hands and forearms. B, Brownish plaques with desquamation in the distribution of neck collar (Casal necklace) because of pellagra in a child with autism on highly restrictive diet. (From Zaenglein A, Martin A, Carlson L, Williams KE. Pellagra secondary to selective eating in a child with autism. *Pediatr Dermatol.* 2020;37:698–700.)

### Clinical Manifestations

The early symptoms of pellagra are vague: anorexia, lassitude, weakness, burning sensation, numbness, and dizziness. After a long period of deficiency, the classic triad of dermatitis, diarrhea, and dementia appears. **Dermatitis**, the most characteristic manifestation of pellagra, can develop suddenly or insidiously and may be initiated by irritants, including intense sunlight. The lesions first appear as symmetric areas of erythema on exposed surfaces, resembling sunburn, and might go unrecognized. The lesions are usually sharply demarcated from the surrounding healthy skin, and their distribution can change frequently. The lesions on the hands and feet often have the appearance of a glove or stocking (Fig. 67.4A). Similar demarcations can also occur around the neck (**Casal necklace**) (see Fig. 67.4B). In some cases, vesicles and bullae develop (wet type). In others there may be suppuration beneath the scaly, crusted epidermis; in still others the swelling can disappear after a short time, followed by desquamation (Fig. 67.5). The healed parts of the skin might remain pigmented. The cutaneous lesions may be preceded by or accompanied by stomatitis, glossitis, vomiting, and diarrhea. Swelling and redness of the tip of the tongue and its lateral margins is often followed by intense redness, even ulceration, of the entire tongue and the papillae. Central nervous system symptoms include depression, disorientation, insomnia, and delirium.

The classic symptoms of pellagra usually are not well developed in infants and young children, but anorexia, irritability, anxiety, and apathy are common. Young patients might also have sore tongues and lips and usually have dry scaly skin. Diarrhea and constipation can alternate, and anemia can occur. Children who have pellagra often have evidence of other nutritional deficiency diseases.

### Diagnosis

Because of lack of a good functional test to evaluate niacin status, the diagnosis of deficiency is usually made from the physical signs of glossitis, GI symptoms, and a symmetric dermatitis. Rapid clinical response to niacin is an important confirmatory test. A decrease in the concentration and/or a change in the proportion of the niacin metabolites N<sup>1</sup>-methyl-nicotinamide and 2-pyridone in the urine provide biochemical evidence of deficiency and can be seen before the appearance of overt signs of deficiency. Histopathologic changes from the affected skin include dilated blood vessels without significant inflammatory infiltrates, ballooning of the keratinocytes, hyperkeratosis, and epidermal necrosis.



**Fig. 67.5** Clinical manifestations of niacin deficiency before (A) and after (B) therapy. (From Weinsier RL, Morgan SL. *Fundamentals of Clinical Nutrition.* St Louis: Mosby; 1993:99.)

### Prevention

Adequate intake of niacin is easily met by consumption of a diet that consists of a variety of foods and includes meat, eggs, milk, and enriched or fortified cereal products. The dietary reference intake (DRI) is expressed in milligram niacin equivalents (NE) in which 1 mg NE = 1 mg niacin or 60 mg tryptophan. The DRI is summarized in Table 67.1.



**Treatment**

Children usually respond rapidly to treatment. A liberal and varied diet should be supplemented with 50-300 mg/day of niacin; in severe cases or in patients with poor intestinal absorption, 100 mg may be given IV. The diet should also be supplemented with other vitamins, especially other B-complex vitamins. Sun exposure should be avoided during the active phase of pellagra, and the skin lesions may be covered with soothing applications. Other coexisting nutrient deficiencies such as iron-deficiency anemia should be treated. Even after successful treatment, the diet should continue to be monitored to prevent recurrence.

**NIACIN TOXICITY**

No toxic effects are associated with the intake of naturally occurring niacin in foods. Shortly after the ingestion of large doses of nicotinic acid taken as a supplement or a pharmacologic agent, a person often experiences a burning, tingling, and itching sensation, as well as flushing on the face, arms, and chest. Large doses of niacin also can have nonspecific GI effects and can cause cholestatic jaundice or hepatotoxicity. Tolerable upper intake levels for children are 10 mg/day for 1-3 years, 15 mg/day for 4-8 years, 20 mg/day for 9-13 years, and 30 mg/day for 14-18 years.

Visit Elsevier eBooks+ at [eBooks.Health.Elsevier.com](http://eBooks.Health.Elsevier.com) for Bibliography.

**67.4 Vitamin B6 (Pyridoxine)**

H.P.S. Sachdev and Dheeraj Shah

Vitamin B6 includes a group of closely related compounds: pyridoxine, pyridoxal, pyridoxamine, and their phosphorylated derivatives. **Pyridoxal 5'-phosphate (PLP)** and, to a lesser extent, pyridoxamine phosphate function as coenzymes for many enzymes involved in amino acid metabolism, neurotransmitter synthesis, glycogen metabolism, and steroid action. If vitamin B6 is lacking, glycine metabolism can lead to oxaluria. The major excretory product in the urine is 4-pyridoxic acid.

The vitamin B6 content of human milk and infant formulas is adequate. Good food sources of the vitamin include fortified ready-to-eat cereals, meat, fish, poultry, liver, bananas, rice, and certain vegetables. Large losses of the vitamin can occur during high-temperature processing of foods or milling of cereals, whereas parboiling of rice prevents its loss.

**VITAMIN B6 DEFICIENCY**

Because of the importance of vitamin B6 in amino acid metabolism, high protein intake can increase the requirement for the vitamin; the recommended daily allowances are sufficient to cover the expected range of protein intake in the population. The risk of deficiency is increased in persons taking medications that inhibit the activity of vitamin B6 (e.g., isoniazid, penicillamine, corticosteroids, phenytoin, carbamazepine), in young women taking oral progesterone-estrogen contraceptives, and in patients receiving maintenance dialysis.

**Clinical Manifestations**

The vitamin B6 deficiency symptoms seen in infants are listlessness, irritability, seizures, vomiting, and failure to thrive. Peripheral neuritis is a feature of deficiency in adults but is not usually seen in children. EEG abnormalities have been reported in infants and in young adults in controlled depletion studies. Skin lesions include cheilosis, glossitis, and seborrheic dermatitis around the eyes, nose, and mouth. Microcytic anemia can occur in infants but is not common. Oxaluria, oxalic acid bladder stones, hyperglycinemia, lymphopenia, decreased antibody formation, and infections also are associated with vitamin B6 deficiency.

Several types of vitamin B6 **dependence syndromes**, presumably resulting from errors in metabolism or transport of PLP or

pyridoxine, respond to large doses of pyridoxine. These syndromes include pyridoxine-dependent epilepsy, a vitamin B6-responsive anemia, xanthurenic aciduria, cystathioninuria, and homocystinuria. Pyridoxine-dependent epilepsy involves pathologic variants in the *ALDH7A1* gene causing deficiency of antiquitin, an enzyme involved in dehydrogenation of  $\alpha$ -amino adipic semialdehyde. Pathologic variants of the genes *PROSC*, which encodes a PLP binding protein, and *PNPO* encoding for the pyridoxamine 5-phosphate oxidase enzyme also cause epilepsy responsive to PLP or high doses of pyridoxine. Neonatal epileptic encephalopathy and hypophosphatasia are associated with impaired import of PLP into the neuronal cells, and seizures occurring in these conditions also respond to pyridoxine therapy.

**Diagnosis**

The activity of aspartate (glutamic-oxaloacetic) transaminase (AST) and alanine (glutamic-pyruvic) transaminase (ALT) is low in vitamin B6 deficiency; tests measuring the activity of these enzymes before and after the addition of PLP may be useful as indicators of vitamin B6 status. Abnormally high xanthurenic acid excretion after tryptophan ingestion also provides evidence of deficiency. Plasma PLP assays are being used more often, but factors such as inflammation, renal function, and hypoalbuminemia can influence the results. Ratios between substrate-product pairs (e.g., PAr index, 3-hydroxykynurenine/xanthurenic acid ratio, oxoglutarate/glutamate ratio) may attenuate such influence. Quantification of a large number of metabolites, using mass spectrometry-based metabolomics, are being evaluated as functional biomarkers of pyridoxine status.

Vitamin B6 deficiency or dependence should be suspected in all infants with **seizures**. If more common causes of infantile seizures have been eliminated, 100 mg of pyridoxine can be injected, with EEG monitoring if possible. If the seizure stops, vitamin B6 deficiency should be suspected. In older children, 100 mg of pyridoxine may be injected IM while the EEG is being recorded; a favorable response of the EEG suggests pyridoxine deficiency.

**Prevention**

Deficiency is unlikely in children consuming diets that meet their energy needs and contain a variety of foods. Parboiling of rice prevents the loss of vitamin B6 from the grains. The dietary reference intake for vitamin B6 is shown in [Table 67.1](#). Infants whose mothers have received large doses of pyridoxine during pregnancy are at increased risk for seizures from pyridoxine dependence, and supplements during the first few weeks of life should be considered. Any child receiving a pyridoxine antagonist, such as isoniazid, should be carefully observed for neurologic manifestations; if these develop, vitamin B6 should be administered or the dose of the antagonist should be decreased.

**Treatment**

Intramuscular or intravenous administration of 100 mg of pyridoxine is used to treat convulsions caused by vitamin B6 deficiency. One dose should be sufficient if adequate dietary intake follows. For pyridoxine-dependent children, daily doses of 2-10 mg IM or 10-100 mg PO may be necessary.

**VITAMIN B6 TOXICITY**

Adverse effects have not been associated with high intakes of vitamin B6 from food sources. However, ataxia and sensory neuropathy have been reported with dosages above 200 mg/day in adults taking vitamin B6 supplements for several months. Tolerable upper intake levels for children are 30 mg/day for 1-3 years, 40 mg/day for 4-8 years, 60 mg/day for 9-13 years, and 80 mg/day for 14-18 years.

Visit Elsevier eBooks+ at [eBooks.Health.Elsevier.com](http://eBooks.Health.Elsevier.com) for Bibliography.

## 67.5 Biotin

H.P.S. Sachdev and Dheeraj Shah

Biotin (vitamin B7 or vitamin H) functions as a cofactor for enzymes involved in carboxylation reactions within and outside mitochondria. These biotin-dependent carboxylases catalyze key reactions in gluconeogenesis, fatty acid metabolism, and amino acid catabolism.

There is limited information on the biotin content of foods; biotin is believed to be widely distributed, making a deficiency unlikely. *Avidin* found in raw egg whites acts as a biotin antagonist. Signs of biotin deficiency have been demonstrated in persons who consume large amounts of raw egg whites over long periods. Deficiency also has been described in infants and children receiving enteral and parenteral nutrition formula that lacks biotin. Treatment with valproic acid may result in a low biotinidase activity and/or biotin deficiency.

The clinical findings of biotin deficiency include scaly periorificial dermatitis, conjunctivitis, thinning of hair, and alopecia (Fig. 67.6). Central nervous system (CNS) abnormalities seen with biotin deficiency are lethargy, hypotonia, seizures, ataxia, and withdrawn behavior. Biotin deficiency can be successfully treated using 1-10 mg of biotin orally daily. The dietary reference intake for biotin is shown in Table 67.1. No toxic effects have been reported with very high doses.

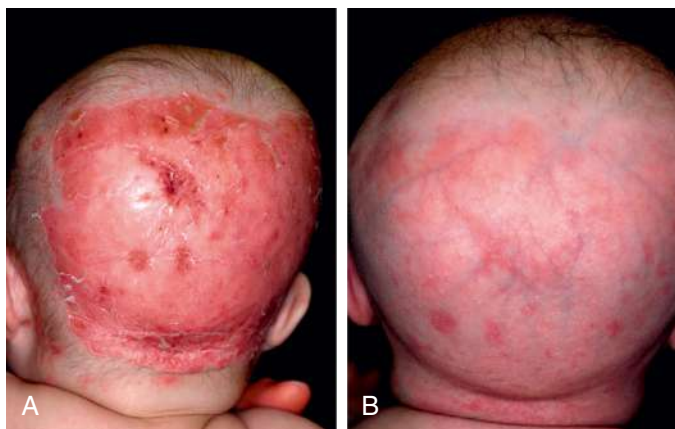
**Biotin-responsive basal ganglia disease or biotin and thiamine-responsive basal ganglia disease** is a rare childhood neurologic disorder characterized by encephalopathy, seizures, extrapyramidal manifestations, altered signals in basal ganglia (bilateral involvement of caudate nuclei and putamen with sparing of globus pallidus) on MRI, and homozygous pathologic variation in the *SLC19A3* gene (see Table 67.2). Chapter 105 describes conditions involving deficiencies in the enzymes holocarboxylase synthetase and biotinidase that respond to treatment with biotin.

Visit Elsevier eBooks+ at [eBooks.Health.Elsevier.com](http://eBooks.Health.Elsevier.com) for Bibliography.

## 67.6 Folate

H.P.S. Sachdev and Dheeraj Shah

Folate exists in different chemical forms (Fig. 67.7). **Folic acid** (pteroylglutamic acid) is the synthetic form used in fortified foods and supplements. Naturally occurring folates in foods retain the core chemical



**Fig. 67.6** A, Scalp rash in an infant with biotin deficiency before treatment with biotin. B, After 3 weeks of biotin treatment. (From Ito T, Nishie W, Fujita Y, et al. Infantile eczema caused by formula milk. *Lancet*. 2013;381:1958.)

structure of pteroylglutamic acid but vary in their state of reduction, the single-carbon moiety they bear, or the length of the glutamate chain. These polyglutamates are broken down and reduced in the small intestine to dihydrofolates and tetrahydrofolates, which are involved as coenzymes in amino acid and nucleotide metabolism as acceptors and donors of 1-carbon units. Folate is important for CNS development during embryogenesis.

Rice and cereals are rich dietary sources of folate, especially if enriched. Beans, leafy vegetables, and fruits such as oranges and papaya are good sources as well. The vitamin is readily absorbed from the small intestine and is broken down to monoglutamate derivatives by mucosal polyglutamate hydrolases. A high-affinity proton-coupled folate transporter (PCFT) seems to be essential for absorption of folate in the intestine and in various cell types at low pH. The vitamin is also synthesized by colonic bacteria, and its half-life is prolonged by enterohepatic recirculation.

### FOLATE DEFICIENCY

Because of folate's role in protein, DNA, and RNA synthesis, the risk of deficiency is increased during periods of rapid growth or increased cellular metabolism. Folate deficiency can result from poor nutrient content in the diet, inadequate absorption (celiac disease, inflammatory bowel disease), increased requirement (sickle cell anemia, psoriasis, malignancies, periods of rapid growth as in infancy and adolescence), or inadequate use (long-term treatment with high-dose nonsteroidal antiinflammatory drugs; anticonvulsants such as phenytoin and phenobarbital; methotrexate). Rare causes of deficiency are hereditary folate malabsorption, inborn errors of folate metabolism (methylene tetrahydrofolate reductase, methionine synthase reductase, and glutamate formiminotransferase deficiencies), and cerebral folate deficiency. A loss-of-function pathologic variant in the gene coding for PCFT is the molecular basis for hereditary folate malabsorption. A high-affinity blocking autoantibody against the membrane-bound folate receptor in the choroid plexus preventing its transport across the blood-brain barrier is the likely cause of **infantile cerebral folate deficiency**.

### Clinical Manifestations

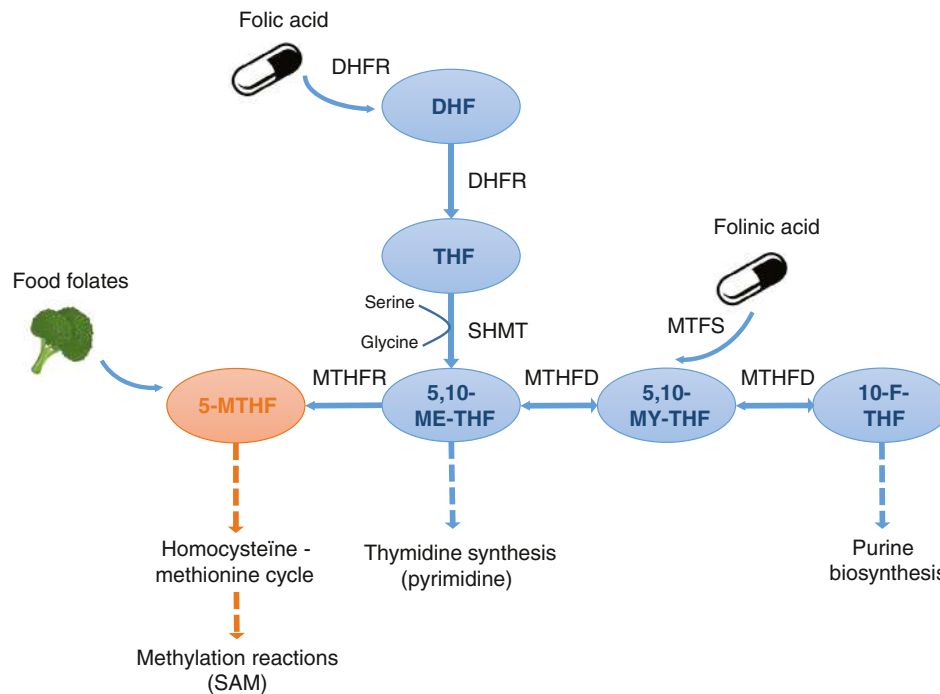
Folic acid deficiency results in megaloblastic anemia and hypersegmentation of neutrophils. Nonhematologic manifestations include glossitis, listlessness, and growth retardation not related to anemia. An association exists between low maternal folic acid status and neural tube defects, primarily spina bifida and anencephaly, and the role of periconceptual folic acid in their prevention is well established (see Chapter 503.1).

**Hereditary folate malabsorption** manifests at 1-3 months of age with recurrent or chronic diarrhea, failure to thrive (malnutrition), oral ulcerations, neurologic deterioration, megaloblastic anemia, and opportunistic infections. **Cerebral folate deficiency** manifests at 4-6 months of age with irritability, microcephaly, developmental delay, cerebellar ataxia, pyramidal tract signs, choreoathetosis, ballismus, seizures, and blindness as a result of optic atrophy. 5-Methyltetrahydrofolate levels are normal in serum and red blood cells (RBCs) but greatly depressed in the cerebrospinal fluid (CSF).

### Diagnosis

The diagnosis of folic acid deficiency anemia is made in the presence of macrocytosis along with low folate levels in serum or RBCs. Normal serum folic acid levels are 5-20 ng/mL; with deficiency, levels are <3 ng/mL. Levels of RBC folate are a better indicator of chronic deficiency. The normal RBC folate level is 150-600 ng/mL of packed cells. The bone marrow is hypercellular because of erythroid hyperplasia, and megaloblastic changes are prominent. Large, abnormal neutrophilic forms (giant metamyelocytes) with cytoplasmic vacuolation also are seen.

Cerebral folate deficiency is associated with low levels of 5-methyltetrahydrofolate in CSF and normal folate levels in the plasma



**Fig. 67.7** Simplified scheme of folate metabolism; 5-MTHF is the predominant form in which dietary folate enters the circulation. Synthetic folic acid first has to be metabolized in two steps to the biologically active form THF, whereas the biologically derived folinic acid is already reduced and easily converted to 5,10-methenyl-THF. Serine is an important one carbon donor and allows entry of THF into the active one-carbon pool of intermediates by way of 5,10-methylene-THF, which functions as a cofactor for the synthesis of thymidine. 5,10-Methylene-THF can be metabolized to 5-MTHF for the remethylation of homocysteine to methionine, or it can be converted to 10-formyl-THF for use in purine synthesis. 1 DHF, dihydrofolate; DHFR, dihydrofolate reductase; THF, tetrahydrofolate; 5-MTHF, 5-methyltetrahydrofolate; SAM, S-adenosylmethionine; 5,10-ME-THF, 5,10-methylene-THF; 5,10-MY-THF, 5,10-methenyl-THF; 10-F-THF, 10-formyl-THF; MTFS, 5,10-methenyltetrahydrofolate synthetase. (From Lubout CMA, Goorden SMI, van den Hurk K, et al. Successful treatment of hereditary folate malabsorption with intramuscular folinic acid. *Pediatr Neurol.* 2020;102:62-66, Fig. 2, p. 64.)

and RBCs. Pathologic variants of the *PCFT* gene are demonstrated in hereditary folate malabsorption.

### Prevention

Breastfed infants have better folate nutrition than nonbreastfed infants throughout infancy. Consumption of folate-rich foods and food fortification programs are important to ensure adequate intake in children and in women of childbearing age. The dietary reference intakes (DRIs) for folate are 65  $\mu\text{g}$  of dietary folate equivalents (DFE) for infants 0-6 months of age and 80  $\mu\text{g}$  of DFE for infants 6-12 months. (1 DFE = 1  $\mu\text{g}$  food folate = 0.6  $\mu\text{g}$  of folate from fortified food or as a supplement consumed with food = 0.5  $\mu\text{g}$  of a supplement taken on an empty stomach.) For the DRIs in older children, see [Table 67.1](#). All women desirous of becoming pregnant should consume 400-800  $\mu\text{g}$  folic acid daily; the dose is 4 mg/day in those having delivered a child with a neural tube defect. To be effective, supplementation should be started at least 1 month before conception and continued through the first 2-3 months of pregnancy. The benefit of periconceptional folate supplementation in prevention of congenital heart defects, orofacial clefts, childhood cancers, and autism spectrum disorders are unclear. Preconceptional folate supplementation continued throughout pregnancy may marginally reduce the risk of delivering a preterm or small-for-gestational-age infant. Providing iron and folic acid tablets for prevention of anemia in children and pregnant women is a routine strategy in at-risk populations. Mandatory fortification of cereal flours with folic acid

coupled with health education programs has been associated with a substantial reduction in incidence of neural tube defects in many countries.

### Treatment

When the diagnosis of folate deficiency is established, folic acid may be administered orally or parenterally at 0.5-1.0 mg/day. Folic acid therapy should be continued for 3-4 weeks or until a definite hematologic response has occurred. Maintenance therapy with 0.2 mg/day of folate is adequate. Prolonged treatment with oral or parenteral folinic acid is required in cerebral folate deficiency, and the response may be incomplete. High-dose intravenous folinic acid may help in refractory cases. Treatment of hereditary folate malabsorption may be possible with intramuscular folinic acid; some patients may respond to high-dose oral folinic acid therapy.

### FOLATE TOXICITY

No adverse effects have been associated with consumption of the amounts of folate normally found in fortified foods. Tolerable upper intake levels for children are 300  $\mu\text{g}/\text{day}$  for 1-3 years, 400  $\mu\text{g}/\text{day}$  for 4-8 years, 600  $\mu\text{g}/\text{day}$  for 9-13 years, and 800  $\mu\text{g}/\text{day}$  for 14-18 years. Excessive intake of folate supplements might obscure and potentially delay the diagnosis of vitamin B12 deficiency. Massive doses given by injection have the potential to cause neurotoxicity.

Visit Elsevier eBooks+ at [eBooks.Elsevier.com](https://www.elsevier.com/ebooksplus) for Bibliography.

## 67.7 Vitamin B12 (Cobalamin)

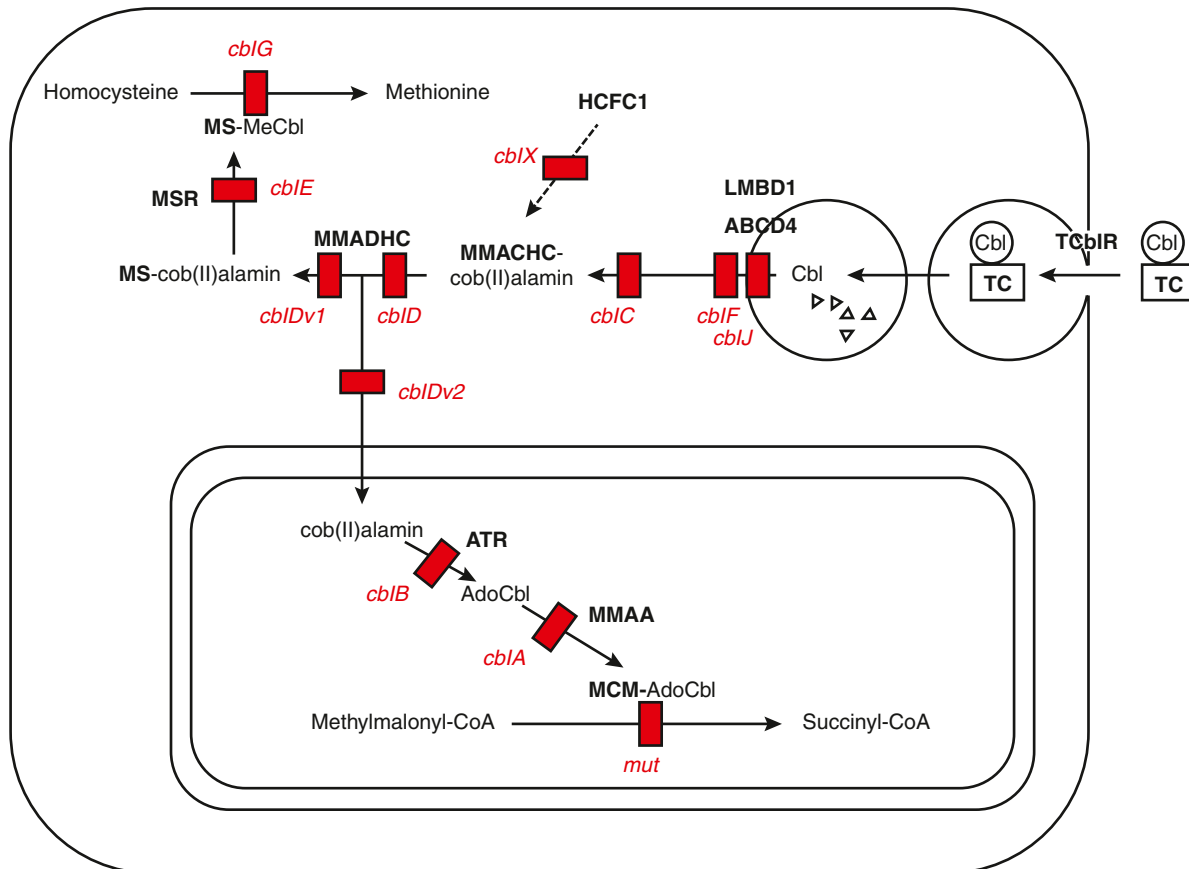
H.P.S. Sachdev and Dheeraj Shah

Vitamin B12, in the form of deoxyadenosylcobalamin, functions as a cofactor for isomerization of methylmalonyl-CoA to succinyl-CoA, an essential reaction in lipid and carbohydrate metabolism. Methylcobalamin is another circulating form of vitamin B12 and is essential for methyl group transfer during the conversion of homocysteine to methionine. This reaction also requires a folic acid cofactor and is important for protein and nucleic acid biosynthesis. Vitamin B12 is important for hematopoiesis, CNS myelination, and mental and psychomotor development (Fig. 67.8).

Dietary sources of vitamin B12 are almost exclusively from animal foods. Organ meats, muscle meats, seafood (mollusks, oysters, fish), poultry, and egg yolk are rich sources. Fortified ready-to-eat cereals and milk and their products are the important sources of the vitamin for vegetarians. Human milk is an adequate source for breastfeeding infants if the maternal serum B12 levels are adequate. Vitamin B12 is absorbed from ileum at alkaline pH after binding with intrinsic factor. Enterohepatic circulation, direct absorption, and synthesis by intestinal bacteria are additional mechanisms helping to maintain the vitamin B12 nutriture.

### VITAMIN B12 DEFICIENCY

Deficiency of vitamin B12 caused by inadequate dietary intake occurs primarily in persons consuming strict vegetarian or vegan diets. Prevalence of vitamin B12 deficiency is high in predominantly vegetarian or lactovegetarian populations. Breastfeeding infants of B12-deficient mothers are also at risk for significant deficiency. Malabsorption of B<sub>12</sub> occurs in celiac disease, ileal resections, Crohn disease, *Helicobacter pylori* infection, and autoimmune atrophic gastritis (pernicious anemia). Obesity, type 1 diabetes, and use of metformin and proton pump inhibitors histamine (H<sub>2</sub>) receptor antagonists and misuse of nitrous oxide—usually in the form of inhaling aerosol whipped cream (whippits)—may increase the risk of deficiency. **Hereditary intrinsic factor deficiency** and **Imlerslund-Gräsbeck disease** are inborn errors of metabolism leading to vitamin B12 malabsorption. Pathologic variants of the hereditary intrinsic factor gene cause hereditary intrinsic factor deficiency, whereas pathologic variation in any of the two subunits (cubilin and amnionless) of the intrinsic factor receptor cause Imlerslund-Gräsbeck disease. Maternal vitamin B12 deficiency may produce neonatal B12 deficiency, which may be detected by elevated levels of homocysteine and methylmalonic acid on the newborn screen.



**Fig. 67.8** Scheme of cobalamin (Cbl) metabolism. The sites affected by methylmalonyl-CoA mutase deficiency (*mut*) and inborn errors of cobalamin metabolism (*cbIA-cbIG*, *cbIJ*, and *cbIX*) are shown in red. The *cbIA* disorder is caused by defects in the MMAA protein; the *cbIB* disorder by defects in the cob(II)alamin adenosyltransferase (MMAB) protein; the *cbIC* disorder by defects in the MMACHC protein; the *cbID*, *cbID* variant 1 (*cbIDv1*), and *cbID* variant 2 (*cbIDv2*) disorders are caused by defects in the MMADHC protein; *cbIE* disorder is caused by defects in the methionine synthase reductase (MSR) protein; *cbIG* disorder by defects in the methionine synthase (MS) protein; *cbIJ* disorder by pathologic variants in the ABCD4 protein; *cbIX* disorder by pathologic variation in the HCFC1 protein, and the *mut* disorder by defects in methylmalonyl-CoA mutase (MCM). The protein affected in the *cbIF* disorder is unknown. MCM-AdoCbl, Holomethylmalonyl-CoA mutase (mutase with bound adenosylcobalamin); MS-cob(II)alamin, methionine synthase with bound cob(II)alamin; MS-MeCbl, holomethionine synthase (synthase with bound methylcobalamin); TC, transcobalamin. (From Orkin SH, Fisher DE, Ginsburg D, et al., eds. *Nathan and Oski's Hematology and Oncology of Infancy and Childhood*, 8th ed. Philadelphia: Elsevier; 2015:318.)





**Fig. 67.9** MRI of the cervical spine illustrating a long segment of T2 hyperintensity involving the dorsal column of virtually the entire cervical spinal cord consistent with a diagnosis of subacute combined degeneration from vitamin B12 deficiency. (From Stockton L, Simonsen C, Seago S. Nitrous oxide-induced vitamin B12 deficiency. *Proc [Bayl Univ Med Cent]*. 2017;30[2]:171–172.)

### Clinical Manifestations

The hematologic manifestations of vitamin B12 deficiency are similar to manifestations of folate deficiency and are discussed in Chapter 503.2. Irritability, hypotonia, developmental delay, developmental regression, and involuntary movements (predominantly coarse tremors) are the common neurologic symptoms in infants. Older children with vitamin B12 deficiency may show poor growth and poor school performance, whereas sensory deficits, paresthesias, peripheral neuritis, and psychosis are seen in adolescents and adults (Fig. 67.9). Hyperpigmentation of the knuckles, palms, and soles is another common observation with B12 deficiency in children and adolescents (Fig. 67.10).

### Diagnosis

See Chapter 503.2.

Vitamin B12 deficiency may be present with vitamin B12 levels in the normal or low normal range and without macrocytosis. Ancillary testing of methylmalonic acid and homocysteine levels may enhance the diagnosis.

### Treatment

The hematologic symptoms respond promptly to parenteral administration of 250–1,000 µg vitamin B12. Children with severe deficiency and those with neurologic symptoms need repeated doses, daily or on alternate days in the first week, followed by weekly for the first 1–2 months and then monthly. Children with only hematologic presentation recover fully within 2–3 months, whereas those with neurologic disease need at least 6 months of therapy. Children with a continuing malabsorptive state and those with inborn errors of vitamin B12 malabsorption need lifelong treatment. Daily treatment with high-dose (500–1,000 µg) oral vitamin B12 preparations has also been shown to be equally effective in correcting biochemical vitamin B12 deficiency in a few trials in children, but data are inadequate to support use of the oral route in children with neurologic manifestations and severe anemia. The sublingual route has recently been explored in infants and children and has been found to be effective in normalizing serum vitamin B12 levels.



**Fig. 67.10** Hyperpigmentation of (A) knuckles and (B) soles in an adolescent female with severe anemia and vitamin B12 deficiency.

### Prevention

Vitamin B12 dietary reference intakes (DRIs) are shown in Table 67.1. In pregnancy the DRI is 2.6 µg/day and in lactation 2.8 µg/day. Pregnant and breastfeeding women should ensure an adequate consumption of animal products to prevent cobalamin deficiency in infants. Strict vegetarians, especially vegans, should ensure regular consumption of vitamin B12. Food fortification with the vitamin helps to prevent deficiency in predominantly vegetarian populations. Though metabolic derangements suggestive of vitamin B12 deficiency are present in a high proportion of infants and children from low-income country settings, routine supplementation with vitamin B12 does not seem to significantly improve their growth, development, or hemoglobin status.

### Toxicity

Administration of therapeutic doses, both in oral and parenteral forms, is usually safe. Transient erythroderma and chromaturia have been reported with administration of adult-equivalent doses of intravenous hydroxycobalamin in a child. Acneiform eruptions, palpitations, headache, and insomnia have been occasionally reported in young adults receiving repeated high parenteral doses.

Visit Elsevier eBooks+ at [eBooks.Health.Elsevier.com](http://eBooks.Health.Elsevier.com) for Bibliography.

## Chapter 68

# Vitamin C (Ascorbic Acid) Deficiency and Excess

Dheeraj Shah and H.P.S. Sachdev

Vitamin C is important for synthesis of collagen at the level of hydroxylation of lysine and proline in precollagen. It is also involved in neurotransmitter metabolism (conversion of dopamine to norepinephrine and tryptophan to serotonin), cholesterol metabolism (conversion of cholesterol to steroid hormones and bile acids), and the biosynthesis of carnitine. Vitamin C functions to maintain the iron and copper atoms, cofactors of the metalloenzymes, in a reduced (active) state. Vitamin C is an important antioxidant (electron donor) in the aqueous milieu of the body. Vitamin C enhances nonheme iron absorption, the transfer of iron from transferrin to ferritin, and the formation of tetrahydrofolic acid and thus can affect the cellular and immunologic functions of the hematopoietic system. Though vitamin C has antiinflammatory and immunomodulating effects, there is no evidence of clinical benefit of vitamin C supplementation in pediatric critical illnesses and respiratory tract infections, including COVID-19.

## DIETARY NEEDS AND SOURCES OF VITAMIN C

Humans depend on dietary sources for vitamin C. An adequate intake is 40 mg for ages 0-6 months and 50 mg for 6-12 months. For older children, the recommended dietary allowance is 15 mg for ages 1-3 years, 25 mg for 4-8 years, 45 mg for 9-13 years, and 65-75 mg for 14-18 years. The recommended dietary allowances during pregnancy and lactation are 85 mg/day and 120 mg/day, respectively. The requirement for vitamin C is increased during infectious and diarrheal diseases. Children exposed to smoking or environmental tobacco smoke also require increased amounts of foods rich in vitamin C. The best food sources of vitamin C are citrus fruits and fruit juices, peppers, berries, melons, guava, kiwifruit, tomatoes, cauliflower, and green leafy vegetables. Vitamin C is easily destroyed by prolonged storage, overcooking, and processing of foods.

Absorption of vitamin C occurs in the upper small intestine by an active process or by simple diffusion when large amounts are ingested. Vitamin C is not stored in the body but is taken up by all tissues; the highest levels are found in the pituitary and adrenal glands. The brain ascorbate content in the fetus and neonate is markedly higher than the content in the adult brain, a finding probably related to its function in neurotransmitter synthesis.

When a mother's intake of vitamin C during pregnancy and lactation is adequate, the newborn will have adequate tissue levels of vitamin C related to active placental transfer, subsequently maintained by the vitamin C in breast milk or commercial infant formulas. Breast milk contains sufficient vitamin C to prevent deficiency throughout infancy. Infants consuming pasteurized or boiled animal milk are at significant risk of developing deficiency if the other sources of vitamin C are also lacking in the diet. Neonates whose feeding has been delayed because of a clinical condition can also have ascorbic acid deficiency. For patients receiving total parenteral nutrition (TPN), 80 mg/day is recommended for full-term infants and 25 mg/kg/day for preterm infants. Parents and children who choose a limited (selective) diet or those on fad diets are at risk for vitamin C deficiency.

## VITAMIN C DEFICIENCY

A deficiency of vitamin C results in the clinical presentation of **scurvy**. Children fed predominantly heat-treated (ultra-high-temperature or pasteurized) milk or unfortified formulas and not receiving fruits and fruit juices are at significant risk for symptomatic

disease. In the last decade, most cases of scurvy from North America and Europe have been reported in children with developmental and behavioral disorders, *especially autism spectrum disorders*, on highly restrictive diets. Such dietary patterns occur mainly due to severe self-imposed dietary restrictions due to child preference or parental belief in unsubstantiated claims of benefit of such restrictions in autism and other developmental disorders. In scurvy, there is defective formation of connective tissues and collagen in skin, cartilage, dentine, bone, and blood vessels, leading to their fragility. In the long bones, osteoid is not deposited by osteoblasts, the cortex is thin, and the trabeculae become brittle and fracture easily.

## Clinical Features

The early manifestations of vitamin C deficiency are irritability, loss of appetite, low-grade fever, musculoskeletal pain, and tenderness in the legs. These signs and symptoms are followed by leg swelling—most marked at the knees and the ankles—and **pseudoparalysis**. The infant might lie with the hips and knees semiflexed and the feet rotated outward. Subperiosteal hemorrhages in the lower-limb bones sometimes acutely increase the swelling and pain, and the condition might mimic acute osteomyelitis or arthritis. A “rosary” at the costochondral junctions and depression of the sternum are other typical features (Fig. 68.1). The angulation of scorbutic beads is usually sharper than that of a rachitic rosary. Gum changes are seen in older children after teeth have erupted, manifested as bluish purple, spongy swellings of the mucous membrane, especially over the upper incisors (Fig. 68.2). **Anemia**, a common finding in infants and young children with scurvy, is related to impaired iron absorption and coexistent hematopoietic nutrient deficiencies, including iron, vitamin B<sub>12</sub>, and folate. Hemorrhagic manifestations of scurvy include petechiae, purpura, and ecchymoses at pressure points; epistaxis; gum bleeding; and the characteristic perifollicular hemorrhages (Fig. 68.3). Other manifestations are poor wound and fracture healing, hyperkeratosis of hair follicles, arthralgia, and muscle weakness.

## Laboratory Findings and Diagnosis

The diagnosis of vitamin C deficiency is usually based on the characteristic clinical picture, the radiographic appearance of the long bones, and a history of poor vitamin C intake. A high index of suspicion is required in children on restrictive diets, particularly those with autism and other developmental disorders, and they should be evaluated for scurvy whenever they present with difficulty in walking or bone pains. The typical radiographic changes occur at the distal ends of the long bones and are particularly common at the knees. The shafts of the long bones have a ground-glass appearance because of trabecular atrophy. The cortex is thin and dense, giving the appearance of *pencil outlining* of the diaphysis and epiphysis. The *white line of Fränkel*, an irregular but thickened white line at the metaphysis, represents the zone of well-calcified cartilage. The epiphyseal centers of ossification also have a ground-glass appearance and are surrounded by a sclerotic ring (Fig. 68.4). The more specific but late radiologic feature of scurvy is a zone of rarefaction under the white line at the metaphysis. This zone of rarefaction (*Trümmerfeld zone*), a linear break in the bone that is proximal and parallel to the white line, represents an area of debris of broken-down bone trabeculae and connective tissue. A *Pelkan spur* is a lateral prolongation of the white line and may be present at the cortical ends. Epiphyseal separation can occur along the line of destruction, with either linear displacement or compression of the epiphysis against the shaft (Fig. 68.5). Subperiosteal hemorrhages are not visible using plain radiographs during the active phase of scurvy. However, during healing, the elevated periosteum becomes calcified and radiopaque (see Fig. 68.5), sometimes giving a dumb-bell or club shape to the affected bone. MRI can demonstrate both acute and healing subperiosteal hematomas along with periostitis, metaphyseal changes (Fig. 68.4), and heterogeneous bone marrow signal intensity, even in the absence of changes in plain radiographs. Gelatinous transformation of bone marrow on aspiration has been reported in children with suspected malignancy.





**Fig. 68.1** Sharp angulation of beading at costochondral junction (scurvitic rosary) in scurvy. (Courtesy Dr. J.D. MacLean, McGill Centre for Tropical Diseases, Montreal.)



**Fig. 68.2** Clinical photograph showing inflamed marginal gingiva in scurvy. (From Agarwal A, Shaharyar A, Kumar A, Bhat MS, Mishra M. Scurvy in pediatric age group: a disease often forgotten? *J Clin Orthop Trauma*. 2015;6:101–107, Fig. 1, p. 103.)

Biochemical tests are not very useful in the diagnosis of scurvy, because they do not reflect the tissue status. A plasma ascorbate concentration of  $<0.2$  mg/dL usually is considered deficient. Leukocyte concentration of vitamin C is a better indicator of body stores, but this measurement is technically more difficult to perform. Leukocyte concentrations of  $\leq 10$   $\mu\text{g}/10^8$  white blood cells are considered deficient and indicate latent scurvy, even in the absence of clinical signs of deficiency. Saturation of the tissues with vitamin C can be estimated from the urinary excretion of the vitamin after a test dose of ascorbic acid. In healthy children, 80% of the test dose appears in the urine within 3–5 hours after parenteral administration. Generalized nonspecific aminoaciduria is common in scurvy, whereas plasma amino acid levels remain normal.

### Differential Diagnosis

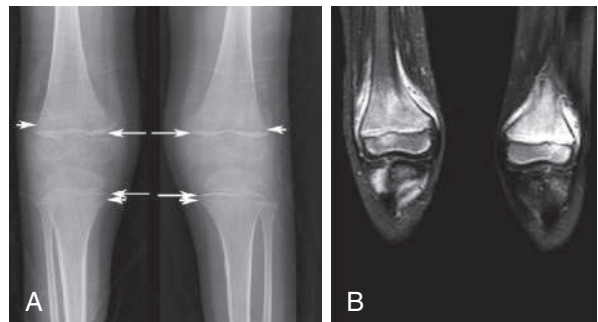
Scurvy is often misdiagnosed as infectious or juvenile idiopathic arthritis, osteomyelitis, nonaccidental trauma (child abuse), malignancy, or acrodynia. The early irritability and bone pain are sometimes attributed to nonspecific pains or other nutritional deficiencies. Copper deficiency results in a radiographic picture similar to that of scurvy. Henoch-Schönlein purpura, (IgA vasculitis) thrombocytopenic purpura, or leukemia is sometimes suspected in children presenting with hemorrhagic manifestations.

### Treatment

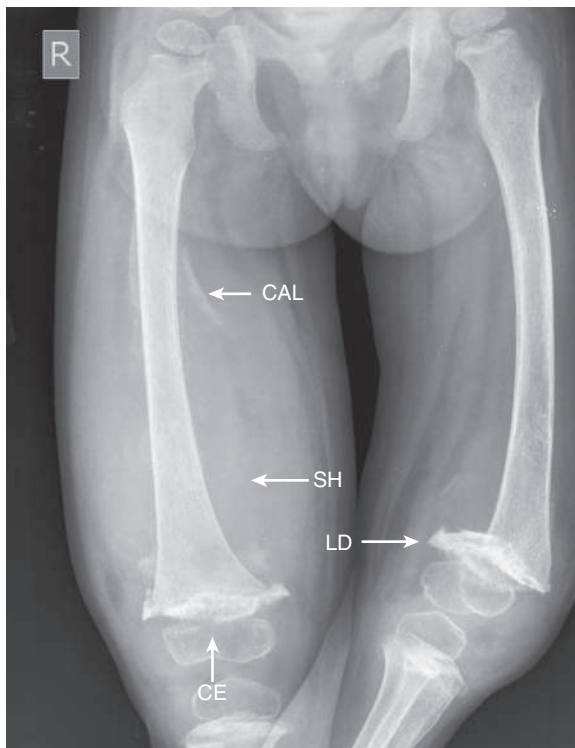
Vitamin C supplements of 100–200 mg/day orally or parenterally ensure rapid and complete cure. The clinical improvement is seen within 1 week in most cases, but the treatment should be continued for up to 3 months for complete recovery.



**Fig. 68.3** Scurvy. A, Perifollicular hemorrhages. B, Corkscrew hairs with perifollicular hyperkeratotic papules. (Modified from Lipner S. A classic case of scurvy. *Lancet*. 2018;392[10145]:431.)



**Fig. 68.4** A, Radiograph of the knee in scurvy demonstrates a radiodense band at the chondroosseous junction (Fränkel line; long arrows) and a translucent band in the metaphysis (Trümmerfeld zone; short arrows) of the distal femora and the proximal tibiae. B, Magnetic resonance imaging (coronal fat saturation T2-weighted imaging) of the knee demonstrates ill-defined T2 hyperintensities in the metaphyses and juxtaosseous soft tissue. The diaphysis was spared. (From Seya M, Handa A, Hasegawa D, et al. Scurvy: from a selective diet in children with developmental delay. *J Pediatr*. 2016;177:331, Fig. A and B, p. 331.)



**Fig. 68.5** Large subperiosteal hematoma (SH) with areas of calcification (CAL) is seen along the shaft of the right femur of a child with advanced scurvy. Epiphyseal separation is seen in both knees, with linear displacement (LD) in the left knee and compression (CE) against the shaft in the right knee.

### Prevention

Breastfeeding protects against vitamin C deficiency throughout infancy. In children consuming milk formula, fortification with vitamin C must be ensured. Children consuming heat-treated milk or plant-based beverages (e.g., almond milk, soy milk) should consume adequate vitamin C-rich foods in infancy. Dietary or medicinal supplements are required in children on restrictive diets deficient in vitamin C, severely malnourished children, and those with chronic debilitating conditions (e.g., malignancies, neurologic disorders). Providing antenatal supplements of vitamin C to smoking mothers may mitigate some of the harmful effects of smoking on fetal and infant lung development and function.

### VITAMIN C TOXICITY

Daily intake of <2 g of vitamin C is generally without adverse effects in adults. Larger doses can cause gastrointestinal problems, such as abdominal pain and osmotic diarrhea. Hemolysis has rarely been reported after high doses of ascorbic acid. Megadoses of vitamin C should be avoided in patients with a history of urolithiasis or conditions related to excessive iron accumulation, such as thalassemia and hemochromatosis. Data are sparse regarding vitamin C toxicity in children. The following values for tolerable upper intake levels are extrapolated from data for adults based on body weight differences: ages 1-3 years, 400 mg; 4-8 years, 650 mg; 9-13 years, 1,200 mg; and 14-18 years, 1,800 mg.

Visit Elsevier eBooks+ at [eBooks.Elsevier.com](http://eBooks.Elsevier.com) for Bibliography.

## Chapter 69

# Vitamin D Deficiency (Rickets) and Excess

Larry A. Greenbaum

### RICKETS

Bone consists of a protein matrix called *osteoid* and a mineral phase, principally composed of calcium and phosphate, mostly in the form of *hydroxyapatite*. **Osteomalacia** occurs with inadequate mineralization of bone osteoid in children and adults. **Rickets** is a disease of growing bone caused by unmineralized matrix at the growth plates in children only before fusion of the epiphyses. Because growth plate cartilage and osteoid continue to expand but mineralization is inadequate, the growth plate thickens. Circumference of the growth plate and metaphysis is also greater, increasing bone width at the growth plates and causing classic clinical manifestations, such as widening of the wrists and ankles. The general softening of the bones causes them to bend easily when subject to forces such as weight bearing or muscle pull. This softening leads to a variety of bone deformities.

Rickets is principally caused by vitamin D deficiency. Although largely corrected through public health measures that provided children with adequate vitamin D, rickets remains a persistent problem in developed countries, especially in children with restrictive diets (autism) or elimination diets (fear of allergies). It remains a significant problem in developing countries and may be secondary to nutritional vitamin D deficiency and inadequate intake of calcium (Table 69.1).

### Etiology

There are many causes of rickets, including vitamin D disorders, calcium deficiency, phosphorus deficiency, and distal renal tubular acidosis (Table 69.2).

### Clinical Manifestations

Most manifestations of rickets are a result of skeletal changes (Table 69.3). **Craniotabes** is a softening of the cranial bones and can be detected by applying pressure at the occiput or over the parietal bones. The sensation is similar to the feel of pressing into a Ping-Pong ball and then releasing. Craniotabes may also be secondary to osteogenesis imperfecta, hydrocephalus, and syphilis. It is a normal finding in many newborns, especially near the suture lines, but typically disappears within a few months of birth. Widening of the costochondral junctions results in a **rachitic "rosary,"** which feels like the beads of a rosary as the examiner's fingers move along the costochondral junctions from rib to rib (Fig. 69.1). Growth plate widening is also responsible for the enlargement at the wrists and ankles (Fig. 69.2). The horizontal depression along the lower anterior chest known as the *Harrison groove* occurs from pulling of the softened ribs by the diaphragm during inspiration. Softening of the ribs also impairs air movement and predisposes patients to atelectasis and pneumonia. Valgus or varus deformities of the legs are common; **windswept deformity** occurs when one leg is in extreme valgus and the other is in extreme varus (Fig. 69.3).

The clinical presentation of rickets may vary based on the etiology. Changes in the lower extremities tend to be the dominant feature in X-linked hypophosphatemic rickets. Symptoms secondary to hypocalcemia occur only in those forms of rickets associated with decreased serum calcium.



**Table 69.1** Physical and Metabolic Properties and Food Sources of Vitamins D, E, and K

NAMES AND SYNONYMS	CHARACTERISTICS	BIOCHEMICAL ACTION	EFFECTS OF DEFICIENCY	EFFECTS OF EXCESS	SOURCES
<b>VITAMIN D</b> Vitamin D3 (3-cholecalciferol), which is synthesized in the skin, and vitamin D2 (from plants or yeast) are biologically equivalent; 1 µg = 40IU vitamin D	Fat-soluble, stable to heat, acid, alkali, and oxidation; bile necessary for absorption; hydroxylation in the liver and kidney necessary for biologic activity	Necessary for GI absorption of calcium; also increases absorption of phosphate; direct actions on bone, including mediating resorption	Rickets in growing children; osteomalacia; hypocalcemia can cause tetany and seizures	Hypercalcemia, which can cause emesis, anorexia, pancreatitis, hypertension, arrhythmias, CNS effects, polyuria, nephrolithiasis, renal failure	Exposure to sunlight (UV light); fish oils, fatty fish, egg yolks, and vitamin D–fortified formula, milk, cereals, bread
<b>VITAMIN E</b> Group of related compounds with similar biologic activities; α-tocopherol is the most potent and most common form	Fat-soluble; readily oxidized by oxygen, iron, rancid fats; bile acids necessary for absorption	Antioxidant; protection of cell membranes from lipid peroxidation and formation of free radicals	Red cell hemolysis in premature infants; posterior column and cerebellar dysfunction; pigmentary retinopathy	Unknown	Vegetable oils, seeds, nuts, green leafy vegetables, margarine
<b>VITAMIN K</b> Group of naphthoquinones with similar biologic activities; K <sub>1</sub> (phylloquinone) from diet; K <sub>2</sub> (menaquinones) from intestinal bacteria	Natural compounds are fat-soluble; stable to heat and reducing agents; labile to oxidizing agent, strong acids, alkali, light; bile salts necessary for intestinal absorption	Vitamin K–dependent proteins include coagulation factors II, VII, IX, and X; proteins C, S, Z; matrix Gla protein, osteocalcin	Hemorrhagic manifestations; long-term bone and vascular health	Not established; analogs (no longer used) caused hemolytic anemia, jaundice, kernicterus, death	Green leafy vegetables, liver, certain legumes and plant oils; widely distributed

CNS, Central nervous system; GI, gastrointestinal; UV, ultraviolet.

**Table 69.2** Causes of Rickets**VITAMIN D DISORDERS**

Nutritional vitamin D deficiency  
 Congenital vitamin D deficiency  
 Secondary vitamin D deficiency  
 Malabsorption  
 Increased degradation  
 Decreased liver 25-hydroxylase  
 Vitamin D–dependent rickets types 1A and 1B  
 Vitamin D–dependent rickets types 2A and 2B  
 Chronic kidney disease

**CALCIUM DEFICIENCY**

Low intake  
 Diet  
 Premature infants (rickets of prematurity)  
 Malabsorption  
 Primary disease  
 Dietary inhibitors of calcium absorption

**PHOSPHORUS DEFICIENCY**

Inadequate intake  
 Premature infants (rickets of prematurity)  
 Aluminum-containing antacids

**RENAL LOSSES**

X-linked hypophosphatemic rickets\*  
 Autosomal dominant hypophosphatemic rickets\*  
 Autosomal recessive hypophosphatemic rickets types 1, 2, and 3\*  
 Hereditary hypophosphatemic rickets with hypercalciuria  
 Hypophosphatemic rickets with nephrolithiasis and osteoporosis types 1 and 2  
 Overproduction of fibroblast growth factor-23  
 Tumor-induced rickets\*  
 McCune-Albright syndrome\*  
 Epidermal nevus syndrome (cutaneous skeletal hypophosphatemia syndrome)\*  
 Neurofibromatosis\*  
 Fanconi syndrome  
 Dent disease  
 Distal renal tubular acidosis

\*Disorders secondary to excess fibroblast growth factor-23.

**Table 69.3** Clinical Features of Rickets**GENERAL**

Failure to thrive (malnutrition)  
 Listlessness  
 Protruding abdomen  
 Muscle weakness (especially proximal)  
 Hypocalcemic dilated cardiomyopathy  
 Fractures (pathologic, minimal trauma)  
 Increased intracranial pressure

**HEAD**

Craniotabes  
 Frontal bossing  
 Delayed fontanel closure (usually closed by 2 yr)  
 Delayed dentition  
 No incisors by age 10 mo  
 No molars by age 18 mo  
 Caries  
 Craniosynostosis

**CHEST**

Rachitic rosary  
 Harrison groove  
 Respiratory infections and atelectasis\*

**BACK**

Scoliosis  
 Kyphosis  
 Lordosis

**EXTREMITIES**

Enlargement of wrists and ankles  
 Valgus or varus deformities  
 Windswept deformity (valgus deformity of one leg with varus deformity of other leg)  
 Anterior bowing of tibia and femur  
 Coxa vara  
 Leg pain

**HYPOCALCEMIC SYMPTOMS<sup>†</sup>**

Tetany  
 Seizures  
 Stridor caused by laryngeal spasm

\*These features are most frequently associated with the vitamin D deficiency disorders.

<sup>†</sup>These symptoms develop only in children with disorders that produce hypocalcemia (see Table 69.4).



**Fig. 69.1** Rachitic “rosary” in a child with rickets. (Courtesy Dr. Thomas D. Thacher, Rochester, MN.)



**Fig. 69.2** Hands and forearms of a young child with rickets show prominence above the wrist, resulting from flaring and poor mineralization of lower end of the radius and ulna. (From Bullough PG. *Orthopaedic Pathology*, 5th ed. St Louis: Mosby; 2010: Fig 8-31.)

The chief complaint in a child with rickets is quite variable. Many children present because of skeletal deformities, whereas others have difficulty walking owing to a combination of deformity and weakness. Other common presenting complaints include failure to thrive (malnutrition) and symptomatic hypocalcemia (see Chapters 610-612).

### Radiology

Rachitic changes are most easily visualized on posteroanterior radiographs of the wrist, although characteristic rachitic changes can be seen at other growth plates (Figs. 69.4 and 69.5). Decreased calcification leads to thickening of the growth plate. The edge of the metaphysis loses its sharp border, which is described as *fraying*. The edge of the metaphysis changes from a convex or flat surface to a more concave surface. This change to a concave surface is termed *cupping* and is most easily seen at the distal ends of the radius, ulna, and fibula. There is widening of the distal end of the metaphysis, corresponding to the clinical observation of thickened wrists and ankles, as well as the rachitic rosary. Other radiologic features include coarse trabeculation of the diaphysis and generalized rarefaction.

### Diagnosis

The diagnosis of rickets is based on the presence of classic radiographic abnormalities. It is supported by physical examination findings, history, and laboratory results consistent with a specific etiology (Table 69.4).

### Clinical Evaluation

Because the majority of children with rickets have a nutritional deficiency, the initial evaluation should focus on a **dietary history**,



**Fig. 69.3** Windswept deformity of the legs in an older child with rickets. (From Rickets and osteomalacia. In Hochberg MC, Silman AJ, Smolen JS, et al., eds. *Rheumatology*, 4th ed. London: Mosby; 2008: Fig 192-6.)

emphasizing intake of both vitamin D and calcium. Most children in industrialized nations receive vitamin D from formula, fortified milk, or vitamin supplements. Along with the amount, the exact composition of the formula or milk is pertinent, because rickets has occurred in children given products that are called “milk” (e.g., soy milk) but are deficient in vitamin D and minerals.

**Cutaneous synthesis** mediated by sunlight exposure is an important source of vitamin D. It is important to ask about time spent outside, sunscreen use, and clothing, especially if there may be a cultural reason for increased covering of the skin. Because winter sunlight is ineffective at stimulating cutaneous synthesis of vitamin D, the season is an additional consideration. Children with increased skin pigmentation are at increased risk for vitamin D deficiency because of decreased cutaneous synthesis.

The presence of **maternal** risk factors for nutritional vitamin D deficiency, including diet and sun exposure, is an important consideration when a neonate or young infant has rachitic findings, especially if the infant is breastfed (Table 69.5). Determining a child’s intake of dairy products, the main dietary source of calcium, provides a general sense of calcium intake. High dietary fiber can interfere with calcium absorption.

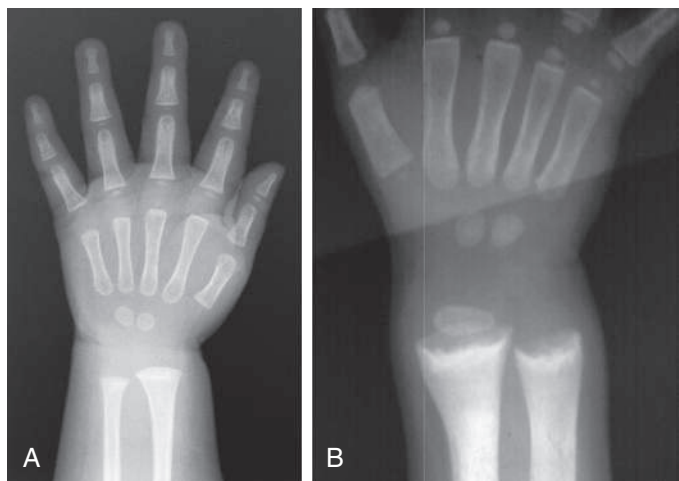
The child’s **medication** use is relevant, because certain medications, such as the anticonvulsants phenobarbital and phenytoin, increase degradation of vitamin D, and phosphate binders or aluminum-containing antacids interfere with the absorption of phosphate.

**Malabsorption** of vitamin D is suggested by a history of liver or intestinal disease. Undiagnosed liver or intestinal disease should be suspected if the child has gastrointestinal (GI) symptoms, although occasionally rickets is the presenting complaint. Fat malabsorption is often associated with diarrhea or oily stools, and there may be signs or symptoms suggesting deficiencies of other fat-soluble vitamins (A, E, and K; see Chapters 66, 70, and 71).

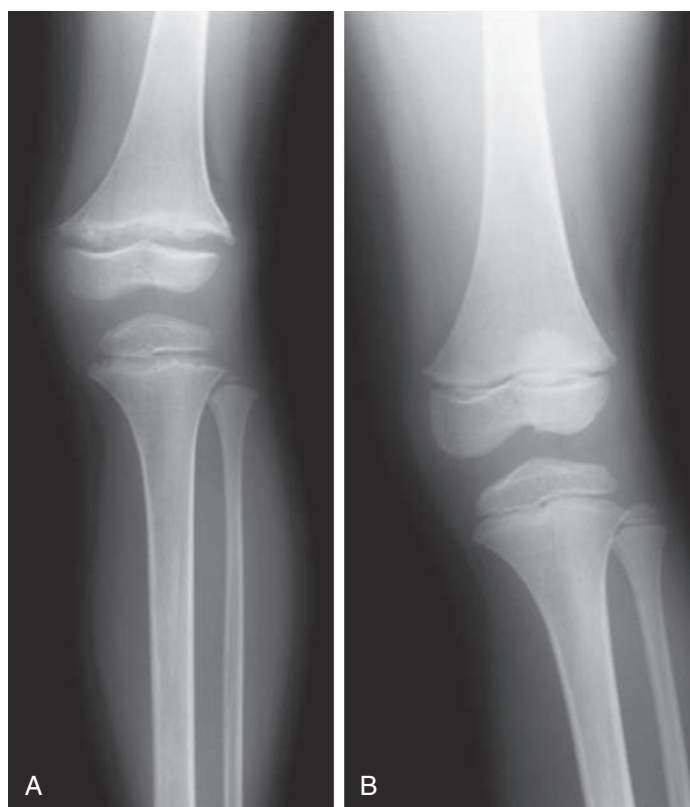
A history of **renal disease** (proteinuria, hematuria, urinary tract infections) is an additional significant consideration, given the importance of chronic kidney disease as a cause of rickets. Polyuria can occur in children with chronic kidney disease or Fanconi syndrome.

Children with rickets might have a history of dental caries, poor growth, delayed walking, waddling gait, pneumonia, and hypocalcemic symptoms.

The family history is critical, given the large number of **genetic causes** of rickets, although most of these causes are rare. Along with bone disease, it is important to inquire about leg deformities,



**Fig. 69.4** Radiographs of the wrist in normal child (A) and child with rickets (B), who has metaphyseal fraying and cupping of the distal radius and ulna.



**Fig. 69.5** Radiographs of the knees in 7-year-old female with distal renal tubular acidosis and rickets. A, At initial presentation, there is widening of the growth plate and metaphyseal fraying. B, Dramatic improvement after 4 months of therapy with alkali.

**Table 69.4** Laboratory Findings in Various Disorders Causing Rickets

DISORDER	Ca	Pi	PTH	25-(OH)D	1,25-(OH) <sub>2</sub> D	ALP	URINE Ca	URINE Pi
Vitamin D deficiency	N, ↓	↓	↑	↓	↓, N, ↑	↑	↓	↑
VDDR, type 1A	N, ↓	↓	↑	N	↓	↑	↓	↑
VDDR, type 1B	N, ↓	↓	↑	↓	N	↑	↓	↑
VDDR, type 2A	N, ↓	↓	↑	N	↑↑	↑	↓	↑
VDDR, type 2B	N, ↓	↓	↑	N	↑↑	↑	↓	↑
Chronic kidney disease	N, ↓	↑	↑	N	↓	↑	N, ↓	↓
Dietary Pi deficiency	N	↓	N, ↓	N	↑	↑	↑	↓
XLH*	N	↓	N, ↑	N	RD	↑	↓	↑
ADHR*	N	↓	N	N	RD	↑	↓	↑
HHRH	N	↓	N, ↓	N	↑	↑	↑	↑
ARHR, type 1 or type 2*	N	↓	N	N	RD	↑	↓	↑
Tumor-induced rickets†	N	↓	N	N	RD	↑	↓	↑
Fanconi syndrome	N	↓	N	N	RD or ↑	↑	↓ or ↑	↑
Dent's disease	N	↓	N	N	N	↑	↑	↑
Dietary Ca deficiency	N, ↓	↓	↑	N	↑	↑	↓	↑

\*Elevated fibroblast growth factor-23 (FGF-23).

†FGF-23 elevated in some patients.

ADHR, Autosomal dominant hypophosphatemic rickets; ALP, alkaline phosphatase; ARHR, autosomal recessive hypophosphatemic rickets; Ca, calcium; HHRH, hereditary hypophosphatemic rickets with hypercalciuria; N, normal; Pi, inorganic phosphorus; PTH, parathyroid hormone; RD, relatively decreased (because it should be increased given the concurrent hypophosphatemia); VDDR, vitamin D–dependent rickets; XLH, X-linked hypophosphatemic rickets; 1,25-(OH)<sub>2</sub>D, 1,25-dihydroxyvitamin D; 25-OHD, 25-hydroxyvitamin D; ↓, decreased; ↑, increased; ↑↑, extremely increased.

**Table 69.5** Risk Factors for Nutritional Rickets and Osteomalacia and Their Prevention**MATERNAL FACTORS**

Vitamin D deficiency  
 Dark skin pigmentation  
 Full body clothing cover  
 High latitude during winter/spring season  
 Other causes of restricted sun (UVB) exposure (e.g., predominant indoor living, disability, pollution, cloud cover)  
 Low-vitamin D diet  
 Low-calcium diet  
 Poverty, malnutrition, special diets

**INFANT/CHILDHOOD FACTORS**

Neonatal vitamin D deficiency secondary to maternal deficiency/vitamin D deficiency  
 Lack of infant supplementation with vitamin D  
 Prolonged breastfeeding without appropriate complementary feeding from 6 mo  
 High latitude during winter/spring season  
 Dark skin pigmentation and/or restricted sun (UVB) exposure (e.g., predominant indoor living, disability, pollution, cloud cover)  
 Avoidant restrictive food intake disorder  
 Low-vitamin D diet  
 Low-calcium diet  
 Poverty, malnutrition, special diets

**PREVENTIVE MEASURES**

Sun exposure (UVB content of sunlight depends on latitude and season)  
 Vitamin D supplementation  
 Strategic fortification of the habitual food supply  
 Normal calcium intake

Adapted from Munns CF, Shaw N, Kiely M, et al. Global consensus recommendations on prevention and management of nutritional rickets. *J Clin Endocrinol Metab*. 2016;101:394–415, p. 401.

difficulties with walking, or unexplained short stature, because some parents may be unaware of their diagnosis. Undiagnosed disease in the mother is not unusual in X-linked hypophosphatemia. A history of an unexplained sibling death during infancy may be present in the child with cystinosis, the most common cause of Fanconi syndrome in children.

The physical examination focuses on detecting manifestations of rickets (see Table 69.3). It is important to observe the child's gait, auscultate the lungs to detect atelectasis or pneumonia, and plot the patient's growth. *Alopecia* suggests vitamin D–dependent rickets type 2.

The initial **laboratory tests** in a child with rickets should include serum calcium, phosphorus, alkaline phosphatase (ALP), parathyroid hormone (PTH), 25-hydroxyvitamin D, 1,25-dihydroxyvitamin D (1,25-D), creatinine, and electrolytes (see Table 69.4 for interpretation). Urinalysis is useful for detecting the glycosuria seen with Fanconi syndrome. Evaluation of urinary excretion of calcium (24-hour collection for calcium or calcium:creatinine ratio) is helpful if hereditary hypophosphatemic rickets with hypercalciuria or Dent disease is suspected. Direct measurement of other fat-soluble vitamins (A, E, and K) or indirect assessment of deficiency (prothrombin time for vitamin K deficiency) is appropriate if malabsorption is a consideration.

**VITAMIN D DISORDERS****Vitamin D Physiology**

Vitamin D can be synthesized in skin epithelial cells and therefore technically is not a vitamin. Cutaneous synthesis is normally the most important source of vitamin D and depends on the conversion of 7-dehydrocholesterol to vitamin D<sub>3</sub> (3-cholecalciferol) by ultraviolet B (UVB) radiation from the sun. The efficiency of this process is decreased by melanin; therefore more sun exposure is necessary for

vitamin D synthesis in people with increased skin pigmentation. Measures to decrease sun exposure, such as covering the skin with clothing or applying sunscreen, also decrease vitamin D synthesis. Children who spend less time outside have reduced vitamin D synthesis. The winter sun away from the equator is ineffective at stimulating vitamin D synthesis.

There are few natural dietary sources of vitamin D. Fish liver oils have a high vitamin D content. Other good dietary sources include fatty fish and egg yolks. Most children in industrialized countries receive vitamin D via fortified foods, especially formula and milk (both of which contain 400 IU/L) and some breakfast cereals and breads. Supplemental vitamin D may be vitamin D<sub>2</sub> (which comes from plants or yeast) or vitamin D<sub>3</sub>. Breast milk has a low vitamin D content, approximately 12–60 IU/L.

Vitamin D is transported bound to vitamin D–binding protein to the liver, where 25-hydroxylase converts vitamin D into 25-hydroxyvitamin D (25-D), the most abundant circulating form of vitamin D. Because there is little regulation of this liver hydroxylation step, measurement of 25-D is the standard method for determining a patient's vitamin D status. The final step in activation occurs in the kidney, where the enzyme 1 $\alpha$ -hydroxylase adds a second hydroxyl group, resulting in 1,25-D. The 1 $\alpha$ -hydroxylase is upregulated by PTH and hypophosphatemia and inhibited by hyperphosphatemia and 1,25-D. Most 1,25-D circulates bound to vitamin D–binding protein.

1,25-Dihydroxyvitamin D acts by binding to an intracellular receptor, and the complex affects gene expression by interacting with vitamin D response elements. In the intestine, this binding results in a marked increase in calcium absorption, which is highly dependent on 1,25-D. There is also an increase in phosphorus absorption, but this effect is less significant because most dietary phosphorus absorption is vitamin D independent. 1,25-D also has direct effects on bone, including mediating resorption. 1,25-D directly suppresses PTH secretion by the parathyroid gland, thus completing a negative feedback loop. PTH secretion is also suppressed by the increase in serum calcium mediated by 1,25-D. 1,25-D inhibits its own synthesis in the kidney and increases the synthesis of inactive metabolites.

**Nutritional Vitamin D Deficiency**

Vitamin D deficiency remains the most common cause of rickets globally and even occurs in industrialized countries. Because vitamin D can be obtained from dietary sources or from cutaneous synthesis, most patients in industrialized countries have a combination of risk factors that lead to vitamin D deficiency.

**Etiology**

Vitamin D deficiency most frequently occurs in infancy because of a combination of poor intake and inadequate cutaneous synthesis. Transplacental transport of vitamin D, mostly 25-D, typically provides enough vitamin D for the first or second months of life unless there is severe maternal vitamin D deficiency. Infants who receive formula receive adequate vitamin D, even without cutaneous synthesis. Because of the low vitamin D content of breast milk, breastfed infants rely on cutaneous synthesis or vitamin supplements. Cutaneous synthesis can be limited because of the ineffectiveness of the winter sun in stimulating vitamin D synthesis; avoidance of sunlight because of concerns about cancer, neighborhood safety, or cultural practices; and decreased cutaneous synthesis because of increased skin pigmentation.

The effect of skin pigmentation explains why most cases of nutritional rickets in the United States and Northern Europe occur in breastfed children of African descent or other dark-pigmented populations. The additional impact of the winter sun is supported by such infants more often presenting in the late winter or spring. In some groups, complete covering of infants or the practice of not taking infants outside has a significant role, explaining the occurrence of rickets in infants living in areas of abundant sunshine, such as the Middle East. Because the mothers of some infants can



have the same risk factors, decreased maternal vitamin D can also contribute, both by leading to reduced vitamin D content in breast milk and by lessening transplacental delivery of vitamin D. Rickets caused by vitamin D deficiency can also be secondary to dietary practices, such as vegan diets that use unfortified soy milk or rice milk. Children with restrictive food habits (autism) or food elimination diets (fear of allergies) may be at risk for vitamin D deficiency.

### Clinical Manifestations

The clinical features are typical of rickets (see Table 69.3), with a significant minority presenting with symptoms of hypocalcemia. Prolonged laryngospasm is occasionally fatal. These children have an increased risk of pneumonia and muscle weakness leading to a delay in motor development.

### Laboratory Findings

Table 69.4 summarizes the principal laboratory findings. Hypocalcemia is a variable finding because the elevated PTH acts to increase the serum calcium concentration. The hypophosphatemia is caused by PTH-induced renal losses of phosphate, combined with a decrease in intestinal absorption.

The wide variation in 1,25-D levels (low, normal, or high) is secondary to the upregulation of renal 1 $\alpha$ -hydroxylase caused by concomitant hypophosphatemia and hyperparathyroidism. Because serum levels of 1,25-D are much lower than the levels of 25-D, even with low levels of 25-D, there is often enough 25-D still present to act as a precursor for 1,25-D synthesis in the presence of upregulated 1 $\alpha$ -hydroxylase. The level of 1,25-D is only low when there is severe vitamin D deficiency.

Some patients have a metabolic acidosis secondary to PTH-induced renal bicarbonate wasting. There may also be generalized aminoaciduria.

### Diagnosis and Differential Diagnosis

The diagnosis of nutritional vitamin D deficiency is based on the combination of a history of poor vitamin D intake and risk factors for decreased cutaneous synthesis, radiographic changes consistent with rickets, and typical laboratory findings (see Table 69.4). A normal PTH level almost never occurs with vitamin D deficiency and suggests a primary phosphate disorder.

### Treatment

Children with nutritional vitamin D deficiency should receive vitamin D and adequate nutritional intake of calcium and phosphorus. There are two strategies for administration of vitamin D. With **stoss therapy**, vitamin D (300,000-600,000 IU) is administered orally (preferred) or intramuscularly as 2-4 doses over 1 day (vitamin D3 is preferred to D2 because of the longer half-life of D3). Because the doses are observed, stoss therapy is ideal in patients in whom adherence to therapy is questionable. The alternative strategy is daily vitamin D with a minimum dose of 2,000 IU/day for a minimum of 3 months. Either strategy should be followed by daily vitamin D intake of 400 IU/day if <1 year old or 600 IU/day if >1 year old. It is important to ensure that children receive adequate dietary calcium (minimum of 500 mg/day) and phosphorus; this dietary intake is usually provided by milk, formula, and other dairy products, although calcium supplements may be needed in some patients.

Children who have symptomatic hypocalcemia might need intravenous (IV) calcium acutely, followed by oral calcium supplements, which typically can be tapered over 2-6 weeks in children who receive adequate dietary calcium. Transient use of IV or oral 1,25-D (**calcitriol**) is often helpful in reversing hypocalcemia in the acute phase by providing active vitamin D during the delay, as supplemental vitamin D is converted to active vitamin D. Calcitriol doses are typically 0.05  $\mu$ g/kg/day. IV calcium is initially given as an acute bolus for symptomatic hypocalcemia (20 mg/kg calcium chloride

or 100 mg/kg calcium gluconate). Some patients require a continuous IV calcium drip, titrated to maintain the desired serum calcium level. These patients should transition to enteral calcium, and most infants require approximately 1,000 mg of elemental calcium.

### Prognosis

Most children with nutritional vitamin D deficiency have an excellent response to treatment, with radiologic healing occurring within a few months. Laboratory test results should also normalize rapidly. Many of the bone malformations improve dramatically, but children with severe disease can have permanent deformities and short stature. Rarely, patients benefit from orthopedic intervention for leg deformities, although this is generally not done until the metabolic bone disease has healed, there is clear evidence that the deformity will not self-resolve, and the deformity is causing functional problems.

### Prevention

Most cases of nutritional rickets can be prevented by universal administration of 400 IU of vitamin D to infants <1 year old. Older children with risk factors for inadequate intake should receive 600 IU/day. Vitamin D may be administered as a component of a multivitamin or as a vitamin D supplement.

### Congenital Vitamin D Deficiency

**Congenital rickets** is quite rare in industrialized countries and occurs when there is severe maternal vitamin D deficiency during pregnancy. Maternal risk factors include poor dietary intake of vitamin D, lack of adequate sun exposure, and closely spaced pregnancies. These newborns can have symptomatic hypocalcemia, intrauterine growth restriction, and decreased bone ossification, along with classic rachitic changes (craniotables, large fontanelle, fractures). In addition, neonates with congenital rickets may have bone pain, weakness, elevated PTH and ALP levels, and hypocalcemia with low serum 25-hydroxyvitamin D levels. Subtler maternal vitamin D deficiency can have an adverse effect on neonatal bone density and birthweight, cause a defect in dental enamel, and predispose infants to neonatal hypocalcemic tetany. Treatment of congenital rickets includes vitamin D supplementation and adequate intake of calcium and phosphorus. Use of prenatal vitamins containing vitamin D (600 IU) prevents this entity.

### Secondary Vitamin D Deficiency

#### Etiology

Along with inadequate intake, vitamin D deficiency can result from inadequate absorption, decreased hydroxylation in the liver, and increased degradation. Because vitamin D is fat soluble, its absorption may be decreased in patients with a variety of liver and GI diseases, including cholestatic liver disease, defects in bile acid metabolism, cystic fibrosis and other causes of pancreatic dysfunction, celiac disease, and Crohn disease. Malabsorption of vitamin D can also occur with intestinal lymphangiectasia and after intestinal resection.

Severe liver disease, which usually is also associated with malabsorption, can cause a decrease in 25-D formation as a result of insufficient enzyme activity. Because of the large reserve of 25-hydroxylase activity in the liver, vitamin D deficiency caused by liver disease usually requires a loss of >90% of liver function. A variety of medications increase the degradation of vitamin D by inducing the cytochrome P450 (CYP) system. Rickets from vitamin D deficiency can develop in children receiving anticonvulsants (e.g., phenobarbital, phenytoin) or antituberculosis medications (e.g., isoniazid, rifampin).

#### Treatment

Treatment of vitamin D deficiency attributable to malabsorption requires high doses of vitamin D. Because of its better absorption, 25-D (25-50  $\mu$ g/day or 5-7  $\mu$ g/kg/day) is superior to vitamin D3. The dose is adjusted based on monitoring of serum levels of 25-D. Alternatively,

patients may be treated with 1,25-D, which also is better absorbed in the presence of fat malabsorption, or with parenteral vitamin D. Children with rickets as a result of increased degradation of vitamin D by the CYP system require the same acute therapy as indicated for nutritional deficiency (discussed earlier), followed by long-term administration of high doses of vitamin D (e.g., 1,000 IU/day), with dosing titrated based on serum levels of 25-D. Some patients require as much as 4,000 IU/day.

### Vitamin D–Dependent Rickets, Type 1

Children with vitamin D–dependent rickets **type 1A**, an autosomal recessive disorder, have pathologic gene variants in *CYP27B*, which encodes the renal 1 $\alpha$ -hydroxylase, preventing conversion of 25-D into 1,25-D. These patients normally present during the first 2 years of life and can have any of the classic features of rickets (see [Table 69.3](#)), including symptomatic hypocalcemia. They have normal levels of 25-D but low levels of 1,25-D (see [Table 69.4](#)). Occasionally, 1,25-D levels are at the lower limit of normal, inappropriately low given the high PTH and low serum phosphorus levels, both of which should increase the activity of renal 1 $\alpha$ -hydroxylase and cause elevated levels of 1,25-D. As in nutritional vitamin D deficiency, renal tubular dysfunction can cause a metabolic acidosis and generalized aminoaciduria.

Vitamin D–dependent rickets **type 1B** is secondary to pathologic variants in the gene (*CYP2R1*) for the principal 25-hydroxylase. Patients have low levels of 25-D but normal levels of 1,25-D (see [Table 69.4](#)).

#### Treatment

Vitamin D–dependent rickets type 1A responds to long-term treatment with 1,25-D (calcitriol). Initial doses are 0.25–2  $\mu$ g/day, and lower doses are used once the rickets has healed. Especially during initial therapy, it is important to ensure adequate intake of calcium. The dose of calcitriol is adjusted to maintain a low-normal serum calcium level, a normal serum phosphorus level, and a high-normal serum PTH level. Targeting a low-normal calcium concentration and a high-normal PTH level avoids excessive dosing of calcitriol, which can cause hypercalciuria and nephrocalcinosis. Therefore patient monitoring includes periodic assessment of urinary calcium excretion, with a target of <4 mg/kg/day.

Vitamin D–dependent rickets type 1B may respond to pharmacologic doses of vitamin D<sub>2</sub> (3,000 U/day) as a result of alternative enzymes with 25-hydroxylase activity or residual activity of the abnormal protein.

### Vitamin D–Dependent Rickets, Type 2

Patients with vitamin D–dependent rickets **type 2A** have pathologic variants in *VDR*, the gene encoding the vitamin D receptor, preventing a normal physiologic response to 1,25-D. Levels of 1,25-D are extremely elevated in this autosomal recessive disorder (see [Table 69.4](#)). Most patients present during infancy, although rickets in less severely affected patients might not be diagnosed until adulthood. Less severe disease is associated with a partially functional vitamin D receptor. Approximately 50–70% of children have **alopecia**, which tends to be associated with a more severe form of the disease and can range from alopecia areata to alopecia totalis. Epidermal cysts are a less common manifestation.

Vitamin D–dependent rickets **type 2B** appears to result from overexpression of a hormone response element–binding protein that interferes with the actions of 1,25-D. Alopecia may be present.

#### Treatment

Some patients respond to extremely high doses of vitamin D<sub>2</sub> (25-D or 1,25-D), especially patients without alopecia. This response is caused by a partially functional vitamin D receptor in patients with vitamin D–dependent rickets type 2A, but may also occur in vitamin D–dependent rickets type 2B. All patients should be given a 3- to 6-month trial of high-dose vitamin D and oral calcium. The initial dose of 1,25-D should be 2  $\mu$ g/day, but some patients require doses as high as 50–60

$\mu$ g/day. Calcium doses are 1,000–3,000 mg/day. Patients who do not respond to high-dose vitamin D may be treated with long-term IV calcium, with possible transition to very high-dose oral calcium supplements. Treatment of patients who do not respond to vitamin D is difficult.

### Chronic Kidney Disease

With chronic kidney disease, there is decreased activity of 1 $\alpha$ -hydroxylase in the kidney, leading to diminished production of 1,25-D. In chronic kidney disease, unlike the other causes of vitamin D deficiency, patients have hyperphosphatemia as a result of decreased renal excretion (see [Table 69.4](#) and Chapter 572.2).

#### Treatment

Therapy requires the use of a form of vitamin D that can act without 1-hydroxylation by the kidney (calcitriol), which both permits adequate absorption of calcium and directly suppresses the parathyroid gland. Because hyperphosphatemia is a stimulus for PTH secretion, normalization of the serum phosphorus level through a combination of dietary phosphorus restriction and use of oral phosphate binders is as important as the use of activated vitamin D.

## CALCIUM DEFICIENCY

### Pathophysiology

Rickets secondary to inadequate dietary calcium is a significant problem in some countries in Africa, although there are cases in other regions of the world, including industrialized countries. Because breast milk and formula are excellent sources of calcium, this form of rickets develops after children have been weaned from breast milk or formula and is more likely to occur in children who are weaned early. Rickets develops because the diet has low calcium content, typically <200 mg/day if <12 months old or <300 mg/day if >12 months old. The child has minimal intake of dairy products or other sources of calcium. In addition, because of reliance on grains and green leafy vegetables, the diet may be high in phytate, oxalate, and phosphate, which decrease absorption of dietary calcium. In industrialized countries, rickets caused by calcium deficiency can occur in children who consume an unconventional diet. Examples include children with milk allergy who have low dietary calcium and children who transition from formula or breast milk to juice, soda, or a calcium-poor soy drink, without an alternative source of dietary calcium.

This type of rickets can develop in children who receive IV nutrition without adequate calcium. Malabsorption of calcium can occur in celiac disease, intestinal abetalipoproteinemia, and after small bowel resection. There may be concurrent malabsorption of vitamin D.

### Clinical Manifestations

Children with calcium deficiency have the classic signs and symptoms of rickets (see [Table 69.3](#)). Presentation can occur during infancy or early childhood, although some cases are diagnosed in teenagers. Because calcium deficiency occurs after the cessation of breastfeeding, it tends to occur later than the nutritional vitamin D deficiency that is associated with breastfeeding. In Nigeria, nutritional vitamin D deficiency is most common at 4–15 months of age, whereas calcium deficiency rickets typically occurs at 15–25 months.

### Diagnosis

Laboratory findings include increased levels of ALP, PTH, and 1,25-D (see [Table 69.4](#)). Calcium levels may be normal or low, although symptomatic hypocalcemia is uncommon. There is decreased urinary excretion of calcium, and serum phosphorus levels may be low as a result of renal wasting of phosphate from secondary hyperparathyroidism. In some children, there is coexisting nutritional vitamin D deficiency, with low 25-D levels.

### Treatment

Treatment focuses on providing adequate calcium, typically as a dietary supplement (doses of 700 [age 1–3 years], 1,000 [4–8 years],

and 1,300 [9-18 years] mg/day of elemental calcium are effective). Vitamin D supplementation is necessary if there is concurrent vitamin D deficiency (discussed earlier). Prevention strategies include discouraging early cessation of breastfeeding and increasing dietary sources of calcium. In countries such as Kenya, where many children have diets high in cereal with negligible intake of cow's milk, school-based milk programs have been effective in reducing the prevalence of rickets.

## PHOSPHORUS DEFICIENCY

### Inadequate Intake

With the exception of starvation or severe anorexia, it is almost impossible to have a diet that is deficient in phosphorus, because phosphorus is present in most foods. Decreased phosphorus absorption can occur in diseases associated with malabsorption (celiac disease, cystic fibrosis, cholestatic liver disease), but if rickets develops, the primary problem is usually malabsorption of vitamin D and/or calcium.

Isolated malabsorption of phosphorus occurs in patients with long-term use of **aluminum-containing antacids**. These compounds are very effective at chelating phosphate in the GI tract, leading to decreased absorption. This decreased absorption results in hypophosphatemia with secondary osteomalacia in adults and rickets in children. This entity responds to discontinuation of the antacid and short-term phosphorus supplementation.

### Fibroblast Growth Factor-23

Fibroblast growth factor-23 (FGF-23) is a humoral mediator that decreases renal tubular reabsorption of phosphate and therefore decreases serum phosphorus. FGF-23, synthesized by osteocytes, also decreases the activity of renal 1 $\alpha$ -hydroxylase, resulting in a decrease in the production of 1,25-D. Increased levels of FGF-23 cause many of the renal phosphate-wasting diseases (see Table 69.2).

### X-Linked Hypophosphatemic Rickets

Among the genetic disorders causing rickets because of hypophosphatemia, X-linked hypophosphatemic rickets (XLH) is the most common, with a prevalence of 1/20,000. The defective gene is on the X chromosome, but female carriers are affected, so it is an X-linked-dominant disorder.

### Pathophysiology

The pathologic variants are in a gene called *PHEX* because it is a phosphate-regulating gene with homology to endopeptidases on the X chromosome. The product of this gene appears to have an indirect role in inactivating FGF-23. Thus pathologic variants in *PHEX* lead to increased levels of FGF-23. Because the actions of FGF-23 include inhibition of phosphate reabsorption in the proximal tubule, phosphate excretion is increased. FGF-23 also inhibits renal 1 $\alpha$ -hydroxylase, leading to decreased production of 1,25-D.

### Clinical Manifestations

These patients have rickets, but abnormalities of the lower extremities and poor growth are the dominant features. Delayed dentition and tooth abscesses are also common. Some patients have hypophosphatemia and short stature without clinically evident bone disease.

### Laboratory Findings

Patients have high renal excretion of phosphate, hypophosphatemia, and increased ALP; PTH and serum calcium levels are normal (see Table 69.4). Hypophosphatemia normally upregulates renal 1 $\alpha$ -hydroxylase and should lead to an increase in 1,25-D, but these patients have low or inappropriately normal levels of 1,25-D.

### Treatment

Burosumab is a monoclonal antibody to FGF-23 that is approved for treating XLH in children >1 year, although cost may limit its availability in low-resourced countries. Outcomes are better and side effects decreased when compared with conventional therapy. The dose of

burosumab is titrated to normalize the serum phosphorus; it is contraindicated in patients with severe renal impairment.

Conventional treatment is a combination of oral phosphorus and 1,25-D (calcitriol). The daily need for phosphorus supplementation is 1-3 g of elemental phosphorus divided into four or five doses. Frequent dosing helps to prevent prolonged decrements in serum phosphorus because there is a rapid decline after each dose. In addition, frequent dosing decreases diarrhea, a complication of high-dose oral phosphorus. Calcitriol is administered at 30-70 ng/kg/day in two doses.

Complications of conventional treatment occur when there is not an adequate balance between phosphorus supplementation and calcitriol. Excess phosphorus, by decreasing enteral calcium absorption, leads to secondary hyperparathyroidism, with worsening of the bone lesions. In contrast, excess calcitriol causes hypercalciuria and nephrocalcinosis and can even cause hypercalcemia. Therefore laboratory monitoring of treatment includes serum calcium, phosphorus, ALP, PTH, and urinary calcium, as well as periodic renal ultrasound to evaluate patients for nephrocalcinosis. Because of variation in the serum phosphorus level and the importance of avoiding excessive phosphorus dosing, normalization of ALP levels is a more useful method of assessing the therapeutic response than measuring serum phosphorus. For children with significant short stature, growth hormone is an effective option. Children with severe deformities might need osteotomies, but these procedures should be done only when treatment has led to resolution of the bone disease.

### Prognosis

The response to therapy is usually good, although frequent dosing can lead to problems with compliance with conventional therapy. Girls generally have less severe disease than boys, probably because of the X-linked inheritance. Short stature can persist despite healing of the rickets. Adults generally do well with less aggressive treatment, and options include burosumab, conventional treatment, and no treatment. Adults with bone pain, poorly healing fractures, or other symptoms improve with treatment.

### Autosomal Dominant Hypophosphatemic Rickets

Autosomal dominant hypophosphatemic rickets (ADHR) is much less common than XLH. There is incomplete penetrance and variable age of onset. Patients with ADHR have a pathologic variant in the gene encoding FGF-23 (*FGF23*). The pathologic variant prevents degradation of FGF-23 by proteases, leading its level to increase. The actions of FGF-23 include decreased reabsorption of phosphate in the renal proximal tubule, which results in hypophosphatemia, and inhibition of 1 $\alpha$ -hydroxylase in the kidney, causing a decrease in 1,25-D synthesis.

In ADHR, as in XLH, abnormal laboratory findings are hypophosphatemia, elevated ALP level, and a low or inappropriately normal 1,25-D level (see Table 69.4). Treatment is similar to the conventional approach with phosphate supplementation and calcitriol used in XLH. However, iron deficiency, which upregulates FGF-23 synthesis, should be corrected if present.

### Autosomal Recessive Hypophosphatemic Rickets

Autosomal recessive hypophosphatemic rickets (ARHR) **type 1** is an extremely rare disorder caused by pathologic variants in the *DMP1* gene. ARHR **type 2** occurs in patients with pathologic variants in *ENPP1*. Pathologic variants in *ENPP1* also cause generalized arterial calcification of infancy. **Raine syndrome**, also called ARHR **type 3**, is an autosomal recessive disorder caused by pathologic variants in *FAM20C* and is an osteosclerotic bone dysplasia that is often fatal in the neonatal period. However, patients who survive into childhood may develop rickets.

The three types of ARHR are associated with elevated levels of FGF-23, leading to renal phosphate wasting, hypophosphatemia, and low or inappropriately normal levels of 1,25-D. Treatment is similar to the approach used in XLH, although monitoring for arterial calcification is prudent in patients with *ENPP1* pathologic variants.



### Hereditary Hypophosphatemic Rickets with Hypercalciuria

Hereditary hypophosphatemic rickets with hypercalciuria (HHRH) is a rare disorder that is mainly found in the Middle East.

#### Pathophysiology

This autosomal recessive disorder is caused by pathologic variants in the gene for a sodium-phosphate co-transporter in the proximal tubule (*SLC34A3*). The renal phosphate leak causes hypophosphatemia, which then stimulates production of 1,25-D. The high level of 1,25-D increases intestinal absorption of calcium, suppressing PTH. Hypercalciuria ensues as a result of the high absorption of calcium and the low level of PTH, which normally decreases renal excretion of calcium.

#### Clinical Manifestations

The dominant symptoms of HHRH are rachitic leg abnormalities (see Table 69.3), muscle weakness, and bone pain. Patients can have short stature, with a disproportionate decrease in the length of the lower extremities. The severity of the disease varies, and some family members have no evidence of rickets but have kidney stones secondary to hypercalciuria.

#### Laboratory Findings

Laboratory findings include hypophosphatemia, renal phosphate wasting, elevated serum ALP levels, and elevated 1,25-D levels. PTH levels are low (see Table 69.4).

#### Treatment

Therapy for HHRH patients relies on oral phosphorus replacement (1-2.5 g/day of elemental phosphorus in five divided doses). Treatment of the hypophosphatemia decreases serum levels of 1,25-D and corrects the hypercalciuria. The response to therapy is usually excellent, with resolution of pain, weakness, and radiographic evidence of rickets.

### Hypophosphatemic Rickets with Nephrolithiasis and Osteoporosis Types 1 and 2

Hypophosphatemic rickets with nephrolithiasis and osteoporosis type 1 is an autosomal recessive disorder caused by pathologic variants of *SL34A1*, which encodes a phosphate transporter in the proximal tubule. Pathologic variants in the same gene can also cause Fanconi syndrome and infantile hypercalcemia. Hypophosphatemic rickets with nephrolithiasis and osteoporosis type 2 is an autosomal dominant disorder resulting from pathologic variants in *SLC9A3R1* that cause renal phosphate wasting. Laboratory findings and treatment for these disorders are similar to HHRH, with the exception of the features of Fanconi syndrome (see later and Chapter 569) in some patients with the type 1 disorder.

### Overproduction of FGF-23

**Tumor-induced osteomalacia** is more common in adults; in children it can produce classic rachitic findings. Most tumors are mesenchymal in origin and are usually benign, small, and located in bone. These tumors secrete FGF-23 and produce a biochemical phenotype similar to XLH, including urinary phosphate wasting, hypophosphatemia, elevated ALP levels, and low or inappropriately normal 1,25-D levels (see Table 69.4). Curative treatment is excision of the tumor. If the tumor cannot be removed, treatment is identical to that for XLH, including use of burosumab.

Renal phosphate wasting leading to hypophosphatemia and rickets (or osteomalacia in adults) is a potential complication in **McCune-Albright syndrome**, an entity that includes the triad of polyostotic fibrous dysplasia, hyperpigmented macules, and polyendocrinopathy (see Chapter 600.06). Affected patients have inappropriately low levels of 1,25-D and elevated ALP levels. The renal phosphate wasting and inhibition of 1,25-D synthesis are related

to the polyostotic fibrous dysplasia. Patients have elevated FGF-23, presumably caused by the dysplastic bone. Hypophosphatemic rickets can also occur in children with isolated polyostotic fibrous dysplasia. Although it is rarely possible, removal of the abnormal bone can cure this disorder in children with McCune-Albright syndrome. Most patients receive the same conventional treatment as children with XLH, with case reports describing off-label treatment with burosumab. Bisphosphonate treatment decreases the pain and fracture risk associated with the bone lesions.

Rickets is an unusual complication of **epidermal nevus syndrome**, which is caused by somatic pathologic variants (Ras family of genes and others). It is called **cutaneous skeletal hypophosphatemia syndrome** when associated with hypophosphatemic rickets or osteomalacia (see Chapter 692). Excessive production of FGF-23 causes renal phosphate wasting and an inappropriately normal or low level of 1,25-D. The timing of presentation with rickets varies from infancy to early adolescence. Hypophosphatemia and rickets have resolved after excision of the epidermal nevi in some patients, but not in others. In most the skin lesions are too extensive to be removed, necessitating treatment with phosphorus supplementation and 1,25-D. Rickets caused by phosphate wasting is an extremely rare complication in children with **neurofibromatosis** (see Chapter 636.1).

### Fanconi Syndrome

Fanconi syndrome is secondary to generalized dysfunction of the renal proximal tubule (see Chapter 569.1). There are renal losses of phosphate, amino acids, bicarbonate, glucose, urate, and other molecules that are normally reabsorbed in the proximal tubule. Some patients have partial dysfunction, with less generalized losses. The most clinically relevant consequences are hypophosphatemia caused by phosphate losses and proximal renal tubular acidosis caused by bicarbonate losses. Patients have rickets as a result of hypophosphatemia, with exacerbation from the chronic metabolic acidosis, which causes bone dissolution. Failure to thrive is a consequence of both rickets and renal tubular acidosis. Treatment is dictated by the etiology (see Chapter 569).

### Dent Disease

Dent disease is an X-linked disorder usually caused by pathologic variants in the gene encoding a chloride channel expressed in the kidney (*CLCN5*). Some patients have pathologic variants in the *OCRL1* gene, which can also cause Lowe syndrome (see Chapter 571.3). Affected males have variable manifestations, including hematuria, nephrolithiasis, nephrocalcinosis, rickets, and chronic kidney disease. Almost all patients have low-molecular-weight proteinuria and hypercalciuria. Other, less universal abnormalities are aminoaciduria, glycosuria, hypophosphatemia, and hypokalemia. Rickets occurs in approximately 25% of patients, and it responds to oral phosphorus supplements. Some patients also need 1,25-D, but this treatment should be used cautiously because it can worsen the hypercalciuria.

### RICKETS OF PREMATURITY

Rickets in very low birthweight infants has become a significant problem as the survival rate for this group of infants has increased (see Chapter 119.2).

### Pathogenesis

The transfer of calcium and phosphorus from mother to fetus occurs throughout pregnancy, but 80% occurs during the third trimester. Premature birth interrupts this process, with rickets developing when the premature infant does not have an adequate supply of calcium and phosphorus to support mineralization of the growing skeleton.

Most cases of rickets of prematurity occur in infants with a birthweight <1,000 g. It is more likely to develop in infants with lower



birthweight and younger gestational age. Rickets occurs because unsupplemented breast milk and standard infant formula do not contain enough calcium and phosphorus to supply the needs of the premature infant. Other risk factors include cholestatic jaundice, a complicated neonatal course, prolonged use of parenteral nutrition, the use of soy formula, and medications such as diuretics and corticosteroids.

### Clinical Manifestations

Rickets of prematurity occurs 1-4 months after birth. Infants can have nontraumatic fractures, especially of the legs, arms, and ribs. Most fractures are not suspected clinically. Because fractures and softening of the ribs lead to decreased chest compliance, some infants have respiratory distress from atelectasis and poor ventilation. This rachitic respiratory distress usually develops >5 weeks after birth, distinguishing it from the early-onset respiratory disease of premature infants. These infants have poor linear growth, with negative effects on growth persisting beyond 1 year of age. An additional long-term effect is enamel hypoplasia. Poor bone mineralization can contribute to dolichocephaly. There may be classic rachitic findings, such as frontal bossing, rachitic rosary (see Fig. 69.1), craniotabes, and widened wrists and ankles (see Table 69.3). Most infants with rickets of prematurity have no clinical manifestations, and the diagnosis is based on radiographic and laboratory findings.

### Laboratory Findings

Because of inadequate intake, the serum phosphorus level is low or low-normal in patients with rickets of prematurity. The renal response is appropriate, with conservation of phosphate leading to a low urine phosphate level; tubular reabsorption of phosphate is >95%. Most patients have normal levels of 25-D unless there has been inadequate intake or poor absorption (discussed earlier). The hypophosphatemia stimulates renal 1 $\alpha$ -hydroxylase, so levels of 1,25-D are high or high-normal. These high levels can contribute to bone demineralization because 1,25-D stimulates bone resorption. Serum levels of calcium are low, normal, or high, and patients often have hypercalciuria. Elevated serum calcium levels and hypercalciuria are secondary to increased intestinal absorption and bone dissolution caused by elevated 1,25-D levels and inability to deposit calcium in bone because of an inadequate phosphorus supply. The hypercalciuria indicates that phosphorus is the limiting nutrient for bone mineralization, although increased provision of phosphorus alone often cannot correct the mineralization defect; increased calcium is also necessary. Thus there is an inadequate supply of calcium and phosphorus, but the deficiency in phosphorus is greater.

Alkaline phosphatase levels are often elevated, but some affected infants have normal levels. In some cases, normal ALP levels may be secondary to resolution of the bone demineralization because of an adequate mineral supply despite the continued presence of radiologic changes, which take longer to resolve. However, ALP levels may be normal despite active disease. No single blood test is 100% sensitive for the diagnosis of rickets. The diagnosis should be suspected in infants with ALP >5-6 times the upper limit of normal (UL) for adults (unless there is concomitant liver disease) or phosphorus <5.6 mg/dL. The diagnosis is confirmed by radiologic evidence of rickets, which is best seen on radiographs of the wrists and ankles. Films of the arms and legs might reveal fractures. The rachitic rosary may be visible on chest radiograph. Unfortunately, radiographs cannot show early demineralization of bone because changes are not evident until there is >20-30% reduction in the bone mineral content.

### Diagnosis

Because many premature infants have no overt clinical manifestations of rickets, screening tests are recommended. These tests should include

weekly measurements of calcium, phosphorus, and ALP. Periodic measurement of the serum bicarbonate concentration is also important because metabolic acidosis causes dissolution of bone. At least one screening radiograph for rickets at 6-8 weeks of age is appropriate in infants who are at high risk for it; additional films may be indicated in high-risk infants.

### Prevention

Provision of adequate amounts of calcium, phosphorus, and vitamin D significantly decreases the risk of rickets of prematurity. Parenteral nutrition is often necessary initially in very premature infants. In the past, adequate parenteral calcium and phosphorus delivery was difficult because of limits secondary to insolubility of these ions when their concentrations were increased. Current amino acid preparations allow higher concentrations of calcium and phosphate, decreasing the risk of rickets. Early transition to enteral feedings is also helpful. These infants should receive either human milk fortified with calcium and phosphorus or preterm infant formula, which has higher concentrations of calcium and phosphorus than standard formula. Soy formula should be avoided because there is decreased bioavailability of calcium and phosphorus. Increased mineral feedings should continue until the infant weighs 3-3.5 kg. These infants should also receive approximately 400 IU/day of vitamin D through formula and vitamin supplements.

### Treatment

Therapy for rickets of prematurity focuses on ensuring adequate delivery of calcium, phosphorus, and vitamin D. If mineral delivery has been good and there is no evidence of healing, it is important to screen for vitamin D deficiency by measuring serum 25-D. Measurement of PTH, 1,25-D, and urinary calcium and phosphorus may be helpful in some cases.

### DISTAL RENAL TUBULAR ACIDOSIS

Distal renal tubular acidosis usually manifests with failure to thrive. Patients have a metabolic acidosis with an inability to acidify the urine appropriately. Hypercalciuria and nephrocalcinosis are typically present. The many etiologies include autosomal recessive and autosomal dominant forms. Rickets is variable and responds to alkali therapy (see Fig. 69.5 and Chapter 569.2).

### HYPERVITAMINOSIS D

#### Etiology

Hypervitaminosis D is caused by excessive intake of vitamin D. It can occur with long-term high intake or with a substantial, acute ingestion (see Table 69.1). Most cases are secondary to misuse of prescribed or nonprescription vitamin D supplements, but other cases have been secondary to accidental overfortification of milk, contamination of table sugar, and inadvertent use of vitamin D supplements as cooking oil. The recommended upper limits for long-term vitamin D intake are 1,000 IU for children <1 year old and 2,000 IU for older children and adults.

Hypervitaminosis D can also result from excessive intake of synthetic vitamin D analogs (25-D, 1,25-D). Vitamin D intoxication is never secondary to excessive exposure to sunlight, probably because ultraviolet irradiation can transform vitamin D<sub>3</sub> and its precursor into inactive metabolites.

#### Pathogenesis

Although vitamin D increases intestinal absorption of calcium, the dominant mechanism of the hypercalcemia is excessive bone resorption.

### Clinical Manifestations

The signs and symptoms of vitamin D intoxication are secondary to hypercalcemia. GI manifestations include nausea, vomiting, poor feeding, constipation, abdominal pain, and pancreatitis.

Possible cardiac findings are hypertension, decreased QT interval, and arrhythmias. The central nervous system effects of hypercalcemia include lethargy, hypotonia, confusion, disorientation, depression, psychosis, hallucinations, and coma. Hypercalcemia impairs renal concentrating mechanisms, which can lead to polyuria, dehydration, and hyponatremia. Hypercalcemia can also lead to acute kidney injury, nephrolithiasis, and nephrocalcinosis, which can result in chronic kidney disease. Deaths are usually associated with arrhythmias or dehydration.

### Laboratory Findings

The classic findings in vitamin D intoxication are hypercalcemia, elevated levels of 25-D (>100 ng/mL), hypercalciuria, and suppressed PTH. Hyperphosphatemia is also common. Hypercalciuria can lead to nephrocalcinosis, which is visible on renal ultrasound. Hypercalcemia and nephrocalcinosis can lead to renal insufficiency.

Surprisingly, levels of 1,25-D are usually normal. This may result from downregulation of renal 1 $\alpha$ -hydroxylase by the combination of low PTH, hyperphosphatemia, and a direct effect of 1,25-D. The level of free 1,25-D may be high because of displacement from vitamin D-binding proteins by 25-D. Anemia is sometimes present; the mechanism is unknown.

### Diagnosis and Differential Diagnosis

The diagnosis is based on the presence of hypercalcemia and an elevated serum 25-D level, although children with excess intake of 1,25-D or another synthetic vitamin D preparation have normal levels of 25-D. With careful sleuthing, there is usually a history of excess intake of vitamin D, although in some situations (overfortification of milk by a dairy), the patient and family may be unaware.

The differential diagnosis of vitamin D intoxication focuses on **other causes of hypercalcemia**. Hyperparathyroidism produces hypophosphatemia, whereas vitamin D intoxication usually causes hyperphosphatemia. Williams syndrome is often suggested by phenotypic features and accompanying cardiac disease. Idiopathic infantile hypercalcemia occurs in children taking appropriate doses of vitamin D. Subcutaneous fat necrosis is a common cause of hypercalcemia in young infants; skin findings are usually present. The hypercalcemia of familial benign hypocalciuric hypercalcemia is mild, asymptomatic, and associated with hypocalciuria. Hypercalcemia of malignancy is an important consideration. Hypercalcemia may occur on a ketogenic diet. High intake of calcium can also cause hypercalcemia, especially in the presence of renal insufficiency. Inquiring about calcium intake should be part of the history in a patient with hypercalcemia. Occasionally, patients are intentionally taking high doses of calcium and vitamin D.

### Treatment

The treatment of vitamin D intoxication focuses on control of hypercalcemia. Many patients with hypercalcemia are dehydrated as a result of polyuria from nephrogenic diabetes insipidus, poor oral intake, and vomiting. Rehydration lowers the serum calcium level by dilution and corrects prerenal azotemia. The resultant increased urine output increases urinary calcium excretion. Urinary calcium excretion is also increased by high urinary sodium excretion. The mainstay of the initial treatment is aggressive therapy with normal saline, often in conjunction with a loop diuretic to further increase calcium excretion; this is often adequate for treating mild or moderate hypercalcemia. More significant hypercalcemia usually requires other therapies. Glucocorticoids decrease intestinal absorption of calcium by blocking the action of 1,25-D. There is also a decrease in the levels of 25-D and 1,25-D. The usual dosage of prednisone is 1-2 mg/kg/24 hr.

Calcitonin, which lowers calcium by inhibiting bone resorption, is a useful adjunct, but its effect is usually not dramatic. There is an excellent response to IV or oral bisphosphonates in vitamin D intoxication. Bisphosphonates inhibit bone resorption through their effects on osteoclasts. Hemodialysis using a low or zero dialysate calcium can rapidly lower serum calcium in patients with severe hypercalcemia that is refractory to other measures.

Along with controlling hypercalcemia, it is imperative to eliminate the source of excess vitamin D. Additional sources of vitamin D such as multivitamins and fortified foods should be eliminated or reduced. Avoidance of sun exposure, including the use of sunscreen, is prudent. The patient should also restrict calcium intake.

### Prognosis

Most children make a full recovery, but hypervitaminosis D may be fatal or can lead to chronic kidney disease. Because vitamin D is stored in fat, levels can remain elevated for months, necessitating regular monitoring of 25-D, serum calcium, and urine calcium.

Visit Elsevier eBooks+ at [eBooks.Health.Elsevier.com](http://eBooks.Health.Elsevier.com) for Bibliography.

## Chapter 70

# Vitamin E Deficiency

Larry A. Greenbaum

Vitamin E is a fat-soluble vitamin and functions as an antioxidant, but its precise biochemical functions are not known. Vitamin E deficiency can cause hemolysis or neurologic manifestations and occurs in premature infants, in patients with malabsorption, and in an autosomal recessive disorder affecting vitamin E transport. Because of its role as an antioxidant, there is considerable research on vitamin E supplementation in chronic illnesses.

### PATHOGENESIS

The term *vitamin E* denotes a group of 8 compounds with similar structures and antioxidant activity. The most potent member of these compounds is  $\alpha$ -**tocopherol**, which is also the main form in humans. The best dietary sources of vitamin E are vegetable oils, seeds, nuts, green leafy vegetables, and margarine (see [Table 69.1](#)).

The majority of vitamin E is located within cell membranes, where it prevents lipid peroxidation and the formation of free radicals. Other antioxidants, such as ascorbic acid, enhance the antioxidant activity of vitamin E. The importance of other functions of vitamin E is still being delineated.

Premature infants are particularly susceptible to vitamin E deficiency because there is significant transfer of vitamin E during the last trimester of pregnancy. Vitamin E deficiency in premature infants causes thrombocytosis, edema, and hemolysis, potentially causing anemia. The risk of symptomatic vitamin E deficiency was increased by the use of formulas for premature infants that had a high content of polyunsaturated fatty acids (PUFAs). These formulas led to a high content of PUFAs in red blood cell membranes, making them more susceptible to oxidative stress, which could be ameliorated by vitamin E. Oxidative stress was augmented by aggressive use of iron supplementation; iron increases the production of oxygen radicals. The incidence of hemolysis as a result of vitamin E deficiency in premature infants decreased secondary to the use of formulas with a lower content of PUFAs, less aggressive use of iron, and provision of adequate vitamin E.

Because vitamin E is plentiful in common foods, primary dietary deficiency is rare except in premature infants and in severe, generalized malnutrition. Vitamin E deficiency does occur in children with fat malabsorption secondary to the bile acid needed for vitamin E absorption. Although symptomatic disease is most common in children with cholestatic liver disease, it can occur in patients with

cystic fibrosis, celiac disease, short bowel syndrome, and Crohn disease. The autosomal recessive disorder **abetalipoproteinemia** causes fat malabsorption, and vitamin E deficiency is a common complication (see Chapter 106).

In **ataxia with isolated vitamin E deficiency (AVED)**, a rare autosomal recessive disorder, there are pathologic variants in *TTPA*, the gene for  $\alpha$ -tocopherol transfer protein. Patients with this disorder are unable to incorporate vitamin E into lipoproteins before their release from the liver, leading to reduced serum levels of vitamin E. There is no associated fat malabsorption, and absorption of vitamin E from the intestine occurs normally.

### CLINICAL MANIFESTATIONS

A severe, progressive neurologic disorder occurs in patients with prolonged vitamin E deficiency. Clinical manifestations do not appear until after 1 year of age, even in children with cholestasis since birth. Patients may have cerebellar disease, posterior column dysfunction, and retinal disease. Loss of deep tendon reflexes is usually the initial finding. Subsequent manifestations include limb ataxia (intention tremor, dysdiadochokinesia), truncal ataxia (wide-based, unsteady gait), dysarthria, ophthalmoplegia (limited upward gaze), nystagmus, decreased proprioception (positive Romberg test), decreased vibratory sensation, and dysarthria. Some patients have pigmentary retinopathy. Visual field constriction can progress to blindness. Cognition and behavior can also be affected. Myopathy and cardiac arrhythmias are less common findings.

In premature infants, hemolysis as a result of vitamin E deficiency typically develops during the second month of life. Edema may also be present.

### LABORATORY FINDINGS

Serum vitamin E levels increase in the presence of high serum lipid levels, even when vitamin E deficiency is present. Therefore vitamin E status is best determined by measuring the ratio of vitamin E to serum lipids; a ratio  $<0.8$  mg/g is abnormal in older children and adults;  $<0.6$  mg/g is abnormal in infants  $<1$  year. Premature infants with hemolysis caused by vitamin E deficiency also often have elevated platelet counts.

Neurologic involvement can cause abnormal somatosensory evoked potentials and nerve conduction studies. Abnormalities on electroretinography can precede physical examination findings in patients with retinal involvement.

### DIAGNOSIS AND DIFFERENTIAL DIAGNOSIS

Premature infants with unexplained hemolytic anemia after the first month of life, especially if thrombocytosis is present, either should be empirically treated with vitamin E or should have serum vitamin E and lipid levels measured. Children with neurologic findings and a disease that causes fat malabsorption should have their vitamin E status evaluated.

Because children with AVED do not have symptoms of malabsorption, a correct diagnosis requires a high index of suspicion. **Friedreich ataxia** has been misdiagnosed in some patients (see Chapter 637.1). Children with unexplained ataxia should be screened for vitamin E deficiency.

### TREATMENT

For correction of deficiency in neonates, the dose of vitamin E is 25–50 units/day for 1 week, followed by adequate dietary intake. Children with deficiency as a result of malabsorption should receive 1 unit/kg/day, with the dose adjusted based on levels; ongoing treatment is necessary. Children with AVED normalize their serum vitamin E levels with high doses of vitamin E and require ongoing treatment.

### PROGNOSIS

The hemolytic anemia in infants resolves with correction of the vitamin E deficiency. Some neurologic manifestations of vitamin E

deficiency may be reversible with early treatment, but many patients have little or no improvement. Importantly, treatment prevents progression.

### PREVENTION

Premature infants should receive sufficient vitamin E through formula or breast milk fortifier and formula without a high content of PUFAs. Children at risk for vitamin E deficiency as a result of malabsorption should be screened for deficiency and given adequate vitamin E supplementation. Vitamin preparations with high content of all the fat-soluble vitamins are available.

Visit Elsevier eBooks+ at [eBooks.Health.Elsevier.com](http://eBooks.Health.Elsevier.com) for Bibliography.

## Chapter 71

# Vitamin K Deficiency

Larry A. Greenbaum

Vitamin K is necessary for the synthesis of clotting factors II, VII, IX, and X; deficiency of vitamin K can result in clinically significant bleeding. Vitamin K deficiency typically affects infants, who experience a transient deficiency related to inadequate intake, or patients of any age who have decreased vitamin K absorption. Mild vitamin K deficiency can affect long-term bone and vascular health (see Chapters 142 and 529).

### PATHOGENESIS

Vitamin K is a group of compounds that have a common naphthoquinone ring structure (see Table 69.1). **Phylloquinone**, called *vitamin K<sub>1</sub>*, is present in a variety of dietary sources, with green leafy vegetables, liver, and certain legumes and plant oils having the highest content. Vitamin K<sub>1</sub> is the form used to fortify foods and as a medication in the United States. *Vitamin K<sub>2</sub>* is a group of compounds called **menaquinones**, which are produced by intestinal bacteria. There is uncertainty regarding the relative importance of intestinally produced vitamin K<sub>2</sub>. Menaquinones are also present in meat, especially liver, and cheese. A menaquinone is used pharmacologically in some countries.

Vitamin K is a cofactor for  $\gamma$ -glutamyl carboxylase, an enzyme that performs posttranslational carboxylation, converting glutamate residues in proteins to  $\gamma$ -**carboxylglutamate (Gla)**. The Gla residues, by facilitating calcium binding, are necessary for protein function.

The classic Gla-containing proteins involved in blood coagulation that are decreased in vitamin K deficiency are factors II (prothrombin), VII, IX, and X. Vitamin K deficiency causes a decrease in proteins C and S, which inhibit blood coagulation, and protein Z, which also has a role in coagulation. All these proteins are made only in the liver, except for protein S, a product of various tissues.

Gla-containing proteins are also involved in bone biology (osteocalcin and protein S) and vascular biology (matrix Gla protein and protein S). Based on the presence of reduced levels of Gla, these proteins appear more sensitive than the coagulation proteins to subtle vitamin K deficiency. Evidence suggests that mild vitamin K deficiency might have a deleterious effect on long-term bone strength and vascular health.

Because it is fat soluble, vitamin K requires the presence of bile salts for its absorption. Unlike other fat-soluble vitamins, there are



limited body stores of vitamin K. In addition, there is high turnover of vitamin K, and the vitamin K–dependent clotting factors have a short half-life. Thus symptomatic vitamin K deficiency can develop within weeks when there is inadequate supply because of low intake or malabsorption.

There are three forms of **vitamin K deficiency bleeding (VKDB)** of the newborn (see Chapter 142). **Early VKDB** was formerly called *classic hemorrhagic disease of the newborn* and occurs at 1–14 days of age. Early VKDB is secondary to low stores of vitamin K at birth as a result of the poor transfer of vitamin K across the placenta and inadequate intake during the first few days of life. In addition, there is no intestinal synthesis of vitamin K<sub>2</sub> because the newborn gut is sterile. Early VKDB occurs mostly in breastfed infants as a consequence of the low vitamin K content of breast milk (formula is fortified). Delayed feeding is an additional risk factor.

**Late VKDB** most often occurs at 2–12 weeks of age, although cases can occur up to 6 months after birth. Almost all cases are in breastfed infants because of the low vitamin K content of breast milk. An additional risk factor is occult malabsorption of vitamin K, as occurs in children with undiagnosed cystic fibrosis or cholestatic liver disease (e.g., biliary atresia,  $\alpha_1$ -antitrypsin deficiency). Without vitamin K prophylaxis, the incidence is 4–10 per 100,000 newborns.

The third form of VKDB of the newborn occurs **at birth** or shortly thereafter. It is secondary to maternal intake of medications (warfarin, phenobarbital, phenytoin) that cross the placenta and interfere with vitamin K function.

VKDB as a result of fat malabsorption can occur in children of any age. Potential etiologies include cholestatic liver disease, pancreatic disease, and intestinal disorders (celiac sprue, inflammatory bowel disease, short bowel syndrome). Prolonged diarrhea can cause vitamin K deficiency, especially in breastfed infants. Children with cystic fibrosis are most likely to have vitamin K deficiency if they have pancreatic insufficiency and liver disease.

Beyond infancy, low dietary intake by itself never causes vitamin K deficiency. However, the combination of poor intake and the use of broad-spectrum antibiotics that eliminate the intestine's vitamin K<sub>2</sub>-producing bacteria can cause vitamin K deficiency. This scenario is especially common in the intensive care unit. Vitamin K deficiency can also occur in patients who receive total parenteral nutrition (TPN) without vitamin K supplementation.

## CLINICAL MANIFESTATIONS

In early VKDB, the most common sites of bleeding are the gastrointestinal (GI) tract, mucosal and cutaneous tissue, umbilical stump, and the postcircumcision site; intracranial bleeding is less common. GI blood loss can be severe enough to require a transfusion. In contrast, the most common site of bleeding in late VKDB is intracranial, although cutaneous and GI bleeding may be the initial manifestation. Intracranial bleeding can cause convulsions, permanent neurologic sequelae, or death. In some patients with late VKDB, the presence of an underlying disorder may be suggested by jaundice or failure to thrive (malnutrition). Older children with vitamin K deficiency can present with bruising, mucocutaneous bleeding, or more serious bleeding.

## Laboratory Findings

In patients with bleeding as a result of vitamin K deficiency, the prothrombin time (PT) is prolonged. The PT must be interpreted based on the patient's age because it is normally prolonged in newborns (see Chapters 142 and 524). The partial thromboplastin time (PTT) is usually prolonged, but may be normal in early deficiency. Factor VII has the shortest half-life of the coagulation factors and is the first to be affected by vitamin K deficiency, but isolated factor VII deficiency does not affect PTT. The platelet count and fibrinogen level are normal.

When there is mild vitamin K deficiency, the PT is normal, but there are elevated levels of the undercarboxylated forms of the proteins that are normally carboxylated in the presence of vitamin K. These undercarboxylated proteins are called *proteins induced by vitamin K absence* (PIVKA). Measurement of undercarboxylated factor II (PIVKA-II) can be used to detect mild vitamin K deficiency. Determination of blood vitamin K levels is less useful because of significant variation based on recent dietary intake; levels do not always reflect tissue stores.

## DIAGNOSIS AND DIFFERENTIAL DIAGNOSIS

The diagnosis is established by the presence of a prolonged PT that corrects rapidly after administration of vitamin K, which stops the active bleeding. Other possible causes of bleeding and a prolonged PT include disseminated intravascular coagulation (DIC), liver failure, and rare hereditary deficiencies of clotting factors. DIC, which is usually secondary to sepsis, is associated with thrombocytopenia, low fibrinogen, and elevated D-dimers. Severe liver disease results in decreased production of clotting factors; the PT does not fully correct with administration of vitamin K. Children with a hereditary disorder have a deficiency in a specific clotting factor (I, II, V, VII, X).

Coumarin derivatives inhibit the action of vitamin K by preventing its recycling to an active form after it functions as a cofactor for  $\gamma$ -glutamyl carboxylase. Bleeding can occur with overdosage of the common anticoagulant **warfarin** or with ingestion of rodent poison, which contains a coumarin derivative. High doses of salicylates also inhibit vitamin K regeneration, potentially leading to a prolonged PT and clinical bleeding.

## TREATMENT

Infants with VKDB should receive 1 mg of parenteral vitamin K. The PT should decrease within 6 hours and normalize within 24 hours. For rapid correction in adolescents, the parenteral dose is 2.5–10 mg. In addition to vitamin K, a patient with severe, life-threatening bleeding should receive an infusion of fresh-frozen plasma (FFP), which corrects the coagulopathy rapidly. Children with vitamin K deficiency caused by malabsorption require chronic administration of high doses of oral vitamin K (2.5 mg twice/week to 5 mg/day). Parenteral vitamin K may be necessary if oral vitamin K is ineffective.

## PREVENTION

Administration of either oral or parenteral vitamin K soon after birth prevents early VKDB of the newborn. In contrast, a single dose of oral vitamin K does not prevent a substantial number of cases of late VKDB. However, a single intramuscular (IM) injection of vitamin K (1 mg), the current practice in the United States, is almost universally effective, except in children with severe malabsorption. This increased efficacy of the IM form is thought to be the result of a depot effect. Concerns about an association between parenteral vitamin K at birth and the later development of malignancy are unsubstantiated. Oral vitamin K is a less effective alternative for parents who refuse IM vitamin K, but multiple doses are necessary and rely on home administration.

Discontinuing the offending medications before delivery can prevent VKDB attributable to maternal medications. If this is not possible, administration of vitamin K to the mother may be helpful. In addition, the neonate should receive parenteral vitamin K immediately after birth. If parenteral vitamin K does not correct the coagulopathy rapidly, the child should receive FFP.

Children who are at high risk for malabsorption of vitamin K should receive supplemental vitamin K and periodic measurement of the PT.

Visit Elsevier eBooks+ at [eBooks.Health.Elsevier.com](http://eBooks.Health.Elsevier.com) for Bibliography.



## Chapter 72

# Micronutrient Mineral Deficiencies

Larry A. Greenbaum

Micronutrients include vitamins (see Chapters 66-71) and trace elements. By definition, a **trace element** is <0.01% of the body weight. Trace elements have a variety of essential functions (Table 72.1), although the evidence is not always strong (chromium). With the exception of iron deficiency, trace element deficiency is uncommon in developed countries, but some deficiencies (iodine, zinc, selenium) are important public health problems in a number of developing countries. Because of low nutritional requirements and plentiful supply, deficiencies of some of the trace elements are extremely rare in humans and

typically occur in patients receiving unusual diets or prolonged total parenteral nutrition without adequate delivery of a specific trace element. Trace element deficiencies can also occur in children with short bowel syndrome or malabsorption. Excess intake of trace elements is uncommon, but can result from environmental exposure or overuse of supplements (see Table 72.1).

For a number of reasons, children are especially susceptible to trace element deficiency. First, growth creates an increased demand for most trace elements. Second, some organs are more likely to sustain permanent damage because of trace element deficiency during childhood. The developing brain is particularly vulnerable to the consequences of certain deficiency states (iron, iodide). Similarly, adequate fluoride is most critical for dental health during childhood. Third, children, especially in the developing world, are more prone to gastrointestinal disorders that can cause trace element deficiencies because of malabsorption.

A normal diet provides adequate intake of most trace elements. However, the intake of certain trace elements varies significantly in different geographic locations. Iodide-containing food is plentiful near the ocean, but inland areas often have inadequate sources, leading to goiter and **hypothyroidism**. **Iodine deficiency** is not a problem in the United States because of the widespread use of iodized salt; however, symptomatic

Table 72.1

Trace Elements

ELEMENT	PHYSIOLOGY	EFFECTS OF DEFICIENCY	EFFECTS OF EXCESS	DIETARY SOURCES
Chromium	Potentiates the action of insulin	Impaired glucose tolerance, peripheral neuropathy, and encephalopathy	Unknown	Meat, grains, fruits, and vegetables
Copper	Absorbed via specific intestinal transporter Circulates bound to ceruloplasmin Enzyme cofactor (superoxide dismutase, cytochrome oxidase, and enzymes involved in iron metabolism and connective tissue formation)	Microcytic anemia, osteoporosis, neutropenia, neurologic symptoms, depigmentation of hair and skin	Acute: nausea, emesis, abdominal pain, coma, and hepatic necrosis Chronic toxicity (liver and brain injury) occurs in <b>Wilson disease</b> (see Chapter 405.2) and secondary to excess intake (see Chapter 405.3)	Vegetables, grains, nuts, liver, margarine, legumes, corn oil
Fluoride	Incorporated into bone	Dental caries (see Chapter 358)	Chronic: dental fluorosis (see Chapter 353)	Toothpaste, fluoridated water
Iodine	Component of thyroid hormone (see Chapter 580)	Hypothyroidism (see Chapters 601 and 603)	Hypothyroidism and goiter (see Chapters 603 and 605); maternal excess can cause congenital hypothyroidism and goiter (see Chapter 603.1)	Saltwater fish, iodized salt
Iron	Component of hemoglobin, myoglobin, cytochromes, and other enzymes	Anemia (see Chapter 504), decreased alertness, impaired learning	Acute (see Chapter 94): nausea, vomiting, diarrhea, abdominal pain, and hypotension Chronic excess usually secondary to hereditary disorders (see Chapter 511); causes organ dysfunction	Meat, fortified foods Deficiency can also result from blood loss (hookworm infestation, menorrhagia)
Manganese	Enzyme cofactor	Hypercholesterolemia, weight loss, decreased clotting proteins*	Neurologic manifestations, cholestatic jaundice	Nuts, meat, grains, tea
Molybdenum	Enzyme cofactor (xanthine oxidase and others)	Tachycardia, tachypnea, night blindness, irritability, coma*	Hyperuricemia and increased risk of gout	Legumes, grains, liver
Selenium	Enzyme cofactor (prevents oxidative damage)	Cardiomyopathy ( <b>Keshan disease</b> ), myopathy	Nausea, diarrhea, neurologic manifestations, nail and hair changes, garlic odor	Meat, seafood, whole grains, garlic
Zinc	Enzyme cofactor Constituent of zinc-finger proteins, which regulate gene transcription	Decreased growth, dermatitis of extremities and around orifices, impaired immunity, poor wound healing, hypogonadism, diarrhea Supplements are beneficial in diarrhea and improve neurodevelopmental outcomes	Abdominal pain, diarrhea, vomiting Can worsen copper deficiency	Meat, shellfish, whole grains, legumes, cheese

\*These deficiency states have been reported only in case reports associated with parenteral nutrition or highly unusual diets.

iodine deficiency (goiter, hypothyroidism) is common in many developing countries. Selenium content of the soil and consequently of food is also quite variable. Dietary **selenium deficiency** (associated with cardiomyopathy) occurs in certain locations, such as some parts of China.

The consequences of severe isolated trace mineral deficiency are illustrated in certain genetic disorders. The manifestations of **Menkes disease** are caused by pathologic variants in the gene coding for a protein that facilitates intestinal copper absorption (see Chapters 639.5 and 703). These pathologic variants result in severe copper deficiency; subcutaneous copper is an effective treatment. Nutritional copper deficiency has been reported in children receiving unsupplemented parenteral nutrition and in children on a ketogenic diet (with associated neutropenia and anemia). The recessive disorder **acrodermatitis enteropathica** is secondary to malabsorption of zinc (see Chapter 712). These patients respond dramatically to zinc supplementation.

Children can have apparently asymptomatic deficiencies of certain trace elements but still benefit from supplementation. As an example, zinc is highly effective in treating children before or during diarrheal illnesses in the developing world.

**Zinc deficiency** is quite common in the developing world and is often associated with malnutrition or other micronutrient deficiencies (iron). Chronic zinc deficiency is associated with dwarfism, hypogonadism, dermatitis, and T-cell immunodeficiency. Diets rich in phytates bind zinc, impairing its absorption. Zinc supplementation in at-risk children reduces the incidence and severity of diarrhea, pneumonia, and possibly malaria. In developing countries, children who have diarrhea may benefit from zinc supplementation, especially if there is underlying malnutrition.

Visit Elsevier eBooks+ at [eBooks.Health.Elsevier.com](http://eBooks.Health.Elsevier.com) for Bibliography.

# Fluid and Electrolyte Disorders

## PART VI

### Chapter 73

## Electrolyte and Acid-Base Disorders

### 73.1 Composition of Body Fluids

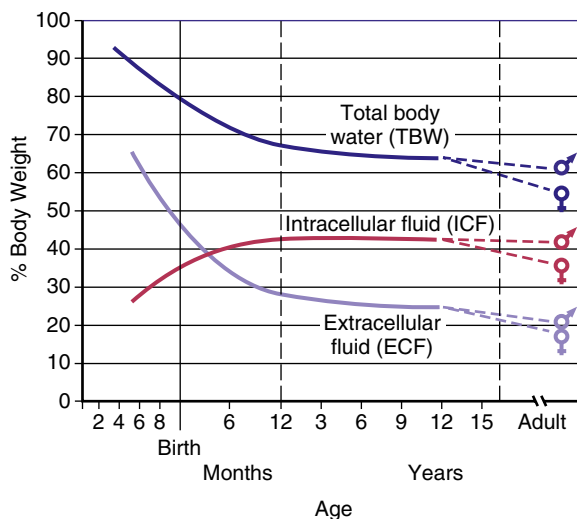
Larry A. Greenbaum

#### TOTAL BODY WATER

Total body water (TBW) as a percentage of body weight varies with age (Fig. 73.1). The fetus has very high TBW, which gradually decreases to approximately 75% of birthweight for a term infant. Premature infants have higher TBW than term infants. During the first year of life, TBW decreases to approximately 60% of body weight and remains at this level until puberty. At puberty, the fat content of females increases more than that in males, who acquire more muscle mass than females. Because fat has very low water content and muscle has high water content, by the end of puberty TBW in males remains at 60%, but TBW in females decreases to approximately 50% of body weight. The high fat content in overweight children causes a decrease in TBW as a percentage of body weight. During dehydration, TBW decreases and thus is a smaller percentage of body weight.

#### FLUID COMPARTMENTS

TBW is divided between two main compartments: **intracellular fluid (ICF)** and **extracellular fluid (ECF)**. In the fetus and newborn, the ECF volume is larger than the ICF volume (see Fig. 73.1). The normal postnatal diuresis causes an immediate decrease in the

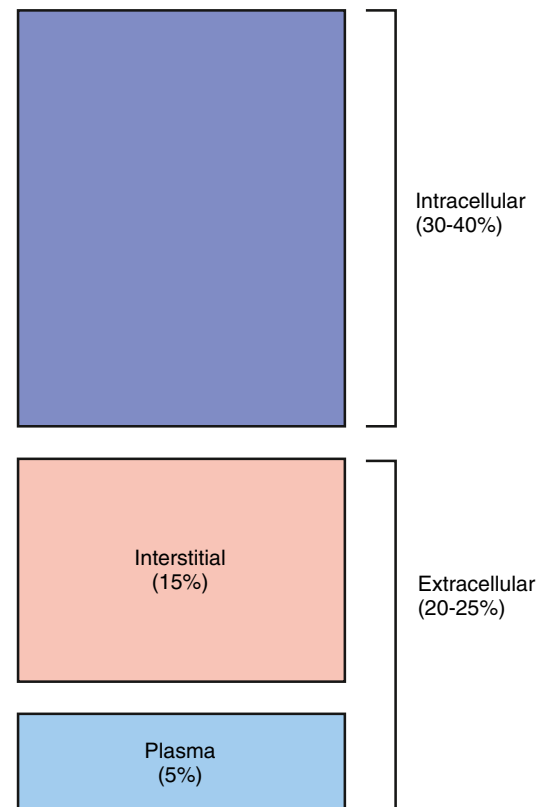


**Fig. 73.1** Total body water, intracellular fluid, and extracellular fluid as a percentage of body weight as a function of age. (From Winters RW. *Water and electrolyte regulation*. In: Winters RW, ed. *The Body Fluids in Pediatrics*. Little, Brown; 1973.)

ECF volume. This is followed by continued expansion of the ICF volume, which results from cellular growth. By 1 year of age, the ratio of ICF volume to ECF volume approaches adult levels. The ECF volume is approximately 20–25% of body weight, and the ICF volume is approximately 30–40% of body weight, close to twice the ECF volume (Fig. 73.2). With puberty, the increased muscle mass of males causes them to have a higher ICF volume than females. There is no significant difference in the ECF volume between postpubertal females and males.

The ECF is further divided into the plasma water and the interstitial fluid (see Fig. 73.2). The *plasma water* is 5% of body weight. The blood volume, given a hematocrit of 40%, is usually 8% of body weight, although it is higher in newborns and young infants; in premature newborns it is approximately 10% of body weight. The volume of plasma water can be altered by pathologic conditions, including dehydration, anemia, polycythemia, heart failure, abnormal plasma osmolality, and hypoalbuminemia. The *interstitial fluid*, normally 15% of body weight, can increase dramatically in diseases associated with edema, such as heart failure, protein-losing enteropathy, liver failure, nephrotic syndrome, and sepsis. An increase in interstitial fluid also occurs in patients with ascites or pleural effusions.

There is a delicate equilibrium between the intravascular fluid and the interstitial fluid. The balance between hydrostatic and



**Fig. 73.2** Compartments of total body water, expressed as percentages of body weight, in an older child or adult.

oncotic forces regulates the intravascular volume, which is critical for proper tissue perfusion. The *intravascular fluid* has a higher concentration of albumin than the interstitial fluid, and the consequent oncotic force draws water into the intravascular space. The maintenance of this gradient depends on the limited permeability of albumin across the capillaries. The hydrostatic pressure of the intravascular space, which is caused by the pumping action of the heart, drives fluid out of the intravascular space. These forces favor movement into the interstitial space at the arterial ends of the capillaries. The decreased hydrostatic forces and increased oncotic forces, which result from the dilutional increase in albumin concentration, cause movement of fluid into the venous ends of the capillaries. Overall, there is usually a net movement of fluid out of the intravascular space to the interstitial space, but this fluid is returned to the circulation via the *lymphatics*.

An imbalance in these forces may cause expansion of the interstitial volume at the expense of the intravascular volume. In children with hypoalbuminemia, the decreased oncotic pressure of the intravascular fluid contributes to the development of **edema**. Loss of fluid from the intravascular space may compromise the intravascular volume, placing the child at risk for inadequate blood flow to vital organs. This is especially likely in diseases in which capillary leak occurs because the loss of albumin from the intravascular space is associated with an increase in the albumin concentration in the interstitial space, further compromising the oncotic forces that normally maintain intravascular volume. In contrast, with **heart failure**, there is an increase in venous hydrostatic pressure from expansion of the intravascular volume, which is caused by impaired pumping by the heart, and the increase in venous pressure causes fluid to move from the intravascular space to the interstitial space. Expansion of the intravascular volume and increased intravascular pressure also cause the edema that occurs with acute glomerulonephritis.

### ELECTROLYTE COMPOSITION

The composition of the solutes in the ICF and ECF are very different (Fig. 73.3). **Sodium** ( $\text{Na}^+$ ) and **chloride** ( $\text{Cl}^-$ ) are the dominant cation and anion, respectively, in ECF. The sodium and chloride concentrations ( $[\text{Na}^+]$ ,  $[\text{Cl}^-]$ ) in the ICF are much lower. **Potassium** ( $\text{K}^+$ ) is the most abundant cation in the ICF, and its concentration

( $[\text{K}^+]$ ) within the cells is approximately 30 times higher than in the ECF. Proteins, organic anions, and phosphate are the most plentiful anions in the ICF. The dissimilarity between the anions in the ICF and the ECF is largely determined by the presence of intracellular molecules that do not cross the cell membrane, the barrier separating the ECF and the ICF. In contrast, the difference in the distribution of cations ( $\text{Na}^+$  and  $\text{K}^+$ ) relies on activity of the  $\text{Na}^+, \text{K}^+$ -adenosine triphosphatase (ATPase) pump and membrane ion channels.

The difference in the electrolyte compositions of the ECF and the ICF has important ramifications in the evaluation and treatment of electrolyte disorders. Serum concentrations of electrolytes ( $[\text{Na}^+]$ ,  $[\text{K}^+]$ , and  $[\text{Cl}^-]$ ) do not always reflect total body content. Intracellular  $[\text{K}^+]$  is much higher than the serum concentration. A shift of  $\text{K}^+$  from the **intracellular space (ICS)** can maintain a normal or even an elevated serum  $[\text{K}^+]$  despite massive losses of  $\text{K}^+$  from the ICS. This effect is seen in diabetic ketoacidosis, in which significant  $\text{K}^+$  depletion is masked by transmembrane shift of  $\text{K}^+$  from the ICF to the ECF. Therefore, for  $\text{K}^+$  and phosphorus, electrolytes with a high intracellular concentration, serum level may not reflect total body content. Similarly, the serum **calcium** concentration ( $[\text{Ca}^{2+}]$ ) does not reflect total body content of  $\text{Ca}^{2+}$ , which is largely contained in bone (see Chapter 69).

### OSMOLALITY

The ICF and the ECF are in **osmotic equilibrium** because the cell membrane is permeable to water. If the osmolality in one compartment changes, then water movement leads to a rapid equalization of osmolality, with a shift of water between the ICS and **extracellular space (ECS)**. Clinically, the primary process is usually a change in the osmolality of the ECF, with resultant shift of water into the ICF if ECF osmolality decreases, or vice versa if ECF osmolality increases. The *ECF osmolality* can be determined and *usually equals ICF osmolality*. **Plasma osmolality**, normally 285–295 mOsm/kg, is measured by the degree of freezing-point depression. The plasma osmolality can also be *estimated* by a calculation based on the following formula:

$$\text{Osmolality} = 2 \times [\text{Na}] + [\text{glucose}] / 18 + [\text{BUN}] / 2.8$$

Glucose and blood urea nitrogen (BUN) are reported in mg/dL. Division of these values by 18 and 2.8, respectively, converts the units into mmol/L. Multiplication of the  $[\text{Na}^+]$  value by 2 accounts for its accompanying anions, principally  $\text{Cl}^-$  and bicarbonate. The calculated osmolality is usually slightly lower than measured osmolality.

Urea is not confined to the ECS because it readily crosses the cell membrane, and its intracellular concentration approximately equals its extracellular concentration. Whereas an elevated  $[\text{Na}^+]$  causes a shift of water from the ICS, with **uremia** there is no osmolar gradient between the two compartments and consequently no movement of water. The only exception is during **hemodialysis**, when the decrease in extracellular urea is so rapid that intracellular urea does not have time to equilibrate. **Disequilibrium syndrome** during hemodialysis may result in a shift of water into brain cells and lead to severe symptoms. Ethanol, because it freely crosses cell membranes, is another ineffective osmole. Hence, the effective osmolality can be calculated as follows:

$$\text{Effective osmolality} = 2 \times [\text{Na}] + [\text{glucose}] / 18$$

The *effective osmolality* determines the osmotic force that is mediating the shift of water between the ECF and the ICF.

PLASMA		INTRACELLULAR	
Cations	Anions	Cations	Anions
$\text{Na}^+$ (140)	$\text{Cl}^-$ (104)	$\text{K}^+$ (140)	Phos <sup>-</sup> (107)
	$\text{HCO}_3^-$ (24)		Prot <sup>-</sup> (40)
	Prot <sup>-</sup> (14)		$\text{HCO}_3^-$ (10)
$\text{K}^+$ (4)	Other (6)	$\text{Na}^+$ (13)	$\text{Cl}^-$ (3)
$\text{Ca}^+$ (2.5)	Phos <sup>-</sup> (2)	$\text{Mg}^+$ (7)	
$\text{Mg}^+$ (1.1)			

**Fig. 73.3** Concentrations of the major cations and anions in the intracellular space and the plasma, expressed in mEq/L.



**Hyperglycemia** causes an increase in the plasma osmolality because it is not in equilibrium with the ICS. During hyperglycemia, there is shift of water from the ICS to the ECS. This shift causes dilution of the  $\text{Na}^+$  in the ECS, causing hyponatremia despite elevated plasma osmolality. The magnitude of this effect can be calculated as follows:

$$[\text{Na}]_{\text{corrected}} = [\text{Na}]_{\text{measured}} + 1.6 \times ([\text{glucose}] - 100 \text{ mg/dL}) / 100$$

where  $[\text{Na}]_{\text{measured}} = \text{Na}^+$  concentration measured by the clinical laboratory and  $[\text{Na}]_{\text{corrected}} =$  corrected  $\text{Na}^+$  concentration (the  $\text{Na}^+$  concentration if the glucose concentration were normal and its accompanying water moved back into the cells). The  $[\text{Na}]_{\text{corrected}}$  is the more reliable indicator of the ratio of total body  $\text{Na}^+$  to TBW, the usual determinant of the  $[\text{Na}^+]$ .

Normally, measured osmolality and calculated osmolality are within 10 mOsm/kg. However, there are some clinical situations in which this difference does not occur. The presence of **unmeasured osmoles** causes measured osmolality to be significantly elevated in comparison with the calculated osmolality. An **osmolal gap** is present when the difference between measured osmolality exceeds calculated osmolality by  $>10$  mOsm/kg. Examples of unmeasured osmoles include ethanol, ethylene glycol, methanol, sucrose, sorbitol, and mannitol. These substances increase measured osmolality but are not part of the equation for calculating osmolality. The presence of an osmolal gap is a clinical clue to the presence of unmeasured osmoles and may be diagnostically useful when there is clinical suspicion of poisoning with methanol or ethylene glycol.

**Pseudohyponatremia** is a second situation in which there is discordance between measured osmolality and calculated osmolality. Lipids and proteins are the solids of the serum. In patients with elevated serum lipids or proteins, the water content of the serum decreases because water is displaced by the larger amounts of solids. Some instruments measure  $[\text{Na}^+]$  by determining the amount of  $\text{Na}^+$  per liter of serum, including the solid component. When the solid component increases, there is a decrease in  $[\text{Na}^+]$  per liter of serum, despite a normal concentration when based on the amount of  $\text{Na}^+$  per liter of serum water. *It is the concentration of  $\text{Na}^+$  in serum water that is physiologically relevant.* A similar problem occurs when using instruments that require dilution of the sample before measurement of  $\text{Na}^+$  (indirect potentiometry). In both situations, the plasma osmolality is normal despite the presence of pseudohyponatremia, because the method for measuring osmolality is not appreciably influenced by the percentage of serum that is composed of lipids and proteins. Pseudohyponatremia is diagnosed by the finding of a normal measured plasma osmolality despite hyponatremia. This laboratory artifact does not occur if the  $[\text{Na}^+]$  in water is measured directly with an ion-specific electrode, as with arterial blood gas (ABG) analyzers. **Pseudohyponatremia** may occur in patients with very low levels of serum proteins by a similar mechanism.

When there are no unmeasured osmoles and pseudohyponatremia is not a concern, the calculated osmolality provides an accurate estimate of the plasma osmolality. Measurement of plasma osmolality is useful for detecting or monitoring unmeasured osmoles and confirming the presence of true hyponatremia. Whereas many children with high plasma osmolality are dehydrated—as seen with hypernatremic dehydration or diabetic ketoacidosis—high osmolality does not always equate with dehydration. A child with salt poisoning or uremia has an elevated plasma osmolality but may be volume overloaded.

### POINT-OF-CARE TESTING

Point-of-care (POC) testing offers a number of advantages, including rapid turnaround and usually smaller blood sample volume

required. POC devices may provide more accurate results in certain situations, such as pseudohyponatremia (see earlier) and pseudohyperkalemia (see Chapter 73.4). However, the agreement between POC and the laboratory is variable, and thus caution is needed when interpreting results. Because of bias, POC and laboratory results should not be used on an alternating basis when following critical trends (e.g., during correction of hypernatremia or hyponatremia; see Chapter 73.3).

Visit Elsevier eBooks+ at [eBooks.Elsevier.com](http://eBooks.Elsevier.com) for Bibliography.

## 73.2 Regulation of Osmolality and Volume

Larry A. Greenbaum

The regulation of plasma **osmolality** and the intravascular **volume** is controlled by independent systems for water balance, which determines osmolality, and sodium balance, which determines volume status. Maintenance of normal osmolality depends on control of water balance. Control of volume status depends on regulation of sodium balance. When present, volume depletion takes precedence over regulation of osmolality, and retention of water contributes to the maintenance of intravascular volume.

### REGULATION OF OSMOLALITY

The plasma osmolality is tightly regulated and maintained at 285–295 mOsm/kg. Modification of water intake and excretion maintains normal plasma osmolality. In the steady state, the combination of water intake and water produced by the body from oxidation balances water losses from the skin, lungs, urine, and gastrointestinal (GI) tract. Only water intake and urinary losses can be regulated.

Osmoreceptors in the hypothalamus sense plasma osmolality (see Chapter 594). An elevated effective osmolality leads to secretion of **antidiuretic hormone (ADH)** by neurons in the supraoptic and paraventricular nuclei in the hypothalamus. The axons of these neurons terminate in the posterior pituitary. Circulating ADH binds to its  $V_2$  receptors in the collecting duct cells of the kidney and causes insertion of water channels (aquaporin-2) into the renal collecting duct cells. This produces increased permeability to water, permitting resorption of water into the hypertonic renal medulla. Urine concentration increases and water excretion decreases. Urinary water losses cannot be eliminated because there is obligatory excretion of urinary solutes, such as urea and sodium. The regulation of ADH secretion is tightly linked to plasma osmolality, responses being detectable with a 1% change in osmolality. ADH secretion virtually disappears when plasma osmolality is low, allowing excretion of maximally dilute urine. The resulting loss of free water (i.e., water without  $\text{Na}^+$ ) corrects plasma osmolality. ADH secretion is not an all-or-nothing response; there is a graded adjustment as the osmolality changes.

Water intake is regulated by hypothalamic osmoreceptors, which stimulate thirst when the serum osmolality increases. Thirst occurs with a small increase in the serum osmolality. *Control of osmolality is subordinate to maintenance of an adequate intravascular volume.* When volume depletion is present, both ADH secretion and thirst are stimulated, regardless of the plasma osmolality. The sensation of thirst requires moderate volume depletion but only a 1–2% change in the plasma osmolality.

A number of conditions can limit the kidney's ability to excrete adequate water to correct low plasma osmolality. In the **syndrome of inappropriate antidiuretic hormone (SIADH)**, ADH continues to be produced despite a low plasma osmolality (see Chapters 73.3 and 597).

The glomerular filtration rate (GFR) affects the kidney's ability to eliminate water. With a decrease in the GFR, less water is delivered to

the collecting duct, limiting the amount of water that can be excreted. The impairment in the GFR must be quite significant to limit the kidney's ability to respond to an excess of water.

The **minimum urine osmolality** is approximately 30–50 mOsm/kg. This places an upper limit on the kidney's ability to excrete water; sufficient solute must be present to permit water loss. Massive water intoxication may exceed this limit, whereas a lesser amount of water is necessary in the child with a diet that has very little solute. This can produce severe hyponatremia in children who receive little salt and have minimal urea production as a result of inadequate protein intake. Volume depletion is an extremely important cause of decreased water loss by the kidney despite a low plasma osmolality. This “appropriate” secretion of ADH occurs because volume depletion takes precedence over the osmolality in the regulation of ADH.

The **maximum urine osmolality** is approximately 1,200 mOsm/kg. The obligatory solute losses dictate the minimum volume of urine that must be produced, even when maximally concentrated. Obligatory water losses increase in patients with high salt intake or high urea losses, as may occur after relief of a urinary obstruction or during recovery from acute kidney injury. An increase in urinary solute and thus water losses occurs with an **osmotic diuresis**, which results classically from glycosuria in diabetes mellitus as well as iatrogenically after mannitol administration. There are developmental changes in the kidney's ability to concentrate the urine. The maximum urine osmolality in a newborn, especially a premature newborn, is less than that in an older infant or child. This limits the ability to conserve water and makes such a patient more vulnerable to hypernatremic dehydration. Very high fluid intake, as seen with **psychogenic polydipsia**, can dilute the high osmolality in the renal medulla, which is necessary for maximal urinary concentration. If fluid intake is restricted in patients with this condition, the kidney's ability to concentrate the urine may be somewhat impaired, although this defect corrects after a few days without polydipsia. This may also occur during the initial treatment of central diabetes insipidus with desmopressin acetate; the renal medulla takes time to achieve its normal maximum osmolality.

## REGULATION OF VOLUME

An appropriate intravascular volume is critical for survival; both volume depletion and volume overload may cause significant morbidity and mortality. Because sodium is the principal extracellular cation and is restricted to the ECF, adequate body sodium is necessary for maintenance of intravascular volume. The principal extracellular anion,  $\text{Cl}^-$ , is also necessary, but for simplicity,  $\text{Na}^+$  balance is considered the main regulator of volume status because body content of sodium and that of chloride usually change proportionally, given the need for equal numbers of cations and anions. In some situations,  $\text{Cl}^-$  depletion is considered the dominant derangement causing volume depletion (metabolic alkalosis with volume depletion).

The kidney determines sodium balance because there is little homeostatic control of sodium intake, even though **salt craving** does occasionally occur, typically in children with chronic renal salt loss. The kidney regulates  $\text{Na}^+$  balance by altering the percentage of filtered  $\text{Na}^+$  that is resorbed along the nephron. Normally, the kidney excretes <1% of the  $\text{Na}^+$  filtered at the glomerulus. In the absence of disease, extrarenal losses and urinary output match intake, with the kidney having the capacity to adapt to large variations in sodium intake. When necessary, urinary sodium excretion can be reduced to virtually undetectable levels or increased dramatically.

The most important determinant of renal  $\text{Na}^+$  excretion is the volume status of the child; it is the effective intravascular volume that influences urinary  $\text{Na}^+$  excretion. The *effective intravascular volume* is the volume status that is sensed by the body's regulatory mechanisms. Heart failure is a state of volume overload, but the effective intravascular volume is low because poor cardiac function prevents adequate perfusion of the kidneys and other organs. This explains the avid renal  $\text{Na}^+$  retention often present in patients with heart failure.

The **renin-angiotensin system** is an important regulator of renal  $\text{Na}^+$  excretion. The juxtaglomerular apparatus produces renin in response to decreased effective intravascular volume. Specific stimuli for renin release are decreased perfusion pressure in the afferent arteriole of the glomerulus, decreased delivery of sodium to the distal nephron, and  $\beta_1$ -adrenergic agonists, which increase in response to intravascular volume depletion. Renin, a proteolytic enzyme, cleaves angiotensinogen, producing angiotensin I. Angiotensin-converting enzyme (ACE) converts angiotensin I into angiotensin II. The actions of angiotensin II include direct stimulation of the proximal tubule to increase sodium resorption and stimulation of the adrenal gland to increase aldosterone secretion. Through its actions in the distal nephron—specifically, the late distal convoluted tubule and the collecting duct—aldosterone increases sodium resorption. Aldosterone also stimulates potassium excretion, increasing urinary losses. Along with decreasing urinary loss of sodium, angiotensin II acts as a vasoconstrictor, which helps maintain adequate blood pressure in the presence of volume depletion.

Volume expansion stimulates the synthesis of **atrial natriuretic peptide (ANP)**, which is produced by the atria in response to atrial wall distention. Along with increasing the GFR, ANP inhibits  $\text{Na}^+$  resorption in the medullary portion of the collecting duct, facilitating an increase in urinary  $\text{Na}^+$  excretion.

**Volume overload** occurs when  $\text{Na}^+$  intake exceeds output. Children with kidney failure have impaired ability to excrete  $\text{Na}^+$ . The GFR is low at birth, limiting a newborn's ability to excrete a  $\text{Na}^+$  load. In other situations, there is a loss of the appropriate regulation of renal  $\text{Na}^+$  excretion. This loss of regulation occurs in patients with excessive aldosterone, as seen in primary hyperaldosteronism or renal artery stenosis, where excess renin production leads to high aldosterone levels. In acute glomerulonephritis, even without significantly reduced GFR, the normal intrarenal mechanisms that regulate  $\text{Na}^+$  excretion malfunction, causing excessive renal retention of  $\text{Na}^+$  and volume overload.

Renal retention of  $\text{Na}^+$  occurs during volume depletion, but this appropriate response causes the severe excess in total body  $\text{Na}^+$  that is present in heart failure, liver failure, nephrotic syndrome, and other causes of hypoalbuminemia. In these diseases, the effective intravascular volume is decreased, causing the kidney and the various regulatory systems to respond, leading to renal  $\text{Na}^+$  retention and edema formation.

**Volume depletion** usually occurs when  $\text{Na}^+$  losses exceed intake. The most common etiology in children is gastroenteritis. Excessive losses of sodium may also occur from the skin in children with burns, in sweat from patients with cystic fibrosis, or after vigorous exercise. Inadequate intake of  $\text{Na}^+$  is uncommon except in neglect, in famine, or with an inappropriate choice of liquid diet in a child who cannot take solids. Urinary  $\text{Na}^+$  wasting may occur in a range of renal diseases, from renal dysplasia to tubular disorders, such as Bartter syndrome. The neonate, especially if premature, has a mild impairment in the ability to conserve  $\text{Na}^+$ . Iatrogenic renal  $\text{Na}^+$  wasting takes place during diuretic therapy. Renal  $\text{Na}^+$  loss occurs as a result of derangement in the normal regulatory systems. An absence of aldosterone, seen most frequently in children with **congenital adrenal hyperplasia** caused by 21-hydroxylase deficiency, causes sodium wasting (see Chapter 616).

Isolated disorders of water balance can affect volume status and  $\text{Na}^+$  balance. Because the cell membrane is permeable to water, changes in TBW influence both the extracellular volume and the intracellular volume. In isolated water loss, as occurs in diabetes insipidus, the impact is greater on the ICS because it has a greater volume than the ECS. Thus, compared with other types of dehydration, hypernatremic dehydration has less impact on plasma volume; most of the fluid loss comes from the ICS. Yet, significant water loss eventually affects intravascular volume and will stimulate renal  $\text{Na}^+$  retention, even if total body  $\text{Na}^+$  content is normal. Similarly, with acute water intoxication or SIADH, there is an excess of TBW, but most is in the ICS. However, there is some effect on the intravascular volume, which causes renal excretion

of  $\text{Na}^+$ . Children with SIADH or water intoxication have high urine  $\text{Na}^+$  concentration despite hyponatremia. This finding reinforces the concept of independent control systems for water and  $\text{Na}^+$ , but the 2 systems interact when pathophysiologic processes dictate, and control of effective intravascular volume always takes precedence over control of osmolality.

Visit Elsevier eBooks+ at [eBooks.Health.Elsevier.com](http://eBooks.Health.Elsevier.com) for Bibliography.

## 73.3 Sodium

Larry A. Greenbaum

### SODIUM METABOLISM

#### Body Content and Physiologic Function

Sodium is the dominant cation of the ECF (see Fig. 73.3), and it is the principal determinant of extracellular osmolality.  $\text{Na}^+$  is therefore necessary for the maintenance of intravascular volume. Less than 3% of  $\text{Na}^+$  is intracellular. More than 40% of total body  $\text{Na}^+$  is in bone; the remainder is in the interstitial and intravascular spaces. The low intracellular  $[\text{Na}^+]$ , approximately 10 mEq/L, is maintained by  $\text{Na}^+, \text{K}^+$ -ATPase, which exchanges intracellular  $\text{Na}^+$  for extracellular  $\text{K}^+$ .

#### Sodium Intake

A child's diet determines the amount of  $\text{Na}^+$  ingested—a predominantly cultural determination in older children. An occasional child has salt craving because of an underlying salt-wasting renal disease or adrenal insufficiency. Children in the United States tend to have very high salt intakes because their diets include a large amount of “junk” food or fast food. Infants receive sodium from breast milk (approximately 7 mEq/L) and formula (7–13 mEq/L, for 20 calorie/oz formula).

Sodium is readily absorbed throughout the GI tract. Mineralocorticoids increase sodium transport into the body, although this effect has limited clinical significance. The presence of glucose enhances sodium absorption because of the presence of a co-transport system. This is the rationale for including sodium and glucose in oral rehydration solutions (see Chapter 387).

#### Sodium Excretion

Sodium excretion occurs in stool and sweat, but the kidney regulates  $\text{Na}^+$  balance and is the principal site of  $\text{Na}^+$  excretion. There is some  $\text{Na}^+$  loss in stool, but it is minimal unless diarrhea is present. Normally, sweat has 5–40 mEq/L of sodium. Sweat  $[\text{Na}^+]$  is increased in children with cystic fibrosis, aldosterone deficiency, or pseudohypoaldosteronism. The higher sweat losses in these conditions may cause or contribute to  $\text{Na}^+$  depletion.

Sodium is unique among electrolytes because water balance, not  $\text{Na}^+$  balance, usually determines its concentration. When the  $[\text{Na}^+]$  increases, the resultant higher plasma osmolality causes increased thirst and increased secretion of ADH, which leads to renal conservation of water. Both these mechanisms increase the water content of the body, and the  $[\text{Na}^+]$  returns to normal. During hyponatremia, the decrease in plasma osmolality stops ADH secretion, and consequent renal water excretion leads to an increase in the  $[\text{Na}^+]$ . Even though water balance is usually regulated by osmolality, volume depletion does stimulate thirst, ADH secretion, and renal conservation of water. Volume depletion takes precedence over osmolality; volume depletion stimulates ADH secretion, even if a patient has hyponatremia.

The excretion of  $\text{Na}^+$  by the kidney is not regulated by the plasma osmolality. The patient's effective plasma volume determines the amount of sodium in the urine. This is mediated by a variety of regulatory systems, including the renin-angiotensin-aldosterone system and intrarenal mechanisms. In hyponatremia or hypernatremia, the underlying pathophysiology determines the amount of urinary  $\text{Na}^+$ , not the serum  $[\text{Na}^+]$ .

**Table 73.1** Causes of Hypernatremia

#### EXCESSIVE SODIUM

Improperly mixed formula  
Excess sodium bicarbonate  
Ingestion of seawater or sodium chloride  
Intentional salt poisoning (child abuse or fictitious disorder inflicted on another)  
Intravenous hypertonic saline  
Sodium phosphate enemas  
Hyperaldosteronism

#### WATER DEFICIT

##### *Nephrogenic Diabetes Insipidus*

Acquired  
X-linked (OMIM 304800)  
Autosomal recessive (OMIM 125800)  
Autosomal dominant (OMIM 125800)

##### *Central Diabetes Insipidus*

Acquired\*  
Autosomal recessive (OMIM 125700/600955)  
Autosomal dominant (OMIM 125700)  
Wolfram syndrome (OMIM 222300/604928/598500)  
Hypothalamic neurogenic (essential) adipsic hypernatremia

#### Increased Insensible Losses

Premature infants  
Radiant warmers  
Phototherapy

#### Inadequate Intake

Ineffective breastfeeding  
Child neglect or abuse  
Adipsia (lack of thirst)

#### WATER AND SODIUM DEFICITS

##### *Gastrointestinal Losses*

Diarrhea  
Emesis/nasogastric suction  
Osmotic cathartics (lactulose)

##### *Cutaneous Losses*

Burns  
Excessive sweating

##### *Renal Losses*

Osmotic diuretics (mannitol)  
Diabetes mellitus  
Chronic kidney disease (dysplasia and obstructive uropathy)  
Polyuric phase of acute tubular necrosis  
Postobstructive diuresis

\*Acquired: central diabetes insipidus from CNS malformations, trauma, meningitis, tumor, infiltration, unknown.

OMIM, database number from the Online Mendelian Inheritance in Man (<http://www.ncbi.nlm.nih.gov/omim>).

## HYPERNATREMIA

Hypernatremia is a  $[\text{Na}^+] >145$  mEq/L, although it is sometimes defined as  $>150$  mEq/L. Mild hypernatremia is common in children, especially among infants with gastroenteritis. Hypernatremia in hospitalized patients may be iatrogenic, which is caused by inadequate water administration or, less often, by excessive  $\text{Na}^+$  administration. Moderate or severe hypernatremia has significant morbidity because of the underlying disease, the effects of hypernatremia on the brain, and the risks of overly rapid correction.



## Etiology and Pathophysiology

There are three basic mechanisms of hypernatremia (Table 73.1). *Sodium intoxication* may be iatrogenic in a hospital setting because of correction of metabolic acidosis with sodium bicarbonate. Baking soda, a putative home remedy for upset stomach, is another source of sodium bicarbonate; the hypernatremia is accompanied by a profound metabolic alkalosis. Hypernatremia may develop following sodium phosphate emesis. In hyperaldosteronism, there is renal retention of sodium and resultant hypertension; hypernatremia may not be present or is usually mild.

The classic causes of hypernatremia from a *water deficit* are **nephrogenic** and **central diabetes insipidus** (see Chapters 570 and 596). Hypernatremia develops in diabetes insipidus only if the patient does not have access to water or cannot drink adequately because of immaturity, neurologic impairment, emesis, or anorexia. Infants are at high risk because of their inability to control their own water intake. Central diabetes insipidus and the genetic forms of nephrogenic diabetes insipidus typically cause massive urinary water losses and very dilute urine. The water losses are less dramatic, and the urine often has the same osmolality as plasma when nephrogenic diabetes insipidus is secondary to intrinsic renal disease (obstructive uropathy, renal dysplasia, sickle cell disease).

The other causes of a water deficit are also secondary to an imbalance between losses and intake. Newborns, especially if premature, have high insensible water losses. Losses are further increased if the infant is placed under a radiant warmer or with the use of phototherapy for hyperbilirubinemia. The renal concentrating mechanisms are not optimal at birth, providing an additional source of water loss. Ineffective breastfeeding, often in a primiparous mother, can cause severe hypernatremic dehydration. **Adipsia**, the absence of thirst, is usually secondary to damage to the hypothalamus, such as from trauma, tumor, hydrocephalus, or histiocytosis. Primary adipsia (**essential hypernatremia**) is rare but is seen in children with central nervous system (CNS) malformations (septo-optic dysplasia, holoprosencephaly, optic nerve hypoplasia).

When hypernatremia occurs in conditions with *deficits of sodium and water*, the water deficit exceeds the sodium deficit. This occurs only if the patient is unable to ingest adequate water. Diarrhea results in depletion of both  $\text{Na}^+$  and water. Because diarrhea is hypotonic—typical  $\text{Na}^+$  concentration of 35–65 mEq/L—water losses exceed  $\text{Na}^+$  losses, potentially leading to hypernatremia. Most children with gastroenteritis do not have hypernatremia because they drink enough hypotonic fluid to compensate for stool water losses (see Chapter 387). Fluids such as water, juice, and formula are more hypotonic than the stool losses, allowing correction of the water deficit and potentially even causing hyponatremia. Hypernatremia is most likely to occur in the child with diarrhea who has inadequate intake because of emesis, lack of access to water, or anorexia.

Osmotic agents, including mannitol, and glucose in diabetes mellitus, cause excessive renal losses of water and  $\text{Na}^+$ . Because the urine is hypotonic ( $[\text{Na}^+]$  of approximately 50 mEq/L) during an osmotic diuresis, water loss exceeds  $\text{Na}^+$  loss, and hypernatremia may occur if water intake is inadequate. Certain chronic kidney diseases, such as renal dysplasia and obstructive uropathy, are associated with tubular dysfunction, leading to excessive losses of water and  $\text{Na}^+$ . Many children with such diseases have disproportionate water loss and are at risk for hypernatremic dehydration, especially if gastroenteritis supervenes. Similar mechanisms occur during the polyuric phase of acute kidney injury and after relief of urinary obstruction (postobstructive diuresis). Patients with either condition may have an osmotic diuresis from urinary losses of urea and an inability to conserve water because of tubular dysfunction.

## Clinical Manifestations

Most children with hypernatremia are dehydrated and show the typical clinical signs and symptoms (see Chapter 75). Children with hypernatremic dehydration tend to have better preservation of intravascular volume because of the shift of water from the ICS to the ECS. This shift

maintains blood pressure and urine output and allows hypernatremic infants to be less symptomatic initially and potentially to become more dehydrated before medical attention is sought. Breastfed infants with hypernatremia are often profoundly dehydrated, with failure to thrive (malnutrition). Probably because of intracellular water loss, the pinched abdominal skin of a dehydrated, hypernatremic infant has a “doughy” feel.

Hypernatremia, even without dehydration, causes central nervous system (CNS) symptoms that tend to parallel the degree of  $[\text{Na}^+]$  elevation and the acuity of the increase. Patients are irritable, restless, weak, and lethargic. Some infants have a high-pitched cry and hyperpnea. Alert patients are very thirsty, even though nausea may be present. Hypernatremia may cause fever, although many patients have an underlying process that contributes to the fever. Hypernatremia is associated with hyperglycemia and mild hypocalcemia; the mechanisms are unknown. Beyond the sequelae of dehydration, there is no clear direct effect of hypernatremia on other organs or tissues, except the brain.

**Brain hemorrhage** is the most devastating consequence of *untreated* hypernatremia. As the extracellular osmolality increases, water moves out of brain cells, leading to a decrease in brain volume. This decrease can result in tearing of intracerebral veins and bridging blood vessels as the brain moves away from the skull and the meninges. Patients may have subarachnoid, subdural, and parenchymal hemorrhages. Seizures and coma are possible sequelae of the hemorrhage, although seizures are more common during correction of hypernatremia. The cerebrospinal fluid protein is often elevated in infants with significant hypernatremia, probably because of leakage from damaged blood vessels. Neonates, especially if premature, seem especially vulnerable to hypernatremia and excessive sodium intake. There is an association between rapid or hyperosmolar sodium bicarbonate administration and the development of intraventricular hemorrhages in neonates. Even though **osmotic demyelination syndrome (ODS)**, which includes central pontine myelinolysis and extrapontine myelinolysis, is classically associated with overly rapid correction of hyponatremia, it can occur in children with hypernatremia (see “Treatment”). Thrombotic complications occur in severe hypernatremic dehydration, including stroke, dural sinus thrombosis, peripheral thrombosis, and renal vein thrombosis. This is secondary to dehydration and possibly hypercoagulability associated with hypernatremia.

## Diagnosis

The etiology of hypernatremia is usually apparent from the history. Hypernatremia resulting from water loss occurs only if the patient does not have access to water or is unable to drink. In the absence of dehydration, it is important to ask about sodium intake. Children with excess salt intake do not have signs of dehydration, unless another process is present. Severe  $\text{Na}^+$  intoxication causes signs of volume overload, such as pulmonary edema and weight gain. **Salt poisoning** is associated with an elevated fractional excretion of  $\text{Na}^+$ , whereas hypernatremic dehydration causes a low fractional excretion of  $\text{Na}^+$ . Gastric sodium concentrations are often elevated in salt poisoning. In hyperaldosteronism, hypernatremia is usually mild or absent and is associated with edema, hypertension, hypokalemia, and metabolic alkalosis.

When there is isolated water loss, the signs of volume depletion are usually less severe initially because much of the loss is from the ICS. When pure water loss causes signs of dehydration, the hypernatremia and water deficit are usually severe. In the child with renal water loss, either central or nephrogenic diabetes insipidus, the urine is inappropriately dilute and urine volume is not low. The urine is maximally concentrated and urine volume is low if the losses are extrarenal or caused by inadequate intake. With extrarenal causes of loss of water, the urine osmolality should be  $>1,000$  mOsm/kg. When diabetes insipidus is suspected, the evaluation may include measurement of ADH and a water-deprivation test, including a trial of desmopressin acetate (synthetic ADH analog) to differentiate between nephrogenic diabetes insipidus and central



diabetes insipidus (see Chapters 570 and 596). A water-deprivation test is unnecessary if the patient has simultaneous documentation of hypernatremia and poorly concentrated urine (osmolality lower than that of plasma). In children with central diabetes insipidus, administration of desmopressin acetate increases the urine osmolality above the plasma osmolality, although maximum osmolality does not occur immediately because of the decreased osmolality of the renal medulla as a result of the chronic lack of ADH. In children with nephrogenic diabetes insipidus, there is no response to desmopressin acetate. *Hypercalcemia or hypokalemia may produce a nephrogenic diabetes insipidus-like syndrome.*

With combined  $\text{Na}^+$  and water deficits, analysis of the urine differentiates between renal and nonrenal etiologies. When the losses are extrarenal, the kidney responds to volume depletion with low urine volume, concentrated urine, and  $\text{Na}^+$  retention (urine  $[\text{Na}^+] < 20$  mEq/L, fractional excretion of  $\text{Na}^+ < 1\%$ ). With renal causes, the urine volume is not appropriately low, the urine is not maximally concentrated, and the urine  $[\text{Na}^+]$  may be inappropriately elevated.

### Treatment

As hypernatremia develops, the brain generates **idiogenic osmoles** to increase the intracellular osmolality and prevent the loss of brain water. This mechanism is not instantaneous and is most prominent when hypernatremia has developed gradually. If the serum  $[\text{Na}^+]$  is lowered rapidly, there is movement of water from the serum into the brain cells to equalize the osmolality in the two compartments. The resultant brain swelling may manifest as seizures or coma.

Because of the associated dangers, *chronic hypernatremia should not be corrected rapidly*. The goal is to decrease the serum  $[\text{Na}^+]$ , but avoid a decrease of more than 10 mEq/L every 24 hours. The most important component of correcting moderate or severe hypernatremia is frequent monitoring of the serum  $[\text{Na}^+]$  value so that fluid therapy can be adjusted to provide adequate correction, neither too slow nor too fast. If a child has seizures because of brain edema secondary to rapid correction, administration of hypotonic fluid should be stopped. An infusion of 3% saline can acutely increase the serum  $[\text{Na}^+]$ , reversing the cerebral edema.

Chapter 75 outlines a detailed approach to the child with hypernatremic dehydration. Acute, severe hypernatremia, usually secondary to sodium administration, can be corrected more rapidly with 5% dextrose in water (D5W) because idiogenic osmoles have not had time to accumulate. This fact balances the high morbidity and mortality rates associated with hypernatremia with the dangers of overly rapid correction. When hypernatremia is severe and is caused by sodium intoxication, it may be impossible to administer enough water to correct the hypernatremia rapidly without worsening the volume overload. In this situation, dialysis allows for removal of the excess  $\text{Na}^+$ , with the precise strategy dependent on the mode of dialysis. In less severe cases, the addition of a loop diuretic increases the removal of excess  $\text{Na}^+$  and water, decreasing the risk of volume overload. With  $\text{Na}^+$  overload, hypernatremia is corrected with  $\text{Na}^+$ -free intravenous (IV) fluid (D5W).

Hyperglycemia from hypernatremia is not usually a problem and is not treated with insulin because the acute decrease in glucose may precipitate cerebral edema by lowering plasma osmolality. Rarely, the glucose concentration of IV fluids must be reduced (from 5% to 2.5% dextrose in water). The secondary hypocalcemia is treated as needed.

It is important to address the underlying cause of the hypernatremia, if possible. The child with central diabetes insipidus should receive desmopressin acetate. Because this treatment reduces renal excretion of water, excessive intake of water must be avoided to prevent both overly rapid correction of the hypernatremia and the development of hyponatremia. Over the long-term, reduced sodium intake and the use of medications can somewhat ameliorate the water losses in nephrogenic diabetes insipidus (see Chapter 570). The daily water intake of a child receiving tube feeding may need to be increased to compensate for high losses. The patient with

significant ongoing losses, such as through diarrhea, may need supplemental water and electrolytes (see Chapter 74). Sodium intake is reduced if it contributed to the hypernatremia.

### HYPONATREMIA

Hyponatremia, a very common electrolyte abnormality in hospitalized patients, is a serum sodium level  $< 135$  mEq/L. Both total body sodium and TBW determine the serum sodium concentration. Hyponatremia exists when the ratio of water to  $\text{Na}^+$  is increased. This condition can occur with low, normal, or high levels of body  $\text{Na}^+$ . Similarly, body water can be low, normal, or high.

### Etiology and Pathophysiology

Table 73.2 lists the causes of hyponatremia. **Pseudohyponatremia** is a laboratory artifact present when the plasma contains very high concentrations of protein (multiple myeloma, intravenous immune globulin [IVIG] infusion) or lipid (hypertriglyceridemia, hypercholesterolemia). It does not occur when a direct ion-selective electrode determines the  $[\text{Na}^+]$  in undiluted plasma, a technique that is used by ABG analyzers or POC instruments (see Chapter 73.1). In true hyponatremia, the measured osmolality is low, whereas it is normal in pseudohyponatremia. **Hyperosmolality**, as may occur with hyperglycemia, causes a low  $[\text{Na}^+]$  because water moves down its osmotic gradient from the ICS into the ECS, diluting the  $[\text{Na}^+]$ . However, because the manifestations of hyponatremia are a result of the low plasma osmolality, patients with hyponatremia resulting from hyperosmolality do not have symptoms of hyponatremia. When the etiology of the hyperosmolality resolves, such as hyperglycemia in diabetes mellitus, water moves back into the cells, and the  $[\text{Na}^+]$  rises to its “true” value. Mannitol or sucrose, a component of IVIG preparations, may cause hyponatremia because of hyperosmolality.

Classification of hyponatremia is based on the patient’s volume status. In **hypovolemic hyponatremia**, the child has lost  $\text{Na}^+$  from the body. The water balance may be positive or negative, but  $\text{Na}^+$  loss has been higher than water loss. The pathogenesis of the hyponatremia is usually a combination of  $\text{Na}^+$  loss and water retention to compensate for the volume depletion. The patient has a pathologic increase in fluid loss, and this fluid contains  $\text{Na}^+$ . Most fluid that is lost has a lower  $[\text{Na}^+]$  than that of plasma. Viral diarrhea fluid has an average  $[\text{Na}^+]$  of 50 mEq/L. Replacing diarrhea fluid, which has  $[\text{Na}^+]$  of 50 mEq/L, with formula, which has only approximately 7–10 mEq/L of  $\text{Na}^+$ , reduces the serum  $[\text{Na}^+]$ . Intravascular volume depletion interferes with renal water excretion, the body’s usual mechanism for preventing hyponatremia. The volume depletion stimulates ADH synthesis, resulting in renal water retention. Volume depletion also decreases the GFR and enhances water resorption in the proximal tubule, thereby reducing water delivery to the collecting duct.

Diarrhea as a result of gastroenteritis is the most common cause of hypovolemic hyponatremia in children. Emesis causes hyponatremia if the patient takes in hypotonic fluid, either IV or enterally, despite the emesis. Most patients with emesis have either a normal  $[\text{Na}^+]$  or hypernatremia. Burns may cause massive losses of isotonic fluid and resultant volume depletion. Hyponatremia develops if the patient receives hypotonic fluid. Losses of sodium from sweat are especially high in children with cystic fibrosis, aldosterone deficiency, or pseudohypoaldosteronism, although high losses can also occur in a hot climate. Third space losses are isotonic and can cause significant volume depletion, leading to ADH production and water retention, which can cause hyponatremia if the patient receives hypotonic fluid. In diseases that cause volume depletion through extrarenal  $\text{Na}^+$  loss, the urine  $\text{Na}^+$  level should be low ( $< 10$  mEq/L) as part of the renal response to maintain the intravascular volume. The only exceptions are diseases that cause both extrarenal and renal  $\text{Na}^+$  losses: adrenal insufficiency and pseudohypoaldosteronism.

**Table 73.2** Causes of Hyponatremia**PSEUDOHYPONATREMIA**

Hyperlipidemia  
Hyperproteinemia

**HYPEROSMOLALITY**

Hyperglycemia  
Iatrogenic (mannitol, sucrose, glycine)

**HYPOVOLEMIC HYPONATREMIA****Extrarenal Losses**

Gastrointestinal (emesis, diarrhea)  
Skin (sweating or burns)  
Third space losses (bowel obstruction, peritonitis, sepsis)

**Renal Losses**

Thiazide or loop diuretics  
Osmotic diuresis  
Postobstructive diuresis  
Polyuric phase of acute tubular necrosis  
Juvenile nephronophthisis (OMIM 256100/606966/602088/604387/611498)  
Autosomal recessive polycystic kidney disease (OMIM 263200)  
Tubulointerstitial nephritis  
Obstructive uropathy  
Cerebral salt wasting  
Proximal (type II) renal tubular acidosis (OMIM 604278)\*  
Lack of aldosterone effect (high serum potassium):  
Absence of aldosterone (e.g., 21-hydroxylase deficiency [OMIM 201910])  
Pseudohypoaldosteronism type I (OMIM 264350/177735)  
Urinary tract obstruction and/or infection  
Addison disease

**EUVOLEMIC HYPONATREMIA**

Syndrome of inappropriate antidiuretic hormone secretion (SIADH)  
Nephrogenic syndrome of inappropriate antidiuresis (OMIM 304800)  
Desmopressin acetate  
Glucocorticoid deficiency  
Hypothyroidism  
Antidepressant medications  
Water intoxication  
Iatrogenic (excess hypotonic intravenous fluids)  
Feeding infants excessive water products  
Swimming lessons  
Tap water enema  
Child abuse  
Psychogenic polydipsia  
Diluted formula  
Beer potomania  
Exercise-induced hyponatremia

**HYPERVOLEMIC HYPONATREMIA**

Heart failure  
Cirrhosis  
Nephrotic syndrome  
Acute, chronic kidney injury  
Capillary leak caused by sepsis  
Hypoalbuminemia caused by gastrointestinal disease (protein-losing enteropathy)

\*Most cases of proximal renal tubular acidosis are not caused by this primary genetic disorder. Proximal renal tubular acidosis is usually part of Fanconi syndrome, which has multiple etiologies.

OMIM, database number from the Online Mendelian Inheritance in Man (<http://www.ncbi.nlm.nih.gov/omim>).

Renal Na<sup>+</sup> loss may occur in a variety of situations. In some situations the urine [Na<sup>+</sup>] is >140 mEq/L; thus hyponatremia may occur without any fluid intake. In many cases, the urine Na<sup>+</sup> level is less than the serum [Na<sup>+</sup>]; hence, the intake of hypotonic fluid

**Table 73.3** Diagnostic Criteria for Syndrome of Inappropriate Antidiuretic Hormone Secretion

- Absence of:  
Renal, adrenal, or thyroid insufficiency  
Heart failure, nephrotic syndrome, or cirrhosis  
Diuretic ingestion  
Dehydration
- Urine osmolality >100 mOsm/kg (usually > plasma)
- Serum osmolality <280 mOsm/kg and serum sodium <135 mEq/L
- Urine sodium >30 mEq/L
- Reversal of "sodium wasting" and correction of hyponatremia with water restriction

is necessary for hyponatremia to develop. In diseases associated with urinary Na<sup>+</sup> loss, the urine Na<sup>+</sup> level is >20 mEq/L despite volume depletion. This may not be true if the urinary Na<sup>+</sup> loss is no longer occurring, as is frequently the case if diuretics are discontinued. Because loop diuretics prevent generation of a maximally hypertonic renal medulla, the patient can neither maximally dilute nor concentrate the urine. The inability to maximally retain water provides some protection against severe hyponatremia. The patient receiving thiazide diuretics can concentrate the urine and is at higher risk for severe hyponatremia. Osmotic agents, such as glucose during diabetic ketoacidosis, cause loss of both water and Na<sup>+</sup>. Urea accumulates during kidney failure and then acts as an osmotic diuretic after relief of urinary tract obstruction and during the polyuric phase of acute tubular necrosis. Transient tubular damage in these conditions further impairs Na<sup>+</sup> conservation. The serum [Na<sup>+</sup>] in these conditions depends on [Na<sup>+</sup>] of the fluid used to replace the losses. Hyponatremia develops when the fluid is hypotonic relative to the urinary losses.

**Renal salt wasting** occurs in hereditary kidney diseases, such as juvenile nephronophthisis and autosomal recessive polycystic kidney disease. Obstructive uropathy, most often a result of posterior urethral valves, produces salt wasting, but patients with the disease may also have hypernatremia as a result of impaired ability to concentrate urine and high-water loss. Acquired tubulointerstitial nephritis, usually secondary to either medications or infections, may cause salt wasting, along with other evidence of tubular dysfunction. CNS injury may produce cerebral salt wasting, which is theoretically caused by the production of a natriuretic peptide that causes renal salt wasting. In type II **renal tubular acidosis (RTA)**, usually associated with Fanconi syndrome (see Chapter 569.1), there is increased excretion of Na<sup>+</sup> and bicarbonate in the urine. Patients with Fanconi syndrome also have glycosuria, aminoaciduria, and hypophosphatemia because of renal phosphate wasting.

Aldosterone is necessary for renal Na<sup>+</sup> retention and for the excretion of K<sup>+</sup> and acid. In congenital adrenal hyperplasia caused by 21-hydroxylase deficiency, the block of aldosterone production results in hyponatremia, hyperkalemia, and metabolic acidosis. Decreased aldosterone secretion may be seen in Addison disease (adrenal insufficiency). In pseudohypoaldosteronism, aldosterone levels are elevated, but there is no response because of either a defective Na<sup>+</sup> channel or a deficiency of aldosterone receptors. A lack of tubular response to aldosterone may occur in children with urinary tract obstruction, especially during an acute urinary tract infection.

In **hypervolemic hyponatremia**, there is an excess of TBW and Na<sup>+</sup>, although the increase in water is greater than the increase in Na<sup>+</sup>. In most conditions that cause hypervolemic hyponatremia, there is a decrease in the *effective blood volume*, resulting from third space fluid loss, vasodilation, or poor cardiac output. The regulatory systems sense a decrease in effective blood volume and attempt to retain water and Na<sup>+</sup> to correct the problem. ADH causes renal water retention, and the kidney, under the influence of aldosterone and other intrarenal mechanisms, retains sodium. The patient's

sodium concentration decreases because water intake exceeds sodium intake and ADH prevents the normal loss of excess water.

In these disorders, there is low urine  $[\text{Na}^+]$  ( $<10$  mEq/L) and an excess of both TBW and  $\text{Na}^+$ . The only exception is in patients with kidney failure and hyponatremia. These patients have an expanded intravascular volume, and hyponatremia can therefore appropriately suppress ADH production. Water cannot be excreted because very little urine is being made. Serum  $\text{Na}^+$  is diluted through ingestion of water. Because of renal dysfunction, the urine  $[\text{Na}^+]$  may be elevated, but urine volume is so low that urine  $\text{Na}^+$  excretion has not kept up with  $\text{Na}^+$  intake, leading to sodium overload. The urine  $[\text{Na}^+]$  in kidney failure varies. In patients with acute glomerulonephritis, because it does not affect the tubules, the urine  $\text{Na}^+$  level is usually low, whereas in patients with acute tubular necrosis, it is elevated because of tubular dysfunction.

Patients with hyponatremia and no evidence of volume overload or volume depletion have **euvolemic hyponatremia**. These patients typically have an excess of TBW and a slight decrease in total body  $\text{Na}^+$ . Some of these patients have an increase in weight, implying that they are volume overloaded. Nevertheless, from a clinical standpoint, they usually appear normal or have subtle signs of fluid overload. In SIADH the secretion of ADH is not inhibited by either low serum osmolality or expanded intravascular volume (see Chapter 597). The result is that the child with SIADH is unable to excrete water. This results in dilution of the serum  $\text{Na}^+$  and hyponatremia. The expansion of the extracellular volume because of the retained water causes a mild increase in intravascular volume. The kidney increases  $\text{Na}^+$  excretion to decrease intravascular volume to normal; thus the patient has a mild decrease in body  $\text{Na}^+$ . SIADH typically occurs with disorders of the CNS (infection, hemorrhage, trauma, tumor, thrombosis, Guillain-Barré syndrome), but lung disease (infection, asthma, positive pressure ventilation) and malignant tumors (producing ADH) are other potential causes. A variety of medications may cause SIADH, including recreational use of 3,4-methylenedioxymethylamphetamine (MDMA, or “Ecstasy”), opiates, antiepileptic drugs (carbamazepine, oxcarbazepine, valproate), tricyclic antidepressants, vincristine, cyclophosphamide, and selective serotonin reuptake inhibitors (SSRIs). The diagnosis of SIADH is one of exclusion, because other causes of hyponatremia must be eliminated (Table 73.3). Because SIADH is a state of intravascular volume expansion, low serum uric acid and BUN levels are supportive of the diagnosis. A rare gain-of-function pathogenic variant in the renal ADH receptor causes **nephrogenic syndrome of inappropriate antidiuresis**. Patients with this X-linked disorder appear to have SIADH but have undetectable levels of ADH.

Hyponatremia in hospitalized patients is frequently caused by inappropriate production of ADH and administration of hypotonic IV fluids (see Chapter 74). Causes of inappropriate ADH production include stress, medications such as narcotics or anesthetics, nausea, and respiratory illness. The synthetic analog of ADH, desmopressin acetate, causes water retention and may cause hyponatremia if fluid intake is not appropriately limited. The main uses of desmopressin acetate in children are for the management of central diabetes insipidus and nocturnal enuresis.

**Excess water ingestion** can produce hyponatremia. In these cases,  $[\text{Na}^+]$  decreases as a result of dilution. This decrease suppresses ADH secretion, and there is a marked water diuresis by the kidney. Hyponatremia develops only because the intake of water exceeds the kidney's ability to eliminate water. This condition is more likely to occur in infants because their lower GFR limits their ability to excrete water.

Hyponatremia may develop in infants  $<6$  months of age when caregivers offer water to their infant as a supplement, during hot weather, or when they run out of formula. Hyponatremia may result in transient seizures, hypothermia, and poor tone. With cessation of water intake, the hyponatremia rapidly corrects. *Infants  $<6$  months of age should not be given water to drink; infants 6–12 months of age should not receive  $>1$ –2 ounces. If the infant appears thirsty, the parent should offer formula or breastfeed the child.*

In some situations the water intoxication causes acute hyponatremia and is caused by a massive **acute water load**. Causes include infant swimming lessons, inappropriate use of hypotonic IV fluids, water enemas, and forced water intake as a form of child abuse. Chronic hyponatremia occurs in children who receive water but limited sodium and protein. The minimum urine osmolality is approximately 50 mOsm/kg; the kidney can excrete 1 L of water only if there is enough solute ingested to produce 50 mOsm for urinary excretion. Because  $\text{Na}^+$  and urea (a breakdown product of protein) are the principal urinary solutes, a lack of intake of  $\text{Na}^+$  and protein prevents adequate water excretion. This occurs with the use of diluted formula or other inappropriate diets. Subsistence on beer, a poor source of  $\text{Na}^+$  and protein, causes hyponatremia because of the inability to excrete the high water load (“beer potomania”). **Exercise-induced hyponatremia**, reported frequently during marathons, is caused by excessive water intake, salt losses from sweat, and secretion of ADH.

The pathogenesis of the hyponatremia in glucocorticoid deficiency (adrenal insufficiency) is multifactorial and includes increased ADH secretion. In hypothyroidism there is an inappropriate retention of water by the kidney, but the precise mechanisms are not clearly elucidated.

**Cerebral salt wasting**, an uncommon disorder in children, may be confused with SIADH and is often associated with CNS injury or lesions. Cerebral salt wasting produces renal salt losses and hypovolemia (orthostatic hypotension and elevated hematocrit, BUN, or creatinine). Hypovolemia is not seen in SIADH.

### Clinical Manifestations

Hyponatremia causes a decrease in the osmolality of the ECS. Because the ICS then has a higher osmolality, water moves from the ECS to the ICS to maintain osmotic equilibrium. The increase in intracellular water causes cells to swell. Although cell swelling is not problematic in most tissues, it is dangerous for the brain, which is confined by the skull. As brain cells swell, there is an increase in intracranial pressure (ICP), which impairs cerebral blood flow. Acute, severe hyponatremia can cause brainstem herniation and apnea; respiratory support is often necessary. Brain cell swelling is responsible for most of the symptoms of hyponatremia. Neurologic symptoms of hyponatremia include anorexia, nausea, emesis, malaise, lethargy, confusion, agitation, headache, seizures, coma, and decreased reflexes. Patients may have hypothermia and Cheyne-Stokes respirations. Hyponatremia can cause muscle cramps and weakness; rhabdomyolysis can occur with water intoxication.

The symptoms of hyponatremia are mostly a result of the decrease in extracellular osmolality and the resulting movement of water down its osmotic gradient into the ICS. Brain swelling can be significantly obviated if the hyponatremia develops gradually, because brain cells adapt to the decreased extracellular osmolality by reducing intracellular osmolality. This reduction is achieved by extrusion of the main intracellular ions ( $\text{K}^+$ ,  $\text{Cl}^-$ ) and a variety of small organic molecules. This process explains why the range of symptoms in hyponatremia is related to both the serum  $[\text{Na}^+]$  and its rate of decrease. A patient with chronic hyponatremia may have only subtle neurologic abnormalities with a serum  $[\text{Na}^+]$  of 110 mEq/L, but another patient may have seizures because of an acute decline in serum  $[\text{Na}^+]$  from 140 to 125 mEq/L.

### Diagnosis

The history usually points to a likely etiology of the hyponatremia. Most patients with hyponatremia have a history of volume depletion. Diarrhea and diuretic use are common causes of hyponatremia in children. A history of polyuria, perhaps with enuresis, and/or salt craving is present in children with primary kidney diseases or absence of aldosterone effect. Children may have signs or symptoms suggesting a diagnosis of hypothyroidism or adrenal insufficiency (see Chapters 603 and 615). Brain injury raises the possibility of SIADH or cerebral salt wasting, with the caveat that SIADH is much more likely. Liver disease, nephrotic syndrome, kidney failure, or congestive heart failure may be



acute or chronic. The history should include a review of the patient's intake, both IV and enteral, with careful attention to the amounts of water,  $\text{Na}^+$ , and protein.

The traditional first step in the diagnostic process is determination of the plasma osmolality. This is done because some patients with a low serum  $[\text{Na}^+]$  do not have low osmolality. The clinical effects of hyponatremia are secondary to the associated low osmolality. Without a low osmolality, there is no movement of water into the ICS.

A patient with hyponatremia can have a low, normal, or high osmolality. A normal osmolality in combination with hyponatremia occurs in pseudohyponatremia. Children with elevation of serum glucose concentration or of another effective osmole (mannitol) have a high plasma osmolality and hyponatremia. The presence of a low osmolality indicates "true" hyponatremia. Patients with low osmolality are at risk for neurologic symptoms and require further evaluation to determine the etiology of the hyponatremia.

In some situations, true hyponatremia is present despite a normal or elevated plasma osmolality. The presence of an ineffective osmole, usually urea, increases the plasma osmolality, but because urea has the same concentration in the ICS, it does not cause fluid to move into the ECS. There is no dilution of the serum  $\text{Na}^+$  by water, and the  $[\text{Na}^+]$  remains unchanged if the ineffective osmole is eliminated. Most importantly, the ineffective osmole does not protect the brain from edema caused by hyponatremia. Therefore a patient may have symptoms of hyponatremia despite having a normal or increased osmolality because of uremia.

In patients with true hyponatremia, the next step in the diagnostic process is to clinically evaluate the volume status. Patients with hyponatremia can be hypovolemic, hypervolemic, or euvolemic. The diagnosis of volume depletion relies on the usual findings with dehydration (see Chapter 75), although subtle volume depletion may not be clinically apparent. Children with hypervolemia are edematous on physical examination. They may have ascites, pulmonary edema, pleural effusion, or hypertension.

Hypovolemic hyponatremia can have renal or nonrenal causes. The urine  $[\text{Na}^+]$  is very useful in differentiating between renal and nonrenal causes. When the losses are nonrenal and the kidney is working properly, there is renal retention of  $\text{Na}^+$ , a normal homeostatic response to volume depletion. Thus the urinary  $[\text{Na}^+]$  is low, typically  $<10$  mEq/L, although  $\text{Na}^+$  conservation in neonates is less avid. When the kidney is the cause of the  $\text{Na}^+$  loss, the urine  $[\text{Na}^+]$  is  $>20$  mEq/L, reflecting the defect in renal  $\text{Na}^+$  retention. The interpretation of the urine  $\text{Na}^+$  level is challenging with diuretic therapy because it is high when diuretics are being used but low after the diuretic effect is gone. This becomes an issue only when diuretic use is surreptitious. The urine  $[\text{Na}^+]$  is not useful if a metabolic alkalosis is present; the urine  $[\text{Cl}^-]$  must be used instead (see Chapter 73.7).

Differentiating among the nonrenal causes of hypovolemic hyponatremia is usually facilitated by the history. Although the renal causes are more challenging to distinguish, a high serum  $[\text{K}^+]$  is associated with disorders in which the  $\text{Na}^+$  wasting is caused by absence of or ineffectiveness of aldosterone.

In the patient with hypervolemic hyponatremia, the urine  $[\text{Na}^+]$  is a helpful parameter. It is usually  $<10$  mEq/L, except in the patient with kidney failure.

### Treatment

The management of hyponatremia is based on the pathophysiology of the specific etiology. The management of all causes requires judicious monitoring and avoidance of an overly quick normalization of the serum  $[\text{Na}^+]$ . A patient with severe symptoms (seizures), no matter the etiology, should be given a bolus of hypertonic saline to produce a small, rapid increase in serum sodium. *Hypoxia worsens cerebral edema, and hyponatremia may exacerbate hypoxic cell swelling.* Therefore pulse oximetry should be monitored and hypoxia aggressively corrected.

With all causes of hyponatremia, it is important to avoid overly rapid correction, which may cause *osmotic demyelination syndrome*

(ODS), which includes central pontine myelinolysis and extrapontine myelinolysis. This syndrome, which occurs within several days of rapid correction of hyponatremia, produces neurologic symptoms, including confusion, agitation, flaccid or spastic quadriparesis, and death. There are usually characteristic pathologic and radiologic changes in the brain. Despite severe symptoms, full recovery does occur in some patients.

ODS is more common in patients who are treated for *chronic* hyponatremia than for acute hyponatremia. Presumably, this difference is based on the adaptation of brain cells to the hyponatremia. The reduced intracellular osmolality, an adaptive mechanism for chronic hyponatremia, makes brain cells susceptible to dehydration during rapid correction of the hyponatremia, which may be the mechanism of ODS. Even though ODS is rare in pediatric patients, it is advisable to avoid correcting the serum  $[\text{Na}^+]$  by  $>10$  mEq/L/24 hr or  $>18$  mEq/L/48 hr. Desmopressin is a potential option if the serum  $[\text{Na}^+]$  is increasing too rapidly. This guideline *does not* apply to acute hyponatremia, as may occur with water intoxication, because the hyponatremia is more often symptomatic, and the adaptive decrease in brain osmolality has not had time to occur. The consequences of brain edema in acute hyponatremia exceed the small risk of ODS.

Patients with hyponatremia can have severe neurologic symptoms, such as seizures and coma. The seizures associated with hyponatremia generally are poorly responsive to anticonvulsants. The child with hyponatremia and severe symptoms needs treatment that will quickly reduce cerebral edema. This goal is best accomplished by increasing the extracellular osmolality so that water moves down its osmolar gradient from the ICS to the ECS.

Intravenous hypertonic saline rapidly increases serum  $[\text{Na}^+]$ , and the effect on serum osmolality leads to a decrease in brain edema. Each mL/kg of 3% NaCl increases the serum  $[\text{Na}^+]$  by approximately 1 mEq/L. A child with active symptoms often improves after receiving 4-6 mL/kg of 3% NaCl.

The child with **hypovolemic hyponatremia** has a deficiency in  $\text{Na}^+$  and may have a deficiency in water. The cornerstone of therapy is to replace the  $\text{Na}^+$  deficit and any water deficit present. The first step in treating any dehydrated patient is to restore the intravascular volume with isotonic saline. Ultimately, complete restoration of intravascular volume suppresses ADH production, thereby permitting excretion of the excess water. Chapter 75 discusses the management of hyponatremic dehydration.

The management of **hypervolemic hyponatremia** is difficult; patients have an excess of both water and  $\text{Na}^+$ . Administration of  $\text{Na}^+$  leads to worsening volume overload and edema. In addition, patients are retaining water and  $\text{Na}^+$  because of their ineffective intravascular volume or renal insufficiency. The cornerstone of therapy is water and  $\text{Na}^+$  restriction, because patients have volume overload. Diuretics may help by causing excretion of both  $\text{Na}^+$  and water. Vasopressin receptor antagonists (**vaptans**), by blocking the action of ADH and causing a water diuresis, are effective in correcting the hypervolemic hyponatremia caused by heart failure. Vaptans are contraindicated if there are moderate to severe CNS symptoms.

Hyponatremic patients with low albumin from nephrotic syndrome have a better response to diuretics after an infusion of 25% albumin; the  $[\text{Na}^+]$  often normalizes as a result of expansion of the intravascular volume. A child with heart failure may have an increase in renal water and  $\text{Na}^+$  excretion if there is an improvement in cardiac output. This improvement will "turn off" the regulatory hormones causing renal water (ADH) and  $\text{Na}^+$  (aldosterone) retention. The patient with kidney failure cannot respond to any of these therapies except fluid restriction. Insensible fluid losses eventually result in an increase in the  $[\text{Na}^+]$  as long as insensible and urinary losses are greater than intake. A more definitive approach in children with kidney failure is to perform dialysis, which removes water and  $\text{Na}^+$ .

In **isovolumic hyponatremia** there is usually an excess of water and a mild  $\text{Na}^+$  deficit. Therapy is directed at eliminating the excess water. The child with acute excessive water intake loses water in the urine



because ADH production is turned off as a result of the low plasma osmolality. Children may correct their hyponatremia spontaneously over 3–6 hours. For acute, symptomatic hyponatremia as a result of water intoxication, hypertonic saline may be needed to reverse cerebral edema. For chronic hyponatremia from poor solute intake, the child needs an appropriate formula, and excess water intake should be eliminated.

Children with **iatrogenic hyponatremia** caused by the administration of hypotonic IV fluids should receive 3% saline if symptomatic. Subsequent management is dictated by the patient's volume status. The hypovolemic child should receive isotonic IV fluids. The child with nonphysiologic stimuli for ADH production should undergo fluid restriction. Prevention of this iatrogenic complication requires judicious use of IV fluids (see [Chapter 74](#)).

Specific hormone replacement is the cornerstone of therapy for the hyponatremia of hypothyroidism or cortisol deficiency. Correction of the underlying defect permits appropriate elimination of the excess water.

SIADH is a condition of excess water, with limited ability of the kidney to excrete water. The mainstay of its therapy is fluid restriction with normal sodium intake. Furosemide and NaCl supplementation are effective in the patient with SIADH and *severe* hyponatremia. Even in a patient with SIADH, furosemide causes an increase in water and Na<sup>+</sup> excretion. The loss of Na<sup>+</sup> is somewhat counterproductive, but this Na<sup>+</sup> can be replaced with hypertonic saline. Because the patient has a net loss of water and the urinary losses of Na<sup>+</sup> have been replaced, there is an increase in the [Na<sup>+</sup>], but no significant increase in blood pressure. Vaptans, which block the action of ADH and cause a water diuresis, are effective at correcting **euvolemic hyponatremia**, but overly rapid correction is a potential complication. Vaptans are not appropriate for treating symptomatic hyponatremia because it can take a few hours before the water diuresis occurs.

Treatment of chronic SIADH is challenging. Fluid restriction in children is difficult for nutritional and behavioral reasons. Other options are long-term furosemide therapy with Na<sup>+</sup> supplementation, an oral vaptan (tolvaptan), or oral urea.

Visit Elsevier eBooks+ at [eBooks.Health.Elsevier.com](http://eBooks.Health.Elsevier.com) for Bibliography.

## 73.4 Potassium

Larry A. Greenbaum

### POTASSIUM METABOLISM

#### Body Content and Physiologic Function

The intracellular [K<sup>+</sup>], approximately 150 mEq/L, is much higher than the plasma [K<sup>+</sup>] (see [Fig. 73.3](#)). The majority of body K<sup>+</sup> is contained in muscle. As muscle mass increases, there is an increase in body K<sup>+</sup>. Thus an increase in body K<sup>+</sup> occurs during puberty, and it is more significant in males. The majority of extracellular K<sup>+</sup> is in bone; <1% of total body K<sup>+</sup> is in plasma.

Because most K<sup>+</sup> is intracellular, the plasma concentration does not always reflect the total body K<sup>+</sup> content. A variety of conditions alter the distribution of K<sup>+</sup> between the intracellular and extracellular compartments. Na<sup>+</sup>,K<sup>+</sup>-ATPase maintains the high intracellular [K<sup>+</sup>] by pumping Na<sup>+</sup> out of the cell and K<sup>+</sup> into the cell. This activity balances the normal leak of K<sup>+</sup> out of cells via potassium channels that is driven by the favorable chemical gradient. Insulin increases K<sup>+</sup> movement into cells by activating Na<sup>+</sup>,K<sup>+</sup>-ATPase. Hyperkalemia stimulates insulin secretion, which helps mitigate the hyperkalemia. Acid-base status affects K<sup>+</sup> distribution, probably via K<sup>+</sup> channels and the Na<sup>+</sup>,K<sup>+</sup>-ATPase. A decrease in pH drives potassium extracellularly; an increase in pH has the opposite effect. β-Adrenergic agonists stimulate the

Na<sup>+</sup>,K<sup>+</sup>-ATPase, increasing cellular uptake of K<sup>+</sup>. This increase is protective, in that hyperkalemia stimulates adrenal release of catecholamines. α-Adrenergic agonists and exercise cause a net movement of K<sup>+</sup> out of the ICS. An increase in plasma osmolality, as with mannitol infusion, leads to water movement out of the cells, and K<sup>+</sup> follows as a result of solvent drag. The serum [K<sup>+</sup>] increases by approximately 0.6 mEq/L with each 10 mOsm rise in plasma osmolality.

The high intracellular concentration of K<sup>+</sup>, the principal intracellular cation, is maintained through Na<sup>+</sup>,K<sup>+</sup>-ATPase. The resulting chemical gradient is used to produce the resting membrane potential of cells. K<sup>+</sup> is necessary for the electrical responsiveness of nerve and muscle cells and for the contractility of cardiac, skeletal, and smooth muscle. The changes in membrane polarization that occur during muscle contraction or nerve conduction make these cells susceptible to changes in serum [K<sup>+</sup>]. The ratio of intracellular to extracellular K<sup>+</sup> determines the threshold for a cell to generate an action potential and the rate of cellular repolarization. The intracellular [K<sup>+</sup>] affects cellular enzymes. K<sup>+</sup> is necessary for maintaining cell volume because of its important contribution to intracellular osmolality.

#### Potassium Intake

Potassium is plentiful in food. Dietary consumption varies considerably, even though 1–2 mEq/kg is the recommended intake. The intestines normally absorb approximately 90% of ingested K<sup>+</sup>. Most absorption occurs in the small intestine, whereas the colon exchanges body K<sup>+</sup> for luminal Na<sup>+</sup>. Regulation of intestinal losses normally has a minimal role in maintaining potassium homeostasis, although kidney failure, aldosterone, and glucocorticoids increase colonic secretion of K<sup>+</sup>. The increase in intestinal losses in the setting of kidney failure and hyperkalemia, which stimulates aldosterone production, is clinically significant, helping to protect against hyperkalemia.

#### Potassium Excretion

Some loss of K<sup>+</sup> occurs in sweat but is normally minimal. The colon has the ability to eliminate some K<sup>+</sup>. In addition, after an acute K<sup>+</sup> load, much of the K<sup>+</sup> (>40%) moves intracellularly, through the actions of epinephrine and insulin, which are produced in response to hyperkalemia. This process provides transient protection from hyperkalemia, but most ingested K<sup>+</sup> is eventually excreted in the urine. The kidneys principally regulate long-term K<sup>+</sup> balance, and they alter excretion in response to a variety of signals. K<sup>+</sup> is freely filtered at the glomerulus, but 90% is resorbed before reaching the distal tubule and collecting duct, the principal sites of K<sup>+</sup> regulation that have the ability to absorb and secrete K<sup>+</sup>. The amount of tubular secretion regulates the amount of K<sup>+</sup> that appears in the urine. The plasma [K<sup>+</sup>] directly influences secretion in the distal nephron. As the [K<sup>+</sup>] increases, secretion increases.

The principal hormone regulating potassium secretion is **aldosterone**, which is released by the adrenal cortex in response to increased plasma K<sup>+</sup>. Its main site of action is the cortical collecting duct, where aldosterone stimulates Na<sup>+</sup> movement from the tubule into the cells. This movement creates a negative charge in the tubular lumen, facilitating K<sup>+</sup> excretion. In addition, the increased intracellular Na<sup>+</sup> stimulates the basolateral Na<sup>+</sup>,K<sup>+</sup>-ATPase, causing more K<sup>+</sup> to move into the cells lining the cortical collecting duct. Glucocorticoids, ADH, a high urinary flow rate, and high Na<sup>+</sup> delivery to the distal nephron also increase urinary K<sup>+</sup> excretion. Insulin, catecholamines, and urinary ammonia decrease K<sup>+</sup> excretion. Whereas ADH increases K<sup>+</sup> secretion, it also causes water resorption, decreasing urinary flow. The net effect is that ADH has little overall impact on K<sup>+</sup> balance. Alkalosis causes potassium to move into cells, including the cells lining the collecting duct. This movement increases K<sup>+</sup> secretion, and because acidosis has the opposite effect; acidosis decreases K<sup>+</sup> secretion.

The kidney can dramatically vary  $K^+$  excretion in response to changes in intake. Normally, approximately 10–15% of the filtered load is excreted. In an adult, excretion of  $K^+$  can vary from 5–1,000 mEq/day.

## HYPERKALEMIA

Hyperkalemia—because of the potential for lethal arrhythmias—is one of the most alarming electrolyte abnormalities.

### Etiology and Pathophysiology

Three basic mechanisms cause hyperkalemia including increased intake, cellular shifts, and decreased excretion; spurious lab values are also commonly seen (Table 73.4). In the individual patient, the etiology is sometimes multifactorial.

**Spurious hyperkalemia** or **pseudohyperkalemia** is very common in children because of the difficulties in obtaining blood specimens. This laboratory result is usually caused by hemolysis during a heelstick or phlebotomy, but it can be the result of prolonged tourniquet application or fist clenching, either of which causes local potassium release from muscle.

The serum  $[K^+]$  is normally 0.4 mEq/L higher than the plasma value, secondary to  $K^+$  release from cells during clot formation. This phenomenon is exaggerated with thrombocytosis because of  $K^+$  release from platelets. For every 100,000/ $m^3$  increase in the platelet count, the serum  $[K^+]$  rises by approximately 0.15 mEq/L. This phenomenon also occurs with the marked white blood cell (WBC) count elevations sometimes seen with leukemia. Elevated WBC counts, typically  $>200,000/m^3$ , can cause a dramatic elevation in the measured serum  $[K^+]$ . Analysis of a plasma sample usually provides an accurate result. It is important to analyze the sample promptly to avoid  $K^+$  release from cells, which occurs if the sample is stored in the cold, or cellular uptake of  $K^+$  and spurious hypokalemia, which occurs with storage at room temperature. Pneumatic tube transport can cause pseudohyperkalemia if cell membranes are fragile (leukemia). Occasionally, heparin causes lysis of leukemic cells and a false elevation of the plasma sample; a blood gas syringe has less heparin and may provide a more accurate reading than a standard tube. There are rare genetic disorders causing in vitro leakage of  $K^+$  from red blood cells (RBCs) that may cause familial **pseudo-hyperkalemia** (autosomal dominant; *ABCB6* gene).

Because of the kidney's ability to excrete  $K^+$ , it is unusual for excessive intake, by itself, to cause hyperkalemia. This condition can occur in a patient who is receiving large quantities of IV or oral  $K^+$  for excessive losses that are no longer present. Frequent or rapid blood transfusions can acutely increase the  $[K^+]$  because of the  $K^+$  content of blood, which is variably elevated. Increased intake may precipitate hyperkalemia if there is an underlying defect in  $K^+$  excretion.

The ICS has a very high  $[K^+]$ , so a shift of  $K^+$  from the ICS to the ECS can have a significant effect on the plasma  $[K^+]$ . This shift occurs with metabolic acidosis, but the effect is minimal with an organic acid (lactic acidosis, ketoacidosis). A respiratory acidosis has less impact than a metabolic acidosis. Cell destruction, as seen with rhabdomyolysis, tumor lysis syndrome, tissue necrosis, or hemolysis, releases  $K^+$  into the extracellular milieu. The  $K^+$  released from RBCs in internal bleeding, such as hematomas, is resorbed and enters the ECS.

Normal doses of succinylcholine or  $\beta$  blockers and fluoride or digitalis intoxication all cause a shift of  $K^+$  out of the intracellular compartment. *Succinylcholine should not be used during anesthesia in patients at risk for hyperkalemia.*  $\beta$  Blockers prevent the normal cellular uptake of  $K^+$  mediated by binding of  $\beta$ -agonists to the  $\beta_2$ -adrenergic receptors.  $K^+$  release from muscle cells occurs during exercise, and levels can increase by 1–2 mEq/L with high activity. With an increased plasma osmolality, water moves from the ICS, and  $K^+$  follows. This process occurs with hyperglycemia, although in nondiabetic patients the resultant increase in insulin causes  $K^+$  to move intracellularly. In diabetic ketoacidosis (DKA), the absence of insulin causes potassium to leave the ICS, and the problem is compounded by the hyperosmolality. The effect of hyperosmolality causes a transcellular shift of  $K^+$  into the ECS

**Table 73.4** Causes of Hyperkalemia

#### SPURIOUS LABORATORY VALUE

- Hemolysis
- Tissue ischemia during blood drawing
- Thrombocytosis
- Leukocytosis
- Familial pseudohyperkalemia (OMIM 609153)

#### INCREASED INTAKE

- Intravenous or oral
- Blood transfusions

#### TRANSCELLULAR SHIFTS

- Acidosis
- Rhabdomyolysis
- Tumor lysis syndrome
- Tissue necrosis
- Hemolysis/hematomas/gastrointestinal bleeding
- Succinylcholine
- Digitalis intoxication
- Fluoride intoxication
- $\beta$ -Adrenergic blockers
- Exercise
- Hyperosmolality
- Insulin deficiency
- Malignant hyperthermia (OMIM 145600/601887/601888)
- Hyperkalemic periodic paralysis (OMIM 170500)

#### DECREASED EXCRETION

- Kidney failure
- Primary adrenal disease
  - Acquired Addison disease
  - 21-Hydroxylase deficiency (OMIM 201910)
  - $3\beta$ -Hydroxysteroid dehydrogenase deficiency (OMIM 201810)
  - Lipoid congenital adrenal hyperplasia (OMIM 201710)
  - Adrenal hypoplasia congenita (OMIM 300200)
  - Aldosterone synthase deficiency (OMIM 203400/610600)
  - Adrenoleukodystrophy (OMIM 300100)
- Hyporeninemic hypoaldosteronism
  - Urinary tract obstruction
  - Sickle cell disease (OMIM 603903)
  - Kidney transplant
  - Lupus nephritis
- Renal tubular disease
  - Pseudohypoaldosteronism type I (OMIM 264350/177735)
  - Pseudohypoaldosteronism type II (OMIM 614491/614492/614495)
  - Bartter syndrome, type 2 (OMIM 241200)
  - Urinary tract obstruction
  - Kidney transplant
- Medications
  - Renin inhibitors
  - Angiotensin-converting enzyme inhibitors
  - Angiotensin II blockers
  - Potassium-sparing diuretics
  - Calcineurin inhibitors
  - Nonsteroidal antiinflammatory drugs
  - Trimethoprim
  - Heparin
  - Drospirenone (in some oral contraceptives)

OMIM, database number from the Online Mendelian Inheritance in Man (<http://www.ncbi.nlm.nih.gov/omim>).

after mannitol or hypertonic saline infusions. **Malignant hyperthermia**, which is triggered by some inhaled anesthetics, causes muscle release of potassium (see Chapter 651.2). **Hyperkalemic periodic paralysis** is an autosomal dominant disorder caused by pathogenic variants in *SCN4A*, the gene for a  $Na^+$  channel. It results in episodic cellular release of  $K^+$  and attacks of paralysis (see Chapter 651.1).

The kidneys excrete most of the daily  $K^+$  intake, so a decrease in kidney function can cause hyperkalemia. Newborn infants in general, and especially premature infants, have decreased kidney function at birth; thus they are at increased risk for hyperkalemia despite an absence of intrinsic renal disease. Neonates also have decreased expression of  $K^+$  channels, further limiting  $K^+$  excretion.

A wide range of primary **adrenal disorders**, both hereditary and acquired, can cause decreased production of aldosterone, with secondary hyperkalemia (see Chapters 615 and 616). Patients with these disorders typically have metabolic acidosis and salt wasting with hyponatremia. Children with subtle adrenal insufficiency may have electrolyte problems only during acute illnesses. The most common form of **congenital adrenal hyperplasia**, 21-hydroxylase deficiency, typically manifests in male infants as hyperkalemia, metabolic acidosis, hyponatremia, and volume depletion. Females with this disorder usually are diagnosed as newborns because of their ambiguous genitals; treatment prevents the development of electrolyte problems.

Renin, via angiotensin II, stimulates aldosterone production. A deficiency in renin, a result of kidney damage, can lead to decreased aldosterone production. **Hyporeninemia** occurs in many kidney diseases, with some of the more common pediatric causes listed in Table 73.4. These patients typically have hyperkalemia and a metabolic acidosis, without hyponatremia. Some of these patients have impaired renal function, partially accounting for the hyperkalemia, but the impairment in  $K^+$  excretion is more extreme than expected for the degree of renal insufficiency.

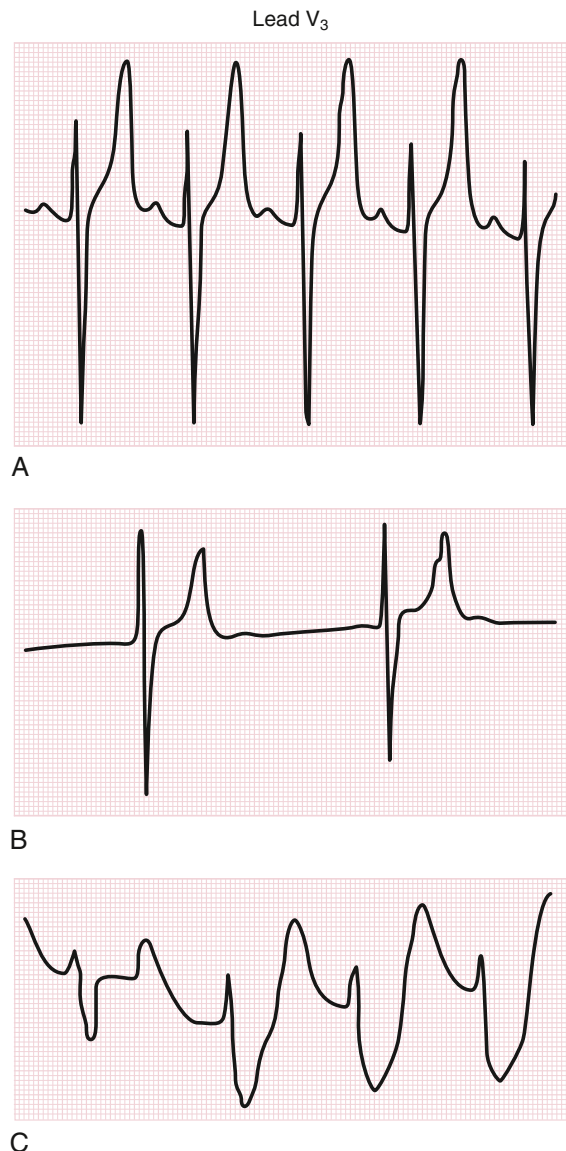
A variety of **renal tubular disorders** impair renal excretion of  $K^+$ . Children with **pseudohypoaldosteronism type 1** have hyperkalemia, metabolic acidosis, and salt wasting (kidney, colon, sweat) leading to hyponatremia and volume depletion; aldosterone values are elevated. In the autosomal recessive variant, there is a defect in the renal  $Na^+$  channel that is normally activated by aldosterone. Patients with this variant have severe symptoms (failure to thrive, diarrhea, recurrent respiratory infections, miliaria-rubra like rash), beginning in infancy. Patients with the autosomal dominant form have a defect in the aldosterone receptor, and the disease is milder, often remitting in adulthood. **Pseudohypoaldosteronism type 2 (familial hyperkalemic hypertension)**, also called **Gordon syndrome**, is an autosomal dominant disorder characterized by hypertension caused by salt retention and impaired excretion of  $K^+$  and acid, leading to hyperkalemia and hyperchloremic metabolic acidosis. Pathogenic variants in at least four genes (*WNK4*, *WNK1*, *KLHL3*, *CUL3*) may cause Gordon syndrome. Patients may respond well to thiazide diuretics. In **Bartter syndrome**, caused by pathogenic variants in the potassium channel *ROMK* (type 2 Bartter syndrome), there can be transient hyperkalemia in neonates, but hypokalemia subsequently develops (see Chapter 571.1).

Acquired renal tubular dysfunction, with an impaired ability to excrete  $K^+$ , occurs in a number of conditions. These disorders, all characterized by **tubulointerstitial disease**, are often associated with impaired acid secretion and a secondary metabolic acidosis. In some affected children, the metabolic acidosis is the dominant feature, although a high  $K^+$  intake may unmask the defect in  $K^+$  handling. The tubular dysfunction can cause renal salt wasting, potentially leading to hyponatremia. Because of the tubulointerstitial damage, these conditions may also cause hyperkalemia as a result of hyporeninemic hypoaldosteronism.

The risk of hyperkalemia resulting from medications is greatest in patients with underlying renal insufficiency. The predominant mechanism of medication-induced hyperkalemia is impaired renal excretion, although ACE inhibitors may worsen hyperkalemia in anuric patients, probably by inhibiting GI potassium loss, which is normally upregulated in renal insufficiency. The hyperkalemia caused by trimethoprim is especially problematic at higher doses. Potassium-sparing diuretics may easily cause hyperkalemia because they are often used in patients receiving oral  $K^+$  supplements. Oral contraceptives containing drospirenone, which blocks the action of aldosterone, may cause hyperkalemia and should not be used in patients with decreased renal function.

### Clinical Manifestations

The most important effects of hyperkalemia result from the role of  $K^+$  in membrane polarization. The cardiac conduction system is usually the dominant concern. Changes in the electrocardiogram (ECG) begin with peaking of the T waves. This is followed, as  $K^+$  level increases, by ST-segment depression, an increased PR interval, flattening of the P wave, and widening of the QRS complex (Fig. 73.4). However, the correlation between  $K^+$  level and ECG changes is poor. This process can eventually progress to ventricular fibrillation. Asystole may also occur. Some patients have paresthesias, fasciculations, weakness, and even an ascending paralysis, but cardiac toxicity usually precedes these clinical symptoms, emphasizing the danger of assuming that an absence of symptoms implies an absence of danger. Chronic hyperkalemia is generally better tolerated than acute hyperkalemia.



**Fig. 73.4** The effects of progressive hyperkalemia on the electrocardiogram. All of the ECGs are from lead  $V_3$ . A, Serum potassium concentration ( $[K^+]$ ) = 6.8 mEq/L; note the peaked T waves together with normal sinus rhythm. B, Serum  $[K^+] = 8.9$  mEq/L; note the peaked T waves and absent P waves. C, Serum  $[K^+] > 8.9$  mEq/L; note the classic sine wave with absent P waves, marked prolongation of the QRS complex, and peaked T waves. (From Goldman L, Schafer AI, eds. *Goldman-Cecil Medicine*. 26th ed. Elsevier; 2020. Fig. 109.2, p. 727.)



## Diagnosis

The etiology of hyperkalemia is often readily apparent. Spurious hyperkalemia is very common in children, so obtaining a second potassium measurement is often appropriate. If there is a significant elevation of WBC or platelet count, the second measurement should be performed on a plasma sample that is evaluated promptly. The history should initially focus on potassium intake, risk factors for transcellular shifts of  $K^+$ , medications that cause hyperkalemia, and signs of renal insufficiency, such as oliguria and edema. Initial laboratory evaluation should include creatinine, BUN, and assessment of the acid-base status. Many etiologies of hyperkalemia cause **metabolic acidosis**, which worsens hyperkalemia through the transcellular shift of  $K^+$  out of cells. Decreased kidney function is a common cause of the combination of metabolic acidosis and hyperkalemia, also seen in diseases associated with aldosterone insufficiency or aldosterone resistance. Children with absent or ineffective aldosterone often have hyponatremia and volume depletion because of salt wasting. Genetic diseases, such as congenital adrenal hyperplasia and pseudohypoaldosteronism, usually manifest in infancy and should be strongly considered in the infant with hyperkalemia and metabolic acidosis, especially if hyponatremia is present.

It is important to consider the various etiologies of a transcellular  $K^+$  shift. In some of these disorders, the  $K^+$  level continues to increase, despite the elimination of all  $K^+$  intake, especially with concurrent renal insufficiency. This increase is potentially seen in tumor lysis syndrome, hemolysis, rhabdomyolysis, and other causes of cell death. All these entities can cause concomitant hyperphosphatemia and hyperuricemia. **Rhabdomyolysis** produces an elevated creatinine phosphokinase (CPK) value and hypocalcemia, whereas children with hemolysis have hemoglobinuria and a decreasing hematocrit. For the child with diabetes, elevated blood glucose and acidosis suggest a transcellular shift of  $K^+$ .

## Treatment

The plasma  $K^+$  level, the ECG, and the risk of the problem worsening determine the aggressiveness of the therapeutic approach. High serum  $[K^+]$  and the presence of ECG changes require vigorous treatment. An additional source of concern is the patient in whom plasma  $K^+$  levels are rising despite minimal intake. This situation can happen if there is cellular release of  $K^+$  (tumor lysis syndrome), especially in the setting of diminished excretion (kidney failure).

The first action in a child with a concerning elevation of plasma  $[K^+]$  is to stop all sources of additional  $K^+$  (oral, IV). Washed RBCs can be used for patients who require blood transfusions. If the  $[K^+]$  is  $>6.5$  mEq/L, an ECG should be obtained to help assess the urgency of the situation. Peaked T waves are the first sign of hyperkalemia, followed by a prolonged PR interval, and when most severe, prolonged QRS complex. Life-threatening ventricular arrhythmias may also develop. The treatment of hyperkalemia has two basic goals: (1) to stabilize the heart to prevent life-threatening arrhythmias and (2) to remove  $K^+$  from the body. The treatments that acutely prevent arrhythmias all have the advantage of working quickly (within minutes) but do not remove  $K^+$  from the body. **Calcium** stabilizes the cell membrane of heart cells, preventing arrhythmias; it is given IV over a few minutes, and its action is almost immediate. Calcium should be given over 30 minutes in a patient receiving digitalis because the calcium may cause arrhythmias. **Bicarbonate** causes potassium to move intracellularly, lowering the plasma  $[K^+]$ ; it is most efficacious in a patient with a metabolic acidosis. **Insulin** causes  $K^+$  to move intracellularly but must be given with **glucose** to avoid hypoglycemia. The combination of insulin and glucose works within 30 minutes. Nebulized **albuterol**, by stimulation of  $\beta_1$ -adrenergic receptors, leads to rapid intracellular movement of  $K^+$ . This has the advantage of not requiring an IV route of administration, allowing it to be given concurrently with the other measures.

It is critical to begin measures that remove  $K^+$  from the body. In patients who are not anuric, a **loop diuretic** increases renal excretion of  $K^+$ . A high dose may be required in a patient with significant renal insufficiency. **Sodium polystyrene sulfonate (SPS; Kayexalate)** is an exchange resin that is given either rectally or orally. **Patiromer** and **sodium zirconium cyclosilicate** are oral exchange resins for treating hyperkalemia. Some patients require **dialysis** for acute  $K^+$  removal. Dialysis is often necessary if the patient has either severe kidney failure or an especially high rate of endogenous  $K^+$  release, as is sometimes present with tumor lysis syndrome or rhabdomyolysis. Hemodialysis rapidly lowers plasma  $[K^+]$ . Peritoneal dialysis is not nearly as quick or reliable, but it is usually adequate as long as the acute problem can be managed with medications and the endogenous release of  $K^+$  is not high.

Long-term management of hyperkalemia includes reducing intake through dietary changes and eliminating or reducing medications that cause hyperkalemia (see Chapter 572). Some patients require medications to increase potassium excretion, such as SPS, patiromer, sodium zirconium cyclosilicate, and loop or thiazide diuretics. Some infants with chronic kidney disease may need to start dialysis to allow adequate caloric intake without hyperkalemia. It is unusual for an older child to require dialysis principally to control chronic hyperkalemia. The disorders caused by aldosterone deficiency respond to replacement therapy with fludrocortisone.

## HYPOKALEMIA

Hypokalemia is common in children, with most cases related to gastroenteritis.

### Etiology and Pathophysiology

There are four basic mechanisms of hypokalemia (Table 73.5). **Spurious hypokalemia** occurs in patients with leukemia and very elevated WBC counts if plasma for analysis is left at room temperature, permitting the WBCs to take up  $K^+$  from the plasma. With a transcellular shift, there is no change in total body  $K^+$ , although there may be concomitant potassium depletion resulting from other factors. Decreased intake, extrarenal losses, and renal losses are all associated with total body  $K^+$  depletion. In addition, seasonal pseudo-hypokalemia is seen during warm summer months as a laboratory phenomenon when blood samples are exposed to a warm environment. On immediate retesting, the potassium level is normal. This should not be confused with a pseudo-Bartter syndrome (hypokalemic, hypochloremic, alkalosis) seen in children with cystic fibrosis in a very warm environment due to excessive sweating.

Because the intracellular  $[K^+]$  is much higher than the plasma level, a significant amount of  $K^+$  can move into cells without greatly changing the intracellular  $[K^+]$ . **Alkalemia** is one of the more common causes of a transcellular shift. The effect is much greater with a *metabolic* alkalosis than with a respiratory alkalosis. The impact of exogenous insulin on  $K^+$  movement into the cells is substantial in patients with DKA. Endogenous insulin may be the cause when a patient is given a bolus of glucose. Both endogenous (epinephrine in stress) and exogenous (albuterol)  $\beta$ -adrenergic agonists stimulate cellular uptake of  $K^+$ . Theophylline overdose, barium intoxication, administration of cesium chloride (a homeopathic cancer remedy), and toluene intoxication from paint or glue sniffing can cause a transcellular shift hypokalemia, often with severe clinical manifestations. Children with **hypokalemic periodic paralysis**, a rare autosomal dominant disorder, have acute cellular uptake of  $K^+$  (see Chapter 651). **Thyrotoxic periodic paralysis**, which is more common in Asians, is an unusual initial manifestation of hyperthyroidism. Affected patients have dramatic hypokalemia as a result of a transcellular shift of potassium. Hypokalemia can occur during refeeding syndrome (see Chapters 63 and 385.7).

Inadequate  $K^+$  intake occurs in **anorexia nervosa**; accompanying bulimia and laxative or diuretic abuse exacerbates the  $K^+$  deficiency.



**Table 73.5** Causes of Hypokalemia

<p><b>SPURIOUS LABORATORY VALUE</b> High white blood cell count</p> <p><b>TRANSCELLULAR SHIFTS</b> Alkalemia Insulin <math>\alpha</math>-Adrenergic agonists Drugs/toxins (theophylline, barium, toluene, cesium chloride, hydroxychloroquine) Hypokalemic periodic paralysis (OMIM 170400) Thyrotoxic period paralysis Refeeding syndrome</p> <p><b>DECREASED INTAKE</b> Anorexia nervosa</p> <p><b>EXTRARENAL LOSSES</b> Diarrhea Laxative abuse Sweating Sodium polystyrene sulfonate (Kayexalate) or clay ingestion</p> <p><b>RENAL LOSSES</b> <i>With Metabolic Acidosis</i> Distal renal tubular acidosis (OMIM 179800/602722/267300/611590) Proximal renal tubular acidosis (OMIM 604278)* Ureterosigmoidostomy Diabetic ketoacidosis</p> <p><i>Without Specific Acid-Base Disturbance</i> Tubular toxins: amphotericin, cisplatin, aminoglycosides Interstitial nephritis Diuretic phase of acute tubular necrosis Postobstructive diuresis Hypomagnesemia High urine anions (e.g., penicillin or penicillin derivatives)</p>	<p><i>With Metabolic Alkalosis</i> Low urine chloride Emesis or nasogastric suction Chloride-losing diarrhea (OMIM 214700) Cystic fibrosis (OMIM 219700) Low-chloride formula Posthypercapnia Previous loop or thiazide diuretic use High urine chloride and normal blood pressure Gitelman syndrome (OMIM 263800) Bartter syndrome (OMIM 241200/607364/602522/601678/300971/601198/613090) Autosomal dominant hypoparathyroidism (OMIM 146200) EAST syndrome (OMIM 612780) Autosomal dominant kidney hypomagnesemia due to <i>Rragd</i> variant (OMIM not assigned) Loop and thiazide diuretics (current) High urine chloride and high blood pressure Adrenal adenoma or hyperplasia Glucocorticoid-remediable aldosteronism (OMIM 103900) Hyperaldosteronism type II (OMIM 605635) Familial hyperaldosteronism type III (OMIM 613677) Familial hyperaldosteronism type IV (OMIM 617027) Renovascular disease Renin-secreting tumor 17<math>\beta</math>-Hydroxylase deficiency (OMIM 202110) 11<math>\beta</math>-Hydroxylase deficiency (OMIM 202010) Cushing syndrome 11<math>\beta</math>-Hydroxysteroid dehydrogenase deficiency (OMIM 218030) Licorice ingestion Liddle syndrome (OMIM 177200) Early-onset autosomal dominant hypertension with exacerbation in pregnancy (OMIM 605115)</p>
---	--

\*Most cases of proximal renal tubular acidosis are not caused by this primary genetic disorder. Proximal renal tubular acidosis is usually part of Fanconi syndrome, which has multiple etiologies.

EAST, Epilepsy, ataxia, sensorineural hearing loss, and tubulopathy; OMIM, database number from the Online Mendelian Inheritance in Man (<http://www.ncbi.nlm.nih.gov/omim>).

Sweat losses of  $K^+$  can be significant during vigorous exercise in a hot climate. Associated volume depletion and hyperaldosteronism increase renal losses of  $K^+$  (discussed later). Diarrheal fluid has a high concentration of  $K^+$ , and hypokalemia because of diarrhea is usually associated with metabolic acidosis resulting from stool losses of bicarbonate. In contrast, normal acid-base balance or mild metabolic alkalosis is seen with laxative abuse. Intake of potassium-binding resins (SPS) or ingestion of clay because of pica increases stool losses of potassium.

**Urinary potassium wasting** may be accompanied by a **metabolic acidosis** (proximal or distal RTA). In DKA, although it is often associated with normal plasma  $[K^+]$  from transcellular shifts, there is significant total body  $K^+$  depletion from urinary losses because of the osmotic diuresis, and the  $K^+$  level may decrease dramatically with insulin therapy (see Chapter 629). Both the polyuric phase of acute tubular necrosis and postobstructive diuresis cause transient, highly variable  $K^+$  wasting and may be associated with metabolic acidosis. Tubular damage, which occurs either directly from medications or secondary to interstitial nephritis, is often accompanied by other tubular losses, including magnesium,  $Na^+$ , and water. Such tubular damage may cause a secondary RTA with metabolic acidosis. Isolated magnesium deficiency causes renal  $K^+$  wasting. Penicillin is an anion excreted in the urine, resulting in increased  $K^+$  excretion because the penicillin anion must be accompanied by a

cation. Hypokalemia from penicillin therapy occurs only with the *sodium* salt of penicillin, not with the potassium salt.

Urinary  $K^+$  wasting is often accompanied by a **metabolic alkalosis**. This condition is usually associated with increased aldosterone, which increases urinary  $K^+$  and acid losses, contributing to the hypokalemia and the metabolic alkalosis. Other mechanisms often contribute to both the  $K^+$  losses and the metabolic alkalosis. With emesis or nasogastric suction, there is gastric loss of  $K^+$ , but this is minimal given the low  $K^+$  content of gastric fluid, approximately 10 mEq/L. More important is the gastric loss of hydrochloric acid (HCl), leading to metabolic alkalosis and a state of volume depletion. The kidney compensates for metabolic alkalosis by excreting bicarbonate in the urine, but there is obligate loss of  $K^+$  and  $Na^+$  with the bicarbonate. The volume depletion raises aldosterone levels, further increasing urinary  $K^+$  losses and preventing correction of metabolic alkalosis and hypokalemia until the volume depletion is corrected.

Urinary chloride ( $Cl^-$ ) is low as a response to the volume depletion. Because the volume depletion is secondary to  $Cl^-$  loss, this is a **state of  $Cl^-$  deficiency**. There were cases of  $Cl^-$  deficiency resulting from infant formula deficient in  $Cl^-$ , which caused a metabolic alkalosis with hypokalemia and low urine  $[Cl^-]$ . Current infant formula is not deficient in  $Cl^-$ . A similar mechanism occurs in cystic fibrosis because of  $Cl^-$  loss in sweat. In **congenital chloride-losing diarrhea**, an autosomal recessive

disorder, there is high stool loss of  $\text{Cl}^-$ , leading to metabolic alkalosis, an unusual sequela of diarrhea. Because of stool  $\text{K}^+$  losses,  $\text{Cl}^-$  deficiency, and metabolic alkalosis, patients with congenital chloride-losing diarrhea have hypokalemia.

During respiratory acidosis, there is renal compensation, with retention of bicarbonate and excretion of  $\text{Cl}^-$ . After the respiratory acidosis is corrected, the patients have  $\text{Cl}^-$  deficiency and post-hypercapnic alkalosis with secondary hypokalemia. Patients with  $\text{Cl}^-$  deficiency, metabolic alkalosis, and hypokalemia have a urinary  $[\text{Cl}^-]$  of  $<10$  mEq/L. Loop and thiazide diuretics lead to hypokalemia, metabolic alkalosis, and  $\text{Cl}^-$  deficiency. During treatment, these patients have high urine chloride levels resulting from the effect of the diuretic. However, after the diuretics are discontinued, there is residual  $\text{Cl}^-$  deficiency, the urinary  $[\text{Cl}^-]$  is appropriately low, and neither the hypokalemia nor the alkalosis resolves until the  $\text{Cl}^-$  deficiency is corrected.

The combination of metabolic alkalosis, hypokalemia, high urine  $[\text{Cl}^-]$ , and normal blood pressure is characteristic of Bartter syndrome, Gitelman syndrome, and current diuretic use. Patients with any of these conditions have high urinary losses of  $\text{Cl}^-$  despite a state of relative volume depletion with secondary hyperaldosteronism with high plasma renin. Bartter and Gitelman syndromes are autosomal recessive disorders caused by defects in tubular transporters (see Chapter 571). **Bartter syndrome** is usually associated with hypercalciuria, and often with nephrocalcinosis, whereas children with **Gitelman syndrome** have low urinary calcium losses but hypomagnesemia because of urinary magnesium losses. Some patients with Bartter syndrome have hypomagnesemia. A transient antenatal form of Bartter syndrome is associated with severe polyhydramnios and pathogenic variants in *MAGED2*.

Some patients with hypoparathyroidism and hypocalcemia caused by activating pathogenic variants of the calcium-sensing receptor (**autosomal dominant hypoparathyroidism**) have hypokalemia, hypomagnesemia, and metabolic alkalosis. The reason is that activation of the calcium-sensing receptor in the loop of Henle impairs tubular resorption of sodium and chloride, causing volume depletion and secondary hyperaldosteronism. **EAST syndrome**, an autosomal recessive disorder caused by pathologic variants in the gene for a potassium channel in the kidney, inner ear, and brain, consists of epilepsy, ataxia, sensorineural hearing loss, and tubulopathy (hypokalemia, metabolic alkalosis, hypomagnesemia, and hypocalciuria).

In the presence of *high aldosterone levels*, there is urinary loss of  $\text{K}^+$ , hypokalemia, metabolic alkalosis, and elevated urinary  $[\text{Cl}^-]$ ; renal retention of  $\text{Na}^+$  leads to **hypertension**. Primary hyperaldosteronism caused by adenoma or hyperplasia is much less common in children than in adults (see Chapters 619 and 620). **Glucocorticoid-remediable aldosteronism**, an autosomal dominant disorder that leads to high levels of aldosterone (but low renin levels), is often diagnosed in childhood, although hypokalemia is not always present. **Familial hyperaldosteronism type II**, an autosomal dominant disorder, is due to a gain-of-function variant in *CLCN2* that causes increased aldosterone synthesis. **Familial hyperaldosteronism type III**, an autosomal dominant disorder, is due to a gain-of-function variant in *KCNJ5* that causes a dramatic increase in aldosterone synthesis and severe hypertension and hypokalemia. **Familial hyperaldosteronism type IV**, an autosomal dominant disorder, is due to a gain-of-function variant in *CACNA1H* that causes increased aldosterone synthesis.

Increased aldosterone levels may also be *secondary* to increased renin production. Renal artery stenosis leads to hypertension from increased renin and secondary hyperaldosteronism. The increased aldosterone can cause hypokalemia and metabolic alkalosis, although most patients have normal electrolyte levels. Renin-producing tumors, which are extremely rare, can cause hypokalemia.

A variety of disorders cause hypertension and hypokalemia without increased aldosterone levels. Some are a result of increased levels of mineralocorticoids other than aldosterone. Such increases

occur in two forms of **congenital adrenal hyperplasia** (see Chapter 616). In **11 $\beta$ -hydroxylase deficiency**, which is associated with virilization, 11-deoxycorticosterone is elevated, causing variable hypertension and hypokalemia. A similar mechanism, increased 11-deoxycorticosterone, occurs in **17 $\alpha$ -hydroxylase deficiency**, but patients with this disorder are more uniformly hypertensive and hypokalemic, and they have a defect in sex hormone production. **Cushing syndrome**, frequently associated with hypertension, less frequently causes metabolic alkalosis and hypokalemia, secondary to the mineralocorticoid activity of cortisol. In **11 $\beta$ -hydroxysteroid dehydrogenase deficiency**, an autosomal recessive disorder, the enzymatic defect prevents the conversion of cortisol to cortisone in the kidney. Because cortisol binds to and activates the aldosterone receptor, children with this deficiency have all the features of excessive mineralocorticoids, including hypertension, hypokalemia, and metabolic alkalosis, but low levels of aldosterone and renin. Patients with this disorder, which is also called **apparent mineralocorticoid excess**, respond to spironolactone therapy, which blocks the mineralocorticoid receptor. An acquired form of 11 $\beta$ -hydroxysteroid dehydrogenase deficiency occurs from the ingestion of substances that inhibit this enzyme. A classic example is glycyrrhizic acid, which is found in natural licorice. **Liddle syndrome** is an autosomal dominant disorder that results from activating pathogenic variants of the distal nephron sodium channel that is normally upregulated by aldosterone. Patients have the characteristics of hyperaldosteronism—hypertension, hypokalemia, and alkalosis—but low serum renin and aldosterone levels. These patients respond to the potassium-sparing diuretics (triamterene and amiloride) that inhibit this sodium channel (see Chapter 571.3). A pathogenic variant in the mineralocorticoid receptor causes **early-onset autosomal dominant hypertension with exacerbation in pregnancy**. Hypokalemia is usually mild but worsens during pregnancy; renin and aldosterone levels are low.

### Clinical Manifestations

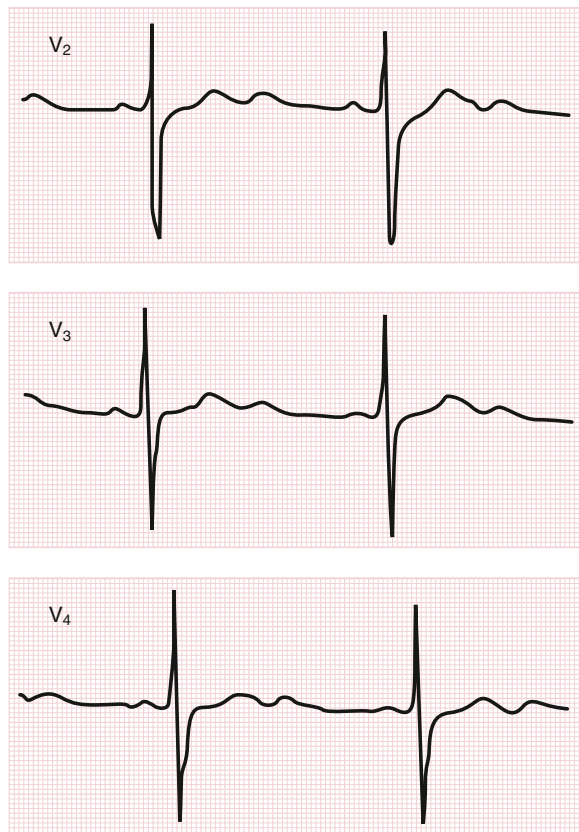
The heart and skeletal muscle are especially vulnerable to hypokalemia. ECG changes include a flattened T wave, a depressed ST segment, and the appearance of a U wave, which is located between the T wave (if still visible) and the P wave (Fig. 73.5). Ventricular fibrillation and torsades de pointes may occur, although usually only in the context of underlying heart disease. Hypokalemia makes the heart especially susceptible to digitalis-induced arrhythmias, such as supraventricular tachycardia, ventricular tachycardia, and heart block (see Chapter 484).

The clinical consequences of hypokalemia in skeletal muscle include muscle weakness and cramps. Paralysis is a possible complication, generally only at  $[\text{K}^+] <2.5$  mEq/L. It usually starts in the legs and moves to the arms. Respiratory paralysis may require mechanical ventilation. Some patients have rhabdomyolysis; the risk increases with exercise. Hypokalemia slows GI motility. This effect manifests as constipation; with  $\text{K}^+$  levels  $<2.5$  mEq/L, an ileus may occur. Hypokalemia impairs bladder function, potentially leading to urinary retention.

Hypokalemia causes **polyuria** and **polydipsia** by impairing urinary concentrating ability, which produces nephrogenic diabetes insipidus. Hypokalemia stimulates renal ammonia production, an effect that is clinically significant if hepatic failure is present, because the liver cannot metabolize the ammonia. Consequently, hypokalemia may worsen hepatic encephalopathy. Chronic hypokalemia may cause kidney damage, including interstitial nephritis and renal cysts.

### Diagnosis

Most causes of hypokalemia are readily apparent from the history. It is important to review the child's diet, GI losses, and medications. Both emesis and diuretic use can be surreptitious. The presence of **hypertension** suggests excess mineralocorticoid effects or levels. Concomitant electrolyte abnormalities are useful clues. The combination of hypokalemia and metabolic acidosis is characteristic of diarrhea and distal and proximal RTA. A concurrent metabolic alkalosis is characteristic of emesis or nasogastric losses, aldosterone excess, use of diuretics, and



**Fig. 73.5** The ECG manifestations of hypokalemia. The serum potassium concentration was 2.2 mEq/L. The ST segment is prolonged, primarily because of a U wave following the T wave, and the T wave is flattened. (From Goldman L, Schafer AJ, eds. *Goldman-Cecil Medicine*. 26th ed. Elsevier; 2020. Fig. 109.1, p 727.)

Bartter and Gitelman syndromes. Figure 73.6 shows an approach to persistent hypokalemia.

If a clear etiology is not apparent, the measurement of urinary  $K^+$  distinguishes between renal and extrarenal losses. The kidneys should conserve  $K^+$  in the presence of extrarenal losses. Urinary  $K^+$  losses can be assessed with a 24-hour urine collection, spot  $K^+$ :creatinine ratio, fractional excretion of  $K^+$ , or calculation of the *transtubular  $K^+$  gradient* (TTKG), which is the most widely used approach in children:

$$TTKG = [K]_{urine} / [K]_{plasma} \times (\text{plasma osmolality} / \text{urine osmolality})$$

where  $[K]_{urine}$  = urine potassium concentration and  $[K]_{plasma}$  = plasma potassium concentration.

The urine osmolality must be greater than the serum osmolality for the result of this calculation to be valid. A TTKG >4 in the presence of hypokalemia suggests excessive urinary losses of  $K^+$ . The urinary  $K^+$  excretion value can be misleading if the stimulus for renal loss, such as a diuretic, is no longer present.

### Treatment

Factors that influence the treatment of hypokalemia include the  $K^+$  level, clinical symptoms, kidney function, the presence of transcellular shifts of  $K^+$ , ongoing losses, and the patient's ability to tolerate oral  $K^+$ . Severe, symptomatic hypokalemia requires aggressive treatment. Supplementation is more cautious if renal function is decreased because of the kidney's limited ability to excrete excessive

$K^+$ . The plasma potassium level does not always provide an accurate estimation of the total body  $K^+$  deficit because there may be shifts of  $K^+$  from the ICS to the plasma. Clinically, such shifts occur most often with metabolic acidosis and the insulin deficiency of DKA; the plasma  $[K^+]$  measurement underestimates the degree of total body  $K^+$  depletion. When these problems are corrected,  $K^+$  moves into the ICS, so more  $K^+$  supplementation is required to correct the hypokalemia. Likewise, the presence of a transcellular shift of  $K^+$  into the cells indicates that the total body  $K^+$  depletion is less severe. In an isolated transcellular shift, as in hypokalemic periodic paralysis,  $K^+$  supplementation should be used cautiously, given the risk of hyperkalemia when the transcellular shift resolves. This caution is especially required in thyrotoxic periodic paralysis, which responds dramatically to propranolol, with correction of weakness and hypokalemia. Patients who have ongoing losses of  $K^+$  need correction of the deficit and replacement of the ongoing losses.

Because of the risk of hyperkalemia, IV  $K^+$  should be used very cautiously. Oral  $K^+$  is safer, but not as rapid in urgent situations. Liquid preparations are bitter tasting; microencapsulated or wax matrix formulations are less irritating than tablets to the gastric mucosa. Oral dosing is variable depending on the clinical situation. A typical starting dose is 1-2 mEq/kg/day, with a maximum of 60 mEq/day in divided doses. The dose of IV potassium is 0.5-1.0 mEq/kg, usually given over 1 hour. The adult maximum dose is 40 mEq. Conservative dosing is generally preferred. Potassium chloride is the usual choice for supplementation, although the presence of concurrent electrolyte abnormalities may dictate other options. Patients with acidosis and hypokalemia can receive potassium acetate or potassium citrate. If hypophosphatemia is present, some of the potassium deficit can be replaced with potassium phosphate. It is sometimes possible to decrease ongoing  $K^+$  losses. For patients with excessive urinary losses, potassium-sparing diuretics are effective, but they need to be used cautiously in patients with decreased kidney function. If hypokalemia, metabolic alkalosis, and volume depletion are present (with gastric losses), restoration of intravascular volume with adequate NaCl will decrease urinary  $K^+$  losses. Correction of concurrent hypomagnesemia is important because it may cause hypokalemia. Disease-specific therapy is effective in many of the genetic tubular disorders.

Visit Elsevier eBooks+ at [eBooks.Health.Elsevier.com](http://eBooks.Health.Elsevier.com) for Bibliography.

## 73.5 Magnesium

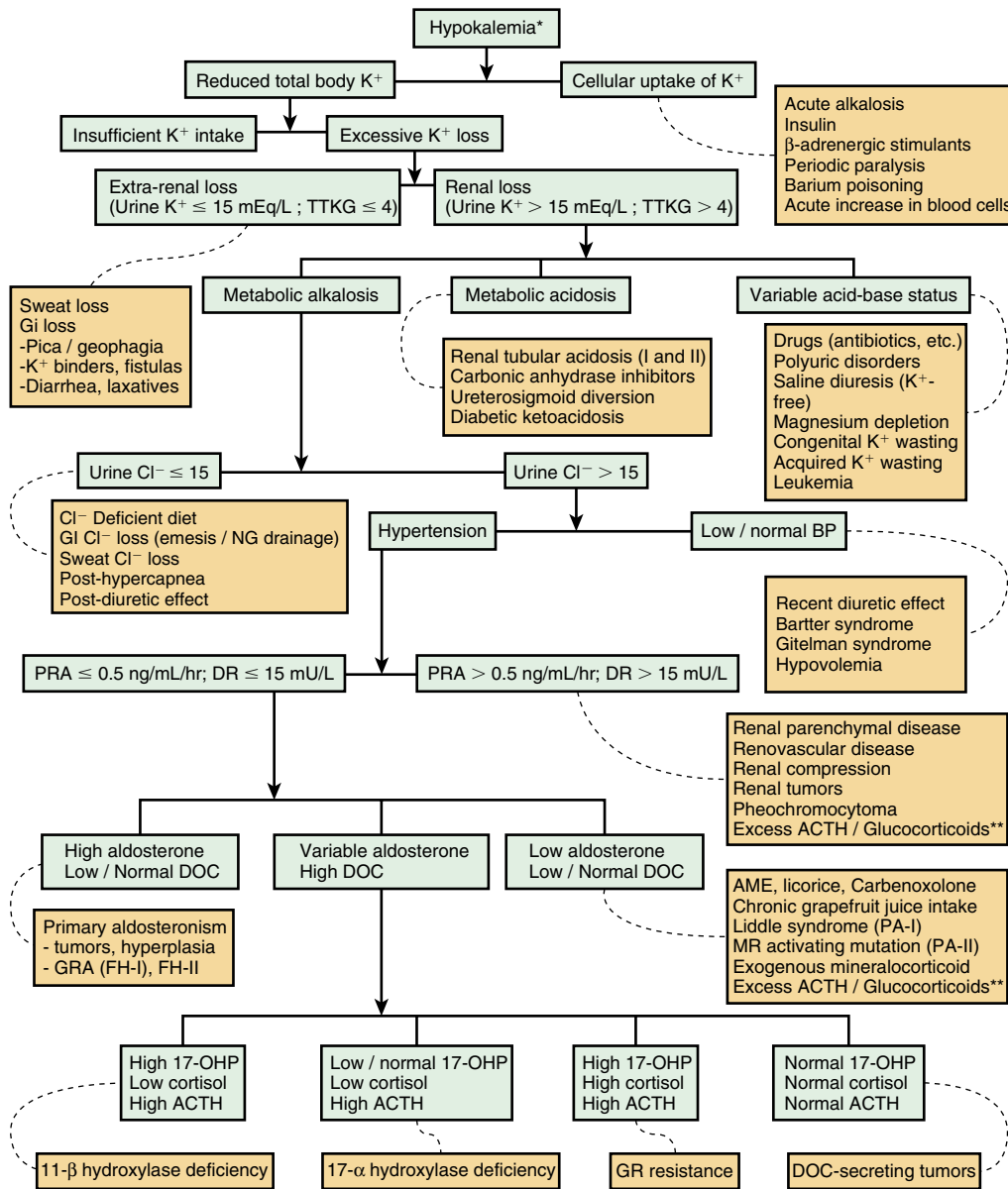
Larry A. Greenbaum

### MAGNESIUM METABOLISM

#### Body Content and Physiologic Function

Magnesium is the fourth most common cation in the body and the third most common intracellular cation (see Fig. 73.3). From 50–60% of body magnesium is in bone, where it serves as a reservoir because 30% is exchangeable, allowing movement to the ECS. Most intracellular magnesium is bound to proteins; only approximately 25% is exchangeable. Because cells with higher metabolic rates have higher magnesium concentrations, most intracellular magnesium is present in muscle and liver.

The normal plasma magnesium concentration is 1.5-2.3 mg/dL (1.2-1.9 mEq/L; 0.62-0.94 mmol/L), with some variation among clinical laboratories. Infants have slightly higher plasma magnesium concentrations than older children and adults. Only 1% of body magnesium is extracellular (60% ionized, 15% complexed, 25% protein bound). In the United States, serum magnesium is reported as mg/dL (Table 73.6). Values in the left-column unit are converted into the right-column unit by multiplying the conversion factor (e.g., calcium of 10 mg/dL  $\times$  0.25 = 2.5 mmol/L). Dividing the right-column unit by the conversion factor converts to the units of the left-column unit.



**Fig. 73.6** Diagnostic algorithm to evaluate persistent hypokalemia. \*Spurious hypokalemia must be excluded. \*\*Hypokalemia is uncommon in uncomplicated edematous disorders and in conditions associated with excessive glucocorticosteroids. Conditions associated with high circulating levels of glucocorticosteroids often have normal renin activity. 17-OHP, 17-Hydroxyprogesterone; ACTH, adrenocorticotropic hormone; AME, apparent mineralocorticoid excess; BP, blood pressure; Cl<sup>-</sup>, chloride; DOC, 11-deoxycorticosterone; DR, direct renin assay; GI, gastrointestinal; FH-II, familial hyperaldosteronism type II; GR, glucocorticoid receptor; GRA (FH-I), glucocorticoid remediable aldosteronism (familial hyperaldosteronism type I); K<sup>+</sup>, potassium; MR, mineralocorticoid receptor; PA-I, pseudohyperaldosteronism type I; PA-II, pseudohyperaldosteronism type II; PRA, plasma renin activity; TTKG, transtubular potassium gradient. (From Shoemaker LR, Eaton BV, Buchino JJ. A three-year-old with persistent hypokalemia. *J Pediatr.* 2007;151[6]:696–699.)

Magnesium is a necessary cofactor for hundreds of enzymes. It is important for membrane stabilization and nerve conduction. Adenosine triphosphate (ATP) and guanosine triphosphate need associated magnesium when they are used by ATPases, cyclases, and kinases.

### Magnesium Intake

Between 30% and 50% of dietary magnesium is absorbed. Good dietary sources include green vegetables, cereals, nuts, meats, and hard water, although many foods contain magnesium. Human milk contains approximately 35 mg/L of magnesium; formula contains 40–70 mg/L. The small intestine is the major site of magnesium absorption, but the regulation of magnesium absorption is poorly understood. There is passive absorption, which permits high absorption in the presence

of excessive intake. It probably occurs by a paracellular mechanism. Absorption is diminished in the presence of substances that complex with magnesium (free fatty acids, fiber, phytate, phosphate, oxalate); increased intestinal motility and calcium also decrease magnesium absorption. Vitamin D and parathyroid hormone (PTH) may enhance absorption, although this effect is limited. Intestinal absorption does increase when intake is decreased, possibly by a saturable, active transport system. If there is no oral intake of magnesium, obligatory secretory losses prevent the complete elimination of intestinal losses.

### Magnesium Excretion

Renal excretion is the principal regulator of magnesium balance. There is no defined hormonal regulatory system, although PTH may increase



tubular resorption. Approximately 15% of resorption occurs in the proximal tubule and 70% in the thick ascending limb (TAL) of the loop of Henle. Proximal resorption may be higher in neonates. High serum magnesium levels inhibit resorption in the TAL, suggesting that active transport is involved. Approximately 5–10% of filtered magnesium is resorbed in the distal tubule. Hypomagnesemia increases absorption in the TAL and the distal tubule.

### HYPOMAGNESEMIA

Hypomagnesemia is relatively common in hospitalized patients, although most cases are asymptomatic. Detection requires a high index of suspicion because magnesium is not measured in most basic metabolic panels.

Table 73.6 Conversion Factors for Calcium, Magnesium, and Phosphorus			
	UNIT	CONVERSION FACTOR	UNIT
Calcium	mg/dL	0.25	mmol/L
	mEq/L	0.5	mmol/L
	mg/dL	0.5	mEq/L
Magnesium	mg/dL	0.411	mmol/L
	mEq/L	0.5	mmol/L
	mg/dL	0.822	mEq/L
Phosphorus	mg/dL	0.32	mmol/L

Table 73.7 Causes of Hypomagnesemia

Causes of Hypomagnesemia	
<b>GASTROINTESTINAL LOSSES</b>	Primary aldosteronism
Diarrhea	Genetic diseases
Nasogastric suction or emesis	Gitelman syndrome (OMIM 263800)
Inflammatory bowel disease	Bartter syndrome (OMIM 241200/607364/602522/601678/300971/601198/613090)
Celiac disease	Familial hypomagnesemia with hypercalciuria and nephrocalcinosis (OMIM 248250)
Cystic fibrosis	Familial hypomagnesemia with hypercalciuria, nephrocalcinosis, and severe ocular involvement (OMIM 248190)
Intestinal lymphangiectasia	Autosomal recessive renal magnesium wasting with normocalciuria (OMIM 611718)
Small bowel resection or bypass	Renal cysts and diabetes syndrome due to <i>HNF1β</i> variants (OMIM 137920)
Pancreatitis	Autosomal dominant hypomagnesemia (OMIM 160120/613882/154020)
Protein-calorie malnutrition	EAST syndrome (OMIM 612780)
Patiromer	Autosomal dominant hypoparathyroidism (OMIM 146200)
Hypomagnesemia with secondary hypocalcemia (OMIM 602014)*	Mitochondrial disorders (OMIM 500005)
<b>RENAL DISORDERS</b>	Hyperuricemia, pulmonary hypertension, renal failure in infancy and alkalosis, HUPRA syndrome (OMIM 613845)
Medications	Transient neonatal hyperphenylalaninemia followed by hypomagnesemia and maturity onset diabetes of the young (OMIM 264070)
Amphotericin	Hypomagnesemia, seizures and mental retardation due to <i>CNNM2</i> pathogenic variants (OMIM 616418)
Cisplatin	Autosomal dominant kidney hypomagnesemia due to <i>RRAGD</i> pathogenic variants (OMIM not assigned)
Cyclosporine, tacrolimus	
Loop and thiazide diuretics	<b>MISCELLANEOUS CAUSES</b>
Mannitol	Poor intake
Pentamidine	Hungry bone syndrome
Proton pump inhibitors	Insulin administration
Aminoglycosides	Pancreatitis
Thiazide diuretics	Intrauterine growth restriction
Epidermal growth factor receptor inhibitors	Infants of diabetic mothers
Diabetes	Exchange transfusion
Acute tubular necrosis (recovery phase)	
Postobstructive nephropathy	
Chronic kidney diseases	
Interstitial nephritis	
Glomerulonephritis	
Post-renal transplantation	
Hypercalcemia	
Intravenous fluids	

\*This disorder is also associated with renal magnesium wasting.

EAST, Epilepsy, ataxia, sensorineural hearing loss, and tubulopathy; OMIM, database number from the Online Mendelian Inheritance in Man (<http://www.ncbi.nlm.nih.gov/omim>).

### Etiology and Pathophysiology

GI and renal losses are the major causes of hypomagnesemia (Table 73.7). Diarrheal fluid contains up to 200 mg/L of magnesium; gastric contents have only approximately 15 mg/L, but high losses can cause depletion. Steatorrhea causes magnesium loss because of the formation of magnesium-lipid salts; restriction of dietary fat can decrease losses. The potassium-lowering agent patiromer binds magnesium and may cause hypomagnesemia.

**Hypomagnesemia with secondary hypocalcemia**, a rare autosomal recessive disorder, is caused by decreased intestinal absorption of magnesium and renal magnesium wasting. Patients with this disorder have pathogenic variants in a gene expressed in intestine and kidney; *TRPM6* codes for a transient receptor potential cation channel. The patients have seizures, tetany, tremor, or restlessness at 2–8 weeks of life because of severe hypomagnesemia (0.2–0.8 mg/dL) and secondary hypocalcemia.

Renal losses may occur because of medications that are direct tubular toxins. Amphotericin frequently causes significant magnesium wasting and is typically associated with other tubular defects (especially potassium wasting). Cisplatin produces dramatic renal magnesium losses. Diuretics affect tubular handling of magnesium. Loop diuretics cause a mild increase in magnesium excretion, and thiazide diuretics have even less effect. Chronic use of proton pump inhibitors (PPIs) may cause hypomagnesemia. Potassium-sparing diuretics reduce magnesium losses. Osmotic agents, such as mannitol, glucose in diabetes mellitus, and urea in the recovery phase of acute tubular necrosis, increase urinary magnesium losses. Epidermal growth factor (EGF) receptor inhibitors cause renal magnesium wasting. IV fluid, by expanding the intravascular volume, decreases renal resorption of

sodium and water, thereby impairing magnesium resorption. Hypercalcemia inhibits magnesium resorption in the loop of Henle, although this inhibition does not occur in hypercalcemia caused by familial hypercalcemic hypocalciuria or lithium.

A number of rare genetic diseases cause renal magnesium loss. Gitelman and Bartter syndromes, both autosomal recessive disorders, are the most common entities (see Chapter 571). **Gitelman syndrome**, caused by a defect in the thiazide-sensitive  $\text{Na}^+\text{-Cl}^-$  cotransporter in the distal tubule, is usually associated with hypomagnesemia. Hypomagnesemia occurs in a minority of patients with **Bartter syndrome**, which can be caused by pathogenic variants in multiple genes necessary for  $\text{Na}^+$  and  $\text{Cl}^-$  reabsorption in the loop of Henle. In both disorders, there is hypokalemic metabolic alkalosis. Typically, hypomagnesemia is not severe and is asymptomatic, although tetany as a result of hypomagnesemia occasionally occurs.

**Familial hypomagnesemia with hypercalciuria and nephrocalcinosis (Michelis-Castrillo syndrome)**, an autosomal recessive disorder, is caused by pathogenic variants in the gene for claudin 16 (paracellin-1), located in the tight junctions of the TAL of the loop of Henle. Patients with the disease have severe renal wasting of magnesium and calcium with secondary hypomagnesemia and nephrocalcinosis; serum calcium levels are normal. Chronic kidney failure frequently occurs during childhood. Other features include kidney stones, urinary tract infections, hematuria, increased PTH levels, tetany, seizures, incomplete distal RTA, hyperuricemia, polyuria, and polydipsia. Patients with **familial hypomagnesemia with hypercalciuria, nephrocalcinosis, and severe ocular involvement** have pathogenic variants in the gene for claudin 19.

**Autosomal recessive renal magnesium wasting with normocalciuria** is caused by pathogenic variants in the EGF gene. Clinical manifestations include seizures, mild to moderate psychomotor retardation, and brisk tendon reflexes.

**Autosomal dominant renal magnesium wasting** is caused by pathogenic variants in a number of different genes. A dominant-negative pathogenic variant in the gene encoding the  $\text{Na}^+, \text{K}^+$ -ATPase  $\gamma$  subunit is associated with hypomagnesemia, increased urinary magnesium losses, hypocalciuria, and normocalcemia. Patients may present with seizures; most are asymptomatic, despite serum magnesium levels of 0.8–1.5 mg/dL. Pathogenic variants in *CNNM2*, which encodes a protein that mediates magnesium-sensitive sodium currents, cause isolated hypomagnesemia. A pathogenic variant in *KCNA1*, a gene that encodes a  $\text{K}^+$  channel, also causes an autosomal dominant form of hypomagnesemia; symptoms may be severe.

**Renal cysts and diabetes syndrome**, which is caused by pathogenic variants in the gene for hepatocyte nuclear factor- $1\beta$ , is associated with hypomagnesemia, despite the frequent presence of decreased kidney function. The hypomagnesemia is usually mild but may cause symptomatic hypocalcemia. **EAST syndrome** is caused by pathogenic variants in a potassium channel, and patients with this autosomal recessive disorder have hypokalemia, metabolic alkalosis, and hypomagnesemia. Pathogenic variants of *RRAGD* cause **autosomal dominant kidney hypomagnesemia**, and affected patients may have hypokalemia, hypomagnesemia, metabolic alkalosis, hypercalciuria, nephrocalcinosis, and a severe cardiomyopathy. **Autosomal dominant hypoparathyroidism** is caused by an activating pathogenic variant in the calcium-sensing receptor, which also senses magnesium levels in the kidney (see Chapter 611). The abnormal receptor inappropriately perceives that magnesium and calcium levels are elevated, leading to urinary wasting of both cations. Hypomagnesemia, if present, is usually mild. A pathogenic variant in a mitochondrially encoded transfer RNA is associated with hypomagnesemia, hypertension, and hypercholesterolemia. Hypomagnesemia is occasionally present in children with other mitochondrial disorders.

Poor intake is an unusual cause of hypomagnesemia, although it can be seen in children who are hospitalized and receive only IV fluids without magnesium. In **hungry bone syndrome**, which most

frequently occurs after parathyroidectomy in patients with hyperparathyroidism, magnesium moves into bone as a result of accelerated bone formation. These patients usually have hypocalcemia and hypophosphatemia through the same mechanism. A similar mechanism can occur during the **refeeding phase of protein-calorie malnutrition** in children, with high magnesium use during cell growth depleting the patient's limited reserves. Insulin therapy stimulates uptake of magnesium by cells, and in DKA, in which total body magnesium is low because of osmotic losses, hypomagnesemia frequently occurs. In **pancreatitis** there is saponification of magnesium and calcium in necrotic fat, causing both hypomagnesemia and hypocalcemia.

**Transient hypomagnesemia in newborns**, which is sometimes idiopathic, is more common in infants of diabetic mothers, presumably as a result of maternal depletion from osmotic losses. Other maternal diseases that cause magnesium losses predispose infants to hypomagnesemia. Hypomagnesemia is more common in infants with intrauterine growth restriction. Hypomagnesemia may develop in newborn infants who require exchange transfusions because of magnesium removal by the citrate in banked blood.

### Clinical Manifestations

Hypomagnesemia causes secondary hypocalcemia by impairing the release of PTH by the parathyroid gland and through blunting of the tissue response to PTH. Thus hypomagnesemia is part of the differential diagnosis of hypocalcemia. It usually occurs only at magnesium levels  $<0.7$  mg/dL. The dominant manifestations of hypomagnesemia are caused by hypocalcemia: tetany, presence of Chvostek and Trousseau signs, and seizures. However, with severe hypomagnesemia, these same signs and symptoms may be present despite normocalcemia. Persistent hypocalcemia caused by hypomagnesemia is a rare cause of rickets.

Many causes of hypomagnesemia also result in hypokalemia. Hypomagnesemia may produce renal potassium wasting and hypokalemia that corrects only with magnesium therapy. ECG changes with hypomagnesemia include flattening of the T wave and lengthening of the ST segment. Arrhythmias may occur, almost always in the setting of underlying heart disease.

### Diagnosis

The etiology of hypomagnesemia is often readily apparent from the clinical situation. The child should be assessed for GI disease, adequate intake, and kidney disease, with close attention paid to medications that may cause renal magnesium wasting. When the diagnosis is uncertain, an evaluation of urinary magnesium losses distinguishes between renal and nonrenal causes. The *fractional excretion of magnesium* ( $\text{FE}_{\text{Mg}}$ ) is calculated via the following formula:

$$\text{FE}_{\text{Mg}} = (\text{U}_{\text{Mg}} \times \text{P}_{\text{Cr}}) / ([0.7 \times \text{P}_{\text{Mg}}] \times \text{U}_{\text{Cr}}) \times 100$$

where  $\text{U}_{\text{Mg}}$  = urinary magnesium concentration,  $\text{P}_{\text{Cr}}$  = plasma creatinine concentration,  $\text{P}_{\text{Mg}}$  = plasma magnesium concentration, and  $\text{U}_{\text{Cr}}$  = urinary magnesium concentration. The plasma magnesium concentration is multiplied by 0.7 because approximately 30% is bound to albumin and not filtered at the glomerulus.

The  $\text{FE}_{\text{Mg}}$  does not vary with age, but it does change according to the serum magnesium concentration. The  $\text{FE}_{\text{Mg}}$  ranges from 1–8% in children with normal magnesium levels. In the patient with hypomagnesemia as a result of extrarenal causes,  $\text{FE}_{\text{Mg}}$  should be low because of renal conservation, typically  $<2\%$ . The  $\text{FE}_{\text{Mg}}$  is inappropriately elevated in the setting of renal magnesium wasting; values are usually  $>4\%$  and frequently  $>10\%$ . The measurement should not be made during a magnesium infusion, because the acute increase in serum magnesium increases urinary magnesium. Other approaches for evaluating urinary magnesium losses include calculation of 24-hour urinary magnesium losses and the urine magnesium/creatinine ratio, both of which vary with age.

The genetic causes of renal magnesium loss are distinguished based on the measurement of other serum and urinary electrolytes. *Children with Gitelman or Bartter syndrome have hypokalemia and metabolic alkalosis.*

### Treatment

Severe hypomagnesemia is treated with parenteral magnesium. Magnesium sulfate is given at a dose of 25–50 mg/kg (0.05–0.1 mL/kg of a 50% solution; 2.5–5.0 mg/kg of elemental magnesium). It is administered as a slow IV infusion, although it may be given intramuscularly in neonates. The rate of IV infusion should be slowed if a patient experiences diaphoresis, flushing, or a warm sensation. The dose is often repeated every 6 hours (every 8–12 hours in neonates), for a total of 2–3 doses, before the plasma magnesium concentration is rechecked. Lower doses are used in children with decreased kidney function.

Long-term therapy is usually given orally. Preparations include magnesium gluconate (5.4 mg elemental magnesium/100 mg), magnesium oxide (60 mg elemental magnesium/100 mg), and magnesium sulfate (10 mg elemental magnesium/100 mg). Sustained-release preparations include Slow-Mag (60 mg elemental magnesium/tablet) and Mag-Tab SR (84 mg elemental magnesium/tablet). Oral magnesium dosing should be divided to decrease cathartic side effects. Alternatives to oral magnesium are intramuscular injections and nighttime nasogastric infusion, both designed to minimize diarrhea. Magnesium supplementation must be used cautiously in the context of renal insufficiency.

### HYPERMAGNESEMIA

Clinically significant hypermagnesemia is almost always secondary to excessive intake. It is unusual, except in neonates born to mothers who are receiving IV magnesium for preeclampsia or eclampsia (see Chapter 121.5).

### Etiology and Pathophysiology

There is no feedback mechanism to prevent magnesium absorption from the GI tract. Magnesium is present in high amounts in certain laxatives, enemas, cathartics used to treat drug overdoses, and antacids. It is also usually present in total parenteral nutrition (TPN), and neonates may receive high amounts transplacentally if maternal levels are elevated. Usually the kidneys excrete excessive magnesium, but this ability is diminished in patients with chronic kidney disease. In addition, neonates and young infants are vulnerable to excessive magnesium ingestion because of their reduced GFR. Most pediatric cases not related to maternal hypermagnesemia occur in infants because of excessive use of antacids or laxatives. Mild hypermagnesemia may occur in chronic kidney disease, familial hypocalciuric hypercalcemia, DKA, lithium ingestion, milk-alkali syndrome, and tumor lysis syndrome. The hypermagnesemia in DKA occurs despite significant intracellular magnesium depletion because of urinary losses; hypomagnesemia often occurs after insulin treatment.

### Clinical Manifestations

Symptoms usually do not appear until the plasma magnesium level is >4.5 mg/dL. Hypermagnesemia inhibits acetylcholine release at the neuromuscular junction, producing hypotonia, hyporeflexia, and weakness; paralysis occurs at high concentrations. The neuromuscular effects may be exacerbated by aminoglycoside antibiotics. Direct CNS depression causes lethargy and sleepiness; infants have a poor suck. Elevated magnesium values are associated with hypotension because of vascular dilation, which also causes flushing. Hypotension can be profound at higher concentrations from a direct effect on cardiac function. ECG changes include prolonged PR interval, QRS complex, and QT interval. Severe hypermagnesemia (>15 mg/dL) causes complete heart block and cardiac arrest. Other manifestations of hypermagnesemia include nausea, vomiting, and hypocalcemia.

### Diagnosis

Except for the case of the neonate with transplacental exposure, a high index of suspicion and a good history are necessary to determine the etiology of hypermagnesemia. Prevention is essential; magnesium-containing compounds should be used judiciously in children with decreased kidney function.

### Treatment

Most patients with normal kidney function rapidly clear excess magnesium. Intravenous hydration and loop diuretics can accelerate this process. In severe cases, especially in patients with underlying renal insufficiency, dialysis may be necessary. Hemodialysis works faster than peritoneal dialysis. Exchange transfusion is another option in newborn infants. Supportive care includes monitoring of cardiorespiratory status, provision of fluids, monitoring of electrolyte levels, and the use of pressors for hypotension. In acute emergencies, especially in the context of severe neurologic or cardiac manifestations, 100 mg/kg of IV calcium gluconate is transiently effective.

Visit Elsevier eBooks+ at [eBooks.Health.Elsevier.com](http://eBooks.Health.Elsevier.com) for Bibliography.

## 73.6 Phosphorus

Larry A. Greenbaum

Approximately 65% of plasma phosphorus is in phospholipids, but these compounds are insoluble in acid and are not measured by clinical laboratories. It is the phosphorus content of *plasma phosphate* that is determined. The result is reported as either phosphate or phosphorus, although even when the term *phosphate* is used, it is actually the *phosphorus* concentration that is measured and reported. The result is that the terms phosphate and phosphorus are often used interchangeably. The term *phosphorus* is preferred when referring to the plasma concentration. Conversion from the units used in the United States (mg/dL) to mmol/L is straightforward (see Table 73.6).

### PHOSPHORUS METABOLISM

#### Body Content and Physiologic Function

Most phosphorus is in bone or is intracellular, with <1% in plasma. At a physiologic pH, there are monovalent and divalent forms of phosphate because the  $pK_a$  (ionization constant of acid) of these forms is 6.8. Approximately 80% is divalent, and the remainder is monovalent at a pH of 7.4. A small percentage of plasma phosphate, approximately 15%, is protein bound. The remainder can be filtered by the glomerulus, with most existing as free phosphate and a small percentage complexed with calcium, magnesium, or sodium. Phosphate is the most plentiful intracellular anion, although the majority is part of a larger compound (ATP).

More than that of any other electrolyte, the phosphorus concentration varies with age (Table 73.8). The teleologic explanation for the high concentration during childhood is the need for phosphorus to facilitate growth. There is diurnal variation in the plasma phosphorus concentration, with the peak during sleep.

**Table 73.8** Serum Phosphorus Levels During Childhood

AGE	PHOSPHORUS LEVEL (mg/dL)
0-5 day	4.8-8.2
1-3yr	3.8-6.5
4-11 yr	3.7-5.6
12-15yr	2.9-5.4
16-19yr	2.7-4.7



Phosphorus, as a component of adenosine triphosphate (ATP) and other trinucleotides, is critical for cellular energy metabolism. It is necessary for cell signaling and nucleic acid synthesis, and it is a component of cell membranes and other structures. Along with calcium, phosphorus is necessary for skeletal mineralization. A net positive phosphorus balance is required during growth, with the growing skeleton especially vulnerable to deficiency.

### Phosphorus Intake

Phosphorus is readily available in food. Milk and milk products are the best sources of phosphorus; high concentrations are present in meat and fish. Vegetables have more phosphorus than fruits and grains. GI absorption of phosphorus is proportional to intake, with approximately 65% of intake being absorbed, including a small amount that is secreted. Absorption, almost exclusively in the small intestine, occurs via a paracellular diffusive process and a vitamin D–regulated transcellular pathway. However, the impact of the change in phosphorus absorption caused by vitamin D is relatively small compared with the effect of variations in phosphorus intake.

### Phosphorus Excretion

Despite the wide variation in phosphorus absorption dictated by oral intake, excretion matches intake, except for the needs for growth. The kidney regulates phosphorus balance, which is determined by intrarenal mechanisms and hormonal actions on the nephron.

Approximately 90% of plasma phosphate is filtered at the glomerulus, although there is some variation based on plasma phosphate and calcium concentrations. There is no significant secretion of phosphate along the nephron. Resorption of phosphate occurs mostly in the proximal tubule, although a small amount can be resorbed in the distal tubule. Normally, approximately 85% of the filtered load is resorbed. Sodium-phosphate co-transporters mediate the uptake of phosphate into the cells of the proximal tubule.

Dietary phosphorus determines the amount of phosphate resorbed by the nephron. There are both acute and chronic changes in phosphate resorption that are based on intake. Many of these changes appear to be mediated by intrarenal mechanisms that are independent of regulatory hormones. **Fibroblast growth factor-23 (FGF-23)** inhibits renal resorption of phosphorus in the proximal tubule, and its level increases in the setting of hyperphosphatemia. FGF-23 also inhibits synthesis of 1,25-vitamin D in the kidney by decreasing 1 $\alpha$ -hydroxylase activity.

Secreted in response to a low plasma calcium level, PTH decreases resorption of phosphate, increasing the urinary phosphate level. This process appears to have a minimal effect during normal physiologic variation in PTH levels. However, it does affect urinary phosphate in the setting of pathologic changes in PTH synthesis.

Low plasma phosphorus stimulates the 1 $\alpha$ -hydroxylase in the kidney that converts 25-hydroxyvitamin D (25-D) to 1,25-dihydroxyvitamin D (1,25-D; calcitriol). Calcitriol increases intestinal absorption of phosphorus and is necessary for maximal renal resorption of phosphate. The effect of a change in calcitriol on urinary phosphate is significant only when the level of calcitriol was initially low, arguing against a role for calcitriol in nonpathologic conditions.

### HYPOPHOSPHATEMIA

Because of the wide variation in normal plasma phosphorus levels, the definition of hypophosphatemia is age dependent (see [Table 73.8](#)). The normal range reported by a laboratory may be based on adult normal values and therefore may be misleading in children. A serum phosphorus level of 3 mg/dL, a normal value in an adult, indicates clinically significant hypophosphatemia in an infant.

The plasma phosphorus level does not always reflect the total body stores because only 1% of phosphorus is extracellular. Thus a child may have significant phosphorus deficiency despite a normal plasma phosphorus concentration when there is a shift of phosphorus from the ICS.

### Etiology and Pathophysiology

A variety of mechanisms cause hypophosphatemia ([Table 73.9](#)). A transcellular shift of phosphorus into cells occurs with processes that stimulate cellular usage of phosphorus (glycolysis). Usually, this shift causes only a minor, transient decrease in plasma phosphorus, but if intracellular phosphorus deficiency is present, the plasma phosphorus level can decrease significantly, producing symptoms of acute hypophosphatemia. Glucose infusion stimulates insulin release, leading to entry of glucose and phosphorus into the cells. Phosphorus is then used during glycolysis and other metabolic processes. A similar phenomenon can occur during the treatment of DKA, and patients with DKA are typically phosphorus depleted because of urinary phosphorus losses.

**Table 73.9** Causes of Hypophosphatemia

#### TRANSCELLULAR SHIFTS

- Glucose infusion
- Insulin
- Refeeding
- Total parenteral nutrition
- Respiratory alkalosis
- Tumor growth
- Bone marrow transplantation
- Hungry bone syndrome

#### DECREASED INTAKE

- Nutritional
- Premature infants
- Low phosphorus formula
- Antacids and other phosphate binders

#### RENAL LOSSES

- Hyperparathyroidism
- Parathyroid hormone–related peptide
- X-linked hypophosphatemic rickets (OMIM 307800)
- Overproduction of fibroblast growth factor-23
  - Tumor-induced rickets
  - McCune-Albright syndrome (OMIM 174800)
  - Epidermal nevus syndrome
  - Neurofibromatosis
  - Autosomal dominant hypophosphatemic rickets (OMIM 193100)
  - Autosomal recessive hypophosphatemic rickets, types 1, 2, and 3 (OMIM 241520/613312)
- Ferric carboxymaltose
- Dent disease (OMIM 300009/300555)
- Fanconi syndrome (OMIM 134600/613388/615605/616026/618913/612392)\*
- Hypophosphatemic rickets with hypercalciuria (OMIM 241530)
- Hypophosphatemic rickets with nephrolithiasis and osteoporosis types 1 and 2 (OMIM 612286/612287)
- Volume expansion and intravenous fluids
- Metabolic acidosis
- Diuretics
- Glycosuria
- Glucocorticoids
- Chemotherapy (cisplatin, ifosfamide)
- Kidney transplantation

#### MULTIFACTORIAL

- Vitamin D deficiency
- Vitamin D–dependent rickets type 1 (OMIM 264700)
- Vitamin D–dependent rickets type 2 (OMIM 277440)
- Alcoholism
- Sepsis
- Dialysis

\*These are primary genetic causes of Fanconi syndrome. Fanconi syndrome may also be secondary to medications, genetic disorders (cystinosis) or systemic disease (Sjögren syndrome).  
OMIM, database number from the Online Mendelian Inheritance in Man (<http://www.ncbi.nlm.nih.gov/omim>).



Refeeding of patients with protein-calorie malnutrition causes anabolism, which leads to significant cellular demand for phosphorus (see Chapter 63). The increased phosphorus uptake for incorporation into newly synthesized compounds containing phosphorus leads to hypophosphatemia, which can be severe and symptomatic. **Refeeding hypophosphatemia** occurs frequently during treatment of severe anorexia nervosa. It can occur during treatment of children with malnutrition from any cause, such as cystic fibrosis, Crohn disease, burns, neglect, chronic infection, or famine. Hypophosphatemia usually occurs within the first 5 days of refeeding and is prevented by a gradual increase in nutrition with appropriate phosphorus supplementation. TPN without adequate phosphorus can cause hypophosphatemia.

Phosphorus moves into the ICS during a respiratory alkalosis and during recovery from a respiratory acidosis. An acute decrease in the carbon dioxide concentration, by raising the intracellular pH, stimulates glycolysis, leading to intracellular use of phosphorus and hypophosphatemia. Because a metabolic alkalosis has less effect on the intracellular pH ( $\text{CO}_2$  diffuses across cell membranes much faster than bicarbonate), transcellular phosphorus movement is minimal with a metabolic alkalosis.

**Tumors** that grow rapidly, such as those associated with leukemia and lymphoma, may use large amounts of phosphorus, leading to hypophosphatemia. A similar phenomenon may occur during the hematopoietic reconstitution that follows bone marrow transplantation. In **hungry bone syndrome**, there is avid bone uptake of phosphorus, along with calcium and magnesium, which can produce plasma deficiency of all three ions. Hungry bone syndrome is most common after parathyroidectomy for hyperparathyroidism because the stimulus for bone dissolution is acutely removed, but bone synthesis continues.

Nutritional phosphorus deficiency is unusual because most foods contain phosphorus. However, infants are especially susceptible because of their high demand for phosphorus to support growth, especially of the skeleton. Very low birthweight infants have particularly rapid skeletal growth, and phosphorus deficiency and rickets may develop if they are fed human milk or formula for term infants. There is also a relative deficiency of calcium. The provision of additional calcium and phosphorus, using breast milk fortifier or special premature infant formula, prevents this complication. Phosphorus deficiency, sometimes with concomitant calcium and vitamin D deficiencies, occurs in infants who are not given enough milk or who receive a milk substitute that is nutritionally inadequate.

**Antacids** containing aluminum hydroxide (e.g., Maalox, Mylanta) bind dietary phosphorus and secrete phosphorus, preventing absorption. This process can cause phosphorus deficiency and rickets in growing children. A similar mechanism causes hypophosphatemia in patients who are overtreated for hyperphosphatemia with phosphorus binders. In children with kidney failure, the addition of dialysis to phosphorus binders increases the risk of iatrogenic hypophosphatemia in these normally hyperphosphatemic patients. This complication, which is more common in infants, can worsen kidney osteodystrophy.

Excessive renal losses of phosphorus occur in a variety of inherited and acquired disorders. Because PTH inhibits the resorption of phosphorus in the proximal tubule, **hyperparathyroidism** causes hypophosphatemia (see Chapter 613). The dominant clinical manifestation, however, is hypercalcemia, and the hypophosphatemia is usually asymptomatic. The phosphorus level in hyperparathyroidism is not extremely low, and there is no continued loss of phosphorus because a new steady state is achieved at the lower plasma phosphorus level. Renal excretion therefore does not exceed intake over the long term. Occasional malignancies produce PTH-related peptide, which has the same actions as PTH and causes hypophosphatemia and hypercalcemia.

A variety of diseases cause renal phosphate wasting, hypophosphatemia, and rickets resulting from excess FGF-23 (see Chapter

69). These disorders include X-linked hypophosphatemic rickets, tumor-induced osteomalacia, autosomal dominant hypophosphatemic rickets, and autosomal recessive hypophosphatemic rickets types 1-3. Ferric carboxymaltose, an IV iron preparation for correcting iron deficiency, causes hypophosphatemia via increased levels of FGF-23.

**Fanconi syndrome** is a generalized defect in the proximal tubule leading to urinary wasting of bicarbonate, phosphorus, amino acids, uric acid, and glucose (see Chapter 569.1). The clinical sequelae result from the metabolic acidosis and hypophosphatemia. In children, an underlying genetic disease, usually cystinosis, often causes Fanconi syndrome, but it can be secondary to a variety of toxins and acquired diseases. Some patients have incomplete Fanconi syndrome, and phosphorus wasting may be one of the manifestations.

**Dent disease**, an X-linked disorder, can cause renal phosphorus wasting and hypophosphatemia, although the latter is not present in most cases. Other possible manifestations of Dent disease include tubular proteinuria, hypercalciuria, nephrolithiasis, rickets, and decreased kidney function. Dent disease may be secondary to pathologic variants in a gene that encodes a chloride channel or the *OCRL1* gene, which may also cause Lowe syndrome (see Chapter 569.1). **Hypophosphatemic rickets with hypercalciuria** is a rare autosomal recessive disorder, principally described in kindreds from the Middle East (see Chapter 69). Pathologic variants in a sodium-phosphate co-transporter cause hypophosphatemia in this disorder, and complications may include nephrolithiasis and osteoporosis. Similar findings are seen in hypophosphatemic rickets with nephrolithiasis and osteoporosis types 1 and 2 (see Chapter 69).

Metabolic acidosis inhibits resorption of phosphorus in the proximal tubule. In addition, metabolic acidosis causes a transcellular shift of phosphorus out of cells because of intracellular catabolism. This released phosphorus is subsequently lost in the urine, leading to significant phosphorus depletion, even though the plasma phosphorus level may be normal. This classically occurs in DKA, in which renal phosphorus loss is further increased by the osmotic diuresis. With correction of the metabolic acidosis and the administration of insulin, both of which cause a transcellular movement of phosphorus into the cells, there is a marked decrease in the plasma phosphorus level.

Volume expansion from any cause, such as hyperaldosteronism or SIADH, inhibits resorption of phosphorus in the proximal tubule. This effect also occurs with high rates of IV fluids. Thiazide and loop diuretics can increase renal phosphorus excretion, but the increase is seldom clinically significant. Glycosuria and glucocorticoids inhibit renal conservation of phosphorus. Hypophosphatemia is common after kidney transplantation because of urinary phosphorus losses. Possible explanations include preexisting secondary hyperparathyroidism from chronic kidney disease, glucocorticoid therapy, and upregulation of FGF-23 before transplantation. The hypophosphatemia usually resolves in a few months.

Both acquired and genetic causes of **vitamin D deficiency** are associated with hypophosphatemia (see Chapter 69). The pathogenesis is multifactorial. By impairing intestinal calcium absorption, vitamin D deficiency causes secondary hyperparathyroidism that leads to increased urinary phosphorus wasting. An absence of vitamin D decreases intestinal absorption of phosphorus and directly decreases renal resorption of phosphorus. The dominant clinical manifestation is rickets, although some patients have muscle weakness that may be related to phosphorus deficiency.

**Alcoholism** is the most common cause of severe hypophosphatemia in adults. Fortunately, many of the risk factors that predispose alcoholic adults to hypophosphatemia are not usually present in adolescents (malnutrition, antacid abuse, recurrent DKA episodes). Hypophosphatemia often occurs in sepsis, but the mechanism is not clear. Aggressive, protracted hemodialysis, as might be used for

the treatment of methanol or ethylene glycol ingestion, can cause hypophosphatemia.

### Clinical Manifestations

There are acute and chronic manifestations of hypophosphatemia. **Rickets** occurs in children with long-term phosphorus deficiency. The clinical features of rickets are described in [Chapter 69](#).

Severe hypophosphatemia, typically at levels <1.0-1.5 mg/dL, may affect every organ in the body because phosphorus has a critical role in maintaining adequate cellular energy. Phosphorus is a component of ATP and is necessary for glycolysis. With inadequate phosphorus, 2,3-diphosphoglycerate levels in RBCs decrease, impairing release of oxygen to the tissues. Severe hypophosphatemia can cause hemolysis and dysfunction of WBCs. Chronic hypophosphatemia causes proximal muscle weakness and atrophy. In the intensive care unit, phosphorus deficiency may slow weaning from mechanical ventilation or cause acute respiratory failure. **Rhabdomyolysis** is the most common complication of acute hypophosphatemia, usually in the setting of an acute transcellular shift of phosphorus into cells in a child with chronic phosphorus depletion (anorexia nervosa). The rhabdomyolysis is actually somewhat protective, in that cellular release of phosphorus occurs. Other manifestations of severe hypophosphatemia include cardiac dysfunction and neurologic symptoms, such as tremor, paresthesia, ataxia, seizures, delirium, and coma.

### Diagnosis

The history and basic laboratory evaluation often suggest the etiology of hypophosphatemia. The history should investigate nutrition, medications, and familial disease. Hypophosphatemia and rickets in an otherwise healthy young child suggest a genetic defect in renal phosphorus conservation, Fanconi syndrome, inappropriate use of antacids, poor nutrition, vitamin D deficiency, or a genetic defect in vitamin D metabolism. The patient with Fanconi syndrome usually has metabolic acidosis, glycosuria, aminoaciduria, and a low plasma uric acid level. Measurement of 25-D and 1,25-D, calcium, and PTH differentiates among the various vitamin D deficiency disorders and primary renal phosphate wasting (see [Chapter 69](#)). Hyperparathyroidism is easily distinguished by the presence of elevated plasma PTH and calcium values.

### Treatment

The plasma phosphorus level, the presence of symptoms, the likelihood of chronic depletion, and the presence of ongoing losses dictate the approach to therapy. Mild hypophosphatemia does not require treatment unless the clinical situation suggests that chronic phosphorus depletion is present or that losses are ongoing. Oral phosphorus can cause diarrhea, so the doses should be divided. IV therapy is effective in patients who have severe deficiency or who cannot tolerate oral medications. IV phosphorus is available as either sodium phosphate or potassium phosphate, with the choice usually based on the patient's plasma potassium level. Starting doses are 0.08-0.16 mmol/kg over 6 hours. The oral preparations of phosphorus are available with various ratios of sodium and potassium. This is an important consideration because some patients may not tolerate the potassium load, whereas supplemental potassium may be helpful in some diseases, such as Fanconi syndrome and malnutrition. Oral maintenance dosages are 2-3 mmol/kg/day in divided doses, although the maintenance dose varies considerably between patients.

Increasing dietary phosphorus is the only intervention needed in infants with inadequate intake. Other patients may also benefit from increased dietary phosphorus, usually from dairy products. Phosphorus-binding antacids should be discontinued in patients with hypophosphatemia. Certain diseases require specific therapy (see [Chapter 69](#)). Specifically, X-linked hypophosphatemia responds to burosumab, a monoclonal antibody targeting FGF-23.

**Table 73.10** Causes of Hyperphosphatemia

#### TRANSCELLULAR SHIFTS

Tumor lysis syndrome  
Rhabdomyolysis  
Acute hemolysis  
Diabetic ketoacidosis and lactic acidosis

#### INCREASED INTAKE

Enemas and laxatives  
Cow's milk in infants  
Treatment of hypophosphatemia  
Vitamin D intoxication

#### DECREASED EXCRETION

Kidney failure  
Hypoparathyroidism or pseudohypoparathyroidism (OMIM 146200/603233/103580/241410/203330)  
Acromegaly  
Hyperthyroidism  
Tumoral calcinosis with hyperphosphatemia: genetic (OMIM 211900/617993/617994) or autoimmune

OMIM, database number from the Online Mendelian Inheritance in Man (<http://www.ncbi.nlm.nih.gov/omim>).

## HYPERPHOSPHATEMIA

### Etiology and Pathophysiology

**Renal insufficiency** is the most common cause of hyperphosphatemia, with the severity proportional to the degree of kidney impairment (see [Chapter 572](#)). This occurs because GI absorption of the large dietary intake of phosphorus is unregulated, and the kidneys normally excrete this phosphorus. As kidney function deteriorates, increased excretion of phosphorus is able to compensate. When kidney function is <30% of normal, hyperphosphatemia usually develops, although this varies considerably depending on dietary intake. Many of the other causes of hyperphosphatemia are more likely to develop in the setting of decreased kidney function ([Table 73.10](#)).

Cellular content of phosphorus is high relative to plasma phosphorus, and cell lysis can release substantial phosphorus. This is the etiology of hyperphosphatemia in **tumor lysis syndrome**, **rhabdomyolysis**, and **acute hemolysis**. These disorders cause concomitant potassium release and the risk of hyperkalemia. Additional features of tumor lysis and rhabdomyolysis are hyperuricemia and hypocalcemia, whereas indirect hyperbilirubinemia and elevated lactate dehydrogenase (LDH) values are often present with hemolysis. An elevated CPK level is suggestive of rhabdomyolysis. During lactic acidosis or DKA, use of phosphorus by cells decreases, and phosphorus shifts into the ECS. This problem reverses when the underlying problem is corrected, and especially with DKA, patients subsequently become hypophosphatemic because of previous renal phosphorus loss.

Excessive intake of phosphorus is especially dangerous in children with decreased kidney function. Neonates are at risk because kidney function is normally reduced during the first few months of life. In addition, they may erroneously be given doses of phosphorus that are meant for an older child or adult. In infants fed cow's milk, which has higher phosphorus content than breast milk or formula, hyperphosphatemia may develop. **Fleet Enema** has a high amount of phosphorus that can be absorbed, especially in the patient with an ileus; infants and children with Hirschsprung disease are especially vulnerable. There is often associated hypernatremia from sodium absorption and water loss from diarrhea. Sodium phosphorus laxatives may cause hyperphosphatemia if the dose is excessive or if renal insufficiency is present. Hyperphosphatemia occurs in children who receive overaggressive treatment for hypophosphatemia. **Vitamin D intoxication** causes excessive GI absorption of both calcium and phosphorus, and the suppression of PTH by hypercalcemia decreases renal phosphorus excretion.

The absence of PTH in **hypoparathyroidism** or PTH responsiveness in **pseudohypoparathyroidism** causes hyperphosphatemia because of increased resorption of phosphorus in the proximal tubule of the kidney (see Chapters 611 and 612). The associated hypocalcemia is responsible for the clinical symptoms. The hyperphosphatemia in hyperthyroidism or acromegaly is usually mild. It is secondary to increased resorption of phosphorus in the proximal tubule from the actions of thyroxine or growth hormone. Excessive thyroxine can also cause bone resorption, which may contribute to the hyperphosphatemia and cause hypercalcemia. Patients with **familial tumoral calcinosis** (three types), a rare autosomal recessive disorder, have hyperphosphatemia because of decreased renal phosphate excretion and heterotopic calcifications. The disease may be secondary to pathologic variants in the genes for a glycosyltransferase (most common etiology), FGF-23, or klotho, which encodes the co-receptor for FGF-23. Autoimmune hyperphosphatemic tumoral calcinosis occurs with antibodies producing FGF-23 resistance.

### Clinical Manifestations

The principal clinical consequences of hyperphosphatemia are hypocalcemia and systemic calcification. The hypocalcemia is probably caused by tissue deposition of calcium-phosphorus salt, inhibition of 1,25-D production, and decreased bone resorption. Symptomatic hypocalcemia is most likely to occur when the phosphorus level increases rapidly or when diseases predisposing to hypocalcemia are present (chronic kidney disease, rhabdomyolysis). Systemic calcification occurs because the solubility of phosphorus and calcium in the plasma is exceeded. Clinically, this condition is often apparent in the conjunctiva, where it manifests as a foreign body feeling, erythema, and injection. More ominous manifestations are hypoxia from pulmonary calcification and kidney failure from nephrocalcinosis.

### Diagnosis

Plasma creatinine and BUN levels should be assessed in any patient with hyperphosphatemia. The history should focus on intake of phosphorus and the presence of chronic diseases that may cause hyperphosphatemia. Measurement of  $K^+$ , uric acid, calcium, LDH, bilirubin, hemoglobin, and CPK may be indicated if rhabdomyolysis, tumor lysis, or hemolysis is suspected. With mild hyperphosphatemia and significant hypocalcemia, measurement of the serum PTH level distinguishes between hypoparathyroidism and pseudohypoparathyroidism.

### Treatment

The treatment of acute hyperphosphatemia depends on its severity and etiology. Mild hyperphosphatemia in a patient with reasonable renal function spontaneously resolves; the resolution can be accelerated by dietary phosphorus restriction. If kidney function is not impaired, IV fluids can enhance renal phosphorus excretion. For more significant hyperphosphatemia or a situation such as tumor lysis or rhabdomyolysis, in which endogenous phosphorus generation is likely to continue, addition of an oral phosphorus binder prevents absorption of dietary phosphorus and can remove phosphorus from the body by binding what is normally secreted and absorbed by the GI tract. Phosphorus binders are most effective when given with food. Binders containing aluminum hydroxide are especially efficient, but calcium carbonate is an effective alternative and may be preferred if there is a need to treat concomitant hypocalcemia. Preservation of renal function, as with high urine flow in rhabdomyolysis or tumor lysis, is an important adjunct because it will permit continued excretion of phosphorus. If the hyperphosphatemia is not responding to conservative management, especially if acute kidney injury is supervening, dialysis may be necessary to increase phosphorus removal.

Dietary phosphorus restriction is necessary for diseases causing chronic hyperphosphatemia. However, such diets are often difficult

to follow, given the abundance of phosphorus in a variety of foods. Dietary restriction is often sufficient in conditions such as hypoparathyroidism and mild chronic kidney disease. For more problematic hyperphosphatemia, such as with moderate chronic kidney disease and end-stage kidney disease, phosphorus binders are usually necessary. They include calcium carbonate, calcium acetate, sevelamer, ferric citrate, sucroferric oxyhydroxide, and lanthanum. Aluminum-containing phosphorus binders are no longer used in patients with **chronic kidney disease** because of the risk of aluminum toxicity. Dialysis directly removes phosphorus from the blood in patients with end-stage kidney disease, but it is only an adjunct to dietary restriction and phosphorus binders; removal by dialysis does not keep up with normal dietary intake.

Visit Elsevier eBooks+ at [eBooks.Health.Elsevier.com](http://eBooks.Health.Elsevier.com) for Bibliography.

## 73.7 Acid-Base Balance

Larry A. Greenbaum

### ACID-BASE PHYSIOLOGY

#### Terminology

Chronic, mild derangements in acid-base status may interfere with normal growth and development, whereas acute, severe changes in pH can be fatal. Control of acid-base balance depends on the kidneys, the lungs, and intracellular and extracellular buffers.

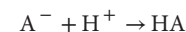
A normal pH is 7.35-7.45. There is an inverse relationship between the pH and the hydrogen ion concentration ( $[H^+]$ ). At a pH of 7.40,  $[H^+]$  is 40 nmol/L. A normal serum sodium concentration, 140 mEq/L, is 1 million times higher. Maintaining a normal pH is necessary because hydrogen ions are highly reactive and are especially likely to combine with proteins, altering their function.

An **acid** is a substance that releases (“donates”) a hydrogen ion ( $H^+$ ). A **base** is a substance that accepts a hydrogen ion. An acid (HA) can dissociate into a hydrogen ion and a conjugate base ( $A^-$ ), as follows:



A strong acid is highly dissociated, so in this reaction, there is little HA. A weak acid is poorly dissociated; not all the hydrogen ions are released from HA.  $A^-$  acts as a base when the reaction moves to the left. These reactions are in equilibrium. When HA is added to the system, there is dissociation of some HA until the concentrations of  $H^+$  and  $A^-$  increase enough that a new equilibrium is reached. Addition of hydrogen ions causes a decrease in  $A^-$  and an increase in HA. Addition of  $A^-$  causes a decrease in hydrogen ions and an increase in HA.

**Buffers** are substances that attenuate the change in pH that occurs when acids or bases are added to the body. Given the extremely low  $[H^+]$  in the body at physiologic pH, without buffers a small amount of hydrogen ions could cause a dramatic decline in the pH. Buffers prevent the decrease in pH by binding the added hydrogen ions, as follows:



The increase in  $[H^+]$  drives this reaction to the right. Similarly, when base is added to the body, buffers prevent the pH from increasing by releasing hydrogen ions, as follows:



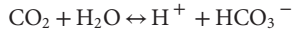
The best buffers are weak acids and bases. This is because a buffer works best when it is 50% dissociated (half HA and half  $A^-$ ). The pH at which a buffer is 50% dissociated is its  $pK_a$  (ionization constant



of acid). The best physiologic buffers have a  $pK_a$  close to 7.40. The concentration of a buffer and its  $pK_a$  determine the buffer's effectiveness (buffering capacity). When the pH is lower than the  $pK_a$  of a buffer, there is more HA than  $A^-$ . When the pH is higher than the  $pK_a$ , there is more  $A^-$  than HA.

### Physiologic Buffers

The bicarbonate and nonbicarbonate buffers protect the body against major changes in pH. The **bicarbonate buffer system** is routinely monitored clinically and is based on the relationship between carbon dioxide ( $CO_2$ ) and bicarbonate ( $HCO_3^-$ ):



$CO_2$  acts as an acid in that, after combining with water, it releases an  $H^+$ ; bicarbonate acts as its conjugate base in that it accepts an  $H^+$ . The  $pK_a$  of this reaction is 6.1. The **Henderson-Hasselbalch equation** expresses the relationship among pH,  $pK_a$ , and the concentrations of an acid and its conjugate base. This relationship is valid for any buffer. The Henderson-Hasselbalch equation for bicarbonate and  $CO_2$  is as follows:

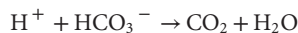
$$pH = 6.1 + \log [HCO_3^-] / [CO_2]$$

The **Henderson-Hasselbalch equation** for the bicarbonate buffer system has three variables: pH, bicarbonate concentration ( $[HCO_3^-]$ ), and carbon dioxide concentration ( $[CO_2]$ ). Thus, if any two of these variables are known, it is possible to calculate the third. When one is using the Henderson-Hasselbalch equation, it is important that  $CO_2$  and bicarbonate have the same units.  $CO_2$  is reported clinically as mm Hg and must be multiplied by its solubility constant, 0.03 mmol/L/mm Hg, before the equation can be used. Mathematical manipulation of the Henderson-Hasselbalch equation produces the following relationship:

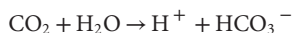
$$[H^+] = 24 \times PCO_2 / [HCO_3^-]$$

At a normal  $[H^+]$  of 40 nmol (pH 7.40), the partial pressure of carbon dioxide ( $PCO_2$ ), which is expressed as mm Hg in this equation, is 40 when the  $[HCO_3^-]$  is 24 mEq/L. This equation emphasizes that  $[H^+]$ , and thus pH, can be determined by the ratio of  $PCO_2$  and  $[HCO_3^-]$ .

The bicarbonate buffer system is very effective because of the high concentration of bicarbonate in the body (24 mEq/L) and because it is an open system. The remaining body buffers are in a closed system. The bicarbonate buffer system is an open system because the lungs increase  $CO_2$  excretion when the blood  $CO_2$  concentration increases. When acid is added to the body, the following reaction occurs:



In a closed system, the  $CO_2$  would increase. The higher  $CO_2$  concentration would lead to an increase in the reverse reaction:

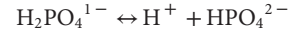


This would increase  $[H^+]$ , limiting the buffering capacity of bicarbonate. However, because the lungs excrete the excess  $CO_2$ , the reverse reaction does not increase; this fact enhances the buffering capacity of bicarbonate. The same principle holds with the addition of base, because the lungs decrease  $CO_2$  excretion and prevent the  $CO_2$  level from falling. The lack of change in  $[CO_2]$  dramatically increases the buffering capacity of bicarbonate.

The **nonbicarbonate buffers** include proteins, phosphate, and bone. Protein buffers consist of extracellular proteins, mostly albumin

and intracellular proteins, including hemoglobin. Proteins are effective buffers, largely because of the presence of the amino acid *histidine*, which has a side chain that can bind or release  $H^+$ . The  $pK_a$  of histidine varies slightly, depending on its position in the protein molecule, but its average  $pK_a$  is approximately 6.5. This is close enough to a normal pH (7.4) to make histidine an effective buffer. Hemoglobin and albumin have 34 and 16 histidine molecules, respectively.

Phosphate can bind up to three hydrogen molecules, so it can exist as  $PO_4^{3-}$ ,  $HPO_4^{2-}$ ,  $H_2PO_4^{1-}$ , or  $H_3PO_4$ . However, at a physiologic pH, most phosphate exists as either  $HPO_4^{2-}$  or  $H_2PO_4^{1-}$ .  $H_2PO_4^{1-}$  is an acid, and  $HPO_4^{2-}$  is its conjugate base:



The  $pK_a$  of this reaction is 6.8, making phosphate an effective buffer. The concentration of phosphate in the ECS is relatively low, limiting the overall buffering capacity of phosphate; it is less important than albumin. However, phosphate is found at a much higher concentration in the urine, where it is an important buffer. In the ICS, most phosphate is covalently bound to organic molecules (ATP), but it still serves as an effective buffer.

Bone is an important buffer. Bone is *basic*—it is composed of compounds such as sodium bicarbonate and calcium carbonate—and thus dissolution of bone releases base. This release can buffer an acid load, although at the expense of bone density, if it occurs over an extended period. In contrast, bone formation, by consuming base, helps buffer excess base.

Clinically, we measure the extracellular pH, but it is the intracellular pH that affects cell function. Measurement of the intracellular pH is unnecessary because changes in the intracellular pH parallel the changes in the extracellular pH. However, the change in the intracellular pH tends to be less than the change in the extracellular pH because of the greater buffering capacity in the ICS.

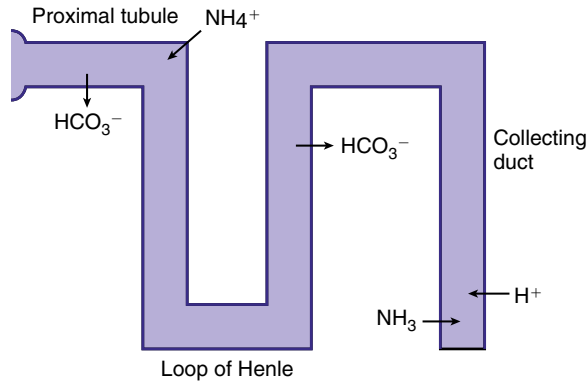
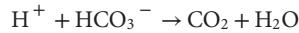
### NORMAL ACID-BASE BALANCE

The lungs and kidneys maintain a normal acid-base balance. Carbon dioxide generated during normal metabolism is a weak acid. The lungs prevent an increase in the  $PCO_2$  in the blood by excreting the  $CO_2$  that the body produces.  $CO_2$  production varies according to the body's metabolic needs, increasing with physical activity. The rapid pulmonary response to changes in the  $CO_2$  concentration occurs via central sensing of the  $PCO_2$  and a subsequent increase or decrease in ventilation to maintain a normal  $PCO_2$  (35–45 mm Hg). An increase in ventilation decreases the  $PCO_2$ , and a decrease in ventilation increases the  $PCO_2$ .

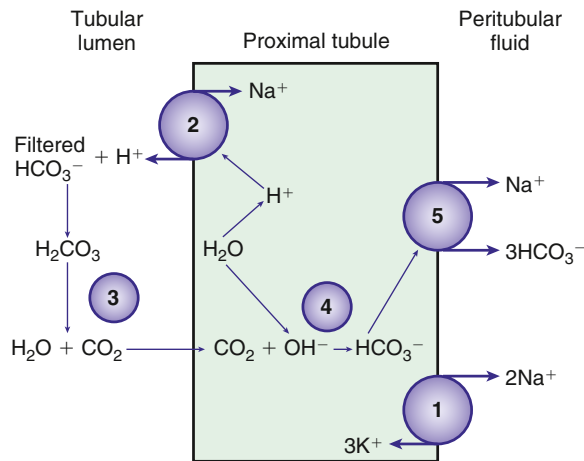
The kidneys excrete endogenous acid. An adult normally produces approximately 1–2 mEq/kg/24 hr of  $H^+$ . Children normally produce 2–3 mEq/kg/24 hr of  $H^+$ . The three principal sources of  $H^+$  are dietary protein metabolism, incomplete metabolism of carbohydrates and fat, and stool losses of bicarbonate. Because metabolism of protein generates  $H^+$ , endogenous acid production varies with protein intake. The complete oxidation of carbohydrates or fats to  $CO_2$  and water does not generate  $H^+$ ; the lungs remove the  $CO_2$ . However, incomplete metabolism of carbohydrates or fats produces  $H^+$ . Incomplete glucose metabolism can produce lactic acid, and incomplete triglyceride metabolism can produce ketoacids, such as  $\beta$ -hydroxybutyric acid and acetoacetic acid. There is always some baseline incomplete metabolism that contributes to endogenous acid production. This factor increases in pathologic conditions, such as **lactic acidosis** and diabetic ketoacidosis (DKA). Stool loss of bicarbonate is the third major source of endogenous acid production. The stomach secretes  $H^+$ , but most of the remainder of the GI tract secretes bicarbonate, and the net effect is a loss of bicarbonate from the body. To secrete bicarbonate, the cells of the intestine produce hydrogen ions that are released into the bloodstream. For each bicarbonate molecule lost in the stool, the body gains one  $H^+$ . This source of endogenous acid production is normally minimal but may increase dramatically in a patient with diarrhea.



The hydrogen ions formed from endogenous acid production are neutralized by bicarbonate, potentially causing the bicarbonate concentration to decrease. The kidneys regenerate this bicarbonate by secreting  $H^+$ . The lungs cannot regenerate bicarbonate, even though loss of  $CO_2$  lowers the  $[H^+]$ , as shown in the following reaction:

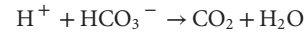


**Fig. 73.7** Tubular sites involved in acid-base balance. The proximal tubule is the site where most filtered bicarbonate is reclaimed, even though other sites along the nephron, especially the thick ascending limb of the loop of Henle, resorb some of the filtered bicarbonate. The collecting duct is the principal location for the hydrogen ion secretion that acidifies the urine. The proximal tubule generates the ammonia that serves as a urinary buffer in the collecting duct.



**Fig. 73.8** Resorption of filtered bicarbonate in the proximal tubule. The  $Na^+, K^+$ -ATPase (1) excretes sodium across the basolateral cell membrane, maintaining a low intracellular sodium concentration. The low intracellular sodium provides the energy for the  $Na^+, H^+$  antiporter (2), which exchanges sodium from the tubular lumen for intracellular hydrogen ions. The hydrogen ions that are secreted into the tubular lumen then combine with filtered bicarbonate to generate carbonic acid.  $CO_2$  and water are produced from carbonic acid ( $H_2CO_3$ ). This reaction is catalyzed by luminal carbonic anhydrase (3).  $CO_2$  diffuses into the cell and combines with  $OH^-$  ions to generate bicarbonate. This reaction is catalyzed by an intracellular carbonic anhydrase (4). The dissociation of water generates an  $OH^-$  ion and an  $H^+$  ion. The  $Na^+, H^+$  antiporter (2) secretes the hydrogen ions. Bicarbonate ions cross the basolateral membrane and enter the blood via the  $3HCO_3^-/1Na^+$  co-transporter (5). The energy for the  $3HCO_3^-/1Na^+$  co-transporter comes from the negatively charged cell interior, which makes it electrically favorable to transport a net negative charge (i.e., 3 bicarbonates and only 1 sodium) out of the cell.

A decrease in  $[CO_2]$  causes the reaction to move to the right, which decreases  $[H^+]$ , but it also lowers  $[HCO_3^-]$ . During a metabolic acidosis, hyperventilation can lower  $[CO_2]$ , decrease  $[H^+]$ , and thus increase pH. The underlying metabolic acidosis is still present. Similarly, the kidneys cannot correct an abnormally high  $[CO_2]$ , as shown in the following reaction:



An increase in  $[HCO_3^-]$  also causes the reaction to move to the right, which increases  $[CO_2]$  while simultaneously decreasing  $[H^+]$ . During a respiratory acidosis, increased renal generation of bicarbonate can decrease  $[H^+]$  and increase pH but cannot repair the respiratory acidosis. Both the lungs and the kidneys can affect  $[H^+]$  and thus pH. However, only the lungs can regulate  $[CO_2]$ , and only the kidneys can regulate  $[HCO_3^-]$ .

### Renal Mechanisms

The kidneys regulate the serum bicarbonate concentration by modifying acid excretion in the urine. This requires a two-step process. First, the renal tubules resorb the bicarbonate that is filtered at the glomerulus. Second, there is tubular secretion of  $H^+$ . The urinary excretion of  $H^+$  generates bicarbonate that neutralizes endogenous acid production. The tubular actions necessary for renal acid excretion occur throughout the nephron (Fig. 73.7).

The resorption of filtered bicarbonate is a necessary first step in renal regulation of the acid-base balance. A normal adult has a GFR of approximately 180 L/24 hr. This fluid enters Bowman's space with  $[HCO_3^-]$  that is essentially identical to the plasma concentration, normally 24 mEq/L. Multiplying 180 L by 24 mEq/L indicates that >4,000 mEq of bicarbonate enters Bowman's space each day. This bicarbonate, if not reclaimed along the nephron, would be lost in the urine and would cause a profound metabolic acidosis.

The proximal tubule reclaims approximately 85% of the filtered bicarbonate (Fig. 73.8). The final 15% is reclaimed beyond the proximal tubule, mostly in the ascending limb of the loop of Henle. Bicarbonate molecules are not transported from the tubular fluid into the cells of the proximal tubule. Rather, hydrogen ions are secreted into the tubular fluid, leading to conversion of filtered bicarbonate into  $CO_2$  and water. The secretion of  $H^+$  by the cells of the proximal tubule is coupled to generation of intracellular bicarbonate, which is transported across the basolateral membrane of the proximal tubule cell and enters the capillaries. The bicarbonate produced in the cell replaces the bicarbonate filtered at the glomerulus.

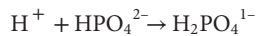
Increased bicarbonate resorption by the cells of the proximal tubule—the result of increased  $H^+$  secretion—occurs in a variety of clinical situations. Volume depletion increases bicarbonate resorption. This is partially mediated by activation of the renin-angiotensin system; angiotensin II increases bicarbonate resorption. Increased bicarbonate resorption in the proximal tubule is one of the mechanisms that accounts for the metabolic alkalosis that may occur in some patients with volume depletion. Other stimuli that increase bicarbonate resorption include hypokalemia and an increased  $P_{CO_2}$ . This partially explains the observations that hypokalemia causes a metabolic alkalosis, and that a respiratory acidosis leads to a compensatory increase in serum  $[HCO_3^-]$ .

Stimuli that decrease bicarbonate resorption in the proximal tubule may cause a decrease in the serum  $[HCO_3^-]$ . A decrease in the  $P_{CO_2}$  (respiratory alkalosis) decreases proximal tubule bicarbonate resorption, partially mediating the decrease in serum  $[HCO_3^-]$  that compensates for a respiratory alkalosis. PTH decreases proximal tubule bicarbonate resorption; hyperparathyroidism may cause a mild metabolic acidosis. A variety of medications and diseases cause a metabolic acidosis by impairing bicarbonate resorption in the proximal tubule. Examples are the medication acetazolamide, which directly inhibits carbonic anhydrase, and the many disorders that cause proximal RTA (see Chapter 569.1).

After reclaiming filtered bicarbonate, the kidneys perform the second step in renal acid-base handling, the excretion of the acid created by endogenous acid production. Excretion of acid occurs mostly in the collecting duct, with a small role for the distal tubule.

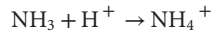
Along with secretion of  $H^+$  by the tubular cells lining the collecting duct, adequate excretion of endogenous acid requires the presence of urinary buffers. The hydrogen pumps in the collecting duct cannot lower the urine pH below 4.5. The  $[H^+]$  at pH 4.5 is  $<0.04$  mEq/L; it would require  $>25$  L of water with a pH of 4.5 to excrete one mEq of  $H^+$ . A 10-kg child, with an endogenous acid production of 20 mEq  $H^+$  each day, would need to have a daily urinary output of  $>500$  L without the presence of urinary buffers. As in the blood, buffers in the urine attenuate the decrease in pH that occurs with the addition of  $H^+$ . The two principal urinary buffers are phosphate and ammonia.

Urinary **phosphate** is proportional to dietary intake. Whereas most of the phosphate filtered at the glomerulus is resorbed in the proximal tubule, the urinary phosphate concentration is usually much greater than the serum phosphate concentration. This arrangement allows phosphate to serve as an effective buffer through the following reaction:

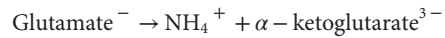


The  $pK_a$  of this reaction is 6.8, making phosphate an effective buffer as the urinary pH decreases from 7.0 to 5.0 within the collecting duct. Although phosphate is an effective buffer, its buffering capacity is limited by its concentration; there is no mechanism for increasing urinary phosphate excretion in response to changes in acid-base status.

In contrast, **ammonia** production can be modified, allowing for regulation of acid excretion. The buffering capacity of ammonia ( $NH_3$ ) is based on the reaction of ammonia with hydrogen ions to form ammonium:



The cells of the proximal tubule are the source of the excreted ammonia, mostly through metabolism of glutamine through the following reactions:



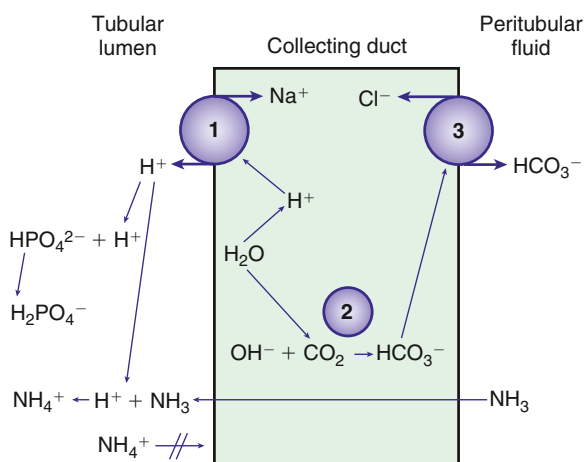
The metabolism of glutamine generates two ammonium ions. In addition, the metabolism of  $\alpha$ -ketoglutarate generates two bicarbonate molecules. The ammonium ions are secreted into the lumen of the proximal tubule, whereas the bicarbonate molecules exit the proximal tubule cells via the basolateral  $Na^+, 3HCO_3^-$  co-transporter (see Fig. 73.8). This arrangement would seem to accomplish the goal of excreting  $H^+$  (as  $NH_4^+$ ) and regenerating bicarbonate molecules. However, the ammonium ions secreted in the proximal tubule do not remain within the tubular lumen. Cells of the TAL of the loop of Henle resorb the ammonium ions. The result is that there is a high medullary interstitial concentration of ammonia, but the tubular fluid entering the collecting duct does not have significant amounts of ammonium ions. Moreover, the hydrogen ions that were secreted with ammonia (as ammonium ions) in the proximal tubule enter the bloodstream, canceling the effect of the bicarbonate generated in the proximal tubule. The excretion of ammonium ions, and thus of hydrogen ions, depends on the cells of the collecting duct.

The cells of the collecting duct secrete  $H^+$  and regenerate bicarbonate, which is returned to the bloodstream (Fig. 73.9). This bicarbonate neutralizes endogenous acid production. Phosphate and ammonia buffer the  $H^+$  secreted by the collecting duct. Ammonia is an effective buffer because of the high concentrations in the medullary interstitium and because the cells of the collecting duct are permeable to ammonia but not to ammonium. As ammonia diffuses into the lumen of the collecting duct, the low urine pH causes almost all the ammonia to be converted into ammonium. This process maintains a low luminal ammonia concentration. Because the luminal pH is lower than the pH in the medullary interstitium, there is a higher concentration of ammonia within the medullary interstitium than in the tubular lumen, favoring movement of ammonia into the tubular lumen. Even though the concentration of ammonium in the tubular lumen is higher than in the interstitium, the cells of the collecting duct are impermeable to ammonium, preventing back-diffusion of ammonium out of the tubular lumen and permitting ammonia to be an effective buffer.

The kidneys adjust  $H^+$  excretion according to physiologic needs. There is variation in endogenous acid production, largely a result of diet and pathophysiologic stresses, such as diarrheal losses of bicarbonate, which increase the need for acid excretion.  $H^+$  excretion is increased by upregulation of  $H^+$  secretion in the collecting duct, causing the pH of the urine to decrease. This response is prompt, occurring within hours of an acid load, but it is limited by the buffering capacity of the urine; the hydrogen pumps in the collecting duct cannot lower the pH to  $<4.5$ . A more significant increase in acid excretion requires upregulation of ammonia production by the proximal tubule so that more ammonia is available to serve as a buffer in the tubular lumen of the collecting duct. This response to a low serum pH reaches its maximum within 5-6 days; ammonia excretion can increase approximately 10-fold over the baseline value.

Acid excretion by the collecting duct increases in a number of different clinical situations. The extracellular pH is the most important regulator of renal acid excretion. A decrease in the extracellular pH from either a respiratory or a metabolic acidosis causes an increase in renal acid excretion. Aldosterone stimulates  $H^+$  excretion in the collecting duct, causing an increase in the serum bicarbonate concentration. This explains the metabolic alkalosis that occurs with primary hyperaldosteronism or secondary hyperaldosteronism caused by volume depletion. Hypokalemia increases acid secretion, by both stimulating ammonia production in the proximal tubule and increasing  $H^+$  secretion in the collecting duct. Hypokalemia therefore tends to produce a metabolic alkalosis. Hyperkalemia has the opposite effects, which may cause a metabolic acidosis.

In patients with an increased pH, the kidney has two principal mechanisms for correcting the problem. First, less bicarbonate is resorbed in the proximal tubule, leading to an increase in urinary bicarbonate losses. Second, in a limited number of specialized cells, the process for



**Fig. 73.9** Secretion of hydrogen ions in the collecting duct. The dissociation of water generates an  $OH^-$  ion and an  $H^+$  ion. The  $H^+$ -ATPase (1) secretes hydrogen ions into the tubular lumen. Bicarbonate is formed when an  $OH^-$  ion combines with  $CO_2$  in a reaction mediated by carbonic anhydrase (2). Bicarbonate ions cross the basolateral membrane and enter the blood via the  $HCO_3^-/Cl^-$  exchanger (3). The hydrogen ions in the tubular lumen are buffered by phosphate and ammonia ( $NH_3$ ).  $NH_3$  can diffuse from the peritubular fluid into the tubular lumen, but ammonium ( $NH_4^+$ ) cannot pass through the cells of the collecting duct.

secretion of  $H^+$  by the collecting duct can be reversed (see Fig. 73.9), leading to secretion of bicarbonate into the tubular lumen and secretion of hydrogen ions into the peritubular fluid, where they enter the bloodstream.

### CLINICAL ASSESSMENT OF ACID-BASE DISORDERS

The following rearrangement of the Henderson-Hasselbalch equation emphasizes the relationship among  $P_{CO_2}$ , bicarbonate concentration, and hydrogen ion concentration:

$$[H^+] = 24 \times P_{CO_2} [HCO_3^-]$$

An increase in the  $P_{CO_2}$  or a decrease in  $[HCO_3^-]$  increases  $[H^+]$ ; the pH decreases. A decrease in the  $P_{CO_2}$  or an increase in  $[HCO_3^-]$  decreases  $[H^+]$ ; the pH increases.

### Terminology

**Acidemia** is a pH below normal (<7.35), and **alkalemia** is a pH above normal (>7.45). An **acidosis** is a pathologic process that causes an increase in  $[H^+]$ , and an **alkalosis** is a pathologic process that causes a decrease in  $[H^+]$ . Whereas acidemia is always accompanied by an acidosis, a patient can have an acidosis and a low, normal, or high pH. For example, a patient may have a mild metabolic acidosis but a simultaneous, severe respiratory alkalosis; the net result may be alkalemia. Acidemia and alkalemia indicate the pH abnormality; acidosis and alkalosis indicate the pathologic process that is taking place.

A **simple acid-base disorder** is a single primary disturbance. During a simple metabolic disorder, there is respiratory compensation. With a metabolic acidosis, the decrease in the pH increases the ventilatory drive, causing a decrease in  $P_{CO_2}$ . The decrease in the  $[CO_2]$  leads to an increase in the pH. This appropriate respiratory compensation is expected with a primary metabolic acidosis. Despite the decrease in  $[CO_2]$ , appropriate respiratory compensation is not a respiratory alkalosis, even though it is sometimes erroneously called a “compensatory” respiratory alkalosis. A low  $P_{CO_2}$  can result either from a primary respiratory alkalosis or from appropriate respiratory compensation for a metabolic acidosis. Appropriate respiratory compensation also occurs with a primary

metabolic alkalosis, although in this case  $[CO_2]$  increases to attenuate the increase in the pH. The respiratory compensation for a metabolic process happens quickly and is complete within 12–24 hours; it cannot overcompensate for or normalize the pH.

During a primary respiratory process, there is metabolic compensation, mediated by the kidneys. The kidneys respond to a respiratory acidosis by increasing  $H^+$  excretion, thereby increasing bicarbonate generation and raising the serum  $[HCO_3^-]$ . The kidneys increase bicarbonate excretion to compensate for a respiratory alkalosis;  $[HCO_3^-]$  decreases. Unlike respiratory compensation, which occurs rapidly, it takes 3–4 days for the kidneys to complete appropriate metabolic compensation. There is, however, a small and rapid compensatory change in  $[HCO_3^-]$  during a primary respiratory process. The expected appropriate metabolic compensation for a respiratory disorder depends on whether the process is acute or chronic.

A **mixed acid-base disorder** is present when there is more than one primary acid-base disturbance. An infant with bronchopulmonary dysplasia may have a respiratory acidosis from chronic lung disease and a metabolic alkalosis from the furosemide used to treat the chronic lung disease. More dramatically, a child with pneumonia and sepsis may have severe acidemia because of a combined metabolic acidosis caused by lactic acid and respiratory acidosis caused by ventilatory failure.

There are formulas for calculating the appropriate metabolic or respiratory compensation for the six primary simple acid-base disorders (Table 73.11). The appropriate compensation is expected in a simple disorder; it is not optional. If a patient does not have the appropriate compensation, a mixed acid-base disorder is present. For example, if a patient has a primary metabolic acidosis with a serum  $[HCO_3^-]$  of 10 mEq/L, the expected respiratory compensation is  $[CO_2]$  of 23 mm Hg  $\pm 2$  ( $1.5 \times 10 + 8 \pm 2 = 23 \pm 2$ ; see Table 73.11). If the patient’s  $[CO_2]$  is >25 mm Hg, a concurrent respiratory acidosis is present;  $[CO_2]$  is higher than expected. A patient may have a respiratory acidosis despite a  $CO_2$  level below the “normal” value of 35–45 mm Hg. In this example,  $[CO_2]$  <21 mm Hg indicates a concurrent respiratory alkalosis;  $[CO_2]$  is lower than expected.

### Diagnosis

A systematic evaluation of an arterial blood gas (ABG) sample, combined with the clinical history, can usually explain the patient’s acid-base disturbance. Assessment of an ABG sample requires knowledge of normal values (Table 73.12). In most cases, this is accomplished through a three-step process (Fig. 73.10):

1. Determine whether acidemia or alkalemia is present.
2. Determine a cause of the acidemia or alkalemia.
3. Determine whether a mixed disorder is present.

Most patients with an acid-base disturbance have an abnormal pH, although there are two exceptions. One exception is in the patient with a mixed disorder in which the two processes have opposite effects on pH (a metabolic acidosis and a respiratory alkalosis) and cause changes in  $[H^+]$  that are comparable in magnitude, although opposite. The other exception is in the patient with a simple chronic respiratory alkalosis; in some cases, the appropriate metabolic compensation is enough to normalize the pH. In both situations, the presence of an acid-base disturbance is deduced because of the abnormal  $CO_2$  and bicarbonate levels. Determining the acid-base disturbance in these patients requires proceeding to the third step of the process.

The second step requires inspection of the serum  $[HCO_3^-]$  and  $P_{CO_2}$  to determine a cause of the abnormal pH (see Fig. 73.10). In most cases, there is only one obvious explanation for the abnormal pH. In some mixed disorders, however, there may be two possibilities (e.g., a high  $P_{CO_2}$  and a low  $[HCO_3^-]$  in a patient with acidemia). In such cases, the patient has two causes for abnormal pH—a metabolic acidosis and a respiratory acidosis, in this instance—and it is unnecessary to proceed to the third step.

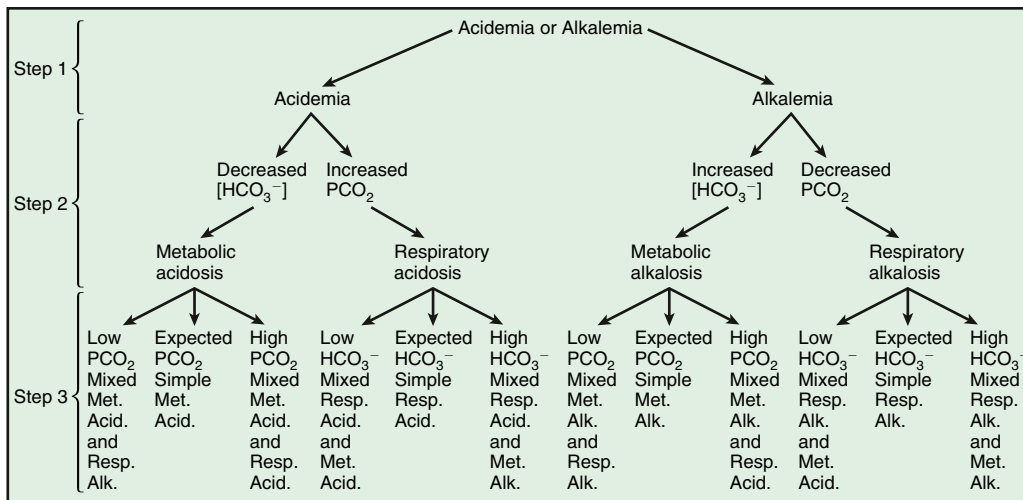
The third step requires determining whether the patient’s compensation is appropriate. It is assumed that the primary disorder was

**Table 73.11** Appropriate Compensation During Simple Acid-Base Disorders

DISORDER	EXPECTED COMPENSATION
Metabolic acidosis	$P_{CO_2} = 1.5 \times [HCO_3^-] + 8 \pm 2$
Metabolic alkalosis	$P_{CO_2}$ increases by 7 mm Hg for each 10 mEq/L increase in serum $[HCO_3^-]$
<b>Respiratory Acidosis</b>	
Acute	$[HCO_3^-]$ increases by 1 for each 10 mm Hg increase in $P_{CO_2}$
Chronic	$[HCO_3^-]$ increases by 3.5 for each 10 mm Hg increase in $P_{CO_2}$
<b>Respiratory Alkalosis</b>	
Acute	$[HCO_3^-]$ falls by 2 for each 10 mm Hg decrease in $P_{CO_2}$
Chronic	$[HCO_3^-]$ falls by 4 for each 10 mm Hg decrease in $P_{CO_2}$

**Table 73.12** Normal Values of Arterial Blood Gases

pH	7.35–7.45
$[HCO_3^-]$	20–28 mEq/L
$P_{CO_2}$	35–45 mm Hg



**Fig. 73.10** Three-step process for interpreting acid-base disturbances. In step 1, determine whether the pH is low (acidemia) or high (alkalemia). In step 2, establish an explanation for the acidemia or alkalemia. In step 3, calculate the expected compensation (see Table 73.11) and determine whether a mixed disturbance is present. Met. Acid., metabolic acidosis; Met. Alk., metabolic alkalosis; Resp. Acid., respiratory acidosis; Resp. Alk., respiratory alkalosis.

diagnosed in the second step, and the expected compensation is calculated (see Table 73.11). If the compensation is appropriate, a simple acid-base disorder is present. If the compensation is not appropriate, a mixed disorder is present. The identity of the second disorder is determined by deciding whether the compensation is too little or too much compared with what was expected (see Fig. 73.10).

The history is always useful in evaluating and diagnosing patients with acid-base disturbances. It is especially helpful in a respiratory process. The expected metabolic compensation for a respiratory process changes according to whether the process is **acute** or **chronic**, which can be deduced only from the history. The metabolic compensation for an acute respiratory acidosis is less than that for a chronic respiratory acidosis. In a patient with a respiratory acidosis, a small increase in  $[\text{HCO}_3^-]$  would be consistent with a simple acute respiratory acidosis or a mixed disorder (a chronic respiratory acidosis and a metabolic acidosis). Only the history can differentiate among the possibilities. Knowledge of the length of the respiratory process and the presence or absence of a risk factor for a metabolic acidosis (diarrhea) allows the correct conclusion to be reached.

An alternative to the **physiologic** approach just described (which includes calculation of the anion gap; see later) is the **physiochemical** approach, often called the **Stewart method**. Some view this approach as superior to the physiologic approach, but it requires multiple calculations and additional laboratory values and is thus more challenging to use in the clinical setting. The physiochemical approach requires measurement of the blood pH and  $\text{PCO}_2$  and calculation of the apparent strong ion difference (SIDa), the effective strong ion difference (SIDE), the strong ion gap (SIG), and the total concentration of weak acids ( $A_{\text{TOT}}$ ).

## METABOLIC ACIDOSIS

Metabolic acidosis occurs frequently in hospitalized children; diarrhea is the most common etiology. For a patient with an unknown medical problem, the presence of a metabolic acidosis is often helpful diagnostically, because it suggests a relatively narrow differential diagnosis.

Patients with a metabolic acidosis have a low serum  $[\text{HCO}_3^-]$ , although not every patient with a low serum  $[\text{HCO}_3^-]$  has a metabolic acidosis. The exception is the patient with a respiratory alkalosis, which causes a decrease in the serum  $[\text{HCO}_3^-]$  as part of appropriate renal compensation. In a patient with an isolated metabolic acidosis, there is a predictable decrease in the blood  $[\text{CO}_2]$ , as follows:

$$\text{PCO}_2 = 1.5 \times [\text{HCO}_3^-] + 8 \pm 2$$

A mixed acid-base disturbance is present if the respiratory compensation is not appropriate. If the  $\text{PCO}_2$  is greater than predicted, the patient has a concurrent respiratory acidosis. A lower  $\text{PCO}_2$  than predicted indicates a concurrent respiratory alkalosis or, less frequently, an isolated respiratory alkalosis. Because the appropriate respiratory compensation for a metabolic acidosis never normalizes the patient's pH, the presence of a normal pH and a low  $[\text{HCO}_3^-]$  occurs only if some degree of respiratory alkalosis is present. In this situation, distinguishing an isolated chronic respiratory alkalosis from a mixed metabolic acidosis and acute respiratory alkalosis may be possible only clinically. In contrast, the combination of a low serum pH and a low  $[\text{HCO}_3^-]$  occurs only if a metabolic acidosis is present.

## Etiology and Pathophysiology

There are many causes of a metabolic acidosis (Table 73.13), resulting from three basic mechanisms:

1. Loss of bicarbonate from the body
2. Impaired ability to excrete acid by the kidney
3. Addition of acid to the body (exogenous or endogenous)

**Diarrhea**, the most common cause of metabolic acidosis in children, causes a loss of bicarbonate from the body. The amount of bicarbonate lost in the stool depends on the volume of diarrhea and  $[\text{HCO}_3^-]$  of the stool, which tends to increase with more severe diarrhea. The kidneys attempt to balance the losses by increasing acid secretion, but metabolic acidosis occurs when this compensation is inadequate. Diarrhea often causes volume depletion because of losses of sodium and water, potentially exacerbating the acidosis by causing shock and a lactic acidosis. In addition, diarrheal losses of potassium lead to hypokalemia. Moreover, the volume depletion causes increased production of aldosterone. This increase stimulates renal retention of sodium, helping to maintain intravascular volume, but also leads to increased urinary losses of potassium, exacerbating the hypokalemia.

There are four forms of renal tubular acidosis (RTA): distal (type I), proximal (type II), mixed (type III), and hyperkalemic (type IV) (see Chapter 569). In **distal** RTA, children may have accompanying hypokalemia, hypercalciuria, nephrolithiasis, and nephrocalcinosis. Failure



**Table 73.13** Causes of Metabolic Acidosis**NORMAL ANION GAP**

Diarrhea

RTA

Distal (type I) RTA (OMIM 179800/602722/267300/611590)\*

Proximal (type II) RTA (OMIM 604278)†

Mixed (type III) RTA (OMIM 259730)

Hyperkalemic (type IV) RTA (OMIM 201910/264350/177735/145260)‡

Urinary tract diversions

Posthypocapnia

Ammonium chloride intake

**INCREASED ANION GAP****Lactic Acidosis**

Tissue hypoxia

Shock

Hypoxemia

Severe anemia

Liver failure

Malignancy

Intestinal bacterial overgrowth

Inborn errors of metabolism

Medications

Nucleoside reverse transcriptase inhibitors

Metformin

Propofol

Linezolid

**Ketoacidosis**

Diabetic ketoacidosis

Starvation ketoacidosis

Alcoholic ketoacidosis

**Kidney Failure****Poisoning**

Ethylene glycol

Methanol

Salicylate

Toluene

Paraldehyde

\*Along with these genetic disorders, distal RTA may be secondary to renal disease or medications.

†Most cases of proximal RTA are not caused by this primary genetic disorder. Proximal RTA is usually part of Fanconi syndrome, which has multiple etiologies.

‡Hyperkalemic RTA can be secondary to a genetic disorder (some of the more common are listed) or other etiologies.

OMIM, database number from the Online Mendelian Inheritance in Man (<http://www.ncbi.nlm.nih.gov/omim>); RTA, renal tubular acidosis.

to thrive because of chronic metabolic acidosis is the most common presenting complaint. Patients with distal RTA cannot acidify their urine and thus have a urine pH >5.5 despite a metabolic acidosis.

**Proximal RTA** is rarely present in isolation. In most patients, proximal RTA is part of **Fanconi syndrome**, a generalized dysfunction of the proximal tubule. The dysfunction leads to glycosuria, aminoaciduria, and excessive urinary losses of phosphate and uric acid. The presence of a low serum uric acid level, glycosuria, and aminoaciduria is helpful diagnostically. Chronic hypophosphatemia leads to rickets in children (see [Chapter 69](#)). Rickets and/or failure to thrive may be the presenting complaint. The ability to acidify the urine is intact in proximal RTA; thus untreated patients have a urine pH <5.5. However, bicarbonate therapy increases bicarbonate losses in the urine, and the urine pH increases. A mixed RTA (combined distal and proximal) occurs in patients with autosomal recessive osteopetrosis caused by pathologic variants in the gene for carbonic anhydrase II.

In **hyperkalemic RTA**, renal excretion of acid and potassium is impaired. Hyperkalemic RTA is the result of hyperkalemia, absence of aldosterone, or inability of the kidney to respond to aldosterone. In severe **aldosterone deficiency**, as occurs with congenital adrenal hyperplasia because of 21 $\alpha$ -hydroxylase deficiency, the hyperkalemia and metabolic acidosis are accompanied by hyponatremia and volume depletion from renal salt wasting. Incomplete aldosterone deficiency causes less severe electrolyte disturbances; children may have isolated hyperkalemic RTA, hyperkalemia without acidosis, or isolated hyponatremia. Patients may have aldosterone deficiency caused by decreased renin production by the kidney; renin normally stimulates aldosterone synthesis. Children with hyporeninemic hypoaldosteronism usually have either isolated hyperkalemia or hyperkalemic RTA. The manifestations of aldosterone resistance depend on the severity of the resistance. In the autosomal recessive form of **pseudohypoaldosteronism** type I, which is the result of an absence of the sodium channel that normally responds to aldosterone, there is often severe salt wasting and hyponatremia. In contrast, the aldosterone resistance in kidney transplant recipients usually produces either isolated hyperkalemia or hyperkalemic RTA; hyponatremia is unusual. Similarly, the medications that cause hyperkalemic RTA do not cause hyponatremia. Pseudohypoaldosteronism type II, an autosomal dominant disorder also known as **Gordon syndrome**, is a unique cause of hyperkalemic RTA because the genetic defect causes volume expansion and hypertension.

Children with abnormal urinary tracts, usually secondary to congenital malformations, may require diversion of urine through intestinal segments. Ureterosigmoidostomy, anastomosis of a ureter to the sigmoid colon, almost always produces a metabolic acidosis and hypokalemia. Consequently, ileal conduits are the more commonly used procedure, although there is still a risk of a metabolic acidosis.

The appropriate metabolic compensation for a chronic respiratory alkalosis is a decrease in renal acid excretion. The resultant decrease in the serum [HCO<sub>3</sub><sup>-</sup>] lessens the alkalemia caused by the respiratory alkalosis. If the respiratory alkalosis resolves quickly, the patient continues to have a decreased serum [HCO<sub>3</sub><sup>-</sup>], causing acidemia as the result of a metabolic acidosis. This resolves over 1-2 days through increased acid excretion by the kidneys.

**Lactic acidosis** (L-lactic) typically occurs when inadequate oxygen delivery to the tissues leads to anaerobic metabolism and excess production of lactic acid. Lactic acidosis may be secondary to shock, severe anemia, or hypoxemia. When the underlying cause of the lactic acidosis is alleviated, the liver is able to metabolize the accumulated lactate into bicarbonate, correcting the metabolic acidosis. There is normally some tissue production of lactate metabolized by the liver. In children with severe liver dysfunction, impairment of lactate metabolism may produce a lactic acidosis. Rarely, a metabolically active malignancy grows so fast that its blood supply becomes inadequate, with resultant anaerobic metabolism and lactic acidosis. Patients who have **short bowel syndrome** resulting from small bowel resection can have bacterial overgrowth. In these patients, excessive intestinal bacterial metabolism of glucose into *D*-lactic acid can cause a lactic acidosis. Lactic acidosis occurs in a variety of **inborn errors of metabolism**, especially those affecting mitochondrial oxidation (see [Chapters 107.4](#) and [108](#)). **Medications** also can cause lactic acidosis. Nucleoside reverse transcriptase inhibitors that are used to treat HIV infection inhibit mitochondrial replication; lactic acidosis is a rare complication, although elevated serum lactate concentrations without acidosis are quite common. Metformin, used to treat type 2 diabetes mellitus, is most likely to cause a lactic acidosis in patients with chronic kidney disease. High dosages and prolonged use of propofol can cause lactic acidosis. Propylene glycol is a diluent in a variety of oral and IV medications; excessive intake causes a lactic acidosis, principally from accumulation of *D*-lactic acid. Linezolid is another medication that may cause a lactic acidosis

In **insulin-dependent diabetes mellitus**, inadequate insulin leads to hyperglycemia and DKA (see Chapter 629). Production of acetoacetic acid and  $\beta$ -hydroxybutyric acid causes the metabolic acidosis. Administration of insulin corrects the underlying metabolic problem and permits conversion of acetoacetate and  $\beta$ -hydroxybutyrate into bicarbonate, which helps correct the metabolic acidosis. However, in some patients, urinary losses of acetoacetate and  $\beta$ -hydroxybutyrate may be substantial, preventing rapid regeneration of bicarbonate. In these patients, full correction of the metabolic acidosis requires renal regeneration of bicarbonate, a slower process. The hyperglycemia causes an osmotic diuresis, usually producing volume depletion, along with substantial losses of potassium, sodium, and phosphate.

In **starvation ketoacidosis** the lack of glucose leads to ketoacid production, which in turn can produce a metabolic acidosis, although it is usually mild as a result of increased acid secretion by the kidney. In **alcoholic ketoacidosis**, which is much less common in children than in adults, the acidosis usually follows a combination of an alcoholic binge with vomiting and poor intake of food. The acidosis is potentially more severe than with isolated starvation, and the blood glucose level may be low, normal, or high. Hypoglycemia and acidosis also suggest an inborn error of metabolism.

**Kidney failure** causes a metabolic acidosis because of the need for the kidneys to excrete the acid produced by normal metabolism. With mild or moderate chronic kidney disease, the remaining nephrons are usually able to compensate by increasing acid excretion. When the GFR is <20–30% of normal, the compensation is inadequate, and a metabolic acidosis develops. In some children, especially those with chronic kidney disease because of tubular damage, the acidosis develops at a higher GFR because of a concurrent defect in acid secretion by the distal tubule (distal RTA).

A variety of **toxic ingestions** can cause a metabolic acidosis (see Chapter 94). **Salicylate** intoxication is now much less common because aspirin is no longer recommended for fever control in children. Acute salicylate intoxication occurs after a large overdose. Chronic salicylate intoxication is possible with gradual buildup of the drug. Especially in adults, respiratory alkalosis may be the dominant acid-base disturbance. In children, the metabolic acidosis is usually the more significant finding. Other symptoms of salicylate intoxication are fever, seizures, lethargy, and coma. Hyperventilation may be particularly marked. Tinnitus, vertigo, and hearing impairment are more likely with chronic salicylate intoxication.

**Ethylene glycol**, a component of antifreeze, is converted in the liver to glyoxylic and oxalic acids, causing a severe metabolic acidosis. Excessive oxalate excretion causes calcium oxalate crystals to appear in the urine, and calcium oxalate precipitation in the kidney tubules can cause kidney failure. The toxicity of **methanol** ingestion also depends on liver metabolism; formic acid is the toxic end product that causes the metabolic acidosis and other sequelae, which include damage to the optic nerve and CNS. Symptoms may include nausea, emesis, visual impairment, and altered mental status. **Toluene** inhalation and **paraldehyde** ingestion are other potential causes of a metabolic acidosis.

Many **inborn errors of metabolism** cause a metabolic acidosis (see Chapters 104–107). The metabolic acidosis may be the result of excessive production of ketoacids, lactic acid, and other organic anions. Some patients have accompanying hypoglycemia or hyperammonemia. In most patients, the acidosis occurs episodically during acute decompensations, which may be precipitated by ingestion of specific dietary substrates, the stress of a mild illness, or poor compliance with dietary or medical therapy. In a few inborn errors of metabolism, patients have a chronic metabolic acidosis.

### Clinical Manifestations

The underlying disorder usually produces most of the signs and symptoms in children with a mild or moderate metabolic acidosis. The clinical manifestations of the acidosis are related to the degree of acidemia; patients with appropriate respiratory compensation and less severe

acidemia have fewer manifestations than those with a concomitant respiratory acidosis. At a serum pH <7.2, there may be impaired cardiac contractility and an increased risk of arrhythmias, especially if underlying heart disease or other predisposing electrolyte disorders are present. With acidemia, there may be a decrease in the cardiovascular response to catecholamines, potentially exacerbating hypotension in children with volume depletion or shock. Acidemia causes vasoconstriction of the pulmonary vasculature, which is especially problematic in newborn infants with **persistent pulmonary hypertension** (see Chapter 130).

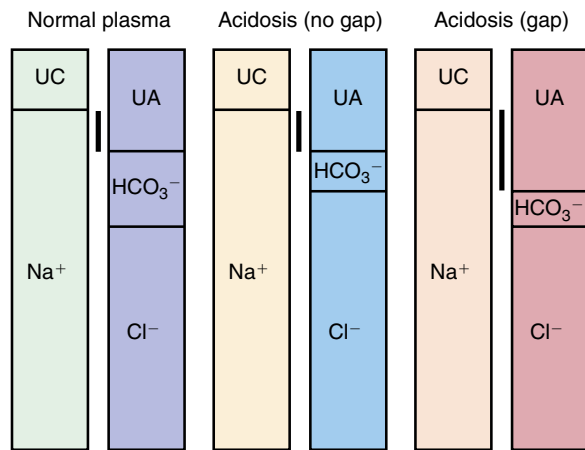
The normal respiratory response to metabolic acidosis—compensatory hyperventilation—may be subtle with mild metabolic acidosis, but it causes discernible increased respiratory effort with worsening acidemia. The acute metabolic effects of acidemia include insulin resistance, increased protein degradation, and reduced ATP synthesis. Chronic metabolic acidosis causes failure to thrive in children. Acidemia causes potassium to move from the ICS to the ECS, thereby increasing the serum  $[K^+]$ . Severe acidemia impairs brain metabolism, eventually resulting in lethargy and coma.

### Diagnosis

The etiology of a metabolic acidosis is often apparent from the history and physical examination. Acutely, diarrhea and shock are common causes of a metabolic acidosis. Shock, which causes a lactic acidosis, is usually apparent on physical examination and can be secondary to dehydration, acute blood loss, sepsis, or heart disease. Failure to thrive suggests a chronic metabolic acidosis, as with renal insufficiency or RTA. New onset of polyuria occurs in children with undiagnosed diabetes mellitus and DKA. Metabolic acidosis with seizures and/or a depressed sensorium, especially in an infant, warrants consideration of an inborn error of metabolism. Meningitis and sepsis with lactic acidosis are more common explanations for metabolic acidosis with neurologic signs and symptoms. Identification of a toxic ingestion (e.g., ethylene glycol, methanol) is especially important because of the potentially excellent response to specific therapy. A variety of medications can cause a metabolic acidosis, whether prescribed or accidentally ingested. Hepatomegaly and metabolic acidosis may occur in children with sepsis, congenital or acquired heart disease, hepatic failure, or inborn errors of metabolism.

Basic laboratory tests in a child with a metabolic acidosis should include measurements of BUN, serum creatinine, serum glucose, urinalysis, and serum electrolytes. Metabolic acidosis, hyperglycemia, glycosuria, and ketonuria support a diagnosis of DKA. Starvation causes ketosis, but the metabolic acidosis, if present, is usually mild ( $HCO_3^- >18$  mEq/L). Most children with ketosis from poor intake and metabolic acidosis have a concomitant disorder, such as gastroenteritis with diarrhea, that explains the metabolic acidosis. Alternatively, metabolic acidosis with or without ketosis occurs in inborn errors of metabolism; patients with these disorders may have hyperglycemia, normoglycemia, or hypoglycemia. Adrenal insufficiency may cause metabolic acidosis and hypoglycemia. Metabolic acidosis with hypoglycemia also occurs with liver failure. Metabolic acidosis, normoglycemia, and glycosuria occur in children when type II RTA is part of Fanconi syndrome; the defect in resorption of glucose by the proximal tubule of the kidney causes the glycosuria.

The serum  $[K^+]$  is often abnormal in children with a metabolic acidosis. Even though a metabolic acidosis causes potassium to move from the ICS to the ECS, many patients with a metabolic acidosis have a low serum  $[K^+]$  because of excessive body losses of  $K^+$ . With diarrhea, there are high stool losses of  $K^+$  and, often, secondary renal losses of  $K^+$ , whereas in type I or type II RTA, there are increased urinary losses of  $K^+$ . In DKA, urinary losses of  $K^+$  are high, but the shift of  $K^+$  out of cells because of a lack of insulin and metabolic acidosis is especially significant. Consequently, the initial serum  $[K^+]$  can be low, normal, or high, even though total body  $K^+$  is almost always decreased. The serum  $[K^+]$  is usually increased in patients with acidosis caused



**Fig. 73.11** Anion gap. The anion gap is the difference between the sodium concentration and the combined concentrations of chloride and bicarbonate (vertical black bars). In both a gap and a nongap metabolic acidosis, there is a decrease in the bicarbonate concentration. There is an increase in unmeasured anions (UA) in patients with a gap metabolic acidosis. In a nongap metabolic acidosis, there is an increase in the serum chloride concentration. UC, Unmeasured cations.

by renal insufficiency; urinary K<sup>+</sup> excretion is impaired. The combination of metabolic acidosis, hyperkalemia, and hyponatremia occurs in patients with severe aldosterone deficiency (adrenogenital syndrome) or aldosterone resistance. Patients with less severe, type IV RTA often have only hyperkalemia and metabolic acidosis. Very ill children with metabolic acidosis may have an elevated serum K<sup>+</sup> because of a combination of renal insufficiency, tissue breakdown, and a shift of K<sup>+</sup> from the ICS to the ECS secondary to the metabolic acidosis.

The **plasma anion gap** is useful for evaluating patients with a metabolic acidosis. It divides patients into two diagnostic groups, those with normal anion gap and those with increased anion gap. The following formula determines the anion gap:

$$\text{Anion gap} = [\text{Na}^+] - ([\text{Cl}^-] + [\text{HCO}_3^-])$$

A normal anion gap is 4–11, although there is variation among laboratories. Approximately 11 mEq of the anion gap is normally secondary to albumin. A 1 g/dL decrease in the albumin concentration decreases the anion gap by approximately 2.5 mEq/L. Thus, if the albumin is not close to 4 g/dL, the anion gap should be corrected for the albumin concentration:

$$\text{Anion gap (corrected for albumin)} = [\text{Na}^+] - ([\text{Cl}^-] + [\text{HCO}_3^-]) + [2.5 \times (4 - \text{observed albumin})]$$

The number of serum anions must equal the number of serum cations to maintain electrical neutrality (Fig. 73.11). The anion gap is the difference between the measured cation (Na<sup>+</sup>) and the measured anions (Cl<sup>-</sup> + bicarbonate). The anion gap is also the difference between the unmeasured cations (K<sup>+</sup>, magnesium, calcium) and the unmeasured anions (albumin, phosphate, urate, sulfate). An increased anion gap occurs when there is an increase in unmeasured anions. With a lactic acidosis, there is endogenous production of lactic acid, which is composed of positively charged hydrogen ions and negatively charged lactate anions. The hydrogen ions are largely buffered by serum bicarbonate, resulting in a decrease in [HCO<sub>3</sub><sup>-</sup>]. The hydrogen ions that are not buffered by bicarbonate cause the serum pH to decrease. The lactate anions remain, causing the increase in the anion gap.

An increase in unmeasured anions, along with H<sup>+</sup> generation, is present in all causes of an increased gap metabolic acidosis (see Table 73.13). In DKA, the ketoacids β-hydroxybutyrate and acetoacetate are the unmeasured anions. In kidney failure there is retention of unmeasured anions, including phosphate, urate, and sulfate. The increase in unmeasured anions in kidney failure is usually less than the decrease in [HCO<sub>3</sub><sup>-</sup>]. Kidney failure is thus a mix of an increased-gap and a normal-gap metabolic acidosis. The normal-gap metabolic acidosis is especially prominent in children with kidney failure because of tubular damage, as occurs with renal dysplasia or obstructive uropathy, because these patients have a concurrent RTA. The unmeasured anions in toxic ingestions vary: formate in methanol intoxication, glycolate in ethylene glycol intoxication, and lactate and ketoacids in salicylate intoxication. In inborn errors of metabolism, the unmeasured anions depend on the specific etiology and may include ketoacids, lactate, and other organic anions. In a few inborn errors of metabolism, the acidosis occurs without generation of unmeasured anions; thus the anion gap is normal.

A **normal-anion gap metabolic acidosis** occurs when there is a decrease in [HCO<sub>3</sub><sup>-</sup>] without an increase in the unmeasured anions. With diarrhea, there is a loss of bicarbonate in the stool, causing a decrease in the serum pH and [HCO<sub>3</sub><sup>-</sup>]; the serum [Cl<sup>-</sup>] increases to maintain electrical neutrality (see Fig. 73.11). **Hyperchloremic metabolic acidosis** is an alternative term for a normal-anion gap metabolic acidosis. Calculation of the anion gap is more precise than using [Cl<sup>-</sup>] to differentiate between a normal-gap and an increased-gap metabolic acidosis, in that the anion gap directly determines the presence of unmeasured anions. Electrical neutrality dictates that the [Cl<sup>-</sup>] increases or decreases according to the serum [Na<sup>+</sup>], making [Cl<sup>-</sup>] a less reliable predictor of unmeasured anions than the more direct measure, calculation of the anion gap.

An increase in unmeasured cations, such as calcium, potassium, and magnesium, decreases the anion gap. Conversely, a decrease in unmeasured cations is a very unusual cause of an increased anion gap. Because of these variables, the broad range of a normal anion gap, and other variables, the presence of a normal or an increased anion gap is not always reliable in differentiating among the causes of a metabolic acidosis, especially when the metabolic acidosis is mild. In some patients, there is more than one explanation for the metabolic acidosis, such as the child with diarrhea and lactic acidosis as a result of poor perfusion. The anion gap should not be interpreted in dogmatic isolation; consideration of other laboratory abnormalities and the clinical history improves its diagnostic utility.

### Treatment

The most effective therapeutic approach for patients with a metabolic acidosis is repair of the underlying disorder, if possible. The administration of insulin in DKA and the restoration of adequate perfusion with IV fluids in lactic acidosis because of hypovolemia or shock eventually result in normalization of the acid-base balance. In other diseases, the use of bicarbonate therapy is indicated because the underlying disorder is irreparable. Children with metabolic acidosis caused by RTA or chronic kidney disease require long-term base therapy. Patients with acute kidney injury and metabolic acidosis may need base therapy until their kidneys' ability to excrete hydrogen normalizes. In other disorders the cause of the metabolic acidosis eventually resolves, but base therapy may be necessary during the acute illness. In salicylate poisoning, alkali administration increases renal clearance of salicylate and decreases the amount of salicylate in brain cells. Short-term base therapy is often necessary in other poisonings (ethylene glycol, methanol) and inborn errors of metabolism (pyruvate carboxylase deficiency, propionic acidemia). Some inborn errors of metabolism require long-term base therapy.

The use of base therapy in DKA with lactic acidosis is controversial; *there is little evidence that it improves patient outcome, and it has a variety of potential side effects.* The risks of giving sodium bicarbonate



include the possibility of causing hypernatremia or volume overload. Furthermore, the patient may have overcorrection of the metabolic acidosis once the underlying disorder resolves, because metabolism of lactate or ketoacids generates bicarbonate. The rapid change from acidemia to alkalemia can cause a variety of problems, including hypokalemia and hypophosphatemia. Bicarbonate therapy increases the generation of CO<sub>2</sub>, which can accumulate in patients with respiratory failure. Because CO<sub>2</sub> readily diffuses into cells, the administration of bicarbonate can lower the intracellular pH, potentially worsening cell function. Base therapy is usually reserved for children with severe acute lactic acidosis and severe DKA.

**Oral base therapy** is given to children with chronic metabolic acidosis. Sodium bicarbonate tablets are available for older children. Younger children generally take citrate solutions; the liver generates bicarbonate from citrate. Citrate solutions are available as sodium citrate, potassium citrate, and a 1:1 mix of sodium citrate and potassium citrate. The patient's potassium needs dictate the choice. Children with type I or type II RTA may have hypokalemia and benefit from potassium supplements, but most children with chronic kidney failure cannot tolerate additional potassium.

Oral or IV base can be used in acute metabolic acidosis; IV therapy is generally used when a rapid response is necessary. Sodium bicarbonate may be given as a bolus, usually at a dose of 1 mEq/kg, in an emergency situation. Another approach is to add sodium bicarbonate or sodium acetate to the patient's IV fluids, remembering to remove an equal amount of sodium chloride from the solution to avoid giving an excessive sodium load. Careful monitoring is mandatory so that the dose of base can be titrated appropriately. Tris(hydroxymethyl)aminomethane (**tromethamine, THAM**) is an option in patients with a metabolic acidosis and a respiratory acidosis, because it neutralizes acids without releasing CO<sub>2</sub>. THAM also diffuses into cells and therefore provides intracellular buffering.

**Hemodialysis** is another option for correcting a metabolic acidosis, and it is an appropriate choice in patients with renal insufficiency, especially if significant uremia or hyperkalemia is also present. Hemodialysis is advantageous for correcting the metabolic acidosis caused by methanol or ethylene glycol intoxication, because hemodialysis efficiently removes the offending toxin. In addition, these patients often have a severe metabolic acidosis that does not respond easily to IV bicarbonate therapy. Peritoneal dialysis is another option for correcting the metabolic acidosis due to chronic kidney disease.

Many causes of metabolic acidosis require specific therapy. Administration of a glucocorticoid and a mineralocorticoid is necessary in patients with adrenal insufficiency. Patients with DKA require insulin therapy, whereas patients with lactic acidosis respond to measures that alleviate tissue hypoxia. Along with correction of acidosis, patients with methanol or ethylene glycol ingestion should receive an agent that prevents the breakdown of the toxic substance to its toxic metabolites. Fomepizole has supplanted ethanol as the treatment of choice. These agents work by inhibiting alcohol dehydrogenase, the enzyme that performs the first step in the metabolism of ethylene glycol or methanol. There are a variety of disease-specific therapies for patients with a metabolic acidosis resulting from an inborn error of metabolism.

## METABOLIC ALKALOSIS

Metabolic alkalosis in children is most often secondary to emesis or diuretic use. The serum bicarbonate concentration is increased with a metabolic alkalosis, although a respiratory acidosis also leads to a compensatory elevation of the serum [HCO<sub>3</sub><sup>-</sup>]. With a simple metabolic alkalosis, however, the pH is elevated; alkalemia is present. Patients with a respiratory acidosis are acidemic. Decreasing ventilation causes appropriate respiratory compensation for a metabolic alkalosis. PCO<sub>2</sub> increases by 7 mm Hg for each 10 mEq/L increase in the serum [HCO<sub>3</sub><sup>-</sup>]. Appropriate respiratory compensation never exceeds a PCO<sub>2</sub> of 55-60 mm Hg. The patient has a concurrent respiratory alkalosis

**Table 73.14** Causes of Metabolic Alkalosis

### CHLORIDE-RESPONSIVE (URINARY CHLORIDE <15 MEQ/L)

Gastric losses  
 Emesis  
 Nasogastric suction  
 Diuretics (loop or thiazide)  
 Chloride-losing diarrhea (OMIM 214700)  
 Low chloride formula  
 Cystic fibrosis (OMIM 219700)  
 Posthypercapnia

### CHLORIDE-RESISTANT (URINARY CHLORIDE >20 MEQ/L)

#### High Blood Pressure

Adrenal adenoma or hyperplasia  
 Glucocorticoid-remediable aldosteronism/Familial hyperaldosteronism type I (OMIM 103900)  
 Familial hyperaldosteronism type II (OMIM 605635)  
 Familial hyperaldosteronism type III (OMIM 613677)  
 Familial hyperaldosteronism type IV (OMIM 617027)  
 Renovascular disease  
 Renin-secreting tumor  
 17 $\alpha$ -Hydroxylase deficiency (OMIM 202110)  
 11 $\beta$ -Hydroxylase deficiency (OMIM 202010)  
 Cushing syndrome  
 11 $\beta$ -Hydroxysteroid dehydrogenase deficiency (OMIM 218030)  
 Licorice ingestion  
 Liddle syndrome (OMIM 177200)

#### Normal Blood Pressure

Gitelman syndrome (OMIM 263800)  
 Bartter syndrome (OMIM 241200/607364/602522/601678/300971/601198/613090)  
 Autosomal dominant hypoparathyroidism (OMIM 146200)  
 EAST syndrome (OMIM 612780)  
 Hyperuricemia, Pulmonary Hypertension, Renal Failure in Infancy and Alkalosis, HUPRA Syndrome (OMIM 613845)  
 Autosomal dominant kidney hypomagnesemia due to *RRAGD* variant (OMIM not assigned)  
 Base administration

EAST, Epilepsy, ataxia, sensorineural hearing loss, and tubulopathy; OMIM, database number from the Online Mendelian Inheritance in Man (<http://www.ncbi.nlm.nih.gov/omim>).

if the PCO<sub>2</sub> is lower than the expected compensation. A greater than expected PCO<sub>2</sub> occurs with a concurrent respiratory acidosis.

## Etiology and Pathophysiology

The kidneys normally respond promptly to a metabolic alkalosis by increasing base excretion. Two processes are therefore usually present to produce a metabolic alkalosis: (1) the generation of the metabolic alkalosis, which requires the addition of base to the body, and (2) the maintenance of the metabolic alkalosis, which requires impairment in the kidney's ability to excrete base.

The etiologies of a metabolic alkalosis are divided into two categories based on the urinary chloride level (Table 73.14). The alkalosis in patients with a low urinary [Cl<sup>-</sup>] is maintained by **volume depletion**; thus volume repletion is necessary for correction of the alkalosis. The volume depletion in these patients is caused by losses of Na<sup>+</sup> and K<sup>+</sup>, but the loss of Cl<sup>-</sup> is usually greater than the losses of Na<sup>+</sup> and K<sup>+</sup> combined. Because Cl<sup>-</sup> losses are the dominant cause of the volume depletion, these patients require Cl<sup>-</sup> to correct the volume depletion and metabolic alkalosis; they are said to have **Cl<sup>-</sup>-responsive metabolic alkalosis**. In contrast, the alkalosis in a patient with an elevated urinary [Cl<sup>-</sup>] does not respond to volume repletion and so is termed **Cl<sup>-</sup>-resistant metabolic alkalosis**.



Emesis or nasogastric suction results in **loss of gastric fluid**, which has a high content of HCl. Generation of H<sup>+</sup> by the gastric mucosa causes simultaneous release of bicarbonate into the bloodstream. Normally, the hydrogen ions in gastric fluid are reclaimed in the small intestine (by neutralizing secreted bicarbonate); thus there is no net loss of acid. With loss of gastric fluid, this does not occur, and a metabolic alkalosis develops. This period is the *generation phase* of the metabolic alkalosis.

The *maintenance phase* of the metabolic alkalosis from gastric losses is caused by the volume depletion (“chloride depletion” from gastric loss of HCl). Volume depletion interferes with urinary loss of bicarbonate, the normal renal response to a metabolic alkalosis. During volume depletion, several mechanisms prevent renal bicarbonate loss. First, there is a reduction in the GFR, so less bicarbonate is filtered. Second, volume depletion increases resorption of sodium and bicarbonate in the proximal tubule, limiting the amount of bicarbonate that can be excreted in the urine. This effect is mediated by angiotensin II and adrenergic stimulation of the kidney, both of which are increased in response to volume depletion. Third, the increase in aldosterone during volume depletion increases bicarbonate resorption and H<sup>+</sup> secretion in the collecting duct.

In addition to volume depletion, gastric losses are usually associated with hypokalemia as a result of both gastric loss of K<sup>+</sup> and, most importantly, increased urinary K<sup>+</sup> losses. The increased urinary losses of K<sup>+</sup> are mediated by aldosterone, through volume depletion, and by the increase in intracellular K<sup>+</sup> secondary to the metabolic alkalosis, which causes K<sup>+</sup> to move into the cells of the kidney, causing increased K<sup>+</sup> excretion. Hypokalemia contributes to the maintenance of the metabolic alkalosis by decreasing bicarbonate loss. Hypokalemia increases H<sup>+</sup> secretion in the distal nephron and stimulates ammonia production in the proximal tubule. Ammonia production enhances renal excretion of H<sup>+</sup>.

A metabolic alkalosis can develop in patients receiving **loop or thiazide diuretics**. Diuretic use leads to volume depletion, which increases angiotensin II, aldosterone, and adrenergic stimulation of the kidney. Diuretics increase the delivery of sodium to the distal nephron, further enhancing acid excretion. Moreover, these diuretics cause hypokalemia, which increases acid excretion by the kidney. The increase in renal acid excretion generates the metabolic alkalosis, and the decrease in bicarbonate loss maintains it. In addition, patients who are receiving diuretics have a “contraction alkalosis.” Diuretic use causes fluid loss without bicarbonate; thus the remaining body bicarbonate is contained in a smaller total body fluid compartment. The [HCO<sub>3</sub><sup>-</sup>] increases, helping to generate the metabolic alkalosis.

Diuretics are often used in patients with edema, such as those with nephrotic syndrome, heart failure, or liver failure. In many of these patients, metabolic alkalosis resulting from diuretic use develops despite the continued presence of edema. This is because the effective intravascular volume is low, and it is the effective intravascular volume that stimulates the compensatory mechanisms that cause and maintain a metabolic alkalosis. Many of these patients have a decreased effective intravascular volume before they begin diuretic therapy, increasing the likelihood of diuretic-induced metabolic alkalosis.

Diuretic use increases chloride excretion in the urine. Consequently, while a patient is receiving diuretics, the urine [Cl<sup>-</sup>] is typically high (>20 mEq/L). After the diuretic effect has worn off, the urinary [Cl<sup>-</sup>] is low (<15 mEq/L) because of appropriate renal Cl<sup>-</sup> retention in response to volume depletion. Thus categorization of diuretics because of urinary [Cl<sup>-</sup>] depends on the timing of the measurement. However, the metabolic alkalosis from diuretics is Cl<sup>-</sup> responsive; it is corrected after adequate volume repletion. This is the rationale for including this process among the chloride-responsive causes of a metabolic alkalosis.

Most patients with diarrhea have a metabolic acidosis because of stool losses of bicarbonate. In **chloride-losing diarrhea**, an autosomal recessive disorder, there is a defect in the normal intestinal exchange of bicarbonate for chloride, causing excessive stool losses of chloride (see Chapter 385). In addition, stool losses of H<sup>+</sup> and K<sup>+</sup> cause metabolic alkalosis and hypokalemia, both of which are exacerbated by increased renal H<sup>+</sup> and K<sup>+</sup> losses from volume depletion. Treatment is with oral supplements of K<sup>+</sup> and NaCl. Use of a gastric proton pump inhibitor (PPI), by decreasing gastric HCl production, reduces both the volume of diarrhea and the need for electrolyte supplementation.

Formulas with extremely low Cl<sup>-</sup> content have led to Cl<sup>-</sup> deficiency and volume depletion. There is secondary metabolic alkalosis and hypokalemia. **Cystic fibrosis** can rarely cause metabolic alkalosis, hypokalemia, and hyponatremia because of excessive NaCl losses in sweat (see Chapter 454). The volume depletion causes the metabolic alkalosis and hypokalemia through increased urinary losses, whereas the hyponatremia, a less common finding, is secondary to Na<sup>+</sup> loss combined with renal water conservation in an effort to protect the intravascular volume (“appropriate” ADH production).

A **posthypercapnic metabolic alkalosis** occurs after the correction of a chronic respiratory acidosis. This is typically seen in patients with chronic lung disease who are started on mechanical ventilation. During chronic respiratory acidosis, appropriate renal compensation leads to an increase in the serum [HCO<sub>3</sub><sup>-</sup>]. Because it is still present after acute correction of the respiratory acidosis, the elevated [HCO<sub>3</sub><sup>-</sup>] causes a metabolic alkalosis. The metabolic alkalosis persists because the patient with a chronic respiratory acidosis is intravascularly depleted because of the Cl<sup>-</sup> loss that occurred during the initial metabolic compensation for the primary respiratory acidosis. In addition, many children with a chronic respiratory acidosis receive diuretics, which further decrease the intravascular volume. The metabolic alkalosis responds to correction of the intravascular volume deficit.

The **chloride-resistant** causes of metabolic alkalosis can be subdivided according to blood pressure status. Patients with **hypertension** either have increased aldosterone levels or act as if they do. Aldosterone levels are elevated in children with adrenal adenomas or hyperplasia. Aldosterone causes renal retention of sodium, with resultant hypertension. Metabolic alkalosis and hypokalemia result from aldosterone-mediated renal excretion of H<sup>+</sup> and K<sup>+</sup>. The urinary Cl<sup>-</sup> level is not low because these patients are volume overloaded, not volume depleted. The volume expansion and hypertension allow normal excretion of Na<sup>+</sup> and Cl<sup>-</sup> despite the presence of aldosterone. This is known as the *mineralocorticoid escape phenomenon*.

In **glucocorticoid-remediable aldosteronism**, an autosomal dominant disorder, excess production of aldosterone results from the presence of an aldosterone synthase gene regulated by adrenocorticotropic hormone (ACTH) (see Chapter 616.8). Glucocorticoids effectively treat this disorder by inhibiting ACTH production by the pituitary, downregulating the inappropriate aldosterone production. Familial hyperaldosteronism type II, which causes elevated aldosterone levels, responds to spironolactone. Familial hyperaldosteronism type III typically requires bilateral adrenalectomy due to the severity of the hyperaldosteronism. Renovascular disease and renin-secreting tumors both cause excessive renin, leading to an increase in aldosterone, although hypokalemia and metabolic alkalosis are less common findings than hypertension. In two forms of **congenital adrenal hyperplasia**, 11β-hydroxylase deficiency and 17α-hydroxylase deficiency, there is excessive production of the mineralocorticoid 11-deoxycorticosterone (see Chapters 616.2 and 616.4). Hypertension, hypokalemia, and metabolic alkalosis are more likely in 17α-hydroxylase deficiency than in 11β-hydroxylase deficiency. These disorders respond to glucocorticoids because the excess production of 11-deoxycorticosterone is under the control of ACTH.

**Cushing syndrome** frequently causes hypertension. Cortisol has some mineralocorticoid activity, and high levels can produce hypokalemia and metabolic alkalosis in patients with Cushing syndrome.

Cortisol can bind to the mineralocorticoid receptors in the kidney and function as a mineralocorticoid. This binding normally does not occur because 11 $\beta$ -hydroxysteroid dehydrogenase in the kidney converts cortisol to cortisone, which does not bind to the mineralocorticoid receptor. In the autosomal recessive disorder 11 $\beta$ -hydroxysteroid dehydrogenase deficiency, also called **apparent mineralocorticoid excess**, cortisol is not converted in the kidney to cortisone. Cortisol is therefore available to bind to the mineralocorticoid receptor in the kidney and act as a mineralocorticoid. Patients with this deficiency, despite low levels of aldosterone, are hypertensive and hypokalemic, and they have a metabolic alkalosis. The same phenomenon can occur with excessive intake of natural licorice, a component of which, glycyrrhizic acid, inhibits 11 $\beta$ -hydroxysteroid dehydrogenase. The autosomal dominant disorder **Liddle syndrome** is secondary to an activating variant in the gene for the sodium channel in the distal nephron (see Chapter 571.3). Upregulation of this sodium channel is one of the principal actions of aldosterone. Because this Na<sup>+</sup> channel is continuously open, children with Liddle syndrome have the features of hyperaldosteronism, including hypertension, hypokalemia, and metabolic alkalosis, but low serum levels of aldosterone.

Bartter and Gitelman syndromes are autosomal recessive disorders associated with normal blood pressure, elevated urinary Cl<sup>-</sup>, metabolic alkalosis, and hypokalemia (see Chapter 571). In **Bartter syndrome**, patients have a defect in Na<sup>+</sup> and Cl<sup>-</sup> resorption in the loop of Henle. This leads to excessive urinary losses of Na<sup>+</sup> and Cl<sup>-</sup>, and as in patients receiving loop diuretics, volume depletion and secondary hyperaldosteronism occur, causing hypokalemia and metabolic alkalosis. **Gitelman syndrome** is usually milder than Bartter syndrome. Patients have renal Na<sup>+</sup> and Cl<sup>-</sup> wasting with volume depletion caused by variants in the gene encoding the thiazide-sensitive Na<sup>+</sup>-Cl<sup>-</sup> transporter in the distal tubule. As in patients receiving a thiazide diuretic, affected patients have volume depletion and secondary hyperaldosteronism with hypokalemia and metabolic alkalosis. Children with Gitelman syndrome have hypocalciuria and hypomagnesemia. Some patients with autosomal dominant hypoparathyroidism have hypokalemia and metabolic alkalosis from impaired Na<sup>+</sup> and Cl<sup>-</sup> resorption in the loop of Henle. **EAST syndrome** causes hypokalemia, metabolic alkalosis, and hypomagnesemia.

**Excessive base intake** can cause a metabolic alkalosis. Affected patients do not have low urine [Cl<sup>-</sup>], unless there is associated volume depletion. In the absence of volume depletion, excess base is rapidly corrected via renal excretion of bicarbonate. Rarely, massive base intake can cause a metabolic alkalosis by overwhelming the kidney's ability to excrete bicarbonate. This may occur in infants who are given baking soda as a "home remedy" for colic or stomach upset. Each teaspoon of baking soda has 42 mEq of sodium bicarbonate. Infants have increased vulnerability because of a lower GFR, limiting the rate of compensatory renal bicarbonate excretion. A metabolic alkalosis may also occur in patients who receive a large amount of sodium bicarbonate during cardiopulmonary resuscitation. Blood products are anticoagulated with citrate, which is converted into bicarbonate by the liver. Patients who receive large amounts of blood products may have a metabolic alkalosis. Iatrogenic metabolic alkalosis can occur because of acetate in TPN. Aggressive use of bicarbonate therapy in a child with a lactic acidosis or DKA may cause a metabolic alkalosis. This is especially likely in a patient in whom the underlying cause of the lactic acidosis is successfully corrected (restoration of intravascular volume in a patient with severe dehydration). Once the cause of the lactic acidosis resolves, lactate can be converted by the liver into bicarbonate, which when combined with infused bicarbonate can create

a metabolic alkalosis. A similar phenomenon can occur in a child with DKA because the administration of insulin allows ketoacids to be metabolized, producing bicarbonate. However, this phenomenon rarely occurs because of judicious use of bicarbonate therapy in DKA and because there are usually significant pretreatment losses of ketoacids in the urine, preventing massive regeneration of bicarbonate. Base administration is most likely to cause a metabolic alkalosis in patients who have an impaired ability to excrete bicarbonate in the urine. This impairment occurs in patients with concurrent volume depletion or renal insufficiency.

### Clinical Manifestations

The symptoms in patients with a metabolic alkalosis are often related to the underlying disease and associated electrolyte disturbances. Children with Cl<sup>-</sup>-responsive causes of metabolic alkalosis often have symptoms related to volume depletion, such as thirst and lethargy. In contrast, children with Cl<sup>-</sup>-unresponsive causes may have symptoms related to hypertension.

Alkalemia causes potassium to shift into the ICS, producing a decrease in the extracellular [K<sup>+</sup>]. Alkalemia leads to increased urinary losses of K<sup>+</sup>. Increased K<sup>+</sup> losses are present in many of the conditions that cause a metabolic alkalosis. Therefore most patients with a metabolic alkalosis have hypokalemia, and their symptoms may be related to the hypokalemia (see Chapter 73.4).

The symptoms of a metabolic alkalosis are caused by the associated alkalemia. The magnitude of the alkalemia is related to the severity of the metabolic alkalosis and the presence of concurrent respiratory acid-base disturbances. During alkalemia, the ionized calcium concentration decreases because of increased binding of calcium to albumin. The decrease in the ionized calcium concentration may cause symptoms of **tetany (carpopedal spasm)**.

**Arrhythmias** are a potential complication of a metabolic alkalosis, and the risk for arrhythmia increases if there is concomitant hypokalemia. Alkalemia increases the risk of digoxin toxicity, and antiarrhythmic medications are less effective in the presence of alkalemia. In addition, alkalemia may decrease cardiac output. A metabolic alkalosis causes a compensatory increase in the Pco<sub>2</sub> by decreasing ventilation. The decrease in ventilatory drive can cause hypoxia.

### Diagnosis

Measurement of the urine [Cl<sup>-</sup>] is the most helpful test in differentiating among the causes of a metabolic alkalosis. The urine [Cl<sup>-</sup>] is low in patients with a metabolic alkalosis resulting from volume depletion, unless there is a defect in renal handling of Cl<sup>-</sup>. The urine [Cl<sup>-</sup>] is superior to the urine [Na<sup>+</sup>] in assessment of volume status in patients with a metabolic alkalosis because the normal renal response to a metabolic alkalosis is to excrete bicarbonate. Because bicarbonate is negatively charged, it can only be excreted with cations, usually Na<sup>+</sup> and K<sup>+</sup>. Therefore a patient with a metabolic alkalosis may excrete Na<sup>+</sup> in the urine despite the presence of volume depletion, which normally causes avid Na<sup>+</sup> retention. The urine [Cl<sup>-</sup>] is usually a good indicator of volume status, and it differentiates Cl<sup>-</sup>-resistant and Cl<sup>-</sup>-responsive causes of a metabolic alkalosis.

Diuretics and gastric losses are the most common causes of metabolic alkalosis and are usually apparent from the patient history. Occasionally, metabolic alkalosis, usually with hypokalemia, may be a clue to the presence of bulimia or surreptitious diuretic use (see Chapter 41). Patients with bulimia have a low urine Cl<sup>-</sup> level, indicating that they have volume depletion because of an extrarenal etiology, but there is no alternative explanation for their volume depletion. Surreptitious diuretic use may be diagnosed by obtaining a urine toxicology screen for diuretics. The urine [Cl<sup>-</sup>] is increased while a patient is using diuretics but is low when the patient stops taking them. *Rarely, children with mild Bartter or Gitelman syndrome are misdiagnosed as having bulimia or abusing diuretics.* The

urine  $[\text{Cl}^-]$  is always elevated in Bartter and Gitelman syndromes, and the urine toxicology screen for diuretics has a negative result. Metabolic alkalosis with hypokalemia is occasionally the initial manifestation of cystic fibrosis. An elevated sweat  $\text{Cl}^-$  finding is diagnostic.

Patients with a metabolic alkalosis and a high urinary  $[\text{Cl}^-]$  are subdivided according to blood pressure status. Children with normal blood pressure may have Bartter or Gitelman syndrome. Excess base administration is another diagnostic possibility, but it is usually apparent from the history. In patients with sodium bicarbonate ingestion (baking soda), which may be unreported by the parent, the metabolic alkalosis usually occurs with significant hyponatremia. In addition, unless volume depletion is superimposed, the metabolic alkalosis from base ingestion resolves itself once the source of base is eliminated.

Measuring serum concentrations of renin and aldosterone differentiates children with a metabolic alkalosis, a high urinary  $[\text{Cl}^-]$ , and elevated blood pressure. Both renin and aldosterone are elevated in children with either renovascular disease or a renin-secreting tumor. Aldosterone is high and renin is low in patients with adrenal adenomas or hyperplasia and glucocorticoid-remediable aldosteronism. Renin and aldosterone are low in children with Cushing syndrome, Liddle syndrome, licorice ingestion, and  $17\alpha$ -hydroxylase,  $11\beta$ -hydroxylase, and  $11\beta$ -hydroxysteroid dehydrogenase deficiencies. An elevated 24-hour urine cortisol value is diagnostic of Cushing syndrome, which is suspected from the presence of the other classic features of this disease (see Chapter 619). Elevations of  $11$ -deoxycorticosterone values are seen in  $17\alpha$ -hydroxylase and  $11\beta$ -hydroxylase deficiency.

### Treatment

The approach to treatment of metabolic alkalosis depends on the severity of the alkalosis and the underlying etiology. In children with a mild metabolic alkalosis ( $[\text{HCO}_3^-] < 32 \text{ mEq/L}$ ), intervention is often unnecessary, although this depends on the specific circumstances. In a child with congenital heart disease who is receiving a stable dose of a loop diuretic, a mild alkalosis does not require treatment. In contrast, intervention may be appropriate in a child with a worsening mild metabolic alkalosis because of nasogastric suction. The presence of a concurrent respiratory acid-base disturbance also influences therapeutic decision-making. A patient with a concurrent respiratory acidosis should have some increase in bicarbonate from metabolic compensation; thus the severity of the pH elevation is more important than  $[\text{HCO}_3^-]$ . In contrast, a patient with respiratory alkalosis and a metabolic alkalosis is at risk for severe alkalemia; treatment may be indicated, even if the increase in bicarbonate value is only mild.

Intervention is usually necessary in children with moderate or severe metabolic alkalosis. The most effective approach is to address the underlying etiology. In some children, nasogastric suction may be decreased or discontinued. Alternatively, the addition of a gastric PPI reduces gastric secretion and losses of HCl. Diuretics are an important cause of metabolic alkalosis, and if a change is tolerated, they should be eliminated or the dose reduced. Adequate potassium supplementation or the addition of a potassium-sparing diuretic is also helpful in a child with a metabolic alkalosis from diuretics. Potassium-sparing diuretics not only decrease renal  $\text{K}^+$  losses but, by blocking the action of aldosterone, also decrease  $\text{H}^+$  secretion in the distal nephron, increasing urinary bicarbonate excretion. Many children cannot tolerate discontinuation of diuretic therapy; hence, potassium supplementation and potassium-sparing diuretics are the principal therapeutic approach. Arginine HCl may also be used to treat chloride-responsive metabolic acidosis if sodium or potassium salts are not appropriate. Arginine HCl may raise the serum  $\text{K}^+$  levels during administration. Rarely, in cases of severe metabolic alkalosis, acetazolamide is an option. A carbonic anhydrase inhibitor, acetazolamide decreases resorption of bicarbonate in the proximal tubule, causing significant bicarbonate loss in the urine. The patient receiving this drug

must be monitored closely, because acetazolamide produces major losses of potassium in the urine and increases fluid losses, potentially necessitating a reduction in dosage of other diuretics.

Most children with a metabolic alkalosis have one of the **chloride-responsive** etiologies. In these situations, administration of sufficient sodium chloride and potassium chloride to correct the volume deficit and the potassium deficit is necessary to correct the metabolic alkalosis. This approach may not be an option in the child who has volume depletion due to diuretics, because volume repletion may be contraindicated. Adequate replacement of gastric losses of sodium and potassium in a child with a nasogastric tube can minimize or prevent the development of the metabolic alkalosis. With adequate intravascular volume and a normal serum  $[\text{K}^+]$ , the kidney excretes the excess bicarbonate within 2 days.

In children with the **chloride-resistant** causes of a metabolic alkalosis that are associated with hypertension, volume repletion is contraindicated because it would exacerbate the hypertension and would not repair the metabolic alkalosis. Ideally, treatment focuses on eliminating the excess aldosterone effect. Adrenal adenomas can be resected, licorice intake can be eliminated, and renovascular disease can be repaired. Glucocorticoid-remediable aldosteronism,  $17\alpha$ -hydroxylase deficiency, and  $11\beta$ -hydroxylase deficiency respond to the administration of glucocorticoids. The mineralocorticoid effect of cortisol in  $11\beta$ -hydroxysteroid dehydrogenase deficiency can be decreased with the use of spironolactone, which blocks the mineralocorticoid receptor. In contrast, the metabolic alkalosis in children with Liddle syndrome does not respond to spironolactone; however, either triamterene or amiloride is effective therapy because both agents block the sodium channel that is constitutively active in Liddle syndrome.

In children with Bartter or Gitelman syndrome, therapy includes oral potassium and sodium supplementation; potassium-sparing diuretics may be helpful in select cases. Children with Gitelman syndrome often require magnesium supplementation, whereas children with severe Bartter syndrome often benefit from indomethacin.

### RESPIRATORY ACIDOSIS

A respiratory acidosis is an inappropriate increase in blood carbon dioxide tension ( $\text{PCO}_2$ ).  $\text{CO}_2$  is a by-product of metabolism and is removed from the body by the lungs. During a respiratory acidosis, the effectiveness of  $\text{CO}_2$  removal by the lungs is decreased. A respiratory acidosis is secondary to either pulmonary disease, such as severe bronchiolitis, or nonpulmonary disease, such as a narcotic overdose (see Chapter 86). Even though body production of  $\text{CO}_2$  can vary, normal lungs are able to accommodate this variation; excess production of  $\text{CO}_2$  is not an isolated cause of a respiratory acidosis. With impairment of alveolar ventilation, the rate of body production of  $\text{CO}_2$  may affect the severity of the respiratory acidosis, but this is usually not a significant factor.

A respiratory acidosis causes a decrease in the blood pH, but there is normally a metabolic response that partially compensates, minimizing the severity of the acidemia. The acute metabolic response to a respiratory alkalosis occurs within minutes. The metabolic compensation for an acute respiratory acidosis is secondary to titration of acid by nonbicarbonate buffers. This buffering of  $\text{H}^+$  causes a predictable increase in the serum  $[\text{HCO}_3^-]$ : Plasma bicarbonate increases by 1 for each 10 mm Hg increase in the  $\text{PCO}_2$  (acute compensation).

With a *chronic* respiratory acidosis, there is more significant metabolic compensation and thus less severe acidemia than in an acute respiratory acidosis with the same increase in  $\text{PCO}_2$ . During a chronic respiratory acidosis, the kidneys increase acid excretion. This response occurs over 3-4 days and causes a predictable increase in the serum  $[\text{HCO}_3^-]$ : Plasma bicarbonate increases by 3.5 for each 10 mm Hg increase in the  $\text{PCO}_2$  (chronic compensation).

The increase of serum  $[\text{HCO}_3^-]$  during a chronic respiratory acidosis is associated with a decrease in body chloride. After acute correction of a chronic respiratory acidosis, the plasma bicarbonate continues to

**Table 73.15** Causes of Respiratory Acidosis

<p><b>CENTRAL NERVOUS SYSTEM DEPRESSION</b></p> <ul style="list-style-type: none"> <li>Encephalitis</li> <li>Head trauma</li> <li>Brain tumor</li> <li>Central sleep apnea</li> <li>Primary pulmonary hypoventilation (Ondine curse)</li> <li>Stroke</li> <li>Hypoxic brain damage</li> <li>Obesity-hypoventilation (Pickwickian) syndrome</li> <li>Increased intracranial pressure</li> <li>Medications               <ul style="list-style-type: none"> <li>Narcotics</li> <li>Barbiturates</li> <li>Anesthesia</li> <li>Benzodiazepines</li> <li>Propofol</li> <li>Alcohols</li> </ul> </li> </ul> <p><b>DISORDERS OF SPINAL CORD, PERIPHERAL NERVES, OR NEUROMUSCULAR JUNCTION</b></p> <ul style="list-style-type: none"> <li>Diaphragmatic paralysis</li> <li>Guillain-Barré syndrome</li> <li>Poliomyelitis</li> <li>Acute flaccid myelitis</li> <li>Spinal muscular atrophies</li> <li>Tick paralysis</li> <li>Botulism</li> <li>Myasthenia</li> <li>Multiple sclerosis</li> <li>Spinal cord injury</li> <li>Medications               <ul style="list-style-type: none"> <li>Vecuronium</li> <li>Aminoglycosides</li> <li>Organophosphates (pesticides)</li> </ul> </li> </ul> <p><b>RESPIRATORY MUSCLE WEAKNESS</b></p> <ul style="list-style-type: none"> <li>Muscular dystrophy</li> <li>Hypothyroidism</li> <li>Malnutrition</li> <li>Hypokalemia</li> <li>Hypophosphatemia</li> <li>Medications               <ul style="list-style-type: none"> <li>Succinylcholine</li> <li>Corticosteroids</li> </ul> </li> </ul>	<p><b>PULMONARY DISEASE</b></p> <ul style="list-style-type: none"> <li>Pneumonia</li> <li>Pneumothorax</li> <li>Asthma</li> <li>Bronchiolitis</li> <li>Pulmonary edema</li> <li>Pulmonary hemorrhage</li> <li>Acute respiratory distress syndrome</li> <li>Neonatal respiratory distress syndrome</li> <li>Cystic fibrosis</li> <li>Bronchopulmonary dysplasia</li> <li>Hypoplastic lungs</li> <li>Meconium aspiration</li> <li>Pulmonary thromboembolus</li> <li>Interstitial fibrosis</li> </ul> <p><b>UPPER AIRWAY DISEASE</b></p> <ul style="list-style-type: none"> <li>Aspiration</li> <li>Laryngospasm</li> <li>Angioedema</li> <li>Obstructive sleep apnea</li> <li>Tonsillar hypertrophy</li> <li>Vocal cord paralysis</li> <li>Extrinsic tumor</li> <li>Extrinsic or intrinsic hemangioma</li> </ul> <p><b>MISCELLANEOUS</b></p> <ul style="list-style-type: none"> <li>Flail chest</li> <li>Cardiac arrest</li> <li>Kyphoscoliosis</li> <li>Decreased diaphragmatic movement due to ascites or peritoneal dialysis</li> </ul>
---	--

be increased, and the patient has a metabolic alkalosis. Because of the  $\text{Cl}^-$  deficit, this is a chloride-responsive metabolic alkalosis; it corrects once the patient's  $\text{Cl}^-$  deficit is replaced.

A **mixed disorder** is present if the metabolic compensation is inappropriate. A higher than expected bicarbonate value occurs in the setting of a concurrent metabolic alkalosis, and a lower than expected bicarbonate value occurs in the setting of a concurrent metabolic acidosis. Evaluating whether compensation is appropriate during a respiratory acidosis requires clinical knowledge of the acuity of the process, because the expected compensation is different, depending on whether the process is acute or chronic.

The  $\text{PCO}_2$  cannot be interpreted in isolation to determine whether a patient has a respiratory acidosis. A respiratory acidosis is always present if a patient has acidemia and an elevated  $\text{PCO}_2$ . However, an elevated  $\text{PCO}_2$  also occurs as appropriate respiratory compensation for a simple metabolic alkalosis. The patient is *alkalemic*; this is not a respiratory acidosis. During a mixed disturbance, a patient can have a respiratory acidosis and a normal or even low  $\text{PCO}_2$ . This condition may occur in a patient with a metabolic acidosis. A respiratory acidosis is present if the patient does not have appropriate respiratory

compensation (the  $\text{PCO}_2$  is higher than expected from the severity of the metabolic acidosis).

### Etiology and Pathophysiology

The causes of a respiratory acidosis are either pulmonary or nonpulmonary (Table 73.15). CNS disorders can decrease the activity of the central respiratory center, reducing ventilatory drive. A variety of medications and illicit drugs suppress the respiratory center. The signals from the respiratory center need to be transmitted to the respiratory muscles via the nervous system. Respiratory muscle failure can be secondary to disruption of the signal from the CNS in the spinal cord, the phrenic nerve, or the neuromuscular junction. Disorders directly affecting the muscles of respiration can prevent adequate ventilation, causing a respiratory acidosis.

Mild or moderate lung disease often causes a respiratory alkalosis as a result of hyperventilation secondary to hypoxia or stimulation of lung mechanoreceptors or chemoreceptors. Only more severe lung disease causes a respiratory acidosis. Upper airway diseases, by impairing air entry into the lungs, may decrease ventilation, producing a respiratory acidosis.



Increased production of  $\text{CO}_2$  is never the sole cause of a respiratory acidosis, but it can increase the severity of the disease in a patient with decreased ventilation of  $\text{CO}_2$ . Increased production of  $\text{CO}_2$  occurs in patients with fever, hyperthyroidism, excess caloric intake, and high levels of physical activity. Increased respiratory muscle work also increases  $\text{CO}_2$  production.

### Clinical Manifestations

Patients with a respiratory acidosis are often tachypneic in an effort to correct the inadequate ventilation. Exceptions include patients with a respiratory acidosis resulting from CNS depression and patients who are on the verge of complete respiratory failure secondary to fatigue of the respiratory muscles.

The symptoms of respiratory acidosis are related to the severity of the **hypercarbia**. Acute respiratory acidosis is usually more symptomatic than chronic respiratory acidosis. Symptoms are also increased by concurrent hypoxia or metabolic acidosis. In a patient breathing room air, hypoxia is always present if a respiratory acidosis is present. The potential CNS manifestations of respiratory acidosis include anxiety, dizziness, headache, confusion, asterixis, myoclonic jerks, hallucinations, psychosis, coma, and seizures.

Acidemia, no matter the etiology, affects the cardiovascular system. An arterial pH  $<7.2$  impairs cardiac contractility and the normal response to catecholamines in both the heart and the peripheral vasculature. Hypercapnia causes vasodilation, most dramatically in the cerebral vasculature, but hypercapnia produces vasoconstriction of the pulmonary circulation. Respiratory acidosis increases the risk of cardiac **arrhythmias**, especially in a child with underlying cardiac disease.

### Diagnosis

The history and physical findings often point to a clear etiology. For the obtunded patient with poor respiratory effort, evaluation of the CNS is often indicated. This may include imaging studies (CT or MRI) and, potentially, a lumbar puncture for cerebrospinal fluid analysis. A toxicology screen for illicit drugs may also be appropriate. A response to naloxone is both diagnostic and therapeutic. In many of the diseases affecting the respiratory muscles, there is evidence of weakness in other muscles. Stridor is a clue that the child may have upper airway disease. Along with a physical examination, a chest radiograph is often helpful in diagnosing pulmonary disease.

In many patients, respiratory acidosis may be multifactorial. A child with bronchopulmonary dysplasia, an intrinsic lung disease, may worsen because of respiratory muscle dysfunction caused by severe hypokalemia resulting from long-term diuretic therapy. Conversely, a child with muscular dystrophy, a muscle disease, may worsen because of aspiration pneumonia.

For a patient with respiratory acidosis, calculation of the gradient between the alveolar oxygen concentration and the arterial oxygen concentration, the A-a  $\text{O}_2$  gradient, is useful for distinguishing between poor respiratory effort and intrinsic lung disease. The A-a  $\text{O}_2$  gradient is increased if the hypoxemia is caused by intrinsic lung disease (see Chapter 421).

### Treatment

Respiratory acidosis is best managed by treatment of the underlying etiology. In some patients, the response is very rapid, such as after the administration of naloxone to a patient with a narcotic overdose. In contrast, in the child with pneumonia, a number of days of antibiotic therapy may be required before the respiratory status improves. In many children with a chronic respiratory acidosis, there is no curative therapy, although an acute respiratory illness superimposed on a chronic respiratory condition is usually reversible.

All patients with an *acute* respiratory acidosis are hypoxic and therefore need to receive supplemental oxygen. Mechanical ventilation is necessary in some children with respiratory acidosis. Children with significant respiratory acidosis caused by CNS disease usually

require mechanical ventilation because such a disorder is unlikely to respond quickly to therapy. In addition, hypercarbia causes cerebral vasodilation, and the increase in ICP can be dangerous in a child with an underlying CNS disease. Readily reversible CNS depression, as from a narcotic overdose, may not require mechanical ventilation. Decisions on mechanical ventilation for other patients depend on a number of factors. Patients with severe hypercarbia ( $\text{PCO}_2 >75$  mm Hg) usually require mechanical ventilation (see Chapter 86.1). The threshold for intubation is lower if there is concomitant metabolic acidosis, a slowly responsive underlying disease, or hypoxia that responds poorly to oxygen, or if the patient appears to be tiring and respiratory arrest seems likely.

In patients with a *chronic* respiratory acidosis, the respiratory drive is often less responsive to hypercarbia and more responsive to hypoxia. Thus, with chronic respiratory acidosis, excessive use of oxygen can blunt the respiratory drive and therefore increase the  $\text{PCO}_2$ . In these patients, oxygen must be used cautiously.

When possible, it is best to avoid mechanical ventilation in a patient with chronic respiratory acidosis because extubation is often difficult. However, an acute illness may necessitate mechanical ventilation in a child with a chronic respiratory acidosis. When intubation is necessary, the  $\text{PCO}_2$  should be lowered only to the patient's normal baseline, and this should be done gradually. These patients normally have an elevated serum  $[\text{HCO}_3^-]$  as a result of metabolic compensation for their respiratory acidosis. A rapid lowering of the  $\text{PCO}_2$  can cause a severe metabolic alkalosis, potentially leading to complications, including cardiac arrhythmias, decreased cardiac output, and decreased cerebral blood flow. In addition, prolonged mechanical ventilation at a normal  $\text{PCO}_2$  causes the metabolic compensation to resolve. When the patient is subsequently extubated, the patient will no longer benefit from metabolic compensation, causing a more severe acidemia because of the respiratory acidosis.

### RESPIRATORY ALKALOSIS

A respiratory alkalosis is an inappropriate reduction in the blood  $\text{CO}_2$  concentration. This is usually secondary to hyperventilation, initially causing removal of  $\text{CO}_2$  to surpass production. Eventually, a new steady state is achieved, with removal equaling production, although at a lower  $\text{CO}_2$  tension ( $\text{PCO}_2$ ). A respiratory alkalosis that is not the result of hyperventilation may occur in children receiving extracorporeal membrane oxygenation, with  $\text{CO}_2$  lost directly from the blood in the extracorporeal circuit.

With a simple respiratory alkalosis, the pH increases, but there is a normal metabolic response that attenuates some of the change in the blood pH. A metabolic response to an acute respiratory alkalosis occurs within minutes, mediated by hydrogen ion release from nonbicarbonate buffers. The metabolic response to an acute respiratory alkalosis is predictable: Plasma bicarbonate falls by 2 for each 10 mm Hg decrease in the  $\text{PCO}_2$  (acute compensation).

A chronic respiratory alkalosis leads to more significant metabolic compensation because of the actions of the kidneys, which decrease acid secretion, producing a decrease in the serum  $[\text{HCO}_3^-]$ . Both the proximal and distal tubules decrease acid secretion. Metabolic compensation for a respiratory alkalosis develops gradually and takes 2-3 days to produce the full effect: Plasma bicarbonate falls by 4 for each 10 mm Hg decrease in the  $\text{PCO}_2$  (chronic compensation).

A chronic respiratory alkalosis is the only acid-base disturbance in which appropriate compensation may *normalize the pH*, although  $>7.4$ .

A **mixed disorder** is present if the metabolic compensation is inappropriate. A higher than expected  $\text{HCO}_3^-$  level occurs in the setting of a concurrent metabolic alkalosis, and a lower than expected  $\text{HCO}_3^-$  level occurs in the setting of a concurrent metabolic acidosis. Evaluating whether compensation is appropriate during a respiratory alkalosis requires clinical knowledge of the acuity of the process, because the expected compensation differs according to whether the process is acute or chronic.

A low  $\text{PCO}_2$  value does not always indicate a respiratory alkalosis. The  $\text{PCO}_2$  also decreases as part of the appropriate respiratory compensation for a metabolic acidosis; this is not a respiratory alkalosis.

**Table 73.16** Causes of Respiratory Alkalosis**HYPOXEMIA OR TISSUE HYPOXIA**

Pneumonia  
 Pulmonary edema  
 Cyanotic heart disease  
 Congestive heart failure  
 Asthma  
 Severe anemia  
 High altitude  
 Laryngospasm  
 Aspiration  
 Carbon monoxide poisoning  
 Pulmonary embolism  
 Interstitial lung disease  
 Hypotension

**LUNG RECEPTOR STIMULATION**

Pneumonia  
 Pulmonary edema  
 Asthma  
 Pulmonary embolism  
 Hemothorax  
 Pneumothorax  
 Respiratory distress syndrome (adult or infant)

**CENTRAL STIMULATION**

Central nervous system disease  
 Subarachnoid hemorrhage  
 Encephalitis or meningitis  
 Trauma  
 Brain tumor  
 Stroke  
 Fever  
 Pain  
 Anxiety (panic attack)  
 Psychogenic hyperventilation or anxiety  
 Liver failure  
 Sepsis  
 Pregnancy  
 Mechanical ventilation  
 Hyperammonemia  
 Extracorporeal membrane oxygenation or hemodialysis  
 Medications  
 Salicylate intoxication  
 Theophylline  
 Progesterone  
 Exogenous catecholamines  
 Caffeine

A metabolic acidosis is the dominant acid-base disturbance in a patient with acidemia and a low  $PCO_2$ , even though there could still be a concurrent respiratory alkalosis. In contrast, a respiratory alkalosis is always present in a patient with alkalemia and a low  $PCO_2$ . Even a normal  $PCO_2$  value may be consistent with a respiratory alkalosis in a patient with a metabolic alkalosis, because an elevated  $PCO_2$  is expected as part of appropriate respiratory compensation for the metabolic alkalosis.

**Etiology and Pathophysiology**

A variety of stimuli can increase the ventilatory drive and cause a respiratory alkalosis (Table 73.16). Arterial hypoxemia or tissue hypoxia stimulates peripheral chemoreceptors to signal the central respiratory center in the medulla to increase ventilation. The resultant greater respiratory effort increases the oxygen content of the blood ( $PO_2$ ) but depresses the  $PCO_2$ . The effect of hypoxemia on ventilation begins when the arterial oxygen saturation ( $SaO_2$ ) decreases to approximately 90% ( $PO_2 = 60$  mm Hg), and hyperventilation increases as hypoxemia worsens. Acute hypoxia is a more potent stimulus for hyperventilation

than chronic hypoxia; thus chronic hypoxia, as occurs in cyanotic heart disease, causes a much less severe respiratory alkalosis than an equivalent degree of acute hypoxia. The many causes of hypoxemia or tissue hypoxia include primary lung disease, severe anemia, and carbon monoxide (CO) poisoning.

The lungs contain chemoreceptors and mechanoreceptors that respond to irritants and stretching and send signals to the respiratory center to increase ventilation. Aspiration or pneumonia may stimulate the chemoreceptors, whereas pulmonary edema may stimulate the mechanoreceptors. Most of the diseases that activate these receptors may also cause hypoxemia and can therefore potentially lead to hyperventilation by two mechanisms. Patients with primary lung disease may initially have a respiratory alkalosis, but worsening of the disease, combined with respiratory muscle fatigue, often causes respiratory failure and the development of a respiratory acidosis.

**Hyperventilation in the absence of lung disease** occurs with direct stimulation of the central respiratory center. This occurs with CNS diseases such as meningitis, hemorrhage, and trauma. Central hyperventilation caused by lesions, such as infarcts or tumors near the central respiratory center in the midbrain, increases the rate and depth of the respiratory effort. This respiratory pattern portends a poor prognosis because these midbrain lesions are frequently fatal. Systemic processes may cause centrally mediated hyperventilation. Although the exact mechanisms are not clear, liver disease causes a respiratory alkalosis that is usually proportional to the degree of liver failure. **Pregnancy** causes a chronic respiratory alkalosis, probably mediated by progesterone acting on the respiratory centers. **Salicylates**, although often causing a concurrent metabolic acidosis, directly stimulate the respiratory center to produce a respiratory alkalosis. The respiratory alkalosis during sepsis is probably caused by cytokine release.

*Hyperventilation may be secondary to an underlying disease that causes pain, stress, or anxiety.* In psychogenic hyperventilation or in **panic attacks**, there is no disease process accounting for the hyperventilation. This disorder may occur in a child who has had an emotionally stressful experience. Alternatively, it may be part of a panic disorder, especially if there are repeated episodes of hyperventilation. In such a patient, the symptoms of acute alkalemia increase anxiety, potentially perpetuating the hyperventilation.

A respiratory alkalosis is quite common in children receiving mechanical ventilation because the respiratory center is not controlling ventilation. In addition, these children may have a decreased metabolic rate and thus less  $CO_2$  production because of sedation and paralytic medications. Normally, decreased  $CO_2$  production and the resultant hypocapnia decrease ventilation, but this physiologic response cannot occur in a child who cannot reduce ventilatory effort.

**Clinical Manifestations**

The disease process causing the respiratory alkalosis is usually more concerning than the clinical manifestations. Chronic respiratory alkalosis is usually asymptomatic because metabolic compensation decreases the magnitude of the alkalemia.

Acute respiratory alkalosis may cause chest tightness, palpitations, lightheadedness, circumoral numbness, and paresthesias of the extremities. Less common manifestations include tetany, seizures, muscle cramps, and syncope. The lightheadedness and syncope probably result from the reduction in cerebral blood flow caused by hypocapnia. The reduction in cerebral blood flow is the rationale for using hyperventilation to treat children with increased intracranial pressure (ICP). The paresthesias, tetany, and seizures may be partially related to the reduction in ionized calcium that occurs because alkalemia causes more calcium to bind to albumin. A respiratory alkalosis also causes a mild reduction in the serum potassium level. Patients with psychogenic hyperventilation tend to be symptomatic because of the respiratory alkalosis, and these symptoms, along with a sensation of breathlessness, exacerbate the hyperventilation.

**Diagnosis**

In many patients, hyperventilation producing a respiratory alkalosis is not clinically detectable, even with careful observation of the patient's

respiratory effort. Metabolic compensation for a respiratory alkalosis causes a low serum  $[\text{HCO}_3^-]$ . When hyperventilation is not appreciated and only serum electrolytes are evaluated, there is often a presumptive diagnosis of a metabolic acidosis. If a respiratory alkalosis is suspected, only ABG determination can make the diagnosis.

Hyperventilation does not always indicate a primary respiratory disorder. In some patients, the hyperventilation is appropriate respiratory compensation for a metabolic acidosis. With a primary metabolic acidosis, acidemia is present, and the serum  $\text{HCO}_3^-$  level is usually quite low if there is clinically detectable hyperventilation. In contrast, the serum  $\text{HCO}_3^-$  level never goes below 17 mEq/L as part of the metabolic compensation for acute respiratory alkalosis, and simple acute respiratory alkalosis causes alkalemia.

The etiology of a respiratory alkalosis is often apparent from the physical examination or history, and it may consist of lung disease, neurologic disease, or cyanotic heart disease. **Hypoxemia** is a common cause of hyperventilation, and it is important to diagnose because it suggests a significant underlying disease that requires expeditious treatment. Hypoxemia may be detected on physical examination (cyanosis) or by pulse oximetry. However, normal pulse oximetry values do not eliminate hypoxemia as the etiology of the hyperventilation. There are two reasons why pulse oximetry is not adequate for eliminating hypoxemia as a cause of a respiratory alkalosis. First, pulse oximetry is not very sensitive at detecting a mildly low arterial  $\text{PO}_2$  ( $\text{PaO}_2$ ). Second, the hyperventilation during a respiratory alkalosis causes  $\text{PaO}_2$  to increase, possibly to a level that is not identified as abnormal by pulse oximetry. Only ABG measurement can eliminate hypoxia as an explanation for a respiratory alkalosis. Along with hypoxemia, it is important to consider processes that cause **tissue hypoxia without necessarily causing hypoxemia**. Examples are CO or cyanide poisoning, severe anemia, and heart failure.

Lung disease without hypoxemia may cause hyperventilation. Although lung disease is often apparent by history or physical examination, a chest radiograph may detect more subtle disease. The patient with a pulmonary embolism may have benign chest radiograph findings, normal  $\text{PaO}_2$ , and isolated respiratory alkalosis, although hypoxia may eventually occur. Diagnosis of a pulmonary embolism requires a high index of suspicion and should be considered in children without another explanation for respiratory alkalosis, especially if risk factors are present, such as prolonged bed rest and a hypercoagulable state (e.g., nephrotic syndrome, lupus anticoagulant).

### Treatment

There is seldom a need for specific treatment of respiratory alkalosis. Rather, treatment focuses on the underlying disease. Mechanical ventilator settings are adjusted to correct **iatrogenic** respiratory alkalosis, unless the hyperventilation has a therapeutic purpose (e.g., treatment of increased ICP).

For the patient with hyperventilation secondary to anxiety, efforts should be undertaken to reassure the child, usually enlisting the parents. Along with reassurance, patients with **psychogenic hyperventilation** may benefit from benzodiazepines. During an acute episode of psychogenic hyperventilation, rebreathing into a paper bag increases the patient's  $\text{PCO}_2$ . Using a paper bag instead of a plastic bag allows adequate oxygenation but permits  $[\text{CO}_2]$  in the bag to increase. The resultant increase in the patient's  $\text{PCO}_2$  decreases the symptoms of the respiratory alkalosis that tend to perpetuate the hyperventilation. Rebreathing should be performed only when other causes of hyperventilation have been eliminated; pulse oximetry during the rebreathing is prudent.

Visit Elsevier eBooks+ at [eBooks.Health.Elsevier.com](http://eBooks.Health.Elsevier.com) for Bibliography.

## Chapter 74

# Maintenance and Replacement Therapy

Larry A. Greenbaum

**Maintenance intravenous (IV) fluids** are used in a child who cannot be fed enterally. Along with maintenance fluids, children may require concurrent **replacement fluids** if they have continued excessive losses, as may occur with drainage from a nasogastric (NG) tube or with high urine output because of nephrogenic diabetes insipidus. If dehydration is present, the patient also needs to receive **deficit** replacement (see Chapter 75). A child awaiting surgery may need only maintenance fluids, whereas a child with diarrheal dehydration needs maintenance and deficit therapy and also may require replacement fluids if significant diarrhea continues.

### MAINTENANCE THERAPY

Children normally have large variations in their daily intake of water and electrolytes. The only exceptions are patients who receive fixed dietary regimens orally, via a gastric tube, or as IV total parenteral nutrition (TPN). Healthy children can tolerate significant variations in intake because of the many homeostatic mechanisms that can adjust absorption and excretion of water and electrolytes (see Chapter 73). The calculated water and electrolyte need that form the basis of maintenance therapy are not absolute requirements. Rather, these calculations provide reasonable guidelines for a *starting point to estimate IV therapy*. Children do not need to be started on IV fluids simply because their intake is being monitored in a hospital and they are not taking “maintenance fluids” orally, unless there is a pathologic process present that necessitates high fluid intake.

Maintenance fluids are most often necessary in preoperative and postoperative surgical patients; many nonsurgical patients also require maintenance fluids. It is important to recognize when it is necessary to begin maintenance fluids. A normal teenager who is given nothing by mouth (NPO) overnight for a morning procedure does not require maintenance fluids because a healthy adolescent can easily tolerate 12–18 hours without oral intake. In contrast, a 6-month-old child waiting for surgery should begin receiving IV fluids within 8 hours of the last feeding. Infants become dehydrated more quickly than older patients. A child with obligatory high urine output from nephrogenic diabetes insipidus should begin receiving IV fluids soon after being classified as NPO.

Maintenance fluids are composed of a solution of water, glucose, sodium ( $\text{Na}^+$ ), and potassium ( $\text{K}^+$ ). This solution has the advantages of simplicity, long shelf life, low cost, and compatibility with peripheral IV administration. Such a solution accomplishes the major objectives of maintenance fluids (Table 74.1). Patients lose water,  $\text{Na}^+$ , and  $\text{K}^+$  in their urine and stool; water is also lost from the skin and lungs. Maintenance fluids replace these losses, thereby avoiding the development of dehydration and  $\text{Na}^+$  or  $\text{K}^+$  deficiency.

**Table 74.1** Goals of Maintenance Fluids

- Prevent dehydration
- Prevent electrolyte disorders
- Prevent ketoacidosis
- Prevent protein degradation



The glucose in maintenance fluids provides approximately 20% of the normal caloric needs of the patient, prevents the development of starvation ketoacidosis, and diminishes the protein degradation that would occur if the patient received no calories. Maintenance fluids do not provide adequate calories, protein, fat, minerals, or vitamins. This fact is typically not problematic for a patient receiving IV fluids for a few days. A patient receiving maintenance IV fluids is receiving inadequate calories and will lose 0.5–1% of weight each day. It is imperative that patients not remain on maintenance therapy indefinitely; TPN should be used for children who cannot be fed enterally for more than a few days, especially patients with underlying malnutrition.

Prototypical maintenance fluid therapy does not provide electrolytes such as calcium, phosphorus, magnesium, and bicarbonate. For most patients, this lack is not problematic for a few days, although there are patients who will not tolerate this omission, usually because of excessive losses. A child with proximal renal tubular acidosis wastes bicarbonate in urine. Such a patient will rapidly become acidemic unless bicarbonate (or another base) is added to the maintenance fluids. It is important to remember the limitations of maintenance fluid therapy.

### MAINTENANCE WATER

Water is a crucial component of maintenance fluid therapy because of the obligatory daily water losses. These losses are both measurable (urine, stool) and not measurable (**insensible losses** from the skin and lungs). Failure to replace these losses leads to a child who is thirsty, uncomfortable, and ultimately dehydrated.

The goal of maintenance water is to provide enough water to replace these losses. Although urinary losses are approximately 60% of the total, the normal kidney can greatly modify water losses, with daily urine volume potentially varying by more than a factor of 20. Maintenance water is designed to provide enough water so that the kidney does not need to significantly dilute or concentrate the urine. It also provides a margin of safety so that normal homeostatic mechanisms can adjust urinary water losses to prevent overhydration and dehydration. This adaptability obviates the need for absolute precision in determining water requirements. This fact is important, given the absence of absolute accuracy in the formulas for calculation of water needs.

Table 74.2 provides a system for calculating maintenance water on the basis of the patient's weight and emphasizes the high water needs of smaller, less mature patients. This approach is reliable, although calculations based on weight do overestimate the water needs of an overweight child, in whom it is better to base the calculations on the lean body weight, which can be estimated by using the 50th percentile of body weight for the child's height. It is also important to remember that there is an upper limit of 2.4 L/24 hr

**Table 74.2** Body Weight Method for Calculating Daily Maintenance Fluid Volume

BODY WEIGHT	FLUID PER DAY
0-10 kg	100 mL/kg
11-20 kg	1,000 mL + 50 mL/kg for each kg >10 kg
>20 kg	1,500 mL + 20 mL/kg for each kg >20 kg*

\*The maximum total fluid per day is normally 2,400 mL.

**Table 74.3** Hourly Maintenance Water Rate

For body weight 0-10 kg: 4 mL/kg/hr
For body weight 10-20 kg: 40 mL/hr + 2 mL/kg/hr × (wt – 10 kg)
For body weight >20 kg: 60 mL/hr + 1 mL/kg/hr × (wt – 20 kg)*

\*The maximum fluid rate is normally 100 mL/hr.

in adult-sized patients. IV fluids are written as an hourly rate. The formulas in Table 74.3 enable rapid calculation of the rate of maintenance fluids.

### INTRAVENOUS SOLUTIONS

The components of available solutions are shown in Table 74.4. These solutions are available with 5% dextrose (D5), 10% dextrose (D10), or without dextrose. Except for Ringer lactate (lactated Ringer, LR), they are also available with added potassium (10 or 20 mEq/L). A *balanced IV fluid* contains a base (lactate or acetate), a more physiologic chloride concentration than normal saline (NS), and additional physiologic concentrations of electrolytes such as potassium, calcium, and magnesium. Examples include LR and Plasma-Lyte, and there is evidence suggesting benefit versus NS in some but not all clinical situations. A hospital pharmacy can also prepare custom-made solutions with different concentrations of sodium or potassium. In addition, other electrolytes, such as calcium, magnesium, phosphate, acetate, and bicarbonate, can be added to IV solutions. Custom-made solutions take time to prepare and are much more expensive than commercial solutions. The use of custom-made solutions is necessary only for patients who have underlying disorders that cause significant electrolyte imbalances. The use of commercial solutions saves time and expense.

A normal plasma osmolality is 285–295 mOsm/kg. Infusing an IV solution peripherally with a much lower osmolality can cause water to move into red blood cells, leading to hemolysis. Thus IV fluids are generally designed to have an osmolality that is either close to 285 or greater (fluids with moderately higher osmolality do not cause problems). Thus 0.2NS (osmolality = 68) should not be administered peripherally, but D5 0.2NS (osmolality = 346) or D5 1/2NS + 20 mEq/L potassium chloride (KCl) with an osmolality of 472 can be administered.

**Hypotonic** fluids seem more physiologic given the low Na<sup>+</sup> content of breast milk and formula (~7 mEq/L). However, hospitalized children often have impaired water excretion because of volume depletion or nonosmotic stimuli for antidiuretic hormone (ADH) production, such as respiratory disease, central nervous system disease, stress, pain, nausea, and medications (e.g., narcotics). Hypotonic fluids increase the risk of hyponatremia, which may have serious sequelae; *hence, isotonic fluids with D5 are recommended as standard maintenance fluid except in neonates <28 days of age.*

### GLUCOSE

Maintenance fluids usually contain D5, which provides 17 calories/100 mL and nearly 20% of the daily caloric needs. This level is enough to prevent ketone production and helps minimize protein degradation, but the child will lose weight on this regimen. Maintenance fluids are also lacking in such crucial nutrients as protein, fat, vitamins, and minerals. Hence, a patient needs to be started on TPN after a few days of maintenance fluids if enteral feedings are still not possible.

### SELECTION OF MAINTENANCE FLUIDS

An isotonic fluid (NS, LR, Plasma-Lyte) with D5 and KCl (10–20 mEq/L is usually added to NS) is recommended for maintenance IV fluids. Surgical patients typically receive isotonic fluids (NS, LR) during surgery and in the recovery room for 6–8 hours postoperatively; the rate is typically approximately two thirds the calculated maintenance rate, with dextrose added if clinically indicated. Subsequent maintenance fluids have the addition of D5 and 10–20 mEq/L KCl based on the serum K<sup>+</sup> and the clinical setting. Electrolytes should be measured at least daily in all children receiving >50% of maintenance fluids intravenously unless the child is receiving prolonged IV fluids (TPN).

These guidelines assume that no disease process is present that would require an adjustment in either the volume or the electrolyte composition of maintenance fluids. Neonates, and especially premature infants, are outside the scope of these guidelines given their unique physiology. Children with renal insufficiency may be hyperkalemic or unable to excrete K<sup>+</sup> and may not tolerate 10 or 20 mEq/L of potassium. Patients with persistent ADH production because of an underlying disease process (syndrome of inappropriate ADH secretion, congestive heart failure, nephrotic syndrome, liver disease) should receive less



**Table 74.4** Composition of Intravenous Solutions\*

FLUID	[NA <sup>+</sup> ]	[CL <sup>-</sup> ]	[K <sup>+</sup> ]	[CA <sup>2+</sup> ]	[LACTATE <sup>-</sup> ]
Normal saline (0.9% NaCl)	154	154	—	—	—
Half-normal saline (0.45% NaCl)	77	77	—	—	—
0.2 normal saline (0.2% NaCl)	34	34	—	—	—
Ringer lactate	130	109	4	3	28

\*Electrolyte concentrations in mEq/L.

than maintenance fluids. Children with meningitis are fluid restricted unless intravascular volume depletion is present (see Chapter 643.1). Treatment is individualized, and careful monitoring is critical.

In children with complicated pathophysiologic derangements, it may be necessary to adjust empirically the electrolyte composition and rate of maintenance fluids on the basis of electrolyte measurements and assessment of fluid balance. In all children it is critical to monitor weight, urine output, and electrolytes carefully to identify overhydration and underhydration, hyponatremia, and other electrolyte disturbances, and then adjust the rate or composition of the IV solution accordingly.

## VARIATIONS IN MAINTENANCE WATER AND ELECTROLYTES

The calculation of maintenance water is based on standard assumptions regarding water losses. In some patients, however, these assumptions are incorrect. To identify such situations, it is helpful to understand the source and magnitude of normal water losses. Table 74.5 lists the three sources of normal water loss.

Urine is the most important contributor to normal water loss. Insensible losses represent approximately one third of total maintenance water (40% in infants; 25% in adolescents and adults). Insensible losses are composed of evaporative losses from the skin and lungs that cannot be quantitated. The evaporative losses from the skin *do not* include sweat, which would be considered an additional (sensible) source of water loss. Stool normally represents a minor source of water loss.

Maintenance water and electrolyte needs may be increased or decreased, depending on the clinical situation. This may be obvious, as in the infant with profuse diarrhea, or subtle, as in the patient who has decreased insensible losses while receiving mechanical ventilation. It is helpful to consider the sources of normal water and electrolyte losses and to determine whether any of these sources is being modified in a specific patient. It is then necessary to adjust maintenance water and electrolyte calculations.

Table 74.6 lists a variety of clinical situations that modify normal water and electrolyte losses. The skin can be a source of very significant water loss, particularly in neonates, especially premature infants, who are under radiant warmers or are receiving phototherapy. Very low birthweight infants can have insensible losses of 100–200 mL/kg/24 hr. Burns can result in massive losses of water and electrolytes, and there are specific guidelines for fluid management in children with burns (see Chapter 89). Sweat losses of water and electrolytes, especially in a warm climate, can also be significant. Children with cystic fibrosis and some children with pseudohypoaldosteronism have increased sodium losses from the skin.

Fever increases evaporative losses from the skin. These losses are somewhat predictable, leading to a 10–15% increase in maintenance water needs for each 1°C (1.8°F) increase in temperature above 38°C (100.4°F). These guidelines are for a patient with a persistent fever; a 1-hour fever spike does not cause an appreciable increase in water needs.

Tachypnea or a tracheostomy increases evaporative losses from the lungs. A humidified system (nasal cannula, mask, ventilator) causes a decrease in insensible losses from the lungs and can even lead to water absorption via the lungs; a ventilated patient has a decrease in

**Table 74.5** Sources of Water Loss

- Urine: 60%
- Insensible losses: ≈35% (skin and lungs)
- Stool: 5%

maintenance water requirements. It may be difficult to quantify the changes that take place in the individual patient in these situations.

## REPLACEMENT FLUIDS

The gastrointestinal (GI) tract is potentially a source of considerable water loss. GI water losses are accompanied by electrolytes and thus may cause disturbances in intravascular volume and electrolyte concentrations. GI losses are often associated with loss of potassium, leading to hypokalemia. Because of the high bicarbonate concentration in stool, children with diarrhea usually have a **metabolic acidosis**, which may be accentuated if volume depletion causes hypoperfusion and a concurrent lactic acidosis. Emesis or losses from an NG tube can cause a **metabolic alkalosis** (see Chapter 73).

In the absence of vomiting, diarrhea, or NG drainage, GI losses of water and electrolytes are usually quite small. All GI losses are considered excessive, and the increase in the water requirement is equal to the volume of fluid losses. Because GI water and electrolyte losses can be precisely measured, an appropriate replacement solution can be used.

It is impossible to predict the losses for the next 24 hours; it is better to replace excessive GI losses as they occur. The child should receive an appropriate maintenance fluid that does not consider the GI losses. The losses should then be replaced after they occur, with use of a solution with a similar electrolyte concentration as the GI fluid. The losses are usually replaced every 1–6 hours, depending on the rate of loss, with very rapid losses being replaced more frequently.

**Diarrhea** is a common cause of fluid loss in children and can result in dehydration and electrolyte disorders. In the unusual patient with significant diarrhea and a limited ability to take oral fluid, it is important to have a plan for replacing excessive stool losses. The volume of stool should be measured, and an equal volume of replacement solution should be given. Data are available on the average electrolyte composition of diarrhea in children (see Table 74.7). With this information, an appropriate replacement solution can be designed. The solution shown in Table 74.7 replaces stool losses of Na<sup>+</sup>, K<sup>+</sup>, chloride (Cl<sup>-</sup>), and bicarbonate. Each 1 mL of stool should be replaced by 1 mL of this solution. The average electrolyte composition of diarrhea is just an average, and there may be considerable variation. It is therefore advisable to consider measuring the electrolyte composition of a patient's diarrhea if the amount is especially excessive or if the patient's serum electrolyte levels are problematic.

**Loss of gastric fluid**, through emesis or NG suction, is also likely to cause dehydration, in that most patients with either condition have impaired oral intake of fluids. Electrolyte disturbances, particularly hypokalemia and metabolic alkalosis, are also common. These complications can be avoided by judicious use of a replacement solution. The composition of gastric fluid shown in Table 74.8 is the basis for designing a replacement solution.

**Table 74.6** Adjustments in Maintenance Water

SOURCE	CAUSES OF INCREASED WATER NEEDS	CAUSES OF DECREASED WATER NEEDS
Skin	Radiant warmer	Incubator (premature infant)
	Phototherapy	
	Fever	
	Sweat	
	Burns	
Lungs	Tachypnea	Humidified system (nasal cannula, mask, ventilator)
	Tracheostomy	
Gastrointestinal tract	Diarrhea	—
	Emesis	
	Nasogastric suction	
Renal	Polyuria	Oliguria/anuria
Miscellaneous	Surgical drain	—
	Third spacing	

**Table 74.7** Replacement Fluid for Diarrhea

<b>AVERAGE COMPOSITION OF DIARRHEA</b>
Sodium: 55 mEq/L
Potassium: 25 mEq/L
Bicarbonate: 15 mEq/L
<b>APPROACH TO REPLACEMENT OF ONGOING LOSSES</b>
Solution: D5 1/2NS + 30 mEq/L sodium bicarbonate + 20 mEq/L KCl
Replace stool mL/mL every 1-6 hr

D5, 5% dextrose; NS, normal saline.

**Table 74.8** Replacement Fluid for Emesis or Nasogastric Losses

<b>AVERAGE COMPOSITION OF GASTRIC FLUID</b>
Sodium: 60 mEq/L
Potassium: 10 mEq/L
Chloride: 90 mEq/L
<b>APPROACH TO REPLACEMENT OF ONGOING LOSSES</b>
Solution: normal saline + 10 mEq/L KCl
Replace output mL/mL every 1-6 hr

Patients with gastric losses frequently have hypokalemia, although the K<sup>+</sup> concentration of gastric fluid is relatively low. The associated urinary K<sup>+</sup> loss is an important cause of hypokalemia in this situation (see Chapter 73). These patients may need additional potassium either in their maintenance fluids or in their replacement fluids to compensate for prior or ongoing urinary losses. Restoration of the patient's intravascular volume, by decreasing aldosterone synthesis, lessens the urinary K<sup>+</sup> losses.

**Urine output** is normally the largest cause of water loss. Diseases such as renal failure and syndrome of inappropriate ADH secretion can lead to a decrease in urine volume. The patient with oliguria or anuria has a decreased need for water and electrolytes; continuation of maintenance fluids produces fluid overload. In contrast, postobstructive diuresis, the polyuric phase of acute tubular necrosis, diabetes mellitus, and diabetes insipidus increase urine production. To prevent dehydration, the patient must receive more than standard maintenance fluids

**Table 74.9** Adjusting Fluid Therapy for Altered Renal Output

<b>OLIGURIA/ANURIA</b>
Replacement of insensible fluid losses (25–40% of maintenance) with D5 1/2NS
Replace urine output mL/mL with D5 1/2NS ± KCl
<b>POLYURIA</b>
Replacement of insensible fluid losses (25–40% of maintenance) with D5 1/2NS ± KCl
Measure urine electrolytes
Replace urine output mL/mL with solution based on measured urine electrolytes

D5, 5% dextrose; NS, normal saline.

when urine output is excessive. The electrolyte losses in patients with polyuria are variable. In diabetes insipidus, the urine electrolyte concentration is usually low, whereas children with diseases such as juvenile nephronophthisis and obstructive uropathy usually have increased losses of both water and sodium.

The approach to decreased or increased urine output is similar (Table 74.9). The patient receives fluids at a rate to replace insensible losses. This is accomplished by a rate of fluid administration that is 25–40% of the normal maintenance rate, depending on the patient's age. Replacing insensible losses in the anuric child will theoretically maintain an even fluid balance, with the caveat that 25–40% of the normal maintenance rate is only an estimate of insensible losses. In the individual patient, this rate is adjusted on the basis of monitoring of the patient's weight and volume status. Most children with renal insufficiency receive little or no potassium because the kidney is the principal site of K<sup>+</sup> excretion.

For the **oliguric** child, it is important to add a urine replacement solution to prevent dehydration. This issue is especially important in the patient with acute kidney injury, in whom output may increase, potentially leading to volume depletion and worsening of kidney injury if the patient remains on only insensible fluids. A replacement solution of D5 1/2NS is usually appropriate initially, although its composition may have to be adjusted if urine output increases significantly.

Most children with **polyuria** (except in diabetes mellitus; see Chapter 629) should be started on replacement of insensible fluid plus urine losses. This approach avoids the need to attempt to calculate the volume of urine output that is “normal” so that the patient can be given

replacement fluid for the excess. In these patients, urine output is, by definition, excessive, and it is often helpful to measure  $\text{Na}^+$  and  $\text{K}^+$  concentrations of the urine to help in formulating the urine replacement solution.

Surgical drains and chest tubes can produce measurable fluid output. These fluid losses should be replaced when they are significant. They can be measured and replaced with an appropriate solution. **Third space losses**, which manifest as edema and ascites, are caused by a shift of fluid from the intravascular space into the interstitial space. Although these losses cannot be quantitated easily, third space losses can be large and may lead to intravascular volume depletion, despite the patient's weight gain. Replacement of third space fluid is empirical but should be anticipated in patients who are at risk, such as children who have burns or abdominal surgery. Third space losses and chest tube output are isotonic, so they usually require replacement with an isotonic fluid, such as NS or LR. Adjustments in the amount of replacement fluid for third space losses are based on continuing assessment of the patient's intravascular volume status. Protein losses from chest tube drainage can be significant, occasionally necessitating that 5% albumin be used as a replacement solution.

Visit Elsevier eBooks+ at [eBooks.Health.Elsevier.com](http://eBooks.Health.Elsevier.com) for Bibliography.

## Chapter 75

# Deficit Therapy

Larry A. Greenbaum

Dehydration, most often caused by gastroenteritis, is a common problem in children. Most cases can be managed with oral rehydration (see Chapter 387). *Even children with mild to moderate hyponatremic or hypernatremic dehydration can be managed with oral rehydration.*

### CLINICAL MANIFESTATIONS

The first step in caring for the child with dehydration is to assess the degree of dehydration (Table 75.1), which dictates both the urgency of the situation and the volume of fluid needed for rehydration. The infant with mild dehydration (3–5% of body weight dehydrated) has few clinical signs or symptoms. The infant may be thirsty; the alert parent may notice a decline in urine output. The history is most helpful. The infant with moderate dehydration has clear physical signs and symptoms. Intravascular volume depletion is evident from an increased heart rate and reduced urine output. This patient needs fairly prompt intervention. The infant with severe dehydration is gravely ill. The decrease in blood pressure indicates that vital organs may be receiving inadequate

**Table 75.1** Clinical Evaluation of Dehydration

<b>Mild dehydration</b> (<5% in an infant; <3% in an older child or adult): Normal or increased pulse; decreased urine output; thirsty; normal physical findings
<b>Moderate dehydration</b> (5–10% in an infant; 3–6% in an older child or adult): Tachycardia; little or no urine output; irritable/lethargic; sunken eyes and fontanel; decreased tears; dry mucous membranes; mild delay in elasticity (skin turgor); delayed capillary refill (>1.5 sec); cool and pale
<b>Severe dehydration</b> (>10% in an infant; >6% in an older child or adult): Peripheral pulses either rapid and weak or absent; decreased blood pressure; no urine output; very sunken eyes and fontanel; no tears; parched mucous membranes; delayed elasticity (poor skin turgor); very delayed capillary refill (>3 sec); cold and mottled; limp, depressed consciousness

perfusion. Immediate and aggressive intervention is necessary. If possible, the child with severe dehydration should initially receive intravenous (IV) therapy. For older children and adults, mild, moderate, or severe dehydration represents a lower percentage of body weight lost. This difference occurs because water accounts for a higher percentage of body weight in infants (see Chapter 73).

Clinical assessment of dehydration is only an estimate; thus the patient must be continually reevaluated during therapy. The degree of dehydration is underestimated in hypernatremic dehydration because the movement of water from the intracellular space (ICS) to the extracellular space (ECS) helps preserve the intravascular volume.

The history usually suggests the etiology of the dehydration and may predict whether the patient will have a normal sodium concentration (isotonic dehydration), hyponatremic dehydration, or hypernatremic dehydration. The neonate with dehydration caused by poor intake of breast milk often has hypernatremic dehydration. **Hypernatremic dehydration** is likely in any child with losses of hypotonic fluid and poor water intake, as may occur with diarrhea, and poor oral intake because of anorexia or emesis. **Hyponatremic dehydration** occurs in the child with diarrhea who is taking in large quantities of low-salt fluid, such as water or formula.

Some children with dehydration are appropriately thirsty, but in others the lack of intake is part of the pathophysiology of the dehydration. Even though decreased urine output is present in most children with dehydration, good urine output may be deceptively present if a child has an underlying renal defect, such as diabetes insipidus or a salt-wasting nephropathy, or in infants with hypernatremic dehydration.

Physical examination findings are usually proportional to the degree of dehydration. Parents may be helpful in assessment of the child for the presence of sunken eyes, because this finding may be subtle. Pinching and gently twisting the skin of the abdominal or thoracic wall detects tenting of the skin (turgor, elasticity). Tenting skin remains in a pinched position rather than springing quickly back to normal. It is difficult to properly assess tenting of the skin in premature infants or severely malnourished children. Activation of the sympathetic nervous system causes **tachycardia** in children with intravascular volume depletion; diaphoresis may also be present. Postural changes in blood pressure are often helpful for evaluating and assessing the response to therapy in children with dehydration. **Tachypnea** in children with dehydration may be present secondary to a metabolic acidosis from stool losses of bicarbonate or lactic acidosis from shock (see Chapter 85).

### LABORATORY FINDINGS

Several laboratory findings are useful for evaluating the child with dehydration. The serum sodium concentration determines the type of dehydration. **Metabolic acidosis** may be a result of stool bicarbonate losses in children with diarrhea, secondary **acute kidney injury** (see Chapter 572.1), or lactic acidosis from shock. The anion gap is useful for differentiating among the various causes of a metabolic acidosis (see Chapter 73). Emesis or nasogastric losses usually cause a **metabolic alkalosis**. The serum potassium ( $\text{K}^+$ ) concentration may be low as a result of diarrheal losses. In children with dehydration as a result of emesis, gastric  $\text{K}^+$  losses, metabolic alkalosis, and urinary  $\text{K}^+$  losses all contribute to hypokalemia. Metabolic acidosis, which causes a shift of  $\text{K}^+$  out of cells, and acute kidney injury may lead to hyperkalemia. A combination of mechanisms may be present; thus it may be difficult to predict the child's acid-base status or serum  $\text{K}^+$  level from the history alone.

The blood urea nitrogen (BUN) value and serum creatinine concentration are useful in assessing the child with dehydration. Volume depletion without parenchymal kidney injury may cause a disproportionate increase in the BUN with little or no change in the creatinine concentration. This condition is secondary to increased passive resorption of urea in the proximal tubule as a result of appropriate renal conservation of sodium and water. The increase in the BUN with moderate or severe dehydration may be absent or blunted in the child with poor protein intake, because urea production depends on protein degradation. The BUN may be disproportionately increased in the child with increased urea production, as occurs with a gastrointestinal bleed or

with the use of glucocorticoids, which increase catabolism. A significant elevation of the creatinine concentration suggests acute kidney injury, although a small, transient increase can occur with dehydration. Decreased kidney perfusion is the most common etiology of acute kidney injury in a child with volume depletion, but occasionally the child may have previously undetected chronic kidney disease or an alternative explanation for the acute kidney injury. **Renal vein thrombosis** is a well-described sequela of severe dehydration in infants; findings may include thrombocytopenia and hematuria (see Chapter 562.2).

Hemoconcentration from dehydration causes increases in hematocrit, hemoglobin, and serum proteins. These values normalize with rehydration. A normal hemoglobin concentration during acute dehydration may mask an underlying anemia. A decreased albumin level in a dehydrated patient suggests a chronic disease, such as malnutrition, nephrotic syndrome, or liver disease, or an acute process, such as capillary leak. An acute or chronic protein-losing enteropathy may also cause a low serum albumin concentration.

### CALCULATION OF THE FLUID DEFICIT

Determining the fluid deficit necessitates clinical determination of the percentage of dehydration and multiplication of this percentage by the patient's weight; a child who weighs 10 kg and is 10% dehydrated has a fluid deficit of 1 L.

### APPROACH TO SEVERE DEHYDRATION

The child with dehydration needs acute intervention to ensure that there is adequate tissue perfusion. This resuscitation phase requires rapid restoration of the circulating intravascular volume and treatment of **shock** with an isotonic solution, such as normal saline (NS), Ringer lactate (lactated Ringer solution, LR), or Plasma-Lyte (see Chapter 85). The child is given a fluid bolus, usually 20 mL/kg of the isotonic fluid, over approximately 20 minutes. The child with severe dehydration may require multiple fluid boluses and may need to receive the boluses as fast as possible. In a child with a known or probable *metabolic alkalosis* (e.g., child with isolated vomiting), LR or Plasma-Lyte should not be used because the lactate or acetate would worsen the alkalosis. However, LR or Plasma-Lyte may be preferable to NS in shock since it is a balanced solution (see Chapters 74 and 85); NS may cause a hyperchloremic metabolic acidosis.

Colloids, such as blood, 5% albumin, and plasma, are rarely needed for fluid boluses. A crystalloid solution (NS or LR) is satisfactory, with both lower risk of infection and lower cost. Blood is obviously indicated in the child with significant anemia or acute blood loss. Plasma is useful for children with a coagulopathy. The child with hypoalbuminemia may benefit from 5% albumin, although there is evidence that albumin infusions increase mortality in adults. The volume and the infusion rate for colloids are generally modified compared with crystalloids (see Chapter 522).

The initial resuscitation and rehydration phase is complete when the child has an adequate intravascular volume. Typically, the child shows clinical improvement, including a lower heart rate, normalization of blood pressure, improved perfusion, better urine output, and a more alert affect.

With adequate intravascular volume, it is appropriate to plan the fluid therapy for the next 24 hours. A general approach is outlined in Table 75.2, with the caveat that there are many different

approaches to correcting dehydration. A balanced solution can be substituted for NS. In isonatremic or hyponatremic dehydration, the entire fluid deficit is corrected over 24 hours; a slower approach is used for hypernatremic dehydration (discussed later). The volume of isotonic fluids that the patient has received is subtracted from this total. The remaining fluid volume is then administered over 24 hours. The potassium concentration may need to be decreased or, less frequently, increased, depending on the clinical situation. Potassium is not usually included in the IV fluids until the patient voids and normal renal function is documented by measurement of BUN and creatinine. Children with significant ongoing losses need to receive an appropriate replacement solution (see Chapter 74).

### MONITORING AND ADJUSTING THERAPY

The formulation of a plan for correcting a child's dehydration is only the beginning of management. *All calculations in fluid therapy are only approximations.* This statement is especially true for the assessment of percentage dehydration. It is equally important to monitor the patient during treatment and to modify therapy on the basis of the clinical situation. Table 75.3 lists the cornerstones of patient monitoring. The patient's vital signs are useful indicators of intravascular volume status. The child with decreased blood pressure and an increased heart rate will probably benefit from a fluid bolus.

The patient's intake and output are critically important in the dehydrated child. The child who, after 8 hours of therapy, has more output than input because of continuing diarrhea needs to be started on a replacement solution. See the guidelines in Chapter 74 for selecting an appropriate replacement solution. Urine output is useful for evaluating the success of therapy. Good urine output indicates that rehydration has been successful.

Signs of dehydration on physical examination suggest the need for continued rehydration. Signs of fluid overload, such as edema and pulmonary congestion, are present in the child who is overhydrated. An accurate daily weight measurement is critical for the management of the dehydrated child. There should be a gain in weight during successful therapy.

Measurement of serum electrolyte levels at least daily is appropriate for any child who is receiving IV rehydration. Such a child is at risk for sodium, potassium, and acid-base disorders. It is always important to look at trends. For example, a sodium concentration ( $[Na^+]$ ) of 144 mEq/L is normal; but if the  $[Na^+]$  was 136 mEq/L 12 hours earlier, there is a distinct risk that the child will be hypernatremic in 12 or 24 hours. It is advisable to be proactive in adjusting fluid therapy.

Both hypokalemia and hyperkalemia are potentially serious (see Chapter 73). Because dehydration can be associated with acute kidney injury and hyperkalemia, potassium is withheld from IV fluids until the patient has voided. The potassium concentration in the patient's IV fluids is not rigidly prescribed. Rather, the patient's serum  $K^+$  level and underlying kidney function are used to modify potassium delivery. The patient with an elevated creatinine value and  $K^+$  level of 5 mEq/L does not receive any potassium until the serum  $K^+$  level decreases.

**Table 75.2** Fluid Management of Dehydration

1. Restore intravascular volume  
Isotonic fluid (NS or LR): 20 mL/kg over 20 min  
Repeat as needed
2. Calculate 24 hr fluid needs: maintenance + deficit volume
3. Subtract isotonic fluid already administered from 24 hr fluid needs
4. Administer remaining volume over 24 hr using 5% dextrose NS + 20 mEq/L KCl
5. Replace ongoing losses as they occur

LR, Ringer lactate; NS, normal saline.

**Table 75.3** Monitoring Therapy

Vital signs
Pulse
Blood pressure
Intake and output
Fluid balance
Urine output
Physical examination
Weight
Clinical signs of depletion or overload
Electrolytes



Conversely, the patient with a  $K^+$  level of 2.5 mEq/L may require additional potassium.

Metabolic acidosis can be quite severe in dehydrated children. Although normal kidneys eventually correct this problem, a child with renal dysfunction may be unable to correct a metabolic acidosis, and a portion of the patient's IV sodium chloride may have to be replaced with sodium bicarbonate, sodium lactate (as in LR), or sodium acetate.

The serum  $K^+$  level is modified by the patient's acid-base status. Acidosis increases serum  $K^+$  by causing intracellular  $K^+$  to move into the ECS. Thus, as acidosis is corrected, the serum potassium concentration ( $[K^+]$ ) decreases. Again, it is best to anticipate this problem and to monitor the serum  $[K^+]$  and adjust potassium administration appropriately.

### HYPONATREMIC DEHYDRATION

The pathogenesis of hyponatremic dehydration usually involves a combination of sodium and water loss and water retention to compensate for the volume depletion. The patient has a pathologic increase in fluid loss, and the lost fluid contains sodium. Most fluid that is lost has a lower sodium concentration, so patients with only fluid loss would have hypernatremia. Diarrhea has, on average, a sodium concentration of 50 mEq/L. Replacing diarrheal fluid with water, which has almost no sodium, causes a reduction in the serum  $[Na^+]$  (see Chapter 74). The volume depletion stimulates synthesis of antidiuretic hormone, resulting in reduced renal water excretion. Therefore the body's usual mechanism for preventing hyponatremia, renal water excretion, is blocked. The risk of hyponatremia is further increased if the volume depletion is a result of loss of fluid with a higher sodium concentration, as may occur with renal salt wasting, third space losses, or diarrhea with high sodium content (cholera).

The initial goal in treating hyponatremia is correction of intravascular volume depletion with isotonic fluid. An overly rapid ( $>8$ - $10$  mEq/L over the first 24 hours) or overcorrection in the serum  $[Na^+]$  ( $>135$  mEq/L) is associated with an increased risk of **osmotic demyelination syndrome** (formerly *central pontine myelinolysis*) (see Chapter 73). Most patients with hyponatremic dehydration do well with the same basic strategy outlined in Table 75.2. Again,  $K^+$  delivery is adjusted according to the initial serum  $K^+$  level and the patient's renal function. Potassium is not given until the patient voids.

The patient's  $[Na^+]$  is monitored closely to ensure appropriate correction, and the sodium concentration of the fluid is adjusted accordingly. Patients with ongoing losses require an appropriate replacement solution (see Chapter 74). Patients with neurologic symptoms (seizures) as a result of hyponatremia need to receive an acute infusion of hypertonic (3%) saline to increase the serum  $[Na^+]$  rapidly (see Chapter 73).

### HYPERNATREMIC DEHYDRATION

Hypernatremic dehydration is the most dangerous form of dehydration because of complications of hypernatremia itself and of its therapy. Hypernatremia can cause serious neurologic damage, including central nervous system hemorrhages and thrombosis. This damage appears to be secondary to the movement of water from the brain cells into the hypertonic extracellular fluid (ECF), causing brain cell shrinkage and tearing blood vessels within the brain (see Chapter 73).

The movement of water from the ICS to the ECS during hypernatremic dehydration partially protects the intravascular volume. Unfortunately, because the initial manifestations are milder, children with hypernatremic dehydration are often brought for medical attention with more profound dehydration.

Children with hypernatremic dehydration are often lethargic, and they may be irritable when touched. Hypernatremia may cause fever, hypertonicity, and hyperreflexia. More severe neurologic symptoms may develop if cerebral bleeding or thrombosis occurs.

Overly rapid treatment of hypernatremic dehydration may cause significant morbidity and mortality. **Idiogenic osmoles** are generated within the brain during the development of hypernatremia; they increase the osmolality within the cells of the brain, providing protection against brain cell shrinkage caused by movement of water out of the cells and into the hypertonic ECF. Idiogenic osmoles dissipate slowly during the correction of hypernatremia. With overly rapid lowering of the extracellular osmolality during the correction of hypernatremia, an osmotic gradient may be created that causes water movement from the ECS into the cells of the brain, producing cerebral edema. Symptoms of the resultant cerebral edema can range from seizures to brain herniation and death.

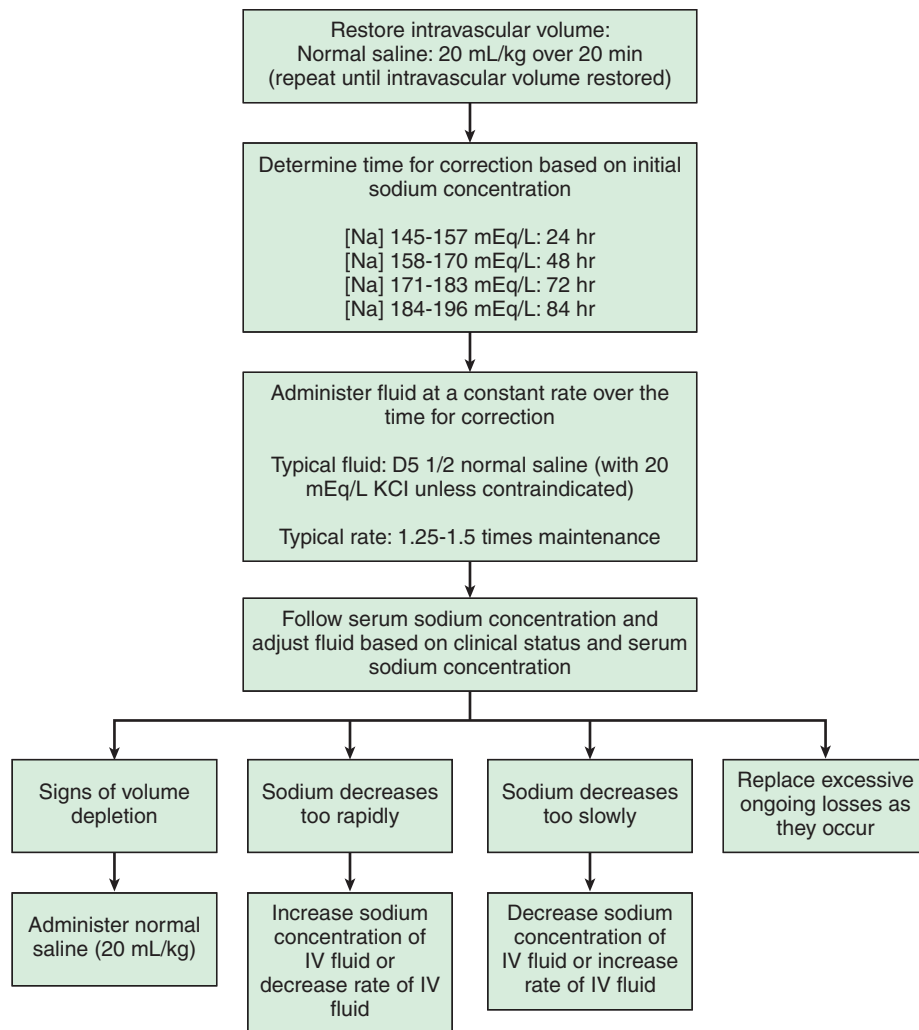
To minimize the risk of **cerebral edema** during the correction of hypernatremic dehydration, the *serum sodium concentration should not decrease by  $>10$  mEq/L every 24 hours*. The deficits in severe hypernatremic dehydration may need to be corrected over 2-4 days (Fig. 75.1).

The initial resuscitation of hypernatremic dehydration requires restoration of the intravascular volume with NS. LR should not be used because it is more hypotonic than NS and may cause too rapid a decrease in the serum  $[Na^+]$ , especially if multiple fluid boluses are necessary.

To avoid cerebral edema during correction of hypernatremic dehydration, the fluid deficit is corrected slowly. The rate of correction depends on the initial sodium concentration (see Fig. 75.1). There is no general agreement on the choice or the rate of fluid administration for correcting hypernatremic dehydration; these factors are not nearly as important as vigilant monitoring of the serum  $[Na^+]$  and adjustment of the therapy according to the result. The rate of decrease of the serum  $[Na^+]$  is roughly related to the "free water" delivery, although there is considerable variation between patients. Free water is water without sodium. NS contains no free water, half-normal saline ( $\frac{1}{2}$  NS) is 50% free water, and water is 100% free water. Smaller patients, to achieve the same decrease in the sodium concentration, tend to need higher amounts of free water delivery per kilogram because of **higher insensible fluid losses**. Five percent dextrose (D5) with  $\frac{1}{2}$  NS is usually an appropriate starting solution for correction of a patient with hypernatremic dehydration. Some patients, especially infants with ongoing high insensible water losses, may rarely need to receive D5 0.2NS, which should be used with great caution and constant monitoring. Others require D5 NS. A child with dehydration as a result of pure free water loss, as usually occurs with diabetes insipidus, usually needs a more hypotonic fluid than a child with depletion of both sodium and water from diarrhea.

Adjustment in the sodium concentration of the IV fluid is the most common approach to modify the rate of decrease in the serum concentration (see Fig. 75.1). For difficult-to-manage patients with severe hypernatremia, having two IV solutions (e.g., D5  $\frac{1}{2}$  NS and D5 NS, both with the same concentration of potassium) at the bedside can facilitate this approach by allowing for rapid adjustments of the rates of the two fluids. If the serum  $[Na^+]$  decreases too rapidly, the rate of D5 NS can be increased and the rate of D5  $\frac{1}{2}$  NS can be decreased by the same amount. Adjustment in the total rate of fluid delivery is another approach to modifying free water delivery. For example, if the serum  $[Na^+]$  is decreasing too slowly, the rate of a hypotonic IV fluid can be increased, thereby increasing the delivery of free water. There is limited flexibility in modifying the rate of the IV fluid because patients generally should receive 1.25-1.5 times the normal maintenance fluid rate. Nevertheless, in some situations, it can be a helpful adjustment.

Because increasing the rate of the IV fluid increases the rate of decline of the sodium concentration, signs of volume depletion are treated with additional isotonic fluid boluses. The serum  $[K^+]$  and the level of renal function dictate the potassium concentration of the IV fluid; potassium is withheld until the patient voids. Patients with hypernatremic dehydration need an appropriate replacement solution if they have ongoing, excessive losses (see Chapter 74).



**Fig. 75.1** Algorithm for the treatment of hypernatremic dehydration. (From Londeree JT, Greenbaum LA. *Dehydration and replacement therapy*. In: Marcidante KJ, Kliegman RM, Schuh AM, eds. *Nelson Essentials of Pediatrics*, 9th ed. Philadelphia: Elsevier, 2023. Fig 33.1.)

**Seizures** and a depressed level of consciousness are the most common manifestations of **cerebral edema** from an overly rapid decrease of the serum  $[\text{Na}^+]$  during correction of hypernatremic dehydration. Signs of increased intracranial pressure or impending herniation may develop quite rapidly (see [Chapter 82](#)). Acutely, increasing the serum  $[\text{Na}^+]$  through an infusion of 3% sodium chloride can reverse the cerebral edema. Each 1 mL/kg of 3% NaCl increases the serum  $[\text{Na}^+]$  by approximately 1 mEq/L. An infusion of 4 mL/kg often results in resolution of the symptoms. This strategy is similar to that used for treating symptomatic hyponatremia (see [Chapter 73](#)).

Many patients with mild to moderate hypernatremic dehydration as a result of gastroenteritis can be managed with oral rehydration (see

[Chapter 387](#)). In patients with severe hypernatremia, oral fluids must be used cautiously. Infant formula, because of its low sodium concentration, has a high free water content, and especially if added to IV therapy, it may contribute to a rapid decrease in the serum  $[\text{Na}^+]$ . Less hypotonic fluid, such as an oral rehydration solution, may be more appropriate initially. If oral intake is allowed, its contribution to free water delivery must be taken into account, and adjustment in the IV fluid is usually appropriate. Judicious monitoring of the serum  $[\text{Na}^+]$  is critical.

Visit Elsevier eBooks+ at eBooks.Health.Elsevier.com for Bibliography.

Chapter 76

# Fluid and Electrolyte Treatment of Specific Disorders

## **ACUTE DIARRHEA**

See Chapter 387.

## **PYLORIC STENOSIS**

See Chapter 375.1.

## **PERIOPERATIVE FLUIDS**

See Chapter 91.

## Chapter 77

# Emergency Medical Services for Children

Charles G. Macias, Katherine E. Remick,  
and Steven E. Krug

The overwhelming majority of the 27 million children who present annually for emergency care in the United States are seen at community-based general emergency departments (EDs). Visits to children's hospital EDs account for just 10% of initial ED encounters. Additionally, across emergency medical services, children account for approximately 10% of all transports. This distribution suggests that the greatest opportunity to optimize care for acutely ill or injured pediatric patients, on a population basis, occurs broadly as part of a systems-based approach to emergency services, an approach that incorporates the unique needs of children at every level. Conceptually, emergency medical services for children are characterized by an integrated, continuum-of-care model (Fig. 77.1). The model is designed such that patient care flows seamlessly from the primary care medical home through transport and on to hospital-based definitive care. It includes the following five principal domains of activity:

1. Prevention, both primary and secondary
2. Out-of-hospital care, both emergency response and prehospital transport
3. Hospital-based care: ED and inpatient, including critical care
4. Interfacility transport, as necessary, for definitive or pediatric medical and surgical subspecialty care (see Chapter 77.1)
5. Rehabilitation



**Fig. 77.1** The emergency medical services for children (EMSC) continuum of care. Seriously ill and injured children interface with a large number of healthcare personnel as they move through the EMSC system.

The federal **Emergency Medical Services for Children (EMSC)** program of the Health Resources and Services Administration Maternal and Child Health Bureau has stewarded improvements in the care of children in the context of the continuum-of-care model. The programmatic mission of the EMSC program is as follows:

- To ensure U.S. emergency care systems across the continuum of care are pediatric-ready, meaning pediatric-specific needs are incorporated into every aspect of patient care, including patient safety practices, equipment and supplies, competency requirements, policies and procedures, quality improvement efforts, and administrative oversight and coordination of care.
- To ensure access to high-quality emergency medical care for ill or injured children and adolescents of all ages regardless of geographic location.
- To ensure that pediatric services are well integrated into an emergency medical services (EMS) system and backed by optimal resources.
- To ensure that the entire spectrum of emergency services—including primary prevention of illness and injury, acute care, and rehabilitation—is provided to infants, children, and adolescents at a level equal to that of adults.

## PRIMARY CARE PHYSICIAN AND OFFICE PREPAREDNESS

The primary care physician (PCP) has multiple important roles in the EMS system. Through anticipatory guidance, the PCP can help shape the attitudes, knowledge, and behaviors of parent and child, with the primary goal of preventing acute medical events, such as injury and exacerbations of illness. The point-of-care initiation for many acute problems is often the PCP office. From the standpoint of personnel, equipment, training, and protocols, the PCP office setting must be adequately prepared to initially manage acute and emergency exacerbations of common pediatric conditions, such as respiratory distress and seizures. Furthermore, on rare occasion, the PCP office environment may be confronted with a child in clinical extremis who requires resuscitation and stabilization. It is therefore incumbent on the PCP not only to ensure access to EMS, that is, 911 system activation, but also to ensure that there is adequate equipment and supplies and on-site cognitive and psychomotor skill preparation to deal with such an emergency. **Office preparedness** requires training and continuing education for staff members, protocols for emergency interventions, ready availability of appropriate resuscitation drugs and equipment, and knowledge of local EMS resources and ED capabilities. PCPs can also play a pivotal role in informing and advocating for pediatric emergency and disaster readiness for families (especially those of children and youth with special healthcare needs) and in local EMS agencies, schools and childcare programs, and community hospitals. In all communities, the medical home plays a vital role in promoting family readiness for emergencies and disasters.

### Staff Training and Continuing Education

It is a reasonable expectation that all office staff, including receptionists and medical assistants, be trained in cardiopulmonary resuscitation (CPR) with recertification maintained every 2 years. Nurses and physicians should also have training in a systematic approach to pediatric resuscitation that optimizes performance of high-quality CPR. Core knowledge may be obtained through standardized courses in **advanced life support (ALS)** offered by national medical associations and professional organizations. Frequent practice and timely



recertification are important for knowledge retention and skill maintenance. Examples include the Pediatric Advanced Life Support (PALS) and Pediatric Emergency Assessment, Recognition and Stabilization (PEARS) courses sponsored by the American Heart Association (AHA), the Advanced Pediatric Life Support (APLS) course sponsored by the American Academy of Pediatrics (AAP) and American College of Emergency Physicians (ACEP), and the Emergency Nurses Pediatric Course (ENPC) sponsored by the Emergency Nurses Association (ENA).

### Protocols

Standardized protocols for telephone triage of seriously ill or injured children are essential. When a child's clinical status is guarded and pre-hospital care is available, ambulance transport in the care of trained personnel is always preferable to transport by other means (e.g., private vehicle). This obviates the potentially serious medical consequences of relying on distraught, often untrained, parents who lack essential equipment and supplies to provide even **basic life support (BLS)** measures to an unstable child during transport. Practitioners can work with their regional pediatric emergency care resource center (e.g., children's hospital, academic medical center, trauma center) to develop and maintain written protocols for office-based management of a range of conditions, including anaphylaxis, cardiopulmonary arrest, head trauma, ingestions, shock, status asthmaticus, status epilepticus, extremity injuries, and upper airway obstruction. Regular practice using mock code scenarios improves office-based practitioner and staff performance and self-efficacy in managing these problems.

### Resuscitation Equipment

Availability of necessary equipment is a vital part of an emergency response. Every physician's office should have essential resuscitation equipment and medications packaged in a weight-based pediatric resuscitation cart or kit (Table 77.1). This cart or kit should be checked on a regular basis and kept in an accessible location known to all office staff. Outdated medication, a laryngoscope with a failed light source, or an empty oxygen tank represents a potential catastrophe in a resuscitation scenario. Such an incident can be easily avoided if an equipment checklist and regular maintenance schedule are implemented. A pediatric kit that includes posters to reinforce clinical management and procedures, a drug-dosing formulary, and a color-coded length-based resuscitation tape specifying weight and emergency equipment size are invaluable in avoiding critical therapeutic errors during resuscitation.

To facilitate emergency response when a child needs rapid intervention in the office, all personnel should have designated roles. Organizing a "rapid response team" within the office ensures that necessary equipment is made available to the physician in charge, an appropriate medical record detailing all interventions and the child's response is generated, and the 911 call for EMS response or a critical care transport team is made in a timely fashion. Regular practice for these infrequent events will promote timely response when needed.

### Transport

Once efforts to stabilize the child have begun, a decision must be made on how best to transport a child to a facility capable of providing definitive care. If a child requires airway or cardiovascular support, has an altered mental state or unstable vital signs, or has significant potential to deteriorate en route, it is not appropriate to send the child via privately owned vehicle, regardless of proximity to a hospital. Even when an ambulance is called, it is the PCP's responsibility to initiate essential life support measures and to attempt to stabilize the child before transport.

In metropolitan centers with numerous public and private ambulance agencies, the PCP must be knowledgeable about the scope of service provided by each. The availability of BLS vs ALS services, the configuration of the transport team, and pediatric expertise vary greatly among agencies and across jurisdictions. BLS services provide basic support of airway, breathing, and circulation, whereas ALS units are capable of providing resuscitation drugs and procedural interventions as well. Some communities may have only BLS services available,

**Table 77.1** Recommended Drugs and Equipment for Pediatric Office Emergencies

DRUGS/EQUIPMENT	PRIORITY
<b>DRUGS</b>	
Oxygen	E
Albuterol for inhalation	E
Epinephrine (1:1,000 [1 mg/mL])	E
Activated charcoal	S
Antibiotics	S
Anticonvulsants (diazepam/lorazepam)	S
Corticosteroids (parenteral/oral)	S
Dextrose (25%)	S
Diphenhydramine (parenteral, 50 mg/mL)	S
Epinephrine (1:10,000 [0.1 mg/mL])	S
Atropine sulfate (0.1 mg/mL)	S
Naloxone (0.4 mg/mL)	S
Sodium bicarbonate (4.2%)	S
<b>INTRAVENOUS FLUIDS</b>	
Normal saline (0.9 NS) or lactated Ringer solution (500-mL bags)	S
5% dextrose, 0.45 NS (500-mL bags)	S
<b>EQUIPMENT FOR AIRWAY MANAGEMENT</b>	
Oxygen and delivery system	E
Bag-valve-mask (450 mL and 1,000 mL)	E
Clear oxygen masks, breather and non-rebreather, with reservoirs (infant, child, adult)	E
Suction device, tonsil tip, bulb syringe	E
Nebulizer (or metered-dose inhaler with spacer/mask)	E
Oropharyngeal airways (sizes 00-5)	E
Pulse oximeter	E
Nasopharyngeal airways (sizes 12-30F)	S
Magill forceps (pediatric, adult)	S
Suction catheters (sizes 5-16F and Yankauer suction tip)	S
Nasogastric tubes (sizes 6-14F)	S
Laryngoscope handle (pediatric, adult) with extra batteries, bulbs	S
Laryngoscope blades (straight 0-2; curved 2-3)	S
Endotracheal tubes (uncuffed 2.5-5.5; cuffed 6.0-8.0)	S
Stylets (pediatric, adult)	S
Esophageal intubation detector or end-tidal carbon dioxide detector	S
<b>EQUIPMENT FOR VASCULAR ACCESS AND FLUID MANAGEMENT</b>	
Butterfly needles (19-25 gauge)	S
Catheter-over-needle device (14-24 gauge)	S
Arm boards, tape, tourniquet	S
Intraosseous needles (16 and 18 gauge)	S
Intravenous tubing, micro-drip	S
<b>MISCELLANEOUS EQUIPMENT AND SUPPLIES</b>	
Color-coded tape or preprinted drug doses	E
Cardiac arrest board/backboard	E
Sphygmomanometer (infant, child, adult, thigh cuffs)	E
Splints, sterile dressings	E
Automated external defibrillator with pediatric capabilities	S
Spot glucose test	S
Stiff neck collars (small/large)	S
Heating source (overhead warmer/infrared lamp)	S

E, essential; S, strongly suggested.

From Frush K, American Academy of Pediatrics, Committee on Pediatric Emergency Medicine. Policy statement-preparation for emergencies in the offices of pediatricians and pediatric primary care providers. *Pediatrics*. 2007;120:200-212. Reaffirmed in *Pediatrics*. 2011;128:e748.

whereas others may have a two-tiered system, providing both BLS and ALS. It may be appropriate to consider medical air transport when definitive or specialized care is not available within the community or when ground transport times are prolonged. In that case, initial transport via ground to an appropriate helicopter landing zone or a local hospital for interval stabilization may be undertaken, pending arrival

of the air transport team. Independent of whether a child is to be transported by air or ground, copies of the pertinent medical records and any imaging or laboratory studies should be sent with the patient and a call made to the physician at the receiving facility to alert them to the referral and any treatments administered. Such notification is not merely a courtesy; direct physician-to-physician communication is essential for optimal care quality and to ensure adequate transmission of patient care information, to allow mobilization of necessary resources in the ED, and to redirect the transport if the emergency physician believes that the child would be more optimally treated at an alternative facility.

### PEDIATRIC PREHOSPITAL CARE

*Prehospital care* refers to emergency assistance rendered by trained emergency medical personnel before a child reaches a treating medical facility. The goals of prehospital care are to further minimize systemic insult or injury through a series of well-defined and appropriate interventions and serve as the first link in high-quality emergency care. Prehospital emergency care services embrace patient safety, family-centered care, and timely and effective interventions as core tenets. Most U.S. communities have a formalized EMS system; the organizational structure and nature of emergency medical response depend greatly on local demographics and population base. EMS may be provided by volunteers or career professionals working in a fire department-based or independent third-service response system. All EMS and fire-based agencies have an identified medical director who defines provider competencies and scope of practice. Key points to recognize in negotiation of the juncture between the community physician and the local EMS system include access to the system, provider capability, and destination determination.

### Access to the EMS System

Virtually all Americans have access to the 911 telephone service that provides direct access to a dispatcher who coordinates police, fire, and EMS responses. Many communities have a next-generation 911 system, in which the location of the caller is automatically provided to the call taker and/or dispatcher regardless of landline or mobile device use, permitting emergency response even if the caller, such as a young child, cannot give an address. Next-generation 911 also provides text-messaging capabilities. The extent of medical training for call takers and dispatchers varies among communities, as do the protocols by which they assign an emergency response level (BLS vs ALS). Many dispatch centers have adopted the Medical Priority Dispatch System (MPDS) to use standardized protocols and prearrival/postdispatch instructions. MPDS requires emergency medical dispatchers to ask a series of questions that determine the appropriate level of priority and EMS response. In some smaller communities, no coordinated dispatch exists, and emergency medical calls are handled by the local law enforcement agency or fire department. When activating the 911 system, the physician must make clear to the dispatcher the nature of the medical emergency and the condition of the child.

### Provider Capability

There are many levels of training for prehospital EMS providers, ranging from individuals capable of providing only first aid to those trained and licensed to provide ALS. All EMS personnel, whether basic **emergency medical technicians (EMTs)** or paramedics, receive some initial training in pediatric emergencies; however, in most programs the dedicated time allotted to pediatric emergencies is minimal. Furthermore, state requirements vary for pediatric continuing education, and exposure to critically ill or injured children in the prehospital setting is infrequent, even in urban settings. PCPs should recognize that prehospital providers may need additional consultation or support, especially when managing children with uncommon medical conditions. PCPs can support maintenance of pediatric knowledge by EMS providers by serving as or working closely with an identified pediatric emergency care coordinator (PECC) within the EMS agency to fully integrate the needs of children into every aspect of system-based care: policies,

protocols, quality improvement, patient safety, family-centered care, staff competencies, and equipment and supplies. Although children represent a minority population in the prehospital setting, the joint policy statement, *Pediatric Readiness in Emergency Medical Services Systems*, provides a comprehensive overview of how EMS systems can address the needs of children throughout all aspects of care. The identification of a PECC and physical demonstration of pediatric-specific skills represent two of the reference standards that the federal EMSC program has adopted as performance measures for state-level operational readiness to care for children in an EMS system.

First responders may be law enforcement officers or firefighters, who are dispatched to provide emergency medical assistance, or bystanders. Public safety personnel have a minimum of 40 hours of training in first aid and CPR. Their role is to provide rapid response and stabilization pending the arrival of more highly trained personnel. In some smaller communities, this may be the only prehospital emergency medical response available.

In the United States the bulk of emergency medical response is provided by EMTs, who may be volunteers or paid professionals. Basic EMTs may staff an ambulance after undergoing a training program of approximately 100 hours. They are licensed to provide BLS services but may receive further training in some jurisdictions to expand their scope of practice to include intravenous catheter placement and fluid administration, management of airway adjuncts, and use of an automated external defibrillator (AED).

**Paramedics**, or EMT-Ps, represent the highest level of EMT response, with medical training and supervised field experience of at least 1,000 hours. Paramedic skills include advanced airway management, including endotracheal intubation; placement of peripheral vascular or intraosseous lines; intravenous administration of drugs and blood products; administration of nebulized aerosols; needle and finger thoracostomy; and cardioversion, cardiac pacing, and manual defibrillation. These professionals provide ALS services, functioning out of an ambulance equipped as a mobile intensive care unit (ICU). The joint position statement *Recommended Essential Equipment for Basic Life Support and Advanced Life Support Ground Ambulances 2020* published by the AAP, ACEP, American College of Surgeons Committee on Trauma, EMSC Innovation and Improvement Center, ENA, National Association of EMS Physicians, and National Association of EMS Officials outlines national standards for essential equipment, medications, and supplies necessary to provide BLS and ALS care across the age spectrum.

Both basic EMTs and paramedics function under the delegated licensing authority of a supervisory EMS medical director. This physician oversight of prehospital practice is broadly characterized under the umbrella term *medical control*. **Direct**, or **online, medical control** refers to medical direction either at the scene or in real time via voice or video transmission. **Indirect**, or **offline, medical control** refers to the administration of medical direction before and after the provision of care (i.e., clinical protocols). Offline activities, such as provider education and training, protocol development, and medical leadership of quality assurance/quality improvement programs, represent areas in need of greater pediatric input. Whether in the presence or absence of a PECC, a pediatric advisory committee may provide additional pediatric knowledge and expertise. Evaluation and tracking of pediatric performance is critical to ensuring high-quality care for children in a community. The National EMS Information System (NEMSIS) serves as a registry for standardized EMS data collection. EMS agency participation in NEMSIS-compliant data submission is one of the federal EMSC performance measures. The National EMS Quality Alliance (NEMQA) and the National EMS Model Clinical Guidelines complement the NEMSIS program by providing evidence-derived pediatric quality measures for adoption in any EMS agency. As a measure of the degree to which EMSC permanence is being established in state EMS systems, the federal EMSC program has required demonstration of the presence of an EMSC advisory committee at the state level. These advisory bodies are well positioned to support EMS agencies in their pediatric readiness and provide a forum for the active engagement of pediatric care experts at a system level.

## Destination Determination

The destination to which a pediatric patient is transported may be defined by parental preference, provider preference, or jurisdictional protocol, which is typically predicated on field assessment and, in the case of trauma, mechanism of injury. The 2021 National Guidelines for the Field Triage of Injured Patients relies on injury patterns, physiologic criteria, mechanism of injury, and other special considerations (e.g., suspicion for child maltreatment). Based on these criteria, EMS providers determine the optimal trauma center destination in the setting of injury. In communities served by an organized trauma system that incorporates pediatric designation based on objectively verified hospital capabilities (i.e., pediatric readiness), seriously injured children may be triaged by protocol to the highest-level pediatric-capable trauma center reachable within a reasonable amount of time. Other communities have established state or regional emergency care systems that use pediatric readiness criteria to recognize EDs appropriate for pediatric patients. A high level of pediatric readiness in both medical and trauma centers is linked to decreased mortality in critically ill and injured children. The mantra is to deliver the child to the *right care in the right time*, even if it requires bypassing closer hospitals.

**Regionalization** in the context of EMS is defined as a geographically organized system of services that ensures access to care at a level appropriate to patient needs while maintaining efficient use of available resources. This system concept is especially germane in the care of children, given the relative scarcity of facilities and their associated providers that are capable of managing the full range and scope of pediatric conditions (Fig. 77.2). Regionalized systems of care coordinated with emergency medical dispatch, field triage, and EMS transport have demonstrated efficacy in improving outcomes for pediatric medical and trauma patients. The existence of statewide or regional standardized systems that formally recognize hospitals able to stabilize and/or manage pediatric medical and traumatic emergencies is a federal EMSC performance measure against which operational capacity to provide optimal pediatric emergency care in the United States is currently being evaluated. Over 15 states now offer pediatric medical facility recognition programs. For the majority, hospital participation in these programs is voluntary. EMSC state partnership programs in the respective jurisdiction can provide further guidance on the application process and requirements for participation. Similarly, several state trauma systems now integrate elements of pediatric readiness into trauma center designation. Moreover, beginning in 2023, the American College of Surgeons (ACS) Committee on Trauma requires all

ACS-verified trauma centers to adhere to specific pediatric readiness criteria.

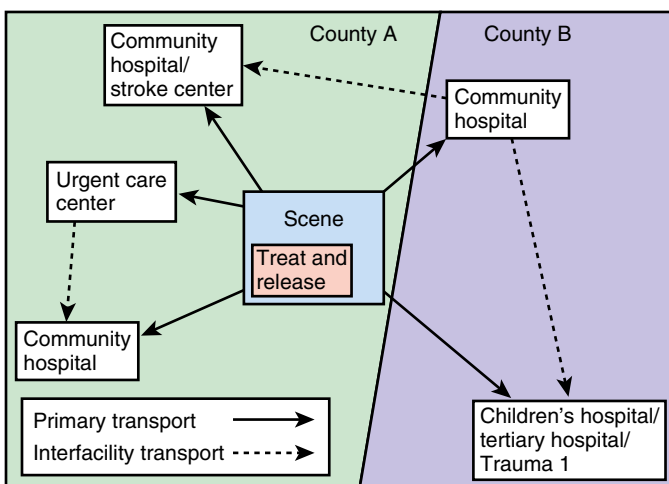
In communities that do not have a hospital with the equipment and personnel resources to provide definitive pediatric inpatient care, **interfacility transport** of a child to a regional pediatric center should be undertaken after initial stabilization (see Chapter 77.1). In the end, all emergency care facilities must stand ready to provide care to ill and injured children of all ages.

## THE EMERGENCY DEPARTMENT

The ability of EDs to respond to critically ill and injured children depends on all aspects of pediatric readiness: administrative oversight, staff competencies, pediatric-specific policies and procedures, patient and medication safety, quality improvement, and equipment and supplies. Training, awareness, and experience of the staff as well as access to support services, pediatricians, and medical and surgical subspecialists also play a key role. The majority of children who require emergency care are evaluated in community EDs. Emergency care staff, including physicians, nurses, and advanced practice providers, may have variable degrees of pediatric training and experience. Although children account for approximately 25% of all ED visits, only a fraction of these encounters represents true emergencies. Because the volume of critical pediatric cases is low, emergency physicians and nurses working in lower-volume EDs often have limited opportunity to reinforce and sustain their knowledge and skills in the assessment and stabilization of severely ill or injured children. Indeed, nearly 70% of U.S. EDs provide care for <15 children per day. General pediatricians from the community or pediatric hospitalists may be consulted when a seriously ill or injured child presents to the ED, and they should have a structured approach to the initial evaluation and treatment of an unstable child of any age, regardless of the underlying diagnosis. Telemedicine and e-health may serve as a mechanism to provide better connectivity between patients, primary care, EDs, and tertiary/quaternary institutions. *Early recognition of life-threatening abnormalities in oxygenation, ventilation, perfusion, and central nervous system function and rapid intervention to correct those abnormalities are key to successful resuscitation and stabilization of the pediatric patient.*

The **National Pediatric Readiness Project (NPRP)** is a national quality improvement initiative started by the federal EMSC program, AAP, ACEP, and ENA to ensure high-quality emergency care for all children. The effort began in 2013 with a national assessment of pediatric readiness in U.S. EDs (as measured by compliance with published guidelines). Initial results demonstrated a high level of engagement in pediatric readiness but notable gaps in the ability of U.S. EDs to meet the needs of children: 48% of EDs had a physician PECC; 59% of EDs had a nurse PECC; 46% of EDs included pediatric-specific needs in quality improvement efforts; and 47% had a disaster plan that addressed the needs of children. Higher readiness levels are seen in larger-volume EDs and in EDs with physician and nurse PECCs and/or quality improvement plans that included children. Since then, numerous efforts, including national quality improvement collaboratives, have targeted key areas of readiness. A second NPRP assessment was completed in 2021, and national efforts continue to promote widespread adoption of pediatric readiness within U.S. EDs. In 2019, the National Prehospital Pediatric Readiness Project launched with similar efforts focused on ensuring high-quality prehospital emergency care for children. Table 77.2 lists essential policies, procedures, and protocols specifically addressing the needs of children in the ED. ED staff and other stakeholders can access pediatric readiness checklists and toolkits and identify opportunities to participate in pediatric readiness efforts on the website of the EMSC Innovation and Improvement Center, <https://emscimprovement.center/>. Given the link between pediatric readiness and increased survival for critically ill and injured children, baseline readiness standards must be met by all EDs and EMS agencies to ensure that children receive the best emergency care possible.

The way the family supports the child during a crisis, and consequently how the family is supported by the local EMS agency and in the ED when caring for the child, are critical to patient recovery,



**Fig. 77.2** Transport options within a coordinated, regionalized emergency medical services system model. The objective is to ensure access to definitive care at a level appropriate to meet patient needs. Solid arrows, Primary transport; dashed arrows, interfacility transport. (Adapted from Institute of Medicine, Committee on the Future of Emergency Care in the U.S. Health System. Hospital-Based Emergency Care: At the Breaking Point. Washington, DC: National Academies Press; 2006.)



**Table 77.2** Guidelines for Pediatric-Specific Policies, Procedures, and Protocols for the Emergency Department (ED)

<p>Illness and injury triage</p> <p>Pediatric patient assessment and reassessment</p> <p>Documentation of pediatric vital signs, abnormal vital signs, and actions to be taken for abnormal vital signs</p> <p>Identification and notification of the responsible provider of abnormal vital signs (age or weight based)</p> <p>Immunization assessment and management of the underimmunized patient</p> <p>Sedation and analgesia for procedures, including medical imaging</p> <p>Consent (including situations in which a parent is not immediately available)</p> <p>Social and mental health issues</p> <p>Physical or chemical restraint of patients</p> <p>Child maltreatment (physical and sexual abuse, sexual assault, and neglect) mandated reporting criteria, requirements, and processes</p> <p>Death of the child in the ED</p> <p>Do-not-resuscitate orders</p> <p>Lack of a medical home</p> <p>Children with special healthcare needs</p> <p>Family-centered care, including:</p> <ol style="list-style-type: none"> <li>1. Involving families in patient care decision-making and in medication safety processes</li> <li>2. Family and guardian presence during all aspects of emergency care, including resuscitation</li> <li>3. Education of the patient, family, and regular caregivers</li> <li>4. Discharge planning and instruction</li> <li>5. Bereavement counseling</li> </ol> <p>Communication with patient's medical home or primary healthcare provider</p> <p>Telehealth and telecommunications</p> <p>Medical imaging policies that address age- or weight-appropriate dosing for children receiving studies that impart ionizing radiation, consistent with ALARA (as low as reasonably achievable) principles</p> <p>All-hazard disaster preparedness plan that addresses the following pediatric issues:</p> <ol style="list-style-type: none"> <li>1. Availability of medications, vaccines, equipment, and appropriately trained providers for children in disasters</li> <li>2. Pediatric surge capacity for both injured and noninjured children</li> </ol>	<ol style="list-style-type: none"> <li>3. Decontamination, isolation, and quarantine of families and children of all ages</li> <li>4. Minimization of parent-child separation and includes system tracking of pediatric patients, allowing for the timely reunification of separated children with their families</li> <li>5. Access to specific medical and mental health therapies, as well as social services, for children in the event of a disaster</li> <li>6. Disaster drills, which should include a pediatric mass casualty incident at least every 2 years</li> <li>7. Care of children with special healthcare needs</li> <li>8. A plan that includes evacuation of pediatric units and pediatric critical care and specialty units</li> </ol> <p>Evidence-based clinical pathways, order sets, or decision support tools</p> <p>Written interfacility transfer procedure and agreements that include the following components:</p> <ol style="list-style-type: none"> <li>1. Defined process for initiation of transfer, including the roles and responsibilities of the referring facility and referral center (including responsibilities for requesting transfer, method of transport, and communication)</li> <li>2. Transport plan to deliver children safely (including the use of child passenger restraint devices) and in a timely manner to the appropriate facility capable of providing definitive care</li> <li>3. Process for selecting the appropriate care facility for pediatric specialty services not available at the hospital</li> <li>4. Process for selecting the appropriately staffed transport service to match the patient's acuity level (i.e., level of care required and equipment needed for transport) and appropriate for children with special healthcare needs</li> <li>5. Process for patient transfer (including obtaining informed consent)</li> <li>6. Plan for transfer of critical patient information (i.e., medical record, imaging, copy of signed transport consent), as well as personal belongings and provision of directions and referral institution information to family</li> <li>7. Process for return transfer of the pediatric patient to the referring facility as appropriate</li> <li>8. Integration with telehealth/telecommunications processes and mobile integrated health/community paramedicine as appropriate</li> </ol>
---	--

Adapted from Remick K, Gausche-Hill M, Joseph MM, Brown K, Snow SK, Wright JL; American Academy of Pediatrics Committee on Pediatric Emergency Medicine and Section on Surgery; American College of Emergency Physicians Pediatric Emergency Medicine Committee; Emergency Nurses Association Pediatric Committee. Pediatric readiness in the emergency department. *Pediatrics*. 2018;142(5):e20182459.

family satisfaction, and mitigation of behavioral and mental health impact. Commitment to patient- and family-centered care in the ED ensures that the patient and family experience guides the practice of culturally sensitive care and promotes patient dignity, comfort, and autonomy. In both the ED and EMS settings, particular issues, such as family presence, deserve specific attention. Surveys of parents have indicated that most want to be with their child during invasive procedures and even during resuscitation. Allowing their presence has been shown to reduce parental and patient anxiety and does not interfere with procedure performance. Patient- and family-centered care practices are also strongly associated with improved care quality and patient safety.

### Disaster Preparedness

Throughout a public health emergency or catastrophic event, natural or human-made, several unique factors place children at disproportionate, increased risk. Combined with other factors, global climate change has promoted increased frequency and severity of weather-related disasters. During an average workday, an estimated 69 million U.S. children are separated from their families in schools and childcare centers, where mass casualty events can easily occur. This separation adds the further challenge of safe and timely reunification of children with family during or after an incident. Furthermore, in the event of a biologic, chemical, or radio-nuclear attack, unique anatomic, developmental, and physiologic features make children especially vulnerable to absorption, ingestion, or inhalation of toxic agents and related morbidity and mortality (see [Chapter 763](#)).

Pediatric planning considerations include training of first responders and other care providers, patient triage, decontamination, surge capacity and capabilities, medical countermeasures (medications, vaccines, equipment, supplies), evacuation, transport, sheltering, and family reunification. The community plays a significant role in preparedness and is inclusive of schools, school nurses, faith-based organizations, and other community entities.

All levels of the healthcare system must be prepared for disaster-driven surges in patient care needs. Surge capacity refers to the ability to evaluate and care for a markedly increased volume of patients—one that challenges or exceeds normal variations in operating capacity. Surge capability refers to the ability to provide specialized medical services for unique patient populations, such as children, that may not be routinely available under normal operating conditions. Surges may require alternative care processes and additional resources to meet the demand for services. Critical surges may require consideration of contingency plans that typically require activation of alternative care standards. Surges that exceed the additional capacity of contingency plans may require implementation of crisis care standards as a means to increase capacity beyond levels that exceed normal daily operations. During a public health emergency, surge requirements may extend beyond direct patient care to include tasks such as laboratory screening or epidemiologic investigations. All levels of the healthcare system may be challenged to increase their capabilities, providing medical services for patient populations, such as children, that may not be routinely available. As an example, the community hospital that routinely transfers higher-acuity ill or injured children or children with medical



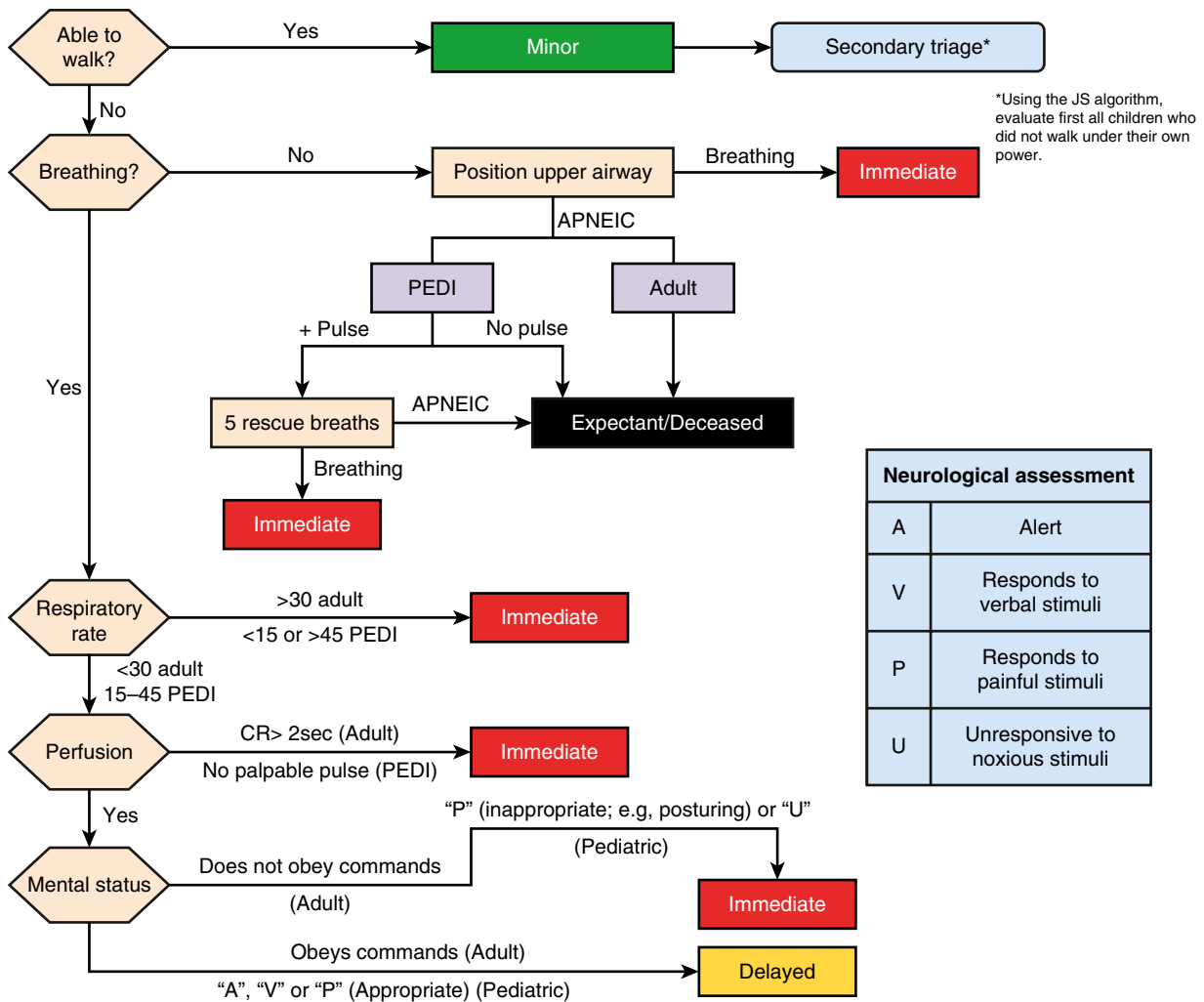


Fig. 77.3 Combined START/Jump START triage algorithm. (Copyright 2002, Lou Romig, MD.)

complexity to a pediatric tertiary center may be unable to do so during a disaster. Mechanisms for remote consultation and support of pediatric care, leveraging community pediatricians and tertiary pediatric subspecialists via telemedicine, should be considered.

Beyond acute medical treatment needs, pediatric planning must also consider the typically broad mental and behavioral health impact disasters have on children and families. Mental and behavioral health concerns commonly represent the largest impact of disasters on children and adolescents. Pediatric plans must also be in place for locations where children congregate, such as schools and childcare; these plans must be aligned with local jurisdiction planning and communicated to families.

Community practice and healthcare system readiness and resiliency begin with *personal and family readiness planning* engaged by healthcare providers and support staff; these efforts should also include attention to provider wellness.

The AAP's Children and Disasters website\* (<https://www.aap.org/en/community/aap-councils/council-on-disaster-preparedness-and-recovery-codpr/>) contains toolkits, checklists, and other resources pertinent to pediatric readiness within the community, schools, the medical home, and hospitals; educational materials are also available for families. Reliable information and excellent disaster readiness resources are also located on the websites of the EMSC Innovation and Improvement Center and U.S. Department of Health and Human Services (HHS) and Assistant Secretary for Preparedness and Response (ASPR) Eastern Great Lakes Pediatric Disaster Center of Excellence

(<https://emscimprovement.center>), U.S. Centers for Disease Control and Prevention (<https://emergency.cdc.gov>), U.S. Department of Health and Human Services (<https://www.phe.gov/preparedness/Pages/default.aspx>), U.S. HHS ASPR Technical Resources, Assistance Center, and Information Exchange (TRACIE) (<https://asprtracie.hhs.gov/>), U.S. Federal Emergency Management Agency (<https://www.fema.gov>), HHS ASPR Western Regional Alliance for Pediatric Emergency Management (WRAP-EM) (<https://www.wrap-em.org/index.php/resources-edocman-public>), and HHS HRS Pediatric Network (PPN) (<https://pedspandemicnetwork.org/>).

### Triage in Disaster Pediatric Medical Care

Mass causality events (hurricanes, bombings, gas leaks, bus or plane crashes, earthquakes, mass shootings, fires, others) require *scene-based* assessment, assignment, and tagging (Figs. 77.3 and 77.4). Assessment must be rapid (~30 seconds) and includes breathing, circulation, and mental status. These parameters are incorporated in the **START** (simple triage and rapid treatment) triage tool for adolescent and adults and the **Jump START** assessment for 0- to 14-year-old children. The combined algorithm is noted in Figure 77.3. The “jump” in Jump START relates to one difference between pediatric and adult approaches wherein children are given a rescue breath if they remain apneic with a pulse after positioning the airway (see Fig. 77.3). Triage categories are color coded (see Fig. 77.4) at the site of the disaster based on risk. **Red** – immediate life-threatening injury; **Yellow** – potentially stable for a short period; **Green** – minor injury, walking wounded; **Black** – dead or not expected to survive.

\* <https://www.aap.org/en-us/advocacy-and-policy/aap-health-initiatives/Children-and-Disasters/Pages/default.aspx>.

## Triage categories

Expectant	Black triage tag color	Delayed	Yellow triage tag color
<ul style="list-style-type: none"> <li>• Victim unlikely to survive given severity of injuries, level of available care, or both</li> <li>• Palliative care and pain relief should be provided</li> </ul>		<ul style="list-style-type: none"> <li>• Victim's transport can be delayed</li> <li>• Includes serious and potentially life-threatening injuries, but status not expected to deteriorate significantly over several hours</li> </ul>	
Immediate	Red triage tag color	Minor	Green triage tag color
<ul style="list-style-type: none"> <li>• Victim can be helped by immediate intervention and transport</li> <li>• Requires medical attention within minutes for survival (up to 60)</li> <li>• Includes compromises to patient's Airway, Breathing, Circulation</li> </ul>		<ul style="list-style-type: none"> <li>• Victim with relatively minor injuries</li> <li>• Status unlikely to deteriorate over days</li> <li>• May be able to assist in own care: "Walking wounded"</li> </ul>	

Fig. 77.4 Triage categories. (From US Department of Health and Human Services: <https://chemm.hhs.gov/startpediatric.htm>.)

## 77.1 Interfacility Transport of the Seriously Ill or Injured Pediatric Patient

Corina Noje, Mary Beth Howard, and Bruce L. Klein\*

Patients often seek treatment at facilities that lack sufficient expertise to treat their conditions, necessitating transfer to more appropriate specialty centers. This is especially pronounced in pediatrics. Emergency medical services (EMS) providers or parents usually take children to local emergency departments (EDs) first, where their conditions and physiologic stabilities are assessed. Although bringing a child directly to the local ED may be proper logistically, community-based local EDs can be less than ideal for pediatric emergencies. Children have been reported to account for about 20% of all ED visits, but not all EDs have the necessary supplies for pediatric emergencies. Also, general EDs are less likely to have pediatric expertise or policies in place for the care of children. Outcomes for critically ill children treated in pediatric intensive care units (PICUs) are better than for those treated in adult ICUs. When pediatric critical care is required, transport to a regional PICU is indicated. In addition, often the type of subspecialty care needed (e.g., pediatric orthopedics) is available only at the pediatric center.

**Pediatric transport medicine** consists of the interfacility transfer of infants, children, and adolescents from community facilities to pediatric centers that can provide the needed level of expertise. Transport is performed by professionals proficient in pediatric transport using age-equipped ground, rotorcraft, or fixed-wing ambulances. Pediatric transport medicine is a multidisciplinary field comprising pediatric critical care and pediatric emergency medicine (PEM) physicians (and, sometimes for newborn infants, neonatologists); nurses, respiratory therapists, and paramedics with advanced training for pediatric transport; and communications specialists. The goal is to deliver quality pediatric care to the region's children, while optimizing the use of regional resources. For the individual child, the aim is to stabilize and, when appropriate, begin treating as soon as possible—that is, at the local ED and during transport, well before arrival at the referral center.

Models for pediatric transport services vary depending on the needs and available resources in a geographic region, but all should have certain basic components: a network of community hospitals and regional pediatric centers; an established communications and dispatch system that easily facilitates transfer to the pediatric center; ground and/or air ambulances; medical and nursing leadership from pediatric critical care or PEM (or neonatology); experienced pediatric **medical control physicians (MCPs)**; a multidisciplinary team of pediatric transport professionals specially trained and equipped to provide the appropriate level of care required during transport; operational and clinical policies

and procedures that guarantee safe, state-of-the-art, and timely pediatric critical care transport; and a database for quality and performance assessment.

### COMMUNICATIONS AND DISPATCH CENTER

Communications are one of the most vital components of a regional transport system. Treating a critically ill or injured child is generally an uncommon event for most community physicians. Therefore they need to know *whom, how, and when* to call for assistance in the stabilization and transfer of a pediatric patient. The communications and dispatch center provides a single telephone number for such calls.

The communications and dispatch center coordinates communications among the outlying facility, receiving unit, MCP, transport team, and other consultants. This center may be part of a hospital unit (e.g., ED, PICU), self-contained in a single institution (e.g., emergency communications and information center), or based off-site as a freestanding center coordinating communications and dispatch for multiple transport programs.

Staffing varies depending on the type of center. On-duty nurses or physicians may receive calls at unit-based models with low volumes. In contrast, dedicated communications specialists usually staff self-contained or freestanding centers, which tend to be busier. The communications specialist has numerous responsibilities, including answering the referring physician's call promptly; documenting essential patient demographic information; arranging for immediate consultation with the MCP; dispatching the transport team to the referring facility expeditiously; updating the referring facility with any changes in the arrival time; and coordinating medical control and other necessary transport-related calls. The transport team must be able to contact the receiving and referring facilities immediately, when necessary. Furthermore, with advances in technology and wireless communication systems, **telemedicine**—either *interactive* (synchronous) or *store and forward* (asynchronous)—is being used during pediatric transport, and certain programs have incorporated it into their routine transport operations.

### MEDICAL CONTROL PHYSICIAN

The MCP is involved in the clinical care and safe transport of the patient from the time of referral through arrival at the receiving hospital unit. The MCP's oversight increases once the transport team arrives at the referring facility. The MCP should have expertise in pediatric critical care or PEM (or sometimes neonatology). Besides having the knowledge required to stabilize a critically ill or injured child, the MCP must be familiar with the transport environment; the transport team members' resources and capabilities; the program's policies and procedures; and the region's geography, medical resources, and regulations regarding interhospital transport. The MCP must possess good interpersonal and communication skills and must be able to maintain

\* Adapted initially from Dr. Lorry R. Frankel's chapter in the 18th edition of this book. We also want to thank Dr. Beth Edgerton, who co-authored a prior version of this chapter.

collegiality with the referring hospital's staff during a potentially difficult and stressful situation.

Once a transport call is received, the MCP must be immediately available to confer with the referring physician. Although the MCP may have other responsibilities, these transport responsibilities take priority in order to avoid undue delays when transferring a critically ill child. Often the MCP recommends further testing or therapeutic interventions that can be delivered by the referring hospital before the transport team arrives. The MCP may seek additional guidance from other specialists, as necessary. Because the child's condition may change rapidly, the MCP must remain ready to give additional advice. All conversations and recommendations regarding the care of the patient should be documented. Some centers record these conversations.

After discussion with the referring physician—and when warranted, with the transport staff—the MCP determines the best team composition and vehicle for transport. The MCP usually does not accompany the team but remains available to supervise care. With advances in video conferencing capabilities, there has been increased use of telemedicine in the pediatric transport medical direction process. For some acutely ill patients or those requiring visual diagnoses, telemedicine has been reported to improve disposition at the receiving hospital, potentially leading to improved clinical outcomes.

### TRANSPORT TEAM

Transport team composition varies greatly among programs—and sometimes within an individual program. The team's composition is based on a variety of factors, including the child's age; the severity of the illness or injury; the distance to the referring facility; the transport vehicle used; the team members' advanced practice scope and abilities; the referrer's insistence that a physician be present; the program's historical professional makeup; and the region's staffing regulations. The pediatric transport workforce may include physicians, advanced practice providers, nurses, respiratory therapists, and paramedics who have expertise in pediatric critical care, PEM, or neonatology (in some cases), as well as advanced education and training in those cognitive and procedural areas important for pediatric critical care transport. Physician trainees—usually fellows and, less often, residents—may also participate in transport in some capacity. There is a lower incidence of transport-related morbidity for critically ill and injured children transported by pediatric specialty teams than for those transported by generalist teams. Nevertheless, in-transit critical events occur in ~10% of pediatric critical care transports.

Various scoring systems that can help guide team composition and/or mode of transport have been developed to aid in transport planning. A team member's training, experience, and skill in treating critically ill patients are more important considerations than that team member's professional degree. Team members must understand basic pediatric pathophysiology and collectively must be able to assess and monitor a critically ill or injured child; manage the airway and provide respiratory support; obtain vascular access; perform point-of-care testing; and administer fluids and medications (including infusions) typically used in pediatric critical care transport. They must be familiar with the physiologic alterations and practical difficulties of the transport environment and, importantly, must be comfortable working in an out-of-hospital setting. Physicians are less often deployed on transport teams in part because of the advanced training that other healthcare professionals on the transport team receive.

The transport team should have a designated team leader who, in addition to the team leader's many other responsibilities, interacts with the MCP during the transport. Once the team arrives at the referring facility, the team should reassess the child's condition, review all the pertinent diagnostic studies and therapies, and discuss the situation with the referring staff and parents. If the patient's condition has changed significantly, the team leader may need to contact the MCP for additional advice. Otherwise, the team leader should generally notify the MCP before starting to bring the child to the receiving facility. Any care delivered by the team during transport should be documented, and copies of all medical records—including laboratory data, radiographs, and scans—should accompany the child to the pediatric center.

The receiving unit must be updated before arrival so it can finalize preparations for the patient.

### GROUND VS AIR AMBULANCE

Transport vehicle options include ground, rotorcraft, and fixed-wing ambulances. Vehicle selection depends on the child's emergency needs, transport team's capabilities, any out-of-ordinary staffing or equipment requirements (e.g., extracorporeal membrane oxygenation, inhaled nitric oxide, heliox), referring facility's abilities, distance, terrain, traffic patterns, ground or air ambulance availability, helicopter landing pad or airport access, weather conditions, and expense.

The transport vehicle must be equipped with electrical power, oxygen, and suction and must have sufficient space for the equipment and supplies that the team brings along—stretcher or isolette, monitor, ventilator, oxygen tank(s), medication pack(s), infusion pumps, and more. Compared with helicopters, ambulances typically are more spacious and able to carry more weight, so they can accommodate larger teams and more equipment. Another advantage of ground ambulance transport is the ability to stop en route if the patient's condition deteriorates; this may facilitate the performance of certain interventions or procedures, such as intubation.

An airplane may be able to fly to an area when distance (>150 miles), altitude, or weather precludes helicopter use. However, the use of an airplane necessitates several ambulance transfers, with their attendant delays and additional risks. There also are delays when the plane must fly from a remote base to the program's jurisdiction.

### TRANSPORT PHYSIOLOGY

When possible, the transport team tries to provide the same care during transport as the patient would receive in the specialty center. This can be difficult, however, because of limitations in personnel, equipment, and space, as well as other environmental challenges.

The team and child are subjected to variable intensities of background noise and vibration while traveling in the vehicle cabin. **Noise** can impair the team's ability to auscultate breath sounds and heart sounds or accurately measure the blood pressure manually—another reason for monitoring vital signs mechanically and relying on other assessment modalities, such as the level of mentation, skin color, and capillary refill. For rotor transports in particular, the crew and patient should wear helmets or headphones (or another wearable noise attenuator) to mitigate noise. **Motion** and **vibration** are additional transport hazards and can lead to increased metabolic rate, shortness of breath, and fatigue in the patient, as well as motion sickness in the patient and staff.

On fixed-wing or certain rotary-wing transports, the patient may suffer adverse physiologic effects from **altitude**. With increasing altitude, the barometric (atmospheric) pressure decreases, and gas expands to occupy a greater volume due to the decreased pressure exerted on it. Therefore, as barometric pressure drops with altitude, the partial pressures of inspired oxygen ( $P_{iO_2}$ ) and, consequently, arterial oxygen ( $P_{aO_2}$ ) decrease, as does the arterial oxygen-hemoglobin saturation ( $SpO_2$ ). For example, at 8,000 feet—an elevation at which unpressurized airplanes may fly, as well as the effective cabin altitude for many pressurized airplanes flying at 35,000–40,000 feet—the barometric pressure,  $P_{iO_2}$ ,  $P_{aO_2}$ , and  $SpO_2$  fall to 565 mm Hg, 118 mm Hg, 61 mm Hg, and 93%, respectively. In comparison, the barometric pressure,  $P_{iO_2}$ ,  $P_{aO_2}$ , and  $SpO_2$  are 760 mm Hg, 159 mm Hg, 95 mm Hg, and 100% at sea level. Although healthy individuals usually tolerate these changes well, patients with respiratory insufficiency, pulmonary hypertension, significant blood loss, or shock may decompensate and should receive supplemental oxygen and/or have the cabin pressurized at sea level.

Gases expand up to 10% at the few thousand feet where helicopters typically fly, and approximately 30–40% at 8,000 feet. Gases within the body itself also expand as the altitude increases. The degree of gas expansion must be considered during transport via air of any patient with pneumocephalus, pneumothorax, bowel obstruction, or another condition involving entrapped gas. Before transport, a pneumothorax should generally be decompressed and a nasogastric tube inserted for ileus.

## SAFETY

Safety is of paramount importance and mandates constant vigilance by everyone involved. Accident rates for pediatric air and ground transport have been estimated at approximately 1 in 1,000 transports. The team should routinely attend pilot briefs and perform safety inspections of the vehicles and equipment, aided by checklists. When in doubt, the MCP should solicit input from the staff about whether to transport via air or ground ambulance or to employ lights and sirens, decisions that cannot be taken lightly. The pilot's or driver's judgment as to the safety of proceeding during inclement weather or with a mechanical problem must not be overruled.

Organizations such as the Federal Aviation Administration (FAA) and the National Transportation Safety Board (NTSB) play a role in ensuring safe interfacility transport. The **Commission on Accreditation of Medical Transport Systems (CAMTS)** is an independent, peer-review organization established in 1990 in response to the number of air medical accidents in the 1980s. CAMTS, through voluntary participation, audits and accredits fixed-wing, rotary-wing, and ground interfacility medical transport services.

## FAMILY-CENTERED CARE

Family-centered care represents a philosophy that respects the important role that family members play in a child's care. It recognizes family members and healthcare providers as partners in caring for the child. Family presence during transport is beneficial because it provides support to both children and parents in stressful situations and assists healthcare providers in delivering care to patients with complex and chronic medical problems.

As care is transitioned from the referring hospital, it is the transport team's responsibility to maintain culturally sensitive, family-centered care. The team meets with family members to explain the transport process, help obtain consent, and discuss anticipated management. When possible, the transport team should attempt to accommodate a family member's presence onboard. However, the family member and child may need to be separated when the child is critically ill and rapid transport is essential, or in case of space or weight limitations in the air or ground ambulance. In these situations, it is important that family members have a clear understanding of how the child will be cared for during the separation.

## REFERRING HOSPITAL RESPONSIBILITIES

Transfer of a child to another facility requires written documentation by the referring physician of the need and reasons for transfer, including a statement that the risks and benefits, as well as any alternatives, have been discussed with the parents. Informed consent should be obtained from the parent/legal guardian before transfer.

Federal law under the Emergency Medical Treatment and Active Labor Act (EMTALA), part of the Consolidated Omnibus Budget Reconciliation Act (COBRA), imposes specific requirements that a patient presenting to an ED be given a medical screening examination without regard for ability to pay. If on examination an emergency medical condition is found, the hospital is required to stabilize the patient or to transfer the patient to another facility if unable to stabilize the patient (or if requested by the patient in writing after being informed of the risks). The primary requirement is that the referring physician must certify that the medical risks of transfer are outweighed by its potential benefits. The receiving hospital must agree to accept the patient if it has the space and staff to provide the necessary level of care. The transferring hospital is responsible for arranging for the transfer and ensuring that it is performed by qualified medical personnel with appropriate equipment. The transferring hospital must also send copies of the patient's medical records and test results, even those that become available after the transfer is complete.

Some referring hospitals have entered into transfer agreements with specialty centers to facilitate the smooth and safe transfer of pediatric patients. Having prepared forms for all the purposes noted earlier also aids in the transfer process.

Each hospital needs to review its facility's guidelines; if established guidelines do not exist, the Emergency Medical Services for Children National Resource Center in partnership with the Emergency Nurses Association and the Society of Trauma Nurses has developed the "Interfacility Transfer Tool Kit for the Pediatric Patient" (available at: <https://emscimprovement.center/education-and-resources/toolkits/interfacility-transfer-toolbox/>). This tool kit includes the essentials for comprehensively and safely transferring the pediatric patient to the most appropriate level of care in a timely manner.

## EDUCATIONAL OUTREACH

Besides safe and rapid transport, regional pediatric transport programs (and their specialty centers) have an obligation to provide educational opportunities to community healthcare providers so that these providers can acquire the necessary skills to evaluate and stabilize a critically ill or injured child until the transport team arrives. These learning activities may include transport case reviews; lectures on pediatric acute care topics; resuscitation and related programs such as the Pediatric Advanced Life Support (PALS) course, Advanced Pediatric Life Support (APLS) course, Pediatric Education for Prehospital Professionals (PEPP) course, and S.T.A.B.L.E. (sugar and safe care, temperature, airway, blood pressure, lab work, emotional support) program; and rotations through the specialty center's pediatric ED and PICU. These activities also help cement relationships with the referring facility's staff.

Visit Elsevier eBooks+ at [eBooks.Health.Elsevier.com](https://eBooks.Health.Elsevier.com) for Bibliography.

## 77.2 Risk Adjustment and Outcomes Measurement of Pediatric Emergency Medical Services

Anna K. Weiss

Health services research has demonstrated wide variation in implementation of equitable, evidence-based care for pediatric patients in U.S. hospitals, a reality that can negatively affect the health of children and youth (see [Chapter 2](#)). The complexities of delivering high-quality, evidence-based care are magnified in the emergency department (ED), where patients are often in crisis, patient-physician interactions are brief, and the variety and volume of complaints and diagnoses are immense. In the context of this frenetic environment, practitioners can only assess their local system relative to recognized benchmarks and standards of care if there are clear guidelines for measurement of performance. However, no two places of practice are the same, and a single ED may differ significantly from a theoretical "best practice" standard. To reflect this, practitioners seeking to make local improvements must assess not only raw outcomes (e.g., throughput times, mortality, patient satisfaction) but must also adjust for severity of illness, case mix, and risk of morbidity.

## OUTCOME MEASURES IN EMERGENCY MEDICAL SERVICES FOR CHILDREN

To ensure delivery of equitable, evidence-based care in the ED, pediatric emergency medical systems must support the use of national standards for emergency care performance measurement. The *Donabedian structure-process-outcome model* provides a framework for most contemporary quality measurement and improvement activities. In this framework, **structural** elements provide indirect quality-of-care measures related to a physical setting and resources (e.g., available staff, equipment, and supplies). **Process** indicators provide a measure of the quality of care and services by evaluating the method or process by which care is delivered, including both technical and interpersonal components. **Outcome** elements describe valued results related to lengthening life, relieving pain, reducing disabilities, and satisfying the consumer.



A true *outcome-based* approach to **performance improvement** describes observable measures such as mortality, risk of organ system failure, and disability. An alternative approach is a *resource-based* outcome measure with a definition that is relative to the level of care required. Children who are more ill generally require more resources; therefore resource use across groups of patients reflects relative **severity of illness** within the groups, provided clinicians have a similar approach to practice. Examples of resource-based outcomes include need for hospital admission (ED disposition), ED length of stay, costs, and diagnostic and therapeutic interventions performed in the ED. Although this approach provides a measurement of clinical activity, when used in a vacuum it does not indicate whether the patient receiving the therapeutic interventions or resources actually needed them (i.e., data may also reflect physician behavior and/or [lack of] experience). Therefore some other assessment is needed that incorporates information on *how sick* the patient is or their specific diagnosis.

Table 77.3 provides a list of performance measures for pediatric ED care developed by the **Emergency Medical Services for Children Innovation and Improvement Center** supported by the Health Resources and Services Administration of the U.S. Department of Health and Human Services.

### RISK ADJUSTMENT

The purpose of measuring outcomes in the ED is to evaluate **performance**—offering EDs and other components of the healthcare system the opportunity to make meaningful improvements over time using benchmarks within and between units. When making comparisons over time, one must ensure that patient-related attributes (e.g., age, preexisting conditions, severity of illness) have not changed; otherwise, one may be looking at changes in demography and case mix rather than at true change in performance. To ensure fair and meaningful measurement across time, **risk adjustment** is necessary to *level the playing field*. As an example, illness severity typifies the concept of *risk*—the higher the severity, the higher the risk of a given outcome. Without risk adjustment, EDs with sicker patients may appear to have poorer outcomes.

### Risk Adjustment Tools in the ED

Although other risk adjustment scoring systems—such as the PRISM score for pediatric critical care—use mortality and morbidity as primary outcomes, this approach is not appropriate for the ED setting. Across U.S. EDs, pediatric mortality is low, and a patient's presenting physiology may reflect interventions performed in the prehospital setting. Similarly, eventual morbidity and/or mortality may reflect what happens in the PICU or during hospital ward care.

**Table 77.3** Stakeholder-Endorsed Performance Measures for Pediatric Emergency Care

- Measuring weight in kilograms for patients <18 years of age
- Presence of a method to identify age-based abnormal pediatric vital signs
- Pediatric equipment in the ED
- Presence of on-site pediatric coordinator(s)
- Parent/caregiver understanding of discharge instructions
- Door to provider time
- Total length of stay
- Reducing pain in children with acute fractures
- Children with minor head trauma receiving a head CT scan
- Protocol for suspected child abuse in place
- Systemic corticosteroids in asthma patients with acute exacerbation
- Evidence-based guideline for bronchiolitis
- Reducing antibiotic use in children with viral illnesses
- Return visits within 48 hours resulting in admission
- Medication error rates

ACEP, American College of Emergency Physicians; AAP, American Academy of Pediatrics; ENA, Emergency Nurses' Association; GCS, Glasgow Coma Score; CT, computed tomography.

In the ED, the choice of a risk adjustment tool depends on ED-specific outcomes of interest. Two general risk adjustment tools have been developed specifically for PEM, the second-generation Pediatric Risk of Admission (PRISA II) score and the Revised Pediatric Emergency Assessment Tool (RePEAT).

### Pediatric Risk of Admission II

PRISA II uses components of acute and chronic medical history as well as acute physiology to determine the probability of hospitalization. The outcome measure of interest is *mandatory hospital admission* (admissions using therapies that are best delivered in the inpatient setting). Table 77.4 lists the patient-related attributes contributing to the PRISA II risk adjustment score. Analytic models, including the PRISA II score, have good **calibration** (how well the probabilities predicted from the model correlated with the observed outcomes in the population) and **discrimination** (the ability to categorize subjects correctly into the categories of interest) with respect to mandatory hospital admission. Construct validity of the PRISA II score has been demonstrated by measuring rates of the secondary outcomes: mandatory admission, PICU admission, and mortality. As the probability of hospital admission rises, the proportion of patients with these increasing care requirements also increases. This finding supports the use of the PRISA II score as a measure of illness severity. PRISA II has also been used to demonstrate racial/ethnic differences in severity-adjusted hospitalization rates, as well as variation in hospitalization rates between teaching and nonteaching hospitals.

### Revised Pediatric Emergency Assessment Tool

RePEAT uses a limited set of data collected at the time of ED triage to model severity of illness as reflected by the level of care provided in the ED—for example, routine assessment (clinical examination only ± nonprescription medicine) vs specific ED care (ED diagnostics and/or therapeutic) vs hospital admission. In this model, it is assumed that patients needing a higher level of care have a higher severity of illness. Table 77.5 lists the patient-related attributes contributing to

**Table 77.4** Elements of the PRISA II Score

- Age
- Injury severity
- Temperature
- Referral status (e.g., self-referral vs referral from physician's office or from another ED)
- Presence of:
  - Abdominal pain in an adolescent
  - Immunodeficiency
  - Indwelling medical device
  - Controller asthma medication
  - Decreased mental status
  - Low systolic blood pressure (<70 neonates and infants; <83 children; <100 adolescents)
  - High diastolic blood pressure (>59 neonates and infants; >70 children; >90 adolescents)
  - Low serum bicarbonate value (<20 mEq/L)
  - High potassium value (>4.9 mEq/L)
  - High blood urea nitrogen value (>80 mg/dL)
  - High white blood cell count (>20,000/mm<sup>3</sup>)
  - Oxygen therapy other than during inhaled bronchodilator treatments
  - Low bicarbonate and high potassium values

**Table 77.5** Elements of the RePEAT Score

- Age
- Chief complaint
- Triage category
- Current use of prescription medications
- Arrival via EMS (ground/air)
- Heart rate (relative to age-based norms)
- Respiratory rate (relative to age-based norms)
- Temperature

the RePEAT risk adjustment score. Analytic models such as RePEAT have good calibration and discrimination with respect to predicting ED care and hospital admission. Furthermore, analytic models that compare costs and length of stay between EDs are improved by adjusting for severity of illness using the RePEAT score. RePEAT is a reasonable objective marker of severity of illness that could be used in the administrative process comparing outcomes between EDs. With implementation of scoring systems such as PRISA II and RePEAT, U.S. EDs can benchmark the care that they provide to children and make meaningful improvements to ensure that this care is equitable and evidence-based.

Visit Elsevier eBooks+ at [eBooks.Health.Elsevier.com](http://eBooks.Health.Elsevier.com) for Bibliography.

### 77.3 Principles Applicable to the Developing World

David M. Walker and Victorio R. Tolentino Jr.

The maturity of pediatric emergency medicine (PEM) in any given area depends on the healthcare priorities and resources of that geographic or physical setting. The places in which emergency care takes place range from the community (especially for those with no access to organized medical care) to state-of-the-art pediatric emergency departments (EDs), typically in larger population centers. The scope ranges from the care of the individual patient to the management of populations of children involved in large-scale disasters. Barriers to quality care vary in each situation and in each part of the world, with the implication for the PEM practitioner that the care provided must be relevant to the local context of healthcare.

#### CONTINUUM-OF-CARE MODEL

This Emergency Medical Services for Children (EMSC) framework can also be applied to discussion of emergency care for children on a global level (see [Chapter 77](#)). Although medical infrastructure in some parts of the developing world may not be consistent or well organized, or has been weakened by civil strife, natural disasters, or economic loss, the EMSC framework can still apply generally to individual healthcare systems.

#### Prevention Infectious Diseases

International child health has focused mainly on reducing the incidence of preventable childhood illnesses, primarily through immunization initiatives. Enormous advances have been realized in measles, neonatal tetanus, and polio; wild-type smallpox was eradicated in 1978. Although there are advocates for providing primary care interventions (e.g., vaccinations) in the ED, the role of the PEM practitioner in this area of prevention has been limited.

#### Injuries

Injuries are a leading cause of childhood morbidity and mortality. Unintentional injuries constitute 90% of injury mortality to children 5-19 years old and are the cause of 9% of the world's mortality (see [Chapter 14](#)). Intentional injuries, which remain underrecognized and underreported, make a smaller but significant contribution. Unintentional injuries cause more than 2,000 childhood deaths daily, or 950,000 annually worldwide. The burden of these deaths is borne disproportionately by children in middle- and lower-income countries, where >95% of all injury-related deaths occur. For each of these deaths, many more children are permanently disabled, and an even larger number are treated and released without permanent sequelae.

Traffic-related injuries, burns, and drowning are the main causes of injury-related mortality in children. The World Health Organization (WHO) and United Nations Children's Fund (UNICEF) have outlined several proven injury prevention strategies of which child health practitioners in the global community must be aware. Although these

strategies have proved effective, the data are based on U.S. research and may not be generalizable to other countries.

#### Out-of-Hospital Care

Out-of-hospital care comprises access to emergency services, pre-hospital care, and interfacility transport of patients. Morbidity and mortality arise from delayed or limited access to emergency care, lack of prehospital care, transport without proper monitoring or trained personnel, or delayed transport to a higher level of care. Safe transport of seriously ill children is a neglected global health issue. An emergency response system must address the following links in the patient's care: a communication system with prompt activation of emergency medical services (EMS), the correct assessment and initial treatment of the patient, and the rapid transport to definitive care.

#### Access to Care

When a child is injured or ill, a parent or caretaker must be able to access help and activate EMS. In the majority of low- and middle-income countries, no universal emergency numbers have been established, requiring access by direct dialing to an ambulance, if such private services exist. In countries that have a universal emergency number, barriers remain related to absence of phones in some households, unclear addresses in rural areas, and insufficient reach of the emergency system.

In most low- and middle-income countries, the family must bring the ill or injured child to the health facility for stabilization and treatment. For this to occur, families must also overcome financial and geographic barriers, which can result in delayed presentation for care. This delay predictably increases the likelihood of associated complications and decreases the likelihood of full recovery and survival.

#### Prehospital Care

In regions with maturing EMS systems, there must be adequately trained personnel to stabilize and transport the child to a medical facility. The quality and level of training of such prehospital personnel vary among countries and within regions of the same country. In urban areas, there is a greater concentration of medical care and therefore a greater opportunity to have strong prehospital training. In most of Asia and sub-Saharan Africa, trained personnel are used primarily to transfer patients between health facilities, not from the initial site of illness or injury. In most high-income countries, medical services are dispatched to the patient.

Around the world, the effort to establish standardized approaches to prehospital care exists primarily in the form of courses to educate EMS and hospital personnel in the emergency management of patients. The WHO manuals *Prehospital Trauma Care Systems* and *Guidelines for Essential Trauma Care* focus on guidelines for prehospital and trauma care systems that are affordable and sustainable. The American Academy of Pediatrics (AAP) course "Pediatric Education for Prehospital Professionals" is a dynamic, modularized teaching tool designed to provide specific pediatric prehospital education that can be adapted to any EMS system. [Table 77.6](#) describes additional prehospital resources.

Although most middle- and high-income countries have a system of trained EMS workers, lower-income countries lack this advanced tier of emergency care. In these countries, commercial drivers, volunteers, and willing bystanders provide the first line of care. Training a cadre of first responders can rely on existing networks of aid or can be drawn from specific populations, such as students, soldiers, or public servants. Training needs to emphasize basic lifesaving and limb-saving interventions, including how to stop bleeding and support breathing, access advanced care, and splint broken limbs. In Ghana, for example, taxi drivers participated in a first-aid course that relied heavily on demonstration and practice rather than knowledge transfer through didactic sessions. Taxi drivers were selected because they already provided much of the transport for injured patients. Two years after the course, external evaluators favorably rated the quality

**Table 77.6** Pediatric Emergency Care Resources**PREHOSPITAL CARE**

## Emergency Pediatric Care

Course developed by the National Association of Emergency Medical Technicians (NAEMT) focused on field treatment of sick and injured children. Course is open to physicians, nurses, EMTs, and paramedics.

Website: <https://www.naemt.org/education/epc>

## Pediatric Trauma Life Support for Prehospital Care Providers

An 8-hour pediatric prehospital course sponsored by the global organization International Trauma Life Support (ITLS)

Website: <https://www.itrauma.org/education/itls-pediatric/>

## Pediatric Education for Prehospital Professionals (PEPP)

Curriculum designed specifically to teach prehospital professionals how to assess and manage ill or injured children.

Website: <https://www.peppsite.com/>

**HOSPITAL CARE**

## Pocket Book of Hospital Care for Children: Second Edition

WHO publication providing guidelines for the management of common illnesses in resource-limited settings; incorporates both the Emergency Triage Assessment and Treatment (ETAT) and Integrated Management of Childhood Illness (IMCI) guidelines.

Website: <https://www.who.int/publications/i/item/978-92-4-154837-3>

## African Federation of Emergency Medicine (AFEM) Handbook of Acute and Emergency Care

Management strategies organized according to low-, moderate-, and full-resource settings.

Website: <https://afem.africa/project/afem-handbook-of-acute-and-emergency-care/>

## African Federation of Emergency Medicine (AFEM) Rapid Approach Protocols for Children

Open-access clinical protocols for common presenting problems in children. Includes differential diagnoses and recommendations on initial investigations.

Website: <https://www.dropbox.com/sh/cwhcl3eu8vrwqu/AAA-MSDs9u3Y0S1gwU1R3hFxa?dl=0>

## African Federation of Emergency Medicine (AFEM) Tier 1 Paediatric Emergency Medicine Curriculum

Open-access curriculum targeted to nurses, EMS personnel, pharmacists, and other providers who care for acutely ill and injured children. Organized into modules by clinical presentation or disease processes.

Website: [https://www.dropbox.com/sh/pgv8zd5y6z1elvo/AAA\\_df2fUj1bSzABbjZFjSgfa?dl=0](https://www.dropbox.com/sh/pgv8zd5y6z1elvo/AAA_df2fUj1bSzABbjZFjSgfa?dl=0)

## Standards of Care for Children in Emergency Departments, Version 3.0

Open-access document from the International Federation of Emergency Medicine that proposes worldwide standards for pediatric emergency care.

Website: [https://www.ifem.cc/standards\\_of\\_care\\_for\\_children\\_in\\_emergency\\_departments\\_v3\\_2019](https://www.ifem.cc/standards_of_care_for_children_in_emergency_departments_v3_2019)

## African Emergency Nursing Curriculum

Open-access educational framework for emergency nursing practice in resource-limited settings. Developed by the African Federation of Emergency Nurses.

Website: <http://afem.co.za/wp-content/uploads/2017/10/AFEM-African-Emergency-Nursing-Curriculum.pdf>

**HUMANITARIAN EMERGENCIES**

Manual for the Health Care of Children in Humanitarian Emergencies WHO publication that provides comprehensive guidance on childcare in emergencies; includes information on care of traumatic injuries and mental health emergencies.

Website: <https://www.who.int/publications/i/item/9789241596879>

## Pediatric Disaster Care Centers of Excellence (United States)

Coalition of medical centers and government agencies established to guide the delivery of pediatric healthcare services in a disaster.

Website: <https://emscimprovement.center/domains/preparedness/asprcoe/>

**MENTAL HEALTH EMERGENCIES**

## The Mental Health &amp; Psychosocial Support Network

A hosted online practice network organized around crowdsourcing of mental health and psychosocial support resources for use in emergencies and ongoing humanitarian crises in the developing world.

Website: <https://mhps.net/>

## Save the Children Psychological First Aid Training

Practitioner training manual dedicated to the provision of psychological first aid to children exposed to trauma.

Website: <https://resourcecentre.savethechildren.net/document-collections/save-children-psychological-first-aid-training>

## Psychological First Aid: Guide for Field Workers

Open-access training manual from the WHO for those who may respond to large-scale crises.

Website: <https://www.who.int/publications/i/item/9789241548205>

**ACCESS TO ACADEMIC PUBLICATIONS RELEVANT TO PEM**

## PEMdatabase.org

A website devoted to pediatric emergency medicine (PEM). Contains links to conferences, evidence-based medicine reviews, research networks, and professional organizations.

Website: [www.pemdatabase.org](http://www.pemdatabase.org)

## HINARI Access to Research for Health Programme

Program established by WHO and others to enable developing countries to gain access to one of the world's largest collections of biomedical and health literature.

Website: <https://partnership.who.int/hinari>

**ORGANIZATIONS INVOLVED IN GLOBAL PEM ACTIVITIES**

American College of Emergency Physicians (ACEP) Ambassador Program Provides the names of U.S.-boarded emergency medicine physicians who can provide advice and information on issues pertaining to the progress and status of emergency medicine in their assigned countries.

Website: <https://www.acep.org/intl/ambassador-program/>

## U.S. Agency for International Development (USAID)

Government agency providing U.S. economic and humanitarian assistance worldwide.

Website: <https://www.usaid.gov/global-health/health-areas/maternal-and-child-health/technical-areas/child-health>

Child Health and Development Unit, World Health Organization (WHO) United Nations agency dedicated to child health.

Website: <https://www.who.int/teams/maternal-newborn-child-adolescent-health-and-ageing/child-health>

## United Nations Children's Fund (UNICEF)

Organization dedicated to providing lifesaving assistance to children affected by disasters and to protecting their rights in any circumstances; formerly United Nations International Children's Emergency Fund.

Website: [www.unicef.org](http://www.unicef.org)

## Safe Kids Worldwide

International nonprofit organization dedicated to preventing unintentional childhood injury.

Website: [www.safekids.org](http://www.safekids.org)

of their care compared with untrained drivers. In rural areas, such first responders become vital in providing emergency interventions when more definitive care is distant. Thus a system of trained first responders forms the foundation of an effective prehospital system.

In the French model, a physician, often an emergency medicine specialist, will review calls for acuity and can dispatch a physician-led team by ambulance to go to the patient's home to assess, stabilize, and initiate treatment. This Franco-German system is used in other countries,

including many in Latin America and Europe. There are no clear data on the cost-effectiveness and patient outcomes associated with delivery of patients to the nearest facility vs bringing hospital resources to the patient.

**Methods of Transport**

In many low-income countries, there is no reliable means of transport. Health centers may only have one vehicle for transport to a



higher-level facility. This vehicle may also be used for outreach primary care services, such as offering immunizations and collecting drugs and equipment from a central supply location, and sometimes, improperly for personal reasons by local officials or politicians. In large cities, taxis and auto rickshaws are frequently used because they are rapidly available, well disseminated, and able to pass around traffic jams. Where organized prehospital systems exist, different types of vehicles are adapted for emergency transportation. The WHO recommends identifying transport vehicles in advance, choosing vehicles that can be repaired and maintained locally, and equipping the vehicles according to recognized standards. The provision of available and appropriately staffed and equipped transport vehicles is crucial to the realization of recommended emergency care plans.

### Hospital-Based Care

Once a child has reached a medical facility for the care of an injury or illness, adequate emergency services should be available. In many countries the ED serves only as a triage area where patients are distinguished by their likely disease process and directed for admission to the corresponding unit within the hospital. Strengthening emergency services includes seeing the ED as a unit where definitive treatment can be provided to the ill and injured child. Critically ill children must receive not only prompt care but also correct care. Such expedience and accuracy are ensured by implementation of an effective triage system, moving the sickest patients to immediate care and standardizing the initial care of emergency conditions.

### Triage

Too often, children presenting to EDs are treated on a first-come first-served basis in an approach that creates long waiting times for critically ill children, a contributor to unnecessary mortality. Medical facilities should adopt an efficient and effective triage system to respond rapidly to the needs of patients and to assign the appropriate amount of resources. The WHO has developed a course entitled **Emergency Triage Assessment and Treatment (ETAT)**. This course teaches emergency, priority, or nonurgent signs and how to provide emergency treatment for life-threatening conditions. ETAT emphasizes the evaluation of a patient's ABCD status to identify emergency situations—the patency of the airway (A), the quality of breathing (B), the quality of circulation and presence of coma or convulsions (C), and the presence of severe dehydration (D).

One of the benefits of the ETAT guidelines is that they can be adapted to centers with limited resources and are applicable to areas with high morbidity and mortality from meningitis, dehydration, malaria, respiratory illness, and malnutrition. Another benefit is that the care algorithms are based on limited diagnostic studies, that is, hemoglobin measurement, blood smear for malaria, and bedside blood glucose testing. Widely accepted triage assessment guidelines are teachable to emergency care staff, and their adoption can provide better organization within a healthcare center. At the Queen Elizabeth Central Hospital in Blantyre, Malawi, for example, the institution of triage and rapid treatment in its emergency care center led to a 50% decrease in the mortality of children within 24 hours of presentation to the hospital, with a further 50% decrease as implementation and practice of triaging patients have continued.

Beyond triage, education on overall emergency center organization is a low-resource intervention that can reduce some of the obstacles to quality care delivery. Additionally, the arrangement of short-stay areas (hydration and infusion rooms) within or near the ED can lessen the burden on inpatient units.

### Pediatric-Specific Emergency Centers

Anecdotally, most countries have developed at least one pediatric-capable center, usually as part of an academic medical center. The emergency services in these centers are variable, but certainly can be a starting point from which to build overall improvement in pediatric emergency care.

### Practitioners

Throughout the world, nurses, paramedics, nonphysician clinicians, and nonspecialist physicians deliver most of the care to acutely ill or injured children. The majority of sick children attend local clinics or district or central hospitals, where financial and human resources are not always matched to the potential acuity of presenting patient complaints. Nominal supervision is provided to staff attending these patients. Pediatric EDs located in tertiary hospitals are often staffed by training physicians with little or no supervision from faculty, who themselves may have limited exposure to or training in pediatric emergencies. General hospitals lack dedicated pediatric staff; guidelines as to which patients should be moved to a higher level of care are often not standardized and depend on local influences and/or cultural beliefs about health and illness.

### Clinical Guidelines

The **Integrated Management of Childhood Illnesses (IMCI)** guidelines were developed by the WHO and UNICEF to provide assistance in the initial triage and management of the presenting signs and symptoms of the major killers of children <5 years old in first-level health facilities (e.g., clinics, health centers, outpatient departments of hospitals). The flow charts within each chapter of the IMCI manuals allow easy accessibility to materials that can enhance education and outreach to less experienced health workers.

Evaluations in various countries of the implementation of IMCI guidelines have shown improvements in health worker performance and quality of care, as well as decreases in delay in treatment and mortality of the under-5 population. These guidelines also dramatically reduce the cost of healthcare. The WHO website provides all the necessary implementation tools, including course manuals and evaluation tools.

The International Federation of Emergency Medicine developed Standards of Care for Children in Emergency Departments to improve emergency care globally. These standards are not just aimed at dedicated EDs, but at any setting where emergency care takes place, regardless of the providers or the resources available. At the same time, however, the existence of the standards allows sites to advocate for improved resources dedicated to expertise in the various aspects of providing quality emergency care for children. The standards address design of care spaces, child- and family-centered care, assessment of ill and injured children, staff training and competencies, quality and safety, and disaster response.

### Trauma

Morbidity and mortality from trauma are among the most prevalent problems for children worldwide. Trauma care presents the challenge of sequential, often simple, interventions that must be performed in a timely manner to limit the severity of the outcome. However, with lack of specific training, signs and symptoms of pediatric trauma may go unrecognized or may be underappreciated. Trauma courses such as Advanced Trauma Life Support (ATLS) are educational tools that can be disseminated to improve the quality of care at emergency centers worldwide. For low-resource settings, the WHO has developed the Integrated Management for Emergency and Essential Surgical Care toolkit, which provides clear directions and reasoning for the initial care of injured patients. Not expressly addressed in the ATLS course is specific concern about child abuse as the cause of trauma. This is an area of pediatric care that many countries do not yet address comprehensively in their medical training, their law enforcement, or their judicial systems. The epidemiologic need for reliable trauma registries is great, as is the need to identify personnel with trauma management skill sets and dedicated trauma centers to serve as higher-level referral sites.

### Equipment

Pediatric emergency equipment guidelines are available for a variety of settings where acutely ill and injured children would present. Although these equipment guidelines may represent minimum supplies to treat



the widest variety of pediatric emergencies, the roles of substitution and improvisation often provide for the equivalent function of recommended supplies.

### Inpatient Services

After the initial stabilization, children requiring ongoing care are admitted to the hospital. The quality of inpatient services varies greatly depending on institutional and provider experience, comfort with pediatric conditions, and the resources available to treat them. The WHO has produced the *Pocket Book of Hospital Care for Children*, which is based on IMCI guidelines and focuses on inpatient management of high-morbidity/high-mortality illnesses common in developing countries.

### Mental Health Emergencies

The recognition of mental health conditions among the pediatric population is continuing to evolve. It is estimated that about 15% of children globally suffer from anxiety, depression, or other mental health challenges. The prevalence of mental health problems is likely higher, as much of the existing data comes from Europe and North America, whereas a majority of children live in middle- and lower-income regions of the world.

Mental health capacity varies by country and is reflective of cultural beliefs about mental health and the priority and funding that local governments have allocated to address these concerns. It is widely accepted that the current global mental health infrastructure fails to meet the existing demands of the world's population. These concerns are amplified in the developing world and disproportionately affect children whose lives are often touched by emotional and social trauma (e.g., poverty, natural disasters, armed conflict).

Increasingly, children are presenting to emergency settings in crisis. In many developing countries, mental health services are concentrated in urban settings and lacking in rural areas. Where there is no shortage of medical personnel, expertise in child psychiatry corresponds with the local development of this specialty. In areas with no formal mental health system, care is provided by an informal network of family members, faith healers, or community leaders who do not have formal medical training. It is essential that children presenting for mental health evaluation receive a comprehensive examination, as certain psychiatric presentations can be rooted in infectious diseases conditions or inadequate nutrition, which are prevalent in some developing world contexts.

The WHO has provided examples of best practice in the acute treatment of mental health conditions in *Hospital-Based Mental Health Services: Promoting Person-Centered and Rights-Based Approaches*. This document is available as a section of the *Guidance and Technical Packages on Community Mental Health Services* available on the WHO website. Although the publication does not include examples of pediatric-specific care, the document is meant to be tailored to the local context and can be adapted to the needs of children.

### Telemedicine

Telemedicine technology is one way to overcome provider shortages or geographic challenges that can affect the care of acutely ill and injured

children. Patients and families can potentially access basic emergency care through video-based platforms. The responding provider can use established triage techniques to help determine the severity of illness and the need for consultation at a healthcare center; they can also recommend basic first aid as needed.

Access to real-time lectures, case discussions, and conferences, led by experts in PEM, can increase the capacity of those in limited-resource settings to provide care for pediatric emergency patients. These educational offerings can also provide a forum for a bilateral exchange of ideas and perspectives. Expert consultations via real-time telemedicine programs or a store-and-forward process, in which the request for consultation is recorded and sent to an expert who can reply typically over email, can be used. Additionally, within a given region, telemedicine can link the referring hospital to the receiving hospital in order to collaborate on decisions about management and the need for transfer.

The success of telemedicine collaborations depends on a variety of factors, including availability of easy-to-use technology and reliable internet access.

### HUMANITARIAN DISASTERS

Children are a vulnerable population who experience disproportionate suffering during humanitarian emergencies, either natural (earthquakes, tsunamis, hurricanes, floods, droughts) or manmade (armed conflicts, terrorist attacks). The under-5 population is especially susceptible to infectious diseases, malnutrition, and trauma after disasters.

The WHO *Manual for the Health Care of Children in Humanitarian Emergencies* is based on IMCI guidelines and addresses the emergency care of children in disaster situations where hospital facilities and resources are not immediately available. It goes beyond the IMCI guidelines by discussing initial assessment and management of trauma, burns, poisonings, neonatal illness, and psychosocial problems, which are considered high priority in acute care settings.

### Exchange and Dissemination of Information

The WHO established the internet-based **HINARI** Access to Research for Health Programme in 2002 to provide institutions in low-resource countries free or reduced-cost access to medical literature. Registration for the program is required. Eligibility is based on national economic or development criteria.

Another valuable tool is the website [pemdatabase.org](http://pemdatabase.org). This nonproprietary site was started as an online resource for PEM practitioners. It contains links to PEM abstracts and articles, evidence-based reviews, pediatric resuscitation websites, and relevant journals, as well as PEM conferences and professional organizations.

In countries where internet access continues to be a barrier, resources for education and research may be limited to out-of-date textbooks and journals.

Visit Elsevier eBooks+ at [eBooks.Health.Elsevier.com](http://eBooks.Health.Elsevier.com) for Bibliography.

## Chapter 78

## Triage of the Acutely Ill Child

Anna K. Weiss and Frances B. Balamuth

Identifying the acutely ill child in the ambulatory setting is a challenge. Children presenting to pediatricians' offices, urgent care practices, and emergency departments (EDs) may have a range of illnesses from simple viral infections to life-threatening emergencies. Although most children in this setting will have a benign course of illness, it is incumbent on the pediatric practitioner to discern quickly and accurately which children are likely to deteriorate from potentially serious or life-threatening disease. When assessing an acutely ill child, practitioners must remember that the early signs of severe illness may be subtle. There are about five pediatric triage system tools that assess the severity of illness and thus the degree of needed interventions. One example is presented in Table 78.1.

## ASSESSMENT OF VITAL SIGNS

Assessment of vital signs is critical in all pediatric visits for acute illness, including temperature, heart rate, respiratory rate, and blood pressure. Normal vital signs vary with age. Although there have been increasing efforts to build evidence-based vital sign cutoffs for different age-groups, most institutions use nonempirically derived cutoffs such as those in Pediatric Advanced Life Support (PALS). **Tachycardia** is common in children presenting for acute care and can result from benign (fever, pain, dehydration) to life-threatening (septic shock, hemorrhage, multisystem inflammatory system in children [MIS-C], dysrhythmia, heart failure, hyperthyroidism) conditions. An abnormal heart rate should prompt a full history and physical examination, as described later, and careful *reassessment* (often multiple times) after the presumed cause is identified and treated. Most children will improve after initiation of simple interventions such as antipyretics or analgesia. Tachycardia that persists after fever, pain, and dehydration have been treated *must* be evaluated further, particularly if the child appears ill or has a deficit in perfusion or altered mental state.

**Tachypnea** is also common among ill children and has many causes, including fever, respiratory conditions (bronchiolitis, asthma, pneumonia), cardiac disease (heart failure), and metabolic acidosis (shock, poisoning, diabetic ketoacidosis). Like tachycardia, tachypnea often resolves with antipyretics in febrile children and should be reassessed to ensure resolution once fever has been managed. In cases where bronchiolitis and asthma have been ruled out, persistent tachypnea and fever can be a sign of pneumonia, even in the absence of focal lung findings on examination. Consider evaluation for metabolic acidosis in cases of significant tachypnea without apparent pulmonary or cardiac causes. **Apnea** is a sign of respiratory failure and should be treated emergently with bag-valve-mask ventilation and immediate ED evaluation.

**Hypotension** is rare in children and, when present, it is a sign of critical illness. Children with hypotension should be evaluated in an ED. Hypotension is evidence of decompensated circulatory shock and can result from severe dehydration, sepsis, hemorrhage, neurogenic spinal shock, anaphylaxis, or cardiogenic shock.

Pulse oximetry (oxygen-hemoglobin saturation, SpO<sub>2</sub>) should be assessed in children with respiratory or cardiac illness/compromise and in children with underlying abnormalities of oxygenation. Healthy children have SpO<sub>2</sub> >95%. The practitioner should consider evaluating for any underlying respiratory or cardiac causes in children with SpO<sub>2</sub> <93–95%. For children with underlying abnormalities, the child's baseline SpO<sub>2</sub> should be assessed and alterations from that baseline should be investigated further.

The combination of bradycardia, hypertension, and altered breathing known as **Cushing triad** can be a sign of life-threatening increased intracranial pressure (ICP) and should be evaluated in an ED. Anisocoria and a sixth cranial nerve palsy are other signs of increased ICP. **Toxidromes** should also be considered in children with abnormal combinations of vital signs (see Chapter 94).

## HISTORY

A thorough history is paramount to identifying patients whose condition will require prompt intervention. Obtaining an accurate history from young patients is challenging, particularly with preverbal or anxious children who are unable or unwilling to localize the source of their discomfort. In such instances, parents or caretakers often provide the most important information, and their perceptions of the child's course of illness must be carefully considered. Pediatricians should be guided by the patient's chief complaint to ask *open-ended questions* that help distinguish between benign and potentially life-threatening disease entities. The most common complaints leading to acute care visits among children include fever, headache and altered mental status, trauma, abdominal pain and vomiting, respiratory distress, and chest pain. Table 78.2 describes signs and symptoms and risk factors that should prompt immediate transfer to an ED or, if already in the ED, initiation of rapid intervention.

**Fever** is the most common reason for a sick-child visit. Most cases of fever are the result of self-limited viral infection. However, pediatricians need to be aware of the age-dependent potential for serious bacterial or viral infections, such as urinary tract infection (UTI), sepsis, meningitis, pneumonia, acute abdominal infection, and osteoarticular infection.

During the first 2 months of life, the neonate is at risk for sepsis caused by pathogens that are uncommon in older children. These organisms include group B streptococcus, *Escherichia coli*, *Listeria monocytogenes*, and herpes simplex virus (HSV). In neonates, the history must include maternal obstetric information and the patient's birth history. Risk factors for sepsis include untreated maternal group B streptococcus colonization, prematurity, chorioamnionitis, and prolonged rupture of membranes. If there is a maternal history of sexually transmitted infections (STIs) during the pregnancy, the differential diagnosis must be expanded to include infection with those pathogens. Septic infants can present with lethargy, poor feeding, grunting respirations, and cool or mottled extremities in addition to fever (or hypothermia). Febrile infants in the first 1 to 2 months of life should be evaluated broadly for infection, including sampling blood, urine, and, in some cases, cerebrospinal fluid (CSF) (see Chapter 220).

When the infant matures beyond 2 months of age and receives their first set of vaccinations, serious bacterial infections become less common. Evaluation to rule out serious infection is an important part of treating the febrile older child. Children with fever should have a full set of vital signs, history, and physical examination to ensure that critical illness is absent and to identify any focal source. Red flags for **septic shock** include hypotension, poor perfusion, altered mental status, or the presence of purpuric or erythroidemic rash. Red flags for **meningitis** include severe headache, meningismus, and altered mental state. The presence of any of these signs should prompt emergency evaluation in the ED or rapid treatment if the patient is already in the ED.

Additional focal findings to consider include evaluation for acute otitis media, pharyngitis, pneumonia, abdominal infections (bacterial enteritis, appendicitis), skin and soft tissue infections, septic arthritis, and osteomyelitis. Occult UTI should be considered if three of the following risk factors are present: age <1 year, fever >39°C, fever >48 hours, and no focal source of fever. Pneumonia should be considered in the presence of tachypnea, hypoxia, or focal findings on chest examination. Bacteremia is rare in the post-pneumococcal and *Haemophilus influenzae* vaccine era but should be considered if staphylococcal infection or meningococemia is suspected and in unvaccinated children or children with signs of septic shock. In addition to infection, inflammatory conditions to consider include juvenile idiopathic arthritis (JIA), macrophage activating syndrome (MAS), Kawasaki disease (KD), and MIS-C. The diagnosis of KD, MIS-C, or MAS should be considered if

**Table 78.1** Definition of Emergency Severity Index for Children

LEVEL 1	LEVEL 2	LEVEL 3	LEVEL 4	LEVEL 5
Cardiac arrest	Seizures	Multiple resources needed	Single resource needed	Only history, physical exam required
Respiratory arrest	Sepsis, severe dehydration	3 mo to 3 yr of age		
Severe respiratory distress	Diabetic ketoacidosis	T >39°C (102.2°F)		
SpO <sub>2</sub> <90	Child abuse, burns			
Critically injured and unresponsive trauma patient	Head trauma			
Severe respiratory distress with agonal or	Vitamins/iron or other overdoses/ ingestions			
Gasping-type respirations	Infant less than 28 days of age with a fever of 38°C (100.4°F) or greater			
Severe bradycardia or tachycardia with signs of	1-3 mo of age with a fever of 38°C (100.4°F) or greater may be considered up to II			
Hypoperfusion	Vital signs not stable			
Hypotension with signs of hypoperfusion				
Trauma patient who needs resuscitation				
Anaphylactic reaction				
Baby who is flaccid				
Hypoglycemia with a change in mental status				

From Wang L, Zhou H, Zhu JF. Application of emergency severity index in pediatric emergency department. *World J Emerg Med.* 2011;2(4):279-282, Table 1, p. 280.

the patient meets the diagnostic criteria for that illness, although some patients may have an atypical or incomplete presentation (see [Chapters 207](#) and [208](#)).

For patients presenting in an **altered mental state**, the pediatrician should inquire about symptoms such as fever or headache. Screening questions should explore feeding changes, medications in the household, ill contacts, and the possibility of trauma. Parents will often describe a febrile child as lethargic, but further questioning will reveal a tired-appearing child who interacts appropriately when no longer febrile. The child who appears ill only when febrile must be differentiated from the lethargic patient who presents with suspected sepsis or meningitis and from the child whose altered behavior is secondary to an intracranial emergency or seizure. Infants with meningitis, sepsis, or cardiac defects may have a history of irritability, inconsolability, poor feeding, grunting breathing, seizures, poor urine output, and/or color changes such as pallor, mottling, or cyanosis. Patients with poisoning or inborn error of metabolism can also present with lethargy, poor feeding, unusual odors, seizures, and vomiting. **Nonaccidental trauma** should always be considered in a lethargic infant, particularly in the absence of additional signs or symptoms. In infants and young toddlers, rapidly growing head circumference or bulging anterior fontanel may signal increased ICP. Older children may present with altered mental state as a result of meningitis/encephalitis, trauma, or ingestions. School-age children and adolescents with meningitis may have a history of fever and neck pain; other associated symptoms may include rash, headache, photophobia, or vomiting. Children with ingestions can present with other abnormal neurologic symptoms, such as ataxia, slurred speech, and seizures, or with characteristic constellations of vital sign changes and other physical findings consistent with certain toxidromes.

In patients with **headache**, ask questions about the chronicity of the headache and any accompanying symptoms. Headaches that occur upon arising in the morning, that are worse when lying flat, or that are accompanied by vomiting are concerning for increased ICP. Similarly, headache accompanied by focal neurologic deficit(s) should be referred to an ED for urgent head imaging. Although migraine headaches in teenagers are similar in presentation to those in adults (unilateral, throbbing, accompanied by an aura), pediatric practitioners should be aware that migraines in prepubertal children may have a nonclassic presentation; may be bilateral; and may not be accompanied by aura, photophobia, or phonophobia.

Parents may interpret a variety of symptoms as **respiratory distress**, and care must be taken to distinguish normal and benign respiratory patterns from true respiratory distress. Tachypnea secondary to fever is a common source of parental anxiety, and parents of newborn infants are sometimes alarmed by the presence of periodic breathing. Parents should be questioned about their child's other symptoms, such as fever, limitation of neck movement, drooling, choking, and the presence of stridor or wheezing. A history of apnea or cyanosis warrants further investigation. Practitioners should also remember that tachypnea in a child without evidence of true respiratory distress may be evidence of compensation for shock or metabolic acidosis, both of which will require rapid treatment. Although wheezing is often secondary to bronchospasm, it can also be caused by cardiac disease or congenital airway anomalies such as vascular rings. Parents may interpret **stridor** as noisy breathing or wheezing. Stridor is most frequently caused by upper airway obstruction such as croup. However, anatomic abnormalities such as laryngeal webs, laryngomalacia, subglottic stenosis, and paralyzed vocal cords also cause stridor. Toddlers who present with breathing difficulty after a coughing or choking episode should be evaluated for **foreign body aspiration**. In these cases, practitioners must ask about the possibility of button-battery ingestion, as this constitutes a true medical emergency that warrants immediate endoscopic removal or transfer to a facility that can perform the procedure. In toxic-appearing children with stridor, the pediatrician should consider epiglottitis, bacterial tracheitis, or a rapidly expanding retropharyngeal abscess. The incidence of epiglottitis has greatly declined with the advent of the *H. influenzae* type b (Hib) vaccine, but it remains a possibility in the unimmunized or partially immunized patient. Children with retropharyngeal abscesses may also present with drooling and limitation of neck movement (especially hyperextension) after a recent upper respiratory infection or penetrating mouth injury.

**Abdominal pain** is a common complaint in the ambulatory setting and can herald either acute intraabdominal or pelvic pathology, or it can be a subtler sign of systemic illness. Both relatively benign (e.g., streptococcal infection, UTI, pneumonia) and severe abdominal (e.g., appendicitis) or systemic (e.g., diabetic ketoacidosis, MIS-C) illness can present with abdominal pain, and questions to the patient and parent should include whether there is an extraabdominal source of discomfort. Questions should include details about pain onset and location; presence of accompanying symptoms, such

**Table 78.2** History and Examination Findings that Should Prompt Immediate Intervention and/or Transfer to Emergency Department

HISTORY AND EXAM FINDINGS	RISK FACTORS
<b>RED FLAGS FOR RESPIRATORY FAILURE</b>	
Tachycardia	Tracheostomy
Tachypnea	Ventilator dependence
Cyanosis	History of critical airway
Apnea	
Brief resolved unexplained event (BRUE) with cyanosis or change in tone	
Suspected button-battery ingestion	
Foreign body aspiration with respiratory distress	
Sitting up, leaning forward, drooling	
Respiratory distress with hypoxemia	
Altered mental status	
<b>RED FLAGS FOR CIRCULATORY FAILURE</b>	
Tachycardia	Oncology (or other immunosuppressed) patients
Tachypnea	
Cyanosis	Bone marrow or solid organ transplants
Cold extremities, poor pulses	Sickle cell (or otherwise asplenic) patients
Apnea	
Petechial or purpuric rashes	Infants <60 days old
Erythroderma	Unrepaired or repaired congenital heart disease with change from baseline pulse oximetry
Peritonitis	Bleeding disorder with trauma
Bilious emesis	
Post-tonsillectomy or post-adenoidectomy with bleeding	
Extremity trauma with neurovascular deficits	
<b>RED FLAGS FOR NEUROLOGIC FAILURE</b>	
Tachycardia	Ventriculoperitoneal shunt
Bradycardia-hypertension	Diabetes or metabolic disease with altered mental status
Double vision	
Ptosis	Hypoxic-ischemic encephalopathy
Unequal pupils	Clotting disorder with neurologic change(s)
Apnea	
Frequent or prolonged seizure(s)	Drug ingestion
Focal neurologic deficit(s)	
Acute onset of severe headache	
Suicidal or homicidal ideation	
Psychosis	

Adapted from Farah MM, Tay Y, Lavelle J. A general approach to ill and injured children. In: Shaw KN, Bachur RG, eds. *Fleischer and Ludwig's Textbook of Pediatric Emergency Medicine*, 8th ed. Philadelphia: Lippincott, Williams & Wilkins; 2020.

as fever and abdominal distention; and changes in feeding, urination, and stooling patterns. Care should be taken to elicit a history of peritonitis or obstruction, including worsening pain with abrupt movements and persistent or bilious vomiting.

In neonates, a tender abdomen with or without bilious emesis should raise concern for the presence of a small bowel obstruction (e.g., volvulus). These infants appear ill and may have a history of decreased stooling. Pediatricians should be wary of neonates with abdominal tenderness and bloody stools, as 10% of cases of necrotizing enterocolitis occur in term infants. Infants with milk protein intolerance can also present with bloody stools, but these infants appear well and do not have abdominal tenderness. In older patients the differential diagnosis for emergency causes of abdominal pain expands to include intussusception and appendicitis. Patients with intussusception present in a variety of ways, ranging from colicky abdominal pain but otherwise well between episodes to being lethargic or in shock. The diagnosis of appendicitis in the

child younger than 3 years is extremely difficult because children in this age-group cannot localize pain well. In adolescent females with abdominal pain, practitioners must obtain a menstrual and sexual history, as acute lower abdominal pain may be caused by adnexal pathology, including ovarian torsion or ectopic pregnancy.

For patients with **vomiting**, pediatricians should ask if they have experienced bilious or blood-stained emesis, abdominal distention or constipation, weight changes, and diarrhea or bloody stools. An infant with bilious emesis and abdominal distention may have intestinal obstruction (as with midgut volvulus or Hirschsprung disease), whereas an infant who appears immediately hungry after nonbilious projectile vomiting may have pyloric stenosis. In an older child, vomiting may be caused by peritonitis or obstruction and by systemic illnesses, including diabetic ketoacidosis, ingestion, or trauma. Patients with headache and vomiting raise the concern for increased ICP and should be questioned about neurologic changes, meningismus, and fever.

Practitioners should also obtain a thorough account of the child's **past medical history**. It is important to be aware of any underlying chronic problems that might predispose the child to recurring infections or a serious acute illness. Children with sickle cell anemia, indwelling central venous access devices, or immune compromise are at increased risk for bacteremia and sepsis. Similarly, children with prior surgery, including ventriculoperitoneal shunt placement or intraabdominal procedures, can develop complications from their previous surgeries.

## PHYSICAL EXAMINATION

Observation is important when evaluating the acutely ill child. Most observational data that the pediatrician gathers should focus on assessing the child's response to stimuli. Does the child awaken easily? Does the child smile and interact with the parent or with the examiner? Evaluating these responses requires knowledge of normal child development and an understanding of the manner in which normal responses are elicited, depending on the child's age.

During the physical examination, the pediatric practitioner seeks evidence of illness. The portions of the exam that require the child to be most cooperative are completed first. Initially, it is best to seat the child on the parent's lap; the older child may be seated on the examination table. It is also important to assess the child's willingness to move, as well as ease of movement. It is reassuring to see the child moving about on the parent's lap with ease and without discomfort. *Vital signs are often overlooked but are invaluable in assessing ill children.* The presence of tachycardia out of proportion to fever and the presence of tachypnea and blood pressure abnormalities raise the suspicion for more serious illness. The respiratory evaluation includes determining respiratory rate; noting the presence or absence of hypoxia by  $SpO_2$ ; and noting any evidence of inspiratory stridor, expiratory wheezing, grunting, coughing, or increased work of breathing (e.g., retractions, nasal flaring, accessory muscle use). The **skin** should be carefully examined for rashes. Frequently, viral infections cause an exanthem, and many of these eruptions are diagnostic, such as the reticulated rash and slapped-cheek appearance of parvovirus infections and the stereotypical appearance of hand-foot-and-mouth disease caused by coxsackieviruses, as well as measles, chickenpox, and roseola. The skin examination may also yield evidence of more serious infections, including petechiae and purpura associated with bacteremia and erythroderma associated with a toxin-producing systemic infection. Cutaneous perfusion should be assessed by warmth and capillary refill time. The extremities may then be evaluated not only for ease of movement but also for the presence of swelling, warmth, tenderness, or alterations in perfusion. Such abnormalities may indicate focal infections (e.g., cellulitis, bone/joint infection) or vascular changes (e.g., arterial or venous thromboembolus).

When an infant is seated and is least perturbed, the examiner should assess the anterior fontanel to determine whether it is depressed, flat, or bulging. While the child is calm and cooperative, the **eyes** should be examined to identify features that might indicate an infectious or neurologic process. Often, viral infections result in watery discharge or redness of the bulbar conjunctivae. Bacterial infection, if superficial,



results in purulent drainage; if the infection is more deep-seated, tenderness, swelling, and redness of the tissues surrounding the eye may be present, as well as proptosis, altered visual acuity, and impaired extraocular movements. Abnormalities in pupillary response, extraocular movements, or ptosis may also be indicators of cranial nerve abnormalities and, if new, are indications for head imaging.

During this initial portion of the physical examination, when the child is most comfortable (and therefore most likely to be quiet), the **heart and lungs** are auscultated. It is important to assess the adequacy of air entry into the lungs; the equality of breath sounds; and any evidence of adventitious breath sounds, especially wheezes, rales, or rhonchi. The coarse sound of air moving through a congested nasal passage is frequently transmitted to the lungs. The examiner can become attuned to these coarse sounds by placing the stethoscope near the child's nose and then compensating for this sound as the chest is auscultated. The cardiac examination is next; findings such as pericardial friction rubs, loud murmurs, irregular rhythms, gallop rhythm, and distant heart sounds may indicate cardiac inflammation or infection. In the neonate, murmurs may herald congenital heart disease, especially in the presence of cyanosis, unequal extremity pulses, or a differential in upper- vs lower-extremity blood pressures. A complete cardiac exam should also look for displacement of the point of maximal impulse (PMI) and the presence of jugular venous distention or facial plethora.

The components of the physical examination that are more bothersome to the child are completed last. This is best done with the patient on the examination table. Initially, the **neck** is examined to assess for areas of swelling, redness, or tenderness, as may be seen in cervical adenitis. Resistance to neck movement should prompt evaluation for signs of meningeal irritation or retropharyngeal abscess. During examination of the **abdomen**, the diaper—if present—is removed. The abdomen is inspected for distention. Auscultation is performed to assess adequacy of bowel sounds, followed by palpation. Every attempt should be made to quiet a fussing child during this part of the exam; if this is not possible, practitioners should note that increased crying as the abdomen is palpated may indicate tenderness, especially if this finding is focally reproducible. In addition to focal tenderness, palpation may elicit involuntary guarding or rebound tenderness (including tenderness to percussion); these findings indicate peritoneal irritation, as may be seen in appendicitis. During palpation of the abdomen, practitioners should look for signs of hepatomegaly or splenomegaly. When palpating the bottom-most edge of the liver or spleen, examiners should begin in the pelvis and work upward toward the ribs, because severe organomegaly can be missed if the examiner begins palpating in the mid-abdomen. The **inguinal area and genitals** are then examined. One should assess the inguinal area for hernias. Care should be taken to examine the testicles of males with abdominal pain; testicular trauma, testicular torsion, and epididymitis all may present with abdominal discomfort. A unilateral swollen or painful testicle with an absent cremasteric reflex on the affected side is concerning for testicular torsion and should be referred for emergent ultrasound and urologic consultation. After the genital exam, the child is then placed in the prone position, and abnormalities of the **back** are sought. The spine and costovertebral angle areas are percussed to elicit any tenderness; such findings may be indicative of vertebral osteomyelitis or diskitis and pyelonephritis, respectively.

Examining the **ears and throat** completes the physical examination. These are usually the most bothersome parts of the examination for the child, and parents frequently can be helpful in minimizing head movement. During the oropharyngeal examination, it is important to document the presence of enanthems; these may be seen in many infectious processes, such as stomatitis caused by herpes or enteroviruses. This portion of the examination is also important in documenting inflammation or exudates on the tonsils, which may indicate viral or bacterial infection. Findings such as trismus or unilateral tonsillar swelling are concerning for peritonsillar abscess and for infections in the parapharyngeal and retropharyngeal spaces; such cases should be referred for specialist ear, nose, and throat evaluation and potential imaging of the neck.

*Repeating portions of the assessment may be indicated.* If the child cried continuously during the initial clinical evaluation, the examiner may not be certain whether the crying was caused by the high fever, stranger anxiety, or pain or is indicative of a serious or localizing illness. Constant crying also makes portions of the physical examination, such as auscultation of the chest, more difficult. Before a repeat assessment is performed, efforts to make the child as comfortable as possible are indicated. In young infants, **persistent irritability**, even when the examiner is absent from the room, is concerning for meningitis, encephalitis, or other causes of meningeal irritation (e.g., intracranial injury from nonaccidental trauma). When faced with a truly inconsolable infant, practitioners should have a low threshold to obtain head imaging and/or perform lumbar puncture, as the clinical scenario dictates.

## MANAGEMENT

Most patients who present to the pediatrician's office with an acute illness will not require acute stabilization. However, the pediatrician needs to be prepared to evaluate and begin resuscitation for the seriously ill or unstable child. Outpatient pediatric offices and urgent care facilities should be stocked with appropriate equipment necessary to stabilize an acutely ill child. Maintenance of that equipment and ongoing training of the office staff in its use are required, and every effort should be made to ensure that pediatric clinicians are PALS certified (see Chapter 79).

The evaluation of the potentially unstable child must begin with assessment of the ABCs—airway, breathing, and circulation. When assessing the **airway**, chest rise should be evaluated and evidence of increased work of breathing sought. The examiner should ensure that the trachea is midline and should listen carefully for evidence of air exchange at the level of the extrathoracic airway. If the airway is patent and no signs of obstruction are present, the patient is allowed to assume a position of comfort. If the child shows signs of airway obstruction, repositioning of the head with the chin-lift maneuver may alleviate the obstruction. An oral or nasal airway may be necessary in patients in whom airway patency cannot be maintained. These devices are not well tolerated in conscious patients because they may induce gagging or vomiting; instead, they are most often used to facilitate effective bag-valve-mask ventilation in semiconscious or unconscious children. Once airway patency has been established, the adequacy of **breathing** should be evaluated. Slow respiratory rates or cyanosis may signal impending respiratory failure. If the airway is patent but the child's respiratory effort is inadequate, positive pressure ventilation via bag-valve-mask support should be initiated. Oxygen should be administered to all seriously ill or hypoxic children via nasal cannula or face mask. Auscultation of the lung fields should assess for air entry, symmetry of breath sounds, and presence of adventitious breath sounds such as crackles or wheezes. Bronchodilator therapy can be initiated to alleviate bronchospasm. Racemic epinephrine is indicated for stridor at rest in a patient with upper airway obstruction (e.g., croup). Once airway and breathing have been addressed, **circulation** must be evaluated. Symptoms of *shock* include tachycardia, cool extremities, delayed capillary refill time, mottled or pale skin, and effortless tachypnea. In children, hypotension is a late finding in shock and indicates that significant decompensation has already taken place. Vascular access is necessary for volume resuscitation in patients with impaired circulation, and an intraosseous line should be considered early if there is any difficulty in obtaining vascular access for a patient requiring resuscitation. Each time an intervention is performed, the clinician should **reassess the patient** to determine whether interventions have been successful and whether additional care is needed.

## DISPOSITION

Most children evaluated for acute illness in the office or urgent care setting can be managed on an **outpatient** basis. These patients should have a reassuring physical examination, stable vital signs, and an adequate follow-up plan before being sent home. A mildly dehydrated

patient can be discharged home for a trial of oral rehydration. Patients with respiratory illness who exhibit signs of mild respiratory distress may be monitored at home, with a repeat examination scheduled the next day. Depending on the child's condition, the comfort of the parents, and the relationship of the family with the physician, telephone follow-up may be all that is necessary. When no specific diagnosis has been established at the first outpatient visit, a follow-up examination may yield the diagnosis and can provide reassurance for both the caregiver and the practitioner that a child's severity of illness has not progressed.

However, if it is deemed that the child needs a higher level of care, it is the pediatrician's responsibility to decide what method of transfer is appropriate. Physicians may be reluctant to call for help because of a misperception that emergency 911 services should be activated only for ongoing resuscitation. Emergency medical services (EMS) transport should be initiated for any child who is physiologically unstable (e.g., with severe respiratory distress, hypoxia, signs of shock, or altered mental state). If the family's ability to adhere promptly to a recommendation for ED evaluation is in question, this patient also should be transported by EMS. Some physicians and families may defer calling EMS because of the perception that a parent can reach the hospital faster by private motor vehicle. Although rapidity of transport should be considered, the need for further interventions during transport and the risk of clinical decompensation are other important factors in the decision to activate EMS. Ultimately, the legal responsibility for choosing an appropriate level of transport for a patient lies with the referring physician until responsibility of care is officially transferred to another medical provider.

Visit Elsevier eBooks+ at [eBooks.Health.Elsevier.com](http://eBooks.Health.Elsevier.com) for Bibliography.

## Chapter 79

# Pediatric Cardiorespiratory Emergencies and Resuscitation

Ryan W. Morgan and Alexis A. Topjian

Children in the community and those in the hospital are at risk for a variety of injuries and life-threatening disease processes that lead to cardiac or respiratory compromise, which require prompt evaluation and intervention.

### ASSESSMENT AND EVALUATION OF CHILDREN WITH CARDIORESPIRATORY EMERGENCIES

The first response to a pediatric emergency of any cause is a rapid and systematic **general assessment** of the scene and the child to identify immediate threats to the child, care providers, and others. If an emergency is identified, the emergency response system (emergency medical services [EMS]) should be activated immediately. Care providers should then proceed through **primary**, **secondary**, and **tertiary** assessments as allowed by the child's condition, safety of the scene, and resources available. This standardized approach organizes what might otherwise be a confusing or chaotic situation and ensures that key elements of assessment and treatment are not omitted. If at any point during these assessments the provider identifies a life-threatening problem, progression through the systematic assessment is paused and targeted lifesaving interventions are prioritized. Further assessments and interventions should be delayed until other providers arrive to assist or until the life-threatening condition is successfully treated or stabilized.

### General Assessment

Upon arrival at the scene of a critically ill or injured child or upon the child's presentation for medical care, a provider's first task is a quick survey of the scene itself. Is the rescuer or child in imminent danger because of circumstances at the scene (e.g., fire, high-voltage electricity)? If so, can the child be safely extricated to a safe location for assessment and treatment? Can the child be safely moved with the appropriate precautions (e.g., cervical spine protection) if indicated? A rescuer is expected to proceed only if these important safety conditions have been met so that they do not jeopardize their own safety.

Once the provider's and child's safety have been ensured, the provider performs a rapid **visual survey** of the child, assessing the child's **general appearance** and **cardiopulmonary function**. This action should only take a few seconds and includes assessment of (1) general appearance, determining color, tone, alertness, and responsiveness; (2) adequacy of breathing, distinguishing between normal, comfortable respirations versus respiratory distress or apnea; and (3) adequacy of circulation, identifying cyanosis, pallor, or mottling. If a child is found unresponsive or becomes unresponsive during the provider's assessment, the provider should stimulate the patient and assess the patient's response to voice. If there is no response, the provider should assess for breathing. If the child is breathing but ineffectively, rescue breathing should be started. If the child is not breathing or has agonal respirations, the provider should initiate cardiopulmonary resuscitation (CPR) and follow Basic Life Support (BLS) pediatric cardiac arrest algorithms for one rescuer or two or more rescuers (Figs. 79.1 and 79.2).

### Primary Assessment

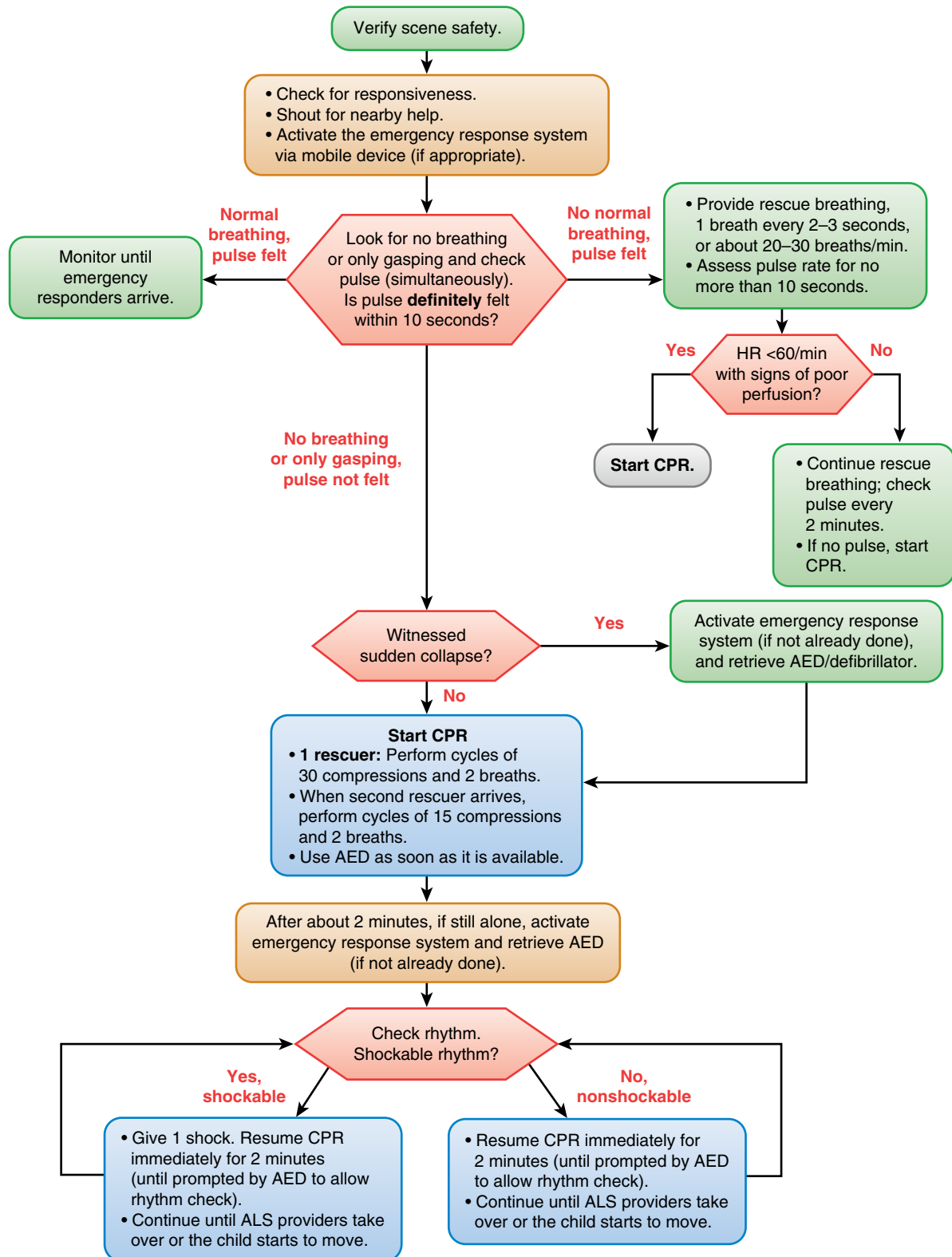
Once the emergency response system has been activated and the child is determined not to require CPR, the provider should proceed with a primary assessment that includes a brief, hands-on evaluation of cardiopulmonary and neurologic function. This assessment includes a limited physical examination, evaluation of vital signs, and measurement of pulse oximetry if available. The American Heart Association (AHA), in its Pediatric Advanced Life Support (PALS) curriculum, supports the structured format of **airway**, **breathing**, **circulation**, **disability**, **exposure** (ABCDE). *The goal of the primary assessment is to obtain a focused, systems-based assessment of the child's injuries or abnormalities so that resuscitative efforts can be rapidly targeted to these areas;* if the provider identifies a life-threatening abnormality, further evaluation is postponed until appropriate corrective action has been taken.

The exam and vital sign data can be interpreted only if the provider has a thorough understanding of normal values. In pediatrics, normal respiratory rate, heart rate, and blood pressure have age-specific norms (Table 79.1). These ranges can be difficult to remember, especially if used infrequently, and providers should therefore maintain ready access to these normal ranges. Hypotension is defined as blood pressure less than the fifth percentile for age. This is considered a systolic blood pressure of <60 mm Hg for neonates up to 28 days, <70 mm Hg for infants from 1 month to 1 year, <70+ (age in years × 2) mm Hg for children 1-10 years, and <90 mm Hg for children older than 10 years of age.

### Airway and Breathing

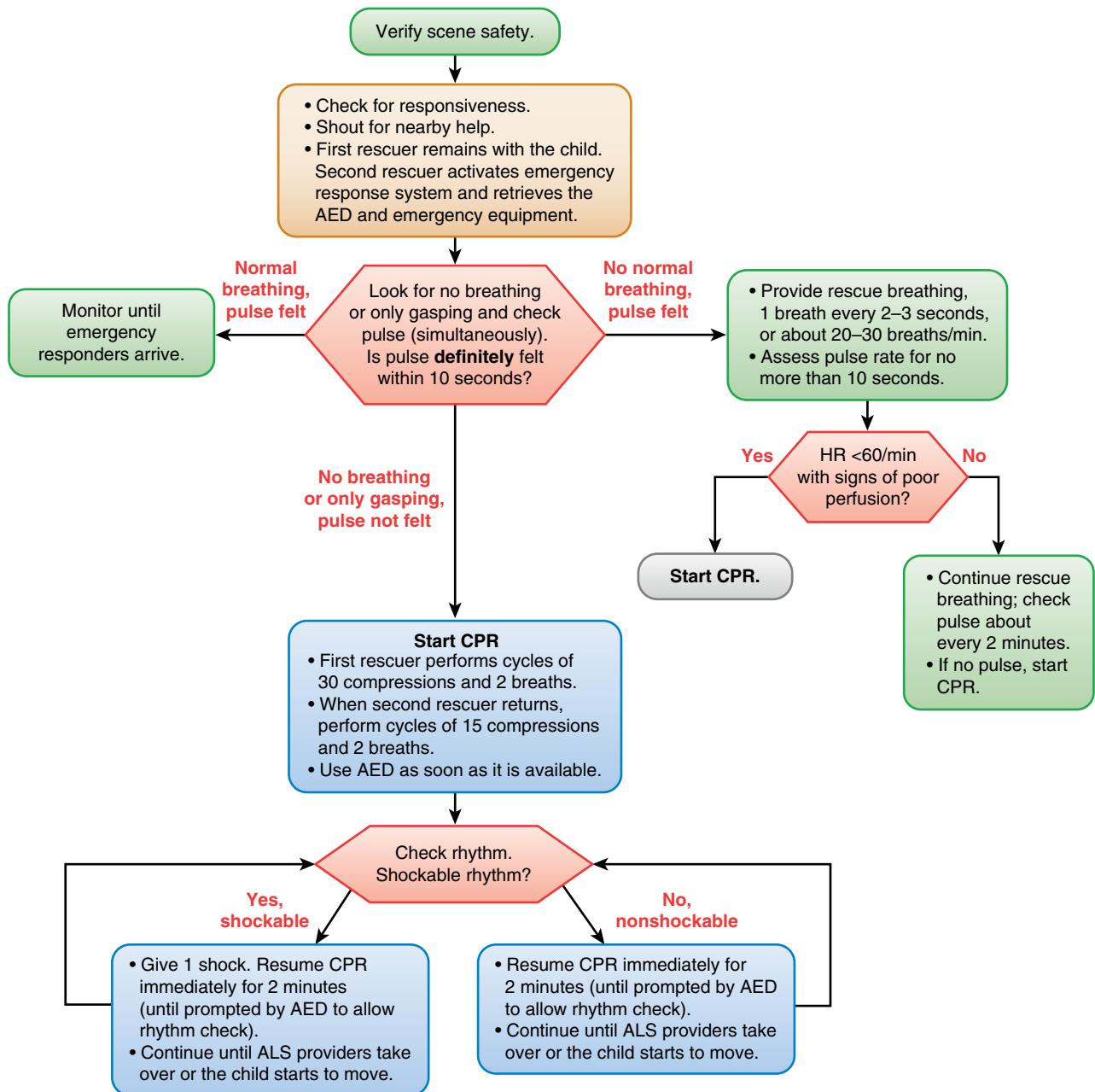
The most common precipitating event for cardiac instability in infants and children is respiratory failure (the inability to adequately oxygenate or ventilate). Therefore *rapid assessment for respiratory failure and immediate restoration of adequate ventilation and oxygenation remain the first priorities in the resuscitation of a child.* Using a systematic approach, the provider should first assess whether the child's airway is patent and maintainable. A **patent** airway is unobstructed, allowing normal respiration without noise or effort. A **maintainable** airway is one that is either already patent or can be made patent with a simple maneuver. To assess airway patency, the provider should look for breathing movements in the child's chest and abdomen, listen for breath sounds, and feel for the movement of air at the child's mouth and nose. Abnormal breathing sounds (e.g., snoring or stridor), increased work of breathing,

Pediatric BLS for healthcare providers—single rescuer



**Fig. 79.1** Basic Life Support (BLS) algorithm for healthcare providers: Pediatric cardiac arrest algorithm for the single rescuer—2020 update. AED, Automated external defibrillator; ALS, advanced life support; CPR, cardiopulmonary resuscitation. (From Topjian AA, Raymond TT, Atkins D, et al. Part 4: Pediatric Basic and Advanced Life Support: 2020 American Heart Association Guidelines for Cardiopulmonary Resuscitation and Emergency Cardiovascular Care. *Circulation*. 2020;142[16 Suppl 2]:S469-S523.)

## Pediatric BLS healthcare providers—2 or more rescuers



**Fig. 79.2** Basic Life Support (BLS) algorithm for healthcare providers: Pediatric cardiac arrest algorithm for two or more rescuers—2020 update. AED, Automated external defibrillator; ALS, advanced life support; CPR, cardiopulmonary resuscitation. (From Topjian AA, Raymond TT, Atkins D, et al. Part 4: Pediatric Basic and Advanced Life Support: 2020 American Heart Association Guidelines for Cardiopulmonary Resuscitation and Emergency Cardiovascular Care. *Circulation*. 2020;142[16 Suppl 2]:S469-S523.)

and apnea are all findings potentially consistent with airway obstruction. If there is evidence of obstruction, the provider should start with repositioning and “head-tilt, chin-lift” if neck injury is not suspected or a jaw thrust if neck injury is a concern (Fig. 79.3). Suctioning of the airway or placement of adjunct airway devices such as a nasopharyngeal airway should be considered based on the exam findings and the likely etiologies of airway obstruction. Maneuvers to relieve the obstruction should be instituted before the provider proceeds to evaluate the child’s breathing.

Assessment of breathing includes evaluation of the child’s respiratory rate, respiratory effort, breath sounds, and peripheral oxygen saturation via pulse oximetry. Normal breathing appears comfortable, is quiet, and occurs at an age-appropriate rate. Abnormal respiratory

rates include apnea and rates that are either abnormally slow (bradypnea) or fast (tachypnea). *Bradypnea and irregular respiratory patterns (such as gasping or agonal respirations) require urgent attention because they are often signs of impending respiratory failure, apnea, or cardiorespiratory arrest.* Signs of increased respiratory effort include nasal flaring, grunting, chest or neck muscle retractions, head bobbing, and seesaw respirations. Hypoxemia, measured by pulse oximetry, often accompanies parenchymal lung disease, apnea, or airway obstruction. However, providers should keep in mind that adequate perfusion is required to produce a reliable peripheral oxygen saturation measurement. Central cyanosis is a sign of severe hypoxemia and indicates an emergent need for oxygen supplementation and respiratory support.



AGE	HEART RATE (beats/min)	BLOOD PRESSURE <sup>†</sup> (mm Hg)	RESPIRATORY RATE <sup>‡</sup> (breaths/min)
Premature	120-205*	60-76/31-45	40-70
Neonate	100-205*	67-84/35-53	35-55
Infant	100-180	72-104/37-56	30-53
Toddler	98-140	86-106/42-63	22-37
Preschooler	80-120	89-112/46-72	20-29
School-age child	75-118	97-120/57-80	18-25
Adolescent	60-100	110-131/64-83	12-20

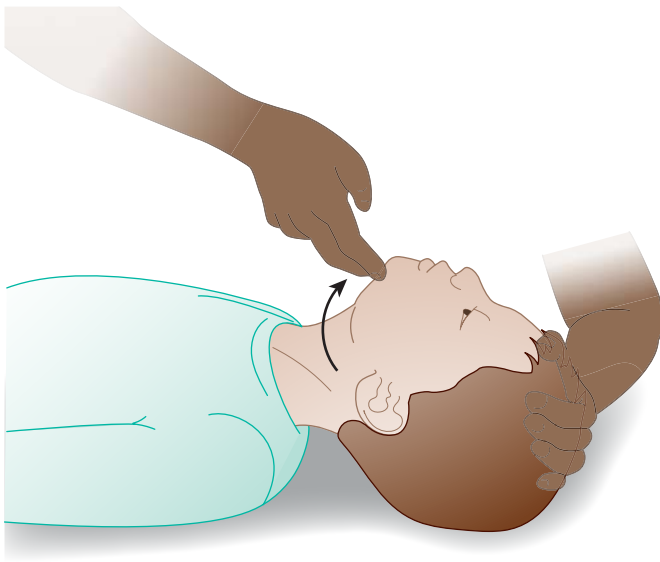
\*In sleep, heart rates may be significantly lower, but if perfusion is maintained, no intervention is required.

<sup>†</sup>A blood pressure cuff should cover approximately two-thirds of the arm; too small a cuff yields spuriously high pressure readings, and too large a cuff yields spuriously low pressure readings. Values are systolic/diastolic and assume 50th percentile for height for children 1 year and older.

<sup>‡</sup>The respiratory rate is expected to increase in the presence of fever and stress.

‡Approximately equal to postconception age in weeks (may add 5 mm Hg).

Modified from Hazinski MF. Children are different. In Hazinski MF, ed. *Nursing Care of the Critically Ill Child*, 3rd ed. Philadelphia: Mosby; 2013:1-18.



**Fig. 79.3** Opening the airway with the head-tilt/chin-lift maneuver. One hand is used to tilt the head, extending the neck. The index finger of the rescuer's other hand lifts the mandible outward by lifting the chin.

### Circulation

Cardiovascular function is assessed by evaluation of skin color and temperature, heart rate, heart rhythm, presence and quality of pulses, capillary refill time, and blood pressure. In nonhospital settings, much of this important information can be obtained without measuring the blood pressure; lack of blood pressure data should not prevent the provider from determining adequacy of circulation or implementing lifesaving support. Mottling, pallor, delayed capillary refill, cyanosis, weak pulses, and cool extremities are all signs of diminished perfusion and compromised cardiac output. **Tachycardia** is the earliest and most common sign of shock but lacks both sensitivity and specificity and should be correlated with other components of the exam, such as weakness, threadiness, or absence of pulses. An age-specific approach to heart rate assessment will yield the most reliable interpretation. **Bradycardia** can be normal in athletic children

A	The child is awake, alert, and appropriately responsive to caregivers and stimuli.
V	The child responds only to voice such as calling the child's name or speaking loudly.
P	The child responds only to painful stimuli, such as sternal rub or pinching the trapezius.
U	The child is unresponsive to all stimuli.

A, Alert; V, verbal; P, pain; U, unresponsive.

From Ralston M, Hazinski MF, Zaritsky AL, et al., eds. *Pediatric Advanced Life Support Course Guide and PALS Provider Manual*. Dallas: American Heart Association; 2007.

≥2 YEARS	<2 YEARS		
<b>EYE OPENING</b>			
Spontaneous	4	Spontaneous	4
To sound	3	To sound	3
To pressure	2	To pressure	2
None	1	None	1
<b>VERBAL RESPONSE</b>			
Oriented; words/phrases normal for chronological age	5	Babbles, coos; words/phrases normal for chronological age	5
Confused; some words/phrases not normal for chronological age	4	Some words/phrases not normal for chronological age	4
Words	3	Inconsolable crying	3
Sounds	2	Sounds	2
None	1	None	1
<b>MOTOR RESPONSE</b>			
Obeys commands	6	Normal spontaneous movement	6
Localizes pain	5	Rapidly withdraws extremity to stimulation	5
Normal flexion	4	Normal flexion	4
Abnormal flexion	3	Abnormal flexion	3
Extension	2	Extension	2
None	1	None	1

Adapted from Kirschen MP, Snyder M, Smith K, et al. Inter-rater reliability between critical care nurses performing a pediatric modification to the Glasgow Coma Scale. *Pediatr Crit Care Med*. 2019;20(7):660-666.

but should be assessed in the context of the child's perfusion, blood pressure, mental status, and oxygen saturation, as it can be a sign of impending cardiac arrest.

### Disability

In the setting of a pediatric emergency, *disability* refers to a child's neurologic function in terms of the level of consciousness and cortical function. Standard evaluation of a child's neurologic condition can be done quickly with an assessment of pupillary response to light (if one is available) and use of either of the standard scores used in children: the Alert, Verbal, Pain, Unresponsive (AVPU) Pediatric Response Scale and the Glasgow Coma Scale (GCS) (Tables 79.2 and 79.3). The

Table 79.4 Pupillary Responses	
DILATED (MYDRIASIS)	PINPOINT (MIOSIS)
<b>Bilateral</b> Anticholinergic agents (systemic, topical) Sympathomimetic agents Serotonin syndrome Botulism Brain death (fixed, nonreactive usually midposition)	<b>Bilateral</b> Opiates Organophosphates Barbiturates Pontine lesions
<b>Unilateral</b> Third nerve compression with uncal herniation	<b>Unilateral</b> Horner syndrome

causes of decreased level of consciousness in children are numerous and include conditions as diverse as respiratory failure with hypoxia or hypercarbia, hypoglycemia, poisonings or drug overdose, trauma, seizures, infection, and shock. *Most often, an acutely ill or injured child has an altered level of consciousness because of respiratory compromise, circulatory compromise, or both.* Any child with a depressed level of consciousness should be immediately assessed for abnormalities in cardiorespiratory status.

**Alert, Verbal, Pain, Unresponsive (AVPU) Pediatric Response Scale:** The AVPU scoring system is used to determine a child's level of consciousness and cerebral cortex function (see Table 79.2). Unlike the GCS, the AVPU scale is not developmentally dependent—a child does not have to understand spoken language or follow commands, merely respond to a stimulus. The child is scored according to the amount of stimulus required to obtain a response, from *alert* (no stimulus; the child is already awake and interactive) to *unresponsive* (child does not respond to any stimulus).




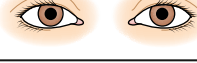



**Glasgow Coma Scale (GCS):** Although it has not been systematically validated as a prognostic scoring system for infants and young children, the GCS is frequently employed to describe level of consciousness and neurologic status. It has value as a way to communicate mental status to other providers and when used serially to detect improvement or deterioration. The GCS has three components: eyes, verbal, and motor. Individual scores for eye opening, verbal response, and motor response are added together, with a maximum of 15 points (see Table 79.3). There are numerous versions of the pediatric GCS, but most importantly, the pediatric GCS accounts for differences in development and the inability for children <2 years of age to follow commands and talk. Patients who have severe head injury with a GCS score  $\leq 8$  require aggressive management, generally including securement of the airway with endotracheal intubation and breathing with mechanical ventilation and, if indicated, placement of an intracranial pressure monitoring device.

**The Full Outline of Unresponsiveness (FOUR) score** is a neurologic assessment that incorporates brainstem reflex components and is associated with outcomes; it is commonly used in the intensive care unit setting (Table 82.1).

The pupillary response can give insight to causes of altered mental status. Pinpoint pupils can be due to many conditions, including narcotic ingestion, and dilated *asymmetric* pupils (anisocoria) can be caused by uncal herniation (Table 79.4 and Fig. 79.4). If a patient has a normal mental status, other causes of pupillary dilation and asymmetry should be considered.

## Exposure

Exposure is the final component of the pediatric primary assessment. This component of the exam is reached only after the child's airway, breathing, circulation, and disability have been assessed and reasonably stabilized. In this setting, *exposure* stands for the dual responsibility of the provider both to expose the child to assess for previously unidentified injuries and to consider prolonged exposure

Lesion/process associated with coma	Pupils	Comment
<b>Metabolic</b>		Normal
<b>Bilateral hypothalamic</b>		Small but reactive
<b>Uncal herniation</b>		Ipsilateral "blown," unreactive pupil, ptosis
<b>Tectal</b>		Midposition and unreactive to light
<b>Midbrain</b>		Dilated and unreactive
<b>Pontine</b>		Pinpoint but reactive
<b>Brain death</b>		Midposition to large, unreactive

**Fig. 79.4** Pupils in comatose patients. (From Balcer LJ: *Pupillary disorders*. In Liu G, Volpe L, Galetta S (eds): *Liu, Volpe, and Galetta's Neuro-Ophthalmology: Diagnosis and Management*, 3rd ed. Philadelphia: Elsevier, 2018. Fig 13.32.)

in a cold environment as a possible cause of hypothermia and cardiopulmonary instability. The provider should undress the child (as is feasible and reasonable) to perform a physical exam, assessing for burns, bruising, bleeding, joint laxity, and fractures. If possible, the provider should assess the child's temperature. All maneuvers should be performed with careful maintenance of cervical spine precautions when indicated.

## Secondary and Tertiary Assessment

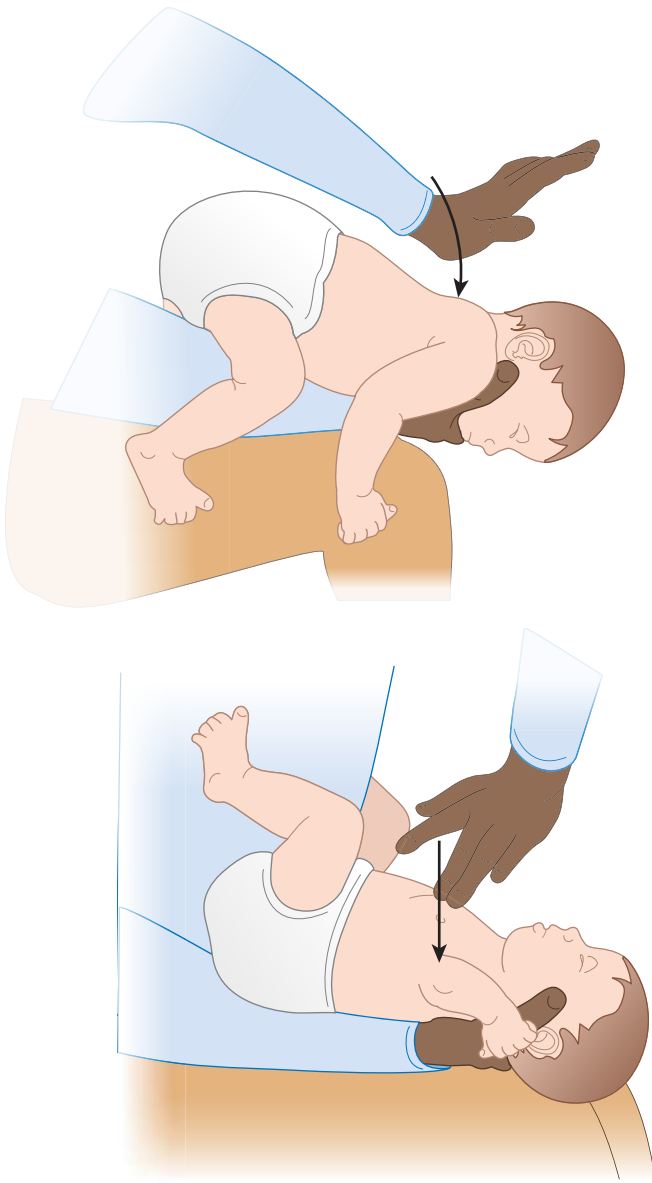
### Secondary Assessment

For healthcare providers in community or outpatient settings, transfer of care of a child to emergency or hospital personnel may occur before a full secondary assessment is possible. However, before the child is removed from the scene and separated from witnesses or family, a brief history should be obtained for medical providers at the accepting facility. The components of a secondary assessment include a **focused history** and **focused physical examination**.

The history should be targeted to information that could explain cardiorespiratory or neurologic dysfunction and should take the form of a **SAMPLE history**: signs/symptoms; allergies; medications; past medical history; timing of last meal; and events leading to this situation. Medical personnel not engaged in resuscitative efforts can be dispatched to elicit history from witnesses or relatives. The physical examination during the secondary assessment is a thorough head-to-toe exam, although the severity of the child's illness or injury could necessitate curtailing portions of the exam or postponing nonessential elements until a later time.

### Tertiary Assessment

The tertiary assessment occurs in a hospital setting, where ancillary laboratory and radiographic assessments contribute to a thorough understanding of the child's condition. A basic blood chemistry profile, complete blood count, liver function tests, coagulation studies, and arterial blood gas analyses provide estimates of renal function, acid-base balance, cardiorespiratory function, and presence or absence of shock. Chest radiographs can be useful to evaluate both the heart and



**Fig. 79.5** Back blows (top) and chest thrusts (bottom) to relieve foreign body airway obstruction in the infant.

lungs, although more detailed assessment of cardiac function can be performed with echocardiography.

### RECOGNITION AND TREATMENT OF RESPIRATORY DISTRESS AND FAILURE

The goals of initial management of respiratory distress or failure are to rapidly stabilize the child's airway and breathing and to identify the cause of the problem so that further therapeutic efforts can be appropriately directed.

#### Airway Obstruction Due to Foreign Body

Children under 5 years of age are particularly susceptible to foreign body aspiration and choking. Liquids are the most common cause of choking in infants, whereas small objects and food (e.g., grapes, nuts, hot dogs, candy) are the most common source of foreign bodies in the airways of toddlers and older children. A history consistent with foreign body aspiration is considered diagnostic. Any child in the proper setting with the sudden onset of choking, stridor, or wheezing should be considered to have a foreign body aspiration until proven otherwise.



**Fig. 79.6** Abdominal thrusts with the conscious victim standing or sitting.

Unfortunately, this classic history is not always present in all cases of foreign body aspiration.

Airway obstruction is treated with a sequential approach starting with the head-tilt/chin-lift maneuver to open and support the airway, followed by inspection for a foreign body, and finger-sweep clearance or suctioning if one is visualized. *Blind suctioning or finger sweeps of the mouth are not recommended.* A conscious child suspected of having a partial foreign body obstruction should be permitted to cough spontaneously until coughing is no longer effective, respiratory distress and stridor increase, or the child becomes unconscious. They can be allowed to find a comfortable position to facilitate air entry.

For *conscious infants*, providers should administer five back blows and then five chest thrusts (Fig. 79.5). After each cycle of back blows and chest thrusts, the child's mouth should be visually inspected for the presence of the foreign body. If identified within finger's reach, it should be removed with a gentle finger sweep. If no foreign body is visualized and the child is conscious, repeat back blows and chest thrusts. Do not blindly sweep for objects if they are not visible, as this can push the object farther into the airway.

For *conscious children* older than 1 year, providers should give a series of five abdominal thrusts (**Heimlich maneuver**) with the child standing or sitting (Fig. 79.6). After the abdominal thrusts, the airway is examined for a foreign body, which should be removed if visualized. If no foreign body is seen, abdominal thrusts should be repeated. For both infants and children, the sequence is repeated until the object is expelled or the patient loses consciousness, at which time CPR with ventilations should be initiated.

If the child becomes *unconscious*, the child should be gently placed on the ground in a supine position and ventilations should be initiated; compressions should also be started if the child is pulseless. The airway should be inspected for a foreign body at the time of ventilations.

### Airway Obstruction or Narrowing from Other Causes

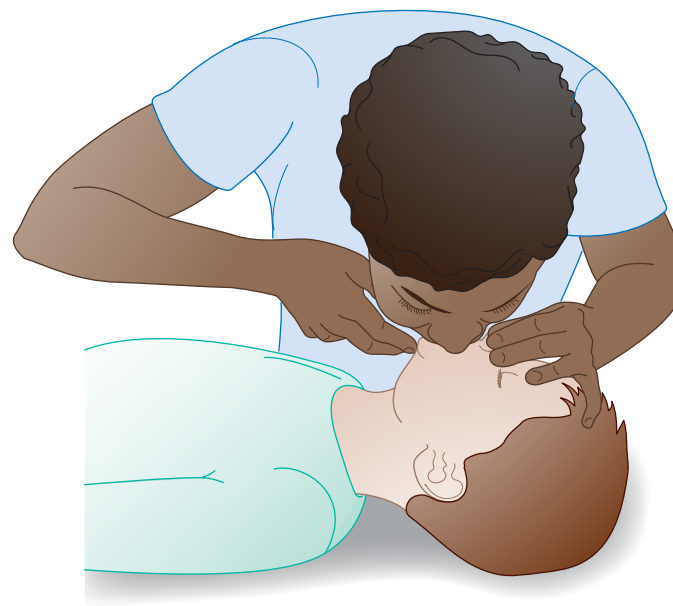
Airway obstruction can also be caused by airway narrowing in both the upper and lower airways. Upper airway obstruction refers to narrowing of the extrathoracic portion of the airway, including the oropharynx, larynx, epiglottitis, and trachea. In the upper airways, narrowing is most often caused by airway edema (e.g., croup or anaphylaxis) or epiglottic edema (e.g., epiglottitis) and often manifests with stridor. Stridor, in cases of extrathoracic airway obstruction, is a high-pitched sound heard on inspiration. When airway obstruction is intrathoracic, stridor can be biphasic, heard during both inspiration and expiration. Lower airway obstruction affects all intrathoracic airways, notably the bronchi and bronchioles. **Bronchiolitis** and acute **asthma** exacerbations are the major causes of intrathoracic airway obstruction in children, causing lower airway narrowing through a combination of airway swelling, mucus production, and circumferential smooth muscle constriction of smaller airways.

The approach to upper airway obstruction is dictated by both the underlying condition and the clinical severity of the problem. In cases of mild upper airway obstruction, the child has minimally increased work of breathing (evidenced by tachypnea and absent to mild retractions). Stridor, if present at all, should be audible with only coughing or activity. Children with these findings can often be supported with supplemental oxygen as needed. In cases with moderate obstruction, in which the child has more significant work of breathing or more pronounced stridor, nebulized **racemic epinephrine** and oral or intravenous (IV) **dexamethasone** can be added, particularly for **croup** (i.e., laryngotracheobronchitis) (see Chapter 434). **Heliox** (combined helium-oxygen therapy) administration may also be considered. Children with severe upper airway obstruction have marked intercostal retractions, prominent stridor, and decreased air entry on auscultation of the lung fields. They can also be hypoxemic, dyspneic, and either agitated or somnolent. A child in severe distress that does not rapidly respond to therapies may require endotracheal intubation to overcome the area of obstruction. Clinicians need to carefully observe patients, as impending respiratory failure may be initially confused with improvement. Stridor becomes quieter and retractions less prominent when a child's respiratory effort begins to diminish. This can either be the result of improvement or progressive respiratory failure with less air entry. The child in respiratory failure may have poor air movement on auscultation and decreased level of consciousness from hypercarbia, hypoxia, or both. When **anaphylaxis** is suspected as the cause for upper airway edema, providers should administer an intramuscular dose of epinephrine as needed (see Chapter 190). Racemic epinephrine can also help decrease localized airway edema. **Epiglottitis** often presents with a muffled voice, drooling, and difficulty swallowing. Epiglottitis is a medical emergency for which the initial focus should be on alerting otolaryngology and/or anesthesiology experts to be immediately present while keeping the patient calm. These patients usually need to have their airway secured in an operating room with contingency planning for emergency surgical airway placement. No matter the cause, any child with upper airway obstruction and impending respiratory failure should be prepared to undergo endotracheal intubation and respiratory support. Prompt notification of providers trained in advanced airway management is essential.

In cases of lower airway obstruction, therapies are targeted to both relieve the obstruction and reduce the child's work of breathing. For asthma, **inhaled bronchodilators**, such as albuterol, augmented by oral or IV **corticosteroids**, remain the mainstay of therapy in mild to moderate acute distress. Children with more significant obstruction appear dyspneic, with tachypnea, retractions, forced expiration, and audible wheezing or reduced breath sounds. In these cases, the addition of an anticholinergic agent, such as nebulized ipratropium bromide, or a smooth muscle relaxant, such as magnesium sulfate, may provide further relief, although the evidence for these measures remains controversial (see Chapter 185). Supplemental oxygen and IV fluid hydration can be useful adjuncts. Infants and young children with bronchiolitis often present with tachypnea. Patients with moderate to severe disease may have retractions, nasal flaring, or



**Fig. 79.7** Rescue breathing in an infant. The rescuer's mouth covers the infant's nose and mouth, creating a seal. One hand performs the head-tilt while the other hand lifts the infant's jaw.

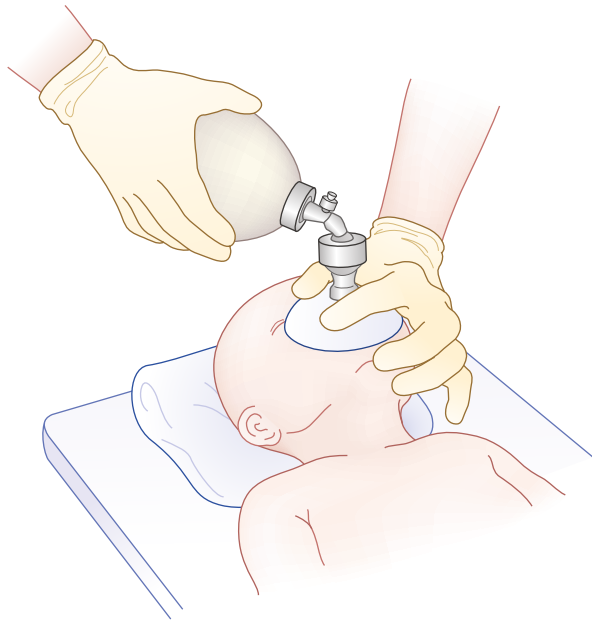


**Fig. 79.8** Rescue breathing in a child. The rescuer's mouth covers the child's mouth, creating a mouth-to-mouth seal. One hand maintains the head-tilt; the thumb and forefinger of the same hand are used to pinch the child's nose. The other hand lifts the child's jaw.

grunting and can be hypoxemic. These patients often do not respond to bronchodilators. Supportive care with chest physiotherapy to support mucous clearance and noninvasive positive pressure ventilation support can be used as these patients recover from this lower airway viral disease process.

Impending respiratory failure in children with lower airway obstruction can be insidious. When diagnosed early in a school-age child who is cooperative, respiratory failure can potentially be averted through judicious use of noninvasive support, including heated, high-flow nasal cannula (HFNC) therapy, continuous positive airway pressure (CPAP), or bilevel positive airway pressure (BiPAP). Endotracheal intubation should be performed only by skilled providers, preferably in a hospital setting, because there is a high risk of cardiorespiratory compromise in patients with lower airway obstruction during the procedure.





**Fig. 79.9** “C-E” grip to secure a mask to a child’s face with appropriate seal.

### Parenchymal Lung Disease

Parenchymal lung disease includes a heterogeneous list of conditions, such as pneumonia, pediatric acute respiratory distress syndrome (PARDS), pneumonitis, bronchiolitis, bronchopulmonary dysplasia, cystic fibrosis, and pulmonary edema. The commonalities of these conditions are their effects on the small airways and alveoli, including inflammation and exudation leading to consolidation of lung tissue, decreased gas exchange, and increased work of breathing. Clinical management of these conditions includes specific treatment as indicated (e.g., antibiotics for bacterial pneumonia) and supportive care with oxygen, noninvasive respiratory support (e.g., HFNC, CPAP, or BiPAP), or invasive mechanical ventilation. The severity of work of breathing and degree of oxygenation or ventilation failure determine the degree of respiratory support needed and should be expected to evolve with time.

### Airway and Breathing Management Rescue Breathing

If a child is unconscious and not breathing effectively or apneic, **rescue breathing** should be provided. The provider should open the airway with the head-tilt/chin-lift maneuver and attempt mouth-to-mouth ventilation (Figs. 79.7 and 79.8). In trauma patients with suspected cervical spine injuries, a jaw thrust should be performed without the head-tilt maneuver. If ventilation is unsuccessful, the airway is repositioned, and ventilation should be attempted again.

### Bag-Mask Ventilation

Ventilation with a bag-mask apparatus can be as effective as endotracheal intubation and safer when the provider is inexperienced with intubation. Bag-mask ventilation (BMV) requires training to ensure that the provider is competent to select the correct mask size, open the child’s airway, form a tight seal between the mask and the child’s face, deliver effective ventilation, and assess the effectiveness of ventilations. An appropriately sized mask is one that fits over the child’s mouth and nose but does not extend below the chin or over the eyes. An adequate seal is best achieved through a combination “C-E” grip on the mask, in which the thumb and index finger form the letter “C” on top of the mask, holding the mask onto the child’s face, and the remaining three fingers form an “E” grip under the child’s mandible, holding the jaw forward without pressing on the soft tissues and extending the head up toward the mask. Using this method, the care provider can secure

the mask to the child’s face with one hand and use the other hand to compress the ventilation bag (Fig. 79.9).

The provider may have to move the head and neck through a range of positions to find the one that best maintains airway patency with adequate chest rise. In infants and young children, optimal ventilation is often provided when the child’s head is in the neutral sniffing position without hyperextension of the head. Poor chest rise or persistent hypoxemia indicate inadequate ventilation. In this setting, the care provider should recheck the mask’s seal on the child’s face, reposition the child’s head, and consider suctioning the airway. If these maneuvers do not restore ventilation, the provider should consider placement of a nasopharyngeal or oral airway. The inability to ventilate a patient with positive pressure after the previous measures is an emergency requiring expert consultation while preparing for endotracheal intubation.

### Endotracheal Intubation

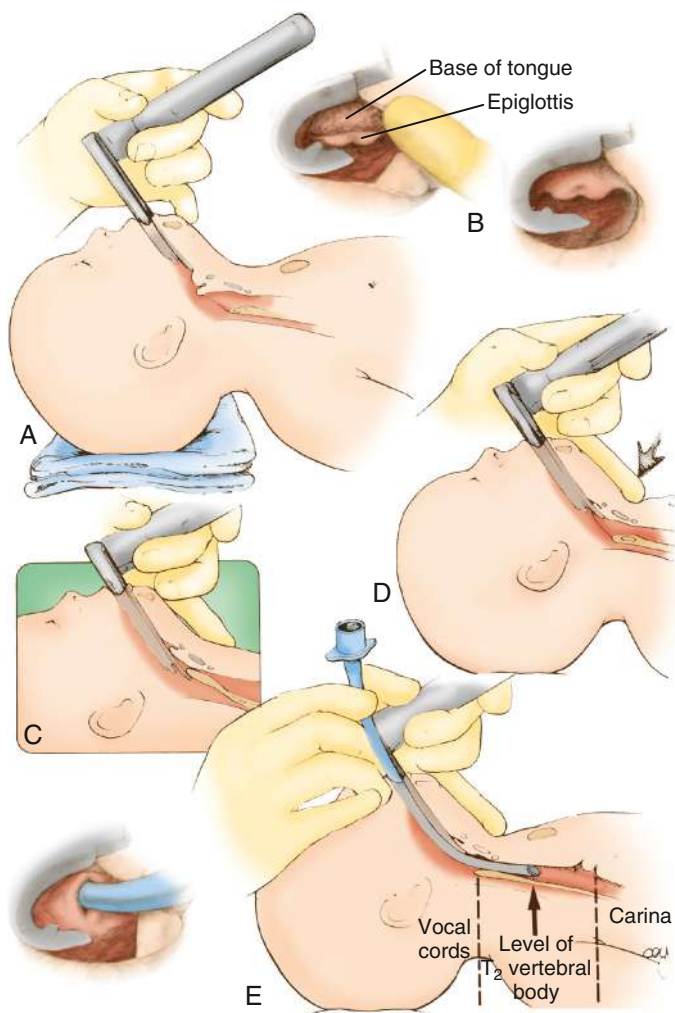
A child generally requires intubation when at least one of these conditions exists: (1) the child is unable to maintain airway patency or protect against aspiration (as occurs in settings of neurologic compromise such as seizures or traumatic brain injury); (2) the child is failing to maintain adequate oxygenation despite supplemental oxygen or non-invasive therapies; (3) the child cannot be adequately ventilated with evidence of elevated blood carbon dioxide levels and an unsafe acid-base balance; (4) sedation and/or paralysis is required for a procedure; (5) the need to decrease metabolic demand by sedating the patient to support extrapulmonary organs (e.g., septic shock or heart failure) is present; and (6) providers anticipate a deteriorating course that will eventually lead to any of the first five conditions. It should be noted that in centers experienced in noninvasive respiratory support, a trial of HFNC, CPAP, or BiPAP may be indicated based on the specific clinical scenario.

There are few *absolute contraindications* to tracheal intubation, but experts generally agree that in settings of known complete airway obstruction (e.g., severe subglottic stenosis), endotracheal intubation should be avoided, and emergency cricothyroidotomy or tracheostomy performed instead. It is important to assess a patient’s airway before initiating endotracheal intubation. Any history of a difficult airway (difficult to intubate) or critical airway (unable to bag-mask ventilate) should prompt further investigation and expert consultation. Both history and physical exam features such as limited mouth opening, limited neck mobility, or micrognathia should raise concern for further assessment. Another important consideration is to ensure that providers maintain appropriate cervical spine (C-spine) protection during the intubation procedure when neck or spinal cord injury is suspected.

A critical phase of the intubation procedure is the preprocedural preparation, when the provider ensures all the equipment and staff needed for safe intubation are present and functioning. An easy mnemonic for this is **SOAP MM**: *suction* (Yankauer suction catheter attached to wall suction); *oxygen* (both preoxygenation of the patient and devices needed to deliver oxygen, such as a bag-mask); *airway* (appropriately sized endotracheal tube and laryngoscope as well as adjunct airway devices); *people* (all those needed during and immediately after the procedure, including respiratory therapists and nurses); *monitor* (pulse oximetry, ECG, blood pressure, capnography); and *medications* (sedation and often neuromuscular blockade to facilitate intubation). A simple formula for selecting the appropriately sized endotracheal tube (ETT) is:

$$\text{Uncuffed ETT size (in mm)} = \left( \frac{\text{age in years}}{4} \right) + 4$$

Cuffed ETTs should generally be 0.5 mm smaller. Providers should always have a range of ETTs available, given the heterogeneity of patients and airway size. The use of cuffed ETTs is recommended in most pediatric populations, as it may decrease the need for ETT changes caused by difficulty ventilating and may decrease the risk of aspiration.



**Fig. 79.10** A-E, Tracheal intubation technique. (From Fleisher G, Ludwig S. *Textbook of Pediatric Emergency Medicine*, Baltimore: Williams & Wilkins; 1983:1250.)

Analgesia is recommended to reduce metabolic stress, discomfort, and anxiety during intubation. Pretreatment with a sedative, an analgesic, or an anesthetic or dissociative medication and potentially a neuromuscular relaxing agent (paralytic agent) is recommended unless the situation is emergent (e.g., cardiac arrest) and the administration of drugs would cause an unacceptable delay. Neuromuscular blocking agents should generally be avoided in patients who cannot be bag-mask ventilated because if the patient cannot be successfully intubated and cannot be bag-mask ventilated, they may progress to cardiopulmonary arrest.

Because many intubations in critically ill children are emergency procedures, providers should be prepared to rapidly intubate (Fig. 79.10). Rapid sequence intubation (RSI)—the process of intubating with a sedative (etomidate, ketamine, propofol) and neuromuscular blockade (rocuronium, succinylcholine) preintubation medications (order of administration not important)—is not always feasible in critically ill patients because BMV is necessary to maintain oxygenation and ventilation due to severe lung disease or intracranial hypertension. The routine use of cricoid pressure is not recommended because it does not decrease the risk of regurgitation of stomach contents, and it can impede effective BMV and airway visualization. Although there is a risk of regurgitation and aspiration, supporting the patient during induction and supporting rapid intubation is critical to minimize the risk to the patient.

Once the patient is intubated, proper ETT placement should be assessed by auscultation of breath sounds, observation of symmetric chest rise, and analysis of exhaled carbon dioxide ( $\text{CO}_2$ ) by a

colorimetric device or a capnographic device that quantifies  $\text{CO}_2$  elimination. Chest radiography should be obtained to confirm appropriate tube position. Clinicians should assess ETT cuff pressures to minimize the risk of airway trauma.

## RECOGNITION AND MANAGEMENT OF SHOCK

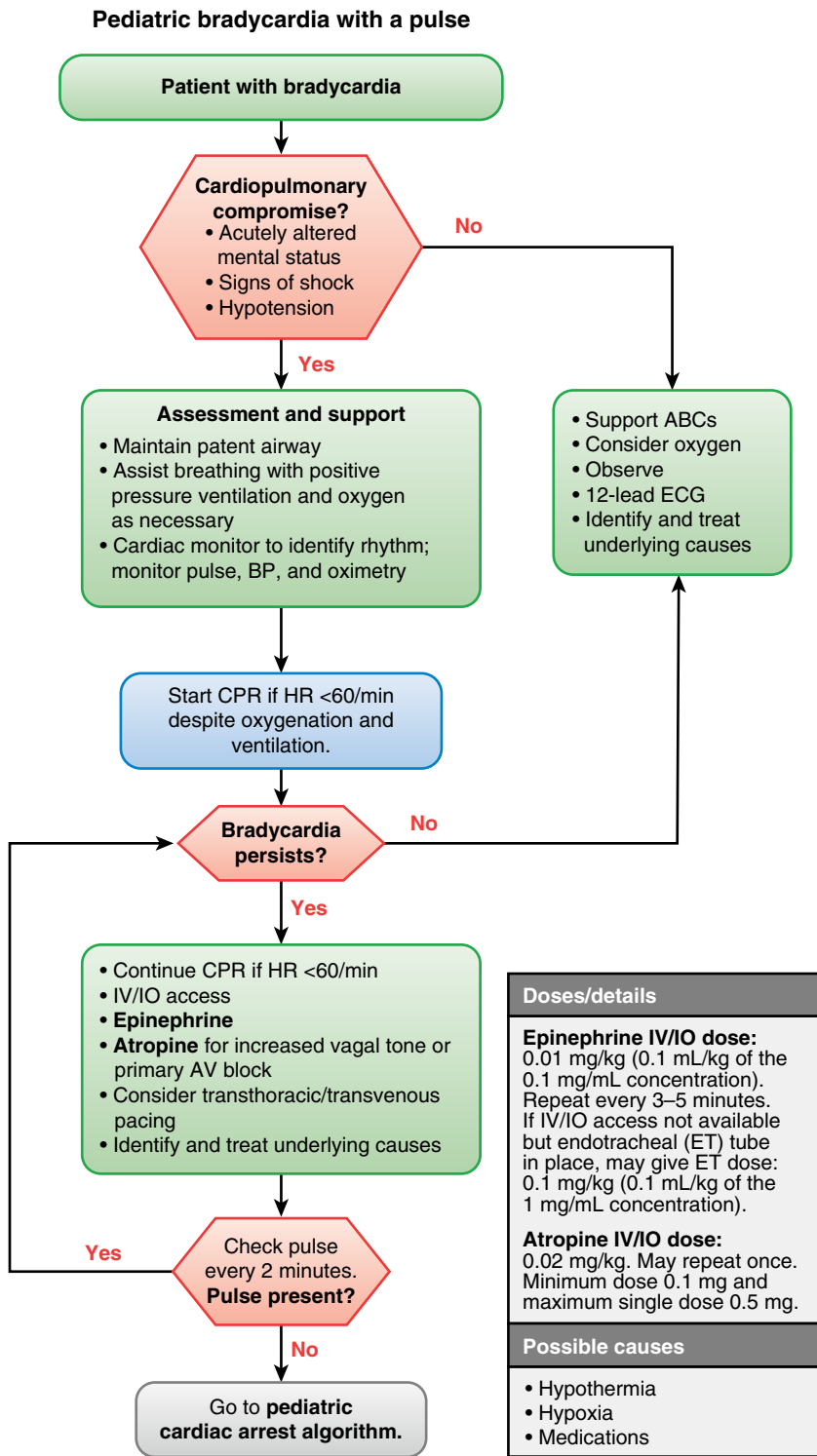
Shock occurs when oxygen and nutrient delivery to the tissues is inadequate to meet metabolic demands (see Chapter 85). A diagnosis of shock does not require the presence of hypotension. It is important for providers to recognize that **shock can occur with hypertension, normotension, or hypotension**. In early *compensated* shock, blood pressure is maintained, and oxygen delivery is mostly preserved through compensatory mechanisms such as tachycardia, increased systemic vascular resistance, or increased cardiac contractility. When compensatory mechanisms fail or are inadequate, the patient progresses to *decompensated* shock, which is defined by hypotension and organ dysfunction. If shock is not rapidly identified and treated, it can progress to multisystem organ dysfunction, cardiac arrest, and death.

Shock is also often described according to the underlying pathophysiology, which dictates the appropriate therapeutic response. **Hypovolemic shock** is the most common type of shock in children worldwide, usually related to fluid losses from severe diarrhea. Hemorrhagic shock is a specific type of hypovolemic shock after trauma or other causes of bleeding. **Distributive shock** occurs because of pathogenic dilation of the body's blood vessels and is often accompanied by relative intravascular hypovolemia due to capillary leak and "third-spacing" of intravascular fluids into the extravascular compartment. The most common causes of distributive shock are sepsis, anaphylaxis, and burn injuries, in which release of inflammatory cytokines causes massive capillary leak of fluid and proteins, leading to low oncotic pressure and intravascular volume. In the setting of myocardial dysfunction, a child has tissue hypoperfusion from **cardiogenic shock**. Common causes of cardiogenic shock are myocarditis, cardiomyopathy, and congenital heart disease, often in the postoperative setting. Severe sepsis and septic shock are often accompanied by myocardial dysfunction, and children with septic shock thus frequently manifest components of hypovolemic, distributive, and cardiogenic shock. **Obstructive shock** occurs when cardiac output is lowered by obstruction of blood flow to the body, as occurs with pericardial tamponade, tension pneumothorax, or massive pulmonary embolism. **Dissociative shock** manifests with normal cardiac and volume status but poor oxygen delivery due to severe anemia and carbon monoxide or cyanide poisoning.

The evaluation of a child in shock should proceed based on the primary, secondary, and tertiary assessments. Initial resuscitation should include the administration of crystalloid fluids in 10-20 mL/kg aliquots up to 60 mL/kg in the first hour if hypotension is present while paying close attention for signs of volume overload. If shock persists, volume overload is evident, or myocardial dysfunction is suspected, vasoactive infusions (e.g., epinephrine, norepinephrine) should be initiated. In hospital settings, catecholamine-dependent shock should trigger providers to consider placing a central venous catheter for stable venous access and an arterial line for continuous blood pressure monitoring. Laboratory assessment should include studies of renal and liver function; acid-base balance, including the presence of lactic acidosis, hypoxemia, and/or hypercapnia; and evidence of coagulopathy or disseminated intravascular coagulation to assess for signs of end-organ dysfunction and response to treatment. Assessment of peripheral perfusion, mental status, and urine output are also important to monitor. Treatment of the various etiologies of shock is noted in Chapter 85.

## RECOGNITION AND TREATMENT OF ARRHYTHMIAS

In the advanced life support setting, arrhythmias are most usefully classified according to the observed heart rate (i.e., bradycardia or tachycardia) and the presence of cardiopulmonary compromise (e.g., altered mental status, hypotension, signs of shock). If the primary survey identifies a child with an abnormal heart rate and altered mental



**Fig. 79.11** Pediatric advanced life support: Bradycardia with a pulse algorithm. ABCs, Airway, breathing, and circulation; AV, atrioventricular (conductor); ECG, electrocardiogram; HR, heart rate; IO/IV, intraosseous/intravenous. (From Topjian AA, Raymond TT, Atkins D, et al. Part 4: Pediatric Basic and Advanced Life Support: 2020 American Heart Association Guidelines for Cardiopulmonary Resuscitation and Emergency Cardiovascular Care. *Circulation*. 2020;142[16 Suppl 2]:S469-S523.)

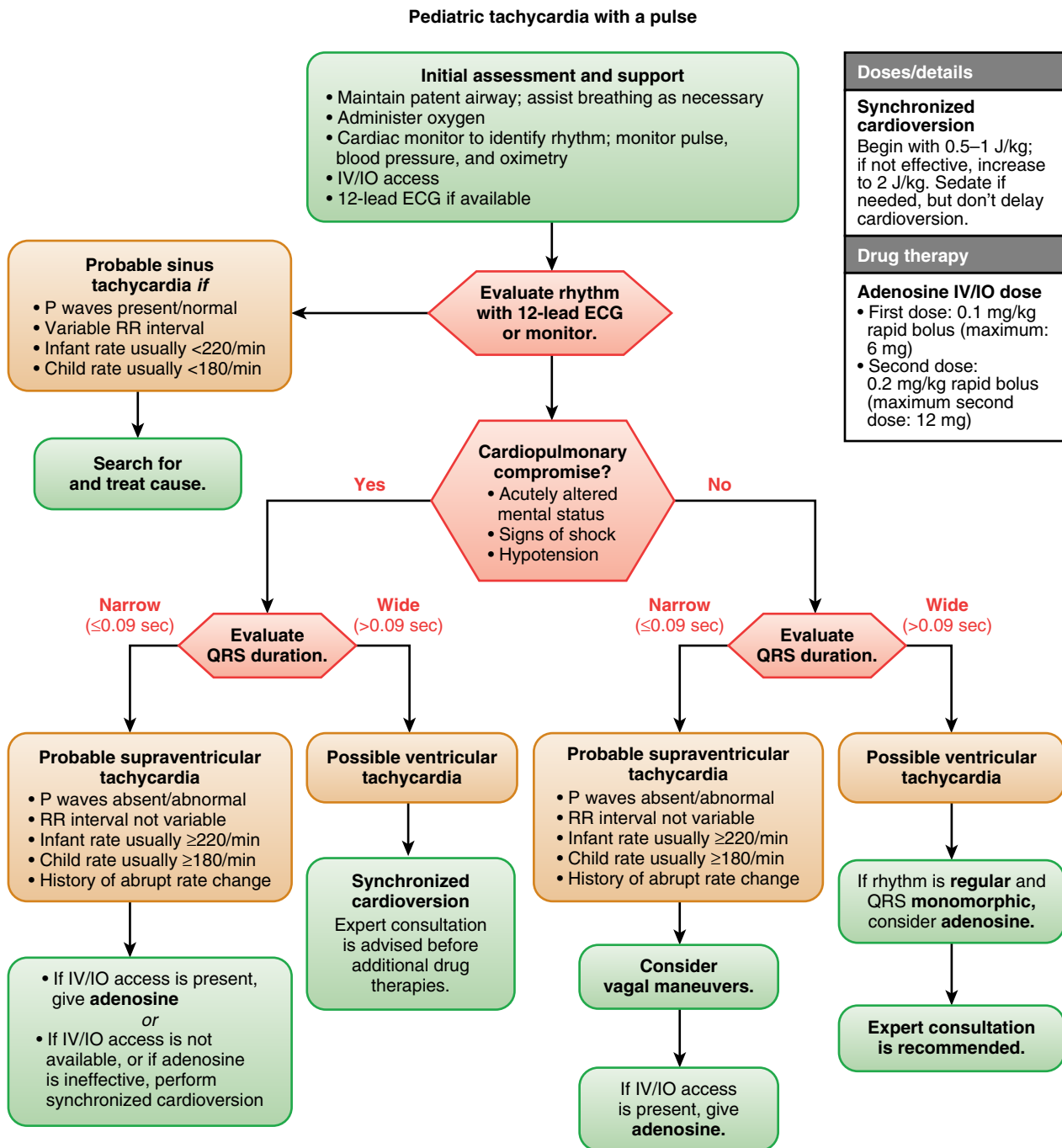
status or other signs of shock or hypotension, the rhythm is inadequate no matter its rate.

**Bradyarrhythmias**

By definition, a child is *bradycardic* when the heart rate is slower than the normal range for age (see Table 79.1). Sinus bradycardia can be a harmless incidental finding in an otherwise healthy person and is not usually associated with cardiac compromise. A clinically significant bradycardia occurs when the heart rate is slow and there are signs of systemic hypoperfusion (i.e., pallor, altered mental status, hypotension,

acidosis). Symptomatic bradycardia occurs most often in the setting of hypoxemia but can also be caused by hypoglycemia, hypocalcemia, other electrolyte abnormalities, hypothermia, heart block, and intracranial hypertension. Bradyarrhythmias are often the most common *prearrest* rhythms in young children.

Initial management of symptomatic bradycardia includes support or opening of the airway and confirming or establishing adequate oxygenation and ventilation (Fig. 79.11). After adequate oxygenation and ventilation have been confirmed, the child should be reassessed for continued bradycardia and poor perfusion. If cardiac



**Fig. 79.12** Pediatric advanced life support: Tachycardia with a pulse algorithm. AV, Atrioventricular (conductor); ECG, electrocardiogram; HR, heart rate; IO/IV, intraosseous/intravenous. (From Topjian AA, Raymond TT, Atkins D, et al. Part 4: Pediatric Basic and Advanced Life Support: 2020 American Heart Association Guidelines for Cardiopulmonary Resuscitation and Emergency Cardiovascular Care. *Circulation*. 2020;142[16 Suppl 2]:S469-S523.)

compromise was solely the result of respiratory insufficiency, support of the child's airway and breathing may have been sufficient to restore normal hemodynamics. If respiratory support does not quickly correct the perfusion abnormalities, further care is based on the quality of perfusion and degree of bradycardia. A heart rate  $<60$  beats/min with cardiopulmonary compromise is an indication to begin CPR, including the administration of epinephrine. If increased vagal tone or primary atrioventricular block is suspected, atropine can be administered. For cases of refractory bradycardia, cardiac pacing should be considered (see Fig. 79.11).

### Tachyarrhythmias

Tachyarrhythmias represent a wide variety of rhythm disturbances of atrial and ventricular origin (see Chapter 484). Sinus tachycardia is a normal physiologic response to the body's need for increased cardiac output or oxygen delivery, as occurs with fever, exercise, or stress. It can also occur in more pathologic states, such as hypovolemia, anemia, pain, anxiety, thyrotoxicosis, and shock. Non-sinus tachyarrhythmias that do not originate in the sinus node are often categorized as either *narrow complex rhythms* (i.e., originating in the atrium, such as supraventricular tachycardia or atrial flutter) or *wide*



Table 79.5 Medications for Pediatric Resuscitation and Arrhythmias		
MEDICATION	DOSE	REMARKS
Adenosine	0.1 mg/kg (max dose: 6 mg) Repeat: 0.2 mg/kg (max dose: 12 mg)	Monitor ECG Rapid IV/IO bolus with flush
Amiodarone	5 mg/kg IV/IO; repeat 5 mg/kg doses up to 15 mg/kg Max dose: 300 mg	Monitor ECG and blood pressure, as it can cause hypotension Give over 20-60 min (can give via IV push for patients in cardiac arrest) Use caution when administering with other drugs that prolong QT interval (consider expert consultation)
Atropine	IV/IO: 0.02 mg/kg Minimum dose: 0.1 mg for bradycardia treatment Max dose: • Child: 0.5 mg • Adolescent: 1 mg Repeat once if needed ETT* 0.04-0.06 mg/kg Max dose: 2 mg	Higher doses may be used with organophosphate poisoning ETT dosing only if no IV/IO access
Calcium chloride (10%) Calcium gluconate	20 mg/kg IV/IO 50-100 mg/kg Max dose: 2 g	Administer slowly; fast push can cause heart block/asystole Use only with documented hypocalcemia
Dextrose	0.5-1 g/kg IV/IO • D10W: 5-10 mL/kg • D25W: 2-4 mL/kg • D50W: 1-2 mL/kg	Recheck serial blood sugars after administration, as hypoglycemia can recur
Epinephrine	IV/IO: 0.01 mg/kg (0.1 mL/kg of the 0.1 mg/mL concentration) Max dose: 1 mg ETT*: 0.1 mg/kg (0.1 mL/kg of the 1 mg/mL concentration) Max dose: 2.5 mg	May repeat every 3-5 min as needed Only give via ETT if no IV/IO access
Lidocaine	IV/IO: 1 mg/kg bolus Max dose: 100 mg Infusion: 20-50 µg/kg/min ETT*: 2-3 mg/kg	Repeat bolus dose if infusion is initiated >15 min after initial bolus
Magnesium sulfate	25-50 mg/kg IV/IO Max dose: 2 g	Can cause hypotension Administer over 10-20 min; faster in torsades de pointes
Naloxone	IV/IO/IM/SQ: 0.1 mg/kg for full reversal Max dose 2 mg IN: 4 mg spray; may repeat q2-3min ETT*: 2-3 times IV dose	Use lower doses in patients with opioid-induced respiratory depression from therapeutic opioid dosing (0.001-0.005 mg/kg) May need to redose every 2-3 minutes, as half-life is shorter than most narcotics ETT if IV/IO routine not available
Sodium bicarbonate	1 mEq/kg IV/IO	Administer slowly; ensure adequate ventilation

\*Flush with 5 mL of normal saline and follow with 5 ventilations.

D5W, 5% Dextrose in water; IO, intraosseous; IV, intravenous; ETT, endotracheal tube; IM, intramuscular; IN, intranasal.

*complex rhythms* (i.e., rhythms of ventricular origin, such as ventricular tachycardia).

The initial management of tachycardia should include assessment for cardiopulmonary compromise (Fig. 79.12). If the patient has evidence of cardiopulmonary compromise (i.e., hypotension, altered mental status, or other signs of shock), further treatment is based on whether the QRS complex of the ECG is narrow ( $\leq 0.09$  sec) or wide ( $>0.09$  sec). For narrow complex tachycardia, providers must distinguish between sinus tachycardia and supraventricular tachycardia (SVT). In **sinus tachycardia**, the history and onset are consistent with a known cause of tachycardia, such as fever or dehydration. Sinus tachycardia usually has some degree of rate variability, and p-waves are consistently present on the ECG and are of normal morphology and axis. Treatment is then geared toward identifying and treating the cause of sinus tachycardia. In **SVT**, onset is often abrupt without prodrome, and p-waves are absent or have a nonsinus ECG axis. When SVT is associated with cardiopulmonary compromise, providers should rapidly move to convert the child's heart rhythm back to sinus rhythm. If the child already has IV access, adenosine should be administered (Table 79.5). Adenosine has an extremely short half-life,

so administration through an IV close to the heart (e.g., upper extremity) is best. Adenosine should be administered with a three-way stopcock inline so that it can be given and immediately flushed into the circulation. If the child does not have IV access or adenosine does not successfully convert the heart rhythm back to sinus rhythm, then **synchronized cardioversion** (0.5-1.0 joule [J]/kg) should be performed. For wide-complex tachycardia (i.e., **ventricular tachycardia [VT]**) with a pulse and evidence of cardiopulmonary compromise, synchronized cardioversion should be performed.

For patients with tachycardia without cardiopulmonary compromise, the rhythm assessment proceeds in the same fashion, but treatment potentially differs. Vagal maneuvers can be considered for SVT in the stable patient, followed by administration of adenosine and obtaining expert consultation. Wide-complex tachyarrhythmias without cardiovascular compromise should also trigger expert consultation before administration of antiarrhythmic medications. If the rhythm is monomorphic, adenosine can be given, as some stable wide-complex tachycardias are SVT with aberrant conduction and thus have a wide QRS complex. Patients should be continually reassessed for development of cardiovascular compromise.

## CARDIAC ARREST AND CARDIOPULMONARY RESUSCITATION

### Overview

Cardiac arrest occurs when the heart fails as an effective pump and blood flow ceases. Outwardly, the patient in cardiac arrest presents as unresponsive and apneic with no palpable pulse. Internally, the cessation of cardiac output and oxygen delivery causes progressive tissue ischemia and organ failure. If not rapidly reversed, cardiac arrest leads to progressive deterioration in brain, heart, and other organ function, such that resuscitation and recovery are no longer possible. Cardiac arrest outcomes in children have improved as a result of improvements in the recognition of deteriorating patients and delivery of high-quality CPR. Prehospital and hospital providers should understand that pediatric cardiac arrest is an inter-venable process for which favorable outcomes are common. Early recognition and rapid treatment with high-quality CPR can be lifesaving.

### Prevention of Cardiac Arrest

Out-of-hospital cardiac arrest (OHCA) occurs due to a variety of causes, including sudden infant death syndrome (SIDS), drowning, foreign body aspiration, poisoning or drug overdose, and trauma. Sudden cardiac arrest due to arrhythmias or cardiac disease do occur (usually in adolescents and those with preexisting congenital heart disease) and should be recognized and promptly treated, but most pediatric OHCA have an underlying respiratory etiology. Preventive measures such as “back to sleep” for infants to lower the risk of SIDS (see Chapter 423), child supervision around bodies of water, and minimizing access to high-risk choking foods substantially decrease the incidence of cardiac arrest. Recognition of the child with respiratory distress or impending respiratory failure and delivery of appropriate care, as outlined earlier, is the most common and practical means of preventing pediatric OHCA.

In hospitalized children, cardiac arrest is most often the result of the progression or worsening of an underlying respiratory, cardiac, or neuromuscular disease process. Most pediatric in-hospital cardiac arrests (IHCA) occur in the setting of progressive respiratory failure or shock. Recognition of deteriorating patients, transfer to monitored settings (i.e., intensive care units), and institution of appropriate directed and supportive therapies are effective means of preventing IHCA or ensuring that if it does occur, care is delivered in a well-equipped and prepared setting.

### Recognition of Cardiac Arrest

Cardiac arrest is recognized from general assessment and primary survey findings consistent with a pale or cyanotic child who is unresponsive, apneic, and pulseless. Even experienced providers have a relatively high error rate when asked to determine presence or absence of pulse in a child. Therefore lay rescuers should begin CPR immediately for any patient without signs of life. Healthcare providers can palpate for a pulse for up to 10 seconds but should provide CPR unless a pulse is definitively felt.

Although initial responders should focus on signs of lifelessness when determining if a patient requires CPR, recognition and understanding of cardiac arrest rhythms is also important for providers. Most pediatric cardiac arrest rhythms are “nonshockable” (i.e., asystole, pulseless electrical activity [PEA], or bradycardia with cardiopulmonary compromise). It is important pediatric providers recognize that bradycardia with cardiopulmonary compromise that does not swiftly resolve with ventilation and oxygenation should be treated with CPR. “Shockable” rhythms (ventricular fibrillation [VF] and pulseless VT) account for a relatively small proportion of pediatric OHCA or IHCA. However, these rhythms can occur as a secondary rhythm later in arrest. Because these rhythms require prompt defibrillation in addition to high-quality CPR, it is important to recognize and be prepared to treat VF or pulseless VT when present.

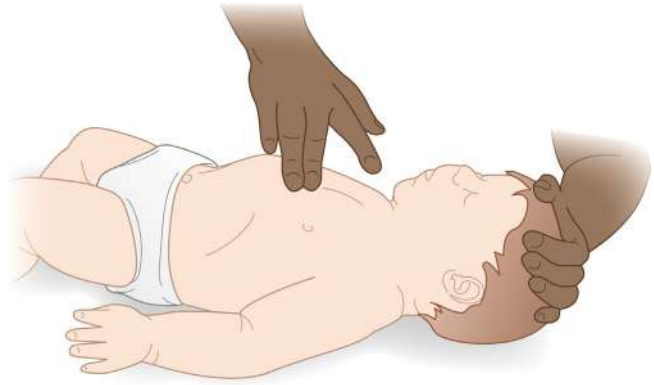


Fig. 79.13 Hand position for infant CPR for the single provider. The two-finger technique.

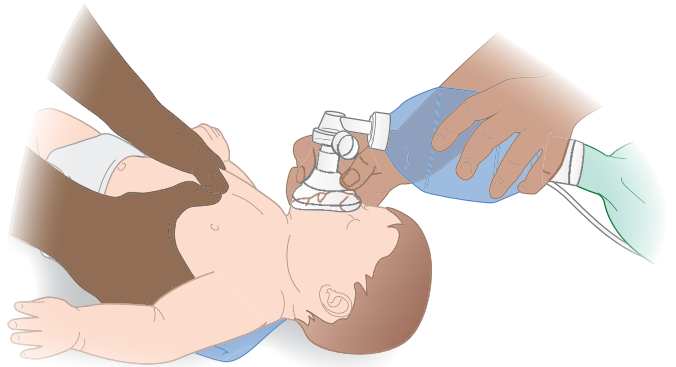


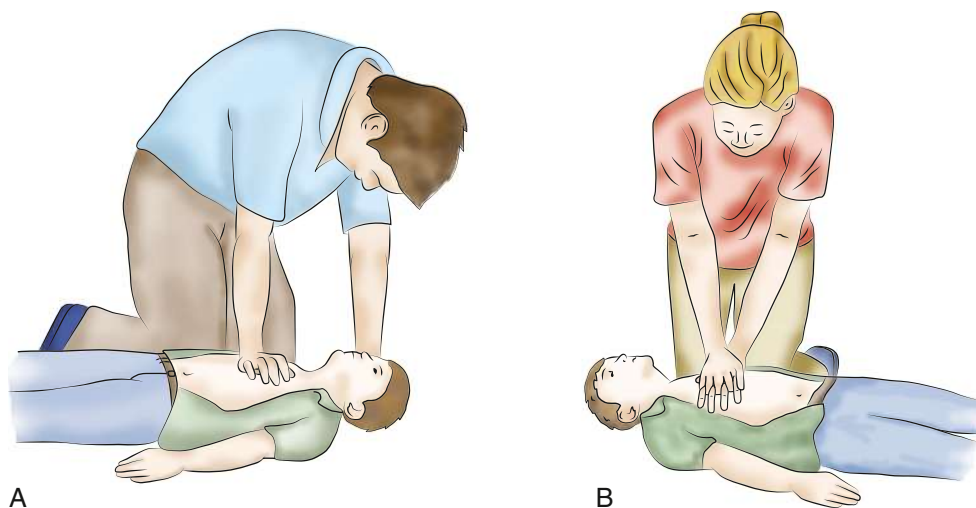
Fig. 79.14 Hand position for infant CPR for two providers. The 2-thumb-encircling hands technique.

### Basic Life Support

The AHA Pediatric BLS algorithms for both single- and two-rescuer scenarios are depicted in Figures 79.1 and 79.2. Upon recognition of cardiac arrest, rescuers should begin CPR with both chest compressions and rescue breaths. Single rescuers who witness a sudden collapse should activate the emergency response system and retrieve an automated electronic defibrillator (AED) or defibrillator, if immediately available, before starting compressions, as many of these children have shockable rhythms. For single rescuers treating children in cardiac arrest without a witnessed sudden collapse, CPR should begin immediately with cycles of 30 compressions followed by two rescuer breaths for at least 2 minutes. An AED should be applied, and automated directions followed as soon as it is available. When two or more rescuers are present, one rescuer should be responsible for activating the emergency response system and retrieving an AED while the other rescuer(s) begins CPR. When both rescuers are providing CPR for an infant or prepubescent child, cycles of 15 compressions followed by two ventilations should be provided. Adolescents should receive cycles of 30 compressions and two ventilations regardless of the number of rescuers.

### Components of High-Quality Cardiopulmonary Resuscitation

The goal of CPR is to provide temporary blood flow and oxygen delivery to the body during cardiac arrest. High-quality CPR that meets established goals and metrics optimizes this blood flow and is associated with improved outcomes from cardiac arrest. **Components of high-quality CPR include optimal hand positioning, appropriate chest compression rate, adequate chest compression depth, allowing for full chest recoil, minimization of interruptions, and appropriate ventilation rate.**



**Fig. 79.15** Hand position for child CPR. A, One-handed chest compressions in a child. B, Two-handed chest compressions in a child or adult.

**Hand positioning and CPR technique:** Chest compressions in infants <1 year old performed by a single provider may be performed by placing two fingers or two thumbs just below the intramammary line (Fig. 79.13). When two providers are present, the two-thumb-encircling hands technique (Fig. 79.14) is recommended unless the rescuer cannot physically encircle the victim's chest, in which case two fingers can be used. If goal depths cannot be reached with these techniques, it is reasonable to use the heel of one hand for chest compressions. For children >1 year old, the care provider should perform chest compressions over the lower half of the sternum with the heel of one hand, or with two hands as used for adult resuscitation (Fig. 79.15). In all cases, care should be taken to avoid compression of the xiphoid and the ribs. When feasible, a backboard should be placed under the child's back and the hospital bed should be placed into "CPR mode" when applicable to maximize the effectiveness of compressions.

**Chest compression mechanics:** Chest compressions should be provided at a rate of **100-120 compressions per minute**. The goal chest compression depth for infants and children is at least **one-third the anterior-posterior diameter of the chest**, which is approximately 4 cm (1.5 inches) in infants and 5 cm (2 inches) in children. For children who have reached puberty, the adult depth of 5-6 cm can be used. Rescuers should avoid leaning and **allow the chest to fully recoil** after each compression in order to facilitate venous return to the heart. Resuscitation teams should seek to **minimize the duration and frequency of chest compression interruptions** during CPR. These chest compression mechanics can be measured during CPR through CPR quality-monitoring defibrillators, which are now widely used.

### Advanced Life Support

The AHA PALS algorithm for cardiac arrest is depicted in Figure 79.16. Chest compressions should be delivered as detailed earlier. Ventilation is a key component of pediatric CPR because most patients have concomitant respiratory failure. For children without an advanced airway in place, chest compressions are paused to allow for the delivery of ventilations via mask with the compression-to-ventilation ratios discussed previously. For children with an advanced airway at the time of arrest, ventilations should be provided asynchronously (i.e., without interrupting chest compressions) at a rate of 20-30 breaths/minute. Providers should avoid overventilation during CPR, as this may increase intrathoracic pressure and decrease venous return to the heart.

Epinephrine is administered during CPR to increase systemic vascular resistance and coronary perfusion pressure in order to restore spontaneous circulation. Epinephrine should be administered intravenously or intraosseously (IO), though it can be administered via ETT if IV or IO access is not available (see Table 79.5). **The first dose of epinephrine should be given within 5 minutes of the onset of cardiac**

**arrest and repeated every 3-5 minutes** until return of spontaneous circulation (ROSC) is achieved. Pulse and rhythm checks should be performed approximately every 2 minutes but should not last more than 10 seconds.

CPR quality can also be gauged by monitoring the patient's physiologic response to resuscitation. End-tidal carbon dioxide, which reflects pulmonary blood flow, can be an indicator of the adequacy of chest compressions. Diastolic blood pressure, measured via an arterial line, is used as a surrogate of coronary perfusion pressure, and values are therefore correlated with the likelihood of ROSC. Either of these tools can be used during CPR by practitioners appropriately trained in the nuances of their interpretation.

### Defibrillation and Antiarrhythmic Medications

For those children with VF or pulseless VT, emergency defibrillation is indicated (see Fig. 79.16). Defibrillator pads should be applied to the bare chest during CPR regardless of initial rhythm, as these rhythms can develop later during cardiac arrest. Lay providers should follow the verbal instructions given by the AED. Ideally, the AED used for children <8 years of age should deliver an attenuated adult dose or should be designed for children; if neither of these options is available, a standard adult AED should be used. Healthcare providers should use either an AED or a manual defibrillator. **An initial defibrillation should be provided at a dose of 2 J/kg** with subsequent dosing per the PALS algorithm. CPR should be promptly resumed after each defibrillation attempt, with additional rhythm assessments and defibrillation attempts every 2 minutes while a shockable rhythm persists. Either amiodarone or lidocaine can be given as an antiarrhythmic for shock-refractory VF or VT (see Table 79.5).

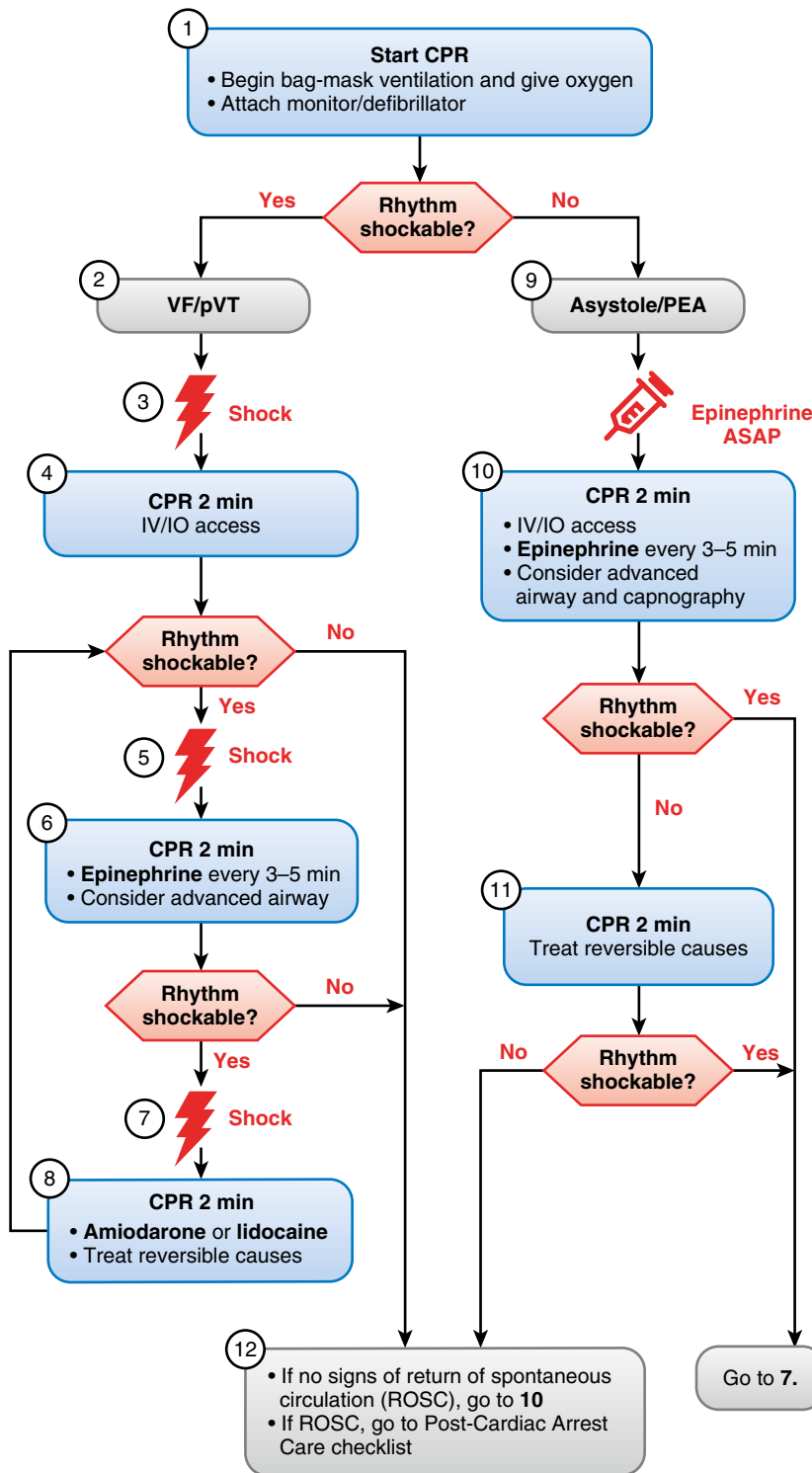
### Identification and Treatment of Underlying Causes of Cardiac Arrest

Pediatric cardiac arrest can occur because of a discrete and clear event (e.g., drowning), due to the progression of underlying disease processes (e.g., refractory hypoxemic respiratory failure), or for reasons that are unclear to the resuscitation team at the time of the arrest. In addition to providing high-quality CPR, reversing the underlying cause of cardiac arrest is critical in order to restore and maintain spontaneous circulation. Focused evaluation of likely etiologies based on the patient's history, risk factors, physical exam, and other findings often reveals addressable cause. Additionally, providers should systematically address common and correctable causes of cardiac arrest (e.g., the "Hs and Ts"; Table 79.6).

### Duration of CPR

Unsurprisingly, children who receive prolonged CPR have worse outcomes than those who require brief CPR. However, previous assertions

Pediatric cardiac arrest algorithm



<b>CPR quality</b>
<ul style="list-style-type: none"> <li>• Push hard (<math>\geq\frac{1}{3}</math> of anteroposterior diameter of chest) and fast (100–120/min) and allow complete chest recoil</li> <li>• Minimize interruptions in compressions</li> <li>• Change compressor every 2 minutes, or sooner if fatigued</li> <li>• If no advanced airway, 15:2 compression-ventilation ratio</li> <li>• If advanced airway, provide continuous compressions and give a breath every 2–3 seconds</li> </ul>
<b>Shock energy for defibrillation</b>
<ul style="list-style-type: none"> <li>• First shock 2 J/kg</li> <li>• Second shock 4 J/kg</li> <li>• Subsequent shocks <math>\geq 4</math> J/kg, maximum 10 J/kg or adult dose</li> </ul>
<b>Drug therapy</b>
<ul style="list-style-type: none"> <li>• <b>Epinephrine IV/IO dose:</b> 0.01 mg/kg (0.1 mL/kg of the 0.1 mg/mL concentration). Max dose 1 mg. Repeat every 3–5 minutes. If no IV/IO access, may give endotracheal dose: 0.1 mg/kg (0.1 mL/kg of the 1 mg/mL concentration).</li> <li>• <b>Amiodarone IV/IO dose:</b> 5 mg/kg bolus during cardiac arrest. May repeat up to 3 total doses for refractory VF/pulseless VT</li> <li>or</li> <li>• <b>Lidocaine IV/IO dose:</b> Initial: 1 mg/kg loading dose</li> </ul>
<b>Advanced airway</b>
<ul style="list-style-type: none"> <li>• Endotracheal intubation or supraglottic advanced airway</li> <li>• Waveform capnography or capnometry to confirm and monitor ET tube placement</li> </ul>
<b>Reversible causes</b>
<ul style="list-style-type: none"> <li>• Hypovolemia</li> <li>• Hypoxia</li> <li>• Hydrogen ion (acidosis)</li> <li>• Hypoglycemia</li> <li>• Hypo-/hyperkalemia</li> <li>• Hypothermia</li> <li>• Tension pneumothorax</li> <li>• Tamponade, cardiac</li> <li>• Toxins</li> <li>• Thrombosis, pulmonary</li> <li>• Thrombosis, coronary</li> </ul>

**Fig. 79.16** Pediatric advanced life support cardiac arrest algorithm. CPR, Cardiopulmonary resuscitation; IO/IV, intraosseous/intravenous; PEA, pulseless electrical activity; VF/VT, ventricular fibrillation/tachycardia. (From Topjian AA, Raymond TT, Atkins D, et al. Part 4: Pediatric Basic and Advanced Life Support: 2020 American Heart Association Guidelines for Cardiopulmonary Resuscitation and Emergency Cardiovascular Care. *Circulation*. 2020;142[16 Suppl 2]:S469-S523.)

that CPR >20 minutes in duration was futile have been disproven. More than 15% of children who received >35 minutes of CPR for IHCA survived to hospital discharge in one large registry study. Therefore decisions regarding futility and when to cease resuscitation efforts should take into account patient factors, goals of care, arrest etiology and characteristics, and a host of other factors, rather than CPR duration alone.

**Extracorporeal Membrane Oxygenation and Extracorporeal Cardiopulmonary Resuscitation**

Extracorporeal membrane oxygenation (ECMO) is a modified form of cardiopulmonary bypass that can be employed in children with severe cardiac or respiratory failure. Blood is removed from a large central vein, carried through tubing to an oxygenator for gas



**Table 79.6** Potentially Reversible Causes of Cardiac Arrest

CONDITION	COMMON CLINICAL SETTINGS	TREATMENT
<b>THE H'S</b>		
Hypovolemia	Dehydration, hemorrhage, major burns, diabetes, gastrointestinal losses, shock, and trauma	Administer fluids For hemorrhage, administer packed red blood cells and other blood products
Hypoxemia	Upper airway obstruction (croup, anaphylaxis, foreign body) Lower airway obstruction (asthma, bronchiolitis) Parenchymal lung disease (pneumonia) Restrictive lung disease (pleural effusion)	Provide supplemental oxygen Confirm endotracheal tube placement and chest rise
Hydrogen ion (acidosis)	Preexisting acidosis, diabetes, diarrhea, drugs and toxins, prolonged resuscitation, renal disease, and shock	Reassess the adequacy of cardiopulmonary resuscitation, oxygenation, and ventilation; reconfirm endotracheal tube placement Ensure adequate ventilation and avoid concomitant respiratory acidosis Administer IV fluids May consider bicarbonate administration with documented severe acidosis
Hypoglycemia	Starvation, toxin, diabetes medications, metabolic disease	Administer dextrose (glucagon if dextrose not available) Discontinue causative medications
Hyperkalemia	Metabolic acidosis, excessive administration of potassium, renal failure, drugs and toxins, vigorous exercise, hemolysis, rhabdomyolysis, tumor lysis syndrome, and clinically significant tissue injury	Stop potassium-containing fluids Stabilize cardiac membrane: calcium Treat acidosis: sodium bicarbonate Shift potassium intracellularly: sodium bicarbonate, insulin (with glucose to prevent hypoglycemia), and albuterol Promote potassium excretion: loop diuretics, Kayexalate Removal of potassium: dialysis
Hypokalemia	Diabetes, diuretic use, drugs and toxins, profound gastrointestinal losses	If profound hypokalemia is accompanied by cardiac arrest, initiate urgent IV potassium replacement
Hypothermia	Alcohol abuse, burns, central nervous system disease, debilitated patient, drowning, drugs and toxins, endocrine disease, history of exposure, homelessness, extensive skin disease, spinal cord disease, and trauma	If hypothermia is severe (temperature <30°C [86°F]), defibrillation may be ineffective; initiate active internal rewarming with cardiopulmonary support; can consider extracorporeal rewarming If hypothermia is moderate (temperature 30-34°C [86-93.2°F]), actively rewarm during CPR
<b>THE T'S</b>		
Tension pneumothorax	Procedural complication, mechanical ventilation complication, pulmonary disease with "air leak" (including asthma, chronic obstructive pulmonary disease, and necrotizing pneumonia), thoracentesis, and trauma	Needle decompression followed by chest tube insertion or primary chest tube insertion
Cardiac tamponade	Hemorrhage, malignancy, pericarditis, trauma, cardiac surgery, post-myocardial infarction	Administer fluids to increase cardiac preload (temporizing only); obtain bedside echocardiogram, if available Perform pericardiocentesis; immediate surgical intervention is appropriate if pericardiocentesis is unhelpful but cardiac tamponade is known or highly suspected
Toxins	Alcohol abuse, behavioral or metabolic presentation, classic toxicologic syndrome, psychiatric disease, depressed mental status of unclear etiology, medications in the home, history of depression/suicidality	Supportive care and toxin-directed therapies in consultation with a toxicologist
Thrombosis, pulmonary	Hospitalized patient, recent surgical procedure, peripartum, known risk factors for venous thromboembolism, history of venous thromboembolism, or prearrest presentation consistent with a diagnosis of acute pulmonary embolism, recent immobility or fractures	Administer fluids; augment with vasoactive medications as necessary Consider pulmonary vasodilators (e.g., inhaled nitric oxide) Consider systemic or site-directed thrombolytic therapy Consider mechanical thrombectomy Consider ECMO
Thrombosis, coronary	Known risk factors for myocardial infarction (congenital heart disease, family history of sudden cardiac death)	Consider fibrinolytic therapy Consider percutaneous coronary intervention

Adapted from Kleinman ME, Chameides L, Schexnayder SM, et al. Part 14: Pediatric advanced life support: 2010 American Heart Association Guidelines for Cardiopulmonary Resuscitation and Emergency Cardiovascular Care. *Circulation*. 2010;122(18 Suppl 3):S876-S908.

exchange, and then returned to the body via either a vein (venovenous or VV-ECMO) or an artery (venoarterial or VA-ECMO). VV-ECMO is typically used in patients with refractory respiratory failure who require ECMO for gas exchange but continue to rely on their native cardiac function for cardiac output. VA-ECMO is used for

patients with shock or cardiac failure, with or without concomitant respiratory failure, with the ECMO pump and circuit augmenting or replacing native cardiac output. The processes of determining ECMO candidacy, performing ECMO cannulation, maintaining ECMO circuit integrity, and caring for critically ill children on ECMO are

**Table 79.7** Medications to Maintain Cardiac Output and for Postarrest Stabilization\*

MEDICATION	DOSE RANGE	COMMENT
Dobutamine	2-20 µg/kg/min IV/IO	Inotrope, chronotrope, vasodilator
Dopamine	2-20 µg/kg/min IV/IO	Inotrope, chronotrope, vasodilator at low doses, vasoconstrictor at high doses
Epinephrine	0.01-1 µg/kg/min IV/IO	Inotrope, chronotrope, vasodilator at low doses, vasoconstrictor at medium and high doses
Milrinone	50 µg/kg IV/IO over 10-60 min then 0.25-0.75 µg/kg/min	Inodilator, lusitrope, vasodilator
Norepinephrine	0.01-1 µg/kg/min	Vasopressor; weak inotrope

\*Alternative formula for calculating an infusion: Infusion rate (mL/hr) = [weight (kg) × dose (µg/kg/min) × 60 (min/hr)]/concentration µg/mL.

Data from Kleinman ME, Brennan EE, Goldberger ZD, et al. Part 5: Adult Basic Life Support and Cardiopulmonary Resuscitation Quality: 2015 American Heart Association Guidelines Update for Cardiopulmonary Resuscitation and Emergency Cardiovascular Care. *Circulation*. 2015;132(18 Suppl 2):S414-S435.

complex; ECMO is thus performed only at centers with appropriate expertise and equipment.

Extracorporeal support can be employed as a rescue therapy for refractory cardiac arrest. Extracorporeal CPR (ECPR), which involves cannulating and placing a patient on VA-ECMO while CPR is in progress, has been successfully used in children. Its efficacy has been best demonstrated in hospitalized children with underlying cardiac disease; AHA guidelines therefore state that it can be considered for children “with cardiac diagnoses who have IHCA in settings with existing ECMO protocols, expertise, and equipment.” In addition, ECPR has been employed in patients with noncardiac etiologies of cardiopulmonary arrest who are not responding to standard resuscitation protocols.

### Post-Cardiac Arrest Care

After resuscitation from cardiac arrest, patients are at risk for developing **post-cardiac arrest syndrome (PCAS)**. PCAS is composed of post-cardiac arrest brain injury, myocardial dysfunction, systemic ischemia-reperfusion response, and persistence of preexisting pathophysiology and can last for days to weeks after the cardiac arrest. Primary brain injury occurs due to hypoxia and ischemia during the no-flow (pre-CPR) and low-flow (during CPR) periods. Secondary brain injury occurs during the postarrest period. Signs and symptoms of brain injury are encephalopathy, seizures, cerebral edema, and autonomic dysfunction. Myocardial dysfunction can present as hypotension, depressed left or right ventricular systolic or diastolic function, arrhythmias, or pulmonary edema. The systemic ischemia-reperfusion response is a “sepsis-like” syndrome and has clinical findings of hyperglycemia, coagulopathy, hypovolemia, fever, and multisystem organ dysfunction. These three components combined with the precipitant that caused the arrest (e.g., septic shock or PARDS) result in varied severity of PCAS ranging from minimal symptoms, with patients returning quickly to their neurologic baseline, to severe multisystem organ failure with high risk of repeat cardiac arrest.

To address this clinical spectrum, it is important to be deliberate and vigilant in caring for the postarrest patient. Thus close postarrest observation in an intensive care unit, where the child can receive ongoing multiorgan system assessments and support, is critical. To prevent secondary brain injury, which occurs during the postarrest period, clinicians should monitor for, prevent, and treat PCAS. Hypotension is common and can lead to organ hypoperfusion. Clinicians should frequently monitor blood pressure and should do so continuously with an arterial catheter if appropriate resources are available. IV fluids and vasoactive agents such as epinephrine or norepinephrine should be used to maintain a blood pressure greater than the fifth percentile for age. Clinicians should be proactive and not wait for hypotension to occur. Rather, they should be prepared with fluids, vasoactive infusions, and clearly defined postarrest blood pressure targets. Continuous arterial blood pressure monitoring can help the provider determine

the need for, and response to, inotropic and chronotropic medications (Table 79.7).

Hyperoxia (Pao<sub>2</sub> >300) and hypoxemia after cardiac arrest should be prevented because both can worsen secondary brain injury. Clinicians should wean supplemental oxygen after ROSC, targeting a saturation of 94–99%. In most cases, weaning supplemental oxygen when patients are saturating 100% is not harmful. For patients with hypoxemia, clinicians may need to try alternative ventilator strategies if supplemental oxygen is insufficient to achieve a saturation above 94% or higher.

Fever is common after cardiac arrest and may worsen secondary brain injury. **Targeted temperature management (TTM)** is performed with an active temperature control device and should be used for children postarrest who do not return to their neurologic baseline. Because there is no difference in survival or neurologic outcomes between patients who receive TTM 33°C (32–34°C [89.6–91.4°F]) and patients who receive TTM 36.8°C (98.2°F) (36–37.5°C [96.8–99.5°F]), either can be selected. Patients should have continuous core temperature monitoring and receive sedation and analgesics to prevent discomfort. If shivering occurs, patients should be treated with a sedative or neuromuscular blockade. Hyperthermia must be avoided.

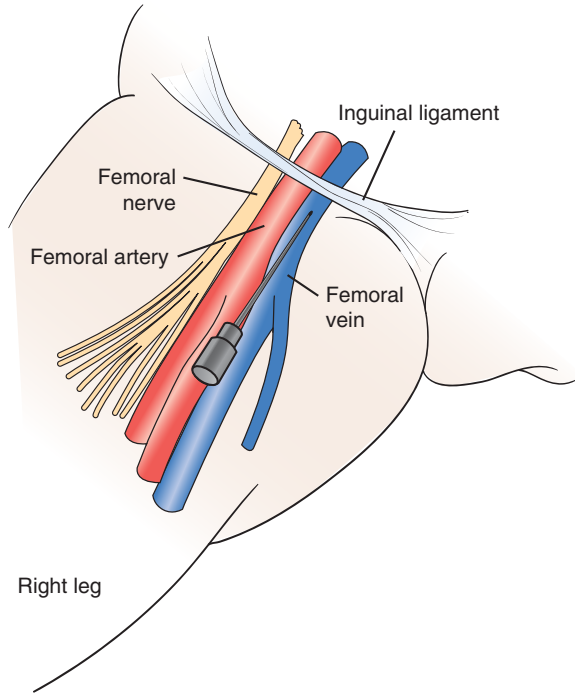
Seizures are common after cardiac arrest and often are nonconvulsive and therefore can only be detected on an EEG. It is unclear if treatment improves outcomes; however, antiseizure medications can be administered for convulsive and nonconvulsive seizures.

Most care is supportive, but close monitoring for organ injury that can be treated (e.g., coagulopathy or adrenal insufficiency) or that may require modification of therapies (e.g., medication dose adjusting in patients with acute kidney injury) should be considered. Survivors of cardiac arrest can have long-standing neurologic, cognitive, physical, and quality-of-life deficits. Clinicians should refer children for ongoing evaluation and assessments.

Communication with the patient’s family is an essential element of postarrest care, as it is for the care of any acutely ill or injured child. The family should be thoroughly briefed on the elements of the resuscitation performed, the child’s condition, and ongoing medical concerns, uncertainties, or issues. The provider should be available to answer the family’s questions, clarify information, and provide comfort. Other support staff, including social workers and chaplains, should be contacted, as the family wishes, to provide additional support and comfort. For situations in which the resuscitation is ongoing, it is recommended that the provider make every effort possible to have the family present at the bedside, if they wish. Family presence during CPR or other emergency resuscitative efforts, even if the child dies, is associated with a more positive medical experience than if they are excluded. In situations where the child is critically ill but stable, the family should be brought to the bedside as soon as the healthcare team deems it safe and appropriate (see Chapter 8).

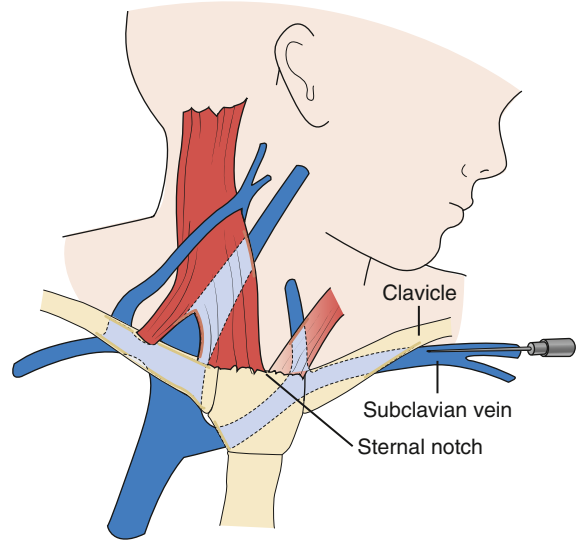
**PROCEDURES**  
**Vascular Access**  
**Venous Access**

Veins suitable for cannulation are numerous, but there is considerable anatomic variation from patient to patient. In the upper extremities,

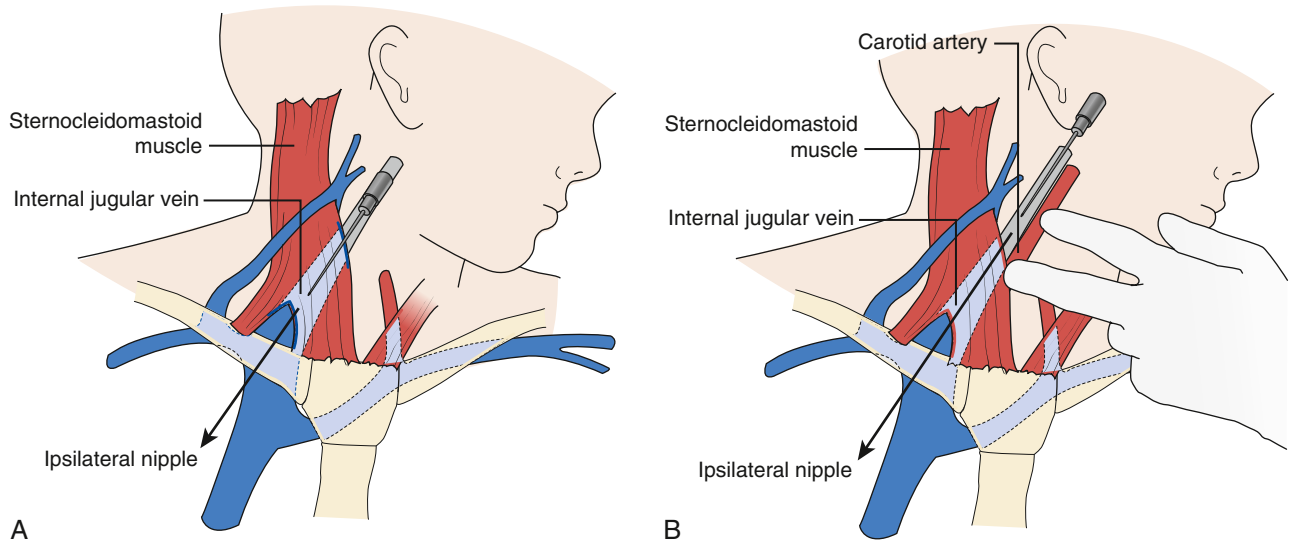


**Fig. 79.17** Approach to the femoral vein. The patient is flat and supine, with the thigh slightly abducted and externally rotated. The introducer needle enters the skin 1-2 cm distal to the inguinal ligament and 0.5-1 cm medial to the pulse of the femoral artery. Remember the lateral to medial mnemonic NAVEL for nerve, artery, vein, empty space, and lymphatics. (From Edwards LR, Malone MP, Prodhm P, Schexnayder SM. Pediatric vascular access and centeses. In: Zimmerman JJ, Rotta AT, eds. *Fuhrman & Zimmerman's Pediatric Critical Care*, 6th ed. Philadelphia: Elsevier; 2022: Fig. 14.6, p. 102.)

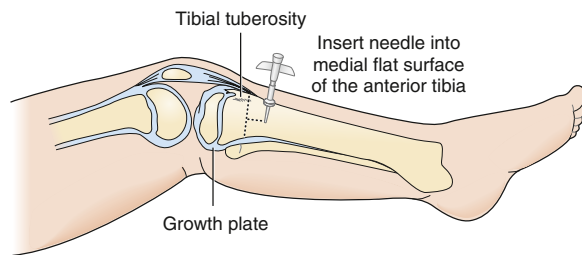
the *median antecubital vein*, located in the antecubital fossa, is often the largest and easiest to access. Many veins on the dorsum of the hand are also suitable for cannulation because they are often large and easily located, and their cannulation is generally well tolerated. The *cephalic vein* is usually cannulated at the wrist, along the forearm, or at the elbow. The *median vein* of the forearm is also suitable as it lies along a flat surface of the forearm. In the lower extremity, the *great saphenous vein*, located just anterior to the medial malleolus, is accessible in most patients. The dorsum of the foot usually has a large vein in the midline, passing across the ankle joint, but catheters are difficult to maintain in



**Fig. 79.19** Approach to the subclavian vein. The patient is supine, in slight Trendelenburg position, with a small roll along the spine between the shoulders. The needle enters the skin at the junction of the lateral and middle thirds of the inferior clavicle and is directed toward the suprasternal notch, passing along the inferior edge of the clavicle. (From Edwards LR, Malone MP, Prodhm P, Schexnayder SM. Pediatric vascular access and centeses. In: Zimmerman JJ, Rotta AT, eds. *Fuhrman & Zimmerman's Pediatric Critical Care*, 6th ed. Philadelphia: Elsevier; 2022: Fig. 14.5, p. 102.)



**Fig. 79.18** Approaches to the internal jugular vein. The patient is supine, in slight Trendelenburg position, with the neck extended over a shoulder roll and the head rotated to the contralateral side. **A**, Middle approach: The introducer needle enters the skin at a 30-degree angle at the apex of the triangle formed by the heads of the sternocleidomastoid muscle and clavicle, directing it toward the ipsilateral nipple. **B**, Anterior approach: The carotid pulse is palpated and may be slightly retracted medially. The introducer needle enters along the anterior margin of the sternocleidomastoid, about halfway between the suprasternal notch and mastoid process, while being directed toward the ipsilateral nipple. (Modified from Edwards LR, Malone MP, Prodhm P, Schexnayder SM. Pediatric vascular access and centeses. In: Zimmerman JJ, Rotta AT, eds. *Fuhrman & Zimmerman's Pediatric Critical Care*, 6th ed. Philadelphia: Elsevier; 2022: Fig. 14.4, p. 101.)



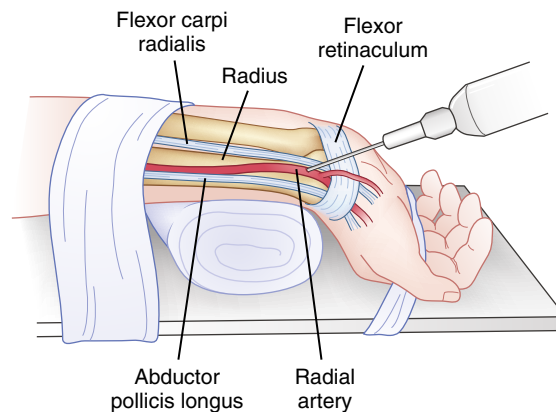
**Fig 79.20** Insertion of the intraosseous needle into the anterior tibia. (From Edwards LR, Malone MP, Prodhon P, Schexnayder SM. *Pediatric vascular access and centeses*. In: Zimmerman JJ, Rotta AT, eds. *Fuhrman & Zimmerman's Pediatric Critical Care*, 6th ed. Philadelphia: Elsevier; 2022: Fig. 14.2, p. 95.)

this vein because dorsiflexion tends to dislodge them. A second large vein on the lateral side of the foot, running in the horizontal plane, usually 1-2 cm dorsal to the lower margin of the foot, is preferable. The most notable scalp veins are the *superficial temporal* (just anterior to the ear) and *posterior auricular* (just behind the ear).

Deeper and larger central veins can provide more reliable access for medications, nutritive solutions, and blood sampling than peripheral venous lines. Placement of central access should be considered in the patient with difficult peripheral access where IVs may be challenging to obtain or may last for brief periods with increased risk of infiltration; when a patient is critically ill requiring numerous medications and needs stable access; when a patient requires IV vasoactive medications for more than a brief period; if long-term medications need to be administered in the hospital or at home; or if administered agents are vascular irritants (IV nutrition, electrolyte infusions, certain antibiotics). Central veins may be reached by percutaneous cannulation or surgical exposure. In infants and young children, the *femoral vein* or *internal jugular vein* are often the easiest to access and cannulate, but the subclavian veins may also be used (Figs. 79.17, 79.18, and 79.19). Peripherally inserted central catheters (PICCs) can be placed for longer-term access through the upper or lower extremity to administer medications or IV nutrition and can be used at home. With the expansion of bedside ultrasound availability and expertise, central venous catheters should be placed under ultrasound guidance to improve first-pass success and minimize the risk of complications.

### Intraosseous Access

IO needles (for intramedullary venous plexus access) are specialized, rigid, large-bore needles. IO cannulation is recommended for patients in whom IV access proves difficult or unattainable in an emergent setting, even in older children. If venous access is not available within approximately 1 minute in a child with cardiopulmonary arrest, an IO needle should be placed in the anterior proximal tibia (with care taken to avoid traversing the epiphyseal plate) or other approved site. The needle should penetrate the anterior layer of compact bone, and its tip is advanced into the spongy interior of the bone (Fig. 79.20). Commercially available IO kits frequently include drills that mitigate the complications of needle placement associated with manual placement. All medications, blood products, and fluids may be administered through the IO route, including medications required for emergency resuscitation. Laboratory values can be sampled, although a complete blood count will be unreliable. Complications are uncommon but may include osteomyelitis with prolonged infusions, tibial fracture, and infiltration of fluids with dislodgement.



**Fig. 79.21** Radial artery anatomy and cannulation.

### Arterial Access

Arterial access is indicated when care providers need frequent blood sampling, particularly to assess adequacy of oxygenation, ventilation, or acid-base balance, or continuous blood pressure monitoring. The *radial artery*, the most commonly cannulated artery, lies on the lateral side of the anterior wrist, just medial to the styloid process of the radius (Fig. 79.21). The *ulnar artery*, just lateral to the tendon of the flexor carpi ulnaris, is used less often because of its proximity to the ulnar nerve. Useful sites in the lower extremity, particularly in neonates and infants, are the *dorsalis pedis artery*, on the dorsum of the foot between the tendons of the tibialis anterior and the extensor hallucis longus, and the *posterior tibial artery*, posterior to the medial malleolus. Arterial catheters require special care for insertion and subsequent management. Clinicians should monitor for signs of decreased perfusion distal to catheter placement.

## NONVASCULAR EMERGENCY PROCEDURES

### Thoracentesis and Chest Tube Placement

Thoracentesis is the placement of a needle or catheter into the pleural space to evacuate fluid, blood, or air. Most insertions are performed in one of the intercostal spaces between the fourth and sixth ribs in the plane of the midaxillary line. After appropriate systemic and local anesthesia/sedation, a needle (and later the chest tube) that enters the pleural space should penetrate the intercostal space by passing over the superior edge of the lower rib, because there are larger vessels along the inferior edge of the rib. Ideally, the chest tube should lie *anterior* in the pleural space for air accumulation and *posterior* for fluid accumulation. A radiograph must be obtained to verify chest tube placement and evacuation of the pleural space.

### Pericardiocentesis

When fluid, blood, or gas accumulates in the pericardial sac, the heart may become compressed and may be unable to fill/empty with normal volumes of blood, leading to diminished cardiac output (i.e., pericardial tamponade with obstructive shock). The cardinal signs of such a restrictive pericardial effusion are tachycardia and hypotension, generally with a narrowed pulse pressure. Pericardiocentesis includes needle aspiration of the pericardial sac, often followed by the placement of a catheter for continuous drainage. As with thoracentesis, chest radiography should be done to confirm catheter location and to evaluate for any complications, such as pneumothorax or hemothorax. Pericardiocentesis may be performed with echocardiography.

Visit Elsevier eBooks+ at [eBooks.Health.Elsevier.com](https://eBooks.Health.Elsevier.com) for Bibliography.



## Chapter 80

## Acute Care of Multiple Trauma

Courtney W. Mangus, Howard I. Pryor II, and Bruce L. Klein

### EPIDEMIOLOGY

Injury is a leading cause of death and disability in children throughout the world (see Chapter 14). Deaths represent only a small fraction of the total trauma burden. Approximately 140,000 children were treated in U.S. trauma centers in 2016 for serious injury. Many survivors of trauma have permanent or temporary functional limitations. Motor vehicle–related injuries and falls rank among the top 15 causes of disability-adjusted life years in children worldwide. In childhood, blunt trauma predominates, accounting for the majority of injuries. In adolescence, penetrating trauma increases in frequency, accounting for approximately 13% of injuries, and penetrating trauma secondary to a firearm is associated with a high case fatality rate of 11%.

### REGIONALIZATION AND TRAUMA TEAMS

Morbidity and mortality rates have decreased in geographic regions with comprehensive, coordinated trauma systems. Treatment at designated trauma centers is associated with decreased mortality. At the scene of injury, paramedics should administer necessary advanced life support and perform triage (Fig. 80.1). It is usually preferable to bypass local hospitals and rapidly transport a seriously injured child directly to a pediatric trauma center (or a trauma center with pediatric commitment). *Children have lower mortality rates, lower complication rates, and fewer operative interventions after severe blunt trauma when they are treated in designated pediatric trauma centers or in hospitals with pediatric intensive care units.*

When the receiving emergency department (ED) is notified before the child's arrival, the trauma team should be mobilized in advance. Each member has defined tasks. A senior surgeon (surgical coordinator) or an emergency physician leads the team. Team compositions vary somewhat from hospital to hospital; Figure 80.2 shows the model used at the Johns Hopkins Hospital Bloomberg Children's Center (Baltimore, MD). Consultants, especially neurosurgeons and orthopedic surgeons, must be promptly available, and the operating room staff should be alerted.

Physiologic status and mechanism of injury are used for field triage and to determine whether to activate the trauma team. More importance should be placed on physiologic compromise and less on mechanism of injury. Scoring scales such as the Abbreviated Injury Scale (AIS), Injury Severity Score (ISS), Pediatric Trauma Score (Table 80.1), and Revised Trauma Score use these parameters to predict patient outcome. The AIS and ISS are used together. First, the AIS is used to numerically score injuries—as 1 minor, 2 moderate, 3 serious, 4 severe, 5 critical, or 6 probably lethal—in each of six ISS body regions: head/neck, face, thorax, abdomen and pelvic contents, extremities/bony pelvis, and external. The ISS is the sum of the squares of the highest three AIS region scores.

### ATLS: SYSTEMATIC EVALUATION OF THE INJURED PATIENT

The American College of Surgeons (ACS) endorses a systematic approach to trauma patients known as **Advanced Trauma Life Support** (ATLS). ATLS is accepted as the standard of care for the initial assessment of injured patients and is used internationally. The approach is centered on a standardized patient evaluation that prioritizes identification and management of injuries in a specific order that addresses their immediate risk to life. ATLS principles are detailed here

and include performance of the primary survey with initial adjuncts followed by the secondary survey.

### PRIMARY SURVEY

During the primary survey, the trauma team quickly assesses and treats life-threatening injuries (see also Chapter 79). The principal causes of death shortly after trauma are airway obstruction, respiratory insufficiency, shock from hemorrhage, and central nervous system (CNS) injury. The primary survey addresses the **ABCDEs**: Airway, Breathing, Circulation, Disability/Neurologic Deficit, and Exposure of the patient and control of the Environment.

#### Airway

Optimizing oxygenation and ventilation, while protecting the cervical spine (C-spine) from potential further injury, is of paramount importance. Airway obstruction manifests as snoring, gurgling, hoarseness, stridor, and/or diminished breath sounds even with apparently good respiratory effort. Children are more likely than adults to have airway obstruction because of their smaller oral and nasal cavities, proportionately larger tongues, more tonsillar and adenoidal tissue, higher and more anterior glottic opening, and narrower larynx and trachea. Obstruction is common in patients with severe head injuries, partly because of decreased muscle tone, which allows the tongue to fall posteriorly and occlude the airway. With trauma, obstruction can also result from fractures of the mandible or facial bones, secretions such as blood or vomit, crush injuries of the larynx or trachea, and foreign body aspiration.

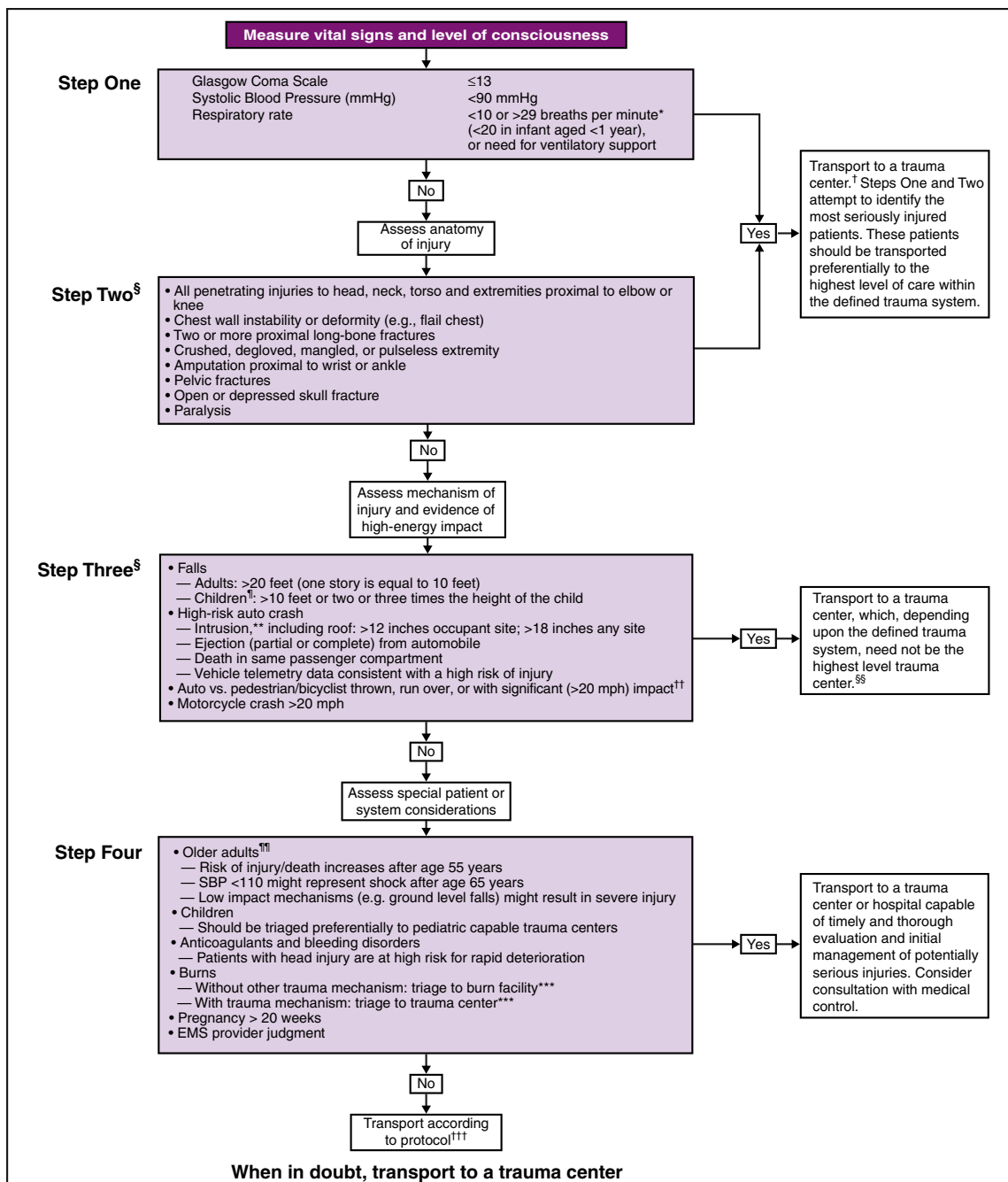
If it is necessary to open the airway, a jaw thrust without head tilt is recommended. This procedure minimizes cervical spine motion. In an unconscious child, an oropharyngeal airway may be inserted to prevent posterior displacement of the mandibular tissues. A semiconscious child will gag with an oropharyngeal airway but may tolerate a nasopharyngeal airway. A nasopharyngeal airway is contraindicated when there is significant nasal trauma or possibility of cribriform plate fracture. If these maneuvers plus suctioning do not clear the airway, oral endotracheal intubation is indicated. When endotracheal intubation proves difficult, a laryngeal mask airway can be used as a temporary alternative. A laryngeal mask airway consists of a tube with an inflatable cuff that rests above the larynx and thus does not require placement of the tube into the trachea. Other extraglottic devices that can be blindly inserted in a difficult airway scenario include the Combitube and King laryngeal airway tube; these devices are considered temporary and should be exchanged for a definitive airway as soon as possible. Video-assisted laryngoscopy or the use of a bougie can also be particularly helpful in the management of a difficult airway. Emergency cricothyrotomy is needed in <1% of trauma victims.

#### Breathing

The physician assesses breathing by counting the respiratory rate; visualizing chest wall motion for symmetry, expansion, and accessory muscle use; and auscultating breath sounds in both axillae. Pulse oximetry and continuous waveform capnography monitoring should also be used; however, they may be less reliable in patients with shock. If ventilation is inadequate, bag-valve-mask ventilation with 100% oxygen must be initiated immediately, followed by endotracheal intubation. End-expiratory carbon dioxide (CO<sub>2</sub>) detectors or capnography help verify accurate tube placement.

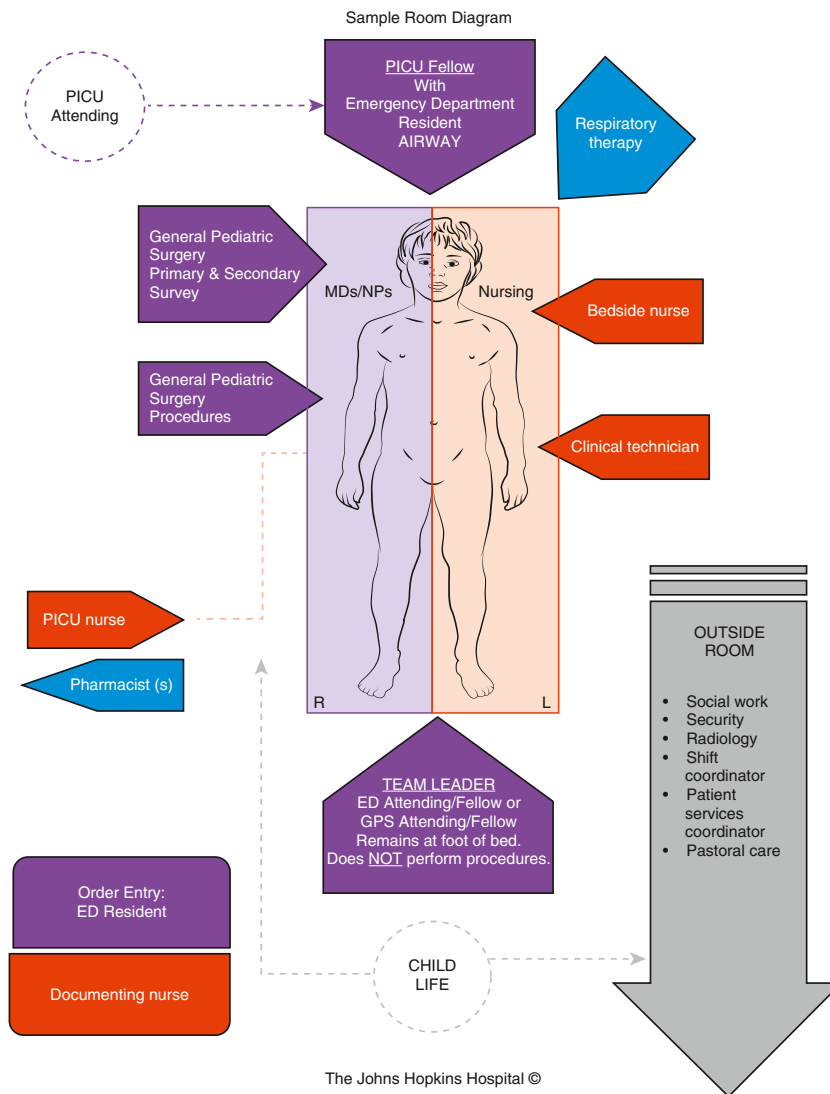
Head trauma is the most common cause of respiratory insufficiency. An unconscious child with severe head injury may have a variety of breathing abnormalities, including Cheyne-Stokes respiration, slow irregular breaths, and apnea. A child with significant neurologic impairment will require endotracheal intubation and mechanical ventilation.

Although less common than a pulmonary contusion, tension pneumothorax and massive hemothorax are immediately life threatening (Tables 80.2 and 80.3). A **tension pneumothorax** occurs when air accumulates under pressure in the pleural space. The adjacent lung is compacted; the mediastinum is pushed toward the opposite hemothorax; and the heart, great vessels, and contralateral lung are compressed



\* The upper limit of respiratory rate in infants is >29 breaths per minute to maintain a higher level of overtriage for infants.  
 † Trauma centers are designated Level I-IV. A Level I center has the greatest amount of resources and personnel for care of the injured patient and provides regional leadership in education, research, and prevention programs. A Level II facility offers similar resources to a Level I facility, possibly differing only in continuous availability of certain subspecialties or sufficient prevention, education, and research activities for Level I designation; Level II facilities are not required to be resident or fellow education centers. A Level III center is capable of assessment, resuscitation, and emergency surgery, with severely injured patients being transferred to a Level I or II facility. A Level IV trauma center is capable of providing 24-hour physician coverage, resuscitation, and stabilization to injured patients before transfer to a facility that provides a higher level of trauma care.  
 § Any injury noted in Step Two or mechanism identified in Step Three triggers a "yes" response.  
 ¶ Age <math>< 15</math> years.  
 \*\* Intrusion refers to interior compartment intrusion, as opposed to deformation which refers to exterior damage.  
 †† Includes pedestrians or bicyclists thrown or run over by a motor vehicle or those with estimated impact >20 mph with a motor vehicle.  
 §§ Local or regional protocols should be used to determine the most appropriate level of trauma center within the defined trauma system; need not be the highest-level trauma center.  
 ¶¶ Age >55 years.  
 \*\*\* Patients with both burns and concomitant trauma for whom the burn injury poses the greatest risk for morbidity and mortality should be transferred to a burn center. If the nonburn trauma presents a greater immediate risk, the patient may be stabilized in a trauma center and then transferred to a burn center.  
 ††† Patients who do not meet any of the triage criteria in Steps One through Four should be transported to the most appropriate medical facility as outlined in local EMS protocols.

Fig. 80.1 Algorithm showing guidelines for field triage of injured patients—United States, 2011. (From Guidelines for Field Triage of Injured Patients: Recommendations of the National Expert Panel on Field Triage. MMWR. 2012;61:6.)



**Fig. 80.2** Staff in the ED trauma bay at Johns Hopkins Hospital Bloomberg Children’s Center. ED, Emergency department; NP, nurse practitioner; GPS, general pediatric surgery; PICU, pediatric intensive care unit. (Courtesy The Johns Hopkins Hospital, Baltimore, Maryland.)

Table 80.1 Pediatric Trauma Score*			
COMPONENT	+2	+1	-1
Size	≥20kg	10-20kg	<10kg
Airway	Normal	Maintainable	Unmaintainable
Systolic BP	≥90 mm Hg	50-90mm Hg	<50mm Hg
CNS	Awake	Obtunded/ LOC	Coma/ decerebrate
Open wound	None	Minor	Major/penetrating
Skeletal	None	Closed fracture	Open/multiple fractures
Sum total points			

\*Children with a Pediatric Trauma Score ≤6 are at increased risk of mortality and morbidity.  
BP, Blood pressure; CNS, central nervous system; LOC, loss of consciousness.  
From Tepas JJ 3rd, Mollitt DL, Talbert JL, et al. The Pediatric Trauma Score as a predictor of injury severity in the injured child. *J Pediatr Surg.* 1987;22:14-18, Table 1, p. 15.

(see Chapter 461). Both ventilation and cardiac output are impaired. Characteristic findings include cyanosis, tachypnea, retractions, asymmetric chest rise, contralateral tracheal deviation, diminished breath sounds on the ipsilateral (more than contralateral) side, and signs of shock. When suspected, a tension pneumothorax should be treated before obtaining chest radiographs. Needle thoracostomy, followed by thoracostomy tube insertion, is diagnostic and lifesaving. **Hemothorax** results from injury to the intercostal vessels, lungs, heart, or great vessels. When ventilation is adequate, volume resuscitation should begin before evacuation, because a large volume of blood may drain through the chest tube, resulting in shock.

**Circulation**

Signs of **shock** include tachycardia; weak pulse; delayed capillary refill; altered mental status; and cool, mottled, or pale skin (see Chapter 85). The most common type of shock in trauma is *hypovolemic shock* caused by hemorrhage. Cardiac tamponade, which is a form of *obstructive shock*, occurs when blood or fluid accumulates in the pericardium. It may be suspected clinically with the classic findings of jugular venous distension, muffled heart sounds, and low blood pressure—collectively known as **Beck’s triad**. Cardiac tamponade may be definitively diagnosed by ultrasound during a **focused assessment with sonography in**

**Table 80.2** Differential Diagnosis of Immediately Life-Threatening Cardiopulmonary Injuries

	TENSION PNEUMOTHORAX	MASSIVE HEMOTHORAX	CARDIAC TAMPONADE
Breath sounds	Ipsilaterally decreased more than contralaterally	Ipsilaterally decreased	Normal
Percussion note	Hyperresonant	Dull	Normal
Tracheal location	Contralaterally shifted	Midline or shifted	Midline
Neck veins	Distended	Flat	Distended
Heart tones	Normal	Normal	Muffled

Modified from Cooper A, Foltin GL. Thoracic trauma. In: Barkin RM, ed. *Pediatric Emergency Medicine*, 2nd ed. St Louis: Mosby; 1997:325.

**Table 80.3** Life-Threatening Chest Injuries**TENSION PNEUMOTHORAX**

One-way valve leak from the lung parenchyma or tracheobronchial tree  
 Lung collapse with mediastinal and tracheal shift to the side opposite the leak  
 Compromises venous return and decreases ventilation of the other lung  
 Clinically, manifests as respiratory distress, unilateral absence of breath sounds, tracheal deviation, distended neck veins, tympany to percussion of the involved side, and cyanosis  
 Relieve first with needle aspiration, then with chest tube drainage

**OPEN PNEUMOTHORAX (SUCKING CHEST WOUND)**

Effect on ventilation depends on size

**MAJOR FLAIL CHEST**

Usually caused by blunt injury resulting in multiple rib fractures  
 Loss of bone stability of the thoracic cage  
 Major disruption of synchronous chest wall motion  
 Mechanical ventilation and positive end-expiratory pressure required

**MASSIVE HEMOTHORAX**

Must be drained with a large-bore tube  
 Initiate drainage only with concurrent vascular volume replacement

**CARDIAC TAMPONADE**

Beck's triad:

1. Decreased or muffled heart sounds
2. Jugular venous distention
3. Hypotension (with narrow pulse pressure)

Must be drained

Modified from Krug SE. The acutely ill or injured child. In: Behrman RE, Kliegman RM, eds. *Nelson Essentials of Pediatrics*, 4th ed. Philadelphia: Saunders; 2002:97.

**trauma (FAST) examination or echocardiography.** Cardiac tamponade is best managed by thoracotomy or pericardial window, although pericardiocentesis may be a necessary temporizing maneuver (see [Table 80.3](#)).

Early in shock, blood pressure remains normal because of compensatory increases in heart rate and peripheral vascular resistance ([Table 80.4](#)). Some individuals can lose up to 30% of blood volume before blood pressure declines. Notably, 25% of blood volume equals 20 mL/kg, which is only 200 mL in a 10-kg child. Loss of >40% of blood volume causes severe hypotension that, if prolonged, may be irreversible. Direct pressure should be applied to control external hemorrhage. When direct pressure does not control hemorrhage, a tourniquet should be applied to a proximal pressure point. Blind clamping of bleeding vessels, which risks damaging adjacent structures, is not advisable.

Cannulating a larger vein, such as an antecubital vein, is usually the quickest way to achieve intravenous (IV) access (see [Chapter 79](#)). A short, large-bore catheter offers less resistance to flow, allowing for more rapid fluid administration. Ideally, a second catheter should be

placed within the first few minutes of resuscitation in a severely injured child. If IV access is not rapidly obtainable, an intraosseous (IO) needle should be inserted; all medications and fluids can be administered intraosseously (see [Chapter 79](#)). Other alternatives are central venous access using the Seldinger technique (e.g., in the femoral vein) and, rarely, surgical cutdown (e.g., in the saphenous vein). Ultrasonography may be employed to safely facilitate both peripheral IV placement and central venous catheter placement.

Traditionally, fluids are administered aggressively early in hemorrhagic shock to reverse and prevent further clinical deterioration. Isotonic crystalloid solution, such as lactated Ringer's or normal saline (20 mL/kg), should be infused rapidly. When necessary, repeated crystalloid boluses may be given. Most children are stabilized with administration of crystalloid solution alone; however, if the patient remains in shock after boluses totaling 40 mL/kg of crystalloid, packed red blood cells should be transfused. Massive transfusion protocols (including fresh-frozen plasma) should be initiated early to prevent coagulopathy, and tranexamic acid (TXA) should be considered. When shock persists despite these measures, exploratory surgery to stop internal hemorrhage is usually indicated. Emerging literature suggests modern trauma techniques for adults, including permissive hypotension, hemostatic resuscitation, and damage control surgery, confer similar benefits in children.

**Disability/Neurologic Deficit**

Neurologic status is briefly assessed by determining the level of consciousness and evaluating pupil size and reactivity. The level of consciousness can be classified using the mnemonic **AVPU**: Alert, responsive to Verbal commands, responsive to Painful stimuli, or Unresponsive. A **Glasgow Coma Scale (GCS)** or Pediatric GCS score (see [Chapters 79 and 82](#)) should be assigned to every child with significant head trauma or neurologic impairment. This scale assesses eye opening and motor and verbal responses. In the Pediatric GCS, the verbal score is modified for age. The GCS helps categorize neurologic disability, and serial measurements identify improvement or deterioration over time. Patients with GCS  $\leq 8$  should undergo endotracheal intubation and supportive mechanical ventilation. Importantly, the patient's pupil size/reactivity and ability to move extremities should be quickly assessed before administration of anticholinergics, sedatives, and paralytics in preparation for intubation.

The majority of pediatric blunt trauma deaths are accounted for by head injuries. Primary direct cerebral injury occurs within seconds of the event and is irreversible. Secondary injury is caused by subsequent anoxia or ischemia. *The goal is to minimize secondary injury by ensuring adequate oxygenation, ventilation, and perfusion and by maintaining normal cerebral perfusion pressure.* Focal hemorrhagic lesions (e.g., epidural or subdural hematomas) are less common but may require immediate neurosurgical intervention ([Fig. 80.3](#)).

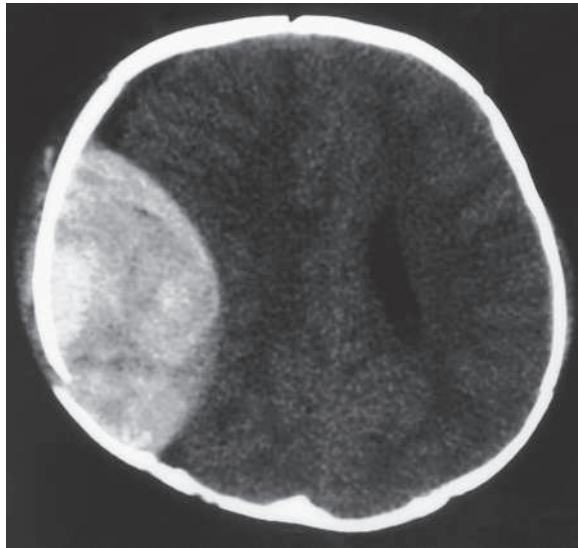
Signs of increased intracranial pressure (ICP), including progressive neurologic deterioration and evidence of transtentorial herniation, must be treated immediately (see [Chapter 82](#)). Hyperventilation lowers the arterial partial pressure of carbon dioxide ( $P_{aCO_2}$ ), resulting in cerebral vasoconstriction, reduced cerebral blood flow, and decreased



**Table 80.4** Systemic Responses to Blood Loss in Pediatric Patients

SYSTEM	MILD BLOOD LOSS (<30%)	MODERATE BLOOD LOSS (30–45%)	SEVERE BLOOD LOSS (>45%)
Cardiovascular	Increased heart rate; weak, thready peripheral pulses; normal systolic blood pressure; normal pulse pressure	Markedly increased heart rate; weak, thready central pulses; peripheral pulses absent; low normal systolic blood pressure; narrowed pulse pressure	Tachycardia followed by bradycardia; central pulses very weak or absent; peripheral pulses absent; hypotension; narrowed pulse pressure (or undetectable diastolic blood pressure)
Central nervous	Anxiety; irritability; confusion	Lethargy; dulled response to pain	Coma
Skin	Cool, mottled; capillary refill prolonged	Cyanotic; capillary refill markedly prolonged	Pale and cold
Urine output	Low to very low	Minimal	None

Adapted from American College of Surgeons Committee on Trauma. *Advanced Trauma Life Support: Student Course Manual*, 10th ed. Chicago: American College of Surgeons; 2018:196.



**Fig. 80.3** Epidural hematoma. CT head scan from 7-mo-old female who, according to the history provided, did not wake up for her nightly feeding and began vomiting in the morning. The mother's friend reported that the infant had fallen from a chair the previous day. The CT scan shows a large epidural hematoma on the right and marked shift of the midline from right to left. The right lateral ventricle is compressed as a result of the mass effect, and the left lateral ventricle is slightly prominent. The infant underwent emergency surgical evacuation of the epidural hematoma and recovered uneventfully. (From O'Neill JA Jr. *Principles of Pediatric Surgery*, 2nd ed. St Louis: Mosby; 2003:191.)

ICP. Brief hyperventilation, targeting an end-tidal CO<sub>2</sub> goal of 30–35 mm Hg, remains an immediate option for patients with acute increases in ICP. Prophylactic hyperventilation, or vigorous or prolonged hyperventilation, is not recommended, because the consequent vasoconstriction may excessively decrease cerebral perfusion and oxygenation. Mannitol and hypertonic saline lower ICP and may improve survival. Because mannitol induces an osmotic diuresis, it can exacerbate hypovolemia and must be used cautiously. Hypertonic saline may be a more useful agent for control of increased ICP in patients with severe head injury. Neurosurgical consultation is mandatory and will dictate further management, including ICP monitoring and emergent neurosurgical interventions.

### Exposure and Environmental Control

Full exposure of the patient occurs during the primary survey. Using trauma shears, all clothing should be removed to reveal any injuries. Cutting clothing is fastest and minimizes unnecessary patient movement. Children often arrive in the ED mildly hypothermic because of their higher body surface area-to-mass ratios. They can be warmed

with use of radiant heat and heated IV fluids, as necessary. After a thorough physical exam, the patient should be covered with warmed blankets with close monitoring of body temperature.

### Initial Adjuncts

While the primary survey is being performed, the patient will simultaneously be placed on a cardiac monitor, vitals obtained, and vascular access established. Fluid resuscitation can be initiated as soon as access is established. Initial laboratory work generally includes a complete blood count, electrolytes, blood urea nitrogen, creatinine, liver function tests, lipase, lactate, blood gas, coagulation studies, type and cross match, and urinalysis. Per ATLS, portable (single, anterior-posterior view) radiographs of the chest and pelvis should be obtained to screen for life-threatening injury and identify potential causes of hemorrhage (e.g., pelvic fracture, hemothorax, great vessel injury as suggested by a widened mediastinum). Finally, a FAST exam should be performed at the bedside to assess for the presence of free fluid (blood) and guide resuscitation.

### FAST Exam

The FAST exam and extended FAST (eFAST) are other adjuncts to the initial trauma survey. This bedside ultrasound can be performed by any trained member of the trauma team to assess for the presence of blood or free fluid in the intraperitoneal, pericardial, or pleural space. The exam assesses four windows: the right upper quadrant abdominal view, the left upper quadrant abdominal view, the suprapubic view, and the subxiphoid cardiac view. The eFAST adds additional views of bilateral lungs to assess for the absence of lung sliding, which is indicative of a pneumothorax. In addition to detection of hemoperitoneum, the eFAST can identify findings that may require emergent management in an unstable patient—such as a pneumothorax requiring needle decompression or a large pericardial effusion requiring pericardiocentesis.

Although the FAST examination helps detect hemoperitoneum, the variably low sensitivity of this test in children suggests that it should not be used alone to exclude intraabdominal injury in patients with a moderate to high pretest probability for injury (e.g., a patient with elevated serum lipase or transaminases). A positive FAST exam for hemoperitoneum requires further investigation. The FAST exam is most clinically useful in patients who have blunt trauma and are hemodynamically unstable or in patients who require immediate operative intervention for nonabdominal injuries, because in these cases the performance of a CT scan will delay emergency surgery.

### SECONDARY SURVEY

During the secondary survey, the trauma team completes a thorough, head-to-toe physical examination to assess for additional injuries. In critically ill or hemodynamically unstable patients, emergent interventions may delay the secondary survey until the patient has been stabilized.

### Head Trauma

Initial management of traumatic brain injuries is discussed earlier. The secondary survey of the head should identify and document injuries,

including scalp hematomas and lacerations. The skull and face should be carefully palpated to assess for possible fractures. Findings suggestive of basilar skull fractures include bruising around the eyes (“raccoon eyes”), bruising over the mastoid process (Battle sign), and blood behind the tympanic membrane (hemotympanum). The eyes should be assessed for conjunctival hemorrhages, hyphemas, and corneal injuries. Limitation in extraocular movements may suggest orbital fractures with muscle entrapment. The nares should be inspected for bleeding and presence of a nasal septal hematoma, which must be evacuated urgently to prevent permanent disfigurement. The mouth should be assessed for injuries to the tongue, teeth, gums, palate, and oropharynx; normal jaw mobility should be ensured. Patients with suspected head or facial injuries will typically undergo CT of the head, orbits, and/or maxillofacial region.

## Spinal Trauma

### Spinal Immobilization

Initially, spinal injury should be suspected in any child sustaining multiple blunt trauma. To prevent further spinal injury, paramedics have traditionally been taught to immobilize the C-spine in neutral position with a stiff collar, head blocks, and tape or cloth placed across the forehead. To immobilize the rest of the spine, the child is typically placed on a rigid backboard, and straps or tape are placed across the torso and thighs to restrain them. Care should be taken to continue spinal immobilization during initial evaluation and resuscitation until spinal injury can be excluded (see [Chapter 81](#)).

### C-Spine Trauma

Cervical spine injuries occur in <3% of children with blunt trauma—with the risk being substantially higher in those with GCS scores  $\leq 8$ —but they are associated with significant mortality and morbidity (see [Chapter 81](#)). Bony injuries occur mainly from C1 to C4 in children younger than 8 years. In older children, they occur equally in the upper and lower cervical spine. The mortality rate is significantly higher in patients with upper C-spine injuries, and ~30% of all patients with C-spine injuries have permanent neurologic deficits.

### Evaluation

Evaluation begins with a detailed history and neurologic examination. Identifying the mechanism of injury helps in estimating the likelihood of a spinal injury. Both the patient and the paramedic should be asked whether any neurologic symptoms or signs, such as weakness or abnormal sensation, were present before arrival in the ED. The spine should then be examined while maintaining immobilization. If no other distracting injuries are present (e.g., a displaced femur fracture), the collar can be carefully removed by one provider while a second provider manually stabilizes the neck. The C-spine should be palpated to assess for tenderness or step-offs. If the patient has neck pain, has neurologic symptoms, or is unable to participate in the exam, the collar should be replaced immediately. To assess the thoracic and lumbar spine, multiple providers are required to log-roll the patient and maintain spinal immobilization. A third provider will palpate the spine, assess for cutaneous injuries, and evaluate rectal tone. Before rolling the patient back to the supine position, the backboard must be removed to prevent further injury or patient discomfort.

Whenever the history, physical examination, or mechanism of injury suggests a spinal injury, imaging must be obtained after initial resuscitation. Depending on clinical suspicion, mechanism of injury, and the patient's symptoms and physiologic status, the provider may elect either radiography, CT, or MRI as the initial imaging modality.

The **National Emergency X-Radiography Utilization Study (NEXUS)** cervical spine rule helps identify low-risk patients who may not require radiographs ([Table 80.5](#)). The standard series of plain radiographs includes lateral, anteroposterior (AP), and odontoid views. Some centers use C-spine CT as the primary diagnostic tool, particularly in patients with abnormal GCS scores or significant injury mechanisms, recognizing that CT is more sensitive in detecting bony injury than plain radiographs. CT is also helpful if an odontoid fracture is suspected, because young children typically do not cooperate enough

**Table 80.5** National Emergency X-Radiography Utilization Study (NEXUS) to Rule Out Cervical Spine Injury After Blunt Trauma

If **NONE** of the following is present, the patient is at very low risk for clinically significant cervical spine injury:

- Midline cervical tenderness
- Evidence of intoxication
- Altered level of alertness
- Focal neurologic deficit
- Distracting painful injury

Data from Hoffman JR, Mower WR, Wolfson AB, et al. Validity of a set of clinical criteria to rule out injury to the cervical spine in patients with blunt trauma. *N Engl J Med*. 2000;343:94-99; and Viccellio P, Simon H, Pressman BD, et al. A prospective multicenter study of cervical spine injury in children. *Pediatrics*. 2001;108:e20.

to obtain an open-mouth (odontoid) radiographic view. Use of cervical spine CT scan must be balanced with the knowledge that CT exposes thyroid tissue to 90-200 times the amount of radiation from plain films.

### SCIWORA

In a child with neurologic symptoms and normal findings on C-spine plain radiographs and CT scan, **spinal cord injury without radiographic abnormalities (SCIWORA)** must be considered. MRI of the spine is indicated in a child with suspected SCIWORA and in the evaluation of children who remain obtunded.

### Thoracic Trauma

**Pulmonary contusions** occur frequently in young children with blunt chest trauma. A child's chest wall is relatively pliable; therefore less force is absorbed by the rib cage and more is transmitted to the lungs. Respiratory distress may be noted initially or may develop during the first 24 hours after injury.

**Rib fractures** result from significant external force. They are noted in patients with more severe injuries and are associated with a higher mortality rate. Flail chest, which is caused by multiple rib fractures, is rare in children. [Table 80.6](#) lists indications for operative management in thoracic trauma. (See [Table 80.2](#) for the differential diagnosis of immediately life-threatening cardiopulmonary injuries.) Thoracic trauma can be investigated via chest radiograph or CT, depending on the patient's symptoms, physical exam findings, mechanism of injury, and index of suspicion for injury.

### Abdominal Trauma

Liver and spleen contusions, hematomas, and lacerations account for the majority of intraabdominal injuries from blunt trauma. The kidneys, pancreas, and duodenum are relatively spared because of their retroperitoneal location. Pancreatic and duodenal injuries are more common after a bicycle handlebar impact or a direct blow to the abdomen.

Although a thorough examination for intraabdominal injuries is essential, achieving it often proves difficult. Misleading findings can result from gastric distention after crying or in an uncooperative toddler. Calm reassurance, distraction, and gentle, persistent palpation help with the examination. Important findings include distention, bruises, and tenderness. Specific symptoms and signs give insight into the mechanism of injury and the potential for particular injuries. Pain in the left shoulder may signify splenic trauma. A lap belt mark across the abdomen raises concern for bowel or mesentery injury. The presence of certain other injuries, such as lumbar spinal fractures and femur fractures, increases the likelihood of intraabdominal injury.

An abdominal (and pelvic) CT scan with IV contrast medium enhancement rapidly identifies structural abnormalities and is the preferred study in a stable child. A negative abdominal CT scan has been shown to have a negative predictive value (NPV) of 99.6%. It has excellent sensitivity and specificity for splenic ([Fig. 80.4](#)), hepatic ([Fig. 80.5](#)), and renal injuries, but is less sensitive for diaphragmatic, pancreatic, or intestinal injuries. Small amounts of free fluid or air or a mesenteric

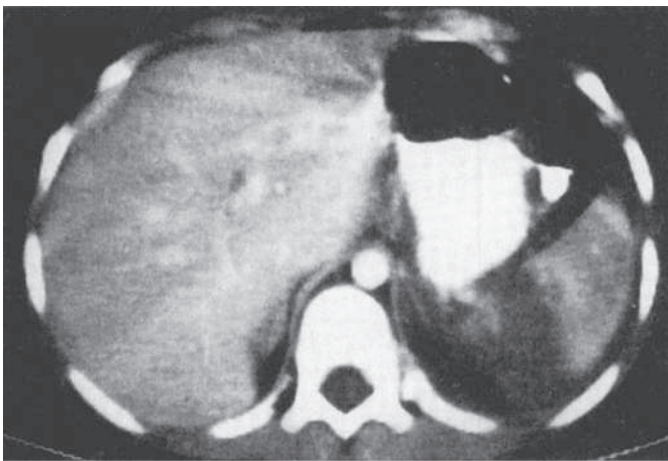
**Table 80.6** Indications for Operation in Thoracic Trauma**THORACOTOMY IMMEDIATELY OR SHORTLY AFTER INJURY**

Massive continuing pneumothorax or large air leak from tracheobronchial injury (cannot expand lung and ventilate)  
 Cardiac tamponade  
 Open pneumothorax  
 Esophageal injury  
 Aortic or other vascular injury  
 Acute rupture of the diaphragm

**DELAYED THORACOTOMY OR THORACOSCOPY**

Chronic rupture of the diaphragm  
 Clotted hemothorax  
 Persistent chylothorax  
 Traumatic intracardiac defects  
 Evacuation of large foreign bodies  
 Chronic atelectasis from traumatic bronchial stenosis

Modified from O'Neill JA Jr. *Principles of Pediatric Surgery*, 2nd ed. St Louis: Mosby; 2003:157.



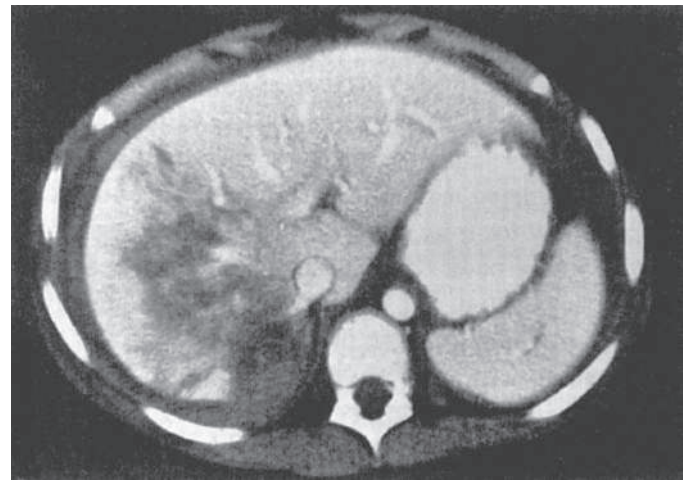
**Fig. 80.4** Splenic rupture. CT scan with intravenous and gastrointestinal contrast enhancement shows an isolated splenic rupture that resulted from blunt trauma. This injury responded to nonoperative management, as do most splenic injuries. (From O'Neill JA Jr. *Principles of Pediatric Surgery*, 2nd ed. St Louis: Mosby; 2003:166.)

hematoma may be the only sign of an intestinal injury. Administration of an oral contrast agent is not routinely recommended for all abdominal CT scans, but it sometimes aids in identifying an intestinal, especially a duodenal, injury.

Nonoperative treatment has become standard for hemodynamically stable children with splenic, hepatic, and renal injuries from blunt trauma. The majority of such children can be treated nonsurgically. In addition to avoiding perioperative complications, nonoperative treatment decreases the need for blood transfusions and shortens hospital stay. When laparotomy is indicated, splenic repair is preferable to splenectomy.

### Pelvic Trauma

Pelvic fractures in children are much less common than in adults, occurring in approximately 4% of children with more severe blunt trauma. Pelvic fractures are typically caused by high forces (e.g., high-speed motor vehicle crashes or pedestrian impacts) and are often associated with intraabdominal and/or vascular injuries. The pelvis itself



**Fig. 80.5** Liver injury. CT scan performed after severe blunt injury of the abdomen shows a bursting injury of the liver. The patient was stable, and no operative intervention was required. The decision to perform surgery should be based on the patient's physiologic stability. (From O'Neill JA Jr. *Principles of Pediatric Surgery*, 2nd ed. St Louis: Mosby; 2003:168.)

forms a ring, and high-force impacts can lead to disruption of this ring. When the ring is disrupted in more than one location, such as the symphysis pubis and the sacroiliac joint, the ring can become unstable and displaced, potentially injuring large pelvic vessels and leading to massive blood loss. Catheter-directed embolization to control bleeding, performed by an interventional radiologist, may be required.

The pelvis should be assessed for stability by means of compression-distraction maneuvers. If instability is noted, immediate external fixation with a pelvis-stabilizing device or a sheet should be applied and orthopedic consultation sought. A trauma patient with a potential pelvic fracture should receive an AP pelvic radiograph in the trauma bay followed by a CT scan if there is still suspicion of injury. Children *without* a high-risk clinical finding (e.g., GCS <14; abdominal pain or tenderness; pelvic tenderness, laceration, ecchymosis, or abrasion; gross hematuria or >20 red blood cells/high-power field on urinalysis; or femur fracture) or a high-risk mechanism of injury (e.g., unrestrained motor vehicle collision, motor vehicle collision with ejection, motor vehicle collision rollover, auto vs pedestrian, or auto vs bicycle), however, are unlikely to have pelvic fractures.

### Genitourinary Trauma

The perineum should be inspected and the stability of the bones of the pelvis assessed. Urethral injuries are more common in males. Findings suggestive of urethral injury include scrotal or labial ecchymosis, blood at the urethral meatus, gross hematuria, and a superiorly positioned prostate on rectal examination (in an adolescent male). Certain pelvic fractures also increase the risk for potential genitourinary injury. Any of these findings is a contraindication to urethral catheter insertion and warrants consultation with a urologist. Retrograde urethrocytogram and CT scan of the pelvis and abdomen are used to determine the extent of injury.

### Extremity Trauma

Thorough examination of the extremities is essential because extremity fractures are among the most frequently overlooked injuries in children with multiple traumas. All limbs should be inspected for deformity, swelling, and bruises; palpated for tenderness; and assessed for active and passive range of motion, sensory function, and perfusion.



Before radiographs are obtained, suspected fractures and dislocations should be immobilized and an analgesic administered. Splinting a femur fracture helps alleviate pain and may decrease blood loss. An orthopedic surgeon should be consulted immediately to evaluate children with compartment syndrome, neurovascular compromise, open fracture, or traumatic amputations.

An acute extremity compartment syndrome is a surgical emergency usually associated with extremity fractures (e.g., tibia, supracondylar humerus, distal radius) but has also been noted after thermal and electric injuries, rhabdomyolysis, coagulopathies, or nephrotic syndrome. Manifestations include pain out of proportion to the injury, pain with passive stretching of the muscles, poor distal pulses, pallor, paresthesia, and weakness. In children, escalating pain not relieved by pain medications, anxiety, and agitation are additional features. If needed, compartmental pressure should be measured (normal is 8 mm Hg in adults, 10–15 mm Hg in children). Absolute pressure  $\geq 30$  mm Hg is one indication for fasciotomy. Another indication for fasciotomy is a diastolic blood pressure minus compartment pressure  $< 30$  mm Hg.

### Advanced Imaging

After completion of the primary survey, diagnostic adjuncts, and secondary survey, most stable trauma patients will require advanced imaging with CT or additional plain radiographs. As detailed earlier, injury mechanism, patient history, and clinical exam findings will help determine the specific imaging to be obtained. Additionally, clinical prediction rules have been developed to identify those at low risk of injury for whom specific imaging studies may not be necessary. The NEXUS C-spine rule is a sensitive, easily applicable rule that was validated for adults and children, although there were fewer young patients studied (see Table 80.5). Several clinical prediction rules have been developed to identify children at low risk of traumatic brain injury in whom head CT can be safely avoided (Table 80.7). Another clinical prediction rule has been developed to identify children at very low risk of clinically important intraabdominal injuries after blunt trauma (Table 80.8). Although this rule has an NPV of 99.9%, it needs to be externally validated before widespread implementation. One benefit of standardizing the evaluation of patients with major trauma is that fewer decisions need to be made on an individual basis, possibly expediting ED management.

### DISPOSITION

Disposition from the ED trauma bay is determined by several factors. Patients who are critically unstable with suspected internal hemorrhage are emergently transferred to the operating room (OR) for exploratory surgery before advanced imaging. Up to 30% of children evaluated for trauma require hospitalization. Of the children admitted for trauma, 30% have operative injuries identified on the physical exam or advanced imaging and undergo surgery during that hospitalization. Of those requiring surgery, 25% will require surgery within 24 hours of admission, and of that group, 57% require emergent intervention. Nonoperative patients who are critically injured will ultimately benefit from continued management in an ICU capable of caring for children and in a facility with the necessary surgical subspecialists.

### PSYCHOLOGIC AND SOCIAL SUPPORT

Serious multisystem trauma may result in significant long-term psychologic and social difficulties for the child and family, particularly

**Table 80.7** Prediction Rule for Identification of Children at Very Low Risk of Clinically Important Brain Injuries After Head Trauma

Children  $< 2$  yr old are at very low risk of clinically important traumatic brain injury if they have **NONE** of the following:

- Severe mechanism of injury
- History of LOC  $> 5$  sec
- GCS  $\leq 14$  or other signs of altered mental status
- Not acting normally per parent
- Palpable skull fracture
- Occipital/parietal/temporal scalp hematoma

Children 2–18 yr old are at very low risk of clinically important traumatic brain injury if they have **NONE** of the following:

- Severe mechanism of injury
- History of LOC
- History of vomiting
- GCS  $\leq 14$  or other signs of altered mental status
- Severe headache in the ED
- Signs of basilar skull fracture

LOC, Loss of consciousness; GCS, Glasgow Coma Scale score; ED, emergency department.

Modified from Kuppermann N, Holmes JF, Dayan PS, et al. Identification of children at very low risk of clinically-important brain injuries after head trauma: A prospective cohort study. *Lancet*. 2009;374:1160-1170.

**Table 80.8** Prediction Rule for Identification of Children at Very Low Risk of Clinically Important Intraabdominal Injuries After Blunt Trauma

If **NONE** of the following is present, the patient is at very low risk for clinically significant intraabdominal injury:

- Glasgow Coma Scale score  $< 14$
- Vomiting
- Evidence of thoracic wall trauma
- Decreased breath sounds
- Evidence of abdominal wall trauma or seatbelt sign
- Abdominal pain
- Abdominal tenderness

Modified from Holmes JF, Lillis K, Monroe D, et al. Identifying children at very low risk of clinically important blunt abdominal injuries. *Ann Emerg Med*. 2013;62:107-116, e2.

when there is a major head injury. Like adults, children are at risk for depressive symptoms and posttraumatic stress disorder. Caregivers face persistent stress and have been noted to have more psychologic symptoms. Psychologic and social support, during the resuscitation period and afterward, is extremely important. Parents often prefer to be offered the choice to be present during resuscitations. A member of the resuscitation team should be made responsible for answering the family's questions and supporting them in the trauma room.

Visit Elsevier eBooks+ at [eBooks.Health.Elsevier.com](http://eBooks.Health.Elsevier.com) for Bibliography.



## Chapter 81

## Spinal Cord Injuries in Children

Katie P. Fehnel and Mark R. Proctor

See also [Chapter 751](#).

Compared with adults, spine and spinal cord injuries are rare in children, particularly young children, because of both anatomic differences and etiologies of injury. The main mechanisms of injury to the spine are motor vehicle crashes, falls, sports, and violence, which affect young children less often (see [Chapter 80](#)).

Several anatomic differences affect the pediatric spine. The head of a young child is larger relative to body mass than in adults, and the neck muscles are still underdeveloped, which places the fulcrum of movement higher in the spine. Therefore children <9 years old have a higher percentage of injuries in the upper cervical spine (C-spine) than do older children and adults. The spine of a small child also is very mobile, with pliable bones and ligaments, so fractures of the spine are exceedingly rare. However, this increased mobility is not always a positive feature. Transfer of energy leading to spinal distortion may not affect the structural integrity of the bones and ligaments of the spine but can still lead to significant injuries of the spinal cord. This phenomenon of **spinal cord injury without radiographic abnormalities (SCIWORA)** is more common in children than in adults (see [Chapter 80](#)). The term is relatively outdated, because almost all injuries are detectable by MRI, but is still clinically useful when referring to spinal cord injuries evaluated by plain radiographs or CT. There seem to be two distinct forms of SCIWORA. The **infantile** form involves severe injury of the cervical or thoracic spinal cord; these patients have a poor chance of complete recovery. In older children and adolescents, SCIWORA is more likely to be a less severe injury, with a high likelihood of complete recovery over time. The **adolescent** form, also called *transient neurapraxia*, is assumed to be a spinal cord concussion or mild contusion, as opposed to the severe spinal cord injury related to the mobility of the spine in small children.

Although the mechanisms of spinal cord injury in children include birth trauma, falls, and child abuse, the major cause of morbidity and mortality across all ages remains **motor vehicle injuries**. Adolescents incur spinal cord injuries with epidemiology similar to that of adults, including significant male predominance and a high likelihood of fracture dislocations of the lower cervical spine or thoracolumbar region. In infants and children <5 years old, fractures and mechanical disruption of spinal elements are more likely to occur in the upper cervical spine between the occiput and C3. Certain conditions predispose to C-spine injury ([Table 81.1](#)).

### CLINICAL MANIFESTATIONS

One in three patients with significant trauma to the spine and spinal cord will have a concomitant severe head injury, which makes early diagnosis challenging. For these patients, clinical evaluation may be difficult. Patients with a potential spine injury need to be maintained in a protective environment, such as a collar, until the spine can be cleared by clinical and/or radiographic means. A careful neurologic examination is necessary for infants with suspected spinal cord injuries. Complete spinal cord injury will lead to **spinal shock** with early areflexia (see [Chapter 751](#)). Severe C-spine injuries will usually lead to paradoxical respiration in patients who are breathing spontaneously. **Paradoxical respiration** occurs when the

**Table 81.1** Conditions that Predispose Patients to a Cervical Spine Injury

CATEGORY	CONDITIONS
Abnormal development of the cervical spine	Trisomy 21 Larsen syndrome Mucopolysaccharidosis IV/Morquio syndrome Klippel-Feil syndrome Achondroplasia Chiari malformation Syringomyelia
Abnormal bone and soft tissue	Marfan syndrome Ehlers-Danlos syndrome Osteogenesis imperfecta
Arthritis	Ankylosing spondylitis Rheumatoid arthritis
History of cervical spine injury or surgery	

Modified from McCollum M, Guse S. Neck trauma: Cervical spine, seatbelt sign and penetrating palate injuries. *Emerg Med Clin N Am*. 2021;39:573-588, [Table 1](#), p. 574.

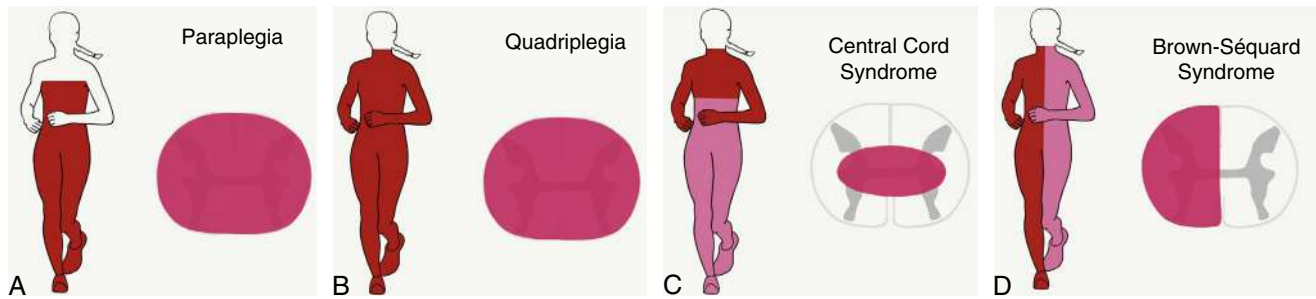
diaphragm, which is innervated by the phrenic nerves with contributions from C3, C4, and C5, is functioning normally, but the intercostal musculature innervated by the thoracic spinal cord is paralyzed. In this situation, inspiration fails to expand the chest wall but distends the abdomen. Other complications during the acute (2-48 hours) phase include autonomic dysfunction (bradyarrhythmias and tachyarrhythmias, orthostatic hypotension, hypertension), temperature instability, thromboembolism, dysphagia, and bowel/bladder dysfunction.

The *mildest* injury to the spinal cord is **transient quadriparesis** evident for seconds or minutes with complete recovery in 24 hours. This injury follows a concussion of the cord and is most frequently seen in adolescent athletes. If their imaging is normal, these children can generally return to normal activities after a period of rest from days to weeks, depending on the initial severity, similar to cerebral concussion management.

Significant spinal cord injury in the cervical region is characterized by flaccid quadriparesis, loss of sphincter function, and a sensory level corresponding to the level of injury. An injury at the high cervical level (C1-C2) can cause respiratory arrest and death in the absence of ventilatory support. Injuries in the thoracic region are generally the result of fracture dislocations. They may produce paraplegia when at T10 or above or the **conus medullaris syndrome** if at the T12-L1 level. This includes a loss of urinary and rectal sphincter control, flaccid weakness, and sensory disturbances of the legs. A **central cord lesion** may result from contusion and hemorrhage in the center of the spinal cord ([Fig. 81.1](#)). It typically involves the upper extremities to a greater degree than the legs because the motor fibers to the cervical and thoracic region are more centrally located in the spinal cord. There are lower motor neuron signs in the upper extremities and upper motor neuron signs in the legs, bladder dysfunction, and loss of sensation caudal to the lesion. There may be considerable recovery, particularly in the lower extremities, although sequelae are common (see [Chapter 751](#)).

### CLEARING THE CERVICAL SPINE IN CHILDREN

The management of children after major trauma is challenging. For older children, the clearance is similar to a lucid adult, and the National Emergency X-Radiography Utilization Study (NEXUS) criteria are appropriate (see [Chapter 80](#), [Table 80.5](#)). Clearing the cervical spine in younger and uncooperative children involves similar issues as in adults with an altered level of consciousness



**Fig 81.1** Patterns of spinal cord injury. Note the contrast between these syndromes and peripheral nerve/radicular injuries based on the distribution of motor and/or sensory loss beyond the affected extremity. *Paraplegia* (A) and *quadriplegia* (B): Complete loss of motor and sensory function below the level of injury resulting in loss of function of the legs only or arms and legs, respectively. *Central cord syndrome* (C): Injury of the central spinal cord resulting in functional greater impact of arm motor function than legs. Sensory deficits in this injury are variable. *Brown-Séquard syndrome* (D): Injury to one-half of the spinal cord resulting in ipsilateral motor weakness with contralateral sensory loss below the level of the lesion. (From Jea A, Belal A, Zaazoue MA, Martin J. Cervical spine injury in children and adolescents. *Pediatr Clin N Am*. 2021;68:875-894: Fig. 11, p. 886.)

**Table 81.2** Risk Factors that Preclude Clinical Clearance of the C-Spine

HISTORY	PHYSICAL EXAMINATION
Child or parent reports persistent neck pain, abnormal head posture, or difficulty with neck movement	Visible known substantial injury to chest, abdomen, or pelvis (injury that is life-threatening, warrants surgical intervention or inpatient admission)
History of focal sensory abnormality or motor deficit	GCS of <14
High-risk injury*	Torticollis/abnormal head position
	Posterior midline neck tenderness
	Limited cervical range of motion
	Inability to maintain focus due to other injuries

\*Diving, high speed motor vehicle crash, bike crash, motorized all-terrain vehicle. GCS, Glasgow Coma Scale.

Modified from McCollum M, Guse S. Neck trauma: Cervical spine, seatbelt sign and penetrating palate injuries. *Emerg Med Clin N Am*. 2021;39:573-588, Table 2, p. 575.

(Table 81.2). Small children generally have a difficult-to-assess physical examination, and it is difficult to determine if they have cervical pain. Plain radiography remains a mainstay for assessing the spine because it is easy to obtain. There has been increasing emphasis on MRI for evaluation of potential C-spine instability, but in small children MRI requires sedation and in most centers the presence of an anesthesiologist (Fig. 81.2). CT scan is another important study with high sensitivity and specificity, but the risk of radiation exposure must be considered.

In addition to C-spine injury, neck trauma may also produce a radiculopathy or neuropathy (Table 81.3).

## TREATMENT

The cervical spine should be immobilized in the field by the emergency medical technicians. In cases of acute spinal cord injury, weak data suggest acute infusion of a bolus of high-dose (30 mg/kg) methylprednisolone, followed by a 23-hour infusion (5.4 mg/kg/hr). The data for this treatment are controversial; the current neurosurgical guidelines for management of adult spine trauma do not recommend methylprednisolone; corticosteroids have not been specifically tested in children. *As such, many centers no longer use them routinely.*



**Fig. 81.2** T2-weighted MRI performed the day after the accident showed cervical spinal cord swelling combined with high signal intensity (C1-C3) (arrow) and dislocation of C5-C6 (arrowhead). (From Inoue K, Kumada T, Fujii T, Kimura N. Progressive cervical spinal cord atrophy after a traffic accident. *J Pediatr*. 2017;180:287: Fig. 1, p. 287.)

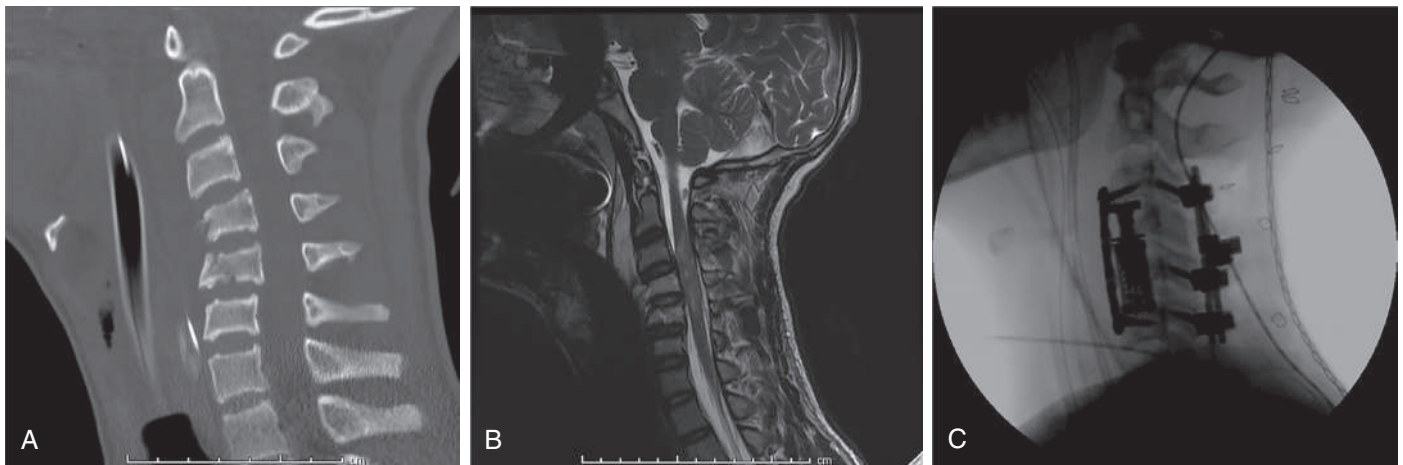
Maintenance of euolemia and normotension is important, and vasopressors might be needed if the sympathetic nervous system has been compromised.

Surgical management of spinal injuries must be tailored to the patient's age but can be a crucial step in management. Any compression of the spinal cord must be surgically relieved to afford the best chance of a favorable outcome. In addition, spinal cord injury can be worsened by instability, so surgical stabilization can prevent further injury (Fig. 81.3). In general, younger children have a higher healing capacity for bones and ligaments, and external immobilization might be considered for injuries that require surgery in older children and adults. However, some injuries are highly unstable and always require surgery. **Occipitocervical dislocation** is one such highly unstable injury, and early surgery with fusion from the occiput to C2 or C3 should be performed, even in very young children. Fixation of the subaxial spine must be tailored to the size of the pedicles and other osseous structures of the developing axial skeleton.

**Table 81.3** History and Examination Features Allowing for Discrimination of Myelopathy, Radiculopathy, and Peripheral Neuropathy

FINDING	PERIPHERAL NEUROPATHY	RADICULOPATHY	MYELOPATHY
Pain <ul style="list-style-type: none"> <li>• Quality</li> <li>• Location</li> </ul>	“Electric” Radiates either proximally or distally from injury site	Sharp, aching Radiates distally from the neck	Typically painless
Weakness	Variable, usually present	Variable, usually present	Variable, may be present
Sensory loss	Sharply demarcated borders	Indistinct borders	Indistinct borders, typically extends beyond single extremity
Tone/reflexes	Decreased	Decreased	Increased

From Jea A, Belal A, Zaazoue MA, Martin J. Cervical spine injury in children and adolescents. *Pediatr Clin N Am.* 2021;68:875-894, Table 4, p. 883.



**Fig. 81.3** A 15-year-old hockey player suffered acute paraplegia after his head struck the boards during a hockey game. **A**, CT scan shows compression fractures of C4 and C5. **B**, MRI shows severe spinal cord contusion. **C**, Because of the need to decompress the spinal cord and stabilize the spine, anterior and posterior surgery was performed. No meaningful recovery was obtained.

## PREVENTION

The most important aspect of the care of spinal cord injuries in children is injury prevention. Use of appropriate child restraints in automobiles is the most important precaution. In older children and adolescents, rules against “spear tackling” in American football and the *Feet First, First Time* aimed at adolescents diving into swimming pools and natural water areas are important ways to help prevent severe cervical spinal cord injuries. Safe driving practices, such as using safety belts, avoiding distracted driving, and following the speed limit, can have substantial beneficial effects on injury rates.

Visit Elsevier eBooks+ at [eBooks.Health.Elsevier.com](https://ebooks.health.elsevier.com) for Bibliography.

## Chapter 82

# Neurologic Emergencies and Stabilization

Patrick M. Kochanek and Michael J. Bell

## NEUROCRITICAL CARE PRINCIPLES

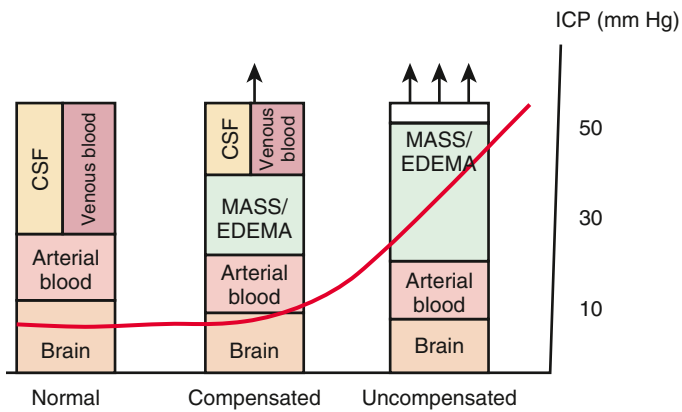
The brain has high metabolic demands, which are further increased during growth and development. Preservation of nutrient supply to the brain is the mainstay of care for children with evolving brain injuries. *Intracranial dynamics* describes the physics of the interactions of

the contents—brain parenchyma, blood (arterial, venous, capillary), and cerebrospinal fluid (CSF)—within the cranium. Normally, brain parenchyma accounts for up to 85% of the contents of the cranial vault, and the remaining portion is divided between CSF and blood. The brain resides in a relatively rigid cranial vault, and cranial compliance decreases with age as the skull ossification centers gradually replace cartilage with bone. The **intracranial pressure (ICP)** is derived from the volume of its components and the bony compliance. The **perfusion pressure** of the brain (cerebral perfusion pressure [CPP]) is equal to the pressure of blood entering the cranium (mean arterial pressure [MAP]) minus the ICP, in most cases.

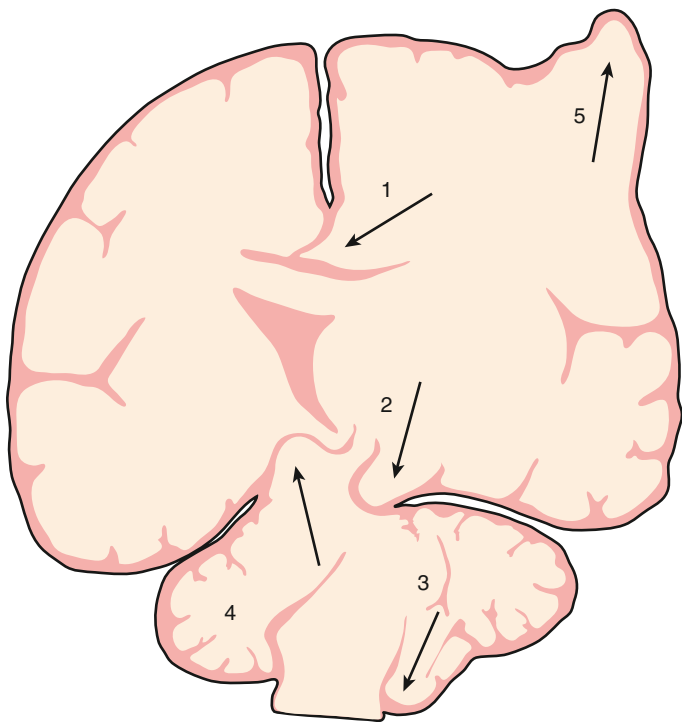
Increases in intracranial volume can result from swelling, masses, or increases in blood and CSF volumes. As these volumes increase, compensatory mechanisms prevent increases in ICP by (1) decreasing CSF volume (CSF is displaced into the spinal canal or absorbed by arachnoid villi), (2) decreasing cerebral blood volume (venous blood return to the thorax is augmented), and/or (3) increasing cranial volume (sutures pathologically expand or bone is remodeled). Once compensatory mechanisms are exhausted (the increase in cranial volume is too large), small increases in volume lead to clinically meaningful increases in ICP or intracranial hypertension (Fig. 82.1). As ICP continues to increase, brain ischemia can occur as CPP falls. Further increases in ICP can ultimately displace the brain downward into the foramen magnum—a process called **cerebral herniation**, which can become irreversible in minutes and may lead to severe disability or death; Figure 82.2 notes other sites of brain herniation.

Oxygen and glucose are required by brain cells for normal functioning, and these nutrients must be constantly supplied by cerebral blood flow (CBF). Normally, CBF is constant over a wide range of blood pressures (blood pressure autoregulation of CBF) via actions mainly within



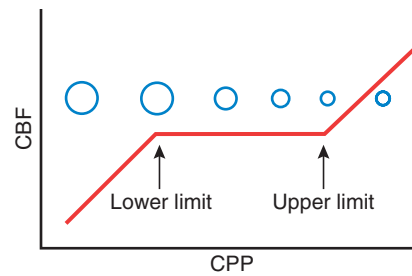


**Fig. 82.1** The Munro-Kellie doctrine describes intracranial dynamics in the setting of an expanding mass lesion (i.e., hemorrhage, tumor) or brain edema. In the normal state, the brain parenchyma, arterial blood, CSF, and venous blood occupy the cranial vault at a low pressure, generally <10 mm Hg. With an expanding mass lesion or brain edema, initially there is a compensated state as a result of reduced CSF and venous blood volumes, and ICP remains low. Further expansion of the lesion, however, leads to an uncompensated state when compensatory mechanisms are exhausted and intracranial hypertension results.



**Fig. 82.2** Different forms of brain herniation. 1, Cingulate. 2, Uncal. 3, Cerebellar tonsillar. 4, Upward cerebellar. 5, Transcalvarial. (From Fishman RA. Cerebrospinal Fluid in Diseases of the Nervous System. Philadelphia: Saunders; 1980.)

the cerebral arterioles. Cerebral arterioles are maximally dilated at lower blood pressures and maximally constricted at higher pressures so that CBF does not vary during normal fluctuations (Fig. 82.3). Above the upper limit of autoregulation, breakthrough dilation occurs that, if severe, can produce hypertensive encephalopathy. Acid-base balance of the CSF (often reflected by acute changes in arterial partial pressure of carbon dioxide [ $P_{aCO_2}$ ]), body/brain temperature, glucose utilization,



**Fig. 82.3** Schematic of the relationship between CBF and CPP. The diameter of a representative cerebral arteriole is also shown across the center of the y axis to facilitate understanding of the vascular response across CPP that underlies blood pressure autoregulation of CBF. CPP is generally defined as the mean arterial pressure (MAP) minus the ICP. At normal values for ICP, this generally represents MAP. Thus, normally, CBF is kept constant between the lower limit and upper limit of autoregulation; in normal adults, these values are  $\approx 50$  mm Hg and 150 mm Hg, respectively. In children, the upper limit of autoregulation is likely proportionally lower than the adult value relative to normal MAP for age. However, according to the work of Vavilala et al. (2003), lower limit values are surprisingly similar in infants and older children. Thus infants and young children may have less reserve for adequate CPP. See text for details.

blood viscosity, and other vasoactive mediators (i.e., adenosine, nitric oxide, prostanoids) can also affect the cerebral vasculature.

Knowledge of these concepts is instrumental to preventing secondary brain injury. Increases in CSF pH that occur because of inadvertent hyperventilation (decreased  $P_{aCO_2}$ ) can produce cerebral ischemia. Hyperthermia-mediated increases in cerebral metabolic demands may damage vulnerable brain regions after injury. Hypoglycemia can produce neuronal death when CBF fails to compensate. Prolonged seizures can lead to permanent injuries if hypoxemia occurs from loss of airway control.

Attention to detail and constant reassessment are paramount in managing children with critical neurologic insults. Among the most valuable tools for serial, objective assessments of neurologic condition is the **Glasgow Coma Scale (GCS)** (Table 82.1 and see Table 79.3). Originally developed to assess level of consciousness after traumatic brain injury (TBI) in adults, the GCS is also valuable in pediatrics. Modifications to the GCS have been made for nonverbal children and are available for infants and toddlers (see Table 79.3 in Chapter 79). Serial assessments of the GCS score along with a focused neurologic examination are invaluable to detect injuries before permanent damage occurs in the vulnerable brain. The **FOUR (full outline of unresponsiveness) score** (see Table 82.1) is a modification of the GCS, which eliminates the patient's verbal response but adds functional assessments of the brainstem (pupil, corneal, and cough reflexes) and respiratory pattern.

The most-studied monitoring device in clinical practice is the **ICP monitor**. Monitoring is accomplished by a catheter inserted either into the cerebral ventricle (externalized ventricular drain) or into brain parenchyma (parenchymal transducer). ICP-directed therapies are standard of care in TBI and are used in other conditions, such as intracranial hemorrhage, Reye syndrome, and some cases of encephalopathy, meningitis, and encephalitis. Other devices being used include catheters that measure brain tissue oxygen concentration, external probes that noninvasively assess brain oxygenation by absorbance of near-infrared light (near-infrared spectroscopy [NIRS]), monitors of brain electrical activity (continuous electroencephalography [EEG] or somatosensory, visual, or auditory evoked potentials), and CBF monitors (transcranial Doppler, xenon CT, perfusion MRI, or tissue probes). In the severe TBI guidelines, brain tissue oxygen concentration monitoring received level III support and thus may be considered as an adjunct to ICP-directed therapy.



**Table 82.1** Commonly Used Coma Scores**GLASGOW COMA SCALE****Eye Opening**

- 1 = does not open eyes
- 2 = opens eyes in response to noxious stimuli
- 3 = opens eyes in response to voice
- 4 = opens eyes spontaneously

**Verbal Output**

- 1 = makes no sounds
- 2 = makes incomprehensible sounds
- 3 = utters inappropriate words
- 4 = confused and disoriented
- 5 = speaks normally and oriented

**Motor Response (Best)**

- 1 = makes no movements
- 2 = extension to painful stimuli
- 3 = abnormal flexion to painful stimuli
- 4 = flexion/withdrawal to painful stimuli
- 5 = localized to painful stimuli
- 6 = obeys commands

**FULL OUTLINE OF UNRESPONSIVENESS (FOUR) SCORE****Eye Response**

- 4 = eyelids open or opened, tracking, or blinking to command
- 3 = eyelids open but not tracking
- 2 = eyelids closed but open to loud voice
- 1 = eyelids closed but open to pain
- 0 = eyelids remain closed with pain

**Motor Response**

- 4 = thumbs-up, fist, or peace sign
- 3 = localizing to pain
- 2 = flexion response to pain
- 1 = extension response to pain
- 0 = no response to pain or generalized myoclonus status

**Brainstem Reflexes**

- 4 = pupil and corneal reflexes present
- 3 = one pupil wide and fixed
- 2 = pupil or corneal reflexes absent
- 1 = pupil and corneal reflexes absent
- 0 = absent pupil, corneal, and cough reflex

**Respiration**

- 4 = not intubated, regular breathing pattern
- 3 = not intubated, Cheyne-Stokes breathing pattern
- 2 = not intubated, irregular breathing
- 1 = breathes above ventilatory rate
- 0 = breathes at ventilator rate or apnea

From Edlow JA, Rabinstein A, Traub SJ, Wijdicks EFM. Diagnosis of reversible causes of coma. *Lancet*. 2014;384:2064-2076.

**TRAUMATIC BRAIN INJURY****Etiology**

Mechanisms of TBI include motor vehicle crashes, falls, assaults, and abusive head trauma. Most TBIs in children are from closed-head injuries.

**Epidemiology**

TBI is an important pediatric public health problem, with over 800,000 emergency department visits, 23,000 hospitalizations, and over 2,500 deaths in children annually in the United States. It is also 1 of the top 10 causes of years lost to disability throughout infancy, childhood, and adolescence.

**Pathology**

Epidural, subdural, and parenchymal intracranial hemorrhages can result. Injury to gray or white matter is also commonly seen and includes focal cerebral contusions, diffuse cerebral swelling, axonal injury, and injury to the cerebellum or brainstem. Patients with severe

TBI often have multiple findings; diffuse and potentially delayed cerebral swelling is common.

**Pathogenesis**

TBI results in primary and secondary injury. Primary injury from the impact produces irreversible tissue disruption. In contrast, two types of secondary injury are targets of neurointensive care. First, some of the ultimate damage seen in the injured brain evolves over hours or days, and the underlying mechanisms involved (including edema, apoptosis, programmed necrosis, and secondary axotomy) are therapeutic targets. Second, the injured brain is vulnerable to additional insults because injury disrupts normal autoregulatory defense mechanisms; disruption of autoregulation of CBF can lead to ischemia from hypotension that would otherwise be tolerated by the uninjured brain.

**Clinical Manifestations**

The hallmark of **severe TBI** is coma (**GCS score 3-8**). Coma is often seen immediately after the injury and is sustained. In some cases, such as with an epidural hematoma, a child may be initially alert on presentation but may deteriorate after a period of hours. A similar picture can be seen in children with diffuse swelling in whom a *talk-and-die* scenario has been described. Clinicians should also not be lulled into underappreciating the potential for deterioration of a child with **moderate TBI (GCS score 9-12)** with a significant contusion, because progressive swelling can potentially lead to devastating complications. In the comatose child with severe TBI, the second key clinical manifestation is the development of *intracranial hypertension*. The development of increased ICP with impending herniation may be heralded by new-onset or worsening headache, depressed level of consciousness, vital sign changes (hypertension, bradycardia, irregular respirations), and signs of sixth (lateral rectus palsy) or third (anisocoria [dilated pupil], ptosis, down-and-out position of globe as a result of rectus muscle palsies) cranial nerve compression. Increased ICP is managed with continuous ICP monitoring, as well as monitoring for clinical signs of increased ICP or impending herniation. The development of brain swelling is progressive. Significantly raised ICP (>20 mm Hg) can occur early after severe TBI, but peak ICP generally is seen at 48-72 hours. Need for ICP-directed therapy may persist for longer than a week. A few children have coma without increased ICP resulting from axonal injury or brainstem injury. *In addition to head trauma, it is critical to identify potential cervical spine injury (see Chapter 81).*

**Laboratory Findings**

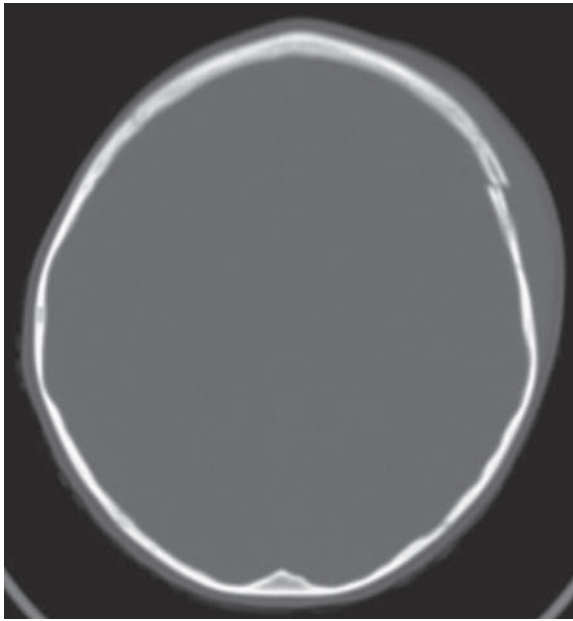
Cranial CT should be obtained immediately after resuscitation and cardiopulmonary stabilization (Figs. 82.4-82.10). In some cases, MRI can be diagnostic (Fig. 82.11). An approach to CT scanning is noted in Figure 82.12. Generally, other laboratory findings are normal in isolated TBI, although occasionally coagulopathy or the development of the syndrome of inappropriate antidiuretic hormone (SIADH) secretion or cerebral salt wasting (CSW) is seen. In the setting of TBI with polytrauma, other injuries can result in laboratory and/or radiographic abnormalities, and a **full trauma survey** is important in all patients with severe TBI (see Chapter 80).

**Diagnosis and Differential Diagnosis**

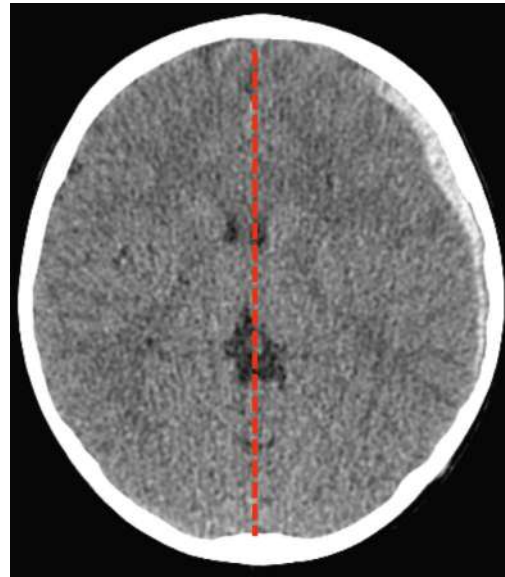
In severe TBI, the diagnosis is generally obvious from the history and clinical presentation. Occasionally, TBI severity can be overestimated because of concurrent alcohol or drug intoxication. The diagnosis of TBI can be problematic in cases of abusive head trauma or after an anoxic event such as drowning or smoke inhalation.

**Treatment**

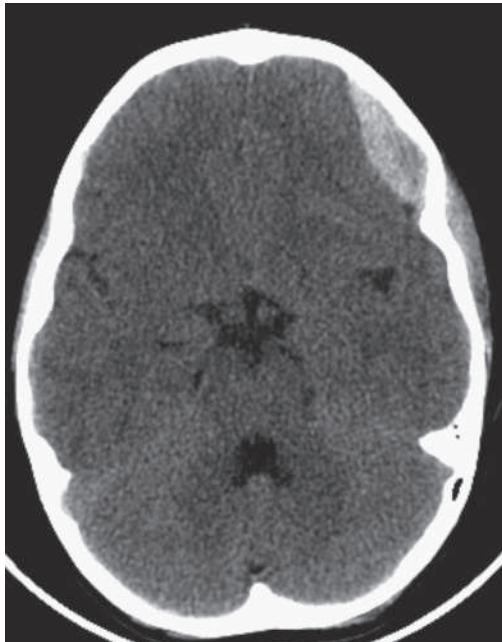
Infants and children with severe or moderate TBI (GCS score 3-8 or 9-12, respectively) receive intensive care unit (ICU) monitoring. Evidence-based guidelines for the management of severe TBI have been published (Fig. 82.13 and Fig. 82.14). This approach to ICP-directed therapy is also reasonable for other conditions in which ICP is monitored. Care involves a multidisciplinary team comprising pediatric caregivers from neurologic surgery, critical care medicine, surgery, and rehabilitation, among other services, and is directed at



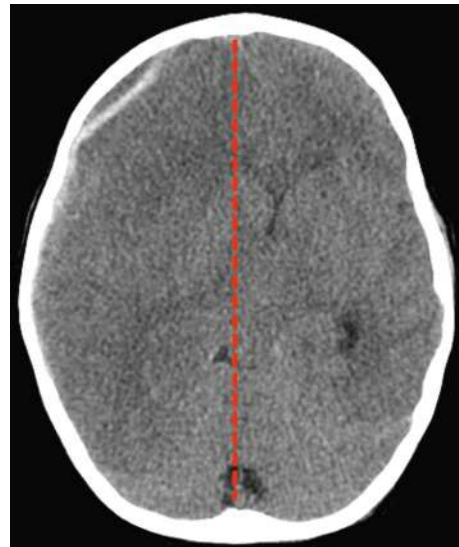
**Fig. 82.4** Skull fracture. Mildly displaced skull fracture seen on CT imaging (bone window view) in a 4-year-old who fell and hit her head on a curb.



**Fig. 82.6** Subdural hematoma. Left subdural hematoma observed on CT imaging in a 10-year-old child after a motor vehicle accident. Note effacement of the left lateral ventricle and midline shift (see *dashed line* for midline reference).



**Fig. 82.5** Epidural hematoma. Left frontal epidural hematoma observed on CT imaging in a 12-year-old child who fell off his bike onto a concrete surface.

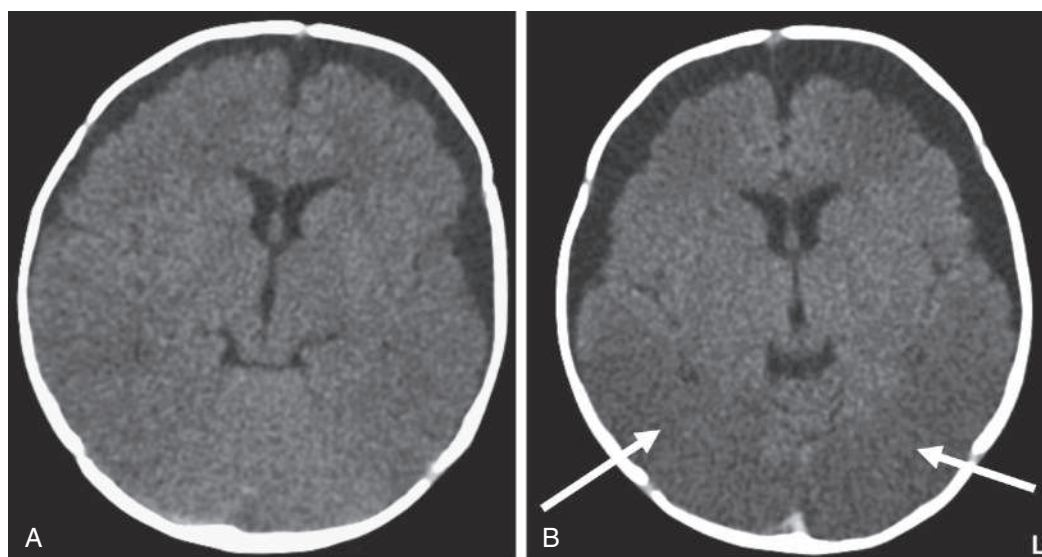


**Fig. 82.7** Subdural hematoma. Hyperacute right frontal subdural hematoma observed on CT imaging in a 5-year-old after a motor vehicle accident. Note that the hyperacute aspect of the subdural hematoma is dark on CT imaging in the early stage after injury. Also, note that there is marked midline shift of intracranial contents, as both lateral ventricles are displaced into the left side of the skull.

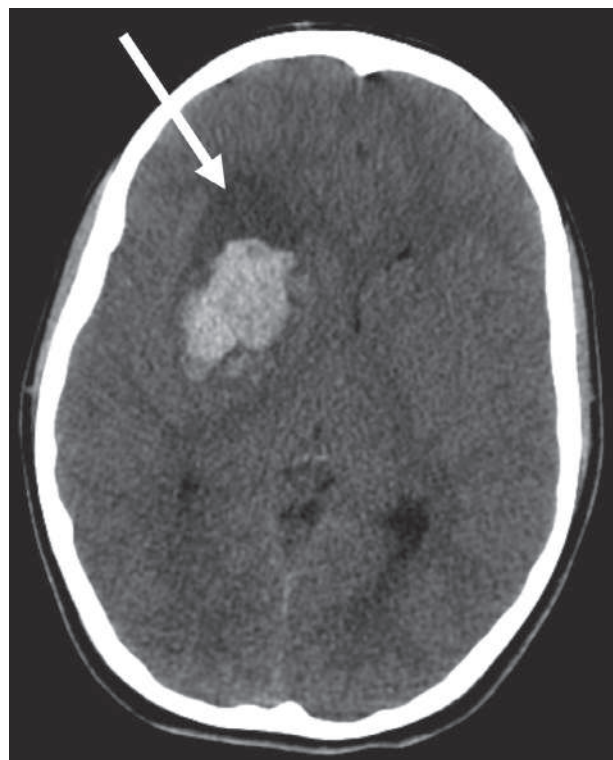
preventing secondary insults and managing raised ICP. Initial stabilization of infants and children with severe TBI includes rapid sequence tracheal intubation with spine precautions along with maintenance of normal extracerebral hemodynamics, including blood gas values ( $P_{aO_2}$  and  $P_{aCO_2}$ ), MAP, and temperature. Intravenous fluid boluses may be required to treat hypotension. Euvolemia is the target, and hypotonic fluids must be rigorously avoided; *normal saline is the fluid of choice*. Pressors may be needed as guided by monitoring of central venous pressure, with avoidance of both fluid overload and exacerbation of brain edema. A trauma survey should be performed. Once stabilized, the patient should be taken for CT scanning to rule out the need for

emergency neurosurgical intervention. If surgery is not required, an ICP monitor should be inserted to guide the treatment of intracranial hypertension. Repeat CT scan may help determine whether a new lesion requiring surgical intervention has developed; this should be obtained if there is a change in examination or for refractory intracranial hypertension.

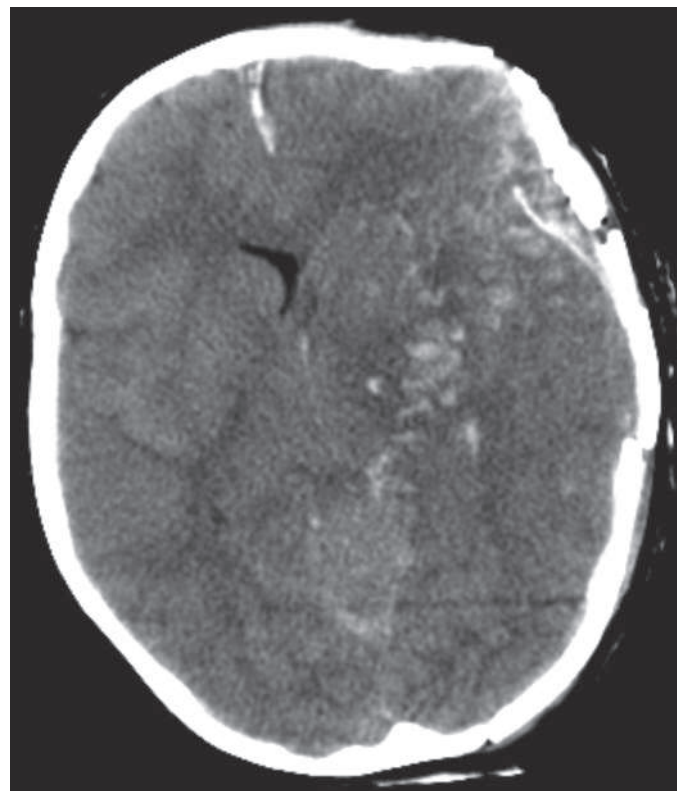
During stabilization or at any time during the treatment course, patients can present with signs and symptoms of *cerebral herniation* (pupillary dilation, systemic hypertension, bradycardia, extensor posturing). Because herniation and its devastating consequences can sometimes be reversed if promptly addressed, it should be treated as a medical emergency, with use of hyperventilation with a fraction of inspired oxygen of 1.0 titrated to reversal of pupillary dilation and



**Fig. 82.8** Subdural hematoma. In a 3-month-old child who suffered from abusive head trauma, initial CT imaging (A) demonstrates chronic subdural hematoma bilaterally. Three days after hospitalization (B), the subdural hematomas are slightly larger but infarctions are noted in the posterior areas of brain parenchyma (arrows).



**Fig. 82.9** Hemorrhage and edema. In a 16-year-old who fell from his dirt bike, CT imaging demonstrates intraparenchymal hemorrhage and significant surrounding edema (arrow).



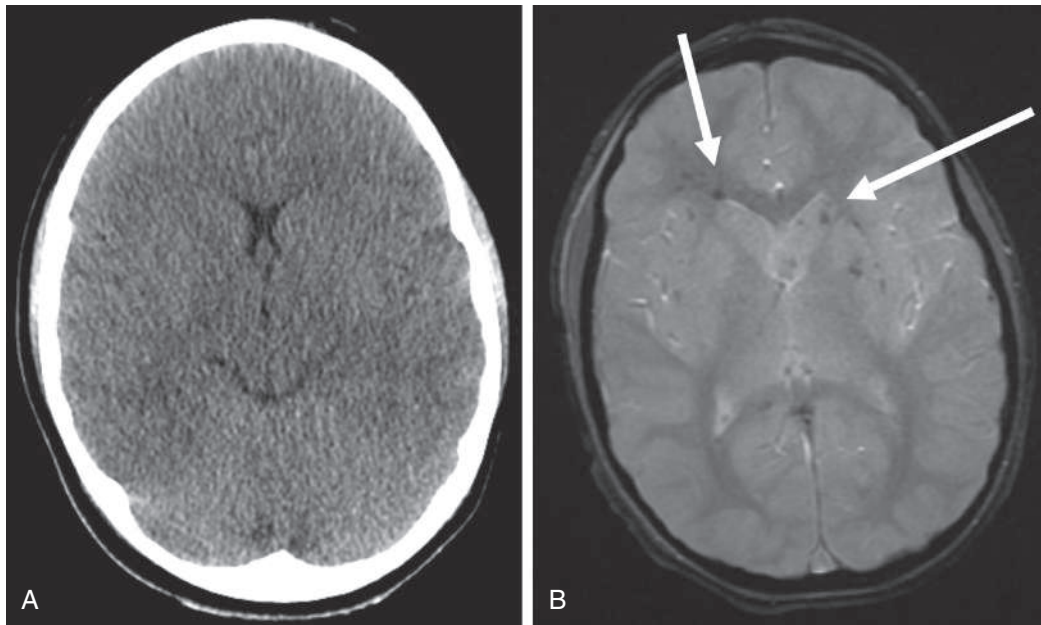
**Fig. 82.10** Skull fractures and hemorrhage. An 11-year-old child was hit in the head by a horse, and CT imaging demonstrates multiple comminuted skull fractures with fragments of bone within the brain parenchyma, multifocal areas of intraparenchymal hemorrhage, and obliteration of the left lateral ventricle.

administration of either hypertonic saline (3% solution, 5-10 mL/kg IV) or mannitol (0.25-1.0 g/kg IV). If an external ventricular drain is in place, it should be opened to continuous drainage. Pentobarbital administration can also be considered if a prompt clinical response has not been observed.

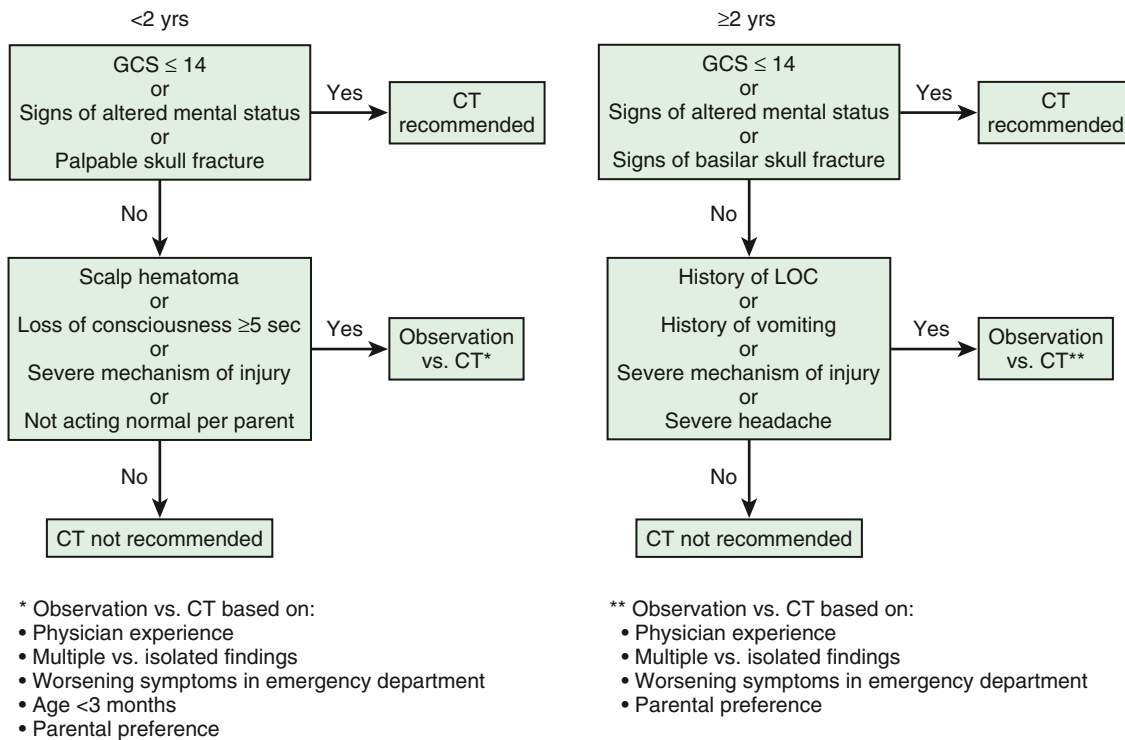
ICP should be maintained at <20 mm Hg; age-dependent CPP targets are approximately 50 mm Hg for children 2-6 years of age, 55 mm Hg for those 7-10 years of age, and 65 mm Hg for those 11-16 years of age. First-tier therapy includes elevation of the head of the bed, ensuring mid-line positioning of the head, controlled mechanical ventilation, and

analgesia and sedation (i.e., narcotics and benzodiazepines). If neuromuscular blockade is needed, it may be desirable to monitor EEG continuously because *status epilepticus* can occur; this complication will not be recognized in a paralyzed patient and is associated with raised ICP and unfavorable outcome. If a ventricular rather than parenchymal catheter is used to monitor ICP, therapeutic CSF drainage is available and can be provided either continuously (often targeting an ICP >5 mm Hg) or intermittently in response to ICP spikes, generally >20





**Fig. 82.11** Hemorrhages and axonal injury. In a 6-year-old child who was hit by a car while riding his bike, initial CT imaging demonstrates no obvious abnormality (A). However, immediate MRI demonstrates multiple areas of punctate hemorrhages (lucencies) consistent with diffuse axonal injury (B, arrows).



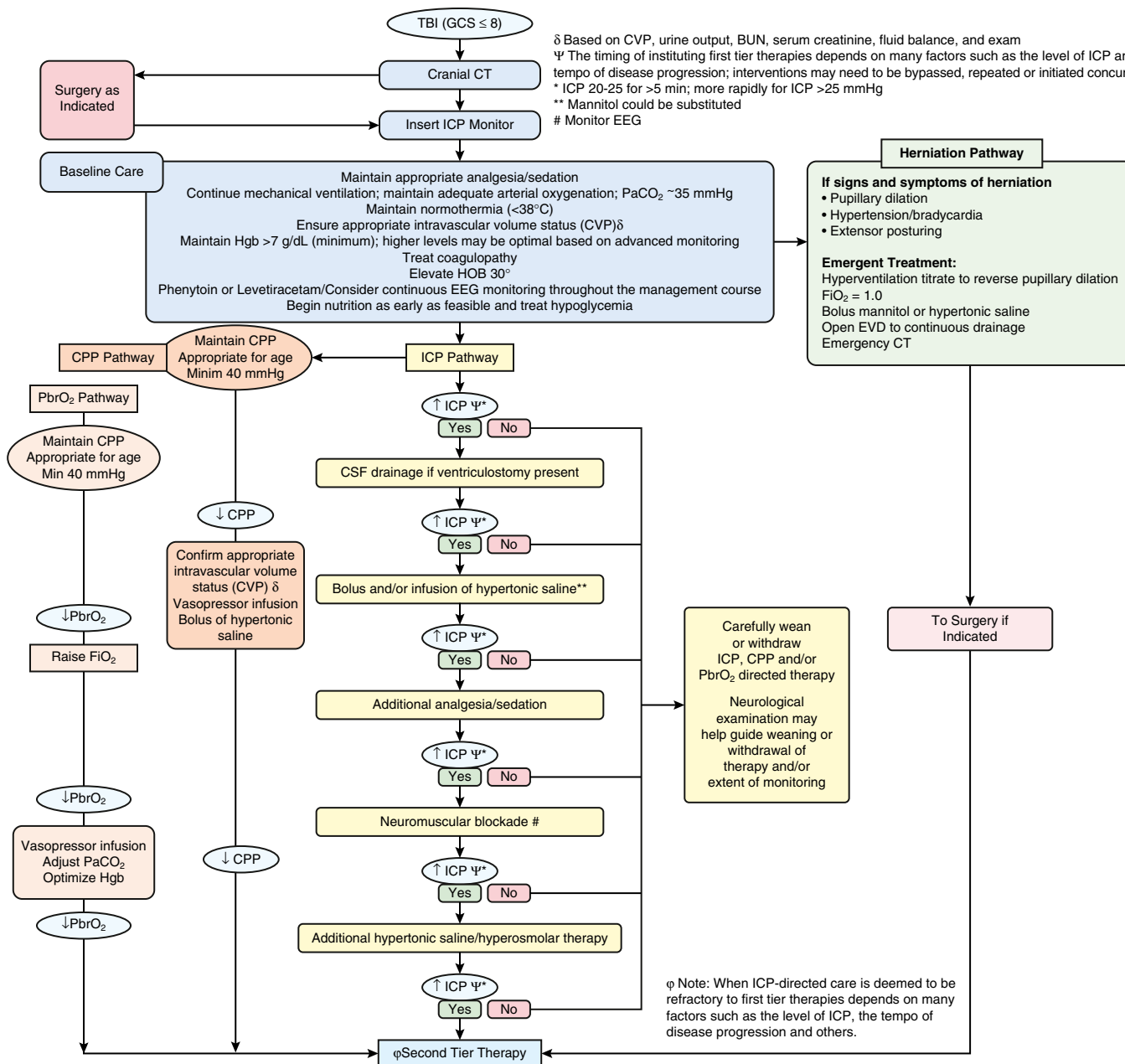
**Fig. 82.12** Algorithm for head computed tomography (CT) scan using predictive rules. GCS, Glasgow Coma Scale; LOC, level of consciousness. (Modified from Kupperman N, Holmes JF, Dayan PS, et al. Identification of children at very low risk of clinically important brain injuries after head trauma: A prospective cohort study. *Lancet*. 2009;374:1160-1170.)

mm Hg. Other first-tier therapies include the osmolar agents hypertonic saline or mannitol. Bolus administration of 3% **hypertonic saline** (between 2 and 5 mL/kg over 10-20 minutes) has guideline-based level II evidence supporting its use to treat ICP spikes >20 mm Hg or using a fixed (q4-q6h) dosing interval. It can also be given as a continuous infusion of 3% saline at 0.1-1.0 mL/kg/hr. **Mannitol** (0.25-1.0 g/kg IV over 20 minutes) represents an alternative. These agents can be used concurrently. It is recommended to avoid serum osmolality >320

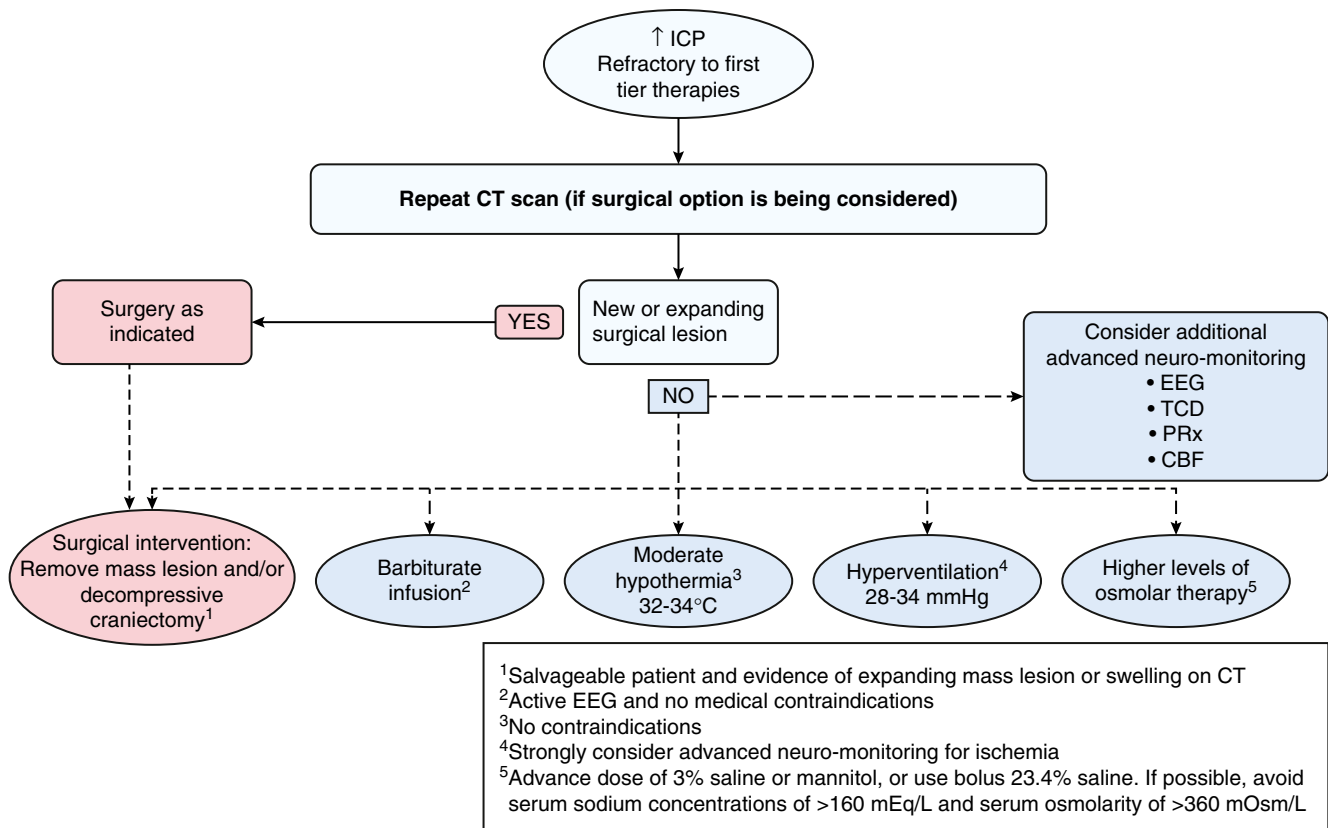
mOsm/L. A Foley urinary catheter should be placed to monitor urine output.

If increased ICP remains refractory to treatment, careful reassessment of the patient is needed to rule out unrecognized hypercarbia, hypoxemia, fever, hypotension, hypoglycemia, pain, and seizures. Repeat imaging should be considered to rule out a surgical lesion. Guideline-based **second-tier** therapies for refractory raised ICP are available, but evidence favoring a given second-tier therapy is limited.





**Fig. 82.13** Algorithm for use at the bedside to guide first-tier therapies to treat severe pediatric traumatic brain injury (TBI). This evidence- and consensus-based document that accompanied the third edition of the guidelines includes baseline care (gray), an intracranial pressure (ICP) pathway (yellow), a herniation pathway (green), a cerebral perfusion pressure (CPP) pathway (orange), a brain tissue partial pressure of oxygen (PbrO<sub>2</sub>) pathway (purple), and surgical intervention (red). The caregiver should integrate all the available information and implement the evidence in the guidelines in the context of each patient’s unique response to therapies to craft the most optimal treatment regimen. Although a linear approach in each pathway is provided, variations in tempo and timing during which therapies are implemented will vary from case to case. In some cases, a single intervention for raised ICP may suffice, whereas in others, multiple simultaneous interventions may be required. The blue box indicates the need for second-tier therapy (see Fig. 82.14). BUN, Blood urea nitrogen; CSF, cerebrospinal fluid; CT, computed tomography; CVP, central venous pressure; EEG, electroencephalogram; EVD, external ventricular drain; FiO<sub>2</sub>, fraction of inspired oxygen concentration; GCS, Glasgow Coma Scale; Hgb, hemoglobin; HOB, head of bed; PaCO<sub>2</sub>, partial pressure of arterial carbon dioxide; Pao<sub>2</sub>, partial pressure of arterial oxygen. (From Kochanek PM, Bell MJ, Simon DW, et al. Traumatic brain injury. In: Zimmerman JJ, Totta AT, eds. *Fuhrman & Zimmerman’s Pediatric Critical Care*, 6th ed. Philadelphia: Elsevier; 2022: Fig. 118.11, p. 1391.)



**Fig. 82.14** Bedside algorithm to guide second-tier therapies to treat refractory intracranial hypertension in severe pediatric traumatic brain injury (TBI). This evidence- and consensus-based document that accompanied the third edition of the guidelines represents the treatment options when tier 1 approaches are inadequate. These therapies may be applied singly, serially, or in combination. In addition, as shown, management of refractory intracranial hypertension in the second-tier phase may be aided by advanced monitoring. CBF, Cerebral blood flow; CT, computed tomography; EEG, electroencephalogram; ICP, intracranial pressure; PRx, pressure reactivity index; TCD, transcranial Doppler ultrasonography. (From Kochanek PM, Bell MJ, Simon DW, et al. *Traumatic brain injury*. In: Zimmerman JJ, Totta AT, eds. *Fuhrman & Zimmerman's Pediatric Critical Care*, 6th ed. Philadelphia: Elsevier; 2022: Fig. 118.12, p. 1394.)

In some centers, decompressive **craniectomy** is used. Others use a **pentobarbital infusion**, with a loading dose of 5-10 mg/kg over 30 minutes followed by 5 mg/kg every hour for 3 doses and then maintenance with an infusion of 1 mg/kg/hr. Careful blood pressure monitoring is required because of the possibility of drug-induced hypotension and the frequent need for support with fluids and/or pressors. Mild hypothermia (32–34°C [89.6–93.2°F]) to control refractory ICP is controversial but can be induced and maintained by means of surface cooling. Sedation and neuromuscular blockade are used to prevent shivering, and rewarming should be slow. Hypotension should be prevented during rewarming. Refractory raised ICP can also be treated with hyperventilation ( $\text{PaCO}_2 = 25\text{--}30$  mm Hg). Combinations of these second-tier therapies are often required.

### Supportive Care

Euvolemia should be maintained, and isotonic fluids are recommended throughout the ICU stay. Either SIADH or CSW can develop and are important to differentiate, because management of SIADH is fluid restriction and that of CSW is sodium replacement. Severe hyperglycemia (blood glucose level >200 mg/dL) should be avoided and treated. The blood glucose level should be monitored frequently. Early nutrition with enteral feedings is advocated. Corticosteroids should generally not be used unless adrenal insufficiency is documented. Tracheal suctioning can exacerbate raised ICP. Timing of the use of analgesics or sedatives around suctioning events and/or use of tracheal or IV

lidocaine can be helpful. Seizures are common after severe acute TBI. Early posttraumatic seizures (within 1 week) will complicate management of TBI and are often difficult to treat. Anticonvulsant prophylaxis with fosphenytoin or levetiracetam is recommended. Late posttraumatic seizures ( $\geq 7$  days after TBI) and, if recurrent, late posttraumatic epilepsy are not prevented by prophylactic anticonvulsants, whereas early posttraumatic seizures are prevented by initiating anticonvulsants soon after TBI. Antifibrinolytic agents (tranexamic acid) reduce hemorrhage size, as well as the development of new focal ischemic cerebral lesions and improve survival in adults with severe TBI.

### Prognosis

Mortality rates for children with severe TBI who reach the pediatric ICU range between 10% and 30%. Ability to control ICP is related to patient survival, and the extent of cranial and systemic injuries correlates with quality of life. Motor and cognitive sequelae resulting from severe TBI generally benefit from rehabilitation to minimize long-term disabilities. Recovery from TBI may take months or years to achieve. Physical therapy, and in some centers methylphenidate or amantadine, helps with motor and behavioral recovery. Pituitary insufficiency may be an uncommon but significant complication of severe TBI.

Visit Elsevier eBooks+ at [eBooks.Health.Elsevier.com](https://eBooks.Health.Elsevier.com) for Bibliography.

## Chapter 83

## Brain Death: Death by Neurologic Criteria

Matthew P. Kirschen and Wynne Morrison

**Brain death**, also known as **death by neurologic criteria**, is legally and culturally accepted as death in most of the world. In the United States, the **Uniform Determination of Death Act (UDDA)** defines brain death as the irreversible (some use “permanent”) cessation of all functions of the entire brain, including the brainstem. The UDDA or a similar statute has been adopted in all states. Guidelines for the declaration of brain death in infants and children were published jointly by the Society of Critical Care Medicine (SCCM), American Academy of Pediatrics (AAP), and Child Neurology Society (CNS) in 2011. In 2020, the World Brain Death Project published a consensus statement with recommendations for the minimum clinical standards for determination of brain death in adults and children.

**EPIDEMIOLOGY**

Brain death by definition must occur as a result of catastrophic permanent global brain injury. Approximately 20% of children who die in pediatric intensive care units (PICUs) are declared brain dead. The most common etiologies of brain injury leading to brain death are hypoxic-ischemic injury from cardiac arrest, shock and/or respiratory failure without cardiac arrest, traumatic brain injury, intracranial infections, toxic ingestions, and causes of malignant cerebral edema. Mimics of brain death include botulism, Guillain-Barré syndrome, and high cervical cord injuries.

**CLINICAL EVALUATION AND DIAGNOSIS**

Brain death is determined by a careful, thorough clinical evaluation. The fundamental components of brain death are **coma**, **absence of brainstem reflexes**, and **apnea**. The first step in the brain death evaluation is to confirm that the catastrophic brain injury occurred because of an etiology known to lead to brain death. The next step is to ensure that there are no confounding conditions that could mimic or falsely suggest brain death. This is done by meticulously ensuring the patient is not hypotensive or hypothermic; does not have severe metabolic abnormalities like hypoglycemia, hyponatremia, or acidosis; and that sufficient time has passed to allow for clearance of all sedating medication or other toxins that could confound the examination. This involves review of the medical history, neuroimaging, electroencephalography (EEG), and laboratory data to rule out reversible causes of coma. Additionally, the patient should be observed for a sufficient amount of time (typically at least 24 hours after CPR or from their severe acute brain injury) to ensure there is no recovery of neurologic function. Checklists are very helpful in ensuring no prerequisites are missed (Fig. 83.1). Confounding factors must be corrected, if feasible, before initiation of the brain death evaluation. If all confounders are unable to be adequately corrected, ancillary testing is required to diagnose brain death. Brain death evaluation should not be performed in infants <37 weeks corrected gestational age.

**Brain Death Neurologic Examination**

The clinical examination evaluates for coma; absence of motor responses of the head, neck, and extremities; and brainstem areflexia including apnea in a setting of an adequate respiratory stimulus. The patient must be unresponsive to tactile, auditory, and visual stimulation other than spinally mediated reflexes. If it is unclear if motor movements are spinally mediated, ancillary testing may be necessary before brain death can be diagnosed. Brainstem reflexes must be absent. Table 83.1 lists the components of the neurologic examination, including brainstem reflexes to be tested, the brainstem location of each reflex, and the exam finding that is consistent with brain death. Several injuries and conditions can

preclude completion or interpretation of the clinical examination. These include spinal cord injury, orbital/facial trauma, and severe neuromuscular disorders. In these situations, an ancillary test must be performed before declaring brain death. It is still necessary to perform all examination components that can be completed, and every component assessed must be consistent with brain death to allow declaration.

**Apnea Test**

Apnea is the absence of respiratory effort. The purpose of the required apnea test is to evaluate whether the chemoreceptors in the brainstem's medulla, which stimulate respiration when exposed to hypercarbia and acidosis, are functional. The patient should be euvoletic, normotensive, and euthermic before beginning the apnea test. The apnea test can result in cardiopulmonary decompensation and should only be performed in a PICU by clinicians with skills to stabilize or resuscitate the patient if needed. Before the apnea test, the patient is preoxygenated with 100% oxygen for approximately 10 minutes, and ventilation is adjusted to achieve a  $P_{aCO_2}$  of approximately 40 mm Hg. A baseline arterial blood gas (ABG) documents the starting  $P_{aCO_2}$  value. The patient is then removed from intermittent mechanical ventilation and provided apneic oxygenation by delivering 100% oxygen via continuous positive airway pressure (CPAP) on the ventilator or via flow-inflating resuscitation bag with a functioning peak end-expiratory pressure (PEEP) valve. The patient's hemodynamics and pulse oximetry oxygen-hemoglobin saturation ( $SpO_2$ ) are monitored continuously while the physician observes for respiratory effort. An ABG sample is obtained approximately 5-10 minutes into the test and every 2 minutes thereafter until the target  $P_{aCO_2}$  is surpassed; ventilatory support is resumed at that time. Absence of respiratory effort with a  $P_{aCO_2} \geq 60$  mm Hg and  $>20$  mm Hg above baseline is consistent with brain death. If at any point during the test the patient becomes hypoxic ( $SpO_2 < 85\%$ ) or hypotensive, the test is aborted and ventilatory support resumed.

**OBSERVATION PERIODS**

To determine brain death in the United States, current guidelines recommend the neurologic examination and apnea test be performed by different attending physicians separated by an observation period. The examination determines that the child has met criteria for brain death. An observation period before the examination is based on the patient's age: For infants ( $\geq 37$  weeks corrected gestational age) and children <24 months, observe for at least 48 hours. For patients >2 years, observe for at least 24 hours. Before testing, core body temperature should be maintained  $\geq 36^\circ C$ . In addition in adults, systolic blood pressure (SBP) should be  $\geq 100$  mm Hg and mean arterial blood pressure (MAP) should be  $\geq 75$  mm Hg; in children SBP and MAP should be  $\geq 5$ th percentile for age.

Similar MAPs are recommended for patients on venoarterial ECMO. Furthermore, before treating metabolic disorders, intoxication and effects of therapeutic medications that depress the CNS and peripheral nervous system (paralytics) must be excluded. In children, two different clinicians must perform independent neurological and apnea examinations separated by a minimal interval of 12 hours.

**ANCILLARY STUDIES**

Ancillary studies are not required for the diagnosis of brain death and should only be used to assist the clinician in declaring brain death (1) when components of the neurologic examination or apnea test cannot be completed safely because of the underlying medical condition of the patient; (2) if there is uncertainty about the results of the neurologic examination; (3) if a medication effect may be present; or (4) to reduce the observation period between examinations. If an ancillary test is used to shorten the observation period, the physician is still required to complete two clinical examinations and apnea tests, along with the ancillary study.

The most common ancillary tests are EEG and radionuclide perfusion scintigraphy (or cerebral blood flow) studies. Other tests are available (Table 83.2); however, these have not been incorporated into clinical practice in the United States, although they are used outside of the United States in some practice settings. A valid **electroencephalogram** to support a diagnosis of brain death must be performed according to the American EEG Society standards and technical requirements. Confounders should be excluded, and the EEG must demonstrate

Checklist for Documentation of Brain Death

Brain Death Examination for Infants and Children <sup>a</sup>			
Age of Patient	Timing of First Examination	Interexamination Interval	
Term newborn 37 weeks gestational age and up to 30 days old	<input type="checkbox"/> First examination may be performed 24 hours after birth OR following cardiopulmonary resuscitation or other severe brain injury	<input type="checkbox"/> At least 24 hours	
31 days to 18 years old	<input type="checkbox"/> First examination may be performed 24 hours following cardiopulmonary resuscitation or other severe brain injury	<input type="checkbox"/> Interval shortened because ancillary study (Section 4) is consistent with brain death <input type="checkbox"/> At least 12 hours OR <input type="checkbox"/> Interval shortened because ancillary study (Section 4) is consistent with brain death	
Section 1. Prerequisites for Brain Death Examination and Apnea Test			
A. Irreversible and Identifiable Cause of Coma (please check)			
<input type="checkbox"/> Traumatic brain injury <input type="checkbox"/> Anoxic brain injury <input type="checkbox"/> Known metabolic disorder <input type="checkbox"/> Other (specify) _____			
B. Correction of Contributing Factors That Can Interfere with the Neurologic Examination			
	<b>Examination 1</b>	<b>Examination 2</b>	
a. Core body temperature is >95°F (35°C)	<input type="checkbox"/> Yes <input type="checkbox"/> No	<input type="checkbox"/> Yes	<input type="checkbox"/> No
b. Systolic blood pressure or MAP in acceptable range (Systolic BP not less than 2 standard deviations below age-appropriate norm) based on age	<input type="checkbox"/> Yes <input type="checkbox"/> No	<input type="checkbox"/> Yes	<input type="checkbox"/> No
c. Sedative/analgesic drug effect excluded as a contributing factor	<input type="checkbox"/> Yes <input type="checkbox"/> No	<input type="checkbox"/> Yes	<input type="checkbox"/> No
d. Metabolic intoxication excluded as a contributing factor	<input type="checkbox"/> Yes <input type="checkbox"/> No	<input type="checkbox"/> Yes	<input type="checkbox"/> No
e. Neuromuscular blockade excluded as a contributing factor	<input type="checkbox"/> Yes <input type="checkbox"/> No	<input type="checkbox"/> Yes	<input type="checkbox"/> No
<input type="checkbox"/> If ALL prerequisites are marked YES, then proceed to section 2, OR <input type="checkbox"/> _____ confounding variable was present. Ancillary study was therefore performed to document brain death (Section 4).			
Section 2. Physical Examination (please check); Note: Spinal Cord Reflexes Are Acceptable			
	<b>Examination 1,</b> Date/Time: _____	<b>Examination 2,</b> Date/Time: _____	
a. Flaccid tone, patient unresponsive to deep painful stimuli	<input type="checkbox"/> Yes <input type="checkbox"/> No	<input type="checkbox"/> Yes	<input type="checkbox"/> No
b. Pupils are midposition or fully dilated and light reflexes are absent	<input type="checkbox"/> Yes <input type="checkbox"/> No	<input type="checkbox"/> Yes	<input type="checkbox"/> No
c. Corneal, cough, gag reflexes are absent	<input type="checkbox"/> Yes <input type="checkbox"/> No	<input type="checkbox"/> Yes	<input type="checkbox"/> No
d. Sucking and rooting reflexes are absent (in neonates and infants)	<input type="checkbox"/> Yes <input type="checkbox"/> No	<input type="checkbox"/> Yes	<input type="checkbox"/> No
e. Oculovestibular reflexes are absent	<input type="checkbox"/> Yes <input type="checkbox"/> No	<input type="checkbox"/> Yes	<input type="checkbox"/> No
f. Spontaneous respiratory effort while on mechanical ventilation is absent	<input type="checkbox"/> Yes <input type="checkbox"/> No	<input type="checkbox"/> Yes	<input type="checkbox"/> No
<input type="checkbox"/> The _____ (specify) element of the examination could not be performed because _____. Ancillary study (EEG or radionuclide CBF) was therefore performed to document brain death (Section 4).			
Section 3. Apnea Test			
	<b>Examination 1,</b> Date/Time: _____	<b>Examination 2,</b> Date/Time: _____	
No spontaneous respiratory efforts were observed despite final PaCO <sub>2</sub> ≥60mmHg and a ≥20mmHg increase above baseline (Examination 1). No spontaneous respiratory efforts were observed despite final PaCO <sub>2</sub> ≥60mmHg and a ≥20mmHg increase above baseline (Examination 2).	Pretest PaCO <sub>2</sub> : _____	Pretest PaCO <sub>2</sub> : _____	
Apnea test is contraindicated or could not be performed to completion because _____.	Apnea duration: _____ min	Apnea duration: _____ min	
Ancillary study (EEG or radionuclide CBF) was therefore performed to document brain death (Section 4).	Post-test PaCO <sub>2</sub> : _____	Post-test PaCO <sub>2</sub> : _____	
Section 4. Ancillary Testing			
Ancillary testing is required (1) when any components of the examination or apnea testing cannot be completed; (2) if there is uncertainty about the results of the neurologic examination; or (3) if a medication effect may be present. Ancillary testing can be performed to reduce the interexamination period; however, a second neurologic examination is required. Components of the neurologic examination that can be performed safely should be completed in close proximity to the ancillary test.			Date/Time: _____
<input type="checkbox"/> EEG report documents electrocerebral silence OR <input type="checkbox"/> CBF study report documents no cerebral perfusion			<input type="checkbox"/> Yes <input type="checkbox"/> No <input type="checkbox"/> Yes <input type="checkbox"/> No
Section 5. Signatures			
<b>Examiner 1</b> I certify that my examination is consistent with cessation of function of the brain and brainstem. Confirmatory examination to follow. Printed name _____ Signature _____ Specialty _____ Pager #/license # _____ Date mm/dd/yyyy _____ Time _____			
<b>Examiner 2</b> I certify that my examination <input type="checkbox"/> and/or ancillary test report <input type="checkbox"/> confirms unchanged and irreversible cessation of function of the brain and brainstem. The patient is declared brain dead at this time. Date/time of death _____ Printed name _____ Signature _____ Specialty _____ Pager #/license # _____ Date mm/dd/yyyy _____ Time _____			
<sup>a</sup> Two physicians must perform independent examinations separated by specified intervals. BP = blood pressure; CBF = cerebral blood flow; EEG = electroencephalography; MAP = mean arterial pressure.			

Fig. 83.1 Checklist for documentation of brain death. (From Nakagawa TA, Ashwal S, Mathur M, et al. Guidelines for the determination of brain death in infants and children: An update of the 1987 Task Force recommendations—executive summary. Ann Neurol. 2012;71:573-585, Table 2.)



**Table 83.1** Neurologic Examination to Evaluate a Patient for Brain Death

EXAM COMPONENT	HOW TO PERFORM	RESPONSE CONSISTENT WITH BRAIN DEATH
Coma	Visual response: blink to visual threat Auditory response: clapping and yelling the child's name loudly Tactile response: apply deep pressure to the condyles at the level of the temporomandibular joints, the supraorbital notch bilaterally, the sternum, and all four extremities proximally and distally	No response to visual or auditory stimuli; noxious stimuli do not produce grimacing, facial or body muscle movement, or any motor response other than spinally mediated reflexes
Pupillary light reflex (CNs II and III)	Shine a bright light into each eye while closely observing pupillary size and reactivity	Absence of ipsilateral and contralateral pupillary response, with pupils fixed in a midsize or dilated position (4-6 mm) in both eyes
Corneal reflex (CNs III, V, VII)	Touch the cornea of each eye with a cotton swab at the external border of the iris, applying light pressure and observing for any eyelid movement	Absence of eyelid movement
Oculocephalic reflex (CNs III, VI, and VIII)	Confirm integrity of the cervical spine. Secure the endotracheal tube to prevent dislodgement; briskly rotate the head horizontally to both sides and observe for movement of the eyes	Absence of movement of the eyes relative to head movement; eyes follow the head movement, staying in mid-position
Oculovestibular reflex (CNs III, IV, VI, and VIII)	Irrigate the ear canal with 50-60 mL of ice water for at least 60 sec while observing for eye movement; test each side separately and with a 5-min interval in between	Absence of eye movement
Gag and cough reflex (CNs IX and X)	Touch the posterior pharynx with a tongue depressor or a rigid suction catheter to stimulate a gag; touch the tracheobronchial wall at the level of the carina with placement of a suction catheter through the endotracheal tube to stimulate a cough	Absence of both cough and gag
Sucking and rooting reflexes	Place a gloved finger inside the baby's mouth to stimulate sucking; stroke the external surface of both cheeks and corners of the mouth to stimulate rooting	Absence of sucking and rooting

CN, Cranial nerve.

**Table 83.2** Ancillary Tests for Determining Brain Death

TEST	CONFOUNDER/LIMITATION*	SENSITIVITY/SPECIFICITY
<b>BRAIN BLOOD FLOW</b>		
Computed tomography angiography	Requires transport to the scanner Image variability based on injection technique Potential to miss a slow flow state Risk of nephrotoxicity Not recommended by AAN 2023 Guidelines <sup>#</sup>	52-97% / 100%
Digital subtraction angiography <sup>†</sup>	Requires transport to angiography suite Risk of nephrotoxicity Image variability based on injection technique	100% / 100%
Magnetic resonance angiography	Requires transport to the scanner Image variability based on injection technique	93-100% / 100%
Radionuclide angiography <sup>†</sup>	Limited evaluation of brainstem	99% / 56%
Radionuclide scintigraphy <sup>†</sup>	Requires transport to the scanner Planar imaging may have limited evaluation of brainstem	Planar: 78% / 100% SPECT: 88% / 100%
Transcranial Doppler ultrasonography <sup>†</sup>	Potential for technical difficulties in performance Potential for lack of windows	90% / 98%
<b>ELECTROPHYSIOLOGIC FUNCTION</b>		
Electroencephalography	Risk of environmental artifact Confounded by sedation, hypothermia and toxic-metabolic derangements Predominantly provides information about cortical function	53-80% / 97%
Evoked potentials-auditory	Can be absent in comatose patients with other intact brainstem reflexes Confounded by sedation, hypothermia, isolated eighth nerve and brainstem lesions Only evaluates auditory pathways Performance/interpretation may be limited by experience	NA / NA
Evoked potentials-somatosensory	Can be absent in comatose patients with ongoing brain function Confounded by cervical spine injury, isolated brainstem lesions, sedation, and hypothermia Only evaluates somatosensory pathways Performance/interpretation may be limited by experience	100% / 78%
Evoked potentials-visual	Can be absent in comatose patients with ongoing brain function Confounded by sedation, retinal or optic nerve lesions Only evaluates visual pathways Performance/interpretation may be limited by experience	NA / NA

\*Performance/interpretation of all ancillary tests may be limited by experience

<sup>†</sup>Accepted by the World Brain Death Project (WBDP).<sup>#</sup>Report of the AAN Guidelines Subcommittee, AAP, CNS, SCCM. Pediatric and adult brain death/death by neurologic criteria consensus guideline. *Neurology* 2023;101:1-21. NA, Not available.From Lewis A, Kirschen MP, Badenes R. Quality improvement in the determination of death by neurologic criteria around the world. *Crit Care*. 2023;27(1):96.

**electrocerebral silence.** A **radionuclide cerebral blood flow study** consists of intravenous injection of a radiopharmaceutical agent followed by imaging of the brain by planar or single-photon emission computed tomography (SPECT) imaging. A study that demonstrates absence of intracranial blood flow and cerebral perfusion is supportive of brain death. CT and MR angiography are not recommended.

Interpretation of both EEG and cerebral blood flow studies should only be performed by trained and qualified individuals. If the study shows any evidence of electrical activity or cerebral blood flow, brain death cannot be declared. A 24-hour waiting period is recommended before repeating the brain death evaluation.

## DOCUMENTATION

Documentation is an important aspect of the brain death evaluation and determination and should follow a checklist, including the following points:

1. Etiology of brain injury
2. Absence of confounding factors, including hypothermia, hypotension, metabolic abnormalities, and recent doses of sedative or neuromuscular blocking agents
3. Absence of motor response to tactile, auditory, and visual stimuli
4. Absence of brainstem reflexes, including pupillary light reflex, oculocephalic/oculovestibular reflex, corneal reflex, cough reflex, and gag reflex
5. ABG values during the apnea test and statement about respiratory effort
6. Results of ancillary testing (if indicated)

## AFTER DECLARATION OF BRAIN DEATH

*After brain death has been declared, the child is legally dead.* The time of death is the time the final required component of the evaluation is completed: either ABG results or ancillary test. Families may be approached by representatives of organ procurement organizations to discuss options for organ donation after brain death. For families that choose not to donate organs, the next appropriate step in the care of the child is removal of technologic supports, including mechanical ventilation, after which the child's heart will become asystolic. It is important for care providers to be supportive of the family dealing with this difficult situation. Child life and palliative care specialists can be helpful in guiding families during this time. Technologic support is typically stopped within a few hours of declaring brain death, although in some situations it can be delayed at the discretion of the physician and in accordance with hospital protocols.

## OBJECTIONS TO THE CONCEPT OF BRAIN DEATH

The concept of brain death may not be accepted by families for personal, religious, or cultural reasons. Some families have difficulty comprehending the fact that their child meets criteria for legal death despite having a heartbeat, blood pressure, and being warm to the touch. Other families maintain hope for recovery, and some have religious views that death can only be declared after cessation of cardiorespiratory function. Some individuals have challenged the brain death guidelines claiming that they do not sufficiently evaluate "all functions of the entire brain, including the brainstem," as mandated by the UDDA, particularly as some patients who meet brain death criteria continue to show evidence of *integrative functioning*, such as control over free water homeostasis (absence of diabetes insipidus), control of temperature regulation, and capacity for growth and wound healing. Others argue that the intent of the UDDA is met by the current clinical evaluation. Objections to performing the brain death evaluation or declaration of death should be handled by a multidisciplinary team with experience in these situations. These teams often include physicians, social workers, ethicists, chaplains, hospital administrators, and lawyers as appropriate.

Visit Elsevier eBooks+ at [eBooks.Health.Elsevier.com](http://eBooks.Health.Elsevier.com) for Bibliography.

## Chapter 84

# Syncope

Aarti S. Dalal and George F. Van Hare

*Syncope* is defined as a sudden transient loss of consciousness with inability to maintain postural tone. The most common cause of syncope in the normal pediatric population is **neurocardiogenic syncope** (vasovagal syncope, fainting). **Vasovagal syncope** is classically associated with a prodrome that includes diaphoresis, warmth, pallor, or feeling lightheaded and is often triggered by acute position changes or by a specific situation or event such as pain, medical procedures, or emotional distress (Table 84.1). This type of syncope is characterized by hypotension and bradycardia. Approximately 30–50% of children will have had a **fainting** episode before 18 years of age. The symptoms of vasovagal syncope can overlap with those of postural orthostatic tachycardia syndrome (POTS), a constellation of symptoms characterized by symptoms of rapid heart rate and supported by a positional increase in heart rate by 40 beats per minute with normal blood pressure (see Chapter 84.1).

Most patients with a vasovagal syncope episode will have prodromal features followed by loss of motor tone. Once in a horizontal position, consciousness returns rapidly, usually in 1–2 minutes; some patients may have a brief period of stiffening or jerking, which should not be confused with a **seizure** (Table 84.2). Syncope must also be distinguished from **vertigo** and **ataxia** (Table 84.3).

Although this type of syncope is very common in adolescence and has an excellent prognosis, other causes for loss of consciousness are more dangerous; thus syncope may be the first sign of more serious conditions (Table 84.4). Indeed, the occurrence of syncope may well be the pediatrician's best opportunity to diagnose a life-threatening condition before the patient subsequently succumbs. The task of the clinician therefore is not only to counsel the family and the patient concerning the common form but also to rule out a number of important life-threatening cardiac problems.

## MECHANISMS

Syncope by whatever mechanism is caused by a lack of adequate cerebral blood flow with loss of consciousness and inability to remain upright.

Primary **cardiac causes** of syncope (see Table 84.4) include conditions that predispose a patient to arrhythmias or conditions such as congenital or acquired structural heart disease. Arrhythmic causes of syncope include Wolff-Parkinson-White syndrome (particularly with atrial fibrillation), ventricular tachycardia (VT), and occasionally supraventricular tachycardia (see Chapter 484). VT may be associated with hypertrophic cardiomyopathy (HCM), arrhythmogenic cardiomyopathy, repaired congenital heart disease, or an inherited arrhythmia syndrome such as catecholaminergic polymorphous ventricular tachycardia (CPVT) or long QT syndrome (LQTS) (Table 84.5). Other arrhythmias that may lead to syncope are bradyarrhythmias such as sinus node dysfunction and high-grade second- or third-degree atrioventricular (AV) block. Syncope may also be caused by cardiac obstructive lesions, such as critical aortic stenosis, or coronary artery anomalies, such as an aberrant left coronary artery arising from the right sinus of Valsalva. Patients with primary pulmonary hypertension or Eisenmenger syndrome may also experience syncope. In all the obstructive forms of syncope, exercise increases the likelihood of an episode because the obstruction interferes with the ability of the heart to increase cardiac output in response to exercise.

**Noncardiac causes** of loss of consciousness include epilepsy, basilar artery migraine, hysterical syncope, and psychogenic nonepileptic seizures (see Table 84.1). Occasionally, patients with narcolepsy may present with syncope. Hypoglycemia and hyperventilation may also present as syncope.

**Table 84.1** Noncardiac Causes of Syncope

<p><b>REFLEX VASODEPRESSOR SYNCOPE</b>            Neurocardiogenic (vasovagal)            Emotion (seeing blood)            Pain (needle phobia)            Reflex asystolic syncope (pallid breath-holding)</p> <p><b>MISCELLANEOUS SITUATIONAL REFLEX</b>            Tussive            Sneeze            Exercise, after exercise            Swallowing            Stretching            Defecation            Micturition            Hair grooming            Valsalva (increased intrathoracic pressure)            Trumpet playing            Weightlifting            Breath-holding spells (cyanotic)</p> <p><b>SYSTEMIC ILLNESS</b>            Hypoglycemia            Anemia            Infection            Hypovolemia, dehydration            Adrenal insufficiency            Narcolepsy, cataplexy            Pulmonary embolism            Pheochromocytoma            Mastocytosis            Ruptured ectopic pregnancy</p>	<p><b>CENTRAL NERVOUS SYSTEM</b>            Seizure (atonic, absence, myoclonic-astatic)            Hyperekplexia            Stroke, transient ischemic attack            Friedreich ataxia            Subarachnoid hemorrhage</p> <p><b>OTHER NEUROLOGIC</b>            Dysautonomia            Myotonic dystrophy            Kearns-Sayre syndrome            Congenital myasthenia gravis            Basilar artery migraine            Arnold Chiari malformation</p> <p><b>DRUG EFFECTS</b>  <math>\beta</math>-Blocking agents            Vasodilating agents            Opiates            Sedatives            Diuretics            Anticonvulsant agents            Antihistamines            Antidepressant agents            Anxiolytic agents            Drugs of abuse            Insulin, oral hypoglycemic agents            Carbon monoxide</p> <p><b>OTHER ETIOLOGIES</b>            Carotid sinus sensitivity            Subclavian steal            Panic attack, anxiety            Conversion disorder</p>
---	---

**Table 84.2** Comparison of Clinical Features of Syncope and Seizures

FEATURES	SYNCOPE	SEIZURES	FEATURES	SYNCOPE	SEIZURES
Relation to posture	Common	No	Urinary incontinence	Rare	Common
Time of day	Diurnal	Diurnal or nocturnal	Tongue biting	No	Common with convulsive seizures
Precipitating factors	Emotion, injury, pain, crowds, heat, exercise, fear, dehydration, coughing, micturition, venipuncture, prolonged standing	Sleep loss, drug/alcohol withdrawal, illness, medication nonadherence	Postictal confusion	Rare	Common
Skin color	Pallor	Cyanosis or normal	Postictal headache	No	Common
Diaphoresis	Common	Rare	Focal neurologic signs	No	Occasional
Aura or premonitory symptoms	Often minutes or longer, but can be very brief	Brief	Cardiovascular signs	Common to have low blood pressure and heart rate during event; cardiovascular exam may be completely normal after event unless there is an underlying cardiac disorder	Rare
Convulsion	Rare	Common	Abnormal findings on EEG	Rare (generalized slowing may occur during the event)	Common
Other abnormal movements	Minor irregular twitching	Rhythmic jerks			
Injury	Rare	Common (with convulsive seizures)			

From Winkel D, Cassimatis D. Episodic impairment of consciousness. In: Jankovic JM, Mazziotta JC, Pomeroy SL, Newman NJ, eds. *Bradley and Daroff's Neurology in Clinical Practice*, 8th ed. Philadelphia: Elsevier; 2021.

Table 84.3		Syncope and Dizziness			
	VERTIGO	PRESYNCOPE	DISEQUILIBRIUM	LIGHTHEADEDNESS	
Patient complaint	"My head is spinning." "The room is whirling."	"I feel I might pass out." "I feel faint." "I feel like blacking out."	"I feel unsteady." "My balance is off."	"I feel dizzy." "I feel disconnected, drugged."	
Associated features	Motion, swaying, spinning, nystagmus	Syncope: loss of postural tone, brief loss of consciousness Situational	Poor balance No vertigo or ataxia	Anxiety, hyperventilation, paresthesias, respiratory alkalosis, panic attacks	
Usual cause	Vestibular disorders	Impaired cerebral perfusion	Sensory and/or central neurologic dysfunction	Decreased venous return	
Key differential diagnoses	Peripheral (labyrinthine-cochlear) vs central neurologic disorder	Neurocardiogenic (vagal) vs cardiac syncope vs neuropsychiatric syncope	Sensory deficit vs central neurologic disease	Anxiety/depression vs hyperventilation vs medication effects	

Adapted from Cohen G. Syncope and dizziness. In: Kliegman RM, Lye PS, Bordini BJ, et al., eds. *Nelson Pediatric Symptom-Based Diagnosis*; 2018: Table 6.1, p. 84.

Table 84.4		Causes of Cardiovascular Syncope: Potentially Fatal If Unrecognized	
<b>ARRHYTHMIAS</b> <b>Bradyarrhythmias</b> 1. Sinus node dysfunction (especially in patients with congenital heart defects) 2. Atrioventricular block (congenital or acquired; Lyme, Fabry, Chagas diseases) 3. Kearns-Sayre syndrome 4. Pacemaker malfunction  <b>Tachyarrhythmias</b> 1. Supraventricular a. Wolff-Parkinson-White syndrome b. Supraventricular tachycardia/atrial arrhythmias (especially in patients with congenital heart defects) 2. Ventricular: ventricular tachycardia/torsades/ventricular fibrillation a. Channelopathies • Long QT syndromes • Catecholaminergic polymorphic ventricular tachycardia • Brugada syndrome • Short QT syndrome b. Drug induced c. Idiopathic • Ventricular fibrillation • Ventricular tachycardia from outflow tract		<b>STRUCTURAL/FUNCTIONAL HEART DISEASE</b> <b>Cardiomyopathy</b> 1. Hypertrophic cardiomyopathy 2. Dilated cardiomyopathy 3. Arrhythmogenic right ventricular dysplasia 4. Left ventricular noncompaction  <b>Coronary Anomalies</b> 1. Anomalous origin 2. Kawasaki disease 3. Multisystemic inflammatory syndrome in children (MIS-C) secondary to SARS-CoV-2  <b>Valvar Aortic Mitral or Pulmonary Stenosis</b> <b>Takotsubo Disease</b> <b>Acute Myocarditis</b> <b>Congenital Heart Disease (Repaired and Unrepaired)</b> <b>Pulmonary Hypertension, Pulmonary Embolus</b> <b>Aortic Dissection (Marfan Syndrome)</b> <b>Cardiac Masses (Myxoma, Rhabdomyoma, Thrombus)</b> <b>Eisenmenger Syndrome</b>	

From MacNeill E, Vashist S. Approach to syncope and altered mental status. *Pediatr Clin N Am*. 2013;60:1083-1106.

## EVALUATION

The most important goal in the evaluation of the new patient with syncope is to diagnose life-threatening causes of syncope so that these causes can be managed and more severe outcomes avoided. Many patients presenting with sudden cardiac arrest caused by conditions such as LQTS will have previously experienced an episode of syncope, so the presentation with syncope is an opportunity to prevent sudden death.

The most important tool in evaluation of syncope is a careful **personal and family history**. The characteristics of cardiac syncope differ significantly from benign causes of syncope such as neurocardiogenic syncope (Table 84.6). Several red flags can be identified that should lead the clinician to suspect that the mechanism is a life-threatening cardiac cause rather than simple fainting (Table 84.7). The occurrence *during* exercise suggests an arrhythmia or an outflow tract or coronary artery obstruction. Noncardiac (postexercise) syncope is seen in athletes *after* a strenuous workout or competition and has no associated cardiac features. The occurrence of syncope resulting in injury also suggests an arrhythmia, as it indicates a sudden onset with a lack of adequate prodromal symptoms. The occurrence of syncope while recumbent would be quite unusual in a patient with neurocardiogenic syncope and therefore suggests a cardiac or neurologic cause. Occasionally, a patient with syncope caused by a tachyarrhythmia will report the sensation of a racing heart before the event, but this is often not present.

A careful family history is essential in evaluation of syncope. Specifically, if there are first-degree relatives with inherited syndromes, such as LQTS, CPVT, or HCM, this should lead to more specific evaluation of the patient. If relatives died suddenly at a young age without a clear and convincing cause, inherited cardiac arrhythmias or cardiomyopathies should also be suspected. Other questions that may increase suspicion for an inherited arrhythmia include family history of congenital deafness, unexplained recurrent syncope, poorly controlled seizures, single-vehicle car accidents, or drowning events.

Patients with a history of heart disease requiring surgical repair may have causes of syncope that are specific to their repair. Sinus node dysfunction is common after the Senning or Mustard procedure for transposition of the great vessels or after the Fontan procedure for single-ventricle palliation. VT may be seen after repair of tetralogy of Fallot. A patient with a history of repair of a ventricular septal defect or an AV canal defect should be evaluated for the late occurrence of AV block. Patients with an implanted pacemaker should be evaluated for pacemaker lead failure.

The **physical examination** may also offer clues (see Table 84.7) that point toward cardiac syncope. Patients with HCM or aortic stenosis may have a prominent cardiac impulse and/or an ejection murmur. A patient with primary pulmonary hypertension will have a displaced apical impulse, with a loud and single second



**Table 84.5** Primary Electrical Abnormalities: Features, ECG, and Treatment

PRIMARY ELECTRICAL ABNORMALITIES	FEATURES	ECG	TREATMENT
LQTS: Romano-Ward, Jervell-Lange-Nielsen, acquired	<ul style="list-style-type: none"> <li>Familial genetic or acquired disorders</li> <li>Ion channel pathologic gene variant (~17 genes)*</li> <li>Presents in torsades de pointes</li> <li>Romano-Ward is most common inherited</li> <li>LQTS Jervell-Lange-Nielsen has congenital deafness</li> </ul>	<ul style="list-style-type: none"> <li>Prolonged QT measured from the onset of the Q wave to the end of the T wave in lead II</li> <li>Varies with HR but &gt;0.44 in men, &gt;0.46 in children and women for HR 50-90 beats/min is prolonged</li> <li>Torsades de pointes can occur</li> <li>Can deteriorate from polymorphic ventricular tachycardia to ventricular fibrillation</li> </ul>	<ul style="list-style-type: none"> <li>β-Blocker therapy</li> <li>Recommendations on exercise intensity by a cardiologist</li> <li>ICD if β blockers fail</li> </ul>
Brugada syndrome	<ul style="list-style-type: none"> <li>Inherited autosomal dominant arrhythmogenic syndrome characterized by life-threatening ventricular arrhythmias</li> <li>Pathologic gene variant in SCN5A and 13 other genes</li> </ul>	<ul style="list-style-type: none"> <li>ECG abnormalities are from repolarization and depolarization abnormalities</li> <li>Coved-type ST-segment elevations in the right precordial leads</li> <li>J wave amplitude ≥2 mm followed by a negative T wave</li> </ul>	<ul style="list-style-type: none"> <li>Placement of ICD</li> </ul>
Wolff-Parkinson-White	<ul style="list-style-type: none"> <li>Owing to one or more reentrant pathways inducing SVT or atrial fibrillation</li> <li>Up to 14% associated with malignant tachycardias</li> <li>Malignant arrhythmias from short reentrant pathway repolarization or multiple pathways</li> </ul>	<ul style="list-style-type: none"> <li>Short PR interval</li> <li>Delta waves present</li> </ul>	<ul style="list-style-type: none"> <li>Undergo EPS and ablation</li> </ul>
Dilated cardiomyopathy: ventricular tachycardia/fibrillation	<ul style="list-style-type: none"> <li>Cardiac dilation and systolic dysfunction</li> <li>Inherited or acquired</li> <li>Lamin AC pathologic gene variant a common cause of DCM and SCD</li> </ul>	<ul style="list-style-type: none"> <li>Marked LVH</li> <li>Poor R-wave progression</li> <li>Left atrial enlargement</li> <li>Right axis deviation</li> </ul>	<ul style="list-style-type: none"> <li>Permanent pacemaker and ICD placement</li> </ul>
Catecholamine-exercise: ventricular tachycardia	<ul style="list-style-type: none"> <li>Ventricular ectopy induced by exercise or emotional stress</li> <li>Variant in gene that encodes Ca-mediated sarcoplasmic fibers</li> <li>Lethal in 30–50% if left untreated</li> </ul>	<ul style="list-style-type: none"> <li>Preexercise ECG is usually normal, stress testing recommended</li> <li>ECG with exercise</li> <li>Nonsustained wide ventricular tachycardia</li> </ul>	<ul style="list-style-type: none"> <li>β-Blocker therapy</li> <li>Recommendations on exercise intensity by a cardiologist</li> <li>ICD if β blockers fail</li> </ul>

DCM, Dilated cardiomyopathy; EPS, electrophysiology study; HR, heart rate; ICD, implantable cardioverter defibrillator; LQTS, long QT syndrome; LVH, left ventricular hypertrophy; SCD, sudden cardiac death; SVT, supraventricular tachycardia.

\*Major genes: *KCNQ1*, *KCNH2*, *SCN5A* in ~75% cases.

Modified from Ellison S. Sudden cardiac death in adolescents. *Prim Care Clin Office Pract.* 2015;42:57-76.

**Table 84.6** Differentiating Features for Causes of Syncope

<p><b>NEUROCARDIOGENIC</b></p> <p>Symptoms after prolonged motionless standing, sudden unexpected pain, fear, or unpleasant sight, sound, or smell; pallor</p> <p>Syncope in a well-trained athlete after exertion (without heart disease)</p> <p>Situational syncope during or immediately after micturition, cough, swallowing, or defecation</p> <p>Syncope with throat or facial pain (glossopharyngeal or trigeminal neuralgia)</p>
<p><b>ORGANIC HEART DISEASE (PRIMARY ARRHYTHMIA, OBSTRUCTIVE HYPERTROPHIC CARDIOMYOPATHY, PULMONARY HYPERTENSION)</b></p> <p>Brief sudden loss of consciousness, no prodrome, history of heart disease</p> <p>Syncope while sitting or supine</p> <p>Syncope with exertion</p> <p>History of palpitations</p> <p>Family history of sudden death</p>
<p><b>NEUROLOGIC</b></p> <p>Seizures: preceding aura, postevent symptoms lasting &gt;5 min (includes postictal state of decreased level of consciousness, confusion, headache, or paralysis)</p> <p>Migraine: syncope associated with antecedent headaches with or without aura</p>
<p><b>OTHER VASCULAR</b></p> <p>Carotid sinus: syncope with head rotation or pressure on the carotid sinus (as in tumors, shaving, tight collars)</p> <p>Orthostatic hypotension: syncope immediately on standing, especially after prolonged bed rest</p>
<p><b>DRUG INDUCED</b></p> <p>Patient is taking a medication that may lead to long QT syndrome, orthostasis, or bradycardia</p>
<p><b>PSYCHIATRIC ILLNESS</b></p> <p>Frequent syncope, somatic complaints, no heart disease</p>

From Cohen G. Syncope and dizziness. In: Kliegman RM, Lye PS, Bordini BJ, et al., eds. *Nelson Pediatric Symptom-Based Diagnosis*. Philadelphia: Elsevier; 2018: Table 6.4.

**Table 84.7** Red Flags in Evaluation of Patients with Syncope

Syncope with activity or exercise or supine  
 Syncope not associated with prolonged standing  
 Syncope precipitated by loud noise or extreme emotion  
 Absence of presyncope or lightheadedness  
 Family history of syncope, drowning, sudden death, familial ventricular arrhythmia syndromes,\* cardiomyopathy  
 Syncope requiring CPR  
 Injury with syncope  
 Anemia  
 Other cardiac symptoms  
 Chest pain  
 Dyspnea  
 Palpitations  
 History of cardiac surgery  
 History of Kawasaki disease  
 Implanted pacemaker  
 Abnormal physical examination  
 Murmur  
 Gallop rhythm  
 Loud and single second heart sound  
 Systolic click  
 Increased apical impulse (tachycardia)  
 Irregular rhythm  
 Hypotension or hypertension  
 Digital clubbing  
 Cyanosis

\*Long QT syndrome, Brugada syndrome, catecholamine polymorphic ventricular tachycardia, arrhythmogenic cardiomyopathy.

heart sound, with an ejection click or murmur of pulmonary insufficiency. Patients with repaired congenital heart disease will have obvious scars on their chest and abdomen from prior cardiac surgery or device implantation.

All patients presenting with syncope *should* have an **electrocardiogram**, looking primarily for QT interval prolongation, preexcitation, ventricular hypertrophy, T-wave abnormalities, and conduction abnormalities. Additional tests that may be needed include echocardiography, exercise testing, cardiac MRI, or 24-hour Holter monitoring. In patients for whom there is a strong suspicion of a paroxysmal arrhythmia, an insertable cardiac monitor (loop recorder) may offer the most effective means of diagnosis. Additional tests may be useful to look for anemia, hypoglycemia, drugs of abuse, and other etiologies noted in [Table 84.1](#) as determined by the history and physical examination.

## TREATMENT

Therapy for vasovagal syncope includes avoiding triggering events (if possible), fluid and salt supplementation, and if needed, specific therapies targeting the orthostatic hypotension (i.e., midodrine) ([Table 84.8](#)). Immediately after the event, the patient should remain supine until symptoms abate to avoid recurrence.

**Treatment for cardiac causes of syncope will be determined by the diagnosis.** If supraventricular tachycardia (SVT) is found, then a catheter ablation may be indicated. If bradycardia from sinus node dysfunction or AV block is the cause of the syncope, a pacemaker may be warranted. Patients with syncope from medically refractory malignant arrhythmias, as may be seen in HCM, LQTS, arrhythmogenic cardiomyopathy, or CPVT, require an implantable cardioverter-defibrillator. Patients with structural heart disease (valvular disease or coronary artery anomalies) should be referred for surgery.

Visit Elsevier eBooks+ at [eBooks.Elsevier.com](http://eBooks.Elsevier.com) for Bibliography.

**Table 84.8** Treatment of Neurocardiogenic Syncope/Vasovagal Syncope (V-VS)

**Patient education on the diagnosis and prognosis of V-VS is recommended.**

In all patients with the common faint or V-VS, an explanation of the diagnosis, education targeting awareness of and possible avoidance of triggers (prolonged standing, warm environments, coping with dental and medical settings), and reassurance about the benign nature of the condition should be provided.

**Physical counterpressure maneuvers can be useful in patients with V-VS who have a sufficiently long prodromal period.**

Patients with a syncope prodrome should be instructed to assume a supine position to prevent a faint and minimize possible injury. In patients with a sufficiently long prodrome, physical counter-maneuvers (leg crossing, limb and/or abdominal contraction, squatting, isometric handgrip, arm tensing) are a core management strategy.

**Midodrine is reasonable in patients with recurrent V-VS with no history of hypertension, heart failure, or urinary retention.**

Midodrine is a prodrug that is metabolized to desglymidodrine, which is a peripherally active  $\alpha$ -agonist used to ameliorate the reduction in peripheral sympathetic neural outflow responsible for venous pooling and vasodepression in V-VS.

**The usefulness of orthostatic training is uncertain in patients with frequent V-VS.**

There are 2 main methods of orthostatic training. Patients undergo repetitive tilt-table tests in a monitored setting until a negative tilt-table test occurs and then are encouraged to stand quietly against a wall for 30-60 min daily, or patients simply stand quietly against a wall at home for a prolonged period daily.

**Fludrocortisone might be reasonable for patients with recurrent V-VS and inadequate response to salt and fluid intake, unless contraindicated.**

Fludrocortisone has mineralocorticoid activity resulting in sodium and water retention and potassium excretion, which results in increased blood volume. Serum potassium level should be monitored because of potential drug-induced hypokalemia. POST II (Prevention of Syncope Trial II) reported a marginally insignificant 31% risk of reduction in adults with moderately frequent V-VS, which was significant in patients after a 2-wk dose stabilization period.

**Encouraging increases in salt and fluid intake may be reasonable in selected patients with V-VS, unless contraindicated.**

Evidence for the effectiveness of salt and fluid intake for patients with V-VS is limited. Nonetheless, in patients with recurrent V-VS and no clear contraindication, such as a history of hypertension, renal disease, heart failure, or cardiac dysfunction, it may be reasonable to encourage ingestion of 2-3 L of fluid per day and a total of 6-9 g (100-150 mmol) of salt per day, or about 1-2 heaping teaspoonfuls. The long-term balance of risks and benefits of a strategy of increasing salt and water intake is unknown.

**In selected patients with V-VS, it may be reasonable to reduce or withdraw medications that cause hypotension when appropriate.**

A careful examination of the patient's history for medications that may lower blood pressure (hypotensive agents) should be performed. Care should be taken to withdraw or reduce medications only when safe to do so and in conjunction with the prescribing healthcare provider.

**In patients with recurrent V-VS, a selective serotonin reuptake inhibitor might be considered.**

Serotonin has central neurophysiologic effects on blood pressure and heart rate and acutely induces syncope during tilt-table testing.

Modified from Shen WK, Sheldon RS, Benditt DG, et al. 2017 ACC/AHA/HRS guideline for the evaluation and management of patients with syncope: A report of the American College of Cardiology/American Heart Association Task Force on Clinical Practice Guidelines and the Heart Rhythm Society [published correction appears in *Circulation*. 2017 Oct 17;136(16):e271-e272]. *Circulation*. 2017;136(5):e60-e122.

## 84.1 Postural Tachycardia Syndrome

Gisela G. Chelimsky and Thomas Chelimsky

Several complex and interrelated mechanisms allow humans to stand despite the pull of gravity on the cerebral circulation. In the supine posture, most blood sits in the thoracic cavity, with 25–30% of total volume in the splanchnic vasculature. When an adult stands up, about 500 mL of blood shifts to the lower extremities and to the splanchnic vasculature. The decrease in hydrostatic pressure in the carotid sinuses produces vasoconstriction in the peripheral vessels mediated by sympathetic outflow and in the splanchnic vasculature. This action is mediated by norepinephrine, adenosine triphosphate (ATP), and neuropeptide Y. The muscles in the legs and gluteal area work as a pump when the individual is upright and during exercise to help return the blood to the heart.

Understanding postural tachycardia syndrome, or postural orthostatic tachycardia syndrome (POTS), requires an understanding of other orthostatic conditions. Many adolescents have lightheadedness or tunnel vision in the first few seconds of assuming the upright posture. This phenomenon, termed **initial orthostatic hypotension (IOH)**, can lead to *syncope*, but usually is very short, perhaps 30–60 seconds, and occurs primarily with active standing. Blood pressure (BP) may drop 30% of baseline at 10–20 seconds of standing and may be associated with tachycardia. BP returns to baseline in 30–60 seconds, whereas heart rate (HR) typically returns to a new, higher value above the baseline when supine. Because of its transient rapidity, IOH escapes detection with standard BP machines and requires beat-to-beat monitoring of BP and HR. The clinical diagnosis requires a careful history. The symptoms usually happen after prolonged recumbence and when the individual stands. The person complains of lightheadedness and “blacking out” or tunnel vision 5–10 seconds after standing.

In contrast to IOH, **orthostatic hypotension (OH)** is defined as a *sustained* decrease in the systolic BP of >20 mm Hg or diastolic BP >10 mm Hg in the first 3 minutes of upright tilt. OH rarely occurs in children. The patient often has no orthostatic symptoms while upright despite very low pressures (Fig. 84.1). This distinguishes OH from POTS, which *requires* symptoms while upright. A third orthostatic disorder, **reflex syncope** (i.e., vasovagal or neurally mediated), is defined as relatively sudden change in autonomic

nervous system activity that leads to a sudden decrease in BP, HR, and cerebral perfusion (Fig. 84.2).

In children, POTS is defined as a syndrome characterized by HR increase of >40 beats/min during the first 10 minutes of upright tilt test without associated hypotension, (>30 beats/min if >19 years old) while replicating orthostatic symptoms that occur when upright (Fig. 84.3). Improvement of symptoms in the supine position is expected. The diagnosis of POTS also requires *daily* orthostatic symptoms. In patients with POTS, the larger decline in cardiac stroke volume appears to be the primary trigger for the tachycardia, which may result from various pathophysiologic mechanisms, such as the following:

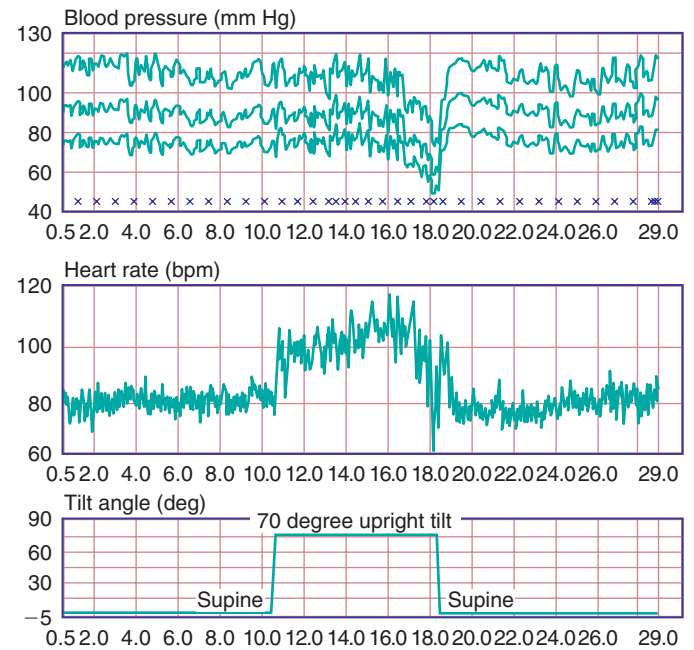


Fig. 84.2 Example of neurally mediated syncope.

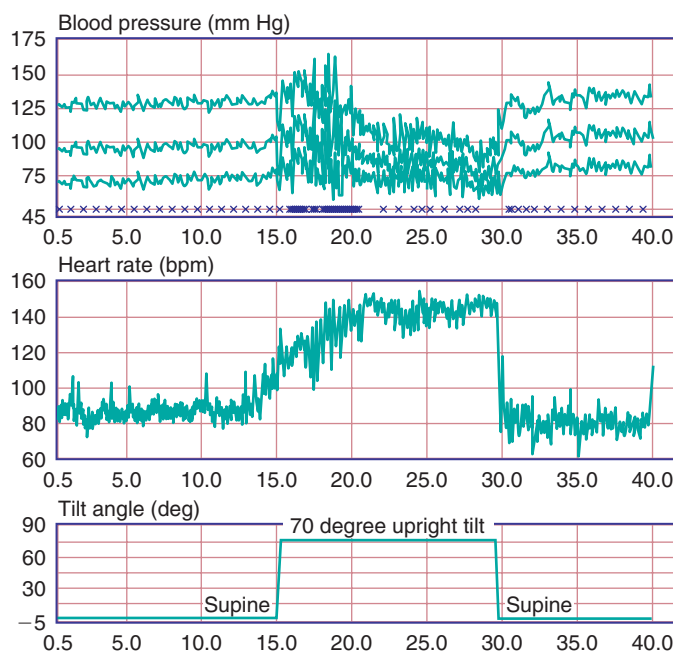


Fig. 84.1 Example of orthostatic hypotension.

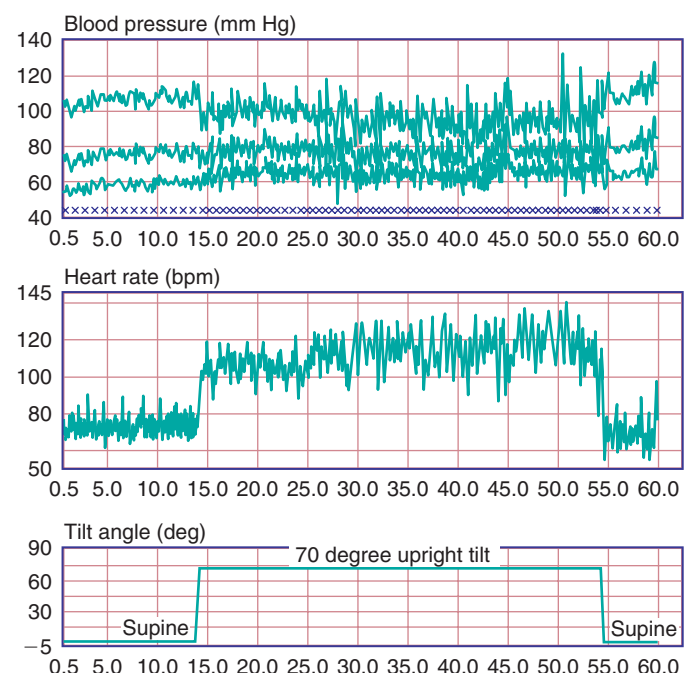


Fig. 84.3 Example of postural tachycardia syndrome.

- **Neuropathic POTS**, an autonomic neuropathy impairing sympathetic vasoconstriction in the lower extremities or splanchnic circulation, decreasing stroke volume and consequently resulting in tachycardia.
- **Hypovolemic POTS**, a common contributor, often related to decreased aldosterone with reduced renin activity, resulting in tachycardia caused by decreased blood volume.
- **Hyperadrenergic POTS**, with norepinephrine levels rising threefold to fourfold in the standing position (norepinephrine normally doubles on standing), which may occur in norepinephrine transporter deficiency or strong stimulation of central baroreflex responses.
- **Autoimmune POTS**, typically assumed based on a postviral chronology, but seldom proven; such a form may or may not exist. The anti-ganglionic antibody is almost never elevated in these patients. Nonetheless, a group of patients report that intravenous immunoglobulin (IVIG) is helpful to them. Whether they benefit from the increase in intravascular volume or an actual immune effect is unknown.

Some patients have orthostatic symptoms while upright but do not meet criteria for syncope, OH, or POTS. This group has **orthostatic intolerance not otherwise specified (OI-NOS)**.

## CLINICAL PRESENTATION

The symptoms that intrinsically relate to POTS are those that are replicated during upright tilt testing or standing. Many other symptoms also occur in patients with POTS, fitting the description of comorbid conditions, but not reproduced while upright. A patient may have nausea while upright associated with lightheadedness and have a diagnosis of POTS. Another patient may complain of nausea on awakening and have POTS, but have no nausea while upright. In the former patient the nausea is a symptom of POTS itself, whereas in the latter nausea is an associated condition. The symptoms that often directly relate to POTS include lightheadedness, orthostatic nausea, orthostatic headaches, fatigue, tunnel vision, and brain fog. About 20–30% of pediatric patients with POTS will also have syncope (Fig. 84.4). Other comorbid conditions frequently occur in these patients but are not caused by POTS (i.e., not an orthostatic phenomenon). These comorbidities include (1) sleep issues, usually delayed onset of sleep, frequent awakening, and not feeling refreshed in the morning; (2) joint hypermobility and aches in different parts of the body; (3) abdominal pain; (4) headaches and migraines; (5) nausea and vomiting; (6) depression and

anxiety; and (7) Raynaud-like symptoms and other, less frequent problems (e.g., urinary symptoms).

The association between upper gastrointestinal (GI) symptoms and POTS is well described. Nausea, early satiety, and bloating are described in association with POTS. Such GI symptoms relate mechanistically to POTS only when they occur in the upright position. Many patients with POTS have comorbid GI symptoms that are not a consequence of the orthostatic challenge. Therefore only the GI symptoms replicated during tilt testing will improve with treatment aimed at orthostasis. Patients with POTS have changes in the electrical activity of the stomach while upright, which may explain the upright GI symptoms; they usually do not have delayed gastric emptying. The emptying is either normal or accelerated, implying that the cause of nausea is not gastroparesis.

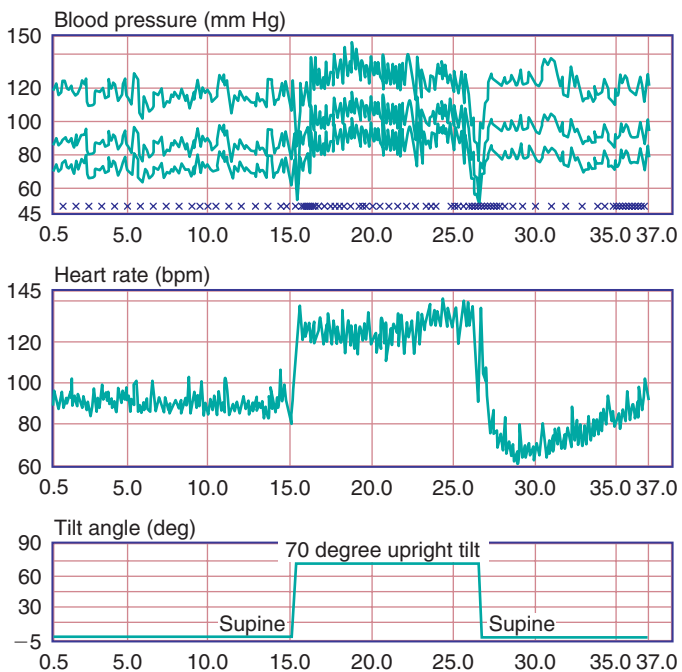
Patients with **hypermobility Ehlers-Danlos syndrome (h-EDS)** may have POTS. Typically, such individuals have more migraines and syncope. Joint hypermobility itself in *adults* is associated with more autonomic complaints such as syncope, presyncope, palpitations, chest discomfort, fatigue, and heat intolerance. Those with hypermobility have more frequent positive tilt tests than healthy controls. Interestingly, in children, joint hypermobility does not influence the number of comorbidities or autonomic disorders. Similarly, those with pediatric chronic overlapping pain conditions with or without POTS have the same comorbidities, suggesting that neither POTS nor hypermobility are drivers of the comorbidities or the chronic overlapping pain condition, but rather another associated disorder (see Chapter 212).

## DIAGNOSIS

*Orthostatic intolerance* is clinically diagnosed by detailed history attending specifically to symptoms as they relate to body position. Dizziness that begins in the supine position cannot be a manifestation of orthostatic intolerance. Furthermore, those symptoms that do develop while upright should improve or resolve when supine. Importantly, the history should include a detailed description of current physical exercise habits, with frequency, type, and endurance. One should also assess sleep, diet (mainly evaluating intake of salt), fluid intake, and other comorbidities. The physical examination is also important and should include a cardiac and neurologic evaluation with supine and standing BP and HR. Examination of the extremities may provide information about venous pooling, such as mild edema or reddish-purple discoloration when sitting or standing. Cold, clammy hands can signify excess sympathetic activity.

To diagnose POTS the patient needs to undergo a *head-up tilt test for at least 10 minutes*. It is important to have the patient supine for at least 20 minutes before the tilt test. POTS can also be assessed by a standing test, measuring BP and HR at 1, 3, 5, and 10 minutes standing, but to have a reliable test similar to the tilt test, the patient needs to be supine for 1 hour before standing. The HR increase with active standing is typically less than with tilt, because the lower-extremity muscle pump is less active in tilt. The diagnosis of POTS requires replication of the day-to-day symptoms while upright, not just the increased HR while upright. A small but significant proportion of healthy teenagers in school will have an increased HR that may be diagnosed as POTS but will not have associated symptoms.

Other tests may include electrocardiogram, echocardiogram, and Holter monitor when there is concern of a primary cardiac cause of tachycardia or if there is a need to determine if symptoms correlate with tachycardia (see Chapter 84). Supine and standing plasma catecholamines help confirm the diagnosis of POTS, as one expects to see either the normal doubling of norepinephrine levels from supine to standing or a tripling with hyperadrenergic POTS. Beyond tilt table testing, autonomic testing will also include cardiac response to deep breathing (checking cardiac parasympathetic function), Valsalva maneuver (checking cardiac sympathetic and parasympathetic functions and vasomotor sympathetic function), and quantitative axon reflex sudomotor test (to assess for an autonomic neuropathy and vasomotor sympathetic dysfunction).



**Fig. 84.4** Example of postural tachycardia syndrome (POTS) followed by a neurally mediated syncope.



**Table 84.9** First-Line Medications in Treatment of Postural Tachycardia Syndrome (POTS)

DRUG	MECHANISM OF ACTION	SIDE EFFECTS	TREATMENT GUIDELINES
Fludrocortisone	Low dose: sensitizes $\alpha$ -receptors Higher doses: mineralocorticoid effect	Peripheral edema, headache, irritability, hypokalemia, hypomagnesemia, acne	Monitor basic metabolic panel and magnesium
Midodrine	$\alpha_1$ -Agonist; produces vasoconstriction	Scalp tingling, urinary retention, goosebumps, headache, supine hypertension	Monitor supine blood pressure 30-60 min after dose
Metoprolol succinate/ tartrate	$\beta$ Blocker	Worsening of asthma, dizziness, fatigue	Use with caution in asthma If fatigue is severe, use at bedtime
Propranolol	Nonselective $\beta$ blocker	Bradycardia, gastrointestinal symptoms, lightheadedness, sleepiness, hypotension, syncope	Use with caution in diabetes and asthma
Pyridostigmine	Peripheral acetylcholinesterase inhibitor that increases synaptic acetylcholine in autonomic ganglia and at peripheral muscarinic receptors	Symptoms of excessive cholinergic activity (diarrhea, urinary incontinence, salivation)	Very useful if patient has POTS and constipation Use with caution in asthma Contraindicated in urinary or bowel obstruction

Additional studies depend on the clinical symptoms and include morning cortisol (to rule out Addison disease) and thyroid studies if the patient has unusually severe fatigue or is not responsive to usual treatment. Serum tryptase and urine methylhistamine are tested if mast cell activation disorder is suspected, based on a history of flushing during the spells. If an autoimmune cause for the POTS is a concern, antibodies such as voltage-gated potassium channel and acetylcholine receptor antibodies could be checked, but this etiology for POTS is being questioned. Patients rarely (<5 in 1,000) benefit from IVIG; if this mechanism is really causing POTS, such patients should experience peak benefit at about 10 days after the infusion rather than immediately (which may simply reflect increasing intravascular volume). If the patient has hypertension, plasma and urine metanephrines should be measured to test for a pheochromocytoma. In addition, if symptoms are associated with perimenstrual timing, an assessment of sex hormone axis is helpful, with occult polycystic ovarian syndrome or low testosterone levels sometimes present.

## MANAGEMENT

The core of POTS management is **nonpharmacologic**. Medications will be of little benefit without these measures being undertaken first. The best measure for treating POTS is a regular **aerobic exercise** program. Given the combination of orthostatic symptoms and severe deconditioning found in most patients, the exercise program must be introduced in a slow, progressive manner. Patients with POTS typically have moderate to severe exercise intolerance, and compared with sedentary healthy controls, have decreased peak oxygen uptake. After 3 months of exercise, POTS patients have an increase in cardiac mass and size, blood volume, and peak oxygen uptake, as reflected in a better exercise performance. The tachycardia in POTS is caused by a decrease in stroke volume and not an intrinsic circulatory problem. An exercise program should start with water exercises combined with recumbent aerobic activities (recumbent bike or rowing machine), slowly increasing the exercise time to 45 minutes at least 5 times per week. When

tolerance increases, patients can advance to more upright aerobic activities. These aerobic activities need to be combined with light core- and limb-strengthening exercises.

Exercise usually cannot be performed without simultaneous expansion of the intravascular volume. To this end, encourage teenagers to drink >80 oz of fluids daily and to add 2 g of salt to their usual diet in both the morning and the early afternoon. **Salt supplementation** increases plasma and blood volume, improves orthostatic tolerance, and decreases baroreflex sensitivity. Salt also reduces nitric oxide production, resulting in less vasodilation. Trial and error of different salt formulations can help to identify the best method for each individual patient. Salt tablets are simple and inexpensive but may make some people nauseous. An alternative is simply to obtain empty capsules on the internet and fill them with table salt. A “0” size capsule contains about 400 mg of salt.

The content of sodium in the body determines the extracellular fluid volume that in turn dictates orthostatic tolerance. Patients with POTS who have lower urinary sodium excretion have more symptoms than those with higher urinary sodium (>123 mmol/24 hours), and they often respond less well to salt supplementation. Those with severe orthostatic symptoms either in the morning or before sports should drink 16 oz of plain water, which is known to increase sympathetic response mainly in individuals with baroreflex dysregulation. The effect starts soon after drinking the water and lasts for about 1 hour. Compression garments may also be useful. These can be thigh or waist high; the waist-high compression garments may not be tolerated.

**Medications** can be added when the nonpharmacologic interventions are not sufficient. Different centers use different strategies, and there is no single correct evidence-based approach. [Table 84.9](#) addresses first-line medications that primary care physicians could use; only the most common side effects are included.

Visit Elsevier eBooks+ at [eBooks.Elsevier.com](http://eBooks.Elsevier.com) for Bibliography.

## Chapter 85

## Shock

Scott L. Weiss, Pierre Tissières, and Mark J. Peters

*Shock* is an acute, life-threatening process of cardiovascular insufficiency characterized by inadequate delivery of oxygen and nutrients (e.g., glucose) by the circulatory system to meet the metabolic demands of vital organs that results in cellular dysfunction and injury. The initial imbalance between oxygen/nutrient delivery through the circulation and oxygen/nutrient consumption within organ systems can be compensated for by increasing tissue oxygen extraction. However, with further limitations in delivery of oxygen and nutrients as the shock state progresses, energy production gradually shifts from aerobic metabolism to less efficient anaerobic metabolic pathways, and a cellular bioenergetic crisis can ensue. If this process is not corrected, numerous adverse vascular, inflammatory, metabolic, cellular, and endocrine responses contribute to a state of **multiple organ dysfunction syndrome (MODS)**, cardiovascular collapse, and death.

It is important to recognize that the shock state can be present *before* the onset of hypotension, especially in children, and that inadequate cellular metabolism of oxygen and nutrients (not just impaired delivery) contributes to the clinical manifestations and outcomes observed in patients with shock. Therefore it is necessary to recognize early symptoms and signs of impaired circulation, including tachycardia, altered mental status (e.g., irritability, confusion, lethargy), tachypnea (often secondary to acidemia), abnormal capillary refill time, diminished peripheral pulses, and oliguria, in combination with metabolic markers such as acidemia, hyperlactatemia, and low central venous oxygen saturation. Hypotension, when present, is also important to recognize, but children—especially infants and preschool-age children—with *compensated* shock may be able to maintain a normal blood pressure (BP) for age until the later phases of shock. When hypotension is present, the child has reached a state of *uncompensated shock* and is at risk of irreversible organ damage and death without immediate treatment.

### EPIDEMIOLOGY

Shock occurs in approximately 2% of all hospitalized infants, children, and adults in developed countries, and the mortality rate varies substantially depending on the etiology and clinical circumstances. Of patients who do not survive, many do not die in the initial acute phase of shock, but rather because of associated complications and MODS. MODS is defined as dysfunction in two or more organ systems; the presence of MODS in patients with shock substantially increases the probability of death. In 2017, there were an estimated 20.3 million cases of sepsis, with 2.9 million deaths, worldwide among children younger than 5 years and 4.9 million cases of sepsis, with 454,000 deaths, among older children and adolescents. In the United States, over 70,000 children are hospitalized with sepsis each year at an annual healthcare cost of \$7.31 billion. In pediatrics, educational efforts and the use of standardized management guidelines that emphasize early recognition and intervention, along with the rapid transfer of critically ill patients to a pediatric intensive care unit (PICU), have decreased mortality from shock.

### TYPES OF SHOCK

Shock classification systems generally define five major types of shock: hypovolemic, cardiogenic, obstructive, distributive, and dissociative (Table 85.1 and Fig. 85.1). **Hypovolemic shock**, the most common cause of shock in children worldwide, is most frequently caused by acute fluid losses resulting from diarrhea, vomiting, or hemorrhage. A special cause of hypovolemic shock is hemorrhagic shock, which may be caused by traumatic injury or gastrointestinal (GI), peritoneal, vaginal, soft tissue, or

other sources of severe bleeding. **Cardiogenic shock** is seen in patients with congenital heart disease (before or after surgery, including heart transplantation) or those with congenital or acquired cardiomyopathies, including acute myocarditis and multisystem inflammatory syndrome in children (MIS-C). **Obstructive shock** stems from any lesion that creates a mechanical impediment to ventricular blood outflow, which includes pericardial tamponade, tension pneumothorax, pulmonary embolism, and ductal-dependent left-sided heart lesions (hypertrophic left heart syndrome, aortic coarctation, interrupted aortic arch, and critical aortic valve stenosis). **Distributive shock** is caused by inappropriate vasodilation, pooling of blood in the peripheral vasculature, leakage of blood plasma into the interstitium through a compromised endothelial barrier, and microvascular shunting. Common causes of distributive shock in children include sepsis, anaphylaxis, and accidental or intentional drug overdose (e.g., calcium channel blockers, atypical antipsychotics). Neurogenic shock is a type of distributive shock caused by a sudden disruption of sympathetic nerve stimulation to the vascular smooth muscle leading to a profound decrease in vasomotor tone, typically with severe traumatic brain or cervical spine injury. Unlike other types of shock, the unopposed vagal activity classically results in bradycardia, or at least absence of the usual tachycardic response to hypotension. **Dissociative shock** is a special category of shock in which cellular oxygen delivery or utilization is severely impaired despite sustained or supranormal tissue perfusion and is typically caused by exposure to a toxic metabolite or drug, such as severe anemia, methemoglobinemia, carbon monoxide poisoning, or thiamine deficiency (beriberi).

**Septic shock** is life-threatening cardiovascular dysfunction in patients with suspected or confirmed infection and confers a high risk for mortality in children compared to those with uncomplicated infections or sepsis without shock. Sepsis in children is operationalized as a Phoenix Sepsis Score of at least 2 points from a composite four-organ system model that includes criteria for respiratory, neurologic, coagulation, and cardiovascular dysfunction, with septic shock requiring at least 1 point in the cardiovascular subscore (Table 85.2). Many children with septic shock also have MODS, including respiratory, kidney, hematologic (disseminated intravascular coagulation [DIC]), hepatobiliary, and neurologic dysfunction. Septic shock classically presents as a type of distributive shock with high cardiac output and low systemic vascular resistance (SVR). However, most children with sepsis also have features of hypovolemic shock from poor oral intake, GI fluid losses, and vascular leak as well as cardiogenic shock due to decreased myocardial contractility. In younger children, septic shock often presents with low cardiac output and high SVR in which features of cardiogenic and hypovolemic shock predominate.

### PATHOPHYSIOLOGY

An initial insult triggers shock, leading to a decrease in effective cardiac output with inadequate oxygen delivery to organs and tissues. Compensatory mechanisms attempt to maintain BP by increasing cardiac output and SVR. The body also attempts to optimize oxygen delivery to the tissues by increasing oxygen extraction and redistributing blood flow to the brain, heart, and kidneys at the expense of the skin, skeletal muscles, and GI tract. These responses lead to an initial state of **compensated shock** in which BP is often maintained near normal levels for age. If resuscitative treatment is not initiated or is inadequate during this period, **uncompensated shock** develops, with hypotension and tissue damage that may lead to irreversible organ damage, MODS, and, ultimately, death.

In the early phases of shock, multiple compensatory physiologic mechanisms act to maintain BP and preserve tissue perfusion and oxygen delivery. Cardiovascular effects include increases in heart rate (HR), stroke volume, and vascular smooth muscle tone, which are regulated through sympathetic nervous system activation and neurohormonal responses. Respiratory compensation involves greater carbon dioxide (CO<sub>2</sub>) elimination in response to the metabolic acidosis and increased CO<sub>2</sub> production from poor tissue perfusion. Renal excretion of hydrogen ions (H<sup>+</sup>) and retention of bicarbonate (HCO<sub>3</sub><sup>-</sup>) also increase in an effort to maintain normal body pH (see Chapter 73.7). Maintenance of intravascular volume is facilitated via renal sodium retention mediated by activation of the renin-angiotensin-aldosterone and atrial natriuretic factor axes, cortisol and catecholamine synthesis

**Table 85.1** Types of Shock

TYPES OF SHOCK	PATHOPHYSIOLOGY	APPEARANCE	EXAMPLES	TREATMENTS
Hypovolemic*	Decreased cardiac output due to volume depletion → decreased preload	Tachycardia and vasoconstriction maintain adequate circulation up to 30% of circulating volume Narrowed pulse pressure, delayed capillary refill, orthostatic changes, late hypotension, AMS, and decreased UOP	Nonhemorrhagic (vomiting and diarrhea) Hemorrhagic (trauma)	IV fluid bolus Vasopressors Blood replacement
Cardiogenic	Decreased cardiac output due to myocardial dysfunction, increased afterload, and/or lack of ventricular filling	Tachycardia, vasoconstriction, cool extremities, narrow pulse pressure, delayed capillary refill, respiratory distress, rales or gallop rhythm, enlarged liver, JVD, cardiomegaly on chest radiograph Significant gradient between upper and lower extremity blood pressures	Cardiomyopathies, infectious myocarditis, and systemic inflammatory process, autoimmune disease, impaired coronary perfusion, cardiopulmonary bypass, acidosis, HIE, and dysrhythmias Infants: ductal-dependent lesions, tachydysrhythmias	Judicious IV fluid resuscitation, inotropic agents to improve contractility, vasodilators to reduce afterload, and management of tachyarrhythmias PGE for infants <2 mo
Distributive	Decreased cardiac output and systemic vascular resistance due to peripheral vasodilation → decreased afterload and preload, redistribution of blood flow away from vital organs, and loss of sympathetic outflow	Tachycardic, vasodilated, flushed, warm extremities, wide pulse pressure, bounding pulses, flash capillary refill Anaphylaxis: rash; facial swelling; lip, tongue, or airway swelling; bronchospasm; hypotension Spinal shock: unable to raise HR, hypotension Neurogenic: Control ↑ ICP	Septic shock Toxic ingestions Anaphylaxis  Spinal cord injuries	IV fluids, vasopressors, antibiotics Specific antidotes Remove triggers, IV fluids, IM epinephrine, antihistamines, vasopressors IV fluids, vasoconstrictors
Obstructive	Decreased cardiac output due to increased afterload of the right ventricle from an obstructive process	Tachycardia, delayed capillary refill, cool extremities, narrow pulse pressure, distended neck veins, distant heart tones, asymmetric breath sounds	Tension pneumothorax Pulmonary embolism Cardiac tamponade	Anticoagulants Drain pericardial effusion Evacuate pneumothorax
Dissociative	High cardiac output failure due to inadequate oxygen-releasing capacity	Tachycardia ± delayed capillary refill, cool extremities, weakened pulse, pallor or flushed cheeks	Anemia Carbon monoxide Methemoglobinemia Cyanide	Gradual fluid replacement and blood replacement 5 mL/dL Oxygen, hyperbaric chamber Methylene blue Hydroxocobalamin and cyanide antidote kit (sodium thiosulfate, sodium nitrate, amyl nitrite) plus oxygen

\*Most common.

AMS, Altered mental status; HIE, hypoxic ischemic encephalopathies; HR, heart rate; IM, intramuscular; ICP, intracranial pressure; IV, intravenous; JVD, jugular venous distention; PGE, prostaglandin; UOP, urine output.

Modified from Baumer-Mouradian SH, Drendel AL. Shock. In: Kliegman RM, Toth H, Bordini BJ, Basel D, eds. *Nelson Pediatric Symptom-Based Diagnosis*, 2nd ed. Philadelphia: Elsevier;2023: Table 10.4.

and release, and antidiuretic hormone secretion. Despite these compensatory mechanisms, the underlying shock and host response lead to vascular endothelial cell injury and loss of endothelial adhesion proteins that allow significant leakage of intravascular fluid into the interstitial extracellular space.

Another important aspect of the initial pathophysiology of shock is the impact on cardiac output. All forms of shock affect cardiac output through several mechanisms, with changes in HR, preload, afterload, and myocardial contractility occurring separately or in combination (see Fig. 85.1). **Hypovolemic shock** is characterized primarily by fluid loss and decreased preload. Tachycardia and an increase in SVR are the initial compensatory responses that seek to maintain cardiac output, systemic BP, and tissue perfusion. Without adequate volume replacement, hypotension inevitably develops, followed by tissue ischemia and further clinical deterioration. When there is preexisting low plasma oncotic pressure (caused by nephrotic syndrome, malnutrition, hepatic dysfunction, acute severe burns, etc.), further volume loss and exacerbation of shock may result from worsening vascular leak.

In contrast, the underlying pathophysiologic mechanism leading to **distributive shock** is a state of abnormal vasodilation and decreased

SVR. In sepsis, loss of normal regulation of vasomotor tone is due to a combination of factors, including excessive nitric oxide (NO) produced from an increase in inducible NO synthase, altered sympathetic and parasympathetic tone, and diminished circulating levels and/or reduced responsiveness to vasopressin, endogenous catecholamines, and cortisol. In anaphylaxis, vasodilation is caused by an acute release of histamine and other mediators from mast cells. Irrespective of the inciting event, the sudden fall in SVR is accompanied initially by a maldistribution of blood flow away from vital organs and a compensatory increase in cardiac output caused by an increase in HR and, potentially, left ventricular stroke volume. This process leads to significant decreases in both preload and afterload. Therapies for distributive shock must address both these problems simultaneously.

**Cardiogenic shock** may be seen in patients with myocarditis, cardiomyopathy, arrhythmias, and congenital heart disease (generally after cardiac surgery) (see Chapter 483). In these patients, myocardial contractility is directly impaired, leading to systolic and/or diastolic dysfunction. The later phases of all forms of shock frequently have a negative impact on the myocardium, leading to development of a cardiogenic component to the initial shock state.

<b>Shock</b>					
Type	Hypovolemic	Cardiogenic	Obstructive	Distributive	Dissociative
<b>Etiology</b>	Major trauma Gastrointestinal bleed Dehydration	Myocardial infarction Myocarditis Arrhythmia	Pulmonary embolus Cardiac tamponade Tension pneumothorax Status asthmaticus	Sepsis Spinal cord injury Anaphylaxis Ingestion Neurogenic	Anemia, carbon monoxide or cyanide poisoning, methemoglobinemia*
<b>Cardiovascular findings</b>					
Preload (filling pressures)	↓	↑	↕	↓	↕
Cardiac contractility	↑	↓	↕	↑	↑
Cardiac output	↓	↓	↓	↕	↑
Afterload (peripheral tone)	↑	↑	↑	↓	↕
<b>Hemodynamic support</b>					
Relieve obstruction			+++		
Volume expansion	+++	+	+	+++	+
Inotropes		+++	+	+	
Vasopressors	+	+	+	++	

**Fig. 85.1** The causes, cardiovascular findings, and hemodynamic support for different types of shock. Under cardiovascular findings, *bidirectional* arrows indicate variation in findings among patients with the particular type. Under hemodynamic support, the number of + signs indicates the importance of therapy. A combined + and - indicates that the intervention could help some patients but must be used with caution. \*Treat specific etiology transfusion or specific antidotes. (Modified from Angus DC. Approach to the patient with shock. In: Goldman L, Schafer AI, eds. Goldman-Cecil Medicine, 26th ed. Philadelphia: Elsevier; 2020:642, Fig. 98-1.)



**Table 85.2** The Phoenix Sepsis Score<sup>a</sup>

VARIABLES	0 POINTS	1 POINT	2 POINTS	3 POINTS
<b>RESPIRATORY, 0–3 POINTS</b>	PaO <sub>2</sub> :FIO <sub>2</sub> ≥400 or SpO <sub>2</sub> :FIO <sub>2</sub> ≥292 <sup>b</sup>	PaO <sub>2</sub> :FIO <sub>2</sub> <400 on any respiratory support or SpO <sub>2</sub> :FIO <sub>2</sub> <292 on any respiratory support <sup>b,c</sup>	PaO <sub>2</sub> :FIO <sub>2</sub> 100–200 and IMV or SpO <sub>2</sub> :FIO <sub>2</sub> 148–220 and IMV <sup>b</sup>	PaO <sub>2</sub> :FIO <sub>2</sub> <100 and IMV or SpO <sub>2</sub> :FIO <sub>2</sub> <148 and IMV <sup>b</sup>
<b>CARDIOVASCULAR, 0–6 POINTS</b>		<b>1 point each (up to 3)</b>	<b>2 points each (up to 6)</b>	
	No vasoactive medications <sup>d</sup>	1 Vasoactive medication <sup>d</sup>	≥2 Vasoactive medications <sup>d</sup>	
	Lactate <5 mmol/L <sup>e</sup>	Lactate 5–10.9 mmol/L <sup>e</sup>	Lactate ≥11 mmol/L <sup>e</sup>	
<b>AGE BASED<sup>f</sup></b>	<b>Mean Arterial Pressure, mm Hg<sup>g</sup></b>			
<1 mo	>30	17–30	<17	
1 to 11 mo	>38	25–38	<25	
1 to <2 yr	>43	31–43	<31	
2 to <5 yr	>44	32–44	<32	
5 to <12 yr	>48	36–48	<36	
12 to 17 yr	>51	38–51	<38	
<b>COAGULATION, 0–2 POINTS<sup>h</sup></b>		<b>1 point each (maximum 2 points)</b>		
	Platelets ≥100 × 10 <sup>3</sup> /μL	Platelets <100 × 10 <sup>3</sup> /μL		
	International normalized ratio ≤1.3	International normalized ratio >1.3		
	D-dimer ≤2 mg/L FEU	D-dimer >2 mg/L FEU		
	Fibrinogen ≥100 mg/dL	Fibrinogen <100 mg/dL		
<b>NEUROLOGIC, 0–2 POINTS<sup>i</sup></b>	Glasgow Coma Scale score >10; pupils reactive <sup>i</sup>	Glasgow Coma Scale score ≤10 <sup>i</sup>	Fixed pupils bilaterally	
<b>PHOENIX SEPSIS CRITERIA</b>				
Sepsis	Suspected infection and Phoenix Sepsis Score ≥2 points			
Septic shock	Sepsis with ≥1 cardiovascular point(s)			

<sup>a</sup>The score may be calculated in the absence of some variables (eg, even if lactate level is not measured and vasoactive medications are not used, a cardiovascular score can still be ascertained using blood pressure). It is expected that laboratory tests and other measurements will be obtained at the discretion of the medical team based on clinical judgment. Unmeasured variables contribute no points to the score. Ages are not adjusted for prematurity, and the criteria do not apply to birth hospitalizations, neonates whose postconceptional age is younger than 37 weeks, or those 18 years of age or older.

<sup>b</sup>SpO<sub>2</sub>:FIO<sub>2</sub> ratio is only calculated if SpO<sub>2</sub> is 97% or less.

<sup>c</sup>The respiratory dysfunction of 1 point can be assessed in any patient receiving oxygen, high-flow, noninvasive positive pressure, or IMV respiratory support, and includes a PaO<sub>2</sub>:FIO<sub>2</sub> ratio of less than 200 and a SpO<sub>2</sub>:FIO<sub>2</sub> ratio of less than 220 in children who are not receiving IMV. For children receiving IMV with a PaO<sub>2</sub>:FIO<sub>2</sub> less than 200 and SpO<sub>2</sub>:FIO<sub>2</sub> less than 220, see criteria for 2 and 3 points.

<sup>d</sup>Vasoactive medications include any dose of epinephrine, norepinephrine, dopamine, dobutamine, milrinone, and/or vasopressin (for shock).

<sup>e</sup>Lactate reference range is 0.5 to 2.2 mmol/L. Lactate can be arterial or venous.

<sup>f</sup>Age is not adjusted for prematurity, and the criteria do not apply to birth hospitalizations, children whose postconceptional age is younger than 37 weeks, or those 18 years or older.

<sup>g</sup>Use measured MAP preferentially (invasive arterial if available or noninvasive oscillometric), and if measured MAP is not available, a calculated MAP (1/3 × systolic + 2/3 × diastolic) may be used as an alternative.

<sup>h</sup>Coagulation variable reference ranges: platelets, 150 to 450 × 10<sup>3</sup>/μL; D-dimer, <0.5mg/L FEU; fibrinogen, 180 to 410mg/dL. The INR reference range is based on the local reference prothrombin time.

<sup>i</sup>The neurological dysfunction subscore was pragmatically validated in both sedated and nonsedated patients, and those receiving or not receiving IMV support.

<sup>j</sup>The Glasgow Coma Scale score measures level of consciousness based on verbal, eye, and motor response (range, 3–15, with a higher score indicating better neurological function). FEU, fibrinogen equivalent units; IMV, invasive mechanical ventilation; INR, international normalized ratio of prothrombin time; MAP, mean arterial pressure; PaO<sub>2</sub>:FIO<sub>2</sub>, arterial partial pressure of oxygen to fraction of inspired oxygen ratio; SpO<sub>2</sub>, oxygen saturation measured by pulse oximetry (only SpO<sub>2</sub> of ≤97%).

SI conversion factor: To convert lactate from mmol/L to mg/dL, divide by 0.111.

From Schlapbach LJ, Watson RS, Sorce LR, et al. International Consensus Criteria for Pediatric Sepsis and Septic Shock. *JAMA*. Published online January 21, 2024. <https://doi.org/10.1001/jama.2024.0179>.

**Obstructive shock** manifests as an acute increase in SVR typically in response to a sudden decrease in cardiac output that resembles a state of functional hypovolemia. A compensatory increase in HR and afterload provides temporary support, but compensation will soon fail without relief of the mechanical obstruction.

**Dissociative shock** is caused by the inability to deliver oxygen due to severe anemia or a congenital or acquired hemoglobinopathy, such as carbon monoxide intoxication. Alternatively, oxygen delivery may be preserved, but consumption can be impaired by a metabolic disorder or acquired state of mitochondrial dysfunction, such as cyanide

**Table 85.3** Differential Diagnosis of Systemic Inflammatory Response Syndrome (SIRS)

<p><b>INFECTIOUS</b></p> <p>Bacteremia or meningitis (<i>Streptococcus pneumoniae</i>, <i>Haemophilus influenzae</i> type b, <i>Neisseria meningitidis</i>, group A <i>Streptococcus</i>, <i>Staphylococcus aureus</i>)</p> <p>Viral illness (influenza, enteroviruses, hemorrhagic fever group, herpes simplex virus, respiratory syncytial virus, cytomegalovirus, Epstein-Barr virus, COVID-19)</p> <p>Encephalitis (arboviruses, enteroviruses, herpes simplex virus)</p> <p>Rickettsiae (Rocky Mountain spotted fever, Ehrlichia, Q fever)</p> <p>Syphilis</p> <p>Vaccine reaction (pertussis, influenza, measles)</p> <p>Toxin-mediated reaction (toxic shock, staphylococcal scalded skin syndrome)</p> <p><b>CARDIOPULMONARY</b></p> <p>Pneumonia (bacteria, virus, mycobacteria, fungi, allergic reaction)</p> <p>Pulmonary emboli</p> <p>Heart failure</p> <p>Arrhythmia</p> <p>Pericarditis</p> <p>Myocarditis</p> <p><b>METABOLIC-ENDOCRINE</b></p> <p>Adrenal insufficiency (adrenogenital syndrome, Addison disease, corticosteroid withdrawal)</p> <p>Electrolyte disturbances (hyponatremia or hypernatremia, hypocalcemia or hypercalcemia)</p> <p>Diabetes insipidus</p> <p>Diabetes mellitus</p> <p>Inborn errors of metabolism (organic acidosis, urea cycle, carnitine deficiency, mitochondrial disorders)</p> <p>Hypoglycemia</p> <p><b>GASTROINTESTINAL</b></p> <p>Gastroenteritis with dehydration</p> <p>Volvulus</p> <p>Intussusception</p> <p>Appendicitis</p> <p>Peritonitis (spontaneous, associated with perforation or peritoneal dialysis)</p> <p>Necrotizing enterocolitis</p> <p>Hepatitis</p> <p>Hemorrhage</p> <p>Pancreatitis</p>	<p><b>HEMATOLOGIC/IMMUNE</b></p> <p>Anemia (sickle cell disease, blood loss, nutritional)</p> <p>Methemoglobinemia</p> <p>Splenic sequestration crisis</p> <p>Leukemia or lymphoma</p> <p>Hemophagocytic syndromes</p> <p>Cytokine release syndrome s/p CAR-T therapy</p> <p>Immune reconstitution syndrome</p> <p>Graft-versus-host disease</p> <p><b>NEUROLOGIC</b></p> <p>Intoxication (drugs, carbon monoxide, intentional or unintentional overdose)</p> <p>Intracranial hemorrhage</p> <p>Infant botulism</p> <p>Trauma (child abuse, accidental)</p> <p>Guillain-Barre syndrome</p> <p>Myasthenia gravis</p> <p><b>OTHER</b></p> <p>Anaphylaxis (food, drug, insect sting, idiopathic)</p> <p>Hemolytic-uremic syndrome</p> <p>Kawasaki disease</p> <p>Erythema multiforme, toxic epidermal necrolysis</p> <p>MIS-C</p> <p>Poisoning, iron, cyanide</p> <p>Toxic envenomation</p> <p>Systemic JIA</p> <p>Macrophage activation syndrome</p> <p>Idiopathic systemic capillary leak (Clarkson) syndrome</p>
---	--

CAR-T, Chimeric antigen receptor T-cell; JIA, juvenile idiopathic arthritis; MIS-C, multisystem inflammatory syndrome in children; S/P, status post.

From Baumer-Mouradian SH, Drendel AL. Shock. In: Kliegman RM, Bordini BJ, Toth H, Basel D, eds. *Nelson Pediatric Symptom-Based Diagnosis*, 2nd ed. Elsevier: Philadelphia; 2022: Table 10.6.

toxicity. Notably, varying degrees of dissociative shock may also be present in other shock types, especially sepsis, in which acquired pyruvate dehydrogenase deficiency or mitochondrial dysfunction have been increasingly recognized.

**Septic shock** is generally a unique combination of distributive, hypovolemic, and cardiogenic shock, as well as dissociative shock. Hypovolemia from insufficient fluid intake, GI losses, and/or vascular leak is common. Cardiogenic shock results from the myocardial-depressant effects of sepsis, and distributive shock is the result of decreased SVR. The degree to which a patient exhibits each of these responses varies, but there are frequently alterations in preload, afterload, and myocardial contractility.

In septic shock, it is important to distinguish between the inciting infection and the host inflammatory response. Normally, host immunity prevents the development of sepsis through activation of the reticular endothelial system along with the cellular and humoral immune systems. This host immune response produces an *inflammatory cascade* mediated by hormones, cytokines, and chemokines. If this inflammatory cascade is uncontrolled, derangement of the microcirculatory system leads to subsequent organ and cellular dysfunction.

**Systemic inflammatory response syndrome (SIRS)** is an inflammatory cascade that is initiated by the host response to an infectious or noninfectious trigger (Table 85.3). This inflammatory cascade is triggered when the host defense system does not adequately recognize and/or eliminate the triggering event. The inflammatory cascade initiated by shock can lead

to hypovolemia, cardiac and vascular failure, acute respiratory distress syndrome (ARDS), insulin resistance, decreased cytochrome P450 activity (decreased steroid synthesis), coagulopathy, and unresolved or secondary infection. Tumor necrosis factor (TNF) and other inflammatory mediators increase vascular permeability, causing diffuse vascular leak, decreased vascular tone, and an imbalance between perfusion and metabolic demands of the tissues. Early increases in TNF, interleukin (IL)-1, and IL-6 stimulate the release of both proinflammatory and antiinflammatory mediators, causing fever, vasodilation, and myocardial dysfunction. Simultaneous upregulation of antiinflammatory mediators (such as circulating levels of IL-4, IL-10, and transforming growth factor- $\beta$ ), downregulation of hematopoietic growth factors (such as IL-7), and increased expression of immune cell surface checkpoint proteins (such as programmed death [PD]-1 and its PD ligand [PD-L1/2]), as well as production of immature immune cells through emergency myelopoiesis contribute to a state of immune dysregulation that can impair pathogen clearance and allow for secondary infections.

The inflammatory cascade is initiated by toxins or superantigens through macrophage binding or lymphocyte activation. The vascular endothelium is both a target of tissue injury and a source of mediators that may cause further injury. Biochemical responses include the production of arachidonic acid metabolites, release of myocardial-depressant factors and endogenous opiates, activation of the complement system, and production and release of other mediators, which

**Table 85.4** Signs of Decreased Perfusion

ORGAN SYSTEM	↓ PERFUSION	⇓ PERFUSION	⇓⇓ PERFUSION
Central nervous system	—	Restless, apathetic, anxious	Agitated/confused, stuporous, coma
Respiratory	—	↑ Ventilation	↑↑ Ventilation
Metabolic	—	Compensated metabolic acidemia	Uncompensated metabolic acidemia
Gastrointestinal	—	↓ Motility	Ileus
Kidney	↓ Urine volume ↑ Urinary specific gravity	Oliguria (<0.5 mL/kg/hr)	Oliguria/anuria
Skin	Delayed capillary refill	Cool extremities	Mottled, cyanotic, cold extremities
Cardiovascular system	↑ Heart rate	↑↑ Heart rate ↓ Peripheral pulses	↑↑ Heart rate ↓ Blood pressure, central pulses only

may be proinflammatory or antiinflammatory. The balance among these mediator groups for an individual patient contributes to the progression (and resolution) of disease and affects the prognosis.

### CLINICAL MANIFESTATIONS

Table 85.1 and Figure 85.1 show a classification system for shock. Categorization is important, but there may be significant overlap among these groups, especially in septic shock. The clinical presentation of shock depends in part on the underlying etiology, but if unrecognized and untreated, all forms of shock follow a common progression of clinical signs and pathophysiologic changes that may ultimately lead to irreversible organ injury and death. Among the first physiologic responses is sympathetic adrenergic system activation and its related signs and symptoms.

*Shock may initially manifest as only tachycardia, with or without tachypnea.* Progression leads to decreased urine output, poor peripheral perfusion, respiratory distress or failure, alteration of mental status, and low BP (Table 85.4). A significant misconception is that shock occurs only with low BP. Hypotension is often a late finding, especially in infants and young children, and is not a criterion for the diagnosis of shock because of a complex set of compensatory mechanisms that attempt to preserve BP and peripheral perfusion. Hypotension reflects an advanced state of uncompensated shock and is associated with increased morbidity and mortality.

**Hypovolemic shock** often manifests initially as tachycardia and orthostatic hypotension and is associated with dry mucous membranes, dry axillae, poor skin turgor, and decreased urine output. Depending on the degree of dehydration, the patient with hypovolemic shock may present with either normal or slightly cool distal extremities, and peripheral pulses may be normal, decreased, or absent depending on disease severity.

The presenting signs of **cardiogenic shock** are often tachypnea, cool extremities, delayed capillary filling time, poor peripheral and/or central pulses, reduced pulse pressure, declining mental status, and decreased urine output caused by the combination of decreased cardiac output and compensatory peripheral vasoconstriction (see Chapter 491.1).

**Obstructive shock** often also manifests as inadequate cardiac output because of a physical restriction of forward blood flow with tachycardia, delayed capillary refill, cool extremities, diminished peripheral pulses, and decreased pulse pressure (difference between systolic and diastolic BP) or presence of pulsus paradoxus. The acute presentation may quickly progress to cardiac arrest. Obstructive shock due to tension pneumothorax typically includes signs of respiratory distress, hypoxia, and diminished breath sounds. Pericardial tamponade includes Beck's triad of hypotension, jugular vein distention, and muffled heart sounds. A saddle pulmonary embolism often presents with a sudden cardiac arrest. Left-heart obstructive lesions may present in newborns with discrepant perfusion of the upper and lower extremities.

**Distributive shock** includes signs of vasodilation, including tachycardia, flash capillary refill, warm extremities, bounding peripheral

pulses, and increased pulse pressure, often with diastolic hypotension. In neurogenic shock, tachycardia may be absent or frank bradycardia may be present. Similar to distributive shock, signs of vasodilation may be present, although in the immediate phase, the patient can feel cool peripherally with delayed capillary refill.

**Septic shock** can be difficult to diagnose because of the wide spectrum of presenting signs and symptoms. A key historical clue is the presence of fever (or hypothermia) along with evidence for either a *systemic* (e.g., bacteremia, rickettsial disease, fungemia, viremia) or *localized* (e.g., meningitis, pneumonia, pyelonephritis, peritonitis, necrotizing fasciitis) infection. Infants and young children most commonly present with “cold shock,” with features of hypovolemic and cardiogenic shock predominating, including tachycardia, delayed capillary refill, cool extremities, diminished peripheral pulses, and decreased pulse pressure. Older children and adolescents, especially those with sepsis from indwelling central venous catheters, more commonly present with “warm shock” that resembles distributive shock, including tachycardia, flash capillary refill, warm extremities, bounding peripheral pulses, and increased pulse pressure. However, the pathobiology of sepsis can evolve over time and with treatment in the children, such that “warm shock” may shift to “cold shock” or vice versa.

In addition to the traditional description of septic shock, a subgroup immunophenotype presents with **hyperferritinemia**. Ferritin levels >3,000 mg/mL often predict a poor prognosis and the need for intensive care unit (ICU) admission. Hyperferritinemic septic shock may be due to familial primary genetic hemophagocytic lymphohistiocytosis (HLH) (usually age <2 years; see Chapter 556.2) or, more often, secondary HLH initiated by an infectious agent or macrophage activation syndrome (MAS) (see Chapter 207) associated with autoimmune diseases (Table 85.6).

Regardless of etiology, uncompensated shock, with hypotension, high SVR, decreased cardiac output, respiratory failure, obtundation, and oliguria, occurs late in the progression of disease. Table 85.1 lists the hemodynamic findings in various shock states. Additional clinical findings in shock include cutaneous lesions such as petechiae, diffuse erythema, ecchymoses, ecthyma gangrenosum, and peripheral gangrene. Jaundice can be present either as a sign of infection or as a result of MODS.

### DIAGNOSIS

Shock is a clinical diagnosis that should be primarily based on a thorough history and physical examination (see Tables 85.1, 85.4, and 85.6). Important clues to consider in the history are recent trauma or bleeding, exposure to new medications or substances, preceding or concurrent symptoms of infection or fluid losses, the patient's comorbid conditions, and a brief review of systems. The physical examination should include rapid assessment of vital signs (including pulse oximetry), mental status/level of consciousness, extremity temperature, peripheral and central pulses, capillary refill, and presence of rashes or skin changes.

Increasingly, point-of-care ultrasound (POCUS) is being incorporated into the initial assessment of children with shock to assess intravascular volume status, likelihood of a positive hemodynamic response to fluid

**Table 85.5** Considerations in Management of Hyperferritinemic Sepsis Beyond Usual Diagnostic and Therapeutic Measures Used in Sepsis Patients Without Hyperferritinemia

**WHAT OCCULT INFECTION IS PRIMING AND WHAT CO-INFECTION IS PRESENT FOR THE HYPERFERRITINEMIC PROCESS?**

Perform diagnostic workup for **viruses** (e.g., herpes simplex virus 1, HHV-6, HHV-8, Epstein-Barr virus, adenovirus, cytomegalovirus, parvovirus, Ebola, COVID-19, Dengue, hepatitis A, HIV, severe fever with thrombocytopenia syndrome virus, influenza, hemorrhagic fevers), **parasites** (e.g., toxoplasmosis, leishmaniasis, malaria, scrub typhus, babesiosis), **intracellular bacteria** (e.g., tuberculosis, atypical mycobacteria, mycoplasma, fusobacteria, babesiosis, ehrlichiosis), rickettsia, and **fungi** (e.g., histoplasmosis).

Begin empiric therapy and specific therapies according to context.

Give IVIG if no specific therapy is available to neutralize infection.

**IS HEMOLYSIS AND FREE HEMOGLOBIN DRIVING THE HYPERFERRITINEMIC PROCESS?**

Measure free hemoglobin and ferritin sequentially.

Minimize blood transfusions.

If unable to reverse hemolysis or hyperferritinemia, consider 5 days of plasma exchange to remove free hemoglobin and ferritin and to resolve inflammation.

**IS AN ANTIINFLAMMATORY STRATEGY NEEDED TO SAFELY CONTROL INFLAMMASOME ACTIVATION?**

If ferritin is >3,000 ng/mL in the high-resource PICU setting, or >500 ng/mL in the resource-poor PICU setting, then mortality risk is increased.

Methylprednisone, IVIG, and interleukin 1 receptor antagonist (anakinra) can be safely given to reduce mortality risk in these children.

HHV, human herpes virus; PICU; pediatric intensive care unit; IVIG, IV immunoglobulin. Modified from Carcillo JA, Kernan KK, Horvat CM, et al. Why and how is hyperferritinemic sepsis different from sepsis without hyperferritinemia? *Pediatr Crit Care Med.* 21(5):509-512, Table 1, p. 511.

therapy, and myocardial function. Cardiac and lung POCUS may also provide important diagnostic information about the etiology of shock, such as the presence of pericardial fluid to support tamponade, pneumothorax, or dilated right ventricle to support pulmonary embolus. The focused assessment with sonography for trauma (FAST) is commonly performed to screen for pericardial effusion and hemoperitoneum.

## LABORATORY FINDINGS

Although the initial diagnosis of shock can and should be based on clinical data from the history and physical examination, the overall evaluation of shock should also include early laboratory testing to screen for hyperlactatemia (as a sign of increased anaerobic metabolism), acidemia, and electrolyte disturbances, including hypoglycemia and hypocalcemia. In children with septic shock, elevations in both venous and arterial blood lactate levels in the emergency department (ED) are associated with risk of organ dysfunction when measured in the ED and are associated with higher risk of death if elevated at the time of PICU admission. Although the optimal cutoff remains to be defined, arterial lactate  $\geq 2$  mmol/L is worrisome and associated with worse outcome. Laboratory evidence of concurrent MODS should also be sought, including a complete blood count, renal function tests, liver function tests, and coagulation profile (including fibrinogen and D-dimer or fibrin split products). Elevated neutrophil counts with increased immature forms (i.e., bands, myelocytes, promyelocytes) and elevated CRP and procalcitonin levels may be seen with infection. A blood gas analysis may be helpful to assess the degree of respiratory dysfunction, and an elevated venous to arterial  $P_{CO_2}$  gap  $\geq 5$  mm Hg ( $\geq 0.67$  kPa) may signify an early shock state. For septic shock, at least one blood culture should be collected along with other cultures as supported by the history and physical. Ferritin levels should be determined in all patients with septic shock. In the presence of hyperferritinemia,

laboratory studies for HLH and MAS should be obtained, including fibrinogen, triglycerides, CBC, soluble IL-2 receptor, natural killer (NK) cells, and specific genetic testing.

The hallmark of *uncompensated* shock is an imbalance between oxygen delivery ( $DO_2$ ) and oxygen consumption ( $VO_2$ ). Oxygen delivery normally exceeds oxygen consumption by threefold. The oxygen extraction ratio is approximately 25%, thus producing a normal central venous oxygen saturation ( $SvO_2$ ) of approximately 75%, most commonly measured from a catheter at the junction of the superior vena cava and right atrium.  $SvO_2$  values <70% reflect an increased oxygen extraction ratio and document a decrease in oxygen delivery relative to consumption. This increase in tissue oxygen extraction is an attempt to maintain adequate oxygen delivery at the cellular level. This state is manifested clinically by increased lactic acid production (e.g., high anion gap, metabolic acidemia) caused by anaerobic metabolism and a compensatory increase in tissue oxygen extraction. Notably, in dissociative shock, hyperlactatemia is often accompanied by an elevated  $SvO_2$  >80–85%, which reflects a state of impaired oxygen use despite adequate tissue perfusion. *Elevated blood lactate levels reflect poor tissue oxygen delivery noted in all forms of shock.*

## TREATMENT

Almost all healthcare professionals that care for ill children will be faced with managing the clinical syndrome of shock, given that many childhood illnesses, such as gastroenteritis, infection, trauma, and toxic ingestions, can precipitate shock. Without timely medical intervention, the child in shock will inevitably follow a common pathway to MODS and death. Early recognition and resuscitation are therefore critical to limit morbidity and mortality associated with shock.

### General Principles of Shock Management

Initial management begins with early recognition of the compensated or uncompensated shock state based on the history, physical examination, and laboratory assessments outlined earlier. Once recognized, immediate efforts to restore oxygen (and other nutrient) delivery by supporting the circulation and identifying and reversing the underlying etiology of shock are necessary (Fig. 85.2). Restoration of oxygen delivery includes ensuring airway patency and adequacy of breathing, providing supplemental oxygen if hypoxemia ( $SpO_2$  <92–94%) is present, establishing vascular access, expanding the circulating blood volume, supporting the cardiac and vascular system with appropriate vasoactive agents when necessary, and frequently reassessing the patient's response to initial therapy. The management strategies discussed in the following sections apply to all shock types, with additional discussion at the end of the section for type-specific management recommendations.

**Vascular access** should be established within the first few minutes of shock recognition, ideally with at least two large-bore peripheral intravenous (IV) catheters. If peripheral IV access is not successful within 5 minutes, intraosseous (IO) access should be established until more definitive access is secured. Central venous access should be considered for patients with unstable peripheral IV access, persistence of shock despite 40–60 mL/kg fluid bolus therapy (*fluid-refractory shock*), or need for vasoactive medications or concentrated dextrose/electrolyte administration. In addition to optimizing safe administration of certain medications, central venous access will also enable measurement of  $SvO_2$ . Placement of an arterial catheter should be considered for patients with fluid-refractory shock who require active titration of vasoactive medications and/or those who may need serial laboratory tests, including frequent reassessment of blood lactate or electrolyte derangements. Notably, placement of a central venous or arterial catheter requires specialized skills that may not be immediately available, in which case continued resuscitation through peripheral IV or IO access, including initiation of vasoactive medications, is safe and appropriate.

**Volume resuscitation** with fluid bolus therapy in aliquots of 10–20 mL/kg pushed over 5–10 minutes is currently recommended for most types of shock and in most settings in children (see special considerations in septic shock later and Fig. 85.3). Several observational studies have demonstrated improved outcomes in children with shock with initial volume resuscitation titrated to improvements in hemodynamic targets, including decrease in HR; increase in BP; normalization of capillary refill, peripheral pulse strength, and extremity temperature;



**Table 85.6** Physical Examination and Selected Laboratory Signs in Shock

Central nervous system	Acute delirium, restlessness, disorientation, confusion, and coma, which may be secondary to decreased cerebral perfusion pressure (mean arterial pressure minus intracranial pressure). Patients with chronic hypertension or increased intracranial pressure may be symptomatic at normal blood pressures. Cheyne-Stokes respirations may be seen with severe decompensated heart failure. Blindness can be a presenting complaint or complication.
Temperature	Hyperthermia results in excess tissue respiration and greater systemic oxygen delivery requirements. Hypothermia can occur when decreased systemic oxygen delivery or impaired cellular respiration decreases heat generation.
Skin	Cool distal extremities (combined low serum bicarbonate and high arterial lactate levels) aid in identifying patients with hypoperfusion. Pallor, cyanosis, sweating, and decreased capillary refill and pale, dusky, clammy, or mottled extremities indicate systemic hypoperfusion. Dry mucous membranes and decreased skin turgor indicate low vascular volume. Low toe temperature correlates with the severity of shock.
General cardiovascular	Neck vein distention (e.g., heart failure, pulmonary embolus, pericardial tamponade) or flattening (e.g., hypovolemia), tachycardia, and arrhythmias. Decreased coronary perfusion pressures can lead to ischemia, decreased ventricular compliance, and increased left ventricular diastolic pressure. A “mill wheel” heart murmur may be heard with an air embolus.
Heart rate	Usually elevated. However, paradoxical bradycardia can be seen in patients with preexisting cardiac disease and severe hemorrhage. Heart rate variability is associated with poor outcomes.
Systolic blood pressure	May actually increase slightly when cardiac contractility increases in early shock and then fall as shock advances.
Diastolic blood pressure	Correlates with arteriolar vasoconstriction and may rise early in shock and then fall when cardiovascular compensation fails.
Pulse pressure	Defined as systolic minus diastolic pressure and related to stroke volume and the rigidity of the aorta. Increases early in shock and decreases before systolic pressure decreases.
Pulsus paradoxus	An exaggerated change in systolic blood pressure with respiration (systolic blood pressure declines >10 mm Hg with inspiration) seen in asthma, cardiac tamponade, and air embolus.
Mean arterial blood pressure	Diastolic blood pressure + [pulse pressure/3]
Shock index	Heart rate/systolic blood pressure. Normal = 0.5-0.7. A persistent elevation of the shock index (>1.0) indicates impaired left ventricular function (as a result of blood loss or cardiac depression) and is associated with increased mortality.
Respiratory	Tachypnea, increased minute ventilation, increased dead space, bronchospasm, hypocapnia with progression to respiratory failure, acute lung injury, and adult respiratory distress syndrome.
Abdomen	Low-flow states may result in abdominal pain, ileus, gastrointestinal bleeding, pancreatitis, acalculous cholecystitis, mesenteric ischemia, and shock liver.
Renal	Because the kidney receives 20% of cardiac output, low cardiac output reduces the glomerular filtration rate and redistributes renal blood flow from the renal cortex toward the renal medulla, thereby leading to oliguria. Paradoxical polyuria in early sepsis may be confused with adequate hydration.
Metabolic	Respiratory alkalosis is the first acid-base abnormality, but metabolic acidosis rapidly occurs as shock progresses. Hyperglycemia, hypoglycemia, and hyperkalemia may develop. Hyperferritinemia suggests a poor prognosis.

From Angus DC. Approach to the patient with shock. In Goldman L, Schafer AI, eds. *Goldman-Cecil Medicine*, 26th ed. Philadelphia: Elsevier; 2020:643, Table 98-1.

improved urine output; and fall in blood lactate by  $\geq 10$ –20%. Fluid boluses totaling up to 60 mL/kg may be needed in the first hour of resuscitation, with volumes exceeding 200 mL/kg over several hours. Fluid should be administered via IV push or a rapid infuser system. IV push delivery may be facilitated by attaching a large syringe with a three-way stopcock to the IV tubing from the fluid bag, creating a “push-pull system” that allows the user to rapidly draw up fluid into the syringe and then administer to the patient without repeatedly disconnecting and reconnecting the syringe to the patient’s IV. In patients >50 kg, a pressure bag or rapid infuser may be used to rapidly administer fluid through a large-gauge peripheral IV. Notably, in neonates, additional caution should be paid to fluid resuscitation, as tolerance may be limited by reduced myocardial ventricular compliance at baseline.

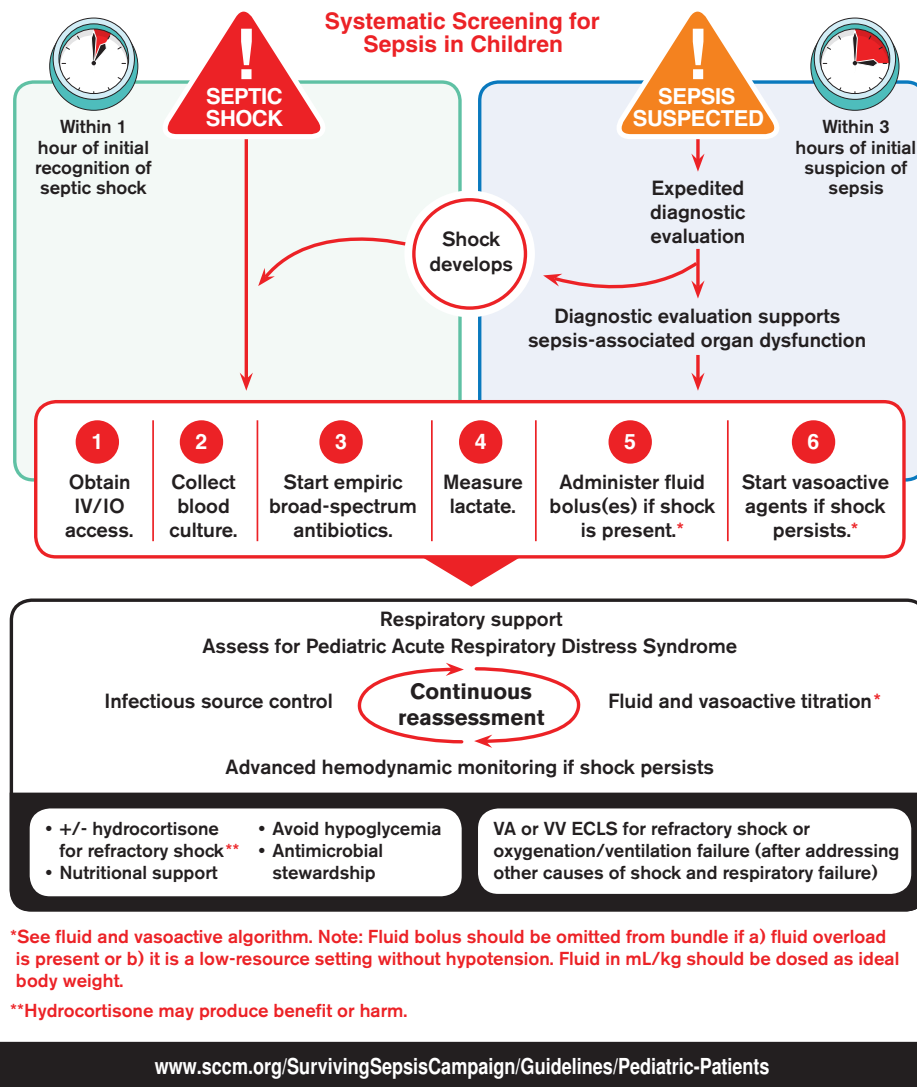
Importantly, not all children with shock will continue to improve with repeated volume resuscitation, particularly those with cardiogenic and dissociative shock, severe anemia, or malnutrition. Before repeating a fluid bolus, the clinician should determine if the patient responded in a hemodynamically desirable way after the prior fluid bolus and ensure that signs of fluid overload, such as rales, gallop rhythm, or hepatomegaly, have not developed. POCUS may also be helpful to identify ongoing hypovolemia and predict response to ongoing volume resuscitation. For children with evidence of fluid overload, adequate intravascular volume, or lack of hemodynamic improvement

with prior fluid boluses, resuscitation should shift from volume resuscitation to vasoactive medications. Trials of earlier initiation of vasoactive support are ongoing to further clarify the optimal role of volume resuscitation in pediatric shock.

The optimal fluid type for initial shock resuscitation remains a matter of debate. Most studies have not demonstrated a clear benefit for use of colloids, such as 4–5% albumin, over crystalloids, though there may be a small clinical benefit for resuscitation with colloids in septic shock. There is also evidence supporting a risk of kidney injury and coagulopathy with the use of synthetic colloids, such as hydroxyethyl starch and gelatin, and their use is currently not recommended. Because crystalloids are inexpensive, easy to administer, and readily available, current guidelines generally recommend initial resuscitation begin with these fluids. Exceptions include children with hemorrhagic shock and dissociative shock resulting from severe anemia for whom early blood product transfusion is preferred.

Crystalloid volume resuscitation may include 0.9% normal saline or balanced/buffered fluids, such as lactated Ringer solution, Hartmann solution, and Plasma-Lyte. Saline consists of only sodium and chloride in a 1:1 ratio with a supraphysiologic chloride concentration, whereas balanced fluids have an anion buffer and electrolyte composition closer to human blood plasma, though formulations vary. As a result, high-volume resuscitation with 0.9% saline often induces a hyperchloremic metabolic acidemia. Although 0.9% remains the most commonly used crystalloid

## Initial Resuscitation Algorithm for Children



\*See fluid and vasoactive algorithm. Note: Fluid bolus should be omitted from bundle if a) fluid overload is present or b) it is a low-resource setting without hypotension. Fluid in mL/kg should be dosed as ideal body weight.

\*\*Hydrocortisone may produce benefit or harm.

**Fig. 85.2** Surviving Sepsis Campaign 2020 Initial Resuscitation Algorithm for Children. For children with clinical signs of shock, the following six key management steps should be completed within 1 hour of initial recognition of shock: (1) obtain intravenous/intraosseous access, (2) collect blood culture, (3) start empiric broad-spectrum antibiotics, (4) measure blood lactate, (5) administer crystalloid fluid therapy with volume and rate reflecting healthcare setting and titrated to patient response, and (6) initiate vasoactive medications if shock persists despite fluid and other therapy. VA, venoarterial; VV, venovenous; ECLS, extracorporeal life support. (© 2020 the Society of Critical Care Medicine and the European Society of Intensive Care Medicine. All Rights Reserved. <https://www.sccm.org/getattachment/SurvivingSepsisCampaign/Guidelines/Pediatric-Patients/Initial-Resuscitation-Algorithm-for-Children.pdf.aspx?lang=en-US>.)

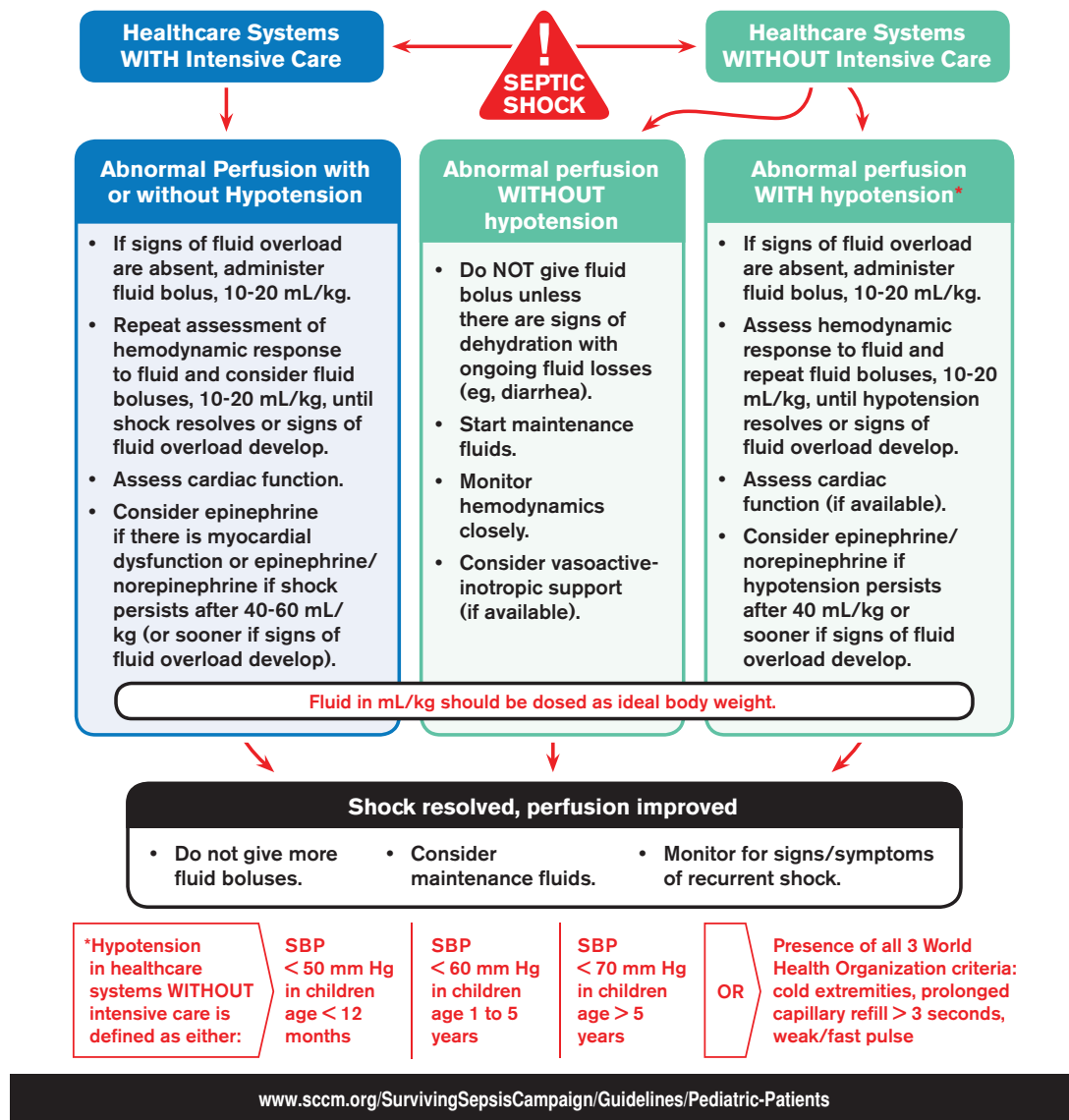
for pediatric volume resuscitation, increasing data suggest that balanced/buffered fluids are associated with less acute kidney injury, inflammation, coagulopathy, endotheliopathy, and death. However, pediatric studies comparing balanced/buffered fluids with 0.9% saline have reported conflicting results, and adult interventional trials have not shown a consistent benefit for either crystalloid fluid type. Consequently, pending further data from ongoing studies, either 0.9% saline or balanced/buffered crystalloids are appropriate for initial volume resuscitation.

Resuscitation with blood products should be prioritized for children with hemorrhagic shock. The *Advanced Trauma Life Support* guidelines recommend resuscitation with red blood cells, plasma, and platelets in a ratio of 1:1:1 to limit coagulopathy and other risks associated with large-scale transfusion. For children with other forms of shock, the criteria to transfuse red blood cells are not clear, though it is reasonable to target

hemoglobin levels >9 g/dL for children who remain hemodynamically unstable with low  $SvO_2$  and/or high blood lactate despite other interventions. Notably, transfusion of plasma or platelets should be reserved to treat active bleeding or reduce risk of bleeding before an invasive procedure rather than used solely to correct laboratory abnormalities or as volume expanders.

**Vasoactive medications** should be initiated for children with fluid-refractory shock, with early consideration for inotropes, such as epinephrine, when myocardial dysfunction is present and vasopressors, such as norepinephrine, when vasoplegia is present (Table 85.7). For children with septic shock, two randomized trials have demonstrated that epinephrine as first-line vasoactive therapy is more effective at reducing mortality than dopamine. As such, epinephrine is the preferred first-line vasoactive therapy for fluid-refractory septic shock.

### Fluid and Vasoactive-Inotrope Management Algorithm For Children



**Fig. 85.3** Surviving Sepsis Campaign 2020 Fluid and Vasoactive-Inotrope Management Algorithm for Children. For children with septic shock treated in healthcare systems in which intensive care is accessible (either locally or via transport), fluid bolus therapy up to 40-60 mL/kg is recommended in the first hour of therapy until shock resolves or signs of fluid overload develop. For children with septic shock treated in healthcare systems in which intensive care is not available locally or via transport, fluid bolus therapy is not recommended unless hypotension is present. For all children, early assessment of cardiac function is recommended with consideration for initiation of epinephrine (or alternative inotrope) if myocardial dysfunction is evident. SBP, systolic blood pressure. (© 2020 the Society of Critical Care Medicine and the European Society of Intensive Care Medicine. All Rights Reserved. <https://www.sccm.org/getattachment/SurvivingSepsisCampaign/Guidelines/Pediatric-Patients/Initial-Resuscitation-Algorithm-for-Children.pdf.aspx?lang=en-US>.)

Epinephrine is also a potent inotrope and is the recommended initial vasoactive agent in children with cardiogenic shock. However, in children with a low-SVR state, as may be seen with distributive, septic, or neurogenic shock, norepinephrine should be preferentially prescribed as the first-line vasoactive therapy. Although vasoactive agents are ideally administered through a central venous line, these medications can be safely initiated through a peripheral IV or an IO in dilute concentrations while central venous access is obtained.

**Electrolyte abnormalities**, such as hypoglycemia and hypocalcemia, may precipitate or worsen shock. Blood glucose and ionized

calcium can both be measured rapidly via bedside point-of-care testing, and if present, hypoglycemia and hypocalcemia should be corrected during the initial resuscitation. Other patterns of electrolyte abnormalities may indicate the presence of an underlying inborn error of metabolism, particularly in a neonate with shock. Any provider treating a patient with known or suspected inborn error of metabolism should consult immediately with a specialty center while resuscitating with volume and dextrose.

**Airway management** is an essential component of the initial management of shock. Early intervention to maintain an unobstructed

**Table 85.7** Vasoactive Medications to Treat Shock

DRUG	EFFECT(S)	DOSING RANGE	COMMENT(S)
Epinephrine	↑ Heart rate and ↑ cardiac contractility  Vasodilator at low doses, but potent vasoconstrictor at doses >0.1 mcg/kg/min	0.05-2.0 μg/kg/min	May ↓ renal perfusion at high doses ↑ Myocardial O <sub>2</sub> consumption Risk of arrhythmia at high doses
Norepinephrine	Potent vasoconstriction  ↑ Cardiac contractility (but may be blunted by increased afterload)	0.05-2.0 μg/kg/min	↑ Blood pressure secondary to ↑ systemic vascular resistance ↑ Left ventricular afterload
Dopamine	↑ Cardiac contractility Significant peripheral vasoconstriction at >10 μg/kg/min	3-20 μg/kg/min	↑ Risk of arrhythmias at high doses
Dobutamine	↑ Cardiac contractility Peripheral vasodilator	3-10 μg/kg/min	—
Phenylephrine	Potent vasoconstriction No effect on cardiac contractility	0.25-2.0 μg/kg/min	Can cause sudden hypertension
Vasopressin	Potent vasoconstriction	0.5-20 milliunits/kg/min	Can cause sudden hypertension
Angiotensin II	Potent vasoconstrictor	Stepwise increase 5-10-25-40-80 ng/kg/min over 3 hr with titration down to 1.25-40 ng/kg/min after 3 hr	Can cause sudden hypertension, arterial ischemia
Methylene blue	Reduce responsiveness to cGMP-dependent (e.g., ischemia-reperfusion, NO mediated) vasodilators	Bolus 1-2 mg/kg, then consider continuous infusion 0.5-.01 mg/kg/hr	Causes blue/green discoloration of skin and urine
Milrinone	Increased cardiac contractility Improves cardiac diastolic function Peripheral vasodilation	0.25-1.0 μg/kg/min	Phosphodiesterase inhibitor—slows cyclic adenosine monophosphate breakdown
Prostaglandin E <sub>1</sub>	Vasodilator Maintains an open ductus arteriosus in the newborn with ductal-dependent congenital heart disease	0.01-0.2 μg/kg/min	Can lead to hypotension Risk of apnea

airway may be needed in patients who are obtunded or have suffered a traumatic neck or chest injury. Supplemental oxygen should be provided to correct hypoxemia if SpO<sub>2</sub> is <92–94%. Although universal supplemental oxygen administration can, in theory, augment tissue oxygen delivery by increasing oxygen content of the blood, this approach is of little benefit if the oxyhemoglobin saturation is >92–94%, and some studies suggest harm from hyperoxia. However, universal administration of high fraction of inspired oxygen is likely to be beneficial for patients with severe anemia or dissociative shock. When oxygen is required, use of a 100% non-rebreather mask provides the highest amount of noninvasive supplemental oxygen delivery.

Indications for intubation and mechanical ventilation include acute hypoxemic or hypercarbic respiratory failure or persistence of circulatory failure, in which case a reduction in metabolic demand facilitated by sedation and ventilatory support can be helpful. Sedation and endotracheal intubation reduce the work of breathing, which can divert cardiac output away from the muscles of respiration and improve perfusion to other organs. However, extra caution needs to be taken during intubation and the transition from negative pressure to positive pressure ventilation. Positive pressure ventilation will decrease venous return in a patient who is already hypovolemic, which could precipitate cardiovascular collapse. It is therefore prudent to have fluid boluses readily available and vasoactive agents started or immediately ready to administer during this transition. Of the sedative agents available for intubation, ketamine is generally preferred because of its favorable hemodynamic effects that typically augment cardiac output and BP. As several studies have reported adverse outcomes after intubation with etomidate, pediatric septic shock guidelines recommend against using etomidate in these patients.

### Specific Management Considerations by Shock Type

For children with **cardiogenic shock** due to congenital heart disease, cardiomyopathies, myocarditis, MIS-C, or other causes, decreased myocardial contractility must be reversed by early treatment with inotropes, such as epinephrine, dopamine, dobutamine, or milrinone. Gentle volume resuscitation to optimize preload may also be helpful, but excessive fluid administration can worsen volume overload and further compromise heart function. Despite adequate cardiac output with the support of inotropic agents, a high SVR with poor peripheral perfusion and acidosis may persist in cardiogenic shock. Therefore, if not already started, inodilators such as milrinone may improve systolic function and decrease SVR without causing a significant increase in HR. Furthermore, this agent has the added benefit of enhancing diastolic relaxation. Dobutamine or other vasodilating agents, such as nitroprusside, may also be considered in this setting (see Table 85.7).

In **obstructive shock**, action is often needed to relieve the point of mechanical obstruction. Examples include thoracentesis for tension pneumothorax, pericardiocentesis for cardiac tamponade, and administration of systemic fibrinolytic medications for pulmonary embolism. For neonates or young infants (typically <2-3 weeks of age) with shock caused by ductal-dependent congenital heart disease, a prostaglandin infusion should be started to maintain systemic cardiac output while preparing to transfer to a pediatric specialty center.

The management of **septic shock** should follow the recommendations of the 2020 Surviving Sepsis Campaign International Guidelines for the Management of Septic Shock and Sepsis-Associated Organ Dysfunction in Children (see Fig. 85.2 and Fig. 85.3). These guidelines recommend six initial management steps in the first hour after shock



recognition, including obtaining IV/IO access, collecting a blood culture, administering empiric broad-spectrum antibiotics, measuring lactate, providing volume resuscitation, and initiating vasoactive medication if shock persists despite fluid therapy. Early administration of antibiotics targeted to the most likely pathogens for each patient has been associated with reduced mortality and more rapid resolution of organ dysfunction.

Notably, the Surviving Sepsis Campaign suggests volume resuscitation with up to 40–60 mL/kg in bolus fluid (10–20 mL/kg per bolus) over the first hour, titrated to clinical markers of cardiac output and discontinued if signs of fluid overload develop, for children with septic shock treated in geographic regions that have access to intensive care (either locally or via transport) or in any setting when hypotension is present. However, in healthcare systems with no availability to access intensive care, fluid bolus therapy was associated with increased risk of mortality in the FEAST clinical trial when hypotension was not present, and thus fluid management should focus on starting maintenance fluids only in these settings (see Fig. 85.3).

### Fluid-Refractory and Catecholamine-Resistant Shock

If shock persists despite volume resuscitation and vasoactive support with an initial catecholaminergic agent, such as epinephrine, the child has **fluid-refractory and catecholamine-resistant shock**. Such children have an increased risk for MODS and death, especially if requirement for vasoactive support is high, blood lactate exceeds 8 mmol/L (or is rising after 6 hours of resuscitation), and/or myocardial dysfunction is present. Several additional management considerations must be taken into account in this scenario, including evaluation for atypical and/or reversible etiologies, second-line vasoactive medications, stress-dose corticosteroids, and extracorporeal membrane oxygenation (ECMO).

**Atypical and reversible etiologies** that may contribute to refractory shock include hypothyroidism and intraabdominal hypertension/abdominal compartment syndrome. In addition, one must consider the presence of obstructive shock (tamponade, pneumothorax), an unrecognized closing ductus arteriosus, uncontrolled hemorrhage (which often requires surgical intervention), anaphylaxis, and need for removal of an infectious source (e.g., infected catheter, empyema, abdominal abscess).

**Stress-dose corticosteroids** are indicated for patients with septic shock who have absolute adrenal insufficiency, such as that caused by congenital adrenal hyperplasia, septic shock with purpura, prior steroid therapy for chronic illness, or hypopituitarism. Some children with septic shock may also develop *critical illness–related corticosteroid insufficiency* with an inadequate adrenal response to a severe stress. Stress doses of hydrocortisone (50–100 mg per m<sup>2</sup> per day) are recommended for those with risk factors for absolute adrenal insufficiency (e.g., septic shock with purpura, prior steroid therapy for chronic illness, known pituitary or adrenal abnormalities) and can be considered for children with fluid-refractory, catecholamine-resistant shock without a reversible etiology pending further data from ongoing clinical trials.

**Second-line vasoactive therapy** should be considered for patients in whom shock persists despite titration of the initial vasoactive agent. For patients with “warm” shock or evidence of low SVR initially treated with norepinephrine, the addition of vasopressin or epinephrine may be considered. Case reports, case series, and one trial indicate that administration of vasopressin is associated with an increase in mean arterial BP and urine output in children with fluid-refractory, catecholamine-resistant septic shock. However, in a multicenter trial of 65 children with vasodilatory shock, low-dose vasopressin did not decrease the time to hemodynamic stability off of vasoactive agents versus placebo (49.7 vs 47.1 hours), and there was a concerning trend toward increased mortality in the vasopressin group (30% vs 16%,  $p = 0.24$ ). For patients with “cold” shock or evidence of myocardial dysfunction, priority should be given to improving cardiac contractility

with inotropes. First-line therapy with epinephrine is recommended, with addition of dopamine, dobutamine, or norepinephrine as second-line agents, but these agents should be carefully titrated, as they may contribute to arrhythmias and increase myocardial oxygen demand. Initiation of inodilators, such as milrinone, can help to augment contractility, improve lusitropy (diastolic relaxation), and lower SVR but are generally longer-acting and should be carefully titrated to avoid worsening hypotension. Notably, it may be difficult to accurately differentiate between “warm” (low SVR) from “cold” (high SVR) shock using only clinical signs, such as extremity temperature, strength of peripheral pulses, and capillary refill time. Frequent reassessment and response to therapy are therefore paramount to ensure optimal titration of vasoactive therapies.

ECMO is a rescue option for patients suffering refractory septic shock, with reported survival rates of ~70% for newborns and ~50% for older children. One study suggests that central cannulation via sternotomy may achieve survival rates of 74% for refractory septic shock. In cardiogenic shock due to myocarditis treated with ECMO, survival rates of 70% have been reported. Although counterintuitive because of the need for systemic anticoagulation, ECMO has also been used successfully in hemorrhagic shock in a small series. In most cases of refractory shock, venoarterial ECMO is preferred over the venovenous route due to the presence of hemodynamic instability. A ventricular assist device may be considered as an alternative to ECMO in some children with cardiogenic shock.

### Targets for Shock Reversal

Clinical signs of successful resuscitation include a decrease in HR and respiratory rate, increase in BP, improved urine output to >0.5 mL/kg/hr, normalization of mental status, decreased capillary refill time, warmth of distal extremities, and improved peripheral pulses. Serial laboratory measurements should aim for a rise in Svo<sub>2</sub> to >70% and a decreasing trend in blood lactate levels as evidence for increased tissue oxygen extraction and adequate oxygen delivery to meet cellular metabolic demand. In one observational study of septic shock in children, normalization of blood lactate to <2 mmol/L within 4 hours was associated with reduced organ dysfunction. Blood pH and base deficit may also be used as laboratory surrogates for improved tissue perfusion, but these may be affected by the degree of hyperchloremia after fluid resuscitation or by changes in ventilation.

Other parameters to monitor for improvement in shock include serial POCUS to assess volume status, cardiac output, and tissue perfusion; cutaneous near-infrared spectroscopy (NIRS) to measure regional tissue perfusion; and other devices that can estimate cardiac output based on the relationship among BP, stroke volume, arterial compliance, and SVR (e.g., pulse contour waveform analysis). If cardiac output is measured, aiming for a cardiac index between 3.3 and 6.0 L/min/m<sup>2</sup> is appropriate.

Though children can have isolated cardiovascular dysfunction with shock, many have additional associated organ dysfunctions or MODS. Ongoing support of noncardiovascular organ dysfunction is often required even after improvement or resolution of shock.

### PROGNOSIS

In septic shock, mortality rates are as low as 3% in previously healthy children and 6–9% in children with chronic illness (compared with 25–30% in adults). With early recognition and therapy, the mortality rate for pediatric shock continues to improve, but shock and MODS remain one of the leading causes of nonaccidental death in infants and children. The risk of death involves a complex interaction of factors, including the underlying etiology, presence of chronic illness, host immune response, and timing of recognition and therapy.

Visit Elsevier eBooks+ at [eBooks.Health.Elsevier.com](http://eBooks.Health.Elsevier.com) for Bibliography.

## Chapter 86

## Acute Care of Respiratory Distress and Failure

Alexandre T. Rotta, Martin C.J. Kneyber, and Ashok P. Sarnaik

The term *respiratory distress* is used to denote signs and symptoms of an abnormal respiratory pattern. A child with nasal flaring, tachypnea, chest wall retractions, stridor, grunting, dyspnea, or wheezing has respiratory distress. Taken together, the magnitude of these findings is used to judge clinical severity. Nasal flaring is nonspecific, but the other signs are useful in localizing the site of pathology (see Chapter 421). *Respiratory failure* is defined as the inability of the lungs to provide sufficient oxygen (hypoxic respiratory failure) or remove carbon dioxide (ventilatory failure) to meet metabolic demands. Therefore, whereas respiratory distress is determined by a clinical impression, respiratory failure is diagnosed when inadequate oxygenation or ventilation (or both) are present. Respiratory distress can occur in patients without respiratory disease, and respiratory failure can occur in patients without respiratory distress.

## RESPIRATORY DISTRESS

A careful physical examination must be performed when evaluating a child in respiratory distress. **Nasal flaring**, although nonspecific, is an extremely important sign of distress in infants. It may indicate discomfort, pain, fatigue, acidosis, or breathing difficulty. The state of **responsiveness** is another crucial sign. Lethargy, disinterest in surroundings, and weak cry are suggestive of exhaustion, hypercarbia, and impending respiratory failure. Abnormalities of the rate and depth of **breathing** can occur with both pulmonary and nonpulmonary causes of respiratory distress. In diseases of decreased lung compliance, such as pneumonia and pulmonary edema, breathing is characteristically rapid and shallow (decreased tidal volume). In obstructive airway diseases, such as asthma and laryngotracheitis, breathing generally is deep with increased tidal volume, but less rapid. Rapid and deep breathing (tachypnea and hyperpnea) without other respiratory signs should raise suspicion of possible nonpulmonary or nonthoracic causes of respiratory distress, such as response to metabolic acidosis (e.g., diabetic ketoacidosis, renal tubular acidosis) or stimulation of the respiratory center (e.g., encephalitis, ingestion of central nervous system stimulants). Suprasternal, intercostal, and subcostal **retractions** are manifestations of increased inspiratory effort, weak chest wall, or both. Inspiratory **stridor** indicates airway obstruction above the thoracic inlet, whereas expiratory **wheezing** results from airway obstruction below the thoracic inlet. **Grunting** is most commonly heard in diseases with decreased functional residual capacity (e.g., pneumonia, pulmonary edema) or peripheral airway obstruction (e.g., bronchiolitis).

## Respiratory Disease Manifesting as Respiratory Distress

Clinical examination is paramount in localizing the site of pathology and creating a differential diagnosis. Extrathoracic airway obstruction occurs anywhere above the thoracic inlet and is marked by inspiratory stridor, retractions, and prolongation of inspiration. In contrast, features of intrathoracic airway obstruction are prolongation of expiration and expiratory wheezing. Typical manifestations of alveolar interstitial pathology are rapid, shallow respirations, chest wall retractions, and grunting (Tables 86.1 and 86.2).

## Respiratory Distress Without Respiratory Disease

Although respiratory distress most frequently results from diseases of lungs, airways, and chest wall, pathology in other organ systems can manifest as respiratory distress and lead to misdiagnosis and inappropriate management (Table 86.3). Respiratory distress resulting from heart failure or diabetic ketoacidosis may be misdiagnosed as asthma and improperly treated with albuterol, resulting in worsened hemodynamic state or ketoacidosis. Careful history and physical examination provide essential clues in avoiding misdiagnosis.

## Cardiovascular Disease Manifesting as Respiratory Distress

A child with cardiovascular pathology may present with respiratory distress caused by either *decreased lung compliance* or *cardiogenic shock* (Table 86.4). Diseases that result in increased pulmonary arterial blood flow (e.g., left-to-right shunts) or increased pulmonary venous pressure (e.g., left ventricular dysfunction from hypertension or myocarditis, obstructed total anomalous pulmonary venous return) cause an increase in pulmonary capillary pressure and transudation of fluid into the pulmonary interstitium and alveoli. The increased pulmonary blood and water content lead to decreased lung compliance and result in rapid shallow breathing.

It is important to recognize that interstitial lung edema may not only manifest as alveolar fluid but as small airway obstruction as well. **Wheezing** as a sign of congestive cardiac disease is common in infants and young children and should be recognized. Patients with cardiac lesions that result in low cardiac output often present in shock. For example, obstructive lesions of the left side of the heart (e.g., critical coarctation of the aorta) and acquired or congenital cardiomyopathy result in decreased perfusion and metabolic acidosis, as well as respiratory distress because of chemoreceptor and baroreceptor stimulation. The likelihood of a particular cardiovascular illness manifesting as respiratory distress depends on age at presentation (Table 86.5).

## Neurologic Disease Manifesting as Respiratory Distress

Central nervous system (CNS) dysfunction can lead to alterations in respiratory patterns and manifest as respiratory distress. Increased intracranial pressure (ICP) may manifest as respiratory distress. Early rise in ICP results in stimulation of respiratory centers, leading to increases in the rate (**tachypnea**) and depth (**hyperpnea**) of respiration. The resultant decrease in arterial blood partial pressure of carbon dioxide (PaCO<sub>2</sub>) and elevation of cerebrospinal fluid (CSF) pH leads to cerebral vasoconstriction and temporary amelioration of intracranial hypertension. Stereotypical respiratory patterns are associated

Table 86.1 Typical Localizing Signs for Pulmonary Pathology

SITE OF PATHOLOGY	RESPIRATORY RATE	RETRACTIONS	AUDIBLE MANIFESTATION
Extrathoracic airway	↑	↑↑↑↑	Stridor
Intrathoracic extrapulmonary	↑	↑↑	Wheezing
Intrathoracic intrapulmonary	↑↑	↑↑	Wheezing
Alveolar or interstitial	↑↑↑	↑↑↑	Grunting, crackles

Table 86.2 Examples of Anatomic Sites of Lesions Causing Respiratory Failure	
LUNG	RESPIRATORY PUMP
<b>CENTRAL AIRWAY OBSTRUCTION</b>	<b>THORACIC CAGE</b>
Choanal atresia Tonsilloadenoidal hypertrophy Retropharyngeal/peritonsillar abscess Laryngomalacia Epiglottitis Vocal cord paralysis Laryngotracheitis Subglottic stenosis Vascular ring/pulmonary sling Mediastinal mass Foreign body	Kyphoscoliosis Diaphragmatic hernia Flail chest Eventration of diaphragm Asphyxiating thoracic dystrophy Prune-belly syndrome Dermatomyositis Abdominal distention
<b>PERIPHERAL AIRWAY OBSTRUCTION</b>	<b>BRAINSTEM</b>
Asthma Bronchiolitis Foreign body Aspiration of gastric contents Cystic fibrosis $\alpha_1$ -Antitrypsin deficiency	Arnold-Chiari malformation Central hypoventilation syndrome CNS depressants, including drug overdose Trauma Increased intracranial pressure CNS infections
<b>ALVEOLAR OR INTERSTITIAL DISEASE</b>	<b>SPINAL CORD</b>
Lobar pneumonia* ARDS Surfactant deficiency Interstitial pneumonia Hydrocarbon pneumonitis Pulmonary hemorrhage/hemosiderosis Vaping lung injury Smoke inhalation Drowning	Trauma Transverse myelitis Spinal muscular atrophy Poliomyelitis Compression (tumor, abscess, bleed) Acute flaccid myelitis
	<b>NEUROMUSCULAR</b>
	Phrenic nerve injury Birth trauma Infant botulism Guillain-Barré syndrome Muscular dystrophy Myasthenia gravis Organophosphate poisoning

\*Including bacteria and viral; fungal or parasitic less common.  
ARDS, Acute respiratory distress syndrome; CNS, central nervous system.

with dysfunction at various levels of the brain. Cerebral hemisphere and midbrain lesions result in hyperpnea and tachypnea. In such situations, arterial blood gas (ABG) measurements typically show respiratory alkalosis without hypoxemia. Pathology affecting the pons and medulla manifests as irregular breathing patterns such as **apneustic breathing** (prolonged inspiration with brief expiratory periods), **Cheyne-Stokes breathing** (alternate periods of rapid and slow breathing), and irregular, ineffective breathing or apnea (Table 86.6). Along with respiratory changes, other manifestations of CNS dysfunction and increased ICP generally are present, such as focal neurologic signs, pupillary abnormalities, hypertension, and bradycardia (see Chapter 82). Occasionally, severe CNS dysfunction can result in **neurogenic pulmonary edema** and respiratory distress, which may follow excessive sympathetic discharge resulting in increased pulmonary venous hydrostatic pressure and increased pulmonary capillary permeability. **Central neurogenic hyperventilation** is characteristically observed in illnesses such as urea cycle defects and encephalitis. **Bradycardia** and **apnea** may be caused by CNS-depressant medications, poisoning, prolonged hypoxia, trauma, or infection (see Table 86.2).

Table 86.3 Nonpulmonary Causes of Respiratory Distress		
DOMAIN	EXAMPLE(S)	MECHANISM(S)
Cardiovascular	Left-to-right shunt Congestive heart failure Cardiogenic shock	↑ Pulmonary blood/water content Metabolic acidosis Baroreceptor stimulation
CNS	Increased intracranial pressure Encephalitis Neurogenic pulmonary edema Toxic encephalopathy	Stimulation of brainstem respiratory centers
Metabolic	Diabetic ketoacidosis Organic acidemia Hyperammonemia	Stimulation of central and peripheral chemoreceptors
Renal	Renal tubular acidosis  Hypertension	Stimulation of central and peripheral chemoreceptors  Left ventricular dysfunction → increased pulmonary blood/water content
Infection	Toxic shock syndrome Septic shock Meningococemia	Cytokine stimulation of respiratory centers Baroreceptor stimulation from shock Metabolic acidosis

CNS, Central nervous system.  
Courtesy Dr. Ashok Sarnaik.

### Toxic Metabolic States Manifesting as Respiratory Distress

Direct stimulation of respiratory centers resulting in respiratory alkalosis is encountered in intoxication involving agents such as salicylates and theophylline. Similarly, intoxication with general CNS stimulants, such as cocaine and amphetamines, may result in increased respiration. Presence of endogenous (e.g., organic acids) or exogenous (e.g., methanol, ethylene glycol, salicylates) toxins causes metabolic acidosis and compensatory hyperventilation, which can manifest as respiratory distress. ABG measurements show decreased pH and compensatory hypocarbia with normal oxygenation. Conversely, metabolic disorders with hyperammonemia cause respiratory alkalosis (decreased  $P_{aCO_2}$  with increased pH) as ammonia directly stimulates the respiratory centers. Cyanide poisoning and methemoglobinemia may also produce respiratory distress.

### Other Nonpulmonary Entities Manifesting as Respiratory Distress

**Sepsis** and **septic shock** may cause respiratory distress from hypovolemic stimulation of baroreceptors, cytokine stimulation of respiratory centers, and lactic acidosis; they can also lead to **acute respiratory distress syndrome (ARDS)**. Other indirect causes of ARDS include systemic inflammatory conditions, trauma, transfusion-related acute lung injury, and pancreatitis. Similarly, renal disease may manifest as respiratory distress by causing metabolic acidosis (e.g., renal tubular acidosis or renal failure) or hypertensive left ventricular failure and fluid overload.

### RESPIRATORY FAILURE

Respiratory failure occurs when oxygenation and ventilation are insufficient to meet the metabolic demands of the body. Respiratory failure may result from an abnormality in (1) lung and airways, (2) chest wall and muscles of breathing, or (3) central and peripheral chemoreceptors. Clinical manifestations depend largely on the site of pathology. Although respiratory failure is traditionally defined as respiratory

**Table 86.4** Cardiovascular Pathology Manifesting as Respiratory Distress**I. DECREASED LUNG COMPLIANCE****A. Left-to-right shunts**

- Ventricular septal defect, atrial septal defect, patent ductus arteriosus, atrioventricular canal, truncus arteriosus
- Cerebral or hepatic arteriovenous fistula

**B. Ventricular failure**

- Left heart obstructive lesions
  - Aortic stenosis
  - Coarctation of the aorta
  - Interrupted aortic arch
  - Mitral stenosis
  - Hypoplastic left heart syndrome
- Myocardial infarction
  - Anomalous left coronary artery from the pulmonary artery (ALCAPA)
  - Ventriculocoronary arterial connections (coronary sinusoids)
- Hypertension
  - Acute glomerulonephritis
- Inflammatory/infectious
  - Myocarditis
  - Pericardial effusion
- Idiopathic/genetic
  - Dilated cardiomyopathy
  - Hypertrophic obstructive cardiomyopathy
  - Takotsubo syndrome

**C. Pulmonary venous obstruction**

- Total anomalous pulmonary venous connection with obstruction
- Cor triatriatum

**II. SHOCK RESULTING IN METABOLIC ACIDOSIS****A. Left heart obstructive lesions****B. Acute ventricular failure**

- Myocarditis, myocardial infarction

dysfunction resulting in arterial partial pressure of oxygen ( $P_{aO_2}$ ) <60 mm Hg when breathing ambient air and  $P_{aCO_2}$  >50 mm Hg resulting in acidemia, the patient's general state, respiratory effort, and potential for impending exhaustion are more important indicators than ABG values.

**Pathophysiology**

Respiratory failure can be classified into *hypoxic* respiratory failure (failure of oxygenation) and *hypercarbic* respiratory failure (failure of ventilation). Systemic venous (pulmonary arterial) blood is arterialized through equilibration with alveolar gas in the pulmonary capillaries and is carried back to the heart by pulmonary veins. Arterial blood oxygen and carbon dioxide content are influenced by the composition of the inspired gas, effectiveness of alveolar ventilation, pulmonary capillary perfusion, and diffusion capacity of the alveolar capillary membrane. An abnormality in any of these steps can result in respiratory failure. **Hypoxic respiratory failure** results from intrapulmonary shunting and venous admixture or insufficient diffusion of oxygen from alveoli into pulmonary capillaries. This physiology can be caused by small airways obstruction, increased barriers to diffusion (e.g., interstitial edema, fibrosis), and conditions in which alveoli are collapsed or filled with fluid (e.g., pneumonia, atelectasis, pulmonary edema). In most cases, hypoxic respiratory failure is associated with decreased functional residual capacity and can be managed by lung volume recruitment with positive pressure ventilation. **Hypercarbic respiratory failure** is caused by decreased minute ventilation (i.e., tidal volume multiplied by respiratory rate). This can result from centrally mediated disorders of respiratory drive, increased dead space ventilation, or obstructive airway disease. *Hypoxic and hypercarbic respiratory failure may coexist as a combined failure of oxygenation and ventilation.*

**Table 86.5** Typical Chronology of Heart Disease Presentation in Children

AGE	MECHANISM	DISEASE
Newborn (1-10 days)	↑ Arteriovenous pressure difference	Arteriovenous malformation (brain, liver)
	Ductal closure	Single ventricle lesions or severe ventricular outflow obstruction
	Independent pulmonary and systemic blood flow	Transposition of the great arteries
Young infant (1-6 mo)	Pulmonary venous obstruction	Total anomalous pulmonary venous return (TAPVR)
	↓ Pulmonary vascular resistance	Left-to-right shunt lesions
Any age	↓ Pulmonary artery pressure	Anomalous left coronary artery from the pulmonary artery (ALCAPA)
	Heart rate disturbance	Tachyarrhythmias or bradyarrhythmias
	Infection	Myocarditis, endocarditis, pericarditis
	Abnormal cardiac myocytes	Cardiomyopathy
	Excess afterload	Hypertension

**Ventilation-Perfusion Mismatch**






For exchange of  $O_2$  and  $CO_2$  to occur, alveolar gas must be exposed to blood transiting in close proximity through the pulmonary capillaries. Both ventilation and perfusion are lower in nondependent areas (upper lobes in upright position) of the lung and higher in dependent areas (lower lobes in upright position). The difference in perfusion ( $\dot{Q}$ ) is greater than the difference in ventilation ( $\dot{V}$ ). Perfusion in excess of ventilation results in incomplete arterialization of systemic venous (pulmonary arterial) blood and is referred to as **venous admixture**. Perfusion of unventilated areas is referred to as **intrapulmonary shunting**. Conversely, ventilation that is in excess of perfusion is wasted; that is, it does not contribute to gas exchange and is referred to as **dead space ventilation**. Dead space ventilation results in return of greater amounts of atmospheric gas (which has not participated in gas exchange and has negligible  $CO_2$ ) back to the atmosphere during exhalation. The respiratory dead space is divided into the **anatomic dead space** and the **alveolar dead space**. The *anatomic dead space* includes the conducting airways from the nasopharynx to the terminal bronchioles, ends at the alveoli, and has no contact with the pulmonary capillary bed. The *alveolar dead space* refers to areas of the lung where alveoli are ventilated but not perfused. Under normal conditions, this usually occurs in West zone I, where alveolar pressure is greater than pulmonary capillary pressure, thus restricting blood flow. Under clinical conditions, this alveolar dead space may result from dynamic hyperinflation, high levels of positive end-expiratory pressure (PEEP), or large tidal volume in mechanically ventilated patients. Additionally, conditions that cause decreased pulmonary artery perfusion (e.g., pulmonary embolism, decreased cardiac output, hypovolemia) can result in alveolar dead space. The result is a decrease in mixed expired  $CO_2$  ( $P_{E}CO_2$ ) and an increase in the  $P_{aCO_2} - P_{E}CO_2$  gradient. Dead space as a fraction of tidal volume ( $V_D/V_T$ ) is calculated as:

$$(P_{aCO_2} - P_{E}CO_2) \div P_{aCO_2}$$

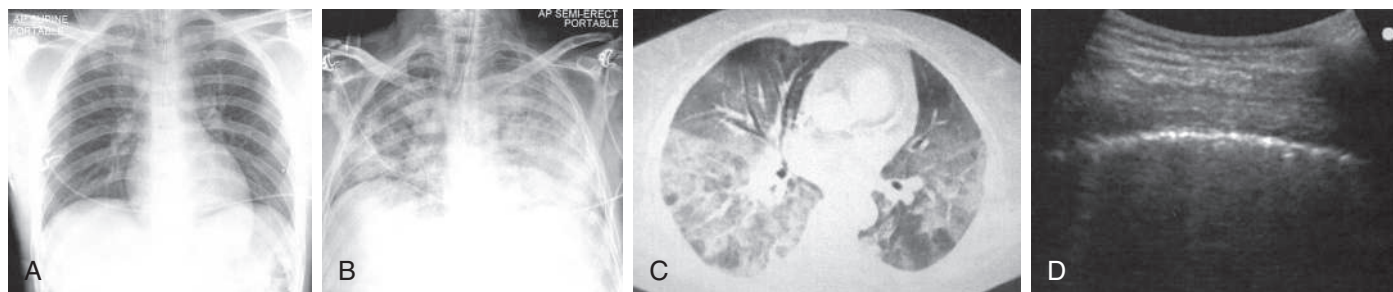
Normal  $V_D/V_T$  is approximately 0.33. Venous admixture and intrapulmonary shunting predominantly affect oxygenation, resulting in an alveolar partial pressure of oxygen ( $P_{AO_2}$ ) to  $P_{aO_2}$  ( $A-aO_2$ ) gradient without elevation in  $P_{aCO_2}$ . This occurs due to greater ventilation of perfused areas, which is sufficient to normalize  $P_{aCO_2}$  but not  $P_{aO_2}$  because of their respective dissociation curves. The relative straight-line



**Table 86.6** Respiratory Patterns in Neurologic Disease

INJURY SITE	PATTERN*	COMMENTS
Normal		Variable $V_T$ with normal respiratory pauses and sighs
Cortex		Hyperpnea and tachypnea
Midbrain		<i>Cheyne-Stokes breathing</i> : Gradually increasing and decreasing $V_T$
Pons		<i>Apneustic breathing</i> : Prolonged inspiration followed by prolonged expiration
Medulla and pons		<i>Biot breathing</i> : Rapid and irregular respirations with pauses

\*Pattern tracings represent lung volume over time.  
 $V_T$ , Tidal volume.



**Fig. 86.1** Acute respiratory distress syndrome (ARDS). A, Normal chest radiograph. B, Chest radiograph demonstrating bilateral alveolar infiltrates consistent with ARDS. C, Chest CT showing bilateral pneumonitis and consolidation with air bronchograms consistent with ARDS. D, Lung ultrasonogram illustrating smooth pleural line, absence of horizontal A lines, and presence of vertical B lines suggestive of ARDS. (Modified from MacSweeney R, McAuley DF. Acute respiratory distress syndrome. *Lancet*. 2016;388:2416-2430, Fig. 3.)

relationship of the hemoglobin- $\text{CO}_2$  dissociation allows for averaging of capillary  $\text{PCO}_2$  ( $\text{P}_{\text{CCO}_2}$ ) from hyperventilated and hypoventilated areas. Because the association between oxygen tension and hemoglobin saturation plateaus with increasing  $\text{Pao}_2$  (i.e., “S-shaped” curve), the decreased hemoglobin- $\text{O}_2$  saturation in poorly ventilated areas cannot be compensated for by well-ventilated areas where hemoglobin- $\text{O}_2$  saturation has already reached near-maximum. This results in decreased arterial oxyhemoglobin saturation ( $\text{Sao}_2$ ) and  $\text{Pao}_2$ . Elevation of  $\text{Paco}_2$  in such situations is indicative of coincident alveolar hypoventilation. Examples of diseases leading to venous admixture include asthma and aspiration pneumonia and pulmonary embolism, and those of intrapulmonary shunt include lobar pneumonia and ARDS.

### Diffusion

Even if ventilation and perfusion are matched, gas exchange requires diffusion across the interstitial space between the alveoli and pulmonary capillaries. Under normal conditions, there is sufficient time for the pulmonary capillary blood to equilibrate with alveolar gas across the interstitial space. When the interstitial space is thickened by extravasated fluid or inflammatory cells, diffusion is impaired. Because the diffusion capacity of  $\text{CO}_2$  is 20 times greater than that of  $\text{O}_2$ , diffusion defects manifest as hypoxemia rather than hypercarbia. Even with the administration of 100% oxygen,  $\text{PAO}_2$  increases to approximately 660

mm Hg from 100 mm Hg at sea level, and the concentration gradient for diffusion of  $\text{O}_2$  is increased by only 6.6 times. Therefore, with diffusion defects, lethal hypoxemia will set in before clinically significant  $\text{CO}_2$  retention results. In fact, in such situations,  $\text{Paco}_2$  is often decreased because of the hyperventilation that accompanies hypoxemia. The presence of hypercarbia in diseases that impair diffusion is indicative of alveolar hypoventilation from coexisting airway obstruction, CNS depression, or exhaustion. Examples of disease that impair diffusion are interstitial pneumonia, scleroderma, pulmonary lymphangiectasia, and ARDS.

### Acute Respiratory Distress Syndrome

Some patients with respiratory failure meet criteria for ARDS, a pulmonary condition of myriad etiologies characterized by hypoxemia of acute onset and chest radiograph findings consistent with acute pulmonary parenchymal disease (Fig. 86.1). ARDS affects both children and adults and can be the result of pulmonary (direct) or extrapulmonary (indirect) insults. Causes of direct ARDS include pneumonia, aspiration of gastric contents or toxic chemicals, lung contusion, and smoke inhalation. Causes of indirect ARDS include sepsis, transfusion-related lung injury, and pancreatitis, to name a few. The diagnostic criteria for pediatric acute respiratory distress syndrome (PARDS) are outlined in Table 86.7.

**Table 86.7** Pediatric Acute Respiratory Distress Syndrome (PARDS 2.0) Definition

Age	Excludes patients with perinatal-related lung disease		
Timing	Within 7 days of a known clinical insult		
Origin of edema	Not fully explained by cardiac failure or fluid overload		
Chest imaging	New opacities (unilateral or bilateral) consistent with acute pulmonary parenchymal disease and which are not due primarily to atelectasis or pleural effusion <sup>a</sup>		
Oxygenation <sup>b</sup>	IMV: OI $\geq$ 4 or OSI $\geq$ 5 NIV <sup>c</sup> : PaO <sub>2</sub> / FiO <sub>2</sub> $\leq$ 300 or SpO <sub>2</sub> / FiO <sub>2</sub> $\leq$ 250		
	<b>Stratification of PARDS severity:</b> Apply $\geq$ 4 after initial diagnosis of PARDS		
	IMV PARDS	Mild/moderate: OI $<$ 16 or OSI $<$ 12	Severe: OI $\geq$ 16 or OSI $\geq$ 12
	NIV PARDS <sup>c</sup>	Mild/moderate: PaO <sub>2</sub> / FiO <sub>2</sub> $>$ 100 or SpO <sub>2</sub> / FiO <sub>2</sub> $>$ 150	Severe: PaO <sub>2</sub> / FiO <sub>2</sub> $\leq$ 100 or SpO <sub>2</sub> / FiO <sub>2</sub> $\leq$ 150
Special Populations <sup>d</sup>			
Cyanotic heart disease	Above criteria, with acute deterioration in oxygenation not explained by cardiac disease		
Chronic lung disease	Above criteria, with acute deterioration in oxygenation from baseline		

<sup>a</sup>Children in resource-limited settings where imaging is not available who otherwise meet PARDS criteria are considered to have possible PARDS.

<sup>b</sup>Oxygenation should be measured at steady state and not during transient desaturation episodes. When SpO<sub>2</sub> is used, ensure that SpO<sub>2</sub> is  $\leq$  97%.

<sup>c</sup>Diagnosis of PARDS on NIV (NIV PARDS) requires full facemask interface with continuous airway positive pressure/positive end-expiratory pressure  $\geq$  5 cm H<sub>2</sub>O.

<sup>d</sup>Stratification of PARDS severity does not apply to these populations.

IMV, invasive mechanical ventilation; NIV noninvasive ventilation; OI, oxygenation index; OSI, oxygen saturation index; PARDS, pediatric acute respiratory distress syndrome; SpO<sub>2</sub>, pulse oximeter oxygen saturation; PaO<sub>2</sub>, partial pressure of arterial oxygen; FiO<sub>2</sub>, fraction of inspired oxygen.

OI = mean airway pressure (MAP) (cm H<sub>2</sub>O)  $\times$  FiO<sub>2</sub> / PaO<sub>2</sub> (mm Hg).

OSI = MAP (cm H<sub>2</sub>O)  $\times$  FiO<sub>2</sub> / SpO<sub>2</sub>.

Adapted from Executive Summary of the Second International Guidelines for the Diagnosis and Management of Pediatric Acute Respiratory Distress Syndrome (PALICC-2): *Pediatr Crit Care Med* 2023;24:143–168.

## MONITORING A CHILD IN RESPIRATORY DISTRESS AND RESPIRATORY FAILURE

### Clinical Examination

Clinical observation is the most important component of monitoring. The presence and magnitude of abnormal clinical findings, their progression with time, and their temporal relation to therapeutic interventions serve as guides to diagnosis and management (see [Chapter 421](#)). As much as possible, the child with respiratory distress or failure should be observed in the position of greatest comfort and in the least threatening environment.

**Pulse oximetry** is the most commonly used technique to monitor oxygenation. Noninvasive and safe, it is the standard of care in bedside monitoring of children during transport, procedural sedation, surgery, and critical illness. It indirectly measures arterial hemoglobin-O<sub>2</sub> saturation by differentiating oxyhemoglobin from deoxygenated hemoglobin through their respective light absorption at wavelengths of 660 nm (red) and 940 nm (infrared). A pulsatile circulation is required to enable detection of arterialized blood entering the capillary bed. Percentage of arterial oxyhemoglobin is reported as SaO<sub>2</sub>; however, the correct description is *oxyhemoglobin saturation as measured by pulse oximetry* (SpO<sub>2</sub>). Such precision is needed because SpO<sub>2</sub> may not always reflect SaO<sub>2</sub>. It is important to be familiar with the hemoglobin-O<sub>2</sub> dissociation curve (see [Chapter 421](#)) to estimate PaO<sub>2</sub> at a given oxyhemoglobin saturation. Because of the shape of the hemoglobin-O<sub>2</sub> dissociation curve, changes in PaO<sub>2</sub> above 70 mm Hg are not readily identified by pulse oximetry. Also, at the same PaO<sub>2</sub>, there may be significant change in SpO<sub>2</sub> at a different blood pH value. In most situations, SpO<sub>2</sub>  $>$ 95% is a reasonable goal, especially in emergency care. In patients receiving supplemental oxygen, a target saturation range of 94–96% should be considered in order to decrease unnecessary exposure that could result in oxygen toxicity. There are exceptions, such as in patients with large left-to-right shunts (e.g., ventricular septal defect, patent ductus arteriosus) or with single-ventricle cardiac lesions in whom the pulmonary and systemic circulations are receiving blood flow from the same ventricle (e.g., after stage I palliation for hypoplastic left heart syndrome). In the latter, a lower SpO<sub>2</sub> (75–85%) is desired to avoid excessive blood flow to the lungs and reduced blood flow to the systemic circulation that can lead to morbidity and death.

Because most commercially available pulse oximeters recognize all types of hemoglobin as either oxyhemoglobin or deoxygenated hemoglobin, they provide inaccurate information in the presence of carboxyhemoglobin and methemoglobin. In carbon monoxide poisoning, **carboxyhemoglobin** absorbs light in the same (red) wavelength as oxyhemoglobin, leading to overestimation of oxygen saturation. **Methemoglobin** absorbs light in both the oxygenated and deoxygenated wavelengths, which can cause either an overestimation or underestimation of oxygen saturation. Data suggest that increasing methemoglobin concentrations tend to drive SpO<sub>2</sub> toward 85%, no matter the actual percent of oxyhemoglobin. At lower methemoglobin levels, the pulse oximetry reading is falsely low, whereas high levels lead to a falsely high pulse oximetry reading. Newer specialized pulse oximeters can distinguish dyshemoglobinemias and prevent false readings, but their use is not widespread. It should be recognized that dangerous levels of hypercarbia may exist in patients with ventilatory failure, who have satisfactory SpO<sub>2</sub> if they are receiving supplemental oxygen. Pulse oximetry should not be the only monitoring method in patients with primary ventilatory failure, such as neuromuscular weakness and CNS depression. It is also unreliable in patients with poor perfusion and poor pulsatile flow to the extremities. Pulse oximetry may underestimate the degree of hypoxia in Black patients. Despite these limitations, pulse oximetry is a noninvasive, easily applicable, and effective means of assessing oxygenation in most patients.

**Volumetric capnography** (end-tidal CO<sub>2</sub> [PetCO<sub>2</sub>] measurement) is helpful to noninvasively assess the effectiveness of ventilation and pulmonary circulation. The PetCO<sub>2</sub> can be used to determine the alveolar dead space fraction (V<sub>D</sub>/V<sub>T</sub>) and is calculated as follows:

$$V_D/V_T = (\text{PaCO}_2 - \text{PetCO}_2) \div \text{PaCO}_2$$

Changes in the alveolar dead space fraction usually correlate well with changes in the gradient of PaCO<sub>2</sub> and PetCO<sub>2</sub> (PaCO<sub>2</sub> – PetCO<sub>2</sub>). Thus a change in PaCO<sub>2</sub> – PetCO<sub>2</sub> can be used as an index of changes in alveolar dead space. Diseases resulting in increased alveolar dead space (e.g., asthma with dynamic hyperinflation) or decreased pulmonary blood flow (e.g., pulmonary embolism, low cardiac output) lead to decreases in PetCO<sub>2</sub> and an increase in PaCO<sub>2</sub> – PetCO<sub>2</sub>. PetCO<sub>2</sub> alone may overestimate adequacy of ventilation.

### Blood Gas Abnormalities

Arterial blood gas analysis offers valuable assistance in diagnosis, monitoring, and management of a child in respiratory distress and failure. Because arterial blood sampling in children can be impractical without an indwelling catheter, a *capillary blood gas* (CBG) sample often is obtained, especially in emergency situations. A properly arterialized CBG sample obtained by warming the digit or heel that yields free-flowing blood is an acceptable surrogate. The blood sample needs to be processed without delay. CBG provides a good estimate of  $P_{aCO_2}$  and arterial pH, but less so for  $P_{aO_2}$ . In patients who mainly require monitoring of ventilation (especially those whose oxygenation is being monitored with pulse oximetry), a *venous blood gas* sample provides a reasonable estimate of arterial pH and  $P_{aCO_2}$  values, provided tissue perfusion is adequate. Venous  $PCO_2$  ( $P_{vCO_2}$ ) is approximately 6 mm Hg higher and pH approximately 0.03 lower than the arterial values.  $P_{vO_2}$  has a poor correlation with  $P_{aO_2}$ . Mixed venous  $O_2$  saturation obtained from a central venous catheter in the right atrium is a useful marker of the balance between oxygen delivery and oxygen consumption. In patients with a constant arterial  $O_2$  content and  $O_2$  consumption, mixed venous  $O_2$  saturation offers valuable information about cardiac output.

Blood gas analysis is important not only for determining the adequacy of oxygenation and ventilation but also for determining the site of respiratory pathology and planning treatment (see Chapter 421). Briefly, in the presence of pure alveolar hypoventilation (e.g., airway obstruction above carina, decreased  $CO_2$  responsiveness, neuromuscular weakness), the blood gas will show respiratory acidosis with an elevated  $P_{aCO_2}$  but a relative sparing of oxygenation.  $\dot{V}/\dot{Q}$  mismatch (peripheral airway obstruction, bronchopneumonia) will be reflected in increasing hypoxemia and variable levels of  $P_{aCO_2}$  (low, normal, high) depending on severity of disease. Intrapulmonary right-to-left shunting and diffusion defects (alveolar-interstitial diseases such as pulmonary edema, ARDS) will be associated with a large A-a $O_2$  gradient and hypoxemia with relative sparing of  $CO_2$  elimination, unless there is coincident fatigue or CNS depression.

### Acid-Base Abnormalities

It is crucial to analyze the magnitude and appropriateness of changes in pH,  $P_{aCO_2}$ , and bicarbonate concentration ( $[HCO_3^-]$ ) because they provide useful clues to the underlying pathophysiology and presence of more than one disorder. To do so, it is useful to assume baseline values of pH 7.40,  $P_{aCO_2}$  40 mm Hg, and  $[HCO_3^-]$  24 mEq/L. Newborns have a lower renal threshold for bicarbonate and therefore have slightly different baseline values of pH 7.38,  $P_{aCO_2}$  35 mm Hg, and  $[HCO_3^-]$  20 mEq/L.

### Metabolic Acidosis with Respiratory Compensation

Patients with metabolic acidosis have decreased pH resulting from decreased serum  $[HCO_3^-]$ . Chemoreceptor stimulation results in hyperventilation and respiratory compensation that may clinically manifest as respiratory distress. Normal compensation does not completely correct the pH, but rather minimizes a change in pH that would otherwise occur without compensation. The adequacy of respiratory compensation is judged by the extent of the decline in  $P_{aCO_2}$  in response to the decline in  $[HCO_3^-]$  or pH. A normal compensation for metabolic acidosis results in a fall in  $P_{aCO_2}$  by 1.2 mm Hg for every 1 mEq/L fall in  $[HCO_3^-]$ . The most commonly used method to analyze the adequacy of respiratory compensation is Winter's formula:

$$P_{aCO_2} \text{ mm Hg} = (HCO_3^- \times 1.5) + 8 \pm 2$$

A quick method is to look at the last two digits of pH (provided it is not <7.10), which should be within 2 mm Hg of  $P_{aCO_2}$ . For example, pH 7.27,  $P_{aCO_2}$  26 mm Hg, and  $[HCO_3^-]$  12 mEq/L represent metabolic acidosis with a normal respiratory compensation response. On the other hand, pH 7.15,  $P_{aCO_2}$  30 mm Hg, and  $[HCO_3^-]$  10 mEq/L constitutes metabolic acidosis with inadequate respiratory compensation. The reasons for inadequate compensation include decreased  $CO_2$  responsiveness (e.g., narcotic poisoning, cerebral edema), abnormalities of lungs and airways, or neuromuscular weakness. A decrease in

$P_{aCO_2}$  that is greater than what could be expected as a normal compensatory response to metabolic acidosis is indicative of a mixed disorder. A pH 7.20,  $P_{aCO_2}$  15 mm Hg, and  $[HCO_3^-]$  7.5 mEq/L represent metabolic acidosis with a concomitant respiratory alkalosis because the decline in  $P_{aCO_2}$  is greater than what can be expected as normal compensation. A combination of metabolic acidosis and respiratory alkalosis is often encountered in serious conditions such as cardiogenic shock (e.g., stimulation of baroreceptors), sepsis, or toxic-metabolic states (e.g., salicylates, organic acidemia).

### Respiratory Acidosis with Metabolic Compensation

Patients with respiratory acidosis have decreased pH as a result of elevated  $P_{aCO_2}$ . An acute increase in  $P_{aCO_2}$  of 10 mm Hg results in a decrease in pH by 0.08. Thus a child with severe critical asthma and a  $P_{aCO_2}$  of 60 mm Hg will have a blood pH of approximately 7.24. Chronically elevated (>3-5 days)  $P_{aCO_2}$  is accompanied by renal compensation and increase in serum  $[HCO_3^-]$ , limiting the fall in pH to 0.03 for every 10 mm Hg rise in  $P_{aCO_2}$ . Thus an infant with bronchopulmonary dysplasia who has a basal  $P_{aCO_2}$  of 60 mm Hg will have a blood pH of approximately 7.34. These findings are helpful in distinguishing acute from chronic changes in  $P_{aCO_2}$ . Also, for a given level of  $CO_2$  accumulation, a decrease in pH that is greater than expected is indicative of concomitant metabolic acidosis, and a decline in pH that is less than expected is caused by accompanying metabolic alkalosis.

### Assessment of Oxygenation and Ventilation Deficits

For standardizing management, following clinical progress, and determining prognosis for patients with defects in oxygenation or ventilation, the following indicators have been proposed, each with its strengths and limitations:

**A-a $O_2$  gradient** is calculated by the subtraction,  $P_{A_{O_2}} - P_{aO_2}$ . For the comparison to be valid, both values must be taken at the same time and with the same fraction of oxygen in the inspired gas ( $F_{IO_2}$ ).

**$P_{aO_2}/F_{IO_2}$  ratio (P/F ratio)** is calculated by dividing  $P_{aO_2}$  by  $F_{IO_2}$ . The P/F ratio is the measure of oxygenation adequacy employed in the Berlin definition of ARDS in adults (Table 86.8). According to the Berlin definition, a P/F  $\leq 300$  mm Hg is consistent with mild ARDS, a P/F ratio between 100 and 200 mm Hg is consistent with moderate ARDS, and a P/F ratio  $\leq 100$  mm Hg is consistent with severe ARDS. Although the intent is to gauge the degree of  $\dot{V}/\dot{Q}$  mismatch, intrapulmonary shunt, and diffusion defect, the status of alveolar hypoventilation could have a significant impact on P/F ratio.

**$Sp_{O_2}/F_{IO_2}$  ratio** may be used as a surrogate measure of oxygenation adequacy when  $P_{aO_2}$  is not available. It is calculated by dividing the pulse oximeter saturation by the  $F_{IO_2}$ . P/F ratios of 200 mm

**Table 86.8** The Berlin Definition of ARDS

- Acute onset (within 7 days of new or worsening respiratory symptoms)
- Bilateral radiographic opacities that are not fully explained by effusion, atelectasis, or masses
- Arterial hypoxemia defined by thresholds:  
Mild:  $200 < P_{aO_2}/F_{IO_2}$  ratio  $\leq 300$  mm Hg, on CPAP\* or PEEP†  $\geq 5$  cm  $H_2O$  (observed mortality 27%)  
Moderate:  $100 < P_{aO_2}/F_{IO_2}$  ratio  $\leq 200$  mm Hg, on PEEP  $\geq 5$  cm  $H_2O$  (observed mortality 32%)  
Severe:  $P_{aO_2}/F_{IO_2}$  ratio  $\leq 100$  mm Hg, on PEEP  $\geq 5$  cm  $H_2O$  (observed mortality 45%)
- Identified risk factor for ARDS (if no clear risk factor, exclude heart failure as a cause)
- Not exclusively the result of cardiac causes

ARDS, acute respiratory distress syndrome; CPAP, continuous positive airway pressure;  $F_{IO_2}$ , fraction of inspired oxygen;  $P_{aO_2}$ , partial pressure of oxygen; PEEP, positive end-expiratory pressure.

\*Delivered by noninvasive or invasive ventilation.

†Delivered by invasive mechanical ventilation.

From Meyer NJ, Gattinoni L, Calfee CS. Acute respiratory distress syndrome. *Lancet*. 2021;398:622-637, Panel 1, p. 622.



Hg and 300 mm Hg correlate approximately with S/F ratios of 235 and 315, respectively. This relationship is most valid for SpO<sub>2</sub> values between 80% and 97%.

**PaO<sub>2</sub>/PAO<sub>2</sub> ratio** is determined by dividing PaO<sub>2</sub> by PAO<sub>2</sub>. The level of alveolar ventilation is accounted for in the calculation of PAO<sub>2</sub>. Therefore PaO<sub>2</sub>/PAO<sub>2</sub> is more indicative of  $\dot{V}/\dot{Q}$  mismatch and alveolar capillary integrity.

**Oxygenation index (OI)** is aimed at standardizing oxygenation to the level of concomitant therapeutic interventions (e.g., mean airway pressure [MAP] and FIO<sub>2</sub>) that influence oxygenation. None of the indicators of oxygenation mentioned earlier take into account the degree of positive pressure respiratory support. The OI is calculated as follows:

$$OI = (MAP \times FIO_2 \times 100) / PaO_2$$

**Oxygenation saturation index (OSI)** is analogous to OI and useful when PaO<sub>2</sub> measurements are not available. It substitutes SpO<sub>2</sub> for PaO<sub>2</sub> in the formula as follows:

$$OSI = (MAP \times FIO_2 \times 100) / SpO_2$$

Both the OI and OSI are used in the Pediatric Acute Lung Injury Consensus Conference (PALICC) definition of PARDS. The main limitation of OI and OSI is that level of ventilation is not accounted for in the assessment.

## MANAGEMENT

The goal of management for respiratory distress and respiratory failure is to ensure a patent airway and provide necessary support for adequate oxygenation of the blood and removal of CO<sub>2</sub>. Compared with hypercapnia, **hypoxemia** is a life-threatening condition; therefore initial therapy for respiratory failure should be aimed at ensuring adequate oxygenation.

### Oxygen Administration

Supplemental oxygen administration is the least invasive and most easily tolerated therapy for hypoxemic respiratory failure. **Nasal cannula** oxygen provides low levels of oxygen supplementation and is easy to administer. Oxygen is humidified in a bubble humidifier and delivered via nasal prongs inserted into the nares. In children, a flow rate <5 L/min is most often used because of increasing nasal irritation with higher flow rates. A common formula for an estimation of the FIO<sub>2</sub> during use of a nasal cannula in older children and adults follows:

$$FIO_2 \text{ (as a percentage)} = 21\% + (\text{Nasal cannula flow [L/min]} \times 3)$$

The typical FIO<sub>2</sub> value (expressed as a percentage rather than a fraction of 1) using this method is between 23% and 40%, although the FIO<sub>2</sub> varies according to the size of the child, the respiratory rate, and the volume of air moved with each breath. In a young child, because typical nasal cannula flow rates are a greater percentage of total minute ventilation, significantly higher FIO<sub>2</sub> may be provided. Alternatively, a **simple mask** may be used, which consists of a mask with open side ports and a valveless oxygen source. Variable amounts of room air are entrained through the ports and around the side of the mask, depending on the fit, size, and minute volume of the child. Oxygen flow rates administered through a simple mask generally vary from 5 to 10 L/min, yielding typical FIO<sub>2</sub> values (expressed as a percentage rather than a fraction of 1) between 30% and 65%. If more precise delivery of oxygen is desired, other mask devices should be used.

A **Venturi mask** provides preset FIO<sub>2</sub> through a mask and reservoir system by entraining precise flow rates of room air into the reservoir along with high-flow oxygen. The adapter at the end of each mask reservoir determines the flow rate of entrained room air and the subsequent FIO<sub>2</sub> adapters provide FIO<sub>2</sub> of 0.30-0.50. Oxygen flow rates of 5-10 L/min are recommended to achieve the desired FIO<sub>2</sub> and to prevent rebreathing. Partial rebreather and non-rebreather masks use a reservoir bag attached to a mask to provide higher FIO<sub>2</sub>. **Partial rebreather masks** have two open exhalation ports and contain a valveless oxygen reservoir bag. Some exhaled gas can mix with reservoir gas, although most exhaled gas exits the mask via the exhalation ports. Through these same ports, room air is entrained, and the partial rebreather mask can

provide FIO<sub>2</sub> up to 0.60 for as long as oxygen flow is adequate to keep the bag from collapsing (typically 10-15 L/min). As with nasal cannulas, smaller children with smaller tidal volumes entrain less room air, and their delivered FIO<sub>2</sub> will be higher. **Non-rebreather masks** include two one-way valves, one between the oxygen reservoir bag and the mask and the other on one of the two exhalation ports. This arrangement minimizes mixing of exhaled and fresh gas and entrainment of room air during inspiration. The second exhalation port has no valve, a safeguard to allow some room air to enter the mask in the event of disconnection from the oxygen source. A non-rebreather mask can provide FIO<sub>2</sub> up to 0.95. The use of a non-rebreather mask in conjunction with an oxygen blender allows delivery of FIO<sub>2</sub> between 0.50 and 0.95 (Table 86.9). When supplemental oxygen alone is inadequate to improve oxygenation, or when ventilation impairments coexist, additional therapies may be necessary.

### Airway Adjuncts

Maintenance of a patent airway is a critical step in establishing adequate oxygenation and ventilation. Artificial pharyngeal airways may be useful in patients with oropharyngeal or nasopharyngeal airway obstruction and in those with neuromuscular weakness in whom inherent extrathoracic airway resistance contributes to respiratory compromise. An **oropharyngeal airway** is a stiff plastic spacer with grooves along each side that is placed in the mouth to run from the teeth along the tongue to its base just above the vallecula. The spacer prevents the tongue from opposing the posterior pharynx and occluding the airway. Because the tip sits at the base of the tongue, it is usually not tolerated by patients who are awake or whose gag reflex is strong. The **nasopharyngeal airway**, or *nasal trumpet*, is a flexible tube that can be inserted into the nose to run from the nostril along the top of the hard and soft palate with the tip ending in the hypopharynx. It is useful in bypassing obstruction from enlarged adenoids or from contact of the soft palate with the posterior pharynx. Because it is inserted past the adenoids, a nasopharyngeal airway should be used with caution in patients with bleeding tendencies.

### Inhaled Gases

**Helium-oxygen mixture (heliox)** is useful in overcoming airway obstruction and improving ventilation. Helium is much less dense and slightly more viscous than nitrogen. When substituted for nitrogen in the inspired gas, helium helps maintain laminar flow across an obstructed airway, decreases airway resistance, and improves ventilation. It is especially helpful in diseases of large airways obstruction in which turbulent airflow is more common, such as acute laryngotracheobronchitis, subglottic stenosis, and vascular ring. To be effective, helium should be administered in concentrations of at least 60%, so associated hypoxemia may limit its use in patients requiring >40% oxygen.

**Table 86.9** Approximate Oxygen Delivery According to Device and Flow Rates in Infants and Older Children\*

DEVICE	FLOW (L/min)	FIO <sub>2</sub> DELIVERED
Nasal cannula	0.1-6	0.21-0.4
Simple face mask	5-10	0.4-0.6
Partial rebreather	6-15	0.55-0.7
Non-rebreather	6-15	0.7-0.95
Venturi mask	5-10	0.25-0.5
Hood/tent	7-12	0.21-1.0
High-flow systems	1-60	0.21-1.0

\*Individual delivery varies and depends on the patient's size, respiratory rate, and gas volume moved with every breath.



**Inhaled nitric oxide (iNO)** is a powerful pulmonary vasodilator. Its use may improve pulmonary blood flow and  $\dot{V}/\dot{Q}$  matching in patients with diseases that elevate pulmonary vascular resistance, such as persistent pulmonary hypertension of the newborn, primary pulmonary hypertension, and secondary pulmonary hypertension from chronic excess pulmonary blood flow (e.g., ventriculoseptal defect) or collagen vascular diseases. iNO is administered in doses ranging generally from 5 to 20 parts per million of inspired gas. Although administration of iNO to unintubated patients is possible, it is most commonly used in patients undergoing mechanical ventilation via an endotracheal tube.

### Positive Pressure Respiratory Support

Noninvasive positive pressure respiratory support is useful in treating both hypoxemic and hypoventilatory respiratory failure. Positive airway pressure helps with aeration of partially atelectatic or fluid-filled alveoli, prevention of alveolar collapse at end exhalation, and increase in functional residual capacity (FRC). These actions improve pulmonary compliance and hypoxemia, and decrease intrapulmonary shunt. In addition, positive pressure ventilation is useful in preventing collapse of extrathoracic airways by maintaining positive airway pressure during inspiration. Improving compliance and overcoming airway resistance also improves tidal volume and, therefore, ventilation.

A **high-flow nasal cannula (HFNC)** delivers conditioned (heated and humidified) gas at flows generally ranging from 0.5 to 2 L/kg/min up to a maximum of 60 L/min. The  $F_{iO_2}$  can be adjusted by provision of gas flow through an oxygen blender, or directly, when a dedicated commercial high-flow system is employed. A properly sized cannula for HFNC support should have prongs that occupy no more than 50% of the cross-sectional area of the nostrils, thus allowing for ample leakage of gas (open system). Therefore although elevated pressures may be generated in areas of the nasopharynx, very low levels of positive expiratory pressure (<1 cm  $H_2O$ ) thought to be clinically insignificant are transmitted to the intrathoracic airway. The principal mechanisms of action of HFNC are washout of  $CO_2$  from the pharyngeal anatomic dead space and facilitation of gas movement across the nasopharyngeal airway resistor. This is in contrast to **continuous positive airway pressure (CPAP)**, a clinically equivalent support modality predicated on the use of a tight-fitting interface (closed system) in the form of nasal prongs, masks, or helmet. CPAP creates a stable level of operator-selected airway pressure that is transmitted to the intrathoracic airway. CPAP levels of 6-7 cm  $H_2O$  have been shown to unload the diaphragm and decrease work of breathing in infants with bronchiolitis. CPAP is most useful in diseases of mildly decreased lung compliance and low FRC, such as bronchiolitis with atelectasis and pneumonia. Patients with diseases of extrathoracic airway obstruction, in which extrathoracic negative airway pressures during inspiration result in airway narrowing (e.g., laryngotracheitis, laryngomalacia, obstructive sleep apnea, postextubation airway edema), may also benefit from CPAP. Potential risks include nasal irritation, pressure injury, hyperinflation from excessive CPAP in smaller patients, and abdominal distention from swallowed air.

**Noninvasive positive airway pressure ventilation (NIPPV)** provides positive airway pressure during exhalation and a higher pressure that supports inspiration, also termed *bilevel noninvasive ventilation* (see Chapter 86.1).

### Endotracheal Intubation and Mechanical Ventilation

When hypoxemia or significant hypoventilation persists despite the interventions already described, endotracheal intubation and mechanical ventilation are indicated. Additional indications for intubation include maintaining airway patency in patients who have the potential for airway compromise, such as those with actual or potential neurologic deterioration, and in patients with hemodynamic instability.

Proper monitoring is essential to ensuring a safe and successful endotracheal intubation. Pulse oximetry, heart rate, and blood pressure monitoring are mandatory and should be forgone only in situations calling for emergency intubation. All necessary equipment, including bag-mask ventilation device, laryngoscope, endotracheal tube (ETT) with stylet, and suction equipment, must be available and working

properly before intubation. The proper internal diameter (ID) for the ETT can be estimated using the following formula:

$$ID = (\text{Age [yr]}/4) + 4$$

Table 86.10 provides average values for age, size, and depth of insertion for tracheal tubes. Preoxygenation of the patient with high  $F_{iO_2}$  is essential and will allow maximum procedure time before the onset of hypoxemia. Although intubation can be accomplished without sedation and pharmacologic paralysis in selected patients, the physiologic benefits of these measures to the patient and to the facilitation of the intubation usually far outweigh the risks. Administration of a sedative and analgesic followed by a neuromuscular-blocking agent is a common pharmacologic regimen for facilitating intubation. In fact, sedation and paralysis with neuromuscular blocking agents should be considered standard unless contraindicated. The particular type and dose of each agent often depends on the underlying disease and clinician preference. Table 86.11 lists commonly used agents. *Dexmedetomidine* has been a standard sedating agent for maintenance during mechanical ventilation. An alternative to this pharmacologic approach is **rapid sequence intubation**, used when endotracheal intubation is urgent or the patient is suspected of having a full stomach and at increased risk of aspiration (see Chapter 79).

Once adequate sedation and/or paralysis has been achieved, ventilation should be assisted with a **bag-mask device**. After optimal preoxygenation, intubation can be performed. The clinician uses the dominant hand to open the patient's mouth and insert the laryngoscope blade gently along the tongue to its base. The airway opening can be visualized by lifting up and away from the clinician, along the axis of the laryngoscope handle. When a *straight* (Miller) laryngoscope blade is used to visualize the glottis, the tip of the blade lifts the epiglottis anteriorly. When a *curved* (Macintosh) blade is used to visualize the glottis, the tip of the blade should be advanced into the vallecula and then lifted. Secretions often obscure visualization at this step and should be suctioned clear. Once clear visualization of the vocal cords is accomplished, the ETT can be placed through the vocal cords. Rapid confirmation of ETT placement is essential and should be assessed by as many of the following steps as possible: (1) presence of exhaled  $CO_2$  determined by a colorimetric device, capnometry, or, preferably, capnography, attached in-line with the ETT; (2) auscultation of both lung fields for equal breath sounds and the epigastrium; (3) bilateral chest wall expansion; and (4) condensation (misting) inside the ETT. An increasing heart rate, if heart rate had decreased before or during

**Table 86.10** Average Size and Depth Dimensions for Tracheal Tubes

PATIENT AGE	INTERNAL DIAMETER (mm)	OROTRACHEAL DEPTH (cm)	NASOTRACHEAL DEPTH (cm)
Premature	2.0-3.0	8-9	9-10
Full-term neonate	3.0-3.5	10	11
6 mo	4.0	11	13
12-24 mo	4.5	13-14	16-17
4 yr	5.0	15	17-18
6 yr	5.5	17	19-20
8 yr	6.0	19	21-22
10 yr	6.5	20	22-23
12 yr	7.0	21	23-24
14 yr	7.5	22	24-25
Adult	8.0-9.0	23-25	25-28

Courtesy Dr. Ashok Sarnaik.

**Table 86.11** Medications Commonly Used for Intubation

DRUG	DOSE	ONSET (min)	DURATION (min)	COMMENTS
<b>SEDATIVES/ANESTHETICS</b>				
Midazolam	0.1 mg/kg IV	3-5	60-120	Amnesia Respiratory depression
Lorazepam	0.1 mg/kg IV	3-5	120-240	Amnesia Respiratory depression
Ketamine	1-2 mg/kg IV 4-6 mg/kg IM	2-3	10-15	↑ HR, BP, and ICP Bronchodilation, sialorrhea
Propofol	1-3 mg/kg IV	0.5-2	10-15	↓ BP Apnea
Thiopental	4-7 mg/kg IV	0.5-1	5-10	↓ BP Apnea
<b>ANALGESICS</b>				
Fentanyl	2-5 μg/kg IV	3-5	30-90	Respiratory depression Chest wall rigidity
Morphine	0.1 mg/kg IV	5-15	120-240	↓ BP Respiratory depression
<b>NEUROMUSCULAR BLOCKING AGENTS</b>				
Vecuronium	0.1 mg/kg IV	1.5-2	30-75	↑ HR Renal elimination
Rocuronium	0.6-1.2 mg/kg IV 1 mg/kg IM	1-1.5	15-60	↑ HR Renal elimination
Cisatracurium	0.1 mg/kg IV	3-5	25-30	Histamine release Nonrenal elimination

BP, Blood pressure; HR, heart rate; ICP, intracranial pressure; IM, intramuscularly; IV, intravenously.

the attempt, and a rising or normal SpO<sub>2</sub> reading are suggestive of successful tube placement. Preoxygenation may significantly delay any drop in SpO<sub>2</sub> with improper tube placement, leading to a delay in its recognition. A properly placed ETT should be well secured to avoid displacement or dislodgement. As soon as feasible, a chest radiograph should also be obtained to confirm proper position of the ETT, which should lie with the tip about halfway between the thoracic inlet and the carina (see Chapter 79).

### Transient Manual Ventilation in Immediate Preintubation and Postintubation Periods

Establishment of supportive ventilation via bag-mask or bag-ETT is required before transport of the patient to a setting of continued critical care. The technique of manual ventilation should take into account the underlying pathology. Mechanical ventilation of patients with diseases characterized by low FRC (e.g., pneumonia, pulmonary edema, ARDS) should include the application of PEEP to prevent alveolar derecruitment. Lung volume recruitment can be accomplished with a PEEP valve on a self-inflating ventilation bag or by careful manipulation of exhaust gas using an anesthesia bag. Such diseases are also characterized by a short time constant for lung deflation and therefore are best managed with relatively small tidal volumes and high ventilation rates.

In contrast, diseases characterized by airway obstruction, such as critical asthma, have prolonged deflation time constants and are therefore best managed with relatively slow rates and high tidal volumes.

Visit Elsevier eBooks+ at [eBooks.Elsevier.com](http://eBooks.Elsevier.com) for Bibliography.

## 86.1 Mechanical Ventilation

Martin C.J. Kneyber, Ashok P. Sarnaik, and  
Alexandre T. Rotta

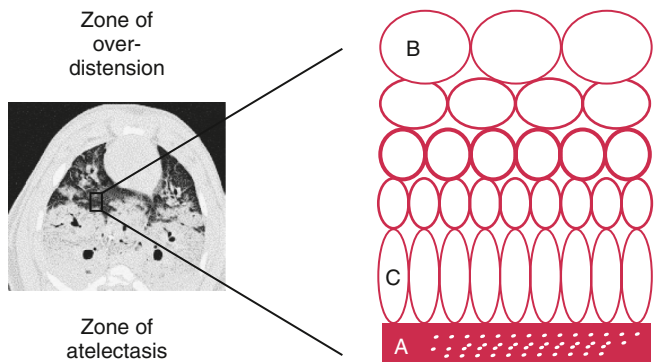
The decision to institute mechanical ventilation is based mainly on the need to assist native pulmonary function in patients with acute respiratory failure; supporting performance of the left ventricle (LV), decreasing metabolic demand, and modulating of cerebral blood flow

in intracranial hypertension are additional indications. Respiratory distress leading to fatigue and impending exhaustion are also indications for respiratory support, even in the presence of adequate gas exchange. Although there are no absolute criteria for derangement of gas exchange, PaO<sub>2</sub> <60 mm Hg while breathing >60% oxygen, PaCO<sub>2</sub> >60 mm Hg, and pH <7.25 are often used in the decision-making to institute respiratory support. Positive pressure ventilation is a powerful means of decreasing LV afterload, and it is used for this purpose in patients with cardiogenic shock resulting from LV dysfunction. Mechanical ventilation is also used in patients whose breathing is unreliable (e.g., unconscious patients, those with neuromuscular dysfunction) and when deliberate hyperventilation is desired, such as in patients with intracranial hypertension.

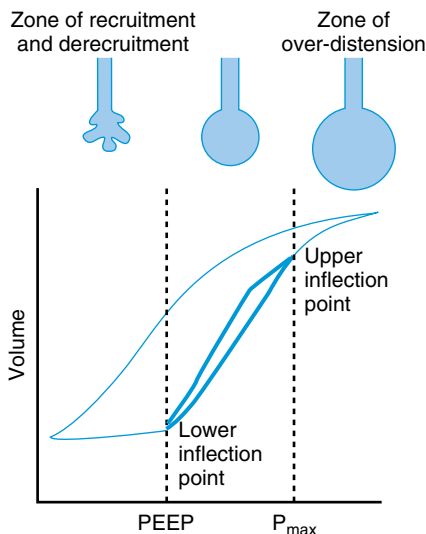
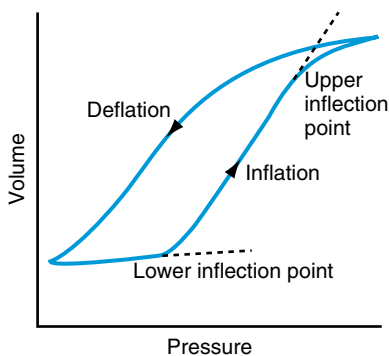
Mechanical ventilation is not intended to normalize gas exchange. The goals are to maintain sufficient oxygenation and ventilation to ensure tissue viability until the disease process that has compromised the patient's lung function has resolved, while minimizing excessive work of breathing and complications. When precisely employed, mechanical ventilation is a lifesaving intervention, yet care must be taken to avoid ventilator-induced lung injury (VILI). Several factors have been identified as contributors to VILI. These include lung strain from the delivery of excessive tidal volume (**volutrauma**), injury from the repetitive opening and closing of alveoli (**atelectrauma**), injury from excessive pressure delivery (**barotrauma**), local and systemic cytokine release (**biotrauma**), and damage caused by oxygen toxicity (Figs. 86.2 and 86.3).

### BASIC CONCEPTS OF VENTILATOR MANAGEMENT Equation of Motion

A pressure gradient is required for air to move from one place to another. During natural spontaneous ventilation, inspiration results from generation of negative intrapleural pressure from contraction of the diaphragm and intercostal muscles, drawing air from the atmosphere across the airways into the alveoli. During mechanical ventilation, inspiration results from positive pressure created by compressed gases through the ventilator, which pushes air across the airways into alveoli. In both spontaneous and mechanical ventilation, exhalation results from alveolar pressure generated by the elastic recoil of the lung

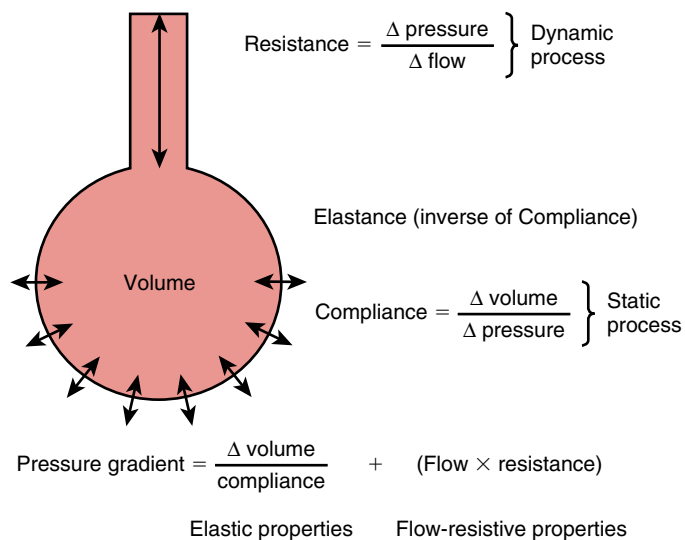


**Fig. 86.2** Atelectrauma. The interface between collapsed and consolidated lung (A) and overdistended lung units (B) is heterogeneous and unstable. Depending on ambient conditions, this region is prone to cyclic recruitment and derecruitment and localized asymmetric stretch of lung units (C) immediately apposed to regions of collapsed lung. (From Pinhu L, Whitehead T, Evans T, et al. Ventilator-associated lung injury. Lancet. 2003;361:332-340.)



**Fig. 86.3** Pulmonary pressure-volume relation in a patient with acute lung injury. Top, The lower inflection point is typically 12-18 cm H<sub>2</sub>O and the upper inflection point 26-32 cm H<sub>2</sub>O. Bottom, Specific protective ventilation strategies require that positive end-expiratory pressure (PEEP) is set just above the lower inflection point and the pressure limit (P<sub>max</sub>) just below the upper inflection point. Thus the lung is ventilated in the safe zone between the zone of recruitment and derecruitment and the zone of overdistention, and both high-volume and low-volume injuries are avoided. This zone is located on the deflation limb of the pressure-volume curve, making use of the pulmonary hysteresis. (From Pinhu L, Whitehead T, Evans T, et al. Ventilator-associated lung injury. Lancet. 2003;361:332-340.)

1. Pressure gradient is required to move air from one place to another
2. Movement of air is opposed by flow-resistive and elastic properties of the system



**Fig. 86.4** Equation of motion. A pressure gradient is required to move air from one place to another. In the lungs, the required pressure gradient must overcome the lung and chest wall elastance (static component) and the flow-resistive properties (dynamic component). The static component is increased in alveolar interstitial diseases and stiff chest wall, whereas the dynamic component is increased with airway obstruction.

and the chest wall. Pressure necessary to move a given amount of air into the lung is determined by two factors: lung and chest wall elastance and airway resistance. Figure 86.4 describes the relationship in pressure gradient, compliance, and resistance. *Elastance*—defined as the change in pressure ( $\Delta P$ ) divided by the change in volume ( $\Delta V$ )—refers to the property of a substance to oppose deformation. It is opposite of *compliance* ( $\Delta V \div \Delta P$ ), the property of a substance to allow distention or lengthening when subjected to pressure. Compliance (C) is therefore expressed as  $1/\text{elastance}$ .

The pressure needed to overcome tissue elastance is measured in conditions in which there is no flow (at end inspiration and end expiration) and is therefore a reflection of static conditions in the lung. It is influenced by tidal volume ( $V_T$ ) and compliance ( $P = \Delta V \div C$ ). It is increased with high  $V_T$  and low compliance. This pressure gradient is used to calculate the static compliance of the respiratory system ( $C_{STAT}$ ).

*Resistance* (R) refers to the opposition to generation of flow. It is measured as the amount of pressure needed to generate a unit of flow ( $\Delta P \div \Delta \text{Flow}$ ). Pressure needed to overcome airway resistance is calculated as flow multiplied by resistance. Because this pressure is needed only when the flow is occurring through the airways, it is referred to as the *dynamic component*. Pressure to overcome flow-resistive properties is measured when there is maximum flow and is therefore under dynamic conditions. It is increased in conditions with greater airway resistance and flow rate. Flow rate depends on the time allowed for inspiration and expiration. At higher respiratory rates, there is less time available for each inspiration and expiration, necessitating higher flows; therefore higher pressure is required to overcome flow-resistive properties. The pressure gradient necessary to move air from one place to another is the sum of pressure needed to overcome the elastic and flow-resistive properties of the lung. This pressure gradient is taken into account to calculate the dynamic compliance of the respiratory system ( $C_{DYN}$ ). The difference in change in pressure between static conditions and dynamic conditions is attributable to airway resistance.

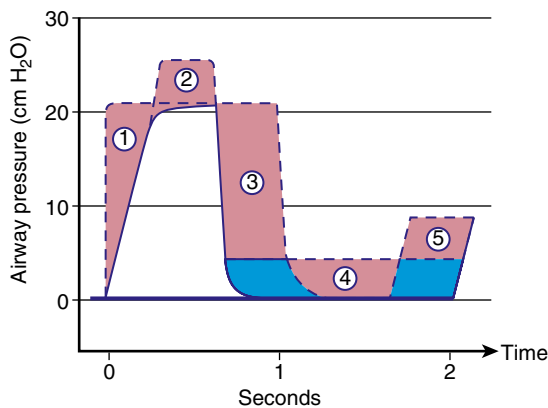
### Functional Residual Capacity

During inspiration, oxygen-enriched gas enters alveoli. During exhalation, oxygen continues to be removed by the pulmonary capillary

circulation. Functional residual capacity (FRC) is the volume of gas left in the alveoli at end expiration; in mechanically ventilated patients, it is generally referred to as *end-expiratory lung volume* (EELV). It is the only source of gas available for gas exchange during exhalation. In diseases with decreased FRC (e.g., pediatric acute respiratory distress syndrome [PARDS], pulmonary edema),  $PAO_2$  declines sharply throughout expiration, resulting in hypoxemia. Two ventilator strategies used to improve oxygenation in such situations are the application of PEEP and increasing the *inspiratory time* ( $T_i$ ) (Fig. 86.5). Positive end-expiratory pressure (PEEP) increases EELV by stabilizing recruited alveoli, whereas a longer  $T_i$  allows longer exposure of pulmonary capillary blood to a higher concentration of  $O_2$  during inspiration (see also Chapter 421).

### Time Constant

At the beginning of inspiration, the atmospheric pressure is higher than the pressure in the alveoli, resulting in movement of air into the alveoli. During mechanical ventilation, the ventilator circuit serves as the patient's atmosphere. As alveoli expand with air, the alveolar pressure rises throughout inspiration until it equilibrates with the ventilator pressure, at which time airflow ceases. Expiration starts when the ventilator pressure falls below the alveolar pressure. Alveolar pressure



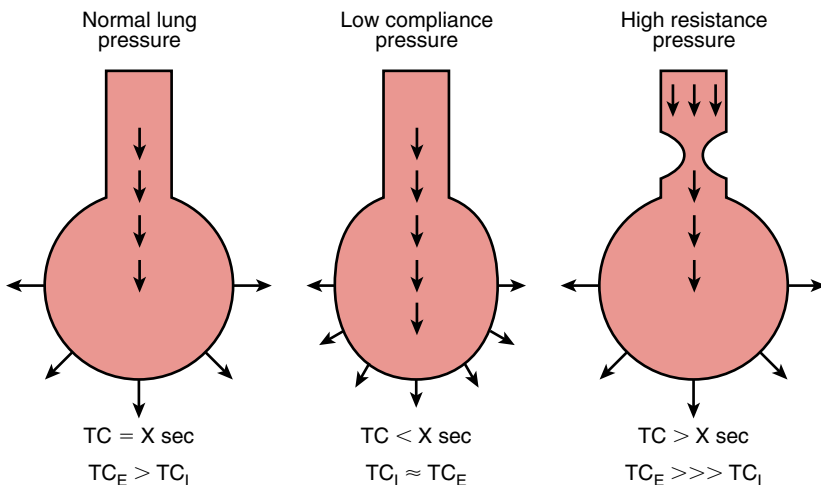
**Fig. 86.5** Five different ways to increase mean airway pressure. (1) Increase the respiratory flow rate, producing a square wave inspiratory pattern; (2) increase the peak inspiratory pressure; (3) reverse the inspiratory-expiratory ratio or prolong the inspiratory time without changing the rate; (4) increase positive end-expiratory pressure; and (5) increase the ventilatory rate by reducing the expiratory time without changing the inspiratory time. (From Harris TR, Wood BR. *Physiologic principles*. In Goldsmith JP, Karotkin EH, eds. *Assisted Ventilation of the Neonate*, 3rd ed. Philadelphia: Saunders;1996.)

decreases throughout expiration until it reaches the ventilator pressure, at which time no further egress of air from the alveoli occurs. If inspiration or expiration is terminated before pressure equilibration between alveoli and the ventilator is allowed to occur, alveolar expansion during inspiration or alveolar emptying during expiration is incomplete. Incomplete inspiration results in delivery of decreased  $V_T$ , whereas incomplete expiration is associated with air trapping and the presence of residual PEEP in the alveoli that is greater than the PEEP set at the ventilator, referred to as **auto-PEEP**. Some time is required for pressure equilibration to occur between alveoli and the atmosphere, which is reflected in the *time constant* (TC). It takes 3 TCs for 95% (and 5 TCs for 99%) of pressure equilibration to occur. The TC depends on compliance (C) and resistance (R), and their relationship is depicted in Figure 86.6. TC is calculated as compliance multiplied by resistance ( $C \times R$ ) and is measured in seconds.

Diseases with decreased compliance (increased elastance) are characterized by high elastic recoil pressure, which results in more rapid equilibration of alveolar and ventilator pressures, thereby decreasing TC. Diseases with increased airway resistance are associated with slower flow rates, require longer time for movement of air from one place to another, and therefore have increased TC. Airways expand during inspiration and narrow during expiration. Therefore expiratory time constant ( $TC_E$ ) is longer than inspiratory time constant ( $TC_I$ ). In intrathoracic airway obstruction (e.g., asthma, bronchiolitis, aspirated foreign body), airway narrowing is much more pronounced during expiration. Therefore although both  $TC_E$  and  $TC_I$  are prolonged in such diseases,  $TC_E$  is much more prolonged than  $TC_I$ . Patients with such diseases therefore are best ventilated with slower rates, larger  $V_T$ , and longer expiratory time than inspiratory time. In diseases characterized by decreased compliance, both  $TC_E$  and  $TC_I$  are short; however, the  $TC_E$  is closer to  $TC_I$  than in normal lungs because the stiffer alveoli recoil with greater force. Patients with these diseases are best ventilated with smaller  $V_T$  to prevent VILI, increased respiratory rate, and a relatively longer inspiratory time in each breath to improve oxygenation.

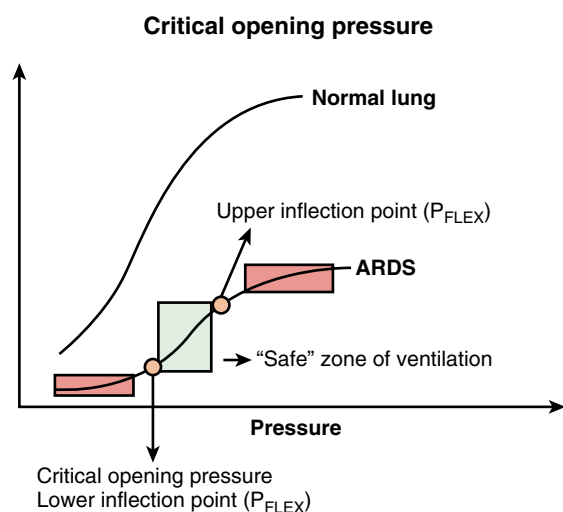
### Critical Opening Pressure

Collapsed or atelectatic alveoli require a considerable amount of pressure to open. Once open, the alveoli require relatively less pressure for continued expansion. The process of opening atelectatic alveoli is called **recruitment**. In a normal lung, alveoli remain open at end expiration, and therefore the lung requires relatively less pressure to receive its  $V_T$ . In a disease process in which alveoli collapse at end expiration (e.g., PARDS), a substantial amount of pressure is required to open the alveoli during inspiration. This pressure causes VILI by two mechanisms: *barotrauma* at the terminal airway-alveolar junction and *volutrauma* as a result of overdistention of alveoli that are already open (see Figs. 86.2 and 86.3). Although pulmonary parenchymal disease is rarely uniform and each of the millions of alveoli may have its own mechanical characteristics, a composite volume-pressure relationship could be conceptualized for the whole lung (Fig. 86.7).



**Fig. 86.6** Time constant (TC). A certain amount of time is necessary for pressure equilibration (and therefore completion of delivery of gas) to occur between the proximal airway and alveoli. TC, a reflection of time required for pressure equilibration, is a product of compliance and resistance. In diseases of decreased lung compliance, less time is needed for pressure equilibration to occur, whereas in diseases of increased airway resistance, more time is required. Expiratory TC ( $TC_E$ ) is increased much more than inspiratory TC ( $TC_I$ ) in obstructive airway diseases because airway narrowing is exaggerated during expiration.





**Fig. 86.7** Volume-pressure relationship in normal lung and in acute respiratory distress syndrome (ARDS). In ARDS, atelectatic alveoli require a considerable amount of pressure to open. Critical opening pressure, also referred to as lower  $P_{FLEX}$ , is the airway pressure above which further alveolar expansion occurs with relatively less pressure. Upper  $P_{FLEX}$  is the airway pressure above which further increase in pressure results in less alveolar expansion; this is the area of alveolar overdistention. Keeping tidal volume between upper and lower  $P_{FLEX}$  values is considered less injurious to the lung.

In these situations, the lower and upper portions of the curve are relatively horizontal and the middle portion is more vertical. At the beginning of inspiration, atelectatic alveoli are being recruited, requiring high pressure for a relatively small increase in volume. Once they are recruited, further increase in volume requires relatively less pressure. The pressure at which most alveoli are open is called *critical opening pressure*; this point is also referred to as the *lower inflection point* (lower  $P_{FLEX}$ ). After the lower  $P_{FLEX}$ , greater volume can be delivered for relatively less pressure until the upper  $P_{FLEX}$  is reached, at which point the volume-pressure curve again becomes relatively horizontal. The goal of mechanical ventilation in alveolar interstitial pathology is to deliver a  $V_T$  between the lower and upper inflection points, the so-called *safe zone of ventilation*. If  $V_T$  is delivered with a change in inflation pressure that includes the lower  $P_{FLEX}$ , alveoli are likely to open and close during every breath, a process termed **tidal recruitment** that is injurious to the lung (atelectrauma), especially at the terminal airway-alveolar junction. If  $V_T$  is delivered with a change of pressure that includes the upper  $P_{FLEX}$ , overdistention of alveoli is likely to occur, resulting in volutrauma and barotrauma. Keeping tidal ventilation between the upper and lower  $P_{FLEX}$  values is accomplished by maintaining a level of PEEP to produce baseline alveolar recruitment and delivering a relatively small  $V_T$ . This lung-protective ventilation is also known as “open lung” strategy and is the preferred approach in diffuse alveolar interstitial diseases such as PARDS.

Mechanical ventilation may be delivered either noninvasively with a patient-machine interface other than an ETT or invasively after endotracheal intubation.

### NONINVASIVE MECHANICAL VENTILATION

Delivering positive pressure mechanical respiratory support without the use of endotracheal intubation is called noninvasive positive pressure ventilation (NIPPV). This type of respiratory support has been increasingly used in the pediatric intensive care setting.

The most common techniques applied are continuous positive airway pressure (CPAP) or biphasic (inspiratory and expiratory) positive airway pressure (BiPAP). Of note, CPAP is only the delivery of a continuous airway pressure; therefore by definition, it is not a true form of noninvasive ventilation because a minute volume is generated exclusively by the patient, not by the device. A variety of devices with increasing sophistication has been developed in recent years, and

different interfaces are available, such as nasal prongs, nasal and full-face masks, and helmets. Especially in the pediatric population, an age-appropriate, properly sized, and comfortable interface that minimizes air leak is critical for the successful application of NIPPV. NIPPV has been successfully used in acute and chronic hypoxic and/or hypercarbic respiratory failure. Indications range from acute lower airway obstruction, such as asthma, or acute upper airway obstruction, including postextubation airway swelling, to parenchymal lung diseases such as pneumonia and mild to moderate PARDS. Acute and chronic respiratory failure from neuromuscular weakness or chest wall deformities have been the classic indication for its use. NIPPV can also be used to help prevent reintubation after prolonged mechanical ventilation.

BiPAP provides positive airway pressure during exhalation and additional positive pressure during inspiration. These pressures can be adjusted independently to suit individual needs and comfort, and a respiratory rate can be delivered. The additional positive pressure during inspiration helps improve alveolar ventilation in low compliance and obstructive lung disease. During exhalation, expiratory positive airway pressure can decrease the effects of airway closure by raising intraluminal pressure and ameliorating intrathoracic airway collapse. During inspiration, inspiratory positive airway pressure unloads inspiratory muscle work.

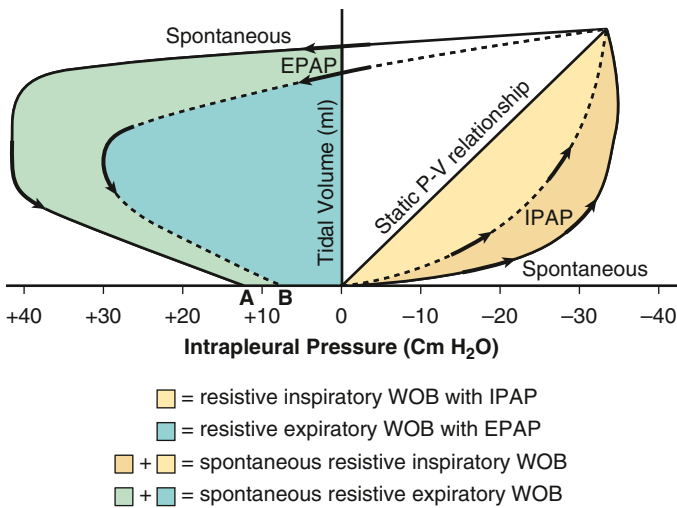
These mechanics may explain many of the physiologic benefits of NIPPV, including an increase in lung compliance and FRC, a decrease of dynamic airway narrowing, augmentation of  $V_T$  and alveolar ventilation, and decreased work of breathing. Physiologic benefits of NIPPV in obstructive (e.g., asthma) and restrictive (e.g., PARDS) lung disease are schematically presented in Figures 86.8 and 86.9. Additional benefits result from improving cardiopulmonary interactions, especially LV afterload reduction, thereby improving cardiac output in patients with acute or chronic LV dysfunction.

NIPPV is often well tolerated and may be associated with fewer complications compared to invasive mechanical ventilation; airway trauma from endotracheal intubation can be avoided, and less sedation is required. Breaks can be given for the administration of oral medications and clearance of respiratory secretions, and selected stable patients can be fed by mouth. The rate of nosocomial infections, ventilator-associated pneumonia, and VILI is expected to decrease as well. In addition, aerosol therapy delivered by NIPPV appears to be more effective.

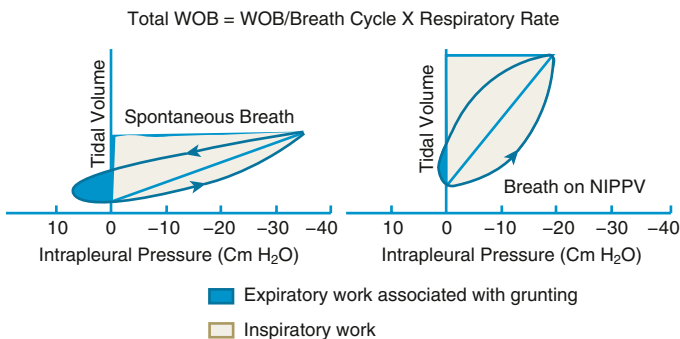
Complications of NIPPV include pressure injury, upper airway mucosal irritation, abdominal distention, aspiration, feeding intolerance, and pulmonary hyperinflation with resulting interstitial emphysema, pneumomediastinum, and pneumothorax. Patients initiated on NIPPV need close cardiorespiratory monitoring because the respiratory failure may progress, leading to the need for endotracheal intubation. Patients with more severe respiratory distress and those who do not show improvement of respiratory indices (i.e., respiratory rate,  $SpO_2/FiO_2$  ratio, reduction in  $F_{iO_2}$ ) within 2 hours of initiation are more likely to require invasive ventilation. Patients with underlying severe systemic diseases such as sepsis, multiorgan dysfunction, and malignancies are less likely to respond favorably to NIPPV. Absolute contraindications include loss of airway reflexes, acute severe neurologic insults, cardiorespiratory arrest, and severe hemodynamic instability. Patients with midface abnormalities or facial trauma and burns should not be considered candidates for NIPPV. Other contraindications include the immediate postoperative period after facial and upper airway surgery, recent gastrointestinal surgery, or patients with bowel obstruction and vomiting. Patients who are severely agitated and confused should not be initiated on NIPPV. NIPPV has been shown to decrease intubation rates and reintubation rates after liberation from invasive mechanical ventilation, and has been increasingly used to treat acute or chronic respiratory failure in pediatric patients.

### INVASIVE MECHANICAL VENTILATION

Mechanical ventilation involves considering the four phases of the respiratory cycle: (1) initiation of respiration and a variable that is controlled, often referred to as *mode*; (2) inspiratory phase characteristics, which determine the duration of inspiration and how the pressure or



**Fig. 86.8** Work of breathing (WOB) in status asthmaticus with and without noninvasive positive pressure ventilation. In the expiratory limb of the respiratory cycle, the equal pressure point is displaced distally, causing airways to begin to close at a higher lung volume (increased closing capacity), leading to dynamic hyperinflation, and auto-positive end-expiratory pressure (auto-PEEP). (A), Application of expiratory positive airway pressure (EPAP) stents the airways, reducing intrathoracic airway collapse, dynamic hyperinflation, auto-PEEP (B), and WOB. In the inspiratory limb, the patient needs to generate less negative pressure to initiate inspiration because of lower auto-PEEP. Inspiratory muscles are further unloaded by inspiratory positive airway pressure (IPAP) throughout inspiration for the given tidal volume. Both expiratory and inspiratory WOB are thus reduced by application of noninvasive positive pressure ventilation. P-V, Pressure-volume. (From Sarnaik AA, Sarnaik AP. *Noninvasive ventilation in pediatric status asthmaticus: Sound physiologic rationale but is it really safe, effective, and cost-efficient?* *Pediatr Crit Care Med.* 2012;13:484-485.)



**Fig. 86.9** Beneficial physiologic pulmonary effects of noninvasive positive pressure ventilation (NIPPV) in restrictive lung disease (e.g., ARDS). *Left*, Without NIPPV, the slope of pressure-volume relationship is flatter, resulting in lower tidal volume for a given inflation pressure and necessitating an increased respiratory rate to maintain required minute alveolar ventilation. Start of inspiration is at a lower lung volume, indicating decreased functional residual capacity (FRC). Expiration is active toward the end as a result of grunting aimed at increasing FRC. *Right*, On institution of NIPPV, the slope of the pressure-volume relationship is increased, resulting in greater tidal volume for a given inflation pressure, with a subsequent decrease in respiratory rate and inspiratory work of breathing (WOB). FRC is increased because of expiratory positive airway pressure (EPAP), resulting in improved oxygenation and decreased expiratory work associated with grunting.

volume is delivered; (3) termination of inspiration, often referred to as *cycle*; and (4) expiratory phase characteristics. Ventilation should not completely take over the work of breathing unless indicated in specific clinical conditions, such as in severe traumatic brain injury or

pulmonary hypertensive crisis, but rather should assist the patient's own respiratory effort, if present.

### Initiation of Inspiration and the Control Variable (Mode)

The initiation of inspiration may be set to occur at a predetermined rate and interval regardless of patient effort, or it could be timed in response to patient effort. Once inspiration is initiated, the ventilator breath either is controlled entirely by the ventilator (*control mode*) or supports the patient's inspiratory effort to a predetermined inspiratory volume or pressure target (*support mode*). Advances in technology allow for greater patient-ventilator synchrony to occur. The ventilator may be set to be *triggered* by the signal it receives as a result of patient effort. This feature may be in the form of lowering of either pressure (*pressure trigger*) or airflow (*flow trigger*) in the ventilator circuit generated by the patient's inspiratory effort. If no such signal is received because of lack of patient effort, the ventilator delivers a breath at an interval selected by the operator. Most ventilators make use of flow triggering.

### Control Modes

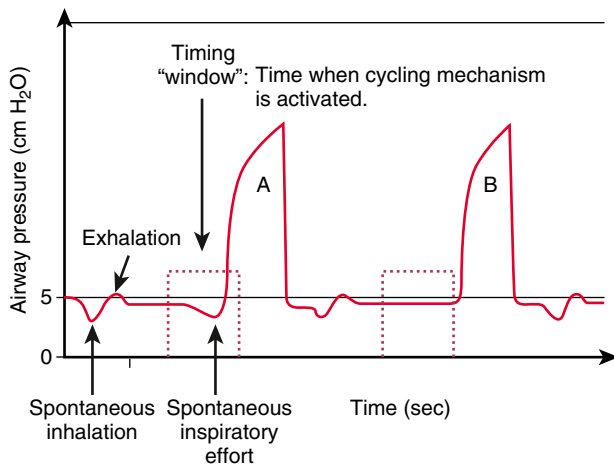
**Intermittent Mandatory Ventilation Mode.** In intermittent mandatory ventilation (IMV), inspiration is initiated at a set frequency with a timing mechanism independent of patient effort. In between machine-delivered breaths, the patient can breathe spontaneously from a fresh source of gas. IMV allows for adjustment of ventilator support according to the patient's needs, making it useful in the weaning process. Lack of synchrony between machine-delivered breaths and patient efforts may result in ineffective ventilation and patient discomfort, especially when IMV is delivered at a high rate. In such cases the patient may require sedation and pharmacologic neuromuscular blockade for efficient delivery of  $V_T$ . To obviate this problem, **synchronized IMV (SIMV)** is preferred, whereby the machine-delivered breaths are triggered by the patient's inspiratory efforts (Fig. 86.10). In between the machine-delivered breaths, a fresh source of gas is available for spontaneous patient breaths. In the absence of patient effort, the patient receives a predetermined backup rate. Even with SIMV, ventilator-patient asynchrony can occur because  $V_T$ , inflation pressure, and inspiratory time are determined by the ventilator alone.

**Assist-Control Mode.** In assist-control (AC) mode, every patient breath is triggered by pressure or flow generated by patient inspiratory effort and "assisted" with either preselected inspiratory pressure or volume. The rate of delivered breaths is therefore determined by the patient's inherent respiratory rate. A backup total (patient and ventilator) obligatory rate is set to deliver a minimum number of breaths. For illustration, on AC mode with a backup rate of 20 breaths/min and a patient's inherent rate of 15 breaths/min, the ventilator will assist all the patient's breaths and the patient will receive 5 additional breaths/min. On the other hand, a patient with an inherent rate of 25 breaths/min will receive all 25 breaths assisted. Although useful in some patients, the AC mode cannot be used in the weaning process, which involves gradual decrease in ventilator support.

### Control Variable

Once initiated, either the  $V_T$  or the pressure delivered by the machine can be controlled. The machine-delivered breath is thus referred to as either volume controlled or pressure controlled (Table 86.12). With **volume-controlled ventilation (VCV)**, machine-delivered volume is the primary control, and the inflation pressure generated depends on the respiratory system's compliance and resistance. Changes in respiratory system compliance and resistance are therefore easily detected from changes observed in inflation pressure. In **pressure-controlled ventilation (PCV)**, the pressure change above the baseline is the primary control, and the  $V_T$  delivered to the lungs depends on the respiratory system's C and R. Changes in respiratory system C and R do not affect inflation pressure and may therefore go undetected unless the exhaled  $V_T$  is closely monitored. VCV and PCV have their own advantages and disadvantages (see Table 86.12). Favoring one mode over the other is largely driven by institutional preference and personal beliefs. VCV is characterized by a constant inspiratory flow with

a constant, preset  $V_T$ , whereas PCV makes use of a decelerative flow pattern, with a variable delivered  $V_T$ . A potential benefit of PCV is that the inspiratory pressures are limited, making it a more attractive mode in disease conditions where there is airway obstruction, preventing the normally compliant alveolus from being exposed to large  $V_T$ . Generally speaking, PCV is more efficient than VCV in terms of amount of  $V_T$  delivered for a given inflation pressure during ventilation of a lung that has nonuniform TC, as in asthma. In VCV, relatively less-obstructed airways are likely to receive more of the machine-delivered volume throughout inspiration than relatively more obstructed airways with longer TC (Fig. 86.11A). This situation would result in uneven ventilation, higher peak inspiratory pressure (PIP), and a decrease in  $C_{DYN}$ . In PCV, because of a constant inflation pressure that is held throughout inspiration, relatively less obstructed lung units with shorter TC would achieve pressure equilibration earlier during inspiration than the relatively more obstructed areas. Thus units with shorter TCs would attain their final volume earlier in inspiration, and those with longer TCs would continue to receive additional volume later in inspiration (see Fig. 86.11B). This situation would result in more uniform distribution



**Fig. 86.10** Synchronized intermittent mandatory ventilation. At set intervals, the ventilator’s timing circuit becomes activated and a timing “window” appears (dashed line area). If the patient initiates a breath in the timing window, the ventilator delivers a mandatory breath (A). If no spontaneous effort occurs, the ventilator delivers a mandatory breath at a fixed time after the timing window (B). (From Banner MJ, Gallagher TJ. *Respiratory failure in the adult: Ventilatory support*. In: Kirby RR, Smith RA, Desautels DA, eds. *Mechanical Ventilation*. New York: Churchill Livingstone;1985.)

of inspired gas, delivery of more  $V_T$  for the same inflation pressure, and improved  $C_{DYN}$  compared with VCV.

**Pressure-regulated volume control (PRVC)** combines the characteristics of VCV and PCV. In this mode,  $V_T$  and  $T_I$  are controlled as primary variables, but the ventilator determines the lowest amount of pressure needed to deliver the desired  $V_T$ . Inflation pressure is thus continuously adjusted to deliver the prescribed  $V_T$  over the  $T_I$ , depending on the patient’s respiratory C and R.

**Support Modes**

**Pressure-support ventilation (PSV)** and **volume-support ventilation (VSV)** are designed to support the patient’s spontaneous respirations. With PSV, initiation of inspiration is triggered by the patient’s spontaneous breath, which is then “supported” by a rapid rise in ventilator pressure to a preselected level. The inspiration is continued until the inspiratory flow rate falls to a set level (generally 25% of peak flow rate) as the patient’s lungs inflate. Each inspiration is initiated and terminated by the patient, thus  $T_I$  is controlled by the patient’s own efforts. PSV has no backup rate, so a ventilator breath will not be delivered to the apneic patient. PSV can be combined with SIMV so that any breath above the SIMV rate is supported by PSV. Allowing the patient to control as much of the rate,  $V_T$ , and inspiratory time as possible is considered to be a more comfortable form of mechanical ventilation than those in which the  $V_T$  (or inflation pressure) and  $T_I$  are preset. PSV as the sole source of mechanical ventilator support is often inadequate for patients with severe lung disease and those with a depressed respiratory drive, but may be especially useful in patients being weaned and in those who require mechanical ventilation for relatively minor lung disease or for neuromuscular weakness.

VSV is similar to PSV, in that all the spontaneous breaths are supported. In VSV, inspiratory pressure to support spontaneous breaths is adjusted to guarantee a preset  $V_T$  goal. If there is a change in respiratory mechanics or patient effort, the inspiratory pressure to support the breath initiated by patient effort is automatically adjusted to achieve the set  $V_T$ .

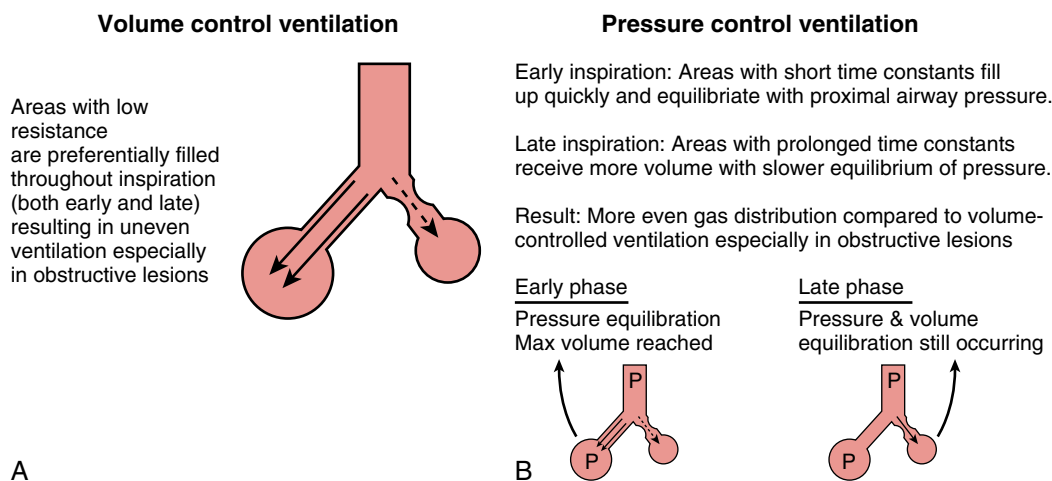
**Inspiratory Phase Characteristics**

Inspiratory flow waveform,  $T_I$ , and pressure rise time can be adjusted in the inspiratory phase to suit the patient’s respiratory mechanics.

In PCV the duration of  $T_I$  is directly set in seconds. In VCV the  $T_I$  can be adjusted by adjusting the inspiratory flow (volume/time) and/or setting an inspiratory pause before exhalation starts. Irrespective of ventilator mode, the choice of  $T_I$  value depends on the respiratory rate, which determines the total duration of each breath, and on the estimation of inspiratory and expiratory TCs. Decreasing the flow rate delivery increases  $T_I$ , and vice versa. With an increase in  $T_I$ , the pulmonary capillary blood is exposed to a higher level of  $PAO_2$  for a longer time. This feature is beneficial in diseases with decreased EELV, such as PARDS and pulmonary edema. An increase

Table 86.12 Characteristics of Pressure-Controlled and Volume-Controlled Methods of Ventilation		
	PRESSURE-CONTROLLED VENTILATION	VOLUME-CONTROLLED VENTILATION
Control setting(s)	Inflation pressure Inspiratory time Rise time	Tidal volume Flow rate Inspiratory flow pattern (constant vs decelerating)
Machine-delivered volume	Depends on respiratory system compliance and resistance	Constant
Inflation pressure	Constant	Depends on respiratory system compliance and resistance
Endotracheal tube leak	Somewhat compensated	Leaked volume part of tidal volume
Distribution of ventilation	More uniform in lungs with varying time constant units	Less uniform in lungs with varying time constant units
Patient comfort	Possibly compromised	Possibly enhanced
Weaning	Inflation pressure adjustment required to deliver desired tidal volume	Tidal volume remains constant; inflation pressure automatically weaned





**Fig. 86.11** A, In volume-controlled ventilation (VCV), tidal volume ( $V_T$ ) is delivered to the less obstructed areas throughout inspiration. Obstructed areas of the lung therefore receive a lower proportion of  $V_T$ , resulting in uneven ventilation. B, In pressure-controlled ventilation (PCV), less obstructed areas equilibrate with inflation pressure and therefore receive most of their  $V_T$  early during inspiration. More obstructed areas, with prolonged time constants, require longer time for pressure equilibration and therefore continue to receive a portion of their  $V_T$  later during inspiration. The entire  $V_T$  is more evenly distributed than with volume-cycled ventilation.

in  $T_i$  also increases  $V_T$  without increasing inflation pressure in PCV if inspiratory flow is still occurring at end expiration. It must be recognized that at a given ventilator rate, an increase in  $T_i$  decreases expiratory time ( $T_E$ ). Therefore any strategy that employs an increase in the inspiratory component of the respiratory cycle should ensure that the decreased  $T_E$  is still sufficient for complete exhalation.

*Inspiratory flow waveform* can be adjusted in VCV mode as either a constant flow (square waveform) or a decelerating flow (descending ramp waveform). With a square waveform, flow is held constant throughout inspiration. In a descending ramp waveform, flow is maximal at the start of inspiration and declines throughout its duration. It is debatable which flow pattern is better for a given disease.

In PCV and PSV, the prescribed PIP is reached through delivery of airflow. *Pressure rise time* reflects the time required for the ventilator to reach PIP and can be adjusted by control of flow at the beginning of the inspiratory phase. The inspiratory flow rise time may be adjusted to prevent too rapid a rise in inspiratory pressure, which can be uncomfortable for a patient who is awake and lead to dyssynchrony.

### Termination of Inspiration (Cycle)

The two most commonly used inspiratory terminating mechanisms in control modes are time-cycled and volume-cycled. With a **time-cycled** mechanical breath, inspiration is terminated after a preselected  $T_i$  has elapsed, whereas with **volume-cycled** breath, the inspiration ends after a preselected volume has been delivered by the machine into the ventilator circuit. A time-cycled breath is almost always pressure-limited, with the PIP held constant for the duration of inspiration. A volume-cycled breath can be pressure-limited as a safety mechanism to avoid barotrauma. The inspiration-terminating mechanism is set somewhat differently in support modes. In PSV the inspiration is set to end after the inspiratory flow decreases below a certain percentage (usually 25%) of peak inspiratory flow. This happens when the patient no longer desires to receive additional  $V_T$ . Such a breath is termed **flow-cycled**. In VSV the inspiration is terminated when the patient has received the selected  $V_T$ .

### Expiratory Phase Maneuvers

The most useful expiratory phase maneuver is the application of PEEP, which is applied to both the control breath and the assisted breath. The most important clinical benefits of PEEP are to stabilize recruited alveoli to increase EELV in patients with alveolar-interstitial diseases and thereby improve oxygenation. Any situation where there is zero end-expiratory pressure (ZEEP), as is the case when the patient is disconnected from the ventilator circuit (even if briefly), will result in alveolar **derecruitment** and decline in oxygenation. In patients with obstructive lesions in which

insufficient exhalation results in air trapping and auto-PEEP, extrinsic PEEP (applied through a mechanical device) can prevent airway closure during expiration and improve ventilation. Other salutary effects of PEEP include redistribution of extravascular lung water away from gas-exchanging areas, improved  $\dot{V}/\dot{Q}$  relationship, stabilization of the chest wall, and reduction in work of breathing in patients with intrinsic PEEP. The effect of PEEP on lung C is variable, depending on the level of PEEP provided and the patient's pulmonary mechanics. By shifting tidal ventilation to a more favorable part of the pressure-volume curve, PEEP may maintain more recruited alveoli, delay airway closure, and improve lung C. Excessive PEEP, on the other hand, may lead to overdistention of alveoli and reduced C. The effect of PEEP in individual patients can be ascertained by measuring exhaled  $V_T$  and calculating  $C_{DYN}$ . Other potentially deleterious effects of PEEP include decreased venous return, increased pulmonary vascular resistance, and decreased cardiac output.

## ADDITIONAL VENTILATORY MODALITIES

### Airway Pressure Release Ventilation

Airway pressure release ventilation (APRV) aims to improve oxygenation in patients with preserved respiratory drive suffering from severe hypoxic respiratory failure due to alveolar-interstitial disease. This modality applies a CPAP, designated  $CPAP_{HIGH}$ , to recruit and maintain EELV with brief intermittent release phases of  $CPAP_{LOW}$  to allow alveolar gas to escape.  $CPAP_{HIGH}$  is analogous to PIP, and  $CPAP_{LOW}$  is similar to setting PEEP. In contrast to the patient receiving conventional mechanical ventilation, a patient receiving APRV spends the majority of time in the  $CPAP_{HIGH}$  phase, which may last as long as 3-5 seconds with a brief (0.3-0.5 seconds) time in the  $CPAP_{LOW}$  phase. These atypically long  $T_i$ s are tolerated because of a floating expiratory valve in the ventilator circuit that permits spontaneous breathing during  $CPAP_{HIGH}$  phase. Therefore even if the  $CPAP_{HIGH}$  phase can be considered "inspiratory" and the  $CPAP_{LOW}$  phase "expiratory" in regard to the ventilator, the patient is able to breathe spontaneously during both these phases. The longer ventilator  $T_i$  recruits lung units, and the ability to breathe spontaneously during this phase allows distribution of gas flow to atelectatic lung regions. The outcome benefit of APRV in pediatric hypoxic respiratory failure has not been proven.

### High-Frequency Ventilation

Mechanical ventilation at supraphysiologic rates and low  $V_T$ , known as high-frequency ventilation (HFV), improves gas exchange in a select group of patients who show no response to more traditional ventilatory modalities. The mechanism of alveolar ventilation in HFV is very different from that in conventional ventilation, in that HFV is less dependent



on  $V_T$  and more dependent on asymmetric velocities and convective dispersion of inspired gas. Patients with severe persistent hypoxic failure are most likely to benefit from HFV. HFV is also helpful in patients with bronchopleural fistula and persistent air leaks. The main tenet of HFV is to recruit lung volume with a high mean airway pressure (MAP) and produce smaller fluctuations in alveolar pressure during inspiration and expiration, thus maintaining a satisfactory EELV and reducing alveolar stretch. The two most investigated techniques of HFV are HFOV and HFJV.

The most commonly used HFV modality is **high-frequency oscillatory ventilation (HFOV)**, which employs a mechanism to generate to-and-fro air movement. Additional air is drawn in (entrained) through a parallel circuit via a Venturi effect. Air is pushed in during inspiration and actively pulled out during expiration. The main determinants of oxygenation are  $F_{IO_2}$  and MAP, whereas ventilation is determined by changes in pressure (amplitude) around the MAP and frequency. The optimal frequency varies for the individual patient and disease process and depends on the so-called *corner frequency*, where the pressure cost of ventilation is the lowest. In PARDS this usually means frequency  $>8$  Hz, irrespective of age.

In **high-frequency jet ventilation (HFJV)**, a high-frequency interrupter is interposed between a high-pressure gas source and a small cannula that is incorporated in the ETT. The cannula propels tiny amounts of gas (jets) at high velocity and high frequency through the ETT. An additional amount of gas is entrained from a parallel circuit. Unlike in HFOV, expiration occurs passively in HFJV as a result of elastic recoil of the lung and the chest wall. PEEP is set through the parallel circuit by a conventional ventilator in-line. Respiratory rate is generally set at 420 breaths/min. Major determinants of oxygenation are  $F_{IO_2}$  and PEEP, and the major determinant of ventilation is PIP.

## CONVENTIONAL VENTILATOR SETTINGS

### Fraction of Inspired Oxygen

The shape of the hemoglobin- $O_2$  dissociation curve dictates that oxygen content in the blood is not linearly related to  $P_{aO_2}$ . A  $P_{aO_2}$  value that results in an oxyhemoglobin saturation of  $\leq 97\%$  is reasonable in most situations, because a higher  $P_{aO_2}$  would cause minimal increase in arterial oxygen content, and a modest (10 mm Hg) drop in  $P_{aO_2}$  would result in minimal decrease in oxyhemoglobin saturation. In most cases, a  $P_{aO_2}$  value of  $>60$  mm Hg is a reasonable goal.  $F_{IO_2}$  values that are higher than those necessary to attain oxyhemoglobin saturations of approximately 95% expose the patient to unnecessary oxygen toxicity. Whenever possible,  $F_{IO_2}$  values should be decreased to a level  $\leq 0.40$  as long as oxyhemoglobin saturation remains  $\geq 92\%$ . In patients with severe lung disease, oxyhemoglobin saturation of 88–92% may be acceptable.

### Mode

The choice of mode of ventilation depends on the disease entity that is being treated and how much ventilator-patient interaction is desired. SIMV or AC is chosen as the control mode; PCV, VCV, or PRVC as the variable that is to be controlled; and pressure support and volume support are the choices for support modes. SIMV pressure-controlled modes are most commonly used in children.

### Tidal Volume and Rate

As previously discussed, alveolar ventilation, the chief determinant of  $P_{aCO_2}$ , is calculated using  $V_T$ , respiratory rate, and  $V_D$ . A change in  $V_T$  results in a corresponding change in alveolar ventilation without affecting  $V_D$ -ventilation. A change in respiratory rate will affect alveolar ventilation and the  $V_D$ -ventilation. Choice of  $V_T$  and rate depends on the TC. In a patient with relatively normal lung compliance, an age-appropriate ventilator rate and a  $V_T$  of 5–8 mL/kg would be appropriate initial settings. Diseases associated with decreased TC (decreased static compliance; e.g., PARDS, pneumonia, pulmonary edema) are best treated with small (4–6 mL/kg)  $V_T$  and relatively rapid rates (e.g., 25–40 breaths/min). Diseases associated with prolonged TCs (increased airway resistance; e.g., asthma, bronchiolitis) are best treated with relatively slow rates and higher (10–12 mL/kg)  $V_T$ . In PCV the delivered  $V_T$  depends on the C and R of the patient's respiratory system and needs to be monitored to ensure the appropriate amount for a given situation. The operator titrates the inflation pressure, depending on the volume of exhaled  $V_T$ . It should be emphasized that achieving a *normal*  $P_{aCO_2}$  value is not a goal of mechanical ventilation. Some degree of

hypercapnia (permissive hypercapnia) should be accepted, especially when one is attempting to limit injurious inflation pressures or  $V_T$ .

### Inspiratory Time and Expiratory Time

$T_I$  and  $T_E$  are adjusted by setting inspiratory flow rate and/or inspiratory pause in VCV and by setting the precise  $T_I$  in PCV. Increasing the  $T_I$  results in increased MAP, improved oxygenation in diseases with decreased EELV, and potentially a better distribution of  $V_T$  in obstructive lung disease. Sufficient expiratory time must be provided to ensure adequate emptying of the alveoli.

### Positive End-Expiratory Pressure

The best level of PEEP depends on the disease entity that is being treated, and it may change in the same patient from time to time. Decisions are often based on the  $P_{aO_2}/F_{IO_2}$  ratio and the measurement of  $C_{DYN}$ . For patients with PARDS, the adult-based PEEP/ $F_{IO_2}$  grid may be useful.

## PATIENT-VENTILATOR ASYNCHRONY

Patient-ventilator asynchrony occurs when the patient's respiratory pattern does not match that of the ventilator. This can occur during all phases of respiration. Adverse effects of patient-ventilator asynchrony include wasted effort, ineffective delivery of desired  $V_T$ , excessive generation of intrathoracic pressure resulting in injury and adverse effects on cardiac output, increased work of breathing, and patient discomfort. Although several mechanisms exist to facilitate patient-ventilator synchrony, a certain amount of asynchrony is inevitable unless the patient is pharmacologically sedated and paralyzed.

### Triggering the Ventilator

The patient must be able to trigger the ventilator without excessive effort. Ventilators can be pressure-triggered or flow-triggered. With **pressure triggering**, the inspiratory valve opens and flow is delivered when a set negative pressure is generated within the patient-ventilator circuit during inspiration. The amount of pressure required to trigger an inspiration depends on the pressure trigger sensitivity. In **flow triggering**, the ventilator provides a base flow of gas through the ventilator-patient circuit. When a flow sensor on the expiratory limb of the patient-ventilator circuit detects a decrease in flow as a result of the patient's inspiratory effort, the inspiratory valve opens and a ventilator breath is delivered. The degree of change in flow required to trigger an inspiration depends on the flow trigger sensitivity. Flow triggering is considered to be more comfortable, primarily because the patient receives some flow before triggering the ventilator, in contrast to pressure triggering, in which no flow is provided until the ventilator breath is triggered through generation of negative pressure. Increasing the trigger sensitivity by decreasing the change in either pressure or flow needed to trigger an inspiration decreases the work of breathing and may improve comfort. However, reducing the required pressure or flow excessively could result in accidental triggering and unwanted breaths by turbulence, caused by condensation in the ventilator circuit, endotracheal tube (ETT) air leaks, or cardiac oscillations.

### Selection of Appropriate Inspiratory Time

The duration of  $T_I$  should match the patient's own inspiratory phase. If  $T_I$  is too long, the patient's drive to exhale may begin before the ventilator breath has cycled off. When this occurs, exhalation occurs against inspiratory flow and a closed exhalation valve, resulting in increased work of breathing, excessive rise in intrathoracic pressure, and discomfort. If  $T_I$  is too short, the patient may be still inhaling without respirator support. In general terms,  $T_I$  is usually initiated at 0.5–0.7 second for neonates, 0.8–1 second in older children, and 1–1.2 second for adolescents and adults, but should really be driven by the inspiratory TC. Adjustments need to be made through individual patient observations and according to the type of lung disease present. In patients with severe lung disease (both obstructive and restrictive), unnatural  $T_I$  and  $T_E$  values may have to be selected, as discussed earlier. In such situations, adequate analgesia, sedation, and, in extreme cases, neuromuscular blockade may be needed.

### Selection of Inspiratory Flow Pattern

In VCV, inappropriate flow may be another source of patient-ventilator dyssynchrony. After initiation of inspiration, if the set amount of flow is

inadequate to meet patient demand, a state of **flow starvation** occurs, resulting in excessive work of breathing and discomfort. Such patients may require a decelerating inspiratory flow pattern, in which a higher flow is provided in the beginning of inspiration and less toward the end as the lungs fill up. On the other hand, such a pattern may be uncomfortable for a patient who desires more gradual alveolar filling. The selection of inspiratory flow pattern should be based on the individual patient's respiratory mechanics. In PCV and PSV, the inspiratory rise time determines the manner in which the airway pressure is raised and  $V_T$  delivered. Considerations for choosing the appropriate rise time in PCV and PSV are similar to those for choosing the inspiratory flow pattern in VCV.

### Use of Support Modes

A conscious patient should be allowed to have spontaneous breaths that are supported by either PSV or VSV. This approach minimizes the mandatory breaths generated by the ventilator that are beyond the patient's control to modulate. Therefore continued assessments should be made to determine whether the patient is able to maintain ventilatory requirements more in support modes and less in control modes.

### Use of Sedation and Neuromuscular Blockade

Having a conscious yet comfortable patient is a desirable goal during mechanical ventilation. Spontaneous breaths with good muscle tone and presence of cough are important for adequate clearance of tracheobronchial secretions. The patient's ability to indicate distress is also important in identifying and preventing potential injurious factors. In certain situations, management of patient-ventilator asynchrony assumes much greater importance when the asynchrony is causing unacceptable derangement of gas exchange and VILI. Both alveolar interstitial lung pathology and obstructive airway diseases may necessitate unnatural and uncomfortable settings for respiratory rate,  $T_i$ , and inflation pressures. In such patients, deep sedation is often necessary; dexmedetomidine, benzodiazepines, and opiates are the agents most commonly used for this purpose. In extreme situations, pharmacologic neuromuscular blockade is required to abolish any patient effort and respiratory muscle tone. When such pharmacologic paralysis is used, deep sedation must be ensured so that the patient does not sense pain and discomfort. Pharmacologic sedation and paralysis can ensure total control of the patient's ventilation by mechanical means and may result in lifesaving improvement in gas exchange with reduction in inflation pressures. However, long-term use of such agents may be associated with undesirable consequences and higher morbidity. The risk of inadequate clearance of tracheobronchial secretions and atelectasis is potentially greater. Long-term use of pharmacologic sedation may be associated with chemical dependency and withdrawal manifestations, and prolonged neuromuscular blockade is associated with neuromyopathy in critically ill patients. The benefits of sedation and pharmacologic paralysis therefore should be carefully balanced with the risks, and periodic assessments should be made to determine the need for their continuation.

### Cardiopulmonary Interactions

Mechanical ventilation can have salutary and adverse effects on cardiac performance. By decreasing oxygen consumption necessary for work of breathing, oxygen supply to vital organs is improved. Positive pressure breathing decreases LV afterload, thus enhancing stroke volume and cardiac output in patients with a failing myocardium (e.g., myocarditis). On the other hand, the decreased systemic venous return may further compromise stroke volume in hypovolemic (preload-dependent) patients. Such patients will require intravascular fluid loading when subjected to positive pressure ventilation. Also, an increase in pulmonary vascular resistance (PVR) caused by positive intrathoracic pressure may result in further decompensation of a poorly performing right ventricle. PVR is at its lowest value at an optimum FRC. When FRC is too low or too high, PVR (and therefore the right ventricular afterload) is increased. Both desirable and undesirable effects of cardiopulmonary interactions may coexist and require ongoing assessment and necessary interventions (Table 86.13).

## MONITORING RESPIRATORY MECHANICS

### Exhaled Tidal Volume

Exhaled tidal volume ( $V_{TE}$ ) is measured by a pneumotachometer in the ventilator circuit during exhalation; in small children, it is preferably

**Table 86.13** Suggested Mechanical Ventilation Strategies in Various Clinical Situations

SITUATION	DISEASE	STRATEGY
Low compliance, normal resistance	ARDS	PCV, APRV, HFOV
Normal compliance, high resistance	Asthma	PCV, PRVC
Normal compliance, normal resistance, for weaning	Head trauma, drug overdose, subglottic stenosis	VCV

APRV, Airway pressure release ventilation; ARDS, acute respiratory distress syndrome; HFOV, high-frequency oscillatory ventilation; PCV, pressure-controlled ventilation; PRVC, pressure-regulated volume control; VCV, volume-controlled ventilation.

measured near the connection of the ETT. Measurement of  $V_{TE}$  more accurately describes the  $V_T$  that is contributing to the patient's alveolar ventilation. In PCV the  $V_{TE}$  depends on the patient's respiratory system compliance and resistance and therefore offers valuable diagnostic clues. A decrease in  $V_{TE}$  during PCV is indicative of either decrease in compliance or increase in resistance and is helpful in directing the clinician to appropriate investigation and management. An increase in  $V_{TE}$  is indicative of improvement and may require weaning of inflation pressures to adjust the  $V_{TE}$ .

### Peak Inspiratory Pressure

In VCV and PRVC, the PIP is the secondary variable determined by the patient's respiratory system compliance and resistance. An increase in PIP in these modes is indicative of decreased C (e.g., atelectasis, pulmonary edema, pneumothorax) or increased R (e.g., bronchospasm, obstructed ETT). During VCV and PRVC, decreasing the respiratory rate or prolonging the  $T_i$  will result in a lower PIP in patients with prolonged TCs because more time will be available for alveoli to fill. In such patients, a decrease in PIP (or plateau pressure when an inspiratory pause is set during VCV) suggests increased C or decreased R of the respiratory system.

### Respiratory System Dynamic Compliance and Static Compliance

The changes in PIP (or plateau pressure) during VCV and PRVC, and in  $V_{TE}$  during PCV, are determined by  $C_{DYN}$  of the respiratory system (lung and chest wall).  $C_{DYN}$  is calculated as follows

$$C_{DYN} = V_{TE} \div (PIP - PEEP)$$

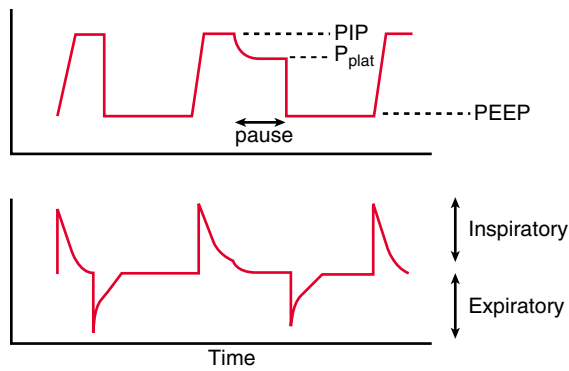
$C_{DYN}$  takes into account both the flow-resistive and the elastic properties of the respiratory system. Changes in  $C_{DYN}$  can be used to assess effects of different levels of PEEP as tidal ventilation is shifted along the slope of the volume-pressure curve (see Fig. 86.7). An increase in PEEP in alveolar-interstitial diseases (increased elastance), resulting in an increase in  $C_{DYN}$ , suggests alveolar recruitment, whereas a decrease in  $C_{DYN}$  may indicate overdistention. Similarly, in obstructive diseases (increased R), adjustment in PEEP levels to ameliorate airway collapse during exhalation can be guided by monitoring  $C_{DYN}$ . To assess only the elastic recoil of the lung, measurement of  $C_{STAT}$  when there is no airflow is required. This measurement is performed by using an inspiratory hold maneuver with the patient under neuromuscular blockade and observing pressure-time and flow-time waveforms (Fig. 86.12). During this maneuver, inspiratory flow ceases while the expiratory valve continues to remain closed, thus allowing pressure to equilibrate throughout the ventilator circuit and the patient's lungs. This pressure, referred to as the *plateau pressure* ( $P_{plat}$ ), reflects alveolar pressure.  $C_{STAT}$  is calculated as follows:

$$C_{STAT} = V_{TE} \div (P_{plat} - PEEP)$$

The difference between  $C_{DYN}$  and  $C_{STAT}$  is attributable to airway resistance. This difference is minimal in alveolar-interstitial diseases but substantial in airway obstruction.

### Assessment of Auto-PEEP

Auto-PEEP is assessed with the use of an expiratory pause maneuver in which inspiration is delayed and alveolar pressure is allowed to



**Fig. 86.12** Alveolar pressure is best determined by measurement of plateau pressure ( $P_{\text{plat}}$ ). Inspiration is paused for an extended period, and alveolar gas pressure is allowed to equilibrate with the ventilator circuit pressure. Airway pressure at the end of the inspiratory pause is  $P_{\text{plat}}$ . The difference between peak inspiratory pressure (PIP) and  $P_{\text{plat}}$  is meant to overcome flow-resistive properties of the lung, whereas  $P_{\text{plat}}$  reflects the pressure needed to overcome elastic properties of the lung and chest wall. PEEP, Positive end-expiratory pressure.

equilibrate with the airway. In diseases with airway obstruction, insufficient alveolar emptying may occur if exhalation time is not adequate. The alveolar pressure in excess of the set PEEP at the completion of the expiratory pause is measured as auto-PEEP or intrinsic PEEP. Auto-PEEP can have adverse effects on ventilation and hemodynamic status. It can be managed by decreasing the respiratory rate or  $T_i$  and thus allowing longer time for exhalation. Auto-PEEP may also be managed by increasing the set PEEP (*extrinsic* PEEP), thereby delaying airway closure during exhalation and improving alveolar emptying.

### Assessment of Dead Space Ventilation

Positive pressure ventilation and application of PEEP may result in a decrease in venous return, cardiac output, and therefore pulmonary perfusion. Ventilation of poorly perfused alveoli results in dead space ventilation, which does not contribute to gas exchange. The  $V_D/V_T$  fraction can be calculated (see Chapter 86). Normal  $V_D/V_T$  is 0.33. Increased  $V_D/V_T$  is indicative of poorly perfused alveoli. Patients with increased  $V_D/V_T$  may require intravascular volume infusion or other means of augmenting the cardiac output to improve pulmonary perfusion. The  $V_D/V_T$  fraction is calculated and displayed by commercially available capnographs, which measure endotracheal  $\text{PetCO}_2$  continuously.

### VENTILATOR-INDUCED LUNG INJURY (VILI)

As with most medical therapies, mechanical ventilation can be harmful. Pathophysiology of VILI can be multifactorial. Large tidal volumes and high inspiratory pressures delivered with increased frequency cause cyclic strain, which may lead to disruption of the tight junctions between the alveolar epithelial and capillary endothelial cells, with intracapillary blebs resulting in alveolar and interstitial edema. This may cause the release of proinflammatory mediators (**biotrauma**) that further injure the lung and travel in the blood outside the lung, contributing to the development of multiorgan failure. Evidence shows that in patients with ARDS, avoidance of  $V_T \geq 10 \text{ mL/kg}$  and  $P_{\text{plat}} \geq 30 \text{ cm H}_2\text{O}$  limits diffuse alveolar damage.

**Atelectrauma** is shear stress on the alveolar walls caused by cyclic opening and closing of the alveoli. PEEP can be used to prevent collapse and keep alveoli open. It is important that alveolar units are neither overdistended nor collapsed. Careful adjustments of PEEP may also permit the clinician to wean a patient from a high  $\text{FiO}_2$ , another potential source of lung injury, through exposure to reactive oxygen species (**oxytrauma**). Although most patients receive an  $\text{FiO}_2$  of 1.0 at the time of endotracheal intubation and at the beginning of mechanical ventilation, increasing PEEP to recruit alveoli without overdistention should be quickly instituted to improve oxygenation and permit weaning of the  $\text{FiO}_2$ . Although the  $\text{FiO}_2$  value below which there is no risk of oxygen toxicity is unknown, most

clinicians aim for a value  $<0.6$ . Regional mechanics may play a role in lung injury.

### Ventilator-Associated Pneumonia

The pathophysiology of ventilator-associated pneumonia (VAP) is multifactorial. Aspiration of oral and/or gastric secretions, colonization of the ETT, and suppression of cough reflexes from sedation all play a role. New-onset fever and leukocytosis accompanied by demonstration of an infiltrative process on chest radiography are consistent with a diagnosis of VAP. This complication can lead to worsened gas exchange, increased duration of ventilation, and even death. Elevation of the head of the bed to 30 degrees after initiation of mechanical ventilation and use of a protocol for oral decontamination during mechanical ventilation are common means of reducing the risk for VAP. The most effective strategy to minimize any of the aforementioned complications is regular assessment of extubation readiness and liberation from mechanical ventilation as soon as clinically possible.

### Weaning

Weaning from mechanical ventilation should be considered as a patient's respiratory insufficiency begins to improve. Most pediatricians favor gradual weaning from ventilator support. With SIMV, the ventilator rate is slowly reduced, allowing the patient's spontaneous breaths (typically assisted with pressure or volume support) to assume a larger proportion of the minute ventilation. When the ventilator rate is low ( $<5$  breaths/min) such that its contribution to minute ventilation is minimal, assessment of extubation readiness is performed. An alternative method of gradual weaning is transition to PSV. In this mode, no ventilator rate is set, allowing all triggered breaths to be assisted with pressure support. The clinician reduces the pressure support slowly to a low value ( $<5$ – $10 \text{ cm H}_2\text{O}$ ), at which point assessment of extubation readiness is performed. During either technique, weaning should be halted if tachypnea, increased work of breathing, hypoxemia, hypercapnia, acidosis, diaphoresis, tachycardia, or hypotension occurs.

The most objective means of assessing extubation readiness is a **spontaneous breathing trial (SBT)**. Before performance of an SBT, a patient should be awake with intact airway reflexes, capable of handling oropharyngeal secretions, and with stable hemodynamic status. In addition, gas exchange should be adequate, defined as  $\text{PaO}_2 >60 \text{ mm Hg}$  while receiving  $\text{FiO}_2 <0.4$  and  $\text{PEEP} \leq 5 \text{ cm H}_2\text{O}$ . If these criteria are present, a patient should be started on CPAP with minimal ( $\leq 5 \text{ cm H}_2\text{O}$ ) or no pressure support. If this SBT is tolerated with no episodes of respiratory or cardiovascular decompensation, successful extubation is likely.

Some neonates and small children cannot be calmed or consoled long enough to complete the SBT. In this situation, extubation readiness must be assessed on a low level of ventilator support. Data suggest a low risk of extubation failure if the patient is comfortable and has stable hemodynamic status, with adequate gas exchange and spontaneous  $V_T >6.5 \text{ mL/kg}$  while receiving  $<20\%$  of total minute ventilation from the ventilator. Certain patient populations are at increased risk for extubation failure, such as young infants, children mechanically ventilated for longer than 7 days, and patients with chronic respiratory or neurologic conditions. These children often benefit from transition to a noninvasive form of respiratory support (e.g., high-flow nasal cannula, CPAP, or BiPAP) upon liberation from mechanical ventilation to increase the odds of successful extubation.

The likelihood of **postextubation upper airway obstruction**, the most common cause of extubation failure in children, cannot be predicted by the results of an SBT or bedside measurements of physiologic variables. Traumatic endotracheal intubation and subglottic swelling from ETT irritation, especially in patients who exhibit agitation while receiving mechanical ventilation, are common causes of airway narrowing after extubation. Administration of intravenous corticosteroids (dexamethasone  $0.5 \text{ mg/kg}$  every 6 hr for four doses before extubation) has been shown to decrease the incidence of postextubation airway obstruction. In patients in whom postextubation airway obstruction develops, the need for reintubation may be obviated by administration of nebulized racemic epinephrine and helium-oxygen mixtures.

Visit Elsevier eBooks+ at [eBooks.Health.Elsevier.com](http://eBooks.Health.Elsevier.com) for Bibliography.



blood cells, which begin to appear in the circulation in 4 or 5 days. Hypoxemia also increases 2,3-DPG, resulting in a rightward shift of the oxyhemoglobin dissociation curve and favoring release of oxygen from the blood to the tissues. This is counteracted by the leftward shift of the oxyhemoglobin dissociation curve caused by the respiratory alkalosis from hyperventilation. The result is a net null change in the oxyhemoglobin curve and an increase in oxygen-hemoglobin binding in the lung, raising  $\text{Sao}_2$ . Climbers at extreme altitude respond with marked hyperventilation, alkalosis, and leftward shift. This leftward shift favors oxygen loading in a hypoxic environment and increases  $\text{Sao}_2$ .

## ACUTE MOUNTAIN SICKNESS

### Epidemiology and Risk Factors

The incidence of high-altitude illness depends on several variables, including the rate of ascent, previous altitude exposure, and individual genetic susceptibility. Sleeping altitude, final altitude reached, and duration of stay at altitude are also risk factors for AMS development. Individual susceptibility for the development of AMS plays a significant role in risk assessment. Most individuals with previous histories of AMS after acute ascent are likely to experience similar symptoms with repeated visits to altitude. Gender and age do not affect the incidence of AMS.

AMS is very common with **rapid ascent**. Climbers around the world who ascend quickly (1 or 2 days) from sea level to altitudes of 4,000-6,000 m (~13,000-20,000 ft) have a very high incidence of AMS (27–83%). The rapid ascent profile associated with air travel to high altitude locations also results in high AMS rates. Trekkers who fly into the Khumbu region to explore the Mt. Everest area have a higher incidence of AMS (47%) compared with those who walk (23%). Skiers who visit resorts in the western United States from sea level generally fly or drive to the region but sleep at relatively moderate altitudes: 2,000-3,000 m (~6,500-9,800 ft). Among this population, AMS occurs in approximately 25%.

### Pathophysiology

The symptoms of AMS develop several hours after arrival at high altitude, whereas the development of HAPE and HACE generally require several days of altitude exposure. Because hypoxemia occurs within minutes of arrival, it cannot be the direct cause of high-altitude illness, but rather the initiating factor for a cascade of events that lead to the development of the altitude clinical syndromes.

The clinical manifestations of AMS/HACE are primarily the result of central nervous system (CNS) dysfunction caused by hemodynamic mechanical factors and biochemical mediators of permeability. The CNS vasodilatory response to hypoxemia causes an increase in cerebral blood flow and volume. Significant elevation of brain volume is observed in moderate to severe AMS and HACE but has not been demonstrated in mild AMS. Hypoxic alteration of CNS vascular autoregulation and hypertension from exercise may increase pressure transmission to the brain's capillary beds, resulting in transcapillary leakage and vasogenic edema. Inflammatory mediators also contribute to vascular permeability and edema formation. HIF-mediated vascular endothelial growth factor, the inducible form of nitric oxide synthase, reactive cytokines, and free radical formation can increase permeability. Both mechanical and biochemical activation of the trigeminovascular system have been proposed as the cause of *high-altitude headache*, the primary symptom of AMS. Although vasogenic edema has been implicated in severe AMS and HACE, MRI reveals signal changes in subjects with and without clinical AMS.

Many of these responses to hypoxia and altitude exposure occur both in individuals who develop symptoms and those who remain free of AMS. To address the discrepancy in symptomatic illness, the "tight fit" hypothesis was proposed. This theory suggests that the development of AMS/HACE is due to a lack of intracranial space to accommodate increasing volume from brain swelling and edema that develop at

altitude. The adequacy of the intracranial and intraspinal space to buffer changes in brain and cerebrospinal fluid (CSF) volume is the central concept. Buffering occurs as the intracranial CSF is displaced via the foramen magnum into the space available in the spinal canal, followed by increased CSF absorption and decreased CSF production. Individuals with less CSF buffering capacity have less compliance and are hypothesized to become more symptomatic (develop AMS).

### Diagnosis

The diagnosis of AMS in older children and adults requires the history of a recent gain in altitude, presence at the new altitude for at least several hours, and the report of a headache plus one or more of the following symptoms: gastrointestinal (GI) upset (anorexia, nausea, or vomiting), general weakness or fatigue, dizziness, or lightheadedness. The **2018 Lake Louise Acute Mountain Sickness Score** is based on self-report of symptoms and aids clinicians in making the diagnosis and quantifying AMS severity in older children and adolescents (Table 87.1). Symptoms develop within a few hours after ascent and generally reach maximum severity between 24 and 48 hours, followed by gradual resolution. Sleep disturbance caused by periodic breathing is common in all visitors to high altitudes and is not part of the adult diagnostic criteria; sleep disturbance is likely the result of hypoxia rather than AMS. There are no diagnostic physical signs in cases of mild AMS. Any evidence of CNS dysfunction, such as mild ataxia or altered mentation, is early evidence of HACE. Similarly, whereas shortness of breath on exertion is common at high altitudes, dyspnea at rest is an early indicator of HAPE.

**Table 87.1** 2018 Lake Louise Acute Mountain Sickness Score

<b>HEADACHE</b>
0 – None at all
1 – Mild headache
2 – Moderate headache
3 – Severe headache, incapacitating
<b>GASTROINTESTINAL SYMPTOMS</b>
0 – Good appetite
1 – Poor appetite or nausea
2 – Moderate nausea or vomiting
3 – Severe nausea and vomiting, incapacitating
<b>FATIGUE AND/OR WEAKNESS</b>
0 – Not tired or weak
1 – Mild fatigue/weakness
2 – Moderate fatigue/weakness
3 – Severe fatigue/weakness, incapacitating
<b>DIZZINESS/LIGHTEADEDNESS</b>
0 – No dizziness/lightheadedness
1 – Mild dizziness/lightheadedness
2 – Moderate dizziness/lightheadedness
3 – Severe dizziness/lightheadedness, incapacitating
<b>AMS CLINICAL FUNCTIONAL SCORE</b>
Overall, if you had AMS symptoms, how did they affect your activities?
0 – Not at all
1 – Symptoms present, but did not force any change in activity or itinerary
2 – My symptoms forced me to stop the ascent or to go down on my own power
3 – Had to be evacuated to a lower altitude
To obtain the AMS score, add number from each category earlier. Although no official severity rankings exist, many consider mild AMS to be 3-5 points, moderate AMS 6-9 points, and severe AMS 10-12 points.

From Roach RC, Hackett PH, Oelz O, et al. The 2018 Lake Louise Acute Mountain Sickness Score. *High Alt Med Biol.* 2018;19(1):4-6, Table 1.



The diagnosis of AMS in children with early language skills (age 4-11 years) may be made with cautious use of the 2018 Lake Louise criteria (see Table 87.1). The language used in this adult questionnaire may be too complex and may underestimate AMS if not understood by the child. This is particularly true for questions regarding headache (the key symptom of AMS) and GI symptoms.

In preverbal young children and infants, recognition of AMS relies on observable signs and exclusion of other causes. In this age range, AMS is manifested by increased fussiness, decreased playfulness, decreased appetite, and sleep disturbance. In most cases of AMS in very young children, all these symptoms are present. Fussiness is defined as a state of irritability that is not easily explained by another cause, such as tiredness, wet diaper, hunger, teething, or pain from an injury. Fussy behavior may include crying, restlessness, or muscular tension. Decreased playfulness may be profound. Alterations of appetite may progress to frank vomiting. Sleep disturbance can manifest with either increased or decreased sleep when compared with normal patterns. Most often, decreased sleep and the inability to nap are noted.

The Children's Lake Louise Score (CLLS) has been successfully tested in preverbal children <4 years old by parents briefed on the use of the scoring system. The CLLS combines a score for the amount and intensity of unexplained fussiness with a symptom score of how well the child has eaten, played, and slept in the past 24 hours. Evaluating for the presence of headache can be accomplished by asking if the "head hurts" or by using a visual "faces" pain scale. GI symptoms are evaluated by asking children if they are "hungry" rather than trying to evaluate their appetite. A combined score of  $\geq 7$  is indicative of AMS (Fig. 87.1). Many of the symptoms manifested by AMS in children may also result from the disruption of the normal routine with travel. A change in environment, sleeping accommodation, or eating options can result in a fussy child. The threshold scores for AMS diagnostic criteria are modified to account for these baseline variations. Educating parents to recognize the symptoms of AMS in themselves is also important, as an ill parent can indirectly compromise a child's safety.

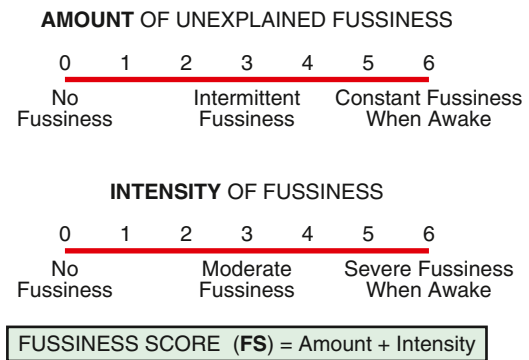
Other acute illnesses can mimic AMS in young children. *It must be emphasized that altered mental status, neurologic abnormalities, breathing difficulty, and cyanosis are not part of uncomplicated AMS. Any of these signs warrant immediate medical attention.* If serious bacterial illness, a surgical condition, or another problem meriting specific intervention is suspected in a child, descent to lower altitude is recommended to eliminate the confounding variable of altitude illness.

### Periodic Breathing

Periodic breathing at altitude is common at all ages during sleep, resulting in brief repeated episodes of oxyhemoglobin desaturation. Prepubertal children (9-12 years old) have similar nighttime oxygen desaturations as their parents; however, they have somewhat more stable breathing patterns with less periodicity. Although periodic breathing is not a sign of AMS, the exacerbation of hypoxia during sleep plays a role in AMS development. Newborn infants normally have periodicity in their respiratory pattern, and this periodicity is increased by high-altitude exposure and sleep. Oxygen saturations of awake neonates born at 3,100 m (~10,100 ft) in Colorado range from 88% to 91%. During sleep with increased periodic breathing, oxygen saturation may drop to 81% during the first week of life. The amount and magnitude of respiratory periodicity decrease as the child matures, and saturation during sleep increases to 86% after 2 months. A stable mature pattern is usually reached by 6 months of age. Preterm babies may demonstrate marked periodicity with prolonged desaturation because of their immaturity. Acute ascent with a child born preterm is best delayed until maturity, when normal pulmonary function and respiratory drive can be demonstrated. Parents of normal young babies may become distressed as they note marked periodic breathing patterns in their child after ascent to moderate altitude. Clinicians can reassure parents that this is generally not a precursor of true apnea; desaturation can occur with periodic breathing in sleep, especially at higher altitudes.

### Management

The management of AMS must include strict adherence to the principle that further ascent to a higher sleeping altitude is



RATE HOW WELL YOUR CHILD HAS **EATEN** TODAY (E)

- 0—Normal
- 1—Slightly less than normal
- 2—Much less than normal
- 3—Vomiting or not eating

RATE HOW **PLAYFUL** YOUR CHILD IS TODAY (P)

- 0—Normal
- 1—Playing slightly less
- 2—Playing much less than normal
- 3—Not playing

RATE ABILITY OF YOUR CHILD TO **SLEEP** TODAY (S)

- 0—Normal
- 1—Slightly less or more than normal
- 2—Much less or more than normal
- 3—Not able to sleep

<b>CLLS = FS + E + P + S</b>
------------------------------

The CLLS must be  $\geq 7$  with both the FS  $\geq 4$  and E+P+S  $\geq 3$  to confirm acute mountain sickness.

**Fig. 87.1** Children's Lake Louise Score (CLLS). Fussiness is defined as a state of irritability that is not easily explained by a cause, such as tiredness, hunger, teething, or pain from an injury. Fussy behavior may include crying, restlessness, or muscular tension. Please rate your child's typical fussy behavior *during the last 24 hours* without the benefit of your intervention.

**contraindicated after the symptoms of altitude illness occur.** Halting ascent or activity to allow further acclimatization may reverse the symptoms; however, continuing the ascent exacerbates the underlying pathologic processes and may lead to disastrous results. Stopping further ascent and waiting for acclimatization treats most AMS in 1-4 days. Mild cases of AMS may be treated without descent if monitoring by a reliable caregiver is available. Conservative treatment may be provided, including rest, analgesics for headache, and antiemetics for nausea. When conservative measures are inadequate, acetazolamide and/or oxygen titrated to maintain  $\text{SaO}_2 > 94\%$  are generally effective. Although no studies have formally assessed its use in pediatric patients, anecdotal reports have demonstrated efficacy of acetazolamide in treating mild AMS in this population. AMS that becomes worse or does not respond to maintenance of altitude, rest, and pharmacologic intervention mandates descent. Descent (500-1,000 m, ~1,600-3,300 ft) is effective treatment for all forms of altitude illness and should be tailored to the individual response. The presence of neurologic abnormalities (e.g., ataxia or altered mentation) mandates descent because these signs indicate a progression of AMS to severe altitude illness (HACE).

Supplemental oxygen administration relieves AMS symptoms, including small amounts (1-2 L/min) given during sleep. In the wilderness, oxygen tanks are impractically heavy and are usually unavailable in adequate amounts; therefore oxygen therapy is usually reserved for the more serious manifestations of high-altitude illness. Hyperbaric therapy that simulates descent is also effective.

Treatment of headache and nausea can be beneficial for mild AMS, and in many cases this may be all that is necessary. Evidence supports the use of ibuprofen and acetaminophen for the treatment of high-altitude headache in children; aspirin and combination products containing aspirin should be avoided in children because of possible association with Reye syndrome. For nausea and vomiting, ondansetron may be used.

Acetazolamide is a carbonic anhydrase inhibitor that induces a renal bicarbonate diuresis, causing a metabolic acidosis that increases ventilation and arterial oxygenation. This respiratory stimulation improves sleep when the hypoxemia caused by periodic breathing is eradicated by acetazolamide. Acetazolamide accelerates acclimatization and, if given early in the development of AMS, rapidly resolves symptoms. Anecdotal experience supports the use of acetazolamide in children, particularly when conservative measures have been insufficient (Table 87.2). Treatment for 48 hours is usually adequate for resolution of symptoms. Acetazolamide may be prepared as a solution by a compounding pharmacy.

Adverse reactions to acetazolamide in adults include paresthesias, polyuria, and taste alterations for carbonated beverages. Less common reactions include nausea, drowsiness, tinnitus, transient myopia, and rarely, rash. Acetazolamide is a nonantibiotic sulfa compound that carries a low risk of cross-reactivity for individuals with an allergy to sulfa antibiotics. A history of anaphylaxis or severe skin reactions to any sulfa-containing medication contraindicates the use of acetazolamide. Acetazolamide should be avoided in breastfeeding mothers and pregnant women.

Dexamethasone is an effective alternative treatment for AMS in adults. Although dexamethasone can resolve the symptoms of AMS, it does not play a role in acclimatization, and symptoms may recur when the treatment is withdrawn. Adverse reactions to dexamethasone of concern in the pediatric population are pancreatitis, pseudotumor cerebri, and interference with normal growth. Although these reactions are generally seen with prolonged use, dexamethasone should be used for treatment in children only in extreme situations where alternatives such as descent or oxygen therapy are unavailable.

### Prevention

Individuals who have a known susceptibility to the development of AMS and those for whom slow ascent is impractical may consider prophylactic medication. *Acetazolamide remains the compound of choice for AMS prophylaxis.* Numerous studies have demonstrated its effectiveness in adults starting 24 hours before ascent and continuing for the first 2 days at high

altitude. Controlled studies for prophylaxis with acetazolamide in children are unavailable; however, anecdotal evidence supports its use (see Table 87.2). Ibuprofen, when compared with acetazolamide, has been found to be equally efficacious in preventing headache in adults. Dexamethasone also prevents AMS; however, the potential adverse effects in children preclude its use for prophylaxis in this age group. Recommendations for hyperhydration are frequently given in the lay literature, yet no evidence supports this advice. Drinking excessive amounts of free water may lead to hyponatremia and possibly complicate altitude illness.

## HIGH-ALTITUDE CEREBRAL EDEMA

### Epidemiology and Risk Factors

HACE is rare and may occur in children. Prompt recognition and treatment are necessary, because if unrecognized, it is rapidly fatal. HACE is generally seen in adults with prolonged stays above 4,000 m (~13,000 ft), but in rare cases has been reported as low as 2,100 m (~6,900 ft). HACE is usually associated with concurrent AMS or HAPE, but can occur on its own.

### Pathophysiology

HACE is regarded as the extreme expression of the same pathophysiology underlying AMS. The edema and increased intracranial pressure are believed to be primarily caused by a vasogenic process where fluid moves from the vascular to the interstitial space due to a combination of increased hydrostatic pressure and increased vascular permeability. In the later stages of HACE, a cytotoxic component may contribute to the edema. These proposed mechanisms are supported by MRI studies revealing white matter changes consistent with vasogenic and cytotoxic edema.

### Diagnosis

HACE is differentiated from severe AMS by the presence of **neurologic signs**. Most common are ataxia and altered mental status, including confusion, progressive decrease in responsiveness, and eventually coma. Less common are focal cranial nerve palsies, motor and sensory deficits, and seizures. CT imaging is consistent with edema and increased intracranial pressure. MRI shows a high T2 signal in the white matter, specifically in the splenium of the corpus callosum, with diffusion-weighted technique.

### Management

**Descent remains the most effective treatment for HACE.** Supplemental oxygen, if available, is useful, especially if descent is not possible or

**Table 87.2** Medications for Treatment of Altitude-Associated Illness in Children\*

MEDICATION	CLASSIFICATION	INDICATION	DOSE AND ROUTE	ADVERSE EFFECTS
Acetazolamide	Carbonic anhydrase inhibitor	AMS treatment	2.5 mg/kg PO every 12 hours; maximum 250 mg/dose	Collateral effects include paresthesias, altered taste and visual acuity, electrolyte disturbance
		AMS or re-entry HAPE prevention <sup>1</sup>	1.25 mg/kg PO every 12 hours; maximum dose 125 mg/dose	Collateral effects reduced at lower doses
Dexamethasone	Steroid	AMS or HACE treatment <sup>2,3</sup>	0.15 mg/kg PO/IM/IV every 6 hours; maximum 4 mg/dose	Hypertension, GI hemorrhage, pancreatitis, growth inhibition
Nifedipine	Calcium-channel blocker	HAPE treatment or prevention <sup>4</sup>	If > 50 kg use adult dosing of 30 mg extended-release PO every 12 hours	Flushing, gastrointestinal distress, hypotension
Amlodipine	Calcium-channel blocker	HAPE treatment or prevention <sup>4,5</sup>	1-5 years: 0.1-0.6 mg/kg/dose PO daily; maximum 5 mg/day 6-17 years: 2.5-5.0 mg PO daily (tablet or liquid suspension)	Flushing, abdominal pain, dizziness, hypotension

\*No studies in children for high-altitude indications.

<sup>1</sup>AMS prophylaxis is not routinely recommended in children but indicated when rapid ascent profile is unavoidable or previous altitude illness occurred in a child about to undergo similar ascent profile. AMS and re-entry HAPE prophylaxis should be started 24 hours before ascent and continued for 2 days at altitude.

<sup>2</sup>Oxygen and descent are the treatment of choice for severe AMS. If acetazolamide is not tolerated, dexamethasone may be used. Oxygen, descent and dexamethasone should be used in HACE.

<sup>3</sup>Prophylactic use of dexamethasone for AMS is not warranted because of potential adverse effects. Use slow graded ascent or acetazolamide.

<sup>4</sup>In emergency settings where oxygen and descent are not an option, amlodipine or nifedipine may be used for treatment. Extended-release (ER) nifedipine formulations cannot be broken to obtain smaller doses. If  $\geq 50$  kg, 30 mg extended-release nifedipine is preferred.

<sup>5</sup>Amlodipine offers advantages over nifedipine for small children because of once daily dosing and availability as liquid or appropriately sized tablet.

Adapted from Luks AM, Beidleman BA, Freer L et al. Wilderness Medical Society Clinical Practice Guidelines for the Prevention, Diagnosis and Treatment of Acute Altitude Illness: 2024 Update. *Wilderness Environ Med.* 2023;Oct 11:51080-6032(23)00167-9.

delayed. Portable hyperbaric treatment is beneficial, but its use should not delay descent. Dexamethasone should be administered at a dose of 0.15 mg/kg per dose given orally every 6 hours to a maximum of 4 mg per dose (see Table 87.2). The few mild cases of HACE reported in children have recovered with dexamethasone and descent.

## HIGH-ALTITUDE PULMONARY EDEMA

### Epidemiology and Risk Factors

HAPE is a noncardiogenic pulmonary edema caused by intense pulmonary vasoconstriction and subsequent high capillary pressure, secondary to hypoxia, resulting in altered permeability of the alveolocapillary membrane and the extravasation of intravascular fluid into the extravascular space of the lung. The development of HAPE depends on factors affecting pulmonary vasoreactivity, rate of ascent, altitude achieved, and time spent at that altitude. HAPE generally occurs in the setting of recent ascent, most often at altitudes above 3,000 m (~9,800 ft), but in some cases at altitudes as low as 1,740 m (~5,700 ft). Among children HAPE occurs in 2 distinct settings. Most commonly, HAPE occurs in a child who resides at low altitude who travels to high altitude. Reentry HAPE affects children who reside at high altitude but become ill on their return home after descent to lower altitudes (see Special Considerations). HAPE may also occur with or without ascent in children who develop acute respiratory illnesses that exacerbate hypoxia at high altitude. Fatal outcomes of HAPE in children have been reported. Most mild and moderate cases resolve without difficulty; however, if unrecognized and untreated, rapid progression to death can occur, especially when infection or cardiac conditions complicate the illness.

HAPE affects male and female children more equally than adults, among whom the observed male predominance appears due to strenuous sport activities and military assignments. The occurrence, and even the pathophysiology, of HAPE may vary by population and genetic background. Several conditions may predispose a child to HAPE (Table 87.3). Preexisting viral respiratory infections have been linked to HAPE, especially in children. Cardiorespiratory conditions associated with pulmonary hypertension, such as atrial and ventricular septal defects, pulmonary vein stenosis, congenital absence of a pulmonary artery, and obstructive sleep apnea, also predispose to HAPE. Down syndrome is a risk factor for HAPE development, as are previously repaired congenital heart defects and the presence of hypoplastic lungs. Undiagnosed structural cardiopulmonary abnormalities may result in severe hypoxia and/or altitude illness once ascent occurs; for this reason, a new diagnosis of HAPE in a child warrants active investigation of underlying causes.

### Physiology

Alveolar hypoxia results in vasoconstriction of the pulmonary arterioles just proximal to the alveolar capillary bed. Hypoxic pulmonary vasoconstriction is a normal physiologic response to optimize ventilation/perfusion ( $\dot{V}/\dot{Q}$ ) matching by redistributing regional pulmonary blood flow to areas of highest ventilation, thereby optimizing arterial oxygenation. However, under conditions that result in widespread alveolar hypoxia, extensive pulmonary vasoconstriction will lead to significant elevations in pulmonary arterial pressure, and uneven pulmonary vasoconstriction can result in localized overperfusion, increased capillary pressures, distention, and leakage in the remaining vessels. This explains the patchy and heterogeneous edema that is classically observed in HAPE. The combination of pulmonary hypertension and uneven pulmonary vasoconstriction appears to be necessary in the pathogenesis of HAPE. Children and adolescents acutely exposed to high-altitude hypoxia demonstrate pulmonary hypertension, with increases in pulmonary artery pressure inversely related to age. Once the vascular leak occurs and alveolar fluid accumulates, a defect in transepithelial sodium transport impairs the clearance of alveolar fluid and contributes to HAPE.

The conditions that predispose to HAPE are often directly referable to elements in the cascade of pathophysiology. Viral infections result in inflammation that may predispose the pulmonary endothelium to mechanical injury and increase susceptibility to alveolar fluid accumulation and HAPE during ascent. Exercise and cold stress at altitude may increase hypoxemia and exacerbate pulmonary hypertension. Overperfusion of a restricted vascular bed is illustrated by cases of congenital

**Table 87.3** Conditions Associated with Increased Risk of HAPE

#### ENVIRONMENTAL

Ascent above 2,500 m (~8,200 ft)  
Rapid rate of ascent (generally >1,000 m [~3,300 ft] per day)  
Cold exposure

#### CARDIAC

Anomalies causing increased pulmonary blood flow or increased pulmonary arterial pressure

- Ventricular septal defect, atrial septal defect, patent foramen ovale, patent ductus arteriosus
- Anomalous pulmonary venous return or pulmonary vein stenosis
- Unilateral absent pulmonary artery or isolated pulmonary artery of ductal origin

Coarctation of the aorta  
Congestive heart failure

#### PULMONARY

Chronic lung disease  
Bronchopulmonary dysplasia  
Cystic fibrosis (FEV-1 <30% predicted)  
Pulmonary hypoplasia  
Supplemental oxygen requirement at sea level  
Pulmonary hypertension  
Perinatal respiratory distress  
Persistent pulmonary hypertension of the newborn  
Perinatal asphyxia or depression  
Sleep apnea

#### INFECTIOUS

Upper respiratory tract infection  
Bronchitis/bronchiolitis  
Pneumonitis  
Otitis media

#### PHARMACOLOGIC

Any medication causing central nervous system and respiratory depression  
Alcohol  
Sympathomimetics

#### SYSTEMIC

Down syndrome (trisomy 21)  
History of premature birth or low birthweight

unilateral absence of a pulmonary artery in which the entire cardiac output is delivered to one lung, predisposing to pulmonary hypertension and overperfusion injury. Although data from mechanistic studies of children are lacking, adult HAPE-susceptible subjects have been characterized as having significantly elevated pulmonary artery pressure during altitude exposure and illness, altered vascular permeability, augmented hypoxic pulmonary vasoreactivity during hypoxia and normoxic exercise, blunted hypoxic ventilatory responsiveness, smaller lung volumes, and impaired alveolar fluid clearance.

### Diagnosis

The diagnosis of HAPE is based on clinical findings and their evolution in the context of recent ascent from lower elevation. There is no single diagnostic test or constellation of laboratory findings. Symptoms commonly develop within 24-96 hours, and onset of symptoms often occurs during the first or second night at altitude, when hypoxia may be exacerbated during sleep. HAPE is rarely observed beyond 5 days after ascent to altitude (unless additional ascent occurs) because pulmonary vascular remodeling and acclimatization have taken place. The diagnosis of HAPE is made by observing the combination of symptoms, including dyspnea at rest, cough, weakness, or decreased exercise performance, and signs including crackles or wheezing in at least one lung field, central cyanosis, tachypnea, or tachycardia. Determining the onset and timing of the illness relative to ascent and radiographic evidence of alveolar infiltrates may help confirm the diagnosis.



The symptoms of AMS and HAPE show considerable overlap, and AMS may precede the development of HAPE in approximately half of patients. Frequently patients with HAPE first exhibit general malaise, which may progress to more specific signs of cardiopulmonary distress. Young children may show agitation and general debility. Older children may complain of headache, and children of all ages frequently experience nausea and vomiting. Cough is a common pulmonary sign. Dyspnea at rest, orthopnea, cyanosis, tachycardia, and chest pain herald worsening compromise, which may advance within hours to production of pink-tinged sputum.

Findings on physical exam frequently are less severe than a patient's chest radiograph and the hypoxemia on pulse oximetry would predict. Children often appear pale, with or without visible cyanosis. Low-grade fever (<38.5°C) is common, and respiratory rate is generally increased. Auscultation typically reveals rales, usually greater in the right lung than the left, on presentation. The radiographic pattern of pulmonary edema can be highly variable, from patchy and peripheral to more homogeneous in severe cases. Often, the right lung shows more radiographic changes of edema than the left (Fig. 87.2). Cardiomegaly is an uncommon finding, but peribronchial and perivascular cuffing are frequent, as is enlargement of the pulmonary artery silhouette and dilation of more peripheral pulmonary arteries. Portable ultrasound has been shown useful to diagnose HAPE through the finding of "comet tails," artifacts created by microreflections of the ultrasound beam within interlobular septae thickened by interstitial and/or alveolar edema. Significant arterial oxygen desaturation, as measured by pulse oximetry, is a consistent finding, with saturations frequently below 75%. A complete blood count often reveals a leukocytosis with a left shift of the granulocyte series.

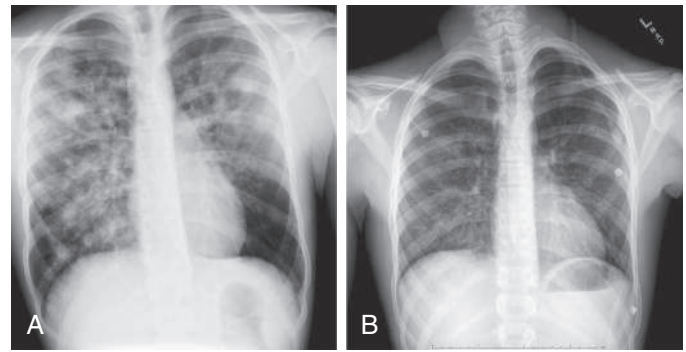
The differential diagnosis of HAPE includes viral and bacterial pneumonia, bronchitis/bronchiolitis, asthma, vaping-associated lung disease, and other forms of cardiogenic and noncardiogenic pulmonary edema as well as pulmonary embolism. HAPE is most frequently misdiagnosed as pneumonia or a viral respiratory illness, especially when suspicion of altitude-associated pathology is not appropriately high. The presenting signs of cough, dyspnea, and orthopnea, followed by sputum production, can easily be misinterpreted as pneumonia, an impression that is reinforced by the frequent accompaniment of low-grade fever. Respiratory viral infections increase the risk of developing HAPE, which may lead to further confusion in diagnosis.

Complications of HAPE in children often relate to underlying, sometimes undiagnosed, cardiopulmonary pathology or coexisting viral infections, which potentiate the severity of pulmonary edema and pulmonary hypertension. Acute altitude exposure in such circumstances may lead to severe presentations that progress rapidly to extreme hypoxemia or cardiac failure and death. Children with Down syndrome, with or without structural cardiac anomalies, show increased susceptibility to HAPE and rapid symptom progression. Neonatal respiratory distress with pulmonary hypertension has been linked to exaggerated hypoxic pulmonary vaso-reactivity in early adulthood and thereby a theoretical predisposition to HAPE. Other conditions related to pulmonary overcirculation (atrial and ventricular septal defects, patent foramen ovale, patent ductus arteriosus), small cross-sectional area of the pulmonary vascular bed (unilateral absent pulmonary artery, pulmonary hypoplasia), obstruction to pulmonary venous return (total anomalous pulmonary venous return, pulmonary vein stenosis), or left-sided obstruction (coarctation of the aorta) potentiate HAPE. Recent inflammatory processes, such as viral infection, predispose to HAPE and may worsen hypoxemia. Infection with respiratory syncytial virus in particular may trigger severe pulmonary hypertension.

### Management

*Descent with supplemental oxygen is the treatment of choice for HAPE in children.* When feasible, or in the absence of medical care, rapid descent of at least 500-1,000 m (~1,500-3,300 ft) usually results in rapid recovery. As with all altitude illness, the magnitude of the descent is tailored to the resolution of symptoms. Oxygen and bed rest without descent can be safe and effective treatment for mild HAPE in children where careful medical observation is available.

Supplemental oxygen at altitude is administered at 2-6 L/min by nasal cannula for 48-72 hours to maintain an arterial oxygen saturation of at least 90%. Increasing oxygen saturation above 90% does not



**Fig. 87.2** High-altitude pulmonary edema (HAPE). A healthy teenager who resides at low altitude flew to Denver, Colorado, with a school group and immediately drove to a ski resort at 9,300 feet. The following day he felt dizzy and complained of headache. Symptoms progressed over the next 2 days to include emesis, dyspnea, cough, and fatigue. He was taken to an emergency department, where pulse oximetry showed an arterial saturation of 51%. Chest x-ray was obtained. **A**, This diagnostic image of HAPE was obtained at the altitude of presentation. The chest x-ray shows patchy, nodular infiltrates generalized through the right lung and the left upper lobe. The patient was started on supplemental oxygen and transported to Denver. Saturations improved with descent and were 94% on room air at time of arrival. **B**, Repeat radiograph obtained at lower altitude 2 days after presentation with HAPE. This diagnostic image shows substantial resolution of patchy pulmonary edema. (Courtesy Children's Hospital Colorado, Department of Radiology.)

result in further reduction in pulmonary artery pressure and does not accelerate edema resolution in adults. Oxygen flow can be weaned with improvement in symptoms and saturations; at flow rates below 2-4 L/min, children may be sufficiently stable and comfortable to continue treatment at home under the monitoring of family. Instructions to avoid physical exertion and exposure to cold should be given to reduce exposure to factors known to elevate pulmonary artery pressure. Most children experience complete resolution of mild HAPE within 24-72 hours of oxygen therapy when treated at the altitude of symptom onset.

Pharmacotherapy for pediatric HAPE is rarely needed because oxygen and descent are so effective. In emergency situations without the options of supplemental oxygen or descent, pharmacotherapy aimed at reducing pulmonary hypertension is indicated (see Table 87.2). Although not systematically studied in children, nifedipine is indicated for the treatment of adult HAPE. Amlodipine offers advantages over nifedipine in children because of daily dosing and availability of a liquid suspension. Patients should be monitored for hypotension during calcium channel blocker administration.

### SPECIAL CONSIDERATIONS

#### Reentry HAPE and HAPE in High-Altitude Residents Without Travel

Children residing at high altitude may experience reentry HAPE upon reascent to the altitude of residence after a sojourn to low altitude. Although stays at low altitude as short as 24 hours may be sufficient to trigger reentry HAPE, most cases occur after several days at lower altitude. Several case series have demonstrated that children between 4 and 18 years of age are much more likely to develop reentry HAPE than adults. Observations from Colorado and Peru suggest that reentry HAPE may occur in 6-17% of children 2-19 years of age compared with <1-3% of adult residents. Various explanations have been proposed for the greater incidence and severity of reentry HAPE among children, including general lack of moderated behavior on ascent, increased likelihood of preexisting inflammatory processes, developmental differences in endothelial cell tight junctions, occult chronic pulmonary artery hypertension, and retained pulmonary arteriolar muscularity with potential for elevated pulmonary arterial pressure and potentially uneven pulmonary arterial vasoconstriction.

Reentry HAPE has a significant probability of recurrence and may justify pharmacologic prophylaxis to prevent the accumulated burden



of morbidity. There are no controlled trials of prophylaxis for reentry HAPE in children; however, acetazolamide has been used empirically (see Table 87.2), based on its blunting of hypoxic pulmonary vasoconstriction in adults and the potential risk of hypotension and reflex tachycardia with calcium channel blockers.

HAPE can also occur in children residing at high altitude without travel, and it should be considered in the differential diagnosis of children who present with hypoxemia at high altitude. The chest radiograph may be consistent with HAPE or viral pneumonia. When rapid improvement with oxygen and little to no response to bronchodilators suggest HAPE, the use of antibiotics and other treatments can be minimized.

### Symptomatic High-Altitude Pulmonary Hypertension

Infants and young children residing at high altitude may experience symptomatic high-altitude pulmonary hypertension (SHAPH). All infants, regardless of altitude of gestation and birth, have thickened and muscularized interlobular and intralobular pulmonary arteries and pulmonary artery pressures that are initially near systemic. Although muscular regression and fall in pulmonary artery pressure occur rapidly at sea level, infants permanently residing at high altitude demonstrate slowed regression of these characteristics through infancy and even childhood. Similar changes may occur in infants who experience pulmonary complications at birth (respiratory distress syndrome of prematurity, persistent pulmonary hypertension of the newborn). Infants with SHAPH become symptomatic with exaggerated hypoxemia and signs of subacute pulmonary hypertension; these signs correlate with pathologic findings of right ventricular hypertrophy and dilation, increased muscularization of the pulmonary arterial bed, and eventual right-sided congestive heart failure. Although supplemental oxygen and medications may be used, definitive treatment is relocation to a lower altitude.

### Cognitive Dysfunction

It is known that adults may have reversible changes in cognitive function with acute exposure to high altitude. A small study evaluating cognitive function in healthy 10- to 17-year-old children found impairment in verbal short-term memory, episodic memory, and executive functions 24 hours after ascent to 3,450 m (~11,400 ft). These findings were no longer present upon reassessment 3 months after returning to sea level. Similar results were found in children with permanent residence at high altitude; however, additional study is needed to assess the long-term implications of these findings.

### Travel with Young Infants

Newborn infants retain some of the circulatory characteristics of recent fetal life, and these can pose a unique risk for altitude exposure. The fetal circulation has high pulmonary resistance, low pulmonary blood flow, and both intracardiac and extracardiac shunts that optimize oxygenation via the placenta instead of the fetal lungs. After birth, a transition begins that closes fetal shunts and establishes normal pulmonary circulation and oxygen transport. Exposure to marked hypoxia can result in reversion to fetal shunting patterns despite the absence of a placenta. Normal infants at sea level complete these changes in 4-6 weeks, though for infants born at moderate or high altitude, changes may last 3 months or longer. Travel to high altitude with young infants is generally safe after 4-6 weeks, when circulatory changes have occurred, breastfeeding is established, and congenital abnormalities may have been detected.

Air travel with young infants frequently raises questions about the effects of exposure to hypobaric hypoxia, as the pressurization of aircraft cabins may vary up to an altitude equivalent of 8,500 ft (~2,600 m). Even transoceanic flights are generally not long enough to trigger AMS or HAPE. However, infants may experience transient desaturation with feedings during flight and likely experience discomfort due to dry air and stress resulting from noise and vibration, much as adults do. Former preterm infants without chronic lung disease who have attained 3 months corrected gestational age do not appear to experience greater hypoxia during air travel than term infants; infants with more significant lung disease merit hypoxic challenge or provision of supplemental oxygen in flight.

### Sickle Cell Disease/Trait

Children with sickle cell disease or sickle cell trait should avoid travel to altitude, as hypoxemia may trigger intravascular sickling, leading to acute vasoocclusive pain crises or splenic infarction or sequestration. Up to 20% of pediatric patients with sickle cell disease and sickle-thalassemia disease may experience a vasoocclusive crisis at moderate altitude or in pressurized aircraft. Oxygen is advised for air travelers with known sickle cell disease. Although many children with sickle cell trait remain asymptomatic, children can experience splenic ischemia or infarction with severe left upper quadrant pain.

### Recommendations for High-Altitude Travel with Children

A comprehensive approach to travel to high altitude with children should focus on 3 phases: planning the ascent and assessment of risk, recognition and management of altitude-associated illness, and follow-up of any illness relative to future travel or diagnostic testing necessary. Planning for travel to high altitude with children should consider rate of ascent, formulation of an emergency plan for communication and evacuation, and availability of medical care at the high-altitude destination. Slow ascent with time for acclimatization is the best prevention for all forms of altitude illness. Ideally, the first night should not be spent at an altitude higher than 2,800 m (9,000 ft), and then 2-3 nights should be spent at 2,500-3,000 m (~8,200-9,800 ft), with a subsequent increase (to a new sleeping altitude) of not more than 500 m (1,600 ft) each night. One extra night of acclimatization (at the same sleeping altitude) should be taken for every 1,000 m (~3,300 ft) gained. Rapid ascent by air may be avoidable through alternative routes or means of transportation. Difficult descent situations (where further ascent may be necessary before descent is possible) should be avoided with children. Widespread coverage by cellular and satellite phone service may give a false sense of security in remote regions where both terrain and weather can limit the arrival of definitive help.

Prompt recognition of altitude-associated illness requires awareness of the context in which illness occurs and familiarity with the signs and symptoms. Parents are generally adept at recognizing deviation from baseline behavior of their children. Scales such as the Lake Louise Acute Mountain Sickness Score and CLLS may aid parents in modifying activity and/or seeking treatment. Clinicians should emphasize to parents that breathing difficulty, cyanosis, cough productive of pink-tinted sputum, altered mental status, and neurologic abnormalities are *not* part of uncomplicated AMS, but instead are serious signs of potential HAPE or HACE that deserve immediate medical attention.

*Descent is the mainstay of therapy for all forms of altitude-associated illness in children.* When descent is not feasible or illness is mild, other therapeutic options may be considered. Severe altitude illness or death can be avoided in children by adherence to three general principles:

1. Recognition of the early signs of altitude illness and willingness by adult caregivers to acknowledge them
2. No further ascent, especially to sleep at a higher altitude, when experiencing even minor symptoms/signs of altitude illness
3. Immediate descent if signs/symptoms worsen while resting/receiving treatment at the altitude of onset

Altitude-associated illness in children merits follow-up with the primary care physician. Uncomplicated AMS with full resolution of symptoms upon descent or treatment does not require diagnostic workup, but may prompt discussion of slower ascent, specific plans for treatment, or even prophylaxis for future travel. Signs of HAPE or severe hypoxemia in a child out of proportion to the altitude reached should prompt further diagnostic evaluation, including consideration of echocardiography. Underlying cardiac conditions may not be apparent on physical examination at low altitude; therefore cardiac catheterization or echocardiography under conditions of controlled hypoxia or hypoxic exercise may be necessary. Families of HAPE-susceptible children should be advised to avoid travel during or shortly after viral infections.

### ACKNOWLEDGMENTS

The authors thank Dr. Dunbar Ivy and Dr. Deborah Liptzin for their careful review of the manuscript.

Visit Elsevier eBooks+ at [eBooks.Health.Elsevier.com](http://eBooks.Health.Elsevier.com) for Bibliography.

## Chapter 88

## Drowning and Submersion Injury

William Benjamin Prince

Drowning is the second most frequent cause of unintentional injury death among children in the United States after traffic accidents. Prevention is the most important step to reducing the impact of drowning injury, followed by early initiation of cardiopulmonary resuscitation (CPR) at the scene.

## ETIOLOGY

Children are at risk of drowning when they are exposed to a water hazard in their environment. The World Congress on Drowning and the World Health Organization (WHO) definition of drowning is “the process of experiencing respiratory impairment from submersion/immersion in liquid.” Drowning outcomes are classified as death, no morbidity, or morbidity further divided into moderately or severely disabled, vegetative state/coma, and brain death. Use of confusing descriptive terms such as “near,” “wet,” “dry,” “secondary,” “silent,” “passive,” and “active” should not be used.

## EPIDEMIOLOGY

From 2010 to 2020, an average of 4012 people per year were victims of **fatal drowning**, and an estimated 8061 persons per year were treated in U.S. hospital emergency departments (EDs) for **nonfatal drowning**. Compared with other types of injuries, drowning has one of the highest case fatality rates and is in the top 10 causes of death related to unintentional injuries for all pediatric age-groups. In 2019, the highest drowning death rates were seen in children age 1-4 years (crude rate of 2.4 per 100,000); in children age 1-4 years, drowning was the number-one cause of death from *unintentional injury* in the United States in 2019 (Fig. 88.1). Rates of fatal drowning hospitalization declined by ~25% during the same period (Fig. 88.2).

The risk of drowning and the circumstances leading to it vary by age. Drowning risk also relates to other host factors, including male sex, alcohol or drug use, a history of seizures, autism, or cardiac arrhythmia, and swimming lessons. Environmental risk factors include exposure to water and varying supervision. These factors are embedded in the context of geography, climate, socioeconomic status, and culture.

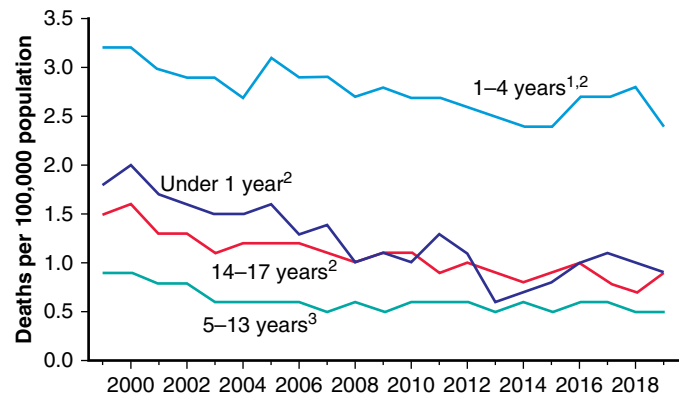
## Children &lt;1 Year Old

Most (75%) drowning deaths in children younger than 1 year occur in the **bath tub**, when an infant is left alone or with an older sibling. Infant tub seats or rings may exacerbate the risk by giving caregivers a false sense of security that the child is safe in the tub. The next major risk to children <1 year is the large (5-gallon) household bucket. These buckets are approximately 30 cm (1 ft) tall and designed not to tip over when half-full. The average 9-month-old child tends to be top-heavy and thus can easily fall headfirst into a half-full bucket, become stuck, and quickly drown.

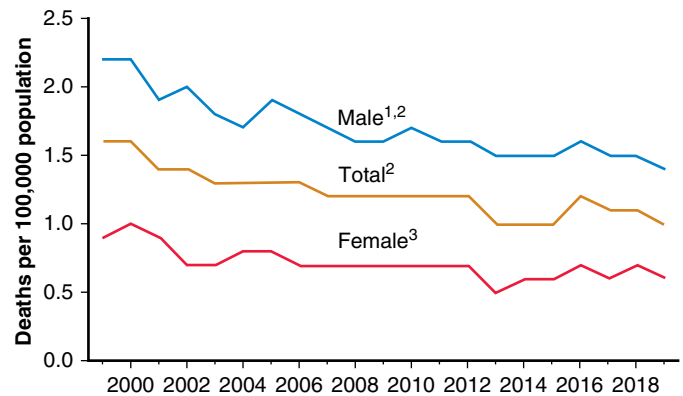
## Children 1-4 Years Old

Drowning rates are consistently highest in 1- to 4-year-old children, likely because of their curious but unaware nature, coupled with the rapid progression of their physical capabilities. A common factor in many of these deaths is a lapse in adult supervision, often reportedly <5 minutes. Most U.S. drownings occur in residential **swimming pools**. Usually, the child is in their own home, and the caregiver does not expect the child to be near the pool.

In rural areas, children 1-4 years old often drown in irrigation ditches or nearby ponds and rivers. The circumstances are like those



**Fig. 88.1** Unintentional drowning death rates among children age 0-17 years, by age group: United States, 1999-2019. <sup>1</sup>Rates significantly higher than those for other age groups over the study period,  $p < 0.05$ . <sup>2</sup>Significant decreasing trend from 1999 through 2019,  $p < 0.05$ . <sup>3</sup>Significant decreasing trend from 1999 through 2005  $p < 0.05$ ; stable trend from 2005 through 2019. Notes: Unintentional drowning deaths are identified using *International Classification of Diseases, 10th Revision* underlying cause-of-death codes W65-W74 Accidental drowning and submersion. Rates shown are crude rates (deaths per 100,000). Source: National Center for Health Statistics, National Vital Statistics System, Mortality. (From Spencer MR, Hedegaard H, Warner M. Unintentional drowning deaths among children aged 0-17 years: United States, 1999-2019. NCHS Data Brief. 2021;413. Fig. 2.)



**Fig 88.2** Unintentional drowning death rates among children age 0-17 years, by sex: United States, 1999-2019. <sup>1</sup>Rates significantly higher than those for females over the study period,  $p < 0.05$ . <sup>2</sup>Significant decreasing trend from 1999 through 2019, with different rates of change over time,  $p < 0.05$ . <sup>3</sup>Significant decreasing trend from 1999 through 2014; stable trend from 2014 through 2019,  $p < 0.05$ . Notes: Unintentional drowning deaths are identified using *International Classification of Diseases, 10th Revision* underlying cause-of-death codes W65-W74 Accidental drowning and submersion. Drowning deaths totaled 756 in 2019 among children age 0-17 years. Rates shown are crude rates (deaths per 100,000). Source: National Center for Health Statistics, National Vital Statistics System, Mortality. (From Spencer MR, Hedegaard H, Warner M. Unintentional drowning deaths among children aged 0-17 years: United States, 1999-2019. NCHS Data Brief. 2021;413. Fig. 1.)

noted previously, in a body of water that is near the house. Drowning is one of the leading causes of *farm injury-related deaths* in children.

## School-Age Children

School-age children are at increased risk of drowning in natural bodies of water such as lakes, ponds, rivers, and canals. Hazards such as unknown depths, undefined areas, and presence of currents and waves increase this risk. Although swimming pools account for most nonfatal drownings across all ages, **natural waterways** account for a higher death rate in children 10-19 years old. Unlike for preschool children,

swimming or boating activities are important factors in drowning injuries in school-age children.

### Adolescents

The second peak incidence in drowning death rates occurs in older adolescents, age 15-19 years. Almost 90% drown in open water. In this age-group particularly, striking disparities in drowning deaths exist in gender and ethnicity. Drowning death is roughly twice as common for males when compared with females, but among adolescents, the rate is almost 10 times higher among males. The gender disparity may likely be related to males' greater exposure to aquatic environments, overestimation of swimming ability, underestimation of dangerous situations, increased risk-taking behavior, and greater alcohol use.

**Dangerous underwater breath-holding behaviors (DUBBs)** are often performed by experienced healthy swimmers or fitness enthusiasts (hypoxic training) or when teenagers hold breath-holding contests during horseplay. DUBBs have been primarily reported in regulated swimming facilities. Behaviors include intentional hyperventilation before submersion, static apnea, and extended periods of underwater distance swimming or breath-hold intervals.

### Ethnic Disparities

There is significant ethnic disparity seen across drowning rates and causes. Among children age 0-19 years, the drowning rates from 2014 to 2018 are highest among Black (1.79 per 100,000) and Indigenous Nations people and Alaska Native (1.49 per 100,000) individuals. Rates are lower among White (1.06 per 100,000), Asian American and Pacific Islander (0.85 per 100,000), and Hispanic (0.82 per 100,000) individuals. Age dramatically influences drowning disparities. Black children drown at significantly higher rates than those for White and Hispanic children at every age from 5 to 18 years. Black children are more likely to drown in unguarded public pools, apartment pools, or hotel pools; White children are more likely to drown in private residential pools. Reasons for disparities in drowning rates may include cultural attitudes toward swimming, prohibitive cost and location of swimming lessons, fears about swimming, and lack of lifeguards at pools in many communities.

### Underlying Conditions

Several underlying medical conditions are associated with drowning at all ages. **Epilepsy** is a known risk factor in drowning, with a relative risk for fatal and nonfatal drowning 7.5- to 10-fold higher than children without seizures. Drowning is the most common cause of death from unintentional injury for people with epilepsy. **Cardiac etiologies**, including arrhythmias, myocarditis, and prolonged QT or catecholaminergic polymorphic ventricular tachycardia syndromes, have been found in some children who die suddenly in the water, particularly in those with a family history of syncope, cardiac arrest, prior drowning, or QT prolongation. Exertion and fright while swimming can trigger arrhythmia among individuals with long QT and should be considered a possible cause for unexplained submersion injuries, particularly among proficient swimmers in low-risk settings (see [Chapter 484.5](#)).

Children with autism spectrum disorder (ASD) are at a significantly higher risk of drowning when compared with the general population; wandering was the most reported behavior leading to drowning in children with ASD. Children with muscle disease or peripheral neuropathies have an increased risk for drowning because of the degree of fatigability.

Drowning may also be an **intentional injury**. A history of the event that changes or is inconsistent with the child's developmental stage is the key to recognition of intentional drowning. Physical examination and other physical injuries rarely provide clues. **Child abuse** is more often recognized in bathtub-related drownings. **Suicide** usually occurs in lone swimmers in open water.

### Alcohol Use

The use of alcohol and drugs greatly increases the risk of drowning. A meta-analysis found that 30-70% of swimming and boating fatal drowning victims have a measurable blood alcohol concentration. Alcohol can impair judgment, leading to riskier behavior, decreased

balance and coordination, hypothermia, and blunted ability to self-rescue. Alcohol use while boating is also associated with low life jacket use. Furthermore, an intoxicated adult may provide less effective supervision of children around water.

### Sports and Recreation

Most U.S. drowning deaths occur during recreational activities. Drowning is the leading cause of *noncardiac sports-related deaths*. Surveys confirm that not using a personal flotation device (PFD) is common during boating activities. In 2021 the U.S. Coast Guard reported that 83% of those who drowned in boating accidents were not wearing a PFD.

### Global Impact of Drowning

Drowning injury is the third leading cause of unintentional death worldwide, with the majority (90%) of fatalities occurring in low- and middle-income countries. More than half of the global drowning occurs in the WHO Western Pacific and Southeast Asia regions. Global drowning rates are vastly underestimated, because many drowning deaths in this region go unreported, and many immediate fatalities are unrecognized. In addition, these data exclude any cases of drowning as the result of intentional harm or assault, accidents of watercraft or water transport, and drowning related to forces of nature or cataclysmic storms, which usually claim large numbers of lives per incident; thus true numbers of fatal drowning are likely much higher.

Some patterns of pediatric drowning are similar in all countries. By most accounts, the highest rates are seen in males and in children 1-4 years old. The predominant locations are near or around the home, involving bodies of water used for activities of daily living. These include water-collecting systems, ponds, ditches, creeks, and watering holes. In tropical areas, death rates increase during monsoon season, when ditches and holes rapidly fill with rain, and are highest during daylight hours, when caregivers are busy with daily chores.

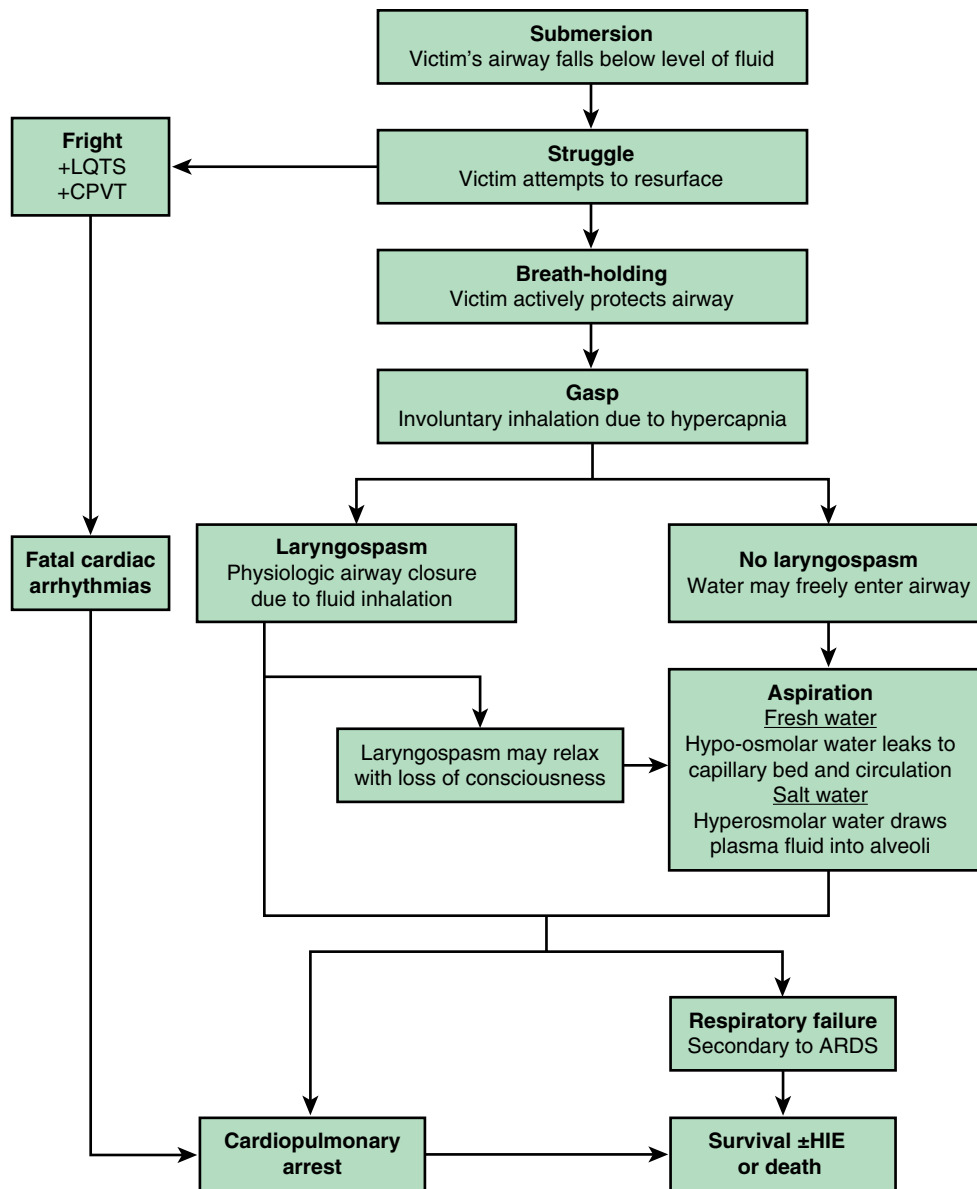
Drowning during natural disasters such as **storms** and **floods** is important in all areas of the world. The largest numbers of reported flood-related deaths occur in developing nations; most are drownings that occur during the storm surge. In the United States and much of Europe, advances in weather monitoring and warning systems have reduced such deaths. U.S. flooding incidents, including hurricanes Katrina and Sandy, showed that drowning caused the most deaths, particularly when people became trapped in their vehicles, were unable or refused to evacuate homes, or attempted to rescue others.

### PATHOPHYSIOLOGY

Drowning victims drown quickly and quietly and do not signal distress or call for help. Vocalization is precluded by efforts to achieve maximal lung volume to keep the head above the water or by aspiration leading to laryngospasm ([Fig. 88.3](#)). Young children can struggle for only 10-20 seconds and adolescents for 30-60 seconds before final submersion. The *instinctive drowning response* is a phenomenon where actual or perceived suffocation in water triggers autonomic nervous system responses resulting in unlearned, instinctive drowning movements. A swimmer in distress is vertical in the water, with arms extended to the side to lift the body up and bring the mouth above water to breathe. This splashing or efforts to breathe are often misconstrued by nearby persons as merely playing in the water, until the victim sinks.

### Anoxic-Ischemic Injury

During drowning there is a period of voluntary breath-holding, typically less than 1 minute, before small amounts of water enter the hypopharynx, triggering laryngospasm as a protective reflex. There is a progressive decrease in arterial blood oxyhemoglobin saturation ( $\text{Sao}_2$ ), and the person soon loses consciousness from hypoxia. Profound hypoxia and medullary depression lead to terminal apnea. Laryngospasm resolves, allowing additional fluid (water, stomach contents) into the lungs. At the same time, the cardiovascular response progresses to decreasing cardiac output and oxygen delivery to other organs. By 3-4 minutes, myocardial hypoxia leads to peripheral vasoconstriction, decreased cardiac output, and abrupt circulatory



**Fig. 88.3** Pathophysiologic events of the drowning process. LQTS, Long QT syndrome; CPVT, catecholaminergic polymorphic ventricular tachycardia; HIE, hypoxic-ischemic encephalopathy; ARDS, acute respiratory distress syndrome. (Courtesy Andrew Schmidt, DO, MPH.)

failure. Cardiac arrhythmias progress from tachycardia, to bradycardia, followed by ineffective cardiac contractions with electrical activity (**pulseless electrical activity**). With early initiation of CPR, spontaneous circulation may initially be successfully restored. The extent of the global **hypoxic-ischemic injury** determines the outcome and becomes more evident over subsequent hours.

With modern intensive care, the cardiorespiratory effects of resuscitated drowning victims are usually manageable and are less often the cause of death than irreversible hypoxic-ischemic central nervous system (CNS) injury (see [Chapter 82](#)). CNS injury is the most common cause of mortality and long-term morbidity. Although the duration of anoxia before irreversible CNS injury begins is uncertain, it is probably on the order of 3-5 minutes. Submersion <5 minutes is associated with a favorable prognosis, whereas those >25 minutes are generally fatal.

Several hours after cardiopulmonary arrest, **cerebral edema** may occur, although the mechanism is not entirely clear. Severe cerebral edema can elevate intracranial pressure (ICP), contributing to further ischemia; intracranial hypertension is an ominous sign of profound CNS damage.

All other organs and tissues may exhibit signs of hypoxic-ischemic injury. In the lung, damage to the pulmonary vascular endothelium can lead to **acute respiratory distress syndrome** (ARDS; see [Chapter 86](#)). Aspiration may also compound pulmonary injury. Myocardial dysfunction, arterial hypotension, decreased cardiac output, arrhythmias, and cardiac infarction may also occur. Acute kidney injury, cortical necrosis, and renal failure are common complications of major hypoxic-ischemic events (see [Chapter 572.1](#)). Vascular endothelial injury may initiate disseminated intravascular coagulation, hemolysis, and thrombocytopenia. Many factors contribute to gastrointestinal damage; bloody diarrhea with mucosal sloughing may be seen and often portends a fatal injury. Serum levels of hepatic transaminases and pancreatic enzymes are often acutely increased. Violation of normal mucosal protective barriers predisposes the victim to bacteremia and sepsis.

### Pulmonary Injury

Pulmonary aspiration occurs in many drowning victims, but the amount of aspirated fluid is usually small (see [Chapter 446](#)). Aspirated water does not obstruct airways and is readily moved into the



pulmonary circulation with positive pressure ventilation. More importantly, it can wash out surfactant and cause alveolar instability, ventilation-perfusion mismatch, and intrapulmonary shunting. The disruption of the alveolar capillary membrane leads to alveolar edema resulting in local ARDS-like syndrome.

In humans, aspiration of small amounts (1-3 mL/kg) can lead to marked hypoxemia and a 10–40% reduction in lung compliance. The composition of aspirated material can also affect the patient's clinical course: gastric contents, oropharyngeal flora, pathogenic organisms, toxic chemicals, and other foreign matter can injure the lung or cause airway obstruction. Aspiration is typically considered the source of pneumonia in cases of drowning, and antibiotics should be initiated based on radiographic evidence and clinical suspicion; no mortality benefit has been shown in those patients who received empiric or prophylactic antimicrobial therapy. Clinical management is not significantly different in saltwater and freshwater aspirations, because most victims do not aspirate enough fluid volume to make a clinical difference.

### Cold Water Injury

Drowning should be differentiated from cold water **immersion** injuries, in which the victim remains afloat, keeping the head above water without respiratory impairment in cold waters. The definition of cold water varies from <15–20°C (<59–68°F).

Heat loss through conduction and convection is more efficient in water than in air. Children are at increased risk for **hypothermia** because of their relatively high ratio of body surface area (BSA) to mass, decreased subcutaneous fat, and limited thermogenic capacity. Body temperature may also continue to fall after removal from the water because of cold air, wet clothes, hypoxia, and hospital transport time. Hypothermia in pediatric drowning victims may be observed even after drowning in relatively warm water and in warm climates (see Chapter 90).

Immersion in cold water has immediate respiratory and cardiovascular effects. Victims experience **cold water shock**, a dynamic series of cardiorespiratory physiologic responses that can cause drowning. In adults, immersion in icy water results in intense involuntary reflex hyperventilation and a decrease in breath-holding ability to <10 seconds, which leads to fluid aspiration. Severe bradycardia, the *diving reflex*, occurs in adults but is transient and rapidly followed by supraventricular and ectopic tachycardia and hypertension. There is *no evidence* that the diving reflex has any protective effect.

Even after surviving the chaotic minutes of cold-water shock, after an additional 5-10 minutes of cold-water immersion, the victim can become incapacitated. Cooling of large and small muscles disables the victim's ability to grab hold, swim, or perform other self-rescue maneuvers. Severe hypothermia with body temperatures below 28°C (82.4°F) can lead to cardiac arrhythmia and asystole.

Depending on water and air temperature, insulation, BSA, thermogenic capacity, physical condition, swimming efforts, or high-water flow rates, heat loss with continued immersion can significantly decrease core temperature to hypothermic levels within 30-60 minutes.

The symptoms and severity of hypothermia are categorized based on body temperature. The victim with mild hypothermia has a core body temperature of 32–35°C (90–95°F) with intact thermogenic mechanisms (shivering and nonshivering thermogenesis, vasoconstriction) and active movements. Compensatory mechanisms usually attempt to restore normothermia at body temperatures >32°C (89.6°F). Lower core temperatures lead to impaired cognition, coordination, and muscle strength and, with it, less ability to self-rescue. Thermoregulation may fail, and spontaneous rewarming will not occur. With moderate hypothermia (28 to <32°C [82 to <90°F]), loss of consciousness leads to water aspiration. Progressive bradycardia, impaired myocardial contractility, and loss of vasomotor tone contribute to inadequate perfusion, hypotension, and possible shock. At body temperatures <28°C (82.4°F), extreme bradycardia is usually present with decreases in cardiac output, and the propensity for spontaneous ventricular fibrillation or asystole is high. Central respiratory center depression with moderate to severe hypothermia results in hypoventilation and eventual apnea. A deep coma, with fixed and dilated pupils and absence of

reflexes at very low body temperatures (<25–29°C [77–84.2°F]), may give the false appearance of death.

If the cooling process is quick—and cardiac output lasts long enough for sufficient heat loss to occur before the onset of severe hypoxia—the brain can cool to a level that may be considered in the *neuroprotective* range, approximately 33°C (91.4°F) in controlled, experimental conditions. However, if submersion leading to drowning occurs before development of a neuroprotective level of hypothermia, severe anoxia devastates tissue organs. The theoretical benefits, implications, and consequences of hypothermia in drowning victims are areas of controversy. Known adverse effects are associated with hypothermia, and these must be balanced against the potential benefits observed in experimental data. One should clearly differentiate among **controlled hypothermia**, such as that used in the operating room before the onset of hypoxia or ischemia; **accidental hypothermia**, such as occurs in drowning, which is uncontrolled and variable, with onset during or shortly after hypoxia-ischemia; and **therapeutic hypothermia**, involving the purposeful and controlled lowering and maintenance of body (or brain) temperature after a hypoxic-ischemic event.

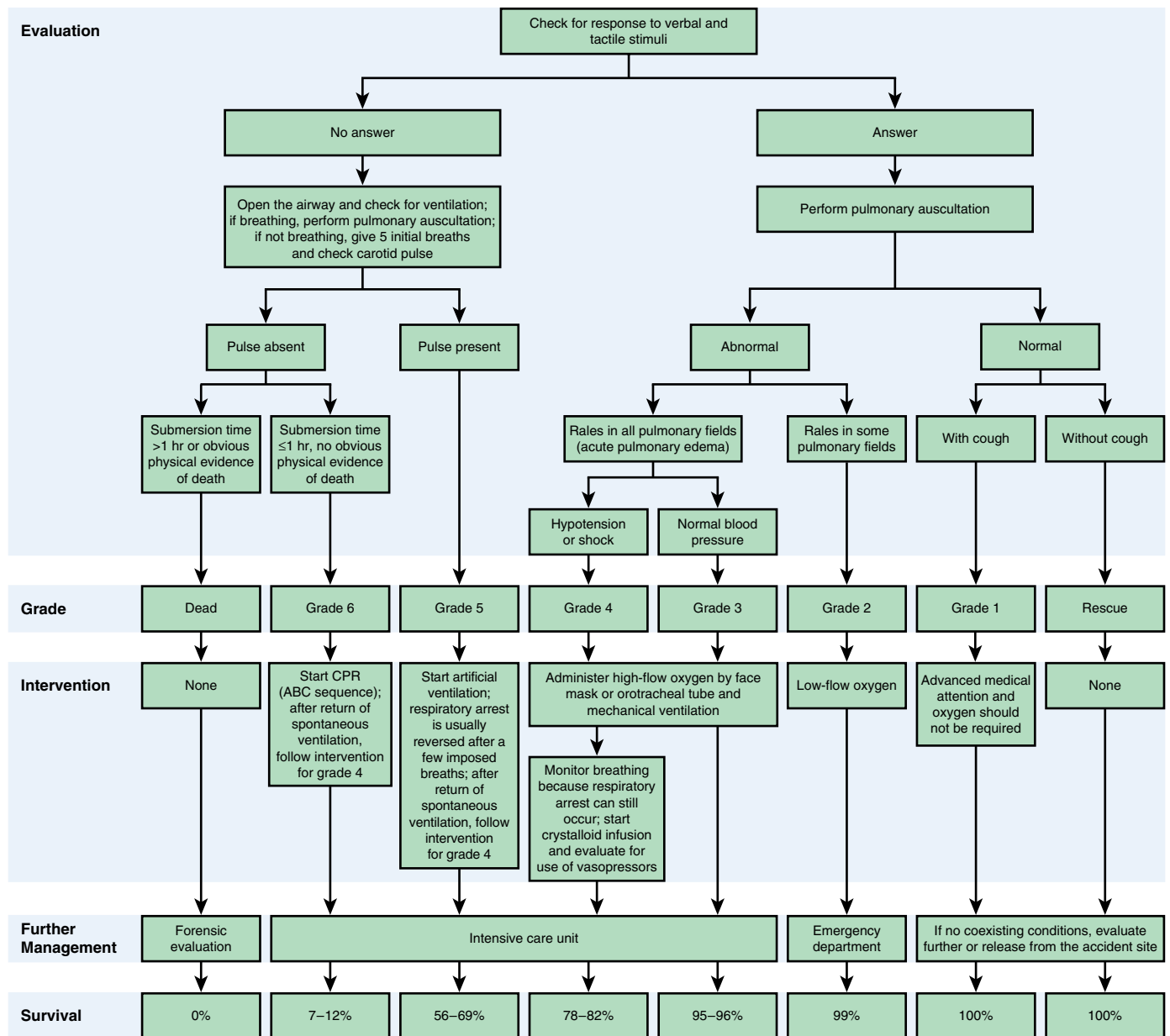
In drowning victims with uncontrolled accidental hypothermia associated with icy water submersion, there are isolated and rare reports of good neurologic recovery after prolonged (10-150 minutes) cardiopulmonary arrest. Almost all these rare survivors have been in freezing water (<5°C [41°F]) and had core body temperatures <30°C (86°F), often much lower. Presumably, very rapid and sufficiently deep hypothermia developed in these fortunate survivors before irreversible hypoxic-ischemic injury occurred. Intact neurologic functioning after sustaining a severe hypothermic submersion is likely associated with a combination of variables, including submersion times (most important), water temperature, immediate resuscitation, quality and duration of resuscitation, idioventricular bradycardia, and rewarming speed.

Most often, hypothermia is a poor prognostic sign, and a neuroprotective effect has not universally been demonstrated. A 2014 study from Washington State found that submersion duration <6 minutes is most strongly related to good outcome, not water temperature. In another study of comatose drowning patients admitted to the pediatric intensive care unit (PICU), 65% of hypothermic patients (body temperature <35°C [95°F]) died, compared with a 27% observed mortality rate in nonhypothermic victims. Thus a beneficial effect of drowning-associated hypothermia has not been seen in most pediatric submersion victims.

### MANAGEMENT

Duration of submersion, speed of the rescue, effectiveness of resuscitative efforts, and clinical course determine the outcome in submersion victims (Fig. 88.4). Two groups may be identified based on responsiveness at the scene. The first group consists of children who require minimal resuscitation at the scene and quickly regain spontaneous respiration and consciousness. They have good outcomes and minimal complications. In awake, alert victims with hypoxemia, the first line of therapy is supplemental oxygen. These victims should be transported from the scene to the ED for further evaluation and observation. The second group comprises children in cardiac arrest who require aggressive or prolonged resuscitation and have a high risk of multiple organ system complications, major neurologic morbidity, or death. Compared with cardiac arrest from other causes, cardiac arrest from drowning has a higher survival rate.

Initial management of drowning victims requires coordinated and experienced prehospital care following the ABCs (airway, breathing, circulation) of emergency resuscitation. CPR of drowning victims must include providing adequate ventilation as the initial phase of respiratory arrest, as these children may still have intact circulation. However, this phase will progress to cardiac arrest if hypoxia persists. Children with severe hypoxic injury and symptoms often remain comatose and lack brainstem reflexes despite the restoration of oxygenation and circulation. Subsequent ED and PICU care often involve advanced life support (ALS) strategies and management of multiorgan dysfunction with discussions about end-of-life care.



**Fig. 88.4** Treatment of persons who have drowned, with classification system. (From Szpilman D, Bierens J, Handley A, Orloveski J. *Drowning*. *N Engl J Med* 2012;366:2102–2110. Fig. 1.)

### Initial Evaluation and Resuscitation

See Chapter 79.

Immediate resuscitation at the submersion site, even before arrival of emergency medical services (EMS) personnel, is the most effective method to improve outcomes after drowning. Neurologic prognosis is significantly improved by prompt bystander CPR and activation of prehospital ALS. The goal is to reverse the anoxia from submersion and limit secondary hypoxic injury after submersion. Every minute that passes without the reestablishment of adequate breathing and circulation dramatically decreases the possibility of a good outcome. When safe for the victim and the rescuer, institution of in-water resuscitation for nonbreathing victims by trained personnel may improve the likelihood of survival. In-water resuscitation protocols recommend performing up to 1 minute of ventilation before attempting to bring the unconscious and apneic patient to shore. For patients in deep water, in-water resuscitation requires rescue flotation equipment or at least 2 rescuers. Practically, victims usually need to be extricated from the water as quickly as possible so that effective CPR can be provided.

Initial resuscitation must focus on rapidly restoring oxygenation, ventilation, and adequate circulation. The airway should be clear of vomitus and foreign material, which may cause obstruction or aspiration. Abdominal thrusts *should not* be used for fluid removal, because many victims have a distended abdomen from swallowed water; abdominal thrusts may increase the risk of regurgitation and aspiration. In cases of suspected airway foreign body, chest compressions or back blows are preferable maneuvers.

*The cervical spine (C-spine) should be protected in anyone with potential traumatic neck injury* (see Chapters 80 and 81). Cervical spine injury is a rare concomitant injury in drowning; approximately 0.5% of submersion victims have C-spine injuries, and history of the event and victim's age should guide suspicion of C-spine injury. Drowning victims with C-spine injury are usually preteens or teenagers whose drowning event involved diving, a motor vehicle crash, a fall from a height, a water sport accident, child abuse, or other clinical signs of serious traumatic injury. In such cases, the neck should be maintained in a neutral position and protected with a well-fitting cervical collar. Patients

rescued from unknown circumstances may also warrant C-spine precautions. In low-impact submersions, spinal injuries are exceedingly rare, and routine spinal immobilization is not warranted.

If the victim has ineffective respirations or apnea, ventilatory support must be initiated immediately. Mouth-to-mouth or mouth-to-nose breathing by trained bystanders often restores spontaneous ventilation. As soon as it is available, supplemental oxygen should be administered to all victims. Positive pressure bag-mask ventilation with 100% inspired oxygen should be instituted in patients with respiratory insufficiency. If apnea, cyanosis, hypoventilation, or labored respiration persists, trained personnel should perform endotracheal intubation as soon as possible. Intubation is also indicated to protect the airway in patients with depressed mental status or hemodynamic instability. Hypoxia must be corrected rapidly to optimize the chance of recovery.

Concurrent with securing of airway control, oxygenation, and ventilation, the child's cardiovascular status must be evaluated and treated according to the usual resuscitation guidelines and protocols. Heart rate and rhythm, blood pressure, temperature, and end-organ perfusion require urgent assessment. CPR should be instituted immediately in pulseless, bradycardic, or severely hypotensive victims, as studies have shown receiving bystander CPR is associated with neurologically favorable survival in all age groups. Continuous monitoring of the electrocardiogram (ECG) allows appropriate diagnosis and treatment of arrhythmias. Slow capillary refill, cool extremities, and altered mental status are potential indicators of shock (see [Chapter 85](#)).

Recognition and treatment of hypothermia are unique aspects of cardiac resuscitation in the drowning victim. Core temperature must be evaluated, especially in children, because moderate to severe hypothermia can depress myocardial function and cause arrhythmias. Wet clothing should be removed to prevent ongoing heat losses, although in the hemodynamically stable patient, rewarming should be initiated in the controlled environment of the receiving ED or PICU. Unstable patients (i.e., arrhythmias) should be warmed to 34°C (93.2°F), taking care not to overheat (see [Chapter 90](#), [Fig. 90.2](#)).

Often, intravenous (IV) fluids and vasoactive medications are required to improve circulation and perfusion. Vascular access should be established as quickly as possible for the administration of fluids or pressors. Intraosseous catheter placement is a potentially lifesaving vascular access technique that avoids the delay usually associated with multiple attempts to establish IV access in critically ill children. Epinephrine is the initial drug of choice in victims with brady-asystolic cardiopulmonary arrest (IV dose is 0.01 mg/kg using the 1:10,000 [0.1 mg/mL] solution given every 3-5 minutes, as needed). Epinephrine can be given intratracheally (endotracheal tube dose is 0.1-0.2 mg/kg of 1:1,000 [1 mg/mL] solution) if no IV access is available. An intravascular bolus of lactated Ringer solution or 0.9% normal saline (10-20 mL/kg) is often used to augment preload; repeated doses may be necessary.

### Hospital-Based Evaluation and Treatment

Most pediatric drowning victims should be observed for at least 4-6 hours, even if they are asymptomatic on presentation to the ED. Serial monitoring of vital signs and oxygenation by pulse oximetry, repeated pulmonary examination, and neurologic assessment should be performed in all drowning victims. Additional studies may also be warranted, depending on the specific circumstances (possible abuse or neglect, traumatic injuries, or suspected intoxication). Almost half of asymptomatic or minimally symptomatic alert children (who did not require ALS in the prehospital setting or who have an initial ED Glasgow Coma Scale [GCS] score of  $\geq 13$ ) experience some level of respiratory distress or hypoxemia progressing to pulmonary edema during the initial 4-6 hours after submersion. Most alert children with early respiratory symptoms respond to oxygen and, despite abnormal initial radiographs, become asymptomatic with a return of normal room-air pulse oximetry oxyhemoglobin saturation (SpO<sub>2</sub>) and pulmonary examination by 4-6 hours. Subsequent delayed respiratory deterioration is extremely unlikely in such children. Low-risk patients who present with normal mental status and normal respiratory function may be considered for discharge after 4-6 hours of observation if there is no deterioration of respiratory symptoms and appropriate follow-up can be ensured.

Initial ED management of symptomatic patients with respiratory distress or lethargy may require further testing depending on clinical severity. Initial studies may include blood gas monitoring, a complete metabolic panel, a complete blood count, and chest radiography. Toxicology tests, including drug and alcohol levels, should be considered when appropriate.

There has been much misinformation about **dry drowning** and **secondary drowning**. These are misnomers and not accepted medical terms. Dry drowning has been described historically as cases in which no water was found in the lungs at autopsy. Secondary drowning has been used interchangeably to describe patients who clinically worsen due to pulmonary edema after aspiration of water. These terms cause harm by misdiagnosing cases of sudden death as drowning when there is an alternative diagnosis. They also cause confusion when describing and monitoring drowning events. Drowning victims with no or minimal clinical signs of distress will either improve or worsen within 4-6 hours, and patients will not unexpectedly die of drowning days or weeks later without preceding signs.

### Cardiorespiratory Management

For children who are not in cardiac arrest, the level of respiratory support should be appropriate to the patient's condition and is a continuation of prehospital management. Frequent assessments are required to ensure that adequate oxygenation, ventilation, and airway control are maintained (see [Chapter 86](#)). Hypercapnia should generally be avoided in potentially brain-injured children. Patients with altered mental status, actual or potential hypoventilation, or markedly elevated work of breathing should receive mechanical ventilation to avoid hypercapnia and decrease the energy expenditures of labored respiration. Noninvasive ventilation (NIV) strategies such as bilevel positive airway pressure (BiPAP) and high-flow nasal canula (HFNC) have been associated with rapid improvement in the early phase of oxygenation in patients without altered mental status to reduce mortality.

Measures to stabilize cardiovascular status should also continue. Conditions contributing to myocardial insufficiency include hypoxic-ischemic injury, hypoxia, hypothermia, acidosis, high airway pressures during mechanical ventilation, alterations of intravascular volume, and electrolyte disorders. Heart failure, shock, arrhythmias, or cardiac arrest may occur. Continuous ECG monitoring is mandatory for recognition and treatment of arrhythmias (see [Chapter 484](#)).

The provision of adequate oxygenation and ventilation is a prerequisite to improving myocardial function. Patients should be given 100% inspired oxygen until oxygen saturation can be reasonably measured. Fluid resuscitation and inotropic agents are often necessary to improve heart function and restore tissue perfusion (see [Chapter 79](#)). Increasing preload with IV fluids may be beneficial through improvements in stroke volume and cardiac output. Overzealous fluid administration, however, especially in the presence of poor myocardial function, can worsen pulmonary edema.

For patients with persistent cardiopulmonary arrest on arrival in the ED after *non-icy water* drowning, the decision to withhold or stop resuscitative efforts can be addressed by review of the history and the response to treatment. Because there are reports of good outcome after ongoing CPR in the ED, most drowning victims should be treated aggressively on presentation. However, for children who do not show ready response to aggressive resuscitative efforts, the need for prolonged ongoing CPR after non-icy water submersion almost invariably predicts death or persistent vegetative state. Consequently, in most cases, discontinuation of CPR in the ED is probably warranted for victims of non-icy water submersion who do not respond to resuscitation within 25-30 minutes. Final decisions regarding whether and when to discontinue resuscitative efforts must be individualized, with the understanding that the possibility of good outcome is generally very low with protracted resuscitation efforts. In circumstances of severe ARDS or cardiac insufficiency, extracorporeal life support has been successfully employed.

### Neurologic Management

Drowning victims who present to the hospital awake and alert usually have normal neurologic outcomes. In comatose victims, irreversible



CNS injury is highly likely. The most critical and effective neurologic intensive care measures after drowning are rapid restoration and maintenance of adequate oxygenation, ventilation, and perfusion. Core body temperature and glucose management are important modulators of neurologic injury after hypoxia-ischemia.

Comatose drowning patients are at risk for intracranial hypertension. There is little evidence that ICP monitoring and therapy to reduce intracranial hypertension improve outcomes for drowning victims. Patients with elevated ICP usually have poor outcomes—either death or persistent vegetative state. Children with normal ICP can also have poor outcomes, although less frequently. Conventional neurologic intensive care therapies, such as fluid restriction; hyperventilation; and administration of muscle relaxants, osmotic agents, diuretics, barbiturates, and corticosteroids, have not been shown to benefit the drowning victim, either individually or in combination. There is some evidence that these therapies may reduce overall mortality but increase the number of survivors with severe neurologic morbidity.

Seizures after hypoxic brain injury are common, although detection is often difficult in the ICU because these patients are frequently sedated. Continuous electroencephalographic (EEG) monitoring in critically ill patients revealed a 13% incidence of seizures, 92% of which were exclusively nonconvulsive. However, EEG monitoring has only limited value in the management of drowning victims, except to detect seizures or as an adjunct in the clinical evaluation of brain death (see Chapter 83). Seizures should be treated, if possible, to stabilize cerebral oxygen use, although benefits are inconclusive. Fosphenytoin or phenytoin (loading dose of 10–20 mg of phenytoin equivalents/kg, followed by maintenance dosing with 5–8 mg of phenytoin equivalents/kg/day in two or three divided doses; levels should be monitored) may be considered as an anticonvulsant; it may have some neuroprotective effects and may mitigate neurogenic pulmonary edema. Benzodiazepines, barbiturates, and other anticonvulsants may also have some role in seizure therapy, although no conclusive studies have shown improved neurologic outcome.

With optimal management, many initially comatose children can have impressive neurologic improvement, but usually do so within the first 24–72 hours. Unfortunately, half of deeply comatose drowning victims admitted to the PICU die of their hypoxic brain injury or survive with severe neurologic damage. Deeply comatose drowning victims who do not show substantial improvement on neurologic examination after 24–72 hours and whose coma cannot be otherwise explained should be seriously considered for limitation or withdrawal of support.

### Additional Management Issues

Many drowning victims may have traumatic injury (see Chapter 80), especially if their drowning event involved participation in high-energy water sports such as personal watercraft, boating, diving, or surfing. A high index of suspicion for such injury is required. *Spinal precautions should be maintained in victims with altered mental status and suspected traumatic injury.*

Hypoxic-ischemic injury can have multiple systemic effects, although protracted organ dysfunction is uncommon in the absence of severe CNS injury. Hyperglycemia is associated with a poor outcome in critically ill pediatric drowning victims. Glucose control in patients after drowning should be focused on avoiding hypoglycemia, hyperglycemia, and wide or rapid fluctuations in serum glucose to prevent further harm.

Manifestations of acute kidney injury may be seen after hypoxic-ischemic injury (see Chapter 572). Diuretics, fluid restriction, and dialysis are occasionally needed to treat fluid overload or electrolyte disturbances; renal function usually normalizes in survivors. Rhabdomyolysis after drowning has been reported.

Profuse bloody diarrhea and mucosal sloughing usually portend a grim prognosis; conservative management includes bowel rest, nasogastric suction, and gastric pH neutralization. Nutritional support for most drowning victims is usually not difficult, because most children either die or recover quickly and resume a normal diet within a few days. Enteral tube feeding or parenteral nutrition is occasionally indicated in children who do not recover quickly.

*Hyperthermia after drowning or other types of brain injury may increase the risk of mortality and exacerbate hypoxic-ischemic CNS damage.* Almost half of drowning victims have a fever during the first 48 hours after submersion. Hyperthermia is usually not caused by infection and resolves without antibiotics in approximately 80% of patients. Generally, prophylactic antibiotics are not recommended. However, there is general consensus that fever or hyperthermia (core body temperature  $>37.5^{\circ}\text{C}$  [ $99.5^{\circ}\text{F}$ ]) in comatose drowning victims resuscitated from cardiac arrest should be prevented at all times in the acute recovery period (at least the first 24–48 hours).

**Psychiatric and psychosocial sequelae** in the family of a pediatric drowning victim are common. Grief, guilt, and anger are typical among family members, including siblings. Divorce rates increase within a few years of the injury, and parents often report difficulties with employment or substance abuse. Friends and family may blame the parents for the event. Professional counseling, pastoral care, or social work referral should be initiated for drowning victims and their families.

### Hypothermia Management

Attention to core body temperature starts in the field and continues during transport and in the hospital. The goal is to prevent or treat moderate or severe hypothermia. Damp clothing should be removed from all drowning victims. Rewarming measures are generally categorized as passive, active external, or active internal (see Chapter 90). **Passive rewarming measures** can be applied in the prehospital or hospital setting and include the provision of dry blankets, a warm environment, and protection from further heat loss. These should be instituted as soon as possible for hypothermic drowning victims who have not had a cardiac arrest.

Full CPR with chest compressions is indicated for hypothermic victims if no pulse can be found or if narrow complex QRS activity is absent on ECG (see Chapters 79 and 90). When core body temperature is  $<30^{\circ}\text{C}$  ( $86^{\circ}\text{F}$ ), resuscitative efforts should proceed according to the American Heart Association guidelines for CPR, but IV medications may be given at a lower frequency in moderate hypothermia because of decreased drug clearance. When ventricular fibrillation is present in severely hypothermic victims (core temperature  $<30^{\circ}\text{C}$  [ $86^{\circ}\text{F}$ ]), defibrillation should be initiated, but may not be effective until the core temperature is  $\geq 30^{\circ}\text{C}$  ( $86^{\circ}\text{F}$ ), at which time successful defibrillation may be more likely.

Significant controversy surrounds the discontinuation of prolonged resuscitative efforts in hypothermic drowning victims. Body temperature should be considered before resuscitative efforts are terminated. Other considerations include whether the victim may have been immersed before submerging, whether water was icy, or the cooling was very rapid with fast-flowing cold water. Victims with profound hypothermia may appear clinically dead, but full neurologic recovery is possible, although rare. Attempts at lifesaving resuscitation should not be withheld based on initial clinical presentation unless the victim is obviously dead (dependent lividity or rigor mortis). Rewarming efforts should usually be continued until the temperature is  $32\text{--}34^{\circ}\text{C}$  ( $89.6\text{--}93.2^{\circ}\text{F}$ ); if the victim continues to have no effective cardiac rhythm and remains unresponsive to aggressive CPR, resuscitative efforts can be discontinued.

Complete rewarming is not indicated for all arrest victims before resuscitative efforts are abandoned. Discontinuing resuscitation in victims of non-icy water submersion who remain asystolic despite 30 minutes of CPR is probably warranted. Physicians must use their individual clinical judgment about deciding to stop resuscitative efforts, taking into account the unique circumstances of each incident.

Once a drowning victim has undergone successful CPR after a cardiac arrest, temperature management should be carefully considered and body temperature continuously monitored. In victims in whom resuscitation duration was brief and who are awake soon after resuscitation, attempts to restore and maintain normothermia are warranted. Careful monitoring is necessary to prevent unrecognized worsening hypothermia, which can have untoward consequences.

For drowning victims who remain comatose after successful CPR, more contentious issues include rewarming of hypothermic patients and controlled application of therapeutic hypothermia. Although there is no evidence basis or opinion consensus, many investigators



cautiously recommend that hypothermic drowning victims who remain unresponsive because of hypoxic-ischemic encephalopathy after restoration of adequate spontaneous circulation should not be actively rewarmed to normal body temperatures. Active rewarming should be limited to victims with core body temperatures  $<32^{\circ}\text{C}$  ( $89.6^{\circ}\text{F}$ ), but temperatures  $32\text{--}37.5^{\circ}\text{C}$  ( $89.6\text{--}99.5^{\circ}\text{F}$ ) should be allowed without further rewarming efforts.

More controversial is the **induction of therapeutic hypothermia** in drowning victims who remain comatose because of hypoxic-ischemic encephalopathy after CPR for cardiac arrest. *A specific recommendation for therapeutic hypothermia, especially in children, is not yet generally accepted.* The Advanced Life Support Task Force of the International Liaison Committee on Resuscitation (2002) did not recommend therapeutic hypothermia in drowned children resuscitated after cardiopulmonary arrest, citing insufficient evidence and older studies demonstrating a potential deleterious effect in pediatric drowning victims. Several subsequent studies evaluating extracorporeal membrane circulation, rewarming, and therapeutic hypothermia in pediatric and adult drowning patients have shown no significant improvement in neurologic outcome or mortality.

The Therapeutic Hypothermia After Out-of-Hospital Pediatric Cardiac Arrest (THAPCA) randomized controlled trial (RCT) investigators analyzed post hoc the findings of *targeted temperature management* (TTM) in pediatric comatose survivors of out-of-hospital cardiac arrest caused by drowning. Drowning comprised 28% of the landmark pediatric TTM ( $33^{\circ}\text{C}$  vs  $36.8^{\circ}\text{C}$ ) RCT, and the authors' principal observation is that targeting hypothermia, compared with targeting normothermia, did not result in better survival.

## PROGNOSIS

The outcomes for drowning victims are remarkably bimodal: The great majority of victims either have a good outcome (intact or mild neurologic sequelae) or a poor outcome (severe neurologic sequelae, persistent vegetative state, or death), with very few exhibiting intermediate neurologic injury at hospital discharge. Subsequent evaluation of good-outcome survivors may identify significant persistent cognitive deficits. Of hospitalized pediatric drowning victims, 15% die and as many as 20% survive with severe permanent neurologic damage.

Strong predictors of outcome are based on the incident and response to treatment at the scene. Intact survival or mild neurologic impairment has been seen in 91% of children with submersion duration  $<5$  minutes and in 87% with resuscitation duration  $<10$  minutes. Children with normal sinus rhythm, reactive pupils, or neurologic responsiveness at the scene virtually always had good outcomes (99%). Poor outcome is highly likely in patients with deep coma, apnea, absence of pupil responses (fixed dilated pupils), and hyperglycemia in the ED; with submersion durations  $>10$  minutes; and with failure of response to CPR given for 25 minutes. In one comprehensive case series, all children with resuscitation durations  $>25$  minutes either died or had severe neurologic morbidity, and all victims with submersion durations  $>25$  minutes died. Long-term health-related quality of life and school performance in those who had received either bystander- or emergency medical service personnel-initiated CPR were high if their submersion duration was  $<5$  minutes. Higher morbidity, higher mortality, and lower quality of life were reported in patients with  $>10$  minutes submersion duration. In several studies of pediatric drowning, submersion duration was the best predictor of outcome and water temperature was not. However, there are rare case reports of intact recovery after non-icy water drowning with longer submersion or resuscitation duration.

The GCS score has some limited utility in predicting recovery. Children with a score  $\geq 6$  on hospital admission generally have a good outcome, whereas those with a score  $\leq 5$  have a much higher probability of poor neurologic outcome. Improvement in the GCS score during the first several hours of hospitalization may indicate a better prognosis. Overall, early GCS assessments fail to adequately distinguish children who will survive intact from those with major neurologic injury.

Neurologic examination and progression during the first 24-72 hours are the best prognosticators of long-term CNS outcome. Children who

regain consciousness within 48-72 hours, even after prolonged resuscitation, are unlikely to have serious neurologic sequelae. Laboratory and technologic methods to improve prognostication have not yet proved superior to neurologic examination. Serial neurologic evaluations after CPR should be performed over the ensuing 48-72 hours, with consideration given to limitation or withdrawal of support in patients who do not have significant neurologic recovery, even though this may occur before absolute prognostic certainty is achieved. Patients with minimal improvement during this initial period rarely show significant subsequent neurologic recovery despite aggressive resuscitation efforts and remain in a persistent vegetative state or die. Survivors with severe neurologic limitations necessitate neurorehabilitation to restore function and facilitate psychomotor development and prevent long-term damage caused by contractures, deformities, or scoliosis.

## PREVENTION

The most effective way to decrease the injury burden of drowning is prevention. Drowning is a multifaceted problem, but several evidence-based preventive strategies are effective. The pediatrician has a prime opportunity to identify and inform families at risk of these strategies through anticipatory guidance. Advocacy should focus on anticipatory guidance regarding the appropriate supervision of children, access to swim lessons, presence of lifeguards, barriers to swimming pools, and use of PFDs. A family-centered approach to anticipatory guidance for water safety helps explore and identify the water hazards that each family is exposed to in their environment. The practitioner can then discuss the best tools and strategies for prevention that are relevant for the family. It is important to identify the risk both in and around the home and in other locations they may frequent, often when vacationing, such as vacation or relatives' homes. If the family recreates near or on open water, they also need to learn about safety around boats and open water. In a rural environment, water collection systems and natural bodies of water may pose great risk.

Parents must build layers of water protection around their children. **Table 88.1** provides an approach to the hazards and preventive strategies relevant to the most common sources of water involved in childhood drowning. A common preventive strategy for exposure to all water types and all ages is ensuring **appropriate supervision**. Pediatricians should define for parents what constitutes appropriate supervision at the various developmental levels of childhood. Many parents either underestimate the importance of adequate supervision or are simply unaware of the risks associated with water. Even parents who say that constant supervision is necessary will often admit to brief lapses while their child is alone near water. Parents also overestimate the supervisory abilities of older siblings; many bathtub drownings occur when an infant or toddler is left with a child  $<5$  years old.

Drowning most often occurs quickly and quietly during periods of inadequate supervision. Supervisory behavior is composed of three components: proximity, attention, and continuity. The caregiver must be alert, must not be consuming alcohol or other drugs or socializing, and must be attentive and focused entirely on watching the child. If the child cannot swim independently, *touch supervision* is required, meaning that the caregiver should always be within arm's reach. Adolescents require active adult supervision and avoidance of alcohol or drug use during water activities.

**Learning to swim** offers another layer of protection. Children may start swim lessons at an early age that are developmentally appropriate and aimed at the individual child's readiness and skill level. Swim lessons are beneficial and provide some level of protection to young children. A study from Bangladesh, where drowning accounts for 20% of all deaths in children age 1-4 years, showed that swim lessons and water safety curricula are cost-effective and led to a decrease in mortality from drowning. As with any other water safety intervention, parents need to know that swimming lessons and acquisition of swim skills cannot be solely relied on to prevent drowning. *No child can be drown-proof.* A supervising caretaker should be aware of where and how to get help and know how to safely rescue a child in trouble. Because only those trained in water rescue can safely attempt it, families should be encouraged to swim in designated areas only when and where a lifeguard is on duty.

**Table 88.1** Approach to Prevention Strategies for Drowning

	HOME	RECREATION	NEIGHBORHOOD
Water hazards	<ul style="list-style-type: none"> <li>Swimming pools</li> <li>Ponds</li> <li>Bathtubs</li> <li>Large buckets</li> <li>Drain entrapment</li> </ul>	<ul style="list-style-type: none"> <li>Playing in water (swimming, wading)</li> <li>Playing near water</li> <li>Being on water (boating)</li> </ul>	<ul style="list-style-type: none"> <li>Irrigation ditches</li> <li>Watering holes</li> <li>Water drainage</li> </ul>
Common risks	<ul style="list-style-type: none"> <li>Lapse in supervision</li> <li>Unexpected toddler exposure</li> <li>Delayed discovery of child</li> <li>Reliance on water wings or pool toys</li> <li>Reliance on sibling or bath seat for bathing supervision</li> <li>Epilepsy</li> <li>Autism</li> <li>ADHD</li> <li>LQTS</li> </ul>	<ul style="list-style-type: none"> <li>Lapse in supervision</li> <li>Change in weather</li> <li>Unfamiliarity with or change(s) in water conditions:               <ul style="list-style-type: none"> <li>Steep drop-off</li> <li>Current/tide</li> <li>Low temperature</li> </ul> </li> <li>Alcohol and other drug use</li> <li>Peer pressure</li> </ul>	<ul style="list-style-type: none"> <li>Lapse in supervision, particularly when caregiver is socializing</li> <li>Risky behavior when with peers</li> </ul>
Prevention strategies	<ul style="list-style-type: none"> <li>Recognize hazards and risks</li> <li>Provide constant adult supervision around water</li> <li>Install 4-sided, isolation locked fencing of pools</li> <li>Install rescue equipment and phone at poolside</li> <li>Learn swimming and water survival skills</li> <li>Avoid unsupervised baths in older child/teen with seizure disorder; instead, shower</li> <li>Learn first aid and CPR</li> </ul>	<ul style="list-style-type: none"> <li>Provide constant adult supervision</li> <li>Swim in lifeguarded areas</li> <li>Know when and how to wear US Coast Guard–approved PFDs</li> <li>Avoid alcohol and other drugs</li> <li>Learn swimming and water survival skills</li> <li>Teach children about water safety</li> <li>Be aware of current weather and water conditions</li> <li>Buddy system</li> <li>Learn first aid and CPR</li> </ul>	<ul style="list-style-type: none"> <li>Identify hazardous bodies of water</li> <li>Prevent access to water with barriers</li> <li>Provide fenced-in “safe area” for water recreation</li> <li>Provide lifeguarded swim sites</li> <li>Provide access to low-cost swim/water survival lessons</li> </ul>

ADHD, attention deficit hyperactivity disorder; CPR, cardiopulmonary resuscitation; LQTS, long QT syndrome; PFDs, personal floatation devices.

Children and adolescents should never swim alone regardless of their swimming abilities. Even as they become more independent and participate in recreational activities without their parents, they should be encouraged to seek areas that are watched by **lifeguards**. The United States Lifesaving Association (USLA) reports that more than 75% of drownings at USLA sites occurred at times when the beaches were unguarded. It is important to emphasize that even if the child is considered a strong swimmer, the ability to swim in a pool does not translate to being safe in open water, where water temperature, currents, and underwater obstacles can present additional and unfamiliar challenges. For swimmers, supervision by lifeguards reduces drowning risk, because lifeguards monitor risk behaviors and are trained in the difficult and potentially dangerous task of rescuing drowning victims.

Two of the preventive strategies listed in [Table 88.1](#) deserve special mention. The most vigorously evaluated and effective drowning intervention applies to swimming pools. Compared with no fencing, installation of four-sided **isolation fencing** surrounding in-ground and aboveground pools with a secure, self-locking gate decreases the number of pool immersion injuries among young children by more than 50%. Guidelines for appropriate fencing, provided by the U.S. Consumer Product Safety Commission (CPSC), are very specific; they were developed through testing of active toddlers in a gymnastics program on their ability to climb barriers of different materials and heights, and recent studies show them to be effective in preventing drowning in young children. In families who have a pool on their property, caregivers often erroneously believe that if a child falls into the water, there will be a loud noise or splash to alert them. Unfortunately, these events are usually silent, delaying timely rescue. This finding highlights the need for a fence that separates the pool from the house, not just surrounds the entire property. The CPSC recommends power safety covers be installed on pools, as well as door alarms if the pool is not completely separated from the house and the yard by a fence. Entrapment and hair entanglement in open drains or pipes are other risks commonly associated with drowning in the pediatric population; special drain covers, safety vacuum release systems, and filter pumps with multiple drains can help prevent this.

The use of U.S. Coast Guard–approved **lifejackets or PFDs** should be advised with all families spending time around open water, not just those who consider themselves boaters. A PFD should be chosen with respect to the weight of the child and the proposed activity. Young children should wear PFDs that will float their head up. Parents should be urged to wear PFDs as well, because their use of PFDs is associated with greater use by their children. Toys such as water wings and “float-ies” should not be relied on as drowning prevention measures. The use of life jackets decreases boat-related drowning morbidity and mortality by 50%; unfortunately, their use remains low.

Effective preventive efforts must also consider **cultural practices**. Different ethnic groups may have certain attitudes, beliefs, dress, or other customs that may affect their water safety. The higher drowning risk of minority children needs to be addressed by community-based prevention programs.

In addition to anticipatory guidance, pediatricians can play an active role in drowning prevention by participating in advocacy efforts to improve legislation for pool fencing, PFD use, and alcohol consumption in various water activities. Several counties in the United States, Australia, and New Zealand have laws requiring isolation fencing for pools. Their effectiveness has been limited by a lack of enforcement. Similarly, all states have boating-under-the-influence laws but, similarly, rarely enforce them. Furthermore, efforts at the community level may be needed to ensure the availability of swimming lessons for underserved populations and lifeguarded swim areas.

The Drowning Chain of Survival refers to a series of steps that, when followed, attempt to reduce mortality associated with drowning. The steps of the chain include prevent drowning, recognize distress, provide flotation, remove from water, and provide care as needed. These interventions may be used by the drowning victim for self-rescue or via bystanders who recognize child distress, initiate rescue, and provide resuscitation. The timeline shows that rescue and resuscitation must occur within minutes to save lives, and care should be taken by rescuers to not become victims themselves.

Visit Elsevier eBooks+ at [eBooks.Health.Elsevier.com](http://eBooks.Health.Elsevier.com) for Bibliography.

## Chapter 89

## Burn Injuries

Tina L. Palmieri

Burns are among the top five leading causes of *unintentional injury* in children, after motor vehicle crashes, suffocation, drowning, and poisoning. There has been a decline in the incidence of burn injury requiring medical care that has coincided with a stronger focus on burn treatment and prevention, increased fire and burn prevention education, greater availability of regional treatment centers, widespread use of smoke detectors, greater regulation of consumer products and occupational safety, and societal changes such as reductions in smoking and alcohol abuse.

## EPIDEMIOLOGY

Approximately 1.1 million people in the United States require medical care for burn injuries each year, with over 100,000 children admitted to a hospital or treated in the emergency department (ED). **Fires** remain a major cause of mortality in children, but children <14 years old have a lower relative risk of dying in a fire than the general population.

**Thermal burns** are caused when an external heat source comes in contact with the skin and tissues causing injury; thermal burns may occur from contact with hot surfaces, hot liquids, steam, or flame. **Scald burns** are most prevalent in children ≤4 years old and account for 65% of burn-related admissions in this age-group. Although the incidence of hot water scalding has been reduced by legislation requiring water heaters to be preset at 48.9°C (120°F), scald injury remains the leading cause of hospitalization for burns in this age-group. **Steam** inhalation used as a home remedy to treat respiratory infections is a rare potential cause of burns. **Flame burns** are the most common cause of burn injury in all age-groups ≥5 years old. Electrical and chemical burns are also more common in older children and adults than in young children. **Clothing ignition** events have declined since passage of the Federal Flammable Fabric Act requiring sleepwear to be flame-retardant. Polyester is the fabric most resistant to ignition by a small flame source. Polyester burns deeply as it melts, but it self-extinguishes when the flame source is removed. Cotton, on the other hand, continues to burn after the flame source has been removed, resulting in large, deep burns. Polyester melts downward, sparing the face and respiratory tract; cotton burns upward toward the face. Pellet stoves, glass front stoves, and flat top stoves are frequent sources of hand burns in children, as is contact with hot hair appliances, such as curling irons and hair straighteners. Approximately 18% of burns are the result of **child abuse** (usually scalds), making it important to assess the pattern and site of injury and their consistency with the patient's history (see [Chapter 17](#)). **Friction burns** from treadmills are also a problem. Hands are the most commonly injured sites, with burns ranging from deep second-degree to fourth-degree with tendon disruption and fractures from the friction injury. **Anoxia**, not the actual burn, is a major cause of morbidity and mortality in house fires.

Review of the history usually shows a common pattern: a v-shaped distribution of the scald burns to the chest and abdomen if liquid is pulled from a table or stove, burns in the pant leg area if clothing ignites, burns in a splash pattern from a hot liquid spill, and burns on the palm of the hand from contact with a hot stove or curling iron. However, **glove or stocking burns** of the hands and feet; single-area deep burns on the trunk, buttocks, or back; and small, full-thickness burns (e.g., cigarette burns) in young children should raise the suspicion of child abuse.

**Burn care** involves a range of activities: prevention, acute care and resuscitation, wound management, pain relief, reconstruction, rehabilitation, and psychosocial adjustment. Children with massive burns require early and appropriate psychologic and social support as well as resuscitation. Surgical debridement, wound closure, and rehabilitative

efforts should be instituted concurrently to promote optimal outcomes. To maximize survival, the clinical approach includes aggressive surgical removal of devitalized tissue with timely skin closure via grafting, infection control, and judicious use of antibiotics; life support with endotracheal intubation and mechanical ventilation; and use of early enteral nutrition. Children who have sustained burn injuries differ in appearance from their peers, necessitating supportive efforts for reentry to school and social and sporting activities.

## PREVENTION

The aim of burn prevention is a continuing reduction in the number of serious burn injuries ([Table 89.1](#)). Effective first aid and triage can decrease both the extent (area) and the severity (depth) of injuries. The use of flame-retardant clothing and smoke detectors, control of hot water temperature (thermostat settings) to 48.9°C (120°F) within buildings, and prohibition of cigarette smoking have been partially successful in reducing the incidence of burn injuries. Treatment of children with significant burn injuries in dedicated burn centers facilitates medically effective care, improves survival, and leads to greater cost efficiency. Survival of at least 80% of patients with burns of 90% of the total body surface area (TBSA) is possible for children and young adults. Death is more likely in children with irreversible anoxic brain injury sustained at the time of the burn. Some burns occur on a seasonal basis, including:

*Winter:*

- Glass-front fireplaces/pellet stoves and radiators increase hand burns
- Treadmill injuries as more people exercise inside—child imitates adults or young child touches belt
- Soup scald burns from spilling liquid while removing bowl from microwave

*Summer:*

- Fireworks, sparklers—temperatures reach 537.8°C (1,000°F)
- Burn contact with hot grill; hand/feet burn from hot embers
- Burns from children walking or falling into a campfire
- Lawnmowers

*Spring/Fall:*

- Burning leaves
- Gasoline burns
- Tap water scalds
- House fires from propane heater explosion

Pediatricians can play a major role in preventing the most common burns by educating parents and healthcare providers. Simple, effective, efficient, and cost-effective preventive measures include the use of appropriate clothing and smoke detectors and the planning of routes for emergency exit from the home. The National Fire Protection Association (NFPA) recommends replacing smoke detector batteries

**Table 89.1** Burn Prophylaxis

## PREVENT FIRES

Install and use smoke detectors.

Control the hot water thermostat; maximum water temperature should be 48.9°C (120°F).

Keep fire, matches, and lighters out of the reach of children.

Avoid cigarette smoking, especially in bed.

Do not leave lit candles unattended.

Keep hair appliances such as curling irons and straighteners out of the reach of children.

Use caution when cooking, especially with oil.

Keep cloth items off heaters.

## PREVENT INJURY

Stop, drop, and roll (do not run) if clothing catches fire; wrap in a blanket.

Practice escape procedures.

Crawl beneath smoke if a fire occurs indoors.

Use educational materials.\*

\*National Fire Protection Association pamphlets and videos.



**Table 89.2** Indications for Referral to a Burn Center

Partial-thickness burns affecting >10% TBSA
Full-thickness burn affecting >5% TBSA
Third-degree burns
Electrical burns caused by high-tension wires or lightning
Chemical burns
Inhalation injury, regardless of the amount of TBSA burned
Inadequate home or social environment
Suspected child abuse or neglect
Burns to the face, hands, feet, perineum, genitals, or major joints
Burns in patients with preexisting medical conditions that may complicate the acute recovery phase
Associated injuries (fractures)

TBSA, Total body surface area.

Adapted from American Burn Association/American College of Surgeons. Guidelines for the operation of burn centers. *J Burn Care Res.* 2007;28(1):134–141 and Bettencourt AP, Romanowski KS, Joe V, et al. Updating the Burn Center Referral Criteria: Results from the 2018 eDelphi Consensus Study. *J Burn Care Res.* 2020;41(5):1052–1062.

annually and the smoke detector alarm every 10 years (or earlier, if indicated on the device).

## ACUTE CARE, RESUSCITATION, AND ASSESSMENT

### Indications for Admission

Burns covering >10% TBSA, burns associated with smoke inhalation, burns resulting from high-tension (voltage) electrical injuries, and burns associated with suspected child abuse or neglect should be treated emergently and referred to a burn center for definitive care (Table 89.2). Small first- and second-degree burns of the hands, feet, face, perineum, and joint surfaces may require admission if close follow-up care is difficult to provide. Children who have been in enclosed-space fires and those who have significant face and neck burns should be evaluated carefully for airway or neurologic compromise, including monitoring for 24 hours in the hospital for potential central nervous system (CNS) effects of anoxia from carbon monoxide (CO) poisoning or pulmonary effects from smoke inhalation.

### First Aid Measures

Acute care should include the following measures:

1. Extinguish flames by rolling the child on the ground; cover the child with a blanket, coat, or carpet.
2. Remove smoldering clothing or clothing saturated with hot liquid. Jewelry, particularly rings and bracelets, should be removed or cut away to prevent constriction and vascular compromise during the edema phase in the first 24–72 hours after burn injury.
3. In cases of **chemical injury**, brush off any remaining chemical, if powdered or solid; then use copious irrigation or wash the affected area with water. Call the local poison control center for the neutralizing agent to treat a chemical ingestion.
4. Wash the burned area with soap and cool running water. For burns on less than 10% of the body, irrigate with cool tap water for 10–20 minutes. Significant large-burn injury (>15% TBSA) decreases body temperature control so the use of cold water is contraindicated.
5. Cover the burned area with clean, dry sheeting or dressing. Avoid using tape.
6. If the burn is caused by *hot tar*, cool the burn and then use mineral oil to remove the tar.
7. Administer analgesic medications.

### Emergency Care

Supportive measures are as follows (Table 89.3 and Table 89.4):

1. Rapidly review the cardiovascular and pulmonary status and document preexisting or physiologic lesions (asthma, congenital heart disease, renal or hepatic disease).
2. Ensure and maintain an adequate airway (Fig. 89.1). For any child with a facial burn or suspected inhalation of smoke, the following actions are indicated:

**Table 89.3** Acute Treatment of Burns

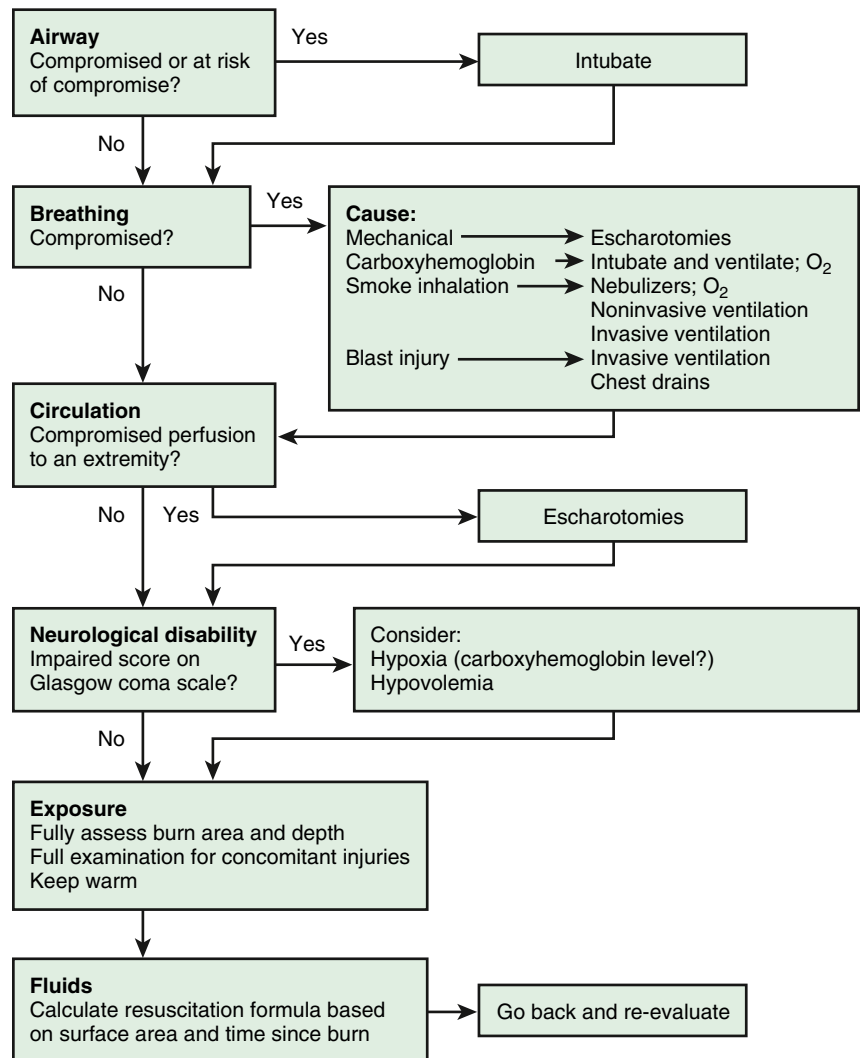
First aid, including washing of wounds and removal of devitalized tissue
Fluid resuscitation
Provision of energy requirements
Control of pain
Prevention of infection
Early excision and grafting
Prevention of excessive metabolic expenditures
Control of bacterial wound flora
Early mobility, range of motion, and strength exercises

- a. Start 100% oxygen and measure carboxyhemoglobin (CO) levels as well as a blood gas, because cutaneous oxygen saturations are not accurate in CO poisoning (see Chapters 79 and 86).
  - b. Assess for laryngeal edema (examine mouth; assess for stridor, retractions) and intubate for evidence of significant airway compromise.
  - c. Assess oxygenation to evaluate for lung damage from smoke inhalation. Bronchoscopy may be helpful in the intubated child to further delineate the extent of smoke inhalation injury. Use a humidified ventilator circuit to prevent dry secretions that can obstruct an airway.
3. Children with burns >15% TBSA require intravenous (IV) fluid resuscitation to maintain adequate perfusion. IV access is preferably obtained in a nonburned area, but if none is readily available, placing the initial line through a burn may be necessary. Monitor peripheral IV sites closely for infiltration, as extremities will become edematous after burn injury. In an emergency situation in which IV access is unattainable, an intraosseous (IO) line may be placed. The IO line should be replaced in a timely fashion with a central line, as IO needles may be unable to sustain the large fluid volume needed for major burn resuscitation. Patients with inhalation injury, regardless of the extent of TBSA burn, require large volumes of fluid for resuscitation due to insensible losses from the injured airway epithelium. Significant high-tension and electrical injuries require venous access to ensure sufficient fluid resuscitation volumes, as forced alkaline diuresis may be needed in fluid-refractory myoglobinuria to avoid renal damage. Lactated Ringer solution, 10–20 mL/kg/hr (normal saline may be used if lactated Ringer solution is not available), is initially infused until proper fluid replacement can be calculated. Consultation with a specialized burn unit should be made to coordinate fluid therapy, including the type of fluid, the preferred formula for calculation, and preferences for the use of colloid agents, particularly if transfer to a burn center is anticipated.
  4. For patients with circumferential burns of the extremities, elevate the extremities and monitor perfusion (capillary refill, pulses), as compartment syndrome (see Chapter 80) may develop and require escharotomy.
  5. Evaluate the child for associated injuries. Children with burns may have associated accidental traumatic injuries (fall) or nonaccidental injuries (child abuse). In cases of high-voltage electrical burn (>1,000 volts), especially if there has also been a fall from a height, injuries to the spine, bones, and thoracic or intraabdominal organs may occur (see Chapter 80). Cervical spine precautions should be observed until this injury is ruled out. If ventricular fibrillation occurs at the scene of an electrocution, cardiopulmonary resuscitation (CPR) should be instituted promptly, and cardiac monitoring started on the patient's arrival at the ED (see Chapter 79).
  6. Children with burns of >15% TBSA should not initially receive oral fluids because gastric distention may develop. These children may require insertion of a nasogastric tube in the ED to prevent aspiration.
  7. A Foley catheter should be inserted into the bladder to monitor urine output in children who require IV fluid resuscitation.



**Table 89.4** Phases of Burn Care

PHASE AND TIMING	PHYSIOLOGIC CHANGES	OBJECTIVES
1: Resuscitation, 0-72 hours	Massive capillary leak, edema, and burn shock	Airway, breathing, and circulation optimization via accurate fluid resuscitation and thorough evaluation
2: Acute treatment phase, day 3 through discharge	Hyperdynamic and catabolic state, immunosuppression, risk of infection	Enteral nutrition to optimize wound healing; excision and biologic wound closure of full-thickness wounds with excision and grafting within 7 days of injury
3: Rehabilitation, day 1 through discharge	Gradual waning of initial catabolic state, wounds heal, scars form, and strength recovers	Maintain and restore range of motion; reduce edema; strengthen muscles; facilitate return to home, work, and school



**Fig. 89.1** Algorithm for primary survey of a major burn injury. (From Hettiaratchy S, Papini R. Initial management of a major burn. I. Overview. *BMJ*. 2004;328:1555–1557.)

- In general, wounds should be wrapped with a clean sheet or dressing until it is decided whether to treat the patient on an outpatient basis or refer to an appropriate facility.
- For children trapped in a fire, a CO measurement (carboxyhemoglobin [HbCO]) should be obtained and 100% oxygen administered until the result is known. Pulse oximetry is unreliable in CO poisoning.
- Review child immunizations, including tetanus immunization. Use diphtheria, tetanus toxoids, and acellular pertussis (DTaP) for tetanus prophylaxis for children <7 years old, and use tetanus, diphtheria, and pertussis (Tdap) for children ≥7 years old (see [Chapter 257](#)).

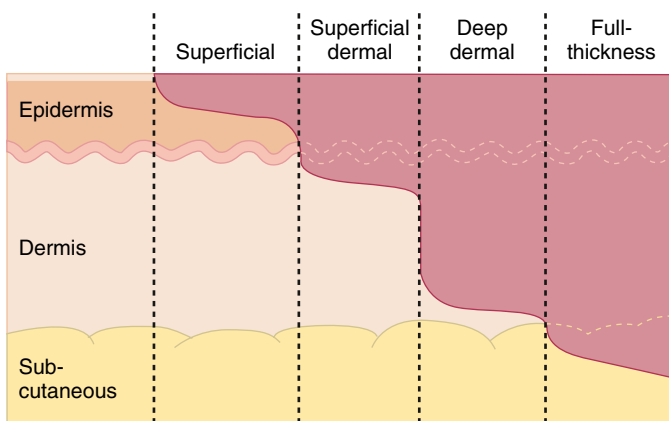
### Classification of Burns

Proper triage and treatment of burn injury require assessment of the extent and depth of the injury ([Table 89.5](#) and [Fig. 89.2](#)). **First-degree burns** involve only the epidermis and are characterized by swelling, erythema, and pain (similar to mild sunburn). Tissue damage is usually minimal, and there is no blistering. Pain resolves in 48-72 hours; in a small percentage of patients, the damaged epithelium peels off, leaving no residual scars.

A **second-degree burn** involves injury to the entire epidermis and a variable portion of the dermal layer (vesicle and blister formation are characteristic). A *superficial* second-degree burn is extremely painful because many remaining viable nerve endings are exposed. Superficial

**Table 89.5** Categories of Burn Depth

	FIRST-DEGREE BURN	SECOND-DEGREE BURN (PARTIAL THICKNESS)	THIRD-DEGREE BURN (FULL-THICKNESS)
Surface appearance	Dry, no blisters Minimal or no edema Erythematous Blanches, bleeds	Moist blebs, blisters Underlying tissue is mottled pink and white, with fair capillary refill Bleeds	Dry, leathery eschar Mixed white, waxy, khaki, mahogany, soot-stained No blanching or bleeding
Pain	Very painful	Very painful	Insensate centrally, edges (usually less deep) may still have sensation
Histologic depth	Epidermal layers only	Epidermis, papillary, and reticular layers of dermis May include domes of subcutaneous layers	Through all layers of the skin to subcutaneous tissue (loss of muscle, bone is fourth-degree burn)
Healing time	2-5 days with no scarring	Superficial: 5-21 days with no grafting Deep partial: 21-35 days with no infection, but scar is expected; if infected, converts to full-thickness burn	Large areas require grafting, but small areas may heal from the edges after weeks



**Fig. 89.2** Diagram of different burn depths. (From Hettiaratchy S, Papini R. *Initial management of a major burn. II. Assessment and resuscitation. BMJ. 2004;329:101–103.*)

second-degree burns heal in 7-14 days as the epithelium regenerates in the absence of infection. *Mid-level to deep* second-degree burns will generally heal in 14-21 days, but often result in significant scarring. Deep second-degree burns tend to be dry, pale, and white (flame) or red (scald); they are often grafted to mitigate scarring (Fig. 89.3). Pain may be less with these burns than in more superficial burns because fewer nerve endings remain viable; however, the edge of the burn, which will be less deep, will still cause pain. Fluid losses and metabolic effects of deep dermal (second-degree) burns are essentially the same as those of third-degree burns. If a blister is intact in a burned area, the burn is at least second-degree but may be deeper. Definitive diagnosis of burn depth is not possible because the blister blocks visualization of the burned tissue under the blister.

**Full-thickness, or third-degree burns,** involve destruction of the entire epidermis and dermis, leaving no residual epidermal cells to repopulate the damaged area. The wound heals by wound contraction or skin grafting. Wounds are either white or leathery (flame burn) or mottled, nonblanching, and cherry red (scald) (Fig. 89.4). The absence of painful sensation and capillary filling demonstrates the loss of nerve and capillary elements. Pain exists at the edges of the burn. Hence, using pain to determine burn depth is not accurate.

Technologies can help accurately determine the depth of burns. *Laser Doppler imaging* can be used from 25 days after the burn. It produces a color map of the affected tissue; *yellow* indicates second-degree burns, reflecting the presence of capillaries, arterioles, and venules, and *blue* reflects very low or absence of blood flow, which indicates third-degree burns. Although early reports are promising, the clinical utility

of laser Doppler imaging for burn depth determination is not clearly established.

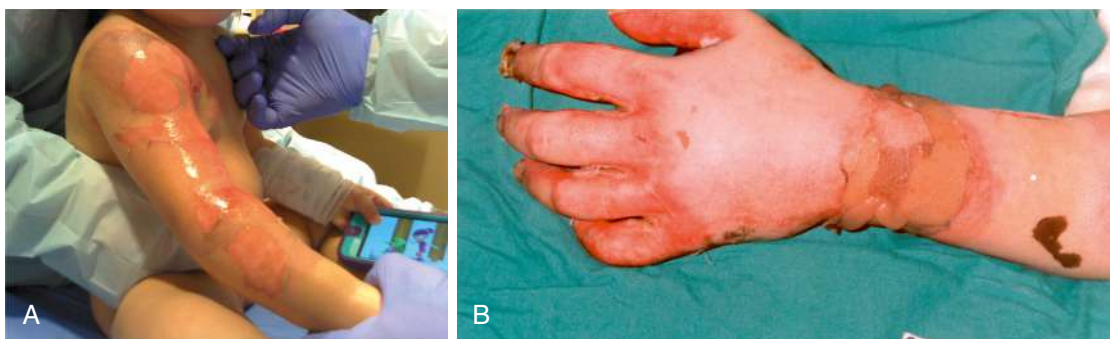
### Estimation of Total Body Surface Area for a Burn

Appropriate burn charts for different childhood age-groups should be used to accurately estimate the extent of TBSA burned. The extent and depth of the burn are the largest determinants of fluid resuscitation requirements. Mortality and morbidity also depend on the extent and depth of the burn. Children have a larger surface area to mass ratio than adults, and the variable growth rate of the child's head and extremities makes it necessary to use body surface area (BSA) charts, such as that modified by Lund and Brower, to accurately calculate burn size (Fig. 89.5). Another method of estimating burn size is to employ the palm rule. The palm of the child's hand (from base of palm to fingertip) is 1% of the child's TBSA. A quick method of estimating burn size is to hold your hand up to the child's hand to gauge the area and use that to determine burn size. The **rule of nines** used in adults should only be used in children >14 years old or >20 kg as a rough estimate to institute therapy before transfer to a burn center. The rule of nines divides body regions by 9% BSA: head and neck, chest and upper back, each arm, abdomen, lower back, upper leg, and lower leg; hand or genitals (1%).

## TREATMENT

### Outpatient Management of Minor Burns

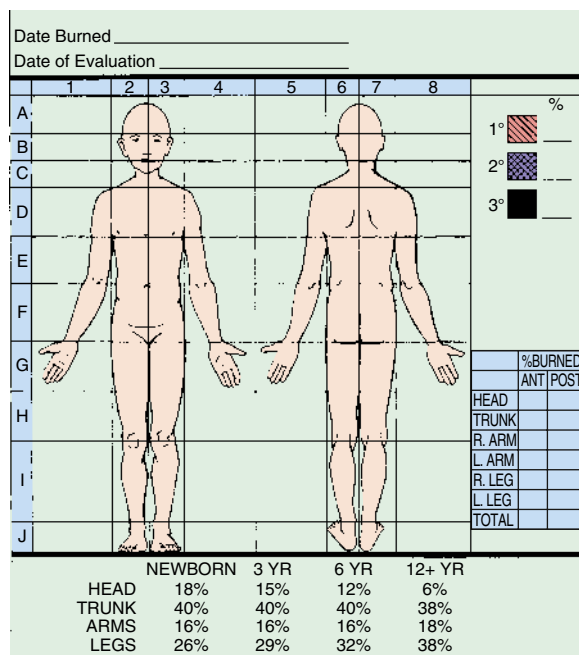
A patient with first- and second-degree burns <10% TBSA may be treated on an outpatient basis unless pain is uncontrolled on oral agents, the family cannot successfully complete wound care, or there are issues of child neglect or abuse. These outpatients do not require prophylactic antibiotics. Blisters should be left intact and dressed with a nonstick dressing such as Telfa or Xeroform. Topical creams do not penetrate the blister and are not indicated unless the blister ruptures. Dressings should be changed once daily, after the wound is washed with lukewarm water. Very small wounds, especially those on the face, may be treated with bacitracin ointment and left open. **Debridement** (i.e., removal) of the devitalized skin is indicated when the blisters rupture. A variety of wound dressings are available for application to second-degree burns; the affected area should be subsequently wrapped with a dry, clean dressing. Silver dressings are popular because they provide pain relief, prevent wound desiccation, reduce wound colonization, and can be left in place for 5-7 days (Table 89.6). Although silver dressings are antimicrobial, wound infections can occur beneath these dressings. Patients should be instructed to seek immediate medical care for signs and symptoms of infection (elevated temperature, malaise, pain) and should be reevaluated at least weekly by the medical team. The great majority of superficial burns heal in 7-10 days, with deep second-degree burns taking longer to heal. Burns that have not healed within 2 weeks (or clearly will not be healed in 2 weeks) have a >97% chance of developing a significant scar and should be referred to a burn center.



**Fig. 89.3** Second-degree burns. A, Superficial partial-thickness (second-degree) burn, which is pink and glistening. B, Deep partial-thickness (second-degree) burn. The white-appearing area over the dorsum of the hand is a deep partial-thickness burn. (From Singer AJ, Lee CC. Thermal burns. In: Walls RM, Hockberger RS, Gausche-Hill M, et al., eds. *Rosen's Emergency Medicine*, 9th ed. Philadelphia: Elsevier; 2018: Figs. 56.1 and 56.2, p. 717.)



**Fig. 89.4** Full-thickness (third-degree) burn over both feet. The central area is depressed and has a yellowish color indicating it is full thickness. (Modified from Singer AJ, Lee CC. Thermal burns. In: Walls RM, Hockberger RS, Gausche-Hill M, et al., eds. *Rosen's Emergency Medicine*, 9th ed. Philadelphia: Elsevier; 2018: Fig. 56.3, p. 717.)



**Fig. 89.5** Chart to determine developmentally related percentage of body surface area affected by burn injury. ANT, Anterior; POST, posterior; R., right; L., left. (Courtesy Shriners Hospital, Burn Institute, Boston Unit.)

**Table 89.6** Select Silver Antimicrobial Dressings for Burns

DRESSING	CHARACTERISTIC(S)
Mepitel Ag	Silicone mesh dressing
Mepilex Ag	Foam dressing
ACTICOAT	Polyethylene nonadherent net dressing
AQUACEL Ag	Absorptive Hydrofiber
Silverlon	Knitted nylon nonadherent dressing

The palm of the hand is one of the most frequently burned areas in children, particularly toddlers. Because the skin on the palm of the hand is thicker than other parts of the body, burns to the palm often heal. Generally, blisters of the palm can be left intact unless they are already open, or they are so large that they will likely rupture (usually about 1-2 cm in height), or purulence is draining from the blister. If leaving a blister intact, inform the family to either return to the office if the blister ruptures or instruct them on how to remove the blister and apply bacitracin to the wound. If a palm burn has not healed in 2 weeks (or it is clear that it will not be healed), referral to a burn center is needed.

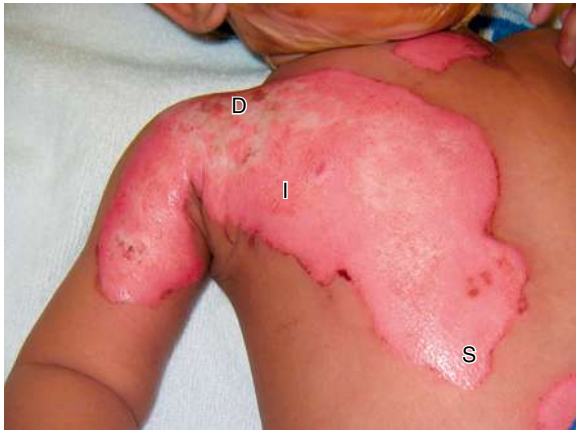
The depth of scald injuries is difficult to assess early, as the wounds are often reddish in color. Nonoperative treatment is appropriate initially. Generally, third-degree scald burns will become increasingly pale and white by 4-5 days post injury, whereas those that heal will be a lighter pink color. A wound that has not healed in 2 weeks will likely need grafting (Fig. 89.6). This conservative approach obviates the risk of anesthesia and unnecessary grafting.

### Fluid Resuscitation

Fluid resuscitation, if required, should begin as soon as possible (at the scene, in the ED, or before transfer) after the injury has occurred because delays of as little as 30 minutes affect outcomes. Numerous formulas exist to help guide practitioners in calculating fluid resuscitation needs in patients with burns. For most children, the *Parkland formula* is an appropriate *guideline* to determine starting IV fluid resuscitation rate; however, fluids should be adjusted hourly based on the patient's response. The steps in calculating the starting rate are as follows:

1. Calculate the 24-hour fluid requirement: 4 mL lactated Ringer solution per (times) weight in kg per (times) % TBSA burned. The TBSA burned is a whole number, NOT a percentage.
2. Determine the volume of fluid to be given in the first 8 hours: for the Parkland formula, that is half of the 24-hour requirement.
3. Calculate the starting hourly infusion rate: divide the volume to be given in the first 8 hours by 8 to determine the starting rate. The





**Fig. 89.6** Tea scald over the chest and shoulder of a child showing heterogeneity of burn depth. D, Deep; I, intermediate; S, superficial. (From Enoch S, Roshan A, Shah M. *Emergency and early management of burns and scalds*. *BMJ*. 2009;338:937–941.)

infusion rate is adjusted hourly based on urine output goals of 0.8–1 mL/hour in children <20 kg or <12 years of age and 0.4–0.5 mL/kg/hr (maximum of 30 mL/hr) in children >12 years or >20 kg.

Providers should increase the fluid rate by 10% if urine output is below the hourly target and decrease the fluids by 10% if over the target. Because major burns have a hypermetabolic response, tachycardia is NOT an accurate measure of resuscitation in a child with a major burn. Acid-base balance, mental status, serum lactate, and noninvasive monitoring are useful adjuncts to evaluate the adequacy of resuscitation. Because of interstitial edema and sequestration of fluid in muscle cells, patients may gain up to 20% over baseline (preburn) body weight. Patients with burns of >20% TBSA often require a large venous access (central venous line) to deliver the fluid required over the critical first 24 hours; these patients are best cared for in a specialized pediatric burn unit. In addition to fluid resuscitation, children <20 kg should receive standard maintenance fluids (see Chapter 74).

During the second 24 hours after the burn, patients begin to reabsorb edema fluid and to experience diuresis. IV fluid requirements after resuscitation will consist of isotonic crystalloid infusion for insensible losses (see Chapter 73) plus the fluid losses from the burn wound. Controversy surrounds whether *colloid* should be provided in the early period of burn resuscitation. One preference is to administer albumin if a patient is not responding to crystalloid resuscitation. In children <12 months old, sodium tolerance is limited; the volume and sodium concentration of the resuscitation solution should be decreased if the urinary sodium level is rising. The adequacy of resuscitation should be constantly reassessed by integrating vital signs with urine output, blood gas, serum lactate, base deficit, hematocrit, and serum protein measurements. Some patients require arterial and central venous lines, particularly those undergoing multiple excision and grafting procedures, for monitoring and fluid replacement purposes. Central venous pressure monitoring may be indicated to assess circulation in patients with hemodynamic or cardiopulmonary instability. Femoral vein cannulation is a safe access for fluid resuscitation, especially in infants and children. Burn patients who require frequent blood gas monitoring benefit from radial or femoral arterial catheterization.

Oral supplementation may start as soon as enteral access is obtained. Early nutrition helps to minimize effects of the hypermetabolic response. Milk formula, artificial feedings, homogenized milk, or soy-based products can be given by bolus or constant infusion through a nasogastric or small bowel feeding tube. These feedings are not part of the initial 24-hour fluid resuscitation, as absorption may be variable. When oral fluids are tolerated after several days, IV fluids are decreased proportionately to keep the total fluid intake constant, particularly if pulmonary dysfunction is present.

Colloids such as albumin are lost through the burn wound. To maintain oncotic pressure and protein binding, a 5% or 25% albumin

infusion may be used to maintain the serum albumin levels at a desired 2 g/dL. Infusion of **packed red blood cells** is recommended if the hematocrit falls to <20% (hemoglobin = 7 g/dL). Most patients are hemoconcentrated during resuscitation; thus transfusion in the first 24–48 hours is rare unless there is accompanying trauma. **Fresh-frozen plasma** (FFP) is indicated if clinical and laboratory assessment shows a deficiency of clotting factors, a prothrombin level >1.5 times control, or a partial thromboplastin time >1.2 times control in children who are bleeding or are scheduled for an invasive procedure or a grafting procedure that could result in an estimated blood loss of more than half of blood volume. Although FFP use for volume resuscitation during the first 24 hours of injury is advocated by some, this strategy has not yet undergone rigorous evaluation through randomized prospective trials.

**Sodium supplementation** may be required for children with burns of >20% TBSA, particularly if 0.5% silver nitrate solution is used as the topical antibacterial burn dressing. Sodium losses with silver nitrate therapy are regularly as high as 350 mEq/m<sup>2</sup> burn surface area. The aim is to maintain serum sodium levels >130 mEq/L and urinary sodium concentration >30 mEq/L. Young children <5 years are especially susceptible to hyponatremia and cerebral edema. IV **potassium supplementation** is supplied to maintain a serum potassium level >3 mEq/dL. Potassium losses may be significantly increased when 0.5% silver nitrate solution is used as the topical antibacterial agent or when aminoglycoside, diuretic, or amphotericin therapy is required. Magnesium and ionized calcium can also become rapidly depleted and should be assessed at least daily for the first week and weekly thereafter in major burns.

### Prevention of Infection and Surgical Management of the Burn Wound

In general, prophylactic antibiotic administration is not indicated for burn injuries because it predisposes patients to development of resistant pathogens. Topical antimicrobial creams or silver agents reduce wound colonization; systemic antibiotics do not reach the nonviable tissue in the burn wound. There is conflicting evidence as to whether relocation of the IV catheter every 48–72 hours decreases or increases the incidence of catheter-related sepsis in burn injury. Central venous catheters should be monitored closely for infection. Many burn units replace or relocate central lines every 5–7 days, even if the site is not inflamed and there is no suspicion of catheter-related sepsis, particularly if the line is near a burn wound. The incidence of central line-associated bloodstream infection is directly related to the distance between the catheter and the burn wound. The fragile tissue and frequency of patient turning and movement, combined with the moisture of the burn wound, make it imperative to securely attach central venous catheters with sutures placed securely in at least three locations to prevent catheter movement, kinking, or accidental removal.

Mortality related to burn injury is associated not with the toxic effect of thermally injured skin, but with the metabolic and bacterial consequences of a large open wound, reduction of the patient's immune response, and malnutrition. These abnormalities set the stage for life-threatening bacterial infection originating from the burn wound. Thorough early wound cleaning, application of topical antimicrobial creams, and early wound excision and grafting promote wound healing and improve aesthetic and functional outcomes. Topical antimicrobial agents for burn wound treatment include bacitracin (second-degree burns or burns that will heal in a week), silver sulfadiazine cream (third-degree burns), mafenide acetate (Sulfamylon) cream (third-degree burns on ears, cartilage), or 0.5% silver nitrate solution (third-degree burns with sulfa allergy) (Table 89.7). Regardless of the choice of topical antimicrobial agent, it is essential that all third-degree burn tissue be fully excised and grafted before bacterial colonization progresses to systemic infection. Children with a burn of >20% TBSA should be housed in reverse isolation with all personnel required to wear gown, gloves, mask, and hat to prevent cross-contamination and to provide a temperature- and humidity-controlled environment that minimizes hypermetabolism.

Deep third-degree burns of >10% TBSA benefit from early excision and grafting. To improve outcome, sequential excision and grafting of



**Table 89.7** Topical Agents Used for Burns

AGENT	EFFECTIVENESS	SIDE EFFECTS	EASE OF USE
Bacitracin	Gram-positive organisms; good for wounds that will heal in 7-10 days	May cause yeast overgrowth rash or pustules if on intact skin; resolves with discontinuation	Clear ointment, 1-2 times daily, easy to clean off
Silver sulfadiazine cream (Silvadene)	Broad spectrum including gram-positive and -negative organisms, some fungus; may cause leukopenia	Leukopenia, self-limited; may be painful Leaves adherent residue	Changed twice daily Residue <i>must</i> be washed off with each dressing change
Mafenide acetate cream* (Sulfamylon)	Targets resistant gram-negative organisms, particularly <i>Pseudomonas</i> , some gram-positive coverage  Rapid and deep wound penetration; used on cartilage (ears) and deep wound infection	Carbonic anhydrase inhibitor, may cause metabolic acidosis	Changed twice daily; application may be painful  Residue <i>must</i> be washed off with each dressing change
0.5% Silver nitrate solution	Bacteriostatic  Broad spectrum, including some fungi  Superficial penetration	Permanent staining of surfaces from silver oxidation; electrolyte disturbances from hypotonic solution, potential methemoglobinemia	Closed bulky dressing soaked every 2hr and changed 1-2 times daily

\*Mafenide acetate solution at concentrations of 2.5% or 5% for use on heavily colonized, multidrug-resistant organisms to be used for 5 days only.

third-degree and deep second-degree burns may be required in children with large burns. Prompt excision with immediate wound closure is achieved with **autografts**, skin obtained from another part of the patient's body, which may be meshed to increase the efficiency of coverings. Alternatives for wound closure, such as allografts, dermal substitutes, and other biologic dressings, may be important for wound coverage in patients with extensive injury to limit fluid, electrolyte, and protein losses and to reduce pain and minimize temperature loss. Cultured epidermal cells (autologous keratinocytes), grown from a skin biopsy from the patient, are a costly alternative and are not always successful. Another approach employs an autologous cell spray (theoretically containing stem cells) as an adjunct to meshed skin for wound closure. An experienced burn team can safely perform early stage or total excision while burn fluid resuscitation continues. Important keys to success are (1) accurate preoperative and intraoperative determination of burn depth, (2) the choice of excision area and appropriate timing, (3) control of intraoperative blood loss, (4) specific instrumentation, and (5) the type of wound coverage chosen.

### Nutritional Support

Supporting the increased energy requirements of a patient with a burn is a high priority. The burn injury produces a hypermetabolic response characterized by both protein and fat catabolism. Depending on the time lapse since the burn, children with a burn of 40% TBSA require basal energy expenditure (oxygen consumption) approximately 50–100% higher than predicted for their age. Early excision and grafting can decrease the energy requirement. Pain, anxiety, and immobilization increase the physiologic demands. Additional energy expenditure is caused by cold stress if environmental humidity and temperature are not controlled; this is especially true in young infants, in whom the large BSA:mass ratio allows proportionately greater heat loss than in adolescents and adults. Providing environmental temperatures of 28–33°C (82.4–91.4°F), adequate covering during transport, and liberal use of analgesics and anxiolytics can decrease caloric demands. Appropriate sleep intervals are necessary and should be part of the regimen. Early enteral nutrition, initially with high-carbohydrate, high-protein caloric content (1,800 kcal/m<sup>2</sup>/24-hr maintenance plus 2,200 kcal/m<sup>2</sup> of burn/24 hr) reduces metabolic stress.

The objective of nutrition supplementation programs is to maintain body weight and minimize weight loss by meeting metabolic demands.

This reduces the loss of lean body mass. Calories are provided at approximately 1.5 times the basal metabolic rate, with 3-4 g/kg of protein/day. The focus of nutritional therapy is to support and compensate for the metabolic needs. Multivitamins, particularly the B vitamin group, vitamin C, vitamin A, vitamin D, vitamin E, copper, selenium, and zinc, are also necessary.

Alimentation should be started as soon as is practical, preferably enterally, to meet all caloric needs and maintain gastrointestinal (GI) tract function throughout treatment. Patients with burns of >40% of TBSA need a flexible nasogastric or small bowel feeding tube to facilitate continuous delivery of calories without the risk of aspiration at the time of admission. To decrease the risk of infectious complications, parenteral nutrition should be avoided or discontinued as soon as is practical after delivery of sufficient enteral calories is established. Continuous GI feeding is essential, even if feeding is interrupted for frequent visits to the operating room, until full grafting takes place. In third-degree burns >20% the use of anabolic agents such as *oxandrolone* to improve wound healing and promote protein synthesis or anticatabolic agents (propranolol) to reduce metabolic stress is common practice. It is vital to continue enteral feeding while using these agents to obtain maximal response. Liver function studies should be monitored weekly when giving oxandrolone, and oxandrolone should be discontinued if liver function deteriorates.

### Topical Therapy

Topical therapy is widely used to decrease wound colonization from a wide variety of wound pathogens (see Table 89.7). Preferences vary among burn units. Each topical agent has advantages and disadvantages in application, comfort, and bacteriostatic spectrum. However, all agents impair wound healing. The type of organism on a wound varies with the age of the wound. In the first week, gram-positive organisms predominate. During weeks 2-4, gram-negative organisms are frequently found in burn wounds. Prolonged open burn wounds eventually tend to develop resistant gram-negative organisms, fungus, or mold. The choice of topical antimicrobial depends on wound age and depth. *Bacitracin* is a clear ointment effective against gram-positive organisms and is often used in wounds that will heal within a week. If placed on nonburned skin, it may cause a yeast rash or pimples that resolve with discontinuation. *Silver sulfadiazine* is a white cream containing silver with a broad spectrum of coverage, including

gram-positive and gram-negative organisms and some fungi. It is used commonly in deep third-degree burns that require grafting and may cause transient self-limiting leukopenia if applied over large areas. *Mafenide acetate* is a white cream with the ability to diffuse through the burn eschar; it is the treatment of choice for injury to cartilaginous surfaces, such as the ear. Mafenide acetate solution at a concentration of 5% is useful for the treatment of burn wounds that are heavily colonized with multidrug-resistant gram-negative bacteria and is often used postoperatively to keep grafts moist. The carbonic anhydrase inhibition activity of mafenide acetate may cause metabolic acidosis if large surface areas are treated in a small child. No sulfa-containing agent should be used if the child has a history of sulfa allergies. Silver nitrate solution may be used in children with sulfa allergy because of its broad spectrum of coverage. However, it causes gray staining of the environment and wound from silver oxidation as well as electrolyte disturbances because of the hypotonic nature of the solution.

### Inhalation Injury

Inhalation injury is serious in the infant and child, particularly if pre-existing pulmonary conditions are present (see [Chapter 86](#)). Inhalation injury should be suspected based on history of sustained exposure to smoke in association with the burn injury, such as being confined in a closed space or from an indoor explosion, with decreased level of consciousness or with evidence of carbon deposits in the oropharynx or nose, singed facial hair, or carbonaceous sputum. Mortality estimates vary, depending on the type of inhalation injury and the extent of exposure. Each of the three types of inhalation injury (toxic gases, upper airway edema, and lower airway injury) has a different treatment.

### Toxic Gases

Carbon monoxide poisoning from the burning of organic materials is caused by displacement of oxygen from the hemoglobin molecule by CO, leading to tissue hypoxia (see [Chapter 94](#)). CO poisoning should be treated with 100% oxygen until carboxyhemoglobin levels drop below 10%. Toxic fumes, including cyanides from combustible plastics as well as sulfur and nitrogen oxides and alkalis formed during the combustion of synthetic fabrics, produce corrosive chemicals that may erode the mucosa and cause significant tissue sloughing. Exposure to smoke may cause degradation of surfactant and decrease its production, resulting in atelectasis. Inhalation injury and burn injury are synergistic, and the combined effect can increase morbidity and mortality.

Injury from gases generally manifests early in the course of treatment. Acute asphyxia is the leading cause of death at the fire scene and can cause anoxic brain injury, particularly in children. Signs of CNS injury from hypoxemia caused by asphyxia or CO poisoning vary from irritability to depression. CO poisoning may be *mild*, with slight dyspnea, headache, nausea, and decreased visual acuity and higher cerebral functions; *moderate*, with irritability, agitation, nausea, dimness of vision, impaired judgment, and rapid fatigue; or *severe*, producing confusion, hallucination, ataxia, cardiovascular collapse, acidosis, and coma. Measurement of HbCO is important for diagnosis and treatment. Pulse oximetry is NOT a reliable marker of oxygenation in CO poisoning. If significant CO exposure is suspected, a blood gas with co-oximetry and a HbCO level should be obtained to determine PaO<sub>2</sub> and CO toxicity extent. CO poisoning and hypoxia are assumed to be present until the tests are performed, and patients should receive 100% oxygen until the HbCO level is <10% and adequate oxygenation is confirmed. Significant CO poisoning (level >25%) may require hyperbaric oxygen therapy; the risk of transporting a burn patient to the hyperbaric chamber needs to be carefully considered. **Cyanide poisoning** should be suspected if a metabolic acidosis persists despite adequate fluid resuscitation and in environments containing synthetic polymers (see [Chapter 94](#)). Unless specifically suspected, most burn centers do not routinely screen for cyanide poisoning.

### Upper Airway Edema

The treatment priority for edema of the upper airway caused by inhalation injury focuses on establishing and maintaining a patent airway. If airway obstruction is apparent, prompt and early nasotracheal or

oro-tracheal intubation is indicated to maintain airway patency and assure adequate ventilation and oxygenation. The most experienced provider should perform the intubation, as edema may allow only one attempt. The endotracheal tube size should be chosen carefully, as replacement during the first 1-3 days is often not possible. Endotracheal tubes should *not be secured* with tape if a facial burn is present, as the tape will not adhere to the moist surface. The endotracheal tube can be secured to a tooth, to the maxilla, or tied in two planes. Monitoring the security of the endotracheal tube and assuring it remains in the same location at the level of the teeth is essential, as edema may alter tube position.

### Parenchymal Injury

Intubation and mechanical ventilation may be required in patients who have significant hypoxia, hypercarbia, or mental status changes caused by smoke inhalation. Wheezing and bronchospasm are common, and use of inhaled bronchodilators is often helpful. Smoke inhalation injury is gauged via clinical progression and bronchoscopy. Aggressive pulmonary toilet and chest physiotherapy are necessary, as casts and airway obstruction from debris are common. Extubation should be delayed until the patient has adequate oxygenation and ventilation, is able to sustain the increased minute ventilation and work of breathing that accompanies burn injury, and edema has resolved. A spontaneous breathing trial and a cuff leak test are often used to gauge readiness for extubation. Children with an anticipated need for mechanical ventilation >2 weeks may benefit from tracheostomy, as it provides a secure, comfortable airway with decreased sedation requirements. Tracheostomy should only be performed under general anesthesia by experienced surgeons using optimal positioning, proper tracheostomy tube size, and hemostatic conditions. In children with deep burns of the face, tracheostomy provides a secure airway that facilitates excision and grafting yet allows for oral movement, including a pacifier.

Patients with severe inhalation injury or with other causes of respiratory deterioration that lead to pediatric acute respiratory distress syndrome who do not improve with conventional pressure-controlled ventilation (progressive oxygenation failure, as manifested by oxygen saturation <90% while receiving F<sub>IO</sub><sub>2</sub> of 0.9-1.0 and positive end-expiratory pressure of at least 12 cm H<sub>2</sub>O) may benefit from high-frequency ventilation or nitric oxide inhalation treatment. Nitric oxide usually is administered through the ventilator at 5 parts per million (ppm) and increased to 30 ppm. This method of therapy reduces the need for extracorporeal membrane oxygenation (ECMO; see [Chapter 86](#)). ECMO may be indicated for failure of these conventional techniques.

### Pain Relief and Psychologic Adjustment

See [Chapter 93](#).

It is important to provide adequate analgesia, anxiolysis, sedation, and psychologic support to reduce early metabolic stress, decrease the potential for posttraumatic stress disorder (PTSD), and allow future stabilization as well as physical and psychologic rehabilitation. Patients and family members require team support to work through the grieving process and accept long-term changes in appearance.

Children with burn injury have frequent and wide fluctuations in pain intensity. Appreciation of pain depends on the depth of the burn; the stage of healing; the patient's age, stage of emotional development, and cognition; the experience and efficiency of the treating team; the use of analgesics and other drugs; the patient's pain threshold; and interpersonal and cultural factors. From the onset of treatment, **pre-emptive pain control** during dressing changes is crucial. The use of a variety of nonpharmacologic interventions and pharmacologic agents must be reviewed throughout the treatment period. Opioid analgesia, prescribed in an adequate dose and timed to cover dressing changes, is essential to comfort management. A supportive person who is consistently present and knows the patient profile can integrate and encourage patient participation in burn care. The problem of *under-medication* is most prevalent in adolescents, in whom fear of drug dependence may inappropriately influence treatment. A related problem is that the child's specific pain experience may be misinterpreted;

for anxious patients, those who are confused and alone, or those with preexisting emotional disorders, even small wounds may illicit intense pain. Anxiolytic medication added to the analgesic is usually helpful and has more than a synergistic effect. Equal attention is necessary to decrease stress in the intubated patient. Other modalities of pain and anxiety relief (**relaxation techniques**) can decrease the physiologic stress response.

A multimodal pain strategy is recommended for burns, as burn pain is a combination of background, acute, procedural, neuropathic, and inflammatory pain. The specific agents used will vary by institution and provider training. *Background pain*, which exists primarily in burns >20%, should be addressed with long-acting oral agents administered twice daily, such as methadone or long-acting morphine. This helps to maintain a steady state of pain relief. *Acute pain* from the injury (all burn sizes) is generally treated initially with oral acetaminophen, escalating to a short-acting opioid such as morphine, hydromorphone, oxycodone, or similar agents orally. If oral administration is not sufficient (a common scenario in major burn injury), intermittent IV opioids are used. The use of *codeine* is not recommended because of the possibility of ultrarapid metabolism of codeine. *Procedural pain*, such as for dressing changes, is short-lived but severe. Potent IV opioids such as fentanyl, morphine, or hydromorphone are effective but require appropriate monitoring. Naloxone is rarely needed but should be immediately available to reverse the effect of IV narcotics. Ketamine 1-4 mg/kg IV can be employed for children with high opioid requirements; however, continuous cardiovascular monitoring is mandatory, and ketamine should be administered by a provider trained in advanced airway techniques. *Neuropathic pain* (pins and needles sensation) should be addressed with scheduled oral gabapentin given 4 times daily. *Inflammatory pain* can be effectively treated with nonsteroidal antiinflammatory agents unless the patient has upcoming surgery, as this may increase surgical complications. *Midazolam* is very useful for conscious sedation at a dose of 0.01-0.02 mg/kg for nonintubated patients and 0.05-0.1 mg/kg for intubated patients as an IV bolus and may be repeated in 10 minutes; if used with an opioid, continuous cardiovascular monitoring is warranted. Oral midazolam for premedication before a dressing change at 0.5 mg/kg can be highly effective in reducing anxiety surrounding dressings. Dexmedetomidine infusion may be required for children with high levels of anxiety or who are refractory to benzodiazepine therapy, but this requires monitoring in an intensive care unit (ICU) setting. Postoperative pain after burn surgery, which is severe because of the combination of donor sites and the wound itself, is often treated with a multimodal continuous infusion of an opioid (hydromorphone or morphine) and sedative (dexmedetomidine and/or ketamine). This combination decreases opioid requirements and improves pain but requires monitoring in an ICU. Regional blocks by a trained anesthesiologist can mitigate donor site pain.

During the process of weaning from IV analgesics, the dose of opiates is reduced by 25% over 1-3 days, sometimes with the addition of oral opioids and then acetaminophen as opioids are tapered. When weaning off antianxiety medications, the approach involves reducing the dose of benzodiazepines, at 25-50% per dose, daily over 1-3 days.

Regular evaluation of burned children during hospitalization by a trained psychologist or psychiatrist is necessary, as PTSD, anxiety, depression, acute stress disorder, and other psychiatric issues are common after burn injury. Early recognition and treatment of the patient and family improve psychosocial outcomes. As a result, there is a growing use of *psychotropic medication* in the care of children with burns, including prescription of selective serotonin reuptake inhibitors as antidepressants, the use of neuroleptic agents in the critical care setting, and the treatment of PTSD with prazosin.

### Reconstruction and Rehabilitation

To ensure maximum cosmetic and functional outcome, occupational and physical therapy must begin on the day of admission, continue throughout hospitalization, and for many patients, continue after discharge. Physical rehabilitation involves body and limb positioning, splinting, exercises (active and passive movement), assistance with activities of daily living, and gradual ambulation. These measures

maintain adequate joint and muscle activity with as normal a range of movement as possible after healing or reconstruction. **Pressure therapy** is necessary to reduce hypertrophic scar formation; a variety of prefabricated and custom-made garments are available for use in different body areas. These custom-made garments deliver consistent pressure on scarred areas; shorten the time of scar maturation; and decrease scar thickness, redness, and associated itching. Continued adjustments to scarred areas (scar release, grafting, rearrangement) and multiple minor cosmetic surgical procedures are necessary to optimize long-term function and improve appearance. Replacement of areas of alopecia and scarring has been achieved with the use of tissue-expander techniques. The use of ultrapulse laser for reduction of scarring is an adjunct in scar management. Pruritis can be a severe issue in the rehabilitative phase. Commonly used oral agents include antihistamines such as loratadine, hydroxyzine, and diphenhydramine, as well as gabapentin or H2 blockers. Topical agents include moisturizers, topical steroid creams, or colloidal oatmeal baths. Refractory itching may be treated with desensitization therapy or laser treatment, although literature supporting these therapies is scarce.

### School Reentry and Long-Term Outcome

Optimally the child will return to school immediately after discharge. Occasionally, a child may need to attend on an altered schedule because of rehabilitation needs. It is important for the child to return to the normal routine of attending school and being with peers to begin the resocialization process. Planning for a return to home and school often requires a **school reentry program** that is individualized to each child's needs. For a school-age child, planning for the return to school occurs simultaneously with planning for discharge. The hospital schoolteacher contacts the local school and plans the program with the school faculty, nurses, social workers, recreational/child-life therapists, and rehabilitation therapists. This team should work with students and staff to ease anxiety, answer questions, and provide information. Burns and scars evoke fears in those who are not familiar with this type of injury and can result in a tendency to withdraw from or reject the burned child. A school reentry program designed based on the child's developmental and educational needs can alleviate these fears and facilitate the child's reintegration into the school environment.

Major medical advances have made it possible to save the lives of children with massive burns. Although some children have lingering physical difficulties, most have a satisfactory quality of life. The comprehensive burn care that includes experienced multidisciplinary after-care plays an important role in recovery. **Table 89.8** lists the long-term disabilities and complications of burns.

### ELECTRICAL BURNS

Three types of burns are caused by electricity: electrical burns, caused by electricity passing through the body; arc burns, caused by the heat released from high-amperage currents discharging through the air; and thermal contact burns, from touching a hot electrical device. Electrical burns are divided into high voltage (>1,000 volts) and low voltage (<1,000 volts). Electricity is delivered via alternating current (AC), which is generally used in households, or direct current (DC), often used in industry or car batteries. The majority of pediatric electrical burns involve 110 volts AC electricity and occur in the household. **Minor electrical burns** in children usually occur as a result of biting on an extension cord or inserting an object in an electrical outlet. These injuries produce localized burns to the mouth or finger. Children who chew electrical cords usually sustain burns to portions of the upper and lower lips that come in contact with the extension cord, particularly the corners of the mouth. Because these are *nonconductive* injuries (do not extend beyond the site of injury), hospital admission is not necessary. Care is focused on the area of the injury visible in the mouth, ensuring it is low voltage and does not cause entry or exit wounds or cardiac issues. Treatment with topical antibiotic creams is sufficient until the patient is seen in a burn unit outpatient department or by a plastic surgeon for potential reconstruction or excision of the burn site.

A more serious category of electrical burn is the **high-voltage electrical burn**, for which children must be admitted for observation,

**Table 89.8** Common Long-Term Complications and Disabilities in Patients with Burn Injuries**COMPLICATIONS AFFECTING THE SKIN AND SOFT TISSUE**

Hypertrophic scars  
 Susceptibility to minor trauma  
 Dry skin  
 Contractures  
 Itching and neuropathic pain  
 Alopecia  
 Chronic open wounds  
 Skin cancers  
 Epidermal inclusion cysts  
 Cutaneous abscesses

**ORTHOPEDIC DISABILITIES**

Amputations  
 Contractures  
 Heterotopic ossification  
 Temporary reduction in bone density  
 Decreased endurance and weakness

**METABOLIC DISABILITIES**

Heat sensitivity  
 Obesity  
 Glucose intolerance  
 Hypertension

**PSYCHIATRIC AND NEUROLOGIC DISABILITIES**

Sleep disorders  
 Adjustment disorders  
 Posttraumatic stress disorder  
 Depression  
 Body image issues  
 Neuropathy and neuropathic pain  
 Long-term neurologic effects of carbon monoxide poisoning  
 Anoxic brain injury

**LONG-TERM COMPLICATIONS OF CRITICAL CARE**

Deep vein thrombosis, venous insufficiency, or varicose veins  
 Tracheal stenosis, vocal cord disorders, or swallowing disorders  
 Renal or adrenal dysfunction  
 Hepatobiliary or pancreatic disease  
 Cardiovascular disease  
 Reactive airway disease or bronchial polyposis

**PREEXISTING DISABILITIES THAT CONTRIBUTED TO THE INJURIES**

Risk-taking behavior  
 Untreated or poorly treated psychiatric disorder

Modified from Sheridan RL, Schultz JT, Ryan CM, et al. Case records of the Massachusetts General Hospital. Weekly clinicopathological exercises. Case 6-2004: A 35-year-old woman with extensive, deep burns from a nightclub fire. *N Engl J Med.* 2004;350:810–821.

regardless of the extent of the surface area burn. Deep muscle injury is typical and cannot be readily assessed initially. These injuries occur in high-voltage installations, such as electric power stations or railroads; children climb an electric pole and touch an electric box out of curiosity or accidentally touch a high-tension electrical wire. Such injuries have a mortality rate of 3–15% for children who arrive at the hospital for treatment. Survivors have a high rate of morbidity, including major limb amputations. Points of entry of current through the skin and the exit site show characteristic features consistent with current density and heat. The majority of entrance wounds involve the upper extremity, with small exit wounds in the lower extremity. The current is conducted throughout the body, regardless of entry and exit points. Virtually any structure in the body is at risk (Table 89.9). Damage to the abdominal viscera, thoracic structures, and nervous system (confusion, coma, paralysis) in areas remote from obvious extremity injury occurs and must be sought, particularly in injuries with multiple current pathways or those in which the victim falls from a high pole. *Cardiac abnormalities*, manifested as ventricular fibrillation or cardiac arrest, are common; patients with high-tension electrical injury need an initial electrocardiogram (ECG) and cardiac monitoring until they are stable and have been fully assessed. Higher-risk patients have abnormal ECG findings and a history of loss of consciousness. Renal damage from *deep muscle necrosis* and subsequent myoglobinuria is another complication; such patients need forced alkaline diuresis to minimize renal damage. Soft tissue (muscle) injury of an extremity may produce a **compartment syndrome** (see Chapter 80). Aggressive removal of all dead and devitalized tissue, even with the risk of functional loss, remains the key to effective management of the electrically damaged extremity. Early debridement facilitates early closure of the wound. Damaged major vessels must be isolated and buried in a viable muscle to prevent exposure. Survival depends on immediate intensive care; functional result depends on long-term care and delayed reconstructive surgery. The incidence of cataract formation is also increased in patients who have sustained electrical injuries; patients should be referred to an ophthalmologist for regular examinations.

**Arc burns** generally are caused by clothing *ignition* from the superheated arc that can be emitted from high-amperage current discharge. The hallmark of this injury is a large cutaneous burn following clothing

lines and covered in thick soot. Discreet entrance and exit points are not generally seen. Muscle injury is rare, as current does not actually traverse the skin. Treatment should follow the principles for major flame burn injury treatment.

**Contact burns**, in which tissue destruction is localized to a small area of contact with an electrical box with no evidence of electricity conducted through the body, are generally treated as any other burn injury. Careful history and physical examination should be performed to assure that there was no transmission of electricity.

Visit Elsevier eBooks+ at [eBooks.Elsevier.com](http://eBooks.Elsevier.com) for Bibliography.

## 89.1 Lightning Burns

Tina L. Palmieri

Worldwide, lightning occurs approximately 50 times per second, primarily via ground strikes involving 30,000–100,000 amperes at 30,000 Kelvin temperature. Fortunately, the incidence of lightning burns is low, with 400 injuries and 40 deaths per year attributed to lightning. Lightning injury occurs via (1) direct strike (electrical current), (2) thermal burns from conversion of electrical energy to heat, or (3) mechanical trauma from the acoustic shock wave, flying debris, fall, or muscle contraction. The most common form of lightning burn, accounting for approximately half of lightning injuries, is **ground current**, in which lightning strikes the ground or an object near an individual and travels through the ground to the individual. **Side splash** injuries constitute ~30% of lightning injuries and occurs when current jumps from a nearby object, then follows the path of least resistance to an individual. Direct strikes account for 5% of lightning injuries. Sudden death after a direct strike is due to simultaneous cardiac and respiratory arrest from depolarization of cardiac muscle cells and paralysis of the medullary respiratory center.

Lightning cutaneous burns depend on the current path, the type of clothing worn, the presence of metal, and cutaneous moisture. Entry, exit, and path lesions are possible; the prognosis is poorest for lesions of the head or legs. Internal organ injury along the path is common



**Table 89.9** Electrical Injury: Clinical Considerations

SYSTEM	CLINICAL MANIFESTATIONS	MANAGEMENT
General	—	<ul style="list-style-type: none"> <li>• Extricate the patient</li> <li>• Perform ABCs of resuscitation; immobilize the spine</li> <li>• Obtain history: voltage, type of current</li> <li>• Obtain complete blood count with platelets, electrolytes, BUN, creatinine, and glucose</li> </ul>
Cardiac	Dysrhythmias: asystole, ventricular fibrillation, sinus tachycardia, sinus bradycardia, premature atrial contractions, premature ventricular contractions, conduction defects, atrial fibrillation, ST- and T-wave changes	<ul style="list-style-type: none"> <li>• Treat dysrhythmias</li> <li>• Provide cardiac monitor, electrocardiogram, and radiographs with suspected thoracic injury</li> <li>• Perform creatinine phosphokinase with isoenzyme measurements if indicated</li> </ul>
Pulmonary	Respiratory arrest, acute respiratory distress, aspiration syndrome	<ul style="list-style-type: none"> <li>• Protect and maintain the airway</li> <li>• Provide mechanical ventilation if indicated, chest radiograph, and arterial blood gas levels</li> </ul>
Renal	Acute kidney injury, myoglobinuria	<ul style="list-style-type: none"> <li>• Provide aggressive fluid management unless central nervous system injury is present</li> <li>• Maintain adequate urine output, &gt;1 mL/kg/hr if myoglobinuria; addition of HCO<sub>3</sub><sup>-</sup>, mannitol may be needed to alkalinize urine and stimulate diuresis, respectively</li> <li>• Consider central venous or pulmonary artery pressure monitoring</li> <li>• Measure urine myoglobin; perform urinalysis; measure BUN, creatinine</li> </ul>
Neurologic	<p>Immediate: loss of consciousness, motor paralysis, visual disturbances, amnesia, agitation; intracranial hematoma</p> <p>Secondary: pain, paraplegia, brachial plexus injury, syndrome of inappropriate antidiuretic hormone secretion, autonomic disturbances, cerebral edema</p> <p>Delayed: paralysis, seizures, headache, peripheral neuropathy</p>	<ul style="list-style-type: none"> <li>• Treat seizures</li> <li>• Provide fluid restriction if indicated</li> <li>• Consider spine radiographs and MRI, especially cervical</li> <li>• Perform CT or MRI scan of the brain if indicated</li> </ul>
Cutaneous/oral	<p>Oral commissure burns, tongue and dental injuries; skin burns resulting from ignition of clothes, entrance and exit burns, and arc burns</p> <p>Electrical burns to mouth could include oral commissures and lips; low-voltage electrical burns secondary to high conductivity of saliva</p>	<ul style="list-style-type: none"> <li>• Document entrance and exit wounds</li> <li>• Treat cutaneous burns; determine patient's tetanus status</li> <li>• Obtain consultation for plastic surgery of ear, nose, and throat, if indicated</li> <li>• Ensure no entry or exit wounds and no cardiac involvement</li> <li>• Confirm all injuries are localized</li> <li>• Management is observation until eschar sloughs off and granulation tissue fills in</li> <li>• If bleeding at corner of mouth from labial artery, pinch lower lip to stop bleeding and consult surgeon</li> <li>• High risk for scarring; refer to burn center for long-term management</li> </ul>
Abdominal	Viscus perforation and solid-organ damage; ileus; abdominal injury rare without visible abdominal burns	<ul style="list-style-type: none"> <li>• Place nasogastric tube if patient has airway compromise or ileus</li> <li>• Obtain serum ALT, AST, amylase, BUN, and creatinine measurements and CT scans as indicated</li> </ul>
Musculoskeletal	<p>Compartment syndrome from subcutaneous necrosis limb edema and deep burns</p> <p>Long-bone fractures, spine injuries</p>	<ul style="list-style-type: none"> <li>• Monitor patient for possible compartment syndrome</li> <li>• Obtain radiographs and orthopedic/general surgery consultations as indicated</li> </ul>
Ocular	Visual changes, optic neuritis, cataracts, extraocular muscle paresis	<ul style="list-style-type: none"> <li>• Obtain an ophthalmology consultation to document and follow for cataract formation</li> </ul>

AST, Aspartate transaminase; ALT, alanine transaminase; BUN, blood urea nitrogen.

Adapted from Hall ML, Sills RM. Electrical and lightning injuries. In: Barkin RM, ed. *Pediatric Emergency Medicine*. St Louis: Mosby; 1997: p. 484.

and *does not* relate to the severity of the cutaneous burn. Linear burns, usually first- or second-degree, are in the locations where sweat is present. **Feathering**, also called *Lichtenberg figures*, is an arborescent pattern appearing on the skin and is pathognomonic for lightning injury (Fig. 89.7). The feathering skin appearance, thought to be caused by changes in cutaneous blood flow, is transient and disappears within several hours. Lightning may ignite clothing or produce serious cutaneous burns from heated metal in the clothing. Internal complications of lightning burns include cardiac arrest caused by asystole, transient hypertension, premature ventricular contractions, ventricular fibrillation, and myocardial ischemia. Most severe cardiac complications

resolve if the patient is supported with CPR (see Chapter 79). CNS complications include cerebral edema, hemorrhage, seizures, mood changes, depression, and paralysis of the lower extremities. Rhabdomyolysis and myoglobinuria (with possible renal failure) also occur but are rare. Ocular manifestations include vitreous hemorrhage, iridocyclitis, retinal tearing, or retinal detachment. Rupture of the tympanic membrane occurs in 50–80% of those sustaining a direct strike.

Treatment of lightning injury generally follows traditional trauma management with one exception: In the event of multiple lightning injuries (mass casualty), a “reverse triage” system is employed, in which initial treatment is focused on those who appear to be in cardiac arrest,



**Fig. 89.7** Lightning burn: Lichtenberg feathering. (Courtesy Dr. Mary Ann Cooper.)

which is often reversible. Early attention to ventilation after restoration of cardiac rhythm in lightning-injured patients is crucial to prevent recurrent cardiovascular collapse and hypoxic brain injury. This triage algorithm is employed because those who have cardiorespiratory function immediately after the strike rarely succumb to their injury before hospital arrival. Ultimate outcomes depend on injury severity, mental status, organ involvement, cardiac arrest presence, and arrhythmias. Lightning survivors who have a normal ECG and normal vital signs and no obvious injury can be discharged home if they *do not* have history of a direct strike, loss of consciousness, focal neurologic complaint, major trauma, significant burns, or chest pain or dyspnea. However, they should be referred for ophthalmologic evaluation and audio-vestibular evaluation should there be ocular or otic injury. Neurologic effects of lightning injury may be significant. CNS dysfunction can be immediate or delayed and includes spinal cord injury, ischemic stroke, or *keraunoparalysis* (temporary condition that mimics spinal cord injury) as well as trauma-related injuries such as skull fractures or spinal cord injury. Personality alterations and sleep disorders may develop over time post injury.

Visit Elsevier eBooks+ at [eBooks.Health.Elsevier.com](http://eBooks.Health.Elsevier.com) for Bibliography.

## Chapter 90

# Cold Injuries

Jennifer Dow

Children and youth are exposed to cold environments through outdoor recreation, occupational activities, or housing crises. Although cold injuries are commonly attributed to subfreezing temperatures, it is a misnomer that it must be below 0°C (32°F) for systemic injury or local tissue damage to occur. Injury from cold occurs when the body's ability to generate heat is overwhelmed by environmental loss.

### MECHANISMS OF HEAT TRANSFER

Environmental heat or cold injury occurs when the metabolic capacity for thermoregulation cannot maintain core body temperature in the setting of extreme environmental temperatures. The hypothalamus

controls the production and conservation of heat, responding to central and peripheral receptors. Local skin temperature is partially responsible for the regulation of peripheral blood flow. Heat production is a product of cellular metabolism and by both voluntary (exercise) and involuntary (shivering) muscle use, while vasoconstriction and behavioral action influence conservation. Heat is transferred to the environment by five mechanisms: radiation, conduction, convection, respiration, and evaporation.

**Radiation** is the transfer of heat from one object to another without physical contact. This type of heat loss is moderated by vasoconstriction, diminishing warm blood flow to the periphery, and behavioral adaptation of wearing insulating layers. Medications or conditions that prohibit the vasoconstrictive response contribute to heat loss by radiation. Children may not have the knowledge or experience to recognize when additional clothing is necessary; adults are obliged to ensure that appropriate clothing is available. In a dry environment, radiation is the predominant method of heat transfer. **Conduction** is the direct transfer of heat to another object and is the primary mechanism of heat loss when a body is immersed, as water has up to 30 times more thermal conductivity than air. Heat is also conducted when an individual touches a cold object (e.g., a cold rock, snow, metal chair). Behavioral adaptations include avoidance and placement of insulation between the individual and the surface. **Convective** loss of body heat to cooler circulating air or water can be mitigated by clothing and vasoconstriction. Convection is a method of rewarming, using hot air as a delivery method. **Evaporative** heat loss results from the conversion of water (sweat) to vapor; like *respiratory* loss, it is a small but obligate contribution to thermal balance.

### HYPOTHERMIA

Accidental hypothermia is the unintentional drop in core temperature below 35°C (95°F), occurring when the combination of physiologic and behavioral mechanisms to maintain core temperature are overwhelmed by environmental losses. Although cold and wet environments pose the most significant risk, accidental hypothermia can occur in any season and in most climates. The predominant clinical manifestations are reflective of disruptions of the cardiopulmonary and central nervous systems (Table 90.1). Cerebral function begins to diminish at a core temperature of 33–34°C (91.4–93.2°F), with early manifestations being irritability, confusion, and poor decision-making, progressing to lethargy, somnolence, and coma. Cerebral oxygen requirements are decreased by cooling, affording transient protection in cardiac standstill or cold-water drowning events. The initial cardiopulmonary response to cold is an increase in cardiac output and ventilation to support the metabolic demand of shivering. Further cardiac cooling manifests as bradycardia and abnormalities of cardiac conduction (atrial and ventricular dysrhythmias, including fibrillation) (Fig. 90.1). The crucial factors for reducing morbidity and mortality due to hypothermia are prevention, prompt recognition, and rapid treatment.

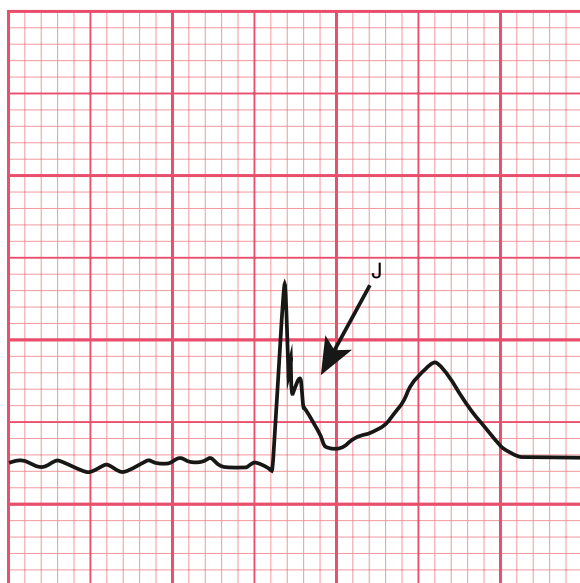
### Risk Factors and Prevention of Hypothermia

The risk factors associated with hypothermia are extensive. Illnesses, medications, and substance use can disrupt the normal physiologic responses to cold. Vasoconstriction is disrupted by ethanol, vasodilatory medications, and infections. Central nervous system (CNS) trauma, stroke, medications (antidepressants, mood stabilizers, anxiolytics), and endocrine disorders (hypothyroid, adrenal insufficiency, diabetes, hypoglycemia, hypopituitarism) disrupt the hypothalamic response to cold. Mental illness, intoxication (opiates, organophosphates, barbiturates, carbon monoxide), and lack of awareness, as seen in the extremes of age, may impair the ability to recognize cold. General conditions of malnutrition and inability to move make it such that the patient does not have the caloric reserves to shiver or cannot move safely out of the cold. Autonomic dysfunction may produce hypothermia. Knowledge of these conditions ideally results in a heightened attentiveness to the potential for hypothermia. Active prevention includes awareness of the weather conditions and the utilization of appropriate clothing. Insulation

**Table 90.1** Physiologic Characteristics of the Four Zones of Hypothermia

STATE	CORE TEMPERATURE °C (°F)	CHARACTERISTICS
Mild	35 (95)	Urine temperature, 34.8°C (94.6°F); increased shivering thermogenesis; increase in metabolic rate
	34 (93.2)	Amnesia and dysarthria develop; normal blood pressure; maximum respiratory stimulation
	33 (91.4)	Ataxia, apathy develop
Moderate	32 (89.6)	Stupor; 25% decrease in oxygen consumption
	31 (87.8)	Decreased shivering thermogenesis
	30 (86)	Atrial fibrillation and other dysrhythmias; poikilothermia; pulse and cardiac output two-thirds normal; insulin ineffective
	29 (85.2)	Progressive decrease in level of consciousness, pulse, and respiration; pupils dilated
Severe	28 (82.4)	Ventricular fibrillation susceptibility; 50% decrease in oxygen consumption and pulse
	27 (80.6)	Losing reflexes and voluntary motion
	26 (78.8)	Major acid-base disturbances; no reflexes or response to pain
	25 (77)	Cerebral blood flow one-third normal; cardiac output 45% normal; pulmonary edema may develop
	24 (75.2)	Significant hypotension
	23 (73.4)	No corneal or oculocephalic reflexes
	22 (71.6)	Maximum risk of ventricular fibrillation; 75% decrease in oxygen consumption
Profound	20 (68)	Lowest resumption of cardiac electromechanical activity; pulse 20% of normal
	19 (66.2)	Flat electroencephalogram
	18 (64.4)	Asystole develops
	14.2 (57.6)	Lowest accidental hypothermia survival in an infant
	13.7 (56.7)	Lowest accidental hypothermia survival in an adult
	9 (48.2)	Lowest therapeutic hypothermia survival

From Zafren K, Danzl DF. Accidental hypothermia. In: Walls RM, Hockberger RS, Gausche-Hill M, et al., eds. *Rosen's Emergency Medicine*, 9th ed. Philadelphia: Elsevier; 2018, Table 132.1, p. 1744.



**Fig. 90.1** Characteristic J or Osborne wave of hypothermia (temp <32°C) closely follows QRS. It may be mistaken for a T wave with narrow QT interval if the true T wave is not appreciated. The slightly rounded peak distinguishes it from R' of bundle branch block. (From Gunnarsson B, Heard CMB. Accidental hypothermia. In: Zimmerman JJ, Clark RSB, Fuhrman BP, et al., eds. *Fuhrman & Zimmerman's Pediatric Critical Care*, 6th ed. Elsevier: Philadelphia; 2022: Fig. 114.1, p. 1333.)

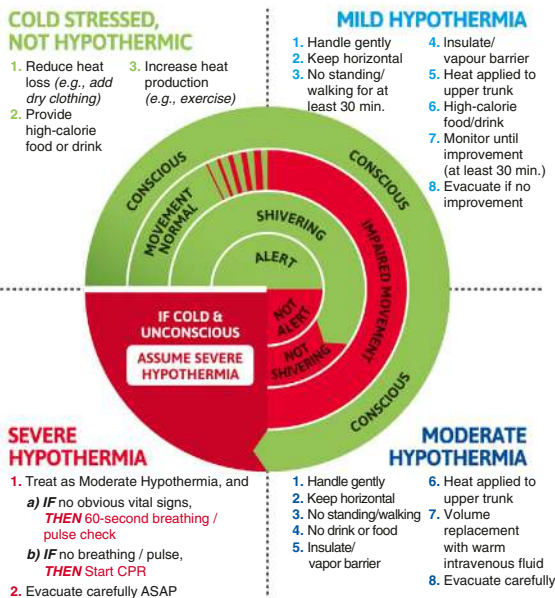
and ease of layering are factors to be considered when choosing clothing. Removing a layer while engaging in aerobic activity helps prevent sweating and subsequent evaporative heat loss; replacing it when activity slows prevents loss by radiation through the inadequate insulation. Socks and gloves should fit properly, without circulatory impingement, and be constructed of materials other than cotton. Covering the head and face prevents losses through these exposed areas. Infants and young children will lose more heat by radiation through the head than adults because of its relatively increased surface area. The utilization of wind-blocking materials mitigates loss due to convection, and waterproofing keeps clothing dry and minimizes losses resulting from convection and radiation. Additional preventative measures are ensuring adequate nutrition for the activity, recognizing an increased metabolic demand in the cold, and having access to shelter for warmth.

### Clinical Presentation of Hypothermia

Hypothermia is a cold injury syndrome with progressive signs and symptoms (see Table 90.1 and Fig. 90.2). The differential diagnosis is broad, and the clinician must be aware of the environment from which the patient presents. It is also essential that the clinician recognize that each patient is unique and presents with subtle differences. A patient may continue to shiver below the 30°C (86°F) “cut-off” but manifest all other signs of moderate to severe hypothermia. Standard classification is based on measured core temperature, whereas field classification is based on signs and symptoms (see Fig. 90.2). Treatment of all stages includes preventing further heat loss and initiating rewarming (Fig. 90.3).

## Prehospital Assessment of a Cold Patient

1. From outside ring to center assess Consciousness, Movement, Shivering, Alertness
2. Assess whether normal function, or impaired or no function
3. Treat according to appropriate result-quadrant



**Fig. 90.2** Algorithm for field assessment and treatment of a cold patient. (Sources: BICOrescue.com; Zafren K, Giesbrecht GG, Danzl DF, et al. Wilderness Medical Society practice guidelines for the out-of-hospital evaluation and treatment of accidental hypothermia: 2014 update. *Wilderness Environ Med.* 2014;25(4 Suppl):S66-S85.)

### Cold Stress

Cold stress is marked by shivering and a core temperature  $>35^{\circ}\text{C}$  ( $95^{\circ}\text{F}$ ). Measures to prevent further heat loss and increase heat production are all that are necessary for reversal. This may entail increasing physical activity to generate warmth, relocating to a warm environment, or adding clothing layers.

### Mild Hypothermia

Patients with mild hypothermia are conscious and alert with measured core temperatures of  $32\text{--}35^{\circ}\text{C}$  ( $89.6\text{--}95^{\circ}\text{F}$ ). Most will shiver, even violently, if there are enough energy reserves. As the core temperature drops, the patient may begin to demonstrate discoordination or loss of fine motor control. Hemodynamic parameters are generally stable, with tachycardia and tachypnea observed due, in part, to the increased catecholamine response and support of the metabolic demands of shivering. Protection from further heat loss, removal and replacement of wet clothing, and calorie replacement should be initiated simultaneously. Application of insulation (e.g., sleeping bag) and a vapor barrier will optimize passive rewarming. Active external rewarming can be initiated using hot water bottles or rewarming heat packs applied to the neck, chest, upper torso, axilla, and groin. Try to avoid burns to exposed skin. Patients with mild hypothermia retain consciousness but may demonstrate diminished alertness. Transport for further evaluation and observation is recommended if they do not return to full alertness and function in the field.

### Moderate Hypothermia

Moderate hypothermia, with core temperatures of  $28\text{--}32^{\circ}\text{C}$  ( $82.4\text{--}89.6^{\circ}\text{F}$ ), is the slowing phase of symptom progression. Patients present with bradycardia, respiratory depression, and altered mental status, manifesting as depressed level of consciousness, often stuporous, and hyporeflexia. Shivering generally stops at  $30^{\circ}\text{C}$  ( $86^{\circ}\text{F}$ ), but there is variation among patients. Active external rewarming should be initiated with heat applied to the upper torso, chest, axilla, and back. Fluid

replacement is initiated with intravenous fluids, ideally containing glucose, warmed to  $40\text{--}42^{\circ}\text{C}$  ( $104\text{--}107.6^{\circ}\text{F}$ ). Cardiac monitoring is indicated, as a cold heart and hypothermia-associated acidosis increases the risk of unstable arrhythmias. Hemodynamically stable patients may be transported to any hospital; however, if unstable, a hospital with extracorporeal membrane oxygenation (ECMO) is recommended.

### Severe/Profound Hypothermia

Core temperatures  $<28^{\circ}\text{C}$  ( $82.4^{\circ}\text{F}$ ) are characterized by stupor, leading to coma with loss of cerebrovascular autoregulation. Further cardiovascular instability manifests as bradycardia, hypotension, and a significant risk for unstable tachycardias, often beginning as atrial fibrillation with progression to ventricular dysrhythmias. There is no coordinated musculoskeletal activity. Patients with severe hypothermia may appear dead. Cardiopulmonary resuscitation (CPR) should be initiated if there is no cardiac activity, as determined by a pulse check of at least 1 minute duration or the absence of organized electrical activity on a monitor. Bedside echocardiography may also be used to identify cardiac activity. Vasoactive medications should be held until the core temperature is  $>30^{\circ}\text{C}$  ( $86^{\circ}\text{F}$ ) and then administered at twice the dosing interval until  $35^{\circ}\text{C}$  ( $95^{\circ}\text{F}$ ). Defibrillation or cardioversion, if indicated, is attempted once, at maximum power, then held until the core temperature is above  $30^{\circ}\text{C}$  ( $86^{\circ}\text{F}$ ).

In hypothermic cardiac arrest, rescuers should initiate CPR regardless of the patient's temperature. Contraindications to initiation of CPR include if there is obvious fatal injury, ice or snow is visualized in the airway, chest wall compression is impossible, or rescuers are at risk. The usual signs of death—rigor, pupillary dilation, and lividity—are unreliable in the hypothermic patient.

Complications of hypothermia include compartment syndrome, rhabdomyolysis, hyperkalemia or hypokalemia, hemoconcentration, hypercoagulability, disseminated intravascular coagulation (DIC), confusion (paradoxical undressing), Takotsubo cardiomyopathy, and mydriasis. Core temperature **afterdrop** is a decrease in core temperature after removal from the cold and/or when external rewarming begins; external rewarming extremities with frostbite is another risk factor.

Hypothermia is fatal if not treated. Prevention and risk mitigation through awareness of weather conditions, appropriate clothing and layering systems, and breaks for rewarming during outdoor activities will limit its incidence. Adults supervising children and adolescents participating in outdoor activities must be aware that behavior changes and apparent clumsiness might signal the onset of hypothermia.

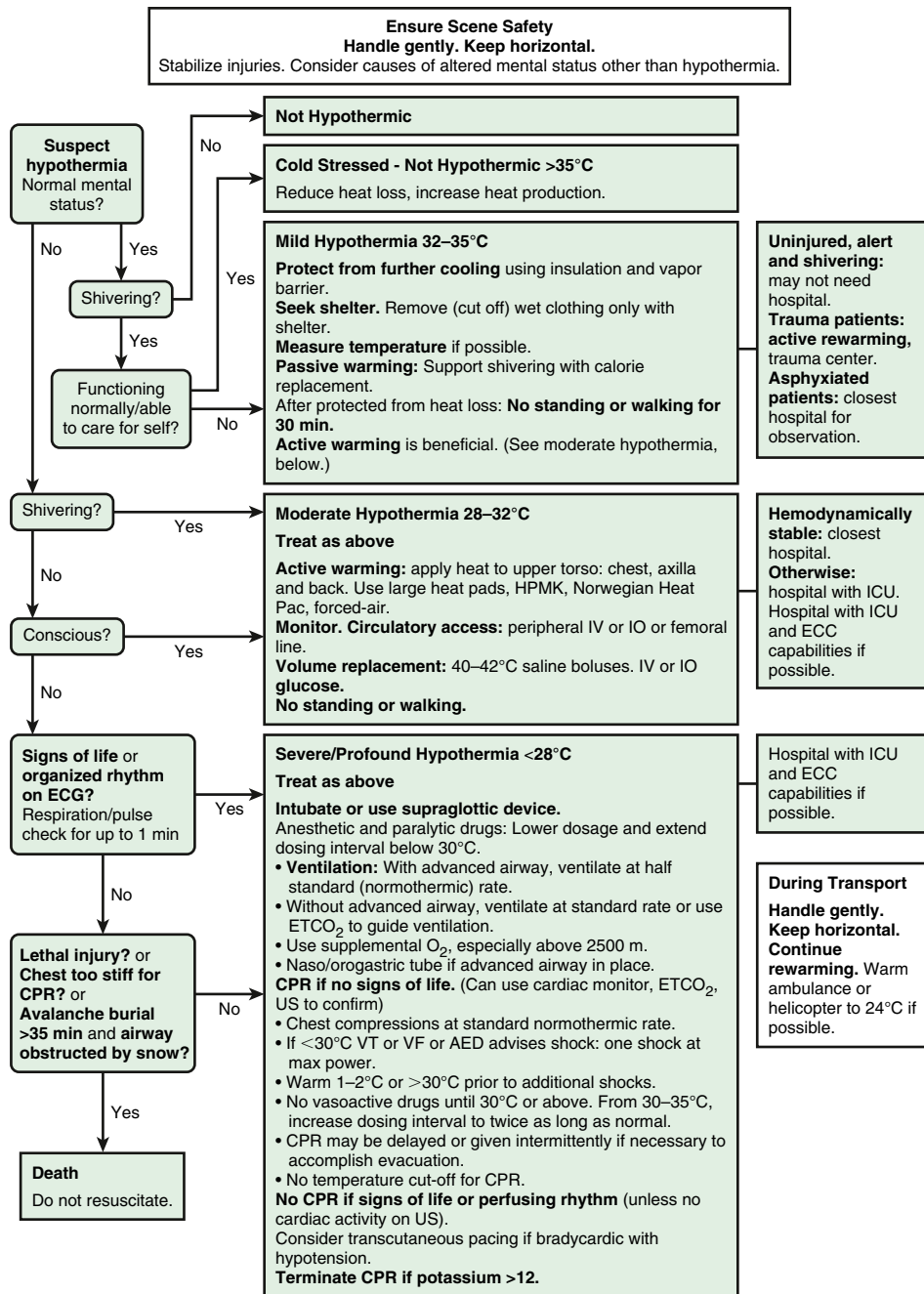
### SOFT TISSUE COLD INJURY

Soft tissue injuries caused by cold are divided into freezing and non-freezing injuries. Frostbite is a freezing injury, whereas frostnip, chilblains (pernio), cold immersion, and cold-induced fat necrosis are nonfreezing injuries.

### FROSTBITE

Frostbite is an injury occurring at or below freezing temperatures. It can have devastating effects with tissue loss leading to functional debility. It is preventable. Frostbite, like hypothermia, is a condition occurring when tissue heat loss is greater than the warmth delivered by peripheral perfusion. Minimizing exposure to cold, either by avoidance, use of appropriate clothing, and responding to changing conditions appropriately, are keys to frostbite prevention. Clothing, especially hand and footwear, should insulate well and not be constricting. Vasoconstriction inhibits peripheral cutaneous warming. Inhibitors of peripheral perfusion, such as vasoconstricting medications, circulatory disorders (e.g., Raynaud syndrome), and chronic skin conditions (e.g., psoriasis), increase frostbite risk. Emollients applied to the skin do not protect from the cold. Any complaints of numbness are to be taken seriously, and the child should be assessed for signs of cold injury in a protected environment. Frostnip, although not a freezing injury, does indicate that the temperature and exposure conditions may promote frostbite.





**Fig. 90.3** Recommendations for out-of-hospital evaluation and treatment of accidental hypothermia. AED, Automatic external defibrillator; CPR, cardiopulmonary resuscitation; ECC, extracorporeal circulation; ECG, electrocardiogram; ET<sub>CO</sub><sub>2</sub>, end-tidal carbon dioxide; HPMK, Hypothermia Prevention Management Kit; ICU, intensive care unit; IO, intraosseous; IV, intravenous; US, ultrasound; VF, ventricular fibrillation; VT, ventricular tachycardia. (From Zafren K, Giesbrecht GG, Danzl DF, et al. Wilderness Medical Society practice guidelines for the out-of-hospital evaluation and treatment of accidental hypothermia: 2014 update. *Wilderness Environ Med.* 2014;25:S66–S85, Fig. 2.)

GRADE I INJURY	GRADE II INJURY	GRADE III INJURY	GRADE IV INJURY
<ul style="list-style-type: none"> <li>• Superficial</li> <li>• Edema and redness without tissue necrosis in the affected area</li> <li>• Numbness, firm white-yellow plaque</li> <li>• No blisters or necrosis</li> <li>• Occasional skin desquamation (5-10 days later)</li> </ul>	<ul style="list-style-type: none"> <li>• Blister formation</li> <li>• Erythema, substantial edema</li> <li>• Vesicles with clear or milky fluid</li> <li>• Blisters</li> <li>• Desquamation and black eschar formed</li> </ul>	<ul style="list-style-type: none"> <li>• Tissue necrosis</li> <li>• Hemorrhagic deeper blisters</li> <li>• Skin necrosis</li> <li>• Blue-gray discoloration</li> </ul>	<ul style="list-style-type: none"> <li>• Development of gangrene, requiring amputation</li> <li>• Full-thickness skin, subcutaneous tissue, muscle, tendon, and bone freezing</li> <li>• Little edema</li> <li>• Initially mottled, deep red or eventually dry, black, and mummified</li> </ul>

Modified from Joshi K, Goyary D, Mazumder B, et al. Frostbite: Current status and advancements in therapeutics. *J Therm Biol.* 2020;93:102716, Table 1.

### Pathophysiology of Frostbite

Frostbite is a freezing injury with four phases: prefreeze, freeze-thaw, vascular stasis, and late ischemic. The degree of cold, duration of exposure, and physiologic compromise caused by medications and

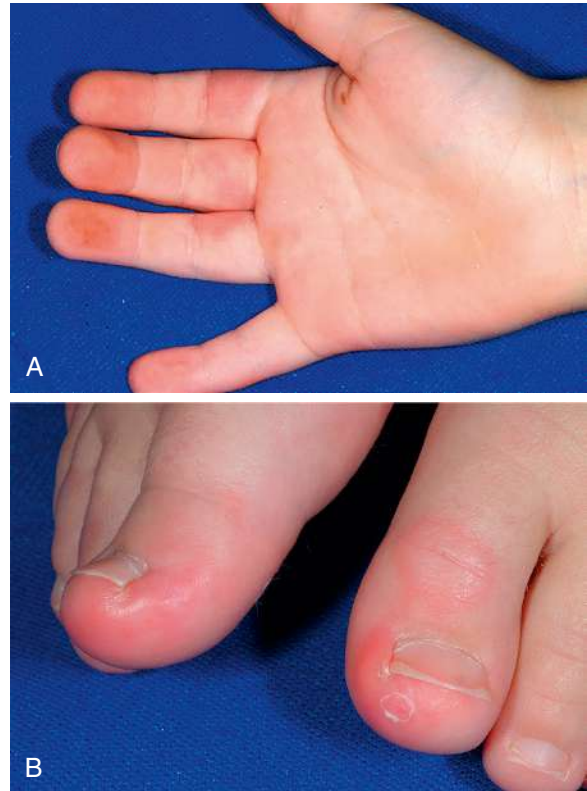


**Fig. 90.4** Frostbite with clear vesiculations. (Courtesy Dr. Bill Mills.)

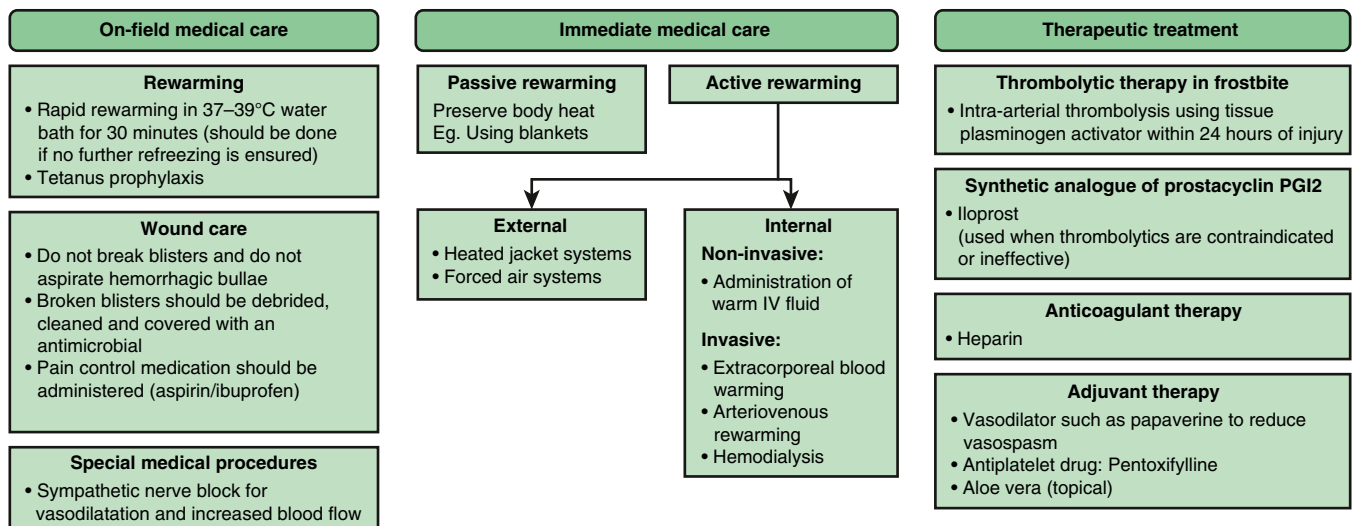


**Fig. 90.5** Early appearance of severe frostbite of the hand after thawing. A purple color and absence of blisters are very unfavorable prognostic signs. (Courtesy Dr. Ken Zafren.)

underlying illness determine how severe the injury will be. The tissue cooling of **prefreeze** is marked by local vasoconstriction and ischemia without the formation of ice crystals. Intracellular and extracellular ice crystal development causes cellular damage during the **freeze-thaw phase**. Reperfusion leads to ischemic-reperfusion injury and initiation of the inflammatory cascade. **Vascular stasis** is characterized by both blood leaking from vessels and the formation of thrombi. Progressive tissue ischemia from micro-emboli, local thrombosis, and persistent



**Fig. 90.7** A, Perniosis (chilblains). Edematous, red, painful nodules appeared on the fingers after exposure to cold. B, Perniosis (chilblains). Note the inflamed nodules on the toes of this adolescent girl. Although nodules resolved, painful nodules continued to develop on an annual basis beginning in January and lasting until April. She was otherwise healthy. (From Paller AS, Mancini AJ. *Hurwitz Clinical Pediatric Dermatology*, 6th ed. Elsevier: Philadelphia; 2022, Figs. 20.48 and 20.49, p. 566.)



**Fig. 90.6** Treatment protocol for the management of frostbite. (Modified from Joshi K, Goyary D, Mazumder B, et al. *Frostbite: Current status and advancements in therapeutics*. *J Therm Biol.* 2020;93:102716, Fig. 2.)

reperfusion injury marks the **late-ischemic phase**. Compromise of microcirculation and cellular destruction from crystal formation are the main factors contributing to cellular death.

### Clinical Presentation of Frostbite

The depth of injury is the basis for the classification of frostbite injury. In the field, frostbite is classified as superficial or deep. Upon arrival to a healthcare facility, a degree or grade of injury is assigned after the tissue has thawed and any advanced imaging is performed (Table 90.2).

**First-degree** frostbite is marked by numbness and local erythema with a pale raised plaque in the area of injury. Only mild tissue sloughing occurs, and there is no infarction. **Second-degree** injury presents with clear, fluid-filled blisters and surrounding erythema (Fig. 90.4). Local edema may be present. First- and second-degree frostbite injury results in minimal tissue loss and is considered superficial in the field. **Third-degree** frostbite extends into the dermis and dermal vascular plexus. The resulting blisters are hemorrhagic. **Fourth-degree** injury involves the dermis and underlying tissues, extending into muscle and bone (Fig. 90.5). Third- and fourth-degree frostbite has anticipated tissue loss and is field classified as deep.

### Treatment of Frostbite

Prevention is preferred for any environmental injury, but rapid recognition and treatment will mitigate the long-term impact. Once frostbite is suspected, the patient should be assessed for concomitant hypothermia. The injury must be protected from the cold and prevented from refreezing if spontaneous thawing has begun. Any constricting items, such as jewelry, are removed. Thawing should be initiated with a circulating water bath at 37–39°C (98.6–102.2°F). Pain medication should be administered. There are numerous combined therapies for frostbite, including anticoagulants, thrombolytics, and vasodilators (Fig. 90.6). The indications for each therapy depend on the extent of injury, length of time since tissue thaw, local availability, and individual national regulatory decisions. It is recommended that the clinician be aware of their local resources and protocols. Regardless, treatment with these agents must be initiated within 12–72 hours of tissue thaw.

## NONFREEZING COLD INJURY

Nonfreezing cold injuries include but are not limited to frostnip, chilblains (pernio), cold-immersion foot, and cold-induced fat necrosis.

**Frostnip** is associated with vasoconstriction of skin exposed to the cold with ice crystals, or frost, forming on the skin surface. The tissue may be numb, and local pallor is present. There is no cellular damage, and the condition resolves rapidly upon warming. Frostnip does indicate that conditions are appropriate for frostbite, and preventative measures should be taken.

**Chilblains**, also called **pernio**, is an idiopathic condition suspected to be a vasculopathy. Typically occurring in cold, damp conditions, vasculitic-appearing lesions develop on the fingers and toes, ears, and exposed areas of the legs after environmental exposure (Fig. 90.7). It is suspected that vasoconstriction and inflammatory reaction are responsible for the lesions. Recognition and prevention of further cold exposure is key to treatment. The lesions are self-limiting, and symptoms may be addressed with nonsteroidal antiinflammatory drugs (NSAIDs) and topical soothing creams. Continued exposure to cold can cause persistent lesions. Lesions similar to chilblains have been noted in children with COVID-19 infection. **Familial chilblain lupus**, an autosomal dominant variant of lupus, is caused by variants in the *TREX1* and *SAMHD1* genes (see Chapter 90.1). Patients develop cold-induced erythematous peripheral skin lesions and manifest systemic disease typical of lupus. In addition, fever and arthralgias may be present.

**Immersion foot** or **trench foot** occurs with continuous immersion in warm or cold water. The injury occurs more rapidly in cold water. Continuous exposure to the wet environment, whether through actual immersion in water or saturated footwear, causes hyperemia, edema, and ultimately blister formation with skin sloughing. The condition can progress to ischemia and gangrene. Awareness of wet footwear and

subsequent changing, or drying, of shoes and socks is the method of prevention. Vapor barrier socks or boots do not prevent sweat from accumulating and creating a wet environment. Like other cold injuries, treatment consists of thoroughly drying and warming the tissue. Antibiotics are not necessary unless signs of infection are present.

**Cold-induced fat necrosis** is secondary to local cold injury to the superficial adipose tissue. It presents with raised, erythematous nodules or plaques, evolving over 12–72 hours after exposure to cold. Distribution in children is predominantly on the face, specifically the cheeks and forehead. Obese children and adolescents may have lesions on areas poorly protected from the cold, including the buttocks, thighs, abdominal pannus, and under the chin. Lesions are self-limiting and typically resolve in 10–20 days. Treatment consists of rewarming, avoidance of the cold, and NSAIDs as necessary for discomfort.

Visit Elsevier eBooks+ at eBooks.Health.Elsevier.com for Bibliography.

## 90.1 Cold-Induced Autoinflammatory and Other Genetic Disorders

James J. Nocton and James W. Verbsky

A number of **autoinflammatory** and other genetic disorders have been identified that are characterized by an *exacerbation of symptoms upon exposure to cold temperatures*. These disorders differ from **cold injury**, **cold urticaria**, and problems related primarily to vasoconstriction because they typically manifest very early in life and are associated with a wider spectrum of signs and symptoms, reflecting either underlying systemic inflammation or the protean effects of specific genetic variants. A relatively lower ambient temperature or rapid cooling and evaporation from the skin are often sufficient to produce the signs and symptoms of these disorders; therefore the relationship to cold temperature is not always obvious. The genetic variants associated with most of these disorders impact cellular signaling pathways that lead to the expression of proinflammatory cytokines in the absence of an extrinsic trigger; therefore most of these diseases are classified as autoinflammatory.

These conditions should be suspected primarily in infants or very young children who develop persistent, recurrent, or periodic fevers associated with rashes or arthralgias that cannot be explained by an infectious disease or another chronic inflammatory or rheumatic disease. Signs and symptoms associated with these diseases may begin as early as the first week of life. The very early onset distinguishes these genetic diseases from acquired conditions such as Raynaud phenomenon, pernio, cryoglobulinemia, cold urticaria, and other cold-induced problems potentially related to acquired autoimmunity. The rashes are most often evanescent and appear similar to urticaria; however, they are usually not pruritic and are histologically different from urticaria. Laboratory evidence of chronic inflammation is often present, including elevations of the erythrocyte sedimentation rate and C-reactive protein. The association with cold exposure may be subtle and not initially apparent.

The diagnostic algorithm for these disorders should begin with a thorough history and a careful examination, paying particular attention to potential additional signs of conjunctivitis, a frequent accompanying feature, decreased limb movement that might indicate arthralgia or arthritis, the morphology of any cutaneous lesions, and the association of symptoms and signs with cooling or colder temperatures. Unlike cold urticaria, the hivelike lesions often associated with these disorders cannot be precipitated by a cold stimulation test using the application of an ice cube to the skin. Measurement of serum inflammatory markers may help distinguish autoinflammatory disease from more benign conditions; infectious diseases may need to be excluded with appropriate testing. A skin biopsy may provide information that will help narrow the differential diagnosis by identifying either a neutrophilic dermatosis, granulomatous inflammation, or vasculitis characteristic of one of these diseases. Ultimately, focused genetic sequencing can



be performed, searching for specific genetic variants that will confirm a diagnosis.

**Familial cold autoinflammatory syndrome (FCAS)**, along with neonatal-onset multisystem inflammatory disorder (NOMID) and Muckle-Wells syndrome (MWS), constitute the **cryopyrin-associated periodic syndromes (CAPS)** (see Chapter 204). These diseases are all the result of pathogenic variants in *NLRP3* which encodes the protein **cryopyrin**, a component of the inflammasome complex, which is critical in the production of the proinflammatory cytokines interleukin (IL)-1 $\beta$  and IL-18. Although each of these diseases may be exacerbated by cold exposure or cooling, the association with cold is most consistent in those with **FCAS**. **FCAS** should be considered in infants who develop episodes of a hivelike rash, often beginning in the neonatal period, accompanied by fever, conjunctivitis, joint pain, neutrophilia, thrombocytosis, and elevated inflammatory markers, and triggered by exposure to cold or low ambient temperatures. The rash is typically not pruritic and histologically consists of a neutrophilic perivascular and perieccrine inflammatory infiltrate. Episodes are short and generally last less than 24 hours. **MWS** is more severe than **FCAS**, causing more frequent hivelike rashes and fevers, along with arthralgias, conjunctivitis, and aseptic meningitis, and with potential eventual progression to hearing loss. Like **FCAS**, the onset of symptoms is most often in infancy, and the histology of skin lesions in these two disorders is similar. **NOMID** is the most severe form of **CAPS** and is associated with a nonpruritic urticarial rash often present at birth and more profound neurologic and bone disease. **CAPS** are inherited in an autosomal dominant manner, and the diagnosis is made based on clinical features and the identification of a variant in the *NLRP3* gene. Variants in *NLRP12* and in *NLRC4* have also been associated with similar clinical syndromes sometimes referred to as **FCAS2** and **FCAS4**, respectively. Treatment with the IL-1 inhibitors anakinra and canakinumab has been effective in most individuals with **CAPS**.

**PLCG2-associated antibody deficiency and immune dysregulation (PLAID)** (sometimes referred to as **FCAS3**) is an autosomal dominant disease resulting from a pathogenic variant of *PLCG2*, which encodes a transmembrane enzyme expressed primarily in myeloid and lymphoid cells that regulates inflammatory activity and proinflammatory cytokine production. **PLAID** causes pruritic urticaria from birth induced by ambient cold temperatures or cooling and lasting for minutes to hours. In some individuals, acral blistering lesions resembling a burn may also be present during infancy on the ears, nose, and fingers. Histology of urticarial lesions reveals increased mast cells. Because *PLCG2* is expressed in mast cells and affects mast cell degranulation, these subjects can have more classic hives as compared with other **FCAS** syndromes. Other lesions reveal noncaseating granulomas. Older individuals may develop syncope induced by cold exposure and a burning sensation in the throat when eating cold foods. Hypogammaglobulinemia may lead to frequent sinopulmonary and other infections. The diagnosis is made based on clinical features and the identification of variants in the *PLCG2* gene. Treatment of **PLAID** includes avoiding evaporative cooling and minimizing cold exposure, antihistamines, and for those with evidence of immunodeficiency, intravenous immunoglobulin infusions to prevent frequent infections.

**STING-associated vasculopathy with onset in infancy (SAVI)** is an autosomal dominant disease resulting from a pathogenic variant in *TMEM173*, which encodes **stimulator of interferon genes (STING)**, an activator of interferon gene transcription (see Chapter 205). Signs

and symptoms usually appear in infancy but may also appear later and include fever and a variety of cutaneous lesions. Violaceous nodules and plaques on the cheeks, ears, and nose and telangiectasias, pustules, or blisters, often most noticeable on the extremities, may occur. The skin lesions are exacerbated by cold temperatures, and some develop ulcerative or gangrenous lesions. In time, interstitial lung disease progressing to fibrosis has been described. Histology reveals vasculitis of medium and small vessels. The diagnosis is made based on clinical features and the identification of the variant in the *TMEM173* gene. Responses to treatment with corticosteroids and immunomodulators, including cyclophosphamide and mycophenolate mofetil, have been variable and inconsistent. Janus kinase inhibitors, which inhibit interferon receptor signaling, have shown promise in treatment of these disorders.

**Familial chilblain lupus** is a rare condition triggered by cold exposure that presents with painful, bluish-red, papular or nodular lesions of the skin in acral locations. Ulceration can occur, but deep ulceration and necrosis are infrequent, and the lesions tend to heal without scarring. This is an autosomal dominant disorder caused by heterozygous variants in *TREX1* or *SAMHD1*, the same genes containing variants associated with Aicardi-Goutières syndrome (**AGS**). **AGS** is a syndrome characterized by developmental delay, abnormal neurologic signs, microcephaly with brain calcifications, and CNS pleocytosis, as well as skin lesions resembling chilblains. Both *TREX1* and *SAMHD1* are involved in DNA degradation, and their deficiencies result in intracellular nucleic acid that stimulates interferon production. **AGS** and familial chilblain lupus can be considered a spectrum of severity of the same genetic defect.

**Factor XII-associated cold autoinflammatory syndrome** is an autosomal dominant disease resulting from a pathogenic variant in *F12* encoding the coagulation factor XII. The variant leads to spontaneous activation of factor XII, which in turn increases bradykinin and IL-1 levels. Individuals with this mutation develop an urticarial-like rash that begins in the first few weeks of life precipitated by cold. The rash is nonpruritic and evanescent, and as individuals age it is accompanied by more severe systemic symptoms of chills, headaches, arthralgias, and fatigue. Serum inflammatory markers are elevated, and skin histology reveals perivascular macrophage and neutrophilic infiltrates. The diagnosis is made by identifying a variant in *F12*. Treatment with the IL-1 receptor antagonist anakinra or the bradykinin B2 receptor antagonist icatibant has shown promise in a small number of individuals.

**Crisponi syndrome/cold-induced sweating syndrome (CS/CISS)** is an autosomal recessive disease resulting from variants in *CRLF1* or *CLCF1*. These genes encode proteins involved in neurologic development, including facial motor neurons and the sympathetic nervous system; therefore this syndrome is not classified as an autoinflammatory syndrome. Symptoms and signs are typically apparent in the neonatal period and include fever, camptodactyly, and involuntary episodic contractions of facial and pharyngeal muscles resulting in breathing and feeding difficulties. There is high neonatal mortality, and those that survive develop cold-induced profuse sweating in childhood. Scoliosis and other dysmorphic features (depressed nasal bridge, high arched palate) are also common. The diagnosis is made by identifying a variant most commonly in *CRLF1*. Treatment of the neonatal symptoms is supportive. The cold-induced sweating is managed with clonidine, amitriptyline, or moxonidine.

Visit Elsevier eBooks+ at [eBooks.Health.Elsevier.com](http://eBooks.Health.Elsevier.com) for Bibliography.



## Chapter 91

## Anesthesia and Perioperative Care

John P. Scott

The continuum of anesthesia includes varying degrees of sedation (i.e., mild, moderate, or deep) and general anesthesia. All forms of **sedation** are characterized by some preservation of purposeful movement (see [Chapter 92](#)), whereas **general anesthesia** is defined by the complete loss of consciousness. Potent pharmacologic agents are required to suppress the perception and physiologic response to noxious stimuli. Perioperatively, the anesthesiologist is responsible for providing hypnosis and analgesia while preserving physiologic homeostasis ([Table 91.1](#)). This begins with the performance of a comprehensive preanesthesia history ([Table 91.2](#)). Although anesthetic risk has greatly decreased with advancements in pharmacology and monitoring technology, the persistent risk of perioperative morbidity and mortality demands vigilance. The risk is elevated in certain disease states ([Table 91.3](#)).

**PREANESTHETIC EVALUATION**

All children presenting for surgery should undergo a preanesthetic history and multiorgan system assessment with assignment of **American Society of Anesthesiologists Physical Status (ASA-PS)** ([Table 91.4](#)). Children of ASA-PS I-II generally require a brief focused history and physical examination with no additional testing. Patients with a complex medical history of ASA-PS ≥III require a more comprehensive preanesthetic assessment, often with ancillary preoperative testing. Every patient should be screened for anesthetic risks, including drug allergies, previous reactions to anesthetics, and family history of problems with anesthesia (e.g., sudden perioperative death, hyperthermia after surgery), which may indicate risk of malignant hyperthermia.

**Respiratory System**

Recent respiratory tract infections should be noted. *Clear rhinorrhea without fever or evidence of lower respiratory disease is not associated with increased anesthetic risk.* Respiratory illnesses associated with fever, mucopurulent nasal discharge, productive cough, or lower respiratory symptoms (wheezing, rales) are associated with increased airway reactivity and anesthetic complications (laryngospasm, bronchospasm, reduced mucociliary clearance, atelectasis, and hypoxemia) for up to 6 weeks thereafter. Thus elective procedures requiring general anesthesia should be postponed 4-6 weeks in this setting.

Children with reactive airway disease require a thorough preanesthetic assessment. Acute, potentially fatal bronchospasm can occur during induction of anesthesia and endotracheal intubation for routine, minor surgery in children with asthma. Risk factors for anesthetic complications include previous asthma exacerbations requiring (1) hospital admission within the previous year, (2) emergency department (ED) care within the last 6 months, (3) previous intensive care unit (ICU) admission, or (4) previous parenteral systemic corticosteroids. Ideally, children should be free of wheezing for least several days before surgery, even if this necessitates

increased controller medication administration ( $\beta$ -adrenergic agonist and corticosteroids). Active wheezing may be an indication to delay elective surgery. Chronic respiratory conditions such as bronchopulmonary dysplasia and cystic fibrosis are also associated with significant intraoperative risks. Every effort should be made to ensure that children with such disorders achieve optimal respiratory status before surgery.

**Airway Evaluation**

Induction of general anesthesia is associated with reduced spontaneous ventilation and airway reflexes. Prediction of difficult bag-mask ventilation and/or intubation before anesthesia is critical. Congenital anomalies associated with airway compromise include micrognathia, macroglossia, and thoracic anomalies ([Table 91.5](#)). Conditions that impair mouth opening (e.g., temporomandibular joint disease) should be noted. A history of wheezing or stridor may indicate postoperative airway complications and difficult intraoperative airway management. It is imperative to ask about a history of sleep-disordered breathing, including obstructive and central sleep apnea, as this may lead to increased risk of peri-anesthetic respiratory complications in children. Polysomnography is the gold standard for diagnosis and grading of sleep-disordered breathing. The **STBUR** (snoring, trouble breathing, unrefreshed) questionnaire is used to identify patients with sleep-disordered breathing who may be at risk for perioperative respiratory complications. Postoperative admission for monitoring may be indicated for patients with moderate and severe forms of sleep-disordered breathing.

**Cardiovascular System**

Most anesthetic agents possess myocardial depressant properties. All patients should be screened for the presence of heart disease. Important cardiovascular considerations include history of congenital heart disease (CHD), cyanosis, arrhythmias, or cardiomyopathy. Room-air pulse oximetry should be performed as part of the preanesthetic evaluation. Accurate diagnosis of cardiac murmurs in neonates is essential. A history of cardiac dysrhythmias should be investigated because inhalational anesthetics may be arrhythmogenic. A pediatric cardiologist should evaluate children with known CHD undergoing surgery. Preoperative ancillary studies may include chest x-ray, electrocardiogram (ECG), echocardiogram, or cardiac catheterization. Lesions associated with increased anesthetic risk include single-ventricle heart disease, fixed obstructive outflow tract lesions (aortic valve and pulmonary valve stenosis), and cardiomyopathy. Children with these conditions should be cared for by a **cardiac anesthesia service**. Antibiotic prophylaxis for the prevention of bacterial endocarditis should be administered when appropriate in accordance with the American Heart Association (AHA) guidelines.

**Hematologic System**

Evidence of coagulopathy should be sought. Easy bruising, familial bleeding disorders, and anticoagulant (e.g., aspirin, heparin, direct oral anticoagulant [DOAC], warfarin) use should be discussed. Preoperative adequacy of hemostatic function (e.g., platelet count, fibrinogen, prothrombin time, partial thromboplastin time) and correction of coagulopathic disorders may be indicated for complex procedures associated with significant risk of perioperative hemorrhage. In neonates, assurance of vitamin K prophylaxis and adequate coagulation status is critical before any major surgery. Although anemia may be well tolerated in healthy children, anesthesia and surgery increase oxygen consumption. Preoperative anemia should be corrected when oxygen delivery is limited or blood loss is expected. In the patient with life-threatening hemorrhage (trauma), massive transfusion protocols of 1:1:1 replacement of packed red blood cells:fresh-frozen plasma:platelets should be used. Initiation of early antifibrinolytic therapy in the setting of life-threatening hemorrhage has been linked to reduced early mortality.

**Neurologic System**

A history of neurologic and neuromuscular disorders should be sought. Preoperative developmental assessments may be helpful in interpreting age-dependent variation in the response to pain. Maintenance of appropriate perioperative anticonvulsant therapy is essential

**Table 91.1** Goals of Anesthesia

Analgnesia
Amnesia
Hypnosis
Akinesia
Maintenance of physiologic homeostasis
Vigilance

**Table 91.2** The Preanesthetic History**Child's Previous Anesthetic and Surgical Procedures**

- Review previous anesthetic records:
  - Ease of mask ventilation
  - Grade of laryngoscopy; type and size of laryngoscope; endotracheal tube size
  - Issues during emergence (awakening) from anesthesia (postoperative vomiting, emergence delirium)
  - History of hyperthermia or acidosis in the child or family members

**Perinatal Problems (Especially for Infants)**

- Prematurity
- Need for supplemental oxygen or intubation and ventilation
- History of apnea and bradycardia
- History of cardiovascular compromise
- Other major illnesses and hospitalizations
- Family history of anesthetic complications, malignant hyperthermia, or pseudocholinesterase deficiency

**Respiratory Problems**

- Long-term exposure to environmental tobacco smoke
- Obstructive breathing score
- STBUR (snoring, trouble breathing, unrefreshed)
- Cyanosis (especially in infants <6 mo of age)
- Recurrent respiratory infections
- Recent lower respiratory tract infection
- Previous laryngotracheitis (croup) or laryngomalacia
- Reactive airway disease
- Airway abnormalities, facial anomalies, mucopolysaccharidosis

**Cardiac Problems**

- Murmur or history of congenital heart disease
- Dysrhythmia
- Exercise intolerance
- Syncope
- Cyanosis

**Gastrointestinal Problems**

- Reflux and vomiting
- Feeding difficulties
- Failure to thrive
- Liver disease
- Exposure to infectious pathogens

**Neuromuscular Problems**

- Neuromuscular diseases
- Developmental delay
- Myopathy
- Seizure disorder

**Hematologic Problems**

- Anemia
- Bleeding diathesis
- Tumor
- Immunocompromise
- Prior blood transfusions and reactions

**Renal Problems**

- Renal insufficiency, oliguria, anuria
- Fluid and electrolyte abnormalities

**Psychosocial Considerations**

- Drug abuse, use of cigarettes or alcohol
- Physical or sexual abuse
- Family dysfunction
- Previous traumatic medical or surgical experience
- Psychosis, anxiety, depression

**Gynecologic Considerations**

- Sexual history (sexually transmitted infections)
- Possibility of pregnancy

**Current Medications**

- Prior administration of corticosteroids

**Allergies**

- Drugs
- Iodine
- Latex products
- Surgical tape
- Food (especially soy and egg albumin)

**Other**

- Dental condition (loose or cracked teeth)
- When and what the child last ate (especially in emergency procedures)

in children with seizure disorders because the seizure threshold may be lowered perioperatively. Children with obstructive hydrocephalus typically require ventriculoperitoneal (VP) shunt insertion to divert cerebrospinal fluid (CSF) and to prevent intracranial hypertension (ICH). Repeated shunt malfunction is common, and these children may present for shunt revision with signs of ICH (vomiting, altered mentation, sundowning). Similarly, shunt patency and function should be ensured preoperatively in children with VP shunts presenting for non-neurosurgical procedures.

**Psychologic Assessment**

Surgery and painful medical procedures are psychologically traumatic events for children and families. Children who require anesthesia may experience fear and anxiety. They may also sense stressful signals from parents and caregivers. Children undergoing surgery may exhibit negative behavioral changes postoperatively. These maladaptive behavioral responses may include enuresis, separation anxiety, temper tantrums, and nighttime crying, as well as fear of strangers, medical providers, and hospitals. Sleep quality may be altered postoperatively, resulting in further behavioral compromise. Preoperative psychologic preparation programs have been developed to reduce the incidence of perioperative behavioral changes. **Parental presence during induction (PPI)** has not been shown to improve postoperative behavior. Oral preoperative midazolam (0.5 mg/kg) produces

rapid-onset anxiolysis and amnesia and may decrease negative behavioral changes.

**Genetic Evaluation**

Children with genetic conditions may have syndrome-specific anesthetic considerations. For example, children with trisomy 21 may have cardiac anomalies, macroglossia, upper airway obstruction, and hypothyroidism (see [Chapter 99.2](#)). Atlantoaxial instability, common in trisomy 21, has been linked to cervical dislocation and spinal cord trauma with neck extension during intubation. Some anesthesiologists recommend extension and flexion lateral neck films to detect instability before surgery. For children with other known genetic disorders, it is essential to review specific anesthetic considerations.

**PREOPERATIVE PREPARATION****Preoperative Fasting**

Preoperative fasting guidelines have been developed to reduce the incidence of aspiration of gastric contents during anesthesia. Aspiration may lead to laryngospasm, bronchospasm, and postoperative pneumonia. Aspiration of gastric contents may be a potentially lethal complication in children with chronic lung disease or critical illness. [Table 91.6](#) lists preoperative fasting guidelines (e.g., nothing by mouth, or nil per os [NPO] status). Clear, sweet liquids (e.g., Pedialyte, 5% dextrose

**Table 91.3** Specific Pediatric Diseases and Their Anesthetic Implications

DISEASE	IMPLICATIONS	DISEASE	IMPLICATIONS
<b>RESPIRATORY SYSTEM</b>		<b>GASTROINTESTINAL</b>	
Asthma	Intraoperative bronchospasm that may be life threatening Pneumothorax or atelectasis Optimal preoperative medical management is essential	Esophageal, gastric Liver	Potential for reflux and aspiration Altered metabolism of many anesthetic drugs Potential for coagulopathy and uncontrollable intraoperative bleeding
Difficult airway	Special equipment and personnel may be required Should be anticipated with dysmorphic features or storage diseases Patients with trisomy 21 may require atlantooccipital joint evaluation Increased risk with acute airway obstruction, epiglottitis, laryngotracheobronchitis, or airway foreign body	<b>RENAL</b>	
Bronchopulmonary dysplasia	Barotrauma with positive pressure ventilation Oxygen toxicity, pneumothorax a risk	Altered electrolyte and acid-base status Altered clearance of many anesthetic drugs Need for preoperative dialysis in selected cases Succinylcholine to be used with extreme caution and only when the serum potassium level has recently been shown to be normal	
Cystic fibrosis	Airway reactivity, bronchorrhea, increased intraoperative pulmonary shunt and hypoxia Risk of pneumothorax, pulmonary hemorrhage Atelectasis, risk of prolonged postoperative ventilation	<b>NEUROLOGIC</b>	
Sleep apnea	Patient should be assessed for cor pulmonale Pulmonary hypertension and cor pulmonale must be excluded Careful postoperative observation for obstruction required	Seizure disorder	Avoidance of anesthetics that may lower the seizure threshold Optimal control ascertained preoperatively Preoperative serum anticonvulsant measurements
<b>CARDIAC</b>		Increased intracranial pressure	Avoidance of agents that increase cerebral blood flow Maintain cerebral perfusion pressure.
	Bacterial endocarditis prophylaxis as indicated Use of air filters; careful purging of air from the intravenous equipment Physician must understand the effects of various anesthetics on the hemodynamics of specific lesions Possible need for preoperative evaluation of myocardial function and pulmonary vascular resistance Provide information about pacemaker function and ventricular device function	Neuromuscular disease	Avoidance of depolarizing relaxants; at risk for hyperkalemia Patient may be at risk for malignant hyperthermia; avoid volatile anesthetics in myopathies
<b>HEMATOLOGIC</b>		Developmental delay	Patient may be uncooperative during induction and emergence
Sickle cell disease	Possible need for simple or exchange transfusion based on preoperative hemoglobin concentration and percentage of hemoglobin S Avoid hypoxemia, hypothermia, dehydration, and hyperviscosity states	Psychiatric	Monoamine oxidase inhibitor (or cocaine) may interact with meperidine, resulting in hyperthermia and seizures Selective serotonin reuptake inhibitors may induce or inhibit various hepatic enzymes that may alter anesthetic drug clearance Illicit drugs may have adverse effects on cardiorespiratory homeostasis and may potentiate the action of anesthetics
Oncology	Pulmonary evaluation of patients who have received bleomycin, bis-chloroethyl-nitrosourea, chloroethyl-cyclohexyl-nitrosourea, methotrexate, or radiation to the chest Avoidance of high oxygen concentration Cardiac evaluation of patients who have received anthracyclines; risk of severe myocardial depression with volatile agents Potential for coagulopathy	<b>ENDOCRINE</b>	
<b>RHEUMATOLOGIC</b>		Diabetes	Greatest risk is unrecognized intraoperative hypoglycemia; intraoperative blood glucose level monitoring needed especially when insulin is administered
	Limited mobility of the temporomandibular joint, cervical spine, arytenoid cartilages Careful preoperative evaluation required Possible difficult airway	<b>SKIN</b>	
		Burns	Difficult airway Fluid shifts Bleeding Risk of rhabdomyolysis and hyperkalemia from succinylcholine after burns for many months
		<b>IMMUNOLOGIC</b>	
			Retroviral drugs may inhibit benzodiazepine clearance Immunodeficiency requires careful infection control practices Cytomegalovirus-negative blood products, irradiation, or leukofiltration may be required
		<b>METABOLIC</b>	
			Careful assessment of glucose homeostasis in infants

in water [D5W]) facilitate gastric emptying, prevent hypoglycemia, and may be given up to 2 hours before anesthesia. Breast milk may be given to infants up to 4 hours before surgery. Solids should be avoided for 6-8 hours before surgery. Conditions associated with delayed gastric emptying may require prolonged periods of fasting. The optimal

duration of preoperative fasting in otherwise well patients without risk factors for delayed gastric emptying remains a source of controversy. Many efforts have sought to shorten NPO duration for clear liquids from 2 hours to 1 hour in order to preserve fluid and glycemic balance in children presenting for surgery.

**Table 91.4** American Society of Anesthesiology Physical Status Classification

Class 1: Healthy patient, no systemic disease
Class 2: Mild systemic disease with no functional limitations (mild chronic renal failure, iron-deficiency anemia, mild asthma)
Class 3: Severe systemic disease with functional limitations (hypertension, poorly controlled asthma or diabetes, congenital heart disease, cystic fibrosis)
Class 4: Severe systemic disease that is a constant threat to life (critically and/or acutely ill patients with major systemic disease)
Class 5: Moribund patients not expected to survive 24 hr, with or without surgery
Additional classification: "E"—emergency surgery

Copyright American Society of Anesthesiology, <http://www.asahq.org>.

**Table 91.5** Common Difficult Airway Syndromes

Achondroplasia
Airway tumors, hemangiomas
Apert syndrome
Beckwith-Wiedemann syndrome
Choanal atresia
Cornelia de Lange syndrome
Cystic hygroma/teratoma
DiGeorge syndrome
Fractured mandible
Goldenhar syndrome
Juvenile rheumatoid arthritis
Mucopolysaccharidosis
Pierre Robin syndrome
Smith-Lemli-Opitz syndrome
Treacher-Collins syndrome
Trisomy 21
Turner syndrome

### The Full Stomach

Gastric emptying may be delayed for up to 96 hours after an acute episode of trauma or surgical illness. To mitigate risk of aspiration, it is desirable to secure the airway as rapidly as possible during induction of anesthesia in patients at risk for having a full stomach. Under these circumstances, rapid sequence induction of anesthesia is indicated (**rapid sequence induction**; see [Chapter 86](#)).

### Parental Presence During Induction of Anesthesia

Parents or guardians may expect to be with their child during the induction of anesthesia. Removing a fearful child from a parent is stressful for the child and caregivers. Premedication with an oral benzodiazepine (e.g., midazolam) frequently provides calm, smooth parental separation conditions. When parental separation cannot be achieved comfortably with premedication and behavioral modification (patient education and desensitization to the operative environment), PPI may be indicated. Although PPI in the hands of a confident, competent anesthesia practitioner may replace the need for preoperative medication, it does not reliably predict smooth induction. PPI has not been shown to decrease emergence delirium or postoperative behavioral changes, and it does not appear to be superior to premedication with oral midazolam.

## GENERAL ANESTHESIA

### Analgesia

Pediatric anesthesiologists are responsible for providing analgesia to children for procedures within operating room (OR) and non-OR settings ([Table 91.7](#)). Multimodal techniques exist to provide pain relief during operative procedures for children of all ages, including critically ill infants. Effective analgesia is essential to blunt physiologic responses

**Table 91.6** Guidelines for Preoperative Fasting ("2-4-6-8 Rule")\*

TIME BEFORE SURGERY (hr)	ORAL INTAKE
2	Clear, sweet liquids
4	Breast milk
6	Infant formula, fruit juices, gelatin
8	Solid food

\*These are general guidelines and may differ among hospitals.

to painful stimuli (surgery) and modulate the deleterious physiologic and metabolic consequences. The response to painful and stressful stimuli may provoke **systemic inflammatory response syndrome (SIRS)**, which has been linked to increased catabolism, physiologic instability, and mortality (see [Chapter 85](#)).

### Hypnosis and Amnesia

The attenuation of both consciousness (**hypnosis**) and conscious recall (**amnesia**) is critical during pediatric anesthesia care. Awareness during procedures may be as physically and psychologically deleterious as the experience of pain. A primary goal of anesthetic management is to minimize fear and anxiety during both painful and nonpainful procedures. Many drugs provide anxiolysis and amnesia for such events ([Table 91.8](#)). However, it is important to remember that sedative-hypnotic agents may alter consciousness without producing analgesia; *analgesia* and *hypnosis* are not synonymous. It is also possible to provide analgesia (local, spinal, or epidural) without altering consciousness.

**Sedation** describes a medically induced state in the continuum between wakefulness and general anesthesia in which patients maintain the ability to respond purposefully to varying degrees of stimulation (see [Table 91.7](#)). *Light (minimal) sedation* is defined as anxiolysis with minimally reduced reflexes or airway patency with normal response to verbal commands. In *moderate sedation*, the patient continues to respond purposefully to verbal commands, either alone or with light touch. *Deep sedation* is defined by preservation of purposeful movement with repeated or painful stimulation. **General anesthesia** is characterized by unconsciousness, amnesia, and reduced physiologic reflexes, including cardiorespiratory reflexes (**airway-protective** and **vasomotor reflexes**). It is common to transition between states of sedation and general anesthesia with loss of consciousness, airway patency, and airway-protective reflexes; in this scenario, loss of cardiovascular stability may occur. Individuals providing sedation and anesthesia for children must be able to identify the anesthetic state of the patient and support cardiorespiratory insufficiency.

### Akinesia (Immobility or Muscular Relaxation)

*Akinesia*, the absence of movement, is commonly indicated to ensure safe and adequate operative conditions. Neuromuscular blocking agents (NMBAs) may be used to produce akinesia (see [Table 91.8](#)). However, the absence of movement is not indicative of hypnosis, amnesia, or analgesia. Whenever NMBAs are used, *sedation and analgesia must be provided*.

### Monitoring

Administration of anesthesia increases the need to monitor and support physiologic integrity and homeostasis because of potentially life-threatening physiologic consequences (see [Tables 91.7](#) and [91.8](#)). Consequently, the ASA mandates routine monitoring of oxygenation, ventilation, and circulation during the provision of anesthesia. This includes assessment of continuous pulse oximetry, capnography, electrocardiography, intermittent blood pressure measurements (every 5 minutes), and temperature when temperature instability is anticipated. The use of advanced invasive (arterial and central venous pressure) or noninvasive (near-infrared spectroscopy) monitoring varies based on procedural complexity and ASA-PS.



**Table 91.7** Definitions of Anesthesia Care**MONITORED ANESTHESIA CARE**

A designated anesthesia service in which an anesthesiologist has been requested to participate in the care of a patient undergoing a diagnostic or therapeutic procedure.

Monitored anesthesia care includes all aspects of anesthesia care: a preprocedure assessment, intraprocedure care, and postprocedure anesthesia management.

During monitored anesthesia care, the anesthesiologist or a member of the anesthesia care team provides a number of specific services, which may include but are not limited to the following:

- Discussing anesthesia care with the family and child, obtaining consent for anesthesia, allaying anxiety and answering questions—family-centered anesthesia care.
- Monitoring of vital signs, maintenance of the patient's airway, and continual evaluation of vital functions.
- Diagnosing and treating clinical problems that occur during the procedure.
- Administering sedatives, analgesics, hypnotics, anesthetic agents, or other medications as necessary to ensure patient safety and comfort.
- Providing other medical services as needed to accomplish the safe completion of the procedure.

Anesthesia care often includes the administration of medications for which the loss of normal protective reflexes or loss of consciousness is likely.

*Monitored anesthesia care* refers to those clinical situations in which the patient remains able to protect the airway for the majority of the procedure.

If the patient is rendered unconscious and/or loses normal protective reflexes for an extended period, this is considered a general anesthetic.

**LIGHT SEDATION**

Administration of anxiolysis or analgesia that obtunds consciousness but does not obtund normal protective reflexes (cough, gag, swallow, hemodynamic) or spontaneous ventilation; patient responds normally to verbal commands.

**MODERATE SEDATION**

No interventions are required to maintain a patent airway or spontaneous ventilation; patient responds purposefully to verbal commands either on their own or with light touch.

**DEEP SEDATION**

Sedation that obtunds consciousness and normal protective reflexes or possesses a significant risk of blunting normal protective reflexes (cough, gag, swallow, hemodynamic); hemodynamic and respiratory insufficiency may occur.

**GENERAL ANESTHESIA**

Administration of hypnosis, sedation, and analgesia that results in the loss of normal protective reflexes.

**REGIONAL ANESTHESIA**

Induction of neural blockade (either central, neuraxial, epidural, or spinal; or peripheral nerve block, e.g., digital nerve block, brachial plexus block), which provides analgesia and is associated with regional motor blockade.

Consciousness is not obtunded.

Special expertise is required.

Frequently, in children, anxiolysis and sedation are also necessary for this technique to be successful.

Regional anesthesia (e.g., caudal epidural blockade) is used to supplement general anesthesia and provide postoperative analgesia.

**LOCAL ANESTHESIA**

Provision of analgesia by local infiltration of an appropriate anesthetic agent.

Does not require the presence or involvement of an anesthesiologist, although an anesthesiologist may provide local anesthesia services.

## Specific Medications

### Inhalational Anesthetics

Inhalational anesthetics are frequently used for the induction and maintenance of general anesthesia in children. Pediatric inhalational anesthetics include sevoflurane, isoflurane, and desflurane. Although halothane is the prototypical pediatric inhalational anesthetic and may be used in other parts of the world, it has been replaced by sevoflurane and is no longer used in the United States and Europe.

The **minimum alveolar concentration (MAC)** of an inhalational anesthetic is the alveolar concentration (expressed as percent at 1 atmosphere) that provides sufficient depth of anesthesia for surgery in 50% of patients. For potent inhalational agents, the alveolar concentration of an anesthetic reflects the arterial concentration of anesthetic in the blood perfusing the brain. MAC is a measure of anesthetic potency analogous to the **ED<sub>50</sub>** (effective dose in 50% of recipients) of a drug. MAC is age dependent; it is lower in premature than in full-term infants and decreases from term through infancy to preadolescence. In adolescence, MAC again increases, falling thereafter.

**Respiratory Effects.** The advantages of inhalational anesthesia are rapid onset and offset with the convenient route of delivery and respiratory excretion. These agents provide profound analgesia and amnesia. Inhalational volatile anesthetic agents are poorly soluble in blood but rapidly equilibrate between alveolar gas and blood. They may irritate the airway and provoke laryngospasm. All inhalational anesthetics depress ventilation in a dose-dependent manner. Thus expired carbon dioxide (CO<sub>2</sub>) and PaCO<sub>2</sub> (arterial partial pressure of CO<sub>2</sub>) will increase in spontaneously breathing children. Volatile anesthetics shift the CO<sub>2</sub> response curve to the right, thus decreasing the normal increase in minute ventilation with increasing PaCO<sub>2</sub>. Inhalational anesthesia decreases end-expiratory lung volume (functional residual capacity). Small lung volumes are associated with reduced lung compliance,

increased pulmonary vascular resistance, and restrictive lung defects. Volatile agents depress normal hypoxic pulmonary vasoconstriction, increasing intrapulmonary arteriovenous shunting and hypoxemia.

**Cardiovascular Effects.** All volatile anesthetics reduce cardiac output and peripheral vascular resistance; hypotension is common. This is accentuated in hypovolemic patients and more pronounced in neonates. Inhalational anesthetics also depress baroreceptor and heart rate responses. The administration of inhalational anesthesia may result in decreased tissue oxygen delivery. Perioperatively, cellular metabolism increases, creating a potential imbalance between oxygen demand and oxygen delivery. Development of intraoperative dysoxia is a sign of this imbalance. All volatile inhalational anesthetic agents cause **cerebrovasodilation** and uncouple cerebral blood flow with cerebral metabolic rate. Although inhalational anesthetics decrease cerebral oxygen consumption, they may disproportionately increase cerebral oxygen blood flow. Thus inhalational anesthetics should be used with caution in children who have elevated intracranial pressure (ICP) or impaired cerebral perfusion (i.e., traumatic brain injury).

**Sevoflurane**

Sevoflurane is the most commonly used inhalational agent for induction and maintenance of general anesthesia in children. Sevoflurane possesses minimal airway irritant properties and is a useful induction agent when co-administered with nitrous oxide. Emergence from sevoflurane anesthesia is rapid; however, there is a significant incidence of **emergence delirium**, especially with inadequate pain control. This effect may be attenuated with adequate analgesia and supplemental hypnotic agents (e.g., midazolam, dexmedetomidine, propofol). Metabolism of sevoflurane by cytochrome P450 (CYP) yields free fluoride, which may be nephrotoxic. Sevoflurane degradation by desiccated CO<sub>2</sub> absorbents at low fresh gas flows (<2 L/min) may produce

**Table 91.8** Selected Drugs Used in Anesthesia

DRUG	USES AND IMPLICATIONS
<b>MUSCLE RELAXANTS</b>	
Succinylcholine	<p>A depolarizing neuromuscular blocking agent with rapid onset and offset properties</p> <p>Used to facilitate endotracheal intubation and maintain muscle relaxation in emergency situations; rarely used</p> <p>Associated with the development of malignant hyperthermia in susceptible patients</p> <p>Degraded by plasma cholinesterase, which may be deficient in some individuals; such a deficiency may result in prolonged effect</p> <p>Fasciculations may be associated with immediate increases in intracranial and intraocular pressures and postoperative muscle pain</p>
Vecuronium, rocuronium, cisatracurium, all aminosteroids	<p>Nondepolarizing neuromuscular blockers</p> <p>Have less rapid onset than succinylcholine but are longer acting</p> <p>Prolonged ICU use may lead to profound muscle weakness</p> <p>Vecuronium and rocuronium are metabolized by the liver and excreted in bile; they are the most commonly used neuromuscular blocking agents</p> <p>Cisatracurium is metabolized by plasma cholinesterase and therefore may be of benefit in patients with hepatic or renal disease</p>
<b>HYPNOTICS</b>	
Propofol	<p>Rapid-acting hypnotic amnestic agent</p> <p>No analgesic properties</p> <p>Respiratory depressant</p> <p>Increases seizure threshold</p> <p>Antiemetic</p>
Etomidate	<p>Propofol infusion syndrome may occur with prolonged intravenous infusion (&gt;24 hr)</p> <p>Cardiovascular stability on induction</p> <p>Inhibits corticosteroid synthesis</p> <p>Increases ICU mortality after use</p>
Ketamine	<p>Associated with myoclonus and pain on injection</p> <p>Hypnotic analgesic</p> <p>Causes sialorrhea and may be co-administered with an antisialagogue, such as atropine or glycopyrrolate</p> <p>Induces endogenous catecholamine release and tachycardia</p> <p>Bronchodilator</p> <p>Increases intracranial and intraocular pressures</p> <p>Decreases the seizure threshold</p>
<b>SEDATIVE-ANXIOLYTICS</b>	
Benzodiazepines	<p>Produce sedation, anxiolysis, amnesia, and hypnosis</p> <p>All agents raise the seizure threshold, are metabolized by the liver, and depress respiration, especially when administered with opioids</p> <p>Effective as premedication</p> <p>Diazepam may be painful on injection and has active metabolites</p> <p>Midazolam can be administered by various routes</p> <p>Lorazepam has no active metabolites</p> <p>Reversed with flumazenil</p>
Dexmedetomidine	<p>Produces anxiolysis, sedation, and sympatholysis by <math>\alpha_2</math>-receptor stimulation centrally; has mild analgesic properties</p> <p>Side effects include hypertension, hypotension, and bradycardia</p> <p>Commonly used for procedural sedation; IV, IN, and IM dosing available</p> <p>Continuous infusion useful for ICU sedation</p>
<b>ANALGESIC-SEDATIVES</b>	
Opioids	<p>Gold standard for providing analgesia</p> <p>All cause respiratory depression</p> <p>Morphine and, to a lesser extent, hydromorphone may cause histamine release</p> <p>The synthetic opioids fentanyl, sufentanil, and short-acting alfentanil may have a greater propensity to cause chest wall rigidity when administered rapidly or in high doses and are also associated with the rapid development of tolerance; these drugs have particular utility in cardiac surgery because of the hemodynamic stability associated with their use</p> <p>Remifentanil is an ultrashort-acting synthetic opioid that is metabolized by plasma cholinesterase; it may have particular utility when deep sedation and analgesia are required along with the ability to assess neurologic status intermittently</p>
<b>INHALATIONAL AGENTS</b>	
Nitrous oxide	<p>Produces amnesia and analgesia at low concentrations</p> <p>Danger of hypoxic gas mixture if the oxygen concentration is not monitored and preventive safety mechanisms are not in place</p>
Potent vapors, sevoflurane, desflurane, isoflurane	<p>“Complete anesthetics”—induce hypnosis, analgesia, and amnesia</p> <p>All are myocardial depressants, and some are vasodilators</p> <p>May trigger malignant hyperthermia in susceptible individuals</p> <p>Sevoflurane is used for induction of anesthesia in children</p> <p>All bronchodilate at equipotent concentrations</p> <p>Isoflurane and desflurane are associated with laryngospasm and should not be used for anesthesia induction</p>

the nephrotoxin Compound A. Large-scale studies of sevoflurane-associated renal injury in humans are lacking. However, the U.S. Food and Drug Administration (FDA) has recommended maintenance of fresh gas flow rates >2 L/min for surgical cases lasting more than 2 hours of monitored anesthesia care.

### Isoflurane

Isoflurane is a pungent volatile anesthetic and airway irritant and is not suitable for induction because of the high incidence of complications, such as laryngospasm. However, maintenance of anesthesia with isoflurane is common after induction with sevoflurane or an intravenous (IV) hypnotic. Emergence from anesthesia with isoflurane is slower than for sevoflurane. Isoflurane administration in the setting of desiccated CO<sub>2</sub> absorbents may yield the production of carbon monoxide.

### Desflurane

Desflurane is a potent airway irritant associated with coughing, breath holding, and laryngospasm and is *not* useful for induction. Desflurane has the lowest solubility and potency of all commonly used volatile agents. It is frequently administered for maintenance of anesthesia. Emergence from desflurane anesthesia is rapid because of its low tissue solubility.

### Nitrous Oxide

Nitrous oxide (N<sub>2</sub>O) is a tasteless, colorless, odorless gas with potent analgesic properties. It produces a state of euphoria (thus its nickname, “laughing gas”). The MAC of N<sub>2</sub>O is >100; consequently, it may not be used as a sole agent to maintain anesthesia. N<sub>2</sub>O produces little hemodynamic or respiratory depression. It is typically used in combination with volatile and IV anesthetic agents during maintenance of general anesthesia. The deleterious effects of N<sub>2</sub>O include postoperative nausea and vomiting (PONV) and, with long-term use (i.e., days), bone marrow suppression. N<sub>2</sub>O diffuses out of blood rapidly and is contraindicated in patients with closed gas-filled body cavities (pneumothorax, lung cysts, bowel injury).

### Intravenous Anesthetic Agents

IV anesthetics may be administered for induction and maintenance of anesthesia in bolus form or as continuous infusions. Common IV agents include propofol, opioids, benzodiazepines, ketamine, dexmedetomidine, and barbiturates. For children with vascular access, IV induction should be routine. All IV agents affect cardiorespiratory function.

### Propofol

Propofol is the most commonly administered IV induction agent. Administered in doses of 2-5 mg/kg, propofol rapidly produces unconsciousness. Propofol may burn and itch on injection. After induction of anesthesia, propofol is a useful agent for maintaining hypnosis and amnesia and may be used as a sole anesthetic agent for nonpainful procedures (e.g., radiation therapy) and imaging studies. When combined with opioids, propofol provides excellent anesthesia for brief painful procedures, such as lumbar puncture and bone marrow aspiration. Although hemodynamic stability, and even spontaneous respirations, may be maintained during propofol administration, it remains a potent anesthetic that can obtund airway reflexes, respiration, and hemodynamic function. As such, some hospitals have limited its use to anesthesia professionals. Propofol may produce both respiratory depression and hypotension. Extrapyramidal symptoms are a rarer complication. Prolonged use may cause hemodynamic collapse, bradycardia, metabolic acidosis, cardiac failure, rhabdomyolysis, hyperlipidemia, profound shock, and death (**propofol infusion syndrome**). Prolonged propofol administration (>24-48 hours) in the ICU in children is not recommended. Propofol is formulated in 10% soy emulsion with egg emulsifiers and was once thought to be contraindicated in patients with soy or egg allergy. According to the American Academy of Allergy, Asthma, and Immunology, patients with soy and egg allergies may safely receive propofol for anesthesia.

### Etomidate

Etomidate is an imidazole derivative used for the induction of anesthesia, frequently in emergent situations. Its onset of action is slower than propofol. Etomidate lacks significant cardiovascular depressant effects, making it a popular induction agent in patients with hemodynamic compromise and cardiac disease. However, etomidate inhibits 11 $\beta$ -hydroxylase, thereby suppressing mineralocorticoid and glucocorticoid synthesis for up to 72 hours after a single induction dose. Etomidate is associated with increased mortality when used as a sedative in the ICU (for which it is contraindicated); the effect of a single induction dose on mortality remains controversial. Any decision to use etomidate must weigh the short-term benefits of hemodynamic stability with the serious risks of adrenal suppression.

### Ketamine

Ketamine (1-3 mg/kg IV) produces rapid induction of general anesthesia that lasts for 15-30 minutes. Ketamine is effective when given intramuscularly (IM), subcutaneously (SC), intranasally (IN), or orally (PO). However, the dose must be increased for alternative routes. Ketamine dissociates connections between the cerebral cortex and limbic system (*dissociative anesthesia*) through inhibition of *N*-methyl-D-aspartate receptors. Ketamine is also an analgesic and may be used as a sole IV agent to provide general anesthesia. It has few side effects and generally preserves blood pressure and cardiac output. However, ketamine increases myocardial oxygen demand and should be used cautiously in patients with impaired myocardial oxygen delivery or ventricular outflow tract obstruction. With low-dose (1-2 mg/kg) ketamine, airway reflexes and spontaneous ventilation may be maintained; at higher doses (3-5 mg/kg), loss of airway reflexes, apnea, and respiratory depression occur. Aspiration of gastric contents remains a risk during deep sedation with ketamine. IV ketamine is a useful general anesthetic agent for short procedures.

Ketamine has been linked to disturbing postanesthetic dreams and hallucinations after emergence from anesthesia. In adults the incidence of this effect is 30-50%; in prepubertal children it may be 5-10%. Benzodiazepines (e.g., midazolam) reduce these sequelae and may be given to children receiving ketamine. Ketamine is also a potent secretagogue, enhancing oral and bronchial secretions. An antisialagogue, such as atropine or glycopyrrolate, should also be considered before the administration of ketamine. Ketamine is a bronchodilator and is a useful agent for sedating patients with asthma in the ICU. Ketamine has been reported to increase ICP and therefore is contraindicated in patients with elevated ICP.

### Opioids

Opioids are superb analgesics for painful procedures and postprocedural pain (see Chapters 92 and 93). Opioids are respiratory depressants that suppress CO<sub>2</sub> responsiveness and can produce apnea. Importantly, in equianalgesic doses, all opioids are equally potent respiratory depressants. Other inhalational or IV anesthetics generally potentiate opioid-induced respiratory depression.

**Morphine** is a long-acting opioid analgesic with important age-dependent pharmacokinetics. Equivalent doses of morphine per kilogram are associated with higher blood levels in neonates than in older children, with plasma concentrations approximating three times those of adults. Morphine exhibits a longer elimination half-life (14 hours) in young children than in adults (2 hours). The immature blood-brain barrier of neonates is more permeable to morphine. Morphine is often associated with hypotension and bronchospasm from histamine release and should be used with caution in children with asthma. Morphine has renally excreted active metabolites and is relatively contraindicated in renal failure. Because of morphine's prolonged duration of action and cardiorespiratory side effects, the fentanyl class of synthetic opioids has increased in popularity for perioperative analgesia.

**Fentanyl** is a potent synthetic opioid with a shorter duration of action and a more stable hemodynamic profile than morphine. Fentanyl attenuates the hemodynamic response to surgery and provides stable operating conditions. Effective analgesia and anesthesia may be provided with IV fentanyl administered as a 2-3  $\mu$ g/kg bolus followed

by a 1-3  $\mu\text{g}/\text{kg}/\text{hr}$  continuous infusion. Nitrous-narcotic anesthetic techniques that incorporate fentanyl are effective for maintenance of stable hemodynamics while still providing adequate hypnosis and analgesia. Fentanyl is the most commonly used *synthetic* opioid, but other formulations of varying potency are available (alfentanil < fentanyl < sufentanil). *Sufentanil* is ten times more potent than fentanyl and is frequently used during pediatric cardiac anesthesia. *Alfentanil* is approximately 25% as potent as fentanyl. *Remifentanil* has very rapid onset and offset of action. In doses of 0.25  $\mu\text{g}/\text{kg}/\text{min}$ , surgical anesthesia can be maintained with this agent. Remifentanil is metabolized through nonspecific ester hydrolysis and has a short elimination half-life (<10 minutes), advantageous for rapid emergence from anesthesia. Unfortunately, this short duration of action has been linked to inadequate postprocedural analgesia and increased need for postprocedural opioid analgesic supplementation, limiting remifentanil's use.

### Benzodiazepines

Benzodiazepines induce hypnosis, anxiolysis, sedation, and amnesia and have anticonvulsant properties. In high doses, benzodiazepines cause respiratory depression and are synergistic with opioids and barbiturates in their respiratory depressant effects. Benzodiazepines are  $\gamma$ -aminobutyric acid (GABA) agonists.

**Midazolam** is the most commonly used benzodiazepine in pediatric anesthesia. Short acting and water soluble, it can be injected without pain. It is a potent hypnotic-anxiolytic-anticonvulsant and is approximately four times more potent than diazepam. Midazolam may be administered orally, nasally, rectally, intravenously, or intramuscularly. Midazolam (0.10-0.15 mg/kg IV) has minimal effect on respiratory rate, heart rate, or blood pressure and provides excellent preoperative anxiolysis and amnesia. Premedication with oral midazolam (0.5-1.0 mg/kg) mixed in sweet-flavored syrup induces anxiolysis in approximately 90% of children without hemodynamic or respiratory depressant effects. However, children may experience loss of coordination (head control), blurred vision, and rarely, dysphoria. A child sedated with midazolam should not be left unattended. Most children readily accept an inhalational anesthetic by face mask after oral midazolam premedication. The widespread use of preoperative oral midazolam has decreased the practice of PPI.

### Dexmedetomidine

Dexmedetomidine is a central  $\alpha_2$  adrenergic receptor agonist similar to clonidine. Dexmedetomidine lacks respiratory depressant effects and produces anxiolysis, sedation, mild analgesia, and sympatholysis. Rapid administration may produce hypertension and bradycardia, whereas continuous infusions may produce hypotension and bradycardia. Dexmedetomidine is frequently used for sedation in ICU patients and for procedures. Dexmedetomidine has become a popular adjuvant for general anesthesia during pediatric cardiac surgery.

### Barbiturates

**Sodium thiopental** is the classic barbiturate IV induction agent, although it is now rarely used. Side effects of thiopental include respiratory depression, apnea, and hypotension. Induction with 3-5 mg/kg of thiopental produces unconsciousness within seconds, lasting 5-10 minutes. Thiopental is not useful for maintenance of anesthesia, which requires other IV or inhalational anesthetics. Pentobarbital is a barbiturate traditionally administered IV for sedation in children during imaging procedures of intermediate duration (e.g., diagnostic studies) that require akinesia. **Pentobarbital** is a potent respiratory depressant, particularly when combined with opioids and benzodiazepines. Pentobarbital has a prolonged duration of action. Pentobarbital sedation for nonpainful procedures generally results in delayed emergence. **Sodium methohexital** (Brevital) is another IV induction agent, similar to sodium thiopental in respiratory depressant effects. Barbiturates lack analgesic properties, and painful procedures require supplemental analgesia.

### Neuromuscular Blocking Agents

Neuromuscular blockade is performed to facilitate endotracheal intubation and akinesia during surgery. NMBAs may be *depolarizing* (e.g., succinylcholine) or *nondepolarizing* (e.g., vecuronium, rocuronium,

cisatracurium). **Succinylcholine** has a high-risk profile in children. Its use is associated with postoperative pain from muscle spasms; hyperkalemia; elevated intracranial, intraocular, and intragastric pressures; malignant hyperthermia; myoglobinuria; and renal damage. Consequently, succinylcholine is rarely used, except to provide rapid relief of laryngospasm. Endotracheal intubation is most often facilitated with nondepolarizing NMBAs. **Rocuronium** is most commonly used for intubation because of its rapid onset of action. For procedures that last >40 minutes, **vecuronium** and **cisatracurium** are also suitable to induce muscle relaxation for intubation. After intubation, repeat administration of NMBAs may be indicated to maintain muscle relaxation to facilitate surgery. Prolonged use of nondepolarizing NMBAs in critical illness may contribute to myopathy, especially when combined with high-dose corticosteroids.

### INDUCTION OF GENERAL ANESTHESIA

The goal of induction of general anesthesia is the safe transition to a state of unconsciousness. Induction in children is typically achieved with inhalational anesthetics, although IV agents are indicated when patients have IV access. Many children will not tolerate the establishment of vascular access before induction of anesthesia, and it is routine to induce anesthesia by face mask with inhaled anesthetics. Before the induction of anesthesia, monitors applied may include pulse oximetry, ECG, and noninvasive blood pressure cuff. The child is then cautiously introduced to the face mask, which contains a high gas flow (5-7 L/min  $\text{O}_2$ ), frequently mixed with  $\text{N}_2\text{O}$ . Inhalation of  $\text{N}_2\text{O}$  and  $\text{O}_2$  for 60-90 seconds induces a state of euphoria. Nitrous oxide blunts the airway responses to potent volatile inhalational agents, and sevoflurane may then be safely introduced into the inhaled gas mixture. This leads to unconsciousness within 30-60 seconds while the child continues to breathe spontaneously.

After induction, IV access is obtained and standard intraoperative monitoring initiated. Thereafter, definitive airway management is performed. Airway management for short procedures (i.e., myringotomy tubes) frequently includes a mask airway and spontaneous ventilation; this is safe when the airway is secure and patent and aspiration risk is low. Longer procedures (>30-60 minutes) are not usually performed with mask airways. Definitive artificial airways include laryngeal mask airways and endotracheal tubes (ETTs). The **laryngeal mask** is a supraglottic airway generally reserved for procedures in spontaneously ventilating patients and does not effectively prevent the aspiration of gastric contents.

For complex surgical procedures, **endotracheal intubation** is generally required (e.g., intraabdominal, intrathoracic, airway procedures). Although endotracheal intubation may be performed under deep inhalational anesthesia, the depth of anesthesia required to attenuate airway reflexes may produce hemodynamic instability. Therefore NMBAs are frequently administered to facilitate intubation. The depolarizing NMBA succinylcholine is rarely used, and nondepolarizing NMBAs such as rocuronium and vecuronium are most frequently used (see earlier). After muscle relaxation, direct laryngoscopy and endotracheal intubation can be performed. Correct ETT placement is confirmed by direct laryngoscopy, end-tidal  $\text{CO}_2$  measurement, and assessment of bilaterally equal breath sounds. Additional confirmatory tests include chest radiograph and fiberoptic bronchoscopy. After endotracheal intubation, controlled mechanical ventilation is required in the setting of neuromuscular blockade (see Chapter 86).

Children with full stomach precautions may require **rapid sequence induction**. Before performing a rapid sequence induction, preoxygenation with 100% oxygen for 2-5 minutes increases alveolar oxygen content and delays hypoxemia if intubation is difficult. Rapid sequence induction involves concurrent administration of hypnotic agents and NMBAs. Assisted ventilation before or after drug administration is avoided because of the risk of gastric distention, regurgitation, and aspiration. Traditionally, after administering a sedative and NMBA, the Sellick maneuver (cricoid pressure) was performed by applying firm pressure in a posterior direction against the cricoid cartilage. This displaces the cricoid cartilage into the esophagus and was thought to form an artificial sphincter to prevent reflux of the gastroesophageal contents. However, evidence suggests that cricoid pressure may be counterproductive, as it does not appear to prevent pulmonary aspiration



and may increase time to intubation. Because of this controversy, the clinician must consider the risks and benefits of cricoid pressure in each case.

The major risk of rapid sequence induction is intubation failure. In this situation the child is paralyzed without a protected airway, and ventilation may be hazardous or impossible. Only experienced airway specialists should undertake rapid sequence induction. It should be avoided in patients with a history of failed endotracheal intubation or features (micrognathia) associated with difficult intubation. Under these circumstances, bronchoscopic awake intubation may be indicated.

### Complications During Induction

During induction of anesthesia, the transition between full wakefulness to unconsciousness is fraught with potential complications, including laryngospasm, bronchospasm, vomiting, and aspiration. Concerns for vomiting and aspiration dictate adherence to preanesthetic fasting guidelines and may be an indication for rapid sequence anesthetic induction.

During induction of anesthesia, especially with inhalational anesthetics, a period of excitement may occur. This period is associated with heightened airway reflexes, which can lead to coughing, gagging, laryngospasm, and bronchospasm. **Laryngospasm** is the reflex closure of the larynx, which prevents spontaneous or assisted ventilation. The child may make violent inspiratory efforts against a closed glottis, generating significantly negative intrathoracic pressure and resulting in postobstructive pulmonary edema. Laryngospasm can be prolonged, and hypoxia may ensue. Laryngospasm occurs in up to 2% of all anesthetic inductions in children <9 years old and is much less common in older patients. Laryngospasm occurs twice as frequently in children with active or recent upper respiratory tract infection. A history of tobacco exposure increases the likelihood of laryngospasm significantly.

Laryngospasm can be relieved by increasing the depth of anesthesia, either intravenously or through inhalation (although with the glottis closed, further administration of inhalational anesthesia is not possible). Neuromuscular blockade relieves laryngospasm, and an acute situation may be an indication for succinylcholine administration. Continuous positive airway pressure administration may be beneficial in alleviating laryngospasm. Laryngospasm may also occur during emergence from anesthesia because airway tone is increased during the transition to wakefulness.

**Bronchospasm** may result from increased airway reactivity during the hyperexcitable stage of induction or secondary to histamine release induced by anesthetic agents. Endotracheal intubation may provoke bronchospasm, especially in patients with asthma, which may be associated with life-threatening hypoxemia and inability to ventilate. Alternative airway management strategies such as laryngeal mask should be considered when appropriate in children with severe reactive airway disease. The use of histamine-releasing anesthetic agents has been associated with severe bronchospasm and, in rare instances, cardiopulmonary failure. Environmental tobacco smoke is another risk factor.

Hypoxemia during induction may be secondary to reduced functional residual capacity, atelectasis, and ventilation-perfusion ( $\dot{V}/\dot{Q}$ ) mismatch. Volatile anesthetics blunt hypoxic pulmonary vasoconstriction, further contributing to  $\dot{V}/\dot{Q}$  abnormalities. **Hypersecretion** may result in airway obstruction and should be managed with antisialagogues, such as glycopyrrolate and atropine. The newer inhalation agents are less potent secretagogues, and the routine use of atropine premedication is much less common but often indicated when ketamine is used.

Hemodynamic complications may also develop during induction of anesthesia. **Hypotension** is common and may be exaggerated in the setting of hypervolemia, decreased myocardial function, or congenital heart disease. Inhalational anesthetics sensitize the myocardium to circulating catecholamines, and induction and excitement are associated with a hypercatecholaminergic state.

### MAINTENANCE OF ANESTHESIA

Maintenance of anesthesia is the period between induction and emergence. The child should be unaware of pain, unresponsive to painful stimuli, and physiologically supported. Anesthesia is typically

maintained with a volatile anesthetic (e.g., isoflurane, sevoflurane) supplemented with opioid-based analgesia. IV hypnotic agents (e.g., dexmedetomidine, benzodiazepines) may be administered to augment hypnosis and amnesia. Choice of ventilatory strategy (spontaneous, assisted, or controlled) varies according to procedure type and patient condition (see Chapter 86). Surgical trauma may result in hypothermia and hypovolemia caused by blood loss and significant fluid shifts (third spacing). Management of these physiologic disturbances is the responsibility of the anesthesiologist during maintenance.

### Temperature Management

**Thermoregulation** is critical during anesthesia. The absence of movement and inhibition of shivering reduce thermogenesis. Although temperature sensing may remain normal, the autonomic response to hypothermia is reduced. Anesthetic agents cause vasoparesis, which further impairs thermoregulation and increases heat loss. In newborns, inhalational anesthetics inhibit nonshivering thermogenesis from brown fat, increasing the risk for hypothermia. Mechanisms of heat loss during anesthesia include radiation, convection, evaporation, and conduction. Radiant and convective heat loss are most common and may be minimized by preheating the operating room and by use of radiant heat lamps and forced-air warming blankets. Humidification and warming of inspired gases may also be useful.

### Fluid Management

Most anesthetics produce vasodilation and increase venous capacitance, effectively reducing myocardial preload. Surgical bleeding and insensible/third space fluid losses further contribute to intravascular volume depletion. Volume expansion with isotonic salt-containing solutions (normal saline, lactated Ringer, Plasma-Lyte) may be required to maintain cardiac output and organ perfusion. Increased renin-angiotensin-aldosterone axis activation and antidiuretic hormone (ADH) secretion further complicate fluid regulation.

Intraoperative fluid management must account for (1) deficits acquired during preoperative fasting, (2) maintenance fluid requirements, (3) surgical blood loss, and (4) insensible fluid loss. Infants should receive glucose-containing isotonic fluid to prevent perioperative hypoglycemia. Table 91.9 is a guideline for determining fluid deficits and maintenance requirements in the OR. For longer procedures, fluid deficits should be replaced with isotonic fluid over the first 3 hours of intraoperative management. Deficits are generally calculated as the number of hours of fasting status multiplied by the hourly maintenance rate for the child. Half the deficit is replaced during the first hour and half during the subsequent 2 hours. If hypotension or tachycardia persists in the early stages of anesthesia, more rapid replacement of the fluid deficit may be indicated.

Third space interstitial fluid losses should be replaced with isotonic salt solutions. For smaller operations, such as herniorrhaphy, pyloromyotomy, and minor procedures, fluid replacement at 3-5 mL/kg/hr is indicated for insensible losses. Complex abdominal or thoracic procedures with large insensible losses may require an additional 8-10 mL/kg/hr of IV fluid replacement. Crystalloid solution is indicated for blood loss as a 3:1 ratio. Allogenic blood products should be replaced as a 1:1 ratio. Colloid (albumin) administration also may decrease the amount of crystalloid replacement needed for blood loss. During large-volume transfusions, active fluid warming should be performed to prevent hypothermia. With major surgery and resultant SIRS, capillary

**Table 91.9** Intraoperative Pediatric Fluid Replacement

INFUSION RATE	PATIENT WEIGHT
4 mL/kg/hr	1-10 kg
2 mL/kg/hr	10-20 kg
1 mL/kg/hr	per kg >20 kg
<i>Example: 22 kg child requires (4 × 10) + (2 × 10) + (1 × 2) = 62 mL/hr</i>	

integrity is lost, and third space losses are common. Failure to replace fluid loss and restore intravascular volume may lead to shock.

Perioperative **hypoglycemia** may result from preoperative fasting, most often in neonates or in children with metabolic disorders. In neonates, perioperative glucose monitoring is indicated, and glucose replacement is frequently required. In older children with normal nutritional status, isotonic salt solutions without glucose are adequate. In patients receiving total parenteral alimentation containing high glucose concentrations (>10%), continuous glucose administration should be ensured to avoid rebound hypoglycemia.

Postprocedural care includes supervision of emergence and recovery from anesthesia and surgery. **Emergence** describes the transition period between the anesthetized state and consciousness. During emergence, patients experience decreased anesthetic effect and increased physiologic and psychologic responses to painful stimuli (e.g., reactive autonomic tone, excitement, anxiety). Inhalational anesthetic agents are rapidly excreted during ventilation, and muscle relaxants can be reversed; however, the effects of opioids, benzodiazepines, and IV hypnotics may be prolonged. Normal physiologic functions such as spontaneous ventilation resume, and hemodynamic function improves. Before leaving the OR after routine elective procedures, the child should be conscious with intact airway reflexes and a patent airway. The effects of muscle relaxants should be reversed. Ideally, emergence should be as brief as possible, with maintenance of analgesia and anxiolysis and restoration of cardiorespiratory function. However, critically ill patients scheduled for ICU admission may require postoperative endotracheal intubation and mechanical ventilation. In these patients, deeper levels of sedation and analgesia should be maintained after the procedure.

During emergence, it is essential to assess whether **residual neuromuscular blockade** (NMB) exists. If weakness or respiratory depression is observed in the postoperative phase, prolonged NMB should be considered. *Reversal of residual NMB is standard anesthetic practice.* With the virtual abandonment of succinylcholine, only nondepolarizing NMBAs are routinely used for intubation. The termination of NMB depends on metabolism and elution away from the neuromuscular junction. Classically, nondepolarizing muscle relaxants are reversed by increasing the acetylcholine concentration at the neuromuscular junction with acetylcholine esterase inhibitors (neostigmine, edrophonium), which work through competitive antagonism. Vagolytic agents (e.g., atropine, glycopyrrolate) must be co-administered to prevent bradycardia. This process, even for the shortest-acting muscle relaxant, rocuronium, can take several minutes. An intubating dose of rocuronium to rapidly induce paralysis in emergency situations may not spontaneously reverse for 20 minutes or longer (compared with about 3 minutes for succinylcholine). The effects of long-acting, nondepolarizing NMBAs (vecuronium, pancuronium) are invariably reversed. Acetylcholine esterase inhibitor efficacy is dependent on the degree of NMB at the time of administration, and residual NMB is common despite reversal with these agents. **Sugammadex** is an alternative reversal agent that has a very low rate of residual NMB induced by the aminosteroids rocuronium and vecuronium. Its mechanism of action involves noncompetitive antagonism through encapsulation of neuromuscular agents.

### POSTANESTHESIA CARE UNIT

In the postanesthesia care unit (PACU), the child is observed until there is adequate recovery from anesthesia. Achievement of spontaneous breathing, adequate pulse oximetry saturation (>95%), and hemodynamic stability are key recovery end-points. The child should be arousable, responsive, and oriented before discharge from the PACU. The amount of time spent in the PACU varies based on disposition (transfer to acute care or ICU, transfer to day surgery postrecovery unit, or discharge to home). Parents should be permitted to comfort their children in the PACU. Discharge from the PACU depends on the child's overall functional status, which includes physiologic end-points, adequate analgesia, and control of PONV. Various scoring systems have been used for determining readiness for discharge from the PACU (Table 91.10).

### Postanesthetic Complications

**Respiratory insufficiency** after general anesthesia is common. Prolonged emergence from anesthesia and respiratory depression may be caused by the residual effects of opioids, hypnotic agents, or NMBAs. Pain may also cause significant hypoventilation, especially after thoracic or abdominal surgery. Delayed emergence from anesthesia may result from retention of inhaled anesthetics worsened by hypoventilation. Hypothermia, especially in neonates, delays metabolism and excretion of anesthetics and prolongs neuromuscular blockade. Hypoventilation after surgery is associated with the development of **atelectasis**. Microatelectasis may lead to postoperative infections. When airway obstruction is present, maintenance of airway patency may necessitate oropharyngeal or nasopharyngeal airway placement. In the setting of profound respiratory depression, endotracheal intubation and mechanical ventilation may be indicated.

Opioid reversal with naloxone may be indicated in rare instances when excessive **opioid effect** is suspected. However, naloxone reverses both the respiratory depressant and the analgesic properties. After naloxone administration, a somnolent child with respiratory depression may experience increased pain. Opioid reversal requires bedside attention by the physician to monitor the child's behavioral, hemodynamic, and respiratory status. Importantly, naloxone is shorter acting than most opioid analgesics, which may result in renarcotization.

**Postoperative stridor** occurs in up to 2% of all pediatric patients. The use of appropriately sized ETs and assurance of an air leak <30 cm H<sub>2</sub>O

**Table 91.10** Postanesthesia Recovery Scores

ALDRETE RECOVERY SCORE	≥9 REQUIRED FOR DISCHARGE
<b>ACTIVITY—VOLUNTARILY OR ON COMMAND</b>	
Moves four extremities	2
Moves two extremities	1
No motion	0
<b>BREATHING</b>	
Deep breath, cough, cry	2
Dyspnea or shallow breathing	1
Apnea	0
<b>BLOOD PRESSURE</b>	
Within 20% of preanesthetic value	2
Within 20–50% of preanesthetic value	1
>50% outside preanesthetic value	0
<b>COLOR</b>	
Pink	2
Pale, blotchy, dusky	1
Cyanotic	0
<b>CONSCIOUSNESS</b>	
Fully aware, responds	2
Arouses to stimulus	1
Unresponsive	0
STEWART RECOVERY SCORE	6 REQUIRED FOR DISCHARGE
<b>ACTIVITY</b>	
Moves limbs purposefully	2
Nonpurposeful movement	1
Still	0
<b>CONSCIOUSNESS</b>	
Awake	2
Responsive	1
Unresponsive	0
<b>AIRWAY</b>	
Coughing on command or crying	2
Maintaining patent airway	1
Requires airway maintenance	0

pressure decreases the risk of airway trauma or edema. A history of stridor increases the likelihood of postoperative complications. Stridor may be severe enough after extubation to require reintubation. Racemic epinephrine aerosols and dexamethasone are commonly employed therapies; their use requires prolonged observation because of the potential for rebound stridor. Stridor in infants may be an indication for overnight observation.

**Cardiovascular complications** are less frequently encountered in the PACU. Fluid administration may be required to augment cardiac output, perfusion, and urine output. Large-volume fluid resuscitation (>30 mL/kg) in the postoperative period may be an indication of evolving shock physiology, and sources of hypovolemia (e.g., occult bleeding) or myocardial dysfunction (e.g., tamponade, pneumothorax) should be considered.

**Emergence delirium** immediately after anesthesia is noted in 5–10% of children and is more common in those 3–9 years old. Manifestations include restlessness, combativeness, disorientation, and inconsolability. Almost all anesthetic agents have been linked to the development of delirium, especially newer volatile anesthetic agents (e.g., sevoflurane, desflurane). Potential postoperative complications, such as hypoglycemia and hypoxemia, should also be ruled out. Occasionally, it is necessary to provide additional sedation (e.g., propofol, dexmedetomidine, benzodiazepines), although these agents prolong postanesthesia recovery time and may not effectively reduce delirium.

### Awareness During Anesthesia

A fundamental aim of anesthesia is to prevent recall by inducing hypnosis and amnesia. In adults, certain anesthetic techniques and surgical procedures have been associated with increased incidence of recall. The long-term sequelae of recall in children are unknown. Continuous cerebral bispectral index (BIS) electroencephalographic monitoring has been used to assess consciousness and aid in the prevention of intraoperative awareness. Unfortunately, pediatric studies have not confirmed the usefulness of BIS monitoring as a means of determining anesthetic depth. Existing data do not support the routine use of BIS monitoring during pediatric anesthesia. Volatile anesthetic agents reliably produce dose-dependent hypnotic and amnestic effects and remain a mainstay of general anesthesia.

### Postoperative Nausea and Vomiting

After general anesthesia, 40–50% of children may experience PONV that generally lasts for several hours. This complication prolongs recovery room times and requires significant nursing attention. The etiology is not completely understood but is likely multifactorial and related to the emetic effects of anesthetics, pain, and surgical stress. Opioid analgesics may also provoke nausea and vomiting. Other risk factors for PONV include surgery lasting greater than 30 minutes, age  $\geq$  3 years, strabismus surgery, and a history of PONV in the patient or their relatives. Importantly, preoperative fasting does not decrease the incidence of PONV. Indeed, hydration and glucose supplementation appear to be important factors in decreasing PONV. Multimodal analgesia with nonopioid agents (e.g., acetaminophen, ibuprofen, ketorolac) and regional or local anesthesia may be associated with reduced PONV. The serotonin antagonist ondansetron is an effective treatment of PONV. Ondansetron prophylaxis is recommended for patients at increased risk of PONV. Serotonin antagonists are contraindicated in children taking serotonin reuptake inhibitors for migraine headaches. Dexamethasone may also be used for the treatment of PONV.

### Thermoregulation and Malignant Hyperthermia

After anesthesia, thermoregulation remains abnormal for several hours. **Hypothermia**, especially in neonates, may be associated with cardiorespiratory depression and prolongation of the effect of opioids and NMBAs. Although hypothermia has deleterious effects, active rewarming should be performed cautiously to avoid hyperthermia and cutaneous burns. Postoperative shivering is common and may occur in the absence of hypothermia. **Hyperthermia**, with temperatures in excess of 39°C (102.2°F), is of concern in the postoperative period. When high fevers occur within hours of the use of an inhalational anesthetic, especially if succinylcholine was used, malignant hyperthermia (MH) must be ruled out.

**Malignant hyperthermia** is a hypermetabolic syndrome triggered by volatile anesthetic agents and succinylcholine. The onset of MH may be acute, fulminant, and lethal without appropriate interventions. The disease is genetically heterogeneous, with >10 genes contributing to susceptibility, but typically displays an autosomal dominant inheritance pattern. A family history of death or febrile reactions during anesthesia should alert the anesthesiologist to its potential. Pathogenic variants within the gene encoding for the ryanodine receptor (the calcium channel of the sarcoplasmic reticulum) predispose to MH susceptibility and have been identified in 20–40% of humans with MH. Certain **myopathies** are associated with the risk of MH, including Duchenne muscular dystrophy, central core disease, and King Denborough syndrome.

The pathophysiology of MH involves uncontrolled intracellular calcium release from skeletal muscle sarcolemma, resulting in prolonged muscle contraction, adenosine triphosphate (ATP) depletion, and muscle cell death. Rhabdomyolysis results in the release of myoglobin, creatine phosphokinase (CPK), and potassium into the blood. The clinical course of MH is characterized by rapid onset of high fever (>38.5°C [101.3°F]), muscle rigidity, acidosis (metabolic and respiratory), high end-tidal CO<sub>2</sub>, and multiorgan dysfunction. Death may ensue secondary to hemodynamic collapse from shock and cardiac dysrhythmias. Signs of MH generally occur within the first 2 hours of anesthesia but (rarely) can occur up to 24 hours later.

When MH is suspected, treatment involves discontinuation of all inhalational anesthetics, correction of the metabolic acidosis, and administration of the muscle relaxant dantrolene. The initial dose of dantrolene is 2.5 mg/kg, and repeat doses, up to a maximum of 10 mg/kg, are indicated for persistent fever, muscle rigidity, acidosis, and tachycardia. Once symptoms are controlled, the patient should be observed for at least 24 hours, because recrudescence may occur. The MH mortality rate was once >70% and is now <5% with standardized treatment algorithms. An MH cart with sufficient supplies of dantrolene should be present at every site where pediatric anesthesia is provided.

Certain phenomena suggest an increased risk of MH. Masseter spasm during induction, with rigid clenching of the masseter muscles and an inability to open the mouth, may signal MH susceptibility. Acute myoglobinuria associated with an MH-triggering agent is another clue. The child may not be hypermetabolic or febrile but may have dark urine, high CPK levels, and risk of myoglobin-induced renal tubular damage. The finding of dark urine after administration of an anesthetic requires further investigation, including measurement of electrolytes and CPK. Prevention of MH in susceptible patients requires the avoidance of triggering agents, which include inhalational anesthetics and succinylcholine. IV anesthesia and nitrous-opioid techniques are safe. MH-safe anesthesia machines devoid of trace concentrations of volatile anesthetic vapors should be used. Dantrolene prophylaxis is not recommended because MH is rapidly treatable, and the drug causes respiratory depression and muscle weakness. For a child in whom MH is suspected, the MH hotline, 1-800-MHHYPER (1-800-644-9737), should be used to notify the Malignant Hyperthermia Association of the United States (MHAUS). MHAUS registers susceptible patients and provides diagnostic and therapeutic information. Preanesthesia susceptibility testing includes genetic analysis of the ryanodine receptor gene, muscle biopsies, in vitro contraction studies, and possibly measurement of muscle CO<sub>2</sub> production in response to intramuscular caffeine.

### Mediastinal Masses

Children with anterior mediastinal masses such as lymphomas, teratomas, and other primary mediastinal tumors are at serious risk for cardiorespiratory failure during anesthesia secondary to airway compromise, difficult ventilation, cardiac tamponade, vascular obstruction, and circulatory collapse. These patients generally require surgical tissue diagnosis before treatment is initiated. Significant compression of vital structures can occur with seemingly mild symptoms. Tachypnea, orthopnea, wheezing, and avoidance of prone or supine positions are significant indications of serious risk. Echocardiographic or CT evidence of pericardial tamponade, right ventricular compression, or compression of the pulmonary artery suggests severe risk. Biopsy with light sedation under local anesthesia may be indicated. When anesthesia is required, preservation of spontaneous ventilation is critical during



induction of anesthesia. Rigid bronchoscopy may be used to assist with ventilation in the setting of external airway compression. Provisions to provide mechanical circulatory support (cardiopulmonary bypass) should also be available. In high-risk children, consideration should be given to initiating treatment with corticosteroids, radiation therapy, and chemotherapy before obtaining a tissue diagnosis.

### Postoperative Apnea

Neonates and infants are at increased risk for the development of postoperative apnea after exposure to potent hypnotic and analgesic medications. Both central and obstructive apnea may occur. Postanesthetic apnea is most common within the first 12 hours, although apnea has been reported in premature infants up to 48 hours later. Risk factors for postoperative apnea include history of apnea, caffeine treatment, chronic hypoventilation, and anemia. The risk of apnea is inversely proportional to postconceptual age (PCA) at surgery and is highest in premature neonates less than 36 weeks estimated gestational age. This risk is minimal by the time premature infants have reached 60 weeks PCA. When surgery is required in early infancy, overnight observation and monitoring may be indicated. In term infants >44 weeks PCA without risk factors, management should include observation and monitoring for 6 hours with at least one sleep-wake-feed cycle without hypoxia, bradycardia, or supplemental oxygen. Premature infants with risk factors <52 weeks PCA require admission for observation for 12 hours after anesthesia.

## POSTOPERATIVE PAIN MANAGEMENT

Postprocedural pain management should ensure adequate analgesia and anxiolysis (see [Chapter 93](#)). Preoperative education focusing on pain management through development of skills designed to decrease anticipatory anxiety and participation in treatment planning can be helpful for children and families. Pediatric pain management relies on multimodal therapy, including opioid and nonopioid analgesics. Nonsteroidal antiinflammatory drugs, cyclooxygenase-2 inhibitors, acetaminophen, opioids, and regional analgesia all have roles in postoperative pain management. Repeated evaluation is critical to effective pain management. Adjunctive therapy, such as pet therapy, may also decrease the need for potent analgesics postoperatively.

**Patient-controlled analgesia (PCA) and parent/nurse-controlled analgesia (PNCA)** are widely accepted postoperative pain regimens. PCA/PNCA may be used to administer a low-dose continuous (basal) infusion of opioid with intermittent (bolus) supplements as needed. The practitioner must determine the basal rate, bolus dose, lockout interval, and acceptable number of bolus doses per hour. PCA/PNCA safety requires appropriate medication dosing and assumes that patients are unlikely to overdose because somnolence will limit repeated self-administration. In young children, proper PCA/PNCA use may be more difficult to ensure, although children as young as 5 years have been able to use PNCA successfully. In older children and adolescents, PCA is a standard modality of postoperative pain management.

### Regional Anesthesia

Regional anesthesia is the use of anesthetics to block the conduction of afferent neural impulses to the central nervous system. Forms of regional anesthesia include local anesthesia, peripheral nerve blocks, nerve plexus blocks, and neuraxial (epidural and subarachnoid/spinal) blocks. Anesthetics may be administered as a single injection or as a continuous infusion. Regional anesthesia may be used for both intraoperative and postoperative analgesia and has been linked to shortened recovery times and hospital stays in children. A major benefit of regional anesthesia is lesser central cardiorespiratory depressant effects. Injection of local anesthetics (e.g., lidocaine, bupivacaine) into the affected area may provide procedural analgesia lasting for hours to days. Wound infiltration with local anesthetics at the conclusion of surgery may also decrease early postoperative pain.

**Neuraxial (epidural, spinal) analgesia** is common in pediatric practice. The epidural space lies between the dura and the pia and arachnoid membranes, an area through which all nerve roots pass. Caudal epidural analgesia is placed through the sacral hiatus, inferior to the distal end of the spinal cord. This site is often used for pelvic and lower-limb anesthesia during urologic and orthopedic surgery in infants and toddlers. A single dose of caudal epidural anesthesia may provide hours of pain relief, and

a continuous infusion may provide effective pain relief for hours to days. The epidural injection of opioids can provide analgesia for 12-24 hours and is a potential supplement to postoperative analgesia. Longer-acting local anesthetics (e.g., bupivacaine, ropivacaine) combined with an opioid (e.g., fentanyl, preservative-free morphine) are typically used in single-injection and continuous epidural therapy. It is also possible to provide epidural PCA with a continuous infusion pump and the patient's ability to self-administer analgesia as needed. Epidural analgesia can also provide pain relief in patients with chronic pain or pain caused by advanced malignant conditions.

Complications of neuraxial anesthesia include cephalad spread of blockade with respiratory depression, paralysis of respiratory muscles, and brainstem depression. Common complications of neuraxial analgesia are paresthesias and, if opioids are used, pruritus, nausea, and vomiting. Neuraxial opioid use necessitates antipruritic and antiemetic therapy. Infection and epidural hematoma are extremely rare. Neuraxial opioids, especially when administered intrathecally, may cause respiratory depression and require postoperative monitoring.

Visit Elsevier eBooks+ at [eBooks.Health.Elsevier.com](http://eBooks.Health.Elsevier.com) for Bibliography.

## 91.1 Anesthetic Neurotoxicity

John P. Scott

Laboratory animal studies have suggested a link between anesthetic exposure at an early age and neurotoxicity in developing brains. Existing nonclinical data implicate *N*-methyl-D-aspartate and  $\gamma$ -aminobutyric acid (GABA) pathways in apoptosis and neuronal cell death. Histopathologic changes and adverse neurodevelopmental outcomes have been associated with exposure to both inhalational and IV anesthetics, including isoflurane, sevoflurane, ketamine, benzodiazepines, and propofol. Animal studies were initially performed in nonprimates (rodents), and controversy remains concerning experimental design (dose, duration of treatment, species differences). However, work in nonhuman primates has also shown an increased incidence of adverse neurodevelopmental outcomes after prolonged and/or multiple exposures to volatile anesthetics.

Human studies of anesthesia-induced neurotoxicity have yielded conflicting results. Further complicating the situation are other potential triggers for adverse neurodevelopmental outcomes, including comorbidities, surgical trauma, and perioperative cardiorespiratory status. Multiple population-based epidemiologic studies have suggested a potential association between anesthetic exposure and adverse neurodevelopmental outcomes after multiple or prolonged anesthetic exposures. Large-scale European and Canadian cohort studies using national registries have revealed subtle differences in standardized psychometric testing of early school-age children after exposure to general anesthesia. Interestingly, other studies in children have failed to yield similar results. The Pediatric Anesthesia and Neurodevelopmental Assessment (PANDA), a multicenter matched-sibling control study, revealed no association between brief anesthetic exposure for inguinal hernia repair and aptitude on psychometric testing. Similarly, the General Anaesthesia and Awake-Regional Anaesthesia in Infancy (GAS) study, a prospective multicenter randomized controlled trial comparing general and neuraxial spinal anesthesia in infants for hernia repair, *did not* demonstrate any significant differences in neurodevelopment at 2 years of age between groups. A follow-up study at 5 years of age similarly showed no difference in neurodevelopment between groups receiving general and spinal anesthesia. Importantly, studies have not shown an association between adverse neurodevelopmental outcomes and anesthetic exposure <3 hours.

Alternatives to general anesthesia for many procedures in young children do not exist. Regional anesthetic techniques and narcotic-based anesthetics may gain popularity. Dexmedetomidine may also have some neuroprotective properties. Currently, there are insufficient data to make conclusions regarding the safety of one anesthetic approach over another. Ultimately, the potential for neurotoxicity must be balanced against the necessity of providing adequate anesthesia for children presenting for surgery.

Visit Elsevier eBooks+ at [eBooks.Health.Elsevier.com](http://eBooks.Health.Elsevier.com) for Bibliography.



## Chapter 92

## Procedural Sedation

John P. Scott

See also Chapters 91 and 93.

**Sedation** describes the continuum between wakefulness and general anesthesia (see [Table 91.7](#)). Many of the same medications used to induce general anesthesia may be used to provide sedation (see [Table 91.8](#)). Analogous to the provision of anesthesia, performance of procedural sedation requires a comprehensive presedation evaluation, intraprocedural monitoring, and postsedation recovery care. The term **conscious sedation** refers to a condition in which a patient is sleepy, comfortable, and cooperative but maintains airway-protective and ventilatory reflexes. Depending on the choice of pharmacotherapy, sedation may not provide analgesia. Sedation that is sufficient to obtund painful responses describes deep sedation. **Deep sedation** is a state of unarousability to voice and may be accompanied by suppression of reflex responses, with preservation of ability to respond purposefully to repeated or painful stimulation.

Pediatric procedural sedation requires vigilance and knowledge to ensure safety and is governed by the same guidelines as anesthesia care ([Table 92.1](#)). Adherence to guidelines for appropriate monitoring and management of sedation in children is imperative. Sedative doses that cause minimal sedation in one patient may produce complete unconsciousness and apnea in another. Anxiolysis or light sedation with chloral hydrate, benzodiazepines, and dexmedetomidine is often sufficient for nonpainful procedures. The use of dexmedetomidine for procedural sedation is safe, but recovery time can be prolonged and success variable. For painful procedures (e.g., bone marrow aspiration), the combination of hypnosis and analgesia is required. The addition of opioids to sedation regimens increases the risk of respiratory insufficiency. Short-acting anesthetics (e.g., propofol, methohexital, remifentanyl) provide effective procedural sedation, but their use carries a higher likelihood of inadvertent induction of general anesthesia. Use of

these medications requires the presence of an anesthesiologist and/or specially trained, experienced, credentialed, and qualified physicians.

Many pediatric subspecialists provide sedation and anesthesia care for children. The use of anesthetic agents is not limited to anesthesiologists, but anesthesiology departments are obligated to help develop, manage, and oversee sedation services. Together, hospitals and providers, including anesthesiologists, share responsibility for the oversight and credentialing of individuals administering sedation and anesthesia.

The elements of a safe pediatric procedural sedation system include the following:

- Clearly defined knowledge and skill sets
- Adequate prerequisite training
- Credentialing of providers
- Maintenance of certification
- Ensuring that sedation sites meet recognized standards
- Continuous quality improvement

[Table 92.2](#) provides an approach to proper language to help the child cope with procedural pain.

Visit Elsevier eBooks+ at [eBooks.Health.Elsevier.com](http://eBooks.Health.Elsevier.com) for Bibliography.

**Table 92.1** Systematic Approach to Sedation in Children

Comprehensive medical history and organ system assessment, anticipating underlying medical problems that predispose the patient to anesthetic complications
Careful physical examination focused on the cardiorespiratory system and airway
Appropriate fasting
Informed consent
Pediatric drug dosing (mg/kg)
Appropriately sized equipment
Documentation of vital signs and condition on a time-based record
Rapid response ("code") team to respond to emergencies with "crash cart"
Fully equipped and staffed recovery area
Discharge criteria documenting recovery from sedation

**Table 92.2** Suggested Language for Parents and Healthcare Providers

LANGUAGE TO AVOID	LANGUAGE TO USE
You will be fine; there is nothing to worry about. (reassurance)	What did you do in school today? (distraction)
This is going to hurt/this will not hurt. (vague; negative focus)	It might feel like a pinch. (sensory information)
The nurse is going to take some blood. (vague information)	First, the nurse will clean your arm, you will feel the cold alcohol pad, and next . . . (sensory and procedural information)
You are acting like a baby. (criticism)	Let's get your mind off of it; tell me about that film . . . (distraction)
It will feel like a bee sting. (negative focus)	Tell me how it feels. (information)
The procedure will last as long as . . . (negative focus)	The procedure will be shorter than . . . (television program or other familiar time for child) (procedural information; positive focus)
The medicine will burn. (negative focus)	Some children say they feel a warm feeling. (sensory information; positive focus)
Tell me when you are ready. (too much control)	When I count to 3, blow the feeling away from your body. (coaching to cope; distraction-limited control)
I am sorry. (apologizing)	You are being very brave. (praise; encouragement)
Do not cry. (negative focus)	That was hard; I am proud of you. (praise)
It is over. (negative focus)	You did a great job doing the deep breathing, holding still . . . (labeled praise)

Adapted from Krauss BS, Calligaris L, Green SM, Barbi E. Current concepts in management of pain in children in the emergency department. *Lancet*. 2016;387:83-92.

## Chapter 93

# Pediatric Pain Management

Stacy J.B. Peterson and Steven J. Weisman

Pain is both a sensory and an emotional experience. Infants, children, and adolescents experience a wide range of acute and chronic pain etiologies. When unrecognized and undertreated, pain extracts a significant physiologic, biochemical, and psychologic toll on both the child and the family. Many disease processes and most interventional diagnostic or treatment procedures in pediatrics are associated with pain. Similarly, traumatic, developmental, cognitive, psychologic, and social experiences can also trigger and maintain chronic pain.

## DEFINITION AND CATEGORIES OF PAIN

The International Association for the Study of Pain (IASP) defines **pain** as “an unpleasant sensory and emotional experience associated with, or resembling that associated with, actual or potential tissue damage.” Furthermore, the IASP expanded the definition to include the following six key notes:

1. Pain is always a personal experience that is influenced to varying degrees by biologic, psychologic, and social factors.
2. Pain and nociception are different phenomena. Pain cannot be inferred solely from activity in sensory neurons.
3. Through their life experiences, individuals learn the concept of pain.
4. A person's report of an experience as pain should be respected.
5. Although pain usually serves an adaptive role, it may have adverse effects on function and social and psychologic well-being.
6. Verbal description is only one of several behaviors to express pain; inability to communicate does not negate the possibility that a human experiences pain.

Important elements to emphasize in this definition are (1) pain encompasses both peripheral physiologic and central neural components and (2) pain may or may not be associated with ongoing tissue damage. The experience of pain lies primarily in the strength and patterning of central neural connectivity (Fig. 93.1). Although immediate upstream neural activation can originate from inflammatory, structural, or biochemical events, processes not only in the periphery but also in the spinal cord and the brain influence the intensity and duration of pain. Similarly, central neural processes in the brain are associated with the location, intensity, and distress associated with pain. Chronic pain can develop when the upstream neural signaling continues to activate central neural circuits, such as with continued peripheral inflammatory or structural pain-associated processes. Sometimes, this signaling does not regress and the individual experiences ongoing chronic pain after the resolution of the original process.

Often, however, pediatricians face the most difficult problems when either acute pain becomes chronic or chronic pain develops and is maintained without a definable infectious, inflammatory, metabolic, or structural cause. When no “cause” can be found, patients are often referred to mental health specialists, or the cause for the pain is labeled as “stress.” Children read this message as, “The doctor thinks I am faking pain, or I am crazy.” Parents see their child suffering and often seek care from additional providers, with the child undergoing numerous tests, procedures, medication trials, and visits and many physicians looking for the cause of the pain so it can be “fixed” or to “get an answer.” Meanwhile, the child is often missing school, social, and physical activities. In addition, they often develop poor sleep habits, nonrestorative sleep, and exhibit increasing fatigue.

It is recognized that chronic pain, in the absence of a specific identified structural, biochemical, or inflammatory cause, develops through the initiation, maintenance, and strength of central neural connectivity

patterns (see Chapter 212). *Centrally mediated pain* derives from neural connectivity patterns in the brain that include centers involved in autonomic nervous system control, memory, and other cognitive centers, as well as emotional centers of the brain. In pediatrics, birth history and child development overlay these central patterns that contribute to the development of chronic pain. Parents may understand the concept of a “sticky nervous system” as the perpetuator of the continued pain in such a child. This model of brain connectivity patterns, or “top-down” mediators of chronic pain, is important, because it explains how psychologic and other nonpharmacologic interventions work to reduce chronic pain and suffering.

Table 93.1 specifies important pain categories typically treated (somatic, visceral, and neuropathic) and defines the elements and characteristics of **nociception**, the peripheral physiologic aspect of pain perception. Nociception refers to how specialized fibers (largely, but not exclusively, the small, unmyelinated A-delta and C fibers) in the peripheral nervous system transmit nerve impulses (usually transmitting signals originating from peripheral mechanoreceptors and chemoreceptors) through synapses in the spinal cord's dorsal horn through (but not exclusively through) the spinothalamic tracts to the brain's higher centers, where the development of neural connectivity patterns creates the experience of pain.

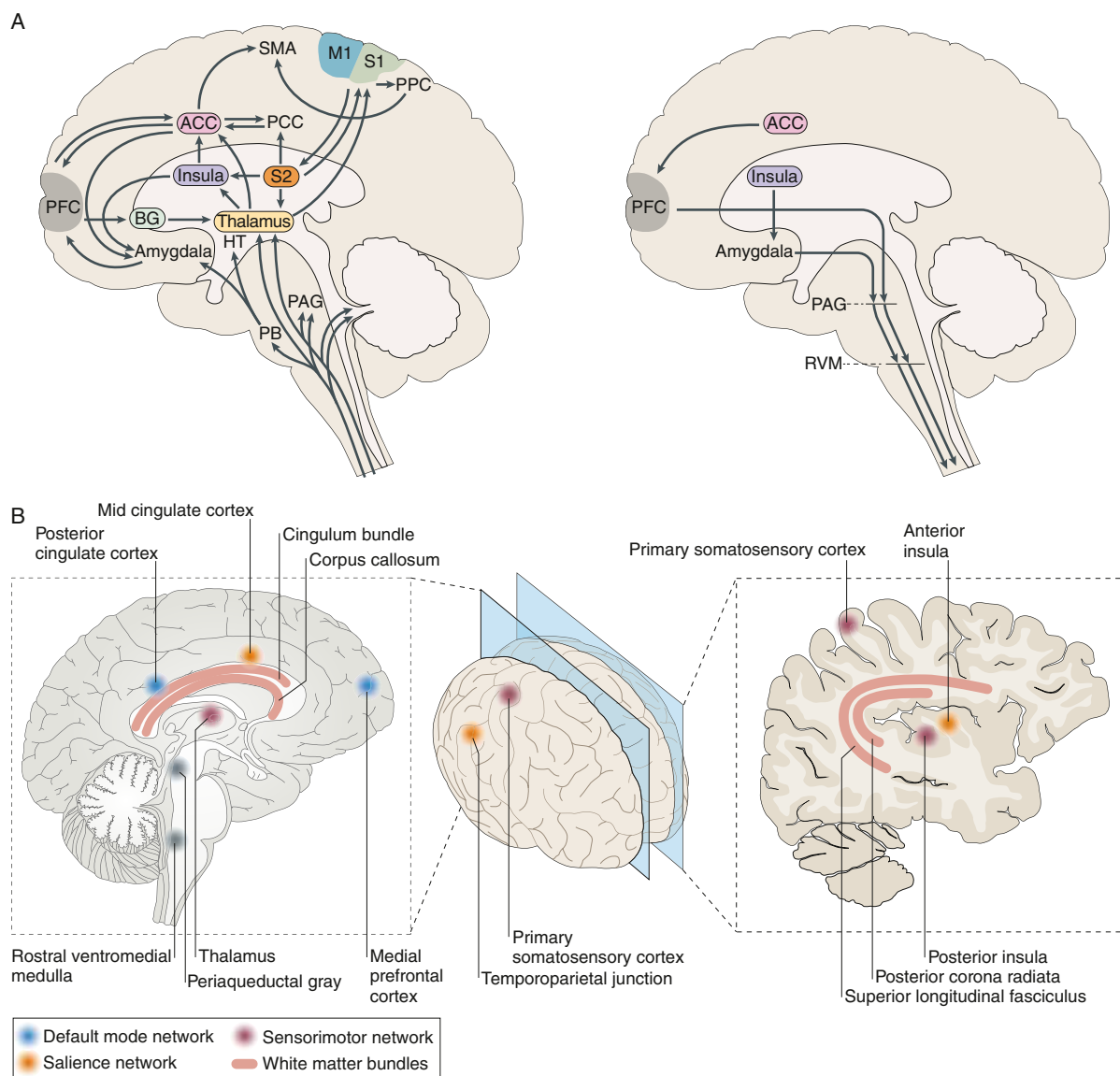
## ASSESSMENT AND MEASUREMENT OF PAIN IN CHILDREN

Assessing pain entails much more than merely quantifying it. Whenever feasible, the physician should ask the patient about the character, location, quality, duration, frequency, and intensity of the pain. Depending on their age, children may be able to answer some or all the questions independently or with assistance from their parents. Severity can also be assessed via utilization of various scales, which will be discussed later. Some children may not report pain because of fears of talking to strangers, disappointing, or bothering others, receiving an injection if they report pain, returning to the hospital if they admit to pain, and other negative reactions. For infants and nonverbal children, their parents, pediatricians, nurses, and other caregivers are constantly challenged to interpret whether the child's distressed behaviors represent pain, fear, hunger, or a range of other perceptions or emotions. Similarly, lack of normal interest in play without behavioral distress signals can be manifestations of pain. Therapeutic trials of comfort measures (cuddling, feeding) and analgesic medication may be helpful in clarifying the triggers of the behaviors.

Behavior and physiologic signs are useful but can be misleading. A toddler may scream and grimace during an ear examination because of fear rather than pain. Conversely, children with inadequately relieved persistent pain from cancer, sickle cell disease, trauma, or surgery may withdraw from their surroundings and appear very quiet, leading observers to conclude falsely that these children are comfortable or sedated. In adolescents, increased reports of pain may be misinterpreted as “drug seeking” behaviors. In these situations, it is important to assess pain appropriately and determine how to best improve pain and function. Although this may be best accomplished by adjustment to analgesic medications, it may also involve the optimization of other nonpharmacologic techniques. This approach, although increasing the number or amount of interventions, may make the child become more, not less, interactive and alert as pain control improves. Similarly, neonates and young infants may close their eyes, furrow their brows, and clench their fists in response to pain. Adequate analgesia is often associated with eye opening and increased involvement in surroundings. A child who is experiencing significant chronic pain may play normally to distract attention away from pain. These coping behaviors are sometimes misinterpreted as evidence of the child's “faking” or exaggerating pain.

## Age-Specific and Developmentally Specific Measures

Because infants, young children, and nonverbal children cannot express the quantity of pain they experience, several pain scales have been devised attempting to quantify pain in these populations (Fig. 93.2 and Table 93.2).



**Fig. 93.1** Brain pathways, regions, and networks involved in acute and chronic pain. ACC, Anterior cingulate cortex; PCC, posterior cingulate cortex; BG, basal ganglia; HT, hypothalamus; PAG, periaqueductal gray; PB, parabrachial nuclei; PFC, prefrontal cortex; PPC, posterior parietal cortex; SMA, supplementary motor area; RVM, rostral ventromedial medulla. (A, left panel from Apkarian AV, Bushnell MC, Treede RD, Zubieta JK. Human brain mechanisms of pain perception and regulation in health and disease. *Eur J Pain*. 2005;9:463–484; A, right panel from Schweinhardt P, Bushnell MC. Pain imaging in health and disease—how far have we come? *J Clin Invest*. 2010;120:3788–3797; B from Davis KD, Flor H, Greely HT, et al. Brain imaging tests for chronic pain: Medical, legal and ethical issues and recommendations. *Nat Rev Neurol*. 2017;13:624–638.)

**Table 93.1** Pain Categories and Characteristics

PAIN CATEGORY	DEFINITION	EXAMPLES	CHARACTERISTICS
Somatic	Pain resulting from injury to or inflammation of tissues (e.g., skin, muscle, tendons, bone, joints, fascia, vasculature)	Burns, lacerations, fractures, infections, inflammatory conditions	<i>In skin and superficial structures:</i> sharp, pulsatile, well localized <i>In deep somatic structures:</i> dull, aching, pulsatile, not well localized
Visceral	Pain resulting from injury to or inflammation of viscera	Angina, hepatic distention, bowel distention or hypermobility, pancreatitis	Aching and cramping; nonpulsatile; poorly localized (e.g., appendiceal pain perceived around umbilicus) or referred to distant locations (e.g., angina perceived in shoulder)
Neuropathic	Pain resulting from injury to, inflammation of, or dysfunction of the peripheral or central nervous system	Complex regional pain syndrome (CRPS), phantom limb pain, Guillain-Barré syndrome, sciatica	Spontaneous; burning; lancinating or shooting; dysesthesias (pins and needles, electrical sensations); <b>hyperalgesia</b> (amplification of noxious stimuli); <b>hyperpathia</b> (widespread pain in response to a discrete noxious stimulus); <b>allodynia</b> (pain in response to nonpainful stimulation); pain may be perceived distal or proximal to site of injury, often corresponding to innervation pathways (e.g., sciatica)

**Behavioral Indicators**

**Facial grimacing:** The Neonatal Facial Coding System uses several facial actions that may be indicators of pain. Pain is characterized by a bulging brow with tight creases in between; tightly closed eyelids; a deeply furrowed nasolabial groove; a horizontal, wide opened mouth; and a taut tongue that may be quivering along with the chin.

**Crying:** May be an indicator of pain.

**Activity:** Withdrawal or immobilization of a limb may be an indicator of pain.

**Response to comfort measures:** Feeding, swaddling, holding, and ensuring that the infant is neither wet nor cold may help to discriminate between pain and other conditions.

**Physiologic indicators:** Alterations in heart rate, blood pressure, SpO<sub>2</sub>, respiratory rate, or alterations in pattern of respiration may be nonspecific indicators of pain.

**Self-Report of Pain**

**Categorical description:** Toddlers or young children are asked to say if they are having "a little bit," a "middle amount," or "a lot" of pain.

**Faces Scales:** Children who do not have an appreciation of ordinal numbering are asked to rate their pain based upon cartoons depicting facial indicators of distress.



**Numerical Rating Scale (NRS):** Older children and teenagers are asked to rate their pain on a scale of "0" (no pain) to "10" (worst pain).

**Visual Analog Scale (VAS):** Children or teenagers are asked to move an indicator along a mechanical slide to depict the level of pain; the clinician reads a number along a 10-cm indicator on the back to determine the numeric score.

**Fig. 93.2** Clinically useful pain assessment tools. (Adapted from Burg FD, Ingelfinger JR, Polin RA, et al., eds. *Current Pediatric Therapy*, 18th ed. Philadelphia: Saunders; 2006:16; and Hicks CL, von Baeyer CL, Spafford P, et al. *The Faces Pain Scale—revised: Toward a common metric in pediatric pain measurement*. *Pain*. 2001;93:173–183.)

Table 93.2 Pain Measurement Tools					
NAME	FEATURES	AGE RANGE	ADVANTAGES	VALIDATION AND USES	LIMITATIONS
Visual Analog Scale (VAS)	Horizontal 10-cm line; subject marks a spot on the line between anchors of "no pain" and "most pain imaginable"	6-8yr and older	Good psychometric properties; validated for research purposes	Acute pain Surgical pain Chronic pain	Cannot be used in younger children or in those with cognitive limitations Requires language skills and numerical processing; upper anchor of "most pain" requires an experiential reference point that is lacking in many children
Numerical Rating Scale (NRS)	Integers from 0 to 10, inclusive, corresponding to a range from no pain to most pain	6-8yr and older	Good psychometric properties; validated for research purposes	Acute pain Surgical pain Chronic pain	Same as for VAS
Faces Scales (e.g., FACES-R, Wong-Baker, Oucher, Bieri, McGrath scales)	Subjects rate their pain by identifying with line drawings of faces or photos of children	3yr and older	Can be used at younger ages than VAS and NRS	Acute pain Surgical pain	Choice of "no pain" face affects responses (neutral vs smiling); not culturally universal
Behavioral or combined behavioral-physiologic scales (e.g., FLACC, N-PASS, CHEOPS, OPS, FACS, NIPS)	Scoring of observed behaviors (e.g., facial expression, limb movement) ± heart rate and blood pressure	Some work for any ages; some work for specific age-groups, including preterm infants	May be used in both infants and nonverbal children	FLACC, N-PASS: Acute pain Surgical pain	Nonspecific; overrates pain in toddlers and preschool children; underrates persistent pain; some measures are convenient, but others require videotaping and complex processing; vital sign changes unrelated to pain can occur and may affect total score
Autonomic measures (e.g., heart rate, blood pressure, heart rate spectral analyses)	Scores changes in heart rate, blood pressure, or measures of heart rate variability (e.g., "vagal tone")	All ages	Can be used at all ages; useful for patients receiving mechanical ventilation		Nonspecific; vital sign changes unrelated to pain may occur and may artifactually increase or decrease score
Hormonal-metabolic measures	Plasma or salivary sampling of "stress" hormones (e.g., cortisol, epinephrine)	All ages	Can be used at all ages		Nonspecific; changes unrelated to pain can occur; inconvenient; cannot provide "real-time" information; standard normal values not available for every age bracket

VAS, visual analog scale; NRS, numerical rating scale; FLACC, face, legs activity, cry, and consolability pain scale for preverbal/nonverbal patients; N-PASS, neonatal pain agitation and sedation scale.



## The Newborn and Infant

There are several behavioral distress scales for the infant and young child, mostly emphasizing the patient's facial expressions, crying, and body movement. Facial expression measures appear most useful and specific in neonates. Autonomic and vital signs can indicate pain, but because

**Table 93.3** Signs and Symptoms of Pain in Infants and Young Children

PHYSIOLOGIC CHANGES	BEHAVIORAL CHANGES
<ul style="list-style-type: none"> <li>• Increase in heart rate, respiratory rate, blood pressure, muscle tone</li> <li>• Oxygen desaturation</li> <li>• Sweating</li> <li>• Flushing</li> <li>• Pallor</li> </ul>	<ul style="list-style-type: none"> <li>• Change in facial expression (grimacing, frowning of the brow, nasal flaring, deep nasolabial groove, curving of the tongue, quivering of the chin)</li> <li>• Finger clenching</li> <li>• Thrashing of limbs</li> <li>• Writhing</li> <li>• Back arching</li> <li>• Head banging</li> <li>• Poor feeding</li> <li>• Sleep disturbance</li> <li>• Pseudoparalysis</li> </ul>

From Krauss BS, Calligaris L, Green SM, Barbi E. Current concepts in management of pain in children in the emergency department. *Lancet*. 2016;387:83–92.

**Table 93.4** CRIES Neonatal Pain Assessment Scale

	0	1	2
Crying	No	High pitched but consolable	Inconsolable
Requires oxygen for saturation >95%	No	FiO <sub>2</sub> <30%	FiO <sub>2</sub> >30%
Increased vital signs	No	HR or BP <20%	HR or BP >20%
Expression	No	Grimace	Grimace and grunt
Sleepless	No	Wakes often	Constantly awake

Score <4 initiate nonpharmacologic measures

Score >4 initiate pharmacologic and nonpharmacologic measures

BP, Blood pressure; HR, heart rate.

From Davis PJ, Cladis FP, eds. *Smith's Anesthesia for Infants and Children*, 10th ed.

Philadelphia: Elsevier; 2022, Table 23.2, p. 487.

**Table 93.5** Revised FLACC for Pain Assessment in the Cognitively Impaired\*

	0	1	2
Face	No particular expression or smile	Occasional grimace/frown; withdrawn or disinterested (appears sad or worried)	Consistent grimace or frown; frequent/constant quivering chin, clenched jaw (distressed-looking face; expression of fright or panic)
Legs	Normal position or relaxed	Uneasy, restless, tense (occasional tremors)	Kicking or legs drawn up (marked increase in spasticity, constant tremors, or jerking)
Activity	Lying quietly, normal position, moves easily	Squirming, shifting back and forth, tense (mildly agitated [e.g., head back and forth, aggression]; shallow, splinting respirations, intermittent sighs)	Arched, rigid, or jerking (severe agitation, head banging; shivering [not rigors]; breath-holding, gasping or sharp intake of breath; severe splinting)
Cry	No cry (awake or asleep)	Moans or whimpers, occasional complaint (occasional verbal outburst or grunt)	Crying steadily, screams or sobs, frequent complaints (repeated outbursts, constant grunting)
Consolability	Content, relaxed	Reassured by occasional touching, hugging, or talking; distractible	Difficult to console or comfort (pushing away caregiver, resisting care or comfort measures)

\*Revised descriptors for children with disabilities shown in brackets.

0= Relaxed/comfortable

1–3 = Mild discomfort

4–6 = Moderate pain

7–10 = Severe pain

FLACC Scoring System: May be used in preverbal, mechanically ventilated, or cognitively impaired patients; it is an acronym that includes 5 indicators, each scored as a 0, 1, or 2, that form a 10-point composite scale with a range from 0 (no pain) to 10 (worst pain). FLACC: Score each category between 0 and 2. The total score may be any number from 0 to 10.

From Davis PJ, Cladis FP, eds. *Smith's Anesthesia for Infants and Children*, 10th ed. Philadelphia: Elsevier; 2022, Table 23.3, p. 488.

they are nonspecific, they may reflect other processes, including fever, hypoxemia, and cardiac or renal dysfunction (Tables 93.3 and 93.4).

## The Older Child

Children age 3–7 years old become increasingly articulate in describing the intensity, location, and quality of pain. Pain is occasionally referred to adjacent areas; referral of hip pain to the thigh or area above the knee is common in this age range. Self-report measures for children this age include using drawings, pictures of faces, or graded color intensities. Children ≥8 years old can usually use verbal numerical rating scales (NRS) or visual analog pain scales (VAS) accurately (see Fig. 93.2). Verbal numerical ratings are preferred and considered the gold standard: valid and reliable ratings can be obtained from children ≥8 years of age. The NRS consists of numbers from 0 to 10, in which 0 represents no pain and 10 represents very severe pain. There is debate about the label for the highest pain rating, but the current agreement is *not* to use the phrase “worst pain possible,” because children can always imagine a greater pain. In the United States, regularly documented pain assessments are required for hospitalized children and children attending outpatient hospital clinics and emergency departments. Pain scores do not always correlate with changes in heart rate or blood pressure.

## The Cognitively Impaired Child

Measuring pain in cognitively impaired children remains a challenge. Understanding pain expression and experience in this population is important because behaviors may be misinterpreted as indicating that cognitively impaired children are more insensitive to pain than neurotypical children. Children with trisomy 21 may express pain less precisely and more slowly than the general population. Pain in children with autism spectrum disorder (ASD) may be difficult to assess because these children may be both *hyposensitive* and *hypersensitive* to many different types of sensory stimuli, and they may have limited communication abilities. Although self-reports of pain can be elicited from some children who are cognitively impaired, observational measures have better validation among these children. The **Noncommunicating Child's Pain Checklist—Postoperative Version** is recommended for children up to 18 years old. In addition, the FLACC pain scale has been validated in nonverbal and cognitively impaired children (Table 93.5). Maladaptive behaviors and reduction in function may also indicate pain. Children with severe cognitive impairments experience pain frequently, and children with the fewest abilities experience the most pain. For this reason, providers must be able to recognize subtle signs and symptoms of pain (see Table 93.3)

## CONCEPTUAL FRAMEWORK FOR TREATMENT OF PEDIATRIC PAIN

Many models of pain focus on factors that explain the interindividual variability in pain perception and the chronicity and impairment experienced with pain. Central to these models are interrelationships among biologic, cognitive, affective, and social factors that influence children's pain and disability, commonly referred to as *biopsychosocial models* of pain. **Biologic** factors include the child's physical health, central nervous system (CNS) factors (pain processing), gender, pubertal status, and genetic factors. Individual child **cognitive and affective** factors related to perception of pain include anxiety, fear, negative affect, pain behaviors, and functional disability, whereas **social** factors include such areas as culture, socioeconomic status, school environment, social and peer interactions, adverse childhood events, and parental and family factors. For children, **developmental** factors need to be considered, such as cognitive and motor development, birth history, and epigenetic factors (the interaction in development between genetic and environmental factors).

A framework that considers the interplay of biologic, psychological, and social factors is useful for understanding pediatric pain and to guide pain assessment and the delivery of pain prevention and management. Many simple interventions designed to promote relaxation and patient control can work either alone or synergistically with pain medications for relief of pain and related distress. Moreover, psychological interventions are often coupled with physical therapy interventions to assist in the management of disabling chronic pain.

### Pharmacologic Treatment of Pain

The pharmacokinetics and pharmacodynamics of analgesics vary with age. This results in drug responses in infants and young children that differ from those in older children and adults. The elimination half-life of most analgesics is prolonged in neonates and young infants because of their immature hepatic enzyme systems and reduced glomerular filtration. Clearance of analgesics may also be variable in young infants and children. Renal blood flow, glomerular filtration, and tubular secretion increase dramatically in the first few weeks after birth, approaching adult values by 3-5 months of age. Renal clearance of analgesics is often greater in toddlers and preschool-age children than in adults, whereas in premature infants, clearance is reduced. Age-related differences in body composition and protein binding also exist. Total

body water as a fraction of body weight is greater in neonates than in children or adults. Tissues with high perfusion, such as the brain and heart, account for a larger proportion of body mass in neonates than do other tissues, such as muscle and fat. Because of decreased serum concentrations of albumin and  $\alpha_1$ -acid glycoprotein, neonates have reduced protein binding of some drugs, resulting in higher amounts of free, unbound, pharmacologically active drugs.

### Acetaminophen, Aspirin, and Nonsteroidal Antiinflammatory Drugs

Acetaminophen and nonsteroidal antiinflammatory drugs (NSAIDs) have replaced aspirin as the most used antipyretics and oral, nonopioid analgesics (Table 93.6). This is because of the association of Reye syndrome with the use of aspirin in children with a viral infection, such as influenza or chickenpox.

**Acetaminophen**, a generally safe, nonopioid analgesic and antipyretic, has the advantage of intravenous (IV), rectal, and oral routes of administration. Acetaminophen is not associated with the gastrointestinal (GI) or antiplatelet effects of aspirin and NSAIDs, making it a particularly useful drug in patients with cancer. Unlike aspirin and NSAIDs, acetaminophen has only mild antiinflammatory action. Although acetaminophen alone may not adequately treat various types of pain, in conjunction with other agents, it can lead to improved pain control and decreased opioid use. One effective management strategy can be to schedule acetaminophen and/or NSAIDs to decrease the need for opioids, while still maintaining good pain control.

Acetaminophen toxicity can result from a large single dose or cumulative excessive dosing over days or weeks (see Chapter 94). Toxicity manifests as fulminant hepatic necrosis and liver failure in infants, children, and adults. Drug biotransformation processes are immature in neonates, very active in young children, and somewhat less active in adults. Young children are more resistant to acetaminophen-induced hepatotoxicity than are adults as a result of metabolic differences. Sulfation predominates over glucuronidation in young children, leading to a reduction in NAPQI production.

**Aspirin** is indicated for certain rheumatologic conditions and for inhibition of platelet adhesiveness, as in the treatment of Kawasaki disease. Concerns about Reye syndrome have resulted in a substantial decline in pediatric aspirin use. In general, aspirin should not be used for routine pain control in children. It is important to be aware of

**Table 93.6** Commonly Used Nonopioid Medications (Antiinflammatory Medications)

MEDICATION	DOSAGE	COMMENT(S)
Acetaminophen	10-15 mg/kg PO q4h 10 mg/kg IV q4h 15 mg/kg IV q6h 10 mg/kg IV q6h (<2 yr) 20-30 mg/kg/PR q4h 40 mg/kg/PR q6-8h <i>Maximum daily dosing:</i> 75 mg/kg/24 hr (children) 60 mg/kg/24 hr (<2 yr) 30-45 mg/kg/24 hr (neonates)	Minimal antiinflammatory action; no antiplatelet or adverse gastric effects; overdosing can produce fulminant hepatic failure.
Ibuprofen	8-10 mg/kg PO q6h 10 mg/kg IV q4-6h to maximum of 400 mg <i>Maximum daily dose:</i> 2,400 mg	Antiinflammatory; transient antiplatelet effects; may cause gastritis; extensive pediatric safety experience.
Naproxen	5-7 mg/kg PO q8-12h <i>Maximum daily dose:</i> 1,000 mg	Antiinflammatory; transient antiplatelet effects; may cause gastritis; more prolonged duration than that of ibuprofen.
Ketorolac	Loading dose 0.3 mg/kg, then 0.25-0.3 mg/kg IV q6h to a maximum of 5 days; maximum single dose 15 mg for those < 50 kg and 30 mg for those ≥ 50 kg	Antiinflammatory; reversible antiplatelet effects; may cause gastritis; useful for short-term situations in which oral dosing is not feasible.
Diclofenac sodium	2-3 mg/kg/day divided in 2 or 3 doses <i>Maximum daily dose:</i> 150 mg	Antiinflammatory; reversible antiplatelet effects; lower risk of gastritis and ulceration compared with other NSAIDs.
Celecoxib	Only approved for children ≥2 yr; ≥10 kg to ≤25 kg: 50 mg PO bid >25 kg: 100 mg PO bid	Antiinflammatory; no or minimal antiplatelet or gastric effects; cross-reactivity with sulfa allergies.

aspirin-containing medications that may be available over the counter when treating patients.

**NSAIDs** are used widely to treat pain and fever in children. Most currently available NSAIDs are nonselective cyclooxygenase (COX) inhibitors, that is, drugs that nonselectively block the activity of both COX-1 (found in gastric mucosa and platelets) and COX-2 (active in inflammatory pathways and cortical renal blood flow regulation) enzymes that synthesize prostaglandins. In children with juvenile idiopathic arthritis, ibuprofen and aspirin are equally effective, but ibuprofen is associated with fewer side effects and better drug adherence. NSAIDs, used adjunctively in surgical patients, reduce opioid requirements (and therefore opioid side effects) by as much as 35–40%. Although NSAIDs can be useful postoperatively, they should be used as an adjunct to, not as a substitute for, opioids in patients with acute moderate to severe pain.

Ketorolac is useful in treating moderate to severe acute pain in patients who are unable or unwilling to take oral NSAIDs. Intravenous diclofenac is also available in other countries. U.S. Food and Drug Administration (FDA) recommendations limit ketorolac to five consecutive days of administration. IV ibuprofen (Caldolor) is FDA approved for the management of pain and fever in infants and children >6 months of age, but is not widely available.

Adverse effects of NSAIDs are uncommon but may be serious when they occur, including gastritis with pain and bleeding; decreased renal blood flow that may reduce glomerular filtration and enhance sodium reabsorption, in some cases leading to tubular necrosis; hepatic dysfunction and liver failure; inhibition of platelet function; and an increased incidence of cardiovascular events in patients predisposed to stroke and myocardial infarction. Although the overall incidence of bleeding is very low, gastric bleeding is the most common cause of serious morbidity related to this class of analgesics. NSAIDs should not be used in the child with a bleeding diathesis or at risk for bleeding and should be used with caution postsurgically. Use after surgeries such as tonsillectomy has been debated, but current postoperative guidelines do include the use of NSAIDs. Renal injury from short-term use of ibuprofen in euvolemic children is quite rare; the risk is increased by hypovolemia or cardiac dysfunction. The safety of both ibuprofen and acetaminophen for short-term use is well established (see Table 93.6).

The only **COX-2 specific NSAID** currently available in the United States is oral celecoxib, whereas in other countries parenteral parecoxib and oral rofecoxib are also available. The coxib drugs are selective COX-2 enzyme inhibitors. Therefore they are effective antiinflammatory and analgesic molecules that generally do not result in platelet inhibition with enhanced bleeding or in gastric inflammation or ulceration, findings that may be seen with the nonselective COX inhibitors in the NSAID class. COX-2 selective NSAIDs do inhibit regulation of cortical renal blood flow and therefore carry the same risk of renal toxicity and acute tubular necrosis, particularly in the setting of low cardiac output states or dehydration. Celecoxib is therefore an appropriate primary or adjunctive analgesic to use in children after surgery, in children with gastric mucosal pathology, or in oncology patients in whom concern for hemostasis contraindicates conventional NSAIDs.

Use of NSAIDs for pain management in children less than 6 months is not generally recommended due to immature glomerular filtration. However, limited use between 3 and 6 months may be appropriate.

## Opioids

Opioids are analgesic substances either derived from the opium poppy (**opiates**) or synthesized to have a similar chemical structure and mechanism of action (**opioids**). The term “narcotics” (narcotic analgesics) should be avoided for these agents, as it connotes criminality and lacks pharmacologic descriptive specificity. Opioids are administered for moderate and severe pain, such as acute postoperative pain, pain from trauma, sickle cell crisis pain, and cancer pain. Opioids can be administered by the oral, rectal, oral transmucosal, transdermal, intranasal, epidural, intrathecal, IV, subcutaneous (SC), or intramuscular (IM) route. Regardless of route of administration, the site of action is at mu ( $\mu$ ) opioid receptors in the peripheral nervous system, spinal cord, brainstem, and higher CNS centers. Infants

and young children are sometimes underdosed with opioids because of concern about significant respiratory side effects. Opioids’ respiratory depressant effects result from infants’ lower metabolic clearance of opioids and higher blood levels with frequent dosing. With proper understanding of the pharmacokinetic and pharmacodynamics of opioids, children can receive effective relief of pain and suffering with a good margin of safety, regardless of pharmacokinetic maturity, age, or size (Tables 93.7–93.9).

Opioids act by mimicking the actions of endogenous opioid peptides, binding to receptors in the brain, brainstem, spinal cord, and to a lesser extent in the peripheral nervous system, thus leading to inhibition of nociception. Opioids also bind to  $\mu$  receptors in the pleasure centers of the midbrain, particularly in genetically susceptible individuals, a factor responsible for the euphoric effect in some individuals and the predilection to psychologic dependence and addictive behavior. Opioids also have dose-dependent respiratory depressant effects when interacting with the  $\mu$ -opioid receptors in the respiratory centers of the brainstem, depressing ventilatory drive and blunting ventilatory responses to both hypoxia and hypercarbia. These respiratory depressant effects are increased with co-administration of other sedating drugs, particularly benzodiazepines or barbiturates.

Optimal use of opioids requires proactive and anticipatory management of side effects (see Table 93.8) as well as dose adjustments for renal or hepatic disease (Table 93.10). Common side effects include sedation, constipation, nausea, vomiting, urinary retention, and pruritus. Tolerance usually develops to the side effect of **nausea**, which typically subsides with long-term dosing, but nausea may require treatment with antiemetics, such as a phenothiazine, butyrophenones, antihistamines, or a serotonin receptor antagonist such as ondansetron or granisetron. Pruritus and other complications during patient-controlled analgesia with opioids may be effectively managed by low-dose IV naloxone.

The most common troubling, but treatable, side effect is **constipation**. Patients who take opioids for chronic pain for long periods predictably develop tolerance to the sedative and analgesic effects of opioids over time, but tolerance to constipation does not occur, and constipation remains a troublesome and distressing problem in almost all patients with long-term opioid administration. Stool softeners and stimulant laxatives should be administered to most patients receiving opioids for more than a few days. Osmotic and bulk laxatives are less effective, usually producing more distention and discomfort. A peripherally acting opiate  $\mu$ -receptor antagonist, **methylnaltrexone**, promptly and effectively reverses opioid-induced constipation in patients with chronic pain who are receiving opioids daily. Methylnaltrexone is approved for use as either an injectable or oral formulation, but only the SC injection is commercially available, which most children will object to receiving. Naldemedine and naloxegol are other agents with actions similar to methylnaltrexone. **Lubiprostone** is a colonic chloride channel inhibitor that impairs water reabsorption in the colon and is very effective for opioid-induced constipation.

Media and government attention to the “opioid epidemic” has reasonably led to scrutiny of the prescription of opioids to children, and FDA approval of opioid formulations for children has raised alarm and criticism by some vocal critics of the use of opioids for medical purposes. Thus one of the potent barriers to effective management of pain with opioids is the fear of addiction held by many prescribing pediatricians and parents alike. Pediatricians should understand the phenomena of tolerance, dependence, withdrawal, and addiction (Table 93.11). **Opioid addiction** is the result of the complex interplay of genetic predisposition, psychiatric pathology, and social forces, including poverty, joblessness, hopelessness, and despair. The dramatic increase in the amount of opioid abuse and overdoses and opioid-related deaths, although highest in the adult non-Hispanic American Indian or Alaska Native population age 35–44 years old, has also significantly risen in children and adolescents. Among persons 14–18 years, overdose deaths increased 114% from 2019 to 2021 with 2,037 (91.3%) of adolescent overdose deaths in 2021 involving at least one opioid. Despite this rise in abuse of opioids, a longitudinal study of children and adolescents treated for medical reasons with opioids found that there was no increased risk of the development of substance abuse, at least until their

**Table 93.7** Pediatric Dosage Guidelines for Opioid Analgesics

DRUG	EQUI-ANALGESIC DOSES		PARENTERAL DOSING		IV:PO DOSE RATIO	ORAL DOSING		COMMENTS
	IV	ORAL	<50kg	≥50kg		<50kg	≥50kg	
Fentanyl	10µg	100µg	0.5-1 µg/kg q1-2h 0.5-1.5 µg/kg/hr	0.5-1 µg/kg q1-2h 0.5-1.5 µg/kg/hr	Oral transmucosal: 1:10 Transdermal: 1:1	Oral transmucosal: 10 µg/kg Transdermal: 12.5-50 µg/hr	Transdermal patches available; patch reaches steady state at 24 hr and should be changed q72h	70-100 times as potent as morphine with rapid onset and shorter duration. With high doses and rapid administration, can cause chest wall rigidity. Useful for short procedures; transdermal form should be used only in opioid-tolerant patients with chronic pain.
Hydrocodone	N/A	1.5mg	N/A	N/A	N/A	0.15 mg/kg	10 mg	Weak opioid; only available in form with acetaminophen.
Hydromorphone	0.2mg	0.6mg	0.01 mg q2-4h 0.002 mg/kg/hr	0.01 mg q2-4h 0.002 mg/kg/hr	1:3	0.04-0.08 mg/kg q3-4h	2-4 mg q3-4h	Five times the potency of morphine; no histamine release and fewer adverse events than morphine.
Methadone	1 mg	2 mg	0.1 mg/kg q8-24h	0.1 mg/kg q8-24h	1:2	0.2 mg/kg q8-12h PO; available as liquid or tablet	2.5 mg TID	Duration 12-24 hr; useful in certain types of chronic pain; requires additional vigilance because it will accumulate over 72 hr and produce delayed sedation. When patients tolerant of opioids are switched to methadone, they show incomplete cross-tolerance and improved efficacy. Because methadone is associated with prolonged QTc, monitoring is needed for children receiving high and extended dosing.
Morphine	1 mg	3 mg	0.05 mg/kg q2-4h 0.01-0.03 mg/kg/hr	0.1 mg/kg q2-4h 0.01-0.03 mg/kg/hr	1:3	Immediate release: 0.3 mg/kg q3-4h Sustained release: 20-35 kg: 10-15 mg q8-12h 35-50 kg: 15-30 mg q8-12h	Immediate release: 15-20 mg q3-4h Sustained release: 30-90 mg q8-12h	Potent opioid for moderate/severe pain; may cause histamine release. Sustained-release form must be swallowed whole; if crushed, becomes immediate acting, leading to acute overdose.
Oxycodone	N/A	3 mg	N/A	N/A	N/A	0.1-0.2 mg q3-4h; available in liquid (1 mg/mL)	Immediate release: 5-10 mg q4h Sustained release: 10-120 mg q8-12h	Strong opioid only available as an oral agent in North America; more potent than and preferable to hydrocodone. Sustained-release form must be swallowed whole; if crushed, becomes immediate acting, leading to acute overdose.

N/A, not available.



**Table 93.8** Management of Opioid-Induced Adverse Effects

Respiratory depression	<p><i>Naloxone</i>: 0.01-0.02 mg/kg up to a full reversal dose of 0.1 mg/kg. May be given IV, IM, IN, SC, or via ETT. The full reversal dose should initially be used for apnea in opioid-naive patients. In opioid-tolerant patients, a reduced dose should be given and titrated up slowly to treat symptoms but prevent acute withdrawal. Ventilation may need to be supported during this process. Dose may be repeated every 2 min to a total of 10 mg. Adult maximum dose is 2 mg/dose. Give with caution to patients who are receiving long-term opioid therapy, as it may precipitate acute withdrawal. Duration of effect is 1-4 hr; therefore close observation for recurrent symptoms is essential.</p>
Excessive sedation without evidence of respiratory depression	<p>Change opioid or decrease the dose. In palliative patients or other special circumstances, can consider treating with stimulants.</p> <p><i>Methylphenidate*</i>: 0.3 mg/kg per dose PO (typically 10-20 mg/dose to a teenager) before breakfast and lunch. Do not administer to patients receiving clonidine, because dysrhythmias may develop.</p> <p><i>Dextroamphetamine</i>: 2.5-10 mg on awakening and at noon. Not for use in young children or in patients with cardiovascular disease or hypertension.</p> <p><i>Modafinil</i>: Pediatric dose not established. May be useful in selected patients. Typical adult dose: 50-200 mg/day.</p>
Nausea and vomiting	<p><i>Metoclopramide</i><sup>†</sup>: 0.15 mg/kg IV up to 10 mg/dose q6-12h for 24 hr.</p> <p><i>Trimethobenzamide</i>: if weight &lt;15 kg, 100 mg PO or PR q6h; if &gt;15 kg, 200 mg PO or PR q6h. (Note: Suppository contains benzocaine 2%.) Not for use in newborn infants or premature infants.</p> <p>5-HT<sub>3</sub> receptor blockers:</p> <p><i>Ondansetron</i>: 0.15 mg/kg up to 8 mg IV q6-8h not to exceed 32 mg/day (also available as a sublingual tablet).</p> <p><i>Granisetron</i>: 10 to 20 µg/kg IV q12-24h.</p> <p><i>Prochlorperazine</i><sup>‡</sup> (Compazine): &gt;2 yr or &gt;20 kg, 0.1 mg/kg per dose q8h IM or PO up to 10 mg/dose. Change opioid.</p>
Pruritus	<p><i>Hydroxyzine</i>: 0.5 mg/kg PO q6h.</p> <p><i>Nalbuphine</i>: 0.1 mg/kg IV q6h for pruritus caused by intraaxial opioids, especially fentanyl. Administer slowly over 15-20 min. May cause acute reversal of systemic µ-receptor effects and leave κ-agonism intact.</p> <p><i>Naloxone</i>: 0.5-2 mcg/kg/hr IV infusion (titrate up to decrease pruritus and reduce infusion if pain increases).</p> <p><i>Ondansetron</i>: 0.05-0.1 mg/kg IV or PO q8h.</p> <p><i>Cyproheptadine</i><sup>†</sup>: 0.1-0.2 mg/kg PO q8-12h. Maximum dose 12 mg. Change opioid.</p>
Constipation	<p>Encourage water consumption, high-fiber diet, and vegetable fiber.</p> <p><i>Bulk laxatives</i>: Metamucil, Maltsupex.</p> <p><i>Lubricants</i>: Mineral oil 15-30 mL PO daily as needed (not for use in infants because of aspiration risk).</p> <p><i>Surfactants</i>: Sodium docusate (Colace):</p> <p>&lt;3 yr: 10 mg PO q8h</p> <p>3-6 yr: 15 mg PO q8h</p> <p>6-12 yr: 50 mg PO q8h</p> <p>&gt;12 yr: 100 mg PO q8h</p> <p><i>Stimulants</i>:</p> <p><i>Bisacodyl</i> suppository (Dulcolax):</p> <p>&lt;2 yr: 5 mg PR qhs</p> <p>&gt;2 yr: 10 mg PR qhs</p> <p><i>Senna syrup</i> (218 mg/5 mL): &gt;3 yr: 5 mL qhs</p> <p><i>Enema</i>: Fleet hypertonic phosphate enema (older children; risk of hyperphosphatemia).</p> <p><i>Electrolytic/osmotic</i>: Milk of magnesia; for severe impaction: polyethylene glycol (GoLYTELY, MiraLAX).</p> <p><i>Methylnaltrexone</i> is an opioid antagonist that works in the colon and does not cross the blood-brain barrier to reverse analgesia; given as subcutaneous injection every day or every other day (0.15 mg/kg) and is effective in producing stool in 30-60 min in most patients.</p>
Urinary retention	<p>Straight catheterization, indwelling catheter.</p> <p>Decrease opioids, use naloxone drip.</p>

\*Avoid in patients taking monoamine oxidase inhibitors.

†May be associated with extrapyramidal side effects, which may be more often seen in children than in adults.

‡Consider pretreatment with diphenhydramine to decrease risk of anti-dopaminergic adverse events (e.g., dystonia).

ETT, Endotracheal tube; IV, intravenously; IM, intramuscularly; IN, intranasally; PO, orally; PR, rectally; SC, subcutaneously.

Modified from Burg FD, Ingelfinger JR, Polin RA, et al., eds. *Current Pediatric Therapy*, 18th ed. Philadelphia: Saunders; 2006, p 16.

mid-20s. Thus the rational short- or even long-term use of opioids in children does not lead to a predilection for or risk of addiction in a child not otherwise at risk because of genetic background, economic factors, or social milieu.

It is equally important for pediatricians to realize that even patients with recognized substance abuse diagnoses are entitled to effective analgesic management, which often includes the use of opioids. If legitimate concerns exist about addiction in a patient, safe, effective opioid pain management is often best provided by specialists in pain management and addiction medicine. [Table 93.12](#) outlines the U.S. Centers for Disease Control and Prevention (CDC) opioid recommendations for **chronic pain** (primarily in adults).

There is no longer a reason to administer opioids by IM injection. Continuous IV infusion of opioids is an effective option that permits

more constant plasma concentrations and clinical effects than intermittent IV bolus dosing without the pain associated with IM injection. The most common approach in pediatric centers is to administer a low-dose basal opioid infusion while permitting patients to use a **patient-controlled analgesia (PCA)** device to titrate the dosage above the infusion ([Fig. 93.3](#)) (see [Chapter 91](#)). Compared with children given intermittent IM morphine, children using PCA reported better pain scores. PCA has several other advantages: (1) dosing can be adjusted to account for individual pharmacokinetic and pharmacodynamic variation and for changing pain intensity during the day; (2) psychologically the patient is more in control, actively coping with the pain; (3) overall opioid consumption tends to be lower; (4) fewer opioid side effects occur; and (5) patient satisfaction is generally much higher. Children as young as 5-6 years old can effectively use PCA. The device can also

be activated by parents or nurses, known as **PCA-by-proxy (PCA-P) or parent-nurse controlled analgesia (PNCA)**, which produces analgesia in a safe, effective manner for children who cannot activate the

OPIOID	IM/IV DOSE (mg)	ORAL DOSE (mg)	$T_{1/2\beta}$ (hr)
Morphine	10	30	2-3
Oxycodone	15	20-30	2-3
Fentanyl	0.15-0.2	—	3-5
Alfentanil	0.75-1.5	—	1-2
Sufentanil	0.02	—	2-3
Methadone	10	10-15	15-40
Hydromorphone	1.5	7.5	3-4
Tramadol <sup>†</sup>	100	100	5-7
Buprenorphine	0.4	0.8 (sublingual)	3-5
Pentazocine	60	150	3-5
Nalbuphine	10-20	—	2-4
Butorphanol	2	—	2-3

<sup>†</sup>Only part of its analgesic action results from action on  $\mu$ -opioid receptors.

NOTES:

- Published reports vary in the suggested doses considered to be equianalgesic to morphine. Therefore titration to clinical response in each patient is necessary.
- Suggested doses are the results of single-dose studies only. Therefore use of the data to calculate total daily dose requirements and repeated or continuous doses may not be appropriate.
- There may be incomplete cross-tolerance between these drugs. In patients who have been receiving one opioid for a prolonged period, it is usually necessary to use a dose lower than the expected equianalgesic dose when changing to another opioid and to titrate to effect.

Modified from Macintyre PE, Ready LB. *Acute Pain Management: A Practical Guide*, 2nd ed. Philadelphia: Saunders; 2001, p 19.

PCA demand button themselves because they are too young or intellectually or physically impaired. PCA overdoses have occurred when well-meaning, inadequately instructed parents pushed the PCA button in medically complicated situations, with or without the use of PCA-P, highlighting the need for patient and family education, use of protocols, physiologic monitoring, and adequate nursing supervision.

Because of the high risk of adverse side effects (respiratory depression), the FDA has issued **contraindications** for the pediatric use of codeine and tramadol (Table 93.13).

### Local Anesthetics

Local anesthetics are widely used in children for topical application, cutaneous infiltration, peripheral nerve block, neuraxial blocks (intra-thecal or epidural infusions), and IV infusions (see Chapter 91). Local anesthetics can be used with excellent safety and effectiveness. Local anesthetics interfere with neural transmission by blocking neuronal sodium channels. Excessive systemic dosing can cause seizures, CNS depression, and (by cardiac and arteriolar sodium channel blockade) hypotension, arrhythmias, cardiac depression, and cardiovascular collapse. Local anesthetics therefore require a strict maximum dosing schedule. Pediatricians should be aware of the need to calculate these doses and adhere to guidelines.

Topical local anesthetic preparations do not generally result in measurable systemic blood levels and can reduce pain in diverse circumstances: suturing of lacerations, placement of peripheral IV catheters, lumbar punctures, and accessing indwelling central venous ports (Table 93.14). The application of tetracaine, epinephrine (adrenaline), and cocaine (TAC) results in good anesthesia for suturing wounds but should not be used on mucous membranes or the hypervascular faces of young children. An alternative combination of lidocaine, epinephrine, and tetracaine (LET) is preferred to avoid the psychomimetic properties of cocaine. EMLA, a topical eutectic mixture of lidocaine and prilocaine used to anesthetize intact skin, is frequently applied for venipuncture, lumbar puncture, and other needle procedures. A 5% liposomal lidocaine cream (LMX4) is also effective as a topical anesthetic. Another unique device is the needle-free J-tip, which uses a CO<sub>2</sub> cartridge to deliver lidocaine into the subcutaneous tissue via a micro-atomizing tip. This can be used to

DRUG	PKA	PROTEIN BINDING (%)	PHASE 1 METABOLISM	PHASE 2 METABOLISM	ACTIVE METABOLITE	BILIARY EXCRETION <sup>1</sup> (%)	RENAL EXCRETION <sup>2</sup>	USE IN RENAL FAILURE
Morphine	8.0	30	None	Glucuronidation	M6G	10	Metabolites	Use with caution <sup>a,c</sup>
Fentanyl	8.4	80	CYP3A4	None	None		Norfentanyl	Preferred <sup>b,e</sup>
Hydromorphone	8.2	20	None	Glucuronidation	H6G		H3G & H6G	Use with caution <sup>a,d</sup>
Methadone	8.3	90	CYP2B6 CYP3A4, CYP2D6	None	None	20-40	Metabolites	Use with caution <sup>b,e</sup>
Codeine	8.2	25	CYP2D6	None	Morphine, Hydrocodone M6G		M6G	No <sup>b,d</sup>
Oxycodone	8.5	45	CYP3A4, CYP2D6	None	Oxymorphone		Noroxycodone	Use with caution <sup>f</sup>
Oxymorphone	8.2	10	CYP3A4	Glucuronidation	None		Noroxymorphone	Use with caution <sup>a,c</sup>
Remifentanyl	7.1	70	Esterase	None	None		Metabolite	

<sup>1</sup>In the setting of hepatic dysfunction, all opioids should be used cautiously (“go low, go slow”). Meperidine (inactive metabolite associated with seizures) and codeine (cannot be metabolized into active metabolite, morphine) should not be used. Fentanyl may be the best opioid to use (in severe liver dysfunction, plasma cholinesterase may not be available to metabolize remifentanyl).

<sup>2</sup>In the setting of renal failure, metabolites of morphine, codeine, hydromorphone, hydrocodone, and meperidine can accumulate, producing increased therapeutic and adverse effects.

<sup>a</sup>Parent drug removed by dialysis; <sup>b</sup>Parent drug not/poorly dialyzed; <sup>c</sup>Metabolites removed by dialysis; <sup>d</sup>Metabolites not/poorly dialyzed; <sup>e</sup>Metabolites inactive;

From Davis PJ, Cladis FP, eds. *Smith's Anesthesia for Infants and Children*, 10th ed. Philadelphia: Elsevier; 2022, Table 23.6, p. 496.

**Table 93.11** Practical Aspects of Prescribing Opioids

- Morphine, hydromorphone, or fentanyl is regarded as first choice for severe pain.
- Dosing should be titrated and individualized. There is no “right” dose for everyone.
- The right dose is the dose that relieves pain with a good margin of safety.
- Dosing should be more cautious in infants, in patients with coexisting diseases that increase risk or impair drug clearance, and with concomitant administration of sedatives.
- Hydromorphone is metabolized by CYP2D6 and fentanyl by CYP3A4 and to some extent 2D6; drugs that compete for 2D6 enzyme will raise blood levels and increase risk of respiratory depression.
- Morphine is metabolized by glucuronidation to an active metabolite, morphine-6-glucuronide, which accumulates and causes CNS toxicity in renal impairment.
- Anticipate and treat peripheral side effects, including constipation, nausea, and itching.
- Give doses at sufficient frequency to prevent the return of severe pain before the next dose.
- Use a drug delivery method, such as patient-controlled anesthesia or continuous infusions, that avoids the need for “prn” decision-making.
- With opioid dosing for >1 wk, taper gradually to avoid abstinence syndrome.
- When converting between parenteral and oral opioid doses, use appropriate potency ratios (see Table 93.9).
- *Tolerance* refers to decreasing drug effect with continued administration of a drug. Over time a patient will need higher dosing to achieve the same clinical effect; however, tolerance to sedation and respiratory depression develop more rapidly than tolerance to analgesia. Thus with higher doses, patients do not experience oversedation or respiratory depression.
- *Dependence* refers to the need for continued drug dosing to prevent abstinence syndrome when a drug is abruptly discontinued or its dose reduced. Abstinence syndrome is characterized by irritability, agitation, autonomic arousal, nasal congestion, piloerection, diarrhea, jitteriness, and yawning; it is produced by administration of potent opioids for >5-7 days.
- *Addiction*, a psychiatric pathology, refers to psychologic craving, compulsive drug-seeking behavior, and drug use despite medical harm. Addiction has strong genetic and environmental determinants. Opioid therapy will not lead to addiction in nonsusceptible individuals, and opioid underdosing does not prevent addiction; it may in fact increase drug-seeking behavior for relief of pain (e.g., watching the clock), referred to as “pseudoaddiction.”

start IVs or provide superficial analgesia before a procedure (e.g., lumbar puncture).

**Lidocaine** is the most commonly used local anesthetic for cutaneous infiltration. Maximum safe doses of lidocaine are 5 mg/kg without epinephrine and 7 mg/kg with epinephrine. Although concentrated solutions (2%) are commonly available from hospital pharmacies, more dilute solutions (0.25% and 0.5%) are equally as effective as 1–2% solutions. The diluted solutions cause less burning discomfort on injection and permit use of larger volumes without achieving toxic doses. In the surgical setting, cutaneous infiltration is more often performed with bupivacaine 0.25% or ropivacaine 0.2% because of the much longer duration of effect; maximum dosage of these long-acting amide anesthetics is 2–3 mg/kg and 3–4 mg/kg, respectively. Liposomal bupivacaine injectable suspension (Exparel) is approved for children age 6 years old and above. It is an excellent choice for surgical wound infiltration. The maximum dose for children is 4 mg/kg.

**Neuropathic pain** may respond well to the local application of a 5% lidocaine topical patch (Lidoderm) for 12 hours/day (see Table 93.14), although access to lidocaine topical patches may be limited by insurance coverage. Over-the-counter 4% lidocaine patches are available without prescription. Peripheral and central neuropathic pain also may respond to IV lidocaine infusions, which may be used in hospital

settings for refractory pain, complex regional pain syndromes, and pain associated with malignancies or the therapy of malignancies, such as oral mucositis after bone marrow transplantation. In these patients, 1–2 mg/kg/hr should be administered and the infusion titrated to achieve a blood lidocaine level in the 2–5 µg/mL range, with use of twice-daily therapeutic blood monitoring.

## UNCONVENTIONAL MEDICATIONS IN PEDIATRIC PAIN

*Unconventional analgesic medication* refers to a wide number of drugs developed for other indications but found to have analgesic properties. These drugs have been used for acute and chronic pain and include antidepressants, antiepileptic drugs, and neurotropic drugs (Tables 93.15 and 93.16).

The unconventional analgesics are generally used to manage neuropathic pain conditions, migraine disorders, fibromyalgia syndrome, and some forms of functional chronic abdominal pain syndromes. These agents also are used as components of multimodal analgesia in the management of surgical, somatic, and musculoskeletal pain. Figure 93.4 presents a decision-making tree to help the physician select the appropriate analgesic category for various types of pain.

Although several unconventional pain medications are FDA approved for analgesic use, most are not approved for use in youth with acute or chronic pain. Thus these drugs should be used with caution, with a focus on mitigating pain to allow a child to participate effectively in therapies and return to normal activity as soon as possible. The use of psychotropic medications should be guided by the principles applied to pharmacologic treatment of any symptom or disease. Target symptoms should be identified and medication side effects monitored. To determine dosing regimens, the physician should consider the child's weight and the effects that the medical condition and other medications, such as psychotropic drugs, may have on the child's metabolism. Therapeutic blood level monitoring can be considered. Side effects should be addressed in detail with both parent and child and specific instructions given for responding to possible adverse events. Directly addressing concerns about addiction, dependence, and tolerance may be necessary to decrease treatment-related anxiety and improve medication adherence.

### Antidepressant Medications

Antidepressants are useful in adults with chronic pain, including neuropathic pain, headaches, and rheumatoid arthritis, independent of their effects on depressive disorders. Antidepressants' analgesic mechanism of action is inhibition of norepinephrine reuptake in the CNS. In children, because clinical trials have been limited, the practitioner should use antidepressants cautiously to treat chronic pain or associated depressive or anxiety symptoms. The FDA has issued a “black box warning” to inform the public of a small but significant increase in suicidal thoughts and attempts in children and adolescents receiving antidepressants. A meta-analysis of studies involving children and adolescents receiving antidepressants for pain indicated that no suicides had been completed. The pediatrician should address this issue with parents of patients being treated with antidepressants and should develop monitoring plans consistent with current FDA recommendations (see Table 93.16).

**Tricyclic antidepressants (TCAs)** have been studied in children with chronic pain and found to be effective in pain relief for symptoms that include neuropathic pain, functional abdominal pain, and migraine. TCA efficacy may be based on inhibition of the neurochemical pathways involved in norepinephrine and serotonin reuptake and interference with other neurochemicals involved in the perception or neural conduction of pain. Because sedation is a common side effect, TCAs may also be effective in treating the sleep disorders that frequently accompany pediatric pain. Biotransformation of TCAs is extensive in healthy children. Typically, TCAs are administered only at bedtime, especially the more sedating tricyclic medications such as amitriptyline. Alternatively, the patient can be started on a bedtime dose of a TCA, which may be able to then be titrated to a daily divided dose, with the larger dose given at bedtime. It should be noted that pain symptoms usually remit at lower doses than those recommended

**Table 93.12** CDC Practice Guideline for Prescribing Opioids for Pain (2022) Excluding Sickle Cell Anemia, Cancer, Palliative Care and End of Life Care**DETERMINING WHETHER OR NOT TO INITIATE OPIOIDS FOR PAIN**

All patients with pain should receive treatment that provides the greatest benefits relative to risks. (See *Recommendation 1* for determining whether or not to initiate opioids for acute pain [i.e., pain lasting <1 month] and *Recommendation 2* for determining whether or not to initiate opioids for subacute pain [i.e., pain lasting 1–3 months] or chronic pain [i.e., pain lasting >3 months].)

**Recommendation 1**

Nonopioid therapies are at least as effective as opioids for many common types of acute pain. Clinicians should maximize use of nonpharmacologic and nonopioid pharmacologic therapies as appropriate for the specific condition and patient and only consider opioid therapy for acute pain if benefits are anticipated to outweigh risks to the patient. Before prescribing opioid therapy for acute pain, clinicians should discuss with patients the realistic benefits and known risks of opioid therapy.

**Recommendation 2**

Nonopioid therapies are preferred for subacute and chronic pain. Clinicians should maximize use of nonpharmacologic and nonopioid pharmacologic therapies as appropriate for the specific condition and patient and only consider initiating opioid therapy if expected benefits for pain and function are anticipated to outweigh risks to the patient. Before starting opioid therapy for subacute or chronic pain, clinicians should discuss with patients the realistic benefits and known risks of opioid therapy, should work with patients to establish treatment goals for pain and function, and should consider how opioid therapy will be discontinued if benefits do not outweigh risks.

**SELECTING OPIOIDS AND DETERMINING OPIOIDS DOSAGES****Recommendation 3**

When starting opioid therapy for acute, subacute, or chronic pain, clinicians should prescribe immediate-release opioids instead of extended-release and long-acting (ER/LA) opioids.

**Recommendation 4**

When opioids are initiated for opioid-naïve patients with acute, subacute, or chronic pain, clinicians should prescribe the lowest effective dosage. If opioids are continued for subacute or chronic pain, clinicians should use caution when prescribing opioids at any dosage, should carefully evaluate individual benefits and risks when considering increasing dosage, and should avoid increasing dosage above levels likely to yield diminishing returns in benefits relative to risks to patients.

**Recommendation 5**

For patients already receiving opioid therapy, clinicians should carefully weigh benefits and risks and exercise care when changing opioid dosage. If benefits outweigh the risks of continued opioid therapy, clinicians should work closely with patients to optimize nonopioid therapies while continuing opioid therapy. If benefits do not outweigh risks of continued opioid therapy, clinicians should optimize other therapies and work closely with patients to gradually taper to lower dosages or, if warranted based on the individual circumstances of the patient, appropriately taper and discontinue opioids. Unless there are indications of a life-threatening issue such as warning signs of impending overdose (e.g., confusion, sedation, or slurred speech), opioid therapy should not be discontinued abruptly, and clinicians should not rapidly reduce opioid dosages from higher dosages.

**DECIDING DURATION OF INITIAL OPIOID PRESCRIPTION AND CONDUCTING FOLLOW-UP****Recommendation 6**

When opioids are needed for acute pain, clinicians should prescribe no greater quantity than needed for the expected duration of pain severe enough to require opioids.

**Recommendation 7**

Clinicians should evaluate benefits and risks with patients within 1–4 weeks of starting opioid therapy for subacute or chronic pain or of dosage escalation. Clinicians should regularly reevaluate benefits and risks of continued opioid therapy with patients.

**ASSESSING RISK AND ADDRESSING POTENTIAL HARMS OF OPIOID USE****Recommendation 8**

Before starting and periodically during continuation of opioid therapy, clinicians should evaluate risk for opioid-related harms and discuss risk with patients. Clinicians should work with patients to incorporate into the management plan strategies to mitigate risk, including offering naloxone.

**Recommendation 9**

When prescribing initial opioid therapy for acute, subacute, or chronic pain, and periodically during opioid therapy for chronic pain, clinicians should review the patient's history of controlled substance prescriptions using state prescription drug monitoring program (PDMP) data to determine whether the patient is receiving opioid dosages or combinations that put the patient at high risk for overdose.

**Recommendation 10**

When prescribing opioids for subacute or chronic pain, clinicians should consider the benefits and risks of toxicology testing to assess for prescribed medications as well as other prescribed and nonprescribed controlled substances.

**Recommendation 11**

Clinicians should use particular caution when prescribing opioid pain medication and benzodiazepines concurrently and consider whether benefits outweigh risks of concurrent prescribing of opioids and other central nervous system depressants.

**Recommendation 12**

Clinicians should offer or arrange treatment with evidence-based medications to treat patients with opioid use disorder. Detoxification on its own, without medications for opioid use disorder, is not recommended for opioid use disorder because of increased risks for resuming drug use, overdose, and overdose death.

From Dowell D, Ragan KR, Jones CM, et al: CDC clinical practice guidelines for prescribing opioids for pain – United States, 2022. *MMWR* 2022;71(3):1-95.

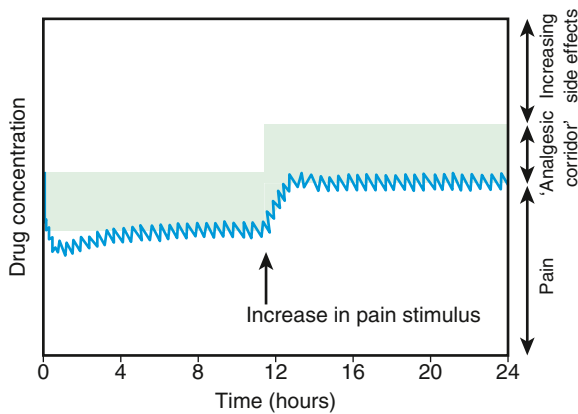
or required for the treatment of mood disorders. Most children and adolescents do not require more than 0.25-1 mg/kg of amitriptyline or nortriptyline once daily at bedtime.

Attention should also be paid to hepatic microsomal enzyme metabolism, because CYP2D6 inhibitors, such as cimetidine and quinidine, can increase levels of TCAs. Anticholinergic side effects, which are less common in children than in adults, may remit over time. Constipation, orthostatic hypotension, and dental caries from dry mouth should be addressed by emphasizing the importance of hydration, good oral hygiene, and regular dental visits. Other side effects include weight gain, mild bone marrow suppression, and liver dysfunction. Some practitioners recommend monitoring CBC and liver function values at baseline and periodically

during therapy. TCA blood levels can be obtained as well, but the need for therapeutic blood monitoring should be assessed on an individual basis. Reasons for blood level monitoring include concerns for altered metabolism, adherence, overdose, or sudden change in mental status.

All TCAs inhibit cardiac conduction pathways and prolong the QT interval. Sudden cardiac death has been reported in children taking TCAs, principally desipramine, probably related to QTc prolongation. There is no general agreement for monitoring the electrophysiologic effects of these drugs, but it is prudent to obtain a careful personal and family history focusing on cardiac arrhythmias, heart disease, and syncope before the initiation of treatment. A baseline electrocardiogram (ECG) should be obtained, with care taken to ensure that





**Fig. 93.3** Patient-controlled analgesia is more likely to keep blood concentrations of opioid within the “analgesic corridor” and allows rapid titration if there is an increase in pain stimulus requiring higher blood levels of opioid to maintain the analgesia. (From Burg FD, Ingelfinger JR, Polin RA, et al., eds. *Current Pediatric Therapy*, 18th ed. Philadelphia: Saunders; 2006:16.)

**Table 93.13** Summary of FDA Recommendations

- Use of codeine to treat pain or cough in children <12 yr old is contraindicated.
- Use of tramadol to treat pain in children <12 yr old is contraindicated.
- Use of tramadol for treatment of pain after tonsillectomy or adenoidectomy in patients <18 yr old is contraindicated. (Codeine was already contraindicated in such patients.)
- Use of codeine or tramadol in children 12-18 yr old who are obese or who have an increased risk of serious breathing problems, such as those with obstructive sleep apnea or severe lung disease, is not recommended.
- Use of codeine or tramadol in breastfeeding women should be avoided.

From FDA warns against use of codeine and tramadol in children and breastfeeding women. *Med Lett*. 2017;59(1521):86–88.

**Table 93.14** Topical Pharmacologic Management of Acute Pain in Children

DRUG	DOSE	NOTES
<b>INTACT SKIN</b>		
Lidocaine 2.5% and prilocaine 2.5% (EMLA cream)	<3 mo old or <5 kg: 1 g 3-12 mo and >5 kg: 2 g 1-6 yr and >10 kg: 10 g 7-12 yr and >20 kg: 20 g	60 min is needed to achieve maximum effect; cover cream with an occlusive dressing (Tegaderm)
Lidocaine, liposomal 5% (LMX4)	1-20 g as noted earlier	30-60 min needed to achieve maximum effect; cover with an occlusive dressing (Tegaderm)
Lidocaine 70 mg and tetracaine 70 mg (Synera patch)	Age ≥3yr: apply patch	20-30 min needed to achieve maximum effect
Tetracaine 4% (Ametop)	>1 mo and <5yr: apply 1 tube of gel (1 g) >5 yr: apply up to 5 tubes of gel (5 g)	30 min before venipuncture 45 min before intravenous cannulation
<b>WOUNDS</b>		
Lidocaine, epinephrine, tetracaine (LET) solution or gel*	Age ≥1 yr: apply to wound	20 min needed for maximum effect

\*Also referred to as ALA on the basis of alternative names for the constituents: adrenaline, lignocaine, amethocaine. These mixtures are locally made by hospital formularies, with a common formula being lidocaine 4% plus epinephrine 0.1% plus tetracaine 0.5%. The cocaine-based formulation was historically avoided on wounds of digits, ears, penis, nose, mucous membranes, close to the eye, or deep wounds involving bone, cartilage, tendon, or vessels. The lidocaine-based formulation can be used in such settings.

Adapted from Krauss BS, Calligaris L, Green SM, Barbi E. Current concepts in management of pain in children in the emergency department. *Lancet*. 2016;387:83–92.

the QTc is <450 msec. If the dose of amitriptyline or nortriptyline is increased beyond 0.5 mg/kg/day, an ECG should be performed for each dosing increase. With TCAs, as with other antidepressants, physical dependence and a known discontinuation syndrome can occur. The **discontinuation syndrome** includes agitation, sleep disturbances, appetite changes, and GI symptoms. These medications should be tapered slowly to assist in distinguishing among symptoms that indicate rebound, withdrawal, or the need for continuing the medication.

**Selective serotonin reuptake inhibitors (SSRIs)** have minimal efficacy in the treatment of a variety of pain syndromes in adults. SSRIs are very useful when symptoms of depression or anxiety are present and cannot be addressed adequately by nonpharmacologic means. Escitalopram (Lexapro), fluoxetine (Prozac), and sertraline (Zoloft) have been approved by the FDA for use in children and adolescents. SSRIs have a significantly milder side effect profile than TCAs (most side effects are transient), and they have no anticholinergic side effects. Chief side effects include GI symptoms, headaches, agitation, insomnia, sexual dysfunction, and anxiety. Rarely, hyponatremia, or the syndrome of inappropriate antidiuretic hormone secretion (SIADH), may occur. Interactions with other medications that have serotonergic effects may also occur. When multiple medications with serotonergic activity are used in combination, there may be increased likelihood that a life-threatening **serotonin syndrome** may occur, with associated symptoms of myoclonus, hyperreflexia, autonomic instability, muscle rigidity, and delirium (see [Chapter 94](#)). It is important to note that although triptans have serotonergic effects, it is unlikely that the combination will lead to serotonin syndrome. This is because it is hypothesized that serotonin receptors 2A and 1A are the receptors involved in serotonin syndrome, whereas triptans are selective for serotonin antagonists 1B and 1D. There is also a **discontinuation syndrome** associated with shorter-acting SSRIs (e.g., paroxetine), which includes dizziness, lethargy, paresthesias, irritability, and vivid dreams. To avoid this, dosages of medications should be tapered slowly over several weeks.

The **selective serotonin-norepinephrine reuptake inhibitors (SNRIs)** duloxetine and venlafaxine have demonstrated significant efficacy with chronic neuropathic and other pain syndromes because they inhibit both serotonin and norepinephrine reuptake, and they may directly block associated pain receptors as well. Venlafaxine has no pain indication labeling. Duloxetine is FDA approved for managing neuropathic pain (specifically, diabetic neuropathy) and fibromyalgia

**Table 93.15** Commonly Used Adjunctive Analgesics

DRUG NAME (TRADE NAME)	SUGGESTED STARTING DOSE AND DOSING INTERVAL MAXIMUM DOSE PER DAY	ADVANTAGES (INDICATION FOR USE)	DISADVANTAGES (SIDE EFFECTS)
Gabapentin (Neurontin)	10-15 mg/kg per day divided bid or tid Max dose: 50 mg/kg per day (3 g/day)	Adjunct for the management of pediatric neuropathic pain, epilepsy	Drug reaction with eosinophilia and systemic symptoms (DRESS), anaphylaxis, somnolence, dizziness, peripheral edema, emotional lability, respiratory depression when combined with opioids
Pregabalin (Lyrica)	2.5 mg/kg per day divided bid or tid Max dose: 600 mg per day	Adjunct for the management of neuropathic pain associated with spinal cord injury, fibromyalgia, and epilepsy	Ataxia, blurred vision, visual field loss, constipation, drowsiness, headaches, peripheral edema, weight gain, tremor
Clonidine (Catapres)	5-25 mcg/kg per day divided every 4-8 hours if PO dosing Max dose: 2.4 mg/day	Used to treat hypertension and mitigate drug withdrawal symptoms; also used as a pain or peripheral nerve block additive	Drowsiness, dizziness, fatigue, headache, dry mouth, hypotension
Dexmedetomidine (Precedex)	Loading dose: 0.5-1 mcg/kg Infusion rate: 0.2-0.7 mcg/kg per hour titrated to effect Suggested max dose: 2.5 mcg/kg per hour	Sedative and analgesic properties; intraoperative bolus dose of 1 mcg/kg decreases postoperative morphine consumption and 2 mg/kg decreases emergence delirium	Bradycardia, hypotension
Tizanidine (Zanaflex)	Patients >18 yr: starting dose 2 mg q6-8h Max single dose: 16 mg Max daily dose: 36 mg	Antispasmodic agent	Dizziness, drowsiness, bradycardia, hypotension, fatigue, hallucinations, xerostomia
Diazepam (Valium)	PO: 0.1-0.8 mg/kg/day IV: 0.05-0.3 mg/kg/dose every 4-8 hr Max dose: 10 mg Use lowest needed dose; use lower dose when combined with opioids or other sedating medications	Antispasmodic, anxiolytic, sedative, seizure prophylaxis, promotes sleep	Somnolence, unsteady gait
Cyclobenzaprine (Flexeril)	Patients >15 yr: 5 mg PO bid-tid Max dose: 10 mg PO tid	Antispasmodic	Blurry vision, dizziness, drowsiness, lightheadedness, xerostomia
Ketamine	Loading dose: 0.25-0.5 mg/kg IV before incision Infusion rate: 0.1-1 mg/kg per hr intraoperatively 0.05-0.1 mg/kg per hr postoperatively Max parenteral dose 3,600 mg/day	Sedation, analgesic adjunct, especially beneficial for opioid-tolerant or chronic pain patients	Hallucinations, double/blurred vision, jerky muscle movements, drowsiness, loss of appetite, nausea
Lidocaine	Loading dose: 1-1.5 mg/kg IV Infusion rate: 1-2 mg/kg per hr intraoperatively Max dose: 4.5 mg/kg (not to exceed 300 mg in 2 hr)	Used during intraabdominal procedures to prevent severe postoperative pain	Cardiac arrhythmia, epilepsy/seizures, renal failure

Modified from Davis PJ, Cladis FP, eds. *Smith's Anesthesia for Infants and Children*, 10th ed. Philadelphia: Elsevier; 2022, Table 23.12, p. 510.

syndrome. It is approved for the treatment of pediatric fibromyalgia in adolescents 13-17 years of age and for the treatment of generalized anxiety disorder in children 7-17. A significant advantage of SNRIs over TCAs when used for headache prophylaxis or neuropathic pain is that they have therapeutic effects on mood and anxiety at dosages effective for pain control.

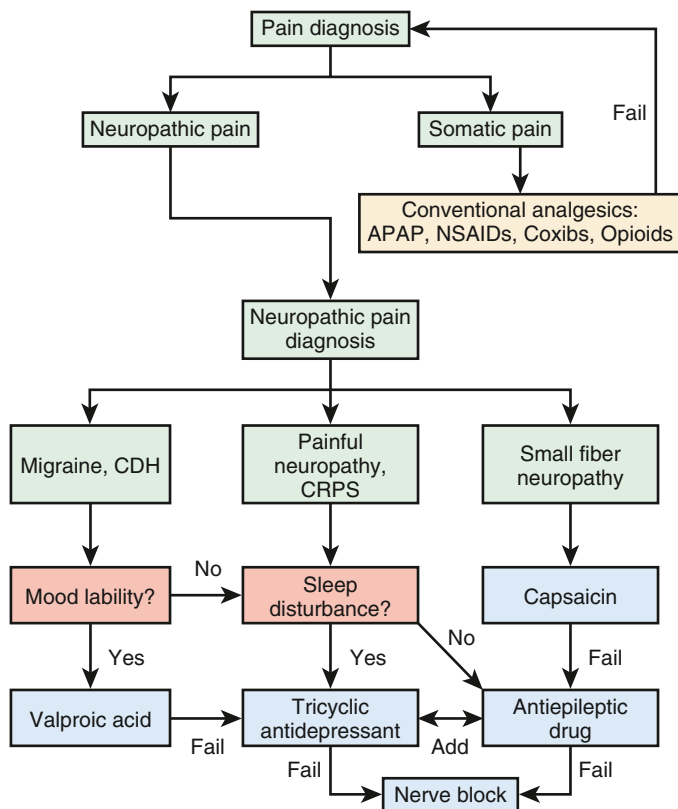
Because both SSRIs and SNRIs have fewer anticholinergic side effects than TCAs, adherence to them is better than in psychiatric populations taking TCAs. Side effects of both types of drugs include GI symptoms, hyperhidrosis, dizziness, and agitation, but these effects generally wane over time. Hypertension and orthostatic hypotension may occur; in addition, the patient's blood pressure should be closely followed, and appropriate hydration should be stressed. Note that whereas appetite stimulation and weight gain are associated with all TCAs, duloxetine is often associated with weight loss, frequently a desirable side effect, especially in overweight adolescents.

All antidepressants, including the TCAs, SSRIs, and SNRIs, are thought to have the potential to increase the risk of suicidal ideation and the risk of suicide in patients, as noted earlier. The FDA states, "All pediatric patients being treated with antidepressants for any indication should be observed closely for clinical worsening, suicidality, and unusual changes in behavior, especially during the initial few months of a course of drug therapy, or at times of dose changes, either increases or decreases." However, the FDA also notes, "Although there has been a long-standing concern that antidepressants may have a role in inducing worsening of depression and the emergence of suicidality in certain patients, a causal role for antidepressants in inducing such behaviors has not been established. Nevertheless, patients being treated with antidepressants should be observed closely for clinical worsening and suicidality, especially at the beginning of a course of drug therapy, or at the time of dose changes, either increases or decreases."

**Table 93.16** Medications for Pediatric Chronic Pain

MEDICATION	DOSING	COMMENTS
<b>TRICYCLIC ANTIDEPRESSANTS</b>		
Amitriptyline, nortriptyline	For patients $\geq 50$ kg: Initial dose 5-10 mg PO qhs; titrate over 2-3 weeks to 25-50 mg PO qhs For patients 25-50 kg: Initial dose 0.1 mg/kg PO qhs. Titrate over 2-3 weeks to max dose of 0.5 mg/kg	Obtain 12-lead ECG for prolonged QT interval Side effects are related to anticholinergic effects, including tachycardia, dry mouth, urinary retention, and sedation Use with caution with other antidepressants because of risk of serotonin syndrome Concomitant use with CYP2D6 inhibitors may lead to increased serum concentration
<b>SELECTIVE SEROTONIN-NOREPINEPHRINE REUPTAKE INHIBITORS</b>		
Duloxetine (Cymbalta)	For patients $> 13$ yr: Dose 30-60 mg PO daily; max 600 mg/day	Review risk of suicidality
<b>ANTICONVULSANTS</b>		
Gabapentin (Neurontin)	For patients $\geq 50$ kg: Initial dose 100-300 mg PO 1-2 times daily; titrate slowly to max dose of 1,800 mg/day divided tid; higher dosing possible in select patients For patients $< 50$ kg: Initial dose 2-5 mg/kg PO daily; titrate slowly to max dose of 35 mg/day divided tid; higher dosing possible in select patients	Side effects include drowsiness, concentration and memory impairments, and peripheral edema (rare) Dose adjustment necessary with renal impairment
Pregabalin (Lyrica)	Patients $> 12$ yr of age: Initial dose 25-75 mg PO 1-2 times daily; titrate up to max of 300 mg/day divided bid or tid	Side effects include drowsiness, headaches, peripheral edema (rare), and thrombocytopenia (rare)
Titrate all medications according to clinical benefit and side effects; use lowest effective dose. Antidepressants and anticonvulsants may increase the risk of suicidal thinking and behavior in children, adolescents, and young adults. Monitor closely for changes in mood or behavior.		

Modified from Davis PJ, Cladis FP, eds. *Smith's Anesthesia for Infants and Children*, 10th ed. Philadelphia: Elsevier; 2022, Table 25.2, p. 580.



**Fig. 93.4** Algorithm for selection of conventional and nonconventional analgesics. APAP, Acetaminophen; CDH, chronic daily headaches; CRPS, complex regional pain syndrome; NSAIDs, nonsteroidal anti-inflammatory drugs.

### Antiepileptic Drugs

Antiepileptic drugs (AEDs), such as gabapentin, pregabalin, carbamazepine, and valproic acid, are believed to relieve chronic pain by blocking sodium (valproate and the gabapentinoids) or calcium

(carbamazepine and oxcarbazepine) channels at the cellular neuronal level, thereby suppressing spontaneous electrical activity and restoring the normal threshold to depolarization of hypersensitive nociceptive neurons, without affecting normal nerve conduction. These medications are particularly useful in patients with mood disorders who have neuropathic pain. In adults, the FDA has approved carbamazepine for trigeminal neuralgia; valproate for migraine prophylaxis; and pregabalin for neuropathic pain complicating diabetes, herpes zoster, and for management of fibromyalgia. AEDs generally have GI side effects in addition to sedation, anemia, ataxia, rash, and hepatotoxicity. The majority are also associated with weight gain. Carbamazepine and oxcarbazepine are also associated with Stevens-Johnson syndrome.

Liver function and CBC should be monitored at the start of therapy and periodically with AEDs. Carbamazepine and valproic acid have narrow therapeutic windows and variability in therapeutic blood medication levels, in addition to many drug-drug interactions, and may cause liver disease and renal impairment. Drug levels should be measured with each dose increase and periodically thereafter. Carbamazepine, in particular, causes autoinduction of hepatic microsomal enzymes, which can further complicate obtaining a therapeutic medication level. Female patients should have pregnancy testing before taking valproate, and those who are sexually active must be cautioned to use effective contraception, because neural tube defects are associated with carbamazepine.

Less toxic AEDs (gabapentin and pregabalin) have supplanted the use of valproate and carbamazepine in patients with pain. These agents have their own side effect profiles, but they are much less toxic than their predecessors and do not require monitoring of liver or bone marrow function or blood levels. Furthermore, they are also far less lethal in accidental or deliberate overdose.

Gabapentin is approved for treatment of postherpetic neuralgia and is also widely prescribed for other pain disorders. It has demonstrated some efficacy in treating children with chronic pain, particularly neuropathic pain, and is used in treatment of chronic headache disorders, complex regional pain syndromes, chemotherapy-induced neuropathy, and diabetic neuropathy in both children and adults. Gabapentin has a relatively benign side effect profile and no drug interactions. Side effects include somnolence, dizziness, and ataxia; children occasionally demonstrate side effects not reported in adults, such as impulsive

or oppositional behavior, agitation, and occasionally depression. These side effects do not seem to be dose related.

**Pregabalin** works by similar mechanisms as gabapentin and may have a lower side effect profile. It is most often dosed twice a day rather than three times a day, which may lead to increased adherence. Both gabapentin and pregabalin undergo virtually no hepatic metabolism, with no significant drug-drug interactions, a common concern in patients with chronic pain, who frequently take multiple medications—for both the pain and the underlying medical condition associated with the pain. However, because both AEDs depend on renal function for clearance, doses must be adjusted in the presence of renal dysfunction.

**Topiramate** also demonstrates greater success than traditional AEDs in treating trigeminal neuralgia in adults and in migraine prophylaxis. Topiramate is approved for migraine prophylaxis in children and adolescents from the age of 12-17. Topiramate therapy results more frequently in cognitive dysfunction and short-term memory loss than gabapentin or pregabalin, and although these neurocognitive effects are often well tolerated, they should be monitored. The pediatrician should also be aware that topiramate is associated with weight loss, whereas other AEDs are typically associated with significant weight gain. This side effect is particularly valuable in weight-conscious adolescents, whereas in the anorexic cancer patient, a TCA would be preferable to induce appetite and weight gain. In at-risk populations, routine weight checks are recommended.

### Benzodiazepines

Children and adolescents with chronic pain may have comorbid psychological conditions, such as depressed mood, sleep disturbances, and anxiety disorders, including generalized anxiety disorder, separation anxiety, posttraumatic stress disorder (PTSD), and panic attacks. Psychological factors affect a youth's perception of pain and mechanisms of coping with a pain disorder. A *conditioned response* to pain may be to feel out of control and increase anxiety and pain, and conversely, *anticipatory anxiety* related to pain will inhibit activities and recovery. Feelings of helplessness sensitize the child to increasing amounts of pain, leading the child to perseverate on pain, think catastrophically, and feel hopeless. Changes in children's normal routines, with a negative impact on participation in valued activities, may further promote hopelessness, resulting in increased pain experiences and development of a depressive disorder.

Benzodiazepines are anxiolytic medications that also have muscle relaxant effects. They have a role in the treatment of acute pain in the hospital, where they are useful adjuncts because they inhibit painful muscle spasms in postsurgical patients. They also can suppress the anxiety that often occurs in hospitalized children, anxiety that interferes with restorative sleep and amplifies the child's perception of pain. Benzodiazepines are useful to calm children with anxiety and anticipatory anxiety about planned painful procedures. They are frequently used as a part of procedural sedation or preoperatively before surgical procedures.

Because dependence, tolerance, and withdrawal may occur with prolonged use, benzodiazepines are generally not recommended for the routine management of *chronic pain* or anxiety in children. Further, the risk of respiratory depression when benzodiazepines are combined with opioid therapy has contributed to the increasing number of opioid-related deaths in the United States. In concert with psychotherapy, benzodiazepines may help control anxiety symptoms that amplify the perception of pain, but we recommend the appropriate use of benzodiazepines in the chronic setting occur under the direction of a psychiatrist. In addition, other alternatives such as hydroxyzine may provide similar benefit without the negative aspects encountered with chronic benzodiazepine use.

Infrequently, benzodiazepines may cause behavioral disinhibition, psychosis-like behaviors, or, in large doses, respiratory depression. When dosing these medications, the pediatrician should consider that many benzodiazepines are metabolized by the cytochrome P450 microsomal enzyme system. This issue may be less significant with lorazepam and oxazepam, which undergo first-pass hepatic conjugation. Side effects common to benzodiazepines include sedation, ataxia,

anemia, increased bronchial secretions, and depressed mood. If a benzodiazepine is administered for more than 5 consecutive days, the dosage should be slowly tapered. Abrupt discontinuation of therapy can lead to autonomic instability, delirium, agitation, seizures, and profound insomnia. The routine use of benzodiazepines to treat anxiety during hospitalization is not recommended and should only be used under expert guidance.

### Antipsychotics and Major Sedatives

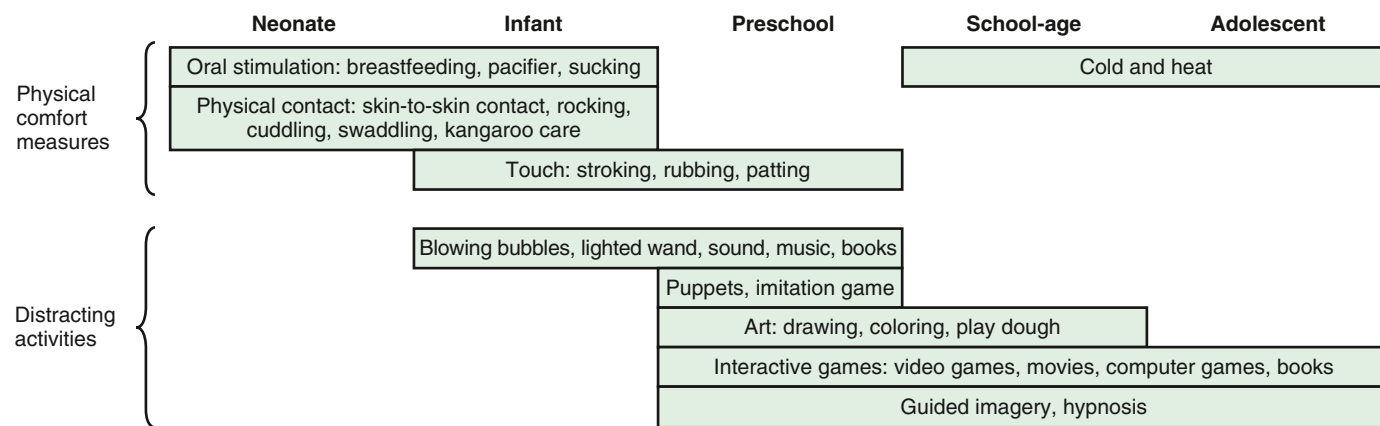
Low doses of antipsychotic medications are often used to address the more severe anxiety, agitation, and behavioral decompensation sometimes associated with severe pain. The use of these medications is controversial because associated adverse events may be severe and irreversible. Typical antipsychotics used in the past, including thioridazine (Mellaril), haloperidol (Haldol), and chlorpromazine (Thorazine), are associated with a decreased seizure threshold, dystonia, agranulocytosis, weight gain, cardiac conduction disturbances, tardive dyskinesia, orthostatic hypotension, hepatic dysfunction, and life-threatening laryngeal dystonia and have little role in the routine treatment of pain in children. Chlorpromazine is approved in adults for intractable hiccups, and its use may be appropriate in select settings such as the palliative setting, although this is not considered a first-line medication. Side effects are generally less severe with atypical antipsychotics. Because these effects may still occur, however, the pediatrician should obtain a baseline ECG, liver function values, and CBC and, if possible, obtain a child psychiatry consultation. If the pediatrician is using typical antipsychotics, an inventory of movement disturbances, such as the Abnormal Involuntary Movement Scale (AIMS) test, should be performed at baseline and at every follow-up visit, because movement disorders can worsen with abrupt withdrawal of medications or can become irreversible.

**Atypical antipsychotics** are generally associated with less severe side effect profiles, particularly dyskinesias and dystonias. Use of olanzapine (Zyprexa), which is particularly helpful with insomnia and severe anxiety, requires assessing and monitoring blood levels of glucose, cholesterol, and triglyceride; olanzapine's side effects may include diabetes, hypercholesterolemia, or significant weight gain. The anticholinergic side effects associated with quetiapine (Seroquel) warrant frequent monitoring of blood pressure. Risperidone at doses >6 mg may cause side effects similar to those of typical antipsychotics. Aripiprazole (Abilify) has been used for severe anxiety and/or for treatment-resistant depression. All antipsychotics are associated with the rare but potentially lethal **neuroleptic malignant syndrome**, which includes severe autonomic instability, muscular rigidity, hyperthermia, catatonia, and altered mental status (see [Chapter 33](#)).

### Other Pain Control Medications

Alpha-adrenergic receptor agonists such as clonidine are typically used as antihypertensive agents. However, they are often helpful as both anxiolytics and sleep-onset agents in the anxious hospitalized child. The  $\alpha$ -agonists also have central effects on pain reduction. **Clonidine** can be given orally or transdermally if the child's blood pressure permits. In certain settings, IV **dexmedetomidine**, an  $\alpha$ -agonist sedating agent, can be used preoperatively for anxiety, in the intensive care unit (ICU) for sedation, and may be used for pain in certain circumstances. Weaning off dexmedetomidine can often be accomplished with a transition to clonidine. **Propranolol** and metoprolol are both  $\beta$ -blocking agents typically used for the child with autonomic instability and for thalamic storm. They may also be used in migraine prophylaxis. There are reports that  $\beta$  blockers can enhance depression in a child who already has a major depressive disorder, and discussion with a child psychiatrist may be helpful in decisions about using propranolol if needed. Both clonidine and propranolol have been found useful for the agitated child with ASD. Another  $\alpha$ -agonist, **guanfacine**, is more likely to be used during the day for the child with ASD because it is less sedating than clonidine. Despite research on the impact of clonidine on chronic pain, no data are available to determine if guanfacine is as effective in reducing pain. **Ketamine**, a blocker of *N*-methyl-D-aspartate (NMDA) receptors, has been used for intractable pain in hospitalized children





**Fig. 93.5** Nonpharmacologic interventions for pediatric pain. (From Krauss BS, Calligaris L, Green SM, Barbi E. Current concepts in management of pain in children in the emergency department. *Lancet*. 2016;387:83–92.)

and in outpatients with severe sickle cell disease–related chronic pain, as well as others in palliative care for whom opioids are not sufficient to reduce pain. Recommended doses for pain management in non-ICU settings are between 0.1 and 0.3 mg/kg/hr. Higher doses may result in increased side effects, sedation with little benefit, and possible ICU admission. Because ketamine can have central hallucinatory effects, such children should be monitored closely.

### NONPHARMACOLOGIC TREATMENT OF PAIN

Numerous psychologic and physical treatments for relieving pain, fear, and anxiety as well as enhancing functioning have excellent safety profiles and proven effectiveness and should always be considered for incorporation into pediatric pain treatment (Fig. 93.5). In acute and procedural pain, nonpharmacologic strategies have long been used to help reduce distress in children undergoing medical procedures and surgery. Many of these methods aim to help children shift attention from pain and alter pain perception (e.g., distraction, hypnosis, imagery). Similarly, in the treatment of chronic pain, several strategies, often falling under the umbrella category of **cognitive-behavioral therapies (CBTs)**, have been shown to reduce pain and improve functioning and quality of life. CBT was developed with the goal of modifying social/environmental and behavioral factors that may exacerbate the child's experience of pain and pain-related disability. Meta-analyses of randomized controlled trials (RCTs) of CBT interventions have found large positive effects of psychologic intervention on reductions in pain and/or its deleterious effects in children with headache, abdominal pain, and fibromyalgia, with relative or comparative effectiveness of different interventions examined in areas such as headache and abdominal pain in children. **Biofeedback** and **relaxation therapies** have been found to have superior effects to pharmacologic treatments in reducing headache pain in children and adolescents. Similarly, for recurrent abdominal pain, positive effects for CBT were found relative to attention-control conditions and pharmaceutical, botanical, and dietary interventions (which had very weak evidence). Positive results have even resulted from very brief (three sessions) and remotely delivered (telephone or internet) therapies, with outcomes lasting up to 12 months after intervention.

When deciding how to incorporate nonpharmacologic techniques to treat pain, the practitioner should (1) conduct a thorough assessment of individual, social, and environmental factors that may be contributing to the patient's pain and functioning limitations; (2) based on this assessment, decide whether nonpharmacologic techniques alone may be sufficient as a beginning to treatment or if these treatments should be integrated with appropriate analgesics; (3) give children (and family members) developmentally and situationally appropriate information as to the rationale for treatment selection and what to expect, given the child's medical condition, procedures, and treatments; (4) include patients and their families in decision-making to ensure an appropriate treatment choice and to optimize adherence to treatment protocols;

and (5) above all, develop a communication plan among the different care providers, typically with the pediatrician as the case manager, so that the messages to the child and parent are consistent and the modes of therapy are organized into an integrative team approach. Finally, it is important to recognize that in addition to pain, other psychologic disorders (e.g., anxiety disorders, major depression) may affect the presenting pain complaint and may need to be identified and addressed as part of, or separate from, the pain management plan. Individual psychotherapy or psychiatric intervention may be warranted to adequately treat a comorbid disorder.

CBT strategies refer to a range of techniques that teach children (and their caregivers) how to manage pain by learning new ways to think about the pain and how to change behaviors associated with it. Strategies focusing on **cognitions** are typically aimed at enhancing parents' and children's confidence and self-efficacy to handle pain and decrease fear of pain. In addition, pain coping skills may shift the child's attentional focus away from pain and painful stimuli.

The goals of those strategies focusing on **behavior change** are to modify (1) contingencies in the child's environment, such as teaching parents how to respond to pain behaviors in ways that encourage wellness, rather than illness behaviors; (2) the ways parents model reactions to pain or discomfort; (3) child and parent coping techniques when psychosocial distress or problems in social relations exist; and (4) the child's behavioral reactions to situations, such as relaxation and exposure to previously avoided activities. Common examples of these strategies are discussed in the next several paragraphs. Whereas comprehensive CBTs are typically conducted by trained mental health specialists over several sessions, some basic CBT strategies can be briefly and easily introduced by practitioners into most medical settings. If more in-depth CBT treatment is needed, a referral to a qualified mental health specialist with CBT skills is warranted.

**Parent and family education** and/or **psychotherapy**, particularly within cognitive-behavioral family approaches, is one treatment modality through which these goals are accomplished and has been shown to be effective for treating chronic pain. Parents can learn to cope with their own distress and to understand pain mechanisms and appropriate treatment of pain. Key components include teaching parents to alter family patterns that may inadvertently exacerbate pain through developing behavior plans. Parents are taught to create plans for the child to manage the child's own symptoms and increase independent functioning. Often, adult caregivers (e.g., parents, teachers) need only guidance on developing a behavioral incentive plan to help the child return to school, gradually increase attendance, and receive tutoring after a prolonged, pain-related absence. *Suggested sample brief strategy:* Ask caregivers how they react to the child's pain complaints; assess whether they encourage wellness activities or give attention and "rewards" primarily when the child says he or she does not feel well; and suggest that caregivers respond to the child in ways that encourage wellness, both when complaining and not complaining.

**Relaxation training** is often employed to promote muscle relaxation and reduction of anxiety, which often accompanies and increases pain. Relaxation training, along with distraction and biofeedback, are treatments often included in CBT, but also are discussed in the literature without mention of CBT.

**Controlled breathing and progressive muscle relaxation** are commonly used relaxation techniques taught to preschool-age and older children. *Suggested sample brief strategy:* Ask the child (or instruct the caregiver to do so) to practice the following and use if pain is coming on: focus on the breath and pretend to be blowing up a big balloon while pursing the lips and exhaling slowly. This is one way to help induce controlled breathing.

**Distraction** can be used to help a child of any age shift attention away from pain and onto other activities. Common attention sustainers in the environment include bubbles, music, video games, television, the telephone, conversation, school, and play. Asking children to tell stories, asking parents to read to the child, and even mutual storytelling can be helpful distracters. Being involved with social, school, physical, or other activities helps the child in chronic pain to regain function. *Suggested sample brief strategy:* Encourage the child (or instruct the caregiver to do so) to shift attention away from the pain by continuing to engage in other activities and/or think of something else.

**Biofeedback** involves controlled breathing, relaxation, or hypnotic techniques with a computer synchronized device that provides visual or auditory feedback to the child when the desired action is approximated. Common targets of actions include muscle tension, peripheral skin temperature through peripheral vasodilation, and anal control through rectal muscle contraction and relaxation. Biofeedback also enhances the child's sense of mastery and control, especially for the child who needs more "proof" of change than that generated through hypnotherapy alone.

**Hypnotherapy** has also been used in the treatment of chronic pain in children, although the evidence for its effectiveness has not been as extensively studied as CBT. Hypnotherapy helps a child focus on an imaginative experience that is comforting, safe, fun, or intriguing. Hypnotherapy captures the child's attention, alters his or her sensory experiences, reduces distress, reframes pain experiences, creates time distortions, helps the child dissociate from the pain, and enhances feelings of mastery and self-control. Children with chronic pain can use *metaphor*, for example, imagining they have overcome something feared because of pain in real life. As the child increases mastery of imagined experiences, the enhanced sense of control can be used during actual pain rehabilitation. Hypnotherapy is best for children of school age or older.

Nonpharmacologic treatments of pain may also be applied to other treatment needs. A child who learns relaxation to reduce distress from lumbar punctures in cancer treatment may also apply this skill to other stressful medical and nonmedical situations, such as stressors caused by school.

Yoga is intended to achieve balance in mind, body, and spirit. **Therapeutic yoga** can be helpful in treating chronic pain; improving mood, energy, and sleep; and reducing anxiety. Yoga involves a series of *asanas* (body poses) oriented to the specific medical condition or symptoms. Some forms of yoga use poses within a movement flow and format. *Iyengar* yoga is an alignment-based system that uses props, such as blankets, bolsters, blocks, and belts, to support the body while the practitioner assumes more healing poses. Yoga promotes a sense of energy, relaxation, strength, balance, and flexibility and, over time, enhances a sense of mastery and control. Within a yoga practice, the child may learn certain types of breathing (*pranayama*) for added benefit. With a focus on body postures or in types of flow yoga, the child learns mindfulness or being present in the moment. By focusing on body and breath, the child can develop strategies to avoid ruminating about the past or worrying about the future.

**Mindfulness meditation** involves a focus on the present, "in-the-moment" experience using a variety of strategies. Many studies in adults report the value of meditation for chronic pain states and for anxiety and depression. These strategies help children learn how to be mindful and in the present with enhanced parasympathetic control. Many mindfulness smartphone applications are geared to children of

different ages, as well as books for parents on how to help their children achieve a mindful state to enhance relaxation. Although there are different schools of mindfulness, such as *Vipassana* (insight-oriented meditation, often using a focus on the breath) and *transcendental* meditation (in which the child learns the use of a silent mantra to facilitate acquiring a deeper inner calmness), the goal is to help the child learn strategies that enhance self-competence in reducing stress and enhancing a state of well-being.

**Massage therapy** involves the therapist's touching and applying varied degrees of pressure on the child's muscles. Massage is very useful for children with chronic pain and especially helpful for those with myofascial pain. There are several types of massage, including cranio-sacral therapy. For young children, it can be helpful to have parents learn and perform brief massage on their children before bedtime. Massage therapy likely will not be helpful to or tolerated by the child with sensory sensitivity and sensory aversion.

**Physical therapy** can be especially useful for children with chronic musculoskeletal pain and for those deconditioned from inactivity. Exercise appears specifically to benefit muscle functioning, circulation, and posture while also improving body image, body mechanics, sleep, and mood. The physical therapist and the child can develop a graded exercise plan for enhancing the child's overall function for the child to continue at home. Research indicates that physical therapy affects central neurobiologic mechanisms that enhance "top-down" pain control.

**Acupuncture/acupressure** involves the placement of needles or pressure at specific points along a *meridian*, or energy field, after the acupuncturist has made a diagnosis of excess or deficient energy in that meridian as the primary cause of the pain. Acupuncture/acupressure is a feasible, popular part of a pain management plan for children with chronic pain. Acupuncture/acupressure alleviates chronic nausea, fatigue, and several chronic pain states, including migraine and chronic daily headaches, abdominal pain, and myofascial pain. Acupuncture/acupressure also has efficacy in adults with myofascial pain, primary dysmenorrhea, sickle cell crisis pain, and sore throat pain. The acupuncturist must relate well to children so that the experience is not traumatic, because added stress would undo the benefits gained.

**Transcutaneous electrical nerve stimulation (TENS)** is the use of a battery-operated tool worn on the body to send electrical impulses into the body at certain frequencies set by the machine. TENS is believed to be safe and can be tried for many forms of localized pain. Children often find TENS helpful and effective.

**Music therapy and art therapy** can be especially helpful for young and nonverbal children who would otherwise have trouble with traditional talk psychotherapies. Also, many creative children can more easily express fears and negative emotions through creative expression and, with the therapist's help, learn about themselves in the process. There is also increasing research on the impact of art and music therapy on altering central neural circuits that maintain and enhance pain.

**Dance, movement, pet therapies, and aromatherapy** have also been used and may be helpful, but these have not been as well studied in children for pain control as have other complementary therapies. Often, clinical experience helps guide the pediatrician in the benefits of these therapies with individual patients. For example, pet therapy is gaining favor in hospitals and in stress reduction for sick children. Pets often can become self-regulators for the child with ASD, although the neurobiologic mechanisms are not yet understood.

## INVASIVE INTERVENTIONS FOR TREATING PAIN

Various interventional neuraxial and peripheral nerve blocks may have a role in the treatment of pain acutely (e.g., long-bone fracture), perioperatively, and for the patient with chronic pain (e.g., headache, abdominal pain, complex regional pain syndrome [CRPS], or cancer pain). Interventions also provide intraoperative anesthesia and post-operative analgesia (see [Chapter 91](#)). Use of interventional procedures varies greatly across institutions; they may be frequently used at some hospitals, whereas other institutions focus mainly on noninterventional treatment plans. Interventional procedures may be useful in some children who have specific types of chronic pain, but their use in children (as widely practiced in adult pain clinics) generally is not

recommended because the pediatric research is insufficient. Therefore the data are largely extrapolated from the adult population. Use of such procedures in children should generally not be considered or undertaken by an adult chronic pain provider who is willing to perform such a procedure on a child or adolescent. Rather, the potential procedure or block should be undertaken only at the direction or guidance of a pediatric pain specialist. Complications and lack of benefit can occur in children, as may occur in adults; however, more harm may be done in the pediatric populations. This is especially true as children and families may “pin their hopes” on a particular intervention “curing their child,” when in reality chronic pain is a complex phenomenon that responds best to multidisciplinary management. This does not mean that no block should be recommended in children, but that procedural interventions should be used judiciously, appropriately, and in conjunction with other biopsychosocial treatments by or under the guidance of a pediatric pain expert.

**Regional anesthesia** provides several benefits, particularly in the acute perioperative setting. As an alternative to or in augmentation of opioid-based pain control, regional anesthesia minimizes opioid requirements and therefore opioid side effects, including nausea, vomiting, somnolence, respiratory depression, pruritus, constipation, and physical dependence. It can provide equal or improved analgesia, as it interrupts nociceptive pathways and may profoundly inhibit endocrine stress responses. Regional anesthesia also results in earlier ambulation in recovering surgical patients, helps prevent atelectasis in the patient with chest pain, and usually results in earlier discharge from the hospital. Theoretically, the interruption of nociceptive pathways in the periphery by regional anesthetics will prevent or reverse the process of amplification of pain signals induced by nociception (e.g., CNS wind-up, glial cell activation). For postoperative pain, effective regional anesthesia reduces the risks of acute pain evolving to chronic pain. Regional anesthesia is considered safe and effective if performed by trained staff with the proper instruments and equipment. Most frequently, nerve blocks are performed by an anesthesiologist or pain management physician; a few are easily performed by a nonanesthesiologist with appropriate training. The benefits of regional anesthesia are dependent on adequate coverage of the surgical area, the patient and family's expectation of the block, and the expertise of the provider performing the block. When procedures fail to provide adequate analgesia, it can lead to the need to “catch up” with pain control after surgery.

### Head and Neck Blocks

Primary pain syndromes of the head, such as trigeminal neuralgia, are distinctly unusual in the pediatric population, and few surgical procedures in the head and neck are amenable to regional anesthesia. Headache disorders, very common in the pediatric age-group, may respond well to regional anesthesia of the greater occipital nerve. However, this is not generally considered a first-line treatment of pediatric headache. The greater occipital nerve (second cervical, C2) provides sensation to much of the cranial structures, from the upper cervical region, the occiput to the apex of the head, or even to the hairline. The greater occipital nerve can be blocked medial to the occipital artery, which can usually be identified at the occipital ridge midway between the occipital prominence and the mastoid process by palpation, Doppler sound amplification, or visualization by ultrasound. The short-term and especially long-lasting effects of nerve blocks for chronic headaches in children have not been documented by research. Studies are needed to determine which children with which types of headaches will benefit most from occipital nerve blocks. Sphenopalatine blocks are increasingly used in the treatment of multiple types of headaches in adults, including migraine and postdural puncture headache (PDPH). There is some evidence to support the benefit of this procedure in children and adolescents. The sphenopalatine ganglion (SPG) is a collection of cells closely related to the trigeminal nerve that plays a role in headache pathology. This block can be performed in a minimally invasive fashion through the nasal cavity. The procedure may be performed either with the use of marketed devices or with the use of cotton-tipped applicators. SPG blocks may be performed with or without fluoroscopic guidance.

Onabotulinum toxin A (Botox) may also be used for the treatment of chronic migraine in children and adolescents. As with many interventions, the available data for benefit of this treatment for pediatric migraine are lacking compared with the adult data. However, many children or adolescents, who may have experienced treatment failure with medical management of headache, may be considered as candidates for the use of Botox.

### Upper Extremity Blocks

The brachial plexus block controls pain of the upper extremity. These blocks also protect the extremity from movement, reduce arterial spasm, and block sympathetic tone of the upper extremity. The brachial plexus, responsible for cutaneous and motor innervation of the upper extremity, is an arrangement of nerve fibers originating from spinal nerves C5 through T1, extending from the neck into the axilla, arm, and hand. The brachial plexus innervates the entire upper limb, except for the trapezius muscle and an area of skin near the axilla. If pain is located proximal to the elbow, the brachial plexus may be blocked above the clavicle (roots and trunks); if the pain is located distal to the elbow, the brachial plexus may be blocked at the axilla (cords and nerves). The block may be given as a single injection with a long-acting anesthetic such as bupivacaine or ropivacaine. This may provide up to 12-16 hours of analgesia. Use of a catheter and infusion pump may increase duration and provide continuous analgesia for several days.

### Trunk and Abdominal Visceral Blocks

Trunk blocks provide somatic and visceral analgesia and anesthesia for pain or surgery of the thorax and abdominal area. Sympathetic, motor, and sensory blockade may be obtained. These blocks are often used in combination to provide optimal relief. Intercostal and paravertebral blocks may be beneficial in patients for whom a thoracic epidural injection or catheter is contraindicated (e.g., patient with coagulopathy). Respiratory function is maintained, and the side effects of opioid therapy are eliminated.

The intercostal, paravertebral, erector spinae, rectus sheath, and transverse abdominal plane blocks are most useful for pediatric chest and somatic abdominal pain. The celiac plexus and splanchnic nerve block can be useful for abdominal visceral pain, such as that caused by malignancy or pancreatitis. These blocks are best performed by an experienced anesthesiologist, pain physician, or interventional radiologist using ultrasound or CT imaging guidance.

The **intercostal block** is used to block the intercostal nerves, the anterior rami of the thoracic nerves from T1 to T11. These nerves lie inferior to each rib, between the inner and innermost intercostal muscles with their corresponding vein and artery, where they can be blocked, generally posterior to the posterior axillary line. Guidance with either fluoroscopy or ultrasound is often employed to decrease risks associated with this block. With use of ultrasound imaging, the intercostal nerves and the pleura can be identified, which can decrease risks such as pneumothorax or hemothorax that are associated with this procedure. The **erector spinae plane** block has also shown to be effective for blocking several levels of intercostal nerves while avoiding the attendant risks of multilevel intercostal nerve blocks.

The **paravertebral block**, another alternative to intercostal nerve block or epidural analgesia, is useful for pain associated with thoracotomy or with unilateral abdominal surgery, such as nephrectomy or splenectomy. Essentially this block results in multiple intercostal blocks with a single injection. The thoracic paravertebral space, lateral to the vertebral column, contains the sympathetic chain, rami communicantes, dorsal and ventral roots of the spinal nerves, and dorsal root ganglion. Because it is a continuous space, local anesthetic injection will provide sensory, motor, and sympathetic blockade to several dermatomes. The paravertebral block may be performed as a single injection or, for a very prolonged effect, as a continuous infusion over several days or weeks via a catheter. This block is best performed by an anesthesiologist or interventional pain physician under ultrasound guidance.



**Ilioinguinal and iliohypogastric nerve blocks** are indicated with surgery for inguinal hernia repair, hydrocele, or orchidopexy repair and for chronic pain subsequent to these procedures. The first lumbar (L1) nerve divides into the iliohypogastric and ilioinguinal nerves, which emerge from the lateral border of the psoas major muscle. The iliohypogastric nerve supplies the suprapubic area as it pierces the transversus abdominis muscle and runs deep to the internal oblique muscle. The ilioinguinal nerve supplies the upper medial thigh and superior inguinal region, as it also pierces the transversus abdominis muscle and runs across the inguinal canal. Ultrasound guidance helps ensure success for this nerve block.

The **celiac plexus block** is indicated for surgery or pain of the pancreas and upper abdominal viscera. The celiac plexus, located on each side of the L1 vertebral body, contains one to five ganglia. The aorta lies posterior, the pancreas anterior, and the inferior vena cava lateral to these nerves. The celiac plexus receives sympathetic fibers from the greater, lesser, and least splanchnic nerves, as well as from parasympathetic fibers from the vagus nerve. Autonomic fibers from the liver, gallbladder, pancreas, stomach, spleen, kidneys, intestines, and adrenal glands originate from the celiac plexus. This block is best performed with CT guidance to provide direct visualization of the appropriate landmarks, avoid vascular and visceral structures, and confirm correct needle placement. The close proximity of structures such as the aorta and vena cava make this a technical procedure best performed by an anesthesiologist, interventional pain physician, or interventional radiologist. The evidence for use of this block for chronic pediatric pain is lacking; as such, this block should not be routinely employed in the treatment of chronic noncancer pain.

Nerve blocks have been used for the treatment of *anterior cutaneous nerve entrapment syndrome (ACNES)*. ACNES is characterized by pain associated with use of abdominal muscles. On exam, this can be identified via Carnett sign. Pathology and causation in the pediatric population are not well understood. Treatment may include infiltration of a specific pain source under ultrasound guidance with infiltration of a local anesthetic or local anesthetic and steroid mixture. Evidence for use of this procedure is limited.

### Lower Extremity Blocks

**Lumbar plexus and sciatic nerve blocks** provide pain control for painful conditions or surgical procedures of the lower extremities, with the benefit of providing analgesia to only one extremity while preserving motor and sensory function of the other. The lumbosacral plexus is

an arrangement of nerve fibers originating from spinal nerves L2-L4 and S1-S3. The lumbar plexus arises from L2-L4 and forms the lateral femoral cutaneous, femoral, and obturator nerves. These nerves supply the muscles and sensation of the upper leg, with a sensory branch of the femoral nerve (saphenous nerve) extending below the knee to innervate the medial aspect of the foreleg, ankle, and foot. The sacral plexus arises from L4-S3 and divides into the major branches of the sciatic, tibial, and common peroneal nerves. These nerves in turn supply the posterior thigh, lower leg, and foot. Unlike the brachial plexus block, blockade of the entire lower extremity requires more than one injection because the lumbosacral sheath is not accessible. Separate injections are necessary for the posterior (sciatic) and anterior (lumbar plexus) branches, and the injections can be performed at any of several levels during the course of the nerve, as is clinically expedient. The lumbar plexus can be blocked in the back, resulting in analgesia of the femoral, lateral femoral cutaneous, and obturator nerves. Alternatively, any of these three nerves can be individually anesthetized, depending on the location of the pain. Similarly, the sciatic nerve can be anesthetized proximally as it emerges from the pelvis or, more distally, in the posterior thigh, or its major branches (tibial and peroneal nerves) can be individually anesthetized. These nerve blocks are generally best performed by an anesthesiologist, pain physician, or radiologist.

### Sympathetic Blocks

Sympathetic blocks were once thought to be useful in the diagnosis and treatment of sympathetically mediated pain, CRPS (Table 93.17), and other neuropathic pain conditions (Table 93.18), but large meta-analyses have shown their utility to be minimal. When blocks of the sympathetic plexuses are performed, sympathectomy is obtained

**Table 93.18** Examples of Neuropathic Pain Syndromes

#### PERIPHERAL NERVOUS SYSTEM FOCAL AND MULTIFOCAL LESIONS

Postherpetic neuralgia  
Cranial neuralgias (e.g., trigeminal neuralgia, glossopharyngeal neuralgia)  
Diabetic mononeuropathy  
Nerve entrapment syndromes  
Plexopathy from malignancy or irradiation  
Phantom limb pain  
Posttraumatic neuralgia (e.g., nerve root compression, after thoracotomy)  
Ischemic neuropathy  
Complex regional pain syndrome types 1 and 2  
Erythromelalgia

#### PERIPHERAL NERVOUS SYSTEM GENERALIZED POLYNEUROPATHIES

*Metabolic/nutritional:* Diabetes mellitus, pellagra, beriberi, multiple nutritional deficiency, hypothyroidism  
*Toxic:* Alcohol-, platinum-, or taxane-based chemotherapy; isoniazid; antiretroviral drugs  
*Infective/autoimmune:* HIV, acute inflammatory polyneuropathy (Guillain-Barré syndrome), neuroborreliosis (Bannwarth syndrome)  
*Hereditary:* Fabry disease  
*Malignancy:* Carcinomatosis  
*Others:* Idiopathic small fiber neuropathy, erythromelalgia

#### CENTRAL NERVOUS SYSTEM LESIONS

Spinal cord injury  
Prolapsed disc  
Stroke (brain infarction, spinal infarction)  
Multiple sclerosis  
Surgical lesions (e.g., rhizotomy, cordotomy)  
Complex neuropathic disorders  
Complex regional pain syndrome types 1 and 2

**Table 93.17** Budapest Criteria for Clinical Diagnosis of CRPS

1. **Pain** (ongoing and disproportionate to any inciting event)
2. **Symptoms (reported):** At least one symptom in three out of four of the following categories:
  - *Sensory* – Hyperesthesia and/or allodynia
  - *Vasomotor* – Temperature asymmetry and/or skin color changes and/or skin color asymmetry
  - *Sudomotor/Edema* – Edema and/or sweating changes and/or sweating asymmetry
  - *Motor/Trophic* – Decreased range of motion and/or motor dysfunction (weakness, tremor, dystonia) and/or trophic changes (hair, nail, skin)
3. **Signs (examined):** At least one sign in two out of four of the following categories:
  - *Sensory* – Hyperalgesia (to pinprick) and/or allodynia (to light touch and/or temperature sensation and/or deep somatic pressure and/or joint movement)
  - *Vasomotor* – Temperature asymmetry (>1°C) and/or skin color changes and/or asymmetry
  - *Sudomotor/Edema* – Edema and/or sweating changes and/or sweating asymmetry
  - *Motor/Trophic* – Decreased range of motion and/or motor dysfunction (weakness, tremor, dystonia) and/or trophic changes (hair, nail, skin)
4. **Diagnosis of exclusion:** No other diagnosis better explains the signs and symptoms.

CRPS, Complex regional pain syndrome

From Davis PJ, Cladis FP, eds. *Smith's Anesthesia for Infants and Children*, 10th ed. Philadelphia: Elsevier; 2022, Box 25.1, p. 583.

Adapted from Freynhagen R, Bennett MI. Diagnosis and management of neuropathic pain. *BMJ*. 2009;339:b3002.



without attendant motor or sensory anesthesia. Their use for pain management was grounded in the notion that many types of chronic pain were mediated via the sympathetic nerves. This mechanistic model has been proven to be false.

The **stellate ganglion block** was indicated for pain in the face or upper extremity and for CRPS, phantom limb pain, amputation stump pain, or circulatory insufficiency of the upper extremities. The lumbar sympathetic block addressed pain in the lower extremity, CRPS, phantom limb pain, amputation stump pain, and pain from circulatory insufficiency.

The analgesia produced by peripheral sympathetic blocks usually outlives the duration of the local anesthetic, often persisting for weeks or indefinitely. If analgesia is transient, the blocks may be performed with catheter insertion for continuous local anesthesia of the sympathetic chain over days or weeks. Because precise, radiographically guided placement of the needle and/or catheter is required for safety and success, sympathetic blocks are generally best performed by an anesthesiologist, interventional pain physician, or interventional radiologist.

While all these procedures can be considered for the treatment of certain chronic pediatric pain conditions, there is overall a lack of evidence to support routine use in children and adolescents. This information should be used for learning and awareness rather than as a guide map for specific treatment of these conditions. When needed, a dedicated pediatric pain provider should be consulted and these blocks used judiciously when appropriate.

In addition, any time these procedures are considered for the treatment of chronic pain, special consideration should be given to potential risks and complications.

### Epidural Anesthesia (Thoracic, Lumbar, and Caudal)

Epidural anesthesia and analgesia are indicated for pain below the clavicles, management of regional pain syndromes, cancer pain unresponsive to systemic opioids, and pain limited by opioid side effects.

The three layers of the spinal meninges—dura mater (outer), arachnoid mater (middle), and pia mater (inner)—envelop the spinal neural tissue. The subarachnoid space contains cerebrospinal fluid between the arachnoid mater and pia mater. The epidural space extends from the foramen magnum to the sacral hiatus and contains fat, lymphatics, blood vessels, and the spinal nerves as they leave the spinal cord. The epidural space separates the dura mater from the periosteum of the surrounding vertebral bodies. In children, the fat in the epidural space is not as dense as in adults, predisposing to greater spread of the local anesthetic from the site of injection.

Epidural local anesthetics block both sensory and sympathetic fibers, and if the local anesthetic is of sufficient concentration, they also block motor fibers. Mild hypotension may occur, although it is unusual in children <6 years of age. Epidural local anesthetics high in the thoracic spine may also anesthetize the sympathetic nerves to the heart (the cardiac accelerator fibers), producing bradycardia. In addition to using local anesthetics, it is routine to use opioids and sometimes  $\alpha$ -agonists as adjunctive medications in the epidural space. Clonidine and opioids have been well studied and shown not to be neurotoxic. Side effects of epidural opioid administration include delayed respiratory depression, particularly when hydrophilic opioids such as morphine are used. The risk of this effect requires that children receiving epidural opioids by intermittent injection or continuous infusion be monitored by continuous pulse oximetry and nursing observation, particularly during the first 24 hours of therapy or after significant dose escalations. Respiratory depression occurring after the first 24 hours of epidural opioid administration is distinctly unusual.

Epidural clonidine (an  $\alpha_2$ -agonist with  $\mu$ -opioid analgesic properties) is associated with minimal risk and side effects. Although product labeling indicates use only in children with severe cancer pain, clonidine may be used for treatment of routine postoperative pain as well as pain syndromes such as CRPS. Mild sedation is the most common side effect of epidural clonidine, and it is not associated with respiratory depression.

Because performing epidural blockade is technical and may result in spinal cord injury, it is best done by an anesthesiologist or pain

physician skilled in the technique. Caution is advised in the use of epidural anesthesia/analgesia for CRPS in children because no published RCTs have shown these procedures superior to a combination of less invasive physical and psychological therapy, with or without neuropathic pain-focused medications.

### INTRATHECAL ANALGESIA

Intrathecal catheters infused with opioids, clonidine, ziconotide (derived from a marine neurotoxin produced by the cone snail), and local anesthetics are occasionally applicable in pediatric patients with intractable pain from cancer or other life-threatening conditions. Typically, intrathecal catheters are attached to an implanted electronic pump containing a drug reservoir sufficient for several months of dosing. The technique is technical and best performed by an experienced pain management physician or neurosurgeon.

### NERVE ABLATION AND DESTRUCTION

In some cases, pain remains refractory despite maximal reliance on oral and IV medications and nerve blockade. In these patients, temporary (pulsed radiofrequency ablation) or permanent neurolytic destruction (phenol or alcohol) of one or more nerves may be performed. The techniques should be carefully weighed against the consideration of permanent nerve destruction in a growing child with decades of life ahead. On the other hand, when pain is severe in life-limiting disease processes, the long-term considerations are less concerning, and these techniques should be discussed with a skilled pain management specialist.

### CONSIDERATIONS FOR SPECIAL PEDIATRIC POPULATIONS

#### Pain Perception and Effects of Pain on Newborns and Infants

Pain may result from a number of circumstances in the newborn period, including acute pain (diagnostic and therapeutic procedures, minor surgery, monitoring), continuous pain (pain from thermal/chemical burns, postsurgical and inflammatory pain), and chronic or disease-related pain (necrotizing enterocolitis, nerve injury, chronic conditions, thrombophlebitis). The most common sources of pain in healthy infants are acute procedures, such as heel lances, surgical procedures, and in males, circumcision.

Many procedures are performed for premature infants in the neonatal intensive care unit (NICU). In the first week of life, approximately 94% of preterm infants <28 weeks gestational age are mechanically ventilated; in these situations, heelsticks and airway suctioning are frequent, yet few of these procedures are preceded by any type of analgesia. Repeated handling and acute pain episodes sensitize the neonate to increased reactivity and stress responses to subsequent procedures. Typical stress responses include increases in heart rate, respiratory rate, blood pressure, and intracranial pressure. Cardiac vagal tone, transcutaneous oxygen saturation, carbon dioxide levels, and peripheral blood flow are decreased. Autonomic signs include changes in skin color, vomiting, gagging, hiccupping, diaphoresis, dilated pupils, and palmar and forehead sweating (see [Table 93.4](#)).

Untreated pain in the newborn has serious short- and long-term consequences. There has been a shift in most NICUs to more liberal use of opioids. Nonetheless, **morphine**, the traditional gold standard of analgesia for acute pain, may not be effective and may have adverse long-term consequences. No differences have been found in the incidence of severe intraventricular hemorrhage or in the mortality rate when infants receiving morphine are compared with a placebo group, and there are no changes in assessed pain from tracheal suctioning in ventilated infants receiving morphine compared with those receiving a placebo infusion. Morphine may not alleviate acute pain in ventilated preterm neonates, although there are few data on the effects of morphine and fentanyl in nonventilated newborns. The lack of opioid effects for acute pain in neonates may result from immaturity of opioid receptors; acute pain may cause the uncoupling of  $\mu$ -opioid receptors in the forebrain. Repetitive acute pain may create central neural changes in the newborn that may have long-term consequences for later pain vulnerability, cognitive effects, and opioid tolerance. Most

**Table 93.19** World Health Organization Analgesic Ladder for Cancer Pain**STEP 1**

Patients who present with mild to moderate pain should be treated with a nonopioid.

**STEP 2**

Patients who present with moderate to severe pain or for whom the step 1 regimen fails should be treated with an oral opioid for moderate pain combined with a nonopioid analgesic.

**STEP 3**

Patients who present with very severe pain or for whom the step 2 regimen fails should be treated with an opioid used for severe pain, with or without a nonopioid analgesic.

neonatologists use opioids in painful situations. Sucrose and pacifiers are also being used in the NICU. The effects of 24% **sucrose** (Sweetase) are believed to be opioid mediated because the effect can be reversed with naloxone. Sucrose, with or without a pacifier, may be effective for acute pain and stress control. Other nonpharmacologic strategies for stress and pain control include infant care by an individual primary nurse, tactile-kinesthetic stimuli (massage), “kangaroo care,” and soothing sensorial saturation.

### Children With Cancer Pain

The World Health Organization (WHO) proposed an analgesic therapy model for cancer pain known as the *analgesic ladder* (Table 93.19). Designed to guide therapy in care systems with limited access to analgesic experts, this ladder consists of a hierarchy of oral pharmacologic interventions intended to treat pain of increasing magnitude. The hierarchy ignores modalities such as the use of nonconventional analgesics and interventional pain procedures, which physicians in developed countries are often able to prescribe. Nevertheless, because oral medications are simple and efficacious, especially for home use, the ladder presents a framework for rationally using them, before applying other drugs and techniques of drug administration.

Oral medications are the first line of analgesic treatment. Because NSAIDs affect platelet adhesiveness, they are typically not used. As noted earlier, celecoxib may be the exception to this rule. Opioid therapy is the preferred approach for moderate or severe pain. Nonopioid analgesics are used for mild pain, a weak opioid is added for moderate pain, and strong opioids are administered for more severe pain. Adjuvant analgesics can be added, and side effects and comorbid symptoms are actively managed. Determining the type and sources of the pain will help develop an effective analgesic plan. Certain treatments, such as the chemotherapeutic agent vincristine, are associated with neuropathic pain. Such pain might require anticonvulsants or TCAs. Stretching pain from tumor growth within an organ might require strong opioids and/or radiation therapy if the tumor is radiosensitive. Organ obstruction, such as intestinal obstruction, should be diagnosed to relieve or bypass the obstruction.

It is important to consider both pharmacologic and nonpharmacologic strategies (e.g., CBT, family/parent support) to treat pain in children with cancer.

### Children with Pain Associated with Advanced Disease

Patients with advanced diseases, including cancer, acquired immunodeficiency syndrome (AIDS), neurodegenerative disorders, and cystic fibrosis, need palliative care approaches that focus on optimal quality of life. Nonpharmacologic and pharmacologic management of pain and other distressing symptoms is a key component. *Palliative care* should be offered to all children with serious diseases, whether or not the diseases are potentially curable or long life expectancy is predicted (see Chapter 8). Examples include young children diagnosed with acute lymphoblastic leukemia (>90% posttreatment life

expectancy) and children undergoing organ transplantation. Palliative care in pediatrics connotes treatment that focuses on symptom reduction, quality of life, and good family and clinical team communication. It is not only for patients in hospice care or those at the end of life. Differences in the progression of underlying illness, associated distressing symptoms, and common emotional responses in these conditions should shape individual treatment plans. For end-of-life care, >90% of children and adolescents with cancer can be made comfortable by standard escalation of opioids according to the WHO protocol. A small subgroup (5%) requires enormous opioid dose escalation to >100 times the standard morphine or other opiate infusion rate. Most of these patients have spread of solid tumors to the spinal cord, roots, or plexus, and signs of neuropathic pain are evident. **Methadone** given orally is often used in palliative care, not only end-of-life care, because of its long half-life and its targets at both opioid and NMDA receptors.

The type of pain experienced by the patient (neuropathic, myofascial) should determine the need for adjunctive agents. Complementary measures, such as massage, hypnotherapy, and spiritual care, must also be offered in palliative care. Although the oral route of opioid administration should be encouraged, especially to facilitate care at home, if possible, some children are unable to take oral opioids. Transdermal and sublingual routes, as well as IV infusion with PCA, are likely next choices. Small, portable infusion pumps are convenient for home use. If venous access is limited, a useful alternative is to administer opioids (especially morphine or hydromorphone, but not methadone or meperidine) through continuous SC infusion, with or without a bolus option. A small (e.g., 22-gauge) cannula is placed under the skin and secured on the thorax, abdomen, or thigh. Sites may be changed every 3-7 days, as needed. As noted, alternative routes for opioids include the transdermal and oral transmucosal routes. These latter routes are preferred over IV and SC drug delivery when the patient is being treated at home.

### CHRONIC AND RECURRENT PAIN SYNDROMES

*Chronic pain* is defined as recurrent or persistent pain lasting longer than the normal tissue healing time (3-6 months). Children may experience pain related to injury (e.g., burns) or to a chronic or underlying disease process (e.g., cancer, arthritis), or pain can also be the chronic condition itself (e.g., CRPS, fibromyalgia, functional abdominal pain) (see Chapter 212). During childhood, abdominal, musculoskeletal, and headache pain are the most frequently occurring conditions. However, definitions of chronic pain do not take into account standard criteria for assessing particular pain symptoms or for evaluating the intensity or impact of pain and therefore include individuals with varying symptoms and experiences. Consequently, in epidemiologic surveys, prevalence estimates vary widely. Overall prevalence rates for different childhood pains range from 4% to 88%. An average of 13.5–31.8% of adolescents in a community sample reported having weekly abdominal, headache, or musculoskeletal pains. Most epidemiologic studies report prevalence and do not report the *severity* or impact of the pain. Research indicates that only a subset of children and adolescents with chronic pain (approximately 5%) experience moderate to severe disability, and this likely better represents the estimated population for whom help is needed to treat pain and associated problems.

### Neuropathic Pain Syndromes

Neuropathic pain is caused by abnormal excitability in the peripheral or central nervous system that may persist after an injury heals or inflammation subsides. The pain, which can be acute or chronic, is typically described as burning or stabbing and may be associated with cutaneous hypersensitivity (**allodynia**), distortion of sensation (**dysesthesia**), and amplification of noxious sensations (**hyperalgesia** and **hyperpathia**). Neuropathic pain conditions may be responsible for >35% of referrals to chronic pain clinics, conditions that typically include posttraumatic and postsurgical peripheral nerve injuries, phantom pain after amputation, pain after spinal cord injury, and pain caused by metabolic neuropathies (see Table 93.18). Patients with neuropathic pain typically respond poorly to opioids. Evidence supports

the efficacy of antidepressants (nortriptyline, amitriptyline, venlafaxine, duloxetine) and anticonvulsants (gabapentin, pregabalin, oxcarbazepine) for treatment of neuropathic pain (see Table 93.16).

**Complex regional pain syndrome** is well described in the pediatric population (see Chapter 211 and Table 93.17). **CRPS type 1** is a syndrome of neuropathic pain that typically follows an antecedent and usually minor injury or surgery to an extremity without identifiable nerve injury. It is seen after injury such as sprain or fracture or even in instances as minimal as an IV start. The syndrome of CRPS type 1 includes severe spontaneous neuropathic pain, hyperpathia, hyperalgesia, severe cutaneous allodynia to touch and cold, changes in blood flow (typically extremity cyanosis), and increased sweating. In more advanced cases, symptoms include dystrophic changes of the hair, nails, and skin; immobility of the extremity (dystonia); and muscle atrophy. In the most advanced cases, symptoms include ankylosis of the joints of the extremity. Specific causal factors in CRPS type 1 in both children and adults remain elusive, although coincidental events may be noted. **CRPS type 2** clinically appears the same with respect to symptoms but is associated with a known nerve injury.

Treatment of CRPS in children has been extrapolated from that in adults, with some evidence for efficacy of physical therapy, CBT, nerve blocks, antidepressants, AEDs, and other related drugs. All experts in pediatric pain management agree on the value of aggressive physical therapy, including desensitization. Some centers provide aggressive therapy without the use of pharmacologic agents or interventional nerve blocks. Unfortunately, recurrent episodes of CRPS may be seen in up to 25–50% of patients, particularly adolescent females. Physical therapy can be extraordinarily painful for children to endure; it is tolerated only by the most stoic and motivated patients. If children have difficulty enduring the pain, there is a well-established role for pharmacologic agents, with or without peripheral or central neuraxial nerve blocks, to render the affected limb sufficiently analgesic so that physical therapy can be tolerated. Pharmacologic interventions include the use of AEDs such as gabapentin and/or TCAs such as amitriptyline (see Fig. 93.4). Although there is clear evidence of a peripheral inflammatory component of CRPS, with release of cytokines and other inflammatory mediators from the peripheral nervous system in the affected limb, the use of antiinflammatory agents has been disappointing. Common nerve block techniques include IV regional anesthetics, epidural analgesia, and peripheral nerve blocks. In extreme and refractory cases,

more invasive strategies have been reported, including surgical sympathectomy and spinal cord stimulation, although these are not generally recommended in the pediatric population.

Although an array of treatments has some benefit, the mainstay of treatment remains **physical therapy** emphasizing desensitization, strengthening, and functional improvement. Additionally, pharmacologic agents and psychologic and complementary therapies are important components of a treatment plan. Invasive techniques, although not curative, can be helpful if they permit the performance of frequent and aggressive physical therapy that cannot be carried out otherwise. A good biopsychosocial evaluation will help determine the orientation of the treatment components. There are insufficient data to indicate the superior value of interventional blocks, such as epidural anesthesia, in children with CRPS over physical and psychologic interventions, with or without pharmacologic support.

### Myofascial Pain Disorders and Fibromyalgia

Myofascial pain disorders are associated with tender points in the affected muscles and with muscle spasms (tight muscles). Treatment is targeted at relaxing the affected muscles through physical therapy, Iyengar yoga, massage, and acupuncture. Rarely are pharmacologic muscle relaxants helpful other than for creating tiredness at night for sleep. Dry needling or injections of local anesthetic into the tender points has been advocated, but the data do not support this as a standard treatment. Similarly, although botulinum toxin injections may be used, no data support this practice in children. Often, poor body postures, repetitive use of a body part not accustomed to that movement, or carrying heavy backpacks initiates pain. When it becomes widespread, a diagnosis may be made of **juvenile fibromyalgia**, which may or may not continue to subsequently become adult fibromyalgia. Newer guidelines do not use “tender points” in the diagnosis of fibromyalgia. Instead, diagnosis relies on a model that assesses for widespread pain and symptom severity (see Chapter 211). Likely there are different subtypes of widespread pain syndromes, and physical therapy is a key component of treatment. Psychologic interventions may play an important role to assist the child in resuming normal activities and to manage any psychologic comorbidities. Any pain rehabilitation plan should enhance return to full function. Because there is a high incidence of chronic pain in parents of children presenting with a chronic pain condition, especially fibromyalgia, attention to parent and family

**Table 93.20** Clinical Features of Human Disorders Caused by Pathologic Variants in Ion-Channel Genes That Lead to Altered Pain Perception and Are Inherited in a Mendelian Manner

	AFFECTED GENE (PROTEIN)	TYPE AND EFFECT OF MUTATION	MAIN PHENOTYPE	ADDITIONAL FEATURES
Inherited erythromelalgia	SCN9A (Na <sub>v</sub> 1.7)	Heterozygous, activating	Onset by age 20 yr; episodic pain triggered by warmth; feet affected more frequently than hands	Erythema of feet
Paroxysmal extreme pain disorder	SCN9A (Na <sub>v</sub> 1.7)	Heterozygous, activating	Onset at birth; episodic pain; sacral region is affected most frequently, face is affected more often than the limbs; physical triggers include defecation	Erythema of the sacrum; tonic attacks
Small fiber neuropathy	SCN9A (Na <sub>v</sub> 1.7)	Heterozygous, activating	Onset at any age but more common in early adulthood; persistent burning pain; feet affected more frequently than hands	Could be autonomic features
Small fiber neuropathy	SCN10A (Na <sub>v</sub> 1.8)	Heterozygous, activating	Persistent burning pain	Could be autonomic features
Familial episodic pain syndrome type I	TRPA1 (TRPA1)	Heterozygous, activating	Onset at birth or in infancy; episodic chest or arm pain; triggers are hunger and cold	—
Familial episodic pain syndrome type III	SCN11A (Na <sub>v</sub> 1.9)	Heterozygous, activating	Onset in first decade; episodic hand and foot pain; triggers are intercurrent illness or exercise	—

Na<sub>v</sub>, Sodium ion channel.

Modified from Bennett DLH, Woods CG. Painful and painless channelopathies. *Lancet Neurol*. 2014;13:587–599, Table 1, p. 590.



factors is important. Parent training may entail teaching the parent to model more appropriate pain coping behaviors and to recognize the child's independent attempts to manage pain and function adaptively. Parents may also need referrals to obtain appropriate pain management for their own pain condition.

Pregabalin and duloxetine are FDA approved for management of fibromyalgia in adults; duloxetine is also approved for adolescents ages 13-17. However, the best evidence for the treatment of adolescents with fibromyalgia remains a multimodal approach including CBT and physical therapy. This is generally considered superior to solitary use of pharmacologic agents.

### Erythromelalgia

Erythromelalgia in children is generally primary, whereas in adults it may be either primary or secondary to malignancy or other hematologic disorders, such as polycythemia vera (see Chapter 211.5). Patients with erythromelalgia exhibit red, warm, hyperperfused distal limbs. The disorder is usually bilateral and may involve either or both the hands and feet. Patients perceive burning pain and typically seek relief by immersing the affected extremities in ice water, sometimes so often and for so long so that skin pathology results. **Primary erythromelalgia** is caused by a gain of function pathogenic variant (autosomal dominant) in the gene for the NaV1.7 neuronal sodium channel on peripheral C nociceptive fibers, resulting in their spontaneous depolarization, and thus continuous burning pain. The most common pathogenic variant identified is in the *SCN9A* gene, although there are several variants that affect the NaV1.7 channel (Table 93.20). Other ion channel pathologic gene variants are associated with rare pain syndromes (see Table 93.20). Another pathogenic variant (loss of function) in the NaV1.7 channel results in a rare but serious genetic condition, the congenital indifference to pain.

Although some similarities to CRPS may be present in erythromelalgia, there are differences to distinguish the two conditions. CRPS in general is a unilateral phenomenon rather than bilateral. CRPS often presents with a cold, cyanotic limb (although "hot" CRPS with a warm, erythematous limb may occur as well). In addition, erythromelalgia is associated with intermittent pain compared with the more continuous nature and symptoms seen in CRPS. In erythromelalgia, ice water immersion is analgesic, the condition is bilateral and symmetric, and it is associated with hyperperfusion of the distal extremity.

The evaluation of hyperperfused limbs with burning pain should include genetic testing for **Fabry disease (alpha-galactosidase deficiency)** and screening for hematologic malignancies, with diagnosis of primary erythromelalgia being one of exclusion. The definitive treatment of Fabry disease includes enzyme replacement (as disease-modifying treatment) and administration of neuropathic pain medications such as gabapentin, although the success of antineuropathic pain drugs in small fiber neuropathies has not been impressive. The treatment of erythromelalgia is much more difficult. Antineuropathic pain medications (AEDs, TCAs) are typically prescribed but rarely helpful (see Fig. 93.4). Although one might predict that sodium channel-blocking AEDs might be effective in this sodium channelopathy, oxcarbazepine has not proved to be a particularly effective modality. The pain responds well to regional anesthetic nerve blocks, but it returns immediately when the effects of the nerve block resolve. In contrast, in other neuropathic syndromes, the analgesia usually (and inexplicably) persists well after the resolution of the pharmacologic nerve block. Aspirin and even nitroprusside infusions have been anecdotally reported to be of benefit with secondary erythromelalgia but have not been reported to be helpful in children with primary erythromelalgia. Case reports in adults and clinical experience in children suggest that periodic treatment with high-dose **capsaicin cream (8%)** may be effective in alleviating the burning pain and disability of erythromelalgia. Capsaicin (essence of chili pepper) cream is a vanilloid receptor (TRPV1) agonist that depletes small fiber peripheral nerve endings of the neurotransmitter substance P, an important neurotransmitter in the generation and transmission of nociceptive impulses. Once depleted, these nerve endings are no longer capable of generating spontaneous pain until the receptors regenerate, a process that takes many months.

### Other Chronic Pain Conditions in Children

A variety of genetic and other medical/surgical conditions are often associated with chronic pain. Examples include Fabry disease, Chiari malformation/syringomyelia, epidermolysis bullosa, juvenile idiopathic arthritis, porphyria, mitochondrial disorders, degenerative neurologic diseases, cerebral palsy, ASD, intestinal pseudoobstruction, inflammatory bowel disease, chronic migraine/daily headaches, and irritable bowel disease. In many cases, treating the underlying disease, such as with enzyme replacement in Fabry disease and in other lysosomal disorders, will reduce what otherwise might be progression of symptoms but may not totally reduce pain and suffering, and other modalities will be needed. Pain that persists and is not well treated can lead to central sensitization and widespread pain, such as seen in children with one pain source who then develop fibromyalgia.

### MANAGING COMPLEX CHRONIC PAIN PROBLEMS

Some patients with chronic pain have a prolonged course of evaluation in attempts to find what is expected as the singular "cause" of the pain and thus also undergo many failed treatments (see Chapter 212). Parents worry that the doctors have not yet discovered the cause that may be serious and life threatening, and children often feel not believed, that others perceive they are faking their pain or are "crazy." There may be no identifiable or diagnosable condition, and families may seek opinions from multiple treatment facilities to find help for their suffering child. For some children, what may have begun as an acute injury or infectious event may result in a chronic pain syndrome, with changes in the neurobiology of the pain-signaling system.

In the context of disabling chronic pain, it is very important for the pediatrician to avoid overmedication, because this can exacerbate associated disability. In addition, it is important to maintain an open mind and reassess the diagnosis if the clinical presentation changes. It is essential to communicate to the family that pain has a biologic basis (likely related to neural signaling and neurotransmitter dysregulation) and that the pain is naturally distressing to the child and family. All patients and families should receive a simple explanation of pain physiology that helps them understand the importance of (1) functional rehabilitation to normalize pain signaling, (2) the low risk of causing further injury with systematic increases in normal functioning, and (3) the likely failure of treatment if pain is managed as if it were acute. Because it is counterintuitive for most people to move a part of the body that hurts, many patients with chronic pain have atrophy or contractures of a painful extremity from disuse. Associated increases in worry and anxiety may exacerbate pain and leave the body even more vulnerable to further illness, injury, and disability.

Pain can have a significant impact on many areas of normal functioning and routines for children, and school absenteeism and related consequences of missed schooling are often significant problems. Appropriate assessment and evaluation of the child with chronic pain and the family is the critical first step in developing a treatment plan. For example, a high-academically functioning child might have an acute injury that leads to chronic pain and significant school absenteeism. Although many downstream contributors to pain and disability maintenance can accumulate the more school that is missed, often previously unrecognized focal learning disabilities may become the increasing trigger for a downhill cascade of pain, disability, and school absenteeism. Even for the child with outstanding grades, it may be helpful to learn about the amount of time spent on each subject. As certain subjects become more complicated, such as math, the child with a previously unrecognized math learning disability may be spending hours on math homework each night, even with good grades in math. In this case, the acute illness or injury becomes the "final straw" that breaks down the child's coping and turns the acute pain into a chronic problem.

**Interdisciplinary pediatric pain programs** have become the standard of care for treating complex chronic pain problems in youth. Although available in many parts of the United States, Canada, Europe, Australia, and New Zealand, the overall number of programs is still small. Therefore many children and adolescents with chronic pain will



be unable to receive specialized pain treatment in their local communities. In recognition of the severity and complexity of pain and disability for some children, different settings and treatment delivery models for providing pain care have been explored. One option is inpatient and day hospital treatment programs, which often address barriers to access to outpatient treatment and coordination of care. In addition, these programs provide an intensive treatment option for children who do not make adequate progress in outpatient treatment or who are severely disabled by pain. Early programs developed in the 1990s focused on CRPS treatment through intensive inpatient rehabilitation and exercise-based programs. Later programs expanded to other clinical populations and broadened the treatment focus to incorporate a range of rehabilitation and psychologic therapies delivered both individually and in groups. The typical length of inpatient admissions for children with chronic pain in such programs is 3-4 weeks, and emerging evidence suggests benefit from these programs. A major problem that limits such care for children with complex chronic disabling pain is the long waiting list for entry into these programs, as well as obtaining financial coverage for the treatment. Additional, more widespread models of care are needed.

Another intervention delivery option is *remote management*, referring to pain interventions used outside the clinic/hospital setting to reach children in their homes or communities. Interventions are typically delivered using some form of technology, such as the internet, or may rely on other media, such as telephone counseling or written self-help materials. Typically, remote management of pain includes monitoring, counseling, and delivery of behavioral and CBT interventions. Internet interventions have received the most research attention to date, with published examples of several different pediatric chronic pain conditions with promising findings for pain reduction. *Telemedicine* may offer additional ways to connect experts in pediatric pain with patients in remote communities. Within any community, the pediatrician will need to locate appropriate referral sources for patients with complex chronic pain. However, although psychologic interventions can be delivered through these telemedicine strategies, the pediatrician is still relied on to obtain the needed biopsychosocial history, complete a thorough physical examination, and provide the pharmacologic management as needed. The pediatrician also communicates with the family to help the child and family understand the pain and how the different pharmacologic and nonpharmacologic treatments will enhance function and alter the long-term neural processes underlying pain.

Visit Elsevier eBooks+ at [eBooks.Health.Elsevier.com](http://eBooks.Health.Elsevier.com) for Bibliography

## Chapter 94

# Poisoning

Jillian L. Theobald and Justin N. Corcoran

Poisoning is the leading cause of injury-related death in the United States, surpassing that from motor vehicle crashes. Most of these deaths are unintentional (i.e., not suicide). In adolescents, poisoning is the second leading cause of injury-related death. Of the more than 2 million human poisoning exposures reported annually to the National Poison Data System (NPDS) of the American Association of Poison Control Centers (AAPCC), approximately 50% occur in children <6 years old, with the highest number of exposures occurring in 1- and 2-year-olds. Almost all these exposures are unintentional and reflect the propensity for young children to put virtually anything in their mouth. Fortunately, children <6 years old account for <2% of all poisoning fatalities reported to NPDS.

More than 90% of toxic exposures in children occur in the home, and most involve a single substance. Ingestion accounts for the majority of exposures, with a minority occurring by the dermal, inhalational, and ophthalmic routes. Approximately 40% of cases involve nondrug substances, such as cosmetics, personal care items, cleaning solutions, plants, and foreign bodies. Pharmaceutical preparations account for the remainder of exposures, and analgesics, topical preparations, vitamins, and antihistamines are most commonly reported.

The majority of poisoning exposures in children <6 years old can be managed without direct medical intervention beyond a call to the regional **poison control center (PCC)**. This is because the product involved is not inherently toxic or the quantity of the material is not sufficient to produce clinically relevant toxic effects. However, a number of substances can be highly toxic to toddlers in small doses (Table 94.1). In 2019, carbon monoxide (CO), batteries, and analgesics (mainly opioids) were the leading identifiable causes of poison-related fatalities in young children (<6 years). In addition, anesthetics, antihistamines, chemicals, cough and cold preparations, tobacco/nicotine/e-cigarette products, and hydrocarbons were significant causes of mortality.

Poison prevention education should be an integral part of all well-child visits, starting at the 6-month visit. Counseling parents and other caregivers about potential poisoning risks, poison-proofing a child's environment, and actions in the event of an ingestion diminish the likelihood of serious morbidity or mortality. Poison prevention education materials are available from the American Academy of Pediatrics (AAP) and regional PCCs. Through a U.S. network of PCCs, anyone at any time can contact a regional poison center by calling the toll-free number **1-800-222-1222**. Parents should be encouraged to share this number with grandparents, relatives, babysitters, and any other caregivers.

Product safety measures, poison prevention education, early recognition of exposures, and around-the-clock access to regionally based PCCs all contribute to the favorable exposure outcomes in young children. Poisoning exposures in children 6-12 years are much less common, involving only approximately 10% of all reported pediatric exposures. A second peak in pediatric exposures occurs in adolescence. Exposures in the adolescent age-group are primarily intentional (suicide or abuse or misuse of substances) and thus often result in more severe toxicity (see Chapter 157). Families should be informed and given anticipatory guidance that nonprescription and prescription medications, and even household products (e.g., inhalants), are common sources of adolescent exposures. Although adolescents (age 13-19 years) account for only about 16% of pediatric exposures, they constitute a larger proportion of deaths. Of the 159 poison-related pediatric deaths in 2021 reported to NPDS, 86 were adolescents (2% of all fatalities called in to poison centers). Pediatricians should be aware of the signs of drug abuse or suicidal ideation in adolescents and should aggressively intervene (see Chapter 40).

## PREVENTION

Deaths caused by unintentional poisoning among younger children have decreased dramatically over the past 2 decades, particularly among children <5 years old. In 1970, when the U.S. Poison Packaging Prevention Act was passed, 226 poisoning deaths of children <5 years old occurred, compared with only 25 in 2021. Poisoning prevention demonstrates the effectiveness of passive strategies, including the use of child-resistant packaging and limited doses per container. Difficulty using child-resistant containers by adults is an important cause of poisoning in young children today. In 18.5% of households in which poisoning occurred in children <5 years old, the child-resistant closure was replaced, and 65% of the packaging used did not work properly. Almost 20% of ingestions occur from drugs belonging to grandparents, who have difficulty using traditional child-resistant containers and often put their medications in pill organizers that are not childproof.

Even though there has been success in preventing poisoning in young children, there has been a remarkable rise in adolescent poison-related death over the past 20 years. This has mirrored the increasing rate of antidepressant prescriptions written by healthcare providers and the epidemic increase in opioid-related fatalities.

**Table 94.1** Common Agents Potentially Toxic to Young Children (<6 yr) in Small Doses\*

SUBSTANCE	TOXICITY
Aliphatic hydrocarbons (e.g., gasoline, kerosene, lamp oil)	Acute lung injury
Antimalarials (chloroquine, quinine)	Seizures, dysrhythmias
Benzocaine	Methemoglobinemia
β-Adrenergic receptor blockers†	Bradycardia, hypotension
Calcium channel blockers	Bradycardia, hypotension, hyperglycemia
Camphor	Seizures
Caustics (pH <2 or >12)	Airway, esophageal and gastric burns
Clonidine	Lethargy, bradycardia, hypotension
Diphenoxylate and atropine (Lomotil)	CNS depression, respiratory depression
Ethylene glycol	Altered mental status, seizures
Hypoglycemics, oral (sulfonylureas and meglitinides)	Hypoglycemia, seizures
Imidazolines (oxymetazoline, tetrahydrozoline)	CNS depression, respiratory depression
Laundry detergent packets (pods)	Airway issues, respiratory distress, altered mental status
Lindane	Seizures
Marijuana (cannabis, THC)	Lethargy, seizures, coma
Monoamine oxidase inhibitors	Hypertension followed by delayed cardiovascular collapse
Methyl salicylate	Tachypnea, metabolic acidosis, seizures
Opioids (especially methadone, buprenorphine)	CNS depression, respiratory depression
Organophosphate pesticides	Cholinergic crisis
Phenothiazines (especially chlorpromazine, thioridazine)	Seizures, dysrhythmias
Sulfonylureas (glipizide, glyburide)	Hypoglycemia
Theophylline	Seizures, dysrhythmias
Tricyclic antidepressants	CNS depression, seizures, dysrhythmias, hypotension

\*“Small dose” typically implies one to two pills or 5 mL.

†Lipid-soluble β blockers (e.g., propranolol) are more toxic than water-soluble β blockers (e.g., atenolol).

CNS, Central nervous system.

## APPROACH TO THE POISONED PATIENT

The initial approach to the patient with a witnessed or suspected poisoning should be no different than that in any other sick child, starting with stabilization and rapid assessment of the airway, breathing, circulation (pulse, blood pressure), and mental state. In any patient with altered mental status, a serum glucose concentration should be obtained early, and naloxone administration should be considered if there is coma or respiratory depression. A targeted history and physical examination serve as the foundation for a thoughtful differential

diagnosis, which can then be further refined through laboratory testing and other diagnostic studies.

## History

Obtaining an accurate problem-oriented history is of paramount importance. *Intentional* poisonings (suicide attempts, drug abuse/misuse) are typically more severe than unintentional, exploratory ingestions. In patients without a witnessed exposure, historical features such as age of the child (toddler or adolescent), acute onset of symptoms without prodrome, multisystem organ dysfunction, or high levels of household stress should suggest a possible diagnosis of poisoning. In patients with a witnessed exposure, determining exactly what the child was exposed to and the circumstances surrounding the exposure is crucial to initiating directed therapy quickly. For household and workplace products, names (brand, generic, chemical) and specific ingredients, along with their concentrations, can often be obtained from the labels. PCC specialists can also help to identify possible ingredients and review the potential toxicities of each component. Poison center specialists can also help identify pills based on markings, shape, and color. If referred to the hospital for evaluation, parents should be instructed to bring the products, pills, and/or containers with them to assist with identifying and quantifying the exposure. If a child is found with an unknown pill, a list of all medications in the child’s environment, including medications that grandparents, parents, siblings, caregivers, or other visitors might have brought into the house, must be obtained. In the case of an unknown exposure, clarifying where the child was found (e.g., garage, kitchen, laundry room, bathroom, backyard, workplace) can help to generate a list of potential toxins.

Next, it is important to clarify the *timing* of the ingestion and to obtain some estimate of how much of the substance may have been ingested. It is better to overestimate the amount ingested to prepare for the worst-case scenario. Counting pills or measuring the remaining volume of a liquid ingested can sometimes be useful in generating estimates. For inhalational, ocular, or dermal exposures, the concentration of the agent and the length of contact time with the material should be determined, if possible.

## Symptoms

Obtaining a description of symptoms experienced after ingestion, including their timing of onset relative to the time of ingestion and their progression, can generate a list of potential toxins and help anticipate the severity of the ingestion. Coupled with physical exam findings, reported symptoms assist practitioners in identifying **toxidromes**, or recognized poisoning syndromes, suggestive of toxicity from specific substances or classes of substances (Tables 94.2 to 94.5).

## Past Medical and Developmental History

Underlying diseases can make a child more susceptible to the effects of a toxin. Concurrent drug therapy can also increase toxicity because certain drugs may interact with the toxin. A history of psychiatric illness can make patients more prone to substance abuse, misuse, intentional ingestions, and polypharmacy complications. Pregnancy is a common precipitating factor in adolescent suicide attempts and can influence both evaluation of the patient and subsequent treatment. A developmental history is important to ensure that the exposure history provided is appropriate for the child’s developmental stage (e.g., report of 6-month-old picking up a large container of laundry detergent and drinking it should indicate a “red flag”).

## Social History

Understanding the child’s social environment helps to identify potential sources of exposure (caregivers, visitors, grandparents, recent parties or social gatherings) and social circumstances (new baby, parent’s illness, financial stress) that might have contributed to the ingestion (suicide or unintentional). Unfortunately, some poisonings occur in the setting of serious neglect or intentional abuse.

**Table 94.2** Selected Historical and Physical Findings in Poisoning

SIGN	TOXIN
<b>ODOR</b>	
Bitter almonds	Cyanide
Acetone	Isopropyl alcohol, methanol, paraldehyde, salicylates
Rotten eggs	Hydrogen sulfide, sulfur dioxide, methyl mercaptans (additive to natural gas)
Wintergreen	Methyl salicylate
Garlic	Arsenic, thallium, organophosphates, selenium
Mothballs	Camphor, naphthalene
Freshly mowed hay	Phosgene
Carrots	Water hemlock
Gasoline	Petroleum distillates
<b>OCULAR SIGNS</b>	
Miosis	Opioids (except propoxyphene, meperidine, and pentazocine), organophosphates and other cholinergics, clonidine, phenothiazines (typical antipsychotics), sedative-hypnotics, olanzapine
Mydriasis	Anticholinergics (e.g., antihistamines, TCAs, atropine), sympathomimetics (cocaine, amphetamines, PCP), post-anoxic encephalopathy, opiate withdrawal, cathinones, MDMA
Nystagmus	Anticonvulsants, sedative-hypnotics, alcohols, PCP, ketamine, dextromethorphan
Lacrimation	Organophosphates, irritant gas or vapors
Retinal hyperemia	Methanol
<b>CUTANEOUS SIGNS</b>	
Diaphoresis	Cholinergics (organophosphates), sympathomimetics, salicylates, phencyclidine (PCP), withdrawal syndromes
Alopecia	Thallium, arsenic
Erythema	Boric acid, elemental mercury, cyanide, carbon monoxide, disulfiram, scombroid, anticholinergics, vancomycin
Cyanosis (unresponsive to oxygen)	Methemoglobinemia (e.g., benzocaine, dapsone, nitrites, phenazopyridine), amiodarone, silver
Bullae/blisters	Barbiturates, mustard gas, xylazine, snake, spiders
<b>ORAL SIGNS</b>	
Salivation	Organophosphates, salicylates, corrosives, ketamine, PCP, strychnine
Oral burns	Corrosives, oxalate-containing plants
Gum lines	Lead, mercury, arsenic, bismuth
<b>GASTROINTESTINAL SIGNS</b>	
Diarrhea	Antimicrobials, arsenic, iron, boric acid, cholinergics, colchicine, opioid withdrawal
Hematemesis	Arsenic, iron, caustics, NSAIDs, salicylates
Constipation	Lead
<b>CARDIAC SIGNS</b>	
Tachycardia	Sympathomimetics, anticholinergics, antidepressants, antipsychotics, methylxanthines (theophylline, caffeine), salicylates, cellular asphyxiants (cyanide, carbon monoxide, hydrogen sulfide), withdrawal (ethanol, sedatives, clonidine, opioids), serotonin syndrome, neuroleptic malignant syndrome, MDMA, cathinones
Bradycardia	$\beta$ Blockers, calcium channel blockers, digoxin, clonidine, organophosphates, opioids, sedative-hypnotics, xylazine
Hypertension	Sympathomimetics, anticholinergics, monoamine oxidase inhibitors, serotonin syndrome, nicotine, caffeine, neuroleptic malignant syndrome, clonidine withdrawal
Hypotension	$\beta$ Blockers, calcium channel blockers, cyclic antidepressants, iron, antipsychotics, barbiturates, clonidine, opioids, arsenic, amatoxin mushrooms, cellular asphyxiants (cyanide, carbon monoxide, hydrogen sulfide), snake envenomation, xylazine
<b>RESPIRATORY SIGNS</b>	
Depressed respirations	Opioids, sedative-hypnotics, alcohol, clonidine, marijuana, barbiturates, xylazine
Tachypnea	Salicylates, sympathomimetics, caffeine, metabolic acidosis, carbon monoxide, hydrocarbon aspiration
<b>CENTRAL NERVOUS SYSTEM SIGNS</b>	
Ataxia	Alcohols, anticonvulsants, sedative-hypnotics, lithium, dextromethorphan, carbon monoxide, inhalants
Coma	Opioids, sedative-hypnotics, anticonvulsants, antidepressants, antipsychotics, ethanol, anticholinergics, clonidine, GHB, alcohols, salicylates, barbiturates, hypoglycemics, lead, arsenic, rohypnol, carbon monoxide
Seizures	Sympathomimetics, anticholinergics, antidepressants (especially TCAs, bupropion, venlafaxine), cholinergics (organophosphates), isoniazid, camphor, lindane, salicylates, lead, nicotine, tramadol, water hemlock, withdrawal (especially ethanol), strychnine, cocaine
Delirium/psychosis	Sympathomimetics, anticholinergics, LSD, PCP, hallucinogens, lithium, dextromethorphan, steroids, withdrawal, MDMA, cathinones
Peripheral neuropathy	Lead, arsenic, mercury, organophosphates, nicotine
Hypothermia	Carbon monoxide, opioids, oral hypoglycemics, liquor, sedative-hypnotics
Hyperthermia	Antihistamines, amphetamines, salicylates, antidepressants (TCAs), antipsychotics, serotonin syndrome, neuroleptic malignant syndrome, withdrawal (alcohol, baclofen)

GHB,  $\gamma$ -Hydroxybutyrate; LSD, lysergic acid diethylamide; MDMA, 3,4-methylenedioxymethamphetamine (ecstasy); NSAIDs, nonsteroidal antiinflammatory drugs; PCP, phencyclidine; TCAs, tricyclic antidepressants.

Table 94.3 Recognizable Poison Syndromes (“Toxidromes”)

TOXIDROME	SIGNS					POSSIBLE TOXINS
	VITAL SIGNS	MENTAL STATUS	PUPILS	SKIN	BOWEL SOUNDS	
Sympathomimetic	Hypertension, tachycardia, hyperthermia	Agitation, psychosis, delirium, violence	Dilated	Diaphoretic, flushed	Normal to increased	Amphetamines, cocaine, PCP, bath salts (cathinones), ADHD medication
Anticholinergic	Hypertension, tachycardia, hyperthermia	Agitated, delirium, coma, seizures	Dilated	Dry, hot, flushed	Diminished	Antihistamines, TCAs, atropine, jimsonweed
Cholinergic	Bradycardia, BP and temp typically normal	Confusion, coma, fasciculations	Small	Diaphoretic	Hyperactive	Organophosphates (insecticides, nerve agents), carbamates (physostigmine, neostigmine, pyridostigmine) Alzheimer medications, myasthenia treatments
Opioids	Respiratory depression, bradycardia, hypotension, hypothermia	Depression, coma, euphoria	Pinpoint	Normal	Normal to decreased	Methadone, buprenorphine, morphine, oxycodone, heroin, etc.
Sedative-hypnotics	Respiratory depression, HR normal to decreased, BP normal to decreased, temp normal to decreased	Somnolence, coma	Small or normal	Normal	Normal	Barbiturates, benzodiazepines, ethanol xylazine
Serotonin syndrome (similar findings with neuroleptic malignant syndrome)	Hyperthermia, tachycardia, hypertension or hypotension (autonomic instability)	Agitation, confusion, coma	Dilated	Diaphoretic	Increased	Neuromuscular hyperexcitability: clonus, hyperreflexia (lower > upper extremities)
Salicylates	Tachypnea, hyperpnea, tachycardia, hyperthermia	Agitation, confusion, coma	Normal	Diaphoretic	Normal	Aspirin and aspirin-containing products, methyl salicylate
Withdrawal (sedative-hypnotic)	Tachycardia, tachypnea, hyperthermia	Agitation, tremor, seizure, hallucinosis, delirium tremens	Dilated	Diaphoretic	Increased	Lack of access to ethanol, benzodiazepines, barbiturates, GHB, or excessive use of flumazenil
Withdrawal (opioid)	Tachycardia	Restlessness, anxiety	Dilated	Diaphoretic	Hyperactive	Lack of access to opioids or excessive use of naloxone

ABGs, Arterial blood gases; ADHD, attention-deficit/hyperactivity disorder; BP, blood pressure; GHB,  $\gamma$ -hydroxybutyrate; HR, heart rate; MAOIs, monoamine oxidase inhibitors; PCP, phencyclidine; SSRIs, selective serotonin reuptake inhibitors; temp, temperature; TCAs, tricyclic antidepressants.



**Table 94.4** Mini-Toxidromes

TOXIDROME	SYMPTOMS AND SIGNS	EXAMPLES
$\alpha_1$ -Adrenergic receptor antagonists	CNS depression, tachycardia, miosis	Chlorpromazine, quetiapine, clozapine, olanzapine, risperidone
$\alpha_2$ -Adrenergic receptor agonist	CNS depression, bradycardia, hypertension (early), hypotension (late), miosis	Clonidine, oxymetazoline, tetrahydrozoline, tizanidine, dexmedetomidine
Clonus/myoclonus	CNS depression, myoclonic jerks, clonus, hyperreflexia	Carisoprodol, lithium, serotonergic agents, bismuth, organic lead, organic mercury, serotonin or neuroleptic malignant syndrome
Sodium channel blockers	CNS toxicity, wide QRS	Cyclic antidepressants and structurally related agents, propoxyphene, quinidine/quinine, amantadine, antihistamines, bupropion, cocaine
Potassium channel blockers	CNS toxicity, long QT interval	Antipsychotics, methadone, phenothiazines
Cathinones, synthetic cannabinoids	Hyperthermia, tachycardia, delirium, agitation, mydriases	See <a href="#">Chapter 157</a> .

CNS, Central nervous system.

From Ruha AM, Levine M. Central nervous system toxicity. *Emerg Med Clin North Am.* 2015;32(1):205–221, p. 208.

**Table 94.5** Predicting Toxicity from Vital Signs

<p><b>BRADYCARDIA (PACED)</b>            Propranolol (<math>\beta</math> blockers), poppies (opioids), propoxyphene, physostigmine            Anticholinesterase drugs, antiarrhythmics            Clonidine, calcium channel blockers            Ethanol or other alcohols            Digoxin, digitalis</p> <p><b>TACHYCARDIA (FAST)</b>            Free base or other forms of cocaine, Freon            Anticholinergics, antihistamines, antipsychotics amphetamines, alcohol withdrawal            Sympathomimetics (cocaine, caffeine, amphetamines, phencyclidine [PCP]), solvent abuse, strychnine            Theophylline, tricyclic antidepressants (TCAs), thyroid hormones</p> <p><b>HYPOTHERMIA (COOLS)</b>            Carbon monoxide            Opioids            Oral hypoglycemics, insulin            Liquor (alcohols)            Sedative-hypnotics</p> <p><b>HYPERTHERMIA (NASA)</b>            Neuroleptic malignant syndrome (NMS), nicotine            Antihistamines, alcohol withdrawal            Salicylates, sympathomimetics, serotonin syndrome            Anticholinergics, antidepressants, antipsychotics</p>	<p><b>HYPOTENSION (CRASH)</b>            Clonidine, calcium channel blockers            Rodenticides (containing arsenic, cyanide)            Antidepressants, aminophylline, antihypertensives            Sedative-hypnotics (xylazine)            Heroin or other opioids</p> <p><b>HYPERTENSION (CT SCAN)</b>            Cocaine            Thyroid supplements            Sympathomimetics            Caffeine            Anticholinergics, amphetamines            Nicotine</p> <p><b>RAPID RESPIRATION (PANT)</b>            PCP, paraquat, pneumonitis, phosgene            Acetylsalicylic acid (ASA) and other salicylates            Noncardiogenic pulmonary edema, nerve agents            Toxin-induced metabolic acidosis</p> <p><b>SLOW RESPIRATION (SLOW)</b>            Sedative-hypnotics (barbiturates, benzodiazepines, xylazine)            Liquor (alcohols)            Opioids            Weed (marijuana)</p>
---	---

From Meehan TJ. Approach to the poisoned patient. In: Walls RM, Hockberger RS, Gausche-Hill M, et al., eds. *Rosen's Emergency Medicine*, 9th ed. Philadelphia: Elsevier; 2018, Box 139.6, p. 1816.

### Physical Examination

A targeted physical examination is important to identifying the potential toxin and assessing the severity of the exposure. Initial efforts should be directed toward assessing and stabilizing the airway, breathing, circulation, and mental status. Once the airway is secure and the patient is stable from a cardiopulmonary standpoint, a more extensive physical exam can help to identify characteristic findings of specific toxins or classes of toxins.

In the poisoned patient, key features of the physical exam are vital signs, mental status, pupils (size, reactivity), nystagmus, skin, bowel sounds, and muscle tone. These findings might suggest a toxidrome, which can then guide the differential diagnosis and management.

### Laboratory Evaluation

A basic chemistry panel (electrolytes, renal function, glucose) is necessary for all poisoned or potentially poisoned patients. Any patient with acidosis (low serum bicarbonate level on serum chemistry panel) must have an anion gap calculated because of the more specific differential diagnoses associated with an elevated **anion gap metabolic acidosis** (Table 94.6). Patients with a known overdose of acetaminophen should have liver transaminases (alanine transaminase [ALT], aspartate transaminase [AST]) and international normalized ratio (INR) assessed. A serum creatinine kinase level is indicated on any patient with a prolonged “down time” to evaluate for **rhabdomyolysis**. A urine pregnancy test is mandatory for all postpubertal female patients. Based

**Table 94.6** Laboratory Clues in Toxicologic Diagnosis

<p><b>ANION GAP METABOLIC ACIDOSIS (MNEMONIC = MUDPILES CAT)</b></p> <p>Methanol, metformin Uremia Diabetic ketoacidosis Propylene glycol Isoniazid, iron, massive ibuprofen Lactic acidosis Ethylene glycol Salicylates Cellular asphyxiants (cyanide, carbon monoxide, hydrogen sulfide) Alcoholic ketoacidosis Tylenol (clinical significance depends upon presence or absence of liver injury), toluene</p> <p><b>ELEVATED OSMOLAR GAP</b></p> <p>Alcohols: ethanol, isopropyl, methanol, ethylene glycol</p> <p><b>HYPOGLYCEMIA (MNEMONIC = HOBBIES)</b></p> <p>Hypoglycemics, oral: sulfonylureas, meglitinides Other: quinine, unripe ackee fruit Beta Blockers Insulin Ethanol Salicylates (late)</p>	<p><b>HYPERGLYCEMIA</b></p> <p>Salicylates (early) Calcium channel blockers Caffeine</p> <p><b>HYPOCALCEMIA</b></p> <p>Ethylene glycol Fluoride</p> <p><b>RHABDOMYOLYSIS</b></p> <p>Neuroleptic malignant syndrome, serotonin syndrome Statins Mushrooms (<i>Tricholoma equestre</i>) Any toxin causing prolonged immobilization (e.g., opioids, antipsychotics) or excessive muscle activity or seizures (e.g., sympathomimetics)</p> <p><b>RADIOPAQUE SUBSTANCE ON KUB (MNEMONIC = CHIPPED)</b></p> <p>Chloral hydrate, calcium carbonate Heavy metals (lead, zinc, barium, arsenic, lithium, bismuth) Iron Phenothiazines Play-Doh, potassium chloride Enteric-coated pills Dental amalgam, drug packets</p>
---	---

KUB, Kidney-ureter-bladder radiograph.

on the clinical presentation and the presumed poison, additional laboratory tests may also be helpful. Acetaminophen is a widely available medication and a commonly detected co-ingestant with the potential for severe toxicity. There is an effective antidote to acetaminophen poisoning that is time dependent. Given that patients might initially be asymptomatic and might not report or be aware of acetaminophen ingestion, an acetaminophen level should be checked in all patients who present after an intentional exposure or ingestion.

For select intoxications (e.g., salicylates, some anticonvulsants, acetaminophen, iron, digoxin, methanol, ethanol, lithium, ethylene glycol, theophylline, CO, lead), **quantitative blood concentrations** are integral to confirming the diagnosis and formulating a treatment plan. However, for most other exposures, quantitative measurement is not readily available and is not likely to alter management. All intoxicant levels must be interpreted in conjunction with the history. For example, a methanol level of 20 mg/dL 1 hour after ingestion may be nontoxic, whereas a similar level 24 hours after ingestion implies a significant poisoning. In general, patients with multiple or chronic exposures to a drug or other chemical will be more symptomatic at lower drug levels than those with a single acute exposure.

Both the rapid urine drug-of-abuse screens and the more comprehensive drug screens vary widely in their ability to detect toxins and generally add little information to the clinical assessment. This is particularly true if the agent is known and the patient's symptoms are consistent with that agent. If a drug screen is ordered, it is important to know that the components screened for, and the lower limits of detection, vary from laboratory to laboratory. In addition, the interpretation of most drug screens is hampered by many false-positive and false-negative results. Many opiate toxicology screens poorly detect hydrocodone and do not detect the fully synthetic opioids at all (e.g., meperidine, methadone, buprenorphine, fentanyl, carfentanil, furanylfentanyl, tramadol). Several common benzodiazepines (e.g., alprazolam and clonazepam) may not be detected; synthetic cannabinoids or "bath salts" may also be missed. The amphetamine screen, on the other hand, is typically overly sensitive

and often is triggered by prescription amphetamines and some over-the-counter cold preparations. As such, the urine drug-of-abuse screen is typically of limited utility for the poisoned patient but may serve a useful function for other providers, including psychiatrists, in their evaluation of the adolescent patient. Urine drug-of-abuse screens are potentially helpful in patients with altered mental status of unknown etiology, persistent unexplained tachycardia, and acute myocardial ischemia or stroke at a young age. These screens can also be useful in the assessment of a neglected or abused child. Consultation with a medical toxicologist can be helpful in interpreting drug screens and directing which specific drug levels or other laboratory analyses might aid in patient management.

In the case of a neglected or allegedly abused child, a positive toxicology screen can add substantial weight to a claim of abuse or neglect. In these cases, and any case with medicolegal implications, any positive screen *must* be followed by confirmatory testing (most commonly via gas chromatography/mass spectroscopy), which is considered the gold-standard measurement for legal purposes.

### Additional Diagnostic Testing

An electrocardiogram (ECG) is a quick and noninvasive bedside test that can yield important clues to diagnosis and prognosis. Particular attention should be paid to the ECG intervals (Table 94.7). A widened QRS interval, putting the patient at risk for monomorphic ventricular tachycardia, suggests blockade of fast sodium channels. A widened QTc interval suggests effects at the potassium rectifier channels and portends a risk of torsades de pointes (polymorphic ventricular tachycardia).

Further diagnostic testing is based on the differential diagnosis and pattern of presentation. For example, adjunctive chest radiography may reveal signs of pneumonitis (e.g., hydrocarbon aspiration), non-cardiogenic pulmonary edema (e.g., salicylate toxicity), or a foreign body. Abdominal radiography is most helpful in screening for the presence of lead paint chips or other foreign bodies. It may detect a *bezoar* (concretion), demonstrate radiopaque tablets, or reveal drug packets in a "body packer."

**Table 94.7** Electrocardiographic Findings in Poisoning**PR INTERVAL PROLONGATION**

Digoxin  
Lithium  
Calcium channel antagonists  
β-Antagonists

**QRS PROLONGATION**

Tricyclic antidepressants  
Diphenhydramine  
Carbamazepine  
Cardiac glycosides  
Chloroquine, hydroxychloroquine  
Cocaine  
Lamotrigine  
Quinidine, quinine, procainamide, disopyramide  
Phenothiazines  
Propoxyphene  
Propranolol  
Bupropion, venlafaxine (rare)

**QTc PROLONGATION\***

Amiodarone  
Antipsychotics (typical and atypical)  
Arsenic  
Cisapride  
Citalopram  
Clarithromycin, erythromycin  
Disopyramide, dofetilide, ibutilide  
Fluconazole, ketoconazole, itraconazole  
Methadone  
Pentamidine  
Phenothiazines  
Sotalol

\*This is a select list of important toxins; other medications are also associated with QTc prolongation.

**PRINCIPLES OF MANAGEMENT**

The principles of management of the poisoned patient are supportive care, decontamination, directed therapy, and enhanced elimination. Few patients meet criteria for all these interventions, although clinicians should consider each option in every poisoned patient so as not to miss a potentially lifesaving intervention. Antidotes are available for relatively few poisons (Tables 94.8 and 94.9), thus emphasizing the importance of meticulous supportive care and close clinical monitoring.

Poison control center personnel are specifically trained to provide expertise in the management of poisoning exposures. Parents should be instructed to call the poison control center (1-800-222-1222) for any concerning exposure. PCC specialists can assist parents in assessing the potential toxicity and severity of the exposure. They can further determine which children can be safely monitored at home and which children should be referred to the emergency department for further evaluation and care. Although up to one third of calls to PCCs involve hospitalized patients, 86% of PCC calls for exposures in children <6 years old are managed at home. The AAPCC has generated consensus statements for out-of-hospital management of common ingestions (e.g., acetaminophen, iron, calcium channel blockers [CCBs]) that serve to guide poison center recommendations.

**Supportive Care**

Careful attention is paid first to the “ABCs” of airway, breathing, and circulation; there should be a low threshold to aggressively manage the airway of a poisoned patient because of the patient’s propensity to quickly become comatose. Endotracheal intubation is often the only significant intervention needed in many poisoned patients. An important caveat is the tachypneic patient with a clear lung examination and normal

oxygen saturation. This should alert the clinician to the likelihood that the patient is compensating for an acidemia. Paralyzing such a patient and underventilating might prove fatal. If intubation is necessary for airway protection or a tiring patient, a good rule of thumb is to match the ventilatory settings to the patient’s preintubation minute ventilation.

Hypotensive poisoned patients often are not hypovolemic, and aggressive fluid resuscitation may lead to fluid overload. If hypotension persists after one to two standard boluses of crystalloid, infusion of a direct-acting vasopressor, such as norepinephrine or epinephrine, is preferred. Dysrhythmias are typically managed in the standard manner. The exceptions are for dysrhythmias caused by agents that block fast sodium channels of the heart, for which boluses of sodium bicarbonate are given; dysrhythmias caused by hydrocarbons, which should be treated with β blockers; and an overall avoidance of amiodarone for toxicologic-induced arrhythmias.

Seizures should primarily be managed with agents that potentiate the γ-aminobutyric acid (GABA) complex, such as benzodiazepines or barbiturates. Using sodium channel blockers such as phenytoin is likely to be ineffective and potentially harmful. The goal of supportive therapy is to support the patient’s vital functions until the patient can eliminate the toxin. Patients with an elevated creatine phosphokinase (CPK) should be aggressively hydrated with crystalloid, with a goal urine output of 1-2 mL/kg/hr and close monitoring of CPK trend.

**Decontamination**

Most poisonings in children are from ingestion, although exposures can also occur by inhalational, dermal, and ocular routes (Table 94.10). The goal of decontamination is to minimize absorption of the toxic substance. The specific method employed depends on the properties of the toxin itself and the route of exposure. Regardless of the decontamination method used, the efficacy of the intervention decreases with increasing time since exposure. *Decontamination should not be routinely employed for every poisoned patient.* Instead, careful decisions regarding the utility of decontamination should be made for each patient and should include consideration of the toxicity and pharmacologic properties of the exposure, route of the exposure, time since the exposure, and risks vs benefits of the decontamination method.

Dermal and ocular decontamination begins with removal of any contaminated clothing and particulate matter, followed by flushing of the affected area with tepid water or normal saline (NS). Treating clinicians should wear proper protective gear when performing irrigation. Flushing for a minimum of 10-20 minutes is recommended for most exposures, although some chemicals (e.g., alkaline corrosives) require much longer periods of flushing. Dermal decontamination, especially after exposure to adherent or lipophilic (e.g., organophosphates) agents, should include thorough cleansing with soap and water. Water should *not* be used for decontamination after exposure to highly reactive agents, such as elemental sodium, phosphorus, calcium oxide, and titanium tetrachloride. After an inhalational exposure, decontamination involves moving the patient to fresh air and administering supplemental oxygen if indicated.

*Gastrointestinal (GI) decontamination strategies are most likely to be effective in the 1-2 hours after an acute ingestion.* GI absorption may be delayed after ingestion of agents that slow GI motility (anticholinergic medications, opioids), massive amounts of pills, sustained-release (SR) preparations, and agents that can form pharmacologic bezoars (e.g., enteric-coated salicylates). GI decontamination more than 2 hours after ingestion may be considered in patients who ingest toxic substances with these properties. However, even rapid institution of GI decontamination with activated charcoal will bind only approximately 30% of the ingested substance. GI decontamination should never supplant excellent supportive care and should not be employed in an unstable or persistently vomiting patient. Methods of GI decontamination include induced emesis with ipecac, gastric lavage, cathartics, activated charcoal, and whole-bowel irrigation (WBI). *Of these, only activated charcoal and WBI are of potential benefit.*

**Table 94.8** Common Antidotes for Poisoning

POISON	ANTIDOTE	DOSAGE	ROUTE	ADVERSE EFFECTS, WARNINGS, COMMENTS
Acetaminophen	N-Acetylcysteine (Mucomyst)	140mg/kg loading, followed by 70mg/kg q4h for 17 additional doses (total of 72 hr)	PO	Vomiting (patient-tailored regimens are the norm)
	N-Acetylcysteine (Acetadote)	150mg/kg over 1 hr, followed by 50 mg/kg over 4 hr, followed by 100mg/kg over 16 hr	IV	Anaphylactoid reactions (most commonly seen with loading dose) Higher doses of the infusion are often recommended depending on acetaminophen level or degree of injury
Anticholinergics	Physostigmine	0.02mg/kg over 5 min; may repeat q5-10 min to 2 mg max	IV/IM	Bradycardia, seizures, bronchospasm Note: Relatively contraindicated if conduction delays on ECG.
Benzodiazepines	Flumazenil	0.2 mg over 30sec; if response is inadequate, repeat q1min to 1 mg max	IV	Agitation, seizures from precipitated withdrawal (doses over 1 mg) <b>Relatively contraindicated for unknown or polypharmacy ingestions</b>
β Blockers	Glucagon	0.15 mg/kg bolus followed by infusion of 0.05-0.15 mg/kg/hr	IV	Vomiting, relative lack of efficacy
Calcium channel blockers	Insulin	1 unit/kg bolus followed by infusion of 1-10 units/kg/hr	IV	Hypoglycemia Follow serum potassium and glucose closely.
	Calcium salts	Dose depends on the specific calcium salt	IV	
Carbon monoxide	Oxygen	100% Fio <sub>2</sub> by non-rebreather mask (or ETT if intubated)	Inhalation	Some patients may benefit from hyperbaric oxygen (see text).
Cyanide	Hydroxocobalamin (Cyanokit)	70 mg/kg (adults: 5g) given over 15 min	IV	Flushing/erythema, nausea, rash, chromaturia, hypertension, headache
Digitalis	Digoxin-specific Fab antibodies (Digibind, DigiFab)	1 vial binds 0.6 mg of digitalis glycoside; #vials = digitalis level × weight in kg/100	IV	Allergic reactions (rare), return of condition being treated with digitalis glycoside
Ethylene glycol, methanol	Fomepizole	15 mg/kg load; 10mg/kg q12h × 4 doses; 15mg/kg q12h until ethylene glycol level is <20mg/dL	IV	Infuse slowly over 30 min If fomepizole is not available, can treat with oral ethanol (80 proof)
Iron	Deferoxamine	Infusion of 15 mg/kg/hr (max: 6 g/24 hr)	IV	Hypotension (minimized by titrating dose up slowly)
Isoniazid (INH)	Pyridoxine	Empirical dosing: 70mg/kg (max dose = 5g) If ingested dose is known: 1 g per gram of INH	IV	May also be used for <i>Gyromitra</i> mushroom ingestions
Lead and other heavy metals (e.g., arsenic, inorganic mercury)	BAL (dimercaprol)	3-5 mg/kg/dose q4h, for the first day; subsequent dosing depends on the toxin	Deep IM	Local injection site pain and sterile abscess, vomiting, fever, salivation, nephrotoxicity <i>Caution:</i> Prepared in peanut oil; contraindicated in patients with peanut allergy
	Calcium disodium EDTA	35-50 mg/kg/day × 5 days; may be given as a continuous infusion or 2 divided doses/day	IV	Vomiting, fever, hypertension, arthralgias, allergic reactions, local inflammation, nephrotoxicity (maintain adequate hydration; follow UA and renal function)
	Dimercaptosuccinic acid (succimer, DMSA, Chemet)	10 mg/kg/dose q8h × 5 days, then 10 mg/kg q12h × 14 days	PO	Vomiting, hepatic transaminase elevation, rash
Methemoglobinemia	Methylene blue, 1% solution	0.1-0.2 mL/kg (1-2 mg/kg) over 5-10 min; may be repeated q30-60 min	IV	Vomiting, headache, dizziness, blue discoloration of urine
Opioids	Naloxone	1 mg if patient not likely to be addicted 0.04-0.4 mg if possibly addicted; repeated as needed; may need continuous infusion; higher and prolonged dosing is required for novel potent opioid overdose	IV, intranasal, IO, IM, nebulized	Acute withdrawal symptoms if given to addicted patients May also be useful for clonidine ingestions (typically at higher doses)



**Table 94.8** Common Antidotes for Poisoning—cont'd

POISON	ANTIDOTE	DOSAGE	ROUTE	ADVERSE EFFECTS, WARNINGS, COMMENTS
Organophosphates	Atropine	0.05-0.1 mg/kg repeated q5-10 min as needed	IV/ET	Tachycardia, dry mouth, blurred vision, urinary retention
	Pralidoxime (2-PAM)	25-50 mg/kg over 5-10 min (max: 200 mg/min); can be repeated after 1-2 hr, then q10-12h as needed	IV/IM	Nausea, dizziness, headache, tachycardia, muscle rigidity, bronchospasm (rapid administration)
Salicylates	Sodium bicarbonate	Bolus 1-2 mEq/kg followed by continuous infusion	IV	Follow potassium closely and replace as necessary. Goal urine pH: 7.5-8.0
Sulfonylureas	Octreotide and dextrose	1-2 µg/kg/dose (adults 50-100 µg) q6-8h	IV/SC	
Tricyclic antidepressants	Sodium bicarbonate	Bolus 1-2 mEq/kg; repeated bolus dosing as needed to keep QRS <110 msec	IV	Indications: QRS widening (≥110 msec), hemodynamic instability; follow potassium.

BAL, British antilewisite; DMSA, dimercaptosuccinic acid; ECG, electrocardiogram;  $F_{iO_2}$ , fraction of inspired oxygen; EDTA, ethylenediaminetetraacetic acid; ET, endotracheal tube; IO, intraosseous; max, maximum; UA, urinalysis.

**Table 94.9** Other Antidotes

ANTIDOTES	TOXIN OR POISON
Latrodectus antivenin	Black widow spider
Botulinum antitoxin	Botulinum toxin
Diphenhydramine and/or benzotropine	Dystonic reactions
Calcium salts	Fluoride, calcium channel blockers
Intravenous lipid emulsion (ILE)	Local anesthetics; consider for bupropion, calcium channel blockers, $\beta$ blockers, and type I antidysrhythmics
Protamine	Heparin
Folinic acid	Methotrexate, trimethoprim, pyrimethamine, methanol
Crotalidae-specific Fab antibodies	Rattlesnake envenomation
Sodium bicarbonate	Sodium channel blockade (tricyclic antidepressants, type 1 antiarrhythmics)

**Table 94.10** Toxins Associated with Systemic Toxicity After Dermal Absorption

Aniline dyes
Camphor
Dinitrophenol
Hexachlorophene
Hydrofluoric acid
Lindane ( $\gamma$ -benzene hydrochloride)
Organophosphate insecticide
Nerve agents
Nitrobenzene
Organic mercury
Phenol
Thallium

From Shannon MW. Emergency management of poisoning. In: Shannon MW, Borron SW, Burns MJ, eds. *Haddad and Winchester's Clinical Management of Poisoning and Drug Overdose*, 4th ed. Philadelphia: Saunders; 2007, Box 2A-12, p. 28.

### Syrup of Ipecac

Syrup of ipecac contains two emetic alkaloids that work in both the central nervous system (CNS) and locally in the GI tract to produce vomiting. Many studies have failed to document a significant clinical impact from the use of ipecac and have documented multiple adverse events from its use. The AAP, the American Academy of Clinical Toxicology (AACT), and the AAPCC have all published statements in favor of *abandoning the use of ipecac*.

### Gastric Lavage

Gastric lavage involves placing a large tube orally into the stomach to aspirate contents, followed by flushing with aliquots of fluid, usually water or NS. Although gastric lavage was used routinely for many years, objective data do not document or support clinically relevant efficacy. This is particularly true in children, in whom only small-bore tubes can be used. Lavage is time-consuming and painful and can induce bradycardia through a vagal response to tube placement. It can delay administration of more definitive treatment (activated charcoal) and under the best circumstances, only removes a fraction of gastric contents. *Thus, in most clinical scenarios, the use of gastric lavage is no longer recommended.*

### Single-Dose Activated Charcoal

Activated charcoal is a potentially useful method of GI decontamination. Charcoal is "activated" by heating to extreme temperatures, creating an extensive network of pores that provides a very large adsorptive surface area that many (but not all) toxins will bind to, preventing absorption from the GI tract. Charged molecules (i.e., heavy metals, lithium, iron) and liquids do not bind well to activated charcoal (Table 94.11). Administration should also be avoided after ingestion of a caustic substance, as it can impede subsequent endoscopic evaluation. *Charcoal is most likely to be effective when given within 1 hour of ingestion.* A repeat dose of activated charcoal may be warranted in the cases of ingestion of an extended-release product or, more frequently, with significant salicylate poisoning as a result of its delayed and erratic absorption pattern.

The dose of activated charcoal, with or without sorbitol, is 1g/kg in children or 50-100 g in adolescents and adults. Before administering charcoal, one *must* ensure that the patient's airway is intact or protected and that the patient has a benign abdominal examination. In the awake, uncooperative adolescent or child who refuses to drink the activated charcoal, there is little utility and potential morbidity associated

**Table 94.11** Substances Poorly Adsorbed by Activated Charcoal

Alcohols
Caustics: alkalis and acids
Cyanide
Heavy metals (e.g., lead)
Hydrocarbons
Iron
Lithium

with forcing activated charcoal down a nasogastric (NG) tube, and such practice should be avoided. In young children, practitioners can attempt to improve palatability by adding flavorings (chocolate or cherry syrup) or giving the mixture over ice cream. Approximately 20% of children vomit after receiving a dose of charcoal, emphasizing the importance of an intact airway and avoiding administration of charcoal after ingestion of substances that are particularly toxic when aspirated (e.g., hydrocarbons). If charcoal is given through a gastric tube in an intubated patient, placement of the tube should be confirmed before activated charcoal is given. Instillation of charcoal directly into the lungs can have disastrous effects. Constipation is another common side effect of activated charcoal, and in rare cases, bowel perforation has been reported.

**Cathartics** (sorbitol, magnesium sulfate, magnesium citrate) have been used in conjunction with activated charcoal to prevent constipation and accelerate evacuation of the charcoal-toxin complex. There are no data demonstrating their value and numerous reports of adverse effects from cathartics, such as dehydration and electrolyte imbalance.

### Whole-Bowel Irrigation

WBI involves instilling large volumes (25 mL/kg/hr in children or 1-2 L/hr in adolescents) of a polyethylene glycol electrolyte solution (e.g., GoLYTELY) to “wash out” the entire GI tract. This technique may have some success for the ingestion of SR preparations, substances not well adsorbed by charcoal (e.g., lithium, iron), transdermal patches, foreign bodies, and drug packets. WBI is most frequently administered to decontaminate the gut of a child whose abdominal radiograph demonstrates multiple lead paint chips. Careful attention should be paid to assessment of the airway and abdominal exam before initiating WBI. WBI should never be given to a patient with signs of obstruction or ileus or with a compromised airway. Given the rate of administration and volume needed to flush the system, WBI is typically administered by NG tube. WBI is continued until the rectal effluent is clear. If the WBI is for a child with ingested paint chips, the end-point will be clearing of the chips from the bowel based on repeat radiographs. Complications of WBI include vomiting, abdominal pain, and abdominal distention. Bezoar formation might respond to WBI but may also require endoscopy or surgery.

### Directed Therapy

#### Antidotal Therapy

Antidotes are available for relatively few toxins (see [Tables 94.8 and 94.9](#)), but early and appropriate use of an antidote is a key element in managing the poisoned patient.

### Intravenous Lipid Emulsion Therapy

Intravenous lipid emulsion (ILE) therapy is a potentially lifesaving intervention. ILE therapy sequesters fat-soluble drugs, decreasing their impact at target organs; this is known as a “lipid sink.” It also enhances cardiac function by supplying an alternative energy source to a depressed myocardium and acting on calcium channels in the heart, increasing myocardial calcium and thus cardiac function. ILE is most effective as a reversal agent for toxicity from inadvertent intravenous (IV) injection of bupivacaine. Using the same 20% lipid solution used for total parenteral nutrition (TPN), a bolus dose of 1.5 mL/kg is

given over 3 minutes, followed by an infusion of 0.25 mL/kg/min until recovery or until a total of 10 mL/kg has been infused. *Lipophilic drugs*, those in which the logarithm of the coefficient describing the partition between two solvents (hydrophobic phase and hydrophilic phase) is  $>2$ , have the most potential to be bound by ILE. These include but are not limited to CCBs (verapamil, diltiazem), bupropion, tricyclic antidepressants, and refractory  $\beta$ -blocker overdose. Complications associated with ILE include significant lipemia that interferes with serum laboratory tests, pancreatitis, and acute respiratory distress syndrome (ARDS).

### Enhanced Elimination

Enhancing elimination results in increased clearance of a poison that has already been absorbed. It is only useful for a few toxins and in these cases is a potentially lifesaving intervention. Methods of enhanced elimination include urinary alkalization, hemodialysis, and multi-dose activated charcoal.

### Urinary Alkalinization

Urinary alkalization enhances the elimination of drugs that are weak acids by forming charged molecules, which then become trapped in the renal tubules. Charged molecules, being polar and hydrophilic, do not easily cross cellular membranes; thus they remain in the renal tubules and are excreted. Urinary alkalization is accomplished by a continuous infusion of sodium bicarbonate-containing IV fluids, with a goal urine pH of 7.5-8. Alkalinization of the urine is most useful in managing salicylate and methotrexate toxicity. Complications of urinary alkalization include electrolyte derangements (e.g., hypokalemia, hypocalcemia), fluid overload, and excessive serum alkalization. Serum pH should be closely monitored and not exceed a pH  $>7.55$ . Patients typically unable to tolerate the volumes required for alkalization are those with heart failure, kidney failure, pulmonary edema, or cerebral edema.

### Hemodialysis

Few drugs or toxins are removed by dialysis in amounts sufficient to justify the risks and difficulty of dialysis. Toxins amenable to dialysis have the following properties: low volume of distribution ( $<1$  L/kg) with a high degree of water solubility, low molecular weight, and low degree of protein binding. Hemodialysis may be useful for toxicity from methanol, ethylene glycol, salicylates, theophylline, bromide, lithium, and valproic acid. Hemodialysis is also used to correct severe electrolyte disturbances and acid-base derangements resulting from the ingestion (e.g., severe metformin-associated lactic acidosis).

### Multidose Activated Charcoal

Whereas single-dose activated charcoal is used as a method of decontamination, multidose activated charcoal (MDAC) can help to enhance the elimination of certain toxins. MDAC is typically given as 0.5 g/kg every 4-6 hr (for four doses). MDAC enhances elimination by two proposed mechanisms: interruption of enterohepatic recirculation and “GI dialysis.” The concept of GI dialysis involves using the intestinal mucosa as a dialysis membrane and pulling toxins from the bloodstream back into the intraluminal space, where they are adsorbed to the charcoal. The AACT/European Association of Poisons Centres and Clinical Toxicologists position statement recommends MDAC in managing significant ingestions of carbamazepine, dapsone, phenobarbital, quinine, and theophylline. As with single-dose activated charcoal, contraindications to the use of MDAC include an unprotected airway and a concerning abdominal examination (e.g., ileus, distention, peritoneal signs). Thus the airway and abdominal exam *should be assessed before each dose*. A cathartic (e.g., sorbitol) may be given with the first dose, but it should not be used with subsequent doses because of the risk of dehydration and electrolyte derangements. Although MDAC reduces the serum level of an intoxicant quicker than without MDAC, it has not been shown to have a significant impact on outcome.

## SELECT COMPOUNDS IN PEDIATRIC POISONING

See other chapters for drug use (Chapter 157) and environmental health hazards (Chapters 757-763).

### Pharmaceuticals

#### Analgesics

**Acetaminophen.** Acetaminophen (APAP) is the most widely used analgesic and antipyretic in pediatrics, available in multiple formulations, strengths, and combinations. Consequently, APAP is commonly available in the home, where it can be unintentionally ingested by young children, taken in an intentional overdose by adolescents and adults, or inappropriately dosed in all ages. In the United States, APAP toxicity remains the most common cause of acute liver failure and one of the leading causes of death from oral poisonings.

**Pathophysiology.** APAP toxicity results from the formation of a highly reactive intermediate metabolite, *N*-acetyl-*p*-benzoquinone imine (NAPQI). In therapeutic use, only a small percentage of a dose (approximately 5%) is metabolized by the hepatic cytochrome P450 enzyme CYP2E1 to NAPQI, which is then immediately conjugated with glutathione to form a nontoxic mercapturic acid conjugate. In overdose, glutathione stores are overwhelmed, and free NAPQI is able to combine with hepatic macromolecules to produce hepatocellular necrosis. The single acute toxic dose of APAP is generally considered to be >200 mg/kg in children and >7.5-10 g in adolescents and adults. Repeated administration of APAP at supratherapeutic doses (>90 mg/kg/day for consecutive days) can lead to hepatic injury or failure in some children, especially in the setting of fever, dehydration, poor nutrition, and other conditions that serve to reduce glutathione stores.

Any child with a history of acute ingestion of >200 mg/kg (unusual in children <6 years) or with an acute intentional ingestion of any amount should be referred to a healthcare facility for clinical assessment and measurement of a serum APAP level.

**Clinical and Laboratory Manifestations.** Classically, four general stages of APAP toxicity have been described (Table 94.12). In the first 24 hours after ingestion, patients are most frequently asymptomatic, although they may have nonspecific symptoms such as nausea/vomiting. Thus the diagnosis of APAP toxicity cannot be based on clinical symptoms alone, but instead requires consideration of the combination of the patient's history, symptoms, and laboratory findings.

If a toxic ingestion is suspected, a serum APAP level should be measured 4 hours after the reported time of ingestion. For patients who present to medical care more than 4 hours after ingestion, a stat APAP level should be obtained. *APAP levels obtained <4 hours after ingestion, unless "nondetectable," are difficult to interpret and cannot be used to estimate the potential for toxicity.* Other important baseline laboratory tests include hepatic transaminases, bilirubin, renal function tests, and coagulation parameters.

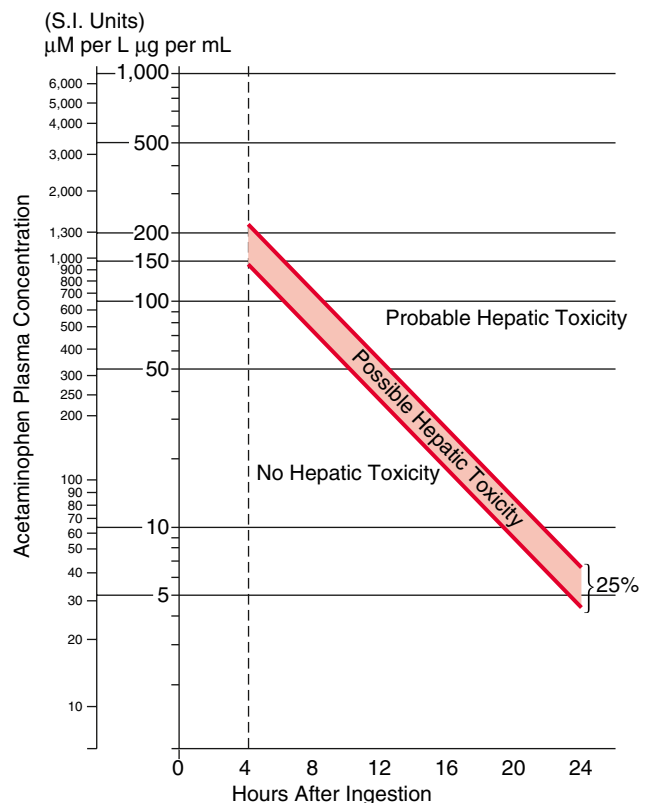
**Table 94.12** Classic Stages in Clinical Course of Acetaminophen Toxicity

STAGE	TIME AFTER INGESTION	CHARACTERISTICS
I	0-24 hr	Anorexia, vomiting, malaise Laboratory tests typically normal, except for acetaminophen level
II	24-48 hr	Resolution of earlier symptoms; right upper quadrant abdominal pain and tenderness; elevated hepatic transaminases (aspartate > alanine), INR
III	3-5 days	Peak transaminase elevations; development of liver failure, multiorgan system failure, death or recovery begins
IV	4 days to 2wk	Resolution of liver function abnormalities Clinical recovery precedes histologic recovery

**Treatment.** When considering the treatment of a patient poisoned or potentially poisoned with APAP, and after assessment of the ABCs, it is helpful to place the patient into one of the following four categories:

**1. Prophylactic.** These patients have a normal AST. If the APAP level is known and the ingestion is within 24 hours of the level being drawn, treatment decisions are based on where the level falls on the Rumack-Matthew nomogram (Fig. 94.1). Any patient with a serum APAP level in the possible or probable hepatotoxicity range per the nomogram should be treated with *N*-acetylcysteine (NAC). This nomogram is only intended for use in patients who present within 24 hours of a single acute APAP ingestion with a known time of ingestion. If treatment is recommended, they should receive NAC. Food and Drug Administration (FDA)-approved treatment regimens include a 21-hour protocol for IV administration and a 72-hour protocol for oral administration. Several shorter dosing regimens have been described and may be considered in consultation with a toxicologist. Regardless of treatment duration, serial transaminases and APAP level should be monitored. If the AST becomes elevated while receiving NAC, the patient moves into the next category of treatment (hepatic injury, see later). If AST remains normal but APAP is still present, NAC should be continued until the level is nondetectable. In the case of a patient with a documented APAP level, normal AST, and an unknown time of ingestion, treatment should ensue until the level is undetectable, with normal transaminases.

The importance of instituting therapy with either IV or oral NAC *no later than 8 hours from the time of ingestion* cannot be overemphasized.



**Fig. 94.1** Rumack-Matthew nomogram for acetaminophen poisoning, a semilogarithmic plot of plasma acetaminophen concentrations vs time. *Cautions for the use of this chart:* The time coordinates refer to time after ingestion; serum concentrations obtained before 4 hours are not interpretable, and the graph should be used only in relation to a single acute ingestion with a known time of ingestion. This nomogram is not useful for chronic exposures or unknown time of ingestion and should be used with caution in the setting of co-ingestants that slow gastrointestinal motility. The lower solid line is typically used in the United States to define toxicity and direct treatment, whereas the upper line is generally used in Europe. (From Rumack BH, Hess AJ, eds. *Poisoning, Denver: Micromedex; 1995. Adapted from Rumack BH, Matthew H. Acetaminophen poisoning and toxicity. Pediatrics. 1975;55:871-876.*)



No patient, regardless of the size of the ingestion, who receives NAC within 8 hours of overdose should die from liver failure. The longer from the 8-hour mark that the initiation of therapy is delayed, the greater the risk of acute liver failure. Any patient presenting close to or beyond the 8-hour mark after an APAP overdose should be empirically started on NAC pending laboratory results.

**2. Hepatic Injury.** These patients exhibit evidence of hepatocellular necrosis, manifested first as elevated liver transaminases (usually AST first, then ALT), followed by a rise in the INR. Any patient in this category requires therapy with NAC (IV or oral). When to discontinue therapy in the clinically well-appearing patient remains controversial, but in general NAC can be discontinued when the transaminases and INR have peaked and are declining significantly (they do not need to be normal). Most patients' liver enzymes will peak 3-4 days after their ingestion.

**3. Acute Liver Failure.** The King's College criteria are used to determine which patients should be referred for consideration of liver transplant. These criteria are met when a patient exhibits either acidemia (serum pH <7.3) after adequate fluid resuscitation or all three of the following: coagulopathy (INR >6.5), renal dysfunction (creatinine >3.4 mg/dL), and grade III or IV hepatic encephalopathy (see [Chapter 412](#)). A serum lactic acid >3 mmol/L (after IV fluids) adds to both sensitivity and specificity of the criteria to predict death without liver transplant. The degree of transaminase elevation does not factor into this decision-making process.

**4. Repeated Supratherapeutic Ingestion.** APAP is particularly prone to unintentional overdose through the ingestion of multiple medications containing the drug or simply because people assume it to be safe at any dose. Ingestion of amounts significantly greater than the recommended daily dose for several days or more puts one at risk for liver injury. Because the Rumack-Matthew nomogram is not helpful in this scenario, a conservative approach is taken. In the asymptomatic patient, if the AST is normal and the APAP is <10 µg/mL, no therapy is indicated. A normal AST and an elevated APAP warrant NAC dosing for at least long enough for the drug to metabolize while the AST remains normal. An elevated AST puts the patient in the "hepatic injury" category previously described. A patient presenting with symptoms (i.e., right upper quadrant pain, vomiting, jaundice) should be empirically started on NAC pending laboratory results.

NAC is available in oral and IV forms, and both are considered equally efficacious (see [Table 94.8](#) for the dosing regimens of the oral and IV form). The IV form is used in patients with intractable vomiting, those with evidence of hepatic failure, and pregnant patients. Oral NAC has an unpleasant taste and smell and can be mixed in a soft drink or fruit juice or given by NG tube to improve tolerability of the oral regimen. Administration of IV NAC (as a standard 3% solution to avoid administering excess free water, typically in 5% dextrose), especially the initial loading dose, is associated in some patients with the development of anaphylactoid reactions (non-immunoglobulin E mediated). These reactions are typically managed by stopping the infusion; treating with diphenhydramine, albuterol, and/or epinephrine as indicated; and restarting the infusion at a slower rate once symptoms have resolved. IV NAC is also associated with mild elevation in measured INR (range: 1.2-1.5) because of laboratory interference. IV dosing, however, delivers less medication to the liver compared with the oral regimen. As a result, many toxicologists now recommend higher doses of the IV formulation in patients with large overdoses. Transaminases, synthetic function, and renal function should be followed at least daily while the patient is being treated with NAC. Patients with worsening hepatic function or clinical status might benefit from more frequent laboratory monitoring. A patient-tailored approach is now the norm for when to stop NAC therapy, for deciding whom to refer for transplantation evaluation, and often for the dose of IV NAC in patients with either very high APAP levels or signs of injury. Consultation with the regional PCC and medical toxicologist can help streamline the care of these patients, ultimately shortening their length of stay with potentially improved outcomes.

### Adjunctive Therapies

Although activated charcoal binds acetaminophen, risks of vomiting associated with large APAP overdoses as well as the likelihood of

co-ingestion that may affect mental status must be considered. Activated charcoal may be considered in the first 1-2 hours after ingestion in an alert patient, but its use should not have bearing on the need for NAC. Similarly, hemodialysis is not routinely used in APAP overdose but may be indicated in massive ingestions in consultation with a toxicologist.

**Salicylates.** The incidence of salicylate poisoning in young children has declined dramatically since APAP and ibuprofen replaced aspirin as commonly used analgesics and antipyretics in pediatrics. However, salicylates remain widely available not only in aspirin-containing products but also in antidiarrheal medications, topical agents (e.g., keratolytics, sports creams), oil of wintergreen, and some herbal products. Oil of wintergreen contains 5 g of salicylate in 5 mL, meaning ingestion of very small volumes of this product has the potential to cause severe toxicity.

**Pathophysiology.** Salicylates lead to toxicity by interacting with a wide array of physiologic processes, including direct stimulation of the respiratory center, uncoupling of oxidative phosphorylation, inhibition of the tricarboxylic acid cycle, and stimulation of glycolysis and gluconeogenesis. The acute toxic dose of salicylates is generally considered to be >150 mg/kg. More significant toxicity is seen after ingestions of >300 mg/kg, and severe, potentially fatal, toxicity is described after ingestions of >500 mg/kg.

**Clinical and Laboratory Manifestations.** Salicylate ingestions are classified as acute or chronic, and acute toxicity is much more common in pediatric patients. Early signs of **acute salicylism** include nausea, vomiting, diaphoresis, and tinnitus. Moderate salicylate toxicity can manifest as tachypnea and hyperpnea, tachycardia, and altered mental status. The tachycardia largely results from marked insensible losses from vomiting, tachypnea, diaphoresis, and uncoupling of oxidative phosphorylation. Thus careful attention should be paid to volume status and early volume resuscitation in the significantly poisoned patient. Signs of severe salicylate toxicity include mild hyperthermia, coma, and seizures. **Chronic salicylism** can have a more insidious presentation, and patients can show marked toxicity (e.g., altered mental status, noncardiogenic pulmonary edema, acidemia) at significantly lower salicylate levels than in acute toxicity.

Classically, laboratory values from a patient poisoned with salicylates reveal a primary respiratory alkalosis and a primary, elevated anion gap metabolic acidosis. Early in the course of acute salicylism, respiratory alkalosis dominates and the patient is alkalemic. As the respiratory stimulation diminishes, the patient will move toward acidemia. Hyperglycemia (early) and hypoglycemia (late) have been described. Abnormal coagulation studies and acute kidney injury may be seen but are not common.

Serial serum salicylate levels should be closely monitored (every 2-4 hours initially) until they are consistently downtrending (three consecutive levels <30 mg/dL and decreasing by at least 10-20% on each subsequent measurement). Salicylate absorption in overdose is unpredictable and erratic, especially with an enteric-coated product, and levels can rapidly increase into the highly toxic range, even many hours after the ingestion. The Done nomogram is of poor value and should not be used. Serum and urine pH and electrolytes should be followed closely. An APAP level should be checked in any patient who intentionally overdoses on salicylates, because APAP is a common co-ingestant, and people often confuse or combine their nonprescription analgesic medications. Salicylate toxicity can cause a noncardiogenic pulmonary edema, especially in chronic overdose; consequently, a chest radiograph is recommended in any patient in respiratory distress.

**Treatment.** For the patient who presents soon after an acute ingestion, initial treatment should include gastric decontamination with activated charcoal. Salicylate pills occasionally form bezoars, which should be suspected if serum salicylate concentrations continue to rise many hours after ingestion or are persistently elevated despite appropriate management. Gastric decontamination is typically not useful after chronic exposure.

Initial therapy focuses on aggressive volume resuscitation and prompt initiation of sodium bicarbonate therapy in the symptomatic patient, even before obtaining serum salicylate levels. Therapeutic salicylate levels are 10-20 mg/dL, and levels >30 mg/dL warrant treatment.



The primary mode of therapy for salicylate toxicity is **urinary alkalinization**. Urinary alkalinization enhances the elimination of salicylates by converting salicylate to its ionized form, “trapping” it in the renal tubules. In addition, maintaining an alkalemic serum pH decreases CNS penetration of salicylates because charged particles are less able to cross the blood-brain barrier. Alkalinization is achieved by administration of a sodium bicarbonate infusion at approximately two times maintenance fluid rates. *The goals of therapy include a urine pH of 7.5-8, a serum pH of 7.45-7.55, and decreasing serum salicylate levels.* In general, the lower the patient’s serum pH, the greater the relative amount of salicylate in the uncharged, nonpolar form and the greater amount of salicylate penetration of the blood-brain barrier. Salicylate penetration of the brain leads to severe consequences such as cerebral edema; therefore maintaining alkalemia is imperative. Careful attention should also be paid to serial potassium levels in any patient on a bicarbonate infusion, because potassium will be driven intracellularly, and hypokalemia impairs alkalinization of the urine. For these reasons, potassium is often added to the bicarbonate drip. Repeat doses of charcoal may be beneficial because of the often delayed and erratic absorption of aspirin. Parenteral glucose should be provided to any salicylate-poisoned patients with altered mental status because they may have CNS hypoglycemia (i.e., neuroglycopenia) not seen in a peripheral serum glucose test.

In patients with severe toxicity, hemodialysis may be required. Indications for dialysis include severe acid-base abnormalities (specifically severe acidosis and acidemia), a rising salicylate level (despite adequate decontamination and properly alkalinized urine), pulmonary edema or respiratory failure, cerebral edema, seizures, hepatic failure, and renal failure. Serum salicylate concentrations alone are not a clear indicator of the need for dialysis and should always be interpreted along with the clinical status of the patient.

**Ibuprofen and Other Nonsteroidal Antiinflammatory Drugs (NSAIDs).** Ibuprofen and other NSAIDs are often involved in unintentional and intentional overdoses because of their widespread availability and common use as analgesics and antipyretics. Fortunately, serious effects after acute NSAID overdose are rare because of their wide therapeutic index.

**Pathophysiology.** NSAIDs inhibit prostaglandin synthesis by reversibly inhibiting the activity of cyclooxygenase (COX), the primary enzyme responsible for the biosynthesis of prostaglandins. In therapeutic use, side effects include GI irritation, reduced renal blood flow, and platelet dysfunction. To minimize these side effects, NSAID analogs have been developed that are more specific for the inducible form of COX (the COX-2 isoform) than the constitutive form (COX-1). However, overdose of the more selective COX-2 inhibitors (e.g., celecoxib [Celebrex]) is treated the same as overdose of nonspecific COX inhibitors (e.g., ibuprofen) because at higher doses, COX-2-selective agents lose their COX inhibitory selectivity.

Ibuprofen, the primary NSAID used in pediatrics, is well tolerated, even in overdose. In children, acute doses of <200 mg/kg rarely cause toxicity, but ingestions of >400 mg/kg can produce more serious effects, including altered mental status and metabolic acidosis.

**Clinical and Laboratory Manifestations.** Symptoms usually develop within 4-6 hours of ingestion and resolve within 24 hours. If toxicity does develop, it is typically manifested as nausea, vomiting, and abdominal pain. Although GI bleeding and ulcers have been described with chronic use, they are rare in the setting of acute ingestion. After massive ingestions, patients can develop marked CNS depression, anion gap metabolic acidosis, renal insufficiency, and (rarely) respiratory depression. Seizures have also been described, especially after overdose of mefenamic acid. Specific drug levels are not readily available, nor do they inform management decisions. Renal function studies, acid-base balance, complete blood count (CBC), and coagulation parameters should be monitored after very large ingestions. Co-ingestants, especially APAP, should be ruled out after any intentional ingestion.

**Treatment.** Supportive care, including use of antiemetics and acid blockade as indicated, is the primary therapy for NSAID toxicity. Decontamination with activated charcoal should be considered if a patient presents within 1-2 hours of a potentially toxic ingestion. There

is no specific antidote for this class of drugs. Given the high degree of protein binding and excretion pattern of NSAIDs, none of the modalities used to enhance elimination is particularly useful in managing these overdoses. Unlike in patients with salicylate toxicity, urinary alkalinization is not helpful for NSAID toxicity. Patients who develop significant clinical signs of toxicity should be admitted to the hospital for ongoing supportive care and monitoring. Patients who remain asymptomatic for 4-6 hours after ingestion do not require further medical care but may need psychiatric assessment if their ingestion was intentional.

**Prescription Opioids.** Opioids are a frequently abused class of medications in both IV and oral forms. The opioid epidemic gripping the United States and other countries is discussed in [Chapter 157](#). Two specific oral opioids, buprenorphine and methadone, merit mention because of potential life-threatening toxicity in toddlers with ingestion of even one pill. Both agents are used in managing opioid use disorder, although **buprenorphine** is the drug of choice. **Methadone** is also widely used in the treatment of chronic pain, meaning multiday prescriptions can be filled. Other agents commonly available in the home include morphine, oxycodone, and hydrocodone, as they are frequently prescribed to patients after injuries or surgical procedures. All of these drugs are also readily available for illicit purchase and potential abuse. Opioids are of great potential toxicity to small children if not dosed appropriately, especially buprenorphine because of its long half-life and high potency.

**Pathophysiology.** Opioids are well absorbed via multiple routes, including the GI tract, which is the most common route of accidental overdose in young children. At therapeutic dosing, opioids are typically absorbed within a few hours, but absorption may be slowed and symptoms prolonged in overdose. Individual opioids cross the blood-brain barrier to varying degrees. Opioids all undergo hepatic metabolism with renal excretion.

Methadone is a lipophilic synthetic opioid with potent agonist effects at  $\mu$ -opioid receptors, leading to both its desired analgesic effects and undesired side effects, including sedation, respiratory depression, and impaired GI motility. Methadone is thought to cause QTc interval prolongation through interactions with the human ether-a-go-go-related gene (hERG)-encoded potassium rectifier channel. Its duration of effect for pain control averages only about 8 hours, whereas the dangerous side effects can occur up to 24 hours from the last dose and longer after overdose. Methadone has an average half-life >25 hours, which may be extended to >50 hours in overdose.

Suboxone is a combination of buprenorphine, a potent opioid with partial agonism at  $\mu$ -opioid receptors and weak antagonism at  $\kappa$ -opioid receptors, and naloxone. Naloxone has poor oral bioavailability but is included in the formulation to discourage diversion for IV use, during which it can precipitate withdrawal. Suboxone is formulated for buccal or sublingual administration; consequently, toddlers can absorb significant amounts of drug even by sucking on a tablet. Buprenorphine has an average half-life of 37 hours.

**Clinical and Laboratory Manifestations.** In children, opioid ingestions can manifest with the classic toxidrome of respiratory depression, sedation, and miosis. Signs of more severe toxicity can include bradycardia, hypotension, and hypothermia. Many opioids have clinical features that are unique to their chemical structure ([Table 94.13](#)). Even in therapeutic use, methadone is associated with a prolonged QTc interval and risk of torsades de pointes. Accordingly, an ECG should be part of the initial evaluation after ingestion of methadone or any unknown opioid. Many prescription opioids, including methadone and buprenorphine, are not detected on routine urine opiate screens, although some centers have added a separate urine methadone screen. Levels of many drugs can be measured, although this is rarely done clinically and is seldom helpful in the acute setting. An exception may be in the cases involving concerns about neglect or abuse, at which point urine for gas chromatography/mass spectroscopy, the legal gold standard, should be sent to confirm and document the presence of the drug.

**Treatment.** Patients with significant respiratory depression or CNS depression should be treated with the opioid antidote **naloxone**

**Table 94.13** Clinical Properties of Select Prescription Opioids

CLINICAL EFFECT	OPIOID
QRS widening, sodium channel blockade	Propoxyphene
QT widening, potassium channel blockade	Methadone
Seizures	Propoxyphene, meperidine
Serotonin syndrome	Meperidine, methadone, tramadol
Hearing loss, ototoxicity	Methadone, hydrocodone

Modified from Nikolaidis JK, Thompson TM. Opioids. In: Walls RM, Hockberger RS, Gausche-Hill M, et al., eds. *Rosen's Emergency Medicine*, 9th ed. Philadelphia: Elsevier; 2018, Table 156.2, p. 1944.

(see Table 94.8). In pediatric patients who are not chronically taking opioids, the full reversal dose of 1-2 mg should be used. In contrast, opioid-dependent patients should be treated with smaller initial doses (0.04-0.4 mg), which can then be repeated as needed to achieve the desired clinical response, avoiding abrupt induction of withdrawal. Because the half-life of many opioids is much longer than that of naloxone, patients can require multiple doses of naloxone. These patients may benefit from a continuous infusion of naloxone, typically started at two thirds of the reversal dose per hour and titrated to maintain an adequate respiratory rate and level of consciousness. Patients who have ingested methadone should be placed on a cardiac monitor and have serial ECGs to monitor for the development of a prolonged QTc interval. If a patient does develop a prolonged QTc, management includes close cardiac monitoring, repletion of electrolytes (potassium, calcium, and magnesium), and having a defibrillator readily available should the patient develop torsades de pointes.

Given the potential for clinically significant and prolonged toxicity, any toddler who has ingested methadone, even if asymptomatic, should be admitted to the hospital for at least 24 hours of monitoring. Duration of observation after ingestion of other opioids depends on the half-life and dose of the agent ingested. All such cases should be discussed with a PCC or medical toxicologist before determining disposition.

## Cardiovascular Medications

**β-Adrenergic Receptor Blockers.** β Blockers competitively inhibit the action of catecholamines at the β-adrenergic receptor. Therapeutically, β blockers are used for a variety of conditions, including hypertension, coronary artery disease, tachydysrhythmias, anxiety disorders, migraines, essential tremor, and hyperthyroidism. Because of its lipophilicity and blockade of fast sodium channels, **propranolol** is considered to be the most toxic member of the β-blocker class. Overdoses of water-soluble β blockers (e.g., atenolol) are associated with milder symptoms.

**Pathophysiology.** In overdose, β blockers decrease chronotropy and inotropy in addition to slowing conduction through atrioventricular (AV) nodal tissue. Clinically, these effects are manifested as bradycardia, hypotension, and heart block. Patients with reactive airway disease can experience bronchospasm as a result of blockade of β<sub>2</sub>-mediated bronchodilation. β<sub>2</sub> Blockers interfere with glycogenolysis and gluconeogenesis, which can sometimes lead to hypoglycemia, especially in patients with poor glycogen stores (e.g., toddlers).

**Clinical and Laboratory Manifestations.** Toxicity typically develops within 6 hours of ingestion, although it may be delayed after ingestion of sotalol or SR preparations. The most common features of severe poisoning are bradycardia and hypotension. Lipophilic agents, including propranolol, can enter the CNS and cause altered mental status, coma, and seizures. Overdose of β blockers with sodium channel-blocking properties (e.g., propranolol) can cause QRS interval widening and ventricular dysrhythmias.

Evaluation after β-blocker overdose should include an ECG, frequent reassessments of hemodynamic status, and blood glucose. Serum levels of β blockers are not readily available for routine clinical use and are not useful in management of the poisoned patient.

**Treatment.** In addition to supportive care and GI decontamination as indicated, **glucagon** is theoretically the preferred antidote of choice for β-blocker toxicity (see Table 94.8). Glucagon stimulates adenylate cyclase and increases levels of cyclic adenosine monophosphate (cAMP) independent of the β-receptor. Glucagon is typically given as a bolus and, if this is effective, followed by a continuous infusion. In practice, glucagon is often only marginally effective, limited by its pro-emetic effects, especially at the high doses typically required. Other useful interventions include calcium, vasopressors, and high-dose insulin. Seizures are managed with benzodiazepines, and QRS widening should be treated with sodium bicarbonate. Lipid emulsion therapy (discussed earlier) may be considered in patients with signs of shock who do not respond to conventional treatments. Children who ingest one or two water-soluble β blockers are unlikely to develop toxicity and can typically be discharged to home if they remain asymptomatic over a 6-hour observation period. Children who ingest SR products, highly lipid-soluble agents, and sotalol require longer periods of observation before safe discharge. Any symptomatic child should be admitted for ongoing monitoring and directed therapy.

**Calcium Channel Blockers.** CCBs are used for a variety of therapeutic indications and have the potential to cause severe toxicity, even after exploratory ingestions. Specific agents include verapamil, diltiazem, and the dihydropyridines (e.g., amlodipine, nifedipine). Of these, diltiazem and verapamil are the most dangerous in overdose because of their higher lipophilicity and direct cardiac suppressant effects.

**Pathophysiology.** CCBs antagonize L-type calcium channels, inhibiting calcium influx into myocardial and vascular smooth muscle cells. Verapamil works primarily by slowing inotropy and chronotropy and in therapeutic dosing has no effect on systemic vascular resistance (SVR). Diltiazem has effects both on the heart and the peripheral vasculature. The dihydropyridines exclusively diminish SVR. Verapamil and diltiazem can significantly diminish myocardial contractility and conduction, with diltiazem also lowering SVR. By contrast, dihydropyridines will decrease the SVR, leading to vasodilation and reflex tachycardia, although this receptor selectivity may be lost after a large overdose. Because the same L-type calcium channels blocked by CCBs are also on the pancreatic islet cells, any patient significantly poisoned with a CCB may develop hyperglycemia.

**Clinical and Laboratory Manifestations.** Overdoses of CCBs lead to hypotension, accompanied by bradycardia, normal heart rate, or even tachycardia, depending on the agent. Other rhythm disturbances, including AV block, bundle branch blocks, QT prolongation, and junctional rhythms, may also be seen. A common feature of CCB overdose is the patient exhibiting profound hypotension with preserved consciousness.

Initial evaluation should include an ECG, continuous and careful hemodynamic monitoring, and rapid measurement of serum glucose levels. Both the absolute degree of hyperglycemia and the percentage increase in serum glucose have been correlated with the severity of CCB toxicity in adults. The development of hyperglycemia can even precede the development of hemodynamic instability. Blood levels of CCBs are not readily available and are not useful in guiding therapy.

**Treatment.** Once initial supportive care has been instituted, GI decontamination should begin with activated charcoal as appropriate. WBI may be beneficial in a stable patient after ingestion of an SR product. Calcium channel blockade in the smooth muscles of the GI tract can lead to greatly diminished motility; thus any form of GI decontamination should be undertaken with careful attention to serial abdominal exams.

Calcium salts, administered through a peripheral IV line as calcium gluconate or a central line as calcium chloride, help to overcome blocked calcium channels. **High-dose insulin euglycemia therapy** is considered the antidote of choice for CCB toxicity. An initial bolus of 1 unit/kg of regular insulin is followed by an infusion at 1-10 units/kg/hr (see Table 94.8). The main mechanism of high-dose insulin euglycemia

is to improve the metabolic efficiency of a poisoned heart that needs carbohydrates for energy (instead of the usual free fatty acids) but has minimal circulating insulin. Blood glucose and serum potassium levels should be closely monitored, and supplemental dextrose may be necessary to maintain euglycemia. Mild hypokalemia may be tolerated, as this reflects intracellular shifting of potassium rather than whole-body potassium depletion; severe hypokalemia (e.g.,  $K < 2.8$  mEq/L) is treated with IV potassium supplementation.

Additional therapies include judicious IV fluid boluses and vasopressors (often in very high doses). Cardiac pacing is rarely of value. Lipid emulsion therapy (discussed earlier) is a potentially lifesaving intervention, especially for patients poisoned with the more lipid-soluble CCBs, verapamil and diltiazem. In extreme cases an intraaortic balloon pump or extracorporeal membrane oxygenation (ECMO) are potential treatments. Given the potential for profound and sometimes delayed toxicity in toddlers after ingestion of one or two CCB tablets, hospital admission and 12–24 hours of monitoring for all of these patients is strongly recommended.

**$\alpha_2$ -Adrenergic Agonists.** Although originally intended for use as antihypertensives, the number of **clonidine** and **guanfacine** prescriptions in the pediatric population has greatly increased because of its reported efficacy in the management of attention-deficit/hyperactivity disorder (ADHD), tic disorders, and other behavioral disorders. With this increased use has come a significant rise in pediatric ingestions and therapeutic misadventures. Clonidine is available in pill and transdermal patch forms, while guanfacine is available in pill form.

**Pathophysiology.** Clonidine, along with the closely related agent guanfacine, is a centrally acting  $\alpha_2$ -adrenergic receptor agonist with a very narrow therapeutic index. Agonism at central  $\alpha_2$  receptors decreases sympathetic outflow, producing lethargy, bradycardia, hypotension, and apnea. Toxicity can develop after ingestion of only one pill or after sucking on or swallowing a discarded transdermal patch. Even a “used” transdermal patch might contain as much as one third to one half the original amount of drug.

**Clinical and Laboratory Manifestations.** The most common clinical manifestations of toxicity are lethargy, miosis, and bradycardia. Hypotension, respiratory depression, and apnea may be seen in severe cases. Very early after ingestion, patients may be hypertensive in the setting of agonism at peripheral  $\alpha$ -receptors and resulting vasoconstriction. Symptoms develop relatively soon after ingestion and typically resolve within 24 hours. Serum clonidine concentrations are not readily available and are of no clinical value in the acute setting. Although signs of clinical toxicity are common after clonidine or guanfacine overdose, death is extremely unusual.

**Treatment.** Given the potential for significant toxicity, most young children warrant referral to a healthcare facility for evaluation after unintentional ingestions of  $\alpha_2$ -adrenergic agonists. Gastric decontamination is of minimal value because of the small quantities ingested and the rapid onset of serious symptoms. Aggressive supportive care is imperative and is the cornerstone of management. Naloxone, often in high doses (i.e., 10 mg IV), has shown variable efficacy in treating clonidine toxicity. Other potentially useful therapies include atropine, IV fluid boluses, and vasopressors. Symptomatic children should be admitted to the hospital for close cardiovascular and neurologic monitoring. Also, in a patient receiving chronic clonidine or guanfacine therapy, rapid discontinuation of the drug, or even missing one or two doses, could lead to potentially dangerous elevations in blood pressure.

**Digoxin.** Digoxin is a cardiac glycoside extracted from the leaves of *Digitalis lanata*. Other natural sources of cardiac glycosides include *Digitalis purpurea* (foxglove), *Nerium oleander* (oleander), *Convallaria majalis* (lily of the valley), Siberian ginseng, and the *Bufo marinus* toad. Therapeutically, digoxin is used in the management of heart failure and some supraventricular tachydysrhythmias. Acute overdose can occur in the setting of dosing errors (especially in younger children), unintentional or intentional medication ingestion, or exposure to plant material containing digitalis glycosides. Regarding exposure to such plants, toxicity is unusual unless the poison is concentrated in the form of a tea. Chronic toxicity can result from alteration of the digoxin dose, alteration in digoxin clearance as a result of renal impairment, or drug interactions.

**Pathophysiology.** Digoxin blocks the sodium-potassium adenosine triphosphatase ( $Na^+, K^+$ -ATPase) pump, leading to intracellular loss of  $K^+$  and gain of  $Na^+$  and calcium ( $Ca^{2+}$ ). This resulting rise in  $Ca^{2+}$  available to the contractile myocardium improves inotropy. An increase in myocardial automaticity leads to subsequent atrial, nodal, and ventricular ectopy. Digoxin also affects nodal conduction, leading to a prolonged refractory period, decreased sinus node firing, and slowed conduction through the AV node. Impaired  $Na^+/K^+$  exchange can lead to elevated serum  $K^+$ . Overall, digoxin overdose manifests as a combination of slowed or blocked conduction and increased ectopy.

**Clinical and Laboratory Manifestations.** Nausea and vomiting are common initial symptoms of acute digoxin toxicity, manifesting within 6 hours of overdose. Cardiovascular manifestations include bradycardia, heart block, and a wide variety of dysrhythmias. CNS manifestations consist of lethargy, confusion, and weakness. Chronic toxicity (which is rare in children) is more insidious and may also manifest as altered mental status and visual disturbances.

Initial assessment should include an ECG, serum digoxin level, serum potassium, and kidney function tests. The serum digoxin level should be assessed at least 6 hours after ingestion and carefully interpreted in the setting of clinical symptoms, because the digoxin level alone does not entirely reflect the severity of intoxication. In acute ingestions, serum potassium is an independent marker of morbidity and mortality, with levels  $> 5$  mEq/L predicting poor outcomes. In chronic toxicity, serum  $K^+$  concentration is less useful as a prognostic marker and may be altered from concomitant use of diuretics or renal dysfunction.

Digoxin has a very narrow therapeutic index. Therapeutic plasma digoxin concentrations are 0.5–2 ng/mL; a level  $> 2$  ng/mL is considered toxic, and  $> 6$  ng/mL is considered potentially fatal (in chronic poisonings). As with all serum levels of intoxicants, one must be careful to interpret the number in the context of the scenario of the poisoning and the status of the patient. An acutely poisoned patient may have a very high serum level and minimal to no symptoms, whereas a patient with a chronic or acute-on-chronic poisoning will usually be sicker with a lower serum level.

Numerous drug interactions affect plasma digoxin concentrations. Medications known to increase serum digoxin concentrations include the macrolides, erythromycin and clarithromycin, spironolactone, verapamil, amiodarone, and itraconazole.

**Treatment.** Initial treatment includes good general supportive care and gastric decontamination with activated charcoal if the ingestion was recent. An antidote for digoxin, digoxin-specific antibody fragments (Fab: Digibind or DigiFab) is available (see Table 94.8). Fab fragments bind free digoxin in both the intravascular and the interstitial spaces to form a pharmacologically inactive complex that is subsequently eliminated renally. Indications for administration of Fab fragments in children are listed in Table 94.14. Atropine is potentially useful in managing symptomatic bradycardia. Although dogma states that patients on digoxin with severe hyperkalemia and QRS widening on the ECG should not receive calcium salts, this has not been supported in the literature. Once stabilized, consultation with a cardiologist is recommended in the management of patients receiving chronic digoxin therapy, because administration of Fab fragments can lead to recurrence of the patient’s underlying dysrhythmias or dysfunction.

**Iron.** Historically, iron was a common cause of childhood poisoning deaths. However, preventive measures such as childproof packaging have significantly decreased the rates of serious iron toxicity in young children. Iron-containing products remain widely available, with the most potentially toxic being adult iron preparations and prenatal vitamins. The severity of an exposure is related to the amount of *elemental iron* ingested. Ferrous sulfate contains 20% elemental iron, ferrous gluconate 12%, and ferrous fumarate 33%. Multivitamin preparations and children’s vitamins rarely contain enough elemental iron to cause significant toxicity. Furthermore, nonionic forms of iron, carbonyl iron and iron polysaccharide, also do not cause significant toxicity.

**Pathophysiology.** Iron is directly corrosive to the GI mucosa, leading to hematemesis, melena, ulceration, and potential perforation.



**Table 94.14** Indications for Administration of Digoxin Antibody Fragments in Children

Ingestion of >0.1-0.3 mg/kg or steady-state digoxin concentration >5 ng/mL PLUS one of the following: <ul style="list-style-type: none"> <li>• Rapidly progressive symptoms</li> <li>• Signs of cardioactive steroid intoxication</li> <li>• Potentially life-threatening dysrhythmias or conduction blocks</li> <li>• Serum potassium concentration &gt;5 mEq/L</li> </ul>
Co-ingestion of other cardiotoxic drugs with additive or synergistic toxicity
Ingestion of plant known to contain cardioactive steroids plus severe dysrhythmias

Modified from Cole JB. Cardiovascular drugs. In: Walls RM, Hockberger RS, Gausche-Hill M, et al., eds. *Rosen's Emergency Medicine*, 9th ed. Philadelphia: Elsevier; 2018, Box 147.4, p. 1879.

**Table 94.15** Clinical Manifestations of Iron Toxicity After Acute Overdose

PHASE	CLINICAL FEATURES
1. Gastrointestinal (6 hr)	Vomiting Diarrhea Hematemesis Hematochezia
2. Latent (6-24 hr)	Resolution of GI symptoms Tachycardia Acidosis Depressed mental status
3. Systemic (12-24 hr)	Return of GI symptoms Acidosis Leukocytosis Coagulopathy Renal failure Lethargy or coma Cardiovascular collapse
4. Hepatic (2-5 days)	Fulminant liver failure Coagulopathy
5. Obstructive (3-6 wk)	Pyloric or bowel scarring Obstruction

GI, Gastrointestinal.

Modified from Theobald JL, Mycyk MB. Iron and heavy metals. In: Walls RM, Hockberger RS, Gausche-Hill M, et al., eds. *Rosen's Emergency Medicine*, 9th ed. Philadelphia: Elsevier; 2018, Table 151.2, p. 1913.

Early iron-induced hypotension is caused by massive volume losses, increased permeability of capillary membranes, and vasodilation mediated by free iron. Iron accumulates in tissues, including the Kupffer cells of the liver and myocardial cells, leading to hepatotoxicity, coagulopathy, and cardiac dysfunction. Metabolic acidosis develops in the setting of hypotension, hypovolemia, and iron's direct interference with oxidative phosphorylation and the Krebs cycle. Pediatric patients who ingest >40 mg/kg of elemental iron should be referred to medical care for evaluation, although moderate to severe toxicity is typically seen with ingestions >60 mg/kg.

**Clinical and Laboratory Manifestations.** Iron toxicity is described in five often-overlapping stages (Table 94.15). Patients who do not develop GI symptoms within 6 hours of ingestion are unlikely to develop serious toxicity. Symptomatic patients and patients with a large exposure by history should have serum iron levels drawn 4-6 hours after ingestion. Serum iron concentrations of <350 µg/dL 4-8 hours after ingestion suggest a low risk of significant toxicity, concentrations of 350-500 µg/dL suggest moderate toxicity, and concentrations of >500 µg/dL indicate that significant toxicity is likely. Additional laboratory evaluation in the ill patient should include arterial or venous blood gas,

lactate, CBC, serum glucose level, liver transaminases, and coagulation parameters. Careful attention should be paid to the patient's hemodynamic status. An abdominal radiograph may reveal the presence of iron tablets, although not all formulations of iron are radiopaque.

**Treatment.** Close clinical monitoring, combined with aggressive supportive and symptomatic care, is essential to the management of iron poisoning. Activated charcoal does not adsorb iron, and WBI remains the decontamination strategy of choice. **Deferoxamine**, a specific chelator of iron, is the antidote for moderate to severe iron intoxication (see Table 94.8). Indications for deferoxamine treatment include a serum iron concentration >500 µg/dL or moderate to severe symptoms of toxicity (e.g., acidosis), regardless of serum iron concentration. Deferoxamine is preferably given by continuous IV infusion at 15 mg/kg/hr. Hypotension is a common side effect of deferoxamine infusion and is managed by slowing the rate of the infusion and administering fluids and vasopressors as needed. Prolonged deferoxamine infusion (>24 hours) has been associated with pulmonary toxicity (ARDS) and *Yersinia* sepsis. The deferoxamine-iron complex can color the urine reddish ("vin rosé"), although the degree of this coloration should not guide therapy. Deferoxamine is typically continued until clinical symptoms and acidosis resolve. Consultation with a PCC or medical toxicologist can yield guidelines for discontinuing deferoxamine.

### Oral Hypoglycemics

Oral medications used in the management of type 2 diabetes include sulfonylureas, biguanides (e.g., metformin), thiazolidinediones, and meglitinides. Of these, only the sulfonylureas and meglitinides have the potential to cause profound hypoglycemia in both diabetic and nondiabetic patients. These classes of medications are widely prescribed and thus readily available. In toddlers, unintentional ingestion of a single sulfonylurea tablet can lead to significant toxicity.

**Pathophysiology.** Sulfonylureas work primarily by enhancing endogenous insulin secretion. In binding to the sulfonylurea receptor, these drugs induce closure of K<sup>+</sup> channels, leading to membrane depolarization, opening of Ca<sup>2+</sup> channels, and stimulation of Ca<sup>2+</sup>-mediated insulin release. Even in therapeutic use, the duration of hypoglycemic action can last up to 24 hours.

**Clinical and Laboratory Manifestations.** Hypoglycemia and symptoms associated with hypoglycemia are the primary clinical manifestations of sulfonylurea toxicity. These signs and symptoms can include diaphoresis, tachycardia, lethargy, irritability, coma, seizures, and even focal neurologic findings. As with other hyperinsulinemic states, sulfonylurea overdoses are associated with a nonketotic hypoglycemia. In the majority of patients, hypoglycemia develops within 6 hours of ingestion but can be delayed up to 16-18 hours after ingestion. Toddlers are particularly susceptible to hypoglycemia during an overnight fast.

**Treatment.** Patients with symptomatic hypoglycemia should be promptly treated with dextrose. In patients with mild symptoms, oral dextrose may be sufficient. However, patients with severe symptoms or profound hypoglycemia should be treated with a bolus of IV dextrose. Continuous dextrose infusions and repeated IV dextrose boluses should be avoided, if possible, because this can stimulate further insulin release and lead to recurrent and prolonged hypoglycemia. Instead, the preferred antidote for persistent (i.e., requiring ≥2 doses of IV dextrose) sulfonylurea toxicity is **octreotide** (see Table 94.8). Octreotide is a somatostatin analog that inhibits insulin release. Octreotide is given IV or subcutaneously (SC), typically in doses of 1-2 µg/kg (50-100 µg in teens or adults) every 6-8 hours.

Given the potential for significant hypoglycemia, toddlers with witnessed or suspected sulfonylurea ingestions should be admitted to the hospital for serial glucose measurements for at least 12 hours, including an overnight fast. Patients of any age who develop hypoglycemia are also candidates for admission, given the prolonged duration of hypoglycemic activity with these medications. Prophylactic IV dextrose infusions are not recommended because they can mask the symptoms of toxicity and stimulate further insulin secretion. Patients who require IV dextrose and/or octreotide should be monitored until they can demonstrate euglycemia for at least 8 hours off all therapy.



With the increasing numbers of adolescents with type 2 diabetes, pediatricians should be familiar with the toxic effects of **metformin** as well. Although metformin does not cause hypoglycemia, its association with lactic acidosis is well documented (metformin-associated lactic acidosis [MALA]). This state typically arises after a large overdose in which the agent interferes with the liver's ability to clear lactic acid. Dangerously high serum lactate levels can result, leading to hemodynamic instability. Hemodialysis is usually the best option for patients with severe MALA.

### Psychiatric Medications: Antidepressants

Selective serotonin reuptake inhibitors (SSRIs; e.g., fluoxetine, sertraline, paroxetine, citalopram) are the most commonly prescribed class of antidepressants. This trend largely results from their wide therapeutic index and more favorable side effect profile compared with older agents such as tricyclic antidepressants (TCAs; amitriptyline, clomipramine, desipramine, doxepin, nortriptyline, imipramine) and monoamine oxidase inhibitors (MAOIs). Other agents include the serotonin-norepinephrine reuptake inhibitors (SNRIs; e.g., venlafaxine) and atypical antidepressants (e.g., bupropion).

**Tricyclic Antidepressants.** Although now prescribed less often for depression, TCAs remain in use for a variety of other conditions, including chronic pain syndromes, enuresis, ADHD, and obsessive-compulsive disorder. TCAs can cause significant toxicity in children, even with ingestion of one or two pills (10-20 mg/kg).

**Pathophysiology.** TCAs achieve their desired antidepressant effects primarily through blockade of norepinephrine and serotonin reuptake. TCAs have complex interactions with other receptor types. Antagonism at muscarinic acetylcholine receptors leads to clinical features of the anticholinergic toxidrome. Antagonism at peripheral  $\alpha$ -receptors leads to hypotension and syncope. Key to the toxicity of TCAs is their ability to block fast sodium channels, leading to impaired cardiac conduction and arrhythmias.

**Clinical and Laboratory Manifestations.** Cardiovascular and CNS symptoms dominate the clinical presentation of TCA toxicity. Symptoms typically develop within 1-2 hours of ingestion, and serious toxicity usually manifests within 6 hours of ingestion. Patients can have an extremely rapid progression from mild symptoms to life-threatening dysrhythmias. Patients often develop features of **anticholinergic toxidrome**, including delirium, mydriasis, dry mucous membranes, tachycardia, hyperthermia, urinary retention, and slow GI motility. CNS toxicity can include lethargy, coma, myoclonic jerks, and seizures. Sinus tachycardia is the most common cardiovascular manifestation of toxicity; however, patients can also develop widening of the QRS complex, premature ventricular contractions, and ventricular dysrhythmias. Refractory hypotension is a poor prognostic indicator and is the most common cause of death in TCA overdose.

An ECG can help determine the diagnosis and prognosis of the TCA-poisoned patient (Fig. 94.2; see Table 94.7). A QRS duration  $>100$  msec identifies patients who are at risk for seizures and cardiac arrhythmias. An R wave in lead aVR of  $\geq 3$  mm is also an independent predictor of toxicity. Both ECG parameters are superior to measured serum TCA concentrations for identifying patients at risk for serious toxicity, and obtaining levels is rarely helpful in management of the acutely ill patient.

**Treatment.** Initial attention should be directed to supporting vital functions, including airway and ventilation as needed. Gastric decontamination can be accomplished with activated charcoal in patients who are alert and cooperative without clinical signs of toxicity. Treating clinicians should obtain an ECG as soon as possible and follow serial ECGs to monitor for progression of toxicity. The four primary effects described next may be seen at the bedside.

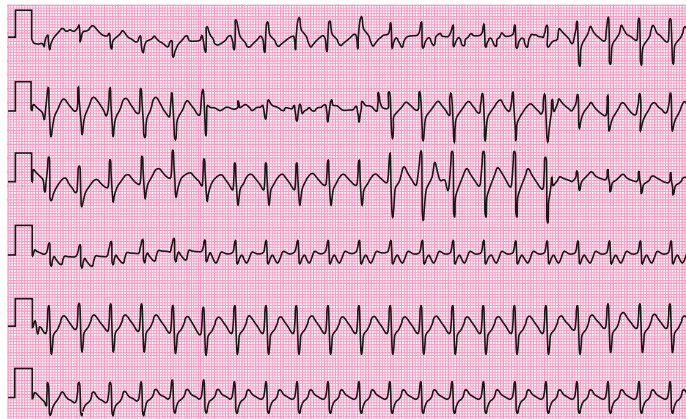
**1. Altered Mental State.** TCA-poisoned patients can become deeply comatose relatively quickly, so careful and prompt attention to the airway and placement of an endotracheal tube is of paramount importance.

**2. Widened QRS on ECG.** TCAs, as well as other agents (e.g., diphenhydramine, cocaine), block the fast  $\text{Na}^+$  channels on the myocardial cells, slowing the upstroke of the QRS complex. Because the effect on  $\text{Na}^+$  channels is greatest within the first 6 hours, frequent ECGs (i.e., every 20-30 minutes) during this period are important. As the QRS approaches 160 msec, the risk of the patient developing monomorphic ventricular tachycardia rises to 30%. Sodium, usually in the form of sodium bicarbonate, is the antidote of choice. *Indications for sodium bicarbonate include a QRS duration  $\geq 100$  msec, ventricular dysrhythmias, and hypotension.* Multiple bolus doses of sodium bicarbonate, 1-2 mEq/kg each, may be needed to narrow the QRS to  $<100$  msec. Some prefer then to place the patient on an infusion of sodium bicarbonate, but this may not be necessary if the QRS is carefully monitored after the initial doses and repeat bolus dosing is provided as needed during the first 6-12 hours. Hypertonic (3%) saline and/or lipid emulsion therapy may be beneficial in refractory cases.

**3. Hypotension.** A direct-acting vasopressor such as norepinephrine or epinephrine is the agent of choice. Boluses of IV crystalloid fluids should be used with caution to prevent fluid overload.

**4. Seizures.** Seizures are relatively common and likely the result of multiple factors, including increased synaptic monoamines, sodium channel inhibition, and GABA receptor antagonism. Seizures are typically brief and should be treated with agents targeting the GABA-receptor complex in the brain. Benzodiazepines are the agent of choice.

Asymptomatic children should receive appropriate decontamination and have continuous cardiac monitoring and serial ECGs for at least 6 hours after exposure. If any manifestations of toxicity develop, the child should be admitted to a monitored setting. Children who remain



**Fig. 94.2** Electrocardiographic findings in tricyclic antidepressant toxicity. Note the tachycardia, widened QRS interval (144 msec), and prominent R wave in lead aVR. These findings are consistent with blockade of fast sodium channels.

completely asymptomatic with normal serial ECGs may be candidates for discharge after that monitoring period.

**Selective Serotonin Reuptake Inhibitors.** In overdose, SSRIs are considerably less toxic than TCAs. SSRIs are unlikely to cause significant toxicity in exploratory ingestions. Some data suggest that initiating SSRI therapy is associated with an increased risk of suicidal ideation and behavior (see Chapter 40).

**Pathophysiology.** SSRIs selectively block the reuptake of serotonin in the CNS. In contrast to TCAs and atypical antidepressants, SSRIs do not directly interact with other receptors.

**Clinical and Laboratory Manifestations.** Although seen more often after therapeutic use or overdose of several serotonergic agents in combination, **serotonin syndrome** has also been described in ingestion of SSRIs alone (Table 94.16). Clinically, serotonin syndrome describes a spectrum of altered mental status, autonomic instability, fever, and neuromuscular hyperactivity (hyperreflexia, tremors, clonus in lower extremities > upper extremities) (Table 94.17). One or all of these signs may be present to varying degrees.

In overdose, the principal clinical manifestations of toxicity are sedation and tachycardia. Cardiac conduction abnormalities (primarily QTc prolongation) and seizures have been described in significant overdoses, especially after ingestions of citalopram. An ECG should be part of the initial assessment after SSRI ingestion. Serum creatine kinase (CK) levels are almost always elevated in a patient with clinically significant serotonin syndrome. The differential diagnosis includes neuroleptic malignant syndrome and malignant hyperthermia (Table 94.18).

**Treatment.** Initial management includes a careful assessment for signs and symptoms of serotonin syndrome and an ECG. Most patients simply require supportive care and observation until their mental status improves and tachycardia, if present, resolves. Management of serotonin syndrome is directed by the severity of symptoms; possible therapeutic interventions include benzodiazepines in mild cases and intubation, sedation, and paralysis in patients with severe manifestations (e.g., significant hyperthermia). Because agonism at the 5-HT<sub>2A</sub> serotonin receptor is thought to be primarily responsible for the development of serotonin syndrome, use of the 5-HT<sub>2A</sub> receptor antagonist cyproheptadine has been considered a possible antidote; the efficacy of cyproheptadine in managing serotonin syndrome is not well-supported by the available literature. Furthermore, cyproheptadine should be used with caution when the diagnosis is unclear, as it can worsen anticholinergic toxicity.

**Atypical Antidepressants.** The atypical antidepressant class includes agents such as venlafaxine and duloxetine (SNRIs), bupropion (dopamine, norepinephrine, and some serotonin reuptake blockade), and trazodone (serotonin reuptake blockade and peripheral  $\alpha$ -receptor antagonism). The variable receptor affinities of these agents lead to some distinctions in their clinical manifestations and management.

**Clinical and Laboratory Manifestations.** In overdose, **venlafaxine** and other SNRIs have been associated with cardiac conduction defects, including QRS and QTc prolongation, and seizures (typically within a few hours of ingestion). **Bupropion** warrants special consideration because it is one of the most common etiologies of toxicant-induced seizures in the United States. After ingestion of SR or extended-release (ER) preparations of bupropion, seizures can occur as late as 18–20 hours after ingestion. In addition, bupropion can cause tachycardia, agitation, and QRS and QTc prolongation. These cardiac effects are thought to result from a reduction in cardiac intracellular coupling caused by inhibition at gap junctions in the heart. Mortality results from not only status epilepticus but also the cardiac conduction disturbances causing ventricular tachycardia and dysrhythmias. In addition to sedation and signs of serotonin excess, trazodone overdose may be associated with hypotension from blockade of peripheral  $\alpha$ -receptors.

**Treatment.** Management is directed at clinical signs and symptoms. QRS and QTc interval prolongation after bupropion poisoning is typically resistant to the standard treatments of sodium bicarbonate and magnesium. Seizures are often brief and self-limited but can be treated with benzodiazepines if necessary. A patient poisoned with bupropion who shows unstable hemodynamics with prolonged ECG intervals or persistent seizure activity after the appropriate therapies should be discussed with a toxicologist for possible lipid emulsion therapy. Because of the potential for delayed seizures, asymptomatic patients who have ingested an SR preparation of bupropion should be admitted to a monitored setting for at least 20–24 hours. Trazodone-associated hypotension typically responds to fluids, though it can require vasopressors in extreme cases.

**Monoamine Oxidase Inhibitors.** Although now rarely used therapeutically, MAOIs remain important agents given their potential for serious and delayed toxicity. Ingestions of only one or two pills (6 mg/kg) are associated with toxicity in children. Clinical manifestations initially include hypertension, hyperthermia, tachycardia, muscle rigidity, and seizures, followed up to 24 hours later by hemodynamic instability and cardiovascular collapse. *Any child who ingests a MAOI should be admitted to a monitored setting for at least 24 hours, regardless of symptoms.* Management includes blood pressure control, cooling and benzodiazepines for hyperthermia, serial monitoring of CK and renal function, and fluid and vasopressor therapy for hemodynamic instability.

### Psychiatric Medications: Antipsychotics

Clinicians are increasingly prescribing antipsychotic medications in the pediatric population. Antipsychotics are usually classified as either typical or atypical. In general, typical agents are associated with more side effects and toxicity than the atypical agents.

**Table 94.16** Drugs Associated with Serotonin Syndrome

DRUG TYPE	DRUGS
Selective serotonin reuptake inhibitors	Sertraline, fluoxetine, fluvoxamine, paroxetine, citalopram, escitalopram
Antidepressant drugs	Trazodone, nefazodone, buspirone, clomipramine, venlafaxine, amitriptyline, nortriptyline
Monoamine oxidase inhibitors	Phenelzine, moclobemide, clorgyline, isocarboxazid
Anticonvulsants	Valproate
Analgesics	Meperidine, fentanyl, tramadol, pentazocine
Antiemetic agents	Ondansetron, granisetron, metoclopramide
Antimigraine drugs	Sumatriptan
Bariatric medications	Sibutramine
Antibiotics	Linezolid (a monoamine oxidase inhibitor), ritonavir (through inhibition of cytochrome P450 enzyme isoform 3A4)
Nonprescription cough and cold remedies	Dextromethorphan
Drugs of abuse	Methylenedioxymethamphetamine (MDMA, "ecstasy"), lysergic acid diethylamide (LSD), 5-methoxydiisopropyltryptamine ("foxy methoxy"), Syrian rue (contains harmine and harmaline, both monoamine oxidase inhibitors)
Dietary supplements and herbal products	Tryptophan, <i>Hypericum perforatum</i> (St. John's wort), <i>Panax ginseng</i> (ginseng)
Other	Lithium

From Boyer EW, Shannon M. The serotonin syndrome. *N Engl J Med.* 2005;352:1112–1120.

**Table 94.17** Spectrum of Symptoms of Serotonergic Toxicity

SEVERITY	NEUROMUSCULAR EXCITATION	ALTERED MENTAL STATUS	AUTONOMIC DYSFUNCTION
Mild	Hyperreflexia Tremor Myoclonus	Anxiety Restlessness Insomnia	Diaphoresis Mydriasis Tachycardia
Moderate	Opsoclonus Spontaneous or inducible clonus	Agitation	Hypertension Hyperthermia (<40°C [ $<104^{\circ}\text{F}$ ]) Hyperactive bowel sounds Diarrhea, nausea, vomiting
Severe	Rigidity Respiratory failure Tonic-clonic seizure	Coma Delirium Confusion	Severe hyperthermia ( $\geq 40^{\circ}\text{C}$ [ $\geq 104^{\circ}\text{F}$ ]) Dynamic blood pressure

Adapted from Wang RZ, Vashistha V, Kaur S, Houchens NW. Serotonin syndrome: Preventing, recognizing, and treating it. *Clev Clin J Med*. 2016;83(11):810–817, Table 2, p. 812.

**Table 94.18** Signs and Symptoms of Neuroleptic Malignant Syndrome (NMS)/Serotonin Syndrome/Malignant Hyperthermia

CLINICAL FEATURES	NMS	SEROTONIN SYNDROME	MALIGNANT HYPERTHERMIA
Triggering agent	Neuroleptic	Proserotonergic agent	Succinylcholine or inhaled anesthetic
Onset	Slow (hours to days)	Fast (minutes to hours)	Very fast to fast (minutes to hours)
Duration	Long (days to weeks)	Short (1–2 days)	Short (1–3 days)
Agitation	Sometimes	Yes	No
Confusion	Yes	Sometimes	Unusual
Hyperactivity	No	Yes	No
Bradykinesia/stupor	Yes	No	Unusual
Myoclonus	No	Yes	No
Shivering	No	Yes/sometimes	No
Tremor	Sometimes	Yes	No
Pupils	Mid-sized	Large	Not specific
Hyperreflexia	No	Yes (especially lower extremities)	No
Rigidity	Severe	Sometimes	Severe
Rigidity type	Extrapyramidal (lead pipe)	Pyramidal (clasp-knife)	Generalized
Hyperpyrexia	Yes	Yes	Severe
Tachypnea	Yes	Yes	Yes
Tachycardia	Yes	Yes	Yes (severe)
Hypertension	Sometimes	Yes	Sometimes
Leukocytosis	Yes	Uncommon	Not typical
Elevated creatine phosphokinase	Severe	Mild	Severe

Adapted from Gillman PK. The serotonin syndrome and its treatment. *J Psychopharmacol* 1999;13:100–109; Gillman K. Serotonin toxicity [www.psychotropic.com/serotonin-toxicity](http://www.psychotropic.com/serotonin-toxicity); and Wappler F, Fiege M, Schulte am Esch J. Pathophysiological role of the serotonin system in malignant hyperthermia. *Br J Anaesth*. 2001;87(5):794–798.

**Pathophysiology.** Typical, or “traditional,” antipsychotics (haloperidol, droperidol, thioridazine, chlorpromazine, fluphenazine) are characterized by their antagonism at  $D_2$  dopamine receptors. In therapeutic use, these agents are associated with extrapyramidal symptoms, tardive dyskinesia, and, rarely, development of **neuroleptic malignant syndrome (NMS)** (see Table 94.18). The *atypical* agents (aripiprazole, clozapine, quetiapine, risperidone, ziprasidone) were developed with relatively less dopamine ( $D_2$ -receptor) antagonism in the nigrostriatum to avoid these side effects and improve their efficacy in managing the “negative” symptoms of schizophrenia. Instead, these agents have complex and varied interactions with multiple receptor types, including  $\alpha$ -receptors, serotonin receptors, muscarinic acetylcholine receptors, and histamine receptors.

**Clinical and Laboratory Manifestations.** Typical antipsychotic toxicity usually includes sedation, tachycardia, and QTc prolongation.

Patients can present with acute dystonia, akathisia, and NMS, although these are seen less frequently in acute overdoses than in therapeutic use. The phenothiazines (e.g., thioridazine) can cause widening of the QRS interval from blockade of fast sodium channels. Clinically, NMS can be difficult to distinguish from serotonin syndrome.

Although the presentation of atypical antipsychotic toxicity can vary based on the receptor affinities of the specific agent, sedation, tachycardia, and QTc prolongation are common. Peripheral  $\alpha$ -receptor blockade (e.g., with quetiapine) is associated with hypotension. In therapeutic use, clozapine is associated with agranulocytosis. Atypical antipsychotics that antagonize muscarinic acetylcholine receptors (e.g., olanzapine, quetiapine) may cause symptoms of anticholinergic toxidrome.

Diagnostic testing should include an ECG. Patients with hyperthermia or muscle rigidity should have a serum CK level sent to monitor



for possible rhabdomyolysis. CBC is indicated in patients with fever to evaluate for neutropenia. Antipsychotic levels are not readily available and are not helpful in managing acute poisoning.

**Management.** Initial management involves assessing and supporting vital functions. In some patients, CNS depression may be so profound as to require intubation for airway control. Acute dystonia is treated with diphenhydramine and benztropine. Management of NMS includes aggressive supportive care, IV fluids, active cooling, benzodiazepines, and bromocriptine or dantrolene in severe cases. QTc prolongation is managed with repletion of electrolytes (especially calcium, magnesium, and potassium), continuous cardiac monitoring, prevention of bradycardia (overdrive pacing, isoproterenol, atropine), and defibrillation if the patient develops torsades de pointes. Delirium associated with anticholinergic toxicity may be managed with benzodiazepines, and a specific antidote (physostigmine) can be considered in consultation with a medical toxicologist (see Table 94.8). Seizures typically are well controlled with benzodiazepines. Hypotension usually responds to boluses of IV fluids, although vasopressor therapy is necessary in some patients.

### Household Products Caustics

Caustics include acids and alkalis as well as a few common oxidizing agents (see Chapter 373). Strong acids and alkalis can produce severe injury even in small-volume ingestions.

**Pathophysiology.** Alkalis produce a *liquefaction necrosis*, allowing further tissue penetration of the toxin and setting the stage for possible perforation. Acids produce a *coagulative necrosis*, which limits further tissue penetration, although perforation can still occur. The severity of the corrosive injury depends on the pH and concentration of the product and the length of contact time with the product. Agents with a pH of <2 or >12 are most likely to produce significant injury.

**Clinical Manifestations.** Ingestion of caustic materials can produce injury to the oral mucosa, posterior pharynx, vocal cords, esophagus, and stomach. Patients can have significant esophageal injury even in the absence of visible oral burns. Symptoms include pain, drooling, vomiting, abdominal pain, and difficulty swallowing or refusal to swallow. Laryngeal injury can manifest as stridor and respiratory distress, necessitating intubation. In the most severe cases, patients can present in shock after perforation of a hollow viscus. Circumferential burns of the esophagus are likely to cause strictures when they heal, which can require repeated dilation or surgical correction and long-term follow-up for neoplastic changes in adulthood. Caustic exposures on the skin or in the eye can cause significant tissue damage.

**Treatment.** Initial treatment of caustic exposures includes thorough removal of the product from the skin or eye by flushing with water. *Emesis and lavage are contraindicated.* Activated charcoal should not be used because it does not bind these agents, interferes with endoscopy, and can predispose the patient to vomiting and subsequent aspiration. Stridor or other signs of respiratory distress should alert the provider to the need for a thorough evaluation of the airway for potential intubation or surgical airway management. Endoscopy can be performed within 12-24 hours of ingestion in *symptomatic* patients or those with suspected injury based on history and known characteristics of the ingested product. The role of endoscopy is purely diagnostic and is contraindicated in patients with severe oropharyngeal injury with edema and necrosis, evidence of perforation, respiratory distress, or hemodynamic instability, as these patients instead require immediate surgical consultation. Expectant management with a period of nothing by mouth (NPO) and proton pump inhibitor therapy is likely appropriate for most *asymptomatic* patients. Corticosteroids or prophylactic antibiotics are not beneficial.

### Pesticides

**Cholinesterase-Inhibiting Insecticides.** The most commonly used insecticides in agriculture are **organophosphates** and **carbamates**; both are inhibitors of cholinesterase enzymes: acetylcholinesterase (AChE), pseudocholinesterase, and erythrocyte AChE. Most pediatric poisonings occur as the result of unintentional exposure to insecticides

in and around the home or farm. The chemical warfare weapons known as “nerve agents” are also organophosphate compounds with a similar mechanism of action but much greater potency.

**Pathophysiology.** Organophosphates and carbamates produce toxicity by binding to and inhibiting AChE, preventing the degradation of acetylcholine (ACh) and resulting in its accumulation at nerve synapses. If left untreated, organophosphates form an irreversible bond to AChE, permanently inactivating the enzyme. This process, called *aging*, occurs over a variable period, depending on the characteristics of the specific organophosphate. A period of weeks to months is required to regenerate inactivated enzymes. In contrast, carbamates form a temporary bond with the enzymes, typically allowing reactivation of AChE within 24 hours.

**Clinical and Laboratory Manifestations.** Clinical manifestations of organophosphate and carbamate toxicity relate to ACh accumulation at peripheral nicotinic and muscarinic synapses and in the CNS. Symptoms of carbamate toxicity are usually less severe than those seen with organophosphates. A commonly used mnemonic for the symptoms of cholinergic excess at muscarinic receptors is **DUMBELS**: diarrhea/defecation, urination, miosis, bronchorrhea/bronchospasm, bradycardia, emesis, lacrimation, and salivation. Nicotinic signs and symptoms include muscle weakness, fasciculation, tremors, hypoventilation (diaphragm weakness), hypertension, tachycardia, and dysrhythmias. Severe manifestations include coma, seizures, shock, arrhythmias, and respiratory failure.

Diagnosis of poisoning is based primarily on history and physical exam findings. Red blood cell cholinesterase and pseudocholinesterase activity levels can be measured in the laboratory. These are only helpful when compared with the patient's known baseline. As such, these assessments are typically limited to farmworkers undergoing ongoing occupational surveillance.

**Treatment.** Basic decontamination should be performed, including washing all exposed skin with soap and water and immediately removing all clothing. Activated charcoal is unlikely to be of benefit because these are liquids that are rapidly absorbed. Basic supportive care should be provided, including fluid and electrolyte replacement, intubation, and ventilation if necessary. The use of succinylcholine for rapid sequence intubation should be avoided because the same cholinesterase enzymes that are poisoned metabolize this neuromuscular blocking agent, leading to prolonged paralysis.

Two antidotes are useful in treating cholinesterase inhibitor poisoning: atropine and pralidoxime (see Table 94.8). **Atropine**, which antagonizes the muscarinic ACh receptor, is useful for both organophosphate and carbamate intoxication. Often, large doses of atropine must be administered by intermittent bolus or continuous infusion to control symptoms. Atropine dosing is primarily targeted to drying the respiratory secretions. **Pralidoxime** breaks the bond between the organophosphate and the enzyme, reactivating AChE. Pralidoxime is only effective if it is used before the bond ages and becomes permanent. Pralidoxime is not necessary for carbamate poisonings because the bond between the insecticide and the enzyme degrades spontaneously.

Without treatment, symptoms of organophosphate poisoning can persist for weeks, requiring continuous supportive care. Even with treatment, some patients develop a delayed polyneuropathy and a range of chronic neuropsychiatric symptoms.

**Pyrethrins and Pyrethroids.** Pyrethrins are derived from the chrysanthemum flower and, along with synthetic derivatives, pyrethroids, are the most used pesticides in the home. Although >1,000 pyrethrins and pyrethroids exist, <20 are available in the United States, with **permethrin** being the most common. Exposure to these compounds occurs by inhalation, dermal absorption, or ingestion. Ingestion is the predominant route and typically occurs by eating contaminated foods. Permethrin is also a prescribed medication for the treatment of scabies and lice.

**Pathophysiology.** Pyrethrins and pyrethroids prolong the open state of the voltage-gated Na<sup>+</sup> channel conduction, which is the main mechanism resulting in its pesticide activity. Pyrethrins have minimal toxicity in mammals because of rapid metabolism, higher affinity for the insect Na<sup>+</sup> channel, and decreased activity at higher temperatures



seen in warm-blooded animals. Because pyrethroids were specifically manufactured to be more stable in the environment, they have a higher likelihood of toxicity.

**Clinical and Laboratory Manifestations.** Pyrethrin exposures can lead to allergic reactions ranging from dermatitis to urticaria to anaphylaxis. Acute pyrethroid exposure can result in headache, nausea, dizziness, tremors, ataxia, choreoathetosis, loss of consciousness, and seizures. The severity of the symptoms depends on the magnitude of the exposure. Reports of acute lung injury have also occurred after pyrethroid exposures, although this is likely from the other components of the insecticide, such as surfactants and solvents. Paresthesias limited to the cutaneous exposure area can also occur after a dermal exposure. Chronic exposures have not been shown to result in any clinical manifestations. Although one can test for urinary pyrethroid metabolites, this is only useful for monitoring occupational exposure and has no role in the acute exposure.

**Treatment.** Initial treatment should focus on decontamination, which involves removing all clothing and irrigation of exposed areas. Allergic reactions are treated with oral antihistamines and topical corticosteroids. Systemic toxicity should be treated with excellent supportive care, using benzodiazepines for tremors and seizures.

## Hydrocarbons

Hydrocarbons include a wide array of chemical substances found in thousands of commercial products. Specific characteristics of each product determine whether exposure will produce systemic toxicity, local toxicity, both, or neither. Nevertheless, aspiration of even small amounts of certain hydrocarbons can lead to serious, potentially life-threatening toxicity.

**Pathophysiology.** The most important manifestation of hydrocarbon toxicity is *aspiration pneumonitis* through inactivation of the type II pneumocytes and resulting in surfactant deficiency (see [Chapter 446](#)). Aspiration usually occurs during coughing and gagging at the time of ingestion or vomiting after the attempted ingestion of an aliphatic hydrocarbon. The propensity of a hydrocarbon to cause aspiration pneumonitis is inversely proportional to its viscosity and directly proportional to its volatility. Compounds with low viscosity and high volatility, such as mineral spirits, naphtha, kerosene, gasoline, and lamp oil, spread rapidly across surfaces and cover large areas of the lungs when aspirated. Only small quantities (<1 mL) of such chemicals need be aspirated to produce significant injury. Pneumonitis does not result from dermal absorption of hydrocarbons or from ingestion in the absence of aspiration. Gasoline and kerosene are poorly absorbed, but they often cause considerable irritation of the GI mucosa as they pass through the intestines.

Certain hydrocarbons have unique toxicities and can cause symptoms after ingestion, inhalation, or dermal exposures. Several chlorinated solvents, most notably carbon tetrachloride, can produce hepatic toxicity. **Methylene chloride**, found in some paint removers, is metabolized to carbon monoxide. **Benzene** is known to cause cancer, most often acute myelogenous leukemia, after long-term exposure. Nitrobenzene, aniline, and related compounds can produce methemoglobinemia. A number of **volatile** hydrocarbons, including toluene, propellants, refrigerants, and volatile nitrites, are frequently abused by inhalation. Some of these substances, principally the **halogenated** hydrocarbons (which contain a chlorine, bromine, or fluorine), can sensitize the myocardium to the effects of endogenous catecholamines. This can result in dysrhythmias and “sudden sniffing death.” Chronic abuse of these agents can lead to cerebral atrophy, neuropsychologic changes, peripheral neuropathy, and kidney disease (see [Chapter 157](#)).

**Clinical and Laboratory Manifestations.** Transient, mild CNS depression is common after hydrocarbon ingestion or inhalation. Aspiration is characterized by coughing, which usually is the first clinical finding. Chest radiographs may initially be normal, but they often show abnormalities within 6 hours of exposure in patients who have aspirated. Respiratory symptoms can remain mild or progress rapidly to ARDS and respiratory failure. Fever and leukocytosis are common accompanying signs in patients with pneumonitis and do not necessarily imply bacterial superinfection. Chest radiographs can remain

abnormal long after the patient returns to their clinical baseline. Pneumatoceles can appear on the chest radiograph 2-3 weeks after exposure.

After inhalational exposures to halogenated hydrocarbons, patients can present with ventricular dysrhythmias, often refractory to conventional management. Recurrent inhalation of the aromatic hydrocarbon **toluene** can lead to a type IV renal tubular acidosis.

**Treatment.** *Emesis and lavage are contraindicated given the risk of aspiration.* Activated charcoal is not useful because it does not bind the common hydrocarbons and can also induce vomiting. If hydrocarbon-induced pneumonitis develops, respiratory treatment is supportive (see [Chapter 446](#)). Neither corticosteroids nor prophylactic antibiotics have shown any clear benefit. Standard mechanical ventilation, high-frequency ventilation, and ECMO have all been used to manage the respiratory failure and ARDS associated with severe hydrocarbon-induced pneumonitis.

Patients with dysrhythmias in the setting of halogenated hydrocarbon inhalation should be treated with  $\beta$  blockers (usually esmolol) to block the effects of endogenous catecholamines on the sensitized myocardium.

## Toxic Alcohols

**Methanol** is found in windshield washer fluids, deicers, paint removers, fuel additives, liquid fuel canisters, and industrial solvents. **Ethylene glycol** is found in antifreeze. Unintentional ingestion is the most common exposure in children, and small-volume ingestions of concentrated products can theoretically cause toxicity. The pathophysiology, acid-base derangements, and treatment of both chemicals are similar, although they differ in their primary end-organ toxicity. In both cases the metabolites of the parent compounds are responsible for the serious clinical effects that can follow exposure.

**Isopropyl alcohol** (rubbing alcohol), found in hand sanitizers, causes intoxication similar to that associated with ethanol but can also cause a hemorrhagic gastritis and myocardial depression in massive ingestions. Unlike ethylene glycol and methanol, isopropyl alcohol is metabolized to a ketone and does not cause a metabolic acidosis. Management is similar to that of ethanol ingestions (see [Chapter 157](#)) and is not further discussed here.

### Methanol

**Pathophysiology.** Methanol is oxidized in the liver by alcohol dehydrogenase to formaldehyde, which is further oxidized to formic acid by aldehyde dehydrogenase. Toxicity is caused primarily by formic acid, which inhibits mitochondrial respiration.

**Clinical and Laboratory Manifestations.** Drowsiness, mild inebriation, nausea, and vomiting develop early after methanol ingestion. The onset of serious effects, including profound metabolic acidosis and visual disturbances, is often delayed up to 12-24 hours as methanol undergoes metabolism to its toxic metabolites. This metabolism is further slowed if *ethanol* has also been ingested, because the liver will preferentially metabolize ethanol. Visual disturbances include blurred or cloudy vision, constricted visual fields, decreased acuity, and the “feeling of being in a snowstorm” and appear only after acidosis is well established. These visual defects may be reversible if treated early, but untreated can lead to permanent blindness. On examination, dilated pupils, retinal edema, and optic disc hyperemia may be noted. Initially, patients have an elevated osmolar gap, then develop an anion gap metabolic acidosis as the parent compound is metabolized to formic acid.

In young children, determining if a significant exposure has occurred is usually difficult based on history. Methanol blood levels are available at some laboratories and should be sent after a concerning exposure. If methanol blood levels are not readily available, estimation of an osmolar gap may be used as a surrogate marker, but a normal osmolar gap does not rule out ingestion of any alcohol. Serum osmolality is measured by the freezing-point depression method and compared with a calculated serum osmolality.

**Treatment.** Treatment is as discussed for ethylene glycol toxicity.

### Ethylene Glycol

**Pathophysiology.** Ethylene glycol is oxidized by alcohol dehydrogenase in the liver to glycolaldehyde, which is further converted to

glycolic acid by aldehyde dehydrogenase. Glycolic acid is responsible for the metabolic acidosis and is further metabolized to glyoxylic and then to oxalic acid. Oxalic acid combines with serum and tissue calcium, forming calcium oxalate crystals that deposit throughout the body, especially in the renal parenchyma, leading to acute tubular necrosis.

**Clinical and Laboratory Manifestations.** Early symptoms include nausea, vomiting, CNS depression, and inebriation. Delayed manifestations include an anion gap metabolic acidosis, hypocalcemia, and acute kidney injury. Even later, patients can develop cranial nerve palsies.

Both ethylene glycol and methanol can produce profound, life-threatening metabolic acidosis and acidemia, with measured serum bicarbonates that may even be nondetectable. The onset of the acidosis is delayed up to 4-12 hours after ethylene glycol ingestion and may be delayed further with any concomitant ingestion of ethanol. Ethylene glycol blood concentrations are technically difficult to perform and are available only at some larger reference laboratories. In the absence of readily available ethylene glycol concentrations, calculation of the osmolar gap may be helpful as a surrogate marker.

Examination of the urine with a Wood lamp is neither sensitive nor specific for ethylene glycol ingestion. The earliest sign on a urinalysis of ethylene glycol poisoning is usually hematuria. Calcium oxalate crystals can be seen on urine microscopy but might not be evident early after exposure. Electrolytes (including calcium), acid-base status, kidney function, and ECG should be closely monitored in poisoned patients.

**Treatment.** Because methanol and ethylene glycol are rapidly absorbed, gastric decontamination is generally not of value. The classic antidote for methanol and ethylene glycol poisoning was ethanol, a preferential substrate for alcohol dehydrogenase, thus preventing the metabolism of parent compounds to toxic metabolites. **Fomepizole**, a potent competitive inhibitor of alcohol dehydrogenase, has almost entirely replaced ethanol because of its ease of administration, lack of CNS and metabolic effects, and overall excellent patient tolerability profile (see [Table 94.8](#)). A serum concentration must be interpreted along with the time removed from exposure. A patient with a methanol level of 20 mg/dL 24 hours after exposure had a much larger dose than a patient with the same level only 1 hour after ingestion. Indications for fomepizole include ethylene glycol or methanol level >20 mg/dL (assuming no ethanol is present), history of potentially toxic ingestion (e.g., any intentional overdose), or history of ingestion with evidence of acidosis. There are few disadvantages to giving the initial dose of fomepizole to patients with a concerning history of ingestion or laboratory findings. Given the dosing schedule of fomepizole (every 12 hours), this strategy buys the clinician time to confirm or exclude the diagnosis before giving a second dose. Adjunctive therapy includes folate (methanol toxicity), pyridoxine (ethylene glycol toxicity), and sodium bicarbonate infusion (if acidemic). If a child has had an unintentional exposure and the toxic alcohol level cannot be obtained, a reasonable approach is to follow serum chemistries every 4 hours until 12 hours after the exposure. If the bicarbonate level on the chemistry panel does not fall in that period, a toxic exposure is unlikely (assuming no ethanol is present).

**Hemodialysis** effectively removes ethylene glycol, methanol, and their metabolites (except calcium oxalate) and corrects acid-base and electrolyte disturbances. Fomepizole should be given both before and immediately after dialysis. Indications for dialysis include a methanol or ethylene glycol level >50 mg/dL, acidosis, severe electrolyte disturbances, renal failure, and hemodynamic instability. However, in the absence of acidosis and kidney failure, even massive ethylene glycol ingestions have been managed without dialysis. Methanol, however, because its elimination in the setting of alcohol dehydrogenase inhibition is prolonged, often warrants dialysis to remove the parent compound. Therapy (fomepizole and/or dialysis) should be continued until ethylene glycol and methanol levels are <20 mg/dL. Although the visual effects from methanol poisoning are usually permanent, the kidney injury from ethylene glycol injury is not. Patients requiring hemodialysis after ethylene glycol poisoning will almost always

recover complete renal function within 2-6 weeks. Consultation with a PCC, medical toxicologist, and nephrologist may be helpful in managing toxic alcohol ingestions.

## Plants

Exposure to plants, both inside the home and outside in backyards and fields, is one of the most common causes of unintentional poisoning in children. Fortunately, most ingestions of plant parts (leaves, seeds, flowers) result in either no toxicity or mild, self-limiting effects. However, ingestion of certain plants can lead to serious toxicity ([Table 94.19](#)).

The potential toxicity of a particular plant is highly variable, depending on the part of the plant involved (flowers are generally less toxic than the root or seed), the time of year, growing conditions, and the route of exposure. Assessment of the potential severity after an exposure is also complicated by the difficulty in properly identifying the plant. Many plants are known by several common names, which can vary among communities. PCCs have access to professionals who can assist in properly identifying plants. They also are well versed in the common poisonous plants in their service area and the seasons when they are more abundant. For these reasons, consultation with the local PCC may be very helpful in the management of these ingestions.

For potentially toxic plant ingestions, consider decontamination with activated charcoal in patients who present within 1-2 hours of ingestion; otherwise, treatment is primarily supportive and based on symptoms. The most common manifestation of toxicity after plant ingestion is GI upset, which can be managed with antiemetics and fluid and electrolyte support. [Table 94.19](#) outlines management strategies for a few specific toxicities.

## Herbal Remedies

Herbal remedies represent a relatively common exposure in children; despite this, reports of life-threatening toxicity are rare.

There are several mechanisms by which herbal remedies may be poisonous. Many herbal remedies are inherently toxic; it is either the dose used or specific processing of the remedy that renders them safe for use. For example, oil of wintergreen used as a liniment contains a high concentration of methyl salicylate, a concerning source of salicylate poisoning in small children. A remedy intended to contain one compound may accidentally contain another; reports exist of contamination of skin creams with mercury, herbal remedies contaminated with lead, and weight loss supplements contaminated with cardioactive steroids. Herbal remedies may interfere with the metabolism of pharmaceuticals; an example is St. John's wort, which by induction of the cytochrome oxidase system (specifically, CYP3A4) may render certain medications less effective.

Management of toxicity associated with herbal remedies remains largely the same as for other organic compounds. Decontamination with activated charcoal should be considered for patients arriving within 1-2 hours of an ingestion. Signs and symptoms should be treated as outlined previously in this chapter, with excellent supportive care and therapy directed toward the suspected toxin. In the rare case of concern for contamination with a heavy metal, specific assays may be obtained for confirmation of exposure. A list of herbal remedies and their associated toxicities are provided in [Table 94.20](#).

In limited cases, specific antidotes are suggested based on the pathophysiologic mechanism. Several plant and animal species contain cardioactive steroids with digoxin-like toxicity. Although digoxin-specific immune fragments are only evidence based for the management of yellow oleander (*Thevetia peruviana*) toxicity, it is reasonable to use this therapy in a critically ill patient who has developed cardiac toxicity or hyperkalemia after ingestion of lily of the valley, squill, or oleander. Several essential oils (pennyroyal oil, clove oil) deplete glutathione as part of their toxic mechanism, and thus treatment with NAC may be of benefit. Gingko causes a depletion of active pyridoxine stores, and thus pyridoxine administration may be helpful in the setting of benzodiazepine-refractory seizures.

**Table 94.19** Commonly Ingested Plants with Significant Toxic Potential

PLANT	SYMPTOMS	MANAGEMENT
Autumn crocus ( <i>Colchicum autumnale</i> )	Vomiting Diarrhea Initial leukocytosis followed by bone marrow failure Multisystem organ failure	Activated charcoal decontamination Aggressive fluid resuscitation and supportive care
Belladonna alkaloids: jimsonweed ( <i>Datura stramonium</i> ) Belladonna ("deadly nightshade"; <i>Atropa belladonna</i> )	Anticholinergic toxidrome Seizures	Supportive care, benzodiazepines Consider physostigmine; only use if no conduction delays on ECG
Cardiac glycoside-containing plants (e.g., foxglove, lily of the valley, oleander, yellow oleander)	Nausea Vomiting Bradycardia Dysrhythmias (AV block, ventricular ectopy) Hyperkalemia	Digoxin-specific Fab fragments
Jequirity bean and other abrin-containing species (e.g., rosary pea, precatory bean)	Oral pain Vomiting Diarrhea Shock Hemolysis Renal failure	Supportive care, including aggressive volume resuscitation and correction of electrolyte abnormalities
Monkshood ( <i>Aconitum</i> species)	Numbness and tingling of lips/tongue Vomiting Bradycardia	Atropine for bradycardia Supportive care
Oxalate-containing plants: <i>Philodendron</i> , <i>Dieffenbachia</i> , <i>Colocasia</i> ("elephant ear")	Local tissue injury Oral pain Vomiting	Supportive care, pain control
Poison hemlock ( <i>Conium maculatum</i> )	Vomiting Agitation followed by CNS depression Paralysis Respiratory failure	Supportive care
Pokeweed	Hemorrhagic gastroenteritis Burning of mouth and throat	Supportive care
Rhododendron	Vomiting Diarrhea Bradycardia	Atropine for symptomatic bradycardia Supportive care
Tobacco	Vomiting Agitation Diaphoresis Fasciculations Seizures	Supportive care
Water hemlock ( <i>Cicuta</i> species)	Abdominal pain Vomiting Delirium Seizures	Supportive care, including benzodiazepines for seizures
Yew ( <i>Taxus</i> species)	GI symptoms QRS widening Hypotension CV collapse	Supportive care Atropine for bradycardia Sodium bicarbonate does not appear to be effective

AV, Atrioventricular; CNS, central nervous system; CV, cardiovascular; ECG, electrocardiogram; Fab, fragment, antigen binding; GI, gastrointestinal.

## Toxic Gases

### Carbon Monoxide

Although many industrial and naturally occurring gases pose a health risk by inhalation, the most common gas involved in pediatric exposures is CO. CO is a colorless, odorless gas produced during the combustion of any carbon-containing fuel; the less efficient the combustion, the greater the amount of CO produced. Wood-burning stoves, kerosene heaters, old furnaces, hot-water heaters, closed-space fires, and automobiles are a few of the potential sources of CO.

**Pathophysiology.** CO binds to hemoglobin with an affinity >200 times that of oxygen, forming carboxyhemoglobin (HbCO).

In doing so, CO displaces oxygen and creates a conformational change in hemoglobin that impairs the delivery of oxygen to the tissues, leading to tissue hypoxia. HbCO levels are not well correlated with clinical signs of toxicity, likely because CO interacts with multiple proteins in addition to hemoglobin. CO binds to cytochrome oxidase, disrupting cellular respiration. CO displaces nitric oxide (NO) from proteins, allowing NO to bind with free radicals to form the toxic metabolite peroxynitrite, leading to lipid peroxidation and cellular damage. NO is also a potent vasodilator, in part responsible for clinical symptoms such as headache, syncope, and hypotension.

**Table 94.20** Clinical Toxicity of Selected Herbs

COMMON NAME	BOTANICAL NAME	THERAPEUTIC USES	POTENTIAL TOXICITY
Aconite (monkshood, wolfsbane)	<i>Aconitum</i> spp.	Sedative, analgesic, antihypertensive	Cardiac arrhythmias
Aloe	<i>Aloe</i> spp.	Burns, skin diseases	Nephritis, GI upset
Betel nut	<i>Areca catechu</i>	Mood elevation	Bronchoconstriction, oral cancers
Bloodroot	<i>Sanguinaria canadensis</i>	Emetic, cathartic, eczema	GI upset, vertigo, visual disturbances
Chaparral (greasewood)	<i>Larrea tridentata</i>	Aging, free radical scavenging	Hepatitis
Compound Q	<i>Trichosanthes kirilowii</i>	Anthelmintic, cathartic	Diarrhea, hypoglycemia, CNS toxicity
Dandelion	<i>Taraxacum officinale</i>	Diuretic, heartburn remedy	Anaphylaxis
Figwort (xuan shen)	<i>Scrophularia</i> spp.	Antiinflammatory, antibacterial	Cardiac stimulation
Ginseng	<i>Panax quinquefolium</i>	Antihypertensive, aphrodisiac, stimulant, mood elevation, digestive aid	Ginseng abuse syndrome
Goldenseal	<i>Hydrastis canadensis</i>	Digestive aid, mucolytic, antiinfective	Uterine, cardiac stimulation; GI upset, leukopenia
Hellebore	<i>Veratrum</i> spp.	Antihypertensive	Vomiting, bradycardia, hypotension
Hyssop	<i>Hyssopus officinalis</i>	Asthma, mucolytic	Seizures
Juniper	<i>Juniperus communis</i>	Hallucinogen	GI upset, seizures, renal injury, hypotension, bradycardia
Kava	<i>Piper methysticum</i>	Sedative	Inebriation
Kombucha		Stimulant	Metabolic acidosis, hepatotoxicity, death
Licorice	<i>Glycyrrhiza</i> spp.	Indigestion	Mineralocorticoid effects
Lily of the valley	<i>Convallaria</i> spp.	Cardiotonic	GI (nausea, vomiting), cardiac arrhythmias
Linn (willow)	<i>Salix caprea</i>	Purgative	Hemolysis with glucose-6-phosphate dehydrogenase deficiency
Lobelia (Indian tobacco)	<i>Lobelia</i> spp.	Stimulant	Nicotine intoxication
Ma Huang	<i>Ephedra sinica</i>	Stimulant	Sympathetic crisis, especially with monoamine oxidase inhibitors
Mandrake	<i>Mandragora officinarum</i>	Hallucinogen	Anticholinergic syndrome
Mormon tea	<i>Ephedra nevadensis</i>	Stimulant, asthma, antipyretic	Hypertension, sympathomimetic
Nutmeg	<i>Myristica fragrans</i>	Hallucinogen, abortifacient	Hallucinations, GI upset
Oleander	<i>Nerium oleander</i>	Cardiac stimulant	Cardiac arrhythmias
Passionflower	<i>Passiflora caerulea</i>	Hallucinogen	Hallucinations, seizures, hypotension
Periwinkle	<i>Vinca</i> spp.	Antiinflammatory, diabetes	Alopecia, seizures, hepatotoxicity
Pokeweed	<i>Phytolacca</i> spp.	Arthritis, chronic pain	GI upset, seizures, death
Sabah	<i>Sauropus androgynus</i>	Weight loss, vision	Pulmonary injury
Sage	<i>Salvia</i> spp.	CNS stimulant	Seizures
Snakeroot	<i>Rauwolfia serpentina</i>	Sedative, antihypertensive	Bradycardia, coma
Squill	<i>Urginea maritima</i>	Arthritis, cardiac stimulant	Seizures, arrhythmias, death
Thorn apple (jimsonweed)	<i>Datura stramonium</i>	Hallucinations	Anticholinergic
Tonka bean	<i>Dipteryx odorata</i>	Anticoagulant	Bleeding diathesis
Valerian root	<i>Valeriana</i> spp.	Sedative	Sedation, obtundation
Wild (squirting) cucumber	<i>Ecballium elaterium</i>	Constipation, antiinflammatory, rheumatic disease	Airway obstruction
Wormwood (mugwort)	<i>Artemisia</i> spp.	Stimulant, hallucinogen	Hallucinations, seizures, uterine stimulation
Yohimbine	<i>Corynanthe yohimbe</i>	Aphrodisiac, stimulant	Hypertension, sympathetic crisis

CNS, Central nervous system; GI, gastrointestinal.

From Kingston RL, Foley C. Herbal, traditional, and alternative medicines. In: Shannon MW, Borron SW, Burns MJ, eds. *Haddad and Winchester's Clinical Management of Poisoning and Drug Overdose*, 4th ed. Philadelphia: Saunders; 2007, Table 68.1, p. 1081.



**Clinical and Laboratory Manifestations.** Early symptoms are nonspecific and include headache, malaise, nausea, and vomiting. These symptoms are often misdiagnosed as indicating flu or food poisoning. At higher exposure levels, patients can develop mental status changes, confusion, ataxia, syncope, tachycardia, and tachypnea. Severe poisoning is manifested by coma, seizures, myocardial ischemia, acidosis, cardiovascular collapse, and potentially death. Physical examination should focus on the cardiovascular and neurologic systems because these are the most detrimentally affected by CO. Emergency department evaluation should include arterial or venous blood gas analysis with HbCO determined by CO-oximetry, CK level in severely poisoned patients, pregnancy test, and ECG and troponin in any patient with cardiac symptoms.

**Treatment.** Prevention of CO poisoning is paramount and should involve educational initiatives and the use of home CO detectors. Treatment of CO poisoning focuses on the administration of 100% oxygen to enhance elimination of CO. In ambient air the average half-life of HbCO is 4-6 hours. This is dramatically reduced to 60-90 minutes by providing 100% oxygen at normal atmospheric pressures by non-rebreather face mask. Severely poisoned patients might benefit from **hyperbaric oxygen (HBO)**, which decreases the half-life of HbCO to 20-30 minutes and is thought also to decrease the risk of delayed neurologic sequelae. Although the clinical benefits and referral guidelines for HBO therapy remain controversial, frequently cited indications include syncope, coma, seizure, altered mental status, evidence of myocardial ischemia, HbCO level >25% (or >15% in pregnancy), and abnormal cerebellar examination. Consultation with a PCC, medical toxicologist, or HBO facility can assist clinicians in determining which patients could benefit from HBO therapy. Sequelae of CO poisoning include persistent and delayed cognitive and cerebellar effects. HBO advocates believe that the risk of such sequelae is minimized through the delivery of 100% oxygen at 3 atm of pressure. Patients typically receive oxygen, by non-rebreather mask or hyperbaric chamber, for 6 hours.

## Hydrogen Cyanide

**Pathophysiology.** Cyanide inhibits cytochrome-*c* oxidase, part of the electron transport chain, interrupting cellular respiration and leading to profound tissue hypoxia. Patients may be exposed to hydrogen cyanide (HCN) gas in the workplace (manufacturing of synthetic fibers, nitriles, and plastics) by smoke inhalation in a closed-space fire or by ingestion of cassava flour.

**Clinical and Laboratory Manifestations.** Onset of symptoms is rapid after significant exposure. Clinical manifestations of toxicity include headache, agitation/confusion, sudden loss of consciousness, tachycardia, cardiac dysrhythmias, and metabolic acidosis. Cyanide levels can be measured in whole blood but are not readily available at most institutions. A severe lactic acidosis (lactate >10 mmol/L) in fire victims suggests cyanide toxicity. Impaired oxygen extraction by tissues is implied by elevated mixed-venous oxyhemoglobin saturation, another laboratory finding suggesting cyanide toxicity.

**Treatment.** Treatment includes removal from the source of exposure, rapid administration of high concentrations of oxygen, and antidotal therapy.

**Hydroxocobalamin** is the preferred agent for use in known or suspected cyanide poisoning (see [Table 94.8](#)). This antidote reacts with cyanide to form the nontoxic cyanocobalamin (vitamin B<sub>12</sub>), which is then excreted in urine. Side effects of hydroxocobalamin include red discoloration of the skin and urine, transient hypertension, and interference with colorimetric laboratory assays. Other FDA-approved treatments for cyanide poisoning include sodium nitrite and sodium thiosulfate, either alone or in combination. Sodium nitrite induces methemoglobinemia, which may exacerbate symptoms of carboxyhemoglobinemia and thus should be avoided in patients with smoke inhalation.

## Miscellaneous Toxic Agents Found in the Home Nicotine-Containing Products

Nicotine poisoning has become increasingly common with the recent advent of vaporizer (“vaping”) and e-cigarette devices (see [Chapter](#)

157). Although there are many nicotine-containing products (patches, gums, snuff, chewing tobacco, sprays, lozenges), tobacco cigarettes remain the main source of exposure. Prescription medications (varenicline and cytisine) are available that are partial nicotine receptor agonists. For children, some of the most concerning exposures are from the bottles of liquid nicotine used to refill vaping and e-cigarette devices. These bottles typically do not have childproof caps and contain a large amount of concentrated nicotine.

**Pathophysiology.** Nicotine acts on nicotinic ACh receptors in the nervous system, neuromuscular junctions, and adrenal medulla, stimulating neurotransmitter release. Nicotine’s effects on the dopaminergic reward pathway play a significant role in its addictive properties. The effects of nicotine are dose dependent; at lower doses it primarily acts on the brain, causing stimulation. At higher doses, nicotine overstimulates receptors, leading to inhibition and resulting in neuromuscular and nervous system blockade.

**Clinical and Laboratory Manifestations.** Clinical effects of nicotine also depend on the dose. At low doses typically achieved through smoking, nicotine results in cognitive and mood enhancement, increased energy, and appetite suppression. Shortness of breath, cough, and fever may be seen with e-cigarette use-associated lung injury (EVALI), an inflammatory response in the lungs triggered by vaping. At higher doses, significant toxicity follows a biphasic pattern, where cholinergic stimulation symptoms predominate and are later followed by inhibition. The first signs of nicotine poisoning are nausea, vomiting, diarrhea, and often muscle fasciculations. Tachycardia and hypertension occur initially, although in severe poisoning these progress to bradycardia, hypotension, coma, and respiratory muscle failure, which typically leads to death if not treated. Serum and urinary levels of nicotine and its metabolite cotinine can be obtained, but these rarely are available in real time and therefore have little effect on diagnosis and management.

**Treatment.** Treatment of nicotine poisoning focuses on maximizing symptomatic and supportive care. Aggressive airway management should be the priority, especially in severe poisonings, because death usually occurs from respiratory muscle paralysis. IV fluids with escalation to vasopressors should be used for hypotension. Seizures should be managed with benzodiazepines, barbiturates, or propofol.

## Single-Use Detergent Sacs

Commonly known as laundry “pods” for clothing, these products resemble candy to many children. When bitten into, a relatively large dose of concentrated detergent is expelled under pressure onto the posterior pharynx and vocal cords. This can lead to stridor and other signs of respiratory distress. Occasionally, and for unknown reasons, these children may also develop altered mental status. Supportive care with attention to any airway and breathing issues is warranted. Admission to the hospital is often indicated. Importantly, these are not considered caustic ingestions; the pH of these products is in the neutral zone. Upper GI endoscopy is rarely indicated. Curiously, laundry detergent ingested from a bottle is rarely of significant concern.

## Electric Dishwasher Detergent

Especially when in the form of crystals, these products are highly alkaline (pH >13), and exposure by ingestion can cause significant burns to the vocal cords and GI tract. Admission for expectant management or upper GI endoscopy is usually indicated.

## Magnets

Most foreign body ingestions pass through the GI tract once known to have passed into the stomach. However, ingestion of ≥2 magnets (unless very weak refrigerator-style magnets) cause concern for bowel obstruction and perforation (see [Chapter 380](#)). Admission for attempted retrieval by endoscopy or clearance by WBI should be considered.

## Batteries

Any disk or button-style battery lodged in the esophagus or airway should be considered a true emergency warranting immediate referral

to an endoscopist for removal (see [Chapter 373](#)). These batteries can cause necrosis of the tissues in which they are lodged by continued electrical discharge and leaking of their contents (the former is likely the primary method of injury). Mucosal contact for even 2 hours might induce necrosis. Once past the lower esophageal sphincter, button or

even larger batteries (e.g., AA, AAA) can usually be allowed to pass through the GI tract with close follow-up.

Visit *Elsevier eBooks+* at [eBooks.Health.Elsevier.com](http://eBooks.Health.Elsevier.com) for Bibliography.

## Chapter 95

# Genetics in Pediatric Medicine

Daryl A. Scott and Brendan Lee

Since the completion of the Human Genome Project, there has been an unprecedented expansion in the understanding of how human health is impacted by variations in genomic sequence and epigenetic, non-sequence-based changes that affect gene expression. There has also been the development and implementation of accurate clinical tests that makes it easier for physicians to detect pathogenic variant changes. In addition, there has been a dramatic increase in the availability of information about the genetic aspects of pediatric diseases, particularly on the internet (Table 95.1).

### THE BURDEN OF GENETIC DISORDERS IN CHILDHOOD

Medical problems associated with genetic disorders can appear at any age, with the most obvious and serious problems typically manifesting in childhood. It has been estimated that 53/1,000 children and young adults can be expected to have diseases with an important genetic component. If congenital anomalies are included, the rate increases to 79/1,000. In 1978 just over half of admissions to pediatric hospitals were for a genetic condition. By 1996, because of changes in healthcare

delivery and a greater understanding of the genetic basis of many disorders, that percentage increased to 71% in one large pediatric hospital in the United States, with 96% of chronic disorders leading to admission having an obvious genetic component or influenced by genetic susceptibility.

Major categories of genetic disorders include single-gene, genomic, chromosomal, and multifactorial conditions.

Individually, each **single-gene disorder** is rare, but collectively they represent an important contribution to childhood disease. The hallmark of a single-gene disorder is that the phenotype is overwhelmingly determined by changes that affect an individual gene. The character and severity of a phenotype associated with some single-gene disorders can vary from one patient to another. In some cases, this may be due to differences in the severity of the change affecting the gene. In other cases, variability is seen in individuals who carry the same pathogenic variant or variants. This is termed **variable expressivity**; the same pathogenic variants in *GJB2* can cause mild, moderate, severe, or profound sensorineural hearing loss in different individuals. This variability may be due to differences in other genetic, epigenetic, environmental, and/or stochastic factors. If this variability results in some individuals being completely unaffected, we say that the disorder shows **incomplete penetrance**. Some single-gene disorders are associated with phenotypes that affect different organ systems or biologic functions that may appear unrelated. Pendred syndrome is caused by pathogenic variants in *SLC26A4* and is characterized by both hearing loss and thyroid enlargement (goiter). This feature of some genetic diseases is referred to as **pleiotropy**.

Common single-gene disorders include sickle cell anemia and cystic fibrosis. Some identifiable syndromes and diseases can be caused by more than one gene. Noonan syndrome can be caused by pathogenic variants in at least 12 different genes. In addition, pathogenic variants

**Table 95.1** Useful Internet Genetic Reference Sites

RESOURCE	WEB ADDRESS
<b>National Center for Biotechnology Information</b> A general reference maintained by the National Library of Medicine	<a href="http://www.ncbi.nlm.nih.gov">www.ncbi.nlm.nih.gov</a>
<b>Online Mendelian Inheritance in Man</b> A useful resource for clinicians containing information on all known mendelian disorders and >12,000 genes. Information focuses on the relationship between phenotype and genotype.	<a href="http://www.ncbi.nlm.nih.gov/omim">www.ncbi.nlm.nih.gov/omim</a>
<b>Genetic Testing Registry</b> A resource that provides information on individual genes, genetic tests, clinical laboratories, and medical conditions. This resource also provides access to GeneReviews, a collection of expert-authored reviews on a variety of genetic disorders.	<a href="http://www.ncbi.nlm.nih.gov/gtr/">www.ncbi.nlm.nih.gov/gtr/</a>
<b>Genetics — MedlinePlus</b> A resource that provides consumer-friendly information about the effects of genetic variations on human health	<a href="http://medlineplus.gov/genetics/">http://medlineplus.gov/genetics/</a>
<b>National Human Genome Research Institute</b> A resource for information about human genetics and ethical issues	<a href="http://www.genome.gov">www.genome.gov</a>
<b>Human Gene Mutation Database</b> A searchable index of all described pathogenic variants in human genes with phenotypes and references	<a href="http://www.hgmd.cf.ac.uk">www.hgmd.cf.ac.uk</a>
<b>DECIPHER</b> A database designed to aid physicians in determining the potential consequences of chromosomal deletions and duplications	<a href="http://decipher.sanger.ac.uk">http://decipher.sanger.ac.uk</a>
<b>Database of Genomic Variants</b> A database of chromosomal alterations seen in normal controls	<a href="http://dgv.tcag.ca/dgv/app/home">http://dgv.tcag.ca/dgv/app/home</a>
<b>American Society of Human Genetics</b>	<a href="http://www.ashg.org">www.ashg.org</a>
<b>American College of Medical Genetics and Genomics</b>	<a href="http://www.acmg.net">www.acmg.net</a>

affecting a single gene may cause more than one disorder. Variants in *SCN5A* can cause Brugada syndrome type 1, long QT syndrome type 3, dilated cardiomyopathy type 1E, familial atrial fibrillation type 10, familial ventricular fibrillation type 1, progressive heart block type 1A, nonprogressive heart block, and sick sinus syndrome type 1.

Single-gene disorders tend to occur when changes in a gene have a profound effect on the *quantity* of the gene product produced, either too much or too little, or the *function* of the gene product, either a loss of function or a harmful gain of function. Single-gene disorders can be caused by de novo sequence changes that are not found in the unaffected parents of the affected individual, or they may be caused by inheriting the affected gene. When a single-gene disorder is known to be caused by changes in only one gene, or a small number of individual genes, searching for deleterious changes is classically performed by directly sequencing that gene and, in some cases, looking for small deletions and/or duplications in that gene. When multiple genes can cause a particular disorder, it is sometimes more efficient and cost-effective to screen large numbers of disease-causing genes using a disease-specific panel, which takes advantage of massively parallel or next-generation sequencing technology, rather than screening genes individually. When such panels are not available, or when the diagnosis is in question, physicians may consider screening the protein-coding regions of all genes by **exome sequencing (ES)**, also termed whole exome sequencing (WES), on a clinical basis. In many circumstances, ES is less expensive than sequencing multiple individual genes. **Whole genome sequencing (WGS)**, in which an individual's entire genome is sequenced, is another clinical option (see [Chapter 98](#); [Table 95.2](#)).

The risk of having a child with a particular single-gene disorder can vary from one population to another. This may be the result of a **founder effect**, in which a specific change affecting a disease-causing gene becomes relatively common in a population derived from a small number of founder individuals. This high frequency is maintained when there is relatively little interbreeding with persons outside that population because of social, religious, or physical barriers. This is the case for Tay-Sachs disease in Ashkenazi Jews and French Canadians. Other changes may be subject to **positive selection** when found in the heterozygous carrier state. In this case, individuals who carry a single copy of a genetic change (**heterozygotes**) have a survival advantage over noncarriers. This can occur even when individuals who inherit two copies of the change (**homozygotes**) have severe medical problems. This type of positive selection is evident among individuals in sub-Saharan Africa who carry a single copy of a hemoglobin pathogenic variant that confers relative resistance to malaria but causes sickle cell anemia in homozygotes.

**Genomic disorders** are a group of diseases caused by alterations in the genome, including **deletions** (copy number loss), **duplications** (copy number gain), **inversions** (altered orientation of a genomic region), and **chromosomal rearrangements** (altered location of a genomic region). **Contiguous gene disorders** are caused by changes that affect two or more genes that contribute to the clinical phenotype and are located near one another on a chromosome. DiGeorge syndrome, which is caused by deletions of genes located on chromosome 22q11, is a common example. Some genomic disorders are associated with distinctive phenotypes whose patterns can be recognized clinically. Other genomic disorders do not have a distinctive pattern of anomalies but can cause developmental delay, cognitive impairment, structural birth defects, abnormal growth patterns, and changes in physical appearance.

**Fluorescent in situ hybridization (FISH)** can provide information about the copy number and location of a specific genomic region. **Array-based copy number detection assays**, sometimes referred to as chromosomal microarray analyses, can be used to screen for chromosomal deletions and duplications (large and small) across the genome but do not provide information about the orientation or location of genomic regions. A **chromosome analysis (karyotype)** can detect relatively large chromosomal deletions and duplications and can also be useful in identifying inversions and chromosomal rearrangements even when they are **copy number neutral** changes that do not result in a deletion or duplication of genomic material (e.g., balanced translocations).

**Table 95.2** Indications for Single Gene, Gene Panel, Exome, and Genome Sequencing

INDICATIONS	EXAMPLES
<b>SINGLE GENE</b>	
Minimal locus heterogeneity (only one or a small number of genes known to cause the condition)	<i>CFTR</i> for cystic fibrosis
Distinctive clinical findings that clearly point to specific gene	<i>PAH</i> for phenylketonuria
<b>GENE PANEL</b>	
Locus heterogeneity (multiple genes are known to cause the same or similar conditions)	Muscular dystrophy panel
Disorders with overlapping phenotypes	Cardiomyopathy panel
Disorders that share one manifestation but can have very different presentations	Epilepsy panel
Disorders associated with genes from a common pathway or structure	<i>RAS</i> opathy panel
<b>EXOME</b>	
Extreme heterogeneity and de novo mutations common	Autism, intellectual disability
Two or more unrelated phenotypes in one patient	Oculocutaneous albinism and neutropenia
No distinctive phenotypic feature present	Kabuki syndrome
Phenotype indistinct and underlying cause not clear	Congenital diarrhea, Zellweger syndrome
<b>GENOME</b>	
<i>As above for Exome, plus:</i>	
Noncoding variation is suspected as a cause	Hypertrophic cardiomyopathy
Structural variation is suspected as a cause	DiGeorge syndrome
Exome sequencing already performed and was nondiagnostic	Undiagnosed Diseases Network
Rapid generation of sequencing data needed for patients who are critically ill	Neonates and children in intensive care
Suspected mitochondrial disorder: multisystem (heart, brain, muscle, liver) disorder	Whole genome and/or mitochondrial DNA (tissue) sequencing

From Manolio TA, Rowley R, Williams MS, et al. Opportunities, resources, and techniques for implementing genomics in clinical care. *Lancet*. 2019;394:511–520. Table 2.

Deletions, duplications, and chromosomal rearrangements that affect whole chromosomes, or large portions of a chromosome, are typically referred to as **chromosomal disorders**. One of the most common chromosomal disorders is Down syndrome, which is most often associated with the presence of an extra copy, or **trisomy**, of an entire chromosome 21. When all or part of a chromosome is missing, the disorder is referred to as **monosomy**. **Translocations** are a type of chromosomal rearrangement in which a genomic region from one chromosome is transferred to a different location on the same chromosome or on a different (nonhomologous) chromosome. Translocations can be *balanced*, meaning that no genetic material has been lost or gained, or they can be *unbalanced*, in which some genetic material has been deleted or duplicated.

In some cases, only a portion of cells that make up a person's body are affected by a single-gene defect, a genomic disorder, or a chromosomal defect. This is referred to as **mosaicism** and indicates that the individual's body is made up of two or more distinct cell populations. Through use of technologies with high sensitivity, it has become



evident that there can be significant low-level mosaicism in *somatic* tissues.

**Polygenic** disorders are caused by the cumulative effects of variations in more than one gene. **Multifactorial** disorders are caused by the cumulative effects of variations in multiple genes or the combined effects of genetic, epigenetic, and/or environmental factors. Spina bifida and isolated cleft lip or palate are common birth defects that display multifactorial inheritance patterns. Multifactorial inheritance is seen in many common pediatric disorders, such as asthma and diabetes mellitus. These traits can cluster in families but do not have a mendelian pattern of inheritance (see [Chapter 97](#)). In these cases, the genetic changes or variations that are contributing to a particular disorder are often unknown, and genetic counseling is based on empirical data and estimates.

## THE CHANGING PARADIGM OF GENETICS IN MEDICINE

Genetic testing is increasingly available for a wide variety of both rare and relatively common genetic disorders. Genetic testing is typically used in pediatric medicine to resolve uncertainty regarding the underlying etiology of a child's medical problems. Identifying a molecular cause often provides the basis for improved genetic counseling, may alter medical management, and may suggest that a specific therapy should be employed. Even in cases where a specific treatment is not available, identifying a genetic cause can aid physicians in providing individuals and families with accurate prognostic and recurrence risk information, can often help to relieve unfounded feelings of guilt, and may stem the tide of misdirected blame.

Genetic tests are influencing an increasing number of medical decisions and are becoming a seamless part of routine medical care. Although most genetic testing is presently aimed at identifying or confirming a diagnosis, in the future genetic testing may find wider application as a means of determining whether an individual is predisposed to develop a particular disease. Another area in which genetic testing could make a significant impact is on individualized drug treatment (pharmacogenetics). It has long been known that genetic variation in the enzymes involved in drug metabolism underlies differences in the therapeutic effect and toxicity of some drugs. When the genetic changes that underlie these variations are identified, new genetic tests can be developed that allow physicians to tailor treatments based on individual variations in drug metabolism, responsiveness, and susceptibility to toxicity. It is likely that the expansion of such testing will depend, at least in part, on the extent to which such tests can be linked to strategies to prevent disease or improve outcome (see [Chapter 98](#)).

Long-standing and highly successful carrier screening programs have existed for disorders such as Tay-Sachs disease and many other rare, single-gene disorders that are prevalent in specific populations. Couples are usually offered screening for a variety of conditions based, in part, on ancestry (Tay-Sachs disease, hemoglobinopathies, cystic fibrosis). Couples found to be at increased risk for such disorders can be offered preconception or prenatal testing aimed at detecting specific disease-causing variants.

Prenatal screening is routinely offered for chromosomal disorders such as trisomy 13, trisomy 18, and Down syndrome. Pregnancies affected by these, and possibly other genetic disorders, are being recognized by noninvasive screening tests targeting **fetal cell-free DNA** in maternal blood and by fetal ultrasound. When genetic disorders are suspected, chorionic villus sampling at 10-12 weeks of gestation or amniocentesis at 16-18 weeks of gestation can provide material for genetic testing. When a couple are at risk for a specific genetic defect, **preimplantation genetic diagnosis** can sometimes be used to select unaffected early embryos, which are then implanted as part of an *in vitro* fertilization procedure.

Although prenatally obtained genetic material can be used to identify single-gene disorders, genomic disorders, and chromosomal anomalies, the information obtained on any pregnancy depends on the tests that are ordered. It is important that physicians select the most appropriate prenatal tests and that couples understand the limitations

of these tests. No amount of genetic testing can guarantee the birth of a healthy child.

Specific treatments are not available for most genetic disorders, although some important exceptions exist (see [Chapter 98](#)). **Inborn errors of metabolism** were the first genetic disorders to be recognized, and many are amenable to treatment by dietary manipulation (see [Chapter 104](#)). These conditions result from genetically determined deficiency of specific enzymes, leading to the buildup of toxic substrates and/or deficiency of critical end products.

Individual metabolic disorders tend to be very rare, but their combined impact on the pediatric population is significant. Tandem mass spectrometry has made it relatively inexpensive to screen for a large number of these disorders in the newborn period. Use of this technology not only dramatically increases the number of metabolic disorders identified within a population but also allows treatment to be initiated at a much earlier stage in development. Broader screening in the postnatal period, in the form of metabolomic screening, has increased the potential for identifying an increasing list of rare inborn errors of metabolism, especially when combined with exome or genome sequencing.

Progress in genetic therapies has improved the treatment of some **lysosomal storage disorders** (see [Chapter 106.4](#)). These metabolic diseases are caused by defects in lysosomal function. Lysosomes are cellular organelles that contain specific digestive enzymes. Some of these disorders that were characterized by early lethal or intractable chronic illness can now be treated using specially modified enzymes administered by intravenous infusion. These enzymes are taken up by cells and incorporated into lysosomes. Conditions such as Gaucher disease and Fabry disease are routinely treated using **enzyme replacement**; similar therapies are being developed for other lysosomal disorders.

Therapeutic advances are also being made in the treatment of non-metabolic genetic disorders. Improvements in surgical techniques and intensive care medicine are extending the survival of children with life-threatening birth defects such as congenital diaphragmatic hernia and severe cardiac defects. In many cases, the life expectancy of children with debilitating genetic disorders is also increasing. Improvements in nutrition and the management of chronic pulmonary disease in patients with cystic fibrosis allow an increasing percentage of affected patients to survive into adulthood, creating a need to transition care from pediatric to adult providers.

Gene replacement therapies are being used in the treatment of a variety of genetic disorders (see [Chapter 98](#)). Stem cell-based therapies have also been employed as a potential treatment for a number of intractable disorders.

## DIRECT-TO-CONSUMER GENETIC TESTING

In most cases, healthcare providers order genetic tests, interpret the results, communicate these results to their patients, and then document these findings in the medical record. The costs of these tests are often covered completely or in part by a health insurance company. In contrast, some companies are offering direct-to-consumer genetic tests in which individuals order their own tests and receive test results directly from the company. The individual usually pays for these tests, and the results are not recorded in their medical record unless the individual chooses to share this information with their healthcare providers. Some direct-to-consumer genetic tests only provide information about common traits or information about an individual's ancestry or relationship to others (**ancestry testing**). Other direct-to-consumer tests are designed to make predictions about health and/or to identify pathogenic variants associated with specific genetic disorders. In some cases, individuals ordering these tests may have the option of reviewing their results with a healthcare provider employed by the company performing the test.

One of the main benefits of direct-to-consumer testing is that it allows individuals to privately access their genetic information without having to involve a healthcare provider or their insurance company. Although this could be seen as a means of empowering individuals with regards to their healthcare, the benefits derived from such testing depend heavily on the appropriateness of the test ordered, the quality of

the testing/reporting services, the capacity of the individual to understand the test results, and their ability to make informed choices based on those results.

## ETHICS ISSUES

Genetic testing, diagnosis, and treatment should be performed *confidentially*. Nothing is as personal as one's genetic information, and all efforts should be made to avoid any stigma for the patient. Many people worry that results of genetic testing will put them, or their child, at risk for genetic discrimination. **Genetic discrimination** occurs when people are treated unfairly because of a difference in their DNA that suggests they have a genetic disorder or they are at an increased risk of developing a certain disease. In the United States the Genetic Information Nondiscrimination Act of 2008 protects individuals from genetic discrimination at the hands of health insurers and employers but does not extend protection against discrimination from providers of life, disability, or long-term care insurance.

The decisions about genetic testing should be based on a careful evaluation of the potential benefits and risks. In the pediatric setting, these decisions may be more difficult because physicians and parents are often called on to make decisions for a child who cannot directly participate in discussions about testing. Molecular diagnostic tests are often used to diagnose malformation syndromes, cognitive delay, or other disabilities in which there is a clear benefit to the child. In other cases, such as genetic testing for susceptibility to adult-onset diseases, it is appropriate to wait until the child or adolescent is mature enough to weigh the potential risks and benefits and make their own decisions about genetic testing.

Policies regarding genetic testing of children have been developed collaboratively by the American Academy of Pediatrics (AAP) and the American College of Medical Genetics and Genomics (ACMG; *Pediatrics* 131[3]:620–622, 2013). These recommendations are outlined in the following list.

### General Recommendations

1. Decisions about whether to offer genetic testing and screening should be driven by the best interest of the child.
2. Genetic testing is best offered in the context of genetic counseling. Genetic counseling can be performed by clinical geneticists, genetic counselors, or any other healthcare provider with appropriate training and expertise. AAP and ACMG support the expansion of educational opportunities in human genomics and genetics for medical students, residents, and practicing pediatric primary care providers.

### Diagnostic Testing

3. In a child with symptoms of a genetic condition, the rationale for genetic testing is similar to other medical diagnostic evaluations. Parents or guardians should be informed about the risks and benefits of testing, and their permission should be obtained. Ideally, and when appropriate, the assent of the child should be obtained.
4. When performed for therapeutic purposes, pharmacogenetic testing of children is acceptable, with permission of parents or guardians and, when appropriate, the child's assent. If a pharmacogenetic test result carries implications beyond drug targeting or dose responsiveness, the broader implications should be discussed before testing.

### Newborn Screening

5. AAP and ACMG support the mandatory offering of newborn screening for all children. After education and counseling about the substantial benefits of newborn screening, its remote risks, and the next steps in the event of a positive screening result, parents should have the option of refusing the procedure, and an informed refusal should be respected.

### Carrier Testing

6. AAP and ACMG do not support routine carrier testing in minors when such testing does not provide health benefits in childhood. The AAP and ACMG advise against school-based testing or screening programs, because the school environment

is unlikely to be conducive to voluntary participation, thoughtful consent, privacy, confidentiality, or appropriate counseling about test results.

7. For pregnant adolescents or for adolescents considering reproduction, genetic testing and screening should be offered as clinically indicated, and the risks and benefits should be explained clearly.

### Predictive Genetic Testing

8. Parents or guardians may authorize predictive genetic testing for asymptomatic children at risk of childhood-onset conditions. Ideally, the assent of the child should be obtained.
9. Predictive genetic testing for adult-onset conditions generally should be deferred unless an intervention initiated in childhood may reduce morbidity or mortality. An exception might be made for families for whom diagnostic uncertainty poses a significant psychosocial burden, particularly when an adolescent and the parents concur in their interest in predictive testing.
10. For ethical and legal reasons, healthcare providers should be cautious about providing predictive genetic testing to minors without the involvement of their parents or guardians, even if a minor is mature. Results of such tests may have significant medical, psychologic, and social implications, not only for the minor but also for other family members.

### Histocompatibility Testing

11. Tissue compatibility testing of minors of all ages is permissible to benefit immediate family members but should be conducted only after thorough exploration of the psychosocial, emotional, and physical implications of the minor serving as a potential stem cell donor. A donor advocate or similar mechanism should be in place from the outset to avert coercion and safeguard the interests of the child.

### Adoption

12. The rationale for genetic testing of children in biological families should apply for adopted children and children awaiting placement for adoption. If a child has a known genetic risk, prospective adoptive parents must be made aware of this possibility. In rare cases, it may be in a child's best interest to undergo predictive genetic testing for a known risk before adoption to ensure the child's placement with a family capable of and willing to accept the child's potential medical and developmental challenges. In the absence of such indications, genetic testing should not be performed as a condition of adoption.

### Disclosure

13. At the time of genetic testing, parents or guardians should be encouraged to inform their child of the test results at an appropriate age. Parents or guardians should be advised that, under most circumstances, a request by a mature adolescent for test results should be honored.
14. Results from genetic testing of a child may have implications for the parents and other family members. Healthcare providers have an obligation to inform parents and the child, when appropriate, about these potential implications. Healthcare providers should encourage patients and families to share this information and offer to help explain the results to the extended family or refer them for genetic counseling.
15. Misattributed paternity, use of donor gametes, adoption, or other questions about family relationships may be uncovered "incidentally" whenever genetic testing is performed, particularly when testing multiple family members. This risk should be discussed, and a plan about disclosure or nondisclosure should be in place before testing.

### Direct-to-Consumer Testing

16. AAP and ACMG strongly discourage the use of direct-to-consumer and home-kit genetic testing of children because of the lack of oversight on test content, accuracy, and interpretation.

## Chapter 96

## Principles of Human Genetics

Daryl A. Scott and Brendan Lee

## THE HUMAN GENOME

The human genome has approximately 20,000 genes that encode the wide variety of proteins found in the human body. Reproductive or germline cells contain one copy (N) of this genetic complement and are **haploid**, whereas somatic (nongermline) cells contain two complete copies (2N) and are **diploid**. Genes are organized into long segments of deoxyribonucleic acid (DNA), which, during cell division, are compacted into intricate structures together with proteins to form chromosomes. Each somatic cell has 46 chromosomes: 22 pairs of **autosomes**, or nonsex chromosomes, and one pair of **sex chromosomes** (XY in a male, XX in a female). Germ cells (ova or sperm) contain 22 autosomes and one sex chromosome, for a total of 23. At fertilization, the full diploid chromosome complement of 46 is again realized in the embryo.

Most of the genetic material is contained in the cell's nucleus. The mitochondria (the cell's energy-producing organelles) contain their own unique genome. The **mitochondrial chromosome** consists of a double-stranded circular piece of DNA, which contains 16,568 base pairs (bp) of DNA and is present in multiple copies per cell. The proteins that occupy the mitochondria are produced either in the mitochondria, using information contained in the mitochondrial genome, or are produced outside of the mitochondria, using information contained in the nuclear genome, and then transported into the organelle. Sperm do not usually contribute mitochondria to the developing embryo, so all mitochondria are maternally derived, and a child's mitochondrial genetic makeup derives exclusively from the child's biologic mother (see Chapter 108).

## FUNDAMENTALS OF MOLECULAR GENETICS

DNA consists of a pair of chains of a sugar-phosphate backbone linked by pyrimidine and purine bases to form a **double helix** (Fig. 96.1). The sugar in DNA is deoxyribose. The pyrimidines are cytosine (C) and thymine (T), and the purines are guanine (G) and adenine (A). The bases are linked by hydrogen bonds such that A always pairs with T and G with C. Each strand of the double helix has polarity, with a free phosphate at one end (5') and an unbonded hydroxyl on the sugar at the other end (3'). The two strands are oriented in opposite polarity in the double helix.

The replication of DNA follows the pairing of bases in the parent DNA strand. The original two strands unwind by breaking the hydrogen bonds between base pairs. Free nucleotides, consisting of a base attached to a sugar-phosphate chain, form new hydrogen bonds with their complementary bases on the parent strand; new phosphodiester bonds are created by enzymes called **DNA polymerases**. Replication of chromosomes begins simultaneously at multiple sites, forming replication bubbles that expand bidirectionally until the entire DNA molecule (chromosome) is replicated. Errors in DNA replication, or pathogenic variants induced by environmental mutagens such as irradiation or chemicals, are detected and potentially corrected by DNA repair systems.

Information encoded in DNA, predominantly located in the cell's nucleus, is transcribed into **messenger** ribonucleic acid (**mRNA**), which is then transported to the cytoplasm, where it is translated into protein. A prototypical gene consists of a regulatory region, segments called **exons** that encode the amino acid sequence of a protein, and intervening segments called **introns** (Fig. 96.2).

**Transcription** is initiated by attachment of ribonucleic acid (RNA) polymerase to the promoter site upstream of the beginning of the

coding sequence. Specific proteins bind to the region to repress or activate transcription by compacting or opening chromatin, which is a complex of DNA and histone proteins. It is the action of these regulatory proteins (**transcription factors**) that determines, in large part, when a gene is turned on or off. Some genes are also turned on and off by methylation of cytosine bases that are adjacent to guanine bases (**cytosine-phosphate-guanine bases [CpGs]**). Methylation is an example of an **epigenetic** change, meaning a change that can affect gene expression, and possibly the characteristics of a cell or organism, but that *does not* involve a change in the underlying genetic sequence. Gene regulation is flexible and responsive, with genes being turned on or off during development and in response to internal and external environmental conditions and stimuli. Another epigenetic mechanism that controls gene expression is the biochemical modification of histone proteins around which DNA is wound. These modifications can affect the relative accessibility of chromatin by enzymes for transcription.

Transcription proceeds through the entire length of the gene in a 5' to 3' direction to form an mRNA transcript whose sequence is complementary to that of one of the DNA strands. RNA is a sugar-phosphate chain with pyrimidines and purines. In RNA the sugar is ribose, and uracil replaces the thymine found in DNA. A "cap" consisting of 7-methylguanosine is added to the 5' end of the RNA in a 5'-5' bond and, for most transcripts, several hundred adenine bases are enzymatically added to the 3' end after transcription.

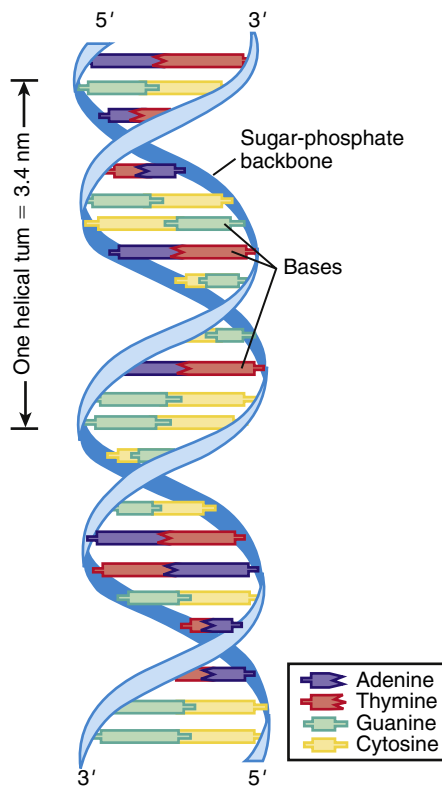
**mRNA processing** occurs in the nucleus and consists of excision of the introns and splicing together of the exons. Specific sequences at the start and end of introns mark the sites where the splicing machinery will act on the transcript. In some cases, there may be tissue-specific patterns to splicing, so that the same primary transcript can produce multiple distinct proteins.

The processed transcript is next exported to the cytoplasm, where it binds to ribosomes, which are complexes of protein and **ribosomal RNA (rRNA)**. The genetic code is then read in triplets of bases, each triplet corresponding with a specific amino acid or providing a signal that terminates **translation**. The triplet codons are recognized by **transfer RNAs (tRNAs)** that include complementary anticodons and bind the corresponding amino acid, delivering it to the growing peptide. New amino acids are enzymatically, sequentially attached to the growing peptide. Each time an amino acid is added, the ribosome moves one triplet codon step along the mRNA. Eventually a **stop codon** is reached, at which point translation ends and the peptide is released. In some proteins, there are **posttranslational modifications**, such as attachment of sugars (**glycosylation**). The protein is then delivered to its destination within or outside the cell by trafficking mechanisms that recognize portions of the peptide.

Another mechanism of gene regulation is **noncoding RNAs**, which are RNAs transcribed from DNA but not translated into proteins. Noncoding RNAs function in many contexts, including mediating splicing, the processing of coding RNAs in the nucleus, and the translation of coding mRNAs in ribosomes. The roles of *long* noncoding RNAs (>200 bp) and *short* noncoding RNAs (<200 bp) extend beyond these processes to impact a diverse set of biologic functions, including the regulation of gene expression. **MicroRNAs (miRNAs)** are a class of small RNAs that control gene expression in the cell by directly targeting specific sets of coding RNAs by direct RNA-RNA binding. This RNA-RNA interaction can lead to degradation of the target-coding RNA or inhibition of translation of the protein specified by that coding RNA. miRNAs often target and regulate several hundred mRNAs.

## GENETIC VARIATION

The process of producing protein from a gene is subject to disruption at multiple levels because of alterations in the DNA sequence (Fig. 96.3). Changes in the regulatory region can lead to altered gene expression, including increased or decreased rates of transcription, failure of gene activation, or activation of the gene at inappropriate times or in inappropriate cells. Changes in the coding sequence can lead to **substitution** of one amino acid for another (**missense variant** or **nonsynonymous variant**) or creation of a stop codon in the place of an amino acid codon (**nonsense** or **stop-gain variant**).

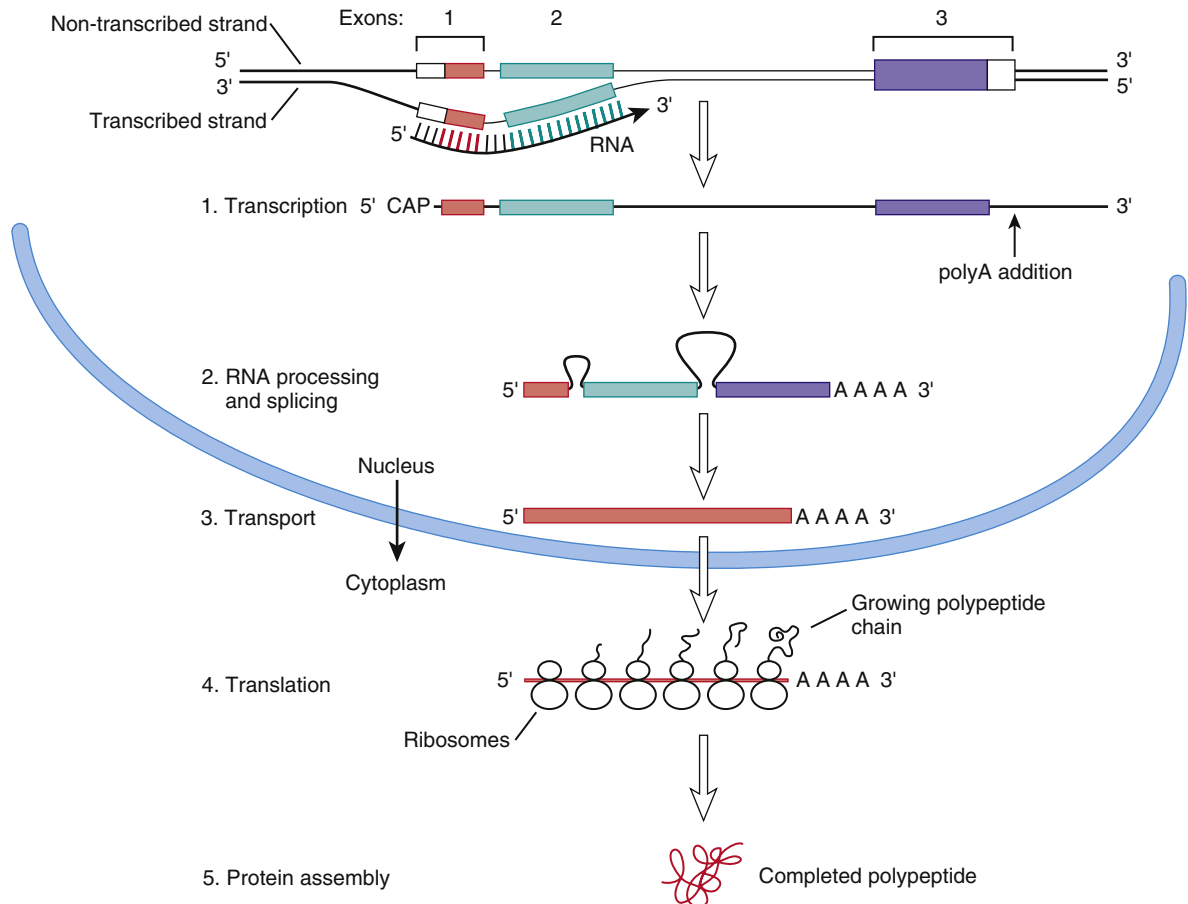


**Fig. 96.1** DNA double helix, with sugar-phosphate backbone and nitrogenous bases. (From Jorde LB, Carey JC, Bamshad MJ, et al., eds. *Medical Genetics*, 2nd ed. St Louis: Mosby; 1999: p. 8.)

Overall, missense and nonsense variants are the most common (56% of variants); small deletions or insertions represent approximately 24% of variants (Table 96.1). Some single-base changes do not affect the amino acid (**silent, wobble, or synonymous variants**) because there may be several triplet codons that correspond to the same single amino acid. Amino acid substitutions can have a profound effect on protein function if the chemical properties of the substituted amino acid are markedly different. Other substitutions can have a subtle or no effect on protein function, particularly if the substituted amino acid is chemically similar to the original. Single nucleotide changes, whether silent or missense, are termed **single nucleotide variants (SNV)**.

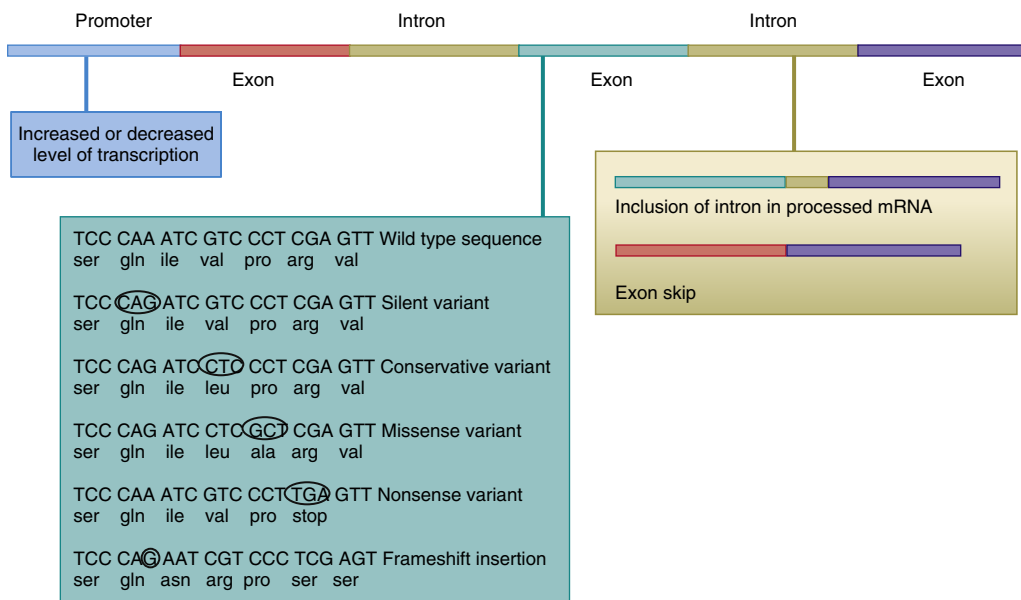
Genetic changes can also include **insertions or deletions** (“**in-dels**”). Insertions or deletions of a nonintegral multiple of three bases into the coding sequence leads to a **frameshift**, altering the grouping of bases into triplets. This leads to translation of an incorrect amino acid sequence and often a premature stop to translation. Insertion or deletion of an integral multiple of three bases into the coding sequence will insert or delete a corresponding number of amino acids from the protein, leading to **in-frame** alterations that maintain the amino acid sequence outside the deleted or duplicated amino acids. Larger scale insertions or deletions can disrupt a coding sequence or result in complete deletion of an entire gene or group of genes.

Pathogenic variants usually can be classified as causing a loss of function or a gain of function. **Loss-of-function variants** lead to a reduction in the level of protein function as a result of decreased expression or production of a protein that does not work as efficiently. In some cases, loss of protein function from one of two alleles is sufficient to cause disease. **Haploinsufficiency** describes the situation in which maintenance of a normal phenotype requires the proteins produced by both alleles of a gene, and a 50% decrease in gene function results in an abnormal phenotype. *Haploinsufficient phenotypes are dominantly inherited.* Loss-of-function variants can also have a **dominant**



**Fig. 96.2** Flow of information from DNA to RNA to protein for a hypothetical gene with three exons and two introns. Within the exons, colored regions indicate coding sequences. Steps include transcription, RNA processing and splicing, RNA transport from the nucleus to the cytoplasm, translation, and protein assembly. (From Nussbaum RL, McInnis RR, Willard HF, Hamosh A, eds. *Thompson & Thompson Genetics in Medicine*, 7th ed. Philadelphia: Saunders; 2007: p. 31.)





**Fig. 96.3** Various types of intragenic sequence variants. Promoter variants alter rate of transcription or disrupt gene regulation. Base changes within exons can have various effects, as shown. Variants within introns can lead to inclusion of some intronic sequence in the final processed mRNA, or it can lead to exon skipping.

**Table 96.1** Main Classes, Groups, and Types of Sequence Variants and Their Effects on Protein Products

CLASS	GROUP	TYPE	EFFECT ON PROTEIN PRODUCT
Substitution	Synonymous	Silent*	Same amino acid
		Nonsynonymous	Altered amino acid—may affect protein function or stability
	Nonsynonymous	Nonsense or stop-gain*	Stop codon—loss of function or expression from degradation of mRNA
		Splice site	Aberrant splicing—exon skipping or intron retention
		Promoter	Altered gene expression
Deletion	Multiple of three (codon)		In-frame deletion of one or more amino acid(s)—may affect protein function or stability
	Not multiple of three	Frameshift	Likely to result in premature termination with loss of function or expression
	Large deletion	Partial gene deletion	May result in premature termination with loss of function or expression
		Whole gene deletion	Loss of expression
Insertion	Multiple of three (codon)		In-frame insertion of one or more amino acid(s)—may affect protein function or stability
	Not multiple of three	Frameshift	Likely to result in premature termination with loss of function or expression
	Large insertion	Partial gene duplication	May result in premature termination with loss of function or expression
		Whole gene duplication	May have an effect because of increased gene dosage
	Expansion of trinucleotide repeat	Dynamic pathogenic variant	Altered gene expression or altered protein stability or function

\*Some have been shown to cause aberrant splicing.

From Turnpenny P, Ellard S, eds. *Emery's Elements of Medical Genetics*, 14th ed. Philadelphia: Churchill Livingstone; 2012: p. 23.

**negative** effect when the abnormal protein product actively interferes with the function of the normal protein product. Both situations lead to diseases inherited in a dominant fashion. Haploinsufficiency of type I collagen can cause relatively mild osteogenesis imperfecta (OI) type I. In contrast, heterozygous, missense glycine substitutions in type I collagen can act in a dominant negative fashion to cause severe OI type II, III, and IV. In other cases, loss-of-function variants must be present in both copies of a gene before an abnormal phenotype results. This situation typically results in diseases inherited in a **recessive** fashion (see

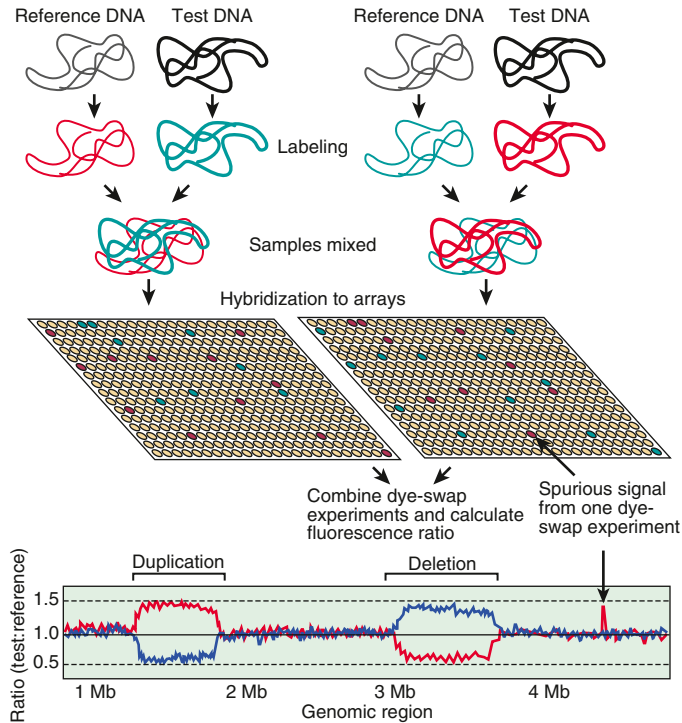
**Chapter 97**). Some conditions are **semidominant** where one affected copy (heterozygous pathogenic variant) causes a milder phenotype than when both copies are affected (compound heterozygous or homozygous pathogenic variants). This is seen in classical achondroplasia vs homozygous achondroplasia.

**Gain-of-function variants** typically cause dominantly inherited diseases. These variants can result in production of a protein molecule with an increased ability to perform a normal function or can confer a novel property on the protein. The gain-of-function variant

in **achondroplasia**, the most common of the disproportionate, short-limbed short stature disorders, exemplifies the enhanced function of a normal protein. Achondroplasia results from a pathogenic variant in the fibroblast growth factor (FGF) receptor three gene (*FGFR3*), which leads to activation of the receptor, even in the absence of FGF. In **sickle cell disease**, an amino acid is substituted into the hemoglobin molecule and has little effect on the ability of the protein to transport oxygen. However, sickle hemoglobin chains have a novel property. Unlike normal hemoglobin, sickle hemoglobin chains aggregate under conditions of deoxygenation, forming fibers that deform the red cells.

Other gain-of-function variants result in overexpression or inappropriate expression of a gene product. Many cancer-causing genes (**oncogenes**) are normal regulators of cellular proliferation during development. However, expression of these genes in adult life and/or in cells in which they usually are not expressed can result in neoplasia.

In some cases, changes in gene expression are caused by changes in the number of copies of a gene that are present in the genome (Fig. 96.4). Although some **copy number variations** are common and do not appear to cause or predispose to disease, others are clearly disease causing. **Charcot-Marie-Tooth disease type 1A**, the most common inherited form of chronic peripheral neuropathy of childhood, is caused by duplications of the gene for peripheral myelin protein 22, resulting in overexpression due to the existence of three active copies of this gene (see Chapter 653.1). Deletions of this same gene, leaving



**Fig. 96.4** Array comparative genomic hybridization. Test and reference DNA samples are differentially labeled, mixed, and passed over a target array of probes (e.g., bacterial artificial chromosome clones or oligonucleotides) containing DNA fragments from across the whole human genome. The experiment is often repeated with reversal of the test and reference dyes to detect dye effects or identify spurious signals. DNA samples hybridize with their corresponding probe, and the ratio of fluorescence from each probe (*test:reference*) is used to detect regions that vary in copy number between the test and the reference sample (*red line*, original hybridization; *blue line*, dye-swapped hybridization). Equal copy number for both the test and the reference DNA is identified by equal binding, resulting in a ratio of 1:1. Duplication in a genomic region of the test sample is identified by an increased ratio, and a deletion is identified by a decreased ratio, but a deletion in the test sample is indistinguishable from a duplication in the reference sample. These ratios are usually converted to  $\log_2$  scale for further analysis. Mb, megabase. (Adapted from Feuk L, Carson AR, Scherer SW. *Structural variation in the human genome*. *Nat Rev Genet* 2006;7:85–97.)

only one active copy, are responsible for a different disorder, **hereditary neuropathy with liability to pressure palsies**.

Deletions and duplications can vary in their extent and can involve several genes, even when they are not detectable using a traditional chromosome analysis. Such changes are commonly called **microdeletions** and **microduplications**. When deletion or duplication of two or more genes in the same chromosomal region each play a role in the resulting clinical features, the condition can also be referred to as a **contiguous gene disorder**.

In some cases, the recognition of a specific constellation of features leads clinicians to suspect a specific microdeletion or microduplication syndrome. Examples of such disorders include Smith-Magenis, DiGeorge, and Williams syndromes. In other cases, the clinician may be alerted to this possibility by an unusually diverse array of clinical features in one patient or the presence of unusual features in a person with a known condition. Because of the close physical proximity of a series of genes, different deletions involving the short arm of the X chromosome can produce individuals with various combinations of ichthyosis, Kallmann syndrome, ocular albinism, intellectual disability, chondrodysplasia punctata, and short stature.

DNA rearrangements can also take place in **somatic cells** (cells that do not go on to produce ova or sperm). Rearrangements that occur in **lymphoid cells** are required for the normal formation of functional immunoglobulin in B cells and antigen-recognizing receptors on T cells. Large segments of DNA, which code for the variable and the constant regions of either immunoglobulin or the T-cell receptor (TCR), are physically joined at a specific stage in the development of an immunocompetent lymphocyte. These rearrangements take place during development of the lymphoid cell lineage in humans and result in the extensive diversity of immunoglobulin and TCR molecules. Because of this postgermline DNA rearrangement, no two individuals, not even identical twins, are fully identical, because mature lymphocytes from each will have undergone random DNA rearrangements at these loci.

The human genome demonstrates that any two individuals will differ in about one base in 1,000. Some of these differences are silent; some result in changes that explain phenotypic differences (hair or eye color, physical appearance); and some have medical significance, causing single-gene disorders such as sickle cell anemia or explaining susceptibility to common pediatric disorders such as asthma. Genetic variants in a single gene that occur at a frequency of >1% in a population are often referred to as **polymorphisms**. These variations may be silent or subtle or may have significant phenotypic effects.

## GENOTYPE-PHENOTYPE CORRELATIONS IN GENETIC DISEASE

The term **genotype** is used to signify the internally coded, heritable information of an individual and can also be used to refer to which particular alternative version (**allele**) of a gene is present at a specific location (**locus**) on a chromosome. A **phenotype** is the observed structural, biochemical, and physiologic characteristics of an individual, determined by the genotype, and can also refer to the observed structural and functional effects of a variant allele at a specific locus. Many sequence variants result in predictable phenotypes; physicians can predict clinical outcomes and plan appropriate treatment strategies based on a patient's genotype. There is also phenotypic expansion where multiple alleles (variants) within a gene can be associated with often diverse and distinct clinical presentations.

**Long QT syndrome** exemplifies a disorder with predictable associations between a patient's genotype and his or her phenotype (see Chapter 484.5). Long QT syndrome is genetically heterogeneous, meaning that pathogenic variants in *several different genes* can cause the same disorder. The risk for cardiac events (syncope, aborted cardiac arrest, or sudden death) is higher in patients with long QT syndrome involving *KCNQ1* (63%) or *KCNH2* (46%) than in those with pathogenic variants in *SCN5A* (18%). In addition, individuals with *KCNQ1* variants experience most of their episodes during exercise and rarely during rest or sleep. In contrast, individuals with pathogenic variants in *KCNH2* and *SCN5A* are more likely to have episodes during sleep or rest and rarely during exercise. Therefore variants in specific genes

(genotype) are correlated with specific manifestations (phenotype) of long QT syndrome. These types of relationships are commonly referred to as *genotype-phenotype correlations*.

Pathogenic variants in the fibrillin-1 gene associated with **Marfan syndrome** represent another example of predictable genotype-phenotype correlations (see Chapter 743). Marfan syndrome is characterized by the combination of skeletal, ocular, and aortic manifestations, with the most devastating outcome being aortic root dissection and sudden death. The fibrillin-1 gene consists of 65 exons, and pathogenic variants have been found in almost all these. The location of the variant within the gene (genotype) might play a significant role in determining the severity of the condition (phenotype). Neonatal Marfan syndrome is often caused by variants in exons 24-27 and in exons 31 and 32, whereas milder forms are caused by variants in exons 59-65 and in exons 37 and 41.

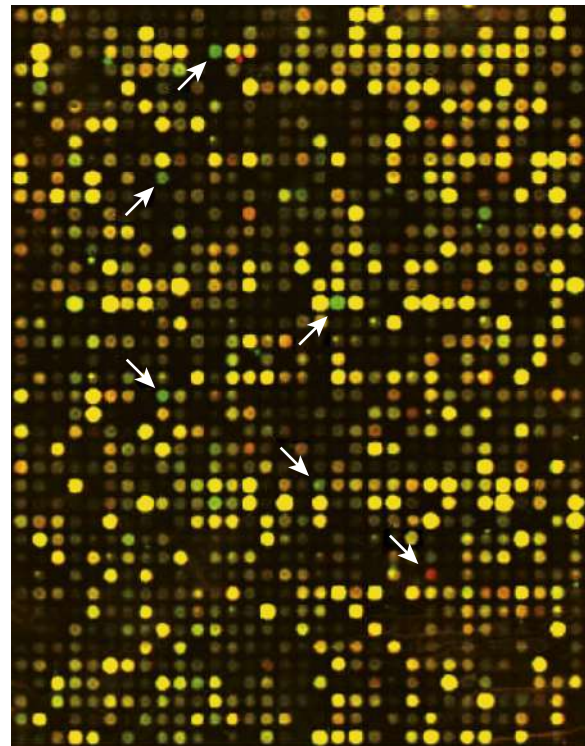
Genotype-phenotype correlations have also been observed in some complications of **cystic fibrosis** (CF; see Chapter 454). Although pulmonary disease is the major cause of morbidity and mortality, CF is a multi-system disorder that affects not only the epithelia of the respiratory tract but also the exocrine pancreas, intestine, male genital tract, hepatobiliary system, and exocrine sweat glands. CF is caused by pathogenic variants in the CF transmembrane conductance regulator (*CFTR*) gene. More than 1,600 different pathogenic *CFTR* variants have been identified. The most common is a deletion of three nucleotides that removes the amino acid phenylalanine (F) at the 508th position on the protein ( $\Delta F508$  variant), which accounts for approximately 70% of all pathogenic CF variants and is associated with severe disease. The best genotype-phenotype correlations in CF are seen in the context of pancreatic function, with common pathogenic variants being classified as either *pancreatic sufficient* or *pancreatic insufficient*. Persons with pancreatic sufficiency usually have either one or two pancreatic-sufficient alleles, indicating that pancreatic-sufficient alleles are dominant. In contrast, the genotype-phenotype correlation in pulmonary disease is much weaker, and persons with identical genotypes have wide variations in the severity of their pulmonary disease. This finding may be accounted for, in part, by genetic modifiers or environmental factors.

In many disorders, the effects of variants on phenotype can be modified by changes in the other allele of the same gene, by changes in specific **modifier genes**, and/or by variations in a number of unspecified genes (**genetic background**). When sickle cell anemia is co-inherited with the gene for hereditary persistence of fetal hemoglobin, the sickle cell phenotypic expression is less severe. Modifier genes in CF can influence the development of congenital meconium ileus, or colonization with *Pseudomonas aeruginosa*. Modifier genes can also affect the manifestations of Hirschsprung disease, neurofibromatosis type 2, craniosynostosis, and congenital adrenal hyperplasia. The combination of genetic variants producing glucose-6-phosphate dehydrogenase deficiency and longer versions of the TATAA element in the uridine diphosphate–glucuronosyltransferase gene promoter exacerbates neonatal physiologic hyperbilirubinemia.

## HUMAN GENOME PROJECT

A rudimentary genetic map can be made using genetic linkage, which is based on the principle that alleles at two genetic loci that are located near each other segregate together in a family unless they are separated by genetic **recombination**. In contrast to linkage maps, physical maps rely on overlapping DNA fragments to determine the location of loci with respect to one another. Overlapping segments of the genomic regions can be identified and used to piece together a map composed of overlapping DNA fragments to obtain the DNA sequence of the entire region. An alternative strategy involves breaking the entire genome into random fragments, sequencing the fragments, and then computationally assembling them into overlapping segments. This whole genome approach in combination with next-generation sequencing technologies has resulted in a dramatic reduction in the cost of sequencing an individual's entire genome.

Analysis of the human genome has produced some surprising results. The number of genes appears to be ~20,000. However, the number of protein products encoded by the genome is far greater than the



**Fig. 96.5** Microarray containing 36,000 oligonucleotides. The microarray was exposed to RNA from normal fibroblasts (labeled in red; see arrows) and fibroblasts from a patient with Niemann-Pick disease, type C (labeled green). Arrows point to regions in which there was a strong hybridization signal with either normal or disease RNA. This microarray was used to search for genes that are highly expressed in the fibroblasts of patients. (From Jorde LB, Carey JC, Bamshad MJ, White RL. *Medical Genetics*, 3rd ed. St Louis: Mosby; 2006: p. 116.)

number of genes. This is a result of the presence of alternative promoter regions, alternative splicing, and posttranslational modifications, which can allow a single gene to encode a number of protein products.

It is also apparent that most of the human genome *does not* encode protein, with <5% being transcribed and translated, although a much larger percentage may be transcribed without translation. Many transcribed sequences are not translated but represent genes that encode RNAs that serve *regulatory* roles. A large fraction of the genome consists of repeated sequences that are interspersed among the genes. Some of these are transposable genetic elements that can move from place to place in the genome. Others are static elements that were expanded and dispersed in the past during human evolution. Other repeated sequences might play a structural role. There are also regions of *genomic duplications*. Such duplications are substrate for evolution, allowing genetic motifs to be copied and modified to serve new roles in the cell. Duplications can also play a role in chromosomal rearrangement, permitting nonhomologous chromosome segments to pair during meiosis and exchange material. This is another source of evolutionary change and a potential source of chromosomal instability leading to congenital anomalies or cancer. Low copy repeats also play an important role in causing genomic disorders. When low copy repeats flank unique genomic segments, these regions can be duplicated or deleted through a process known as *nonallelic homologous recombination*.

Availability of the entire human genomic sequence permits the study of large groups of genes, looking for patterns of gene expression or genome alteration. Studies of gene expression are performed using next-generation sequencing techniques to obtain information about all RNA transcripts in a tissue or single cell. The patterns of gene expression may provide signatures for particular disease states, such as cancer, or change in response to therapy (Fig. 96.5).

Visit Elsevier eBooks+ at [eBooks.Health.Elsevier.com](http://eBooks.Health.Elsevier.com) for Bibliography.



## Chapter 97

## Patterns of Genetic Transmission

Daryl A. Scott and Brendan Lee

## FAMILY HISTORY AND PEDIGREE NOTATION

The family history remains the most important screening tool for pediatricians in identifying a patient's risk for developing a wide range of diseases, from multifactorial conditions such as diabetes and attention-deficit/hyperactivity disorder, to single-gene disorders such as sickle cell anemia and cystic fibrosis. Through a detailed family history, the physician can often ascertain the mode of genetic transmission and the risks to family members. Because not all familial clustering of disease is caused by genetic factors, a family history can also identify common environmental and behavioral factors that influence the occurrence of disease. The main goal of the family history is to identify genetic susceptibility, and the cornerstone of the family history is a systematic and standardized pedigree.

A **pedigree** provides a graphic depiction of a family's structure and medical history. It is important when taking a pedigree to be systematic and use standard symbols and configurations so that anyone can read and understand the information (Figs. 97.1-97.4). In the pediatric setting, the **proband** is typically the child or adolescent who is being evaluated. The proband is designated in the pedigree by an arrow.

A three- to four-generation pedigree should be obtained for every new patient as an initial screen for genetic disorders segregating within the family. The pedigree can provide clues to the inheritance pattern of these disorders and can aid the clinician in determining the risk to the proband and other family members. The closer the relationship of the proband to the person in the family with the genetic disorder, the greater is the shared genetic complement. **First-degree** relatives, such as a parent, full sibling, or child, share one half their genetic information on average; first cousins share one eighth. Sometimes the person providing the family history may mention a distant relative who is affected with a genetic disorder. In such cases a more extensive pedigree may be needed to identify the risk to other family members. For example, a history of a distant maternally related cousin with intellectual disability caused by fragile X syndrome can still place a male proband at an elevated risk for this disorder.

## MENDELIAN INHERITANCE

There are three classic forms of genetic inheritance: **autosomal dominant**, **autosomal recessive**, and **X-linked**; these are referred to as **mendelian inheritance** forms.

## Autosomal Dominant Inheritance

Autosomal dominant inheritance is determined by the presence of one abnormal gene on one of the **autosomes** (chromosomes 1-22). Autosomal genes exist in pairs, with each parent contributing one copy. In an autosomal dominant trait, a change in one of the paired genes affects the phenotype of an individual, even though the other copy of the gene is functioning correctly. A **phenotype** can refer to a physical manifestation, a behavioral characteristic, or a difference detectable only through laboratory tests.

The pedigree for autosomal dominant disorders demonstrates certain characteristics. These disorders show a **vertical transmission** (parent-to-child) pattern and can appear in multiple generations (Fig. 97.5). An affected individual has a 50% chance of passing on the deleterious gene in *each* pregnancy and, therefore, of having a child affected by the disorder. This is referred to as the **recurrence risk** for the disorder. Unaffected individuals (family members who do not manifest the

trait and do not harbor a copy of the deleterious gene) do not pass the disorder to their children. Males and females are equally affected.

Although not a characteristic per se, the finding of male-to-male transmission essentially confirms autosomal dominant inheritance. Vertical transmission can also be seen with X-linked traits. However, because a father passes on his Y chromosome to a son, male-to-male transmission cannot be seen with an X-linked trait. Therefore male-to-male transmission eliminates X-linked inheritance as a possible explanation. Although male-to-male transmission can occur with Y-linked genes as well, there are very few Y-linked disorders, compared with thousands having the autosomal dominant inheritance pattern.

































Although parent-to-child transmission is a characteristic of autosomal dominant inheritance, many patients with an autosomal dominant disorder have no history of an affected family member, for several possible reasons. First, the patient may have the disorder due to a **de novo** (new) pathogenic variant that occurred in the DNA of the egg or sperm that formed that individual. Second, many autosomal dominant conditions demonstrate **incomplete penetrance**, meaning that not all individuals who carry the pathogenic variant have phenotypic manifestations. In a pedigree, this can appear as a **skipped generation**, in which an unaffected individual links two affected persons (Fig. 97.6). There are many potential reasons that a disorder might exhibit incomplete penetrance including the effect of modifier genes, environmental factors, gender, and age. Third, individuals with the same autosomal dominant variant can manifest the disorder to different degrees. This is termed **variable expression** and is a characteristic of many autosomal dominant disorders.

Fourth, some spontaneous genetic pathogenic variants occur not in the egg or sperm that forms a child, but rather in a *cell* in the developing embryo or in a tissue after birth. Such events are referred to as **somatic pathogenic variants**. Because only a subset of cells in the body are affected, the change is said to be **mosaic**. The phenotypes caused by a somatic pathogenic variant can vary but are usually milder than if all cells were affected by the pathogenic variant. Some cancers typically arise from cells that have been affected by multiple somatic pathogenic variants. In **germline mosaicism**, the pathogenic variant occurs in a subset of cells that ultimately produce ova or sperm. An individual who is germline mosaic for a pathogenic variant might not have any manifestations of the associated disorder but may pass that change on to his or her offspring by producing ova or sperm that carry the pathogenic variant. Children whose bodies derive from those ova or sperm will carry the pathogenic variant in all of their cells unless the change undergoes a rare reversion of the somatic pathogenic variant. Recurrence of a dominantly inherited condition to apparently unaffected parents can sometimes be explained by germline mosaicism for the dominantly transmitted variant in one of the parents.

## Autosomal Recessive Inheritance

Autosomal recessive inheritance requires deleterious variants in both copies of a gene to cause disease. Examples include cystic fibrosis and sickle cell disease. Autosomal recessive disorders are characterized by **horizontal transmission**, the observation of multiple affected members of a kindred in the same generation, but no affected family members in other generations (Fig. 97.7). They are associated with a recurrence risk of 25% for carrier parents who have had a previous affected child. Male and female offspring are equally likely to be affected, although some traits exhibit differential expression between sexes. The offspring of consanguineous parents are at increased risk for rare, autosomal recessive traits due to the increased chance that both parents may carry a gene affected by a deleterious variant that they inherited from a common ancestor. **Consanguinity** between parents of a child with a suspected genetic disorder implies, but certainly does not prove, autosomal recessive inheritance. Although consanguineous unions are uncommon in Europe and the Americas, in other parts of the world (southern India, Japan, and the Middle East) as high as 50% of all children may be conceived in consanguineous unions. The risk of a genetic disorder in the offspring of a first-cousin union (6-8%) is about double the risk in the general population (3-4%).



Instructions:				
—Key should contain all information relevant to interpretation of pedigree (e.g., define fill/shading)				
—For clinical (non-published) pedigrees include:				
a) name of proband/consultand				
b) family names/initials of relatives for identification, as appropriate				
c) name and title of person recording pedigree				
d) historian (person relaying family history information)				
e) date of intake/update				
f) reason for taking pedigree (e.g., abnormal ultrasound, familial cancer, developmental delay, etc.)				
g) ancestry of both sides of family				
—Recommended order of information placed below symbol (or to lower right)				
a) age; can note year of birth (e.g., b.1978) and/or death (e.g., d. 2007)				
b) evaluation (see Fig. 97.4)				
c) pedigree number (e.g., I-1, I-2, I-3)				
—Limit identifying information to maintain confidentiality and privacy				
	Male	Female	Gender not specified	Comments
1. Individual	 b.1925	 30 y	 4 mo	Assign gender by phenotype (see text for disorders of sex development, etc.). Do not write age in symbol.
2. Affected individual				Key/legend used to define shading or other fill (e.g., hatches, dots, etc.). Use only when individual is clinically affected.
				With $\geq 2$ conditions, the individual's symbol can be partitioned accordingly, each segment shaded with a different fill and defined in legend.
3. Multiple individuals, number known				Number of siblings written inside symbol. (Affected individuals should not be grouped.)
4. Multiple individuals, number unknown or unstated				"n" used in place of "?".
5. Deceased individual	 d. 35	 d. 4 mo	 d. 60's	Indicate cause of death if known. Do not use a cross (†) to indicate death to avoid confusion with evaluation positive (+).
6. Consultand				Individual(s) seeking genetic counseling/testing.
7. Proband				An affected family member coming to medical attention independent of other family members.
8. Stillbirth (SB)	 SB 28 wk	 SB 30 wk	 SB 34 wk	Include gestational age and karyotype, if known.
9. Pregnancy (P)	 LMP: 7/1/2007 47,XY,+21	 20 wk 46,XX		Gestational age and karyotype below symbol. Light shading can be used for affected; define in key/legend.
Pregnancies not carried to term		Affected	Unaffected	
10. Spontaneous abortion (SAB)		 17 wks female cystic hygroma	 <10 wks	If gestational age/gender known, write below symbol. Key/legend used to define shading.
11. Termination of pregnancy (TOP)		 18 wks 47,XY,+18		Other abbreviations (e.g., TAB, VTOP) not used for sake of consistency.
12. Ectopic pregnancy (ECT)		 ECT		Write ECT below symbol.

**Fig. 97.1** Common pedigree symbols, definitions, and abbreviations. (From Bennett RL, French KS, Resta RG, et al. Standardized human pedigree nomenclature: update and assessment of the recommendations of the National Society of Genetic Counselors. *J Genet Couns.* 2008;17:424–433.)

1. Definitions		Comments								
<p>1. relationship line</p> <p>2. line of descent</p> <p>3. sibship line</p> <p>4. individual's line</p>	<p>If possible, male partner should be to left of female partner on relationship line.</p> <p>Siblings should be listed from left to right in birth order (oldest to youngest).</p>									
2. Relationship line (horizontal)										
a. Relationships		A break in a relationship line indicates the relationship no longer exists. Multiple previous partners do not need to be shown if they do not affect genetic assessment.								
b. Consanguinity		If degree of relationship not obvious from pedigree, it should be stated (e.g., third cousins) above relationship line.								
3. Line of descent (vertical or diagonal)										
a. Genetic		Biologic parents shown.								
- Multiple gestation	<table border="1"> <tr> <td>Monozygotic</td> <td>Dizygotic</td> <td>Unknown</td> <td>Trizygotic</td> </tr> <tr> <td></td> <td></td> <td></td> <td></td> </tr> </table>	Monozygotic	Dizygotic	Unknown	Trizygotic					The horizontal line indicating monozygosity is placed between the individual's line and not between each symbol. An asterisk (*) can be used if zygosity proven.
Monozygotic	Dizygotic	Unknown	Trizygotic							
- Family history not available/known for individual	<table border="1"> <tr> <td></td> <td></td> <td></td> </tr> </table>									
- No children by choice or reason unknown	<table border="1"> <tr> <td></td> <td>                     or  </td> <td>                     or  </td> <td>Indicate reason, if known.</td> </tr> </table>		or 	or 	Indicate reason, if known.					
	or 	or 	Indicate reason, if known.							
- Infertility	<table border="1"> <tr> <td></td> <td>                     or  </td> <td>                     or  </td> <td>Indicate reason, if known.</td> </tr> </table>		or 	or 	Indicate reason, if known.					
	or 	or 	Indicate reason, if known.							
b. Adoption	<table border="1"> <tr> <td>in</td> <td>out</td> <td>by relative</td> <td></td> </tr> <tr> <td></td> <td></td> <td></td> <td>Brackets used for all adoptions. Adoptive and biological parents denoted by dashed and solid lines of descent, respectively.</td> </tr> </table>	in	out	by relative					Brackets used for all adoptions. Adoptive and biological parents denoted by dashed and solid lines of descent, respectively.	
in	out	by relative								
			Brackets used for all adoptions. Adoptive and biological parents denoted by dashed and solid lines of descent, respectively.							

**Fig. 97.2** Pedigree line definitions. (From Bennett RL, French KS, Resta RG, et al. *Standardized human pedigree nomenclature: update and assessment of the recommendations of the National Society of Genetic Counselors*. *J Genet Couns*. 2008;17:424–433.)

Every individual probably carries several rare, deleterious recessive pathogenic sequence variants. Because most pathogenic variants carried in the general population occur at a very low frequency, it does not make economic sense to screen the entire population to identify the small number of persons who carry these variants. These variants typically remain undetected unless an affected child is born to a couple who both carry pathogenic variants affecting the same gene.

However, in some **genetic isolates** (small populations isolated by geography, religion, culture, or language), certain rare recessive pathogenic variants are much more common than in the general population. Even though there may be no known consanguinity, couples from these genetic isolates have a greater chance of sharing pathogenic alleles inherited from a common ancestor. Screening programs have been developed among some such groups to detect persons who carry common disease-causing variants and, therefore, are at increased risk for having affected children.

A variety of autosomal recessive conditions are more common among Ashkenazi Jews than in the general population. Couples of Ashkenazi Jewish ancestry should be offered prenatal or preconception screening for Gaucher disease type one (carrier rate 1:14), cystic fibrosis (1:25), Tay-Sachs disease (1:25), familial dysautonomia (1:30), Canavan disease (1:40), glycogen storage disease type 1A (1:71), maple syrup urine disease (1:81), Fanconi anemia type C (1:89), Niemann-Pick disease type A (1:90), Bloom syndrome (1:100), mucopolysaccharidosis IV (1:120), and possibly neonatal familial hyperinsulinemic hypoglycemia.

The prevalence of carriers of certain autosomal recessive variants in some larger populations is unusually high. In such cases, **heterozygote advantage** is postulated. The carrier frequencies of sickle cell disease in the African population and of cystic fibrosis in the northern European population are much higher than would be expected from the rate of new pathogenic variants. In these populations,

Instructions:		
<ul style="list-style-type: none"> <li>— D represents egg or sperm donor</li> <li>— S represents surrogate (gestational carrier)</li> <li>— If the woman is both the ovum donor and a surrogate, in the interest of genetic assessment, she will only be referred to as a donor (e.g., 4 and 5); the pregnancy symbol and its line of descent are positioned below the woman who is carrying the pregnancy</li> <li>— Available family history should be noted on the gamete donor and/or gestational carrier</li> </ul>		
Possible Reproductive Scenarios	Comments	
1. Sperm donor		Couple in which woman is carrying pregnancy using donor sperm. No relationship line is shown between the woman carrying the pregnancy and the sperm donor.
2. Ovum donor		Couple in which woman is carrying pregnancy using a donor egg and partner's sperm. The line of descent from the birth mother is solid because there is a biologic relationship that may affect the fetus (e.g., teratogens).
3. Surrogate only		Couple whose gametes are used to impregnate a woman (surrogate) who carries the pregnancy. The line of descent from the surrogate is solid because there is a biological relationship that may affect the fetus (e.g., teratogens).
4. Surrogate ovum donor		Couple in which male partner's sperm is used to inseminate (a) an unrelated woman or (b) a sister who is carrying the pregnancy for the couple.
5. Planned adoption		Couple contracts with a woman to carry a pregnancy using ovum of the woman carrying the pregnancy and donor sperm.

**Fig. 97.3** Assisted reproductive technology symbols and definitions. (From Bennett RL, French KS, Resta RG, et al. Standardized human pedigree nomenclature: update and assessment of the recommendations of the National Society of Genetic Counselors. *J Genet Couns.* 2008;17:424–433.)

heterozygous carriers may have had an advantage in terms of survival and reproduction over noncarriers. In sickle cell disease, the carrier state is thought to confer some resistance to malaria. In cystic fibrosis, the carrier state has been postulated to confer resistance to cholera or enteropathogenic *Escherichia coli* infections. Population-based **carrier screening** for cystic fibrosis is recommended for persons of northern European and Ashkenazi Jewish ancestry, and population-based screening for sickle cell disease is recommended for persons of African ancestry.

If the frequency of an autosomal recessive disease is known, the frequency of the heterozygote or carrier state can be calculated from the **Hardy-Weinberg formula**:

$$p^2 + 2pq + q^2 = 1$$

where  $p$  is the frequency of one of a pair of alleles and  $q$  is the frequency of the other. For example, if the frequency of cystic fibrosis among White Americans is one in 2,500 ( $p^2$ ), then the frequency of the

heterozygote ( $2pq$ ) can be calculated: If  $p^2 = 1/2,500$ , then  $p = 1/50$  and  $q = 49/50$ ;  $2pq = 2 \times (1/50) \times (49/50) = 98/2,500$ , or 3.92%.

### Pseudodominant Inheritance

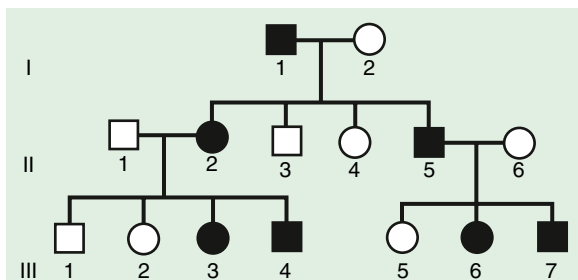
Pseudodominant inheritance refers to the observation of apparent dominant (parent to child) transmission of a known autosomal recessive disorder (Fig. 97.8). This occurs when a homozygous affected individual has a partner who is a heterozygous carrier. This is most likely to occur for relatively common recessive traits within a population, such as sickle cell anemia or nonsyndromic autosomal recessive hearing loss caused by deleterious variants in *GJB2*, the gene that encodes connexin 26.

### X-Linked Inheritance

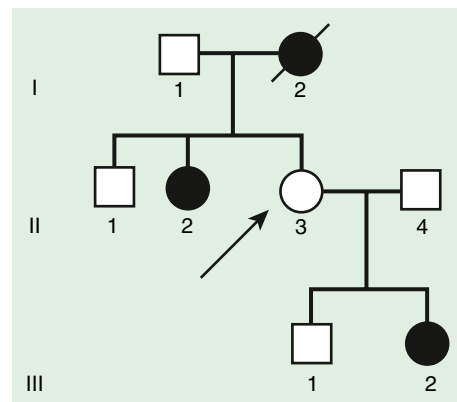
X-linked inheritance describes the inheritance pattern of most disorders caused by deleterious changes in genes located on the X chromosome (Fig. 97.9). In X-linked disorders, males are more commonly

Instructions:		
— E is used for evaluation to represent clinical and/or test information on the pedigree a. E is to be defined in key/legend b. If more than one evaluation, use subscript (E <sub>1</sub> , E <sub>2</sub> , E <sub>3</sub> ) and define in key c. Test results should be put in parentheses or defined in key/legend — A symbol is shaded only when an individual is clinically symptomatic — For linkage studies, haplotype information is written below the individual. The haplotype of interest should be on left and appropriately highlighted — Repetitive sequences, trinucleotides, and expansion numbers are written with affected allele first and placed in parentheses — If variant known, identify in parentheses		
Definition	Symbol	Scenario
1. Documented evaluation (*) Use only if examined/evaluated by you or your research/clinical team or if the outside evaluation has been reviewed and verified.		Woman with negative echocardiogram.  E- (echo)
2. Carrier—not likely to manifest disease regardless of inheritance pattern		Male carrier of Tay-Sachs disease by patient report (* not used because results not verified).
3. Asymptomatic/presymptomatic carrier—clinically unaffected at this time but could later exhibit symptoms		Woman age 25 with negative mammogram and positive BRCA1 DNA test.  25 y E <sub>1</sub> - (mammogram) E <sub>2</sub> + (5385insC BRCA1)
4. Uninformative study (u)		Man age 25 with normal physical exam and uninformative DNA test for Huntington disease (E <sub>2</sub> ).  25 y E <sub>1</sub> - (physical exam) E <sub>2</sub> u (36n/18n)
5. Affected individual with positive evaluation (E+)		Individual with cystic fibrosis and positive variant study; only one variant has currently been identified.  E+ (ΔF508)    Eu E+ (ΔF508/u)  ----- 10 week male fetus with a trisomy 18 karyotype.  P 10 wk E+ (CVS) 47,XY,+18

**Fig. 97.4** Pedigree symbols of genetic evaluation and testing information. (From Bennett RL, French KS, Resta RG, et al. Standardized human pedigree nomenclature: update and assessment of the recommendations of the National Society of Genetic Counselors. *J Genet Couns.* 2008;17:424–433.)

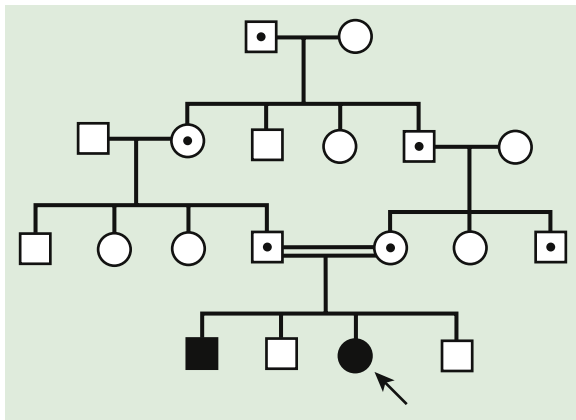


**Fig. 97.5** Autosomal dominant pedigree. Pedigree showing typical inheritance of a form of achondroplasia (*FGFR3*) inherited as an autosomal dominant trait. *Black*, Affected patients.

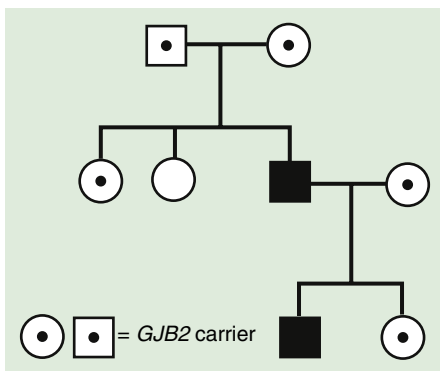


**Fig. 97.6** Incomplete penetrance. This family segregates a familial cancer syndrome, familial adenomatous polyposis. Individual II.3 is an obligate carrier (arrow), but there are no findings to suggest the disorder. This disorder is nonpenetrant in this individual. *Black*, Affected patients.

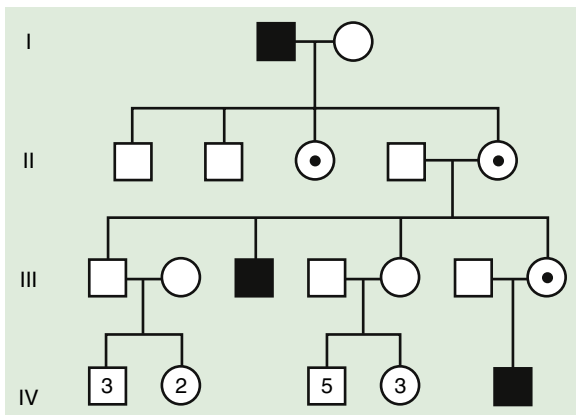




**Fig. 97.7** Autosomal recessive pedigree with parental consanguinity. Central dot, Carriers; Black, affected patients.



**Fig. 97.8** Pseudodominant inheritance. Black, Affected (deaf); central dot shows carrier who is asymptomatic (unaffected).



**Fig. 97.9** Pedigree demonstrating X-linked recessive inheritance. Central dot, Carriers; black, affected patients.

affected than females. Female carriers of these disorders are generally unaffected, or if affected, they are affected more mildly than males. In each pregnancy, female carriers have a 25% chance of having an affected son, a 25% chance of having a carrier daughter, and a 50% chance of having a child that does not inherit the mutated X-linked gene. Because affected males pass their X chromosome to all their daughters and their Y chromosome to all their sons, they have a 50% chance of having a daughter who is a carrier. Male-to-male transmission excludes X-linked inheritance but is seen with autosomal dominant and Y-linked inheritance.

A female occasionally exhibits signs of an X-linked trait similar to a male. This occurs rarely from homozygosity for an X-linked

trait or the presence of a sex chromosome abnormality (45,X or 46,XY female) but more commonly from skewed or nonrandom X-inactivation. **X chromosome inactivation** occurs early in development and involves the random and irreversible inactivation of most genes on one X chromosome in female cells (Fig. 97.10). In some cases, a preponderance of cells inactivates the same X chromosome, resulting in phenotypic expression of an X-linked pathogenic variant if it resides on the active chromosome. This can occur because of chance, selection against cells that have inactivated the X chromosome carrying the normal gene, or an X chromosome abnormality that results in inactivation of the X chromosome carrying the normal gene.

In some X-linked disorders, both **hemizygous** males and **heterozygous** females who carry an affected X-linked gene have similar phenotypic manifestations. In these cases, an affected male will have a 50% chance of having an affected daughter and a 50% chance of having an unaffected son in each pregnancy, whereas half the male and female offspring of an affected mother will be affected (Fig. 97.11). Some X-linked conditions are lethal in a high percentage of males, such as **incontinentia pigmenti**. In such cases the pedigree typically shows only affected females and an overall female/male ratio of 2:1, with an increased number of miscarriages (Fig. 97.12).

### Y-LINKED INHERITANCE

There are few Y-linked traits. These demonstrate *only* male-to-male transmission, and only males are affected (Fig. 97.13). Most Y-linked genes are related to male sex determination and reproduction and are associated with infertility. Therefore it is rare to see familial transmission of a Y-linked disorder. However, advances in assisted reproductive technologies might make it possible to have familial transmission of male infertility.

### INHERITANCE ASSOCIATED WITH PSEUDOAUTOSOMAL REGIONS

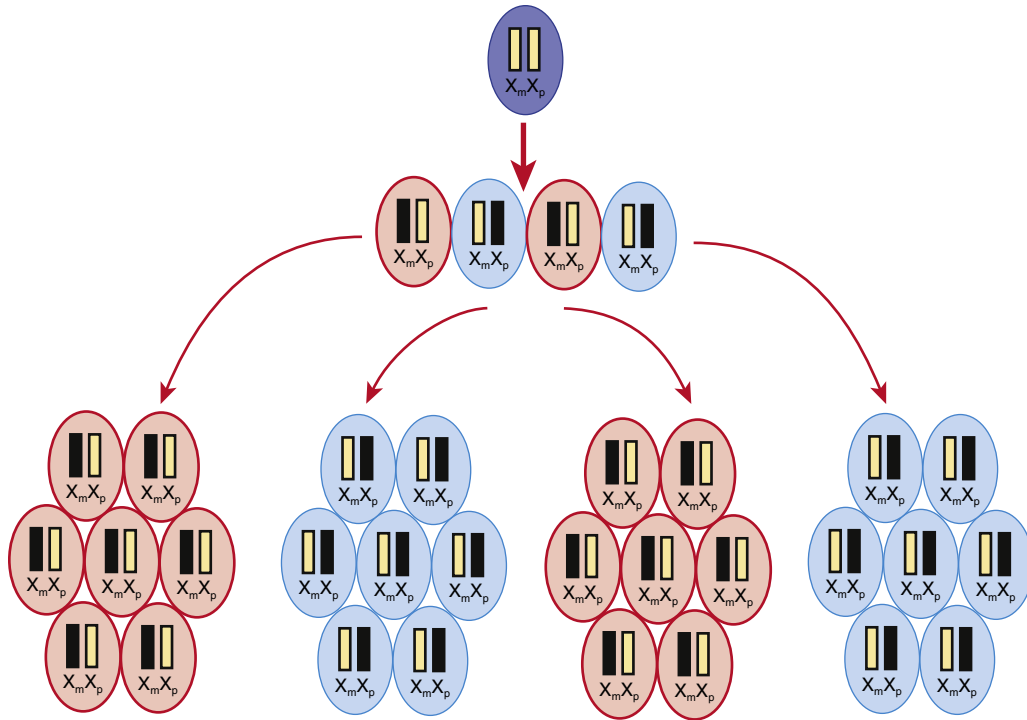
There are pseudoautosomal regions on the X and Y chromosomes. Because these regions are made up of homologous sequences of nucleotides, genes that are located in these regions are present in equal numbers among both males and females. *SHOX* is one of the best-characterized disease genes located in these regions. Heterozygous *SHOX* pathogenic variants cause **Leri-Weil dyschondrosteosis**, a rare skeletal dysplasia that involves bilateral bowing of the forearms with dislocations of the ulna at the wrist and generalized short stature. Homozygous *SHOX* pathogenic variants cause the much more severe **Langer mesomelic dwarfism**.

### DIGENIC INHERITANCE

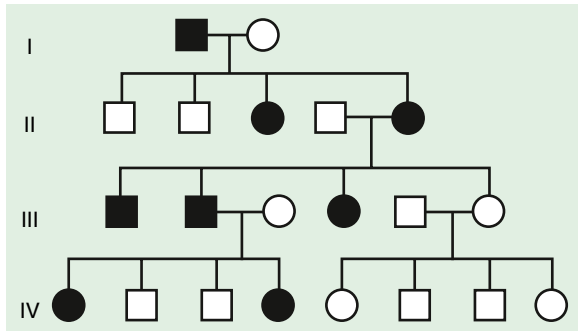
Digenic inheritance explains the occasional occurrence of **retinitis pigmentosa (RP)** in children of parents who each carry a pathogenic variant in a different RP-associated gene (Fig. 97.14). Both parents have normal vision, as would be expected, but their offspring who are **double heterozygotes**—having inherited both variants—develop RP. Digenic pedigrees can exhibit characteristics of both autosomal dominant (vertical transmission) and autosomal recessive inheritance (one in four recurrence risk). A couple in which the two unaffected partners are carriers for variants in two different RP-associated genes that show digenic inheritance have a one in four risk of having an affected child, similar to what is seen in autosomal recessive inheritance. However, their affected children, and affected children in subsequent generations, have a one in four risk of transmitting both variants to their offspring, who would be affected (vertical transmission).

### PSEUDOGENETIC INHERITANCE AND FAMILIAL CLUSTERING

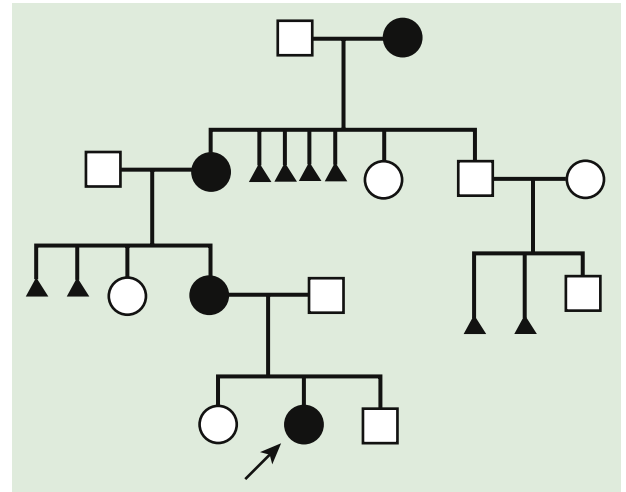
Sometimes nongenetic causes of a particular disease in multiple family members can produce a pattern that mimics genetic transmission. These nongenetic factors can include identifiable environmental factors, teratogenic exposures, or undetermined or undefined factors.



**Fig. 97.10** X-inactivation. Black marks the active X chromosome. Color of the cell represents its active X chromosome is paternally ( $X_p$ , blue) or maternally ( $X_m$ , pink) derived.



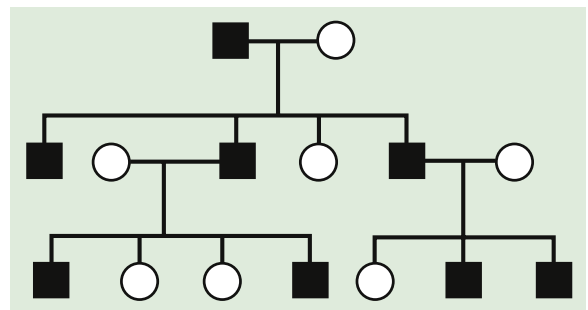
**Fig. 97.11** Pedigree pattern demonstrating X-linked dominant inheritance. Black, Affected patients. Note there is no father-to-son transmission in this situation, and hemizyosity (i.e., X-linked gene in a male) is not lethal. In some X-linked dominant conditions, X-linked males have a more severe phenotype and might not survive. In that case, only females manifest the disease (see Fig. 97.12).



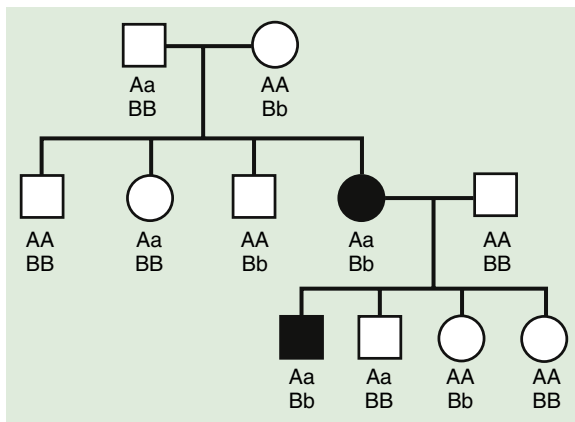
**Fig. 97.12** Pedigree of an X-linked dominant disorder with male lethality, such as incontinentia pigmenti. Black, Affected patients.

Examples of identifiable factors might include multiple siblings in a family having asthma because of exposure to cigarette smoke from their parents or having failure to thrive, developmental delay, and unusual facial appearance caused by exposure to alcohol during pregnancy.

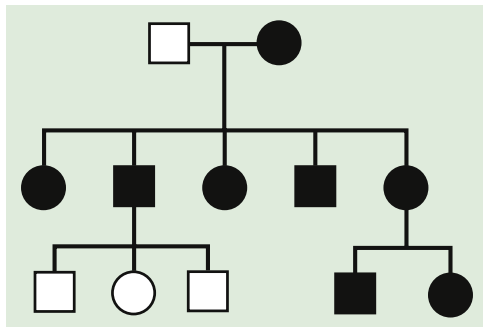
In some cases, the disease is sufficiently common in the general population that some familial clustering occurs simply by chance. Breast cancer affects 11% of all women, and it is possible that several women in a family will develop breast cancer even in the absence of a specific genetic predisposition. However, hereditary breast cancer associated with pathogenic variants in *BRCA1* and *BRCA2* should be suspected in any individual who has a personal history of breast cancer with onset before age 50, early-onset breast and ovarian cancer at any age, bilateral or multifocal breast cancer, a family history of breast cancer or breast and ovarian cancer consistent with autosomal dominant inheritance, or a personal or family history of male breast



**Fig. 97.13** Y-linked inheritance. Black, Affected patients.



**Fig. 97.14** Digenic pedigree. Here, the disease alleles are *a* and *b* and they reside on distinct genetic loci or genes. For a person to have the disease, heterozygosity for variant alleles in both genes (*A/a*; *B/b*) is required. *Black*, Affected patients.



**Fig. 97.15** Pedigree of a mitochondrial disorder, exhibiting maternal inheritance. *Black*, Affected patients.

cancer. In other cases, clustering within a family may be caused by undefined genetic factors or unidentified pathogenic sequence variants (nuclear or mitochondrial).

## NONTRADITIONAL INHERITANCE

Some genetic disorders are inherited in a manner that does not follow classical Mendelian patterns. Nontraditional inheritance is seen in mitochondrial disorders, triplet repeat expansion diseases, and imprinting defects.

### Mitochondrial Inheritance

An individual's mitochondrial genome is entirely derived from the mother because sperm contain relatively few mitochondria, which are degraded after fertilization. It follows that **mitochondrial inheritance** is, essentially, **maternal inheritance**. A female with a mitochondrially inherited genetic disorder can have affected offspring of either sex, but an affected father cannot pass on the disease to his offspring (Fig. 97.15). Mitochondrial DNA pathogenic variants are often deletions or point pathogenic variants. Overall, one person in 400 has a maternally inherited pathogenic mitochondrial DNA pathogenic variant (see Chapter 108). In individual families, mitochondrial inheritance may be difficult to distinguish from autosomal dominant or X-linked inheritance, but in many cases, the sex of the transmitting and nontransmitting parents can suggest a mitochondrial basis (Table 97.1).

Mitochondria are the cell's suppliers of energy; the organs that are most affected by the presence of abnormal mitochondria are those that have the greatest energy requirements, such as the brain, muscle,

heart, and liver (see Chapters 107.4, 409, 638.2, and 651.4; Fig. 97.16). Common manifestations include developmental delay, seizures, cardiac dysfunction, decreased muscle strength and tone, and hearing and vision problems.

Mitochondrial diseases can be highly variable in their clinical manifestations. This is partly because cells can contain multiple mitochondria, each bearing several copies of the mitochondrial genome. Thus a cell can have a mixture of normal and abnormal mitochondrial genomes, which is referred to as **heteroplasmy**. In contrast, **homoplasmy** refers to a state in which all copies of the mitochondrial genome carry the same sequence variant. Unequal segregation of mitochondria carrying normal and abnormal genomes and replicative advantage can result in varying degrees of heteroplasmy in the cells of an affected individual, including the individual ova of an affected female. Because of this, a mother may be asymptomatic and yet have children who are severely affected. The level of heteroplasmy at which disease symptoms typically appear can also vary based on the type of mitochondrial variant.

Detection of variants in the mitochondrial genome may require sampling of the affected tissue for DNA analysis. In some tissues, such as blood, testing for mitochondrial DNA variants may be inadequate because the variant may be found primarily in affected tissues such as muscle (Fig. 97.17). Growth and differentiation factor 15 (GDF-15) and blood lactate levels are screening tests for mitochondrial disorders. GDF-15 is only accurate in children  $\geq 1$  year of age and in the absence of heart, liver, or renal disease.

### Triplet Repeat Expansion Disorders

Triplet repeat expansion disorders are distinguished by the special dynamic nature of the disease-causing variant. Triplet repeat expansion disorders include fragile X syndrome, myotonic dystrophy, Huntington disease, and spinocerebellar ataxias (Table 97.2 and Fig. 97.18). These disorders are caused by expansion in the number of 3-bp repeats. The fragile X gene, *FMRI*, normally has 5–40 CGG triplets. An error in replication can result in expansion of that number to a level in the gray zone between 41 and 58 repeats or to a level referred to as a **prepathogenic variant**, which comprises 59–200 repeats. Some prepathogenic variant carriers, more often males, develop fragile X–associated tremor/ataxia syndrome (FXTAS) as adults. Female prepathogenic variant carriers are at risk for fragile X–associated primary ovarian insufficiency (FXPOI). Persons, especially females, with a prepathogenic variant are also at risk for having the repeat expand further in subsequent meiosis, thus crossing into the range of a **full pathogenic variant** (>200 repeats) in offspring. With this number of repeats, the *FMRI* gene becomes hypermethylated, and protein production is lost.

Some triplet expansions associated with other genes can cause disease through a mechanism other than decreased protein production. In Huntington disease, the expansion causes the gene product to have a new, toxic effect on the neurons of the basal ganglia. For most triplet repeat disorders, there is a clinical correlation to the size of the expansion, with a greater expansion causing more severe symptoms and having an earlier age of disease onset. The observation of increasing severity of disease and early age at onset in subsequent generations is termed **genetic anticipation** and is a defining characteristic of many triplet repeat expansion disorders (Fig. 97.19).

### Genetic Imprinting

The two copies of most autosomal genes are functionally equivalent. However, in some cases, only one copy of a gene is transcribed, and the second copy is silenced. This gene silencing is typically associated with methylation of DNA, which is an **epigenetic** modification; it does not change the nucleotide sequence of the DNA (Fig. 97.20). In **imprinting**, gene expression depends on the *parent of origin* of the chromosome (see Chapter 99.7). Imprinting disorders result from an imbalance of active copies of a given gene, which can occur for several reasons. Prader-Willi and Angelman syndromes,

**Table 97.1** Representative Examples of Disorders Caused by Pathogenic Variants in Mitochondrial DNA and Their Inheritance

DISEASE	PHENOTYPE	MOST FREQUENT PATHOGENIC VARIANT IN mtDNA MOLECULE	HOMOPLASMY vs HETEROPLASMY	INHERITANCE
Leber hereditary optic neuropathy	Rapid optic nerve atrophy, leading to blindness in young adult life; sex bias approximately 50% males with visual loss, only 10% females	Substitution p.Arg340His in <i>ND1</i> gene of complex I of electron transport chain; other complex I missense pathogenic variants	Homoplasmic (usually)	Maternal
NARP, Leigh disease	Neuropathy, ataxia, retinitis pigmentosa, developmental delay, intellectual disability lactic acidemia	Point pathogenic variants in ATPase subunit six gene	Heteroplasmic	Maternal
MELAS	Mitochondrial encephalomyopathy, lactic acidosis, and strokelike episodes; may manifest only as diabetes mellitus or deafness	Point pathogenic variant in tRNA <sup>Leu</sup>	Heteroplasmic	Maternal
MERRF	Myoclonic epilepsy, ragged red fibers in muscle, ataxia, sensorineural deafness	Point pathogenic variant in tRNA <sup>Lys</sup>	Heteroplasmic	Maternal
Deafness	Progressive sensorineural deafness, often induced by aminoglycoside antibiotics	m.1555A>G pathogenic variant in 12S rRNA	Homoplasmic	Maternal
	Nonsyndromic sensorineural deafness	m.7445A>G pathogenic variant in 12S rRNA	Homoplasmic	Maternal
Chronic progressive external ophthalmoplegia (CPEO)	Progressive weakness of extraocular muscles, cardiomyopathy, ptosis, heart block, ataxia, retinal pigmentation, diabetes	The common MELAS point pathogenic variant in tRNA <sup>Lys</sup> ; large deletions similar to KSS	Heteroplasmic	Maternal if point pathogenic variants
Pearson syndrome	Pancreatic insufficiency, pancytopenia, lactic acidosis	Large deletions	Heteroplasmic	Sporadic, somatic pathogenic variants
Kearns-Sayre syndrome (KSS)	PEO of early onset with heart block, retinal pigmentation	5-kb large deletion	Heteroplasmic	Sporadic, somatic pathogenic variants

mtDNA, Mitochondrial DNA; rRNA, ribosomal RNA; tRNA, transfer RNA.

From Nussbaum RL, McInnes RR, Willard HF, eds. *Thompson & Thompson Genetics in Medicine*, 6th ed. Philadelphia: Saunders; 2001: p. 246.

two distinct disorders associated with developmental impairment, are caused by microdeletions of chromosome 15q11-12. The microdeletion in **Prader-Willi syndrome** is always on the *paternally* derived chromosome 15, whereas in **Angelman syndrome** it is on the *maternal* copy. *UBE3A* is the gene responsible for Angelman syndrome. The paternal copy of *UBE3A* is transcriptionally silenced in the brain, but the maternal copy continues to be transcribed. If an individual has a maternally derived deletion, an insufficient amount of *UBE3A* protein is produced in the brain, resulting in the neurologic deficits seen in Angelman syndrome.

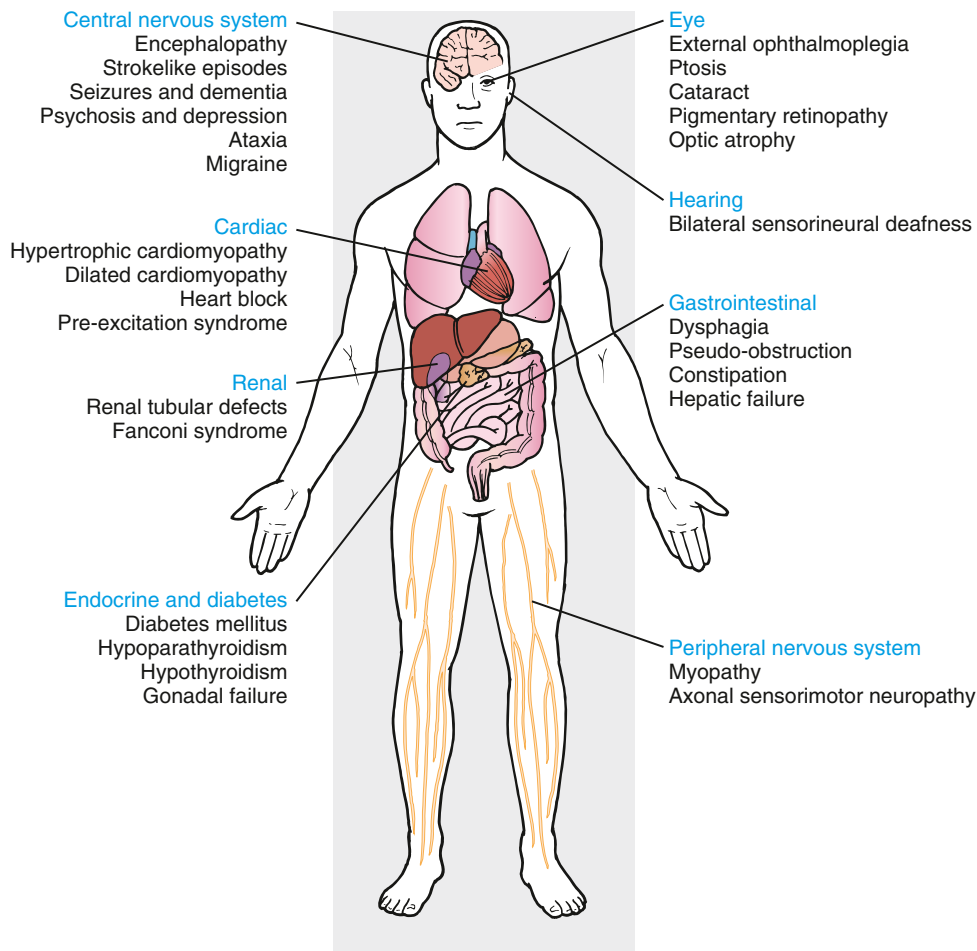
**Uniparental disomy (UPD)**, the rare occurrence of a child inheriting both copies of a chromosome from the *same parent*, is another genetic mechanism that can cause Prader-Willi and Angelman syndromes. Inheriting both chromosomes 15 from the mother is functionally the same as deletion of the paternal 15q12 region and results in Prader-Willi syndrome. Approximately 30% of cases of Prader-Willi syndrome are caused by maternal UPD15, whereas paternal UPD15 accounts for only 3% of Angelman syndrome (see [Chapter 99.7](#)). Pathogenic variants in *UBE3A* account for ~11% of patients with Angelman syndrome and result in familial transmission. The least common cause is a pathogenic variant affecting the imprinting center, which results in an inability to correctly imprint

*UBE3A*. In a mother, inability to reset the imprinting on her paternally inherited chromosome 15 imprint results in a 50% risk of passing on an incorrectly methylated copy of *UBE3A* to a child, who would then develop Angelman syndrome.

Other imprinted regions of clinical interest include the short arm of chromosome 11, where the genes for Beckwith-Wiedemann syndrome and nesidioblastosis map, and the long arm of chromosome seven with maternal UPD of 7q being associated with some cases of idiopathic short stature and Russell-Silver syndrome.

Imprinting of a gene can occur during gametogenesis or early embryonic development (**reprogramming**). Genes can become inactive or active by various mechanisms including DNA methylation or demethylation or histone acetylation or deacetylation, with different patterns of (de)methylation noted on paternal or maternal imprinted chromosome regions. Some genes demonstrate tissue-specific imprinting (see [Fig. 97.20](#)). There is a small but increased incidence of imprinting disorders, specifically Beckwith-Wiedemann and Angelman syndrome, following assisted reproductive technologies such as in vitro fertilization and intracytoplasmic sperm injection. The overall incidence of these disorders in children conceived using assisted reproductive technologies is likely to be <1%.





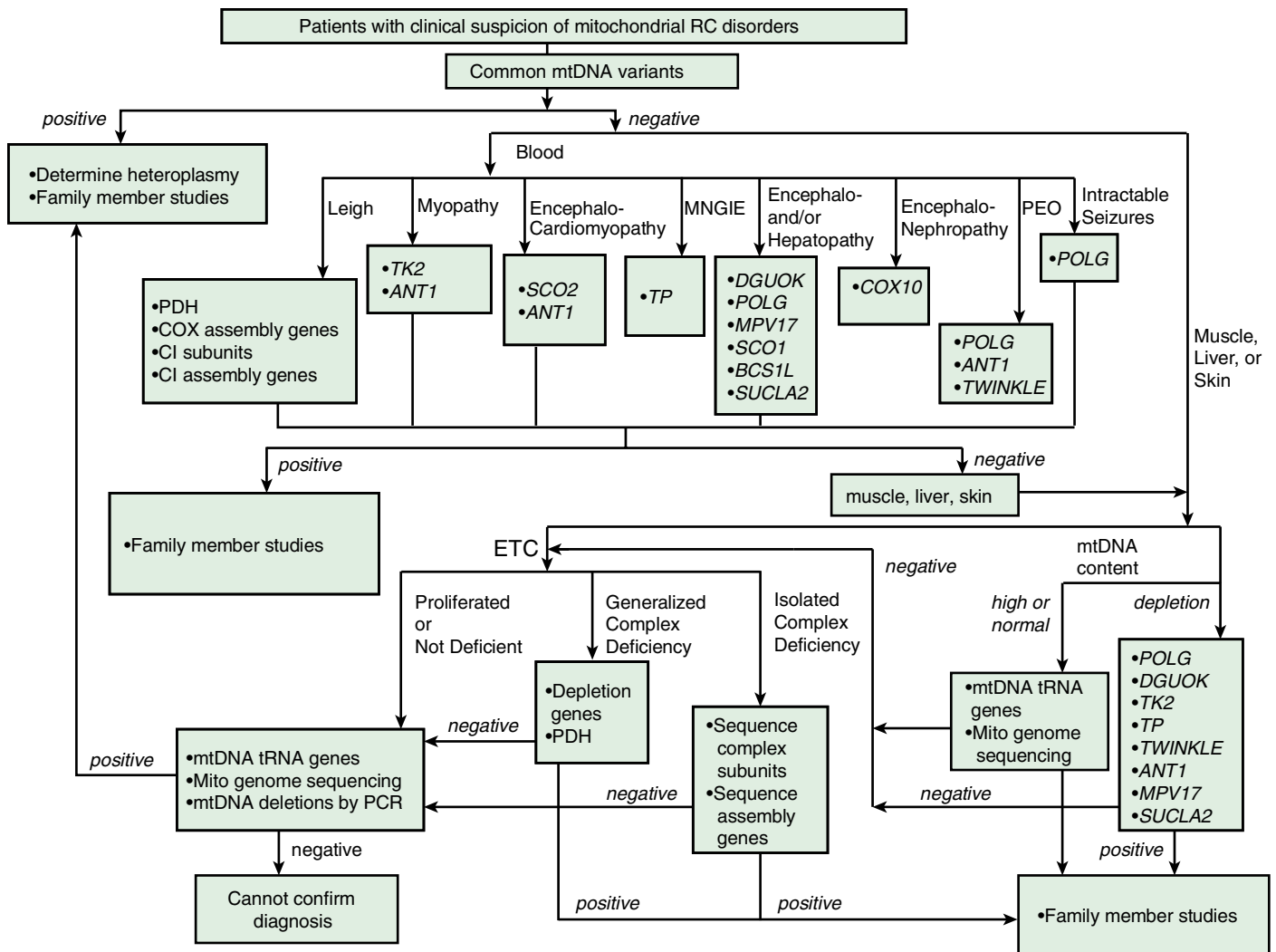
**Fig. 97.16** The range of affected tissues and clinical phenotypes associated with pathogenic variants in mitochondrial DNA (mtDNA). (Modified from Chinnery PF, Turnbull DM. Mitochondrial DNA and disease. *Lancet*. 1999;345:SI17–SI21.)

### MULTIFACTORIAL AND POLYGENIC INHERITANCE

Multifactorial inheritance refers to traits that are caused by a combination of inherited, environmental, and stochastic factors (Fig. 97.21). Multifactorial traits differ from polygenic inheritance, which refers to traits that result from the additive effects of multiple genes. Multifactorial traits segregate within families but do not exhibit a consistent or recognizable inheritance pattern. Characteristics include the following:

- There is a similar rate of recurrence among all first-degree relatives (parents, siblings, offspring of affected child). It is unusual to find a substantial increase in risk for relatives related more distantly than second degree to the index case.
- The risk of recurrence is related to the incidence of the disease.
- Some disorders have a sex predilection, as indicated by an unequal male:female incidence. Pyloric stenosis, for example, is more common in males, whereas congenital dislocation of the hips is more common in females. With an altered sex ratio, the risk is higher for the relatives of an index case whose gender is less often affected than relatives of an index case of the more frequently affected gender. The risk to the son of an affected female with infantile pyloric stenosis is 18%, compared with the 5% risk for the son of an affected male. An affected female presumably has a greater genetic susceptibility, which can be passed on to offspring.
- The likelihood that both identical twins will be affected with the same malformation is <100% but much greater than the chance that both members of a nonidentical twin pair will be affected. This contrasts with the pattern seen in mendelian inheritance, in which identical twins almost always share fully penetrant genetic disorders.
- The risk of recurrence is increased when multiple family members are affected. A simple example is that the risk of recurrence for unilateral cleft lip and palate is 4% for a couple with one affected child and increases to 9% with two affected children. It is sometimes difficult to distinguish between a multifactorial and mendelian etiology in families with multiple affected individuals.
- The risk of recurrence may be greater when the disorder is more severe. For example, an infant who has long-segment Hirschsprung disease has a greater chance of having an affected sibling than the infant who has short-segment Hirschsprung disease.

There are two types of multifactorial traits. One exhibits **continuous variation**, with “normal” individuals falling within a statistical range—often defined as having a value two standard deviations (SDs) above and/or below the mean—and “abnormals” falling outside that range. Examples include such traits as intelligence, blood pressure, height, and head circumference. For many of these traits, offspring values can be estimated based on a modified average of their parental values, with nutritional and environmental factors playing an important role.



**Fig. 97.17** Clinical algorithm for genetic diagnostic testing of mitochondrial DNA (mtDNA) and nuclear DNA (nDNA) genes in patients suspected of mitochondrial disorders (Baylor College of Medicine, Mitochondrial Diagnostics Laboratory). RC, Respiratory chain; MNGIE, mitochondrial neuro-gastrointestinal encephalopathy; PEO, progressive external ophthalmoplegia; PDH, pyruvate dehydrogenase; CI, respiratory complex I; ETC, electron transport chain; PCR, polymerase chain reaction. (From Haas RH, Parikh S, Falk MJ, et al. *The in-depth evaluation of suspected mitochondrial disease. Mol Genet Metab.* 2008;94:16–37.)

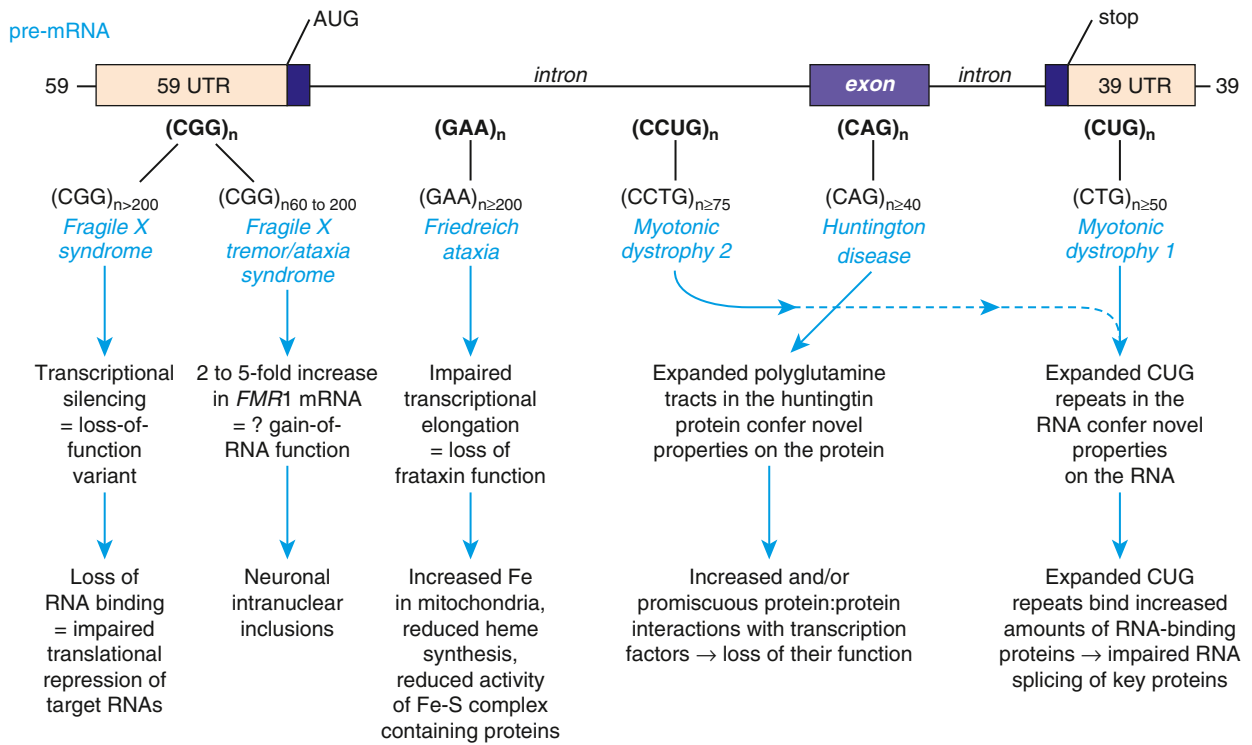
Table 97.2 Diseases Associated with Polynucleotide Repeat Expansions						
DISEASE	DESCRIPTION	REPEAT SEQUENCE	NORMAL RANGE	ABNORMAL RANGE	PARENT IN WHOM EXPANSION USUALLY OCCURS	LOCATION OF EXPANSION
<b>CATEGORY 1</b>						
Huntington disease	Loss of motor control, dementia, affective disorder	CAG	6-34	36-100 or more	More often through father	Exon
Spinal and bulbar muscular atrophy	Adult-onset motor-neuron disease associated with androgen insensitivity	CAG	11-34	40-62	More often through father	Exon
Spinocerebellar ataxia type 1	Progressive ataxia, dysarthria, dysmetria	CAG	6-39	41-81	More often through father	Exon
Spinocerebellar ataxia type 2	Progressive ataxia, dysarthria	CAG	15-29	35-59	—	Exon
Spinocerebellar ataxia type three (Machado-Joseph disease)	Dystonia, distal muscular atrophy, ataxia, external ophthalmoplegia	CAG	13-36	68-79	More often through father	Exon

Continued

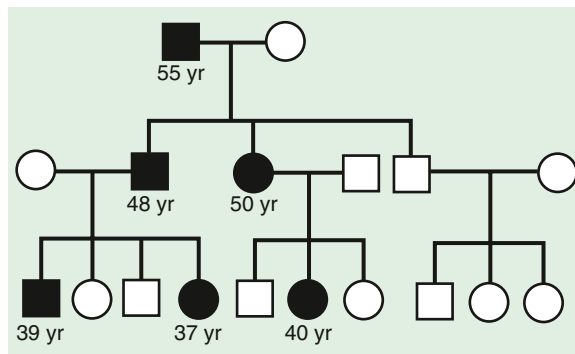
**Table 97.2** Diseases Associated with Polynucleotide Repeat Expansions—cont'd

DISEASE	DESCRIPTION	REPEAT SEQUENCE	NORMAL RANGE	ABNORMAL RANGE	PARENT IN WHOM EXPANSION USUALLY OCCURS	LOCATION OF EXPANSION
<b>CATEGORY 1</b>						
Spinocerebellar ataxia type 6	Progressive ataxia, dysarthria, nystagmus	CAG	4-16	21-27	—	Exon
Spinocerebellar ataxia type 7	Progressive ataxia, dysarthria, retinal degeneration	CAG	7-35	38-200	More often through father	—
Spinocerebellar ataxia type 17	Progressive ataxia, dementia, bradykinesia, dysmetria	CAG	29-42	47-55	—	Exon
Dentatorubral-pallidoluysian atrophy/Haw River syndrome	Cerebellar atrophy, ataxia, myoclonic epilepsy, choreoathetosis, dementia	CAG	7-25	49-88	More often through father	Exon
<b>CATEGORY 2</b>						
Pseudoachondroplasia, multiple epiphyseal dysplasia	Short stature, joint laxity, degenerative joint disease	GAC	5	6-7	—	Exon
Oculopharyngeal muscular dystrophy	Proximal limb weakness, dysphagia, ptosis	GCG	6	7-13	—	Exon
Cleidocranial dysplasia	Short stature, open skull sutures with bulging calvaria, clavicular hypoplasia, shortened fingers, dental anomalies	GCG, GCT, GCA	17	27 (expansion observed in one family)	—	Exon
Synpolydactyly	Polydactyly and syndactyly	GCG, GCT, GCA	15	22-25	—	Exon
<b>CATEGORY 3</b>						
Myotonic dystrophy (DM1; chromosome 19)	Muscle loss, cardiac arrhythmia, cataracts, frontal balding	CTG	5-37	100 to several thousand	Either parent, but expansion to congenital form through mother	3' untranslated region
Myotonic dystrophy (DM2; chromosome 3)	Muscle loss, cardiac arrhythmia, cataracts, frontal balding	CCTG	<75	75-11,000	—	3' untranslated region
Friedreich ataxia	Progressive limb ataxia, dysarthria, hypertrophic cardiomyopathy, pyramidal weakness in legs	GAA	7-2	200-900 or more	Autosomal recessive inheritance, so disease alleles are inherited from both parents	Intron
Fragile X syndrome (FRAXA)	Intellectual impairment, large ears and jaws, macroorchidism in males	CGG	6-52	200-2,000 or more	Exclusively through mother	5' untranslated region
Fragile site (FRAXE)	Mild intellectual impairment	GCC	6-35	>200	More often through mother	5' untranslated region
Spinocerebellar ataxia type 8	Adult-onset ataxia, dysarthria, nystagmus	CTG	16-37	107-127	More often through mother	3' untranslated region
Spinocerebellar ataxia type 10	Ataxia and seizures	ATTCT	12-16	800-4,500	More often through father	Intron
Spinocerebellar ataxia type 12	Ataxia, eye movement disorders; variable age at onset	CAG	7-28	66-78	—	5' untranslated region
Progressive myoclonic epilepsy type 1	Juvenile-onset seizures, myoclonus, dementia	12-bp repeat motif	2-3	30-75	Autosomal recessive inheritance, so transmitted by both parents	5' untranslated region

From Jorde LB, Carey JC, Bamshad MJ, White, RL. *Medical Genetics*, 3rd ed. St Louis: Mosby; 2006: p. 82.

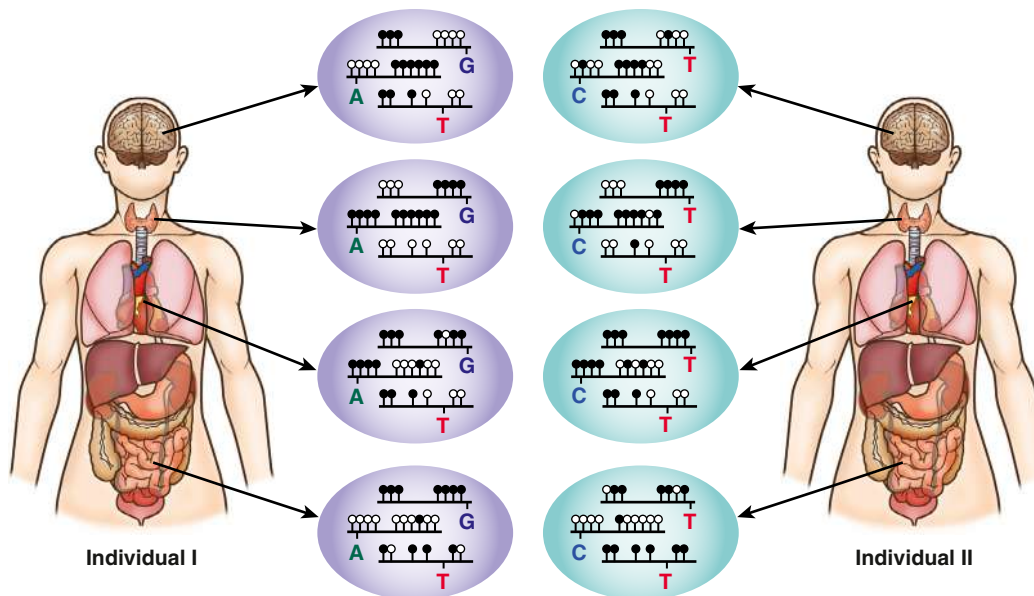


**Fig. 97.18** The locations of the trinucleotide repeat expansions and the sequence of each trinucleotide in five representative trinucleotide repeat diseases, shown on a schematic of a generic pre-messenger RNA (mRNA). The minimal number of repeats in the DNA sequence of the affected gene associated with the disease is also indicated, as well as the effect of the expansion on the mutant RNA or protein. (From Nussbaum RL, McInnes RR, Willard HF, eds. *Thompson & Thompson Genetics in Medicine, 8th ed.* Philadelphia: Elsevier; 2016; based partly on an unpublished figure from John A. Phillips III, Vanderbilt University.)

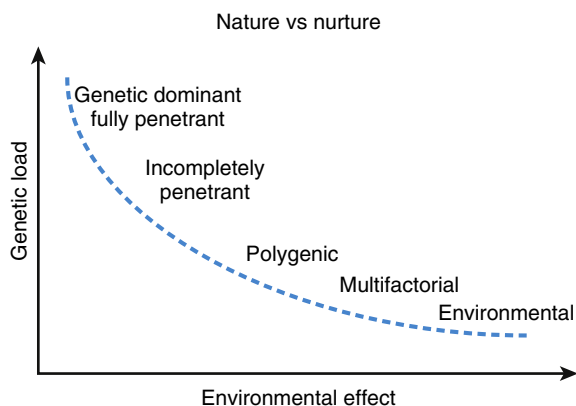


**Fig. 97.19** Myotonic dystrophy pedigree illustrating genetic anticipation. In this case the age at onset for family members affected with an autosomal dominant disease is lower in more recent generations. *Black*, Affected patients.





**Fig. 97.20** Tissue-specific DNA methylation and epigenetic heterogeneity among individuals. A subset of the DNA methylation patterns within a cell is characteristic of that cell type. Cell type-specific and tissue-specific DNA methylation patterns are illustrated by organ-to-organ variations in the clusters of methylated cytosine-phosphate-guanine bases (CpGs) within the same individual. Despite overall consistency in tissue-specific DNA methylation patterns, variations in these patterns exist among different individuals. Methylated CpGs are indicated by a filled circle and unmethylated CpGs by an open circle. Single nucleotide polymorphisms (SNPs) are indicated by the corresponding base. (Redrawn from Brena RM, Huang THM, Plass C. *Toward a human epigenome*. *Nat Genet*. 2006;38:1359–1360.)



**Fig. 97.21** The progressive decrease in the genetic load contributing to the development of a disease creates a smooth transition in the distribution of illnesses on an etiologic diagram. In theory, no diseases are completely free from the influence of both genetic and environmental factors. (From Bompreszi R, Kovanen PE, Martin R. *New approaches to investigating heterogeneity in complex traits*. *J Med Genet*. 2003;40:553–559.)

With other multifactorial traits, the distinction between normal and abnormal is based on the **qualitative** presence or absence of a particular trait. Examples include pyloric stenosis, neural tube defects, congenital heart defects, and cleft lip and cleft palate. Such traits follow a **threshold model** (see Fig. 97.15). A distribution of liability because of genetic and nongenetic factors is postulated in the population. Individuals who exceed a threshold liability develop the trait, and those below the threshold do not.

The balance between genetic and environmental factors is demonstrated by neural tube defects. Genetic factors are implicated by the increased recurrence risk for parents of an affected child compared with the general population, yet the recurrence risk is about 3%, less than what would be expected if the trait was caused by a single, fully penetrant pathogenic variant. The role of nongenetic environmental factors is shown by the recurrence risk decreasing up to 87% if the mother-to-be takes 4 mg of folic acid daily starting 3 months before conception.

Visit Elsevier eBooks+ at [eBooks.Health.Elsevier.com](http://eBooks.Health.Elsevier.com) for Bibliography.

## Chapter 98

## Integration of Genetics into Pediatric Practice

Brendan Lee and Nicola Brunetti-Pierri

Genetic testing involves analyzing genetic material to obtain information related to a person's health status using chromosomal (cytogenetic) analysis (see Chapter 99) and nucleic acid (primarily DNA but also RNA)-based testing.

**DIAGNOSTIC TESTING**

Diagnostic genetic testing helps to aggregate a set of signs and symptoms (phenotype) for disease diagnosis. The list of disorders for which specific genetic tests are available is extensive and growing. The website <http://www.ncbi.nlm.nih.gov/gtr/> provides one database of reported available tests.

Single-gene disorders can be tested by at least three different approaches: linkage analysis (a classical approach now rarely used), chromosome microarray (CMA), and direct pathogenic variant analysis, usually by DNA sequencing (Table 98.1). Linkage analysis is used if the responsible gene is mapped but not yet identified, or if it is impractical to find specific pathogenic variants, usually because of the large size and large number of different pathogenic variants in some genes. CMA can be used to detect large, multigene deletions or duplications (**copy number variations, or CNVs**). In addition, with increasing resolution, single-gene or smaller intragenic deletions or duplications can be detected by CMA, although it is important to note that coverage of each gene varies by array type used. *Direct DNA pathogenic variant identification is readily available with the advent of the complete human genome sequence next-generation sequencing (NGS) tools.* We also recognize the relatively frequent co-occurrence of multiple disorders, each caused by distinct pathogenic variants, in patients with complex or “blended” features. This may include partial to minimal clinical manifestations in a substantial percentage of individuals harboring pathogenic variants in known disease genes that remain undiagnosed. The ability to simultaneously sequence hundreds to thousands of genes (via NGS approaches) has provided insight into this complexity of disease pathogenesis.

**Linkage testing** involves tracking a genetic trait through a family using closely linked polymorphic markers as a surrogate for the trait

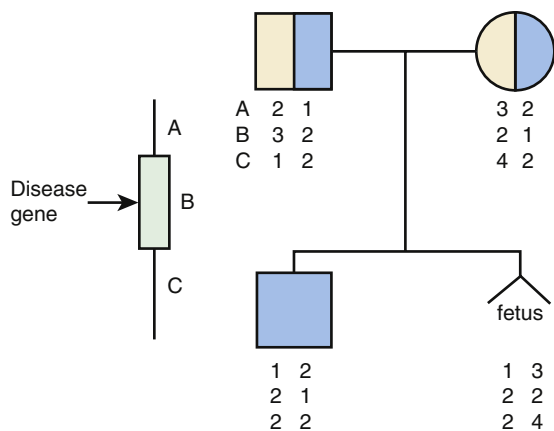
(Fig. 98.1). It requires testing an extended family and is vulnerable to several pitfalls, such as genetic recombination, genetic heterogeneity, and incorrect diagnosis in the proband or family member. **Genetic recombination** occurs between any pair of loci, with the frequency being proportional to the distance between them. This problem is minimized using very closely linked markers and, if possible, using markers that flank the specific gene. **Genetic heterogeneity** can be problematic for a linkage-based test if there are multiple distinct genomic loci that can cause the same phenotype, resulting in the risk that the locus tested for is not the one responsible for disease in the family. **Incorrect diagnosis** in the proband also leads to tracking the wrong gene. Linkage testing remains useful for several genetic conditions, but it has been superseded by the availability of DNA sequencing of either single gene, panel, or exome sequencing.

**CMAs** can detect CNVs in a patient's DNA (see Chapter 99). CMA provides a level of genetic resolution between that available with DNA sequencing (single nucleotide) and that available with chromosome analysis (~5 million base pairs). CMA can resolve deletions or duplications of several kilobases within one gene. In theory, this approach can detect deletion and duplication pathogenic variants that would be missed by either chromosome analysis or direct pathogenic variant testing by DNA sequencing. However, because the specific resolution and coverage of different CMA platforms can vary tremendously for different gene regions, the sensitivity for detecting deletions and duplications can vary for different diseases and laboratories. The highest resolution used is detection of a deletion or duplication at the single exon level.

**Direct DNA-based pathogenic variant testing** avoids the pitfalls of linkage testing by detecting the specific gene pathogenic variant (i.e., sequence change). The specific approach used is customized to the biology of the gene being tested. In some disorders, one or a few distinct pathogenic variants occur in all affected individuals and a specific assay for that variant could be used. This is the case in sickle cell anemia, in which the same single-base substitution occurs in everyone with the disorder. In other conditions, many possible pathogenic variants may account for the disorder in different individuals. In cystic fibrosis, for example, >1,000 distinct pathogenic variants have been found in the *CFTR* gene. Pathogenic variant analysis is challenging because no single technique can detect all possible pathogenic variants (e.g., single nucleotide variation [SNV]), small (several nucleotide) insertion-deletions (“indels”), CNV (larger deletion or duplications), complex structural variations (e.g., translocations, inversions, etc.), DNA repeat expansions (e.g., variable repeat expansions), and epigenetic alterations (e.g., changes in DNA methylation without changing the underlying DNA sequence). However, with high-throughput DNA sequencing technology, the most frequently used approach is to

**Table 98.1** Approaches for Genetic Testing

TYPE OF TESTING	RESOLUTION	ADVANTAGES	DISADVANTAGES	SAMPLE REQUIREMENTS
Linkage analysis	Depends on location of polymorphic markers near putative disease gene	Possible when specific disease-causing genetic pathogenic variant is not identifiable or found	Can give only diagnostic probability based on likelihood of genetic recombination between presumed DNA pathogenic variant and polymorphic markers	Requires multiple family members with documented Mendelian pattern of inheritance within family
Chromosome microarray (CMA)	Several hundred base pairs to several hundreds of kilobases	Able to detect small deletion or duplications within one or more genes	Can miss small deletions or insertions depending on the resolution of the array used	Single patient sample sufficient, but having sample from biological parents can help with interpretation
Direct DNA-based testing (e.g., DNA sequencing)	Single-base-pair changes	High specificity if previously described deleterious pathogenic variant is found	Can miss deletion or duplication of a segment of gene	Single patient sample sufficient, but having sample from biological parents and siblings (affected or unaffected) can help with interpretation



**Fig. 98.1** Use of linkage analysis in prenatal diagnosis of an autosomal recessive disorder. Both parents are carriers, and they have one affected son. The numbers below the symbols indicate alleles at three polymorphic loci: A, B, and C. Locus B resides within the disease gene. The affected son inherited the 1-2 chromosome from his father and the 2-2 chromosome from his mother. The fetus has inherited the same chromosome from the father but the 3-2 chromosome from the mother and therefore is most likely to be a carrier.

directly sequence DNA segments “captured” and amplified from DNA isolated from peripheral blood white blood cells. The limitation of this approach is that only amplified DNA segments are sequenced and are usually restricted to the *coding exonic* regions of a gene. Because pathogenic variants sometimes occur in the *noncoding* and *intronic* regions, failure to detect a pathogenic variant does not fully exclude the diagnosis. In addition, deleted genes or regions may not be detected.

NGS tests panels of genes that target disease symptoms (e.g., epilepsy, brain malformations, sensorineural deafness, or skeletal dysplasias) or the majority of the exome (**exome sequencing**). **Genome sequencing**, where both *coding* and *noncoding* sequences are sequenced, can provide even more information. However, clinical interpretation is limited predominantly to the coding sequences of the approximately 20,000 human genes, the “digital exome,” as it is extracted electronically from genome data. Genome sequencing, compared with exome sequencing, also has the advantage of providing improved detection of CNV, structural variation, and repeat expansions, although this is highly dependent on the bioinformatics algorithms used in interpretation.

With NGS, the challenge is the interpretation of enormous genetic variation within a single individual. Direct sequencing of tens to hundreds of genes in NGS panels offers a potentially higher sensitivity because the “depth” of read is higher without complicating high discovery rate of **variants of unknown sequences (VUS)** (Fig. 98.2). Exome and genome sequencing also offer the potential for identifying new disease-gene associations as well as the ability to detect clinical presentations caused by more than one altered gene (i.e., oligogenic phenotypes).

An important ethical consideration is the reporting of *incidental findings*, whether medically actionable or not medically actionable in a patient. For example, exome and genome sequencing may identify pathogenic variants that cause aminoglycoside-sensitive hearing loss, which would be medically actionable but unrelated to the primary indication for which the test was ordered. At the same time, the discovery of apolipoprotein E variants in a child that increase Alzheimer disease risk susceptibility would not typically be medically actionable. Therefore counseling for patients undergoing these tests is important so that only requested results are reported back to the patient. Guidelines continue to evolve for reporting of incidental findings from exome and genome sequencing by the American College of Medical Genetics and Genomics ([www.acmg.net](http://www.acmg.net)). Practice and recommendations continue to vary among international genetic organizations revealing incidental findings to patients, and many strongly advocate the engagement of the patient and family in the decision. Some groups require revealing to

the patient and/or family significant diseases (actionable) with a specific and successful treatment or prevention strategy (Table 98.2).

Genetic testing is interpreted by three factors: analytical validity, clinical validity, and clinical utility. **Analytical validity** is test accuracy: Does the test correctly detect the presence or absence of pathogenic variant? Most genetic tests have a very high analytical validity assuming human error has not occurred. Human errors are possible, and unlike most medical tests, a genetic test is unlikely to be repeated because it is assumed that the result will not change over time. Therefore human errors can go undetected for long periods of time. *In addition, variants may be reinterpreted over time as our knowledge base of disease-causing pathogenic variants and genes increases.*

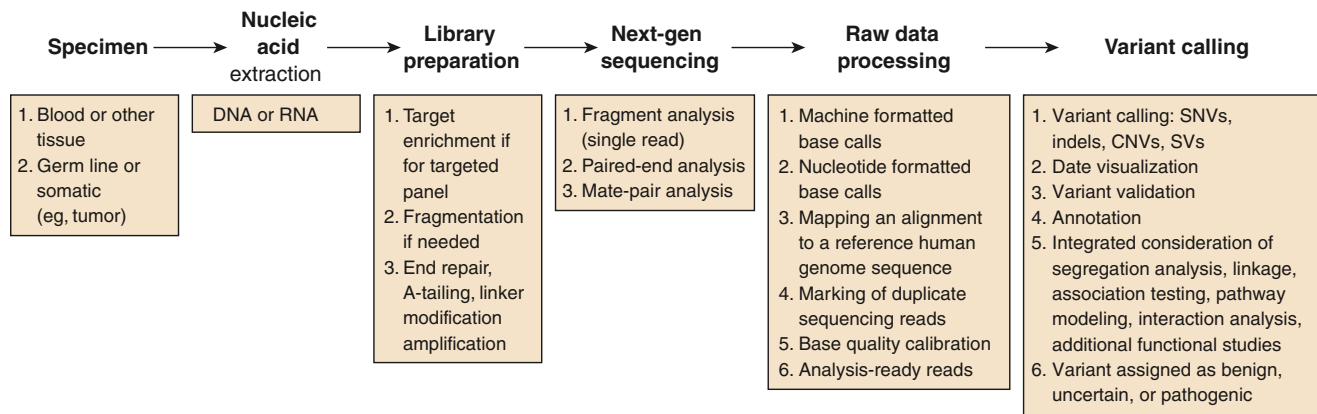
**Clinical validity** is the degree to which the test correctly predicts presence or absence of disease. False-positive and false-negative test results can occur. **False-positive results** are more likely for predictive tests than for diagnostic tests. An important contributing factor is **nonpenetrance**, where an individual with an at-risk genotype might not clinically express the condition. Another factor is the finding of a **VUS**. Detection of a base sequence variation in an affected patient does not prove that it is the cause of the patient’s disorder. Exome sequencing of an individual may identify more than 30,000 VUS and more than 3,000,000 VUS for genome sequencing. Various lines of evidence are used to establish pathogenicity. These include the absence of the variant in large populations of control individuals, finding the variant in affected individuals, demonstration or inference that the variant alters the function of the gene product, noting that the amino acid altered by the pathogenic variant is conserved in evolution, and segregation of the variant with disease in a family. For many variants, it is possible to be certain whether the variant is pathogenic or benign, but for others it might be impossible to definitively assign causality or noncontribution with 100% confidence. For these reasons, they are noted as **VUS**. *Notably, interpretation of pathogenicity for a specific VUS may change over time as our knowledge base increases, underscoring the importance of counseling and reinterpretation.*

**False-negative results** reflect an inability to detect a pathogenic variant in an affected patient. This occurs principally in disorders with genetic heterogeneity—**allelic** (different pathogenic variants occur in one causative gene) or **locus** (>1 gene can cause a disease) heterogeneity. It is often difficult to detect all possible pathogenic variants within a gene because pathogenic variants vary, both in location within the gene and in the type of variant. Direct sequencing can miss gene deletions or rearrangements (i.e., structural variants), and pathogenic variants may be found within noncoding sequences such as introns or promoter. Therefore a negative DNA test does not necessarily exclude a diagnosis.

**Clinical utility** is the degree to which the results of a test guide clinical management. For genetic testing, clinical utility includes establishing a diagnosis that obviates the need for additional workup or guiding surveillance or treatment. Test results may also be used as a basis for genetic counseling. For some disorders, genetic testing is possible, but the test results do not add to the clinical assessment. If the diagnosis and genetic implications are already clear, it might not be necessary to pursue genetic testing.

**Predictive genetic testing** involves performing a test in a person at risk for developing a genetic disorder (**presymptomatic**), usually on the basis of family history, yet who does not manifest signs or symptoms. This is usually done for disorders that display age-dependent penetrance (e.g., the likelihood of manifesting signs and symptoms increases with age, as in cancer genetic syndromes or Huntington disease).

A major caution with predictive testing is that the presence of a gene pathogenic variant does not necessarily mean that the disease will develop. Many of the disorders with age-dependent penetrance display **incomplete penetrance**. A person who inherits a pathogenic variant may never develop signs of the disorder. There is concern that a positive DNA test could result in stigmatization of the person and might not provide information that will guide medical management. Stigmatization might include psychological stress, but it could also include



**Fig. 98.2** Overview of the next-generation DNA sequencing workflow. CNV, Copy number variant; Indels, insertions and deletions; SNV, single nucleotide variant; SV, structural variant. (Adapted from Casey G, Conti D, Haile R, et al. Next generation sequencing and a new era of medicine. *Gut*. 2013;62[6]:920–932.)

**Table 98.2** Variants That Are Incidental Findings Are Assigned to One of Four Categories

Childhood onset	Medically actionable*
Childhood onset	Not medically actionable†
Adult onset	Medically actionable*
Adult onset	Not medically actionable†

\*“Medically actionable” refers to a variant in a gene in which knowledge of the particular variant will affect medical decision-making, such as initiation of a treatment or family planning.

†“Not medically actionable” refers to variants that increase the individual’s risk for a disease in which no treatment is proven to significantly change the disease natural history.

From Bick D, Dimmock D. Whole exome and whole genome sequencing. *Curr Opin Pediatr*. 2011;23:594–600.

discrimination, including denial of health, life, or disability insurance, or employment (see [Chapter 95](#)).

It is generally agreed that predictive genetic tests should be performed for children only if the results of the test will benefit the medical management during childhood; otherwise, the test should be deferred until the individual understands the risks and benefits of testing and can provide their own informed consent. Individual states offer varying degrees of protection from discrimination on the basis of genetic testing. A major milestone in the prevention of genetic discrimination was the passage of the **Genetic Information Nondiscrimination Act (GINA)** in 2008, which is a U.S. federal law that prohibits discrimination in health coverage or employment based on genetic information. *Of note, it does not* protect against refusal of life insurance.

**Predispositional genetic testing** is available with the goal of predicting risk of disease. The rationale for predispositional testing is that the results would lead to strategies aimed at risk reduction as part of a *personalized approach* to healthcare maintenance. This might include avoidance of environmental exposures that would increase risk of disease (cigarette smoking and  $\alpha_1$ -antitrypsin deficiency), medical surveillance (familial breast cancer and mammography), or in some cases, pharmacologic treatment (statins and hypercholesterolemia).

Common disorders are multifactorial in etiology, and many different genes may contribute to risk of any specific condition (see [Chapter 103](#)). Most genetic variants found to correlate with risk of a common disease add small increments of relative risk and, in most cases, too little to guide management based on a single variant.

Statistical models for predicting risk based on a collection of DNA variants has been integrated into approaches such as *polygenic risk scores*. By combining the relative risk conferred by a group of DNA variants, the goal is to quantify a larger proportion of risk for a specific disease. These predictions are confounded by the source of data

from which they are generated, and current population genetic data have limitations including lack of ethnic diversity and population stratification.

## PHARMACOGENETICS

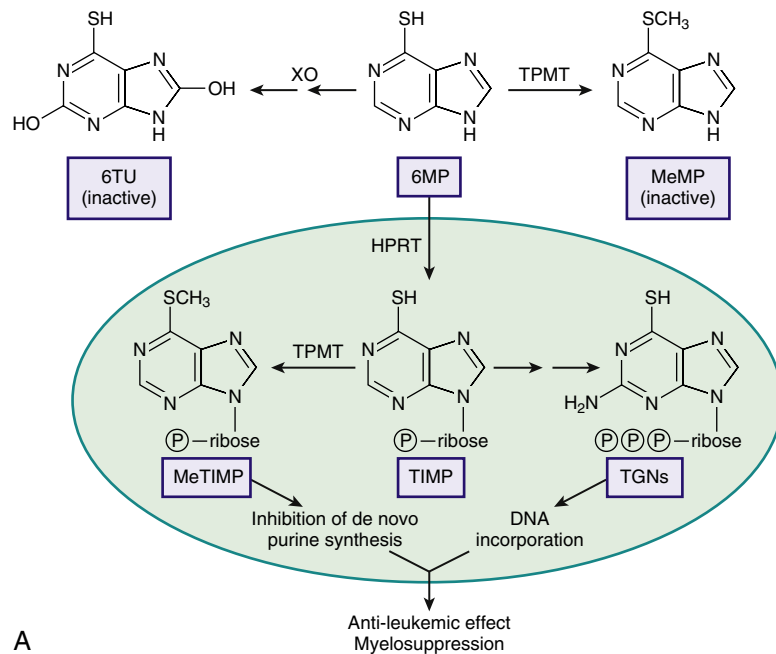
Polymorphisms in drug metabolism genes can result in distinctive patterns of drug absorption, metabolism, excretion, or effectiveness. Knowledge of individual genotypes can guide pharmacologic therapy, allowing customization drug choice and dosage to avoid toxicity and provide a therapeutic response. Well-known examples include testing for polymorphisms within the methylenetetrahydrofolate reductase (*MTHFR*) gene for susceptibility of potentially increased toxicity to methotrexate antimetabolite therapy and thiopurine S-methyltransferase (*TPMT*) to avoid adverse effects with 6-mercaptopurine therapy ([Fig. 98.3](#)).

## Pediatric Pharmacogenomics

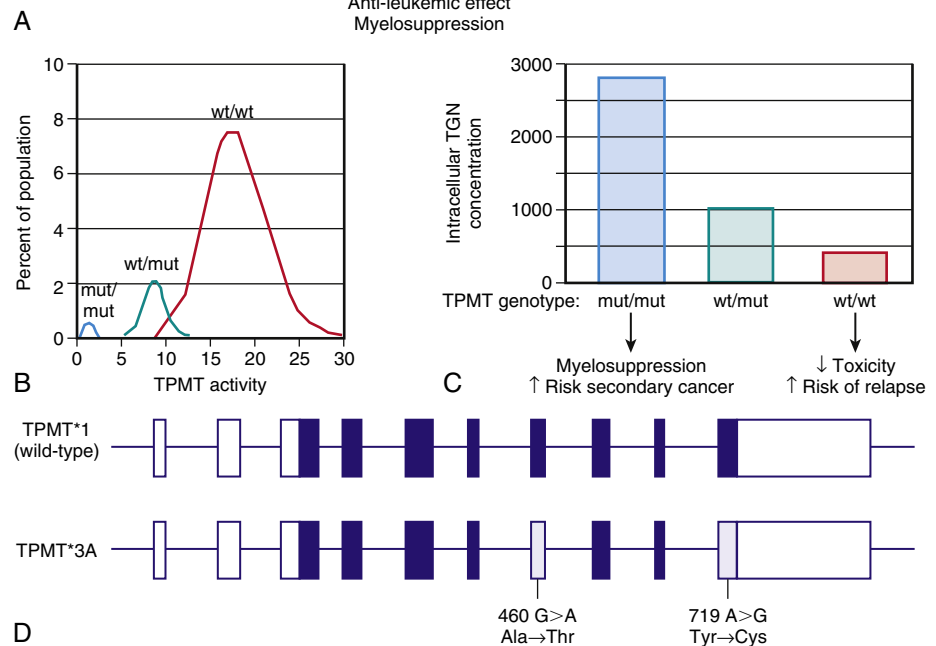
Pharmacogenomics is the study of how variants contribute to interindividual variability in drug response. The finding that drug responses can be influenced by the patient’s genetic profile offers great hope for realizing *individualized* pharmacotherapy, in which the relationship between genotype and phenotype (either disease and/or drug response) is predictive of drug response. In addition to genetic differences, environmental factors (e.g., diet, concomitant drug or toxic exposure), physiologic variables (age, sex, pregnancy), and patient adherence all contribute to variations in drug metabolism and response. Interindividual differences in children are further complicated by the changing patterns of gene expression occurring during the developmental processes from birth through adolescence. Combining these genetic and nongenetic individual-specific variables, it is expected that children will benefit from the promise of precision medicine, e.g., identifying the right drug for the right patient at the right time and dosing ([Fig. 98.4](#)).

Examples of pharmacogenomic traits include specific adverse drug reactions, such as prolonged respiratory muscle paralysis due to succinylcholine, hemolysis associated with antimalarial therapy, carbamazepine-induced Stevens-Johnson syndrome, isoniazid-induced neurotoxicity, and others ([Table 98.3](#)). The pharmacokinetic properties of a drug are determined by genes that control drug absorption, distribution, metabolism, and excretion. Drug-metabolizing enzymes and drug transporters play a particularly important role in this process. One of the better recognized clinical manifestations of pharmacogenomic variability in drug biotransformation is an increased risk of concentration-dependent toxicity caused by reduced clearance and consequent tissue drug accumulation. Equally important is the lack of efficacy caused by variations in metabolism of prodrugs that require biotransformation to be converted into a pharmacologically active form. The pharmacogenomics of drug receptors and other target proteins involved in signal transduction or disease pathogenesis are also expected to contribute to interindividual variability in drug disposition and response.



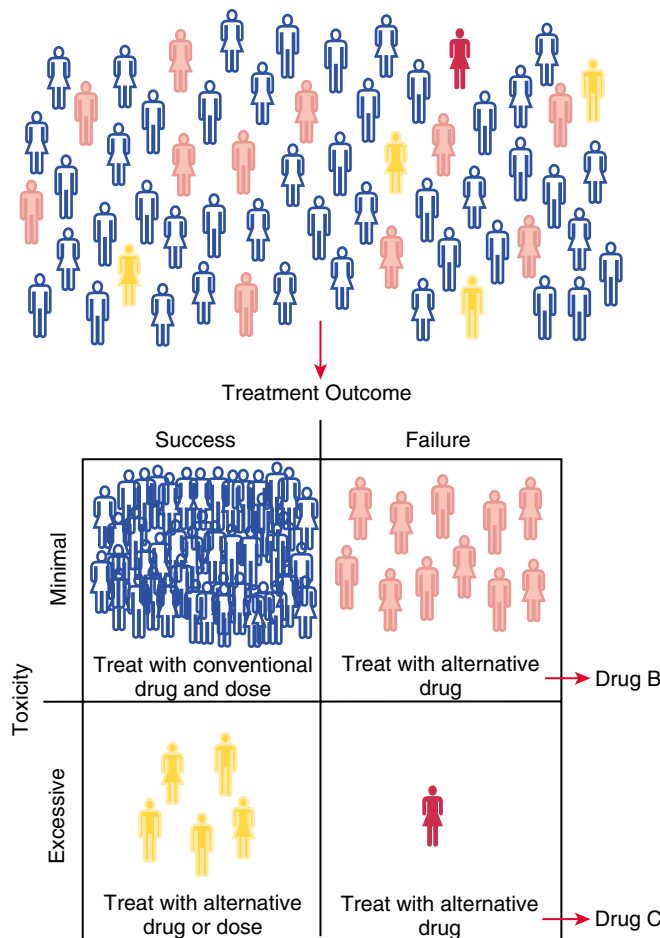


**Fig. 98.3** Thiopurine S-methyltransferase (TPMT) polymorphism. **A**, 6-Mercaptopurine (6MP) undergoes metabolism to thioguanine nucleotides (TGNs) to exert its cytotoxic effects. TPMT and xanthine oxidase reduce the amount of 6MP available for the bioactivation pathway to TGNs. TPMT can also methylate 6-thioinosine 5-monophosphate (TIMP) to generate a methylated compound capable of inhibiting de novo purine synthesis. **B**, Distribution of TPMT activity in humans. Of the population, 89% has high activity, whereas 11% has intermediate activity. Approximately 1 in 300 individuals homozygous for two loss-of-function alleles has very low activity. **C**, Correlation between the TPMT genotype and intracellular TGN concentrations. In TPMT-poor metabolizers, more 6MP is available to go down the bioactivation pathway to form TGNs; this situation is associated with an increased risk of myelosuppression. **D**, The most common variant TPMT allele is the result of two pathogenic variants that give rise to an unstable protein product that undergoes proteolytic degradation. Each box represents an exon. Non-coding sequences are shown as white boxes and colored boxes indicate coding sequences. 6TU, 6-Thiouric acid; MeMP, 6-methylmercaptopurine; HPRT, 6-thiomethylinosine 5-monophosphate; MeTIMP, hypoxanthine-guanine phosphoribosyl transferase; wt, wild type; mut, mutant; Ala, alanine; Thr, threonine; Tyr, tyrosine; Cys, cysteine. (Modified from Relling MV, Dervieux T. *Pharmacogenetics and cancer therapy*. *Nat Rev Cancer*. 2001;11:99–108.)



Individuals are classified as “fast,” “rapid,” or “extensive” metabolizers at one end and “slow” or “poor” metabolizers at the other end of the continuum. For biotransformation, fetuses and newborns may be phenotypically “slow” or “poor” metabolizers for certain drug-metabolizing pathways because of their stage of development, and they may acquire a phenotype consistent with their genotype at some point later in the developmental process. Moreover, not all infants acquire drug metabolism activity at the same rate, and there is inter-individual variability in the trajectory (i.e., rate and extent) of drug biotransformation capacity (Fig. 98.5). The primary organ responsible for drug metabolism is the liver, although the kidney, intestine, lung, adrenals, blood (phosphatases, esterases), and skin can also biotransform certain compounds. Drug biotransformation is characterized by three important features: (1) broad substrate specificity, in which a single isozyme may metabolize a large variety of chemically diverse compounds; (2) many different enzymes may be involved in the biotransformation of a single drug (enzyme multiplicity); and (3) a given drug may undergo several different types of reactions. Drug biotransformation reactions are classified into phase I reactions that

introduce or reveal (through oxidation, reduction, or hydrolysis) a functional group within the substrate drug molecule that serves as a site for phase II reactions. These reactions involve conjugation with endogenous substrates (such as acetate, glucuronic acid, glutathione, glycine, and sulfate), making the compound more water soluble to be excreted in urine. A supergene family with at least 16 primary cytochrome P450 (CYP) enzymes are quantitatively the most important phase I enzymes and catalyze the metabolism of many lipophilic endogenous (steroids, fatty acids, fat-soluble vitamins, prostaglandins, leukotrienes, thromboxanes) and exogenous compounds, including a multitude of drugs and environment toxins. The specific CYP isoforms responsible for the majority of human drug metabolism are CYP1A2, CYP2C9, CYP2C19, CYP2D6, CYP2E1, and CYP3A4. These enzymes are the products of genes that in some cases are polymorphically expressed, with allelic variants producing enzymes generally resulting in either no or reduced catalytic activity. At birth the activities of drug-oxidizing enzymes in the liver are reduced, which results in slow clearance (and prolonged elimination) of several substrate drugs (e.g., phenytoin, caffeine, diazepam). Phase



**Fig. 98.4** The promise of genomic medicine to human health and disease. The goal of personalized medicine is to identify subgroups of patients who will respond favorably to a given drug with minimum side effects, as well as those who will not respond or who will show toxicity with standard doses. A further benefit of pharmacogenomics is to select the most appropriate alternative drug for patients who cannot be treated successfully with conventional drugs and doses. (Adapted from Yaffe SJ, Aranda JV. *Neonatal and Pediatric Pharmacology*, 3rd ed. Philadelphia: Lippincott Williams & Wilkins; 2004.)

If enzymes include arylamine *N*-acetyltransferases (NAT1, NAT2), uridine diphospho-glucuronosyltransferases (UGTs), epoxide hydrolyase, glutathione *S*-transferases (GSTs), sulfotransferases (SULTs), and methyltransferases (catechol *O*-methyltransferase, thiopurine *S*-methyltransferase, several *N*-methyltransferases). Phase II enzyme activity is decreased in the newborn and increases into childhood. Conjugation of compounds metabolized by isoforms of UGT (e.g., morphine, bilirubin, chloramphenicol) is reduced at birth but can exceed adult values by 3–4 years of age.

Membrane transporters are involved in drug disposition and actively transport substrate drugs between organs and tissues. They include organic anion transporters (OATs), organic anion-transporting polypeptides (OATPs), organic cation transporters (OCTs), and the adenosine triphosphate-binding cassette (ABC) transporters, such as P-glycoprotein and the multidrug-resistant proteins. Drug transporters are expressed at numerous barriers, such as intestinal epithelial cells, hepatocytes, renal tubular cells, and the blood-brain barrier (Fig. 98.6). Transporters are often determinants of drug resistance, and many drugs work by affecting the function of transporters. Polymorphisms in the genes encoding these transporters might affect drug absorption, distribution, metabolism, and excretion.

## 98.1 Genetic Counseling

Brendan Lee and Pilar L. Magoulas

Genetic counseling is a communication process in which the genetic contribution to health, specific risks of transmission of a trait, and options to manage the condition are explained to individuals and their family members (Table 98.4). Genetic counselors are specialized healthcare providers trained in the psychosocial aspects of counseling and the science of medical genetics who may serve as members of medical teams in many different specialties. The genetic counselor is expected to present information in a neutral, nondirective manner while providing resources and psychosocial support to the individual and family to cope with decisions that are made (see Table 98.4).

In the prenatal setting, a common indication for genetic counseling is to assess risk of occurrence or recurrence of having a child with a genetic condition and to discuss management or treatment options that might be available before, during, or after the pregnancy, such as preimplantation genetic testing, noninvasive prenatal screening, prenatal diagnosis or fetal intervention, and perinatal management. In pediatric and adult genetics practices, the goals of genetic counseling are to help establish a diagnosis in an individual, provide longitudinal care and psychosocial support to the family, and discuss the genetic basis and inheritance of the condition as it relates to immediate and distant family members.

The genetic counseling role has expanded, particularly with advances in understanding the genetics of adult-onset or common and rare disease therapeutics. In the former context, genetic counseling has a major role in risk assessment for cancer, especially breast, ovarian, or colon cancer, for which well-defined risk models and genetic tests are available to assess risk to an individual. In the latter, the genetic counselor may discuss developments in rare disease therapeutics and make appropriate referral for medical therapies.

There are several situations in which genetic counseling plays a particularly important role. The first situation is the **prenatal diagnosis** of a congenital anomaly or genetic disease. The need for information is urgent because a family must often make time-sensitive decisions about treatment and management options, such as fetal intervention or continuation of a pregnancy in the context of fetal anomalies. Risks to the mother must also be considered. The second type of situation occurs when a child is born with a life-threatening **congenital anomaly** or suspected **genetic disease**. Decisions must be made immediately on how much support should be provided to the child and whether certain types of therapy should be attempted. The third situation arises when there are concerns about a **genetic condition** affecting one later in life. This may occur in an adolescent or young adult with a family history of an adult-onset genetic disorder (e.g., Huntington disease, hereditary breast/ovarian cancer), in an individual with a suspected yet undiagnosed genetic condition, or if a couple with a personal or family history of a genetic condition (or a carrier) is planning a family. In these situations, it is often necessary to have several meetings with a family to discuss possible testing, screening, and management options. Urgency is not as much of an issue as being sure that they have as much information and as many options as are available. Last, with the advent of genomic testing in all areas of clinical care, **pretest genetic counseling** before testing is essential to provide individuals with accurate information regarding the types of results they may receive. During this process, individuals are also given the option of what type of results they want reported back to them, such as medically actionable results unrelated to the primary indication for testing and incidental findings.

### GENETIC COUNSELING ELEMENTS

Components of a genetic counseling session and providing accurate information to families requires the following:

- Taking a targeted family history and constructing a pedigree that diagrams the patient's relatives (including miscarriages, abortions, stillbirths, deceased persons) with their sex, age, ethnicity, and state of health, up to and including third-degree relatives.

**Table 98.3** Examples of Effects of Gene Polymorphisms on Drug Response

GENE	ENZYME/TARGET	DRUG	CLINICAL RESPONSE
<i>BCHE</i>	Butyrylcholinesterase	Succinylcholine	Prolonged paralysis
<i>CYP2C9</i>	Cytochrome P450 2C9	Warfarin	Individuals having $\geq 1$ reduced function alleles require lower doses of warfarin for optimal anticoagulation, especially initial anticoagulant control.
<i>CYP2C19</i>	Cytochrome P450 2C19	Clopidogrel	Individuals having $\geq 1$ loss-of-function alleles have reduced capacity to form pharmacologically active metabolite of clopidogrel and reduced antiplatelet effect.
<i>CYP2D6</i>	Cytochrome P450 2D6	Codeine	Poor metabolizers (individuals with two loss-of-function alleles) do not metabolize codeine to morphine and thus experience no analgesic effect. Ultrarapid metabolizers (individuals with $\geq 3$ functional alleles) may experience morphine toxicity.
<i>G6PD</i>	Glucose-6-phosphate dehydrogenase	Primaquine (others)	Hemolysis
<i>HLA-A*3101</i>	Human leukocyte antigen A31	Carbamazepine	Carriers of <i>HLA-A*3101</i> allele have increased risk of SJS and TEN from carbamazepine.
<i>HLA-B*1502</i>	Human leukocyte antigen B15	Allopurinol	Han Chinese carriers of <i>HLA-B*1502</i> allele have increased risk of SJS and TEN from carbamazepine.
<i>HLA-B*5701</i>	Human leukocyte antigen B57	Abacavir Flucloxacillin	Carriers of <i>HLA-B*5701</i> allele have increased risk of hypersensitivity reactions to abacavir- and flucloxacillin-induced liver injury.
<i>HLA-B*5801</i>	Human leukocyte antigen B58	Allopurinol	Carriers of <i>HLA-B*5801</i> allele have increased risk of severe cutaneous adverse reactions to allopurinol, including hypersensitivity reactions, SJS, and TEN.
<i>NAT2</i>	N-Acetyltransferase 2	Isoniazid, hydralazine	Individuals homozygous for “slow acetylation” polymorphisms are more susceptible to isoniazid toxicity, or hydralazine-induced systemic lupus erythematosus.
<i>SLCO1B1</i>	Organic anion-transporting protein (OATP) 1B1	Simvastatin	Carriers of the <i>SLCO1B1*5</i> allele are at increased risk for musculoskeletal side effects from simvastatin.
<i>TPMT</i>	Thiopurine S-methyltransferase	Azathioprine 6-Mercaptopurine	Individuals homozygous for an inactivating pathogenic variant have severe toxicity if treated with standard doses of azathioprine or 6-mercaptopurine; rapid metabolism causes undertreatment.
<i>UGT1A1</i>	Uridine diphospho-glucuronosyltransferase 1A1	Irinotecan	<i>UGT1A1*28</i> allele is associated with decreased glucuronidation of SN-38, the active metabolite of irinotecan, and increased risk of neutropenia.
<i>VKORC1</i>	Vitamin K oxidoreductase complex 1	Warfarin	Individuals with a haplotype associated with reduced expression of <i>VKORC1</i> protein (therapeutic target of warfarin) require lower doses of the drug for stable anticoagulation.

SJS, Stevens-Johnson syndrome; TEN, toxic epidermal necrolysis.

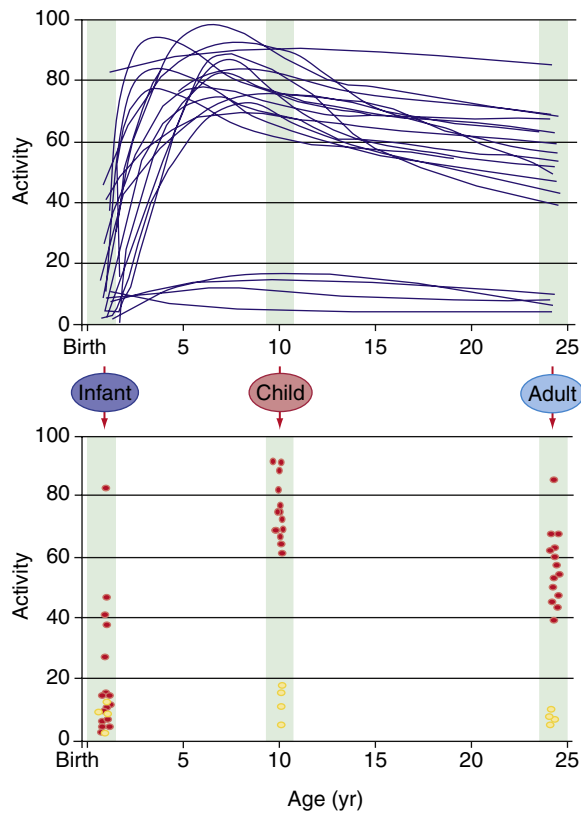
- Gathering information from hospital records about the affected individual and, in some cases, about other family members.
- Documenting prenatal, pregnancy, and delivery histories.
- Reviewing the latest available medical, laboratory, and genetic information concerning the disorder.
- Reviewing a careful physical examination of the affected individual (photographs, measurements) and of apparently unaffected individuals in the family (typically performed by a physician rather than a genetic counselor).
- Reviewing genetic testing and screening options.
- Establishing or confirming the diagnosis by the diagnostic tests available.
- Providing psychosocial support to the individual and family throughout the diagnostic process.
- Giving the family information about support groups and local and national resources.
- Providing new information to the family as it becomes available (a mechanism for updating needs to be established).

Genetic counseling sessions often include anticipatory guidance regarding the occurrence or risk of occurrence of a specific condition, knowledge of the diagnosis of the particular condition, natural history of the condition, genetic aspects of the condition, risk of recurrence, prenatal diagnosis and reproductive options, therapies and referrals, and provision of support resources.

### The Diagnostic Process

If a specific diagnosis is made and confirmed, this should be discussed with the family and information provided in writing. Often, however, the disorder fits into a spectrum (e.g., one of many types of arthrogyrosis) or the diagnosis is clinical rather than confirmed with molecular testing. In these situations, the family needs to understand the limits of the diagnostic process and present knowledge, and that additional research will probably lead to better information in the future.

Although it is not always possible to make an exact diagnosis, having a diagnosis *as accurate as possible* is important. Estimates of recurrence risk for various family members depend on an accurate diagnosis that

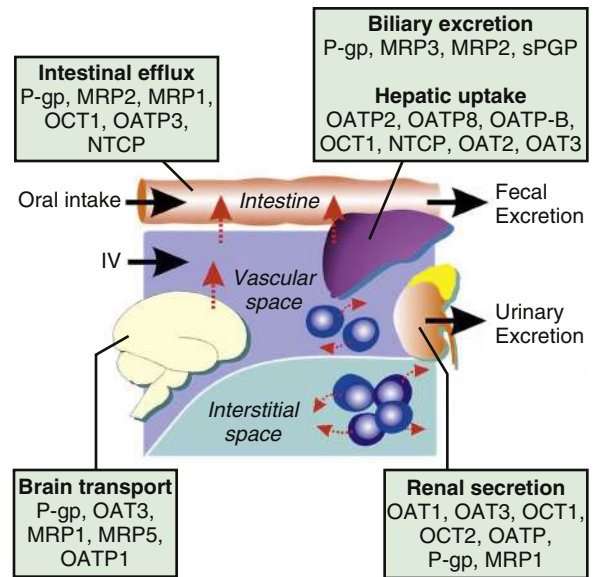


**Fig. 98.5** “Developmental” phenotypes. Variability in developmental changes in gene expression and functional enzyme activity are superimposed on pharmacogenetic determinants. **Top**, Developmental profile of a theoretical drug-metabolizing enzyme over a 25-year span in 20 individuals. **Bottom**, At maturity (adults), allelic variation within the coding region of the gene gives rise to two distinct phenotypes: high activity in 92% of the population (“extensive metabolizers”; red circles) and low activity in 8% of the population (“poor metabolizers”; yellow circles). However, there is also interindividual variability in the rate at which functional activity is acquired after birth. For example, the two phenotypes may not be readily distinguishable in newborn infants. Furthermore, there may be discrete periods during childhood in which the genotype-phenotype relationship may differ from that observed in adults (e.g., developmental stages at which enzyme activity appears to be greater in children than in adults). (Adapted from Leeder JS. *Translating pharmacogenetics and pharmacogenomics into drug development for clinical pediatric and beyond*. *Drug Discov Today*. 2004;9:567–573.)

considers the likelihood that a particular finding is isolated, associated with a syndrome, or nonsyndromic (e.g., isolated cleft lip and palate). When a specific diagnosis cannot be made (as in many cases of multiple congenital anomalies), the various possibilities in the differential diagnosis should be discussed with the family and empirical information provided. If available, specific diagnostic tests should be discussed. Often, empirical recurrence risks can be given even without a specific laboratory-based diagnosis. At the same time, even negative laboratory testing can further modify this risk.

### Natural History of the Condition

It is important to discuss the natural history of the specific genetic disorder in the family. Affected persons and their families have questions regarding the prognosis and potential management or therapy that can be answered only with knowledge of the natural history. If there are other possible diagnoses, their natural history may also be discussed. If the disorder is associated with a spectrum of clinical outcomes or complications, the range of possible outcomes and variability of the condition, as well as treatment and referral to the appropriate specialist, should be addressed.



**Fig. 98.6** Schematic diagram of important transport proteins and their known locations in humans. Spheres correspond to drug molecules. (From *American Pharmacists Association*. Ritschel WA, Kearns GL, eds. *Handbook of Basic Pharmacokinetics Including Clinical Applications*, 7th ed. Washington, DC: American Pharmacists Association, 2009. p 45.)

### Genetic Aspects of the Condition and Recurrence Risk

The genetic aspects and risk of recurrence are important because all family members should be informed of their reproductive choices. The genetic basis of the disorder can be explained with visual aids (e.g., diagrams of chromosomes and inheritance patterns). It is important to provide accurate occurrence and recurrence risks for various members of the family, including unaffected individuals. If a definite diagnosis cannot be made, it is necessary to use empirical recurrence risks. Genetic counseling gives patients the necessary information to understand the various options and to make their own informed decisions regarding pregnancy, adoption, assistive reproductive technologies, prenatal diagnosis, screening, carrier detection, or termination of pregnancy. It may be necessary to have more than one counseling session. Even if a specific molecular diagnosis has been made and a well-defined inheritance pattern has been described for the condition, it is important to recognize that the principles of incomplete penetrance, variable expressivity, and germline/somatic mosaicism can contribute uncertainty to the recurrence risk and severity of a potentially affected pregnancy conception or child.

### Prenatal Diagnosis and Prevention

Many different methods of prenatal screening and diagnosis are available, depending on the specific genetic disorder (see [Chapter 117](#)). The use of ultrasonography allows prenatal screening of anatomic abnormalities such as congenital heart defects. Amniocentesis and chorionic villus sampling are used to obtain fetal tissue for analysis of chromosomal abnormalities, biochemical disorders, and DNA studies. Maternal blood or serum sampling is used for some types of screening, including noninvasive prenatal screening by direct analysis of cell-free fetal DNA found in maternal blood, which is used for screening of conditions such as trisomy 21 and other aneuploidies. In addition, this source of cell-free fetal DNA has also been used clinically for DNA sequencing for selected dominant de novo conditions in the fetus that may occur with increased frequency with increasing paternal age. Current tests of fetal DNA from maternal blood should be considered screening tests, and invasive testing like amniocentesis or chorionic villus sampling should be considered for confirmatory diagnostic testing.



**Table 98.4** Indications for Genetic Counseling

Advanced parental age
• Maternal age $\geq 35$ years
• Paternal age $\geq 40$ years
Previous child with or family history of:
• Congenital abnormality
• Dysmorphology
• Intellectual disability
• Isolated birth defect
• Metabolic disorder
• Chromosome abnormality
• Single-gene disorder
Adult-onset genetic disease (presymptomatic testing)
• Cancer
• Huntington disease
Pharmacogenomics
Consanguinity
Teratogen exposure (occupational, abuse)
Repeated pregnancy loss or infertility
Pregnancy screening abnormality
• Maternal serum $\alpha$ -fetoprotein
Maternal first-trimester screen
• Maternal triple or quad screen or variant of this test
• Fetal ultrasonography
Noninvasive prenatal testing (NIPT)
• Fetal karyotype
Heterozygote screening based on ethnic risk
• Sickle cell anemia
• Tay-Sachs, Canavan, and Gaucher diseases
• Thalassemias
Universal carrier screening panels
Follow-up to abnormal neonatal genetic testing
Prior to whole genome or exome sequencing
Prior to preimplantation genetic testing

### Therapies and Referral

Some genetic disorders require the care of multiple specialists. Many genetic conditions have diagnosis and management guidelines to aid in the treatment and management of these complex patients. Prevention of known complications is a priority, so close follow-up with the necessary specialists involved in the child's care is essential to identify any potentially concerning issues early. The psychologic adjustment of the family might also require specific intervention. Some challenges may involve when to discuss the diagnosis of a chronic disease with the patient, siblings, and other family members or friends. The decision to do so should always involve the parents and an assessment of the maturity and capacity of the child or adolescent.

Alternative medicines or nontraditional therapies are often brought to attention by parents after exhaustive internet searches. Such treatments should not necessarily be dismissed since the physician and genetic counselor should serve as an important resource for helping parents navigate the maze of nonstandard treatments. Instead, the relative merits of treatments should be framed in the context of cost and benefit, scientific rationale, evidence from controlled and observational studies, the placebo effect, safety of the treatment, and the gaps in our own scientific knowledge base.

### Support Groups

A large number of community and online lay disease-specific support groups have been formed to provide information and to fund research on specific genetic and nongenetic conditions. An important part of genetic counseling is to give information about these groups to patients and to suggest a contact person for the families. Many groups have established websites and social media platforms with very helpful information. With the rise of social media and its ability to connect

families with rare syndromes from around the world, it is important to stress to families that their individual disease course will be unique and significant biases of reporting occur on such platforms. This should be balanced by the benefit of sharing potential important natural history elements of the underlying rare disease.

### Follow-Up

Families should be encouraged to continue to ask questions and keep up with new information about the specific disorder. New developments often influence the diagnosis and therapy of specific genetic disorders.

### Nondirective Counseling

Genetic counseling is usually nondirective; choices about reproduction are left to the family to decide what is right for them. The role of the counselor (physician, genetic counselor, nurse, medical geneticist) is to provide information in understandable terms and outline the range of options available.

## 98.2 Principles of Management and Treatment of Genetic Disorders

Brendan Lee and Nicola Brunetti-Pierri

### TREATMENT OF GENETIC DISEASES

Genetic conditions are often chronic disorders. Some are amenable to curative therapies, although there has been a rapid increase in the number of treatable disorders. Based on ongoing preclinical and clinical investigations, new therapies for a growing number of diseases are expected to become available in the near future. Surgical management is available for many conditions that are associated with congenital anomalies or predisposition to tumors. All patients and families should be provided information about the disorder, genetic counseling, anticipatory guidance, and appropriate medical surveillance.

Resources for patients include the National Organization of Rare Disorders ([www.rarediseases.org](http://www.rarediseases.org)), the Genetic Alliance ([www.geneticalliance.org](http://www.geneticalliance.org)), the National Library of Medicine ([www.nlm.nih.gov/medlineplus/geneticdisorders.html](http://www.nlm.nih.gov/medlineplus/geneticdisorders.html)), and a large number of disease-specific websites. A current listing of federally and privately funded clinical trials, including many for genetic diseases, is available at [www.ClinicalTrials.gov](http://www.ClinicalTrials.gov).

Specific medical therapies for genetic disorders can be classified into **physiologic** and **replacement** therapies. Another approach to *correct protein misfolding* induced by missense pathogenic variants is through use of small molecules that specifically bind to mutant proteins, stabilizing their conformation, thereby preventing early degradation, and allowing proper cellular trafficking and localization. This strategy has found successful applications for therapy of cystic fibrosis caused by specific *CFTR* pathogenic variants, including the F508del (see Chapter 454).

### PHYSIOLOGIC THERAPIES

Physiologic therapies attempt to ameliorate the phenotype of a genetic disorder by modifying the physiology of the affected individual. The underlying defect itself is not altered by treatment. Physiologic therapies are used in the treatment of **inborn errors of metabolism** (see Chapter 104). These include dietary manipulations, such as reducing phenylalanine intake by persons with phenylketonuria, coenzyme supplementation for some patients with methylmalonic acidemia and mitochondrial diseases, stimulation of alternative pathways to excrete ammonia for those with urea cycle disorders, phototherapy to increase excretion of neurotoxic unconjugated bilirubin in Crigler-Najjar syndrome, bisphosphonate treatment for those with osteogenesis imperfecta to reduce bone fractures, and avoiding cigarette smoking by persons with  $\alpha_1$ -antitrypsin deficiency or specific foods and drugs by persons with glucose-6-phosphate dehydrogenase deficiency or acute intermittent porphyria. Physiologic treatments can be highly effective, but they usually need to be maintained for a lifetime because they do not affect the underlying genetic disorder. Many of these treatments are most effective early in life

before irreversible damage has occurred. This is the rationale for comprehensive newborn screening for inborn errors of metabolism.

Many physiologic therapies use small-molecule pharmaceuticals (e.g., to remove ammonia in those with urea cycle disorders). **Pharmacologic treatments** directly target a defective cellular pathway that is altered by an abnormal or a missing gene product. One approach is the inhibition of an enzyme reaction that is upstream of the deficient enzyme to prevent accumulation of the toxic metabolites, such as the nitisinone (NTBC) for therapy of tyrosinemia type I. A similar approach focuses on partially reducing the synthesis of the substrate of the abnormal enzyme or its precursors in lysosomal storage disorders (see Chapter 106.4). Other examples include targeting the FGFR3 signaling pathway by the C-type natriuretic peptide in achondroplasia, FGF23 by the monoclonal antibody burosumab in X-linked hypophosphatemia, or the angiopoietin-like protein 3 (ANGPTL3) by the monoclonal antibody evinacumab in homozygous familial hypercholesterolemia.

## REPLACEMENT THERAPIES

Replacement therapies include replacement of a missing metabolite, an enzyme, an organ, or even a specific gene.

### Enzyme Replacement

Enzyme replacement therapy is a component of the treatment of cystic fibrosis to manage intestinal malabsorption. Pancreatic enzymes are easily administered orally, because they must be delivered to the gastrointestinal tract. Recombinant alkaline phosphatase coupled to a bone-targeting motif is available for intravenous therapy of hypophosphatasia, a skeletal disorder caused by alkaline-phosphatase deficiency.

Enzyme replacement strategies are effective for several lysosomal storage disorders. Enzymes are targeted for the lysosome by modification with mannose-6-phosphate, which binds to a specific receptor. This receptor is also present on the cell surface, so lysosomal enzymes with exposed mannose-6-phosphate residues can be infused into the blood and are taken into cells and delivered to lysosomes. Enzyme replacement therapies are available for Gaucher disease and Fabry disease, most of the mucopolysaccharidoses (MPS I, II, IVA, VI, VII), acid lipase deficiency,  $\alpha$ -mannosidosis, neuronal ceroid lipofuscinosis late infantile (CLN2), and Pompe disease, and are being tested for MPS IIIA and IIIB, metachromatic leukodystrophy, and Niemann-Pick disease type B. Other examples include enzyme replacement therapy with pegylated recombinant phenylalanine ammonia lyase for phenylketonuria that is effective at reducing blood phenylalanine concentrations in most patients, such that most of them can come off a phenylalanine-restricted diet.

One complication of enzyme replacement therapy is antibody response to the infused recombinant enzyme. The magnitude of this response is not always predictable and varies depending on the enzyme preparation and the disease. In most cases, the patient's antibody response does not affect the treatment's efficacy (e.g., Gaucher disease), but in other situations it may be a significant hurdle (e.g., Pompe disease and phenylketonuria).

### Transplantation

Cell transplantation and organ transplantation are potentially effective approaches to replacement of a defective gene. Aside from transplantation to replace damaged tissues, transplantation of stem cells, liver, or bone marrow is also used for several diseases, mainly inborn errors of metabolism, and hematologic or immunologic disorders. A successful transplant can be essentially curative, although there may be significant risks and side effects (see Chapters 177-181). Cell and tissue transplantation is effective in many clinical scenarios, but there is always short-term morbidity, often associated with either surgical (liver) or preparative (bone marrow) regimens, and long-term morbidity related to chronic immunosuppression and graft failure. Bone marrow transplantation is the best example of stem cell therapy, but much effort also is focused on identifying, characterizing, expanding, and using other tissue stem cells for regenerative therapies. In contrast to transplantation from a healthy donor, the infused cells are the patient's own cells in ex vivo gene therapy of hematopoietic stem cells. Therefore, although it requires preparative

myeloablation akin to regular bone marrow transplantation from healthy donors, engraftment of genetically modified hematopoietic stem cells is devoid of risks of rejection or graft-versus-host disease. Increasingly, this approach is combined with gene therapy after genetic correction of autologous stem cells.

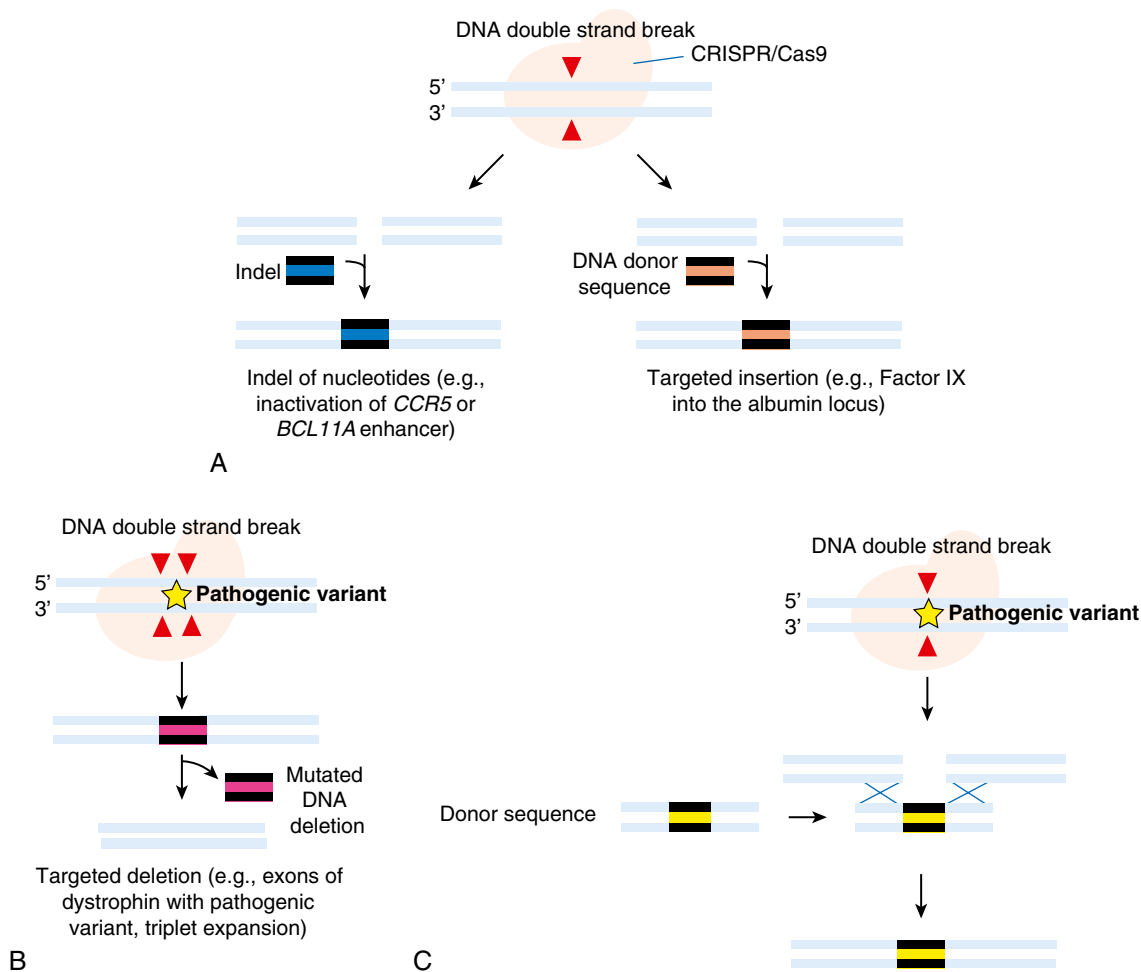
### Gene Therapy

Another approach focuses on replacing or correcting a defective gene (**gene therapy**). In theory, if one can target the specific tissue that has a deficiency in the gene or gene product, this can offer a less invasive means of achieving a cure for a genetic disorder compared to transplantations. Ultimately, gene therapy depends on the unique interaction of the disease pathophysiology, which is specific to the patient, and the gene delivery vehicle.

Gene-transfer vehicles include viral and nonviral vectors administered through ex vivo or in vivo approaches. In ex vivo approaches the patient's cells are removed and after gene correction or replacement are infused into the patient. An example of this is the US Food and Drug Administration (FDA)-approved chimeric antigen receptor (CAR) T-cell therapy for lymphomas and leukemias. In the in vivo approaches the gene therapy vector is directly injected into the body by either systemic (e.g., intravenous) or localized (e.g., intracerebral, intraocular) injections. Most human clinical trials have used viral vectors because of their efficiency of gene delivery to tissues. In some diseases, such as X-linked and adenosine deaminase-deficient severe combined immunodeficiency, chronic granulomatous disease, and Wiskott-Aldrich syndrome, clinical gene therapy is a viable and effective option. Ex vivo gene transfer of hematopoietic stem cells can be considered at least as effective to allogeneic hematopoietic stem cell transplantation in presymptomatic patients with X-linked adrenoleukodystrophy, metachromatic leukodystrophy and Hurler syndrome.

In vivo gene therapy is also promising for Leber congenital amaurosis by intraocular delivery, and hemophilias and several inborn errors of liver metabolism by systemic intravenous injection. In vivo gene therapy is FDA approved for treatment of a specific RPE65-deficient form of retinitis pigmentosa using adeno-associated virus (AAV)-mediated expression of the normal RPE65 gene via subretinal injections. In vivo AAV-mediated gene therapy is also an approved treatment that has significantly changed the early course of the disease and improved motor function in children with spinal muscular atrophy (SMA) (see Chapter 652.2). Although patients with SMA typically present with muscle atrophy, respiratory failure, and die before 2 years of age, treated patients have remained healthy and attained motor milestones that are typically not achieved in any of the untreated patients. Similar efficacy has also been achieved by intrathecal delivery of antisense oligonucleotides (ASOs) correcting SMN2 splicing. Brain-directed gene therapy is available for aromatic L-amino acid decarboxylase (AADC) deficiency by intracerebral injections of an AAV-based vector. Systemic intravenous AAV-based gene therapy vectors have been approved for both hemophilia A and B.

**Gene editing** with *direct correction* of a disease-causing pathogenic variant is another possible approach to genetic therapy. Various nucleases with specific DNA-recognition sequences are available for genome editing; they include zinc finger nucleases (ZFNs), transcription activator–like effector nucleases (TALENs), and clustered regularly interspaced short palindromic repeat (CRISPR)/CRISPR-associated nine (Cas9). They all permit permanent gene modification of genes in cells. This is achieved by DNA site-specific double-strand breaks (DSBs) induced by the endonuclease and a template encompassing the wild-type sequence to be used as a substrate for repair by **homology-directed repair (HDR)**. Following site-specific DSB, DNA repair is mediated by either non-homologous end joining (NHEJ) or HDR that repairs DNA in the presence of a donor sequence (Fig. 98.7A and B). NHEJ repairs the DSB by joining the two ends of the DSB, often introducing small insertions or deletions (indels) at the DSB site that generally inactivate gene function (see Fig. 98.7A). Compared with NHEJ, HDR is less efficient and requires a donor DNA template (see Fig. 98.7C). The wild-type copy of the mutated gene can be integrated into the endogenous locus or into “safe harbors” that allow high expression levels of the therapeutic gene (see Fig. 98.7A). Based on



**Fig. 98.7** A, Double-strand breaks can be repaired by nonhomologous end-joining (NHEJ) repair mechanisms, giving rise to small insertions and deletions (Indel) that can disrupt gene expression (blue). B, Two double-strand breaks can also be corrected by NHEJ and can eliminate the DNA carrying the pathogenic variant (pink) located between the two breaks. C, Double-strand breaks can be repaired by homology-directed repair mechanisms in the presence of a donor template allowing the incorporation of a donor sequence (yellow) that correct the mutated gene. CRISPR/Cas9, Clustered regularly interspaced short palindromic repeat/CRISPR-associated nine (Cas9).

these features, genome editing has the potential to overcome several limitations of gene replacement therapy. First, genotoxicity due to ectopic activation of nearby protooncogenes or knockout of tumor suppressor genes does not occur with on-target editing. Second, genome editing allows physiologic regulation of the expression of the corrected gene in contrast to gene replacement therapy. Third, gene editing is maintained in proliferating cells, and it overcomes the dilution effect due to cell division that is observed with gene replacement therapy by nonintegrating vectors such as AAV vectors.

Genome editing tools have corrected the gene defect in several preclinical murine models and are in clinical trials. ZFNs have been used *ex vivo* to disrupt *CCR5* expression in human T cells to induce resistance to HIV infection. ZFNs and CRISPR/Cas9 are being used to boost fetal hemoglobin in  $\beta$ -thalassemia and sickle cell disease by disrupting the enhancer of the *BCL11A* gene, which suppresses fetal hemoglobin production. Moreover, ZFN-mediated targeted introduction of therapeutic genes downstream of the highly active albumin promoter in hepatocytes is currently under clinical investigation for several diseases.

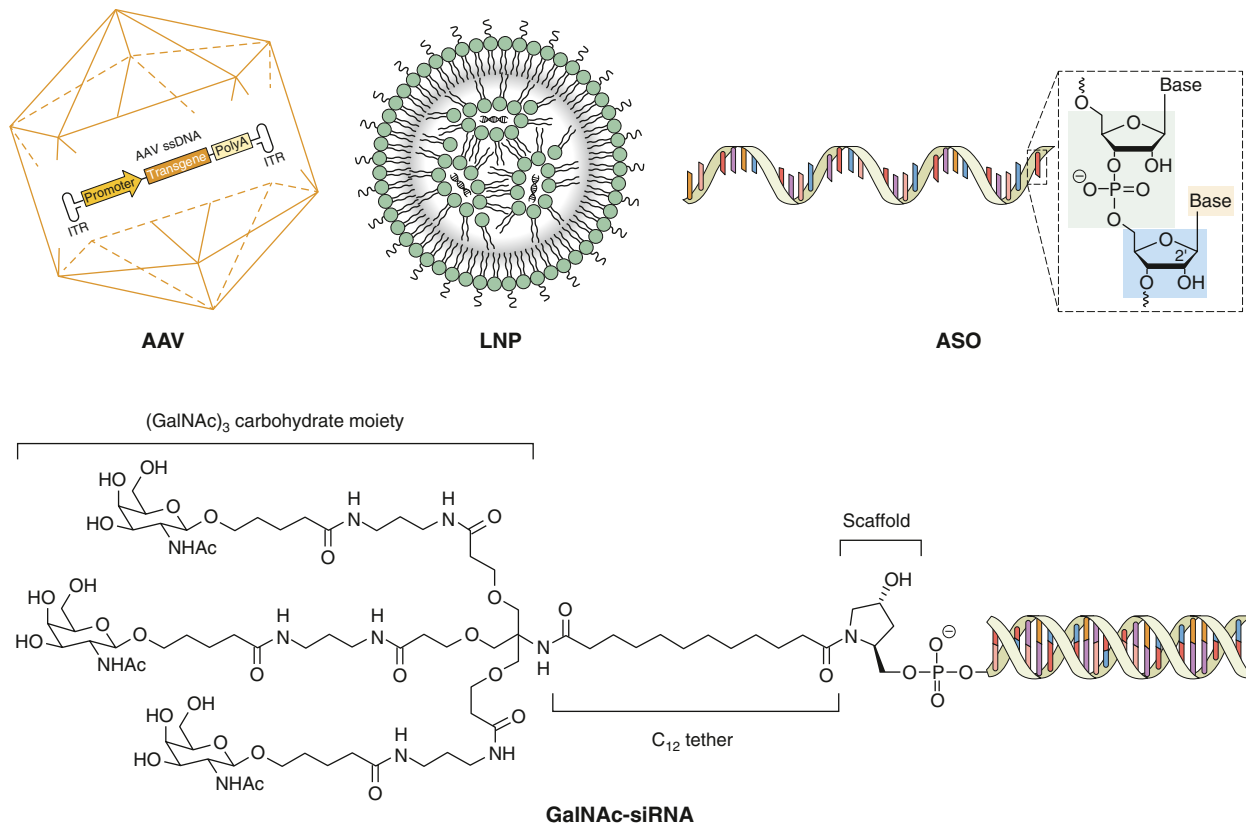
### RNA-Targeted Therapy

**Antisense oligonucleotides (ASOs)** are short synthetic nucleic acids that hybridize with cellular RNA using classic base pairing to modulate gene expression. To ensure specificity, their sequences are complementary to their target sequences (Fig. 98.8). Through binding to pre-mRNA or mRNA, ASOs can posttranscriptionally regulate protein

synthesis by mechanisms including modification of pre-mRNA processing and splicing, competitive inhibition, steric blockade of translational machinery, and degradation of the target RNA. Clinical ASOs have been developed for treatment of Duchenne muscular dystrophy and SMA, respectively (Table 98.5). In SMA, *SMN1* and *SMN2* genes are identical (99% homology), except for an 11-nucleotide sequence in exon seven that alters splicing (see Chapter 652.2). Splicing of the *SMN2* pre-mRNA leads to the exclusion of exon seven, generating a truncated, unstable protein that is rapidly degraded. Therefore *SMN2* cannot compensate for *SMN1* loss in SMA. The ASO designed to correct *SMN2* splicing by promoting the inclusion of exon seven allows *SMN2* to compensate for the loss of expression caused by the *SMN1* pathogenic variant. ASOs are also effective for treatment of homozygous familial hypercholesterolemia and have been also designed to inhibit HTT mRNA to reduce concentrations of mutant huntingtin in Huntington disease.

Conjugation of siRNA with GalNAc to target the asialoglycoprotein receptor is an efficient strategy to facilitate cell uptake and to increase siRNA liver accumulation (see Fig. 98.8). A GalNAc-siRNA targeting the mRNA for aminolevulinate synthase 1 (*ALAS1*), the first enzyme in the heme synthesis pathway, has been developed for treatment of acute hepatic porphyria, and a similar strategy targeting glycolate oxidase is effective at reducing oxalate levels for treatment of primary hyperoxaluria type 1.

Lipid nanoparticles (LNPs) are spherical structures with a composition very similar to cell membranes and are suitable carriers for



**Fig. 98.8** Approved delivery technologies for in vivo gene therapy. Four platform technologies have been clinically approved for gene-based therapies of genetic diseases: adeno-associated virus (AAV) vector containing a 4.7-kb single-stranded DNA with inverted terminal repeats (ITRs), antisense oligonucleotides (ASO) therapeutics, lipid nanoparticle (LNP) containing siRNA or mRNA including key lipid components, and N-acetylgalactosamine-short-interfering RNA (GALNAc-siRNA) therapeutics made of a trivalent ligand with terminal GalNAc moieties covalently linked to siRNA at the 3'-end of the sense strand.

**Table 98.5** Approved In Vivo Gene-Based (DNA and RNA) Therapies for Genetic Disorders

PRODUCT	GENE TARGET	DISEASE	ROUTE OF ADMINISTRATION
<b>ASO</b>			
Eteplirsen	Dystrophin (exon 51)	Duchenne muscular dystrophy	Intrathecal
Golodirsen	Dystrophin (exon 53)	Duchenne muscular dystrophy	Subcutaneous
Casimersen	Dystrophin (exon 45)	Duchenne muscular dystrophy	Subcutaneous
Inotersen	Transthyretin (TTR)	TTR-mediated amyloidosis	Subcutaneous
Nusinersen	Survival of motor neuron two (SMN2)	Spinal muscular atrophy	Intrathecal
Mipomersen	Apolipoprotein B-100	Hypercholesterolemia	Subcutaneous
Volanesorsen	Apolipoprotein CIII	Familial chylomicronemia	Subcutaneous
<b>GALNAc-siRNA CONJUGATES</b>			
Givosiran	ALAS1	Acute hepatic porphyrias	Subcutaneous
Inclisiran	PCSK9	Hypercholesterolemia	Subcutaneous
Lumasiran	Glycolate oxidase	Primary hyperoxaluria type 1	Subcutaneous
<b>LNP-RNA</b>			
Patisiran	TTR siRNA	TTR-mediated amyloidosis	Intravenous
<b>AAV VECTORS</b>			
Voretigene neparovec-rzyl	RPE65 (AAV2)	Leber congenital amaurosis	Subretinal
Onasemnogene abeparovec	SMN1 (AAV9)	Spinal muscular atrophy	Intravenous
Eladocogene exuparovec	DDC (AAV2)	AADC deficiency	Bilateral intraputaminial infusions
Valoctocogene roxaparovec	Factor VIII (AAV5)	Hemophilia A	Intravenous
Etranacogene dezaparovec	Factor IX (AAV5)	Hemophilia B	Intravenous

AAV, Adeno-associated virus; AADC, aromatic L-amino acid decarboxylase; ASO, antisense oligonucleotides; LNP, lipid nanoparticle.



nucleic acid delivery, such as siRNA and mRNAs (see Fig. 98.8). A liver targeting LNP carrying an siRNA targeting transthyretin has been effective for treatment of hereditary transthyretin amyloidosis that has been recently approved. In various preclinical models, LNPs have been shown to deliver mRNA molecules to hepatocytes with high efficiency. LNPs are being used for the delivery of gene editing molecules such as ZFNs and Cas9 mRNA together with a single guide (sg)RNA. In addition, LNPs have been used for delivery of genome editing tools such as ZFNs and CRISPR/Cas9 together with a viral vector carrying a promoterless DNA sequence capable of homologous recombination that can result in high levels of the integrated sequence and short-term expression of the endonucleases.

### Correction of Genetic Diseases in the Human Germline

Prevention of genetic diseases has been accomplished by **preimplantation genetic diagnosis (PGD)**. This procedure requires in vitro fertilization and single-embryo cell genetic testing of the known families' pathogenic variant and is performed with polymerase chain reaction (PCR) amplification of the affected gene. To avoid disease recurrence, only the unaffected embryos are implanted. With the advent of efficient genome editing by CRISPR/Cas9, editing human embryos is technically possible. The announcement of the birth of "CRISPR babies" has led to calls for a moratorium on human germline genome editing, and currently, germline and/or embryonic gene editing studies in humans have not been approved. Given the limited understanding of the consequences of CRISPR/Cas9-mediated DSBs on the germline human genome, it is unlikely that these approaches will become available any time soon.

In contrast, **mitochondrial replacement therapies** to avoid mitochondrial DNA pathogenic variants are available. In one technique, the pathogenic variant carrier mother's nuclear DNA is removed from the unfertilized oocyte and transferred to an unaffected mitochondrial donor oocyte (minus that cell's nuclear DNA). In another approach, the pronucleus from the pathogenic variant-carrier mother's fertilized oocyte is transferred to the unaffected mitochondrial donor's fertilized oocyte (minus the pronucleus).

Visit Elsevier eBooks+ at [eBooks.Health.Elsevier.com](http://eBooks.Health.Elsevier.com) for Bibliography.

## Chapter 99

# Chromosome Disorders

Carlos A. Bacino and Brendan Lee

### 99.1 Methods of Chromosome Analysis

Carlos A. Bacino and Brendan Lee

Clinical cytogenetics is the study of chromosomes, including their structure, function, inheritance, and abnormalities. Chromosome abnormalities are very common and occur in approximately 1–2% of live births, 5% of stillbirths, and 50% of early fetal losses in the first trimester of pregnancy (Table 99.1). Chromosome abnormalities are more common among individuals with intellectual disability and play a significant role in the development of some neoplasias.

Chromosome analyses are indicated in persons presenting with multiple congenital anomalies, dysmorphic features, and/or intellectual disability. The specific indications for studies include prenatal testing in conceptuses of women with advanced maternal age (>35 years), multiple abnormalities on fetal ultrasound, multiple congenital anomalies, unexplained growth restriction in the fetus, postnatal problems

**Table 99.1** Incidence of Chromosomal Abnormalities in Newborn Surveys

TYPE OF ABNORMALITY	NUMBER	APPROXIMATE INCIDENCE
<b>SEX CHROMOSOME ANEUPLOIDY</b>		
<i>Males (43,612 newborns)</i>		
47,XXY	45	1/1,000*
47,XYY	45	1/1,000
Other X or Y aneuploidy	32	1/1,350
<b>Total</b>	<b>122</b>	<b>1/360 male births</b>
<i>Females (24,547 newborns)</i>		
45,X	6	1/4,000
47,XXX	27	1/900
Other X aneuploidy	9	1/2,700
<b>Total</b>	<b>42</b>	<b>1/580 female births</b>
<b>AUTOSOMAL ANEUPLOIDY (68,159 NEWBORNS)</b>		
Trisomy 21	82	1/830
Trisomy 18	9	1/7,500
Trisomy 13	3	1/22,700
Other aneuploidy	2	1/34,000
<b>Total</b>	<b>96</b>	<b>1/700 live births</b>
<b>STRUCTURAL ABNORMALITIES (68,159 NEWBORNS)</b>		
<i>Balanced Rearrangements</i>		
Robertsonian	62	1/1,100
Other	77	1/885
<i>Unbalanced Rearrangements</i>		
Robertsonian	5	1/13,600
Other	38	1/1,800
<b>Total</b>	<b>182</b>	<b>1/375 live births</b>
<b>All chromosome abnormalities</b>	<b>442</b>	<b>1/154 live births</b>

\*Recent studies show the prevalence is currently 1:580 (Morris JK, Alberman E, Scott C, Jacobs P. Is the prevalence of Klinefelter syndrome increasing? *Eur J Hum Genet.* 2008;16(2):163–170.)

Data from Hsu LYF. Prenatal diagnosis of chromosomal abnormalities through amniocentesis. In: Milunsky A, ed. *Genetic Disorders and the Fetus*, 4th ed. Baltimore: Johns Hopkins University Press; 1998: pp. 179–248.

in growth and development, ambiguous genitalia, unexplained intellectual disability with or without associated anatomic abnormalities, primary amenorrhea or infertility, recurrent miscarriages ( $\geq 3$ ) or prior history of stillbirths and neonatal deaths, a first-degree relative with a known or suspected structural chromosome abnormality, clinical findings consistent with a known anomaly, some malignancies, and chromosome breakage syndromes (e.g., Bloom syndrome, Fanconi anemia).

Cytogenetic studies are usually performed on peripheral blood lymphocytes, although cultured fibroblasts obtained from a skin biopsy may also be used. Prenatal (fetal) chromosome studies are performed with cells obtained from the amniotic fluid (amniocytes), chorionic villus tissue, and fetal blood or, in the case of preimplantation diagnosis, by analysis of a *blastomere* (cleavage stage) biopsy, polar body biopsy, or blastocyst biopsy. Cytogenetic studies of bone marrow have an important role in tumor surveillance, particularly among patients with leukemia. These are useful to determine induction of remission and success of therapy, or in some cases the occurrence of relapses.

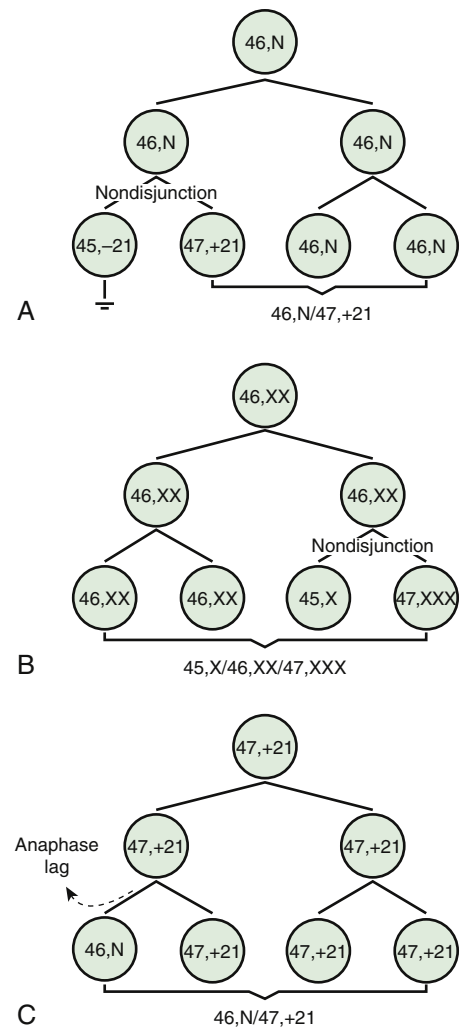
Chromosome anomalies include abnormalities of number and structure and are the result of errors during cell division. There are two types of cell division: mitosis, which occurs in most somatic cells, and meiosis, which is limited to the germ cells. In **mitosis**, two genetically identical daughter cells are produced from a single parent cell. DNA replication (duplication of DNA material) has already occurred during **interphase** in the S phase of the cell cycle (DNA synthesis). Therefore, at the beginning of mitosis, the chromosomes consist of two double DNA strands joined together at the centromere, known as *sister chromatids*. Mitosis can be divided into four stages: prophase, metaphase, anaphase, and telophase. **Prophase** is characterized by condensation of the DNA. Also during prophase, the nuclear membrane and the nucleolus disappear and the mitotic spindle forms. In **metaphase** the chromosomes are maximally compacted and are clearly visible as distinct structures. The chromosomes align at the center of the cell, and spindle fibers connect to the centromere of each chromosome and extend to centrioles at the two poles of the mitotic figure. In **anaphase** the chromosomes divide along their longitudinal axes to form two separate daughter chromatids, which then migrate to opposite poles of the cell. **Telophase** is characterized by formation of two new nuclear membranes and nucleoli, duplication of the centrioles, and cytoplasmic cleavage to form the two daughter cells.

**Meiosis** begins in the female oocyte during fetal life and is completed years to decades later. In males it begins in a spermatogonial cell sometime between adolescence and adult life and is completed in a few days. Meiosis is preceded by DNA replication so that at the outset, each of the 46 chromosomes consists of two chromatids. In meiosis, a **diploid cell** ( $2n = 46$  chromosomes) divides to form four **haploid cells** ( $n = 23$  chromosomes). Meiosis consists of two major rounds of cell division. In **meiosis I**, each of the homologous chromosomes pair precisely so that **genetic recombination**, involving exchange between two DNA strands (**crossing over**), can occur. This results in reshuffling of the genetic information for the recombined chromosomes and allows further genetic diversity. Each daughter cell then receives one of each of the 23 homologous chromosomes. In oogenesis, one of the daughter cells receives most of the cytoplasm and becomes the egg, whereas the other smaller cell becomes the first polar body. **Meiosis II** is similar to a mitotic division but without a preceding round of DNA replication. Each of the 23 chromosomes divides longitudinally, and the homologous chromatids migrate to opposite poles of the cell. This produces four spermatogonia in males, or an egg cell and a second polar body in females, each with a haploid ( $n = 23$ ) set of chromosomes. Consequently, meiosis fulfills two crucial roles: It enables genetic recombination, and it reduces the chromosome number from diploid (46) to haploid (23) so that on fertilization a diploid number is restored.

Two common errors of cell division may occur during meiosis or mitosis, and either can result in an abnormal number of chromosomes. The first error is **nondisjunction**, in which two chromosomes fail to separate during meiosis and thus migrate together into one of the new cells, producing one cell with two copies of the chromosome and another with no copy. The second error is **anaphase lag**, in which a chromatid or chromosome is lost during mitosis because it fails to move quickly enough during anaphase to become incorporated into one of the new daughter cells (Fig. 99.1).

For chromosome analysis, cells are cultured (for varying periods depending on cell type), with or without stimulation, and then artificially arrested in mitosis during metaphase (or prometaphase), later subjected to a hypotonic solution to allow disruption of the nuclear cell membrane and proper dispersion of the chromosomes for analysis, fixed, banded, and finally stained. The most commonly used banding and staining method is the **GTG banding** (G bands by trypsin using Giemsa), also known as **G banding**, which produces a unique combination of dark (G-positive) and light (G-negative) bands that permits recognition of all individual 23 chromosome pairs for analysis.

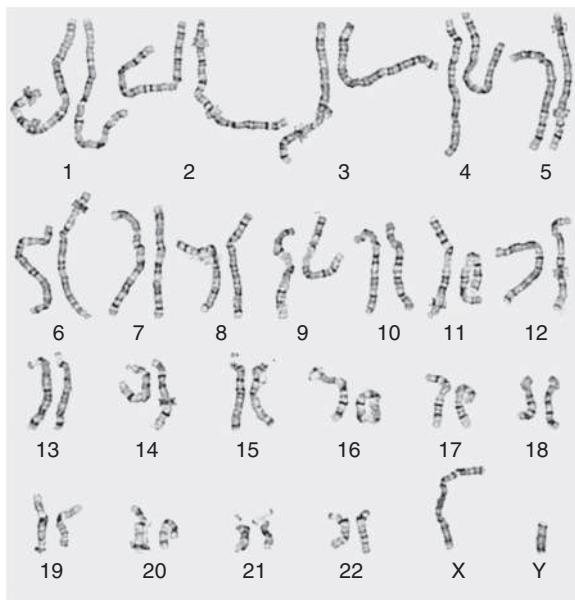
Metaphase chromosome spreads are first evaluated microscopically, and then their images are photographed or captured by a video camera and stored on a computer for later analysis. Humans have 46 chromosomes or 23 pairs, which are classified as *autosomes* for chromosomes



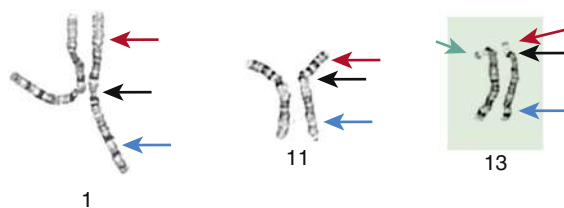
**Fig. 99.1** Generation of mosaicism. A, Postzygotic nondisjunction in an initially normal conceptus. In this example, one cell line (monosomic 21) is subsequently lost, with the final karyotype  $46,N/47,+21$ . B, Postzygotic nondisjunction in an initially  $46,XX$  conceptus, resulting in  $45,X/46,XX/47,XXX$  mosaicism. C, Postzygotic anaphase lag in an initially  $47,+21$  conceptus. (From Gardner RJM, Sutherland GR. *Chromosome Abnormalities and Genetic Counseling*, 3rd ed. New York: Oxford University Press; 2003: Fig. 43.1, p. 33.)

1-22, and the *sex chromosomes*, often referred as *sex complement*: XX for females and XY for males. The homologous chromosomes from a metaphase spread can then be paired and arranged systematically to assemble a karyotype according to well-defined standard conventions such as those established by International System for Human Cytogenetic Nomenclature (ISCN), with chromosome 1 being the largest and 22 the smallest. According to nomenclature, the description of the karyotype includes the total number of chromosomes followed by the sex chromosome constitution. A normal karyotype is  $46,XX$  for females and  $46,XY$  for males (Fig. 99.2). Abnormalities are noted after the sex chromosome complement.

Although the internationally accepted system for human chromosome classification relies largely on the length and banding pattern of each chromosome, the position of the centromere relative to the ends of the chromosome also is a useful distinguishing feature (Fig. 99.3). The centromere divides the chromosome in two, with the short arm designated the **p arm** and the long arm designated the **q arm**. A plus or minus sign before the number of a chromosome indicates that there is an extra or missing chromosome, respectively. Table 99.2 lists some of the abbreviations used for the descriptions of chromosomes and their abnormalities. A metaphase chromosome spread usually



**Fig. 99.2** Karyotype of a normal male at the 550-600 band level. The longer the chromosomes are captured at metaphase or sometimes prometaphase, the more bands can be visualized.



**Fig. 99.3** Example of different chromosome types according to the position of the centromere. On the *left* is a chromosome one pair with the centromere equidistant from the short and long arm (also known as *metacentric*). In the *center* is a chromosome 11 pair that is *submetacentric*. On the *right* is a chromosome 13 pair that is an example of an *acrocentric* chromosome. Acrocentric chromosomes contain a very small short arm, stalks, and satellite DNA. The *black arrow* indicates the position of the centromere. The *blue arrow* shows the long arm of a chromosome. The *red arrow* shows the short arm of a chromosome. The *green arrow* highlights the satellite region, which is made of DNA repeats. The *light area* between the short arm and the satellite is known as the *stalk*.

shows 450-550 bands. Prophase and prometaphase chromosomes are longer, are less condensed, and often show 550-850 bands. High-resolution analysis may detect small chromosome abnormalities, although this has been mostly replaced by chromosome **microarray analysis (CMA)**, also called array comparative genomic hybridization (aCGH).

Molecular techniques (e.g., fluorescence in situ hybridization [FISH], CMA) identify subtle abnormalities that are often below the resolution of standard cytogenetic studies. **FISH** is used to identify the presence, absence, or rearrangement of *specific* DNA segments and is performed with gene- or region-specific DNA probes. Several FISH probes are used in the clinical setting: unique sequence or single-copy probes, repetitive-sequence probes (alpha satellites in the pericentromeric regions), and multiple-copy probes (chromosome specific or painting) (Fig. 99.4A,B). FISH involves using a unique, known DNA sequence or probe labeled with a fluorescent dye that is complementary to the studied region of disease interest. The labeled probe is exposed to the DNA on a microscope slide, typically metaphase or interphase chromosomal DNA. When the probe pairs with its complementary DNA

sequence, it can then be visualized by fluorescence microscopy (Fig. 99.5). In metaphase chromosome spreads, the exact chromosomal location of each probe copy can be documented, and often the *number of copies* (deletions, duplications) of the DNA sequence as well. When the interrogated segments (as in genomic duplications) are close together, interphase cells can accurately determine the presence of two or more copies or signals, because in chromosome-condensed metaphase cells some duplications might falsely appear as a single signal.

Chromosome rearrangements <5 million bp (5 Mbp) cannot be detected by conventional cytogenetic techniques. FISH has facilitated the clinical characterization of several **microdeletion syndromes** (50-200 kb of DNA). Some FISH probes hybridize to repetitive sequences located in the pericentromeric regions. Pericentromeric probes are still used for rapid identification of certain trisomies in interphase cells of blood smears, or even in the rapid analysis of prenatal samples from cells obtained through amniocentesis. Such probes are available for chromosomes 13, 18, and 21 and for the sex pair X and Y (see Fig. 99.4C and D). FISH is *no longer* the first line of testing, and its role has also mostly changed to the confirmation of chromosome microarray findings. FISH is reserved for (1) confirmation studies of abnormalities detected by CMA, (2) rapid prenatal screening on interphase amniotic fluid cells, and (3) interphase blood smear for sex assignment of newborns who present with ambiguous genitalia.

**Array comparative genomic hybridization (aCGH)** is a type of **chromosomal microarray (CMA)** that uses a molecular-based technique that differentially labels the patient's DNA with a fluorescent dye (green fluorophore) and a normal reference DNA with a red fluorophore (Figs. 99.6 and 99.7). Oligonucleotides (short DNA segments) encompassing the entire genome are spotted onto a slide or **microarray grid**. Equal amounts of the two-labeled DNA samples are mixed, and the green:red fluorescence ratio is measured along each tested area. Regions of amplification of the patient's DNA display an excess of green fluorescence, and regions of loss show excess red fluorescence. If the patient's and the control DNA are equally represented, the green:red ratio is 1:1, and the tested regions are represented as yellow (see Chapter 96 and Fig. 96.5).

Another frequently used chromosome microarray type in the clinical setting is the **single nucleotide polymorphism (SNP) array**. SNPs are polymorphic variations between two nucleotides and, when analyzed in massive parallel fashion, they can provide valuable clinical information. Several million SNPs normally occur in the human genome. SNP arrays can help with the detection of **uniparental disomies** (i.e., genetic information derived from only one parent), as well as consanguinity in the family. Many arrays used in clinical practice combine the use of oligonucleotides for the detection of copy number variations (CNVs) in conjunction with SNPs.

The detection of abnormalities by CMA is possible at the single-exon resolution level, depending on the configuration of the array used. The many advantages of CMA include its ability to test for duplications or deletions in critical disease-causing regions of the genome at once, including single-gene and contiguous gene deletion syndromes. In addition, CMA does not require cell cultures to generate sufficient DNA, which may be important in the context of prenatal testing because of timing. However, CMA cannot detect balanced translocations or inversions and may not detect low levels of chromosomal mosaicism. **Targeted CMAs** can detect clinically known cryptic chromosomal aberrations associated with known disease phenotypes. CNV detection can also be diagnosed by next-generation sequencing in the context of whole *genome* sequencing.

There are large numbers of deletion and duplication CNVs in the human genome. Thus many detected genetic abnormalities, unless associated with well-known clinical phenotypes, may require *parental investigations* because a detected CNV that is inherited could be benign or an incidental polymorphic variant often described as variants of uncertain significance (VUS). A **de novo** abnormality (i.e., one found only in the child and not the parents) is often significant if it is associated with an abnormal phenotype found only in the child and if it involves genes with important functions.

**Table 99.2** Some Abbreviations Used for Description of Chromosomes and Their Abnormalities

ABBREVIATION	MEANING	EXAMPLE	CONDITION
XX	Female	46,XX	Normal female karyotype
XY	Male	46,XY	Normal male karyotype
[##]	Number [#] of cells	46,XY[12]/47,XXY[10]	Number of cells in each clone, typically inside brackets Mosaicism in Klinefelter syndrome with 12 normal cells and 10 cells with an extra X chromosome
cen	Centromere		
del	Deletion	46,XY,del(5p)	Male with deletion of chromosome 5 short arm
der	Derivative	46,XX,der(2),t(2p12;7q13)	Female with a structurally rearranged chromosome 2 that resulted from a translocation between chromosomes 2 (short arm) and 7 (long arm)
dup	Duplication	46,XY,dup(15)(q11-q13)	Male with interstitial duplication in the long arm of chromosome 15 in the Prader-Willi/Angelman syndrome region
ins	Insertion	46,XY,ins(3)(p13q21q26)	Male with an insertion within chromosome 3 A piece between q21 and q26 has reinserted on p13
inv	Inversion	46,XY,inv(2)(p21q31)	Male with pericentric inversion of chromosome 2 with breakpoints at bands p21 and q31
ish	Metaphase FISH	46,XX.ish del(7)(q11.23q11.23)	Female with deletion in the Williams syndrome region detected by in situ hybridization
nuc ish	Interphase FISH	nuc ish(DXZ1 × 3)	Interphase in situ hybridization showing three signals for the X chromosome centromeric region
mar	Marker	47,XY,+mar	Male with extra, unidentified chromosome material
mos	Mosaic	mos 45,X[14]/46,XX[16]	Turner syndrome mosaicism (analysis of 30 cells showed that 14 cells were 45,X and 16 cells were 46,XX)
p	Short arm	46,XY,del(5)(p12)	Male with a deletion on the short arm of chromosome 5, band p12 (short nomenclature)
q	Long arm	46,XY,del(5)(q14)	Male with a deletion on the long arm of chromosome 5, band 14
r	Ring chromosome	46,X,r(X)(p21q27)	Female with one normal X chromosome and a ring X chromosome
t	Translocation	t(2;8)(q33;q24.1)	Interchange of material between chromosomes 2 and 8 with breakpoints at bands 2q33 and 8q24.1
ter	Terminal	46,XY,del(5)(p12-pter)	Male with a deletion of chromosome 5 between p12 and the end of the short arm (long nomenclature)
/	Slash	45,X/46,XY	Separate lines or clones Mosaicism for monosomy X and a male cell line
+	Gain of	47,XX,+21	Female with trisomy 21
-	Loss of	45,XY,-21	Male with monosomy 21

FISH, Fluorescence in situ hybridization.

## 99.2 Abnormalities of Chromosome Number

Carlos A. Bacino and Brendan Lee

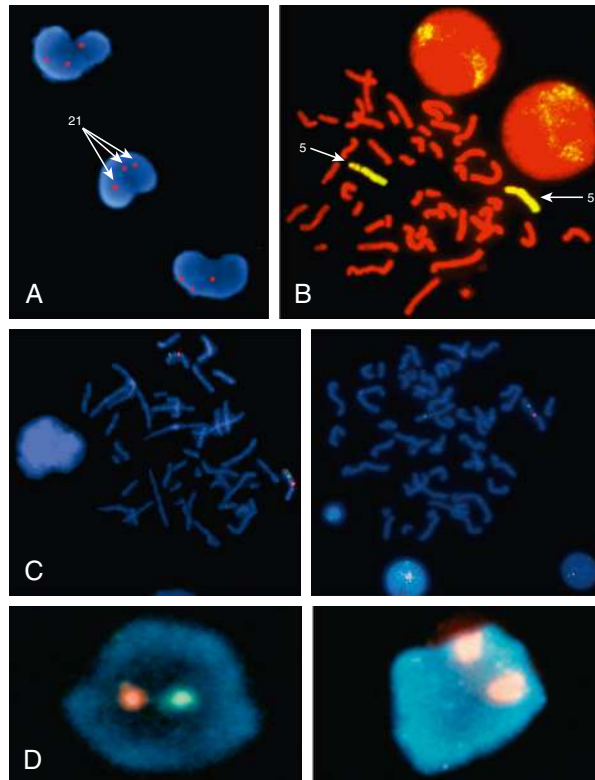
### ANEUPLOIDY AND POLYPLOIDY

Typical human cells contain 46 chromosomes, which is a multiple of 23 chromosomes. Haploid cells contain 23 chromosomes ( $n=23$ , typically in the ovum or sperm). If a cell's chromosomes are an exact multiple of 23 (46, 69, 92 in humans), those cells are referred to as **euploid**. **Poly-ploid** cells are euploid cells with more than the normal **diploid** number of 46 ( $2n$ ) chromosomes, such as  $3n$ ,  $4n$ . Polyploid conceptions are usually not viable, but the presence of mosaicism with a karyotypically normal cell line can allow survival. **Mosaicism** is an abnormality defined as the presence of two or more different cell lines in a single

individual. **Polyploidy** is a common abnormality seen in first-trimester pregnancy losses.

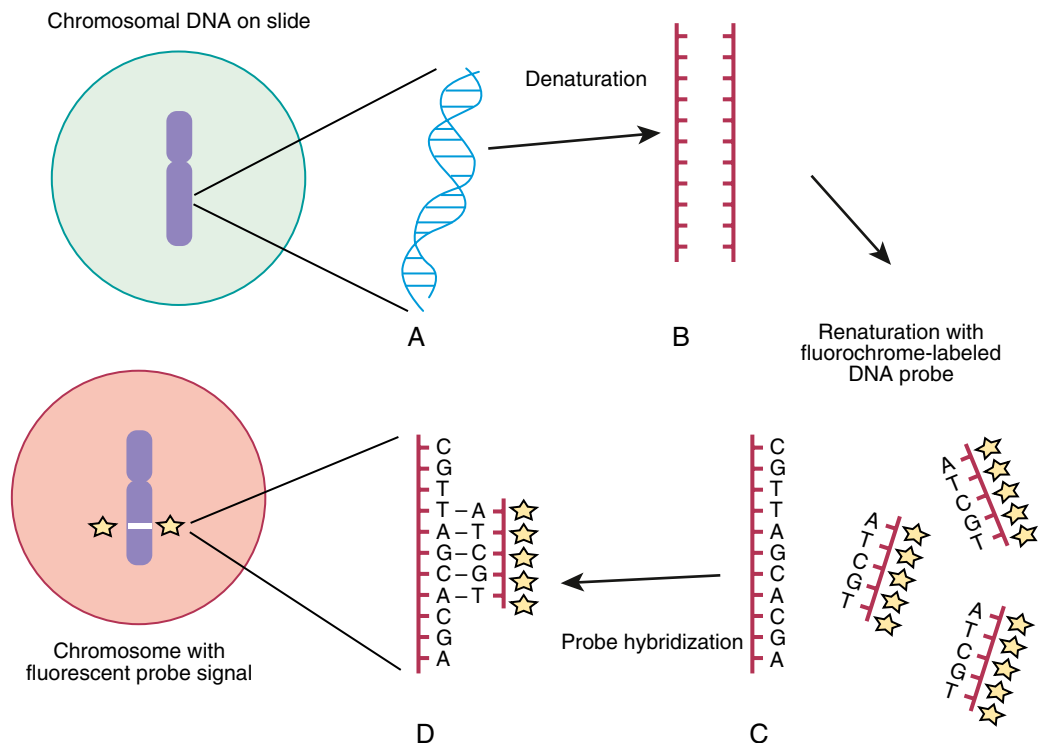
**Triploid cells** are those with three haploid sets of chromosomes ( $3n$ ) and are only viable in a mosaic form. Nonmosaic triploid infants can be liveborn but typically die shortly after birth. **Triploidy** is often the result of fertilization of an egg by two sperm (dispermy). Failure of one of the meiotic divisions, resulting in a diploid egg or sperm, can also result in triploidy. The phenotype of a triploid conception depends on the origin of the extra chromosome set. If the extra set is of **paternal** origin, it results in a partial *hydatidiform mole* (excessive placental growth) with poor embryonic development, but triploid conceptions that have an extra set of **maternal** chromosomes result in severe embryonic restriction with a small, fibrotic placenta (insufficient placental development) that is typically spontaneously aborted.

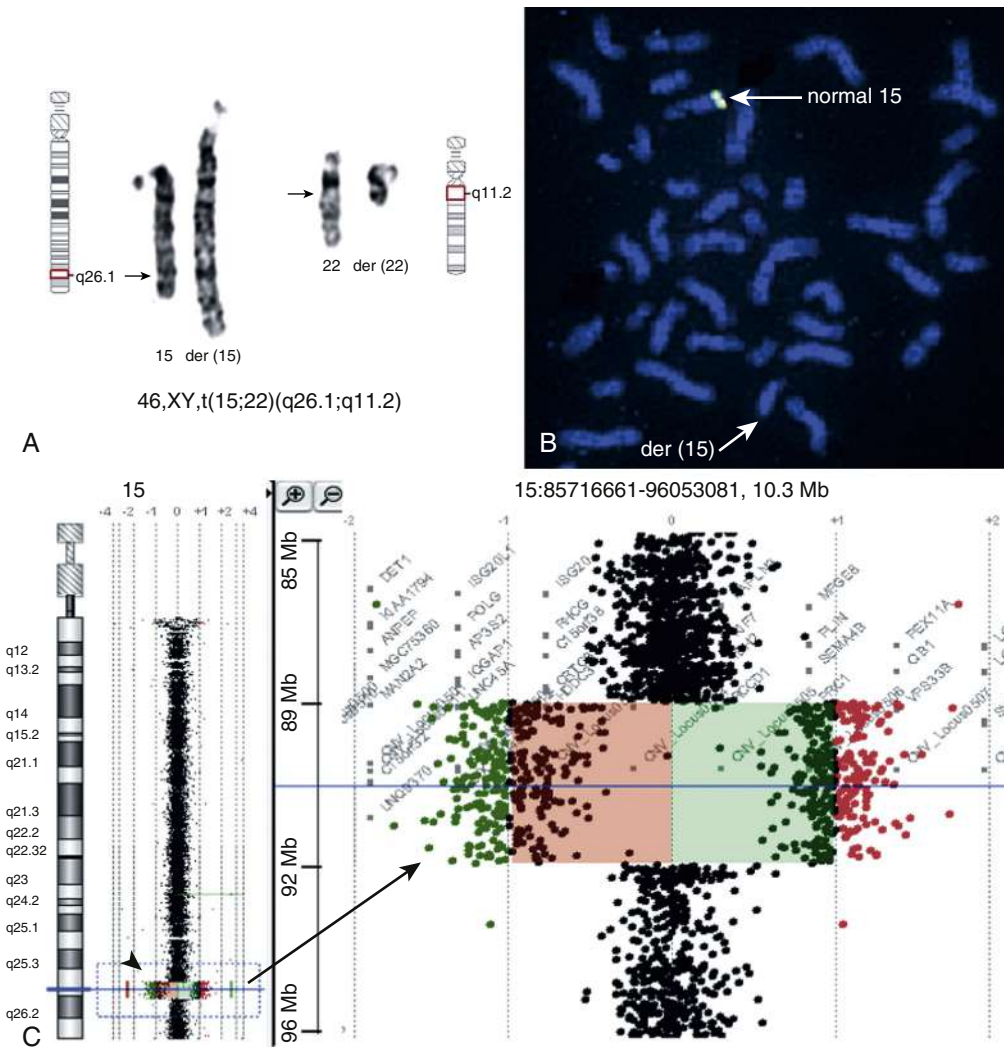




**Fig. 99.4** A, Fluorescence in situ hybridization (FISH) analysis of interphase peripheral blood cells from a patient with Down syndrome using a chromosome 21–specific probe. The three *red signals* mark the presence of three chromosomes 21. B, FISH analysis of a metaphase chromosome spread from a clinically normal individual using a whole chromosome paint specific for chromosome 5. Both chromosome 5s are completely labeled (*yellow*) along their entire length. C, FISH on metaphase cells using a unique sequence probe that hybridizes to the elastin gene on chromosome 7q11.23, inside the Williams syndrome critical region. The elastin probe is labeled in *red*, and a control probe on chromosome 7 is labeled in *green*. The *left* image shows normal hybridization to chromosome 7, with two signals for the elastin region and two for the control probe. The *right* image shows a normal chromosome on the right with control and elastin signals and a deleted chromosome 7 on the left, evidenced by a single signal for the control probe. This image corresponds to a patient with a Williams syndrome region deletion. D, FISH in interphase cells using DNA probes that hybridize to repetitive  $\alpha$ -satellite sequences in the pericentromeric region for the sex chromosomes. *Left*, interphase cells with two signals, one labeled in *red* for the X chromosome and *green* for the Y chromosome, consistent with a normal male chromosome complement. *Right*, interphase cell showing two *red* signals for the X chromosome, compatible with a normal female chromosome complement.

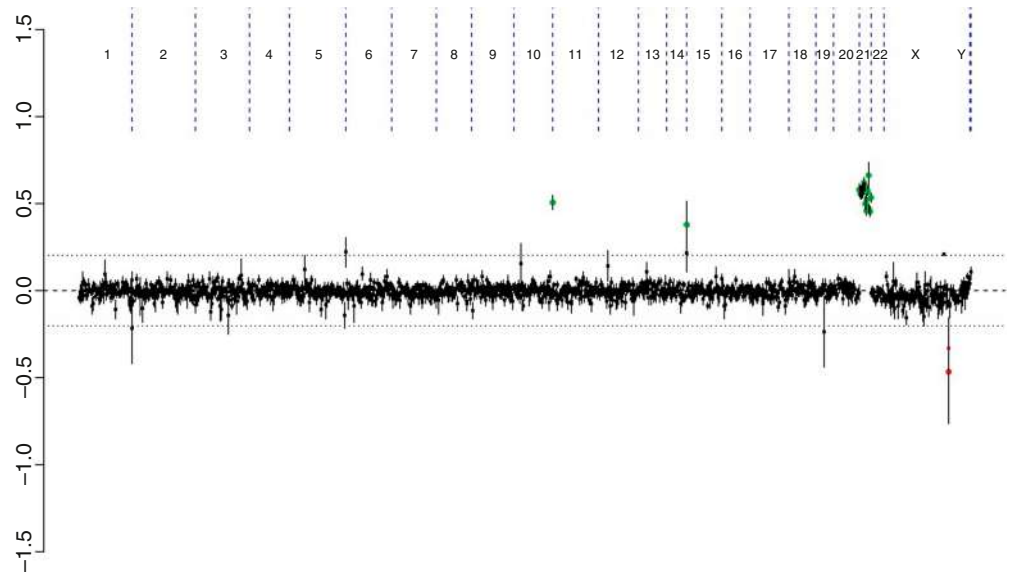
**Fig. 99.5** FISH involves denaturation of double-stranded DNA as present in metaphase chromosomes or interphase nuclei on cytogenetic slide preparations (A) into single-stranded DNA (B). The slide-bound (in situ) DNA is then renatured or reannealed in the presence of excess copies of a single-stranded, fluorochrome-labeled DNA base-pair sequence or probe (C). The probe anneals or “hybridizes” to sites of complementary DNA sequence (D) within the chromosomal genome. Probe signal is visualized and imaged on the chromosome by fluorescent microscopy. (From Lin RL, Cherry AM, Bangs CD, et al. *FISHing for answers: the use of molecular cytogenetic techniques in adolescent medicine practice*. In: Hyme HE, Greydanus D, eds, *Genetic Disorders in Adolescents: State of the art reviews. Adolescent medicine*. Philadelphia: Hanley and Belfus; 2002: pp. 305–313.)





**Fig. 99.6** Example of a cryptic microdeletion at a translocation breakpoint of an apparently balanced translocation in a patient with developmental delay (dd) and growth defect. **A**, Partial karyotype shows t(15;22)(q26.1;q11.2). **B**, Fluorescence in situ hybridization (FISH) with clones 2O19 (top arrow) and 354M14 (bottom arrow) at 15q26.1; arrows indicate signals only present on the normal chromosome 15, suggesting a deletion on the der(15). **C**, Two-color array comparative genomic hybridization (aCGH) with dye swap with 244 K oligo probes; arrowhead indicates a 3.3-Mbp deletion at chromosome 15q26.1-q26.2; arrow points to the close-up view of the deletion. (From Li MM, Andersson HC. Clinical application of microarray-based molecular cytogenetics: an emerging new era of genomic medicine. *J Pediatr.* 2009;155:311–317, with permission of the authors and publisher.)

**Fig. 99.7** Array comparative genomic hybridization (aCGH) in a female patient with Down syndrome. Each black dot represents a piece of DNA segment specific for different chromosome location. Most of the dots displayed between the 0.0 and 0.2 axis are considered within normal range. Exceptions are often a result of polymorphic variations. A group of dots colored in green clusters on chromosome 21 and above 0.5. These represent a gain in copy number of DNA segments for chromosome 21, as seen in Down syndrome and consistent with trisomy 21.



**Table 99.3** Chromosomal Trisomies and Their Clinical Findings\*

SYNDROME	INCIDENCE	CLINICAL MANIFESTATIONS
Trisomy 13, Patau syndrome	1/10,000 births	Cleft lip often midline; flexed fingers with postaxial polydactyly; ocular hypotelorism, bulbous nose; low-set, malformed ears; microcephaly; cerebral malformation, especially holoprosencephaly; microphthalmia, cardiac malformations; scalp defects; hypoplastic or absent ribs; visceral and genital anomalies Early lethality in most cases, with a median survival of 12 days; ~80% die by 1 year; 10-year survival ~13%; survivors have significant neurodevelopmental delay
Trisomy 18, Edwards syndrome	1/6,000 births	Low birthweight, closed fists with index finger overlapping the third digit and the fifth digit overlapping the fourth, narrow hips with limited abduction, short sternum, rocker-bottom feet, microcephaly, prominent occiput, micrognathia, cardiac and renal malformations, intellectual disability ~88% of children die in the first year; 10-year survival ~10%; survivors have significant neurodevelopmental delay
Trisomy 8, mosaicism	1/20,000 births	Long face; high, prominent forehead; wide, upturned nose; thick, everted lower lip; microretrognathia; low-set ears; high-arched, sometimes cleft, palate; osteoarticular anomalies common (camptodactyly of second through fifth digits, small patella); deep plantar and palmar creases; moderate intellectual disability

\*For trisomy 21, see Chapter 57.

Abnormal cells that do not contain a multiple of haploid number of chromosomes are termed **aneuploid** cells. **Aneuploidy** is the most common and clinically significant type of human chromosome abnormality, occurring in at least 3–4% of all clinically recognized pregnancies. **Monosomies** occur when only one, instead of the normal pair (two), of a given chromosome is present in an otherwise diploid cell. In humans, most autosomal monosomies appear to be lethal early in development, and survival is possible in **mosaic forms** or by means of chromosome rescue (restoration of the normal number by duplication of single monosomic chromosome, also known as monosomy rescue). An exception to this rule is monosomy for the X chromosome (45,X), seen in Turner syndrome; nonetheless, the majority of 45,X conceptions are believed to be lost early in pregnancy for as yet unexplained reasons.

The most common cause of aneuploidy is **nondisjunction**, the failure of chromosomes to disjoin normally during meiosis (see Fig. 99.1). Nondisjunction can occur during meiosis I or II or during mitosis, although maternal meiosis I is the most common nondisjunction in aneuploidies (e.g., Down syndrome, trisomy 18). After meiotic nondisjunction, the resulting gamete either lacks a chromosome or has two copies instead of one normal copy, resulting in a monosomic or trisomic zygote, respectively.

**Trisomy** is characterized by the presence of three chromosomes, instead of the normal pair (two), of any particular chromosome. Trisomy is the most common form of aneuploidy. Trisomy can occur in all cells, or it may be mosaic. Most individuals with a trisomy exhibit a consistent and specific phenotype depending on the chromosome involved.

FISH is a technique that can be used for rapid diagnosis in the prenatal detection of common fetal aneuploidies, including chromosomes 13, 18, and 21, as well as sex chromosomes (see Fig. 99.4C and D). Direct detection of cell-free fetal DNA (trophoblastic or placental origin) in maternal plasma for fetal trisomy detection is a safe and highly effective screening test for fetal aneuploidy. The most common numerical abnormalities in liveborn children include trisomy 21 (Down syndrome) (see Chapter 57); trisomy 18 (Edwards syndrome); trisomy 13 (Patau syndrome); and sex chromosomal aneuploidies, such as Turner syndrome (usually 45,X), Klinefelter syndrome (47,XXY), 47,XXX, and 47,XYY. By far the most common type of trisomy in liveborn infants is trisomy 21 (47,XX,+21 or 47,XY,+21) (see Table 99.1). Trisomy 18 and trisomy 13 are relatively less common and are associated with a characteristic set of congenital anomalies and severe intellectual disability (Table 99.3). The occurrence

of trisomy 21 and other trisomies increases with advanced maternal age ( $\geq 35$  years). Because of this increased risk, women who are  $\geq 35$  years old at delivery should be offered genetic counseling and prenatal diagnosis (including serum screening, ultrasonography, and cell-free DNA detection, amniocentesis, or chorionic villus sampling; see Chapter 117).

## 99.3 Abnormalities of Chromosome Structure

Carlos A. Bacino and Brendan Lee

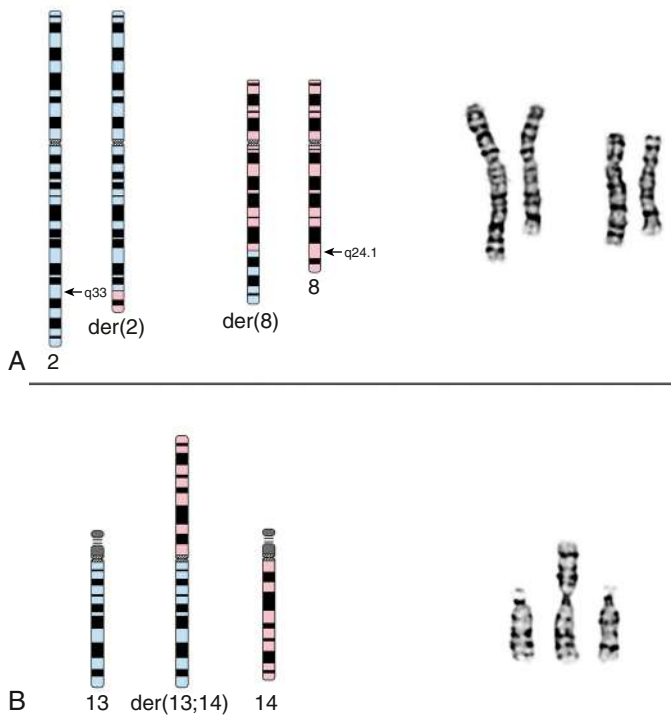
### TRANSLOCATIONS

Translocations, which involve the transfer of material from one chromosome to another, occur with a frequency of 1 in 500 live-born human infants. They may be inherited from a carrier parent or appear *de novo*, with no other affected family member. Translocations are usually reciprocal or Robertsonian, involving two chromosomes (Fig. 99.8).

**Reciprocal translocations** are the result of breaks in nonhomologous chromosomes, with reciprocal exchange of the broken segments. Carriers of a reciprocal translocation are usually phenotypically normal but are at an increased risk for miscarriage caused by transmission of unbalanced reciprocal translocations and for bearing chromosomally abnormal offspring. Unbalanced translocations are the result of abnormalities in the segregation or crossover of the translocation carrier chromosomes in the germ cells.

**Robertsonian translocations** involve two acrocentric chromosomes (chromosomes 13, 14, 15, 21, and 22) that fuse near the centromeric region with a subsequent loss of the short arms. Because the short arms of all five pairs of acrocentric chromosomes have multiple copies of genes encoding for ribosomal RNA, loss of the short arms of acrocentric chromosomes has no deleterious effect. The resulting karyotype has only 45 chromosomes, including the translocated chromosome, which consists of the long arms of the two fused chromosomes. Carriers of Robertsonian translocations are usually phenotypically normal. However, they are at increased risk for miscarriage and unbalanced translocations in phenotypically abnormal offspring.

In some rare instances, translocations can involve three or more chromosomes, as seen in complex rearrangements. Another less



**Fig. 99.8** A, Schematic diagram (left) and partial G-banded karyotype (right) of a reciprocal translocation between chromosome two (blue) and chromosome eight (pink). The breakpoints are on the long (q) arm of both chromosomes at bands 2q33 and 8q24.1, with the reciprocal exchange of material between the derivative (der) chromosomes 2 and 8. This translocation is balanced, with no net gain or loss of material. The nomenclature for this exchange is  $t(2;8)(q33;q24.1)$ . B, Schematic diagram (left) and partial G-banded karyotype (right) of a Robertsonian translocation between chromosomes 13 (blue) and 14 (pink). The breakpoints are at the centromere (band q10) of both chromosomes, with fusion of the long arms into a single derivative chromosome and loss of the short (p) arm material. The nomenclature for this exchange is  $der(13;14)(q10;q10)$ .

common type is the insertional translocation. **Insertional translocations** result from a piece of chromosome material that breaks away and later is reinserted within the same chromosome at a different site or inserted into another chromosome.

## INVERSIONS

An inversion requires that a single chromosome breaks at two points; the broken piece is then inverted and joined into the same chromosome. Inversions occur in 1 in 100 live births. There are two types of inversions, pericentric and paracentric. In **pericentric inversions** the breaks are in the two opposite arms of the chromosome and include the centromere. They are usually discovered because they change the position of the centromere. The breaks in **paracentric inversions** occur in only one arm. Carriers of inversions are usually phenotypically normal, but they are at increased risk for miscarriages, typically in paracentric inversions, and chromosomally abnormal offspring in pericentric inversions.

## DELETIONS AND DUPLICATIONS

Deletions involve loss of chromosome material and, depending on their location, can be classified as **terminal** (at the end of chromosomes) or **interstitial** (within the arm of a chromosome). They may be isolated or may occur along with a duplication of another chromosome segment. The latter typically occurs in unbalanced reciprocal chromosomal translocation secondary to abnormal crossover or segregation in a translocation or inversion carrier.

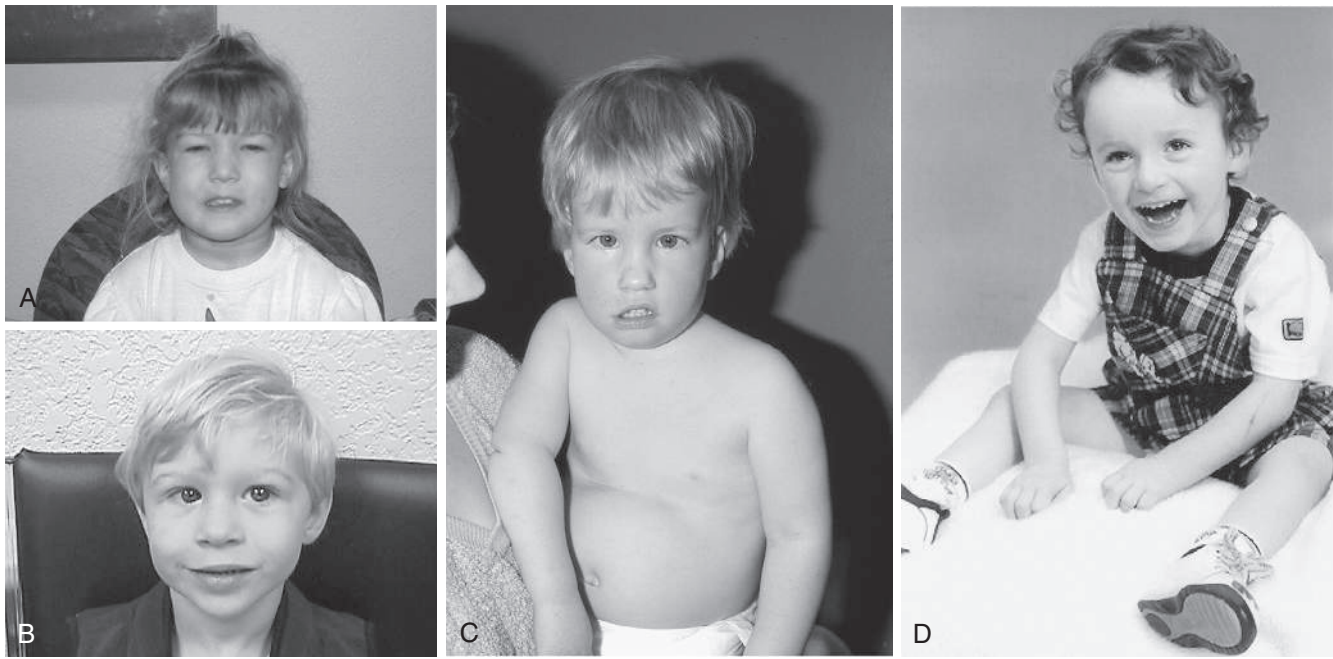
A carrier of a deletion is monosomic for the genetic information of the missing segment. Deletions are usually associated with intellectual disability and malformations. The most commonly observed deletions in routine chromosome preparations include 1p-, 4p-, 5p-, 9p-, 11p-, 13q-, 18p-, 18q-, and 21q- (Table 99.4 and Fig. 99.9), all distal or terminal deletions of the short or the long arms of chromosomes. Deletions may be observed in routine chromosome preparations, and deletions and translocations larger than 5-10 Mbp are usually visible microscopically.

High-resolution banding techniques, FISH, and molecular studies such as CMA can reveal deletions that are too small to be seen in ordinary or routine chromosome spreads (see Fig. 99.7). **Microdeletions** involve loss of small chromosome regions, the largest of which are detectable only with prophase chromosome studies and molecular methods. For submicroscopic deletions, the missing piece can only be detected using molecular methodologies such as DNA-based studies (e.g., CMA, FISH). The presence of extra genetic material from the same chromosome is referred to as **duplication**. Duplications can also

**Table 99.4** Common Deletions and Their Clinical Manifestations

DELETION	CLINICAL ABNORMALITIES
4p-	Wolf-Hirschhorn syndrome. The main features are a typical "Greek helmet" facies secondary to ocular hypertelorism, prominent glabella, frontal bossing, microcephaly, dolichocephaly, hypoplasia of the orbits, ptosis, strabismus, nystagmus, bilateral epicanthic folds, cleft lip and palate, beaked nose with prominent bridge, hypospadias, cardiac malformations, and intellectual disability.
5p-	Cri du chat syndrome. The main features are hypotonia, short stature, characteristic shrill cry in the first few weeks of life (also called cat's cry syndrome), microcephaly with protruding metopic suture, hypertelorism, bilateral epicanthic folds, high arched palate, wide and flat nasal bridge, and intellectual disability.
9p-	The main features are craniofacial dysmorphic features with trigonocephaly, slanted palpebral fissures, discrete exophthalmos secondary to supraorbital hypoplasia, arched eyebrows, flat and wide nasal bridge, short neck with low hairline, genital anomalies, long fingers and toes with extra flexion creases, cardiac malformations, and intellectual disability.
13q-	The main features are low birthweight, failure to thrive, microcephaly, and severe intellectual disability. Facial features include high, wide nasal bridge; hypertelorism; ptosis; and micrognathia. Ocular malformations are common (retinoblastoma). The hands have hypoplastic or absent thumbs and syndactyly.
18p-	A few patients (15%) are severely affected and have cephalic and ocular malformations: holoprosencephaly, cleft lip and palate, ptosis, epicanthal folds, and varying degrees of intellectual disability. Most (80%) have only minor malformations and mild intellectual disability.
18q-	The main features are growth deficiency and hypotonia with a "froglike" position with the legs flexed, externally rotated, and in hyperabduction. The face is characteristic, with depressed midface and apparent protrusion of the mandible, deep-set eyes, short upper lip, and everted lower lip ("carplike" mouth); antihelix of the ears is very prominent. Varying degrees of intellectual disability and belligerent personality are present. Myelination abnormalities occur in the central nervous system.





**Fig. 99.9** A, Child with velocardiofacial syndrome (deletion 22q11.2). B, Child with Williams syndrome (deletion 7q11.23). C, Child with Prader-Willi syndrome (deletion 15q11-13). D, Child with Angelman syndrome (deletion 15q11-13). (From Lin RL, Cherry AM, Bangs CD, et al. *FISHing for answers: the use of molecular cytogenetic techniques in adolescent medicine practice*. In: Hyme HE, Greydanus D, eds, *Genetic Disorders in Adolescents: state of the art reviews*. Adolescent medicine. Philadelphia: Hanley and Belfus; 2002: pp. 305–313.)

<b>Table 99.5</b> Microdeletion and Contiguous Gene Syndromes and Their Clinical Manifestations		
<b>DELETION</b>	<b>SYNDROME</b>	<b>CLINICAL MANIFESTATIONS</b>
1p36	1p deletion	Growth restriction, dysmorphic features with midface hypoplasia, straight thin eyebrows, pointy chin, sensorineural hearing loss, progressive cardiomyopathy, hypothyroidism, seizures, intellectual disability
5q35	Sotos (50% are deletions of <i>NSD1</i> gene in Asians but only 6% in Whites)	Overgrowth, macrocephaly, prominent forehead, prominence of extraaxial fluid spaces on brain imaging, large hands and feet, hypotonia, clumsiness, mental disabilities
6p25	Axenfeld-Rieger	Axenfeld-Rieger malformation, hearing loss, congenital heart defects, dental anomalies, developmental delays, facial dysmorphism
7q11.23	Williams	Round face with full cheeks and lips, long philtrum, stellate pattern in iris, strabismus, supravalvular aortic stenosis and other cardiac malformations, varying degrees of intellectual disability, friendly personality
8p11	8p11	Kallmann syndrome type 2 (hypogonadotropic hypogonadism and anosmia), spherocytosis (deletions of <i>ankyrin 1</i> ), multiple congenital anomalies, intellectual disability
8q24.1-q24.13	Langer-Giedion or trichorhinophalangeal type II	Sparse hair, multiple cone-shaped epiphyses, multiple cartilaginous exostoses, bulbous nasal tip, thickened alar cartilage, upturned nares, prominent philtrum, large protruding ears, mild intellectual disability
9q22	Gorlin	Multiple basal cell carcinomas, odontogenic keratocysts, palmoplantar pits, calcification <i>falx cerebri</i>
9q34	9q34 deletion	Distinct face with synophrys, anteverted nares, tented upper lip, protruding tongue, midface hypoplasia, conotruncal heart defects, intellectual disability
10p12-p13	DiGeorge type 2	Many of the DiGeorge type 1 and velocardiofacial type 1 features (conotruncal defects, immunodeficiency, hypoparathyroidism, dysmorphic features)
11p11.2	Potocki-Shaffer	Multiple exostoses, parietal foramina, craniosynostosis, facial dysmorphism, syndactyly, intellectual disability
11p13	WAGR	Hypernephroma (Wilms tumor), aniridia, male genital hypoplasia of varying degrees, gonadoblastoma, long face, upward-slanting palpebral fissures, ptosis, beaked nose, low-set poorly formed auricles, intellectual disability (retardation)
11q24.1-11qter	Jacobsen	Growth restriction, intellectual disability, cardiac and digit anomalies, thrombocytopenia
15q11-q13 (paternal)	Prader-Willi	Severe hypotonia and feeding difficulties at birth, voracious appetite and obesity in infancy, short stature (responsive to growth hormone), small hands and feet, hypogonadism, intellectual disability

Continued

<b>Table 99.5</b> Microdeletion and Contiguous Gene Syndromes and Their Clinical Manifestations—cont'd		
<b>DELETION</b>	<b>SYNDROME</b>	<b>CLINICAL MANIFESTATIONS</b>
15q11-q13 (maternal)	Angelman	Hypotonia, feeding difficulties, gastroesophageal reflux, fair hair and skin, midface hypoplasia, prognathism, seizures, tremors, ataxia, sleep disturbances, inappropriate laughter, poor or absent speech, severe intellectual disability
16p13.3	Rubinstein-Taybi	Microcephaly, ptosis, beaked nose with low-lying philtrum, broad thumbs and large toes, intellectual disability
17p11.2	Smith-Magenis	Brachycephaly, midfacial hypoplasia, prognathism, myopia, cleft palate, short stature, severe behavioral problems, intellectual disability
17p13.3	Miller-Dieker	Microcephaly, lissencephaly, pachygyria, narrow forehead, hypoplastic male external genitals, growth restriction, seizures, profound intellectual disability
20p12	Alagille	Bile duct paucity with cholestasis; heart defects, particularly pulmonary artery stenosis; ocular abnormalities (posterior embryotoxon); skeletal defects such as butterfly vertebrae; long nose
22q11.2	Velocardiofacial-DiGeorge	Conotruncal cardiac anomalies, cleft palate, velopharyngeal incompetence, hypoplasia or agenesis of thymus and parathyroid glands, hypocalcemia, hypoplasia of auricle, learning disabilities, psychiatric disorders
22q13.3 deletion		Hypotonia, developmental delay, normal or accelerated growth, severe expressive language deficits, autistic behavior
Xp21.2-p21.3		Duchenne muscular dystrophy, retinitis pigmentosa, adrenal hypoplasia, intellectual disability, glycerol kinase deficiency
Xp22.2-p22.3		Ichthyosis, Kallmann syndrome, intellectual disability, chondrodysplasia punctata
Xp22.3	MLS	Microphthalmia, linear skin defects, poikiloderma, congenital heart defects, seizures, intellectual disability

<b>Table 99.6</b> Microduplications and Their Clinical Manifestations		
<b>DUPLICATION CHROMOSOME REGION</b>	<b>DISEASE REGION</b>	<b>CLINICAL FEATURES</b>
1q21.1		Macrocephaly, DD, learning disabilities
3q29		Mild to moderate DD, ID, microcephaly
7q11.23	Williams syndrome	DD and severe expressive language disorder, autistic features, subtle dysmorphisms
15q13.3	Prader-Willi/Angelman syndrome	DD, ID, autistic features in duplications of maternal origin
15q24		Growth restriction, DD, microcephaly, digital anomalies, hypospadias, connective tissue abnormalities
16p11.2		FTT, severe DD, short stature, GH deficiency, dysmorphic features
17p11.2	Potocki-Lupski syndrome	Hypotonia, cardiovascular anomalies, FTT, DD, verbal apraxia, autism, anxiety
17q21.31		Severe DD, microcephaly, short and broad digits, dysmorphic features
22q11.2	Velocardiofacial-DiGeorge syndrome	Cardiovascular defects, velopharyngeal insufficiency
Xq28	<i>MECP2</i> gene (Rett syndrome)	In males: infantile hypotonia, immune deficiency, dysmorphic features, DD, speech delay, autistic behavior, regression in childhood

DD, Developmental delay; FTT, failure to thrive; GH, growth hormone; ID, intellectual disability.

be sporadic or result from abnormal segregation in translocation or inversion carriers.

Microdeletions and microduplications usually involve regions that include several genes, so the affected individuals can have a distinctive phenotype depending on the number of genes involved. When such a deletion involves more than a single gene, the condition is referred to as a **contiguous gene deletion syndrome** (Table 99.5). With the advent of chromosome microarray, a large number of microduplications, have been uncovered. Many of those **microduplication syndromes** are the reciprocal duplications of the known deletions or microdeletion counterparts and have distinctive clinical features (Table 99.6).

**Subtelomeric regions** are often involved in chromosome rearrangements that cannot be visualized using routine cytogenetics. *Telomeres*, which are the distal ends of the chromosomes, are gene-rich regions. The distal repetitive sequence structure of telomeres is essentially common to all chromosomes, but proximal to these are unique regions known as *subtelomeres*, which typically are involved in deletions and other chromosome rearrangements. Small subtelomeric deletions, duplications, or rearrangements (translocations, inversions) may be relatively common in children with nonspecific intellectual disability and minor anomalies. Subtelomeric rearrangements have been found in 3–7% of children with moderate to severe intellectual disability and 0.5% of those with mild intellectual disability and can be detected by CMA studies.

Pathogenic variants affecting telomere function and length have been associated with dyskeratosis congenita and other aplastic anemia syndromes, as well as pulmonary or hepatic fibrosis. Both the subtelomeric rearrangements and the microdeletion and microduplication syndromes are typically diagnosed by molecular techniques like CMA and multiple ligation-dependent probe amplification (MLPA) studies. CMA can detect 14–18% of abnormalities in patients who previously had normal cytogenetic studies.

## INSERTIONS

Insertions occur when a piece of a chromosome broken at two points is incorporated into a break of a chromosome in another location. A total of three breakpoints are then required, and they can occur between two or within one chromosome. A form of non-reciprocal translocation, insertions are rare. Insertion carriers are at risk of having offspring with deletions or duplications of the inserted segment.

## ISOCHROMOSOMES

Isochromosomes consist of two copies of the same chromosome arm joined through a single centromere and forming mirror images of one another. The most commonly reported autosomal isochromosomes tend to involve chromosomes with small arms. Some of the more common chromosome arms involved in this formation include 5p, 8p, 9p, 12p, 18p, and 18q. There is also a common isochromosome abnormality seen in long arm of the X chromosome and associated with Turner syndrome. Individuals who have one isochromosome X within 46 chromosomes are monosomic for genes in the lost short arm and trisomic for the genes present in the long arm of the X chromosome.

## MARKER AND RING CHROMOSOMES

Marker chromosomes are rare and are usually chromosome fragments that are too small to be identified by conventional cytogenetics; they usually occur in addition to the normal complement of 46 chromosomes. Most are sporadic (70%); mosaicism is often (50%) noted because of the mitotic instability of the marker chromosomes. The incidence in newborn infants is 1 in 3,300, and the incidence in persons with intellectual disability is 1 in 300. The associated phenotype ranges from normal to severely abnormal, depending on the

amount of chromosome material and number of genes included in the fragment.

**Ring chromosomes**, which are found for all human chromosomes, are rare. A ring chromosome is formed when both ends of a chromosome are deleted and the ends are then joined to form a ring. Depending on the amount of chromosome material that is lacking or in excess (if the ring has duplicated chromosomal material), a patient with a ring chromosome can appear normal or can have different degrees of intellectual disability and/or multiple congenital anomalies.

Marker and ring chromosomes can be found in the cells of solid tumors of children. Some of these markers can be the result of tumor-specific rearrangements, such as translocations, deletions, and duplications, ultimately leading to gene fusions and tumor gene amplifications.

Visit Elsevier eBooks+ at [eBooks.Health.Elsevier.com](http://eBooks.Health.Elsevier.com) for Bibliography.

## 99.4 Sex Chromosome Aneuploidy

Carlos A. Bacino and Brendan Lee

About 1 in 400 males and 1 in 650 females have some form of sex chromosome abnormality. Considered together, sex chromosome abnormalities are the most common chromosome abnormalities seen in liveborn infants, children, and adults. Sex chromosome abnormalities can be either structural or numerical and can be present in all cells or in a mosaic form. Those affected with these abnormalities might have few or no physical or developmental problems (Table 99.7).

### TURNER SYNDROME

Turner syndrome is a condition characterized by complete or partial monosomy of the X chromosome and defined by a combination of phenotypic features (see Table 99.7 and Table 99.8). Half the patients with Turner syndrome have a 45,X chromosome complement. The other half exhibit mosaicism and varied structural abnormalities of the X or Y chromosome. Maternal age is not a predisposing factor for children with 45,X. Turner syndrome occurs in approximately 1

**Table 99.7** Sex Chromosome Abnormalities

DISORDER	KARYOTYPE	APPROXIMATE INCIDENCE
Klinefelter syndrome	47,XXY	1/580 males
	48,XXXY	1/50,000-1/80,000 male births
	Other (48,XXYY; 49,XXXYY; mosaics)	
XYY syndrome	47,XYY	1/800-1,000 males
Other X or Y chromosome abnormalities		1/1,500 males
XX males	46,XX	1/20,000 males
Turner syndrome	45,X	1/2,500-1/5,000 females
	Variants and mosaics	
Trisomy X	47,XXX	1/1,000 females
	48,XXXX and 49,XXXXX	Rare
Other X chromosome abnormalities		1/3,000 females
XY females	46,XY	1/20,000 females

**Table 99.8** Signs Associated with Turner Syndrome

Short stature
Congenital lymphedema
Horseshoe kidneys
Patella dislocation
Increased carrying angle of elbow (cubitus valgus)
Madelung deformity (chondrodysplasia of distal radial epiphysis)
Congenital hip dislocation
Scoliosis
Widespread nipples
Shield chest
Redundant nuchal skin (in utero cystic hygroma)
Low posterior hairline
Coarctation of aorta
Bicuspid aortic valve
Cardiac conduction abnormalities
Hypoplastic left heart syndrome and other left-sided heart abnormalities
Gonadal dysgenesis (infertility, primary amenorrhea)
Gonadoblastoma (increased risk if Y chromosome material is present)
Learning disabilities (nonverbal perceptual motor and visuospatial skills) (in 70%)
Developmental delay (in 10%)
Social awkwardness
Hypothyroidism (acquired in 15–30%)
Type 2 diabetes mellitus (insulin resistance)
Strabismus
Cataracts
Red-green color blindness (as in males)
Recurrent otitis media
Sensorineural hearing loss
Inflammatory bowel disease
Celiac disease (increased incidence)

in 5,000 female live births. In 75% of patients, the lost sex chromosome is of paternal origin (whether an X or a Y). 45,X is one of the chromosome abnormalities most often associated with spontaneous pregnancy losses. It has been estimated that 95–99% of 45,X conceptions are miscarried.

Clinical findings in the newborns can include small size for gestational age, webbing of the neck, protruding ears, and lymphedema of the hands and feet, although many newborns are phenotypically normal (Fig. 99.10). Older children and adults have short stature and exhibit variable dysmorphic features. Congenital heart defects (40%) and structural renal anomalies (60%) are common. The most common heart defects are bicuspid aortic valves, coarctation of the aorta, aortic stenosis, and mitral valve prolapse. The gonads are generally streaks of fibrous tissue (**gonadal dysgenesis**) (see Chapter 626). There is primary amenorrhea and lack of secondary sex characteristics. These children should receive regular endocrinologic testing.

Patients with **45,X/46,XY mosaicism** can have Turner syndrome, although this form of mosaicism can also be associated with male pseudohermaphroditism, male or female genitalia in association with mixed gonadal dysgenesis, or a normal male phenotype. This variant is estimated to represent approximately 6% of patients with mosaic Turner syndrome. Some of the patients with Turner syndrome phenotype and a Y cell line exhibit masculinization. Phenotypic females with 45,X/46,XY mosaicism have a 15–30% risk of developing **gonadoblastoma**. The risk for the patients with a male phenotype and external

testes is not so high, but tumor surveillance is nevertheless recommended. The American Academy of Pediatrics (AAP) has recommended the use of FISH analysis to look for Y chromosome mosaicism in all 45,X patients. If Y chromosome material is identified, laparoscopic gonadectomy is recommended.

**Noonan syndrome** (see Chapter 101.1) shares many clinical features with Turner syndrome and was formerly called *pseudo-Turner syndrome*, although it is an autosomal dominant disorder resulting from pathogenic variants in several genes involved in the RAS-MAPK pathway. In contrast to Turner syndrome, Noonan syndrome affects both sexes and has a different pattern of congenital heart disease, typically involving right-sided heart lesions.

### KLINFELTER SYNDROME

Persons with Klinefelter syndrome are phenotypically male. This syndrome is the most common cause of hypogonadism and infertility in males and the most common sex chromosome aneuploidy in humans (see Chapter 623). Eighty percent of children with Klinefelter syndrome have a male karyotype with an extra chromosome X-47,XXY. The remaining 20% have multiple sex chromosome aneuploidies (48,XXXYY; 48,XXYY; 49,XXXXXY), mosaicism (46,XY/47,XXY), or structurally abnormal X chromosomes; the greater the aneuploidy, the more severe the mental impairment and dysmorphism. The prevalence of 47,XXY is 1 in 580 liveborn males. Errors in paternal nondisjunction in meiosis I account for ~50% of the cases.

### 47,XXY

The incidence of 47,XXY is approximately 1 in 800–1,000 males, with many cases remaining undiagnosed, because most affected individuals have a normal appearance and normal fertility. The extra Y is the result of nondisjunction at paternal meiosis II. Those with this abnormality have normal intelligence but are at risk for learning disabilities. Behavioral abnormalities, including hyperactive behavior, pervasive developmental disorder, and aggressive behavior, have been reported. Early reports that assigned stigmata of criminality to this disorder have long been disproved.

Visit Elsevier eBooks+ at [eBooks.Health.Elsevier.com](http://eBooks.Health.Elsevier.com) for Bibliography.

## 99.5 Mosaicism

Carlos A. Bacino and Brendan Lee

Mosaicism describes an individual or tissue that contains  $\geq 2$  genetically different cell lines typically derived from a single zygote. Genetic differences can result from mitotic nondisjunction (see Fig. 99.1; Table 99.9) or sporadic variant. Study of placental tissue from chorionic villus samples collected at or before the 10th week of gestation has shown that  $\geq 2\%$  of all conceptions are mosaic for a chromosome abnormality. With the exception of chromosomes 13, 18, and 21, complete autosomal trisomies are usually nonviable, and the contribution of a normal cell line might allow these other trisomic conceptions to survive to term. Depending on the point at which the new cell line arises during early embryogenesis, mosaicism may be present in some tissues but not in others. **Germline mosaicism**, which refers to the presence of mosaicism in the germ cells of the gonad, may be associated with an increased risk for recurrence of an affected child if the germ cells are affected with a chromosomal abnormality or with a specific gene pathogenic variant.

### PALLISTER-KILLIAN SYNDROME

Pallister-Killian syndrome is characterized by coarse facies (prominent full cheeks), abnormal ear lobes, localized alopecia (sparse hair





**Fig. 99.10** Physical manifestations associated with Turner syndrome. **A**, This newborn shows a webbed neck with low hairline, shield chest with widespread nipples, abnormal ears, and micrognathia. **B**, The low-set posterior hairline can be better appreciated in this older child, who also has protruding ears. **C**, In this frontal view, mild webbing of the neck and small, widely spaced nipples are evident, along with a midline scar from prior cardiac surgery. The ears are low-set and prominent, protruding forward. **D** and **E**, The newborn shown in **A** also has prominent lymphedema of the hands and feet. (From Madan-Khetarpal S, Arnold G. *Genetic disorders and dysmorphic conditions*. In: Zitelli BJ, McIntire SC, Nowalk AJ, eds, *Zitelli and Davis' Atlas of Pediatric Physical Diagnosis*, 6th ed. Philadelphia: Elsevier; 2012: Fig. 1.25.)

in the temporal regions), pigmentary skin anomalies, diaphragmatic hernia, cardiovascular anomalies, supernumerary nipples, seizures, and profound intellectual disability. The syndrome is caused by mosaicism for an isochromosome of the short chromosome of 12 (12p). The presence of the isochromosome 12p in cells gives four functional copies for the short arm of chromosome 12 in the affected cells. The isochromosome 12p is preferentially cultured from fibroblasts that can be readily obtained from a skin punch biopsy and is seldom present in lymphocytes. A CMA obtained from a buccal swab can be another tool to detect this disorder. The abnormalities seen in affected persons probably reflect the presence of abnormal cells during early embryogenesis.

#### HYPOMELANOSIS OF ITO

Hypomelanosis of Ito is characterized by unilateral or bilateral macular hypo- or hyperpigmented whorls, streaks, and patches (see Chapter 694). Sometimes these pigmentary defects follow the lines of Blaschko that represent areas of early epidermal cell migration. Hair and tooth anomalies are common. Abnormalities of the eyes, musculoskeletal system (growth asymmetry, syndactyly, polydactyly, clinodactyly), and central nervous system (microcephaly, seizures, intellectual disability) may also be present. Patients with hypomelanosis of Ito might have two genetically distinct cell lines. The mosaicism anomalies that have been observed involve both autosomes and sex chromosomes and have been demonstrated in about

**Table 99.9** Other Rare Mosaic Aneuploidy Syndromes

DISORDER	KARYOTYPE	CLINICAL MANIFESTATIONS
Trisomy 8	47,XX/XY,+8	Variable growth and intellectual deficiency The majority of patients are mosaic Deep palmar and plantar furrows Joint contractures
Trisomy 9	47,XX/XY,+9	The majority of patients are mosaic Craniofacial (high forehead, microphthalmia, low-set malformed ears, bulbous nose) Skeletal (joint contractures) Heart defects (60%)
Trisomy 16	47,XX/XY,+16	The most commonly observed autosomal aneuploidy in spontaneous abortion Recurrence risk negligible
Tetrasomy 12p	46,XX[12]/46,XX,+i(12p)[8] (mosaicism for an isochromosome 12p)	Pallister-Killian syndrome Sparse anterior scalp hair (more so temporal region), eyebrows, and eyelashes; prominent forehead; full cheeks; long philtrum with thin upper lip and cupid-bow configuration; polydactyly; streaks of hyper- and hypopigmentation

50% of clinically affected patients. The mosaicism might not be visible in lymphocyte-derived chromosome studies; it is more likely to be found when chromosomes are analyzed from skin fibroblasts. The distinct cell lines might not always be caused by observable chromosomal anomalies but might result from single-gene pathogenic variants or other mechanisms.

## 99.6 Chromosome Instability Syndromes

Carlos A. Bacino and Brendan Lee

Chromosome instability syndromes, formerly known as *chromosome breakage syndromes*, are characterized by an increased risk of malignancy and specific phenotypes. They display autosomal recessive inheritance and have an increased frequency of chromosome breakage and/or rearrangement, either spontaneous or induced. Chromosome instability syndromes result from specific defects in DNA repair, cell cycle control, and apoptosis. The resulting chromosomal instability leads to the increased risk of developing neoplasms. The classic chromosome instability syndromes are Fanconi anemia, ataxia telangiectasia, Nijmegen syndrome, ICF (immunodeficiency, centromere instability, facial anomalies) syndrome, Roberts syndrome, and Bloom syndrome (Table 99.10).

## 99.7 Uniparental Disomy and Imprinting

Carlos A. Bacino and Brendan Lee

### UNIPARENTAL DISOMY

Uniparental disomy (UPD) occurs when both chromosomes of a pair or areas from one chromosome in any individual have been inherited from a single parent. UPD can be of two types, uniparental *isodisomy* or uniparental *heterodisomy*. **Uniparental isodisomy** means that both chromosomes or chromosomal regions are identical (typically the result of monosomy rescue by duplication). **Uniparental heterodisomy** means that the two chromosomes are different members of a pair, both of which were still inherited from one parent. This results from a trisomy that is later reduced to disomy, leaving two copies from one parent. The phenotypic result of UPD varies according to the chromosome involved, the parent who contributed the chromosomes, and whether it is isodisomy or heterodisomy. Three types of phenotypic effects are seen in UPD: those related to imprinted genes (i.e., the absence of a gene that is normally expressed only when inherited from a parent of a specific sex), those related to the uncovering of autosomal recessive disorders, and those related to a vestigial aneuploidy producing mosaicism (see Chapter 97).

In **uniparental isodisomy**, both chromosomes or regions (and thus the genes) in the pair are identical. This is particularly important when the parent is a carrier of an autosomal recessive disorder. If the offspring of a carrier parent has UPD with isodisomy for a chromosome that carries an abnormal gene, the abnormal gene will be present in two copies, and the phenotype will be that of the autosomal recessive disorder; the child has an autosomal recessive disorder even though only one parent is a carrier of that recessive disorder. It is estimated that all humans carry approximately 20 abnormal autosomal recessive genes. Some autosomal recessive disorders, such as spinal muscular atrophy, cystic fibrosis, cartilage-hair hypoplasia,  $\alpha$ - and  $\beta$ -thalassemias, and Bloom syndrome, have been reported in cases of UPD. The possibility of uniparental isodisomy should also be considered when a person is affected with >1 recessive disorder because the abnormal genes for both disorders could be carried on the same isodisomic chromosome. Uniparental isodisomy is a *rare* cause of recessively inherited disorders. Uniparental isodisomies can also be detected by SNP microarrays.

**Maternal UPD** involving chromosomes 2, 7, 14, and 15 and **paternal UPD** involving chromosomes 6, 11, 15, and 20 are associated with phenotypic abnormalities of growth and behavior. UPD of maternal chromosome 7 is associated with Russell-Silver syndrome with intra-uterine growth restriction. These phenotypic effects may be related to imprinting (see later) (Fig. 99.11).

Although microdeletions cause the majority of cases, UPD for chromosome 15 is seen in some instances of Prader-Willi syndrome and Angelman syndrome. In **Prader-Willi syndrome**, approximately 25–29% of cases have maternal UPD (missing the paternal chromosome 15) (Fig. 99.12). In **Angelman syndrome**, paternal UPD of chromosome 15 is only observed in approximately 5% of the cases (missing the maternal chromosome 15). The phenotype for Prader-Willi syndrome and Angelman syndrome in cases of UPD is thought to result from the lack of specific parental contributions from chromosome 15. In Prader-Willi syndrome the paternal contribution is missing, and the maternal contribution is missing in Angelman syndrome. Prader-Willi syndrome may be caused by paternal deficiency of a cluster of small nucleolar RNAs (snoRNAs).

**Table 99.10** Chromosome Instability Syndromes

SYNDROME	LABORATORY FINDINGS AND GENES INVOLVED	CLINICAL FINDINGS
Fanconi anemia (FA)	Chromosome breakage induced by diepoxybutane and mitomycin C There are at least 21 FA genes, most are autosomal recessive, only one is X linked	Short stature, microcephaly in 1/3 of cases, radial ray defects including thumb anomalies, pancytopenia, skeletal anomalies, renal anomalies, café-au-lait macules, ear abnormalities and hearing loss
Ataxia telangiectasia	Chromosome instability with rearrangements between chromosomes 7 and 14 in lymphocytes often involving the T-cell receptors in those chromosomes Decreased IgA levels Pathogenic variants in the <i>ATM</i> gene. Autosomal recessive	Progressive cerebellar ataxia with later development of conjunctival telangiectasias, choreoathetosis, and dystonia Sinopulmonary infections Predisposition to malignancies like B-cell lymphomas, T-cell leukemias and solid tumors
Nijmegen syndrome	Translocations involving chromosomes 7 and 14 in up to 50% of cells Pathogenic variants in the <i>NBN</i> gene (autosomal recessive)	IUGR, short stature, progressive microcephaly, and intellectual disability, recurrent sinopulmonary infections Susceptibility to malignancies before age 20 years like T- and B-cell lymphomas, medulloblastomas, gliomas, rhabdomyosarcoma
ICF (immunodeficiency, centromere instability, facial anomalies) syndrome, types I and II	Pericentromeric chromosomal instability on PHA-stimulated metaphases in chromosomes 1, 9, and 16 Decrease of IgG and IgE in type I, IgM and IgE in type II Low T cells, like NK cells. Pathogenic variants in <i>DNMT3B</i> and <i>ZBTB24</i> genes in types I and II, respectively Autosomal recessive	Immunodeficiency, recurrent infections, intellectual disability, facial dysmorphic features
Roberts-SC phocomelia syndrome	Premature chromosome separation with chromatid/centromere repulsion in prophase or early metaphase easily detected using C-banding Pathogenic variants in <i>ESCO2</i> gene Autosomal recessive	Prenatal growth deficiency, absent or hypoplastic arms typically symmetric with reduction of digits' length including thumbs that are usually more affected than lower extremities, bilateral cleft lip and palate, dysmorphic features, cardiac anomalies, renal anomalies, and intellectual disability
Bloom syndrome	Marked chromosomal increase of sister chromatid exchange in the presence of BrdU and increased spontaneous chromosome breakage Decreased IgG, IgA, IgM Pathogenic variants in the <i>RECQL3</i> gene. Autosomal recessive	Severe prenatal and postnatal growth deficiency, microcephaly (average intelligence), sensitivity to sunlight (butterfly distribution over the face), café-au-lait macules, insulin resistance, predisposition to malignancies: lymphomas, leukemias, squamous cell carcinoma and solid tumors Hypersensitivity to chemotherapy
Werner syndrome	"Variegated translocation mosaicism": chromosomal aberrations, including translocations, inversions, and deletions Telomere loss Pathogenic variants in <i>RECQL2</i> Autosomal recessive	Short stature, premature aging appearance, and predisposition to malignancies Loss and graying of hair, hoarseness, scleroderma-like changes in the 20s Cataracts, type II diabetes, osteoporosis, hypogonadism in the 30s Neoplasms in >40% of cases including sarcomas, melanomas, and thyroid cancer Myocardial infarction and malignancies are cause of early death

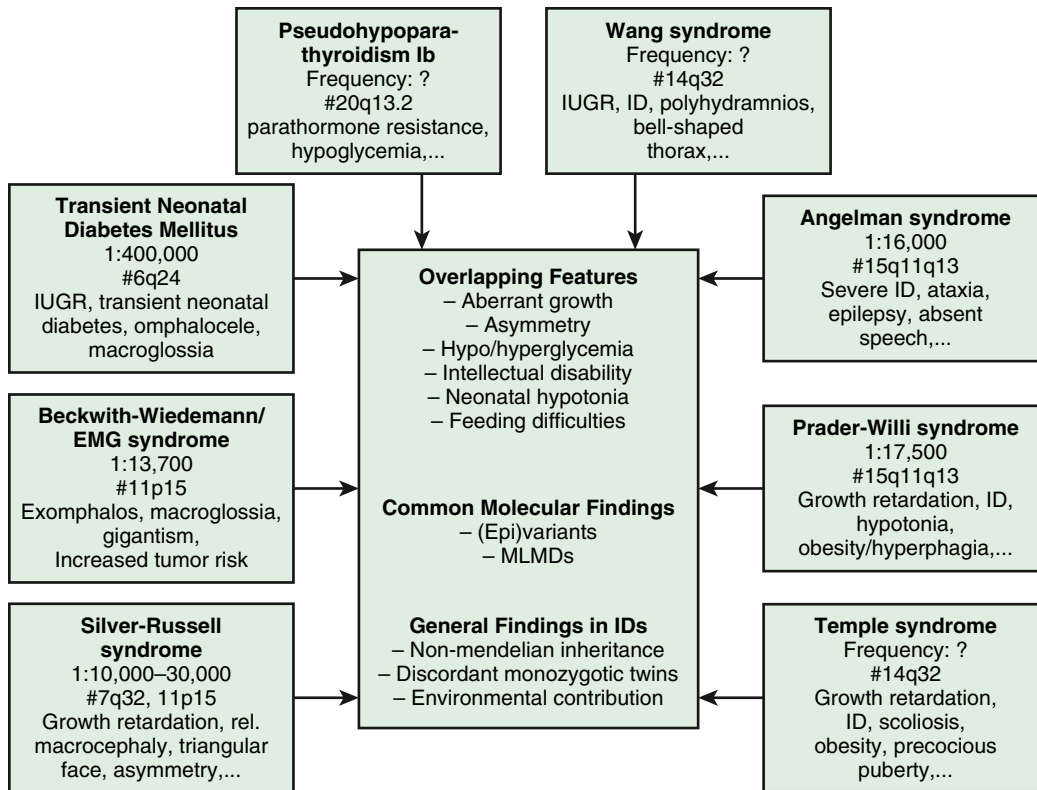
IUGR, Intrauterine growth restriction; PHA, phytohemagglutinin; NK, natural killer.

These findings suggest that there are differences in function of certain regions of chromosome 15, depending on whether it is inherited from the mother or from the father. Angelman syndrome is caused by absent function of the maternal gene *UBE3A* and can be the result of maternal deletion, maternal *UBE3A* pathogenic variant, paternal UPD, and abnormalities in the maternal imprinting center on chromosome 15q11-13 region.

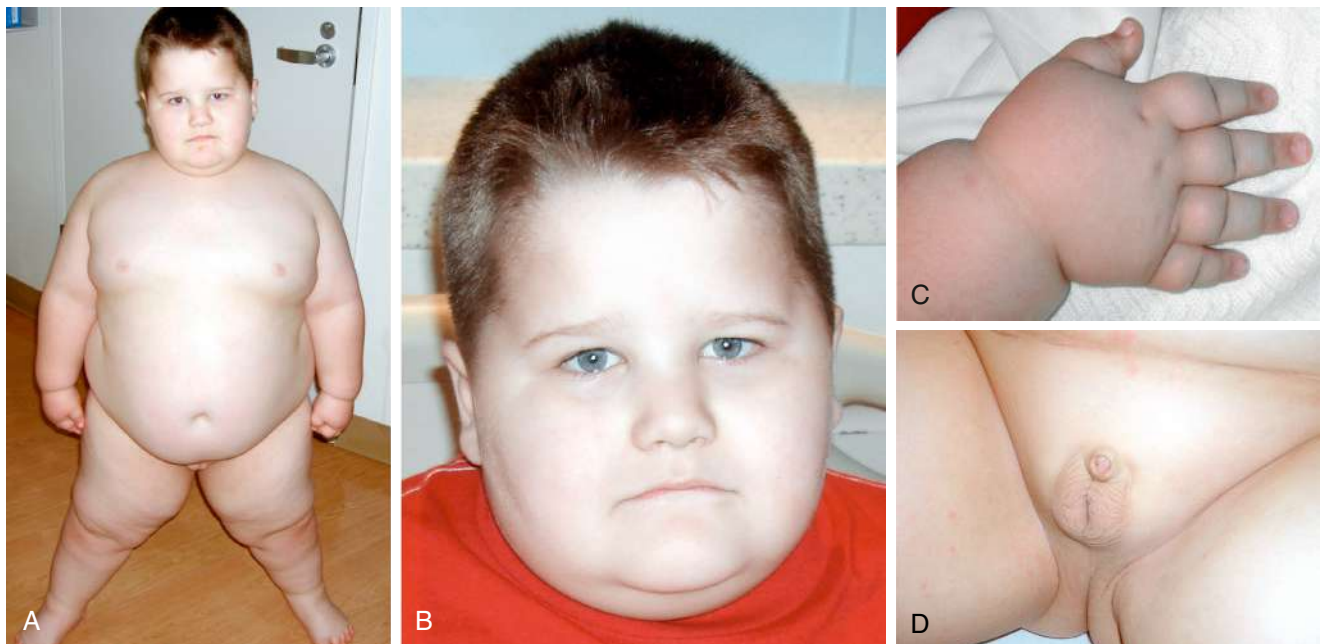
UPD most frequently arises when a pregnancy starts off as a **trisomic conception** followed by **trisomy rescue**. Because most trisomies are lethal, the fetus can only survive if a cell line loses one of the extra chromosomes to revert to the disomic state. One third of the time, the disomic cell line is uniparental. This is the

typical mechanism for Prader-Willi syndrome, and it is often associated with advanced maternal age. The embryo starts off as trisomy 15 secondary to maternal meiosis I nondisjunction, followed by random loss of the paternal chromosome. In this case the disomic cell line becomes the more viable one and outgrows the trisomic cell line. When mosaic trisomy is found at prenatal diagnosis, care should be taken to determine whether UPD has resulted and whether the chromosome involved is one of the disomies known to be associated with phenotypic abnormalities (i.e., chromosome involved in UPD containing imprinted genes). There must always be concern that some residual cells that are trisomic are present in some tissues, leading to malformations or dysfunction. The



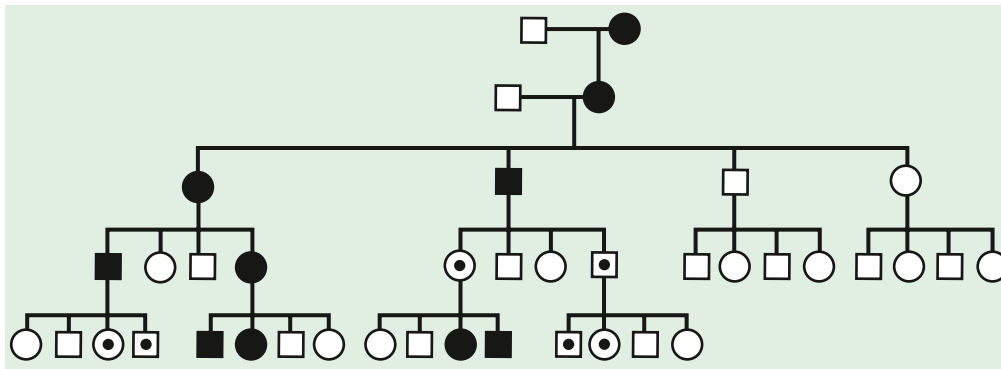


**Fig. 99.11** Overview of the common clinical and molecular findings in the eight known imprinting disorders, including specific features, frequencies, and major chromosomal localization. #6q24, Chromosome 6q24; EMG, exomphalos-macroglossia-gigantism; IUGR, intrauterine growth restriction; ID, intellectual disability; MLMDs, multilocus methylation defects. (From Eggemann T, Elbracht M, Schröder C, et al. *Congenital imprinting disorders: a novel mechanism linking seemingly unrelated disorders.* *J Pediatr.* 2013;163:1204.)

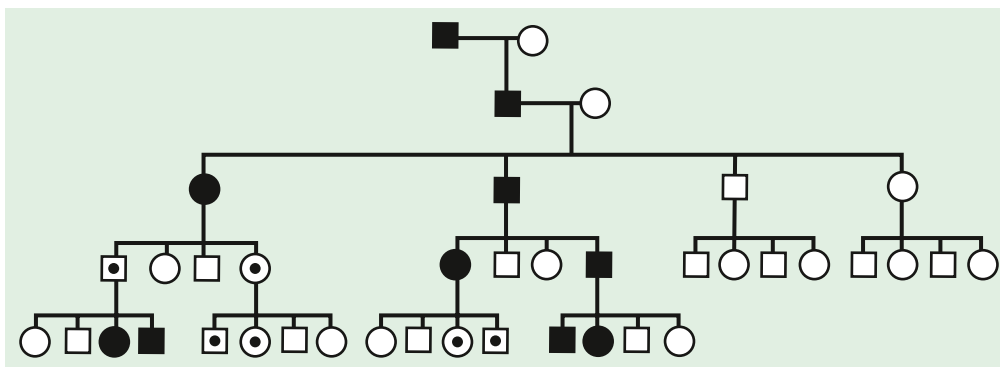


**Fig. 99.12** Prader-Willi phenotype. A and B, Individual showing morbid obesity with facial features as shown. C, Upper extremities are notable for small hands relative to body size. D, External genitalia after laparoscopic orchiopexy at 13 months. Parental informed consent, as approved by the Baylor College of Medicine Institutional Review Board, was obtained to publish the photographs. (From Sahoo T, del Gaudio D, German JR, et al. *Prader-Willi phenotype caused by paternal deficiency for the HBII-85 C/D box small nucleolar RNA cluster.* *Nat Genet.* 2008;40:719–721.)





**Fig. 99.13** In this hypothetical pedigree suggestive of imprinting, phenotypic effects occur only when the mutated gene is transmitted from the mother, but not when it is transmitted from the father, that is, maternal deficiency. Equal numbers of males and females can be affected and not affected phenotypically in each generation. A nonmanifesting transmitter gives a clue to the sex of the parent who passes the expressed genetic information; that is, in maternal deficiency disorders (also termed *paternal imprinting*), there are “skipped” nonmanifesting females. This is theoretical, because in most clinical scenarios of maternal deficiency, such as Angelman syndrome, affected persons do not reproduce.



**Fig. 99.14** In theoretical pedigrees suggestive of paternal deficiency (maternal imprinting), phenotypic effects occur only when the mutated gene is transmitted from the father but not when transmitted from the mother. Equal numbers of males and females can be affected and not affected phenotypically in each generation. In a theoretical situation, a nonmanifesting transmitter gives a clue to the sex of the parent who passes on the expressed genetic information; that is, in paternal deficiency (also known as *maternal imprinting*), there are “skipped” nonmanifesting males. In real-life clinical cases of Prader-Willi syndrome, affected persons do not reproduce.

**Table 99.11** Consensus Diagnostic Criteria for Prader-Willi Syndrome

	MAJOR CRITERIA (1 POINT EACH)	MINOR CRITERIA (1/2 POINT EACH)
1	Neonatal/infantile hypotonia	Decreased fetal movement and infantile lethargy
2	Feeding problems and failure to thrive as an infant	Typical behavior problems
3	Weight gain at 1-6 years; obesity; hyperphagia	Sleep apnea
4	Characteristic dysmorphic facial features	Short stature for family by 15 years
5	Small genitalia; pubertal delay and insufficiency	Hypopigmentation for the family
6	Developmental delay/intellectual disability	Small hands and feet for height
7		Narrow hands, straight ulnar border
8		Esotropia, myopia
9		Thick, viscous saliva
10		Speech articulation defects
11		Skin picking

From Cassidy SB, Schwartz S, Miller JL, Driscoll DJ. Prader-Willi syndrome. *Genet Med.* 2012;14(1):15. Table 2.

**Table 99.12** Nutritional Phases in Prader-Willi Syndrome

PHASE	MEDIAN AGES	CLINICAL CHARACTERISTICS
0	Prenatal to birth	Decreased fetal movements and lower birthweight than siblings
1a	0-9 mo	Hypotonia with difficulty feeding and decreased appetite
1b	9-25 mo	Improved feeding and appetite and growing appropriately
2a	2.1-4.5 yr	Weight increasing without appetite increase or excess calories
2b	4.5-8 yr	Increased appetite and calories, but can feel full
3	8 yr to adulthood	Hyperphagic, rarely feels full
4	Adulthood	Appetite is no longer insatiable

Modified from Miller JL, Lynn CH, Driscoll DC, et al. Nutritional phases in Prader-Willi syndrome. *Am J Med Genet A*. 2011;155A:1040–1049.

**Table 99.13** Molecular Mechanisms Causing Prader-Willi and Angelman Syndromes

	PRADER-WILLI SYNDROME	ANGELMAN SYNDROME
15q11-q13 deletion	~70% (paternal)	~70% (maternal)
Uniparental disomy	~30% (maternal)	~5% (paternal)
Single-gene pathogenic variants	None detected	<i>UBE3A</i> gene encoding the E6-AP ubiquitin-protein ligase (11% of total but mostly in familial cases)
Imprinting center pathogenic variants	5%	1%
Unidentified	<1%	10–15%

Data from Nicholls RD, Knepper JL. Genome organization, function and imprinting in Prader-Willi and Angelman syndromes. *Annu Rev Genomics Hum Genet*. 2001;2:153–175; and Horsthemke B, Buiting K. Imprinting defects on human chromosome 15. *Cytogenet Genome Res*. 2006;113:292–299.

presence of aggregates of trisomic cells might account for the spectrum of abnormalities seen in persons with some UPDs.

## IMPRINTING

Genomic imprinting occurs when the phenotypic expression of a gene depends on the *parent of origin* for certain genes or chromosome regions. Whether the genetic material is expressed or not depends on the sex of the parent from whom it was derived. Genomic imprinting can be suspected in some cases on the basis of a pedigree. In these pedigrees the disease is always transmitted from the same sex and could be passed on silently for several generations by the opposite sex (Figs. 99.13 and 99.14). Imprinting probably occurs in many different parts of the human genome and is thought to be particularly important in gene expression related to development, growth, cancer, and behavior; >60 genes have been classified as imprintable. Imprinting disorders may arise from UPD, deletions or duplications, epigenetic aberrant methylation patterns, or single nucleotide pathogenic variants in a specific gene.

A classic example of imprinting disorder is seen in **Prader-Willi syndrome** and **Angelman syndrome**, two very different clinical conditions. These syndromes are both commonly caused by a deletion of the

same region in the proximal long arm of chromosome 15. A deletion of the paternally derived chromosome causes Prader-Willi syndrome, in which the maternally derived copy is still intact, for which some of the imprinted genes within this region normally remain silent. Prader-Willi syndrome can be diagnosed clinically (Table 99.11) and confirmed with genetic testing. Additional clinical features and issues of weight gain are noted in Table 99.12. The weight gain is difficult to control, but treatment with growth hormone has resulted in improvements in height, lean body mass, decreased adipose tissue, and improvement in cognitive function.

A maternal deletion of the same region as in Prader-Willi syndrome causes Angelman syndrome, leaving intact the paternal copy that in this case has genes that are also normally silent. In other situations, UPD can lead to the same diagnosis (Table 99.13). Many other disorders are associated with this type of parent-of-origin effect, as in some cases of Beckwith-Wiedemann syndrome (see Chapter 598.1), Russell-Silver syndrome, and neonatal diabetes.

Visit Elsevier eBooks+ at [eBooks.Health.Elsevier.com](http://eBooks.Health.Elsevier.com) for Bibliography.

## Chapter 100

Dysmorphology,  
Phenotyping, and  
Sequences

Anne M. Slavotinek

*Dysmorphology* is the study of differences in human form and the mechanisms that cause them. It has been estimated that 1 in 40 newborns, or 2.5%, have a recognizable birth defect or pattern of malformations at birth; ~50% of these newborns have a single, isolated malformation, whereas in the other half, multiple malformations are present. About 20–30% of infant deaths and 30–50% of deaths after the neonatal period are caused by congenital abnormalities (<http://www.marchofdimies.com/peristats/>). In 2021, birth defects accounted for ~1 in 5 infant deaths in the United States, with a rate of 108.2 deaths per 100,000 live births, which was higher than other causes of mortality, such as preterm/low birthweight (80.4/100,000), sudden infant death syndrome (39.8/100,000), maternal complications of pregnancy (33.4/100,000), and unintentional injury (33.5/100,000).

## CLASSIFICATION OF BIRTH DEFECTS

Birth defects can be subdivided into isolated (single) defects or multiple defects, typically described as multiple congenital anomalies (MCAs). An isolated primary defect can be classified, according to the presumed cause of the defect, as a malformation, dysplasia, deformation, or disruption (Table 100.1 and Fig. 100.1). Most birth defects are malformations, a term used interchangeably with anomalies. A malformation is a structural defect arising from a *localized* error in morphogenesis that results in the abnormal formation of a tissue or organ. Dysplasia refers to the *abnormal organization of cells* into tissues. Malformations and dysplasias can both affect the intrinsic structure of tissues and organs. In contrast, a deformation is an *alteration* in the shape or form of a structure or organ that has previously developed or differentiated normally. A disruption is a defect resulting from the *destruction* of a structure that had formed normally before the insult.

Most human disorders with altered morphogenesis display multiple anomalies or malformations rather than an isolated birth defect. When

several malformations coexist in a single individual, they can be classified as a syndrome, sequence, or an association. A **syndrome** is defined as a pattern comprising multiple anomalies that are related by pathophysiology, resulting from a single, defined etiology. **Sequences** consist of multiple anomalies that are caused by a single event, although the sequence itself can have different etiologies. An **association** refers to a nonrandom grouping of anomalies in which there is an unclear, or unknown, relationship among the anomalies, such that they do not fit the criteria for a syndrome or sequence.

## Malformations and Dysplasias

Human anomalies and dysplasias can be caused by pathogenic gene variants, chromosome aberrations and copy number variants, environmental factors, or interactions between genetic and environmental factors (Table 100.2). Some malformations are caused by deleterious sequence variants in single genes, whereas other anomalies arise because of deleterious sequence variants in multiple genes acting in combination, termed *digenic* or *oligogenic* inheritance. In the past, it was thought that malformations were caused by monogenic pathogenic variants in 7.5% of patients; chromosomal anomalies in 6%; multigenic pathogenic variants in 20%; and known environmental factors, such as maternal diseases, infections, and teratogens, in 6–7% (Table 100.3). In the remaining 60–70% of patients, malformations were classified as having an unknown etiology. Currently, the percentages have increased for all of the possible genetic etiologies of malformations due to improved cytogenetic and molecular genetic methods, including microarrays and single nucleotide polymorphism (SNP) arrays for detecting copy number variants, and next-generation sequencing (NGS) technologies, such as exome or genome sequencing, for identifying novel genes and pathogenic sequence variants.

Many developmental abnormalities caused by *pathogenic sequence variants* in a single gene display characteristic of mendelian patterns of inheritance such as autosomal dominant, autosomal recessive, and X-linked inheritance. Genes that cause birth defects or MCA syndromes are often transcription factors, part of evolutionarily conserved signal transduction pathways, or regulatory proteins required for key developmental events (see Chapters 101 and 102 and Table 100.2).

In addition, syndromes with MCA can be caused by chromosomal aberrations or copy number variants and teratogens (see Tables 100.2 and 100.3). **Down syndrome** typically results from an extra copy of an entire chromosome 21 or, less frequently, an extra copy of the Down syndrome critical region on chromosome 21. Chromosome 21 is a small chromosome that contains an estimated 250 genes, and thus individuals with Down syndrome typically have an increased dosage

Table 100.1 Mechanisms, Terminology, and Definitions of Dysmorphology

TERMINOLOGY	DEFINITION	EXAMPLE
Sequence	Single error in morphogenesis that results in a series of subsequent defects	Pierre-Robin sequence, in which a small jaw results in glossoptosis and cleft palate 22q11 deletion sequence of primary fourth brachial arch and third and fourth pharyngeal pouch defects, leading to aplasia or hypoplasia of the thymus and parathyroid glands, aortic arch anomalies, and micrognathia
22q11 deletion	Mechanical (uterine) force that alters structure of intrinsically normal tissue	Oligohydramnios produces deformations by in utero compression of limbs (e.g., dislocated hips, equinovarus foot deformity), crumpled ears, or small thorax
Disruption sequence	In utero tissue destruction after a period of normal morphogenesis	Amnionic membrane rupture sequence, leading to amputation of fingers/toes, tissue fibrosis, and tissue bands
Dysplasia sequence	Atypical organization of cells into tissues or organs	Neurocutaneous melanosis sequence, with atypical migration of melanocyte precursor cells from the neural crest to the periphery, manifesting as melanocytic hamartomas of skin and meninges
Malformation syndrome	Appearance of multiple malformations in unrelated tissues that have a known, unifying cause	Trisomy 21 Teratogens Numerous multiple congenital anomaly syndromes as described above



**Fig. 100.1** Four major types of problems in morphogenesis: malformation, deformation, disruption, and dysplasia. A, Infant with campomelic dysplasia syndrome, which results in multiple anomalies caused by a pathogenic variant in *SOX9*. B, Infant with oligohydramnios deformation sequence caused by premature rupture of membranes from 17 weeks' gestation until birth at 36 weeks; the infant was delivered from a persistent transverse lie. C, Fetus with early amnion rupture sequence with attachment of the placenta to the head and resultant disruption of craniofacial structures with distal limb contractures. D, Infant with diastrophic dysplasia caused by biallelic pathogenic variants in a sulfate transporter protein. (From Graham Jr JM. *Smith's Recognizable Patterns of Human Deformation*, 3rd ed. Philadelphia: Saunders; 2007, Fig. 1-1, p. 4.)

for the genes encoded by this chromosome that causes their physical differences (see Chapter 57).

**Neural tube defects (NTDs)** are an example of a birth defect that typically displays multifactorial inheritance. NTDs and other birth defects, such as cleft lip and palate, can recur in families, but inheritance for the majority of affected individuals does not follow a straightforward, mendelian inheritance pattern, and multiple genes and environmental factors acting together likely contribute to the pathogenesis (see Table 100.2). Many of the genes involved in NTDs are unknown, so one cannot predict with certainty the mode of inheritance or a precise recurrence risk for an individual case. Empirical recurrence risks can be provided on the basis of population studies and the presence of single or multiple family members with the same malformation. However, one important gene/environment interaction has been identified for NTDs (see Chapter 631.1). **Folic acid deficiency** is associated with NTDs and can result from a combination of dietary factors and increased utilization during pregnancy. A common variant in the gene for an enzyme in the folate recycling pathway, 5,10-methylene-tetrahydrofolate reductase (*MTHFR*), that makes this enzyme less stable, may also be important in folic acid status. Several teratogenic causes of birth defects have been described (see Tables 100.2 and 100.3). **Ethanol** causes a recognizable pattern of anomalies that is variably called fetal alcohol syndrome (FAS), fetal alcohol spectrum disorder (FASD), or fetal alcohol effects (FAE) (see Chapter 146). Children who were exposed to ethanol during the pregnancy can display microcephaly, developmental delays, hyperactivity, and facial anomalies. Ethanol, which is toxic to the developing central nervous system (CNS), causes cell death in developing neurons.

### Deformations

Many deformations involve the musculoskeletal system (Fig. 100.2). Fetal movement is required for the proper development of the musculoskeletal system, and restriction of fetal movement can result in musculoskeletal deformations, such as clubfoot, or talipes. Two major intrinsic etiologies of deformations are **primary neuromuscular disorders** and **oligohydramnios**, or decreased amniotic fluid, which can be caused by fetal renal defects. Both primary neuromuscular disorders and oligohydramnios can compromise fetal movements. The major extrinsic causes of deformations are those that result in fetal crowding and restriction of fetal movement. Examples of extrinsic causes include oligohydramnios resulting from chronic leakage of amniotic fluid, and abnormal shape of the amniotic cavity. When a fetus is in the breech position (Fig. 100.3), the incidence of deformations is increased 10-fold. The shape of the amniotic cavity also has a profound effect on the

shape of the fetus and is influenced by many factors, including uterine shape and the volume of amniotic fluid (Fig. 100.4).

It is important to determine whether deformations result from intrinsic or extrinsic causes. Most children with deformations from *extrinsic* causes are otherwise completely normal, and their prognosis is usually excellent. Correction typically occurs spontaneously. Deformations caused by *intrinsic* factors, such as multiple joint contractures resulting from CNS or peripheral nervous system defects, have a different prognosis and may be much more significant for the child (Fig. 100.5).

### Disruptions

Disruptions are caused by destruction of a previously normally formed organ or body part. At least two mechanisms are known to produce disruptions. One involves entanglement followed by tearing apart, or amputation, of a normally developed structure, usually a digit or limb, by strands of amnion floating within amniotic fluid that are termed amniotic bands (Fig. 100.6). The other mechanism involves interruption to the blood supply to a developing body part, which can lead to infarction, necrosis, and resorption of structures distal to the insult. If interruption to the blood supply occurs early in gestation, the disruptive defect typically involves **atresia**, or absence of a body part. Genetic factors have been considered to play a minor role in the pathogenesis of disruptions, as most occur as sporadic events in otherwise healthy individuals, but little is known regarding etiology. The prognosis for a disruptive defect is determined entirely by the extent and location of the tissue loss.

### Multiple Anomalies: Sequences, Associations, and Syndromes

The pattern of multiple anomalies that occurs when a single primary defect in early development produces multiple anomalies because of a cascade of secondary and tertiary developmental effects is called a *sequence* (Fig. 100.7). When evaluating a child with MCAs, the physician must differentiate between multiple anomalies that are caused by a single localized error in morphogenesis (a sequence) from syndromes with multiple anomalies. In the former, recurrence risk counseling for the multiple anomalies depends entirely on the risk of recurrence for the single, localized malformation. **Pierre-Robin sequence** is a pattern of multiple anomalies produced by mandibular hypoplasia. Because the tongue is relatively large for the oral cavity, it drops back (glossop-tosis), blocking closure of the posterior palatal shelves and causing a U-shaped cleft palate. There are numerous causes of mandibular hypoplasia, all of which can result in the characteristic features of Pierre-Robin sequence.

**VATER association** was first defined as the nonrandom occurrence of a combination of congenital anomalies comprising vertebral defects,



**Table 100.2** Examples of Malformations with Distinct Causes, Clinical Features, and Pathogenesis

DISORDER	CAUSE/INHERITANCE	SELECTED CLINICAL FEATURES	PATHOGENESIS
Spondylocostal dysostosis syndrome	Mendelian; autosomal recessive	Abnormal vertebral and rib segmentation	Deleterious sequence variants in <i>DLL3</i> and other genes
Rubinstein-Taybi syndrome	Autosomal dominant	Intellectual disability Broad thumbs and halluces; valgus deviation of these digits Hypoplastic maxillae Prominent nose and columella Congenital heart disease	Deleterious sequence variants in <i>CBP</i> and <i>EP300</i>
X-linked lissencephaly	X-linked	Male: severe intellectual disability, seizures Female: variable	Deleterious sequence variants in <i>DCX</i>
Aniridia	Autosomal dominant	Absent iris or iris/foveal hypoplasia	Deleterious sequence variants in <i>PAX6</i>
Waardenburg syndrome, type I	Autosomal dominant	Deafness White forelock Wide-spaced eyes Iris heterochromia and/or pale skin pigmentation	Deleterious sequence variants in <i>PAX3</i>
Holoprosencephaly	Loss of function or haploinsufficiency for multiple genes	Microcephaly Cyclopia Single central incisor	<i>SHH</i> , multiple other genes
Velocardiofacial syndrome	Microdeletion 22q11.2	Congenital heart disease, including conotruncal defects Cleft palate T-cell defects Facial anomalies	<i>TBX1</i> haploinsufficiency/pathogenic variants; haploinsufficiency for other genes in the deleted interval also contributes to the phenotype
Down syndrome	Additional copy of chromosome 21 (trisomy 21)	Intellectual disability Characteristic facial anomalies Congenital heart disease Increased risk of leukemia Alzheimer disease	Increase in dosage of an estimated 250 genes on chromosome 21
Neural tube defects	Multifactorial	Meningomyelocele	Defects in folate sensitive enzymes or folic acid uptake
Fetal alcohol syndrome	Teratogenic	Microcephaly Developmental delay Facial anomalies Behavioral abnormalities	Ethanol toxicity to developing brain
Retinoic acid embryopathy	Teratogenic	Microtia Congenital heart disease	Isotretinoin effects on neural crest and branchial arch development

anal atresia, tracheoesophageal fistula (TEF) with esophageal atresia, radial anomalies, and renal dysplasia. The association was expanded to include cardiac anomalies (C) and limb anomalies (L), leading to the longer acronym, **VACTERL**. Although there are still no definitively established diagnostic criteria, most clinicians consider that a minimum of three of the seven component features must be present for the diagnosis. In addition, the designation of VATER/VACTERL association is typically one of exclusion; *growth and developmental delays as well as facial anomalies are atypical and should prompt the consideration of alternative diagnoses*. Anorectal defects and TEF are considered more characteristic of VATER/VACTERL association than some of the other components, such as cardiac anomalies. A single umbilical artery is a common finding. The estimated incidence of VATER/VACTERL has ranged from 1 in 10,000 to 1 in 40,000 infants. VACTERL with hydrocephalus, also known as VACTERL-H, is a separate condition.

VATER/VACTERL association has so far defied the identification of a simple mendelian etiology. Many cases are sporadic, although there are rare reports of familial inheritance and first-degree relatives with clinical findings in the component systems of VATER/VACTERL association. Hedgehog signaling has been postulated to be important, as

mouse models with defective Hedgehog and/or ciliary signaling manifest the clinical findings observed in VATER/VACTERL. However, cytogenetic studies have not demonstrated chromosome aberrations or copy number variants. Exome sequencing (ES) has not identified a single causative gene or gene family, although nonrecurrent variants have been described in mendelian disease genes, most typically in patients with renal involvement. Clinical overlap has led to the identification of pathogenic variants in the *SALL1*, *SALL4*, and *MID1* genes in patients with anorectal malformations.

Pathogenic variants in several autosomal recessive genes in the **kyurenine pathway**, including *KYNU*, *HAAO*, and *NADSYN1*, have been associated with a spectrum of anomalies that overlap with VATER/VACTERL association, including vertebral defects, cardiac anomalies, renal malformations, and limb defects of variable severity. Biallelic variants in these genes perturb the synthesis of nicotinamide adenine dinucleotide (NAD) synthesis; these conditions have been grouped together as **congenital NAD deficiency disorders**. The overall contribution of these genes to the pathogenesis of VATER/VACTERL association appears to be small in terms of the entire group of patients but remains an important diagnostic consideration. Interestingly, studies in mice with biallelic

**Table 100.3** Causes of Congenital Malformations**MONOGENIC**

X-linked hydrocephalus  
 Achondroplasia  
 Ectodermal dysplasia  
 Apert syndrome  
 Treacher Collins syndrome

**CHROMOSOMAL ABERRATIONS AND COPY NUMBER VARIANTS**

Trisomy 21, 18, 13  
 XO, XXY  
 Deletions 4p-, 5p-, 7q-, 13q-, 18p-, 18q-, 22q-  
 Prader-Willi syndrome (70% of affected patients have deletion of chromosome 15q11.2-q13)

**MATERNAL INFECTION**

Intrauterine infections (e.g., herpes simplex virus, cytomegalovirus, varicella-zoster virus, rubella virus, Zika virus, toxoplasmosis)

**MATERNAL ILLNESS**

Diabetes mellitus  
 Phenylketonuria  
 Hyperthermia

**UTERINE ENVIRONMENT**

Deformation  
 Uterine pressure, oligohydramnios: clubfoot, torticollis, congenital hip dislocation, pulmonary hypoplasia, seventh nerve palsy  
 Disruption  
 Amniotic bands, congenital amputations, gastroschisis, porencephaly, intestinal atresia  
 Twinning

**ENVIRONMENTAL AGENTS**

Polychlorinated biphenyls  
 Herbicides  
 Mercury  
 Alcohol

**MEDICATIONS**

Thalidomide  
 Diethylstilbestrol  
 Phenytoin  
 Warfarin  
 Cytotoxic drugs  
 Paroxetine  
 Angiotensin-converting enzyme inhibitors  
 Isotretinoin (vitamin A)  
 D-Penicillamine  
 Valproic acid  
 Mycophenolate mofetil

**UNKNOWN ETIOLOGIES**

Neural tube defects, such as anencephaly and spina bifida  
 Cleft lip/palate  
 Pyloric stenosis

**SPORADIC SEQUENCE COMPLEXES**

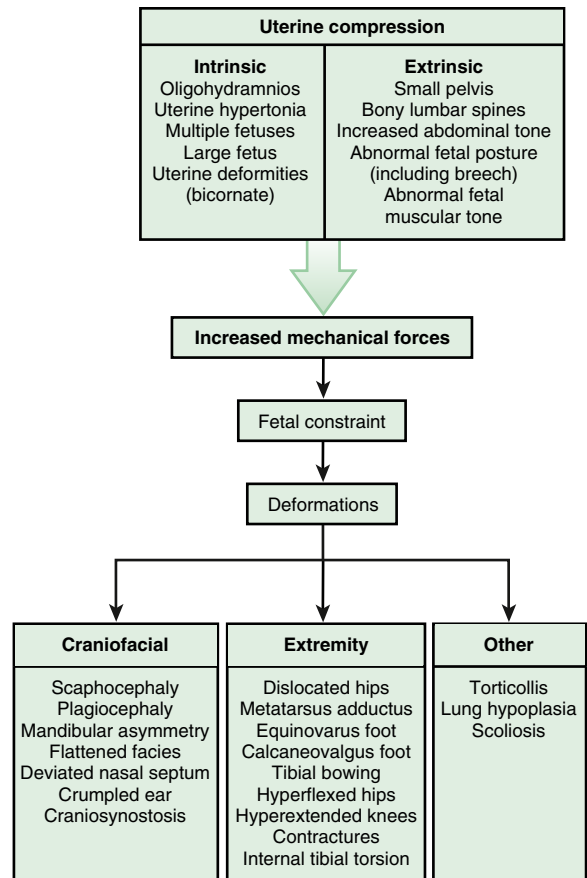
VATER/VACTERL sequence (vertebral defects, anal atresia, cardiac defects, tracheoesophageal fistula with esophageal atresia, radial and renal anomalies)  
 Pierre-Robin sequence

**NUTRITIONAL**

Neural tube defects due to low folic acid

From Behrman RE, Kliegman RM, eds. *Nelson's Essentials of Pediatrics*, 4th ed. Philadelphia: Saunders; 2002.

loss-of-function variants in *Haa0* and *Kynu* that were provided with niacin in their diet showed that the vitamin can overcome the metabolic block associated with loss-of-function for these genes. Niacin enters the NAD biosynthesis pathway downstream to *Haa0* and *Kynu*, and this finding implies that the availability of niacin and other components of the kynurenine pathway can influence NAD levels during pregnancy and consequently the clinical severity resulting from the variants affecting some of the genes involved



**Fig. 100.2** Deformation abnormalities resulting from uterine compression. (From Kliegman RM, Jenson HB, Marc Dante KJ, et al., eds. *Nelson Essentials of Pediatrics*, 5th ed. Philadelphia: Saunders; 2005.)



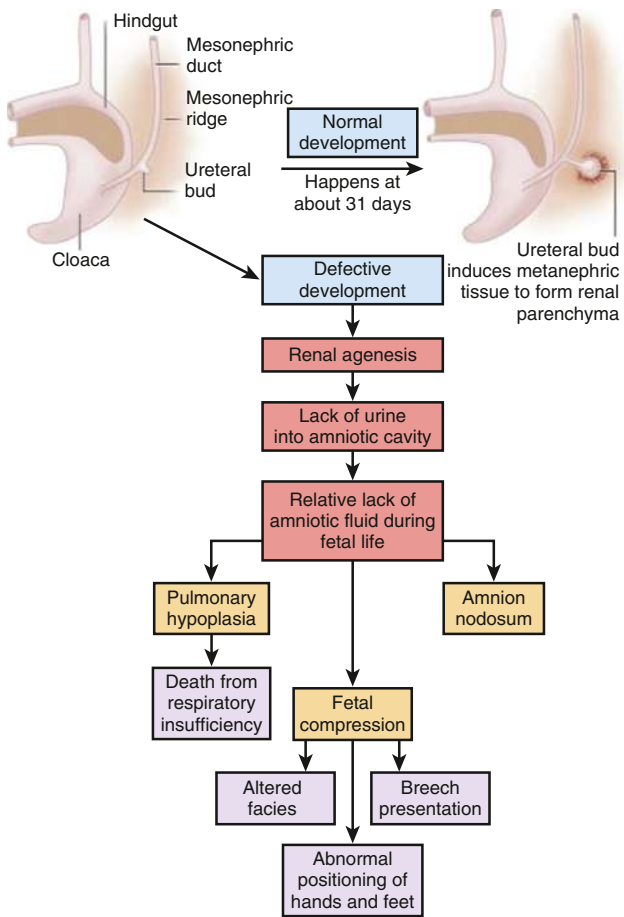
**Fig. 100.3** Breech deformation sequence.

in NAD synthesis. These conditions outline the importance of considering the influence of environmental factors on the phenotype caused by genetic variation.

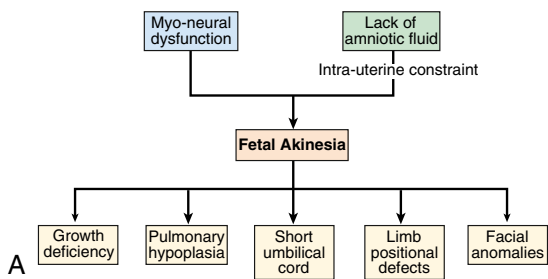
## MOLECULAR MECHANISMS OF MALFORMATIONS

### Inborn Errors of Development

Genes that cause malformation syndromes, as well as genes whose expression is disrupted by environmental agents or teratogens, can participate in numerous cellular processes, including signal transduction, transcription, or the regulation of genes and proteins required for key developmental events. When anomalies are viewed as alterations resulting from disturbances to important developmental pathways, this provides a molecular framework for understanding the birth defects (see [Chapter 101](#)).



**Fig. 100.4** A, Consequences of renal agenesis. B, Multiple deformational defects. C, Defects in amnion nodosum; brown-yellow granules from vernix have been ribbed into defects of the amniotic surface. (From Jones KL, Jones MC, Del Campo M, eds. *Smith's Recognizable Patterns of Human Malformation*, 7th ed. Philadelphia: Elsevier; 2013: p. 821.)



**Fig. 100.5** A, Diagram demonstrating the etiologically heterogeneous phenotype that results from fetal akinesia. B, Infant born with myotonic dystrophy to a mother with the same condition. He had multiple joint contractures with thin bones and respiratory insufficiency. C, Infant immobilized in a transverse lie after amnion rupture at 26 weeks. D, Fetus with bilateral renal agenesis resulting in oligohydramnios. (From Graham JL. *Smith's Recognizable Patterns of Human Malformation*, 3rd ed. Philadelphia: Elsevier; 2007: Fig. 47-2.)



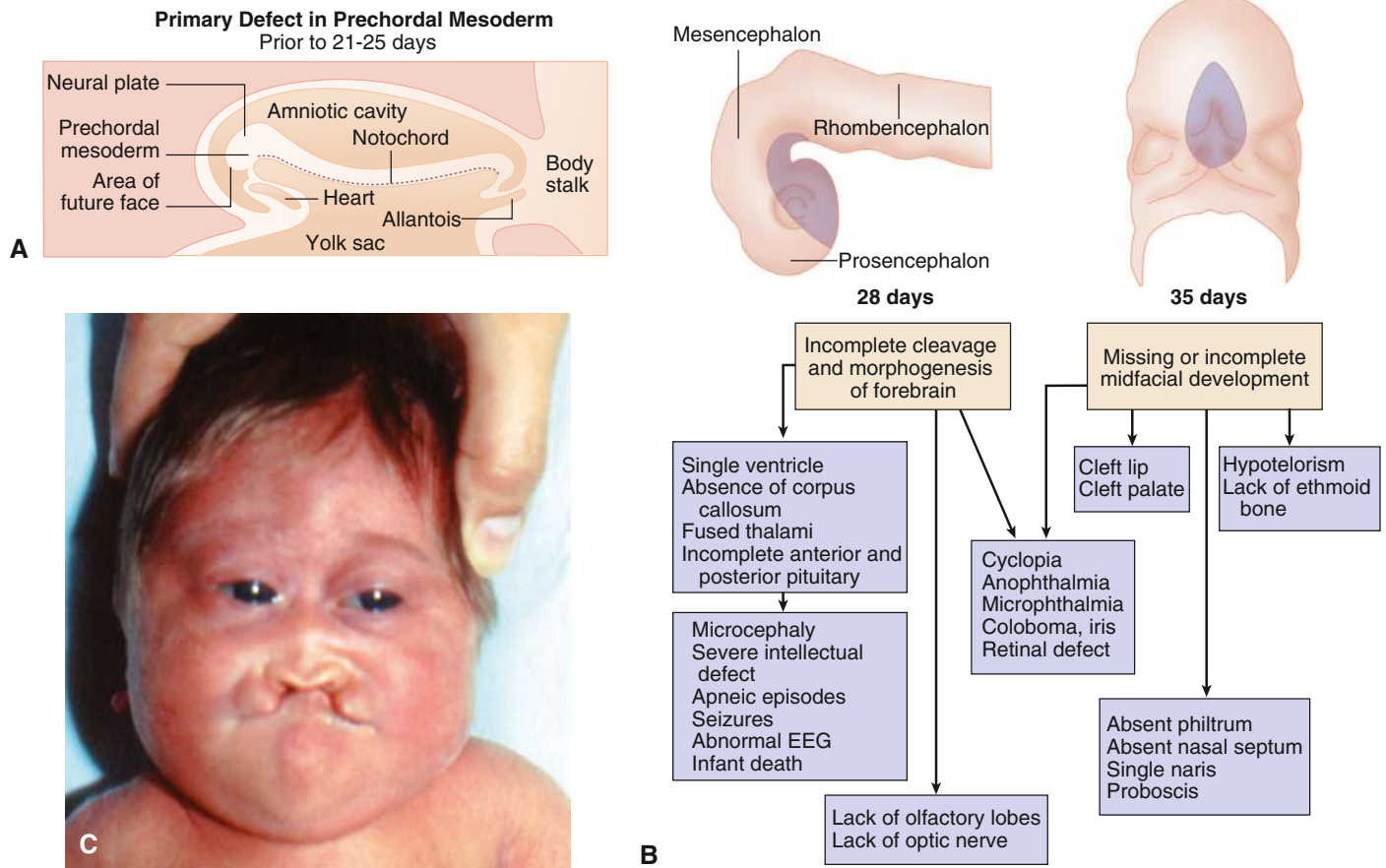
**Fig. 100.6** A, Amniotic band disruption sequence. B, Bands constricting the ankle leading to deformational defects and amputations. (From Jones KJ. *Smith's Recognizable Patterns of Human Malformation*, 6th ed. Philadelphia: Saunders; 2006.)

It is important to consider MCA syndromes as members of a group based on shared or overlapping clinical findings and related causative genes that act in the same developmental or metabolic pathway. See [Chapter 101](#) for the Sonic Hedgehog disorders, RASopathies, craniosynostoses, and chromatin regulatory disorders as examples; disruption of specific steps in this pathway result in a variety of related developmental disorders and anomalies (see [Fig. 100.2](#)).

### Cytogenetic Aberrations and Chromosomal Imbalance

Cytogenetic imbalances resulting from an additional copy of a whole human chromosome can result in characteristic and recognizable





**Fig. 100.7** Holoprosencephaly sequence. A, Schematic longitudinal section of 21-day embryo. B, Developmental pathogenesis of the sequence. C, Affected individual. (From Jones KL, Jones MC, Del Campo M, eds. *Smith's Recognizable Patterns of Human Malformation*, 7th ed. Philadelphia: Elsevier; 2013: pp. 802–803.)

syndromes. An additional copy of chromosome 21 results in **Down syndrome** (see Chapter 57); loss of one of the X chromosomes results in **Turner syndrome** (see Chapter 99.2 for discussion of syndromes with whole chromosomal imbalances). With the advent of high-resolution cytogenetic techniques, such as fluorescence in situ hybridization (FISH), array comparative genomic hybridization (array CGH), and SNP arrays, it has become straightforward to identify **submicroscopic chromosome deletions and duplications**. Several recurrent chromosome deletions and duplications have been identified as the cause of characteristic and recognizable syndromes (see Table 100.6 and Chapter 99), including **Williams syndrome** (deletion of chromosome 7q11.23), **Miller-Dieker syndrome** (deletion of chromosome 17p13.3), **Smith-Magenis syndrome** (deletion of chromosome 17p11.2), and **22q11 deletion syndrome** (deletion of chromosome 22q11.2, also known as **velocardiofacial syndrome**). Collectively, chromosome microarrays (CMAs) and genetic sequencing have made it possible to uncover rare microdeletions, microduplications, and single nucleotide pathogenic variants associated with birth defects, intellectual disability, and neuropsychiatric disorders. The sensitivity and specificity of microarrays made them a standard starting point for the evaluation of a child with MCAs and intellectual disabilities, but exome, genome, and gene panel testing have been preferred due to higher diagnostic yield. It is important to note that unaffected individuals may carry small microdeletions and microduplications as part of familial variation. Therefore it is important to compare copy number variants that are identified in children with birth defects or developmental delays with their parents' chromosome analyses and with databases of normal variants detected in individuals without such birth defects.

### APPROACH TO THE CHILD WITH FACIAL ANOMALIES

One approach to the child with facial anomalies is the *pattern recognition* approach, which compares the physical differences in the patient

against a broad and memorized (or computerized) knowledge of human disorders. This approach can be appropriate for experienced dysmorphologists and clinical geneticists. In conjunction, a systematic *genetic mechanism* approach can also be effective for clinicians who are not dysmorphology experts. By gathering and analyzing the clinical data, the general pediatrician can diagnose the patient in a straightforward case or initiate a referral to an appropriate specialist.

### Medical History

The history for a patient with birth defects includes elements related to etiologic factors. The family history, or *pedigree*, is necessary to assess the inheritance pattern, or lack thereof, for a disorder. For disorders that have a simple mendelian inheritance pattern, recognition of the mode of inheritance can be critical for narrowing the differential diagnosis, then prioritizing common genes with the appropriate inheritance pattern that could cause the patient's clinical features. Many common birth defects have a complex, or multifactorial, genetic etiology, such as isolated cleft palate and spina bifida or NTDs. The recognition of a close relative affected with a birth defect similar to the proband's findings can be useful. Typically, a three-generation pedigree is sufficient for this purpose (see Chapter 97).

The perinatal history is also an essential component of the history. It includes the pregnancy history of the mother, which can be useful for recognition of recurrent miscarriages that may be indicative of a chromosomal disorder, factors that may relate to deformations or disruptions such as oligohydramnios, and maternal exposures to teratogenic drugs or chemicals, including isotretinoin and ethanol, that are potential causes of microcephaly.

Another component of the history that is often useful is the natural history of the **phenotype**. MCA syndromes caused by chromosomal aberrations and single-gene disorders are frequently *static*, meaning that, although the patients can experience new complications over



**Table 100.4** Definitions of Common Clinical Signs of Syndromes with Facial Anomalies

SIGN	DEFINITION
Brachycephaly	A condition in which head shape is shortened from front to back along the sagittal plane; typically the back of the skull (occiput) and face are flatter than normal.
Brachydactyly	Short digits.
Brushfield spots	Speckled white spots or rings about two-thirds of the distance to the periphery of the iris of the eye.
Camptodactyly	Permanent flexion of one or more fingers that can be associated with missing interphalangeal creases.
Clinodactyly	A medial or lateral curving of the fingers or toes; usually refers to incurving of the fifth finger.
Hypoplastic or small nail	A small nail on a digit.
Low-set ears	This designation is made when the helix meets the cranium at a level below a horizontal plane that is an extension of a line through both inner canthi.
Melia	A suffix meaning “limb” (e.g., amelia, missing limb; brachymelia, short limb).
Wide-set eyes	Increased distance between the center of the pupils of the two eyes; can be measured as an <i>increased interpupillary distance</i> (IPD).
Plagiocephaly	A condition in which head shape is asymmetric in the sagittal or coronal plane; can result from asymmetry in cranial suture closure, asymmetry of brain growth, or deformation of the skull.
Posterior hair whorl	A single hair whorl occurs to the right or left of midline and is within 2 cm anterior to the posterior fontanel in 95% of cases.
Postaxial polydactyly	Extra finger or toe present on the lateral side of the hand or foot.
Preaxial polydactyly	Extra finger or toe present on the medial side of the hand or foot.
Prominent lateral palatine ridges	Relative overgrowth of the lateral palatine ridges that can be caused by a deficit of tongue thrust into the hard palate.
Scaphocephaly	A condition in which the head is elongated from front to back in the sagittal plane; most normal skulls are scaphocephalic; also termed <i>dolichocephaly</i> .
Shawl scrotum	The scrotal skin joins around the superior aspect of the penis and represents a mild deficit in full migration of the labial-scrotal folds.
Short palpebral fissures	Decreased horizontal distance of the eyelid folds based on measurements from the inner canthus to the outer canthus.
Syndactyly	Incomplete separation of the fingers or toes. It most commonly occurs between the third and fourth fingers and between the second and third toes.
Synophrys	Eyebrows that meet in the midline.
Telecanthus	Lateral displacement of the inner canthi. The inner canthal distance (ICD) is increased, but the IPD is normal.
Widow's peak	V-shaped midline, downward projection of the scalp hair in the frontal region. It represents an upper forehead intersection of the bilateral fields of periocular hair growth suppression. A widow's peak can occur together with wide-spaced eyes.

time, the phenotype is typically not progressive. In contrast, disorders that cause facial anomalies because of metabolic perturbations, for example, Hunter syndrome or Sanfilippo syndrome, can be mild or may not be apparent at birth, but can progress, causing deterioration of patient status over time.

### Physical Examination

The physical examination is very important for identifying anomalies that can aid a genetic diagnosis. The essential element of the physical evaluation is an assessment of the patient's clinical findings, with the clinician performing an organized evaluation of the size and formation of various body structures. Familiarity with the terminology typically used to describe anomalies is helpful (Table 100.4). The size and shape of the head is relevant; for example, many children with Down syndrome have mild microcephaly and a shortened anteroposterior dimension of skull, termed brachycephaly. Eye position, shape, and the slant of the palpebral fissures are useful signs for many disorders. Reference standards are available with which physical measurements (e.g., interpupillary distance) can be compared. It can be useful to categorize anomalies as “major” or “minor” birth defects. Major defects

either cause significant dysfunction or require surgical correction (see Table 100.5), and minor defects neither cause significant dysfunction nor require surgical correction (e.g., clinodactyly) (Table 100.6 and Fig. 100.8). By cataloging physical parameters, the clinician may be able to identify a characteristic pattern of anomalies and recognize the diagnosis. Facial recognition software has been helpful in identifying the etiology of patients with facial dysmorphology (Fig. 100.9).

### Imaging Studies

Imaging studies can be critical in diagnosing an underlying genetic etiology. If short stature or disproportionate stature (e.g., long trunk and short limbs) is noted, a full skeletal survey with radiographs should be performed. The skeletal survey can detect anomalies in bone number, structure, and formation that can be used to narrow the differential diagnosis. When there are abnormal neurologic signs or symptoms, such as hypotonia, and an abnormal head size, such as microcephaly, brain imaging can be indicated. Other studies and examinations, such as echocardiography, renal ultrasonography, and hearing and ophthalmology evaluation, can also be useful to identify additional major or minor anomalies that may serve as diagnostic clues.

**Table 100.5** Major Malformations\*

<b>NEUROLOGIC</b>	<b>ABDOMINAL WALL</b>
Severe hydrocephalus	Gastroschisis
Lissencephaly	Omphalocele
Schizencephaly	
Megalencephaly	<b>CRANIOFACIAL</b>
Neural tube defect	Craniosynostosis
Meningomyelocele	Facial cleft
Encephalocele	Cleft lip and palate
	Structural eye defect
<b>CARDIOVASCULAR</b>	Coloboma
Various congenital heart	Aniridia
malformations	Structural ear defects
Cardiomyopathy	Microtia
Genetic arrhythmia syndromes	Aplasia of the auditory canal
	<b>LIMB</b>
<b>GENITOURINARY</b>	Amelia
Ambiguous genitalia	Split/hand foot malformation
Kidney malformations	
Urachal defects	
<b>RESPIRATORY</b>	
Congenital pulmonary airway	
malformation	
Tracheoesophageal fistula	

\*Not an inclusive list.

From Basel D. Dysmorphology in a genomic era. *Clin Perinatol.* 2020;47:15–23. Table 1.**Table 100.6** Minor Malformations\*

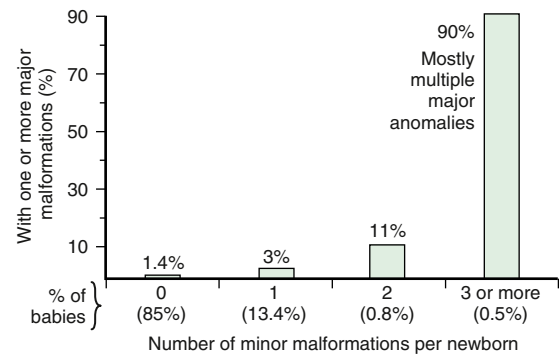
<b>CRANIOFACIAL</b>	<b>HAND</b>
Large fontanel	Simian crease
Flat or low nasal bridge	Bridged upper palmar creases
Saddle nose, upturned nose	Fifth finger clinodactyly
Micrognathia	Joint hypermobility
Cutis aplasia of the scalp	(hyperextension of thumb)
	Cutaneous syndactyly
<b>EYE</b>	Polydactyly
Palpebral fissures	Short, broad thumb
Telecanthus or epicanthus	Narrow or hyperconvex nails
Up or down slanting	Hypoplastic nails
Hypertelorism	Campodactyly
Brushfield spots	Short fourth metacarpal
<b>EAR</b>	<b>FOOT</b>
Posteriorly rotated pinna	Syndactyly of second/third toe
Lack of helical fold	Asymmetric toe length
Preauricular with or without	Clinodactyly of second toe
auricular skin tags	Overlapping toes
Small pinna	Nail hypoplasia
Auricular (preauricular) pit or	Wide gap between hallux and
sinus	second toe
Folding of helix	Deep plantar crease between
Darwinian tubercle	hallux and second toe
Crushed (crinkled) ear	
Asymmetric ear sizes	<b>OTHER</b>
Low-set ears	Mild calcaneovalgus
	Hydrocele
<b>SKIN</b>	Shawl scrotum
Dimpling over the bones	Hypospadias
Capillary hemangioma (face/	Hypoplasia of labia majora
posterior neck)	Supernumerary nipples
Dermal melanosis (African, Asian)	Undescended testes
Sacral dimple	Tongue tie
Pigmented nevi	
Redundant skin folds	
Cutis marmorata	
Café-au-lait macules	

\*Not an inclusive list.

From Basel D. Dysmorphology in a genomic era. *Clin Perinatol.* 2020;47:15–23. Table 2.

## Diagnosis

The examining physician should gather data on the patient's pedigree and perinatal and pediatric history and should have an appreciation for the natural history of the clinical findings. At this point, the physician



**Fig. 100.8** Frequency of major malformations in relation to the number of minor anomalies detected in a given newborn baby. (From Jones KJ. *Smith's Recognizable Patterns of Human Malformation*, 6th ed. Philadelphia: Saunders; 2006.)

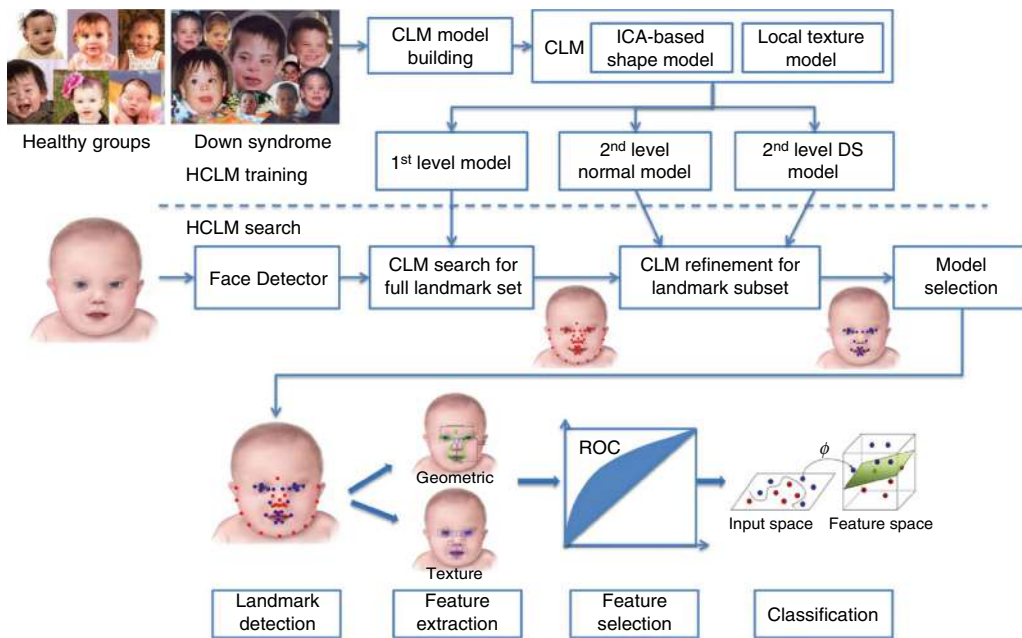
has examined the child, identified atypical physical features, and obtained appropriate imaging studies.

The clinician should now attempt to organize the findings to elucidate potential developmental processes. An assessment based on **specificity** can be helpful for this process. If a child has multiple findings, such as a patent ductus arteriosus (PDA), mild growth restriction, mild microcephaly, and holoprosencephaly, micropenis, and ptosis, a selection of the rarer or pathognomonic findings may be prioritized. The PDA, ptosis, mild growth restriction, and mild microcephaly are considered *nonspecific findings*, as they are present in many disorders or often present as isolated features that are not part of a syndrome. However, holoprosencephaly and micropenis are present in fewer syndromes and are not considered part of normal variation. The clinician can therefore search for disorders that include both holoprosencephaly and micropenis. The search can be performed manually using the features index of a textbook such as *Smith's Recognizable Patterns of Human Malformation* or a computerized database such as Online Mendelian Inheritance in Man (OMIM). Searching for both holoprosencephaly and micropenis returns a list of diagnostic possibilities, and the physician can then return to the patient to examine for additional features of the leading possible candidate disorders. Appropriate genetic testing can then be undertaken to confirm the clinician's hypothesis and verify the diagnosis. Alternatively, broad genetic testing can be undertaken if the patient's clinical findings are nonspecific.

## Laboratory Studies and Genetic Testing

The laboratory evaluation of a child with anomalies can be critical to reach or confirm the correct diagnosis, particularly for metabolic conditions. Array CGH and SNP arrays enable the detection of chromosome abnormalities and copy number variants and, in the case of SNP arrays, evaluation for loss of heterozygosity. Chromosome deletion syndromes may also be identified with specific and sensitive FISH analysis, although this technology has been largely replaced by chromosome arrays and NGS sequencing. Cytogenetic studies with Giemsa-banded (G-banded) chromosome analysis are still useful for the diagnosis of Down syndrome and balanced translocations (Table 100.7). These tests are sensitive methods for the detection of cytogenetic alterations associated with birth defects and MCAs. Cytogenetic alterations can also be detected by whole genome sequencing that is becoming increasingly utilized.

Molecular testing for deleterious sequence variants that cause pleiotropic malformation syndromes is also available for many disorders as clinical testing. In most cases, however, such testing should not be performed indiscriminately; instead, it should be ordered thoughtfully after a differential diagnosis has been considered. *NGS with ES and whole genome sequencing has led to the identification of innumerable novel genes and revolutionized the testing that is available for patients and families with intellectual disability, birth defects, and other genetic diseases.* A strong suspicion of a genetic diagnosis warrants consideration of testing to confirm the diagnosis, facilitate patient treatment and anticipatory guidance, clarify recurrence risks, and enable carrier testing for additional family members. Single genes can still be tested by *Sanger sequencing* that targets single or multiple exons. However,



**Fig. 100.9** The Framework of Facial Recognition for Genetic Syndrome Detection. ICA, Independent component analysis; CLM, constrained local model; HCLM, hierarchical CLM; DS, Down syndrome; ROC, receiver operating characteristics. (From Zhao Q, Okada K, Rosenbaum K, et al. *Digital facial dysmorphology for genetic screening: hierarchical constrained local model using ICA*. *Med Image Anal.* 2014;18:699–710. Fig. 2.)

**Table 100.7** Chromosomal Deletion Syndromes

CONDITION	BRIEF DESCRIPTION	PROBE
Williams syndrome	Proportionate short stature, mild-moderate to severe intellectual disability, friendly personality, stellate pattern of iris pigmentation, supraclavicular aortic stenosis, wide mouth with full lips	7q11
WAGR syndrome	Wilms tumor, aniridia, growth delay, intellectual disability, and genitourinary anomalies	11p13
Prader-Willi syndrome Angelman syndrome	Distinct syndromes with common or overlapping areas of deletion; phenotype depends on gender of the parent of origin of the deletion Prader-Willi syndrome: hypotonia in infancy, short stature, obesity, mild-moderate and occasionally severe intellectual disability, small hands and feet (caused by paternal deletion of 15q11-13 or maternal uniparental disomy for chromosome 15) Angelman syndrome: severe intellectual disability, absence of speech, ataxia, tremulous movements, large mouth, frequent drooling (caused by maternal deletion of chromosome 15q11-13 or paternal uniparental disomy)	15q11
Smith-Magenis syndrome	Brachycephaly, prognathism, self-destructive behavior, wrist biting, pulling out nails, head banging, indifference to pain, intellectual disability, hyperactivity	17p11.2
Miller-Dieker syndrome	Microcephaly, narrow temples, hypotonia/hypertonia, abnormal posturing, seizures, severe to profound intellectual disability, poor growth, lissencephaly and other brain abnormalities on CT or MRI	17p13
22q11 deletion syndrome	Cleft palate, congenital heart disease, learning/behavior problems, long face, prominent nose, limb hypotonia, slender hands with tapering fingers, T-cell deficiency, immunoglobulin deficiency	22q11

WAGR, Wilms tumor, aniridia, genitourinary anomalies, and mental retardation.

From Kliegman RM, Lye PS, et al., eds. *Nelson Pediatric Symptom-Based Diagnosis*, Philadelphia: Elsevier; 2018: Table 25-10.

for diagnoses that have substantial genetic heterogeneity (e.g., hearing loss), *panel testing* often using NGS, in which multiple relevant genes can be interrogated for single nucleotide variants and gene deletions and duplications, is more expeditious than single-gene testing. Panel tests also frequently have the advantage of providing high coverage for the genes on the panel compared with the coverage for the same genes that can be obtained by ES. However, in situations with diagnostic uncertainty, such as the investigation of a child with intellectual disability and facial anomalies for which there is no clearly recognizable pattern, **exome** or **genome sequencing (GS)** may be most useful as a broad testing approach. ES examines approximately 200,000 exons, or the 1–2% of the DNA that comprises the coding regions of the genome. ES is typically performed with a *trio* approach, in which the patient and both biological parents are tested simultaneously, so that the inheritance pattern, or segregation, of deleterious sequence

variants can be determined, thus simplifying analysis. Trio sequencing has resulted in higher diagnostic yields than proband-only sequencing and can approach 30–40% for indications such as intellectual disability. In contrast, GS examines the entire DNA content, including noncoding regions, and increasingly enables analysis for cytogenetic rearrangements in addition to copy number loss or gain. ES and GS are applicable to a wide range of birth defects and genetic diseases and can discover causative variants in known or novel genes associated with a particular condition.

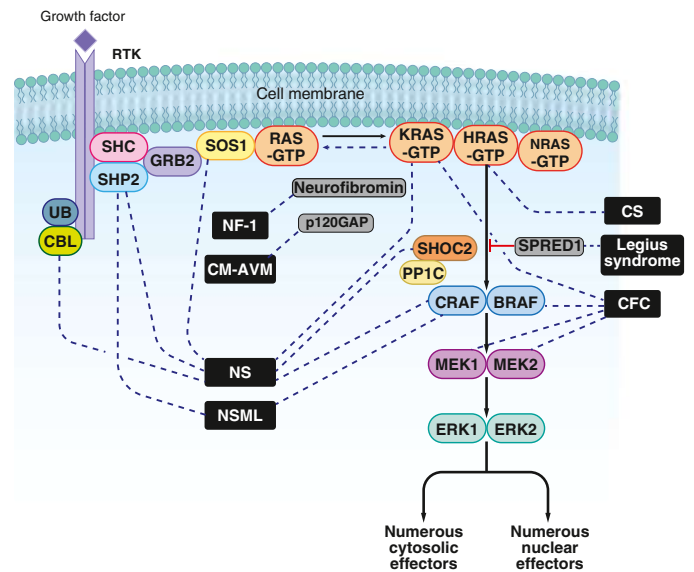
### Management and Counseling

Management and genetic counseling are essential aspects of the approach to a patient with a genetic disorder. For example, children with Down syndrome have a high incidence of hypothyroidism, and children with achondroplasia have a high incidence of cervicomedullary

junction abnormalities and monitoring for both is appropriate. One of the many benefits of an early and accurate diagnosis is that **anticipatory guidance and medical monitoring** of patients for syndrome-specific medical risks can improve their quality of life and prolong it. When a diagnosis is made, the treating physicians can access published information on the natural history and management of the disorder through the medical literature, genetics reference texts, and databases. Providing access to disorder-specific patient support groups can also provide immense benefit to patients and families.

The second major benefit of an accurate diagnosis is that it provides data for **recurrence risk** estimates. Genetic disorders may have direct effects on only one member of the family, but the diagnosis of the condition can have implications for the entire family. One or both parents may be carriers, and siblings may be carriers or may want to know their genetic status when they reach their reproductive years. Recurrence risk provision is an important component of genetic counseling and should be included in all evaluations for families affected with birth defects or other inherited disorders (see Chapter 98).

Visit Elsevier eBooks+ at [eBooks.Health.Elsevier.com](http://eBooks.Health.Elsevier.com) for Bibliography.



**Fig. 101.1** The RAS/MAPK signal transduction pathway. The MAPK signaling pathway of protein kinases is critically involved in cellular proliferation, differentiation, motility, apoptosis, and senescence. The RASopathies are patterns of anomalies caused by pathogenic variants in genes that encode components or regulators of the RAS/MAPK pathway (indicated by dashed lines). These disorders include neurofibromatosis type one (NF1), Noonan syndrome (NS), Noonan syndrome with multiple lentigines (NSML), capillary malformation–arteriovenous malformation syndrome (CM-AVM), Costello syndrome (CS), cardiofaciocutaneous syndrome (CFC), and Legius syndrome. RAS/MAPK, RAS protein family/mitogen-activated protein kinase. (From Rauen KA. *The RASopathies*. *Annu Rev Genom Hum Genet*. 2013;14:355–369.)

## Chapter 101

# Signaling Pathway Disorders

Chad R. Haldeman-Englert and Anne M. Slavotinek

An increasing number of defined molecular genetic etiologies explain many multiple congenital anomaly (MCA) syndromes. Several themes have emerged: (1) many clinical disorders that were believed to represent a single entity have multiple genetic etiologies, often within genes that are functionally related; (2) many disorders believed to be distinct have common underlying genetic bases; and (3) teratogens and genetic disorders with similar clinical features can often be understood in the context of shared underlying pathology.

It is useful to consider MCA syndromes as members of a group of disorders based on shared or overlapping clinical findings and related causative genes that act in the same developmental or metabolic pathway.

## 101.1 RAS/MAPK Pathway

Chad R. Haldeman-Englert and Anne M. Slavotinek

The RASopathies comprise a clinically defined group of conditions caused by germline pathogenic variants in genes encoding the components or regulators of the renin-angiotensin system (RAS)/mitogen-activated protein kinase (MAPK) pathway. This pathway is one of the most important signaling pathways in human development (Fig. 101.1). Signaling is initiated when one of several growth factors or cytokines binds extracellularly to a transmembrane receptor tyrosine kinase (RTK), which transmits the signal to activate one of several intracellular RAS proteins, such as HRAS, KRAS, or NRAS. Phosphorylation then occurs in a stepwise manner to one or more RAF proteins (ARAF, BRAF, and/or CRAF), and subsequently to MEK1 and/or MEK2, and then ERK1 and/or ERK2. Activation of ERK1/2 has downstream targets including transcription factors,

membrane proteins, and other protein kinases that direct cellular growth and differentiation.

More than 20 genes implicated in RAS/MAPK signaling have been implicated in human disorders, most with some degree of clinical overlap. Common RASopathies include **Noonan syndrome (NS)**, NS with multiple lentigines, Costello syndrome, cardiofaciocutaneous (CFC) syndrome, neurofibromatosis type one (NF1), Legius syndrome, and capillary malformation–arteriovenous malformation syndrome (Table 101.1).

NS represents the canonical RASopathy and is an autosomal dominant disorder resulting from pathogenic variants in several genes in the RAS/MAPK pathway. NS occurs in an estimated 1 in 1,000–2,500 live births. Approximately 30–75% of the cases are familial, and the condition typically exhibits autosomal dominant inheritance, although the *LZTR1* gene can be associated with autosomal dominant or autosomal recessive inheritance. Pathogenic variants in RAS/MAPK genes are found in ~70% of individuals with NS, with missense variants activating the *PTPN11* gene that encodes the nonreceptor protein tyrosine phosphatase SHP-2; this is observed in 50% of affected individuals. Pathogenic variants involving *SOS1* occur in 10–13% of affected individuals; variants in *RAF1* and *RIT1* each occur in 5% of patients, and variants in *KRAS*, *BRAF*, *MAP2K1*, *LZTR1*, and *NRAS* and duplications of the 12q24 region containing the *PTPN11* gene are rare. The strong clinical overlap between NS and other RASopathies, such as CFC syndrome, is due to the involvement of the same pathway and often identical genes in pathogenesis.

Common features in NS comprise short stature, a characteristic pattern of facial anomalies including ptosis, wide-spaced eyes with down-slanting palpebral fissures, epicanthal folds, anomalous and low-set ears and micrognathia, congenital heart disease, chest deformities with pectus excavatum and/or pectus carinatum, a short or wide neck with a low posterior hairline, and cryptorchidism



**Table 101.1** Genes and Features of the RAS/MAPK Pathway

SYNDROME	RAS/MAPK PATHWAY GENE	PROTEIN	PROTEIN FUNCTION	CLINICAL PHENOTYPE
Noonan syndrome	<i>PTPN11</i> <i>SOS1</i> <i>RAF1</i> <i>KRAS</i> <i>NRAS</i> <i>SHOC2</i> <i>CBL</i> <i>RIT1</i>	SHP2 SOS1 CRAF KRAS NRAS SHOC2 CBL RIT1	Phosphatase RasGEF Kinase GTPase GTPase Scaffolding E3 ubiquitin ligase GTPase	Craniofacial dysmorphic features, including a broad forehead, hypertelorism, down-slanting palpebral fissures, ptosis, a high-arched palate, and low-set, posteriorly rotated ears; congenital heart defects; short stature; undescended testicles; ophthalmologic abnormalities; bleeding disorders; normal neurocognitive function or mild impairment; predisposition to cancer
Noonan syndrome with multiple lentigines	<i>PTPN11</i> <i>RAF1</i>	SHP2 RAF1/CRAF	Phosphatase Kinase	Same as Noonan syndrome, but with possible development of multiple skin lentigines as individuals age; unclear predisposition to cancer
Capillary malformation–arteriovenous malformation	<i>RASA1</i>	p120-RasGAP	RasGAP	Multifocal capillary malformations, which may be associated with arteriovenous malformations and fistulae; unclear predisposition to cancer
Costello syndrome	<i>HRAS</i>	HRAS	GTPase	Craniofacial features similar to those of Noonan syndrome but potentially more coarse; congenital heart defects; failure to thrive; short stature; ophthalmologic abnormalities; multiple skin manifestations, including papilloma; normal neurocognitive function or mild impairment; hypotonia; predisposition to cancer
Cardiofaciocutaneous syndrome	<i>BRAF</i> <i>MAP2K1</i> <i>MAP2K2</i> <i>KRAS</i>	BRAF MEK1 MEK2 KRAS	Kinase Kinase Kinase GTPase	Craniofacial features similar to those of Noonan syndrome; congenital heart defects; failure to thrive; short stature; ophthalmologic abnormalities; multiple skin manifestations, including progressive formation of nevi; normal neurocognitive function or mild impairment; hypotonia; unclear predisposition to cancer
Neurofibromatosis type 1	<i>NF1</i>	Neurofibromin	RasGAP	Café-au-lait maculae; intertriginous freckling; neurofibromas and plexiform neurofibromas; iris Lisch nodules; osseous dysplasia; optic pathway glioma; normal neurocognitive function or mild impairment; predisposition to other cancers
Legius syndrome	<i>SPRED1</i>	SPRED1	SPROUTY-related, EVH1 domain-containing protein 1	Café-au-lait maculae; intertriginous freckling; macrocephaly; normal neurocognitive function or mild impairment; no apparent predisposition to cancer

Modified from Rauen KA. The RASopathies. *Annu Rev Genom Hum Genet.* 2013;14:355–369. Table 3.

(Table 101.2 and Fig. 101.2). The pattern of congenital heart disease typically involves right-sided lesions, most frequently presenting with pulmonary valvular stenosis and hypertrophic cardiomyopathy, but atrial and ventricular septal defects, branch pulmonary artery stenosis, tetralogy of Fallot, and coarctation of the aorta have all been described. Children with NS can manifest developmental delays in association with hypotonia and may have challenges with articulation and coordination. High-frequency sensorineural hearing loss is common and should be considered in patients with language delays. Hepatosplenomegaly, low levels of clotting factors XI and XII, and primary lymphatic anomalies have also been noted; patients may rarely develop acute lymphoblastic leukemia or juvenile myelomonocytic leukemia (JMML). Puberty may be delayed, and an adult height that reaches the lower limit of the typical range can be achieved by the end of the second decade. Other distinctive phenotypes include NS-like disorder with loose anagen hair caused by *SHOC2* variants and NS-like disorder with or without JMML caused by *CBL* variants.

## DIAGNOSIS

Initial suspicion of a RASopathy generally depends on recognition of one or more characteristic features associated with the various conditions. Genetic testing includes a panel of genes including those in the RAS/MAPK pathway. Multigene panel testing is preferred over single-gene analysis due to the many overlapping symptoms seen in RASopathy disorders. Genetic testing can often be performed on blood, saliva, or a buccal swab. If a gene in the RAS/MAPK pathway is found to have a pathogenic or likely pathogenic variant, this would provide molecular confirmation of the clinical diagnosis.

## TREATMENT

Management of NS is noted in Table 101.3. Human growth hormone will improve growth velocity in many individuals with NS and short stature; it is recommended for those who fall below the third percentile for height. MEK inhibitors, such as trametinib, have been used to treat refractory lymphedema or chylous effusions and possibly severe cardiac hypertrophy.

**Table 101.2** Clinical Findings Associated with Noonan Syndrome

Short stature
Failure to thrive (use of specific Noonan syndrome growth curves is recommended)
Tall forehead
Epicantal folds
Ptosis
Blue-green irides
Wide-spaced eyes
Low nasal bridge, upturned nose
Down-slanting palpebral fissures
Low-set and posteriorly rotated ears
Dental malocclusion
Low posterior hairline
Pectus excavatum
Pectus carinatum superiorly
Scoliosis
Pigmented villonodular synovitis (polyarticular)
Cubitus valgus
Pulmonary valve stenosis (dysplastic valve)
Hypertrophic cardiomyopathy
Atrial septal defect, ventricular septal defect
Lymphedema
Nevi, lentigines, café-au-lait spots
Cryptorchidism
Small penis
Delayed puberty
Bleeding disorders, including thrombocytopenia and coagulation factor deficiencies
Leukemia, myeloproliferative disorders, other malignancies
Cognitive delay

## NEUROFIBROMATOSIS

NF1 is a multisystem disorder that primarily abstractly involves the skin and peripheral nervous system (see Chapter 636.1). NF1 is associated with marked clinical variability. NF1 is inherited in an autosomal dominant manner. The disorder is caused by pathogenic variants in the *NF1* gene, which encodes neurofibromin and functions as a regulator of RAS signaling (see Table 101.1 and Fig. 101.1).

## LEGIUS SYNDROME

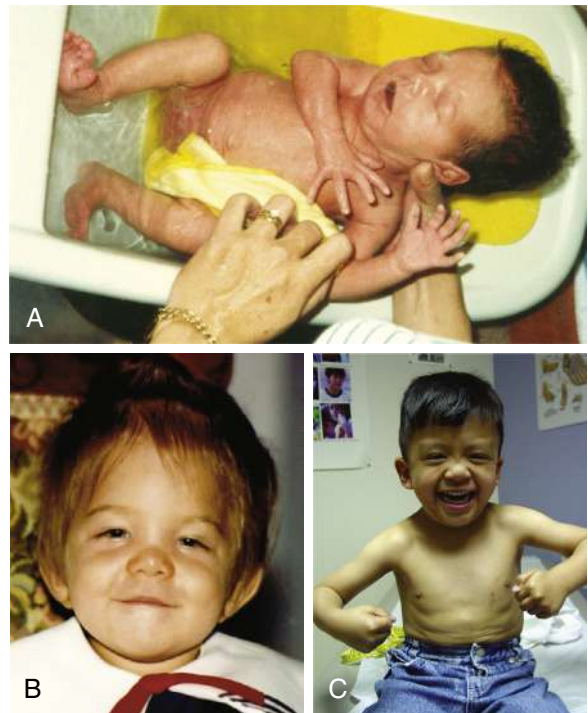
Legius syndrome is a RASopathy caused by pathogenic variants in *SPRED1*, which encodes an HRAS regulator. Individuals with Legius syndrome present with typical multiple café-au-lait macules inherited as an autosomal dominant trait but do not develop the serious medical complications of NF1.

Visit Elsevier eBooks+ at [eBooks.Health.Elsevier.com](https://www.elsevier.com/ebooksplus) for Bibliography.

## 101.2 Sonic Hedgehog Pathway

Chad R. Haldeman-Englert

The Hedgehog signaling pathway plays numerous tissue-specific critical roles during embryogenesis and postnatal life. Disruption of specific steps in this pathway result in a variety of related developmental disorders and anomalies (Fig. 101.3). Activation of this pathway in the child or adult may lead to abnormal cellular proliferation and cancer. Three genes, Sonic (SHH), Indian (IHH), and Desert (DHH), comprise the hedgehog family, with SHH being the most widely expressed. These



**Fig. 101.2** Noonan syndrome. A, Newborn. B, Toddler. C, Affected male. Note the down-slanting palpebral fissures, low-set ears, elevated left shoulder secondary to scoliosis, and wide-spaced nipples. (From Jones KL, Jones MC, Del Campo M, eds. *Smith's Recognizable Patterns of Human Malformation*, 8th ed. Philadelphia: Elsevier; 2022: Fig. 1AC, p. 150 and Fig. 2A, p. 151; A and B courtesy Dr. Jacqueline Noonan, University of Kentucky, Lexington, Kentucky.)

genes encode secreted signaling molecules important in cellular differentiation, proliferation, and survival. Secreted SHH acts as a *ligand* for specific cellular receptors to have a signal transduced by other components of the pathway to regulate downstream gene transcription. The SHH ligand is expressed in the embryo in regions important for development of the brain, face, limbs, and the gut.

Deleterious sequence variants in *SHH* can cause **holoprosencephaly** (see Fig. 100.7), a variably severe, midline defect associated with clinical effects ranging from cyclopia to a single maxillary incisor with close spacing of the ocular orbits. The SHH protein is processed by proteolytic cleavage to an active N-terminal form, which is then further modified by the addition of cholesterol. The steroidal alkaloid cyclopamine exerts a teratogenic effect by inhibiting cholesterol modification of SHH and can result in holoprosencephaly in sheep. In humans, a defect in cholesterol biosynthesis involving the recessive delta-7-dehydrocholesterol reductase gene (*DHCR7*) results in **Smith-Lemli-Opitz syndrome** (SLOS) (see Chapter 106).

In addition to microcephaly and holoprosencephaly, patients with SLOS (see Fig. 101.3) display syndactyly, classically of the second and third toes, postaxial polydactyly of the hands and feet, an upturned or anteverted nose, ptosis, and cryptorchidism.

The cholesterol-modified active form of SHH binds to its transmembrane receptor Patched (PTCH1). This SHH-PTCH1 complex then inhibits the activity of the transmembrane protein Smoothened (SMO). Because SMO normally acts to suppress downstream targets, the GLI family of transcription factors, inhibition of SMO by PTCH1 results in activation of GLI1, GLI2, and GLI3. Pathogenic variants resulting in activation of *SMO* can be oncogenic, particularly in basal cell carcinomas and medulloblastomas. In addition, *PTCH1* and its orthologue, *PTCH2*, act as tumor suppressors, and somatic, inactivating sequence variants can be associated with loss of tumor suppressor function. Relatedly, germline inactivating variants in *PTCH1* result in **Gorlin syndrome** (see Fig. 101.3), an autosomal dominant disorder characterized by a broad face, dental anomalies, rib defects and shortened

**Table 101.3** Management of Noonan Syndrome

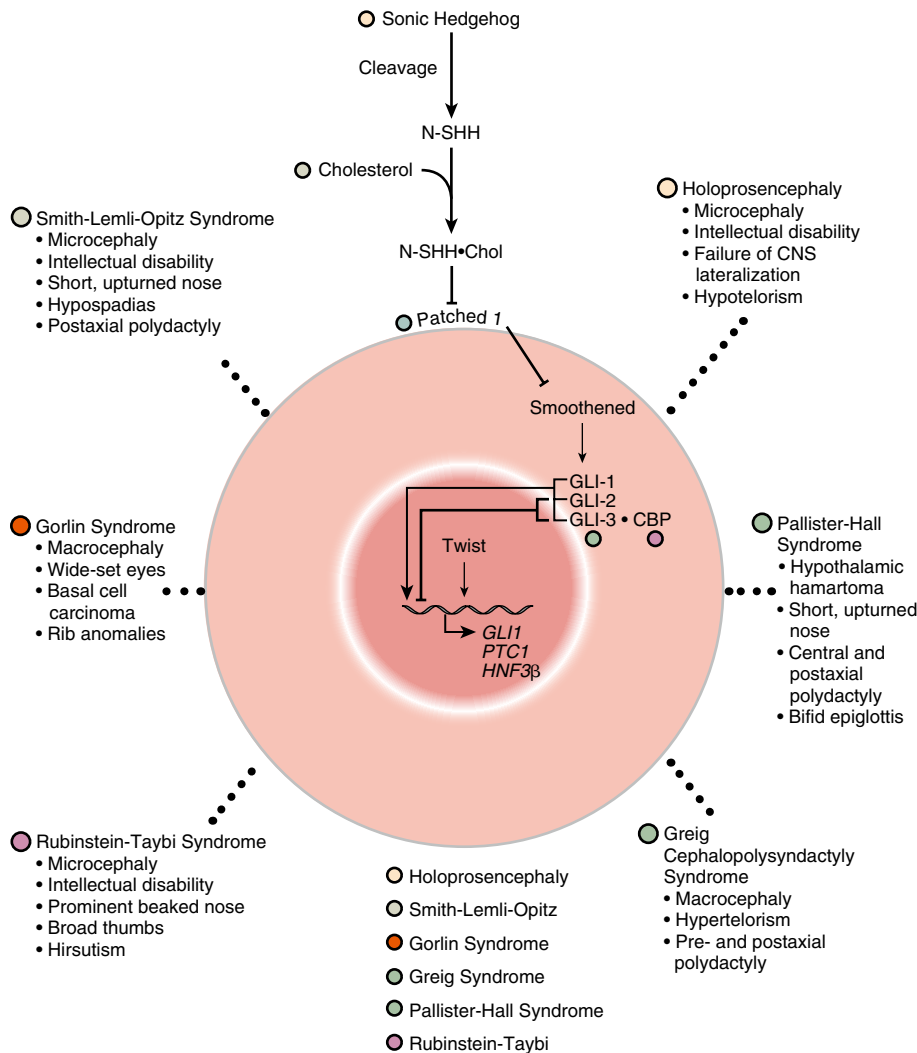
	AT DIAGNOSIS	AFTER DIAGNOSIS	IF SYMPTOMATIC
General	Complete physical and neurologic examination; medical genetics consultation to confirm diagnosis, consider molecular genetic testing and genetic counseling	Yearly complete physical and neurologic examination; return to geneticist if genotype negative or for multisystem assessment; genetic counseling at adolescence or when a young adult	Orchiopexy by age 1 year for cryptorchidism; if lymphoedema, refer to specialty clinic; brain and cervical spine MRI if intracranial pressure increases; electroencephalogram and referral to neurologist if seizures suspected
Developmental	Multidisciplinary developmental assessment	Developmental screening yearly for children age 5-18 years	Neuropsychologist testing if screening abnormal; referral to early intervention if delays detected before age 3 years; individual education plan for children age 5-18 years with delays
Dental	First dental assessment between age 1 year and 2 years	Yearly dental assessment	—
Growth and feeding	Plot growth on curves for Noonan syndrome	Plot growth on curves for Noonan syndrome 3 times per year until age 3 years, then yearly	Refer to gastroenterologist for feeding problems or recurrent vomiting, or if evidence of growth failure without comorbid cause exists; thyroid function tests if signs or symptoms of hypothyroidism
Cardiovascular	Cardiac examination, electrocardiogram, echocardiogram	Follow up on the basis of initial findings. If initial assessment normal, repeat every 5 years	—
Ophthalmologic	Baseline eye examination Baseline audiology examination	Repeat every 2 years, sooner if indicated	—
Audiologic	Baseline audiology examination	Repeat if recurrent otitis media or speech delay	Refer to ear, nose, and throat specialist for recurrent otitis media or serous otitis; hearing aids or classroom interventions for hearing loss
Hematologic	Complete blood cell count with differential, and prothrombin time or activated partial thromboplastin time	Repeat complete blood cell count with differential and prothrombin time or activated partial thromboplastin time if age 6-12 months at initial screen Preoperatively: complete blood cell count with differential and prothrombin time or activated partial thromboplastin time, second tier (in consultation with hematologist) factor IX, XI, and XII concentrations, von Willebrand factor, platelet aggregation	Prothrombin time or activated partial thromboplastin time if bleeding abnormal or persistent, refer to hematologist; complete blood cell count with differential for splenomegaly; complete blood cell count with differential and liver function studies for hepatosplenomegaly
Renal	Kidney ultrasound	—	—
Skeletal	Clinical assessment of spine with radiology if indicated by examination	Repeat spinal examination yearly through adolescence; radiology and referral to orthopaedic specialist if abnormal	—

From Roberts AE, Allanson JE, Tartaglia M, Gelb BD. Noonan syndrome. *Lancet*. 2013;381:333–342.

metacarpals; basal cell nevi that can undergo malignant transformation; and an increased risk of cancers, including medulloblastomas and rhabdomyosarcomas. *GLI1* amplification has been found in several human tumors, including glioblastoma, osteosarcoma, rhabdomyosarcoma, and B-cell lymphomas. Likewise, pathogenic variants in *GLI3* can cause **Greig cephalopolysyndactyly syndrome** (GCPS), **Pallister-Hall syndrome** (PHS), postaxial polydactyly type A (and A/B), and preaxial polydactyly type IV (see Fig. 101.3). GCPS consists of wide-spaced eyes, syndactyly, additional digits on the radial border of the hand or inner aspect of the foot, termed preaxial polydactyly, and broad thumbs and halluces. PHS is an autosomal dominant disorder characterized by postaxial polydactyly, syndactyly, hypothalamic

hamartomas, imperforate anus, and occasionally holoprosencephaly. *GLI3* binds to CBP, the protein that is haploinsufficient in **Rubinstein-Taybi syndrome**.

Disorders that are caused by pathogenic variants in genes that function together in a developmental pathway typically have overlapping clinical manifestations. The overlapping features result from the embryonic tissues in which SHH is important for development, including the brain, face, limbs, and gut as previously noted. Brain defects are present in holoprosencephaly (see Fig. 100.7), SLOS, and PHS. Facial anomalies are found in holoprosencephaly, SLOS, Gorlin syndrome, GCPS, and PHS. Limb defects occur in SLOS, Gorlin syndrome, GCPS, PHS, and the polydactyly syndromes. Overexpression, or activating sequence variants, affecting the SHH pathway results in cancer,



**Fig. 101.3** Signaling components and clinical features of the sonic hedgehog (SHH) signaling pathway. Deleterious sequence variants in genes that function together in a developmental pathway typically have overlapping clinical manifestations. Several components of the SHH pathway have been identified and their relationships elucidated. Pathogenic variants in several members of this pathway result in phenotypes with facial anomalies, as seen in holoprosencephaly, Smith-Lemli-Opitz syndrome, Gorlin syndrome, Greig cephalopolysyndactyly syndrome, Pallister-Hall syndrome, and Rubinstein-Taybi syndrome. CNS, Central nervous system.

including basal cell carcinomas, medulloblastomas, glioblastomas, and rhabdomyosarcomas.

Visit Elsevier eBooks+ at [eBooks.Health.Elsevier.com](https://www.elsevier.com/ebooksplus) for Bibliography.

### 101.3 Ciliopathies

Chad R. Haldeman-Englert

Cilia are microtubule-containing organelles that project from the surface of most human cells. Three types of cilia exist in humans: motile cilia, nodal cilia, and primary cilia. Motile cilia typically contain a sweeping motion and play important roles in the respiratory epithelium (see Chapter 455 for discussion of structure of cilia and their role in primary ciliary dyskinesia and respiratory disorders). Nodal cilia play a very brief role during embryonic development, and their whirling flow in the Henson's node during gastrulation is central in determining the left-right body axis. Defects in this process manifest as alterations in body orientation, including situs inversus and heterotaxy (see Chapter 480.11).

Primary cilia are nonmotile and are present in nearly all cells. The membrane of each cilium is continuous with the plasma membrane. There are unique differences in its membrane that allow cilia to detect changes in the extracellular environment to function as mechanoreceptors, osmosensors, and chemosensors and

convey this information via various intracellular signaling pathways to regulate diverse cellular processes (proliferation, polarity, nerve growth, differentiation, and tissue maintenance). These pathways may include Hedgehog (HH), G-protein-coupled receptors (GPCRs), Wntless and Int-1 (WNT), RTKs, and transforming growth factor  $\beta$  (TGF- $\beta$ ).

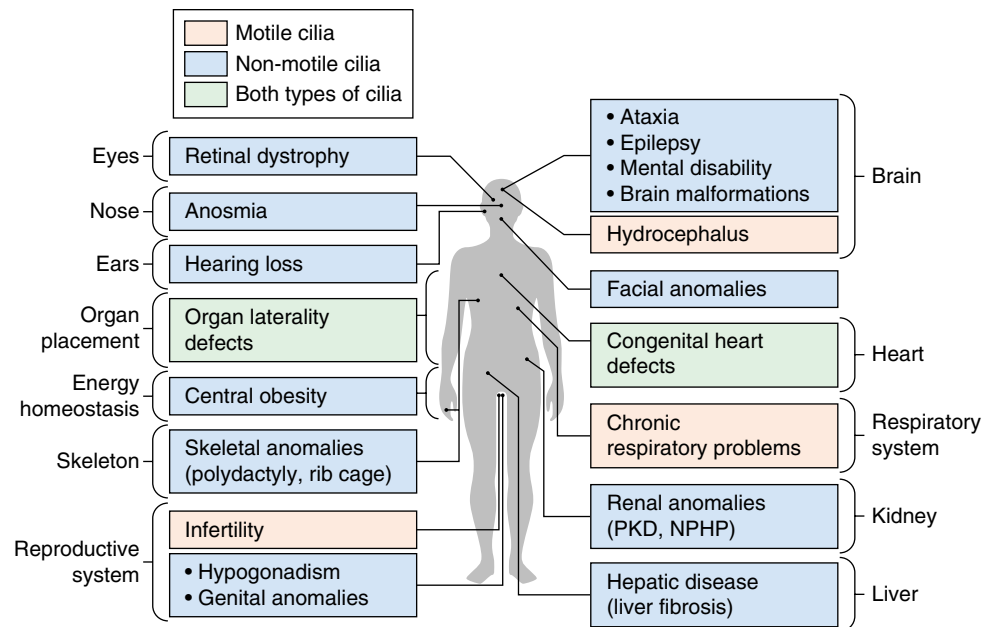
Pathogenic changes to genes that control the function and signaling within the cilia give rise to conditions called *ciliopathies*. Given the extent of cilia located throughout the human body, symptoms associated with ciliopathies can be variable and extensive. Defects can occur to many different organs during fetal development through adulthood. Organ systems generally affected in ciliopathies include the brain, eyes, liver, kidneys, and skeleton (Fig. 101.4). There are many well-described ciliopathy effects, including retinitis pigmentosa, hearing loss, infertility, primary ciliary dyskinesia, polycystic kidney disease, and nephronophthisis, as well as a number of syndromes including Joubert, Bardet-Biedl, Meckel-Gruber, and orofaciocigital syndromes (Table 101.4).

The diagnosis of a ciliopathy is generally based on recognition of the clinical features followed by either targeted gene testing, a multi-gene panel, or exome/genome sequencing. If a diagnosis is established with molecular testing, additional studies may be indicated to evaluate for additional medical and developmental concerns. Surveillance for potential changes to the kidneys, liver, and eyes should be routinely performed.

Visit Elsevier eBooks+ at [eBooks.Health.Elsevier.com](https://www.elsevier.com/ebooksplus) for Bibliography.



**Fig. 101.4** Ciliopathies of motile and/or nonmotile cilia encompass most human organ systems. Different organ systems or tissues are affected in diverse ciliopathies, with the most common phenotypic manifestations for each organ. Ciliopathies caused primarily by defects in motile cilia are in orange, those in nonmotile (primary) cilia are in blue, and those associated with defects in nodal cilia are in green. NPHP, Nephronophthisis; PKD, polycystic kidney disease. (Modified from Reiter JF, Leroux MR. *Genes and molecular pathways underpinning ciliopathies*. *Nat Rev Molec Cell*. 2017;18:533–547. Fig. 2.)



**Table 101.4** Childhood Diseases and Syndromes Associated with Motile and Primary/Sensory Ciliopathies

PEDIATRIC CILIOPATHY	CLINICAL MANIFESTATIONS	SELECTED GENE(S)
<b>MOTOR</b>		
Primary ciliary dyskinesia	Chronic bronchitis, rhinosinusitis, otitis media, laterality defects, infertility, CHD	<i>DNAI1, DNAH5, DNAH11, DNAI2, KTU, TXNDC3, LRRC50, RSPH9, RSPH4A, CCDC40, CCDC39</i>
<b>PRIMARY/SENSORY</b>		
Autosomal recessive polycystic kidney disease	RFD, CHF	<i>PKHD1</i>
Nephronophthisis	RFD, interstitial nephritis, CHF, RP	<i>NPHP1-8, ALMS1, CEP290</i>
Bardet-Biedl syndrome	Obesity, polydactyly, ID, RP, renal anomalies, anosmia, CHD	<i>BBS1-12, MKS1, MKS3, CEP290</i>
Meckel-Gruber syndrome	RFD, polydactyly, ID, CNS anomalies, CHD, cleft lip, cleft palate	<i>MKS1-6, CC2D2A, CEP290, TMEM216</i>
Joubert syndrome	CNS anomalies, ID, ataxia, RP, polydactyly, cleft lip, cleft palate	<i>NPHP1, JBTS1, JBTS3, JBTS4, CORS2, AHI1, CEP290, TMEM216</i>
Alström syndrome	Obesity, RP, DM, hypothyroidism, hypogonadism, skeletal dysplasia, cardiomyopathy, pulmonary fibrosis	<i>ALMS1</i>
Orofaciodigital syndrome type I	Polydactyly, syndactyly, cleft lip, cleft palate, CNS anomalies, ID, RFD	<i>OFD1</i>
Ellis van Creveld syndrome	Chondrodystrophy, polydactyly, ectodermal dysplasia, CHD	<i>EVC, EVC2</i>
Jeune asphyxiating thoracic dystrophy	Narrow thorax, RFD, RP, dwarfism, polydactyly	<i>IFT80</i>
Sensenbrenner syndrome	Dolichocephaly, ectodermal dysplasia, dental dysplasia, narrow thorax, RFD, CHD	<i>IFT122, IFT43, WDR35</i>
Short rib–polydactyly syndromes	Narrow thorax, short limb dwarfism, polydactyly, renal dysplasia	<i>WDR35, DYNC2H1, NEK1</i>

CHD, Congenital heart disease; CHF, congenital hepatic fibrosis; CNS, central nervous system; DM, diabetes mellitus; ID, intellectual disabilities; RFD, renal fibrocystic disease; RP, retinitis pigmentosa.

From Ferkol TW, Leigh MW. Ciliopathies: the central role of cilia in a spectrum of pediatric disorders. *J Pediatr*. 2012;160:366–371.

## 101.4 Craniosynostoses

Chad R. Haldeman-Englert

To permit appropriate brain growth, the cranial sutures do not completely fuse until adulthood. Growth of the skull occurs perpendicular to the direction of each suture. Craniosynostosis arises when one or more cranial sutures prematurely ossify, which usually becomes apparent between the third trimester of pregnancy and the first year of life (see Chapter 631.10). The shape of the skull is often the clue to the affected suture (Fig. 101.5). Most patients with craniosynostosis do not have additional syndromic features; this may depend on the sutures involved. Patients with bicoronal or multisuture craniosynostosis often have an associated genetic syndrome, whereas patients with isolated sagittal craniosynostosis do not have features of an identifiable genetic cause.

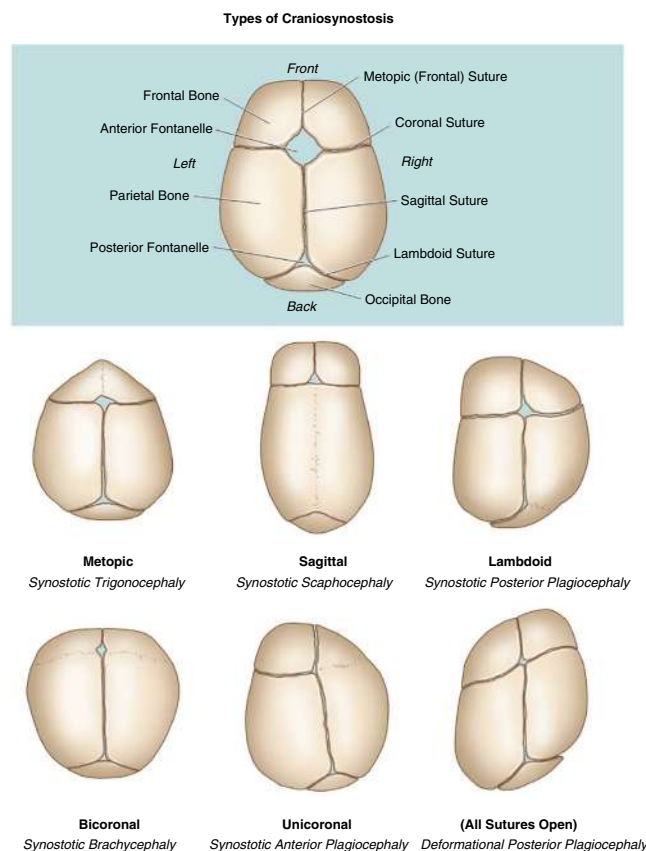
Craniosynostosis can result from reduced intrinsic factors (poor brain growth), increased extrinsic forces (primiparity, multiple pregnancy, fetal position, high birth weight), or genetic abnormalities leading to uncontrolled cranial bone growth. Genes commonly associated with syndromic craniosynostosis include three fibroblast growth factor receptor genes (*FGFR1*, *FGFR2*, *FGFR3*), *TWIST1*, and *EFNB1*. *FGFR1*,

*FGFR2*, and *FGFR3* are associated with recognizable conditions such as Crouzon, Pfeiffer, Apert, and Muenke syndromes; *TWIST1* with Saethre-Chotzen syndrome; and *EFNB1* with craniofrontonasal syndrome. Distinguishing between the FGFR-related craniosynostosis syndromes can often be made based on additional features, particularly of the hands and feet (see Chapter 631.10).

Other pathogenic gene variants have been identified in patients with syndromic and nonsyndromic craniosynostosis (Table 101.5). Given the overlap of clinical features of many of the craniosynostosis conditions, appropriate genetic testing for patients with craniosynostosis could include either a multigene panel or exome/genome sequencing. The diagnosis is made based on the genetic abnormality and clinical features.

Management of patients with craniosynostosis is often complex and performed with a multidisciplinary team of various specialists, including audiology, dentistry, genetics, neurosurgery, ophthalmology, orthodontics, otolaryngology, pediatrics, plastic surgery, and speech therapy (see Chapter 631.10).

Visit Elsevier eBooks+ at [eBooks.Health.Elsevier.com](http://eBooks.Health.Elsevier.com) for Bibliography.



**Fig. 101.5** Types of craniosynostosis. (From Buchanan EP, Xue Y, Olshinka A, Lam S. Multidisciplinary care of craniosynostosis. *J Multidiscip Healthcare*. 2017;10:263–270. Fig. 1. Dove Medical Press Ltd.)

<b>Table 101.5</b> Core Genes For Which Specific Types of Variants Are Associated with Craniosynostosis in More Than Half of Affected Individuals					
<b>GENE (MIM#)</b>	<b>INHERITANCE PATTERN</b>	<b>CLINICAL DISORDER (MIM#)</b>	<b>PREVALENCE (%)</b>	<b>TYPICAL SUTURE FUSION</b>	<b>MAJOR PHENOTYPIC FEATURES</b>
ASXL1(612990)	AD (n)	Bohring-Opitz syndrome (605039)	—	Metopic	Forehead nevus flammeus, ulnar deviation and flexion of wrists and metacarpophalangeal joints, severe intellectual disability
CDC45(603465)	AR	—	—	Coronal	Thin eyebrows, small ears, variable short stature
COLEC11(612502)	AR	3MC syndrome 2 (265050)	—	Metopic	Hypertelorism, blepharoptosis, arched eyebrows, cleft lip/palate, hearing loss, radioulnar synostosis, genital and vesicorenal anomalies
EFNB1(300035)	XLD (male sparing)	Craniofrontonasal syndrome (304110)	0.8	Coronal	Hypertelorism, notched nasal tip, chest anomalies, longitudinal splitting of nails; heterozygous females more severely affected than hemizygous males
ERF(611888)	AD	ERF-related craniosynostosis (600775)	1.1	Multisuture	Exorbitism, midface hypoplasia, Chiari type I malformation, postnatal onset of craniosynostosis
FGFR1(136350)	AD	Pfeiffer syndrome (101600)	—	Coronal	Mild craniofacial features, broad medially deviated thumbs and halluces, cutaneous syndactyly, specific amino acid substitution p.Pro252Arg
FGFR1	AD (n)	Osteoglophonic dysplasia (166250)	—	Multisuture	Prominent brow ridges, depressed nasal bridge, rhizomelic dwarfism, localized lytic lesions of metaphyses
FGFR2(176943)	AD (n)	Apert syndrome (101200)	3.6	Coronal, multisuture	Midface hypoplasia, dilated cerebral ventricles, complex syndactyly of the hands and feet
FGFR2	AD (n)	Beare-Stevenson syndrome (123790)	*	Multisuture	Choanal atresia, prominent umbilical stump, furrowed scalp/neck skin, acanthosis nigricans in survivors
FGFR2	AD	Crouzon syndrome (123500)	2.4	Multisuture, coronal, sagittal	Exorbitism, midface hypoplasia, beaked nose ("crouzonoid" facies), clinically normal hands and feet
FGFR2	AD (n)	Pfeiffer syndrome (101600)	0.8	Multisuture	Broad thumbs and halluces; in severe cases, cloverleaf skull, brain anomalies, tracheal sleeve, fused elbows
FGFR2	AD (n)	Bent bone dysplasia (614592)	*	Coronal	Osteopenia, reduced mineralization of the calvaria, bent long bones; perinatal lethal
FGFR3(134934)	AD	Muenke syndrome (602849)	4.0	Coronal	Defined by specific amino acid substitution p.Pro250Arg; may include sensorineural hearing loss, mild brachydactyly, cone-shaped epiphyses
	AD (n)	Crouzon/acanthosis nigricans (612247)	0.4	Multisuture	Crouzonoid facies, choanal stenosis, hydrocephalus, acanthosis nigricans; specific amino acid substitution p.Ala391Glu
	AD (n)	Thanatophoric dysplasia II (187601)	*	Multisuture	Lethal skeletal dysplasia, micromelic limb shortening, straight femora; specific amino acid substitution p.Lys650Glu
IHH(600726)	AD	Philadelphia craniosynostosis (185900)	—	Sagittal	Cutaneous and osseous syndactyly

**Table 101.5** Core Genes For Which Specific Types of Variants Are Associated with Craniosynostosis in More Than Half of Affected Individuals—cont'd

GENE (MIM#)	INHERITANCE PATTERN	CLINICAL DISORDER (MIM#)	PREVALENCE (%)	TYPICAL SUTURE FUSION	MAJOR PHENOTYPIC FEATURES
<i>IL11RA</i> (600939)	AR	Craniosynostosis and dental anomalies (614188)	—	Multisuture	Maxillary hypoplasia, delayed tooth eruption, supernumerary teeth, minor digit abnormalities, conductive hearing loss
<i>MEGF8</i> (604267)	AR	Carpenter syndrome 2 (614796)	—	Metopic	Hypertelorism, arched eyebrows, lateralization defects, brachydactyly, syndactyly, preaxial polydactyly
<i>MSX2</i> (123101)	AD	Boston craniosynostosis (604757)	—	Sagittal, coronal, multisuture	None diagnostic; syndrome defined by specific amino acid substitutions p.Pro148His, p.Pro148Leu
<i>POR</i> (124015)	AR	Antley-Bixler syndrome (201750)	—	Bicoronal, multisuture	Choanal stenosis, radiohumeral synostosis, bowed femora, multiple joint contractures, genital abnormalities; abnormal steroidogenesis
<i>RAB23</i> (606144)	AR	Carpenter syndrome 1 (201000)	—	Multisuture	Obesity, cardiac defects, polysyndactyly, brachydactyly, genu valgum, hypogenitalism, umbilical hernia, learning disability
<i>RUNX2</i> (600211)	AD (n)	—	—	Multisuture	None diagnostic; syndrome defined by specific gene duplication
<i>SKI</i> (164780)	AD (n)	Shprintzen-Goldberg syndrome (182212)	—	Sagittal, multisuture	Hypertelorism, micrognathia, high-arched palate, arachnodactyly, joint contractures, pectus deformity, aortic root aneurysm, mitral valve prolapse, learning disability
<i>TCF12</i> (600480)	AD	TCF12-related craniosynostosis (615314)	1.3	Coronal	Resembles mild Saethre-Chatzen syndrome; diagnosis defined by presence of mutations in the gene, ~50% nonpenetrance
<i>TWIST1</i> (601622)	AD	Saethre-Chatzen syndrome (101400)	3.6	Coronal	Low frontal hairline, hypertelorism, eyelid ptosis, down-slanting palpebral fissures, blocked tear ducts, small ears with prominent crus helcis
<i>WDR35</i> (613602)	AR	Cranioectodermal dysplasia 2 (613610)	—	Sagittal	Facial dysmorphism, narrow thorax, short long bones, brachydactyly, sparse hair, hypoplastic teeth, cystic kidneys, hepatic fibrosis
<i>ZIC1</i> (600470)	AD (n)	ZIC1-related craniosynostosis	0.2	Coronal	Severe learning disability

The prevalence figures are for percent total craniosynostosis cases with specified mutation, from the cohort attending the Craniofacial Unit, Oxford, born between 1998 and 2008 (n = 531) and surgically treated before end of 2013.

\*Usually lethal at birth.

AD, Autosomal dominant; AR, autosomal recessive; XLD, X-linked dominant; (n), usually arises by new mutation.

From Twigg SRF, Wilkie AOM. A genetic-pathophysiological framework for craniosynostosis. *Am J Hum Genetics*. 2015;97:359–377. Table 1.



## Chapter 102

## Chromatin Regulatory Disorders

Kosuke Izumi

Pathogenic variants in genes that encode chromatin proteins that orchestrate gene expression in a range of human tissues frequently cause pediatric developmental disorders that include developmental delay/intellectual disability and facial dysmorphisms.

**KABUKI SYNDROME**

Kabuki syndrome (MIM: 147920 and 300867) is a genetic disorder characterized by facial features, mild to moderate intellectual disability, growth deficiency, and skeletal anomalies. Kabuki syndrome was originally named “Kabuki make-up syndrome” due to patients’ facial features, suggestive of those of Kabuki actors (Fig. 102.1). Approximately 1:32,000 to 1:86,000 individuals are estimated to have Kabuki syndrome.

**Molecular Etiology**

Heterozygous *KMT2D* pathogenic variants (~90%), and hemizygous (in males) or heterozygous (in females) *KDM6A* pathogenic variants (~10%) cause classic Kabuki syndrome; *KMT2D* encodes a histone methyltransferase and *KDM6A* encodes a histone demethylase. Both of these histone modification enzymes regulate histone codes to orchestrate global gene expression. Most genetic changes causing Kabuki syndrome are due to de novo changes. However, because *KDM6A* locates on the X chromosome, its inheritance pattern can be complex, with most *KDM6A* pathogenic variants being de novo, but maternal transmission of pathogenic *KDM6A* variants has been seen. Kabuki-like syndromes share many clinical features but do not have pathogenic variants in *KMT2D* or *KDM6A*.

**Clinical Features of Kabuki Syndrome (Table 102.1)**

**Physical features:** Common features of Kabuki syndrome include long palpebral fissures with eversion of the lateral third of the lower eyelid, arched broad eyebrows, a short columella, depressed nasal tip, large, prominent or cupped ears, and persistent fingertip pads (see Fig. 102.1). Dental anomalies such as widely spaced teeth and hypodontia are commonly seen.

**Growth and feeding:** Individuals with Kabuki syndrome often have short stature and feeding difficulties. The degree of difficulty with



**Fig. 102.1** Physical features of Kabuki syndrome. A, Patient with *KMT2D* c.10201C>T, p.Gln3401\* pathogenic variant. Dysmorphic features include long and up-slanted palpebral fissures and large prominent ears. B, Patient with *KDM6A* c.3717G>A; p.Trp1239\* pathogenic variant. Dysmorphic features include long and up-slanted palpebral fissures.

feeding and growth varies, but it is not uncommon for infants or children with Kabuki syndrome to require feeding tubes.

**Development and behavior:** Global developmental delay is commonly seen in children with Kabuki syndrome, and individuals with Kabuki syndrome typically have mild to moderate intellectual disability. Most individuals speak and ambulate independently. Although infrequent, autism is seen in Kabuki syndrome.

**Neurology:** Hypotonia is a common feature. Structural brain differences are typically not seen, but individuals with Kabuki syndrome have an ~30% risk for seizures.

**Congenital heart disease:** Approximately 70% of children with Kabuki syndrome have a structural heart defect. The most common types include coarctation of the aorta and septal defects, although complex congenital heart disease is also seen.

**Gastrointestinal:** In addition to feeding difficulties, structural anomalies such as anal atresia, congenital diaphragmatic hernia (CDH), and cholestasis can be seen.

**Endocrinology:** Hypoglycemia or hyperinsulinemia can be seen, and some females with Kabuki syndrome have early premature thelarche.

**Ophthalmology:** The common everted lower eyelid seen in Kabuki can lead to excessive tearing. Other eye differences can include ptosis, cataracts, corneal differences, blue sclerae, or strabismus.

**Ear, nose, and throat:** Hearing loss, mainly conductive hearing loss, and more rarely sensorineural hearing loss, is seen in up to 50% of individuals with Kabuki syndrome. Chronic otitis media is a major cause of conductive hearing loss. Individuals with Kabuki syndrome can also have cleft lip and/or palate.

**Genitourinary:** Kidney and urinary tract disorders occur in more than 25% and can include abnormal renal location, duplicated collecting system, hypospadias and cryptorchidism in males, and hypoplastic labia in females.

**Musculoskeletal:** Many individuals have joint hypermobility that can manifest with scoliosis. Spinal abnormalities such as sagittal clefts and hemivertebrae can be seen in individuals with Kabuki syndrome.

**Immunology and hematology:** Frequent and recurrent infections including sinopulmonary infections and otitis media are common in children with Kabuki syndrome. Some can have hypogammaglobulinemia and immune dysfunction, with some needing regular intravenous immunoglobulin injection. Autoimmune disorders such as vitiligo, immune thrombocytopenia, hemolytic anemia, and coagulopathy are also common.

**Molecular diagnosis of Kabuki syndrome:** This is often made using sequencing and deletion/duplication analyses of *KMT2D* and *KDM6A* following clinical suspicion or by exome sequencing. Often, parental testing is performed to determine whether the identified variant is de novo. In addition, a DNA methylation profile has been identified for Kabuki syndrome caused by *KMT2D* and *KDM6A* variants, and a matching profile can support the diagnosis in the context of uncertain pathogenicity of identified *KMT2D* or *KDM6A* variants.

**RUBINSTEIN-TAYBI SYNDROME**

Rubinstein-Taybi syndrome (RSTS; MIM 180849 and 613684) is characterized by down-slanted palpebral fissures, broad thumb and first toe, developmental delay/intellectual disability, and short stature (Fig. 102.2). It occurs in ~1 in 125,000 births.

**Molecular Etiology**

RSTS is caused by heterozygous pathogenic variants in *CREBBP* and *EP300* genes. These genes encode transcriptional co-activators as histone lysine acetyltransferases. RSTS is caused by pathogenic variants, typically de novo in *CREBBP* in 55% and in *EP300* in ~8%. *CREBBP* pathogenic variants tend to result in more typical RSTS features, with *EP300* alterations resulting in a wider, often milder, phenotypic spectrum.

**Table 102.1** Kabuki Phenotype Scoring List

CLINICAL FEATURES	POSSIBLE SCORE	FEATURES
Facial features	0-5 points (0-3 features = 1 point; 4-6 = 2 point; 7-9 = 3 point; 10-12 = 4 point; 13-15 = 5 point)	Long palpebral fissures; everted lower eyelids; large dysplastic ears; arched eyebrows, sparse lateral one third; flat nasal tip; abnormal dentition; high/cleft palate; strabismus; blue sclera; micrognathia; ptosis; broad nasal root; oligodontia; thin upper and full lower lip; lip nodules
Limb/extremity features	Up to 1 point (0-1 features = 0 point; 2-4 = 1 point)	Persistent fetal pads; brachy- or clinodactyly; lax joints; hip dislocation
Microcephaly	1 point	
Short stature	1 point	
Heart	1 point	
Kidney	1 point	
Sum	0-10	

From Wang YR, Xu NX, Wang J, Wang XM. Kabuki syndrome: review of the clinical features, diagnosis and epigenetic mechanisms. *World J Pediatr.* 2019;15:528–535. Table 1.



**Fig. 102.2** Rubinstein-Taybi syndrome. A, A 21-month-old child. Note the hirsutism, down-slanting palpebral fissures, maxillary hypoplasia, prominent nose with nasal septum extending below alae nasi, and low, posteriorly rotated ears. B, Broad thumbs with radial angulation and persistent fingertip pads. (A courtesy Dr. Marilyn C. Jones, Children's Hospital, San Diego, California; from Jones KL, Jones MC, Del Campo M, eds. *Smith's Recognizable Patterns of Human Malformation, 8th ed.* Philadelphia: Elsevier; 2022, Fig. 1C, p. 108 and Fig. 2C, p. 109.)

### Clinical Features of RSTS

**Physical features:** Characteristic facial features include arched eyebrows, down-slanting palpebral fissures, low-hanging columella, and grinning smile. Individuals often have broad thumbs and/or halluces.

**Growth:** Prenatal growth is usually normal, but most individuals have short stature caused by slow postnatal growth. Obesity may be seen during childhood or adolescence.

**Development:** Global developmental delay is typical with milder features often seen in individuals with *EP300* pathogenic variants. The average age of walking is 30 months and first words 25 months. Speech delay occurs in 90% of children and some remain nonverbal. Features of autism spectrum disorder, as well as impulsivity, distractibility, mood instability, and stereotypies can be seen.

**Intellectual disability:** This is in the moderate to severe range is typical for individuals with RSTS, with an IQ range of 25–79. Verbal ability is typically poorer than other skills.

**Neurologic:** Craniospinal and posterior fossa abnormalities, such as Chiari malformation or cervical cord compression, can be seen as well as seizures or abnormal electroencephalogram (EEG).

**Eye findings:** These can include refractory errors, ptosis, cataracts, coloboma, nystagmus, strabismus, and glaucoma.

**Congenital heart defects:** These are seen in ~30% of individuals with RSTS. Common defects include atrial septal defect, ventricular

septal defect, patent ductus arteriosus, coarctation of the aorta, pulmonary stenosis, aortic stenosis, and vascular ring.

**Respiratory:** Obstructive sleep apnea is common.

**Genitourinary:** Kidney anomalies include hydronephrosis and duplications. Many males have cryptorchidism.

**Gastrointestinal:** Feeding problems due to gastroesophageal reflux and constipation are common.

**Musculoskeletal:** Joint laxity, scoliosis, and vertebral abnormalities can be seen. Hypotonia is common.

**Molecular diagnosis:** This can be made using a gene panel (sequencing and deletion/duplication analyses of *CREBBP* and *EP300*). For individuals with clinical features with atypical RSTS features, exome sequencing is recommended.

### CORNELIA DE LANGE SYNDROME

Cornelia de Lange syndrome (CdLS; MIM 122470) is characterized by craniofacial features including synophrys, high-arched eyebrows and thin downturned upper lip, hirsutism, intellectual disability, microcephaly, growth retardation, limb anomalies, such as micromelia, phocomelia, and oligodactyly, and several other systemic abnormalities. Its population incidence is approximately 1 in 50,000.

### Molecular Mechanism of CdLS

CdLS is caused by pathogenic variants in genes encoding the structural and regulatory components of the cohesin complex. Variants have been found in *NIPBL*, *HDAC8*, *RAD21*, *SMC1A*, and *SMC3* in CdLS. The cohesin complex is composed of *SMC1A*, *SMC3*, *RAD21*, and other subunits that comprise a ringlike structure that “embraces” chromatin. *NIPBL* encodes a protein that controls cohesin complex genome loading. The *SMC3* component of the cohesin complex becomes acetylated once loaded onto the genome and is subsequently deacetylated by *HDAC8* for cohesin protein recycling. Pathogenic variants in *BRD4* are an infrequent cause of CdLS. Cohesin has shown to play a key role in transcriptional regulation, and global transcriptional alterations due to cohesin dysfunction are thought to lead to the pathogenesis of CdLS.

*NIPBL* pathogenic variants are found in approximately 60% of the individuals with CdLS and are more likely to be identified in more severely (or “classically”) affected individuals, with loss-of-function variants resulting in a more severe phenotype. Pathogenic variants in *SMC1A*, *SMC3*, *RAD21*, *HDAC8*, and *BRD4* can be found in 1–5% of the individuals with CdLS. Pathogenic variants in all related genes are typically acquired de novo, although instances of inherited variants from minimally affected mothers have been noted for the X-linked *HDAC8* and *SMC1A* genes.



**Fig. 102.3** Physical features of Cornelia de Lange syndrome. **A**, Patient with *NIPBL* c.3100\_3106del; p.K1034QfsX7 pathogenic variant. Dysmorphic features include synophrys, long eyelashes, upturned nasal tip with anteverted nares, long philtrum, and micrognathia. Severe reduction defects of upper extremities are also depicted. **B**, Patient with *SMC1A* c.2077C>G; p.R693G mutation. Dysmorphic features include mild synophrys.

### Clinical Manifestations of CdLS

**Facial features:** Include synophrys with highly arched and/or thick eyebrows, long/thick eyelashes, short nasal bridge, upturned nasal tip with anteverted nares, long and/or smooth philtrum, thin vermilion of the upper lip, downturned corners of the mouth, highly arched palate with or without cleft palate, small widely spaced teeth, and micrognathia (Fig. 102.3).

**Growth failure:** Prenatal-onset growth failure and microcephaly are common.

**Ophthalmologic:** Common manifestations include ptosis, myopia, and nystagmus.

**Otolaryngologic:** Sensorineural hearing impairment is common, but conductive hearing loss can be seen.

**Cardiovascular:** Approximately 50% of individuals with CdLS have congenital heart disease. The most common abnormalities include pulmonary or peripheral pulmonary stenosis, ventricular septal defects, atrial septal defects, coarctation or hypoplastic aortic arch, aortic valve anomaly, tetralogy of Fallot, double-outlet right ventricle, and atrioventricular canal.

**Gastrointestinal:** Gastroesophageal reflux disease is present in nearly all instances, and some require a feeding tube during infancy/childhood. Other rare gastrointestinal abnormalities include pyloric stenosis (4%), intestinal malrotation (2%), and CDH (1%).

**Genitourinary.** Renal abnormalities such as vesicoureteral reflux and cryptorchidism are common.

**Skeletal:** Severe abnormalities of the upper extremities are seen in 25% of individuals with classical CdLS. Upper extremity deficiencies range from severe reduction defects such as complete absence of the forearms to mild fifth finger clinodactyly (see Fig. 102.3). Radioulnar synostosis is also common.

**Skin:** Hypertrichosis is common, and scalp hair, typically thick, can extend onto the temporal regions.

**Developmental delay/intellectual disability:** Most individuals with classical CdLS demonstrate global developmental delay. The overall range of IQ levels is broad, from below 30 to 85, with an average IQ of 53. Those affected individuals with classic features are more likely to have severe to profound intellectual disability. Fifty percent of children with CdLS walk by 24 months and 95% by 10 years old. A range of behavioral issues have been reported, and behavior problems are often directly related to frustration from an inability to communicate.

**Neurologic:** Approximately 25% of individuals with CdLS experience seizures.

**Molecular Diagnosis of CdLS:** Due to a relatively high frequency of mosaic variants not detected in blood, a next-generation sequencing panel of CdLS genes (*NIPBL*, *SMC1A*, *HDAC8*, *SMC3*, *RAD21*, and *BRD4*) performed on DNA extracted from buccal cells has been recommended as the most effective way of detecting causal variants. For individuals with atypical CdLS features, exome sequencing is recommended.



**Fig. 102.4** Coffin-Siris syndrome. Note the coarse face and wide mouth with full lips (A), and hypoplastic fifth fingernails (B). (From Jones KL, Jones MC, Del Campo M, eds. *Smith's Recognizable Patterns of Human Malformation*, 8th ed. Philadelphia: Elsevier; 2022, Fig. 1A and 1D, p. 819.)

### COFFIN-SIRIS SYNDROME

Coffin-Siris syndrome (CSS) is characterized by thick eyebrows, periorbital fullness, wide mouth with full lips, and coarse facial features; fifth fingernail hypoplasia; absence of terminal phalanges; hypertrichosis; developmental delay/intellectual disability; and short stature (Fig. 102.4).

### Molecular Mechanism of CSS

CSS is typically caused by de novo heterozygous germline pathogenic variants in genes encoding a component of BAF (BRG1/hBRM-associated factors) complex, which belongs to the SWI/SNF chromatin remodeler complex family. Pathogenic variants have been found in *ARID1A*, *ARID1B*, *SMARCA4*, *SMARCB1*, *SMARCE1*, and *SOX11*. Variants in one of these genes can be found in ~60–70% of the patients with CSS.

### Clinical Features of CSS

**Facial features:** Characteristic facial features of CSS include wide mouth with thick, everted upper and lower lips, broad nasal bridge with broad nasal tip, thick eyebrows, and long eyelashes. Facial features typically coarsen over time.

**Growth:** Prenatal growth profile tends to be normal, but postnatal weight and height measurements are usually below the 50th percentile.

**Development:** Global developmental delay is common and variable; children sit around 12 months, walk at around 30 months, and say their first words at 24 months. Most individuals have intellectual disability, typically moderate to severe (IQ range: 40–69). Some individuals with CSS have behavioral concerns, aggression, or autistic features.

**Neurologic:** The majority of children with CSS have hypotonia. Structural brain malformations such as Dandy-Walker variant, and



agenesis of the corpus callosum may be seen. Seizures occur in up to 50% of individuals. Hearing impairment can occur.

**Ophthalmology:** Visual impairment is common, and ocular abnormalities include ptosis, strabismus and myopia.

**Gastrointestinal:** Feeding issues and slow growth are common.

**Genitourinary:** Renal malformation such as horseshoe kidney, and genitourinary malformation such as cryptorchidism and hypospadias have been noted.

**Musculoskeletal:** Fifth digit nail and distal phalanx hypoplasia or aplasia, a diagnostic criterion in the pre-exome era, is commonly seen. Brachydactyly of the fifth finger, joint laxity, and scoliosis are also frequent.

**Cardiac:** Congenital heart defects can be seen and include ventricular septal defects, atrial septal defects, and tetralogy of Fallot.

**Skin:** Hirsutism and hypertrichosis are typical.

### Molecular Diagnosis of CSS

For those whom clinical diagnosis of CSS is strongly suspected, CSS gene sequencing and deletion/duplication panel is recommended. For those with atypical clinical features, comprehensive genetic testing such as exome sequencing is warranted.

### OTHER CHROMATIN DISORDERS

An increasing number of genetic disorders, due to mutations in genes encoding chromatin transcriptional regulatory proteins, have been identified. These disorders include CHARGE syndrome due to *CHD7* pathogenic variants, Wiedemann-Steiner syndrome due to *KMT2A* pathogenic variants, Arboleda-Tham syndrome due to *KAT6A* pathogenic variants, and Say-Barber-Biesecker/Young-Simpson syndrome due to *KAT6B* pathogenic variants. *CHD7* is a chromatin remodeler protein with a chromodomain histone-modification recognition motif. *KAT6A* and *KAT6B* encode histone modification enzymes. Common manifestations of genetic diagnoses due to these chromatin remodelers and histone modification enzyme defects include developmental delay, hypotonia, and facial dysmorphisms. Some of the clinical features enable astute clinicians to distinguish between typical cases of these syndromes. However, in their atypical presentations, a clinical diagnosis may not be feasible. Exome sequencing is recommended in any children with facial dysmorphisms as well as developmental delay to detect possible chromatin disorders.

Visit Elsevier eBooks+ at [eBooks.Health.Elsevier.com](http://eBooks.Health.Elsevier.com) for Bibliography.

## Chapter 103

# Genetics of Common Disorders

Neil A. Hanchard and Brendan Lee

Common pediatric diseases, like many common adult-onset diseases, are usually multifactorial. The combination of many genes and environmental factors contribute to a complex sequence of events leading to disease. The complexity of the combination of contributing factors increases the challenge of finding genetic variants that cause disease. Genetic tools include public databases of genetic variants and the human haplotype map. Genotyping has permitted very large numbers of common genetic variants (those with population frequencies >5%) to be efficiently tested in large numbers of patients. Genetic sequencing technologies are being used to investigate the role of rare coding

sequence variants in common diseases. The incorporation of these tools into large, well-designed population studies has developed into the field of **genetic epidemiology**.

## 103.1 Major Genetic Approaches to the Study of Common Pediatric Disorders

Neil A. Hanchard and Brendan Lee

Millions of genetic variants are present in every person. Many of these variants have no known impact on health, while others have a measurable influence. Sometimes, sequence changes in a single gene consistently cause a disease, as seen with cystic fibrosis and sickle cell anemia; more often, specific genetic changes are insufficient to determine the manifestation of a specific medical condition by themselves. Rather, these changes can contribute indirectly or partially to the development of disease, and these are best conceptualized as *modifiers* of disease risk. **Figure 103.1** demonstrates the relationship between variant frequency and the relative medical impact of the allele. The spectrum of variant impact ranges widely from a slightly increased risk of illness to predetermined, fully expressed disease. Studies aimed at discovering *rare* variants with strong health effects require only small sample populations to achieve statistical significance, whereas those studying *common* variants that contribute partially to the overall effect often require much larger sample sizes because of the small impact of multiple variants.

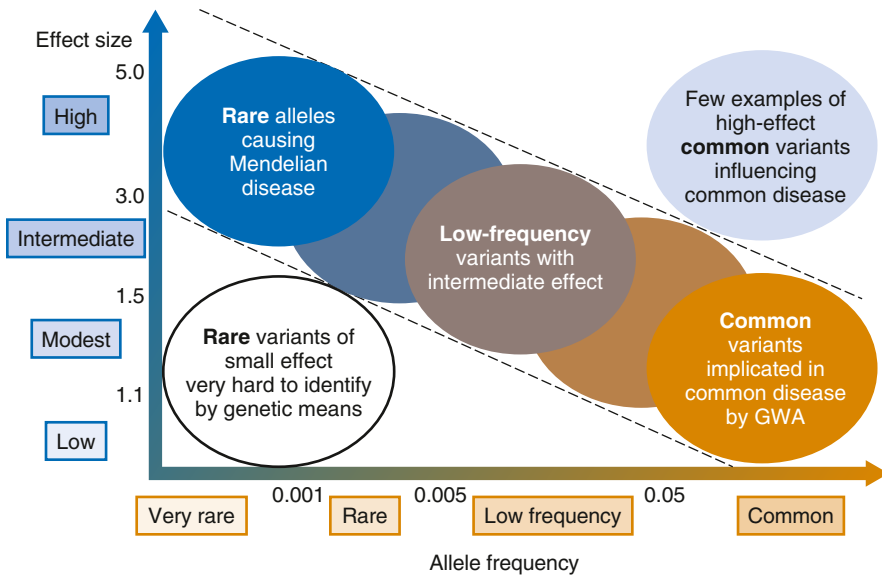
In many cases, genetic susceptibility is the result of the cumulative risk of many common variants. For common conditions, the genetic predisposition alone is not sufficient to cause disease. Everyone inherits a different degree of disease vulnerability, which is then augmented by exposure to certain environmental or other factors. **Figure 103.2** is a model for the contribution of common genetic variants to individual health. One goal of medical genetics is to identify the genes that contribute to initial genetic susceptibility and help prevent the occurrence of disease, either by avoiding inciting environmental factors or by instituting interventions that reduce risk. For persons who cross the threshold of disease, the goal is to better understand the pathogenesis in the hope that this will suggest better approaches to treatment. Common genetic variation can also influence responses to medications and the risk of adverse drug reactions, as well as augments the impact of environmental exposures.

Complex traits may be inherently difficult to study if the precision of diagnosis (**phenotype**) is low, as often occurs with neurobehavioral traits. A starting point in the genetic analysis of a complex trait, therefore, is to obtain evidence in support of a genetic contribution and to estimate the relative strength of genetic and environmental factors. Complex traits typically exhibit familial clustering but are not transmitted in a distinct pattern as seen with classical mendelian autosomal dominant or recessive inheritance. Complex traits often show variation between groups of different ancestries, possibly reflecting the differences in frequency and/or effect of genetic variants within these groups.

Assessing the potential genetic contribution begins by determining whether the trait is seen among related individuals more often than in the general population. A common measure of **familiality** is the first-degree relative risk (usually designated by the symbol  $\lambda_s$ ), which is equal to the ratio of the prevalence rate in siblings and/or parents to the prevalence rate in the general population. The  $\lambda_s$  for type 1 diabetes is about 15. The relative strength of genetic and nongenetic risk factors can be estimated by variance components analysis. The **heritability** of a trait is the estimate of the fraction of the total variance contributed by genetic factors (**Fig. 103.3**).

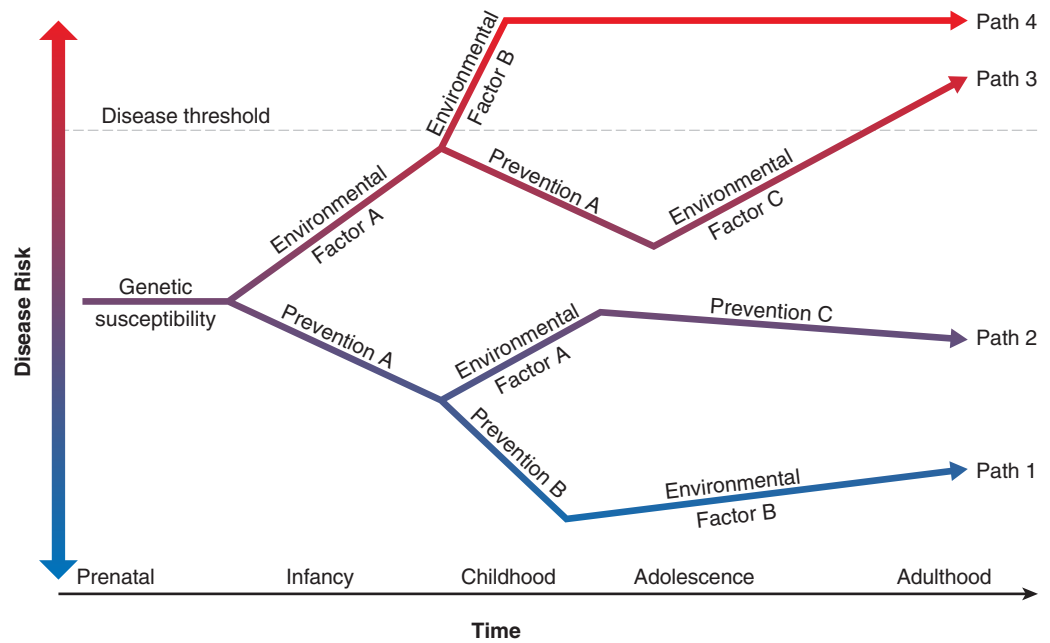
A minority of cases of common diseases such as diabetes may be caused by single-gene pathogenic variants (mendelian inheritance), chromosomal disorders, and other genomic disorders (see Chapter 629.4). However, these *unique* causes of the disease can provide important insight into the molecular pathways involved. Chromosomal regions with genes that might contribute to disease susceptibility have historically been located with **linkage mapping**, which locates regions





**Fig. 103.1** Relationship between allele frequency and relative strength of genetic effect. Alleles with large effect tend to be very rare but can be studied with a small sample size because of the relative ease of allele detection when medical impact is high. Common variants tend to have a modest or low effect on health, requiring large datasets to visualize statistically small effects. The vast majority of disease-associated alleles identified to date have the characteristics shown within the diagonal dotted lines. GWA, Genome-wide association studies for complex traits: consensus, uncertainty and challenges. *Nat Rev Genet.* 2008;9:356–369.)

**Fig. 103.2** Model for the influence of gene-environment interaction on genetic susceptibility to common diseases. Everyone inherits common variants that determine initial genetic liability for disease risk. For multifactorial disorders, the initial genetic susceptibility is insufficient to produce disease on its own. Over time, exposure to environmental factors increases the likelihood of a disease state. Identifying the gene variants responsible for risk can lead to prevention strategies or treatments.

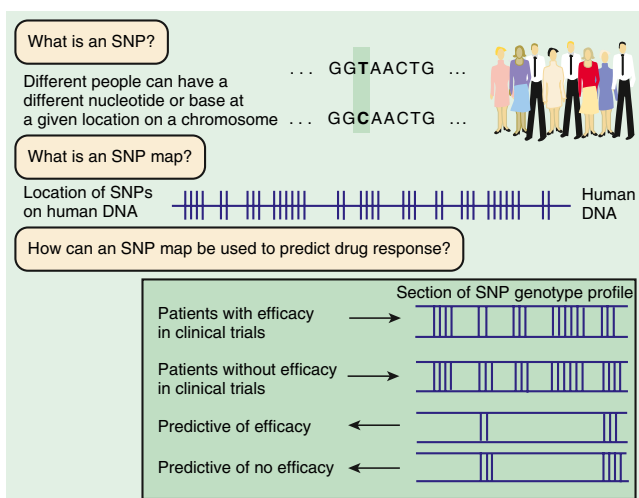


Phenotypic variance	Genetic variance	Environmental variance	Measurement variance
$V_P$	$= V_G$	$+ V_E$	$+ V_M$
$h^2 = V_G / V_P$			
<b>Heritability</b>			

**Fig. 103.3** Heritability concept. The phenotypic variance of a particular trait can be partitioned between the contributions of the genetic variance, environmental variance, and measurement variance. This is usually empirically determined. Heritability is defined by the proportion of the phenotypic variance that is accounted for by the genetic variance. One can estimate the heritability from correlation of a quantitative trait between relatives.

of DNA that are inherited in families with the specific disease. In practical terms, however, this has become quite difficult for most complex traits either because of a dearth of families or because the effects of individual genetic loci are weak; thus linkage mapping is seldom used anymore.

Genetic **association studies** are a powerful way of identifying common gene variants (>5% in the population) that each have an effect on the risk of disease. Detection of the usually small to moderate effect of each variant alongside interactions with environmental factors requires well-powered studies that often include thousands of individuals. A number of parallel approaches for analyzing the aggregate effects of rare variants in genes have also been developed. Such rare variant association methods also require large sample sizes because the gene effects also appear to be relatively weak.



**Fig. 103.4** Different combinations of single nucleotide polymorphisms (SNPs) are found in different individuals. The locations of these SNPs can be pinpointed on maps of human genes. Subsequently, they can be used to create profiles that are associated with difference in response to a drug, such as efficacy and nonefficacy. (Adapted from Roses A. *Pharmacogenetics and the practice of medicine*. *Nature*. 2000;405:857–865.)

Association studies require markers along the DNA that can be **genotyped** (ascertaining the combination of alleles at a locus in a diploid organism), typically with large-scale, high-throughput laboratory techniques. Markers that are typically used are **single nucleotide polymorphisms (SNPs; Fig. 103.4)**. A sample of the same region of genome from 50 people will reveal that approximately 1 in every 200 bases varies between individuals. Catalogues of SNPs identified in thousands of individuals from multiple populations consist of tens of millions of SNPs across the genome (dbSNP; <https://www.ncbi.nlm.nih.gov/snp/>). Although most SNPs lack an obvious function, some will alter the amino acid sequence of the protein, and many have been shown to regulate the expression of nearby or distant genes (<https://gtexportal.org/home/>) or indirectly impact expression by altering the level of surrounding DNA methylation or the ability of proteins to act (*The ENCODE Project Consortium*). Some of these functional alterations can directly affect susceptibility to disease.

A complex clinical **phenotype** can be defined by the presence or absence of a disease as a **dichotomous trait**, or by selection of a clinically meaningful continuous or **quantitative trait**, such as serum glucose in type 2 diabetes. Although it might not be possible to define subgroups of patients in advance based on disease mechanisms, the more uniform the phenotype, the more likely that a genetic study will be informative. **Locus heterogeneity** refers to the situation in which a similar trait results from alteration of different genes. **Allelic heterogeneity** is when more than one variant in a particular gene can contribute to different diseases. The development of a trait or disease from a nongenetic mechanism results in a **phenocopy**. These three factors often contribute to the difficulty in identifying individual disease susceptibility genes, because they reduce the effective size of the study population and thus require even larger sample sizes.

For genetic variants that directly lead to disease, a person bearing any variant or **allele** (inherited unit, DNA segment, or chromosome) in a gene has a given probability of being affected with a specific gene variant-associated disease. This is called the **penetrance**. Some diseases manifest signs only later in life (**age-related penetrance**), which could lead to misclassifying children with the disease-producing variant to be classified as unaffected. Single-gene disorders are typically caused by pathogenic variants with relatively high penetrance. In contrast, most common variants have low penetrance because their overall contribution to the disease is small. Many such common variants

can contribute to disease risk for a complex trait; for example, human height is influenced by >400 genes.

Ideally, important environmental exposures should be measured and accounted for in a population because there may be a dependent interaction between the environmental factor and specific genetic variant. An example is the likely requirement for a viral infection preceding onset of type 1 diabetes. Although **gene-environment interactions** are strongly suspected to play an important role in common diseases, it is difficult to identify and measure them. Very large studies with uniform collection of information about environmental exposures are rare, but are becoming more common with the expansion of large biorepositories that are integrated with electronic health records. Methods, such as genome-wide analyses of DNA methylation, sometimes referred to as epigenome-wide association studies, have been used to assess evidence for early environmental exposures that influence common diseases in later life. This apparent relationship between the environment and DNA methylation (and related genetic features) is being used to discover and validate other possible gene-environment interactions.

### GENOME-WIDE APPROACHES TO ASSOCIATION

For multifactorial common diseases, association analyses have been used to identify disease-related genes. There are two types of association study: **direct association**, in which the risk-altering variant itself is tested to see whether its presence correlates with disease, and **indirect association**, in which markers that are physically close to the biologically important variant are used as proxies. The correlation of markers with other genetic variants in a small region of the genome is called **linkage disequilibrium**. Indirect association is enabled by the construction of linkage disequilibrium maps in continental reference populations (e.g., Europeans, Asians, West Africans) (International HapMap Project). SNPs that proxy most genetic variation have been identified across most of the genome and can be genotyped at low cost using specially designed microarrays that typically include 2–5 million genetic markers. This resolution provides a good proxy of genetic variation in relatively homogenous populations where linkage disequilibrium is generally high (such as Europeans), thus facilitating “genome-wide” testing of variants in those populations.

Three basic study designs are used for association testing:

1. **Case-control design**: the frequency of an allele in an affected group is compared with an unaffected group. This is the mostly commonly used framework for association testing, as it aligns with many more traditional epidemiologic study designs.
2. **Cohort design**: large numbers of people are ascertained and then followed for the onset of any number of diseases. Cohort analysis is very expensive, and there are few true cohort studies. However, investments in genomics of large-scale population-based cohorts in Iceland (<https://www.decode.com/>), the United Kingdom (<https://www.ukbiobank.ac.uk/>), and the United States (<https://allof.us.nih.gov/>) include hundreds of thousands of individuals all tied to electronic health records and have begun to show unique insights to disease risk and pathogenesis.
3. **Family-based control design**: parents or siblings of an affected individual are used as the controls. Family-based control study designs are somewhat attractive for pediatric diseases because it is usually possible to enroll parents. These studies also solve a major problem in testing for association because the parents are perfectly matched for genetic background; however, family-based study designs are inherently less efficient to recruit than case-control studies and are used less commonly.

The success of any association analysis depends on the design of a well-powered study and an accurately measured trait to avoid phenotypic misclassification. In large, population-based studies, confounding by ethnicity or **population stratification**, could distort results. Variants more common in people from a particular ancestry group could cause an apparent association of a variant with a disease. This association would not be a true association between an allele and a disease, because the association would be confounded by genetic background. Methods for measuring subtle mismatching between cases and controls using many thousands of markers routinely genotyped

in genome-wide association studies allow researchers to account for this effect. The implementation of stringent thresholds for statistical significance replicate associations in other groups have helped make genome-wide association studies robust and reproducible.

Association studies are a powerful tool to find genetic variation that confers risk to an individual; however, the effect of any single genetic variant will be a small contribution to the overall risk and pathogenesis of disease. Hundreds of thousands of genetic associations between a variant or gene and disease, such as the *APOE*ε4 allele with an increased risk of Alzheimer disease, have now been observed for thousands of complex diseases and traits, including autoimmune disease, asthma, and bone density/fractures. Genetic variants that implicate a novel gene in a process drive research into systems and pathways that can alter disease outcome. With increasingly large datasets and advances in statistical analyses, all the genetic variants that impact common disease risk can also be combined to derive a composite genetic risk score. This score can then be integrated with known environmental risk factors to identify individuals at particularly high

risk of disease who might require more urgent intervention or monitoring. In adults, this approach is being developed to identify individuals at high risk for coronary heart disease, although concerns about how well genetic risk scores work in different population groups are yet to be overcome.

Low-cost methods for sequencing the complete coding (exomes) and full DNA sequence (genomes) of individuals have facilitated comprehensive evaluation of a wider range of genetic variants involved in common diseases. Rare genetic variants, including small insertions or deletions, are important in pediatric diseases such as neurodevelopmental disorders, cardiovascular malformations, and other birth defects. Common traits such as height, obesity, diabetes, and autoimmune diseases are also affected by rare variants. In common severe disorders such as intellectual disability and complex heart malformations, de novo pathogenic variants (i.e., pathogenic variants not present in either parent) play an important role.

Visit Elsevier eBooks+ at [eBooks.Health.Elsevier.com](http://eBooks.Health.Elsevier.com) for Bibliography.

## Chapter 104

# An Approach to Inborn Errors of Metabolism

Oleg A. Shchelochkov and  
Charles P. Venditti

Many childhood conditions are caused by single-gene pathogenic variants that encode specific proteins. These pathogenic variants can change the primary protein structure or the amount of protein synthesized. The function of a protein, whether it is an enzyme, receptor, transport vehicle, membrane component, transcriptional coregulator, or structural element, may be compromised or abolished. Hereditary diseases that disrupt normal biochemical processes are termed **inborn errors of metabolism** or **inherited metabolic diseases** (Fig. 104.1).

Most genetic changes are clinically inconsequential and represent *benign* variants. However, pathogenic variants produce diseases that range in severity of presentation and the time of onset. Severe metabolic disorders usually become clinically apparent in the newborn period or shortly thereafter, whereas milder forms may present later in childhood and even in adulthood. With some exceptions, the presenting symptoms of most metabolic conditions lack the specificity to enable a definitive diagnosis without further evaluation. The combination of *low specificity* of presenting symptoms and *low prevalence* of metabolic disorders makes specific diagnosis difficult. Progressive symptoms, the absence of a plausible nongenetic diagnosis after detailed evaluation, history of overlapping symptoms in a patient's relatives, or consanguinity should alert a pediatrician to seek a consultation with a geneticist and prompt metabolic testing early in the evaluation.

Correct diagnosis is often only the beginning of a long medical journey for most families affected by metabolic conditions (see Chapter 95). Although each inherited metabolic disorder is individually rare, improved diagnosis and increasing survival of patients with metabolic conditions virtually ensure that a pediatrician will encounter and provide care to affected patients. Pediatricians can play a critical role in establishing the continuity of care; managing some aspects of treatment; fostering adherence; and delivering routine pediatric interventions such as immunizations, referrals to specialists, and elements of genetic counseling (see Chapter 98.1).

The greater awareness of metabolic conditions, wider availability of biochemical laboratories, global metabolomic analysis, and routine application of exome and genome sequencing dramatically increased the detection rate of the known disorders and contributed to the discovery of new metabolic disorders. Nonetheless, collection and analysis of family history remain critical screening tests that a healthcare provider can use to identify an infant or child at risk for a metabolic disorder. The identification of consanguinity or a particular ethnic background with an unusually high incidence of inborn errors of metabolism can be important to direct further studies. For example, tyrosinemia type 1 is more common among French Canadians of Quebec, maple syrup urine disease is seen with higher frequency in the U.S. Amish population, and Canavan disease is more common in patients of the Ashkenazi Jewish ancestry.

## NEWBORN SCREENING

The individual rarity of inborn errors of metabolism, the importance of early diagnosis, and the ensuing genetic counseling ramifications make a strong argument for the universal screening of all newborn infants. **Tandem mass spectrometry** of metabolites and **enzyme assays** form the foundation of first-tier newborn screening. Worldwide, newborn screening programs have begun incorporating reflex second-tier testing using **molecular analysis** of target genes. These methods require only a few drops of blood to be placed on a filter paper and delivered to a central laboratory for assay. Many genetic conditions can be identified by these methods, and the list of disorders continues to grow (Tables 104.1 and 104.2). Pediatricians need to be aware of the general screening procedure and limitations of screening. As a screening method, a positive result may require a repeat newborn screen or confirmatory testing to secure the diagnosis. The time required to return the results varies from country to country and even within states in the same country. Some metabolic conditions can be severe enough to cause clinical manifestations before the results of the newborn screening become available. Conversely, diagnostic metabolites in milder forms of screened disorders may not reach a set threshold to trigger secondary studies, thus leading to negative newborn screen results and delayed diagnosis. *Therefore negative newborn screening in a patient with symptoms suggestive of a metabolic disorder warrants a referral to a genetics specialist for further evaluation.*

Universal newborn screening may also identify mild forms of inherited metabolic conditions, some of which may never cause clinical manifestations in the lifetime of the individual. For example, short-chain acyl-CoA dehydrogenase deficiency has been identified with unexpectedly high frequency in screening programs using tandem mass spectrometry, but most of these children have remained asymptomatic. This highlights the need for an ongoing evaluation of metabolite cutoff values and approaches to confirmatory testing to maximize the diagnostic yield and minimize potential psychosocial and economic implications of such findings. Premature infants represent a special population in whom the incidence of false-positive or false-negative test results can be especially high.

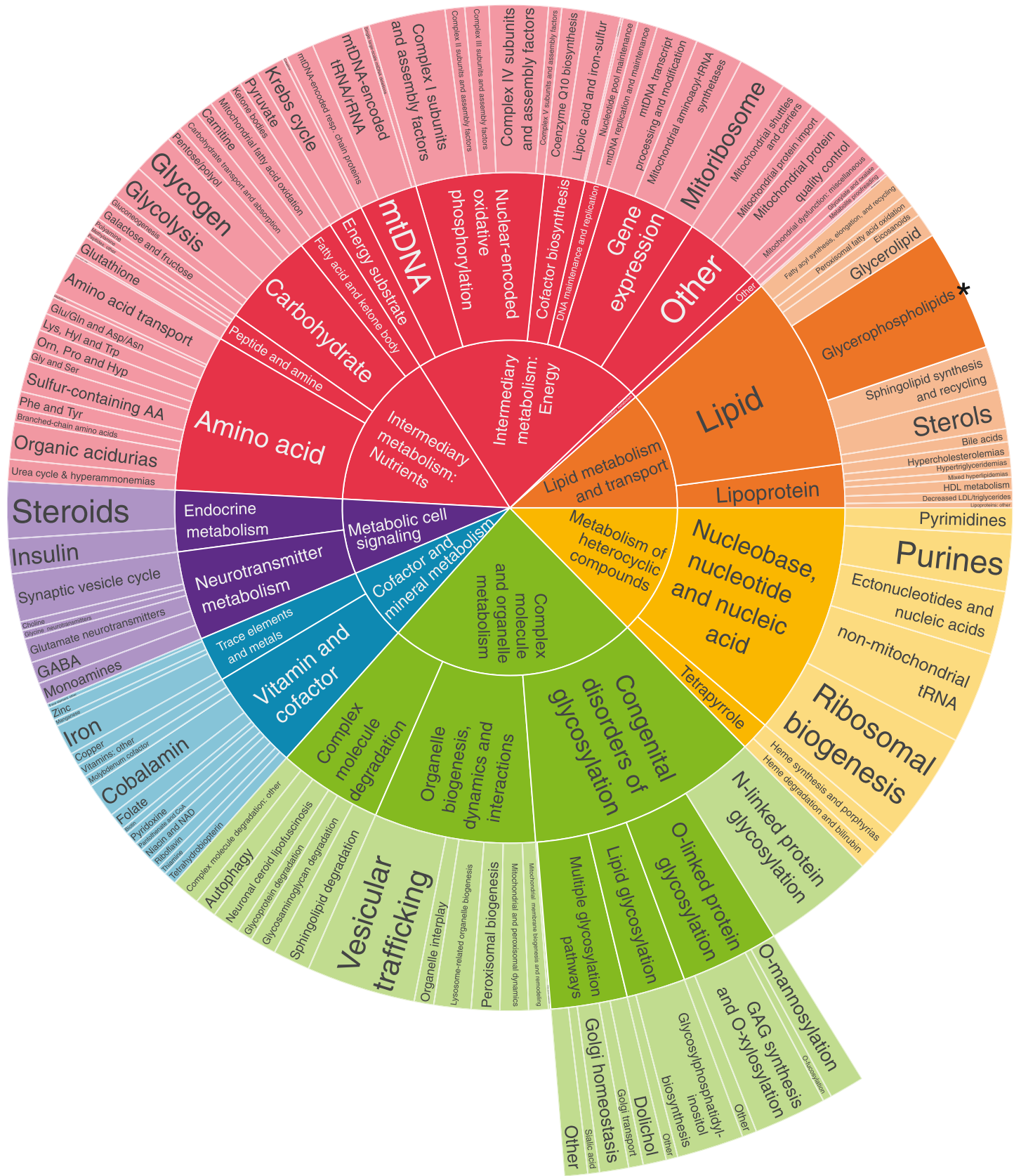
With the advent of genetic therapy for spinal muscular atrophy (SMA) and enzyme replacement therapy for some lysosomal storage diseases (e.g., Pompe disease, Fabry disease, Gaucher disease, and mucopolysaccharidosis type 1), most state newborn screening programs include screening for SMA and lysosomal storage disorders.

## CLINICAL MANIFESTATIONS OF GENETIC METABOLIC DISEASES

Physicians and other healthcare providers who care for children should familiarize themselves with early manifestations of inborn errors of metabolism, because (1) severe forms of some of these conditions may cause symptoms before the results of screening studies become available and (2) the current screening methods, although quite extensive, identify a small number of all inherited metabolic conditions. In the newborn period, the clinical findings are usually nonspecific and similar to those seen in infants with sepsis. An inborn error of metabolism should be considered in the differential diagnosis of a severely ill newborn infant, and special studies should be undertaken if the index of suspicion is high (see Fig. 104.1).

Signs and symptoms such as lethargy, hypotonia, hypothermia, convulsions (Table 104.3), poor feeding, and vomiting may develop as early as a few hours after birth. Occasionally, vomiting may be severe enough to suggest the diagnosis of pyloric stenosis, which is usually not present, although it may occur simultaneously in some infants.





**Fig. 104.1** Sunburst chart depicting the hierarchical nature of the International Classification of Inherited Metabolic Disorders. The size of each section of the chart is directly proportional to the number of disorders in that group. \*Including phosphatidylinositol (with lesser numbers for ether lipids and lesser still for phosphatidylcholine, phosphatidylserine, and phosphatidylethanolamine) (From Ferreira CR, Rahman S, Keller M, et al. An international classification of inherited metabolic disorders [ICIMD]. *J Inherit Metab Dis.* 2021;44:164–177, Fig. 1.)

**Table 104.1** Core Conditions on the Recommended Uniform Screening Panel by the Advisory Committee on Heritable Disorders in Newborns and Children of the U.S. Health Resources & Services Administration\*

<p><b>DISORDERS OF ORGANIC ACID METABOLISM</b>  Propionic acidemia  Methylmalonic acidemia (methylmalonyl-CoA mutase)  Methylmalonic acidemia (cobalamin disorders)  Isovaleric acidemia  3-Methylcrotonyl-CoA carboxylase deficiency  3-Hydroxy-3-methylglutaric aciduria  Holocarboxylase synthase deficiency  <math>\beta</math>-Ketothiolase deficiency  Glutaric acidemia type I</p> <p><b>DISORDERS OF FATTY ACID METABOLISM</b>  Medium-chain acyl-CoA dehydrogenase deficiency  Very-long-chain acyl-CoA dehydrogenase deficiency  Long-chain 3-hydroxy-acyl-CoA dehydrogenase deficiency  Trifunctional protein deficiency  Systemic primary carnitine deficiency</p> <p><b>DISORDERS OF AMINO ACID METABOLISM</b>  Classic phenylketonuria  Maple syrup urine disease  Homocystinuria  Citrullinemia type 1  Argininosuccinic acidemia  Tyrosinemia type I</p>	<p><b>HEMOGLOBINOPATHIES</b>  Sickle cell anemia (hemoglobin SS disease)  Hemoglobin S/<math>\beta</math>-thalassemia  Hemoglobin S/C disease</p> <p><b>ENDOCRINE DISORDERS</b>  Primary congenital hypothyroidism  Congenital adrenal hyperplasia</p> <p><b>OTHER DISORDERS</b>  Classic galactosemia  Biotinidase deficiency  Glycogen storage disease type II (Pompe disease)  Mucopolysaccharidosis type 1  X-linked adrenoleukodystrophy  Cystic fibrosis  Hearing loss  Severe combined immunodeficiency (SCID)  Critical congenital heart disease  Spinal muscular atrophy (SMA) due to homozygous deletion of exon 7 in <i>SMN1</i></p>
--	---

\*Adopted from <https://www.hrsa.gov/advisory-committees/heritable-disorders/rusp/index.html>, last revised in February 2020.

**Table 104.2** Secondary Conditions on the Recommended Uniform Screening Panel by the Advisory Committee on Heritable Disorders in Newborns and Children of the U.S. Health Resources & Services Administration

<p><b>ORGANIC ACID METABOLISM DISORDERS</b>  Methylmalonic acidemia with homocystinuria  Malonic acidemia  2-Methyl-3-hydroxybutyric aciduria  Isobutyryl-CoA dehydrogenase deficiency  2-Methylbutyryl-CoA dehydrogenase deficiency  3-Methylglutaconic aciduria</p> <p><b>FATTY ACID OXIDATION DISORDERS</b>  Short-chain acyl-CoA dehydrogenase deficiency  Glutaric acidemia type 2  Medium-/short-chain 3-hydroxy-acyl-CoA dehydrogenase deficiency  Medium-chain ketoacyl-CoA thiolase deficiency  Carnitine palmitoyltransferase IA deficiency  Carnitine palmitoyltransferase II deficiency  Carnitine-acylcarnitine translocase deficiency  2,4-Dienoyl-CoA reductase deficiency</p>	<p><b>AMINO ACID METABOLISM DISORDERS</b>  Hyperphenylalaninemia, benign (not classic phenylketonuria)  Tyrosinemia type II  Tyrosinemia type III  Defects of biopterin cofactor biosynthesis  Defects of biopterin cofactor regeneration  Argininemia  Hypermethioninemia  Citrullinemia type II (citrin deficiency)</p> <p><b>HEMOGLOBINOPATHIES</b>  Hemoglobin variants (including hemoglobin E)</p> <p><b>OTHERS</b>  Galactose epimerase deficiency  Galactokinase deficiency  T-cell-related lymphocyte deficiencies</p>
---	---

**Table 104.3** Select Inborn Errors of Metabolism Associated with Neurologic and Laboratory Manifestations in Neonates

<p><b>DETERIORATION IN CONSCIOUSNESS</b>  <b>Metabolic Acidosis</b>  Organic acidemias  Disorders of pyruvate metabolism  Fatty acid oxidation defects  Fructose-1,6-bisphosphatase deficiency  Glycogen storage diseases  Mitochondrial respiratory chain defects  Disorders of ketone metabolism</p>	<p><b>HYPOGLYCEMIA*</b>  Fatty acid oxidation defects  Disorders of gluconeogenesis  Disorders of fructose and galactose metabolism  Glycogen storage diseases  Disorders of ketogenesis  Organic acidemias  Hyperinsulinemic hypoglycemia  Mitochondrial respiratory chain defects  Neonatal intrahepatic cholestasis caused by citrin deficiency  Disorders of pyruvate metabolism  Carbonic anhydrase VA deficiency</p>
--	--

Continued

**Table 104.3** Select Inborn Errors of Metabolism Associated with Neurologic and Laboratory Manifestations in Neonates—cont'd**HYPERAMMONEMIA\*\***

Urea cycle disorders  
Organic acidemias  
Fatty acid oxidation disorders  
Disorders of pyruvate metabolism  
*GLUD1*-related hyperinsulinemic hypoglycemia  
Carbonic anhydrase VA deficiency

**SEIZURES AND HYPOTONIA**

Antiquitin deficiency (pyridoxine-dependent epilepsy)  
Pyridoxamine 5'-phosphate oxidase (PNPO) deficiency (pyridoxal phosphate-responsive epilepsy)  
Folate metabolism disorders  
Multiple carboxylase deficiency (holocarboxylase synthetase deficiency and biotinidase deficiency)  
Urea cycle disorders  
Organic acidemias  
Fatty acid oxidation disorders  
Disorders of creatine biosynthesis and transport

Disorders of neurotransmitter metabolism  
Molybdenum cofactor deficiency and sulfite oxidase deficiency  
Serine deficiency disorders  
Glycine encephalopathy  
Asparagine synthetase deficiency  
Mitochondrial respiratory chain defects  
Zellweger spectrum disorders  
Congenital disorders of glycosylation  
Purine and pyrimidine metabolism defects

**NEONATAL APNEA**

Glycine encephalopathy  
Asparagine synthetase deficiency  
Urea cycle disorders  
Organic acidemias  
Disorders of pyruvate metabolism  
Fatty acid oxidation defects  
Mitochondrial respiratory chain defects

\*Refer to Table 104.4 for more details on the metabolic disorders associated with neonatal hypoglycemia.

\*\*Refer to Table 104.5 for more details on the differential diagnosis of neonatal and infantile hyperammonemia.

Modified from El-Hattab AW. Inborn errors of metabolism. *Clin Perinatol.* 2015;42:413-439, Box 1.

**Table 104.4** Select Inborn Errors of Metabolism Associated with Neonatal Hypoglycemia

CATEGORY OF DISORDERS	DISORDERS	CATEGORY OF DISORDERS	DISORDERS
Fatty acid oxidation disorders	Carnitine-acylcarnitine translocase deficiency Carnitine palmitoyltransferase Ia deficiency Carnitine palmitoyltransferase II deficiency Long-chain 3-hydroxyacyl-CoA dehydrogenase Deficiency/trifunctional protein deficiency Medium-chain acyl-CoA dehydrogenase deficiency Very-long-chain acyl-CoA dehydrogenase deficiency Multiple acyl-CoA dehydrogenase deficiency	Disorders of ketone metabolism	3-Hydroxy-3-methylglutaryl-CoA lyase deficiency Mitochondrial 3-hydroxy-3-methylglutaryl-CoA synthase deficiency Succinyl-CoA:3-oxoacid-CoA transferase (SCOT) deficiency β-Ketothiolase deficiency
Disorders of gluconeogenesis	Fructose-1,6-diphosphatase deficiency Phosphoenolpyruvate carboxykinase deficiency	Disorders of amino acid metabolism	Maple syrup urine disease
Disorders of fructose and galactose metabolism	Hereditary fructose intolerance Classic galactosemia	Organic acidemias	Propionic acidemia Methylmalonic acidemia Isovaleric acidemia Multiple carboxylase deficiency (holocarboxylase synthetase deficiency and biotinidase deficiency)
Glycogen storage diseases (GSD)	GSD type Ia (glucose-6-phosphatase deficiency) GSD type Ib (impaired glucose-6-phosphate exchanger) GSD type III (glycogen debrancher enzyme deficiency) GSD type VI (liver glycogen phosphorylase deficiency) GSD type IX (phosphorylase kinase deficiencies)	Hyperinsulinemic hypoglycemia	<i>HADH</i> -related disorder (3-α-hydroxyacyl-CoA dehydrogenase deficiency) <i>GLUD1</i> -related disorder (hyperammonemia-hyperinsulinism syndrome [HIHA])
		Other	Mitochondrial respiratory chain defects Neonatal intrahepatic cholestasis caused by citrin deficiency Pyruvate carboxylase deficiency Carbonic anhydrase VA deficiency

Modified from Zinn AB. Inborn errors of metabolism. In: Martin RJ, Fanaroff AA, Walsh MC, eds. *Fanaroff & Martin's Neonatal-Perinatal Medicine: Diseases of the Fetus and Infant*, 10th ed. Philadelphia: Elsevier; 2015: Table 99.17, p. 1605.

Lethargy, poor feeding, seizures, and coma may also be seen in infants with hypoglycemia (Table 104.4) (see Chapters 113 and 147), hypocalcemia (Chapters 69 and 611), and hyperammonemia (Table 104.5) (Chapter 105). Measurements of blood concentrations of glucose and calcium and prompt response to intravenous injection of glucose or calcium help guide the diagnostic decisions.

Every organ can be affected by metabolic disorders. However, *physical examination* usually reveals nonspecific findings; most signs are related to the central nervous system such as lethargy, coma, seizures, hyperventilation, or opisthotonus. Hepatomegaly is a common finding in a variety of inborn errors of metabolism (Table 104.6). Cardiomyopathy (Table 104.7), dysmorphic features (Table 104.8),

**Table 104.5** Differential Diagnosis of Hyperammonemia**INBORN ERRORS OF METABOLISM****Urea Cycle Enzyme Defects**

N-acetylglutamate synthase (NAGS) deficiency  
 Carbamoyl phosphate synthetase one (CPS1) deficiency  
 Ornithine transcarbamylase (OTC) deficiency  
 Argininosuccinate synthetase (ASS) deficiency (citrullinemia type 1)  
 Argininosuccinate lyase (ASL) deficiency (argininosuccinic aciduria)  
 Arginase 1 deficiency

**Transport and Synthesis Defects of Urea Cycle Intermediates**

Hyperornithinemia-hyperammonemia-homocitrullinemia (HHH syndrome)  
 Citrullinemia type 2 caused by citrin deficiency  
 Lysinuric protein intolerance  
 Ornithine aminotransferase deficiency  
 Carbonic anhydrase VA deficiency

**Organic Acidemias**

Propionic acidemia  
 MMUT-related methylmalonic acidemia and cobalamin metabolism disorders  
 Isovaleric acidemia

**Fatty Acid Oxidation Disorders**

Long-chain fatty acid oxidation defects  
 Systemic primary carnitine deficiency

**Other**

Pyruvate carboxylase deficiency  
 GLUD1-related hyperinsulinemic hypoglycemia  
 Neonatal iron overload disorders (e.g., hereditary hemochromatosis)

**ACQUIRED DISORDERS****Transient Hyperammonemia of the Newborn Diseases of the Liver and Biliary Tract**

Liver failure  
 Biliary atresia  
**Severe Systemic Neonatal Illness**

Neonates sepsis  
 Heart failure

**Medications**

Valproic acid  
 Cyclophosphamide  
 5-Pentanoic acid  
 Asparaginase

**Other**

Reye syndrome

**ANATOMIC VARIANTS**

Vascular bypass of the liver (e.g., a portosystemic anastomosis)

**TECHNICAL**

Inappropriate sample collection (e.g., capillary blood or prolonged placement of a tourniquet)  
 Sample not immediately analyzed

Modified from El-Hattab AW. Inborn errors of metabolism. *Clin Perinatol.* 2015;42:413–439, Box 8.

and fetal hydrops (Table 104.9) are additional potential manifestations of a metabolic disorder (Table 104.10). Occasionally, a peculiar odor may offer an invaluable clue leading to the right diagnosis (Table 104.11).

In an increasing number of patients, a metabolic condition may be recognized months or years after birth. This is more typical in patients carrying milder autosomal recessive pathogenic variants, in mitochondrial disorders, in females affected by X-linked recessive conditions, and specific metabolic conditions that usually present later in life. There may be an episodic or intermittent pattern, with episodes of acute clinical manifestations separated by periods of seemingly disease-free states. The episodes are usually triggered by stress or non-specific catabolic stress such as an infection, overfeeding, prolonged fasting, or physical exertion. Thus an inborn error of metabolism should be considered in any child with one or more of the following unexplained clinical manifestations: failure to thrive; coarse facial features and reduced range of motion in the joints; developmental delay; intellectual disability; developmental regression; motor deficits or adventitious movements (e.g., dystonia, choreoathetosis, ataxia); seizures; catatonia; myopathy; intermittent episodes of unexplained vomiting, acidosis, mental deterioration, psychosis, or coma; hepatomegaly; renal stones; renal dysfunction, especially Fanconi syndrome or renal tubular acidosis; cardiomyopathy; persistent leukopenia; megaloblastic anemia; and unusual odor (particularly during an acute illness) (Table 104.12).

Diagnosis usually requires a variety of specific laboratory studies. Plasma amino acid analysis, total plasma homocysteine, plasma acylcarnitine profile, total and free carnitine levels, and urine organic acid assay, although not exhaustive in their diagnostic scope, are useful as initial screening tests to evaluate for a suspected inborn error of metabolism. Measurements of plasma ammonia, glucose, lactate, bicarbonate, and pH are readily available in hospitals and very helpful initially in differentiating major causes of genetic metabolic disorders (Table 104.13 and Fig. 104.2). Elevation of blood ammonia is usually caused by defects of urea cycle enzymes, organic acidemias, and disorders of fatty acid oxidation. Infants with elevated blood ammonia levels from

urea cycle defects tend to have normal serum pH and bicarbonate values; without measurement of blood ammonia, they may remain undiagnosed and succumb to their disease. In organic acidemias, elevated plasma ammonia is accompanied by severe acidosis caused by accumulation of organic acids, ketone bodies, and lactate in body fluids.

When blood ammonia, pH, and bicarbonate values are normal, other aminoacidopathies (e.g., hyperglycinemia) or galactosemia should be considered. Galactosemic infants may also manifest cataracts, hepatomegaly, ascites, and jaundice.

Currently, more targeted assays, such as those used with newborn screening, have the highest sensitivity in the diagnosis or monitoring of specific disorders in question. However, some success has been shown in the context of undiagnosed individuals where metabolomic (assays for entire small molecule metabolites) data can be correlated with genomic information to provide supporting evidence for a pathogenic variant in a suspected causal gene.

**TREATMENT**

Most patients with genetic disorders of metabolism respond to one or more of the following treatments:

1. Special diets play an important role in the treatment of affected children. Dietary changes should be tailored to the pathophysiology of the condition and vary greatly among disorders.
2. Hemodialysis for expeditious removal of accumulated noxious compounds. This is a very effective modality for treatment of the acute phase of the condition.
3. Catabolic states in patients at risk for metabolic crisis can be treated with fluids containing dextrose and electrolytes.
4. Administration of the deficient metabolite.
5. Administration of the cofactor or coenzyme to maximize the residual enzyme activity.
6. Activation of alternative pathways to reduce the noxious compounds accumulated because of the genetic abnormality.
7. Administration of the deficient enzyme.
8. Bone marrow transplantation.
9. Liver and kidney transplantation.



**Table 104.6** Select Metabolic Disorders Associated with Hepatic Dysfunction

CATEGORY OF DISORDERS	DISORDERS
Disorders of amino acid metabolism	Tyrosinemia type I Citrullinemia type II caused by citrin deficiency Disorders of methionine metabolism Urea cycle disorders
Biliary tract disorders and disorder of bile acid synthesis	See Chapter 383
Disorders of fructose and galactose metabolism	Hereditary fructose intolerance Classic galactosemia Epimerase deficiency galactosemia
Congenital disorders of glycosylation	Multiple types
Fatty acid oxidation disorders	Carnitine-acylcarnitine translocase deficiency Carnitine palmitoyltransferase Ia deficiency Carnitine palmitoyltransferase II deficiency Long-chain 3-hydroxyacyl-CoA dehydrogenase deficiency/trifunctional protein deficiency Very-long-chain acyl-CoA dehydrogenase deficiency Multiple acyl-CoA dehydrogenase deficiency
Glycogen storage disorders (GSD)	GSD type 1a (deficiency of glucose-6-phosphatase catalytic activity) GSD type 1b (a defect in glucose-6-phosphate exchanger encoded by <i>SLC37A4</i> ) GSD type III (glycogen debrancher enzyme deficiency) GSD type IV (glycogen branching enzyme deficiency) GSD type VI (liver glycogen phosphorylase deficiency)
Peroxisomal disorders	Zellweger spectrum disorders Disorders of peroxisomal $\beta$ -oxidation
Mitochondrial respiratory chain (RC) defects	Mitochondrial DNA (mtDNA) or nuclear DNA (nDNA) defects: Specific single-nucleotide pathogenic variants in mtDNA Large-scale mtDNA re-arrangements (Pearson syndrome) Disorders of mitochondrial translation (e.g., tRNA <sup>Glu</sup> ) Disorder of protein synthesis of RC complexes Disorders affected the assembly or stabilization of RC complexes (e.g., <i>BCS1L</i> ) Disorders of cofactor biosynthesis (e.g., coenzyme Q10) Disorders of mitochondrial transport and dynamics mtDNA depletion syndromes (e.g., <i>DGUOK</i> , <i>MPV17</i> , <i>POLG</i> , <i>SUCLG1</i> )
Lysosomal storage disorders	Niemann-Pick disease type C
Other	$\alpha_1$ -Antitrypsin deficiency

Modified from Zinn AB. Inborn errors of metabolism. In: Martin RJ, Fanaroff AA, Walsh MC, eds. *Fanaroff & Martin's Neonatal-Perinatal Medicine: Diseases of the Fetus and Infant*, 10th ed. Philadelphia: Elsevier; 2015: Table 99.5, p. 1579.

**Table 104.7** Select Metabolic Disorders Associated with Cardiomyopathy

CATEGORY OF DISORDERS	DISORDERS
Organic acidemias	Propionic acidemia Cobalamin C deficiency 3-methylglutaconic acidurias (e.g., Barth syndrome and DCMA syndrome)
Lysosomal storage disorders	Sphingolipidoses (e.g., Fabry disease) Oligosaccharidoses and mucopolipidoses (e.g., I-cell disease) Mucopolysaccharidoses
Glycogen storage disorders (GSD)	GSD type II (Pompe disease) GSD type III (glycogen debrancher enzyme deficiency) PRKAG2-related disorders (includes lethal congenital glycogen storage disease of heart)
Congenital disorders of glycosylation	Multiple types
Fatty acid oxidation disorders	Carnitine-acylcarnitine translocase deficiency Carnitine palmitoyltransferase II deficiency Long-chain 3-hydroxyacyl-CoA dehydrogenase deficiency/trifunctional protein deficiency ACAD9-related disorder (mitochondrial acyl-CoA dehydrogenase deficiency) Multiple acyl-CoA dehydrogenase deficiency (includes glutaric aciduria type 2) Very-long-chain acyl-CoA dehydrogenase deficiency Systemic primary carnitine deficiency
Mitochondrial respiratory chain (RC) defects	Mitochondrial DNA (mtDNA) or nuclear DNA (nDNA) defects: Specific single-nucleotide pathogenic variants in mtDNA Large-scale mtDNA deletions Disorders of mitochondrial translation (e.g., tRNA <sup>Leu</sup> ) Disorders of protein synthesis of RC complexes (e.g., <i>MT-ATP6</i> , <i>MT-ATP8</i> , <i>NDUFS2</i> , <i>NDUFV2</i> , <i>SDHA</i> , <i>SCO2</i> , <i>COX10</i> , <i>COX15</i> ) Disorders affecting the assembly or stabilization of RC complexes (e.g., <i>TMEM70</i> ) Disorders of cofactor biosynthesis (e.g., coenzyme Q10) Disorders of mitochondrial transport and dynamics (e.g., <i>SLC25A3</i> ) mtDNA depletion syndromes (e.g., <i>SUCLG1</i> )
Other	Danon disease

DCMA, dilated cardiomyopathy with ataxia.

Modified from Zinn AB. Inborn errors of metabolism. In: Martin RJ, Fanaroff AA, Walsh MC, eds. *Fanaroff & Martin's Neonatal-Perinatal Medicine: Diseases of the Fetus and Infant*, 10th ed. Philadelphia: Elsevier; 2015: Table 99.4, p. 1576.

Table 104.8 Select Inborn Errors of Metabolism Associated with Dysmorphic Features			
CATEGORY OF DISORDERS		DISORDERS	
Congenital disorders of glycosylation	N-Glycosylation disorders (e.g., PMM2-CDG and ALG3-CDG)	Lysosomal storage disorders	Sphingolipidoses
	O-Glycosylation disorders (e.g., Walker-Warburg syndrome)		Oligosaccharidoses and mucopolipidoses
Disorders of cholesterol biosynthesis	Smith-Lemli-Opitz syndrome	Organic acidurias	Multiple acyl-CoA dehydrogenase deficiency (includes glutaric aciduria type 2)
	Desmosterolosis		Mevalonic aciduria*
	Lathosterolosis	Peroxisomal disorders	Zellweger spectrum disorders
	EBP-related disorder (includes Conradi-Hunermann syndrome)		Disorders of peroxisomal β-oxidation
		Other	Pyruvate dehydrogenase complex deficiency

\*Mevalonic aciduria has been classified as an organic acidemia based on the method used for its diagnosis, but it can also be classified as a peroxisomal single-enzyme disorder or as a defect in cholesterol biosynthesis because of its intracellular location or function.

Modified from Zinn AB. Inborn errors of metabolism. In: Martin RJ, Fanaroff AA, Walsh MC, eds. *Fanaroff & Martin's Neonatal-Perinatal Medicine: Diseases of the Fetus and Infant*, 10th ed. Philadelphia: Elsevier; 2015: Table 99.8, p. 1583.

Table 104.9 Select Inborn Errors of Metabolism Associated with Hydrops Fetalis	
<p><b>LYSOSOMAL STORAGE DISORDERS</b></p> <p>Mucopolysaccharidoses types I, IVA, and VII</p> <p>Sphingolipidoses (e.g., Gaucher disease, Farber disease, Niemann-Pick disease A, GM<sub>1</sub> gangliosidosis, multiple sulfatase deficiency)</p> <p>Lipid storage diseases (Wolman and Niemann-Pick disease C)</p> <p>Oligosaccharidoses (e.g., sialidosis type I)</p> <p>Mucolipidoses (e.g., I-cell disease)</p>	<p><b>ZELLWEGER SPECTRUM DISORDERS</b></p> <p>Glycogen storage disease type IV</p> <p>Congenital disorders of glycosylation</p> <p>Mitochondrial respiratory chain defects</p> <p>Transaldolase deficiency</p>

Modified and adapted from El-Hattab AW. Inborn errors of metabolism. *Clin Perinatol*. 2015;42:413–439, Box 6.

Table 104.10 Physical Examination Findings Associated with Inborn Errors of Metabolism (Select Examples)			
FINDINGS		DISORDERS	
Hepatomegaly	Disorders of fructose and galactose metabolism (e.g., classic galactosemia and hereditary fructose intolerance)	Macroglossia	Glycogen storage disease type II (Pompe disease)
	Glycogen storage diseases		Mucopolysaccharidoses
	Disorders of gluconeogenesis		Oligosaccharidoses and mucolipidoses
	Disorders of fatty acid oxidation and transport	Dystonia or extrapyramidal signs	Sphingolipidoses
	Mitochondrial respiratory chain defects		Galactosialidosis
	Tyrosinemia type 1		Gaucher disease type 2
	Urea cycle disorders	Macular "cherry-red spot"	Glutaric acidemia type 1
	Zellweger spectrum disorders		Methylmalonic acidemia
	Niemann-Pick disease type C		Propionic acidemia
	Congenital disorders of glycosylation		Krabbe disease
Hepatosplenomegaly	Mucopolysaccharidoses		Crigler-Najjar syndrome
	Niemann-Pick disease types A, B, and C		Disorders of neurotransmitter metabolism
	Sphingolipidoses (e.g., GM <sub>1</sub> gangliosidosis or Gaucher disease)		Pyruvate dehydrogenase complex deficiency
	Wolman disease		
	Farber disease (acid ceramidase deficiency)		
Macrocephaly	Glutaric acidemia type 1		
	Canavan disease		
Microcephaly	Mitochondrial respiratory chain defects	"Bull eye" maculopathy	cbIc and cbId deficiency (combined methylmalonic acidemia and homocystinuria, type C)
	Disorders of intracellular cobalamin metabolism (e.g., cbIc deficiency)	Retinitis pigmentosa	Mitochondrial respiratory chain defects
Cholesterol metabolism disorders (e.g., Smith-Lemli-Opitz syndrome)			Peroxisomal disorders
	Serine synthesis disorders		Abetalipoproteinemia
Coarse facial features	Mucopolysaccharidoses	Optic nerve atrophy or hypoplasia	Pyruvate dehydrogenase complex deficiency
	Oligosaccharidoses and mucolipidoses (e.g., α-mannosidosis)		Mitochondrial respiratory chain defects
	Sphingolipidoses (e.g., GM <sub>1</sub> gangliosidosis)		Peroxisomal disorders
	Galactosialidosis		Propionic acidemia
			MMUT-related methylmalonic acidemia and cobalamin metabolism disorders

Continued

**Table 104.10** Physical Examination Findings Associated with Inborn Errors of Metabolism (Select Examples)—cont'd

FINDINGS	DISORDERS	FINDINGS	DISORDERS
Corneal clouding or opacities	Mucopolysaccharidoses Mucopolysaccharidoses Steroid sulfatase deficiency Tyrosinemia type II Cystinosis	Ichthyosis	Gaucher disease type 2 Steroid sulfatase deficiency Refsum disease ELOVL4-related disorder Serine deficiency disorders
Cataracts	Disorders of galactose metabolism (e.g., classic galactosemia) Congenital disorders of glycosylation Mitochondrial respiratory chain (RC) defects Peroxisomal disorders Lowe oculocerebrorenal syndrome	Alopecia	Multiple carboxylase deficiency (holocarboxylase synthetase deficiency and biotinidase deficiency)
Dislocated lens	Cystathionine $\beta$ -synthase deficiency Molybdenum cofactor deficiency and sulfite oxidase deficiency	Steely or kinky hair	Menkes disease
Skeletal dysplasias and dysostosis multiplex	Oligosaccharidoses and mucopolysaccharidoses Mucopolysaccharidoses Sphingolipidoses Galactosialidosis Peroxisomal disorders Disorders of cholesterol biosynthesis Congenital disorders of glycosylation	Trichorrhexis nodosa	Argininosuccinic aciduria (ASL deficiency)
Thick skin	Oligosaccharidoses and mucopolysaccharidoses Mucopolysaccharidoses Sphingolipidoses	Megaloblastic anemia	Cobalamin metabolism disorders Folate metabolism disorders Mevalonic aciduria Orotic aciduria Pearson syndrome
Desquamating, eczematous, or vesiculobullous skin lesions	Acrodermatitis enteropathica Essential amino acid deficiencies in organic acidemias Hartnup disorder Multiple carboxylase deficiency (holocarboxylase synthetase deficiency and biotinidase deficiency) Porphyrias	Leukopenia	Folate metabolism disorders Organic acidemias Pearson syndrome
		Persistent diarrhea	Glucose-galactose malabsorption Congenital lactase deficiency Congenital chloride diarrhea Sucrase-isomaltase deficiency Acrodermatitis enteropathica Abetalipoproteinemia Congenital folate malabsorption Wolman disease Lysinuric protein intolerance Classic galactosemia

Modified from Cederbaum S. Introduction to metabolic and biochemical genetic diseases. In: Gleason CA, Juul SE, eds. *Avery's Diseases of the Newborn*, 10th ed. Philadelphia: Elsevier; 2018: Table 21.1, p. 227.

**Table 104.11** Inborn Errors of Amino Acid Metabolism Associated with Peculiar Odor

INBORN ERROR OF METABOLISM	URINE ODOR	INBORN ERROR OF METABOLISM	URINE ODOR
Isovaleric acidemia Glutaric acidemia (type II)	"Sweaty feet," acrid	Trimethylaminuria Dimethylglycine dehydrogenase deficiency	Rotten fish
Maple syrup urine disease	Maple syrup, burnt sugar	Tyrosinemia type 1	Boiled cabbage, rancid butter
Multiple carboxylase deficiency 3-Methylcrotonyl-CoA carboxylase deficiency 3-Hydroxy-3-methylglutaric aciduria	Cat urine	Hypermethioninemia	Boiled cabbage
Phenylketonuria	Mousey or musty	Cystinuria Tyrosinemia type I	Sulfur
		Hawkinsinuria	"Swimming pool"
		Oasthouse urine disease	Hopslike

In select inborn errors of metabolism, organ transplantation modalities may offer the best treatment modality to stabilize a metabolic patient and improve quality of life. To date, replacement of the affected gene with a normal copy using gene therapy has been successful in only a few diseases.

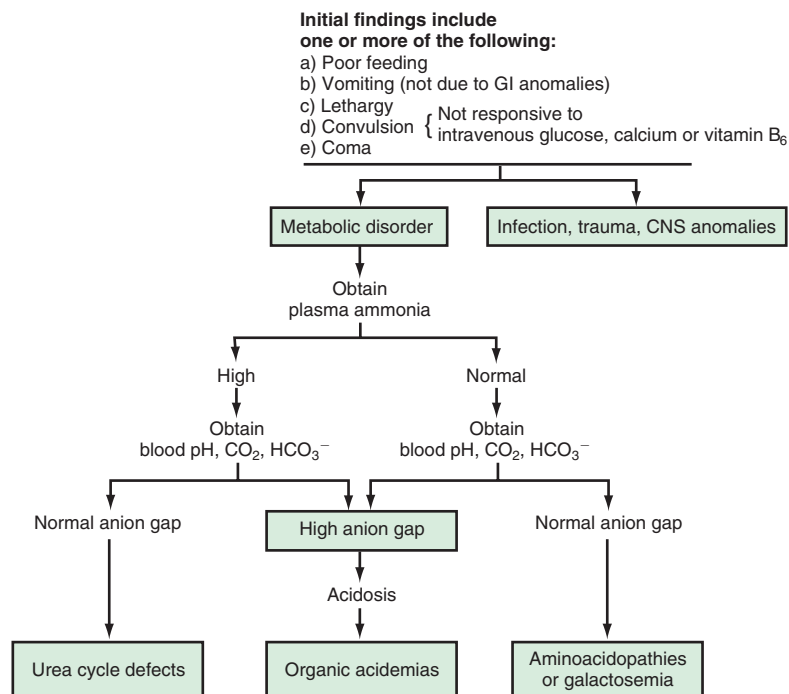
Treatment of genetic disorders of metabolism is complex and requires medical and technical expertise. Effective treatment is best achieved by a team of specialists—metabolic genetics specialist, nutritionist, neurologist, and psychologist—in a major medical center. The

therapeutic regimen often needs to be tailored to the individual patient because of large phenotypic variations in the severity of the disease, even within a single family. Providing genetic counseling, education, and ongoing social services support for the family is the key to successful long-term therapy. Even in patients with poor prognoses, every effort should be made to establish correct diagnoses premortem.

Visit Elsevier eBooks+ at [eBooks.Health.Elsevier.com](http://eBooks.Health.Elsevier.com) for Bibliography.

Table 104.12 Clinical Findings That Should Prompt a Metabolic Workup			
Family history	Sibling(s) who died from unexplained causes or exhibit overlapping symptoms Ethnic groups with a high prevalence of metabolic disorders Consanguinity	Musculoskeletal system	Rhabdomyolysis, myopathy Osteopenia, early-onset osteoporosis, skeletal dysplasia, epiphyseal abnormalities, bone crises
Perinatal history	Intrauterine growth restriction, sepsis-like presentation in the neonatal period, nonimmune fetal hydrops	Eye	Retinitis pigmentosa, macular dystrophy, cataracts, corneal opacities, nystagmus, cherry-red spot
Growth	Postnatal failure to thrive, microcephaly, macrocephaly, short stature	Hearing	Sensorineural hearing loss
Central and peripheral nervous systems	Progressive encephalopathy, lethargy, coma, intractable seizures, developmental delay, developmental regression, intellectual disability, autism spectrum disorder, hypotonia, spasticity, dystonia, strokes, ataxia, psychosis, intracranial calcifications, white matter disease, peripheral neuropathy	Gastrointestinal system	Hepatomegaly, hepatic adenoma, splenomegaly, liver failure, Reye syndrome, cholestasis, cirrhosis, chronic diarrhea, vomiting, acute pancreatitis
Respiratory system	Hyperventilation, apnea	Kidney	Renal dysfunction, renal Fanconi syndrome, renal stones
Cardiovascular system	Cardiac failure with or without cardiomyopathy, arrhythmia	Hematologic system	Anemia, leukopenia, thrombocytopenia, pancytopenia, hemolytic-uremic syndrome
		Skin	Hair abnormality, alopecia, lipodystrophy, recalcitrant eczema

Table 104.13 Laboratory Findings That Should Prompt a Metabolic Workup	
Hyperammonemia	Hypoglycemia
Metabolic acidosis	Liver dysfunction
Lactic acidosis	Pancytopenia
Ketosis	



**Fig. 104.2** Algorithm showing the initial clinical approach to a full-term newborn infant with a suspected genetic metabolic disorder. This schema is a guide to elucidate some of the metabolic disorders in newborn infants. Although some exceptions to this schema exist, it is appropriate for most cases affected by disorders or intermediate metabolism. CNS, Central nervous system; GI, gastrointestinal; HCO<sub>3</sub><sup>-</sup>, bicarbonate.



## Chapter 105

## Defects in Metabolism of Amino Acids

## 105.1 Phenylalanine

Oleg A. Shchelochkov and Charles P. Venditti

Phenylalanine is an essential amino acid. Dietary phenylalanine that is not used for protein synthesis is normally degraded by way of the tyrosine pathway (Fig. 105.1). Deficiency of the enzyme **phenylalanine hydroxylase (PAH)** or one of its cofactors **tetrahydrobiopterin (BH<sub>4</sub>)** causes accumulation of phenylalanine and its metabolites in body fluids and in the brain.

Elevations of phenylalanine in the plasma reflect the degree of enzyme deficiency, presenting as a spectrum of biochemical and clinical findings. In patients with **severe PAH deficiency** (also referred to as *classical phenylketonuria*), plasma phenylalanine levels on an unrestricted diet usually exceed 20 mg/dL (>1,200 μmol/L). Patients with milder PAH pathogenic variants have plasma phenylalanine levels between 10 mg/dL (600 μmol/L) and 20 mg/dL (1,200 μmol/L). Levels between 2 and 10 mg/dL (120 and 600 μmol/L) on an unrestricted diet are observed in patients with **mild hyperphenylalaninemia**. In affected infants with plasma concentrations >20 mg/dL, excess phenylalanine is metabolized to phenylketones (phenylpyruvate and phenylacetate; see Fig. 105.1) that are excreted in the urine, giving rise to the term *phenylketonuria* (PKU). These metabolites have no known role in the mechanisms of central nervous system (CNS) damage in PKU patients, but their presence in body fluids can signify the severity of the condition. The **brain** is most vulnerable to the damage incurred by PKU, but the exact mechanism of injury remains elusive. Both toxic elevations of phenylalanine and insufficient tyrosine may play roles. Phenylalanine hydroxylase converts phenylalanine to **tyrosine**, which is necessary for the production of neurotransmitters such as epinephrine, norepinephrine, and dopamine (Fig. 105.2). If the degree of enzymatic block is severe, tyrosine becomes an essential amino acid and may be deficient if its intake is not adequate. On the other hand, observations that lower concentrations of phenylalanine in plasma and brain tissue are associated with improved neurobehavioral outcomes support the view that toxic levels of phenylalanine are key to PKU pathogenesis. High blood levels of phenylalanine can saturate the transport system across the blood-brain barrier (BBB) and inhibit the cerebral uptake of other large neutral amino acids such as the branched-chain amino acids tyrosine and tryptophan, impairing brain protein synthesis.

**SEVERE PHENYLALANINE HYDROXYLASE DEFICIENCY (CLASSIC PHENYLKETONURIA)**

Elevations of plasma phenylalanine >20 mg/dL (>1,200 μmol/L), if untreated, invariably result in the development of signs and symptoms of classic PKU, except in uncommon and unpredictable cases.

**Clinical Manifestations**

The affected infant appears normal at birth. Profound intellectual disability gradually develops if the infant remains untreated. Cognitive delay may not be evident for the first few months. In untreated patients, 50–70% will have an IQ below 35, and 88–90% will have an IQ below 65. Less than 5% of untreated patients attain IQ scores in the average range. Vomiting, sometimes severe enough to be misdiagnosed as pyloric stenosis, may be an early symptom. Older untreated children become hyperactive and show autistic behaviors, including stereotypic hand movements and rhythmic rocking.

Untreated and undertreated infants are lighter in their complexion than unaffected siblings. Some may have a seborrheic or eczematoid rash, which is usually mild and disappears with age. Affected children have an odor of phenylacetic acid, which has been described as musty or “mousey.” Neurologic signs include seizures (approximately 25%), spasticity, hyperreflexia, tremors, and athetosis; >50% have electroencephalographic (EEG) abnormalities. Microcephaly, prominent maxillae with widely spaced teeth, enamel hypoplasia, and growth retardation are other common findings in untreated children. Low bone mineral density and osteopenia have been reported in affected individuals of all ages. Although inadequate intake of natural proteins seems to be the major culprit, the exact pathogenesis of this sequela remains unclear.

Long-term care of patients with PKU is best achieved by a team of experienced professionals (metabolic specialist, nutritionist, and psychologist), typically in a regional treatment center. The clinical manifestations of classical PKU are rarely seen in countries where neonatal screening programs for the detection of PKU are in effect.

**Non-PKU Hyperphenylalaninemia**

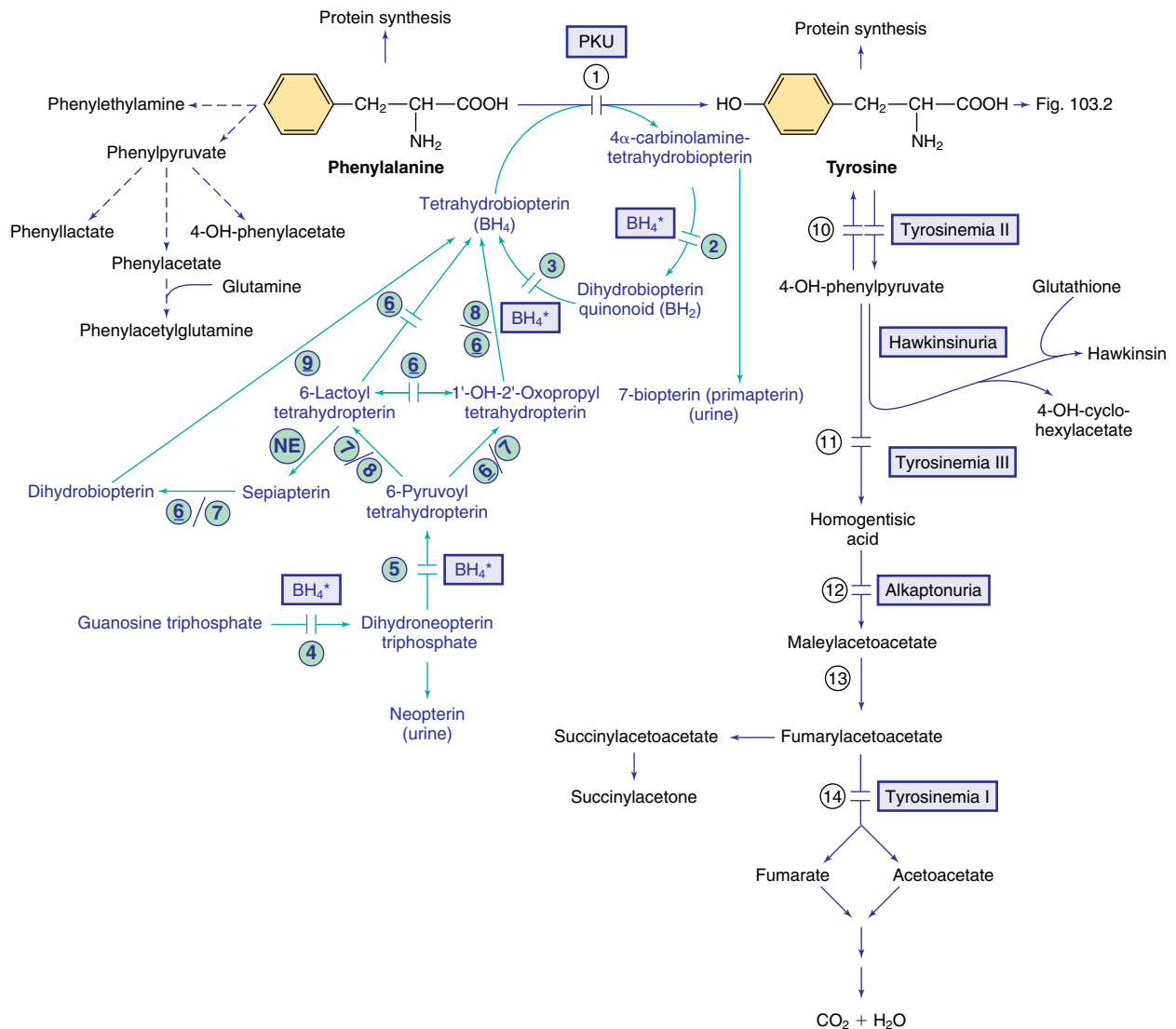
Implementation of universal screening for PKU led to identification of a group of infants in whom initial plasma concentrations of phenylalanine are above normal (i.e., >2 mg/dL, or 120 μmol/L) but <20 mg/dL (1,200 μmol/L). These infants typically do not excrete phenylketones. Patients with non-PKU hyperphenylalaninemia may still require dietary therapy, depending on their untreated plasma phenylalanine level. Attempts have been made to classify these patients into different subgroups depending on the degree of hyperphenylalaninemia, but the effects of this classification on PKU management and outcomes remain to be clarified. The possibility of deficiency of tetrahydrobiopterin (BH<sub>4</sub>) should be investigated in all infants, especially those with milder forms of hyperphenylalaninemia.

**Diagnosis**

Because of the gradual and nonspecific nature of early clinical symptoms such as vomiting, developmental delay, or eczematoid rash, hyperphenylalaninemia is usually diagnosed through newborn screening in all developed countries. In infants with positive screening results, the diagnosis should be confirmed by quantitative measurement of plasma phenylalanine concentration and molecularly by identifying pathogenic variants in *PAH*. Identification and measurement of phenylketones in the urine have no place in any screening program. In countries and places where such programs are not in effect, identification of phenylketones in the urine by ferric chloride may offer a simple test for the diagnosis of infants with developmental and neurologic abnormalities. All patients with a biochemical diagnosis of hyperphenylalaninemia should undergo pterin measurements in blood or urine to evaluate for defects in BH<sub>4</sub> synthesis or recycling.

**Neonatal Screening for Hyperphenylalaninemia**

Effective and relatively inexpensive methods for mass screening of newborn infants are used in the United States and many other countries. A few drops of blood, which are placed on a filter paper and mailed to a central laboratory, are used for assay. The screening method of choice uses **tandem mass spectrometry**, which can identify all forms of hyperphenylalaninemia with a low false-positive rate and excellent accuracy and precision. The addition of the phenylalanine:tyrosine molar ratio can improve test specificity and reduce the number of false-positive results. Diagnosis must be confirmed by measurement of plasma phenylalanine concentration and, ultimately by identifying pathogenic variants in *PAH*. Blood phenylalanine in affected infants with PKU may rise to diagnostic levels as early as 4 hours after birth, even in the absence of protein feeding. However, to reduce the number of false-negative results, especially in the milder forms of the condition, it is recommended that the blood for screening be obtained in the first 24–48 hours of life after feeding protein.



**Fig. 105.1** Pathways of phenylalanine and tyrosine metabolism. Enzyme defects causing genetic conditions are depicted as *horizontal bars* crossing the reaction arrow(s). Pathways for synthesis of cofactor  $BH_4$  are shown in *purple*.  $BH_4^*$  refers to defects of  $BH_4$  metabolism that affect the phenylalanine, tyrosine, and tryptophan hydroxylases (see Figs. 105.2 and 105.5). PKU, Phenylketonuria; NE, nonenzymatic. **Enzymes:** (1) Phenylalanine hydroxylase, (2) pterin-carbinolamine dehydratase, (3) dihydrobiopterin reductase, (4) guanosine triphosphate (GTP) cyclohydrolase, (5) 6-pyruvoyltetrahydropterin synthase, (6) sepiapterin reductase, (7) carbonyl reductase, (8) aldolase reductase, (9) dihydrofolate reductase, (10) tyrosine aminotransferase, (11) 4-hydroxyphenylpyruvate dioxygenase, (12) homogentisic acid dioxygenase, (13) maleylacetoacetate isomerase, (14) fumarylacetoacetate hydrolase.

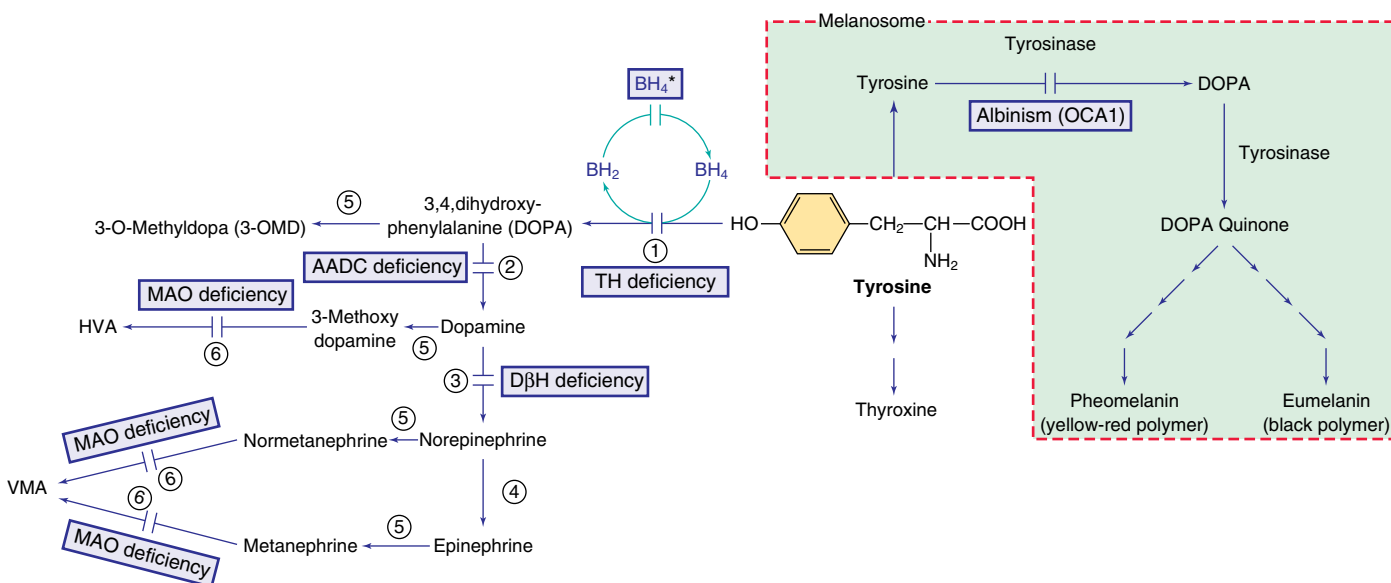
### Treatment

The mainstay of treatment of PKU is a *low-phenylalanine diet*. The general consensus is to start diet treatment immediately in patients with blood phenylalanine levels  $>10$  mg/dL (600  $\mu$ mol/L). It is recommended that infants with persistent (more than a few days) plasma levels of phenylalanine  $\geq 6$  mg/dL (360  $\mu$ mol/L) should also be treated with a phenylalanine-restricted diet similar to that in classic PKU. The goal of therapy is to reduce phenylalanine levels in the plasma and brain. Formulas free of or low in phenylalanine are commercially available. The diet should be started as soon as the diagnosis is established. Because phenylalanine is not synthesized endogenously, the diet should provide phenylalanine to prevent phenylalanine deficiency. Dietary phenylalanine tolerance is determined based on age and severity of the PAH deficiency. **Phenylalanine deficiency** is manifested by lethargy, failure to thrive, anorexia, anemia, rashes, diarrhea, and even death. Furthermore, tyrosine can become an essential amino acid in this disorder, and its adequate intake must be ensured. Special food items low in phenylalanine are commercially available for dietary treatment of affected children and adults.

There is no firm consensus concerning optimal levels of blood phenylalanine in affected patients either across different countries or among treatment centers in the United States. The current recommendation is to maintain blood phenylalanine levels between 2 and 6 mg/dL (120 and 360  $\mu$ mol/L) throughout life. Discontinuation of therapy, even in adulthood, may cause deterioration of neurocognitive performance.

Lifelong adherence to a low-phenylalanine diet is extremely difficult. Patients who maintain good control as children but discontinue the phenylalanine-restricted diet as teenagers or adults may experience significant difficulties with executive function, concentration, emotional lability, and depression. Executive dysfunction may also occur in early-treated children despite diet treatment.

Given the difficulty of maintaining a strict low-phenylalanine diet, there are continuing attempts to find other modalities for treatment of these patients. Administration of **large neutral amino acids** (LNAA) is one approach to dietary therapy. LNAA (tyrosine, tryptophan, leucine, isoleucine, valine, methionine, histidine, and phenylalanine) use the same transporter protein (LNAA type 1 or LAT-1) for transit



**Fig. 105.2** Other pathways involving tyrosine metabolism.  $BH_4^*$  indicates hyperphenylalaninemia caused by tetrahydrobiopterin ( $BH_4$ ) deficiency (see Fig. 105.1). HVA, Homovanillic acid; VMA, vanillylmandelic acid. Enzymes: (1) Tyrosine hydroxylase (TH), (2) aromatic L-amino acid decarboxylase (AADC), (3) dopamine  $\beta$ -hydroxylase (D $\beta$ H), (4) phenylethanolamine-N-methyltransferase (PNMT), (5) catechol O-methyltransferase (COMT), (6) monoamine oxidase (MAO).

through the intestinal cell membrane and BBB. Binding of LNAAs to the transporter is a competitive process. Therefore when LNAAs compete with phenylalanine at the transport level, their large concentrations in the intestinal lumen and blood can reduce the uptake of phenylalanine into the bloodstream and the brain, respectively. Large, controlled clinical trials are necessary to establish the efficacy of this treatment.

Oral administration of  $BH_4$ , the cofactor for PAH, may result in the reduction of plasma phenylalanine in some patients with PAH deficiency. Plasma phenylalanine in these patients may decrease enough to allow for considerable modification of their dietary restriction. In very rare cases the diet may be discontinued because the phenylalanine remains under 6 mg/dL (360  $\mu$ mol/L). The response to  $BH_4$  cannot be predicted consistently based on the genotype alone, especially in compound heterozygous patients. **Sapropterin dihydrochloride**, a synthetic form of  $BH_4$ , which acts as a cofactor in patients with residual PAH activity, is approved by the U.S. Food and Drug Administration (FDA) and the European Medicine Agency (EMA) to reduce phenylalanine levels in PKU. A sustained decrease of plasma phenylalanine by at least 30% is consistent with sapropterin responsiveness. Injectable PEGylated recombinant phenylalanine ammonia-lyase has been approved by the FDA and EMA for adult PKU patients with uncontrolled blood phenylalanine levels greater than 600  $\mu$ mol/L despite prior management.

### Pregnancy in Women with PAH Deficiency (Maternal Phenylketonuria)

Pregnant women with PAH deficiency who are not on a phenylalanine-restricted diet have a very high risk of having offspring with intellectual disability, microcephaly, growth retardation, congenital malformations, and congenital heart disease. These complications are directly correlated with elevated maternal blood phenylalanine levels during pregnancy. Prospective mothers who have been treated for PAH deficiency should be maintained on a phenylalanine-restricted diet before and during pregnancy. The best observed outcomes occur when strict control of maternal blood phenylalanine concentration is instituted before pregnancy. Plasma phenylalanine levels >6 mg/dL (360  $\mu$ mol/L) after conception are associated with increased incidence of intrauterine growth restriction and congenital malformations, as well as lower performance on neurocognitive testing. However, there is strong evidence that phenylalanine control instituted after conception can also result in improved outcomes. The recommended phenylalanine concentration

is 2-6 mg/dL (120-360  $\mu$ mol/L) throughout the pregnancy, although some expert groups advocate plasma phenylalanine levels <4 mg/dL (<240  $\mu$ mol/L). All women with PAH deficiency who are of childbearing age should be counseled properly regarding the risk of congenital anomalies in their offspring.

### HYPERPHENYLALANINEMIA CAUSED BY DEFICIENCY OF THE COFACTOR TETRAHYDROBIOPTERIN

In 1-3% of infants with hyperphenylalaninemia, the defect resides in one of the enzymes necessary for production or recycling of the cofactor  $BH_4$  (see Fig. 105.1). If these infants are misdiagnosed as having PKU, they may deteriorate neurologically despite adequate control of plasma phenylalanine.  $BH_4$  is synthesized from guanosine triphosphate (GTP) through several enzymatic reactions (see Fig. 105.1). In addition to acting as a cofactor for PAH,  $BH_4$  is also a cofactor for tyrosine hydroxylase and tryptophan hydroxylase, which are involved in the biosynthesis of dopamine (see Fig. 105.2) and serotonin (see Fig. 105.5), respectively. Therefore patients with hyperphenylalaninemia resulting from  $BH_4$  deficiency also manifest neurologic findings related to deficiencies of these neurotransmitters. Four enzyme deficiencies leading to defective  $BH_4$  formation cause hyperphenylalaninemia with concomitant deficiencies of dopamine and serotonin: autosomal recessive GTP cyclohydrolase I deficiency (encoded by *GCH1*), 6-pyruvoyl-tetrahydropterin synthase deficiency (encoded by *PTS*), dihydropteridine reductase deficiency (encoded by *QDPR*), and pterin-4- $\alpha$ -carbinolamine dehydratase deficiency (encoded by *PCBD1*). 6-Pyruvoyl-tetrahydropterin synthase is the most frequent cause of hyperphenylalaninemia-associated  $BH_4$  deficiency. Autosomal dominant forms of GTP cyclohydrolase I deficiency and sepiapterin reductase deficiency result in deficiencies of neurotransmitters without hyperphenylalaninemia (see Chapter 105.11).

### Clinical Manifestations

Infants with cofactor  $BH_4$  deficiency are identified during screening programs for PKU because of hyperphenylalaninemia. Plasma phenylalanine levels may be as high as those in classic PKU or may be in the milder range. However, clinical manifestations of the neurotransmitter disorders differ greatly from those of PKU. Neurologic symptoms of the neurotransmitter disorders often manifest in the first few months of life and include extrapyramidal signs (choreoathetotic or dystonic limb movements, axial and truncal hypotonia, hypokinesia), feeding

difficulties, and autonomic abnormalities. Intellectual disability, seizures, hypersalivation, and swallowing difficulties can also be seen. The symptoms are usually progressive and often have a marked diurnal fluctuation. Prognosis and outcome strongly depend on the age of diagnosis, treatment, and the underlying enzyme defect.

### Diagnosis

Despite the low incidence of BH<sub>4</sub> synthesis and recycling defects, all newborns with hyperphenylalaninemia detected through newborn screening *must* be screened for BH<sub>4</sub> synthesis defects. BH<sub>4</sub> deficiency and the responsible enzyme defect may be diagnosed by several studies.

### Measurement of Neopterin and Biopterin

Neopterin (an oxidative product of dihydroneopterin triphosphate) and biopterin (an oxidative product of dihydrobiopterin and BH<sub>4</sub>) are measured in body fluids, especially urine (see Fig. 105.1). In patients with the autosomal recessive form of GTP cyclohydrolase I deficiency, urinary excretion of both neopterin and biopterin is reduced and is often very low. In patients with 6-pyruvoyl-tetrahydropterin synthase deficiency, there is a marked elevation of neopterin excretion and a concomitant decrease in biopterin excretion. Patients with pterin-4- $\alpha$ -carbinolamine dehydratase deficiency can be identified by detecting urinary primapterin (an isomer of biopterin). In dihydropteridine reductase deficiency, no consistent pattern in the excretion of neopterin and biopterin has been observed, thus necessitating enzymatic studies of DHPR in erythrocytes and/or molecular confirmation through QDPR gene analysis.

### Cerebrospinal Fluid Studies

Examination of cerebrospinal fluid (CSF) may reveal decreased levels of dopamine and serotonin metabolites (see Chapter 105.11).

### BH<sub>4</sub> Loading Test

An oral dose of BH<sub>4</sub> (20 mg/kg) normalizes plasma phenylalanine and the phenylalanine:tyrosine ratio in patients with BH<sub>4</sub>-responsive deficiency within 4–12 hours. The baseline blood phenylalanine should be elevated (>400  $\mu$ mol/L) to enable interpretation of the results. This may be achieved by discontinuing diet therapy for 2 days before the test. In BH<sub>4</sub>-responsive PAH deficiency, blood phenylalanine levels may decrease during the BH<sub>4</sub> loading test but increase later, even with BH<sub>4</sub> supplementation. Patients who demonstrate phenylalanine levels within the normal range over at least 1 week without a phenylalanine-restricted diet can continue BH<sub>4</sub> supplementation as the sole treatment for the hyperphenylalaninemia. However, it is imperative that plasma phenylalanine levels be monitored prospectively to ensure that phenylalanine levels remain within the normal range.

### Molecular Testing

Sequencing and deletion/duplication analysis are clinically available and have an important role in confirming the biochemical diagnosis of PAH deficiency and of the BH<sub>4</sub> synthesis and recycling disorders.

### Enzyme Assay

The activity of dihydropteridine reductase can be measured in the dry blood spots on the filter paper used for screening purposes or in erythrocytes. 6-Pyruvoyl-tetrahydropterin synthase activity can be measured in liver tissue, fibroblasts, and erythrocytes. Pterin-4- $\alpha$ -carbinolamine dehydratase activity can be measured in liver tissue and fibroblasts. GTP cyclohydrolase I activity can be measured in the liver and in cytokine (interferon- $\gamma$ )-stimulated mononuclear cells or fibroblasts (the enzyme activity is normally very low in unstimulated cells). Molecular testing offers a more convenient method to secure the diagnosis in this group of disorders.

### Treatment

The goals of therapy are to correct hyperphenylalaninemia and to restore neurotransmitter deficiencies in the CNS. Control of hyperphenylalaninemia is important in patients with cofactor deficiency because high levels of phenylalanine cause intellectual disability and

interfere with the transport of neurotransmitter precursors (tyrosine and tryptophan) into the brain. Plasma phenylalanine should be maintained as close to normal as possible (<6 mg/dL or <360  $\mu$ mol/L). This can be achieved by oral supplementation of BH<sub>4</sub> (5–20 mg/kg/day). Sapropterin dihydrochloride, the synthetic form of BH<sub>4</sub>, is commercially available but expensive. In patients receiving dietary interventions, phenylalanine and tyrosine deficiencies should be avoided.

Lifelong supplementation with neurotransmitter precursors such as L-dopa and 5-hydroxytryptophan, along with carbidopa to inhibit degradation of L-dopa before it enters the CNS, is necessary in most of these patients even when treatment with BH<sub>4</sub> normalizes plasma levels of phenylalanine. BH<sub>4</sub> does not readily enter the brain to restore neurotransmitter production. To minimize untoward side effects (especially L-dopa-induced dyskinesia), the treatment should be started with low doses of L-dopa/carbidopa and 5-hydroxytryptophan. The treatment should be gradually adjusted based on response to therapy and clinical improvement for each individual patient. Supplementation with folic acid is also recommended in patients with dihydropteridine reductase deficiency. Unfortunately, attempting to normalize neurotransmitter levels using neurotransmitter precursors usually does not fully resolve the neurologic symptoms because of the inability to attain normal levels of BH<sub>4</sub> in the brain. Patients often demonstrate intellectual disability, fluctuating abnormalities of tone, eye movement abnormalities, poor balance and coordination, decreased ability to ambulate, and seizures despite supplementation with neurotransmitter precursors.

**Hyperprolactinemia** occurs in patients with BH<sub>4</sub> deficiency and may be the result of hypothalamic dopamine deficiency. Measurement of serum prolactin levels may be a convenient method for monitoring adequacy of neurotransmitter replacement in affected patients.

Some drugs, such as trimethoprim/sulfamethoxazole, methotrexate, and other antileukemic agents, are known to inhibit dihydropteridine reductase enzyme activity and should be used with great caution in patients with BH<sub>4</sub> deficiency.

### Genetics and Prevalence

All defects causing hyperphenylalaninemia are inherited as autosomal recessive traits. Autosomal dominant forms of GTP cyclohydrolase I deficiency and sepiapterin reductase deficiency result in neurotransmitter disorders without hyperphenylalaninemia (see Chapter 105.11). The prevalence of PKU in the United States is estimated at 1 in 14,000 to 1 in 20,000 live births. The prevalence of non-PKU hyperphenylalaninemia is estimated at 1 in 50,000 live births. Most patients are compound heterozygotes for two different pathogenic variants.

## TETRAHYDROBIOPTERIN DEFECTS WITHOUT HYPERPHENYLALANINEMIA

See Chapter 105.11.

Visit Elsevier eBooks+ at eBooks.Health.Elsevier.com for Bibliography.

## 105.2 Tyrosine

Oleg A. Shchelochkov and Charles P. Venditti

Tyrosine is derived from ingested proteins or is synthesized endogenously from phenylalanine. It is used for protein synthesis and as a precursor of dopamine, norepinephrine, epinephrine, melanin, thyroxine, and quinoproteins. Excess tyrosine is metabolized to carbon dioxide and water through the tyrosine degradation pathway (see Fig. 105.1). Hereditary causes of hypertyrosinemia include deficiencies of the enzymes fumarylacetoacetate hydrolase (FAH), tyrosine aminotransferase (TAT), and 4-hydroxyphenylpyruvate dioxygenase (4-HPPD). **Acquired hypertyrosinemia** may occur in severe hepatocellular dysfunction (liver failure), scurvy (vitamin C is a cofactor for 4-HPPD), and hyperthyroidism. Hypertyrosinemia is common in blood samples obtained soon after eating and in premature infants.



## TYROSINEMIA TYPE I (FUMARYLACETOACETATE HYDROLASE DEFICIENCY, HEPATORENAL TYROSINEMIA)

Tyrosinemia type I is a severe multisystemic disease caused by FAH deficiency. Liver, kidney, and nerve damage is likely caused by metabolites of tyrosine degradation, especially fumarylacetoacetate and succinylacetone.

### Clinical Manifestations and Natural History

Affected infants may appear healthy at birth but develop symptoms in the first year of life. Most patients present between 2 and 6 months of age but rarely may become symptomatic in the first month or appear unaffected beyond the first year of life. Earlier presentation confers poorer prognosis. In untreated children, a 1-year mortality can approach 60% if infants develop symptoms before 2 months of age and decrease to 4% in infants who become symptomatic after 6 months.

An acute **hepatic crisis** typically heralds the disease onset and is usually precipitated by an intercurrent illness leading to a catabolic state. Fever, irritability, vomiting, hemorrhage, hepatomegaly, jaundice, elevated levels of serum transaminases, hypoglycemia, and neuropathy are common. An odor resembling boiled cabbage resulting from increased methionine metabolites may be present. Without treatment, hepatic crises may progress to liver failure and death. Between the crises, varying degrees of failure to thrive, hepatomegaly, and coagulation abnormalities often persist. Cirrhosis and eventually hepatocellular carcinoma occur with increasing age.

Episodes of acute **peripheral neuropathy** resembling acute porphyria occur in approximately 40% of affected children. These crises, often triggered by a minor infection, are characterized by severe pain, often in the legs, associated with extensor hypertonia of the neck and trunk, vomiting, paralytic ileus, and occasionally self-induced injuries of the tongue or buccal mucosa. Marked weakness occurs in about 30% of episodes, which may lead to respiratory failure requiring mechanical ventilation. Crises typically last 1-7 days, but recuperation from paralytic crises can take weeks to months.

**Renal involvement** manifests as a Fanconi renal syndrome with hyperphosphaturia, hypophosphatemia, normal-anion gap metabolic acidosis, and vitamin D-resistant rickets. Nephromegaly and nephrocalcinosis may be present on ultrasound examination. Glomerular abnormalities can be observed in adolescents and older patients.

Hypertrophic cardiomyopathy and hyperinsulinism are seen in some infants.

### Laboratory Findings

Elevated levels of succinylacetone in serum and urine are diagnostic for tyrosinemia type I (see Fig. 105.1). Succinylacetone levels may fall below the diagnostic threshold in patients treated with nitisinone. In untreated patients, serum  $\alpha$ -fetoprotein is increased, often greatly, and liver-synthesized coagulation factors are decreased in most patients. Increased levels of  $\alpha$ -fetoprotein are present in the cord blood of affected infants, indicating liver damage beginning prenatally. Serum transaminase levels are often increased, with marked increases during acute hepatic episodes. Serum concentration of bilirubin is usually normal but can be increased in severe liver failure. Plasma tyrosine levels are usually elevated at diagnosis, but this is a nonspecific finding and can vary depending on dietary intake. Plasma levels of other amino acids, particularly methionine, may also be elevated in patients with liver damage. Hyperphosphaturia, hypophosphatemia, and generalized aminoaciduria may occur. Urinary 5-aminolevulinic acid (also known as *delta-aminolevulinic acid*) is elevated due to the inhibition of 5-aminolevulinic acid dehydratase by succinylacetone (see Fig. 112.1).

**Diagnosis** is usually established by demonstration of elevated succinylacetone in urine or blood. Neonatal screening for hypertyrosinemia using tyrosine alone detects only a fraction of patients with tyrosinemia type I. Succinylacetone assayed by many neonatal screening programs has higher sensitivity and specificity than tyrosine and is the preferred metabolite for screening. Tyrosinemia type I should be differentiated from other causes of hepatitis and hepatic failure in infants, including galactosemia, hereditary fructose intolerance, neonatal iron storage

disease, giant cell hepatitis, citrullinemia type II, citrin deficiency, and hemophagocytic lymphohistiocytosis (see Chapter 105.12).

### Treatment and Outcome

A diet low in phenylalanine and tyrosine can slow, but not halt, the progression of the condition. The treatment of choice is **nitisinone** (NTBC), which inhibits 4-HPPD, reduces the flux of tyrosine metabolites to FAH, and decreases the production of the offending compounds fumarylacetoacetate and succinylacetone (see Fig. 105.1). The dose of nitisinone is titrated to the lowest, most effective dose (usually targeting the blood range of 20-40  $\mu\text{mol/L}$ ), aiming to suppress succinylacetone production while maintaining a plasma tyrosine level  $<400 \mu\text{mol/L}$  (7.2 mg/dL). This treatment with nitisinone can prevent acute hepatic and neurologic crises. Although nitisinone greatly slows disease progression, pretreatment liver damage cannot be completely reversed. Therefore patients must be followed for the development of cirrhosis or hepatocellular carcinoma. On imaging, the presence of even a single liver nodule usually indicates underlying cirrhosis. Most liver nodules in FAH-deficient patients are benign, but current imaging techniques cannot accurately distinguish all malignant nodules. For patients with severe liver failure not responding to nitisinone, liver transplantation is an effective therapy, which can also alleviate the risk of hepatocellular carcinoma. The impact of nitisinone treatment on liver transplantation is under study, but the greatest positive effect is seen in patients treated early, such as children detected by neonatal screening, before developing clinical symptoms. In early-treated patients, nitisinone has greatly reduced the need for liver transplantation. Because nitisinone treatment can increase plasma tyrosine, a low-tyrosine, low-phenylalanine diet is recommended. Rarely, nitisinone-treated patients develop corneal crystals, presumably composed of tyrosine, but these tend to be reversible with strict dietary compliance. This finding, combined with observations of developmental delay in some patients with tyrosinemia type II who chronically have elevated tyrosine levels, suggest that a diet low in phenylalanine and tyrosine should be continued in patients treated with nitisinone. The dietary treatment of patients with tyrosine and phenylalanine restriction necessitates surveillance of growth and development by ensuring adequate intake of amino acids and other nutrients.

### Genetics and Prevalence

Tyrosinemia type I is inherited as an autosomal recessive trait and is caused by biallelic pathogenic variants in *FAH*. DNA analysis is useful for carrier testing in groups at risk for specific pathogenic variants, such as French Canadians from the Saguenay-Lac Saint-Jean region of Quebec. The prevalence of tyrosinemia type I is estimated to be 1 in 1,846 live births in the Saguenay-Lac Saint-Jean region and approximately 1 in 100,000 live births worldwide. Prenatal screening can be performed by measurement of succinylacetone in amniotic fluid.

## TYROSINEMIA TYPE II (TYROSINE AMINOTRANSFERASE DEFICIENCY, RICHNER-HANHART SYNDROME, OCULOCUTANEOUS TYROSINEMIA)

Tyrosinemia type II is a rare autosomal recessive disorder caused by deficiency of cytosolic tyrosine aminotransferase that results in palmar and plantar hyperkeratosis, herpetiform corneal ulcers, and intellectual disability (see Fig. 105.1). *Ocular manifestations*, which may occur as early as 6 months of age, include excessive tearing, redness, pain, and photophobia. Corneal lesions are presumed to be caused by tyrosine crystals deposition. In contrast to herpetic ulcers, corneal lesions in tyrosinemia type II stain poorly with fluorescein and often are bilateral. *Skin lesions*, which may develop later in life, include painful, nonpruritic hyperkeratotic plaques on the soles, palms, and fingertips. Intellectual disability, which occurs in approximately 50% of patients, is usually mild to moderate. The contribution of consanguinity in this rare disorder is incompletely understood.

The principal **laboratory finding** in untreated patients is marked hypertyrosinemia,  $>500 \mu\text{mol/L}$ , and it may reach 1,100-2,750  $\mu\text{mol/L}$ . Surprisingly, in some patients urinary 4-hydroxyphenylpyruvic acid and its metabolites can be elevated despite them being downstream

from the metabolic block (see Fig. 105.1). It is hypothesized that other transaminases in the presence of high tyrosine concentrations can produce 4-hydroxyphenylpyruvic acid in mitochondria, where it cannot be further degraded. In contrast to tyrosinemia type I, liver and kidney function tend to be normal, as are serum concentrations of other amino acids and succinylacetone. Tyrosinemia type II is caused by tyrosine aminotransferase (*TAT*) gene pathogenic variants, causing a deficiency of cytosolic *TAT* activity in the liver.

**Diagnosis** of type II tyrosinemia is established by an assay of plasma tyrosine concentration in patients with suggestive findings and can be confirmed molecularly. An assay of hepatic *TAT* requires a liver biopsy and is rarely indicated.

**Treatment** with a diet low in tyrosine and phenylalanine, aiming to achieve plasma tyrosine levels <500 μmol/L, helps improve skin and eye manifestations. Early dietary intervention can lead to improved intellectual outcomes.

### TYROSINEMIA TYPE III (PRIMARY DEFICIENCY OF 4-HYDROXYPHENYLPIRUVATE DIOXYGENASE)

Tyrosinemia type III is an autosomal recessive condition caused by biallelic pathogenic variants in *HPD* encoding the enzyme 4-HPPD. Only a few patients with tyrosinemia type III have been reported. Most were detected by amino acid chromatography performed for various neurologic findings. Therefore ascertainment bias likely confounds current understanding of this disorder. Some asymptomatic infants with 4-HPPD deficiency have been identified by neonatal screening for hypertyrosinemia. Age at presentation varied between 1 and 17 months. In symptomatic patients, developmental delay, seizures, intermittent ataxia, and self-injurious behavior have been reported. Liver and renal abnormalities tend to be absent.

The role of 4-HPPD deficiency in the disease needs further study. The **diagnosis** is suspected in children with sustained moderate increases in plasma levels of tyrosine (typically 350–700 μmol/L on a normal diet) and the presence of 4-hydroxyphenylpyruvic acid and its metabolites, urinary 4-hydroxyphenyllactate and 4-hydroxyphenylacetate. The diagnosis should be confirmed by demonstrating biallelic pathogenic variants in *HPD* or, rarely, by demonstrating a low activity of the 4-HPPD enzyme. The latter requires a liver biopsy and is not usually indicated.

Given a possible association with neurologic abnormalities and corneal deposition of tyrosine crystals, dietary control of plasma tyrosine levels is recommended. One could also consider a trial with vitamin C, the cofactor for 4-HPPD, which can help lower plasma tyrosine in some patients.

### HAWKINSINURIA

Hawkinsinuria is a condition allelic to tyrosinemia type III (4-HPPD deficiency). Some specific missense variants (e.g., p.Ala33Thr or p.Asn241Ser) in *HPD* that encode 4-HPPD can result in uncoupling of typical oxidization of 4-hydroxyphenylpyruvate to homogentisic acid and lead to premature release of quinolacetic acid. The abnormal enzyme, incapable of normally oxidizing 4-hydroxyphenylpyruvate to homogentisic acid, forms an intermediate that reacts with glutathione to form the unusual organic acid **hawkinsin** ([2-L-cystein-5-yl-1,4-dihydroxycyclohex-5-en-1-yl]acetic acid, see Fig. 105.1). As a result, secondary glutathione deficiency may ensue. Hawkinsinuria is inherited as an autosomal dominant trait. In one patient, compound heterozygosity for alleles associated with hawkinsinuria and tyrosinemia type III produced biochemical features of hawkinsinuria.

The clinical course of this rare disorder is incompletely understood. Individuals with hawkinsinuria may present with symptoms only during infancy. The symptoms usually appear in the first few months of life, typically after weaning from breastfeeding and with the introduction of a high-protein diet. Severe metabolic acidosis, ketosis, failure to thrive, anemia, mild hepatomegaly, renal tubular acidosis, and an unusual odor are reported manifestations of this disorder. Neurocognitive development is usually normal.

Symptomatic infants and asymptomatic affected children and adults excrete hawkinsin, 4-hydroxyphenylpyruvate, and its metabolites (4-hydroxyphenyllactate and 4-hydroxyphenylacetate) as well

as 4-hydroxycyclohexylacetate and 5-oxoproline (due to secondary glutathione deficiency) in their urine. Plasma tyrosine is moderately elevated in symptomatic infants and may normalize in asymptomatic older patients.

**Treatment** consists of a low-protein diet during infancy. Breastfeeding is encouraged. Successful long-term use of *N*-acetyl-L-cysteine to treat secondary glutathione deficiency has been reported. A trial with vitamin C is recommended. Although the affected enzyme is susceptible to inhibition by nitisinone, clinical studies showing its efficacy in symptomatic infants are lacking, and the indications for its use are not known.

### TRANSIENT TYROSINEMIA OF THE NEWBORN

In a small number of newborn infants, plasma tyrosine may be as high as 3,300 μmol/L during the first 2 weeks of life. Most affected infants are premature and are on a high-protein diet. Transient tyrosinemia is thought to result from delayed maturation of 4-HPPD (see Fig. 105.1). Lethargy, poor feeding, and decreased motor activity are noted in some patients. Most are asymptomatic and are identified by a high blood phenylalanine or tyrosine level on routine newborn screening. Laboratory findings include marked elevation of plasma tyrosine with a moderate increase in plasma phenylalanine. The finding of hypertyrosinemia differentiates this condition from PKU. 4-Hydroxyphenylpyruvic acid and its metabolites are present in the urine. Hypertyrosinemia tends to resolve spontaneously in the first 2 months of life and can be improved by reducing dietary protein to below 2 g/kg/day and by administering vitamin C. Mild intellectual deficits have been reported in some infants who had this condition, but the causal relationship to hypertyrosinemia has not been conclusively established.

### ALKAPTONURIA

Alkaptonuria is a rare (approximately 1 in 250,000 live births) autosomal recessive disorder caused by a deficiency of homogentisate 1,2-dioxygenase encoded by *HGD*. Large amounts of homogentisic acid are formed (see Fig. 105.1) and excreted in urine or deposited in tissues. Alkaptonuria has a worldwide distribution, with a higher disease prevalence in the Dominican Republic and Slovakia.

The main **clinical manifestations** of alkaptonuria consist of ochronosis and arthritis in adulthood. The only sign in children is blackening of the urine on standing, caused by oxidation and polymerization of homogentisic acid. A history of gray- or black-stained diapers should suggest the diagnosis. This sign may never be noted, thus delaying the diagnosis until adulthood. *Ochronosis*, seen clinically as dark spots on the sclera or ear cartilage, results from the accumulation of the black polymer of homogentisic acid. *Arthritis* is another result of this deposition and can be disabling with advancing age. It can involve the spine and large joints (shoulders, hips, and knees) and is usually more severe in males. As with rheumatoid arthritis, the alkaptonuric arthritis has acute exacerbations, but its radiologic findings are more typical of osteoarthritis, with characteristic narrowing of the joint spaces and calcification of the intervertebral disks. A high incidence of heart disease (mitral and aortic valvulitis, calcification of heart valves, myocardial infarction) has been reported.

The **diagnosis** is confirmed by finding massive excretion of homogentisic acid on urine organic acid testing. Tyrosine levels are normal. The enzyme is expressed in high levels only in the liver and kidneys.

**Treatment** of the arthritis is symptomatic. In clinical trials, nitisinone, an inhibitor of 4-HPPD, has been shown to reduce urinary homogentisic acid. Additional studies are needed to establish its clinical efficacy and safety profile.

### TYROSINE HYDROXYLASE DEFICIENCY

See Chapter 105.11.

### ALBINISM

See also Chapters 662 and 694.

Albinism is caused by impaired synthesis and distribution of **melanin**, the main pigment of the skin and eye (Table 105.1). Melanin is synthesized by melanocytes from tyrosine in a membrane-bound intracellular organelle, the melanosome. Melanocytes

**Table 105.1** Classification of Major Causes of Albinism

TYPE	GENE	DISTINGUISHING MOLECULAR AND CLINICAL FEATURES
<b>OCULOCUTANEOUS ALBINISM (OCA)</b>		
OCA1A (severe deficiency)	TYR	OCA1A (no melanin synthesis) vs OCA1B (minimal amounts of melanin present). OCA1A results in poorer visual outcomes.
OCA2 (tyrosinase positive)	OCA2	Newborns typically have light pigment, and hair color can darken with age.
OCA3 (Rufous, red OCA)	TYRP1	TYRP1 is required for maturation of eumelanin, but not reddish pheomelanin.
OCA4	SLC45A2	Newborns typically have light pigment, and hair color can darken with age. Clinically, it tends to overlap with OCA2.
OCA6	SLC24A5	SLC24A5 encodes the protein NCKX5 involved in the maturation of melanosomes.
OCA7	LRMDA	Tends to be associated with poorer visual outcomes.
OCA8	DCT	DCT encodes dopachrome tautomerase involved in the melanin synthesis upstream of TYRP1. Likely results in milder forms of OCA.
Hermansky-Pudlak syndrome	Multiple genes	A multisystemic, genetically heterogenous disorder characterized by OCA, bleeding tendency, interstitial pneumonia, and granulomatous colitis, among other complications.
Chédiak-Higashi syndrome	LYST	Results in partial OCA, bleeding tendency, immunodeficiency, and hemophagocytic lymphohistiocytosis.
<b>OCULAR ALBINISM (OA)</b>		
OA1 (Nettleship-Falls ocular albinism)	GPR143	X-linked inheritance. Affected males present with significant ocular manifestations with minor skin involvement.
<b>LOCALIZED ALBINISM</b>		
Piebaldism	KIT and SNAI2	Pathogenic variants in KIT have been associated with a number of phenotypes, including piebaldism, mastocytosis, familial, and sporadic cancers.
Waardenburg syndrome (WS1-WS4)	See text.	See text.

originate from the embryonic neural crest and migrate to the skin, eyes (choroid and iris), hair follicles, and inner ear. The melanin in the eye is confined to the iris stromal and retinal pigment epithelia, whereas in skin and hair follicles, it is secreted into the epidermis and hair shaft. Albinism can be caused by deficiencies of melanin synthesis, by some hereditary defects of melanosomes, or by disorders of melanocyte migration. Neither the biosynthetic pathway of melanin nor many facets of melanocyte cell biology are completely elucidated (see Fig. 105.2). The end products are two pigments: *pheomelanin*, which is a yellow-red pigment, and *eumelanin*, a brown-black pigment.

Clinically, primary albinism can be *generalized* or *localized*. Primary generalized albinism can be *ocular* or *oculocutaneous*. Some syndromes feature albinism in association with platelet, immunologic, or neurologic dysfunction. In generalized oculocutaneous albinism, hypopigmentation can be either complete or partial. Individuals with complete albinism do not develop either generalized (tanning) or localized (pigmented nevi) skin pigmentation.

The **diagnosis** of albinism is usually evident, but for some children whose families are particularly light-skinned, normal variation may be a diagnostic consideration. Unlike patients with albinism, unaffected fair-skinned children progressively develop pigmentation with age, do not exhibit the eye manifestations of albinism, and have pigmentary development similar to other family members. The clinical diagnosis of oculocutaneous albinism, as opposed to other types of cutaneous hypopigmentation, requires the presence of characteristic eye findings.

The **ocular manifestations** of albinism include hypopigmentation of the iris and retina, often with foveal hypoplasia, along with reduced visual acuity, refractive errors, nystagmus, alternating strabismus, and iris transillumination (diffuse reddish hue of the iris produced during ophthalmoscopic or slit-lamp examination of the eye).

Albinism is also associated with an abnormality in routing optic fibers at the chiasm. Unlike in pigmented individuals, in patients with albinism, the majority of nerve fibers from the temporal side of the retina cross to the contralateral hemisphere of the brain. This results in impaired depth perception, alternating strabismus, and a characteristic pattern of visual evoked potentials. These findings are highly specific for albinism. Regular ophthalmologic follow-up is recommended for patients with oculocutaneous albinism. Correction of refractive errors can maximize visual function. Usually, the alternating strabismus does not result in amblyopia and does not require surgery.

Patients with albinism should be counseled to avoid ultraviolet (UV) radiation by wearing protective long-sleeved clothing and by using sunscreens with a sun protection factor (SPF) rating >30. Melanin is also present in the cochlea; therefore albino individuals may be more susceptible to ototoxic agents such as gentamicin.

### Genetics of Albinism

Oculocutaneous albinism is inherited as an autosomal recessive trait. Many clinical forms of albinism have been identified. Some of the seemingly distinct clinical forms are caused by different pathogenic variants of the same gene. Implicated genes are involved in different stages of melanogenesis and melanosome maturation (see Table 105.1). The classification outlined next is based on the distribution of albinism in the body and the affected genes. Genetic analysis is clinically available for most forms of albinism (see Table 105.1). Molecular diagnosis is of little use therapeutically in isolated albinism but can be helpful for precise genetic counseling of families.

### Oculocutaneous (Generalized) Albinism

Lack of pigment is generalized, affecting skin, hair, and eyes. At least eight genetically distinct forms of oculocutaneous albinism (OCA) have been identified of which seven have pathogenic variants in



associated genes (OCA1, OCA2, OCA3, OCA4, OCA6, OCA7, and OCA8). Many forms of OCA may not be clinically distinguishable from one another. All affected individuals have ocular manifestations of albinism. All known forms of OCA are inherited as autosomal recessive traits.

### OCA1

The defect in patients with OCA1 resides in the tyrosinase gene, *TYR*. Many pathogenic variants have been identified. Most affected individuals are compound heterozygotes. A clinical clue to the diagnosis of OCA1 is complete lack of pigment at birth. The condition can be subdivided into OCA1A and OCA1B, based on enzyme activity and difference in clinical manifestations as a function of age. In patients with OCA1A, the most severe form of OCA, both *TYR* alleles have pathogenic variants that completely inactivate tyrosinase. Clinically, lack of pigment in the skin (milky white), hair (white hair), and eyes (red-gray irides) is evident at birth and remains unchanged throughout life. They do not tan and do not develop pigmented nevi or freckles.

Patients with OCA1B have *TYR* gene pathogenic variants that preserve some residual activity. Clinically, they completely lack pigment at birth but with age become light blond with light-blue or hazel eyes. They develop pigmented nevi and freckles, and they may tan.

### OCA2

OCA2 is the *most common form of generalized OCA*, particularly in patients of African ancestry. Clinically, the phenotype is highly variable; most patients demonstrate some pigmentation of the skin and eyes at birth and continue to accumulate pigment throughout life. The hair is yellow at birth and may darken with age. They have pigmented nevi and freckles, and some may tan. They may be clinically indistinguishable from OCA1B patients. Individuals with OCA2, however, have normal tyrosinase activity in hair bulbs. The defect is in the *OCA2* gene, which is an orthologue of the *p* (pink-eyed dilution) gene in the mouse. This gene produces the P protein, a melanosome membrane-bound protein. Patients with **Prader-Willi** and **Angelman** syndromes caused by microdeletion of chromosome 15q12 that includes the *OCA2* gene have mild pigmentary deficiency (see [Chapter 98.8](#)).

### OCA3

This form has been identified predominantly in patients of African and Asian ancestry. Patients with OCA3 can make pheomelanin but not eumelanin. Patients have reddish hair and reddish-brown skin as adults. The skin color is peculiar to this form. In young persons the coloration may resemble that of OCA2. The altered gene *TYRP1* encodes the tyrosinase-related protein 1, the function of which is not well-understood.

### OCA4

Similar manifestations to OCA2 (both in the skin and the eyes) have been observed in OCA4 patients (mostly from Japan) with pathogenic variants in the *SLC45A2* gene.

### Ocular Albinism

Patients with ocular albinism (OA) present in the first months of life with nystagmus, hypopigmentation of the iris and fundus, foveal hypoplasia, and decreased visual acuity. Electron microscopy demonstrates characteristic macromelanosomes in skin biopsies or hair root specimens. Most patients affected by OA have ocular albinism type 1 (OA1), an X-linked disorder caused by pathogenic variants in the *GPR143* gene. A rare form of OA with late-onset sensorineural deafness and apparent autosomal dominant inheritance has also been reported.

### Ocular Albinism Type 1 (Nettleship-Falls Ocular Albinism)

OA1 is an X-linked disorder characterized by congenital nystagmus, reduced pigmentation of ocular structures, and visual impairment in affected males. Heterozygous females may present with segments of abnormal retinal pigmentations. Infrequently, depending on the pattern of X chromosome inactivation, heterozygous females may also

present with severe manifestations, including nystagmus, iris and foveal hypopigmentation, foveal hypoplasia, and reduced visual acuity. In families with darker skin complexion, mild skin hypopigmentation can be seen. The diagnosis of OA1 is suspected in males with features of albinism in the eye, normal to mildly reduced skin pigmentation, and a family history suggestive of an X-linked transmission. It is a non-progressive disorder, and the eye findings often improve with age. In patients who are the first of their families to be affected, genetic analysis of *GPR143* helps confirm the diagnosis.

### Syndromic Forms of Generalized Albinism Hermansky-Pudlak Syndrome

This group of autosomal recessive disorders is caused by biallelic pathogenic variants in one of ten genes (*HPS1*, *AP3B1*, *HPS3*, *HPS4*, *HPS5*, *HPS6*, *DTNBP1*, *BLOC1S3*, *BLOC1S6*, *AP3D1*). Hermansky-Pudlak syndrome (HPS) can be suspected in patients with albinism associated with a bleeding diathesis, inflammatory bowel disease (IBD), and/or pulmonary fibrosis. Disease subtype can be established with molecular studies (see Chapter 533). Genes associated with HPS are required for normal structure and function of lysosome-derived organelles, including melanosomes and platelet-dense bodies. Patients have a tyrosinase-positive OCA of variable severity associated with platelet dysfunction (caused by the absence of platelet-dense bodies). A ceroid-like material accumulates in tissues. HPS is pan-ethnic. Patient ancestry can help develop a cost-effective testing strategy. HPS is prevalent in two regions of Puerto Rico (**type 1** in the northwest and **type 3** in the central regions because of different founder effects). The cutaneous and ocular symptoms of albinism are present. Patients can develop epistaxis, postsurgical bleeding, or abundant menses. Bleeding time is prolonged, but platelet count is normal. Major complications include progressive pulmonary fibrosis in young adults and Crohn's-like IBD in adolescents and young adults. Kidney failure and cardiomyopathy have been reported. Neutropenia has been described in HPS **type 2**. Treatment is symptomatic.

### Chédiak-Higashi Syndrome

Patients with this rare autosomal recessive condition have OCA of variable severity and susceptibility to infection (see Chapter 156). Bacterial infections of the skin and the upper respiratory tract are common. Giant peroxidase-positive lysosomal granules can be seen in granulocytes in a blood smear. Patients have a reduced number of melanosomes, which are abnormally large (macromelanosomes) and can have silvery-gray hair. The bleeding tendency is typically mild. If treatment is not successful, children can reach a stage of the disease known as the **accelerated phase**, which is a major, life-threatening complication of Chédiak-Higashi syndrome. It is caused by macrophage activation resulting in hemophagocytic lymphohistiocytosis with manifestations that include fever, lymphadenopathy, hepatosplenomegaly, cytopenia, and an elevated plasma ferritin level. Patients surviving childhood may develop cerebellar atrophy, peripheral neuropathy, and cognitive delay. Pathogenic variants in *LYST* are the only known cause for this syndrome. Hematopoietic stem cell transplantation offers an effective approach to control immunodeficiency and hematologic abnormalities and to prevent development of the accelerated phase.

### Other Disorders Featuring Generalized Albinism

Hypopigmentation can be a feature in other syndromes, some with abnormalities of lysosomal biogenesis or melanosome biology. **Griscelli syndrome** patients have silver-gray hair, pigmentary dilution of skin, and melanosomal clumping in hair shafts and the center of melanocytes, with intellectual disability or macrophage activation with hemophagocytosis in different subtypes. All forms are autosomal recessive caused by pathogenic variants in *MLPH*, *MYO5A*, or *RAB27A*. **Vici syndrome** patients have combined immunodeficiency, intellectual disability, agenesis of the corpus callosum, cataracts, and cleft lip/palate. It is autosomal recessive, caused by pathogenic variants in *EPG5*. Patients with **MAPBP-interacting protein deficiency** have a short stature, recurrent infections, and neutropenia, and inheritance occurs in an autosomal recessive manner due to pathogenic variants in the gene *LAMTOR2*.



### Localized Albinism

Localized albinism refers to localized patches of hypopigmentation of skin and hair, which may be evident at birth or develop with time. These conditions are caused by abnormal migration of melanocytes during embryonic development.

### Piebaldism

Piebaldism is an autosomal dominant inherited condition in which the individual is usually born with a white forelock. The underlying skin is depigmented and devoid of melanocytes. In addition, there are usually white macules on the face, trunk, and extremities. Pathogenic variants in the *KIT* and *SNAI2* genes have been identified in affected patients.

### Waardenburg Syndrome

In Waardenburg syndrome, a white forelock is often associated with lateral displacement of the inner canthi of the eyes, a broad nasal bridge, heterochromia of irides, and sensorineural deafness. This condition is inherited as an autosomal dominant trait with four main subtypes known. Patients with Waardenburg syndrome type 1 (**WS1**, the *most common form*) have all the previous clinical findings, including lateral displacement of the inner canthi. The condition is typically caused by pathogenic variants (>90%) in the *PAX3* gene. Patients with Waardenburg syndrome type 2 (**WS2**) have the clinical findings of WS1 except for the lateral displacement of the inner canthi. Genetically, this is a heterogeneous condition caused by pathogenic variants in several genes, including *MITE*, *SOX10*, and *SNAI2*. Patients with Waardenburg syndrome type 3 (**WS3**) have all the findings seen in individuals with WS1 plus hypoplasia and contractures of the upper limbs. It is caused by heterozygous or homozygous pathogenic variants of the *PAX3* gene. Finally, Waardenburg syndrome type 4 (**WS4**), associated with **Hirschsprung disease**, is genetically heterogeneous, with pathogenic variants in different genes (*EDN3*, *EDNRB*, or *SOX10*) identified.

Other causes of **localized hypopigmentation** include vitiligo and hypomelanosis of Ito (see Chapter 694).

Visit Elsevier eBooks+ at [eBooks.Elsevier.com](http://eBooks.Elsevier.com) for Bibliography.

## 105.3 Methionine

Oleg A. Shchelochkov and Charles P. Venditti

The usual pathway for catabolism of methionine, an essential amino acid, produces *S-adenosylmethionine*, which serves as a methyl group donor for methylation reactions for a variety of compounds, and *cysteine*, which is formed through a series of reactions collectively called *trans-sulfuration* (Fig. 105.3).

### HOMOCYSTINURIA (HOMOCYSTINEMIA)

Normally, most *homocysteine*, an intermediate compound of methionine degradation, is remethylated to methionine. This methionine-sparing reaction is catalyzed by the enzyme methionine synthase, which requires a metabolite of folic acid (5-methyltetrahydrofolate) as a methyl donor and a metabolite of vitamin B<sub>12</sub> (methylcobalamin) as a cofactor (see Fig. 105.3). In healthy individuals, most plasma homocysteine is either protein-bound or exists as disulfides. Three major forms of homocystinemia and homocystinuria have been identified.

### Homocystinuria Caused by Cystathionine β-Synthase Deficiency (Classic Homocystinuria)

Classic homocystinuria is the most common inborn error of methionine metabolism. It is an autosomal recessive condition caused by biallelic pathogenic variants in *CBS* encoding cystathionine β-synthase. Clinical presentation in the first years of life is nonspecific. Universal newborn screening to detect elevated methionine in dried blood spot samples can identify most affected infants. Second-tier testing after a positive newborn screen result should include plasma methionine and total plasma homocysteine and followed up by confirmatory testing using *CBS* molecular gene analysis. Most affected patients are

compound heterozygotes for two different alleles. Heterozygous carriers are asymptomatic.

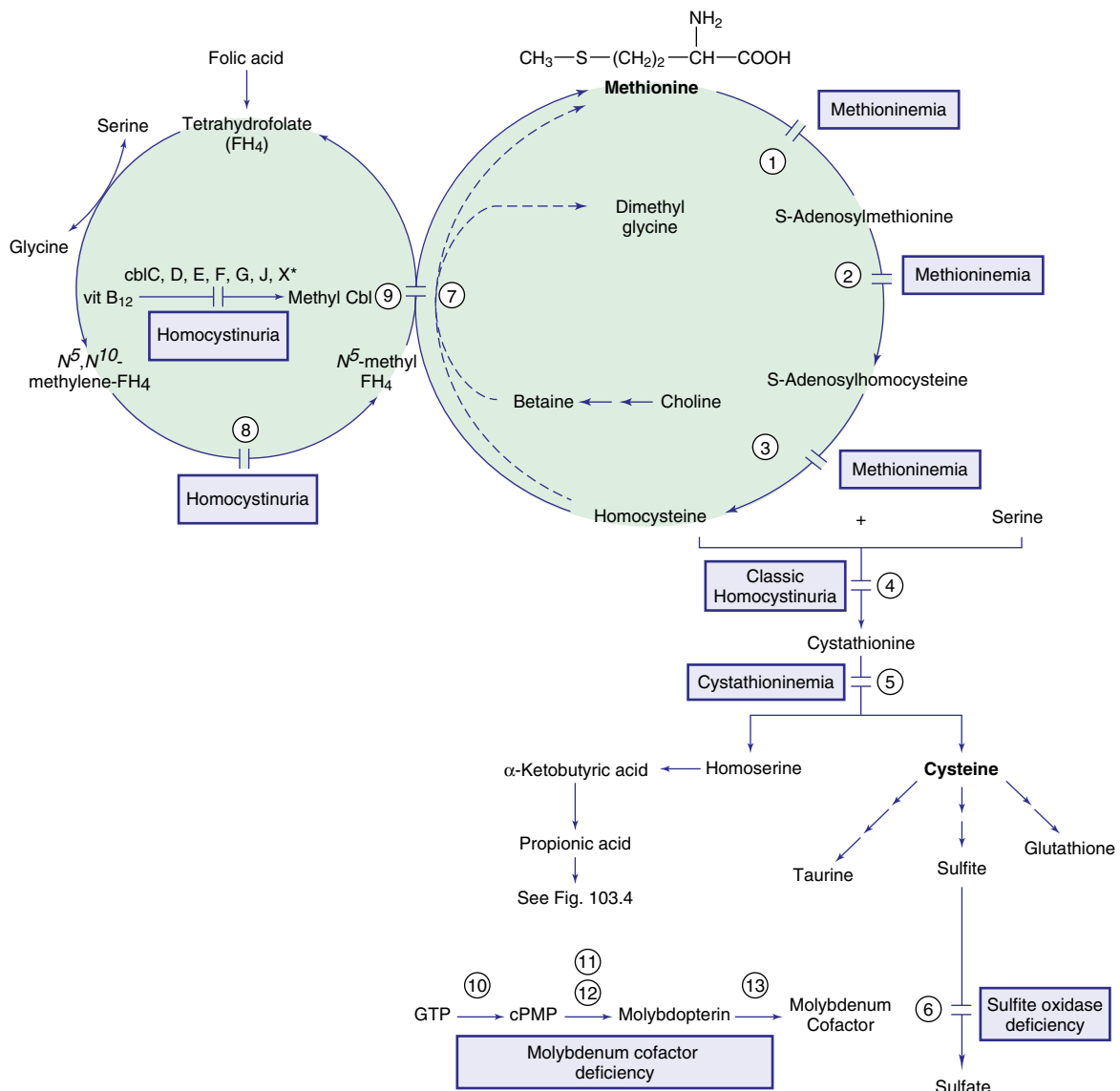
Infants with classic homocystinuria appear healthy at birth. **Clinical manifestations** during infancy are nonspecific and may include failure to thrive and developmental delay. Without newborn screening, the diagnosis can be delayed and is usually made after 3 years of age, when subluxation of the ocular lens (*ectopia lentis*) occurs. This causes severe myopia and iridodonesis (quivering of the iris). Astigmatism, glaucoma, staphyloma, cataracts, retinal detachment, and optic atrophy may develop later in life. Progressive intellectual disability is common. Neurocognitive scores in the average range have been reported; IQ scores range from 10 to 135. Higher IQ scores are seen in vitamin B<sub>6</sub>-responsive patients. Psychiatric and behavioral disorders have been observed in more than 50% of affected patients. Seizures are seen in approximately 20% of untreated patients. Affected individuals with homocystinuria manifest skeletal abnormalities resembling those of Marfan syndrome (see Chapter 743): tall with elongated limbs and arachnodactyly. Scoliosis, pectus excavatum or pectus carinatum, genu valgum, pes cavus, high-arched palate, and crowding of the teeth have been reported. These children usually have a fair complexion, blue eyes, and a peculiar malar flush. Generalized osteoporosis, especially of the spine, is the main x-ray finding. Thromboembolic episodes involving both large and small vessels, especially those of the brain, are common and may occur at any age. Optic atrophy, paralysis, cor pulmonale, and severe hypertension (from renal infarcts) are among the serious consequences of thromboembolism, which is likely caused by elevated homocysteine levels leading to abnormal angiogenesis and inhibition of fibrinolytic activity. The risk of thromboembolism increases after surgical procedures or dehydration. Spontaneous pneumothorax and acute pancreatitis are rare complications.

Elevations of both total plasma homocysteine and methionine in body fluids are the diagnostic laboratory findings. Cysteine is low or absent in plasma. Total plasma homocysteine is the preferred analyte for screening and management of classic homocystinuria. Free plasma homocysteine may normalize or remain normal when total plasma homocysteine is lowered. If urinary homocysteine is used for diagnostic purposes, a freshly voided urine sample is preferred because this compound is unstable and may disappear after prolonged storage. The diagnosis may be established by molecular analysis of *CBS*. Prenatal diagnosis is feasible by DNA analysis or by performing an enzyme assay of cultured amniotic cells.

**Treatment** with high doses of vitamin B<sub>6</sub> (100-200 mg/day) can produce significant improvement in patients who are responsive to this therapy. Approximately 40% of affected patients respond to high doses of vitamin B<sub>6</sub> and usually have milder clinical manifestations than those who are unresponsive to vitamin B<sub>6</sub> therapy. The degree of response to vitamin B<sub>6</sub> treatment may vary across families. Some patients may not respond because of folate depletion; a patient should not be considered unresponsive to vitamin B<sub>6</sub> until folic acid (1-5 mg/day) has been added to the treatment regimen. For patients who are unresponsive to vitamin B<sub>6</sub>, lifelong restriction of methionine intake in conjunction with cysteine supplementation is also recommended. The need for dietary restriction and its extent remains controversial in patients with the vitamin B<sub>6</sub>-responsive form. In some patients with this form, addition of betaine may obviate the need for any dietary restriction. *Betaine* (trimethylglycine, 6 g/day for adults or 100-200 mg/kg/day for children) lowers homocysteine levels in body fluids by remethylating homocysteine to methionine (see Fig. 105.3), which may result in elevation of plasma methionine levels. This treatment has produced clinical improvement (preventing vascular events) in patients who are unresponsive to vitamin B<sub>6</sub> therapy. Cerebral edema has occurred in a patient with vitamin B<sub>6</sub>-nonresponsive homocystinuria and dietary noncompliance during betaine therapy.

More than 100 pregnancies in women with classic homocystinuria have been reported with favorable outcomes for both mothers and infants. The majority of infants were full-term and healthy at birth. Postpartum thromboembolic events occurred in a few mothers.

The screening of newborn infants for classic homocystinuria has been performed worldwide, with an estimated prevalence of 1 in



**Fig. 105.3** Pathways in the metabolism of sulfur-containing amino acids. Enzymes: (1) Methionine adenosyltransferase (MAT I/III), (2) glycine *N*-methyltransferase, (3) *S*-adenosylhomocysteine hydrolase, (4) cystathionine synthase, (5) cystathionase, (6) sulfite oxidase, (7) betaine homocysteine methyltransferase, (8) methylene tetrahydrofolate reductase, (9) methionine synthase (*cblG*), (10) molybdenum cofactor biosynthesis protein 1, (11) molybdopterin synthase, (12) adenyltransferase and sulfurtransferase (*MOCS3*), (13) gephyrin. GTP, Guanosine triphosphate; cPMP, cyclic pyranopterin monophosphate. \*Defects in *cblC*, *D*, *F*, *J*, and *X* result in methylmalonic acidemia and homocystinuria.

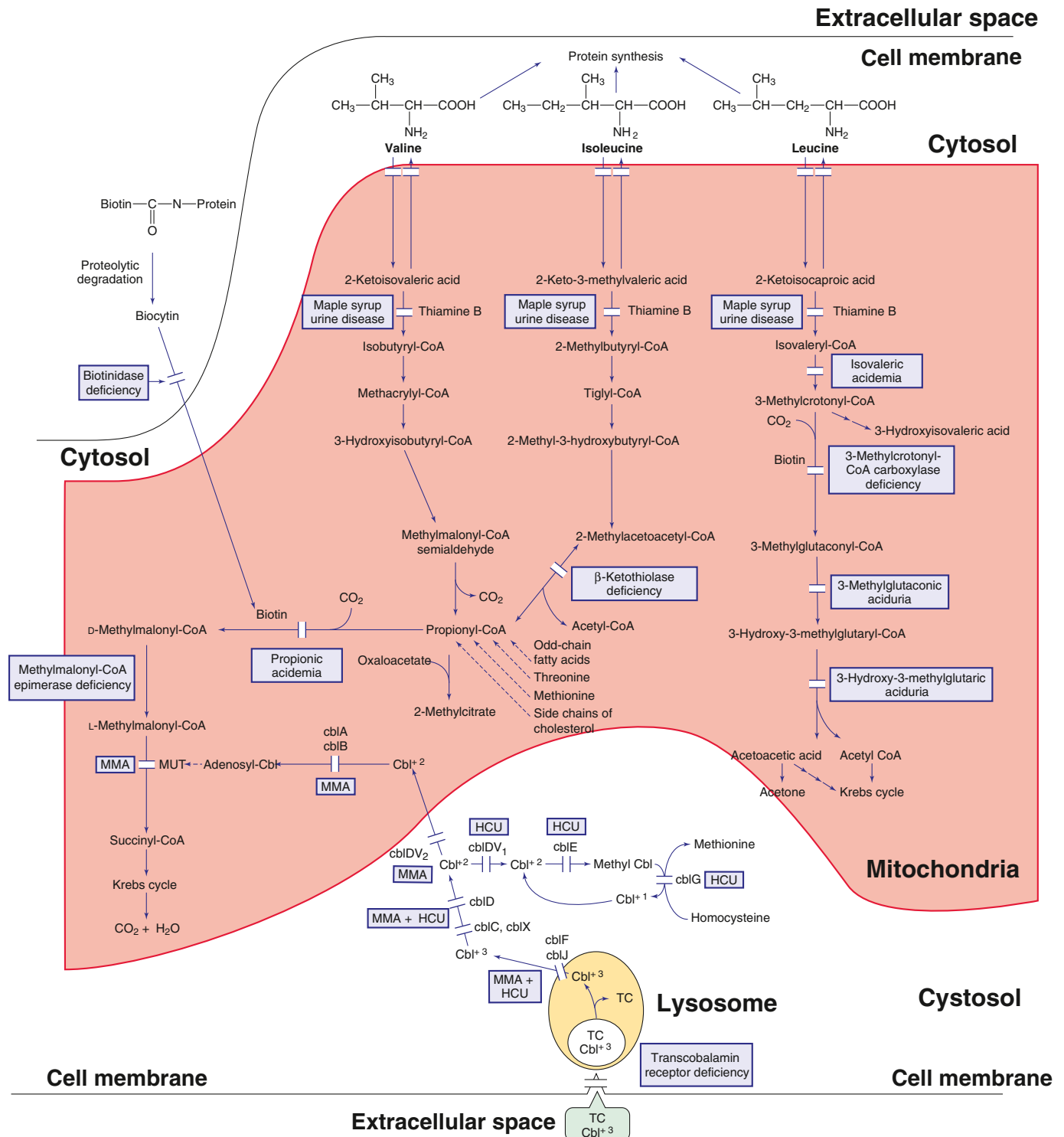
200,000 to 1 in 350,000 live births, although it can be more common in some parts of the world (e.g., 1 in 1,800 in Qatar). Early treatment of patients identified by screening has produced favorable results. The mean IQ of patients with the vitamin B<sub>6</sub>-unresponsive form treated in early infancy was in the normal range. Dislocation of the lens appeared to be preventable in some patients.

### Homocystinuria Caused by Defects in Methylcobalamin Formation

Methylcobalamin is the cofactor for methionine synthase, which catalyzes remethylation of homocysteine to methionine. At least seven distinct defects in the intracellular metabolism of cobalamin may interfere with the formation of methylcobalamin (for a more detailed discussion on cobalamin metabolism, see Chapter 105.6 and Figs. 105.3 and 105.4). The seven defects are designated as *cblC*, *cblD* (including *cblD* variant 1), *cblE* (methionine synthase reductase), *cblG* (methionine synthase), *cblF*, *cblJ*, and *cblX*. Patients with *cblC*, *cblD*, *cblF*, *cblJ*, and *cblX* defects have **methylmalonic acidemia** in addition to homocystinuria, because the formation of both adenosylcobalamin and methylcobalamin is impaired.

Patients with *cblE*, *cblG*, and *cblD* variant one defects are unable to form methylcobalamin and develop homocystinuria without methylmalonic acidemia (Fig. 105.4). The clinical manifestations are similar in patients with these three defects. Nonspecific symptoms such as vomiting, poor feeding, failure to thrive, lethargy, hypotonia, seizures, and developmental delay may occur in the first few months of life. Late-onset forms of these disorders may present with neurocognitive defects, psychosis, and peripheral neuropathy. **Laboratory findings** include megaloblastic anemia, hyperhomocysteinemia, homocystinuria, and hypomethioninemia. The absence of hypermethioninemia differentiates these conditions from cystathionine  $\beta$ -synthase deficiency. Renal artery thrombosis, hemolytic uremic syndrome, pulmonary hypertension, and optic nerve atrophy have been reported in some patients with these defects.

**Diagnosis** is established by DNA testing or using complementation studies performed in cultured fibroblasts. Prenatal diagnosis can be accomplished by studies in amniotic cell cultures. *cblE*, *cblG*, and *cblD* variant one deficiencies are inherited as autosomal recessive traits. The gene for *cblE* is *MTRR*, encoding methionine synthase reductase.



**Fig. 105.4** Pathways in the metabolism of the branched-chain amino acids, biotin, and vitamin B<sub>12</sub> (cobalamin). Adenosyl Cbl, Adenosylcobalamin; Cbl, cobalamin; *cbl*, defect in metabolism of cobalamin; *cbIDV1*, *cbID* variant 1; *cbIDV2*, *cbID* variant 2; HCU, homocystinuria; methyl Cbl, methylcobalamin; MMA, methylmalonic acidemia; MUT, mutase; OHcbl, hydroxycobalamin; TC, transcobalamin; TCR, transcobalamin receptor. See text for the name of the enzymes.

The gene for *cblG* is *MTR*, encoding methionine synthase. The *cbID* variant one deficiency is caused by pathogenic variants affecting the C-terminal of the *MMADHC* gene.

**Treatment** with vitamin B<sub>12</sub> in the form of high-dose parenteral hydroxycobalamin (0.3 mg/kg/day) helps improve the clinical and biochemical findings. Results vary among both diseases and sibships.

### Homocystinuria Caused by Deficiency of Methylene-tetrahydrofolate Reductase (MTHFR Deficiency)

This enzyme reduces 5,10-methylenetetrahydrofolate to form 5-methyltetrahydrofolate, which provides the methyl group needed for remethylation of homocysteine to methionine (see Fig. 105.3). The severity of the enzyme defect and the clinical manifestations vary considerably

in different families. **Clinical findings** vary from apnea, seizure, microcephaly, coma, and death to developmental delay, ataxia, motor abnormalities, peripheral neuropathy, and psychiatric manifestations. Thromboembolism has also been observed. Exposure to the anesthetic nitrous oxide (which inhibits methionine synthase) in patients with MTHFR deficiency may result in neurologic deterioration and death.

**Laboratory findings** include moderate hyperhomocysteinemia and homocystinuria. The methionine concentration is low or low-normal. This finding helps differentiate MTHFR deficiency from classic homocystinuria caused by cystathionine  $\beta$ -synthase deficiency. The diagnosis can be confirmed by molecular analysis of *MTHFR* or by the enzyme assay in cultured fibroblasts or leukocytes.

MTHFR deficiency should be differentiated from **mild hyperhomocysteinemia** due to two common variants in the *MTHFR* gene. Two “thermolabile” polymorphisms have been extensively studied: c.665C>T (p.Ala222Val, previously referred to as c.677C>T) and c.1286A>C (p.Glu429Ala, formerly referred to as c.1298A>C). These variants may minimally affect levels of plasma total homocysteine in some patients and are often confounded by dietary folate deficiency. Population-based studies revealed a surprisingly high prevalence of homozygosity for these polymorphisms in the general population: up to 10–15% of North American Whites and >25% in some Hispanics. The best data support a role for the c.665C>T polymorphic variant (formerly c. 677C>T) as a risk factor for neural tube defects. Although clinical tests for this polymorphic variant are widely available, meta-analyses have not supported the association between the *MTHFR* polymorphic variants and risk for venous thromboembolism or between mild hyperhomocysteinemia and an increased risk for coronary heart disease. It is hypothesized that fortification of flour with folate may have decreased the strength of associations observed in the past.

Homocystinuria caused by the loss of function in MTHFR (MTHFR deficiency) is an autosomal recessive disorder. The **diagnosis** can be confirmed by *MTHFR* gene analysis. Prenatal diagnosis can be achieved by molecular analysis of *MTHFR* of known familial pathogenic variants or by measuring MTHFR enzyme activity in cultured chorionic villus cells or amniocytes.

**Treatment** of MTHFR deficiency with a combination of folic acid, vitamin B<sub>6</sub>, vitamin B<sub>12</sub>, methionine supplementation, and betaine has been tried. Of these, early treatment with betaine appears to have the most beneficial effect.

## HYPERMETHIONINEMIA

### Primary (Genetic) Hypermethioninemia

Elevation of plasma level of methionine occurs in several genetic conditions. These should be differentiated from acquired (nongenetic) forms of hypermethioninemia, which can occur under various conditions of physiologic stress, especially when involving liver dysfunction.

### Classic Homocystinuria

See earlier discussion.

**Hepatic Methionine Adenosyltransferase (MAT I/MAT III) Deficiency (Mudd Disease).** This hepatic enzyme, which has two isoforms, MAT I (tetrameric) and MAT III (dimeric), is encoded by a single gene, *MAT1A*, and is involved in the first step of methionine catabolism (see Fig. 105.3). Another structurally similar enzyme, MAT II, is encoded by a different gene, *MAT2A*, and is expressed predominantly in nonhepatic tissues (e.g., kidney, brain, lymphocytes). Deficiency of MAT I/MAT III causes hypermethioninemia. In severe deficiency, total plasma homocysteine can also be elevated. The majority of these patients have been diagnosed in the neonatal period through screening for classic homocystinuria. Most affected individuals have residual enzyme activity and remain asymptomatic throughout life despite persistent hypermethioninemia. Some complain of an unusual odor to their breath, likely caused by accumulation of dimethylsulfide. A few patients with complete enzyme deficiency have had neurologic abnormalities related to demyelination (intellectual disability, dystonia, dyspraxia).

Laboratory studies reveal markedly elevated levels of plasma methionine with a normal or low level of S-adenosylmethionine, normal

concentrations of S-adenosylhomocysteine, and normal or slightly elevated total plasma homocysteine. These findings help differentiate MAT I/MAT III deficiency from other causes of hypermethioninemia.

No uniformly accepted therapeutic regimen has yet emerged. Long-term follow-up to monitor for neurologic and liver abnormalities should be considered. Diets low in methionine result in lowering of plasma methionine, but the advisability of such diets has been questioned because lowering plasma methionine, an essential amino acid, causes further lowering of S-adenosylmethionine, thus interfering with reactions of remethylation. Supplementation with S-adenosylmethionine in conjunction with a low-methionine diet seems prudent, but no large clinical experience is yet available. Normal pregnancies producing normal offspring have been reported in mothers with MAT I/MAT III (*MAT1A*) deficiency. The condition is inherited as an autosomal recessive trait, although the pathogenic variant p.Arg264His in *MAT1A* appears to disrupt protein dimerization and may result in mild hypermethioninemia even in heterozygous patients.

**Glycine N-Methyltransferase Deficiency.** Glycine N-methyltransferase (*GNMT*) mediates catabolism of S-adenosylmethionine to S-adenosylhomocysteine (see Fig. 105.3). A few patients with deficiency of this enzyme have been reported to date. Clinically, patients were asymptomatic except for mild hepatomegaly and elevated serum levels of aminotransferases. Other laboratory findings included hypermethioninemia and very high levels of serum S-adenosylmethionine. No specific treatment has yet been identified. The condition is inherited as an autosomal recessive trait.

**S-Adenosylhomocysteine Hydrolase (SAHH) Deficiency.** SAHH deficiency (see Fig. 105.3) has been described infrequently. Intellectual disability, severe hypotonia, and progressive liver dysfunction were common clinical findings. Laboratory studies included elevated levels of serum creatine kinase, hypoalbuminemia (associated with fetal hydrops in one family), hypoprothrombinemia, and greatly elevated levels of serum S-adenosylhomocysteine with moderate elevations of plasma methionine and S-adenosylmethionine. Marked elevation in S-adenosylhomocysteine has been thought to cause inhibition of methyltransferases, including those involved in the synthesis of creatine (see Fig. 105.10) and choline, resulting in their deficiencies. Brain MRIs often reveal delayed myelination of the white matter. The diagnosis can be achieved by *AHCY* gene analysis or, if needed, by biochemical assay of red blood cells, cultured skin fibroblasts, or liver biopsy. Treatment with a low-methionine diet has been used, but its long-term effectiveness has not been established.

**Tyrosinemia Type I.** See Chapter 105.2.

**Citrin Deficiency.** See Chapter 105.12.

### Acquired (Nongenetic) Hypermethioninemia

Hypermethioninemia occurs in premature and some full-term infants receiving high-protein diets, in whom it may represent delayed maturation of the enzyme MAT. Adjusting protein intake under the control of plasma methionine usually resolves the abnormality. Hypermethioninemia is also commonly found in patients with various forms of liver disease.

## PRIMARY CYSTATHIONINEMIA (CYSTATHIONINURIA)

Cystathionase (cystathionine  $\gamma$ -lyase encoded by *CTH*) deficiency results in massive cystathioninuria and mild to moderate cystathioninemia. Cystathionase deficiency of this enzyme is inherited as an autosomal recessive trait, with an estimated prevalence of 1 in 14,000 live births. A wide variety of clinical manifestations have been reported. Lack of a consistent clinical picture and the presence of cystathioninuria in some individuals *without* apparent clinical findings suggest that cystathionase deficiency may be of no clinical significance. Many reported cases are responsive to oral administration of large doses of vitamin B<sub>6</sub> (~100 mg/day). When cystathioninuria is discovered in a patient, vitamin B<sub>6</sub> treatment can be tried, but its beneficial effect has not been established.

Primary cystathioninuria needs to be differentiated from secondary cystathioninuria, which can occur in patients with vitamin B<sub>6</sub> and/or



B<sub>12</sub> deficiency, liver disease (particularly damage caused by galactosemia), thyrotoxicosis, hepatoblastoma, neuroblastoma, ganglioblastoma, or defects in remethylation of homocysteine.

Visit Elsevier eBooks+ at [eBooks.Health.Elsevier.com](http://eBooks.Health.Elsevier.com) for Bibliography.

## 105.4 Cysteine and Cystine

Oleg A. Shchelochkov and Charles P. Venditti

Cysteine is a sulfur-containing amino acid synthesized from methionine (see Fig. 105.3). Oxidation of cysteine forms cystine, a poorly soluble dimer. The most common genetic disorders of cysteine and cystine metabolism are cystinuria (see Chapter 584) and cystinosis (see Chapter 569.3).

### SULFITE OXIDASE DEFICIENCY AND MOLYBDENUM COFACTOR DEFICIENCY

In the last step in cysteine metabolism, sulfite is oxidized to sulfate by sulfite oxidase, and the sulfate is excreted in the urine (see Fig. 105.3). Sulfite oxidase is encoded by *SUOX* and requires a molybdenum-pterin complex called *molybdenum cofactor*. This cofactor is also necessary for the function of two other enzymes in humans: xanthine dehydrogenase (oxidizes xanthine and hypoxanthine to uric acid) and aldehyde oxidase (involved in oxidizing a number of natural compounds and drugs). Three enzymes, encoded by three different genes (*MOCS1*, *MOCS2*, and *GPHN*), are involved in the synthesis of the cofactor. Deficiency of any of the three enzymes causes cofactor deficiency with similar phenotypes. Most patients, who were originally diagnosed as having **sulfite oxidase deficiency**, have been shown to have **molybdenum cofactor deficiency**. Sulfite oxidase deficiency and molybdenum cofactor deficiency are autosomal recessive disorders.

The enzyme and cofactor deficiencies present with overlapping and often nonspecific **clinical manifestations**. Refusal to feed, vomiting, an exaggerated startle reaction, severe intractable seizures (tonic, clonic, myoclonic), cortical atrophy with subcortical multicystic lesions, and severe developmental delay may develop within a few weeks after birth. The biochemical diagnosis should be considered in infants presenting with neonatal seizures and neonates with symptoms reminiscent of hypoxic-ischemic encephalopathy. Bilateral dislocation of ocular lenses is a common finding in patients who survive the neonatal period. The intractable seizures seen in this condition are in part a consequence of secondary vitamin B<sub>6</sub> dependency. The accumulation of sulfites in body fluids in this condition causes the inhibition of the *antiquitin* enzyme, which is necessary for the conversion of  $\alpha$ -amino adipic semialdehyde to  $\alpha$ -amino adipic acid; the resultant accumulation of  $\alpha$ -amino adipic semialdehyde and its cyclic form, P6C, causes the inactivation of pyridoxal-5-phosphate (the active form of vitamin B<sub>6</sub>), leading to **vitamin B<sub>6</sub>-dependent epilepsy** (see also Chapter 105.14).

Affected children excrete large amounts of sulfite, thiosulfate, S-sulfocysteine, xanthine, and hypoxanthine in the urine. Serum uric acid and urinary excretion of sulfate and uric acid are diminished. Fresh urine should be used for screening purposes and for quantitative measurements of sulfite, because oxidation of sulfite to sulfate at room temperature may produce false-negative results. Increased concentrations of  $\alpha$ -amino adipic semialdehyde and P6C can be found in the CSF, plasma, and urine.

**Diagnosis** is confirmed by analysis of affected genes (often using a multigene panel). Infrequently, measurement of sulfite oxidase and molybdenum cofactor in fibroblasts and liver biopsies is required. Prenatal diagnosis is possible by DNA studies or by performing an assay of sulfite oxidase activity in cultured amniotic cells, in samples of chorionic villi. The prevalence of these deficiencies in the general population is not known but likely is very low.

Patients with *MOCS1*-related molybdenum cofactor deficiency may benefit from daily intravenous **cyclic pyranopterin monophosphate** (a cPMP analogue), a compound under investigation in a multicenter clinical trial. Large doses of vitamin B<sub>6</sub> may alleviate the frequency and

severity of seizures but do not seem to alter the devastating neurologic outcome. A cysteine-restricted diet under control of plasma amino acids to avoid essential amino acid deficiencies can be attempted in some patients, but the long-term efficacy of this approach is unknown.

Visit Elsevier eBooks+ at [eBooks.Health.Elsevier.com](http://eBooks.Health.Elsevier.com) for Bibliography.

## 105.5 Tryptophan

Oleg A. Shchelochkov and Charles P. Venditti

Tryptophan is an essential amino acid and a precursor for nicotinic acid (niacin) and serotonin (Fig. 105.5). The genetic disorders of metabolism of serotonin, one of the major neurotransmitters, are discussed in Chapter 105.11.

### HARTNUP DISEASE

Hartnup disease is an autosomal recessive condition caused by biallelic pathogenic variants in *SLC6A19*. This gene encodes a monoamino-monocarboxylic amino acid transporter (B<sup>0</sup>AT1), which facilitates transport of neutral amino acids, including tryptophan, across the intestinal mucosa and renal tubules. Patients show significant variability in presentation, likely related to nutritional factors, environment, and genetic heterogeneity of modifier genes (e.g., two proteins, TMEM27 and ACE2, that interact with B<sup>0</sup>AT1). The prevalence of Hartnup disorder is estimated to be 1 in 20,000 to 1 in 55,000 live births. Most children with Hartnup disease remain asymptomatic. Decreased intestinal absorption of tryptophan in conjunction with its increased renal loss can lead to reduced availability of tryptophan for niacin synthesis. **Tryptophan deficiency** can be accentuated by malabsorption such as celiac disease. One of the more noticeable clinical manifestations in the rare symptomatic patient is **cutaneous photosensitivity**. The skin becomes rough and red after moderate exposure to the sun, and with greater exposure, a pellagra-like rash may develop. The rash may be pruritic, and a chronic eczema may develop. The skin changes have been reported in affected infants as young as 10 days of age. Some patients may have intermittent ataxia manifested as an unsteady, wide-based gait. The ataxia may last a few days and can respond to niacin supplementation. Cognitive development is usually normal. Episodic psychiatric manifestations such as irritability, emotional instability, depression, and suicidal tendencies, have been observed; these changes are usually associated with bouts of ataxia. Short stature and atrophic glossitis are seen in some patients.

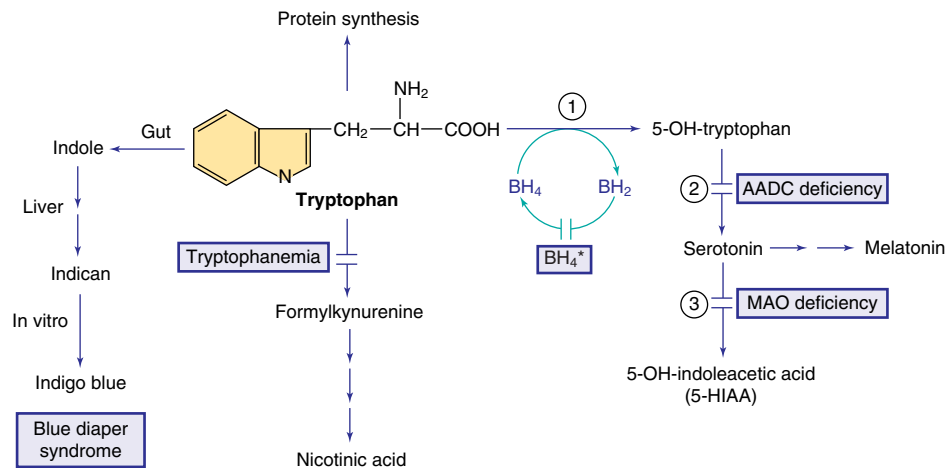
Most children diagnosed with Hartnup disorder by neonatal screening have remained asymptomatic. This indicates that other factors are also involved in the pathogenesis of the clinical condition.

The main laboratory finding is **aminoaciduria**, which is restricted to neutral amino acids (alanine, serine, threonine, valine, leucine, isoleucine, phenylalanine, tyrosine, tryptophan, histidine). Urinary excretion of proline, hydroxyproline, and arginine remains normal. This finding helps differentiate Hartnup disorder from other causes of generalized aminoaciduria, such as renal Fanconi syndrome. Plasma concentrations of neutral amino acids are normal or mildly decreased. This seemingly unexpected finding reflects compensatory mechanisms that maintain normal transport and utilization of amino acids. The indole derivatives (especially indican) may be found in large amounts in some patients, resulting from bacterial breakdown of unabsorbed tryptophan in the intestines.

**Diagnosis** of Hartnup disorder is established by the intermittent nature of symptoms and characteristic findings on the urine amino acid analysis. When necessary, the diagnosis can be confirmed molecularly by *SLC6A19* gene analysis.

**Treatment** with nicotinic acid or nicotinamide (50–300 mg/day) and a high-protein diet results in a favorable response in symptomatic patients with Hartnup disorder. Because of the intermittent nature of the clinical manifestations, the efficacy of these treatments is difficult to establish. Normal outcome for both the mother and fetus has been reported in several affected women.

Visit Elsevier eBooks+ at [eBooks.Health.Elsevier.com](http://eBooks.Health.Elsevier.com) for Bibliography.



**Fig. 105.5** Pathways in the metabolism of tryptophan.  $\text{BH}_4^*$  indicates hyperphenylalaninemia caused by tetrahydrobiopterin deficiency (see Fig. 105.1). Enzymes: (1) Tryptophan hydroxylase, (2) aromatic L-amino acid decarboxylase (AADC), (3) monoamine oxidase (MAO).

## 105.6 Isoleucine, Leucine, Valine, and Related Organic Acidemias

Oleg A. Shchelochkov, Irlini Manoli, and Charles P. Venditti

The early steps in the degradation of the branched-chain amino acids (BCAAs)—isoleucine, leucine, and valine—are similar (see Fig. 105.4). Under catabolic conditions, BCAAs in the muscle tissue undergo a reversible reaction of transamination catalyzed by BCAA transaminase.  $\alpha$ -Ketoacids formed by this reaction then undergo an oxidative decarboxylation step mediated by a branched-chain  $\alpha$ -ketoacid dehydrogenase (BCKDH) complex. The deficiency of BCKDH results in **maple syrup urine disease**, whereas the deficiency of enzymes mediating more distal reactions results in accumulation of enzyme-specific levels of organic acids excreted in the urine, thus giving those inborn errors of metabolism the eponyms **organic acidemias** and **organic acidurias**. These disorders typically cause metabolic acidosis, which usually occurs in the first few days of life. Although most of the clinical findings are nonspecific, some manifestations may provide important clues to the nature of the enzyme deficiency. Figure 105.6 presents an approach to infants suspected of having an organic acidemia. The diagnosis is usually established by identifying and measuring specific organic acids in body fluids (blood, urine), amino acid analysis (blood), and identifying pathogenic variants in the respective gene.

Organic acidemias are not limited to defects in the catabolic pathways of BCAAs. Disorders causing accumulation of other organic acids include those derived from lysine (see Chapter 105.14), disorders of the  $\gamma$ -glutamyl cycle (see Chapter 105.11), those associated with lactic acid (see Chapter 107), and dicarboxylic acidemias associated with defective fatty acid degradation (see Chapter 106).

### MAPLE SYRUP URINE DISEASE

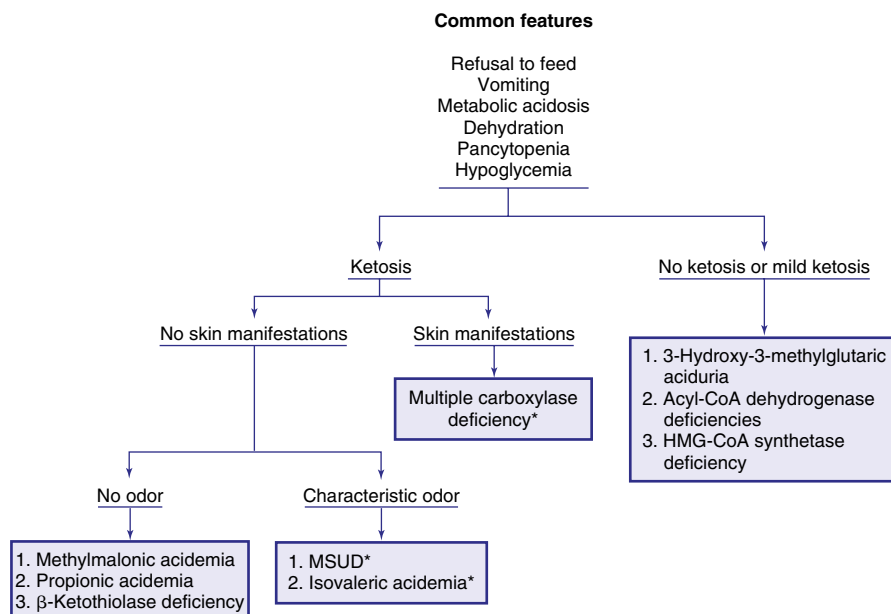
Decarboxylation of leucine, isoleucine, and valine is accomplished by a complex enzyme system (BCKDH) using thiamine (vitamin  $\text{B}_1$ ) pyrophosphate as a coenzyme. This mitochondrial enzyme consists of four subunits:  $\text{E}_{1\alpha}$ ,  $\text{E}_{1\beta}$ ,  $\text{E}_2$ , and  $\text{E}_3$ . The  $\text{E}_3$  subunit is shared with two other dehydrogenases: pyruvate dehydrogenase and  $\alpha$ -ketoglutarate dehydrogenase. Deficiency of any of these subunits causes maple syrup urine disease (MSUD) (see Fig. 105.4), a disorder named after the sweet odor of maple syrup discerned from body fluids, especially cerumen, sweat, and urine. Clinical conditions caused by defects in  $\text{E}_{1\alpha}$ ,  $\text{E}_{1\beta}$ ,  $\text{E}_2$  and  $\text{E}_3$  are designated as MSUD type 1A, type 1B, type 2, and type 3, respectively. This classification, however, is not very helpful clinically because the severity of clinical manifestations does not correlate with, or correspond specifically to, any single enzyme subunit. An affected infant with a type 1A defect can have clinical manifestations ranging

from relatively mild to very severe. A more useful classification, based on clinical findings and response to thiamine administration, delineates five phenotypes of MSUD.

### Classic Maple Syrup Urine Disease

Classic MSUD has the most severe clinical manifestations. The BCKDH complex activity in this group varies between 0% and 2% of controls. Patients with uncontrolled or poorly controlled disease develop signs of acute encephalopathy. The mechanisms underlying this life-threatening complication are complex, but leucine and its derivative,  $\alpha$ -ketoisocaproic acid, appear to be the key factors underlying acute encephalopathy. Elevated leucine competitively inhibits the uptake of other amino acids by the LNAA transporter. Once taken up by the brain tissue, leucine is metabolized by BCAA aminotransferase to  $\alpha$ -ketoisocaproic acid, which disrupts metabolism of neurotransmitters and amino acids (glutamate,  $\gamma$ -aminobutyric acid [GABA], glutamine, alanine, and aspartate).  $\alpha$ -Ketoisocaproic acid can reversibly inhibit oxidative phosphorylation and result in cerebral lactic acidosis. Collectively, these processes are detrimental to the normal function of neurons and glia, clinically manifesting as *encephalopathy* and *brain edema*, referred to as **leucinosis**. Affected infants who appear healthy at birth develop poor feeding and vomiting in the first days of life. Lethargy and coma may ensue within a few days. Physical examination reveals hypertonicity and muscular rigidity with severe opisthotonos. Periods of hypertonicity may alternate with bouts of flaccidity manifested as repetitive movements of the extremities (“boxing” and “bicycling”). Neurologic findings are often mistakenly thought to be caused by generalized sepsis and meningitis. Cerebral edema may be present; seizures occur in most infants, and hypoglycemia is common. In contrast to most hypoglycemic states, correction of the blood glucose concentration does not improve the clinical condition. Aside from the blood glucose and varying degrees of ketoacidosis, routine laboratory findings are usually unremarkable. If left untreated, death can occur in the first few weeks or months of life.

**Diagnosis** was classically suspected because of the peculiar odor of maple syrup in urine, sweat, and cerumen. It is usually confirmed by amino acid analysis showing marked elevations in plasma levels of leucine, isoleucine, valine, and alloisoleucine and a depressed level of alanine. Alloisoleucine is a stereoisomer of isoleucine not normally found in blood and is the most sensitive and specific diagnostic marker for all forms of MSUD. Leucine levels are usually higher than those of isoleucine and valine. Urine contains high levels of leucine, isoleucine, and valine and their respective ketoacids. These ketoacids may be detected qualitatively by adding a few drops of 2,4-dinitrophenylhydrazine reagent (0.1% in 0.1N HCl) to the urine; a yellow precipitate of 2,4-dinitrophenylhydrazone is formed in a positive test. Neuroimaging during the acute state may show cerebral edema, which is most



**Fig. 105.6** Clinical algorithmic approach to infants with organic acidemia. Asterisks indicate disorders in which patients have a characteristic odor (see text and Table 105.2). MSUD, Maple syrup urine disease.

prominent in the cerebellum, dorsal brainstem, cerebral peduncle, and internal capsule. After recovery from the acute state and with advancing age, hypomyelination and cerebral atrophy may be seen in neuroimaging of the brain.

**Treatment** of the acute state is aimed at hydration and rapid removal of the BCAAs and their metabolites from the tissues and body fluids. Uptake of leucine by the brain and accumulation of the downstream metabolite,  $\alpha$ -ketoisocaproic acid, appear to be the key metabolic events underlying the MSUD encephalopathy. Therefore MSUD management strategies focus on decreasing plasma leucine to control acute and chronic manifestations of the disease.

Because renal clearance of leucine is low, hydration alone may not produce a rapid improvement. *Hemodialysis* is the most effective mode of therapy in critically ill infants and should be instituted promptly; significant decreases in plasma levels of leucine, isoleucine, and valine are usually seen within 24 hours. Sufficient calories and nutrients should be provided intravenously or orally as soon as possible to reverse the patient's catabolic state. Cerebral edema, if present, may require treatment with mannitol, diuretics (e.g., furosemide), or hypertonic saline. Counterintuitively, supplementation with isoleucine and valine is also needed to achieve adequate control of the plasma leucine level in MSUD patients and to sustain the net protein synthesis in tissues. Judiciously administered isoleucine and valine will compete with leucine for the LNAA transporter at the BBB, decrease leucine entry into the CNS, and help in the prevention and treatment of leucine encephalopathy. Phenylbutyrate, a nitrogen scavenger used to treat hyperammonemia in urea cycle disorders, has been shown to activate the BCKDH complex and lower BCAA levels, with promising results in a subset of MSUD patients.

Treatment after recovery from the acute state requires a diet low in BCAAs. Synthetic formulas devoid of leucine, isoleucine, and valine are available commercially. Because these amino acids cannot be synthesized endogenously, age-appropriate amounts of BCAAs should be provided in the diet in the form of complete protein. To avoid essential amino acid deficiencies, the amount should be titrated carefully by performing frequent analyses of plasma amino acids, with close attention to plasma isoleucine, leucine, and valine levels. A clinical condition resembling **acrodermatitis enteropathica** (see Chapter 691) occurs in affected infants whose plasma isoleucine or valine had been *over-restricted*; the addition of isoleucine or valine, respectively, to the diet will hasten the recovery of the skin rash. Patients with MSUD need to remain on the diet for life. Liver transplantation is offered to patients

with classic MSUD, allowing some patients to lift protein restrictions and improve metabolic control during intercurrent illnesses.

The long-term prognosis of affected children remains guarded. Severe ketoacidosis, cerebral edema, and death may occur during any stressful situation such as infection or surgery, especially in mid-childhood. Cognitive and other neurologic deficits are common sequelae.

### Intermediate (Mild) Maple Syrup Urine Disease

Children with intermediate MSUD develop milder disease after the neonatal period. Clinical manifestations are insidious and limited to the CNS. Patients have mild to moderate intellectual disability with or without seizures. They have the odor of maple syrup and excrete moderate amounts of the BCAAs and their ketoacid derivatives in the urine. Plasma concentrations of leucine, isoleucine, and valine are moderately increased, whereas those of lactate and pyruvate tend to be normal. These children are commonly diagnosed during an intercurrent illness, when signs and symptoms of classic MSUD may occur. The dehydrogenase activity is 3–40% of the reference population. Because patients with thiamine-responsive MSUD usually have manifestations similar to the mild form, a trial of thiamine therapy is recommended. Diet therapy, similar to that of classic MSUD, is needed.

### Intermittent Maple Syrup Urine Disease

In intermittent MSUD, seemingly normal children develop vomiting, odor of maple syrup, ataxia, lethargy, and coma during any stress or catabolic state such as infection or surgery. During these attacks, laboratory findings are indistinguishable from those of the classic form, and death may occur. Treatment of the acute attack of intermittent MSUD is similar to that of the classic form. After recovery, although a normal diet can be tolerated, a low-BCAA diet is recommended. The BCKDH activity in patients with the intermittent form is higher than in the classic form and may reach 40% of the control activity.

### Thiamine-Responsive Maple Syrup Urine Disease

Some children with mild or intermediate forms of MSUD who are treated with high doses of thiamine show dramatic clinical and biochemical improvement. Although some respond to treatment with thiamine at 10 mg/day, others may require as much as 100 mg/day for at least 3 weeks before a favorable response is observed. These patients also require a BCAA-restricted diet. The enzymatic activity in these patients can be up to 40% of the reference population.



### Maple Syrup Urine Disease Caused by Deficiency of E<sub>3</sub> Subunit (MSUD Type 3)

Although sometimes referred to as “maple syrup urine disease type 3,” this very rare disorder leads to clinical and biochemical abnormalities that encompass a wide range of mitochondrial reactions. The E<sub>3</sub> subunit, dihydrolipoamide dehydrogenase, is a component of the BCKDH complex, pyruvate dehydrogenase complex, and  $\alpha$ -ketoglutarate dehydrogenase complex. Causative biallelic pathogenic variants in *DLA* that encode the E<sub>3</sub> dihydrolipoamide dehydrogenase cause lactic acidosis, elevated pyruvate, and signs and symptoms similar to intermediate MSUD. Progressive neurologic impairment manifested by hypotonia and developmental delay occurs after 2 months of age. Abnormal movements can progress to ataxia or Leigh syndrome. Death may occur in early childhood.

Laboratory findings include persistent lactic acidosis with high levels of plasma pyruvate and alanine. Plasma BCAA concentrations are moderately increased. Patients excrete large amounts of lactate, pyruvate,  $\alpha$ -ketoglutarate, and the three branched-chain ketoacids in their urine.

*No effective treatment is available.* BCAA-restricted diets and treatment with high doses of thiamine, biotin, and lipoic acid have been ineffective.

### Genetics and the Prevalence of Maple Syrup Urine Disease

Biallelic pathogenic variants in any of the following genes may result in the clinical and biochemical manifestations of MSUD: *BCKDHA* (encodes subunit E<sub>1 $\alpha$</sub> ), *BCKDHB* (encodes subunit E<sub>1 $\beta$</sub> ), *DBT* (encodes subunit E<sub>2</sub>), and *DLA* (encodes subunit E<sub>3</sub>). Genotype-phenotype correlations are difficult to establish and are usually imprecise. The exception is thiamine-responsive MSUD, shown to be caused by pathogenic variants in *DBT*. Most patients are compound heterozygotes inheriting two different pathogenic alleles. Pathogenic variants in *BCKDHA* (45%) and *BCKDHB* (35%) account for approximately 80% of cases. Pathogenic variants in *DBT* are responsible for 20% of MSUD cases.

The prevalence is estimated at 1 in 185,000 live births. Classic MSUD is more prevalent in the Old Order Mennonites in the United States, at an estimated 1 in 380 live births. Affected patients in this population are homozygous for a specific pathogenic variant (c.1312T>A) in the *BCKDHA*-encoding E<sub>1 $\alpha$</sub>  subunit.

Early detection of MSUD is possible by universal newborn screening. In many cases, however, especially those with classic MSUD, the infant may be very ill by the time screening results become available (see Chapter 104). Prenatal diagnosis has been accomplished by enzyme assay of the cultured amniocytes, cultured chorionic villus tissue, or direct assay of samples of the chorionic villi and by identification of the known pathogenic variants in the affected gene.

Successful pregnancies have occurred in women with different forms of MSUD. The teratogenic potential of leucine during pregnancy is unknown. Tight control of isoleucine, leucine, and valine before and during the pregnancy is important to minimize the risk of metabolic decompensation and to optimize fetal nutrition. Mothers affected by MSUD require close monitoring and meticulous management of nutrition, electrolytes, and fluids in the postpartum period.

### BRANCHED-CHAIN $\alpha$ -KETOACID DEHYDROGENASE KINASE DEFICIENCY

A defect in the regulation of BCKDH by BCKDH kinase (BCKDK), the enzyme responsible for phosphorylation-mediated inactivation of the BCKDH complex, causes the *reverse* biochemical phenotype of MSUD. Pathogenic variants in *BCKDK* decrease the negative regulation by the kinase, resulting in uncontrolled degradation and depletion of isoleucine, leucine, and valine in plasma and the brain. Patients with BCKDK deficiency present with low plasma concentrations of isoleucine, leucine, and valine associated with autism, intellectual impairment, fine motor coordination problems, and seizures.

### BRANCHED-CHAIN AMINO ACID TRANSPORTER DEFICIENCY

Isoleucine, leucine, and valine are transported across the BBB mainly by the heterodimeric LNAA transporter LAT1 encoded by *SLC7A5*. A

defect in LAT1 caused by pathogenic variants in *SLC7A5* results in low brain concentrations of isoleucine, leucine, and valine. Patients with this defect may present similarly to BCKDK-deficient patients, with autism, microcephaly, gross motor delays, and in some cases, seizures.

### ISOVALERIC ACIDEMIA

Isovaleric acidemia (IVA) is an autosomal recessive condition caused by biallelic pathogenic variants in *IVD* resulting in the deficient activity of isovaleryl-coenzyme A (CoA) dehydrogenase (see Fig. 105.4). The prevalence of IVA is estimated to range between 1 in 62,500 (in parts of Germany) and 1 in 250,000 live births (in the United States). Decreased or absent activity of isovaleryl-CoA dehydrogenase results in impaired leucine degradation. Accumulating derivatives of isovaleric acid, isovalerylcarnitine, isovalerylglycine, and 3-hydroxyisovaleric acid can be detected in body fluids and thus enable the biochemical diagnosis and screening. Clinically, the course of IVA can be highly variable, ranging from essentially asymptomatic to severe. Introduction of newborn screening and proactive management of IVA has changed the prognosis and clinical course. Older siblings of symptomatic newborn infants have been reported with identical genotype and biochemical abnormalities but without clinical manifestations, suggesting that pre-symptomatic detection of affected patients on the newborn screen can improve clinical outcomes.

Patients with severe IVA can present with vomiting, severe acidosis, hyperammonemia, hypoglycemia, hypocalcemia, and bone marrow suppression in infancy. Lethargy, convulsions, and coma may ensue, and death may occur if proper therapy is not initiated. Vomiting may be severe enough to suggest pyloric stenosis. The characteristic odor of “sweaty feet” or “rancid cheese” may be present. Infants who survive this acute episode are at risk of developing episodes of metabolic decompensation later in life. In the mild form without treatment, typical clinical manifestations of severe IVA (vomiting, lethargy, acidosis, or coma) may not appear until the child is a few months or years old. Acute episodes of metabolic decompensation may occur during a catabolic state, such as infection, dehydration, surgery, or high-protein intake. Acute episodes may be mistaken for diabetic ketoacidosis. Some patients may experience acute and recurrent episodes of pancreatitis.

**Laboratory findings** during the acute attacks include ketoacidosis, neutropenia, thrombocytopenia, and occasionally pancytopenia. Hypocalcemia, hypoglycemia, and moderate to severe hyperammonemia may be present in some patients. Increases in plasma ammonia may suggest a defect in the urea cycle (see Chapter 105.12). In urea cycle defects, the infant usually shows no significant ketoacidosis (see Fig. 105.6).

**Diagnosis** is established by demonstrating marked elevations of isovaleric acid metabolites (isovalerylglycine, 3-hydroxyisovaleric acid) in body fluids, especially urine. The main compound in plasma is isovalerylcarnitine (C5-carnitine). C5-carnitine can be measured in dried blood spots, enabling universal newborn screening using tandem mass spectrometry. The diagnosis can be confirmed by molecular analysis of the *IVD* gene. In some patients with equivocal results, measurement of the enzyme activity in cultured skin fibroblasts may be necessary.

**Treatment** of the acute attack is aimed at rehydration, reversal of the catabolic state (by providing adequate calories orally or intravenously), correction of metabolic acidosis, and facilitation of the isovaleric acid excretion. L-Carnitine (100 mg/kg/day orally) also increases removal of isovaleric acid by forming isovalerylcarnitine, which is excreted in the urine. Because isovalerylglycine has a high urinary clearance, some centers recommend glycine supplementation (250 mg/kg/day) to enhance the formation of isovalerylglycine. Temporary restriction of protein intake (<24 hours) may be beneficial in some cases. In patients with significant hyperammonemia (blood ammonia >200  $\mu$ mol/L), measures that reduce blood ammonia should be employed (see Chapter 105.12). Renal replacement therapy may be needed if the previously described measures fail to produce significant clinical and biochemical improvement. Long-term management of IVA patients requires restriction of protein according to age-appropriate intake (recommended dietary allowance of protein). Patients benefit from carnitine supplementation with or without glycine. Normal development can be achieved with early and proper treatment.



**Prenatal diagnosis** can be accomplished using *IVD* gene analysis if causative pathogenic variants are known or, less frequently, by using an enzyme assay of cultured amniocytes. Successful pregnancies with favorable outcomes have been reported. Universal newborn screening of IVA is used in the United States and other countries (see Chapter 104).

### MULTIPLE CARBOXYLASE DEFICIENCIES (DEFECTS OF THE BIOTIN CYCLE)

**Biotin** is a water-soluble vitamin that serves as a cofactor for four carboxylase enzymes in humans: pyruvate carboxylase, acetyl-CoA carboxylase, propionyl-CoA carboxylase, and 3-methylcrotonyl-CoA carboxylase. The latter two are involved in the catabolic pathways of leucine, isoleucine, and valine (see Fig. 105.4).

Most dietary biotin is bound to proteins. Free biotin is generated in the intestine by the action of digestive enzymes, by intestinal bacteria, and perhaps by biotinidase. **Biotinidase**, found in serum and most tissues, is also essential for the recycling of biotin in the body by releasing it from the apoenzymes (carboxylases; see Fig. 105.4). Free biotin must form a covalent bond with the apocarboxylases to produce the activated enzyme (holocarboxylase). This binding is catalyzed by holocarboxylase synthetase. Deficiencies either in holocarboxylase synthetase or in biotinidase result in the impaired catalytic activity of carboxylases and organic acidemias.

#### Holocarboxylase Synthetase Deficiency

Infants with this rare autosomal recessive disorder become symptomatic in the first few weeks of life. Symptoms may appear as early as a few hours after birth to as late as 8 years of age. Clinically, shortly after birth, affected infants develop breathing difficulties (tachypnea and apnea). Feeding problems, vomiting, and hypotonia are also usually present. If the condition remains untreated, *generalized erythematous rash with exfoliation and alopecia*, failure to thrive, irritability, seizures, lethargy, and even coma may occur. Developmental delay is common. Immune deficiency manifests with susceptibility to infection. Urine may have a peculiar odor, which has been described “tomcat urine.” The rash, when present, helps to differentiate this condition from other organic acidemias (see Fig. 105.6).

**Laboratory findings** include metabolic acidosis, ketosis, hyperammonemia, and the presence of a variety of organic acids and their conjugates (lactic acid, 3-methylcrotonic acid, 3-methylcrotonylglycine, tiglylglycine, 3-OH-propionic acid, methylcitric acid, and 3-hydroxyisovaleric acid) in body fluids. **Diagnosis** is confirmed by identification of pathogenic variants in *HLCS* or by the enzyme assay in lymphocytes or cultured fibroblasts. Most pathogenic variants cause the enzyme to have an increased  $K_m$  (Michaelis-Menten dissociation constant) for biotin; the enzyme activity in such patients can be restored by the administration of large doses of biotin. Newborn screening can identify holocarboxylase synthetase-deficient infants by detecting elevated C5-OH-carnitine on tandem mass spectrometry. In these infants, biotinidase enzymatic assay would be normal.

**Treatment** with biotin (10–20 mg/day orally) usually results in an improvement in clinical manifestations and biochemical abnormalities. Early diagnosis and treatment are critical to prevent irreversible neurologic damage. In some patients, complete resolution may not be achieved even with large doses (up to 60 mg/day) of biotin.

**Prenatal diagnosis** can be accomplished by prenatal molecular analysis of known pathogenic variants in *HLCS* or by assaying enzyme activity in cultured amniotic cells. Pregnant mothers who had previous offspring with holocarboxylase synthetase deficiency have been treated with biotin late in pregnancy. Affected infants were normal at birth, but the efficacy of prenatal treatment remains unclear.

#### Biotinidase Deficiency

Impaired biotinidase activity results in biotin deficiency. Affected infants may develop clinical manifestations similar to those seen in infants with holocarboxylase synthetase deficiency. Unlike the latter, however, symptoms tend to appear later, when the child is several months or years old. The delay in onset of symptoms presumably

results from the availability of free biotin derived from the mother or the diet. Clinical manifestations are mostly confined to the skin and the nervous system. Without treatment, atopic or seborrheic dermatitis, candidiasis, alopecia, ataxia, seizures (usually myoclonic), hypotonia, developmental delay, optic nerve atrophy, sensorineural hearing loss, and immunodeficiency resulting from impaired T-cell function may occur. A small number of children with *intractable seborrheic dermatitis* and *partial* (15–30% activity) biotinidase deficiency, in whom the dermatitis resolved with biotin therapy, have been reported; these children were otherwise asymptomatic. Asymptomatic children and adults with this enzyme deficiency have been identified in screening programs. Most of these individuals have been shown to have partial biotinidase deficiency. With universal newborn screening leading to early identification and treatment of the affected patients, the clinical disease should become extinct.

**Laboratory findings** and the pattern of organic acids in body fluids resemble those associated with holocarboxylase synthetase deficiency. **Diagnosis** can be established by measurement of the enzyme activity in the serum and confirmed by identifying biallelic pathogenic variants in *BTD*. **Treatment** with free biotin (5–20 mg/day) results in a dramatic clinical and biochemical improvement. Treatment with biotin is also suggested for individuals with partial biotinidase deficiency. The prevalence of this autosomal recessive disorder is estimated to be 1 in 60,000 live births. **Prenatal diagnosis** is possible by identification of known pathogenic variants in *BTD* or, less frequently, by the measurement of the enzyme activity in the amniotic cells, although in practice, a prenatal approach is rarely used.

#### Multiple Carboxylase Deficiency Caused by Acquired Biotin Deficiency

Acquired deficiency of biotin may occur in infants receiving total parenteral nutrition without added biotin, in patients with prolonged use of antiepileptic drugs (phenobarbital, phenytoin, primidone, carbamazepine), and in children with short bowel syndrome or chronic diarrhea who are receiving formulas low in biotin. Excessive ingestion of raw eggs may also cause biotin deficiency because the protein avidin in egg white binds biotin, decreasing its absorption. Infants with acquired biotin deficiency may develop dermatitis, alopecia, and candidal skin infections. This condition readily responds to treatment with oral biotin.

### 3-METHYLCROTONYL-COA CARBOXYLASE DEFICIENCY

This enzyme is one of the four carboxylases requiring biotin as a cofactor (see Fig. 105.4). An isolated deficiency of this enzyme must be differentiated from disorders of biotin metabolism (multiple carboxylase deficiency), which causes diminished activity of all four carboxylases (see earlier). 3-Methylcrotonyl-CoA carboxylase (3-MCC) is a heteromeric enzyme consisting of  $\alpha$  (biotin containing) and  $\beta$  subunits, encoded by the genes *MCCC1* and *MCCC2*, respectively. 3-MCC deficiency can be detected in the newborn period by identifying elevated 3-hydroxyisovalerylcarnitine (C5-OH) in dried blood spots. Universal newborn screening using tandem mass spectrometry has identified an unexpectedly high number of infants with 3-MCC deficiency, with its prevalence ranging between 1 in 2,400 and 1 in 68,000.

**Clinical manifestations** are highly variable, ranging from completely asymptomatic adults (including mothers of affected newborn infants), to children presenting with developmental delay without episodes of metabolic decompensation, to patients with seizures, hyperammonemia, and metabolic acidosis. Rarely, infants who are affected by severe 3-MCC deficiency may appear healthy at birth but later develop acute episodes of vomiting, hypotonia, lethargy, and convulsions after a minor infection, in some cases progressing to life-threatening complications (e.g., Reye syndrome, coma). In patients prone to developing these symptoms, the onset is usually between 3 weeks and 3 years of age. Among infants identified through newborn screening, 85–90% of children remain apparently asymptomatic. The reason for differences in outcomes is unknown. None of the symptoms reported so far could be clearly attributed to the degree of enzyme deficiency.

**Laboratory findings** during acute episodes include mild to moderate metabolic acidosis, ketosis, hypoglycemia, hyperammonemia, and elevated serum transaminase levels. Large amounts of 3-hydroxyisovalerate and 3-methylcrotonylglycine are found in the urine. Urinary excretion of 3-methylcrotonate is usually not detected in this condition because the accumulated 3-methylcrotonyl-CoA is converted to 3-hydroxyisovalerate. The plasma acylcarnitine profile shows elevated 3-hydroxyisovalerylcarnitine (C5-OH). Severe secondary carnitine deficiency is common. 3-MCC deficiency should be differentiated biochemically from multiple carboxylase deficiency (see earlier), in which, in addition to 3-hydroxyisovalerate, lactate and metabolites of propionic acid are also present. **Diagnosis** may be confirmed by molecular analysis of *MCCC1* and *MCCC2* or by measurement of the enzyme activity in cultured fibroblasts. Documentation of normal activities of other carboxylases is necessary to rule out multiple carboxylase deficiency.

**Treatment** of acute episodes is similar to that of isovaleric acidemia (see earlier). Hydration and measures to correct both hypoglycemia and severe metabolic acidosis by infusing glucose and sodium bicarbonate should be instituted promptly. Secondary carnitine deficiency, seen in up to 50% of patients, can be corrected with L-carnitine supplementation. For symptomatic patients, some centers recommend keeping protein intake at the recommended dietary allowance in conjunction with the oral administration of L-carnitine and the proactive management of catabolic states. Normal physiologic growth and development are expected in most patients.

3-MCC deficiency is an autosomal recessive condition. Biallelic pathogenic variants in either *MCCC1* or *MCCC2* result in the enzyme deficiency with overlapping clinical features.

### 3-METHYLGLUTACONIC ACIDURIAS

The 3-methylglutaconic acidurias comprise a heterogeneous group of metabolic disorders characterized by excessive excretion of 3-methylglutaconic acid in the urine (Table 105.2). Other metabolites found in 3-methylglutaconic aciduria patients may include 3-methylglutaric acid and 3-hydroxyisovaleric acid. The current classification distinguishes between primary and secondary forms. **Primary** 3-methylglutaconic aciduria is caused by the deficiency of mitochondrial 3-methylglutaconyl-CoA hydratase (see Fig. 105.4), formerly 3-methylglutaconic aciduria type I. **Secondary** 3-methylglutaconic aciduria can be further classified based on the underlying mechanism (e.g., defective phospholipid remodeling versus dysfunction of mitochondrial membrane) or now the more preferred classification based on the underlying molecular cause. Known causes of secondary 3-methylglutaconic aciduria include the X-linked TAZ-related syndrome (**Barth syndrome**), *OPA3*-related 3-methylglutaconic aciduria (**Costeff syndrome**), *SERAC1*-related syndrome (**MEGDEL syndrome**), *TMEM70*-related syndrome, and *DNAJC19*-related syndrome (**DCMA syndrome**).

Significant and persistent 3-methylglutaconic aciduria with negative molecular evaluation for known genetic causes represents a heterogeneous group called 3-methylglutaconic aciduria **not otherwise specified** awaiting further molecular characterization. Primary and secondary 3-methylglutaconic aciduria should be distinguished from mild and transient urinary elevations of 3-methylglutaconic acid seen in patients affected by other metabolic disorders or liver dysfunction, such as mitochondrial disorders of diverse etiology.

#### 3-Methylglutaconyl-CoA Hydratase Deficiency

Two main clinical presentations have been described for 3-methylglutaconyl-CoA hydratase deficiency, an autosomal recessive disorder (see Fig. 105.4). In the **childhood** form, nonspecific neurodevelopmental findings such as speech delay or regression, choreoathetoid movements, optic nerve atrophy, and mild psychomotor delay may be present. Metabolic acidosis may occur during a catabolic state. In the **adulthood** form, affected individuals may remain asymptomatic until the second or third decade of life, when a clinical picture of *slowly progressing leukoencephalopathy* with optic nerve atrophy, dysarthria, ataxia, spasticity, and dementia occurs. Brain MRI typically

shows white matter abnormalities, which may precede the appearance of clinical symptoms by years. Asymptomatic pediatric and adult patients have also been reported. Patients excrete large amounts of 3-methylglutaconic acid and moderate amounts of 3-hydroxyisovaleric and 3-methylglutaric acids in urine. **Treatment** with L-carnitine may help some patients. The effectiveness of a low-leucine diet has not been established. The condition is caused by biallelic pathogenic variants in *AUH* and is inherited in an autosomal recessive manner.

#### Barth Syndrome (Tafazzin-Related Disorder)

This X-linked condition is caused by a deficiency of *tafazzin*, a mitochondrial protein, encoded by the *TAFAZIN* gene. This enzyme is necessary for remodeling of immature cardiolipin into its mature form. *Cardiolipin*, a mitochondrial phospholipid, is critical for the integrity of the inner mitochondrial membrane. **Clinical manifestations** of Barth syndrome usually begin in the first year of life in a male infant and include cardiomyopathy, hypotonia, growth restriction, hypoglycemia, and mild to severe neutropenia. The onset of clinical manifestations may be as late as adulthood, but most affected individuals become symptomatic by adolescence. If patients survive infancy, relative improvement may occur with advancing age. Cognitive development is usually normal, although delayed motor function and learning disabilities occur.

**Laboratory findings** include mild to moderate increases in urinary excretion of 3-methylglutaconic, 3-methylglutaric, and 2-ethylhydracrylic acids. Unlike primary 3-methylglutaconic aciduria (type I), urinary excretion of 3-hydroxyisovaleric acid is not elevated. The activity of the enzyme 3-methylglutaconyl-CoA hydratase is normal. *Neutropenia is a common finding*. Lactic acidosis, hypoglycemia, low serum cholesterol, low prealbumin, and abnormal mitochondrial ultrastructure are also common. Total cardiolipin and subclasses of cardiolipin are very low in skin fibroblast cultures from these patients. The monolysocardiolipin/cardiolipin ratio in cultured fibroblast is useful for establishing the diagnosis in patients with negative or equivocal molecular results. Because of its nonspecific presentation, the condition is likely underdiagnosed and underreported.

The condition is inherited in an X-linked recessive manner. The gene (*TAFAZIN*) has been mapped to chromosome Xq28. The modest 3-methylglutaconic aciduria seen in Barth syndrome is thought to be related to the defect in the mitochondrial membrane, causing the leakage of this organic acid. Gene-specific treatment is not available. Patients with an unsatisfactory response to medical management of cardiomyopathy may benefit from cardiac transplantation. Daily aspirin to reduce the risk of strokes has been described. Regular use of granulocyte colony stimulating factor (G-CSF) can help limit recurrent infections in patients with neutropenia.

#### OPA3-Related 3-Methylglutaconic Aciduria (Costeff Syndrome)

Clinical manifestations in patients with Costeff syndrome include early-onset optic nerve atrophy and later development of choreoathetoid movements, spasticity, ataxia, dysarthria, and cognitive impairment. Patients excrete moderate amounts of 3-methylglutaconic and 3-methylglutaric acids. Activity of the enzyme 3-methylglutaconyl-CoA hydratase is normal. The condition is inherited in an autosomal recessive manner. Pathogenic variants in *OPA3* are thought to cause electron transport chain dysfunction. Treatment is supportive.

#### Disorders Formerly Described as 3-Methylglutaconic Aciduria Type IV

3-Methylglutaconic aciduria type IV represents a group of disorders with a diverse genetic etiology. Two disorders in this group have been linked to specific molecular etiology, whereas other conditions are still awaiting the discovery of underlying molecular defects.

**MEGDEL syndrome** (3-methylglutaconic aciduria with deafness, encephalopathy, and Leigh-like) is an autosomal recessive disorder caused by pathogenic variants in *SERAC1*. Affected patients experience optic nerve atrophy, progressive deafness, dystonia, feeding difficulty with dysphagia, spasticity, and basal ganglia injury similar to patients

**Table 105.2** Primary and Select Secondary 3-Methylglutaconic Acidurias

GROUP	DISORDER	GENE (CHROMOSOME)	PREVIOUS CLASSIFICATION	DISEASE MECHANISM	CLINICAL DESCRIPTION
Primary 3-methylglutaconic aciduria	3-Methylglutaconyl-CoA hydratase deficiency	AUH (9q22.31)	Type I	Enzyme deficiency in the leucine degradation pathway	Depending on age, variable presentation is seen ranging from younger asymptomatic patients to older patients with progressive leukoencephalopathy
Secondary 3-methylglutaconic acidurias	Barth syndrome	TAZ (Xq28)	Type II	Defective phospholipid remodeling	X-linked inheritance, cardiomyopathy, endocardial fibroelastosis, proximal myopathy, failure to thrive, neutropenia, dysmorphic findings
	Costeff syndrome	OPA3 (19q13.32)	Type III	Mitochondrial membrane dysfunction	Progressive optic nerve atrophy, chorea, spastic paraparesis, cognitive impairment
	MEGDEL syndrome	SERAC1 (6q25.3)	Type IV	Defective phospholipid remodeling	Progressive deafness, dystonia, spasticity, basal ganglia changes
	TMEM70-related disorder	TMEM70 (8q21.11)	Type IV	Mitochondrial membrane dysfunction	Developmental delay, failure to thrive, metabolic decompensations, microcephaly, cardiomyopathy, dysmorphic findings
	3-Methylglutaconic aciduria, not otherwise specified	Unknown	Type IV	Unknown	Variable presentation
DCMA syndrome	DNAJC19 (3q26.33)	Type V	Mitochondrial membrane dysfunction	Cardiomyopathy, ataxia, optic nerve atrophy, failure to thrive	

DCMA, Dilated cardiomyopathy ataxia syndrome; MEGDEL, 3-methylglutaconic aciduria deafness, encephalopathy, Leigh-like syndrome.

with Leigh syndrome. Laboratory evaluation reveals elevated urinary 3-methylglutaconic, high plasma lactate and alanine. Treatment is symptomatic.

**TMEM70-related disorder** is also inherited in an autosomal recessive manner. Biallelic pathogenic variants in *TMEM70* result in a mitochondrial complex V deficiency, although the exact molecular mechanism of disease is unknown. Clinical manifestations include developmental delay, developmental regression, Reye syndrome–like episodes, intellectual disability, failure to thrive, microcephaly, cardiomyopathy, and dysmorphic findings. Patients are prone to metabolic decompensation, characterized by hyperammonemia (up to 900  $\mu\text{mol/L}$ ) and lactic acidosis, which are more common in the first year of life. **Acute hyperammonemic** episodes are treated with intravenous glucose, lipid emulsion, ammonia-scavenging drugs, and occasionally hemodialysis. Long-term therapy that has been described includes L-carnitine, coenzyme Q<sub>10</sub>, and bicarbonate substitution (e.g., citric acid/sodium citrate). Patients require interval echocardiographic and electrocardiographic (ECG) monitoring to enable early diagnosis and management of cardiomyopathy.

### DCMA Syndrome (DNAJC19-Related Syndrome, 3-Methylglutaconic Aciduria Type V)

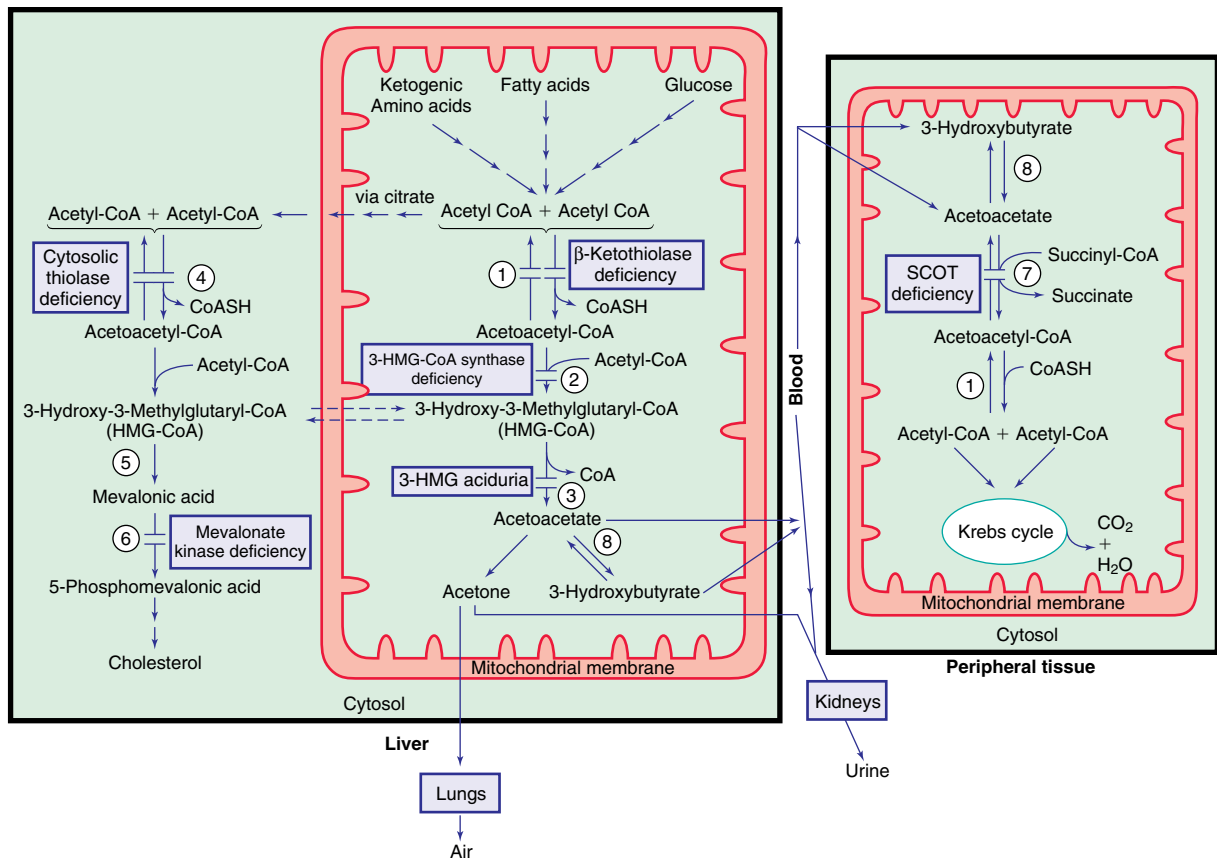
DCMA syndrome (*dilated cardiomyopathy with ataxia*) is an autosomal recessive disorder identified in patients of Canadian Dariusleut Hutterite ancestry in the Great Plains of North America. As the disorder's abbreviated name suggests, affected individuals present with dilated cardiomyopathy, long QTc interval, and CNS involvement. Neurologic symptoms include intellectual disability, cerebellar involvement, and optic atrophy. Growth is affected in all patients. Intrauterine growth restriction is seen in up to 50% of patients. Cryptorchidism and hypospadias are frequent

findings in affected boys. Urine organic acid assay reveals increased 3-methylglutaconic acid and 3-methylglutaric acid. Biallelic pathogenic variants in *DNAJC19* are the underlying cause of DCMA syndrome. Treatment is symptomatic. Interval echocardiography and ECG can prospectively identify patients requiring treatment for cardiomyopathy and long QTc interval.

### $\beta$ -KETOTHIOLASE (3-OXOTHIOLASE) DEFICIENCY (MITOCHONDRIAL ACETOACETYL-COA THIOLASE [T<sub>2</sub>] DEFICIENCY)

The bidirectional reaction catalyzed by mitochondrial  $\beta$ -ketothiolase is involved in the final steps of both isoleucine catabolism and ketolysis. In the isoleucine catabolic pathway, the enzyme cleaves 2-methylacetoacetyl-CoA into propionyl-CoA and acetyl-CoA (see Fig. 105.4). In the fatty acid oxidation pathway, the enzyme generates two moles of acetyl-CoA from one mole of acetoacetyl-CoA (Fig. 105.7). The same enzyme can synthesize 2-methylacetoacetate-CoA and acetoacetyl-CoA in the reverse direction. The hallmark of this disorder is **ketoacidosis**, often triggered by infections, prolonged fasting, and large protein load. The mechanism of ketosis in this condition is incompletely understood, because in this enzyme deficiency one would expect impaired ketone formation (see Fig. 105.7). It is postulated that excess acetoacetyl-CoA produced from other sources can be used as a substrate for 3-hydroxy-3-methylglutaryl-CoA synthesis in the liver.

**Clinical manifestations** are quite variable, ranging from mild cases showing normal development to severe episodes of acidosis starting in the first year of life causing severe cognitive impairment. Unless identified on the newborn screening, affected children present with intermittent episodes of unexplained ketoacidosis. These episodes usually occur after an intercurrent infection and respond promptly to



**Fig. 105.7** Formation (liver) and metabolism (peripheral tissues) of ketone bodies and cholesterol synthesis. Enzymes: (1) Mitochondrial acetoacetyl CoA thiolase, (2) HMG-CoA synthase, (3) HMG-CoA lyase, (4) cytosolic acetoacetyl-CoA thiolase, (5) HMG-CoA reductase, (6) mevalonate kinase, (7) succinyl CoA:3-ketoacid CoA transferase (SCOT), (8) 3-hydroxybutyrate dehydrogenase.

intravenous fluids and bicarbonate therapy. Mild to moderate hyperammonemia may also be present during attacks. Both hypoglycemia and hyperglycemia have been reported in isolated cases. The child may be completely asymptomatic between episodes and may tolerate a normal protein diet. Cognitive development is normal in most children. The episodes may be misdiagnosed as salicylate poisoning because of the similarity of the clinical findings and the interference of elevated blood levels of acetoacetate with the colorimetric assay for salicylate.

**Laboratory findings** during the acute attack include ketoacidosis and hyperammonemia. Findings of ketones in the urine and hyperglycemia may be interpreted as diabetic ketoacidosis, and a high index of suspicion is needed to suspect this metabolic disorder. Urine organic acid assay can provide clues leading to a correct diagnosis. Urine contains large amounts of 2-methylacetoacetate and its decarboxylated products butanone, 2-methyl-3-hydroxybutyrate, and tiglylglycine. Lower concentrations of urinary metabolites can be seen when patients are stable. Mild hyperglycinemia may also be present. The plasma acylcarnitine profile shows elevations of C5:1 and C5-OH carnitines, although these metabolites can normalize between catabolic episodes. Absent or minimal elevations of C5:1 and C5-OH carnitines can result in false-negative results on the newborn screening of affected infants who were clinically well at the time of blood collection. The clinical and biochemical findings should be differentiated from those seen with propionic and methylmalonic acidemias (see later).

**Treatment** of acute episodes includes hydration. Recalcitrant metabolic acidosis can be severe enough to require infusion of bicarbonate. A 10% glucose solution with the appropriate electrolytes is used to suppress protein catabolism, lipolysis, and ketogenesis. Restriction of protein intake to age-appropriate physiologic requirements is recommended for long-term therapy. Oral L-carnitine (50-100 mg/kg/day) is also recommended to prevent possible secondary carnitine deficiency. The long-term prognosis for achieving a normal quality of life seems

very favorable. Successful pregnancy with a normal outcome has been reported.

$\beta$ -Ketothiolase deficiency is inherited in an autosomal recessive manner and may be more prevalent than appreciated. **Diagnosis** may be confirmed by molecular analysis of the *ACAT1* gene or using an enzyme assay of leukocytes or cultured fibroblasts.

### CYTOSOLIC ACETOACETYL-COA THIOLEASE DEFICIENCY

This enzyme catalyzes the cytosolic production of acetoacetyl-CoA from two moles of acetyl-CoA (see Fig. 105.7). Cytosolic acetoacetyl-CoA is the precursor of hepatic cholesterol synthesis. Cytosolic acetoacetyl-CoA thiolase (encoded by *ACAT2*) should be differentiated from the mitochondrial thiolase (see earlier and Fig. 105.4). Clinical manifestations in patients with this very rare enzyme deficiency have been incompletely characterized. Patients may present with severe progressive developmental delay, hypotonia, and choreoathetoid movements in the first few months of life. Laboratory findings are nonspecific; elevated levels of lactate, pyruvate, acetoacetate, and 3-hydroxybutyrate may be found in blood and urine. One patient had normal levels of acetoacetate and 3-hydroxybutyrate. Diagnosis can be aided by demonstrating a deficiency in cytosolic thiolase activity in liver biopsy or in cultured fibroblasts or by DNA analysis of *ACAT2*. No effective treatment has been described, although a low-fat diet helped to diminish ketosis in one patient.

### MITOCHONDRIAL 3-HYDROXY-3-METHYLGLUTARYL-COA SYNTHASE DEFICIENCY

3-Hydroxy-3-methylglutaryl (HMG)-CoA synthase (mitochondrial or type 2) catalyzes synthesis of 3-HMG-CoA from acetoacetyl-CoA and acetyl-CoA in the mitochondria. This is a critical step in ketone body synthesis in the liver (see Fig. 105.7). Only a few patients with



deficiency of this enzyme have been reported. The principal clinical syndrome is *hypoketotic hypoglycemia* triggered by physiologic stress, such as infections or fasting. Age at presentation has ranged from infancy to 6 years. Children tend to be asymptomatic before these episodes and with appropriate management can remain stable after the recovery (except for mild hepatomegaly with fatty infiltration). Future episodes can be prevented by avoiding prolonged fasting during ensuing intercurrent illnesses. Hepatomegaly is the most consistent physical finding in these patients. **Laboratory findings** include hypoglycemia, acidosis with mild or no ketosis, elevated levels in liver function tests, and massive dicarboxylic aciduria. The clinical and laboratory findings may be confused with fatty acid metabolism defects (see Chapter 104). In contrast to the latter, in patients with HMG-CoA synthase deficiency, the blood concentrations of acylcarnitine conjugates are negative for acylcarnitine findings characteristic of fatty acid oxidation disorders. Treatment of the secondary carnitine deficiency with L-carnitine supplementation can result in elevated plasma acetyl-carnitine (C2-carnitine), likely reflecting intracellular accumulation of acetyl-CoA.

**Treatment** consists of provision of adequate calories and avoidance of prolonged periods of fasting. No dietary protein restriction was needed.

The condition is inherited in an autosomal recessive manner and is caused by biallelic pathogenic variants in *HMGCS2*. The condition should be considered in any child with fasting hypoketotic hypoglycemia and may be more common than appreciated.

### 3-HYDROXY-3-METHYLGLUTARYL-COA LYASE DEFICIENCY (3-HYDROXY-3-METHYLGLUTARIC ACIDURIA)

3-HMG-CoA lyase (encoded by *HMGCL*) catalyzes the cleavage of 3-HMG-CoA to acetoacetate, a rate-limiting enzyme for ketogenesis (see Fig. 105.4 and Fig. 105.7). The deficiency of this enzyme is a rare disorder seen with increased frequency in Saudi Arabia, the Iberian Peninsula, and in Brazil in patients of Portuguese ancestry. Clinically, approximately 30% develop symptoms in the first few days of life, and >60% of patients become symptomatic between 3 and 11 months of age. Infrequently, patients may remain asymptomatic until adolescence. With the addition of 3-HMG-CoA lyase deficiency to the newborn screening using C5-OH-carnitine, many infants are identified presymptomatically in the newborn period. Similar to 3-HMG-CoA synthase deficiency, patients affected by 3-HMG-CoA lyase deficiency may present with acute hypoketotic hypoglycemia. Episodes of vomiting, severe hypoglycemia, hypotonia, acidosis with mild or no ketosis, and dehydration may rapidly lead to lethargy, ataxia, and coma. These episodes often occur during a catabolic state such as prolonged fasting or an intercurrent infection. Hepatomegaly is common. These manifestations may be mistaken for Reye syndrome or fatty acid oxidation defects such as medium-chain acyl-CoA dehydrogenase deficiency. Long-term complications can include dilated cardiomyopathy, hepatic steatosis, and pancreatitis. Development can be normal, but intellectual disability and seizures with abnormalities in the white matter seen on brain MRI have been observed in patients after prolonged episodes of hypoglycemia.

**Laboratory findings** include hypoglycemia, moderate to severe hyperammonemia, and acidosis. There is mild or no ketosis (see Fig. 105.7). Urinary excretion of 3-hydroxy-3-methylglutaric acid and other proximal intermediate metabolites of leucine catabolism (3-methylglutaric acid, 3-methylglutaconic acid, and 3-hydroxyisovaleric acid) is markedly increased, causing the urine to smell like “cat’s urine.” Glutaric and dicarboxylic acids may also be increased in urine during acute attacks. Secondary carnitine deficiency is common. The condition is inherited in an autosomal recessive manner. 3-HMG-CoA lyase is encoded by the gene *HMGCL*. **Diagnosis** may be confirmed by molecular analysis of *HMGCL* or by enzyme assay in cultured fibroblasts, leukocytes, or liver specimens. Prenatal diagnosis is possible by molecular DNA analysis if the familial pathogenic variants are known or by enzymatic assay of the cultured amniocytes or a chorionic villi biopsy.

**Treatment** of acute episodes includes hydration, infusion of glucose to control hypoglycemia, provision of adequate calories, and administration of bicarbonate to correct acidosis. Hyperammonemia should be treated promptly (see Chapter 105.12). Dialysis may be required in patients with severe recalcitrant hyperammonemia. Restriction of protein and fat intake can be considered for long-term management. Oral administration of L-carnitine (50–100 mg/kg/day) prevents secondary carnitine deficiency. Prolonged fasting should be avoided.

### SUCCINYL-COA:3-OXOACID-COA TRANSFERASE DEFICIENCY

Succinyl-CoA:3-oxoacid-CoA transferase (SCOT) deficiency and  $\beta$ -ketothiolase deficiency collectively are referred to as **ketone utilization disorders**. SCOT participates in the conversion of ketone bodies (acetoacetate and 3-hydroxybutyrate) generated in liver mitochondria into *acetoacetyl-CoA in the nonhepatic tissues* (see Fig. 105.7). A deficiency of this enzyme results in the accumulation of ketone bodies, ketoacidosis, increased use of glucose, and hypoglycemia. During fasting, patients tend to have a proportional elevation of plasma free fatty acids. The condition may be more common than recognized because many cases tend to be mild and remain undiagnosed. SCOT deficiency can be distinguished from  $\beta$ -ketothiolase deficiency by the absence of 2-methylacetoacetate, 2-methyl-3-hydroxybutyrate, and tiglylglycine, characteristic of the latter disorder. Plasma acylcarnitine profile tends to show no specific abnormalities.

A common clinical presentation is an acute episode of severe ketoacidosis in an infant who had been growing and developing normally. About half the patients become symptomatic in the first weeks of life, and practically all become symptomatic before 2 years of age. The acute episode is often precipitated by a catabolic state triggered by an infection or prolonged fasting. Without treatment, the ketoacidotic episode can result in death. A chronic subclinical ketosis may persist between the attacks. Development is usually normal, although severe and recurrent episodes of ketoacidosis and hypoglycemia can predispose patients to neurocognitive impairment.

**Laboratory findings** during the acute episode are nonspecific and include metabolic acidosis and ketonuria with high levels of acetoacetate and 3-hydroxybutyrate in blood and urine. No other organic acids are found in the blood or in the urine. Blood glucose levels are usually normal, but hypoglycemia has been reported in some affected newborn infants with severe ketoacidosis. Plasma amino acids and the plasma acylcarnitine profile are usually normal. Severe SCOT deficiency can be accompanied by ketosis even when patients are clinically stable. This condition should be considered in any infant with unexplained bouts of ketoacidosis. SCOT deficiency is an autosomal recessive disorder. **Diagnosis** can be established by molecular analysis of *OXCT1* or by demonstrating a deficiency of enzyme activity in cultured fibroblasts.

**Treatment** of acute episodes consists of rehydration with solutions containing dextrose, correction of acidosis, and the provision of a diet adequate in calories. Long-term treatment should include a high-carbohydrate diet and avoidance of prolonged fasting and administration of dextrose before anticipated or during established catabolic states.

### MEVALONATE KINASE DEFICIENCY

Mevalonic acid, an intermediate metabolite of cholesterol synthesis, is converted to 5-phosphomevalonic acid by the action of the enzyme mevalonate kinase (MVK) (see Fig. 105.7). MVK deficiency presents with a range of symptoms. Mevalonic aciduria occupies the more severe end of the spectrum, whereas hyperimmunoglobulinemia D syndrome represents the milder form of the underlying enzyme defect. Both disorders are accompanied by recurrent fever, gastrointestinal symptoms, mucocutaneous manifestations, and lymphadenopathy. Patients with mevalonic aciduria also show growth retardation and nervous system involvement.

#### Mevalonic Aciduria

Clinical manifestations include failure to thrive, growth restriction, intellectual disability, hypotonia, ataxia, myopathy, hepatosplenomegaly,

cataracts, and facial dysmorphisms (dolichocephaly, frontal bossing, low-set ears, downward slanting of eyes, long eyelashes). Most patients experience recurrent crises characterized by fever, vomiting, diarrhea, hepatosplenomegaly, arthralgia, lymphadenopathy, edema, and morbilliform rash. These episodes typically last 2-7 days and recur up to 25 times a year. Death may occur during these crises.

**Laboratory findings** include marked elevation of mevalonic acid in urine; the concentration of urinary mevalonic acid ranges between 500 and 56,000 mmol/mol of creatinine (normal: <0.3 mmol/mol of creatinine). Plasma levels of mevalonic acid are also greatly increased (as high as 540  $\mu\text{mol/L}$ ; normal: <0.04  $\mu\text{mol/L}$ ). Mevalonic acid levels tend to correlate with the severity of the condition and increase during crises. Serum cholesterol concentration is normal or mildly decreased. Serum concentration of creatine kinase can be greatly increased. Inflammatory markers are elevated during the crises. Brain MRI may reveal progressive atrophy of the cerebellum.

**Diagnosis** may be confirmed by molecular analysis of *MVK* or by assaying the *MVK* activity in lymphocytes or cultured fibroblasts. The enzyme activity in this form of the condition is below the detection level. **Treatment** with high doses of prednisone helps in the acute crises, but because of side effects, it is not routinely used long term. TNF- $\alpha$  inhibitors and interleukin-1 receptor antagonists have shown to be effective in bringing significant clinical improvement, especially in patients with chronic inflammation and frequent attacks. The condition is inherited in an autosomal recessive manner. **Prenatal diagnosis** is possible by identifying known familial pathogenic variants in *MVK*, by measurement of mevalonic acid in the amniotic fluid, or by assaying the enzyme activity in cultured amniocytes or chorionic villi samples.

### Hyperimmunoglobulinemia D Syndrome (Hyperimmunoglobulinemia D and Periodic Fever Syndrome)

Some pathogenic variants of the *MVK* gene cause milder enzyme deficiency and produce the clinical picture of **periodic fever with hyperimmunoglobulinemia D**. These patients have periodic bouts of fever associated with abdominal pain, vomiting, diarrhea, arthralgia, arthritis, hepatosplenomegaly, lymphadenopathy, and morbilliform rash (even petechiae and purpura), which usually start before 1 year of age. The attacks can be triggered by vaccination, minor trauma, or stress and can occur every 1-2 months, lasting 2-7 days. Patients are free of symptoms between acute attacks. The diagnostic laboratory finding is elevation of serum immunoglobulin D (IgD). IgA is also elevated in 80% of patients. During acute attacks, leukocytosis, increased C-reactive protein, and mild mevalonic aciduria may be present. High concentrations of serum IgD help differentiate this condition from familial Mediterranean fever. See Chapter 204 for treatment recommendations.

### PROPIONIC ACIDEMIA (PROPIONYL-COA CARBOXYLASE DEFICIENCY)

Propionic acid is an intermediate metabolite of isoleucine, valine, threonine, methionine, odd-chain fatty acids, and side chains of cholesterol. Normally, propionic acid in the form of propionyl-CoA undergoes carboxylation to D-methylmalonyl-CoA, catalyzed by the mitochondrial enzyme propionyl-CoA carboxylase. This enzyme requires biotin as a cofactor; thus the disorders of biotin metabolism, among other findings, can also result in elevation of propionic acid metabolites (see Fig. 105.4). Propionyl-CoA carboxylase is a multimeric enzyme composed of two nonidentical subunits,  $\alpha$  and  $\beta$ , encoded by two genes, *PCCA* and *PCCB*, respectively. Biallelic pathogenic variants in propionyl-CoA carboxylase result in an autosomal recessive disorder called *propionic acidemia*.

**Clinical findings** of propionic acidemia are not specific to this disorder only. In the severe form, patients develop symptoms in the first few days of life. Poor feeding, vomiting, hypotonia, lethargy, dehydration, a sepsis-like picture, and clinical signs of severe ketoacidosis progress rapidly to coma and death. Seizures occur in approximately 30% of affected infants. If an infant survives the first attack, similar episodes of metabolic decompensation may occur during an intercurrent infection, trauma, surgery, prolonged fasting, severe constipation, or after ingestion of a high-protein diet. Moderate to severe intellectual

disability and neurologic manifestations reflective of extrapyramidal (dystonia, choreoathetosis, tremor) and pyramidal (paraplegia) dysfunction are common sequelae in survivors. Neuroimaging shows that these abnormalities, which often occur after an episode of metabolic decompensation, are the result of damage to the basal ganglia, especially to the globus pallidus. This phenomenon has been referred to as **metabolic stroke**. This is the main cause of neurologic sequelae seen in the surviving affected children. Additional long-term complications include failure to thrive, optic nerve atrophy, pancreatitis, cardiomyopathy, and osteopenia.

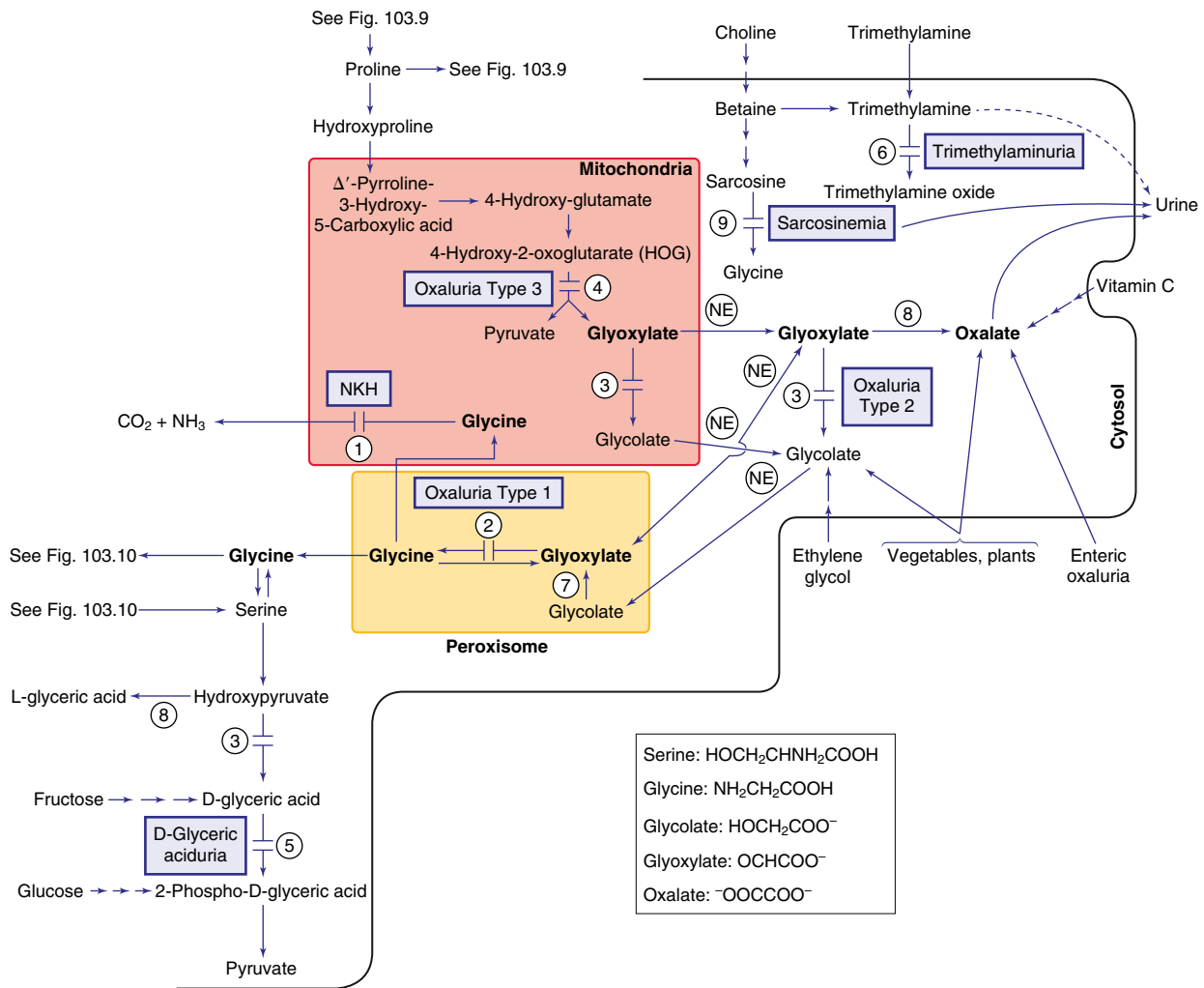
In the *milder* form, episodes of metabolic decompensation are less frequent, but these children are still at risk of developing intellectual disability, seizures, long QTc interval, and severe cardiomyopathy. Universal newborn screening can identify propionic acidemia by detecting elevated propionylcarnitine (C3-carnitine) with an abnormal C3/C2 ratio in dried blood spots. However, in patients with the mild form of propionic acidemia, propionylcarnitine may remain below the cutoff value set by the screening laboratory, resulting in a false-negative result. Therefore physicians should maintain a high index of suspicion for this disorder and follow up with a biochemical evaluation of infants and children presenting with unexplained ketosis or metabolic acidosis.

**Laboratory findings** during the acute attack include various degrees of metabolic acidosis, often with a large anion gap, ketosis, ketonuria, hypoglycemia, anemia, neutropenia, and thrombocytopenia. Moderate to severe hyperammonemia is common; plasma ammonia concentrations usually correlate with the severity of the disease. In contrast to other causes of hyperammonemia, plasma concentration of glutamine tends to be within normal limits or decreased. The presence of severe metabolic acidosis and normal to reduced plasma glutamine help differentiate propionic acidemia from hyperammonemia caused by urea cycle defects. Measurement of plasma ammonia is especially helpful in planning therapeutic strategies during episodes of exacerbation in a patient whose diagnosis has been established. Mechanisms of hyperammonemia in propionic acidemia are not well understood but are likely related to the perturbed biochemical and pH environment of the mitochondrial matrix, where the proximal part of the urea cycle resides.

**Glycine** concentration can be elevated in all body fluids (blood, urine, CSF) and possibly is the result of the inhibited glycine cleavage system in the hepatic mitochondria (Fig. 105.8). Glycine elevation has also been observed in patients with methylmalonic acidemia. These disorders were collectively referred to as *ketotic hyperglycinemia* in the past before the specific enzyme deficiencies were elucidated. Mild to moderate increase in blood lactate and lysine may also be present in these patients. Concentrations of propionylcarnitine, 3-hydroxypropionic acid, and methylcitric acid (presumably formed through condensation of propionyl-CoA with oxaloacetic acid) are greatly elevated in the plasma and urine of infants with propionic acidemia. Propionylglycine and other intermediate metabolites of BCAA catabolism, such as tiglylglycine, can also be found in urine. Moderate elevations in blood levels of glycine and previously mentioned organic acids can persist between the acute attacks. Brain imaging may reveal cerebral atrophy, delayed myelination, and abnormalities in the globus pallidus and other parts of the basal ganglia.

The **diagnosis** of propionic acidemia should be differentiated from multiple carboxylase deficiencies (see earlier and Fig. 105.6). In addition to propionic acid metabolites, infants with the latter condition excrete large amounts of lactic acid, 3-methylcrotonylglycine, and 3-hydroxyisovaleric acid. The presence of hyperammonemia may suggest a genetic defect in the urea cycle enzymes. Infants with defects in the urea cycle are usually *not* acidotic (see Fig. 105.1) and have elevated levels of plasma glutamine. The definitive diagnosis of propionic acidemia can be established through molecular analysis of *PCCA* and *PCCB* or by measuring the enzyme activity in leukocytes or cultured fibroblasts.

**Treatment** of acute episodes of metabolic decompensation includes hydration with solutions containing glucose, correction of acidosis, and amelioration of the catabolic state by provision of adequate calories through enteral or parenteral hyperalimentation. A brief restriction of



**Fig. 105.8** Pathways in the metabolism of glycine and glyoxylic acid. Enzymes: (1) Glycine cleavage system, (2) alanine:glyoxylate aminotransferase, (3) glyoxylic reductase/hydroxypyruvate reductase (GR/HRP), (4) hydroxyoxoglutarate aldolase one (HOGA1), (5) glycerate kinase, (6) trimethylamine oxidase, (7) glycolate oxidase (D-amino acid oxidase), (8) lactate dehydrogenase, (9) sarcosine dehydrogenase. NE, Nonenzymatic; NKH, nonketotic hyperglycinemia.

protein intake, no more than 24 hours, is often necessary. Depending on the clinical status, gradual reintroduction of protein is recommended. If enteral feedings cannot be tolerated after 48 hours of protein restriction, parenteral nutrition should be instituted to achieve the age-specific recommended protein intake. Patients unable to tolerate the recommended dietary allowance of protein can receive specialized medical foods free of isoleucine, valine, threonine, and methionine. The composition and amount of protein typically vary among patients. The metabolic diet composition can be adjusted by monitoring growth and plasma amino acids drawn 3-4 hours after the typical feeding. Some patients may benefit from the suppression of propionogenic gut microflora. This can be achieved by oral antibiotics such as oral neomycin or metronidazole. Prolonged use of metronidazole should be avoided because it has been associated with reversible peripheral neuropathy and increased QTc interval. The risk of QTc prolongation can be problematic in propionic acidemia patients, who are at risk for cardiomyopathy and long QT interval. Baseline and interval ECGs are recommended before and after initiation of metronidazole therapy. Patients may benefit from management of constipation.

Patients with propionic acidemia often develop *secondary carnitine deficiency*, presumably as a result of the urinary loss of propionylcarnitine. Administration of L-carnitine (50-100 mg/kg/day orally or intravenously) helps restore free carnitine in blood. In patients with concomitant hyperammonemia, measures to reduce blood ammonia should be employed (see Chapter 105.12). Very ill patients with severe

acidosis and hyperammonemia require hemodialysis to remove ammonia and other toxic compounds rapidly and efficiently. Carglumic acid and nitrogen scavengers (sodium benzoate, sodium phenylacetate, sodium phenylbutyrate) can aid in the treatment of acute hyperammonemia. Although no infant with propionic acidemia has been found to be responsive to biotin, this compound should be administered (10 mg/day orally) to all infants during the first attack and until the diagnosis is established and multiple carboxylase deficiency ruled out.

Long-term treatment consists of a low-protein diet meeting age-specific recommended dietary allowance and administration of L-carnitine (50-100 mg/kg/day orally). Some centers manage mild cases of propionic acidemia without medical foods, opting for only restricting the protein intake to the recommended dietary allowance. Patients unable to tolerate the recommended dietary intake of protein may require medical foods free of propionate precursors (isoleucine, valine, methionine, and threonine). Excessive use of medical foods while restricting natural-source protein may cause a deficiency of the essential amino acids, especially isoleucine and valine, which may cause a condition resembling **acrodermatitis enteropathica** (see Chapter 712). Over-restriction of methionine, especially in the first years of life, may contribute to the reduced brain growth and microcephaly. To avoid this problem, natural proteins should comprise most of the dietary protein. Some patients may require bicarbonate substitution (e.g., citric acid/sodium citrate) to correct chronic acidosis. The concentration of plasma ammonia usually normalizes between attacks, although



some patients may experience mild chronic hyperammonemia. Acute attacks triggered by infections, fasting, trauma, stress, constipation, or dietary indiscretions should be treated promptly and aggressively. Close monitoring of plasma ammonia, plasma amino acids obtained 3-4 hours after the last typical meal (especially isoleucine, leucine, valine, threonine, and methionine), and growth parameters is necessary to ensure the diet is appropriate. Orthotopic liver transplantation is used in clinically unstable patients experiencing recurrent hyperammonemia, frequent metabolic decompensations, and poor growth. Liver transplantation does not cure propionic acidemia, and lifelong dietary management and proactive management during periods of significant metabolic stress are recommended.

The long-term **prognosis** is poor. Death may occur during an acute attack. Normal psychomotor development is possible in a mild form identified through newborn screening. Children identified clinically may manifest some degree of permanent neurodevelopmental deficit, such as tremor, dystonia, chorea, and spasticity despite adequate therapy. These neurologic findings may be the sequelae of a metabolic stroke occurring during an acute decompensation. A long QTc interval and cardiomyopathy with potential progression to heart failure, fatal arrhythmias, and death may develop in older affected children despite adequate metabolic control. Acute pancreatitis is a common and severe complication in propionic acidemia. Osteoporosis can predispose to fractures, which can occur with minimal mechanical stress.

**Prenatal diagnosis** can be achieved by identification of known familial pathogenic variants in *PCCA* or *PCCB* or by measuring the enzyme activity in cultured amniotic cells or in samples of uncultured chorionic villi.

Propionic acidemia is inherited in an autosomal recessive manner. It has a worldwide prevalence of 1 in 105,000 to 1 in 250,000 live births. It is more prevalent in Greenlandic Inuits (1 in 1,000) and in some Saudi Arabian tribes (1 in 2,000 to 1 in 5,000 live births). Biallelic pathogenic variants in either gene result in similar clinical and biochemical manifestations. Although pregnancies with normal outcomes have been reported, the perinatal period poses special risks to females with propionic acidemia because of hyperemesis gravidarum, worsening cardiomyopathy, changing protein requirements, and risk of metabolic decompensation.

### ISOLATED METHYLMALONIC ACIDEMIAS

Methylmalonic acidemias are a group of metabolic disorders of diverse etiology characterized by impaired conversion of methylmalonyl-CoA into succinyl-CoA. Propionyl-CoA derived from catabolism of isoleucine, valine, threonine, methionine, side chain of cholesterol, and odd-chain fatty acids is catalyzed by propionyl-CoA carboxylase to form D-methylmalonyl-CoA. Methylmalonyl-CoA epimerase then converts D-methylmalonyl-CoA to its enantiomer L-methylmalonyl-CoA. **Methylmalonyl-CoA epimerase deficiency** is a rare disorder associated with persistent elevations of propionate-related metabolites and methylmalonic acid. It may present with metabolic acidosis, ketosis, but patients appear more clinically stable than those with severe forms of methylmalonic acidemia.

In the next biochemical step, L-methylmalonyl-CoA is converted to succinyl-CoA by methylmalonyl-CoA mutase (see Fig. 105.4). The latter enzyme requires 5-deoxyadenosylcobalamin, a metabolite of vitamin B<sub>12</sub>, as a coenzyme. Deficiency of either the mutase or its coenzyme results in the accumulation of methylmalonic acid and its precursors in body fluids. Two biochemical forms of methylmalonyl-CoA mutase deficiencies have been identified. These are designated *mut*<sup>0</sup>, referring to no detectable enzyme activity, and *mut*<sup>-</sup>, indicating residual, although insufficient, mutase activity. Patients with methylmalonic acidemia due to deficiency of the mutase apoenzyme (*mut*<sup>0</sup>) are not responsive to hydroxocobalamin therapy.

In the remaining methylmalonic acidemia patients, the defect resides in the formation of adenosylcobalamin from dietary vitamin B<sub>12</sub>. The absorption of dietary vitamin B<sub>12</sub> in the terminal ileum requires *intrinsic factor*, a glycoprotein secreted by the gastric parietal cells. It is transported in the blood by haptocorrin and transcobalamin II. The transcobalamin II-cobalamin complex (TCII-Cbl) is recognized by

a specific receptor on the cell membrane (a transcobalamin receptor encoded by *CD320*) and enters the cell by endocytosis. In the lysosome, TCII-Cbl is hydrolyzed, and, with the participation of *LMBRD1* (*cblF*) and *ABCD4* (*cblJ*), free cobalamin is released into the cytosol (see Fig. 105.4). Biallelic pathogenic variants in either *LMBRD1* or *ABCD4* genes result in impaired release of cobalamin from lysosomes. In the cytoplasm, cobalamin binds to the MMACHC protein (see *cblC* later), which removes a moiety attached to cobalt in the cobalamin molecule and reduces the cobalt from oxidation state +3 (cob[III]alamin) to +2 (cob[II]alamin). It then enters the mitochondria, where it is catalyzed by *MMAB* (*cblB*) and *MMAA* (*cblA*) to form adenosylcobalamin, a coenzyme for methylmalonyl-CoA mutase. The other arm of the pathway directs cytosolic cobalamin toward methionine synthase reductase (*cblE*), which forms methylcobalamin, acting as a coenzyme for methionine synthase (*cblG*, see Fig. 105.3). The *MMADHC* protein (see *cblD*) appears to play a role in determining whether cobalamin enters the mitochondria or remains in the cytoplasm.

The uptake of TCII-Cbl by cells is impaired in individuals with pathogenic variants affecting the transcobalamin receptor (*CD320*), which is located on the cell surface. Individuals homozygous for pathogenic variants in the *CD320* gene encoding the transcobalamin receptor may have mild elevations of methylmalonic acid in the blood and urine. These patients can be identified by the newborn screen based on the elevated propionylcarnitine (C3-carnitine). In **transcobalamin receptor deficiency**, methylmalonic acid levels and plasma propionylcarnitine tend to normalize in the first year of life. It is not clear whether a long-term clinical phenotype is associated with this defect.

Nine different defects in the intracellular metabolism of cobalamin have been identified. These are designated *cblA* through *cblG*, *cblJ*, and *cblX*, where *cbl* stands for a defect in any step of cobalamin metabolism. The *cblA*, *cblB*, and *cblD*-MMA defects cause methylmalonic acidemia *alone*. In patients with *cblC*, *cblD*-combined methylmalonic acidemia and homocystinuria, *cblF*, *cblJ*, and *cblX* defects, synthesis of both adenosylcobalamin and methylcobalamin is impaired, resulting in *combined* methylmalonic acidemia and homocystinuria. The *cblD*-homocystinuria, *cblE*, and *cblG* defects affect only the synthesis of methylcobalamin, resulting in homocystinuria without methylmalonic aciduria (see Chapter 105.3).

Biochemical manifestations of patients with isolated methylmalonic acidemia caused by *mut*<sup>0</sup>, *mut*<sup>-</sup>, *cblA*, *cblB*, and *cblD*-MMA overlap. The wide variations in the severity of the clinical course range from very sick newborn infants to apparently asymptomatic adults. In **severe** forms, lethargy, feeding problems, vomiting, a sepsis-like picture, tachypnea (from metabolic ketoacidosis), and hypotonia may develop in the first few days of life and may progress to hyperammonemic encephalopathy, coma, and death if left untreated. Infants who survive the first attack may go on to develop similar acute metabolic episodes during a catabolic state such as infection or prolonged fasting or after ingestion of a high-protein diet. In certain situations, such acute events can cause a sudden injury of the basal ganglia, a metabolic stroke, resulting in a debilitating movement disorder. Between the acute attacks, the patient usually continues to exhibit hypotonia and feeding problems with failure to thrive, while other complications of the disease occur with age, including recurrent episodes of pancreatitis, bone marrow suppression, osteopenia, and optic nerve atrophy. Chronic renal failure and tubulointerstitial nephritis necessitating renal transplant have been reported in older patients. Renal complications are more severe in patients with the *mut*<sup>0</sup> and severe *cblB* forms of methylmalonic acidemia. In milder forms, patients may present later in life with hypotonia, failure to thrive, and developmental delay. Neurocognitive development of patients with mild methylmalonic acidemia may remain within the normal range.

The episodic nature of the condition and its biochemical abnormalities in some patients may be confused with those of *ethylene glycol* (*antifreeze*) ingestion. Furthermore, the peak of propionate in a blood sample from an infant with methylmalonic acidemia has been mistaken for ethylene glycol when the sample was assayed by gas chromatography without mass spectrometry.



**Laboratory findings** include ketosis, metabolic acidosis, hyperglycemia, hyperammonemia, hypoglycemia, anemia, neutropenia, thrombocytopenia, and the presence of large quantities of methylmalonic acid in body fluids (see Fig. 105.6). Metabolites of propionic acid (3-hydroxypropionate and methylcitrate) are also found in the urine. The plasma acylcarnitine profile reveals elevated propionylcarnitine (C3-carnitine) and methylmalonylcarnitine (C4DC-carnitine). Hyperammonemia in methylmalonic acidemia may be confused with a urea cycle disorder. However, patients with defects in urea cycle enzymes are typically *not* acidotic and tend to have high plasma glutamine (see Fig. 105.12). The reason for hyperammonemia is not well understood, but it is likely related to the inhibition of the proximal urea cycle in the mitochondrial matrix.

The diagnosis can be confirmed by identifying pathogenic variants in the causal gene, by measuring propionate incorporation with complementation analysis in cultured fibroblasts, and by measuring the specific activity of the mutase enzyme in biopsies or cell extracts.

**Treatment** of acute attacks is similar to propionic acidemia. Long-term treatment consists of administration of a low-protein diet limited to the recommended dietary allowance and L-carnitine (50-100 mg/kg/day orally). Patients with severe forms of methylmalonic acidemia may require protein diet modifications similar to those prescribed for patients with propionic acidemia. Patients with isolated methylmalonic acidemia caused by defects in the intracellular metabolism of cobalamin (*cbIA*, *cbID*-MMA, and some patients with *cbIB*) respond to parenteral hydroxocobalamin. Chronic bicarbonate replacement therapy is usually required to correct chronic acidosis. Carglumic acid is used to improve ureagenic function by stimulating its first step catalyzed by the carbamoyl-phosphate synthetase 1 (CPS1) and to facilitate ammonia detoxification during acute hyperammonemia. Ammonia scavengers (sodium benzoate, sodium phenylacetate, sodium phenylbutyrate) should be used cautiously. Plasma ammonia tends to normalize between attacks, and chronic treatment of hyperammonemia is rarely needed. Stressful situations that may trigger acute attacks (infection, prolonged fasting, trauma, surgeries, high-protein meals) should be treated promptly.

Inadequate oral intake secondary to poor appetite, protein over-restriction, or essential amino acid deficiencies is a common complication in the long-term management of these patients. Consequently, enteral feeding through gastrostomy is often recommended early in the course of treatment. Close monitoring of blood pH, essential amino acid levels, blood and urinary concentrations of methylmalonate, and growth parameters is required to ensure that the nutritional prescription meets the patient's metabolic demands. In addition, frequent monitoring of kidney function, vision, hearing, and bone mineral density are necessary for early recognition and management of chronic complications. Glutathione deficiency responsive to treatment with ascorbate has been described.

Liver, kidney, and combined liver-kidney transplantations have been attempted in an increasing number of affected patients. Liver and liver-kidney transplantation can alleviate, but not eliminate, the metabolic abnormalities. Furthermore, liver and liver-kidney transplants do not provide complete protection against the occurrence of metabolic stroke. Kidney transplantation alone can restore the renal function but results in only minor improvement of the clinical stability of patients.

**Prognosis** depends on the severity of symptoms and the occurrence of complications. In general, patients with complete deficiency of mutase apoenzyme (*mut<sup>0</sup>*) and severe forms of *cbIB* deficiency have the least favorable prognosis, and those with *mut<sup>-</sup>* and *cbIA* defects have a better outcome.

Methylmalonic acidemia can be identified on the universal newborn screening by measuring propionylcarnitine (C3) using tandem mass spectrometry. The prevalence of all forms of methylmalonic aciduria is estimated at 1 in 50,000 to 1 in 100,000 live births. All defects causing isolated methylmalonic acidemia are inherited in an autosomal recessive manner. Pathogenic variants in the genes for *cbIA* (*MMAA*), *cbIB* (*MMAB*), and all forms of *cbID* (*MMADHC*) have been identified in affected patients. The previously described *cbIH* group is identical to the *cbID*-MMA defect.

## COMBINED METHYLMALONIC ACIDURIA AND HOMOCYSTINURIA (*cbIC*, *epi-cbIC*, *cbID*, *cbIF*, *cbIJ*, AND *cbIX* DEFECTS)

Combined methylmalonic acidemia and homocystinuria caused by *cbIC* deficiency is the most common type of intracellular cobalamin (vitamin B<sub>12</sub>) biosynthesis defect. Deficiency of *cbIC* is as common as methylmalonyl-CoA mutase deficiency. The other disorders (*cbID*, *cbIF*, *cbIJ*, *cbIX*) are much rarer (see Figs. 105.3 and 105.4). Neurologic findings are prominent in patients with *cbIC*, *epi-cbIC*, *cbID*-combined, and *cbIX* defects. Most patients with the *cbIC* defect present in the first month of life because of failure to thrive, lethargy, poor feeding, developmental delay, nystagmus, and seizures. Hyperammonemia may be seen infrequently, whereas hyperglycemia is not present, unlike in isolated *mut*-type methylmalonic acidemia. Intrauterine growth restriction and microcephaly suggest that *cbIC* can manifest prenatally in some affected infants. Late-onset patients with sudden development of dementia and myelopathy have been reported, even with presentation in adulthood. Megaloblastic anemia is a common finding in patients with *cbIC* defect. Mild to moderate increases in concentrations of methylmalonic acid and significant elevations in total plasma homocysteine are found in blood. Unlike classic homocystinuria, in untreated *cbIC*, patients' plasma methionine is low to normal. Retinal abnormalities (e.g., bull's eye maculopathy) resulting in severe progressive vision loss are common and can be seen as early as 3 months of age, even in prospectively identified and well-treated patients. **Thrombotic microangiopathy** can present as hemolytic uremic syndrome, pulmonary hypertension, and cor pulmonale. Hydrocephalus and non-compaction cardiomyopathy have been reported as complications in patients with *cbIC* defect.

Similar to *cbIC* patients, males with *cbIX* have elevations of both total plasma homocysteine and methylmalonic acid, but they tend to have milder elevations of these metabolites. Unlike *cbIC*-deficient patients, who tend to respond to treatment, *cbIX*-deficient patients experience failure to thrive, severe developmental delay, and intractable epilepsy despite aggressive treatment.

**Clinical findings** in *cbIF* deficiency are quite variable. Patients may present with poor feeding, growth and developmental delay, and persistent stomatitis manifesting in the first months of life. Delay in diagnosis and treatment can be accompanied by hyperpigmentation of skin, developmental delay, intellectual disability, and short stature. Vitamin B<sub>12</sub> malabsorption and low plasma vitamin B<sub>12</sub> has been noted in patients with *cbIF* defect. Clinical manifestations of *cbIJ* defect show significant overlap with those of the *cbIF* deficiency. Dysmorphic features and congenital heart disease have been reported in some patients with *cbIF* and *cbIJ* defects.

Experience with **treatment** of patients with *cbIC*, *cbID*, *cbIF*, *cbIJ*, and *cbIX* defects is limited. Large doses of hydroxocobalamin (up to 0.3 mg/kg/day) in conjunction with betaine (up to 250 mg/kg/day) produce biochemical improvement with variable clinical effect. Patients with *cbIF* and *cbIJ* deficiency typically show a favorable biochemical and clinical response to smaller hydroxocobalamin doses (1 mg once weekly to 1 mg daily parenterally). Folic or folinic acid supplementation is recommended. Dietary methionine deficiency should be avoided.

The *cbIC* disorder is caused by pathogenic variants in the *MMACHC* gene. A frameshift variant (c.271dupA) is seen in up to 40% of *MMACHC* alleles and is associated with a less favorable clinical outcome. *Epi-cbIC*, with a similar phenotype, is caused by compound heterozygous variants in *MMACHC* and *PRDX1*, a neighboring gene. Pathogenic variants in *PRDX1* cause hypermethylation and silencing of the promoter/exon 1 of *MMACHC*, resulting in repressed gene expression. The *cbID* disorder is caused by pathogenic variants in the *MMADHC* gene. Pathogenic variants resulting in *cbID*-homocystinuria affect the C-terminal domain of the gene product; those resulting in *cbID*-MMA (e.g., causing only methylmalonic aciduria) affect the N-terminus. Patients with classic *cbID*, with both homocystinuria and methylmalonic acidemia, have pathogenic variants resulting in decreased protein expression. The *cbIF* disorder is caused by pathogenic variants in the *LMBRD1* gene encoding a lysosomal membrane protein. The *cbIJ* disorder is associated with pathogenic variants in the *ABCD4*

gene, encoding an adenosine triphosphate-binding cassette protein localized to the lysosomal membrane. The *cbIX* disorder is caused by pathogenic variants in the *HCFC1* gene on the X chromosome (Xq28), which encodes a transcription factor that appears to be essential for expression of the *MMACHC* gene. This is the only X-linked disorder in the B<sub>12</sub> intracellular metabolism pathway. Rare defects resulting in a phenotype overlapping with *cbIX* deficiency have been associated with biallelic pathogenic variants in the genes *THAP11* or *ZNF143*.

### ISOLATED HOMOCYSTINURIA

Patients with *cbID* variant one, *cbIE*, and *cbIG* deficiency present with isolated homocystinuria without methylmalonic acidemia (see Chapter 105.3).

### COMBINED MALONIC AND METHYLMALONIC ACIDURIA (ACSF3-RELATED DISORDER)

Combined malonic and methylmalonic aciduria (CMAMMA) is a rare autosomal recessive disorder resulting from pathogenic variants in *ACSF3*. *ACSF3* is a putative acyl-CoA synthetase required for the conversion of malonic and methylmalonic acids to their CoA derivatives in the mitochondrial matrix. The disorder can be suspected based on the presence of elevated malonic and methylmalonic acids in urine and plasma. It is distinguished from malonyl-CoA decarboxylase because methylmalonic acid is about fivefold greater than malonic acid in the urine. Plasma propionylcarnitine (C3-carnitine) in CMAMMA patients is normal, so universal newborn screening programs using C3-carnitine in blood spots to screen for methylmalonic acidemia would not detect this condition. The clinical phenotype is incompletely understood. Young patients identified prospectively in infancy through urine-based newborn screening were reported to be asymptomatic, but the long-term outcome in this cohort awaits further characterization. Older patients ascertained clinically have highly variable presentations, including metabolic crises, failure to thrive, seizures, memory problems, optic nerve or spinal cord atrophy, and progressive neurodegeneration. Treatment of CMAMMA is supportive and includes avoidance of an excessively high-protein diet. Vitamin B<sub>12</sub> supplementation does not appear to lower malonic and methylmalonic metabolites in body fluids.

Visit Elsevier eBooks+ at eBooks.Health.Elsevier.com for Bibliography.

## 105.7 Glycine

Oleg A. Shchelochkov and Charles P. Venditti

Glycine is a nonessential amino acid synthesized by multiple endogenous sources, including serine, choline, and threonine. Structurally, it is the simplest amino acid. Glycine is involved in many reactions in the body, especially in the nervous system, where it functions as a neurotransmitter (excitatory in the cortex, inhibitory in the brainstem and the spinal cord; see Chapter 105.11). Its main catabolic pathway requires the *glycine cleavage system*, a pyridoxal phosphate-dependent, mitochondrial enzyme complex that converts glycine to carbon dioxide and ammonia and transfers  $\alpha$ -carbon to tetrahydrofolate (see Fig. 105.8). The glycine cleavage system is composed of four proteins: P protein (glycine decarboxylase), H protein, T protein, and L protein, which are encoded by four different genes.

### HYPOGLYCINEMIA

Defects in the biosynthetic pathway of serine (see Chapter 105.8) cause a deficiency of glycine in addition to that of serine in body fluids, especially in the CSF. Isolated primary deficiency of glycine has not been reported.

### HYPERGLYCINEMIA

Elevated levels of glycine in body fluids occur in propionic acidemia, methylmalonic acidemia, isovaleric acidemia, and  $\beta$ -ketothiolase deficiency, which are collectively referred to as **ketotic hyperglycinemia**

because of the coexistence of acidosis and ketosis. The pathogenesis of hyperglycinemia in these disorders is not understood. Inhibition of the glycine cleavage enzyme system by the various organic acids and post-translational modification has been shown to occur in some of these biochemical disorders. The term **nonketotic hyperglycinemia (NKH)** is reserved for the clinical condition caused by the genetic deficiency of the *glycine cleavage enzyme system* (GCS, see Fig. 105.8). In this condition, hyperglycinemia is present without ketosis.

### NONKETOTIC HYPERGLYCINEMIA (GLYCINE ENCEPHALOPATHY)

Four forms of NKH have been identified: neonatal, infantile, late onset, and transient. NKH is an autosomal recessive disorder caused by biallelic pathogenic variants in either of three genes, *GLDC* (encodes P protein), *AMT* (encodes T protein), and *GCSH* (encodes H protein). The L-protein gene (*DLD*) encodes dihydrolipoamide dehydrogenase, the E3 component of  $\alpha$ -ketoacid dehydrogenase complexes, and is discussed in Chapter 105.6. Birth prevalence of NKH is  $\sim$ 1:75,000, but a high frequency of the disorder has been noted in Northern Finland (1:12,000 live births), suggesting that this disorder is likely underdiagnosed in some regions of the world.

NKH should be differentiated from the GCS cofactor deficiency caused by the deficiency of lipoate resulting from biallelic pathogenic variants in genes involved in lipoate synthesis (*LIAS*, *LIPT2*, *BOLA3*, *GLRX5*, *IBA57*, and *NFU1*).

### Neonatal Nonketotic Hyperglycinemia

This is the most common form of NKH. Clinical manifestations become apparent in the first few days of life (between 6 hours and 8 days after birth). Poor feeding, failure to suck, lethargy, and profound hypotonia may progress rapidly to a deep coma, apnea, and death. Convulsions, especially myoclonic seizures, and hiccups are common.

Laboratory findings reveal moderate to severe hyperglycinemia (as high as eight times the upper reference range) and hyperglycinuria. The unequivocal elevation of glycine concentration in CSF (15–30 times the upper reference range) and the high ratio of glycine concentration in CSF to that in plasma (a value  $>0.08$ , reference value  $<0.02$ ) are diagnostic of NKH. Affected patients' blood pH is usually normal. The plasma acylcarnitine profile and urine organic acid assay reveal no abnormalities. CSF serine levels can be low.

Approximately 30% of NKH infants die despite supportive therapy. Those who survive develop profound intellectual disability and intractable seizure disorders (myoclonic and/or grand mal seizures). Hydrocephalus, requiring shunting, and pulmonary hypertension have been noted in survivors. Transient hyperglycemia may prompt evaluation for biochemical phenocopies of NKH (e.g., organic acidemias), brain imaging studies to evaluate for intracerebral hemorrhage or hypoxic-ischemic injury, and ultimately may require molecular studies of *AMT*, *GLDC*, and *GCSH*.

### Transient Nonketotic Hyperglycinemia

Most clinical and laboratory manifestations of transient NKH are indistinguishable from those of the neonatal form. By 2–8 weeks of age, however, a complete clinical recovery may occur, and the elevated glycine levels in plasma and CSF normalize after the patient stops a glycine-lowering medication. Some of these patients develop normally with no neurologic sequelae, but intellectual disability has been noted in others. The etiology of this condition is not known, but it is thought to be a consequence of immaturity of the enzyme system; genetic testing is normal. Transient hyperglycemia should prompt consideration of additional biochemical studies; brain imaging; and molecular studies to evaluate for pathogenic variants in *AMT*, *GLDC*, and *GCSH*.

### Infantile Nonketotic Hyperglycinemia

In infantile NKH, previously healthy-appearing infants develop signs and symptoms of neonatal NKH after 6 months of age. Seizures and hypotonia are common presenting signs. Infantile NKH appears to be a milder form of neonatal NKH; infants usually survive, and intellectual

disability is not as profound as in the neonatal form. Laboratory findings in patients with infantile NKH are identical to those seen in neonatal NKH.

### Late-Onset Nonketotic Hyperglycinemia

Clinical manifestations of this atypical form of NKH include progressive spastic diplegia, optic nerve atrophy, and choreoathetotic movements. Age of onset has been between 2 and 33 years. Symptoms of delirium, chorea, and vertical gaze palsy may occur episodically in some patients during an intercurrent infection. Mental development is usually normal, but mild cognitive impairment and infrequent seizures have been reported in some patients.

Laboratory findings in late-onset NKH are similar but not as pronounced as in neonatal NKH.

All forms of NKH should be differentiated from *ketotic* hyperglycinemia, pyridox(am)ine phosphate oxidase (PNPO) deficiency, ingestion of valproic acid, and transient glycine encephalopathy. Valproic acid can moderately increase blood, CSF, and urinary concentrations of glycine. Repeat assays after discontinuation of the drug will help establish the diagnosis.

### Diagnosis and Treatment

A diagnosis of NKH can be suspected based on the findings of elevated glycine in plasma or CSF and the abnormal CSF/plasma ratio of glycine. The diagnosis is confirmed using molecular analysis of the NKH-related genes (*AMT*, *GLDC*, and *GCSH*). Rarely, enzymatic assay on liver specimens is necessary to establish the diagnosis. Enzyme activity in the neonatal form is close to zero, whereas in the other forms, some residual activity is present. In most patients with neonatal NKH, the enzyme defect resides in the P protein (75%). Defects in the T protein account for approximately 20% of cases, whereas <1% are caused by pathogenic variants in the H protein.

**Prenatal diagnosis** can be accomplished by identifying known familial pathogenic variants in the affected gene or by performing an assay of the enzyme activity in chorionic villus biopsy specimens.

*No effective treatment is currently available.* Exchange transfusion, dietary restriction of glycine, and administration of sodium benzoate or folate have not altered the neurologic outcome in severe forms of NKH. Patients with attenuated NKH may experience clinical improvement from enteral sodium benzoate. Drugs that counteract the effect of glycine on neuronal cells, such as dextromethorphan and felbamate, have shown some beneficial effects in patients with the mild forms of the condition.

### SARCOSINEMIA

Increased concentrations of sarcosine (*N*-methylglycine) are observed in both blood and urine of probands affected by sarcosine dehydrogenase complex deficiency. This autosomal recessive metabolic condition is caused by a defect in sarcosine dehydrogenase, the enzyme that converts sarcosine to glycine (see Fig. 105.8) and is encoded by *SARDH*. No consistent clinical picture has been attributed to sarcosinemia.

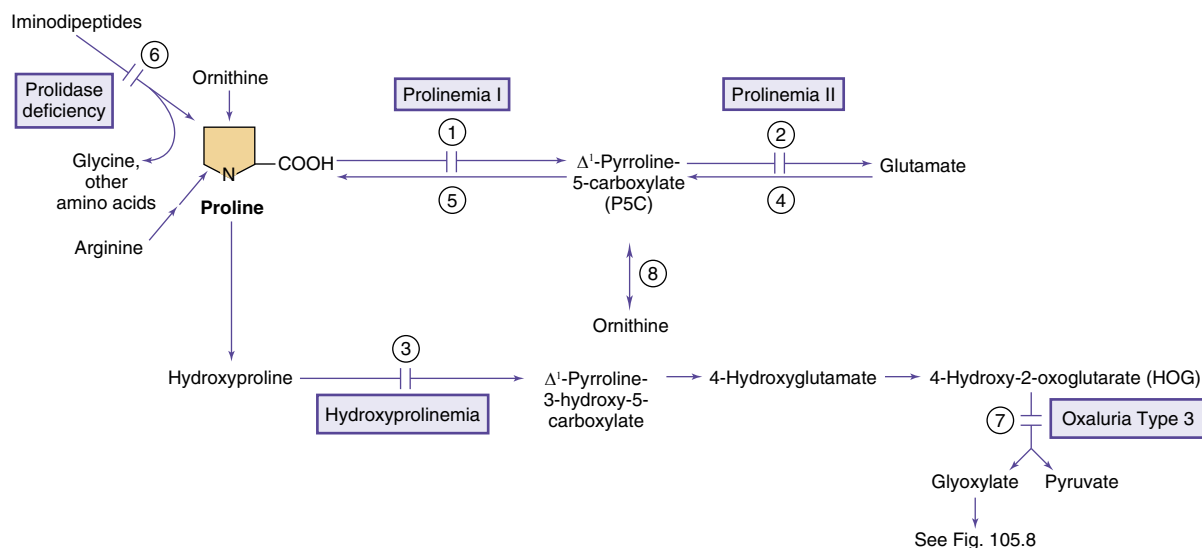
### PRIMARY TRIMETHYLAMINURIA

Trimethylamine is normally produced by intestinal bacteria from the breakdown of dietary choline and trimethylamine oxide by bacteria. Egg yolk and liver are the main sources of choline, and fish is the major source of trimethylamine oxide. Trimethylamine is absorbed and oxidized in the liver by trimethylamine oxidase (a flavin-containing monooxygenase encoded by *FMO3*) to trimethylamine oxide, which is odorless and excreted in the urine (see Fig. 105.8). Deficiency of this enzyme results in massive excretion of trimethylamine in urine. There is a body odor that resembles that of rotting fish, which may have significant psychosocial ramifications. Transient symptomatic trimethylaminuria can occur in normal individuals after ingestion of large quantities of the previously mentioned foods.

**Treatment** with oral activated charcoal and short courses of oral metronidazole, neomycin, or lactulose cause temporary reduction in body odor. Restriction of fish, eggs, liver, and other sources of choline (e.g., nuts, grains) in the diet significantly reduces the odor. Topical use of acidic soaps (pH 5.5) can also help control the odor.

### HYPEROXALURIA AND OXALOSIS

Normally, oxalic acid is derived mostly from oxidation of glyoxylic acid and, to a lesser degree, from oxidation of ascorbic acid (see Fig. 105.8). Glyoxylic acid is formed from oxidation of glycolic acid and glycine in the peroxisomes and catabolism of **hydroxyproline** in the mitochondria mediated by 4-hydroxy-2-oxoglutarate aldolase 1 (encoded by *HOGA1*), the underlying cause of **primary hyperoxaluria type 3** (Fig. 105.9). Vegetables and foods containing oxalic acid, such as spinach, rhubarb, and almond milk, are the main *exogenous* sources of glycolic and oxalic acids; most of glyoxylic and oxalic acids are produced endogenously. Normally, a major portion of glyoxylate produced in the body is shuttled to peroxisomes, where it is converted to glycine by the action of the enzyme alanine:glyoxylate transaminase (AGT encoded by *AGXT*). Deficiency of this enzyme causes **primary hyperoxaluria type 1**. Most of the remaining glyoxylate in the cytosol is reduced to glycolate by the action of the enzyme glyoxylate reductase/



**Fig. 105.9** Pathways in the metabolism of proline. Enzymes: (1) Proline oxidase (dehydrogenase), (2)  $\Delta^1$ -pyrroline-5-carboxylic acid (P5C) dehydrogenase, (3) hydroxyproline oxidase, (4)  $\Delta^1$ -pyrroline-5-carboxylic acid (P5C) synthase, (5)  $\Delta^1$ -pyrroline-5-carboxylic acid (P5C) reductase, (6) prolidase, (7) 4-hydroxyoxoglutarate aldolase one (*HOGA1*), (8) ornithine aminotransferase.



hydroxypyruvate reductase (GR/HPR encoded by *GRHPR*). Deficiency of this enzyme causes **primary hyperoxaluria type 2**. These pathways protect the body from excessive production of oxalic acid (see Fig. 105.8). Any glyoxylate that cannot be disposed of through these pathways is readily converted to oxalic acid by the action of the enzyme lactate dehydrogenase (LDH). Oxalic acid cannot be further metabolized in humans and is excreted in the urine as oxalates. Calcium oxalate is relatively insoluble in water and precipitates in tissues (kidneys and joints) if its concentration increases in the body.

**Secondary hyperoxaluria** has been observed in pyridoxine deficiency (cofactor for alanine:glyoxylate transaminase), in patients with IBD, extensive resection of the small bowel or jejunioleal bypass (*enteric hyperoxaluria*), after ingestion of ethylene glycol or high doses of vitamin C, and after administration of the anesthetic agent methoxyflurane (which can be catabolized to oxalic acid as one of its by-products). Acute, fatal hyperoxaluria may develop after ingestion of plants with high oxalic acid content (e.g., sorrel) or intentional ingestion of oxalic acid. Precipitation of calcium oxalate in tissues causes hypocalcemia, liver necrosis, renal failure, cardiac arrhythmia, and death. The lethal dose of oxalic acid is estimated at 5–30 g.

**Primary hyperoxaluria** is a group of disorders in which large amounts of oxalates accumulate in the body. Three types of primary hyperoxaluria have been identified to date. The term **oxalosis** refers to deposition of calcium oxalate in parenchymal tissues.

### Primary Hyperoxaluria Type 1

This rare autosomal recessive condition (prevalence of 1 in 120,000 live births in Europe) is the most common form of primary hyperoxaluria and can be seen in in ~1% of children diagnosed with end-stage renal disease. Primary hyperoxaluria type 1 is caused by deficiency of the peroxisomal enzyme alanine:glyoxylate transaminase (*AGXT*), which is expressed almost exclusively in the liver peroxisomes and requires pyridoxine (vitamin B<sub>6</sub>) as a cofactor. In the absence of this enzyme, glyoxylic acid cannot be converted to glycine and is transferred to the cytosol, where it is oxidized to oxalic acid (see earlier and Fig. 105.8).

The age of presentation varies widely, from the neonatal period to late adulthood. The majority of patients become symptomatic in late childhood or early adolescence. In about 20% of cases, symptoms develop before the infant's first birthday. The initial clinical manifestations are related to renal stones and nephrocalcinosis. Renal colic and asymptomatic hematuria lead to a gradual deterioration of renal function, manifested by growth retardation and uremia. If the disorder is left untreated, most patients die before 20 years of age from renal failure. Other frequent manifestations of the disease include failure to thrive, short stature, arterial calcifications, arrhythmia, heart failure, hypothyroidism, and skin nodules. Acute arthritis is a rare manifestation and can be misdiagnosed as gout because uric acid is often elevated in patients with type 1 hyperoxaluria, driven in part by the worsening renal function. Crystalline retinopathy and optic neuropathy causing visual loss have been reported.

A marked increase in urinary excretion of oxalate (typical excretion: 10–50 mg/day) is the most important laboratory finding. The presence of oxalate crystals in urinary sediment is rarely helpful for diagnosis because such crystals can also be seen in otherwise healthy individuals. Urinary excretion of glycolic acid and glyoxylic acid is increased in most, but not all, patients. Diagnosis can be confirmed by identification of biallelic pathogenic variants in the *AGXT* gene or by performing an enzymatic assay in liver specimens.

The **diagnosis** of primary hyperoxaluria type 1 can be suspected in patients presenting with recurrent renal stones, nephrocalcinosis, and oxalate crystals in the urine after ruling out possible secondary causes (e.g., gastrointestinal disorders or dietary causes). Laboratory studies will reveal elevated urinary oxalate excretion, high urinary glycolate, and elevated plasma oxalate. Confirmatory testing of *AGXT* as a single gene or part of a multigene panel will secure the ultimate diagnosis. The most common pathogenic variant in patients with high residual enzyme activity (c.508G>A, p.Gly170Arg) results in mislocalization of the enzyme to mitochondria instead of peroxisomes, thus leading to the loss of in vivo function. **Prenatal diagnosis** has been achieved

by DNA analysis of chorionic villus samples when biallelic pathogenic variants are known.

**Treatment** focuses on the reduction of oxalic acid production and on improving calcium oxalate disposal. Patients with primary hyperoxaluria type 1 should receive a 3-month trial of pyridoxine treatment to establish pyridoxine responsiveness. In up to 30% of patients (e.g., those homozygous for the *AGXT* pathogenic variant c.508G>A), administration of large doses of pyridoxine can reduce the plasma level and urinary excretion of oxalate. To increase calcium oxalate disposal and prevent nephrolithiasis, high oral fluid intake (2–3 L/m<sup>2</sup>/day while controlling for fluid balance), urine alkalinization, phosphate supplementation, monitoring of vitamin C and vitamin D intake, and avoidance of drugs that can increase urinary calcium excretion (e.g., loop diuretics) are recommended. Urinary stones should be managed by experienced urologists, as excessive surgical trauma may contribute to renal dysfunction. Renal function replacement strategies (e.g., hemodialysis) are used in some patients (e.g., to bridge patients to transplant or when transplant is not a viable option).

Organ **transplantation** has emerged as the most definitive treatment. The decision to undergo kidney, liver, or liver-kidney transplant is complex, and referral rates may vary from one medical center to another. Except for older patients with the pyridoxine-responsive form of disease, renal transplantation alone in patients with renal failure may not improve the outcome, because oxalosis can recur in the transplanted kidney. Combined liver-kidney transplants have resulted in a significant decrease in plasma and urinary oxalate and thus may be the most effective treatment strategy, particularly in children.

### Primary Hyperoxaluria type 2 (L-Glyceric Aciduria)

This rare autosomal recessive condition is caused by a deficiency of the glyoxylate reductase–hydroxypyruvate reductase enzyme complex encoded by *GRHPR* (see Fig. 105.8). A deficiency in the activity of this complex results in accumulation of two intermediate metabolites: hydroxypyruvate (the ketoacid derivative of serine) and glyoxylic acid. Both these compounds are further metabolized by LDH to L-glycerate and oxalate, respectively. A high prevalence of this disorder is reported in the Sauteaux-Ojibway Indians of Manitoba.

Primary hyperoxaluria type 2 results in the deposition of calcium oxalate in the renal parenchyma and urinary tract. Renal stones presenting with renal colic and hematuria may develop before age 2 years. Renal failure is less common in this condition than in primary hyperoxaluria type 1.

Urinary testing reveals large amounts of L-glyceric acid in addition to high levels of oxalate. Urinary L-glyceric acid is considered a pathognomonic finding in primary hyperoxaluria type 2. Urinary excretion of glycolic acid and glyoxylic acid is not increased. The presence of L-glyceric acid without increased levels of glycolic and glyoxylic acids in urine differentiates this type from type 1 hyperoxaluria. The diagnosis can be confirmed by molecular analysis of *GRHPR* or by the enzyme assay in liver biopsy.

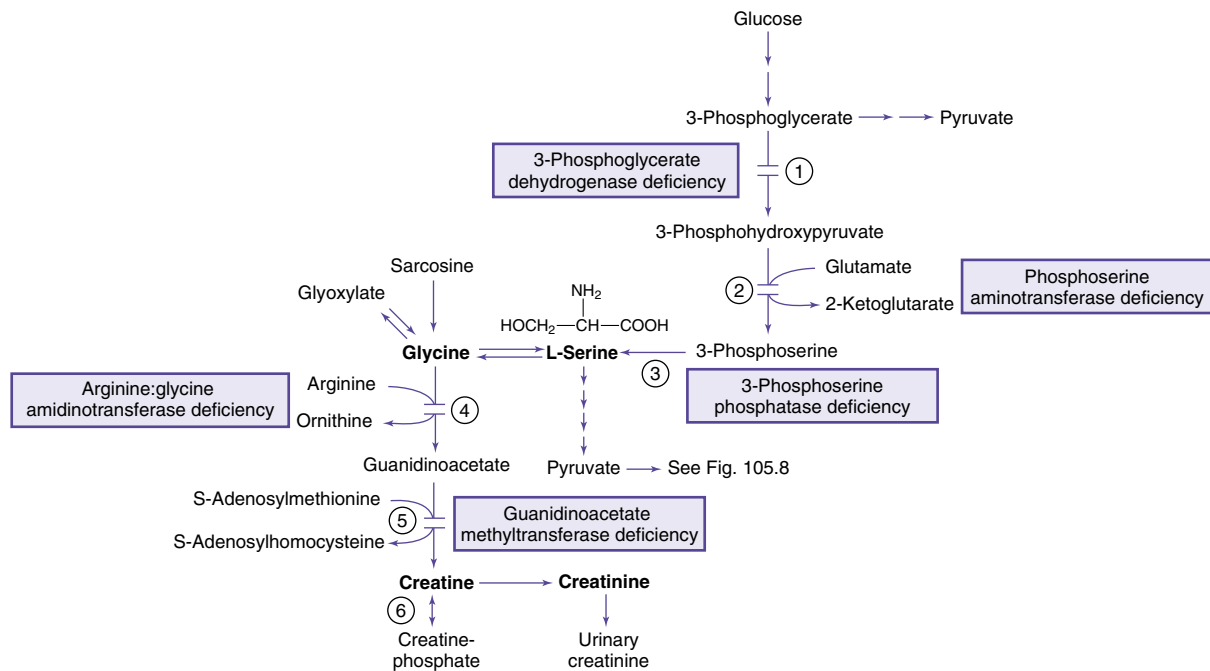
The principles of therapy are similar to those in primary hyperoxaluria type 1. Renal transplant is used in some patients; experience with kidney-liver transplantation is limited at this time.

### Primary Hyperoxaluria Type 3

Approximately 10% of patients with primary hyperoxaluria have deficiency of 4-hydroxy-2-oxoglutarate aldolase 1 (*HOGA1*), the underlying cause of hyperoxaluria type 3. The enzyme is encoded by *HOGA1*. This mitochondrial enzyme catalyzes a step in the metabolic pathway of hydroxyproline that generates pyruvate and glyoxylate from 4-hydroxy-2-oxoglutarate (HOG; see Figs. 105.8 and 105.9). In vitro studies show inhibition of glyoxylate reductase–hydroxypyruvate reductase enzyme activity by a high concentration of HOG that accumulates in patients with hyperoxaluria type 3. *HOGA1* deficiency results in a biochemical phenotype similar to primary hyperoxaluria type 2 (see Fig. 105.8).

Patients with primary hyperoxaluria type 3 usually present with calcium oxalate kidney stones in early childhood, but asymptomatic older siblings have also been identified. Gradually, renal function may





**Fig. 105.10** Biosynthesis of serine and creatine. Enzymes: (1) 3-Phosphoglycerate dehydrogenase, (2) 3-phosphoserine aminotransferase, (3) 3-phosphoserine phosphatase, (4) arginine:glycine amidinotransferase (AGAT), (5) guanidinoacetate methyltransferase (GAMT), (6) creatine kinase.

decline, infrequently resulting in end-stage renal disease. Increased levels of HOG in urine, serum, and liver biopsy samples of these patients are the distinguishing feature of this disorder. **Treatment** involves high oral fluid intake, management of oral citrate or phosphate intake to prevent calcium oxalate renal stone formation, and avoidance of dehydration to prevent acute kidney injury. In severe forms of this disorder, dialysis and transplantation may be required to address the end-stage renal disease.

### Creatine Deficiency Disorders

Creatine is synthesized mainly in the liver, pancreas, and kidneys and to a lesser degree in the brain from arginine and glycine and is transported to muscles and the brain, where there is high activity of the enzyme creatine kinase (Fig. 105.10). Phosphorylation and dephosphorylation of creatine in conjunction with adenosine triphosphate and diphosphate provide high-energy phosphate transfer reactions in these organs. Creatine is nonenzymatically metabolized to creatinine at a relatively constant daily rate and is excreted in the urine. Three genetic conditions are known to cause creatine deficiency in the brain and other tissues. Two enzymes, arginine:glycine amidinotransferase (see Fig. 105.10; AGAT, encoded by *GATM*) and guanidinoacetate methyltransferase (GAMT, encoded by *GAMT*), are involved in the biosynthesis of creatine. Both conditions may respond to creatine supplementation, especially when the treatment is started at an early age. The third condition, an X-linked inherited defect, is caused by a deficiency of the **creatinine transporter** (CRTR, encoded by *SLC6A8*) mediating uptake of creatine by the brain and muscle. A CRTR defect is the most common cause of creatine deficiency, accounting for up to 1–2% of males with intellectual disability of unknown cause.

Clinical manifestations of the three defects overlap, relate to the brain and muscle, and may appear in the first few weeks or months of life. Developmental delay, intellectual disability, speech delay, psychiatric symptoms (autism and psychosis), hypotonia, ataxia, and seizures are common findings. Dystonic movements have been documented in GAMT and CRTR deficiency.

Laboratory findings include decreased creatine in plasma in patients with AGAT and GAMT defects. Plasma creatinine level alone is insufficient to diagnose these disorders. Secondary to impaired reabsorption of creatine in kidneys, the urinary ratio of creatine to creatinine is increased in male patients with a CRTR defect but can also be mildly

elevated in female carriers. Marked elevations of guanidinoacetate in the blood, urine, and especially in CSF are diagnostic of GAMT defects. In contrast, low levels of guanidinoacetate can be found in body fluids in the AGAT defect. Evidence of creatine and creatine phosphate deficiency (in all three defects) and high levels of guanidinoacetate (in the GAMT defect) in the brain can be demonstrated by magnetic resonance spectroscopy (MRS). Brain MRI may show signal hyperintensity in the globus pallidus. Diagnosis of AGAT or GAMT deficiency may be confirmed by DNA analysis or by measuring enzymatic activity in cultured fibroblasts (GAMT) or lymphoblasts (AGAT). The diagnosis of CRTR deficiency can be confirmed by DNA analysis or a creatine uptake assay in fibroblasts.

The outcomes of **treatment** are age-dependent, and the best outcomes are seen when treatment is started in the neonatal period or presymptomatically. In AGAT-deficient patients, oral creatine monohydrate (up to 400–800 mg/kg/day) can improve muscle weakness, seizures, and neurocognitive outcomes in some patients. In GAMT-deficient patients, supplementation with oral creatine monohydrate (up to 400–800 mg/kg/day), ornithine (up to 400–800 mg/kg/day), and dietary arginine restriction may result in improved muscle tone and neurocognitive development and may alleviate seizures. In CRTR-deficient patients, administration of creatine monohydrate and its precursors (arginine and glycine) may improve seizures and neurocognitive outcomes in some patients.

Visit Elsevier eBooks+ at [eBooks.Health.Elsevier.com](http://eBooks.Health.Elsevier.com) for Bibliography.

## 105.8 Serine Deficiency Disorders (Serine Biosynthesis and Transport Defects)

Oleg A. Shchelochkov and Charles P. Venditti

Serine is a nonessential amino acid supplied through dietary sources and through endogenous synthesis, mainly from glucose and glycine. The endogenous production of serine comprises an important portion of the daily requirement of this amino acid, especially in the synaptic junctions, where it contributes to phospholipid metabolism of D-serine and glycine, both of which are involved in neurotransmission (see Chapter 105.11). Consequently, deficiency of any of the enzymes

involved in the biosynthesis of serine or its transport causes neurologic manifestations. The clinical spectrum of serine deficiency disorders ranges widely and varies from **Neu-Laxova syndrome** on the severe end of spectrum to epilepsy and developmental delay on the milder end. Affected patients respond favorably to oral supplementation with serine and glycine when treatment is initiated very early in life. [Figures 105.8 and 105.10](#) show the metabolic pathway for the synthesis and catabolism of serine.

### 3-PHOSPHOGLYCERATE DEHYDROGENASE DEFICIENCY

3-Phosphoglycerate dehydrogenase (**PHGDH** encoded by *PHGDH*) deficiency has a broad range of symptoms and ages of presentation. **Neu-Laxova syndrome type 1**, an autosomal recessive condition, is on the most severe end of the spectrum, presenting prenatally with intrauterine growth restriction and congenital anomalies, including dysmorphic facial features, microcephaly, CNS malformations, limb deformities, and ichthyosis. Most patients with this form are stillborn or have early neonatal mortality. The infantile form of PHGDH deficiency can present with feeding problems, failure to thrive, vomiting, irritability, seizures, severe developmental delay, and hypertonia progressing to spastic quadriplegia. Nystagmus, cataracts, hypogonadism, and megaloblastic anemia have been observed in some affected infants. Patients with a milder form of this disorder experience cognitive impairment, behavioral problems, sensorineural polyneuropathy, and childhood-onset seizures.

**Laboratory findings** include low fasting levels of serine and glycine in plasma and very low levels of serine and glycine in CSF. No abnormal organic acid metabolite is found in the urine. MRI of the brain shows cerebral atrophy with enlarged ventricles, significant attenuation of white matter, and impaired myelination. **Diagnosis** can be confirmed by DNA analysis or by measurement of the enzyme activity in cultured fibroblasts. **Treatment** with high doses of serine (200-700 mg/kg/day orally) and glycine (200-300 mg/kg/day) normalizes the serine levels in the blood and CSF. When started postnatally, this treatment may improve seizures, spasticity, and brain myelination. One case report suggests that developmental delay may be prevented if the treatment commences in the first days of life or prenatally.

If familial pathogenic variants are known, molecular **prenatal diagnosis** is possible. Administration of serine to a mother carrying an affected fetus was associated with stabilization of the fetal head circumference, as evidenced by ultrasound. Treatment with supplemental serine continued postnatally, and the patient remained normal neurologically at 4 years of age. The favorable response of this condition to a relatively straightforward treatment makes this diagnosis an important consideration in any child with microcephaly and neurologic defects such as psychomotor delay or a seizure disorder. Measurements of serine and glycine in the CSF are critical for diagnosis because mild decreases of these amino acids in the plasma can be easily overlooked.

### PHOSPHOSERINE AMINOTRANSFERASE DEFICIENCY

Phosphoserine aminotransferase 1 (**PSAT1** encoded by *PSAT1*) catalyzes conversion of 3-phosphohydroxypyruvate to 3-phosphoserine (see [Fig. 105.10](#)). Deficiency of this enzyme, an autosomal recessive disorder, may present in the neonatal period with poor feeding, cyanotic episodes, and irritability and may progress to intractable, multifocal seizures and microcephaly. Brain imaging may reveal generalized cerebral and cerebellar atrophy. Laboratory studies done on postprandial plasma samples may reveal normal or mildly decreased levels of serine and glycine. Serine and glycine levels are usually more depressed on the CSF amino acid analysis. **Treatment** with serine and glycine as outlined earlier may result in clinical improvement.

### 3-PHOSPHOSERINE PHOSPHATASE DEFICIENCY

3-Phosphoserine phosphatase catalyzes the final step in the L-serine synthesis, converting 3-phosphoserine to L-serine. Deficiency of this enzyme results in an autosomal recessive disorder with clinical and biochemical findings indistinguishable from the PHGDH and PSAT1

deficiencies. The disorder is caused by biallelic pathogenic variants in *PSPH*.

Visit Elsevier eBooks+ at [eBooks.Health.Elsevier.com](http://eBooks.Health.Elsevier.com) for Bibliography.

## 105.9 Proline

Oleg A. Shchelochkov and Charles P. Venditti

Proline is a nonessential amino acid synthesized endogenously from glutamic acid, ornithine, and arginine (see [Fig. 105.9](#)). Proline and hydroxyproline are found in high concentrations in collagen. Normally, neither of these amino acids is found in large quantities in urine. Excretion of proline and hydroxyproline as *iminopeptides* (dipeptides and tripeptides containing proline or hydroxyproline) is increased in disorders of accelerated collagen turnover, such as rickets or hyperparathyroidism. Proline is also found in synapses, where it can interact with glycine and glutamate receptors (see [Chapter 105.11](#)). The catabolic pathway of proline and hydroxyproline produces glyoxylic acid, which can be further metabolized to glycine or oxalic acid (see [Fig. 105.8](#)).

Accumulation of proline in tissues is associated with disorders of hyperprolinemia type 1 and hyperprolinemia type 2. Two types of primary hyperprolinemia have been described. Reduced de novo synthesis of proline may manifest with **cutis laxa** (see [Fig. 700.8](#)) with **progeroid features** or **spastic paraplegia**.

### HYPERPROLINEMIA TYPE I

This rare autosomal recessive condition is caused by a deficiency of proline oxidase (proline dehydrogenase; see [Fig. 105.9](#)). Most patients with hyperprolinemia type I appear asymptomatic, although some may present with intellectual disability, seizures, and behavioral problems. Hyperprolinemia may also be a risk factor for autism spectrum disorders and schizophrenia. The nature of such a wide phenotypic range in this biochemical condition is incompletely understood. The gene encoding proline oxidase (*PRODH*) is mapped to 22q11.2 within the critical region for velocardiofacial syndrome. Laboratory studies reveal high concentrations of proline in plasma, urine, and CSF. Increased urinary excretion of hydroxyproline and glycine is also present, which could be related to saturation of the shared tubular reabsorption mechanism due to massive prolinuria.

*No effective treatment has yet emerged.* Restriction of dietary proline causes a modest improvement in plasma proline but with no proven clinical benefit.

### HYPERPROLINEMIA TYPE II

This is a rare autosomal recessive condition caused by the deficiency of  $\Delta^1$ -pyrroline-5-carboxylate dehydrogenase (aldehyde dehydrogenase 4, *ALDH4A1*; see [Fig. 105.9](#)). Intellectual disability and seizures (usually precipitated by an intercurrent infection) have been reported in affected children, but asymptomatic patients have also been described. The cause for such disparate clinical outcomes is incompletely understood.

Laboratory studies reveal increased concentrations of proline and  $\Delta^1$ -pyrroline-5-carboxylate (P5C) in blood, urine, and CSF. The presence of P5C differentiates this condition from hyperprolinemia type I. An increased level of P5C in body fluids, especially in the CNS, appears to antagonize vitamin B<sub>6</sub> and leads to vitamin B<sub>6</sub> dependency (see [Chapter 105.14](#)). Vitamin B<sub>6</sub> dependency may be the main cause of seizures and neurologic findings in this condition and can explain the variability in clinical manifestations in different patients. **Treatment** with high doses of vitamin B<sub>6</sub> is recommended.

### PROLIDASE DEFICIENCY

During collagen degradation, imidodipeptides are formed and are normally cleaved by tissue prolidase. Prolidase deficiency, an autosomal recessive condition caused by biallelic pathogenic variants in *PEPD*, results in the accumulation of imidodipeptides in body fluids. The age at onset varies from 6 months to the third decade of life.

**Clinical manifestations** vary and include recurrent, severe, and painful skin ulcers typically found on the hands and legs. Other skin lesions may precede ulcers by several years and may include a scaly erythematous maculopapular rash, purpura, and telangiectasia. Most ulcers become infected. Healing of the ulcers may take months. Other findings include developmental delays, intellectual disability, organomegaly, anemia, thrombocytopenia, and immune dysfunction resulting in increased susceptibility to infections (recurrent otitis media, sinusitis, respiratory infection, splenomegaly). Some patients have craniofacial abnormalities such as ptosis, ocular proptosis, hypertelorism, small beaked nose, and prominent cranial sutures. Asymptomatic cases have also been reported. Increased incidence of systemic lupus erythematosus has been noted in children. High levels of urinary excretion of imidodipeptides are diagnostic. The diagnosis can be confirmed using DNA analysis. Enzyme assay may be performed in erythrocytes or cultured skin fibroblasts.

**Treatment** of prolidase deficiency is supportive. Infectious complications can be fatal and warrant close and proactive antibiotic management. Oral supplementation with proline, ascorbic acid, and manganese and topical proline and glycine have not been found to be consistently effective in all patients.

## DISORDERS OF DE NOVO PROLINE SYNTHESIS

De novo synthesis of proline and ornithine from glutamate appears to be critical in the normal biology of connective tissue and to maintain the urea cycle in a repleted state. Correspondingly, clinical manifestations of these disorders encompass connective tissue abnormalities, nervous system abnormalities, and variable biochemical abnormalities reflecting urea cycle dysfunction. Clinical and laboratory findings associated with the deficient function of  $\Delta^1$ -P5C synthase (see Fig. 105.9), encoded by *ALDH18A1*, and P5C, reductase encoded by *PYCR1*, are discussed.

Deficient activity of P5C synthase has been associated with several phenotypes, including **de Barsy syndrome**, characterized by cataracts, growth restriction, intellectual disability, a prematurely aged appearance (progeroid features), and cutis laxa. Some patients may show pyramidal signs. Skin biopsy may reveal decreased size of elastic fibers and collagen abnormalities. Brain imaging studies show cortical atrophy, ventriculomegaly, and reduced creatine. Laboratory findings include reduced levels of proline, ornithine, citrulline, and arginine as well as mild fasting hyperammonemia. Patients may show only intermittent abnormalities on the plasma amino acid profile, likely related to the time of blood sampling in relation to the last meal. Interestingly, both autosomal recessive and autosomal dominant forms of inheritance have been described. The diagnosis can be suspected in a patient presenting with cutis laxa, developmental delay, mild hyperammonemia, and characteristic amino acid abnormalities. The diagnosis can be confirmed using molecular DNA analysis or the glutamine loading test on skin fibroblasts. Treatment is supportive, although supplementation with citrulline or arginine to address hyperammonemia and cerebral creatine depletion have been proposed.

Biallelic pathogenic variants in *PYCR1* result in the abnormal function of the mitochondrial  $\Delta^1$ -pyrroline-5-carboxylate reductase, which catalyzes the last step in the synthesis of proline from P5C. The most consistent finding in patients carrying proven pathogenic variants in *PYCR1* include triangular facies, cutis laxa (**de Barsy-like syndrome**), joint hypermobility, wrinkled skin, geroderma osteodysplastica, and progeroid features. Skin biopsy reveals reduction of the elastic fibers and infiltration with inflammatory cells. Some patients may have epilepsy, developmental delays, intellectual disability, cataracts, osteopenia, and failure to thrive. However, many of the affected families are consanguineous, thus complicating interpretation of the phenotype. Of note, plasma amino acid analysis reveals no specific abnormalities. The diagnosis depends on the recognition of the skin findings and can be confirmed using molecular DNA analysis. Available pedigrees of families affected by *PYCR1*-related disorder supports the autosomal recessive mode of inheritance.

Visit Elsevier eBooks+ at eBooks.Health.Elsevier.com for Bibliography.

## 105.10 Glutamic Acid

Oleg A. Shchelochkov and Charles P. Venditti

Glutamic acid and its amide derivative glutamine have a wide range of functions in the body. *Glutamate* plays numerous biologic roles, functioning as a neurotransmitter, an intermediate compound in many fundamental biochemical reactions, and a precursor of an inhibitory neurotransmitter,  $\gamma$ -aminobutyric acid (GABA) (see Chapter 105.11). Another major product of glutamate is *glutathione* ( $\gamma$ -glutamylcysteinylglycine). This ubiquitous tripeptide, with its function as the major antioxidant in the body, is synthesized and degraded through a complex cycle called the  $\gamma$ -glutamyl cycle (Fig. 105.11). Because of its free sulfhydryl ( $-SH$ ) group and its abundance in the cell, glutathione protects other sulfhydryl-containing compounds (e.g., enzymes, coenzyme A) from oxidation. It is also involved in the detoxification of peroxides, including hydrogen peroxide, and in keeping the intracellular milieu in a reduced state. In addition, glutathione participates in amino acid transport across the cell membrane through the  $\gamma$ -glutamyl cycle.

One of the biochemical manifestations of  $\gamma$ -glutamyl cycle deficiency is increased urinary excretion of 5-oxoproline, which could be the result of both genetic and nongenetic causes. 5-Oxoprolinemia should be routinely considered in the differential diagnosis of **high-anion gap metabolic acidosis** (HAGMA). Two metabolic disorders can present with massive 5-oxoprolinuria: **glutathione synthetase deficiency** and **5-oxoprolinase deficiency** (see Fig. 105.11). However, a more common clinical scenario is a transient and mild urinary elevation of 5-oxoproline that can be seen in a variety of metabolic and acquired conditions, such as exposure to acetaminophen and some hydrolyzed-protein formulas, severe burns, Stevens-Johnson syndrome, homocystinuria, urea cycle defects, and tyrosinemia type I.

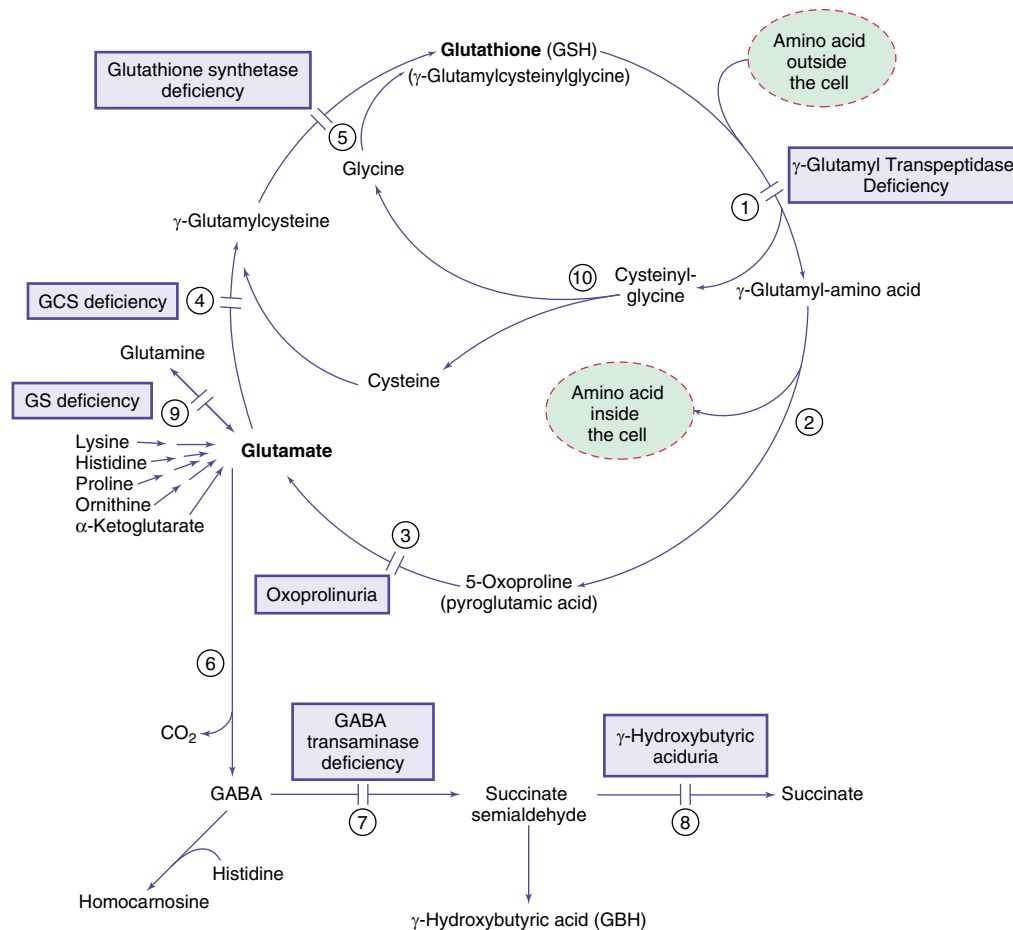
### GLUTATHIONE SYNTHETASE DEFICIENCY

Three forms of this rare autosomal recessive condition have been reported. In the **mild form**, glutathione synthetase deficiency causes glutathione deficiency in erythrocytes. These patients present with hemolytic anemia without chronic metabolic acidosis and demonstrate high residual activity of glutathione synthetase on enzymatic testing. A **moderate form** has also been observed in which the hemolytic anemia is associated with variable degrees of metabolic acidosis and 5-oxoprolinuria. Its **severe form** is distinguished by the presence of hemolytic anemia accompanied by severe acidosis, massive 5-oxoprolinuria, and neurologic manifestations.

### Glutathione Synthetase Deficiency, Moderate and Severe Forms

Affected newborn infants with severe and moderate forms of glutathione synthetase deficiency usually develop acute symptoms of metabolic acidosis, jaundice, and mild to moderate hemolytic anemia in the first days of life. Chronic acidosis continues after recovery. Similar episodes of life-threatening acidosis may occur during an infection (e.g., gastroenteritis) or after a surgical procedure. Progressive neurologic damage develops with age, manifested by intellectual disability, spastic tetraparesis, ataxia, tremor, dysarthria, and seizures. Susceptibility to infections, presumably because of granulocyte dysfunction, is observed in some patients. Patients with the moderate form of glutathione synthetase deficiency have milder acidosis and less 5-oxoprolinuria than is seen in the severe form, with few neurologic manifestations.

**Laboratory findings** include metabolic acidosis, mild to moderate degrees of hemolytic anemia, and 5-oxoprolinuria. High concentrations of 5-oxoproline are also found in the blood. The urinary and blood levels of 5-oxoproline are less pronounced in patients with the moderate form of the condition. The glutathione content of erythrocytes is markedly decreased. Increased synthesis of 5-oxoproline in this disorder is thought to be the result of the conversion of  $\gamma$ -glutamylcysteine to 5-oxoproline by the enzyme  $\gamma$ -glutamyl cyclotransferase (see Fig. 105.11).  $\gamma$ -Glutamylcysteine production increases greatly because the normal inhibitory effect of glutathione on the  $\gamma$ -glutamylcysteine synthetase enzyme is removed.



**Fig. 105.11** The  $\gamma$ -glutamyl cycle and related pathways. Defects of the glutathione (GSH) synthesis and degradation are noted. Enzymes: (1)  $\gamma$ -Glutamyl transpeptidase (GGT), (2)  $\gamma$ -glutamyl cyclotransferase, (3) 5-oxoprolinase, (4)  $\gamma$ -glutamyl-cysteine synthetase, (5) glutathione synthetase, (6) glutamate decarboxylase, (7)  $\gamma$ -aminobutyric acid (GABA) transaminase, (8) succinate-semialdehyde dehydrogenase, (9) glutamine synthetase, (10) dipeptidase.

**Treatment** of acute attack includes hydration, correction of acidosis (by infusion of sodium bicarbonate), and measures to correct anemia and hyperbilirubinemia. Chronic administration of alkali is usually needed indefinitely. Supplementation with vitamin C, vitamin E, and selenium is recommended. Drugs and oxidants known to cause hemolysis and stressful catabolic states should be avoided. Oral administration of glutathione analogs has been tried with variable success.

**Prenatal diagnosis** can be achieved by the measurement of 5-oxoproline in amniotic fluid, by enzyme analysis in cultured amniocytes or chronic villus samples, or by GSS gene analysis. Successful pregnancy in an affected female (moderate form) has been reported, with favorable outcomes for both mother and infant.

### Glutathione Synthetase Deficiency, Mild Form

The mild form has been reported in only a few patients. Mild to moderate hemolytic anemia has been the only clinical finding. Splenomegaly has been reported in some patients. Cognitive development is normal. Chronic metabolic acidosis typically is not seen. Some patients can have increased concentrations of 5-oxoproline in the urine. Biallelic pathogenic variants in GSS, the gene encoding the enzyme, appear to decrease the half-life of the enzyme, causing an increased rate of protein turnover without affecting its catalytic function. The expedited rate of enzyme turnover caused by these pathogenic variants is of little or no consequence for tissues with protein synthetic capability. However, inability of mature erythrocytes to synthesize protein results in glutathione deficiency in the erythrocytes. **Treatment** is that of hemolytic anemia and avoidance of drugs and oxidants that can trigger the hemolytic process.

All forms of glutathione synthetase deficiency are inherited as an autosomal recessive trait. **Diagnosis** can be confirmed by GSS gene analysis or enzyme activity in erythrocytes or skin fibroblasts.

### 5-Oxoprolinase Deficiency

More than 20 patients with 5-oxoprolinuria (4-10 g/day) caused by 5-oxoprolinase (see Fig. 105.11) deficiency (OPLAH) have been described. No specific clinical picture has yet emerged; completely asymptomatic affected individuals have also been identified. It is therefore not clear whether 5-oxoprolinase deficiency is of any clinical consequence. No treatment is currently recommended.

### $\gamma$ -Glutamylcysteine Synthetase Deficiency (Glutamate-Cysteine Ligase Deficiency)

$\gamma$ -Glutamylcysteine synthetase deficiency is an autosomal recessive disorder caused by biallelic pathogenic variants in GCLC. Only a few patients with this enzyme deficiency have been reported. The most consistent clinical manifestation has been mild chronic hemolytic anemia. Acute attacks of hemolysis have occurred after exposure to sulfonamides. Peripheral neuropathy and progressive spinocerebellar degeneration have been noted in two siblings in adulthood. Laboratory findings of chronic hemolytic anemia were present in all patients. Generalized aminoaciduria is also found because the  $\gamma$ -glutamyl cycle is involved in amino acid transport in cells (see Fig. 105.11). **Treatment** focuses on the management of hemolytic anemia and avoidance of drugs and oxidants that may trigger the hemolytic process.



### γ-GLUTAMYL TRANSPEPTIDASE DEFICIENCY (GLUTATHIONEMIA)

γ-Glutamyl transpeptidase (GGT) is expressed in any cell that has secretory or absorptive functions. It is especially abundant in the kidneys, pancreas, intestines, and liver. The enzyme is also present in the bile. Measurement of GGT in the blood is frequently performed to evaluate for liver and bile duct diseases.

GGT deficiency causes elevation in glutathione concentrations in body fluids, but the cellular levels remain normal (see Fig. 105.11). Because only a few patients with GGT deficiency have been reported, the scope of clinical manifestations has not yet been defined. Mild to moderate intellectual disability and severe behavioral problems were observed in three patients. However, one of two sisters with this condition had normal intelligence as an adult, and the other had Prader-Willi syndrome.

**Laboratory findings** include marked elevations in urinary glutathione (up to 1 g/day), γ-glutamylcysteine, and cysteine. None of the reported patients have had generalized aminoaciduria, a finding that would have been expected to occur in this enzyme deficiency (see Fig. 105.11).

**Diagnosis** can be confirmed by measurement of the enzyme activity in leukocytes or cultured skin fibroblasts. *No effective treatment has been proposed.* The condition is inherited as an apparent autosomal recessive trait. The γ-glutamyl transpeptidases represent a large family of enzymes encoded by at least seven genes.

### GENETIC DISORDERS OF METABOLISM OF γ-AMINOBUTYRIC ACID

See Chapter 105.11.

Visit Elsevier eBooks+ at eBooks.Health.Elsevier.com for Bibliography.

## 105.11 Disorders of Neurotransmitter Metabolism

Oleg A. Shchelochkov and Charles P. Venditti

*Neurotransmitters* are chemical substances released from the axonal end of excited neurons at the synaptic junctions; they mediate initiation, amplification, or inhibition of neural impulses. Several amino acids and their metabolites act as neurotransmitters in the central and peripheral nervous system. Pathogenic variants in genes responsible for the synthesis, transport, or degradation of these substances may cause conditions that manifest neurologic and/or psychiatric abnormalities (Table 105.3). Previously, children affected by disorders of neurotransmitters have been given syndromic diagnoses such as cerebral palsy, epilepsy, parkinsonism, dystonia, or autism. Diagnosis, in most cases, requires specialized laboratory studies of the CSF, because some of the neurotransmitters generated in the CNS, dopamine and serotonin, do not cross the BBB, and their abnormal concentrations are not detected in the serum or urine.

### TYROSINE HYDROXYLASE DEFICIENCY (INFANTILE PARKINSONISM, AUTOSOMAL RECESSIVE DOPA-RESPONSIVE DYSTONIA, AUTOSOMAL RECESSIVE SEGAWA SYNDROME)

Tyrosine hydroxylase catalyzes the formation of L-dopa from tyrosine. Deficiency of this enzyme results in deficiencies of dopamine and norepinephrine (see Fig. 105.2 and Fig. 105.12). The differential diagnosis includes a wide range of inherited dystonias, including autosomal dominant dystonia caused by GTP cyclohydrolase 1 deficiency.

**Clinical manifestations** range from mild to very severe. In general, two phenotypes have been recognized. In the **mild** form (dopa-responsive dystonia, or **type A**), symptoms of unilateral limb dystonia causing gait incoordination and postural tremor occur in childhood and worsen with age when the condition remains untreated. Diurnal variation of symptoms (worse at the end of the day) may be present. Cognitive development is usually normal.

In the **severe** form of tyrosine hydroxylase deficiency (infantile parkinsonism, infantile encephalopathy, or **type B**), the clinical manifestations occur at birth or shortly thereafter and include microcephaly, developmental delay, involuntary movements of the limbs with spasticity, dystonia, ptosis, expressionless face, oculogyric crises (upward eye-rolling movements), and autonomic dysfunction (temperature instability, excessive sweating, hypoglycemia, salivation, tremor, gastrointestinal reflux, constipation). Brisk reflexes, myoclonus, athetosis, and distal chorea may be present. The patient with the severe form usually shows incomplete response to treatment with L-dopa and is prone to developing L-dopa-induced dyskinesia as a side effect.

**Laboratory findings** include reduced levels of dopamine and its metabolite homovanillic acid (HVA) and normal concentrations of tetrahydrobiopterin (BH<sub>4</sub>), neopterin, and 5-hydroxyindoleacetic acid (5-HIAA, a metabolite of serotonin) in the CSF. Serum prolactin levels are usually elevated. These findings are not diagnostic of the condition; diagnosis should be established by molecular gene analysis.

**Treatment** with L-dopa/carbidopa results in significant clinical improvement in most patients, but the severe forms are invariably associated with L-dopa-induced dyskinesias. To minimize the side effects of therapy, treatment should be started with a low dose and, if needed, increased very slowly. Other therapeutic interventions include anticholinergics, serotonergic agents, and monoamine oxidase (MAO) B inhibitors, including amantadine, biperiden, and selegiline. Bilateral subthalamic nucleus deep brain stimulation has shown clinical efficacy in one case. Tyrosine hydroxylase deficiency is inherited as an autosomal recessive trait. Molecular testing for pathogenic variants in the *TH* gene is available clinically.

### AROMATIC L-AMINO ACID DECARBOXYLASE DEFICIENCY

Aromatic L-amino acid decarboxylase (AADC encoded by *DDC*) is a vitamin B<sub>6</sub>-dependent enzyme that catalyzes the decarboxylation of both 5-hydroxytryptophan to form serotonin (see Fig. 105.5 and Fig. 105.12) and L-dopa to generate dopamine (see Fig. 105.2 and Fig. 105.12). **Clinical manifestations** of this autosomal recessive disorder reflect the reduced availability of dopamine and serotonin. Poor feeding, lethargy, hypotension, hypothermia, oculogyric crises, and ptosis have been observed in affected neonates. Clinical findings in infants and older children include developmental delay, truncal hypotonia with hypertonia of limbs, oculogyric crises, extrapyramidal movements (choreoathetosis, dystonia, myoclonus), and autonomic abnormalities (sweating, salivation, irritability, temperature instability, hypotension). Symptoms may have a diurnal variation, becoming worse by the end of the day.

**Laboratory findings** include decreased concentrations of dopamine and serotonin and their metabolites (HVA, 5-HIAA, norepinephrine, vanillylmandelic acid [VMA]) and increased levels of 5-hydroxytryptophan, L-dopa, and its metabolite (3-O-methyldopa) in body fluids, especially in CSF. Elevated serum concentrations of prolactin (the result of dopamine deficiency) have also been observed. Brain MRI reveals cerebral atrophy with degenerative changes in the white matter. A urine screening program, focused on 3-O-methyl-dopa and VMA, has demonstrated diagnostic promise in high-disease-prevalence populations.

**Treatment** with neurotransmitter precursors has produced limited clinical improvement. Dopamine and serotonin have no therapeutic value because of their inability to cross the BBB. Nonergot dopamine agonists, MAO inhibitors (tranylcypromine), serotonergic agents, and high doses of pyridoxine/pyridoxal phosphate, a cofactor for the AADC enzyme, are preferred. The demonstration of putamen-directed gene therapy with an adeno-associated viral vector has shown some benefit in patients. Preimplantation genetic diagnosis after in vitro fertilization has been achieved in the high-prevalence Taiwanese population.

### TETRAHYDROBIOPTERIN DEFICIENCY

See Chapter 105.1.

Tetrahydrobiopterin (BH<sub>4</sub>) is the enzymatic cofactor for phenylalanine hydroxylase (see Fig. 105.1 and Fig. 105.12), tyrosine hydroxylase

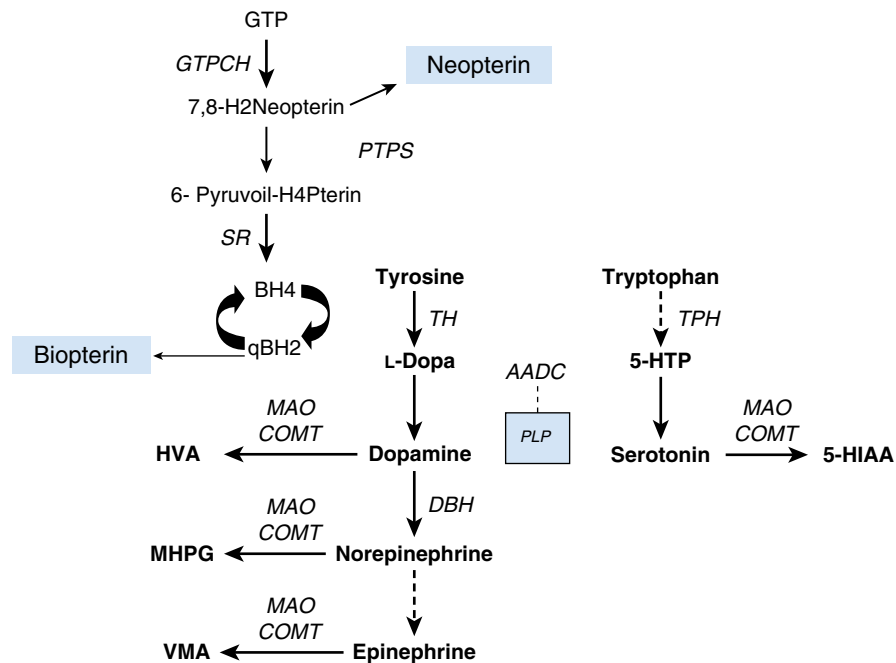
**Table 105.3** Neurotransmitter Disorders Affecting Biogenic Amines and GABA Metabolism and Transport: Biomarker Assessment in Biologic Fluids

CSF MARKER	DISEASE OMIM <sup>A</sup> /GENE	BIOCHEMICAL PATTERN
Biogenic amines	TH deficiency 191290/TH AADC deficiency 107930/DDC MAOA deficiency 309850/MAO-A DBH deficiency 609312/DBH DAT1 deficiency 126455/SLC6A3 VMAT2 deficiency 193001/SLC18A2	CSF: ↓ HVA, MHPG, and HVA/5-HIAA ratio  CSF: ↓ HVA and 5-HIAA; ↑ 3OMD and 5HTP Urine: ↑ vanillactate; blood: ↑ 3OMD  CSF: ↓ 5-HIAA and HVA Plasma/urine: ↑ catecholamines and serotonin CSF: ↑ HVA, HVA/5-HIAA ratio, ↓ MHPG <sup>a</sup> Urine/plasma: ↓ norepinephrine and epinephrine; ↑ dopamine and DOPAC CSF: ↑ HVA and HVA/5-HIAA ratio  Urine: ↑ HVA and 5-HIAA ↓ Norepinephrine and dopamine
Pterins	Dominant GTPCH-I deficiency 600225/GCH SR deficiency 182125/SRD	CSF: ↓ NP, BP, BH <sub>4</sub> , HVA, and 5-HIAA  CSF: ↑ BP and SP; normal NP; ↓ BH <sub>4</sub> , HVA, and 5-HIAA Urine: ↑ SP
GABA	SSADH deficiency 610045/ALDH5A1	CSF: ↑ GABA Plasma and urine: ↑ GHB

<sup>a</sup>Expected values.

↑: Increased values compared with reference aged values; ↓: decreased values compared with reference aged values.

5-HIAA, 5-Hydroxyindoleacetic acid; AADC, aromatic L-amino acid decarboxylase; BP, biopterin; CSF, cerebrospinal fluid; DBH, dopamine β-hydroxylase; DOPAC, dihydroxyphenylacetic acid; GHB, γ-hydroxybutyrate; GTPCH-I, guanosine triphosphate cyclohydrolase-I; HVA, homovanillic acid; MAOA, monoamine oxidase A; MHPG, 3-methoxy-4-hydroxyphenylethylenglycol; NP, neopterin; SP, sepiapterin; SR, sepiapterin reductase; SSADH, succinic semialdehyde dehydrogenase; TH, tyrosine hydroxylase.

From García-Cazorla Á, Artuch R. Neurotransmitter disorders. In Rosenberg RN, Pascual JM, eds. *Rosenberg's Molecular and Genetic Basis of Neurological and Psychiatric Disease*, 6th ed. Vol. 1. London: Elsevier; 2020: Table. 67.1.**Fig. 105.12** Metabolic pathways of monoamines. The first step in their formation is catalyzed by amino acid-specific hydroxylases, which require tetrahydrobiopterin (BH<sub>4</sub>) as a cofactor. The synthesis of BH<sub>4</sub> comes from GTP, and it is initiated by the enzyme GTPCH-I, which forms dihydroneopterin triphosphate. Levodopa and 5-HTP are metabolized by a common B<sub>6</sub>-dependent AADC into dopamine and serotonin. MAOA catabolizes adrenaline and noradrenaline to VMA and MHPG. This enzyme is also involved in the catabolism of both dopamine into HVA and serotonin into 5-HIAA. 5-HIAA, 5-Hydroxyindoleacetic acid; 5-HTP, 5-hydroxytryptophan; AADC, aromatic L-amino acid decarboxylase; GTP, guanosine triphosphate; GTPCH-I, GTP cyclohydrolase-1; HVA, homovanillic acid; MAOA, monoamine oxidase A; MHPG, 3-methoxy-4-hydroxyphenylethylenglycol; VMA, vanillylmandelic acid. (From García-Cazorla Á, Artuch R. Neurotransmitter disorders. In: Rosenberg RN, Pascual JM, eds. *Rosenberg's Molecular and Genetic Basis of Neurological and Psychiatric Disease*, 6th ed. Vol. 1. London: Elsevier; 2020: Fig. 67.1.)

(see Fig. 105.2 and 105.12), tryptophan hydroxylase (see Fig. 105.5 and 105.12), and nitric oxide synthase. It is synthesized from GTP in many tissues (see Fig. 105.1). Deficiencies of enzymes involved in the biosynthesis of BH<sub>4</sub> result in inadequate production of this cofactor, which causes deficiencies of monoamine neurotransmitters with or without concomitant hyperphenylalaninemia.

### Tetrahydrobiopterin Deficiency with Hyperphenylalaninemia

See Chapter 105.1.

### Tetrahydrobiopterin Deficiency Without Hyperphenylalaninemia

#### GTP Cyclohydrolase 1 Deficiency (Hereditary Progressive Dystonia, Autosomal Dominant Dopa-Responsive Dystonia, Autosomal Dominant Segawa Syndrome)

Guanosine triphosphate (GTP) cyclohydrolase 1 catalyzes the first and rate-limiting step in the biopterin biosynthesis pathway (see Fig. 105.1). This form of dystonia, caused by GTP cyclohydrolase 1 deficiency (*GCHI*), has an autosomal dominant mode of inheritance and is more common in females than in males (4:1 ratio) (see Chapter 637.4). **Clinical manifestations** usually start in early childhood with tremor and dystonia of the lower limbs (**toe gait**), which may spread to all extremities within a few years. Torticollis, dystonia of the arms, and poor coordination may precede dystonia of the lower limbs. Early development is generally normal. Symptoms have an impressive diurnal variation, becoming worse by the end of the day and improving with sleep. Autonomic instability is common. Parkinsonism may also be present or develop with advancing age. Late presentation in adult life has also been reported, associated with **action dystonia** (“writer’s cramp”), torticollis, or generalized rigid hyper-tonia with tremor but without postural dystonia. Additionally, limited data on adults suggest symptoms related to serotonin deficiency (sleep disturbance, cognitive impairment, impulsivity).

**Laboratory findings** show reduced levels of BH<sub>4</sub> and neopterin in the CSF without hyperphenylalaninemia (not to be confused with the autosomal recessive form of BH<sub>4</sub>-deficient hyperphenylalaninemia, see Chapter 105.1). Dopamine and its metabolite (HVA) may also be reduced in CSF. The serotonergic pathway is less affected by this enzyme deficiency; thus concentrations of serotonin and its metabolites are usually normal. Plasma phenylalanine is normal, but an oral phenylalanine loading test (100 mg/kg) produces an abnormally high plasma phenylalanine level with an elevated phenylalanine/tyrosine ratio. The ratio, obtained 2-3 hours after the load, in combination with urine neopterin level, has optimal diagnostic specificity and sensitivity. The existence of asymptomatic carriers indicates that other factors or genes may play a role in pathogenesis. Asymptomatic carriers may be identified using molecular testing or by the phenylalanine loading test. **Diagnosis** is confirmed by demonstrating reduced levels of BH<sub>4</sub> and neopterin in CSF, measurement of the enzyme activity, and molecular genetic analysis of *GCHI* (see Chapter 105.1). Clinically, the condition should be differentiated from other causes of dystonias and childhood parkinsonism, especially tyrosine hydroxylase, sepiapterin reductase, and aromatic amino acid decarboxylase deficiencies.

**Treatment** with L-dopa/carbidopa usually produces dramatic clinical improvement. Oral administration of BH<sub>4</sub> is also effective but is rarely used.

### Sepiapterin Reductase Deficiency

Sepiapterin reductase (encoded by *SPR*) is involved in the conversion of 6-pyruvoyl-tetrahydropterin to BH<sub>4</sub>. It also participates in the salvage pathway of BH<sub>4</sub> synthesis (see Fig. 105.1 and Fig. 105.12). Sepiapterin reductase deficiency, an autosomal recessive condition, results in accumulation of 6-lactoyl-tetrahydropterin, which can be converted to sepiapterin nonenzymatically. The majority of sepiapterin is metabolized to BH<sub>4</sub> through the salvage pathway in peripheral tissues (see Fig. 105.1 and Fig. 105.12), but because of the low activity of dihydrofolate reductase in the brain, the amount of BH<sub>4</sub> remains insufficient for proper synthesis of dopamine and serotonin. This explains the absence of hyperphenylalaninemia and the often-delayed diagnosis.

**Clinical manifestations** in severely affected patients usually appear within a few months of life. Cardinal manifestations include paroxysmal stiffening, oculogyric crises, and hypotonia. Additional findings include motor and language delays, weakness, limb hypertonia, dystonia, hyperreflexia, and early-onset parkinsonism. The symptoms usually have a diurnal variation. Misdiagnosis as cerebral palsy is common, and a wide variability of symptoms has been reported. **Diagnosis** is established by measurement of CSF neurotransmitters and pterin metabolites, which reveal decreased dopamine, HVA, norepinephrine, and 5-HIAA and marked elevations of sepiapterin and dihydrobiopterin. The serum concentration of prolactin may be elevated. The phenylalanine loading test may have diagnostic utility, but it is being replaced by molecular genetic analysis, which can confirm the diagnosis. **Treatment** with slowly increasing doses of L-dopa/carbidopa and 5-hydroxytryptophan usually produces dramatic clinical improvement.

### DOPAMINE β-HYDROXYLASE DEFICIENCY

Dopamine β-hydroxylase catalyzes the conversion of dopamine to norepinephrine (see Fig. 105.2 and Fig. 105.12). The deficiency of this enzyme results in reduced or absent synthesis of norepinephrine, leading to dysregulation of the sympathetic function. Infants and children may present with difficulty opening the eyes, ptosis, hypotension, hypothermia, hypoglycemia, and nasal stuffiness. Adult patients may present with profound deficits of autonomic regulation, resulting in severe orthostatic hypotension, and sexual dysfunction in males. Presynaptic symptomatology includes dizziness, blurred vision, dyspnea, nuchal discomfort, and chest pain; olfactory function remains relatively intact. The **diagnosis** can be aided by performing autonomic function testing (measurement of the sinus arrhythmia ratio, blood pressure studies during controlled hyperventilation, Valsalva maneuver, cold pressor, handgrip exercise). **Laboratory findings** include decreased or absent norepinephrine and epinephrine and their metabolites, with elevated levels of dopamine and its metabolite (HVA), in plasma, CSF, and urine. Elevated plasma dopamine may be pathognomonic for this disease. MRI of the brain shows decreased brain volume, consistent with the neurotrophic role of norepinephrine. **Treatment** with L-dihydroxyphenylserine, which is converted to norepinephrine directly in vivo by the action of AADC, leads to significant improvement in orthostatic hypotension and normalizes noradrenaline and its metabolites. The condition is inherited as an autosomal recessive trait. Dopamine β-hydroxylase is encoded by *DBH*.

### MONOAMINE OXIDASE A DEFICIENCY

The human genome encodes two MAO isoenzymes: MAO A and MAO B. Both enzymes catalyze oxidative deamination of most biogenic amines in the body, including serotonin (see Fig. 105.5 and Fig. 105.12), norepinephrine, epinephrine, and dopamine (see Fig. 105.2 and Fig. 105.12). The genes for both isoenzymes are on the X chromosome (Xp11.3). A deletion of both genes can also encompass a neighboring gene, *NDP*, resulting in a contiguous deletion syndrome, which can present as an atypical **Norrie disease** (see Chapter 640). Male patients with MAO A deficiency manifest borderline intellectual deficiency and impaired impulse control. The consequences of the isolated MAO B deficiency are incompletely understood. Combined MAO A and B deficiency causes severe intellectual disability and behavioral problems and can be associated with pronounced laboratory abnormalities (e.g., fourfold to sixfold serotonin elevation in physiologic fluids, elevated O-methylated amine metabolites, and reduced deamination products [VMA, HVA]). Dietary intervention (low tyramine, phenylethylamine, and L-dopa/dopamine intake) did not improve patients’ blood serotonin levels. Inheritance of MAO deficiency is X-linked. **Treatment** of MAO A deficiency is supportive.

### DISORDERS OF GABA METABOLISM

GABA is the main inhibitory neurotransmitter synthesized in the synapses through decarboxylation of glutamic acid by glutamate decarboxylase (GAD). The same pathway is responsible for production of GABA in other organs, especially the kidneys and the β cells of the pancreas. The GAD enzyme requires pyridoxine (vitamin B<sub>6</sub>) as a cofactor.

Two GAD enzymes, GAD1 (GAD<sub>67</sub>) and GAD2 (GAD<sub>65</sub>), have been identified. **GAD1** is the main enzyme in the brain, and **GAD2** is the major enzyme in the  $\beta$  cells. Antibodies against GAD<sub>65</sub> and GAD<sub>67</sub> have been implicated in the development of type 1 diabetes and **stiff-person syndrome**, respectively. GABA is catabolized to succinic acid by two enzymes: GABA transaminase and succinic semialdehyde dehydrogenase (SSADH) (see Figs. 105.11 and 105.12).

### GABA Transaminase Deficiency

Clinical manifestations in the two index infant siblings included severe developmental delay and intellectual disability, hypotonia, hyperreflexia, lethargy, refractory seizures, and increased linear growth likely related to GABA-mediated increased secretion of growth hormone. Increased concentrations of GABA and  $\beta$ -alanine were found in the CSF (see Fig. 105.11 and Fig. 105.12). Evidence of leukodystrophy was noted in the postmortem examination of the brain. A third patient showed severe psychomotor retardation, recurrent episodic lethargy, and intractable seizures with comparable CSF metabolite abnormalities to those of the index probands. GABA transaminase deficiency is demonstrated in the brain and lymphocytes. **Treatment** is symptomatic. Intervention with vitamin B<sub>6</sub>, the cofactor for the enzyme, was without therapeutic benefit. The condition is inherited in the autosomal recessive manner and caused by biallelic pathogenic variants in *ABAT*.

### Succinic Semialdehyde Dehydrogenase Deficiency ( $\beta$ -Hydroxybutyric Aciduria)

Clinical manifestations of SSADH deficiency, an autosomal recessive disorder, usually begin in infancy with developmental delays with a disproportionate deficit in expressive language, hypotonia, and ataxia; seizures occur in approximately 50% of patients (see Fig. 105.11 and Fig. 105.12). Many patients also carry the diagnosis of **autism spectrum disorder**. Neuropsychiatric comorbidity (especially oppositional defiance, obsession-compulsion, and hyperactivity) can be disabling, particularly in adolescents and adults. Abnormal EEG findings include background slowing and generalized spike-wave paroxysms, with variable lateralization in hemispheric onset and voltage predominance. Photosensitivity and electrographic status epilepticus of sleep have been reported in combination with difficulties in sleep maintenance and excessive daytime somnolence. Brain MRI shows an increased T2-weighted hyperintensity involving the globus pallidi, cerebellar dentate nuclei, and subthalamic nuclei, usually in a bilaterally symmetric distribution.

The biochemical hallmark,  $\gamma$ -hydroxybutyric acid (GHB), is elevated in physiologic fluids (CSF, plasma, urine) in all patients. Increased concentrations of GABA are also found in the CSF. Heightened diagnostic suspicion evolves through documentation of elevated urinary GHB, and confirmation is achieved by molecular genetic testing.

Effective **treatment** is lacking. Vigabatrin (a GABA-transaminase inhibitor) has been employed empirically, with mixed outcomes, and there is concern with its use, as it further elevates CNS GABA in an already hyper-GABAergic disorder. Additionally, vigabatrin can cause constriction of the visual field, and long-term use is contraindicated.

SSADH is encoded by *ALDH5A1*, and inheritance follows an autosomal recessive pattern. **Prenatal diagnosis** has been achieved by measurement of GHB in the amniotic fluid, assay of the enzyme activity in the amniocytes, chorionic villus sampling, or DNA analysis.

## DEFECTS IN NEUROTRANSMITTER TRANSPORTER PROTEINS

More than 20 different proteins are involved in transporting neurotransmitters across the neuronal membranes. The main function of most of these transporters is to remove excess neurotransmitters from the synaptic junction into the presynaptic neurons (reuptake). This recycling process not only regulates the precise effect of neurotransmitters at the synaptic junction but also resupplies the presynaptic neurons with neurotransmitters for future use. A few transporter proteins are involved in shuttling neurotransmitters from the neuronal cytoplasm across the membrane of synaptic vesicles for storage (vesicular transporters). On neuronal stimulation, these vesicles release a bolus of neurotransmitters

through exocytosis. As expected, pathogenic variants in transporter proteins interfere with the proper reuptake and storage of neurotransmitters and may result in clinical manifestations similar to those seen in deficiencies of neurotransmitter metabolism. Several conditions caused by pathogenic variants of neurotransmitter protein transporters have been described, including dopamine transporter protein deficiency and dopamine-serotonin vesicular transporter disease.

### SLC6A3-Related Dopamine Transporter Protein Deficiency

This transporter protein is involved in the reuptake of dopamine by the presynaptic neurons, and its deficiency causes depletion of dopamine and thus a dopamine-deficient state. The dopamine transporter protein (DAT) is encoded by *SLC6A3*. Children with biallelic pathogenic variants in *SLC6A3* present with symptoms of infantile **parkinsonism-dystonia syndrome**. Irritability and feeding difficulties start shortly after birth and progress to hypotonia, lack of head control, parkinsonism, dystonia, and global developmental delay by early infancy. Brain MRI usually shows no abnormalities.

CSF examination reveals elevation of HVA and a normal level of 5-HIAAs. The urinary level of HVA and serum concentration of prolactin are increased. Diagnosis can be established by demonstrating loss-of-function pathogenic variants in the *SLC6A3* gene.

### Dopamine-Serotonin Vesicular Transporter Disease (Vesicular Monoamine Transporter Deficiency)

This autosomal recessive condition is caused by pathogenic variants in the *SLC18A2* gene. This gene encodes the vesicular monoamine transporter 2 (VMAT2) involved in transporting dopamine and serotonin from the cytoplasm into the synaptic storage vesicles located in the axonal terminals of the presynaptic neurons. Most affected children presented in the first year of life with symptoms consistent with deficiencies of dopamine (hypotonia progressing into dystonia, parkinsonism, oculogyric crises), serotonin (sleep and psychiatric disturbances), and norepinephrine-epinephrine (excessive sweating, tremors, temperature instability, postural hypotension, ptosis). Neurocognitive delays become apparent in the first year of life. No diurnal variation of the symptoms was noted. Brain imaging studies were within normal limits. Changes in the levels of CNS neurotransmitters and their metabolites have been inconsistent.

The phenotype resembles that seen in AADC and BH<sub>4</sub> deficiencies. Diagnosis requires demonstration of biallelic pathogenic variants in *SLC18A2*. **Treatment** with L-dopa/carbidopa caused exacerbation of symptoms, whereas pramipexole, a dopamine receptor agonist, has resulted in a promising clinical response.

## HISTIDINE DECARBOXYLASE DEFICIENCY

Decarboxylation of histidine by histidine decarboxylase produces histamine, which functions as a neurotransmitter in the brain. Deficiency of this enzyme (expressed mainly in the posterior hypothalamus) results in deficiency of histamine in the CNS and in one family has been reported as an autosomal dominant form of Tourette syndrome (see Chapter 105.13).

## HYPERPROLINEMIA

Intellectual disability and seizures are common findings in most patients with hyperprolinemia types I and II. Patients with **type I** hyperprolinemia typically show a benign clinical course but could have an increased risk of developing schizophrenia. The contribution of increased concentrations of proline to the mechanisms of schizophrenia, however, remains unclear. The neurologic abnormalities observed in hyperprolinemia **type II** are mainly caused by development of vitamin B<sub>6</sub> dependency in this condition (see Chapter 105.9). Dietary intervention in hyperprolinemia type I and II is neither feasible nor recommended.

## 3-PHOSPHOGLYCERATE DEHYDROGENASE DEFICIENCY

See Chapter 105.8.



## PHOSPHOSERINE AMINOTRANSFERASE DEFICIENCY

See Chapter 105.8.

## NONKETOTIC HYPERGLYICINEMIA

See Chapter 105.7.

Visit Elsevier eBooks+ at eBooks.Health.Elsevier.com for Bibliography.

## 105.12 Urea Cycle and Hyperammonemia (Arginine, Citrulline, Ornithine)

Oleg A. Shchelochkov and Charles P. Venditti

Catabolism of amino acids results in the production of free ammonia, which in high concentrations is toxic to the CNS. Mammals detoxify ammonia to urea through a series of reactions known as the **urea cycle** (Fig. 105.13). It is composed of five enzymes: carbamoyl phosphate synthetase 1 (CPS1), ornithine transcarbamylase (OTC), argininosuccinate synthetase (ASS), argininosuccinate lyase (ASL), and arginase 1 (ARG1). A sixth enzyme, *N*-acetylglutamate (NAG) synthetase (NAGS), catalyzes synthesis of NAG, an obligatory activator (effector) of the CPS1 enzyme. Individual deficiencies of these enzymes have been observed and, with an overall estimated prevalence of 1 in 35,000 live births, they are the most common genetic causes of hyperammonemia in infants (Table 105.4).

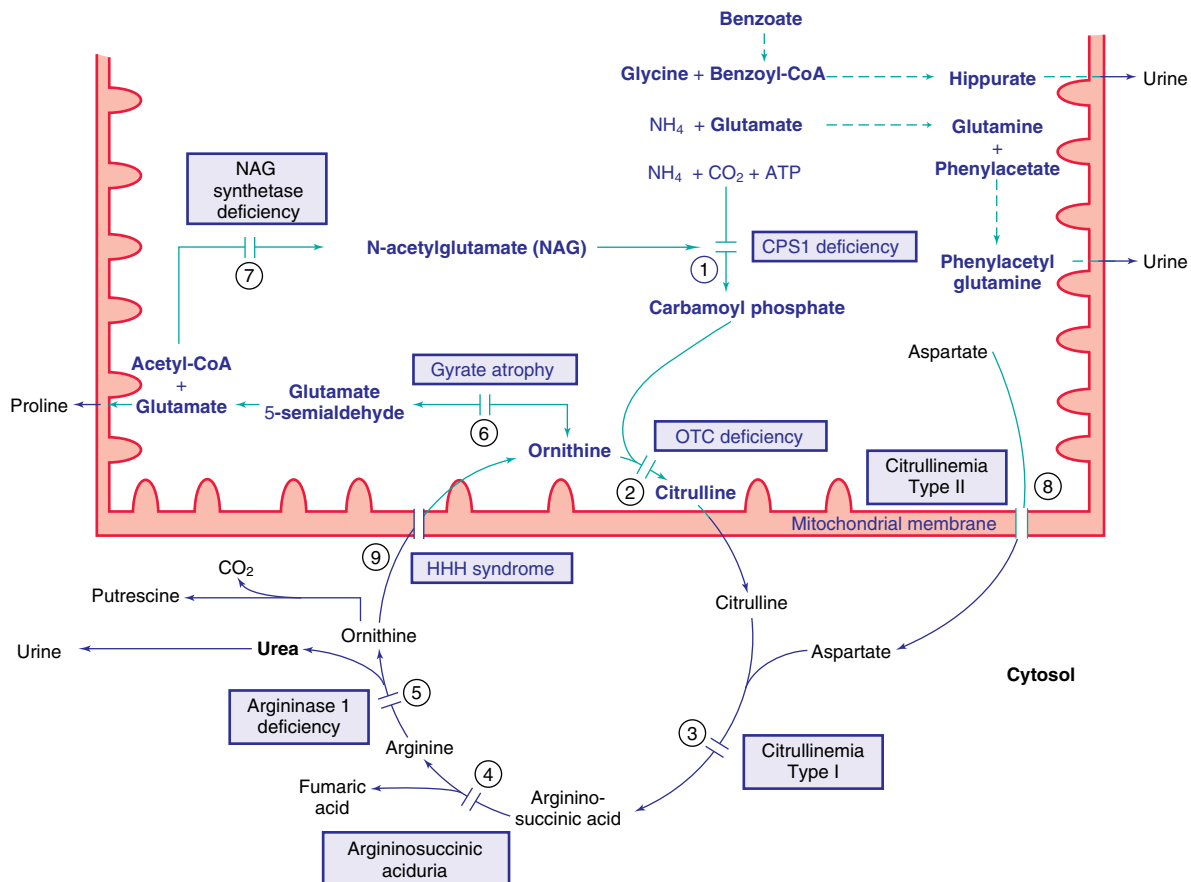
## GENETIC CAUSES OF HYPERAMMONEMIA

Hyperammonemia, sometimes severe, occurs in inborn errors of metabolism other than the urea cycle defects (Table 105.5; see also Table 104.5). The mechanisms of hyperammonemia in some of these conditions are diverse and include accumulation of toxic metabolites (e.g., organic acids), impaired transport of urea cycle intermediates (e.g., HHH syndrome), or depletion of urea cycle intermediates (e.g., lysinuric protein intolerance), leading to compromised function of the urea cycle.

## CLINICAL MANIFESTATIONS OF HYPERAMMONEMIA

In the **neonatal period**, symptoms and signs are mostly related to brain dysfunction and are similar regardless of the cause of the hyperammonemia. The affected infant appears healthy at birth but becomes symptomatic in the first days of life, often following the introduction of dietary protein. Refusal to eat, vomiting, tachypnea, and lethargy can quickly progress to a deep coma. Seizures are common. Physical examination may reveal hepatomegaly in addition to obtundation. Hyperammonemia can trigger increased intracranial pressure that may be manifested by a bulging fontanelle and dilated pupils.

In **infants and older children**, acute hyperammonemia is manifested by vomiting and neurologic abnormalities such as ataxia, confusion, agitation, irritability, combativeness, and psychosis. These manifestations may alternate with periods of lethargy and somnolence that may progress to coma.



**Fig. 105.13** Urea cycle: Pathways for ammonia disposal and ornithine metabolism. Reactions occurring in the mitochondria are depicted in purple. Reactions shown with *interrupted arrows* are the alternative pathways for the disposal of ammonia. Enzymes: (1) Carbamoyl phosphate synthetase type 1 (CPS1), (2) ornithine transcarbamylase (OTC), (3) argininosuccinate synthetase (ASS), (4) argininosuccinate lyase (ASL), (5) arginase 1, (6) ornithine aminotransferase, (7) *N*-acetylglutamate (NAG) synthetase, (8) citrin, (9) ornithine transporter (ORNT1). HHH syndrome, hyperammonemia-hyperornithinemia-homocitrullinemia.

**Table 105.4** The Urea Cycle Disorders

ENZYME OR TRANSPORTER DEFICIENCY	GENE (INHERITANCE)	INCIDENCE	CLINICAL MANIFESTATIONS	AMINO ACIDS (PLASMA, UNLESS OTHERWISE INDICATED)	URINE ORGANIC ACIDS
N-Acetylglutamate synthetase MIM 237310	NAGS (AR)	<1:2,000,000	Acute episodic hyperammonemia Late-onset presentations	↓ Citrulline ↓ Arginine ↑ Glutamine	Unremarkable
Carbamyl phosphate synthetase I MIM 237300	CPS1 (AR)	1:1,300,000	Acute episodic hyperammonemia Late-onset presentations	↓ Citrulline ↓ Arginine ↑ Glutamine	Unremarkable
Ornithine transcarbamylase MIM 311250	OTC (XL)	1:56,500	Acute episodic hyperammonemia Late-onset presentations	↓ Citrulline ↓ Arginine ↑ Glutamine	↑↑ Orotic acid
Argininosuccinate synthetase MIM 215700	ASS1 (AR)	1:250,000	Acute episodic hyperammonemia Late-onset presentations	↑↑ Citrulline ↑ Glutamine ↓ Arginine	N-to-↑ orotic acid
Argininosuccinate lyase MIM 207900	ASL (AR)	1:218,750	Acute episodic hyperammonemia Late-onset presentations ↑ Neurodevelopmental issues Chronic liver disease Trichorrhexis nodosa	↑ Argininosuccinate and anhydrides ↑ Glutamine ↑ Citrulline ↓ Arginine	N-to-↑ orotic acid
Arginase MIM 207800	ARG1 (AR)	1:950,000	Progressive spasticity (LL > UL) Usually mild ID Hyperammonemia (rare)	↑ Arginine	N-to-↑ orotic acid
Citrin MIM 605814, 603471	SLC25A13 (AR)	<1:2,000,000	NICCD Intrahepatic cholestasis Poor growth Spontaneous improvement by 1 yr of age FTTDCD Failure to thrive Dyslipidemia Chronic liver disease Citrullinemia type II Acute episodic hyperammonemia Neuropsychologic manifestations	↑ Citrulline ↑ Arginine ↑ Methionine ↑ Threonine	Unremarkable
Ornithine transporter MIM 238970	SLC25A15 (AR)	<1:2,000,000	Acute episodic hyperammonemia Liver failure (with or without hyperammonemia) Recurrent vomiting Neurologic presentation (e.g., DD, spasticity) Recurrent	↑ Ornithine ↑ Glutamine ↔-to-↓ citrulline ↑ Urine homocitrulline	N-to-↑ orotic acid

AR, Autosomal recessive; DD, developmental delay; FTTDCD, failure to thrive and dyslipidemia caused by citrin deficiency; IV, intravenous; LL, lower limb; NICCD, neonatal intrahepatic cholestasis caused by citrin deficiency; UL, upper limb; XL, X-linked.

From Rossignol F, Ah Mew N, Meltzer MR, Gropman AL. Urea cycle disorders. In: Rosenberg RN, Pascual JM, eds. *Rosenberg's Molecular and Genetic Basis of Neurological and Psychiatric Disease*, 6th ed. Vol. 1. London: Elsevier; 2020: Table 61.1.

Routine laboratory studies show no specific findings when hyperammonemia is caused by defects of the urea cycle enzymes. Blood urea nitrogen is usually low-normal or low in these patients. Some patients may initially present with unexplained elevated serum alanine transaminase (ALT) and aspartate transaminase (AST) and even meet the criteria for acute liver failure. In infants with organic acidemias, hyperammonemia is commonly associated with severe acidosis and ketonuria. Newborn infants with hyperammonemia are often misdiagnosed as having sepsis; they may succumb without a correct diagnosis. Neuroimaging may reveal cerebral edema. Autopsy may reveal microvesicular steatosis, mild cholestasis, and fibrosis of the liver. Thus because of the nonspecific presentation of urea cycle disorders, it is imperative to measure plasma ammonia levels in any ill infant with severe sepsis, unexplained liver dysfunction, recurrent emesis, or progressive encephalopathy.

## DIAGNOSIS

The main criterion for diagnosis is hyperammonemia. Each clinical laboratory should establish its own normal values for blood ammonia.

Normal newborn values are higher than those of the older child or adult. Occasionally, levels as high as 100  $\mu\text{mol/L}$  can occur in healthy term infants. An ill infant usually manifests a blood ammonia level >150  $\mu\text{mol/L}$ . Figure 105.14 illustrates an approach to the differential diagnosis of hyperammonemia in the newborn infant. Careful inspection of individual plasma amino acid profiles usually reveals abnormalities that assist in diagnosis. In patients with deficiencies of CPS1, OTC, or NAGS, frequent findings include elevations in plasma glutamine and alanine with concurrent decrements in citrulline and arginine. These disorders cannot be differentiated from one another by plasma amino acid levels alone. A marked increase in urinary orotic acid in patients with OTC deficiency helps differentiate this defect from CPS1 deficiency (see Table 105.4). Differentiation between the CPS1 deficiency and the NAGS deficiency may require molecular analysis of the relevant genes or, infrequently, an assay of the respective enzyme. Significant clinical improvement occurring after oral administration of carbamylglutamate, however, supports the diagnosis of NAGS deficiency. Patients with a deficiency of ASS, ASL, or arginase 1 have marked increases in the plasma levels of citrulline, argininosuccinate

**Table 105.5** Inborn Errors of Metabolism Causing Hyperammonemia

## DEFICIENCIES OF THE UREA CYCLIC ENZYMES

Carbamyl phosphate synthetase 1  
 Ornithine transcarbamylase  
 Argininosuccinate synthetase  
 Argininosuccinate lyase  
 Arginase 1  
 N-acetylglutamate synthetase

## ORGANIC ACIDEMIA

Propionic acidemia  
 Methylmalonic acidemia  
 Isovaleric acidemia  
 $\beta$ -Ketothiolase deficiency  
 Multiple carboxylase deficiencies  
 Medium-chain fatty acid acyl-CoA dehydrogenase deficiency  
 Glutaric acidemia type I  
 3-Hydroxy-3-methylglutaric aciduria

## OTHERS

Lysinuric protein intolerance  
 Hyperammonemia-hyperornithinemia-homocitrullinemia syndrome  
 Transient hyperammonemia of the newborn  
 Congenital hyperinsulinism with hyperammonemia  
 Carbonic anhydrase VA deficiency

acid, or arginine, respectively. The combination of hyperammonemia and marked hypercitrullinemia or argininosuccinic acidemia is virtually pathognomonic for these disorders. Additional clinical clues may come from the past medical history. Children with urea cycle defects often self-select a low-protein, high-carbohydrate diet, especially those with late-onset disease or symptomatic females with partial OTC deficiency.

Because of the nonspecific clinical and laboratory findings, mass screening of newborn infants has been implemented in many countries, which can identify patients with ASS, ASL, and arginase 1 deficiencies.

**TREATMENT OF ACUTE HYPERAMMONEMIA**

The clinical outcome depends mainly on the severity and the duration of hyperammonemia. Serious neurologic sequelae are likely in newborns with severe elevations in blood ammonia (>300  $\mu\text{mol/L}$ ) lasting more than 12 hours. Thus acute hyperammonemia should be treated promptly and vigorously. The goal of therapy is to lower the concentration of ammonia. This is accomplished by (1) temporarily restricting dietary sources of ammonia (protein), (2) minimizing endogenous protein breakdown and favoring endogenous protein synthesis by providing adequate calories and essential amino acids, and (3) removal of ammonia from the body in a form other than urea (Table 105.6). Fluid, electrolytes, glucose (10–15%), and lipids (1–2 g/kg/day) should be infused intravenously, together with minimal amounts of protein (0.25 g/kg/day), preferably including essential amino acids. Oral feeding with a low-protein formula (0.5–1.0 g/kg/day) through a nasogastric tube should be started as soon as sufficient improvement is seen.

Because the kidneys clear ammonia poorly, its removal from the body must be expedited by formation of compounds with a high renal clearance. An important advance in the treatment of hyperammonemia has been the introduction of **nitrogen scavenging therapy** by using an exogenous organic acid that conjugates to endogenous nonessential amino acids (glycine and glutamine) to form nontoxic compounds with high renal clearance. The main organic acids used for this purpose are sodium salts of benzoic acid and phenylacetic acid. **Benzoate** forms hippurate through enzymatic conjugation with endogenous glycine in the liver (see Fig. 105.13). Each mole of benzoate removes one mole of ammonia as glycine. **Phenylacetate** enzymatically conjugates with glutamine to form phenylacetylglutamine readily excreted in the urine. One mole of phenylacetate can remove two moles of ammonia

**Table 105.6** Treatment of Acute Hyperammonemia in an Infant

1. Provide adequate calories, fluid, and electrolytes intravenously (10% glucose, NaCl\* and intravenous lipids 1 g/kg/day). Add minimal amounts of protein, preferably as a mixture of essential amino acids (0.25 g/kg/day) during the first 24 hr of therapy.
2. Give priming doses of the following compounds (to be added to 20 mL/kg of 10% glucose and infused within 1–2 hr):
  - Sodium benzoate 250 mg/kg<sup>†</sup>
  - Sodium phenylacetate 250 mg/kg<sup>†</sup>
  - Arginine hydrochloride 200–600 mg/kg as a 10% solution
3. Continue infusion of sodium benzoate<sup>†</sup> (250–500 mg/kg/day), sodium phenylacetate<sup>†</sup> (250–500 mg/kg/day), and arginine (200–600 mg/kg/day<sup>‡</sup>) following the above priming doses. These compounds should be added to the daily intravenous fluid.
4. Initiate peritoneal dialysis or hemodialysis if above treatment fails to produce an appreciable decrease in plasma ammonia.

\*The concentration of sodium chloride should be calculated to be 0.45–0.9%, including the amount of the sodium in the drugs.

<sup>†</sup>Sodium from these drugs should be included as part of the daily sodium requirement.

<sup>‡</sup>The higher dose of the range is recommended in the treatment of patients with citrullinemia and argininosuccinic aciduria. Arginine is not recommended in patients with arginase deficiency and in those whose hyperammonemia is secondary to organic acidemia. Sodium benzoate and sodium phenylacetate should be used with caution in patients with organic acidemias.

as glutamine from the body (see Fig. 105.13). Sodium phenylbutyrate, metabolized to phenylacetate, is the primary oral formulation. For intravenous (IV) use, a combined formulation of benzoate and phenylacetate (Ammonul) is commercially available.

Another valuable therapeutic adjunct is IV infusion of **arginine**, which is effective in all patients except those with arginase deficiency. Arginine administration supplies the urea cycle with ornithine (see Fig. 105.13). In patients with citrullinemia, one mole of arginine reacts with one mole of ammonia as carbamoyl phosphate to form citrulline. In patients with argininosuccinic acidemia, two moles of ammonia (as carbamoyl phosphate and aspartate) react with arginine to form argininosuccinic acid. Citrulline and argininosuccinate are less toxic than ammonia and more readily excreted by the kidneys. In patients with CPS1 or OTC deficiencies, arginine administration is indicated because this amino acid is not produced in sufficient amounts to enable endogenous protein synthesis. For enteral therapy, patients with OTC deficiency benefit from supplementation with *citrulline* (200 mg/kg/day) because one mole of citrulline reacts with one mole of ammonia (through aspartic acid) to form arginine. Administration of arginine or citrulline is contraindicated in patients with **arginase deficiency**, a rare condition in which the spastic diplegia is a much more common presenting feature rather than hyperammonemia. Arginine therapy is of no benefit if hyperammonemia is secondary to an organic acidemia. In a newborn infant with an initial episode of hyperammonemia, arginine should be used until the diagnosis is established (see Table 105.6).

Benzoate, phenylacetate, and arginine may be administered together for maximal therapeutic effect. A priming dose of these compounds is followed by continuous infusion until recovery from the acute state occurs. Both benzoate and phenylacetate are usually supplied as concentrated solutions and should be properly diluted (1–2% solution) for IV use. The recommended therapeutic doses of both compounds deliver a substantial amount of sodium to the patient; this amount should be included in the calculation of the daily sodium requirement. Benzoate and phenylacetate (or the combined formulation) should be used with caution in newborn infants with hyperbilirubinemia because they may displace bilirubin from albumin; however, there are no documented cases of kernicterus (see Chapter 123.4) reported in neonates with hyperammonemia who have received such therapies. In infants at risk, it is advisable to monitor and manage bilirubin levels while considering IV administration of benzoate or phenylacetate.

If the initial ammonia level is <500  $\mu\text{mol/L}$  and if the foregoing therapies fail within 4–6 hours to produce any appreciable change in the blood ammonia level, **hemodialysis** should be considered. For patients

presenting with an ammonia level >500  $\mu\text{mol/L}$ , extracorporeal detoxification is the initial method of ammonia removal. Exchange transfusion has little effect on reducing total body ammonia. It should be used only if dialysis cannot be employed promptly or when the patient is a newborn infant with significant hyperbilirubinemia (see earlier). Hemodialysis dramatically lowers blood ammonia within a few hours, but if it is unavailable or technically unfeasible, peritoneal dialysis may be used as a temporary solution. When hyperammonemia is caused by an organic acidemia and hemodialysis is not available, peritoneal dialysis can be used to remove both the offending organic acid and ammonia.

Oral administration of **neomycin** limits the growth of intestinal bacteria that can produce ammonia. However, this modality is of limited use in urea cycle patients (e.g., affected neonates) in whom reduction of hyperammonemia is an urgent priority. Oral **lactulose** acidifies the intestinal lumen, thereby reducing the diffusion of ammonia across the intestinal epithelium. This agent is of limited applicability in newborns, who have a high risk of acidemia and dehydration.

There may be considerable lag between the normalization of ammonia level and an improvement in the patient's neurologic status. Several days may be needed before the infant becomes fully alert.

There has been interest in the use of **cooling** as a therapeutic adjunct in newborn infants with metabolic encephalopathy such as that caused by hyperammonemia. Clinical studies are in progress to evaluate the efficacy of this approach.

### Long-Term Therapy

Once the acute hyperammonemic episode is under control, maintenance therapy should be tailored to address the underlying cause of the hyperammonemia. All patients, regardless of the enzymatic defect, require protein restriction limited to the age-adjusted recommended dietary allowance (RDA). In pediatric patients with urea cycle defects, chronic administration of sodium benzoate (250 mg/kg/day), sodium phenylbutyrate (250-500 mg/kg/day), and arginine (200-400 mg/kg/day) or citrulline (in patients with OTC deficiency, 200-400 mg/kg/day) is effective in maintaining blood ammonia levels within the normal range (doses above are for patients who weigh <20 kg). Arginine and citrulline are contraindicated in patients with argininemia. Patients who have difficulty taking sodium phenylbutyrate can be trialed on glycerol phenylbutyrate. This compound conceals the offensive odor of sodium phenylbutyrate and may help with patient adherence. Benzoate and phenylacetate may lower carnitine levels, but clinical signs of carnitine deficiency or benefit from carnitine supplementation have not yet been demonstrated. These compounds have been used during pregnancy without obvious teratogenic effect. However, experience is still limited, and appropriate caution should be exercised.

Growth parameters, especially head circumference, and nutritional indices (blood albumin, prealbumin, pH, electrolytes, amino acids, zinc, selenium) should be followed closely. Long-term care of these patients is best achieved by a team of experienced professionals (pediatrician, nutritionist, child neurologist, metabolic geneticist). Skin lesions resembling **acrodermatitis enteropathica** (see Chapter 691) have been noted in a few patients with different types of urea cycle defects, presumably resulting from the deficiency of essential amino acids, caused by overzealous dietary protein restriction. Catabolic states (infections, fasting) that may trigger hyperammonemia should be avoided. They must be treated vigorously when they occur. It is important that all children with urea cycle defects avoid valproic acid because this drug can elevate blood ammonia even in some healthy individuals. In patients with CPS1, OTC, or ASS deficiency, acute hyperammonemic attacks may be precipitated by valproate administration.

### CARBAMOYL PHOSPHATE SYNTHETASE 1 AND N-ACETYLGUTAMATE SYNTHASE DEFICIENCIES

Without treatment, deficiencies of these two enzymes produce similar clinical and biochemical manifestations (see Figs. 105.13 and 105.14). There is a wide variation in the severity of symptoms and in the age at presentation. In near-complete enzymatic deficiency, symptoms appear during the first few days or even hours of life with signs and symptoms

of hyperammonemia (refusal to eat, vomiting, lethargy, convulsion, coma). Increased intracranial pressure is frequent. Late forms (as late as the fourth decade of life) may present as an acute bout of hyperammonemia (lethargy, headache, seizures, psychosis) in a seemingly healthy individual. Coma and death may occur during these episodes. Diagnostic confusion with migraine is common. Intermediate forms with intellectual disability and chronic subclinical hyperammonemia interspersed with bouts of acute hyperammonemia have also been observed.

**Laboratory findings** include hyperammonemia. The plasma amino acid analysis typically shows a marked increase of glutamine and alanine with relatively low levels of citrulline and arginine. These are non-diagnostic changes that occur in hyperammonemia of diverse causes. Urinary orotic acid is usually low or may be absent (see Fig. 105.14).

**Treatment** of acute hyperammonemic attacks and the long-term therapy of the condition are outlined earlier (see Table 105.6). Treatment with oral carbamylglutamate of patients with NAGS deficiency can produce successful rescue of biochemical findings and symptoms. It is therefore important to differentiate between CPS1 and NAGS deficiencies by gene analysis of *CPS1* and *NAGS*, respectively.

CPS1 and NAGS deficiencies are both autosomal recessive conditions; the CPS1 enzyme is normally present in the liver and intestine. Neither of these conditions can be reliably identified by the mass screening of the newborn infants using current approaches.

### ORNITHINE TRANSCARBAMYLASE DEFICIENCY

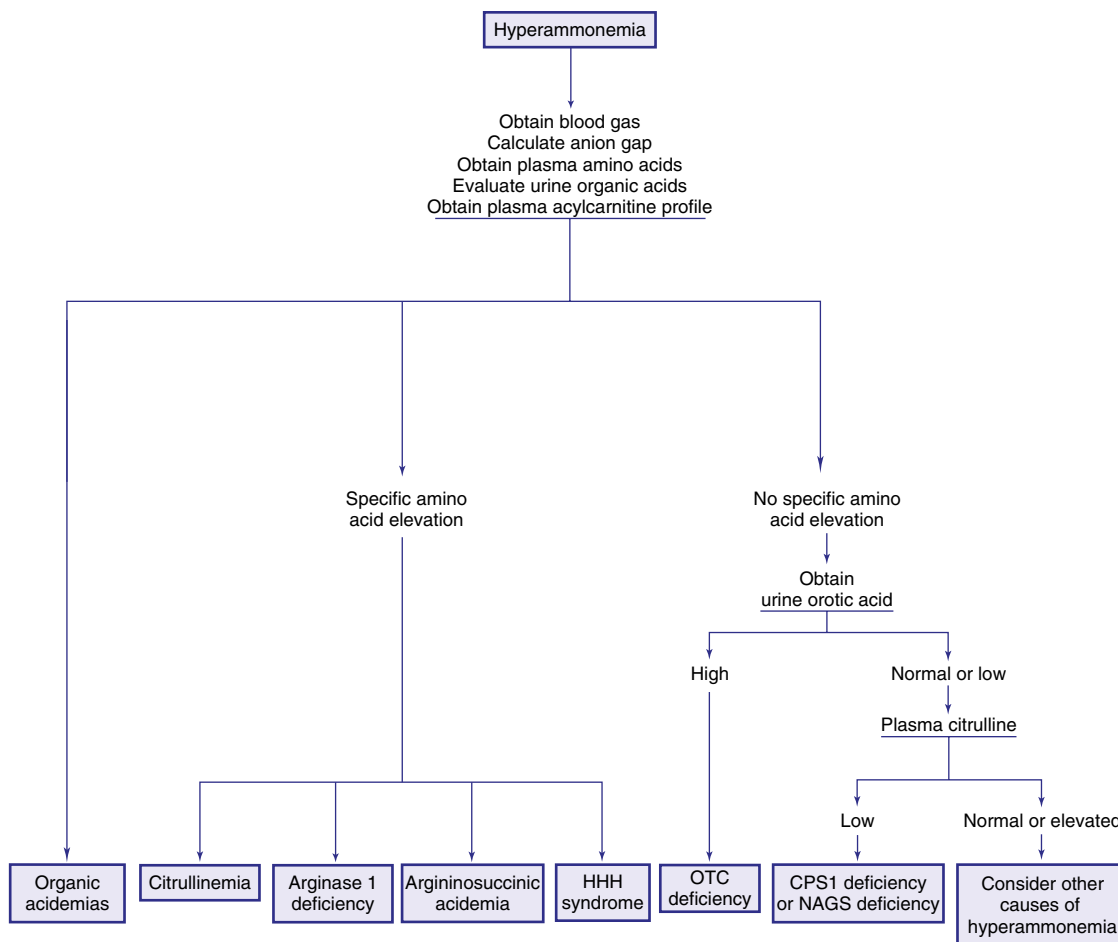
In this X-linked disorder, the hemizygous males are more severely affected than heterozygous females (see Figs. 105.13 and 105.14). The heterozygous females may have a mild form of the disease, but the majority (approximately 75%) remain asymptomatic, although investigations indicate subtle neurologic defects even in females without a discernable history of hyperammonemia. OTC deficiency is the most common form of all the urea cycle disorders, comprising approximately 40% of cases.

**Clinical manifestations** in a male newborn are usually those of **severe** hyperammonemia (see earlier) occurring in the first few days of life. **Mild forms**, such as in some heterozygous females, characteristically have episodic manifestations, which may occur at any age (usually after infancy). Episodes of hyperammonemia, manifested by vomiting and neurologic abnormalities (e.g., ataxia, mental confusion, agitation, combativeness, frank psychosis), are separated by periods of wellness. These episodes usually occur after ingestion of a high-protein diet or as a result of a catabolic state such as infection. Hyperammonemic coma, cerebral edema, and death may occur during one of these attacks. Cognitive development may proceed normally. Mild to moderate intellectual disability, however, is common. Gallstones have been seen in the survivors, although the mechanism remains unclear.

The major **laboratory finding** during the acute attack is hyperammonemia accompanied by marked elevations of plasma concentrations of glutamine and alanine with low levels of citrulline and arginine. The blood level of urea is usually low. A marked increase in the urinary excretion of orotic acid differentiates this condition from CPS1 deficiency (see Fig. 105.14). Orotate may precipitate in urine as pink-colored crystals. In the **mild form**, these laboratory abnormalities may revert to normal between attacks. This form should be differentiated from all the episodic conditions of childhood. Patients with lysinuric protein intolerance (see Chapter 105.14) may demonstrate some features of OTC deficiency, but the former can be differentiated by increased urinary excretion of lysine, ornithine, and arginine and elevated blood concentrations of citrulline.

The prevalence of OTC deficiency is 1 in 56,000 to 1 in 77,000 live births. This condition is not identifiable by the mass screening of newborn infants using current approaches. The **diagnosis** is most conveniently confirmed by OTC gene analysis. Many OTC pathogenic variants (>300) have been identified. Genotype and degree of enzyme deficiency determine the severity of the phenotype in most cases. Mothers of affected infants are expected to be carriers of the mutant gene unless a de novo pathogenic variant has occurred. A mother who gave birth to two affected male offspring was found to have a normal





**Fig. 105.14** Clinical algorithmic approach to a newborn infant with symptomatic hyperammonemia. CPS1, Carbamoyl phosphate synthetase 1; HHH syndrome, hyperornithinemia-hyperammonemia-homocitrullinemia; NAGS, N-acetylglutamate synthetase; OTC, ornithine carbamoyltransferase.

genotype, suggesting that gonadal mosaicism can be seen. As many as 20% of affected patients demonstrate normal results by Sanger sequencing, perhaps because the pathogenic variant involves copy number variants, deep intronic regions, or a promoter sequence. Copy number variants can be evaluated using a chromosomal microarray, and if positive, a contiguous gene deletion should be considered. If the molecular diagnostic approach is negative, a liver biopsy may be indicated. Prenatal diagnosis is feasible by analysis of DNA in amniocytes or chorionic villus samples. Increase in urinary excretion of orotidine after an allopurinol loading test can identify female carriers. Mild cerebral dysfunction may be present in asymptomatic female carriers. The importance of a detailed family history cannot be overemphasized. A history of migraine or protein aversion is common in maternal female relatives of the proband. Indeed, careful scrutiny of the family history may reveal a pattern of unexplained deaths in male newborns in the maternal lineage.

**Treatment** of acute hyperammonemic attacks and the long-term therapy of the condition are as outlined earlier. For enteral use, citrulline is used in place of arginine for patients with OTC deficiency. Liver transplantation is a surgical treatment option for patients with severe OTC deficiency.

## CITRULLINEMIA

Two clinically and genetically distinct forms of citrullinemia have been described. The classic form (**type I**) is caused by the deficiency of the ASS enzyme. Citrullinemia **type II** is caused by the deficiency of a mitochondrial transport protein called *citrin*. (See Figs. 105.13 and 105.14.)

## Citrullinemia Type I (Argininosuccinate Synthetase Deficiency, Classic Citrullinemia)

This condition is caused by the deficiency of ASS (see Fig. 105.13) and has variable clinical manifestations depending on the degree of the enzyme deficiency. Two major forms of the condition have been identified. The **severe or neonatal form**, which is most common, appears in the first few days of life with signs and symptoms of hyperammonemia (see earlier). In the **subacute or mild form**, clinical findings such as failure to thrive, frequent vomiting, developmental delay, and dry, brittle hair appear gradually after 1 year of age. Acute hyperammonemia, triggered by an intercurrent catabolic state, may bring the diagnosis to light.

**Laboratory findings** are similar to those found in patients with OTC deficiency, except that the plasma citrulline concentration is greatly elevated (50–100 times the reference range) (see Fig. 105.14). Urinary excretion of orotic acid is moderately increased; crystalluria may also occur as a result of precipitation of orotates. The diagnosis is confirmed by DNA analysis of *ASS1* or, less frequently, by an assay of enzyme activity in cultured fibroblasts. Prenatal diagnosis is feasible with an enzyme assay in cultured amniotic cells or by DNA analysis of cells obtained from chorionic villus biopsy.

**Treatment** of acute hyperammonemic attacks and long-term therapy are outlined earlier (see Table 105.6). Plasma concentration of citrulline remains elevated at all times and may increase further after administration of arginine. Patients can do well on a protein-restricted diet in conjunction with sodium benzoate, phenylbutyrate, and arginine therapy. Mild to moderate cognitive impairment is a common sequela, even in a well-treated patient.

Citrullinemia is an autosomal recessive condition caused by biallelic pathogenic variants in *ASS1*. The majority of patients are compound heterozygotes for two different alleles. The prevalence of the condition is 1 in 250,000 live births. The recent introduction of neonatal screening for urea cycle defects has shown that some affected patients are ostensibly asymptomatic even on a regular diet. Long-term follow-up is needed to be certain that these individuals do not sustain neurologic sequelae.

### Citrin Deficiency (Citrullinemia Type II)

Citrin (aspartate-glutamate carrier protein) is a mitochondrial transporter encoded by *SLC25A13*. One of this protein's functions is to transport aspartate from mitochondria into cytoplasm and replenish the cytosolic aspartate pool required for converting citrulline to argininosuccinic acid (see Fig. 105.13). If aspartate is unavailable to the cytoplasmic component of the urea cycle, urea will not be formed at a normal rate, and citrulline will accumulate. ASS activity is diminished in the liver of these patients, but no pathogenic variant in the *ASS1* gene has been found. It is postulated that citrin deficiency interferes with translation of the messenger RNA for the ASS enzyme in the liver. The condition initially was reported in Japan (regional prevalence ~1 in 20,000), but many non-Japanese patients have been since identified (worldwide prevalence between 1 in 100,000 and 1 in 230,000). Biallelic pathogenic variants in *SLC25A13* have been associated with three clinical forms of citrin deficiency.

### Neonatal Intrahepatic Cholestasis (Citrullinemia Type II, Neonatal Form)

Clinical and laboratory manifestations, which usually start before the infant's first birthday, include cholestatic jaundice with mild to moderate direct (conjugated) hyperbilirubinemia, marked hypoproteinemia, and clotting dysfunction (increased prothrombin time and partial thromboplastin time); increased serum  $\gamma$ -glutamyltransferase and alkaline phosphatase activities; and liver transaminases are usually normal. Plasma concentrations of ammonia and citrulline are usually normal, but moderate elevations have been reported. There may be increases in plasma concentrations of methionine, tyrosine, alanine, and threonine. Elevated levels of serum galactose have been found, even though the enzymes of galactose metabolism are normal. The reason for hypergalactosemia is not clear. Marked elevation in the serum level of  $\alpha$ -fetoprotein is also present. These findings resemble those of tyrosinemia type I, but unlike the latter condition, urinary excretion of succinylacetone is not elevated (see Chapter 105.2). Liver biopsy shows fatty infiltration, cholestasis with dilated canaliculi, and a moderate degree of fibrosis. The condition is usually self-limiting, and the majority of infants recover spontaneously by 1 year of age with supportive and symptomatic treatment. Hepatic failure requiring liver transplantation has occurred in a few cases. Although the condition is commonly seen in Japan, the diagnosis should be considered in any case of unexplained neonatal hepatitis with cholestasis. Data on the long-term prognosis and the natural history of the condition are limited; development into the adult form of the condition after several years of a seemingly asymptomatic hiatus has been observed.

### Failure to Thrive and Dyslipidemia Due to Citrin Deficiency

Some patients can present between 1 and 10 years of age with peculiar dietary habits favoring high-protein and high-lipid foods. It is accompanied by poor appetite, hypoglycemic episodes, and failure to thrive. Laboratory evaluation may reveal mild hyperammonemia, hypertriglyceridemia, elevated low-density lipoprotein (LDL) cholesterol, and low high-density lipoprotein (HDL) cholesterol levels. This presentation of citrin deficiency in children is often considered a prodromal form of the adult form of citrullinemia type II.

### Citrullinemia Type II, Adult Form (Adult-Onset Citrullinemia; Citrullinemia Type II, Mild Form)

Without prior molecular diagnosis or family history, individuals affected by this form of citrullinemia type II (CTLN2) are often

identified acutely. A previously healthy individual may present with nonspecific neuropsychiatric symptoms such as disorientation, delirium, delusion, aberrant behavior, tremors, and psychosis. Moderate degrees of hyperammonemia and hypercitrullinemia are present. The age at onset is usually between 20 and 40 years but can happen at any point after age 11 years. Patients who recover from the first episode may have recurrent attacks. Pancreatitis, hyperlipidemia, and hepatoma are major complications among the survivors. Medical treatment of CTLN2 has been mostly ineffective to prevent future attacks. A diet enriched in protein and lipids helps restore cytosolic aspartate and stimulate ureagenesis. In confirmed citrin deficiency, a low-protein/high-carbohydrate diet should be avoided. Although liver transplantation appears to be effective in preventing future episodes of hyperammonemia, enteral supplementation with pyruvate, arginine, and medium-chain triglycerides can be tried first to help prevent hyperammonemic episodes and improve growth.

### ARGININOSUCCINATE LYASE DEFICIENCY (ARGININOSUCCINIC ACIDURIA)

The severity of the clinical and biochemical manifestations varies considerably (see Figs. 105.13 and 105.14). In the severe form of ASL deficiency, severe hyperammonemia (see earlier) can develop in the first few days of life, and without treatment affected infants can perish. The clinical course of ASL deficiency in patients who survive the initial acute episode is often characterized by intellectual disability, failure to thrive, hypertension, gallstones, liver fibrosis, and hepatomegaly. A common finding in untreated patients is dry and brittle hair (**trichorrhexis nodosa**), although this finding is relatively nonspecific. Acute attacks of severe hyperammonemia may occur during a catabolic state triggered by infections, trauma, or dietary indiscretion. Laboratory findings include hyperammonemia, moderate elevations in liver enzymes, nonspecific increases in plasma levels of glutamine and alanine, a moderate increase in plasma levels of citrulline (less than in citrullinemia), and a marked increase in the concentration of argininosuccinic acid in plasma, urine, and CSF. The CSF levels are usually higher than those in plasma. The enzyme is present in erythrocytes, the liver, and cultured fibroblasts. **Prenatal diagnosis** is possible by identification of biallelic pathogenic variants in the *ASL* gene or, rarely, by measurement of the enzyme activity in cultured amniotic cells. Argininosuccinic acid is also elevated in the amniotic fluid of affected fetuses.

**Treatment** of acute hyperammonemic attacks and the long-term therapy of the condition are outlined earlier in this chapter. Intellectual disability, persistent hepatomegaly with mild increases in liver enzymes, and bleeding tendencies as a result of abnormal clotting factors are common sequelae. ASL deficiency is an autosomal recessive disorder with a prevalence of about 1 in 220,000 live births. Early detection is achieved through mass screening of newborn infants.

### ARGINASE 1 DEFICIENCY (HYPERARGININEMIA)

Arginase 1 deficiency is an autosomal recessive condition caused by biallelic pathogenic variants in *ARG1* (see Figs. 105.13 and 105.14). Two genetically distinct arginases are present in humans. Arginase 1 (ARG1) is a cytosolic enzyme and is expressed in the liver and can be found in erythrocytes. Arginase 2 (ARG2) is expressed in renal and brain mitochondria. The role of ARG2 is not well understood; its activity in patients with argininemia appears to have no protective effect.

**Clinical manifestations** of arginase 1 deficiency are somewhat different from other urea cycle enzyme defects, although acute neonatal hyperammonemia presenting with intractable seizures, cerebral edema, and death has also been reported. Outside of the neonatal period, the onset of arginase 1 deficiency often is insidious. The infant can remain asymptomatic in the first few months or years of life. A **progressive spastic diplegia** with scissoring of the lower extremities, choreoathetotic movements, loss of developmental milestones, and failure to thrive in a previously normal infant may suggest the diagnosis. Some children were treated for cerebral palsy before arginase 1 deficiency was confirmed. Intellectual disability is progressive; seizures are common, but episodes of severe hyperammonemia are not as frequent as in the more proximal urea cycle defects. Hepatomegaly may be present.

**Laboratory evaluation** reveals marked elevations of arginine in plasma and CSF (see Fig. 105.14). Urinary orotic acid can be increased. Determination of amino acids in plasma is a critical step in the diagnosis of argininemia. Guanidino compounds ( $\alpha$ -keto-guanidinovaleic acid and  $\alpha$ -keto-argininic acid) can be markedly increased in urine. The diagnosis is secured by identification of biallelic pathogenic variants in *ARG1* or, rarely, by assaying arginase activity in erythrocytes.

**Treatment** consists of a low-protein diet at the age-appropriate RDA. The dietary composition and daily intake of protein should be monitored by frequent plasma amino acid determinations. Supplementation with arginine in *ARG1*-deficient patients is contraindicated. Sodium benzoate or sodium phenylbutyrate is also effective in controlling hyperammonemia and lowering plasma arginine levels. Liver transplantation has produced promising results, but experience with long-term outcome is limited. Early detection is feasible through mass screening of newborn infants.

### TRANSIENT HYPERAMMONEMIA OF THE NEWBORN

The blood concentration of ammonia in a full-term infant can be as high as 100  $\mu\text{mol/L}$ , or two to three times greater than that of the older child or adult. Blood levels approach the adult normal values after a few weeks of life (see Fig. 105.14). Plasma ammonia levels greater than 100  $\mu\text{mol/L}$  should prompt additional diagnostic steps to evaluate for possible genetic causes of hyperammonemia. Infrequently, **severe transient hyperammonemia** can be observed in infants whose diagnostic workup reveals no biochemical abnormalities implicating genes encoding components of the urea cycle. The majority of affected infants are premature and have mild respiratory distress syndrome. Hyperammonemic coma can develop within 2-3 days of life, and the infant may succumb to the disease if treatment is not started immediately. Laboratory studies reveal marked hyperammonemia (plasma ammonia as high as 4,000  $\mu\text{mol/L}$ ) with moderate increases in plasma levels of glutamine and alanine. Plasma concentrations of urea cycle intermediate amino acids are usually normal except for citrulline, which may be moderately elevated. The cause of the disorder is unknown. Urea cycle enzyme activities are normal. **Treatment** of hyperammonemia should be initiated promptly and continued vigorously. Recovery without sequelae has been reported, and hyperammonemia does not recur even with a normal-protein diet.

### DISORDERS OF ORNITHINE METABOLISM

Ornithine, a key intermediate of the urea cycle, is not incorporated into natural proteins. Rather, it is generated in the cytosol from arginine and must be transported into mitochondria, where it becomes a substrate in reactions catalyzed by OTC forming citrulline. Excess ornithine is catabolized by two enzymes: ornithine aminotransferase, a mitochondrial enzyme converting ornithine to a proline precursor, and ornithine decarboxylase, which resides in the cytosol and converts ornithine to putrescine (see Fig. 105.13). Two genetic disorders feature **hyperornithinemia**: gyrate atrophy of the retina and hyperammonemia-hyperornithinemia-homocitrullinemia (HHH) syndrome.

#### Gyrate Atrophy of the Retina and Choroid

This rare, autosomal recessive disorder is caused by biallelic pathogenic variants in *OAT* leading to the deficient activity of ornithine aminotransferase (see Fig. 105.13). Approximately 30% of the reported cases are from Finland. Clinical manifestations may include hyperammonemia in the first months of life in some patients. Findings that define the phenotype of ornithine aminotransferase deficiency include night blindness, myopia, loss of peripheral vision, and posterior subcapsular cataracts. These eye changes start between 5 and 10 years of age and progress to complete blindness by the fourth decade of life. Atrophic lesions in the retina resemble cerebral gyri. These patients usually have normal intelligence. Besides the characteristic 10- to 20-fold increase in plasma levels of ornithine (400-1,400  $\mu\text{mol/L}$ ), plasma levels of

glutamate, glutamine, lysine, creatine, and creatinine can be moderately decreased. Some patients show partial improvement with high doses of pyridoxine. An arginine-restricted diet in conjunction with supplemental lysine, proline, and creatine has been successful in reducing plasma ornithine concentration and has produced some clinical improvement.

#### Hyperammonemia-Hyperornithinemia-Homocitrullinemia Syndrome

Biallelic pathogenic variants in *SLC25A15* result in an autosomal recessive disorder, HHH syndrome. This defect of the ornithine transport system leads to accumulation of ornithine in the cytosol and a depletion of this amino acid in mitochondria. The former causes hyperornithinemia, and the latter results in disruption of the urea cycle and hyperammonemia (see Fig. 105.13). Homocitrulline is presumably formed through condensation of mitochondrial carbamoyl phosphate with lysine. Clinical manifestations of hyperammonemia can develop shortly after birth or may be delayed until adulthood. Acute episodes of hyperammonemia manifest as refusal to feed, vomiting, and lethargy; coma may occur during infancy. Progressive neurologic signs, such as lower limb weakness, increased deep tendon reflexes, spasticity, clonus, seizures, and varying degrees of psychomotor retardation may develop if the condition remains undiagnosed. No ocular findings have been observed in these patients. Laboratory findings reveal marked increases in plasma levels of ornithine and homocitrulline in addition to hyperammonemia (see Fig. 105.14). Acute episodes of hyperammonemia should be treated promptly (see earlier). Restriction of protein intake improves hyperammonemia. Oral supplementation with arginine (or citrulline) has produced clinical improvement in some patients.

### CONGENITAL GLUTAMINE DEFICIENCY

Glutamine is synthesized endogenously from glutamate and ammonia by a ubiquitously expressed enzyme, glutamine synthetase (see Fig. 105.11). Glutamine is known to be involved in several important functions, including detoxification of ammonia. Deficiency of this enzyme, resulting in glutamine deficiency, has been reported in three infants from three unrelated families. All affected infants manifested multiorgan involvement, including brain malformations (abnormal gyrations, hypomyelination), facial abnormalities (broad nasal root, low-set ears), hypotonia, and seizures at birth. Two of the patients died from multiorgan failure (respiratory and heart failure) in the neonatal period. One child was alive at 3 years of age with severe developmental delay. Glutamine was absent in plasma, urine, and CSF, but plasma levels of glutamic acid were normal. Congenital glutamine deficiency is an autosomal recessive condition caused by biallelic pathogenic variants in *GLUL*.

Visit Elsevier eBooks+ at [eBooks.Health.Elsevier.com](http://eBooks.Health.Elsevier.com) for Bibliography.

## 105.13 Histidine

Oleg A. Shchelochkov and Charles P. Venditti

Histidine is degraded through the urocanic acid pathway to glutamic acid. Several genetic biochemical aberrations involving the degradative pathway of histidine have been reported, but the clinical significance of elevated histidine levels has not been established.

Decarboxylation of histidine by histidine decarboxylase produces histamine. Deficiency of this enzyme has been implicated in the familial form of **Tourette syndrome** (see Chapter 105.11).

Visit Elsevier eBooks+ at [eBooks.Health.Elsevier.com](http://eBooks.Health.Elsevier.com) for Bibliography.

## 105.14 Lysine

Oleg A. Shchelochkov and Charles P. Venditti

Lysine is catabolized through two pathways. In the first pathway, lysine is condensed with  $\alpha$ -ketoglutaric acid to form saccharopine. Saccharopine is then catabolized to  $\alpha$ -aminoadipic semialdehyde and glutamic acid. These first two steps are catalyzed by  $\alpha$ -aminoadipic semialdehyde synthase, which has two activities: lysine-ketoglutarate reductase and saccharopine dehydrogenase (Fig. 105.15). In the second pathway, lysine is first transaminated and then condensed to its cyclic forms: pipercolic acid and piperideine-6-carboxylic acid (P6C). P6C and its linear form,  $\alpha$ -aminoadipic semialdehyde, are oxidized to  $\alpha$ -aminoadipic acid by the enzyme **antiquitin**. This is the major pathway for D-lysine in the body and for L-lysine in the brain.

**Hyperlysinemia-saccharopinuria,  $\alpha$ -aminoadipic, and  $\alpha$ -ketoadipic acidemia** are biochemical conditions caused by inborn errors of lysine degradation. Individuals with these conditions are usually asymptomatic.

### PYRIDOXINE-DEPENDENT EPILEPSY (PDE)

Pyridoxal 5'-phosphate (P5P), the active form of pyridoxine (vitamin B<sub>6</sub>), is the cofactor for many enzymes, including those involved in the metabolism of neurotransmitters. Intracellular P5P deficiency in the brain may result in a seizure disorder that is refractory to common anticonvulsant agents but is responsive to high doses of pyridoxine. These pyridoxine-responsive phenotypes are seen in the following genetic metabolic conditions.

### Antiquitin ( $\alpha$ -Aminoadipic Semialdehyde Dehydrogenase) Deficiency

This is the most common cause of PDE. A deficiency of antiquitin (encoded by *ALDH7A1*) results in accumulation of P6C in brain tissue (see Fig. 105.15). P6C reacts with P5P and renders it inactive. Large doses of pyridoxine are therefore needed to overcome this inactivation. The condition is inherited as an autosomal recessive trait.

### Pyridox(am)ine 5'-Phosphate Oxidase (PNPO) Deficiency

PNPO deficiency clinically overlaps with antiquitin deficiency. PNPO-deficient patients often present with neonatal-onset seizures, developmental delays, spastic tetraplegia, and nonspecific findings on brain imaging (delayed myelination, cerebral atrophy, and abnormal signals in the basal ganglia). Developmental regression, optic disc pallor, and retinopathy have been reported infrequently. Plasma and CSF amino acid analysis may reveal elevated glycine, prompting evaluation for NKH (see Chapter 105.7), leading to a delay in initiating treatment with P5P. A CSF neurotransmitter assay revealed inconsistent changes in the levels of 3-O-methyldopa, homovanillic acid, and 5-hydroxyindoleacetic acid. A normal CSF level of P5P was reported in one patient, suggesting that a therapeutic trial with P5P and molecular analysis may be a prudent strategy in some patients irrespective of the CSF studies. The lowest effective dose of P5P should be used to avoid toxicity. The disorder is caused by biallelic pathogenic variants in *PNPO*.

### Sulfite Oxidase Deficiency and Molybdenum Cofactor Deficiency

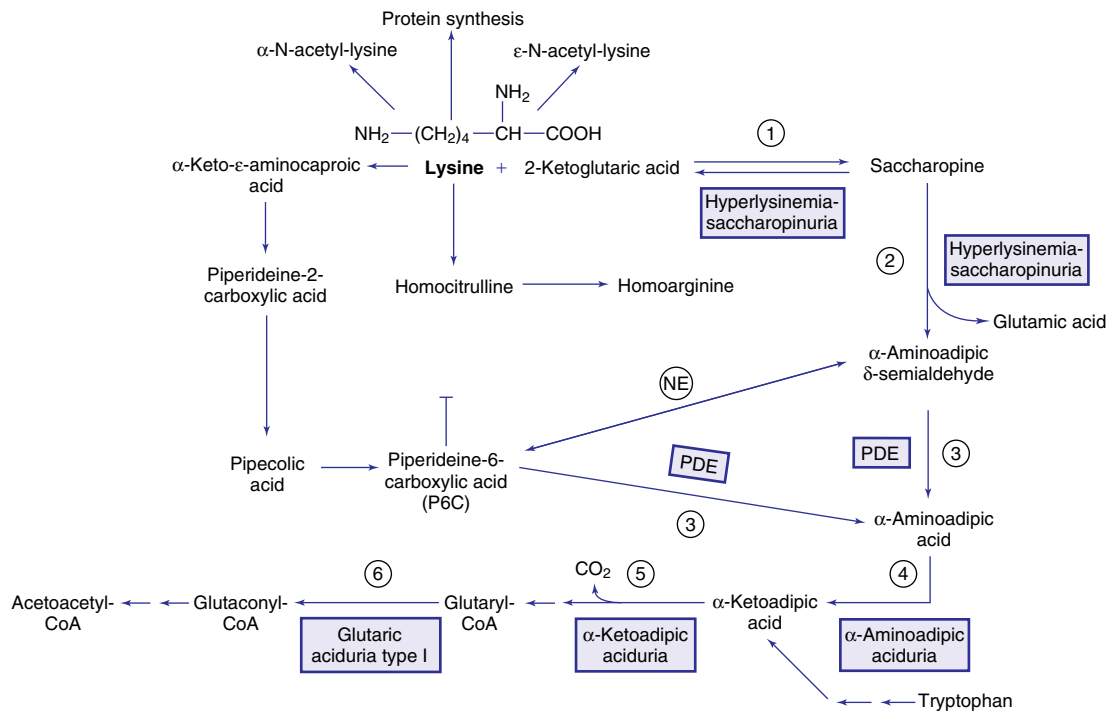
In this rare condition (see Chapter 105.4), accumulation of sulfites causes inhibition of enzymatic activity of antiquitin and accumulation of P6C, which in turn causes inactivation of P5P and vitamin B<sub>6</sub> dependency.

### Hyperprolinemia Type II

In this condition, accumulation of P5C in brain tissue can also cause inactivation of P5P, leading to pyridoxine dependency (see Chapter 105.9 and Fig. 105.9).

### Hypophosphatasia

P5P is the main circulating form of pyridoxine. Alkaline phosphatase (ALP) is required for dephosphorylation of P5P to generate free pyridoxine, which is the only form of vitamin B<sub>6</sub> that can cross the BBB and enter the brain cells. Pyridoxine is rephosphorylated



**Fig. 105.15** Pathways in the metabolism of lysine. Enzymes: (1) Lysine ketoglutarate reductase, (2) saccharopine dehydrogenase, (3)  $\alpha$ -aminoadipic semialdehyde/piperidine-6-carboxylic acid (P6C) dehydrogenase (antiquitin), (4)  $\alpha$ -aminoadipic acid transferase, (5)  $\alpha$ -ketoadipic acid dehydrogenase, (6) glutaryl-CoA-dehydrogenase. NE, Nonenzymatic; PDE, pyridoxine-dependent epilepsy.



intracellularly to form P5P. In the infantile form of hypophosphatasia, P5P cannot be dephosphorylated to free pyridoxine because of the marked deficiency of tissue-nonspecific ALP. This results in deficiency of pyridoxine in the brain and PDE (see Chapters 611 and 724).

The main **clinical manifestation** of PDE caused by antiquitin deficiency is generalized seizures, which usually occur in the first days of life and are unresponsive to conventional anticonvulsant therapies. Some mothers of affected fetuses report abnormal intrauterine fluttering movements. The seizures are usually tonic-clonic in nature but can be almost any type. Other manifestations such as dystonia, respiratory distress, and abdominal distention with vomiting, hepatomegaly, hypoglycemia, and hypothermia may be present. Learning problems and speech delay are common sequelae. Late-onset forms of the condition (as late as 5 years of age) have been reported. Consequently, a trial with vitamin B<sub>6</sub> is recommended in any infant with intractable convulsions (see Chapters 611.04 and 611.06).

**Laboratory findings** show increased concentrations of  $\alpha$ -aminoadipic semialdehyde and pipercolic acid in the CSF, plasma, and urine. EEG abnormalities may normalize after treatment. Neuroimaging may be normal, but cerebellar and cerebral atrophy, periventricular hyperintensity, intracerebral hemorrhage, and hydrocephalus have been reported.

**Treatment** with vitamin B<sub>6</sub> (50-100 mg/day) usually results in a dramatic improvement of both seizures and the EEG abnormalities. High doses of pyridoxine can result in peripheral neuropathy, and doses >500 mg/day should be avoided. The pyridoxine dependency, and thus the therapy, are lifelong. The therapeutic benefit of a lysine-restricted, L-arginine-enriched diet is being evaluated.

### Glutaric Aciduria Type 1 (Glutaryl-CoA Dehydrogenase Deficiency)

Glutaric acid is an intermediate in the degradation of lysine (see Fig. 105.15), hydroxylysine, and tryptophan. Glutaric aciduria type 1, a disorder caused by a deficiency of glutaryl-CoA dehydrogenase, should be differentiated from glutaric aciduria type 2, a distinct clinical and biochemical disorder caused by defects in the mitochondrial electron transport chain (see Chapter 106.1).

Glutaric aciduria type 1 is an autosomal recessive disorder caused by biallelic loss-of-function variants in *GCDH*. Its prevalence is estimated at 1 in 100,000 live births worldwide. The condition is more prevalent in some ethnic populations (e.g., Canadian Oji-Cree Indians, Irish Travelers, Black South Africans, Swedes, and the Old Order Amish population in the United States). A high prevalence of known pathogenic variants in specific ethnic populations can enable a cost-effective molecular evaluation and counseling. **Prenatal diagnosis** can be accomplished by demonstrating increased concentrations of glutaric acid in amniotic fluid, by assay of the enzyme activity in amniocytes or chorionic villus samples, or by identification of the known pathogenic variants in *GCDH*.

### Clinical Manifestations

Macrocephaly is a common, but nonspecific, finding in patients with glutaric aciduria type 1. It develops in the first year of life but can also be present at birth and precede the onset of neurologic manifestations. Some affected infants may also show subtle neurologic symptoms, such as delayed onset of motor milestones, irritability, and feeding problems, during this seemingly asymptomatic period. The onset of the condition is usually heralded by **acute encephalopathic findings**, such as loss of normal developmental milestones (head control, rolling over, or sitting), seizures, generalized rigidity, opisthotonos, choreoathetosis, and dystonia caused by acute striatal injury. These symptoms may occur suddenly in an apparently normal infant after a minor infection. Brain imaging reveals increased extraaxial (particularly frontal) fluid with

stretched bridging veins, striatal lesions, dilated lateral ventricles, cortical atrophy (mainly in the frontotemporal region), and fibrosis. Recovery from the first attack usually occurs slowly, and some residual neurologic abnormalities may persist, especially dystonia and choreoathetosis. Without treatment, additional acute attacks resembling the first can occur during subsequent episodes of intercurrent infections or catabolic states. In some patients, these signs and symptoms may develop gradually in the first few years of life. Hypotonia and choreoathetosis may gradually progress into rigidity and dystonia (**insidious form**). Acute episodes of metabolic decompensation with vomiting, ketosis, seizures, and coma also occur in this form after infection or other catabolic states. Without treatment, death may occur in the first decade of life during one of these episodes. Affected infants are prone to development of subdural hematoma and retinal hemorrhage after minor falls and head traumas. This can be misdiagnosed as child abuse. The intellectual abilities usually remain relatively normal in most patients.

### Laboratory Findings

During acute episodes, mild to moderate metabolic acidosis and ketosis may occur. Hypoglycemia, hyperammonemia, and elevations of serum transaminases are seen in some patients. High concentrations of glutaric acid are usually found in the urine, blood, and CSF. 3-Hydroxyglutaric acid may also be present in the body fluids. The acylcarnitine profile shows elevated glutarylcarnitine (C5DC) in blood and urine. Plasma concentrations of amino acids are usually within normal limits. Laboratory findings may be unremarkable between attacks. Glutaric aciduria type 1 can be identified on the newborn screen by measuring glutarylcarnitine (C5DC) levels in blood spots. The sensitivity of this screening method depends on the cutoff value used by a newborn screen program, and some patients may not be detected. For example, a subset of patients with glutaric aciduria type 1 can present with normal plasma and urinary levels of glutaric acid and variably elevated plasma glutarylcarnitine. This type of glutaric aciduria type 1, referred to as a “low-excretor” phenotype, carries the same risk of developing brain injury as in a “high-excretor” phenotype. In some low-excreting patients, glutaric acid is elevated only in the CSF. Urinary glutarylcarnitine appears to be a more sensitive screening method to identify affected low-excreting patients. Molecular analysis of *GCDH* can aid in identifying patients with a low-excretor phenotype associated with specific pathogenic variants (e.g., p.M405V, p.V400M, p.R227P). We recommend performing molecular analysis of *GCDH* or glutaryl-CoA dehydrogenase enzyme activity in any child presenting with unexplained progressive dystonia and dyskinesia.

### Treatment

Patients require a lysine- and tryptophan-restricted diet while meeting physiologic requirements for protein, micronutrients, and vitamins. Increased dietary arginine may decrease cellular uptake of lysine and decrease the endogenous formation of glutaryl-CoA. Patients should be routinely evaluated for lysine and tryptophan deficiency by monitoring plasma amino acids and growth. L-Carnitine supplementation (50-100 mg/kg/day orally) is recommended in all cases. Emergency treatment during acute illness, including temporary cessation of protein intake for 24 hours, replacement of lost calories using carbohydrates or lipids, IV L-carnitine, IV dextrose, prompt treatment of infection, and control of fever is critical to decreasing the risk of striatal injury. All patients should be provided with an emergency letter describing the underlying diagnosis, recommended evaluation, and treatment. Early diagnosis through newborn screening with prevention and aggressive treatment of intercurrent catabolic states (infections) can help minimize striatal injury and ensure a more favorable prognosis. Patients with movement disorder and spasticity may require treatment with baclofen, diazepam, trihexyphenidyl, and injectable botulinum toxin A.

### LYSINURIC PROTEIN INTOLERANCE (LPI)

This rare autosomal recessive disorder is caused by pathogenic variants in *SLC7A7* leading to impaired function of a protein transporting the cationic amino acids lysine, ornithine, and arginine in the intestine and kidneys. A deficiency of the transporter protein (Y+L amino acid transporter 1) in this condition causes multisystem manifestations, which often start with gastrointestinal symptoms. The transport defect in this condition resides in the basolateral (antiluminal) membrane of enterocytes and renal tubular epithelia. This explains the observation that cationic amino acids are unable to cross these cells even when administered as dipeptides. Lysine in the form of dipeptide crosses the luminal membrane of the enterocytes but hydrolyzes to free lysine in the cytoplasm. Free lysine, unable to cross the basolateral membrane of the cells, can diffuse back into the lumen leading to gastrointestinal symptoms.

Refusal to feed, nausea, aversion to protein, vomiting, and mild diarrhea, which may result in failure to thrive, wasting, and hypotonia, can be seen shortly after birth. Breastfed infants usually remain asymptomatic until soon after weaning, possibly because of the switch to a higher-protein solid foods. Episodes of hyperammonemia caused by the depletion of ornithine and arginine in the urea cycle may occur after ingestion of a high-protein meal. Mild to moderate hepatosplenomegaly, osteoporosis, sparse brittle hair, thin extremities with moderate centripetal adiposity, and growth retardation are common physical findings in patients whose condition has remained undiagnosed. Neurocognitive status is usually normal, but moderate intellectual disability has been observed in some patients.

**Progressive interstitial pneumonitis** with bouts of acute exacerbation often occurs and often progresses to severe alveolar proteinosis. Clinical manifestations include progressive exertional dyspnea, fatigue, cough, diminished breath sound, and inspiratory rales; cyanosis may develop in older patients. Some LPI patients have remained undiagnosed until the appearance of pulmonary manifestations. Radiographic evidence of pulmonary fibrosis has been observed in up to 65% of patients without clinical manifestations of pulmonary involvement.

**Renal involvement** is manifested initially by proteinuria, hematuria, and elevation of serum creatinine, which may progress to end-stage renal failure. Renal tubular involvement with laboratory findings of renal Fanconi syndrome may also be present. Renal biopsy reveals pathologic findings consistent with glomerulonephritis and tubulointerstitial nephritis. Hematologic findings of anemia, leukopenia, thrombocytopenia, and elevated ferritin may also be present.

Other organs are frequently involved. A condition resembling **hemophagocytic lymphohistiocytosis/macrophage activation syndrome** has been reported. Immunologic abnormalities (impaired lymphocyte function, abnormalities in immune globulins, hypocomplementemia) and acute pancreatitis are frequent features of LPI.

Pregnancies in affected mothers have been complicated by anemia, thrombocytopenia, toxemia, and bleeding, but offspring appear healthy at birth.

**Laboratory findings** may reveal hyperammonemia and an elevated concentration of urinary orotic acid, which develop after high-protein feeding. Plasma concentrations of lysine, arginine, and ornithine are usually mildly decreased, but urinary levels of these amino acids, especially lysine, are greatly increased. The pathogenesis of hyperammonemia is likely related to the depletion of urea cycle intermediates caused by poor absorption and the increased renal loss of ornithine and arginine. Plasma concentrations of alanine, glutamine, serine, glycine, and proline are usually increased. Anemia, increased serum levels of ferritin, LDH, thyroxine-binding globulin, hypercholesterolemia, and hypertriglyceridemia are common findings often leading to the workup for hemophagocytic lymphohistiocytosis. This condition should be differentiated from hyperammonemia caused by urea cycle defects (see Chapter 105.12), especially in heterozygous females with OTC deficiency, in whom increased urinary excretion of lysine, ornithine, and arginine is not seen.

**Treatment** with a low-protein diet providing the RDA of protein and supplemented with oral citrulline (50-100 mg/kg/day) can produce biochemical and clinical improvements. Episodes of hyperammonemia should be treated promptly (see Chapter 105.12). Supplementation with lysine (10-30 mg/kg/day) given in small and frequent doses helps improve plasma levels. The dose of lysine should be titrated down if patients develop abdominal pain and diarrhea. Treatment with high doses of prednisone has been effective in the management of acute pulmonary complications in some patients. **Bronchopulmonary lavage** is the treatment of choice for patients with alveolar proteinosis. The condition is more prevalent in Finland and Japan, where the prevalence is 1 in 60,000 and 1 in 57,000 live births, respectively.

Visit Elsevier eBooks+ at [eBooks.Health.Elsevier.com](http://eBooks.Health.Elsevier.com) for Bibliography.

### 105.15 N-Acetylaspartic Acid (Canavan Disease)

Reuben K. Matalon<sup>†</sup> and Dena R. Matalon

**N-Acetylaspartic acid (NAA)**, a derivative of aspartic acid, is synthesized in the brain and is found in a high concentration similar to glutamic acid. NAA has multiple functions, such as serving as an acetate reservoir for myelin synthesis, as well as being an organic osmolyte that helps regulate cerebral osmolality. However, the complete function of NAA is not yet fully understood. **Aspartoacylase (ASPA)** cleaves the *N*-acetyl group from NAA. A deficiency of aspartoacylase leads to **Canavan disease**, a severe **leukodystrophy** characterized by excessive excretion of NAA and spongy degeneration of the white matter of the brain. Canavan disease is an autosomal recessive disorder and is more prevalent in individuals of Ashkenazi Jewish descent than in other ethnic groups. The defective gene for Canavan disease (*ASPA*) can be tested in patients, family members, and at-risk populations.

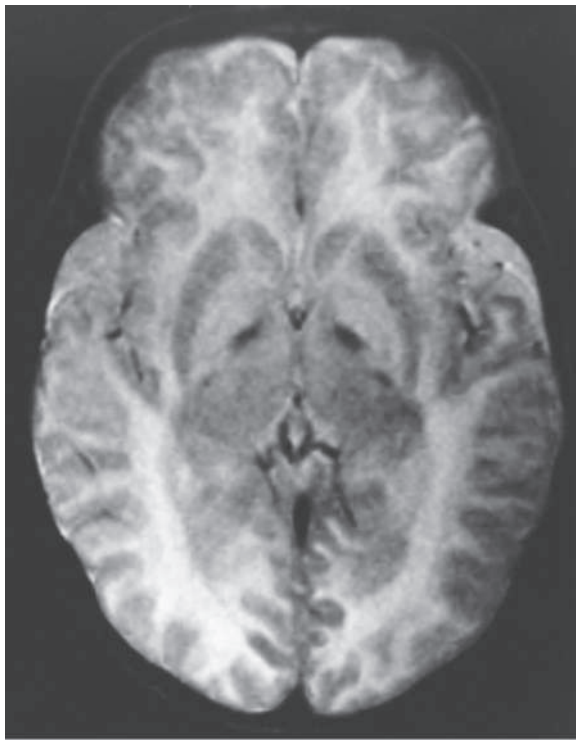
#### ETIOLOGY AND PATHOLOGY

Deficiency of the enzyme aspartoacylase due to pathogenic variants in the *ASPA* gene leads to NAA accumulation in the brain, especially in the white matter, and massive urinary excretion. Excessive amounts of NAA are also present in the blood and CSF. Brain biopsies of patients with Canavan disease show spongy degeneration of the myelin fibers, astrocytic swelling, and elongated mitochondria. There is striking vacuolization and astrocytic swelling in the white matter. Electron microscopy reveals distorted mitochondria. As the disease progresses, the ventricles enlarge because of cerebral atrophy.

#### CLINICAL MANIFESTATIONS

The severity of Canavan disease covers a wide spectrum. Infants usually appear normal at birth and may not manifest symptoms of the disease until 3-6 months of age, when they develop **progressive macrocephaly**, severe hypotonia, persistent head lag, and delayed milestones. As the disease progresses, there is spasticity, joint stiffness, and contractures. Optic atrophy and seizures subsequently develop. Feeding difficulties, poor weight gain, and gastroesophageal reflux may occur in the first year of life followed by swallowing deterioration that may require nasogastric feeding or permanent gastrostomy. In the past, most individuals died in the first decade of life, but with the advances in medical technology and improved supportive care, survival now extends to the second or third decade.

<sup>†</sup>Deceased



**Fig. 105.16** Axial T2-weighted MRI of a 2-yr-old patient with Canavan disease. Extensive thickening of the white matter radiation is seen.

### ATYPICAL CANAVAN DISEASE

**Juvenile** or **mild** Canavan disease is less common than **infantile** Canavan disease and is most prevalent in non-Ashkenazi Jews. Affected individuals with juvenile Canavan disease usually present with mild speech and motor delay and may have **retinitis pigmentosa**. The other typical features of Canavan disease are usually not present. These children have moderately increased urinary excretion of NAA to suggest Canavan disease. Brain MRI demonstrates increased signal intensity in the basal ganglia rather than global white matter disease, sometimes leading to confusion with mitochondrial disease.

### DIAGNOSIS

In a typical individual with Canavan disease, brain MRI shows diffuse white matter degeneration, primarily in the cerebral hemispheres, with less involvement of the cerebellum and brainstem (Fig. 105.16). Repeated evaluations may be required. Magnetic resonance spectroscopy (MRS) can be done to show the high peak of NAA, which strongly suggests Canavan disease. The diagnosis can also be established by finding elevated amounts of NAA in the urine or blood. NAA is found in only trace amounts ( $24 \pm 16 \mu\text{mol}/\text{mmol}$  creatinine) in the urine of unaffected individuals, whereas its concentration is in the range of  $1,440 \pm 873 \mu\text{mol}/\text{mmol}$  creatinine in individuals with Canavan disease. High levels of NAA can also be detected in plasma, CSF, and brain tissue. Aspartoacylase enzyme analysis from fibroblasts is often used to confirm the diagnosis but is not necessary. The activity of aspartoacylase in the fibroblasts of obligate carriers is half or less the activity found in normal individuals. Molecular analysis

for variants in the *ASPA* gene is now recommended for all individuals in which Canavan disease is suspected.

The differential diagnosis of Canavan disease should include Alexander disease, another leukodystrophy associated with macrocephaly. Alexander disease is caused by a defect in the synthesis of glial fibrillary acidic protein, and the diagnosis can be ruled out by genetic testing of variants in the *GFAP* gene.

There are two predominant pathogenic variants leading to Canavan disease in the Ashkenazi Jewish population. The first is an amino acid substitution (p.Glu285Ala) in which glutamic acid is substituted for alanine. This pathogenic variant is the most frequent and encompasses 83% of mutant alleles in Ashkenazi Jewish individuals with Canavan disease. The second most common pathogenic variant is a change from tyrosine to a nonsense pathogenic variant, leading to a stop in the coding sequence (p.Tyr231\*). This accounts for 13% of mutant Ashkenazi alleles. In the non-Jewish population, more diverse pathogenic variants have been observed, with the two variants common in the Ashkenazi Jewish population being rare. A different variant (p.Ala305Glu), the substitution of alanine for glutamic acid, accounts for 40% of mutant alleles in non-Jewish individuals. Over 70 pathogenic variants have been reported in the non-Jewish population. With Canavan disease, it is important to obtain a molecular diagnosis because this will lead to accurate counseling and prenatal guidance for the family. If the specific variants are not known, prenatal diagnosis relies on the NAA level in the amniotic fluid. In Ashkenazi Jewish individuals, the carrier frequency may be as high as 1:40, nearing that of Tay-Sachs disease. Carrier screening for Canavan disease is available. Genotype-phenotype studies and aspartoacylase expression and enzymatic activity help to prognosticate the severity of disease. Patients with juvenile or mild forms of Canavan disease have been compound heterozygotes with a mild pathogenic variant on one allele and a severe variant on the other allele. Mild variants include p.Tyr288Cys and p.Arg71His.

### TREATMENT AND PREVENTION

Treatment for Canavan disease is supportive. After diagnosis, individuals should be monitored closely in terms of feeding and nutritional status, development, and risk for seizures. Medical intervention may be necessary such as antiepileptics, acetazolamide for increased intracranial pressures, and botulinum toxin injections for spasticity. Individuals benefit from early therapy interventions and special education programs to maximize developmental potential and communication. Genetic counseling, carrier testing, and prenatal diagnosis are the only current methods of prevention.

Studies of gene therapy using recombinant adeno-associated viruses (rAAVs) have shown some positive results in knockout mice models. Gene therapy attempts in children with Canavan disease have shown a lack of adverse events, some decrease in the brain elevation of *N*-acetylaspartic acid, improved seizure frequency, and slowing of the progression of brain atrophy. However, there was no improvement in long-term clinical status. Novel rAAV serotypes have been shown to better cross the **blood-brain barrier** and improved longevity of Canavan disease knockout mice, giving promise for further use of gene therapy in individuals with Canavan disease. **Enzyme-replacement therapy** with *ASPA* and pegylated *ASPA* is being studied in mice and has shown a decrease of NAA in the brain.

Visit Elsevier eBooks+ at [eBooks.Health.Elsevier.com](http://eBooks.Health.Elsevier.com) for Bibliography.



## Chapter 106

## Defects in Metabolism of Lipids

106.1 Disorders of Mitochondrial Fatty Acid  $\beta$ -Oxidation

Jerry Vockley

Mitochondrial  $\beta$ -oxidation of fatty acids is an essential energy-producing pathway. It is particularly important during prolonged periods of reduced caloric intake such as fasting or gastrointestinal illness or increased energy expenditure during physiologic stress such as febrile illness. Under these conditions, the body switches from using predominantly *carbohydrate* to predominantly *fat* as its major fuel. Fatty acids are also important fuels for exercising skeletal muscle and are the preferred substrate for normal cardiac metabolism. In these tissues, fatty acids are completely oxidized to carbon dioxide and water. The end products of hepatic fatty acid oxidation are the ketone bodies *3-hydroxybutyrate* and *acetoacetate*. These compounds cannot be oxidized by the liver but are exported to serve as important fuels in peripheral tissues, particularly the brain, where ketone bodies can partially substitute for glucose during periods of fasting.

Genetic defects have been identified in almost all the known steps in the fatty acid oxidation pathway; all are recessively inherited (Table 106.1).

Clinical manifestations characteristically involve tissues with a high  $\beta$ -oxidation flux, including liver, skeletal, and cardiac muscle, and are age dependent. The most common early presentation is an acute episode of life-threatening coma, hepatic encephalopathy, and hypoglycemia with or without hyperammonemia induced by a period of fasting or illness in the first 2-4 years of life. After about age 6 years, muscle symptoms predominate in the disorders of long-chain fatty acid oxidation, including myopathy, fatigability, and recurrent rhabdomyolysis. The latter is often brought on by excess activity or exercise. Cardiomyopathy can occur at any age in individuals with long-chain defects and may be exacerbated with acute episodes of illness. Patients with fatty acid oxidation defects are often asymptomatic when well. Acutely presenting disease may be misdiagnosed as **Reye syndrome** or, if fatal, as **sudden unexpected infant death**. In some circumstances, clinical manifestations appear to arise from toxic effects of fatty acid metabolites rather than inadequate energy production. These circumstances include certain long chain fatty acid oxidation disorders (deficiencies of long chain 3-hydroxyacyl dehydrogenase [**LCHAD**], carnitine palmitoyltransferase-IA [**CPT-IA**], or mitochondrial trifunctional protein [**MTP**; also known as **TFP**]) in which the presence of a homozygous affected fetus increases the risk of a life-threatening illness in the heterozygote mother, resulting in **acute fatty liver of pregnancy** (AFLP) or **preeclampsia with HELLP** (hemolysis, elevated liver enzymes, low platelets) syndrome. The mechanism of these obstetric complications is likely accumulation of toxic intermediates. Malformations of the brain and kidneys have been described in severe deficiencies of electron transfer flavoprotein (ETF), ETF dehydrogenase (ETF-DH), and carnitine palmitoyltransferase-II (CPT-II), which might reflect in utero toxicity of fatty acid metabolites or a developmental role for these enzymes. Progressive retinal degeneration, peripheral neuropathy, and chronic progressive liver disease have been identified in LCHAD and MTP deficiency.

Fatty acid oxidation disorders are easily overlooked because the only specific clue to the diagnosis may be the finding of inappropriately low concentrations of plasma or urinary ketones in an infant who has hypoglycemia unless specialized metabolic testing is performed. Genetic defects in ketone body utilization may also be overlooked because ketonemia is an expected finding with fasting hypoglycemia.

Newborn screening programs using tandem mass spectrometry detect characteristic plasma acylcarnitine profiles in most of these disorders, allowing early and presymptomatic diagnosis. Screening programs have demonstrated that all the fatty acid oxidation disorders combined are among the most common inborn errors of metabolism, at least in predominantly White populations.

Figures 106.1 and 106.2 outline the steps involved in the oxidation of a typical long chain fatty acid. In the *carnitine cycle*, long chain fatty acids are transported across the barrier of the inner mitochondrial membrane as acylcarnitine esters. Medium-chain fatty acids, which are commonly provided as medium-chain triglyceride supplementation in infants who are failing to thrive, can bypass the carnitine cycle and enter the mitochondrial  $\beta$ -oxidation cycle directly. Within the mitochondria, successive rounds of the four-step  *$\beta$ -oxidation cycle* convert the **coenzyme A (CoA)**-activated fatty acids to acetyl-CoA units. Two or three different chain-length-specific isoenzymes are needed for each of these  $\beta$ -oxidation steps to accommodate the different chain-length fatty acyl-CoA species. The electrons generated in the first  $\beta$ -oxidation step (acyl-CoA dehydrogenase) are carried by the *electron transfer pathway* to the *electron transport chain* at the level of coenzyme Q for adenosine triphosphate production, whereas electrons generated from the third step (3-hydroxyacyl-CoA dehydrogenase) enter the *electron transport chain* at the level of complex 1. Most of the acetyl-CoA generated from fatty acid  $\beta$ -oxidation in the liver flows through the *pathway of ketogenesis* to form 3-hydroxybutyrate and acetoacetate, whereas in muscle and heart, the fatty acids are completely oxidized to  $\text{CO}_2$  and water through oxidative phosphorylation. It has been demonstrated that the enzymes of fatty acid oxidation physically and functionally interact with each other and those of the mitochondrial electron transport chain.

DEFECTS IN THE  $\beta$ -OXIDATION CYCLE

## Medium-Chain Acyl-CoA Dehydrogenase Deficiency

Medium-chain acyl-CoA dehydrogenase (MCAD) deficiency is the most common fatty acid oxidation disorder. The disorder shows a strong founder effect; most patients have a northwestern European ancestry, and the majority of these patients have at least one copy of a common MCAD missense pathogenic variant, an A-G transition at cDNA position 985 (c.985A>G) that changes a lysine to glutamic acid at residue 329 (p.Lys329Glu).

## Clinical Manifestations

Previously undiagnosed affected patients usually present in the first 3 months to 5 years of life with episodes of acute illness triggered by prolonged fasting (>12-16 hours). Signs and symptoms include vomiting and lethargy, which rapidly progress to coma or seizures and cardiorespiratory collapse. Sudden unexpected infant death may occur. The liver may be slightly enlarged with fat deposition. Episodes are rare until the infant is beyond the first few months of life, presumably because of more frequent feedings at a younger age. Affected older infants are at higher risk of symptoms as they begin to fast through the night or are exposed to fasting stress during an intercurrent childhood illness. Presentation in the first days of life with neonatal hypoglycemia has been reported in newborns who were fasted inadvertently or were being breastfed exclusively and thus are at higher risk because of early reduced caloric intake. A diagnosis of MCAD has occasionally been documented in previously healthy teenage and adult individuals, indicating that even patients who have been asymptomatic in infancy are still at risk for metabolic decompensation if exposed to sufficient periods of fasting. An unknown number of patients may remain asymptomatic. Prior to routine newborn screening testing, as many as 25% of MCAD-deficient patients died or suffered severe brain injury from their first episode. Most patients are diagnosed in the newborn period by **blood spot acylcarnitine screening** (part of newborn screening), allowing the initiation of early intervention and prevention of most signs and symptoms.

## Laboratory Findings

During acute episodes, hypoglycemia is usually present. Plasma and urinary ketone concentrations are inappropriately low (**hypoketotic**



**Table 106.1** Mitochondrial Fatty Acid Oxidation Disorders: Clinical and Biochemical Features

ENZYME DEFICIENCY	GENE	CLINICAL PHENOTYPE	LABORATORY FINDINGS
Carnitine transporter	<i>SLC22A5</i>	Cardiomyopathy, skeletal myopathy, liver disease, sudden death, endocardial fibroelastosis, cardiac arrhythmia	↓ Total and free carnitine; normal acylcarnitines, acylglycine, and organic acids; prenatal and newborn possible diagnosis reported
Long chain fatty acid transporter	<i>FATP1-6</i>	Rare, acute liver failure in childhood requiring liver transplantation	↓ Intracellular C <sub>14</sub> -C <sub>18</sub> fatty acids; ↓ fatty acid oxidation; disease-causing pathogenic variants have not been identified in patients
Carnitine palmitoyl transferase-1A	<i>CPT1A</i>	Liver failure, renal tubulopathy, and sudden death reported; maternal preeclampsia; HELLP syndrome association described in a few patients	Normal or ↑ free carnitine; normal acylcarnitines, acylglycine, and organic acids; newborn screening diagnosis reported
Carnitine acylcarnitine translocase	<i>SLC25A20</i>	Chronic progressive liver failure, persistent ↑ NH <sub>3</sub> , hypertrophic cardiomyopathy	Normal or ↓ free carnitine, abnormal acylcarnitine profile; newborn screening diagnosis reported
Carnitine palmitoyl transferase-II	<i>CPT2</i>	Early and late onset types; liver failure, encephalopathy, skeletal myopathy, cardiomyopathy, renal cystic changes; adult form with acute rhabdomyolysis, myoglobinuria	Normal or ↓ free carnitine; abnormal acylcarnitine profile; newborn screening diagnosis possible
Short chain acyl-CoA dehydrogenase	<i>ACADS</i>	Biochemical phenotype only; no consistent clinical phenotype	Normal or ↓ free carnitine; elevated urine ethylmalonic acid; inconsistently abnormal acylcarnitine profile
Medium-chain acyl-CoA dehydrogenase	<i>ACADM</i>	Hypoglycemia, hepatic encephalopathy, sudden death; maternal preeclampsia, HELLP syndrome association described rarely, possible long QT interval	Normal or ↓ free carnitine, ↑ urine acylglycine, plasma C <sub>6</sub> -C <sub>10</sub> free fatty acids, ↑ C <sub>8</sub> -C <sub>10</sub> acyl-carnitine; newborn screening diagnosis possible
Very long chain acyl-CoA dehydrogenase (VLCAD)	<i>ACADVL</i>	Dilated cardiomyopathy, arrhythmias, hypoglycemia, and hepatic steatosis; late-onset, stress-induced rhabdomyolysis, episodic myopathy	Normal or ↓ free carnitine; ↑ plasma C <sub>14:1</sub> , C <sub>14</sub> acylcarnitine; ↑ plasma C <sub>10</sub> -C <sub>16</sub> free fatty acids; prenatal and newborn screening diagnosis possible
ETF dehydrogenase*	<i>ETFDH</i>	Nonketotic fasting hypoglycemia, congenital anomalies, milder forms of liver disease, cardiomyopathy, and skeletal myopathy	Normal or ↓ free carnitine; increased ratio of acyl:free carnitine, ↑ blood acylcarnitines; characteristic urine organic acids and acylglycines; newborn screening diagnosis possible
ETF-α*	<i>ETFA</i>	Nonketotic fasting hypoglycemia, congenital anomalies, liver disease, cardiomyopathy; skeletal myopathy also described	Normal or ↓ free carnitine; increased ratio of acyl:free carnitine; ↑ acylcarnitines; urine organic acid and acylglycines; newborn screening diagnosis possible
ETF-β*	<i>ETFB</i>	Fasting hypoglycemia, congenital anomalies, liver disease, cardiomyopathy; skeletal myopathy also described	Normal or ↓ free carnitine; increased ratio of acyl:free carnitine, ↑ blood acylcarnitines; urine organic acid and acylglycines; newborn screening diagnosis possible
Short chain L-3-hydroxyacyl-CoA dehydrogenase (SCHAD)	<i>HAD1</i>	Hyperinsulinemic hypoglycemia, cardiomyopathy, myopathy	Normal or ↓ free carnitine, elevated free fatty acids, inconsistently abnormal urine organic acid, ↑ 3-OH glutarate, ↑ plasma C <sub>4</sub> -OH acylcarnitine; newborn screening diagnosis possible
Long chain L-3-hydroxyacyl-CoA dehydrogenase (LCHAD)	<i>HADHA</i>	Maternal preeclampsia, HELLP syndrome, and AFLP association described frequently; see MTP later for clinical manifestations	Normal or ↓ free carnitine, increased ratio of acyl:free carnitine, ↑ free fatty acids, ↑ C <sub>16</sub> -OH and C <sub>18</sub> -OH carnitines; newborn screening diagnosis possible
MTP	<i>HADHA</i> , <i>HADHB</i>	Severe cardiac and skeletal myopathy, hypoglycemia, acidosis, hyper NH <sub>3</sub> , sudden death, elevated liver enzymes, retinopathy; maternal preeclampsia, HELLP syndrome, and AFLP association described frequently	Normal or ↓ free carnitine, increased ratio of acyl:free carnitine, ↑ free fatty acids, ↑ C <sub>16</sub> -OH and C <sub>18</sub> -OH carnitines; newborn screening diagnosis possible
Long chain 3-ketoacyl-CoA thiolase	<i>HADHB</i>	Severe neonatal presentation, hypoglycemia, acidosis, ↑ creatine kinase, cardiomyopathy, neuropathy, and early death	Normal or ↓ free carnitine, increased ratio of acyl:free carnitine, ↑ free fatty acids, ↑ 2-trans, 4-cis-decadienoylcarnitine; newborn screening diagnosis possible
Short chain 2,3-enoyl-CoA hydratase	<i>ECHS1</i>	Leigh disease, lactic acidosis, seizures, cystic degeneration of white matter, microcephaly, metabolic acidosis, extrapyramidal dystonia, dilated cardiomyopathy	Abnormal organic acids, 2-methacrylglycine, 2-methyl-2,3 dihydroxybutyrate, also S-(2-carboxypropyl)cysteine, S-(2-carboxyethyl) cysteamine; acylcarnitine shows ↑ C4OH (inconsistently)

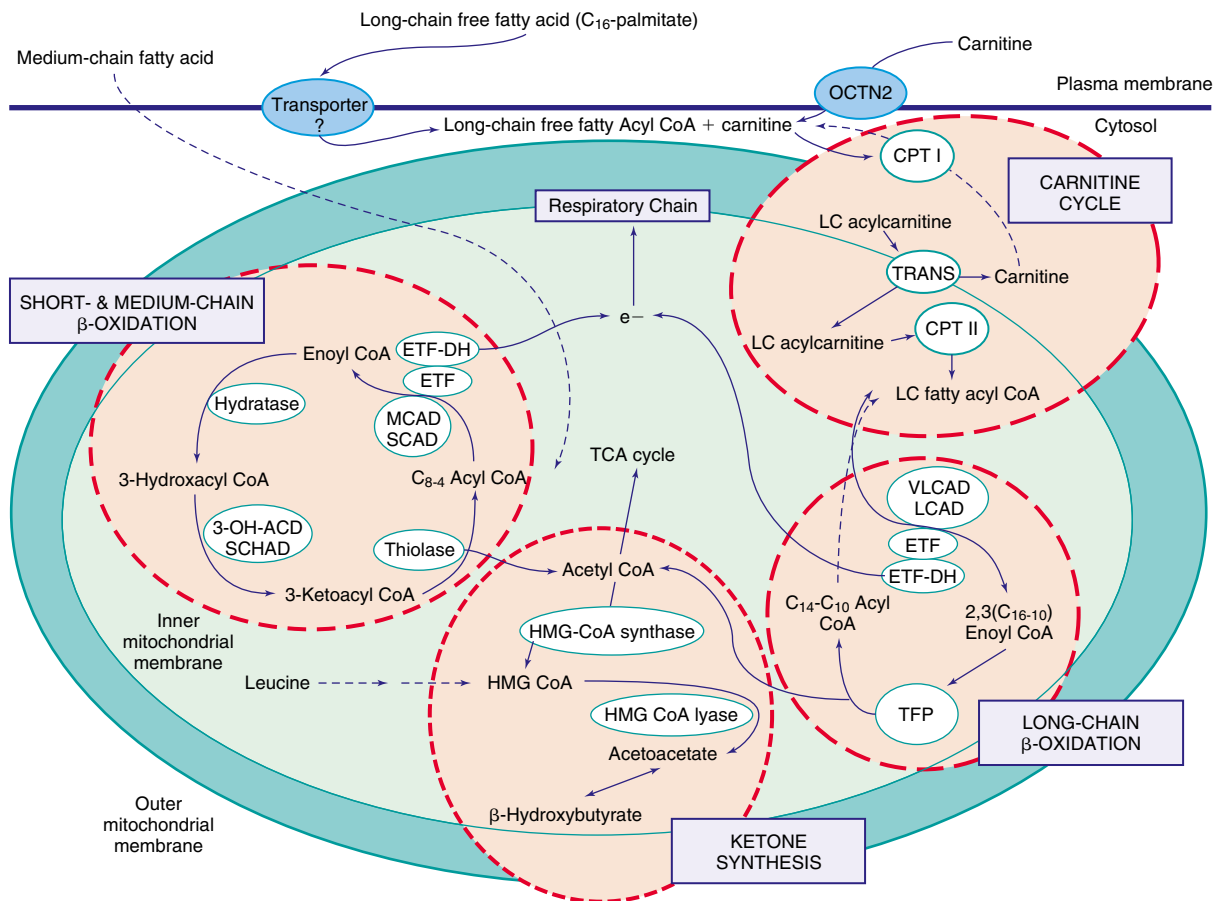
**Table 106.1** Mitochondrial Fatty Acid Oxidation Disorders: Clinical and Biochemical Features—cont'd

ENZYME DEFICIENCY	GENE	CLINICAL PHENOTYPE	LABORATORY FINDINGS
2,4-Dienoyl-CoA reductase	<i>DECR1</i>	Only one patient described, hypotonia in the newborn, mainly severe skeletal myopathy and respiratory failure; hypoglycemia is rare	Normal or ↓ free carnitine, ↑ acyl:free carnitine ratio, normal urine organic acids and acylglycines
HMG CoA synthetase	<i>HMGS2</i>	Hypoketosis and hypoglycemia, rarely myopathy	↑ Total plasma fatty acids; enzyme studies in biopsied liver may be diagnostic; genetic testing preferred
HMG CoA lyase	<i>HMGCL</i>	Hypoketosis and hypoglycemia, rarely myopathy	Normal free carnitine, ↑ C <sub>5</sub> -OH, and methylglutaryl-carnitine; enzymes studies in fibroblasts may be diagnostic
Monocarboxylate transporter 1 (MCT1)	<i>SLC16A1</i>	Severe fasting-induced ketoacidosis, rarely hypoglycemia	Profound ketoacidosis; no specific biomarkers yet identified

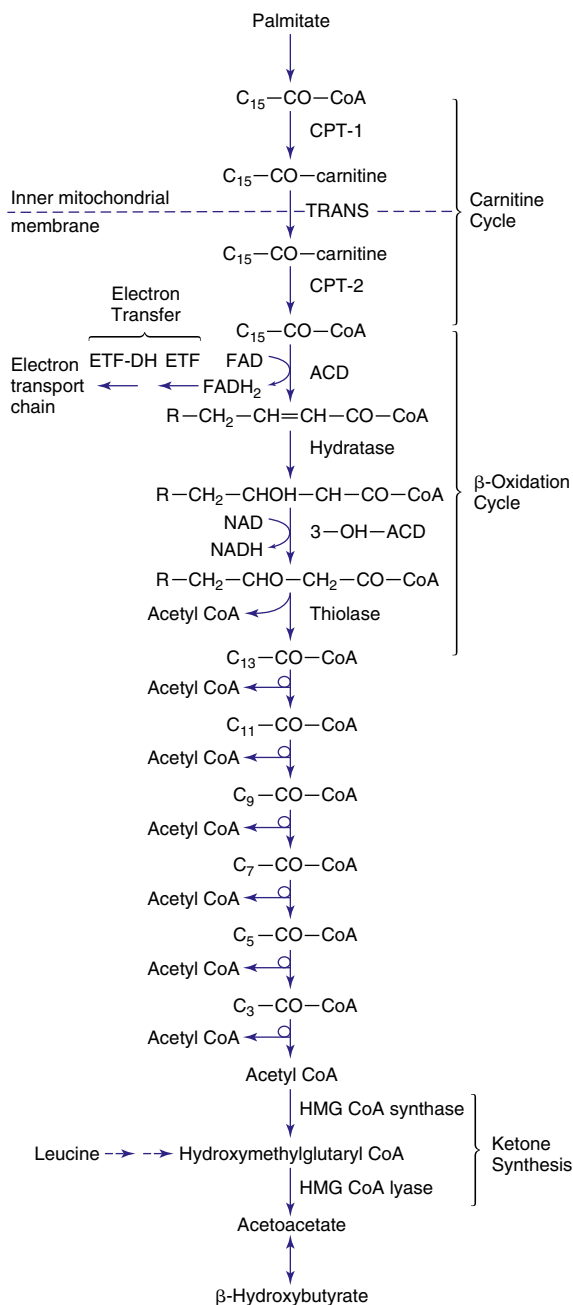
\*Also known as glutaric acidemia type II or multiple acyl-CoA dehydrogenase defect (MADD).

AFLP, Acute fatty liver of pregnancy; CoA, coenzyme A; ETF, electron transfer flavoprotein; HELLP, hemolysis, elevated liver enzymes, low platelets; MTP, mitochondrial trifunctional protein; NH<sub>3</sub>, ammonia.

From Shekhawat PS, Matern D, Strauss AW. Fetal fatty acid oxidation disorders, their effect on maternal health and neonatal outcome: impact of expanded newborn screening on their diagnosis and management. *Pediatr Res*. 2005;57:78R–84R.



**Fig. 106.1** Mitochondrial fatty acid oxidation. Carnitine enters the cell through the action of the organic cation/carnitine transporter (OCTN2). Palmitate, a typical 16-carbon long chain (LC) fatty acid, is transported across the plasma membrane and can be activated to form an LC fatty acyl coenzyme A (CoA). It then enters into the carnitine cycle, where it is transesterified by carnitine palmitoyltransferase-I (CPT-I), translocated across the inner mitochondrial membrane by carnitine/acylcarnitine translocase (TRANS), and then reconverted into an LC fatty acyl-CoA by carnitine palmitoyltransferase-II (CPT-II) to undergo  $\beta$ -oxidation. Very LC acyl-CoA dehydrogenase (VLCAD/LCAD) leads to the production of (C<sub>16</sub>-C<sub>10</sub>) 2,3-enoyl CoA. Mitochondrial trifunctional protein (MTP) contains the activities of enoyl CoA hydratase (hydratase), 3-OH-hydroxyacyl-CoA dehydrogenase (3-OH-ACD), and  $\beta$ -ketothiolase (thiolase). Acetyl-CoA, a reduced form of flavin adenine dinucleotide (FADH), and a reduced form of nicotinamide adenine dinucleotide (NADH) are produced. Medium- and short chain fatty acids (C<sub>8</sub>-4) can enter the mitochondrial matrix independent of the carnitine cycle. Medium-chain acyl-CoA dehydrogenase (MCAD), short chain acyl-CoA dehydrogenase (SCAD), and short chain hydroxy acyl-CoA dehydrogenase (SCHAD) are required. Acetyl-CoA can then enter the Krebs (TCA) cycle. Electrons are transported from FADH to the respiratory chain via the electron transfer flavoprotein (ETF) and the electron transfer flavoprotein dehydrogenase (ETF-DH). NADH enters the electron transport chain through complex I. In the liver, acetyl-CoA can be converted into hydroxymethylglutaryl (HMG) CoA by  $\beta$ -hydroxy- $\beta$ -methylglutaryl-CoA synthase (HMG CoA synthase) and then the ketone body acetoacetate by the action of  $\beta$ -hydroxy- $\beta$ -methylglutaryl-CoA lyase (HMG-CoA lyase).



**Fig. 106.2** Pathway of mitochondrial oxidation of palmitate, a typical 16-carbon long chain fatty acid. Enzyme steps include carnitine palmitoyltransferase (CPT) 1 and 2, carnitine/acylcarnitine translocase (TRANS), electron transfer flavoprotein (ETF), ETF dehydrogenase (ETF-DH), acyl-CoA dehydrogenase (ACD), enoyl CoA hydratase (hydratase), 3-hydroxy-acyl-CoA dehydrogenase (3-OH-ACD), β-ketothiolase (thiolase), β-hydroxy-β-methylglutaryl-CoA (HMG-CoA) synthase, and lyase.

**hypoglycemia).** Because of the hypoketonemia, there is little or no metabolic acidosis, which is typically present in children with hypoglycemia not caused by fatty acid oxidation disorders. Liver function tests (LFTs) are abnormal, with elevations of liver enzymes (alanine transaminase, aspartate transaminase), elevated blood ammonia, and prolonged prothrombin and partial thromboplastin times. Liver biopsy at times of acute illness shows microvesicular or macrovesicular steatosis from triglyceride accumulation. During fasting stress or acute illness, urinary organic acid profiles by gas chromatography/mass spectrometry show inappropriately low concentrations of ketones and elevated levels of medium-chain dicarboxylic acids (adipic, suberic, and sebacic

acids) that derive from microsomal and peroxisomal omega oxidation of accumulated medium-chain fatty acids. Plasma and tissue concentrations of total carnitine are reduced to 25–50% of normal, and the fraction of total esterified carnitine is increased. This pattern of **secondary carnitine deficiency** is seen in most fatty acid oxidation defects and reflects competition between increased acylcarnitine levels and free carnitine for transport at the renal tubular plasma membrane. Significant exceptions to this rule are the plasma membrane carnitine transporter, CPT-1A, and β-hydroxy-β-methylglutaryl-CoA (HMG-CoA) synthase deficiencies, which do not manifest secondary carnitine deficiency.

Diagnostic metabolite patterns for MCAD deficiency include increased plasma C<sub>6:0</sub>, C<sub>8:0</sub>, C<sub>10:0</sub>, and C<sub>10:1</sub> acylcarnitine species and increased urinary acylglycines, including hexanoylglycine, suberylglycine, and 3-phenylpropionylglycine. Newborn screening, performed in all states in the United States and in many other countries, can detect presymptomatic MCAD deficiency based on these abnormal acylcarnitines in filter paper blood spots. The diagnosis can be confirmed by demonstrating the common Ala985Gly pathogenic variant or sequencing the MCAD gene. A second common variant, Thr199Cys, has been detected in infants identified by newborn screening. Interestingly, this allele has not been seen to date in symptomatic MCAD patients, likely because of the significant residual activity of this milder pathogenic variant.

### Treatment

Acute illnesses should be promptly treated with intravenous (IV) fluids containing 10% dextrose to correct or prevent hypoglycemia and to suppress lipolysis as rapidly as possible (see [Chapter 113](#)). Chronic therapy consists of avoiding fasting. This usually requires simply adjusting the diet to ensure that overnight fasting periods are limited to <6 hours in infants under 6 months of age, <8 hours for infants 6–24 months of age, and <12 hours for older children. Restricting dietary fat or treatment with carnitine is unnecessary. There is likely no need for active therapeutic intervention for individuals with the Thr199Cys variant.

### Prognosis

Up to 25% of previously undiagnosed patients may die during their first attack of illness. There is often a history of a previous sibling death that is presumed to be from an unrecognized MCAD deficiency. Some patients may sustain permanent brain injury during an attack of profound hypoglycemia. For survivors without brain damage and essentially all babies identified by newborn screening, the prognosis is excellent because progressive cognitive impairment or cardiomyopathy does not occur in MCAD deficiency. Fasting tolerance improves with age, and the risk of decompensation decreases. Because as many as 35% of affected patients have never had an episode, testing of siblings of affected patients is important to detect asymptomatic family members who did not receive newborn screening.

### Very Long Chain Acyl-CoA Dehydrogenase Deficiency

Very long chain acyl-CoA dehydrogenase (VLCAD) deficiency is the second most common diagnosed disorder of fatty acid oxidation. It was originally termed “long chain acyl-CoA dehydrogenase deficiency” before the existence of the inner mitochondrial membrane-bound VLCAD was known. *All patients previously diagnosed as having long chain acyl-CoA dehydrogenase deficiency have VLCAD gene defects.* Patients with VLCAD deficiency have no ability to oxidize physiologic long chain fatty acids and are usually more severely affected than those with MCAD deficiency, who have a milder oxidative defect. VLCAD deficiency presents earlier in infancy and has more chronic problems with muscle weakness or episodes of muscle pain and rhabdomyolysis. Cardiomyopathy may be present during acute attacks provoked by fasting. The left ventricle may be hypertrophic or dilated and may show poor contractility on echocardiography. Sudden unexpected death has occurred in several patients, but most who survive the initial episode show improvement, including normalization of cardiac function.

Other physical and routine laboratory features are similar to those of MCAD deficiency, including secondary carnitine deficiency. The urinary organic acid profile shows a nonketotic dicarboxylic aciduria with increased levels of C<sub>6-12</sub> dicarboxylic acids. Diagnosis may be suggested by an abnormal acylcarnitine profile with plasma or blood spot C<sub>14:0</sub>, C<sub>14:1</sub>, C<sub>14:2</sub> acylcarnitine species. However, the specific diagnosis requires pathogenic variant analysis of the *VLCAD* gene. Newborn screening by tandem mass spectrometry of dried blood spots is effective in identifying early/severe disease, though it can miss milder, later-onset cases. A common mild variant is identified by a newborn screen that typically predicts later-onset disease. Treatment has traditionally been based primarily on avoidance of fasting for >8-12 hours depending on age, along with supplementation with medium-chain triglycerides. Triheptanoin (Dojolvi) has been approved as a treatment for VLCAD deficiency and for all other disorders of long-chain fatty acid oxidation. The odd-chain fat heptanoate (C7) released from this triglycerol provides acetyl-CoA for the tricarboxylic acid cycle and propionyl-CoA, which is metabolized through methylmalonyl-CoA to succinyl-CoA and succinate. This anaplerotic effect essentially eliminates hypoglycemia in long-chain fatty acid oxidation disorder patients and significantly improves heart function in patients with cardiomyopathy. However, although heptanoin does reduce the incidence, rhabdomyolysis remains a major problem in treated patients. This finding led to the recognition of previously unrecognized inflammation as a component of these disorders, likely caused by the accumulation of a high level of proinflammatory long-chain complex lipids. Patients can develop a secondary carnitine deficiency; however, the need for replacement therapy remains unclear. If the free carnitine level in blood is <10 μM, supplementation with 25-50 mg/kg of oral carnitine (with a maximum of 1,000 mg/day) may be helpful, especially in the face of cardiomyopathy or significant muscular symptoms.

### Short Chain Acyl-CoA Dehydrogenase Deficiency

A small number of patients with two null pathogenic variants in the short chain acyl-CoA dehydrogenase (SCAD) gene have been described with a variable phenotype. Most individuals classified as being SCAD deficient actually have polymorphic DNA changes in the SCAD gene; two common polymorphisms are Gly185Ser and Arg-147Trp, present in biallelic fashion in 7% of the population. Although SCAD deficiency was originally reported with a wide range of symptoms, it was likely a result of the frequency of the common polymorphisms in unrelated disease rather than a true causal relationship. Long-term follow-up of infants identified by newborn screening has failed to demonstrate a convincing, consistent phenotype, and thus SCAD deficiency is best described as a biochemical phenotype rather than a disease. The diagnosis is indicated by elevated levels of butyrylcarnitine (C4-carnitine) on newborn blood spots or plasma and increased excretion of urinary ethylmalonic acid and butyrylglycine. These metabolic abnormalities are most pronounced in patients with null pathogenic variants and are variably present in patients who are homozygous for the common polymorphisms. In the context of metabolic abnormalities consistent with SCAD deficiency in patients with significant clinical problems, a thorough evaluation for another unrelated diagnosis is indicated. There is no need for treatment of individuals with SCAD deficiency.

### Long Chain 3-Hydroxyacyl-CoA Dehydrogenase/ Mitochondrial Trifunctional Protein Deficiency

The LCHAD enzyme is part of the MTP, which also contains two other steps in β-oxidation: long chain 2,3-enoyl CoA hydratase and long chain β-ketothiolase. MTP is a heterotetrameric protein composed of two α and two β chains derived from distinct contiguous genes, *HADHA* and *HADHB*, that share a common promoter. In some patients, only the LCHAD activity of the MTP is affected (**LCHAD deficiency**), whereas others have deficiencies of all three activities (**MTP deficiency**).

**Clinical manifestations** include attacks of acute hypoketotic hypoglycemia similar to VLCAD deficiency; however, patients often show evidence of more severe disease, including cardiomyopathy, muscle cramps and weakness, and abnormal liver function (cholestasis).

Pigmented retinopathy leading to blindness, progressive liver failure, peripheral neuropathy, and rhabdomyolysis are also present, with retinopathy being more severe in isolated LCHAD deficiency and neuropathy worse in combined MTP defects. Life-threatening obstetric complications (AFLP, HELLP syndrome) have been observed in heterozygous mothers carrying homozygous fetuses affected with LCHAD/MTP deficiency. Sudden unexpected infant death may occur, especially in populations where tandem mass spectrometry newborn screening is not routine. The **diagnosis** is indicated by elevated levels of blood spot or plasma 3-hydroxyacylcarnitines of chain lengths C<sub>16</sub>-C<sub>18</sub>. The urinary organic acid profile in patients may show increased levels of 3-hydroxydicarboxylic acids of chain lengths C<sub>6</sub>-C<sub>14</sub>. Secondary carnitine deficiency is common. A common pathogenic variant in the α subunit, E474Q, is seen in more than 60% of isolated LCHAD-deficient patients. This pathogenic variant in the fetus is especially associated with the obstetric complications, but other pathogenic variants in either subunit may also be linked to maternal illness.

**Treatment** is similar to that for VLCAD deficiency; that is, avoiding fasting stress, triheptanoin, and potentially carnitine. Docosahexaenoic acid may slow the retinal changes but does not prevent them. None of these therapeutic measures likely affect the development or progression of peripheral neuropathy. Liver transplantation has been attempted in patients with severe liver failure but does not ameliorate the metabolic abnormalities or prevent the myopathic or retinal complications.

### Short Chain 3-Hydroxyacyl-CoA Dehydrogenase Deficiency

Very few patients with proven pathogenic variants of short chain 3-hydroxyacyl-CoA dehydrogenase (**SCHAD**) have been reported. Most cases with recessive pathogenic variants of the SCHAD gene have presented with episodes of hypoketotic hypoglycemia that was caused by *hyperinsulinism*. In contrast to those with other forms of fatty acid oxidation disorders, these patients required specific therapy with diazoxide for hyperinsulinism to avoid recurrent hypoglycemia. A single patient with compound heterozygous pathogenic variants presented with fulminant hepatic failure at age 10 months. The SCHAD protein has a nonenzymatic function in which it directly interacts with glutamate dehydrogenase (GDH) to inhibit its activity. In the absence of SCHAD protein, this inhibition is removed, leading to upregulation of GDH enzyme activity, a recognized cause of *hyperinsulinism*, usually from activating pathogenic variants of the *GDH* gene. Severe deficiency of SCHAD protein often presents predominantly as **protein-sensitive hypoglycemia** rather than as fasting hypoglycemia. It appears that if SCHAD protein is present, inhibition of GDH is maintained even when there is no SCHAD enzyme activity; these patients may present with a more traditional fatty acid oxidation defect. Specific metabolic markers for SCHAD deficiency include elevated plasma C4-hydroxyacylcarnitine and urine 3-hydroxyglutaric acid. Successful newborn screening for SCHAD deficiency has been recorded, but the sensitivity of the process has not yet been established.

**Treatment** of SCHAD-deficient patients with hyperinsulinism is with diazoxide. There is insufficient experience with the non-hyperinsulinemic form of SCHAD deficiency at present to recommend treatment modalities, but prevention of fasting seems advisable.

### Short Chain 2,3-Enoyl-CoA Hydratase Deficiency

This rare disorder, resulting from pathogenic variants in the *ECHS1* gene, was identified through exome sequencing. The disorder affects a shared pathway of short chain fatty acid and valine metabolism. The clinical phenotypes are more characteristic of mitochondrial disorders of pyruvate metabolism with predominantly a **Leigh-like disease** (see Chapters 108 and 638.2) with profound and often-fatal lactic acidosis. No treatment modalities or specific biomarkers have been established. Several patients were found to excrete increased levels of methacrylylglycine, a highly reactive and potentially toxic intermediate; 2-methyl-2,3-dihydroxybutyrate; S-(2-carboxypropyl) cysteine; and S-(2-carboxypropyl) cysteamine.



## DEFECTS IN THE CARNITINE CYCLE

### Plasma Membrane Carnitine Transport Defect (Primary Carnitine Deficiency)

Primary carnitine deficiency is the only genetic defect in which carnitine deficiency is the *cause*, rather than the consequence, of impaired fatty acid oxidation. The most common presentation is progressive **cardiomyopathy** with or without **skeletal muscle weakness** beginning at age 1-4 years. A smaller number of patients may present with fasting hypoketotic hypoglycemia in the first year of life, before the cardiomyopathy becomes evident. Cardiac arrhythmias are often seen. A common pathogenic variant causes late-onset disease in the Faroe Islands with sudden death caused by cardiomyopathy and/or arrhythmia. The underlying defect involves the high-affinity plasma membrane sodium gradient-dependent carnitine transporter encoded by the *SLC22A5* gene that is expressed at high levels in heart, muscle, and kidney. This transporter is responsible both for maintaining intracellular carnitine concentrations 20- to 50-fold higher than plasma concentrations and for renal conservation of carnitine.

**Diagnosis** of the carnitine transporter defect is aided by patients having extremely reduced carnitine levels in plasma and muscle (1-2% of normal). Heterozygote parents have plasma carnitine levels approximately 50% of normal. Fasting ketogenesis may be normal because liver carnitine transport is normal, but it may become impaired if dietary carnitine intake is interrupted. The fasting urinary organic acid profile may show a hypoketotic dicarboxylic aciduria pattern if hepatic fatty acid oxidation is impaired but is otherwise unremarkable. The defect in carnitine transport can be demonstrated clinically by the severe reduction in renal carnitine threshold or by in vitro assay of carnitine uptake using cultured fibroblasts or lymphoblasts. *SLC22A5* sequencing is the most common method to confirm the diagnosis. A common relatively severe pathogenic variant has been described in the Chinese population in Taiwan. **Treatment** with pharmacologic doses of oral carnitine (100-300 mg/kg/day) is highly effective in correcting the cardiomyopathy and muscle weakness, as well as any impairment in fasting ketogenesis. Muscle total carnitine concentrations remain <5% of normal on treatment.

### Carnitine Palmitoyltransferase-IA Deficiency

Several dozen infants and children have been described with a deficiency of the liver and kidney CPT-I isozyme (CPT-IA). **Clinical manifestations** include fasting-induced hypoketotic hypoglycemia, occasionally with extremely abnormal LFTs and, rarely, with renal tubular acidosis. The heart and skeletal muscles are not involved because the muscle isozyme is unaffected. Fasting urinary organic acid profiles sometimes show a hypoketotic C<sub>6</sub>-C<sub>12</sub> dicarboxylic aciduria but may be normal. Plasma acylcarnitine analysis demonstrates mostly free carnitine with very little acylated carnitine. This observation has been used to identify CPT-IA deficiency on newborn screening by tandem mass spectrometry. CPT-IA deficiency is the only fatty acid oxidation disorder in which plasma total carnitine levels may be elevated, often to 150-200% of normal. This phenomenon is explained by the absence of inhibitory effects of long chain acylcarnitines on the renal tubular carnitine transporter in CPT-IA deficiency. The enzyme defect can be demonstrated in cultured fibroblasts or lymphoblasts. CPT-IA deficiency in the fetus has been associated in a single case report with AFLP in the mother. A common variant in the *CPT1A* gene (c.1436C>t, p.Pro479Leu) has been identified in individuals of Inuit background in the United States, Canada, and Greenland. This variant is associated with an increased risk for sudden infant death syndrome (SIDS) in the Inuit population. The variant can be detected by newborn screening; enzyme activity is reduced by 80%, and regulation by malonyl-CoA is lost. It has not been established whether this variant is a pathologic enzyme variant or an adaptation to ancient Inuit high-fat diets. Another pathogenic variant is common in the Ashkenazi Jewish population and leads to infantile symptoms. **Treatment** for the severe form of CPT-IA deficiency that is found in non-Inuit populations is similar to that for VLCAD deficiency, with avoidance of situations where fasting ketogenesis is necessary and use of triheptanoin to provide an anaplerotic fuel source. The need for treatment of the Inuit variant has not yet been determined.

### Carnitine:Acylcarnitine Translocase Deficiency

This defect of the inner mitochondrial membrane carrier protein for long chain acylcarnitines blocks the entry of long chain fatty acids into the mitochondria for oxidation. The clinical phenotype of this disorder is driven by a typically severe and generalized impairment of fatty acid oxidation. Most newborn patients present with attacks of fasting-induced hypoglycemia, hyperammonemia, and cardiorespiratory collapse. All symptomatic newborns have had evidence of cardiomyopathy and muscle weakness. Several patients with a partial translocase deficiency and milder disease without cardiac involvement have also been identified. No distinctive urinary or plasma organic acids are noted, although increased levels of plasma long chain acylcarnitines of chain lengths C<sub>16</sub>-C<sub>18</sub> are reported, not distinguishable from the pattern seen in CPT-II deficiency (see later). **Diagnosis** can be confirmed using genetic analysis. Functional carnitine:acylcarnitine translocase activity can be measured in cultured fibroblasts or lymphoblasts. **Treatment** is similar to that of VLCAD deficiency and is particularly effective in reducing the hyperammonemia that is often otherwise persistent in severe patients.

### Carnitine Palmitoyltransferase-II Deficiency

Three forms of CPT-II deficiency have been described. A **severe neonatal lethal** presentation associated with a profound enzyme deficiency, and early death has been reported in newborns with hypoglycemia and hyperammonemia in association with dysplastic kidneys, cerebral malformations, and mild facial anomalies. A milder defect is associated with an **adult presentation** of episodic rhabdomyolysis. The first episode usually does not occur until late childhood or early adulthood. Attacks are frequently precipitated by prolonged exercise. There is aching muscle pain and myoglobinuria that may be severe enough to cause renal failure. Hypoglycemia has not been described, but fasting may contribute to attacks of myoglobinuria. Muscle biopsy shows increased deposition of neutral fat. This adult myopathic presentation of CPT-II deficiency is associated with a common *CPT2* pathogenic variant, c.338C>T, p.Ser113Leu, seen as a recurrent pathogenic variant in the Ashkenazi Jewish population. This pathogenic variant produces a heat-labile protein that is unstable to increased muscle temperature during exercise that may contribute to the myopathic presentation. A third **intermediate form** of CPT-II deficiency presents in infancy or early childhood with fasting-induced hepatic failure, cardiomyopathy, and skeletal myopathy with hypoketotic hypoglycemia but is not associated with the severe developmental changes seen in the neonatal lethal presentation. This pattern of illness is similar to VLCAD deficiency, and management is identical. It is often caused by the presence of one severe pathogenic variant in combination with the mild c.338C>T variant.

**Diagnosis** of all forms of CPT-II deficiency can be made by a combination of molecular genetic analysis and demonstrating deficient enzyme activity in muscle or other tissues and in cultured fibroblasts. Severe and intermediate disease can be identified through newborn screening, but patients homozygous for the common mild variant typically have normal newborn screens.

## DEFECTS IN THE ELECTRON TRANSFER PATHWAY

### Electron Transfer Flavoprotein and Electron Transfer Flavoprotein Dehydrogenase Deficiencies (Glutaric Acidemia Type 2, Multiple Acyl-CoA Dehydrogenation Defects)

Electron transfer flavoprotein (ETF) and electron transfer flavoprotein dehydrogenase (ETF-DH) function to transfer electrons into the mitochondrial electron transport chain from dehydrogenation reactions catalyzed by VLCAD, MCAD, SCAD, and glutaryl-CoA dehydrogenase, four enzymes involved in branched-chain amino acid (BCAA) oxidation and sarcosine and dimethylglycine dehydrogenases. Deficiencies of ETF or ETF-DH produce illness that combines the features of impaired fatty acid oxidation and impaired oxidation of several amino acids. Complete deficiencies of either protein are associated with severe illness in the newborn period, characterized by acidosis, hypoketotic hypoglycemia, coma, hypotonia, cardiomyopathy, and

an unusual odor of sweaty feet caused by isovaleryl-CoA dehydrogenase inhibition. Some affected neonates have had congenital facial dysmorphism and polycystic kidneys similar to those in severe CPT-II deficiency, which suggests that toxic effects of accumulated metabolites may occur in utero. Most severely affected infants do not survive the neonatal period. Disorders of cellular or mitochondrial riboflavin transport or flavin adenine dinucleotide (FAD, an essential cofactor for the acyl-CoA dehydrogenases) have been identified with similar biochemical profiles to ETF and ETF-DH deficiency but with more variable features.

**Diagnosis** can be made from the newborn blood spot acylcarnitine profile and urinary organic acids; both tests show abnormalities corresponding to disruptions in the oxidation of fatty acids (ethylmalonate and C<sub>6</sub>-C<sub>10</sub> dicarboxylic acids), lysine (glutarate), and BCAAs (isovaleryl-, isobutyryl-, and 2-methylbutyrylglycine). The diagnosis can be confirmed by genetic testing of *ETFA*, *ETFB*, and *ETFDH*. If no pathogenic variants in these genes are identified, additional testing for the riboflavin transport and FAD synthesis genes should be pursued.

Partial deficiencies of ETF and ETF-DH produce a disorder that may mimic MCAD deficiency or other milder long-chain fatty acid oxidation defects with attacks of fasting hypoketotic coma. The urinary organic acid profile reveals primarily elevations of dicarboxylic acids and ethylmalonate, derived from short chain fatty acid intermediates. Secondary carnitine deficiency is present. Some patients with mild forms of ETF/ETF-DH deficiency may benefit from treatment with high doses of *riboflavin*, a precursor of the various flavoproteins involved in electron transfer.

## DEFECTS IN THE KETONE SYNTHESIS PATHWAY

The final steps in production of ketones from mitochondrial fatty acid  $\beta$ -oxidation convert acetyl-CoA to acetoacetate through two enzymes of the HMG-CoA pathway (see Fig. 106.2).

### $\beta$ -Hydroxy- $\beta$ -Methylglutaryl-CoA (HMG-CoA) Synthase Deficiency

See Chapter 103.6.

HMG-CoA synthase is the rate-limiting step in the conversion of acetyl-CoA derived from fatty acid  $\beta$ -oxidation in the liver to ketones. The presentation of deficiency is one of fasting hypoketotic hypoglycemia without evidence of impaired cardiac or skeletal muscle function. The urinary organic acid profile shows only a nonspecific hypoketotic dicarboxylic aciduria. Plasma and tissue carnitine levels are normal, in contrast to all the other disorders of fatty acid oxidation. A separate synthase enzyme, present in cytosol for cholesterol biosynthesis, is not affected. The HMG-CoA synthase defect is expressed only in the liver and kidney and cannot be demonstrated in cultured fibroblasts. The **diagnosis** can be made by genetic testing. *Avoiding fasting is usually a successful treatment.*

### $\beta$ -Hydroxy- $\beta$ -Methylglutaryl-CoA Lyase Deficiency (3-Hydroxy-3-Methylglutaric Aciduria)

See Chapter 105.6.

## DEFECTS IN KETONE BODY UTILIZATION

The ketone bodies  $\beta$ -hydroxybutyrate and acetoacetate are the end products of hepatic fatty acid oxidation and are important metabolic fuels for the brain during fasting. Three defects in utilization of ketones in brain and other peripheral tissues present as episodes of **hyperketotic coma**, with or without hypoglycemia.

### Monocarboxylate Transporter-1 Deficiency

About 10 patients have been described with recurrent episodes of potentially lethal ketoacidosis, with or without hypoglycemia, caused by a deficiency of monocarboxylate transporter 1 (MCT1), a plasma membrane carrier encoded by *SLC16A1* that is required to transport ketones into tissues from plasma. Although the first cases identified were homozygous for inactivating pathogenic variants of *SLC16A1*, heterozygous carriers can also be affected. Affected patients develop severe ketoacidosis provoked by fasting or infections in their first years

of life; hypoglycemia is not always present. The differential includes ketotic hypoglycemia associated with milder forms of glycogen storage disease, such as phosphorylase or phosphorylase kinase deficiency (see Chapter 107). **Treatment** for acute episodes includes IV dextrose to suppress lipolysis and inhibit ongoing ketogenesis. Long-term treatment includes avoidance of prolonged fasting stress. The **diagnosis** should be suspected by unusually severe ketosis and delayed suppression of ketones after starting treatment with dextrose. There are no specific metabolic markers or newborn screening methods. The diagnosis can be established by genetic sequencing of *SLC16A1*.

### Succinyl-CoA:3-Ketoacid-CoA Transferase Deficiency

See Chapter 103.6.

The characteristic presentation of succinyl-CoA:3-ketoacid-CoA transferase (SCOT) deficiency is an infant with recurrent episodes of severe ketoacidosis induced by fasting. Plasma acylcarnitine and urine organic acid abnormalities do not distinguish SCOT deficiency from other causes of ketoacidosis. **Treatment** of episodes requires infusion of glucose and large amounts of bicarbonate until metabolic stability is reestablished. Patients usually exhibit inappropriate, persistent hyperketonemia even between episodes of illness. SCOT is responsible for activating acetoacetate in peripheral tissues, using succinyl CoA as a donor to form acetoacetyl-CoA. Deficient enzyme activity can be demonstrated in the brain, muscle, and fibroblasts from affected patients. The gene has been cloned, and numerous pathogenic variants have been characterized. The diagnosis is usually established by sequencing analysis of the *OXCT1* gene that encodes the SCOT enzyme.

### $\beta$ -Ketothiolase Deficiency

See Chapter 105.6.

Visit Elsevier eBooks+ at eBooks.Health.Elsevier.com for Bibliography.

## 106.2 Disorders of Very Long Chain Fatty Acids and Other Peroxisomal Functions

Michael F. Wangler

### PEROXISOMAL DISORDERS

Disorders of very long chain fatty acids (VLCFAs) fall within the broader group of peroxisomal diseases. The peroxisomal diseases are genetically determined disorders caused either by the failure to form or maintain the peroxisome or by a defect in the function of a single protein that is localized to the peroxisome. These disorders cause serious disability in childhood and occur more frequently and present a wider range of phenotypes than recognized in the past. Many, but not all, peroxisomal disorders are associated with elevations of VLCFAs.

### Etiology

Peroxisomal disorders are subdivided into two major categories (Table 106.2). In the **peroxisomal biogenesis disorders (PBDs)**, the basic defect is the failure to import one or more proteins into the organelle. In the other group, defects affect a single peroxisomal protein (**single-enzyme defects**). The *peroxisome* is present in all cells except mature erythrocytes and is a subcellular organelle surrounded by a single membrane; there are >50 peroxisomal enzymes. Some enzymes are involved in the production and decomposition of hydrogen peroxide and others in lipid and amino acid metabolism. Peroxisomal enzymes have a unique system to ship them to the peroxisome that uses specific **peroxisome targeting sequences (PTSs)**. These enzymes are first synthesized in their mature form on free polyribosomes and float free in the cytoplasm until their specific PTS is recognized. Most peroxisomal matrix proteins contain a **PTS1**, a short amino acid sequence at the carboxyl terminus. In addition, the amino-terminal-located **PTS2** is critical for the import of enzymes involved in plasmalogen

**Table 106.2** Peroxisomal Disorder Classification, Disorders, and Genes

PEROXISOMAL BIOGENESIS DISORDERS	GENES
Peroxisome biogenesis disorder–Zellweger spectrum disorders (PBD-ZSD)	<i>PEX1, PEX2, PEX3, PEX5, PEX6, PEX10, PEX11B,</i>
Zellweger syndrome (severe PBD-ZSD)	<i>PEX12, PEX13, PEX14,</i>
Neonatal adrenoleukodystrophy (intermediate PBD-ZSD)	<i>PEX16, PEX19, PEX26</i>
Infantile Refsum disease (mild PBD-ZSD)	
Rhizomelic chondrodysplasia punctata, types 1 and 5 (RCDP1 and RCDP5)	<i>PEX7</i> and <i>PEX5</i> , respectively
SINGLE-ENZYME DEFECTS	
X-linked adrenoleukodystrophy	<i>ABCD1</i>
Acyl-CoA oxidase deficiency	<i>ACOX1</i>
D-Bifunctional protein deficiency	<i>HSD17B4</i>
2-Methylacyl-CoA racemase deficiency	<i>AMACR</i>
Rhizomelic chondrodysplasia punctata, types 2 and 3 (RCDP2 and RCDP3)	<i>AGPS, GNPAT</i>
Adult Refsum disease	<i>PHYH</i>

and branched-chain fatty acid metabolism. The peroxisome biogenesis machinery then recognizes, binds, and targets PTS-containing proteins to the peroxisome. This process involves a complex series of reactions mediated by at least 23 distinct proteins. These proteins, referred to as *peroxins*, are encoded by the *PEX* genes. Pathogenic genetic variants in these genes are the cause of PBDs.

### Epidemiology

Except for X-linked adrenoleukodystrophy (ALD), all the peroxisomal disorders listed in Table 106.2 are inherited as *autosomal recessive diseases*. ALD is the most common peroxisomal disorder, with an estimated incidence of 1 in 17,000 live births. The combined incidence of the other peroxisomal disorders is estimated to be 1 in 50,000 live births, although with broader newborn screening, it is expected that the actual incidences of all the disorders of VLCFAs will be more accurately established.

### Pathology

Absence or reduction in the number of peroxisomes is pathognomonic for disorders of peroxisome biogenesis. In most cases, a close examination of cells in these patients reveals membranous sacs that lack the normal complement of matrix proteins; these are peroxisome “ghosts,” and they indicate the inability of the cell to properly localize peroxisomal proteins. Pathologic changes are observed in most organs and include profound and characteristic defects in neuronal migration, micronodular cirrhosis of the liver, renal cysts, chondrodysplasia punctata, sensorineural hearing loss, retinopathy, congenital heart disease, and dysmorphic features.

### Pathogenesis

Clinical pathologic changes of the PBDs are secondary to the underlying peroxisome biogenesis defect. As a result, multiple peroxisomal enzymes fail to function in the PBDs (Table 106.3). PBDs include the Zellweger spectrum disorders (**PBD-ZSD**) and one form of rhizomelic chondrodysplasia punctata (**PBD-RCDP**), which are distinguished by clinical phenotype and differences in the extent of biogenesis abnormality. In PBDs, enzymes that are synthesized cannot be properly located to the peroxisome and are thus degraded abnormally quickly because they are unprotected outside the peroxisome. However, it has yet to be clarified as to how specific peroxisome defects lead to each of the pathologic manifestations.

Pathogenic variants in 14 different *PEX* genes have been identified in PBDs. For PBD-RCDP, *PEX7* pathogenic variants are the most

**Table 106.3** Abnormal Laboratory Findings Common to Zellweger Spectrum Disorders

Defective oxidation and abnormal accumulation of very long chain fatty acids
Peroxisomes absent to reduced in number
Catalase in cytosol
Deficient synthesis and reduced tissue levels of plasmalogens
Deficient oxidation and age-dependent accumulation of phytanic acid
Defects in certain steps of bile acid formation and accumulation of bile acid intermediates
Defects in oxidation and accumulation of L-pipecolic acid
Increased urinary excretion of dicarboxylic acids

common, but rarer *PEX5* pathogenic variants are seen. The pattern and severity of pathologic features vary with the nature of the import defects and the degree of import impairment leading to the severity spectrum of PBD-ZSD. These gene defects lead to disorders named prior to recognizing their relationship to the peroxisome, namely, Zellweger syndrome, neonatal ALD, infantile Refsum disease, and RCDP. The first three disorders are considered to be a form of *clinical continuum*, with Zellweger syndrome the most severe (**severe PBD-ZSD**), infantile Refsum disease the least severe (**mild PBD-ZSD**), and neonatal ALD being intermediate (**intermediate PBD-ZSD**). For PBD-ZSD, 13 genes can be affected to result in autosomal recessive disease (*PEX1, PEX2, PEX3, PEX5, PEX6, PEX10, PEX11B, PEX12, PEX13, PEX14, PEX16, PEX19, PEX26*). Specific gene defects cannot be distinguished by clinical features. Clinical severity varies with the degree to which protein import is impaired. Pathogenic variants that completely abolish import are often associated with the severe PBD-ZSD or Zellweger phenotype, whereas a missense variant, in which some degree of import function is retained, leads to the somewhat milder presentations. A defect in *PEX7* or, very rarely, *PEX5*, which depend on peroxisomal import that use PTS2, is associated with RCDP. *PEX7* defects that leave the import partially intact are associated with milder phenotypes, some of which resemble classic (adult) Refsum disease.

The genetic disorders that involve single peroxisomal enzymes usually have clinical manifestations that are more restricted and relate to the single biochemical defect. The primary adrenal insufficiency of ALD is caused by an accumulation of VLCFAs in the adrenal cortex, and the peripheral neuropathy in adult Refsum disease is caused by the accumulation of phytanic acid in Schwann cells and myelin.

### PBD-ZSD

Newborn infants with *severe* PBD-ZSD, previously described as **Zellweger syndrome**, show striking and consistent recognizable abnormalities. Of central diagnostic importance are the typical facial appearance (large anterior fontanelle, wide sutures, high forehead, hypoplastic supraorbital ridges, flat face, and broad nasal bridge; Fig. 106.3), severe weakness and hypotonia, neonatal seizures, and eye abnormalities. Because of the hypotonia and craniofacial appearance, Down syndrome may be suspected in neonates. Infants with severe PBD-ZSD rarely live more than a few months. More than 90% show postnatal growth failure. Table 106.4 lists the main clinical abnormalities.

Patients with *intermediate* PBD-ZSD, previously described as **neonatal ALD**, show fewer, less prominent craniofacial features. Neonatal seizures occur frequently. Psychomotor developmental delay is present; function remains in the range of severe intellectual disability, and development may regress after 3–5 years of age, likely from progressive leukodystrophy. Hepatomegaly, impaired liver function, pigmentary degeneration of the retina, and severely impaired hearing are invariably present. Adrenocortical function is usually impaired and may require adrenal hormone replacement. Chondrodysplasia punctata and renal cysts are absent.

Patients with *mild* PBD-ZSD, previously described as **infantile Refsum disease**, have survived to adulthood. They can walk, although gait may be ataxic and broad based. Cognitive function is generally





**Fig. 106.3** Zellweger syndrome. Three affected neonates. Note the hypotonia, high forehead with shallow supraorbital ridges, anteverted nares, and mild micrognathia, as well as the talipes equinovarus and contractures at the knees. (From Shaheen R, Al-Dirbashi OY, Al-Hassnan ZN, et al. *Clinical, biochemical and molecular characterization of peroxisomal diseases in Arabs. Clin Genet.* 2011;79[1]:60–70.)

impaired, but accurate assessment is limited, usually by the presence of both vision and hearing impairment. Almost all have some degree of sensorineural hearing loss and pigmentary degeneration of the retina. They have moderately dysmorphic features that may include epicanthal folds, a flat nose bridge, and low-set ears. Early hypotonia and hepatomegaly with impaired function are common. Levels of plasma cholesterol and high-density and low-density lipoprotein are often moderately reduced. Chondrodysplasia punctata and renal cortical cysts are absent. Postmortem study in these mild PBD-ZSD cases reveals micronodular liver cirrhosis and small, hypoplastic adrenals. The brain shows no malformations, except for severe hypoplasia of the cerebellar granule layer and ectopic locations of the Purkinje cells in the molecular layer.

Some patients with PBD-ZSD have milder and atypical phenotypes. They may present with peripheral neuropathy or with retinopathy, impaired vision, or cataracts in childhood, adolescence, or adulthood and have been considered to have Charcot-Marie-Tooth disease or Usher syndrome. Some patients with *PEX16* variants present with cerebellar ataxia. Some patients have survived to the fifth decade.

### Rhizomelic Chondrodysplasia Punctata

RCDP is characterized by the presence of stippled foci of calcification within the hyaline cartilage and is associated with short stature, cataracts (72%), and multiple malformations caused by contractures. Vertebral bodies have coronal clefting filled by cartilage that results from an embryonic arrest. Disproportionate short stature affects the proximal

**Table 106.4** Main Clinical Abnormalities in Zellweger Syndrome

ABNORMAL FEATURE	PATIENTS IN WHOM THE FEATURE WAS PRESENT	
	NUMBER	%
High forehead	58	97
Flat occiput	13	81
Large fontanelle(s), wide sutures	55	96
Shallow orbital ridges	33	100
Low/broad nasal bridge	23	100
Epicanthus	33	92
High-arched palate	35	95
External ear deformity	39	97
Micrognathia	18	100
Redundant skin fold of neck	13	100
Brushfield spots	5	83
Cataract/cloudy cornea	30	86
Glaucoma	7	58
Abnormal retinal pigmentation	6	40
Optic disc pallor	17	74
Severe hypotonia	94	99
Abnormal Moro response	26	100
Hyporeflexia or areflexia	56	98
Poor sucking	74	96
Gavage feeding	26	100
Epileptic seizures	56	92
Intellectual disability	45	100
Impaired hearing	9	40
Nystagmus	30	81

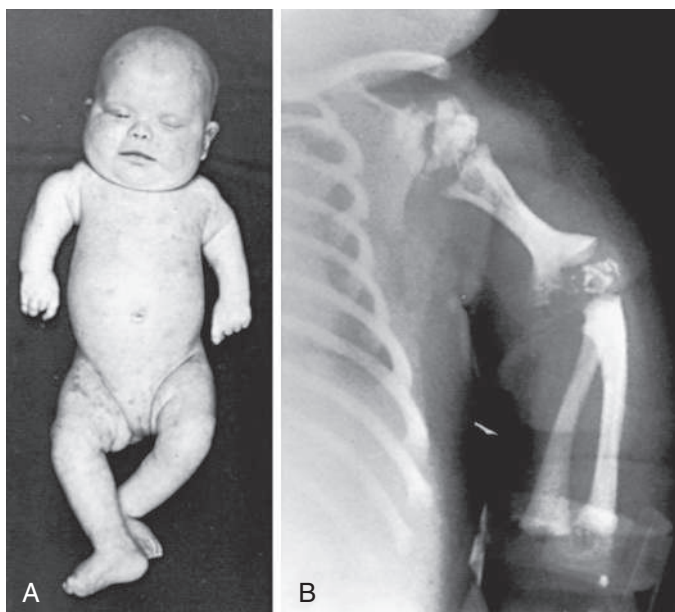
From Heymans HAS. Cerebro-hepato-renal (Zellweger) syndrome: Clinical and biochemical consequences of peroxisomal dysfunctions. Thesis, University of Amsterdam, 1984.

parts of the extremities (rhizomelia; Fig. 106.4A). Radiologic abnormalities consist of shortening of the proximal limb bones, metaphyseal cupping, and disturbed punctate ossification (Fig. 106.4B). Height, weight, and head circumference are less than the third percentile, and these children have a severe intellectual disability. Skin changes such as those observed in ichthyosiform erythroderma are present in approximately 25% of patients. RCDP can be caused by pathogenic variants in one of four genes (*PEX5*, *PEX7*, *AGPS*, *GNPAT*). Defects in *PEX7*, which most frequently lead to the RCDP phenotype, may also lead to a milder phenotype with clinical manifestations similar to those of adult Refsum disease, a later-onset disorder described later.

### Isolated Defects of Peroxisomal Fatty Acid Oxidation

In the group of single-enzyme defects, acyl-CoA oxidase and bifunctional enzyme deficiency involve a single enzymatic step in peroxisomal fatty acid oxidation. Defects of bifunctional enzyme are found in approximately 15% of patients who are initially suspected of having PBD-ZSD. Patients with isolated acyl-CoA oxidase deficiency have a somewhat milder phenotype that resembles mild or intermediate PBD-ZSD or Usher syndrome and typically comes to attention because of the development of an early childhood leukodystrophy.





**Fig. 106.4** A, Newborn infant with rhizomelic chondrodysplasia punctata. Note the severe shortening of the proximal limbs, the depressed bridge of the nose, hypertelorism, and widespread scaling skin lesions. B, Note the marked shortening of the humerus and epiphyseal stippling at the shoulder and elbow joints. (Courtesy John P. Dorst, MD.)

### Isolated Defects of Plasmalogen Synthesis

*Plasmalogens* are lipids in which the first of three glycerol carbons is linked to an alcohol rather than a fatty acid. They are synthesized through a complex series of reactions, the first two steps of which are catalyzed by the peroxisomal enzymes dihydroxyacetone phosphate alkyl transferase (DHAPT, encoded by the gene *GNPAT*) and synthase (AGPS, encoded by the gene *AGPS*). Deficiency of either of these enzymes leads to RCDP types 2 and 3, respectively, phenotypes that are clinically indistinguishable from each other and from the peroxisomal import disorder RCDP1. This latter disorder is caused by a defect in *PEX7*, the receptor for PTS2 upon which DHAPT and AGPS are dependent for peroxisomal import. RCDP1 shares the severe deficiency of plasmalogens with these single-enzyme disorders but also has defects of phytanic oxidation. The fact that these single genetic disorders are associated with the full phenotype of RCDP suggests that a deficiency of plasmalogens is sufficient to produce it.

### Adult (Classic) Refsum Disease

The defective enzyme (phytanoyl-CoA hydroxylase, encoded by the *PHYH* gene) is localized to the peroxisome. The manifestation of Refsum disease includes impaired vision from retinitis pigmentosa, anosmia, ichthyosis, peripheral neuropathy, ataxia, and occasionally cardiac arrhythmias. In contrast to infantile Refsum disease, cognitive function is normal, and there are no congenital malformations. Refsum disease often does not manifest until young adulthood, but visual disturbances such as night blindness, ichthyosis, and peripheral neuropathy may already be present in childhood and adolescence. Early diagnosis is important because institution of a phytanic acid–restricted diet can reverse the peripheral neuropathy and prevent the progression of the visual and central nervous system (CNS) manifestations. Adult Refsum disease may also be caused by defects in *PEX7*.

### 2-Methylacyl-CoA Racemase Deficiency (AMACR)

This disorder is caused by an enzyme defect that leads to the accumulation of the branched-chain fatty acids (phytanic and pristanic acid) and bile acids. Individuals present with typically an adult-onset peripheral neuropathy and may also have pigmentary degeneration of the retina.

### Atypical Autosomal Dominant Disorders

Peroxisomal disorders are classically autosomal recessive in family pedigrees. X-linked adrenoleukodystrophy is a key exception. Several other exceptions of rare dominant inheritance of peroxisomal disease manifesting as neurologic disease have emerged for a few peroxisomal genes, including *ACOX1*, *PEX6*, and *DNM1L*.

### Laboratory Findings

Clinical suspicion would be followed by specific biochemical determination of an abnormality and then confirmation through genetic testing targeted to specific genes. However, an extended gene panel and exome and genome testing have been used to identify pathogenic variants or variants of uncertain significance (VUS) in peroxisomal genes. *These patients still require biochemical testing for confirmation.* In addition, newborn screening for X-linked ALD using dried blood spots on filter paper in states across the United States and many parts of Europe also identifies other forms of peroxisomal deficiency. Early recognition of peroxisomal disorders in newborns will be a clinical reality.

Whether based on clinical suspicion, an abnormal newborn screen, or reported genetic variants, the biochemical characterization of peroxisomal disorders is a necessary step and uses the generally available testing strategy listed in Table 106.5. Measurement of plasma VLCFA levels is the most common assay. It must be emphasized that although plasma VLCFA levels are elevated in many patients with peroxisomal disorders and the same defect is the indirect basis for the newborn screen assay, this is not always the case. The most important exception is RCDP, in which VLCFA levels are normal but plasma phytanic acid levels are increased and red blood cell (RBC) plasmalogen levels are reduced. In other peroxisomal disorders, the biochemical abnormalities are still more restricted. Therefore a panel of tests is recommended and includes plasma levels of VLCFAs and phytanic, pristanic, and piperolic acids and RBC levels of plasmalogens. Tandem mass spectrometry techniques also permit convenient quantitation of bile acids in plasma and urine. This panel of tests can be performed on very small amounts of venous blood and permits detection of most peroxisomal disorders.

Definition of the molecular defect either through gene panel testing or exome sequencing in the *proband* is essential for carrier detection and speeds prenatal diagnosis. Characterization of the pathogenic variant may be of prognostic value in patients with *PEX1* defects. This defect is present in approximately 60% of PBD patients, and about half the *PEX1* defects have the G843D allele, which is associated with a significantly milder phenotype than found in other pathogenic variants.

### Diagnosis

Several noninvasive laboratory tests permit precise and early diagnosis of peroxisomal disorders (see Table 106.5). The challenge in PBDs is to differentiate them from the large variety of other conditions that can cause hypotonia, seizures, failure to thrive, or dysmorphic features. Experienced clinicians readily recognize classic Zellweger syndrome by its clinical manifestations. However, more mildly affected PBD-ZSD patients often do not show the full clinical spectrum of disease and may be identifiable only by laboratory assays. Clinical features that warrant diagnostic assessment include intellectual disability; weakness and hypotonia; dysmorphic features; neonatal seizures; retinopathy, glaucoma, or cataracts; hearing deficits; enlarged liver and impaired liver function; and chondrodysplasia punctata. The presence of one or more of these abnormalities increases the likelihood of this diagnosis. Atypical milder forms presenting as peripheral neuropathy have also been described.

Some patients with the isolated defects of peroxisomal fatty acid oxidation resemble those with ZSD and can be detected by the demonstration of abnormally high levels of VLCFAs.

Patients with RCDP must be distinguished from patients with *other* causes of chondrodysplasia punctata. RCDP is suspected clinically because of the shortness of limbs, developmental delays, and ichthyosis. The most decisive laboratory test is the demonstration of abnormally low plasmalogen levels in RBCs and an alteration in *PEX7*.

**Table 106.5** Diagnostic Biochemical Abnormalities in Peroxisomal Disorders

DISORDER	VLCFA	PHYTANIC ACID	PRISTANIC ACID	PLASMALOGENS
PBD-ZSD	↑↑	↑*	↑*	↓
RCDP	NI	↑	NI	↓↓
ALD	↑	NI	NI	NI
ACoX	↑	NI	NI	NI
Bifunctional enzyme deficiency	↑	↑	↑	NI
AMACR	NI	↑	↑	NI
Refsum disease	NI	↑	↑	NI

\*Phytanic acid and pristanic acid accumulation is age dependent, and normal (NI) levels may be seen in infants and young children. VLCFA, Very long chain fatty acids; ZSD, Zellweger spectrum disorder; RCDP, rhizomelic chondroplasia punctata; ALD, adrenoleukodystrophy; ACoX, acyl-CoA oxidase deficiency; AMACR, 2-methylacyl-CoA racemase deficiency.

### Complications

Patients with severe PBD-ZSD have multiple disabilities involving muscle tone, swallowing, cardiac abnormalities, liver disease, and seizures. These conditions are treated symptomatically, but the prognosis is poor, and most patients succumb in the first years of life. Similarly, individuals with RCDP have multiple systemic and neurologic issues. In addition, they may develop spinal cord compression at any level of the spine.

### Treatment

The most effective therapy is the dietary treatment of adult Refsum disease with a phytanic acid–restricted diet. However, this only applies to this specific condition.

For patients with the somewhat milder variants of the peroxisome import disorders, success has been achieved with multidisciplinary early intervention, including physical and occupational therapy, hearing aids or cochlear implants, augmentative and alternative communication, nutrition, and support for the families. Although most patients continue to function in the impaired range, some make significant gains in self-help skills, and several are in stable condition in their teens or even early 20s.

Attempts to mitigate some of the secondary biochemical abnormalities include the oral administration of docosahexaenoic acid (DHA). The DHA level is greatly reduced in patients with disorders of peroxisome biogenesis, and this therapy normalizes DHA plasma levels. Although there were anecdotal reports of clinical improvement with DHA therapy, a randomized placebo-controlled study failed to find benefit.

### Genetic Counseling

Most of these disorders can be diagnosed prenatally. Prenatal testing using chorionic villus sampling or amniocentesis enables genetic testing when the alteration is known, but biochemical measurements may be made using the same tests as described for postnatal diagnosis (see Table 106.5). Because of the 25% recurrence risk with autosomal recessive inheritance, couples with an affected child should be advised about the availability of prenatal and preconception diagnosis.

### ADRENOLEUKODYSTROPHY

ALD is an X-linked disorder associated with the accumulation of saturated VLCFAs and a progressive dysfunction of the adrenal cortex and nervous system. It is the most common peroxisomal disorder.

### Etiology

The key biochemical abnormality in ALD is the tissue accumulation of saturated VLCFAs, with a carbon chain length of 24 or more. Excess hexacosanoic acid (C<sub>26:0</sub>) is the most striking and characteristic feature. This accumulation of fatty acids is caused by genetically deficient peroxisomal degradation of fatty acid. The defective gene (*ABCD1*) codes for a peroxisomal membrane protein (ALDP, the ALD protein). Many alterations in *ABCD1* have been determined to be pathogenic,

with over half these being private or unique to the family. There is no genotype-phenotype correlation, as wide ranges of clinical severity can occur within a family across multiple individuals with the same pathogenic variant. A curated database of pathogenic variants is maintained ([www.x-ald.nl](http://www.x-ald.nl)). The mechanism by which the ALDP defect leads to VLCFA accumulation appears to be a disruption of transport of saturated fatty acids into the peroxisome, with resultant continued progressive elongation of fatty acids.

### Epidemiology

The incidence of ALD in males is 1 in 21,000, and the combined incidence of ALD males and heterozygous females in the general population is estimated to be 1 in 17,000. All ethnicities are affected. The various phenotypes often occur in members of the same kindred.

### Pathology

Characteristic lamellar cytoplasmic inclusions can be demonstrated on electron microscopy in adrenocortical cells, testicular Leydig cells, and nervous system macrophages. These inclusions probably consist of cholesterol esterified with VLCFA. They are most prominent in cells of the zona fasciculata of the adrenal cortex, which at first are distended with lipids and subsequently atrophy.

The nervous system displays two types of ALD lesions. In the severe cerebral form, demyelination is associated with an inflammatory response manifested by the accumulation of perivascular lymphocytes that is most intense in the involved region. In the slowly progressive adult form, **adrenomyeloneuropathy** (AMN), the main finding is a distal axonopathy that affects the long tracts in the spinal cord. In this form the inflammatory response is mild or absent.

### Pathogenesis

The adrenal dysfunction is probably a direct consequence of the accumulation of VLCFAs. The cells in the adrenal zona fasciculata are distended with abnormal lipids. Cholesterol esterified to VLCFA is relatively resistant to adrenocorticotrophic hormone (ACTH)–stimulated cholesterol ester hydrolases, and this limits the capacity to convert cholesterol to active steroids. In addition, C<sub>26:0</sub> excess increases the viscosity of the plasma membrane, which may interfere with receptor and other cellular functions.

There is no defined correlation between the neurologic phenotype and the nature of the pathogenic variant or the severity of the biochemical defect as assessed by plasma VLCFA levels or between the degree of adrenal involvement and nervous system involvement. The severity of the illness and rate of progression correlate with the intensity of the inflammatory response. The inflammatory response may be partially cytokine mediated and may involve an autoimmune response triggered in an unknown way by the excess of VLCFAs. Mitochondrial damage and oxidative stress also appear to contribute. Approximately half the patients do not experience the inflammatory response, although the basis of this difference is not understood.

### Clinical Manifestations

There are five relatively distinct ALD phenotypes, three of which present in childhood with symptoms and signs. In all the phenotypes, development is usually normal in the first 3–4 years of life.

In the **childhood cerebral form** of ALD, symptoms most often are first noted between ages 4 and 8 years. The most common initial manifestations are hyperactivity, inattention, and worsening school performance in a child who had previously been a good student. *Auditory discrimination* is often impaired, although tone perception is preserved. This may be evidenced by difficulty in using the telephone and greatly impaired performance on intelligence tests in items that are presented verbally. Spatial orientation is often impaired. Other initial symptoms are disturbances of vision, ataxia, poor handwriting, seizures, and strabismus. Visual disturbances are often caused by involvement of the parietooccipital cortex rather than eye or optic tract abnormalities, which leads to variable and seemingly inconsistent visual capacity. Seizures occur in most patients and may represent the first manifestation of the disease. Some patients present with increased intracranial pressure. Impaired cortisol response to ACTH stimulation is present in 85% of patients, and mild hyperpigmentation is noted. In most patients with this phenotype, adrenal dysfunction is recognized only after the condition is diagnosed because of the cerebral symptoms. Cerebral childhood ALD tends to progress rapidly with increasing spasticity and paralysis, visual and hearing loss, and loss of ability to speak or swallow. The mean interval between the first neurologic symptom and an apparently unresponsive wakeful state is 1.9 years. Patients may continue in this apparently unresponsive wakeful state for  $\geq 10$  years.

**Adolescent ALD** designates patients who experience neurologic symptoms between ages 10 and 21 years. The manifestations resemble those of childhood cerebral ALD except that progression is slower. Approximately 10% of patients present acutely with status epilepticus, adrenal crisis, acute encephalopathy, or coma.

**AMN** manifests in late adolescence or adulthood as a progressive paraparesis caused by long tract degeneration in the spinal cord. Approximately half the affected males also have involvement of the cerebral white matter.

The **Addison-only** phenotype is an important condition. Of male patients with Addison disease, 25% may have the biochemical defect of ALD. Many of these patients have intact neurologic systems, whereas others have subtle neurologic signs. Many acquire AMN in adulthood.

The term **asymptomatic ALD** is applied to persons who have the biochemical defect of ALD but are free of neurologic or endocrinal disturbances. Almost all persons with the gene defect eventually become neurologically symptomatic.

Approximately 50% of female heterozygotes acquire a syndrome that resembles AMN but is milder and of later onset. Adrenal insufficiency and cerebral disease are rare.

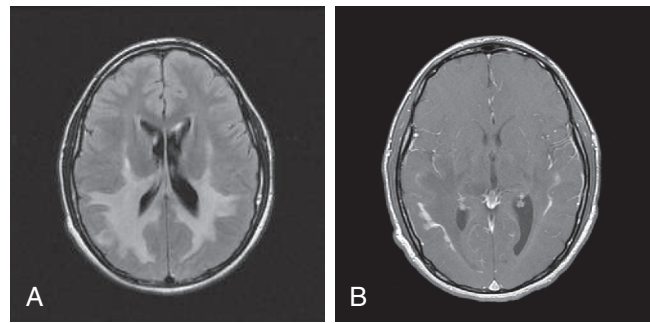
Cases of typical ALD have occurred in relatives of those with AMN. One of the most difficult problems in the management of ALD is the common observation that affected individuals in the same family may have quite different clinical courses. For example, in one family, an affected male may have severe classic ALD culminating in death by age 10 years, and another brother will have the later-onset AMN.

### Laboratory and Radiographic Findings

The most specific and important laboratory finding is the demonstration of abnormally high levels of VLCFAs in plasma, RBCs, or cultured skin fibroblasts. Positive results are obtained in all male patients with ALD and in approximately 85% of female carriers of ALD. Pathogenic variant analysis is the most reliable method for the identification of carriers. Simply finding a variation in ABCD1 is not adequate for making the diagnosis of ALD. It must be shown to segregate with elevated VLCFA levels.

### Neuroimaging

Patients with childhood cerebral or adolescent ALD have characteristic white matter lesions on MRI. In 80% of patients, the lesions are symmetric and involve the splenium of the corpus callosum and periventricular white matter in the posterior parietal and occipital lobes. Many



**Fig. 106.5** Characteristic MRI findings in cerebral adrenoleukodystrophy. A, Symmetric T2-weighted MRI abnormalities involve the posterior white matter, including the corpus callosum. B, Contrast administration reveals a garland of enhancement.

will show a garland of contrast enhancement adjacent and anterior to the posterior hypodense lesions (Fig. 106.5). This zone corresponds to the zones of intense perivascular lymphocytic infiltration where the blood-brain barrier breaks down. In 10–15% of patients, the initial lesions are frontal. Unilateral lesions that produce a mass effect suggestive of a brain tumor may occur rarely. MRI provides a clearer delineation of normal and abnormal white matter than does CT and is the preferred imaging modality.

### Impaired Adrenal Function

More than 85% of patients with the childhood form of ALD have elevated levels of ACTH in plasma and a subnormal rise of cortisol levels in plasma after IV injection of ACTH.

### Newborn Screening and Diagnosis

Diagnosis of asymptomatic males is available by newborn screening, which allows for early diagnosis of ALD years before the manifestations of disease. Males then enter a program of surveillance for adrenal insufficiency and early detection of potential cerebral disease. Females identified through these programs should also have confirmatory testing, genetic counseling for the family, and screening of other at-risk males. Females do not generally require any other monitoring in childhood. This early screening paradigm allows for early surveillance of ALD neurologic symptoms, which are difficult to distinguish from the more common attention-deficit disorders or learning disabilities of school-age children. Early diagnosis could lead to early cortisol treatment for adrenal problems, which could be life-threatening. Early bone marrow transplant is likely to result as a benefit of screening. For positive newborn screens or for individuals with clinical suspicion of ALD, confirmatory VLCFA testing and genetic counseling should be provided.

### The Earliest Manifestations of Childhood Cerebral ALD

Rapid progression, signs of dementia, or difficulty in auditory discrimination suggest ALD. Even in early stages, neuroimaging shows abnormal changes. Other leukodystrophies or multiple sclerosis may sometimes mimic these radiographic findings, although early ALD has more of a predilection for the posterior brain than its mimics. Definitive diagnosis depends on demonstration of VLCFA excess, which occurs only in ALD and the other peroxisomal disorders.

Cerebral forms of ALD, especially if asymmetric, may be misdiagnosed as gliomas or other mass lesions. Individuals have received brain biopsy and, rarely, other therapies before the correct diagnosis was made. Measurement of VLCFAs in plasma is the most reliable differentiating test.

Adolescent or adult cerebral ALD can be confused with psychiatric disorders, dementing disorders, multiple sclerosis, or epilepsy. The first clue to the diagnosis of ALD may be the demonstration of characteristic white matter lesions by neuroimaging; VLCFA assays are confirmatory.

ALD cannot be distinguished clinically from other forms of Addison disease; it is recommended that assays of VLCFA levels be performed



in all male patients with Addison disease. ALD patients *do not* usually have antibodies to adrenal tissue in their plasma.

### Complications

An avoidable complication is the occurrence of adrenal insufficiency. The most difficult neurologic problems are those related to bed rest, contracture, coma, and swallowing disturbances. Other complications involve behavioral disturbances and injuries associated with defects of spatial orientation, impaired vision and hearing, and seizures.

### Treatment

Corticosteroid replacement for adrenal insufficiency or adrenocortical hypofunction is effective. It may be lifesaving and may increase general strength and well-being, but it does not alter the course of the neurologic disability.

### Bone Marrow Transplantation

Bone marrow transplantation (BMT) or hematopoietic stem cell therapy (HSCT) benefits patients who show early evidence of the inflammatory demyelination characteristic of the rapidly progressive neurologic disability in young males and adolescents with the cerebral ALD phenotype. BMT carries risk, and patients must be evaluated and selected with care. The mechanism of the beneficial effect is incompletely understood. Bone marrow-derived cells do express ALDP, the protein that is deficient in ALD; approximately 50% of brain microglial cells are bone marrow derived. The favorable effect may be caused by modification of the brain inflammatory response. Follow-up of young males and adolescents who had early cerebral involvement has shown stabilization. On the other hand, BMT does not arrest the course in those who already had severe brain involvement and may accelerate disease progression under these circumstances. The ALD MRI score and the use of performance measures on IQ testing have shown some predictive ability for boys likely to benefit from this procedure. Transplant is not recommended in patients with performance IQ significantly <80. Unfortunately, in more than half the patients who are diagnosed because of neurologic symptoms, the illness is so advanced at diagnosis that they are not candidates for transplant.

Consideration of BMT is most relevant in neurologically asymptomatic or mildly involved patients. Screening at-risk relatives of symptomatic patients identifies these patients most frequently. Screening by measurement of plasma VLCFA levels in patients with Addison disease may also identify candidates for BMT. Because of its risk (10–20% mortality) and because up to 50% of untreated patients with ALD do not develop inflammatory brain demyelination, transplant is not recommended in patients who are free of demonstrable brain involvement on MRI. MRI is also of key importance for the crucial decision of whether transplant should be performed. MRI abnormalities precede clinically evident neurologic or neuropsychologic abnormalities. The brain MRI should be monitored at 6-month intervals in neurologically asymptomatic young males and adolescents age 3–15 years. If the MRI is normal, BMT is not indicated. If brain MRI abnormalities develop, the young male should be evaluated by a center familiar with transplant for ALD. This should include MRI, neurologic, and neuropsychologic evaluations. It is not known whether BMT has a favorable effect on the noninflammatory spinal cord involvement in adults with the adrenomyeloneuropathy phenotype.

Autologous hematopoietic stem cell gene therapy (**elivaldogene autotemcel**) is approved for patients 4–17 years of age to slow the neurologic progression of early, active cerebral adrenoleukodystrophy.

### Supportive Therapy

The progressive behavioral and neurologic disturbances associated with the childhood form of ALD are extremely difficult for the family. ALD patients require the establishment of a comprehensive management program and partnership among the family, physician, visiting nursing staff, school authorities, and counselors. In addition, parent support groups (e.g., United Leukodystrophy Foundation) are often helpful. Communication with school authorities is important because under the provisions of Public Law 94-142, children with ALD qualify for special services as “other health impaired” or “multi-handicapped.”

Depending on the rate of progression of the disease, special needs might range from relatively low-level resource services within a regular school program to home- and hospital-based teaching programs for children who are not mobile.

Management challenges vary with the stage of the illness. The early stages are characterized by subtle changes in affect, behavior, and attention span. Counseling and communication with school authorities are of prime importance. Changes in the sleep–wake cycle can be benefited by the judicious use of nighttime sleep medications.

As the leukodystrophy progresses, the modulation of muscle tone and support of bulbar muscular function are major concerns. Baclofen in gradually increasing doses (5 mg twice a day to 25 mg four times a day) is an effective pharmacologic agent for the treatment of acute episodic painful muscle spasms. Other agents may also be used, with care taken to monitor the occurrence of side effects and drug interactions. As the leukodystrophy progresses, bulbar muscular control is lost. Although initially this can be managed by changing the diet to soft and pureed foods, most patients eventually require a gastrostomy tube. At least 30% of patients have focal or generalized seizures that usually readily respond to standard anticonvulsant medications.

### Genetic Counseling and Prevention

Genetic counseling and appropriate monitoring are of crucial importance. Extended-family screening should be offered to all at-risk relatives of symptomatic patients; one program led to the identification of >250 asymptomatic affected males and 1,200 women heterozygous for ALD. The plasma assay permits reliable identification of affected males in whom plasma VLCFA levels are increased already on the day of birth. Identification of asymptomatic males permits institution of steroid replacement therapy when appropriate and prevents adrenal crisis, which may be fatal. Monitoring of brain MRI also permits identification of patients who are candidates for BMT at a stage when this procedure has the greatest chance of success. Plasma VLCFA assay is recommended in all male patients with Addison disease. ALD has been shown to be the cause of adrenal insufficiency in >25% of boys with Addison disease of unknown cause. Identification of women heterozygous for ALD is more difficult than that of affected males. Plasma VLCFA levels are normal in 15–20% of heterozygous women, and failure to note this has led to serious errors in genetic counseling. DNA analysis permits accurate identification of carriers, provided that the pathogenic variant has been defined in a family member, and this is the procedure recommended for the identification of heterozygous women.

Prenatal diagnosis of affected male fetuses can be achieved by determination of the known pathogenic variant or by the measurement of VLCFA levels in cultured amniocytes or chorionic villus cells. Whenever a new patient with ALD is identified, a detailed pedigree should be constructed and efforts made to identify all at-risk female carriers and affected males. These investigations should be accompanied by careful and sympathetic attention to social, emotional, and ethical issues during counseling.

Visit Elsevier eBooks+ at [eBooks.Health.Elsevier.com](http://eBooks.Health.Elsevier.com) for Bibliography.

## 106.3 Disorders of Lipoprotein Metabolism and Transport

Lee A. Pyles

### EPIDEMIOLOGY OF BLOOD LIPIDS AND CARDIOVASCULAR DISEASE

There is a strong association between average intake of saturated fats, plasma cholesterol, and mortality from coronary heart disease (CHD). Of all common chronic diseases, none is so clearly influenced by both environmental *and* genetic factors as CHD. This multifactorial disorder is strongly associated with increasing age and male gender, although it is increasingly apparent that heart disease is underrecognized in women. Tobacco use confers a twofold higher lifetime risk.



Sedentary activity and high intake of processed sugars leading to adiposity increase risk through differences in the plasma levels of atherogenic lipoproteins. Family history reflects the combined influence of lifestyle and genetic predisposition to early heart disease. Risk of premature heart disease associated with positive family history is 1.7 times higher than in families with no such history.

**Atherosclerosis** begins during childhood. The Johns Hopkins Precursors Study demonstrated that White male medical students with blood cholesterol levels in the lowest quartile showed only a 10% incidence of CHD 3 decades later, whereas those in the highest quartile had a 40% incidence. The Pathobiological Determinants of Atherosclerosis in Youth Study demonstrated a significant relationship between the weight of the abdominal fat pad and the extent of atherosclerosis found at autopsy on individuals 15–34 years of age. The Bogalusa Heart Study of more than 3,000 Black and White children and adolescents has provided the most comprehensive longitudinal data relating the presence and severity of CHD risk factors with semi-quantifiable severity of atherosclerosis. Coronary atherosclerosis was present in 8.5% of military autopsies performed after combat or unintentional injuries.

The *fetal origins hypothesis* is based on the observation that infants born with low birthweight have a higher incidence of heart disease as adults. Epidemiologic studies support the idea that prenatal and early postnatal conditions may affect adult health status. Children who are large for gestational age at birth and exposed to an intrauterine environment of either diabetes or maternal obesity are at increased risk of eventually developing **metabolic syndrome** (insulin resistance, type 2 diabetes, obesity, CHD). Breastfeeding preterm infants confers a long-term cardioprotective benefit 13–16 years later. Those adolescents who were breastfed as infants had lower C-reactive protein (CRP) concentrations and a 14% lower low-density lipoprotein (LDL)/high-density lipoprotein (HDL) ratio than formula-fed infants. The impact of early nutrition and other lifestyle variables on gene expression via *epigenetics* is one mechanism by which adult metabolism and body composition may be influenced.

Secondary causes of hyperlipidemia may be the result of drugs (cyclosporine, corticosteroids, isotretinoin, protease inhibitors, alcohol, thiazide diuretics,  $\beta$ -blocking agents, valproate) or various diseases (nephrotic syndrome, hypothyroidism, Cushing syndrome, anorexia nervosa, obstructive jaundice). Psychotropic medications, including second-generation antipsychotics such as olanzapine, are also associated with dyslipidemia, obesity, and insulin resistance.

## BLOOD LIPIDS AND ATHEROGENESIS

Numerous epidemiologic studies demonstrate the association of hypercholesterolemia, referring to elevated total, non-HDL, and LDL

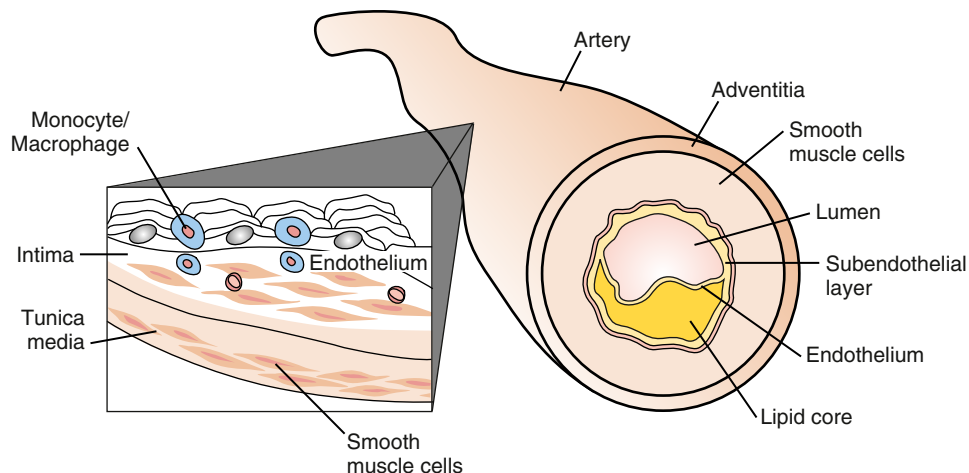
blood cholesterol, with atherosclerotic disease. Atherosclerosis affects primarily the coronary arteries but may also involve the aorta, arteries of the lower extremities, and carotid arteries.

The early stage of development of atherosclerosis is thought to begin with vascular endothelial dysfunction and intima-media thickness, which has been shown to occur in preadolescent children with risk factors such as obesity or familial hypercholesterolemia. The complex process of penetrating the intimal lining of the vessel may result from a variety of insults, including the presence of highly toxic oxidized LDL particles. Lymphocytes and monocytes penetrate the damaged endothelial lining, where they become macrophages laden with LDL lipids and then become foam cells. Such accumulation is counterbalanced by HDL particles capable of removing lipid deposits from the vessel wall. Fundamental to plaque formation is an inflammatory process (elevated CRP) involving macrophages and the arterial wall. The deposition of lipid within the subendothelial lining of the arterial wall appears macroscopically as fatty streaks, which may to some degree be reversible. A later stage of plaque development involves disruption of arterial smooth muscle cells stimulated by the release of tissue cytokines and growth factors. The *atheroma* is composed of a core of fatty substance separated from the lumen by collagen and smooth muscle (Fig. 106.6). Growth of the atherosclerotic plaque may result in ischemia of the tissue supplied by the artery. Chronic inflammation within the atheroma results in plaque instability and subsequent rupture. Platelet adherence leads to clot formation at the site of rupture, resulting in myocardial infarction (MI) or a cerebrovascular accident (CVA), depending on the site of thrombosis or thromboembolism.

## PLASMA LIPOPROTEIN METABOLISM AND TRANSPORT

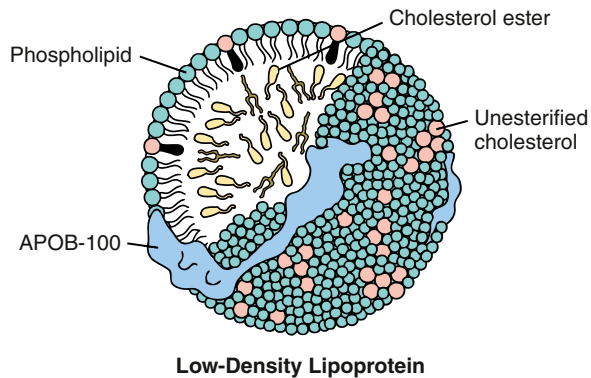
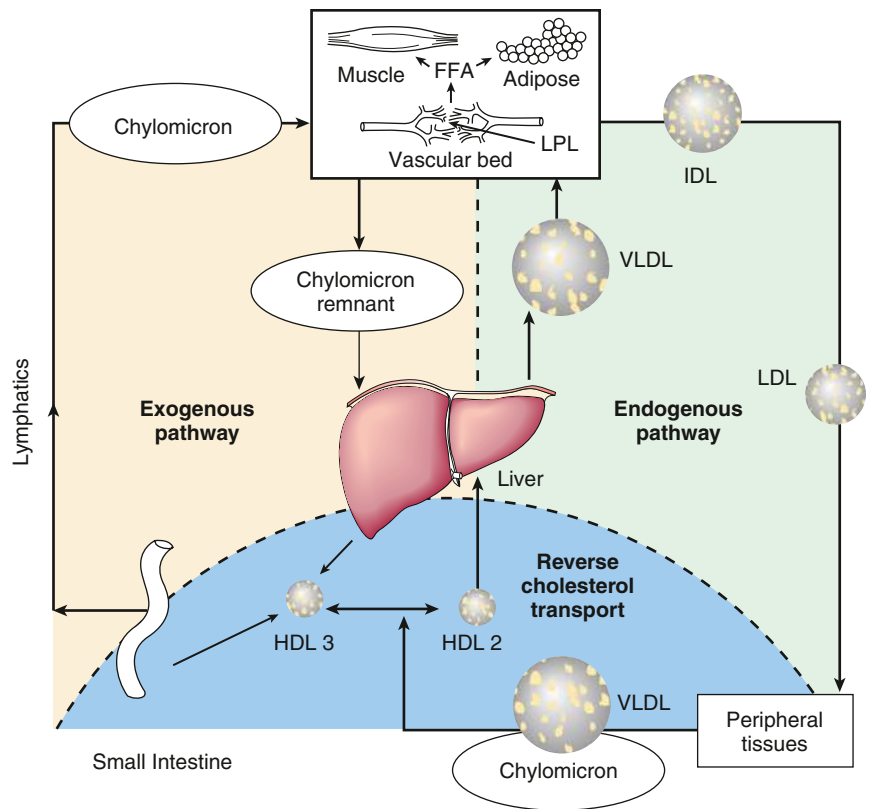
*Lipoproteins* are soluble complexes of lipids and proteins that effect transport of fat absorbed from the diet, or synthesis by the liver and adipose tissues, for utilization and storage. Dietary fat is transported from the small intestine as chylomicrons. Lipids synthesized by the liver as very low-density lipoproteins (VLDLs) are catabolized to intermediate-density lipoproteins (IDLs) and LDLs. HDL is fundamentally involved in VLDL and chylomicron metabolism and cholesterol transport. Nonesterified free fatty acids are metabolically active lipids derived from lipolysis of triglycerides stored in adipose tissue and bound to albumin for circulation in the plasma (Fig. 106.7).

Lipoproteins consist of a central core of triglycerides and cholesteryl esters surrounded by phospholipids, cholesterol, and proteins (Fig. 106.8). The density of the several classes of lipoproteins is inversely proportional to the ratio of lipid to protein, which is generally denser (Fig. 106.9).



**Fig. 106.6** The early stage of development of atherosclerosis begins with penetration of the intimal lining of the vessel by inflammatory cells. Deposition of lipid within the subendothelial lining of the arterial wall eventually leads to disruption of smooth muscle cells to form an atheromatous lipid core that impinges on the lumen. Chronic inflammation leads to plaque instability, setting the stage for plaque rupture and complete occlusion of the vessel lumen by clot formation.

**Fig. 106.7** The exogenous, endogenous, and reverse cholesterol pathways. The exogenous pathway transports dietary fat from the small intestine as chylomicrons to the periphery and the liver. The endogenous pathway denotes the secretion of very low-density lipoprotein (VLDL) from the liver and its catabolism to intermediate-density lipoprotein (IDL) and low-density lipoprotein (LDL). Triglycerides are hydrolyzed from the VLDL particle by the action of lipoprotein lipase (LPL) in the vascular bed, yielding free fatty acids (FFAs) for utilization and storage in muscle and adipose tissue. High-density lipoprotein (HDL) metabolism is responsible for the transport of excess cholesterol from the peripheral tissues back to the liver for excretion in the bile. Nascent HDL-3 particles derived from the liver and small intestine are esterified to more mature HDL-2 particles by enzyme-mediated movement of chylomicron and VLDL into the HDL core, which is removed from the circulation by endocytosis.

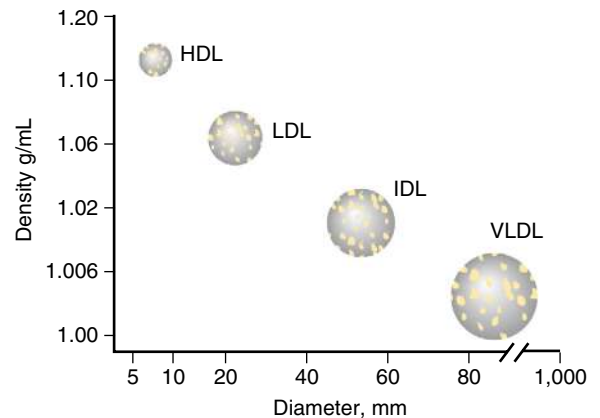


**Fig. 106.8** Schematic of low-density lipoprotein. Lipoprotein consists of a central core of cholesteryl esters surrounded by phospholipids, cholesterol, and protein.

Constituent proteins known as *apolipoproteins* are responsible for a variety of metabolic functions in addition to their structural role, including as cofactors or inhibitors of enzymatic pathways and mediators of lipoprotein binding to cell surface receptors (Table 106.6). **ApoA** is the major apolipoprotein (Apo) of HDL. **ApoB** is present in LDL, VLDL, IDL, and chylomicrons. ApoB-100 is derived from the liver, whereas apoB-48 comes from the small intestine. ApoC-I, C-II, and C-III are small peptides important in triglyceride metabolism. Loss of function and disruptive pathogenic variants of the *APOC3* gene are associated with low levels of triglycerides and a reduced risk of ischemic CHD. Likewise, **apoE**, which is present in VLDL, HDL, chylomicrons, and chylomicron remnants, plays an important role in the clearance of triglycerides.

### Transport of Exogenous (Dietary) Lipids

All dietary fat except medium-chain triglycerides is efficiently carried into the circulation by way of lymphatic drainage from the intestinal



**Fig. 106.9** The density of the several classes of lipoprotein is inversely proportional to the ratio of lipid to protein. As lipid is less dense than protein, the more lipid contained in the particle increases its size and decreases its density. HDL, High-density lipoprotein; LDL, low-density lipoprotein; IDL, intermediate-density lipoprotein; VLDL, very low-density lipoprotein.

mucosa. Triglyceride and cholesteryl esters combine with apoA and apoB-48 in the intestinal mucosa to form chylomicrons, which are carried into the peripheral circulation via the lymphatic system. HDL particles contribute apoC-II to the chylomicrons, required for the activation of *lipoprotein lipase* (LPL) within the capillary endothelium of adipose, heart, and skeletal muscle tissue. Free fatty acids are oxidized, esterified for storage as triglycerides, or released into the circulation bound to albumin for transport to the liver. After hydrolysis of the triglyceride core from the chylomicron, apoC particles are recirculated back to HDL. The subsequent contribution of apoE from HDL to the remnant chylomicron facilitates binding of the particle to the hepatic LDL receptor (LDL-R). Within the hepatocyte, the chylomicron remnant may be incorporated into membranes, resecreted as lipoprotein

**Table 106.6** Characteristics of the Major Lipoproteins

LIPOPROTEIN	SOURCE	SIZE (nm)	DENSITY (g/mL)	COMPOSITION		
				PROTEIN (%)	LIPID (%)	APOLIPOPROTEINS
Chylomicrons	Intestine	80-1,200	<0.95	1-2	98-99	C-I, C-II, C-III, E, A-I, A-II, A-IV, B-48
Chylomicron remnants	Chylomicrons	40-150	<1.0006	6-8	92-94	B-48, E
VLDL	Liver, intestine	30-80	0.95-1.006	7-10	90-93	B-100, C-I, C-II, C-III
IDL	VLDL	25-35	1.006-1.019	11	89	B-100, E
LDL	VLDL	18-25	1.019-1.063	21	79	B-100
HDL	Liver, intestine VLDL, chylomicrons	5-20	1.125-1.210	32-57	43-68	A-I, A-II, A-IV C-I, C-II, C-III D, E

HDL, High-density lipoproteins; IDL, intermediate-density lipoproteins; LDL, low-density lipoproteins; VLDL, very low-density lipoproteins.

back into the circulation, or secreted as bile acids. Normally, all dietary fat is disposed of within 8 hours after the last meal, an exception being individuals with a disorder of chylomicron metabolism. **Postprandial hyperlipidemia** is a risk factor for atherosclerosis. Abnormal transport of chylomicrons and their remnants may result in their absorption into the blood vessel wall as *foam cells*, caused by the ingestion of cholesteryl esters by macrophages, the earliest stage in the development of fatty streaks.

### Transport of Endogenous Lipids from the Liver

The formation and secretion of VLDL from the liver and its catabolism to IDL and LDL particles describe the *endogenous* lipoprotein pathway. Fatty acids used in the hepatic formation of VLDL are derived primarily by uptake from the circulation. VLDL appears to be transported from the liver as rapidly as it is synthesized, and it consists of triglycerides, cholesteryl esters, phospholipids, and apoB-100. Nascent particles of VLDL secreted into the circulation combine with apoC and apoE. The size of the VLDL particle is determined by the amount of triglyceride present, progressively shrinking in size as triglyceride is hydrolyzed by the action of LPL, yielding free fatty acids for utilization or storage in muscle and adipose tissue. Hydrolysis of approximately 80% of the triglyceride present in VLDL particles produces IDL particles containing an equal amount of cholesterol and triglyceride. The remaining remnant IDL is converted to LDL for delivery to peripheral tissues or to the liver. ApoE is attached to the remnant IDL particle to allow binding to the cell and subsequent incorporation into the lysosome. Individuals with a deficiency of either apoE2 or hepatic triglyceride lipase accumulate IDL in the plasma.

LDL particles account for approximately 70% of the plasma cholesterol in normal individuals. LDL receptors are present on the surfaces of nearly all cells. Most LDL is taken up by the liver, and the rest is transported to peripheral tissues such as the adrenal glands and gonads for steroid synthesis. Dyslipidemia is greatly influenced by LDL-R activity. The efficiency with which VLDL is converted into LDL is also important in lipid homeostasis. The normal newborn LDL level of 50 mg/dL is probably adequate for steroid synthesis throughout the life cycle.

### High-Density Lipoprotein and Reverse Cholesterol Transport

Because hepatic secretion of lipid particles into the bile is the only mechanism by which cholesterol can be removed from the body, transport of excess cholesterol from the peripheral cells is a vitally important function of HDL. HDL is heavily laden with apoA-I-containing lipoproteins, which is nonatherogenic, in contrast to B lipoproteins. Cholesterol-poor nascent HDL particles secreted by the liver and small intestine are esterified to more mature HDL-2 particles by the action of the enzyme lecithin-cholesterol acyltransferase (LCAT), which facilitates movement of chylomicrons and VLDL into the HDL core. HDL-2 may transfer cholesteryl esters back to apoB lipoproteins mediated by

cholesteryl ester transfer protein (CETP), or the cholesterol-rich particle may be removed from the plasma by endocytosis, completing reverse cholesterol transport. Low HDL may be genetic (deficiency of apoA-I) or secondary to increased plasma triglyceride.

LCAT deficiency results in diminished maturation of HDL particles, affecting their ability to do reverse cholesterol transport. This reduces its protective effect on atherosclerosis. There are rare reports, however, of less-than-expected severity of atherosclerosis despite low HDL secondary to LCAT deficiency, suggesting that the relationship may, for unknown reasons, be variable.

## HYPERLIPOPROTEINEMIAS

### Hypercholesterolemia

See Table 106.7.

### Familial Hypercholesterolemia

Familial hypercholesterolemia (FH) is a monogenic autosomal dominant disorder characterized by strikingly elevated LDL cholesterol (LDL-C), premature cardiovascular disease (CVD), and tendon xanthomas. It is predominantly associated with defects of LDL-R activity but also includes defects in the genes for apoB (*APOB*) and the proprotein convertase subtilisin/kexin type 9 (*PCSK-9*), a protein important in LDL endocytosis. Of the almost 1,200 *LDLR* pathogenic variants described, some result in failure of synthesis of the LDL-R (receptor negative) and others cause defective binding or release at the lipoprotein-receptor interface. Receptor-negative pathogenic variants result in more severe phenotypes than receptor-defective pathogenic variants. Data from the Netherlands has confirmed the importance of LDL reduction in FH; the major adverse coronary event risk for affected siblings with statin treatment begun at age 10 years mirrored that of unaffected siblings rather than the risk profile of the affected parent.

### Homozygous Familial Hypercholesterolemia

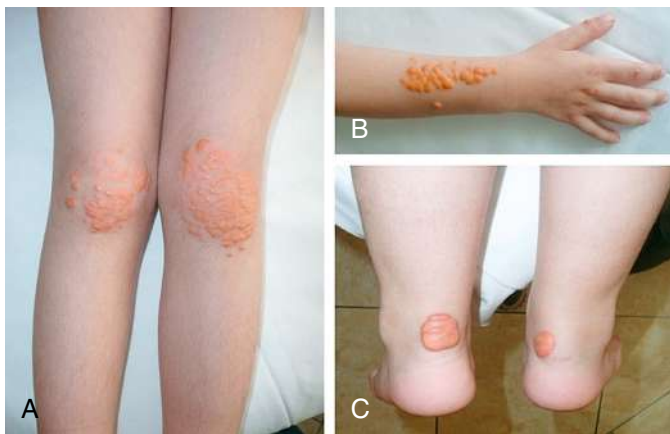
FH homozygotes inherit two abnormal LDL receptor genes, resulting in markedly elevated plasma cholesterol levels ranging between 500 and 1,200 mg/dL. Triglyceride levels are normal to mildly elevated, and HDL levels may be slightly decreased. The condition occurs in 1 in 500,000 persons. Receptor-negative patients have <2% normal LDL-R activity, whereas those who are receptor defective may have as much as 25% normal activity and consequently a better prognosis.

However, the prognosis is poor regardless of the specific LDL-R aberration. Severe atherosclerosis involving the aortic root and coronary arteries is present by early to middle childhood. These children usually present with **xanthomas**, which may cause thickening of the Achilles tendon or extensor tendons of the hands, or cutaneous lesions on the hands, elbows, knees, or buttocks (Figs. 106.10-106.12). Corneal arcus may be present. Family history is informative because premature heart disease is strongly prevalent among relatives of both parents. The diagnosis may be confirmed genetically or by measuring LDL-R

**Table 106.7** Hyperlipoproteinemias

DISORDER	LIPOPROTEINS ELEVATED	CLINICAL FINDINGS	GENETICS	ESTIMATED INCIDENCE
Familial hypercholesterolemia	LDL	Tendon xanthomas, CHD	AD	1 in 500
Familial defective ApoB-100	LDL	Tendon xanthomas, CHD	AD	1 in 1,000
Autosomal recessive hypercholesterolemia	LDL	Tendon xanthomas, CHD	AR	<1 in 1,000,000
Sitosterolemia	LDL	Tendon xanthomas, CHD	AR	<1 in 1,000,000
Polygenic hypercholesterolemia	LDL	CHD		1 in 30?
Familial combined hyperlipidemia	LDL, TG	CHD	AD	1 in 200
Familial dysbetalipoproteinemia	LDL, TG	Tuberoeruptive xanthomas, peripheral vascular disease	AD	1 in 10,000
Familial chylomicronemia (Frederickson type I)	TG ↑↑	Eruptive xanthomas, hepatosplenomegaly, pancreatitis	AR	1 in 1,000,000
Familial hypertriglyceridemia (Frederickson type IV)	TG ↑	±CHD	AD	1 in 500
Familial hypertriglyceridemia (Frederickson type V)	TG ↑↑	Xanthomas ± CHD	AD	—
Familial hepatic lipase deficiency	VLDL	CHD	AR	<1 in 1,000,000

AD, Autosomal dominant; AR, autosomal recessive; CHD, coronary heart disease; LDL, low-density lipoproteins; TG, triglycerides; VLDL, very low-density lipoproteins.



**Fig. 106.10** Homozygous familial hypercholesterolemia. Tendon xanthomas in a 5-year-old boy with homozygous FH noted at the knee (A), wrist (B), and Achilles (C). (Modified from Macchiaiolo M, Gagliardi MG, Toscano A, et al. Homozygous familial hypercholesterolaemia. *Lancet*. 2012;379:1330.)



**Fig. 106.11** Striate palmar xanthomata. (From Durrington P. Dyslipidaemia, *Lancet*. 2003;362:717–731.)



**Fig. 106.12** Eruptive xanthomata on extensor surface of forearm. (From Durrington P. Dyslipidaemia, *Lancet*. 2003;362:717–731.)

activity in cultured skin fibroblasts. Phenotypic expression of the disease may also be assessed by measuring receptor activity on the surface of lymphocytes by using cell-sorting techniques.

Untreated homozygous patients rarely survive to adulthood. Symptoms of coronary insufficiency may occur early, and sudden death is common. LDL apheresis to remove LDL particles selectively from the



circulation is recommended for many children because it slows the progression of atherosclerosis. Liver transplantation is also successful in decreasing LDL-C levels, but complications related to immunosuppression are common. HMG-CoA reductase inhibitors may be modestly effective depending on the specific class of LDL-R defect present. Combination therapy with *ezetimibe*, selectively blocking cholesterol adsorption in the gut, usually results in further decline in LDL levels and has replaced the use of bile acid sequestrants. Clinical trials using microsomal triglyceride transfer protein inhibition with *lomitapide* (an oral agent) resulted in significant reduction of all apoB lipoproteins, including LDL, but hepatic fat deposition as a side effect limits this pharmacologic approach. *Mipomersen* (subcutaneous injection), an antisense oligonucleotide that binds to the apolipoprotein B mRNA, reduces the synthesis of apoB and thus also VLDL and LDL. LDL cholesterol levels may decline approximately 25% with this treatment. Adverse effects include flulike symptoms, hepatic steatosis, and cirrhosis.

### Heterozygous Familial Hypercholesterolemia

Heterozygous FH is the most common single-gene disorder associated with acute coronary syndromes and atherosclerotic CHD in adults. Its prevalence is approximately 1 in 250 individuals worldwide, but the frequency may be greater in select populations, such as French Canadians, Afrikaners, Ashkenazi Jews, and Christian Lebanese, as a result of the founder effect of unique pathogenic variants. Heart disease accounts for more than half of all deaths in Western society, with the pathogenesis having both environmental and genetic influences.

Because heterozygous FH is a dominant condition with nearly full penetrance, 50% of first-degree relatives of affected individuals will have the disease, as will 25% of second-degree relatives. An estimated 20 million people have FH worldwide. Symptoms of CHD usually occur at the mean age of 45-48 years in males and a decade later in females. Genetic testing of both adult and pediatric patients who fulfill clinical diagnostic criteria for the diagnosis of heterozygous FH is variably positive dependent on the population under investigation.

One cannot overemphasize the importance of family history for suspecting the possibility of FH, especially given the low rate of cholesterol screening for children in primary care offices. Because the risk of CHD in individuals with FH can be up to 20 times greater than in the general population, guidelines have advocated for universal screening for cholesterol in childhood. There is also an interest in genetic testing for persons with suspected FH because of variability in phenotype based on genotype.

Plasma levels of LDL-C also do not allow unequivocal diagnosis of FH heterozygotes; values are generally twice normal for age because of one absent or dysfunctional allele. The U.S. MED-PED (*Make Early Diagnosis—Prevent Early Death*) Program has formulated diagnostic criteria.

Similar criteria with minor variations exist in the United Kingdom (Simon Broome criteria) and Holland (Dutch Lipid Clinic Network criteria). Within well-defined FH families, the diagnosis is reliably established according to LDL cutoff points. More stringent criteria are required to establish the diagnosis in previously undiagnosed families, requiring strong evidence of an autosomal inheritance pattern and higher LDL cutoff points. At a total cholesterol level of 310 mg/dL, only 4% of adults in the general population would have FH, whereas 95% of adults who were first-degree relatives of known cases would have the disease.

Very high cholesterol levels in children should prompt extensive screening of adult first- and second-degree relatives (“reverse cascade” cholesterol screening). In the general population, a child younger than age 18 years with total plasma cholesterol of 270 mg/dL and/or LDL-C of 200 mg/dL has an 88% chance of having FH (Table 106.8). *Formal clinical diagnosis of FH is based on the presence of two or more family members having elevated LDL-C levels* (the 95th percentile LDL-C level cutoff points for children vary with age and are lower than for adults; Table 106.9). The criteria for probable FH in a child whose first-degree relative has known FH require only modest elevation of total cholesterol to 220 mg/dL (LDL-C 160 mg/dL; see Table 106.8). The challenge

of childhood FH diagnosis is heightened by the lack of clinical stigmata such as xanthomata that are employed in the Simon Broome and Dutch Lipid Clinic Network schema and highlights the needed shift toward genetic diagnosis.

**Treatment** of children with FH should begin with a rigorous low-fat diet. Diet alone is rarely sufficient for decreasing blood cholesterol levels to acceptable levels (LDL-C <130 mg/dL). *Ezetimibe* blocks cholesterol adsorption in the gastrointestinal (GI) tract and has a low risk of side effects. Data suggest that *ezetimibe* will lower total cholesterol by 20-30 mg/dL. *HMG-CoA reductase inhibitors (statins)* are the drug of choice for treatment of FH because of their remarkable effectiveness and acceptable risk profile. This class of drugs in children over age 10 years is as effective in children as in adults, and the risks of elevated hepatic enzymes and myositis are no greater than in adults. Another class of drugs, the proprotein convertase subtilisin/kexin type 9 (PCSK-9) inhibitors, are monoclonal antibodies (mAbs) that block the action of PCSK-9 to downregulate the LDL-R. These agents boost LDL-R levels and result in a marked decrease in plasma LDL-C levels. PCSK-9 inhibitors have a role in adults intolerant of statins and those with subtherapeutic statin effect. *Use of evolocumab in children over age 10 is FDA approved*. In addition, tobacco avoidance and cessation of use of tobacco in the family should be stressed from the time of diagnosis.

### Familial Defective ApoB-100

Familial defective apoB-100 is an autosomal dominant condition indistinguishable from heterozygous *LDLR* FH. LDL cholesterol levels are increased, triglycerides are normal, adults often develop tendon xanthomas, and premature CHD occurs. Familial defective apoB-100 is caused by a pathogenic variant in the receptor-binding region of apoB-100, the ligand of the LDL receptor, with an estimated frequency of 1 in 700 people in Western cultures. It is usually caused by missense substitution of apoB-100 (p.Arg3527Gln, previously numbered p.Arg3500Gln), which results in reduced ability of the LDL-R to bind LDL-C, thus impairing its removal from the circulation. Specialized laboratory testing can distinguish familial defective apoB-100 from FH, but this is not necessary, except in research settings, because treatment is the same.

### Autosomal Recessive Hypercholesterolemia

This rare condition, caused by a defect in LDL-R-mediated endocytosis in the liver, clinically presents with severe hypercholesterolemia at levels intermediate between those found in homozygous and heterozygous FH. It is disproportionately present among Sardinians, reported in other Mediterranean populations, and is modestly responsive to treatment with HMG-CoA reductase inhibitors.

### Sitosterolemia

A rare autosomal recessive condition characterized by excessive intestinal adsorption of plant sterols, sitosterolemia is caused by pathogenic variants in the adenosine triphosphate (ATP)-binding cassette transporter system (*ABCG5* or *ABCG8*), which is responsible for limiting adsorption of plant sterols in the small intestine and promotes biliary excretion of the small amounts adsorbed. Plasma cholesterol levels may be severely elevated, resulting in tendon xanthomas and premature atherosclerosis. Other features include hemolytic anemia, macrothrombocytopenia (large platelets, reduced number), and hemorrhage. Diagnosis can be confirmed by measuring elevated plasma sitosterol levels. Treatment with HMG-CoA reductase inhibitors is not effective, but cholesterol adsorption inhibitors, such as *ezetimibe*, and bile acid sequestrants are effective.

### Polygenic Hypercholesterolemia

Primary elevation in LDL-C among children and adults is most often polygenic; the small effects of many genes are affected by environmental influences (diet). Plasma cholesterol levels are modestly elevated; triglyceride levels are normal. Polygenic hypercholesterolemia aggregates in families sharing a common lifestyle but does not follow predictable hereditary patterns found in single-gene lipoprotein defects. Treatment of children with polygenic hypercholesterolemia is directed

**Table 106.8** Percentage of Youths Younger than Age 18 years Expected to Have Familial Hypercholesterolemia (FH) According to Cholesterol Levels and Closest Relative with FH

TOTAL CHOL (mg/dL)	LDL CHOL (mg/dL)	PERCENTAGE WITH FH AT THAT LEVEL			
		DEGREE OF RELATIVE			GENERAL POPULATION
		FIRST	SECOND	THIRD	
180	122	7.2	2.4	0.9	0.01
190	130	13.5	5.0	2.2	0.03
200	138	26.4	10.7	4.9	0.07
210	147	48.1	23.6	11.7	0.19
220	155	73.1	47.5	27.9	0.54
230	164	90.0	75.0	56.2	1.8
240	172	97.1	93.7	82.8	6.3
250	181	99.3	97.6	95.3	22.2
260	190	99.9	99.5	99.0	57.6
270	200	100.0	99.9	99.8	88.0
280	210	100.0	100.0	100.0	97.8
290	220	100.0	100.0	100.0	99.6
300	230	100.0	100.0	100.0	99.9
310	240	100.0	100.0	100.0	100.0

Chol, Cholesterol; LDL, low-density lipoprotein.

From Williams RR, Hunt SC, Schumacher MC, et al. Diagnosing heterozygous familial hypercholesterolemia using new practical criteria validated by molecular genetics. *Am J Cardiol.* 1993;72:171–176.

toward adoption of a healthy lifestyle: reduced total and saturated fat consumption and at least 1 hour of physical activity daily. Cholesterol-lowering medication is rarely necessary.

### Hypercholesterolemia with Hypertriglyceridemia Familial Combined Hyperlipidemia

This autosomal dominant condition is characterized by moderate elevation in plasma LDL-C and triglycerides and reduced plasma HDL-C. Familial combined hyperlipidemia (FCHL) is the most common primary lipid disorder, affecting approximately 1 in 200 people. Family history of premature heart disease is typically positive; the formal diagnosis requires that at least two first-degree relatives have evidence of one of three variants of dyslipidemia: (1) >90th percentile plasma LDL-C, (2) >90th percentile LDL-C and triglycerides, and (3) >90th percentile triglycerides. Individuals can switch from one phenotype to another. Xanthomas are not a feature of FCHL. Elevated plasma apoB levels with increased small, dense LDL particles support the diagnosis.

Children and adults with FCHL have coexisting adiposity, hypertension, and hyperinsulinemia, suggesting the presence of **metabolic syndrome**. Formal diagnosis in adults, as defined by the National Cholesterol Education Program (NCEP) Adult Treatment Panel III, identifies six major components: abdominal obesity, atherogenic dyslipidemia, hypertension, insulin resistance with or without impaired glucose tolerance, evidence of vascular inflammation, and prothrombotic state. An estimated 30% of overweight adults fulfill criteria for the diagnosis of metabolic syndrome, including 65% of those with FCHL. *There is no official definition of metabolic syndrome for children.* Absolute cutoffs for diagnosis in children do not account for continuous variables in aging, sexual maturation, and race/ethnicity.

FCHL and type 2 diabetes share many features of metabolic syndrome, suggesting that they are less distinct entities than originally conceptualized. Genetic association studies reveal evidence for a common genetic background. The resultant metabolic overlap is associated with ectopic fat accumulation and insulin resistance. The mechanisms associating visceral adiposity with metabolic syndrome and type 2 diabetes are not fully understood. It is assumed that hypercholesterolemia

and, with less certainty, hypertriglyceridemia confer risk for CVD in patients with FCHL. When features of metabolic syndrome are included in logistic models, shared etiologic features such as increased visceral adiposity become apparent. Visceral adiposity increases with age, and its importance in children as a risk factor for heart disease and diabetes is limited by the relative paucity of data. Body mass index (BMI) remains the surrogate for adiposity in the pediatric clinical setting.

*The cornerstone of management is lifestyle modification.* This includes a diet low in saturated fats, *trans* fats, and cholesterol, as well as reduced consumption of processed sugars. Increased dietary intake of fruits and vegetables is important, as is 1 hour of moderate physical activity daily. Compliance among children and their parents is often a problem, but small incremental steps are more likely to succeed than aggressive weight loss strategies. It is very important that the child's caregivers participate in the process. Plasma triglyceride levels are usually quite responsive to dietary restriction, especially reduction in the amount of sweetened drinks consumed. Blood cholesterol levels may decrease by 10–15%, but if LDL-C remains >160 mg/dL, drug therapy should be considered.

### Familial Dysbetalipoproteinemia (Type III Hyperlipoproteinemia)

Familial dysbetalipoproteinemia (FDBL) is caused by pathogenic variants in *APOE*, which, when exposed to environmental influences (e.g., high-fat high-caloric diet, excessive alcohol intake), results in a mixed type of hyperlipidemia. Patients tend to have elevated plasma cholesterol and triglycerides to a relatively similar degree. HDL-C is typically normal, in contrast to other causes of hypertriglyceridemia associated with low HDL. This rare disorder affects approximately 1 in 10,000 persons. ApoE mediates removal of chylomicron and VLDL remnants from the circulation by binding to hepatic surface receptors. The polymorphic *APOE* gene expresses in three isoforms: *apoE3*, *apoE2*, and *apoE4*. *E4* is the “normal” allele present in the majority of the population. The *apoE2* isoform has lower affinity for the LDL receptor, and its frequency is approximately 7%. Approximately 1% of the population is

**Table 106.9** Plasma Cholesterol and Triglyceride Levels in Childhood and Adolescence: Means and Percentiles

	TOTAL TRIGLYCERIDE (mg/dL)					TOTAL CHOLESTEROL (mg/dL)					LDL CHOLESTEROL (mg/dL)					HDL CHOLESTEROL (mg/dL)*				
	5TH	MEAN	75TH	90TH	95TH	5TH	MEAN	75TH	90TH	95TH	5TH	MEAN	75TH	90TH	95TH	5TH	10TH	25TH	MEAN	95TH
Cord	14	34	—	—	84	42	68	—	—	103	17	29	—	—	50	13	—	—	35	60
<b>1-4 YR</b>																				
Male	29	56	68	85	99	114	155	170	190	203	—	—	—	—	—	—	—	—	—	—
Female	34	64	74	95	112	112	156	173	188	200	—	—	—	—	—	—	—	—	—	—
<b>5-9 YR</b>																				
Male	28	52	58	70	85	125	155	168	183	189	63	93	103	117	129	38	42	49	56	74
Female	32	64	74	103	126	131	164	176	190	197	68	100	115	125	140	36	38	47	53	73
<b>10-14 YR</b>																				
Male	33	63	74	94	111	124	160	173	188	202	64	97	109	122	132	37	40	46	55	74
Female	39	72	85	104	120	125	160	171	191	205	68	97	110	126	136	37	40	45	52	70
<b>15-19 YR</b>																				
Male	38	78	88	125	143	118	153	168	183	191	62	94	109	123	130	30	34	39	46	63
Female	36	73	85	112	126	118	159	176	198	207	59	96	111	129	137	35	38	43	52	74

\*Note that different percentiles are listed for high-density lipoprotein (HDL) cholesterol.  
LDL, Low-density lipoprotein.

Data for cord blood from Strong W. Atherosclerosis: its pediatric roots. In Kaplan N, Stamler J, eds. *Prevention of Coronary Heart Disease*. Philadelphia: Saunders; 1983. Data for children 1-4 yr from Tables 6, 7, 20, and 21, and all other data from Tables 24, 25, 32, 33, 36, and 37 in *Lipid Research Clinics Population Studies Data Book*, Vol 1, "The Prevalence Study," NIH Publication No. 80-1527. Washington, DC: National Institutes of Health; 1980

homozygous for *apoE2/E2*, the most common pathogenic variant associated with FDBL, but only a minority expresses the disease. Expression requires precipitating illnesses such as diabetes, obesity, renal disease, or hypothyroidism. Individuals homozygous for *apoE4/E4* are at risk for late-onset Alzheimer disease and dementia from repeated sports-related head injuries.

Most patients with FDBL present in adulthood with distinctive xanthomas. Tuberoeruptive xanthomas resemble small, grapelike clusters on the knees, buttocks, and elbows. Prominent orange-yellow discoloration of the creases of the hands (palmar xanthomas) is also typically present. Atherosclerosis, often presenting with peripheral vascular disease, usually occurs in the fourth or fifth decade. Children may present with a less distinctive rash and generally have precipitating illnesses.

The diagnosis of FDBL is established by lipoprotein electrophoresis, which demonstrates a broad beta band containing remnant lipoproteins. Direct measurement of VLDL by ultracentrifugation can be performed in specialized lipid laboratories. A VLDL/total triglyceride ratio  $>0.30$  supports the diagnosis. *APOE* genotyping for *apoE2* homozygosity can be performed, confirming the diagnosis in the presence of the distinctive physical findings. A negative result does not necessarily rule out the disease, as other pathogenic variants in *APOE* may cause even more serious manifestations.

Pharmacologic treatment of FDBL is necessary to decrease the likelihood of symptomatic atherosclerosis in adults. HMG-CoA reductase inhibitors, nicotinic acid, and fibrates are all effective. FDBL is quite responsive to recommended dietary restriction.

### Hypertriglyceridemias

The familial disorders of triglyceride-rich lipoproteins include both common and rare variants of the Frederickson classification system. These include familial chylomicronemia (type I), familial hypertriglyceridemia (type IV), and the more severe combined hypertriglyceridemia and chylomicronemia (type V). Hepatic lipase deficiency also results in a similar combined hyperlipidemia.

#### Familial Chylomicronemia (Type I Hyperlipidemia)

This rare single-gene defect, like FH, is caused by pathogenic variants affecting clearance of apoB-containing lipoproteins. A deficiency or absence of lipoprotein lipase (*LPL*) or its cofactor apoC-II (*APOC2*), which facilitates lipolysis by *LPL*, causes severe elevation of triglyceride-rich plasma chylomicrons. HDL-C levels are decreased. Clearance of these particles is greatly delayed, so the plasma is noted to have a turbid appearance even after prolonged fasting (Fig. 106.13). Chylomicronemia caused by *LPL* deficiency is associated with modest elevation in triglycerides, whereas this is not the case when the cause is deficient or absent apoC-II. Both are autosomal recessive conditions with a frequency of approximately 1 in 1 million. The disease usually presents during childhood with acute pancreatitis. Eruptive xanthomas on the arms, knees, and buttocks may be present, and there may be hepatosplenomegaly. The diagnosis is established by assaying triglyceride lipolytic activity. **Treatment** of chylomicronemia is by vigorous dietary fat restriction supplemented by fat-soluble vitamins. Medium-chain triglycerides that are adsorbed into the portal venous system may augment total fat intake, and administration of fish oils may also be beneficial.

#### Familial Hypertriglyceridemia (Type IV Hyperlipidemia)

Familial hypertriglyceridemia (FHTG) is an autosomal dominant disorder of unknown etiology that occurs in approximately 1 in 500 individuals. It is characterized by elevation of plasma triglycerides  $>90$ th percentile (250–1,000 mg/dL range), often accompanied by slight elevation in plasma cholesterol and low HDL. FHTG does not usually manifest until adulthood, although it can be detected in approximately 20% of affected children. In contrast to FCHL, FHTG is not thought to be highly atherogenic. It is most likely caused by defective breakdown of VLDL or, less often, by overproduction of this class of lipoproteins.

The diagnosis should include the presence of at least one first-degree relative with hypertriglyceridemia. FHTG should be distinguished



Fig. 106.13 Milky plasma from a patient with acute abdominal pain. (From Durrington P. Dyslipidaemia, *Lancet*. 2003;362:717–731.)

from FCHL and FDBL, which require more vigorous treatment to prevent coronary or peripheral vascular disease. The differentiation is usually possible on clinical grounds, in that lower LDL-C levels accompany FHTG, but measurement of normal apoB levels in FHTG may be helpful in ambiguous situations.

A more severe hypertriglyceridemia characterized by increased levels of chylomicrons and VLDL particles (Frederickson **type V**) may occasionally be encountered. Triglyceride levels are often  $>1,000$  mg/dL. The disease is rarely seen in children. In contrast to chylomicronemia (Frederickson **type I**), *LPL* or apoC-II deficiency is not present. These patients often develop eruptive xanthomas in adulthood, whereas **type IV** hypertriglyceridemia individuals do not. Acute pancreatitis may be the presenting illness. As with other hypertriglyceridemias, excessive alcohol consumption and estrogen therapy can exacerbate the disease.

Secondary causes of *transient hypertriglyceridemia* should be ruled out before making a diagnosis of FHTG. A diet high in simple sugars and carbohydrates or excessive alcohol consumption, as well as estrogen therapy, may exacerbate hypertriglyceridemia. Adolescents and adults should be questioned about excessive consumption of soda and other sweetened drinks, as it is common to encounter people who drink supersized drinks or multiple 12 oz cans of sweetened drinks daily. Cessation of this practice often results in a dramatic fall in triglyceride levels and weight among those who are obese. HDL-C levels will tend to rise as BMI stabilizes.

Pediatric diseases associated with hyperlipidemia include hypothyroidism, nephrotic syndrome, biliary atresia, glycogen storage disease, Niemann-Pick disease (NPD), Tay-Sachs disease, systemic lupus erythematosus, hepatitis, and anorexia nervosa (Table 106.10). Certain medications exacerbate hyperlipidemia, including isotretinoin (Accutane), thiazide diuretics, second-generation antipsychotic agents, oral contraceptives, corticosteroids,  $\beta$  blockers, immunosuppressants, and protease inhibitors used in HIV treatment.

Treatment of hypertriglyceridemia in children rarely requires medication unless levels  $>1,000$  mg/dL persist after dietary restriction of fats,



**Table 106.10** Secondary Causes of Hyperlipidemia**HYPERCHOLESTEROLEMIA**

Hypothyroidism  
 Nephrotic syndrome  
 Cholestasis  
 Anorexia nervosa  
 Drugs: progesterone, thiazides, carbamazepine (Tegretol), cyclosporine

**HYPERTRIGLYCERIDEMIA**

Glycogen storage disease type 1  
 Obesity  
 Type 2 diabetes  
 Alcohol  
 Renal failure  
 Sepsis  
 Stress  
 Cushing syndrome  
 Pregnancy  
 Hepatitis  
 AIDS, protease inhibitors  
 Drugs: anabolic steroids,  $\beta$  blockers, estrogen, thiazides, Accutane

**REDUCED HIGH-DENSITY LIPOPROTEIN**

Smoking  
 Obesity  
 Type 2 diabetes  
 Malnutrition  
 Drugs:  $\beta$  blockers, anabolic steroids

sugars, and carbohydrates, accompanied by increased physical activity. In such patients the aim is to prevent episodes of pancreatitis. The common use of fibrates (fenofibric acid) and niacin in adults with hypertriglyceridemia is not recommended in children. HMG-CoA reductase inhibitors are variably effective in lowering triglyceride levels, and there is considerably more experience documenting the safety and efficacy of this class of lipid-lowering medications in children. In adults, the U.S. Food and Drug Administration (FDA) has approved prescription (Lovaza, Vascepa) and nonprescription fish oils as adjuncts to diet in the treatment of severe hypertriglyceridemias.

**Hepatic Lipase Deficiency**

Hepatic lipase deficiency is a very rare autosomal recessive condition caused by pathogenic variants in *LMF1* resulting in elevation in both plasma cholesterol and triglycerides. Hepatic lipase hydrolyzes triglycerides and phospholipids in VLDL remnants and IDL, preventing their conversion to LDL. HDL-C levels tend to be increased rather than decreased, suggesting the diagnosis. Laboratory confirmation is established by measuring hepatic lipase activity in heparinized plasma.

**Disorders of High-Density Lipoprotein Metabolism**  
**Primary Hypoalphalipoproteinemia**

Isolated low HDL-C is a familial condition that often follows a pattern suggestive of autosomal dominant inheritance but may occur independent of family history. It is the most common disorder of HDL metabolism. It is defined as HDL-C <10th percentile for gender and age with normal plasma triglycerides and LDL-C. Whether it is associated with more rapid atherosclerosis is uncertain. Primary hypoalphalipoproteinemia appears to be related to a reduction in apoA-I synthesis and increased catabolism of HDL. Secondary causes of low HDL-C, such as metabolic syndrome, and rare diseases such as LCAT deficiency and Tangier disease must be ruled out.

**Familial Hyperalphalipoproteinemia**

This is an unusual condition conferring decreased risk for CHD among family members. Plasma levels of HDL-C exceed 80 mg/dL.

**Familial Apolipoprotein A-I Deficiency**

Pathogenic variants in the *APOA1* gene may result in complete absence of plasma HDL. Nascent HDL is produced in the liver and small intestine. Free cholesterol from peripheral cells is esterified by LCAT, enabling formation of mature HDL particles. ApoA-I is required for normal enzymatic functioning of LCAT. The resultant accumulation of free cholesterol in the circulation eventually leads to corneal opacities, planar xanthomas, and premature atherosclerosis. Some patients, however, may have pathogenic variants of *APOA1* that result in very rapid catabolism of the protein not associated with atherogenesis, despite HDL-C levels in the 15-30 mg/dL range.

**Tangier Disease**

This autosomal dominant disease is associated with HDL-C levels <5 mg/dL. It is caused by pathogenic variants in *ABCA1*, which encodes a protein that facilitates the binding of cellular cholesterol to apoA-I. This results in free cholesterol accumulation in the reticuloendothelial system, manifested by tonsillar hypertrophy of a distinctive orange color and hepatosplenomegaly. Intermittent peripheral neuropathy may occur from cholesterol accumulation in Schwann cells. Diagnosis should be suspected in children with enlarged orange tonsils and extremely low HDL-C levels.

**Familial Lecithin-Cholesterol Acyltransferase Deficiency**

Pathogenic variants of *LCAT* interfere with the esterification of cholesterol, thereby preventing formation of mature HDL particles. This is associated with rapid catabolism of apoA-I. Free circulating cholesterol in the plasma is greatly increased, which leads to corneal opacities and HDL-C levels <10 mg/dL. Partial LCAT deficiency is known as “fish-eye” disease because of the corneal opacities. Complete deficiency causes hemolytic anemia and progressive renal insufficiency early in adulthood. This rare disease is not thought to cause premature atherosclerosis. Laboratory confirmation is based on a demonstration of decreased cholesterol esterification in the plasma.

**Cholesteryl Ester Transfer Protein Deficiency**

Pathogenic variants of the *CETP* gene result in cholesteryl ester transfer protein (CETP) deficiency. CETP facilitates the transfer of lipoproteins from mature HDL to and from VLDL and chylomicron particles, thus ultimately regulating the rate of cholesterol transport to the liver for excretion in the bile. About half of mature HDL-2 particles are directly removed from the circulation by HDL receptors on the surface of the liver. The other half of cholesteryl esters in the core of HDL exchange with triglycerides in the core of apoB lipoproteins (VLDL, IDL, LDL) for transport to the liver. Homozygous deficiency of CETP has been observed in subsets of the Japanese population with extremely high HDL-C levels (>150 mg/dL).

**Conditions Associated with Low Cholesterol**

Disorders of apoB-containing lipoproteins and intracellular cholesterol metabolism are associated with low plasma cholesterol.

**Abetalipoproteinemia**

This rare autosomal recessive disease is caused by pathogenic variants in the *MTTP* gene that encodes the microsomal triglyceride transfer protein necessary for the transfer of lipids to nascent chylomicrons in the small intestine and VLDL in the liver. This results in an absence of chylomicrons, VLDL, LDL, and apoB and very low levels of plasma cholesterol and triglycerides. Fat and fat-soluble vitamin malabsorption, diarrhea, and failure to thrive present in early childhood. Spinocerebellar degeneration, secondary to vitamin E deficiency, manifests in loss of deep tendon reflexes progressing to ataxia and lower-extremity spasticity by adulthood. Patients with abetalipoproteinemia also acquire a progressive pigmented retinopathy associated with decreased night and color vision and eventual blindness. The neurologic symptoms and retinopathy may be mistaken for Friedreich ataxia. Differentiation from Friedreich ataxia is suggested by the presence of malabsorption and acanthocytosis on peripheral blood smear.

in abetalipoproteinemia. Many of the clinical manifestations of the disease are a result of malabsorption of fat-soluble vitamins, such as vitamins E, A, and K. *Early treatment with supplemental vitamins, especially E, may significantly slow the development of neurologic sequelae.* Vitamin E is normally transported from the small intestine to the liver by chylomicrons, where it is dependent on the endogenous VLDL pathway for delivery into the circulation and peripheral tissues. Parents of children with abetalipoproteinemia have normal blood lipid and apoB levels.

### Familial Hypobetalipoproteinemia

Familial homozygous hypobetalipoproteinemia is associated with symptoms very similar to those of abetalipoproteinemia, but the inheritance pattern is autosomal dominant caused by pathogenic variants in *APOB*. It is distinguishable from abetalipoproteinemia in that heterozygous parents of probands have plasma LDL-C and apoB levels less than half of normal. However, few symptoms or sequelae are associated with the heterozygous condition.

The selective inability to secrete apoB-48 from the small intestine results in a condition resembling abetalipoproteinemia or homozygous hypobetalipoproteinemia. Sometimes referred to as **Anderson disease** or chylomicron retention disease, caused by recessive alterations of the *SAR1B* gene, the failure of chylomicron absorption causes steatorrhea and fat-soluble vitamin deficiency. The blood level of apoB-100, derived from normal hepatocyte secretion, is normal in this condition.

### Smith-Lemli-Opitz Syndrome

Smith-Lemli-Opitz syndrome (SLOS) is an autosomal recessive disorder that includes microcephaly, polydactyly, holoprosencephaly, seizures and developmental delay. Phenotypic variance ranges from microcephaly, cardiac and brain malformation, and multiorgan system failure to only subtle dysmorphic features and mild developmental delay. It is associated with low plasma cholesterol and accumulated precursors (Tables 106.11 and 106.12) (see Chapter 628.2). Pathogenic variants in the *DHCR7* (7-dehydrocholesterol- $\Delta^7$  reductase) gene result in deficiency of the microsomal enzyme DHCR7, which is necessary to complete the final step in cholesterol synthesis. Hypotheses to connect the role of cholesterol synthesis in SLOS congenital malformations have implicated the ligand sonic hedgehog (SHH), for which developmental signaling activity is dependent on cholesterol modification. The incidence of SLOS is estimated to be 1 in 20,000-60,000 births.

Spontaneous abortion of SLOS fetuses may occur. **Type II** SLOS often leads to death by the end of the neonatal period. Survival is unlikely when the plasma cholesterol level is <20 mg/dL. Laboratory measurement should be performed by gas chromatography, because standard techniques for lipoprotein assay include measurement of cholesterol precursors, which may yield a false-positive result. Milder cases may not present until late childhood. **Treatment** includes supplemental dietary cholesterol (egg yolk) and HMG-CoA reductase inhibition to prevent the synthesis of toxic precursors proximal to the enzymatic block.

### Disorders of Intracellular Cholesterol Metabolism Cerebrotendinous Xanthomatosis

This autosomal recessive disorder presents in late adolescence with tendon xanthomas, cataracts, and progressive neurodegeneration. It is caused by tissue accumulation of bile acid intermediates that are shunted into production of cholesterol that in turn result from pathogenic variants in the gene for sterol 27-hydroxylase (*CYP27A1*). This enzyme is necessary for normal mitochondrial synthesis of bile acids in the liver. Early treatment with chenodeoxycholic acid reduces cholesterol levels and prevents the development of symptoms.

### Wolman Disease and Cholesterol Ester Storage Disease

These autosomal recessive disorders are caused by pathogenic variants in *LIPA* that result in lack of lysosomal acid lipase. After LDL cholesterol is incorporated into the cell by endocytosis, it is delivered to lysosomes, where it is hydrolyzed by lysosomal lipase. Failure of hydrolysis

**Table 106.11** Major Clinical Characteristics of Smith-Lemli-Opitz Syndrome: Frequent Anomalies (>50% of Patients)

<b>CRANIOFACIAL</b>
Microcephaly
Blepharoptosis
Anteverted nares
Retromicrognathia
Low-set, posteriorly rotated ears
Midline cleft palate
Broad maxillary alveolar ridges
Cataracts (<50%)
<b>SKELETAL ANOMALIES</b>
Syndactyly of toes II/III
Postaxial polydactyly (<50%)
Equinovarus deformity (<50%)
<b>GENITAL ANOMALIES</b>
Hypospadias
Cryptorchidism
Sexual ambiguity (<50%) or XY sex reversal
<b>DEVELOPMENT</b>
Prenatal and postnatal growth retardation
Feeding problems
Intellectual disability
Behavioral abnormalities

From Haas D, Kelley RI, Hoffmann GF. Inherited disorders of cholesterol biosynthesis. *Neuropediatrics*. 2001;32:113-122.

because of complete absence of the enzyme causes accumulation of cholesteryl esters within the cells. Hepatosplenomegaly, steatorrhea, and failure to thrive occur during early infancy, leading to death by the end of the first year. In cholesterol ester storage disease, a less severe form than Wolman disease, there is low but detectable acid lipase activity (see Chapter 106.4).

### Niemann-Pick Disease Type C

This disorder of intracellular cholesterol transport is characterized by accumulation of cholesterol and sphingomyelin in the CNS and reticuloendothelial system. Death from this autosomal recessive neurologic disease usually occurs by adolescence (see Chapter 106.4).

### Lipoprotein Patterns in Children and Adolescents

Derived primarily from the Lipid Research Clinics Population Studies, Table 106.9 shows the distribution of lipoprotein levels in American youth at various ages. Total plasma cholesterol rises rapidly from a mean of 68 mg/dL at birth to a level approximately twice that by the end of the neonatal period. A very gradual rise in total cholesterol level occurs until puberty, when the mean level reaches 160 mg/dL. Total cholesterol falls transiently during puberty in males because of a small decrease in HDL-C and in females secondary to a slight fall in LDL-C. Blood cholesterol levels track reasonably well as individuals age.

High blood cholesterol tends to aggregate in families, a reflection of genetic and environmental influences.

Acceptable total cholesterol among children and adolescents is <170 mg/dL; borderline is 170-199 mg/dL; and high is >200 mg/dL. Acceptable LDL-C is <110 mg/dL; borderline is 110-129 mg/dL; and high is >130 mg/dL. HDL-C should be >40 mg/dL.

### Blood Cholesterol Screening

A lipid profile should be checked for all children between ages 9 and 11 years and then another between ages 17 and 21 years because cholesterol levels may vary after puberty. However, if a child would have met the selective criteria from the previous risk-based guidelines (premature coronary artery disease [CAD] in a parent or grandparent, a parent with cholesterol >240 mg/dL), screening can occur as early as age 2

**Table 106.12** Characteristic Malformations of Internal Organs in Severely Affected Smith-Lemli-Opitz Patients**CENTRAL NERVOUS SYSTEM**

Frontal lobe hypoplasia  
 Enlarged ventricles  
 Agenesis of corpus callosum  
 Cerebellar hypoplasia  
 Holoprosencephaly

**CARDIOVASCULAR**

Atrioventricular canal  
 Secundum atrial septal defect  
 Patent ductus arteriosus  
 Membranous ventricular septal defect

**URINARY TRACT**

Renal hypoplasia or aplasia  
 Renal cortical cysts  
 Hydronephrosis  
 Ureteral duplication

**GASTROINTESTINAL**

Hirschsprung disease  
 Pyloric stenosis  
 Refractory dysmotility  
 Cholestatic and noncholestatic progressive liver disease

**PULMONARY**

Pulmonary hypoplasia  
 Abnormal lobation

**ENDOCRINE**

Adrenal insufficiency

From Haas D, Kelley RI, Hoffmann GF. Inherited disorders of cholesterol biosynthesis. *Neuropediatrics*. 2001;32:113–122.

years. Data also suggest that obtaining a nonfasting lipid profile can be just as useful in detecting severe genetic dyslipidemias as a fasting lipid profile and thus can be used as first-line screening in children. Fasting lipid profiles may also be used depending on parental, child, and clinician preference, especially if there is concern for hypertriglyceridemia, because triglycerides are affected more by fasting status. Abnormal lipid panels should be repeated, and especially when the concern is the triglycerides, the second panel should be obtained  $\geq 2$  weeks later in the fasted state. Treatment other than lifestyle modification is not initiated based on a single lipid panel determination.

**Risk Assessment and Treatment of Hyperlipidemia**

The NCEP recommends a population-based approach toward a healthy lifestyle applicable to all children and an individualized approach directed at those children at high risk (Fig. 106.14). The important focus on maintenance of a healthy lifestyle rather than aggressive weight reduction is recommended by the American Academy of Pediatrics (AAP).

All children with dyslipidemias are stratified according to the presence of high-level or moderate-level risk factors to determine their ultimate treatment. **High-level risk factors** are defined as hypertension requiring drug therapy (blood pressure  $\geq 99$ th percentile + 5 mm Hg), current cigarette smoker, BMI at the  $\geq 97$ th percentile, the presence of type 1 or type 2 diabetes mellitus, chronic kidney disease, postorthotopic heart transplant, and/or Kawasaki disease with current aneurysms. **Moderate-level risk factors** are defined as hypertension that does not require drug therapy, BMI at the  $\geq 95$ th percentile but  $< 97$ th percentile, HDL-C  $< 40$  mg/dL, Kawasaki disease (and possibly multisystem inflammatory syndrome in children [MIS-C]) with regressed coronary aneurysms, chronic inflammatory disease, HIV infection, and/or the presence of nephrotic syndrome.

The initial treatment for dyslipidemia in a child always begins with a 6-month trial of lifestyle modification, namely, improvements in dietary and physical activity patterns. Being overweight confers a special risk of CVD because of the strong association with insulin resistance syndrome (metabolic syndrome). Although there is no standardized definition of metabolic syndrome for youth, it is likely that half of all severely obese children are insulin resistant. Data from the CARDIAC project noted that 49% of fifth-grade children with the hyperpigmented rash, acanthosis nigricans, had three or more factors for insulin resistance syndrome when using the definition classically used for adults, including evidence of insulin resistance, hypertension, HDL-C  $< 40$  mg/dL, and triglycerides  $> 150$  mg/dL, in addition to obesity.

The Cardiovascular Health Integrated Lifestyle Diet-1 (CHILD-1) diet is the first level of dietary change to be recommended for all children with dyslipidemias. The CHILD-1 diet is specially designed for children with risk factors for CAD and focuses on limiting dietary cholesterol to 300 mg/day, limiting sugary drink consumption, using reduced-fat/skim milk, avoiding foods high in *trans*-type fats, limiting foods high in sodium, and encouraging consumption of foods high in fiber. Specific recommendations depend on the child's age. American Heart Association (AHA) diet guidelines for all persons of all ages recommend these measures plus avoidance of highly processed foods. Specific amounts or percentages of saturated vs monosaturated or polyunsaturated fats are not addressed.

The use of the Cardiovascular Health Integrated Lifestyle Diet-2 (CHILD-2) diet is recommended if the CHILD-1 diet alone is unsuccessful. Although similar in many aspects to the CHILD-1 diet, the CHILD-2 diet is geared toward a specific dyslipidemia type; the CHILD-2 LDL diet is recommended for children with elevated LDL levels and the CHILD-2 TG diet for those presenting with elevated triglycerides. The basic recommendations of calorie consumption for the CHILD-2 diet are as follows: only 25–30% of calories from fat,  $\leq 7\%$  of calories from saturated fat, 10% of calories from monounsaturated fat, and  $< 200$  mg/day of cholesterol. If the CHILD-2 LDL diet is recommended, the use of plant sterols and water-soluble fiber is emphasized. If the CHILD-2 TG diet is recommended, increasing consumption of omega-3 fatty acids and complex rather than simple carbohydrates is emphasized.

If followed, these dietary recommendations will provide adequate calories for optimal growth and development without promoting obesity. Compliance on the part of children and their caregivers is challenging. *Children learn eating habits from their parents.* Successful adoption of a healthier lifestyle is much more likely to occur if meals and snacks in the home are applicable to the entire family rather than an individual child. A regular time for meals together as a family is desirable. Grandparents and other nonparental caregivers sometimes need to be reminded not to indulge the child who is on a restricted diet. Additionally, the rise in obesity is prompting some school districts to restrict sweetened drink availability and offer more nutritious cafeteria selections.

Changes in physical activity habits are also an important part of the initial lifestyle modification. The National Association for Sport and Physical Education recommends that children should accumulate at least 60 minutes of age-appropriate physical activity on most days of the week. Extended periods ( $\geq 2$  hr) of daytime inactivity are discouraged, as is  $> 2$  hours of television and other forms of screen time.

**Pharmacologic Therapy.** See Tables 106.13 and 106.14.

Pharmacologic therapy with cholesterol-lowering medication is the cornerstone of treatment for children who fail to respond to 6 months of rigorous lifestyle modification. It should be considered when one of the following conditions are met (also shown in Fig. 106.14):

- LDL cholesterol remains  $> 190$  mg/dL
- LDL cholesterol remains  $> 160$  mg/dL with the presence of one high-level risk factor *and/or* at least two moderate-level risk factors
- LDL cholesterol remains  $> 130$  mg/dL with the presence of at least two high-level risk factors, one high-level risk factor, *and* at least two moderate-level risk factors, *or* evidence of CAD

**HMG-CoA reductase inhibitors**, also known as “statins,” are remarkably effective in lowering LDL-C levels and reducing plaque



**Table 106.13** Drugs Used for the Treatment of Hyperlipidemia

DRUG	MECHANISM OF ACTION	INDICATION	STARTING DOSE
HMG-CoA reductase inhibitors (statins)	↓ Cholesterol and VLDL synthesis ↑ Hepatic LDL receptors	Elevated LDL	5-80 mg every night at bedtime
Bile acid sequestrants: Cholestyramine Colestipol	↑ Bile and excretion	Elevated LDL	4-32 g daily 5-40 g daily
Nicotinic acid	↓ Hepatic VLDL synthesis	Elevated LDL Elevated TG	100-2,000 mg three times daily
Fibric acid derivatives: Gemfibrozil	↑ LPL ↓ VLDL	Elevated TG	600 mg twice daily
Fish oils	↓ VLDL production	Elevated TG	3-10 g daily
Cholesterol absorption inhibitors: Ezetimibe	↓ Intestinal absorption cholesterol	Elevated LDL	10 mg daily
PCSK-9 inhibitor Evolocumab	Upregulation of hepatic LDL receptors to enhance removal of LDL from circulation	Refractory or intolerant to statin	140 mg every 2 weeks or 420 mg subcutaneous injection monthly

LDL, Low-density lipoprotein(s); LPL, lipoprotein lipase; TG, triglycerides; VLDL, very-low-density lipoprotein.

**Table 106.14** Adverse Effects of Cholesterol-Lowering Drugs

<b>STATINS</b> Myalgia, myositis, transaminase elevations, hepatic dysfunction, increased risk of diabetes mellitus Rare: Rhabdomyolysis, hemorrhagic stroke
<b>EZETIMIBE</b> Diarrhea, arthralgia, rhabdomyolysis, hepatitis, pancreatitis, thrombocytopenia
<b>PCSK9 INHIBITORS</b> Nasopharyngitis, upper respiratory tract infection, influenza, back pain, injection site reactions, rash, allergic skin reactions, cognitive effects, antidrug antibodies
<b>BILE ACID SEQUESTRANTS</b> Constipation, heartburn, nausea, eructation, bloating Adverse effects are more common with colestipol and cholestyramine and may diminish over time.
<b>FIBRIC ACID DERIVATIVES</b> Gastrointestinal (GI) disturbances, cholelithiasis, hepatitis, myositis
<b>NIACIN</b> Skin flushing, pruritus, GI disturbances, blurred vision, fatigue, glucose intolerance, hyperuricemia, hepatic toxicity, exacerbation of peptic ulcers Adverse effects, especially flushing, occur more frequently with immediate-release products. Rare: Dry eyes, hyperpigmentation
<b>FISH OIL</b> Eructation, dyspepsia, unpleasant aftertaste

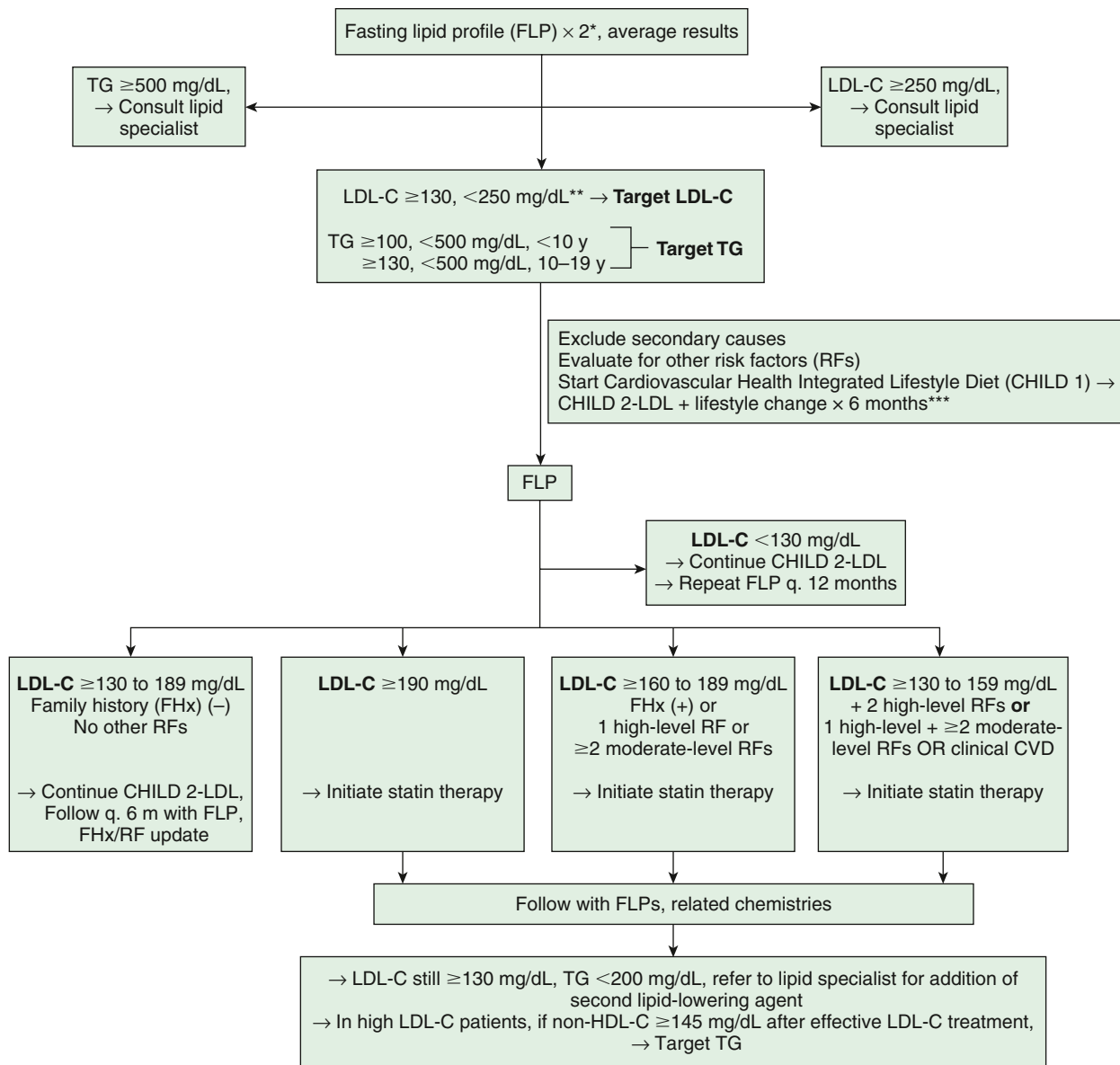
From The Medical Letter. Lipid-lowering drugs. *Med Lett.* 2016;58:133-140, Table 2, p. 136.

inflammation, thereby reducing the likelihood of a sudden coronary event in an at-risk adult within weeks of starting the medication. As a class, they work by blocking the intrahepatic biosynthesis of cholesterol, thereby stimulating the production of more LDL receptors on the cell surface and facilitating the uptake of LDL-C from the bloodstream. The NCEP Adult Treatment Panel advocates aggressive lowering of LDL to <70 mg/dL in individuals with known CAD. This information is relevant because a child who fulfills criteria for consideration of

cholesterol-lowering medication will almost always have inherited the condition from one of the child's parents. Not infrequently, when providing care for the child, questions arise about screening and treatment of parents or grandparents. Statins are equally effective in children, capable of lowering LDL-C levels by 50% when necessary. They are considered first-line therapy for children who meet criteria for pharmacologic therapy. They also will effect a modest reduction in triglycerides and an inconsistent increase in HDL-C. Their side effect profile, mainly liver dysfunction and rarely rhabdomyolysis with secondary renal failure, should be taken into consideration before prescribing the drug. However, there has been no evidence that complications are any more frequent in children than in adults, and skeletal muscle discomfort seems to be somewhat less of a problem. Drug interactions may occur as well, so careful attention should be paid to a child's active prescriptions to avoid potentiation of the side effects. Children should have liver enzymes monitored regularly and creatine phosphokinase measured if muscle aches or weakness occurs. Liver (muscle) enzymes may be allowed to rise threefold before discontinuing the drug. There is a suggested link between the use of statins and increased risk of developing type 2 diabetes mellitus in adults, but these results have not been replicated in children. Sex hormones have been measured in children receiving statins and are unchanged. It should be reemphasized that children with modest elevations in cholesterol, such as that seen in polygenic hypercholesterolemia, are not, as a rule, candidates for statins because of their side effect profile and the childhood response to lifestyle modifications. Statins should be started at the lowest effective dose and allowed at least 8 weeks to achieve their peak effect. If LDL levels are not at goal, which in children who are treated is generally established to be <130 mg, the medication may be titrated upward with careful monitoring of side effects.

Other cholesterol-lowering medications, such as nicotinic acid and fibrates, have been used far less often in children than bile acid sequestrants and statins. Nicotinic acid and fibrates have been used selectively in children with marked hypertriglyceridemia (>500 mg/dL) at risk for acute pancreatitis, though dietary restriction of complex sugars (stressing elimination of sugar-sweetened beverages) and carbohydrates will usually result in significant lowering of triglyceride levels. Guidelines recommend treatment of LDL-C as the initial priority, and after LDL levels are at goal, then if triglycerides remain between 200 and 499 mg/dL and non-HDL cholesterol  $\geq$ 145 mg/dL, pharmacologic treatment to reduce triglyceride levels is indicated. Omega-3 fatty acid supplementation, available in both over-the-counter and prescription form, is a safe and useful treatment thought to reduce triglyceride levels by decreasing the hepatic synthesis of triglycerides. LDL-C levels in adults





\* Obtain FLPs at least 2 weeks but no more than 3 months apart.

\*\* Use of drug therapy is limited to children  $\geq 10$  y with defined risk profiles.

\*\*\* In a child with LDL-C  $> 190$  mg/dL and other RFs, trial of CHILD 2-LDL may be abbreviated.

**Fig. 106.14** Dyslipidemia treatment algorithm: Target LDL-C (low-density lipoprotein cholesterol). Note: Values given are in mg/dL. To convert to SI units, divide results for total cholesterol (TC), low-density lipoprotein cholesterol (LDL-C), high-density lipoprotein cholesterol (HDL-C), and non-HDL-C by 38.6; for triglycerides (TG), divide by 88.6. (From U.S. Department of Health and Human Services, National Institutes of Health, National Heart, Lung, and Blood Institute. Expert Panel on Integrated Guidelines for Cardiovascular Health and Risk Reduction in Children and Adolescents. NIH Publication No. 12-7486A, Oct. 2012, Fig 9-1.)

of about 70 mg/dL were recently associated with coronary artery atherosclerotic plaque reduction and reversal of CAD. Knowledge in this area will continue to evolve.

Ezetimibe has proved to be useful in the pediatric population because of its efficacy and low side effect profile. Ezetimibe reduces plasma LDL-C by blocking sterol absorption in enterocytes. The drug is marketed as an adjunct to statins when adults are not achieving sufficient blood lipid lowering with statins alone. Sufficient reports documenting its effectiveness without side effects support recommending ezetimibe instead of a statin when moderate hypercholesterolemia is encountered or apprehension from parents makes using a statin difficult.

Visit Elsevier eBooks+ at eBooks.Health.Elsevier.com for Bibliography.

## 106.4 Lipidoses (Lysosomal Storage Disorders)

Margaret M. McGovern and Robert J. Desnick

The lysosomal lipid storage diseases are diverse disorders each caused by an inherited deficiency of a lysosomal hydrolase leading to the intralysosomal accumulation of the enzyme's particular substrate (Tables 106.15 and 106.16). With the exceptions of Wolman disease and cholesterol ester storage disease (see Chapter 106.3), the lipid substrates share a common structure that includes a ceramide backbone (2-N-acylsphingosine) from which the various sphingolipids are derived by substitution of hexoses, phosphorylcholine, or one or more

sialic acid residues on the terminal hydroxyl group of the ceramide molecule. The pathway of sphingolipid metabolism in nervous tissue (Fig. 106.15) and in visceral organs (Fig. 106.16) is known. Each catabolic step, with the exception of the catabolism of lactosylceramide, has a genetically determined metabolic defect and a resultant disease. Because sphingolipids are essential components of all cell membranes, the inability to degrade these substances and their subsequent accumulation results in the physiologic and morphologic alterations and characteristic clinical manifestations of the lipid storage disorders (see Tables 106.15 and 106.16). Progressive lysosomal accumulation of glycosphingolipids in the CNS leads to neurodegeneration, whereas storage in visceral cells can lead to organomegaly, pulmonary infiltration, skeletal abnormalities, and other manifestations.

Diagnostic assays for the identification of affected individuals has relied on the measurement of the specific enzymatic activity in isolated leukocytes or cultured fibroblasts or lymphoblasts. An approach to differentiating these disorders is noted in Figure 106.17. In addition, next generation sequencing of lysosomal genes as well as metabolomic/protomic approaches have helped determine a specific diagnosis. For most disorders, carrier identification and prenatal diagnosis are available; a specific diagnosis is essential to permit genetic counseling. The characterization of the genes that encode the specific enzymes required for sphingolipid metabolism permit the development of therapeutic options, such as recombinant enzyme replacement therapy, as well as the potential of cell or gene therapy. Identification of specific disease-causing pathogenic variants improve diagnosis, prenatal detection, and carrier identification. For several disorders (Gaucher, Fabry, and NPD), it has been possible to make genotype-phenotype correlations that predict disease severity and allow more precise genetic counseling. Inheritance is autosomal recessive except for X-linked Fabry disease.

### GM<sub>1</sub> GANGLIOSIDOSIS

GM<sub>1</sub> gangliosidosis most frequently presents in early infancy but has been described in patients with juvenile- and adult-onset subtypes (Fig. 106.18, Table 106.17). Inherited as an autosomal recessive trait, each subtype results from a different gene pathogenic variant that leads to the deficient activity of  $\beta$ -galactosidase, a lysosomal enzyme encoded by the gene *GLB1*. Although the disorder is characterized by the pathologic accumulation of GM<sub>1</sub> gangliosides in the lysosomes of both neural and visceral cells, GM<sub>1</sub> ganglioside accumulation is most marked in the brain. In addition, keratan sulfate, a mucopolysaccharide, accumulates in liver and is excreted in the urine of patients with GM<sub>1</sub> gangliosidosis.

The clinical manifestations of the infantile form of GM<sub>1</sub> gangliosidosis may be evident in the newborn as hepatosplenomegaly, edema, and skin eruptions (angiokeratoma). It most frequently presents in the first 6 months of life with developmental delay followed by progressive psychomotor retardation and the onset of tonic-clonic seizures. Typical facies is characterized by low-set ears, frontal bossing, a depressed nasal bridge, and an abnormally long philtrum. Up to 50% of patients have a macular cherry red spot. Hepatosplenomegaly and skeletal abnormalities similar to those of the mucopolysaccharidoses (see Chapter 109), including anterior beaking of the vertebrae, enlargement of the sella turcica, and thickening of the calvarium, are present. By the end of the first year of life, most patients are blind and deaf, with severe neurologic impairment characterized by decerebrate rigidity. Death usually occurs by 3-4 years of age. The *juvenile-onset* form of GM<sub>1</sub> gangliosidosis is clinically distinct, with a variable age at onset. Affected patients present primarily with neurologic symptoms including ataxia, dysarthria, intellectual disabilities, and spasticity. Deterioration is slow; patients may survive through the fourth decade of life. These patients lack the visceral involvement, facial abnormalities, and skeletal features seen in type 1 disease. *Adult-onset* patients have been described who present with gait and speech abnormalities, dystonia, and mild skeletal abnormalities. There is no specific treatment for any form of GM<sub>1</sub> gangliosidosis.

The diagnosis of GM<sub>1</sub> gangliosidosis should be suspected in infants with typical clinical features and is confirmed by the demonstration of biallelic pathogenic variants in *GLB1* and, as needed, demonstration of deficiency of  $\beta$ -galactosidase activity in peripheral leukocytes. Other disorders that share some of the features of the GM<sub>1</sub> gangliosidoses

include Hurler disease (mucopolysaccharidosis type I), I-cell disease, and NPD type A, each of which can be distinguished by the demonstration of their specific genetic variants and enzymatic deficiencies. Carriers of the disorder are detected by the measurement of the enzymatic activity in peripheral leukocytes or by identifying the specific gene pathogenic variants. Prenatal diagnosis is accomplished by testing of known pathogenic variants or by determination of the enzymatic activity in cultured amniocytes or chorionic villi. Currently only supportive therapy is available for patients with GM<sub>1</sub> gangliosidosis.

### THE GM<sub>2</sub> GANGLIOSIDOSES

The GM<sub>2</sub> gangliosidoses include the autosomal recessive Tay-Sachs disease and Sandhoff disease. Each results from the deficiency of  $\beta$ -hexosaminidase activity and the lysosomal accumulation of GM<sub>2</sub> gangliosides, particularly in the CNS. Both disorders have been classified into infantile-, juvenile-, and adult-onset forms based on the age at onset and clinical features.  $\beta$ -Hexosaminidase occurs as two isozymes:  $\beta$ -hexosaminidase A, which is composed of one  $\alpha$  and one  $\beta$  subunit, and  $\beta$ -hexosaminidase B, which has two  $\beta$  subunits.  $\beta$ -Hexosaminidase A deficiency results from pathogenic variants in the  $\alpha$  subunit and causes Tay-Sachs disease, whereas pathogenic variants in the  $\beta$ -subunit gene result in the deficiency of both  $\beta$ -hexosaminidases A and B and cause Sandhoff disease. Both are autosomal recessive traits, with Tay-Sachs disease having a predilection for the Ashkenazi Jewish population, where the carrier frequency is about 1/25.

More than 100 pathogenic variants in *HEXA* have been identified for Tay-Sachs disease. Most are associated with the infantile forms of disease. Three pathogenic variants account for >98% of mutant alleles among Ashkenazi Jewish carriers, including one allele associated with the adult-onset form. Pathogenic variants that cause the subacute or chronic forms result in enzyme proteins with residual enzymatic activities, the levels of which correlate with the severity of the disease.

Patients with the infantile form of Tay-Sachs disease have clinical manifestations in infancy including loss of motor skills, increased startle reaction, and macular pallor and retinal cherry red spots (see Table 106.15). Affected infants usually develop normally until 4-5 months of age, when decreased eye contact and an exaggerated startle response to noise (hyperacusis) are noted. Macrocephaly, not associated with hydrocephalus, may develop. In the second year of life, seizures develop, which may be refractory to anticonvulsant therapy. Neurodegeneration is relentless, with death occurring by the age of 4 or 5 years. The juvenile- and later-onset forms initially present with ataxia and dysarthria and may not be associated with a macular cherry red spot.

The clinical manifestations of Sandhoff disease are similar to those for Tay-Sachs disease. Infants with Sandhoff disease have hepatosplenomegaly, cardiac involvement, and mild bony abnormalities. The juvenile form of this disorder presents as ataxia, dysarthria, and intellectual deterioration, but without visceral enlargement or a macular cherry red spot. More than 50 pathogenic variants in *HEXB* have been identified for Sandhoff disease.

The diagnosis of infantile Tay-Sachs disease and Sandhoff disease is usually suspected in an infant with neurologic features and a cherry red spot. Definitive diagnosis is made by genetic testing or by determination of enzyme activities in peripheral leukocytes. The two disorders can be distinguished enzymatically, because in Tay-Sachs disease only the  $\beta$ -hexosaminidase A isozyme is deficient, whereas in Sandhoff disease both the  $\beta$ -hexosaminidase A and B isozymes are deficient. At-risk pregnancies for both disorders can be prenatally diagnosed by testing known pathogenic variants or determining enzyme levels in fetal cells obtained by amniocentesis or chorionic villus sampling. Identification of carriers in families is also possible by genetic or enzymatic determination. For Tay-Sachs disease, carrier screening of all couples in which at least one member is of Ashkenazi Jewish descent is recommended before the initiation of pregnancy to identify couples at risk. The incidence of Tay-Sachs disease has been markedly reduced since the introduction of carrier screening programs in the Ashkenazi Jewish population. Newborn screening may be possible by measuring specific glycosphingolipid markers or the relevant enzymatic activities in dried

**Table 106.15** Clinical Findings in Lysosomal Storage Diseases

NATURE	ENZYME DEFECT	HYDROPS FETALIS	COARSE FACIAL FEATURES DYSOSTOSIS MULTIPLEX	HEPATOSPLENOMEGALY
<b>MUCOLIPIDOSES</b>				
Mucopolipidoses II, I-cell disease	N-Acetylglucosaminylphosphotransferase	(+)	++	+
Mucopolipidosis III, Pseudo-Hurler	N-Acetylglucosaminylphosphotransferase	–	+	(+)
Mucopolipidosis IV	Unknown	–	–	+
<b>SPHINGOLIPIDOSES</b>				
Fabry disease	$\alpha$ -Galactosidase	–	–	–
Farber disease	Ceramidase	–	–	(+)
Galactosialidosis	$\beta$ -Galactosidase and sialidase	(+)	++	++
GM1 gangliosidosis	$\beta$ -Galactosidase	(+)	++	+
GM2 gangliosidosis (Tay-Sachs disease, Sandhoff disease)	$\beta$ -Hexosaminidases A and B	–	–	(+)
Gaucher type I	Glucocerebrosidase	–	–	++
Gaucher type II	Glucocerebrosidase	(+)	–	++
Gaucher type III	Glucocerebrosidase	(+)	–	+
Niemann-Pick type A	Sphingomyelinase	(+)	–	++
Niemann-Pick type B	Sphingomyelinase	–	–	++
Metachromatic leukodystrophy	Arylsulfatase A	–	–	–
Krabbe disease	$\beta$ -Galactocerebrosidase	–	–	–
<b>LIPID STORAGE DISORDERS</b>				
Niemann-Pick type C	Intracellular cholesterol transport	–	–	(+)
Wolman disease	Acid lipase	(+)	–	+
Ceroid lipofuscinosis, infantile (Santavuori-Hentia)	Palmitoyl-protein thioesterase (CLN1)	–	–	–
Ceroid lipofuscinosis, late infantile (Jansky-Bielschowsky)	Pepstatin-insensitive peptidase (CLN2); variants in Finland (CLN5), Turkey (CLN7), and Italy (CLN6)	–	–	–
Ceroid lipofuscinosis, juvenile (Spielmeyer-Vogt)	CLN3, membrane protein	–	–	–
Ceroid lipofuscinosis, adult (Kufs, Parry)	CLN4, probably heterogeneous	(+)	–	–
<b>OLIGOSACCHARIDOSES</b>				
Aspartylglucosaminuria	Aspartylglucosaminase	–	+	(+)
Fucosidosis	$\alpha$ -Fucosidase	–	++	(+)
$\alpha$ -Mannosidosis	$\alpha$ -Mannosidase	–	++	+
$\beta$ -Mannosidosis	$\beta$ -Mannosidase	–	+	(+)
Schindler disease	$\alpha$ -N-Acetylgalactosaminidase	–	–	–
Sialidosis I	Sialidase	(+)	–	–
Sialidosis II	Sialidase	(+)	++	+

++, prominent; +, often present, (+), inconstant or occurring later in the disease course; –, not present.

GAG, glycosaminoglycans.

Modified from Hoffmann GF, Nyhan WL, Zschoke J, et al. *Storage Disorders in Inherited Metabolic Diseases*. Philadelphia: Lippincott Williams & Wilkins; 2002:346–351.

Table 106.15 Clinical Findings in Lysosomal Storage Diseases—cont'd

CARDIAC INVOLVEMENT CARDIAC FAILURE	MENTAL DETERIORATION	MYOCLONUS	SPASTICITY	PERIPHERAL NEUROPATHY	CHERRY RED SPOT	CORNEAL CLOUDING	ANGIOKERATOMATA
++	++	-	-	-	-	(+)	-
-	(+)	-	-	-	-	+	-
-	(+)	-	-	-	-	-	-
+	-	-	-	-	-	+	++
++	+	-	-	+	(+)	-	-
+	++	(+)	+	-	+	+	+
(+)	++	-	(+)	-	(+)	+	+
-	++	+	+	-	++	-	-
-	-	-	-	-	-	-	-
-	++	+	+	-	-	-	-
-	+	(+)	(+)	-	-	-	-
-	+	(+)	-	(+)	(++)	-	-
-	-	-	-	(+)	(+)	-	-
-	++	-	+	++	(+)	-	-
-	++	-	+	++	(+)	-	-
-	+	-	-	-	(+)	-	-
(+)	-	-	-	-	(+)	-	-
-	+	+	+	-	-	-	-
-	+	+	+	-	-	-	-
-	+	-	(+)	-	-	-	-
-	+	-	-	-	-	-	-
(+)	+	-	-	-	-	(+)	(+)
+	++	+	+	-	-	-	(+)
-	++	-	(+)	-	-	++	(+)
-	+	-	+	+	-	-	(+)
-	+	+	+	-	-	-	-
-	-	++	+	+	++	(+)	-
+	++	(+)	-	-	++	-	+

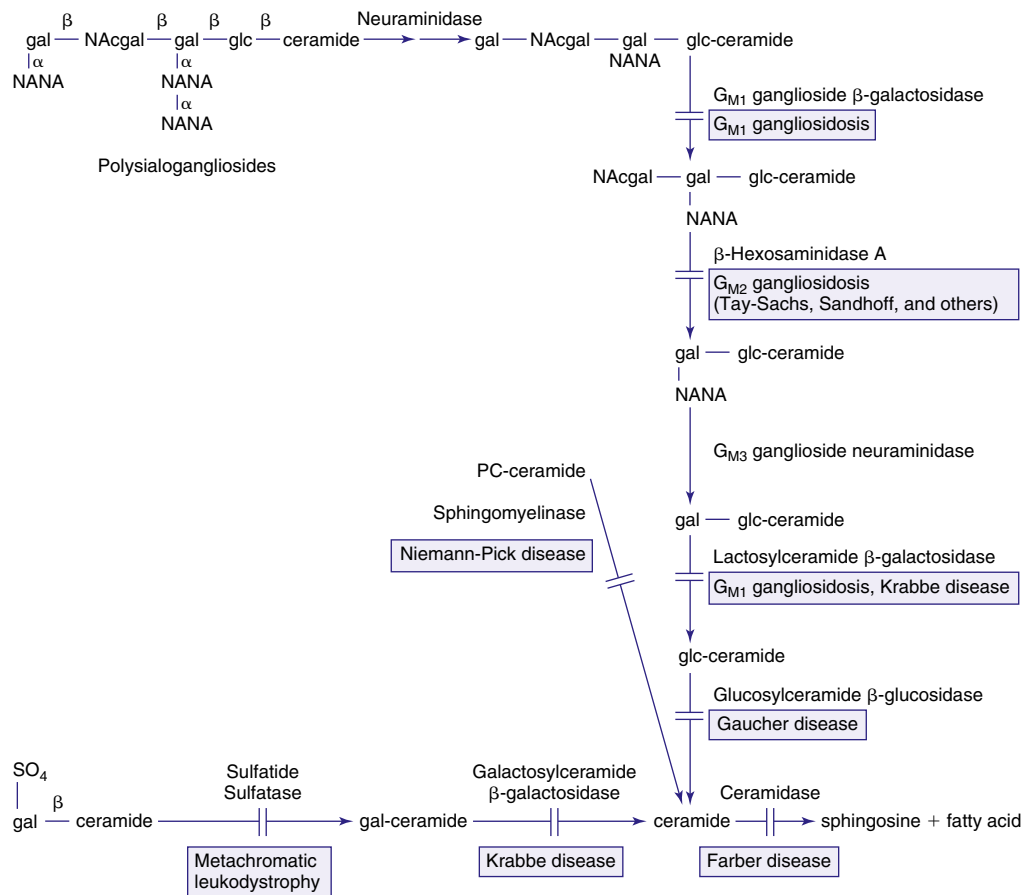


**Table 106.16** Lysosomal Storage Disorders in the Newborn Period: Genetic and Clinical Characteristics of Neonatal Presentation

DISORDER	ONSET	FACIES	NEUROLOGIC FINDINGS	DISTINCTIVE FEATURES
Niemann-Pick A disease	Early infancy	Frontal bossing	Difficulty feeding, apathy, deafness, blindness, hypotonia	Brownish-yellow skin, xanthomas
Niemann-Pick C disease	Birth to 3 mo	Normal	Developmental delay, vertical gaze paralysis, hypotonia, later spasticity	—
Gaucher disease type 2	In utero to 6 mo	Normal	Poor suck and swallow, weak cry, squint, trismus, strabismus, opsoclonus, hypertonic, later flaccidity	Congenital ichthyosis, collodion skin
Krabbe disease	3-6 mo	Normal	Irritability, tonic spasms with light or noise stimulation, seizures, hypertonia, later flaccidity	Increased CSF protein level
GM1 gangliosidosis	Birth	Coarse	Poor suck, weak cry, lethargy, exaggerated startle, blindness, hypotonia, later spasticity	Gingival hypertrophy, edema, rashes
Farber disease type I	2 wk to 4 mo	Normal	Progressive psychomotor impairment, seizures, decreased reflexes, hypotonia	Joint swelling with nodules, hoarseness, lung disease, contractures, fever, granulomas, dysphagia, vomiting, increased CSF protein level
Farber disease types II and III	Birth to 9 mo ( $\leq 20$ mo)	Normal	—	Joint swelling with nodules, hoarseness
Farber disease type IV (neonatal)	Birth	Normal	Nodules not consistent findings	Corneal opacities (1/3)
Congenital sialidosis	In utero to birth	Cognitive, edema	Intellectual impairment, hypotonia	Neonatal ascites, inguinal hernias, renal disease
Galactosialidosis	In utero to birth	Coarse	Intellectual impairment, occasional deafness, hypotonia	Ascites, edema, inguinal hernias, renal disease, telangiectasias
Wolman disease	First weeks of life	Normal	Cognitive deterioration	Vomiting, diarrhea, steatorrhea, abdominal distention, failure to thrive, anemia, adrenal calcifications
Infantile sialic acid storage disease	In utero to birth	Coarse, dysmorphic	Intellectual impairment, hypotonia	Ascites, anemia, diarrhea, failure to thrive
I-cell disease	In utero to birth	Coarse	Intellectual impairment, deafness	Gingival hyperplasia, restricted joint mobility, hernias
Mucopolipidosis type IV	Birth to 3 mo	Normal	Intellectual impairment, hypotonia	—
Mucopolysaccharidosis type VII	In utero to childhood	Variable coarseness	Mild to severe intellectual impairment	Hernias

**Table 106.16** Lysosomal Storage Disorders in the Newborn Period: Genetic and Clinical Characteristics of Neonatal Presentation—cont'd

EYE FINDINGS	DEFECT	GENE LOCATION/MOLECULAR FINDINGS	ETHNIC PREDILECTION
Cherry-red spot (50%)	Sphingomyelinase deficiency	<i>SMPD1</i> gene at 11p15.4; 3 of 18 variants account for approximately 92% of mutant alleles in the Ashkenazi population	1:40,000 in Ashkenazi Jews with a carrier frequency of 1:60
—	Abnormal cholesterol esterification	<i>NPC1</i> gene at 18q11 accounts for >95% of cases; <i>HE1</i> gene variants may account for remaining cases	Increased in French Canadians of Nova Scotia and Spanish Americans in the Southwest United States
—	Glucocerebrosidase deficiency	1q21; large number of variants known; five variants account for approximately 97% of mutant alleles in the Ashkenazi population but approximately 75% in the non-Jewish population	Panethnic
Optic atrophy	Galactocerebrosidase deficiency	14q 24.3-q32.1; >60 variants with some common variants in specific populations	Increased in Scandinavian countries and in a large Druze kindred in Israel
Cherry red spot (50%)	β-Galactosidase deficiency	3pter-3p21; heterogeneous variants; common variants in specific populations	Panethnic
Grayish opacification surrounding the retina in some patients, subtle cherry red spot	Lysosomal acid ceramidase	8p21.3-22; nine disease-causing variants identified	Panethnic
Normal macula, corneal opacities	—	8p21.3-p22	Panethnic
—	—	Unknown	Panethnic
Corneal clouding	Neuraminidase deficiency	<i>NEU 1</i> gene (sialidase) at 6p21	Panethnic
Cherry red spot, corneal clouding	Absence of a protective protein that safeguards neuraminidase and β-galactosidase from premature degradation	20q13.1	Panethnic
—	Lysosomal acid lipase deficiency	10q23.2-q23.3; variety of variants identified	Increased in Iranian Jews and in non-Jewish and Arab populations of Galilee
—	Defective transport of sialic acid out of the lysosome	<i>SLC17A5</i> gene at 6q	Panethnic
Corneal clouding	Lysosomal enzymes lack mannose 6-phosphate recognition marker and fail to enter the lysosome (phosphotransferase deficiency, 3-subunit complex [α2 β2 γ2])	Enzyme encoded by two genes; α and β subunits encoded by gene at 12p; γ subunit encoded by gene at 16p	Panethnic
Severe corneal clouding, retinal degeneration, blindness	Unknown; some patients with partial deficiency of ganglioside sialidase	<i>MCOLN1</i> gene at 19p13.2-13.3 encoding mucopolipin 1; two founder variants accounting for 95% of mutant alleles in the Ashkenazi population	Increased in Ashkenazi Jews
Variable corneal clouding	β-Glucuronidase deficiency	<i>GUSB</i> gene at 7q21.2-q22; heterogeneous variants	Panethnic



**Fig. 106.15** Pathways in the metabolism of sphingolipids found in nervous tissues. The name of the enzyme catalyzing each reaction is given with the name of the substrate acted on. Inborn errors are depicted as bars crossing the reactions arrows, and the name of the associated defect or defects is given in the nearest box. The gangliosides are named according to the nomenclature of Svennerholm. Anomeric configurations are given only at the largest starting compound. Gal, galactose; glc, glucose; NAcgal, N-acetylgalactosamine; NANA, N-acetylneuraminic acid; PC, phosphorylcholine.

blood spots. There is no treatment available for Tay-Sachs disease or Sandhoff disease. The FDA has approved an investigational new drug application to initiate adeno-associated virus vector gene (beta hexosaminidase A and B) therapy for Tay-Sachs and Sandhoff disease.

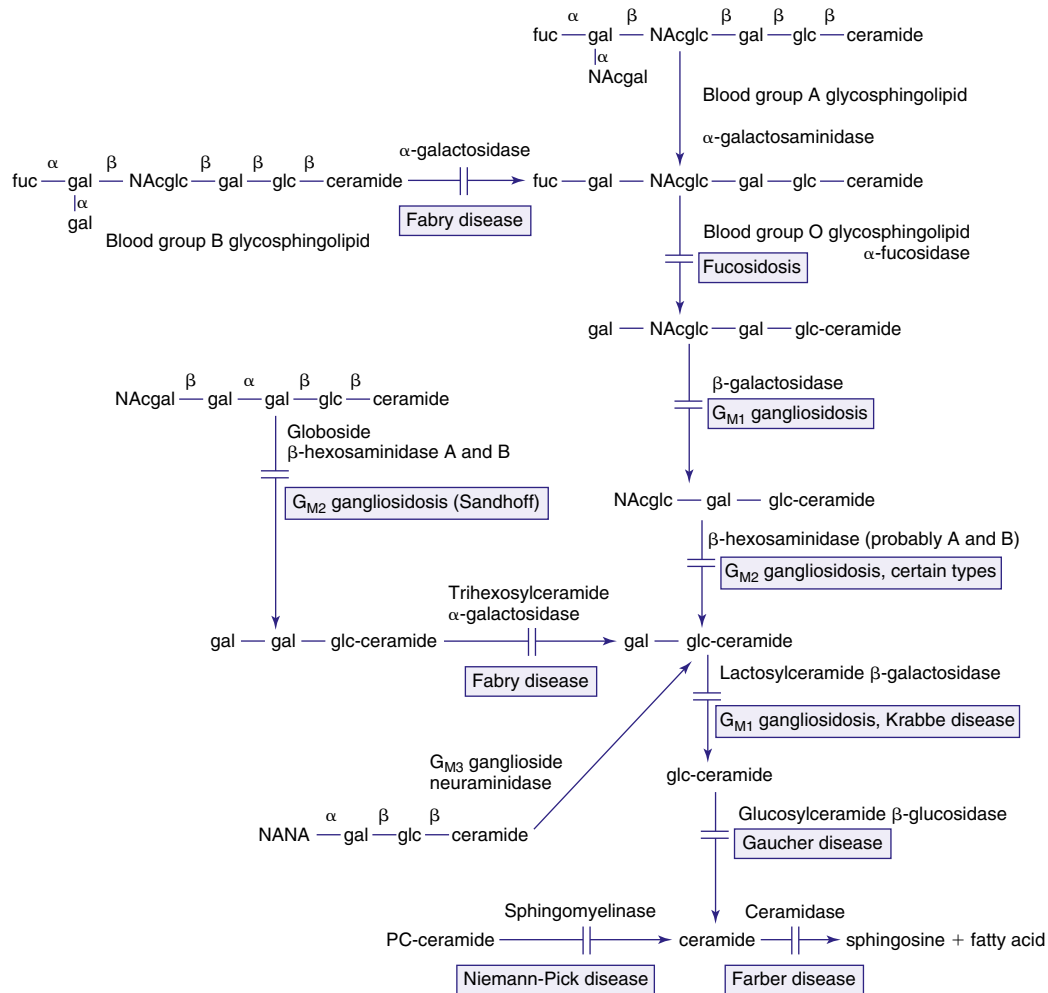
## GAUCHER DISEASE

This disease is a multisystemic lipidosis characterized by hematologic abnormalities, organomegaly, and skeletal involvement, the latter usually manifesting as bone pain and pathologic fractures (see Table 106.15 and 106.16). It is the most common lysosomal storage disease and the most prevalent genetic defect among Ashkenazi Jews. There are three clinical subtypes delineated by the absence or presence and progression of neurologic manifestations: type 1 or the adult, non-neuronopathic form; type 2, the infantile or acute neuronopathic form; and type 3, the juvenile or subacute neuronopathic form. All are autosomal recessive traits. Type 1, which accounts for 99% of cases, has a striking predilection for Ashkenazi Jews, with an incidence of about 1/1,000 and a carrier frequency of about 1/18.

Gaucher disease results from the deficient activity of the lysosomal hydrolase, acid β-glucosidase, which is encoded by the gene *GBA*. The enzymatic defect results in the accumulation of undegraded glycolipid substrates, particularly glucosylceramide, in cells of the reticuloendothelial system. This progressive deposition results in infiltration of the bone marrow, progressive hepatosplenomegaly, and skeletal complications. Four pathogenic variants—p.Asn370Ser, p.Leu444Pro, c.84insG, and IVS2+1G>A—account for about 95% of mutant alleles among Ashkenazi Jewish patients, permitting screening for this disorder in this population. Genotype-phenotype correlations have been noted, providing the

molecular basis for the clinical heterogeneity seen in Gaucher disease type 1. Patients who are homozygous for the p.Asn370Ser pathogenic variant tend to have a later onset, with a more indolent course than patients with one copy of p.Asn370Ser and another common allele.

Clinical manifestations of type 1 Gaucher disease have a variable age at onset, from early childhood to late adulthood, with most symptomatic patients presenting by adolescence. At presentation, patients may have bruising from thrombocytopenia, chronic fatigue secondary to anemia, hepatomegaly with or without elevated LFT results, splenomegaly, and bone pain. Occasional patients have pulmonary involvement at the time of presentation. Patients presenting in the first decade frequently are not Jewish and have growth retardation and a more malignant course. Other patients may be discovered fortuitously during evaluation for other conditions or as part of routine examinations; these patients may have a milder or even a benign course. In symptomatic patients, splenomegaly is progressive and can become massive. Most patients develop radiologic evidence of skeletal involvement, including an Erlenmeyer flask deformity of the distal femur. Clinically apparent bony involvement, which occurs in most patients, can present as bone pain, a pseudo-osteomyelitis pattern, or pathologic fractures. Lytic lesions can develop in the long bones, including the femur, ribs, and pelvis; osteosclerosis may be evident at an early age. Bone crises with severe pain and swelling can occur. Bleeding secondary to thrombocytopenia may manifest as epistaxis or bruising and is frequently overlooked until other symptoms become apparent. With the exception of the severely growth-stunted child, who may experience developmental delay secondary to the effects of chronic disease, development and intelligence are normal.



**Fig. 106.16** Pathways in the degradation of sphingolipids found in visceral organs and red or white blood cells. See also the legend for Figure 106.15. Fuc, fucose; NAcglc, N-acetylglucosamine.

The pathologic hallmark of Gaucher disease is the Gaucher cell in the reticuloendothelial system, particularly in the bone marrow (Fig. 106.19). These cells, which are 20–100  $\mu\text{m}$  in diameter, have a characteristic wrinkled paper appearance resulting from the presence of intracytoplasmic substrate inclusions. The cytoplasm of the Gaucher cell reacts strongly positive with the periodic acid–Schiff stain. The presence of this cell in bone marrow and tissue specimens is highly suggestive of Gaucher disease, although it also may be found in patients with granulocytic leukemia and myeloma.

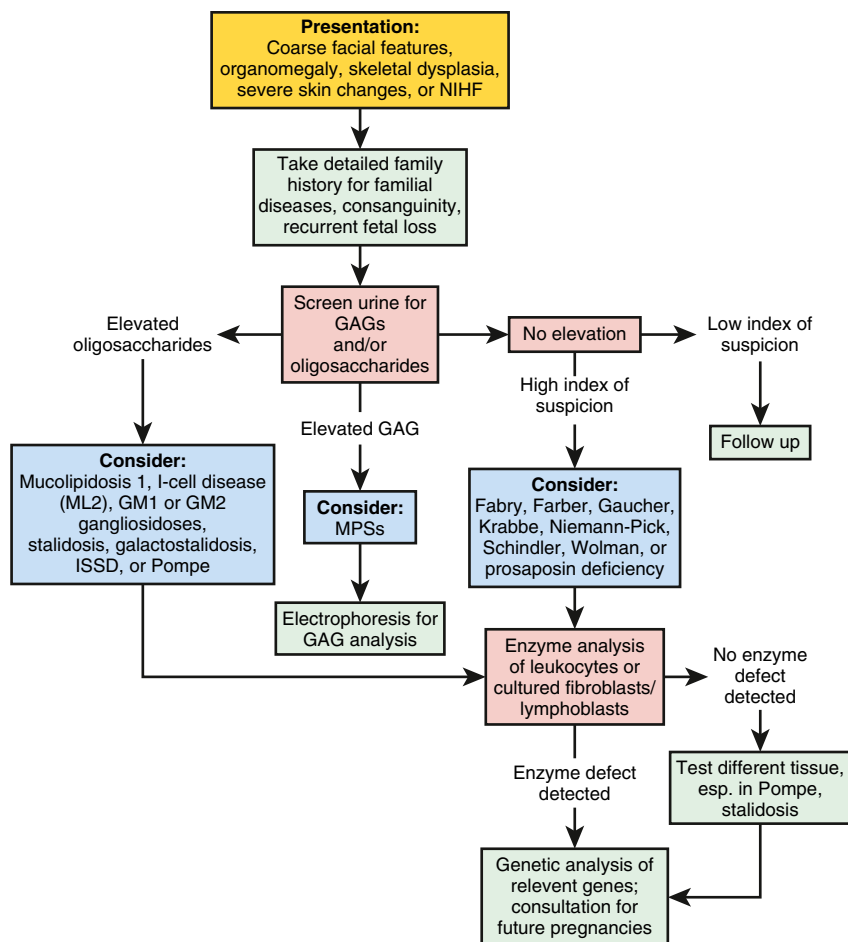
Gaucher disease type 2 is much less common and does not have an ethnic predilection. It is characterized by a rapid neurodegenerative course with extensive visceral involvement and death within the first years of life. It presents in infancy with increased tone, strabismus, and organomegaly. Failure to thrive and stridor caused by laryngospasm are typical. After a several-year period of psychomotor regression, death occurs secondary to respiratory compromise. Gaucher disease type 3 presents as clinical manifestations that are intermediate to those seen in types 1 and 2, with a presentation in childhood and death by age 10–15 years. It has a predilection for the Swedish Norrbottnian population, among which the incidence is about 1/50,000. Neurologic involvement is present. Type 3 disease is further classified as types 3a and 3b based on the extent of neurologic involvement and whether there is progressive myotonia and dementia (type 3a) or isolated supranuclear gaze palsy (type 3b).

Gaucher disease should be considered in the differential diagnosis of patients with unexplained organomegaly, who bruise easily, have bone pain, or have a combination of these conditions. Bone marrow examination usually reveals the presence of Gaucher cells. All suspected

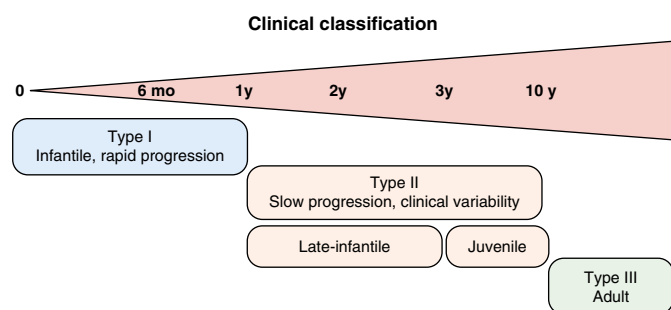
diagnoses should be confirmed by genetic testing or by determination of the acid  $\beta$ -glucosidase activity in isolated leukocytes or cultured fibroblasts. In Ashkenazi Jewish individuals, the identification of carriers can be achieved best by molecular testing for the common pathogenic variants. Testing should be offered to all family members, keeping in mind that heterogeneity, even among members of the same kindred, can be so great that asymptomatic affected individuals may be diagnosed. Prenatal diagnosis is available by determination of the specific family pathogenic variants and/or enzyme activity of chorionic villi or cultured amniotic fluid cells.

Treatment of patients with Gaucher disease type 1 includes enzyme replacement therapy, with recombinant acid  $\beta$ -glucosidase (imiglucerase). Most extraskeletal symptoms (organomegaly, hematologic indices) are reversed by enzymes (60 IU/kg) administered by intravenous infusion every other week. Monthly maintenance enzyme replacement improves bone structure, decreases bone pain, and induces compensatory growth in affected children. A small number of patients have undergone bone marrow transplantation, which can be curative but results in significant morbidity and mortality from the procedure, making the selection of appropriate candidates limited. Although enzyme replacement does not alter the neurologic progression of patients with Gaucher disease types 2 and 3, it has been used in selected patients as a palliative measure, particularly in type 3 patients with severe visceral involvement. Alternative treatments, including the use of agents designed to decrease the synthesis of glucosylceramide by chemical inhibition of glucosylceramide synthase, are available for patients who cannot be treated by enzyme replacement.





**Fig. 106.17** Algorithm of the clinical evaluation recommended for an infant with a suspected lysosomal storage disease. GAGs, Glycosaminoglycans; NIHF, nonimmune hydrops fetalis. (From Staretz-Chacham O, Lang TC, LaMarca ME, et al. *Lysosomal storage disorders in the newborn. Pediatrics.* 2009;123:1191–1207.)



**Fig. 106.18** Classification of GM1 gangliosidosis according to occurrence of the first symptom. (From Arash-Kaps L, Komlosi K, Seegräber M, et al. *The clinical and molecular spectrum of GM1 gangliosidosis. J Pediatr.* 2019;215:152–157.)

## NIEMANN-PICK DISEASE

Type A NPD is a fatal disorder of infancy characterized by failure to thrive, hepatosplenomegaly, and a rapidly progressive neurodegenerative course that leads to death by 2–3 years of age. Type B disease is a non-neuronopathic form observed in children and adults. Type C disease is a neuronopathic form that results from defective cholesterol transport. All subtypes are inherited as autosomal recessive traits and display variable clinical features (see [Tables 106.15 and 106.16](#)).

NPD types A and B result from the deficient activity of acid sphingomyelinase, a lysosomal enzyme encoded by the gene *SMPD1*. The enzymatic defect results in the pathologic accumulation of sphingomyelin, a

ceramide phospholipid, and other lipids in the monocyte-macrophage system as the primary pathologic site. The progressive deposition of sphingomyelin in the CNS results in the neurodegenerative course seen in type A and in non-neural tissue in the systemic disease manifestations of type B, including progressive lung disease in some patients. A variety of pathogenic variants in *SMPD1* that cause types A and B NPD have been identified.

The clinical manifestations and course of type A NPD is uniform and characterized by a normal appearance at birth. Hepatosplenomegaly, moderate lymphadenopathy, and psychomotor retardation are evident by 6 months of age, followed by neurodevelopmental regression and death by 3 years. With advancing age, the loss of motor function and the deterioration of intellectual capabilities are progressively debilitating with spasticity and rigidity and in later stages. Affected infants lose contact with their environment. In contrast to the stereotyped type A phenotype, the clinical presentation and course of patients with type B disease are more variable. Most are diagnosed in infancy or childhood when enlargement of the liver or spleen, or both, is detected during a routine physical examination. At diagnosis, type B NPD patients usually have evidence of mild pulmonary involvement, usually detected as a diffuse reticular or finely nodular infiltration on the chest radiograph. Pulmonary symptoms usually present in adulthood. In most patients, hepatosplenomegaly is particularly prominent in childhood, but with increasing linear growth, the abdominal protuberance decreases and becomes less conspicuous. In mildly affected patients, the splenomegaly may not be noted until adulthood, and there may be minimal disease manifestations.

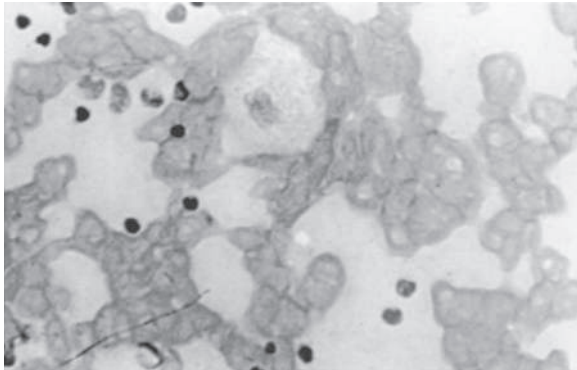
In some type B patients, decreased pulmonary diffusion caused by alveolar infiltration becomes evident in late childhood or early

**Table 106.17** Symptoms and Biochemical Signs in Three Clinical Forms of GM<sub>1</sub> Gangliosidosis

SYMPTOMS AND SIGNS	INFANTILE FORM	LATE-INFANTILE FORM	JUVENILE FORM
<b>CLINICAL SYMPTOMS</b>			
Coarse facial features	+	–	–
Cherry red macula spot	–/+	–	–
Cardiomyopathy	–/+	–/+	–
Hepatosplenomegaly	–/+	–	–
Cognitive decline	+	+	+
Dystonia	–/+	–/+	–/+
Ataxia	–/+	–/+	–/+
Pyramidal signs	+	+	–
<b>LABORATORY SIGNS</b>			
Increased oligosaccharides	+	–/+	–/+
Increased ASAT	–/+	–/+	–
Increased chitotriosidase activity	>1,000	>100–1,000	na

na, Not applicable.

From Arash-Kaps L, Komlosi K, Seegräber M, et al. The clinical and molecular spectrum of GM1 gangliosidosis. *J Pediatr.* 2019;215:152–157, Table II.



**Fig. 106.19** Cells from the spleen of a patient with Gaucher disease. A characteristic spleen cell is shown engorged with glucocerebroside.

adulthood and progresses with age. Severely affected individuals may experience significant pulmonary compromise by 15–20 years of age. Such patients have low  $P_{O_2}$  values and dyspnea on exertion. Life-threatening bronchopneumonias may occur, and *cor pulmonale* has been described. Severely affected patients may have liver involvement leading to life-threatening cirrhosis, portal hypertension, and ascites. Clinically significant pancytopenia caused by secondary hypersplenism may require partial or complete splenectomy; this should be avoided if possible because splenectomy frequently causes progression of pulmonary disease, which can be life-threatening. In general, type B patients do not have neurologic involvement and have a normal IQ. Some patients with type B disease have cherry red maculae or haloes and subtle neurologic symptoms that can include peripheral neuropathy.

Type C NPD patients often present with prolonged neonatal jaundice, appear normal for 1–2 years, and then experience a slowly progressive and variable neurodegenerative course. Their hepato-splenomegaly is less severe than that of patients with types A or B NPD, and they may survive into adulthood. The underlying biochemical defect in type C patients is an abnormality in cholesterol transport, leading to the accumulation of sphingomyelin and cholesterol in their lysosomes and a secondary partial reduction in acid sphingomyelinase activity (see Chapter 106.3).

In type B NPD patients, splenomegaly is usually the first manifestation detected. The splenic enlargement is noted in early childhood. In very mild disease, the enlargement may be subtle and detection may be delayed until adolescence or adulthood. The presence of the characteristic NPD cells in bone marrow aspirates supports the diagnosis of

type B NPD. Patients with type C NPD, however, also have extensive infiltration of NPD cells in the bone marrow, and thus all suspected cases should be evaluated genetically or enzymatically to confirm the clinical diagnosis by measuring the acid sphingomyelinase activity level in peripheral leukocytes, cultured fibroblasts, or lymphoblasts, or a combination of these cells. Patients with types A and B NPD have markedly decreased enzyme levels (1–10%), whereas patients with type C NPD have normal or mildly decreased acid sphingomyelinase activities. Without known genetic causes, the enzymatic identification of NPD carriers is problematic. In families in which the specific genetic lesion has been identified, however, family members can be accurately tested for heterozygote status by DNA analysis. Prenatal diagnosis of types A and B NPD can be made by genetic testing and reliably by the measurement of acid sphingomyelinase activity in cultured amniocytes or chorionic villi. Historically, the diagnosis of Niemann-Pick type C has relied on the demonstration of the cholesterol transport defect in cultured fibroblasts by filipin staining but is now readily accomplished by genetic testing of the *NPC1* and *NPC2* genes and the measurement of oxidative cholesterol metabolites. There is no conclusive treatment for types A and B NPD. Orthotopic liver transplantation in an infant with type A disease and amniotic cell transplantation in several type B NPD patients have been attempted with little or no success. Bone marrow transplantation in a small number of type B NPD patients has been shown to be successful in reducing the spleen and liver volumes, the sphingomyelin content of the liver, the number of Niemann-Pick cells in the marrow, and radiologically detected infiltration of the lungs. In one patient, liver biopsies taken up to 33 months after transplantation showed only a moderate reduction in stored sphingomyelin. Lung transplantation has not been performed in any severely compromised patient with type B disease, although two patients who underwent whole lung lavages with variable results have been reported. Enzyme replacement therapy (ERT) with recombinant human acid sphingomyelinase (olipudase alpha) is in clinical trials for the treatment of NPD type B. A 26-week phase 1b study in adult patients with NPD B established initial proof of concept in this patient group. In a phase 1/2 pediatric trial (ASCEND-Peds/NCT02292654) in children with chronic acid sphingomyelinase deficiency (ASMD), olipudase alfa was generally well-tolerated with improvements in disease pathology, and a phase 1/2 clinical trial in pediatric patients and a randomized phase 2/3 trial in adults (ASCEND) with ASMD documented improvement in lung function and spleen size.

Clinical trials of miglustat (Actelion, Basel, Switzerland) have been performed, and the drug has been approved in Europe for the treatment of type C disease. Treatment of type A disease with bone marrow transplantation has not been successful, presumably because of severe neurologic involvement.

## FABRY DISEASE

Fabry disease is an X-linked inborn error of glycosphingolipid metabolism characterized by angiokeratomas (telangiectatic skin lesions); hypohidrosis; corneal and lenticular opacities; acroparesthesias; and vascular disease of the kidney, heart, and/or brain (see Table 106.15). The classic phenotype is caused by deficient activity of the enzyme  $\alpha$ -galactosidase A and has an estimated prevalence of approximately 1/50,000 males. Later-onset affected males with residual  $\alpha$ -galactosidase A activity may present with cardiac and/or renal disease, including hypertrophic cardio-myopathy and renal failure, and is more prevalent than the classic phenotype. Heterozygous females for the classic phenotype can be either asymptomatic or as severely affected as the males—the variability is a result of random X-inactivation. The disease results from pathogenic variants in  $\alpha$ -galactosidase A encoded by the X-linked *GLA* gene. The enzymatic defect leads to the systemic accumulation of neutral glycosphingolipids, primarily globotriaosylceramide, particularly in the plasma and lysosomes of vascular endothelial and smooth muscle cells. The progressive vascular glycosphingolipid deposition in classically affected males results in ischemia and infarction, leading to the major disease manifestations. The cDNA and genomic sequences encoding  $\alpha$ -galactosidase A have identified more than 500 different pathogenic variants in the  $\alpha$ -galactosidase A gene that are responsible for this lysosomal storage disease, including amino acid substitutions, gene rearrangements, and mRNA splicing defects.

Affected males with the classic phenotype have the skin lesions, acroparesthesias, hypohidrosis, and ocular changes, whereas males with the later-onset phenotypes lack these findings and present with cardiac and/or renal disease in adulthood (Table 106.18). The classic angiokeratomas usually occur in childhood and may lead to early diagnosis (Fig. 106.20). They increase in size and number with age and range from barely visible to several millimeters in diameter. The lesions are punctate, dark red to blue-black, and flat or slightly raised. They do not blanch with pressure, and the larger ones may show slight hyperkeratosis. Characteristically, the lesions are most dense between the umbilicus and knees, in the “bathing trunk area,” but may occur anywhere, including the oral mucosa. The hips, thighs, buttocks, umbilicus, lower abdomen, scrotum, and glans penis are common sites, and there is a tendency toward symmetry. Variants without skin lesions have been described. Sweating is usually decreased or absent. Corneal opacities and characteristic lenticular lesions, observed under slit-lamp examination, are present in affected males and in about 90% of heterozygotes. Conjunctival and retinal vascular tortuosity is common and results from the systemic vascular involvement.

Pain is the most debilitating symptom in childhood and adolescence. Fabry crises, lasting from minutes to several days, consist of agonizing, burning pain in the hands, feet, and proximal extremities and are usually associated with exercise, fatigue, fever, or a combination of these factors. These painful acroparesthesias usually become less frequent in the third and fourth decades of life, although in some men, they may become more frequent and severe. Attacks of abdominal or flank pain may simulate appendicitis or renal colic.

The major morbid symptoms result from the progressive involvement of the vascular system. Early in the course of the disease, casts, red cells, and lipid inclusions with characteristic birefringent “Maltese crosses” appear in the urinary sediment. Proteinuria, isosthenuria, and gradual deterioration of renal function and development of azotemia occur in the second through fourth decades. Cardiovascular findings may include hypertension, left ventricular hypertrophy, anginal chest pain, myocardial ischemia or infarction, and heart failure. Mitral insufficiency is the most common valvular lesion. Abnormal electrocardiographic and echocardiographic findings are common. Cerebrovascular manifestations result from multifocal small vessel involvement. Other features may include

**Table 106.18** Summary of Reported Clinical Manifestations in Fabry Patients (Newborn to 4 Yr)

FABRY-RELATED SIGNS AND SYMPTOMS	EARLIEST REPORT OF SYMPTOM
Storage of globotriaosylceramide found in organs on biopsy	Prenatal
Corneal whorls/verticillata	Prenatal/newborn
Gastrointestinal problems, including nausea, vomiting, diarrhea, constipation, and abdominal pain	1.0 yr
Slow growth in boys (mean height/weight <50th percentile)	2.0 yr
Intermittent acroparesthesia/neuropathic pain triggered by stress, heat, fatigue, or exercise	2.0 yr
Hypohidrosis or anhidrosis	2.5 yr
Fabry crises of agonizing neuropathic pain typically begin in the hands and feet and may radiate proximally	2.5 yr
Heat, cold, and/or exercise intolerance	3.5 yr
Retinal vascular tortuosity	4.0 yr
Tinnitus/vertigo	4.0 yr
Low glomerular filtration rate	4.0 yr
T-wave inversion on electrocardiogram	4.0 yr
Trivial cardiac valve disease	4.0 yr
Angiokeratoma	4.4 yr

From Laney DA, Peck DS, Atherton AM, et al. Fabry disease in infancy and early childhood: A systematic literature review. *Genetics Med.* 2015;17(5):323–330, Table 2.



**Fig. 106.20** Typical angiokeratomas. Angiokeratomas are quite large and easily recognizable, but if only a few lesions exist or they are restricted only to the genitals or umbilical regions, they can be easily missed. (From Zarate VA, Hopkin RJ. *Fabry's disease.* *Lancet.* 2008;372:1427.)

chronic bronchitis and dyspnea, lymphedema of the legs without hypoproteinemia, episodic diarrhea, osteoporosis, retarded growth, and delayed puberty. Death most often results from uremia or vascular disease of the heart or brain. Before hemodialysis or renal transplantation, the mean age at death for affected men was 40 years. Patients with the later-onset phenotype with residual  $\alpha$ -galactosidase A activity have cardiac and/or renal disease. The



**Table 106.19** Common Misdiagnoses for Fabry Disease

<b>INFLAMMATORY</b>
Systemic lupus erythematosus
Rheumatic fever
Fibromyalgia
Dermatomyositis
Raynaud phenomenon
Raynaud syndrome
C1 esterase deficiency
TNF receptor–associated periodic syndrome (TRAPS)
Joint and recurrent fever syndromes (juvenile idiopathic arthritis, familial Mediterranean fever)
Erythromelalgia
<b>NEUROLOGIC</b>
Porphyria
Guillain-Barre syndrome
Hereditary neuropathies
Nutritional neuropathies
Uremic neuropathy
Diabetic neuropathy
Polyneuropathy
Meniere disease
Complex regional pain syndromes
Multiple sclerosis
Mitochondrial disorders
Migraine
<b>MELAS</b>
<b>CADASIL</b>
<b>GASTROINTESTINAL/NUTRITION</b>
Irritable bowel syndrome
Appendicitis
Metabolic bone disease (rickets, uremia, scurvy)
Crohn disease
Celiac disease
Peptic ulcer disease
<b>OTHER</b>
Growing pains
Chronic overlapping pain syndrome
Malingering
Coronary heart disease
Osler-Weber-Rendu disease
Cardiomyopathy
Gaucher disease

MELAS, Mitochondrial encephalopathy lactic acidosis, strokelike symptoms; CADASIL, cerebral autosomal dominant arteriopathy with subcortical infarcts and leukoencephalopathy.

cardiac manifestations include hypertrophy of the left ventricular wall and interventricular septum and electrocardiographic abnormalities consistent with cardiomyopathy. Others have had hypertrophic cardiomyopathy or myocardial infarction, or both.

The diagnosis in classically affected males is most readily made from the history of painful acroparesthesias, hypohidrosis, the presence of characteristic skin lesions, and the observation of the characteristic corneal opacities and lenticular lesions. The disorder is often misdiagnosed as rheumatic fever, erythromelalgia, or neurosis (Table 106.19). The skin lesions must be differentiated from the benign angiokeratomas of the scrotum (Fordyce disease) or from angiokeratoma circumscriptum. Angiokeratomas identical to those of Fabry disease have been reported in fucosidosis, aspartylglycosaminuria, late-onset GM<sub>1</sub> gangliosidosis, galactosialidosis,  $\alpha$ -N-acetylgalactosaminidase deficiency, and sialidosis. Later-onset

patients have been identified among patients on hemodialysis and among patients with hypertrophic cardiomyopathy or who have suffered cryptogenic strokes. Later-onset patients lack the early classic manifestations such as the angiokeratomas, acroparesthesias, hypohidrosis, and corneal opacities. The diagnosis of classic and later-onset patients is confirmed biochemically by the demonstration of markedly decreased  $\alpha$ -galactosidase A activity in plasma, isolated leukocytes, or cultured fibroblasts or lymphoblasts.

Heterozygous females may have corneal opacities, isolated skin lesions, and intermediate activities of  $\alpha$ -galactosidase A in plasma or cells. Rare female heterozygotes may have manifestations as severe as those in affected males. Asymptomatic at-risk females in families affected by Fabry disease, however, should be optimally diagnosed by the direct analysis of their family's specific pathogenic variant. Prenatal detection of affected males can be accomplished by the demonstration of deficient  $\alpha$ -galactosidase A activity or the family's specific gene pathogenic variant in chorionic villi obtained in the first trimester or in cultured amniocytes obtained by amniocentesis in the second trimester of pregnancy. Fabry disease can be detected by newborn screening, and pilot studies have been conducted in Italy and Taiwan.

Treatment for Fabry disease may include the use of phenytoin and/or carbamazepine to decrease the frequency and severity of the chronic acroparesthesias and the periodic crises of excruciating pain. Renal transplantation and long-term hemodialysis are lifesaving procedures for patients with renal failure.

Recombinant  $\alpha$ -galactosidase is a safe and effective ERT of choice for Fabry disease at a dose of 1 mg/kg every other week. It has been shown to clear microvascular endothelial deposits of globotriaosylceramide from the kidneys, heart, and skin in patients with Fabry disease with stabilization of renal disease, regression of hypertrophic cardiomyopathy, reduction of pain, and improvement in quality of life. Migalstat, a protein-folding chaperone therapy, is an oral treatment for Fabry that can both be used as a first-line therapy in ERT-naïve patients and as an alternative to ERT in patients with a migalstat-amenable pathogenic variant.

## FUCOSIDOSIS

This is a rare autosomal recessive disorder caused by the deficient activity of  $\alpha$ -fucosidase and the accumulation of fucose-containing glycosphingolipids, glycoproteins, and oligosaccharides in the lysosomes of the liver, brain, and other organs (see Table 106.15).  $\alpha$ -Fucosidase is encoded by the *FUCA1* gene, and specific pathogenic variants are known. Although the disorder is panethnic, most affected patients are from Italy and the United States. There is wide variability in the clinical phenotype, with the most severely affected patients presenting in the first year of life with developmental delay and somatic features similar to those of the mucopolysaccharidoses. These features include frontal bossing, hepatosplenomegaly, facial features, and macroglossia. The CNS storage results in a relentless neurodegenerative course, with death in childhood. Patients with milder disease have angiokeratomas and longer survival. No specific therapy exists for the disorder, which can be diagnosed by the demonstration of pathogenic variants in *FUCA1* or deficient  $\alpha$ -fucosidase activity in peripheral leukocytes or cultured fibroblasts. Carrier identification studies and prenatal diagnosis are possible by determination of the enzymatic activity or the specific family pathogenic variants.

## SCHINDLER DISEASE

Schindler disease is an autosomal recessive neurodegenerative disorder that results from the deficient activity of  $\alpha$ -N-acetylgalactosaminidase and the accumulation of sialylated and asialoglycopeptides and oligosaccharides (see Table 106.15). The enzyme is encoded by the gene *NAGA*. The disease is clinically heterogeneous, and two major phenotypes have been identified. Type I disease is an infantile-onset neuroaxonal dystrophy. Affected



infants have normal development for the first 9-15 months of life followed by a rapid neurodegenerative course that results in severe intellectual disability, cortical blindness, and frequent myoclonic seizures. Type II disease is characterized by a variable age at onset, mild retardation, and angiokeratomas. There is no specific therapy for either form of the disorder. The diagnosis is by demonstration of the enzymatic deficiency in leukocytes or cultured skin fibroblasts or specific gene pathogenic variants.

### METACHROMATIC LEUKODYSTROPHY (MLD)

This is an autosomal recessive white matter disease caused by a deficiency of arylsulfatase A (ASA) encoded by the gene *ARSA*, which is required for the hydrolysis of sulfated glycosphingolipids. Another form of MLD is caused by a deficiency of a sphingolipid activator protein (SAP1) encoded by the gene *PSAP*, which is required for the formation of the substrate-enzyme complex. The deficiency of this enzymatic activity results in the white matter storage of sulfated glycosphingolipids, which leads to demyelination and a neurodegenerative course. Pathogenic variants fall into two groups that correlate with disease severity.

The clinical manifestations of the late infantile form of MLD, which is most common, usually present between 12 and 18 months of age as irritability, inability to walk, and hyperextension of the knee, causing genu recurvatum. The clinical progression of the disease relates to the pathologic involvement of both central and peripheral nervous systems, giving a mixture of upper and lower motor neuron and cognitive and psychiatric signs. Deep tendon reflexes are diminished or absent. Gradual muscle wasting, weakness, and hypotonia become evident and lead to a debilitated state. As the disease progresses, nystagmus, myoclonic seizures, optic atrophy, and quadriplegia appear, with death in the first decade of life (see Table 106.15). The juvenile form of the disorder has a more indolent course with an onset that may occur as late as 20 years of age. This form of the disease presents with gait disturbances, mental deterioration, urinary incontinence, and emotional difficulties. The adult form, which presents after the second decade, is similar to the juvenile form in its clinical manifestations, although emotional difficulties and psychosis are more prominent features. Dementia, seizures, diminished reflexes, and optic atrophy also occur in both the juvenile and adult forms. The pathologic hallmark of MLD is the deposition of metachromatic bodies, which stain strongly positive with periodic acid-Schiff and Alcian blue, in the white matter of the brain. Neuronal inclusions may be seen in the midbrain, pons, medulla, retina, and spinal cord; demyelination occurs in the peripheral nervous system. Bone marrow transplantation has resulted in normal enzymatic levels in peripheral blood but there is no clear evidence for clinical efficacy in terms of the neurologic course; supportive care remains the primary intervention. Lentiviral transduced ex vivo autologous stem and progenitor cells with human arylsulfatase cDNA treatment has resulted in sustained and clinically important benefits in children with early onset disease. Cognitive function has been preserved, as has motor development in preliminary trials.

The diagnosis of MLD should be suspected in patients with the clinical features of leukodystrophy. Decreased nerve conduction velocities, increased cerebrospinal fluid protein, metachromatic deposits in sampled segments of the sural nerve, and metachromatic granules in urinary sediment are all suggestive of MLD. Confirmation of the diagnosis is based on the demonstration of pathogenic variants in *ARSA* or reduced activity of ASA in leukocytes or cultured skin fibroblasts. Sphingolipid activator protein deficiency is diagnosed by genetic testing of *PSAP* or by measuring the concentration of SAP1 in cultured fibroblasts using a specific antibody to the protein. Carrier detection and prenatal diagnosis are available for all forms of the disorder.

### MULTIPLE SULFATASE DEFICIENCY

This is an autosomal recessive disorder that results from the enzymatic deficiency of at least nine sulfatases including arylsulfatases A, B, and C and iduronate-2-sulfatase. The specific defect has been shown to be an enzyme in the C- $\alpha$ -formylglycine generating system encoded by the gene *SUMF1*, which introduces a common posttranslational modification in all of the affected sulfatases and explains the occurrence of these multiple enzyme defects. Because of the deficiency of these enzymes, sulfatides, mucopolysaccharides, steroid sulfates, and gangliosides accumulate in the cerebral cortex and visceral tissues, resulting in a clinical phenotype with features of leukodystrophy as well as those of the mucopolysaccharidoses. Severe ichthyosis may also occur. Carrier testing and prenatal diagnosis by measurement of the enzymatic activities can be performed. There is no specific treatment for multiple sulfatase deficiency other than supportive care.

### KRABBE DISEASE

This condition, also called *globoid cell leukodystrophy*, is an autosomal recessive fatal disorder of infancy. It results from the deficiency of the enzymatic activity of galactocerebrosidase encoded by the *GALC* gene, leading to white matter accumulation of galactosylceramide, which is normally found almost exclusively in the myelin sheath. Both peripheral and central myelin are affected, resulting in spasticity and cognitive impairment coupled with deceptively normal or even absent deep tendon reflexes. Specific disease-causing pathogenic variants are known. The infantile form of Krabbe disease is rapidly progressive, and patients present in early infancy with irritability, seizures, and hypertonia (see Table 106.16). Optic atrophy is evident in the first years of life, and cognitive development is severely impaired. As the disease progresses, optic atrophy and severe developmental delay become apparent; affected children exhibit opisthotonos and typically die before 3 years of age. A second, late infantile form of Krabbe disease also exists, and patients present after the age of 2 years. Affected individuals, however, have a disease course similar to that of the early infantile form.

The diagnosis of Krabbe disease relies on the demonstration of the specific pathogenic variants or by enzymatic deficiency in white blood cells or cultured skin fibroblasts. Carrier identification and prenatal diagnosis are available. The development of methods to measure *GALC* activity on dried blood spots has led to the inclusion of Krabbe disease in the newborn screening programs of some states. Treatment of infants with Krabbe disease with umbilical cord blood cell transplantation has been reported in prenatally identified asymptomatic newborns and symptomatic infants. The long-term outcome of umbilical cord blood cell transplantation is being evaluated; transplanted infants develop neurologic manifestations at a slower rate but succumb to a neurologic demise.

### FARBER DISEASE

This is a rare autosomal recessive disorder that results from the deficiency of the lysosomal enzyme acid ceramidase and the accumulation of ceramide in various tissues, especially the joints. Symptoms can begin as early as the first year of life with painful joint swelling and nodule formation (Fig. 106.21), which is sometimes diagnosed as rheumatoid arthritis. As the disease progresses, nodule or granulomatous formation on the vocal cords can lead to hoarseness and breathing difficulties; failure to thrive is common. In some patients, moderate CNS dysfunction is present (see Table 106.16). Patients may die of recurrent pneumonias in their teens; there is currently no specific therapy. The diagnosis of this disorder should be suspected in patients who have nodule formation over the joints but no other findings of rheumatoid arthritis. In such patients, ceramidase activity should be determined in cultured skin fibroblasts or peripheral leukocytes. Various disease-causing pathogenic variants have been identified in the gene encoding acid ceramidase (*ASAH1*). Carrier detection and prenatal diagnosis are



**Fig. 106.21** Forearm of an 18-month old girl with Farber disease. Note the painful joint swelling and the nodule formation. The infant was suspected of having rheumatoid arthritis.

available. There is no specific treatment, but a recombinant human acid ceramidase is under development.

### WOLMAN DISEASE AND CHOLESTEROL ESTER STORAGE DISEASE (CESD)

These are autosomal recessive lysosomal storage diseases that result from the deficiency of lysosomal acid lipase and the accumulation of cholesterol esters and triglycerides in histiocytic foam cells of most visceral organs. Wolman disease is the more severe clinical phenotype and is a fatal disorder of infancy. Clinical features become apparent in the first weeks of life and include failure to thrive, relentless vomiting, abdominal distention, steatorrhea, and hepatosplenomegaly (see Table 106.15). There usually is hyperlipidemia. Hepatic dysfunction and fibrosis may occur. Calcification of the adrenal glands is pathognomonic for the disorder. Death usually occurs within 6 months.

CESD is a less severe disorder that may not be diagnosed until adulthood. Hepatomegaly can be the only detectable abnormality, but affected individuals are at significant risk for premature atherosclerosis. Adrenal calcification is not a feature.

Lysosomal acid lipase is encoded by the *LIPA* gene. Diagnosis and carrier identification can be performed by genetic testing or by measuring acid lipase activity in peripheral leukocytes or cultured skin fibroblasts. Prenatal diagnosis can use pathogenic variants or enzyme levels in cultured chorionic villi or amniocytes. Pharmacologic agents to suppress cholesterol synthesis, in combination with cholestyramine and diet modification, have been used in patients with CESD (see Chapter 106.3). Sebelipase alfa (Kanuma) is a commercially available recombinant human lysosomal acid lipase that is approved in the European Union (EU), the United States, and Japan as a long-term ERT for patients diagnosed with LAL deficiency.

Visit Elsevier eBooks+ at [eBooks.Health.Elsevier.com](https://www.elsevier.com/ebooks) for Bibliography.

## 106.5 Mucopolysaccharidoses

Margaret M. McGovern and Robert J. Desnick

I-cell disease (mucopolipidosis II [ML-II]) and pseudo-Hurler polydystrophy (mucopolipidosis III [ML-III]) are rare autosomal recessive

disorders that share some clinical features with Hurler syndrome (see Chapter 109). These diseases result from the abnormal transport of newly synthesized lysosomal enzymes that are normally targeted to the lysosome by the presence of mannose-6-phosphate residues and recognized by specific lysosomal membrane receptors. These mannose-6-phosphate recognition markers are synthesized in a two-step reaction that occurs in the Golgi apparatus and is mediated by two enzymatic activities. The enzyme that catalyzes the first step, the UDP-N-acetylglucosamine:lysosomal enzyme N-acetylglucosamine-1-phosphotransferase, is defective in both ML-II and ML-III, which are allelic disorders resulting from pathogenic variants in the GlcNAc-phosphotransferase alpha/beta-subunits precursor gene (*GNPTAB*). This enzyme deficiency results in the lack of mannose-6-phosphate tagging of lysosomal enzymes to result in disrupted targeting to the lysosome, and they are consequently secreted into the extracellular matrix. Because the lysosomal enzymes require the acidic medium of the lysosome to function, patients with this defect accumulate a variety of different substrates because of the intracellular deficiency of all lysosomal enzymes. The diagnosis of ML-II and ML-III can be made by genetic testing of the *GNPTAB* gene, determination of the serum lysosomal enzymatic activities, which are elevated, or by the demonstration of reduced enzymatic activity levels in cultured skin fibroblasts. Direct measurement of the phosphotransferase activity is possible as well. Prenatal diagnosis is available for both disorders using familial pathogenic variants or by measurement of lysosomal enzymatic activities in amniocytes or chorionic villus cells; carrier identification studies are available for both disorders using cultured skin fibroblasts. Neonatal screening by tandem mass spectroscopy may detect I-cell disease.

### I-CELL DISEASE

This disorder shares many of the clinical manifestations of Hurler syndrome (see Chapter 109), although there is no mucopolysacchariduria and the presentation is earlier (see Table 106.16). Some patients have clinical features evident at birth, including coarse facial features, craniofacial abnormalities, restricted joint movement, and hypotonia. Nonimmune hydrops may be present prenatally. The remainder of patients present in the first year with severe psychomotor retardation, coarse facial features, and skeletal manifestations that include kyphoscoliosis and a lumbar gibbus. Patients may also have congenital dislocation of the hips, inguinal hernias, and gingival hypertrophy. Progressive, severe intellectual disability leads to death in early childhood. No treatment is available.

### PSEUDO-HURLER POLYDYSTROPHY

Pseudo-Hurler polydystrophy is a less severe disorder than I-cell disease, with later onset and survival to adulthood reported. Affected children may present around the age of 4 or 5 years of age with joint stiffness and short stature. Progressive destruction of the hip joints and moderate dysostosis multiplex are evident. Radiographic evidence of low iliac wings, flattening of the proximal femoral epiphyses with valgus deformity of the femoral head, and hypoplasia of the anterior third of the lumbar vertebrae are characteristic findings. Ophthalmic findings include corneal clouding, retinopathy, and astigmatism; visual complaints are uncommon (see Tables 106.15 and 106.16). Some patients have learning disabilities or mental retardation. Treatment, which should include orthopedic care, is symptomatic.

Visit Elsevier eBooks+ at [eBooks.Health.Elsevier.com](https://www.elsevier.com/ebooks) for Bibliography.

## Chapter 107

## Defects in Metabolism of Carbohydrates

Ghada Hijazi and Priya S. Kishnani

Carbohydrate synthesis and degradation provide the energy required for most metabolic processes. The important carbohydrates include three monosaccharides—glucose, galactose, and fructose—and a polysaccharide, glycogen. **Figure 107.1** shows the relevant biochemical pathways of these carbohydrates. **Glucose** is the principal substrate of energy metabolism, continuously available through dietary intake, glycogenolysis (breakdown of glycogen), and gluconeogenesis (glucose made de novo from amino acids, primarily alanine). Metabolism of glucose generates adenosine triphosphate (ATP) via glycolysis (conversion of glucose or glycogen to pyruvate), mitochondrial oxidative phosphorylation (conversion of pyruvate to carbon dioxide and water), or both. Dietary sources of glucose come from polysaccharides, primarily starch, and the disaccharides lactose, maltose, and sucrose. However, oral intake of glucose is intermittent and unreliable. Hepatic glycogenolysis provides the rapid release of glucose and is the most significant factor in maintaining euglycemia (normal levels of glucose in the blood). **Glycogen** is also the primary stored energy source in muscle, providing glucose for muscle activity during exercise. Gluconeogenesis contributes to maintaining euglycemia but is less immediate. Galactose and fructose are monosaccharides that provide fuel for cellular metabolism, though their role is less significant than that of glucose. **Galactose** is derived from lactose (galactose + glucose), which is found in milk and milk products. Galactose is an important energy source in infants. Galactose (exogenous or endogenously synthesized from glucose) is also an important component of certain glycolipids, glycoproteins, and glycosaminoglycans. The dietary sources of **fructose** are fruits, vegetables, and honey. It is also found in the disaccharide sucrose (fructose + glucose) and the sugar alcohol sorbitol.

Defects in glycogen metabolism typically cause an accumulation of glycogen in the tissues, thus the name **glycogen storage disease** (**Table 107.1**). Defects in gluconeogenesis or the glycolytic pathway, including galactose and fructose metabolism, do not result in an accumulation of glycogen (see **Table 107.1**). The defects in pyruvate metabolism in the pathway of the conversion of pyruvate to carbon dioxide and water via mitochondrial oxidative phosphorylation are more often associated with **lactic acidosis**.

### 107.1 Glycogen Storage Diseases

Ghada Hijazi and Priya S. Kishnani

The disorders of glycogen metabolism, the glycogen storage diseases (GSDs), result from deficiencies of enzymes or transport proteins in the pathways of glycogen metabolism (see **Fig. 107.1**). Glycogen found in these disorders is abnormal in quantity, quality, or both. GSDs are categorized by numerical type in accordance with the chronological order in which these enzymatic defects were identified. This numerical classification is still widely used, at least up to number VII. The GSDs can also be classified by organ involvement into liver and muscle glycogenoses (see **Table 107.1**).

There are more than 15 forms of GSDs. Glucose-6-phosphatase deficiency (type I), lysosomal acid  $\alpha$ -glucosidase deficiency (type II), debrancher deficiency (type III), branching enzyme deficiency (type IV), liver phosphorylase deficiency (type VI), and liver phosphorylase kinase deficiency (type IX) are the most common of those that typically

present in early childhood. Myophosphorylase deficiency (type V, McArdle disease) is the most common in adolescents and adults. The cumulative frequency of all forms of GSD is approximately 1 in 10,000–25,000 live births.

#### LIVER GLYCOGENOSES

The GSDs that principally affect the liver include glucose-6-phosphatase deficiency (**type I**), debranching enzyme deficiency (**type III**), branching enzyme deficiency (**type IV**), liver phosphorylase deficiency (**type VI**), phosphorylase kinase deficiency (**type IX**), glycogen synthase deficiency (**type 0**), and glucose transporter-2 (GLUT2) defect (Fanconi-Bickel syndrome). Because hepatic carbohydrate metabolism is responsible for plasma glucose homeostasis, this group of disorders typically causes fasting hypoglycemia and hepatomegaly. Some GSDs (types III, IV, VI, IX) can be associated with liver fibrosis and cirrhosis. Other organs can also be involved and may manifest as renal dysfunction in type I; myopathy (skeletal and/or cardiomyopathy) in types III, IV, and some rare forms of phosphorylase kinase deficiency; and neurologic involvement in types III (peripheral nerves) and IV (diffuse central and peripheral nervous system dysfunction).

#### Type I Glycogen Storage Disease (Glucose-6-Phosphatase or Translocase Deficiency, von Gierke Disease)

Type I GSD is caused by the absence or deficiency of **glucose-6-phosphatase activity** in the liver, kidney, and intestinal mucosa. It has two subtypes: **type Ia**, in which the defective enzyme is glucose-6-phosphatase, and **type Ib**, in which the defective enzyme is a **translocase** that transports glucose-6-phosphate across the microsomal membrane. Deficiency of the enzymes in both types Ia and Ib lead to inadequate hepatic conversion of glucose-6-phosphate to glucose through normal glycogenolysis and gluconeogenesis, resulting in fasting hypoglycemia.

Type I GSD is an autosomal recessive disorder. The gene for subtype Ia is *G6PC*, and the gene for subtype Ib is *SLC37A4*. Common pathogenic variants have been identified in different ancestral populations. Carrier detection and prenatal diagnosis are possible with DNA-based methodologies.

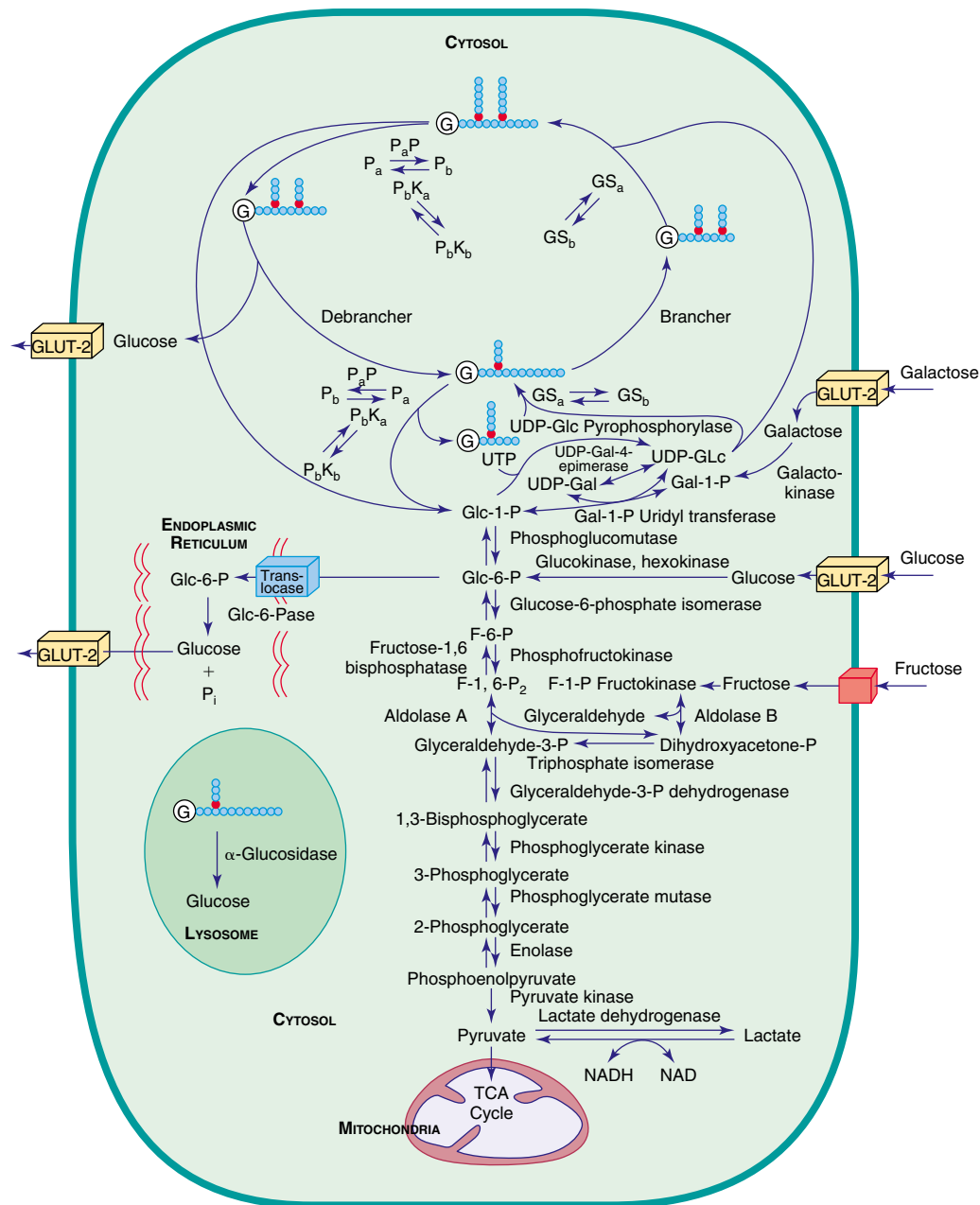
#### Clinical Manifestations

Patients with type I GSD may present in the neonatal period with hypoglycemia and lactic acidosis, but more often present at 3–4 months of age because of increased intervals between feeds and at time of weaning. Infants can present with hepatomegaly, hypoglycemic seizures, or both. Affected children are often described as having “**doll-like**” faces with full cheeks, relatively thin extremities, short stature, and a protuberant abdomen that is a consequence of massive hepatomegaly. The kidneys are also enlarged, whereas the spleen and heart are not involved.

Intermittent diarrhea may occur in GSD I. In patients with GSD Ib, diarrhea appears to be caused by the loss of mucosal barrier function via inflammation, which is likely related to glycogen-mediated impairment of neutrophil function. Easy bruising and epistaxis are common and are associated with a **prolonged bleeding time** as a result of impaired platelet aggregation and adhesion. A von Willebrand factor–like deficiency and/or dysfunction has also been found in GSD Ia patients.

The biochemical characteristics of type I GSD are hypoglycemia, lactic acidosis, hyperuricemia, and hyperlipidemia. Hypoglycemia and lactic acidosis can develop even after short fasts. Hyperuricemia is present in young children and rarely progresses to symptomatic gout before puberty. Despite marked hepatomegaly, the liver transaminase levels are usually normal or only slightly elevated. The plasma may be “milky” in appearance due to strikingly elevated triglyceride levels. Cholesterol and phospholipids are also elevated, albeit less prominently. The lipid abnormality resembles type IV hyperlipidemia and is characterized by increased levels of very low-density lipoprotein, low-density lipoprotein, and a unique apolipoprotein profile consisting of increased levels of apolipoproteins B, C, and E, with relatively normal or reduced levels of apolipoproteins A and D. The histologic appearance of the liver is characterized by a universal distention of hepatocytes by glycogen and





**Fig. 107.1** Pathway related to glycogen storage diseases and galactose and fructose disorders. G, Glycogenin, the primer for glycogen synthesis; GLUT-2, glucose transporter 2; GS<sub>a</sub>, active glycogen synthase; GS<sub>b</sub>, inactive glycogen synthase; NAD/NADH, nicotinamide adenine dinucleotide; P<sub>a</sub>, active phosphorylase; P<sub>a</sub>P, phosphorylase a phosphatase; P<sub>b</sub>, inactive phosphorylase; P<sub>b</sub>K<sub>a</sub>, active phosphorylase b kinase; P<sub>b</sub>K<sub>b</sub>, inactive phosphorylase b kinase; UDP, uridine diphosphate. (Adapted from Beaudet AR. *Glycogen storage disease*. In: Harrison TR, Isselbacher KJ, eds. *Harrison's Principles of Internal Medicine*, 13th ed. New York: McGraw-Hill; 1994.)

fat. The lipid vacuoles are particularly large and prominent, and there is no associated liver fibrosis.

Although type I GSD affects mainly the liver, multiple organ systems are involved. **Delayed puberty** is often seen. Females can have ultrasound findings consistent with **polycystic ovaries**, even though other features of polycystic ovary syndrome (acne, hirsutism) are not seen. Nonetheless, fertility appears to be normal, as evidenced in several reports of successful pregnancy in women with GSD I. Increased bleeding during menstrual cycles, including life-threatening menorrhagia, has been reported and could be related to the impaired platelet aggregation. Symptoms of gout usually start around puberty from long-term hyperuricemia. There is an increased risk of **pancreatitis**, secondary to the lipid abnormalities. The dyslipidemia, together with elevated erythrocyte aggregation, could predispose these patients to atherosclerosis,

but premature atherosclerosis has not yet been clearly documented except in rare cases. Impaired platelet aggregation and increased antioxidant defense to prevent lipid peroxidation may function as protective mechanisms to help reduce the risk of atherosclerosis. Frequent fractures and radiographic evidence of **osteopenia** are common, and bone mineral content is reduced, even in prepubertal patients.

By the second or third decade of life, some patients with type I GSD develop **hepatic adenomas** that can hemorrhage and become malignant in some cases. **Pulmonary hypertension** has been seen in some long-term survivors of the disease. Iron-refractory anemia and an increased prevalence of thyroid autoimmunity are also being recognized.

**Renal disease** is another late complication, and most patients with type I GSD over 20 years of age have proteinuria. Glomerular



**Table 107.1** Features of the Disorders of Carbohydrate Metabolism

DISORDERS	BASIC DEFECTS	CLINICAL PRESENTATION	COMMENTS
<b>LIVER GLYCOGENOSES</b>			
<i>Type/Common Name</i>			
Ia/von Gierke	Glucose-6-phosphatase complex	Growth retardation, hepatomegaly, hypoglycemia; elevated blood lactate, cholesterol, triglyceride, and uric acid levels	Common, severe hypoglycemia. Adulthood: hepatic adenomas and risk for carcinoma, osteoporosis, pulmonary hypertension, and renal failure
Ib	Glucose-6-phosphate translocase	Same as type Ia, with additional findings of neutropenia, periodontal disease, inflammatory bowel disease, and increased risk of autoimmune hypothyroidism	10% of type I
IIIa/Cori or Forbes	Liver and muscle debrancher deficiency	Childhood: hepatomegaly, growth retardation, muscle weakness, hypoglycemia, hyperlipidemia, elevated transaminase levels, hepatic fibrosis, left ventricular hypertrophy. Later childhood to adulthood: muscle atrophy and weakness, liver cirrhosis and failure, risk for hepatocellular carcinoma, cardiac hypertrophy and fibrosis, life-threatening arrhythmia at any age.	Common, intermediate severity of hypoglycemia. Muscle weakness may progress to the point that ambulation assistance such as wheelchair use is required.
IIIb	Liver debrancher deficiency; normal muscle enzyme activity	Liver symptoms same as in type IIIa; no muscle or heart symptoms	15% of type III
IV/Andersen/adult polyglucosan body disease	Branching enzyme	Infancy/childhood failure to thrive, hypotonia, hepatomegaly, splenomegaly, cirrhosis progressing to liver failure (death usually before fifth year), elevated transaminase levels; a subset does not have overt progression to liver failure. Risk for extrahepatic manifestations, such as myopathy and cardiomyopathy. Perinatal: decreased fetal movements, polyhydramnios, fetal hydrops; arthrogryposis, hypotonia, muscle atrophy at birth, death in the perinatal period. Congenital: neonatal hypotonia, respiratory failure, dilated cardiomyopathy, early infantile death. Childhood: neuromuscular manifestations, cardiomyopathy. Adult form, adult polyglucosan body disease (APBD): progressive muscle weakness, neuropathic bladder, gait spasticity, central and peripheral nervous system involvement.	A continuum of disease severity, related to residual enzyme activity; multisystem involvement
VI/Hers	Liver phosphorylase	Hepatomegaly, hypoglycemia, hyperlipidemia, elevated liver enzyme levels, and ketosis	Often underdiagnosed; severe presentation also known
IX/phosphorylase kinase (PhK) deficiency			Common, X-linked GSD IX $\alpha$ 2, typically less severe than autosomal form GSD IX $\gamma$ 2; clinical variability within and between subtypes; severe cases being recognized across different subtypes
IX $\alpha$ 2 (PHKA2 variant)	Liver PhK	Hypoglycemia, hyperketosis, hepatomegaly, chronic liver disease, liver fibrosis, hyperlipidemia, elevated liver enzymes, growth retardation	X-linked
IX $\beta$ (PHKB variant)	Liver and muscle PhK	Hepatomegaly, growth retardation, mild or absent muscle disease.	Autosomal recessive
IX $\gamma$ 2 (PHKG2 variant)	Liver PhK	More severe than IX $\alpha$ 2; marked hepatomegaly, recurrent hypoglycemia, hyperlipidemia, markedly elevated liver enzymes, liver fibrosis/cirrhosis	Autosomal recessive
0a/Liver glycogen synthase deficiency	Liver glycogen synthase	Early morning drowsiness and fatigue, fasting hypoglycemia and ketosis, no hepatomegaly	Decreased liver glycogen stores
XI/Fanconi-Bickel syndrome	Glucose transporter 2 (GLUT-2)	Failure to thrive, rickets, hepatomegaly, renomegaly, proximal renal tubular dysfunction, impaired glucose and galactose use	GLUT-2 expressed in liver, kidney, pancreas, and intestine
<b>MUSCLE GLYCOGENOSES</b>			
<i>Type/Common Name</i>			
II/infantile Pompe	Acid $\alpha$ -glucosidase	Cardiomegaly, hypotonia, hepatomegaly; onset at birth to age 6 mo	Common, cardiorespiratory failure leading to death by age 1-2yr; minimal to no residual enzyme activity
II/late-onset Pompe (juvenile and adult)	Acid $\alpha$ -glucosidase	Myopathy (proximal limb girdle), variable cardiomyopathy, respiratory insufficiency; onset from infancy and early childhood to adulthood	Residual enzyme activity
Danon disease	Lysosome-associated membrane protein 2 (LAMP2)	Hypertrophic cardiomyopathy, heart failure, retinopathy, mild cognitive dysfunction	Rare, X-linked

**Table 107.1** Features of the Disorders of Carbohydrate Metabolism—cont'd

DISORDERS	BASIC DEFECTS	CLINICAL PRESENTATION	COMMENTS
PRKAG2 syndrome	Adenosine monophosphate (AMP)-activated protein kinase $\gamma$	Hypertrophic cardiomyopathy, arrhythmias, myopathy, myalgia, seizures; congenital fetal form is rapidly fatal	Autosomal dominant
Ob/muscle glycogen synthase deficiency	Muscle glycogen synthase	Muscle weakness, hypertrophic cardiomyopathy, abnormal heart rate, sudden cardiac arrest	Rare, few cases reported
XV/Polyglucosan body myopathy 2	Glycogenin-1	Juvenile- or adult-onset proximal muscle weakness, nervous system involvement uncommon	Rare, autosomal recessive
V/McArdle	Myophosphorylase	Exercise intolerance, muscle cramps, myoglobinuria, "second-wind" phenomenon, muscle weakness	Common, male predominance
VII/Tarui	Phosphofructokinase	Exercise intolerance, muscle cramps, compensatory hemolytic anemia, myoglobinuria, "out-of-wind" phenomenon	Prevalent in Japanese and Ashkenazi Jewish populations
IX $\alpha$ 1 (PHKA1 variant)	Muscle PhK	Exercise intolerance, cramps, myalgia, increased CK, myoglobinuria in some; no hepatomegaly	X-linked
Phosphoglycerate kinase deficiency	Phosphoglycerate kinase	As with type V	Rare, X-linked
X/Phosphoglycerate mutase deficiency	M subunit of phosphoglycerate mutase	As with type V	Rare, majority of patients are Black
XI/Lactate dehydrogenase deficiency	M subunit of lactate dehydrogenase	As with type V	Rare
<b>GALACTOSE DISORDERS</b>			
Galactosemia with transferase deficiency	Galactose-1-phosphate uridylyltransferase	Vomiting, feeding difficulties, liver failure/dysfunction/hepatomegaly, cataracts, failure to thrive, <i>E. coli</i> sepsis, generalized aminoaciduria	Black patients tend to have milder symptoms
Galactokinase deficiency	Galactokinase	Cataracts	Benign
Generalized uridine diphosphate galactose-4-epimerase deficiency	Uridine diphosphate galactose-4-epimerase	Similar to transferase deficiency with additional findings of hypotonia and nerve deafness	Benign and intermediate variants also exist
Galactose mutarotase deficiency	Galactose mutarotase	Cataract	Benign
<b>FRUCTOSE DISORDERS</b>			
Essential fructosuria	Fructokinase	Urine-reducing substance	Benign
Hereditary fructose intolerance	Fructose-1-phosphate aldolase (aldolase-B)	Acute; vomiting, hypoglycemia, sweating, lethargy, acute liver failure/liver dysfunction Chronic; failure to thrive, hepatic failure	Prognosis good with fructose restriction
<b>DISORDERS OF GLUCONEOGENESIS</b>			
Fructose-1,6-bisphosphatase deficiency	Fructose-1,6-diphosphatase	Episodic hypoglycemia, lactic acidosis, liver failure/dysfunction	Good prognosis, avoid fasting
Phosphoenolpyruvate carboxykinase deficiency	Phosphoenolpyruvate carboxykinase	Hypoglycemia, hepatomegaly, hypotonia, failure to thrive	Rare
<b>DISORDERS OF PYRUVATE METABOLISM</b>			
Pyruvate dehydrogenase complex defect	Pyruvate dehydrogenase	Severe fatal neonatal to mild late onset, lactic acidosis, psychomotor retardation, failure to thrive, features overlapping fetal alcohol syndrome, MRI findings suggestive of Leigh syndrome, ataxia	Most commonly caused by E <sub>1<math>\alpha</math></sub> subunit defect, X-linked
Pyruvate carboxylase deficiency	Pyruvate carboxylase	Type B: neonatal severe lactic acidosis, hyperammonemia, hypercitrullinemia, hyperlysinemia, and hypoglycemia. Type A: late-onset mild to moderate lactic acidosis and developmental delay. Type C: recurrent episodes of lactic acidosis, ketoacidosis, and mild neurologic deficits.	Rare, autosomal recessive
Respiratory chain defects (oxidative phosphorylation disease)	Complexes I-V, many mitochondrial and nuclear DNA variants	Heterogeneous with multisystem involvement (see <a href="#">Table 107.3</a> and <a href="#">Table 107.5</a> )	Mitochondrial, autosomal recessive, dominant, and X-linked inheritance
<b>DISORDERS IN PENTOSE METABOLISM</b>			
Pentosuria	l-Xylulose reductase	Urine-reducing substance	Benign
Transaldolase deficiency	Transaldolase	Intrauterine growth restriction, oligohydramnios, dysmorphism, cardiovascular anomalies, anemia, thrombocytopenia, hepatosplenomegaly, endocrine abnormalities, cutis laxa	Autosomal recessive, milder form exists
Ribose-5-phosphate isomerase deficiency	Ribose-5-phosphate isomerase	Progressive leukoencephalopathy and peripheral neuropathy	Four cases reported

hyperfiltration, increased renal plasma flow, and microalbuminuria are often found in the early stages of renal dysfunction and can occur before the onset of proteinuria. In younger patients, hyperfiltration and hyperperfusion may be the only signs of renal abnormalities. Many also have hypertension, renal stones, nephrocalcinosis, proteinuria, renal tubular acidosis (proximal and distal renal acidification defects), and altered creatinine clearance. With the advancement of renal disease, focal segmental glomerulosclerosis and interstitial fibrosis become evident. In some patients, renal function has deteriorated and progressed to failure, requiring dialysis and transplantation. Other renal abnormalities include amyloidosis, a Fanconi-like syndrome, hypocitraturia, hypercalciuria, and a distal renal tubular acidification defect. Patients with *GSD 1b* can have additional features of recurrent bacterial infections from **neutropenia** and impaired neutrophil function. Oral involvement, including recurrent mucosal ulceration, gingivitis, and rapidly progressive periodontal disease, may occur in type 1b. Intestinal mucosa ulceration culminating in *GSD* enterocolitis is also common. Type 1b is also associated with a chronic inflammatory bowel disease (IBD)-like picture involving the colon that may be associated with neutropenia and/or neutrophil dysfunction and can resemble ulcerative colitis or Crohn disease.

### Diagnosis

The clinical presentation and laboratory findings of hypoglycemia, lactic acidosis, hyperuricemia, and hyperlipidemia lead to a suspected diagnosis of type I *GSD*. Neutropenia is noted in *GSD 1b* patients, although neutrophil counts may be normal initially. Neutropenia has also been noted in some patients with *GSD 1a*, especially those with the p.G188A variant. Administration of glucagon or epinephrine leads to a negligible increase, if any, in blood glucose levels, but the lactate level rises significantly. Before the availability of genetic testing, a definitive diagnosis required enzyme testing via liver biopsy. Gene-based variant analysis using single-gene sequencing or multigene panel testing provides a noninvasive way to diagnose most patients with *GSD* types 1a and 1b and has become the primary recommended method of diagnosis.

### Treatment

Treatment focuses on maintaining normal blood glucose levels and is achieved by continuous nasogastric (NG) infusion of glucose or administration of uncooked cornstarch. In infancy, overnight NG drip feeding may be needed to maintain normoglycemia. NG feedings can consist of a sucrose- and lactose-free enteral formula or only glucose or a glucose polymer to provide sufficient glucose to maintain euglycemia. During the day, frequent feedings with high-complex carbohydrate content are typically sufficient.

Uncooked cornstarch acts as a slow-release form of glucose and can be introduced at a dose of 1.6 g/kg every 4 hours for children less than 2 years of age. The response of young children is variable. For older children, the cornstarch regimen can be changed to every 4-6 hours at a dose of 1.6-2.5 g/kg body weight and can be given orally mixed with water or a sucrose-, fructose-, and lactose-free beverage. Cornstarch dosing may also be calculated based on hepatic glucose production rate and can be administered more frequently in smaller amounts to improve metabolic control. Other starch products, such as extended-release waxy maize starch with a high amylopectin content, are shown to be beneficial in extending time between overnight feedings in some individuals with hepatic *GSD*. Because fructose and galactose cannot be converted directly to glucose in *GSD* type I, these sugars should be restricted in the diet. Sucrose (table sugar, cane sugar, other ingredients), fructose (fruit, juice, high-fructose corn syrup), lactose (dairy foods), and sorbitol should be avoided or limited. As a result of these dietary restrictions, vitamins and minerals such as calcium and vitamin D may be deficient, and supplementation is required to prevent nutritional deficiencies.

Maintaining normoglycemia and avoiding hypoglycemia necessitate frequent blood glucose measurements in patients with hepatic *GSDs*. This can be accomplished by self-monitoring blood glucose (SMBG) using a finger prick before and after meals, before physical activity,

and overnight. Continuous glucose monitoring systems (CGMSs) are a newer technique that allow for 24-hour glucose monitoring. CGMSs have been shown to be safe and effective tools for monitoring glucose levels in patients with hepatic *GSDs* (*GSD 1*, *GSD 3*, *GSD 6*, *GSD 9*) at all hours of the day. Furthermore, when accompanied with the necessary dietary changes, CGMSs aid in metabolic control, improving disease parameters, avoidance of hospitalizations, and blood glucose stability in these patients.

Dietary therapy improves hyperuricemia, hyperlipidemia, and renal function, as well as slowing the development of renal failure. Blood uric acid and lipid levels may, however, be elevated in some individuals, despite good dietary compliance, especially after puberty. The control of hyperuricemia can be further augmented by the use of allopurinol, a xanthine oxidase inhibitor. Hyperlipidemia can be reduced with lipid-lowering drugs, such as  $\beta$ -hydroxy- $\beta$ -methylglutaryl-coenzyme A (HMG-CoA) reductase inhibitors and fibrates (see [Chapter 106](#)). **Microalbuminuria**, an early indicator of renal dysfunction in type I disease, is treated with angiotensin-converting enzyme (ACE) inhibitors. Citrate supplements can be beneficial for patients with hypocitraturia by preventing or ameliorating nephrocalcinosis and development of urinary calculi. Products containing citric acid reduce the effectiveness of cornstarch and should not be taken concurrently. Thiazide diuretics increase renal reabsorption of filtered calcium and decrease urinary calcium excretion, thereby preventing hypercalciuria and nephrocalcinosis. Growth hormone (GH) should be used with extreme caution and limited to only those with a documented GH deficiency. Even in those patients, there should be close monitoring of metabolic parameters and for the presence of adenomas. Kidney transplantation may be performed to treat end-stage renal disease (ESRD). As needed, combined liver and kidney transplantation is sometimes recommended.

In patients with **type 1b *GSD***, granulocyte colony-stimulating factor is successful in correcting neutropenia, decreasing the number and severity of bacterial infections, and improving chronic IBD; the minimum effective dose should be used, given noted side effects with this agent, including splenomegaly, hypersplenism, and bone pain, with this agent. Vitamin E administration has been shown to improve neutrophil count and function and to reduce the frequency and severity of infections in *GSD 1b* patients. The use of sodium glucose cotransporter-2 (SGLT2) inhibitors (empagliflozin) to improve neutrophil function and reduce neutropenia and IBD symptoms in *GSD 1b* is showing promising results. Bone marrow transplantation has been reported to correct neutropenia in type 1b *GSD*.

Orthotopic liver transplantation is a potential cure for type I *GSD*, especially for patients with liver malignancy, multiple liver adenomas, metabolic derangements refractory to medical management, and liver failure; however, because of the paucity of available organ donors, this can be challenging. Large adenomas (>2 cm) that are rapidly increasing in size and/or number may necessitate partial hepatic resection. Smaller adenomas (<2 cm) may be treated with percutaneous ethanol injection or transcatheter arterial embolization. Recurrence of liver adenomas is a challenge and may potentiate malignant transformation in these patients, ultimately requiring a liver transplant. Before any surgical procedure, the bleeding status must be evaluated and good metabolic control established. Prolonged bleeding times can be normalized with intensive intravenous (IV) glucose infusion for 24-48 hours before surgery. Treatment with DDAVP (1-deamino-8-D-arginine vasopressin) can reduce bleeding complications, but it should be used with caution because of the risk of fluid overload and hyponatremia when administered as an IV infusion. Lactated Ringer solution should be avoided because it contains lactate and no glucose. Glucose levels should be maintained in the normal range throughout surgery with the use of 10% dextrose. Overall, metabolic control is assessed by growth, improvement, and correction of the metabolic abnormalities such as elevated lactate, glucose, triglyceride, cholesterol, and uric acid levels.

*GSD 1* is a promising target for gene therapy because it is caused by pathogenic variants in a single gene. An active phase 3 clinical trial (NCT05139316) is being conducted to determine the efficacy and safety of adeno-associated virus serotype 8 (AAV8)-mediated *G6P* gene replacement in patients ages 8 years and older with *GSD* type 1a.

### Prognosis

Inadequate metabolic control during childhood can lead to long-term complications in adults. Clinical outcomes have improved dramatically with early diagnosis and effective treatment. However, serious complications such as renal disease and formation of hepatic adenomas with potential risk for malignant transformation persist. The ability to identify transformation of liver adenomas to hepatocellular carcinoma remains a challenge as  $\alpha$ -fetoprotein (AFP) and carcinoembryonic antigen (CEA) levels often remain normal in the setting of hepatocellular carcinoma.

### Type III Glycogen Storage Disease (Cori Disease, Forbes Disease, Debrancher Deficiency, Limit Dextrinosis)

Type III GSD is caused by deficient activity of the **glycogen debranching enzyme**. This enzyme, together with phosphorylase and phosphorylase kinase, are responsible for complete degradation of glycogen. When debranching enzyme is defective, glycogen breakdown is incomplete, resulting in the accumulation of an abnormal glycogen with short outer-branch chains that resemble *limit dextrin*. GSD **type IIIa** is the most common type and usually involves both liver and muscle; GSD **type IIIb**, seen in approximately 15% of patients, appears to involve only the liver.

Type III GSD is an autosomal recessive disease that has been reported in many different ethnic groups. The frequency is relatively high in the Sephardic Jewish population from North Africa, inhabitants of the Faroe Islands, and the Inuit population. The gene for debranching enzyme (*AGL*) has been noted, with more than 260 different pathogenic variants. At least two pathogenic variants in exon 2, c.18\_19del (p.Gln6fs) and c.16C>T (p.Gln6Ter), are specifically associated with GSD type IIIb. Carrier detection and prenatal diagnosis are possible using DNA-based testing.

### Clinical Manifestations

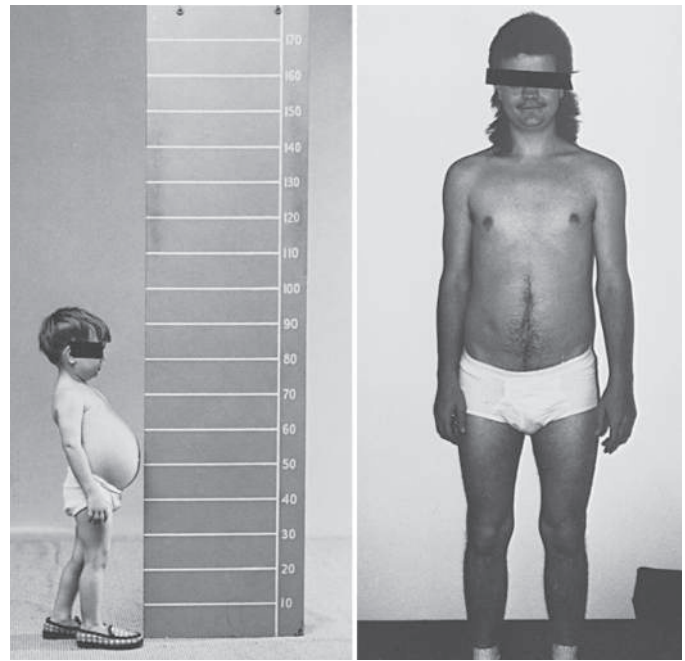
In infancy and childhood, type III GSD may be indistinguishable from type I because of overlapping features such as hepatomegaly, hypoglycemia, hyperlipidemia, and growth stunting (Fig. 107.2). Hepatomegaly in most patients with type III GSD decreases with age; however, liver fibrosis and/or cirrhosis progressing to liver failure are noted in many in late adulthood. Some patients develop hepatocellular carcinoma. Hepatic adenomas with transformation to carcinomas occur less frequently in individuals with GSD III than in those with GSD I. Alpha-fetoprotein (AFP) and carcinoembryonic antigen (CEA) levels are not good predictors of malignant transformation.

In patients with GSD type IIIa, the **muscle weakness** is slowly progressive and associated with muscle wasting. The weakness can present in early childhood but can become severe after the third or fourth decade of life. Myopathy does not follow a particular pattern of involvement, and both proximal and distal muscles are involved. Electromyography (EMG) reveals a widespread myopathy, and nerve conduction studies may be abnormal.

Although overt cardiac dysfunction is rare, ventricular hypertrophy is a frequent finding. **Cardiac pathology** has shown diffuse involvement of various cardiac structures, including vacuolation of myocytes, fibrosis, glycogen accumulation in the conduction system, and hyperplasia of smooth muscles. Life-threatening arrhythmia and the need for heart transplant have been reported in some patients with GSD IIIa. Hepatic symptoms in some patients may be mild and the diagnosis is not made until adulthood, when patients show symptoms and signs of neuromuscular disease.

The initial presentation can be confused with Charcot-Marie-Tooth disease (see Chapter 653.1). Polycystic ovaries are noted; some patients can develop hirsutism, irregular menstrual cycles, and other features of polycystic ovarian syndrome. Fertility does not appear to be affected; successful pregnancies have been reported. Low bone mineral density and myopathy in patients with GSD IIIa put them at an increased risk of potential fractures.

Hypoglycemia and hyperlipidemia are common. In contrast to type I GSD, elevation of liver transaminase levels and fasting ketosis are prominent, but blood lactate and uric acid concentrations are usually



**Fig. 107.2** Growth and development in a patient with type IIIb glycogen storage disease. The patient has debrancher deficiency in the liver but normal activity in muscle. As a child, he had hepatomegaly, hypoglycemia, and growth retardation. After puberty, he no longer had hepatomegaly or hypoglycemia, and his final adult height is normal. He had no muscle weakness or atrophy; this is in contrast to patients with type IIIa, in whom a progressive myopathy is seen in adulthood.

normal. Glucagon administration 2 hours after a carbohydrate meal provokes a normal increase in blood glucose. However, after an overnight fast, glucagon may provoke no change in blood glucose level. Serum creatine kinase levels can be useful to identify patients with muscle involvement, although normal levels do not rule out muscle enzyme deficiency.

### Diagnosis

The histologic appearance of the liver is characterized by a universal distention of hepatocytes by glycogen and the presence of fibrous septa. The fibrosis and the paucity of fat distinguish type III glycogenosis from type I. The fibrosis, which ranges from minimal periportal fibrosis to micronodular cirrhosis, appears in most cases to be progressive. Overt cirrhosis has been seen in some patients with GSD III.

Patients with myopathy and liver symptoms have a generalized enzyme defect (type IIIa). The deficient enzyme activity can be demonstrated not only in liver and muscle but also in other tissues such as heart, erythrocytes, and cultured fibroblasts. Patients with hepatic symptoms without clinical or laboratory evidence of myopathy have debranching enzyme deficiency only in the liver, with enzyme activity retained in the muscle (type IIIb). Before the availability of genetic testing, a definitive diagnosis required enzyme assay in liver, muscle, or both. Gene sequencing allows for diagnosis and subtype assignment in the majority of patients.

### Treatment

The mainstay of treatment of GSD III is dietary management, as in GSD I, although it is less demanding. Patients do not need to restrict dietary intake of fructose and galactose, although simple sugars should be avoided to prevent sudden spikes in blood glucose levels. Hypoglycemia can be prevented by small frequent meals rich in complex carbohydrates, such as cornstarch supplements or nocturnal gastric drip feedings. Additionally, a high-protein diet during the daytime as well as overnight protein enteral infusion is effective in preventing hypoglycemia. The exogenous protein can be used as a substrate for gluconeogenesis, which helps to meet energy needs and prevent endogenous



protein breakdown. Protein in the diet also reduces the overall starch requirement. Overtreatment with cornstarch should be avoided, as it can result in excessive glycogen buildup, which is detrimental and can lead to excessive weight gain. Medium-chain triglyceride (MCT) supplementation and a high-fat diet are being considered as alternative sources of energy. There is no satisfactory treatment for the progressive myopathy other than recommending a high-protein diet, physical therapy, and high-fat diet in some patients. Close monitoring with abdominal MRI is needed to detect progression of liver fibrosis to cirrhosis and hepatocellular carcinoma (HCC). Additional imaging techniques, such as hepatic elastography, are being developed. Liver transplantation has been performed in GSD III patients with progressive cirrhosis and/or HCC. There are reports of cardiac transplant in GSD III patients with end-stage cardiac disease.

### Type IV Glycogen Storage Disease (Branching Enzyme Deficiency, Amylopectinosis, Polyglucosan Disease, Andersen Disease, Adult Polyglucosan Body Disease)

Type IV GSD is caused by the deficiency of **branching enzyme activity**, which results in the accumulation of an abnormal glycogen with poor solubility. The disease is also known as *amylopectinosis* because the abnormal glycogen has fewer  $\alpha$ -1,6 branch points, more  $\alpha$ -1,4 linked glucose units, and longer outer chains, resulting in a structure resembling amylopectin. These excessively long peripheral glucan chains form polyglucosan bodies, which are positive on periodic acid-Schiff (PAS) and resistant to diastase digestion. Polyglucosan body accumulation is seen in all affected patients but to different degrees and in different tissues.

Type IV GSD is an autosomal recessive disorder. The glycogen branching enzyme (*GBE1*) gene has been noted, with more than 128 pathogenic variants responsible for type IV GSD, and their characterization in individual patients can be useful in predicting clinical outcome. The nearly complete absence of glycogen branching enzyme (GBE) activity with null alleles has been associated with perinatal death and fatal neonatal hypotonia. Residual GBE activity results in a continuum of disease manifestations ranging from progressive hepatic cirrhosis, slowly progressive or nonprogressive liver disease, cardiomyopathy, myopathy, peripheral neuropathy, motor neuron disease, and leukodystrophy.

### Clinical Manifestations

A high degree of clinical variability is associated with type IV GSD. The most common and classic form is characterized by **hepatic** involvement with progressive cirrhosis of the liver and manifests in the first 18 months of life as hepatosplenomegaly and failure to thrive. Cirrhosis may present with portal hypertension, ascites, and esophageal varices and may progress to liver failure, usually leading to death by 5 years of age. Some patients survive without progression of liver disease, and they are considered to have a milder hepatic form and do not require liver transplant. Extrahepatic involvement in some patients with GSD IV consists of musculoskeletal involvement, particularly cardiac and skeletal muscles, as well as central nervous system (CNS) and peripheral nervous system (PNS) involvement.

**Neuromuscular** forms of type IV GSD have been reported, with four main subtypes recognized based on age at presentation. The **perinatal** form is characterized by a *fetal akinesia deformation sequence* (FADS) and death in the perinatal period. The **congenital** form presents at birth with severe hypotonia, muscle atrophy, and neuronal involvement, with death in the neonatal period; some patients have cardiomyopathy. The **childhood** form presents primarily with myopathy or cardiomyopathy. The **adult** form, *adult polyglucosan body disease* (APBD), presents with PNS dysfunction and diffuse CNS involvement, accompanied by accumulation of polyglucosan material in the nervous system. Symptoms of neuronal involvement include progressive muscle weakness; gait spasticity; peripheral neuropathy; neuropathic bladder; and, in many cases, leukodystrophy, mood disturbances, and cognitive decline. APBD is often misdiagnosed as multiple sclerosis (MS), amyotrophic lateral sclerosis (ALS), or cerebral small-vessel disease (CSVD).

### Diagnosis

Deposition of amylopectin-like materials varies and can be demonstrated in the liver, heart, muscle, skin, intestine, brain, brainstem, spinal cord, and peripheral nerves (i.e., sural nerve) in type IV GSD. For patients with hepatic involvement, liver histology shows micronodular cirrhosis and faintly stained basophilic inclusions in hepatocytes. The inclusions are composed of coarsely clumped, stored material that is PAS positive and partially resistant to diastase digestion. Electron microscopy (EM) shows, in addition to the conventional  $\alpha$  and  $\beta$  glycogen particles, the accumulation of fibrillar aggregations that are typical of amylopectin. Similar nonmembrane-bound cytoplasmic inclusions (PAS positive, diastase resistant) are observed in the cardiomyocytes and skeletal muscle fibers, and polyglucosan bodies may be present in the muscle biopsy from those with neuromuscular manifestations. In APBD, a peripheral nerve biopsy reveals intra-axonal polyglucosan bodies, and histologic examination of brain tissue shows polyglucosan bodies often visualized in the astrocytes and neurons. The distinct staining properties of the inclusions, as well as EM findings, could be diagnostic. However, polysaccharides with histologic features reminiscent of type IV disease but without enzymatic correlation have been observed. The diagnosis is confirmed by either identification of two pathogenic variants in *GBE1* or a reduction of GBE activity in leukocytes or fibroblasts. Prenatal diagnosis is possible by measuring enzyme activity in cultured amniocytes or chorionic villi or by DNA-based methodologies.

### Treatment

There is no specific treatment for type IV GSD. Nervous system involvement, such as gait problems and bladder involvement, requires supportive, symptomatic management. Unlike patients with other liver GSDs (I, III, VI, IX), those with GSD IV do not typically have hypoglycemia. Liver transplantation has been performed for patients with progressive liver disease, but patients must be carefully selected because this is a multisystem disease and, in some patients, extrahepatic involvement may manifest or worsen after transplant. Liver transplantation corrects the hepatic phenotype of the disease but has no effects on the extrahepatic manifestations such as myopathy and cardiomyopathy. Individuals with significant diffuse reticuloendothelial involvement may have greater risk of morbidity and mortality, which may affect the success rate for liver transplant. Patients with symptomatic cardiomyopathy and skeletal myopathy may benefit from heart transplantation and physical therapy, respectively.

### Type VI Glycogen Storage Disease (Liver Phosphorylase Deficiency, Hers Disease)

Type VI GSD is caused by deficiency of **liver glycogen phosphorylase**. Patients usually present with hepatomegaly and growth stunting in infancy or early childhood. Hypoglycemia, hyperlipidemia, and hyperketosis are of variable severity. Ketotic hypoglycemia may present after overnight or prolonged fasting. Lactic acid and uric acid levels are normal. Type VI GSD presents within a broad spectrum of involvement, some with a more severe clinical presentation. Patients with severe hepatomegaly, recurrent severe hypoglycemia and hyperketosis have been reported. Focal nodular hyperplasia of liver, hepatocellular adenoma with transformation into carcinoma, hepatic fibrosis, and cirrhosis have been reported in some patients.

### Diagnosis

GSD VI is an autosomal recessive disease. Diagnosis can be confirmed through molecular testing of the liver phosphorylase gene (*PYGL*). Many pathogenic variants are known in this gene, and a splice-site variant in intron 13 has been identified in the Mennonite population. A liver biopsy showing elevated glycogen content and decreased hepatic phosphorylase enzyme activity can also be used to make a diagnosis, especially in cases with inconclusive genetic results. However, with the availability of DNA analysis and next-generation sequencing (NGS) panels, liver biopsies are usually unnecessary.

## Treatment

Treatment is symptomatic and aimed at preventing hypoglycemia while ensuring adequate nutrition. A low-carbohydrate (45–50% of total calories), high-protein (2–3 g protein/kg body weight or 20–25% of total calories) diet and frequent feeding are effective in preventing hypoglycemia. Blood glucose and ketones should be monitored routinely, especially during periods of increased activity/illness. Long-term follow-up of these patients is needed to monitor and manage the complications and to expand the understanding of the natural history of this disorder.

### Type IX Glycogen Storage Disease (Phosphorylase Kinase Deficiency)

Type IX GSD represents a heterogeneous group of glycogenoses resulting from deficiency of the enzyme **phosphorylase kinase** (PhK), which is involved in the rate-limiting step of glycogenolysis. This enzyme has four subunits ( $\alpha$ ,  $\beta$ ,  $\gamma$ ,  $\delta$ ), each encoded by different genes differentially expressed in various tissues. Pathogenic variants in the *PHKA1* gene cause muscle PhK deficiency; pathogenic variants in the *PHKA2* and *PHKG2* genes cause liver PhK deficiency, and pathogenic variants in the *PHKB* gene cause PhK deficiency in liver and muscle. Pathogenic variants in the *PHKG1* gene have not been identified.

**Clinical manifestations** of liver PhK deficiency are usually recognizable within the first 2 years of life and include short stature and abdominal distention from moderate to marked hepatomegaly. The clinical severity of liver PhK deficiency varies considerably. Hyperketotic hypoglycemia, if present, can be mild but may be severe in some cases. Ketosis may occur even when glucose levels are normal. Some children may have mild delays in gross motor development and hypotonia. It is becoming increasingly clear that GSD IX is not a benign condition. Severe phenotypes are reported, with liver fibrosis progressing to cirrhosis and HCC, particularly in patients with *PHKG2* variants and also in some patients with *PHKA2* variants. Progressive splenomegaly and portal hypertension are reported secondary to cirrhosis. Interventricular septal hypertrophy has been reported in a patient with GSD IX  $\beta$  (*PHKB* variant). Cognitive and speech delays have been reported in a few individuals, but it is not clear whether these delays are caused by PhK deficiency or are coincidental. Renal tubular acidosis has been reported in rare cases. Unlike in GSD I, lactic acidosis, bleeding tendency, and loose bowel movements are not characteristic. Although growth is retarded during childhood, normal height and complete sexual development are eventually achieved. As with debrancher deficiency, abdominal distention and hepatomegaly usually decrease with age. Some adults with liver PhK deficiency are reportedly asymptomatic, although patients at the other end of the spectrum develop cirrhosis and liver failure. Further studies are needed to fully assess and understand the natural history of this disorder in adults.

Phenotypic variability within each subtype is being uncovered with the availability of molecular testing. The incidence of all subtypes of PhK deficiency is approximately 1:100,000 live births.

### Type IX $\alpha$ 2 Glycogen Storage Disease (X-Linked Liver Phosphorylase Kinase Deficiency, *PHKA2* Variant)

Glycogen storage disease IX  $\alpha$ 2 is one of the most common forms of liver glycogenosis in males. A typical presentation for this condition includes a young male (age 1–5 years) with growth stunting, incidental finding of hepatomegaly, and mild delays in motor development. In addition to the liver, enzyme activity can also be deficient in erythrocytes, leukocytes, and fibroblasts, with normal enzyme activity in muscle. Cholesterol, triglycerides, and liver enzymes are elevated. Ketosis may occur after fasting. Lactate and uric acid levels are normal. Hypoglycemia can range from mild to severe. The response in blood glucose to glucagon is normal. Although hepatomegaly and liver enzymes might gradually reduce and normalize with age in some patients, other groups exhibit an increase in these disease parameters comparable

to those observed in patients with GSD IX  $\gamma$  2. Most adults achieve a normal final height. It is increasingly recognized that this disorder is not benign, as previously thought, and there are patients with severe disease and long-term hepatic sequelae. In some cases, liver fibrosis can occur and progress to cirrhosis. Liver histology shows glycogen-distended hepatocytes, steatosis, fibrosis, and/or cirrhosis. Fibrous septal formation and low-grade inflammatory changes may be seen. Adenomas have been also reported.

The gene for the common liver isoform of the PhK  $\alpha$  subunit, *PHKA2*, is located on the X chromosome (Xp22.2). Pathogenic variants in the *PHKA2* gene account for 75% of all PhK cases. X-linked liver PhK deficiency is further subdivided into two biochemical subtypes: XLG1, with measurable deficiency of PhK activity in both blood cells and liver, and XLG2, with normal in vitro PhK activity in blood cells and variable activity in the liver. The mechanism through which XLG2 exhibits normal or increased in vitro PhK activity is unknown. Because of X-inactivation leading to variable expression of the mutant allele, some female carriers may develop symptoms ranging from mild hepatomegaly to more severe symptoms.

### Type IX $\beta$ Glycogen Storage Disease (Autosomal Liver and Muscle Phosphorylase Kinase Deficiency, *PHKB* Variant)

PhK deficiency in liver and blood cells with an autosomal recessive mode of inheritance has been reported. Similar to the X-linked form, chief symptoms in early childhood include hepatomegaly and growth retardation. Some patients also exhibit muscle hypotonia. In a few cases where enzyme activity has been measured, reduced PhK activity has been demonstrated in muscle. Pathogenic variants are found in *PHKB* (chromosome 16q12–q13), which encodes the  $\beta$  subunit, and result in liver and muscle PhK deficiency (GSD IX  $\beta$ ). Several nonsense and missense variants, a single-base insertion, splice-site pathogenic variants, and a large intragenic pathogenic variant have been identified.

### Type IX $\gamma$ 2 Glycogen Storage Disease (Autosomal Liver Phosphorylase Kinase Deficiency, *PHKG2* Variant)

This form of PhK deficiency is caused by pathogenic variants in the testis/liver isoform (TL) of the  $\gamma$ 2 subunit of the *PHKG2* gene. In contrast to GSD IX  $\alpha$ 2, patients with GSD IX  $\gamma$ 2 typically have more severe phenotypes, with recurrent hypoglycemia, prominent hepatomegaly, significant liver fibrosis, and progressive cirrhosis. Hepatic adenomas have been observed in several patients. Liver involvement occasionally presents with cholestasis, bile duct proliferation, esophageal varices, and splenomegaly. The spectrum of involvement continues to evolve as more cases are recognized. Many pathogenic variants in the *PHKG2* gene have been identified.

## Diagnosis

Individuals with liver PhK deficiency usually have ketotic hypoglycemia, elevated transaminases, elevated triglycerides and cholesterol, normal uric acid and lactic acid concentrations, and normal glucagon response. PhK deficiency may be diagnosed by demonstration of the enzymatic defect in affected tissues. Hepatic PhK activity can be measured in liver, leukocytes, and erythrocytes. The interpretation of PhK activity results is complicated by the possibility of both false-positive and false-negative results. False-positive findings are possible, owing to the labile nature of PhK, which is extremely sensitive to handling circumstances and temperature exposure. As a result, extreme caution is required when storing and transporting such diagnostic specimens. Because the PhK enzyme has several isozymes, the diagnosis can easily be missed without the tissue where it is deficient (liver, muscle, or cardiac studies).

Molecular genetic testing is preferable to enzyme assay for diagnosis, as liver biopsy is an invasive procedure. Gene sequencing is used for diagnostic confirmation and subtyping of GSD IX. The *PHKA2* gene encoding the  $\alpha$  subunit is most frequently involved, followed by the *PHKB* and *PHKG2* genes encoding the  $\beta$  and  $\gamma$  subunits, respectively.

## Treatment and Prognosis

The treatment for liver PhK deficiency is symptomatic and includes a high-protein (2-3 g protein/kg body weight or 20–25% of total calories) diet with complex carbohydrates (45–50% of total calories) and small, frequent feedings to prevent hypoglycemia. Cornstarch can be administered, with symptom-dependent dosage and timing (0.6-2.5 g/kg every 6 hours). Hypoglycemia should be treated with oral glucose, if tolerated; if not, IV glucose should be given.

Patients with pathogenic variants in the  $\gamma$  subunit typically have a more severe clinical course with progressive liver disease. In liver biopsy samples, hepatic fibrosis/cirrhosis was detected in 50% and 95% of patients with *PHKA2* and *PHKG2* pathogenic variants, respectively. Two patients with GSD IX  $\gamma 2$  received liver transplantation, one for liver failure secondary to cirrhosis and the other for HCC. Liver involvement needs to be monitored in all patients with GSD IX by periodic imaging (abdominal ultrasound or MRI every 6-12 months) and serial hepatic function tests.

### Type 0a Glycogen Storage Disease (Liver Glycogen Synthase Deficiency)

Liver glycogen synthase deficiency type 0a (GSD 0a) is caused by deficiency of **hepatic glycogen synthase** activity, leading to a marked decrease of glycogen stored in the liver. It is caused by pathogenic variants in *GYS2*. The disease appears to be rare in humans and, in the true sense, is not a type of GSD because the enzyme deficiency leads to decreased glycogen stores. Patients present in infancy with early-morning (pre-breakfast) drowsiness, pallor, emesis, and fatigue, and occasional convulsions associated with hypoglycemia and hyperketonemia. Blood lactate and alanine levels are low, and there is no hyperlipidemia or hepatomegaly. **Hyperglycemia**, glycosuria, lactic acidosis, and hyperalaninemia, with normal insulin levels after administration of glucose or a meal, suggest a deficiency of glycogen synthase. **Diagnosis** may be through molecular testing that identifies pathogenic variants in *GYS2* or by liver biopsy to measure the enzyme activity.

**Treatment** consists of frequent meals rich in protein and nighttime supplementation with uncooked cornstarch to prevent hypoglycemia and hyperketonemia. Most children with GSD 0a are cognitively and developmentally age appropriate. Short stature and osteopenia are common features. The **prognosis** seems good for patients who survive to adulthood, with a decrease in the frequency and severity of hypoglycemia. Long-term natural history studies are required to have a better understanding of the disease's outcomes and the impact of dietary therapy.

### Hepatic Glycogenosis with Renal Fanconi Syndrome (Fanconi-Bickel Syndrome)

Fanconi-Bickel syndrome is a rare autosomal recessive disorder caused by defects in the facilitative GLUT2, which transports glucose in and out of hepatocytes, pancreatic  $\beta$  cells, and the basolateral membranes of intestinal and renal epithelial cells. The disease is characterized by proximal renal tubular dysfunction, impaired glucose and galactose utilization, and accumulation of glycogen in the liver and kidney.

The affected child typically presents in the first year of life with failure to thrive, rickets, and a protuberant abdomen from hepatomegaly and nephromegaly. The disease may be confused with GSD I because a Fanconi-like syndrome can also develop in that patient population. Adult patients have short stature as a result of hypophosphatemic rickets. Patients are more susceptible to fractures because of early-onset generalized osteopenia. In addition, intestinal malabsorption and diarrhea may occur, and HCC has been seen. Laboratory findings include glycosuria, phosphaturia, generalized aminoaciduria, bicarbonate wasting, hypophosphatemia, increased serum alkaline phosphatase levels, and radiologic findings of rickets. Mild fasting hypoglycemia and hyperlipidemia may be present. Liver transaminase, plasma lactate, and uric acid levels are usually normal. Oral galactose or glucose tolerance tests show intolerance, which could be explained by the functional loss of GLUT2 preventing liver uptake of these sugars. Tissue biopsy results show marked accumulation of glycogen in hepatocytes and proximal renal tubular cells, presumably from the altered glucose

transport out of these organs. Diffuse glomerular mesangial expansion, along with glomerular hyperfiltration and microalbuminuria similar to nephropathy in GSD Ia, and diabetes have been reported.

This condition is rare, and 70% of patients with Fanconi-Bickel syndrome have consanguineous parents. Most patients have homozygous pathogenic variants; some patients are compound heterozygotes. Several types of pathogenic variants in the *SLC2A2* gene have been described, including missense, nonsense, insertion/deletion, and intronic variants.

There is no specific treatment. Symptom-dependent treatment with phosphate, bicarbonate, and uncooked cornstarch can result in growth improvement. Growth may also improve with symptomatic replacement of water, electrolytes, and vitamin D and restriction of galactose intake; a diet similar to that used for diabetes mellitus, with small, frequent meals using complex carbohydrates and adequate caloric intake, is recommended.

## MUSCLE GLYCOGENOSES

The role of glycogen in muscle is to provide substrates for the generation of ATP for muscle contraction. The muscle GSDs are broadly divided into two groups. The first group is characterized by hypertrophic cardiomyopathy, progressive skeletal muscle weakness and atrophy, or both and includes deficiencies of acid  $\alpha$ -glucosidase, a lysosomal glycogen-degrading enzyme (**type II GSD**); lysosomal-associated membrane protein 2 (**LAMP2/Danon disease**); AMP-activated protein kinase  $\gamma 2$  (**PRKAG2/PRKAG2 syndrome**); and muscle glycogen synthase (**type 0b**). Glycogenin-1 deficiency (**GYG1/polyglucosan body myopathy 2**) may manifest as muscle weakness and exercise intolerance to exercise in the absence of cardiomyopathy.

The second group comprises muscle energy disorders characterized by muscle pain, exercise intolerance, myoglobinuria, and susceptibility to fatigue. This group includes myophosphorylase deficiency (McArdle disease, **type V GSD**) and deficiencies of phosphofruktokinase (**type VII**), phosphoglycerate kinase, phosphoglycerate mutase, lactate dehydrogenase (LDH), and muscle-specific phosphorylase kinase (**type IX  $\alpha 1$** ). Some of these latter enzyme deficiencies can also be associated with *compensated hemolysis*, suggesting a more generalized defect in glucose metabolism.

### Type II Glycogen Storage Disease (Lysosomal Acid $\alpha$ -1,4-Glucosidase Deficiency, Pompe Disease)

Pompe disease, also referred to as *GSD type II* or **acid maltase deficiency**, is caused by a deficiency of acid  $\alpha$ -1,4-glucosidase, an enzyme responsible for the degradation of glycogen in lysosomes. This enzyme defect results in lysosomal glycogen accumulation in multiple tissues and cell types, predominantly affecting cardiac, skeletal, and smooth muscle cells and the nervous system. In Pompe disease, glycogen typically accumulates within lysosomes, as opposed to its accumulation in cytoplasm in the other glycogenoses. However, as the disease progresses, lysosomal rupture and leakage lead to the presence of cytoplasmic glycogen as well.

Pompe disease is an autosomal recessive disorder. The incidence was previously reported to be approximately 1 in 40,000 live births in Whites and 1 in 18,000 live births in the Han Chinese population. Newborn screening for Pompe disease in the United States suggests that the prevalence is much higher than previously thought (between 1 in 10,000 and 1 in 25,000). More than 600 pathogenic variants have been identified in the gene for acid  $\alpha$ -glucosidase (*GAA*) and are helpful in delineating the phenotypes. A splice-site variant (c.-32-13 T > G, formerly called IVS1-13 T > G) is commonly seen in White patients with late-onset disease.

## Clinical Manifestations

Pompe disease is broadly classified into infantile and late-onset forms. The infantile presentation is a continuum and is further divided into two categories: classic and nonclassic. Classic **infantile Pompe disease** (IPD) is uniformly lethal *without* enzyme replacement therapy (ERT) with *alglucosidase alfa*. Affected infants present in the first days to weeks of life with hypotonia, generalized muscle weakness with a hypotonic *floppy infant* appearance, hypertrophic cardiomyopathy



with or without left ventricular outflow obstruction, feeding difficulties, macroglossia, and hepatomegaly; if untreated, the condition leads to death from cardiorespiratory failure or respiratory infection by 1 year of age. Nonclassic IPD has a slower disease course and a less severe cardiac phenotype at initial presentation.

**Late-onset Pompe disease** (LOPD; juvenile-, childhood-, and adult-onset disease) is characterized by proximal limb girdle muscle weakness and early involvement of respiratory muscles, especially the diaphragm. The distinguishing feature between IPD and LOPD is absence of cardiomyopathy in the first year of life in patients with LOPD. Symptoms related to progressive dysfunction of skeletal muscles can start within the first year of life to as late as the sixth decade. The clinical picture is dominated by slowly progressive proximal muscle weakness, with truncal involvement and greater involvement of the lower limbs than the upper limbs. The pelvic girdle, paraspinal muscles, and diaphragm are the muscle groups most seriously affected in patients with LOPD. Cardiac involvement can occur and ranges from cardiac rhythm disturbances to cardiomyopathy. Other symptoms may include lingual weakness, ptosis, and dilation of blood vessels (e.g., basilar artery, ascending aorta). With disease progression, patients become confined to a wheelchair and require artificial ventilation. The initial symptoms in some patients may be respiratory insufficiency manifested by somnolence, morning headache, orthopnea, and exertional dyspnea, which eventually lead to sleep-disordered breathing and respiratory failure. Respiratory failure is the cause of significant morbidity and mortality in LOPD. Basilar artery aneurysms with rupture also contribute to mortality in some cases. Small-fiber neuropathy presenting as painful paresthesia has been identified in some LOPD patients. Gastrointestinal disturbances such as postprandial bloating, dysphagia, early satiety, diarrhea, chronic constipation, and IBD have been reported. Genitourinary tract involvement is not uncommon and may present as bladder and bowel incontinence, weak urine stream, or dribbling. If untreated, the age of death varies from early childhood to late adulthood, depending on the rate of disease progression and the extent of respiratory muscle involvement. With the advent of ERT, a new natural history is emerging for survivors of both IPD and LOPD.

### Laboratory Findings

Pertinent laboratory findings include elevated levels of serum creatine kinase (CK), aspartate transaminase (AST), alanine transaminase (ALT), and LDH. Urine glucose tetrasaccharide (Glc4), a glycogen breakdown metabolite, is a reliable biomarker for gauging disease severity and progression, as well as treatment response. Levels of Glc4 are extremely elevated in patients with IPD. In the infantile form, a chest x-ray film showing massive cardiomegaly is frequently the first symptom detected. **Electrocardiographic findings** include a high-voltage QRS complex, Wolff-Parkinson-White (WPW) syndrome, and a *shortened* PR interval. **Echocardiography** reveals thickening of both ventricles and/or the intraventricular septum and/or left ventricular outflow tract obstruction. Dilated cardiomyopathy and a low ejection fraction have also been reported. Muscle biopsy shows the presence of vacuoles that stain positively for glycogen; acid phosphatase is increased, presumably from a compensatory increase of lysosomal enzymes. EM reveals glycogen accumulation within a membranous sac and with disease progression also in the cytoplasm. EMG reveals myopathic features with excessive electrical irritability of muscle fibers and pseudomyotonic discharges. Serum CK is not always elevated in adult patients. Depending on the muscle sampled or tested, the muscle histologic appearance and electromyography may not be abnormal. Some patients with infantile Pompe disease who had peripheral nerve biopsies demonstrated glycogen accumulation in the neurons and Schwann cells.

### Diagnosis

A diagnosis of Pompe disease can be made by either enzyme assay in dried blood spots, leukocytes, blood mononuclear cells, muscle, or cultured skin fibroblasts demonstrating deficient acid  $\alpha$ -glucosidase activity or gene sequencing showing two pathogenic variants in the GAA gene. The enzyme assay should be done in a laboratory with experience using maltose, glycogen, or 4-methylumbelliferyl- $\alpha$ -d-glu-

copyranoside (4MUG) as a substrate. In fibroblast enzyme assays, the infantile form has a more severe enzyme deficiency (less than 1% of that in normal controls) than the late-onset forms (between 1% and 30% of that in normal controls). Blood-based assays, especially dried blood spots, have the advantage of being quick and noninvasive and are increasingly being used as the first-line sample to make a diagnosis. The presence of the neutral  $\alpha$ -glucosidase isoenzyme, which interferes with acid glucosidase, was formerly considered to be a disadvantage in blood-based assays. However, the addition of an inhibitor to this isozyme, acarbose, improves the assay's reliability by blocking isoenzyme activity. A muscle biopsy is often done with suspected muscle disease and a broad diagnostic differential, as it yields faster results and provides additional information about glycogen content and site of glycogen storage within and outside the lysosomes of muscle cells. However, a normal muscle biopsy, especially in patients with LOPD, *does not* exclude a diagnosis of Pompe disease. Late-onset patients show variability in glycogen accumulation in different muscles and within muscle fibers, and muscle histology and glycogen content can vary depending on the site of muscle biopsy. Because of the high risk of complications, anesthesia in infantile cases with significant cardiomyopathy should be reserved for situations where it is necessary. Availability of NGS panels and whole exome or genome sequencing allow for identification of additional patients with Pompe disease, especially when the diagnosis is ambiguous. GAA enzyme activity can be measured in chorionic villi or amniocytes for prenatal diagnosis; however, if the familial pathogenic variants are known, molecular genetic testing is the recommended approach.

### Treatment

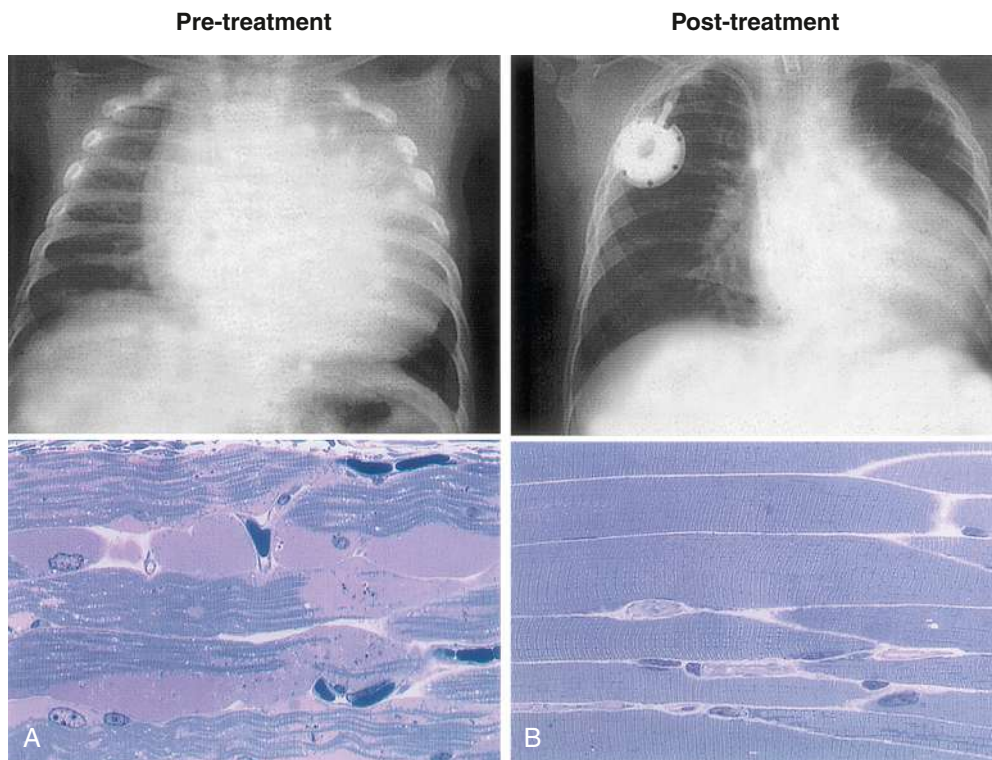
ERT with recombinant human acid  $\alpha$ -glucosidase (alglucosidase alfa and avalgluco) is available for treatment of Pompe disease. Recombinant acid  $\alpha$ -glucosidase can prevent deterioration or reversing abnormal cardiac and skeletal muscle functions (Fig. 107.3). ERT should be initiated as soon as possible across the disease spectrum, especially for infants with the infantile form, because the disease is rapidly progressive. Infants who are negative for cross-reacting immunologic material (CRIM) (i.e., infants that have no detectable GAA on a Western blot), develop a high-titer antibody against the infused enzyme and respond to ERT less favorably. A subset of CRIM-positive patients (presence of some protein on a Western blot) can also develop high and sustained antibody titers to ERT. Treatment using immunomodulating agents such as methotrexate, rituximab, and intravenous immunoglobulin (IVIG) have demonstrated efficacy in preventing the development of an immune response to ERT and immune tolerance. Nocturnal ventilatory support, when indicated, should be used. It has been shown to improve the quality of life and is particularly beneficial during a period of respiratory decompensation. In addition to ERT, other **adjunctive therapies** have demonstrated benefit in patients with Pompe disease. For patients with late-onset disease, a high-protein, low-carbohydrate diet may be beneficial. Respiratory muscle strength training has demonstrated improvements in respiratory parameters when combined with ERT. Submaximal aerobic exercise regimens are beneficial in improving muscle strength, pain, and fatigue.

A second-generation ERT, **avalglucosidase alfa** (NeoGAA), has been recently approved by the Food and Drug Administration (FDA) for the treatment of individuals with LOPD older than 1 year of age. Mannose-6-phosphate (M6P) is more abundant in NeoGAA than in alglucosidase alfa, which improves enzyme uptake into cells. Improvements in respiratory function (forced vital capacity [FVC]) and 6-minute walk test (6MWT) in patients with LOPD have been shown by phase 1/2 and 3 trials.

There are other therapies in development for Pompe disease, including intravenous **cipaglucosidase alfa** (a novel recombinant human GAA with high bis-M6P content; functions as substrate reduction therapy), **miglustat** (an oral chaperone; functions as enzyme stabilizer), small-molecule therapy, and gene therapy.

Early diagnosis and treatment are necessary for optimal outcomes. Newborn screening using blood-based assays in Taiwan and 28 U.S. states has resulted in early identification of Pompe cases, and thus improved disease outcomes, through the early initiation of ERT.





**Fig. 107.3** Chest radiograph and muscle histology findings of an infantile-onset Pompe disease patient before (A) and after (B) enzyme replacement therapy. Note the decrease in heart size and muscle glycogen with therapy. (Modified from Amalfitano A, Bengur AR, Morse RP, et al. Recombinant human acid alpha-glucosidase enzyme therapy for infantile glycogen storage disease type II: results of a phase I/II clinical trial. *Genet Med.* 2001;3:132–138.)

### Danon Disease

Danon disease is caused by pathogenic variants in the *LAMP2* gene, which leads to a deficiency of **lysosomal-associated membrane protein 2 (LAMP2)**. This disorder is inherited in an X-linked dominant pattern. Defects in *LAMP2* lead to accumulation of glycogen in the heart and skeletal muscle, presenting primarily as hypertrophic cardiomyopathy and skeletal muscle weakness. Danon disease can be distinguished from the usual causes of hypertrophic cardiomyopathy (defects in sarcomere-protein genes) by the electrophysiologic abnormalities, particularly ventricular preexcitation and conduction defects. Patients present with cardiac symptoms, including chest pain, palpitations, syncope, and cardiac arrest, usually between ages 8 and 15 years. Other clinical manifestations include peripheral pigmentary retinopathy, lenticular changes, abnormal electroretinogram, and mild cognitive dysfunction. **Diagnosis** can be established by molecular testing of the *LAMP2* gene. The prognosis for *LAMP2* deficiency is poor, with progressive end-stage heart failure early in adulthood. **Treatment** is directed toward management of symptoms in affected individuals, including management of cardiomyopathy, correction of arrhythmias, and physical therapy for muscle weakness. Cardiac transplantation has been successful in some patients. In male patients with Danon disease, a nonrandomized open-label phase 1 study (NCT03882437) is currently being conducted to assess the safety of gene therapy using recombinant adeno-associated virus serotype 9 (AAV9) containing the human lysosome-associated membrane protein 2 isoform B (*LAMP2B*) transgene.

### PRKAG2 Syndrome (Adenosine Monophosphate [AMP]–Activated Protein Kinase $\gamma$ 2 Deficiency)

PRKAG2 syndrome is caused by pathogenic variants in the *PRKAG2* gene that is required for the synthesis of the enzyme AMP-activated protein kinase (AMPK), which regulates cellular pathways involved in ATP metabolism. PRKAG2 syndrome has an autosomal dominant pattern of inheritance. Common presentations include hypertrophic cardiomyopathy and electrophysiologic abnormalities such as WPW

syndrome, atrial fibrillation, and progressive atrioventricular block. Cardiac involvement is variable and includes supraventricular tachycardia, sinus bradycardia, left ventricular dysfunction, and sudden cardiac death in some cases. In addition to cardiac involvement, there is a broad spectrum of phenotypic presentations including myalgia, myopathy, and seizures. Cardiomyopathy caused by *PRKAG2* variants usually allows for long-term survival, although a rare congenital form presenting in early infancy is associated with a rapidly fatal course. Cardiomyopathy in *PRKAG2* syndrome often mimics that in other conditions, especially Pompe disease, and should be considered as a differential diagnosis in infants presenting with severe hypertrophic cardiomyopathy. **Treatment** is primarily symptomatic, including management of cardiac failure and correction of conduction defects. Patients with *PRKAG2* deficiency are at risk for sudden cardiac death and require close monitoring.

### Type 0b Glycogen Storage Disease (Muscle Glycogen Synthase Deficiency)

Muscle glycogen synthase deficiency (GSD 0b) results from biallelic loss-of-function pathogenic variants in the gene *GYS1*. In the true sense, this is not a type of GSD because the enzyme deficiency leads to decreased glycogen stores in skeletal and cardiac muscles. The disease is extremely rare and has only been reported in five cases. Muscle biopsies showed lack of glycogen, predominantly oxidative fibers, and mitochondrial proliferation. Glucose tolerance testing was normal. The phenotype was variable and ranged from sudden cardiac arrest, muscle fatigability, hypertrophic cardiomyopathy, abnormal heart rate, and hypotension while exercising to mildly impaired cardiac function at rest.

### Type XV Glycogen Storage Disease (Glycogenin-1 Deficiency, Polyglucosan Body Myopathy 2, *GYG1* Variant)

Polyglucosan body myopathy 2 is an autosomal recessive, slowly progressive skeletal myopathy caused by pathogenic variants in the *GYG1*

gene disrupting **glycogenin-1** biosynthesis. There is a reduced or complete absence of glycogenin-1, which is a precursor necessary for glycogen formation. Polyglucosan accumulation in skeletal muscles causes juvenile- or adult-onset proximal muscle weakness, prominently affecting the hip and shoulder girdles. Some patients were noted to have a cardiac phenotype. Exertion-induced chest pain, palpitations, and shortness of breath are common early symptoms. Changes in electro-physiological (ECG) parameters and impairment of left ventricular function were reported. Heart transplantation may be necessary in some cases. The missense variant c.304G>C (p. Asp102His) has been observed in homozygosity in the majority of these patients. Compared with GSD IV-APBD, nervous system involvement is uncommon, although polyglucosan deposition is seen in both disorders. Muscle biopsies show PAS-positive, diastase-resistant storage material in 30–40% of muscle fibers. EM reveals the typical polyglucosan structure, consisting of an ovoid form composed of partly filamentous material.

### Type V Glycogen Storage Disease (Muscle Phosphorylase Deficiency, McArdle Disease)

GSD type V, the prototype of muscle energy disorders, is one of the most common GSDs with a prevalence of ~1 in 10,000 and is caused by deficiency of **myophosphorylase** activity. Lack of this enzyme limits muscle ATP generation from glycogenolysis, resulting in muscle glycogen accumulation. A deficiency of myophosphorylase impairs the cleavage of glucosyl molecules from the straight chain of glycogen.

#### Clinical Manifestations

Symptoms usually first develop in late childhood or in the second decade of life. Studies have shown that McArdle disease can manifest in individuals as old as in their seventh decade and in infancy in a fatal, early-onset form characterized by hypotonia, generalized muscle weakness, and respiratory complications. Symptoms are generally characterized by exercise intolerance with muscle cramps and pain and are precipitated by two types of activity: (1) brief, high-intensity exercise, such as sprinting or carrying heavy loads and (2) less intense but sustained activity, such as climbing stairs or walking uphill. Most patients can perform moderate exercise, such as walking on level ground, for long periods. Many patients experience a characteristic *second-wind phenomenon*, with relief of muscle pain and fatigue after a brief period of rest. An increased blood flow of glucose derived from either endogenous liver glycogenolysis or exogenous glucose and free fatty acids, which may be used as an alternative energy source by the exercising muscles, causes the second-wind phenomenon. As a result of the underlying myopathy, these patients may be at risk for **statin-induced myopathy** and rhabdomyolysis. Although patients typically experience episodic muscle pain and cramping from exercise, up to 35% of patients with McArdle disease report permanent pain that has a serious impact on sleep and other activities.

Approximately 50% of patients report burgundy-colored urine after exercise as a result of exercise-induced **myoglobinuria** secondary to **rhabdomyolysis**. Excessive myoglobinuria after intense exercise may precipitate acute renal failure.

Laboratory findings include elevated serum CK levels at rest, which further increase after exercise. Exercise also elevates the levels of blood ammonia, inosine, hypoxanthine, and uric acid, which may be attributed to accelerated recycling of muscle purine nucleotides caused by insufficient ATP production.

#### Diagnosis

Type V GSD is an autosomal recessive disorder. Testing of the gene for muscle phosphorylase (*PYGM*) helps confirm the diagnosis of GSD V. A common nonsense variant, c.148C>T (p.Arg50Ter) in exon 1, is found in 80% of White patients; deletion of a single codon, c.2128\_2130del (p.Phe710del) in exon 17, is found in 61% of patients of Japanese origin. The c.148C>T (p.Arg50Ter) variant represents 55% of alleles in patients of Spanish descent, and the c.2392T>C (p.Trp798Arg) and c.613G>A (p.Gly205Ser) variants represent 10% and 9% of pathogenic alleles in this population. Muscle biopsy can be used to measure glycogen content and enzyme activity in cases where genetic testing results

are inconclusive. Lack of an increase in blood lactate levels and exaggerated blood ammonia elevations suggest a defect in the conversion of muscle glycogen or glucose to lactate. An ischemic exercise test offers rapid diagnostic screening for patients suspected to have McArdle disease, though it should be noted that an abnormal response is *not limited* to type V GSD, as other muscle defects in glycogenolysis or glycolysis produce similar results (deficiencies of muscle phosphofructokinase, phosphoglycerate kinase, phosphoglycerate mutase, or LDH). Additionally, such testing was also associated with severe complications and false-positive results. A nonischemic forearm exercise test with high sensitivity that is easy to perform and is cost-effective has been deemed a more appropriate diagnostic tool; however, it also cannot differentiate abnormal exercise responses due to type V disease from other defects in glycogenolysis or glycolysis.

#### Treatment

To enhance patients' outcomes and physical activity capacity, a multidisciplinary team approach to care composed of a physician, physiotherapist, psychologist, clinical nurse, and dietitian is advised. Avoidance of strenuous exercise prevents symptoms; regular and moderate exercise is recommended to improve exercise capacity. Patients are advised to take advantage of the second-wind phenomenon by commencing exercise slowly and to slow down or stop if muscle weakness or discomfort, increased heart rate, or increased respiratory effort occurs. This *slow-pause-resume* pattern is intended to be maintained as needed until considerable improvement in physical activity tolerance occurs.

High-dose oral ribose, glucagon, verapamil, vitamin B<sub>6</sub>, a high-protein diet, branched-chain amino acid supplementation, dantrolene sodium, high-dose creatine, intravenous gentamicin, and intralipid infusion treatments showed no benefit according to a revised and updated systematic review in the Cochrane Database of nutritional and pharmacologic trials for GSD V. Oral sucrose ingestion before exercise, a carbohydrate-rich diet, ramipril, and low-dose creatine were treatments that showed some promise. There is ongoing research regarding the benefits of a low-carbohydrate ketogenic diet in patients with type V GSD.

### Type VII Glycogen Storage Disease (Muscle Phosphofructokinase Deficiency, Tarui Disease)

Type VII GSD is caused by pathogenic variants in the *PFKM* gene, which result in a deficiency of **muscle phosphofructokinase** enzyme. This enzyme is a key regulatory enzyme of glycolysis and is necessary for the ATP-dependent conversion of fructose-6-phosphate to fructose-1,6-diphosphate. Phosphofructokinase is composed of three isoenzyme subunits according to the tissue type, encoded by different genes: (*PFKM* [M: muscle], *PFKL* [L: liver], and *PFKP* [P: platelet]). Skeletal muscle has only the M subunit, whereas red blood cells (RBCs) express a combination of L and M forms. In type VII GSD, the M isoenzyme is defective, resulting in complete deficiency of enzyme activity in muscle and a partial deficiency in RBCs.

Type VII GSD is an autosomal recessive disorder with increased prevalence in individuals of Japanese ancestry and Ashkenazi Jewish background. A splicing defect and a nucleotide deletion in *PFKM* account for 95% of pathogenic variants in the Ashkenazi Jewish population. Diagnosis based on molecular testing for the common variants is possible in this population.

#### Clinical Manifestations

Although the clinical picture is similar to that of type V GSD, the following features of type VII GSD are distinctive:

- Exercise intolerance, which usually commences in childhood, is more severe than in type V disease and may be associated with nausea, vomiting, and severe muscle pain. Vigorous exercise causes severe muscle cramps and myoglobinuria.
- Compensatory hemolysis occurs, as indicated by an increased level of serum bilirubin and an elevated reticulocyte count.
- Hyperuricemia is common and exaggerated by muscle exercise to a greater degree than that observed in type V GSD.

In addition to normal glycogen, GSD VII is characterized by the accumulation of polyglucosan bodies. The accumulation of glucose-6-phosphate caused by PFKM deficiency and the inhibition of glycolysis stimulate the glycogen synthase enzyme, resulting in the formation of polyglucosan bodies.

Exercise intolerance is especially worse after carbohydrate-rich meals because the ingested glucose prevents lipolysis, thereby depriving muscle of fatty acid and ketone substrates. This is called the *out-of-wind phenomenon*, in contrast to patients with type V disease who can metabolize blood-borne glucose derived from either endogenous liver glycogenolysis or exogenous glucose. Indeed, glucose infusion improves exercise tolerance in patients with type V disease.

The *second-wind phenomenon* is absent because of the inability to break down blood glucose.

Several rare type VII presentations have been described. One form presents in infancy with hypotonia and limb weakness and proceeds to a rapidly progressive myopathy that leads to death by 4 years of age. A second type occurs in infancy and results in congenital myopathy and arthrogryposis, with a fatal outcome. A third form presents in infancy with hypotonia, mild developmental delay, and seizures. An additional presentation is *hereditary nonspherocytic hemolytic anemia*; although these patients do not experience muscle symptoms, it remains unclear whether these symptoms will develop later in life. Another group of individuals with asymptomatic partial red cell PFK deficiency has been described. One phenotype presents in adults and is characterized by a slowly progressive, fixed muscle weakness rather than cramps and myoglobinuria. It may also cause mitral valve thickening from glycogen buildup. Myopathy and hemolysis are hallmarks of the classic form.

### Diagnosis

To establish a diagnosis, gene sequencing can identify pathogenic variants in the *PFKM* gene. Demonstration of the enzymatic deficiency in muscle may be required in some cases. The absence of the M isoenzyme of phosphofructokinase can also be demonstrated in muscle, blood cells, and fibroblasts.

### Treatment

Strenuous exercise should be avoided to prevent acute episodes of muscle cramps, myoglobinuria, acute renal failure, and compartment syndrome. Continuous blood pressure monitoring or compressive devices, as well as the use of tourniquets, are contraindicated in these patients. Patients with GSD VII should follow the same *slow-pause-resume* routine as those with GSD V. Dietary therapy for GSD VII has not been thoroughly investigated. A ketogenic diet has been reported to show clinical improvement in a patient with GSD VII. Carbohydrate meals and glucose infusions have demonstrated worsening symptoms because of the body's inability to use glucose. The administered glucose tends to lower the levels of fatty acids in the blood—a primary source of muscle fuel. *Drugs such as statins should be avoided.* Precautionary measures should be taken to avoid hyperthermia, hypothermia, hypoglycemia, and shivering while undergoing anesthesia in both GSD V and GSD VII.

### Type IX $\alpha$ 1 Glycogen Storage Disease (Muscle-Specific Phosphorylase Kinase Deficiency, *PHKA1* Variant)

X-linked muscle PhK deficiency (IX  $\alpha$ 1 GSD) is caused by pathogenic variants in the *PHKA1* gene, which encodes a muscle-specific regulatory subunit ( $\alpha$  subunit) of phosphorylase kinase and is located on Xq13.11. The condition is male-predominant, but affected heterozygous females have been reported. Patients generally present with mild to severe exercise intolerance in childhood or adolescence. Most patients have elevated serum CK and, in more involved cases, myoglobinuria. There is no evidence of hepatic or cardiac disease in these patients. Blood phosphorylase kinase enzymatic activity is normal, and the enzyme activity is decreased to deficient in the muscle. Muscle biopsy reveals subsarcolemmal accumulations of glycogen, and some patients have myopathic changes on EMG. One patient has been described with comorbid muscle PhK deficiency and intellectual disability; although a connection between *PHKA1* and neurodevelopment has not yet been

established, patients with the diagnosis should be monitored for developmental concerns.

The gene for the muscle  $\gamma$  subunit (*PHKG1*) is on chromosome 7p11.2, and no pathogenic variants in this gene have been reported to date.

### Other Muscle Glycogenoses with Muscle Energy Impairment

Five additional defects in enzymes—phosphoglycerate kinase (PGK), phosphoglycerate mutase (PGAM), LDH, fructose-1,6-bisphosphate aldolase (aldolase A), and  $\beta$ -enolase in the pathway of the terminal glycolysis—cause symptoms and signs of muscle energy impairment similar to those in types V and VII GSD. Deficiency in PGAM, enolase, or LDH causes a myopathic phenotype marked by exercise-induced cramps and myoglobinuria. Patients with aldolase A or PGK deficiencies may present with hemolytic anemia in conjunction with myopathy. The failure of blood lactate to increase in response to exercise is a useful screening test and can be used to differentiate muscle glycogenoses from disorders of lipid metabolism, such as carnitine palmitoyltransferase II deficiency and very long-chain acyl-CoA dehydrogenase deficiency, which also cause muscle cramps and myoglobinuria. Muscle glycogen levels can be normal in the disorders affecting terminal glycolysis, and molecular testing or muscle enzyme activity assay is needed to make a definitive diagnosis. There is no specific treatment (see preceding “Treatment” section).

Visit Elsevier eBooks+ at [eBooks.Health.Elsevier.com](http://eBooks.Health.Elsevier.com) for Bibliography.

## 107.2 Defects in Galactose Metabolism

Ghada Hijazi and Priya S. Kishnani

Milk and dairy products contain **lactose**, the major dietary source of galactose. The metabolism of galactose produces fuel for cellular metabolism through its conversion to glucose-1-phosphate (see [Table 107.1](#)). Galactose also plays an important role in the formation of galactosides, which include glycoproteins, glycolipids, and glycosaminoglycans. **Galactosemia** is a term that refers to an abnormally high quantity of galactose in the blood. It can be caused by one of four distinct inborn defects in galactose metabolism involving one of the following enzymes: galactose mutarotase (GALM), galactokinase (GALK), galactose-1-phosphate uridyl transferase (GALT), and uridine diphosphate galactose-4-epimerase (GALE). Among these, the most serious defect is severe GALT deficiency or classic galactosemia, which is frequently referred to as *galactosemia*.

### GALACTOSE-1-PHOSPHATE URIDYL TRANSFERASE DEFICIENCY GALACTOSEMIA

Two forms of the deficiency exist: infants with complete or near-complete deficiency of the enzyme (classic galactosemia) and those with partial transferase deficiency. **Classic galactosemia** is a serious disease with onset of symptoms typically by the second half of the first week of life. The incidence is approximately 1 in 60,000 live births. The newborn infant receives high amounts of lactose (up to 40% in breast milk and certain formulas), which consists of equal parts of glucose and galactose. Without the transferase enzyme, the infant is unable to metabolize galactose-1-phosphate, the accumulation of which results in injury to the liver, kidney, and brain. This injury may begin prenatally in the affected fetus by endogenous fetal production of galactose.

### Clinical Manifestations

The diagnosis of uridyl transferase deficiency should be considered in newborn or young infants with any of the following features within a few days or weeks after birth: jaundice, hepatomegaly, vomiting, hypoglycemia, seizures, lethargy, irritability, feeding difficulties, poor weight gain or failure to regain birthweight, and aminoaciduria. Untreated children may show nuclear cataracts, vitreous hemorrhage, hepatic failure, cirrhosis, ascites, splenomegaly, or intellectual disability. Patients with galactosemia



are at increased risk for *Escherichia coli* neonatal sepsis; the onset of sepsis often precedes the diagnosis of galactosemia. Pseudotumor cerebri has been reported in some patients, presenting with failure to thrive and a bulging anterior fontanel. Complete withdrawal of lactose from the diet results in improvement of the acute symptoms. If untreated, death from liver failure and sepsis may follow within days. When the diagnosis is not made at birth, damage to the liver (cirrhosis) and brain (intellectual disability) becomes increasingly severe and irreversible.

**Partial transferase deficiency** is classified into two subtypes: clinical variant galactosemia (erythrocyte GALT enzyme activity is  $\geq 1\%$  of controls, but not more than 10–15%) and biochemical (Duarte) variant galactosemia (erythrocyte GALT enzyme activity is  $\geq 25\%$  of controls). Partial transferase deficiency is more common than classic galactosemia and is diagnosed in the newborn screening setting because of moderately elevated blood galactose and/or low transferase activity. Clinical variant galactosemia should be considered in the newborn or young infant who is not thriving or who exhibits any of the classical galactosemia-related symptoms. Generally, biochemical (Duarte) variant galactosemia is asymptomatic. There is no evidence that individuals with biochemical (Duarte) variant galactosemia have an increased risk of neurodevelopmental problems or premature ovarian insufficiency. Additional research is required to properly understand and describe the natural history of this subtype.

### Diagnosis

Historically, the detection of a reducing substance in several urine specimens obtained when the patient is on a diet containing human milk, cow's milk, or any other lactose-containing formula was regarded as strongly indicative of galactosemia. The clue was detecting a reducing substance in urine by Clinitest strips (e.g., glucose, galactose) that is negative by Clinistix (which is specific for glucose only). Galactose can also be identified by chromatography or an enzymatic test specific for galactose. Galactose can be detected in urine, provided the milk feeding was within the last few hours and the child is not vomiting excessively. The addition of galactosemia to the newborn screening panel resulted in a considerable reduction in the utility of Clinitest strips for galactosemia screening. Amino acids may be detected in urine (aminoaciduria) because they are excreted together with glucose as a result of proximal renal tubular dysfunction. Because galactose is injurious to persons with galactosemia, diagnostic challenge tests dependent on administering galactose orally or intravenously should not be used. Direct enzyme assay using erythrocytes establishes the diagnosis. The clinician must confirm that the patient did not receive a blood transfusion before the collection of the blood sample for enzyme assay activity in RBCs, because this may lead to a false-negative result, and the diagnosis could be missed. The activity of galactose-1-phosphate uridyl transferase in erythrocytes can be measured in a variety of ways, one of which involves the use of a nonradioactive assay using high-performance liquid chromatography (HPLC) separation and ultraviolet (UV) light detection. Patients with glucose-6-phosphate-dehydrogenase deficiency can have false-positive results. In classic galactosemia, metabolites (urinary galactitol, red cell galactose-1-phosphate, and blood galactose concentration) may be elevated and can be used to confirm the diagnosis and monitor the response to dietary changes and metabolic control.

### Genetics

GALT deficiency is an autosomal recessive disorder caused by pathogenic variants in the *GALT* gene. Based on newborn screening in the United States, the frequency of the disease is approximately 1 in 47,000 live births. There are several enzymatic variants of galactosemia. More than 327 pathogenic variants have been associated with GALT deficiency. The most common pathogenic variants that result in classic galactosemia phenotype are c.563A>G (p.Gln188Arg), c.855G>T (p.Lys285Asn), and c.584T>C (p.Leu195Pro). In Whites, the p.Gln188Arg variant is linked to an increased incidence of severe disease, premature ovarian insufficiency, and speech problems in a homozygous state. In Blacks p.Ser135Leu is common, which results in a milder phenotype (clinical variant galactosemia) despite the absence of measurable GALT activity in erythrocytes. These patients retain 10% of enzyme activity in the liver and intestinal mucosa. When

treated early, Blacks who are homozygous for this variant are not at risk for neonatal *E. coli* sepsis or chronic complications (i.e., premature ovarian insufficiency and language delay). Four pathogenic variants are unique to the Duarte variant (D2): a four-base pair (bp) deletion in the GALT promoter region (c.-119-116delGTCA), a c.378-27G>C, a c.508-24G>A, and a c.507+62G>A. A fifth variant is a single amino acid substitution (c.940A>G, p.Asn314Asp, also called N314D), which has been observed in both the Duarte variant and functionally normal GALT alleles. Individuals heterozygous for Duarte variant galactosemia typically have 25% of normal galactose activity. Symptoms are minimal or absent, metabolites range from elevated to normal, and there is no need for intervention. Carrier testing and prenatal diagnosis can be performed by molecular testing or, less commonly, direct enzyme assay on amniocytes or chorionic villi.

### Treatment and Prognosis

Consensus guidelines recommend treating patients with an RBC GALT enzyme activity of  $\leq 10\%$  and erythrocyte galactose-1-phosphate concentration of  $>10$  mg/dL. The decision of whether to treat those with 10–15% RBC residual GALT activity is still a matter of debate. All galactose-containing foods should be removed from the diet on initial suspicion of galactosemia. Various non-lactose-containing milk substitutes are available (casein hydrolysates, soybean-based formula). A galactose-restricted diet, along with adequate calcium and vitamin D supplementation, reverses growth failure and hepatic dysfunction. Cataracts regress, and most patients have no persistent impairment of vision. Early diagnosis and treatment have improved the prognosis of galactosemia. On long-term follow-up, patients still manifest ovarian failure with primary or secondary amenorrhea, decreased bone mineral density, developmental delay, and learning disabilities that increase in severity with age. *Hypergonadotropic hypogonadism* is reported in 80–90% of female patients with classic galactosemia. Although most females with classic galactosemia are infertile when they reach child-bearing age, a small number have given birth. Females with the Duarte variant galactosemia and who are homozygous for p.Ser135Leu do not develop premature ovarian insufficiency. Most patients manifest speech disorders, whereas a smaller number demonstrate poor growth and impaired motor function and balance (with or without overt ataxia). Strict dietary restriction and relative control of galactose-1-phosphate levels do not always correlate with long-term outcome, leading to the belief that other factors such as elevated galactitol, decreased uridine diphosphate galactose (a donor for galactolipids and proteins), and endogenous galactose production may be responsible.

### GALACTOKINASE DEFICIENCY

The deficient enzyme is galactokinase, which normally catalyzes the phosphorylation of galactose. The principal metabolites accumulated are galactose and galactitol. Two genes encode enzymes with galactokinase activity, *GALK1* and *GALK2*, although pathogenic variants have been noted only in *GALK1* that cause autosomal recessive galactokinase deficiency. **Cataract** is the most common manifestation of galactokinase deficiency, and pseudotumor cerebri is a rare complication. The incidence of hypoglycemia and infection is comparable to those found in the general population. There is a higher rate of bleeding diathesis, encephalopathy, and elevated liver transaminases than in the general population during the newborn period. Some patients have intellectual impairment and motor and language delays. Heterozygous carriers may be at risk for presenile cataracts. Laboratory findings include increased concentration of blood galactose levels and urinary galactitol, provided the infant has been fed a lactose-containing formula. The diagnosis is made by demonstrating an absence of galactokinase activity in erythrocytes or fibroblasts. GALT activity is normal. Treatment is dietary restriction of galactose.

### URIDINE DIPHOSPHATE GALACTOSE-4-EPIMERASE DEFICIENCY

There are three distinct forms of **epimerase** deficiency based on the level of enzyme activity in different cell types. The first is a **benign** form known as *peripheral epimerase deficiency galactosemia*, diagnosed incidentally through newborn screening programs. Affected individuals are asymptomatic because the enzyme deficiency is limited to



leukocytes and erythrocytes. This form does not require treatment. The second subtype is called **intermediate** form and is caused by epimerase deficiency in RBCs and circulating white blood cells, as well as epimerase activity below 50% of normal in all other cells. Neonates with the intermediate form are typically asymptomatic, even when fed a normal milk diet, and are diagnosed only as a result of newborn screening. The long-term consequences remain unknown. During infancy and early childhood, these individuals are treated with a galactose-/lactose-restricted diet. The third form is rarer and more **severe** as a result of generalized epimerase deficiency. Clinical manifestations resemble GALT transferase deficiency, with additional symptoms of hypotonia and nerve deafness. Clinical symptoms improve with restriction of galactose/lactose in the diet. Although this severe form of epimerase galactosemia is rare, it must be considered in a symptomatic patient with elevated RBC galactose-1-phosphate, urinary galactose, and galactitol levels but with normal GALT transferase activity. The abnormally accumulated metabolites are similar to those in transferase deficiency, with the addition of an increase in cellular uridine diphosphate (UDP) galactose. Biochemical diagnosis is confirmed by the assay of epimerase in erythrocytes demonstrating reduced activity. UDP galactose-4-epimerase is encoded by the *GALE* gene, and pathogenic biallelic variants result in autosomal recessive disease. Carrier detection is possible by measurement of epimerase activity in the erythrocytes. Prenatal diagnosis for the severe form of epimerase deficiency can be done using an enzyme assay of cultured amniotic fluid cells or testing of known familial pathogenic variants.

Patients with the severe form of epimerase deficiency cannot synthesize UDP galactose from UDP glucose and are galactose dependent. Because galactose is an essential component of many nervous system structural proteins, patients are placed on a galactose-restricted diet rather than a galactose-free diet. Galactose restriction is also indicated for infants and young children with the intermediate form. Additional outcome data are needed to optimize these approaches and develop a better understanding of long-term issues in this patient population. Infants with mild epimerase deficiency have not required treatment.

### Galactose Mutarotase Deficiency

GALM catalyzes the first step in the Leloir pathway, the conversion of beta-D-galactose to alpha-D-galactose. There have been a few cases of GALM deficiency reported, with an overall estimated incidence of GALM deficiency in all populations of less than 1 in 200,000, with higher incidences in Black and Japanese populations. Apart from cataracts, individuals with GALM deficiency are often healthy. In some reported cases, elevated blood galactose-1-phosphate (Gal-1-P) and galactose levels were identified during newborn screening. There are no reports of long-term implications of this condition and no formal recommendations regarding optimal dietary intake in this population.

Visit Elsevier eBooks+ at eBooks.Elsevier.com for Bibliography.

## 107.3 Defects in Fructose Metabolism

Ghada Hijazi and Priya S. Kishnani

Two inborn errors are known in the specialized pathway of fructose metabolism: benign or essential fructosuria and hereditary fructose intolerance. Fructose-1,6-bisphosphatase deficiency, not formally a defect of the specialized fructose pathway, is discussed in Chapter 107.4.

### DEFICIENCY OF FRUCTOKINASE (ESSENTIAL OR BENIGN FRUCTOSURIA)

Deficiency of fructokinase is not associated with clinical manifestations. **Fructosuria** is an incidental finding identified in asymptomatic individuals with reducing substances in urine. No treatment is necessary, and the prognosis is excellent. Inheritance of this autosomal recessive trait is caused by biallelic variants in the *KHK* gene, with an incidence of 1 in 120,000 live births.

Fructokinase catalyzes the first step of metabolism of dietary fructose—conversion of fructose to fructose-1-phosphate (see Fig. 107.1). Without this enzyme, fructose consumption results in a rise in the blood level of fructose, which is partially excreted in the urine, as there is little to no renal threshold for fructose. In adipose tissue and muscle, hexokinase converts the remainder to fructose-6-phosphate, which is considered a slower alternative process. Clinitest results reveal the urinary reducing substance, which can be identified as fructose by chromatography.

### DEFICIENCY OF FRUCTOSE-1-PHOSPHATE ALDOLASE (ALDOLASE B, HEREDITARY FRUCTOSE INTOLERANCE)

In comparison to fructokinase, deficiency of fructose-1-phosphate aldolase (**aldolase-B**) is a severe condition in infants resulting from a deficiency of activity in the liver, kidney, and intestine. Fructose-1-phosphate aldolase hydrolyzes fructose-1-phosphate to glyceraldehyde and dihydroxyacetone phosphate. In the glycolytic-gluconeogenic pathway, this enzyme catalyzes the hydrolysis of fructose-1,6-bisphosphate to dihydroxyacetone phosphate and glyceraldehyde phosphate. In the absence of aldolase B activity, there is a rapid accumulation of fructose-1-phosphate and depletion of ATP, which presents with severe symptoms when fructose-containing food is ingested. Accumulation of fructose-1-phosphate also results in inhibition of gluconeogenesis (via inhibition of aldolase A) and glycogenolysis (via inhibition of glycogen phosphorylase A), resulting in decreased glucose production and a rapid decline in blood glucose. Because isozyme fructose-1,6-bisphosphate aldolase (aldolase A) metabolizes fructose-1,6-bisphosphate, glycolysis and gluconeogenesis are not affected in patients with hereditary fructose intolerance in the fasting state.

### Epidemiology and Genetics

The incidence of **hereditary fructose intolerance (HFI)** is estimated to be as high as 1 in 26,000 live births. HFI is inherited in an autosomal recessive manner because of biallelic pathogenic variants in the *ALDOB* gene. At least 60 pathogenic variants causing HFI are known. The most common pathogenic variant identified in the Northern European population is p.Ala150Pro. This variant, along with two other missense variants (p.Ala175Asp and p.Asn335Lys), account for 80–85% of HFI cases in Europe and the United States. The diagnosis of HFI can be made by gene sequencing or demonstration of hepatic fructose-1-phosphate aldolase (aldolase B) activity deficiency on liver biopsy (uncommon).

### Clinical Manifestations

Affected individuals remain asymptomatic until fructose, sucrose (table sugar), or sorbitol is introduced in the diet (usually from fruit, fruit juice, or sweetened cereal). Signs and symptoms typically manifest in infancy when foods or formulas containing these sugars are introduced. Certain patients are very sensitive to fructose, whereas others can tolerate moderate intake (up to 250 mg/kg/day). Early clinical manifestations resemble galactosemia and include jaundice, hepatomegaly, vomiting, lethargy, irritability, and convulsions. There may also be a higher incidence of celiac disease in patients with HFI (>10%) compared with the general population (1–3%). With age, affected individuals typically develop an aversion to fructose-containing foods because of associated symptoms of nausea, vomiting, and abdominal pain.

Characteristic laboratory findings include lactic acidosis, hypophosphatemia, hyperuricemia, and hypermagnesemia. A prolonged prothrombin time, hypoalbuminemia, elevation of bilirubin and transaminase levels, and proximal tubular dysfunction are also seen. Acute fructose ingestion produces symptomatic hypoglycemia as a result of impaired gluconeogenesis, with higher intakes causing a more severe clinical picture. Chronic ingestion results in failure to thrive and hepatic disease. If the intake of fructose persists, hypoglycemic episodes recur, leading to progressive renal and hepatic failure and eventually death.

### Diagnosis

The presence of a reducing substance in urine during an acute episode raises the possibility of HFI. Oral fructose challenge is no longer considered a diagnostic approach because of the high risk to the patient,

who can become acutely ill after the test. A definitive diagnosis is made by demonstration of two pathogenic variants in *ALDOB* on molecular genetic testing. A common pathogenic variant (p.Ala150Pro) accounts for 53% of HFI alleles worldwide. An alternative approach to diagnosis is to demonstrate deficient hepatic fructose-1-phosphate aldolase (aldolase B) activity on liver biopsy. Carbohydrate-deficient transferrin (CDT) testing (see Chapter 107.7) is generally abnormal in patients with HFI and can be used to monitor fructose, sucrose, and sorbitol consumption in the diet.

### Treatment

Acute episodes are managed symptomatically by correcting hypoglycemia with IV glucose (dextrose) administration, providing supportive treatment of hepatic and/or renal insufficiency, and correcting metabolic acidosis. Complete elimination of fructose usually rapidly reverses symptoms and results in normalization of related metabolic disturbances. The cornerstone of long-term treatment is the complete restriction of all sources of fructose, sucrose, and sorbitol from the diet. It may be difficult because these sugars are widely used additives, found even in many medicinal preparations. With treatment, liver and kidney dysfunction improve, and catch-up in growth is common. Intellectual development is usually unimpaired. As the patient matures, symptoms become milder even after fructose ingestion, and the long-term prognosis is good. Because of voluntary dietary avoidance of sucrose, affected patients have few dental caries. Care should be taken to avoid fructose-containing IV fluids during hospitalizations. Regular supplementation with a “sugar-free” multivitamin is required to avoid micronutrient deficiencies resulting from reduced fruit and vegetable consumption.

Visit Elsevier eBooks+ at [eBooks.Health.Elsevier.com](http://eBooks.Health.Elsevier.com) for Bibliography.

## 107.4 Defects in Intermediary Carbohydrate Metabolism Associated with Lactic Acidosis

Ghada Hijazi and Priya S. Kishnani

Lactic acidosis (**type B3**) occurs with inborn errors of metabolism, including defects of carbohydrate metabolism, that interfere with the conversion of pyruvate to glucose via the pathway of *gluconeogenesis*

or to carbon dioxide and water via the mitochondrial enzymes of the Krebs cycle. **Figure 107.4** depicts the relevant metabolic pathways. Type I GSD, fructose-1,6-bisphosphatase deficiency, and phosphoenolpyruvate carboxylase deficiency are disorders of gluconeogenesis associated with lactic acidosis. Other metabolic disorders, including mitochondrial respiratory chain defects, pyruvate dehydrogenase complex deficiency, pyruvate carboxylase deficiency, defects of fatty acid oxidation, organic acidurias (see Chapters 105.6, 105.10, and 106.1), biotin synthesis, and utilization defects also can cause lactic acidosis (**Table 107.2**). Some of these disorders are easily distinguishable by the presence of an abnormal acylcarnitine profile, amino acids in the blood, and urine organic acids. Blood lactate, pyruvate, acylcarnitine profile, and urine organic acids should be ordered in infants and children with unexplained acidosis, especially if there is an increased anion gap.

Lactic acidosis unrelated to an enzymatic defect occurs in conditions associated with hypoxemia and/or hypoperfusion (**type A** lactic acidosis). In this case, and in defects in the respiratory chain, the serum pyruvate concentration may remain normal (<1.0 mg/dL, with increased lactate to pyruvate ratio), whereas pyruvate is usually increased when lactic acidosis results from an enzymatic defect in gluconeogenesis or pyruvate dehydrogenase complex (both lactate and pyruvate are increased, and the ratio is normal). Lactate and pyruvate should be measured in the same blood specimen and on multiple blood specimens obtained when the patient is symptomatic because lactic acidosis can be intermittent. **Figure 107.5** is an algorithm for the differential diagnosis of lactic acidosis. Lactic acidosis is also noted with various underlying diseases (**type B1**) and drugs or toxins (**type B2**) (see **Table 107.2**).

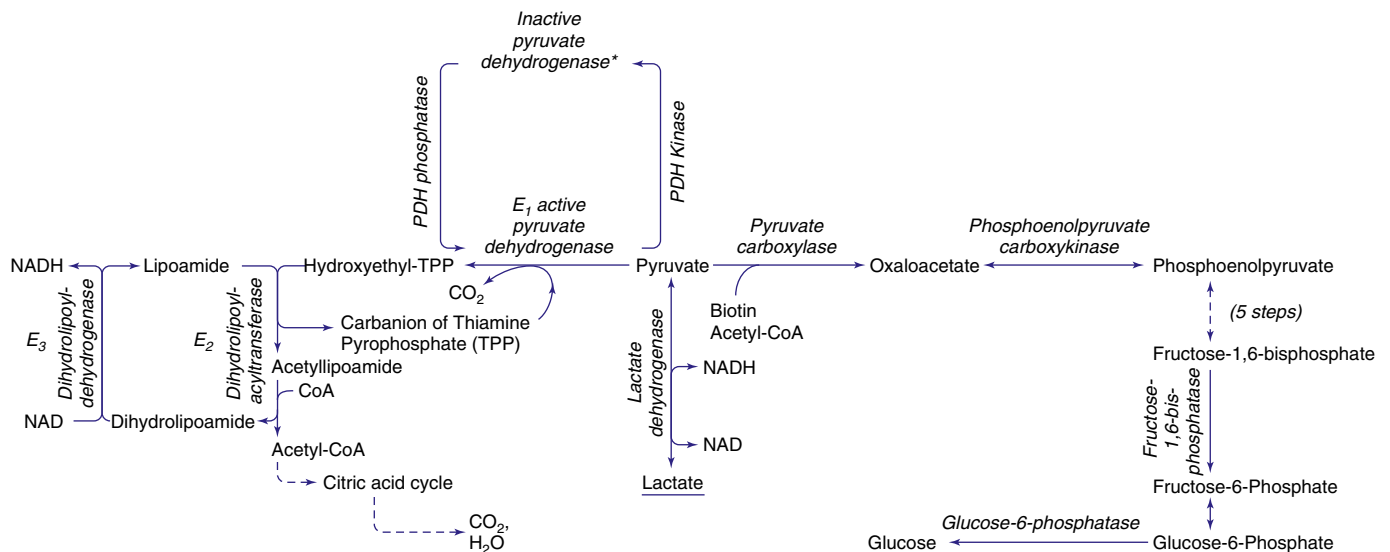
### DISORDERS OF GLUCONEOGENESIS

#### Deficiency of Glucose-6-Phosphatase (Type I Glycogen Storage Disease)

Type I GSD is associated with significant fasting lactic acidosis. The chronic metabolic acidosis predisposes these patients to osteopenia; acute lactic acidosis associated with hypoglycemia is a life-threatening condition in GSD I (see Chapter 107.1).

#### Fructose-1,6-Bisphosphatase Deficiency

Fructose-1,6-bisphosphatase (FBP) deficiency impairs the formation of glucose from all gluconeogenic precursors, including dietary fructose. Hypoglycemia occurs when glycogen reserves are limited or exhausted. The **clinical manifestations** are characterized by life-threatening episodes of acidosis, hypoglycemia, hyperventilation,



**Fig. 107.4** Enzymatic reactions of carbohydrate metabolism, deficiencies of which can give rise to lactic acidosis, pyruvate elevations, or hypoglycemia. The pyruvate dehydrogenase (PDH) complex comprises, in addition to E<sub>1</sub>, E<sub>2</sub>, and E<sub>3</sub>, an E<sub>3</sub>-binding protein (not shown), previously called protein X, and PDH kinase and phosphatase. NAD/NADH, nicotinamide adenine dinucleotide.

**Table 107.2** Causes of Type B Lactic Acidosis

**TYPE B1—UNDERLYING DISEASES**

Renal failure  
 Hepatic failure  
 Diabetes mellitus  
 Malignancy  
 Systemic inflammatory response syndrome  
 Human immunodeficiency virus

**TYPE B2—DRUGS AND TOXINS**

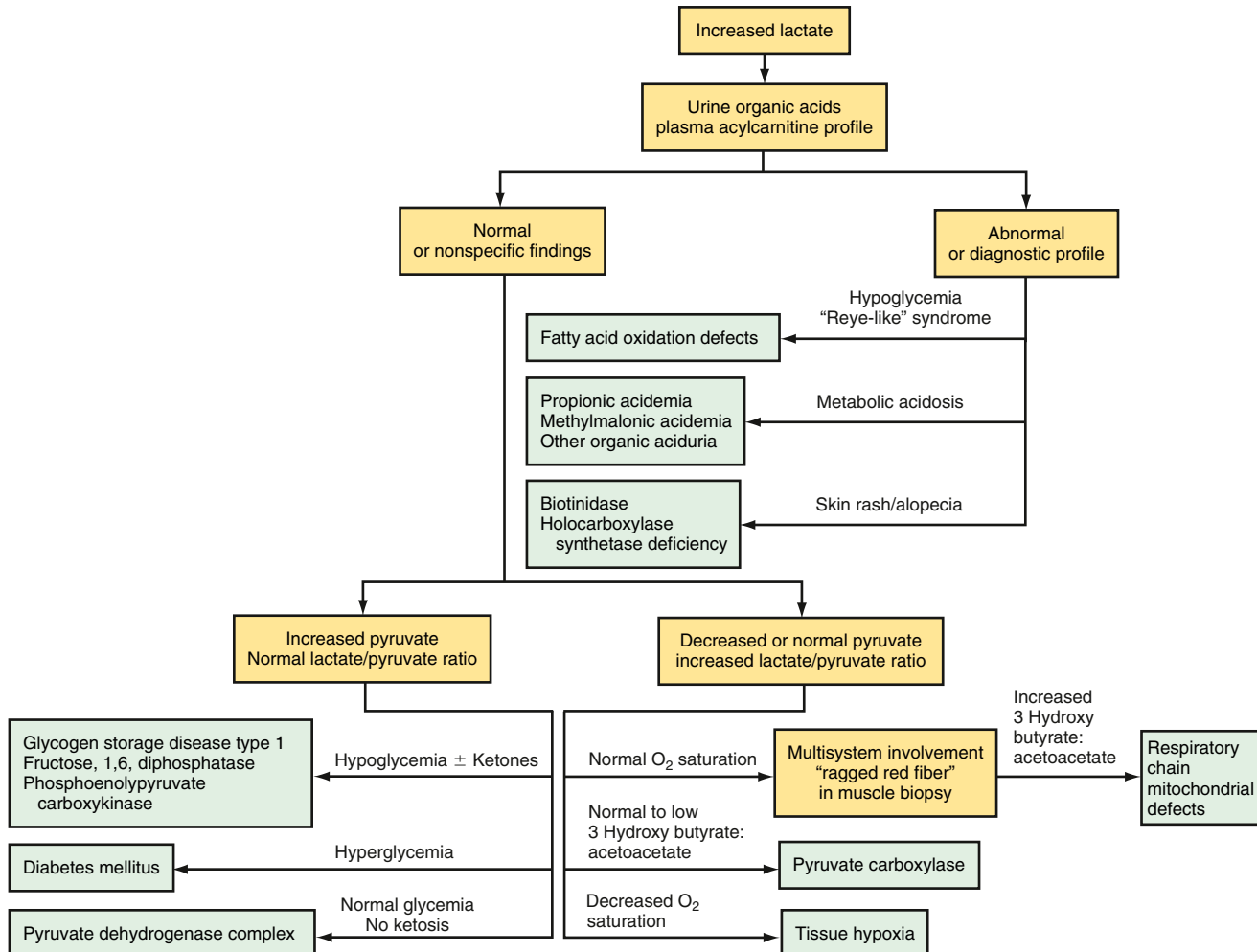
Acetaminophen  
 Alcohols: ethanol, methanol, diethylene glycol, isopropanol, and propylene glycol  
 Antiretroviral nucleoside analogs—zidovudine, didanosine, and lamivudine  
 β-Adrenergic agonists: epinephrine, ritodrine, and terbutaline  
 Biguanides: phenformin and metformin  
 Cocaine, methamphetamine  
 Cyanogenic compounds: cyanide, aliphatic nitriles, and nitroprusside  
 Diethyl ether  
 Fluorouracil  
 Halothane  
 Iron  
 Isoniazid  
 Linezolid  
 Nalidixic acid  
 Niacin

Propofol  
 Salicylates  
 Strychnine  
 Sugars and sugar alcohols: fructose, sorbitol, and xylitol  
 Sulfasalazine  
 Total parenteral nutrition  
 Valproic acid  
 Vitamin deficiencies: thiamine and biotin

**TYPE B3—INBORN ERRORS OF METABOLISM**

Glucose-6-phosphatase deficiency (von Gierke disease)  
 Fructose-1,6-diphosphatase deficiency  
 Phosphoenolpyruvate carboxykinase deficiency  
 Pyruvate carboxylase deficiency  
 Pyruvate dehydrogenase complex (PDHC) deficiency  
 Krebs cycle defects  
 Methylmalonic aciduria and other organic acidemias  
 Kearns-Sayre syndrome  
 Pearson syndrome  
 Barth syndrome  
 Mitochondrial DNA depletion syndromes  
 Nuclear DNA respiratory chain defects  
 Mitochondrial DNA respiratory defects  
 Mitochondrial encephalomyopathy, lactic acidosis, and stroke-like episodes (MELAS)  
 Myoclonic epilepsy with ragged red fibers (MERRF)

Adapted from Vernon C, LeTourneau JL. Lactic acidosis: recognition, kinetics, and associated prognosis. *Crit Care Clin.* 2010;26:255–283, Box 1.



**Fig. 107.5** Algorithm of the differential diagnosis of lactic acidosis.

seizures, and coma. In about half of the cases, the deficiency presents in the first week of life. In certain cases, variable degrees of liver impairment (elevated liver tests) and/or failure have been documented, requiring supportive therapy, including intravenous glucose infusion. In infants and small children, hypoglycemia and/or hepatopathy-like episodes are triggered by fasting or missing meals, febrile infections, gastroenteritis, vomiting, and/or poor oral intake. The frequency of these episodes decreases with age. Laboratory findings include low blood glucose, high lactate, glycerol, and uric acid levels and high anion gap metabolic acidosis. Because of the inability of current biochemical assays for plasma triglycerides to differentiate glycerol from triglycerides, FBP deficiency is usually associated with elevated triglyceride levels. This phenomenon is referred to as *pseudo-hypertriglyceridemia* because the plasma has a high concentration of glycerol rather than triglycerides. In contrast to HFI, there is usually no oral aversion to sweets and fruit. Between episodes, renal tubular and liver function may be normal; however, long-term studies are limited.

The **diagnosis** is established by noninvasive molecular genetic testing for pathogenic variants or demonstrating an enzyme deficiency in either liver biopsy or mononuclear white blood cells. The gene coding for fructose-1,6-bisphosphatase is *FBP1*, and pathogenic variants are known, making carrier detection and prenatal diagnosis possible. **Treatment** of acute attacks consists of correction of hypoglycemia and acidosis by IV glucose infusion, and the response is usually rapid. Avoidance of fasting, frequent feedings, aggressive management of infections, and restriction of fructose, sucrose, glycerol, and/or sorbitol from the diet can prevent further episodes. For long-term prevention of hypoglycemia, a slowly released carbohydrate such as cornstarch is useful. Children remain asymptomatic in between crises, and the majority have normal growth and psychomotor development. A few children have been documented to have suffered brain injury and/or cognitive disabilities, most likely as a result of early and untreated hypoglycemia.

### Phosphoenolpyruvate Carboxykinase Deficiency

Phosphoenolpyruvate carboxykinase (PEPCK) is a key enzyme in gluconeogenesis. It catalyzes the conversion of oxaloacetate to phosphoenolpyruvate and carbon dioxide (see Fig. 107.4). PEPCK deficiency may occur as a cytosolic or mitochondrial enzyme deficiency, as it is encoded by two distinct genes (*PCK1* and *PCK2*, respectively).

PEPCK deficiency has been reported in only a few cases. The **clinical features** are heterogeneous, with hypoglycemia, lactic acidemia, hepatomegaly, hypotonia, developmental delay, and failure to thrive as the major manifestations. There may be multisystem involvement, with neuromuscular deficits, hepatocellular damage, renal dysfunction, and cardiomyopathy. The **diagnosis** is based on the reduced activity of PEPCK in the liver, fibroblasts, or lymphocytes. Fibroblasts and lymphocytes are not suitable for diagnosing the cytosolic form of PEPCK deficiency because these tissues possess only mitochondrial PEPCK. PEPCK deficiency can also occur as a secondary phenomenon caused by other disease, such as mitochondrial depletion disorders. As a result, molecular testing confirming the presence of two pathogenic variants in either the *PCK1* or *PCK2* gene is the recommended gold standard for diagnosis. To avoid hypoglycemia, patients should receive **treatment** with slow-release carbohydrates such as cornstarch, and fasting should be avoided.

## DISORDERS OF PYRUVATE METABOLISM

Pyruvate is formed from glucose and other monosaccharides, from lactate, and from alanine. It is metabolized through four main enzyme systems: LDH, ALT, pyruvate carboxylase, and pyruvate dehydrogenase complex. Deficiency of the M subunit of LDH causes exercise intolerance and myoglobinuria (see Chapter 107.1).

### Pyruvate Dehydrogenase Complex Deficiency

After entering the mitochondria, pyruvate is converted into acetyl-CoA by the pyruvate dehydrogenase complex (PDHC) and then enters the tricarboxylic acid cycle for ATP production. The complex comprises

three functional enzymes: E<sub>1</sub>, an  $\alpha$ -ketoacid decarboxylase; E<sub>2</sub>, a dihydrolipoyl acyltransferase; and E<sub>3</sub>, a dihydrolipoyl dehydrogenase. The complex also contains an E<sub>3</sub>-binding protein (previously called **protein X**) and PDHC kinase and phosphatase, which regulate the complex's activity via phosphorylation/dephosphorylation. Additionally, it requires thiamine pyrophosphate (TPP), lipoic acid, and flavin adenine dinucleotide (FAD) as cofactors. The E<sub>1</sub> subunit, which is made up of two subunits, E<sub>1 $\alpha$</sub>  and E<sub>1 $\beta$</sub> , catalyzes the first and rate-limiting step in the reaction. The most common disorder is caused by a gene defect in the E<sub>1 $\alpha$</sub>  subunit (see Fig. 107.4).

Deficiency of the PDHC is the most common of the disorders leading to lactic acidemia and CNS anomalies and dysfunction. The CNS dysfunction occurs because the brain obtains its energy primarily from oxidation of glucose through glycolysis. Brain acetyl-CoA is synthesized almost exclusively from pyruvate.

PDHC deficiency is mostly caused by pathogenic variants in the gene coding for the E<sub>1 $\alpha$</sub>  subunit, which is inherited in an X-linked dominant fashion; therefore both males and females with a pathogenic variant exhibit features.

### Clinical Manifestations

PDHC deficiency has a wide spectrum of presentations, from the most severe neonatal presentation to a mild late-onset form. The **neonatal onset** is associated with lethal lactic acidosis, white matter cystic lesions, agenesis of the corpus callosum, and severe enzyme deficiency. **Infantile/childhood onset** can be lethal or associated with psychomotor delay and chronic lactic acidosis, cystic lesions in the brainstem and basal ganglia, and features of **Leigh syndrome** (see later and Chapter 638.2). **Late onset** cases, including males, may have less acidosis, greater enzyme activity, and episodic ataxia upon consumption of high-carbohydrate-containing foods. Intelligence in affected males may be normal. Developmental delay, hypotonia, hypertonia, seizures, ataxia, peripheral neuropathy, dystonia, dyskinesia, and/or hemiplegia are among neurologic symptoms of PDHC deficiency. Patients of all ages may have dysmorphic facial features, resembling those seen in fetal alcohol syndrome, as a result of PDHC inhibition and reduction of energy metabolism in the latter. Typically, patients with E<sub>1 $\beta$</sub>  deficiency are more severely affected.

The E<sub>2</sub> deficiency is rare and results in a milder phenotype with varying brain MRI findings and survival into adolescence and adulthood.

The E<sub>3</sub> **lipoamide dehydrogenase** deficiency leads to reduced activity not only in the PDHC but also in the  $\alpha$ -ketoglutarate and branched-chain ketoacid dehydrogenase complexes. This deficiency is more common in the Ashkenazi Jewish population. Individuals deficient in E<sub>3</sub> may present with hypotonia and lactic acidosis during infancy, and affected infants typically die during the first few years of life. Surviving children have been shown to have growth delay and severe neurologic problems. Hepatic disease could be a component of this phenotype or may manifest separately. Only a small number of patients exhibit a myopathic phenotype including muscle weakness and elevated CK. In urine organic acid analysis,  $\alpha$ -ketoglutarate and branched-chain ketoacids can be detected, and plasma amino acid analysis may reveal elevated levels of leucine, isoleucine, valine, and allo-isoleucine. These findings depend greatly on the phenotype of the disease. The E<sub>3</sub> **binding protein deficiency** can present with either neonatal lactic acidosis, severe psychomotor retardation, or seizure, as well as abnormalities on brain MRI. **Pyruvate dehydrogenase phosphatase** and kinase deficiencies have also been reported. These other PDHC defects have clinical manifestations within the variable spectrum associated with PDHC deficiency caused by E<sub>1 $\alpha$</sub>  deficiency.

### Treatment

The general prognosis is poor, except in rare patients whose variants are associated with altered affinity for thiamine pyrophosphate because they may respond to thiamine supplementation. Because carbohydrates can aggravate lactic acidosis, a ketogenic diet is recommended. The ketogenic diet has been found to decrease blood lactate levels and to reduce seizures and improve ataxia and sleep habits. Modified ketogenic diets (a 1:1 fat-to-carbohydrate and protein ratio) have also been



helpful in patients who cannot tolerate a strict ketogenic diet. Infusions of glucose, lactated Ringer, or other drugs known to increase the risk of lactic acidosis, such as metformin, are contraindicated. A potential treatment strategy is to maintain any residual PDHC in its active form by oral administration of dichloroacetate, an inhibitor of E<sub>1</sub> kinase. Beneficial effects of controlling postprandial lactic acidosis have been shown in some patients. Young children generally tolerate **dichloroacetate** well, but continued exposure is associated with peripheral neuropathy, a condition that could be attributable to the drug or the disease. In vitro studies have demonstrated that **phenylbutyrate** increases PDC enzyme activity, especially in those with pathogenic variants linked to residual enzyme activity. In patients with E<sub>3</sub> deficiency, **branched-chain amino acid** restriction and **riboflavin** supplementation are recommended.

### Deficiency of Pyruvate Carboxylase

Pyruvate carboxylase is a mitochondrial, biotin-containing enzyme essential in the process of gluconeogenesis; it catalyzes the conversion of pyruvate to oxaloacetate. The enzyme is also essential for Krebs cycle function as a provider of oxaloacetate and is involved in lipogenesis and formation of nonessential amino acids. **Clinical manifestations** of this deficiency have varied from neonatal severe lactic acidosis accompanied by hyperammonemia, hypercitrullinemia, hyperlysinemia, and hypoglycemia (**type B**) to late-onset mild to moderate lactic acidosis and developmental delay (**type A**). In both types, patients who survive usually have severe psychomotor retardation with seizures, spasticity, and microcephaly. Some patients have pathologic changes in the brainstem and basal ganglia that resemble **Leigh syndrome**. The clinical severity appears to correlate with the level of the residual enzyme activity. A “benign” form of pyruvate carboxylase deficiency has also been described, characterized by recurrent attacks of lactic acidosis and ketoacidosis, as well as mild neurologic deficits (**type C**). Laboratory findings include elevated levels of blood lactate, pyruvate, and alanine and ketonuria. In type B, the lactate-to-pyruvate ratio is increased; this ratio is normal in types A and C. Additionally, in type B, blood ammonia, citrulline, and lysine levels are elevated with low glutamine, which might suggest a primary anaplerotic defect involving the urea cycle. The mechanism is likely the result of depletion of oxaloacetate, which leads to reduced levels of aspartate, a substrate for argininosuccinate synthase in the urea cycle (see [Chapter 105.12](#)). The gene for pyruvate carboxylase is *PC*, and many pathogenic variants have been identified.

**Diagnosis** of pyruvate carboxylase deficiency is made by the measurement of enzyme activity in cultured skin fibroblasts or lymphoblasts and must be differentiated from holocarboxylase synthase (HCS) or biotinidase deficiency. Molecular genetic testing is presently the preferred approach for diagnosis. **Treatment** consists of avoidance of fasting and modifying the diet to include high amounts of carbohydrate and protein. During acute episodes of lactic acidosis, patients should receive continuous IV glucose. Metabolic abnormalities have been reduced with the use of anaplerotic compounds such as citrate, aspartate, or more recently, triheptanoin, but no improvement has been shown in neurologic symptoms or increased life span. Although liver transplantation has been shown to correct biochemical abnormalities in two patients, the long-term benefits of this procedure are still unknown. Biotin is a cofactor used for this condition, but most patients do not respond to biotin. Lactated Ringer solution is contraindicated in this condition because of the theoretical risk of worsening lactic acidosis in these patients.

### Deficiency of Pyruvate Carboxylase Secondary to Deficiency of Holocarboxylase Synthase or Biotinidase

Deficiency of either **HCS** or biotinidase, enzymes involved in biotin metabolism and recycling, respectively, results in multiple-carboxylase deficiency (pyruvate carboxylase, acetyl-CoA carboxylase, 3-methyl-crotonyl-CoA carboxylase, and propionyl-CoA carboxylase) and in **clinical manifestations** associated with the respective deficiencies, including rash, lactic acidosis, and alopecia (see [Chapter 103.6](#)). Both enzyme deficiencies are autosomal recessive disorders.

The incidence of HCS and biotinidase deficiency is approximately 1 in 87,000 and 1 in 80,000 live births, respectively. Ancestry-specific pathogenic variants in the HCS and biotinidase (BTD) genes have been described. Two common pathogenic variants (c.98\_104delinsTCC; p.Cys33PhefsTer36 and c.1612C>T; p.Arg538Cys) in the BTD account for 52% of all pathogenic alleles in symptomatic patients with biotinidase deficiency.

The course of HCS may be more protracted and less responsive to therapy than BTD deficiency. Lack of treatment may be associated with intermittent exacerbations on top of chronic lactic acidosis, failure to thrive, seizures, and hypotonia leading to spasticity, lethargy, coma, and death. Auditory and optic nerve dysfunction can lead to deafness and blindness, respectively. The course of BTD deficiency may be severe if left untreated. Late-onset milder forms have also been reported. Laboratory findings include an anion gap metabolic acidosis, lactic acidosis, and abnormal urine organic acids. Lactate, 3-methylcrotonylglycine, 3-hydroxypropionate, 3-hydroxisovalerate, and methyl citrate may accumulate in urine organic acid chromatography (OAC), though the concentrations of metabolites differ according to the severity of the enzyme deficiency. Blood and/or urine biotin levels can be used to evaluate treatment adherence, but they do not contribute to diagnosis. Biotin concentrations in plasma and urine are normal in patients with HCS deficiency and are often decreased in patients with BTD deficiency, particularly when the assay used does not detect biocytin.

**Diagnosis** of HCS deficiency and biotinidase deficiency can be detected through newborn screening tandem mass spectroscopy, which enables early treatment and improves outcomes. Molecular genetic testing is required to confirm the diagnosis, which involves the detection of two pathogenic variants. BTD deficiency can be diagnosed by reduced enzyme activity in the patient's serum or plasma, which helps to classify the deficiency into two categories: profound deficiency (biotinidase activity less than 10% of mean normal serum BTD activity) and partial deficiency (BTD activity between 10% and 30% of mean normal serum BTD activity). HCS activity in skin fibroblasts or lymphocytes can be assessed when HCS deficiency is suspected but genetic testing is equivocal.

### Treatment

Treatment consists of biotin supplementation 5-20 mg/day and is generally effective if started early before the onset of symptoms or development of brain damage. Newborn screening has facilitated early treatment for patients with partial or profound BTD deficiency, who respond well to 5-10 mg of biotin; some patients may require higher doses during acute illness. Patients identified through newborn screening and treated with biotin have remained asymptomatic.

### Mitochondrial Respiratory Chain Defects (Oxidative Phosphorylation Disease)

The mitochondrial respiratory chain catalyzes the oxidation of fuel molecules and transfers the electrons to molecular oxygen, with concomitant energy transduction into ATP (**oxidative phosphorylation**) (see [Chapter 108](#)). The respiratory chain produces ATP from adenosine diphosphate and inorganic phosphate, using the energy from electrons transferred from nicotinamide adenine dinucleotide (NADH) or flavin adenine dinucleotide, and includes five specific complexes (I: NADH-coenzyme Q reductase; II: succinate-coenzyme Q reductase; III: coenzyme QH<sub>2</sub> cytochrome-c reductase; IV: cytochrome-c oxidase; V: ATP synthase). Each complex is composed of 4-35 individual proteins that are encoded by nuclear or maternally inherited mitochondrial DNA, with the exception of complex II, which is encoded solely by nuclear genes. Alterations of these complexes or assembly systems produce chronic lactic acidosis, presumably because of a change in the reduction-oxidation state with increased concentrations of NADH ([Table 107.3](#)).

In contrast to PDHC or pyruvate carboxylase deficiency, skeletal muscle and the heart are usually involved in the respiratory chain disorders. On muscle biopsy, **ragged red fibers** indicating mitochondrial proliferation are suggestive of mitochondrial involvement when present, especially when observed in young patients with symptoms (see

**Table 107.3** Clinical and Genetic Heterogeneity of Disorders Related to Pathogenic Variants in Mitochondrial DNA\*

SYMPTOMS, SIGNS, AND FINDINGS	LARGE DELETIONS IN MITOCHONDRIAL DNA			PATHOGENIC VARIANT IN TRANSFER RNA		PATHOGENIC VARIANT IN RIBOSOMAL RNA	PATHOGENIC VARIANT IN MESSENGER RNA		
	KSS	PEO	PS	MERRF	MELAS	AID	NARP	MILS	LHON
<b>CENTRAL NERVOUS SYSTEM</b>									
Seizures	–	–	±	+++	+	–	±	+	–
Ataxia	+	–	±	+	+	–	+	±	–
Myoclonus	–	–	–	+	±	–	–	–	–
Psychomotor retardation	–	–	±	–	±	–	–	+	–
Psychomotor regression	+	–	–	±	+	–	±	+	–
Hemiparesis and hemianopia	–	–	–	–	+++	–	–	–	–
Cortical blindness	–	–	–	–	+	–	–	–	–
Migraine-like headaches	–	–	–	±	+	–	–	–	–
Dystonia	–	–	–	–	+	–	–	+	±
<b>PERIPHERAL NERVOUS SYSTEM</b>									
Peripheral neuropathy	±	–	–	±	±	–	+	±	±
<b>MUSCLE</b>									
Weakness ± exercise intolerance	+	+++	±	+	+	–	+	+	±
Ophthalmoplegia	+	+	±	±	±	–	±	±	–
Ptosis	+	+	±	±	–	–	–	±	–
<b>EYE</b>									
Pigmentary retinopathy	+	–	–	±	±	–	+	±	–
Optic atrophy	–	–	–	±	±	–	±	±	+
<b>BLOOD</b>									
Sideroblastic anemia	–	–	+	–	–	–	–	–	–
<b>ENDOCRINE SYSTEM</b>									
Diabetes mellitus	±	–	±	±	±	–	–	±	–
Short stature	+	–	±	+	+	–	±	–	–
Hypoparathyroidism	±	–	±	–	±	–	–	–	–
<b>HEART</b>									
Conduction disorder	+	–	–	±	±	–	±	±	±
Cardiomyopathy	±	–	–	±	±	+	–	±	–
<b>GASTROINTESTINAL SYSTEM</b>									
Exocrine pancreatic dysfunction	±	–	±	–	–	–	–	–	–
Intestinal pseudoobstruction	–	–	–	–	±	–	–	±	–
<b>EAR, NOSE, AND THROAT</b>									
Sensorineural hearing loss	±	–	–	+	+	+	±	±	–
<b>KIDNEY</b>									
Fanconi syndrome/RTA	±	–	±	–	±	–	–	±	–
<b>LABORATORY FINDINGS</b>									
Lactic acidosis	+	±	+	+	+	±	±	±	–
Ragged-red fibers on muscle biopsy	+	+	±	+	+	–	–	±	–
<b>MODE OF INHERITANCE</b>									
Maternal	–	–	–	+	+	+	+	+	+
Sporadic	+	+	+	–	–	–	–	–	–

\*Characteristic constellations of symptoms and signs are in bold.

+, Presence of a symptom, sign, or finding; –, absence of a symptom, sign, or finding; ±, possible presence of a symptom, sign, or finding; AID, aminoglycoside-induced deafness; KSS, Kearns-Sayre syndrome; LHON, Leber hereditary optic neuropathy; MELAS, mitochondrial encephalomyopathy, lactic acidosis, and stroke-like episodes; MERRF, myoclonic epilepsy with ragged red fibers; MILS, maternally inherited Leigh syndrome; NARP, neuropathy, ataxia, and retinitis pigmentosa; PEO, progressive external ophthalmoplegia; PS, Pearson syndrome, RTA, renal tubular acidosis.

Modified from DiMauro S, Schon EA. Mitochondrial respiratory-chain diseases. *N Engl J Med*. 2003;348:2656–2668.

Fig. 107.5). Because of the ubiquitous nature of oxidative phosphorylation, a defect of the mitochondrial respiratory chain accounts for a vast array of clinical manifestations and should be considered in patients of all ages presenting with multisystem involvement. Some deficiencies resemble **Leigh syndrome** with lactic acidosis, whereas others present with stroke-like episodes, myopathies, or ataxia including **MELAS** (mitochondrial encephalopathy, lactic acidosis, and stroke-like episodes), **MERRF** (myoclonic epilepsy and ragged red fibers), and **Kearns-Sayre syndrome** (external ophthalmoplegia, ptosis, metabolic

acidosis, retinal degeneration, heart block, myopathy, and high cerebrospinal fluid protein) (see Table 107.3) (see Chapters 638.2 and 651.4). There is a higher incidence of neuropsychiatric disorders in adults with a primary oxidative phosphorylation disease than in the general population.

**Diagnosis** requires identification of pathogenic variants in mitochondrial DNA or nuclear genes encoding mitochondrial proteins or demonstrating functional abnormalities of oxidative phosphorylation enzyme complex activities in tissues (e.g., skin, muscle, or liver). In



**Table 107.4** Mitochondrial Disease Criteria (Simplified Version for Bedside Use)\*

I. CLINICAL SIGNS AND SYMPTOMS, 1 POINT/SYMPTOM (max. 4 points)				
A. MUSCULAR PRESENTATION (max. 2 points)	B. CNS PRESENTATION (max. 2 points)	C. MULTISYSTEM DISEASE (max. 3 points)	II. METABOLIC/IMAGING STUDIES (max. 4 points)	III. MORPHOLOGY (max. 4 points)
Ophthalmoplegia <sup>†</sup>	Developmental delay	Hematology	Elevated lactate <sup>†</sup>	Ragged red/blue fibers <sup>‡</sup>
Facies myopathica	Loss of skills	GI tract	Elevated L/P ratio	COX-negative fibers <sup>‡</sup>
Exercise intolerance	Stroke-like episode	Endocrine/growth	Elevated alanine <sup>†</sup>	Reduced COX staining <sup>‡</sup>
Muscle weakness	Migraine	Heart	Elevated CSF lactate <sup>†</sup>	Reduced SDH staining
Rhabdomyolysis	Seizures	Kidney	Elevated CSF protein	SDH positive blood vessels <sup>†</sup>
Abnormal EMG	Myoclonus	Vision	Elevated CSF alanine <sup>†</sup>	Abnormal mitochondria/EM <sup>†</sup>
	Cortical blindness	Hearing	Urinary TA excretion <sup>†</sup>	
	Pyramidal signs	Neuropathy	Ethylmalonic aciduria	
	Extrapyramidal signs	Recurrent/familial	Strokelike picture/MRI	
	Brainstem involvement		Leigh syndrome/MRI <sup>†</sup>	
			Elevated lactate/MRS	

\*Score 1: unlikely mitochondrial disorder; score 2-4: possible mitochondrial disorder; score 5-7: probable mitochondrial disorder; score ≥8: definite mitochondrial disorder.

<sup>†</sup>This specific symptom scores 2 points.

<sup>‡</sup>This symptom in a higher percentage scores 4 points.

GI, Gastrointestinal; L/P, lactate/pyruvate; COX, cytochrome C oxidase; SDH, succinate dehydrogenase; EM, electron microscopy; EMG, electromyography; TA, tricarboxylic acid. From Morava E, van den Heuvel L, Hol F, et al. Mitochondrial disease criteria – diagnostic applications in children. *Neurology*. 2006;67:1823–1826.

clinical testing panels that are used to diagnose mitochondrial disorders. An important consideration is that many genetic and multifactorial conditions have been associated with defects in one or more of the four complexes assayed in mitochondrial oxidative phosphorylation testing; these latter conditions feature so-called secondary mitochondrial dysfunction because the conditions are not considered to be causative for primary mitochondrial dysfunction.

**Treatment** remains largely symptomatic and nonspecific and does not cure or significantly alter the outcome of disease. Mitochondrial drugs are mainly medicinal/nutritional supplements designed to sustain and boost the mitochondrial residual oxidative phosphorylation function, while also reducing oxidative stress. Although there is no consensus on which vitamins and cofactors should be used to treat mitochondrial disease, the main supplementations used are CoQ10, L-carnitine, creatine, alpha-lipoic acid (ALA), and B vitamins. Additional medications/supplements are indicated based on the genetic diagnosis and clinical symptoms of the patient. For example, arginine (IV, oral) can be prescribed in patients with MELAS for treatment and prevention of metabolic strokes. Citrulline and taurine have also been used with some success in ongoing clinical trials and case reports demonstrating promising results. Patients with mitochondrial disease should be encouraged to exercise regularly. Patients with mitochondrial disorders are at a greater risk of developing anesthesia-related complications. Avoiding prolonged fasting and receiving dextrose-containing IV fluids before, during, and after procedures and operations are critical for avoiding catabolism. There are an increasing number of clinical studies evaluating various therapeutic approaches, including mitochondrial augmentation therapy in pediatric children with Pearson syndrome (NCT03384420) and AAV gene therapy in individuals with Leber hereditary optic neuropathy (LHON) (NCT02161380).

### Leigh Syndrome (Subacute Necrotizing Encephalomyelopathy)

Leigh syndrome is a heterogeneous neurologic disease historically diagnosed based on neuropathologic findings of demyelination, gliosis, necrosis, relative neuronal sparing, and capillary proliferation in specific brain regions (see Chapter 638.2). Leigh syndrome is characterized by decompensation (neurodevelopmental regression and lactic acidosis) initiated by viral infection or other metabolic stress. Patients frequently present with feeding and swallowing problems, failure to thrive, and developmental delay. The presentation is highly variable and may include seizures, altered consciousness, movement disorders, nystagmus, ophthalmoplegia, cerebellar ataxia, and peripheral

neuropathy. Extraneurologic manifestations may include pericardial effusion, cardiomyopathy, renal tubulopathy, liver involvement, hypertrichosis, and muscle weakness. **Diagnosis** is usually confirmed by radiologic evidence of symmetric lesions affecting the basal ganglia, brainstem, and subthalamic nuclei. Patients with Leigh syndrome have defects in several enzyme complexes. Dysfunction in cytochrome-c oxidase (complex IV) is the most commonly reported defect, followed by NADH-coenzyme Q reductase (complex I), PDHC, and pyruvate carboxylase (see Chapter 108). Pathogenic variants in the nuclear *SURF1* gene, which encodes an assembly factor involved in the biogenesis of cytochrome-c oxidase, and mitochondrial DNA variants in the adenosine triphosphatase 6 (MT-ATP6) coding region have been reported in patients with Leigh syndrome in association with complex IV deficiency. The most common mitochondrial DNA variant in Leigh syndrome is the m.8993T>G variant in MT-ATP6. The **prognosis** for Leigh syndrome is poor. In a study of 14 cases, there were 7 fatalities before age 1.5 years. Pathogenic variants in *MTFMT* had a milder clinical phenotype and disease progression, according to recent research.

Lactic acidosis and encephalopathy have also been reported in patients with thiamine transporter 2 (THTR2) deficiency and with pyridoxine-dependent epilepsy. Thiamine, either alone or in combination with biotin, is required for the treatment of THTR2 deficiency, whereas pyridoxine is used to treat pyridoxine-dependent epilepsy.

Visit Elsevier eBooks+ at [eBooks.Elsevier.com](http://eBooks.Elsevier.com) for Bibliography.

## 107.5 Defects in Pentose Metabolism

Ghada Hijazi and Priya S. Kishnani

Approximately 90% of glucose metabolism in the body is generated via the glycolytic pathway, with the remaining 10% generated via the hexose monophosphate pathway. The hexose monophosphate shunt leads to the formation of pentose and provides NADPH. One of the metabolites of this alternative pathway is ribose-5-phosphate, which is used in the biosynthesis of ribonucleotides and deoxyribonucleotides. Through the transketolase and transaldolase reactions, pentose phosphates can be converted back to fructose-6-phosphate and glucose-6-phosphate.

### ESSENTIAL PENTOSURIA

Essential pentosuria is a benign asymptomatic disorder encountered principally in the Ashkenazi Jewish population and is inherited in an



**Table 107.5** Clues to the Diagnosis of Mitochondrial Disease**NEUROLOGIC**

Cerebral strokelike lesions in a nonvascular pattern  
 Basal ganglia disease  
 Encephalopathy, recurrent or with low/moderate dosing of valproate  
 Neurodegeneration  
 Epilepsia partialis continua  
 Myoclonus  
 Ataxia  
 MRI findings consistent with Leigh syndrome  
 Characteristic MRS peaks  
 Lactate peak at 1.3 ppm TE (time to echo) at 35 and 135  
 Succinate peak at 2.4 ppm

**CARDIOVASCULAR**

Hypertrophic cardiomyopathy with rhythm disturbance  
 Unexplained heart block in a child  
 Cardiomyopathy with lactic acidosis (>5 mM)  
 Dilated cardiomyopathy with muscle weakness  
 Wolff-Parkinson-White arrhythmia

**OPHTHALMOLOGIC**

Retinal degeneration with signs of night blindness, color vision deficits, decreased visual acuity, or pigmentary retinopathy  
 Ophthalmoplegia/paresis  
 Fluctuating, dysconjugate eye movements  
 Ptosis  
 Sudden- or insidious-onset optic neuropathy/atrophy

**GASTROENTEROLOGIC**

Unexplained or valproate-induced liver failure  
 Severe dysmotility  
 Pseudoobstructive episodes

**OTHER**

A newborn, infant, or young child with unexplained hypotonia, weakness, failure to thrive, and a metabolic acidosis (particularly lactic acidosis)  
 Exercise intolerance that is not in proportion to weakness  
 Hypersensitivity to general anesthesia  
 Episodes of acute rhabdomyolysis  
 Elevated GDF-15 level

MRI, Magnetic resonance imaging, MRS, magnetic resonance spectroscopy; GDF, growth and differentiation factor.

From Haas RH, Parikh S, Falk MJ, et al. Mitochondrial disease: a practical approach for primary care physicians. *Pediatrics*. 2007;120:1326–1333, Table 1.

autosomal recessive fashion. The urine contains **L-xylulose**, which is excreted in increased amounts because of a block in the conversion of L-xylulose to xylitol as a result of **xylitol dehydrogenase deficiency**. The condition is usually discovered incidentally in a urine test for reducing substances. No treatment is required.

**TRANSALDOLASE DEFICIENCY**

Transaldolase deficiency is a rare autosomal recessive inborn error of the pentose phosphate pathway. It is more common in Middle Eastern countries and can manifest in three distinct phenotypes. Prenatal intrauterine growth restriction (IUGR), oligohydramnios, and/or hydrops fetalis occur with the most severe phenotype. The second is a neonatal phenotype, where patients may have dysmorphic facial features (triangular-shaped face, low-set ears, wide mouth, and thin lips), cardiovascular abnormalities (ventricular and atrial septal defects), anemia, thrombocytopenia, and hepatosplenomegaly noted in the newborn period. In some cases, hepatic dysfunction was described associated with fibrosis and/or cirrhosis, and transplantation of the liver was indicated in a number of patients. Endocrine abnormalities (abnormal genitalia, vitamin D insufficiency, hypergonadotrophic

hypogonadism), renal tubulopathy, and skin abnormalities (cutis laxa, wrinkled skin, capillary hemangioma) have been observed. A third, milder phenotype is described as presenting later in life. Biochemical abnormalities reveal elevated levels of the polyols arabitol, ribitol, and erythritol and the seven-carbon sugars sedoheptitol, perseitol, sedoheptulose, mannoheptulose, and sedoheptulose-7P in the urine. The **diagnosis** is established with the detection of biallelic pathogenic variants in the *TALDO1* gene. When genetic testing is inconclusive, low transaldolase activity in lymphoblasts, fibroblasts, and liver tissue can be used to confirm the diagnosis. The available **treatment** is symptomatic. Supportive management of the disease manifestations (e.g., hepatic dysfunction) is needed. Transplantation of the liver may be indicated. Regular follow-up and monitoring for complications such as anemia and thrombocytopenia is required. N-acetylcysteine (NAC) supplementation delayed the progression of disease and restored normal alpha fetoprotein levels in a research trial. Additional long-term studies are required to evaluate the broader effectiveness of NAC supplementation.

**RIBOSE-5-PHOSPHATE ISOMERASE DEFICIENCY**

Only four cases of ribose-5-phosphatase isomerase deficiency disorder have been reported. Affected patients may present with psychomotor delay or regression, epilepsy, peripheral neuropathy, and leukoencephalopathy. Magnetic resonance spectroscopy (MRS) and urine analysis usually reveal elevated levels of polyols arabitol and ribitol in these patients. Confirmation of diagnosis is established by identification of biallelic *RPIA* pathogenic variants or by enzyme assay in cultured fibroblasts.

Visit Elsevier eBooks+ at [eBooks.Health.Elsevier.com](http://eBooks.Health.Elsevier.com) for Bibliography.

**107.6 Disorders of Glycoprotein Degradation and Structure**

Margaret M. McGovern and Robert J. Desnick

The disorders of glycoprotein degradation and structure include several lysosomal storage diseases that result from defects in glycoprotein degradation and the congenital disorders of glycosylation (see Chapter 107.7). *Glycoproteins* are macromolecules composed of oligosaccharide chains linked to a peptide backbone. They are synthesized by two pathways: the glycosyltransferase pathway, which synthesizes oligosaccharides linked *O*-glycosidically to serine or threonine residues, and the dolichol, lipid-linked pathway, which synthesizes oligosaccharides linked *N*-glycosidically to asparagine.

The **glycoprotein lysosomal storage diseases** result from the deficiency of the enzymes that normally participate in the degradation of oligosaccharides and include sialidosis, galactosialidosis, aspartylglucosaminuria, and  $\alpha$ -mannosidosis. In some instances, the underlying abnormality that leads to glycoprotein accumulation also results in abnormal degradation of other classes of macromolecules that contain similar oligosaccharide linkages, such as certain glycolipids and proteoglycans. In these cases the underlying enzymatic deficiency results in the accumulation of both glycoproteins and *glycolipids*. The classification of these types of disorders as *lipidoses* or *glycoproteinoses* depends on the nature of the predominantly stored substance. In general, the glycoprotein disorders are characterized by autosomal recessive inheritance and a progressive disease course with clinical features that resemble those seen in the mucopolysaccharidoses.

**SIALIDOSIS AND GALACTOSIALIDOSIS**

**Sialidosis** is an autosomal recessive disorder that results from the primary deficiency of neuraminidase because of pathogenic variants in the gene (*NEU1*) that encodes this protein. In contrast, **galactosialidosis** is caused by the deficiency of two lysosomal enzymes—neuraminidase and  $\beta$ -galactosidase. The loss of these enzymatic activities results from pathogenic variants in a single gene, *CTSA*, that encodes the

protective protein cathepsin A, which functions to stabilize these enzymatic activities. Neuraminidase normally cleaves terminal sialyl linkages of several oligosaccharides and glycoproteins. Its deficiency results in the accumulation of oligosaccharides and the urinary excretion of sialic acid terminal oligosaccharides and sialylglycopeptides. Examination of tissues from affected individuals reveals pathologic storage of substrate in many tissues, including liver, bone marrow, and brain.

The clinical phenotype associated with neuraminidase deficiency is variable and includes **type I** sialidosis, which usually presents in the second decade of life with myoclonus and cherry-red spots in the macula. These patients typically present secondary to gait disturbances, myoclonus, or visual complaints. In contrast, **type II** sialidosis occurs at several ages of onset (congenital, infantile, and juvenile), depending on the severity of the gene pathogenic variant. The **congenital** and **infantile** forms result from isolated neuraminidase deficiency, whereas the **juvenile** form results from both neuraminidase and  $\beta$ -galactosidase deficiency. The congenital type II disease is characterized by hydrops fetalis, neonatal ascites, hepatosplenomegaly, stippling of the epiphyses, periosteal cloaking, and stillbirth or death in infancy. The type II infantile form presents in the first years of life with dysostosis multiplex, moderate global developmental delays, visceromegaly, corneal clouding, cherry-red maculae, and seizures. The juvenile type II form of sialidosis, which is sometimes designated *galactosialidosis*, has a variable age of onset ranging from infancy to adulthood. In infancy, the phenotype is similar to that of GM1 gangliosidosis, with edema, ascites, skeletal dysplasia, and cherry-red spots. Patients with later-onset disease have dysostosis multiplex, visceromegaly, intellectual disability, dysmorphism, corneal clouding, progressive neurologic deterioration, and cherry-red spots.

No specific therapy exists for any form of the disease, although studies in animal models have demonstrated improvement in the phenotype after bone marrow transplantation. The **diagnosis** of sialidosis and galactosialidosis is achieved by the demonstration of the specific enzymatic deficiency or by pathogenic variants in the responsible gene. **Prenatal diagnosis** using cultured amniotic cells or chorionic villi is available by demonstrating the enzyme defect and/or specific gene pathogenic variants.

### ASPARTYLGLUCOSAMINURIA

This is a rare autosomal recessive lysosomal storage disorder, except in Finland, where the carrier frequency is estimated at 1 in 36 adults, the high frequency due to a *founder gene*. The disorder results from the deficient activity of **aspartylglycosaminidase** and the subsequent accumulation of aspartylglycosamine, particularly in the liver, spleen, and thyroid. The gene for the enzyme is *AGA*, and in the Finnish population, a single *AGA* pathogenic variant encoding p.Cys163Ser accounts for most mutant alleles. Outside of Finland, a large number of private pathogenic variants have been described.

Affected individuals with aspartylglucosaminuria typically present in the first year of life with recurrent infections, diarrhea, and umbilical hernias. Coarsening of the facies and short stature usually develop later. Other features include joint laxity, macroglossia, hoarse voice, crystal-like lens opacities, hypotonia, and spasticity. Psychomotor development is usually near normal until age 5 years, when a decline is noted. Behavioral abnormalities are typically seen, and IQ values in affected adults are usually <40 (severe intellectual disability). Survival to adulthood is common, with most early deaths attributable to pneumonia or other pulmonary causes. Definitive **diagnosis** requires demonstration of markedly deficient aspartylglucosaminidase in peripheral blood leukocytes and/or the specific *AGA* pathogenic variant(s). Several patients have undergone allogeneic bone marrow transplants, but this approach has not proved effective, and no specific treatment is available. **Prenatal diagnosis** is available by the determination of aspartylglucosaminidase deficiency and/or the specific *AGA* pathogenic variants in cultured amniocytes or chorionic villi.

### $\alpha$ -MANNOSIDOSIS

This autosomal recessive disorder results from the deficient activity of  **$\alpha$ -mannosidase** and the accumulation of mannose-rich compounds.

The gene *MAN2B1* encodes the enzyme, and to date, >140 gene pathogenic variants have been reported. Affected patients display clinical heterogeneity. There is a severe infantile form, or **type I** disease, and a milder juvenile variant, **type II** disease. All patients have psychomotor retardation, facial coarsening, and dysostosis multiplex. The **infantile** form of the disorder, however, is characterized by more rapid cognitive deterioration, with death occurring between ages 3 and 10 years. Patients with the infantile form also have more severe skeletal involvement and hepatosplenomegaly. The **juvenile** disorder is characterized by onset of symptoms in early childhood or adolescence, with milder somatic features and survival to adulthood. Hearing loss, destructive synovitis, pancytopenia, and spastic paraplegia have been reported in type II patients. The **diagnosis** is made by identification of biallelic pathogenic variants in *MAN2B1* and may be supplemented by the demonstration of the marked deficiency of  $\alpha$ -mannosidase activity in white blood cells or cultured fibroblasts. Clinical trials of ERT with recombinant human  $\alpha$ -mannosidase are underway. **Prenatal diagnosis** can be made by demonstrating the enzyme defect and/or known pathogenic variants in cultured amniocytes or chorionic villi.

Visit Elsevier eBooks+ at [eBooks.Elsevier.com](http://eBooks.Elsevier.com) for Bibliography.

## 107.7 Congenital Disorders of Glycosylation

Eva Morava and Peter Witters

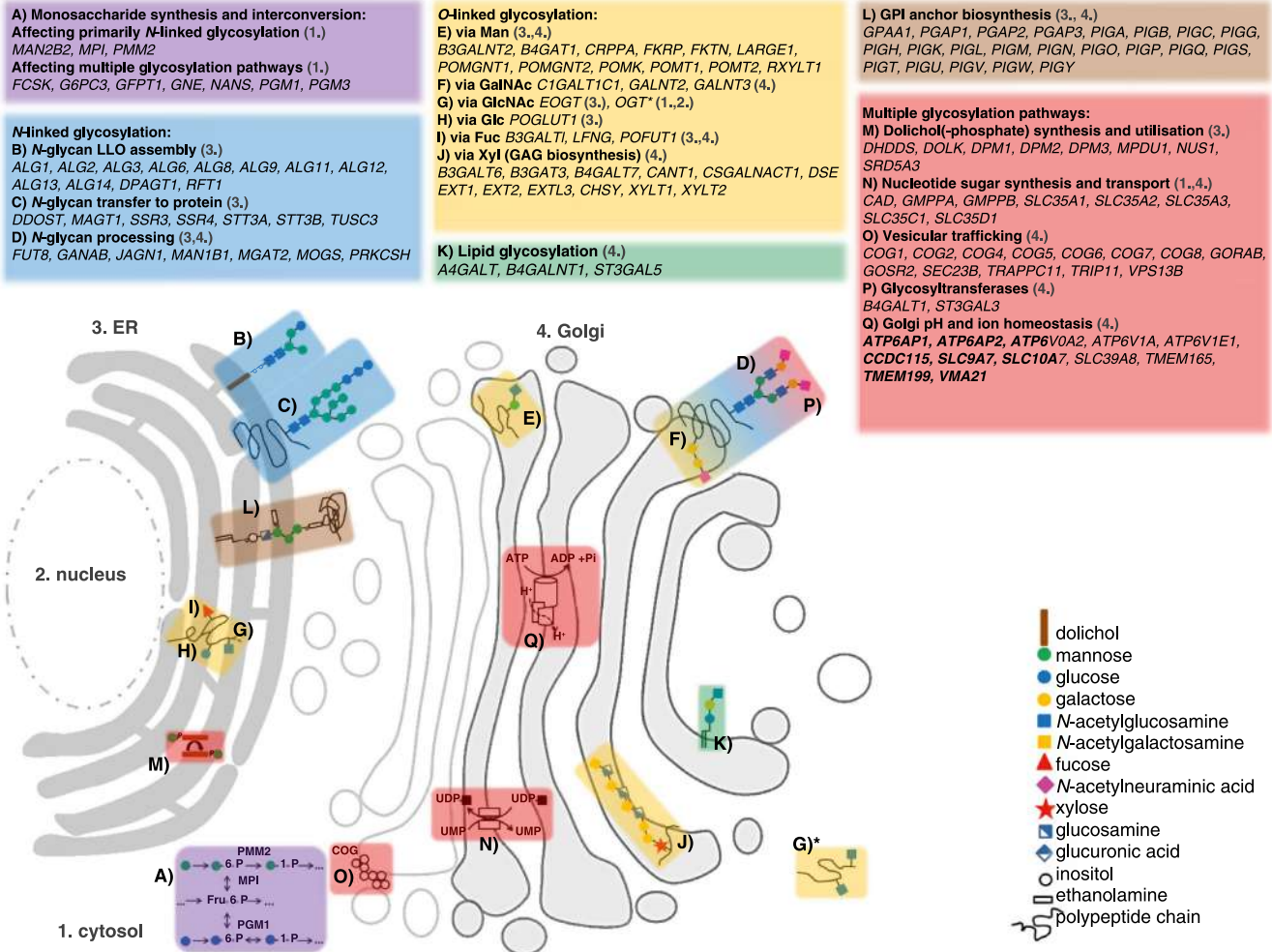
**Glycosylation** is the complex multistep metabolic process of adding (oligo)saccharides to macromolecules such as proteins and lipids. The classification of **disorders of hypoglycosylation** is based on biochemical structures: (1) defects in protein N-linked glycosylation, (2) defects in protein O-linked glycosylation, (3) defects in glycosphingolipid and in glycosylphosphatidylinositol-anchor glycosylation, and (4) defects in multiple glycosylation pathways and in other pathways (Fig. 107.7). No disorders are known to result from abnormal C-linked glycosylation. Congenital disorders of glycosylation (CDGs) are labeled based on their genetic defect.

**Protein glycosylation** is an essential process. Most functional proteins are glycosylated, including serum proteins (e.g., transferrin, ceruloplasmin, thyroxine-binding globulin [TBG]), hormones (e.g., thyroid-stimulating hormone [TSH], follicle-stimulating hormone [FSH], luteinizing hormone [LH], adrenocorticotropic hormone [ACTH], IGFBP3), and clotting and anticoagulation factors (e.g., factors IX and XI, antithrombin). Membrane proteins are also highly glycosylated. Important intracellular glycoproteins include enzymes such as glycosyltransferases or lysosomal enzymes.

**N-glycans** are linked to the amide group of asparagine. They are synthesized in a complicated process throughout the cytoplasm, endoplasmic reticulum (ER), and Golgi complex, starting with sugar activation and nucleotide sugar synthesis, then oligosaccharide assembly, and finally glycan processing (see Fig. 107.7). Most of the pediatric glycosylation disorders are the result of N-glycosylation defects. **O-glycans** are linked to the hydroxyl group of serine or threonine. These diverse glycoproteins are mostly formed in the Golgi complex; their defects can involve xylosylation, fucosylation, mannosylation, or other modifications. An important focus is O-mannosylation defects because of their relevance for dystroglycanopathies.

**Lipid glycosylation** is an essential process for the synthesis of ceramide and ganglioside synthesis. **Glycosylphosphatidylinositols** (GPIs) are very special glycolipids that link various proteins to the plasma membrane, as complex lipid-sugar anchors (GPI anchors, see Fig. 107.7).

CDGs are predominantly multisystem diseases caused by more than 150 different genetic defects in glycoprotein and glycolipid glycan synthesis. Most patients described with CDG have N-glycosylation defects, followed by the fastest-growing groups of CDGs, involving multiple glycosylation pathways and dolicholphosphate synthesis. Smaller groups are O-glycosylation disorders and disorders of GPI. The “oldest” and most common CDG is PMM2-CDG, in which the



**Fig. 107.7** Congenital disorders of glycosylation (CDG): an overview of the currently known subtypes. The picture shows a schematic illustration of the individual 137 CDG subtypes known to date, designated by the symbol of the affected gene, which are categorized according to the nature of the biochemical event impaired within the glycosylation pathway. Glycosylation is a complex metabolic process resulting in the attachment of an oligosaccharide chain of varying length and composition (a glycan) to proteins and lipids. It involves a set of enzyme-catalyzed reactions that take place mainly in the cytosol (1.), endoplasmic reticulum (ER; 3.) and Golgi apparatus (4.), after which the newly formed glycoconjugates are, generally, incorporated into membranes or secreted out of the cell. Depending on how a glycan is linked to the polypeptide backbone, protein glycosylation is classified into N-linked (a bond via the amide group of asparagine) or O-linked (a bond via the hydroxyl group of serine, threonine, or hydroxylysine). N-glycoproteins share a common core structure of the glycan, which is first assembled on a dolichol anchor and then transferred onto the protein in the ER; this is later followed by further modifications of the N-glycan, removing and adding different monosaccharides, in the Golgi apparatus. O-glycosylation consists of a stepwise addition of individual monosaccharide units in the ER and Golgi apparatus, while six subclasses can be distinguished based on which sugar (Man, GalNAc, GlcNAc, Glc, Fuc, or Xyl) is the first one attached to the protein, and thus more varied O-glycan structures are produced. Other specific types of glycosylation involve lipid glycosylation and the modification of proteins by the glycosylphosphatidylinositol (GPI) anchor. The substrates for glycosylation in the form of nucleotide-monosaccharides are synthesized predominantly in the cytosol, and because they are used in different glycosylation reactions, their deficiency possibly influences the structure of various glycoconjugates. Similarly, several defects have been described that affect multiple glycosylation pathways, and, often, other cellular processes might be disturbed as well (e.g., because of altered ion homeostasis in the Golgi apparatus). ADP, adenosine diphosphate; ATP, adenosine triphosphate; COG, conserved oligomeric Golgi (complex); ER, endoplasmic reticulum; Fru-6-P, fructose-6-phosphate; Fuc, fucose; GalNAc, N-acetylgalactosamine; Glc, glucose; GlcNAc, N-acetylglucosamine; GPI, glycosylphosphatidylinositol; H<sup>+</sup>, protons; LLO, lipid-linked oligosaccharides; Man, mannose; MPI, mannose phosphate isomerase; PGM1, phosphoglucomutase 1; PMM2, phosphomannomutase 2; UDP, uridine diphosphate; UMP, uridine monophosphate; Xyl, xylose. (From Ondruskova N, Cechova A, Hansikova H, et al. Congenital disorders of glycosylation: still "hot" in 2020. *Biochim Biophys Acta Gen Subj.* 2021;1865[1]:129751, Fig. 1.)

genetic defect leads to the loss of **phosphomannomutase 2 (PMM2)**, the enzyme that catalyzes the conversion of mannose-6-phosphate into mannose-1-phosphate. The majority of CDGs have an autosomal recessive inheritance. Only two N-linked CDGs are autosomal dominant: GANAB-CDG and PRKCSH-CDG. The dominantly inherited O-linked CDGs include EXT1-CDG, H63ST-CDG, and POFUT1-CDG. Some CDGs have both an autosomal dominant and recessive phenotype

such as EXT2-CDG, POGLUT1-CDG, GNE-CDG, DHDDS-CDG, NUS1-CDG, COG4-CDG, and SEC23B-CDG. X-linked CDGs include ALG13-CDG, MAGT1-CDG, SSR4-CDG, HS6ST2-CDG, OGT-CDG, PIGA-CDG, SLC35A2-CDG, TRAPPC2-CDG, VMA21-CDG, ATP6AP2-CDG, ATP6AP1-CDG, and SLC9A7-CDG.

CDGs can be lethal, with 20% of PMM2-CDG patients dying in the first 2 years of life. Some patients, however, stabilize throughout





**Fig. 107.8** Patients with phosphomannomutase-2 deficiency (PMM2-CDG) and recognizable clinical features. A, Inverted nipples. B and C, Abnormal fat distribution. D, Muscle atrophy caused by peripheral neuropathy after puberty. E, Characteristic facial features with strabismus, short nose, anteverted nares, long philtrum, and large ears. F, T1-weighted sagittal MRI of the brain showing cerebellar vermis hypoplasia (arrow) and brain atrophy.

young adulthood. Almost any clinical phenotype can be present in a patient with CDG. It can affect any organ or organ system and most often includes the CNS. The most **common clinical features** include developmental and speech delay, seizures, ataxia, spasticity, peripheral neuropathy, hypotonia, strabismus, abnormal fat distribution, visual loss, cardiomyopathy, feeding difficulties, liver dysfunction, endocrine abnormalities, bleeding diathesis, and thrombosis (Fig. 107.8 and Table 107.6). Single-organ presentations are rare in CDGs, although some do exist, including TUSC3-CDG and ST3GAL3-CDG: brain; DHDDS-CDG: retina; ALG14-CDG: neuromuscular junction; POFUT1-CDG and POGlut1-CDG: skin; SEC23B-CDG: red cell lineage; EXT1/EXT2-CDG: cartilage; and TMEM199-CDG: liver. Many CDGs are recognizable syndromes. *CDG should be considered in any patient with a developmental disability or an unexplained clinical condition, especially in multisystem disease with neurologic involvement.*

There are also **congenital disorders of deglycosylation**, including known lysosomal disorders and a severe neurologic condition caused by a defective *N*-glycanase function (*NGLY1* defect).

Laboratory evaluations in most *N*-linked CDGs rely on transferrin glycoform analysis in serum or plasma. A common screening method is called serum **transferrin isoelectric focusing (TIEF)**.

Transferrin isoforms, which are hyposialylated (missing terminal sialic acid residues), show different cathodal shifts depending on either missing glycan chains or truncated glycans. A **type 1 pattern** suggests an early metabolic defect in the cytosolic-ER-related glycan synthesis and assembly. A **type 2 pattern** suggests Golgi-related glycan-processing defects (Fig. 107.9). **Isoelectric focusing of apolipoprotein C-III (IEF apoC-III)**, a serum mucine type *O*-glycosylated protein, can detect some *O*-glycosylation disorders (combined *N*- and *O*-linked glycosylation defects). **Mass spectrometry of intact (glycosylated) transferrin in serum** is highly sensitive for mild type 1 glycosylation abnormalities and diagnostic in most CDGs affecting *N*-glycosylation. Mass spectrometry of apoC-III is useful specifically in type II CDG. Glycomics by **matrix-assisted laser desorption/ionization time of flight (MALDI-TOF)** can be diagnostic in specific types of CDG (mostly Golgi related with a type 2 pattern). Dolichol-linked glycan or lipid-linked oligosaccharide (LLO) analysis is a complicated but sensitive method to detect ER-related *N*-glycan assembly (CDG type 1) defects in patient fibroblasts. GPI-anchor defects can be suspected based on *recurrent elevation of alkaline phosphatase levels* in blood.



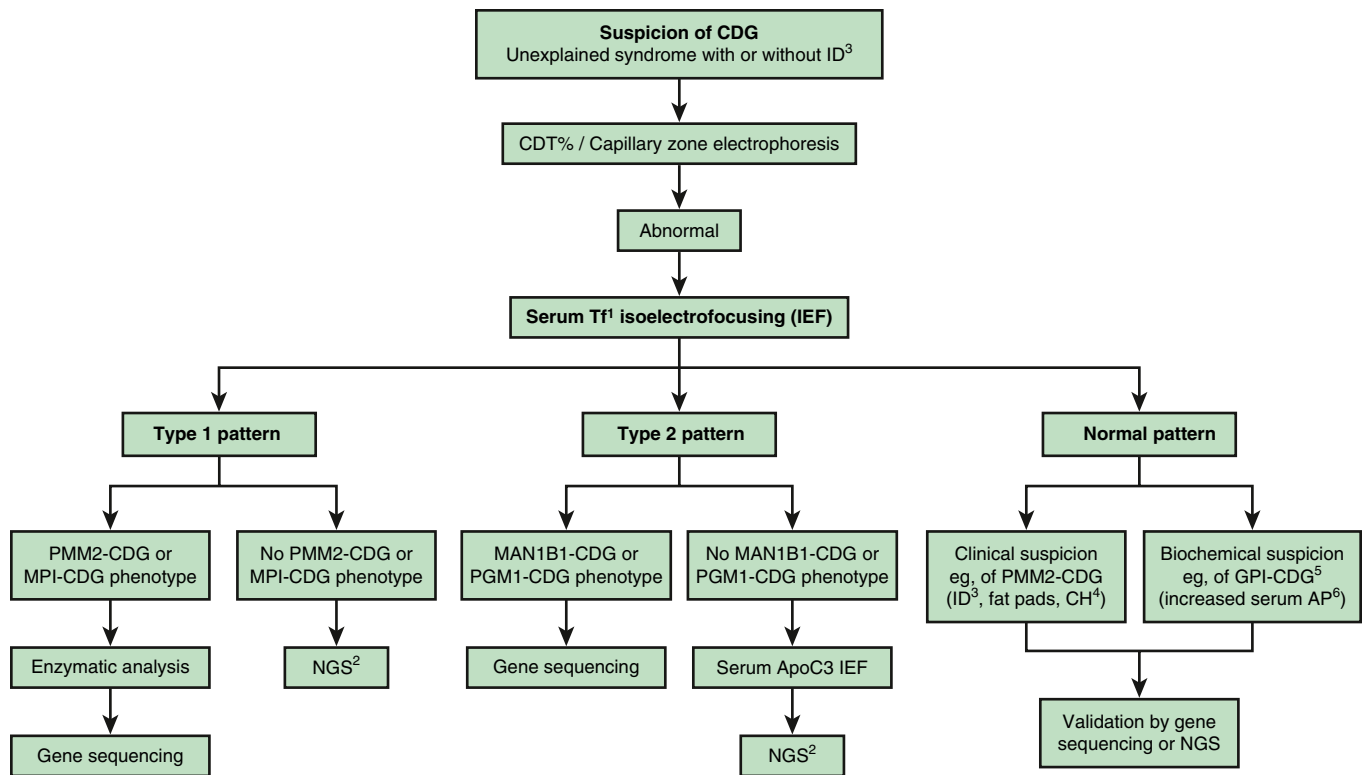
**Table 107.6** Clinical and Laboratory Features in Common Congenital Disorders of Glycosylation (CDGs), with Clinically Recognizable Phenotype and Abnormal Glycosylation, Detectable by Serum Transferrin Isoform Analysis (TIEF)

DEFECTIVE GENE	MOST FREQUENT CLINICAL FEATURES	SUGGESTIVE FEATURES	LABORATORY ABNORMALITIES	OTHER BIOCHEMICAL ANOMALIES
<i>PMM2</i>	Strabismus, nystagmus, smooth philtrum, large ears, vomiting, diarrhea, FTT, axial hypotonia, cerebellar vermis hypoplasia, ataxia, psychomotor disability, seizures, spasticity, neuropathy, pigmentary retinitis	Inverted nipples and/or abnormal fat pads, strokelike episodes	Elevated serum transaminases; hypoalbuminemia; decreased factor IX, XI, and AT activity; low serum ceruloplasmin and TBG levels	Type 1 serum TIEF, decreased PMM activity in leukocytes and fibroblasts
<i>MPI</i>	Cholestasis, hepatomegaly, feeding difficulties, recurrent vomiting, chronic diarrhea, ascites, recurrent thrombosis, gastrointestinal bleeding	Hyperinsulinism, protein-losing enteropathy Normal intelligence and absence of neurologic features	Elevated transaminases; hypoalbuminemia; hypoglycemia; decreased factor IX, XI, and AT-III activity	Type 1 serum TIEF, decreased PMI activity in leukocytes and fibroblasts
<i>ALG6</i>	Hypotonia, muscle weakness, seizures, ataxia, intellectual disability, behavioral abnormalities	Distal limb malformations	Elevated serum transaminases; hypoalbuminemia; decreased factor IX, XI, and AT activity; low serum IgG level	Type 1 serum TIEF, abnormal LLO results in fibroblasts
<i>DPAGT1</i>	Microcephaly, brain malformations, hypotonia, severe psychomotor disability, seizures, spasticity, proximal weakness, failure to thrive, joint contractures	Congenital myasthenia phenotype In multisystem phenotype: cataract	Decreased AT, protein C, and protein S activity; increased creatine kinase; hypoalbuminemia; normal creatine kinase in myasthenia	Type 1 serum TIEF
<i>SRD5A3</i>	Developmental delay, hypotonia, ataxia, cerebellar vermis hypoplasia, intellectual disability, speech delay, visual loss	Congenital cataract, retinal and iridic coloboma, glaucoma, optic nerve dysplasia, ichthyosis	Low anticoagulation factors (AT, protein C, and protein S activity), increased serum transaminases	Type 1 serum TIEF but reported false-negative TIEF
<i>ATP6V0A2</i>	Generalized cutis laxa, hypotonia, strabismus, characteristic facial features, joint laxity, seizures, motor and language developmental delay, spontaneous improvement of cutis laxa by aging	Cobblestone-like brain dysgenesis	Mild coagulation abnormalities, increased serum transaminase levels	Type 2 serum TIEF but reported false-negative TIEF
<i>ATP6V1A</i> and <i>ATP6V1E1</i>		Cardiovascular anomalies	Mild coagulation abnormalities and increased serum transaminase levels, hypercholesterolemia	Abnormal apoC-III IEF, characteristic MALDI TOF profile (Note abnormal skin histology)
<i>PGM1</i>	Pierre Robin sequence, cholestasis, short stature, dilated cardiomyopathy	Cleft palate, hyperinsulinism, normal intelligence	Hypoglycemia, increased serum transaminase levels, decreased AT	Mixed type 1/ serum TIEF, decreased fibroblast PGM1 activity
<i>MAN1B1</i>	Developmental delay, speech delay, intellectual disability, muscle weakness	Obesity, autistic features, inverted nipples, characteristic face	Increased serum transaminase levels, low AT	Type 2 serum TIEF, abnormal apoC-III IEF, diagnostic MALDI TOF profile
<i>TMEM199</i> <i>CCDC115</i> <i>ATP6AP1</i> and <i>ATP6AP2</i>	Cholestasis, hepatomegaly, liver steatosis, liver fibrosis, liver failure, spontaneous bleedings, motor developmental delay	Normal intelligence Hepatomegaly Immune deficiency	Decreased serum ceruloplasmin, increased serum transaminase levels, hypercholesterolemia, high AP	Type 2 serum TIEF, abnormal apoC-III IEF, characteristic MALDI TOF profile
<i>SLC39A8</i>	Seizures, hypsarrhythmia, hypotonia, developmental and speech delay, FTT	Dwarfism, craniosynostosis, rhizomelia, Leigh disease	Decreased serum manganese, high serum transaminases, abnormal coagulation	Type 2 serum TIEF, abnormal apoC-III, characteristic MALDI TOF profile

AP, Alkaline phosphatase; AT, antithrombin; apoC-III: apolipoprotein C-III; FTT, failure to thrive; LLO, lipid-linked oligosaccharides; MALDI-TOF, matrix-assisted laser desorption/ionization time of flight; TBG, thyroxine-binding globulin; TIEF, transferrin isoelectric focusing.

**Fluorescence-activated cell sorting (FACS)** analysis of the membrane-anchored markers CD16 and CD24 in leukocytes is highly suggestive for a GPI-anchor abnormality, especially when alkaline phosphatase in the blood is significantly elevated. **Enzyme analysis** in

blood is only available for a few, more common CDGs (PMM2-CDG, MPI-CDG, PGM1-CDG); it is more reliable in fibroblasts. Dystroglycanopathies can be confirmed based on abnormal immunohistochemistry in a **muscle biopsy**.



**Fig. 107.9** CDG diagnosis algorithm. <sup>1</sup>Transferrin; <sup>2</sup>Next-generation sequencing (CDG panel analysis, WES, WGS); <sup>3</sup>Intellectual disability; <sup>4</sup>Cerebellar hypoplasia; <sup>5</sup>Glycosylphosphatidylinositol anchor synthesis defect; <sup>6</sup>Alkaline phosphatase. ID, intellectual disability; WES, whole exome sequencing; WGS, whole genome sequencing. (From *Quelhas D, Martins E, Azevedo L, et al. Congenital disorders of glycosylation in Portugal – two decades of experience. J Pediatr. 2021;231:148–156.*)

With an abnormal TIEF pattern result or clinical suspicion of any type of CDG, most metabolic centers use a direct **CDG gene panel analysis** or NGS (whole exome sequencing) (see Fig. 107.9).

## CONGENITAL DISORDERS OF PROTEIN N-GLYCOSYLATION

### Phosphomannomutase-2 Deficiency (PMM2-CDG) Clinical Manifestations

PMM2-CDG is the most common and easily recognizable CDG. Over 900 patients have been identified with an estimated incidence of 1:20,000–1:80,000. Most patients have alternating strabismus, characteristic facial features (short nose, long philtrum, large ears) (see Fig. 107.8E), inverted nipples and/or abnormal fat pads (see Fig. 107.8A–C), feeding difficulties, axial hypotonia, and decreased reflexes already in the first few months of life. Nystagmus (caused by pontocerebellar and vermis hypoplasia; see Fig. 107.8F) is also common. Psychomotor disability is present in most patients, but normal intellectual development has been described in a few patients. Most patients develop a **multisystem disease**, and <25% show an isolated neurologic phenotype without other organ involvement, normal endocrine regulation, and no coagulopathy. The **neurologic involvement** is quite diverse, with ataxia, seizures, spasticity, and peripheral neuropathy (see Fig. 107.8D) the most common features. Dystonia, strokelike episodes, and proximal myopathy can also occur. PMM2-CDG is not a progressive disease, but certain features, when present, typically appear at a different age during the disease. From birth, pericardial fluid collection, cardiomyopathy, or chronic vomiting/diarrhea can occur; after the age of 7 years, retinitis pigmentosa and cataracts; and after puberty, scoliosis, neuropathy, and recurrent thrombotic events. Liver function anomalies are mild and usually improve by age, and only a few

patients develop cholestasis or liver fibrosis. Most patients have a hypergonadotropic hypogonadism; no successful pregnancies have been reported. Intellectual disability can be mild to severe; speech development is frequently delayed and can even be absent. Autistic behavior is common, although most patients have a cheerful personality. The oldest patient is 72 years old.

### Pathophysiology

PMM2 catalyzes the conversion of mannose-6-phosphate to mannose-1-phosphate and is essential for the formation of activated mannose units used in the synthesis of the growing glycan chain in the ER. Hypoglycosylation leads to abnormal function affecting many essential glycoproteins, such as coagulation and anticoagulation factors; endocrine regulation; transport proteins; liver function; and immune, membrane, and receptor proteins.

### Diagnosis

The primary screening method for PMM2-CDG is **serum transferrin glycoform analysis**, which is most frequently performed by TIEF or mass spectrometry. Intact transferrin has four negatively charged sialic acid residues (tetrasialotransferrin). Transferrin glycoforms, missing terminal sialic acid residues, show different cathodal shifts, less abundant tetrasialotransferrin, increased disialotransferrin, and some a-sialotransferrin. This is the so-called type 1 pattern, suggestive of a defect in glycan assembly in the cytosol-ER. Transferrin isoforms are detectable by mass spectrometry, which is a more reliable diagnostic method compared with TIEF. Certain other disorders can cause a *false-positive* transferrin isoform pattern, including galactosemia, hereditary fructose intolerance, and excessive alcohol use. PMM enzyme analysis is available in leukocytes and fibroblasts.

The presence of elevated serum transaminases, hypoalbuminemia, decreased factor IX and XI and antithrombin activity, or low ceruloplasmin or TBG level is highly suggestive of CDG, including the most common type, PMM2-CDG.

PMM2-CDG is autosomal recessive. Genetic testing is mostly performed by direct sequencing. The most frequent pathogenic variant (c.422G>A; R141H) is present in 75% of White patients. Prenatal diagnosis is only reliable by genetic testing.

### Treatment

The therapy in PMM2-CDG relies on supportive treatment. Even with the best treatment, mortality is about 20% in the first 2 years of life, mostly from cardiac or kidney involvement and severe infections. Recommended therapy includes adequate nutrition, diet or tube feeding if needed, cardiac support, hormone supplements, physical and occupational therapy, speech therapy, seizure management, and strabismus surgery. Treatment with acetazolamide (7-17 mg/kg/day) resulted in improvement of ataxia and a decrease in disease severity (measured by the Nijmegen Pediatric CDG rating scale). This is likely mediated by the function of the glycosylated CaV2.1 channel. Possible dehydration, changes in plasma pH, and bicarbonate levels (renal tubular acidosis) need to be monitored throughout therapy.

Therapeutic developments include targeted (liposomal) mannose-6-phosphate treatment, drug repurposing, and chaperone therapy; these are only in early trial phases.

### Mannosephosphoisomerase Deficiency (MPI-CDG)

#### Clinical Manifestations

MPI deficiency is a recognizable and treatable CDG. Approximately 35 patients have been published. Most patients show early symptoms of **liver disease** (cholestasis, elevated transaminases) and feeding difficulties, with recurrent vomiting and chronic diarrhea, most frequently with **protein-losing enteropathy**. Life-threatening episodes might appear as early as the first few months of life with recurrent thrombosis and severe gastrointestinal bleeding because of severe coagulation abnormalities. Hypoglycemia is usually caused by hyperinsulinism. Hypoalbuminemia can be severe; patients might develop visible abdominal distention from a combination of ascites and hepatomegaly. Patients with MPI-CDG have no other organ involvement, and the CNS is not affected. There are no dysmorphic features. The liver disease frequently progresses to fibrosis or cirrhosis.

#### Pathophysiology

Mannosephosphoisomerase (MPI) catalyzes the conversion of fructose-6-phosphate to mannose-6-phosphate, one step before PMM2, therefore blocking the formation of activated mannose units (GDP mannose) for oligosaccharide synthesis. Hypoglycosylation leads to abnormal glycoprotein function, the same as in PMM2-CDG, especially coagulation and anticoagulation factors, liver function, and hormone receptors.

#### Diagnosis

The primary screening method in a suspected MPI-CDG patient is **serum transferrin isoform analysis** by mass spectrometry or screening by TIEF (see Fig. 107.9). MPI deficiency leads to a type 1 pattern, as seen in PMM2 deficiency. MPI enzyme analysis is available in leukocytes and fibroblasts. The presence of elevated serum transaminases, hypoalbuminemia, decreased factor IX and XI and antithrombin activity, hyperinsulinism, and nonketotic hypoglycemia are highly suggestive for MPI-CDG.

MPI-CDG is autosomal recessive. Genetic testing is mostly performed by direct sequencing. The exact incidence of MPI-CDG is not known, but it is estimated at 1 in 800,000 in Europe. Prenatal diagnosis is only reliable by genetic testing. Although this is a rare CDG, early diagnosis is imperative because it is treatable.

### Treatment

MPI-CDG is the first CDG type treatable by dietary therapy (Table 107.7). Mannose therapy is clinically effective by both IV and oral supplementation. The dose of oral mannose is 150-170 mg/kg/dose for four or five doses per day (maximum dosing 600-1200 mg/kg/day and maximum of six doses per day). IV mannose should be used only in life-threatening conditions when oral intake is not possible. The maximum dose of IV mannose is 1 g/kg/day as a continuous infusion, combined with IV glucose to prevent hypoglycemia. A known side effect is hemolysis. The treatment uses an alternative pathway: mannose can be phosphorylated by hexokinases to mannose 6-phosphate, bypassing the MPI defect. The clinical symptoms improve rapidly, but liver function may further deteriorate. Liver fibrosis and cirrhosis may necessitate liver transplantation, which will resolve the metabolic disease. The oldest patient known with MPI-CDG has survived into their late 30s.

### Glucosyltransferase-1 Deficiency (ALG6-CDG)

#### Clinical Manifestations

ALG6-CDG is the second most common CDG. Most patients have hypotonia, muscle weakness, seizures, and ataxia. No patient with ALG6-CDG has been reported with normal intelligence. Speech delay and nystagmus are common neurologic signs. Brachydactyly, skeletal abnormalities, and transverse limb defects have been observed. Strabismus and characteristic facial dysmorphism are rare (hypertelorism, oval face, short nose). Inverted nipples and/or abnormal fat pads are exceptional in ALG6-CDG.

The most severe ALG6-CDG patients show a multisystem phenotype in the first few months of life, including severe infections, protein-losing enteropathy, hypoalbuminemia, anemia, and failure to thrive. Autistic behavior and mood changes have been observed in several patients. The oldest patient to date is almost 50 years old.

#### Pathophysiology

The metabolic problem is caused by defective binding of the first of three glucoses to the lipid-linked oligosaccharide in the ER. This glucose binding is essential for attachment of the oligosaccharyltransferase enzyme complex to the newly built oligosaccharide chain and the ability to transfer it to the protein. This leads to protein hypoglycosylation and abnormal glycoprotein function similar to PMM2-CDG and MPI-CDG. Laboratory abnormalities are also similar, including abnormalities in coagulation and anticoagulation factors, liver function, thyroid hormones, and immunoglobulins (IgGs).

#### Diagnosis

The primary screening method in a suspected ALG6-CDG patient is **serum transferrin glycoform analysis** by mass spectrometry or TIEF analysis. ALG6 deficiency leads to a type 1 pattern (see Fig. 107.9), as seen in PMM2 and MPI deficiency. There is no available enzyme analysis, although LLOs could be evaluated in patient fibroblasts.

ALG6-CDG is autosomal recessive. Genetic testing is mostly performed by direct sequencing. The most common pathogenic variants are p.A333V and p.I299Del. Prenatal diagnosis is only reliable by genetic testing. The exact incidence of ALG6-CDG is not known.

#### Treatment

The current therapy in ALG6-CDG relies on supportive treatment. Mortality is about 10% in the first years of life, mostly from protein-losing enteropathy and severe infections.

### UDP-GlcNAc:DoI-P-GlcNAc-P Transferase Deficiency (DPAGT1-CDG)

#### Clinical Manifestations

DPAGT1 deficiency is a recognizable and potentially treatable CDG. About one third of patients show the **congenital myasthenia**

**Table 107.7** Effective Therapies in CDG

CDG	TREATMENT	RECOMMENDED DOSE	CLINICAL EFFECTS	SIDE EFFECTS
MPI-CDG	Mannose	600-1200 mg/kg BW/day in 4-6 oral doses	Improvement of digestive symptoms (13/14), coagulopathy (12/12), and hypoglycemia (9/9); no long-term effect on liver symptoms	Abdominal pain and diarrhea (5/10; responding to dose adjustment)
PGM1-CDG	Galactose	1 g/kg/day (500-2500 mg/kg/day; max 50 g/day), divided in up to 6 oral doses per day	Improvement of hepatopathy (15/18), muscle symptoms (14/14), coagulopathy (10/12), hypoglycemia (10/13), and pubertal delay (2/2); minimal effect on growth (1/8), ID (0/2), and cardiologic symptoms (0/2)	Not reported
SLC35C2-CDG	Galactose	1.5 g/kg/day (up to 3 g/kg/day), divided in up to 5 oral doses per day	Improvement of psychomotor development (5/10), growth (n.s.), gastrointestinal symptoms (n.s.), and seizures (3/5)	Not reported
SLC35C1-CDG	Fucose	400 mg/kg/day (up to 1.2 g/kg/day in severe cases), divided into 2-3 oral doses per day	Normalization of neutrophil count (5/5), decreased incidence of severe infections (3/3), improvement of psychomotor development (1/5), no effect on adult form of the disease (ID, ataxia, epilepsy, autism)	Autoimmune neutropenia and hemolysis (responding to dose adjustment)
CAD-CDG	Uridine	100 mg/kg/day in 4 oral doses	Cessation of pharmacoresistant seizures (3/3), significant developmental progress (3/3), resolution of anemia (2/2), and anisopoikilocytosis (3/3)	Not reported
SLC39A8-CDG	Manganese	15-20 mg MnSO <sub>4</sub> /kg BW/day in 5 oral doses	Improvement of glycosylation (2/2), motor abilities (2/2), epilepsy (1/1), ataxia (1/1), and hearing (1/1)	Not reported, risk of manganism
	Galactose	500-3750 mg/kg BW/day in 5 oral doses	Improvement of glycosylation (2/2), no clinical improvement reported	Not reported
TMEM165-CDG	Galactose	1000 mg/kg/day orally	Improvement of glycosylation (2/2), hepatopathy (2/2), coagulopathy (2/2), and IGF1 levels (2/2) (clinical improvement not mentioned)	Not reported
GFPT1-CDG	Pyridostigmine (cholinesterase inhibitors)	2.5-15 mg/kg/day in 3 oral doses	Improvement of muscle weakness (52/56)	Muscle twitching, depression, and anxiety (2/56)
ALG2-CDG	Pyridostigmine (cholinesterase inhibitors)	Oral, dose n.s.	Improvement of muscle weakness (1/1)	Not reported
ALG14-CDG	Pyridostigmine (cholinesterase inhibitors)	5-8 mg/kg/day in 2-6 oral doses	Improvement of muscle weakness (4/4, in 1 patient the effect was only temporary)	Not reported
PIGM-CDG	Sodium butyrate	60-90 mg/kg/day in 3 oral doses	Effect on seizures (3/3), developmental delay (2/2), and increase in the expression of GPI-linked blood cell surface markers (2/4)	Not reported
PMM2-CDG	Acetazolamide	7-17 mg/kg/day in 2 oral doses	Effect on cerebellar symptoms (20/23), speech (20/23), anxiety (20/23), some coagulation parameters (20/23), stereotypic movements (5/5), and SLE (1/1). No improvement of ID and non-neurologic symptoms.	Acidosis with significant decrease of serum bicarbonate (9/23), asthenia (4/23), and paresthesia (2/23) responding to dose adjustments; risk of urolithiasis, osteopenia

BW, Body weight; GPI, glycosylphosphatidylinositol; ID, intellectual disability; IGF1, insulin-like growth factor 1; n.s., not specified; SLE, stroke-like episodes.

Modified from Ondruskova N, Cechova A, Hansikova H, et al. Congenital disorders of glycosylation: still "hot" in 2020. *Biochim Biophys Acta Gen Subj.* 2021;1865(1):129751, Table 2.

phenotype, indistinguishable from other genetic congenital myasthenias. CK levels are normal. These patients have a relatively good prognosis, especially with early myasthenia therapy. The other patients show a multisystem phenotype with microcephaly, brain malformations, hypotonia, severe psychomotor disability, seizures, spasticity, failure to thrive, joint contractures, and cataracts.

### Pathophysiology

The DPAGT1 defect leads to very early arrest of glycan synthesis outside the ER membrane by slowing the addition of the second GlcNAc sugar to the phosphorylated dolichol arm. Abnormal receptor glycosylation in the *neuromuscular junction* leads to myasthenia. Hypoglycosylation in the multisystem type leads to



abnormal glycoprotein function similar to PMM2-CDG, especially involving the anticoagulation factors, and interestingly leading to high serum CK (in contrast to the congenital myasthenia phenotype) and hypoalbuminemia.

### Diagnosis

The primary screening method is **serum transferrin glycoform analysis** by mass spectroscopy or TIEF analysis. Most patients show a type 1 pattern (see Fig. 107.9), but patients with the congenital myasthenia phenotype can show normal screening. There is no clinically available enzyme analysis.

DPAGT1-CDG is autosomal recessive. Genetic testing is mostly performed by direct sequencing. The exact incidence is not known. Prenatal diagnosis is only reliable by genetic testing. Because of the false-negative TIEF results in several patients with the myasthenic phenotype, congenital myasthenia panel testing is suggested in suspected cases, especially for determining the potential therapy.

### Treatment

The congenital myasthenia phenotype is frequently treatable by high-dose pyridostigmine, eventually enhanced with salbutamol and a potassium channel blocker (amifampridine). In the multisystem phenotype of DPAGT1-CDG, treatment is supportive.

## CONGENITAL DISORDERS OF PROTEIN O-GLYCOSYLATION

### Cerebro-Ocular Dysplasia–Muscular Dystrophy and Muscle-Eye-Brain Disease Spectrum (POMT1-CDG, POMT2-CDG, POMGNT1-CDG)

From isolated muscular dystrophy to **Walker Warburg syndrome**, this group of O-linked glycosylation disorders presents with severe muscle weakness, congenital eye malformations, and neuronal migration defects. Pachygyria, cobblestone dysgenesis, hydrocephalus, polymicrogyria, heterotopias, and corpus callosum agenesis are variably present. Eye malformations include anophthalmia, microphthalmia, congenital cataract, or colobomas. **Congenital muscular dystrophy** is associated with significant CK elevations. There is severe psychomotor disability.

The underlying metabolic defect is the abnormal synthesis of the O-mannosylglycan core, which is essential for the proper glycosylation of  $\alpha$ -dystroglycan. The  $\alpha$ -dystroglycan is heavily O-glycosylated with mannose residues and is expressed in both muscle and brain. Defective mannosylation of  $\alpha$ -dystroglycan leads to muscle degeneration and migration defects. Muscle biopsy shows abnormal  $\alpha$ -dystroglycan staining on immunohistochemistry.

Transferrin glycoform analysis, including TIEF, is normal in patients with isolated O-mannosylation defects. There is also no clinically available enzyme analysis. **Diagnosis** is based on histology (muscle biopsy) and genetic analysis.

POMT1-CDG, POMT2-CDG, and POMGNT1-CDG are the most common autosomal recessive  $\alpha$ -dystroglycanopathies. Additional gene defects occur in the pathway; *POMK*, *FKTN*, *FKRP*, *LARGE*, *B3GALNT2*, *B4GAT1*, *DAG1*, *TMEM5*, and *ISPD* have been described in association with human disease. The exact incidence of  $\alpha$ -dystroglycanopathies is not known.

The treatment for  $\alpha$ -dystroglycanopathies is supportive.

## DEFECTS IN LIPID GLYCOSYLATION AND IN GLYCOSYLPHOSPHATIDYLINOSITOL ANCHOR BIOSYNTHESIS

### Hyperphosphatasia–Intellectual Disability Syndromes: PIGA Deficiency (PIGA-CDG)

This clinically recognizable syndrome is an epilepsy syndrome with intellectual disability, hypotonia, dysmorphic facial features, skin anomalies, congenital brain malformations, and behavioral abnormalities,

including autism. Other organ malformations, including cardiac and renal defects, have also been reported. *Somatic* pathogenic variants with a *PIGA* defect can also lead to paroxysmal nocturnal hemoglobinuria.

*N*-acetylglucosamine (GlcNAc) cannot be efficiently transferred to phosphatidylinositol for glycosylphosphatidylinositol synthesis. Abnormal anchoring of alkaline phosphatase leads to hyperphosphatasemia in the blood and loss of specific surface antigens on blood cells.

Transferrin isoform analysis is normal in GPI-anchor defects. FACS analysis demonstrating reduction of membrane-anchored markers CD16 and CD24 in leukocytes is highly suggestive for a GPI-anchor abnormality, especially in association with increased levels of serum alkaline phosphatase. Pathogenic variant analysis confirms the defect.

PIGA-CDG is X-linked. The exact incidence is not known. A similar phenotype has been described in *PIGO*, *PIGV*, *PIGY*, *PIG*, *PGAP2*, and *PGAP3* defects.

In PIGA-CDG the treatment is supportive.

## DEFECTS IN MULTIPLE GLYCOSYLATION PATHWAYS AND IN OTHER PATHWAYS, INCLUDING DOLICHOLPHOSPHATE BIOSYNTHESIS DEFECTS

### Steroid 5 $\alpha$ -Reductase Deficiency (SRD5A3-CDG)

#### Clinical Manifestations

SRD5A3 deficiency is a clinically recognizable CDG, originally described as a **multiple-congenital malformation syndrome**. About 20 patients have been diagnosed at different ages, including one at 45 years of age. Patients have hypotonia, ataxia, and eye abnormalities, including congenital cataracts, retinal and iridic colobomas, glaucoma, optic nerve dysplasia, and visual loss. Cerebellar vermis hypoplasia can be variable. Intellectual disability has been described in all affected patients thus far. About 30% of patients have severe *congenital ichthyosis*. Hypertrichosis and dysmorphic facial features are common, including squared face, high forehead, large ears, and coarsening. Some children with SRD5A3-CDG have a severe autism spectrum disorder. Skeletal abnormalities (scoliosis) and cardiac malformations are less common.

#### Pathophysiology

SRD5A3 deficiency leads to abnormal dolichol synthesis affecting early glycan synthesis outside the ER membrane and affects O-mannosylation and GPI-anchor synthesis. Hypoglycosylation affects anticoagulation factors and leads to increased serum transaminases.

#### Diagnosis

The primary screening method in a suspected SRD5A3-CDG patient is **serum transferrin glycoform analysis or mass spectroscopy analysis**. Most patients show a type 1 pattern (see Fig. 107.9), but several false-negative cases have been described. There is no clinically available enzyme analysis.

SRD5A3-CDG is autosomal recessive. Genetic testing is mostly performed by direct sequencing. The exact incidence is not known. SRD5A3-CDG treatment is supportive.

### Autosomal Recessive Cutis Laxa Type 2 (ARCL-2A or ATP6V0A2-CDG, ATP6V1A-CDG and ATP6V1E1-CDG)

#### Clinical Manifestations

ATP6V02-CDG is a multiple-malformation syndrome originally described as *cutis laxa syndrome* and recently discovered to be a combined *N*- and *O*-linked glycosylation disorder. Patients show generalized cutis laxa with inelastic, sagging skin at birth, hypotonia, strabismus, myopia, characteristic facial features, and joint laxity. The facial features include hypertelorism, short nose, long philtrum, downslanting palpebral fissures with sagging eyelids, and sagging cheeks. Cardiovascular involvement is rare, and there is variable CNS involvement. Seizures and motor and language

developmental disability are common, but normal intelligence has been described as well. Sensorineural hearing loss is sometimes observed. Some patients have vermis hypoplasia, and several children have been described with cobblestone-like dysgenesis and partial pachygyria on brain MRI. Skeletal abnormalities and short stature are common, as are late-closing fontanels and/or brachydactyly and scoliosis. There is frequently enamel dysplasia. The skin features spontaneously improve with age. *ATP6V1A*-CDG and *ATP6V1E1*-CDG show a highly overlapping phenotype with associated cardiovascular symptoms and hypercholesterolemia.

### Pathophysiology

*ATP6V0A2* is a membrane subunit of the proton pump of the vesicular adenosine triphosphatase (V-ATPase) complex. Abnormal function of the V-ATPase complex alters the pH gradient in the secretory pathway and affects the maturation and transport of several glycosyltransferases and elastic fibers (e.g., elastin). *ATP6V1A* and *ATP6V1E1* are other complex subunits affecting *ATP6V0A2* function and cause secondary ATPase deficiency. Both N- and O-linked glycosylation are affected. There are mild coagulation abnormalities and high serum transaminase levels in some patients.

### Diagnosis

The primary screening method in a suspected *ATP6V0A2*-CDG patient is **serum transferrin glycoform analysis** by mass spectrometry or TIEF analysis. Most patients show a type 2 pattern (see Fig. 107.9), but false-negative cases have been described before the age of 6 weeks. **Apolipoprotein III-C** (apoC-III) is a mucin-type secretory glycoprotein that is only O-glycosylated. ApoC-III TIEF shows a hypoglycosylation pattern by mass spectrometry in patients, even when the TIEF is falsely negative. Skin biopsies in patients show classic histologic changes of cutis laxa with diminished, short, abnormal, and fuzzy elastic fibers.

*ATP6V0A2*-CDG is autosomal recessive. Genetic testing is mostly performed by direct sequencing. The exact incidence is not known. *ATP6V1A* and *ATP6V1E1* defects have been recently described.

### Treatment

In autosomal recessive cutis laxa type 2, the treatment is supportive. Fortunately, there is continuous and spontaneous improvement of skin symptoms throughout the disease course, especially in *ATP6V0A2*-CDG.

## Golgi- $\alpha$ <sub>1,2</sub> Mannosidase-1 Deficiency (MAN1B1-CDG) Clinical Manifestations

The *MAN1B1* defect was originally described as an intellectual disability syndrome in association with dysmorphic features. Additional patients were recognized with psychomotor disability, muscle hypotonia, and inverted nipples in association with truncal obesity. The degree of intellectual disability is quite variable. Autistic behaviors, eating disorders, and aggressive behavior are frequent features. More than 30 patients have been reported.

### Pathophysiology

*MAN1B1* codes for a Golgi mannosidase, which is essential for the final “trimming” of mannose units during the glycan processing in the Golgi apparatus. Hypermannosylation leads to abnormal, truncated glycans and CDG-II. The glycosylation abnormality in serum is relatively mild. Increased serum transaminases and abnormal coagulation are uncommon.

### Diagnosis

Most patients show a mild type 2 pattern by TIEF, but false-negative cases have been described. MALDI-TOF analysis shows characteristic, hybrid glycans in serum. In suspected cases, direct sequence analysis is recommended, even if the TIEF is normal.

*MAN1B1*-CDG is autosomal recessive. The exact incidence is unknown; several adult patients are known.

### Treatment

Only supportive treatment is available.

## Phosphoglucomutase-1 Deficiency (PGM1-CDG)

### Clinical Manifestations

PGM1-CDG is a disorder presenting with midline malformations (cleft palate, Pierre Robin sequence, bifid uvula), liver dysfunction, hypoglycemia, and short stature in almost all patients. *Hypoglycemia* is usually caused by hyperinsulinism in the first years of life. It can resolve with aging; ketotic hypoglycemia has also been observed. Cholestasis, liver fibrosis, and even cirrhosis have been described in a few patients. About one third of patients also show proximal muscle weakness and dilated cardiomyopathy; the latter led to mortality in at least seven reported cases. Other malformations, including cardiac and skeletal anomalies, have also been described. Wound healing is frequently abnormal, and there is a very high risk for bleeding during surgery. Intelligence is normal.

### Pathophysiology

Phosphoglucomutase 1 (PGM1) is an essential enzyme for glycogenolysis and glycolysis. It also provides substrates for the nucleotide sugars needed for normal glycosylation. PGM1 regulates the bidirectional conversion of glucose-1-phosphate and glucose-6-phosphate. During fasting it leads to a glycogenosis-like phenotype (also called GSD XIV, MIM 614921). PGM1-CDG affects both the ER- and Golgi-related glycosylation and causes a mixed type 1/type 2 hypoglycosylation pattern. Abnormal serum proteins include coagulation and anticoagulation factors, insulin-like growth factor-binding protein 3 (IGFBP3), TBG, and TSH, in addition to serum transaminases, hypoglycemia, and elevated CK.

### Diagnosis

The primary screening method in a suspected PGM1-CDG patient is **serum transferrin glycoform analysis** or mass spectrometry analysis. Patients show a mixed type 1/type 2 pattern.

PGM1-CDG is autosomal recessive. It is among the relatively common CDGs; >40 patients have been described. Enzyme testing is possible in blood but is more reliable in fibroblasts. Direct sequencing is available for testing.

### Treatment

PGM1-CDG is a treatable CDG (see Table 107.1). D-Galactose replenishes depleted levels of different nucleotide-sugars (galactose-1-phosphate, UDP-galactose, and UDP-glucose). Adding 1 g/kg/day D-galactose (500–2500 mg/kg/day, maximum 50 g/day, divided in up to six doses/day) to the diet improves glycosylation significantly after a few weeks, although the transferrin glycoform pattern does not fully normalize. This treatment improves liver transaminases and anti-thrombin levels and in some patients the hormonal status. The effect of D-galactose on hypoglycemic episodes, cardiomyopathy, and myopathy is not yet clear.

## Disorders of Golgi Homeostasis: TMEM199-CDG, CCDC115-CDG, ATP6AP2-CDG, and ATP6AP1-CDG Clinical Manifestations

These four disorders are clinically and biochemically indistinguishable. They have been described with liver function anomalies, cholestasis, fibrosis, and cirrhosis with liver failure, necessitating liver transplantation in a few patients. The phenotype resembles **Wilson disease**, especially because of low serum ceruloplasmin and copper levels, but there is no Kayser-Fleischer ring. In CCDC115-CDG there are frequently also neurologic features. The intellectual outcome is variable. Additional abnormalities include hypercholesterolemia

and elevated alkaline phosphatase. In ATP6AP1-CDG there is also immunologic involvement.

### Pathophysiology

TMEM199-, CCDC115-, ATP6AP1-CDG, and ATP6AP2-CDG are important for Golgi homeostasis. The exact pathologic mechanism is not yet known, but it is hypothesized that the secondary Golgi dysfunction affects and delays the normal glycosylation process.

### Diagnosis

The primary screening method in a patient with one of these suspected CDGs is serum transferrin glycoform analysis by mass spectroscopy or TIEF analysis. Patients show a type 2 pattern (see Fig. 107.9). ApoC-III TIEF is abnormal. Glycomics results by MALDI-TOF analysis are characteristic but cannot discriminate between the three defects. The final diagnosis requires pathogenic variant analysis. TMEM199-CDG and CCDC115-CDG are autosomal recessive, whereas ATP6AP1-CDG and ATP6AP2-CDG are X-linked.

### Treatment

Treatment is supportive. Two patients successfully underwent liver transplantation.

## Manganese Transporter Defect: SLC39A8-CDG

### Clinical Manifestations

This intriguing disorder was originally described as a neurologic disease with hypotonia, seizures (hypsarrhythmia), and developmental disability. Some of the later-described patients had severe skeletal dysplasia with rhizomelic chondrodysplasia, craniosynostosis, and dwarfism. Mitochondrial dysfunction (Leigh disease, cerebral lactic acidemia, dystonia) may also be present.

### Pathophysiology

SLC39A8 is a membrane transporter, responsible for manganese (Mn) transmembrane transport. SLC39A8 deficiency affects all Mn-dependent enzymes and therefore different parts of the metabolism. Because several glycosyltransferases (e.g.,  $\beta$ -1,4-galactosyltransferase) are Mn dependent, a secondary Golgi glycosylation occurs with a type 2 glycosylation defect. Low serum Mn levels are suggestive but not always present in patients.

### Diagnosis

The primary screening method in a suspected patient with SLC39A8-CDG is **serum transferrin glycoform analysis** by mass spectroscopy or TIEF analysis. Patients show a type 2 pattern (see Fig. 107.9). MALDI-TOF analysis is suggestive but not discriminative. Low serum Mn levels are not always present in patients. The final diagnosis requires pathogenic variant analysis. SLC39A8-CDG is an autosomal recessive disease. The exact incidence for this rare disease is unknown.

### Treatment

Besides supportive treatment, a few patients have shown biochemical and clinical improvement (better seizure control) with oral D-galactose (1–3.75 g/kg/day) and manganese (II)-sulfate monohydrate (15–20 mg/kg/day) therapy (see Table 107.7).

## CONGENITAL DISORDERS OF DEGLYCOSYLATION

### N-Glycanase 1 Deficiency (NGLY1 Defect)

### Clinical Manifestations

Patients with NGLY1 deficiency have a glycosylation disorder, but not from the deficient synthesis; rather, it is caused by deficient breakdown of glycoproteins. The phenotype comprises severe CNS involvement, microcephaly, intellectual disability, seizures, neuropathy, movement disorders, and hypotonia. The presence of *alacrimia* or hypolacrimia is highly suggestive for the diagnosis, but not all patients have problems with tearing. Other features include failure to thrive, IUGR, and liver involvement. Some patients have a recognizable oval face with a short nose, flat profile, and hypertelorism. Masklike face also occurs, imitating the phenotype of mitochondrial disorders, especially when serum lactic acid levels are also elevated.

### Pathophysiology

N-glycanase is responsible for the deglycosylation of misfolded N-linked glycoproteins. The enzyme is essential for cutting off the glycans before the proteins are degraded in the ER. The exact disease pathomechanism, however, is not yet clear. Serum transaminase and  $\alpha$ -fetoprotein levels are also frequently increased.

### Diagnosis

Serum transferrin isoform analysis shows a normal pattern. In some patients the excretion of a specific urine biomarker (aspartylglucosamine; Neu5Ac1Hex1GlcNAc1-Asn) is present and can be used as screening. The final diagnosis requires genetic analysis.

NGLY1-CDG is an autosomal recessive disease. The most common pathogenic variant is c.1201A>T/p.R401X. The exact incidence of the condition is unknown, but >50 patients have been reported in the few years since the discovery of the disease.

### Treatment

Only supportive treatment is available for the patient with NGLY1 deficiency.

## THERAPEUTIC SUMMARY (SEE TABLE 107.7)

Most CDGs are treatable only with supportive therapy. The initially discovered oral mannose treatment in MPI-CDG (1 g/kg/day) has proved to be efficient for coagulation problems and protein-losing enteropathy but cannot prevent liver fibrosis in all patients. Liver transplantation in MPI-CDG has been successful in a few patients. Oral D-galactose in PGM1-CDG (1g/kg/day) can improve serum transaminases and coagulation and have a positive effect on endocrine function but cannot restore glycosylation fully. Seizure frequency improved in patients with SLC39A8-CDG receiving oral D-galactose treatment (1 g/kg/day) and oral manganese intake. The congenital myasthenic syndrome in DPAGT1-CDG, GFPT1-CDG, and GMPPB-CDG has been successfully treated with a high dose of cholinesterase inhibitors. Several CDGs have been positively controlled by transplantation, including DOLK-CDG (DK1-CDG; heart transplantation), PGM3-CDG (hematopoietic stem cell transplantation), ATP6AP1-CDG, and CCDC155-CDG (liver transplantation).

Patients with CAD-CDG show significant clinical improvement on receiving oral uridine therapy, especially with seizure control. Two children with SLC35C1-CDG–defective immune function improved on oral fucose therapy. GNE-CDG patients showed significant improvement in muscle strength on N-acetylmannosamine therapy.

Visit Elsevier eBooks+ at [eBooks.Health.Elsevier.com](http://eBooks.Health.Elsevier.com) for Bibliography.



## Chapter 108

Mitochondrial Disease  
Diagnosis

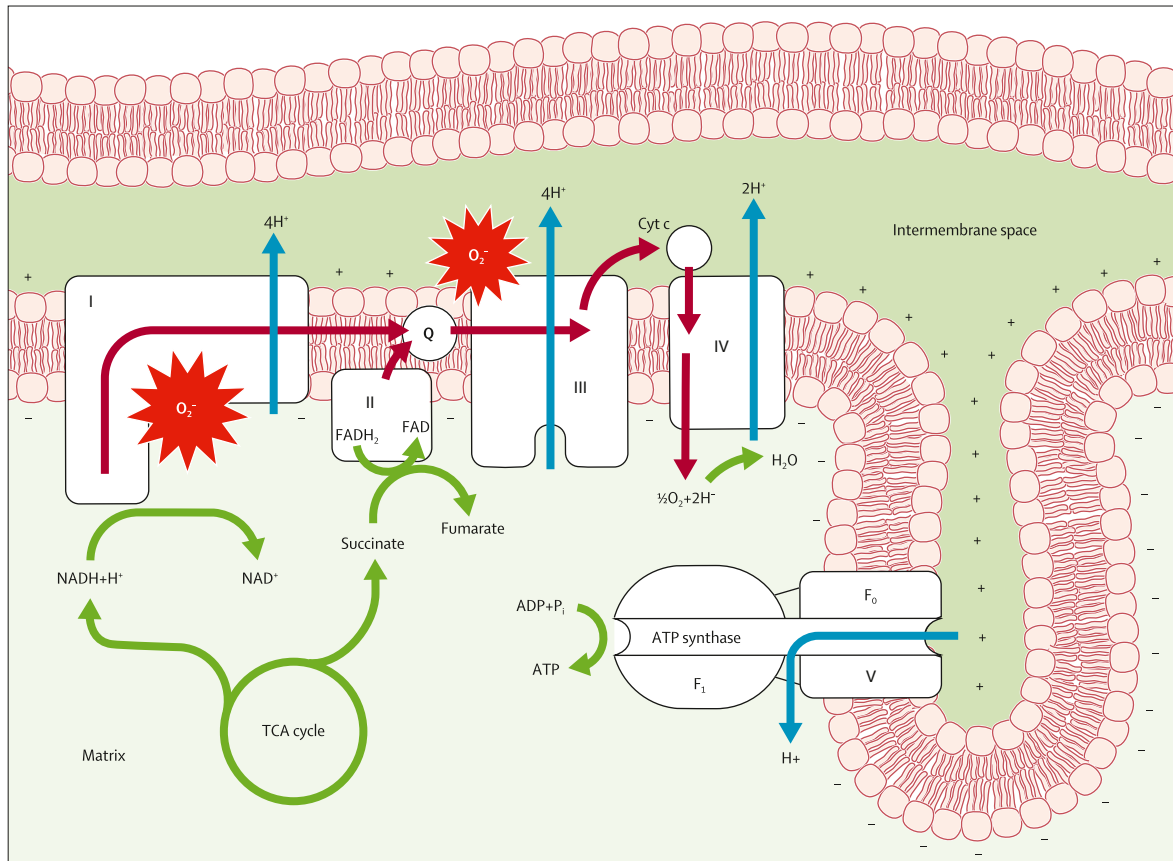
Elizabeth M. McCormick and Marni J. Falk

See also Chapters 107.4, 638.2.

Mitochondrial diseases are multisystemic energy failure states with extensive clinical and genetic heterogeneity. Their common basis is best understood through recognition that mitochondria function as biologic “fuel cells” or “batteries,” producing chemical energy in the form of adenosine triphosphate (ATP) by aerobic metabolism of nutrient-derived reducing equivalents, through the integrated function of the five-complex mitochondrial respiratory chain (RC) (Fig. 108.1). Mitochondria also play other essential roles that can be variably disrupted in disease states, such as regulating calcium homeostasis, diverse aspects of intermediary nutrient metabolism, nucleotide metabolism,

and oxidative stress. Primary mitochondrial disease results from deficient RC function, which can be caused by pathogenic variants in genes that encode RC subunits, assembly factors or cofactors, components of mitochondrial DNA (mtDNA) metabolism and maintenance, or a host of other basic metabolic processes ongoing within mitochondria (Table 108.1). Approximately 1,500 proteins exist within the mitochondrial proteome of different tissues, with variants in more than 350 unique genes across both the nuclear and the mitochondrial genomes already implicated as causal in human mitochondrial disease.

Collectively recognized as the most common group of inherited metabolic diseases, **primary** (genetic based) mitochondrial disease has a combined minimal prevalence of 1 in 4,300 individuals across all ages. In addition, **secondary** mitochondrial dysfunction is broadly implicated in the pathogenesis of a host of complex diseases, ranging from metabolic syndrome to ischemia-reperfusion injury after stroke, to neurodegenerative diseases. Failure of high-energy-demand organs in mitochondrial diseases may clinically present as severe neurodevelopmental, cardiac, myopathic, renal, hepatic, endocrine, immune, gastrointestinal (GI), hearing, and vision disabilities, as well as global metabolic instability with lactic acidosis (Fig. 108.2) (see Tables 107.2 and 107.3). In most mitochondrial disorders, the phenotype may vary depending on the patient's age, the specific gene or genetic variant, or tissue affected. Particularly common mitochondrial disease clinical syndromes that present in children



**Fig. 108.1** Electron transport chain. The electron transport chain consists of four protein complexes (I-IV) coupled to a fifth (V) unlinked complex, ATP synthase. Together, these five complexes are known as the respiratory chain and are the site where oxidative phosphorylation (OXPHOS) occurs to generate energy. The transport chain accepts electrons from NADH (complex I) or FADH<sub>2</sub> (complex II) that have been produced by glycolysis, the formation of acetyl-coenzyme A, and the TCA cycle (green arrows). Electrons flow from one complex to another (red arrows) because of the redox potential of each complex and lose a small amount of energy as they move through the chain. Three of the four complexes act as pumps, driven by electron flow, moving H<sup>+</sup> ions from the matrix to the intermembrane space (blue arrows). This pumping builds a concentration gradient and creates an electrochemical force that is used by ATP synthase to produce ATP. Under normal conditions, this machinery provides almost all (90%) of the ATP in a cell. However, a small proportion of electrons escape the electron transport chain even under normal conditions and can react with oxygen and complexes I and III to form superoxide (O<sub>2</sub><sup>-</sup>). ADP, Adenosine diphosphate; ATP, adenosine triphosphate; Cyt c, cytochrome c; Q, coenzyme Q; NADH, nicotinamide dinucleotide; Pi, inorganic phosphate; TCA, tricarboxylic acid cycle; FADH<sub>2</sub>, 1,5-dihydro-flavin adenine dinucleotide. (Adapted from Hagberg H, Mallard C, Rousset CI, Thornton C. Mitochondria: hub of injury responses in the developing brain. *Lancet Neurol.* 2014;13[2]:217-232.)

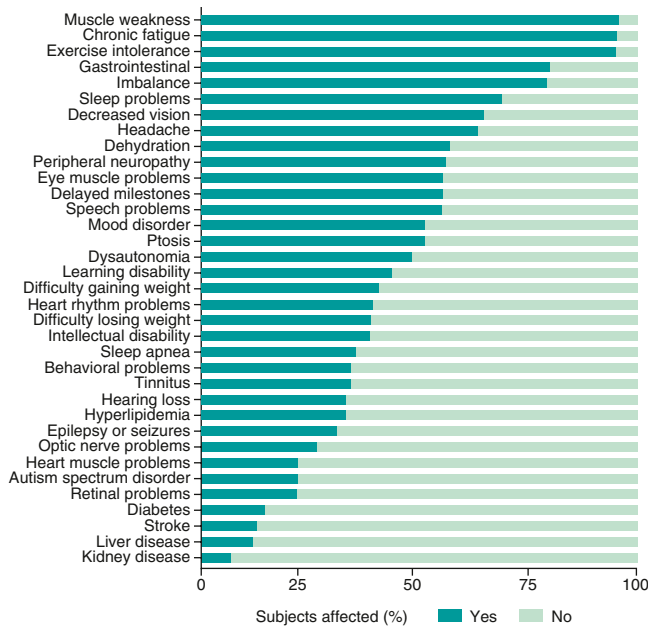


**Table 108.1** Current Mitochondrial Gene Defects and Pathomechanisms

		GENE(S)
<b>OXIDATIVE PHOSPHORYLATION DEFICIENCY</b>		
Complex I subunits and assembly factors		<i>NDUFA1, NDUFA2, NDUFA6, NDUFA9, NDUFA10, NDUFA11, NDUFA12, NDUFA13, NDUFB3, NDUFB8, NDUFB9, NDUFB10, NDUFB11, NDUFS1, NDUFS2, NDUFS3, NDUFS4, NDUFS6, NDUFS7, NDUFS8, NDUFV1, NDUFV2, NDUFAF1, NDUFAF2, NDUFAF3, NDUFAF4, NDUFAF5, NDUFAF6, NDUFAF7, NDUFAF8, ACAD9, ECSIT, FOXRED1, NUBPL, TIMMDC1, TMEM126B, MT-ND1, MT-ND2, MT-ND3, MT-ND4, MT-ND4L, MT-ND5, MT-ND6</i>
Complex II subunits and assembly factors		<i>SDHA, SDHB, SDHC, SDHD, SDHAF1, SDHAF2</i>
Complex III subunits and assembly factors		<i>UQCRCB, UQCRC2, UQCRCF1, UQCRCQ, CYC1, BCS1L, HCCS, TTC19, LYRM7, UQCC2, UQCC3, MT-CYB</i>
Complex IV subunits and assembly factors		<i>COX4I1, COX4I2, COX5A, COX6A1, COX6B1, COX7B, COX8A, NDUFA4, SURF1, SCO1, SCO2, COX10, COX15, COA3, COA5, COA6, COA7, COX14, COX20, FASTKD2, PET100, PET117, CEP89, MT-CO1, MT-CO2, MT-CO3</i>
Complex V subunits and assembly factors		<i>ATP5A1, ATP5D, ATP5E, ATPAF2, TMEM70, USMG5, MT-ATP6, MT-ATP8</i>
<b>DISORDERS OF MITOCHONDRIAL DNA MAINTENANCE</b>		
Nucleotide pool maintenance		<i>ABAT, AK2, DGUOK, RRM2B, SAMHD1, SUCLA2, SUCLG1, TK2, TYMP</i>
Replication, maintenance, and transcription of mtDNA		<i>DNA2, FBXL4, MGME1, MPV17, POLG, POLG2, SSBP1, SLC25A4, TWNK</i>
<b>MITOCHONDRIAL TRANSLATION DEFECTS</b>		
Mitochondrial tRNAs		<i>MT-TA, MT-TC, MT-TD, MT-TE, MT-TF, MT-TG, MT-TH, MT-TI, MT-TK, MT-TL1, MT-TL2, MT-TM, MT-TN, MT-TP, MT-TQ, MT-TR, MT-TS, MT-TT, MT-TV, MT-TW, MT-TY</i>
Mitochondrial aminoacyl-tRNA synthetases		<i>AARS2, CARS2, DARS, DARS2, EARS2, FARS2, GARS, HARS2, IARS, IARS2, KARS, LARS, LARS2, MARS2, NARS2, PARS2, QARS, RARS2, SARS2, TARS2, VARS2, WARS2, YARS2</i>
tRNA modification		<i>ELAC2, MTFMT, NSUN3, PDE12, QRSL1, TRIT1, TRMT5, TRMT10C, TRNT1</i>
Mitochondrial rRNA		<i>MT-RNR1, MT-RNR2</i>
RNA processing		<i>PNPT1</i>
Mitoribosome subunits and assembly		<i>ERAL1, MRPL3, MRPL12, MRPL44, MRPS2, MRPS7, MRPS16, MRPS22, MRPS23, MRPS34, MRM2, RMND1</i>
Protein synthesis		<i>C12orf65, GFM1, GFM2, GTPBP3, GUF1, LRPPRC, MTO1, MTPAP, PUS1, TACO1, TRMU, TSFM, TUFM</i>
<b>MITOCHONDRIAL QUALITY CONTROL DEFECTS</b>		
Mitochondrial membrane phospholipid and import machinery		<i>AGK, CHKB, DNAJC19, GFER, MIPEP, PAM16, PLA2G6, PMPCA, SERAC1, SLC25A3, SLC25A10, SLC25A12, SLC25A22, TAZ, TIMM8A, TIMM50, XPNPEP3</i>
Mitochondrial dynamics		<i>DNM1L, GDAP1, MFF, MFN2, MSTO1, OPA1, STAT2, TRAK1, YME1L1</i>
MICOS complex		<i>CHCHD10, QIL1, SLC25A46</i>
ER-mitochondrial tethering		<i>EMC1</i>
Mitochondrial protein quality control		<i>AFG3L2, ATAD3A, CLPB, CLPP, CLPX, HSPA9, HSPD1, HSPE1, LONP1, PITRM1, SACS, SPG7, TRAP1</i>
Toxicity		<i>ECHS1, ETHE1, HIBCH</i>
Antioxidant defense		<i>NNT, TXN2</i>
<b>METABOLIC DEFECTS</b>		
Tricarboxylic acid cycle enzymes		<i>ACO2, DHTKD1, FH, IDH3A, IDH3B, MDH2, OGDH</i>
Pyruvate metabolism		<i>DLAT, DLD, MPC1, PC, PDHA1, PDHB, PDHX, PDK3, PDP1, PDPR</i>
Fatty acid metabolism		<i>CRAT, ETFA, ETFB, ETFDH, FA2H, HSD17B10, PYCR1, SLC25A1</i>
CoA metabolism and transport		<i>COASY, PANK2, SLC25A42</i>
<b>VITAMIN AND COFACTOR METABOLISM DEFECTS</b>		
Coenzyme Q <sub>10</sub> biosynthesis		<i>COQ2, COQ4, COQ5, COQ6, COQ7, COQ8A, COQ8B, COQ9, PDSS1, PDSS2</i>
Iron-sulfur cluster protein biosynthesis		<i>ABCB7, FDXR, FDX1L, FXN, ISCA1, ISCA2, ISCU, LYRM4, NFS1, NFU1</i>
Lipoic acid biosynthesis		<i>BOLA3, GLRX5, IBA57, LIAS, LIPT1, LIPT2, MECR</i>
Cytochrome c		<i>CYCS</i>
Biotin metabolism		<i>BTD, HLCS</i>
Thiamine metabolism and transport		<i>SLC19A2, SLC19A3, SLC25A19, TPK1</i>
Mitochondrial one-carbon metabolism		<i>SLC25A26, SLC25A32</i>
Heavy metal metabolism		<i>SLC25A24, SLC33A1, SLC39A8</i>
Selenoprotein biosynthesis		<i>SECISBP2, SEPSECS</i>
NADPH metabolism		<i>NADK2, NAXD, NAXE</i>
Riboflavin metabolism and transport		<i>FLAD1, SLC52A2, SLC52A3</i>
<b>OTHER CELLULAR DEFECTS ASSOCIATED WITH MITOCHONDRIAL DYSFUNCTION</b>		
Ca <sup>2+</sup> homeostasis		<i>ANO10, C19ORF70, CISD2, CYP24A1, MICU1, MICU2, WFS1</i>
Heme biosynthesis		<i>ABCB6, ALAS2, SFXN4, SLC25A38</i>
Apoptosis defects		<i>AIFM1, APOPT1, DIABLO, HTRA2, PTRH2</i>
DNA repair		<i>APTX, XRCC4</i>
Miscellaneous or unknown function		<i>ALDH1B1, ALDH18A1, BDH1, CA5A, CTBP1, C1QBP, C19ORF12, DCC, DIAPH1, FHF1, KIF5A, OPA3, PNPLA4, PNPLA8, POP1, PPA2, ROBO3, RTN4IP1, SLC44A1, STXBP1, TANGO2, TMEM65, TMEM126A</i>

mtDNA, Mitochondrial DNA; MICOS, mitochondrial contact site and cristae organizing system; ER, endoplasmic reticulum.

From Rahman J, Rahman S: Mitochondrial medicine in the omics era. *Lancet*. 2018;391:2560–2574, Table 1.



**Fig. 108.2** Mitochondrial disease subject cohort experienced symptoms. Frequency of experienced symptoms as reported by the Rare Diseases Clinical Research Network (RDCRN) self-reported cohort revealed muscle weakness, chronic fatigue, exercise intolerance, imbalance, and gastrointestinal problems to be the top five common symptoms. (Modified from Zolkipli-Cunningham Z, Xiao R, Stoddart A, et al. *Mitochondrial disease patient motivations and barriers to participate in clinical trials*. *PLoS ONE*. 2018;13[5]:e0197513. Fig. 2.)

include **Leigh syndrome** (for which there are more than 110 causal genes; for gene listing visit <https://search.clinalgenome.org/kb/conditions/MONDO:0009723>), **mtDNA depletion syndrome** (MDS, for which there several dozen causal genes), **mtDNA deletion syndromes (Pearson, Kearns Sayre)**, primary lactic acidosis, and pyruvate dehydrogenase deficiency. Common clinical features in children present in at least 90% of patients include fatigue, exercise intolerance, weakness, GI and hepatic dysfunction, ataxia, and developmental delay. Thus mitochondrial diseases present to and must be considered by clinicians across every medical specialty.

**Reversible infantile respiratory chain deficiency** is an unusual mitochondrial disorder that presents in early ( $\leq 3$  months) infancy with muscle weakness, hypotonia, poor feeding, and lactic acidosis and spontaneously resolves beginning around 1 year of age. Responsible maternal inherited genes include *mt-tRNAGlu (MT-TE)* (in 100%) and possible modifier genes (*EARS2*, *TRMU*). Muscle biopsy may show ragged red fibers.

Patients with suspected mitochondrial disease often have an extensive phenotypic heterogeneity without a common biomarker, which presents a challenge to the accurate **clinical diagnosis** of mitochondrial disorders. Lactate and growth differentiation factor 15 (GDF-15) are screening tests that may be elevated in *some* mitochondrial diseases, particularly those involving mtDNA deletions or depletion. In addition, their extensive genetic heterogeneity involving known etiologies in  $>300$  nuclear genes and all 37 mtDNA genes can make the accurate **genetic diagnosis** of an individual patient challenging. The diagnostic uncertainty can be further compounded by poor genotype-phenotype correlations and variable clinical presentations of individual gene disorders, high locus heterogeneity (i.e., multiple different causal disease genes) for similar clinical phenotypes, incomplete penetrance for some gene disorders, variable life stressors or environmental exposures that may exacerbate a given child's disease, and the unique biologic aspects of maternal inheritance for the subset of mitochondrial diseases caused by mtDNA pathogenic variants.

## WHEN TO SUSPECT MITOCHONDRIAL DISEASE

Because of failure in the ability to generate cellular energy, mitochondrial diseases can involve any organ system at any age (see Fig. 108.2). Mitochondrial disease should be suspected when classic symptoms are

present or if unexplained symptoms occur in three or more apparently unrelated organs. Individuals may present with a vast array of symptoms, including fatigue, muscle weakness, exercise intolerance, metabolic strokes, seizures, cardiomyopathy, arrhythmias, developmental or cognitive disabilities, autism, diabetes mellitus, and other endocrinopathies (adrenal, thyroid), dysautonomia, and autoimmune disorders, as well as impairment of hearing, vision, growth, liver, GI, or kidney function. Although individuals may have just one or a few symptoms and a fluctuating disease course in terms of symptom severity, most patients with primary mitochondrial disease tend to develop *progressive* symptoms over time. A study of patients with mitochondrial diseases showed an average of 16 different clinically significant symptoms per patient, with a range of 7-35. When considering the diagnosis, it is helpful to recognize that most symptoms of mitochondrial disease involve *functional*, rather than structural, problems.

When mitochondrial disease is considered in the differential diagnosis, it is often helpful to obtain several **laboratory screening** studies for common biochemical features of mitochondrial disease and overlapping disorders at baseline and, if unrevealing, during an acute illness or period of decompensation. Blood-based metabolic screening studies include comprehensive chemistry panel, complete blood count with differential, blood lactate and pyruvate, plasma amino acid quantitative analysis, carnitine analysis (total, free, acyl-carnitine profile), ammonia, creatine kinase, and testing for common secondary manifestations of mitochondrial disease (e.g., thyroid screen, lipoprotein profile, hemoglobin  $A_{1c}$ ). Urine-based metabolic screening studies include urinalysis, urine organic acid quantitative analysis, and urine amino acid quantitative analysis. Consideration should also be given for screening for congenital disorders of glycosylation or vitamin deficiencies, which may have overlapping clinical features in some cases with mitochondrial disease. Lactic acidemia is neither highly sensitive nor specific for primary mitochondrial disease, but laboratory findings suggestive of primary mitochondrial disease include elevations of blood lactate, pyruvate, lactate:pyruvate ratio, alanine, ratios of alanine to lysine ( $>3$ ) and alanine to the sum of phenylalanine and tyrosine ( $>4$ ), and anion gap. Biochemical alterations further suggestive of mitochondrial disease may include secondary impairment of fatty acid oxidation with elevation of dicarboxylic acids on acyl-carnitine profile, increased branched-chain amino acids and proline on plasma amino acid analysis, increased tricarboxylic acid cycle intermediates and lactate excretion on urine organic acid analysis, and generalized aminoaciduria on urine amino acid analysis. **GDF-15** may be a useful screening test for mitochondrial depletion-based myopathies.

Similarly, when mitochondrial disease is considered in the differential diagnosis, obtaining additional **clinical evaluations** to carefully phenotype the patient for prevalent or highly morbid and potentially modifiable features of mitochondrial disease is important. Because many individuals with mitochondrial disease develop problems with their *vision* (reduced visual acuity not correctable with glasses, photophobia or nyctalopia with reduced peripheral vision associated with retinal disease or optic atrophy, ophthalmoplegia, ptosis), *hearing* (high-frequency sensorineural hearing loss), and *heart* (arrhythmia, conduction block, cardiomyopathy), carefully evaluating for involvement of these high-energy systems is indicated. **Neurologic** evaluation is essential because many mitochondrial disease patients experience a range of *central* (metabolic stroke in cortical or deep gray matter, including basal ganglia, midbrain, and/or brainstem; white matter changes; seizures; ataxia; movement disorder; migraine; cognitive changes), *peripheral* (axonal sensorimotor neuropathy), or *autonomic* nervous system dysfunction; brain imaging (MRI), spectroscopy (MRS), and, on occasion, electromyogram or nerve conduction velocity (EMG/NCV) studies can be helpful to support the diagnosis. Formal **exercise physiology** evaluation can also be useful to quantify and advise patients on their exercise capacity and safety, with some specific features (e.g., reduced  $VO_2$  maximal capacity) suggestive of quantifiable mitochondrial dysfunction. A **sleep** study may be useful for individuals with sleep dysfunction because sleep disorders may mimic mitochondrial disease symptoms, and sleep problems are common and potentially treatable in mitochondrial disease. **Gastrointestinal** symptoms are common and underrecognized in mitochondrial disease patients, usually involving dysmotility of any portion of the GI tract with reflux, swallowing dysfunction, delayed gastric emptying,

feeding and/or growth problems, pseudoobstruction, malabsorption, and constipation. **Endocrine** abnormalities are also common but underappreciated in many patients, including pituitary, adrenal, thyroid, and pancreatic dysfunction.

Such careful phenotyping of patients with suspected mitochondrial disease can thus provide reassurance that the common, and potentially treatable, clinical aspects of mitochondrial disease are not present although they may develop over time, or conversely if identified, increase diagnostic suspicion and direct further diagnostic evaluation. A screening tool for mitochondrial diseases is noted in Table 108.2. The differential diagnosis of mitochondrial disorders is extensive (Table 108.3).

### MITOCHONDRIAL DISEASE INHERITANCE

Primary mitochondrial disease may result from variants in either nuclear genes or mtDNA genes, which may be inherited from a parent or occur de novo in an affected individual (for a list of genes curated for their association with primary mitochondrial disease, visit <https://search.clinicalgenome.org/kb/affiliate/10027>). Thus all *mendelian* (autosomal recessive, autosomal dominant, X-linked) or *maternal* (mtDNA) inheritance patterns can be consistent with mitochondrial diseases. Obtaining a detailed, three-generation pedigree is important to potentially highlight the specific inheritance pattern in a family. Individuals with inherited mtDNA disorders may report family members related through their **maternal** lineage (both males and females may be affected, but only affected individuals will be connected through the female germline), with a range of functional problems in different organs, such as migraines, fatigue, exercise intolerance, stroke, diabetes mellitus, thyroid dysfunction, irritable bowel syndrome, mood disorder, or vision and hearing problems (for a list of curated mtDNA variants, visit <https://erepo.clinicalgenome.org>). Inherited **X-linked** disorders typically present with symptoms only or, more severely, in males related through unaffected or minimally affected females. **Autosomal recessive** disorders are common in pediatric mitochondrial disease, particularly in consanguineous pedigrees, where a rare variant in the general population becomes enriched and passed down through both maternal and paternal lineages to become homozygous in the affected proband and also affect multiple individuals in a given generation without having affected individuals in earlier generations. **Autosomal dominant** variants may occur de novo or are passed on from either parent to their child, although many disorders may have reduced penetrance, which may make the genetic disorder appear to skip a generation. Identifying a likely inheritance pattern through pedigree analysis can inform accurate interpretation of large-scale genetic diagnostic evaluations, such as multigene sequencing and deletion/duplication analysis panels and exome or genome sequencing. Establishing a correct genetic diagnosis for mitochondrial disease in an affected individual is essential to enable reliable recurrence risk counseling and testing options in a given family, whether in a future pregnancy by chorionic villus sampling (CVS, typically performed at 10–12 weeks' gestation) or amniocentesis (typically performed at 16–20 weeks' gestation) or in the in vitro fertilization (IVF) setting with preimplantation genetic testing (PGT) for a specific disease-causing variant. Of note, PGT is readily available to families for known nuclear gene disorders but remains of limited availability in known pathogenic mtDNA variants.

Special mention is warranted to consider the unique aspects of *maternal inheritance* that typify mtDNA disorders. More than 300 disease-causing mtDNA variants have been identified, with extensive variation in disease manifestations and features. Most disease-causing variants are present in only a portion of an individual's mtDNA genomes, a concept known as **heteroplasmy**. For heteroplasmic mtDNA variants, the precise pathogenic variant level (percent) can vary between an individual's different tissues and can change over time, with symptom severity corresponding to different threshold pathogenic variant levels that can be difficult to define and that typically vary between organs. An individual's mtDNA genome background set of fixed sequence variants, known as a **haplogroup**, can also influence the penetrance or severity of an mtDNA disease. When a novel or rare mtDNA variant is identified in a given individual, it may be helpful to use highly sensitive sequencing methods to test the levels of that pathogenic variant (which may be accurate to detect 1% of pathogenic variant levels) in their different tissues (blood, urine, buccal, skin cells, muscle), as well as tissues from their mother or maternal relatives, to accurately

**Table 108.2** Mitochondrial Disease Criteria

FEATURES		
Muscular	Myopathy Abnormal EMG Motor developmental delay Exercise intolerance	Maximal score for muscle is 2
Neurologic	Developmental delay or ID Speech delay Dystonia Ataxia Spasticity Neuropathy Seizures or encephalopathy	Maximal score for neurologic is 2
Multisystem	Any gastrointestinal tract disease Growth delay or failure to thrive Endocrine Immune Eye (vision) or hearing Renal tubular acidosis Cardiomyopathy	Maximal score for multisystem is 3
<b>Total clinical</b>		<b>Total maximal clinical score is 4</b>
Metabolic	Lactate high at least 2×: (score 2) Alanine high at least 2× Krebs cycle intermediates <sup>a</sup> Ethyl malonic and methyl malonic acid 3 methyl glutaconic acid CSF lactate, alanine	
Imaging/other	Leigh disease (score 2) Strokelike episodes (score 2) Lactate peak on MRS Leukoencephalopathy with brainstem and spinal cord involvement <sup>b</sup> Cavitating leukoencephalopathy <sup>b</sup> Leukoencephalopathy with thalamus involvement <sup>b</sup> Deep cerebral white matter involvement and corpus callosum agenesis <sup>b</sup>	Total metabolic and MRI maximal score is 4
<b>Total MDC score (clinical, metabolic, imaging)</b>		<b>Total maximal score is 8</b>

<sup>a</sup>Krebs cycle intermediates: alpha-ketoglutarate, succinate, fumarate.

<sup>b</sup>Numerous MRI patterns characteristic of mitochondrial disease have been described in addition to Leigh syndrome and basal ganglia with brainstem involvement. We include leukoencephalopathy with brainstem and spinal cord involvement (*DARS2*), cavitating leukoencephalopathy (*LYRM7*), leukoencephalopathy with thalamus involvement (*EARS2*), and deep cerebral white matter involvement and corpus callosum agenesis (*NUBPL*).

Every element scores 1 unless indicated differently. The severity of each finding is not taken into account because of the progressive nature of the disease. A total score of 1 indicates unlikely mitochondrial disorder; score 2–4, possible mitochondrial disorder; score 5–7, probable mitochondrial disorder; and score ≥8, definite mitochondrial disorder. COX, Cytochrome c oxidase; EMG, electromyography; L/P, lactate/pyruvate; SDH, succinate dehydrogenase.

From Witters P, Saada A, Honzik T, et al. Revisiting mitochondrial diagnostic criteria in the new era of genomics. *Genetics Med.* 2018;20(4):444–451, Table 2.

determine whether it may be causal of disease in that family. Research-based functional testing may also be necessary to characterize fully the effects of a newly recognized mtDNA variant. When it is not known whether an mtDNA variant is maternally inherited or occurs de novo, the recurrence risk to future offspring of their asymptomatic parent is empirically estimated at 1 in 25 (4%), although the empirical recurrence risk rises to 1 in 2 (50%) when the mother is symptomatic.

**Table 108.3** Differential Diagnosis of Selected Phenotypes Commonly Associated with Mitochondrial Disease

PHENOTYPE	MITOCHONDRIAL CAUSE	LIMITED DIFFERENTIAL DIAGNOSIS
Dystonia	Leigh syndrome, deafness-dystonia syndrome, other mitochondrial encephalomyopathies	Biotinidase deficiency, thiamine transporter deficiency 2, <i>ADAR</i> pathogenic variants (Aicardi-Goutières syndrome 6), organic acidemias (especially glutaric aciduria type I), NBIA, acute (viral) necrotizing encephalopathy, pathogenic variants in <i>NUP62</i> , <i>RANBP2</i> , and <i>PDE8B</i> , primary genetic dystonias
Epileptic encephalopathy	Alpers-Huttenlocher syndrome, many other mitochondrial disorders	Many genetic epileptic encephalopathies, including Dravet syndrome and <i>KCNQ2</i> pathogenic variants, pyridoxine-dependent epilepsies (antiquitin deficiency, PNPO deficiency), viral encephalitis
Progressive myoclonic epilepsy	MERRF	Ramsay Hunt syndrome, Unverricht-Lundborg disease, Lafora body disease, sialidosis, <i>PRICKLE1</i> pathogenic variants
Leukoencephalopathy	Complex I deficiency, complex II deficiency, <i>SURF1</i> deficiency (rarely), disorders of mitochondrial translation and Fe-S cluster assembly	Vanishing white matter disease, lysosomal storage disorders, Canavan disease, Alexander disease, Pelizaeus-Merzbacher(-like), hypo/dysmyelination
Ataxia	<i>ADCK3</i> pathogenic variants, ataxia-neuropathy syndromes, for example, SCAE, MIRAS, MERRF, NARP, disorders of coenzyme Q <sub>10</sub> biosynthesis	Spinocerebellar ataxias, CAPOS syndrome
Demyelination	MNGIE	ADEM, multiple sclerosis
Peripheral neuropathy	Pathogenic variants in <i>POLG</i> , <i>MPV17</i> , <i>KARS</i> , and <i>SURF1</i> ; part of multisystem disease in many mitochondrial disorders, for example, MNGIE	Other nonmitochondrial genetic causes of Charcot-Marie-Tooth syndromes, riboflavin transporter deficiency, toxic neuropathies, critical illness
Ptosis and ophthalmoplegia	PEO, KSS, MNGIE, MELAS	Some congenital myopathies, pseudo-upgaze impairment in <i>OPMD</i> , horizontal gaze palsy and scoliosis ( <i>ROBO3</i> pathogenic variant)
Optic neuropathy	LHON, ADOA, Leigh syndrome	Toxic optic neuropathy (e.g., methanol, cyanide, tobacco)
Hypertrophic cardiomyopathy with lactic acidosis	Complex I deficiency, <i>TMEM70</i> pathogenic variants, Sengers syndrome (AGK deficiency), disorders of mitochondrial translation	Viral infection
Dilated cardiomyopathy with lactic acidosis	Barth syndrome, disorders of mitochondrial phospholipid remodeling, other mitochondrial cardiomyopathies	Viral infection
Exocrine pancreatic insufficiency	Pearson syndrome	Cystic fibrosis
Diabetes and deafness	MIDD, other mtDNA pathogenic variants	Type 2 diabetes mellitus with incidental nonsyndromic deafness
Sideroblastic anemia	Pearson syndrome, MLASA, TRNT1 deficiency, <i>PUS1</i> or <i>YARS2</i> pathogenic variants	Blackfan-Diamond syndrome, Schwachman-Diamond syndrome, X-linked sideroblastic anemia
B-cell immune deficiency	TRNT1 deficiency	Primary immunodeficiency disorder
Liver failure	Mitochondrial DNA (mtDNA) depletion syndromes	NBAS, LARS, and IARS deficiencies, viral infection, lysosomal storage disorders, other syndromic genetic conditions
Renal tubulopathy/failure	Pearson and Kearns-Sayre syndromes, <i>RMND1</i> -related disease	Gitelman syndrome, Fanconi Bickel ( <i>SLC2A2</i> pathogenic variants) syndrome, other syndromic genetic conditions
Myopathy	Part of multisystem disease in many mitochondrial disorders, especially mtDNA depletion syndromes	Congenital muscular dystrophies, myositis, many other disorders
Rhabdomyolysis	Mitochondrial myopathies (e.g., <i>MTCO1</i> , <i>MTCO2</i> , <i>MTCO3</i> , and <i>MTCYB</i> pathogenic variants)	<i>LPIN1</i> pathogenic variants, fatty acid oxidation defects (VLCAD, LCHAD), TANGO deficiency, glycolytic defects, toxic, postexercise
Low copper	Cytochrome oxidase deficiency	Menkes, <i>SLC33A1</i> pathogenic variants
Complex multisystem disorders	Many mitochondrial disorders, particularly in childhood	Congenital disorders of glycosylation, peroxisomal disorders, lysosomal storage disorders, other syndromic genetic conditions

ADEM, Acute disseminated encephalomyelitis; ADOA, autosomal dominant optic atrophy; CAPOS, cerebellar ataxia, areflexia, pes cavus, optic atrophy and sensorineural hearing loss; Fe-S, iron-sulfur; KSS, Kearns-Sayre syndrome; LHON, Leber hereditary optic neuropathy; MERRF, myoclonic epilepsy with ragged red fibers; MIDD, maternally inherited diabetes and deafness; MIRAS, mitochondrial recessive ataxia syndrome; MLASA, myopathy, lactic acidosis, sideroblastic anemia; MNGIE, mitochondrial neurogastrointestinal encephalomyopathy; NBIA, neurodegeneration with brain iron accumulation; PEO, progressive external ophthalmoplegia; SCAE, spinocerebellar ataxia with epilepsy. Modified from Parikh S, Karaa A, Goldstein A, et al. Diagnosis of “possible” mitochondrial disease: an existential crisis. *J Med Genet*. 2019;56(3):123–130, Table 1.



## DIAGNOSTIC TESTING FOR MITOCHONDRIAL DISEASE

The diagnosis of mitochondrial disease relies foremost on genetic testing (genomic analysis), with biochemical screens useful in blood or urine and invasive tissue testing often seen as secondary or sometimes not required at all (Fig. 108.3).

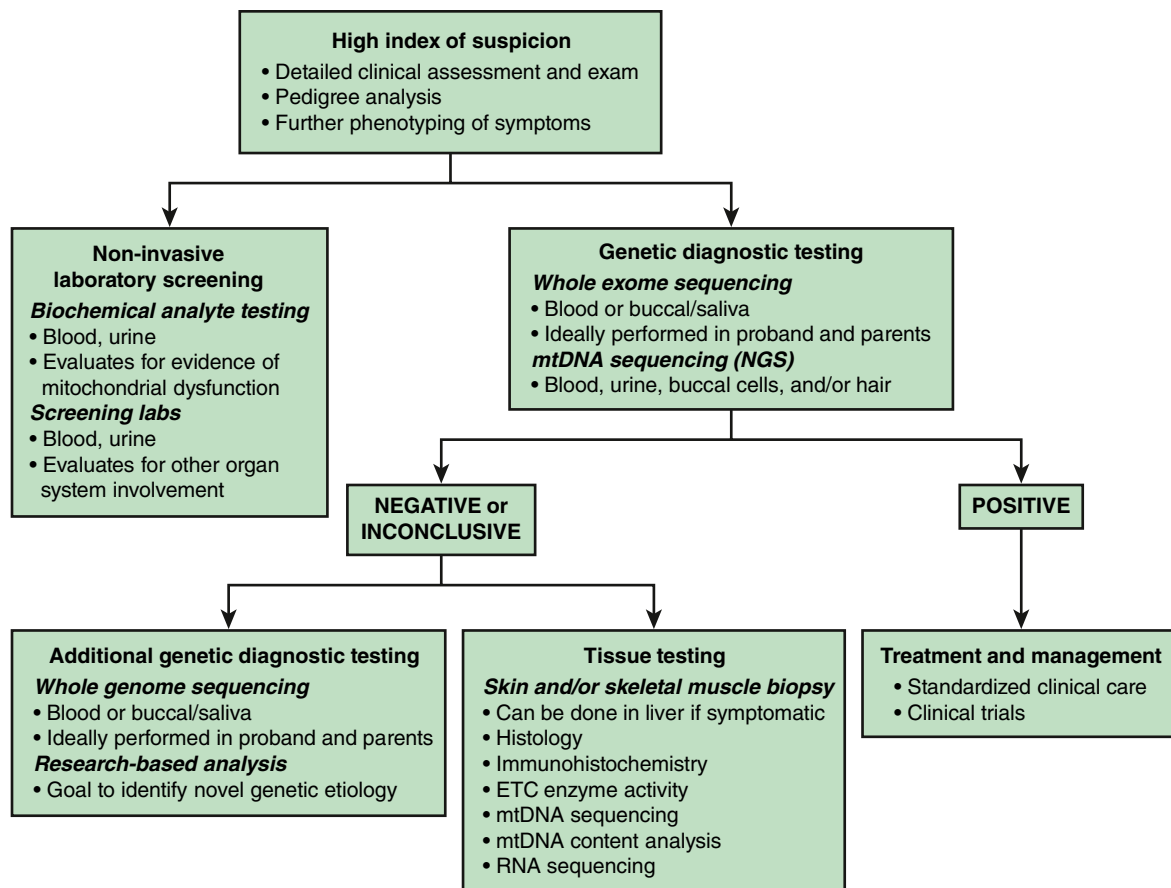
When the clinical evaluation—medical history; detailed review of systems; careful physical, neurologic, and dysmorphic examinations; pedigree review; blood- and urine-based biochemical screening studies; and additional phenotyping clinical evaluations—is suggestive of mitochondrial disease, a range of clinical diagnostic testing options can be pursued. Without a known molecular etiology in an affected family member, first-line genetic diagnostic testing should include whole exome sequencing (WES) and mtDNA genome sequencing using methodologies that will detect both single-nucleotide variants and larger-scale gene deletions and duplications. WES is more comprehensive for genes known not only to cause mitochondrial disease but also to cause all human genetic diseases. The rationale for this diagnostic testing approach includes the following factors:

- The mtDNA genome sequence is often included at no extra cost when clinical WES is ordered in blood or buccal samples but may need to be repeated in a symptomatic tissue (e.g., muscle, liver) to detect heteroplasmic mtDNA variants that may not be present in more accessible tissues such as blood or buccal cells.
- The utility of performing concurrent proband and both parental sample sequencing (*trio-based testing*), as usually pursued with WES but not panel-based testing, thereby allowing concurrent segregation analysis of a suspected pathogenic variants as well as ready identification of *de novo* dominant variants in the proband.
- The ability to use WES raw data (either on a research basis or for reanalysis at a later date by the clinical diagnostic laboratory) to highlight and/or identify “novel” gene disorders not previously recognized or associated with human disease.

Exome sequencing including mtDNA is estimated to identify the definitive genetic etiology for mitochondrial disease in at least 60% of patients

in whom it is strongly suspected. Whole genome sequencing (WGS) is increasingly used when routine molecular testing such as WES with mtDNA sequencing is unrevealing of the genetic etiology. A mitochondrial disease community resource to centrally curate all mitochondrial disease, gene, and variant knowledge across both genomes is publicly accessible at <https://mseqdr.org/>.

**Tissue-based diagnostic testing** has decreased in frequency as a front-line test in all patients with suspected mitochondrial disease, although it still has clinical utility. These include (1) in the setting of rapidly deteriorating clinical status when genetic testing results may not be available in a timely fashion; (2) when a variant of uncertain significance identified on genomic testing has unclear biochemical consequences; and (3) when uninformative genomic sequencing in blood in an individual with myopathy or muscle symptoms raises concern for other disease processes that may be evident on histology, electron microscopy, immunohistochemistry, or enzymatic tissue testing. In addition, some mitochondrial diseases are only evident by tissue-based diagnostic testing. These include mtDNA deletion disorders (typically involving several thousand nucleotides) not present in blood that cause **chronic progressive external ophthalmoplegia (CPEO)** or **Kearns-Sayre syndrome (KSS)** spectrum disorder, as well as different tissue (muscle or liver)-specific mtDNA depletion disorders (e.g., reduced mtDNA tissue content) that confirm a mitochondrial pathophysiology in a given patient and highlight a likely underlying nuclear gene cause for their disease, because mtDNA maintenance requires a host of nuclear-encoded proteins. **Electron transport chain enzyme** activity analyses are the accepted gold standard to evaluate for mitochondrial dysfunction in a previously frozen tissue sample. Skin biopsies are useful to establish fibroblast cell lines in which these same studies of mitochondrial function can be clinically performed. If detected, abnormalities can be revealing of a specific type of mitochondrial disorder, although not all mitochondrial diseases may be expressed or detectable in skin analysis. Thus if fibroblast testing is unrevealing, more invasive tissue studies may subsequently need to be pursued. RNA sequencing may lead to identification of the genetic etiology in an additional 10% of individuals with mitochondrial disease in



**Fig. 108.3** Diagnostic algorithm for suspected mitochondrial disease. (Modified from Muresku CC, McCormick EM, Falk MJ. Mitochondrial disease: advances in clinical diagnosis, management, therapeutic development, and preventative strategies. *Curr Genet Med Rep*. 2018;6:62–72.)

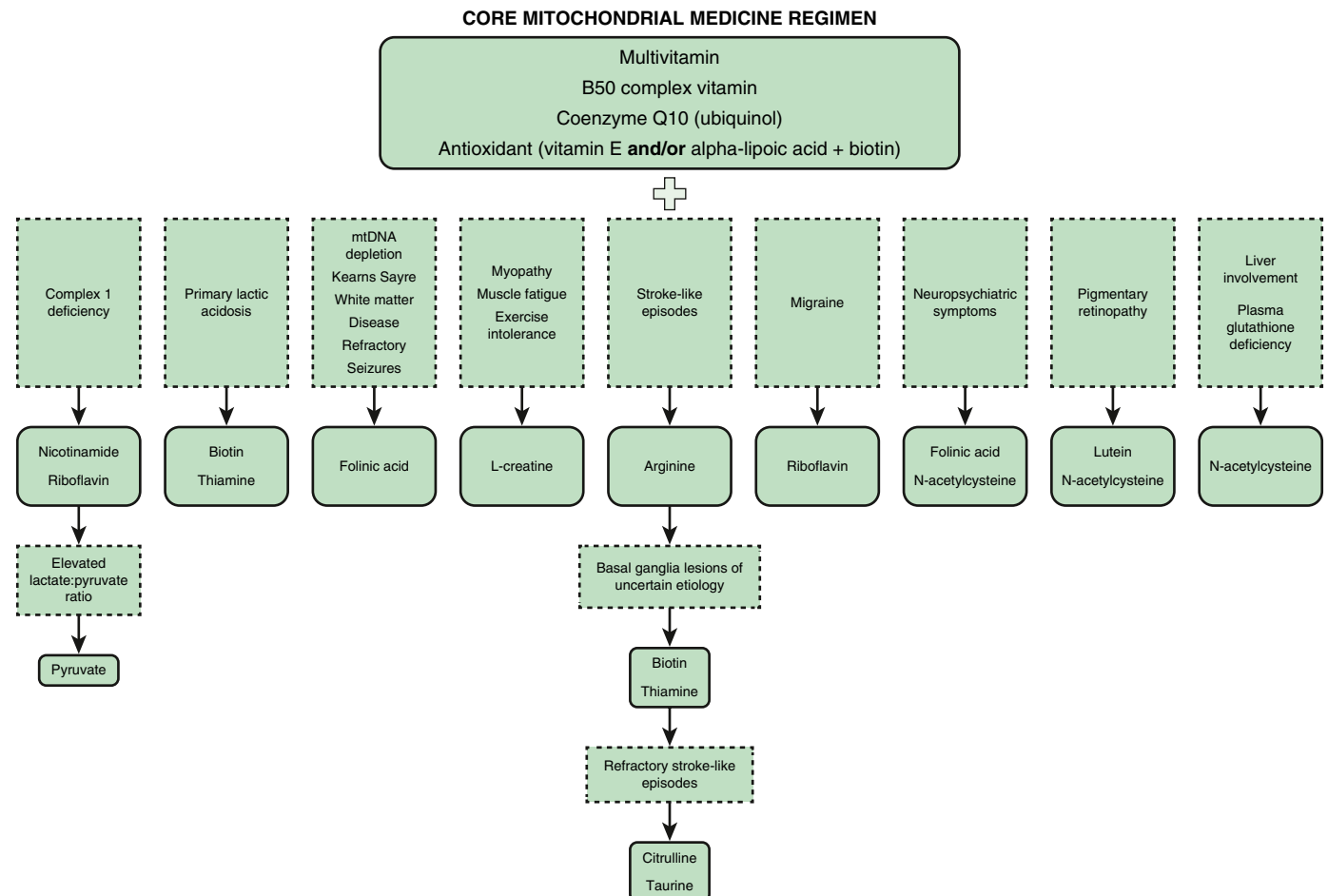
whom DNA-based sequencing did not identify the disease-causing variants. Only a small number of clinical laboratories offer this testing; this test can be performed in muscle, fibroblasts, or blood. Fibroblast cell lines, and occasionally blood-based lymphoblastoid cell lines, also provide a minimally invasive cell source to allow other clinical enzymatic analyses to be performed, as well as novel disease gene validation and research-based therapeutic modeling.

### TREATMENT PRINCIPLES FOR MITOCHONDRIAL DISEASE

Effective therapies for both primary and secondary mitochondrial diseases are lacking. Clinical complexity and imprecisely defined or understood biochemical phenotypes of different mitochondrial disease subtypes have made it difficult for clinicians to effectively apply or monitor targeted therapies for RC disease. *Mitochondrial cocktails* consisting of combinatorial regimens of vitamins and supplements variably include vitamins (B<sub>1</sub>, B<sub>2</sub>, C), antioxidants (CoQ<sub>10</sub>, lipoic acid, vitamin E, *N*-acetylcysteine), and metabolic modifiers (creatine, L-carnitine, L-arginine, folic acid, taurine). Although the efficacy, toxicity, and optimal dose of these drugs are not known and have not been objectively assessed via clinical trials in human RC disease patients, they continue to be empirically prescribed in hopes of enhancing residual RC enzymatic function or quenching toxic metabolites theorized to accumulate in RC dysfunction and because of patient-based reports of improved well-being. However, provision of these therapies has often adopted a one-size-fits-all approach, ignoring the inherent variation in primary mitochondrial disease subtypes, the tissue-specific manifestations, and the major pathogenic factors, such as the predominant downstream metabolic and signaling alterations that occur in different disease subclasses (Fig. 108.4).

Although few mitochondrial diseases have efficacious therapies that have gained regulatory approval, improved molecular delineation has enabled selected therapies to advance from the theoretical, empirical, and largely ineffective stage to a promising horizon of rational, personalized, and effective interventions. An increasing number of mitochondrial disease diagnoses have interventions involving the initiation or *avoidance* of specific medications (corticosteroids, valproic acid, phenytoin, barbiturates, propofol for prolonged duration beyond 30-60 minutes, certain anesthetics, statins,  $\beta$ -blocking agents, amiodarone, nucleoside reverse transcriptase inhibitors), provision of cofactors or diets, and screening regimens for progressive clinical involvement of modifiable manifestations. General therapies for **Leigh syndrome** such as L-arginine and citrulline may prevent or reverse neurodevelopmental sequelae from a metabolic stroke. Nutritional therapies in these disorders are tailored to specific disease genes, such as thiamine and biotin for *SLC19A3* disease, ubiquinol for *PDSS2* (CoQ<sub>10</sub> deficiency) disease, and thiamine and the ketogenic diet for *PDHA1* (pyruvate dehydrogenase) deficiency. Establishing the precise molecular diagnosis can further be lifesaving by avoiding fasting and mitochondrial-toxic medicines or general anesthetics in specific mitochondrial disease subsets, improving recurrence counseling for risk reduction of manifesting mitochondrial disease, enabling targeted screening for reported medical complications, and in some cases providing necessary cofactors or vitamins that may not otherwise have been considered. In addition, reproductive methodologies emerging in some countries for mitochondrial disease prevention, such as PGD and mitochondrial replacement technologies (MRTs), are only appropriate to consider in the setting of known pathogenic, inherited mtDNA variants.

Visit Elsevier eBooks+ at [eBooks.Health.Elsevier.com](http://eBooks.Health.Elsevier.com) for Bibliography.



**Fig. 108.4** Algorithm for the personalized prescribing of mitochondrial supplements. This figure represents the recommended approach to prescribing mitochondrial medicines. (Elevated lactate:pyruvate ratio indicates elevated NADH/NAD<sup>+</sup> ratio.) B50, vitamins B<sub>1</sub>, B<sub>2</sub>, B<sub>3</sub>, B<sub>6</sub>, B<sub>12</sub>. (From Barcelos I, Shadiack E, Ganetzky RD, Falk MJ. *Mitochondrial medicine therapies: rationale, evidence, and dosing guidelines*. *Curr Opin Pediatr*. 2020;32[6]:707–718.)

## Chapter 109

## Mucopolysaccharidoses

Christina Lampe

Mucopolysaccharidoses are hereditary progressive diseases caused by pathogenic variants of genes coding for the lysosomal enzymes needed to degrade glycosaminoglycans (acid mucopolysaccharides). *Glycosaminoglycans* (GAGs) are long-chain complex carbohydrates composed of uronic acids, amino sugars, and neutral sugars. The major GAGs are chondroitin-4-sulfate, chondroitin-6-sulfate, heparan sulfate, dermatan sulfate, keratan sulfate, and hyaluronan. These substances are synthesized and, with the exception of hyaluronan, linked to proteins to form *proteoglycans*, major constituents of the ground substance of connective tissue and of nuclear and cell membranes. Degradation of proteoglycans starts with the proteolytic removal of the protein core, followed by the stepwise degradation of the GAG moiety. Failure of this degradation because of absent or grossly reduced activity of mutated lysosomal enzymes results in the intralysosomal accumulation of GAG fragments (Fig. 109.1). Distended lysosomes accumulate in the cell, interfere with cell function, and lead to characteristic patterns of clinical, radiologic, and biochemical abnormalities (Table 109.1 and Fig. 109.2). Within these patterns, specific diseases can be recognized that evolve from the intracellular accumulation of different degradation products (Table 109.2). As a general rule, the impaired degradation of heparan sulfate is more closely associated with **intellectual disability** and that of dermatan, chondroitin, and keratan sulfate with **mesenchymal abnormalities**. Variable expression within a given entity results from allelic pathogenic variants and varying residual activity of mutated enzymes. For instance, different allelic variants of the gene encoding L-iduronidase may result in severe **Hurler disease** (Hurler syndrome) with early death or in mild **Scheie disease** (Scheie syndrome) manifesting only with limited joint mobility, mild skeletal abnormalities, and corneal opacities. In addition, the features of an individual patient will be modified by secondary effects of lysosomal dysfunction and environmental factors.

Mucopolysaccharidoses are autosomal recessive disorders, with the exception of **Hunter disease** (Hunter syndrome), which is X-linked recessive. Their birth prevalence varies between 1.2 per 100,000 births (United States) and 16.9 per 100,000 births (Saudi Arabia). In the United States the most common subtype is MPS-III, followed by MPS-I and MPS-II.

## CLINICAL ENTITIES

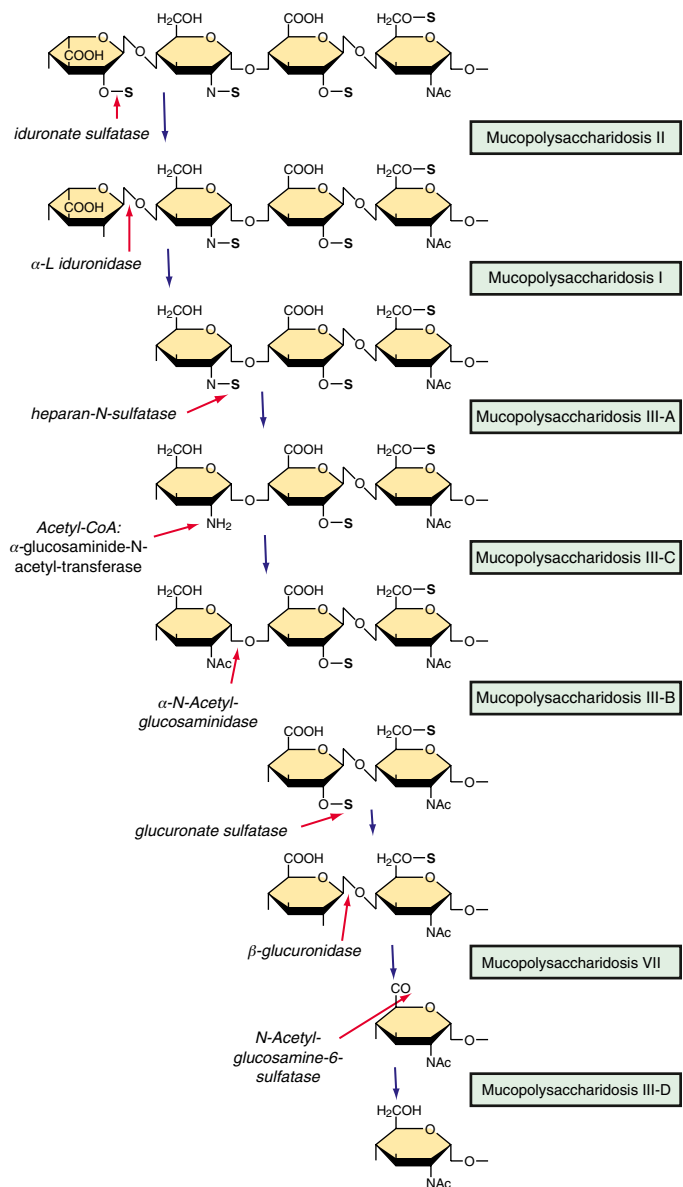
## Mucopolysaccharidosis I

Mucopolysaccharidosis I (MPS-I) is caused by pathogenic variants of the *IUA* gene on chromosome 4p16.3 encoding  $\alpha$ -L-iduronidase. Two major alleles, W402X and Q70X, account for more than half of the MPS-I alleles in the White population. Other pathogenic variants typically occur in only one or a few individuals.

Deficiency of  $\alpha$ -L-iduronidase results in a wide range of clinical involvement. Homozygous nonsense pathogenic variants result in the absence of enzyme and severe forms of MPS-I (Hurler syndrome). In contrast, missense pathogenic variants are more likely to preserve some residual enzyme activity and be associated with a milder form of the disease, including the milder Scheie syndrome.

## Hurler Disease

The Hurler form of MPS-I (**MPS I-H**) is a severe, progressive disorder with involvement of multiple organ and tissue involvement that results in premature death, usually by 10 years of age. An infant with Hurler syndrome appears normal at birth, but inguinal hernias may be present. Diagnosis is usually made at 6–24 months, with evidence of hepatosplenomegaly, coarse facial features, corneal clouding, large tongue, enlarged head circumference, joint stiffness, short stature, and skeletal dysplasia. Acute cardiomyopathy has been found in some



**Fig. 109.1** Degradation of heparan sulfate and mucopolysaccharidoses resulting from the deficiency of individual enzymes. Some of the enzymes are also involved in the degradation of other glycosaminoglycans (not shown).

infants <1 year. Most patients have recurrent upper respiratory tract and ear infections, noisy breathing, and persistent copious nasal discharge. Valvular heart disease, notably with incompetence of the mitral and aortic valves, regularly develops, and narrowing of the coronary arteries occurs. Obstructive airway disease, especially during sleep, may necessitate tracheotomy. Obstructive airway disease, respiratory infection, and cardiac complications are the common causes of death.

Most children with Hurler syndrome acquire only limited language skills because of developmental delay, combined conductive and neurosensory hearing loss, and an enlarged tongue. Progressive ventricular enlargement with increased intracranial pressure caused by communicating hydrocephalus also occurs. Corneal clouding, glaucoma, and retinal degeneration are common. Radiographs show a characteristic skeletal dysplasia known as *dysostosis multiplex* (Figs. 109.3 and 109.4). The earliest radiographic signs are thick ribs and ovoid vertebral bodies. Skeletal abnormalities (in addition to those shown in the figures) include enlarged, coarsely trabeculated diaphyses of the long bones with irregular metaphyses and epiphyses. With progression of disease, macrocephaly develops with thickened calvarium, premature closure

of lambdoid and sagittal sutures, shallow orbits, enlarged J-shaped sella, and abnormal spacing of teeth with dentigerous cysts.

### Hurler-Scheie Disease

The clinical phenotype of the Hurler-Scheie form of MPS-I (MPS I-H/S) is intermediate between Hurler and Scheie diseases and is characterized by progressive somatic involvement, including dysostosis multiplex with little or no intellectual dysfunction. The onset of symptoms is usually observed between 3 and 8 years of age, and survival to adulthood is common. Cardiac involvement and upper airway obstruction contribute to clinical morbidity. Some patients have spondylolisthesis, which may cause cord compression.

### Scheie Syndrome

MPS I-S is a comparatively mild disorder characterized by joint stiffness, aortic valve disease, corneal clouding, and mild dysostosis

multiplex. Onset of significant symptoms is usually after age 5 years, with diagnosis made between 10 and 20 years. Patients with Scheie syndrome have normal intelligence and stature but have significant joint and ocular involvement. A carpal tunnel syndrome often develops. Ophthalmic features include corneal clouding, glaucoma, and retinal degeneration. Obstructive airway disease, causing sleep apnea, develops in some patients, necessitating tracheotomy. Aortic valve disease is common and has required valve replacement in some patients.

### Mucopolysaccharidosis II

**Hunter disease (MPS-II)** is an X-linked disorder caused by the deficiency of iduronate 2-sulfatase (IDS). The gene encoding IDS is located on Xq28. Single-nucleotide variants or small deletions of *IDS* have been detected in approximately 50% of patients with MPS-II. Major deletions or rearrangements of *IDS* have been found in the rest, usually associated with a more severe and complex clinical phenotype. As an X-linked recessive disorder, Hunter syndrome manifests almost exclusively in males. However, it has been observed in females because of unfavorable skewing of inactivation of the normal X chromosome carrying the normal gene.

Marked molecular heterogeneity explains the wide clinical spectrum of Hunter disease. Patients with severe MPS-II have features similar to those of Hurler disease, except for the lack of corneal clouding and the somewhat slower progression of somatic and central nervous system (CNS) deterioration. Coarse facial features, short stature, dysostosis multiplex, joint stiffness, and intellectual disability manifest between 2 and 4 years of age. Grouped skin papules are present in some patients. Extensive congenital dermal melanocytosis (Mongolian spots) present at birth have been observed in African and Asian patients and may be an early marker of the disease. Gastrointestinal (GI) storage may produce chronic diarrhea. Communicating hydrocephalus and spastic paraplegia may develop due to thickened meninges. In severely affected patients, extensive, slowly progressive neurologic involvement precedes death, which usually occurs at age 10-15 years.

Patients with the mild form have a near-normal or normal life span, minimal CNS involvement, and slow progression of somatic deterioration with preservation of cognitive function in adult life. Survival to ages 65 and 87 years has been reported, and some patients have had children. Somatic features are Hurler-like but milder with a greatly

**Table 109.1** Recognition Pattern of Mucopolysaccharidoses

MANIFESTATIONS	MUCOPOLYSACCHARIDOSIS (MPS) TYPE						
	I-H	I-S	II	III	IV	VI	VII
Intellectual disability	+	-	±	+	-	-	±
Coarse facial features	+	(+)	+	+	-	+	±
Corneal clouding	+	+	-	-	(+)	+	±
Visceromegaly	+	(+)	+	(+)	-	+	+
Short stature	+	(+)	+	-	+	+	+
Joint contractures	+	+	+	-	-	+	+
Dysostosis multiplex	+	(+)	+	(+)	+	+	+
Leucocyte inclusions	+	(+)	+	+	-	+	+
Mucopolysacchariduria	+	+	+	+	+	+	+

I-H, Hurler syndrome; I-S, Scheie syndrome; II, Hunter syndrome; III, Sanfilippo syndrome; IV, Morquio syndrome; VI, Maroteaux-Lamy syndrome; VII, Sly syndrome, +, presence of manifestation, -, absence of manifestation; ±, possible presence of manifestation; (+), mild manifestation.



**Fig. 109.2** Patients with various types of mucopolysaccharidoses. MPS-I: Hurler syndrome, age 3 years; MPS-II: Hunter syndrome, 12 years; MPS-III: Sanfilippo syndrome, 4 years; MPS-IV: Morquio syndrome, 10 years; MPS-VI: Maroteaux-Lamy syndrome, 15 years.



**Table 109.2** Mucopolysaccharidoses: Clinical, Molecular, and Biochemical Aspects

MPS TYPE	EPONYM	INHERITANCE	GENE/ CHROMOSOME	MAIN CLINICAL FEATURES	DEFECTIVE ENZYME	ASSAY	MIM NUMBER
I-H	(Pfaundler-) Hurler	AR	<i>IDUA</i> 4p16.3	Severe Hurler phenotype, mental deficiency, corneal clouding, death usually before age 14yr	$\alpha$ -L-iduronidase	L, F, Ac, Cv	252800 607014
I-S	Scheie	AR	<i>IDUA</i> 4p16.4	Stiff joints, corneal clouding, aortic valve disease, normal intelligence, survive to adulthood	$\alpha$ -L-iduronidase	L, F, Ac, Cv	607016
I-HS	Hurler-Scheie	AR	<i>IDUA</i> 4p16.4	Phenotype intermediate between I-H and I-S	$\alpha$ -L-iduronidase	L, F, Ac, Cv	607015
II	Hunter	XLR	<i>IDS</i> Xq27.3-28	Severe course: similar to I-H but clear corneas Mild course: less pronounced features, later manifestation, survival to adulthood with mild mental deficiency or without mental deficiency	Iduronate sulfate sulfatase	S, F, Af, Ac, Cv	309900
IIIA	Sanfilippo A	AR	<i>SGSH</i> 17q25.3	Behavioral problems, sleeping disorder, aggression, progressive dementia, mild dysmorphism, coarse hair, clear corneas	Heparan-S-sulfamidase	L, F, Ac, Cv	252900 605270
IIIB	Sanfilippo B	AR	<i>NAGLU</i> 17q21	Survival to adulthood possible	N-Acetyl-D-glycosaminidase	S, F, Ac, Cv	252920
IIIC	Sanfilippo C	AR	<i>HGSNAT</i> 8p11.21		Acetyl-CoA-glucosaminide N-acetyltransferase	F, Ac	252930
IIID	Sanfilippo D	AR	<i>GNS</i> 12q14		N-Acetylglucosamine-6-sulfate sulfatase	F, Ac	252940 607664
IVA	Morquio A	AR	<i>GALNS</i> 16q24.3	Short-trunk dwarfism, fine corneal opacities, characteristic bone dysplasia; final height <125 cm	N-Acetylgalactosamine-6-sulfate sulfatase	L, F, Ac	253000
IVB	Morquio B	AR	<i>GLB1</i> 3p21.33	Same as IVA, but milder; adult height >120 cm	$\beta$ -Galactosidase	L, F, Ac, Cv	253010 230500
VI	Maroteaux-Lamy	AR	<i>ARSB</i> 5q11-q13	Hurler phenotype with marked corneal clouding but normal intelligence; mild, moderate, and severe expression in different families	N-Acetylgalactosamine- $\alpha$ -4-sulfate sulfatase (arylsulfatase B)	L, F, Ac	253200
VII	Sly	AR	<i>GUSB</i> 7q21.11	Varying from fetal hydrops to mild dysmorphism; dense inclusions in granulocytes	$\beta$ -Glucuronidase	S, F, Ac, Cv	253220
IX	Hyaluronidase deficiency	AR	<i>HYAL1</i> 3p21.3	Periarticular masses, no Hurler phenotype	Hyaluronidase 1	S	601492
MPSPS	MPS plus syndrome	AR	<i>VPS33A</i>	Mild Hurler phenotype, cognitive deficiency, organomegaly, skeletal dysplasia, pancytopenia, renal insufficiency, optic atrophy, early death	No lysosomal enzyme deficiency	L, F	617303

AR, Autosomal recessive; XLR, X-linked recessive; L, Leukocytes; S, serum; F, cultured fibroblasts; Ac, cultured amniotic cells; Af, amniotic fluid; Cv, chorionic villus sampling; MIM, Mendelian Inheritance in Man Catalogue.

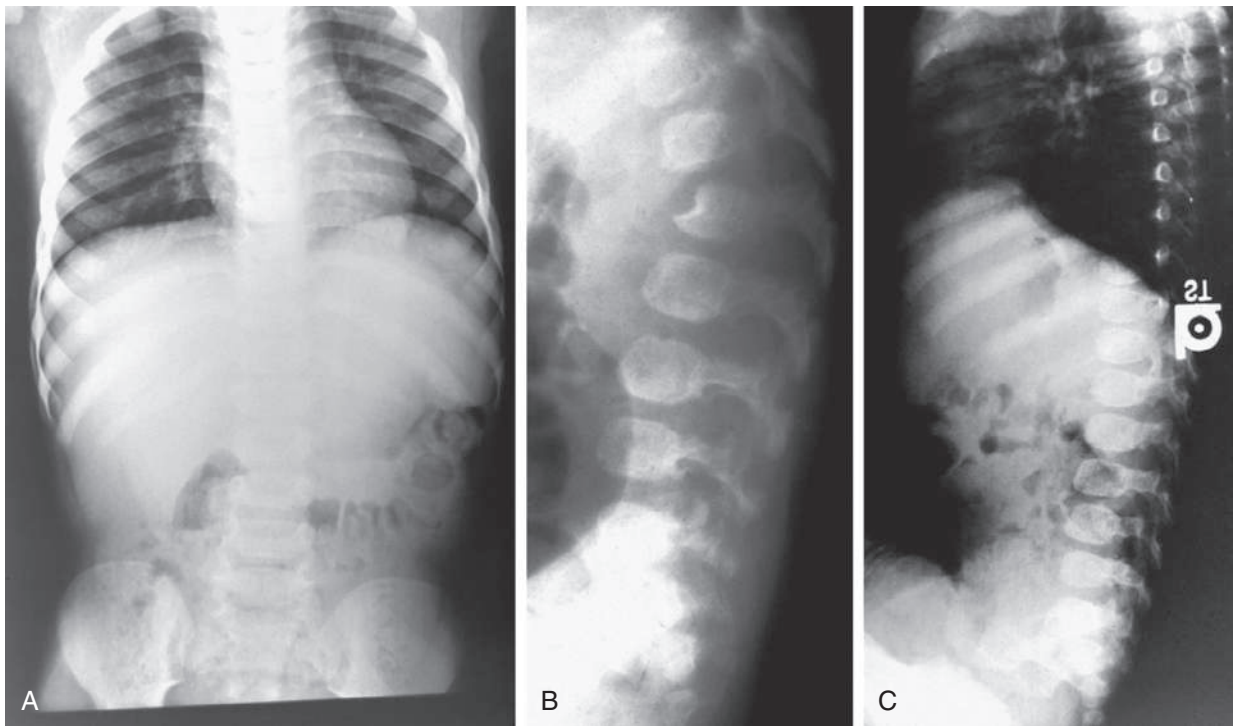
reduced rate of progression. Adult height may exceed 150 cm. Airway involvement, valvular cardiac disease, hearing impairment, carpal tunnel syndrome, and joint stiffness are common and can result in significant loss of function in both the mild and severe forms.

### Mucopolysaccharidosis III

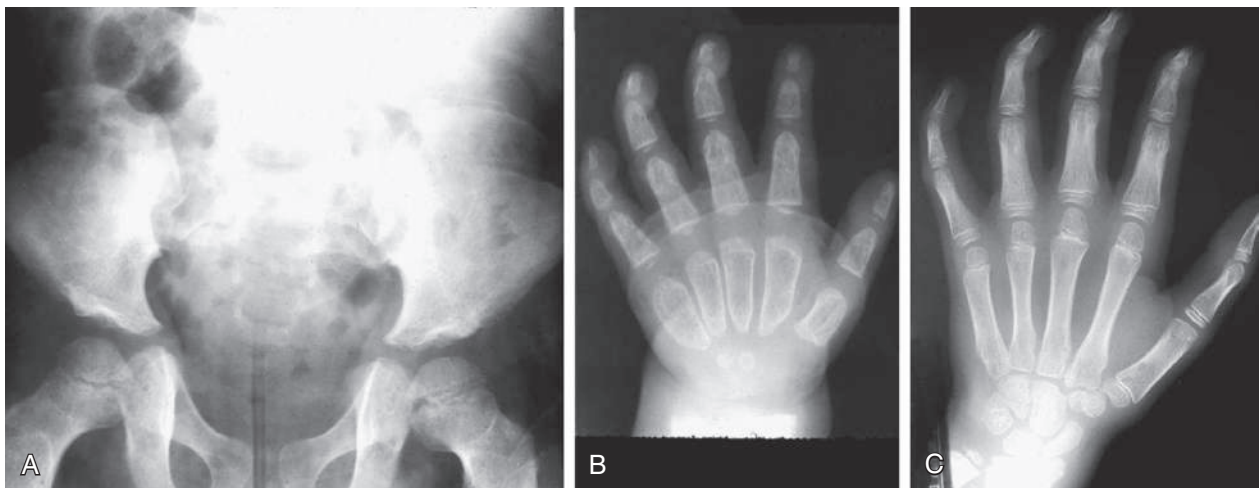
**Sanfilippo disease** makes up a genetically heterogeneous but clinically similar group of four recognized types. Each type is caused by a different enzyme deficiency involved in the degradation of heparan sulfate

(see Fig. 109.1). Pathogenic variants have been found in all the MPS-III disorders for which genes have been isolated.

Phenotypic variation exists in MPS-III patients, but to a lesser degree than in other MPS disorders. Patients with Sanfilippo disease are characterized by slowly progressive, severe CNS involvement with mild somatic disease. Such disproportionate involvement of the CNS versus the connective tissue system is unique to MPS-III. Onset of clinical features usually occurs at age 2-6 years in a child who previously appeared normal. Presenting features include delayed development,



**Fig. 109.3** Dysostosis multiplex. A, Sanfilippo syndrome, patient age 4 years; the ribs are wide. B, Sanfilippo syndrome, age 4 years; immature, ovoid configuration of the vertebral bodies. C, Hurler syndrome, age 18 months; anterosuperior hypoplasia of first lumbar vertebra (L1) resulting in hook-shaped appearance.



**Fig. 109.4** Dysostosis multiplex. A, Mucopolysaccharidosis I-H, patient age 10 years. The inferior portions of the ilia are hypoplastic, with resulting iliac flare and shallow acetabular fossae. The femoral necks are in the valgus position. B, MPS I-H, age 4 years. Metacarpals and phalanges are abnormally short, wide, and deformed with proximal pointing of the metacarpals and bullet-shaped phalanges. Bone trabeculation is coarse, and the cortices are thin. C, MPS I-S, age 13 years. The carpal bones are small, leading to a V-shaped configuration of the digits. The short, tubular bones are well modeled. Flexion of the middle and distal phalanges II-V is caused by joint contractures.

hyperactivity with aggressive behavior, coarse hair, hirsutism, sleep disorders, and mild hepatosplenomegaly. Subclinical cardiac defects are common. Delays in the diagnosis of MPS-III are common because of mild physical features, hyperactivity, and slowly progressive neurologic disease. Severe neurologic deterioration occurs in most patients by age 6-10 years, accompanied by rapid deterioration of social and adaptive skills. Severe behavior problems, such as sleep disturbance, uncontrolled hyperactivity, temper tantrums, destructive behavior, and physical aggression, are common. Profound developmental regression and behavior problems often occur in patients with normal physical strength, making management particularly difficult.

#### Mucopolysaccharidosis IV

**Morquio disease** (MPS-IV) is caused by a deficiency of *N*-acetylgalactosamine-6-sulfatase (MPS-IVA) or of  $\beta$ -galactosidase (MPS-IVB). Both result in the defective degradation of keratan sulfate. The gene encoding *N*-acetylgalactosamine-6-sulfatase is *GALNS* on chromosome 16q24.3, and the gene encoding  $\beta$ -galactosidase is *GLB1* on chromosome 3p21.33.  $\beta$ -Galactosidase catalyzes GM<sub>1</sub> ganglioside in addition to endohydrolysis of keratan sulfate, and most pathogenic variants of *GLB1* result in generalized **gangliosidosis**, a spectrum of neurodegenerative disorders associated with dysostosis multiplex. A W273L pathogenic variant of the *GLB1* gene, either in the homozygous

state or as part of compound heterozygosity, commonly results in Morquio B disease.

Both types of Morquio syndrome are characterized by short-trunk dwarfism, fine corneal deposits, a skeletal dysplasia that is distinct from other mucopolysaccharidoses, and preservation of intelligence. MPS-IVA is usually more severe than MPS-IVB, with an adult height of <125 cm in the former and more than 150 cm in the latter. However, there is considerable variability of expression in both subtypes. The appearance of genu valgum, kyphosis, growth retardation with short trunk and neck, and waddling gait with a tendency to fall are early symptoms of MPS-IV. Extraskelatal manifestations include mild corneal clouding, small teeth with abnormally thin enamel, frequent caries formation, and occasionally hepatomegaly and cardiac valvular lesions. Instability of the odontoid process and ligamentous laxity is regularly present and can result in atlantoaxial instability and life-threatening dislocation. Surgery to stabilize the upper cervical spine, usually by posterior spinal fusion, before the development of cervical myelopathy, can be lifesaving.

### Mucopolysaccharidosis VI

Maroteaux-Lamy disease (MPS-VI) is caused by pathogenic variants of the *ARSB* gene on chromosome 5q11-13 encoding *N*-acetylgalactosamine-4-sulfatase (arylsulfatase B). It is characterized by severe to mild somatic involvement, as seen in MPS-I, but with preservation of intelligence. The somatic involvement of the severe form of MPS VI is characterized by corneal clouding, coarse facial features, joint stiffness, valvular heart disease, communicating hydrocephalus, and dysostosis multiplex. In the severe form, growth can be normal for the first few years of life but seems to virtually stop after age 6-8 years. The mild to intermediate forms of Maroteaux-Lamy syndrome can be easily confused with Scheie syndrome. Spinal cord compression from thickening of the dura in the upper cervical canal with resultant myelopathy is common in patients with MPS-VI.

### Mucopolysaccharidosis VII

Sly disease (MPS-VII) is caused by pathogenic variants of the *GUSB* gene. Pathogenic variants result in a deficiency of  $\beta$ -glucuronidase, intracellular storage of glycosaminoglycan fragments, and a very wide range of clinical involvement. The most severe form presents as lethal nonimmune fetal hydrops and may be detected in utero by ultrasound. Some severely affected newborns survive for months and have, or develop, signs of lysosomal storage, including thick skin, visceromegaly, and dysostosis multiplex. Less severe forms of MPS-VII present during the first years of life with features of MPS-I but slower progression. Corneal clouding varies. Patients with manifestation after 4 years of life have coarse facial features with depressed nasal roots, malpositioned teeth with malformed roots, and skeletal abnormalities of dysostosis multiplex. Intelligence is normal, and corneae are usually clear. Patients may be found incidentally based on a blood smear that shows coarse granulocytic inclusions.

### Mucopolysaccharidosis IX

MPS-IX disease is caused by pathogenic variants in *HYAL1* encoding one of three hyaluronidases. Clinical findings in the first patient, a 14-year-old girl, were bilateral nodular soft tissue periarticular masses, lysosomal storage of histiocytes, mildly dysmorphic craniofacial features, short stature, normal joint movement, and normal intelligence. Clinical findings in the only three additional patients known today were indistinguishable from those in rheumatoid arthritis.

### Mucopolysaccharidosis Plus Syndrome

Coarse facial features, organomegaly, joint contractures, dysostosis multiplex, cognitive deficiency, increased mucopolysacchariduria, and massive intracellular accumulation of heparan sulfate have been found in 13 children in northeastern Siberia and two Turkish children. Additional findings include optic atrophy, intracerebral calcifications, pancytopenia, and renal insufficiency. Most patients died within the first 2 years of life from cardiorespiratory failure. Lysosomal enzyme activities were normal in children with MPS plus syndrome. This autosomal recessive multisystem disorder is caused by biallelic pathogenic

variants of *VPS33A* encoding a protein involved in lysosomal fusion processes.

## DIAGNOSIS AND DIFFERENTIAL DIAGNOSIS

Clinical suspicion of an MPS justifies a skeletal survey. Radiographs of the chest, spine, pelvis, and hands may show early signs of dysostosis multiplex. The next diagnostic step is to assay the urinary excretion of GAGs. Semiquantitative spot tests for increased urinary GAG excretion are quick, inexpensive, and useful for initial evaluation but are subject to both false-positive and false-negative results. Quantitative analysis of a single GAG in material derived from dried blood spots is preferable with few false-negative results. Using tandem mass spectrometry, type-specific profiles can be obtained. Morquio disease is often missed in urinary assays but can be reliably diagnosed in serum using monoclonal antibodies to keratan sulfate.

Newborn screening for MPS (type I, II, VI) is essential for the early detection of subclinical cases and their therapy. It is available from dried blood spots using tandem mass spectrometry of glycosaminoglycans or fluorescence-based enzyme function assays. Any individual with a suspected MPS disorder based on screening tests, clinical features, and radiographic results should have a definitive diagnosis established by enzyme assay. Serum, leukocytes, or cultured fibroblasts are used as the tissue source for measuring lysosomal enzymes (see Table 109.2).

Prenatal diagnosis is available for all MPSs and is carried out on cultured cells from amniotic fluid or chorionic villus biopsy. Molecular analysis is typically performed using appropriate gene panels. In many cases the type and location of the pathogenic variant are related to the future course of the disease and thus have a prognostic value. Carrier testing in Hunter syndrome, an X-linked disorder, requires analysis of *IDS* once the specific pathogenic variant or chromosome arrangement in the family is known. Prenatal molecular analysis should be offered in a male fetus of a proven female carrier of the *IDS* gene. His risk to be affected is 50%. In a female fetus, the risk is small, but not zero, as a result of skewed maternal X chromosome inactivation.

Mucopolysaccharidosis and oligosaccharidoses manifest with the same clinical and radiographic features as MPS. In these conditions the urinary excretion of GAGs is not elevated. Hurler-like facial features, joint contractures, dysostosis multiplex, and elevated urinary GAG excretion differentiate the MPSs from congenital disorders of glycosylation and other neurodegenerative and dwarfing conditions.

## TREATMENT

Hematopoietic stem cell transplantation and enzyme replacement therapy are performed in specialized institutions.

**Bone marrow transplantation** from related or unrelated donors and cord blood transplantation have resulted in significant clinical improvement of somatic disease in MPSs I, II, III, and VII. Clinical effects include increased life expectancy with resolution or improvement of growth, hepatosplenomegaly, joint stiffness, facial appearance, skin changes, obstructive sleep apnea, heart disease, communicating hydrocephalus, and hearing loss. Enzyme activity in serum and urinary GAG excretion normalize. This is true for MPS I-H, II, and III. Some patients with MPS-I who have undergone transplantation before 9 months of age have been reported with normal cognitive development. Transplantation before 24 months and with a baseline mental development index >70 have improved long-term outcomes. Transplantation does not significantly improve the neuropsychologic outcome of MPS patients with impaired cognition at transplantation. Early transplantation in the MPS-II patient may have the same effect. Transplantation in the MPS-VI patient stabilizes or improves cardiac manifestations, posture, and joint mobility. Stem cell transplantation does not correct skeletal or ocular anomalies, and they should be treated with appropriate orthopedic and ophthalmologic procedures. Cord blood transplantation is the therapy of choice in children with MPS-IH, and possibly MPS-II, before the age of 2 years, but transplantation-related death or primary graft failure, which occurs in approximately one third of the patients, must be weighed against other therapeutic options.

**Enzyme replacement therapy (ERT)** using recombinant  $\alpha$ -L-iduronidase has been approved for patients with MPS-I (Table 109.3). It reduces organomegaly and airway infections, improves rate of growth, improves joint mobility, pulmonary function, and endurance, and reduces the number of episodes of sleep apnea and urinary GAG excretion. The enzyme does not cross the blood-brain barrier and does not prevent deterioration of cognition and other neurologic functions. Consequently, ERT is reserved for patients with mild CNS involvement. To stabilize extraneural manifestations it is also recommended in young patients before stem cell transplantation. ERT also ameliorates somatic complications in patients with more severe CNS involvement. Recombinant iduronate-2-sulfatase ameliorates the nonneural manifestations of Hunter disease, such as respiratory dysfunction, reduced physical endurance, and daily activity. ERT with recombinant human *GALNS* improves physical endurance, respiratory function, and daily living activity of patients with MPS-IV. Similar effects produce recombinant *N*-acetylgalactosamine-4-sulfatase in patients with MPS-VI and recombinant  $\beta$ -glucuronidase in MPS VII.

Advanced therapies include enzyme replacement mediated via insulin receptors in MPS I and II or transferrin receptors in MPS II to assist in crossing the blood-brain barrier. A phase I/II and a phase III study using the transferrin receptor have started for MPS II. In MPS IIIA, an intravenous ERT phase 1/2 study with a chemically modified variant of recombinant human sulfamidase and a recombinant human  $\alpha$ -*N*-acetylglucosaminidase for MPS IIIB were recently completed. However, the study results were not convincing. A phase I/II study for MPS III using the transferrin receptor is in planning. Gene therapies for MPS I, II, and III are under investigation. Autologous hematopoietic stem/progenitor cells transduced *ex vivo* with an  $\alpha$ -L-iduronidase–encoded lentiviral vector has resulted in beneficial metabolic correction in peripheral and central nervous system tissues. A clinical trial to ameliorate the intracellular inflammation and, consequently, the CNS involvement in MPS III with anakinra (Kineret) was completed with results pending.

**Symptomatic therapy** focuses on respiratory and cardiovascular complications, hearing loss, carpal tunnel syndrome, spinal cord compression, hydrocephalus, and other problems (Table 109.4). The

**Table 109.3** Therapies For Mucopolysaccharidoses

MPS TYPE	HEMATOPOIETIC STEM CELL TRANSPLANTATION	ENZYME REPLACEMENT THERAPY	REMARKS
I	Yes	Laronidase (Aldurazyme)	Developmental trajectory dependent on time of transplantation. Little effect on connective tissue manifestations. Enzyme replacement immediately after diagnosis.
II	Yes	Idursulfase (Elaprase)	Autologous hematopoietic stem/progenitor cells transduced <i>ex vivo</i> with gene encoding lentiviral vector.
III	No	No	Experimental intraventricular chimeric fusion of recombinant human <i>N</i> -acetyl-D-glucosaminidase and truncated insulin-like growth factor 2 in MPS IIIB
IV	Yes	Elosulfase (Vimizim)	Improved daily activities. No effect on growth or skeletal dysplasia.
VI	Yes	Galsulfase (Naglazyme)	Improved daily activities. Improved growth. No effect on skeletal dysplasia.
VII	Yes	Vestronidase alfa (MEPSEVII)	Improved daily activity. No effect on skeletal dysplasia.

**Table 109.4** Symptomatic Management of Mucopolysaccharidoses

PROBLEM	PREDOMINANTLY IN	MANAGEMENT
<b>NEUROLOGIC</b>		
Hydrocephalus	MPS I, II, VI, VII	Fundoscopy, CT scan
Chronic headaches	All	Ventriculoperitoneal shunting
Behavioral disturbance	MPS-III	Behavioral medication, sometimes CT scan, ventriculoperitoneal shunting
Disturbed sleep–wake cycle	MPS-III	Melatonin
Seizures	MPS I, II, III	EEG, anticonvulsants
Atlantoaxial instability	MPS IV	Cervical MRI, upper cervical fusion
Spinal cord compression	All	Laminectomy, dural excision
<b>OPHTHALMOLOGIC</b>		
Corneal opacity	MPS I, VI, VII	Corneal transplant
Glaucoma	MPS I, VI, VII	Medication, surgery
Retinal degeneration	MPS I, II	Nightlight
<b>EARS, AIRWAYS</b>		
Recurrent otitis media	MPS I, II, VI, VII	Ventilating tubes
Impaired hearing	All except MPS-IV	Audiometry, hearing aids
Obstruction	All except MPS-III	Adenectomy, tonsillectomy, bronchodilator therapy, CPAP at night, laser excision of tracheal lesions, tracheotomy
<b>CARDIAC</b>		
Cardiac valve disease	MPS I, II, VI, VII	Endocarditis prevention, valve replacement
Coronary insufficiency	MPS I, II, VI, VII	Medical therapy
Arrhythmias	MPS I, II, VI, VII	Antiarrhythmic medication, pacemaker



**Table 109.4** Symptomatic Management of Mucopolysaccharidoses—cont'd

PROBLEM	PREDOMINANTLY IN	MANAGEMENT
<b>ORAL, GASTROINTESTINAL</b> Hypertrophic gums, poor teeth Chronic diarrhea	MPS I, II, VI, VII MPS-II	Dental care Diet modification, loperamide
<b>MUSCULOSKELETAL</b> Joint stiffness Scoliosis Weakness Gross long-bone malalignment Carpal tunnel syndrome	All except MPS IV All All All MPS I, II, VI, VII	Physical therapy Bracing, surgery Physical therapy, wheelchair Corrective osteotomies Electromyography, surgical decompression
<b>ANESTHESIA</b>	All except MPS III	Avoid atlantoaxial dislocation; use angulated video intubation laryngoscope and small endotracheal tubes

CT, Computed tomography; CPAP, continuous positive airway pressure; EEG, electroencephalogram; MRI, magnetic resonance imaging.

multisystem involvement and progressive nature of MPS syndromes usually require the standardized and complex care provided by medical centers.

Visit Elsevier eBooks+ at [eBooks.Health.Elsevier.com](http://eBooks.Health.Elsevier.com) for Bibliography.

## Chapter 110

# Disorders of Purine and Pyrimidine Metabolism

H. A. Jinnah

The purines and pyrimidines consist of a family of small organic molecules that are found in all cells. They are often considered together because they provide the fundamental building blocks for nucleic acids, which include DNA and RNA. The purines and pyrimidines are also involved in numerous other cellular processes. Although they share certain biochemical characteristics, the associated clinical disorders are quite varied. Historically, most were identified by characteristic abnormalities found with metabolic tests. Currently, they are increasingly being identified after discovery of a pathogenic variant in a relevant gene in tests that involve broad gene panels or exome sequencing. Most of these disorders are genetic, and most are rare. *However, they are important to recognize because specific treatments are available for some of them* (Table 110.1).

### PURINES

The purines are divided into two groups. The first group involves the base adenine, its corresponding nucleoside (adenosine), and nucleotide (AMP, ADP, ATP) derivatives (Fig. 110.1). ATP serves as one of four building blocks for RNA, and its deoxy derivative (dATP) serves as one of four building blocks for DNA. ATP also provides the energy source for the majority of energy-requiring activities. ATP derivatives act as signaling factors as “second messengers” (cAMP) or cofactors (FAD, NAD, NADP) for a large number of cellular processes. Some purines such as adenosine and the adenine nucleotides serve as extracellular signaling molecules, including acting as neurotransmitters in the nervous system.

The second group of purines involves the base guanine, its corresponding nucleoside (guanosine), and nucleotide (GMP, GDP, GTP) derivatives (see Fig. 110.1). Like the adenine nucleotides, guanine nucleotide derivatives also serve as building blocks for nucleic acids (DNA and RNA). GTP also provides an energy source for some energy-requiring activities. Guanine nucleotides also play a critical role in intercellular signaling (cGMP) via membrane-bound receptors that require GTP during signal transduction (G-proteins). They also play a role in intracellular signaling via a large family of cytosolic GTPases and guanine nucleotide exchange factors.

Because purines play a critical role for so many fundamental cellular processes, their amounts are tightly regulated. The amounts of purines reflect a balance between synthesis, catabolism, and recycling (Fig. 110.2). Purines are synthesized by the *de novo* purine synthesis pathway. This pathway has six enzymes that carry out 10 reactions. When there is a demand for more purines, these six enzymes aggregate dynamically into giant macromolecular complexes known as *purinosomes* to accelerate synthesis. After the demand is met, these aggregates disperse and synthesis abates. In humans, purines are catabolized via several routes. The major end product of purine catabolism is uric acid, produced by the enzyme encoded by the *XDH* gene. The enzyme is known as *xanthine oxidase*, *xanthine reductase*, or *xanthine oxidoreductase*. Most of this uric acid is eliminated from the body in the urine, although some is also eliminated by secretion into the gastrointestinal tract. Because the synthesis of purines is energetically costly, purines are actively recycled (see Fig. 110.2). The key enzymes of purine salvage include hypoxanthine-guanine phosphoribosyl transferase (encoded by *HPRT1*) and adenine phosphoribosyl transferase (encoded by *APRT*).

The metabolism of purines differs considerably across different cells and tissues. For example, the synthetic pathway is absent in erythrocytes, because these postmitotic cells do not require large quantities of new purines to make nucleic acids for cell division. Erythrocytes rely instead predominantly on purine salvage to maintain purine levels. A similar situation is thought to occur for postmitotic neurons of the nervous system. Another example of tissue-specific differences in purine metabolism involves uric acid. The vast majority of uric acid in the human body is produced by the liver, because hepatocytes express high levels of *XDH*, whereas many other cells and tissues express little or none. In addition to tissue differences, several enzymes of purine metabolism have multiple isoforms with different tissue distributions, leading to tissue-specific consequences in disorders where one isoform is affected.

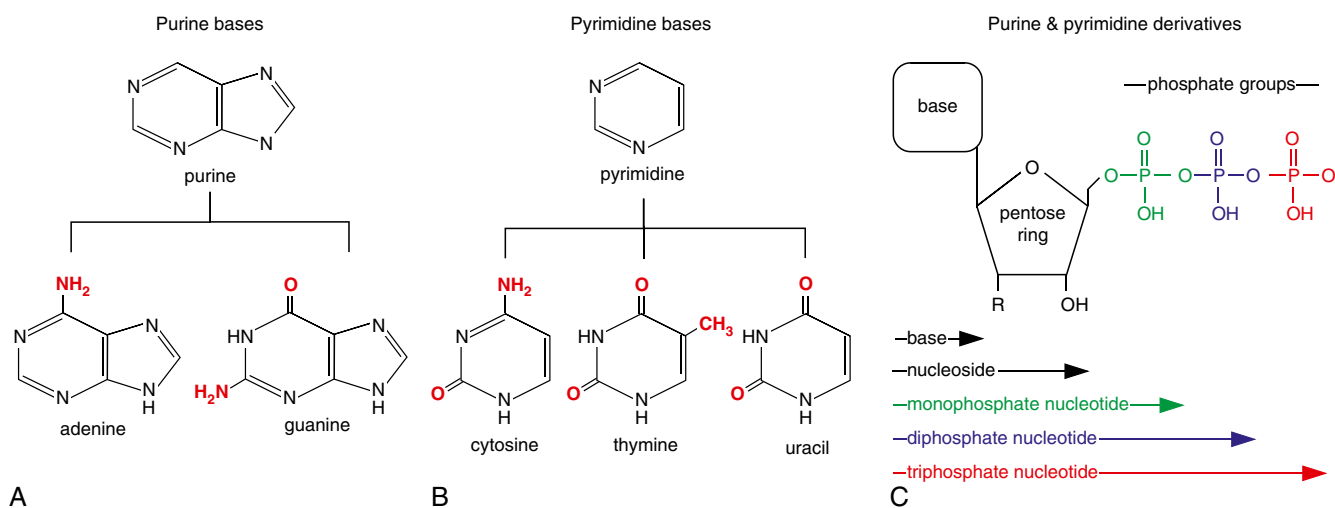
### PYRIMIDINES

The pyrimidines are divided into three groups delineated by the bases cytosine, thymine, and uracil (see Fig. 110.1). Each has a corresponding nucleoside derivative (cytidine, thymidine, uridine) and nucleotide

**Table 110.1** Disorders of Purines and Pyrimidines with Specific Treatments

DISORDER	GENE SYMBOL	TREATMENT	OUTCOME
APRT deficiency	APRT	XOR inhibitor	Prevents renal stones and renal failure
Uridine-responsive epileptic encephalopathy	CAD	Uridine	Suppresses seizures, reverses neurobehavioral and hematologic abnormalities
Familial juvenile hyperuricemic nephropathy	UMOD, REN, MUC, or HNF-1b	XOR inhibitor	Prevents renal stones, renal failure, and gout
Renal hypouricemia	SLC2A9 or SLC22A12	XOR inhibitor	Prevents renal stones and renal failure
Hereditary orotic aciduria	UMPS	Uridine	Reverses neurobehavioral and hematologic deficits
Hereditary xanthinurias			
Type 1	XOR	XOR inhibitor	Prevents renal stones and renal failure
Type 2	MOCOS	XOR inhibitor	Prevents renal stones and renal failure
Molybdenum cofactor deficiencies	MOCS1-3, GPHN	XOR inhibitor	Prevents renal stones and renal failure
MOCS1 deficiency	MOCS1	cPMP	Reverses neurobehavioral deficits
HPRT1-associated disorders	HPRT1	XOR inhibitor	Prevents renal stones, renal failure, and gout
PRPP synthetase hyperactivity	PRPS1	XOR inhibitor	Prevents renal stones, renal failure, and gout
Nucleotidase-associated pervasive developmental delay	Unknown	Uridine	Reverses neurobehavioral deficits

The most common XOR inhibitors include allopurinol, febuxostat, and topiroxostat. cPMP, Cyclic pyranopterin monophosphate; XOR, xanthine oxidoreductase. Copyright H.A. Jinnah.

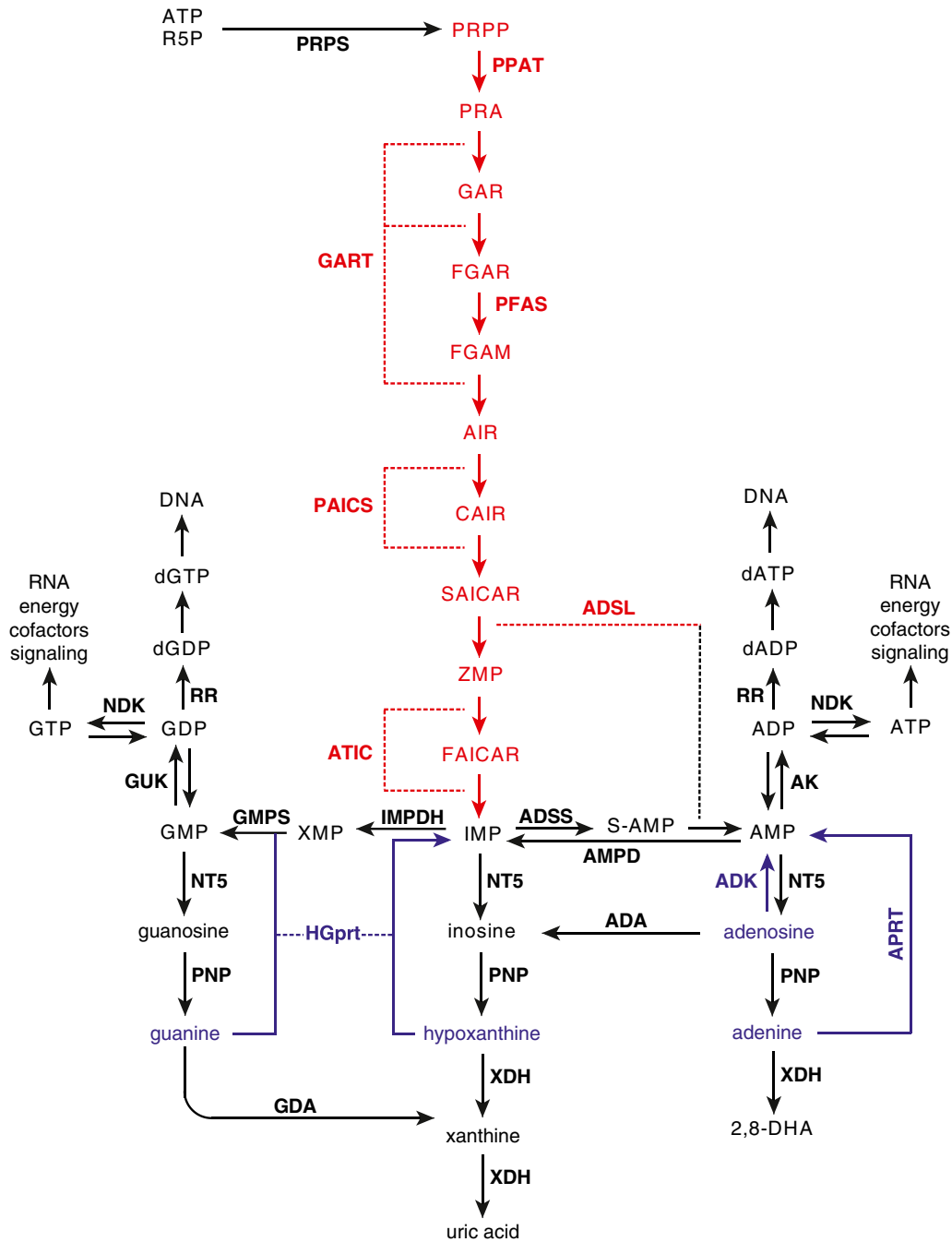


**Fig. 110.1** The structure of purines and pyrimidines. **A**, The fundamental purine base and its variants adenine and guanine. **B**, The fundamental pyrimidine base and its variants cytosine, thymine, and uracil. **C**, The major purine and pyrimidine derivatives. Nucleosides are composed of a purine or pyrimidine base attached to a pentose ring. The R moiety in the pentose ring can be either an OH group (ribose for RNA) or a hydrogen (deoxyribose for DNA). Nucleotides are composed of a nucleoside attached to phosphate groups. (Copyright H.A. Jinnah.)

derivatives (see Fig. 110.1). Like the purines, the pyrimidines are key ingredients for nucleic acids. Nucleotide derivatives of cytosine are used to make DNA and RNA. Nucleotide derivatives of thymidine are used in DNA, but nucleotide derivatives of uridine replace thymidine in RNA.

The pyrimidines also have additional functions; CTP is used to make CDP-choline, an important intermediate in the production of membrane phospholipids such as phosphatidylcholine. UTP is used to make UDP-glucose, an intermediate used in the synthesis of glycogen, as well as other glycosylation reactions, to make glycolipids or glycoproteins. UTP is also used to make UDP-glucuronic acid, an intermediate used in the generation of glucuronide conjugates. Glucuronide conjugates of certain drugs and drug metabolites are excreted in the bile, and glucuronide conjugates of other endogenous biomolecules such as steroid hormones facilitate transport between tissues in the body.

The body's pyrimidine levels reflect a balance between synthesis, catabolism, and recycling. Pyrimidines are synthesized in a pathway that involves three enzymes which carry out six steps leading to the central metabolite UMP (Fig. 110.3). UMP can then be directed toward the synthesis of other pyrimidines. Pyrimidines are catabolized via several routes. Cytidine and uridine derivatives are both converted to uracil, and ultimately to  $\beta$ -alanine. Thymidine is converted to  $\beta$ -aminoisobutyrate. Both  $\beta$ -alanine and  $\beta$ -aminoisobutyrate serve as intermediates in the citric acid cycle. Free pyrimidines are also recycled at several steps by kinases that convert nucleosides to their corresponding nucleotides (see Fig. 110.3). Pyrimidine disorders are rare and clinically heterogeneous. The heterogeneity likely reflects the different functions of pyrimidines in different tissues combined with differences in the



**Fig. 110.2** Purine metabolism. The six enzymes and 10 reactions of de novo purine synthesis are shown in red. The two enzymes and three reactions of the salvage pathways are shown in purple. Enzyme gene names are shown in bold font, and metabolites are shown in regular font. For enzymes with multiple isoforms, only the core gene name is shown, without isoform numbers or letters. Dashed lines show enzymes with multiple functions. 2,8-DHA, Dihydroxyadenine; ADA, adenosine deaminase; ADP, adenosine diphosphate; ADK, adenosine kinase; ADSL, bifunctional adenylosuccinate lyase; ADSS, adenylosuccinate synthase; AICAR, aminoimidazole carboxamide ribotide; AMPD, adenylosuccinate deaminase; AMP, adenosine monophosphate or adenylate; APRT, adenine phosphoribosyltransferase; ATIC, bifunctional AICAR transformylase/IMP cyclohydrolase; AK, adenylosuccinate kinase; ATP, adenosine triphosphate; CAIR, 5'-Phosphoribosyl-4-carboxy-5-aminoimidazole; dADP, deoxy adenosine diphosphate; dGDP, deoxy guanosine diphosphate; FAICAR, formylaminoimidazole carboxamide ribotide; GART, trifunctional phosphoribosylglycinamide formyltransferase/phosphoribosylglycinamide synthetase/phosphoribosylaminoimidazole synthetase; GDA, guanine deaminase (aka guanase or cypin); GDP, guanosine diphosphate; GMP, guanosine monophosphate or guanylate; GMPS, GMP-synthase; GTP, guanosine triphosphate; GUK, guanylate kinase; HGprt, hypoxanthine-guanine phosphoribosyltransferase; IMP, inosine monophosphate or inosinate; IMPDH, IMP-dehydrogenase; NDK, nucleoside diphosphate kinase; NT5, 5'-nucleotidase; PNP, purine nucleoside phosphorylase; PAICS, bifunctional phosphoribosylaminoimidazole carboxylase; PFAS, phosphoribosyl formylglycinamide synthase; PPAT, bifunctional phosphoribosylaminoimidazole carboxylase; PRA, 5-phosphoribosylamine; PRPP, phosphoribosylpyrophosphate; PRPS, PRPP-synthase; RR, ribonucleotide reductase; S-AMP, adenylosuccinate; SAICAR, succinylaminoimidazole carboxamide ribotide; XDH, xanthine dehydrogenase, xanthine oxidase, or xanthine oxidoreductase; XMP, xanthine monophosphate or xanthylate; ZMP, 5-aminoimidazole-4-carboxamide ribonucleotide or Z-nucleotide monophosphate. (Copyright H.A. Jinnah.)

expression levels of different enzymes in different tissues and sometimes tissue-specific isoforms of the same enzyme.

## DISORDERS OF PURINE METABOLISM

### Uric Acid

Serum uric acid levels reflect a balance among production, absorption, and excretion. Most uric acid is produced in the body as a by-product of purine metabolism (see Fig. 110.2). Some also comes from the diet, when DNA and RNA of foods are metabolized by the gut and liver. About two thirds of the body's uric acid is eliminated by the kidneys, with the remainder eliminated by the gut. Normal serum uric acid levels are age dependent. Relatively low levels in young children reach adult values by puberty. After puberty, serum uric acid is lower in females than in males.

In adults, numerous epidemiologic studies have linked abnormal serum uric acid levels with a large number of disorders. High levels of uric acid have been linked with gout, kidney disease, tophi, hypertension, diabetes mellitus, obesity, metabolic syndrome, heart disease, stroke, hemolytic anemia, Down syndrome, asthma, and others. Causal links between uric acid and disease with well-defined biologic mechanisms are well established for gout, kidney disease, and tophi. Low levels of uric acid have been linked with Parkinson disease, Alzheimer disease, multiple sclerosis, and other autoimmune disorders. For these disorders, uric acid has been proposed to have antioxidant properties, so chronically low levels may contribute to cell injury during aging.

In children, low (or even absent) levels of serum uric acid do not appear to have any detrimental clinical effects, but high levels cause problems. Uric acid is normally near its limits of solubility in the body, so even small increases risk precipitation in vulnerable regions. The joints are one of these vulnerable regions, because of the low pH of synovial fluid. Such precipitates can cause an inflammatory arthritis known as **gout**. These precipitates tend to occur in cool regions of the body, such as distal joints of the toes. The typical presentation of gout is acute inflammation of one joint, often the metatarsophalangeal joint of the large toe, although any joint can be involved. Uric acid crystals also precipitate in cool regions of the skin, forming tophi at tendon insertion points over joints or the pinna of the ear. These tophi appear as visible and palpable subcutaneous masses. Excess uric acid is concentrated by the kidneys in the renal collecting system, where high levels precipitate in two different ways. Microscopic crystals may produce an inflammatory nephropathy with painless chronic renal failure. Larger stones may cause urinary obstruction with acute renal colic, dysuria, hematuria, and recurrent urinary infections. These pathologies may also overlap in some cases.

Hyperuricemia and its pathologic consequences are common in adults, especially males. These problems often reflect an inherited predisposition for high uric acid together with lifestyle related to diet and exercise. Hyperuricemia and its consequences are very uncommon in children. Their occurrence in children often signifies an underlying disorder of purine metabolism. Uric acid is a component of many routine clinical chemistry screening panels. As a result, abnormal levels of uric acid often provide an early clue to one of these disorders (Table 110.2). Kidney stones are common in adults, but they are very uncommon in children. Nephrolithiasis and renal failure also provide an important clue to disorders of uric acid and some other disorders of purine and pyrimidine metabolism (Table 110.3). Some are rare inherited disorders affecting specific biochemical pathways; others are acquired or iatrogenic.

### Individual Disorders

Individuals with **renal hypouricemia** have marked reductions in serum uric acid (<2 µg/dL or <120 µM) from birth. The disorder is autosomal recessive and caused by pathogenic variants in the *SLC22A12* or *SLC2A9* genes, which code for transporters important for renal retention of uric acid. Many affected individuals remain asymptomatic for life. Some experience renal impairments after strenuous exercise because physical activity is associated with increased purine turnover and transient elevations of serum uric acid. When a sudden bolus of uric acid after exercise is concentrated quickly in the

renal collecting system, there is a transient risk for stones or “sludge” with nephropathy. This sludge reflects a somewhat viscous mixture of tiny stones and partly solubilized uric acid. Gout is uncommon in renal hypouricemia.

**Familial juvenile hyperuricemic nephropathy** is an autosomal dominant disorder that has been linked to pathogenic variants in *UMOD* (uromodulin), *REN* (renin), *MUC* (mucin), or *HNF-1b* (hepatocyte nuclear factor 1b). All of these genes encode proteins involved in renal handling of uric acid. Affected individuals present in childhood or adolescence with hyperuricemia, renal failure, and/or gout. Individuals with pathogenic variants in the *ABCG2* gene have reduced intestinal secretion of uric acid, along with chronic hyperuricemia and gout.

Overproduction of uric acid may also occur in inherited **disorders of carbohydrate metabolism**. They include disorders associated with pathogenic variants in *ALDOB* (aldolase B deficiency, hereditary fructose intolerance, fructosemia), *SLC37A4* (glucose-6-phosphatase deficiency, glycogen storage disease type I, or von Gierke disease), *AGL* (glycogen debranching enzyme deficiency, glycogen storage disease type III, or Cori disease), *PYGM* (muscle glycogen phosphorylase deficiency, glycogen storage disease type V, or McArdle disease), and *PFKM* (muscle phosphofructokinase deficiency, or glycogen storage disease type VII, or Tarui disease). These disorders may be associated with chronic or episodic hyperuricemia, sometimes with gout or renal impairments. Hyperuricemia is often triggered by exercise because the metabolic defect impairs energy metabolism during muscle activity and leads to catabolism of adenosine triphosphate (ATP).

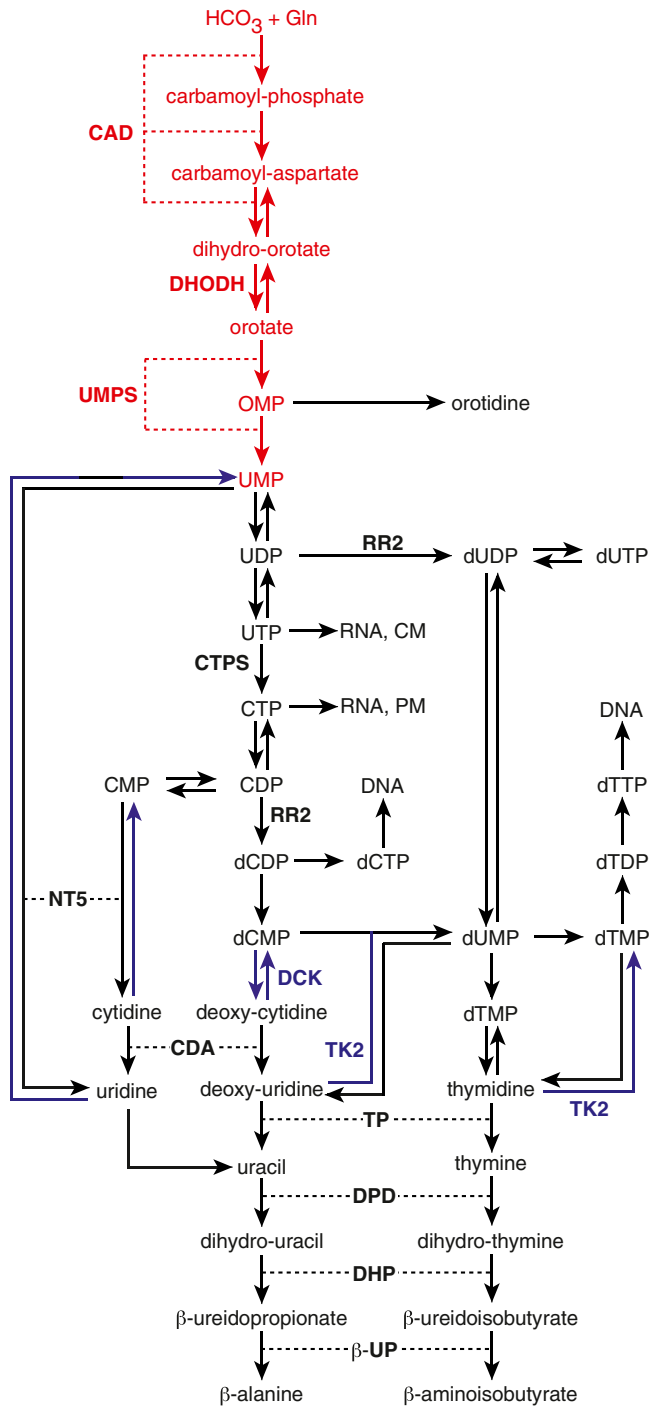
Some disorders of uric acid are *acquired* rather than inherited. Because uric acid is eliminated largely by the kidneys, acute or chronic renal insufficiency may lead to hyperuricemia, which may be severe. A transient but marked elevation of serum uric acid may also occur in **tumor lysis syndrome**, where the treatment of hematologic malignancies is associated with sudden death of many cells in a short period, leading to generation of large amounts of DNA and RNA that are degraded into uric acid. The sudden bolus of uric acid is rapidly concentrated by the kidneys, leading to a risk for kidney stones, sludge, and renal failure. Relatively more modest increases in serum uric acid have been associated with other childhood disorders, including obesity, metabolic syndrome, Down syndrome, asthma, cyanotic congenital heart disease, chronic hemolytic anemia, and certain medications. Medications causing hyperuricemia include thiazide diuretics, cyclosporine, and some anticonvulsants (valproate and phenobarbital).

### Treatment and Prognosis

All renal purine stones, including those made of uric acid, are radiolucent. Unless they calcify, they cannot be detected with plain films or CT, so diagnosis may require ultrasound. Stones passed in the urine may be collected and chemically analyzed. Treatment of small kidney stones may require analgesics for renal colic and/or antibiotics for associated urinary tract infection until the stones are eliminated in the urine. Larger kidney stones may obstruct the urinary collecting system and may require lithotripsy or surgical removal. Because uric acid is more soluble in an alkaline environment, alkalinization of the urine with potassium-sodium citrate or sodium bicarbonate may be useful for individuals at risk for recurrent stones.

The diagnosis of gout can be made finding typical birefringent crystals in an aspirate of joint fluid. Because purine stones are radiolucent, chronic tophaceous gout may have a punched-out appearance on plain films of the joints, where the uric acid crystals have eroded normal bone. The treatment of acute painful gout usually involves nonsteroidal antiinflammatory drugs. However, for both gout and renal stones, treatments directed at uric acid levels are essential to prevent recurrences that may lead to permanent joint damage or chronic renal insufficiency. Chronic hyperuricemia can be treated with three different strategies. One strategy is to increase renal excretion of uric acid with drugs such as probenecid, sulfapyrazone, benzbromarone, or lesinurad. Another strategy is to use drugs that inhibit uric acid production by xanthine oxidoreductase (XOR) such as allopurinol, febuxostat, and topiroxostat. The third involves administration of recombinant uricase





**Fig. 110.3** Pyrimidine metabolism. The three enzymes and six reactions of de novo pyrimidine synthesis are shown in red. The enzymes of the salvage pathways are shown in purple. Enzyme gene names are shown in bold font, and metabolites are shown in regular font. For enzymes with multiple isoforms, only the core gene name is shown, without isoform numbers or letters. Dashed lines show enzymes with multiple functions. 5NT, 5-nucleotidase;  $\beta$ -UP,  $\beta$ -ureidopropionase; CAD, carbamoyl phosphate synthase; CDA, cytidine deaminase; CDP, cytidine diphosphate; CM, carbohydrate metabolism; CMP, cytidine monophosphate; CTP, cytidine triphosphate; CTPS, CTP synthase; dCDP, deoxy cytidine diphosphate; DCK, deoxycytidine kinase; dCMP, deoxycytidine monophosphate; dCTP, deoxycytidine triphosphate; DHODH, dihydro-orotate dehydrogenase; DHP, dihydropyrimidine dehydrogenase; CMP, cytidine monophosphate; dDTP, deoxythymidine diphosphate; dTMP, deoxythymidine monophosphate; dTTP, deoxythymidine triphosphate; dUDP, deoxyuridine diphosphate; dUMP, deoxyuridine monophosphate; dUTP, deoxyuridine triphosphate; gln, glutamine; OMP, orotidine monophosphate or orotic acid; PM, phospholipid metabolism; RR2, ribonucleotide reductase 2; TK2, thymidine kinase 2; TP, thymidine phosphorylase; UDP, uridine diphosphate; UMP, uridine monophosphate; UMPS, UMP synthase; UTP, uridine triphosphate. (Copyright H.A. Jinnah.)

(rasburicase or pegloticase), a nonhuman enzyme that can degrade uric acid.

The best choices for treatment depend on the biologic mechanisms causing excess uric acid. The many causes of hyperuricemia may be divided into two groups. The first group involves renal underexcretion, where hyperuricemia can be treated with uricosuric drugs or XOR inhibitors. The second group involves renal overload, which includes disorders where uric acid is overproduced in the body or underexcreted by the gut. Hyperuricemia associated with renal overload should be treated with XOR inhibitors, not with uricosuric drugs that further increase the burden of uric acid handled by the kidneys. Rasburicase is usually reserved for the transient marked increases in serum uric acid associated with tumor lysis syndrome. Pegloticase is usually reserved for the treatment of gout resistant to other medications.

These medications are usually combined with generous hydration to provide a constant flow of associated purine metabolites from the body. A low-purine diet is sometimes recommended as well. Some foods contain large amounts of purines, such as dried or cured meats (sardines, anchovies) and organ meats (thymus, kidney, liver). Fructose and alcohol also should be avoided because they stimulate purine turnover and result in increased uric acid production.

### THE HEREDITARY XANTHINURIAS

The hereditary xanthinurias are a group of autosomal recessive disorders defined by high levels of xanthine in the urine, along with low or nondetectable serum uric acid. The estimated incidence is 0.5-1 per 100,000 live births. The metabolic abnormalities result from deficiency of XOR, the enzyme that converts hypoxanthine and xanthine into uric acid (see Fig. 110.2). XOR exists in two forms, sometimes called *xanthine oxidase* or *xanthine reductase*, both with a molybdenum-containing cofactor at the active site. These two forms are encoded by the same gene. Xanthine oxidase is derived from posttranslational modification of xanthine reductase.

Although the hereditary xanthinurias all result from XOR deficiency, distinct molecular mechanisms define three different groups. **Hereditary xanthinuria type I** is caused by pathogenic variants in the *XOR* gene. **Hereditary xanthinuria type II** is caused by pathogenic variants in the *MOCOS* gene, which encodes molybdenum cofactor sulfurylase, an enzyme that sulfurates the molybdenum cofactor required for XOR as well as the enzyme aldehyde oxidase. As a result, hereditary xanthinuria type II is characterized by combined deficiency of XOR and aldehyde oxidase. The **third type of hereditary xanthinuria** is caused by defects in the synthesis of the molybdenum cofactor. Molybdenum cofactor deficiency has been linked with four genes: *MOCS1* (molybdenum cofactor synthase 1), *MOCS2* (molybdenum cofactor synthase 2), *MOCS3* (molybdenum cofactor synthase 3), and *GPHN* (gephyrin). *MOCS1* accounts for two thirds of all cases. All are required for the synthesis of the molybdenum cofactor, which is used by four enzymes including XOR, aldehyde oxidase, sulfite oxidase, and mitochondrial amidoxime reducing component. As a result, the molybdenum cofactor deficiencies are characterized by the combined defects of all four enzymes.

### Clinical Features

The clinical features of hereditary xanthinuria type I caused by isolated XOR deficiency may be benign. Many individuals are asymptomatic. The increased excretion of xanthine leads to kidney stones in approximately one third of individuals. These stones may develop any time from early childhood through later adulthood. Clinical signs may be acute with dysuria, hematuria, renal colic, or a history of recurrent urinary tract infections. Alternatively, affected individuals may present with acute or chronic renal failure. Xanthine stones, like other purine stones, are radiolucent; they are detectable with ultrasound but may be missed on abdominal plain films or CT unless they calcify. Some individuals may develop myopathy after strenuous exercise with xanthine crystals in muscle because of the rapid turnover of purines associated with exercise.

The clinical features of combined deficiency of XOR and aldehyde oxidase in hereditary xanthinuria type II are similar to those of type I. There appears to be no obvious clinical impact of the added deficiency of aldehyde oxidase.

**Table 110.2** Disorders Influencing Uric Acid

DISORDER	GENE SYMBOL	SERUM URIC ACID	URINARY URIC ACID
Hereditary xanthinurias Type I	<i>XOR</i>	↓↓	↓↓
Type II	<i>MOCOS</i>		
Molybdenum cofactor deficiencies	<i>MOCS1-3, GPHN</i>		
<i>HPRT1</i> -associated disorders	<i>HPRT1</i>	↑	↑↑
PRPP dysregulation disorders	<i>PRPS1</i>	↑	↑
Excretion disorders			
Renal hypouricemia	<i>SLC22A12, SLC2A9</i>	↓↓	↑↑
Reduced gut excretion	<i>ABCG2</i>	↑	↑
Carbohydrate disorders			
Fructosemia	<i>ALDOB</i>	↑ (chronic or exercise-induced)	↑ (chronic or exercise-induced)
Glucose-6-phosphatase deficiency	<i>SLC37AY</i>		
Glycogen debranching deficiency	<i>AGL</i>		
Glycogen phosphatase deficiency	<i>PYGM</i>		
Phosphofructokinase deficiency	<i>PFKM</i>		
Renal insufficiency	NA	↑	↓
Tumor lysis syndrome	NA	↑↑	↑↑

NA, not applicable. Copyright H.A. Jinnah.

**Table 110.3** Renal Stones in Disorders of Purines and Pyrimidines

DISORDER	GENE SYMBOL	STONES
APRT deficiency	<i>APRT</i>	Dihydroxyadenine
Familial juvenile hyperuricemic nephropathy	<i>UMOD, REN, MUC, or HNF-1b</i>	Uric acid
Hereditary orotic aciduria	<i>UMPS</i>	Orotic acid
Hereditary xanthinurias Type 1	<i>XOR</i>	Xanthine
Type 2	<i>MOCOS</i>	Xanthine
Molybdenum cofactor deficiencies	<i>MOCS1-3, GPHN</i>	Xanthine
<i>HPRT1</i> -associated disorders	<i>HPRT1</i>	Uric acid
PRPP synthetase hyperactivity	<i>PRPS1</i>	Uric acid
Tumor lysis syndrome	Not applicable	Uric acid

Copyright H.A. Jinnah.

The clinical features of the **molybdenum cofactor deficiencies** are more severe. Individuals often present with failure to thrive during infancy, difficulties feeding, intractable seizures, psychomotor delay, and microcephaly. Brain MRI may show diffuse atrophy or cerebellar hypoplasia, multicystic encephalomalacia, and signal abnormalities of

the globus pallidus. Eye findings may include ectopic lens, spherophakia, and nystagmus. Most die in early childhood.

Because uric acid is included in many routine blood chemistry screening panels, the diagnosis of the hereditary xanthinurias often starts with serendipitous identification of low or absent uric acid. Instead, urinary xanthine and hypoxanthine are elevated. However, xanthine is elevated more than hypoxanthine, because the latter can be recycled by HGprt or cleared by the kidneys. In individuals with hereditary xanthinuria type II with combined deficiency of XOR and aldehyde oxidase, urinary methyl-2-pyridone-carboxamide also is low or absent. The characteristic pattern observed among individuals with the molybdenum cofactor deficiencies includes low uric acid in serum and urine along with high urinary xanthine, hypoxanthine, sulfite, and S-sulfocysteine. Enzymatic tests for XOR are feasible but not commonly used for clinical diagnosis. They require biopsy of the liver or small bowel where the amounts of this enzyme reach high enough levels for measurement. A convenient test for aldehyde oxidase involves assessing its ability to oxidize a test dose of allopurinol to oxypurinol. Sulfite oxidase and molybdenum cofactor can be measured in liver or fibroblasts. A molecular diagnosis can be made by finding pathogenic variants in one of the relevant genes.

### Treatment and Prognosis

The treatment of all hereditary xanthinurias involves generous hydration to constantly flush xanthine from the renal collecting system to avoid stone formation. Hydration is sometimes combined with a low-purine diet.

Aside from palliative care, minimal success has been achieved with numerous approaches to the treatment of the molybdenum cofactor deficiencies. However, cyclic pyranopterin monophosphate (fosdenopterin) can have a life-changing impact on the normally serious consequences of molybdenum cofactor deficiency associated with *MOCS1*. Treatment has been reported to normalize metabolic measures and allow near-normal development among individuals who start it at a very early age before there is significant brain damage. It is approved for use in individuals with *MOCS1* defects by the U.S. Food and Drug Administration (FDA).

### HPRT1-ASSOCIATED DISORDERS

Disorders associated with the *HPRT1* gene are rare, with an overall prevalence of approximately three cases per million. Inheritance is X-linked and recessive, although sporadic cases are not uncommon. The gene encodes hypoxanthine-guanine phosphoribosyl transferase (HGprt), an enzyme responsible for two different reactions (see Fig. 110.2). In one reaction, the cosubstrate phosphoribosyl pyrophosphate (PRPP) is combined with the purine base hypoxanthine to produce IMP. In the other reaction, PRPP is combined with guanine to produce GMP. IMP and GMP are then recirculated into the nucleotide pools. When HGprt activity is impaired, its substrates accumulate. Accumulation of PRPP leads to excessive drive of purine synthesis, because PRPP is also used in the first and rate-limiting reaction of the de novo synthetic pathway. The substrates hypoxanthine and guanine also accumulate, and they are ultimately catabolized to uric acid. The combination of accelerated purine synthesis and increased catabolism of hypoxanthine and guanine results in a marked overproduction of uric acid. This overproduction of uric acid is responsible for several clinical features of *HPRT1*-associated disorders, including hyperuricemia, nephrolithiasis, gout, and tophi.

Overproduction of uric acid is *not* responsible for all the clinical features of HGprt deficiency. Reduced HGprt activity also leads to impaired recycling of hypoxanthine and guanine, with purine wasting. This loss of purines may lead to purine deficiency, especially in tissues where the synthetic pathway cannot compensate for purines lost due to the failure of recycling. Erythrocytes lack a fully operational synthetic pathway, so they are dependent on recycling purines taken up from the blood to maintain purines. These observations may account for *macrocytic anemia*, which is common in *HPRT1*-associated disorders.

A similar mechanism may occur in the brain, where purine recycling is important because purine synthesis is relatively low. In individuals

with HGprt deficiency, overt structural malformations are not usually found when performing routine clinical CT or MRI of the brain. Such studies are usually normal or they show only mild diffuse atrophy. However, advanced imaging methods have revealed several abnormalities. Quantitative MRI-based, voxel-based morphometry has revealed subjects with *HPRT1*-associated disorders to have volume loss in several brain regions. Similar studies, along with diffusion tensor imaging MRI, have revealed diffuse loss of white matter. The basal ganglia appear to be more affected than most other regions. In fact, PET scans have revealed a significant reduction in markers associated with basal ganglia dopamine systems.

Autopsy studies of the brains of individuals with *HPRT1*-associated disorders do not show signs of maldevelopment or neurodegeneration. Dopamine neurons are present, but they do not express normal levels of dopamine-related markers. Dysfunction of the basal ganglia is thought to be responsible for several of the neurologic features of *HPRT1*-associated disorders, including dystonia and self-injurious behavior. Dysfunction of corticospinal pathways may be responsible for cognitive impairment, spasticity, and seizures.

### Clinical Features

Pathologic genetic variants in *HPRT1* are associated with a spectrum of clinical phenotypes (Fig. 110.4). Most cases are males, although rare females with defects in both *HPRT1* alleles have been described. More than 600 different gene variants are known. A complete loss of HGprt function is associated with most of these variants, such as deletions, insertions, nonsense substitutions, and some single amino acid substitutions. A partial loss of HGprt function is associated with other variants, usually conservative single amino acid substitutions and some splice variants.

The severity of the clinical phenotypes is related to the degree of associated enzyme impairment. The spectrum of clinical phenotypes is usually subdivided into three overlapping groups. *HPRT1* variants associated with a mean value of 12% of normal HGprt activity are associated with the mildest clinical phenotype. This phenotype is known as **HGprt-related hyperuricemia**. These individuals experience overproduction of uric acid, along with associated problems of hyperuricemia, nephrolithiasis, gout, and tophi. These individuals do not have overt neurologic or behavioral problems, although mild clumsiness or mild cognitive impairments may be disclosed with careful testing. The age at presentation ranges from infancy to adulthood, usually with renal problems or gout.

*HPRT1* variants associated with a mean of 7% of normal HGprt activity are associated with an intermediate phenotype with overproduction of uric acid along with clinically overt neurologic impairments. This phenotype is known as **HGprt-related neurologic dysfunction**. Motor impairments vary widely and may range from minor clumsiness to a phenotype that resembles severe dyskinetic cerebral palsy. Cognitive deficits may range from attention-deficit disorder to moderate intellectual disability. These individuals typically present with delayed motor development, although some present with renal problems or gout.

*HPRT1* variants associated with a mean value of 1% normal HGprt activity are associated with the most severe phenotype, known as **Lesch-Nyhan disease**. These individuals have overproduction of uric acid, disabling motor impairments, moderate intellectual disability, and an unusual behavioral syndrome. The motor problems begin with delayed development in infancy and evolve similar to severe dyskinetic cerebral palsy. Epilepsy is common. The most characteristic aspect of the behavioral syndrome is severe recurrent self-injury, with self-biting, self-hitting, recurrent scratching or poking, and others. Self-injury typically begins between 2 and 4 years of age but may be delayed until the teenage years. Other difficult behaviors are also common, such as impaired attention and impulsivity. Difficult behaviors may be also directed toward others. They include use of language that is foul, sexually inappropriate, or racially charged. Also frequent are hitting, grabbing, or spitting.

The diagnosis of any *HPRT1*-associated disorder should be suspected in a child or young adult with evidence for overproduction of uric acid such as hyperuricemia, uric acid nephrolithiasis, or gout.

Uric acid (pink) crystals in diapers during infancy are frequently the first clue. Suspicion for an *HPRT1*-associated disorder increases when there is evidence for overproduction of uric acid along with a history of delayed motor development. The emergence of self-injurious behavior between 2 and 4 years of age often provides a more specific clue for Lesch-Nyhan disease. A definitive diagnosis requires demonstration of a pathogenic variant in the *HPRT1* gene and/or enzymatic evidence for reduced HGprt function.

### Treatment and Prognosis

For all *HPRT1*-associated disorders, excessive production of uric acid must be treated to avoid renal complications and gouty arthritis. Treatment requires a lifelong combination of an inhibitor of XOR to reduce production of uric acid and generous hydration. The commonly used XOR inhibitor is allopurinol, although others can also be used. Doses are titrated to maintain serum uric acid within normal limits. Stones may continue to form despite treatment, and lithotripsy or surgical removal is sometimes required. High doses of XOR inhibitors that reduce serum uric acid to very low levels are discouraged, because this approach increases the risk of stones composed of the precursors xanthine and hypoxanthine. Some specialists advocate alkalinization of the urine to promote solubility of uric acid or a low-purine diet to reduce intake of purines that are metabolized to uric acid.

The motor disorder is dominated by dystonia, sometimes with spasticity. The increased muscle tone associated with these problems is most often treated with muscle relaxants such as benzodiazepines or baclofen. Anticholinergics and dopamine-related drugs are not generally successful. Several case reports describe great success with deep brain stimulation surgery, but the rate of surgical complications is unusually high, and the overall risk-benefit ratio does not favor universal recommendation of this approach.

The behavioral problems require a combination of physical protective devices, specific behavioral modification techniques, and sometimes pharmacotherapy. Most individuals with Lesch-Nyhan disease require regular restraints of the hands and arms to prevent self-hitting and biting of the fingers. Approximately half of all individuals require tooth removal to prevent biting of the lips and tongue. A custom-designed wheelchair with dangerous regions shielded is often needed. The most useful behavioral techniques involve extinction (ignoring) and redirection (distraction). Methods that use positive reinforcement are useful, but methods that use negative reinforcement amplify negative behaviors.

Individuals with the mildest clinical phenotypes may have a normal life span, provided uric acid is well-managed. Those with more severe phenotypes have a shorter life span, with death occurring in the teens through the fifth decade. Most frequent causes of death include aspiration pneumonia or complications from renal dysfunction. Cases of sudden unexplained death have also been reported.

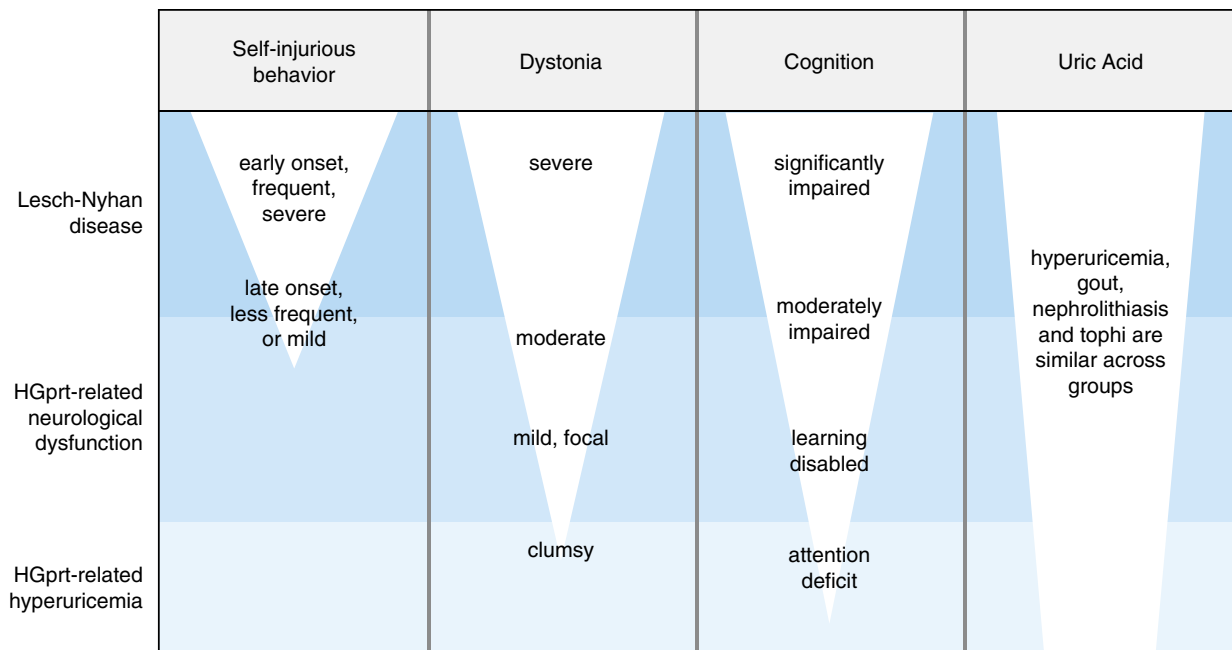
### APRT-ASSOCIATED DISORDERS

Disorders associated with the *APRT* gene are rare, with fewer than 1,000 individuals reported. More than 200 pathogenic variants have been described. Inheritance is autosomal recessive. The disorder has been reported worldwide, but there are clusters of individuals with the same genetic variants originating in Japan, France, and Iceland.

The *APRT* gene encodes adenine phosphoribosyl transferase (APRT), an enzyme that is responsible for catalyzing a reaction in which PRPP is combined with the purine base adenine to produce AMP (see Fig. 110.2). Deficiency of APRT leads to accumulation of adenine, which is metabolized by XOR into 2,8-dihydroxyadenine (DHA). DHA does not accumulate in serum because it is rapidly cleared by the kidneys. Because solubility of DHA is poor, it precipitates in the urinary collecting system as either small crystals or larger stones. Small crystals cause chronic renal insufficiency because they provoke tubulointerstitial nephritis, inflammation, and fibrosis. Larger stones may cause acute obstructive renal failure.

### Clinical Features

Clinical manifestations are attributable to the kidneys, and they may develop in a wide age range from infancy through adulthood.



**Fig. 110.4** *HPRT1*-associated disorders. This schematic provides a graphical representation of the overlapping spectrum of *HPRT1*-associated disorders. The three disorders are listed on the left side of the panel. The most common clinical features are shown in the top row. The white triangles depict the severity of individual clinical features for each of the disorders. For example, problems related to overproduction of uric acid occur in all phenotypes, but self-injurious behavior is limited to the most severe phenotype. Dystonia and cognition both show a wide range of severity across all groups, but severity correlates with overall phenotypic subgroup. This schematic provides only a general guide, as some exceptions may occur. (Copyright H.A. Jinnah.)

Approximately half of individuals with APRT deficiency have no symptoms, or symptoms may develop only in old age. The initial presentations fall into two groups which may overlap: nephrolithiasis and DHA nephropathy. Individuals with nephrolithiasis may present acutely with dysuria, hematuria, renal colic, or recurrent urinary tract infections. They may describe accompanying crystals, larger stones, or gravel in the urine. The precipitates are often reddish-brown in color and easily crushed. Alternatively, DHA nephropathy may result in a more slowly evolving renal insufficiency, with approximately 15% first presenting with end-stage renal failure.

The diagnosis should be suspected when there is evidence for crystalluria or nephrolithiasis, especially in a child. DHA stones, like other purine stones, are radiolucent. Unless they calcify, they may be detected via ultrasound but not with abdominal plain films or CT. The diagnosis may also be suspected in individuals with unexplained renal failure who undergo renal biopsy revealing a crystallopathy with tubulointerstitial nephritis, inflammation, and/or fibrosis. APRT deficiency must be distinguished from other disorders that involve nephrolithiasis and/or renal failure.

Commonly used clinical biochemical methods may not be able to distinguish DHA stones from other purine stones, but more specific methods have been developed at some specialized centers. DHA crystals in the urine can also be identified by light and polarizing microscopy, along with infrared spectrophotometry. Crystals in renal biopsy specimens can be identified by polarizing microscopy with infrared microscopy. Definitive diagnosis can also be achieved by measuring APRT enzyme activity in erythrocytes or by documenting pathogenic variants in the *APRT* gene.

### Treatment and Prognosis

Treatment requires an inhibitor of XOR to reduce production of DHA. The commonly used XOR inhibitors include allopurinol or febuxostat, and they must be continued lifelong. Generous hydration is useful to flush purine metabolites through the renal collecting system. A low-purine diet is sometimes recommended. Large stones may require lithotripsy or surgical removal. Individuals who are diagnosed early in

life and adhere to therapy may have a normal life span. Individuals who are diagnosed late may have chronic renal insufficiency or even renal failure that requires dialysis or kidney transplantation.

### DISORDERS ASSOCIATED WITH AMP-DEAMINASE

The enzyme AMP-deaminase catalyzes the deamination of AMP to IMP with simultaneous production of  $\text{NH}_3$ . The IMP can then be recirculated either to AMP or GMP (see Fig. 110.2). The enzyme is encoded by three homologous genes. *AMPD1* is expressed predominantly in muscle, *AMPD2* is broadly expressed with high levels in the brain, and *AMPD3* is broadly expressed at high levels in bone marrow cells. Each gene has been associated with genetic variants producing null enzyme activity.

### Clinical Features

For *AMPD1*, approximately 20% of White and Black individuals have a c.34C>T variant producing an early termination codon (p.Q12>X) in exon 2. In these populations, 1–2% are homozygotes with null enzyme activity in muscle. Most homozygotes have no symptoms, but **myopathic features** have been reported for some. These features include exercise intolerance with fatigue or myalgia, sometimes with muscle cramping or increased serum creatine kinase. Symptoms may begin at any age from early childhood to later adulthood. Histochemical stains for AMP-deaminase are negative in muscle biopsy specimens, but frank myopathic features are usually lacking. Because of the large numbers of nonsymptomatic individuals, the role of the genetic variant in causing symptoms is not clear. The variant may be benign, or it may combine with other genes or factors to cause symptoms. A diagnosis can be made via the forearm exercise test with measures of lactate and  $\text{NH}_3$  production, histochemical staining of the enzyme in a muscle biopsy, or finding a variant in the *AMPD1* gene.

For *AMPD2*, pathogenic variants have been linked with **pontocerebellar hypoplasia** (PCH9). This neurologic disorder is rare, with fewer than 50 cases reported worldwide. Pontocerebellar hypoplasia is a group of disorders described by dysgenesis of the pons and cerebellum. Individuals with the PCH9 subtype also have dysgenesis of the



corpus callosum and microcephaly. Clinical symptoms include severe psychomotor delay, central visual impairment, and seizures.

### ADSL-ASSOCIATED DISORDERS

Disorders associated with the *ADSL* gene are rare, with fewer than 100 individuals reported. The disorder is autosomal recessive. Pathogenic gene variants with complete loss of enzyme activity are likely incompatible with life. The pathogenic variants associated with disease produce a partial loss of enzyme function. The enzyme is bifunctional, and it mediates two distinct reactions in purine synthesis (see Fig. 110.2). Reduced enzyme function leads to accumulation of succinylpurines (succinyl-aminoimidazole carboxamide riboside and succinyl-adenosine), which are eliminated in the urine. Historically, this disorder was therefore called succinyl-purinuria. The clinical manifestations are thought to result predominantly from pathologic effects of succinyl purines in the brain. Brain MRI reveals varied findings from nearly normal to global or regional atrophy with delayed myelination.

### Clinical Features

The clinical manifestations are often described in three distinct groups, but the groups overlap with a graded spectrum of severity. The most severely affected group is described as a **fatal neonatal encephalopathy**. These individuals have a severe paucity of spontaneous movement from birth, intractable seizures, and respiratory failure. They die within the first weeks of birth. Individuals in the **intermediate group** (type I) present with hypotonia and motor delay. They survive for longer periods, with moderate to severe psychomotor delay and seizures. Abnormal behaviors have been described as autistic with poor eye contact, repetitive stereotyped movements or sounds, and frequent agitation. The least severely affected group is referred to as **type II**. They present within the first years of life with evidence for psychomotor delay, sometimes with seizures and behavioral problems. The diagnosis is made by finding elevated succinyl purines in urine or cerebrospinal fluid (CSF) or by finding pathogenic variants in the *ADSL* gene.

### Treatment and Prognosis

Treatment is palliative. Seizures may be refractory to conventional anticonvulsants, but some success has been reported with the ketogenic diet.

## OTHER INHERITED PURINE DISORDERS

### Adenosine Deaminase

Deficiency of adenosine deaminase results in **severe combined immunodeficiency syndrome (SCID)**, with defects in both humoral (B cells) and cellular (T cells) immunity. Individuals with severe SCID present shortly after birth with life-threatening infections. Individuals with milder disease may present at 2-4 years of age, or even older (see Chapter 165.1). In contrast with adenosine deaminase deficiency, superactivity of the same enzyme causes hemolytic anemia.

**Adenosine kinase.** Adenosine kinase is sometimes considered among the purine salvage enzymes because it recycles adenosine into adenosine monophosphate (AMP). Pathogenic variants of the associated *ADK* gene in multiple cases from independent families have been linked with hypermethioninemia, psychomotor delay, seizures, and multiple dysmorphic features. The disorder is autosomal recessive.

**Adenylate kinase.** There are four isoforms of adenylate kinase encoded by genes *AK1-4*. The enzyme phosphorylates AMP to ADP (see Fig. 110.2). The *AK1* gene is highly expressed in erythrocytes. Pathogenic variants in *AK1* in multiple cases from independent families have been linked with nonspherocytic hemolytic anemia, sometimes with cognitive disability.

The *AK2* gene is more broadly expressed but localizes to mitochondria. Pathogenic variants in *AK2* in multiple cases from independent families have been linked with reticular dysgenesis, a type of SCID, often with sensorineural hearing loss. Disorders associated with *AK1* and *AK2* are autosomal recessive.

**Adenylosuccinate synthase.** The *ADSS* gene encodes adenylosuccinate synthase, an enzyme involved in the conversion of IMP to AMP (see Fig. 110.2). There are multiple isoforms, and pathogenic variants

in *ADSSL1* have been linked with a form of **myopathy, MPD5**. The disorder is autosomal recessive, usually begins in adolescence, and is slowly progressive. One study of affected individuals indicated that distal leg weakness was the most common feature, often with weakness of the hands. Approximately one third had weakness of the face or jaw muscles leading to difficulty with mastication. Some had left ventricular hypertrophy. Involvement of the diaphragm may lead to respiratory insufficiency in later stages of the illness.

**ATIC-associated disorders.** Disorders associated with the *ATIC* gene are very rare. Only four cases from three families have been reported. The disorder is autosomal recessive. The enzyme is bifunctional and mediates two distinct reactions (see Fig. 110.2). Complete loss of the enzyme is probably incompatible with life. Reduced enzyme function leads to accumulation of ZMP along with its phosphorylated derivatives. ZMP and its derivatives can be detected with the Bratton-Marshall test, a routinely used neonatal screen in some countries. All reported cases had prenatal and postnatal growth restriction, severe to profound psychomotor delay, chorioretinal atrophy with severe visual impairment, and dysmorphic facial features. Some had epilepsy. Treatment is palliative.

**Deoxyguanosine kinase.** The *DGK* gene encodes deoxyguanosine kinase, an enzyme that phosphorylates deoxypurine nucleosides into their respective deoxynucleotides for DNA synthesis (see Fig. 110.2). The gene is encoded by the nucleus, but the enzyme functions in mitochondria. Gene defects lead to an impairment of mitochondrial DNA synthesis, so the disorder is classified among the mitochondrial DNA depletion disorders. The disorder is rare and inherited in an autosomal recessive fashion. The clinical features reflect an early-onset multiorgan disorder, most notably liver failure, and psychomotor delay.

**IMPDH-associated disorders.** IMP-dehydrogenase is an enzyme that stands at a branchpoint in purine metabolism, directing the synthesis of purines toward guanine-based nucleotides rather than adenine-based nucleotides (see Fig. 110.2). This enzyme has two isoforms encoded by distinct but homologous genes. The *IMPDH1* gene is expressed primarily in the retina, whereas the *IMPDH2* gene is expressed in most other tissues. Disorders associated with these genes are rare, with only a handful of families reported.

Pathogenic variants in *IMPDH1* have been linked with **autosomal dominant retinopathy**. Affected individuals may have severe congenital retinal dysfunction with vision loss and pendular nystagmus (**Leber congenital amaurosis, LCA11**). Others have childhood-onset retinitis pigmentosa with progressive visual impairment (**retinitis pigmentosa, RP10**). There are no known treatments for either *IMPDH*-associated disorder.

Pathogenic variants in *IMPDH2* have been linked with an autosomal dominant neurologic disorder. Affected individuals may present with developmental delay, infantile dystonia, and seizures. Others present with a milder phenotype of dystonia that emerges in childhood or adolescence. There are no known treatments.

**Phosphoribosylaminoimidazole carboxylase.** The *PAICS* gene encodes a bifunctional enzyme that mediates two steps in the synthesis of purines (see Fig. 110.2). Pathogenic variants associated with *PAICS* are very rare, with only two individuals from a single family identified by exome sequencing. Both had multiple craniocervical malformations, and one had additional limb malformations. Both died within a few days of birth from respiratory failure.

**Purine nucleoside phosphorylase.** Deficiency of purine nucleoside phosphorylase results in selective dysfunction of T cells with susceptibility to viral illnesses. Two thirds have neurologic abnormalities, and one third have anemia. This disorder is covered in more detail in Chapter 165.2.

## DISORDERS OF PYRIMIDINE METABOLISM

### CAD Deficiency

The *CAD* gene encodes a trifunctional enzyme that mediates three of the initial six steps in pyrimidine synthesis (see Fig. 110.3). The disorder takes its name from the three relevant enzymatic activities, which include carbamoyl-phosphate synthetase, aspartate transcarbamylase,

and dihydroorotase. The associated clinical disorder is autosomal recessive.

### Clinical Features

Fewer than 10 cases have been reported. Most presented in infancy with developmental delay, anisocytosis, and poikilocytosis. Most had medication-refractory seizures by 2 years of age, although epilepsy may start later. Many cases had global or cerebellar brain atrophy on MRI. The disorder cannot be identified by any of the metabolic tests routinely used for clinical diagnosis, but the activity of the enzyme can be measured. The disorder can also be identified by finding pathogenic variants in the *CAD* gene.

### Treatment and Prognosis

Although it is quite rare, early diagnosis is important because treatment with uridine produces remarkably positive outcomes. Most of the subjects who were treated experienced a significant reduction in seizures, correction of hematologic abnormalities, and partial reversal of neurodevelopmental impairments. The disorder is therefore sometimes called **uridine-responsive epileptic encephalopathy**. It is likely that the degree of improvement depends on instituting treatments before significant brain damage occurs.

### Dihydroorotate Dehydrogenase Deficiency

The *DHODH* gene encodes an enzyme that mediates the fourth of six steps in pyrimidine synthesis. The enzyme is localized in mitochondria, where electrons from the dehydrogenase are transferred to ubiquinone in the electron transport chain. A complete loss of the enzyme is not compatible with life, so all affected cases have had some residual enzyme function. The disorder is autosomal recessive.

### Clinical Features

Fewer than 100 cases have been reported. Affected individuals have **Miller syndrome**, one of the acrofacial dysostosis syndromes where dysmorphic facial features are combined with abnormalities of the distal limbs. The facial anomalies include malar hypoplasia (underdeveloped cheekbones), micrognathia (small jaw), orofacial clefts (incomplete fusion of the roof of the mouth or lips), hypoplastic lower eyelids, and cup-shaped ears. The limb anomalies include abnormalities of the fifth and/or fourth fingers and toes (webbing, fusion, or hypoplasia), short forearms (ulnar hypoplasia sometimes with fusions to the radius), and hypoplasia of the fibula. Some cases also have other structural abnormalities such as pectus excavatum, rib defects, accessory nipples, or involvement of internal organs.

### Treatment and Prognosis

There are no specific treatments for this disorder.

### Hereditary Orotic Aciduria

The *UMPS* gene encodes a bifunctional enzyme that mediates two of the last six steps in pyrimidine synthesis (see Fig. 110.3). The relevant enzymatic activities are carried out by a single protein and include orotate phosphoribosyltransferase and orotidine 5'-monophosphate decarboxylase. These activities are sometimes combined under the term *UMP synthase*, and the disorder is sometimes known as *UMP synthase deficiency*. Affected individuals cannot convert orotic acid into UMP, so they excrete large amounts of orotic acid in the urine. Levels may be so high that orotic acid crystals may precipitate in the renal collecting system. Inheritance is autosomal recessive.

### Clinical Features

The disorder is rare, with fewer than 50 reported cases. Most present in the first few weeks or months of age with failure to thrive and developmental delay. The majority have megaloblastic anemia, hypochromia, anisocytosis, and poikilocytosis. A few have had strabismus, congenital malformations, or seizures. Heterozygous carriers may excrete high levels of orotic acid without any additional symptoms.

The diagnosis is often first suspected by finding high levels of orotic acid in the urine. UMP synthase deficiency is not the only condition

associated with high urinary orotic acid. Other disorders include urea cycle defects (e.g., ornithine transcarbamylase deficiency), some mitochondrial disorders, Reye syndrome, or treatment with medications (allopurinol and 6-azauridine). A definitive diagnosis of hereditary orotic aciduria comes from genetic testing that reveals pathogenic variants in the *UMPS* gene, and the enzyme can be measured in blood cells or fibroblasts.

### Treatment and Prognosis

Although rare, early diagnosis is important because it is treatable with uridine. In general, supplements with uridine can reverse hematologic abnormalities and stimulate normal growth and development. Long-term treatments are associated with good results. Uridine triacetate is approved for treatment by the FDA.

### Thymidine Phosphorylase Deficiency

The *TYMP* gene encodes thymidine phosphorylase, an enzyme responsible for converting thymidine to thymine (see Fig. 110.3). Deficiency of the enzyme results in marked elevations in blood thymidine. The disorder is autosomal recessive. Accumulation of phosphorylated derivatives of thymidine and deoxyuridine result in abnormal DNA replication in mitochondria and depletion of mitochondrial DNA. The enzyme has had two additional names used in the literature prior to its isolation and molecular identification. It is known as *platelet-derived endothelial cell growth factor* because of its angiogenic properties. It also is known as *gliostatin* because of a suppressive effect on the growth of glia.

### Clinical Features

The disorder is rare and responsible for **mitochondrial neurogastrointestinal encephalomyopathy (MNGIE)**. Symptoms begin in adolescents or young adults. Initial symptoms are often attributable to the gastrointestinal system and include diarrhea, vomiting, malabsorption, weight loss, and episodes of pseudoobstruction. Neurologic features include progressive external ophthalmoparesis, ptosis, myopathy, neuropathy, and hearing loss.

### Treatment and Prognosis

There is no specific treatment for the early-onset severe phenotype. Treatment with 5-fluorouracil and related drugs is contraindicated.

## DIHYDROPYRIMIDINE DEHYDROGENASE DEFICIENCY

The *DPD* gene encodes dihydropyrimidine dehydrogenase, the first enzyme involved in the catabolism of thymine and uracil (see Fig. 110.3). Genetic variants are common. Screening studies have suggested a prevalence of 3–5% for partial deficiency and 0.1–0.5% for severe deficiency. Severe enzyme deficiency is inherited in an autosomal recessive manner, and it is associated with marked elevations of thymine and uracil in urine, blood, and CSF. The associated disorder is therefore sometimes called **thiamine-uraciluria**.

### Clinical Features

The clinical manifestations are quite varied, even among individuals who carry the same genetic variant. Some individuals with severe enzyme deficiency have no symptoms, and they are identified in adulthood because of severe toxicity after treatment with 5-fluorouracil or related drugs. Others are identified in childhood, although fewer than 50 cases have been reported. Approximately half of these cases have had psychomotor delay, often with seizures. A few have presented with growth restriction, microcephaly, ocular abnormalities, or autistic behaviors.

### Treatment and Prognosis

There is no specific treatment for the early-onset severe phenotype. For individuals with partial deficiency, treatment with 5-fluorouracil and related drugs is contraindicated.

### Dihydropyrimidinase Deficiency

The *DPYS* gene encodes dihydropyrimidinase, the second enzyme involved in the catabolism of thymine and uracil (see Fig. 110.3).

Approximately 9% of individuals of European ancestry have genetic variants that substantially reduce enzyme activity, and 0.5% have almost no activity. Associated disorders are autosomal recessive. Severe enzyme deficiency is associated with marked elevations of dihydrothymine and dihydrouracil in urine, blood, and CSF. The associated disorder is therefore sometimes called **dihydropyrimidinuria**.

### Clinical Features

Genetic variants in *DPYS* are associated with very different clinical manifestations, even among individuals who carry the same genetic variant. The severe form of the disorder is rare, with fewer than 50 reported individuals. Some individuals with severe enzyme deficiency have no symptoms. Others are identified in childhood, with approximately half having psychomotor delay and a third having seizures. Gastrointestinal problems are common and include feeding difficulties with recurrent vomiting, malabsorption, and gastroesophageal reflux. A few have presented with growth restriction, microcephaly, or autistic behaviors.

### Treatment and Prognosis

There is no specific treatment for the early-onset severe phenotype. Testing for common genetic variants before the use of 5-fluorouracil and related drugs has been recommended.

### β-Ureidopropionase Deficiency

The *UPBI* gene encodes β-ureidopropionase, also known as *β-alanine synthase*. It is responsible for the last step of pyrimidine catabolism (see Fig. 110.3). Deficiency of the enzyme leads to accumulation of *N*-carbamoyl-β-alanine and *N*-carbamyl-β-aminoisobutyric acid in urine, blood, and CSF. As a result, the disorder is sometimes called ***N*-carbamoyl-β-amino aciduria**. The mechanism by which the enzyme defect leads to clinical disease is not well known.

### Clinical Features

The disorder is autosomal recessive and rare, with fewer than 50 reported individuals. Affected individuals have psychomotor delay, seizures, microcephaly, and autistic behaviors. However, enzyme screening has revealed some individuals with no apparent symptoms. Diagnosis can be made by measuring accumulation of the associated metabolites, enzyme testing from liver biopsy, or finding pathogenic variants in the gene.

### Treatment and Prognosis

There is no specific treatment for this disorder.

## DISORDERS ASSOCIATED WITH THYMIDINE KINASE

Dividing cells rely on *de novo* synthesis of pyrimidines to make most of their nucleotides, but these pathways are downregulated in postmitotic cells, which primarily maintain pyrimidine nucleotides instead via salvage (see Fig. 110.3). Salvage enzymes include cytosolic thymidine kinase (*TK1* gene) and mitochondrial thymidine kinase (*TK2* gene). The *TK1* gene is often overexpressed in rapidly dividing cells and used as a marker for early detection or recurrence of cancer.

Pathogenic variants in the *TK2* gene impair the phosphorylation of thymidine and deoxycytosine, leading to reductions in associated nucleotides needed for DNA synthesis. The result is abnormalities in the rate and/or accuracy of mitochondrial DNA synthesis, with mitochondrial DNA depletion. Disorders associated with *TK2* are autosomal recessive, with three overlapping groups delineated by age at onset. Individuals with **infantile onset** (<1 year) have severe myopathy with proximal muscle weakness, facial diplegia, dysphagia, and respiratory compromise. Some may also have encephalopathy and seizures. Death usually occurs within 1-4 years. Individuals with the **childhood-onset** form (up to 12 years of age) have a more slowly progressive myopathy with weakness and longer survival periods. Those with **late onset** (>12 years of age) may have limited areas of weakness such as chronic progressive ophthalmoplegia, facial diplegia, or oropharyngeal weakness.

There is no known treatment, but trials with relevant pyrimidine derivatives have been initiated.

## COMBINED DISORDERS OF BOTH PURINES AND PYRIMIDINES

### PRPS1-Associated Disorders

The *PRPS1* gene encodes the enzyme PRPP synthase type 1. Two additional isoforms of this enzyme are encoded by separate genes: *PRPS1L1* and *PRPS2*. *PRPS1* and *PRPS2* reside on opposite arms of the X chromosome, and *PRPS1L1* is on chromosome 7. *PRPS1* is ubiquitously expressed. *PRPS1L1* is expressed only in testis, and *PRPS2* is expressed in the gastrointestinal system, endocrine tissues, and reproductive organs. Only *PRPS1* has been linked with human disease. *PRPS1*-associated disorders are rare, with fewer than 1,000 individuals reported.

All three isoforms of PRPP-synthase transfer high-energy phosphate bonds from ATP to ribose-5-phosphate to generate PRPP. The PRPP can then use the high-energy phosphate bonds to drive certain energy-requiring reactions. PRPP is a cosubstrate for the first and rate-limiting reaction in purine synthesis (see Fig. 110.2). PRPP also serves as a cosubstrate for the main purine salvage enzymes HGPrt and APRT. PRPP affects pyrimidine synthesis as well, because it is a cosubstrate for the first step in pyrimidine synthesis (see Fig. 110.3). PRPP is also a cosubstrate for two additional enzymes involved in the synthesis of the pyridine nucleotides: NAD and NADP (Table 110.4). PRPP-synthase plays a key role in regulating the synthesis of both purines and pyrimidines, and overexpression of *PRPS1* is common in certain cancer cells, which need large quantities of purines and pyrimidines for DNA replication during cell division.

Because of its integral involvement in many vital biochemical pathways, complete loss of PRPP-synthase is not compatible with life. Instead, clinical disease results from abnormally high enzyme activity or partial loss of enzyme activity. High levels of the enzyme produce excessive quantities of PRPP, and elevations in PRPP accelerate purine production, with resultant overproduction of uric acid. It is likely that increases in PRPP accelerate pyrimidine metabolism, but measures of this pathway are not widely used in clinical medicine. Conversely, impaired enzyme activity results in reduced metabolism of both purines and pyrimidines.

### Clinical Features

The clinical phenotypes of *PRPS1*-associated disorders are remarkably diverse. Phenotypic variation is caused by varied changes in enzyme function. The phenotypes associated with *reduced enzyme activity* historically have been described as distinct entities, although clinical features overlap, and the reality is a continuous spectrum of severity (Fig. 110.5). The mildest phenotype is **X-linked nonsyndromic hearing loss (DFN2)**. Hearing impairments in males may range from a slowly progressive postlingual hearing loss to profound congenital deafness. A more severe phenotype associated with impaired enzyme activity has been called **Rosenberg-Chutorian syndrome** or **X-linked Charcot-Marie-Tooth disease (CMTX5)**. This phenotype in males combines prelingual hearing loss, progressive optic neuropathy, and peripheral neuropathy beginning at 5-10 years of age and sometimes gait impairments. An even more severe phenotype has been called **Arts syndrome**. It also is X-linked, and males have profound congenital deafness, early-onset optic neuropathy, peripheral neuropathy, psychomotor delay, and recurrent respiratory infections that may cause early death. In addition to these three phenotypes classically associated with reduced enzyme activity, there are reports that suggest a fourth and even more severe phenotype. Males have intrauterine growth restriction and failure to thrive after birth, congenital retinopathy and deafness, diabetes insipidus, and a more severe neurologic condition that includes severe psychomotor delay, spastic tetraparesis, seizures, and evidence for delayed white matter development on brain MRI.

The *PRPS1* gene is X-linked, so variants associated with reduced PRPP-synthase affect males, often from an early age. However, female carriers may express milder or adult-onset phenotypes. In families where males are affected only with early-onset hearing loss, female carriers may develop progressive hearing loss as young adults. In



families where males have a more severe early childhood phenotype that includes additional neurologic signs, female carriers may have progressive hearing loss, retinopathy, optic neuropathy, peripheral neuropathy, and sometimes additional signs attributable to the central nervous system. For the most severe phenotype, female carriers may also have short stature. In some families, only females are clinically affected, with evidence for embryonic lethality of males. These families suggest the existence of a fifth phenotype of embryonic lethality in males. Because hearing loss is the most consistent feature associated with reduced PRPP-synthase, the diagnosis of a *PRPS1*-associated disorder should be considered in males or females with sensorineural hearing loss, especially when combined with other neurologic signs.

There are also two different phenotypes associated with *abnormally high levels* of PRPP-synthase activity. The milder phenotype is associated with overexpression of a normal *PRPS1* mRNA transcript. Males present with signs of uric acid overproduction, including hyperuricemia and gout. Female carriers may also be affected. A more severe phenotype is associated with a point pathogenic variant in *PRPS1*, which renders the protein less durable but insensitive to feedback inhibition. The lack of feedback inhibition results in excessive PRPP production, with acceleration of purine synthesis and overproduction of uric acid. However, tissues with normally low levels of *PRPS1* may experience PRPP shortage because the enzyme is unstable. Erythrocytes lack a nucleus, so there is no ongoing mRNA transcription to provide a constant supply of new enzyme. In individuals with an unstable enzyme, erythrocyte PRPP-synthase is absent. A similar mechanism may explain the neurologic consequences, which overlap with those of PRPP-synthase deficiency syndromes. Affected individuals show signs of overproduction of uric acid combined with sensorineural hearing impairments, neuropathy, and/or psychomotor delay. The diagnosis of a disorder associated with excessive activity of PRPP-synthase should be suspected in any individual with evidence for overproduction of uric acid, especially when combined with the typical neurologic signs.

### Treatment and Prognosis

The overproduction of uric acid in disorders associated with increased activity of PRPP-synthase is treated with inhibitors of XOR (allopurinol or febuxostat) combined with generous hydration. No treatments have proven effective in the treatment of disorders associated with reduced activity of the enzyme.

### Disorders Associated with Nucleotidases

There are numerous enzymes that function as nucleotidases to remove phosphate groups from nucleotides (see Figs. 110.1 and 110.3). Many act nonselectively on multiple nucleotides and other small molecules, but they are often described according to their most prominent (or first discovered) enzymatic activity. At least five of these nucleotidases are

cytosolic, one is bound to the plasma membrane, and another is localized to mitochondria. Early studies based on enzymatic activity did not always identify the exact isoform involved, but more recent studies have more precisely delineated the precise enzyme involved.

**Nucleotidase-associated pervasive developmental delay.** A marked increase in nucleotidase activity was found in cells of nine individuals with motor and cognitive delay, hyperactivity and impulsivity, delayed or absent language, seizures, awkward movements, and other abnormal behaviors. Some had immunologic impairments too. Although the exact enzyme and gene were not delineated, individuals had chronic hypouricemia, indicating reduced purine metabolism. Biochemical studies suggested the disorder was associated with depletion of pyrimidine nucleotides, and the behavioral abnormalities responded to uridine supplements.

**Pyrimidine 5-nucleotidase deficiency.** The *NT5C3A* gene encodes an erythrocyte-specific 5'-nucleotidase isoform (P5N-1) with preferential activity toward the pyrimidines CMP and UMP (see Fig. 110.3). Enzyme deficiency is inherited in an autosomal recessive manner and associated with accumulation of pyrimidine nucleotides in erythrocytes.

The clinical manifestations include chronic nonspherocytic hemolytic anemia; marked basophilic stippling and reticulocytosis; and accompanying splenomegaly, hemoglobinuria, and jaundice resulting from overproduction of bilirubin. The diagnosis is suspected when there is prominent basophilic stippling of erythrocytes, a phenomenon also associated with lead intoxication. Erythrocytes have an overabundance of pyrimidines, and the enzyme can be measured in red cells. The anemia is generally moderate and does not usually require transfusion.

**Spastic paraplegia (SPG45).** The *NT5C2* gene encodes a cytosolic 5'-nucleotidase with preferential activity toward IMP and other purine nucleotides. Pathogenic variants in this gene leading to reduced enzyme function have been linked with spastic paraplegia (SPG45). The disorder is rare and described for fewer than 20 individuals in a few different families. Affected individuals have early-onset gait impairment with leg weakness, spasticity, hyperreflexia, clonus, and extensor plantar reflexes. Many also have cognitive impairments. MRI may show white matter brain changes with dysgenesis of the corpus callosum.

**Desbuquois dysplasia type 1 (DBQB1).** The *CANT1* gene encodes a secreted calcium-dependent enzyme that functions as a triphosphatase or diphosphatase with activity toward ATP, ADP, UTP, and UDP. Pathogenic variants in this gene have been linked with a rare form of osteochondrodysplasia. Affected individuals have short stature with short limbs, joint laxity with frequent joint dislocations, pectus carinatum, osteopenia, dysmorphic facies, and intellectual disability.

### DISORDERS ASSOCIATED WITH RIBONUCLEOTIDE REDUCTASE

Ribonucleotide reductase is the enzyme responsible for generating the deoxynucleotides dADP, dCDP, dGDP, and dUDP (see Figs. 110.1 and 110.3). These deoxynucleotides are used to synthesize DNA, so the enzyme plays a key role in regulating DNA replication for cell division. The enzyme is the target for hydroxyurea used for sickle cell anemia and certain malignancies. The human enzyme has three subunits, but only the subunit encoded by the *RRM2B* gene has been linked with human disease.

### Clinical Features

Pathogenic variants in *RRM2B* are responsible for a **mitochondrial DNA depletion syndrome** with severe encephalomyopathy. The disorder is inherited in an autosomal recessive manner. Only a handful of cases from a few families have been reported. Pathogenic variants in the same gene have also been linked with an autosomal dominant **progressive external ophthalmoplegia (PEOA5)**. Only a few cases have been reported. There is no specific treatment for either disorder.

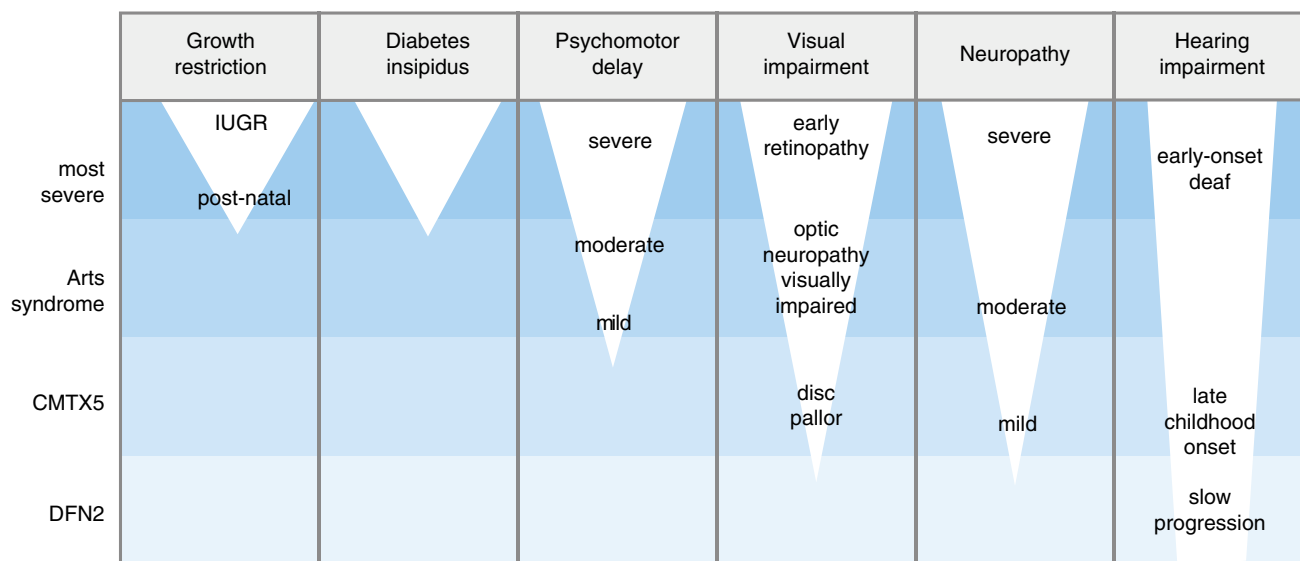
Visit Elsevier eBooks+ at [eBooks.Health.Elsevier.com](http://eBooks.Health.Elsevier.com) for Bibliography.

**Table 110.4** Enzymes Dependent on Phosphoribosylpyrophosphate

ENZYME	GENE	PATHWAY
Amido phosphoribosyl transferase	<i>PPAT</i>	Purine synthesis
Hypoxanthine-guanine phosphoribosyl transferase	<i>HPRT1</i>	Purine recycling
Adenine phosphoribosyl transferase	<i>APRT</i>	Purine recycling
Orotate phosphoribosyl transferase Uridine monophosphate synthetase	<i>UMPS</i>	Pyrimidine synthesis
Nicotinate phosphoribosyl transferase	<i>NAPRT</i>	NAD synthesis
Nicotinamide phosphoribosyl transferase	<i>NAMPT</i>	NADP synthesis

NAD, Nicotinamide adenine dinucleotide; NADP, nicotinamide-adenine dinucleotide phosphate.  
Copyright H.A. Jinnah.





**Fig. 110.5** *PRPS1*-associated disorders. This schematic provides a graphical representation of the overlapping spectrum of *PRPS1*-associated disorders. The four disorders are listed on the left side of the panel. The most common clinical features are shown in the top row. The white triangles depict the severity of individual clinical features for each of the disorders. For example, hearing loss may begin in adulthood with slow progression in the milder phenotypes (DFN2), whereas it may be reflected as earlier or more complete deafness in the more severe phenotypes. Conversely, growth retardation and diabetes insipidus have been reported only for the most severe phenotype. This schematic provides only a general guide, as some exceptions may occur. (Copyright H.A. Jinnah.)

## Chapter 111

# Hutchinson-Gilford Progeria Syndrome (Progeria)

Timothy R. O'Toole and Leslie B. Gordon

Hutchinson-Gilford progeria syndrome (HGPS, or progeria) is a rare, fatal, autosomal dominant segmental premature aging disease. With an estimated incidence of 1 in 4 million live births and prevalence of 1 in 20 million living individuals, there are an estimated total of 400 children living with progeria in 2023 worldwide. There is no gender, ethnic, or regional bias.

Progeria is caused by a single-base pathogenic variant in the *LMNA* gene, which results in the production of an abnormal lamin A protein called **progerin**. Lamin A is an intermediate-filament inner nuclear membrane protein found in most differentiated cells of the body. Without progerin-directed treatment, children with progeria develop **premature progressive atherosclerosis** and die of heart failure, usually between ages 5 and 20 years. Progerin is found in increased concentration in the skin and vascular wall of normal older individuals compared with younger individuals, suggesting a role in normal aging.

### CLINICAL MANIFESTATIONS

Children are born looking normal and begin to develop clinical signs of disease during year one. Physical appearance and clinical findings change

dramatically each year that they age (Figs. 111.1 and 111.2). Both clinical and biologic overlaps with aging are segmental, or partial. The disease features discussed next are roughly in order of clinical appearance.

### Dermatologic Changes in Skin, Hair, and Nails

Skin findings are often apparent as initial signs of progeria—at birth in about 25% of cases and by age 2 months in 80% of cases. These are variable in severity and include areas of discoloration, stippled dyspigmentation, tightened areas that can restrict movement, and areas of the trunk or legs where small (1-2 cm), soft, bulging skin is present.

Although usually born with normal appearance, cranial hair is lost within the first few years. Initial hair loss occurs in the temporal and occipital areas, with preservation of hair on the mid-scalp and vertex for the longest period. Eventually total alopecia occurs, leaving soft, downy, sparse, immature hair on the scalp, no eyebrows, and scant eyelashes.

Nails on hands and feet are usually normal at birth but become dystrophic later in life.

### Failure to Thrive

Children with progeria experience apparently normal fetal and early postnatal development. Between several months and 1 year of age, abnormalities in growth and body composition are readily apparent. Severe failure to thrive ensues, heralding generalized lipodystrophy, with apparent wasting of limbs, circumoral cyanosis, and prominent veins around the scalp, neck, and trunk resulting from a paucity of subcutaneous fat. The weight percentile is usually normal at birth but decreases to below the third percentile despite adequate caloric intake for normal growth and normal resting energy expenditure. A review of 35 children showed an average weight increase



**Fig. 111.1** Distinguishing clinical features in Hutchinson-Gilford progeria syndrome. A, Alopecia, prominent scalp veins, narrowed nasal bridge, retrognathia. B, Generalized lipoatrophy leaves muscular prominence. C, Skin tightening and mottling. D, Skin bulging. E, Digital joint contractures. F, Nail dystrophy with spooning. G, Knee joint contractures, lipodystrophy. H, Corneal scarring secondary to exposure keratopathy. I, Flat umbilicus with scarred-over appearance; J, Calcinosis cutis in a digit. (Photos courtesy The Progeria Research Foundation and Boston Children's Hospital.)

of only 0.44 kg/year, beginning at 24 months of age and persisting through life. Weight gain over time is linear, which contrasts with the pulsatile acceleration in growth velocity for normal age- and gender-matched children. Children reach an average final height of approximately 1 meter and weight of approximately 15-20 kg. Head circumference is normal. The weight deficit is more pronounced than the height deficit and, associated with the loss of subcutaneous fat, results in the emaciated appearance with muscular prominence. Clinical problems caused by the lack of subcutaneous fat include sensitivity to cold temperatures and foot discomfort caused by lack of fat cushioning. Overt diabetes is unusual in progeria, but at least 75% of children eventually develop insulin resistance, usually starting at around age 8 years.

### Musculoskeletal Impairments

Both upper and lower extremity range-of-motion impairments (e.g., fingers, elbows, hips, knees, ankles) may be present at birth and may progress with age. Joint contractures are caused by both bony and cartilaginous disease, along with tightened skin. Along with irregularities in the congruency of articulating joint surfaces, these changes serve to limit joint motion and affect both upper and lower extremity gross and fine motor function. *Physical therapy is recommended routinely and throughout life to maximize joint function.*

### Ocular Abnormalities

Ophthalmic signs and symptoms are caused in part by shallow orbits, tight skin, and a paucity of subcutaneous fat around the eyes. Eyes are prominent and often experience ocular surface disease

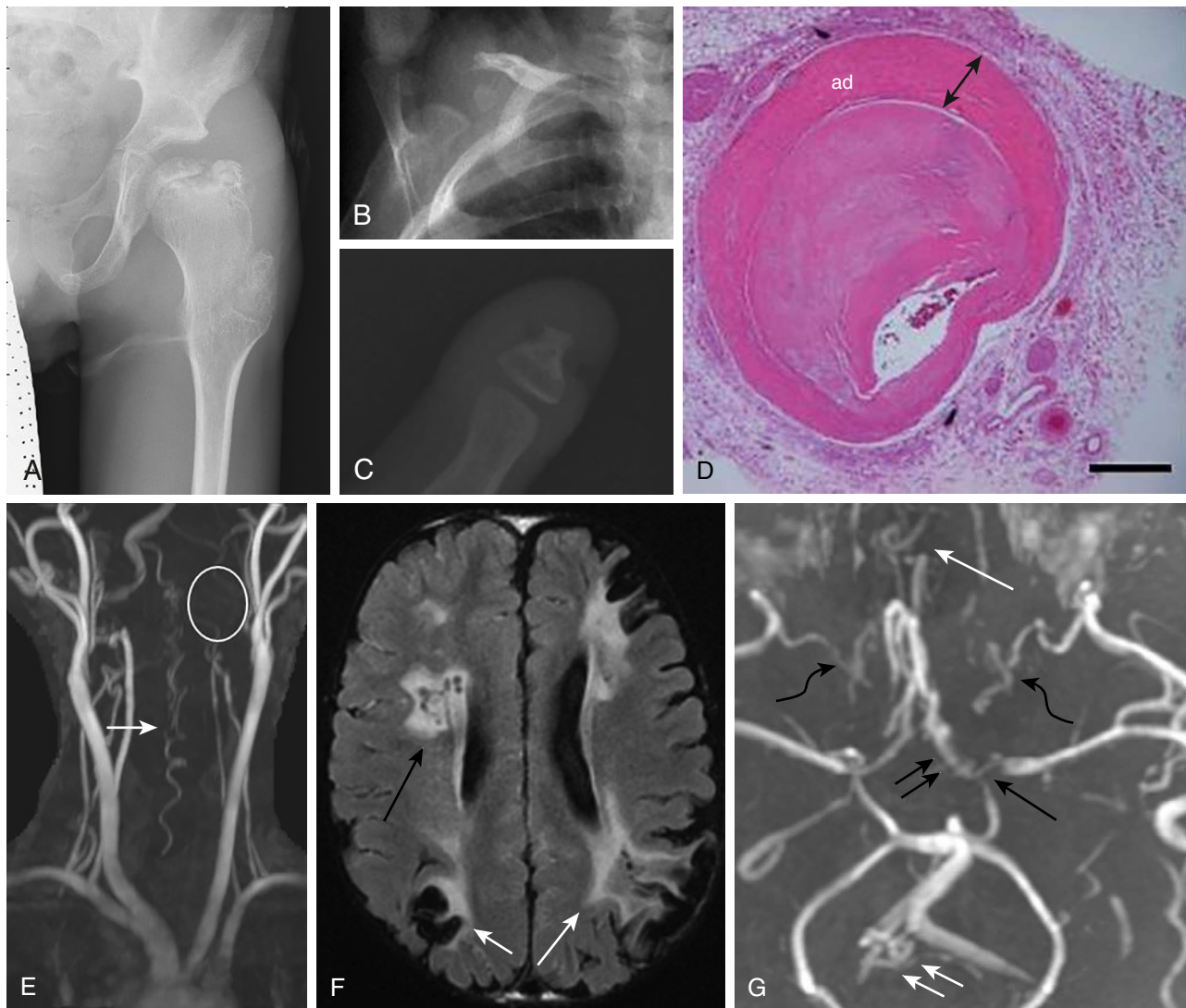
secondary to nocturnal lagophthalmos and exposure keratopathy, which produce photophobia, tearing, ocular irritation, corneal scarring, and corneal ulceration that can lead to vision loss. Most patients have relatively good acuity; however, advanced ophthalmic disease can be associated with reduced acuity. *Children with progeria should have an ophthalmic evaluation at diagnosis and at least yearly thereafter.* Aggressive ocular surface lubrication is recommended, including the use of tape tarsorrhaphy at night.

### Craniofacial and Dental Phenotypes

Children develop craniofacial disproportion, with micrognathia and retrognathia caused by mandibular hypoplasia. Typical oral and dental manifestations include hypodontia, delayed tooth eruption, severe dental crowding caused by hypoplastic maxilla and mandible, ogival palatal arch, ankyloglossia, presence of median sagittal palatal fissure, and generalized gingival recession. Eruption may be delayed for many months, and primary teeth may persist for the duration of life. Secondary teeth are present but may or may not erupt. They sometimes erupt on the lingual and palatal surfaces of the mandibular and maxillary alveolar ridges, rather than in place of the primary incisors. In some, but not all cases, extracting primary teeth promotes movement of secondary teeth into place.

### Skeletal Abnormalities

Development of bone structure and bone density represents a unique skeletal dysplasia that is not based in malnutrition. Acroosteolysis of the distal phalanges, distal clavicular resorption, and thin, tapered ribs are early signs of progeria (as early as 3 months



**Fig. 111.2** Pathologic skeletal and cardiovascular findings in Hutchinson-Gilford progeria. **A**, Coxa valga of the hip. **B**, Clavicular osteolysis. **C**, Acroosteolysis in a thumb. **D**, H&E staining of mid-right coronary artery characterized by an enlarged and highly fibrotic adventitia (arrow). The media is markedly thinned in the area with adventitial fibrosis and plaque showing clinically significant stenosis (90%) and a necrotic core with calcification (staining not shown). **E**, Near-complete loss of the distal vertebral artery (circle) and prominent anterior spinal artery collateral (arrow). **F**, Acute gyral infarcts (black arrow). Bright signal in the sulci indicates slow cortical collateral flow (white arrows). **G**, M1 (single black arrow) and A1 stenoses (double black arrows), internal maxillary artery collaterals (wavy black arrows), subfrontal collaterals (single white arrow), and enlarged anterior and posterior spinal arteries (double white arrows).

of age). Facial disproportion, a narrowed nasal bridge, and retrognathia make intubation extremely difficult, and fiberoptic intubation is recommended. A pyriform chest structure and small clavicles can lead to reducible glenohumeral joint instability. Growth of the spine and bony pelvis is normal. Hip disease is pervasive and results in repeated dislocations in about 20% of cases that are not amenable to splinting. Dysplastic growth of the femoral head and neck axis results in coxa valgus (straightening of the femoral head-neck axis >125 degrees) and coxa magna, where the diameter of the femoral head is disproportionately large for the acetabulum, resulting in hip instability. The resulting hip dysplasia can be progressive and may result in osteoarthritis, avascular necrosis, hip dislocation, and inability to bear weight.

In response to repeated hip dislocations, five instances of either unilateral or bilateral surgical correction of hip dysplasia using periacetabular and femoral osteotomy have been conducted, each at different hospitals. Follow-up after 4-8 years has yielded mixed results.

Other than in a single instance, hip dislocations have not recurred. In two cases, postsurgical healing occurred normally, resulting in ability to bear weight and walk short-to-long distances. In two cases, hardware failure with nonunion of femoral bone necessitated hardware removal and new hardware insertion; skin breakdown and need for additional bone grafting complicated one of these cases. These two cases yielded limited weight-bearing with no assistance when walking short distances, but the patients required wheelchair use for longer distances. Finally, one case healed well with no adverse events, but mobility was not restored because of postsurgery progression of joint contractures, resulting in inability to bear weight or walk and subsequent wheelchair use. Adequate vitamin D levels are likely important for bone healing in all cases.

Other changes to the appendicular skeleton include flaring of the humeral and femoral metaphyses and constriction of the radial neck. Growth plate morphology is generally normal but can be variable within a single radiograph. The appearance of ossification



centers used to define bone age is normal. Bone structure assessed by peripheral quantitative computed tomography (pQCT) of the radius demonstrates distinct and severe abnormalities in bone structural geometry, consistent with progeria representing a *skeletal dysplasia*. Areal bone mineral density (aBMD) *z* scores measured by dual-energy x-ray absorptiometry (DXA) adjusted for height and age and true (volumetric) BMD assessed by pQCT are normal to mildly reduced, refuting the assumption that patients with progeria are osteoporotic. Fracture rates in progeria are normal and not associated with fragility fractures observed in other pediatric metabolic bone diseases, such as osteogenesis imperfecta.

### Hearing

Low-tone conductive hearing loss is pervasive in progeria and likely indicative of a stiff tympanic membrane and/or deficits in the middle ear bony and ligamentous structures. Overall, this does not affect the ability to hear the usual spoken tones, but preferential classroom seating is recommended, along with annual hearing examinations.

### Cardiovascular Disease

Approximately 80% of deaths in progeria are caused by cardiovascular failure, with end-stage events sometimes precipitated by superimposed respiratory infection or stressors surrounding surgical intervention. Progeria is a **primary vasculopathy** characterized by pervasive accelerated vascular stiffening, followed by large- and medium-vessel occlusive disease from atherosclerotic plaque formation, with valvular and cardiac calcification and insufficiency at advanced stages of disease. Some evidence of vascular dysfunction is apparent in all ages tested. ECG abnormalities are generally nonspecific, but indications of left ventricular hypertrophy and nonspecific ST-T wave abnormalities can occur later in disease progression. Hypertension, angina, cardiomegaly, metabolic syndrome, and congestive heart failure are common end-stage events.

Transthoracic echocardiography reveals early-onset diastolic left ventricular dysfunction associated with age-related decline in lateral and septal early (*E'*) diastolic tissue Doppler velocity *z* scores and an increase in the ratio of mitral inflow (*E*) to lateral and septal *E'* velocity *z* scores. Other echocardiographic findings include left ventricular hypertrophy, left ventricular systolic dysfunction, and mitral or aortic valve disease with calcification, which tend to appear later in life.

Vascular stiffening assessed using carotid and femoral ultrasound reveals elevated carotid-femoral pulse wave velocity ( $PWV_{cf}$ ) and wall echodensity with medial and adventitial thickening. These are considered early and important indicators of cardiovascular decline. In the general population, increased  $PWV_{cf}$  is associated with increased risk of cardiac death. Intima-media thickness is normal. In addition, elevated carotid artery mean flow velocities appear early in life, and underscore the presence of arterial occlusive disease.

*Routine blood pressure (BP) monitoring with special attention to proper cuff size is recommended.* When normalized for patient size using height and age correction, both systolic and diastolic BP are increased in about half of patients with HGPS. These elevated BP trends would be expected in the setting of significant vascular stiffness. *Antihypertensive medications have been used in the setting of elevated BP, with special attention to maintaining adequate BP to avoid strokes.*

BP monitoring, ECG, echocardiography, carotid ultrasound for plaque evaluation, and  $PWV_{cf}$  measures for vascular stiffening are recommended.

End-stage cardiovascular disease (CVD) in progeria is often characterized by atherosclerotic plaques in large and medium-sized arteries, severe aortic stenosis, and cardiac failure. Critical aortic stenosis with heart failure is amenable to transcatheter aortic valve implantation and apico-aortic conduit surgeries to alleviate severe aortic stenosis. These carry high risk of death but have yielded significant

symptomatic improvement and prolongation of life in several cases (see treatment section).

### Cerebrovascular Arteriopathy and Stroke

The earliest incidence of stroke occurred at age 0.4 years. More often, strokes occur in the later years. Over the life span, MRI evidence of infarction can be found in as many as 60% of patients with progeria, with half of these clinically silent. Both extracranial and intracranial occlusive disease is present in the neurovascular axis, with resulting extensive collateral vessel formation that pseudo-normalizes intracranial flow. Carotid artery blockages are well documented, but infarction can occur even in their absence. Both large- and small-vessel disease is found; collateral vessel formation is extensive. A propensity for strokes and an underlying stiff vasculature make maintaining adequate blood pressure through oral hydration a priority in patients with progeria; special care should be taken when considering maintenance of consistent BP during general anesthesia, airplane trips, and hot weather. In addition, 15% of deaths in children with progeria occur from head injury or trauma, including subdural hematoma. This implies an underlying susceptibility to subdural hematoma, though known risk of stroke is much higher and frequently warrants low-dose aspirin therapy.

### Sexual Development

Females with progeria can develop Tanner stage II secondary sexual characteristics, including signs of early breast development and sparse pubic hair. Progression to Tanner stage III has not been observed. Despite minimal to absent physical signs of pubertal development and markedly reduced body fat, over half of females experience spontaneous menarche at a median age of 14 years. Menarche is not preceded by gain in body mass or increase in body fat. Timing of menarche is variable; some adolescents start menstruation at Tanner stage I without progression to Tanner II, while others start at Tanner stage II. Those experiencing menarche vs nonmenstruating females have similar body mass indices, percentage body fat, and serum leptin levels, all of which are vastly below the healthy adolescent population. Menorrhagia has been observed and can result in symptomatic anemia. *In addition to iron supplementation, oral contraceptives may be indicated to regulate menses.* Progestin-only or minimal estrogen-content products are preferred because of elevated cardiovascular risks associated with estrogen-based medication in the face of HGPS-associated atherosclerosis. There are no documented cases of reproductive capacity in females or males with progeria; however, the data suggest there is potential for further sexual development and the possibility of fertility in these females. Secondary sexual characteristics in males have not been reported.

### Normally Functioning Systems

Liver, kidney, thyroid, immune, gastrointestinal, and neurologic function (other than stroke related) remain intact. Intellect is normal for age, possibly in part from downregulation of progerin expression in the brain by a brain-specific micro-RNA, miR-9.

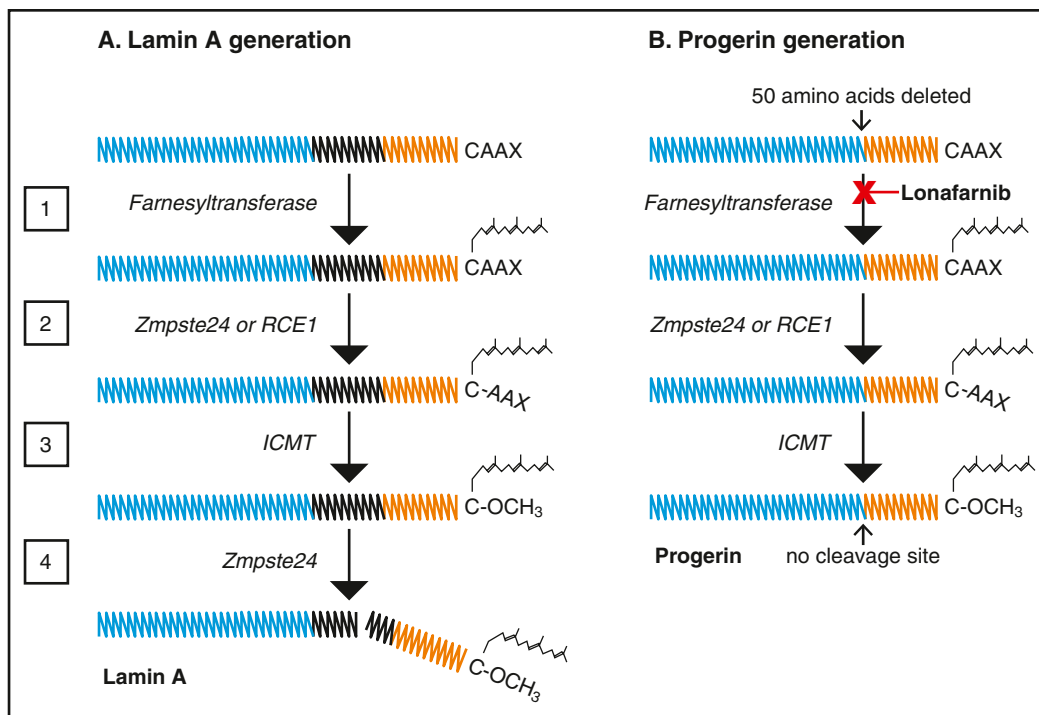
### LABORATORY FINDINGS

The most consistent laboratory findings are low serum leptin below detectable levels (>90%) and insulin resistance (75%, usually starting over age 8 years). Platelet count is often moderately high. High-density lipoprotein (HDL) cholesterol and adiponectin concentrations decrease with increasing age to values significantly below normal. Otherwise, lipid panels, high-sensitivity C-reactive protein, blood chemistries, liver and kidney function tests, endocrine test, and coagulation tests are generally normal.

### MOLECULAR PATHOGENESIS

Pathogenic variants in the *LMNA* gene cause progeria. The normal *LMNA/C* gene encodes the proteins lamins A and C, of which only lamin





**Fig. 111.3** Posttranslational processing pathways producing lamin A and progerin, including the target site for lonafarnib. **A**, Prelamin A polypeptide chain, showing its central  $\alpha$ -helical rod domain and C-terminal-CAAX box, representing cysteine (C), aliphatic amino acids (AA), and any amino acid (X). The  $\alpha$ -helical rod domain is divided into segments that assist in displaying the progerin defect. Posttranslational processing consists of four steps: (1) a farnesyl group is attached to the cysteine residue of the -CAAX box by farnesyltransferase; (2) the last three residues are proteolytically cleaved by the zinc metalloprotease Zmpste24 or Ras-converting enzyme (RCE1); (3) carboxy-methylation by isoprenyl-cysteine carboxyl methyltransferase (ICMT); and (4) the terminal 15 C-terminal residues, including the farnesylated and carboxymethylated cysteine, are cleaved off by Zmpste24. **B**, A 50-amino acid deletion in prelamin A (represented by the black segment of the lamin A rod) is the result of a pathogenic variant that activates a cryptic splice site within exon 11 of the *LMNA* gene. This deletion leaves progerin without an attachment site for the last processing step—cleavage of the farnesylation and carboxymethylated terminal 15 amino acid residues. Thus progerin remains farnesylated and intercalated within the inner nuclear membrane, where it causes much of its cellular damage.

A is associated with human diseases. The lamin proteins are the principal proteins of the nuclear lamina, a complex molecular interface located between the inner membrane of the nuclear envelope and chromatin. The integrity of the lamina is central to many cellular functions, creating and maintaining structural integrity of the nuclear scaffold, DNA replication, RNA transcription, organization of the nucleus, nuclear pore assembly, chromatin function, cell cycling, senescence, and apoptosis.

Progeria is a sporadic autosomal dominant disease in about 98% of cases. Two percent of cases presumably arise from parental mosaicism; The Progeria Research Foundation reports five identified sibling occurrences of genetically confirmed HGPS. HGPS is caused by the accelerated use of an alternative, internal splice site that results in the deletion of 150 base pairs in the 3' portion of exon 11 of the *LMNA* gene. In about 90% of cases, this results from a single C to T transition at nucleotide 1824 that is silent (Gly608Gly) but optimizes an internal splice site within exon 11. The remaining 10% of cases possess one of several single-base pathogenic variants within the intron 11 splice donor site, thus reducing specificity for this site and altering the splicing balance in favor of the internal splice. Subsequent to all these pathogenic variants, translation followed by posttranslational processing of the altered mRNA produces progerin, a shortened abnormal lamin A protein with a 50-amino acid deletion near its C-terminal end. An understanding of the posttranslational processing pathway and how it is altered to create progerin has led to a number of treatment prospects for the disease (Fig. 111.3).

Both prelamin A and preprogerin possess a methylated farnesyl side group attached during posttranslational processing. This is a lipophilic moiety that facilitates intercalation of proteins into the inner nuclear membrane, where most of the lamin and progerin functions are performed. During posttranslational processing of normal lamin A, loss of the methylated farnesyl anchor releases prelamin from the nuclear membrane, rendering it soluble for autophagic degradation. However, preprogerin and, subsequently, progerin retain the farnesyl moiety. Progerin remains anchored to the membrane, binding other proteins, causing blebbing of the nucleus, disrupting mitosis, and altering gene expression. Progerin also retains a methyl moiety.

Disease in progeria is produced by a dominant negative mechanism; the action of progerin, not the diminution of lamin A, causes the disease phenotype. The severity of disease is determined in part by progerin levels, which are regulated by the particular pathogenic variant, tissue type, or other factors influencing use of the internal splice site.

### DIAGNOSIS AND DIFFERENTIAL DIAGNOSIS

Overall, the constellation of small body habitus, bone, hair, subcutaneous fat, and skin changes results in the marked physical resemblance among patients with progeria (Fig. 111.4). For this reason, if disease signs are present, clinical diagnosis can often be achieved or excluded with relative confidence even at young ages. There are rare



**Fig. 111.4** Unrelated 7-yr-old female and 10-yr-old male with progeria. The appearance is remarkably similar between patients. (Photograph courtesy The Progeria Research Foundation.)

cases of mosaicism or relatively low-progerin-expressing patients with extremely mild clinical signs of disease. Thus lack of early disease manifestation should not be considered exclusionary. Clinical suspicion should be followed by *LMNA* genetic sequence testing. In addition, a number of premature aging disorders have features that overlap with HGPS but are not progerin-producing (Table 111.1). Patients may fall under none of these diagnoses and represent ultra-rare, unnamed progeroid diseases that carry either non-progerin-producing pathogenic variants in *LMNA* or the lamin-associated enzyme (ZMPSTE24), or progeroid syndromes without lamin-associated pathogenic variants.

## TREATMENT

Lonafarnib (Zokinvy) is a farnesyltransferase inhibitor that blocks the addition of a farnesyl lipid moiety onto preprogerin, thus preventing progerin from associating with the inner nuclear membrane where it effects much of its damage (see Fig. 111.3). Lonafarnib is approved by the US FDA and European Medicines Agency for use in patients with HGPS and processing-deficient progeroid laminopathies ages 12 months and older. It is the first and only approved indication for either disease. It is initiated at a dose of 115 mg/m<sup>2</sup> orally twice daily. After four months, the dose is increased to 150 mg/m<sup>2</sup> twice daily. The most common side effects are diarrhea, nausea, and loss of appetite, which can be mitigated with loperamide, ondansetron HCl, and cyproheptadine, respectively.

Overall, children with HGPS treated with long-term lonafarnib therapy demonstrated an increase in mean estimated survival of 4.3 years (30%) over untreated children. Treatment decreased plasma progerin levels by an average of 38% starting at 4-6 months and persisting for up to 10 years on therapy. In a single-arm clinical trial with lonafarnib (NCT00425607), subgroups of patients experienced increased rate of weight gain, decreased vascular stiffness measured by decreased PWV<sub>cf</sub> and carotid artery echodensity, improved left ventricular diastolic function, increased radial bone structural rigidity, improved sensorineural hearing, and early evidence of decreased headache, TIA, and stroke rates. Dermatologic, dental, joint contracture, insulin resistance, lipodystrophy, BMD, and joint contractures were unaffected by drug treatment.

**Dosing:** In general, medications should be dosed according to weight or body surface area instead of age because of the small size and decreased weight for height.

**Hydration** is important for maintaining adequate blood flow in the face of generalized vascular stiffness and collateral vascular formation in the brain.

**Low-dose aspirin therapy** is recommended at 2 mg/kg/day, as an extension of what is known about decreasing cardiovascular risk in the general at-risk adult population. It is not known whether low-dose aspirin therapy has any effect on morbidity or mortality in HGPS.

**Antihypertensive medications** have been used with elevated BP, with special attention to maintaining adequate BP to avoid strokes. Due to small, thin body habitus, appropriately sized blood pressure cuff and height-age adjustments when evaluating hypertension (>95th percentile) should be employed.

**Extraskkeletal calcifications** have been observed in patients with progeria radiographically and cutaneously, both at a baseline off therapy (around 30% of patients) and with increasing frequency during a clinical trial when the patients were treated with oral calcium carbonate supplementation, and/or zoledronic acid, pravastatin, and lonafarnib (around 45% of patients). Oral calcium carbonate supplementation may therefore aggravate calcium dysfunction in children with progeria. Given this potential concern, calcium intake via dietary means, along with vitamin D supplementation, is likely the safest intake strategy.

**Physical and occupational therapy** initiation are recommended as young as possible to preserve joint mobility and optimize capacity for activities of daily living.

**Cardiac intervention.** A primary cause of mortality in HGPS is critical aortic stenosis caused by premature atherosclerosis. At end stage, high-risk intervention has been performed using transcatheter aortic valve implantation (TAVI) for patients large enough to receive the smallest valve available, using a transapical approach because the femoral artery is small and calcified, precluding a transfemoral approach. The majority of patients' aortic valves are too small to implement TAVI. In these cases, apico-aortic conduit (aortic valve bypass) surgery has been achieved. Both procedures have resulted in postoperative symptomatic relief and lifespan extension when successful. The procedures carry high risk for perisurgical morbidity and mortality.

**Clinical trials.** One currently ongoing clinical trial adding *everolimus* (an FDA-approved mTOR inhibitor) to a lonafarnib regimen is aimed at accelerating autophagy of progerin, thus theoretically reducing its accumulation and cellular damage (NCT02579044). Patient treatment phase is complete and results are pending.

## PROGNOSIS

Children with progeria develop a severe premature form of atherosclerosis. Before death, cardiac decline with left-sided hypertrophy, valvular insufficiency, and pulmonary edema develop; neurovascular decline with TIAs, strokes, and occasionally seizures can result in significant morbidity.

Without lonafarnib drug treatment, death occurs generally between ages 5 and 20 years, with a median life span of 14.5 years, resulting from heart failure, sometimes with superimposed respiratory infection (approximately 80%); from head injury or trauma, including subdural hematoma (approximately 15%); and, rarely, from stroke (1-3%) or complications from anesthesia during surgery (1-3%). With lonafarnib therapy, long-term use has been associated with up to 4.3 years' (30%) lifespan extension. Surgical intervention for critical aortic stenosis can decrease cardiovascular morbidity and extend lifespan by an indeterminate duration.

## PATIENT RESOURCES

**The Progeria Research Foundation** ([www.progeriaresearch.org](http://www.progeriaresearch.org)) maintains an international progeria patient registry, provides a diagnostics program and complete patient care manual, and coordinates clinical treatment trials. It funds preclinical and clinical research to define the underpinnings of the disorder and to discover

**Table 111.1** Features of Hutchinson-Gilford Progeria Syndrome and Other Premature Aging Disorders with Overlapping Features

DISEASE	CAUSATIVE GENE	ONSET	MAIN CLINICAL FEATURES
Hutchinson-Gilford progeria syndrome (HGPS)	<i>LMNA</i> : de novo dominant point pathogenic variant (c.1824C>T; p.G608G or pathogenic variants in first five intronic bases of intron 11)	Early childhood	Severe failure to thrive in infancy, progressive alopecia leading to total alopecia, skin lesions, characteristic facies, loss of subcutaneous fat, bone changes, skeletal anomalies, musculoskeletal degeneration, hearing loss, high-pitched voice, delayed and crowded dentition, atherosclerosis, cerebrovascular disease, average death in mid-teens from myocardial infarction or stroke (from cardiovascular disease).
Restrictive dermopathy (RD)	<i>ZMPSTE24</i> : recessive null pathogenic variants	Neonatal	Intrauterine growth restriction, reduced fetal movements, and preterm delivery, tight and translucent skin with erosions, facial dysmorphism, skeletal malformations, generalized arthrogryposis; lethal within the first weeks of life
Mandibuloacral dysplasia type B (MADB)	<i>ZMPSTE24</i> : recessive pathogenic variants: often compound heterozygous pathogenic variants with a null allele and one maintaining some residual activity	Early childhood	Generalized lipodystrophy, altered skin pigmentation, alopecia, severe bone and growth defects
Mandibuloacral dysplasia type A (MADA)	<i>LMNA</i> : recessive missense pathogenic variants	Early childhood	Partial lipodystrophy at torso and limbs, bone abnormalities, altered skin pigmentation, lipodystrophic signs and mildly accelerated aging
Nestor-Guillermo progeria syndrome (NGPS)	<i>BANF1</i> : recessive pathogenic variant (c.34G>A; p.Ala12Thr)	Early childhood	Failure to thrive, aged appearance, growth restriction, decreased subcutaneous fat, thin limbs, stiff joints, severe osteolysis, absence of early cardiovascular impairment
Mandibular hypoplasia, deafness, progeroid features, and lipodystrophy syndrome (MDPL)	<i>POLD1</i> : dominant pathogenic variants, including the common de novo pathogenic variant (c.1812_1814delCTC. P.Ser605del) observed in 80% of the patients	Early childhood	Mandibular hypoplasia, prominent loss of subcutaneous fat, progeroid appearance, skin abnormalities, metabolic abnormalities including insulin resistance and diabetes mellitus, sensorineural deafness, hypogonadism in males
Mandibuloacral dysplasia associated with <i>MTX2</i> (MADaM)	<i>MTX2</i> : recessive pathogenic variants	Early childhood	Small viscerocranium with mandibular underdevelopment, growth restriction, lipodystrophy, altered skin pigmentation, distal acroosteolyses, renal focal glomerulosclerosis, severe cardiovascular disease
Atypical progeroid laminopathies	<i>LMNA</i> and <i>ZMPSTE24</i>	Variable from early life to adulthood	Several <i>LMNA</i> pathogenic variants, including dominant and recessive ones, result in a spectrum of progeroid laminopathies ranging in severity from severe RD-like forms to adult-onset atypical WS; atypical (severe) MADB forms can result from recessive <i>ZMPSTE24</i> pathogenic variants
Werner syndrome (WS)	<i>WRN</i> : recessive pathogenic variants	Adulthood	Lack of the pubertal growth spurt during early teen years, graying or loss of hair, scleroderma-like skin lesions, characteristic facies, bilateral cataracts, type 2 diabetes mellitus, hypogonadism, skin ulcers, osteoporosis, arteriosclerosis, increased risk of cancer
Wiedemann-Rautenstrauch syndrome	<i>POLR3A</i>	Neonatal	Severe prenatal and postnatal growth restriction, facial dysmorphism, generalized lipodystrophy with local fatty tissue accumulations
Cockayne syndrome	<i>CSA</i> ( <i>ERCC8</i> ) <i>CSB</i> ( <i>ERCC6</i> )	Neonatal/ infancy	Skin and dental abnormalities, subcutaneous fat loss, short stature, vasculopathy, hypogonadism, hearing loss, cataracts, intellectual disability, neurologic disorders
Rothmund-Thompson syndrome	<i>RECQL4</i>	Infancy	Diffuse hair loss, skin and dental abnormalities, short stature, osteopenia, hypogonadism, hyperkeratosis, cataracts, tumor predisposition

Adapted from Coppedè F. Mutations involved in premature-ageing syndromes. *Appl Clin Genet*. 2021;14:279–295.

treatments and a cure. Additional resources include the National Human Genome Research Institute ([www.genome.gov/11007255/](http://www.genome.gov/11007255/)), National Center for Biotechnology Information GeneReviews ([www.ncbi.nlm.nih.gov/books/NBK1121/](http://www.ncbi.nlm.nih.gov/books/NBK1121/)), National Center for Advancing

Translational Sciences ([www.rarediseases.info.nih.gov/diseases/7467/progeria](http://www.rarediseases.info.nih.gov/diseases/7467/progeria)) and NORD ([rarediseases.org](http://rarediseases.org)).

Visit Elsevier eBooks+ at [eBooks.Health.Elsevier.com](http://eBooks.Health.Elsevier.com) for Bibliography.

## Chapter 112

## The Porphyrins

Manisha Balwani, Robert J. Desnick, and Karl E. Anderson

Porphyrias are metabolic diseases resulting from altered activities of specific enzymes of the heme biosynthetic pathway. These enzymes are most active in bone marrow and liver. **Erythropoietic porphyrias**, in which overproduction of heme pathway intermediates occurs primarily in bone marrow erythroid cells, usually present at birth or in early childhood with *cutaneous photosensitivity*, or in the case of congenital erythropoietic porphyria, even in utero as *nonimmune hydrops*. Erythropoietic protoporphyria is the most common porphyria in children. Most porphyrias are hepatic, with overproduction and initial accumulation of porphyrin precursors or porphyrins in the liver. Activation of hepatic porphyrias is very rare during childhood, reflecting the distinct hepatic regulatory mechanisms for heme biosynthesis that are influenced by pubertal development. Homozygous forms of the hepatic porphyrias may manifest clinically before puberty. Children who are heterozygous for inherited hepatic porphyrias may present with non-specific and unrelated symptoms, and parents often request advice about long-term prognosis and express concerns about drugs that may exacerbate these conditions.

## THE HEME BIOSYNTHETIC PATHWAY

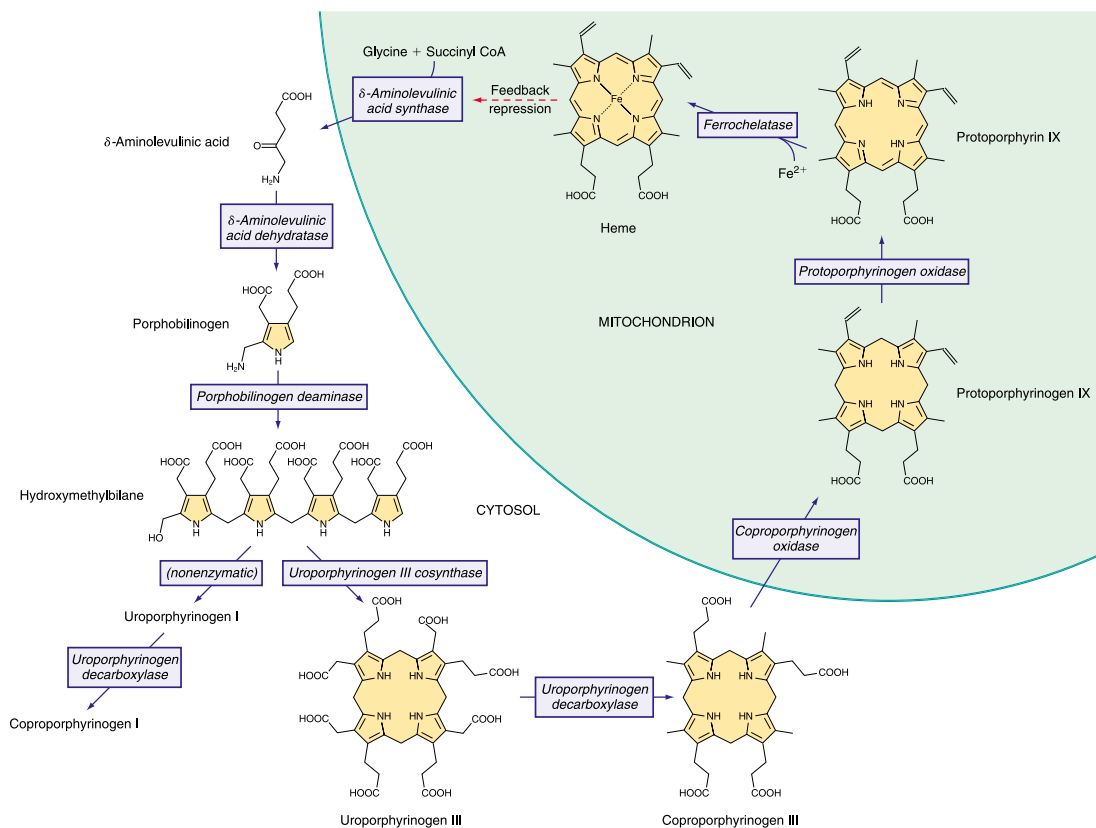
Heme is required for a variety of hemoproteins, such as hemoglobin, myoglobin, respiratory cytochromes, and cytochrome P450 enzymes (CYPs). It is believed that the eight enzymes in the pathway for heme

biosynthesis are active in all tissues. Hemoglobin synthesis in erythroid precursor cells accounts for approximately 85% of daily heme synthesis in humans. Hepatocytes account for most of the rest, primarily for synthesis of CYPs, which are especially abundant in the liver endoplasmic reticulum and turn over more rapidly than many other hemoproteins, such as the mitochondrial respiratory cytochromes. Pathway intermediates are the porphyrin precursors  $\delta$ -aminolevulinic acid (ALA, also known as 5-aminolevulinic acid) and **porphobilinogen (PBG)**, as well as porphyrins (mostly in their reduced forms, known as **porphyrinogens**) (Fig. 112.1). These intermediates do not accumulate in significant amounts or have important physiologic functions under normal conditions.

Altered activity of each enzyme in the pathway has been associated with a specific type of porphyria (Table 112.1). The first enzyme, ALA synthase (ALAS), occurs in two forms. An erythroid-specific form, ALAS2, is deficient in X-linked sideroblastic anemia as a result of pathogenic variants of the *ALAS2* gene on chromosome Xp11.2. Gain-of-function pathogenic variants of *ALAS2* caused by deletions in the last exon cause **X-linked protoporphyria (XLP)**, which is phenotypically identical to erythropoietic protoporphyria.

Regulation of heme synthesis differs in the two major heme-forming tissues. Liver heme biosynthesis is primarily controlled by the ubiquitous form of ALAS (ALAS1). Synthesis of ALAS1 in liver is regulated by a "free" heme pool (see Fig. 112.1), which can be augmented by newly synthesized heme or by existing heme released from hemoproteins and destined for breakdown to biliverdin by heme oxygenase.

In comparison, in the hematopoietic system, novel regulatory mechanisms allow the production of the very large amounts of heme needed for hemoglobin synthesis. The response to stimuli for hemoglobin synthesis occurs during cell differentiation, leading to an increase in cell number. Also, unlike the liver, heme has a stimulatory role in hemoglobin formation, and the stimulation of heme synthesis in erythroid cells is accompanied not only by increases in ALAS2 but also by sequential induction of other heme biosynthetic enzymes. Separate



**Fig. 112.1** Enzymes and intermediates of the heme biosynthetic pathway. The pathway is regulated in the liver by the end product, heme, mainly by feedback repression (dashed red arrow).



**Table 112.1** The Human Porphyrrias: Pathogenic Variants, Time of Presentation, and Tissue- and Symptom-Based Classifications

DISEASE	ENZYME	INHERITANCE	PRESENTATION	CLASSIFICATION*			
				H	E	A/N	C
X-linked protoporphyria (XLP)	δ-Aminolevulinatase synthase 2 (ALAS2)	X-linked	Childhood		X		X
δ-Aminolevulinic acid dehydratase porphyria (ADP)	δ-Aminolevulinic acid dehydratase (ALAD)	Autosomal recessive	Mostly postpuberty	X	X <sup>†</sup>	X	
Acute intermittent porphyria (AIP)	Hydroxymethylbilane synthase (HMBS)	Autosomal dominant	Postpuberty	X		X	
Homozygous AIP		Homozygous dominant	Childhood	X	X	X	
Congenital erythropoietic porphyria (CEP)	Uroporphyrinogen III synthase (UROS)	Autosomal recessive	In utero or infancy		X		X
Porphyria cutanea tarda (PCT) type 1	Uroporphyrinogen decarboxylase (UROD)	Sporadic	Adults	X			X
PCT type 2 <sup>†</sup>		Autosomal dominant	Adults	X			X
PCT type 3		Unknown	Adults	X			X
Hepatoerythropoietic porphyria (HEP)		Homozygous dominant	Childhood	X	X <sup>†</sup>		X
Hereditary coproporphyria (HCP)	Coproporphyrinogen oxidase (CPOX)	Autosomal dominant	Postpuberty	X		X	X
Homozygous HCP		Homozygous dominant	Childhood	X	X	X	X
Variagate porphyria (VP)	Protoporphyrinogen oxidase (PPOX)	Autosomal dominant	Postpuberty	X		X	X
Homozygous VP		Homozygous dominant	Childhood	X	X	X	X
Erythropoietic protoporphyria (EPP)	Ferrochelatase (FECH)	Autosomal recessive (most commonly heteroallelic with hypomorphic allele)	Childhood		X		X

\*Classification abbreviations: H, Hepatic; E, Erythropoietic; A/N, Acute/Neurologic; C, Cutaneous.

<sup>†</sup>PCT is a result of inhibition of hepatic UROD. Autosomal dominant inheritance of a partial deficiency of UROD is a predisposing factor in cases defined as familial (type 2) PCT. Other genetic factors, such as HFE pathogenic variants, are sometimes found in all types of PCT.

<sup>‡</sup>ADP and HEP are considered primarily hepatic porphyrias, but substantial increases in erythrocyte zinc protoporphyrin suggest an erythropoietic component.

erythroid-specific and nonerythroid, or “housekeeping,” transcripts are known for the first four enzymes in the pathway. The separate forms of ALAS are encoded by genes on different chromosomes, but for each of the other three, erythroid and nonerythroid transcripts are transcribed by alternative promoters in the same gene. Heme also regulates the rate of its synthesis in erythroid cells by controlling the transport of iron into reticulocytes.

Intermediates of the heme biosynthetic pathway are efficiently converted to heme and, normally, only small amounts of the intermediates are excreted. Some may undergo chemical modifications before excretion. Whereas the porphyrin precursors ALA and PBG are colorless, nonfluorescent, and largely excreted unchanged in urine, PBG may degrade to colored products such as the brownish pigment called *porphobilin* or spontaneously polymerize to uroporphyrins. Porphyrins are red in color and display bright-red fluorescence when exposed to long-wavelength ultraviolet (UV) light. Porphyrinogens are the reduced form of porphyrins and are colorless and nonfluorescent, but are readily autoxidized to the corresponding porphyrins when they accumulate or are outside the cell. Only the type III isomers of uroporphyrinogen and coproporphyrinogen are converted to heme (see Fig. 112.1).

ALA and PBG are excreted in urine. Excretion of porphyrins and porphyrinogens in urine or bile is determined by the number of carboxyl groups. Those with many carboxyl groups, such as *uroporphyrin* (octacarboxyl porphyrin) and *heptacarboxyl porphyrin*, are water soluble and readily excreted in urine. Those with fewer carboxyl groups, such as *protoporphyrin* (dicarboxyl porphyrin), are not water soluble and are excreted in bile and feces. *Coproporphyrin* (tetracarboxyl

porphyrin) is excreted partly in urine and partly in bile. Because coproporphyrin I is more readily excreted in bile than coproporphyrin III, impaired hepatobiliary function may increase total urinary coproporphyrin excretion and the ratio of these isomers.

## CLASSIFICATION AND DIAGNOSIS OF PORPHYRIAS

Two useful classification schemes reflect either the underlying pathophysiology or the clinical features of porphyrias (see Table 112.1). In **hepatic porphyrias** and **erythropoietic porphyrias** the source of excess production of porphyrin precursors and porphyrins is the liver and bone marrow, respectively. **Acute porphyrias** cause neurologic symptoms that are associated with increases of one or both of the porphyrin precursors, ALA and PBG. In the **cutaneous porphyrias**, photosensitivity results from transport of porphyrins in blood from the liver or bone marrow to the skin. **Dual porphyria** refers to the very rare cases of porphyria with deficiencies of two different heme pathway enzymes.

**Porphyria cutanea tarda (PCT), acute intermittent porphyria (AIP), and erythropoietic protoporphyria (EPP)** are the three most common porphyrias, in that order, considering all age-groups, and are very different in clinical presentation, precipitating factors, methods of diagnosis, and effective therapy (Table 112.2). Two less common acute porphyrias, **hereditary coproporphyria (HCP) and variagate porphyria (VP)**, can also cause blistering photosensitivity (see Table 112.1). **Congenital erythropoietic porphyria (CEP)** causes more severe blistering lesions, often with secondary infection and mutilation. EPP and **X-linked protoporphyria (XLP)** have the same phenotype and are distinct from the other cutaneous porphyrias in causing

**Table 112.2** The Three Most Common Human Porphyrrias and Major Features

	PRESENTING SYMPTOMS	EXACERBATING FACTORS	MOST IMPORTANT SCREENING TESTS	TREATMENT
Acute intermittent porphyria	Neurologic, adult onset	Drugs (mostly P450 inducers), progesterone, dietary restriction	Urinary porphobilinogen	Hemin, glucose, givosiran
Porphyria cutanea tarda	Skin blistering and fragility (chronic), adult onset	Iron, alcohol, smoking, estrogens, hepatitis C, HIV, halogenated hydrocarbons	Plasma or urine porphyrins	Phlebotomy, low-dose hydroxychloroquine, direct acting antivirals (if hepatitis C is present)
Erythropoietic protoporphyria	Phototoxic pain and swelling (mostly acute), childhood onset	Sunlight exposure	Total erythrocyte protoporphyrin with metal-free and zinc protoporphyrin	Sun protection

nonblistering photosensitivity that occurs acutely after sun exposure. EPP is also the most common porphyria to become manifest before puberty.

### First-Line Laboratory Diagnostic Testing

A few sensitive and specific first-line laboratory tests should be obtained whenever symptoms or signs suggest the diagnosis of porphyria. If a first-line or screening test is significantly abnormal, more comprehensive testing should follow to establish the type of porphyria. Overuse of laboratory tests for screening can lead to unnecessary expense and even delay in diagnosis. In patients who present with a past diagnosis of porphyria, laboratory reports that were the basis for the original diagnosis must be reviewed, and if these were inadequate, further testing considered.

Acute porphyria should be suspected in patients with neurovisceral symptoms such as abdominal pain after puberty, when initial clinical evaluation does not suggest another cause. *Urinary PBG* should be measured. Urinary PBG is virtually always increased during acute attacks of AIP, HCP, and VP and is not substantially increased in any other medical conditions. Therefore this measurement is both sensitive and specific. Results from spot (single-void) urine specimens are highly informative because very substantial increases are expected during acute attacks of porphyria. A 24-hour collection can unnecessarily delay diagnosis. The same spot urine specimen should be saved for quantitative determination of PBG (expressed relative to creatinine) to confirm the qualitative PBG result. ALA is often measured as well, but is usually less elevated than PBG in AIP, HCP, and VP. In **ALA dehydratase porphyria (ADP)**, urinary ALA and porphyrins, but not PBG, are greatly elevated. Measurement of urinary porphyrins in addition to PBG is recommended to screen for acute porphyrias because PBG is often less elevated and returns to normal more rapidly in HCP and VP than in AIP. Porphyrin measurement *alone* should be avoided for screening, however, because it is often increased in many disorders other than porphyrias, such as liver diseases, and misdiagnoses of porphyria can result from increases in urinary porphyrins that have no diagnostic significance.

### Blistering Cutaneous Porphyrrias

Blistering skin lesions caused by porphyria are virtually always accompanied by increases in *total plasma* and *urinary porphyrins*. Porphyrins in plasma in VP are mostly covalently linked to plasma proteins and readily detected by a diagnostic peak in a fluorescence scanning method. The normal range for plasma porphyrins is somewhat increased in patients with end-stage renal disease.

### Nonblistering Cutaneous Porphyrria

Measurement of total erythrocyte protoporphyrin and, if the total amount is elevated, fractionation of protoporphyrin into its metal-free and zinc-chelated forms, is essential for diagnosis of EPP and XLP. Unfortunately, this is not offered by some major commercial laboratories. Results of zinc protoporphyrin measurements are often recorded (even in the same report) as both *protoporphyrin* and *free erythrocyte protoporphyrin*, with each calculated differently, based on past practices for screening for lead poisoning (which only increases zinc

protoporphyrin). Thus the obsolete term *free protoporphyrin* does not mean metal-free protoporphyrin, because it was defined as iron-free protoporphyrin and dates from before it was known that (except in protoporphyrias) protoporphyrin in erythrocytes is mostly zinc chelated. This unnecessary confusion makes diagnosis and reliable exclusion of protoporphyrias difficult. Total plasma porphyrins are elevated in most, but not all, cases of protoporphyria, so a normal level should not be relied on to exclude protoporphyria when total erythrocyte protoporphyrin is elevated.

Increases in erythrocyte total and zinc-chelated protoporphyrin occur in many other conditions, including iron deficiency, lead poisoning, hemolysis, anemia of chronic disease, and other erythrocyte disorders. Therefore the diagnosis of EPP must be confirmed by showing a predominant increase in free and metal-free protoporphyrin. In XLP, both free and zinc protoporphyrin are elevated.

### Second-Line Testing

*More extensive testing is well justified when a first-line test is positive.* A substantial increase in PBG may be caused by AIP, HCP, or VP, and these can be distinguished by measuring urinary porphyrins (using the same spot urine sample), fecal porphyrins, and plasma porphyrins. The various porphyrias that cause blistering skin lesions are differentiated by measuring porphyrins in urine, feces, erythrocytes, and plasma. *Confirmation by genetic testing is important once the diagnosis is established by biochemical testing.*

### Testing for Subclinical Porphyrria

It is often difficult to diagnose or rule out porphyria in patients who had suggestive symptoms months or years in the past and in asymptomatic relatives of patients with acute porphyrias because porphyrin precursors and porphyrins may be normal. More extensive testing and consultation with a specialist laboratory and physician may be needed. Before evaluating relatives, the diagnosis of porphyria should be firmly established in an index case and the laboratory results reviewed to guide the choice of tests for the family members. Identification of a disease-causing pathogenic variant in an index case greatly facilitates detection of additional gene carriers because biochemical tests in latent carriers may be normal.

## δ-AMINOLEVULINIC ACID DEHYDRATASE-DEFICIENT PORPHYRIA

**ALA dehydratase-deficient porphyria (ADP)** is sometimes termed *Doss porphyria* after the investigator who described the first cases. The term *plumboporphyria* emphasizes the similarity of this condition to lead poisoning, but incorrectly implies that it is caused by lead exposure.

### Etiology

This porphyria results from a deficiency of ALA dehydratase (ALAD), which is inherited as an autosomal recessive trait. Only eight cases have been confirmed by pathogenic variant analysis. The prevalence of heterozygous ALAD deficiency was estimated to be <1% in Germany and approximately 2% in Sweden.

## Pathology and Pathogenesis

ALAD catalyzes the condensation of two molecules of ALA to form the pyrrole PBG (see Fig. 112.1). The enzyme is subject to inhibition by a number of exogenous and endogenous chemicals. ALAD is the principal lead-binding protein in erythrocytes, and lead can displace the zinc atoms of the enzyme. Inhibition of erythrocyte ALAD activity is a sensitive index of lead exposure.

Eleven abnormal ALAD alleles, most with point pathogenic variants, have been identified, some expressing partial activity, such that heme synthesis is partially preserved. The amount of residual enzyme activity may predict the phenotypic severity of this disease.

ADP is often classified as a hepatic porphyria, although the site of overproduction of ALA is not established. A patient with severe, early-onset disease underwent liver transplantation without significant clinical or biochemical improvement, which might suggest that the excess intermediates did not originate in the liver. Evidence suggests this disease may have an erythropoietic component. Excess urinary coproporphyrin III in ADP might originate from metabolism of ALA to porphyrinogens in a tissue other than the site of ALA overproduction. Administration of large doses of ALA to normal individuals also leads to substantial coproporphyrinuria. Increased erythrocyte zinc protoporphyrin, as in all other homozygous porphyrias, may be explained by accumulation of earlier pathway intermediates in bone marrow erythroid cells during hemoglobin synthesis, followed by their transformation to protoporphyrin after hemoglobin synthesis is complete. Neurologic symptoms are attributed to neurotoxic effects of ALA, but this is unproven.

## Clinical Manifestations

In most cases, symptoms resemble other acute porphyrias, including acute attacks of abdominal pain and peripheral neuropathy. Precipitating factors, such as exposure to harmful drugs, have not been evident in most cases. Six of the reported cases were adolescent males. A Swedish infant had more severe disease, with neurologic impairment and failure to thrive. A 63-year-old man in Belgium developed an acute motor polyneuropathy concurrently with a myeloproliferative disorder. A Dutch patient with symptom onset in infancy presented in adulthood with acute symptoms and progressive asymmetric weakness of both extremities.

## Laboratory Findings

Urinary ALA, coproporphyrin III, and erythrocyte zinc protoporphyrin are substantially increased. Urinary PBG is normal or slightly increased. Erythrocyte ALAD activity is markedly reduced, and both parents have approximately half-normal activity of this enzyme and normal urinary ALA.

## Diagnosis and Differential Diagnosis

The other three acute porphyrias are characterized by substantial increases in both ALA and PBG. In contrast, ALA, but not PBG, is substantially increased in ADP. A marked deficiency of erythrocyte ALAD and half-normal activity in the parents support the diagnosis. Other causes of ALAD deficiency, such as **lead poisoning**, must be excluded. Succinylacetone accumulates in hereditary tyrosinemia type 1 and is structurally similar to ALA, inhibits ALAD, and can cause increased urinary excretion of ALA and clinical manifestations that resemble acute porphyria. Idiopathic acquired ALAD deficiency has been reported. Unlike lead poisoning, the deficient ALAD activity in ADP is not restored by the in vitro addition of sulfhydryl reagents such as dithiothreitol. Even if no other cause of ALAD deficiency is found, it is essential to confirm the diagnosis of ADP by molecular studies.

## Treatment

Treatment experience with ADP is limited but is similar to other acute porphyrias. Glucose seems to have minimal effectiveness but may be tried for mild symptoms. **Hemin therapy** was apparently effective for acute attacks in male adolescents, and weekly infusions prevented attacks in two of these patients. Hemin was not effective either biochemically or clinically in the Swedish child with severe disease, and it

produced a biochemical response but no clinical improvement in the Belgian man with a late-onset form, who had a peripheral neuropathy but no acute attacks. Hemin is also effective in treating porphyria-like symptoms associated with hereditary tyrosinemia and can significantly reduce urinary ALA and coproporphyrin in lead poisoning. Avoidance of drugs that are harmful in other acute porphyrias is advisable. Liver transplantation was not effective in the child with severe disease. In a recent report, weekly blood transfusions and hydroxycarbamide were used in addition to heme-arginate to suppress erythroid heme synthesis.

## Prognosis

Recurrent attacks may occur and require repeated treatment with hemin. The course was unfavorable in the Swedish child with more severe disease and was uncertain in adults with late-onset disease associated with myeloproliferative disorders.

## Prevention and Genetic Counseling

Heterozygous parents should be aware that subsequent children are at risk for ADP, as in any autosomal recessive disorder. Prenatal diagnosis is possible but has not been reported.

## ACUTE INTERMITTENT PORPHYRIA

AIP is also termed *pyrroloporphyria*, *Swedish porphyria*, and *intermittent acute porphyria* and is the most common type of acute porphyria in most countries.

## Etiology

AIP results from the deficient activity of the housekeeping form of porphobilinogen deaminase (PBGD). This enzyme is also known as **hydroxymethylbilane (HMB) synthase** (the prior term, uroporphyrinogen I synthase, is obsolete). HMB synthase catalyzes the deamination and head-to-tail condensation of four PBG molecules to form the linear tetrapyrrole, HMB (also known as *preuroporphyrinogen*; see Fig. 112.1). A unique dipyrromethane cofactor binds the pyrrole intermediates at the catalytic site until six pyrroles (including the dipyrrole cofactor) are assembled in a linear fashion, after which the tetrapyrrole HMB is released. The apo-deaminase generates the dipyrrole cofactor to form the holodeaminase, and this occurs more readily from HMB than from PBG. Indeed, high concentrations of PBG may inhibit formation of the holodeaminase. The product HMB can cyclize nonenzymatically to form nonphysiologic uroporphyrinogen I, but in the presence of the next enzyme in the pathway is more rapidly cyclized to form uroporphyrinogen III.

Erythroid and housekeeping forms of the enzyme are encoded by a single gene. The two isoenzymes are both monomeric proteins, differ only slightly in molecular weight (approximately 40 and 42 kDa), and result from alternative splicing of two distinct messenger RNA (mRNA) transcripts that arise from two different promoters. The housekeeping promoter functions in all cell types, including erythroid cells.

The pattern of inheritance of AIP is autosomal dominant, with very rare homozygous cases that present in childhood. More than 400 *HMBS* pathogenic variants, including missense, nonsense, and splicing pathogenic variants, and insertions and deletions have been identified in AIP and in many population groups. Most pathogenic variants are found in only one or a few families. Because of founder effects, some are more common in certain geographic areas, such as northern Sweden (W198X), Holland (R116W), Argentina (G116R), Nova Scotia (R173W), and Switzerland (W283X). De novo pathogenic variants may be found in approximately 3% of cases. The nature of the *HMBS* pathogenic variant does not account for the severity of the clinical presentation, which varies greatly within families. **Chester porphyria** was initially described as a variant form of acute porphyria in a large English family but was found to be caused by an *HMBS* pathogenic variant.

Most pathogenic variants lead to approximately half-normal activity of the housekeeping and erythroid isozymes and half-normal amounts of their respective enzyme proteins in all tissues of heterozygotes. In approximately 5% of unrelated AIP patients, the housekeeping isozyme is deficient, but the erythroid-specific isozyme is normal. Pathogenic



variants causing this are usually found within exon 1 or its 5' splice donor site or initiation of translation codon.

### Pathology and Pathogenesis

Induction of the rate-limiting hepatic enzyme ALAS1 is thought to underlie acute exacerbations of this and the other acute porphyrias. AIP remains latent (or asymptomatic) in the great majority of those who are heterozygous carriers of *HMBS* pathogenic variants, and this is almost always the case before puberty. In those with no history of acute symptoms, porphyrin precursor excretion is usually normal, suggesting that half-normal hepatic *HMBS* activity is sufficient unless hepatic ALAS1 activity is increased. Patients can also be asymptomatic with elevated levels of porphyrin precursors and are classified as *asymptomatic high excretors*. These patients may have a remote history of symptoms. Many factors that lead to clinical expression of AIP, including certain drugs and steroid hormones, have the capacity to induce hepatic ALAS1 and CYPs. When hepatic heme synthesis is increased, half-normal *HMBS* activity may become limiting, and ALA, PBG, and other heme pathway intermediates may accumulate. In addition, heme synthesis becomes impaired, and heme-mediated repression of hepatic ALAS1 is less effective.

It is not proved, however, that hepatic *HMBS* remains constant at approximately 50% of normal activity during exacerbations and remission of AIP, as in erythrocytes. An early report suggested that the enzyme activity is considerably less than half-normal in the liver during an acute attack. Hepatic *HMBS* activity might be reduced further once AIP becomes activated if, as suggested, excess PBG interferes with assembly of the dipyrromethane cofactor for this enzyme. It also seems likely that currently unknown genetic factors play a contributing role in, for example, patients who continue to have attacks even when known precipitants are avoided.

AIP is almost always latent before puberty and becomes active mostly in adult females, which suggests that endocrine factors, and especially adult levels of female steroid hormones, may be important for clinical expression. Premenstrual attacks are probably the result of endogenous progesterone. Acute porphyrias are sometimes exacerbated by exogenous steroids, including oral contraceptive preparations containing progestins. Surprisingly, pregnancy is usually well tolerated, suggesting that beneficial metabolic changes may ameliorate the effects of high levels of progesterone.

**Drugs** that are unsafe in acute porphyrias (Table 112.3) include those with the capacity to induce hepatic ALAS1, which is closely associated with induction of CYPs. Some chemicals (e.g., griseofulvin) can increase heme turnover by promoting the destruction of specific CYPs to form an inhibitor (e.g., *N*-methyl protoporphyrin) of ferrochelatase (FECH, the final enzyme in the pathway). Sulfonamide antibiotics are harmful but apparently not inducers of hepatic heme synthesis. Ethanol and other alcohols are inducers of ALAS1 and some CYPs.

**Nutritional factors**, in particular reduced intake of calories and carbohydrates, as may occur with illness or attempts to lose weight, can increase porphyrin precursor excretion and induce attacks of porphyria. Increased carbohydrate intake may ameliorate attacks. Hepatic ALAS1 is modulated by the peroxisome proliferator-activated receptor- $\gamma$  coactivator-1 $\alpha$ , which is an important link between nutritional status and exacerbations of acute porphyria.

Other factors have been implicated. Chemicals in cigarette smoke, such as polycyclic aromatic hydrocarbons, can induce hepatic CYPs and heme synthesis. A survey of AIP patients found an association between smoking and repeated porphyric attacks. Attacks may result from metabolic stress and impaired nutrition associated with major illness, infection, or surgery. Clinical observations suggest an additive effect of multiple predisposing factors, including drugs, endogenous hormones, nutritional factors, and smoking.

### Neurologic Mechanisms

The mechanism of neural damage in acute porphyrias is poorly understood. The most favored hypothesis at present is that one or more heme precursors, or perhaps a derivative, are neurotoxic. Increased ALA in AIP, HCP, VP, ADP, plumbism, and hereditary tyrosinemia type 1,

which have similar neurologic manifestations, suggests that this substance or a derivative may be neuropathic. Porphyrins derived from ALA after its uptake into cells may have toxic potential. ALA can also interact with  $\gamma$ -aminobutyric acid (GABA) receptors. Severe AIP greatly improves after allogeneic liver transplantation. This experience and the demonstration that recipients of AIP livers develop porphyria support the hypothesis that heme precursors from the liver cause the neurologic manifestations.

### Epidemiology

AIP occurs in all ethnic groups and is the most common acute porphyria, with an estimated prevalence in most countries of 5 in 100,000. In Sweden, prevalence was estimated to be 7.7 in 100,000, including latent cases with normal porphyrin precursors. A much higher prevalence of 60-100 in 100,000 in northern Sweden is the result of a founder effect. The combined prevalence of AIP and VP in Finland is approximately 3.4 in 100,000. Population screening by erythrocyte *HMBS* activity or DNA analysis revealed a prevalence of 200 heterozygotes per 100,000 people in Finland and 1 in approximately 1,675 (60 in 100,000) in France. Studies using exomic/genomic databases show that the estimated frequency of pathogenic variants in the *HMBS* gene is 0.00056 (56 in 100,000), suggesting that the penetrance of this disorder may be as low as 1% and that carriers of *HMBS* pathogenic variants that can cause AIP are much more common than previously believed. Higher penetrance in some families with AIP suggests a strong role of environmental factors and genetic modifiers.

### Clinical Manifestations

Neurovisceral manifestations of acute porphyrias may appear any time after puberty, but rarely before it (Table 112.4). Porphyria attacks are exceedingly rare before the onset of puberty. Affected children are more often males as opposed to affected adolescents and adults, who are predominantly females. Reported symptomatic childhood cases often lacked adequate biochemical and molecular confirmation. The prepubertal attacks in males may be explained in part by coexisting medical conditions with the potential to upregulate ALAS1. Abdominal pain was the most common presenting symptom in such cases, but seizures, often preceding the diagnosis, were also common. Other manifestations reported in children include tachycardia, peripheral neuropathy, myalgias, hypertension, irritability, lethargy, and behavioral abnormalities. A population-based study in Sweden indicated that symptoms suggestive of porphyria may occur in heterozygotes during childhood, even, in contrast to adults, when urinary porphyria precursors are not elevated. This study did not compare the frequency of such nonspecific symptoms in a control group of children. Very rare cases of homozygous AIP present differently, with severe neurologic manifestations early in childhood.

Acute attacks in adults are characterized by a constellation of nonspecific symptoms, which may become severe and life threatening. **Abdominal pain** occurs in 85-95% of AIP patients and is usually severe, steady, and poorly localized, but is sometimes cramping, and accompanied by signs of ileus, including abdominal distention and decreased bowel sounds. Nausea, vomiting, and constipation are common, but increased bowel sounds and diarrhea may occur. Bladder dysfunction may cause hesitancy and dysuria. **Tachycardia**, the most common physical sign, occurs in up to 80% of attacks. This is often accompanied by **hypertension**, restlessness, coarse or fine tremors, and excess sweating, which are attributed to sympathetic overactivity and increased catecholamines. Other common manifestations include mental symptoms; pain in the extremities, head, neck, or chest; muscle weakness; and sensory loss. Because all these manifestations are neurologic rather than inflammatory, there is little or no abdominal tenderness, fever, or leukocytosis.

**Porphyric neuropathy** is primarily motor and appears to result from axonal degeneration rather than demyelination. Sensory involvement is indicated by neuropathic pain in the extremities, which may be described as muscle or bone pain, and by numbness, paresthesias, and dysesthesias. Paresis may occur early in an attack but is more often a late manifestation in an attack that is not recognized



**Table 112.3** Drugs Regarded as Unsafe and Safe in Acute Porphyrrias

UNSAFE	SAFE
Barbiturates (all)	Narcotic analgesics
Sulfonamide antibiotics*	Aspirin
Meprobamate* (also mebutamate,* tybutamate*)	Acetaminophen (paracetamol)
Carisoprodol*	Phenothiazines
Glutethimide*	Penicillin and derivatives
Methyprylon	Streptomycin
Ethchlorvynol*	Glucocorticoids
Mephenytoin	Bromides
Phenytoin*	Insulin
Succinimides	Atropine
Carbamazepine*	Cimetidine
Clonazepam†	Ranitidine†
Primidone*	Acetazolamide
Valproic acid*	Allopurinol
Pyrazolones (aminopyrine, antipyrine)	Amiloride
Griseofulvin*	Bethanidine
Ergots	Bumetanide
Metoclopramide* ‡	Coumarins
Rifampin*	Fluoxetine
Pyrazinamide* ‡	Gabapentin
Diclofenac* ‡	Gentamicin
Fluconazole*	Guanethidine
Oral contraceptives	Ofloxacin
Progesterone and synthetic progestins*	Propranolol
Danazol*	Succinylcholine
Alcohol	Tetracycline
ACEIs (especially enalapril) ‡	
Spirolactone	
CCBs (especially nifedipine) ‡	
Ketoconazole	
Ketamine*	

\*Porphyria has been listed as a contraindication, warning, precaution, or adverse effect in U.S. labeling for these drugs. Estrogens are also listed as harmful in porphyria but have been implicated as harmful in acute porphyrias, mostly based only on experience with estrogen-progestin combinations. Although estrogens can exacerbate porphyria cutanea tarda, there is little evidence they are harmful in the acute porphyrias.

†Porphyria has been listed as a precaution in U.S. labeling for this drug. However, this drug is regarded as safe by other sources.

‡These drugs have been classified as probably safe by some sources, but this is controversial, and they should be avoided.

This partial listing does not include all available information about drug safety in acute porphyrias. Other sources should be consulted for drugs not listed here.

ACEIs, Angiotensin-converting enzyme inhibitors; CCBs, calcium channel blockers.

and adequately treated. Rarely, severe neuropathy develops when there is little or no abdominal pain. Motor weakness most commonly begins in the proximal muscles of the upper extremities and then progresses to the lower extremities and the periphery. It is usually symmetric, but occasionally asymmetric or focal. Initially, tendon reflexes may be little affected or hyperactive and become decreased or absent. Cranial nerves, most often X and VII, may be affected, and blindness from involvement of the optic nerves or occipital lobes has been reported. More common central nervous system (CNS) manifestations include seizures, anxiety, insomnia, depression, disorientation, hallucinations, and paranoia. Seizures may result from hyponatremia, porphyria itself, or an unrelated cause. Chronic depression and other mental symptoms occur in some patients, but attribution to porphyria is often difficult.

**Hyponatremia** is common during acute attacks. Inappropriate antidiuretic hormone (ADH) secretion is often the most likely

mechanism, but salt depletion from excess renal sodium loss, gastrointestinal (GI) loss, and poor intake have been suggested as causes of hyponatremia in some patients. Unexplained reductions in total blood and red blood cell volumes are sometimes found, and increased ADH secretion might then be an appropriate physiologic response. Other electrolyte abnormalities may include hypomagnesemia and hypercalcemia.

The attack usually resolves within several days unless treatment is delayed. Abdominal pain may resolve within a few hours and paresis within a few days. Even severe motor neuropathy can improve over months or several years but may leave some residual weakness. Progression of neuropathy to respiratory paralysis and death seldom occurs with appropriate treatment and removal of harmful drugs. Sudden death may result from cardiac arrhythmia.

### Laboratory Findings

Levels of ALA and PBG are substantially increased during acute attacks. These levels may decrease after an attack but usually remain increased unless the disease becomes asymptomatic for a prolonged period.

Porphyrias are also markedly increased, which accounts for reddish urine in AIP. These are predominantly uroporphyrins, which can form nonenzymatically from PBG. The increased urinary porphyrins in AIP are predominantly isomer III; however, their formation is likely to be largely enzymatic, which might occur if excess ALA produced in the liver enters cells in other tissues and is then converted to porphyrins by the heme biosynthetic pathway. Porphobilin, a degradation product of PBG, and dipyrromethanes appear to account for brownish urinary discoloration. Total fecal porphyrins and plasma porphyrins are normal or slightly increased in AIP. Erythrocyte protoporphyrin may be somewhat increased in patients with manifest AIP.

Erythrocyte HMBS activity is approximately half-normal in most patients with AIP. The normal range is wide and overlaps with the range for AIP heterozygotes. Some HMBS pathogenic variants cause the enzyme to be deficient only in nonerythroid tissues. HMBS activity is also highly dependent on erythrocyte age, and an increase in erythropoiesis from concurrent illness in an AIP patient may raise the activity into the normal range. Thus measurement of erythrocyte HMBS activity alone is insufficient in testing for AIP.

### Diagnosis and Differential Diagnosis

An increased urinary PBG level establishes that a patient has one of the three most common acute porphyrias (see Table 112.2). Measuring PBG in serum is preferred when there is coexistent severe renal disease but is less sensitive when renal function is normal. Measurement of urinary ALA is less sensitive than PBG and also less specific, but will detect ADP, the fourth type of acute porphyria. Measurement of urinary porphyrins is also useful, because they may remain elevated after ALA and PBG return to normal and are also elevated in ADP. Decreased erythrocyte PBGD activity helps confirm the diagnosis of AIP, but is not found in all AIP patients.

Knowledge of the HMBS pathogenic variant in a family enables reliable identification of other pathogenic variant carriers. Prenatal diagnosis can be performed by amniocentesis or chorionic villus sampling (CVS) in a fetus with a known HMBS pathogenic variant in the family. Prenatal diagnosis is typically not performed because of the low penetrance of the disorder and favorable prognosis with treatment.

### Complications

AIP and other acute porphyrias are typically associated with mild abnormalities in liver function tests; some patients develop chronic liver disease. The risk of hepatocellular carcinoma is also increased, perhaps 60- to 70-fold after age 50, even in asymptomatic individuals. Few patients who developed this neoplasm had increases in serum  $\alpha$ -fetoprotein. Patients with acute porphyrias, especially >50 years old, should be screened by ultrasound or an alternative imaging method at 6-month intervals.

**Table 112.4** Common Presenting Symptoms and Signs of Acute Porphyrria

SYMPTOMS AND SIGNS	FREQUENCY (%)	COMMENT
<b>GASTROINTESTINAL</b>		
Abdominal pain	85–95	Usually unremitting (for hours or longer) and poorly localized but can be cramping.
Vomiting	43–88	Neurologic in origin and rarely accompanied by peritoneal signs, fever, or leukocytosis.
Constipation	48–84	Nausea and vomiting often accompany abdominal pain. May be accompanied by bladder paresis.
Diarrhea	5–12	
<b>NEUROLOGIC</b>		
Pain in extremities, back	50–70	Pain may begin in the chest or back and move to the abdomen. Extremity pain from the chest, neck, or head indicates involvement of sensory nerves; objective sensory loss reported in 10–40% of cases.
Paresis	42–68	May occur early or late during a severe attack. Muscle weakness usually begins proximally rather than distally and more often in the upper than lower extremities.
Respiratory paralysis	9–20	Preceded by progressive peripheral motor neuropathy and paresis.
Mental symptoms	40–58	May range from minor behavioral changes to agitation, confusion, hallucinations, and depression.
Convulsions	10–20	A central neurologic manifestation of porphyria or caused by hyponatremia, which often results from syndrome of inappropriate antidiuretic hormone secretion or sodium depletion.
<b>CARDIOVASCULAR</b>		
Tachycardia	64–85	May warrant treatment to control rate, if symptomatic.
Systemic arterial hypertension	36–55	May require treatment during acute attacks, and sometimes becomes chronic.

From Anderson KE, Bloomer JR, Bonkovsky HL, et al. Desnick recommendations for the diagnosis and treatment of the acute porphyrias, *Ann Intern Med.* 2005;142(6):439–450.

The risk of chronic hypertension and impaired renal function is increased in these patients, most often with evidence of interstitial nephritis. A nephrotoxic effect of ALA may contribute. This may progress to severe renal failure and require renal transplantation.

Patients with recurrent attacks may develop **chronic neuropathic pain**, although this has not been well characterized. Referral to a neurologist is recommended for any patient with ongoing or residual neurologic symptoms. In addition, depression and anxiety are common in these patients.

### Treatment

#### Hemin

*Intravenous (IV) hemin is the treatment of choice for most acute attacks of porphyria.* There is a favorable biochemical and clinical response to early treatment with hemin, but less rapid clinical improvement if treatment is delayed. It is no longer recommended that therapy with hemin for a severe attack be started only after an unsuccessful trial of IV glucose for several days. Mild attacks without severe manifestations, such as paresis, seizures, hyponatremia, or pain requiring opioids, may be treated with IV glucose. After IV administration, hemin binds to hemopexin and albumin in plasma and is taken up primarily in hepatocytes, where it augments the regulatory heme pool in hepatocytes, represses the synthesis of hepatic ALAS1, and dramatically reduces porphyrin precursor overproduction.

Hemin\* is available for IV administration in the United States as *lyophilized hematin* (Panhematin, Recordati). Degradation products begin to form as soon as the lyophilized product is reconstituted with sterile water, and these can cause infusion site phlebitis and a transient anticoagulant effect. Repeated treatment can lead to loss of venous access and iron overload. Reconstitution with 30% human albumin can enhance stability and prevent these adverse effects and is recommended

especially if a peripheral vein is used for the infusion. Uncommon side effects of hemin include fever, aching, malaise, hemolysis, anaphylaxis, and circulatory collapse. Heme arginate, a more stable hemin preparation, is available in Europe and South Africa.

Hemin treatment should be instituted only after a diagnosis of acute porphyria has been initially confirmed by a marked increase in urinary PBG. When prior documentation of the diagnosis is available for review, it is not essential to confirm an increase in PBG with every recurrent attack if other causes of the symptoms are excluded clinically. The standard regimen of hemin for treatment of acute porphyric attacks is 3–4 mg/kg/day for 4 days. Lower doses have less effect on porphyrin precursor excretion and probably less clinical benefit.

Givosiran, an ALAS1-directed interfering RNA therapeutic, is effective for preventing frequent attacks in adults with acute hepatic porphyrias. Clinical trials have demonstrated rapid lowering of ALA and PBG, resulting in a reduction in attacks, chronic symptoms, and hemin utilization.

### General and Supportive Measures

Drugs that may exacerbate porphyrias (see Table 112.3) should be discontinued whenever possible, and other precipitating factors identified. Hospitalization is warranted, except for mild attacks; for treatment of severe pain, nausea, and vomiting; for administration of hemin and fluids; and for monitoring vital capacity, nutritional status, neurologic function, and electrolytes. Pain usually requires an opioid; there is low risk for addiction after recovery from the acute attack. Ondansetron or promethazine is needed for nausea and vomiting and short-acting benzodiazepines for anxiety and restlessness.  $\beta$ -Adrenergic blocking agents may be useful to control tachycardia and hypertension but may be hazardous in patients with hypovolemia and incipient cardiac failure.

### Carbohydrate Loading

The effects of carbohydrates on repressing hepatic ALAS1 and reducing porphyrin precursor excretion are weak compared with those of hemin. Therefore carbohydrate loading is recommended only for

\* Hemin is the generic name for all heme preparations used for IV administration. Hemin is also a chemical term that refers to the oxidized (ferric) form of heme (iron protoporphyrin IX) and is usually isolated as hemin chloride. In alkaline solution, the chloride is replaced by the hydroxyl ion, forming hydroxyheme, or hematin.

mild attacks (e.g., without severe nausea or vomiting, hyponatremia, seizures, paresis, or pain requiring opioids). Glucose polymer solutions by mouth are sometimes tolerated. At least 300 g of IV glucose, usually given as a 10% solution, has been recommended for adults hospitalized with attacks of porphyria. Amounts up to 500 g daily may be more effective, but large volumes may favor the development of hyponatremia.

### Other Therapies

Liver transplantation is effective in patients with severe AIP who are refractory to pharmacologic therapy. Patients can generally expect a complete biochemical and symptomatic resolution after transplantation. However, liver transplantation is a high-risk procedure and should be considered only as a last resort.

### Seizures and Other Complications

Patients who experience seizures during an acute attack, especially if caused by hyponatremia or other electrolyte imbalances, may not require prolonged treatment with anticonvulsant drugs, most of which have at least some potential for exacerbating acute porphyrias. Gabapentin, pregabalin, levetiracetam, and vigabatrin are considered safe or probably safe, and clonazepam is probably less harmful than phenytoin, barbiturates, or valproic acid.

Control of hypertension is important and may help prevent chronic renal impairment, which can progress and require renal transplantation.

### Safe and Unsafe Drugs

Patients often do well with avoidance of harmful drugs. Listings are available from the **European Porphyria Network** ([www.porphyría-europe.com](http://www.porphyría-europe.com)) and **American Porphyria Foundation** (<https://porphyriafoundation.org/drugdatabase/>), but some listings are controversial. Information regarding safety is lacking for many drugs, especially for those recently introduced.

Exogenous progestins can induce attacks of porphyria. Estrogens are seldom reported to be harmful when given alone. Synthetic steroids with an ethynyl substituent can cause a mechanism-based destruction of hepatic CYPs and should probably be avoided in patients with acute porphyria. Danazol is especially contraindicated.

### Other Situations

Major surgery can be carried out safely in patients with acute porphyria, especially if barbiturates are avoided. Halothane has been recommended as an inhalation agent and propofol and midazolam as IV induction agents.

Pregnancy is usually well tolerated, which is surprising, because levels of progesterone, a potent inducer of hepatic ALAS1, are considerably increased during pregnancy. Some females do experience continuing attacks during pregnancy. This has sometimes been attributed to reduced caloric intake or metoclopramide, a drug sometimes used to treat hyperemesis gravidarum and considered by some to be harmful in acute porphyrias.

Diabetes mellitus and other endocrine conditions are not known to precipitate attacks of porphyria. In fact, the onset of diabetes mellitus and resulting high circulating glucose levels may decrease the frequency of attacks and lower porphyrin precursor levels in AIP.

### Prognosis

In Finland, 74% of patients with AIP or VP reported that they led normal lives, and <30% had recurrent attacks during several years of follow-up. In those presenting with acute symptoms, recurrent attacks were most likely within the next 1-3 years. Moreover, only 6% of gene carriers who had never had attacks developed symptoms. The positive outlook may result from earlier detection, better treatment of acute attacks, and replacement of harmful drugs such as barbiturates and sulfonamides with safer drugs. However, some patients continue to have recurrent attacks, chronic pain, and other symptoms, even after avoiding known exacerbating factors.

### Prevention

For prevention of attacks, it is important to identify multiple inciting factors and remove as many as possible. Drugs for concurrent medical conditions should be reviewed. Because dietary factors are often unapparent, consultation with a dietitian may be useful. A well-balanced diet that is somewhat high in carbohydrate (60–70% of total calories) and sufficient to maintain weight is recommended. There is little evidence that additional dietary carbohydrate helps further in preventing attacks, and it may lead to weight gain. Patients who wish to lose excess weight should do so gradually and when they are clinically stable. Rapid weight loss after bariatric surgery may exacerbate acute porphyrias. Iron deficiency, which can be detected by a low serum ferritin level, should be corrected.

*Gonadotropin-releasing hormone* (GnRH) analogs, which reversibly suppress ovulation, can be dramatically effective for preventing frequently recurring luteal-phase attacks, but baseline and continuing gynecologic evaluation and bone mineral density measurements are important; transdermal estrogen or a bisphosphonate may be added to prevent bone loss. Hemin administered once or twice weekly can prevent frequent attacks of porphyria in some patients. Alternatively, single-dose hemin can be administered “on demand” at an outpatient infusion center to abort an attack and prevent hospitalization, if a patient can recognize early “prodromal” symptoms.

Givosiran (Givlaari, Alynlyam) an interfering RNA therapeutic that is administered subcutaneously every month, has been approved by the Food and Drug Administration (FDA) and European Medicines Agency (EMA) for prevention of acute attacks of an AHP.

### Genetic Counseling

A pathogenic variant identified in the index case can be sought in offspring at any age. Counseling should emphasize that the great majority of those who inherit an *HMBS* pathogenic variant never develop symptoms, and the prognosis of those who do is favorable. Therefore a normal, healthy life is expected, especially with avoidance of harmful drugs and other factors and prompt recognition and treatment of symptoms should they occur. Given this favorable outlook, even during pregnancy, having children is not precluded for those who have inherited a pathogenic variant, and prenatal diagnosis of acute porphyrias is less important than it is for many other inherited diseases.

## CONGENITAL ERYTHROPOIETIC PORPHYRIA

Also termed *Günther disease*, this rare disease usually presents with photosensitivity shortly after birth or in utero as nonimmune hydrops.

### Etiology

CEP is an autosomal recessive disease caused by a marked deficiency of uroporphyrinogen III synthase (UROS). Many *UROS* pathogenic variants have been identified among CEP families. Later-onset disease in adults is often less severe and likely to be associated with myeloproliferative disorders and expansion of a clone of erythroblasts that carry a *UROS* pathogenic variant.

### Pathology and Pathogenesis

*UROS*, which is extremely deficient in CEP, catalyzes inversion of pyrrole ring D of HMB and rapid cyclization of the linear tetrapyrrole to form uroporphyrinogen III. This enzyme is also termed *uroporphyrinogen III cosynthase*. The human enzyme is a monomer. The gene for the enzyme is found on chromosome 10q25.3→q26.3 and contains 10 exons. Erythroid and housekeeping transcripts are generated by alternative promoters but encode the same enzyme.

In CEP, HMB accumulates in erythroid cells during hemoglobin synthesis and cyclizes nonenzymatically to form uroporphyrinogen I, which is auto-oxidized to uroporphyrin I. Some of the uroporphyrinogen I that accumulates is metabolized to coproporphyrinogen I, which accumulates because it is not a substrate for coproporphyrinogen oxidase. Thus both uroporphyrin I and coproporphyrin I accumulate in the bone marrow and are then found in circulating erythrocytes, plasma, urine, and feces.



A variety of *UROS* pathogenic variants have been identified in CEP, including missense and nonsense pathogenic variants, large and small deletions and insertions, splicing defects, and intronic branch-point pathogenic variants. At least four pathogenic variants have been identified in the erythroid-specific promoter. Many patients inherited a different pathogenic variant from each parent, and most pathogenic variants have been detected in only one or a few families. An exception is a common pathogenic variant, C73R, which is at a pathogenic variant hot spot and was found in approximately 33% of alleles. One child with CEP had a *GATA1* pathogenic variant, with no *UROS* pathogenic variant. The CEP phenotype may be modulated by gain-of-function *ALAS2* pathogenic variants, which were first identified as causing XLP.

Genotype-phenotype correlations have been based on the *in vitro* expression of various CEP pathogenic variants and the severity of associated phenotypic manifestations. The C73R allele, which is associated with a severe phenotype in homozygotes or in patients heteroallelic for C73R and another pathogenic variant expressing little residual activity, resulted in <1% of normal enzyme activity. Patients with the C73R allele and heteroallelic for other pathogenic variants expressing more residual activity have milder disease.

**Hemolysis** is a common feature of CEP. Excess porphyrins in circulating erythrocytes cause cell damage, perhaps by a phototoxic mechanism, leading to both intravascular hemolysis and increased splenic clearance of erythrocytes. Also important is ineffective erythropoiesis, with intramedullary destruction of porphyrin-laden erythroid cells and breakdown of heme. Expansion of the bone marrow as a result of erythroid hyperplasia may contribute, along with vitamin D deficiency, to bone loss. Nutrient deficiencies sometimes cause erythroid hypoplasia. Despite the marked deficiency of *UROS*, heme production in the bone marrow is increased because of hemolysis and a compensatory increase in hemoglobin production. This occurs, however, at the expense of marked accumulation of HMB, which is converted to porphyrins and porphyrins.

### Clinical Manifestations

In severe cases, CEP can cause fetal loss or may be recognized in utero as causing intrauterine hemolytic anemia and nonimmune hydrops fetalis. CEP may be associated with neonatal hyperbilirubinemia, and *phototherapy may unintentionally induce severe cutaneous photosensitivity and scarring.*

The most characteristic presentation is reddish urine or pink staining of diapers by urine or meconium shortly after birth (Fig. 112.2). With sun exposure, severe blistering lesions appear on exposed areas of skin on the face and hands and have been termed *hydraea estivale* because they are more severe with greater sunlight exposure during summer (Fig. 112.3). Vesicles and bullae, as well as friability, hypertrichosis, scarring, thickening, and areas of hypopigmentation and hyperpigmentation, are very similar to those seen in PCT but usually much more severe. Infection and scarring sometimes cause loss of facial features and fingers and damage to the cornea, ears, and nails. Porphyrins are deposited in dentin and bone in utero. Reddish-brown teeth in normal light, an appearance termed **erythrodontia**, display reddish fluorescence under long-wave UV light (Fig. 112.4). Unaffected children born to a mother with CEP may have erythrodontia. Hemolysis and splenomegaly are common in CEP. Bone marrow compensation may be adequate, especially in milder cases. Patients with severe phenotypes, however, are often transfusion dependent. Splenomegaly may contribute to the anemia and cause leukopenia and thrombocytopenia, which may be complicated by significant bleeding. Neuropathic symptoms are absent, and there is no sensitivity to drugs, hormones, or carbohydrate restriction. The liver may be damaged by iron overload, viral hepatitis, or other causes.

Milder cases of CEP with onset of symptoms in adult life and without erythrodontia may be misdiagnosed initially as PCT. Late-onset cases are likely to be associated with myeloproliferative disorders and expansion of a clone of erythroid cells carrying a *UROS* pathogenic variant.



**Fig. 112.2** Congenital erythropoietic porphyria (CEP). The diaper of a baby with CEP demonstrates the red color of urine. (From Paller AS, Macini AJ. *Hurwitz Clinical Pediatric Dermatology*, 3rd ed. Philadelphia: Saunders; 2006: p. 517.)



**Fig. 112.3** Congenital erythropoietic porphyria. Vesicles, bullae, and crusts on sun-exposed areas. (From Paller AS, Macini AJ. *Hurwitz Clinical Pediatric Dermatology*, 3rd ed. Philadelphia: Saunders; 2006: p. 517.)



**Fig. 112.4** Congenital erythropoietic porphyria. Brownish teeth that fluoresce under Wood's lamp examination. (From Paller AS, Macini AJ. *Hurwitz Clinical Pediatric Dermatology*, 3rd ed. Philadelphia: Saunders; 2006: p. 517.)

### Laboratory Findings

Urinary porphyrin excretion and circulating porphyrin levels in CEP are much higher than in almost all other porphyrias. Urinary porphyrin excretion can be as high as 50-100 mg daily and consists mostly of uroporphyrin I and coproporphyrin I. ALA and PBG are normal. Fecal porphyrins are greatly increased, with a predominance of coproporphyrin I.



Marked increases in erythrocyte porphyrins in CEP also consist mostly of uroporphyrin I and coproporphyrin I. These porphyrins are also increased in bone marrow, spleen, plasma, and to a lesser extent, liver. The porphyrin pattern in erythrocytes is influenced by rates of erythropoiesis and erythroid maturation. A predominance of protoporphyrin has been noted in some CEP patients, and in one such patient, uroporphyrin and coproporphyrin increased when erythropoiesis was stimulated by blood removal.

### Diagnosis and Differential Diagnosis

The diagnosis of CEP should be documented by full characterization of porphyrin patterns and identification of the underlying pathogenic variants. In later-onset cases, an underlying myeloproliferative disorder and a *UROS* somatic pathogenic variant should be suspected and studied in detail.

The clinical picture in hepatoerythropoietic porphyria (HEP) may be similar, but the porphyrin patterns in urine and feces in HEP resemble PCT. A predominant increase in erythrocyte protoporphyrin is not expected in CEP, except in mild cases, but is characteristic of HEP and rare homozygous cases of AIP, HCP, and VP. EPP and XLP are also distinguished by normal urinary porphyrins and by increases in erythrocyte metal-free protoporphyrin, whereas the increased protoporphyrin in other conditions is mostly complexed with zinc.

CEP should be suspected as a cause of nonimmune hydrops or hemolytic anemia in utero. With recognition of the disease at this stage, intrauterine transfusion can be considered, and phototherapy for hyperbilirubinemia after birth, which can cause severe blistering and scarring, can be avoided. Prenatal diagnosis is feasible by finding red-brown discoloration and increased porphyrins in amniotic fluid and measuring porphyrins in fetal erythrocytes and plasma. *UROS* pathogenic variants can be identified in chorionic villi or cultured amniotic cells.

### Treatment

Advising patients to avoid sunlight exposure is essential, because sunlight exposure does not cause immediate severe pain in CEP, in contrast to the protoporphyrias. Minimizing skin trauma and prompt treatment of any cutaneous infections are also essential. Sunscreen lotions and beta-carotene are of little benefit. Transfusions to achieve a level of hemoglobin sufficient to significantly suppress erythropoiesis can be quite effective in reducing porphyrin levels and photosensitivity. Concurrent deferoxamine to reduce iron overload and hydroxyurea to suppress erythropoiesis further may provide additional benefit. Splenectomy reduces hemolysis and transfusion requirements in some patients. Iron restriction by phlebotomy or iron chelators may improve photosensitivity in CEP patients by decreasing *ALAS2* activity and porphyrin production.

The most effective treatment is marrow stem cell transplantation in early childhood, which has greatly reduced porphyrin levels and photosensitivity and increased long-term survival.

### Prognosis

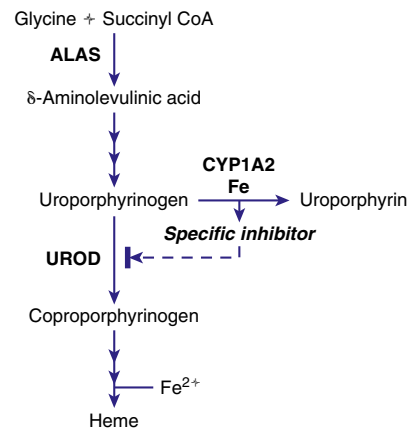
The outlook is favorable in milder cases and in patients with more severe disease, especially after successful bone marrow or stem cell transplantation. Otherwise, prognosis relates to adherence to sunlight avoidance.

### Prevention and Genetic Counseling

Genetic counseling is important for affected families because CEP can be recognized before birth, and a severe phenotype can often be predicted by identifying the nature of the *UROS* pathogenic variants.

## PORPHYRIA CUTANEA TARDA

Porphyria cutanea tarda is the most common and readily treated human porphyria (see Table 112.2). It occurs in mid or late adult life and is rare in children. Previous terms include *symptomatic porphyria*, *PCT symptomatica*, and *idiosyncratic porphyria*. The underlying cause is a liver-specific acquired deficiency of uroporphyrinogen decarboxylase (*UROD*) with contributions by genetic and acquired



**Fig. 112.5** Formation of a specific inhibitor of uroporphyrinogen decarboxylase in the liver in porphyria cutanea tarda. ALAS, δ-Aminolevulinic acid synthase; CYP1A2, cytochrome P450 1A2; UROD, uroporphyrinogen decarboxylase.

susceptibility factors, including heterozygous *UROD* pathogenic variants in familial PCT. HEP, the homozygous form of familial PCT, usually has a more severe presentation in childhood, resembling CEP clinically.

### Etiology

PCT is caused by a reduction of hepatic *UROD* activity to ≤20% of normal activity. An inhibitor of hepatic *UROD* has been characterized as a *uroporphomethene*, which is derived from partial oxidation of the enzyme substrate uroporphyrinogen. CYPs, such as CYP1A2, as well as iron, are involved in its formation (Fig. 112.5). Although enzyme activity is inhibited, the amount of hepatic enzyme protein measured immunochemically remains at its genetically determined level.

*UROD* catalyzes the decarboxylation of the four acetic acid side chains of uroporphyrinogen (an octacarboxyl porphyrinogen) to form coproporphyrinogen (a tetracarboxyl porphyrinogen). The enzyme reaction occurs in a sequential, clockwise fashion, with the intermediate formation of hepta-, hexa-, and pentacarboxyl porphyrinogens. Uroporphyrinogen III, as compared with other uroporphyrinogen isomers, is the preferred substrate. Human *UROD* is a dimer with the two active site clefts juxtaposed. The *UROD* gene contains 10 exons, with only one promoter. Therefore the gene is transcribed as a single mRNA in all tissues.

The majority of PCT patients (80%) have no *UROD* pathogenic variants and have sporadic (**type 1**) disease. Some are heterozygous for *UROD* pathogenic variants and have familial (**type 2**) PCT. Described pathogenic variants include missense, nonsense, and splice-site pathogenic variants; several small and large deletions; and small insertions, with only a few identified in more than one family. A few of these pathogenic variants may be located near the active site cleft, but most appear to involve regions with important structural roles. Being heterozygous for a *UROD* pathogenic variant is insufficient to cause PCT. Individuals with type 2 PCT are born with 50% of normal *UROD* activity, and later in life other susceptibility factors (as in type 1) lead to production of the uroporphomethene inhibitor and further reduction on hepatic *UROD* activity to <20% of normal. Because penetrance of the genetic trait is low, many patients with familial PCT have no family history of the disease.

Induction of hepatic *ALAS1* is not a prominent feature in PCT, although alcohol may increase this enzyme slightly. Iron and estrogens are not potent inducers of *ALAS1*, and drugs that are potent inducers of *ALAS1* and CYPs are much less frequently implicated in PCT than in acute porphyrias.

Blistering skin lesions result from porphyrins that circulate from the liver. Sunlight exposure leads to generation of reactive oxygen species (ROS) in the skin, complement activation, and lysosomal damage.

## Epidemiology

Differences in prevalence probably relate to geographic variations in susceptibility factors such as hepatitis C and ethanol use. The yearly incidence in the United Kingdom was estimated at 2–5 in 1 million in the general population, and the prevalence in the United States and Czechoslovakia was estimated at 1 in 25,000 and 1 in 5,000 in the general population, respectively. The disease was reported to be prevalent in the Bantus of South Africa in association with iron overload. PCT is more common in males, possibly because of greater alcohol intake, and in women it is usually associated with estrogen use.

A massive outbreak of PCT occurred in eastern Turkey in the 1950s. Wheat intended for planting and treated with hexachlorobenzene as a fungicide was consumed by many during a food shortage. Cases and small outbreaks of PCT after exposure to other chemicals, including di- and trichlorophenols and 2,3,7,8-tetrachlorodibenzo-*p*-dioxin (TCDD, dioxin), have been reported. The manifestations improved in most cases when the exposure was stopped. There are reported cases of delayed onset many years after chemical exposure.

## Pathology and Pathogenesis

Generation of a UROD inhibitor in the liver plays an important role in all three types of PCT. Eighty percent of patients with type 1 (**sporadic**) PCT have no UROD pathogenic variants, and UROD activity is normal in nonhepatic tissues such as erythrocytes. In type 2 (**familial**) PCT, a heterozygous UROD pathogenic variant results in a partial (approximately 50%) deficiency of UROD in all tissues from birth, and the disease becomes active in some heterozygotes after further reduction of hepatic UROD activity to  $\leq 20\%$  of normal. **Type 3** is rare and describes PCT without a UROD pathogenic variant occurring in more than one family member. Another genetic basis, such as *HFE* pathogenic variants, may be identified. HEP results from inheritance of a UROD pathogenic variant from each parent and typically causes severe photosensitivity resembling CEP starting in early childhood. Some developed symptoms in childhood more typical of PCT.

CYPs, especially CYP1A2, can catalyze the oxidation of uroporphyrinogen to uroporphyrin. This uroporphyrinogen oxidase activity is enhanced by iron and leads to formation of a UROD inhibitor (see Fig. 112.5). CYP1a2 seems essential for development of uroporphyrin in rodents, because experimental uroporphyrin does not develop in *CYP1a2* knockout mice.

## Susceptibility Factors

The following factors are implicated in the development of PCT, and these occur in various combinations in individual patients.

### Iron

PCT is an iron-related disorder, and a normal or increased amount of iron in the liver is essential for its development. Moreover, treatment by phlebotomy to reduce hepatic iron leads to remission. Serum ferritin levels are usually in the upper part of the normal range or moderately increased, and liver histology commonly shows increased iron staining. Prevalence of the C282Y pathogenic variant of the *HFE* gene, which is the major cause of hemochromatosis in people of Northern European ancestry, is increased in both type 1 and type 2 PCT, and approximately 10% of patients are C282Y homozygotes. In Southern Europe the H63D pathogenic variant is more prevalent. PCT may develop in patients with secondary iron overload. Reduced hepatic expression of the hormone hepcidin occurs in hemochromatosis and also in PCT, regardless of *HFE* genotype, which may explain hepatic siderosis in this condition.

### Hepatitis C

Hepatitis C virus (HCV) infection is highly prevalent in PCT in most geographic locations; in the United States, for example, HCV is present in 56–74% of cases, which is similar to rates in Southern Europe. Prevalence of hepatitis C in PCT is lower in Northern Europe (<20%). Steatosis and oxidative stress in HCV infection may favor iron-mediated generation of ROS and a UROD inhibitor. Dysregulation of hepcidin occurs in hepatitis C and may lead to increased iron absorption.

## Human Immunodeficiency Virus

Many reports suggest that HIV infection can contribute to the development of PCT, although less frequently than HCV.

### Ethanol

The long-recognized association between alcohol and PCT may be explained by the generation of ROS, which may cause oxidative damage, mitochondrial injury, depletion of reduced glutathione and other antioxidant defenses, increased production of endotoxin, and activation of Kupffer cells. Also, alcohol may contribute to iron overload by impairing hepcidin production.

## Smoking and Cytochrome P450 Enzymes

Although not extensively studied as a susceptibility factor, smoking is often associated with alcohol use in PCT. It may act to induce hepatic CYPs and oxidative stress. Hepatic CYPs are thought to be important in oxidizing uroporphyrinogen and generating a UROD inhibitor (see Fig. 112.5). Genetic polymorphisms of *CYP1A2* and *CYP1A1* have been implicated in human PCT. The frequency of an inducible *CYP1A2* genotype was more common in PCT patients than in controls in several studies.

## Antioxidant Status

**Ascorbic acid deficiency** contributes to uroporphyrin in laboratory models and perhaps in human PCT. In one series, plasma ascorbate levels were substantially reduced in 84% of patients with PCT. Low levels of serum carotenoids were also described, further suggesting that oxidant stress in hepatocytes is important in PCT.

## Estrogens

Use of estrogen-containing oral contraceptives (OCs) or postmenopausal estrogen replacement therapy is frequently associated with PCT (type 1 or 2) in women. PCT sometimes occurs during pregnancy, although it is not clear whether the risk is increased.

## Cancer Chemotherapy

Cancer chemotherapeutic agents are commonly associated with rare childhood cases of PCT, although specific agents have not been implicated. Susceptibility factors found in adults are rare in children with PCT.

## Clinical Manifestations

### Cutaneous Manifestations

PCT is readily recognized by blistering and crusted skin lesions on the backs of the hands, which are the most sun-exposed areas of the body, and less often on the forearms, face, ears, neck, legs, and feet (Fig. 112.6). The fluid-filled vesicles usually rupture and become crusted or denuded areas, heal slowly, and are subject to infection. The skin is friable, and minor trauma may cause blisters or denudation of skin. Small white plaques, termed *milia*, may precede or follow vesicle formation. Facial hypertrichosis and hyperpigmentation are also common. Severe scarring and thickening of sun-exposed skin may resemble scleroderma. Skin biopsy findings include subepidermal blistering and deposition of periodic acid–Schiff (PAS)-positive material around blood vessels and fine fibrillar material at the dermoepithelial junction, which may be related to excessive skin fragility. IgG, other immunoglobulins, and complement are also deposited at the dermoepithelial junction and around dermal blood vessels. The skin lesions and histologic changes are not specific for PCT. The same findings occur in VP and HCP and resemble those of CEP and HEP but are usually less severe. PCT usually develops in mid or late adult life. Earlier onset may be seen in those with UROD or *HFE* pathogenic variants and childhood onset with cancer chemotherapy and UROD pathogenic variants.

### Liver Abnormalities

PCT is almost always associated with nonspecific liver abnormalities, especially increased serum transaminases and  $\gamma$ -glutamyltranspeptidase, even in the absence of heavy alcohol intake or hepatitis C. Most histologic findings, such as necrosis, inflammation,



**Fig. 112.6** Porphyrria cutanea tarda (PCT). A, Right hand of a patient with PCT, revealing numerous erosions and erythematous patches. B, Close-up of right hand. (From Horner ME, Alikhan A, Tintle S, et al. Cutaneous porphyrias. Part 1. Epidemiology, pathogenesis, presentation, diagnosis, and histopathology. *Int J Dermatol.* 2013;52:1464–1480, Fig. 2.)

increased iron, and increased fat, are nonspecific. Specific findings include red fluorescence of liver tissue and fluorescent, birefringent, needle-like inclusions presumably consisting of porphyrins. Electron microscopy shows these inclusions are in lysosomes, and paracrystalline inclusions are found in mitochondria. Distorted lobular architecture and cirrhosis are more common with long-standing disease.

The risk of developing hepatocellular carcinoma is increased, with reported incidences ranging from 4% to 47% in PCT. These tumors seldom contain large amounts of porphyrins.

### Other Features and Associations

Mild or moderate erythrocytosis in some adult patients is not well understood, but chronic lung disease from smoking may contribute. An earlier onset of symptoms may be noted in patients with genetic predisposing factors, such as an inherited partial deficiency of UROD or the C282Y/C282Y *HFE* genotype. Iron overload secondary to conditions such as myelofibrosis and end-stage renal disease (ESRD) may be associated with PCT. The disease can be especially severe in patients with ESRD because the lack of urinary excretion leads to much higher concentrations of porphyrins in plasma, and the excess porphyrins are poorly dialyzable. PCT occurs more frequently in patients with systemic lupus erythematosus and other immunologic disorders than would be expected by chance.

### Laboratory Findings

Porphyrins accumulate in the liver mostly as the oxidized porphyrins rather than porphyrinogens in PCT, as indicated by the immediate red fluorescence observed in liver tissue. This develops over weeks or months before porphyrins appear in plasma and are transported to the skin, causing photosensitivity. In contrast to the acute hepatic porphyrias, only a very small increase in synthesis of heme pathway intermediates and little or no increase in hepatic ALAS1 are required to account for the excess porphyrins excreted in PCT.

Hepatic UROD deficiency leads to a complex pattern of excess porphyrins, which initially accumulate as porphyrinogens and then undergo nonenzymatic oxidation to the corresponding porphyrins (uro-, hepta-, hexa-, and pentacarboxyl porphyrins, and isocoproporphyrins). Uroporphyrin and heptacarboxyl porphyrin predominate in urine, with lesser amounts of coproporphyrin and penta- and hexacarboxyl porphyrin. A normally minor pathway is accentuated by UROD deficiency, whereby pentacarboxyl porphyrinogen is oxidized by coproporphyrinogen oxidase (CPOX; the next enzyme in the pathway), forming isocoproporphyrinogen, an atypical tetracarboxyl porphyrinogen. Relative to normal values, urinary porphyrins are increased

to a greater extent than fecal porphyrins. However, the total amount of porphyrins excreted in feces in PCT exceeds that in urine, and total excretion of type III isomers (including isocoproporphyrins, which are mostly derived from the type III series) exceeds that of type I isomers. Perhaps because uroporphyrinogen III is the preferred substrate for UROD, more uroporphyrinogen I than III accumulates and is excreted as uroporphyrin I in PCT. Hepta- and hexacarboxyl porphyrin are mostly isomer III, and pentacarboxyl porphyrin and coproporphyrin are approximately equal mixtures of isomers I and III.

### Diagnosis and Differential Diagnosis

Plasma and urine porphyrins are always increased in clinically manifest PCT, and their measurement is useful for screening. A normal value rules out PCT and other porphyrias that produce blistering skin lesions. It is useful to determine the plasma fluorescence emission maximum at neutral pH, because a maximum near 619 nm is characteristic of PCT (as with CEP and HCP) and, importantly, excludes VP, which has a distinctly different fluorescence maximum. Increased urinary or plasma porphyrins, with a predominance of uroporphyrin and heptacarboxyl porphyrin, is characteristic, although not absolutely specific, for PCT and may occasionally be seen in other porphyrias. Nonspecific increases in urine porphyrins, especially of coproporphyrin, occur in liver disease and other medical conditions. Urinary ALA may be increased slightly in PCT, and PBG is normal. Mild cases of CEP can mimic PCT clinically, and this possibility is ruled out by finding normal or only mildly increased levels of erythrocyte porphyrins.

Familial (type 2) can be distinguished from sporadic (type 1) PCT by finding decreased erythrocyte UROD activity (in type 2) or, more reliably, by finding a disease-related *UROD* pathogenic variant. Type 3 is distinguished from type 1 only by occurrence of PCT in a relative. Biochemical findings in HEP are similar to those in PCT, but with an additional marked increase in erythrocyte zinc protoporphyrin.

**Pseudoporphyria** (also known as *pseudo-PCT*) presents with skin lesions that closely resemble PCT, but without significant increases in plasma or urine porphyrins. A photosensitizing agent such as a nonsteroidal antiinflammatory drug (NSAID) is sometimes implicated. Both PCT and pseudoporphyria may occur in patients with ESRD.

### Complications

Cutaneous blisters may rupture and become infected, sometimes leading to cellulitis. In more severe disease in patients with ESRD, repeated infections can be mutilating, as in CEP. **Pseudoscleroderma**, with scarring, contraction, and calcification of skin and subcutaneous tissue, is a rare complication. Other complications include advanced liver disease and hepatocellular carcinoma.

### Treatment

Two specific and effective forms of treatment, phlebotomy and low-dose hydroxychloroquine, are available. Susceptibility factors should be removed when possible. The diagnosis of PCT must be firmly established because conditions, including other porphyrias, that produce identical cutaneous lesions do not respond to these treatments. Treatment can usually be started after demonstrating an increase in plasma total porphyrins and excluding VP by analysis of the fluorescence spectrum at neutral pH, while urine and fecal studies are still pending. Use of alcohol, estrogens (in women), and smoking should be stopped, and patients tested for HCV, HIV, and *HFE* pathogenic variants. Susceptibility factors and degree of iron overload, as assessed by the serum ferritin concentration, can influence the choice of treatment.

Phlebotomy is considered standard therapy and is effective in both children and adults with PCT because it reduces hepatic iron content. Treatment is guided by plasma (or serum) ferritin and porphyrin levels. Hemoglobin or hematocrit levels should be followed to prevent symptomatic anemia. For adults, a unit of blood (450 mL) is removed at about 2-week intervals until a target serum ferritin near the lower limit of normal (15 ng/mL) is achieved. A total of six to eight phlebotomies is often sufficient in adults. After this, plasma porphyrin



concentrations continue to fall from pretreatment levels (generally 10–25 µg/dL) to below the upper limit of normal (1 µg/dL), usually after several more weeks. This is followed by gradual clearing of skin lesions, sometimes including pseudoscleroderma. Liver function abnormalities may improve, and hepatic siderosis, needle-like inclusions, and red fluorescence of liver tissue will disappear. Although remission usually persists even if ferritin levels later return to normal, it is advisable to follow porphyrin levels and reinstitute phlebotomies if porphyrins begin to increase. Infusions of deferoxamine, an iron chelator, may be used when phlebotomy is contraindicated.

An alternative when phlebotomy is contraindicated or poorly tolerated is a low-dose regimen of hydroxychloroquine (or chloroquine). Normal doses of these 4-aminoquinoline antimalarials in PCT increase plasma and urinary porphyrin levels and increase photosensitivity, reflecting an outpouring of porphyrins from the liver. This is accompanied by acute hepatocellular damage, with fever, malaise, nausea, and increased serum transaminases, but is followed by complete remission of the porphyria. These adverse consequences of normal doses are largely avoided by a low-dose regimen (for adults, hydroxychloroquine 100 mg or chloroquine 125 mg, i.e., half a normal tablet, twice weekly), which can be continued until plasma or urine porphyrins are normalized. In young children, half the adult dose is recommended. There is at least some risk of retinopathy, which may be lower with hydroxychloroquine. The mechanism of action of 4-aminoquinolines in PCT is not known but is quite specific, because these drugs are not useful in other porphyrias. Recent studies indicate that low-dose hydroxychloroquine is as safe and effective as phlebotomy in adults with PCT.

Experience to date supports treatment of patients with PCT and hepatitis C with direct-acting antiviral agents to achieve cure of this viral infection within a few months as well as remission of PCT and avoiding treatment by phlebotomy or low-dose hydroxychloroquine.

PCT in patients with ESRD is often more severe and difficult to treat. However, erythropoietin administration can correct anemia, mobilize iron, and support phlebotomy in many cases. Improvement is expected after renal transplantation, related in part to resumption of endogenous erythropoietic production.

Liver imaging and a serum  $\alpha$ -fetoprotein determination may be advisable in all PCT patients with cirrhosis or advanced fibrosis at 6-month intervals for early detection of hepatocellular carcinoma. Finding low-erythrocyte UROD activity or a UROD pathogenic variant identifies those with an underlying genetic predisposition, which does not alter treatment but is useful for genetic counseling.

### Prognosis

Porphyria cutanea tarda is the most readily treated form of porphyria, and complete remission is expected with treatment by phlebotomy or low-dose hydroxychloroquine or by treatment of hepatitis C. There is little information on rates of recurrence and long-term outlook. Risk for cirrhosis and hepatocellular carcinoma is increased, and some susceptibility factors such as alcohol, hepatitis C, and iron overload can contribute to such risks.

### Prevention and Genetic Counseling

A heritable UROD pathogenic variant can usually be detected or excluded by measuring erythrocyte UROD activity, although DNA studies are more sensitive. Relatives of patients with UROD pathogenic variants have an increased risk for developing PCT and may have increased motivation to avoid adverse behaviors such as ethanol and tobacco use and exposures to HCV and HIV (although such counseling would be given to anyone). The finding of HFE pathogenic variants, and especially C282Y, should prompt screening of relatives, some of whom may be C282Y homozygotes and warrant lifelong monitoring of serum ferritin.

### HEPATOERYTHROPOIETIC PORPHYRIA

HEP is the homozygous form of familial (type 2) PCT; it resembles CEP clinically. Excess porphyrins originate mostly from liver, with a pattern consistent with severe UROD deficiency.

### Etiology

HEP is an autosomal recessive disorder, and most patients have inherited different pathogenic variants from unrelated parents. In contrast to most pathogenic variants in familial PCT, most causing HEP are associated with expression of some residual enzyme activity. At least one genotype is associated with the predominant excretion of pentacarboxyl porphyrin.

### Pathology and Pathogenesis

Excess porphyrins originate primarily from the liver in HEP, although the substantial increase in erythrocyte zinc protoporphyrin indicates that the heme biosynthetic pathway is also impaired in bone marrow erythroid cells. Apparently, porphyrinogens accumulate in the marrow while hemoglobin synthesis is most active and are metabolized to protoporphyrin after hemoglobin synthesis is complete. The cutaneous lesions are a result of photoactivation of porphyrins in skin, as in other cutaneous porphyrias.

### Clinical Manifestations

This disease usually presents with blistering skin lesions, hypertrichosis, scarring, and red urine in infancy or childhood. *Sclerodermoid* skin changes are sometimes prominent. Unusually mild cases have been described. Concurrent conditions that affect liver function can alter disease severity; the disease manifested because of hepatitis A in a 2-year-old child and then improved with recovery of liver function.

### Laboratory Findings

Biochemical findings resemble those in PCT, with accumulation and excretion of uroporphyrin, heptacarboxyl porphyrin, and isocoproporphyrin. In addition, erythrocyte zinc protoporphyrin is substantially increased.

### Diagnosis and Differential Diagnosis

HEP is distinguished from CEP by increases in both uroporphyrin and heptacarboxyl porphyrin and isocoproporphyrins. In CEP, the excess erythrocyte porphyrins are predominantly uroporphyrin I and coproporphyrin I rather than protoporphyrin. Blistering skin lesions are unusual in EPP, the excess erythrocyte protoporphyrin in that disease is metal-free and not complexed with zinc, and urinary porphyrins are normal.

### Treatment and Prognosis

Avoiding sunlight exposure is most important in managing HEP, as in CEP. Oral charcoal was helpful in a severe case associated with dyserythropoiesis. Phlebotomy has shown little or no benefit. The outlook depends on the severity of the enzyme deficiency and may be favorable if sunlight can be avoided.

### Prevention and Genetic Counseling

As part of genetic counseling in affected families, it is feasible to diagnose HEP in utero, either by analysis of porphyrins in amniotic fluid or DNA studies.

### HEREDITARY COPROPORPHYRIA

This autosomal dominant hepatic porphyria is caused by a deficiency of CPOX. The disease presents with acute attacks, as in AIP. Cutaneous photosensitivity may occur, but much less often than in VP. Rare homozygous cases present in childhood, including a variant form known as *harderoporphyria*.

### Etiology

A partial (50%) deficiency in CPOX activity has been found in all cells studied from patients with HCP. A much more profound deficiency is found in homozygous cases. Human CPOX is a homodimer composed of 39-kDa subunits and contains no metals or prosthetic groups. The enzyme requires molecular oxygen and is localized in the mitochondrial intermembrane space. A single active site on the enzyme catalyzes the oxidative decarboxylation of two of the four propionic acid groups of coproporphyrinogen III to form the two vinyl groups at positions



two and four, on rings A and B, respectively, of protoporphyrinogen IX. Most of the intermediate tricarboxyl porphyrinogen, termed *harderoporphyriogen*, is not released before undergoing the second decarboxylation to protoporphyrinogen IX. Coproporphyrinogen I is not a substrate for this enzyme.

The human *CPOX* gene contains a single promoter with elements for both housekeeping and erythroid-specific expression. A variety of *CPOX* pathogenic variants have been described in HCP, with a predominance of missense pathogenic variants and no genotype-phenotype correlations. **Harderoporphyria**, an autosomal recessive biochemical variant form of HCP, is caused by *CPOX* pathogenic variants that impair substrate binding, leading to premature release of harderoporphyriogen.

### Epidemiology

HCP is less common than AIP and VP, but its prevalence has not been carefully estimated. Homozygous HCP is rare and presents during childhood. Harderoporphyria, a biochemically distinguishable variant of HCP, has been recognized in heteroallelic and homoallelic forms.

### Pathology and Pathogenesis

Increased ALA and PBG during acute attacks of HCP may be explained by induction of *ALAS1* and by the normally relatively low activity of *PBGD* in the liver. Hepatic *ALAS1* is increased during acute attacks but is normal when the disease is latent and porphyrin precursor excretion is normal. Because coproporphyrinogen III concentration in the liver is probably less than the  $K_m$  for *CPOX*, the reaction rate is likely to be determined in part by substrate concentration. The substrate coproporphyrinogen appears to be lost more readily from the liver cell than, for example, uroporphyrinogen, especially when heme synthesis is stimulated. Coproporphyrin and coproporphyrinogen are both transported into bile and excreted in urine and do not appear to accumulate in the liver in HCP.

### Clinical Manifestations

Symptoms are identical to those of AIP except that attacks are generally milder, and cutaneous lesions that resemble those in PCT develop occasionally. *Severe motor neuropathy and respiratory paralysis can occur*. HCP is almost always latent before puberty, and symptoms are most common in adult women. Attacks are precipitated by the same factors that cause attacks in AIP, including fasting, OCs, and hormone increases during the luteal phase of the menstrual cycle. Concomitant liver diseases may increase porphyrin retention and photosensitivity. The risk of hepatocellular carcinoma is increased.

The clinical features of homozygous HCP or harderoporphyria begin in early childhood and include jaundice, hemolytic anemia, hepatosplenomegaly, and skin photosensitivity. These symptoms are generally quite distinct from those seen in heterozygotes. Hematologic features are particularly characteristic in harderoporphyria.

### Laboratory Findings

The porphyrin precursors ALA and PBG are increased during acute attacks in HCP but may decrease more rapidly than in AIP. Marked increases in coproporphyrin III in urine and feces are more persistent in HCP. Plasma porphyrins are usually normal or only slightly increased.

In homozygous cases, porphyrin excretion may be more increased and is accompanied by substantial increases in erythrocyte zinc protoporphyrin. Harderoporphyria is characterized by a marked increase in fecal excretion of harderoporphyrin (tricarboxyl porphyrin) and in coproporphyrin.

### Diagnosis and Differential Diagnosis

The diagnosis of HCP is readily established in patients with clinically manifest disease, although urinary ALA, PBG, and uroporphyrin may revert to normal more quickly than in AIP. Urinary coproporphyrin III is increased. Urinary porphyrins, especially coproporphyrin, can be increased in many medical conditions (e.g., liver disease), and small increases that are not diagnostically significant may lead to an incorrect

diagnosis of HCP. Fecal porphyrins are mostly coproporphyrin (isomer III) in HCP, whereas in VP, coproporphyrin III and protoporphyrin are often increased approximately equally. Plasma porphyrins are usually normal in HCP and increased in VP.

The ratio of fecal coproporphyrin III to coproporphyrin I is especially sensitive for detecting latent heterozygotes (especially in adults). Assays for *CPOX*, a mitochondrial enzyme, require cells such as lymphocytes and are not widely available. Identification of a *CPOX* pathogenic variant in an index case greatly facilitates screening family members.

### Treatment and Prognosis

Acute attacks of HCP are treated as in AIP, which includes IV heme and identifying and avoiding precipitating factors. Phlebotomy and chloroquine are not effective. GnRH analogs can be effective for prevention of cyclic attacks. The prognosis is generally better than in AIP. Givosiran, an siRNA therapeutic agent, has been approved for the prevention of acute attacks in all acute hepatic porphyrias, although experience in HCP is limited.

Prevention and genetic counseling are the same as in other acute porphyrias.

### VARIEGATE PORPHYRIA

This hepatic porphyria is caused by a deficiency of protoporphyrinogen oxidase (PPOX), which is inherited as an autosomal dominant trait. The disorder is termed *variegate* because it can present with neurologic or cutaneous manifestations or both. Other terms have included *porphyria variegata*, *protocoproporphyria*, and *South African genetic porphyria*. Rare cases of homozygous VP are symptomatic in childhood.

### Etiology

PPOX is approximately half-normal in all cells studied in patients with VP. The enzyme is more markedly deficient in rare cases of homozygous VP, with approximately half-normal enzyme activity in parents.

Human PPOX is a homodimer that contains flavin adenine dinucleotide and is localized to the cytosolic side of the inner mitochondrial membrane. Membrane-binding domains may be docked onto human FECH, the next enzyme in the pathway, which is embedded in the opposite side of the membrane. PPOX catalyzes the oxidation of protoporphyrinogen IX to protoporphyrin IX by the removal of six hydrogen atoms. The enzyme requires molecular oxygen. The substrate is readily oxidized nonenzymatically to protoporphyrin under aerobic conditions or if exported into the cytosol. PPOX is highly specific for protoporphyrinogen IX and is inhibited by tetrapyrroles such as heme, biliverdin, and bilirubin and by certain herbicides that cause protoporphyrin to accumulate and induce phototoxicity in plants. Inhibition by bilirubin may account for decreased PPOX activity in Gilbert disease.

The human *PPOX* gene consists of one noncoding and 12 coding exons. Many *PPOX* pathogenic variants have been reported in VP families. A missense pathogenic variant, R59W, is prevalent in South Africa. No convincing genotype-phenotype correlations have been identified. Pathogenic variants in homozygous cases of VP are more likely to encode enzyme proteins with residual activity.

### Epidemiology

VP is less common than AIP in most countries. The R59W pathogenic variant is highly prevalent in South African Whites (3 in 1,000 in this population). This example of “genetic drift” or founder effect has been traced to a man or his wife who emigrated from Holland to South Africa in 1688. In Finland, prevalence is 1.3 in 100,000 people and is about as common as AIP.

### Pathology and Pathogenesis

Acute attacks develop in a minority of heterozygotes for PPOX deficiency and are often attributable to drugs, steroids, and nutritional factors that play a role in other acute porphyrias. Protoporphyrinogen IX accumulates and undergoes autoxidation to protoporphyrin IX. Coproporphyrinogen III accumulates, perhaps as the result of a close functional association between PPOX in the inner mitochondrial

membrane and CPOX in the intermembrane space. Liver porphyrin content is not increased. The increased porphyrin content in plasma consists of porphyrin-peptide conjugates, which may be formed from protoporphyrinogen. Increased ALA and PBG during acute attacks may be explained, as in HCP, by induction of ALAS1 by exacerbating factors and by the normally relatively low activity of PBGD in liver. Furthermore, PBGD is inhibited by protoporphyrinogen, the substrate for PPOX.

### Clinical Manifestations

Symptoms develop in some heterozygotes after puberty. Neurovisceral symptoms occurring as acute attacks are identical to AIP but are generally milder and less often fatal. Drugs, steroids, and nutritional alterations such as fasting, which are harmful in AIP, can also induce attacks of VP. Attacks occur equally in males and females, at least in South Africa. Cutaneous fragility, vesicles, bullae, hyperpigmentation, and hypertrichosis of sun-exposed areas are much more common than in HCP. They are likely to occur apart from and to be longer lasting than the neurovisceral symptoms. OCs can precipitate cutaneous manifestations. Acute attacks have become less common, and skin manifestations are more frequently the initial presentation; this may result from earlier diagnosis and counseling. The risk of hepatocellular carcinoma is increased.

Symptoms of homozygous VP begin in infancy or childhood. These children generally have severe photosensitivity, neurologic symptoms, seizures, developmental disturbances, and sometimes growth retardation, but they do not have acute attacks.

### Laboratory Findings

Urinary ALA, PBG, and uroporphyrin are increased during acute attacks, but often less so than in AIP, and may be normal or only slightly increased during remission. Plasma porphyrins, urinary coproporphyrin III, and fecal coproporphyrin III and protoporphyrin are more persistently increased between attacks. The pattern of urinary porphyrins can sometime resemble that seen in PCT. Erythrocyte zinc protoporphyrin levels are greatly increased in homozygous VP and may be modestly increased in heterozygous cases.

### Diagnosis and Differential Diagnosis

VP is readily distinguished biochemically from AIP and HCP, which also present with acute attacks and increases in PBG. Plasma porphyrin analysis is especially useful because the plasma porphyrins in VP are tightly protein bound, resulting in a characteristic fluorescence emission spectrum at neutral pH. Fecal porphyrins are increased, with approximately equal amounts of coproporphyrin III and protoporphyrin. Fluorometric detection of plasma porphyrins is more sensitive than stool porphyrin analysis in asymptomatic VP. PPOX assays using cells that contain mitochondria, such as lymphocytes, are sensitive for identifying asymptomatic carriers but are not widely available. Knowing the PPOX pathogenic variant in an index case enables the identification of relatives who carry the same pathogenic variant.

### Treatment

Acute attacks are treated as in AIP. Hemin is beneficial for acute attacks but not for cutaneous symptoms. Light protection is important in patients with skin manifestations, using long-sleeved clothing, gloves, a broad-brimmed hat, and opaque sunscreen preparations. Exposure to short-wavelength UV light, which does not excite porphyrins, may increase skin pigmentation and provide some protection. Phlebotomy and chloroquine are not effective. Surprisingly, oral activated charcoal was reported to increase porphyrin levels and worsen skin manifestations.

### Prognosis and Prevention

The outlook of patients with VP has improved, which may be attributed to improved treatment, earlier diagnosis, and detection of latent cases. Cyclic acute attacks in women can be prevented with a GnRH analog, as in AIP. Givosiran, an siRNA therapeutic agent, has been approved for the prevention of acute attacks in all acute hepatic porphyrias, although

experience in VP is limited. A diagnosis of VP or any other acute porphyria should not lead to difficulty obtaining insurance, because the prognosis is usually good once the diagnosis is established.

Genetic counseling is the same as in other acute porphyrias.

## ERYTHROPOIETIC PROTOPORPHYRIA AND X-LINKED PROTOPORPHYRIA

These forms of protoporphyria are genetically distinct but have essentially the same phenotype. In EPP, an autosomal recessive disorder, protoporphyrin accumulates as the result of a marked deficiency of FECH, the last enzyme in the heme biosynthetic pathway, because of *FECH* pathogenic variants. EPP is sometimes termed *erythrohepatic protoporphyria*, although the liver does not contribute substantially to production of excess protoporphyrin. XLP is the most recently described porphyria, in which gain-of-function *ALAS2* pathogenic variants lead to overproduction of ALA in the marrow, where it is metabolized to excess amounts of protoporphyrin.

### Etiology

Ferrochelatase (FECH), the enzyme that is deficient in EPP, catalyzes the final step in heme synthesis, which is insertion of ferrous iron ( $\text{Fe}^{2+}$ ) into protoporphyrin IX (see Fig. 112.1). The enzyme is also termed *heme synthetase* or *protoheme ferrolyase*. The human enzyme is a dimer, and each homodimer contains a  $[2\text{Fe}-2\text{S}]$  cluster, which may have a role in bridging homodimers. FECH is found in the mitochondrial inner membrane, where its active site faces the mitochondrial matrix. It may be associated with complex I of the mitochondrial electron transport chain, and the ferrous iron substrate may be produced on nicotinamide adenine dinucleotide oxidation. FECH is specific for the reduced form of iron but can use other metals, such as  $\text{Zn}^{2+}$  and  $\text{Co}^{2+}$ , and other dicarboxyl porphyrins. Accumulation of metal-free protoporphyrin rather than zinc protoporphyrin in EPP indicates that formation of the latter is dependent on FECH activity *in vivo*.

The human *FECH* gene has a single promoter sequence and contains 11 exons. Two mRNAs of 1.6 and 2.5 kb were described, which may be explained by the use of two alternative polyadenylation signals. The larger transcript is more abundant in murine erythroid cells, suggesting erythroid-specific regulation of FECH. A variety of *FECH* pathogenic variants have been reported in EPP, including missense, nonsense, and splicing pathogenic variants; small and large deletions; and an insertion.

The inheritance of two alleles associated with reduced FECH activity is required for disease expression. This is consistent with FECH activities as low as 15–25% of normal in EPP patients. In most patients, a pathogenic variant on one *FECH* allele is combined with a common variant affecting the other allele. This common-variant *FECH* allele (IVS3-48T>C) produces less-than-normal amounts of enzyme because it expresses an aberrantly spliced mRNA that is degraded by a nonsense-mediated RNA decay mechanism. The IVS3-48T>C *FECH* variant by itself does not cause disease, even when homozygous. In a few families, two severe *FECH* pathogenic variants have been found without the IVS3-48T>C allele. EPP with autosomal recessive inheritance occurs naturally in cattle and in mouse models.

XLP is associated with gain-of-function deletions in the last exon of *ALAS2*. These lesions delete the last 10–20 amino acids of the *ALAS2* polypeptide and apparently make the enzyme more stable. Metal-free protoporphyrin predominates in erythrocytes in these cases, but because FECH activity is normal, the proportion of zinc protoporphyrin is greater than in EPP. XLP accounts for approximately 2% of cases with the EPP phenotype in Europe and approximately 10% of cases in North America.

EPP is sometimes associated with myelodysplastic or myeloproliferative disorders and expansion of a clone of hematopoietic cells with deletion of one *FECH* allele or with other *FECH* pathogenic variants. In such cases there is late onset of the disease.

### Epidemiology

EPP is the most common porphyria to cause symptoms in children but is often not diagnosed until adult life. Overall, it is the third most

common porphyria, although its prevalence is not precisely known (see Table 112.2). An analysis from the UK biobank exome sequencing data suggests that EPP is 1.7–3.0 times more common than previously thought in the UK. It is described mostly in Whites but occurs in other ancestries. The IVS3-48T>C splice variant is common in Whites and Japanese but rare in Africans, which explains lower disease prevalence in populations of African origin.

### Pathology and Pathogenesis

FECH is deficient in all tissues in EPP, but bone marrow reticulocytes are thought to be the primary source of the excess protoporphyrin, some of which enters plasma and circulates to the skin. Circulating erythrocytes are no longer synthesizing heme and hemoglobin, but they contain excess free protoporphyrin, which also contributes. In XLP caused by terminal deletions in exon 11 of *ALAS2*, all intermediates of the heme pathway are overproduced and ultimately accumulate in bone marrow erythroblasts as protoporphyrin. FECH is not deficient in XLP, so this enzyme chelates some of the excess protoporphyrin with zinc. An aberrantly spliced mitoferrin transcript, which limits iron transport into mitochondria, has also been described in EPP. The liver functions as an excretory organ rather than a major source for excess protoporphyrin. FECH deficiency in the skin and liver may be important, however, because tissue transplantation studies in mice suggest that skin photosensitivity and liver damage occur only when FECH is deficient in these tissues.

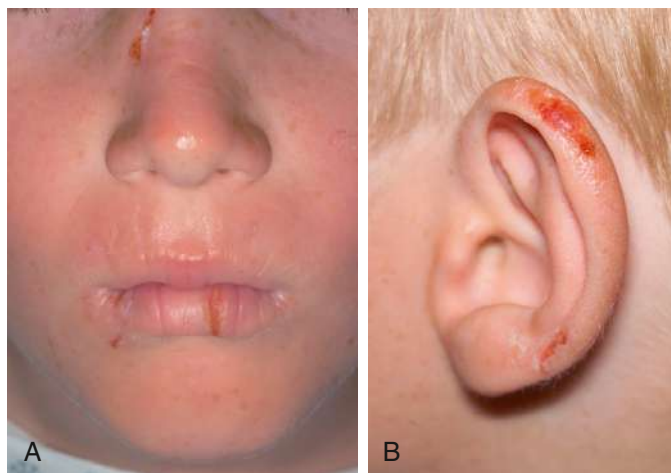
Patients with EPP and XLP are maximally sensitive to light in the 400-nm range, which corresponds to the so-called *Soret band*, the narrow peak absorption maximum that is characteristic for protoporphyrin and other porphyrins. Having absorbed light, porphyrins enter an excited energy state and release energy as fluorescence, singlet oxygen, and other ROS. Resulting tissue damage is accompanied by lipid peroxidation, oxidation of amino acids, cross linking of proteins in cell membranes, and damage to capillary endothelial cells. Such damage may be mediated by photoactivation of the complement system and release of histamine, kinins, and chemotactic factors. Repeated acute damage leads to thickening of the vessel walls and perivascular deposits from accumulation of serum components. Deposition of amorphous material containing immunoglobulin, complement components, glycoproteins, acid glycosaminoglycans, and lipids occurs around blood vessels in the upper dermis.

There is little evidence for impaired erythropoiesis or hemolysis in EPP. However, mild anemia with microcytosis, hypochromia, and reticulocytosis is common. Iron accumulation in erythroblasts and ring sideroblasts has been noted in bone marrow in some patients. Decreased transferrin saturation and low or low-normal serum ferritin suggest iron deficiency. Iron status should be carefully evaluated in EPP patients. Poor response to oral iron supplements is described in EPP and is unexplained, because iron absorption is not impaired. Some patients report increased photosensitivity when given iron supplements, but whether this is from transient increases in porphyrins when iron deficiency is corrected and erythropoiesis increases is not known. Case reports suggest that iron supplementation decreases protoporphyrin and improves anemia, especially in patients with XLP. However, recent evidence suggests that iron deficiency may reduce protoporphyrin levels in some EPP patients.

Liver damage develops in a small proportion of EPP and XLP patients and is attributed to excess protoporphyrin, which is insoluble in water and excreted only by hepatic uptake and biliary excretion. Some may be reabsorbed by the intestine and undergo enterohepatic circulation. At very high levels, protoporphyrin is cholestatic, can damage cholangiocytes, and can accumulate in hepatocytes to form crystalline structures and impair mitochondrial function.

### Clinical Manifestations

Symptoms of cutaneous photosensitivity begin in childhood and consist of acute pain and itching, often occurring within minutes of sunlight exposure and followed by redness and swelling with continued exposure (Fig. 112.7). Petechiae and purpuric lesions may be seen, but blisters are rare. Swelling may resemble angioneurotic edema and



**Fig. 112.7** Erythropoietic protoporphyria (EPP). A, Linear erosions of the lateral nasal bridge and lower lip in a patient with EPP. B, Erosions with crusting on the left helix of a patient with EPP. (From Horner ME, Alikhan A, Tintle S, et al. *Cutaneous porphyrias. Part 1. epidemiology, pathogenesis, presentation, diagnosis, and histopathology.* *Int J Dermatol.* 2013;52:1464–1480, Figs. 7 and 8.)

*solar urticaria*. Symptoms are usually worse in the spring and summer. Chronic changes may include lichenification, leathery pseudovesicles, labial grooving, and nail changes, but changes in pigmentation and pronounced scarring are unusual. Although physical findings in EPP and XLP may not be impressive, efforts to avoid sunlight and resulting symptoms significantly impair quality of life. An association between EPP caused by pathogenic variants affecting both FECH alleles and seasonal palmar keratoderma is unexplained. Neuropathy develops only in some patients with severe hepatic decompensation. XLP males have a more severe phenotype with higher protoporphyrin levels than most EPP patients. XLP females have a variable clinical presentation—some with no symptoms or mild symptoms and others with severe symptoms similar to XLP males. This variability in females is likely the result of random X chromosome inactivation.

Unless hepatic or other complications develop, protoporphyrin levels and symptoms of photosensitivity remain remarkably stable for many years in most patients. Factors that exacerbate hepatic porphyrias play little or no role in EPP or XLP. Erythrocyte protoporphyrin levels may decrease and sunlight tolerance may improve during pregnancy, which is unexplained.

### Laboratory Findings

Protoporphyrin is substantially increased in circulating erythrocytes in EPP and consists almost entirely of metal-free protoporphyrin. In XLP, both zinc protoporphyrin and metal-free protoporphyrin are increased, although the latter still predominates. Protoporphyrin is also increased in bone marrow, plasma, bile, and feces. Other porphyrins and porphyrin precursors are normal in uncomplicated EPP and XLP.

### Diagnosis and Differential Diagnosis

A diagnosis of EPP is confirmed biochemically by finding a substantially elevated concentration of total erythrocyte protoporphyrin, which is predominantly (at least 85%) metal-free and not complexed with zinc. In XLP, both metal-free and zinc-complexed protoporphyrins are elevated. Erythrocyte total protoporphyrin levels are, on average, higher in XLP and more variable between individuals in EPP, possibly reflecting differences in severity of the many reported FECH pathogenic variants. Erythrocyte zinc protoporphyrin concentration is increased with little increase in metal-free protoporphyrin in homozygous porphyrias (except CEP), iron deficiency, lead poisoning, anemia of chronic disease, hemolytic conditions, and many other erythrocytic disorders. Measurement of FECH activity requires cells containing mitochondria and is not widely available.



Plasma total porphyrin concentration is often less increased in EPP than in other cutaneous porphyrias and may be normal. Great care must be taken to avoid light exposure during sample processing, because plasma porphyrins in EPP are particularly subject to photodegradation. Urinary porphyrin precursors and porphyrins are not increased.

DNA studies are strongly recommended for confirming *FECH* or *ALAS2* pathogenic variants and for genetic counseling.

Life-threatening **protoporphyrinic hepatopathy** is characterized by greater increases in erythrocyte and plasma protoporphyrin levels, increased photosensitivity, and either chronically abnormal liver function tests or rapidly progressive hepatic failure. Presumably this is heralded by increases above the patient's baseline erythrocyte and plasma porphyrin levels, but this has not been documented, because most such patients have not had sufficiently long-term determinations of porphyrin values. Increases in urinary porphyrins, especially coproporphyrin, in this setting are attributable to liver dysfunction.

### Complications

There is an increased risk of biliary stones, which contain protoporphyrin and are sometimes symptomatic, requiring cholecystectomy. Protoporphyrinic hepatopathy occurs in <5% of protoporphyria patients, including children, and may be chronic or progress rapidly to death from liver failure. Rarely, hepatopathy is the major presenting feature of EPP or XLP. Protoporphyrinic hepatopathy can cause acute upper abdominal pain suggesting biliary obstruction, and unnecessary laparotomy to exclude this possibility can be detrimental. Other types of liver disease, such as viral hepatitis or alcohol- or drug-induced liver disease, must be excluded, or may contribute to the development of protoporphyric hepatopathy. Whether iron deficiency may contribute is unclear. Liver histology shows marked deposition of protoporphyrin as inclusions in liver cells and bile canaliculi. The bone marrow is probably the major source of protoporphyrin, even in EPP patients with hepatic failure.

### Treatment

Exposure to sunlight should be avoided, which is aided by wearing closely woven clothing. Beta-carotene, oral cysteine, and vitamin C have no proven efficacy. One report suggested that high doses of cimetidine were effective in reducing symptoms in three children with EPP, but no objective clinical evidence of efficacy was presented.

Increasing skin melanin by narrow-band UV-B phototherapy may improve sunlight tolerance. Studies in the United States and Europe of afamelanotide, a synthetic analog of melanocyte-stimulating hormone, darkened the skin, increased pain-free sun exposure, and improved quality of life in patients with protoporphyria. This drug is approved for use in adults in Europe and the United States. Dersimelagon, an orally administered small molecule and a selective melanocortin-1 receptor (MC1R) agonist that increases skin melanin, is currently in phase 3 trials in EPP and XLP in the United States and other countries.

Drugs or hormone preparations that impair hepatic excretory function should be avoided. Iron deficiency should be corrected, particularly in XLP. Vitamin D supplementation and hepatitis A and B vaccination are recommended.

Treatment of protoporphyric hepatopathy must be individualized and exclude other causes of liver disease. Spontaneous resolution may

occur, especially if another reversible cause of liver dysfunction, such as viral hepatitis or alcohol abuse, is contributing. In patients with severe hepatic decompensation, combined treatment with plasmapheresis, transfusion to correct anemia and suppress erythropoiesis, IV hemin to suppress erythroid and possibly hepatic protoporphyrin production, ursodeoxycholic acid, vitamin E, and cholestyramine may be beneficial and bridge patients to liver transplantation.

Motor neuropathy resembling that seen in acute porphyrias sometimes develops in protoporphyria patients with liver disease before or after transfusion or liver transplantation and is sometimes reversible. Artificial lights, such as operating room lights during liver transplantation or other surgery, may cause severe photosensitivity, with extensive burns of the skin and peritoneum and damage to circulating erythrocytes.

Although liver disease may recur in the transplanted liver as a result of continued bone marrow production of excess protoporphyrin, outcomes are comparable to transplantation for other types of liver disease. Bone marrow transplantation can be considered after liver transplantation if a suitable donor is available.

### Prognosis

Typical EPP patients have lifelong photosensitivity but can otherwise expect normal longevity. Protoporphyrinic liver disease is often life-threatening; however, the incidence is low.

### Prevention and Genetic Counseling

Symptoms can be prevented by avoiding sunlight. Avoiding agents that may cause liver damage may help prevent liver complications. Opinions vary on the value of iron replacement, and this is currently under study.

DNA studies to identify *FECH* pathogenic variants, the common IVS3-48T>C *FECH* hypoeexpression allele, or *ALAS2* exon 11 deletions are important for genetic counseling. When EPP is caused by a severe *FECH* pathogenic variant and the common IVS3-48T>C *FECH* allele, DNA studies in the spouse to determine the presence, or more likely the absence, of the hypoeexpression allele can predict whether offspring are at risk for EPP. EPP may improve during pregnancy.

### DUAL PORPHYRIA

An unusual pattern of porphyrin precursors and porphyrins has led to documentation of pathogenic variants of two heme pathway enzymes. One such patient presented with acute porphyria and had heterozygous pathogenic variants of both *CPOX* and *ALAD*. Another had symptoms of AIP and PCT and was reported to have both *HMBS* and *UROD* pathogenic variants. In other reported cases, one or both enzyme deficiencies were based on enzyme measurements.

### PORPHYRIA RESULTING FROM TUMORS

Erythropoietic porphyrias can develop late in life in patients with myelodysplastic or myeloproliferative diseases and clonal expansion of erythroid cells with an inherited or somatic pathogenic variant of an enzyme in the heme biosynthetic pathway.

Visit Elsevier eBooks+ at [eBooks.Health.Elsevier.com](http://eBooks.Health.Elsevier.com) for Bibliography.



## Chapter 113

## Hypoglycemia

Katherine Lord and Diva D. De León-Crutchlow

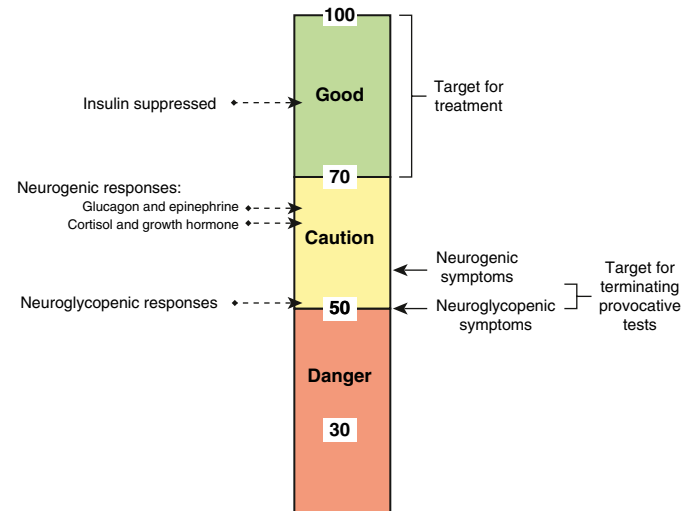
Glucose plays a central role in fuel metabolism and energy storage in the body. It provides 38 mol of adenosine triphosphate (ATP) per mole of glucose oxidized. Glucose is also essential for energy metabolism in the brain, where it is the preferred substrate. Its use accounts for nearly all the brain's oxygen consumption. Cerebral transport of glucose is a glucose transporter-1 (GLUT-1)-facilitated diffusion process that is dependent on blood glucose concentration and not regulated by insulin. *Low concentrations of blood glucose result in cerebral glucopenia, energy failure, and brain injury.* An elaborate regulatory system has evolved to maintain glucose homeostasis and prevent plasma glucose from falling precipitously to levels that impair brain function. The defense against hypoglycemia includes the autonomic nervous system and hormones that act in concert to enhance glucose production through glycogenolysis and gluconeogenesis, while simultaneously limiting peripheral glucose use, which conserves glucose for cerebral metabolism. With prolonged fasting, fat stores are mobilized via lipolysis, and fatty acid oxidation in the liver results in the generation of ketone bodies, an alternative fuel source for the brain (Fig. 113.1). Hypoglycemia results from a failure in one or several of these fasting mechanisms that normally integrate glucose homeostasis.

## DEFINITION

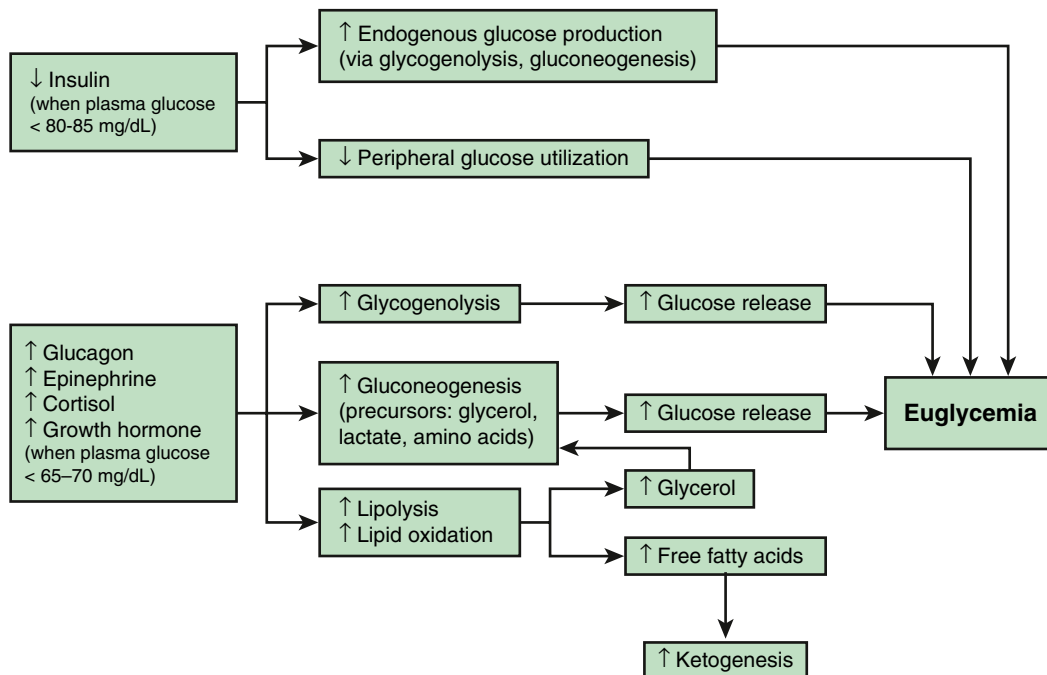
Hypoglycemia is defined as a plasma glucose concentration low enough to cause signs and symptoms of brain dysfunction (Fig. 113.2). However, a numerical value can be difficult to define because the brain responses to hypoglycemia occur across a range of plasma glucose

concentrations. In young children, signs and symptoms of hypoglycemia are suggestive but nonspecific; thus the reliance on signs and symptoms to indicate hypoglycemia in this age-group may be problematic (Table 113.1).

In older children, evidence of hypoglycemia is based on **Whipple's triad**: (1) signs and symptoms consistent with hypoglycemia, (2) a low plasma glucose concentration, and (3) resolution of the symptoms with normalization of the plasma glucose concentration.



**Fig. 113.2** Interpreting glucose levels and glucose treatment targets. Glucose thresholds are shown for suppression of insulin secretion, neurogenic (neuroendocrine hormone-mediated) responses, and neuroglycopenic (impaired cognition) responses. Colors show the normal range (green), the range for symptoms caused by activation of sympathetic nervous system (yellow), and the range for impaired neuronal function (red). (From Stanescu DL, Stanley CA. *Advances in understanding the mechanism of transitional neonatal hypoglycemia and implications for management.* Clin Perinatol. 2022;49:55–72, Fig. 2.)



**Fig. 113.1** The metabolic response to fasting. With fasting, declining glucose levels result in suppression of insulin and a rise of the counter-regulatory hormones. These changes in hormone levels lead to increased glucose output from the liver via glycogenolysis and gluconeogenesis. With prolonged fasting, counter-regulatory hormones stimulate lipolysis, which results in generation of glycerol (a key precursor in the gluconeogenic pathway) and, through ketogenesis, ketone bodies, a critical alternative fuel.

**Table 113.1** Manifestations of Hypoglycemia in Childhood**FEATURES ASSOCIATED WITH ACTIVATION OF AUTONOMIC NERVOUS SYSTEM AND EPINEPHRINE RELEASE\***

Anxiety  
 Perspiration  
 Palpitation (tachycardia)  
 Pallor  
 Tremulousness  
 Weakness  
 Hunger  
 Nausea  
 Emesis

**FEATURES ASSOCIATED WITH CEREBRAL GLUCOPENIA**

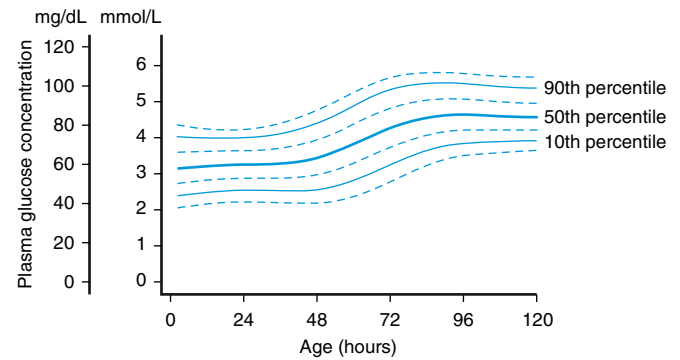
Headache  
 Mental confusion  
 Visual disturbances (l acuity, diplopia)  
 Inability to concentrate  
 Dysarthria  
 Staring  
 Paresthesias  
 Dizziness  
 Amnesia  
 Ataxia  
 Refusal to feed  
 Somnolence, lethargy  
 Seizures  
 Coma  
 Stroke, hemiplegia, aphasia  
 Decerebrate or decorticate posture

\*Some of these features will be attenuated if the patient is receiving  $\beta$ -adrenergic blocking agents.

**SIGNIFICANCE AND SEQUELAE**

Brain metabolism uses the majority of endogenous hepatic glucose production in neonates, infants, and children. Because the brain grows most rapidly in the first year of life and a larger proportion of glucose turnover is used for brain metabolism, hypoglycemia in infants and children can affect brain development and function and can result in developmental delays and learning disabilities. The brain also has the capacity to absorb and oxidize ketone bodies. However, the capacity of the liver to produce ketone bodies is limited in the immediate newborn period. This is especially restricted in the presence of **hyperinsulinism (HI)**, which acutely inhibits hepatic glucose output, lipolysis, and ketogenesis, thereby depriving the brain of any alternative fuel sources. Furthermore, although the brain can metabolize ketones, these alternative fuels cannot completely replace glucose as an essential central nervous system (CNS) fuel. The deprivation of the brain's major energy source during hypoglycemic events has predictable adverse consequences on brain metabolism and growth. These arise from decreased brain oxygen consumption and increased breakdown of endogenous structural brain components, with impairment and loss of functional membrane integrity.

The major long-term sequelae of hypoglycemia are developmental delays, learning disabilities, epilepsy, and behavioral issues. A prospective cohort study of neonates at risk for hypoglycemia found that at 4 years of age, children who had experienced symptomatic hypoglycemia during the neonatal period had a two- to threefold increased risk of low executive and visual-motor function with greater impairment in children with severe or recurrent episodes. Cross-sectional studies in children with HI have found that 26–48% of children with both transient and persistent forms of HI have abnormal neurodevelopment. Children with HI have the highest risk of neurologic damage given the severity of the hypoglycemia in the condition and their inability to generate ketones as an alternative fuel for the brain. In addition, hypoglycemia associated with hypoxic-ischemic encephalopathy increases the risk of CNS sequelae. However, there are no precise data



**Fig. 113.3** Glucose percentiles in healthy term infants. (Modified from Harris DL, Weston PJ, Gamble GD, Harding JE. Glucose profiles in healthy term infants in the first 5 days: the Glucose Well Babies (GLOW) study. *J Pediatr.* 2020;223:34–41, Fig. 2.)

relating the duration or severity of hypoglycemia to subsequent neurologic development of children in a predictable manner. Nonetheless, early detection of hypoglycemia and effective treatment are critical to mitigating the risk of brain damage and developmental delays. Many neonates may have asymptomatic hypoglycemia identified by routine screening or laboratory testing. Although asymptomatic hypoglycemia in an otherwise healthy newborn is usually benign and transient, there remains a risk that if untreated (glucose gel, human milk, formula feedings), the hypoglycemia may become symptomatic. Hypoglycemia in older children may also produce long-term neurologic defects through neuronal death, mediated in part by cerebral excitotoxins released during hypoglycemia.

**PHYSIOLOGIC MECHANISMS OF GLUCOSE HOMEOSTASIS**

Fetal glucose is derived entirely from the mother through placental-facilitated diffusion; therefore fetal glucose concentration reflects, but is slightly lower than, maternal glucose levels. After birth, plasma glucose decreases, reaching a nadir at about 2 hours of life and remaining below the normal adult range of 70–100 mg/dL for the first 3–4 days of life; this is known as *transitional hypoglycemia*. A study of healthy, full-term infants found a mean plasma glucose concentration of  $59 \pm 11$  mg/dL during the first 48 hours of life, which then increased to  $83 \pm 13$  mg/dL during days 4–5 of life (Fig. 113.3). Transitional asymptomatic hypoglycemia is likely caused by a persistence of fetal pancreatic  $\beta$ -cell fuel metabolism, which allows for the secretion of insulin at lower glucose concentrations to support insulin-mediated fetal growth. Beyond this transitional period, plasma glucose concentration and mechanisms that regulate glucose homeostasis in neonates are the same as in older children and adults.

During fasting, mechanisms responsible for the maintenance of glucose homeostasis include glycogenolysis, gluconeogenesis, lipolysis, and fatty acid oxidation, as well as the hormones that regulate the activation of these processes (see Fig. 113.1). Plasma glucose concentrations are maintained by both metabolism of the nutrients consumed in the immediate postprandial period and then by glycogenolysis and gluconeogenesis starting 2–4 hours after the meal. The liver of a 10-kg child contains 20–25 g of glycogen, which is sufficient to meet normal glucose requirements of 4–6 mg/kg/minute during an overnight fast. Glucose production during this time is augmented by gluconeogenesis (see Fig. 113.1). Defects in glycogenolysis or gluconeogenesis may not be manifested in infants until the frequent feeding pattern at 3- to 4-hour intervals ceases and infants sleep through the night, a situation usually present by 3–6 months of age.

With prolonged fasting, the glycogen stores are depleted, and energy metabolism is more dependent on fatty acid and ketone oxidation. **Lipolysis** generates fatty acids, which undergo  $\beta$ -oxidation in the liver to generate ketone bodies. Peripheral tissues use free fatty acids (FFAs) and ketones, whereas the CNS can use ketones for a

portion of its energy needs. Defects in  $\beta$ -oxidation and ketogenesis may not manifest until fasting exceeds the overnight period or, with illnesses, result in catabolism, fasting, and increased body energy requirements.

Amino acid precursors for gluconeogenesis are derived primarily from muscle protein. The muscle bulk of infants and small children is substantially smaller relative to body mass than that of adults, whereas glucose requirements per unit of body mass are greater in children. Therefore the ability to compensate for glucose deprivation by gluconeogenesis is more limited in infants and young children, as is the ability to withstand fasting for prolonged periods. The ability of muscle to generate alanine, the principal gluconeogenic amino acid, may also be limited.

The switch from glycogen synthesis during and immediately after meals to glycogen breakdown and later gluconeogenesis is governed by hormones, with insulin of central importance (see Fig. 113.1). After a meal, plasma insulin concentrations increase to peak levels of 5- to 10-fold greater than their normal baseline concentration, which serves to lower the plasma glucose through the enhancement of peripheral glucose uptake, activation of glycogen synthesis, and inhibition of gluconeogenesis. In addition, lipogenesis is stimulated, whereas lipolysis and ketogenesis are curtailed. During fasting, plasma insulin concentrations fall, and together with the rise of counter-regulatory hormones, result in maintenance of plasma glucose concentration (see Fig. 113.1).

These **counter-regulatory hormones**—glucagon, growth hormone, cortisol, and epinephrine—act synergistically and in concert to increase plasma glucose concentrations by activating glycogenolytic enzymes (glucagon, epinephrine); inducing gluconeogenic enzymes (glucagon, cortisol); inhibiting glucose uptake by muscle (epinephrine, growth hormone, cortisol); mobilizing amino acids from muscle for gluconeogenesis (cortisol); activating lipolysis and thereby providing glycerol for gluconeogenesis and fatty acids for ketogenesis (epinephrine, cortisol, growth hormone, glucagon); and inhibiting insulin release and promoting growth hormone and glucagon secretion (epinephrine).

## CLINICAL MANIFESTATIONS

Clinical features of hypoglycemia fall into two categories: (1) symptoms and signs associated with the activation of the autonomic nervous system and epinephrine release (**autonomic symptoms**) and (2) symptoms and signs caused by decreased cerebral glucose use (**neuroglycopenic symptoms**) (see Table 113.1). In newborns and infants, symptoms and signs of hypoglycemia may be subtler and include cyanosis, apnea, hypothermia, hypotonia, irritability, jitteriness, poor feeding, lethargy, and seizures. *It is important to note that neonates and infants are frequently asymptomatic when hypoglycemic.*

## DIAGNOSIS

Infants and children with a suspected hypoglycemia disorder require a timely and comprehensive diagnostic workup to establish the underlying cause and to initiate specific treatment, prevent hypoglycemia, and minimize the risk of brain damage and neurologic dysfunction. The Pediatric Endocrine Society provides guidelines that outline which children and adolescents should be evaluated for a hypoglycemia disorder:

- ♦ Older children and adolescents who demonstrate Whipple's triad
- ♦ Infants and younger children (who cannot communicate symptoms) with plasma glucoses  $<60$  mg/dL on laboratory-quality assays
  - ♦ Neonates at high risk of a persistent hypoglycemic disorder
  - ♦ Glucose screening is recommended for those born large for gestational age, a history of perinatal stress, premature or postmature delivery, infants of diabetic mothers, family history of hypoglycemia disorder, or a congenital syndrome associated with hypoglycemia.
- ♦ A persistent hypoglycemia disorder should be ruled out in those with severe hypoglycemia (symptomatic or requiring intravenous [IV] dextrose), inability to maintain plasma glucose  $>50$  mg/dL (up to 48 hours of life) or  $>60$  mg/dL (after 48 hours of life), family history of a genetic form of hypoglycemia, and those with a congenital syndrome associated with hypoglycemia.

**Table 113.2** Clinical Features of Hypoglycemia Disorders

<b>BIRTH HISTORY</b>	
Large for gestational age	Congenital HI, BWS
Small for gestational age	Perinatal stress HI
Maternal gestational diabetes	Infant of diabetic mother, dominant $K_{ATP}$ -HI
<b>FAMILY HISTORY</b>	
Sudden infant death	Fatty acid oxidation disorder
Diabetes*	HNF4A-HI, HNF1A-HI, dominant $K_{ATP}$ -HI
<b>PHYSICAL EXAM</b>	
Hepatomegaly	Glycogen storage disease
Congenital heart disease	Perinatal stress HI, Kabuki or Turner syndrome
Midline defect	Hypopituitarism
Macroglossia	BWS
Hyperpigmentation	Primary adrenal insufficiency
Short stature	Growth hormone deficiency, glycogen storage disease

\*Specifically, non-type 1 diabetes diagnosed at a younger age in lean individuals. HI, Hyperinsulinism; BWS, Beckwith-Wiedemann syndrome;  $K_{ATP}$ , ATP-sensitive potassium channel; HNF, hepatocyte nuclear factor.

The etiology of hypoglycemia varies based on the age of the child, associated clinical and laboratory features, and more detailed diagnostic testing, including gene panels or whole exome sequencing (Tables 113.2, 113.3, 113.4, and 113.5).

A thorough history and physical exam may provide clinical clues to the underlying diagnosis (see Table 113.2). Evaluation for hypoglycemia disorders requires obtaining blood and urine at the time of hypoglycemia, ideally when the plasma glucose is  $<50$  mg/dL. This “**critical sample**” is used to measure hormones, which regulate glucose metabolism, and metabolic fuels (Table 113.6, Fig. 113.4). The critical sample can be obtained during a spontaneous episode of hypoglycemia or during a supervised diagnostic fast. Given the likelihood of hypoglycemia, a **diagnostic fast** should be performed in a hospital setting with close supervision and placement of an IV catheter to facilitate obtaining the critical sample. Point-of-care glucose (and  $\beta$ -hydroxybutyrate if available) should be followed closely, so the samples can be obtained as soon as the plasma glucose falls below 50 mg/dL. The evaluation of neonates should not occur during the first 48–72 hours of life to avoid the period of transitional hypoglycemia.

After the critical sample is obtained and before the child is allowed to eat, a **glucagon stimulation test** should be performed to assess for hyperinsulinism. While the child is still hypoglycemic, 1 mg of glucagon is administered, and glucose is measured by a point-of-care meter every 10 minutes for a total of 40 minutes. A greater than 30-point rise in plasma glucose concentration is consistent with insulin excess or hyperinsulinism. If children do not have an increase in their glucose during the first 20 minutes of the test, the test should be terminated and the child should be given juice or IV dextrose as rescue therapy.

The levels of alternative fuels at the time of hypoglycemia ( $\beta$ -hydroxybutyrate, FFAs, and lactate) allow for the classification of the hypoglycemia disorders into four distinct groups (see Fig. 113.4). The results from the critical sample then allow for narrowing of the differential and guide additional testing. Interpretation of the critical sample results has several important caveats. Low cortisol and growth hormone levels on the critical sample are not diagnostic of a hormone deficiency, and in most cases, the appropriate (specific) stimulation testing is needed if these levels are low. Additionally, a low or undetectable insulin level does not rule out hyperinsulinism. Insulin concentrations can be affected by hemolysis, and assays have variable sensitivity for detecting insulin. Other biomarkers of insulin effect, such as  $\beta$ -hydroxybutyrate (to evaluate ketogenesis), FFAs (to evaluate lipolysis), and the glycemic response to glucagon (to evaluate glycogenolysis), should be used to assess for hyperinsulinism.

**Table 113.3** Classification of Hypoglycemia in Infants and Children**NEONATAL TRANSITIONAL (ADAPTIVE) HYPOGLYCEMIA**  
Associated with inadequate substrate or immature enzyme function  
in otherwise normal neonatesPrematurity  
Small for gestational age  
Normal newborn**Transient Neonatal Hyperinsulinism**Infant of diabetic mother  
Small for gestational age  
Discordant twin  
Birth asphyxia  
Infant of toxemic mother**NEONATAL, INFANTILE, OR CHILDHOOD PERSISTENT HYPOGLYCEMIA****Hyperinsulinism (see Tables 113.4 and 113.5)****Counter-Regulatory Hormone Deficiency**Panhypopituitarism  
Isolated growth hormone deficiency  
Adrenocorticotropic hormone deficiency  
Addison disease (including congenital adrenal hypoplasia, adrenal leukodystrophy, triple A syndrome, ACTH receptor deficiency, and autoimmune disease complex)  
Epinephrine deficiency**Glycogenolysis and Gluconeogenesis Disorders**Glucose-6-phosphatase deficiency (GSD Ia)  
Glucose-6-phosphate translocase deficiency (GSD Ib)  
Amylo-1,6-glucosidase (debranching enzyme) deficiency (GSD III)  
Liver phosphorylase deficiency (GSD VI)  
Phosphorylase kinase deficiency (GSD IX)  
Glycogen synthetase deficiency (GSD 0)  
Fructose-1,6-diphosphatase deficiency  
Pyruvate carboxylase deficiency  
Galactosemia  
Hereditary fructose intolerance**Lipolysis Disorders****Fatty Acid Oxidation Disorders**Carnitine transporter deficiency (primary carnitine deficiency)  
Carnitine palmitoyltransferase-1 deficiency  
Carnitine translocase deficiency  
Carnitine palmitoyltransferase-2 deficiency  
Secondary carnitine deficiencies  
Very long-, long-, medium-, and short-chain acyl-CoA dehydrogenase deficiency**OTHER ETIOLOGIES****Substrate-Limited Causes**Ketotic hypoglycemia  
Poisoning—drugs  
Salicylates  
Alcohol  
Oral hypoglycemic agents  
Insulin  
Propranolol  
Pentamidine  
Quinine  
Disopyramide  
Ackee fruit (unripe)—hypoglycin  
Litchi-associated toxin (toxic hypoglycemic syndrome)  
Vacor (rat poison)  
Trimethoprim-sulfamethoxazole (with renal failure)  
L-Asparaginase and other antileukemic drugs**Liver Disease**Reye syndrome  
Hepatitis  
Cirrhosis  
Hepatoma**AMINO ACID AND ORGANIC ACID DISORDERS**Maple syrup urine disease  
Propionic acidemia  
Methylmalonic acidemia  
Tyrosinosis  
Glutaric aciduria  
3-Hydroxy-3-methylglutaric aciduria**SYSTEMIC DISORDERS**Sepsis  
Carcinoma/sarcoma (secreting—insulin-like growth factor II)  
Heart failure  
Malnutrition  
Malabsorption  
Antiinsulin receptor antibodies  
Antiinsulin antibodies  
Neonatal hyperviscosity  
Renal failure  
Diarrhea  
Burns  
Shock  
Chiari malformation  
Postsurgical complication  
Pseudohypoglycemia (leukocytosis, polycythemia)  
Excessive insulin therapy of insulin-dependent diabetes mellitus  
Factitious disorder  
Nissen fundoplication (dumping syndrome)  
Falciparum malaria

GSD, Glycogen storage disease; HI, hyperinsulinemia; KATP, regulated potassium channel.

**Table 113.4** Endocrine and Metabolic Causes of Hyperinsulinemic Hypoglycemia**TRANSIENT**Infant of diabetic mother  
Perinatal asphyxia  
Rhesus hemolytic disease  
Intrauterine growth restriction  
HNF4A / HNF1A**CONGENITAL**ABCC8 / KCNJ11 / GCK / GDH / HADH / HNF4A / HNF1A / UCP2 /  
SLC16A1 / PMM2 / HK1 / PGM1 / FOXA2 / CACNA1D / EIF2S3**OTHERS**Postprandial hyperinsulinemic hypoglycemia  
Insulinoma  
Munchausen by proxy  
Exercise-induced hyperinsulinemic hypoglycemiaModified from Güemes M, Rahman SA, Kapoor RR, et al. Hyperinsulinemic hypoglycemia in children and adolescents: recent advances in understanding of pathophysiology and management. *Rev Endo Metab Dis.* 2020;21:577–597, Table 1.**MANAGEMENT****Acute Treatment**

A child presenting with hypoglycemia should be rapidly treated with oral carbohydrates or IV dextrose to normalize their plasma glucose (&gt;70 mg/dL). If the child is asymptomatic or has mild symptoms and is capable of oral intake, the hypoglycemia can be treated with 15 grams of rapid-acting carbohydrates, such as 4 ounces of juice or two graham crackers. If a child is symptomatic or unable to tolerate oral intake (risk of aspiration, impending depressed level of consciousness), 2 mL/kg of dextrose 10% water (D10W) should be administered. After administration of the bolus, the child should be placed on an IV dextrose infusion (for infants, a glucose infusion rate of 5–6 mg/kg/minute and for older children 2–3 mg/kg/minute) to prevent recurrent hypoglycemia. Plasma glucose via point-of-care testing should be monitored every 15–20 minutes until it is &gt;70 mg/dL, and then checks may be spaced once stable levels are demonstrated.

In an asymptomatic child with a plasma glucose &lt;50 mg/dL, a critical sample can be obtained if the appropriate supplies and tubes are readily available. Otherwise, treatment of the hypoglycemia should not be delayed.



**Table 113.5** Syndromic Forms of Hyperinsulinemic Hypoglycemia\*

SYNDROME NAME	GENETIC ETIOLOGY GENE (LOCATION)	CLINICAL CHARACTERISTICS
<b>PRENATAL AND POSTNATAL OVERGROWTH (MACROSOMIA)</b>		
Beckwith-Wiedemann	(11p15)	Macroglossia, abdominal wall defects, ear lobe pits/creases, hemihypertrophy, tumor risk; IUGR if associated with placental mesenchymal dysplasia
Sotos	<i>NSD1</i> (5q35)	Macrocephaly, frontal bossing, pointed chin, developmental delay, tumor risk
Simpson-Golabi-Behmel	<i>GPC3</i> (Xq26), <i>GPC4</i> (Xp22)	Coarse facial features, broad feet, polydactyly, cryptorchidism, hepatomegaly, tumor risk
Perlman	<i>DIS3L2</i> (2q37)	Inverted V-shaped upper lip, prominent forehead, developmental delay, hypotonia, tumor risk
<b>POSTNATAL GROWTH FAILURE (SHORT STATURE)</b>		
Kabuki	<i>KMT2D</i> (12q13), <i>KDM6A</i> (Xp11.3)	Arched eyebrows, long eyelashes, developmental delay, fetal finger pads, scoliosis, heart defects, hypotonia
Costello	<i>HRAS</i> (11p15)	Deep palmar/plantar creases, developmental delay, coarse facial features, heart abnormalities, papillomas, tumor risk
<b>CHROMOSOMAL ABNORMALITY</b>		
Mosaic Turner	Loss of X in some cells	Milder Turner syndrome phenotype (short stature, coarctation of aorta, gonadal dysgenesis)
Patau	Trisomy 13	Developmental delay, microphthalmia, heart and neural defects
<b>CONGENITAL DISORDERS OF GLYCOSYLATION</b>		
Types 1a, 1b, and 1d	<i>PMM2</i> (16p13.2), <i>MPI</i> (15q24.1), <i>ALG3</i> (3q27.1)	Developmental delay, hypotonia, growth failure
<b>CONTIGUOUS GENE DELETION AFFECTING THE <i>ABCC8</i> GENE</b>		
Usher	11 genes	Hearing loss, visual impairment
<b>ABNORMALITIES IN CALCIUM HOMOEOSTASIS</b>		
Timothy	<i>CACNA1C</i> (12p13.33)	Long QT syndrome, syndactyly, developmental delay, immune deficiency
<b>INSULIN RECEPTOR PATHOGENIC VARIANT</b>		
Insulin resistance syndrome (leprechaunism)	<i>INS</i> (19p13)	Hypoglycemia and hyperglycemia, prenatal and postnatal growth restriction, elfin-like features, hirsutism
<b>OTHER SYNDROMES</b>		
Congenital central hypoventilation syndrome	<i>PHOX2B</i> (4p13)	Central hypoventilation, "box-shaped" face, neurocristopathies (Hirschsprung disease, tumor risk)

IUGR, intrauterine growth restriction.

\*Various developmental syndromes have been described with the gene/s linked to the condition and the common clinical features.

Modified from Güemes M, Rahman SA, Kapoor RR, et al. Hyperinsulinemic hypoglycemia in children and adolescents: recent advances in understanding of pathophysiology and management. *Rev Endo Metab Dis.* 2020;21:577–597, Table 2.

### Ongoing Management

Treatment goals of hypoglycemia disorders include maintaining euglycemia (plasma glucose >70 mg/dL), promoting normal development, and monitoring for medication side effects. Once the diagnostic evaluation identifies a specific hypoglycemia disorder, tailored treatment should be initiated promptly. Effective treatment allows the child to maintain euglycemia, both while eating an age-appropriate diet and fasting overnight. Continuous or forced feeds should not be used as treatment for hypoglycemia, as they result in long-term oral aversion and excessive weight gain. Additionally, hypoglycemia should not routinely be treated with steroids or cornstarch unless indicated as a treatment for specific disorders, such as adrenal insufficiency or glycogen storage disease. Home glucose monitoring is required for all children with hypoglycemia disorders and is particularly important during times of illnesses, as this may provoke additional hypoglycemia.

Management of individual hypoglycemia disorders is given in more detail in the following sections and in [Table 113.7](#).

### DISORDERS OF HYPOGLYCEMIA

Disorders of hypoglycemia can be classified by the metabolic fuel response to fasting (see [Fig. 113.4](#)).

#### Insulin-Mediated Disorders

Insulin-mediated disorders (see [Table 113.4](#)) are characterized by low plasma  $\beta$ -hydroxybutyrate and FFAs and a positive glycemic response to glucagon ([Table 113.8](#)).

#### Hyperinsulinism

HI is the most common cause of *persistent hypoglycemia* in infants and children. HI is caused by dysregulated insulin secretion by the pancreatic  $\beta$ -cells, resulting in severe and recurrent hypoglycemia ([Fig. 113.5](#)). HI can be categorized into three main forms: (1) perinatal stress-induced, (2) congenital or monogenic (see [Table 113.4](#)), and (3) syndromic (see [Table 113.5](#)).

Perinatal stress-induced HI (PSHI), the most common form of HI, occurs in the setting of stress on the fetus in utero or during delivery.

**Table 113.6** Hypoglycemia Diagnostic Evaluation

"CRITICAL SAMPLE" TO BE OBTAINED WHEN PLASMA GLUCOSE <50 MG/DL	
LABORATORY TEST	INTERPRETATION
Comprehensive metabolic panel	Low HCO <sub>3</sub> suggests elevation of ketones or lactate Elevated liver function tests may indicate GSD
β-hydroxybutyrate	Low levels suggest insulin excess (most commonly HI) or FAO disorder Elevated levels suggest GSD, hormone deficiency, or ketone utilization disorder
Insulin C-peptide	Detectable levels consistent with insulin excess Detectable insulin with undetectable c-peptide is consistent with exogenous insulin
Cortisol Growth hormone	Low levels concerning for hormone deficiency; need stimulation testing to confirm
Lactate	Elevated levels concerning for disorder of gluconeogenesis
Ammonia	Elevation can be seen in forms of HI and in IEM
Acylcarnitine profile Free and total carnitine Urine organic acids	Abnormalities suggestive of FAO disorder
IGF-BP1	Low levels suggest insulin excess
<b>GLUCAGON STIMULATION TEST</b>	
Administer 1 mg of glucagon IV or IM when plasma glucose <50 mg/dL	
Check point-of-care glucose every 10 min for 40 min	
If glucose does not increase 20 points in 20 min, terminate test and feed child	
Interpretation: Increase in glucose by 30 points is consistent with insulin excess	

HCO<sub>3</sub>, Bicarbonate; GSD, glycogen storage disorder; HI, hyperinsulinism; FAO, fatty acid oxidation; IEM, inborn errors of metabolism.

In a study of 514 neonates at risk of hypoglycemia, 19% of late-preterm and small-for-gestational-age (SGA) infants had recurrent hypoglycemia, which is concerning for PSHI. Common causes of PSHI include intrauterine growth restriction, being born SGA, maternal preeclampsia, birth asphyxia, and congenital heart disease. *Most infants with PSHI respond to diazoxide, although a subset, particularly those with liver dysfunction and hypoxic ischemic encephalopathy, may fail to respond.* PSHI typically resolves within the first 3-6 months of life.

**Congenital HI** is the result of genetic defects in the insulin secretory pathways of the β-cell. It is estimated to occur in 1:28,000-50,000 live births but may be as high as 1:3,000 in populations with a high frequency of consanguinity. The most common and severe type of congenital HI is caused by inactivating pathogenic variants of *ABCC8* and *KCNJ11*, which encode the ATP-sensitive potassium (K<sub>ATP</sub>) channel of the β-cell. Infants born with K<sub>ATP</sub>-HI are commonly large for gestation age and have high glucose requirements (glucose infusion rate [GIR] >10 mg/kg/min) (see Fig. 113.5). However, the spectrum of presentation is wide, and some infants have normal birthweights and lower glucose requirements. In addition to fasting hypoglycemia, children with this type of HI have protein-induced hypoglycemia, in which isolated protein ingestion leads to increased insulin secretion and low plasma glucose. K<sub>ATP</sub>-HI is most frequently unresponsive to treatment

with diazoxide, the only approved drug for HI, which acts on the K<sub>ATP</sub> channel.

K<sub>ATP</sub>-HI has two distinct histologic forms: a **diffuse form**, in which β-cells throughout the pancreas show evidence of hyperactivity, and a **focal form**, characterized by a localized area of β-cell overgrowth or adenomatosis. The diffuse form is caused by biallelic recessive pathogenic variants in *ABCC8* or *KCNJ11* or, less commonly, monoallelic dominant pathogenic variants of these genes. **Focal HI** occurs as a result of a "two-hit" mechanism: a paternally inherited recessive pathogenic variant in *ABCC8* or *KCNJ11* combined with somatic loss of the maternal 11p15 region, resulting in paternal uniparental isodisomy. Infants with the focal form are cured with resection of the focal lesion. In contrast, those with the diffuse form may require a palliative near-total pancreatectomy if intensive medical therapy fails to control the hypoglycemia (Fig. 113.6). Given the different treatment approaches and outcomes for the diffuse and focal forms of K<sub>ATP</sub>-HI, distinguishing between the two is critical and is best done through genetic testing. A paternally inherited recessive pathogenic variant in *ABCC8* or *KCNJ11* has a 94% positive predictive value for focal K<sub>ATP</sub>-HI.

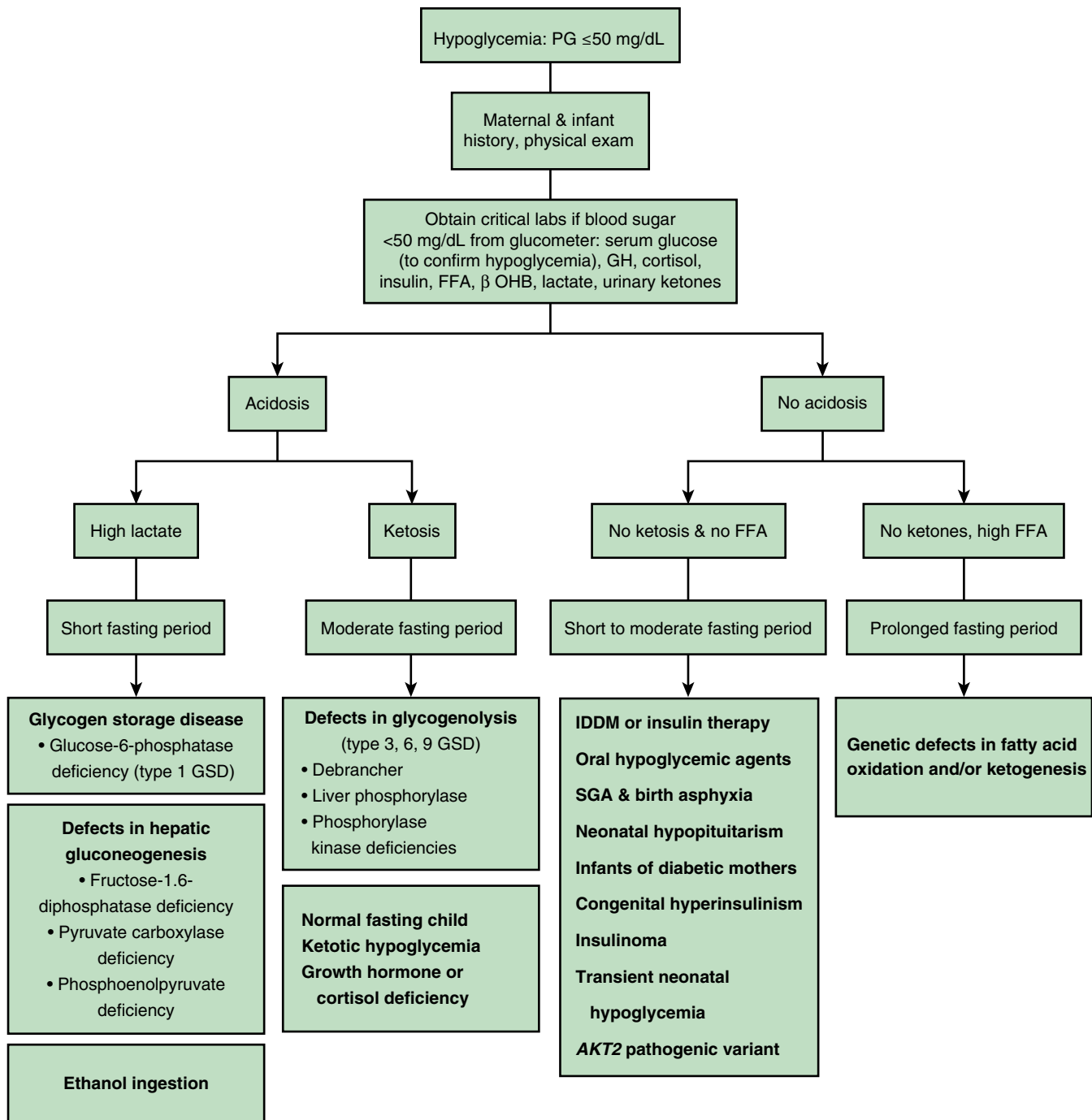
In children with genetic testing consistent with the focal form, an 18-fluoro L-3,4-dihydroxyphenylalanine positron emission tomography (<sup>18</sup>F-DOPA PET) scan is used before surgery to localize the focal lesion (see Fig. 113.6). Frozen section evaluation of biopsies taken during surgery is used to confirm the presence of the focal lesion and guides the extent of the resection. Children with the focal form of HI should receive care at specialized centers with <sup>18</sup>F-DOPA PET access and a multidisciplinary team of endocrinologists, surgeons, pathologists, and radiologists with expertise in HI. Children with the diffuse form also benefit from care at these centers because their management and the decision to pursue intensive medical therapy or a near-total pancreatectomy are complex.

The second most common form of congenital HI is caused by **dominant activating pathogenic variants of *GLUDI***, which encodes **glutamate dehydrogenase (GDH)**. This protein regulates the first step of amino acid-stimulated insulin secretion in the β-cell. Children with GDH-HI or hyperinsulinism-hyperammonemia syndrome (HI/HA) have fasting hypoglycemia, significant protein-induced hypoglycemia, and elevated plasma ammonia concentration. Seizures, attention-deficit disorder, and learning disabilities also occur in this form of HI, and these neurologic issues do not seem to correlate with the degree of hypoglycemia or ammonia elevation. *This form of HI responds well to diazoxide.*

**Activating pathogenic variants of *GCK***, which encodes **glucokinase**, cause an autosomal dominant form of congenital HI. Glucokinase is the key enzyme triggering glucose-mediated insulin secretion. Children with GCK-HI have fasting hypoglycemia of variable severity and diazoxide responsiveness. Severe cases may require a near-total pancreatectomy.

Pathogenic variants in *HNF4A* and *HNF1A*, which encode the transcription factors hepatic nuclear factors 4-alpha and 1-alpha, cause a dominant form of diazoxide-responsive HI. These infants may be large for gestational age and have high GIR requirements at birth. The HI resolves within the first several years of life. However, some individuals experience progressive β-cell failure and progress to an early-onset diabetes, known as *maturity-onset diabetes of the young (MODY)*.

Syndromes associated with HI are increasingly being recognized (see Table 113.5). Beckwith-Wiedemann syndrome (BWS), an imprinting disorder, is characterized by macroglossia, lateralized overgrowth, omphalocele, and a predisposition to embryonal tumors (Fig. 113.7). Hyperinsulinism occurs in approximately 50% of infants with BWS, although most cases are mild and resolve within the first several weeks of life. These cases are typically responsive to diazoxide. Children with BWS caused by paternal uniparental isodisomy of 11p can have severe and persistent HI, which does not respond to diazoxide and may



**Fig. 113.4** Diagnostic algorithm for determining the etiology of hypoglycemia in children. OHB, Hydroxybutyrate; FFA, free fatty acid; GH, growth hormone; GSD, glycogen storage disease; PG, plasma glucose; IDDM, insulin-dependent diabetes mellitus. (Modified from Melmed S, Auchus RJ, Goldfine AB, Koenig RJ, Rosen CJ. *Williams Textbook of Endocrinology*. 14th ed. Elsevier; 2020:1547, Fig. 38.14.)

require a pancreatectomy. Other syndromes known to be associated with HI include Kabuki, Turner, and Rubinstein-Taybi. HI in these syndromes presents with variable degrees of severity and responsiveness to diazoxide.

After establishing a diagnosis of HI, a trial of diazoxide, the first-line agent for the treatment of HI, should be undertaken (Fig. 113.8). Diazoxide opens the  $K_{ATP}$  channel, inhibiting insulin secretion. Children are considered responsive to diazoxide if the cardinal feature of HI, hypoketotic hypoglycemia, is corrected. This is assessed by demonstrating that the child can maintain plasma glucose >70 mg/

dL both while feeding and during an overnight fast and/or plasma  $\beta$ -hydroxybutyrate concentration increases to >2 mmol/L before plasma glucose decreases below 50–60 mg/dL during fasting. *Failure to respond to diazoxide strongly suggests  $K_{ATP}$ -HI, and those children require expedited genetic testing for *ABCC8* and *KCNJ11* to determine their risk for focal HI.* Thus the assessment of the response to diazoxide has important therapeutic and diagnostic implications.

Somatostatin analogs are used off-label as second-line agents for the treatment of diazoxide-unresponsive diffuse HI. Octreotide requires multiple daily injections, and its effectiveness is limited by

**Table 113.7** Treatments for Hypoglycemia Disorders

DRUG/THERAPY	INDICATION	DOSE (ROUTE OF ADMINISTRATION)	SIDE EFFECTS/COMMENTS
Diazoxide	HI	5-15 mg/kg/day every 12 hr (PO)	Hypertrichosis, fluid overload* neutropenia, thrombocytopenia, respiratory distress, hyperglycemia
Octreotide	HI	2-20 mcg/kg/day every 6 hr (SQ)	Gallstones, transaminitis, malabsorption, suppression of thyroid and growth hormones
Lanreotide	HI	60-90 mg every 28 days (SQ)	Gallstones, transaminitis, malabsorption, suppression of thyroid and growth hormones
Enteral D20	HI	Up to 10 mg/kg/min continuously (via gastrostomy or nasogastric tube)	Vomiting, diarrhea, fluid overload
Cornstarch	GSD, rarely FAOD, IKH	1-2 g/kg per dose (PO)	Diarrhea in infants
Growth hormone	Growth hormone deficiency	0.3 mg/kg/wk daily or every 12 hr (infants) (SQ)	Pseudotumor cerebri, edema, slipped capital femoral epiphysis, hyperglycemia
Hydrocortisone	Adrenal insufficiency	8-12 mg/m <sup>2</sup> /day (PO)	High doses: Immunosuppression, hyperglycemia, hypertension, obesity
Acarbose	Postprandial hypoglycemia	12.5-50 mg with meals	Transaminitis, diarrhea, abdominal pain
<b>PANCREATECTOMY</b>			
Partial	Focal HI Insulinoma		>50% pancreatectomy increases risk of diabetes and exocrine insufficiency later in life
Near-total (98%)	Severe diffuse HI		Insulin-dependent diabetes, exocrine insufficiency

\*Concomitant use of diuretics is strongly recommended in neonates and infants; older children may require this as well. HI, Hyperinsulinism; GSD, glycogen storage disease; FAOD, fatty acid oxidation disorder; IKH, idiopathic ketotic hypoglycemia.

**Table 113.8** Criteria for Diagnosing Hyperinsulinism and Other Forms of Insulin Excess

DRAWN AT A TIME OF FASTING HYPOGLYCEMIA: PLASMA GLUCOSE <50 MG/DL
Detectable insulin or c-peptide (plasma insulin $\geq 2$ $\mu$ U/mL or plasma C-peptide $\geq 0.5$ ng/mL)*
Hypofattyacidemia (plasma free fatty acids <1.7 mmol/L)
Hypoketonemia (plasma $\beta$ -hydroxybutyrate <1.8 mmol/L)
Inappropriate glycemic response to glucagon (increase in glucose >30 mg/dL)

\*Depends on sensitivity of insulin assay. Detectable insulin and C-peptide is not necessary to make a diagnosis of HI.

tachyphylaxis. A long-acting analog, lanreotide, is administered monthly in children greater than 1 year old and can be an effective and more convenient alternative to octreotide. Somatostatin analogs should not be used in neonates or infants less than 2 months old because they are associated with fulminant necrotizing enterocolitis. Continuous intragastric dextrose administered via gastrostomy tube is used in combination with a somatostatin analog and allows for an age-appropriate feeding schedule.

### Infants Born to Diabetic Mothers

See Chapter 147.1.

Gestational diabetes affects approximately 2% of pregnant women, and 1 in 1,000 pregnant women have insulin-dependent diabetes. Infants born to mothers with poorly controlled diabetes are born large for gestational age and with severe hypoglycemia resulting from a transient hyperinsulinemic state. Exposed to high glucose concentrations, the fetal islets compensate with increased insulin secretion that, during intrauterine life, leads to overgrowth and, after birth, results in hypoglycemia. The hypoglycemia

resolves within the first 3-7 days of life. Mothers whose diabetes has been well controlled during pregnancy, labor, and delivery generally have infants near normal size who are less likely to develop hypoglycemia.

### Insulinoma

Older children and adolescents presenting with insulin-mediated hypoglycemia should be evaluated for an **insulinoma**, a rare islet cell tumor. These tumors may be insidious, slow growing, and difficult to localize with conventional imaging modalities. Surgical resection is curative. Children diagnosed with an insulinoma should undergo genetic testing for the tumor predisposition syndrome, multiple endocrine neoplasia type 1 (MEN1).

### Factitious Hypoglycemia

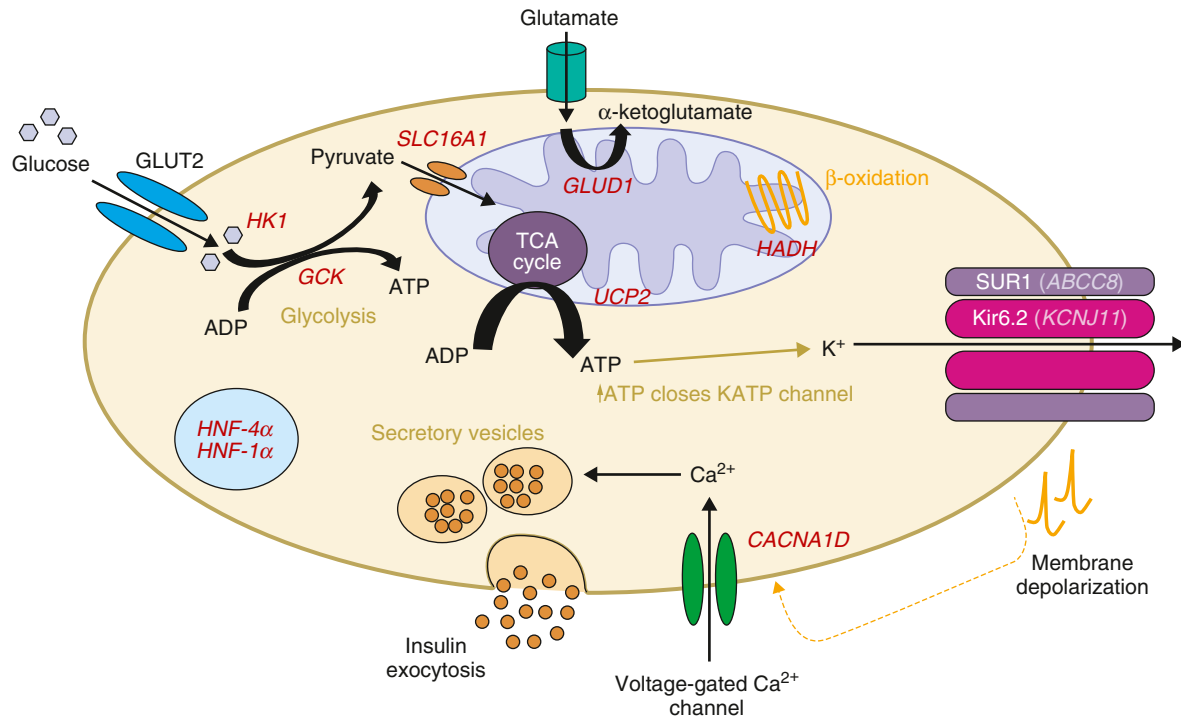
Surreptitious administration of insulin presents with abrupt onset and erratic hypoglycemia. In a younger child, a parent or guardian may provoke hypoglycemia (factitious disorder imposed on another: Munchausen by proxy), but an adolescent may be self-administering insulin. The biochemical hallmark of exogenous insulin administration is a detectable insulin level with undetectable c-peptide. However, specialized assays may be needed to detect the analog insulins, such as aspart or glargine. Intentional or accidental ingestion of sulfonylureas also presents with hypoglycemia. In these cases, both insulin and c-peptide are detectable, and sulfonylurea blood levels are required for confirmation.

### Defects of Fatty Acid Oxidation

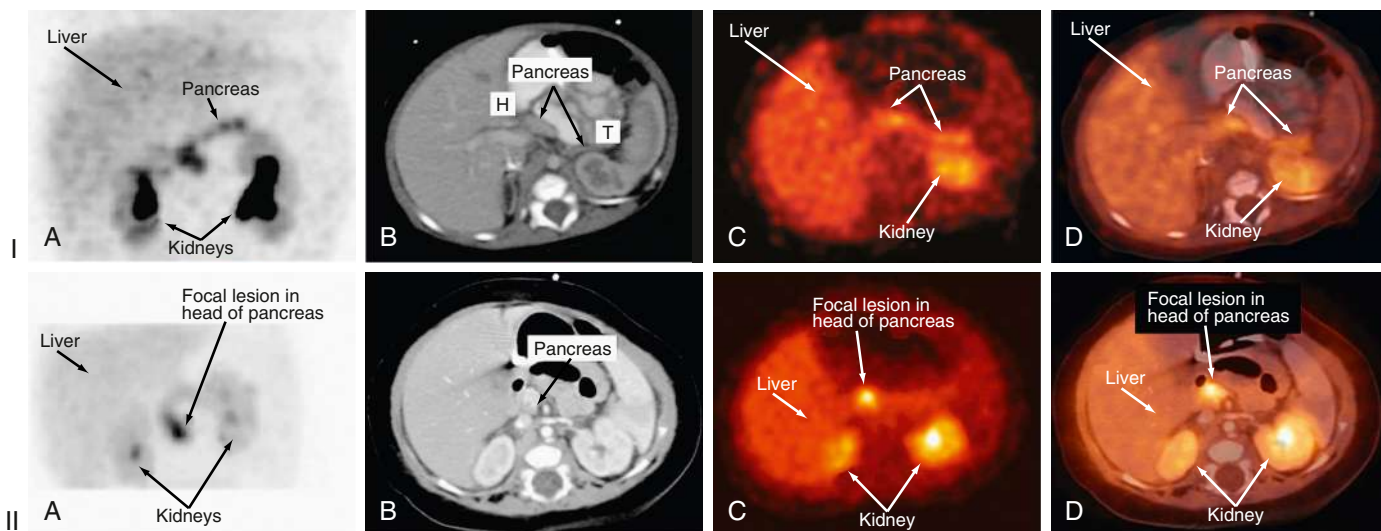
**Fatty acid oxidation disorders** are characterized by low plasma  $\beta$ -hydroxybutyrate and high plasma FFAs. See Chapter 106.1.

Multiple enzymatic deficiencies in the mitochondria pathway of fatty acid oxidation cause defective carnitine or fatty acid metabolism. These disorders are characterized by fasting hypoglycemia, hepatomegaly, cardiomyopathy, and hypotonia, although the spectrum of severity is wide. Infants may present with a Reye-like syndrome (see





**Fig. 113.5** Diagrammatic representation of  $\beta$ -cell function. Genetic defects associated with congenital HI are included in red. Postprandial glucose is taken into the  $\beta$ -cells via the glucose transporter 2 (GLUT-2). Glucose then enters the glycolysis pathway followed by the mitochondrial citric acid cycle (TCA), yielding the high-energy molecule, adenosine triphosphate (ATP). ATP molecules travel to and inhibit the potassium-dependent ATP channels ( $K_{ATP}$ ), which prevents influx of potassium resulting in membrane depolarization. This triggers voltage-gated calcium channels to open, and influx of calcium ( $Ca^{2+}$ ) occurs. The  $Ca^{2+}$  activates the enzyme phospholipase C (PLC) to produce inositol 1,3,5 triphosphate (IP<sub>3</sub>) and diacylglycerol (DAG) from phosphatidyl 1,3 bisphosphate (PIP<sub>2</sub>). The IP<sub>3</sub> molecule binds to the protein receptor on the endoplasmic reticulum (ER) to promote a release of  $Ca^{2+}$  from the ER. This subsequent increase in cytoplasmic  $Ca^{2+}$  promotes exocytosis of the prepackaged mature insulin and active C-peptide, which are released into circulation. GLUT2: Glucose transporter 2; Glucokinase (GCK) encoded by GCK gene; ADP: Adenosine diphosphate; ATP: Adenosine triphosphate; Monocarboxylate transporter (MCT1) encoded by SLC16A1 gene; Glutamate dehydrogenase (GDH) encoded by GLUD1 gene; Uncoupling protein 2 (UCP2) encoded by UCP2 gene; L-3-hydroxyacyl-coenzyme A dehydrogenase (HADH) encoded by HADH gene; SUR1 subunit of the  $K_{ATP}$  channel encoded by the ABCC8 gene; Kir6.2 subunit of the  $K_{ATP}$  channel encoded by KCNJ11 gene; Hepatocyte nuclear factor 4 $\alpha$  (HNF4 $\alpha$ ) encoded by HNF4A gene; Hepatocyte nuclear factor 1 $\alpha$  (HNF1 $\alpha$ ) encoded by HNF1A gene; HK1: Hexokinase 1 encoded by the gene HK1; CACNA1D: calcium voltage-gated channel subunit alpha 1 D. Gene variants in forkhead box protein A2 (FOXA2), phosphoglucomutase 1 (PGM1), and phosphomannomutase 2 (PMM2) are not included in the drawing. (From Güemes M, Rahman SA, Kapoor RR, et al. Hyperinsulinemic hypoglycemia in children and adolescents: recent advances in understanding of pathophysiology and management. *Rev Endo Metab Dis.* 2020;21:577–597, Fig. 1.)



**Fig. 113.6** Imaging of congenital hyperinsulinism. I Panels (*diffuse*): 18-fluoro L-3,4-dihydroxyphenylalanine positron emission tomography ( $^{18}F$ -DOPA PET) of a patient with a diffuse form of congenital hyperinsulinism. A, Diffuse uptake of  $^{18}F$ -DOPA is visualized throughout the pancreas. Transverse views show (B) normal pancreatic tissue on abdominal CT, (C) diffuse uptake of  $^{18}F$ -DOPA in the pancreas, and (D) confirmation of pancreatic uptake of  $^{18}F$ -DOPA with co-registration. H, Head of pancreas; T, tail of pancreas. II Panels (*focal*):  $^{18}F$ -DOPA PET of a patient with a focal form of congenital hyperinsulinism. (A) Discrete area of increased  $^{18}F$ -DOPA uptake is visualized in the head of the pancreas. The intensity of this area is greater than that observed in the liver and neighboring normal pancreatic tissue. Transverse views show (B) normal pancreatic tissue on abdominal CT, (C) focal uptake of  $^{18}F$ -DOPA in the pancreatic head, and (D) confirmation of  $^{18}F$ -DOPA uptake in the pancreatic head with co-registration. (Courtesy Dr. Olga Hardy, Children's Hospital of Philadelphia.)



**Fig. 113.7** Beckwith-Wiedemann syndrome. (Courtesy Dr. Michael Cohen, Dalhousie University, Halifax, Nova Scotia. From Jones KL. *Smith's recognizable patterns of human malformation*, 6th ed. Philadelphia: Saunders; 2006.)

Chapter 409) and recurrent episodes of fasting hypoglycemia, cardiorespiratory arrest, and coma, whereas older children with less severe forms may only develop symptoms with illness. Most cases are detected via newborn screening and confirmed with genetic testing. Abnormalities are seen in the acylcarnitine and urine organic acid profiles in children who are not identified through newborn screening. Treatment typically involves avoidance of fasting and administration of dextrose-containing fluids with illness.

Interference with fatty acid metabolism also underlies the fasting hypoglycemia associated with Jamaican vomiting sickness. In **Jamaican vomiting sickness**, the unripe ackee fruit contains a water-soluble toxin, hypoglycin, which produces vomiting, CNS depression, and severe hypoglycemia. The hypoglycemic activity of hypoglycin derives from its inhibition of gluconeogenesis secondary to its interference with the acyl-CoA and carnitine metabolism essential for the oxidation of long-chain fatty acids. The disease is almost totally confined to Jamaica, where ackee forms a staple of the diet. The ripe ackee fruit no longer contains this toxin. A similar illness noted in India, **acute toxic encephalopathy-hypoglycemic syndrome**, may be caused by litchi consumption. Litchi contains hypoglycin A and/or methylenecyclopropylglycine, which may inhibit fatty acid oxidation or gluconeogenesis.

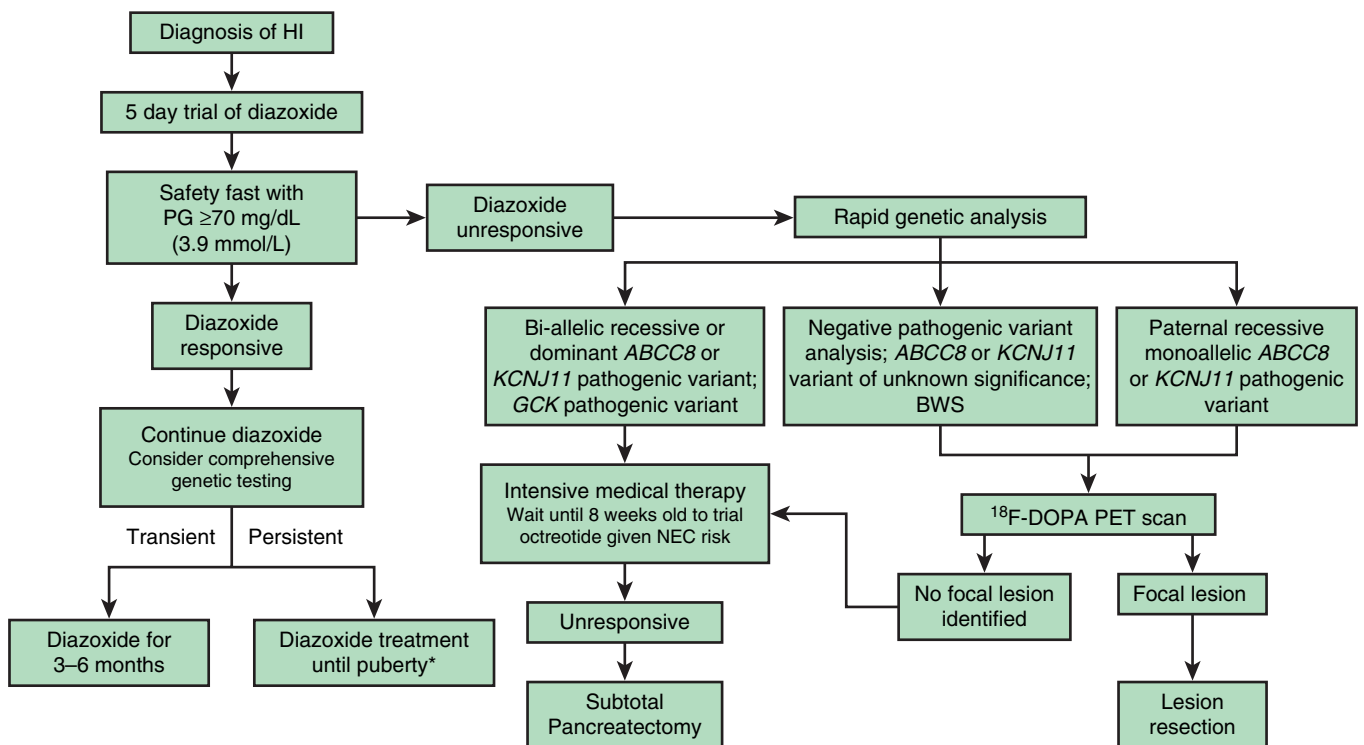
### KETOTIC HYPOGLYCEMIC DISORDERS

These disorders are characterized by elevated levels of plasma  $\beta$ -hydroxybutyrate ( $>2.5$  mmol/L) (Table 113.9).

### Glycogen Storage Disorders

See Chapter 107.1.

The **hepatic glycogen storage disorders** (GSDs; 0, I, III, VI, and IX) result from genetic defects in the enzymes that regulate the synthesis, breakdown, and release of glycogen in the liver. GSD type I also affects gluconeogenesis. GSDs are characterized by fasting ketotic hypoglycemia and various degrees of hepatomegaly, liver function abnormalities, hyperlipidemia, and



**Fig. 113.8** Management algorithm for hyperinsulinism. HI, Hyperinsulinism; BWS, Beckwith-Wiedemann syndrome. \*Some individuals may require diazoxide treatment into adulthood and possibly lifelong.

**Table 113.9** Causes of Ketotic Hypoglycemia in Children

	GENE OR CHROMOSOME	INHERITANCE
<b>HORMONAL</b>		
Growth hormone deficiency or resistance	Genetic or acquired	Variable
ACTH deficiency or resistance; cortisol deficiency	Genetic or acquired	Variable
Glucagon deficiency*	<i>GCG, DBH</i>	N/D
Dopamine β-hydroxylase deficiency*	<i>GCG, DBH</i>	N/D
<b>METABOLIC</b>		
Glycogen storage disease (GSD)		
GSD 0; glycogen synthase deficiency	<i>GYS2</i>	AR
GSD III; glycogen debranching enzyme deficiency	<i>AGL</i>	AR
GSD VI; glycogen phosphorylase deficiency	<i>PYGL</i>	AR
GSD IX; phosphorylase kinase subunit deficiencies	<i>PHKA2, PHKB, PHKG2</i>	X-linked, AR
<b>GLUCOSE METABOLISM AND TRANSPORT</b>		
Phosphoglucomutase I deficiency	<i>PMG1</i>	AR
Pyruvate carboxylase deficiency	<i>PC</i>	AR
<b>ORGANIC ACIDEMIAS</b>		
Maple syrup urine disease, propionic aciduria, methylmalonic aciduria	Multiple genes	AR
Ketone body transport and metabolism		
Monocarboxylase transporter 1 defect	<i>SLC16A1 (MCT1)</i>	AR, AD
Ketolysis		
Succinyl CoA oxoacid transferase deficiency	<i>SCOT</i>	AR
Mitochondrial acetoacetyl-CoA thiolase (β-ketothiolase) deficiency	<i>ACAT1</i>	AR
<b>SYNDROMES</b>		
Silver-Russel syndrome	11p15 or 7**	Mostly sporadic
Prader-Willi syndrome	15q11-q13***	Mostly sporadic
Fanconi-Bickel syndrome	<i>SLC2A2 (GLUT2)</i>	AR
KH secondary to chronic malnutrition, severe malaria, other chronic diseases	—	—
Idiopathic ketotic hypoglycemia		
Physiologic KH in prolonged fasting or acute illness	—	—
Pathologic KH	—	—
IGF2BP1 deficiency*	<i>IGF2BP1</i>	N/D
Sodium glucose co-transporter 2 defect*	<i>SLC5A2</i>	N/D
PEP carboxykinase 1 and G-6P catalytic transcriptional induction*	<i>NCOR1</i>	N/D
Mitosis gene A-related kinase 11 defect*	<i>NEK11</i>	N/D

\*Suggested, not well-established, causes of KH.

\*\*Several mechanisms, rare other mechanisms, or unknown.

\*\*\*Paternal deletion, maternal uniparental disomy, or imprinting defect.

AD, Autosomal dominant; AR, autosomal recessive; N/D, no data; PEP, phosphoenolpyruvate; G-6P, glucose 6-phosphate. The list is not fully inclusive.

From Drachmann D, Hoffman E, Carrigg A, et al. Towards enhanced understanding of idiopathic ketotic hypoglycemia: a literature review and introduction of the patient organization, Ketotic Hypoglycemia International. *Orphanet J Rare Dis.* 2021;16:173, Table 1.

failure to thrive. Muscle involvement is a feature of GSD type III, resulting in proximal muscle weakness and risk of cardiomyopathy. GSD types 0, VI, and IX present with less severe hypoglycemia compared with type I and III. The diagnosis of GSD is suspected in patients presenting with ketotic hypoglycemia, hepatomegaly, and liver enzyme abnormalities and is confirmed through genetic testing. The treatment of GSDs consists of uncooked cornstarch therapy, protein supplementation, and limited fasting.

### Hormone Deficiencies

Deficiencies of cortisol or growth hormone can result in ketotic hypoglycemia, as these counter-regulatory hormones play a role in mobilizing glucose production by the liver. Hypoglycemia occurs in both primary or secondary (central) **adrenal insufficiency** and is commonly seen during an adrenal crisis. **Growth hormone deficiency** results in hypoglycemia mainly during infancy and early toddlerhood. Combined hormone deficiencies, known as hypopituitarism, can also result

in hypoglycemia and are commonly caused by structural abnormalities of the pituitary gland. A clinical clue to the diagnosis of hypopituitarism is the presence of midline defects, cleft lip or palate, or in males, a microphallus. In the neonatal period, hypopituitarism presents with a hypoketotic hypoglycemia pattern that is indistinguishable from the pattern seen in neonates with HI. Thus in neonates with features suggestive of hypopituitarism, it is important to rule out hormone deficiencies before making a diagnosis of HI.

Low cortisol and growth hormone levels on a critical-sample laboratory result are suggestive of hormone deficiencies but not diagnostic. To confirm these diagnoses in a child presenting with hypoglycemia, appropriate hormone stimulation testing is recommended. A child diagnosed with central adrenal insufficiency, growth hormone deficiency, or hypopituitarism requires magnetic resonance imaging of their pituitary gland to assess for structural abnormalities or lesions. Hormone replacement with either hydrocortisone or growth hormone

resolves the hypoglycemia. Neonates and infants require twice-a-day growth hormone dosing to prevent ongoing hypoglycemia.

### Idiopathic Ketotic Hypoglycemia

Idiopathic ketotic hypoglycemia (IKH) commonly occurs during the first 1-4 years of life and typically resolves by age 6-8 years old. Children present with hypoglycemia and elevated  $\beta$ -hydroxybutyrate ( $>2$ -3 mmol/L), frequently in the setting of illness, and demonstrate shortened fasting tolerance on a diagnostic fast. IKH is a diagnosis of exclusion, and it is important to rule out other causes of ketotic hypoglycemia, such as GSDs or hormone deficiencies, before making this diagnosis. IKH is likely the result of the lower energy stores in toddlers and young children and is not caused by an underlying metabolic defect, as evidenced by its spontaneous resolution (see [Table 113.9](#)). Treatment typically consists of limited fasting time and home glucose monitoring during times of illness. IV dextrose infusion may be required with illness if children are unable to tolerate oral feeds.

### Disorders of Gluconeogenesis

Disorders of gluconeogenesis are characterized by elevated plasma lactate levels during hypoglycemia.

### Glycogen Storage Disease Type I

See [Chapter 107.1](#).

Glucose-6-phosphatase regulates the terminal step of gluconeogenesis and glycogenolysis, and deficiency of this enzyme results in GSD type I. Children with this condition experience hypoglycemia within 2-3 hours after a meal and significant elevations of lactate, uric acid, and triglycerides because of shunting of gluconeogenic precursors to alternative pathways in the liver. The diagnosis should be suspected in an infant with hypoglycemia, hepatomegaly, and the characteristic metabolic abnormalities. Sequencing of *G6PC* (type Ia) or *SLC37A4* (type Ib) confirms the diagnosis. Treatment includes frequent meals or feeds and after the first 6-12 months of life, uncooked cornstarch administered every 3-4 hours. Fasting beyond 4-6 hours can provoke life-threatening lactic acidosis.

### Fructose-1,6-Bisphosphatase Deficiency

See [Chapter 107.3](#).

A deficiency of this enzyme results in a block of gluconeogenesis from all possible precursors below the level of fructose-1,6-bisphosphate. Features are similar to GSD type I with fasting hypoglycemia, severe lactic acidosis, and elevations of uric acid and triglycerides. However, glycogenolysis remains intact, so patients do not have significant hepatomegaly or transaminitis. The diagnosis is confirmed through genetic testing of *FBP1*. Similar to GSD type I, treatment involves frequent meals, cornstarch, and avoidance of prolonged fasting.

## OTHER CAUSES OF HYPOGLYCEMIA

### Postprandial Hypoglycemia

Up to 30% of infants and children with **Nissen fundoplication**, a procedure used to ameliorate gastroesophageal reflux, develop **postprandial hypoglycemia**, or “late dumping syndrome.” Characteristic features include hyperglycemia followed by severe hypoglycemia (average 32

mg/dL in one series) 1.5-3 hours later. The early hyperglycemia phase is associated with brisk and excessive insulin release that causes the resultant hypoglycemia. A role for exaggerated GLP-1 secretion has been proposed as being responsible for the excessive insulin release. Treatment consists of feed modifications for formula- or tube-fed children, such as the use of complex formulas or prolonged feeds. Acarbose has been successfully used in some orally fed children.

### Acute Alcohol Intoxication

The generation of reducing equivalents during the oxidation of ethanol in the liver inhibits several gluconeogenic enzymes, resulting in hypoglycemia if glycogen stores are depleted by starvation or by preexisting abnormalities in glycogen metabolism. There is no correlation between blood ethanol levels and the occurrence of hypoglycemia. In toddlers who have been fasting for some time, even the consumption of small quantities of alcohol can precipitate hypoglycemia. *Alcohol-induced hypoglycemia promptly responds to IV dextrose*. However, if there is an associated alcohol toxicity, the patient may not show clinical signs of improvement despite now having a normal blood glucose level. A careful history allows the diagnosis to be made and may avoid additional workup.

### $\beta$ Blockers

$\beta$ -Adrenergic stimulation enhances glucagon secretion and increases glycogenolysis and gluconeogenesis.  $\beta$  blockers impair the counter-regulatory response to hypoglycemia and blunt the autonomic symptoms described earlier. Children at highest risk of hypoglycemia from  $\beta$  blockers include those with insulin-dependent diabetes and infants and toddlers in the setting of prolonged fasting or illness. Despite increased use of propranolol for infantile hemangiomas, the prevalence of hypoglycemia in this population appears to be low (0.9%). Propranolol has also been safely used in children with underlying hypoglycemia disorders, although close monitoring of glucose is needed during illness.

### Salicylate Intoxication

See [Chapter 94](#).

Both hyperglycemia and hypoglycemia occur in children with salicylate intoxication. Accelerated use of glucose, resulting from augmentation of insulin secretion by salicylates, and possible interference with gluconeogenesis may contribute to hypoglycemia. Infants are more susceptible than older children. Monitoring of blood glucose levels with appropriate glucose infusion in the event of hypoglycemia should form part of the therapeutic approach to salicylate intoxication in childhood. Ketosis may occur.

### Systemic Disorders

Several systemic disorders are associated with hypoglycemia in infants and children. Children with acute liver failure develop hypoglycemia because of loss of gluconeogenesis. Sepsis, particularly in neonates, may result in hypoglycemia. Falciparum malaria is also associated with hypoglycemia, which is thought to be the result of increased glucose use and impaired gluconeogenesis.

Visit Elsevier eBooks+ at [eBooks.Elsevier.com](http://eBooks.Elsevier.com) for Bibliography.



**Aneuploidy screening** is offered to pregnant persons in the first trimester or at midgestation to evaluate the risk for common aneuploidies such as Down syndrome (trisomy 21), trisomy 18, trisomy 13, and congenital malformations (e.g., abdominal wall or NTDs) known to cause elevations of various markers. A combination of these biochemical markers (including AFP, inhibin A, estriol, pregnancy-associated plasma protein A,  $\beta$ -human chorionic gonadotropin [ $\beta$ -hCG]) and US increases the positive predictive value (PPV) of these screening tests. Fetal DNA in maternal plasma and fetal cells circulating in maternal blood are potential noninvasive sources of material for prenatal genetic testing. This testing, however, is not diagnostic, and a positive test requires either amniocentesis or postnatal analysis to confirm the diagnosis. Nonetheless, fetal karyotyping by analysis of fetal DNA in maternal plasma is another screening test that is very sensitive for the detection of Down syndrome, with a higher PPV than any other prenatal screening test for Down syndrome. Currently, however, the use of this technology is only advocated in pregnancies deemed at high risk for aneuploidy.

Visit Elsevier eBooks+ at [eBooks.Health.Elsevier.com](http://eBooks.Health.Elsevier.com) for Bibliography.

for the fetus and the parents. **Termination of pregnancy** is also an option that should be discussed during the initial phases of counseling.

**Folic acid supplementation** decreases the incidence and recurrence of NTDs. Because the neural tube closes within the first 28 days of conception, periconceptional supplementation is needed for prevention. It is recommended that women without a prior history of a NTD ingest 400  $\mu$ g/day of folic acid throughout their reproductive years. Women with a history of a prior pregnancy complicated by an NTD or a first-degree relative with an NTD should have preconceptional counseling and should ingest 4 mg/day of supplemental folic acid beginning at least 1 month before conception. Fortification of cereal-grain flour with folic acid is established policy in the United States and some other countries. The optimal concentration of folic acid in enriched grains is somewhat controversial. The incidence of NTD in the United States and other countries has decreased significantly since these public health initiatives were implemented. Use of some antiepileptic drugs (valproate, carbamazepine) during pregnancy is associated with an increased risk of NTD. Women taking these medications should ingest 1-5 mg of folic acid daily in the preconception period.

Visit Elsevier eBooks+ at [eBooks.Health.Elsevier.com](http://eBooks.Health.Elsevier.com) for Bibliography.

## 117.7 Treatment and Prevention of Fetal Disease

Krishna K. Acharya, Alicia J. Sprecher, and Susan S. Cohen

See also [Chapter 118](#).

Management of a fetal disease depends on coordinated advances in diagnostic accuracy and knowledge of the disease's natural history; an understanding of fetal nutrition, pharmacology, immunology, and pathophysiology; the availability of specific active drugs that cross the placenta; and therapeutic procedures. Progress in providing specific treatments for accurately diagnosed diseases has improved with the advent of real-time ultrasonography, amniocentesis, and cordocentesis (see [Tables 117.1 and 117.9](#)).

The incidence of sensitization of Rh-negative women by Rh-positive fetuses has been reduced by prophylactic administration of Rh(D) immunoglobulin to mothers early in pregnancy and after each delivery or abortion, thus reducing the frequency of hemolytic disease in their subsequent offspring. **Fetal erythroblastosis** (see [Chapter 140](#)) may be accurately detected by fetal Doppler assessment of the peak systolic velocity of the middle cerebral artery and treated with intrauterine transfusions of packed Rh-negative blood cells via the intraperitoneal or, more often, intraumbilical vein approach.

**Pharmacologic** approaches to fetal immaturity mostly revolve around the administration of antenatal corticosteroids to the mother to promote fetal production of surfactant with a resultant decrease in the incidence of **respiratory distress syndrome** (see [Chapter 126](#)). Tocolytic agents have been demonstrated to prolong pregnancy to allow the administration of antenatal corticosteroids (48 hours); however, there is no proven benefit beyond this time frame. Maternal administration of magnesium sulfate for fetal/neonatal neuroprotection is recommended in pregnancies deemed to be at risk of imminent delivery before 32 weeks' gestation in light of evidence demonstrating a reduction in frequency of cerebral palsy compared with those who did not receive this treatment.

Management of definitively diagnosed fetal genetic disease or congenital anomalies consists of multidisciplinary parental counseling. Rarely, high-dose **vitamin therapy** for a responsive inborn error of metabolism (e.g., biotin-dependent disorders) or fetal transfusion (with red blood cells or platelets) may be indicated. **Fetal surgery** is well-established treatment for certain conditions but remains a largely experimental approach to therapy for other conditions and is available only in a few, highly specialized perinatal centers (see [Table 117.9](#) and [Chapter 118](#)). The nature of the defect and its consequences must be considered, as well as ethical implications

## Chapter 118

# Fetal Intervention and Surgery

Natalie E. Rintoul, Emily A. Partridge, and Holly L. Hedrick

Congenital anomalies have always been recognized as a therapeutic challenge. Numerous diagnoses have been evaluated for the possibility of fetal intervention ([Tables 118.1 and 118.2](#)). Some have proved beneficial to the developing infant, some have been abandoned, and some remain under investigation.

### FETAL THERAPY ETHICS

With the development of advanced fetal ultrasound (US), ultrafast fetal MRI, and fetal echocardiography, the ability to accurately diagnose fetal disease has improved substantially over the past 3 decades. The first prenatal therapeutic intervention was reported in 1963 with the successful treatment of erythroblastosis fetalis by fetal intraperitoneal infusion. Other innovations, though groundbreaking, brought to light the high morbidity (fetal and maternal) and mortality associated with open fetal interventions, and it would take greater experience and techniques before open fetal surgery would be safer and therapeutic.

### OBSTRUCTIVE UROPATHY

Obstructive uropathy is a diverse set of diseases affecting the bladder neck or urethra and affects between 2.2 and 3.3 per 10,000 live births. It is most frequently caused by **posterior urethral valves (PUVs)** but can be caused by a variety of other defects, including urethral atresia, persistent cloaca, caudal regression, and megacystis-microcolon-intestinal hypoperistalsis syndrome (see [Chapters 577 and 578](#)). Although male fetuses are more commonly affected, females are more commonly associated with severe pathologic variants, and 30% of survivors will require renal replacement therapy or transplantation before age 5. Congenital obstructive uropathy

**Table 118.1** Fetal Diagnoses Evaluated and Treated in Fetal Centers

Amniotic band syndrome (ABS)	Gastroschisis
Anomalies in monochorionic twins	Hydrocephalus
Aortic stenosis	Hydronephrosis
Arachnoid cyst	Hypoplastic left heart syndrome (HLHS)
Bladder exstrophy	Imperforate anus
Bladder outlet obstruction	Intraabdominal cyst
Bronchopulmonary sequestration (BPS)	Lymphangioma
Cervical teratoma	Mediastinal teratoma
Cloaca	Myelomeningocele, spina bifida
Cloaca exstrophy	Neuroblastoma
Complete heart block	Obstructive uropathy
Congenital pulmonary airway malformation (CPAM)	Omphalocele
Congenital diaphragmatic hernia (CDH)	Pentalogy of Cantrell
Congenital high airway obstruction syndrome (CHAOS)	Pericardial teratoma
EXIT to airway procedure for CHAOS	Pleural effusions
Conjoined twins	Pulmonary agenesis
Dandy-Walker malformation	Pulmonary atresia with intact ventricular septum
Duodenal atresia	Sacroccygeal teratoma (SCT)
Encephalocele	Twin reversed arterial perfusion (TRAP) sequence
Enteric duplication atresia	Twin-to-twin transfusion syndrome (TTTS)
Esophageal atresia	Vein of Galen aneurysm

EXIT, Ex utero intrapartum treatment.

**Table 118.2** Indications and Rationales for In Utero Surgery on the Fetus, Placenta, Cord, or Membranes

FETAL SURGERY	PATHOPHYSIOLOGY	RATIONALE FOR IN UTERO INTERVENTION
<b>SURGERY ON THE FETUS</b>		
1. Congenital diaphragmatic hernia	Pulmonary hypoplasia and anatomic substrate for pulmonary hypertension	Reversal of pulmonary hypoplasia and reduced degree of pulmonary hypertension Repair of actual defect delayed until after birth
2. Lower urinary tract obstruction	Progressive renal damage due to obstructive uropathy Pulmonary hypoplasia due to oligohydramnios	Prevention of renal failure and pulmonary hypoplasia by anatomic correction or urinary deviation
3. Sacrococcygeal teratoma	High-output cardiac failure due to AV shunting and/or bleeding Direct anatomic effects of the tumoral mass Polyhydramnios-related preterm labor	Reduction of functional impact of tumor by ablation of tumor or (part of) its vasculature Reduction of anatomic effects by drainage of cysts or bladder Amnioreduction preventing obstetric complications
4. Thoracic space-occupying lesions	Pulmonary hypoplasia (space-occupying mass) Hydrops due to impaired venous return (mediastinal compression)	Creation of space for lung development Reversal of the process of cardiac failure
5. Neural tube defects	Damage to exposed neural tube Chronic CSF leak, leading to Arnold-Chiari malformation and hydrocephalus	Prevention of exposure of the spinal cord to amniotic fluid Restoration of CSF pressure correcting Arnold-Chiari malformation
6. Cardiac malformations	Critical lesions causing irreversible hypoplasia or damage to developing heart	Reversal of process by anatomic correction of restrictive pathology
<b>SURGERY ON THE PLACENTA, CORD, OR MEMBRANES</b>		
7. Chorioangioma	High-output cardiac failure due to AV shunting Effects of polyhydramnios	Reversal of process of cardiac failure and hydrops fetoplacentalis by ablation or reduction of flow
8. Amniotic bands	Progressive constrictions causing irreversible neurologic or vascular damage	Prevention of amniotic band syndrome leading to deformities and function loss
9. Abnormal monochorionic twinning: twin-to-twin transfusion; fetus acardius, and discordant anomalies	Twin-twin transfusion leading to oligopolyhydramnios sequence, hemodynamic changes; preterm labor, and rupture of membranes; in utero damage to brain, heart, or other organs In utero fetal death may cause damage to co-twin Cardiac failure of pump twin and consequences of polyhydramnios Serious anomaly raising the question of termination of pregnancy Selective feticide	Arrest of intertwin transfusion Prevention/reversal of cardiac failure and/or neurologic damage, including at in utero death Prolongation of gestation Selective feticide to arrest parasitic relationship, to prevent consequences of in utero fetal death, and to avoid termination of entire pregnancy

AV, Arteriovenous; CSF, cerebrospinal fluid.

From Deprest J, Hodges R, Gratacos E, Lewi L. Invasive fetal therapy. In: Creasy RK, Resnick R, Iams JD, et al., eds. *Creasy & Resnik's Maternal-Fetal Medicine*. 7th ed. Philadelphia: Elsevier; 2014. Table 35-1.

causes hydronephrosis and renal dysplasia of variable severity. Although the mechanism of renal injury is debated, hypotheses include cyst formation secondary to urinary retention and subsequent disruption of nephrogenesis versus obstruction-associated apoptosis of renal tubular cells.

Obstructive uropathy usually presents on fetal US with an enlarged bladder, bilateral hydronephrosis, and oligohydramnios in the second and third trimester. Mild forms of obstructive uropathy may lead to minimal short- or long-term clinical sequelae. However, reduced fetal urine output resulting in oligohydramnios or anhydramnios in more severe forms can cause significant pulmonary hypoplasia, which is associated with death shortly after delivery in >80% of infants. Pulmonary survivors remain subject to high mortality and chronic morbidity resulting from renal dysplasia, renal failure, and the need for chronic renal replacement therapy. Workup of congenital obstructive uropathy includes genetic and structural evaluation, with additional imaging and fetal urinalysis aiding in prognostication. For example, a fetal urine sodium <100 mEq/L, chloride <90 mEq/L, and urine osmolality >210 mEq/L at a mean gestational age of 23.8 weeks predicts “good outcome,” as reflected by the presence of nondysplastic kidneys at autopsy or biopsy, or normal renal and pulmonary function at birth. Fetuses with salvageable renal function should have downtrending values of urine sodium, chloride, calcium, total protein and  $\beta_2$ -microglobulin on repeat vesicocentesis. Fetal bladder filling time [(fetal bladder volume 48 hours post-vesicocentesis – fetal bladder volume prior to vesicocentesis)/fetal bladder volume prior to vesicocentesis], fetal MRI, and three-dimensional fetal cystoscopy have also been shown to have utility in predicting postnatal renal function.

The primary objective of fetal intervention in fetuses with obstructive uropathy is restoration of amniotic fluid volume to prevent pulmonary hypoplasia. Although prevention of ongoing renal injury is also desired, the efficacy of fetal intervention in achieving this goal is uncertain. Therefore fetal intervention for obstructive uropathy is currently limited to fetuses in whom the obstruction is sufficient to cause oligohydramnios or anhydramnios.

For fetuses that still have adequate renal function and can produce urine, treatment options include vesicoamniotic shunting, valve ablation via cystoscopy, and vesicostomy. **Vesicoamniotic shunting** is the most common and involves percutaneous, US-guided placement of a double-pigtailed shunt from the fetal bladder to the amniotic space, allowing decompression of the obstructed bladder and restoration of the amniotic fluid volume (Figs. 118.1 and 118.2). Although simple in concept, bladder decompression may not always occur, and many catheters will become dislodged as the fetus develops; a fetus typically requires three catheter replacements before completion of pregnancy. Vesicoamniotic shunting may improve perinatal survival, but at the expense of poor long-term renal function. In a systematic review of over 250 fetuses, increased prenatal survival is present in the shunted population, but there is no difference in the 12- and 24-month survival.

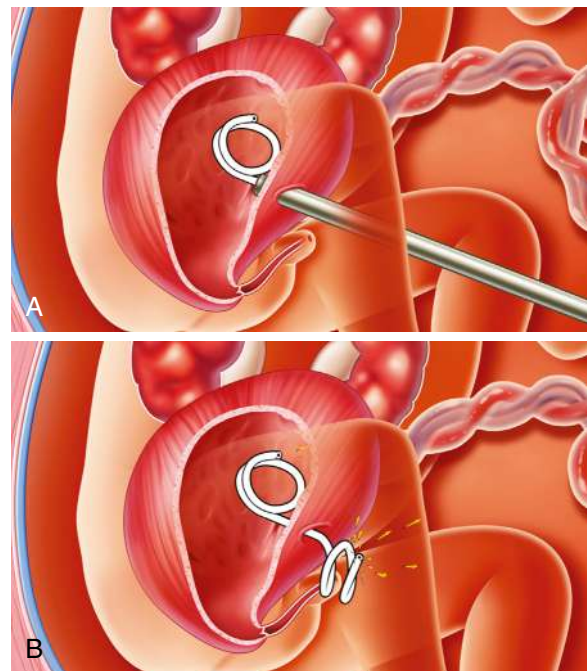


**Fig. 118.1** Ultrasound image showing fetoscopic placement of a transurethral vesicoamniotic shunt in a patient with posterior urethral valves. (Courtesy Dr. Foong Lim, Cincinnati Fetal Center at Cincinnati Children’s Hospital Medical Center.)

Fetal **cystoscopy** is more technically challenging than vesicoamniotic shunt placement, more invasive, and requires more sedation, but this option holds some important advantages. Cystoscopy allows for direct visualization of the obstruction and does not require amnioinfusion. Moreover, when the obstruction is visualized and the diagnosis of PUV confirmed, the valves can be treated, restoring urine flow to the amniotic space, and eliminating the need for repeated fetal interventions in most patients. Creation of a vesicostomy (direct opening from bladder through fetal abdominal wall) by open fetal surgery has improved perinatal survival (Fig. 118.3). However, the current dataset evaluating this approach is still limited, and direct comparisons to shunting suggest no significant difference between these interventions.

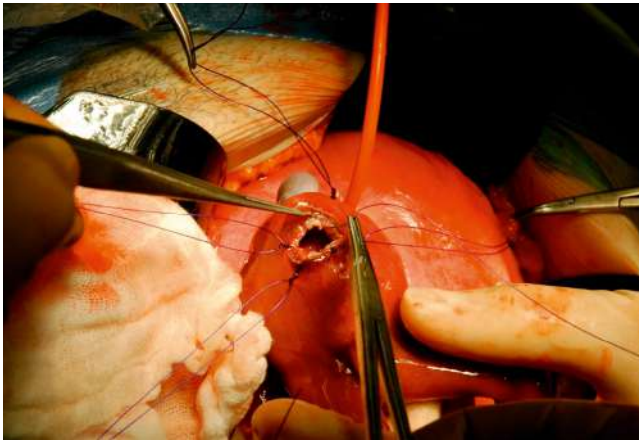
## NONOBSTRUCTIVE RENAL DISEASE

Nonobstructive fetal renal disease can result from renal hypoplasia/dysplasia and from genetic diseases such as autosomal recessive polycystic kidney disease. Similar to obstructive uropathy, fetal therapy is focused on restoring amniotic fluid volume in patients with oligohydramnios or anhydramnios. However, restoration of amniotic fluid volume in nonobstructive renal disease requires external sources of amniotic fluid. Current treatment options include serial percutaneous **amnioinfusion** and infusion of fluid by amnioport. Serial amnioinfusions are less invasive as a single procedure, but most pregnancies will require weekly infusions to maintain adequate amniotic fluid volume. Amnioinfusion through an amnioport involves open surgical placement of a catheter into the amniotic space that is connected to an ex utero subcutaneous port. This allows repeated fluid infusion into the amniotic space. The amnioport is more challenging and invasive as an individual procedure but provides more reliable access to the amniotic space for the duration of the pregnancy. Small studies suggest both these procedures improve pulmonary outcomes and perinatal survival in infants with renal disease, but these infants will require dialysis and then renal transplant when the infant is large enough (2-3 years of age). The Renal Anhydramnios Fetal Therapy (RAFT) is a multi-site clinical trial to determine the feasibility, safety and success rate of serial **amnioinfusions** for early pregnancy renal anhydramnios (EPRA). The trial originally included EPRA caused both by congenital bilateral **renal agenesis** (CoBRA) and by fetal renal failure



**Fig. 118.2** Vesicoamniotic shunt placement. A, The shunt is loaded into the trocar, passed into the bladder, and recoils to a pigtail shape. B, The other end of the shunt recoils to a pigtail outside the abdominal wall, releasing urine into the amniotic fluid space around the fetus. (Copyright 2021, The Children’s Hospital of Philadelphia.)





**Fig. 118.3** Creation of a fetal vesicostomy. The uterine opening is stapled to prevent bleeding, and a catheter is inserted to replace amniotic fluid and maintain uterine volume. The fetus is positioned with the legs to the lower part of the field and the umbilical cord to the upper part of the field. A vesicostomy is created through the bladder and the abdominal wall to allow drainage of the obstructed bladder and restoration of amniotic fluid volume. (Courtesy Dr. Foong Lim, Cincinnati Fetal Center at Cincinnati Children's Hospital Medical Center.)

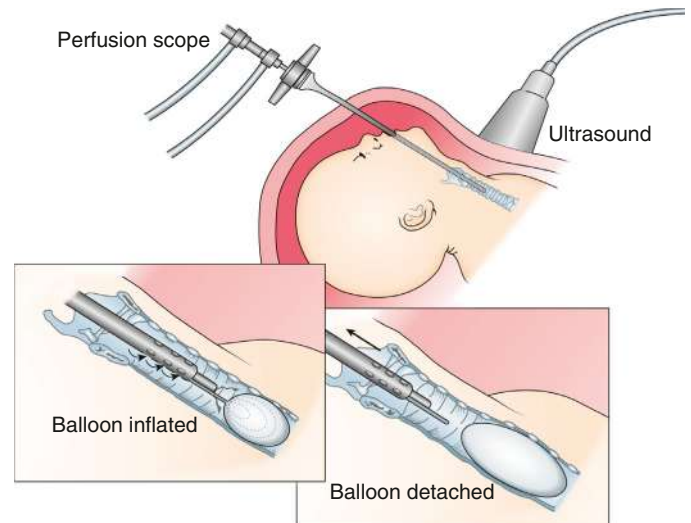
(FRF) with kidney tissue present. At the time of this publication, the CoBRA arm is no longer recruiting. The primary objective of this trial is to determine the proportion of neonates surviving to successful dialysis after serial amnioinfusions.

### CONGENITAL DIAPHRAGMATIC HERNIA

Congenital diaphragmatic hernia (CDH) is a structural birth defect in which the diaphragm fails to fully close during development resulting in herniation of the abdominal contents into the thorax and inhibition of fetal lung growth (see Chapter 131). CDH occurs in 1,500 live births in the United States annually and is the leading cause of in-hospital neonatal deaths as well as the costliest noncardiac birth defect. Although the pathophysiology of CDH remains unclear, most patients are affected by some degree of pulmonary hypoplasia and persistent pulmonary hypertension. A dual-hit hypothesis has been suggested to characterize lung injury in CDH, with an initial injury occurring during organogenesis resulting in bilateral pulmonary hypoplasia and a secondary insult of the ipsilateral lung due to compression by the herniated abdominal viscera. Fetal breathing and fluidic lung distension are features of normal lung development, which are mechanically compromised by the diaphragmatic defect, resulting in not only reduced parenchymal volume but also decreased vascular density. Compensatory vascular remodeling results in hypermuscularization of the arteriolar bed, increased vascular resistance, and ultimately pulmonary hypertension. It is the severity of pulmonary hypoplasia and persistent pulmonary hypertension that represents the greatest determinant of morbidity and mortality.

In mild cases of CDH, surgical repair of the diaphragm is typically performed in the first few days of life after respiratory and hemodynamic stabilization. Although these infants are affected by pulmonary hypoplasia and close monitoring is required during the first years of life, long-term outcomes are excellent in the majority of survivors of mild CDH. In cases of severe CDH, pulmonary hypertension leads to right ventricular dysfunction and right-to-left shunting across the patent foramen ovale and ductus arteriosus, which can result in left ventricular dysfunction and cardiac failure necessitating extracorporeal membrane oxygenation (ECMO) in the perinatal period. Mortality is high in severely affected infants, and survivors often have significant impairments in long-term respiratory, feeding, and neurodevelopmental outcomes.

More than half of all CDH cases are identified on routine second trimester anatomy US, whereas delayed diagnosis may occur secondary to small defects, technical limitations, or unavailability of prenatal care. In 50–70% of cases the lesion is isolated, whereas *syndromic* or *complex* CDH may be associated with additional anomalies warranting further imaging and genetic studies. Fetal echocardiography and ultrafast MRI should be



**Fig. 118.4** Technique for fetoscopic tracheal occlusion using a balloon. (Modified from Hirose S, Harrison MR. *Fetal therapy*. In Holcomb GW III, Murphy JP, eds. *Ashcraft's Pediatric Surgery*. 5th ed. St Louis: Elsevier; 2010. Fig. 10.1.)

included in comprehensive fetal diagnosis, permitting calculation of fetal lung volumes as well as ruling out major structural cardiac anomalies.

The first reports of attempted *in utero* repair of CDH noted impairment of umbilical blood flow after reduction of the liver resulting in fetal demise in a number of cases. Although the procedure proved to be technically feasible in fetuses without liver herniation, comparative analysis revealed higher rates of preterm delivery (32 vs 38 weeks' gestation) and similar rates of survival (75% fetal repair vs 86% postnatal repair), leading to abandonment of prenatal attempts at surgical repair.

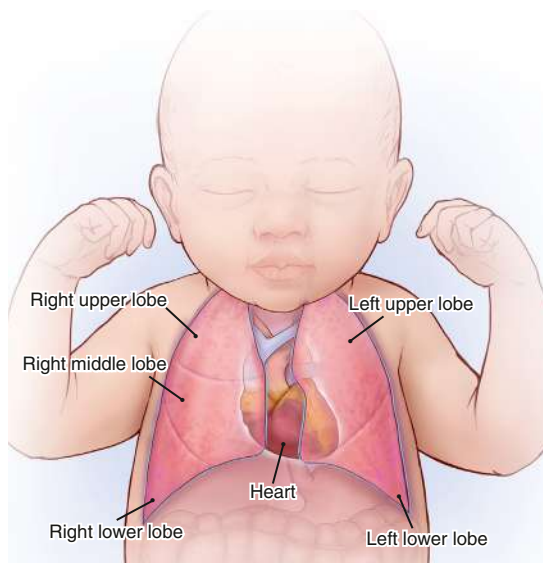
Given the disappointing results after attempted open fetal surgical repair of CDH, researchers turned to the fetal lamb model to assess the impact of tracheal ligation on pulmonary development. By blocking the efflux of fetal lung fluid into the amniotic space, pulmonary distension results in increased lung volumes. To mitigate the risks associated with open tracheal ligation, a **fetoscopic endoluminal tracheal occlusion (FETO)** approach with balloon tracheal occlusion was developed (Fig. 118.4). In a study of 210 fetuses with severe hypoplasia due to isolated CDH, the use of FETO had an acceptable safety profile in the mother with improved neonatal survival but increased risk of preterm birth. In this trial the balloon was inserted at approximately 28 weeks of gestation and removal at 34 weeks, with this timing based on the hypothesis that tracheal occlusion will promote lung expansion while removal of the balloon before delivery will promote alveolar type II cell maturation. The multicenter prospective randomized Tracheal Occlusion to Accelerate Lung Growth (TOTAL) study results had inclusion criteria of gestational age less than 29 weeks 6 days at randomization, isolated left-sided CDH with no other major structural or chromosomal defects, and severe pulmonary hypoplasia defined as observed-to-expected lung-to-head ratios of less than 25%. Forty percent of infants with severe CDH in the FETO group survived to discharge compared to 15% in the expectant care group, with survival to 6 months identical to survival at discharge and increased rate of preterm rupture of membranes (47% vs 11%) and preterm birth (75% vs 29%).

### CONGENITAL PULMONARY AIRWAY MALFORMATION

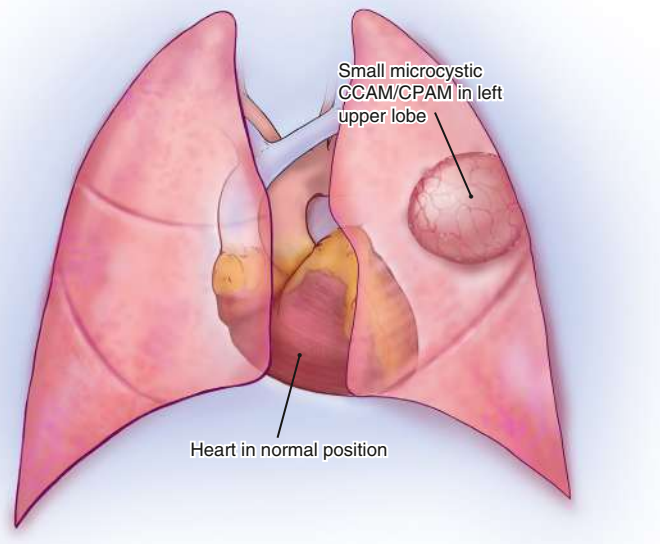
Congenital pulmonary airway malformations (CPAM), or fetal lung lesions, are a group of rare congenital pulmonary neoplasms including congenital cystic adenomatoid malformations (CCAMs), bronchopulmonary sequestrations (BPSs), congenital lobar emphysema, and bronchogenic cysts (Fig. 118.5). The reported incidence of CPAM is 9 per 100,000 live births, with prenatal diagnosis by fetal US most commonly coinciding with the 18–20-week anatomy scan. CCAMs are caused by abnormal branching and hamartomatous growth of the terminal respiratory structures, resulting in cystic and adenomatoid malformations (see Chapter 444), and are the most common congenital lung lesion. CCAMs



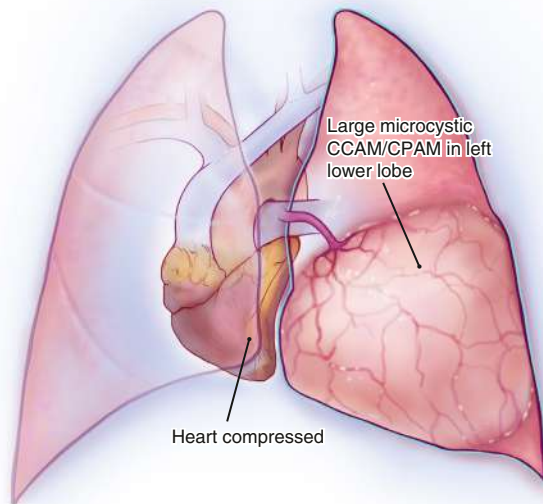
Normal Heart and Lung Anatomy with Lobes of Lungs



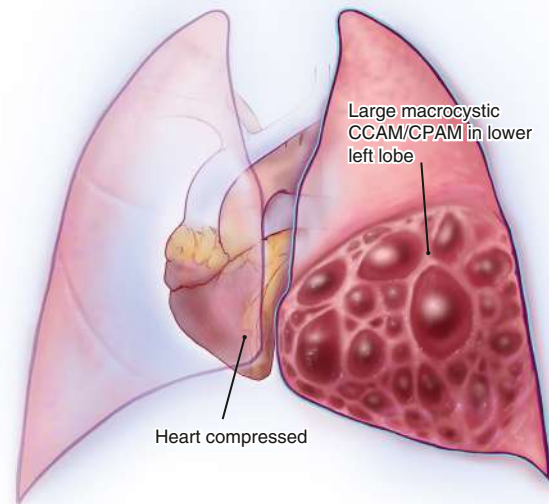
Small Microcystic CCAM/CPAM, Heart Not Compressed



Large Microcystic CCAM/CPAM, Heart Compressed



Large Macrocytic CCAM/CPAM, Heart Compressed



**Fig. 118.5** Different types of congenital cystic adenomatoid malformation (CCAM)/congenital pulmonary airway malformation (CPAM), and how the different sizes and presentations of lung lesions can impact the heart and lungs. (Copyright 2021, The Children's Hospital of Philadelphia.)

have been classified as microcystic (maximal cyst diameter  $<5$  mm) vs macrocystic ( $\geq 5$  mm), and prognosis is correlated with lesion size as well as presence of macrocysts (see Fig. 118.5). In contrast, BPSs appear as echogenic homogeneous masses on US and can be distinguished from CCAM by US evidence of systemic aortic arterial blood supply.

Large CPAMs may cause significant pulmonary hypoplasia and polyhydramnios due to decreased fetal swallowing secondary to esophageal compression. In severe cases, hydrops fetalis may result due to compression of the heart and great vessels. Hydrops with concomitant placentomegaly may result in maternal mirror syndrome, which is postulated to result from the release of vasoactive substances from the inflamed and edematous placenta. Due to the variable natural history of these lesions, a prenatal prognostic parameter, the CPAM volume ratio (CVR), is followed. The CVR is an index that compares the volume of the CPAM to the fetal head circumference. Most studies indicate  $>95\%$  survival in CPAM patients with no hydrops and  $\text{CVR} < 1.6$ , with greater risk for hydrops and need for closer surveillance in patients with a  $\text{CVR} > 1.6$ .

Management of pregnancies complicated by prenatal diagnosis of a fetal lung lesion requires a plan for safe delivery. In the absence of mediastinal shift or flattening, small microcystic lesions will typically meet criteria for community delivery with a plan for close postnatal follow-up. Due to the risk of recurrent infection and malignant transformation, elective postnatal resection is anticipated; a CT angiogram (CTA) is performed at 4-6 weeks of age with surgical intervention following a few weeks later, when the potential for compensatory growth of the remaining lobe(s) is maximized. In the example of large macrocystic lesions with concern for respiratory compromise, delivery at an experienced center with access to ECMO and advanced emergent resection approaches is critical. For large lesions with  $\text{CVR} > 1.6$  or associated hydrops, the presence of macrocysts permits fetal thoracentesis and eventual thoracoamniotic shunt placement, which may reverse hydrops and allow continuation of the pregnancy without open fetal surgical intervention. Irrespective of the presence of drainable cysts, large lesions with threatened hydrops are treated with maternal betamethasone, which has been shown to reduce lesion size and reverse hydrops and may be given in multiple courses

to maximize therapeutic impact. Lesions not responsive to steroids or amenable to drainage may require open fetal surgery if the gestational age is less than 32 weeks; beyond 32 weeks' gestation, early delivery by C-section or ex utero intrapartum therapy (EXIT) with planned immediate resection is recommended.

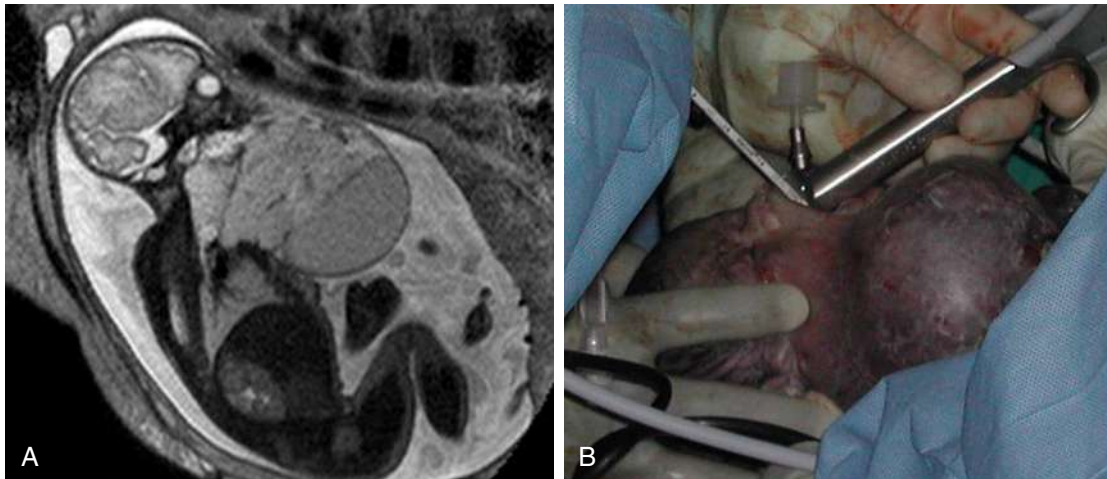
**CONGENITAL HIGH AIRWAY OBSTRUCTION SYNDROME**

Congenital high airway obstruction syndrome (CHAOS) is secondary to partial or complete intrinsic fetal upper airway obstruction. Most often due to laryngeal or tracheal atresia, CHAOS prevents lung fluid efflux

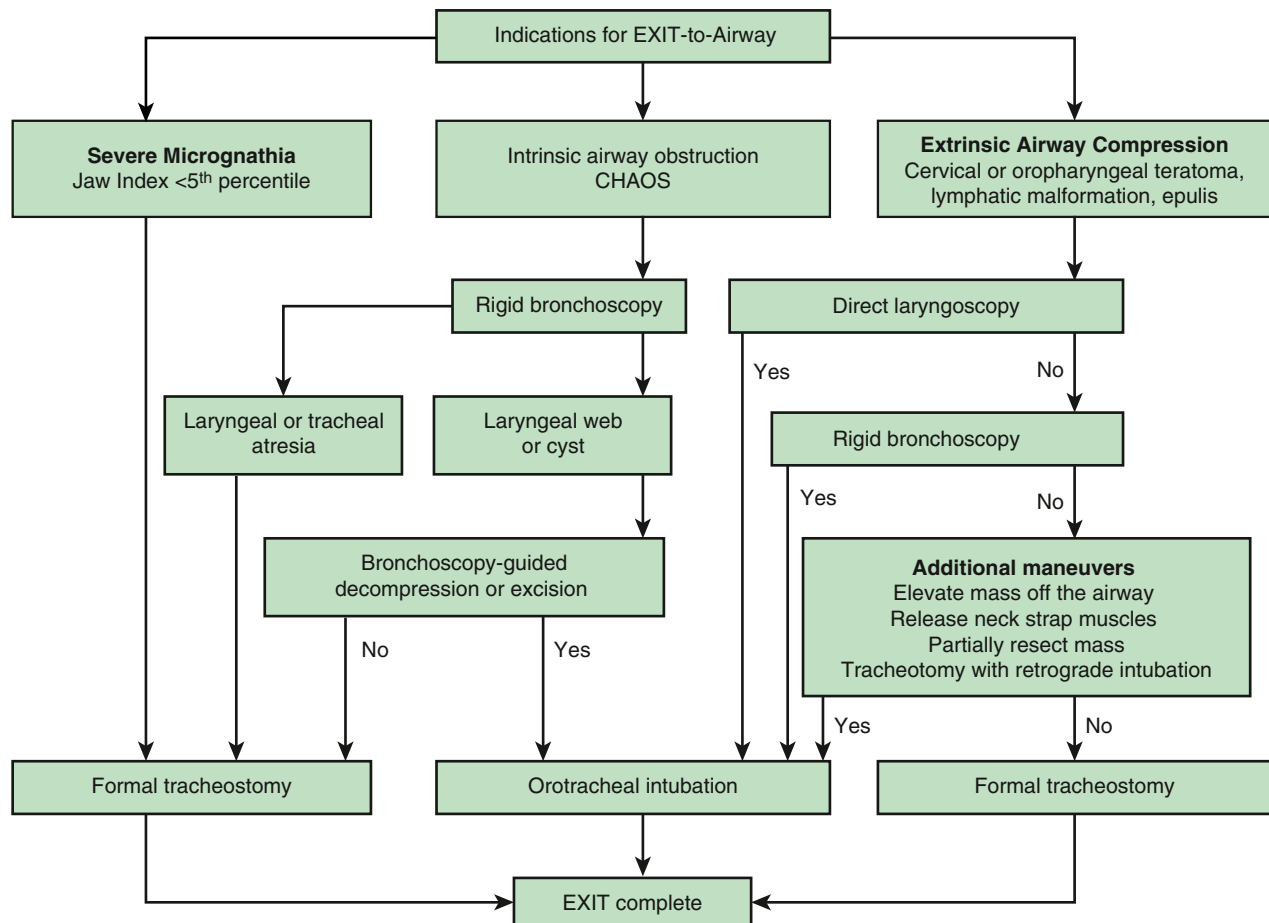
resulting in dilated distal pulmonary airways and enlargement of the fetal lungs with potential for cardiac compression and the development of fetal hydrops. The diagnosis is confirmed by fetal MRI (Fig. 118.6).

In addition to CHAOS, extrinsic compression of the airway may be secondary to mass lesions (lymphangioma, teratoma, goiter) making respiratory efforts after birth difficult.

EXIT (ex utero intrapartum treatment) is a procedure to secure an airway during elective delivery (while the umbilical cord is patent and connected to the placenta), by C-section, before the onset of labor and before the fetus attempts to breathe (Fig. 118.7). The EXIT to airway procedure may be performed by direct laryngoscopy and



**Fig. 118.6** A, Ultrafast MRI of fetus with giant cervical teratoma showing polyhydramnios and hyperextension of the neck. B, Fetus with giant cervical teratoma at the time of intubation by direct laryngoscopy and rigid bronchoscopy. (From Lazar DA, Olutoye OO, Moise KJ, et al. Ex-utero intrapartum treatment procedure for giant neck masses – fetal and maternal outcomes. *J Pediatr Surg.* 2011;46:817–822, Fig. 1.)



**Fig. 118.7** Fetal airway management algorithm for ex utero intrapartum therapy (EXIT) procedures. Yes, Successful; No, not successful; CHAOS, congenital high airway obstruction syndrome. (Adapted from Chatterjee D, Crombleholme TM. Airway management in EXIT procedures. In Jagannathan N, Fiadjoe JE, eds. *Management of the Difficult Pediatric Airway.* Cambridge, UK: Cambridge University Press; 2020.)

endotracheal intubation or, if needed, rigid bronchoscopy, fiberoptic intubation, or tracheostomy (see Fig. 118.6).

### SACROCOCYGEAL TERATOMA

Sacrococcygeal teratoma (SCT) is one of the most common solid tumors of the newborn, with an incidence of 4.8 per 100,000 live births. This germline tumor has a female predominance (4:1) and is rarely associated with other congenital anomalies including nervous, skeletal, and cardiac abnormalities.

The high morbidity and mortality associated with SCT is multifactorial and is associated with both high rates of preterm delivery as well as hemodynamic sequelae. The mechanism of preterm delivery in SCT is believed to be a result of polyhydramnios-associated uterine irritability and premature rupture of membranes. Rupture of the tumor itself is rare but is most often fatal. The vascular composition of the tumor has hemodynamic implications for the fetus/newborn as high-output cardiac failure results from arteriovenous shunting causing vascular steal away from the placenta and the fetus to the SCT and compromised perfusion. Hydropic fetuses with placentomegaly may develop maternal mirror syndrome mandating immediate delivery. Prenatal diagnosis relies on US to identify the lesion and subsequent fetal MRI and echocardiography to assess for placental size, hydrops, and cardiac output physiology. Specific echocardiographic and Doppler US measurements of prognostic utility include cardiac output, cardiac/thoracic ratio, placental thickness, amniotic fluid index, and markers of hydrops including ascites as well as skin and scalp edema.

Given the morbidity and mortality associated with open fetal resection, prenatal intervention is limited to fetuses with mostly external masses manifesting hydrops and fetal cardiac insufficiency. The fetal approach to SCT debulking involves incision of the fetal skin circumferentially around the base of the tumor, application of a Rummel tourniquet, and debulking of the mass with a tissue stapler or energy device to interrupt the high output state (Fig. 118.8). Completion resection of the tumor and coccyx is performed postnatally. More often in the setting of early signs of evolving hydrops in the third trimester, early delivery (28-29 weeks' gestation) and debulking are considered with a similar strategy of staged debulking followed by completion resection when the neonate has stabilized. Resection of the coccyx is critical to avoid recurrence.

Reports of noninvasive interruption of blood flow with laser ablation, radiofrequency ablation, or vascular coiling are tempting but have been complicated by the inability to control the energy source leading to destructive tissue injury and injury to adjacent structures.

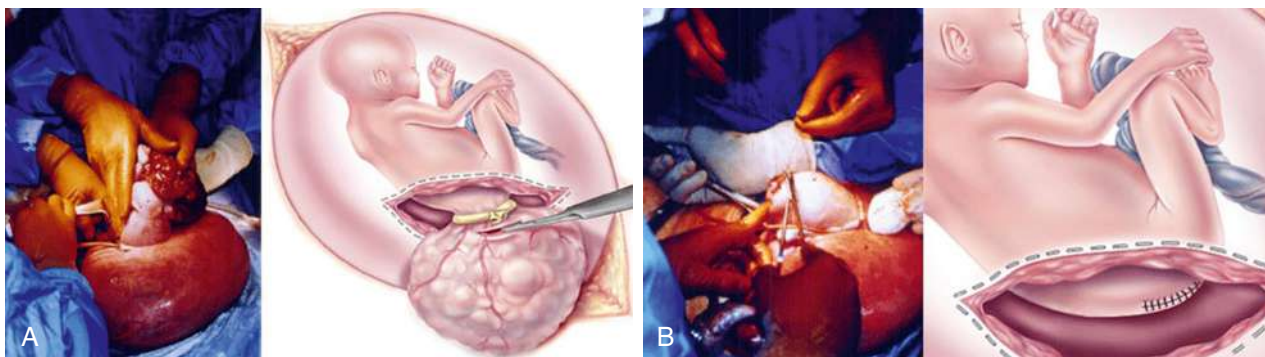
### MYELOMENINGOCELE

Myelomeningocele (MMC) is the most common neural tube defect with an incidence of 1-2 per 1,000 live births. The disease is characterized by an abnormal outgrowth of the nerve root through the meninges with a concomitant vertebral bone and skin defect

resulting in neural tissue exposure to the amniotic fluid. Associated defects include Chiari II malformation, characterized by descent of the cerebellar vermis through the foramen magnum, medullary kinking, and obliteration of the cistern magna leading to brainstem herniation. Hydrocephalus complicates up to 85% of MMC patients and is a major source of long-term morbidity, with high rates of shunting of cerebrospinal fluid required in survivors. Dermoid cysts are also common and may require intervention. Developmental and cognitive impairment is prevalent and profound, and current estimates suggest rates between 60% and 70% of pregnancies complicated by a prenatal diagnosis of MMC end in termination or demise. The etiology of MMC is likely multifactorial, with folic acid deficiency as well as use of folic acid antagonists associated with the development of neural tube defects. Screening for neural tube defects includes measurement of maternal serum  $\alpha$ -fetoprotein (MSAFP) and US. Expectant mothers with screening concerns for MMC should be evaluated at a specialized center with further anatomic US, genetic screening, and ultrafast fetal MRI. In addition to identification of the neural tube defect, expert US can assess lower extremity function, and fetal MRI can define the extent of hindbrain herniation and ventricular size.

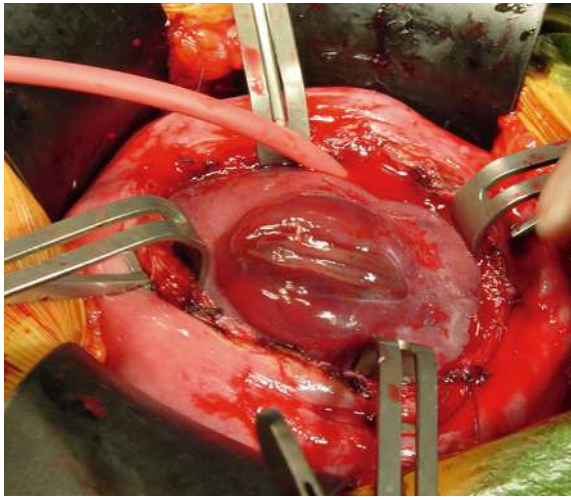
Before the introduction of fetal repair of MMC, fetal surgery was limited to life-threatening anomalies with high predictive mortality for the fetus or infant without intervention. However, a growing body of data suggested that the neurologic outcome in MMC was directly related to progressive injury from ongoing damage to the exposed spinal cord during pregnancy (see Chapter 631.3) (Fig. 118.9). A large multicenter National Institutes of Health-sponsored Management of Myelomeningocele Study (MOMS) comparing the safety and efficacy of prenatal repair of MMC with that of standard postnatal repair was performed and determined a clear advantage for prenatal surgery before 26 weeks' gestation. The MOMS trial demonstrated a significant reduction in the need for ventriculoperitoneal (VP) shunt at 12 months in the fetal repair group (40% vs 82% in postnatal repair group) with reduced hindbrain herniation and improved mental development and motor function at 30 months. Furthermore, the need for shunting was independent of lesion level and degree of hindbrain herniation. The 1-year neurosurgical outcomes for the complete cohort showed that prenatal surgery did not decrease the need for shunting in those fetuses with a cerebral ventricular size of  $\geq 15$  mm at initial screening. Prenatal surgery was associated with an increased risk for earlier gestational age at birth. Delivery occurred before 30 weeks of gestation in 11% of neonates that had fetal MMC repair. Adverse pulmonary sequelae were rare in the prenatal surgery group despite an increased rate of oligohydramnios. The benefits of prenatal surgery outweigh the complications of prematurity.

Open fetal repair of MMC has been a paradigm-shifting advance in fetal surgery and has led to the formation of the North American Fetal Therapy Network (NAFTNet) registry of fetal MMC patients, with follow-up studies continuing to demonstrate the benefits



**Fig. 118.8** A, Exposure of 26-week fetus through hysterotomy revealing sacrococcygeal teratoma (SCT). B, Closure of skin flaps after resection. (Copyright 2021, The Children's Hospital of Philadelphia.)





**Fig. 118.9** Open fetal myelomeningocele repair. (From Hirose S, Harrison MR. *Fetal therapy*. In Holcomb GW III, Murphy JP, eds. *Ashcraft's Pediatric Surgery*. 5th ed. St Louis: Elsevier; 2010. Fig. 10-5.)

observed in the MOMS trial in subsequent series. The risk of prematurity and requirement for cesarean section deliveries for all future pregnancies remain significant considerations for this procedure. The less invasive *fetoscopic* MMC repair approach, which is being developed at a limited number of centers, may reduce maternal morbidity and prematurity rates associated with open fetal MMC repair, but this remains a question of active ongoing investigation. At this time, fetoscopic fetal MMC repair is recommended in an investigational setting according to the American College of Obstetricians and Gynecologists and the Society for Maternal-Fetal Medicine.

### TWIN-TO-TWIN TRANSFUSION SYNDROME

Twin-to-twin transfusion syndrome (TTTS) is a condition that affects approximately 10–15% of *monochorionic diamniotic identical twin* pregnancies. In these cases, shared fetoplacental circulation can lead to unbalanced blood flow between the two fetuses which, left untreated, results in perinatal loss of one or both fetuses in approximately 80% of cases (Fig. 118.10). Unlike dichorionic twins, which do not have any vascular connections between the placentas, monochorionic twins have vascular anastomoses within the shared fetoplacental circulation. Unbalanced deep arteriovenous anastomoses without proper compensation from the superficial bidirectional vessels results in discordant blood supply, with the “donor” fetus presenting with oligohydramnios and intrauterine growth restriction while the “recipient” fetus develops polyhydramnios, heart failure, and hydrops due to hypervolemia. Neurodevelopmental delay is commonly observed in long-term survivors.

TTTS is usually a gradual process that is usually observed in the second trimester. Diagnosis is performed via US in the second trimester. The Quintero classification system is used to stratify TTTS into five stages.

- Stage I: Abnormal amniotic fluid levels (oligo- and polyhydramnios) with bladder filling in the donor twin
- Stage II: Features of stage I with collapsed bladder in the donor twin
- Stage III: New abnormal flow through the umbilical artery or ductus venosus in either the donor or recipient twin with stage II features present
- Stage IV: Hydrops in either the donor or recipient twin
- Stage V: Intrauterine demise of either the donor or recipient twin

Several therapies have been proposed for the treatment of TTTS. Amnioreduction is performed to remove excess fluid from the sac



**Fig. 118.10** In twin-to-twin transfusion syndrome (TTTS), blood flow through vascular connections on the surface of the placenta is unequal. One twin (“donor twin”) pumps blood to the other twin (“recipient”). This unequal blood flow between twins results in the recipient twin (*right*) having too much amniotic fluid, and donor twin (*left*) with little or no amniotic fluid. (Copyright 2021, The Children’s Hospital of Philadelphia.)

with polyhydramnios and can be done serially to help prevent preterm later. Endoscopic or fetoscopic laser ablation of the superficial vascular anastomoses is another therapeutic option. Under local or regional anesthesia, a trocar is placed under US guidance and an endoscope passed, through which superficial anastomoses are then identified and coagulated, followed by amnioreduction. The procedure is performed only once during the pregnancy, usually prior to 26 weeks. Several observational studies have noted perinatal survival approximating 60% with both amnioreduction and laser coagulation. A multicenter randomized trial demonstrated a survival and neurologic advantage after laser coagulation therapy vs amnioreduction; although after 26 weeks, amnioreduction is often still recommended for technical reasons. Other surgical therapies include septostomy (disrupting the membrane between the twins) and selective umbilical cord coagulation in severe cases. Like amnioreduction, septostomy does not alter the underlying pathophysiology. All cases should be referred to tertiary care centers with extensive experience in the treatment of TTTS.

### OTHER INDICATIONS

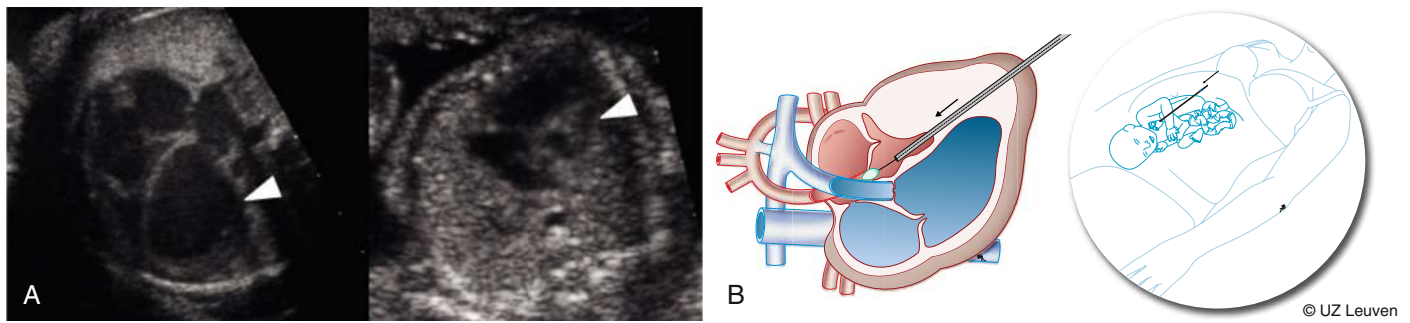
Antenatal intervention for **cardiac defects**, such as aortic stenosis, pulmonic stenosis, and hypoplastic left heart syndrome (HLHS), have been used to dilate, with balloon valvuloplasty, stenotic valves (aortic stenosis) to prevent further development of HLHS (creating biventricular physiology) (Fig. 118.11) (see Chapter 480.10).

**Laser therapy** has been used to treat TTTS (Chapter 119.1) and amniotic bands (Fig. 118.12).

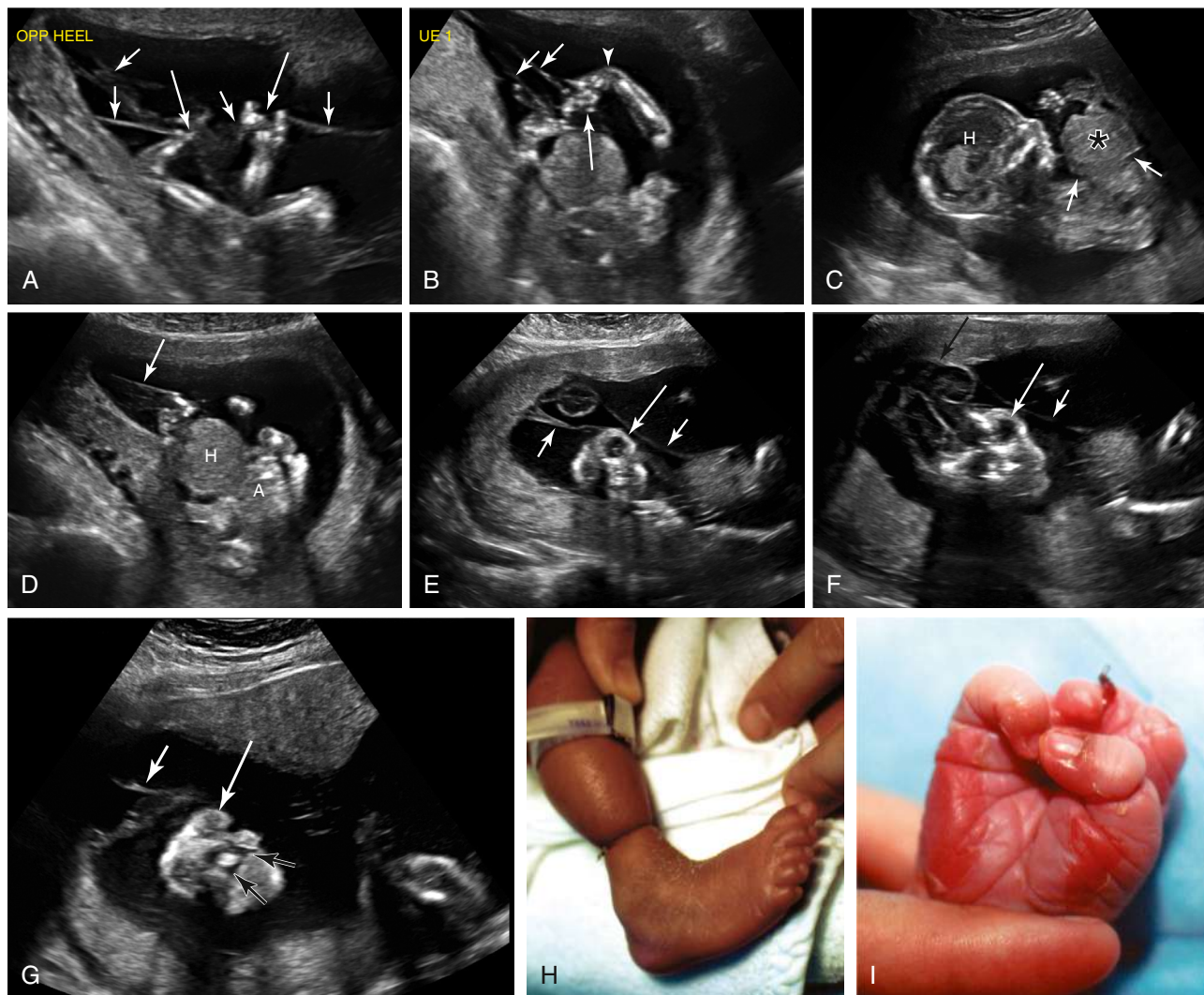
### FETAL CENTERS

The value of fetal surgical program centers extends beyond fetal intervention itself. Often, families will present to a fetal center with a new diagnosis and little understanding of the implications for their baby and family. Prenatal counseling by the fetal team provides the opportunity to confirm the diagnosis, investigate for other anomalies and genetic susceptibilities, and provide detailed counseling to achieve understanding of both the diagnosis and





**Fig. 118.11** A, Ultrasound image (right panel) is a cross section at the level of the fetal chest, demonstrating the four-chamber view in a fetus with aortic stenosis. Notice that the left ventricle (arrowhead) is dilated. Dilatation occurs before the development of hypoplasia, which can be seen (arrowhead) in another fetus (left panel). B, Schematic representation of percutaneous valvuloplasty, in this case of the left ventricular outlet tract. (A from van Mieghem T, Baud D, Devlieger R, et al. *Minimally invasive fetal therapy*. *Best Pract Res Clin Obstet Gynaecol* 2012;26:711–725; B copyright UZ Leuven, Leuven, Belgium.)



**Fig. 118.12** Amniotic band sequence in two different fetuses. A and B, Effects on the extremities. Limbs of a fetus with amniotic band sequence show multiple amniotic bands (short arrows, A and B), amputation of fingers and toes (long arrows, A and B), and a fixed deformity of the hand at the wrist (arrowhead, B). C and D, Effects on the thorax and abdomen of the same fetus as in A and B. Sagittal image (C) shows a thoracoabdominal wall defect (arrows) with a large amount of herniated abdominal and thoracic contents (asterisk) outside the body. White H, Head. D, Axial image of the fetal abdomen (A) confirms the presence of a large ventral abdominal hernia (H), in the setting of amniotic bands (arrow). E to G, Effects on craniofacial structures in a different fetus. E, Coronal image of face shows multiple amniotic bands (short arrows) and nonvisualization of the calvarium. This results in a craniofacial appearance that resembles anencephaly (long arrow). F, A large encephalocele (black arrow) is seen above the level of the orbits (long white arrow) in a different scan plane. An amniotic band (short white arrow) is also seen. G, Coronal image of anterior portion of face shows facial clefts (black arrows) due to amniotic bands. Short white arrow, Amniotic band; long white arrow, orbits. H, Band constricting the ankle, leading to deformational defects. I, Pseudosyndactyly, amputation, and disruption of finger morphogenesis. (A–G from Hertzberg BS, Middleton WD. *Ultrasound: The Requisites*. 3rd ed. Philadelphia: Elsevier; 2016. Figs. 19–22; H and I from Jones KL, Smith DW, Hall BD, et al. *A pattern of craniofacial and limb defects secondary to aberrant tissue bands*. *J Pediatr*. 1974;84:90–95.)

**Table 118.3** Selection of Patients for Fetal Repair

LEVEL OF CERTAINTY	DIAGNOSIS
<b>DIAGNOSTIC CERTAINTY/PROGNOSTIC CERTAINTY</b>	
Genetic problems	Trisomy 13, 15, or 18 Triploidy
Central nervous system abnormalities	Anencephaly/acrania Holoprosencephaly Large encephaloceles
Heart problems	Acardia Inoperable heart anomalies
Kidney problems	Potter syndrome/renal agenesis Multicystic/dysplastic kidneys Polycystic kidney disease
<b>DIAGNOSTIC UNCERTAINTY/PROGNOSTIC CERTAINTY</b>	
Genetic problems	Thanatophoric dwarfism or lethal forms of osteogenesis imperfecta
Early oligo/anhydramnios and pulmonary hypoplasia	Potter syndrome with unknown etiology
Central nervous system abnormalities	Hydranencephaly Congenital severe hydrocephalus with absent or minimal brain growth
Prematurity	<23 weeks' gestation
<b>PROGNOSTIC UNCERTAINTY/BEST INTEREST</b>	
Genetic problems	Errors of metabolism that are expected to be lethal even with available therapy
Mid oligo/anhydramnios	Renal failure requiring dialysis
Central nervous system abnormalities	Complex or severe cases of meningomyelocele Neurodegenerative diseases, such as spinal muscular atrophy
Heart problems	Some cases of hypoplastic left heart syndrome Pentalogy of Cantrell (ectopia cordis)
Other structural anomalies	Some cases of giant omphalocele Severe congenital diaphragmatic hernia with hypoplastic lungs Idiopathic nonimmune hydrops Inoperable conjoined twins Multiple severe anomalies
Prematurity	23-24 weeks' gestation

From Leuthner SR. Fetal palliative care. *Clin Perinatol* 2004;31:649-665. Table 1.

all available treatment options. This collaborative and multidisciplinary family-centered approach allows for the development of a management plan that may include fetal surgery or intervention, enhanced monitoring of the fetus and mother, and coordination of complex deliveries involving multidisciplinary delivery teams and specialized equipment as required for EXIT to ECMO, EXIT to airway, EXIT to tumor resection, delivery to cardiac catheterization, and procedures on placental support.

In some highly specialized fetal centers, delivery may be facilitated with the neonatal intensivists, perinatal anesthesiologist, and pediatric surgical care teams present in the same location to permit expert stabilization and resuscitation of the neonate. The benefits range from

the psychological benefits of avoiding maternal-infant separation as well as improved outcomes in diagnoses such as CDH, in which early stabilization of the neonate is critical to minimize pulmonary hypertensive crisis.

Finally, but equally importantly, not all severely affected fetuses will have available therapies in utero or after birth. In these lethal situations, fetal care planning will provide support for the family and a plan for delivery room or nursery palliative care (Table 118.3) (see Chapter 8).

Visit Elsevier eBooks+ at [eBooks.Health.Elsevier.com](http://eBooks.Health.Elsevier.com) for Bibliography.

## Chapter 119

## The High-Risk Infant

Erik Brandsma, Lori A. Christ, and  
Andrea F. Duncan

The term *high-risk infant* designates an infant at greater risk for neonatal morbidity and mortality; many factors can contribute to an infant being high risk (Table 119.1). There are four broad categories of high-risk infants: the preterm infant, infants with special healthcare needs or

**Table 119.1** Factors in Considering Infants as High Risk for Morbidity or Mortality in the Neonatal Period

## BIRTH PARENT DEMOGRAPHIC FACTORS

Maternal age <16 yr or >40 yr  
Environmental, economic, social disadvantage, racial discrimination

## BIRTH PARENT MEDICAL HISTORY

Genetic disorders  
Diabetes mellitus  
Hypertension  
Asymptomatic bacteriuria  
Rheumatologic illness (systemic lupus erythematosus)  
Immune-mediated diseases  
Long-term medication (see Chapters 117.4 and 117.5)

## PREVIOUS PREGNANCY

Intrauterine fetal demise  
Neonatal death  
Prematurity  
Intrauterine growth restriction  
Congenital malformation  
Incompetent cervix  
Blood group sensitization, neonatal jaundice  
Neonatal thrombocytopenia  
Hydrops  
Inborn errors of metabolism

## PRESENT PREGNANCY

Vaginal bleeding (abruptio placentae, placenta previa)  
Sexually transmitted infections (colonization: herpes simplex, group B streptococcus, chlamydia, syphilis, hepatitis B, HIV)  
Multiple gestation  
Preeclampsia  
Premature rupture of membranes  
Short interpregnancy time  
Poly-/oligohydramnios  
Acute medical or surgical illness  
Familial or acquired hypercoagulable states  
Abnormal fetal ultrasonographic findings  
Treatment of infertility  
Inadequate prenatal care  
Substance use disorder

## LABOR AND DELIVERY

Premature labor (<37 wk)  
Postdates pregnancy (≥42 wk)  
Fetal distress  
Breech presentation  
Meconium-stained fluid  
Nuchal cord  
Cesarean delivery  
Forceps or vacuum assisted delivery  
Apgar score <4 at 5 min

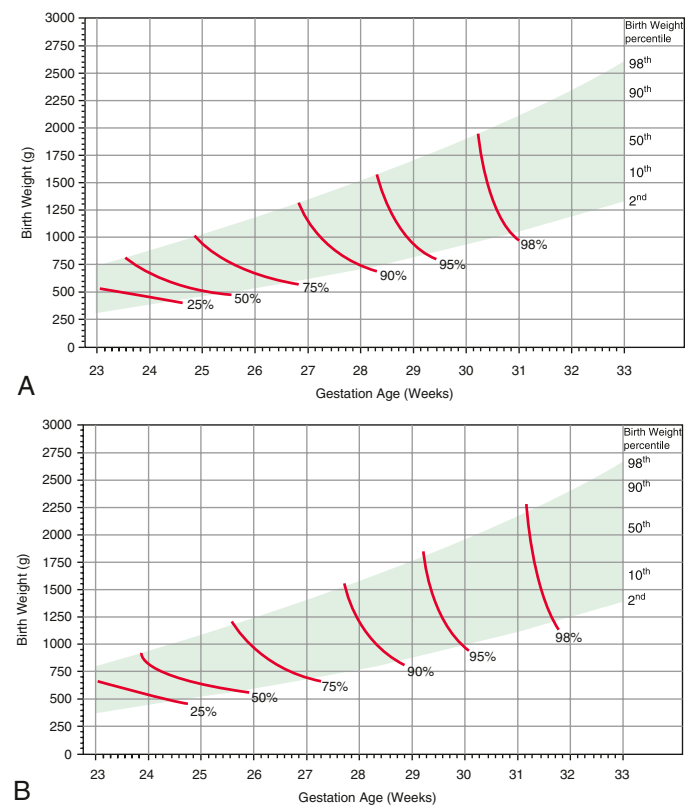
## NEONATE

Birthweight <2,500 g or >4,000 g  
Birth <37 wk or ≥42 wk of gestation  
Small or large for gestational age  
Respiratory distress, cyanosis  
Congenital malformation  
Pallor, plethora, petechiae

dependence on technology, infants at risk because of family issues, and infants with anticipated early death.

All high-risk infants require closer evaluation and/or treatment by experienced physicians and nurses. This often starts before delivery and continues in the delivery room and through a neonatal intensive care unit (NICU) stay (see Chapter 121). Regionalized care for infants is based on the acuity of care that can be provided at hospitals with different levels of care and whether transport should be undertaken (see Chapter 120). It is important to note that additional care does not stop at time of NICU discharge, and that many high-risk infants also benefit from additional resources and follow-up after discharge from the hospital (see Chapter 119.5).

Twins and higher-order multiples are at increased risk for morbidity and mortality and are discussed in Chapter 119.1, whereas other infants deemed high risk are discussed throughout this textbook. Preterm infants comprise the majority of high-risk infants. Approximately 15 million infants are born preterm (before 37 weeks' gestational age) each year worldwide, accounting for about 1 in every 10 babies born. The World Health Organization (WHO) defines infants born before 28 weeks' gestational age as *extremely preterm* infants, infants born between 28 and 31 6/7 weeks as *very preterm* (see Chapter 119.2), and infants born between 32 and 36 6/7 weeks as *moderate to late preterm* infants (see Chapter 119.3). Risk of both morbidity and mortality increases with earlier gestational age. Gestational age, birthweight, and gender are all important factors that impact neonatal mortality (Fig. 119.1). The **highest risk** of neonatal and infant mortality occurs in infants with birthweight <1,000 g and/or with gestational age <28 weeks. The **lowest risk** of neonatal mortality occurs in infants with birthweight of 3,000-4,000 g and a gestational age of 39-41 weeks. As birthweight increases



**Fig. 119.1** Contour plot of predicted survival according to gestational age, birthweight, and gender. **A**, Female. **B**, Male. The contour lines join combinations of gestational age and birthweight of equal estimated probability of survival. Birthweight percentiles are shown for information. Data based on singleton infants born in the United Kingdom between January 2008 and December 2010 who survived to NICU admission. (From Manktelow BN, Seaton SE, Fields DJ, et al. Population-based estimates of in-unit survival for very preterm infants. *Pediatrics*. 2013;131:e425e432. Fig. 2.)



from 400 to 3,000 g and gestational age increases from 23 to 39 weeks, a logarithmic decrease in neonatal mortality occurs. Once birthweight exceeds 4,000 g and/or gestational age exceeds 42 weeks, the incidence of neonatal morbidities and mortality increases (see Chapter 119.4).

## 119.1 Multiple-Gestation Pregnancies

Lori A. Christ

### CLASSIFICATION OF TWINS

#### Monozygotic vs Dizygotic Twins

Traditionally, twins have been classified as either **monozygotic** (originating from one ovum fertilized by one sperm in a single fertilization event that then results in postzygotic division of the conceptus into two embryos) or **dizygotic** (originating from two fertilization events each occurring when a single ovum is fertilized by a single sperm). Identifying twins as monozygotic or dizygotic is useful in determining the relative influence of heredity and environment on human development and disease. Detailed blood typing, gene analysis, or tissue (human leukocyte antigen) typing can be used for zygosity testing (an exception being blood typing in cases of **chimeric** twins, where one or both twins contain distinct cell lines from multiple zygotes). While often referred to as “identical” twins, physical and cognitive differences may still exist between monozygotic twins due to differences in the in utero environment, the mitochondrial genome, in posttranslational gene product modification, or in the epigenetic modification of nuclear genes in response to environmental factors.

#### Chorionicity and Amnionicity

Twins can also be classified by the number of chorions and amnions in the pregnancy. Dizygotic twins largely result in **dichorionic, diamniotic** pregnancies, although rarely may result in atypical twinning (see later). The chorionicity and amnionicity of monozygotic twins depends on the timing of fission of the zygote. One-third of monozygotic twins are dichorionic and diamniotic, and result from splitting on embryonic day 1-3. **Monochorionic, diamniotic** twins result from splitting on embryonic day 3-8, and **monochorionic, monoamniotic** twins result from splitting on day 8-13. Determination of amnionicity and chorionicity are not

reliable ways of determining zygosity. An apparently single placenta may be present with either monozygotic or dizygotic twins, but inspection of a dizygotic placenta usually reveals that each twin has a separate chorion that crosses the placenta between the attachments of the cords and two amnions. Separate or fused dichorionic placentas may be disproportionate in size, resulting in growth restriction or malformation of the fetus attached to the smaller placenta or the smaller portion of the placenta.

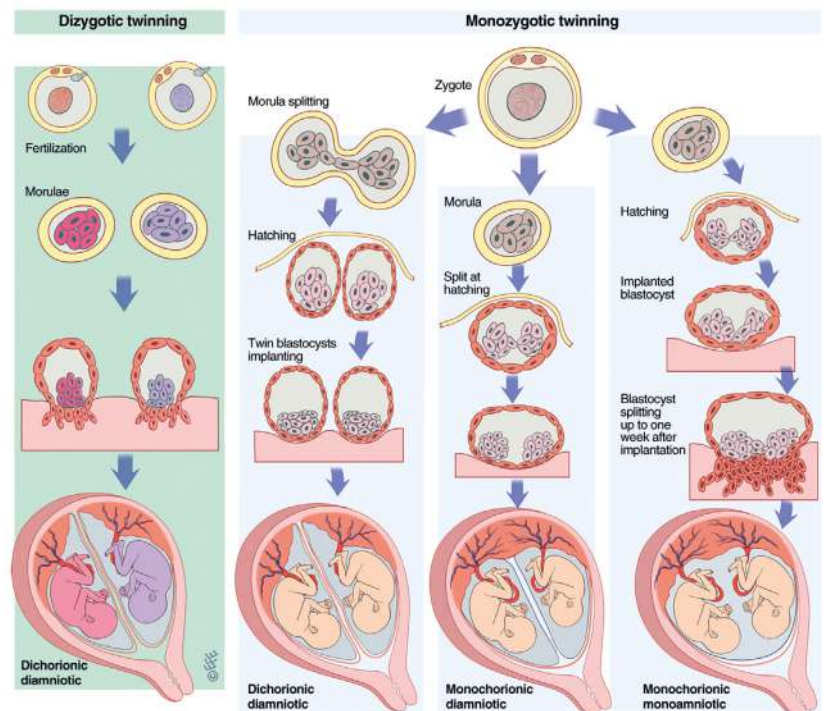
#### Incidence

Differences in the incidence of twins worldwide mainly involve dizygotic twins, as monozygotic twinning appears to be independent of heritable factors. In 2019 the U.S. final natality report recorded a twin rate of 32.1 per 1,000 live births, which has continued to decline after an all-time high in 2014. Increases in monozygotic and dizygotic twinning had been associated with advanced maternal age (AMA) and the use of assisted reproductive technologies (ARTs). The rate of triplets and higher-order multiple births was 87.7 per 100,000 live births in the United States and has continued to decline since 1998. The use of single-embryo transfer in ART has decreased the numbers of triplet births and higher-order multiples.

#### ETIOLOGY

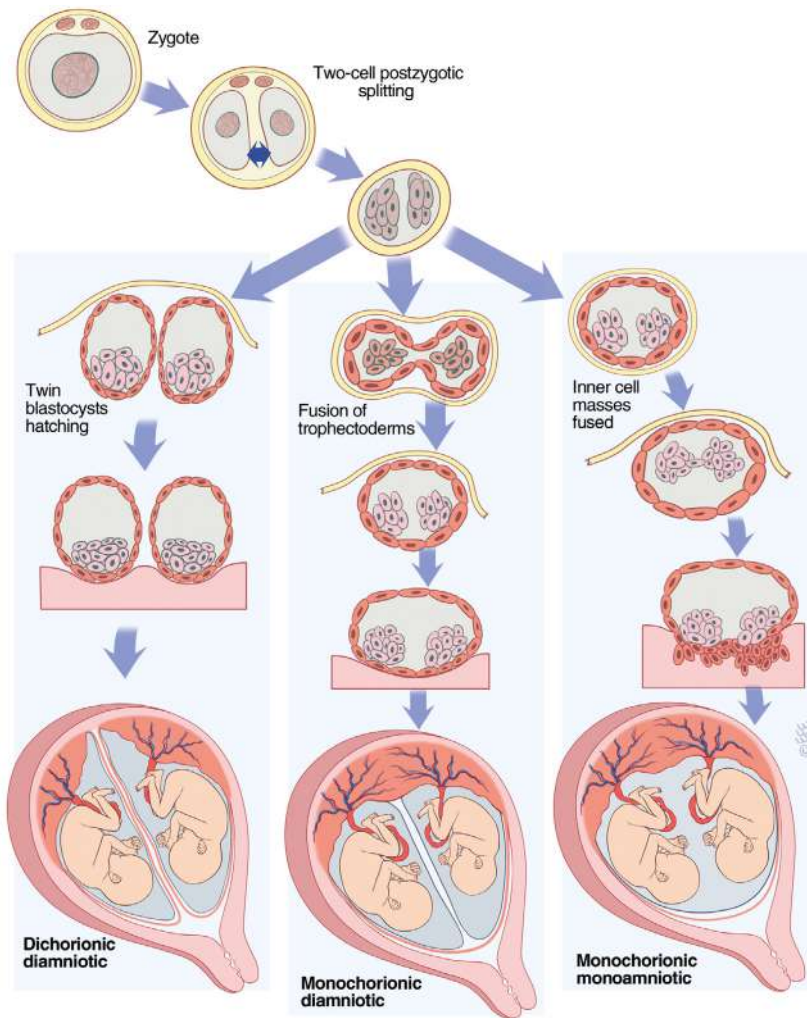
Dizygotic twins result from polyovulation, or the release of more than one ovum at a single ovulation. Polyovular pregnancies are more frequent after the second pregnancy, with increasing maternal age, and in families with a history of dizygotic twins. They may result from simultaneous maturation of multiple ovarian follicles, but follicles containing two ova have also been described as a genetic trait leading to twin pregnancies. Twin-prone women have higher levels of gonadotropin. Polyovular pregnancies occur in many women treated for infertility with ovarian stimulants such as clomiphene or gonadotropins.

The etiology of monozygotic twinning is unknown, but there are two prevailing theories. In the classic **fission theory**, twinning results from the splitting of a single conceptus, with the timing of splitting resulting in differing amnionicity and chorionicity (i.e., the earlier the fission occurs, the more likely the twins are to be diamniotic dichorionic) (Fig. 119.2). However, this theory fails to account for several forms of atypical twinning, including the occurrence of **diamniotic dichorionic monozygotic** twinning after single-embryo transfer in the



**Fig. 119.2** Classical fission theory of twinning. Dizygotic twins result from two distinct fertilization events, with dichorionic diamniotic twins each developing to become a genetically distinct individual. Monozygotic twins result from postzygotic splitting of the product of a single fertilization event. Splitting on days 1-3 (up to the morula stage) results in dichorionic diamniotic twins, on days 3-8 (during which blastocyst hatching occurs) in monochorionic diamniotic twins, on days 8-13 in monochorionic monoamniotic twins. (Illustration copyright LeventEfe, CMI. [www.leventefe.com.au](http://www.leventefe.com.au).)





**Fig. 119.3** Fusion theory of monozygotic twinning. Splitting occurs at the postzygotic two-cell stage, with each cell forming a distinct individual. If twin blastocysts hatch from the zona pellucida together, dichorionic diamniotic twins will result. If the two trophoctoderms fuse before hatching and the inner cell masses are separated within the shared trophoctoderm, monochorionic diamniotic twins will result. If the inner cell masses are fused and separated later, monochorionic monoamniotic twins will result. (Illustration copyright LeventEfe, CMI. [www.leventefe.com.au](http://www.leventefe.com.au))

late blastocyst state, phenotypically discordant monozygotic twins, and asymmetrically attached conjoined twins. An alternate **fusion theory** of twinning has been proposed to account for this discrepancy, in which the inner cell masses of trophoctoderm fuse after the initial two-cell splitting stage (Fig. 119.3).

### Atypical Twinning

**Conjoined twins** occur in 1 in 50,000 pregnancies and 1 in 250,000 live births. Theoretically, they result from later fission of a single zygote (10-14 days) or from fusion of two zygotes (as proposed for asymmetrically attached conjoined twins). Most conjoined twins are female. The prognosis for symmetrically conjoined twins depends on the possibility of surgical separation, which in turn depends on the extent to which vital organs are shared. The site of connections varies, as follows: thoracoomphalopagus (28% of conjoined twins), thoracopagus (18%), omphalopagus (10%), craniopagus (6%), and incomplete duplication (10%). The term *parasitic twin* has historically been used to describe the smaller and less completely developed member of a pair of conjoined twins; this twin has typically had embryonic demise but remains vascularized by the surviving *independent* twin (the **autocyte**). For asymmetrically attached conjoined twins in whom one twin is dependent on the cardiovascular system of the intact autocyte (**exoparasitic twins**, 1 in 1 million live births) survival of the autocyte depends on the feasibility of excising the *exoparasitic* twin. For **endoparasitic twins** (*fetus in fetu*, 1 in 500,000 live births) in whom one

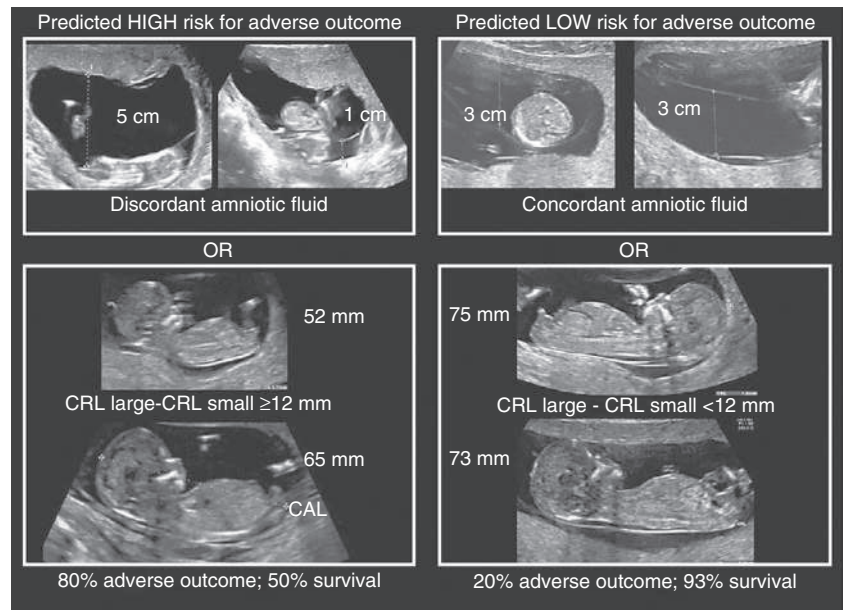
(or more) fetus exists as a benign mass in the autocyte, survival of the autocyte is unaffected. **Superfecundation**, or fertilization of an ovum by an insemination that takes place after one ovum has already been fertilized, and **superfetation**, or fertilization and subsequent development of an embryo when a fetus is already present in the uterus, have been proposed as explanations for differences in size and appearance of certain twins at birth.

### Diagnosis

A prenatal diagnosis of pregnancy with twins is suggested by a uterine size that is greater than that expected for gestational age, auscultation of two fetal heartbeats, and/or elevated maternal serum  $\alpha$ -fetoprotein (AFP) or human chorionic gonadotropin (hCG) levels. It is confirmed by ultrasonography. Physical examination of twins is necessary but not sufficient to determine zygosity of twins. In the event that congenital anomalies are present or there are transfusion or transplantation considerations, genetic testing of zygosity should be performed. Although noninvasive prenatal testing (NIPT) is becoming more common, the results should be interpreted with caution in multiple-gestation pregnancies until normative values are better established.

### Complications

Twin and higher-order pregnancies are associated with poorer neonatal and perinatal outcomes compared with singleton pregnancies of the same gestation. Severe maternal morbidities and death are also



**Fig. 119.4** Representation of first-trimester risk assessment for the development of discordant growth, twin-twin transfusion syndrome (TTTS), or intrauterine demise. Discordant amniotic fluid in the first trimester generally corresponded with deepest vertical pockets  $\leq 3$  cm in one sac and  $\geq 6.5$  cm in the other. Discordance in crown-rump length (CRL) was present if the difference was  $\geq 12$  mm. (From Lewi L, Gucciardo L, Van Mieghem T, et al. Monochorionic diamniotic twin pregnancies: natural history and risk stratification. *Fetal Diagn Ther.* 2010;27:121–133.)

twice as likely in twin pregnancies worldwide compared with singleton pregnancies.

Most twins are born prematurely, which contributes to additional neonatal and childhood morbidity and mortality. Spontaneous single intrauterine demise occurs at a rate of about 6% of all twin pregnancies. Twin-twin transfusion syndrome (TTTS) and early-onset discordant growth are associated with an overall worse prognosis (see Chapter 118). The perinatal mortality of twins is about four times that of singletons, with **monochorionic** twins being particularly at risk. **Monochorionic** twins have an increased risk of a demised twin in utero. The surviving twin has a greater risk for cerebral palsy and other neurodevelopmental sequelae. **Monoamniotic** twins have an increased likelihood of cord entanglement, which may lead to asphyxia. Twins are at greater risk for congenital malformations, with up to 25% of monozygotic twins being affected. Theoretically, the twin delivered second is at higher risk of anoxia than the first because the placenta may separate after birth of the first twin and before birth of the second. In addition, delivery of the second twin may be difficult because it may be in an abnormal presentation (breech, entangled), uterine tone may be decreased, or the cervix may begin to close after the first twin's birth.

Triplet or higher-order births are associated with an increased risk of death or neurodevelopmental impairment compared with extremely low birthweight (ELBW) singleton and twin infants after controlling for gestational age. The mortality for multiple gestations with  $\geq 4$  fetuses is excessively high for each fetus. Because of this poor prognosis, selective fetal reduction has been offered as a treatment option.

### Twin-Twin Transfusion Syndromes

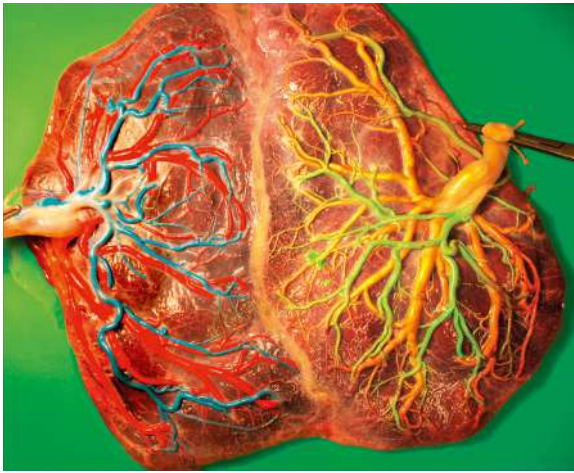
Placental vascular anastomoses occur with high frequency in **monochorionic** twins (see Chapter 118). In monochorionic placentas, the fetal vasculature is usually joined, sometimes in a very complex manner. They are usually balanced and neither twin is appreciably affected. Artery-to-artery communications cross over placental veins, and when anastomoses are present, blood can readily be stroked from one fetal vascular bed to the other. Vein-to-vein communications are similarly recognized but are less common. A combination of artery-to-artery and vein-to-vein anastomoses is associated with the condition of **acardiac fetus**. This rare lethal anomaly (1 in 35,000) is secondary to the **twin reversed arterial perfusion (TRAP) syndrome**. In utero radiofrequency or laser ablation of the anastomosis or cord occlusion can be used to treat heart failure in the surviving twin. However, death of the autocyte is reported in up to 75% of cases. In rare cases, one umbilical

**Table 119.2** Characteristic Changes in Monochorionic Twins with Uncompensated Placental Arteriovenous Shunts

ARTERIAL SIDE—DONOR	TWIN ON:	
	ARTERIAL SIDE—DONOR	VENOUS SIDE—RECIPIENT
Prematurity	Prematurity	Prematurity
Oligohydramnios	Oligohydramnios	Polyhydramnios
Intrauterine growth restriction	Intrauterine growth restriction	Hydrops
Pale	Pale	Plethoric
Anemic	Anemic	Polycythemic
Hypovolemic	Hypovolemic	Hypervolemic
Hypoglycemic	Hypoglycemic	Cardiac hypertrophy
Microcardia	Microcardia	Myocardial dysfunction
Glomeruli small or normal	Glomeruli small or normal	Glomeruli large Tricuspid valve regurgitation Right ventricular outflow obstruction
Arterioles thin walled	Arterioles thin walled	Arterioles thick walled

cord may arise from the other after leaving the placenta, and the twin attached to the secondary cord usually is malformed or dies in utero.

In **twin-twin transfusion syndrome (TTTS)**, an artery from one twin acutely or chronically delivers blood that is drained into the vein of the other. The latter develops polyhydramnios and polycythemia, and the former has oligohydramnios, anemia, and growth restriction (Fig. 119.4). TTTS is more common in monozygotic twins and affects up to 30% of monochorionic twins. Death of the donor twin in utero may result in generalized fibrin thrombi in the smaller arterioles of the recipient twin, possibly as the result of transfusion of thromboplastin-rich blood from the macerating donor fetus. Disseminated intravascular coagulation (DIC) may develop in the surviving twin. Table 119.2 lists the more frequent changes associated with a large shunt. Preterm birth and/or death of the surviving twin is also highly likely. **Treatment** of this highly lethal problem includes aggressive amnioreduction for polyhydramnios, selective twin termination, and most often, laser or fetoscopic ablation of anastomosis (Fig. 119.5).



**Fig. 119.5** Color-dye-stained twin-to-twin transfusion syndrome placenta that was treated using the Solomon technique. Blue and green dye are used to stain the arteries, and pink and yellow dye are used to stain the veins. After identification and coagulation of each individual anastomosis, the complete vascular equator is coagulated from one placental margin to the other. (From Slaghekke F, Lopriore E, Lewi L, et al. Fetoscopic laser coagulation of the vascular equator versus selective coagulation for twin-to-twin transfusion syndrome: an open-label randomized controlled trial, *Lancet*. 2014;383:2144–2150. Fig. 3.)

### Management

Prenatal detection of a multiple gestation pregnancy enables the obstetrician and pediatrician to anticipate complications. The risk of multiple-gestation pregnancies due to ART may be reduced by elective single-embryo transfers. Asymptomatic early cervical dilation may be managed with cerclage, which is 50% effective in preventing delivery before 28 weeks' gestation. Elective delivery of twins at 37 weeks (or earlier for **monochorionic, monoamniotic** twins) reduces the complication rate for the fetuses and the birth parent. Furthermore, in twin pregnancies between 32 and 39 weeks' gestation, planned vaginal delivery is preferred if the first twin is in the cephalic presentation. Close observation and attendance by a pediatric team are indicated in the immediate neonatal period so that prompt treatment of asphyxia or fetal transfusion syndrome can be initiated. The decision to perform an immediate blood transfusion in a severely anemic "donor" twin or a partial exchange transfusion of either twin due to anemia in the "donor" or polycythemia in the "recipient" twin must be based on clinical judgment.

Visit Elsevier eBooks+ at [eBooks.Elsevier.com](https://eBooks.Elsevier.com) for Bibliography.

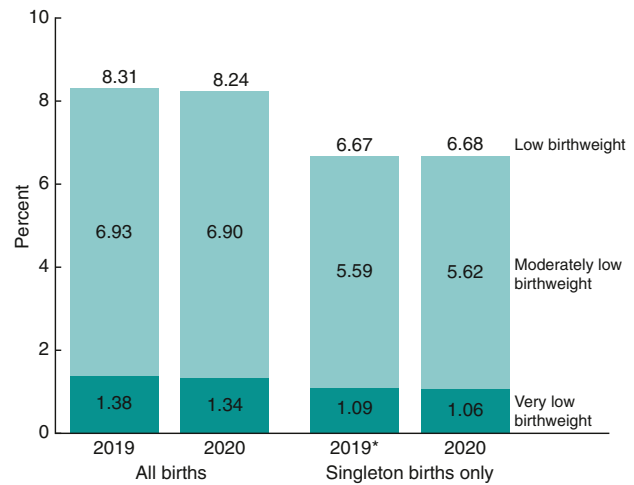
## 119.2 Extremely and Very Preterm Infants

Lori A. Christ and Erik Brandsma

Traditionally, the delivery date is determined 280 days after the last menstrual period (LMP). However, only 4% of pregnant women deliver at 280 days, and only 70% deliver within 10 days of the estimated delivery date.

Infants born before 37 weeks from the first day of the LMP are termed *premature* by WHO. Infants born before 28 weeks' gestation are **extremely preterm**, also referred to as **extremely low gestational age newborns (ELGANs)**; whereas infants born between 28 and 31 weeks and 6 days' gestation are **very preterm**. Moderate and late preterm infants (born between 32 and 36 week 6 days' gestation) are discussed in Chapter 119.3.

In addition to classification by gestational age, classification is also based on birthweight. **ELBW** is used to describe infants with a birthweight <1,000 g, **very low birthweight (VLBW)** describes infants 1,000-1,500 g, and **low birthweight (LBW)** describes infants <2,500



SOURCE: National Center for Health Statistics, National Vital Statistics System, Natality.

**Fig. 119.6** Total and singleton low birthweight rates: United States, 2019 and 2020. \*Numbers do not add to total due to rounding. (From Osterman M, Hamilton B, Martin JA, Driscoll AK, Valenzuela CP. *Births: Final Data for 2020*. Natl Vital Stat Rep. 2021;70[17]:1–50. Fig. 3.)

g at birth. Birthweight, in general, is a proxy for gestational age, but in the cases of intrauterine growth restriction (IUGR) and small-for-gestational-age (SGA) infants, birthweight can sometimes be misleading for true gestational age and is an additional risk factor for comorbidities of prematurity (see Chapter 119.4).

### INCIDENCE

**Preterm birth**, or birth before 37 weeks of gestation, occurs at a rate of approximately 11% worldwide, adding up to a total of 15 million preterm births annually. Significant variations in preterm birthrates exist between countries, with an approximate rate of 10% in the United States. The U.S. preterm birthrate declined 1% in 2020 to 10.09%. Most of this decline is due to a decrease in rate of late preterm births (7.40% of all births in 2020) and in preterm births less than 34 weeks' gestation (2.70%). These results are reflected in birthweight-specific categories (Fig. 119.6). Disparities in preterm birthrates continue to exist, ranging from a high of 14.39% of babies born to non-Hispanic black mothers to a low of 8.72% of babies born to non-Hispanic Asian mothers.

### ETIOLOGY

The etiology of preterm birth is multifactorial and involves complex interactions between fetal, placental, uterine, and maternal factors. In the setting of maternal or fetal conditions that prompt early delivery, as well as placental and uterine pathology, causes of preterm birth can sometimes be identified (Table 119.3). Most preterm births are *spontaneous* without an identifiable cause. AMA, maternal health conditions, history of previous preterm delivery, short interpregnancy interval, and lower socioeconomic status (SES) have all been associated with preterm birth. Racial disparities also exist and can only be partially predicted when factoring in education and income level. Large population studies have found associations between maternal genetics and epigenetics and preterm birth. Gestational duration and actual preterm birth have been noted with genetic variants in the maternal genome. Many of these genes have roles in regulation of the estrogen receptor, uterine development, maternal nutrition, or vascular reactivity.

### ASSESSMENT OF GESTATIONAL AGE

Ultrasound measurement of fetal crown-rump length at 11-14 weeks' gestation remains the most accurate method of gestational age estimation. Estimates based on ultrasound at later gestation are less accurate, but may be improved with newer methods and likely superior to postnatal assessment. With insufficient prenatal care or discrepancies between birthweight and predicted gestational age at birth, it remains helpful to be able to assess infants for an estimated gestational age. With a careful physical exam, one may be able to distinguish SGA and IUGR infants



**Table 119.3** Identifiable Risk Factors for Preterm Birth

<b>FETAL</b>
Fetal distress
Multiple gestation
Erythroblastosis
Nonimmune hydrops
Polyhydramnios
<b>PLACENTAL</b>
Placental dysfunction
Placenta previa
Placental abruption
<b>UTERINE</b>
Bicornuate uterus
Incompetent cervix (premature dilation)
<b>MATERNAL</b>
Previous preterm birth
Preeclampsia
Experiencing racism
Chronic medical illness (cyanotic heart disease, renal disease, thyroid disease)
Short interpregnancy interval
Infection ( <i>Listeria monocytogenes</i> , group B streptococcus, urinary tract infection, bacterial vaginosis, chorioamnionitis)
Obesity
Substance use disorder
Extremes of maternal age
<b>OTHER</b>
Premature rupture of membranes
Polyhydramnios
Iatrogenic due to factors listed above
Assisted reproductive technology
Trauma

Physical maturity

	-1	0	1	2	3	4	5
<b>Skin</b>	Sticky, friable, transparent	Gelatinous, red, translucent	Smooth, pink, visible veins	Superficial peeling and/or rash, few veins	Cracking, pale areas, rare veins	Parchment, deep cracking, no vessels	Leathery, cracked, wrinkled
<b>Lanugo</b>	None	Sparse	Abundant	Thinning	Bald areas	Mostly bald	
<b>Plantar surface</b>	Heel-toe 40-50 mm: -1 <40 mm: -2	>50 mm, no crease	Faint red marks	Anterior transverse crease only	Creases on ant. 2/3	Creases over entire sole	
<b>Breast</b>	Imperceptible	Barely perceptible	Flat areola-no bud	Stripped areola, 1-2 mm bud	Raised areola, 3-4 mm bud	Full areola, 5-10 mm bud	
<b>Eye/ear</b>	Lids fused loosely (-1), tightly (-2)	Lids open, pinna flat, stays folded	Slightly curved pinna; soft; slow recoil	Well-curved pinna, soft but ready recoil	Formed and firm, instant recoil	Thick cartilage, ear stiff	
<b>Genitals, male</b>	Scrotum flat, smooth	Scrotum empty, faint rugae	Testes in upper canal, rare rugae	Testes descending, few rugae	Testes down, good rugae	Testes pendulous, deep rugae	
<b>Genitals, female</b>	Clitoris prominent, labia flat	Prominent clitoris, small labia minora	Prominent clitoris, enlarging minora	Majora and minora equally prominent	Majora large, minora small	Majora cover clitoris and minora	

**Fig. 119.7** Physical criteria for maturity. The expanded New Ballard score includes extremely premature infants and has been refined to improve accuracy in more mature infants. (From Ballard JL, Khoury JC, Wedig K, et al. *New Ballard score, expanded to include extremely premature infants*. *J Pediatr*. 1991;119:417-423.)

from preterm infants. Compared with a premature infant of appropriate weight, an infant with IUGR has a reduced birthweight and may appear to have a disproportionately larger head relative to body size; infants in both groups lack subcutaneous fat. Neurologic maturity (nerve conduction velocity) in the absence of asphyxia correlates with gestational age despite reduced fetal weight. Physical signs may be useful in estimating gestational age at birth. The commonly used **Ballard scoring system** is accurate to within 2 weeks of actual gestational age (Figs. 119.7-119.9).

Neuromuscular maturity

	-1	0	1	2	3	4	5
<b>Posture</b>							
<b>Square window (wrist)</b>	>90°	90°	60°	45°	30°	0°	
<b>Arm recoil</b>		180°	140-180°	110-140°	90-110°	<90°	
<b>Popliteal angle</b>							
<b>Scarf sign</b>							
<b>Heel to ear</b>							

**Fig. 119.8** Neuromuscular criteria for maturity. The expanded New Ballard score includes extremely premature infants and has been refined to improve accuracy in more mature infants. (From Ballard JL, Khoury JC, Wedig K, et al. *New Ballard score, expanded to include extremely premature infants*. *J Pediatr*. 1991;119:417-423.)

Maturity Rating

Score	Weeks
-10	20
-5	22
0	24
5	26
10	28
15	30
20	32
25	34
30	36
35	38
40	40
45	42
50	44

**Fig. 119.9** Maturity rating. The physical and neurologic scores are added to calculate gestational age. (From Ballard JL, Khoury JC, Wedig K, et al. *New Ballard score, expanded to include extremely premature infants*. *J Pediatr*. 1991;119:417-423.)

**NURSERY CARE**

At birth, the general measures needed to clear the airway, initiate breathing, care for the umbilical cord and eyes, and administer vitamin K are the same for premature infants as for those of normal weight and maturity (see Chapter 123). Additional considerations are the need for (1) thermal control and monitoring of the heart rate and respiration, (2) advanced respiratory support, and (3) special attention to the details of fluid requirements and nutrition that may in turn lead to considerations of IV access. Preterm infants are at an increased risk of early and late-onset neonatal sepsis compared with their term counterparts. Routine procedures that disturb these infants may result in hypoxia and stress. The benefits of regular and active participation by the parents in the infant's care in the nursery and the question of prognosis for later growth and development require special consideration.

**Thermal Control**

Avoidance of hypothermia and hyperthermia decreases the risk of morbidity and mortality in ELBW and VLBW infants. Neonates in general, and ELBW and VLBW infants to an even greater extent, are at increased risk of heat loss compared with older children due to an



increased body surface/weight ratio, decreased epidermal and dermal skin thickness, minimal subcutaneous fat, and an immature nervous system.

Preterm infants should be kept in a **neutral thermal environment**. This environment comprises a set of thermal conditions, including air and radiating surface temperatures, relative humidity, and airflow, at which heat production (measured experimentally as oxygen consumption) is minimal and the infant's core temperature is within the normal range. The neutral thermal environment is a function of the size and postnatal age of an infant; larger, older infants require lower environmental temperatures than smaller, younger infants. Incubators or radiant warmers can be used to maintain body temperature. Body heat is conserved through provision of a warm environment and humidity, while minimizing heat loss through conduction, convection, radiation, and evaporation. The optimal environmental temperature for minimal heat loss and oxygen consumption for an unclothed infant is one that maintains the infant's core temperature at 36.5–37.0°C (97.7–98.6°F). The smaller and less mature the infant, the higher is the environmental temperature required. Infant warmth can be maintained by heating the air to a desired temperature or by servo-control. Continuous monitoring of the infant's temperature is required to maintain optimal body temperature. **Kangaroo care**, especially in LBW infants, with direct skin-to-skin contact between infant and parent, with a hat and blanket covering the infant, is to be encouraged (and not delayed), without untoward effects on thermoregulation.

Maintaining increased relative humidity for preterm infants in the first weeks of life aids in stabilizing body temperature by reducing heat loss at lower environmental temperatures. The ideal humidity and duration of increased humidity at a specific gestational age is not known, but typically is maintained between 60% and 80% for a week. Humidification of inspired air for infants requiring respiratory support prevents drying and irritation of the lining of respiratory passages and aids in thinning viscid secretions and reducing insensible water loss. Humidification should be gradually weaned after the first week of life to promote skin barrier formation and to reduce the risk of microbial growth associated with prolonged excessive humidity. The infant should also be weaned and then removed from the incubator or radiant warmer when the gradual change in the atmosphere of the nursery does not result in a significant change in the infant's temperature, color, activity, vital signs, or rate of weight gain.

### Oxygen Administration

Administering oxygen to reduce the risk of injury from hypoxia and circulatory insufficiency (risk of cerebral palsy, death) must be balanced against the risk of hyperoxia to the eyes (**retinopathy of prematurity [ROP]**) and injury to the lungs due to generation of free radicals. For ELBW infants at birth, guidelines should be followed to determine need for supplemental oxygen during resuscitation to maintain goal O<sub>2</sub> saturation limits (see [Chapter 123](#)).

After the initial resuscitation period, ideal target O<sub>2</sub> saturation limits for ELBW infants should be within the range of 90–95% for most infants.

### Nutrition for the High-Risk Infant

In the absence of early parenteral and enteral nutritional support, deficits in protein, energy, and micronutrients will quickly accrue, placing the infant at risk for poor growth and neurodevelopmental outcomes. The goals of early nutritional support for extremely premature infants include approximating the rate and composition of growth for a normal fetus at the same postmenstrual age. Achieving this goal requires an understanding of the intrauterine growth rate to be targeted as well as the unique nutrient requirements of premature infants. Strategies to prevent growth failure include a combined approach of early parenteral and enteral nutrition, fortification of human milk, and the use of standardized feeding guidelines. Careful monitoring of weight gain, length, and head circumference using appropriate growth curves and timely biochemical assessment of bone health and potential nutritional deficiencies is paramount. Consultation with an experienced neonatal dietician is important to achieve optimal outcomes.

### Early Parenteral Nutrition

In the absence of IV amino acids, extremely premature infants lose 1–2% of body protein stores per day. IV amino acids and dextrose should be started immediately after birth. Many units use a *starter* or *stock* solution of amino acids and dextrose to accomplish this goal in infants weighing <1,500 g. Ideally at least 2 g/kg of amino acids should be given in the first 24 hours after birth, with a goal of at least 3 g/kg within 24–48 hours after birth. To meet total energy requirements, up to 3 g/kg of IV lipids will also be needed.

### Benefits of Human Milk

Maternal milk is the preferred source of enteral nutrition for premature infants and is associated with decreased in-hospital morbidity, including lower rates of necrotizing enterocolitis (NEC), late-onset sepsis, bronchopulmonary dysplasia (BPD), and severe ROP. Maternal milk feeding is also associated with superior neurodevelopmental outcomes at 18- and 30-months corrected age compared to infants fed premature formula. Donor human milk is increasingly being used when maternal milk is not available, but it is typically lower in protein and energy content than preterm maternal milk and may result in suboptimal growth unless adequately fortified. Although donor human milk has been associated with a reduction in NEC, the impact of donor human milk on neurodevelopmental outcomes remains unclear.

### Enteral Nutrition

Early enteral feedings are recommended in ELBW and VLBW infants, typically beginning between 6 and 48 hours of life with some period of trophic/minimal enteral feeding volume. Feedings are typically advanced slowly (15–30 mL/kg/day) with a target goal of delivering approximately 110–135 kcal/kg/day and 3.5–4.5 g protein/kg/day. To accomplish these goals, human milk must be fortified, or a premature formula can be given. Additional supplements such as vitamins, iron, or other micronutrients may be required and should be based on ongoing assessment and in consultation with a neonatal dietician.

### Standardized Feeding Guidelines

Standardized feeding guidelines should be developed incorporating evidence-based strategies for the provision of parenteral and enteral nutrition in ELBW and VLBW infants, including a plan to manage feeding intolerance. Regardless of the specific protocol, having a feeding guideline leads to improved outcomes (e.g., time to regain birthweight, time to reach full enteral nutrition), decreased rates of late-onset sepsis and NEC, improved growth at 36 weeks' postmenstrual age, and reduced length of hospital stay.

### Transitioning to Discharge Nutrition

The earlier an infant is born before expected, the greater the likelihood that not all nutritional deficits will be resolved before hospital discharge. Regardless of weight gain during the initial hospital stay, there is strong evidence for improved bone mineralization with the use of higher concentrations of calcium and phosphorus after discharge. Fortified human milk or preterm formula with higher concentrations of protein, minerals, and trace elements is often recommended after discharge. An individualized approach to postdischarge nutrition should be developed to transition from the NICU and communicated with the outpatient pediatrician who will be caring for the infant.

### Prevention of Infection

Extremely preterm infants have an increased susceptibility to infection; thus meticulous attention to infection control is required. Prevention strategies include strict compliance with handwashing and universal precautions, minimizing the risk of catheter contamination and duration, meticulous skin care, encouraging early appropriate advancement of enteral feeding, education and feedback to staff, and surveillance of nosocomial infection rates in the nursery. Although no one with an active infection should be permitted in the nursery, the risks of infection must be balanced against the disadvantages of limiting the infant's contact with the family. Early and frequent participation by parents in the nursery care of their infant does not increase the risk of infection when preventive precautions are maintained.

Preventing transmission of infection from infant to infant is difficult because often neither term nor premature newborn infants have clear clinical evidence of an infection early in their course. When epidemics occur within a nursery, cohort nursing and isolation rooms should be used. **Hand hygiene** is of upmost importance. Because premature infants have immature immune functions, some will develop nosocomial infection even when all precautions are followed.

Awareness of overutilization of antibiotics may mitigate associated complications both at the population level (cost and antibiotics resistance) and for the individual patient (alteration of the microbiome).

Routine **immunizations** should be given on the regular schedule based on chronological age at standard doses.

### Transfusion Medicine

Premature infants are at increased risk of anemia due to impaired erythropoiesis and iatrogenesis due to frequent laboratory sampling. Most infants with a birthweight less than 1,000 g admitted to the NICU receive at least one blood transfusion during their stay. The need for repeated transfusion can be minimized by a thoughtful approach to laboratory sampling and establishing set hemoglobin thresholds for transfusions. A multicenter randomized controlled trial in infants 22 weeks 0 days to 28 weeks 6 days found that a lower transfusion threshold resulted in fewer transfusions per infant without an impact on neurodevelopment at 22 to 26 months' corrected gestational age. The need for transfusions depends in part on the cardiopulmonary stability of the patient, postnatal age, birthweight, and the etiology of the anemia. For severe cardiopulmonary disease, transfusions are recommended to maintain the hematocrit between 40% and 45%. For asymptomatic stable neonates with anemia of prematurity, maintaining the hematocrit at ~25% is acceptable.

Transfusion of platelets is another common practice in the NICU. Premature infants are at high risk for intraventricular hemorrhage in the first week of life, which historically prompted platelet transfusion at thresholds now considered safe. Additionally, preterm infants may also develop thrombocytopenia in the setting of severe bleeding or infection. A multicenter randomized controlled trial found that infants randomized to a higher platelet transfusion threshold (50,000/m<sup>3</sup>) paradoxically had a higher rate of death or severe bleeding that infants randomized to a lower threshold (25,000/m<sup>3</sup>).

### IMMATURITY OF DRUG METABOLISM

Great care must be taken when prescribing and dosing medications for premature infants (Table 119.4). Renal clearance of almost all substances excreted in the urine is diminished in newborn infants, and to even a greater extent in premature infants. The glomerular filtration rate rises with increasing gestational age; therefore drug dosing recommendations vary with age. For drugs primarily excreted by the kidneys, longer intervals between dosages are often needed with increasing degree of prematurity. Drugs that are detoxified in the liver or require chemical conjugation before renal excretion should also be given with caution and in doses smaller than usual.

Many drugs apparently safe for adults on the basis of toxicity studies may be harmful to newborns, especially premature infants. Oxygen and a number of drugs have proved toxic to premature infants in amounts not harmful to term infants. Thus, administering any drug, particularly in high doses, that has not undergone pharmacologic testing in premature infants should be undertaken carefully after risks have been weighed against benefits.

### MORBIDITY AND MORTALITY

Rates of neonatal morbidity and mortality are high in extremely preterm infants, and risks increase with decreasing gestational age and lower birthweight (Table 119.5). Data on extremely preterm infants born between 2003 and 2007 found that 42% of VLBW infants developed BPD, 12% developed ROP requiring treatment, 11% NEC, 36% late-onset sepsis, 16% grade III or IV intraventricular hemorrhage, and 3% periventricular leukomalacia (PVL). Mortality increased with lower gestational age, with a 94% mortality in infants born at 22 weeks and 8% mortality at 28 weeks. The group of extremely preterm infants

**Table 119.4** Potential Adverse Reactions to Drugs Administered to Premature Infants

DRUG	REACTION(S)
Oxygen	Retinopathy of prematurity, bronchopulmonary dysplasia
Sulfisoxazole	Kernicterus
Chloramphenicol	Gray baby syndrome—shock, bone marrow suppression
Novobiocin	Jaundice
Hexachlorophene	Encephalopathy
Benzyl alcohol	Acidosis, collapse, intraventricular bleeding
Intravenous vitamin E	Ascites, shock
Phenolic detergents	Jaundice
NaHCO <sub>3</sub>	Intraventricular hemorrhage
Amphotericin	Anuric renal failure, hypokalemia, hypomagnesemia
Indomethacin	Oliguria, hyponatremia, intestinal perforation
Cisapride	Prolonged QTc interval
Tetracycline	Enamel hypoplasia
Tolazoline	Hypotension, gastrointestinal bleeding
Calcium salts	Subcutaneous necrosis
Aminoglycosides	Deafness, renal toxicity
Prostaglandins	Seizures, diarrhea, apnea, hyperostosis, pyloric stenosis
Phenobarbital	Altered state, drowsiness
Morphine	Hypotension, urine retention, withdrawal
Pancuronium	Edema, hypovolemia, hypotension, tachycardia
Iodine antiseptics	Hypothyroidism, goiter
Fentanyl	Seizures, chest wall rigidity, withdrawal
Dexamethasone	Gastrointestinal bleeding, hypertension, infection, hyperglycemia, cardiomyopathy, reduced growth
Furosemide	Deafness, hyponatremia, hypokalemia, hypochloremia, nephrocalcinosis, biliary stones
Heparin (not low-dose prophylactic use)	Bleeding, intraventricular hemorrhage, thrombocytopenia
Erythromycin	Pyloric stenosis

had a 28% mortality rate, with 37% surviving without a significant neonatal morbidity.

Another study found that morbidity and mortality among VLBW infants decreased between 2000 and 2009. This study was limited to liveborn infants with birthweights of 500-1,500 g. For infants born in 2009, this study found a 12.4% mortality rate; 28% of infants developed BPD, 7% severe ROP, 5% NEC, 15% late-onset sepsis, 6% grade III or IV IVH, and 3% PVL; 51% survived without significant neonatal morbidity.

Outcomes are improving with time; survival among infants born at 22-24 weeks' gestation is ~50-80% in units providing active management. The percentage surviving without neurodevelopmental impairment has also increased. Factors that reduce morbidity and mortality in extremely preterm infants include higher birthweight and gestational age, receipt of antenatal corticosteroids, female sex, singleton pregnancy, and active

**Table 119.5** Neonatal Morbidities Associated with Prematurity

<b>RESPIRATORY</b>
Respiratory distress syndrome (hyaline membrane disease)
Bronchopulmonary dysplasia*
Pneumothorax, pneumomediastinum; interstitial emphysema
Congenital pneumonia
Apnea
<b>CARDIOVASCULAR</b>
Patent ductus arteriosus
Hypotension
Bradycardia (with apnea)
<b>HEMATOLOGIC</b>
Anemia (early or late onset)
<b>GASTROINTESTINAL</b>
Poor gastrointestinal function—poor motility
Necrotizing enterocolitis*
Hyperbilirubinemia—indirect and direct
Spontaneous gastrointestinal isolated perforation
<b>METABOLIC-ENDOCRINE</b>
Hypocalcemia
Hypoglycemia
Hyperglycemia
Metabolic acidosis
Hypothermia
Euthyroid but low thyroxine status
Osteopenia
<b>CENTRAL NERVOUS SYSTEM</b>
Intraventricular hemorrhage*
Periventricular leukomalacia*
Seizures
Retinopathy of prematurity*
Deafness
<b>RENAL</b>
Hyponatremia
Hypernatremia
Hyperkalemia
Renal tubular acidosis
Renal glycosuria
Edema
<b>OTHER</b>
Infections* (congenital, perinatal, nosocomial: bacterial, viral, fungal, protozoal)

\*Major neonatal morbidities.

resuscitation planned at delivery. With improvement in neonatal care, a growing number of centers offer a trial of resuscitation starting at 22 0/7 weeks if that is consistent with parental goals. Outcome prediction tools such as those based on data from the United States (NICHD-VON) or UK (BAPM) and the latter organization's framework to guide management are resources for the clinician that can be used for parental counseling. The prediction tools underscore that extreme prematurity is still associated with significant risk of both mortality and major neonatal morbidities. For infants who survive to discharge, prematurity, as well as neonatal morbidities, put them at increased risk for developmental delays and impairment as they age (see Chapter 119.5). Perinatal centers should develop consensus guidelines regarding an approach to periviable birth to ensure a consistent approach to both maternal and neonatal care. Balanced and unbiased antenatal counseling that includes shared decision-making between neonatologists, obstetricians, and families is imperative.

Visit Elsevier eBooks+ at [eBooks.Elsevier.com](http://eBooks.Elsevier.com) for Bibliography.

### 119.3 Moderate and Late Preterm Infants

Erik Brandsma

Whereas the American Academy of Pediatrics (AAP), the American College of Obstetricians and Gynecologists (ACOG), and the WHO

have precise definitions for preterm, term, and postterm births, there has been some debate on defining subcategories of preterm infants. Because outcomes vary widely within broad gestational age range groups, consensus on definitions of subcategories is important. Based on a now widely adopted recommendation from a 2005 National Institutes of Health (NIH) sponsored workshop, infants born at 34 0/7 through 36 6/7 weeks' gestation are considered late preterm. The WHO defines **moderate to late preterm** birth as infants born at 32 0/7 through 36 6/7 weeks' gestation. Therefore most define **moderate preterm** infants as those born at 32 0/7 through 33 6/7 weeks' gestation.

The initial effect of the NIH-sponsored workshop and the resulting 2007 AAP Clinical Report from the Committee on Fetus and Newborn on late preterm infants was encouraging. The report continues to be a resource for pediatricians caring for late preterm infants, listing recommended minimum criteria for their discharge. A 2019 update from the Committee on Fetus and Newborn addresses the concern of the increasing incidence of late preterm birth since 2015.

The risk of morbidity in the individual infant born moderate or late preterm is lower than infants born before 32 weeks of gestation. Because late and moderate preterm births account for approximately 75% and 11.5% of preterm births in the United States, respectively, morbidities in this group continue to be a significant burden on the healthcare system. Etiology of preterm birth is discussed elsewhere (see Chapter 117.2). The majority of moderate and late preterm births are associated with spontaneous preterm labor, preterm premature rupture of membranes (PPROM), and multiple gestation.

#### MODERATE PRETERM INFANT

Moderate preterm infants are at increased risk for postnatal morbidities, although to a lesser extent and severity than very preterm infants. The most common morbidities associated with preterm birth at this gestational age are temperature instability, respiratory distress, apnea, sepsis, hypoglycemia, feeding difficulties, and hyperbilirubinemia. Moderate preterm infants with birthweight >1,500 g and an unremarkable NICU course are thought to be at minimal risk for IVH and do not routinely need a head ultrasound. Similarly, the AAP does not recommend universal screening for ROP at this gestational age, unless birthweight is below 1,500 g or in select cases for infants with a history of significant cardiopulmonary compromise. Little research has examined moderate preterm infants as an isolated group; more often these infants are grouped with very preterm infants when assessing complications and outcomes. A cohort of approximately 7,000 infants born between 29 and 33 weeks' gestational age were found in a recent study to have a mean hospital stay of 33.3 days. Moderate and late preterm infants are at increased risk of mortality as well. The increased risk of mortality is modest, approximately 10-fold for moderate preterm infants and fourfold for late preterm infants compared to term infants (22 and 8.2 per 1,000 live births, respectively), but because these infants comprise close to 90% of preterm infants overall, this group as a whole contributes significantly to infant mortality.

#### LATE PRETERM INFANT

As described previously, the overall rate of prematurity has increased gradually since 2015. Most of the increase in overall preterm birthrate can be contributed to infants born late preterm. These infants account for approximately 7.5% of all births and almost three fourths of all preterm births in the United States. Historically, late preterm infants were referred to as *near-term infants*, and the approach to their care was similar to that of term infants. It has been increasingly recognized that late preterm infants have significantly increased morbidity, as well as mortality, compared with their term counterparts. Overall, compared to their term counterparts, late preterm infants have approximately a sevenfold risk of morbidities and fourfold risk of mortality. There is an increased incidence of congenital anomalies in preterm infants, but even when these infants are excluded, late preterm infants continue to have significantly more morbidities. Immediately after birth, there is an increased risk of requiring resuscitation, as well as increased incidence of hypoglycemia, respiratory distress due to respiratory distress syndrome (RDS) or transient tachypnea of the newborn (TTN) apnea, and



difficulty with thermoregulation. Their average birth hospital length of stay is approximately 9 days compared to 2 days for term infants. Additional concerns during this initial hospital stay include feeding difficulties and jaundice. They have a higher rehospitalization rate compared to their term peers and an increased risk of long-term morbidities and even mortality (e.g., sudden infant death syndrome [SIDS]). Some studies suggest a higher risk of lower school readiness at kindergarten and increased risk of academic difficulties in childhood when comparing late preterm infants with term peers.

In addition to universal routine newborn care, the potential morbidities associated with preterm birth need to be addressed. This starts before birth with possible interventions to prevent preterm birth or a course of betamethasone for the pregnant women at risk for preterm birth within 7 days as recommended by ACOG and continues in the delivery room, where measures should be in place to prevent and treat common preterm birth associated morbidities such as hypothermia and hypoglycemia. Whether infants are taken care of in a NICU or in a well-baby nursery, continued vigilance is required to address the potential consequences of physiologic immaturity, such as poor feeding, dehydration, and hyperbilirubinemia. Follow-up visits should occur early and additional visits may be required to ensure the infant thrives. Because of ongoing health risks that the preterm infant faces in infancy and childhood, awareness and documentation of the child's birth history is important. It is paramount that all interventions are implemented equitably, with particular attention to non-Hispanic black and Hispanic women and children, who are currently disproportionately affected by preterm birth and account for the largest increase in late preterm birth.

Visit Elsevier eBooks+ at [eBooks.Health.Elsevier.com](http://eBooks.Health.Elsevier.com) for Bibliography.

## 119.4 Term and Postterm Infants

Andrea F. Duncan

The ACOG further divides term infants into subgroups: **early term** (37-38 6/7 weeks), **full term** (39-40 6/7 weeks), and **late term** (41-41 6/7 weeks). Many risk factors for term infants put them at higher risk for complications, such as meconium aspiration syndrome (see Chapter 129.1), hemolytic disease of the newborn (see Chapter 140), infant of a diabetic mother (see Chapter 147), and neonatal abstinence syndrome (see Chapter 145). Both SGA and large-for-gestational-age (LGA) are associated with increased morbidities.

### SMALL FOR GESTATIONAL AGE AND IUGR

There is an important distinction between the terms **small for gestational age (SGA)** and **intrauterine growth restriction (IUGR)**. SGA is based on physical evaluation of an infant at birth, usually by a pediatrician or neonatologist. If the infant's weight is <10th percentile, the infant is SGA. The diagnosis of SGA does not differentiate between normal biologic growth potential and a pathologic or growth-restricted state in utero. In contrast, IUGR is a prenatal diagnosis to describe a fetus who fails to reach in utero growth potential, often diagnosed by the obstetrician using intrauterine growth curves and measures of compromise (e.g., abnormal Doppler flow measurements) (Fig. 119.10). This measure is independent of growth centile at birth. Therefore not all infants with IUGR are SGA, and, similarly, not all infants who are SGA have IUGR.

Although it is important to understand the difference between SGA and IUGR, many studies evaluate postnatal outcomes based on a diagnosis of either SGA or IUGR.



**Fig. 119.10** This is a 36-week male neonate with a birthweight of 1,600 g who was born to a mother with severe preeclampsia. This baby was noted to have asymmetric intrauterine growth restriction (IUGR). Note the loss of fat over the body, visible rib cage, excessive skin folds noted over the whole body, and relatively large head compared to the body. (From Sharma D, Shastri S, Sharma P. Intrauterine growth restriction: antenatal and postnatal aspects. *Clin Med Insights Pediatr.* 2016;10:67–83.)



**Table 119.6** Factors Often Associated with Intrauterine Growth Restriction

<b>FETAL</b>
Chromosomal (trisomies, microdeletions, copy number variants) and monogenetic disorders
Chronic fetal infections (cytomegalic inclusion disease, congenital rubella, syphilis)
Congenital anomalies—syndrome complexes
Irradiation
Multiple gestation
Pancreatic hypoplasia
Insulin deficiency (production or action of insulin)
Insulin-like growth factor type I deficiency
<b>PLACENTAL</b>
Decreased placental weight, cellularity, or both
Decrease in surface area
Villous placentitis (bacterial, viral, parasitic)
Infarction
Tumor (chorioangioma, hydatidiform mole)
Placental separation
Placental mesenchymal dysplasia
Twin transfusion syndrome
<b>MATERNAL/PATERNAL</b>
Preeclampsia
Hypertension or renal disease, or both
Hypoxemia (high altitude, cyanotic cardiac or pulmonary disease)
Malnutrition (micronutrient or macronutrient deficiencies)
Chronic illness
Sickle cell anemia
Drugs (opiates, alcohol, cigarettes, cocaine, prescribed medications, antimetabolites)

IUGR is indicative of compromise in utero and is associated with medical conditions that interfere with the circulation and efficiency of the placenta, with the development or growth of the fetus, or with the general health and nutrition of the mother (Table 119.6). Many factors are common to both prematurely born and LBW infants with IUGR. IUGR is associated with decreased insulin production or insulin-like growth factor (IGF) action at the receptor level. Infants with IGF-1 receptor defects, pancreatic hypoplasia, or transient neonatal diabetes have IUGR. Genetic mutations affecting the glucose-sensing mechanisms of the pancreatic islet cells result in decreased insulin release (loss of function of the glucose-sensing glucokinase gene) and give rise to IUGR.

IUGR may be a normal fetal response to nutritional or oxygen deprivation; therefore the issue is not the IUGR but rather the ongoing risk of fetal malnutrition or hypoxia. IUGR is often classified as *reduced growth* that is *symmetric* (head circumference, length, and weight equally affected) or *asymmetric* (with relative sparing of head growth) (Table 119.7). **Symmetric IUGR** often has an earlier onset in the first trimester of pregnancy and is associated with diseases that seriously affect fetal cell number, such as conditions with chromosomal, genetic, malformation, teratogenic, infectious, or severe maternal hypertensive etiologies. It is important to assess gestational age carefully in infants suspected to have symmetric IUGR because incorrect overestimation of gestational age may lead to the diagnosis of symmetric IUGR. It is also important to assess carefully for dysmorphic features in infants with symmetric IUGR. **Asymmetric IUGR** is often of late onset in the second half of pregnancy, demonstrates preservation of Doppler waveform velocity to the carotid vessels, and is associated with poor maternal nutrition or with late onset or exacerbation of maternal vascular disease (preeclampsia, chronic hypertension).

Table 119.8 lists common problems of infants with IUGR. In addition, in both preterm and term infants, IUGR is associated with increased risk of cardiovascular disease across the life span, and both SGA and IUGR are associated with an increased risk of neurodevelopmental impairment. To properly manage infants born IUGR and SGA, clinicians must prepare for the possible perinatal morbidities (e.g., hypoglycemia, hypothermia, pulmonary hypertension, feeding intolerance), perform any diagnostic testing needed to determine the etiology,

**Table 119.7** Characteristics of Symmetric vs Asymmetric IUGR

CHARACTERISTICS	SYMMETRIC IUGR	ASYMMETRIC IUGR
Typical period of insult and presentation	Earlier gestation (often second trimester)	Later gestation (often detected in the third trimester)
Percentage of all IUGR cases	20–30%	70–80%
Etiology	Genetic disorders Congenital infections	Placental insufficiency
Antenatal scan	Proportionately decreased head circumference (HC), abdominal circumference (AC), biparietal diameter, and femur length	Only abdominal circumference decreased
Cell number	Decreased	Normal
Cell size	Normal	Decreased
Postnatal anthropometry	All parameters (HC, length, and weight) reduced	Reduced weight, HC normal, length low to normal
Features of malnutrition	Less pronounced	More pronounced

IUGR, Intrauterine growth restriction.

Adapted from Sharma D, Shastri S, Sharma P. Intrauterine growth restriction: –part 2. *J Matern Fetal Neonatal Med.* 2016 Mar 15:1–12.

**Table 119.8** Problems of Infants Small for Gestational Age or with Intrauterine Growth Restriction\*

PROBLEM	PATHOGENESIS
Intrauterine fetal demise	Hypoxia, acidosis, infection, lethal anomaly
Perinatal asphyxia	↓ Uteroplacental perfusion during labor ± chronic fetal hypoxia-acidosis; meconium aspiration syndrome
Hypoglycemia	↓ Tissue glycogen stores, ↓ gluconeogenesis, hyperinsulinism, ↑ glucose needs of hypoxia, hypothermia, large brain
Polycythemia-hyperviscosity	Fetal hypoxia with ↑ erythropoietin production
Reduced oxygen consumption/hypothermia	Hypoxia, hypoglycemia, starvation effect, poor subcutaneous fat stores
Dysmorphology	Syndrome anomalies, chromosomal-genetic disorders, oligohydramnios-induced deformation, TORCH <sup>†</sup>

\*Other problems include pulmonary hemorrhage and those common to the gestational age–related risks of prematurity if born at <37 wk.

<sup>†</sup>TORCH, Toxoplasmosis, other agents, rubella, cytomegalovirus, herpes simplex infection. ↓, Decreased; ↑, increased.

and monitor closely for long-term deficits (e.g., growth, neurodevelopment, cardiovascular).

### LARGE-FOR-GESTATIONAL-AGE INFANTS

Infants with birthweight >90th percentile for gestational age are called **large for gestational age (LGA)**. Neonatal mortality rates decrease with increasing birthweight until approximately 4,000 g, after which they increase. These oversized infants are usually born at term, but

preterm infants with high weights for gestational age also have a significantly higher mortality than infants of the same size born at term; maternal diabetes and obesity are predisposing factors. Some infants are constitutionally large because of large parental size. LGA infants, regardless of their gestational age, have a higher incidence of shoulder dystocia and birth injuries, such as cervical and brachial plexus injuries, phrenic nerve damage with paralysis of the diaphragm, fractured clavicles, cephalohematomas, subdural hematomas, and ecchymoses of the head and face. LGA infants are also at increased risk for hypoglycemia and polycythemia.

The incidence of congenital anomalies, particularly congenital heart disease, is also higher in LGA infants than in term infants of normal weight.

### POSTTERM INFANTS

Postterm infants are those born after 42 weeks (294 days) of gestation, as calculated from the mother's LMP. Historically, approximately 12% of pregnancies resulted in delivery after 42 weeks. However, with current evidence demonstrating significantly increased maternal, fetal and neonatal risks after 42 weeks' gestation, obstetric interventions to induce labor often occur before 42 weeks, resulting in a decreasing rate of postterm births. The cause of true postterm birth or postmaturity is unknown, though some have been attributed to genetic influences and defects in fetal production of parturition hormones. Postterm infants are often dysmature, with normal length and head circumference but may have decreased weight, indicating impaired nutritional supply from placental insufficiency. Infants born postterm in association with presumed placental insufficiency may have various physical signs. Desquamation, long nails, abundant hair, pale skin, alert faces, and loose skin, especially around the thighs and buttocks, give them the appearance of having recently lost weight; meconium-stained nails, skin, vernix, umbilical cord, and placental membranes may also be noted. Common complications of postmaturity include perinatal depression, meconium aspiration syndrome, persistent pulmonary hypertension, hypoglycemia, hypocalcemia, and polycythemia.

Perinatal mortality is 5.8% for infants born at  $\geq 42$  weeks' gestational age, compared to 0.7% for those born at term. Mortality may be due to placental insufficiency or umbilical cord compression resulting in hypoxemia and asphyxia. Mortality has been greatly reduced through improved obstetric management. Data suggest that elective delivery between the 39th and 41st week of gestation for both nulliparous and multiparous women is associated with decreased maternal and neonatal complications compared with those who were expectantly managed.

Careful obstetric monitoring, including nonstress testing (NST), biophysical profile (BPP), or Doppler velocimetry, usually provides a rational basis for choosing one of three courses: nonintervention, induction of labor, or cesarean delivery. Induction of labor or cesarean birth may be indicated in older primigravidas  $>2$  weeks beyond term, particularly if evidence of fetal distress is present. Medical problems in the newborn are treated if they arise.

Visit Elsevier eBooks+ at [eBooks.Health.Elsevier.com](http://eBooks.Health.Elsevier.com) for Bibliography.

## 119.5 Follow-Up of High-Risk Infants After Discharge

Andrea F. Duncan

### DISCHARGE FROM THE HOSPITAL

Numerous criteria need to be met before a high-risk infant is ready for discharge from the hospital (Table 119.9). Before discharge, infants should be taking most or all nutrition by nipple, either bottle or breast. Some medically fragile infants may require discharge while receiving gavage feedings or after placement of a gastrostomy tube, after the parents have received appropriate training and education. Growth should be occurring at steady increments, with a goal weight gain of approximately 30 g/day. Temperature should be stable and

**Table 119.9** Readiness for Discharge of High-Risk Infants Criteria

Resolution of acute life-threatening illnesses
Ongoing follow-up for chronic but stable problems:
Bronchopulmonary dysplasia
Intraventricular hemorrhage
Necrotizing enterocolitis after surgery or recovery
Ventricular septal defect, other cardiac lesions
Anemia
Retinopathy of prematurity
Hearing problems
Apnea
Cholestasis
Stable temperature regulation
Gain of weight with enteral feedings:
Breastfeeding
Bottle feeding
Gastric tube feeding
Free of significant apnea
Appropriate immunizations and planning for respiratory syncytial virus prophylaxis if indicated
Hearing screenings
Ophthalmologic examination if $<30$ wk of gestation or $<1,500$ g at birth
Parental knowledge, skill, and confidence documented in:
Administration of medications (diuretics, methylxanthines, aerosols, etc.)
Use of oxygen, apnea monitors, oximeters
Nutritional support:
Timing
Volume
Mixing concentrated formulas
Recognition of illness and deterioration
Basic cardiopulmonary resuscitation
Infant safety
Scheduling of referrals:
Primary care provider
Neonatal follow-up clinic
Occupational therapy/physical therapy
Imaging (head ultrasound)
Assessment of and solution to social risks

Data from American Academy of Pediatrics, American College of Obstetricians: *Guidelines for Perinatal Care*. 7th ed. Elk Grove Village, IL: American Academy of Pediatrics; 2013.

normal in an open crib. Infants should have had no recent episodes of apnea or bradycardia requiring intervention for at least 5-7 days before discharge. Stable infants recovering from BPD may be discharged on a regimen of home oxygen given by nasal cannula as long as careful follow-up is arranged with home pulse oximetry monitoring and outpatient visits. Some children may require discharge on higher ventilatory support in partnership with pulmonology. All infants with birthweight  $<1,500$  g or gestational age  $<30$  weeks at birth should undergo an eye examination to screen for ROP. If born preterm, hemoglobin or hematocrit should be determined to evaluate for possible anemia of prematurity. Every infant should have a hearing test before discharge. Routine vaccinations should be given based on chronological age before discharge. In addition, palivizumab (Synagis) should be given to eligible infants during respiratory syncytial virus (RSV) season immediately before discharge for prophylaxis against RSV, with continued monthly doses arranged as an outpatient as appropriate.

If all major medical problems have resolved and the home setting is adequate, premature infants may then be discharged when their weight approaches 1,800-2,000 g, they are  $>34$ -35 weeks postmenstrual age (PMA), and all the above criteria are met. Parental education, close follow-up, and healthcare provider accessibility are all essential for early discharge protocols. The primary caregivers for the infant should have a chance to provide infant care in the hospital with nursing supervision and support before discharge home. All high-risk infants should follow up with their primary care provider within a few days of discharge and should

**Table 119.10** Sequelae of Prematurity

IMMEDIATE	LATE
Hypoxia, ischemia	Intellectual disability, spastic diplegia, microcephaly, seizures, poor school performance
Intraventricular hemorrhage	Intellectual disability, spasticity, seizures, post hemorrhagic hydrocephalus
Sensorineural injury	Hearing and visual impairment, retinopathy of prematurity, strabismus, myopia
Respiratory failure	Bronchopulmonary dysplasia, pulmonary hypertension, bronchospasm, malnutrition, subglottic stenosis
Necrotizing enterocolitis	Short-bowel syndrome, malabsorption, malnutrition
Cholestatic liver disease	Cirrhosis, hepatic failure, malnutrition
Nutrient deficiency	Osteopenia, fractures, anemia, growth failure
Social stress	Child abuse or neglect, failure to thrive, divorce
Other sequelae	Sudden infant death syndrome, infections, inguinal hernia, cutaneous scars (chest tube, patent ductus arteriosus ligation, intravenous infiltration), gastroesophageal reflux, hypertension, craniosynostosis, cholelithiasis, nephrocalcinosis, cutaneous hemangiomas

be followed in a follow-up program that tracks medical and neurodevelopmental outcomes.

## POSTDISCHARGE FOLLOW-UP

### Medical Follow-Up

Even after discharge from the hospital, high-risk infants need very close medical follow-up. They continue to be at increased risk for poor weight gain and failure to thrive. In the setting of viral illness, premature infants are at increased risk for significant respiratory distress. Infants who are sent home on oxygen need very close medical follow-up with frequent visits and assessments, often with pulmonology. [Table 119.10](#) lists common sequelae of prematurity.

Medically complex infants can go home with a multitude of subspecialty appointments to help manage existing morbidities secondary to prematurity, for example, cardiology for management of a patent ductus arteriosus or pulmonary hypertension, pulmonary for BPD, nephrology for hypertension, ophthalmology for ROP, neurosurgery for hydrocephalus, and neurology for history of seizures. The extensive follow-up requirements can be overwhelming and daunting for families. It is very important that these infants have a primary provider who serves as their “medical home” to help coordinate and assimilate the care from all these providers for families. This may be their primary care provider or subspecialty program provider.

### Developmental Follow-Up

Premature infants are at much greater risk for neurodevelopmental delays than their term counterparts; the more preterm, the greater the

risk of delay. In addition, certain postnatal morbidities (severe BPD, grade III or IV intraventricular hemorrhage, severe ROP, seizures) are associated with significantly increased risk of developmental delays. It is very important that these infants, particularly those born preterm, are followed and assessed for developmental delay, so that if delays are detected targeted interventions can be instituted as early as possible.

It is recommended that developmental follow-up be available for infants born <32 weeks' PMA, or at a minimum <28 weeks' PMA and/or <1 kg birthweight. Developmental follow-up in the United States is most often provided in a neonatal follow-up program for the first 2-3 years of life, and in some cases, until school age. Assessments focus on five main developmental domains: cognitive development, language development, fine and gross motor skills, social development, and emotional development. Although many assessments exist, the most widely used assessment in the United States is the *Bayley Scales of Infant and Toddler Development, 4th Edition*.

It is important to note that for at least the first 2 years of life, a child's corrected age should be used in determining whether a delay exists. Corrected age is calculated by subtracting the weeks born premature from a child's chronological age. In doing so, a corrected age accounts for a child's prematurity. There is some debate whether corrected age should continue to be used after age 2 years.

If it is determined that a delay exists, a child should be referred for appropriate therapy immediately to help minimize the delay as the child ages. Federal law under the Individuals with Disabilities Act requires states to provide *early intervention* services to children <3 years old with developmental delay. States vary greatly in how delay is defined and what services are offered. Early intervention is associated with improved cognitive outcomes in infancy and preschool age, but not lasting into school age. Motor outcomes are improved in infancy for children who receive early intervention, but this has not been shown to be a lasting effect into preschool and school age. However, these findings are difficult to interpret, given the heterogeneity of early interventions included in the reviews. With *targeted* interventions for specific delays, functional outcomes are improved.

Premature infants, especially those with a history of grade III or IV intraventricular hemorrhage or PVL seen on head imaging, are also at increased risk of motor impairments. Cerebral palsy is a *nonprogressive* but *permanent* disorder of movement and posture caused by disturbance to the developing immature brain. Historically, cerebral palsy had not been diagnosed until 18-24 months of age, but it can be diagnosed within the first 6 months of life. Early detection is critical to leveraging the neuroplasticity present in the very early years of life for improved function. International guidelines for early assessment and diagnosis of cerebral palsy and standardized assessments such as the General Movements Assessment (GMA) and the Hammersmith Infant Neurological Examination (HINE) are recommended in the guidelines to help identify children at high risk for or with cerebral palsy within the first few months to a year of life. This enables these children to access early intervention services and therapy at an earlier age, as well as undergo more frequent surveillance as needed.

Children with a history of prematurity who do not show significant developmental delays in the first few years of life are still at risk of later developing learning disabilities, attention problems, and decreased school achievement. Continued screening by their primary care provider is needed as these children age. More subtle deficits may not be recognized until school age; therefore continued surveillance is critical.

Visit Elsevier eBooks+ at [eBooks.Health.Elsevier.com](http://eBooks.Health.Elsevier.com) for Bibliography.



## Chapter 120

## Transport of the Critically Ill Newborn

David A. Munson

**REGIONALIZED CARE OF NEWBORNS**

The concept of regionalized care for neonates emphasizes the importance of providing regionalized care for infants in facilities with adequate personnel and equipment for an infant's severity of illness. Ideally, pregnant people should give birth to infants at a facility with the appropriate level of expertise and resources to care for the degree of prematurity and illness of the infant. Very low birthweight (VLBW) infants, or infants <1,500 g at birth, have decreased morbidity and mortality when born at **Level III** hospitals. In a meta-analysis, neonatal or predischarge death occurred in 38% of VLBW infants receiving care at a non–Level III hospital and 23% of those receiving care at a Level III hospital. A main objective of *Healthy People 2020* addresses this issue, with a goal of increasing the proportion of VLBW infants born at Level III hospitals or subspecialty perinatal centers to 83.7%. When possible it is more preferable to transport the pregnant person to meet the goals of regionalization.

**LEVELS OF NEONATAL CARE**

A **Level I** facility must be able to provide *basic neonatal care*. Appropriate equipment and staff must be available to perform neonatal resuscitation and care for healthy term and late preterm infants. In addition, Level I facilities must have the capacity to work to stabilize ill or preterm infants before transport to a higher level of care. A Level I nursery is the minimum requirement for a hospital providing inpatient maternity care. Providers at Level I facilities usually include pediatricians, family physicians, and nurse practitioners.

In addition to the care provided at a Level I facility, **Level II** nurseries must also be capable of providing care to moderately ill term infants with problems expected to resolve quickly. Level II centers also care for infants born  $\geq 32$  weeks' gestational age and >1,500 g at birth; therefore they must be comfortable with treating conditions common in this population, such as difficulty with oral feeds, apnea of prematurity, respiratory distress requiring continuous positive airway pressure (CPAP), and temperature regulation. These centers must also be capable of stabilizing infants born <32 weeks' gestation and <1,500 g until transfer to a higher-level facility is feasible, including the ability to intubate and provide mechanical ventilation for a brief duration if necessary. In addition to providers in Level I facilities, Level II facilities also typically have pediatric hospitalists, neonatologists, and neonatal nurse practitioners.

**Level III** NICUs are equipped to care for extremely preterm and critically ill neonates in addition to those infants cared for at Level I and II units. Level III units must have continuously available personnel and equipment to treat conditions commonly seen in this population, such as respiratory distress syndrome, pulmonary hypertension, and need for total parenteral nutrition. Resources should be available to obtain and interpret urgent imaging needed (e.g., CT, echocardiography). Pediatric subspecialists and pediatric surgeons should be available either on-site or through prearranged consultative agreements.

In addition to the care available at Level III neonatal intensive care units (NICUs), **Level IV** NICUs are also capable of providing continuously available pediatric subspecialty consultation and pediatric surgical intervention. Many Level IV sites are located at regional children's hospitals and also serve to provide outreach education. Level IV NICUs also have the capacity to provide extracorporeal membrane oxygenation (ECMO), an intervention that requires surgeons for catheter placement and ECMO specialists who are typically

nurses or respiratory therapists with additional training in managing the ECMO circuit.

**TRANSPORT OF THE CRITICALLY ILL NEONATE**

In the event that a neonate requires a higher level of care, transport must be arranged to a unit with the appropriate level of care available. Additional decisions that need to be made before transport include composition of the transport team, equipment required for transport, and mode of transportation.

The composition of the **transport team** varies depending on personnel available and the needs of the infant being transported. The transport team often comprises at least two individuals, whether two registered transport trained nurses (RNs), an RN and a respiratory therapist, or an RN and a paramedic. In addition, a neonatologist, neonatology fellow, or neonatal nurse practitioner will sometimes accompany the transport team for critically ill neonates. A **medical command physician** is also available and can communicate with the transport team during the transport, as needed. The command physician is also able to communicate with the referring neonatologist to discuss the case and offer advice while the transport team is en route.

**Transport staff** must be competent in the treatment of common neonatal conditions and complications, as well as neonatal procedures. Many Level IV facilities have specialized teams designed only for neonatal transports. However, a Cochrane review found no evidence to support or to refute improved infant morbidity or mortality when transport occurred with a specialized neonatal team versus those that transported both neonatal as well as pediatric patients. Depending on the volume of neonatal transports and composition of the team, staff may have limited exposure to neonatal transports and procedures. **Simulation-based learning** is recommended by the American Academy of Pediatrics (AAP) Section on Transport Medicine (SOTM) as a method to help achieve and retain competency in rarely experienced procedures, as well as improve team interactions for transport teams.

The **transport vehicle** should be equipped with appropriate medicines, intravenous (IV) fluids, oxygen tanks, catheters, chest tubes, endotracheal tubes (ETTs), laryngoscopes, bag-valve-mask, and infant warming device. It should be well illuminated and have ample room for emergency procedures and monitoring equipment. Additional needs for an individual transport should be anticipated. Specifically, inhaled nitric oxide is not standard equipment for most transport teams and will need to be requested if thought necessary for safe transport. For neonates with hypoxemic ischemic encephalopathy who require hypothermia therapy, a servo-controlled cooling device is recommended as it will achieve the target temperature faster and there is less risk of overshooting the goal temperature. Prostaglandin E1 should be available for suspected ductal dependent congenital heart disease.

Common **modes of transport** include ground transport by ambulance and air transport by helicopter or fixed-wing aircraft. The stability of the infant, travel distance, traffic, and weather must all be taken into account when deciding the most appropriate mode of transportation.

Steps should be taken to stabilize the infant, as able, in a timely fashion before the transport. Securing an airway, providing oxygen, assisting with infant ventilation, providing antimicrobial therapy, maintaining the circulation, providing a warmed environment, checking a glucose level, and placing IV or arterial lines or chest tubes should be initiated, if indicated, before transport. Appropriate placement of lines and ETT should be evaluated before transport.

Some hospitals and their associated level IV NICUs offer transport of a patient on ECMO. Most commonly this is designed to transport a patient who is already cannulated onto ECMO who needs subspecialized care such as evaluation for transplant, or assessment for longer-term mechanical cardiac support. In other situations, a hospital may have the capacity to cannulate a patient onto ECMO, but do not have a program in place to support the patient for the coming days. These patients may therefore include more common patients who require ECMO such as neonates with persistent pulmonary hypertension, severe hypoxemic respiratory failure, sepsis, congenital diaphragmatic hernia, or hypoplastic left heart syndrome. In these circumstances, a transport team needs to include an ECMO specialist or perfusionist, and commonly adds a



critical care physician or surgeon. There are some programs that will bring the necessary personnel and equipment to cannulate a patient onto an ECMO circuit at the referring hospital before transport. There are considerable logistical challenges and added risks for transporting a patient on ECMO. These include inadvertent decannulation, problems with sustaining flow on the circuit, and bleeding.

**Risks** of transport and **consent** for transportation should be reviewed and obtained from parents before transport. Although transport teams attempt to anticipate and prepare for possible complications that could occur during transport, there is an inherent risk of complications, including death, in the event of a decompensation during transport resulting from the limited resources and personnel available. It is intrinsically more difficult to perform procedures in the physically confined space of an ambulance or helicopter. Additionally, there is the risk associated with the mode of transport itself including car and helicopter crashes. Parents should be made aware of these risks. Efforts should be made to allow parents to see their baby briefly before transport.

**Communication** with the transport team as well as the receiving facility is paramount throughout the transport process. Available prenatal history, information on the infant's resuscitation and hospital course, laboratory data, and radiographic images should be sent with the transport team to the receiving hospital to aid in future care. Video-assisted telecommunications can assist in giving the **medical command physician** visual as well as audio information about what is happening on-site before the patient is loaded onto the ambulance.

**Reverse transport** of an infant back to a lower level of care should be considered when infants are stabilized or have received and recovered from their subspecialist or surgical interventions, and no longer require the higher-level care available at the receiving hospital. Transport back to the hospital of birth aids in appropriate utilization of resources, decreases costs of care, and may further promote parent-infant bonding because of proximity to the mother's home.

Visit Elsevier eBooks+ at [eBooks.Health.Elsevier.com](http://eBooks.Health.Elsevier.com) for Bibliography.

## Chapter 121

# Clinical Manifestations of Diseases in the Newborn Period

Kathleen A. Gibbs and Eric C. Eichenwald

A variety of conditions that affect the newborn originate in utero, during birth, or in the immediate postnatal period. These disorders can be caused by prematurity, congenital malformations, disruption of chromosome structure, or acquired diseases and injuries.

### ABNORMAL MOVEMENTS

**Neonatal seizures** usually suggest a central nervous system (CNS) disorder, such as hypoxic-ischemic encephalopathy (HIE), intracranial hemorrhage, stroke, cerebral anomaly, subdural effusion, or meningitis (see Chapter 633.7). In the neonate, seizures can also be secondary to hypocalcemia, hypoglycemia, benign familial seizures, or rarely, pyridoxine dependence, hyponatremia, hypernatremia, inborn errors of metabolism, or drug withdrawal.

Seizures in premature infants are often subtle and associated with abnormal eye movement (fluttering, tonic horizontal deviation, sustained eye opening with ocular fixation) or facial movement (chewing, tongue thrusting); the motor component is often that of tonic extension of the limbs, neck, and trunk. Autonomic phenomena include hypertension and tachycardia. Term infants may have focal or multifocal, clonic or myoclonic movements, but they may also have subtler manifestations of seizure activity. **Apnea** may be the first manifestation of seizure activity, particularly in a premature infant. Seizures may adversely affect the subsequent neurodevelopmental outcome and may even predispose an infant to seizures outside the neonatal period. Electroencephalographic (EEG) evidence of seizures can occur without clinical manifestations, particularly in premature infants. If seizures are suspected, video-EEG monitoring will improve the detection of both subtle and electrographic but clinically silent seizures. Seizures contribute to brain injury and the impact of treatment on neurodevelopmental outcomes is an active area of research, particularly in patients with HIE. Although many medications used to treat seizures have side effects, it is recommended to treat both clinical and subclinical seizures.

Seizures should be distinguished from the **jitteriness**, defined as *recurrent tremors*, that may be present in healthy newborns, in infants of diabetic mothers, in those who experienced birth asphyxia or drug withdrawal, and in polycythemic neonates. An examiner can suppress the tremors by holding the infant's extremity; jitteriness often depends on sensory stimuli and occurs when the infant is active, and it is not associated with abnormal eye movements. Tremors are often more rapid with a smaller amplitude than those of tonic-clonic seizures.

After severe birth asphyxia, infants may exhibit **motor automatisms** characterized by recurrent oral-buccal-lingual movements, rotary limb activities (rowing, pedaling, swimming), tonic posturing, or myoclonus. These motor activities are not usually accompanied by time-synchronized EEG discharges, may not signify cortical epileptic activity, respond poorly to anticonvulsant therapy, and are associated with a poor prognosis. Such automatisms may represent cortical depression that produces a brainstem release phenomenon or subcortical seizures.

Failure to move an extremity (**pseudoparalysis**) suggests fracture, dislocation, or a paralytic brachial plexus injury, often following a traumatic delivery. It is also seen in neonatal stroke (paralytic) as well as septic arthritis, osteomyelitis, and other infections that cause pain on movement of the affected part.

### ABNORMAL TONE

**Hypotonia**, or low tone in one or more extremities, may be due to specific genetic etiologies or as a result of pathology in the peripheral or central nervous system. Features in the history and physical examination can help narrow the differential diagnosis and guide further diagnostic evaluations (see Chapter 647). A history of decreased fetal movement in utero may be suggestive of a congenital myopathy, or spinal muscular atrophy. In a male infant with cryptorchidism, Prader-Willi syndrome can be considered. **Hypotonia** is a common finding in an infant with trisomy 21. Hypertonia is less common and should be distinguished from fixed joint contractures seen in arthrogryposis. If present in the hours after birth and associated with the need for resuscitation after birth, a case of HIE should be considered.

### ALTERED MENTAL STATUS

**Lethargy** may be a manifestation of infection, asphyxia, hypoglycemia, hypercapnia, sedation from maternal analgesia or anesthesia, an inborn error of metabolism (IEM), or, almost any severe disease. Shortly after birth, lethargy is most likely caused by maternal medications (opioids, magnesium, general anesthesia) or moderate to severe HIE. Lethargy appearing after the second day should suggest infection or an IEM manifesting with hyperammonemia, acidosis, or hypoglycemia. Lethargy with emesis may suggest increased intracranial pressure or an IEM.

critical care physician or surgeon. There are some programs that will bring the necessary personnel and equipment to cannulate a patient onto an ECMO circuit at the referring hospital before transport. There are considerable logistical challenges and added risks for transporting a patient on ECMO. These include inadvertent decannulation, problems with sustaining flow on the circuit, and bleeding.

**Risks** of transport and **consent** for transportation should be reviewed and obtained from parents before transport. Although transport teams attempt to anticipate and prepare for possible complications that could occur during transport, there is an inherent risk of complications, including death, in the event of a decompensation during transport resulting from the limited resources and personnel available. It is intrinsically more difficult to perform procedures in the physically confined space of an ambulance or helicopter. Additionally, there is the risk associated with the mode of transport itself including car and helicopter crashes. Parents should be made aware of these risks. Efforts should be made to allow parents to see their baby briefly before transport.

**Communication** with the transport team as well as the receiving facility is paramount throughout the transport process. Available prenatal history, information on the infant's resuscitation and hospital course, laboratory data, and radiographic images should be sent with the transport team to the receiving hospital to aid in future care. Video-assisted telecommunications can assist in giving the **medical command physician** visual as well as audio information about what is happening on-site before the patient is loaded onto the ambulance.

**Reverse transport** of an infant back to a lower level of care should be considered when infants are stabilized or have received and recovered from their subspecialist or surgical interventions, and no longer require the higher-level care available at the receiving hospital. Transport back to the hospital of birth aids in appropriate utilization of resources, decreases costs of care, and may further promote parent-infant bonding because of proximity to the mother's home.

Visit Elsevier eBooks+ at [eBooks.Health.Elsevier.com](http://eBooks.Health.Elsevier.com) for Bibliography.

## Chapter 121

# Clinical Manifestations of Diseases in the Newborn Period

Kathleen A. Gibbs and Eric C. Eichenwald

A variety of conditions that affect the newborn originate in utero, during birth, or in the immediate postnatal period. These disorders can be caused by prematurity, congenital malformations, disruption of chromosome structure, or acquired diseases and injuries.

### ABNORMAL MOVEMENTS

**Neonatal seizures** usually suggest a central nervous system (CNS) disorder, such as hypoxic-ischemic encephalopathy (HIE), intracranial hemorrhage, stroke, cerebral anomaly, subdural effusion, or meningitis (see Chapter 633.7). In the neonate, seizures can also be secondary to hypocalcemia, hypoglycemia, benign familial seizures, or rarely, pyridoxine dependence, hyponatremia, hypernatremia, inborn errors of metabolism, or drug withdrawal.

Seizures in premature infants are often subtle and associated with abnormal eye movement (fluttering, tonic horizontal deviation, sustained eye opening with ocular fixation) or facial movement (chewing, tongue thrusting); the motor component is often that of tonic extension of the limbs, neck, and trunk. Autonomic phenomena include hypertension and tachycardia. Term infants may have focal or multifocal, clonic or myoclonic movements, but they may also have subtler manifestations of seizure activity. **Apnea** may be the first manifestation of seizure activity, particularly in a premature infant. Seizures may adversely affect the subsequent neurodevelopmental outcome and may even predispose an infant to seizures outside the neonatal period. Electroencephalographic (EEG) evidence of seizures can occur without clinical manifestations, particularly in premature infants. If seizures are suspected, video-EEG monitoring will improve the detection of both subtle and electrographic but clinically silent seizures. Seizures contribute to brain injury and the impact of treatment on neurodevelopmental outcomes is an active area of research, particularly in patients with HIE. Although many medications used to treat seizures have side effects, it is recommended to treat both clinical and subclinical seizures.

Seizures should be distinguished from the **jitteriness**, defined as *recurrent tremors*, that may be present in healthy newborns, in infants of diabetic mothers, in those who experienced birth asphyxia or drug withdrawal, and in polycythemic neonates. An examiner can suppress the tremors by holding the infant's extremity; jitteriness often depends on sensory stimuli and occurs when the infant is active, and it is not associated with abnormal eye movements. Tremors are often more rapid with a smaller amplitude than those of tonic-clonic seizures.

After severe birth asphyxia, infants may exhibit **motor automatisms** characterized by recurrent oral-buccal-lingual movements, rotary limb activities (rowing, pedaling, swimming), tonic posturing, or myoclonus. These motor activities are not usually accompanied by time-synchronized EEG discharges, may not signify cortical epileptic activity, respond poorly to anticonvulsant therapy, and are associated with a poor prognosis. Such automatisms may represent cortical depression that produces a brainstem release phenomenon or subcortical seizures.

Failure to move an extremity (**pseudoparalysis**) suggests fracture, dislocation, or a paralytic brachial plexus injury, often following a traumatic delivery. It is also seen in neonatal stroke (paralytic) as well as septic arthritis, osteomyelitis, and other infections that cause pain on movement of the affected part.

### ABNORMAL TONE

**Hypotonia**, or low tone in one or more extremities, may be due to specific genetic etiologies or as a result of pathology in the peripheral or central nervous system. Features in the history and physical examination can help narrow the differential diagnosis and guide further diagnostic evaluations (see Chapter 647). A history of decreased fetal movement in utero may be suggestive of a congenital myopathy, or spinal muscular atrophy. In a male infant with cryptorchidism, Prader-Willi syndrome can be considered. **Hypotonia** is a common finding in an infant with trisomy 21. Hypertonia is less common and should be distinguished from fixed joint contractures seen in arthrogryposis. If present in the hours after birth and associated with the need for resuscitation after birth, a case of HIE should be considered.

### ALTERED MENTAL STATUS

**Lethargy** may be a manifestation of infection, asphyxia, hypoglycemia, hypercapnia, sedation from maternal analgesia or anesthesia, an inborn error of metabolism (IEM), or, almost any severe disease. Shortly after birth, lethargy is most likely caused by maternal medications (opioids, magnesium, general anesthesia) or moderate to severe HIE. Lethargy appearing after the second day should suggest infection or an IEM manifesting with hyperammonemia, acidosis, or hypoglycemia. Lethargy with emesis may suggest increased intracranial pressure or an IEM.

**Irritability** may be a sign of discomfort accompanying intraabdominal conditions, meningeal irritation, drug withdrawal, infections, trauma (birth or nonaccidental), or any condition producing pain. It must be distinguished from normal crying behavior associated with hunger or benign environmental stimuli.

**The lack of an interest to feed** may indicate a sick infant and should prompt a careful search for infection, a CNS (brain or spine) or peripheral nervous system disorder, IEM, or intestinal obstruction.

### APNEA

Periods of apnea, particularly in premature infants, can be attributed to many different underlying causes (see Chapter 125). When apnea occurs in a term infant, it should be considered pathologic until proven otherwise, and an immediate diagnostic evaluation for the underlying cause is imperative.

### CONGENITAL ANOMALIES

Congenital anomalies are a common cause of neonatal morbidity and mortality worldwide (see Chapters 98–100). Early recognition of anomalies during fetal life is important to plan for delivery room management and subsequent neonatal care. Some malformations, including congenital heart disease, tracheoesophageal fistula, diaphragmatic hernia, choanal atresia, and intestinal obstruction, require immediate medical/surgical therapy for postnatal survival (Table 121.1). Prenatal and postnatal testing strategies, including advanced imaging techniques and genetic testing, have improved the specific diagnosis of congenital anomalies (see Chapter 103.1). Historically, genetic testing was performed by obtaining a karyotype with or without *fluorescence in situ hybridization* (FISH). A karyotype can identify a large number of chromosomal abnormalities; FISH can test for classic microdeletion syndromes such as 22q11. Chromosomal microarray is also indicated for genetic testing of infants with congenital anomalies because it can identify microdeletions or microduplications that are too small to be detected by more traditional techniques. In cases where a common aneuploidy, such as trisomy 13, 18, or 21, is suspected, obtaining a conventional karyotype and/or FISH may be the more appropriate test as those results are available in a few days. Whole exome sequencing (WES) uses next-generation sequencing to identify variants in protein coding genes that may be responsible for a disease phenotype. Rapid WES can have results available in 1-2 weeks. This can be used in a critically ill infant with a suspected genetic disorder that lacks a unifying diagnosis, and it may lead to a specific treatment and prognosis. Limitations of both microarray and WES include the identification of

variants that may not be pathogenic in nature. Parents should receive genetic counseling as part of any testing strategy. It is important that healthcare providers are aware of the indication and limitations of the type of genetic test being performed.

### CYANOSIS

**Central cyanosis** generates a broad differential diagnosis encompassing respiratory, cardiac, CNS, infectious, hematologic, and metabolic etiologies (Table 121.2). Typically, 5 g/dL of deoxyhemoglobin must be present in the blood for central cyanosis to be clinically apparent. If respiratory insufficiency is caused by pulmonary conditions, respirations tend to be rapid with increased work of breathing. If caused by CNS depression, respirations tend to be irregular and weak and are often slow. Cyanosis unaccompanied by obvious signs of respiratory difficulty suggests cyanotic congenital heart disease or methemoglobinemia. Cyanosis resulting from congenital heart disease may be difficult to distinguish clinically from cyanosis caused by respiratory disease. Episodes of cyanosis may also be the initial sign of hypoglycemia, bacteremia, meningitis, shock, or pulmonary hypertension. **Peripheral acrocyanosis** is common in neonates and thought to represent peripheral venous congestion associated with immature control of peripheral vascular tone. It does not usually warrant concern unless poor perfusion is suspected.

### GASTROINTESTINAL DISTURBANCES

**Vomiting** during the first day of life can suggest obstruction in the upper digestive tract, metabolic disease, or may be physiologic. **Abdominal distention** with emesis, usually a sign of intestinal obstruction or an intraabdominal mass, may also be seen in infants with enteritis, necrotizing enterocolitis (NEC), isolated intestinal perforation, ileus accompanying sepsis, respiratory distress, ascites, or hypokalemia. Imaging studies are indicated when obstruction is suspected; proximal intestinal obstruction often occurs with a normal physical examination, whereas distal obstruction will likely be accompanied by distention. Vomiting may also be a nonspecific symptom of an illness such as sepsis with associated abdominal distention and ileus. It is a common manifestation of overfeeding, as well as gastroesophageal or physiologic reflux. Rarely, vomiting is caused by pyloric stenosis, milk protein allergy, duodenal ulcer, stress ulcer, an IEM (hyperammonemia, metabolic acidosis), or adrenal insufficiency. Vomitus containing blood is usually a sign of a serious illness, but the benign possibility of swallowed maternal blood associated with the delivery process should also be considered. Tests for maternal vs fetal hemoglobin can help

**Table 121.1** Common Life-Threatening Congenital Anomalies

ANOMALY	MANIFESTATIONS
Choanal atresia	Respiratory distress in delivery room; nasogastric tube cannot be passed through nares Suspect CHARGE (coloboma of eye, heart anomaly, choanal atresia, retardation, genital and ear anomalies) syndrome
Pierre Robin syndrome, Stickler syndrome	Micrognathia, cleft palate, airway obstruction
Diaphragmatic hernia	Scaphoid abdomen, bowel sounds present in chest, respiratory distress
Tracheoesophageal fistula	Polyhydramnios, aspiration pneumonia, excessive salivation; nasogastric tube cannot be placed in stomach Suspect VATER (vertebral defects, imperforate anus, tracheoesophageal fistula, radial and renal dysplasia) syndrome
Intestinal obstruction: volvulus, duodenal atresia, ileal atresia	Polyhydramnios, bile-stained emesis, abdominal distention Suspect trisomy 21, cystic fibrosis, or cocaine use
Gastroschisis, omphalocele	Polyhydramnios, intestinal obstruction
Renal agenesis, Potter syndrome	Oligohydramnios, anuria, pulmonary hypoplasia, pneumothorax
Neural tube defects: anencephaly, meningomyelocele	Polyhydramnios, elevated $\alpha$ -fetoprotein, decreased fetal activity
Ductus-dependent congenital heart disease	Cyanosis, hypotension, murmur

**Table 121.2** Differential Diagnosis of Cyanosis in the Newborn**CENTRAL OR PERIPHERAL NERVOUS SYSTEM HYPOVENTILATION**

Birth asphyxia  
 Intracranial hypertension, hemorrhage  
 Oversedation (direct or through maternal route)  
 Diaphragm palsy  
 Neuromuscular diseases  
 Seizures

**RESPIRATORY DISEASE****Airway**

Choanal atresia/stenosis  
 Pierre Robin syndrome  
 Intrinsic airway obstruction (laryngeal/bronchial/tracheal stenosis)  
 Extrinsic airway obstruction (bronchogenic cyst, duplication cyst, vascular compression)

**Lung**

Respiratory distress syndrome  
 Transient tachypnea  
 Meconium aspiration  
 Pneumonia (sepsis)  
 Pneumothorax  
 Congenital diaphragmatic hernia  
 Pulmonary hypoplasia

**CARDIAC RIGHT-TO-LEFT SHUNT****Abnormal Connections (Pulmonary Blood Flow Normal or Increased)**

Transposition of great vessels  
 Total anomalous pulmonary venous return  
 Truncus arteriosus  
 Hypoplastic left heart syndrome  
 Single ventricle or tricuspid atresia with large ventricular septal defect but without pulmonic stenosis

**OBSTRUCTED PULMONARY BLOOD FLOW (PULMONARY BLOOD FLOW DECREASED)**

Pulmonic atresia with intact ventricular septum  
 Tetralogy of Fallot  
 Critical pulmonic stenosis with patent foramen ovale or atrial septal defect  
 Tricuspid atresia  
 Single ventricle with pulmonic stenosis  
 Ebstein malformation of tricuspid valve  
 Persistent fetal circulation (persistent pulmonary hypertension of newborn)

**METHEMOGLOBINEMIA**

Congenital (hemoglobin M, methemoglobin reductase deficiency)  
 Acquired (nitrates, nitrites)

**INADEQUATE DELIVERY**

Inadequate ambient O<sub>2</sub> or less O<sub>2</sub> delivered than expected (rare)  
 Disconnection of O<sub>2</sub> supply to nasal cannula, head hood  
 Connection of air, rather than O<sub>2</sub>, to a mechanical ventilator

**SPURIOUS/ARTIFACTUAL**

Oximeter artifact (poor contact between probe and skin, poor pulse searching)  
 Arterial blood gas artifact (contamination with venous blood)

**OTHER**

Hypoglycemia  
 Adrenogenital syndrome  
 Polycythemia  
 Blood loss

From Smith F: Cyanosis. In: Kliegman RM: *Practical Strategies in Pediatric Diagnosis and Therapy*. Philadelphia: Saunders; 1996.

discriminate between these possibilities. Bilious emesis in a term infant should be considered a surgical emergency with a presumed diagnosis of intestinal malrotation with or without volvulus until proven otherwise. This finding warrants urgent contrast radiography of the upper gastrointestinal tract (see [Chapter 376.3](#)).

**Diarrhea** may be a symptom of overfeeding (especially high-caloric density formula), acute gastroenteritis, congenital diarrhea syndromes, or malabsorption, or it may be a nonspecific symptom of infection. Diarrhea should be differentiated from the normal loose, seedy, yellow stool seen typically in breastfed infants. Diarrhea may occur in conditions accompanied by compromised circulation of part of the intestinal or genital tract, such as mesenteric thrombosis, NEC, strangulated hernia, intussusception, and torsion of the ovary or testis.

**HYPOTENSION**

Hypotension in term infants implies hypovolemic shock (hemorrhage, dehydration), a systemic inflammatory response syndrome (bacterial sepsis, intrauterine infection, NEC, cardiac dysfunction, myocarditis, asphyxia-induced myocardial stunning, anomalous coronary artery), congenital heart disease with ductal-dependent systemic blood flow (hypoplastic left heart syndrome, congenital aortic stenosis), pneumothorax, pneumopericardium, pericardial effusion, or metabolic disorders (hypoglycemia, adrenal insufficiency).

Hypotension is a common problem in sick preterm infants and may also be caused by any of the problems noted in a term infant. Some extremely low gestational age infants do not respond to fluids or inotropic agents but may improve with administration of intravenous hydrocortisone ([Fig. 121.1](#)). Sudden onset of hypotension in a very low birthweight (VLBW) infant suggests pneumothorax, intraventricular hemorrhage, or subcapsular hepatic hematoma. Strategies used to support blood pressure include volume expansion with crystalloid and/or colloid, vasopressors (dopamine, dobutamine, epinephrine, norepinephrine, vasopressin), or corticosteroids (hydrocortisone) (see [Chapter 85](#)).

**JAUNDICE**

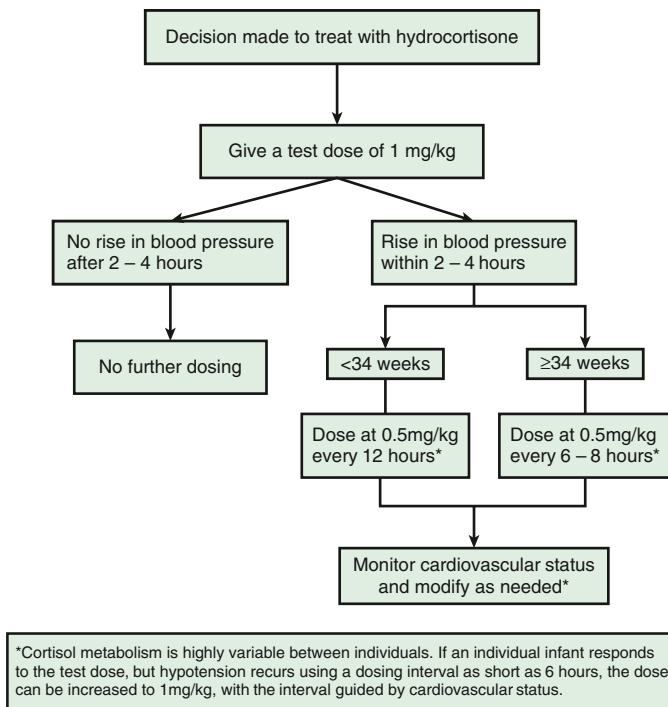
Jaundice during the first 24 hours of life warrants diagnostic evaluation and should be considered pathologic until proven otherwise. Hemolytic disease of the newborn due to rhesus blood group system (Rh) isoimmunization or blood type compatibility are the most common cause (see [Chapter 140](#)). Intrauterine infections (e.g., syphilis, cytomegalovirus, and toxoplasmosis), early-onset sepsis, or gestational alloimmune liver disease (formerly described as neonatal hemochromatosis) should be considered in infants with neonatal cholestasis, identified by an increase in *direct* bilirubin value. Immediate evaluation includes obtaining total and direct bilirubin, infant blood type and Coombs status, CBC, and reticulocyte count. There are nomograms specific to the age (in hours) of the infant to guide the initiation of therapeutic interventions depending on the levels of serum bilirubin values (see [Chapter 137](#)). Phototherapy is the standard first-line therapy. In the case of Coombs-positive hemolysis, strong consideration should be made to giving intravenous immunoglobulin (IVIG) if there is no response to intensive phototherapy. Double volume exchange transfusion is recommended in situations with rapidly rising indirect bilirubin levels, particularly in infants whose bilirubin levels rise over 20 mg/dL. In these cases, obtaining a serum albumin is also recommended.

Jaundice that is identified after the first 24 hours of age may be physiologic or pathologic. Physiologic conditions include breast-milk and breast-feeding jaundice. Pathologic conditions include bacterial sepsis, congenital hypothyroidism, galactosemia, congenital atresia of the bile ducts, or other conditions (see [Chapter 137](#)).

**PAIN**

Pain in neonates may be unrecognized and/or undertreated. The intensive care of neonates may involve several painful procedures, including blood sampling (heelstick, venous or arterial puncture), endotracheal intubation and suctioning, mechanical ventilation, and insertion of chest tubes and intravascular catheters. Pain in neonates results in





**Fig. 121.1** Suggested treatment algorithm for hydrocortisone dosing in the newborn. (From Watterberg KL. Hydrocortisone dosing for hypotension in newborn infants: less is more. *J Pediatr.* 2016;174:23–26.)

obvious distress and acute physiologic stress responses, which may have developmental implications for pain in later life.

Pain and discomfort are potentially avoidable problems during the treatment of sick infants. The most common painful stimuli for healthy newborns include circumcision and phlebotomy while obtaining metabolic screening tests. There are pharmacologic and nonpharmacologic options to both prevent and treat pain. **Oral sucrose solutions** are well tolerated by most infants and have proven efficacy for procedural pain. A dorsal penile nerve block is effective to prevent procedural-related pain during a circumcision. For neonatal intensive care unit (NICU) infants, the most frequently used drugs are intermittent or continuous doses of opioids. Although the specific long-term effects of opioids and sedatives are not well established, the first concern should be the treatment and/or prevention of acute pain (Table 121.3).

Visit Elsevier eBooks+ at [eBooks.Health.Elsevier.com](http://eBooks.Health.Elsevier.com) for Bibliography.

## 121.1 Hyperthermia

Kathleen A. Gibbs and Eric C. Eichenwald

Serious infection (pneumonia, bacteremia, meningitis, and viral infections, particularly herpes simplex or enteroviruses) may cause **fever** and must be considered, although such infections often occur without provoking a febrile response in newborn infants (see Chapter 220). Providers should consider evaluation for bacterial infection in infants <28 days old with a rectal temperature  $\geq 38^{\circ}\text{C}$  ( $100.5^{\circ}\text{F}$ ), including blood culture, urine culture, and lumbar puncture (LP), although stepwise approaches to identify low-risk patients and limiting LP to a subset of higher-risk infants are gaining favor. Fever immediately after birth may be caused by radiant warmers, maternal fever, or maternal epidural analgesia. Fever may also be caused by elevated environmental temperatures because of weather, overheated nurseries, incubators, or radiant warmers, or excessive clothing. It has also been attributed to dehydration, although *dehydration fever* is a diagnosis of exclusion in newborn infants.

Visit Elsevier eBooks+ at [eBooks.Health.Elsevier.com](http://eBooks.Health.Elsevier.com) for Bibliography.

## Table 121.3 Pain in the Neonate: General Considerations

- Pain in newborns is often unrecognized and/or undertreated.
- If a procedure is painful in adults, it should be considered painful in newborns.
- Healthcare institutions should develop and implement patient care policies to assess, prevent, and manage pain in neonates.
- Pharmacologic agents with known pharmacokinetic and pharmacodynamic properties and demonstrated efficacy in neonates should be used. Agents known to compromise cardiorespiratory function should be administered only by persons experienced in neonatal airway management and in settings with the capacity for continuous monitoring.
- Educational programs to increase the skills of healthcare professionals in the assessment and management of stress and pain in neonates should be provided.
- Further research is needed to develop and validate neonatal pain assessment tools that are useful in the clinical setting; to determine optimal behavioral and pharmacologic interventions; and to study long-term effects of pain and pain management.

Data from American Academy of Pediatrics Committee on Fetus and Newborn, Committee on Drugs, Section on Anesthesiology, Section on Surgery; Canadian Paediatric Society, Fetus and Newborn Committee. Prevention and Management of Pain and Stress in the Neonate: An Update. *Pediatrics* 2016;137:e20154271.

## 121.2 Hypothermia and Cold Stress

Kathleen A. Gibbs and Eric C. Eichenwald

Unexplained **hypothermia** may accompany infection or other serious disturbances of the circulation or CNS. A sudden servo-controlled increase in incubator ambient temperature to maintain body temperature is a sign of temperature instability and may be associated with sepsis or any of the conditions already mentioned.

**Cold stress** can lead to profound decompensation, including apnea, bradycardia, respiratory distress, hypoglycemia, and poor feeding. For this reason, it is paramount for the neonate to maintain normothermia in the delivery room and afterward, especially low birthweight and premature infants. For VLBW infants, a combination of occlusive plastic wrap, radiant warmers, and thermal mattresses to maintain normothermia can be used to reduce cold stress.

Visit Elsevier eBooks+ at [eBooks.Health.Elsevier.com](http://eBooks.Health.Elsevier.com) for Bibliography.

## 121.3 Edema

Kathleen A. Gibbs and Eric C. Eichenwald

Generalized edema noted in the delivery room can be caused by hydrops fetalis secondary to several underlying causes (see Chapter 143). An infant with suspected hydrops in utero should be delivered at a specialty perinatal center with capacity for neonatal intubation, thoracentesis, paracentesis, and pericardiocentesis in the delivery room. If noted after 24 hours of age, causes are similar to those of older children and may be multifactorial and likely related to the underlying disease state. Edema may be due to interstitial fluid “third-spacing” due to a systemic inflammatory response seen in sepsis or NEC; or, in the immediate postoperative period, hypoalbuminemia may be due to low production in hepatic synthetic dysfunction or increased losses in underlying renal disease such as congenital nephrotic syndrome (see Chapter 567.3).

## 121.4 Hypocalcemia

Kathleen A. Gibbs and Eric C. Eichenwald

Hypocalcemia in a neonate can manifest as irritability, jitteriness, clonus, or seizures. Electrocardiography can show a prolonged QT interval. The cause may simply represent an exaggerated physiologic decrease in serum calcium levels within the first 24 hours of life or pathologic conditions such as genetic disorders (22q deletions), prematurity, growth restriction, perinatal hypoxia, hypomagnesemia, or maternal diabetes. Hypocalcemia is more common in term infants receiving formula than in those exclusively receiving breast milk. Most infants remain asymptomatic and can be managed conservatively with early nutrition and close monitoring, whereas symptomatic neonates should receive intravenous or oral calcium replacement.

Visit Elsevier eBooks+ at [eBooks.Health.Elsevier.com](http://eBooks.Health.Elsevier.com) for Bibliography.

## 121.5 Hypermagnesemia

Kathleen A. Gibbs and Eric C. Eichenwald

Hypermagnesemia is most often caused by maternal administration of magnesium in the perinatal period for treatment of conditions such as preeclampsia and preterm labor, and as prophylaxis to mitigate brain injury associated with preterm birth. Infants are usually present with signs at birth and improve over the next 24–48 hours. Symptoms include respiratory depression, hypotonia, lethargy, and feeding intolerance. No treatment is indicated other than supportive measures.

## Chapter 122

# Nervous System Disorders

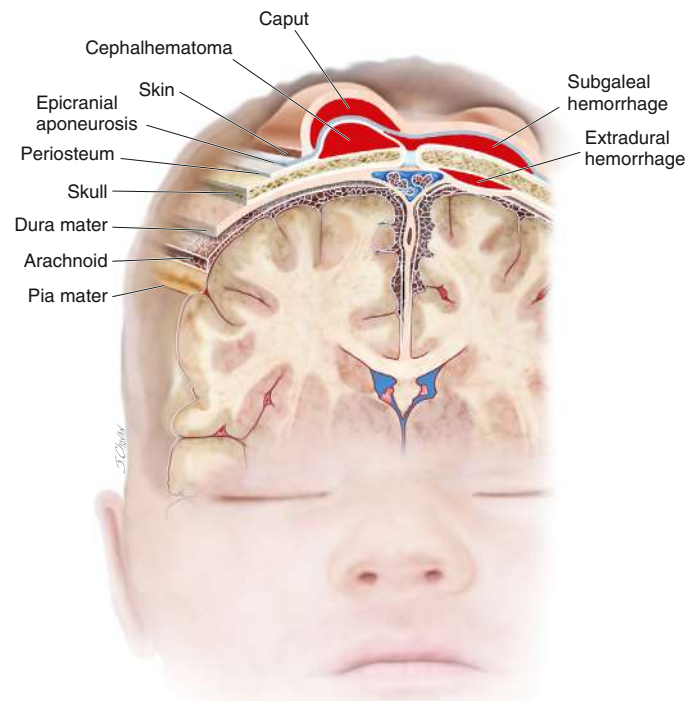
Susan S. Cohen, Alicia J. Sprecher, and  
Krishna K. Acharya

Central nervous system (CNS) disorders are important causes of neonatal mortality and both short-term and long-term morbidity. The CNS can be injured as a result of asphyxia, hemorrhage, trauma, infection, hypoglycemia, or direct cytotoxicity. The etiology of CNS injury is often multifactorial and includes perinatal complications, postnatal hemodynamic instability, and developmental abnormalities that may be genetic and/or environmental. Predisposing factors for brain injury include chronic and acute maternal illness resulting in uteroplacental dysfunction, intrauterine infection, macrosomia/dystocia, malpresentation, prematurity, and intrauterine growth restriction. Acute and often unavoidable emergencies during the delivery process may result in mechanical and hypoxic-ischemic brain injury.

## 122.1 The Cranium

Susan S. Cohen, Alicia J. Sprecher, and  
Krishna K. Acharya

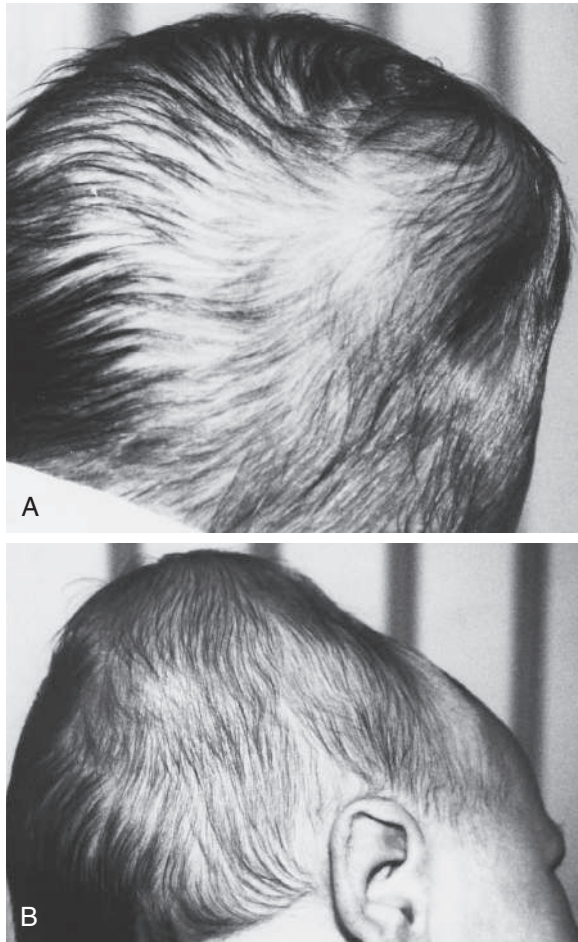
Erythema, abrasions, ecchymoses, and subcutaneous fat necrosis of facial or scalp soft tissues may be noted after a normal delivery or after forceps or vacuum-assisted deliveries. The location depends on the area of contact with the pelvic bones or application of the forceps. Traumatic hemorrhage may involve any layer of the scalp as well as intracranial contents (Fig. 122.1).



**Fig. 122.1** Sites of extracranial (and extradural) hemorrhages in the newborn. Schematic diagram of important tissue planes from skin to dura. (From Volpe JJ. *Injuries of extracranial, cranial, intracranial, spinal cord, and peripheral nervous system structures*. In: Volpe JJ, Inder TE, Darras BT, et al., eds. *Volpe's Neurology of the Newborn*. 6th ed. Philadelphia: Elsevier; 2018: Fig. 36-1.)

**Caput succedaneum** is a diffuse, sometimes ecchymotic, edematous swelling of the soft tissues of the scalp due to the increased pressure of the vaginal and uterine walls on the fetal head during labor. The pressure causes a serosanguinous/edematous infiltration above the periosteum and below the skin or subcutaneous tissue. The edema is soft and extends across the midline of the skull, crossing suture lines and disappears within the first few days of life. Molding of the head and overriding of the parietal bones are frequently associated with caput succedaneum and become more evident after the caput has receded; they disappear during the first few weeks of life. Rarely, a hemorrhagic caput may result in shock and require blood transfusion. Analogous swelling, discoloration, and distortion of the face are seen in face presentations. No specific treatment is needed, but if extensive ecchymoses are present, hyperbilirubinemia may develop.

**Cephalohematoma** is a unilateral subperiosteal hemorrhage that does not cross the suture lines as it usually occurs within a single cranial plate (Fig. 122.2). Cephalohematomas occur in 1–2% of live births regardless of the mode of delivery. No discoloration of the overlying scalp occurs, and due to slow bleeding, the clinical presentation of swelling is delayed for several hours to days. The lesion becomes a firm, tense mass with a palpable rim localized over one area of the skull. Most cephalohematomas are resorbed within 3 to 4 weeks, depending on their size. They may begin to calcify by the end of the second week of life. A few remain for years as bony protuberances and are detectable on radiographs as widening of the diploic space; cystlike defects that may persist for months or years. An underlying skull fracture, usually linear and not depressed, may be associated with 10–25% of cases. A sensation of central depression suggesting but not indicative of an underlying fracture or bony defect is usually encountered on palpation of the organized rim of a cephalohematoma. Osteomyelitis of the skull is a rare complication of cephalohematoma; *Escherichia coli* and *Staphylococcus aureus* are common agents. Cephalohematomas



**Fig. 122.2** Parietal cephalhematoma. Clinical appearance of 10-day-old infant delivered with the aid of mid-forceps. A, Posterior view. B, Right lateral view. Note prominent swelling that extends medially to the sagittal suture, posteriorly to the lambdoid suture, and laterally to the squamosal suture. (From Volpe JJ. *Injuries of extracranial, cranial, intracranial, spinal cord, and peripheral nervous system structures*. In: Volpe JJ, Inder TE, Darras BT, et al. eds. *Volpe's Neurology of the Newborn*. 6th ed. Philadelphia: Elsevier; 2018: Fig. 36-3.)

require no treatment, although phototherapy may be necessary to treat hyperbilirubinemia.

A **subgaleal hemorrhage** is a collection of blood in the loose connective tissue of the subgaleal space, located between the epicranial aponeurosis and the periosteum (see Fig. 122.1). There is often an association with vacuum-assisted delivery. A subgaleal hemorrhage manifests as a fluctuant mass that straddles cranial sutures or fontanelles that increases in size after birth. The mechanism of injury is most likely secondary to rupture of emissary veins connecting the dural sinuses within the skull and the superficial veins of the scalp. Subgaleal hemorrhages are sometimes associated with skull fractures, suture diastasis, and fragmentation of the superior margin of the parietal bone. Extensive subgaleal bleeding can result in sequestration of more than 40% of the newborn's blood volume, which can potentially result in hemorrhagic shock. The mortality can be up to 14% due to hemorrhagic shock and is occasionally secondary to a hereditary coagulopathy (**hemophilia**). In some cases, patients can develop a consumptive coagulopathy from massive blood loss. Subgaleal hemorrhages can present clinically with the triad of tachycardia, decreased hematocrit, and increasing occipital frontal circumference. When subgaleal hemorrhage is suspected, hemoglobin measurements should be performed as soon as possible and should be monitored every 4 to 8 hours, as should coagulation studies. Although it is not necessary to make the clinical diagnosis, optimal imaging for subgaleal hemorrhage is by CT

or MRI. Radiographs of the skull can be done to identify accompanying fractures. These lesions typically resolve over 2 to 3 weeks.

**Fractures of the skull** may be caused by pressure in the setting of a forceps delivery, but they can occur rarely in uncomplicated vaginal deliveries. **Linear fractures**, the most common, cause no symptoms and require no treatment. Linear fractures should be followed up to demonstrate healing and to detect the possible complication of a leptomeningeal cyst. **Depressed fractures** often are referred to as “ping-pong” fractures because on x-ray they resemble an indented ping-pong ball. Affected infants may be asymptomatic unless they have associated intracranial injury. Surgical management of such an injury may not be necessary due to the infants' relatively thin and flexible skull bones rendering them amenable to remodeling, and intervention could be reserved for larger areas of depression. When intervention is required, the obstetric vacuum extractor is an ideal tool because it provides patent tubing unlikely to collapse during the application of suction. No traction is needed during the suction procedure, and the elevation of the depression can be ascertained by direct visualization, an audible “click” sound or a “give” sensation accompanied by an instantaneous pressure release. There is no clear recommendation for imaging in this population, but with newer techniques of low-dose CT imaging, current technology allows axial imaging to be constructed in the coronal and sagittal planes and into three-dimensional reformats, thus increasing the likelihood of detecting a fracture.

**Subconjunctival** and **retinal hemorrhages** are frequent; petechiae of the skin of the head and neck are also common. All are probably secondary to a sudden increase in intrathoracic pressure during passage of the chest through the birth canal. Parents should be assured that these hemorrhages are temporary and the result of normal events of delivery. The lesions resolve rapidly within the first 2 weeks of life.

## 122.2 Neonatal Traumatic Head Injuries

Susan S. Cohen, Alicia J. Sprecher, and  
Krishna K. Acharya

Neonatal traumatic head injuries are estimated to affect ~3% of pregnancies and represent approximately 2% of neonatal deaths. Infrequently, these injuries occur during normal birth but the incidence rises in cases when the fetal head is large in proportion to the size of the mother's pelvic outlet, with prolonged labor, in breech or precipitous deliveries, or as a result of mechanical assistance with delivery. Massive **subdural hemorrhage**, often associated with tears in the tentorium cerebelli or less frequently in the falx cerebri, is rare, but is encountered more often in full-term than in premature infants. Patients with massive hemorrhage caused by tears of the tentorium or falx cerebri rapidly deteriorate and may die soon after birth. Most subdural and epidural hemorrhages resolve without intervention. Consultation with a neurosurgeon is recommended. Asymptomatic subdural hemorrhage may be noted within 48 hours of birth after vaginal or cesarean delivery. These are typically small hemorrhages, especially common in the posterior fossa, discovered incidentally in term infants imaged in the neonatal period, and usually of no clinical significance. The diagnosis of large subdural hemorrhage may be delayed until the chronic subdural fluid volume expands and produces macrocephaly, frontal bossing, a bulging fontanel, anemia, and sometimes seizures. CT scan and MRI are useful imaging techniques to confirm these diagnoses. Symptomatic subdural hemorrhage in term infants can be treated by a neurosurgical evacuation of the subdural fluid collection by a needle placed through the lateral margin of the anterior fontanel, or in severe cases an operative burr hole or craniotomy. In addition to birth trauma, **child abuse** must be suspected in all infants with subdural effusion after the immediate neonatal period. Most asymptomatic subdural hemorrhages following labor should resolve by 4 weeks of age.

**Subarachnoid hemorrhage** is often clinically silent in the neonate. Anastomoses between the penetrating leptomeningeal arteries or the



bridging veins are the most likely source of the bleeding. Most affected infants have no clinical symptoms, but the subarachnoid hemorrhage may be detected because of an elevated number of red blood cells in a lumbar puncture sample. Some infants experience short, benign seizures, which tend to occur on the second day of life. Rarely, an infant has a catastrophic hemorrhage and dies. There are usually no neurologic abnormalities during the acute episode or on follow-up. Significant neurologic findings should suggest an arteriovenous malformation, which can best be detected on CT or MRI.

### 122.3 Intracranial-Intraventricular Hemorrhage and Periventricular Leukomalacia

Susan S. Cohen, Alicia J. Sprecher, and  
Krishna K. Acharya

**Intracranial hemorrhage** in preterm infants usually develops spontaneously. Less frequently, it may be caused by trauma or asphyxia, and rarely, it occurs from a primary hemorrhagic disturbance or congenital cerebrovascular anomaly. The very low birthweight infant (VLBW; birthweight <1,500 g) is at high risk for intracranial hemorrhages, with the risk for severe hemorrhage inversely related to gestational age. Intracranial hemorrhage often involves the ventricles (**intraventricular hemorrhage [IVH]**) of premature infants delivered spontaneously without apparent trauma. Primary hemorrhagic disturbances and vascular malformations are rare and usually give rise to subarachnoid or intracerebral hemorrhage. In utero hemorrhage associated with maternal idiopathic or, more often, fetal alloimmune thrombocytopenia may appear as severe cerebral hemorrhage or as a porencephalic cyst after resolution of a fetal cortical hemorrhage. Intracranial bleeding may be associated with disseminated intravascular coagulation, isoimmune thrombocytopenia, and neonatal vitamin K deficiency, especially in infants born to mothers receiving phenobarbital or phenytoin.

**Periventricular leukomalacia (PVL)** is a disorder of the periventricular cerebral white matter that may be cystic or diffuse in nature. PVL may initially be observed during the first week of life in the VLBW infant as increased echogenicity of the periventricular white matter, sometime described as an echogenic “blush” or “flare.” These areas of white matter abnormalities may become cystic on ultrasonography within 2 to 5 weeks and/or lead to ventriculomegaly from white matter volume loss, which can be visible on repeat ultrasonography at term equivalent age. Clinical risk factors for PVL include gestational age at birth and prenatal/postnatal factors including inflammation, hypoxia, postnatal steroid exposure, and metabolic disturbances.

#### EPIDEMIOLOGY

The overall incidence of IVH has decreased over the last few decades as a result of improved perinatal care, increased use of antenatal corticosteroids, surfactant to treat respiratory distress syndrome (RDS), and improved positive pressure mechanical ventilation strategies. The global incidence of IVH among preterm infants ranges from 14.7–44.7% with considerable variation across gestational age groups, neonatal intensive care units (NICUs), and countries. The risk for severe IVH is associated with infants with a gestational age  $\leq 30$  weeks' gestation, with the highest risk in infants born at  $\leq 24$  weeks' gestation. Infants born at  $>30$  weeks' gestation have a low risk of severe IVH unless they have additional clinical risk factors such as low Apgar scores, metabolic acidosis, hypotension, or lack of antenatal steroids.

PVL can be described in three major pathologic forms: macroscopic cystic white matter injury, microscopic cystic white matter injury, and nonnecrotic diffuse white matter injury. Macroscopic cystic white matter injury represents the most severe form of PVL and fortunately affects  $<5\%$  of very preterm infants born  $<32$  weeks. With advances in neonatal care, there has been a shift from large cystic injury to small punctate injury. In microscopic cystic white matter injury, the necrotic areas are small and result in focal areas of gliosis, which ultrasonography is not sensitive enough to detect. The most common form of PVL

in the preterm population is nonnecrotic diffuse PVL. Diffuse PVL is estimated to affect nearly a third of infants born  $<32$  weeks and is best recognized on MRI.

#### PATHOGENESIS

The major neuropathologic lesions associated with VLBW infants are IVH and PVL. IVH in premature infants occurs in the gelatinous subependymal **germinal matrix**. This periventricular area is the site of origin for embryonal neurons and fetal glial cells, which migrate outwardly to the cortex. Immature and fragile blood vessels in this highly vascular region of the developing brain combined with disturbances in cerebral blood flow and coagulation predispose premature infants to hemorrhage. The germinal matrix involutes as the infant approaches 34 to 36 weeks' gestation, and the tissue's vascular integrity improves; therefore IVH is much less common in the late preterm and term infant. The cerebellum also contains a germinal matrix and is susceptible to hemorrhagic injury. **Periventricular hemorrhagic infarction (PVHI)**, previously known as **grade IV IVH**, often develops after a large IVH because of venous congestion. PVHI is not an extension of the IVH into the parenchyma. Predisposing factors for IVH include prematurity, RDS, hypoxia-ischemia, exaggerated fluctuations in cerebral blood flow (hypotensive injury, hypervolemia, hypertension), reperfusion injury of damaged vessels, reduced vascular integrity, increased venous pressure (pneumothorax, venous thrombus), or thrombocytopenia.

The pathogenesis of PVL appears to involve both intrauterine and postnatal events. A complex interaction exists between the development of the cerebral vasculature and the regulation of cerebral blood flow (both of which depend on gestational age), disturbances in the oligodendrocyte precursors required for myelination, and maternal/fetal infection and inflammation. Postnatal hypoxia or hypotension, necrotizing enterocolitis (NEC) with its resultant inflammation, and severe neonatal infection may all result in white matter injury. The risk for PVL increases in infants with severe IVH or ventriculomegaly.

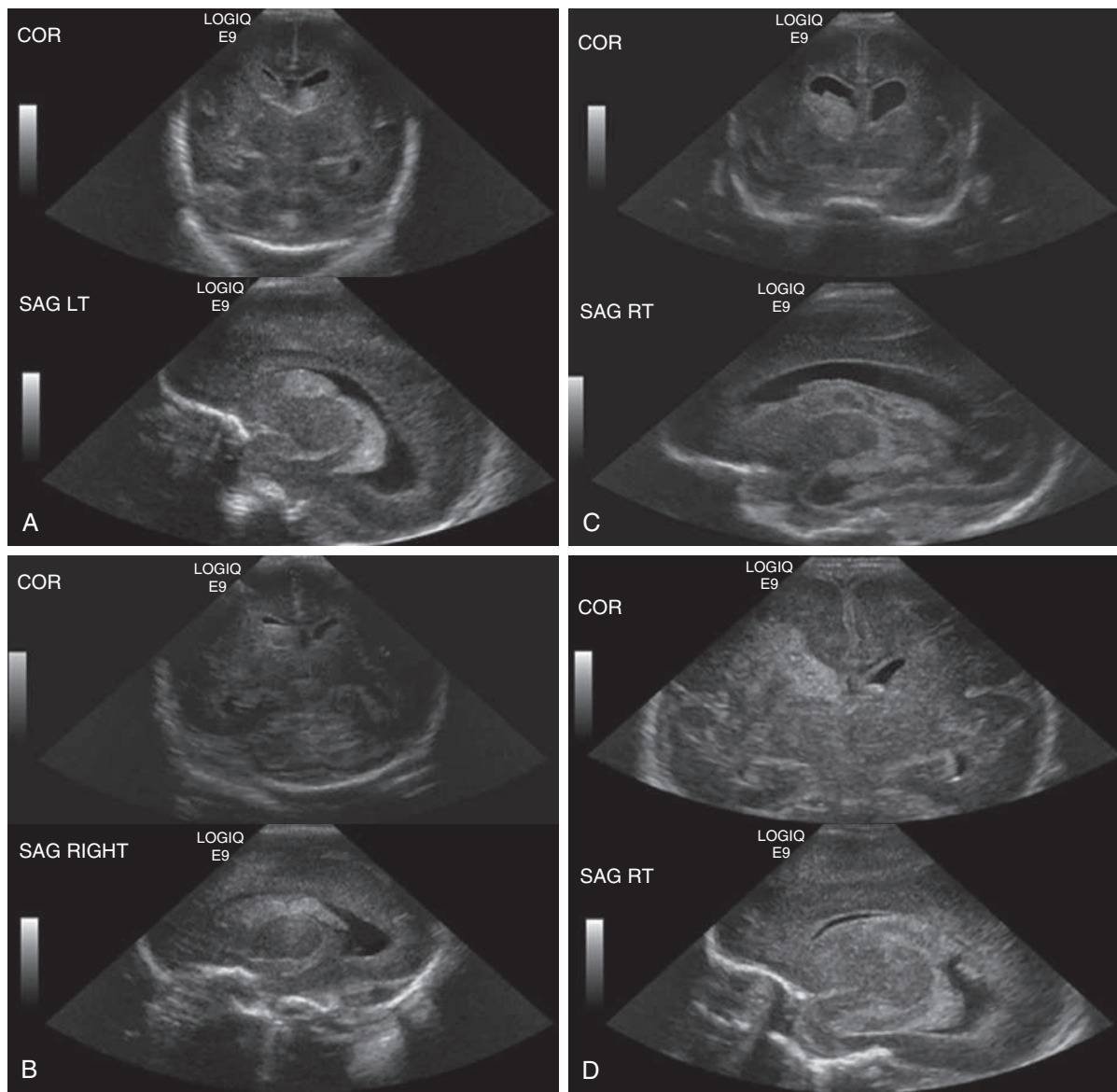
#### CLINICAL MANIFESTATIONS

Most infants with IVH, including some with moderate to severe hemorrhages, have no initial clinical signs (**silent IVH**). Some premature infants with severe IVH may have an acute deterioration on the second or third day of life (**catastrophic IVH**). Hypotension, apnea, pallor, stupor or coma, seizures, decreased muscle tone, metabolic acidosis, shock, and decreased hematocrit (or failure of hematocrit to increase after transfusion) may be the first clinical indications. A *saltatory progression* may occur over several hours to days and manifest as intermittent or progressive alterations of levels of consciousness, abnormalities of tone and movement, respiratory signs, and eventually other features of the acute catastrophic IVH. Rarely, IVH may manifest at birth or even prenatally; the majority of cases of IVH in the preterm infant occur within the first 3 days of life. Of those, approximately 50% of hemorrhages occur within the first 5 hours, 70% occur within the first day of life, and by 7 days of life 95% of IVH will have occurred. A small percentage of infants have late hemorrhage, between days 14 and 30. IVH as a primary event is rare after the first month of life.

The severity of hemorrhage is defined by the location and degree of bleeding and ventricular dilation on cranial imaging. In a **grade I** hemorrhage, bleeding is isolated to the subependymal area. In **grade II** hemorrhage, there is bleeding within the ventricle *without* evidence of ventricular dilation. **Grade III** hemorrhage is IVH with ventricular dilation. In **PVHI** hemorrhage (formerly called **grade IV**, see previously), there is intraventricular and parenchymal hemorrhage (Fig. 122.3). Another grading system describes three levels of increasing severity of IVH detected on ultrasound: In **grade I**, bleeding is confined to the germinal matrix–subependymal region or to  $<10\%$  of the ventricle (approximately 35% of IVH cases); **grade II** is defined as intraventricular bleeding with 10–50% filling of the ventricle (40% of IVH cases); and in **grade III**,  $>50\%$  of the ventricle is involved, with dilated ventricles (see Fig. 122.3).

One of the major complications resulting from IVH is the development of **posthemorrhagic ventricular dilation (PHVD)**. Following a large IVH, multiple small clots throughout the ventricular system may obstruct





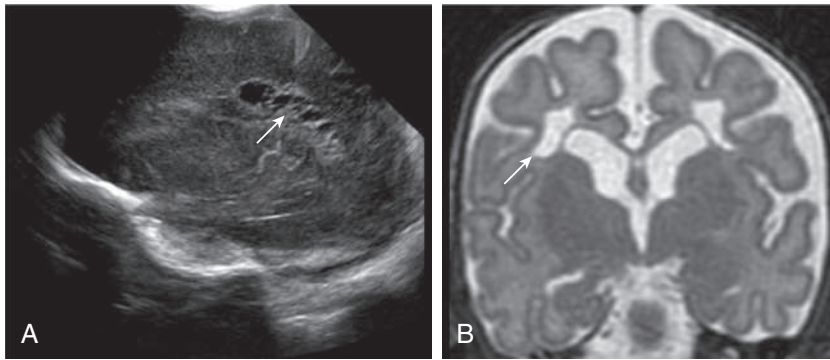
**Fig. 122.3** Grading of the severity of germinal matrix–intraventricular hemorrhage (IVH): coronal (COR) and parasagittal (SAG) ultrasound scans. A, Germinal matrix hemorrhage, grade I. B, IVH (filling <50% of ventricular area), grade II. C, IVH with ventricular dilatation, grade III. D, Large IVH with associated parenchymal echogenicity (hemorrhagic infarct), grade IV. Note that the terminology has now changed for “grade IV” to periventricular hemorrhagic infarction (PVHI). (From Inder TE, Perlman JM, Volpe JJ. *Preterm intraventricular hemorrhage/posthemorrhagic hydrocephalus*. In: Volpe JJ, Inder TE, Darras BT, et al., eds. *Volpe’s Neurology of the Newborn*. 6th ed. Philadelphia: Elsevier; 2018: Fig. 24-2.)

cerebrospinal fluid (CSF) flow and resorption, all in the face of ongoing production of CSF in the choroid plexus in the lateral ventricles and the roof of the third ventricle. The progressive accumulation of CSF changes the shape of the lateral ventricles from a slit to a balloon. The expanding ventricles distort the developing brain and intracerebral pressure (ICP) eventually starts to rise. As the preterm skull is very compliant, the ventricles can expand without pressure rising initially but eventually can result in increased ICP. PHVD develops in 30–50% of infants with severe IVH and is initially asymptomatic in most patients. *Therefore sequential cranial ultrasonography facilitates early detection.* The term ventriculomegaly is occasionally used for both infants with ventricular enlargement following IVH as well as those without hemorrhage. In infants without IVH, ventricular enlargement is more likely due to *white matter loss* rather than an accumulation of CSF. Therefore it is preferable to use the term PHVD when ventricular enlargement follows IVH.

PVL is usually clinically asymptomatic until the neurologic sequelae of white matter damage become apparent in later infancy as spasticity and/or motor deficits. PVL may be present at birth but usually occurs later, when the echodense phase is seen on ultrasound (3 to 10 days of life), followed by the typical echolucent/cystic phase (14 to 20 days).

## DIAGNOSIS

Intracranial hemorrhage is suspected on the basis of history, clinical manifestations, and knowledge of the birthweight-specific risks for IVH. Associated clinical signs of IVH are typically nonspecific or absent. Neuroimaging recommendations that premature infants  $\leq 30$  weeks of gestation and selected infants with gestational age  $>30$  weeks who are believed to be at increased risk for brain injury on the basis of identified risk factors should be screened for IVH with cranial ultrasonography. Standard ultrasonography screening includes views from the anterior and mastoid fontanelles. Additional posterior fontanelle and vascular imaging can be performed for additional information. Routine cranial ultrasonographic screening is recommended by 7 to 10 days of age, but earlier imaging may be warranted if clinical signs and symptoms are suggestive of significant injury. Repeat cranial ultrasonography screening is recommended to be performed at 4 to 6 weeks of age and at term equivalent age or before hospital discharge. CT is not considered a part of routine imaging techniques of the preterm brain. MRI for infants born  $\leq 30$  weeks gestational age is not indicated as a routine procedure, although could be offered to families of high-risk infants after a conversation about the limits of prognosticating long-term outcomes using MRI.



**Fig. 122.4** Severe cystic periventricular leukomalacia. A, Parasagittal ultrasound image showing numerous large cysts superolateral to the lateral ventricle (arrow). B, Coronal T2 weighted MR image in which cysts are present superolateral to the lateral ventricles (arrow). (From Neil JJ, Volpe JJ. *Encephalopathy of prematurity: clinical-neurological features, diagnosis, imaging, prognosis, therapy*. In: Volpe JJ, Inder TE, Darras BT, et al., eds. *Volpe's Neurology of the Newborn*. 6th ed. Philadelphia: Elsevier; 2018: Fig. 16-1.)

**Table 122.1** Short-Term Outcome of Germinal Matrix–Intraventricular Hemorrhage as a Function of Severity of Hemorrhage and Birthweight\*

SEVERITY OF HEMORRHAGE	DEATHS IN FIRST 14 DAYS		PVD (SURVIVORS >14 DAYS)	
	<750 g (n = 75)	751-1500 g (n = 173)	<750 g (n = 56)	751-1500 g (n = 165)
Grade I	3/24 (12)	0/80 (0)	1/21 (5)	3/80 (4)
Grade II	5/21 (24)	1/44 (2)	1/16 (6)	6/43 (14)
Grade III	6/19 (32)	2/26 (8)	10/13 (77)	18/24 (75)
Grade III and apparent PVHI	5/11 (45)	5/23 (22)	5/6 (83)	12/18 (66)

\*Values are n (%). Deaths occurring later in the neonatal period are not shown; the total mortality rates (early and late deaths) are approximately 50–100% greater for each grade of hemorrhage and birthweight than those shown in the table for early deaths alone.

PVHI, Periventricular hemorrhagic infarction; PVD, progressive ventricular dilation.

Adapted from Inder TE, Perlman JM, Volpe JJ. Preterm intraventricular hemorrhage/posthemorrhagic hydrocephalus. In: Volpe JJ, Inder TE, Darras BT, et al., eds. *Volpe's Neurology of the Newborn*. 6th ed. Philadelphia: Elsevier; 2018. Table 24-15; with data from Murphy BP, Inder TE, Rooks V, Taylor GA, et al. Posthemorrhagic ventricular dilatation in the premature infant: natural history and predictors of outcome. *Arch Dis Child Fetal Neonatal Ed*. 2002;87:F37–F41.

**Table 122.2** Long-Term Outcome: Neurologic Sequelae in Survivors with Germinal Matrix–Intraventricular Hemorrhage as a Function of Severity of Hemorrhage\*

SEVERITY OF HEMORRHAGE	INCIDENCE OF DEFINITE NEUROLOGIC SEQUELAE† (%)
Grade I	15
Grade II	25
Grade III	50
Grade III and apparent PVHI	75

\*Data are derived from reports published since 2002 and include personal published and unpublished cases. Mean values (to nearest 5%) and considerable variability among studies was apparent, especially for the severe lesions.

†Definite neurologic sequelae included principally cerebral palsy or mental retardation, or both.

PVHI, Periventricular hemorrhagic infarction.

Adapted From Inder TE, Perlman JM, Volpe JJ. Preterm intraventricular hemorrhage/posthemorrhagic hydrocephalus. In: Volpe JJ, Inder TE, Darras BT, et al., eds. *Volpe's Neurology of the Newborn*. 6th ed. Philadelphia: Elsevier; 2018: Table 24-16.

Sequential ultrasonography appears to have the best yield for identifying lesions associated with cerebral palsy. In one study, 29% of low birthweight (LBW) infants who later experienced cerebral palsy *did not* have radiographic evidence of PVL until after 28 days of age. Ultrasound also detects the precystic and cystic symmetric lesions of PVL and the asymmetric intraparenchymal echogenic lesions of cortical hemorrhagic infarction (Fig. 122.4). Cranial ultrasonography may be useful in monitoring delayed development of cortical atrophy, porencephaly, and the severity, progression, or regression of posthemorrhagic hydrocephalus (PHH).

PHH of prematurity is a common form of pediatric hydrocephalus, accounting for 20% of shunted hydrocephalus in the United States.

Under normal conditions, CSF is primarily secreted into the cerebral ventricles by the choroid plexus and moves via bulk flow through the ventricular system and subarachnoid space before being absorbed at the arachnoid villi/granulations, which are fully developed after 35 weeks. An increase in CSF production or reduction in CSF absorption may result in ventricular enlargement if the system cannot compensate for the changes. Secondary white matter injury resulting from ventricular dilation is likely exacerbated by compression and ischemia from increased ICP of symptomatic PHH. Orbitofrontal head circumference, fontanel fullness, and the splaying of sutures all show limited reliability; therefore serial neuroimaging is highly valuable for clinical decision-making for neurosurgical intervention.

## PROGNOSIS

The degree of IVH and presence of PVL are strongly linked to survival and neurodevelopmental impairment (Tables 122.1 and 122.2). For infants with birthweight <1,000 g, the incidence of severe neurologic impairment (defined as Bayley Scales of Infant Development IV mental developmental index <70, psychomotor development index <70, cerebral palsy, blindness, or deafness) after IVH is highest with grade IV hemorrhage and lower birthweight. PVL, cystic PVL, and progressive hydrocephalus requiring shunt insertion are each independently associated with a poorer prognosis (Table 122.3). The risk of a poor neurodevelopmental outcome is significantly higher when severe IVH is complicated with PHVD (40–60%) and more so for infants who eventually develop PHH (75–88%). In the pre-surfactant era, up to 82% of infants with PHH who survived developed significant neurologic impairments with cerebral palsy being the most common clinical sequelae (74%). The Drainage, Irrigation, Fibrinolytic Therapy (DRIFT) trial performed neurocognitive assessments at both 2 years and 10 years after birth and demonstrated improved cognitive ability when considering birthweight, IVH grade, and sex. Infants who received DRIFT were almost twice as likely to survive without severe cognitive disability than those who received standard treatment. The

**Table 122.3** Ultrasound Diagnosis of Periventricular Leukomalacia

US APPEARANCE	TEMPORAL FEATURES	NEUROPATHOLOGIC CORRELATION
Echogenic foci, bilateral, posterior > anterior	First week	Necrosis with congestion and/or hemorrhage (size >1 cm)
Echolucent foci ("cysts")	1-3 weeks	Cyst formation secondary to tissue dissolution (size >3 mm)
Ventricular enlargement, often with disappearance of "cysts"	≥2-3 months	Deficient myelin formation; gliosis, often with collapse of cyst

From Neil JJ, Volpe JJ. Encephalopathy of prematurity: Clinical-neurological features, diagnosis, imaging, prognosis, therapy. In: Volpe JJ, Inder TE, Darras BT, et al., eds. *Volpe's Neurology of the Newborn*. 6th ed. Philadelphia: Elsevier; 2018: Table 16-6.

**Table 122.4** Proposed Risk Stratification and Management of Infants with PHVD

Green Zone	Yellow Zone	Red Zone
<p><b>Key criteria:</b> Ventricular size with the following</p> <ul style="list-style-type: none"> <li>• VI ≤97<sup>th</sup> percentile and</li> <li>• AHW ≤6 mm</li> </ul> <p><b>And</b> Absence of the following clinical criteria:</p> <ul style="list-style-type: none"> <li>• HC growth &gt;2 cm per week</li> <li>• Separated sutures</li> <li>• Bulging fontanelles</li> </ul> <p><b>Management:</b></p> <ul style="list-style-type: none"> <li>• Observation in NICU</li> <li>• cUS twice a week until stable for 2 weeks then every 1-2 weeks until 34 weeks PMA</li> <li>• MRI at term equivalent</li> </ul>	<p><b>Key criteria:</b> Ventricular size with the following</p> <ul style="list-style-type: none"> <li>• VI &gt;97<sup>th</sup> percentile and</li> <li>• AHW &gt;6 mm and/or TOD &gt;25 mm</li> </ul> <p><b>And</b> Absence of the following clinical criteria:</p> <ul style="list-style-type: none"> <li>• HC growth &gt;2 cm per week</li> <li>• Separated sutures</li> <li>• Bulging fontanelles</li> </ul> <p><b>Management:</b></p> <ul style="list-style-type: none"> <li>• Referral to a regional center for neurosurgical review</li> <li>• Consider LP 2-3 times</li> <li>• cUS 2-3X a week until stable for 2 weeks then every 1-2 weeks until 34 weeks PMA</li> <li>• Neurosurgical intervention when no stabilization occurs</li> <li>• MRI at term equivalent</li> </ul>	<p><b>Key criteria:</b> Ventricular size with the following</p> <ul style="list-style-type: none"> <li>• VI &gt;97<sup>th</sup> percentile + 4mm and</li> <li>• AHW &gt;10 mm and/or TOD &gt;25 mm</li> </ul> <p><b>Or</b> Any of the following clinical criteria:</p> <ul style="list-style-type: none"> <li>• HC growth &gt;2 cm per week</li> <li>• Separated sutures</li> <li>• Bulging fontanelles</li> </ul> <p><b>Management:</b></p> <ul style="list-style-type: none"> <li>• Consider LP 2-3 times</li> <li>• Neurosurgical intervention including either temporizing measures or VP shunt</li> <li>• MRI at term equivalent</li> </ul>
<p><i>Consider alterations in NIRS (i.e., decrease cerebral oxygenation) or Doppler US (i.e., increase in Resistive Index) as additional information that may suggest impairment in cerebral perfusion and more urgent need for intervention.</i></p>		

VI, ventricular index; AHW, anterior horn width; cUS, cranial ultrasound; TOD, thalamo-occipital distance; LP, lumbar puncture; HC, head circumference; NIRS, near-infrared spectroscopy; NICU, neonatal intensive care unit; PMA, postmenstrual age.

From El-Dib M, Limbrick DD, Inder T, et al. Management of post-hemorrhagic ventricular dilation in the infant born preterm. *J Pediatr*. 2020;226:16–26. Fig. 5.

Early versus Late Ventricular Intervention Study (ELVIS) trial demonstrated the effectiveness of intervention at a low threshold of ventricular dilation on the outcomes of death and severe neurodevelopmental disability in preterm infants with PHVD. Post hoc analysis of this study demonstrated that infants who went on to having a shunt had better neurodevelopmental outcome scores if interventions were done at a lower threshold.

## TREATMENT

No treatment is available for **IVH** once it has occurred, and the management is largely symptomatic. Seizures should be treated with anti-convulsant drugs. Anemia and coagulopathy require transfusion with packed red blood cells or fresh-frozen plasma. Shock and acidosis are treated with fluid resuscitation.

Insertion of a **ventriculoperitoneal shunt** is the preferred method to treat progressive and symptomatic **PHH**. Some infants require temporary CSF diversion before a permanent shunt can be safely inserted. Diuretics and acetazolamide are not effective. Ventricular access devices (reservoirs) and externalized ventricular drains are potential temporizing interventions, although there is an associated risk of

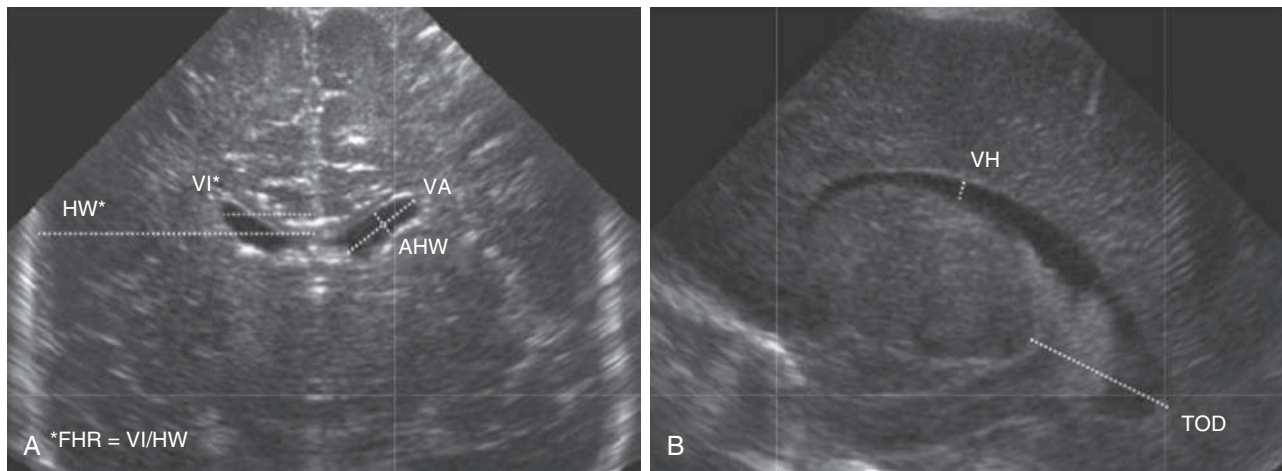
infection and *puncture porencephaly* from injury to the surrounding parenchyma. A **ventriculosubgaleal shunt** inserted from the ventricle into a surgically created subgaleal pocket provides a closed system for constant ventricular decompression without these additional risk factors. Decompression is regulated by the pressure gradient between the ventricle and the subgaleal pocket.

One approach to therapeutic interventions is based on the severity of ultrasonographic dimensions of ventricular size (Table 122.4 and Fig. 122.5)

## PREVENTION

Improved perinatal care is imperative to minimize traumatic brain injury and decrease the risk of preterm delivery. The incidence of traumatic intracranial hemorrhage may be reduced by judicious management of cephalopelvic disproportion and operative delivery. Fetal or neonatal hemorrhage caused by maternal idiopathic thrombocytopenic purpura or alloimmune thrombocytopenia may be reduced by maternal treatment with corticosteroids, intravenous immunoglobulin (IVIG), fetal platelet transfusion, or cesarean birth. Meticulous care of the VLBW infant's respiratory status and fluid-electrolyte





**Fig. 122.5** Ventricular parameters measured in the (A) coronal and (B) sagittal planes by cranial ultrasonography. AHW, anterior horn width; FHR, frontal horn ratio; HW, hemispheric width; TOD, thalamo-occipital distance; VA, ventricular axis; VH, ventricular height; VI, ventricular index. (From Brouwer MJ, de Vries LS, Pistorius L, et al. *Ultrasound measurements of the lateral ventricles in neonates: why, how, and when? A systematic review. Acta Paediatr.* 2010;99:1298–306.)

management—avoidance of acidosis, hypocarbia, hypoxia, hypotension, wide fluctuations in neonatal blood pressure or  $P_{CO_2}$  (and secondarily fluctuation in cerebral perfusion pressure), and pneumothorax—are important factors that may affect the risk for development of IVH and PVL.

The most important protective factor against the development of IVH is antenatal administration of corticosteroids. A single course of antenatal corticosteroids is recommended for pregnant people between 24 0/7 weeks and 36 6/7 weeks of gestation who are at risk for preterm delivery within 7 days. It also may be considered for pregnant people starting at 23 weeks of gestation who are at risk for preterm delivery within 7 days, based on the family's decision regarding resuscitation. A rescue course of corticosteroids could be provided as early as 7 days from the prior dose, if indicated by the clinical scenario. Antenatal administration of magnesium sulfate was not associated with a reduction in the incidence of IVH, although it has been associated with a reduction in the risk of cerebral palsy. Prophylactic indomethacin showed a significant reduction in the incidence of severe IVH; however, this reduction in severe IVH was not associated with a reduction in severe neurosensory impairment.

Visit Elsevier eBooks+ at [eBooks.Health.Elsevier.com](http://eBooks.Health.Elsevier.com) for Bibliography.

## 122.4 Hypoxic-Ischemic Encephalopathy

Susan S. Cohen, Alicia J. Sprecher, and  
Krishna K. Acharya

**Hypoxemia**, a decreased arterial concentration of oxygen, frequently results in **hypoxia**, or decreased oxygenation to cells or organs. **Ischemia** refers to blood flow to cells or organs that is inadequate to maintain physiologic function. **Hypoxic-ischemic encephalopathy (HIE)** is a leading cause of neonatal brain injury, morbidity, and mortality globally. In the developed world, incidence is estimated at 1–8 per 1,000 live births, and in the developing world, estimates are as high as 26 per 1,000.

Approximately 20–30% of infants with HIE (depending on the severity) die in the neonatal period, and 33–50% of survivors are left with permanent neurodevelopmental abnormalities (cerebral palsy, decreased intelligence quotient [IQ], learning/cognitive impairment). The greatest risk of adverse outcome is seen in infants with severe fetal acidosis ( $pH < 6.7$ ) (90% death/impairment) and a base deficit  $> 25$  mmol/L (72% mortality). Multiorgan failure and insult can occur (Table 122.5).

### ETIOLOGY

Neonatal encephalopathy and seizures, in the absence of major congenital malformations or metabolic or genetic syndromes, appear to be

Table 122.5 Multiorgan Systemic Effects of Asphyxia	
SYSTEM	EFFECTS
Central nervous	Hypoxic-ischemic encephalopathy, infarction, intracranial hemorrhage, seizures, cerebral edema, hypotonia, hypertonia
Cardiovascular	Myocardial ischemia, poor contractility, cardiac stunning, tricuspid insufficiency, hypotension
Pulmonary	Pulmonary hypertension, pulmonary hemorrhage, respiratory distress syndrome
Renal	Acute tubular or cortical necrosis
Adrenal	Adrenal hemorrhage
Gastrointestinal	Perforation, ulceration with hemorrhage, necrosis
Metabolic	Inappropriate secretion of antidiuretic hormone, hyponatremia, hypoglycemia, hypocalcemia, myoglobinuria
Integumentary	Subcutaneous fat necrosis
Hematologic	Disseminated intravascular coagulation

caused by perinatal events. Brain MRI or autopsy findings in full-term neonates with encephalopathy demonstrate that 80% have acute injuries,  $< 1\%$  have prenatal injuries, and 3% have non-hypoxic-ischemic diagnoses. Fetal hypoxia may be caused by various disorders in the mother, including (1) inadequate oxygenation of maternal blood from hypoventilation during anesthesia, cyanotic heart disease, respiratory failure, or carbon monoxide poisoning; (2) low maternal blood pressure from acute blood loss, spinal anesthesia, or compression of the vena cava and aorta by the gravid uterus; (3) inadequate relaxation of the uterus to permit placental filling as a result of uterine tetany caused by the administration of excessive oxytocin; (4) premature separation of the placenta; (5) impedance to the circulation of blood through the umbilical cord as a result of compression or knotting of the cord; and (6) placental insufficiency from maternal infections, exposures, diabetes, toxemia or postmaturity.



**Table 122.6** Topography of Brain Injury in Term Infants with Hypoxic-Ischemic Encephalopathy and Clinical Correlates

AREA OF INJURY	LOCATION OF INJURY	CLINICAL CORRELATES	LONG-TERM SEQUELAE
Selective neuronal necrosis	Entire neuraxis, deep cortical area, brainstem and pontosubicular	<ul style="list-style-type: none"> <li>• Stupor or coma</li> <li>• Seizures</li> <li>• Hypotonia</li> <li>• Oculomotor abnormalities</li> <li>• Suck/swallow abnormalities</li> </ul>	<ul style="list-style-type: none"> <li>• Cognitive delay</li> <li>• Cerebral palsy</li> <li>• Dystonia</li> <li>• Seizure disorder</li> <li>• Ataxia</li> <li>• Bulbar and pseudobulbar palsy</li> </ul>
Parasagittal injury	Cortex and subcortical white matter Parasagittal regions, especially posterior	<ul style="list-style-type: none"> <li>• Proximal-limb weakness</li> <li>• Upper extremities affected &gt; lower extremities</li> </ul>	<ul style="list-style-type: none"> <li>• Spastic quadripareisis</li> <li>• Cognitive delay</li> <li>• Visual and auditory processing difficulty</li> </ul>
Focal ischemic necrosis	Cortex and subcortical white matter Vascular injury (usually middle cerebral artery distribution)	<ul style="list-style-type: none"> <li>• Unilateral findings</li> <li>• Seizures common and typically focal</li> </ul>	<ul style="list-style-type: none"> <li>• Hemiparesis</li> <li>• Seizures</li> <li>• Cognitive delays</li> </ul>
Periventricular injury	Injury to motor tracts, especially lower extremity	<ul style="list-style-type: none"> <li>• Bilateral and symmetric weakness in lower extremities</li> <li>• More common in preterm infants</li> </ul>	<ul style="list-style-type: none"> <li>• Spastic diplegia</li> </ul>

Adapted from Volpe JJ, ed. *Neurology of the Newborn*. 4th ed. Philadelphia: Saunders; 2001.

Placental insufficiency often remains undetected on clinical assessment. Intrauterine growth restriction may develop in chronically hypoxic fetuses without the traditional signs of fetal distress. Doppler umbilical waveform velocimetry (demonstrating increased fetal vascular resistance) and cordocentesis (demonstrating fetal hypoxia and lactic acidosis) identify a chronically hypoxic infant (see [Chapter 117](#)). Uterine contractions may further reduce umbilical oxygenation, depressing the fetal cardiovascular system and CNS and resulting in low Apgar scores and respiratory depression at birth.

After birth, hypoxia may be caused by (1) failure of oxygenation as a result of severe forms of cyanotic congenital heart disease or severe pulmonary disease; (2) severe anemia (severe hemorrhage, hemolytic disease); (3) shock severe enough to interfere with the transport of oxygen to vital organs from overwhelming sepsis, massive blood loss, and intracranial or adrenal hemorrhage; or (4) failure to breathe after birth because of in utero CNS injury or drug-induced suppression.

### PATHOPHYSIOLOGY AND PATHOLOGY

The topography of cerebral injury typically correlates with areas of decreased cerebral blood flow and areas of relatively higher metabolic demand, although regional vulnerabilities are impacted by gestational age and severity of insult ([Table 122.6](#)). After an episode of hypoxia and ischemia, anaerobic metabolism occurs and generates increased amounts of lactate and inorganic phosphates. Excitatory and toxic amino acids, particularly glutamatergic mechanism has a role in neurotoxicity. Whether this mechanism involves tissue accumulation of an abnormal amount of glutamate or altered sensitivity to the interaction between glutamate and its endogenous family of receptors (i.e., *N*-methyl-D-aspartate [NMDA], amino-3-hydroxy-5-methyl-4-isoxazole propionate [AMPA], and kainite) is unknown. However, receptor activation results in a cascade of events that leads to cell death by swelling (oncosis) or apoptosis. Along with these changes in the CNS, there are also potentially exacerbating bioenergetic changes as a result of the circulatory response with increased shunting through the ductus venosus, ductus arteriosus, and foramen ovale, at first trying to maintain perfusion of the brain, heart, and adrenal glands in preference to the lungs, liver, kidneys, and intestine.

The pathology of hypoxia-ischemia in tissues outside the CNS depends on the affected organ and the severity of the injury. Early congestion, fluid leak from increased capillary permeability, and endothelial cell swelling may lead to signs of coagulation necrosis and cell death. Congestion and petechiae are seen in the pericardium, pleura, thymus, heart, adrenals, and meninges. Prolonged intrauterine hypoxia may result in inadequate perfusion of the periventricular white matter, resulting in PVL. Pulmonary arteriole smooth muscle hyperplasia may

**Table 122.7** Poor Predictive Variables for Death/Disability After Hypoxic-Ischemic Encephalopathy

- Low (0-3) 10 min Apgar score
- Need for CPR in the delivery room
- Delayed onset ( $\geq 20$  min) of spontaneous breathing
- Severe neurologic signs (coma, hypotonia, hypertonia)
- Seizures onset  $\leq 12$  hr or difficult to treat
- Severe, prolonged ( $\sim 7$  days) EEG findings including burst suppression pattern
- Prominent MRI basal ganglia/thalamic lesions
- Oliguria/anuria  $> 24$  hr
- Abnormal neurologic exam  $\geq 14$  days

CPR, Cardiopulmonary resuscitation; EEG, electroencephalogram.

develop, which predisposes the infant to pulmonary hypertension (see [Chapter 130](#)). If fetal distress produces gasping, amniotic fluid contents (i.e., meconium, desquamation products, lanugo) may be aspirated into the trachea or lungs with subsequent complications, including pulmonary hypertension and pneumothoraces.

### CLINICAL MANIFESTATIONS

At delivery, the presence of meconium-stained amniotic fluid indicates that fetal distress may have occurred. At birth, affected infants may have neurologic impairment and may fail to breathe spontaneously. Pallor, cyanosis, apnea, a slow heart rate, and unresponsiveness to stimulation are also nonspecific initial signs of potential HIE. During the ensuing hours, infants may be hypotonic, may change from a hypotonic to a hypertonic state, or their tone may appear normal ([Tables 122.7 and 122.8](#)). Cerebral edema may develop during the next 24 hours and result in profound brainstem depression. During this time, seizure activity may occur; seizures may be severe and refractory to standard doses of anticonvulsants. Although most often a result of the HIE, seizures in asphyxiated newborns may also be caused by vascular events (hemorrhage, arterial ischemic stroke, or sinus venous thrombosis), metabolic derangements (hypocalcemia, hypoglycemia), CNS infection, and cerebral dysgenesis or genetic disorders (nonketotic hyperglycinemia, vitamin-dependent epilepsies, channelopathies). Congenital conditions that result in neuromuscular weakness and poor respiratory effort may also result secondarily in neonatal hypoxic brain injury and seizure. Such conditions might include congenital myopathies, congenital myotonic dystrophy, or spinal muscular atrophy.

In addition to CNS dysfunction, systemic organ dysfunction is noted in up to 80% of affected neonates. Myocardial dysfunction and

**Table 122.8** Hypoxic-Ischemic Encephalopathy in Term Infants

SIGNS	STAGE 1 (MILD)	STAGE 2 (MODERATE)	STAGE 3 (SEVERE)
Level of consciousness	Hyperalert, responds to minimal stimuli	Lethargic	Stuporous, coma
Spontaneous activity	Normal or decreased	Decreased	None
Posture	Mild flexion of distal joints (fingers, wrist)	Distal flexion or complete extension	Decerebrated
Tone	Normal	Hypotonia (focal or general) or hypertonia	Flaccid or rigid
<b>PRIMITIVE REFLEXES</b>	<b>1</b>	<b>2</b>	<b>3</b>
Suck	Weak or incomplete	Weak or bite	Absent
Moro reflex	Intact, low threshold	Incomplete	Absent
<b>AUTONOMIC NERVOUS SYSTEM</b>	<b>1</b>	<b>2</b>	<b>3</b>
Pupils	Mydriasis	Miosis	Variable or nonreactive
Heart rate	Tachycardia	Bradycardia	Variable heart rate
Respirations	Hyperventilation	Periodic breathing	Apnea or requiring ventilation
Seizures	None	Common	Decerebration
Electroencephalographic findings	Normal	Low voltage changing to seizure activity	Burst suppression to isoelectric activity
Duration	<24 hr if progresses; otherwise, may remain normal	24 hr to 14 days	Days to weeks
Outcome	Good	Variable	Death, severe deficits

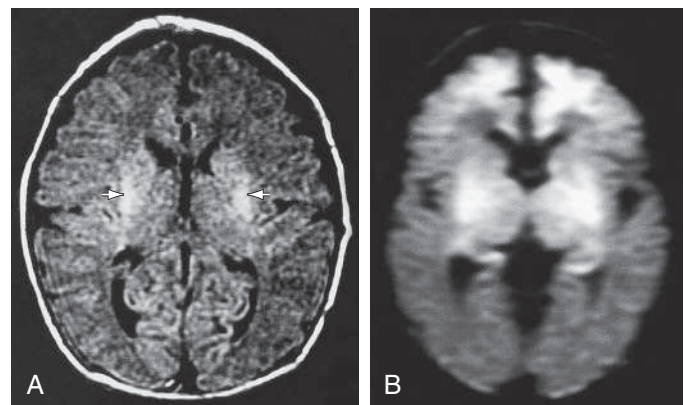
Adapted from Chalak L, Latremouille S, Mir I, Sánchez PJ, Sant'Anna G. A review of the conundrum of mild hypoxic-ischemic encephalopathy: current challenges and moving forward. *Early Hum Dev.* 2018;120:88–94.

cardiogenic shock, persistent pulmonary hypertension, RDS, gastrointestinal perforation, and acute kidney and liver injury are associated with perinatal asphyxia secondary to inadequate perfusion (see [Table 122.5](#)).

The severity of neonatal encephalopathy depends on the duration and timing of injury. The need to define severity is rooted in the need to determine eligibility for *therapeutic hypothermia*, a treatment that decreases death and disability in moderate to severe HIE. A clinical grading score first proposed by Sarnat and colleagues continues to be a useful tool. Symptoms develop over hours and days, making it important to perform serial neurologic examinations (see [Tables 122.7 and 122.8](#)). Infants with moderate to severe HIE are characterized by disturbed neurologic function, altered level of consciousness, depressed tone, abnormal reflexes, and difficulty maintaining spontaneous respirations, and seizures. An empirically validated definition of mild HIE within 6 hours uses two steps: the first step is screening for fetal acidosis and acute perinatal events, and the second step has an examiner use a modified Sarnat scoring, which is expanded to include mild in addition to moderate and severe abnormalities.

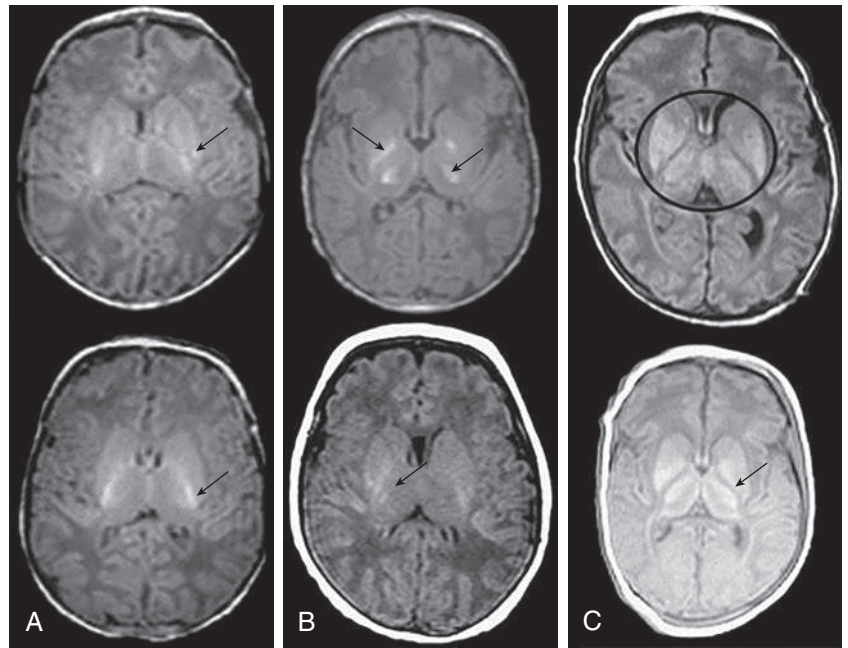
## DIAGNOSIS

MRI is the most sensitive imaging modality for detecting hypoxic brain injury in the neonate. Although such injury can be detected at various times and with varying pulse sequences, diffusion-weighted sequences obtained in the first 3–5 days following a presumed sentinel event are optimal for identifying acute injury ([Figs. 122.6–122.9](#) and [Table 122.9](#)). Severe HIE is characterized on MRI by a central pattern injury that includes the thalamus, posterior limb of the internal capsule, and hippocampus with the most severe HIE resulting in involvement of the entire cortex. Magnetic resonance spectroscopy performed within first 24 hours after birth in a full-term infant is very sensitive to the severity of HIE-related brain injury. Elevated lactate/creatinine ratio on day 1 of life is a predictor of adverse neurologic outcome, whereas absence of lactate predicts a normal outcome. Where MRI is unavailable or prevented by clinical instability, brain CT scans may be helpful in ruling out focal hemorrhagic lesions or

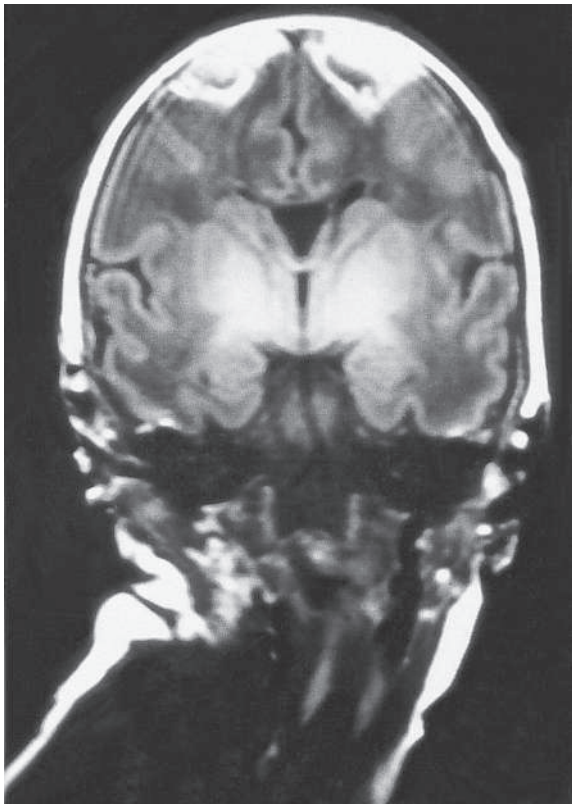


**Fig. 122.6** MR images of selective neuronal injury. The infant experienced intrapartum asphyxia and had seizures on the first postnatal day. MRI was performed on the fifth postnatal day. **A**, Axial, fluid-attenuated, inversion recovery image shows increased signal in the putamen bilaterally (arrows) but no definite abnormality in the cerebral cortex. **B**, By contrast, a diffusion-weighted image shows striking increased signal intensity (i.e., decreased diffusion) in the frontal cortex (in addition to a more pronounced basal ganglia abnormality). (From Volpe JJ, ed. *Neurology of the Newborn*. 5th ed. Philadelphia: Saunders; 2008. p. 420.)

large arterial ischemic strokes. Loss of gray-white differentiation and injury to the basal ganglia in more severe HIE can be detected on CT by experienced readers, but CT often misses more subtle forms of neonatal hypoxic brain injury and results in significant radiation exposure. Ultrasound has limited utility in evaluation of hypoxic injury in the term infant, but it too can be useful for excluding hemorrhagic lesions or hydrocephalus. Because of factors of size and clinical stability, ultrasound is the initial preferred (and sometimes only feasible) modality in evaluation of the preterm infant.



**Fig. 122.7** MR images of basal ganglia/thalamic (BG/T) injury and signal intensity. Top row, Axial T1 weighted MR images showing mild BG/T lesions (arrow) (A), moderate BG/T injury (arrows) (B), and severe BG/T abnormalities (circled) (C). Bottom row, Axial T1 weighted MR images showing normal signal intensity (SI) in the posterior limb of the internal capsule (PLIC) (arrow) (A), equivocal, asymmetric, and slightly reduced SI in the PLIC (arrow) (B), and abnormal, absent SI in the PLIC (arrow) (C). (From Martinez-Biarge M, Diez-Sebastian J, Rutherford MA, Cowan FM. Outcomes after central grey matter injury in term perinatal hypoxic-ischaemic encephalopathy. *Early Hum Dev.* 2010;86:675–682.)



**Fig. 122.8** MR image of a parasagittal cerebral injury. Coronal T1 weighted image, obtained on the fifth postnatal day in an asphyxiated term infant, shows striking triangular lesions in the parasagittal areas bilaterally; increased signal intensity is also apparent in the basal ganglia and thalamus bilaterally. (From Volpe JJ, ed. *Neurology of the Newborn*. 5th ed. Philadelphia: Saunders; 2008. p. 421.)

### Neurophysiology Studies

Monitoring the brain of the sick newborn infant in the NICU using either multichannel electroencephalography (EEG) or limited channel amplitude integrated EEG (aEEG) may help to determine which infants are at highest risk for developmental sequelae of neonatal brain injury (Tables 122.10 and 122.11). Multichannel EEG with video is the gold standard for monitoring

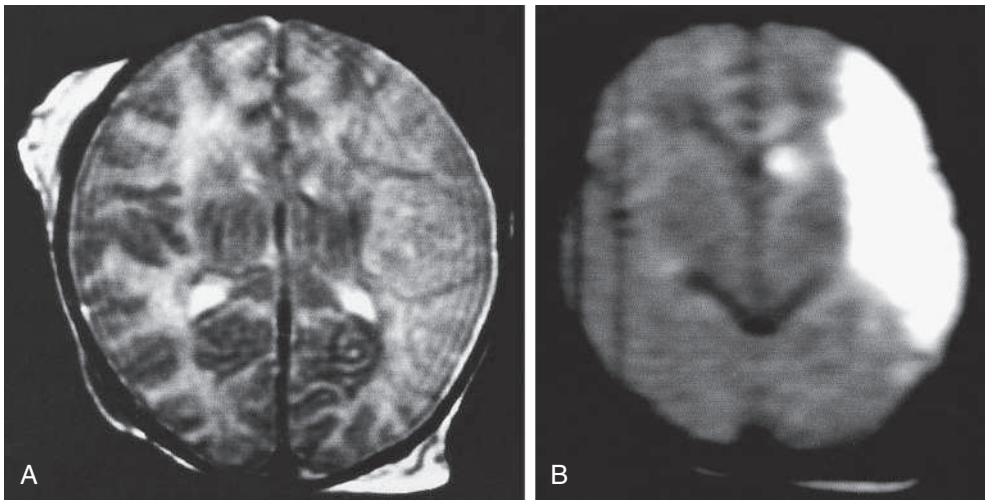
newborn brain function; at least 24-hour monitoring is recommended for infants at risk for seizures. The neonatal EEG contains complex spatiotemporal information and can be difficult to interpret, requiring many years in neurophysiology training. As a result, in many NICUs, EEG signal processing of a limited number of channels, with a more accessible method of data presentation, has been adopted (aEEG). Even in the absence of obvious seizures, a 24-hour multichannel EEG recording is recommended and, in infants undergoing hypothermia therapy, 72 hours is optimal to cover duration of intervention. It is known that EEG in HIE evolves following the primary HIE injury and that EEG monitoring is essential to assess this evolution and recovery. Description of EEG background grades and seizures in HIE include normal trace, which is a normal amplitude with sleep–wake cycling; mildly abnormal trace, which is a period of low amplitude and lack of sleep–wake cycling; moderately abnormal trace, which is periods of discontinuity <10 seconds; and severely abnormal trace with burst suppression pattern and discontinuity of activity for 10–60 seconds (Fig. 122.10). An aEEG is a good option if multichannel EEG is not available. The signal from biparietal electrodes is smoothed and the amplitude integrated and shows the baseline background electrical activity. A voltage classification scheme for aEEG use in HIE has been developed as follows: normal voltage (5–10  $\mu\text{V}$ ) and abnormal voltage (lower margin <5  $\mu\text{V}$  and upper margin >10  $\mu\text{V}$ ).

### TREATMENT

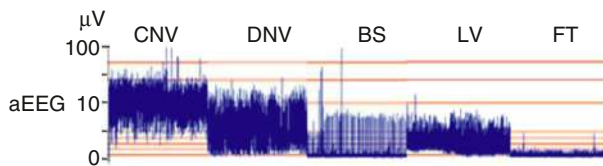
**Therapeutic hypothermia**, whether head cooling or systemic cooling (by servo-control to a core rectal or esophageal temperature of 33.5°C [92.3°F] within the first 6 hours after birth and maintained for 72 hours) has been shown to reduce mortality and major neurodevelopmental impairment at 18 months of age. Infants treated with systemic hypothermia have a lower incidence of cortical neuronal injury on MRI, suggesting systemic hypothermia may result in more uniform cooling of the brain and deeper CNS structures than selective head cooling. The therapeutic effect of hypothermia likely results from decreased secondary neuronal injury achieved by reducing rates of apoptosis and production of mediators related to neurotoxicity. There is also benefit in seizure reduction. The therapeutic benefit of hypothermia noted at 18–22 months of age is maintained later in childhood. Once established, hypothermia may not alter the prognostic findings on MRI.

Numerous studies seeking ways to extend the benefits of therapeutic hypothermia have been attempted. The foundational clinical trials of therapeutic hypothermia had strict treatment protocols and excluded infants born before 35 or 36 weeks completed gestational weeks, those weighing <1,800 g, and infants with major congenital abnormality. Practice variation exists for offering therapeutic hypothermia to infants





**Fig. 122.9** MR images of focal ischemic cerebral injury. MRI was performed on the third postnatal day. **A**, Axial T2 weighted image shows a lesion in the distribution of the main branch of the left middle cerebral artery. **B**, Diffusion-weighted image demonstrates the lesion more strikingly. (From Volpe JJ, ed. *Neurology of the Newborn*. 5th ed. Philadelphia: Saunders; 2008. p. 422.)



**Fig. 122.10** Amplitude EEG patterns. Patterns are highlighted with pattern classification (continuous normal voltage [CNV], discontinuous normal voltage [DNV], burst suppression [BS], low voltage [LV], flat tracings [FT]). (From Chalak L. *New horizons in mild hypoxic-ischemic encephalopathy: A standardized algorithm to move past conundrum of care*. *Clin Perinatol*. 2022;49:279–294. Fig. 3.)

**Table 122.9** Major Aspects of MRI in Diagnosis of Hypoxic-Ischemic Encephalopathy in the Term Infant

#### MAJOR CONVENTIONAL MR FINDINGS IN FIRST WEEK

- Cerebral cortical gray-white differentiation lost (on T1W or T2W)
- Cerebral cortical high signal (T1W and FLAIR), especially in parasagittal peri-rolandic cortex
- Basal ganglia/thalamus, high signal (T1W and FLAIR), usually associated with the cerebral cortical changes but possibly alone with increased signal in brainstem tegmentum in cases of acute severe insult
- Parasagittal cerebral cortex, subcortical white matter, high signal (T1W and FLAIR)
- Periventricular white matter, decreased signal (T1W) or increased signal (T2W)
- Posterior limb of internal capsule, decreased signal (T1W or FLAIR)
- Cerebrum in a vascular distribution, decreased signal (T1W), but much better visualized as decreased diffusion (increased signal) on diffusion-weighted MRI
- Diffusion-weighted MRI more sensitive than conventional sequences in MRI, especially in first days after birth, when former shows decreased diffusion (increased signal) in injured areas

FLAIR, Fluid-attenuated inversion recovery; T1W and T2W, T1 weighted and T2 weighted images.

From Volpe JJ, ed. *Neurology of the Newborn*. 5th ed. Philadelphia: Elsevier; 2008: Table 9-16.

who do not meet the original study criteria, although debate for these practices also exist. A multicenter randomized clinical trial investigating the benefit of use of therapeutic hypothermia beyond 6 hours after birth reported a modest and “nonconclusive” effect. Importantly, this study extended the duration of hypothermia from 72 to 96 hours based on preclinical data suggesting that a longer period of treatment was needed at later initiation times. Assessment of deeper or longer cooling failed to show benefit in short-term outcomes, and its use is

**Table 122.10** Value of Electroencephalography in Assessment of Asphyxiated Term Infants

- Detection of severe abnormalities (i.e., CLV, FT, BSP) in first hours of life has a positive predictive value of an unfavorable outcome of 80–90%.
- Severe abnormalities may improve within 24 hr (~50% of BSP and 10% of CLV/FT).
- Rapid recovery of severe abnormalities is associated with a favorable outcome in 60% of cases.
- The combination of early neonatal neurologic examination and early aEEG enhances the positive predictive value and specificity.

aEEG, Amplitude integrated encephalography; BSP, burst suppression pattern; CLV, continuous low voltage; FT, flat trace.

From Inder TE, Volpe JJ. Hypoxic-ischemic injury in the term infant: clinical-neurological features, diagnosis, imaging, prognosis, therapy. In: Volpe JJ, Inder TE, Darras BT, et al., eds. *Volpe’s Neurology of the Newborn*. 6th ed. Philadelphia: Elsevier; 2018: Table 20-28.

not supported by evidence nor clinically justifiable. Multicenter clinical trials are underway to assess the use of therapeutic hypothermia in preterm infants born between 33 and 35 weeks’ gestation. The term “major congenital anomalies” in the original trials lead to the exclusion of numerous conditions with a favorable prognosis for survival and neurodevelopment, including trisomy 21. Unless the identified anomaly specifically imparts a medical contraindication to therapeutic hypothermia, the infant is moribund, or treatment does not align with the broader goals of care for the infant, categorical exclusion of the infant from therapeutic hypothermia solely based on the presence of one or more major congenital anomalies is likely not ethically justifiable. There have been few studies to investigate the use of therapeutic hypothermia in neonates who are beyond the perinatal period. Presently, clinical research on “targeted temperature management” in infants has been done in the pediatric intensive care setting and has little applicability to NICUs.

Complications of induced hypothermia include thrombocytopenia (usually without bleeding), reduced heart rate, and subcutaneous fat necrosis (sometimes with associated hypercalcemia) as well as the potential for overcooling and the **cold injury syndrome**. The latter is usually avoided with a servo-controlled cooling system. Therapeutic hypothermia may theoretically alter drug metabolism, prolong the QT interval, and affect the interpretation of blood gases. In clinical practice, these concerns have not been observed.

For treating seizures associated with HIE, phenobarbital continues to be used in many instances. It is typically given by intravenous loading dose (20 mg/kg). Additional doses of 5–10 mg/kg (up to 40–50 mg/kg total) may be needed. Phenobarbital levels should be monitored 24 hours after the loading dose has been given and maintenance therapy (5 mg/kg/24 hr) begun. Therapeutic phenobarbital levels are 20–40 µg/mL.



For refractory seizures, there is a high degree of variability regarding choice of a second agent. Historically, phenytoin (20 mg/kg loading dose) or lorazepam (0.1 mg/kg) have been preferred, but currently the use of levetiracetam is preferred (at times even as a first-line agent) as a second-line agent. Pharmacokinetic data suggest that due to the higher volume of distribution created by higher relative body water content in neonates, loading doses should be higher than in older children or adults. Suggested appropriate loading doses may be closer to 60 mg/kg. In addition to levetiracetam and phenytoin, other second- or third-line agents commonly used include midazolam, topiramate, and lidocaine. Pyridoxine should also be attempted, particularly in ongoing refractory seizures with highly abnormal EEG background. Status epilepticus, multifocal seizures, and need for multiple anticonvulsant medications during therapeutic hypothermia are associated with a poor prognosis.

Additional therapy for infants with HIE includes supportive care directed at management of organ system dysfunction. Hyperthermia has been associated with impaired neurodevelopment and should be prevented, particularly in the interval between initial resuscitation and initiation of hypothermia. Careful attention to ventilatory status and adequate oxygenation, blood pressure, hemodynamic status, acid-base balance, and possible infection is important. Secondary hypoxia or hypotension from complications of HIE must be prevented. Aggressive treatment of seizures is critical and may necessitate continuous EEG monitoring. In addition, hyperoxia, hypocarbia, and hypoglycemia are associated with poor outcomes, so careful attention to resuscitation, ventilation, and blood glucose homeostasis is essential.

## PROGNOSIS

The outcome of HIE ranges from complete recovery to death. The prognosis varies depending on the severity of the insult and the treatment. Infants with initial cord or initial (~1 hour of age) blood pH <6.7 have a 90% risk for death or severe neurodevelopmental impairment at 18 months of age. In addition, infants with Apgar scores of 0-3 at 5 minutes, high base deficit (>20-25 mmol/L), decerebrate posture, severe basal ganglia/thalamic (BG/T) lesions (Fig. 122.11; see also Fig. 122.7), persistence of severe HIE by clinical examination at 72 hours, and lack of spontaneous activity are also at increased risk for death or impairment. These predictor variables can be combined to determine a score that helps with prognosis (see Table 122.7). Infants with the

highest risk are likely to die or have severe disability despite aggressive treatment, including hypothermia. Those with intermediate scores are likely to benefit from treatment. In general, severe encephalopathy, characterized by flaccid coma, apnea, absence of oculocephalic reflexes, and refractory seizures, is associated with a poor prognosis (see Table 122.8). Apgar scores alone in patients with HIE can also be associated with subsequent risk of neurodevelopmental impairment. At 10 minutes, each point decrease in Apgar score increases odds of death or disability by 45%. Death or disability occurs in 76–82% of infants with HIE with Apgar scores of 0-2 at 10 minutes. Absence of spontaneous respirations at 20 minutes of age and persistence of abnormal neurologic signs at 2 weeks of age also predict death or severe cognitive and motor deficits.

The combined use of early multichannel EEG or aEEG and MRI offers additional insight in predicting outcome in term infants with HIE (see Table 122.11). EEG or aEEG background characteristics such as pattern, voltage, reactivity, state change, and evolution after acute injury are important predictors of outcome. MRI markers include location of injury, identification of injury by certain pulse sequences, measurement of diffusivity and/or fractional anisotropy, and presence of abnormal metabolite ratios on MR spectroscopy, and all have shown

**Table 122.11** Electroencephalographic Patterns of Prognostic Significance in Asphyxiated Term Infants\*

### ASSOCIATED WITH FAVORABLE OUTCOME

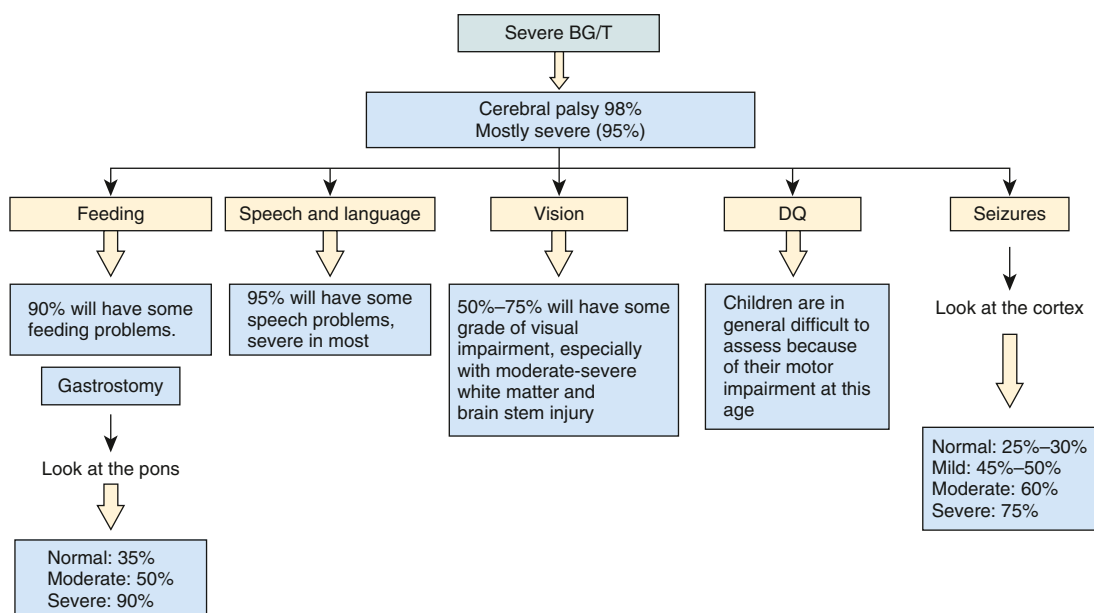
Mild depression (or less) on day 1  
Normal background by day 7

### ASSOCIATED WITH UNFAVORABLE OUTCOME

Predominant interburst interval >20sec on any day  
Burst suppression pattern on any day  
Isoelectric tracing on any day  
Mild (or greater) depression after day 12

\*Associations with favorable or unfavorable outcome are generally ≥90%, but the clinical context must be considered.

From Inder TE, Volpe JJ. Hypoxic-ischemic injury in the term infant: clinical-neurological features, diagnosis, imaging, prognosis, therapy. In: Volpe JJ, Inder TE, Darras BT, et al., eds. *Volpe's Neurology of the Newborn*. 6th ed. Philadelphia: Elsevier; 2018: Table 20-26.



**Fig. 122.11** Flow chart showing patterns of outcome with severe basal ganglia/thalamic (BG/T) injury. DQ, Developmental quotient. (From Martinez-Biarge M, Diez-Sebastian J, Rutherford MA, Cowan FM. Outcomes after central grey matter injury in term perinatal hypoxic-ischaemic encephalopathy. *Early Hum Dev*. 2010;86:675–682.)

correlation with outcome. Severe BG/T lesions with abnormal signal in the posterior limb of the internal capsule are highly predictive of the poorest cognitive and motor prognosis (see Fig. 122.11). Normal MRI and EEG findings are associated with a good recovery.

Microcephaly and poor head growth during the first year of life also correlate with injury to the BG/T and white matter and adverse developmental outcome at 12 months. All survivors of moderate to severe encephalopathy require comprehensive high-risk medical and developmental follow-up. Early identification of neurodevelopmental problems allows prompt referral for developmental, rehabilitative, and neurologic early intervention services so that the best possible outcomes can be achieved.

**Brain death** (death by neurologic criteria) after neonatal HIE is diagnosed from the clinical findings of coma unresponsive to pain, auditory, or visual stimulation; apnea with  $P_{CO_2}$  rising from 40 to >60 mm Hg without ventilatory support; and absence of brainstem reflexes (pupillary, oculocephalic, oculovestibular, corneal, gag, sucking) (see Chapter 83). These findings must occur in the absence of hypothermia, hypotension, and elevations of depressant drugs (phenobarbital), which may take days to be metabolized and cleared completely from the blood. In the term infant, the national guideline for determination should be followed. There is no agreement on such criteria in the preterm infants. Consideration of withdrawal of life support must include discussions with the family and the healthcare team, and, if there is disagreement, an ethics committee. The best interest of the infant involves judgments about the benefits and harm of continuing therapy or avoiding ongoing futile therapy.

Visit Elsevier eBooks+ at [eBooks.Health.Elsevier.com](http://eBooks.Health.Elsevier.com) for Bibliography.

## 122.5 Spine and Spinal Cord

Susan S. Cohen, Alicia J. Sprecher, and  
Krishna K. Acharya

See also Chapter 751.

Injury to the spine/spinal cord during birth is rare but can be devastating. Strong traction exerted when the spine is hyperextended or when the direction of pull is lateral, or forceful longitudinal traction on the trunk while the head is still firmly engaged in the pelvis, especially when combined with flexion and torsion of the vertical axis, may produce fracture and separation of the vertebrae. Such injuries are most likely to occur when difficulty is encountered in delivering the shoulders in cephalic presentations and the head in breech presentations. The injury occurs most often at the level of the 4th cervical vertebra with cephalic presentations and the lower cervical–upper thoracic vertebrae with breech presentations. Transection of the cord may occur *with or without* vertebral fractures; hemorrhage and edema may produce neurologic signs that are indistinguishable from those of transection, except that they may not be permanent. Areflexia, loss of sensation, and complete paralysis of voluntary motion occur below the level of injury, although the persistence of a withdrawal reflex mediated through spinal centers distal to the area of injury is frequently misinterpreted as representing voluntary motion.

If the injury is severe, the infant, who from birth may be in poor condition because of respiratory depression, shock, or hypothermia, may deteriorate rapidly to death within several hours before any neurologic signs are obvious. Alternatively, the course may be protracted, with symptoms and signs appearing at birth or later in the first week; Horner syndrome, immobility, flaccidity, and associated brachial plexus injuries may not be recognized for several days. Constipation may also be present. Some infants survive for prolonged periods, their initial flaccidity, immobility, and areflexia being replaced after several weeks or months by rigid flexion of the extremities, increased muscle tone, and spasms. Apnea on day 1 and poor motor recovery by 3 months are poor prognostic signs.

The **differential diagnosis** of neonatal spine/spinal cord injury includes amyotonia congenita and myelodysplasia associated with spina bifida occulta, spinal muscular atrophy (type 0), spinal vascular malformations (e.g., arteriovenous malformation causing hemorrhage

or stroke), and congenital structural anomalies (syringomyelia, heman-gioblastoma). Ultrasound or MRI confirms the diagnosis. Treatment of the survivors is supportive, including home ventilation; patients often remain permanently disabled. When a fracture or dislocation is causing spinal compression, the prognosis is related to the time elapsed before the compression is relieved.

Visit Elsevier eBooks+ at [eBooks.Health.Elsevier.com](http://eBooks.Health.Elsevier.com) for Bibliography.

## 122.6 Peripheral Nerve Injuries

Susan S. Cohen, Alicia J. Sprecher, and  
Krishna K. Acharya

See also Chapter 753.

### BRACHIAL PALSY

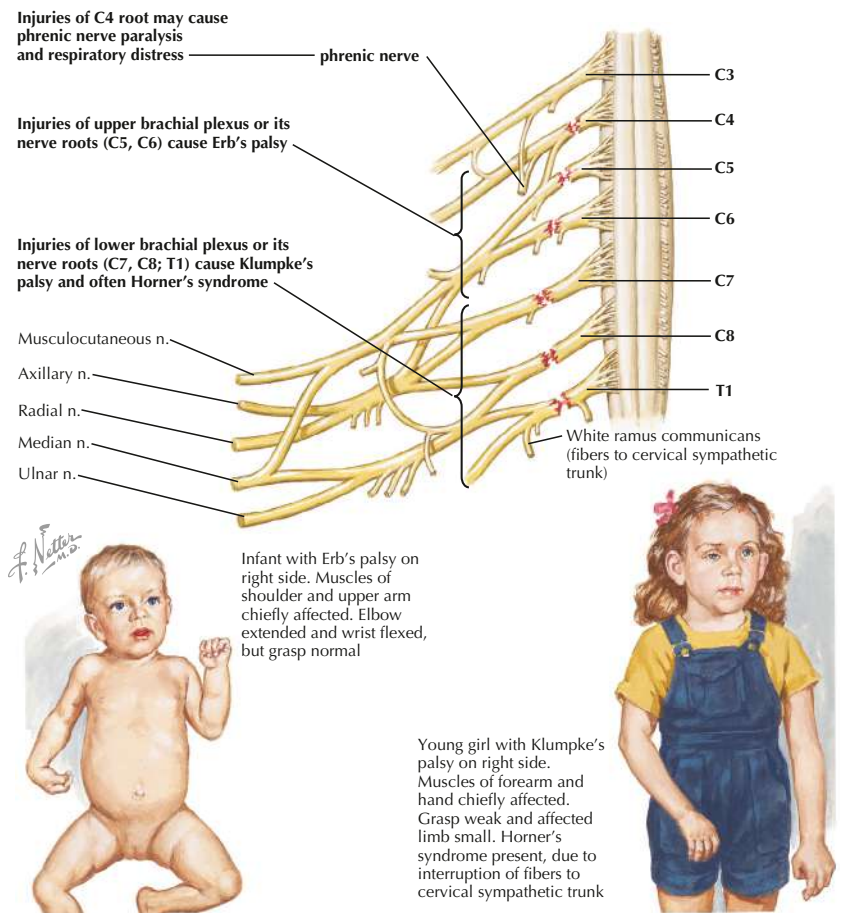
Brachial plexus injury is a common problem, with an incidence of 0.6–4.6 per 1,000 live births. Injury to the brachial plexus may cause paralysis of the upper part of the arm with or without paralysis of the forearm or hand or, more often, paralysis of the entire arm. These injuries occur in macrosomic infants and when lateral traction is exerted on the head and neck during delivery of the shoulder in a vertex presentation, when the arms are extended over the head in a breech presentation, or when excessive traction is placed on the shoulders. The primary risk factor for brachial plexus injuries are shoulder dystocia and macrosomia (birthweight >4,000 g).

**Erb-Duchenne paralysis** results from injury to the nerve roots of the 5th and 6th cervical nerves, with the 7th affected in 50% of instances. The infant loses the power to abduct the arm from the shoulder, rotate the arm externally, and supinate the forearm. The characteristic position consists of adduction and internal rotation of the arm with pronation of the forearm, often described as the “waiter’s tip hand.” Power to extend the forearm is retained, but the biceps reflex is absent; the Moro reflex is absent on the affected side (Fig. 122.12). The outer aspect of the arm may have some sensory impairment. Power in the forearm and hand grasps is preserved unless the lower part of the plexus is also injured; the presence of hand grasp is a favorable prognostic sign. When the injury includes the phrenic nerve (in about 5% of patients), alteration in diaphragmatic excursion may be observed with ultrasound, fluoroscopy, or as asymmetric elevation of the diaphragm on chest radiograph.

**Clumpke paralysis** is a rare form of brachial palsy in which injury to the 7th and 8th cervical nerves and the 1st thoracic nerve produces a paralyzed hand and ipsilateral ptosis and miosis (**Horner syndrome**) if the sympathetic fibers of the first thoracic root are also injured. The incidence is as low as 0.6%, and some suggest the reason for this is modern obstetric practice and a sharp decline in the vaginal breech deliveries where there is a risk of hyperabduction of the arms. Mild cases may not be detected immediately after birth. Differentiation must be made from cerebral injury; from fracture, dislocation, or epiphyseal separation of the humerus; and from fracture of the clavicle. MRI demonstrates nerve root rupture or avulsion.

Most patients have full recovery. If the paralysis was a result of edema and hemorrhage around the nerve fibers, function should return within a few months; if it resulted from laceration, permanent damage may result. Involvement of the deltoid is usually the most serious problem and may result in **shoulder drop** secondary to muscle atrophy. In general, paralysis of the upper part of the arm has a better prognosis than paralysis of the lower part.

Treatment for **peripheral nerve injuries** consists of initial conservative management with monthly follow-up and a decision for surgical intervention by 3 months if function has not improved. Partial immobilization and appropriate positioning are used to prevent the development of contractures. In upper arm paralysis, the arm should be abducted 90 degrees with external rotation at the shoulder, full supination of the forearm, and slight extension at the wrist with the palm turned toward the face. This position may be achieved with a brace or splint during the first 1–2 weeks. Immobilization should be intermittent throughout the day while the infant is asleep and between



**Fig. 122.12** Schematic representation of the brachial plexus with its terminal branches. The major sites of brachial plexus injury are shown. (Courtesy Netter Images, Image ID 19943. [www.netterimages.com](http://www.netterimages.com).)

feedings. In lower arm or hand paralysis, the wrist should be splinted in a neutral position and padding placed in the fist. When the entire arm is paralyzed, the same treatment principles should be followed. Gentle massage and range-of-motion exercises may be started by 7-10 days of age. Infants should be closely monitored with active and passive corrective exercises. If the paralysis persists without improvement for 3 months, neuroplasty, neurolysis, end-to-end anastomosis, and nerve grafting offer hope for partial recovery.

The type of treatment and the prognosis depend on the mechanism of injury and the number of nerve roots involved. The mildest injury to a peripheral nerve (**neurapraxia**) is caused by edema and heals spontaneously within a few weeks. **Axonotmesis** is more severe and is a consequence of nerve fiber disruption with an intact myelin sheath; function usually returns in a few months. Total disruption of nerves (**neurotmesis**) or root avulsion is the most severe, especially if it involves C5-T1; microsurgical repair may be indicated. Fortunately, most (75%) injuries are at the root level C5-C6, involve neurapraxia and axonotmesis, and should heal spontaneously. Botulism toxin may be used to treat biceps-triceps co-contractions.

### PHRENIC NERVE PARALYSIS

Phrenic nerve injury (3rd, 4th, 5th cervical nerves) with diaphragmatic paralysis must be considered when cyanosis and irregular and labored respirations develop. Such injuries, usually unilateral, are associated with ipsilateral upper brachial plexus palsies in 75% of cases. Because breathing is thoracic in type, the abdomen does not bulge with inspiration. Breath sounds are diminished on the affected side. The thrust of the diaphragm, which may often be felt just under the costal margin on the normal side, is absent on the affected side. The diagnosis is established by ultrasound or fluoroscopic examination, which reveals elevation of the diaphragm on the paralyzed side and seesaw movements of the two sides of the diaphragm during respiration. It may also be apparent on chest or abdominal radiograph.

Infants with phrenic nerve injury should be placed on the involved side and given oxygen if necessary. Some may benefit from pressure

introduced by continuous positive airway pressure (CPAP) to expand the paralyzed hemidiaphragm. In extreme cases, mechanical ventilation may be needed. Initially, intravenous feedings may be needed; later, progressive gavage or oral feeding may be started, depending on the infant's condition. Pulmonary infections are a serious complication. If the infant fails to demonstrate spontaneous recovery in 1-2 months, surgical plication of the diaphragm may be indicated.

### FACIAL NERVE PALSY

Facial palsy is usually a peripheral paralysis that results from pressure over the facial nerve in utero, during labor, or from forceps use during delivery. Rarely, it may result from nuclear agenesis of the facial nerve.

**Peripheral facial paralysis** is flaccid and, when complete, involves the entire side of the face, including the forehead. The main reported risk factors associated with traumatic facial paralysis are primigravida, birth-weight >3,500 g, forceps usage, cesarean birth, and prematurity. When the infant cries, movement occurs only on the nonparalyzed side of the face, and the mouth is drawn to that side. On the affected side the forehead is smooth, the eye cannot be closed, the nasolabial fold is absent, and the corner of the mouth droops. **Central facial paralysis** spares the forehead (e.g., forehead wrinkles will still be apparent on the affected side) because the nucleus that innervates the upper face has overlapping dual innervation by corticobulbar fibers originating in bilateral cerebral hemispheres. The infant with central facial paralysis usually has other manifestations of intracranial injury, most often 6th nerve palsy from the proximity of the 6th and 7th cranial nerve nuclei in the brainstem. Prognosis depends on whether the nerve was injured by pressure or the nerve fibers were torn; improvement occurs within a few weeks in the former case. The majority of infants with traumatic facial nerve palsy will recover within the first 2 months of life. Care of the exposed eye is essential. Neuroplasty may be indicated when the paralysis is persistent. Facial palsy may be confused with absence of the depressor muscles of the mouth, which is a benign problem or with variants of Möbius syndrome.

Visit Elsevier eBooks+ at [eBooks.Health.Elsevier.com](http://eBooks.Health.Elsevier.com) for Bibliography.



## Chapter 123

# Neonatal Resuscitation and Delivery Room Emergencies

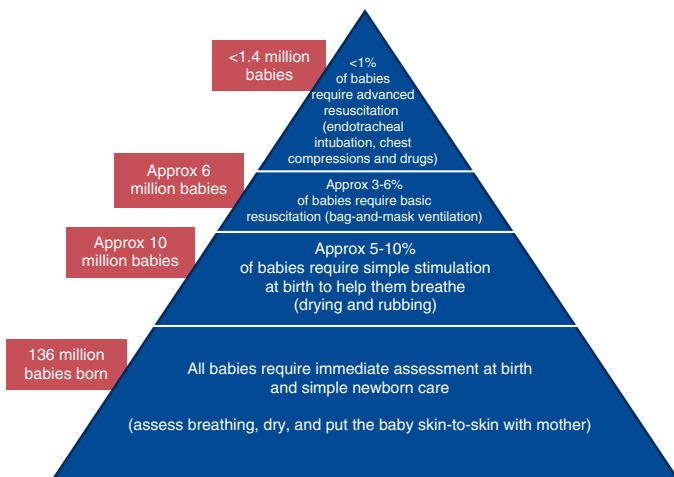
Heidi M. Herrick and Elizabeth E. Foglia

Most infants complete the transition to extrauterine life without difficulty; however, a small proportion require resuscitation after birth (Fig. 123.1). For a newborn infant, the need for resuscitation is often caused by a respiratory problem leading to inadequate ventilation. This is in contrast to an adult cardiac arrest, which is usually caused by inadequate circulation. The goals of neonatal resuscitation are to establish adequate spontaneous respirations, obtain adequate cardiac output, and prevent the morbidity and mortality associated with hypoxic-ischemic tissue (brain, heart, kidney) injury (see Chapter 122). High-risk situations should be anticipated from pregnancy history and labor. Improved perinatal care and prenatal diagnosis of fetal anomalies allow for appropriate maternal transports for high-risk deliveries. Infants who are born limp, cyanotic, apneic, or pulseless require immediate resuscitation before assignment of the 1 minute Apgar score. Rapid and appropriate resuscitative efforts improve the likelihood of preventing brain damage and achieving a successful outcome.

## NEONATAL RESUSCITATION

See also Chapter 79.

Recommendations for the **Neonatal Resuscitation Program (NRP)** propose an *integrated* assessment/response approach for the initial evaluation of an infant, consisting of simultaneous assessment of infant general appearance and risk factors. The fundamental principles include evaluation of the airway and establishing effective respirations and adequate circulation. The guidelines also highlight the importance of the neonatal heart rate as a primary indicator of the need for and response to resuscitation.



**Fig. 123.1** Estimates of infants requiring resuscitation at birth. (From Wall SN, Lee ACC, Niermeyer S, et al. Neonatal resuscitation in low-resource settings: what, who, and how to overcome challenges to scale up? *Int J Gynaecol Obstet.* 2009;107:S47-S64. Fig. 1.)

Before the birth of a baby, sufficient preparation for the birth should occur. At least one individual capable of initiating neonatal resuscitation should be present at the delivery. If advanced resuscitation is anticipated, more providers should be available. Necessary equipment should be available, which routinely includes a warmer bed, blankets, infant hat, stethoscope, bulb suction, suction catheter with wall suction, bag-mask device, oxygen source with blender, pulse oximeter, laryngoscope with blade, endotracheal tubes (ETTs), laryngeal mask airway, pulse oximeter, and electrocardiogram (ECG) leads. Based on the specific details of the pregnancy, further equipment may be needed and should be readily available. The equipment should be checked to make sure it is functioning appropriately. Team members should introduce themselves, define a team leader, assign roles for the resuscitation, and discuss what actions they will take during the resuscitation. For complex resuscitations, there may be one individual whose sole job is to document the resuscitation by keeping track of time and recording interventions performed. This can help ensure the correct steps are performed in a timely manner and inform the team debriefing after resuscitation.

The umbilical cord management plan should be established before delivery. **Delayed cord clamping** after birth can be performed in both preterm and term infants. Benefits to term infants include higher hemoglobin levels at birth with improved iron stores in infancy. Benefits for preterm infants include improved hemodynamic stability, decreased need for inotropic support, and decreased red blood cell transfusions. The 2020 Neonatal Resuscitation Guidelines call for at least 30-60 seconds of delayed cord clamping after birth for vigorous term and preterm infants unless contraindications are present. It is unclear whether delayed cord clamping should be continued when an infant requires resuscitation; this is an area of active research. Umbilical cord milking should not be performed for extremely preterm infants <28 weeks' gestation because this has been associated with an increased risk of intraventricular hemorrhage.

Failure to initiate or sustain respiratory effort at birth is fairly common, with 5-10% of newborns requiring some intervention. Infants with **primary apnea** respond to stimulation by establishing normal breathing. Infants with **secondary apnea** require ventilatory assistance to establish spontaneous respiratory effort. Secondary apnea usually originates as a result of prolonged interruption of adequate oxygen delivery in the perinatal period.

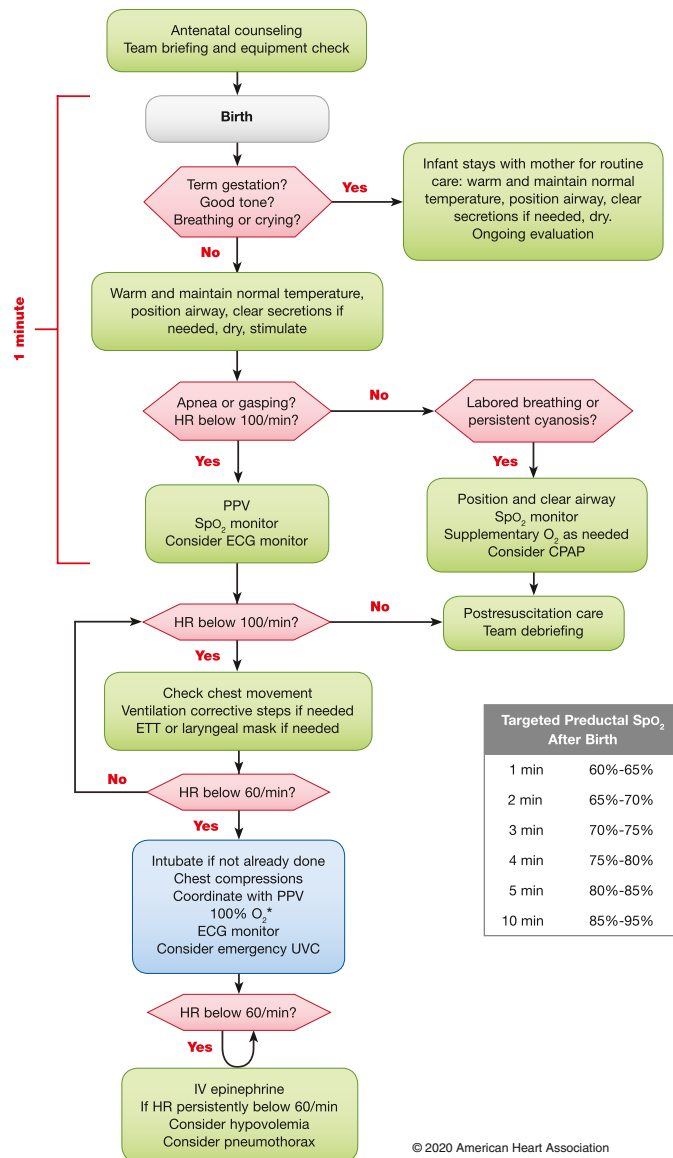
Immediately after birth, all term infants should be dried, warmed, and stimulated. If the infant does not need resuscitation, these steps can occur on the mother's abdomen while delayed cord clamping is taking place. Simultaneously, the infant's tone, respiratory effort, and heart rate should be assessed (Fig. 123.2). If the infant remains apneic or bradycardic (heart rate is <100 beats/min) after stimulation, positive pressure ventilation (PPV) should be given via face mask. PPV should be initiated at peak inspiratory pressures of approximately 20 cm H<sub>2</sub>O, positive end-expiratory pressures of 5 cm H<sub>2</sub>O at a rate of 40-60 breaths/min.

At the same time PPV is initiated, a pulse oximeter should be placed on the right hand (preductal). Resuscitation with room air in **term infants** is effective and may reduce the risk of hyperoxia, which is associated with decreased cerebral blood flow and generation of oxygen free radicals. Room air, which is 21% fraction of inspired oxygen (F<sub>IO<sub>2</sub></sub>), is the preferred *initial gas* for neonatal resuscitation in infants ≥35 weeks. O<sub>2</sub> concentration should then be titrated as needed to meet targeted peripheral oxygen saturations (>80% by 5 minutes), as defined by normal reference range by minute of life (see Fig. 123.2; see the following section on "Resuscitation of the Preterm Infant").

The most important sign of effective ventilation is a rise in heart rate. Additional signs include adequate chest rise, symmetric breath sounds, increasing O<sub>2</sub> saturation, spontaneous respirations, and improved tone. *If after 30 seconds of providing PPV there is no response in heart rate, corrective steps should be performed to improve ventilation.* The six



## Neonatal Resuscitation Algorithm



**Fig. 123.2** Newborn resuscitation algorithm. CPAP, Continuous positive airway pressure; ECG, electrocardiogram; ETT, endotracheal tube; HR, heart rate; IV, intravenous; PPV, positive pressure ventilation; UVC, umbilical venous catheter. (From Aziz K, Lee HC, Escobedo MB, et al. Part 5: Neonatal Resuscitation: 2020 American Heart Association Guidelines for Cardiopulmonary Resuscitation and Emergency Cardiovascular Care. *Circulation* 2020;142[16\_suppl\_2]:S524–S550. Fig. 1.)

ventilation corrective steps can be remembered with the mnemonic **MRSOPA**: *mask* readjustment, *reposition* the head, suction mouth and nose, *open* the mouth, *pressure* increase, and *alternative* airway.

Causes of poor response to ventilation are mask leak, airway obstruction, insufficient pressure, pleural effusions, pneumothorax, excessive air in the stomach leading to abdominal competition, hypovolemia, diaphragmatic hernia, or prolonged intrauterine asphyxia. For infants who do not respond to noninvasive PPV after corrective steps have been taken, endotracheal intubation should be performed. For infants with an otherwise normal airway weighing <1,000 g, ETT size is usually 2.5 mm; for infants 1,000–2,000 g, 3 mm; and for infants >2,000 g, 3.5 mm. A general rule for depth of insertion from upper lip in centimeters is 6 + infant's weight in kilograms. The best method to

confirm accurate ETT position is exhaled CO<sub>2</sub> detection. A laryngeal mask airway is an alternative method to establish an airway, especially if face mask PPV is ineffective or providers skilled in intubation are unavailable.

For most infants, the underlying cause for a persistently low heart rate (<60 beats/min) is not a primary cardiac cause, but instead the result of **ineffective ventilation**. Therefore if the heart rate remains <60 beats/min after 60 seconds of PPV with corrective MRSOPA steps, the infant should be intubated (if not already done) to achieve effective ventilation. *Once the infant is intubated, if the heart rate remains <60 beats/min, chest compressions should be initiated with continued ventilation, and F<sub>IO</sub><sub>2</sub> should be increased to 100%.* Chest compressions should be initiated over the lower third of the sternum at a rate of 90 per minute. A provider, separate from the person providing ventilation, is needed to administer chest compressions. The *thumb technique* should be used for chest compressions; the tips of both thumbs are used to depress the sternum, with the fingers on each side encircling the chest; this is the preferred method to administer chest compressions, because it has been shown to achieve a higher blood pressure, increase coronary perfusion, and result in less fatigue. In infants, regardless of whether an alternative airway has been secured, chest compressions are always coordinated with PPV. The ratio of compressions to ventilation is 3:1 (90 compressions:30 breaths). Chest compressions should continue uninterrupted for 60 seconds before reassessing heart rate to determine next steps.

Medications are rarely required, but **epinephrine** should be administered when the heart rate is <60 beats/min after 60 seconds of combined ventilation and chest compressions or during asystole. An intravenous route is recommended for epinephrine administration. The umbilical vein can generally be readily cannulated and is the preferred method for administration of medications and volume expanders during neonatal resuscitation (Fig. 123.3). An intraosseous route is another option if umbilical venous access is not obtained. Epinephrine (initial dose recommendation of 0.02 mg/kg *intravenously/intraosseously* followed by a 3-mL flush) is given for asystole or for continued heart rate <60 beats/min after 60 seconds of combined resuscitation. The dose may be repeated every 3–5 minutes. Epinephrine may also be given through the ETT (0.1 mg/kg). If adequate resuscitation continues for 20 minutes without a detectable heart rate, it is reasonable to discuss redirection of care with the team and family and to stop resuscitative efforts.

## RESUSCITATION OF THE PRETERM INFANT

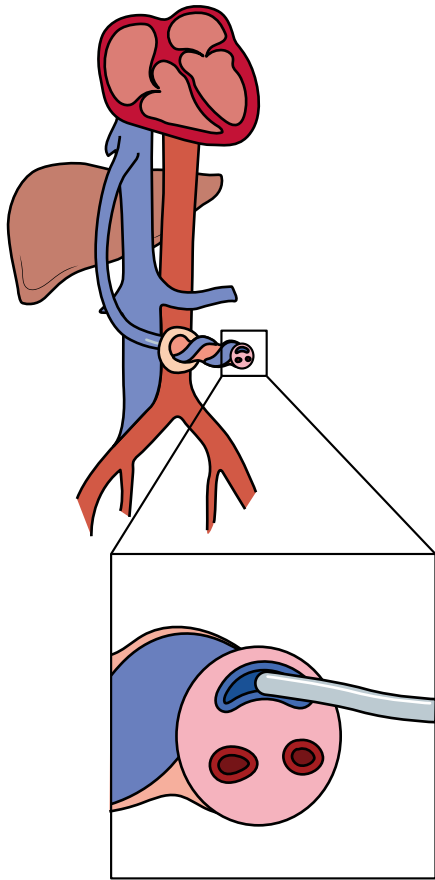
Resuscitation of the preterm infant should follow the same steps as a term infant, with some special considerations. Whereas resuscitation of term infants should start with room air, resuscitation of preterm infants <35 weeks' gestation should be initiated with F<sub>IO</sub><sub>2</sub> between 21% and 30%. Pulse oximetry of the preductal (right) hand should be used to titrate O<sub>2</sub> concentrations for targeted saturations per the NRP algorithm (see Fig. 123.2). Most very low birthweight infants will need more than 30% once titration begins.

Special attention should be paid to *keeping the preterm infant warm in the delivery room*. Quality improvement projects have initiated bundles to improve admission temperatures of preterm infants to the neonatal intensive care unit (NICU) and have included such interventions as higher ambient temperatures in the delivery room, immediate placement of preterm infants into a plastic bag or under plastic wrap rather than drying, and exothermic mattress for resuscitation and transport of the preterm infant.

## SPECIAL CIRCUMSTANCES IN THE DELIVERY ROOM

### Meconium

Meconium staining of the amniotic fluid may be an indication of fetal stress. All infants born through meconium-stained amniotic fluid (regardless if the infant is vigorous or nonvigorous) should receive the same initial steps of neonatal resuscitation as infants without



**Fig. 123.3** Emergently placed umbilical venous catheter suitable for neonatal resuscitation.

meconium-stained fluid and should be assessed as any other infant. Tracheal intubation for meconium aspiration may delay the initiation of effective PPV and ultimately delay effective gas exchange and is not indicated.

### Placental Abruptio

Placental abruptio (abruptio placentae) or uterine rupture at birth can lead to acute fetal blood loss and a hypovolemic, anemic infant at delivery. Infants can present pale and apneic with poor tone, decreased perfusion, and bradycardia. In addition to performing routine neonatal resuscitation, when an infant is suspected to be symptomatic from acute blood loss, an emergency low-lying umbilical venous catheter (UVC) or interosseous needle should be placed and emergent type O Rh-negative blood should be obtained. In acute blood loss, the blood should be administered as quickly as possible in 10 mL/kg aliquots in the delivery room. Adequate communication between obstetrics and pediatrics regarding suspected acute blood loss is crucial to early recognition and treatment of the infant.

### Neonatal Encephalopathy

Infants with neonatal encephalopathy are born with abnormal neurologic function, including level of consciousness, muscle tone, apnea, and reflexes. Although there are many possible etiologies, when symptoms are accompanied by a defined perinatal event such as cord prolapse or placental abruptio, hypoxic-ischemic brain injury is the presumed cause. These infants are often born with impaired respiratory drive. Immediately after initial resuscitation and stabilization, a thorough neurologic examination should be performed to assess if the

infant meets formal criteria for moderate to severe encephalopathy and qualifies for therapeutic hypothermia (see Chapter 122.4).

### Airway Anomalies

Hypoplasia of the mandible with posterior displacement of the tongue may result in upper airway obstruction (Pierre Robin, Stickler, DiGeorge, and other syndromes; see Chapters 118 and 357). Symptoms may sometimes be temporarily relieved by pulling the tongue or mandible forward or placing the infant in the prone position. Other rare anatomic causes of upper airway obstruction at birth include laryngeal atresia or stenosis, teratomas, hygromas, and oral tumors. Critical fetal and then neonatal airway obstruction represents an emergency in the delivery room. High-risk perinatal care has led to the more frequent prenatal diagnosis of these disorders. When diagnosed prenatally, planning can identify the location of delivery and interventions available at delivery. The **ex utero intrapartum treatment (EXIT)** procedure allows time to secure the airway in an infant known prenatally to have critical airway obstruction, before the infant is separated from the placenta (Fig. 123.4; see Chapter 118). Uteroplacental gas exchange is maintained throughout the procedure.

### Pulmonary Disorders

Both congenital and acquired abnormalities can contribute to respiratory failure in the neonate. A **scaphoid abdomen** suggests a diaphragmatic hernia, as does asymmetry in contour or movement of the chest. An infant with a known diaphragmatic hernia should be immediately intubated in the delivery room and an orogastric tube placed to avoid gaseous distention of the bowel from crying or PPV. The infant should then be transferred to a tertiary referral center for surgical evaluation and treatment (see Chapter 124.1).

In infants with a prenatal diagnosis of hydrops, pleural effusions may be present at delivery, preventing adequate lung expansion and gas exchange. Similarly, infants requiring PPV in the delivery room are at risk for **pneumothorax**. Infants with pulmonary hypoplasia or meconium-stained fluid are at increased risk of this complication. Clinically, infants with a pleural effusion or pneumothorax present with respiratory distress and hypoxia, with *diminished* breath sounds on the affected side. Transillumination may be helpful to confirm the diagnosis. Emergency evacuation of a pneumothorax or pleural effusion without radiographic confirmation is indicated in an infant who is unresponsive to resuscitation efforts and has asymmetric breath sounds, bradycardia, and cyanosis. An angi catheter attached to a stopcock and syringe should be used for evacuation. For a pleural effusion, with the infant in the supine position, the angi catheter should be inserted in the fourth or fifth intercostal space in the anterior axillary line and directed posteriorly to evacuate the fluid. For a pneumothorax, an angi catheter can be inserted in the fourth intercostal space in the anterior axillary line or the second intercostal space in the midclavicular line and air evacuated (see Chapter 124).

### Abdominal Wall and Neural Tube Defects

Appropriate management of patients with abdominal wall defects (omphalocele, gastroschisis) in the delivery room prevents excessive fluid loss and minimizes the risk for injury to the exposed viscera. **Gastroschisis** is the more common defect, and typically the intestines are not covered by a membrane. The infant's lower body, including exposed intestines, should be gently placed in a sterile clear plastic bag after delivery. A membrane often covers an **omphalocele**, and care should be taken to prevent its rupture. The omphalocele should either be wrapped in a sterile dressing or the infant's lower body, including the omphalocele, which should be placed within a sterile bag. With both defects, a nasogastric tube should be placed, and the infant transferred to a tertiary referral center for surgical consultation and evaluation for associated anomalies (see Chapter 144).

**Fig. 123.4** Ex utero intrapartum therapy (EXIT) procedure. Baby with teratoma and critical high airway obstruction syndrome (CHAOS). Trachea is displaced to the lateral neck. (Courtesy Dr. Mark Wulkan, Pediatric Surgery, Emory University.)



Similarly, infants born with neural tube defects such as a **myelomeningocele** need special care at delivery to protect the exposed neural tube tissue from trauma and infection; infants should be placed on their side or abdomen for resuscitation. The site of the neural tube defect should be covered with a moist sterile dressing to prevent drying and infection. The infant should then be transferred to a tertiary referral center for surgical evaluation and treatment.

## INJURY DURING DELIVERY

### Central Nervous System

Both extracranial and intracranial birth injuries can be seen in infants after birth. **Extracranial** lesions include cephalohematoma, caput succedaneum, and subgaleal hemorrhage. **Intracranial** birth injuries include subdural hemorrhage, subarachnoid hemorrhage, and epidural hematoma. The most common intracranial injury experienced at birth is **subdural hemorrhage**, with increasing incidence seen with instrument-assisted vaginal deliveries (see Chapters 122.1 and 122.2).

### Fractures

The clavicle is the most frequently fractured bone during labor and delivery. It is particularly vulnerable to injury with difficult delivery of the shoulder in the setting of **shoulder dystocia**, as well as with extended arms in breech deliveries. In the treatment of shoulder dystocia, the obstetrician may intentionally fracture the clavicle so that delivery can proceed. Symptoms of a clavicular fracture include an infant not moving the arm freely on the affected side, palpable crepitus or bony irregularity, and asymmetric or absent Moro reflex on the affected side. The prognosis for this fracture is excellent. Often, no specific treatment is needed, although in some cases the arm and shoulder on the affected side are immobilized for comfort.

Fractures of the long bones are fairly rare. Injuries often present with absent spontaneous movement of the extremity. Associated nerve involvement may also occur. Treatment involves immobilization of the affected extremity with a splint and orthopedic follow-up.

### Brachial Plexus Injuries

Brachial plexus injuries result from stretching and tearing of the brachial plexus (spinal roots C5-T1) at delivery. Although shoulder dystocia is associated with an increased risk of brachial plexus injury, it can also occur during a routine delivery (see Chapter 122.6).

## ONGOING CARE AFTER RESUSCITATION

The “golden hour” after a baby’s birth should emphasize effective neonatal resuscitation, postresuscitation care, prevention of hypothermia (including maternal skin-to-skin contact), immediate breastfeeding if able, prevention of hypoglycemia, and therapeutic hypothermia for cases of moderate to severe neonatal encephalopathy (birth asphyxia). After supportive measures have stabilized the infant’s condition, a specific diagnosis should be established and appropriate continuing treatment instituted.

For infants who receive more intensive resuscitation, a plan for ongoing monitoring and treatment should be established. These infants may experience ongoing acidosis, electrolyte abnormalities, hypo- or hyperglycemia, impaired thermoregulation, and respiratory insufficiency. If infection is suspected, appropriate antibiotics should be started as soon as possible. Severe neonatal encephalopathy may also depress myocardial function and cause cardiogenic shock despite the recovery of heart and respiratory rates. Fluids and dopamine or epinephrine as a continuous infusion should be started after initial resuscitation efforts, to improve cardiac output in an infant with poor peripheral perfusion, weak pulses, hypotension, tachycardia, or poor urine output. Regardless of the severity of neonatal encephalopathy or the response to resuscitation, asphyxiated infants should be monitored closely for signs of multiorgan hypoxic-ischemic tissue injury (see Chapter 122.4).

Visit Elsevier eBooks+ at [eBooks.Health.Elsevier.com](http://eBooks.Health.Elsevier.com) for Bibliography.



## Chapter 124

# Transition to Newborn Pulmonary Respiration

Alicia J. Sprecher, Krishna K. Acharya, and Susan S. Cohen

Successful establishment of adequate lung function at birth depends on airway patency, functional lung development, and maturity of respiratory control. Fetal lung fluid must be removed and replaced with gas. Functional residual capacity (FRC) must be established and maintained to develop a ventilation-perfusion relationship that will provide optimal exchange of oxygen and carbon dioxide between alveoli and blood. Pulmonary blood flow increases dramatically, and the newborn must establish and maintain breathing patterns that are distinct from fetal breathing movements.

## CLEARANCE OF FETAL LUNG FLUID

In utero, lung fluid is actively secreted by epithelial cells into air spaces. This fluid is essential for normal lung development and severe pulmonary hypoplasia results in infants who are unable to maintain appropriate fetal lung fluid. During birth, fluid must be cleared from the airways to allow for gas exchange. During birth, the lung epithelial cells must transition from fluid secreting to fluid absorbing.

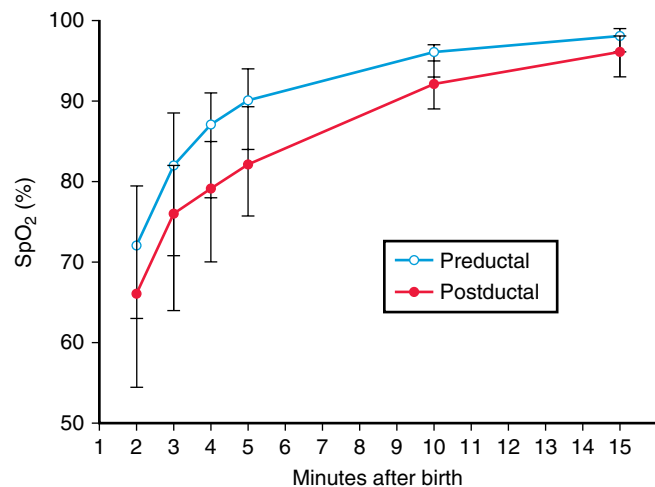
Increased intrathoracic pressure from uterine squeeze and flexion of the infant during delivery likely contribute to movement of fluid out of the infant's nose and mouth at delivery. Additionally, inspiration decreases intrapleural pressure forming a pressure gradient that leads to the movement of fluid toward the smaller airways and ultimately out of the air spaces. As fluid moves out of the airways there is an increased interstitial hydrostatic pressure that contributes to fluid reentering the airway during each expiration until it is eventually cleared from the interstitial tissues over the course of hours.

## ESTABLISHMENT OF A FUNCTIONAL RESIDUAL CAPACITY

FRC represents a balance point between collapsing and distending forces on the lung at end-expiration. Lung recoil comes from a combination of the intrinsic elasticity of the lung tissue and the surface tension within the lung. **Surfactant** plays an important role in reducing surface tension in the newborn. Premature infants and those infants with insufficient surfactant have an increased tendency toward lung collapse as observed in **respiratory distress syndrome** (see Chapter 126). Although the chest wall provides resistance to collapse in older children and adults, the highly compliant chest wall of the newborn and particularly the preterm newborn provides little resistance to lung recoil. Instead, resistance to lung collapse comes from a combination of lung tissue hydrostatic, osmotic, and oncotic pressures in addition to expiratory braking maneuvers. The neonate's expiratory braking maneuvers include adduction of the glottis and engagement of the diaphragm during expiration. Additional activities such as grunting and crying further support establishment of FRC.

## INCREASED PULMONARY BLOOD FLOW

In utero, the placenta is the source of gas exchange, and blood is diverted away from the developing lungs by way of the foramen ovale and ductus arteriosus. Only 10% of the cardiac output passes through the fetal lung circulation. Following birth, blood flow to the pulmonary circulation increases due to decreasing **pulmonary vascular resistance** and closure of in utero shunts. The decline in pulmonary vascular resistance is driven by clearance of fetal lung fluid, oxygen-stimulated



**Fig. 124.1** Pre- and postductal SpO<sub>2</sub> levels during the first 15 minutes after birth (median; IQR). Postductal SpO<sub>2</sub> levels were significantly lower than preductal SpO<sub>2</sub> levels at 3, 4, 5, 10, and 15 minutes. (Modified from Mariani G, Dik PB, Ezquer A, et al. Pre-ductal and post-ductal O<sub>2</sub> saturation in healthy term neonates after birth. *J Pediatr.* 2007;150:418–421.)

smooth muscle relaxation, and release of nitric oxide. Pulmonary vascular resistance decreases 50% over the first 24 hours and continues to decline over the first weeks of life. The foramen ovale is functionally closed after birth due to increased systemic vascular resistance and increased pressures in the left ventricle and left atrium. The ductus arteriosus is slower to close and ductal constriction is driven by a loss of prostaglandins from the placenta, increased oxygen exposure, and decreased local nitric oxide. Increasing pulmonary blood flow and decreasing mixing of oxygenated and deoxygenated blood after birth contributes to changing saturations in the newborn, which rise from 60% immediately after birth to over 90% by approximately 10 minutes of life (Fig. 124.1)

## BREATHING PATTERNS IN NEWBORNS

Fetal breathing movements can be observed before birth. They are generally discontinuous and generate only small tidal volumes. Following delivery, the infant must establish a regular breathing pattern with increased tidal volumes. Triggers driving this change include increased PaCO<sub>2</sub>, activation of chemoreceptors, and a loss of placental prostaglandins, which suppress respiratory drive. Within the fetus, low oxygen tension has an inhibitory effect on breathing. Following birth, hypoxia will eventually become a driver of respiratory effort, but in the immediate postpartum period and in the premature infant, hypoxia may depress respiratory drive.

## DISORDERED TRANSITION TO PULMONARY RESPIRATION

The successful transition from placental derived oxygen delivery to pulmonary respiration requires timely completion of fetal lung fluid clearance, creation of FRC, increased pulmonary blood flow, and establishment of normal breathing patterns. Failures in any of these tasks are associated with respiratory disorders in the neonate. Failure in the timely clearance of fetal lung fluid is associated with **transient tachypnea of the newborn** (see Chapter 128). An inability to establish FRC is a feature of respiratory distress syndrome (see Chapter 126). A failure in decreasing pulmonary vascular resistance causes persistent pulmonary hypertension of the newborn (see Chapter 130) and in infants without appropriate respiratory patterns, **apnea** (see Chapter 125) is a presenting concern.

Visit Elsevier eBooks+ at [eBooks.Health.Elsevier.com](http://eBooks.Health.Elsevier.com) for Bibliography.



## Chapter 125

## Apnea

Alicia J. Sprecher, Krishna K. Acharya, and Susan S. Cohen

Apnea is a prolonged cessation of respiration and must be distinguished from *periodic breathing* because apnea is often associated with serious illness. Although there is no universal agreement, apnea is usually defined as cessation of breathing for a period of  $\geq 20$  seconds, or a period  $< 20$  seconds that is associated with a change in tone, pallor, cyanosis, or bradycardia ( $< 80$ - $100$  beats/min). Based on the absence of respiratory effort and/or airflow, apnea can be obstructive, central, or mixed. **Obstructive apnea** is characterized by absence of airflow but persistent chest wall motion. Pharyngeal collapse may follow the negative airway pressures generated during inspiration, or it may result from incoordination of the tongue and other upper airway muscles involved in maintaining airway patency. **Central apnea** is caused by decreased central nervous system (CNS) stimuli to respiratory muscles and results in both airflow and chest wall motion being absent. Gestational age (GA) is the most important determinant of respiratory control, with the frequency of central apnea being inversely related to GA. The immaturity of the brainstem respiratory centers is manifest by an attenuated response to  $\text{CO}_2$  and a paradoxical response to hypoxia that results in central apnea rather than hyperventilation. Mixed apnea is most often observed in apnea of prematurity with obstructive apnea preceding central apnea. Short episodes of apnea are usually central, whereas prolonged ones are often mixed.

### OBSTRUCTIVE APNEA

Obstructive apnea derives from interrupted upper airway flow. Causes of obstructive apnea can largely be divided into anatomic abnormalities and neuromuscular abnormalities.

Craniofacial disorders are a common cause of obstructive apnea of the newborn. Micrognathia, retrognathia, or Pierre Robin sequence all cause upper airway obstruction due to backward dislodgement of the tongue into the airway. This obstruction may be improved by prone positioning of the neonate. Although cleft lip and palate are not always associated with obstructive apnea, infants with these conditions are at risk for apnea related to abnormal narrowing of the upper airway structures. Additional anatomic abnormalities that can contribute to obstructive apnea include narrowing or occlusion of the nasal passages (i.e., choanal atresia) or narrowing of the airways (i.e., laryngomalacia). Many causes of anatomic obstruction are syndromic and include skeletal dysplasia, VACTERL association, Joubert syndrome, CHARGE syndrome, DiGeorge syndrome, and Stickler syndrome.

Neuromuscular weakness can contribute to **obstructive apnea** via airway collapse in the setting of low tone. Additionally, respiratory muscle weakness may impede the infant from overcoming normal airway resistance.

### CENTRAL APNEA

Central apnea has a wide range of etiologies and should always lead to a diagnostic evaluation as it can often be an early warning sign of clinical decompensation. [Table 125.1](#) provides a framework for the disease processes that can contribute to apnea. Infection or metabolic derangements should always be considered as an etiology for infants with new or worsening apnea. Abnormal CNS control of breathing can be related to prematurity, but other CNS abnormalities including injury or malformation can contribute to central apnea. **Congenital central hypoventilation syndrome** is a rare permanent genetic cause of central apnea that begins in the neonatal period (see Chapter 468.2).

### APNEA OF PREMATURETY

Apnea in preterm infants is defined as cessation of breathing for  $\geq 20$  seconds or for any duration if accompanied by cyanosis and bradycardia ( $< 80$ - $100$  beats/min). The incidence of associated bradycardia increases with the length of the preceding apnea and correlates with the severity of hypoxia. Short apnea episodes (10 seconds) are rarely associated with bradycardia, whereas longer episodes ( $> 20$  seconds) have a higher incidence of bradycardia. Bradycardia follows the apnea by 1-2 seconds in  $> 95\%$  of cases and is most often sinus. Vagal responses and rarely heart block are causes of bradycardia *without* apnea. Short, self-resolving oxygen desaturation episodes noted with continuous monitoring are normal in neonates, and treatment is not necessary.

Apnea of prematurity results from immature respiratory control, most frequently occurs in infants  $< 34$  weeks of GA, and occurs in the absence of identifiable predisposing diseases. The incidence of apnea of prematurity varies inversely with GA. Apnea of prematurity is almost universal in infants born at  $< 28$  weeks of GA, and the incidence rapidly decreases from 85% of infants  $< 30$  weeks of GA to 20% of infants  $< 34$  weeks of GA. The onset of apnea of prematurity can be during the initial days to weeks of age but is often delayed if there is respiratory distress syndrome (RDS) or other causes of respiratory distress. In premature infants without respiratory disease, apneic episodes can occur throughout the first 7 postnatal days with equal frequency. In infants with apnea of prematurity, the events decline significantly by 34 weeks corrected GA. Resolution may be delayed in infants with **bronchopulmonary dysplasia** (see [Chapter 127](#)) because of poorer reserves and an increased incidence of subglottic stenosis, laryngomalacia, or tracheomalacia, which can contribute to **obstructive apneas**.

**Table 125.1** Potential Causes of Neonatal Apnea and Bradycardia

Central nervous system	Intraventricular hemorrhage, drugs, seizures, hypoxic injury, herniation, neuromuscular disorders, Leigh syndrome, brainstem infarction or anomalies (e.g., olivopontocerebellar atrophy), transient following general anesthesia, congenital central hypoventilation syndrome
Respiratory	Pneumonia, obstructive airway lesions, upper airway collapse, atelectasis, extreme prematurity, laryngeal reflex, phrenic nerve paralysis, pneumothorax, paradoxical response to hypoxia
Infectious	Sepsis, meningitis (bacterial, fungal, viral), respiratory syncytial virus, pertussis
Gastrointestinal	Oral feeding, bowel movement, necrotizing enterocolitis, intestinal perforation
Metabolic	↓ Glucose, ↓ calcium, ↓ sodium, ↑ ammonia, ↑ organic acids, ↑ ambient temperature, hypothermia
Cardiovascular	Hypotension, hypertension, heart failure, anemia, hypovolemia, vagal tone
Other	Immaturity of respiratory center (prematurity); sleep state; sudden unexpected postnatal collapse

Preterm infants born at <35 weeks of GA are at risk for apnea of prematurity and therefore should receive cardiorespiratory monitoring. Apnea that occurs in the absence of other clinical signs of illness in the first 2 weeks in a preterm infant is likely apnea of prematurity; therefore additional evaluation for other etiologies is often unwarranted. However, *the onset of apnea in a previously well preterm neonate after the second week of life is a critical event that may be associated with serious underlying pathology*. Prompt investigation for sepsis/meningitis, medication side effects, metabolic derangements, structural CNS anomalies, intracranial hemorrhage, or seizures is warranted.

## TREATMENT

Observation is the most common treatment strategy for infants with **obstructive apnea**, and temporizing measures including prone positioning can help to minimize symptoms until sufficient patient growth alleviates the obstruction. The use of supplemental oxygen, **nasal continuous positive airway pressure (nCPAP)**, or bilevel positive airway pressure may facilitate stenting of airways and limit obstructive events. Surgical interventions depend on the underlying cause and include supraglottoplasty, palatoplasty, tongue-lip adhesion, tongue base reduction, nasal stent, mandibular distraction, and in severe cases, tracheostomy to bypass areas of obstruction.

For apnea of prematurity, gentle tactile stimulation, or provision of flow and/or supplemental oxygen by nasal cannula, is often adequate therapy for mild and intermittent episodes. **nCPAP** (3–5 cm H<sub>2</sub>O) and **high-flow nasal cannula (HFNC)**; 1–4 L/min) are appropriate therapies for **mixed or obstructive apnea**. The efficacy of both nCPAP and HFNC is related to their ability to splint the upper airway to prevent airway obstruction. Additionally, the maintenance of a higher functional residual capacity can decrease the duration of **central apnea**. Both are used widely, but nCPAP may be preferred in extremely preterm infants because of its proven efficacy and safety.

Recurrent or persistent apnea of prematurity is effectively treated with methylxanthines. **Methylxanthines** increase central respiratory drive by lowering the threshold of response to hypercapnia as well as enhancing contractility of the diaphragm. **Caffeine** and **theophylline** are similarly effective methylxanthines, but caffeine is preferred because of its longer half-life and lower potential for side effects (less tachycardia and feeding intolerance). In preterm infants, caffeine reduces the incidence and severity of apnea of prematurity, facilitates successful extubation from mechanical ventilation, reduces the rate of bronchopulmonary dysplasia (see [Chapter 127](#)), and improves neurodevelopmental outcomes. Caffeine therapy can be safely administered orally (PO) or intravenously (IV). Generally, infants are given an initial loading dose of 20 mg/kg of caffeine citrate followed 24 hours later by once-daily maintenance doses of 5–10 mg/kg. Because the therapeutic window is wide and serious side effects associated with caffeine are rare, monitoring of serum drug concentrations is usually unnecessary. Monitoring is primarily through observation of vital signs (tachycardia) and clinical response. Higher doses of caffeine may be more effective without serious adverse events, but additional studies are needed to ensure safety. Studies suggest that early initiation of caffeine, in the first 3 days of life, in extremely preterm infants improves outcomes. However, it is reasonable to delay caffeine therapy until apnea occurs in older infants. Caffeine therapy is usually continued until an infant is free of clinically significant apnea or bradycardia for 5–7 days without positive pressure respiratory support, or at 34 weeks' postmenstrual age (PMA).

In an infant with significant anemia, transfusion of packed red blood cells (RBCs) increases blood O<sub>2</sub>-carrying capacity, improves tissue oxygenation, and may be associated with a short-term reduction in apnea. However, a long-term benefit with regard to apnea appears unlikely.

**Gastroesophageal reflux (GER)** is common in neonates, but despite being associated with apnea anecdotally, data do not support a causal relationship between GER and apneic events. In preterm infants, medications that inhibit gastric acid production have potentially harmful side effects (increased incidence of sepsis, necrotizing enterocolitis,

death) and may increase the incidence of apnea and bradycardia. Therefore the routine use of medications that inhibit gastric acid synthesis or promote gastrointestinal motility to reduce the frequency of apnea in preterm infants should be discouraged. Antireflux treatment does correlate with decreased rates of obstructive apnea; however, this does not seem to be a causal relationship. Feeding strategies including more frequent or slower/longer feedings may be considered. Thickening feedings with xanthan gum is linked to late-onset necrotizing enterocolitis and should not be attempted. Other thickeners (i.e., rice) are not nutritionally appropriate for the preterm infant. The use of elemental or extensively hydrolyzed formulas can decrease transit time and may decrease symptoms of GER and can be considered in age-appropriate populations.

## PROGNOSIS

In 92% of infants by 37 weeks' PMA and in 98% of infants by 40 weeks' PMA, apnea of prematurity resolves spontaneously. However, infants born well before 28 weeks' GA may experience apnea and bradycardic events until 44 weeks' PMA. Beyond 44 weeks' PMA, extreme events (apnea >30 seconds and/or bradycardia <60 beats/min for >10 seconds) are very rare. The period that an infant should be observed to ensure resolution of apnea and bradycardia is not defined and among institutions is highly variable. However, many experts would recommend that an infant demonstrate an event-free period of 5–7 days before discharge. Although the nature and severity of events should dictate the length of observation, sufficiently large retrospective cohort studies suggest that a 1–3-day (infants born at ≥30 weeks' GA), 9–10-day (27–28 weeks' GA), or 13–14-day (<26 weeks' GA) event-free period predicts resolution of apnea in up to 95% of infants successfully. Brief, isolated bradycardic episodes associated with oral feeding are common in preterm infants and are generally not considered significant during the event-free period.

Despite its high frequency in preterm infants, the harm associated with apnea of prematurity is unknown. However, apnea of prematurity does not appear to alter an infant's prognosis unless it is severe, recurrent, and refractory to therapy. Prompt, effective therapy and careful monitoring are vital to avoid prolonged, severe hypoxia, which may increase the risk of death and neurodevelopmental impairment.

## Sudden Infant Death Syndrome and Home Monitoring

Although preterm infants are at higher risk for sudden infant death syndrome (SIDS), apnea of prematurity *does not* further increase that risk. The epidemiologic evidence that placing babies supine during sleep reduces the rate of SIDS deaths by >50% suggests that positioning, and not prematurity, primarily influences the incidence of SIDS. Supine positioning on a firm sleep surface separate from the parents' bed, promotion of breastfeeding, and pacifier use during sleep reduce the incidence of SIDS. Avoidance of cigarette smoke exposure and no parental use of alcohol or illicit drugs during pregnancy and after birth are also important in the prevention of SIDS.

**In-home monitoring** is an area that has received significant interest in prevention of SIDS. In a large cohort study, episodes of apnea and bradycardia were not uncommon (severe events detected in 10% of infants monitored and 2.3% of healthy term infants). Preterm infants remained at risk for apnea until approximately 43 weeks' PMA; however, most SIDS deaths occurred after apnea has resolved occurring at an average of 45.8 weeks' PMA for premature infants and 52.3 weeks' PMA for term infants. There was no evidence that home monitoring impacted the incidence of SIDS. The role for home monitors is likely limited to premature infants with prolonged or extreme episodes of apnea (and should be discontinued after 44 weeks' PMA in this population), infants with specific risk factors for obstructive apnea, or requiring supplemental oxygen or mechanical ventilation.

Visit Elsevier eBooks+ at [eBooks.Health.Elsevier.com](http://eBooks.Health.Elsevier.com) for Bibliography.

## Chapter 126

## Respiratory Distress Syndrome (Hyaline Membrane Disease)

Alicia J. Sprecher, Krishna K. Acharya, and Susan S. Cohen

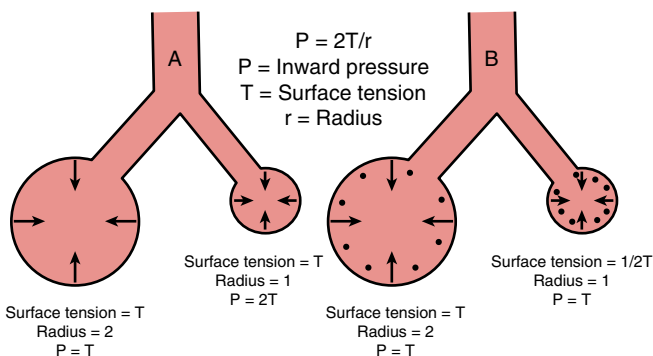
## INCIDENCE

Respiratory distress syndrome (RDS) occurs primarily in premature infants; its incidence is inversely related to gestational age (GA) and birthweight. It occurs in 60–80% of infants <28 weeks' GA, in 15–30% of those between 32 and 36 weeks' GA, and rarely in those >37 weeks' GA. The risk for development of RDS increases with maternal diabetes, multiple births, cesarean delivery, precipitous delivery, asphyxia, cold stress, and a maternal history of previously affected infants. The risk of RDS is reduced in pregnancies with chronic or pregnancy-associated hypertension, maternal opiate use, prolonged rupture of membranes, and antenatal corticosteroid prophylaxis.

## ETIOLOGY AND PATHOPHYSIOLOGY

**Surfactant** deficiency (decreased production and secretion) is the primary cause of RDS. In the absence of pulmonary surfactant, significantly increased alveolar **surface tension** leads to atelectasis, and the ability to attain an adequate **functional residual capacity (FRC)** is impaired. Additionally, insufficient surfactant contributes to heterogeneous lung expansion with atelectatic areas remaining unventilated and progressive overdistension of ventilated regions according to Laplace's law (Fig. 126.1).

Although surfactant is present in high concentrations in fetal lung by 20 weeks of gestation, it does not reach the surface of the lungs until later. It appears in amniotic fluid between 28 and 32 weeks. Mature levels of pulmonary surfactant are present usually after 35 weeks of gestation. The major constituents of surfactant are dipalmitoyl phosphatidylcholine (lecithin), phosphatidylglycerol, apoproteins (surfactant proteins SP-A, SP-B, SP-C, and SP-D), and cholesterol (Fig. 126.2). With advancing GA, increasing amounts of phospholipids



**Fig. 126.1** Laplace's law as it applies to alveolar distension. Laplace's law states that the collapsing pressure in the alveolus is directly related to **surface tension** and inversely related to alveolar radius. In **A** the collapsing pressure is higher in the smaller alveoli thus the smaller alveolus further collapses, and larger alveolus distends leading to asymmetry in ventilation. In **B** with **surfactant** present, the particles become more densely spaced as the alveolus collapses, which decreases **surface tension**, and the resulting collapsing pressure is equalized between the two alveoli.

are synthesized and stored in type II alveolar cells (Fig. 126.3). These surface-active agents are released into the alveoli, where they reduce surface tension and help maintain alveolar stability at end-expiration. Synthesis of surfactant depends in part on normal pH, temperature, and perfusion. Asphyxia, hypoxemia, and pulmonary ischemia, particularly in association with hypovolemia, hypotension, and cold stress, may suppress surfactant synthesis. The epithelial lining of the lungs may also be injured by high  $O_2$  concentrations and mechanical ventilation, thereby further reducing secretion of surfactant.

Atelectasis results in perfused but not ventilated alveoli, causing hypoxia. Decreased lung compliance, small tidal volumes, increased physiologic dead space, and insufficient alveolar ventilation eventually result in hypercapnia. The combination of hypercapnia, hypoxia, and acidosis produces pulmonary arterial vasoconstriction with increased right-to-left shunting through the foramen ovale and ductus arteriosus and within the lung itself. Progressive injury to epithelial and endothelial cells results from atelectasis (atelectrauma), volutrauma, ischemic injury, and oxygen toxicity. This injury leads to effusion of proteinaceous material and cellular debris into the alveolar spaces (forming the classic hyaline membranes) further impairing oxygenation. RDS represents a vicious cycle of diminished surfactant production, worsening atelectasis, lung injury, and severe hypoxia (Fig. 126.4).

## CLINICAL MANIFESTATIONS

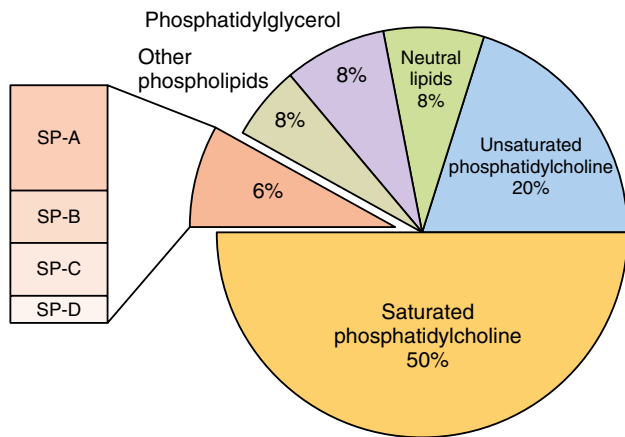
Signs of RDS usually appear within minutes of birth, although they may not be recognized for several hours in larger premature infants, until rapid, shallow respirations and cyanosis become more obvious. A later onset of tachypnea should suggest other conditions. Some patients require resuscitation at birth because of intrapartum asphyxia or initial severe respiratory distress (especially with birthweight <1,000 g). Characteristically, tachypnea, prominent (often audible) expiratory grunting, intercostal and subcostal retractions, nasal flaring, and cyanosis are noted. Breath sounds may be normal or diminished with a harsh tubular quality, and on deep inspiration, fine crackles may be heard. *The natural course of untreated RDS is characterized by progressive worsening of cyanosis and dyspnea. If the condition is inadequately treated, blood pressure may fall; cyanosis and pallor increase, and grunting decreases or disappears, as the condition worsens. Apnea and irregular respirations are ominous signs requiring immediate intervention.* Untreated patients develop a mixed respiratory-metabolic acidosis with hypoxia and the potential to progress to respiratory failure with multisystem organ dysfunction due to inadequate oxygen delivery. In most cases, the signs reach a peak within 3 days, after which improvement is gradual. Improvement is often heralded by spontaneous diuresis and improved blood gas values at lower inspired  $O_2$  levels and/or lower ventilator support. Death can result from severe impairment of gas exchange, pulmonary air leaks (pulmonary interstitial emphysema, pneumothorax; see Chapter 132), pulmonary hemorrhage (see Chapter 133), or intraventricular hemorrhage (IVH).

## DIAGNOSIS

The clinical course, chest x-ray findings, and blood gas values help establish the clinical diagnosis. On chest radiograph, the lungs may have a characteristic but not pathognomonic appearance that includes low lung volumes, a diffuse, fine reticular granularity of the parenchyma (ground-glass appearance), and air bronchograms (Fig. 126.5). The initial x-ray appearance is occasionally normal, with the typical pattern developing during the first day. Considerable variation in radiographic findings may be seen, especially in infants who have already received treatment with surfactant replacement and/or positive pressure respiratory support; this variation often results in poor correlation between radiographic findings and the clinical course. Blood gas findings are characterized initially by hypoxemia and later by progressive hypoxemia, hypercapnia, and variable metabolic acidosis.

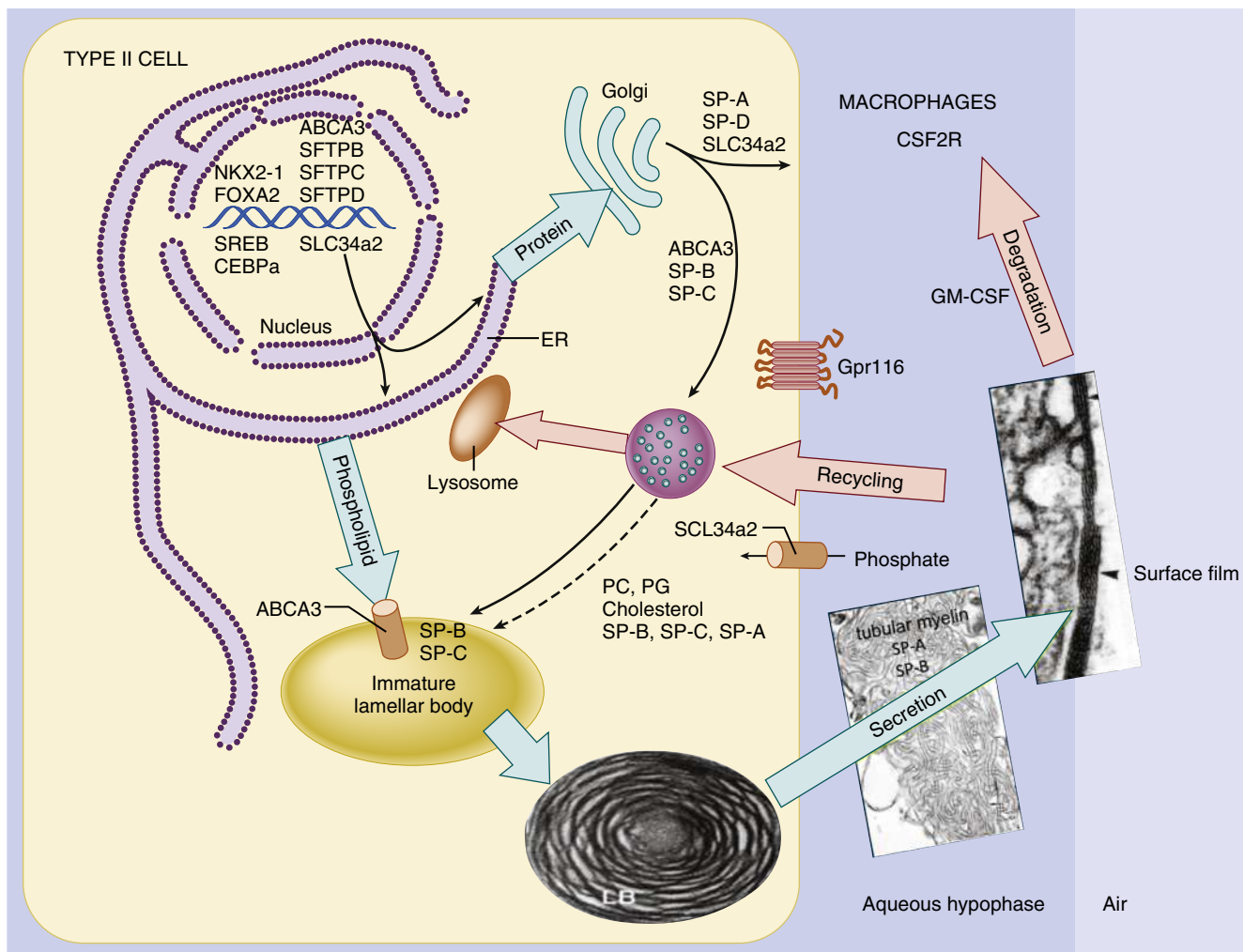
In the differential diagnosis, early-onset sepsis may be indistinguishable from RDS. In neonates with pneumonia, the chest radiograph may be identical to that for RDS. Clinical factors such as maternal group B streptococcal colonization with inadequate intrapartum antibiotic prophylaxis, maternal fever (>38.5°C) or chorioamnionitis, or prolonged





**Fig. 126.2** Composition of surfactant. SP-A, Surfactant-associated protein A; SP-B, surfactant-associated protein B; SP-C, surfactant-associated protein C; SP-D, surfactant-associated protein D. (From Jobe AH, Ikegami M. *Biology of surfactant*. Clin Perinatol. 2001;28:655–669.)

rupture of membranes (>18 hours) are associated with an increased risk of early-onset sepsis. Although complete blood counts are neither sensitive nor specific in the diagnosis of early-onset sepsis, the presence of marked neutropenia has been associated with increased risk. **Transient tachypnea of the newborn (TTN)** (see Chapter 128) is a common consideration that may be distinguished from RDS by its shorter and milder clinical course and is characterized by low or no need for O<sub>2</sub> supplementation. Cyanotic congenital heart disease (in particular, total anomalous pulmonary venous return) can also mimic RDS both clinically and radiographically. Echocardiography with color-flow imaging can be performed in infants who show no response to surfactant replacement, to rule out cyanotic congenital heart disease as well as ascertain patency of the ductus arteriosus and assess pulmonary vascular resistance (PVR). Persistent pulmonary hypertension, aspiration (meconium, amniotic fluid) syndromes, spontaneous pneumothorax, pleural effusions, and congenital anomalies (pulmonary congenital airway malformations, pulmonary lymphangiectasia, diaphragmatic hernia, lobar emphysema) must be considered in patients with an atypical clinical course but can generally be differentiated from RDS through radiographic and other evaluations (Fig. 126.6).



**Fig. 126.3** Biosynthesis of surfactant involves distinct pathways for surfactant proteins and lipids. SP-B and SP-C are trafficked from the endoplasmic reticulum (ER) to lamellar bodies via the Golgi complex and multivesicular body (MVB); in contrast, surfactant phospholipids are likely directly transported from the ER to specific lipid importers (ABCA3) in the lamellar body-limiting membrane. Surfactant proteins and lipids are assembled into bilayer membranes that are secreted into the alveolar airspace, where they form a surface film at the air-liquid interface. Cyclical expansion and compression of the bioactive film results in the incorporation and loss of lipids and proteins from the multilayered surface film. Surfactant components removed from the film are degraded in alveolar macrophages or are taken up by type II epithelial cells for recycling or degradation in the lysosome. The MVB plays a key part in the integration of pathways for surfactant synthesis, recycling, and degradation. NKX2-1, FOXA2, SREBP, and CEBP $\alpha$  are transcription factors regulating surfactant protein and lipid synthesis. SLC34a2 is a phosphate transporter. Gpr116 is a membrane receptor regulating surfactant secretion. ABCA3, ATP-binding cassette transporter A3; GM-CSF, granulocyte-macrophage colony-stimulating factor; PC, phosphatidylcholine; PG, phosphatidylglycerol; SP, surfactant proteins. (From Polin RA, Abman SH, Rowitch DH, Benits WE, eds. *Fetal and Neonatal Physiology*, 6th ed. Philadelphia: Elsevier; 2022: Fig. 75.3.)

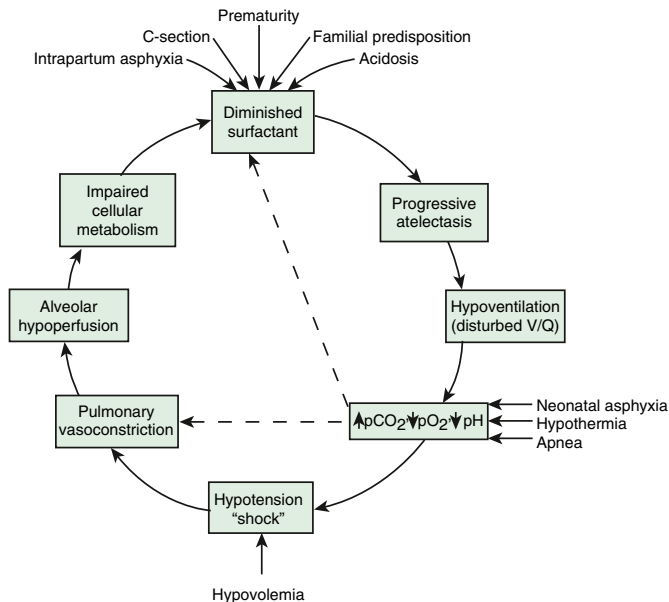


Although rare, genetic disorders may contribute to respiratory distress. Abnormalities in **surfactant protein B and C** genes as well as a gene responsible for transporting surfactant across membranes, ABC transporter 3 (*ABCA3*), are associated with severe and often lethal familial respiratory disease. **Congenital alveolar proteinosis** (congenital surfactant protein B deficiency) is a rare familial disease that manifests as severe and lethal RDS in predominantly term and near-term infants (see Chapter 434). In atypical cases of RDS, a lung profile (lecithin: sphingomyelin ratio and phosphatidylglycerol determination) performed on a tracheal aspirate can be helpful in establishing a diagnosis of surfactant deficiency. Other familial causes of neonatal

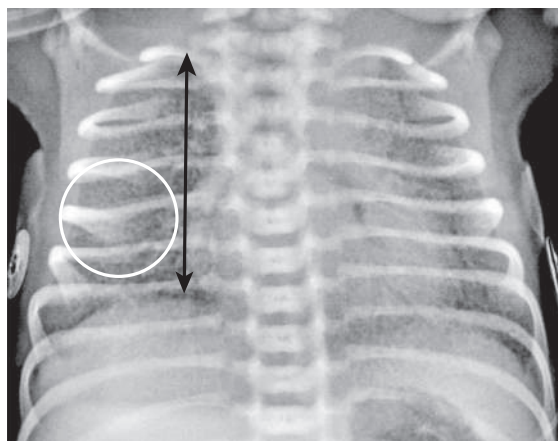
respiratory distress (not RDS) include mucopolysaccharidosis, acinar dysplasia, pulmonary lymphangiectasia, and alveolocapillary dysplasia. Evaluation for these disorders should be pursued with the assistance of pediatric pulmonologists and geneticists. Evaluation may include lung imaging, fluid sampling, tissue biopsy, and genetic testing.

**PREVENTION**

Avoidance of unnecessary or poorly timed early (<39 weeks' GA) cesarean delivery or induction of labor and appropriate management of high-risk pregnancy and labor (including administration of antenatal corticosteroids) are important preventive strategies. Strategies to prevent preterm birth include antenatal use of progesterone; measurement of cervical length and cerclage placement as indicated; and use of antibiotics, tocolytics, and magnesium for threatened preterm labor. In cases where premature delivery cannot be avoided, the transfer of the mother to an institution with appropriate neonatal care capabilities can improve early management of RDS. Antenatal and intrapartum fetal

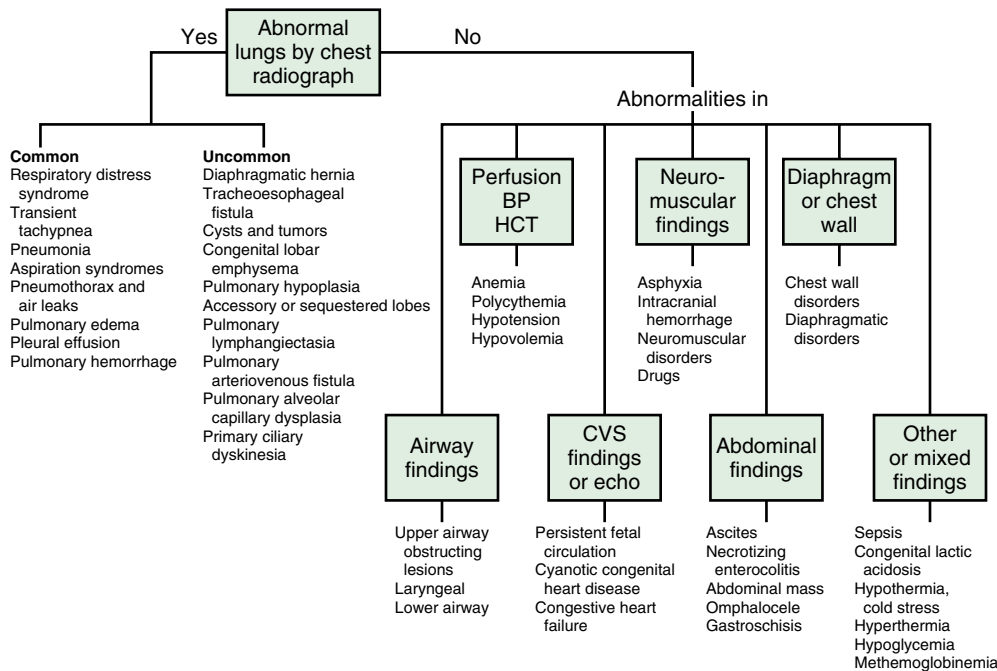


**Fig. 126.4** Contributing factors in the pathogenesis of hyaline membrane disease. The potential “vicious circle” perpetuates hypoxia and pulmonary insufficiency. V/Q, Ventilation-perfusion ratio. (From Farrell P, Zachman R. *Pulmonary surfactant and the respiratory distress syndrome*. In Quilligan EJ, Kretchmer N, eds. *Fetal and Maternal Medicine*. New York: Wiley; 1980.)



**Fig. 126.5** Respiratory distress syndrome (RDS) of the newborn (hyaline membrane disease [HMD]). There is a diffuse ground-glass or finely granular appearance (circle) in a bilateral and symmetric distribution. Hypoaeration is seen in nonventilated lungs (double arrow). (From Herring W. *Learning Radiology: recognizing the Basics*, 4th ed. Philadelphia: Elsevier; 2020: Fig. 28.2.)

**Neonate with acute respiratory distress**



**Fig. 126.6** Neonate with acute respiratory distress. BP, Blood pressure; CVS, chorionic villus sampling; HCT, hematopoietic cell transplant. (From Battista MA, Carlo WA. *Differential diagnosis of acute respiratory distress in the neonate*. In Frantz ID, ed. *Tufts University of School of Medicine and Floating Hospital for Children Reports on Neonatal Respiratory Diseases*. Vol. 2. Issue 3. Newtown, PA: Associates in Medical Marketing Co.; 1992.)

monitoring may decrease the risk of fetal asphyxia; asphyxia is associated with an increased incidence and severity of RDS.

Administration of **antenatal corticosteroids** to women before 37 weeks of gestation significantly reduces the incidence and mortality of RDS as well as overall neonatal mortality. Antenatal corticosteroids also reduce (1) overall mortality, (2) admission to the neonatal intensive care unit (NICU) and need for/duration of ventilatory support, and (3) incidence of severe IVH, necrotizing enterocolitis (NEC), and neurodevelopmental impairment. Betamethasone and dexamethasone have both been used antenatally. The American College of Obstetricians and Gynecologists (ACOG) recommends antenatal corticosteroids for all women presenting between 24- and 34-weeks' gestation in preterm labor. Antenatal corticosteroid use before 24 weeks' gestation for preterm labor or rupture of membranes should be driven by the family's preferences for intervention. ACOG recommends a single course of antenatal corticosteroid for mothers presenting between 34- and 36-weeks' gestation in preterm labor if no previous steroids have been given during the pregnancy. One repeat course of antenatal corticosteroids may be considered for mothers at risk of preterm delivery more than 14 days from the prior course of steroids and with a GA less than 34 weeks. Additional repeat courses of antenatal corticosteroids are not recommended due to impact on birthweight, cerebral myelination, and lung growth. Antenatal corticosteroids do not increase the risk of maternal death, chorioamnionitis, or puerperal sepsis.

## TREATMENT

The basic defect requiring treatment in RDS is inadequate pulmonary  $O_2$ - $CO_2$  exchange. Basic supportive care (thermoregulatory, circulatory, fluid, electrolyte, and respiratory) is essential while FRC is established and maintained. Because most cases of RDS are self-limited, the goal of treatment is to minimize abnormal physiologic variations and superimposed iatrogenic problems. Treatment of infants with RDS is best carried out in the NICU.

Continuous monitoring of vital signs, review of chest radiography, and monitoring of blood gas values guides therapy in RDS. Oxygenation ( $SO_2$ ) should be assessed by continuous pulse oximetry. Capillary blood samples are of limited value for determining  $PO_2$  but may be useful for  $Pco_2$  and pH monitoring. Arterial blood gas samples provide the most accurate assessment of oxygenation. Monitoring of blood gas parameters and mean arterial blood pressure through an umbilical or peripheral arterial catheter is useful in managing the shocklike state that may occur during the initial hours in premature infants who have been asphyxiated or have severe RDS. Because of the difficulty in distinguishing group B streptococcal or other bacterial infections from RDS, empirical antibiotic therapy should be indicated until the results of blood cultures are available. Penicillin or ampicillin with an aminoglycoside is suggested, although the choice of antibiotics should be based on the recent pattern of bacterial sensitivity in the hospital where the infant is being treated (see [Chapter 129](#)).

### Nasal Continuous Positive Airway Pressure

Warm, humidified oxygen should be provided at a concentration sufficient to keep  $Pao_2$  between 50 and 70 mm Hg (91–95%  $Sao_2$ ) to maintain normal tissue oxygenation while minimizing the risk of  $O_2$  toxicity. If there is significant respiratory distress (severe retractions and expiratory grunting) or if  $Sao_2$  cannot be kept >90% at an  $FIO_2$  of  $\geq 40$ , applying nasal continuous positive airway pressure (nCPAP) at 5–8 cm  $H_2O$  is indicated and usually produces a rapid improvement in oxygenation. Nasal CPAP reduces collapse of surfactant-deficient alveoli and improves both FRC and ventilation-perfusion matching. Early use of nCPAP for stabilization of at-risk preterm infants beginning early (in the delivery room) reduces the need for mechanical ventilation. Alternatives to nCPAP include noninvasive positive pressure ventilation (NIPPV) and high-flow nasal cannula (HFNC). NIPPV is generally unsynchronized, but intermittent higher pressures do appear to improve oxygenation and ventilation over several hours. Additionally, NIPPV may limit apnea as a cause of respiratory failure. HFNC used heated and humidified oxygen flow generally upward of 2 L/min to provide distending pressures to the airways. The distending pressure

is variable, which may contribute to HFNC failure. The amount of nCPAP required usually decreases after approximately 72 hours of age, and most infants can be weaned from nCPAP shortly thereafter.

### Surfactant Replacement Therapy

Surfactant deficiency is the primary pathophysiology of RDS. Immediate effects of surfactant replacement therapy include improved alveolar-arterial oxygen gradients, reduced ventilatory support, increased pulmonary compliance, and improved chest radiograph appearance. In the past, *intratracheal* surfactant replacement for symptomatic premature infants immediately after birth (prophylactic) or during the first few hours of life (*early rescue*) showed reduced air leak and mortality from RDS. However, substantial evidence supports the feasibility and efficacy of **nCPAP** as the *primary* means of respiratory support for preterm infants with RDS with addition of surfactant based on clinical indication. Nasal CPAP started at birth is as effective as prophylactic or early surfactant and is associated with a reduction in bronchopulmonary dysplasia (BPD). *Nasal CPAP is therefore the approach of choice for the delivery room management of a preterm neonate at risk for RDS.*

In neonates with RDS who fail nCPAP and require intubation and mechanical ventilation, treatment with endotracheal surfactant should be initiated immediately to avoid lung injury. *Assisted ventilation and surfactant are indicated for infants with RDS who cannot keep oxygen saturation >90% while breathing 40% oxygen and receiving nCPAP.* Delays in delivering surfactant once clinical criteria are met is associated with poorer outcomes including increased mortality, increased incidence of **pulmonary air leak**, and increased risk for **BPD**. Repeated dosing is given every 6–12 hours for a total of two to four doses, depending on the preparation. Exogenous surfactant should be given by a physician who is qualified in neonatal resuscitation and respiratory management. Additional required on-site staff support includes nurses and respiratory therapists experienced in the ventilatory management of preterm infants. Bolus delivery of surfactant is generally associated with better distribution throughout the lungs and faster improvement. Lung recruitment strategies include modest increase in tidal volume or positive end-expiratory pressure (PEEP) before surfactant administration, which may improve distribution. Appropriate monitoring equipment (radiology, blood gas laboratory, pulse oximetry) must also be available. Complications of surfactant replacement therapy include transient hypoxia, hypercapnia, bradycardia and hypotension, blockage of endotracheal tube (ETT), and pulmonary hemorrhage.

A number of surfactant preparations are available, including synthetic surfactants and natural surfactants derived from animal sources. There do not appear to be significant, consistent benefits to one preparation over another. Infants requiring ventilator support after 1 week of age may experience transient episodes of surfactant dysfunction temporally associated with episodes of infection and respiratory deterioration. Surfactant treatment may be beneficial in these infants.

Recognizing the benefits of surfactant replacement therapy, in addition to the potential protective effects of prophylactic nCPAP, some experts recommend intubation for prophylactic or early rescue surfactant replacement therapy, followed by extubation back to nCPAP immediately once the infant is stable (usually within minutes). This method is commonly referred to as *intubate, surfactant, and extubate (INSURE)*. A variation of the INSURE method has evolved known as *MIST (minimally invasive surfactant therapy)* or *LISA (less invasive surfactant administration)*, in which a small feeding tube, rather than an ETT, is used to deliver intratracheal surfactant to a spontaneously breathing infant on nCPAP. LISA and/or MIST are increasingly being utilized as the preferred method for delivering surfactant in infants who are not anticipated to require prolonged invasive ventilation. The combination of LISA, antenatal corticosteroids, nCPAP, and limitation of positive pressure ventilation in the delivery room was associated with decreased rates of BPD when compared to INSURE. Other methods of surfactant delivery are under investigation including the use of laryngeal mask airway and the use of nebulized surfactant to avoid airway manipulation altogether. In two studies of aerosolized surfactant, the need for intubation was reduced by ~50%.

## Mechanical Ventilation

Infants with respiratory failure or persistent apnea require assisted mechanical ventilation. Strict definitions for respiratory failure in extremely preterm infants with RDS are not agreed on universally, but reasonable measures of respiratory failure are (1) arterial blood pH <7.20, (2)  $P_{aCO_2} \geq 60$  mm Hg, (3)  $SaO_2 < 90\%$  at  $O_2$  concentration of 40% and nCPAP of 5–8 cm  $H_2O$ , and (4) persistent or severe apnea. The goal of mechanical ventilation is to improve oxygenation and ventilation without causing pulmonary injury or oxygen toxicity. Acceptable ranges of arterial blood gas (ABG) values vary significantly among institutions but generally range from  $P_{aO_2}$  50–70 mm Hg ( $SpO_2 > 90\%$ ),  $P_{aCO_2}$  45–65 mm Hg (and higher after the first few days when risk of IVH is less), and pH 7.20–7.35. During mechanical ventilation, **oxygenation** is improved by increasing either  $F_{iO_2}$  or the mean airway pressure. The mean airway pressure can be increased by raising the peak inspiratory pressure (PIP), inspiratory time, ventilator rate, or PEEP. Adjustment in PEEP is usually most effective; however, excessive PEEP may impede venous return, thereby reducing cardiac output and  $O_2$  delivery (see Chapter 89.1). PEEP levels of 4–6 cm  $H_2O$  are usually safe and effective and assist in establishing FRC.  **$CO_2$  elimination** is determined by the minute ventilation, which is a product of the tidal volume (dependent on the inspiratory time and PIP) and ventilator rate. Ventilator settings typically include a tidal volume of 4–6 mL/kg and a starting rate of approximately 40 breaths/min. With use of high ventilatory rates, relatively short inspiratory time and sufficient expiratory time should be allowed to avoid air trapping and inadvertent PEEP.

Synchronized intermittent mechanical ventilation (SIMV) delivered by time-cycled pressure-limited, continuous flow ventilators is a common method of conventional ventilation for newborns. With **pressure-limited** SIMV, a set PIP is delivered in synchrony with the patient's own breaths for a specified rate per minute. For breaths above the set rate, pressure support breaths (8–10 cm  $H_2O$  above PEEP) are provided to help overcome the resistance associated with spontaneous breathing through the ETT. In pressure-limited ventilation, the delivered tidal volume is directly proportional to the respiratory compliance. Rapid changes in compliance occur with surfactant replacement therapy, requiring careful attention to tidal volumes and appropriate adjustments in PIP. In **volume-targeted** ventilation a specific tidal volume is set, and the PIP required to deliver it varies inversely with the respiratory compliance. Studies indicate that lung damage is related to recurrent lung collapse and overdistension rather than high pressures, thus volume-targeted ventilation may represent the most lung protective strategy of conventional ventilation. Evidence suggests that volume-targeted ventilation results in fewer pulmonary air leaks and may improve survival without BPD.

**Neurally adjusted ventilatory assist (NAVA)** is a ventilator strategy that integrates electrical signals from the diaphragm to synchronize ventilator breaths with the patient. Increased diaphragmatic electrical signal indicates the impending onset of a breath. The strength of electrical signal indicates the size of breath intended by the patient. Using this strategy, the timing and tidal volume can be customized to the patient on a breath-by-breath basis, and this is believed to decrease overall pressures required and limit lung damage. NAVA technology can also be used to synchronize noninvasive ventilation. To date there is insufficient evidence to compare the outcomes of infants with RDS initially managed on NAVA ventilation to those managed with pressure-limited or volume-limited SIMV.

**High-frequency ventilation (HFV)** achieves desired alveolar ventilation by using smaller tidal volumes and higher rates (300–1,200 breaths/min or 5–20 Hz). This ventilation strategy maintains sustained alveolar expansion and therefore limits injury associated with recurrent atelectasis. HFV may improve elimination of  $CO_2$  and improve oxygenation in patients who show no response to conventional ventilators, as well as those who have severe RDS, interstitial emphysema, recurrent pneumothoraces, or meconium aspiration pneumonia. High-frequency oscillatory ventilation (HFOV) and high-frequency jet ventilation (HFJV) are the most frequently used methods. There is not strong evidence to favor HFOV over HFJV or vice versa. Many

investigators have examined the use of HFV as a primary mode of ventilation in infants with RDS. There is some evidence that HFV may result in decreased rates of BPD and pulmonary air leak when compared to pressure-limited SIMV; however, superiority over volume-targeted SIMV has not been consistently demonstrated.

## Permissive Hypercapnia and Avoidance of Hyperoxia

Permissive hypercapnia is a strategy for management of patients receiving ventilatory support in whom priority is given to limiting ventilator-associated lung injury by tolerating relatively high levels of  $P_{aCO_2}$  (>60–70 mm Hg). Permissive hypercapnia can be implemented during nCPAP and mechanical ventilation but has not been shown to significantly impact outcomes. Hypocarbia is associated with poorer outcomes; therefore careful monitoring of  $PCO_2$  should be undertaken and moderate hypercapnia (>40–50 mmHg) can be tolerated. Hyperoxia may also contribute to lung injury in preterm infants. However, a lower target range of oxygenation (85–89%) compared with a higher range (91–95%) increases mortality and does not alter rates of BPD, BPD/death, blindness, or neurodevelopmental impairment. Therefore the currently recommended range of oxygen saturation targets is 91–95%.

## Discontinuation of Mechanical Ventilation

Strategies for weaning infants from ventilators vary widely and are influenced by lung mechanics as well as the availability of ventilatory modes. Extubation to nCPAP prevents postextubation atelectasis and reduces the need for reintubation. NIPPV may further decrease the need for reintubation in premature infants, particularly when combined with NAVA technology to allow synchronization. HFNC (1–8 L/min) oxygen is often used to support term and near-term infants following extubation and appears to be comparable to nCPAP in preventing postextubation failure. It is not clear whether nCPAP, NIPPV, or HFNC is more efficacious for promoting normal lung development and preventing BPD, but there is more evidence associated with nCPAP in extremely preterm infants. Preloading with methylxanthines enhances the success of extubation.

## Other Pharmacologic Therapies

There are no pharmacologic therapies superior or equal to the efficacy of maintaining FRC (through noninvasive respiratory support and mechanical ventilation when necessary) and providing surfactant replacement therapy in the treatment of RDS. Systemic corticosteroids (predominantly dexamethasone), although effective in improving respiratory mechanics and reducing the incidence of BPD and death, are associated with increased risk of cerebral palsy and neurodevelopmental impairment when used indiscriminately (see Chapter 127).

Inhaled nitric oxide (iNO) has been evaluated in preterm infants following the observation of its effectiveness in term and near-term infants with hypoxemic respiratory failure. Although iNO improves oxygenation in term and near-term infants with hypoxic respiratory failure or persistent pulmonary hypertension of the neonate, trials in preterm infants have not shown significant benefit.

## PROGNOSIS

Early provision of intensive observation and care of high-risk newborn infants can significantly reduce the morbidity and mortality associated with RDS and other acute neonatal illnesses. Antenatal corticosteroids, postnatal surfactant use, and improved modes of ventilation have resulted in low mortality from RDS (approximately 10%). Mortality increases with decreasing GA. Optimal results depend on the availability of experienced and skilled personnel, care in specially designed and organized regional hospital units, proper equipment, and lack of complications such as severe asphyxia, intracranial hemorrhage, or irreparable congenital malformation. Premature infants with RDS may go on to develop chronic lung disease and ultimately BPD (see Chapter 127).

**Pulmonary air leaks** (pneumothorax, pneumomediastinum, pulmonary interstitial emphysema) are observed in 3–9% of extremely preterm infants with RDS (see Chapter 132). PPV with excessive



inspiratory pressures (and therefore excessive tidal volumes), either during resuscitation at delivery or in the initial hours of mechanical ventilation, is a common risk factor, but air leaks can also occur in infants breathing spontaneously. Although the risk of air leak was increased in infants receiving a higher level of nCPAP (up to 8 cm H<sub>2</sub>O) in the CPAP or Intubation at Birth (COIN) trial, subsequent trials have not demonstrated a similar effect.

Additional complications of RDS may result from intubation procedures during the treatment of this disorder. Airway injury may occur at the time of intubation and adequate training is essential. Complications of intubation including ventilator-associated pneumonias and transient obstruction of the artificial airway are possible. With prolonged or recurrent intubation local pressure injury can lead to the development of subglottic stenosis.

Visit Elsevier eBooks+ at [eBooks.Health.Elsevier.com](http://eBooks.Health.Elsevier.com) for Bibliography.

## 126.1 Patent Ductus Arteriosus

Krishna K. Acharya, Alicia J. Sprecher, and Susan S. Cohen

### INCIDENCE AND PATHOPHYSIOLOGY

The ductus arteriosus is a fetal vascular shunt connecting the aorta to the pulmonary artery that allows oxygenated blood to bypass the uninflated fetal lungs and enter the systemic circulation. Following term birth, the ductus arteriosus constricts and is usually closed in the first few days of life. Although ductal closure occurs by 72 hours after birth in almost all term infants, the ductus remains patent in 65% of preterm infants born at <30 weeks' GA and in 85% of infants born at 24 weeks' GA. Risk factors for delayed closure of the PDA include hypoxia, acidosis, increased pulmonary pressure secondary to pulmonary vasoconstriction, systemic hypotension, immaturity, and local release of prostaglandins (which dilate the ductus). Shunting through the patent ductus arteriosus (PDA) may initially be bidirectional or right to left. As RDS resolves, PVR decreases, and predominantly left-to-right shunting may occur, leading to left ventricular (LV) volume overload and pulmonary edema.

### CLINICAL MANIFESTATIONS

Manifestations of PDA may include (1) a hyperdynamic precordium, bounding peripheral pulses, wide pulse pressure, and a machine-like continuous or systolic murmur; (2) radiographic evidence of cardiomegaly and increased pulmonary vascular markings; (3) hepatomegaly; (4) increasing oxygen dependence; (5) carbon dioxide retention; and (6) less often renal failure. Infants with a hemodynamically significant PDA often require escalation of ventilator and oxygen support. The diagnosis is confirmed by echocardiographic visualization of a PDA with Doppler flow imaging that demonstrates left-to-right shunting. A hemodynamically significant PDA by echocardiogram has a PDA  $\geq 1.5$  mm, unrestricted pulsatile transductal flow, left atrial to aortic root ratio  $\geq 1.5$ , and absent (end) diastolic flow in the descending aorta (Table 126.1).

### TREATMENT

Interventions to encourage ductal closure include fluid restriction, cyclooxygenase (COX) inhibitors (indomethacin or ibuprofen), acetaminophen, and surgical ligation. Short-term benefits of any therapy must be balanced against adverse effects, such as transient renal dysfunction and fluid imbalances associated with indomethacin.

By the time of discharge in the majority of extremely preterm infants (>90%), the PDA will close spontaneously. Spontaneous ductal closure may be facilitated by general supportive measures, including early (<7 days of age) avoidance of excessive fluid administration and judicious use of diuretics to manage pulmonary edema. However, within the first week of life, in 30% of infants with birthweight <1,500 g and 70% of infants <1,000 g, the PDA persists. Although

**Table 126.1** Summary of Essential Parameters Used for Echocardiographic Assessment and Hemodynamic Evaluation of PDA

PDA EVALUATION CRITERIA	ESSENTIAL ECHOCARDIOGRAPHIC PARAMETERS FOR ASSESSMENT OF PDA AND HEMODYNAMIC EVALUATION
Ductal characteristics	PDA size (small 2 mm) and flow direction (left to right, right to left, or bidirectional) and Doppler assessment with maximum velocity (V <sub>max</sub> ) in systole and end-diastole
Assessment of pulmonary over circulation	Dilated left side of the heart on visual inspection "eyeballing" and LA/Ao ratio (mild 1.6) OR LVEDD (correlate with z scores) OR LPA diastolic velocity, mean velocity >0.42 m/sec, end-diastolic velocity >0.2 m/sec OR reversal of mitral E/A ratio *Document presence or absence and magnitude of intraatrial shunt
Assessment of systemic hypoperfusion	Retrograde or absent blood flow during diastole in descending aorta OR celiac trunk or SMA OR anterior or middle cerebral artery

A comprehensive echocardiographic assessment should be performed to rule out any underlying congenital heart defect or pulmonary hypertension and delineate orientation of arch (left or right sidedness) before any intervention to close the PDA. E/A ratio, ratio of the early (E) to late (A) ventricular filling velocities; LA/Ao, left atrial to aortic ratio; LPA, left pulmonary artery; LVEDD, left ventricular end-diastolic diameter; PDA, patent ductus arteriosus; SMA, superior mesenteric artery. From Singh Y, Fraise A, Erdev O, Atasay B. Echocardiographic diagnosis and hemodynamic evaluation of patent ductus arteriosus in extremely low gestational age newborn (ELGAN) infants. *Front Pediatr.* 2020;8:Article 573627. Table 1.

many preterm infants with persistent PDA will remain clinically stable while awaiting spontaneous closure, approximately 60% of infants <1,000 g will develop significant clinical instability (hypotension, renal failure, worsening respiratory failure secondary to pulmonary edema). Pharmacologic and surgical ductal closure may be indicated in the premature infant with a moderate to large, hemodynamically significant PDA when there is a delay in clinical improvement or deterioration.

### Pharmacologic Closure

Pharmacologic closure of the PDA has been described using COX inhibitors that inhibit prostaglandin production, with equivalent efficacy and safety profiles described for ibuprofen and indomethacin. The efficacy of pharmacologic therapy is inversely proportional to the gestational and postnatal age, and closure is more likely when medication is administered before 21 days of age. However, successful closure has been reported up to 8 weeks of age. Whether indomethacin or ibuprofen is used, 20–40% of infants demonstrate treatment failure, and of those infants, 10–20% require eventual surgical ligation. Rates of recurrence following successful pharmacologic closure in general are low (<15%). Neither therapy significantly impacts the rate of NEC, BPD, or mortality. **General contraindications** to both indomethacin and ibuprofen include thrombocytopenia (<50,000 platelets/mm<sup>3</sup>), active hemorrhage (including severe IVH), NEC or isolated intestinal perforation, elevated plasma creatinine (>1.8 mg/dL), or oliguria (urine output <1 mL/kg/hr). Importantly, the concomitant use of hydrocortisone and indomethacin in extremely preterm infants must be avoided because the combination is associated with a dramatic increase in spontaneous intestinal perforation. Although indomethacin reduces



mesenteric blood flow, mounting experience suggests that low-volume trophic enteral feeding during administration is safe.

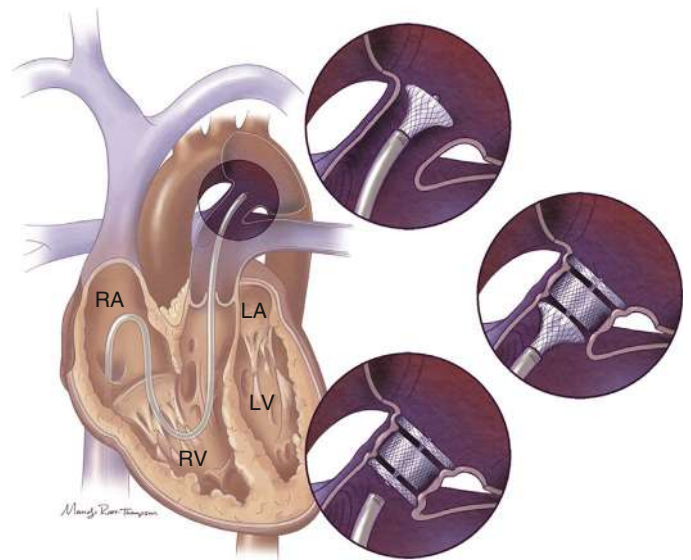
**Prophylactic indomethacin** given over the first 72 hours of age to preterm infants with birthweight <1,000 g reduces the incidence of severe IVH (grade III/IV), pulmonary hemorrhage, symptomatic PDA, and need for surgical PDA ligation. Although often implicated in spontaneous intestinal perforation and NEC, randomized controlled trials (RCTs) have failed to demonstrate that indomethacin increases their risk significantly. Short-term side effects include reductions in cerebral, mesenteric, and renal blood flow. Oliguria unresponsive to diuretic therapy is observed frequently. Dosing regimens for indomethacin vary considerably, but it usually is administered as a slow IV infusion (0.1–0.2 mg/kg/dose over 30 minutes) every 12–24 hours for three doses. A repeat course can be attempted if the duct fails to close or reopens, but additional (>2) courses do not appear to be efficacious. Longer courses (5–7 days) of indomethacin are not recommended because of an increased risk of NEC in one trial.

**Ibuprofen** is as effective as indomethacin in closing a PDA, but ibuprofen is associated with reduced rates of oliguria and a small but significant reduction in the length of mechanical ventilation. Although higher doses may improve closure rates in the most immature infants, the typical IV or enteral dosing regimen for ibuprofen is 10 mg/kg for one dose, followed by two doses of 5 mg/kg every 24 hours. A meta-analysis showed that a higher dose of oral ibuprofen using 20 mg/kg per dose for one dose, followed by 10 mg/kg per dose for two doses 24 hours apart is superior in closing the PDA compared to indomethacin or the traditional ibuprofen dosing. As with indomethacin, a repeat course may be considered, but additional courses of ibuprofen are not efficacious and not recommended. Risk of NEC is *not increased* with indomethacin, but in comparison, ibuprofen *reduces* the relative risk of NEC. Unlike indomethacin, ibuprofen has not been shown to reduce the risk of severe IVH. Compared to the IV route, enteral ibuprofen may be more efficacious. Whether ibuprofen used in combination with hydrocortisone results in increased risk of spontaneous intestinal perforation is unknown.

Oral acetaminophen has been shown to be an effective medication in closing the PDA, with fewer side effects than existing agents. It is given enterally at 15 mg/kg per dose q6h for 3 days. In practice, most clinicians will use a course of one of the previously mentioned medications as first-line therapy (typically ibuprofen) and follow with a second course of acetaminophen in a few days if the PDA remains patent and symptomatic.

### Surgical Ligation

The infant whose *symptomatic* PDA fails to close with pharmacologic interventions or who has contraindications to COX inhibitors is a candidate for surgical closure via an open thoracotomy. Although the long-term benefits are unclear, surgical ligation in infants born at <28 weeks' GA and <1,250 g is associated with improved survival. Surgical mortality is very low even in extremely low birthweight (ELBW) infants. However, **postligation cardiac syndrome**, a significant drop in blood pressure 6–12 hours after ductal ligation, is experienced by up to 50% of low birthweight (LBW) infants. The hypotension has been attributed to increased systemic vascular resistance along with decreased pulmonary venous return, resulting in impaired preload and LV function. Fluid resuscitation, inotropic support (with dobutamine or milrinone), and hydrocortisone are usually effective. Other complications of surgery include hemorrhage, pneumothorax, chylothorax, Horner syndrome, and injury to the recurrent laryngeal nerve resulting in vocal cord dysfunction. Inadvertent ligation of the left pulmonary artery or the transverse aortic arch has rarely been reported. Increased rates of neurodevelopmental impairment have been reported following surgical ligation, although a causal relationship remains uncertain. Due to the complications associated with surgical ligation, many



**Fig. 126.7** Percutaneous device closure of a PDA using the Amplatzer Piccolo Occluder. LA, Left atrium; LV, left ventricle; RA, right atrium; RV, right ventricle. (From Backes CH, Giesinger RE, Rivera BK, et al. Percutaneous closure of the patent ductus arteriosus in very low weight infants: considerations following US Food and Drug Administration approval of a novel device. *J Pediatr.* 2019;213:218–221.)

centers have moved away from this modality and use a less invasive, percutaneous approach to PDA closure.

### Percutaneous Closure of the Patent Ductus Arteriosus

Percutaneous closure of the PDA is a safe and effective procedure for definitive PDA closure. In 2019, the U.S. Food and Drug Administration approved the Amplatzer PiccoloOccluder (Abbott Diagnostics, North Chicago, IL) for percutaneous PDA closure in preterm infants weighing 700 g or more (Fig. 126.7). A trial in 100 infants weighing <2 kg showed that this technique of PDA closure is 99% effective with a 2% risk of adverse events. Although a comparative trial has not been done against the traditional surgical approach, most US centers use percutaneous closure as the first-line approach for PDA closure when conservative treatment fails. This procedure is done under cardiac anesthesia in the catheterization laboratory. The femoral vein is accessed using modified Seldinger technique, and then, under fluoroscopic guidance, a catheter is advanced through the femoral vein all through the right ventricular and across the PDA and the Piccolo device is placed. This technique permits injection of contrast before and after device placement to ensure appropriate device selection, measure size of the PDA, and ensure that there is no occlusion of the descending aorta or left pulmonary artery after device placement. If there is evidence of narrowing, the device can be recaptured and repositioned until a satisfactory result is obtained. Rarely, appropriate device placement is not achieved, and the patient may have to undergo surgical ligation. The short-term complications are bleeding at the insertion site, embolization of the device into the descending aorta or left pulmonary artery, post-PDA ligation syndrome, and residual shunting across PDA. The long-term complications are unknown, but these patients likely need surveillance echocardiography until 2–3 years of age.

Visit Elsevier eBooks+ at [eBooks.Elsevier.com](https://eBooks.Elsevier.com) for Bibliography.

## Chapter 127

# Bronchopulmonary Dysplasia

Krishna K. Acharya, Alicia J. Sprecher, and Susan S. Cohen

## INCIDENCE

Bronchopulmonary dysplasia (BPD; also known as *chronic lung disease of prematurity*) is a clinical pulmonary syndrome that develops in the majority of extremely preterm infants and is defined by a prolonged need for respiratory support and supplemental oxygen. Almost 60% of infants born at  $\leq 28$  weeks' gestation will develop BPD, and the incidence of BPD increases inversely with gestational age. For infants born at 22-24 weeks, essentially 100% will develop BPD, the majority of whom will have moderate to severe disease. As neonatal care has improved and use of antenatal corticosteroids has become the standard of care, survival of infants born at the extreme of viability has improved, and BPD is encountered with increased prevalence. In the United States, an additional 10,000-15,000 new cases occur annually. Despite decades of experience, the incidence of BPD remains largely unchanged.

## ETIOLOGY AND PATHOPHYSIOLOGY

BPD develops following preterm birth and the necessary life-supporting interventions (particularly mechanical ventilation and supplemental oxygen) that cause neonatal lung injury. As very low birthweight (VLBW) infant's survival has improved by advances in neonatal care, the clinical syndrome associated with BPD has evolved. The clinical, radiographic, and lung histology of classic BPD described in 1967 by Northway, before widespread use of antenatal corticosteroids and postnatal surfactant, was that of a disease of preterm infants who were more mature. Infants who developed BPD initially demonstrated classic respiratory distress syndrome (RDS), but the injurious mechanical ventilation and excessive supplemental oxygen required to support them resulted in a progressive, severe fibroproliferative lung disease. Improvements in respiratory care, as well as the introduction of surfactant and antenatal steroids, have allowed for less aggressive respiratory support strategies, and the need for excessive ventilator support and high percentages of inspired supplemental oxygen has decreased.

Despite a reduction in the fibroproliferative disease described previously, infants born in the modern era of neonatal care continued to require supplemental oxygen for prolonged periods. The *new* BPD is a disease primarily of infants with birthweight  $< 1,000$  g who were born at  $< 28$  weeks' gestation, some of whom have initially little or no lung disease at birth but over the first weeks of age experience progressive respiratory failure. Infants with the new BPD are born at a more immature stage of distal lung development, and lung histology demonstrates variable saccular wall fibrosis, minimal airway disease, abnormal pulmonary microvasculature development, and alveolar simplification. Although the etiology remains incompletely understood, the histopathology of BPD indicates interference with normal alveolar septation and microvascular maturation.

The pathogenesis of BPD is likely multifactorial, but pulmonary inflammation and lung injury in an immature lung are consistently observed. Alveolar collapse (**atelectrauma**) as a consequence of surfactant deficiency, together with ventilator-induced phasic overdistention of the lung (**volutrauma**), promotes lung inflammation and injury. Supplemental oxygen produces free radicals that cannot be metabolized by the immature antioxidant systems of VLBW neonates and further contributes to the injury. Pulmonary inflammation evidenced by infiltration of neutrophils and macrophages in alveolar fluid, as well as a host of proinflammatory cytokines, contributes to the progression of

lung injury. Pre- and postnatal infection, excessive pulmonary blood flow via the patent ductus arteriosus (PDA), excessive administration of intravenous fluid, and pre- and postnatal growth failure are also significantly associated with the development of BPD. In addition, pulmonary artery hypertension may complicate BPD. Although the mechanisms are unclear, all likely promote lung injury by necessitating increased or prolonged respiratory support or interfering with lung repair. Regardless, the result is an interference with normal development of the alveolar-capillary unit and interference with normal gas exchange.

## CLINICAL MANIFESTATIONS

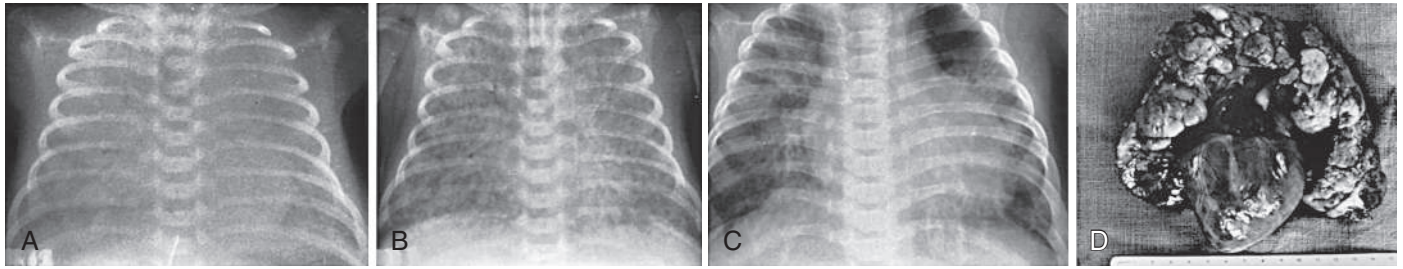
Over the first several weeks of age, infants developing BPD demonstrate persistent, often progressive respiratory distress and the need for respiratory support and supplemental oxygen. In extremely low birthweight (ELBW) infants at risk for BPD, the need for supplemental oxygen over the first 2 weeks of age follows one of three distinct patterns. Infants that follow the natural course of RDS, and by 3-4 days of age require minimal ( $FiO_2 < 0.25$ ) supplemental oxygen, have a low ( $< 20\%$ ) risk of developing BPD. Infants who initially have a low  $O_2$  requirement ( $FiO_2 < 0.25$ ) during the first week, but then experience early pulmonary deterioration and increased  $O_2$  requirement ( $FiO_2 > 0.25$ ) during the second week, have a modest risk (approximately 50%) of developing BPD. Infants that have an early, persistently high ( $FiO_2 > 0.25$ ) need for supplemental oxygen have a significantly high (70%) risk of developing BPD.

Respiratory distress, commonly characterized by tachypnea and retractions, persists or worsens and is associated with hypercapnia, hypoxia, and oxygen dependence. The chest radiograph evolves from that of RDS to relative hyperinflation and fine, diffuse interstitial opacities. Wandering atelectasis is common. In the most severe cases, usually associated with prolonged mechanical ventilation and chronically high supplemental oxygen needs, frank cystic changes and/or pneumatoceles are observed (Fig. 127.1). Infants with severe BPD receiving invasive ventilation often demonstrate airway obstruction. Excessive airway mucus and edema, airway instability caused by acquired tracheobronchomalacia, and bronchospasm are proposed etiologies. Acute airway obstruction is manifest clinically by abrupt hypoxemia and bradycardia and is often referred to as *BPD spells*. Acute, intermittent right-to-left intracardiac or intrapulmonary shunting caused by abrupt elevations in pulmonary artery pressure (PAP) may also contribute and resemble BPD spells. Spells are notoriously difficult to control, but occasionally will respond to bronchodilators, increasing positive end-expiratory pressure (PEEP), and sedation acutely.

A common complication of BPD is **pulmonary hypertension**. Prospective surveillance indicates that in approximately 15% of all infants born at  $< 1,000$  g and  $< 28$  weeks' gestational age, echocardiographic signs of pulmonary hypertension will develop. Prenatal growth restriction, prolonged duration of mechanical ventilation and supplemental oxygen, and increasing severity of BPD are all associated with an increased risk. Pulmonary hypertension has been reported in as many as 40% of infants with the most severe BPD and can progress to right-sided heart failure. Pulmonary hypertension complicating BPD has been associated with increased mortality.

## DIAGNOSIS

BPD is diagnosed when a preterm infant requires supplemental oxygen for the first 28 postnatal days; it is further classified at 36 weeks' postmenstrual age (PMA) according to the degree of  $O_2$  supplementation (Table 127.1). Neonates receiving positive pressure support or  $\geq 30\%$  supplemental  $O_2$  at 36 weeks' PMA or at discharge (whichever occurs first) are diagnosed as having **severe** BPD; those requiring  $< 30\%$  supplemental  $O_2$  have **moderate** BPD; and those who previously required  $O_2$  supplementation for at least 28 days but are currently breathing room air have **mild** BPD. Infants who require oxygen for  $< 28$  days of life have "no BPD." Infants receiving supplemental  $O_2$  should undergo a stepwise reduction in supplemental  $O_2$  to room air at 36 weeks while under continuous observation and with  $SpO_2$  monitoring to determine whether they can be weaned off oxygen



**Fig. 127.1** Pulmonary changes in infants treated with prolonged, intermittent positive pressure breathing with air containing 80–100% oxygen in the immediate postnatal period for the clinical syndrome of hyaline membrane disease. **A**, A 5-day-old infant with nearly complete opacification of the lungs. **B**, A 13-day-old infant with “bubbly lungs” simulating the radiographic appearance of the Wilson-Mikity syndrome. **C**, A 7-month-old infant with irregular, dense strands in both lungs, hyperinflation, and cardiomegaly suggestive of chronic lung disease. **D**, Large right ventricle and a cobbly, irregularly aerated lung of an infant who died at 11 months of age. This infant also had a patent ductus arteriosus. (From Northway WH Jr, Rosan RC, Porter DY. Pulmonary disease following respiratory therapy of hyaline-membrane disease. *N Engl J Med*. 1967;276:357–368.)

**Table 127.1** Definition of Bronchopulmonary Dysplasia: Diagnostic Criteria\*

	GESTATIONAL AGE	
	<32 Wk	≥32 Wk
Time point of assessment	36 wk PMA or discharge home, whichever comes first Treatment with >21% oxygen for at least 28 days plus:	>28 days but <56 days postnatal age or discharge home, whichever comes first Treatment with >21% oxygen for at least 28 days plus:
Mild BPD	Breathing room air at 36 wk PMA or discharge home, whichever comes first	Breathing room air by 56 days postnatal age or discharge home, whichever comes first
Moderate BPD	Need <sup>†</sup> for <30% oxygen at 36 wk PMA or discharge home, whichever comes first	Need <sup>†</sup> for <30% oxygen at 56 days postnatal age or discharge home, whichever comes first
Severe BPD	Need <sup>†</sup> for ≥30% oxygen and/or positive pressure (PPV or nCPAP) at 36 wk PMA or discharge home, whichever comes first	Need <sup>†</sup> for ≥30% oxygen and/or positive pressure (PPV or nCPAP) at 56 days postnatal age or discharge home, whichever comes first

\*BPD usually develops in neonates being treated with oxygen and PPV for respiratory failure, most frequently respiratory distress syndrome (RDS). Persistence of the clinical features of respiratory disease (tachypnea, retractions, crackles) is considered common to the broad description of BPD and has not been included in the diagnostic criteria describing the severity of BPD. Infants treated with >21% oxygen and/or PPV for nonrespiratory disease (e.g., central apnea or diaphragmatic paralysis) do not have BPD unless parenchymal lung disease also develops and they have clinical features of respiratory distress. A day of treatment with >21% oxygen means that the infant received >21% oxygen for >12 hr on that day. Treatment with >21% oxygen and/or PPV at 36 wk PMA or at 56 days postnatal age or discharge should not reflect an “acute” event; rather, it should reflect the infant’s usual daily therapy for several days preceding and after 36 wk PMA, 56 days postnatal age, or discharge.

<sup>†</sup>A physiologic test confirming that the oxygen requirement at the assessment time point remains to be defined. This assessment may include a pulse oximetry saturation range.

BPD, Bronchopulmonary dysplasia; nCPAP, nasal continuous positive airway pressure; PMA, postmenstrual age; PPV, positive pressure ventilation. From Jobe AH, Bancalari E. Bronchopulmonary dysplasia. *Am J Respir Crit Care Med*. 2001;163:1723–1729.

(physiologic definition of BPD). This test is highly reliable and correlated with discharge home on oxygen, length of hospital stay, and hospital readmissions in the first year of life. The risk of neurodevelopmental impairment and pulmonary morbidity and the severity of BPD are directly correlated.

Despite its simplicity, the current severity-based definition of BPD has limitations. Because of incomplete or inaccurate data related to hospital transfer or early discharge, in a significant number of infants the diagnosis of BPD is either not documented or misapplied. Additionally, those infants requiring O<sub>2</sub> support at relatively high flow (>2 L/min) or very low (<0.25 L/min) or those receiving other modes of noninvasive ventilation are not well characterized. Calculation of *effective oxygen* may be helpful but is cumbersome and not well validated. Clinical trials have relied on the need for supplemental O<sub>2</sub> at 36 weeks PMA to define BPD. Although this definition can diagnose BPD in the highest percentage of infants, it cannot discriminate between infants with milder BPD from those with most severe forms of BPD. A National Institute of Child Health and Human Development (NICHD) workshop on BPD developed a definition of BPD that would address some of the concerns mentioned earlier (Table 127.2). Specifically, it incorporates the diverse forms of respiratory support used,

distinguishes infants who are receiving invasive vs noninvasive positive pressure ventilation (PPV), and introduces the term “lethal BPD” or grade III(A) severe BPD to identify infants who die from this disease before 36 weeks’ PMA.

## PREVENTION

In general, there remains a lack of effective interventions that prevent BPD. Avoidance of mechanical ventilation with the early use of nCPAP and early, selective surfactant replacement therapy with rapid extubation decrease the incidence of BPD modestly. The avoidance of mechanical ventilation achieved by the combination of early rescue surfactant by the INSURE, MIST, or LISA method with nasal continuous positive airway pressure (nCPAP) has been associated with a modest reduction in BPD (see Chapter 126). Gentle ventilation strategies, including volume-targeted ventilation and high-frequency oscillatory ventilation (HFOV), have also been associated with small, inconsistent reductions in BPD. Caffeine therapy for apnea of prematurity has also been associated with a decreased risk of BPD. Although the mechanisms are unknown, caffeine likely supports effective spontaneous respiration and decreases the likelihood that an infant will need invasive mechanical ventilation.



**Table 127.2** New Definition of Bronchopulmonary Dysplasia Based on the 2016 NICHD Executive Workshop on Bronchopulmonary Dysplasia

For infants born <32 wk gestation, with radiographic evidence of parenchymal lung disease, who at 36 wk require one of the following  $F_{IO_2}$ /oxygen levels/oxygen concentrations for  $\geq 3$  consecutive days to maintain  $SpO_2$  in the 90–95% range

	INVASIVE IPPV	nCPAP, NIPPV, OR NASAL CANNULA $\geq 3$ L/MIN	NASAL CANNULA 1-3 L/MIN	NASAL CANNULA <1 L/MIN
Grade I BPD	No	21% $F_{IO_2}$	22–29% $F_{IO_2}$	22–70% $F_{IO_2}$
Grade II BPD	21% $F_{IO_2}$	22–29% $F_{IO_2}$	$\geq 30\%$ $F_{IO_2}$	$\geq 70\%$ $F_{IO_2}$
Grade III BPD	>21% $F_{IO_2}$	$\geq 30\%$ $F_{IO_2}$		
Grade III(A) BPD	Infants who die between 14 days to 36 wk PMA from respiratory failure secondary to severe parenchymal lung disease not attributable to other neonatal morbidities			

NICHD, National Institute of Child Health and Human Development; BPD, bronchopulmonary dysplasia; IPPV, invasive positive pressure ventilation; nCPAP, nasal continuous positive airway pressure; NIPPV, noninvasive positive pressure ventilation.

Adapted from Higgins RD, Jobe AH, Koso-Thomas M, et al. Bronchopulmonary dysplasia: executive summary of a workshop. *J Pediatr*. 2018;197:300–308.

Systemic corticosteroids (dexamethasone) given either early (<7 days of age to ventilated infants at risk of BPD) or late (>7 days of age to infants with progressing lung disease) prevent both mortality and BPD significantly, but because of the increased risk of cerebral palsy (CP) and neurodevelopmental impairment, their routine use is not recommended. The risk of neurodevelopmental impairment related to systemic corticosteroid use may be offset by the risk associated with BPD. A systematic review suggested that systemic corticosteroid therapy, when directed to infants with a  $\geq 65\%$  risk of developing BPD, may actually reduce the risk of neurodevelopmental impairment and CP. Although predictive models that use clinical characteristics have been described with promising accuracy, randomized trials using them to guide corticosteroid therapy have not been performed.

**Inhaled corticosteroids** administered to VLBW infants requiring mechanical ventilation at 7–14 days of age did not prevent BPD significantly. However, early, prolonged administration to mechanically ventilated extremely preterm infants until they no longer require oxygen or positive pressure support has been shown to reduce the risk of BPD, but with a concerning trend toward increased mortality. Experience with local delivery of corticosteroids by spiking surfactant with budesonide is emerging, and early data suggest that endotracheal administration of corticosteroids may reduce pulmonary inflammation and the risk of BPD and death. However, additional evidence is needed before widespread use is implemented. The routine use of antibiotics, inhaled bronchodilators, or diuretics has not been shown to prevent BPD.

## TREATMENT

Treatment of evolving and established BPD is supportive. The basic tenets of therapy should include appropriate support of ventilation and aggressive nutritional support to optimize linear growth and encourage normal lung repair and development. Available evidence suggests short-term benefits (improved pulmonary mechanics, modest reductions in respiratory support parameters) without an indication of impact on clinically relevant outcomes (survival, need for long-term respiratory support, recurrent hospitalization). Currently, available evidence does not support the routine use of any pharmacologic agents in infants with evolving or established BPD. Treatment decisions must weigh the perceived benefit against the potential harm.

### Diuretics and Fluid Restriction

Infants with BPD often have excessive pulmonary interstitial fluid that compromises lung function and increases work of breathing. Diuretic therapy (usually with furosemide or chlorothiazide) has been associated with short-term, temporary improvements in pulmonary compliance

and the ability to wean respiratory support. Furosemide (1 mg/kg/dose IV or 2 mg/kg/dose orally [PO] every 12–24 hours) has been demonstrated to decrease pulmonary interstitial edema and pulmonary vascular resistance (PVR), improve pulmonary function, and facilitate weaning from mechanical ventilation and oxygen. Adverse effects of long-term furosemide therapy are common and include hyponatremia, hypokalemia, alkalosis, azotemia, hypocalcemia, hypercalciuria, cholelithiasis, renal stones, nephrocalcinosis, and ototoxicity. Sodium and potassium chloride supplementation is often necessary. Thiazide diuretics (e.g., chlorothiazide, 5–10 mg/kg/dose every 12 hours) have been used as an alternative to avoid hypercalciuria, limit nephrocalcinosis, and preserve bone development. Although avoidance of excessive fluid administration in the first few weeks of age is associated with a reduced risk of BPD, there is no evidence that fluid restriction (130–140 mL/kg/day) in established BPD has any impact. Whether using diuretics or fluid restriction, careful attention to maintaining appropriate electrolyte levels as well as providing adequate caloric intake (often >120–130 kcal/kg/day) is paramount to avoid negatively impacting nutrition.

### Bronchodilators

Inhaled bronchodilators improve lung mechanics by decreasing airway resistance. **Albuterol** is a specific  $\beta_2$ -agonist used to treat bronchospasm in infants with BPD. Albuterol may improve lung compliance by decreasing airway resistance secondary to smooth muscle cell relaxation but can exacerbate bronchomalacia. Changes in pulmonary mechanics may last 4–6 hours. Hypertension and tachycardia are adverse effects. Ipratropium bromide is a muscarinic antagonist related to atropine, but the bronchodilator effect is more potent. Use of ipratropium bromide in BPD has been associated with improved pulmonary mechanics. Compared with either agent used alone, combined use of albuterol and ipratropium bromide may be more effective. Few adverse effects have been noted. With current aerosol administration strategies, exactly how much medication is delivered to the airways and lungs of infants with BPD, especially if they are ventilator dependent, is unclear.

### Corticosteroids

Systemic corticosteroids have been used to treat evolving and established BPD. In mechanically ventilated infants, systemic corticosteroids improve pulmonary mechanics, allow weaning of ventilator support and supplemental  $O_2$ , and facilitate extubation. When given at >7 days of age, long-term benefits include a reduced need for  $O_2$  at 36 weeks PMA, improved survival, and decreased need for home  $O_2$ . Short-term adverse effects include hyperglycemia, hypertension, and transient hypertrophic obstructive cardiomyopathy. Long-term adverse effects include osteopenia, severe retinopathy of



prematurity (ROP), abnormal neurologic examination, poor brain growth, neurodevelopmental impairment, and CP. A strategy that utilizes a low cumulative dose (0.89 mg/kg of dexamethasone given over 10-day taper) in preterm infants who remain ventilator dependent after 7 days of age (and therefore have a high risk of developing BPD) facilitates weaning of ventilator and oxygen support and promotes successful extubation without an impact on long-term outcomes, including the incidence of BPD or neurodevelopmental impairment. The controversy concerning the appropriate use of systemic corticosteroids to prevent and/or treat BPD is ongoing, and until additional evidence is available, their use remains limited to infants with severe respiratory failure (ventilator dependent at >7-14 days of age with significant respiratory and oxygen support needs) at high risk for imminent death.

Inhaled corticosteroids (budesonide, fluticasone, and beclomethasone) have been described as an alternative therapy in evolving or established BPD. Small randomized controlled trials (RCTs) and case reports in infants with established moderate to severe BPD have not shown a significant benefit for pulmonary mechanics or reduction in the need for ventilator or oxygen support. Inhaled fluticasone propionate (corticosteroid) combined with salmeterol (long-acting  $\beta_2$ -agonist) may be beneficial.

### Pulmonary Vasodilators

Many infants with evolving or established moderate and severe BPD demonstrate increased PVR caused by pulmonary microvascular maldevelopment and abnormal vasoreactivity. In infants with BPD with pulmonary hypertension, acute exposure to even modest levels of hypoxemia can cause PAP to increase abruptly. Maintaining infants with established BPD and pulmonary hypertension at higher  $SO_2$  targets (92–96%) can lower PAP effectively. For infants in whom appropriate  $O_2$  supplementation and support of ventilation are ineffective, the use of low-dose inhaled nitric oxide (iNO) may improve oxygenation anecdotally. Despite its frequent use, there is no evidence to support the use of iNO to improve lung function, cardiac function, or oxygenation in evolving BPD. Several case series have reported on the use of the phosphodiesterase-5 inhibitor sildenafil in treating pulmonary hypertension in established moderate to severe BPD. Despite its widespread use, no RCTs are evaluating the safety and efficacy of sildenafil in preterm infants with BPD. However, many experts would recommend a trial of low-dose sildenafil (1 mg/kg/dose every 8 hours) for infants with evidence of pulmonary hypertension and persistent respiratory instability despite appropriate oxygen and ventilator support.

### Chronic Respiratory Support

Experience suggests that maintaining functional residual capacity (FRC) with appropriate positive pressure support (with noninvasive support whenever possible) promotes optimal lung growth and development. Provision of nCPAP until respiratory status improves and oxygen dependence resolves, with subsequent transition directly to room air, may be beneficial. Continuation of caffeine therapy may facilitate spontaneous breathing and weaning from support. Established severe BPD with cystic, heterogeneous lung disease often requires prolonged mechanical ventilation. A long inspiratory time is required to adequately ventilate diseased lung units, and appropriate expiratory time is required to allow exhalation. The use of a low rate (<20-30 breaths/min), long inspiratory time ( $\geq 0.6$  seconds) strategy is usually required. To attain appropriate minute ventilation, larger tidal volumes (10-15 mL/kg) may

be necessary. Higher PEEP (often >6-8 cm  $H_2O$ ) may be needed to attain adequate expansion and minimize gas-trapping caused by dynamic airway collapse. Gradual weaning of ventilator settings should be attempted as the infant grows and lung disease improves, but the incidence of death or tracheostomy placement for chronic ventilation may be as high as 20%. By 2-3 years of age, the majority of infants who undergo tracheostomy for severe BPD are successfully liberated from mechanical ventilation.

### PROGNOSIS

Compared with extremely preterm infants without BPD, infants with BPD have higher rates of neurodevelopmental impairment, lung diffusion impairment, wheezing and airflow obstruction, rehospitalization, and mortality. The risk of these complications increases with BPD severity. Infants with grade III BPD are most likely to either die or have long-term respiratory morbidity. Prolonged mechanical ventilation, intraventricular hemorrhage (IVH), pulmonary hypertension, cor pulmonale, and oxygen dependence beyond 1 year of life are poor prognostic signs. Mortality in infants with BPD ranges from 10–25% and is highest in infants who remain ventilator dependent for >6 months. Cardiorespiratory failure associated with cor pulmonale and acquired infection (respiratory syncytial virus [RSV]) are common causes of death. Infants are at risk for severe RSV infections and must receive prophylactic therapy (see Chapter 307).

Pulmonary function slowly improves in most survivors because of ongoing lung repair and the natural period of lung growth and alveolarization. *Rehospitalization* for impaired pulmonary function is most common during the first 3 years of life and is much more common in infants requiring respiratory support at discharge. The incidence of physician-diagnosed asthma, use of bronchodilators, and wheezing is elevated. Despite a gradual decrease in symptom frequency, persistence of respiratory symptoms and abnormal pulmonary function test results are measurable in children, adolescence, and young adults. Although not always clinically apparent, pulmonary function testing consistently reveals impaired exercise capacity, reduced pulmonary diffusing capacity, and persistent expiratory flow obstruction. High-resolution chest CT scanning or MRI studies in children and adults with a history of BPD reveal lung abnormalities that correlate directly with the degree of pulmonary function abnormality. The ultimate long-term pulmonary health of survivors of BPD is unknown. As trajectories of developing lung function remain abnormal in survivors of BPD, concerns have been raised highlighting the potential for pulmonary emphysema, chronic obstructive pulmonary disease, and pulmonary vascular disease resulting in early debilitating lung dysfunction.

Other complications of BPD include growth failure, neurodevelopmental impairment, and parental stress, as well as sequelae of therapy, such as nephrolithiasis, osteopenia, and electrolyte imbalance. Airway problems such as vocal cord paralysis, subglottic stenosis, and tracheomalacia are common and may aggravate or cause pulmonary hypertension. Subglottic stenosis may require tracheotomy or an anterior cricoid split procedure to relieve upper airway obstruction. Cardiac complications of BPD include pulmonary hypertension, cor pulmonale, systemic hypertension, left ventricular hypertrophy, and development of aortopulmonary collateral vessels, which, if large, may cause heart failure.

Visit Elsevier eBooks+ at [eBooks.Health.Elsevier.com](http://eBooks.Health.Elsevier.com) for Bibliography.

## Chapter 128

# Transient Tachypnea of the Newborn

Alicia J. Sprecher, Krishna K. Acharya, and Susan S. Cohen

## INCIDENCE

Transient tachypnea of the newborn (TTN) is a clinical syndrome of self-limited tachypnea associated with delayed clearance of fetal lung fluid. Although the actual incidence is likely underreported, it is estimated at 3-6 per 1,000 term infant births, making TTN the most common etiology of tachypnea in the newborn. Twin gestation, maternal asthma, maternal hypertension, late prematurity, precipitous delivery, perinatal depression, gestational diabetes, macrosomia, and cesarean delivery, particularly without labor, are common risk factors.

## ETIOLOGY AND PATHOPHYSIOLOGY

TTN is believed to result from ineffective clearance of fetal lung fluid. Retained fetal lung fluid decreases pulmonary compliance and impedes gas exchange. Clearance of fetal lung fluid occurs through increased expression of epithelial sodium channels (ENaCs) and sodium-potassium adenosine triphosphatase ( $\text{Na}^+, \text{K}^+ \text{-ATPase}$ ) that drive active sodium (and thereby fluid) reabsorption. There is evidence that the channels involved in fluid clearance differ for infants with TTN. Additional lung fluid is cleared via compressive forces at the time of delivery and hydrostatic forces with the infant's first breaths (see Chapter 124.1). Decreased respiratory effort can delay fluid clearance and increase the risk for TTN.

## CLINICAL MANIFESTATIONS

TTN is characterized by the early onset of tachypnea ( $>60$  breaths/min), sometimes with retractions or expiratory grunting and occasionally with cyanosis that is relieved by minimal  $\text{O}_2$  supplementation ( $<40\%$ ). The chest generally sounds clear without crackles or wheeze, and the chest radiograph shows prominent perihilar pulmonary vascular markings, fluid in the intralobar fissures, and rarely small pleural effusions (Fig. 128.1). Hypercapnia and acidosis are uncommon. Respiratory failure requiring positive pressure support (either with nasal continuous positive airway pressure [nCPAP] or mechanical ventilation) also is uncommon, but when it occurs usually resolves rapidly ( $<12\text{-}24$  hours). Most infants recover with supportive care alone, and over the first 24-72 hours the tachypnea and  $\text{O}_2$  requirements slowly resolve.

## DIAGNOSIS

Distinguishing TTN from respiratory distress syndrome (RDS) and other respiratory disorders (e.g., pneumonia) may be difficult, and transient tachypnea is frequently a diagnosis of exclusion. The distinctive features of TTN are rapid recovery of the infant and the

absence of radiographic findings for RDS (low lung volumes, diffuse reticulogranular pattern, air bronchograms) and other lung disorders. Other respiratory disorders to consider include meconium aspiration syndrome (see Chapter 129), persistent pulmonary hypertension of the newborn (see Chapter 130), congenital lung anomalies, and spontaneous air leak (see Chapter 132). **Primary ciliary dyskinesia (PCD)** often presents in the newborn period and may resemble TTN or RDS. PCD in the newborn often lasts longer than TTN and requires a longer duration of oxygen therapy (Chapter 455).

## PREVENTION

Prevention of TTN generally focuses on avoidance of modifiable risk factors. As prematurity increases the risk of TTN, the American College of Obstetrics and Gynecology recommends against nonmedically indicated deliveries, either vaginal or cesarean, before 39 weeks. They further state that documentation of fetal lung maturity, previously accomplished via amniocentesis with amniotic fluid testing, should not be used to guide early delivery as this does not ensure appropriate maturation of physiologic processes. When late-preterm delivery is medically indicated or threatened, the use of a single course of antenatal steroids is associated with a decreased risk of TTN and may be considered. Use of antenatal steroids at increasing gestational ages must be balanced against an increased risk of hypoglycemia in the neonate postpartum.

## TREATMENT

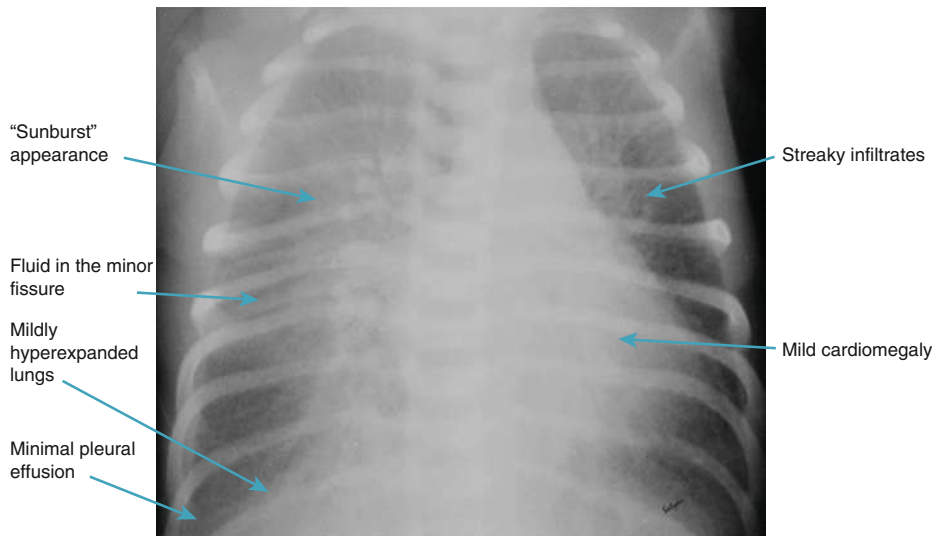
Treatment for TTN is supportive. Based on the degree of symptoms and progression of those symptoms over the first 2 hours after birth, transfer to a facility with appropriate neonatal intensive care unit (NICU) care may be required. Supplemental oxygen should be provided to maintain saturations over 90%. nCPAP can be used to support infants with more significant work of breathing or oxygen requirements. Further evaluation with chest radiograph or blood gas analysis can be undertaken when distress is more significant, or the diagnosis is in question. Infants with significant tachypnea may be unable or unsafe to feed orally and can be supported with intravenous fluids or nasogastric feedings. Generally, TTN is unrelated to an underlying infection; however, antibiotic coverage may be initiated in patients with additional risk factors. Further evaluation for an alternate diagnosis should be undertaken if symptoms are not resolving by 72 hours of age.

Inhaled  $\beta_2$ -agonists such as albuterol (salbutamol) increase expression and activation of ENaC and  $\text{Na}^+, \text{K}^+ \text{-ATPase}$  and facilitate fluid clearance. Emerging evidence suggests that when given early in the course of TTN, albuterol may improve oxygenation, shorten the duration of supplemental  $\text{O}_2$  therapy, and expedite recovery; however, more data are needed before employing this method.

## PROGNOSIS

Infants with a history of TTN do have an increased risk of developing a wheezing diagnosis during childhood. This association persists even after stratifying for the underlying risk factor of maternal asthma.

Visit Elsevier eBooks+ at [eBooks.Health.Elsevier.com](http://eBooks.Health.Elsevier.com) for Bibliography.



**Fig. 128.1** Chest radiograph of an infant with transient tachypnea of the newborn. Notable features include increased pulmonary markings particularly in the perihilar region and fluid in the fissure. This contrasts with the radiograph of an infant with respiratory distress syndrome, which generally includes a homogenous ground glass appearance and hypoinflation. (From Alhassen Z, Vali P, Guglani L, Lakshminrusimha S, Ryan RM. Recent advances in pathophysiology and management of transient tachypnea of newborn. *J Perinatol.* 2021;41:6–16. Fig. 5.)

## Chapter 129

# Aspiration of Foreign Material (Meconium Aspiration Syndrome, Aspiration Pneumonia)

Alicia J. Sprecher, Krishna K. Acharya, and Susan S. Cohen

Aspiration in the neonate can occur intrapartum often as a result of fetal distress or aspiration may occur postpartum, which can be related to a number of conditions including cardiopulmonary dysfunction, gastroesophageal reflux, aerodigestive tract anomalies, neurodevelopmental impairment, and craniofacial abnormalities.

### INTRAPARTUM ASPIRATION

With fetal distress, the fetus often initiates vigorous respiratory movements in utero because of interference with the supply of oxygen through the placenta. Under such circumstances, the infant may aspirate amniotic fluid containing vernix caseosa, epithelial cells, meconium, blood, or material from the birth canal, which may block the smallest airways and interfere with alveolar exchange of  $O_2$  and  $CO_2$ . Pathogenic bacteria may accompany the aspirated material, and pneumonia may ensue, but even in noninfected cases, respiratory distress accompanied by radiographic evidence of aspiration is seen (Fig. 129.1). The most relevant consequences of intrapartum aspiration are pneumonia and meconium aspiration syndrome (MAS).

### Early-Onset Sepsis and Neonatal Pneumonia

Pneumonia as a presentation of early-onset sepsis typically arises following aspiration of infected amniotic fluid (see Chapter 149). The incidence of early-onset sepsis is 0.5 per 1,000 among term infants and increases to 1 per 1,000 among late preterm infants. The mortality rate is 2–3%. The most common causative agent is group B streptococcus

(GBS; 40–45% of cases). Other causative agents include *Escherichia coli* and other gram-negative rods (10–15% of cases), *Enterococcus faecalis*, *Staphylococcus aureus*, and *Listeria monocytogenes*.

Bacteria within the airways causes direct mucosa injury, surfactant dysfunction, pulmonary edema, mechanical airway obstruction due to inflammation and debris, and can trigger vasoconstriction and pulmonary hypertension. Infants are particularly susceptible to infection due to immaturity of their innate and adaptive immune systems, a risk factor that is more pronounced in premature or growth-restricted infants. Additional risk factors for infection include being male, known maternal colonization with GBS, maternal fever, and prolonged rupture of membranes (>18 hours).

Diagnosis of neonatal pneumonia includes radiographic evidence of infiltrate, and consolidation, and less often cavitation or pneumatocele. Infants will display hypoxic and hypercarbic respiratory failure with frequent need for invasive ventilation; hypotension is common. Temperature instability, particularly hypothermia, is also common. White blood cell counts and single values of inflammatory markers have limited predictive potential. Blood cultures are indicated, and cerebrospinal fluid should be obtained if the blood culture is positive.

*Treatment of neonatal pneumonia includes the prompt initiation of empiric broad-spectrum antibiotics.* Commonly, ampicillin and an aminoglycoside (gentamicin) are used as first-line therapy with the substitution of a cephalosporin or meropenem in place of the aminoglycoside when meningitis is a concern or in cases of suspected antibiotic resistance. Therapy is typically 7–14 days in duration and should be completed parenterally.

Prevention of early-onset sepsis has largely involved the targeted intrapartum antibiotic prophylaxis of mothers known to be colonized with GBS. GBS prophylaxis, generally penicillin, is indicated for women who screen positive for colonization via vaginal-rectal culture at 36–37 weeks' gestation, have a history of an infant affected by GBS disease, or for preterm labor when GBS status is unknown. Additional broad-spectrum antibiotic therapy is indicated for women with intrapartum fever to decrease risk of ascending infection.

For more information on early-onset sepsis see Chapter 149.

### Meconium Aspiration Syndrome

Meconium-stained amniotic fluid is found in 10–15% of births and usually occurs in term or postterm infants. MAS develops in 5% of such infants; 30% require mechanical ventilation, and 3–5% die. Usually, but



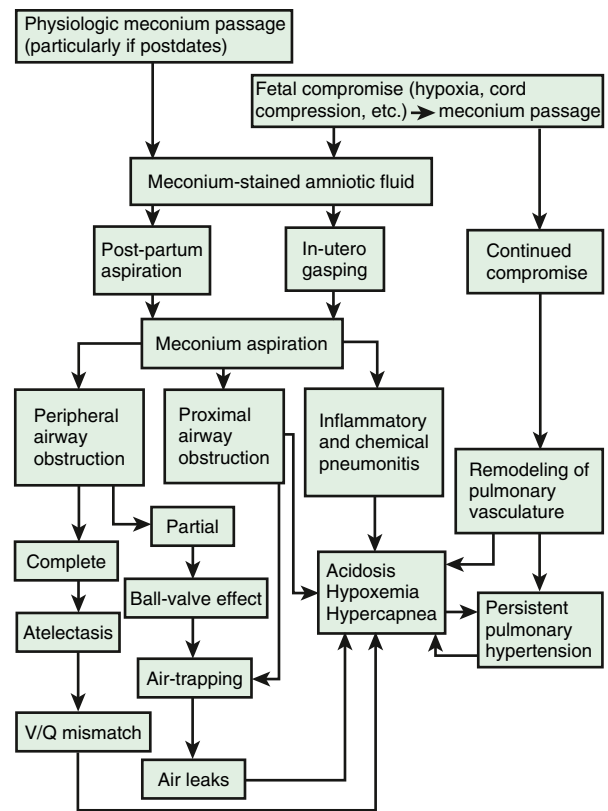
**Fig. 129.1** Anteroposterior chest radiograph of a term infant with meconium aspiration syndrome shows the typical pattern of mixed atelectasis and local emphysema. An endotracheal tube is seen in good position. Two chest tubes are present in the right chest without persistent pneumothorax. (From Rodriguez NE. *Assessment of the neonatal and pediatric patient*. In Heuer AJ, ed. *Wilkins' Clinical Assessment in Respiratory Care*, 9th ed. Philadelphia: Elsevier; 2022: Fig. 12.17)

not invariably, fetal distress and hypoxia occur before the passage of meconium into amniotic fluid. The infants are meconium stained and may be depressed and require resuscitation at birth. Either in utero or with the first breath, thick, particulate meconium is aspirated into the lungs. Partial obstruction of some airways may lead to pneumomediastinum, pneumothorax, or both. Overdistention of the chest may be prominent. Meconium within the lungs causes a chemical pneumonitis leading to surfactant dysfunction and inflammation (Fig. 129.1). The combination of airway obstruction and chemical injury can contribute to the development of persistent pulmonary hypertension of the newborn (PPHN; see Chapter 130). The pathophysiology of MAS is further described in Figure 129.2.

The clinical presentation of MAS is that of respiratory distress and cyanosis. In cases where in utero hypoxia was present, the presentation of MAS may be compounded by hypoxic ischemic encephalopathy and multiorgan dysfunction (including myocardial injury). The condition usually improves within 72 hours, but when its course requires assisted ventilation, it may be severe, prolonged, and with a risk for mortality. Tachypnea may persist for many days or even several weeks. The typical chest radiograph is characterized by patchy infiltrates, coarse streaking of both lung fields, increased anteroposterior diameter, and flattening of the diaphragm with possible pneumothorax (see Fig. 129.1).

The risk of meconium aspiration may be decreased by rapid identification of fetal distress and initiation of prompt delivery. Intrapartum nasopharyngeal suctioning in infants with meconium-stained amniotic fluid does not reduce the risk for MAS. Routine intubation and aspiration of depressed infants (those with hypotonia, bradycardia, or decreased respiratory effort) born through meconium-stained fluid is not effective in reducing the MAS or other major adverse outcomes and is not recommended for neonatal resuscitation. The risk of meconium-stained amniotic fluids increases with increasing gestational age. Additionally, among those infants with meconium-stained fluids, the risk for MAS increases with increasing gestational age (4.8% at >42 weeks vs 2.6% at 40 weeks) therefore limiting significantly postterm deliveries (>42 weeks) decreases the incidence of MAS.

**Treatment** of MAS includes supportive care and standard management for respiratory distress. The beneficial effect of mean airway pressure on oxygenation must be weighed against the risk of pneumothorax. Administration of exogenous surfactant and/or



**Fig. 129.2** Pathophysiology of meconium passage and the meconium aspiration syndrome. V/Q, ventilation-perfusion ratio. (From Wiswell TE, Bent RC. *Meconium staining and the meconium aspiration syndrome: unresolved issues*. *Pediatr Clin North Am*. 1993;40:955–981.)

inhaled nitric oxide (iNO) to infants with MAS and hypoxemic respiratory failure, or pulmonary hypertension requiring mechanical ventilation, decreases the need for extracorporeal membrane oxygenation (ECMO), which is required by the most severely affected infants who show no response to therapy. In infants with MAS who demonstrate no other signs of sepsis, there is no role for continued antibiotic therapy. Severe meconium aspiration may be complicated by persistent pulmonary hypertension. Patients with MAS refractory to conventional mechanical ventilation may benefit from high-frequency ventilation (HFV) or ECMO (see Chapter 130). Management may also include concurrent treatment for hypoxic injury as discussed in Chapter 120.

The mortality rate of meconium-stained infants is considerably higher than that of nonstained infants. The decline in neonatal deaths caused by MAS is related to improvements in obstetric and neonatal care. Residual lung problems are rare but include symptomatic cough, wheezing, and persistent hyperinflation for up to 5–10 years. The ultimate prognosis depends on the extent of central nervous system injury from asphyxia and the presence of associated problems such as pulmonary hypertension.

## POSTPARTUM ASPIRATION

Aspiration in the newborn after birth can be globally divided into categories of anatomic abnormalities and swallowing dysfunction. Regardless of the cause, the consequences of aspiration include pneumonia, chemical pneumonitis, and airway swelling.

### Anatomic Causes of Postpartum Aspiration

Abnormalities of the aerodigestive tract can contribute to the passage of oral secretions and milk into the lungs. Obstruction or narrowing of the nasal cavity or nasopharynx can interrupt the normal



suck-swallow-breath cycle of the infant and increase the risk of aspiration. These conditions include genetic disorders associated with midface hypoplasia, choanal atresia, and congenital nasal masses or tumors. Infants with nasal obstruction will present with stertor, cyanosis improved with crying, and an inability to pass a nasal feeding tube. Oral sources of aspiration include micrognathia/retrognathia and oral masses that compromise airway protection. Cleft lip and palate can impair velopharyngeal closure and increase nasal regurgitation of milk with subsequent aspiration. Anatomic causes of aspiration at the level of the larynx include laryngomalacia due to increased work of breathing with poorer airway protective mechanisms, laryngotracheoesophageal clefts, and vocal fold paralysis or paresis where aspiration occurs as the vocal folds are unable to adduct and protect the airway. Tracheoesophageal fistula (TEF) contributes to aspiration via a direct connection between the esophagus and the airway. TEF can be divided into five types based on the location of the fistula and presence of esophageal atresia. Prenatal diagnosis may occur after the recognition of polyhydramnios and a small fetal stomach. Postnatal symptoms include excessive salivation that worsen with feeding attempts, choking, cough, cyanosis, respiratory distress, and an inability to pass an orogastric (OG) tube. TEF should prompt an evaluation for other anomalies.

When an anatomic abnormality is believed to be contributing to aspiration, initial management should include cessation of feeding pending an evaluation. Some conditions including vocal fold paresis and laryngomalacia may resolve spontaneously, and modified feeding strategies, often under the direction of a speech language pathologist, can allow delivery of nutrition until the condition improves with time and growth. Cleft palate can often be managed with feeding modification until surgical repair in infancy. Other conditions including choanal atresia and TEF require surgical intervention in the newborn period. In some cases, tracheostomy is required for infants unable to adequately protect their airway. Although reflux alone is not the cause of aspiration in these cases, decreasing the acidity of the aspirate may decrease airway swelling, and antireflux medications can be considered in select populations.

### Swallowing Dysfunction

Swallowing dysfunction is another cause of aspiration in the newborn. Swallowing is a complex process and must be coordinated with respirations. Infants with neurologic injury may display abnormalities in the swallowing reflex or in the recognition and prevention of aspiration. Infants with pulmonary or cardiovascular disease leading to tachypnea will have more trouble coordinating a suck-swallow-breath cycle. Premature infants are more likely to have swallowing dysfunction because of prematurity-related pulmonary insufficiency and because of immaturity of the swallow mechanism, which begins to mature between 32 and 34 weeks. Hypotonic infants due to neuromuscular diseases or as a sequelae of hypoxic-ischemic encephalopathy are at increased risk of aspiration.

Evaluation of the swallow in at-risk infants often occurs with the assistance of a speech language pathologist and may include video fluoroscopic swallow studies to evaluate swallowing pattern and document aspiration. A fiberoptic endoscopic evaluation of the swallow (FEES) is another strategy whereby a speech language pathologist and ear, nose, and throat doctor observe a small-volume swallow via direct endoscopic visualization. Neurologic imaging may be indicated to assess for the underlying etiology of an ineffective or uncoordinated swallow.

Treatment strategies include feeding modifications such as pacing (tilting the bottle down every three to five sucks to allow recovery time), modified feeding position, or using a slower flow nipple. In cases where feeding modification does not adequately improve swallow safety, a percutaneous gastric tube for feeding may be indicated.

Visit Elsevier eBooks+ at [eBooks.Health.Elsevier.com](http://eBooks.Health.Elsevier.com) for Bibliography.

## Chapter 130

# Persistent Pulmonary Hypertension of the Newborn (Persistent Fetal Circulation)

Alicia J. Sprecher, Krishna K. Acharya, and Susan S. Cohen

Persistent pulmonary hypertension of the newborn (PPHN) predominantly occurs in term and postterm infants. Predisposing factors include birth asphyxia, meconium aspiration syndrome (MAS), early-onset sepsis, respiratory distress syndrome (RDS), hypoglycemia, polycythemia, maternal use of nonsteroidal antiinflammatory drugs with in utero constriction of the ductus arteriosus, maternal late trimester use of selective serotonin reuptake inhibitors, and pulmonary hypoplasia caused by diaphragmatic hernia (Table 130.1). PPHN is often idiopathic. Some patients with PPHN have low plasma arginine and nitric oxide (NO) metabolite concentrations and polymorphisms of the carbamoyl phosphate synthase gene, findings suggestive of a possible subtle defect in NO production. The incidence is 1 in 500-1,500 live births, with a wide variation among clinical centers. Regardless of etiology of PPHN, profound hypoxemia from right-to-left shunting and normal or elevated PaCO<sub>2</sub> are present (Fig. 130.1).

### PATHOPHYSIOLOGY

Persistence of the fetal circulatory pattern of right-to-left shunting through the patent ductus arteriosus (PDA) and foramen ovale after birth is a result of excessively high pulmonary vascular resistance (PVR). Fetal PVR is usually elevated relative to fetal systemic or postnatal pulmonary pressure. This fetal state normally permits shunting of oxygenated umbilical venous blood to the left atrium (and brain) through the foramen ovale, from which it bypasses the lungs through the ductus arteriosus and passes to the descending aorta. After birth, PVR normally declines rapidly as a consequence of vasodilation secondary to lung inflation, a rise in postnatal PaO<sub>2</sub>, a reduction in PaCO<sub>2</sub>, increased pH, and release of vasoactive substances. Increased neonatal PVR may be (1) **maladaptive** from an acute injury (not demonstrating normal vasodilation in response to increased O<sub>2</sub> and other changes after birth); (2) the result of increased pulmonary artery medial muscle thickness and extension of smooth muscle layers into the usually non-muscular, more peripheral pulmonary arterioles in response to chronic fetal hypoxia; (3) a consequence of **pulmonary hypoplasia** (diaphragmatic hernia, Potter syndrome); or (4) **obstructive** as a result of polycythemia, total anomalous pulmonary venous return (TAPVR), or congenital diffuse development disorders of acinar lung development.

### CLINICAL MANIFESTATIONS

PPHN usually manifests in the delivery room or within the first 12 hours after birth. Idiopathic PPHN or PPHN related to polycythemia, hypoglycemia, hypothermia, or asphyxia may result in severe cyanosis and respiratory distress. In some cases, however, initial signs of respiratory distress may be minimal. Infants who have PPHN associated with meconium aspiration, group B streptococcal pneumonia, diaphragmatic hernia, or pulmonary hypoplasia usually exhibit cyanosis, grunting, flaring, retractions, tachycardia, and shock. Multiorgan involvement may be present. Myocardial ischemia, papillary muscle dysfunction with mitral and tricuspid regurgitation, and biventricular dysfunction produce cardiogenic shock with decreases in pulmonary blood flow, tissue perfusion, and O<sub>2</sub> delivery.

**Table 130.1** Etiology of Persistent Pulmonary Hypertension of the Newborn in Neonates**Maladaptation of pulmonary vasculature (abnormal, "reactive" pulmonary vasoconstriction)**

- Parenchymal lung diseases, such as meconium aspiration syndrome (MAS), respiratory distress syndrome (RDS), and pneumonia
- In response to systemic disorders, such as hypothermia, sepsis, fetal hypoxia/distress, hypercapnia, acidosis, and hyperviscosity
- Toxic/pharmacologic exposure in utero (maternal selective serotonin reuptake inhibitor (SSRI) use)

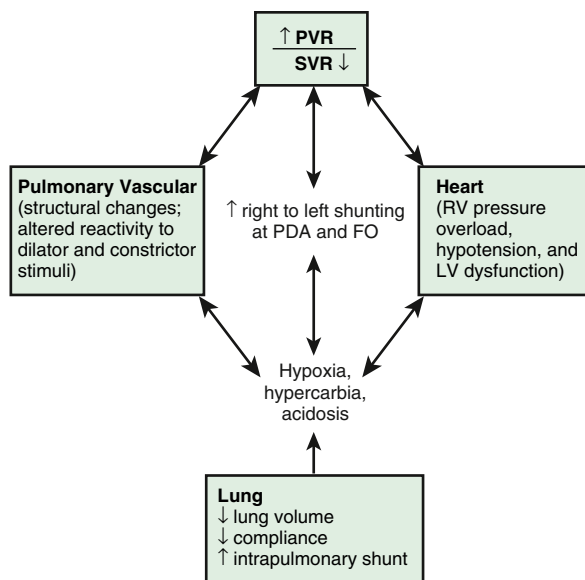
**Maldevelopment of pulmonary vasculature (remodeling of pulmonary vasculature)**

- In utero closure of ductus arteriosus (maternal cyclooxygenase inhibitor use)
- Sustained pulmonary over circulation in congenital heart disease with large left-to-right shunts
- Intrauterine growth restriction
- Genetic/chromosomal anomalies (trisomy 21, alveolar-capillary dysplasia, surfactant protein deficiency)

**Underdevelopment of pulmonary vasculature (hypoplastic pulmonary vessels; ↓ cross-sectional area)**

- Congenital diaphragmatic hernia
- Pulmonary hypoplasia (premature prolonged rupture of membranes, oligohydramnios and anhydramnios, space-occupying lesions in the chest).

From Sharma M, Callan E, Konduri GG. Pulmonary vasodilator therapy in persistent pulmonary hypertension of the newborn. *Clin Perinatol.* 2022;49:103–105. Box 1.

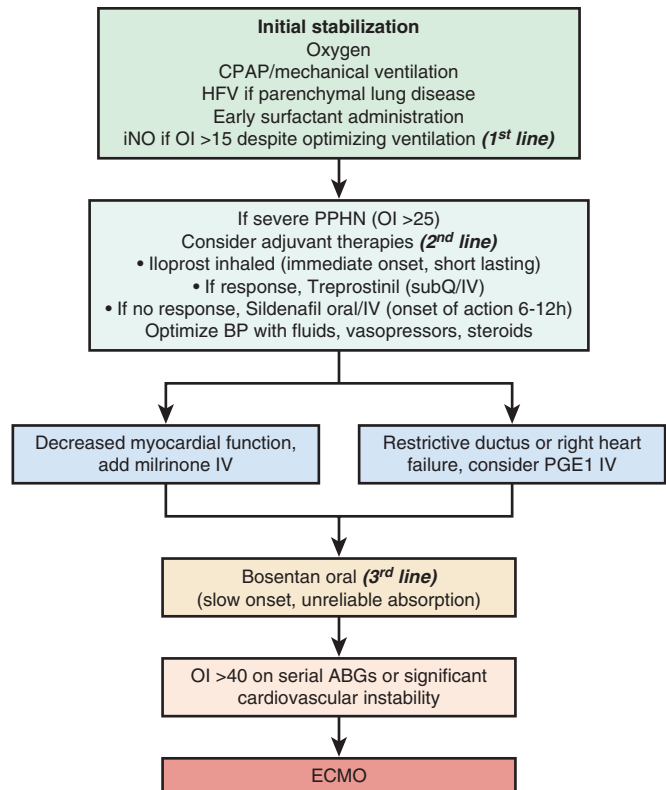


**Fig. 130.1** Cardiopulmonary interactions in persistent pulmonary hypertension of the newborn (PPHN). FO, Foramen ovale; LV, left ventricle; PDA, patent ductus arteriosus; PVR, pulmonary vascular resistance; RV, right ventricle; SVR, systemic vascular resistance. (From Kinsella JP, Abman SH. *Recent developments in the pathophysiology and treatment of persistent pulmonary hypertension of the newborn.* *J Pediatr.* 1995;126:853–864.)

Hypoxemia is often labile and out of proportion to the findings on chest radiographs. In PPHN due to asphyxia and idiopathic PPHN, chest x-ray findings are often normal, whereas in PPHN associated with pneumonia and diaphragmatic hernia, parenchymal opacification and bowel/liver in the chest, respectively, are seen.

## DIAGNOSIS

Independent of the prenatal history, PPHN should be suspected in all term infants who have cyanosis. Hypoxemia is universal and intermittently unresponsive to 100% O<sub>2</sub> given by oxygen hood or nasal



**Fig. 130.2** Algorithm for the suggested approach and timing of interventions for the management of hypoxic respiratory failure (HRF)/persistent pulmonary hypertension of the newborn (PPHN). It is important to consider cardiopulmonary system to be one fully integrated unit and optimize lung recruitment, pulmonary vasodilation, and cardiac function to facilitate successful transition. The algorithm focuses on vasodilator agents and is not meant to be inclusive of all therapies used in the management of PPHN. ABG, Arterial blood gas; BP, blood pressure; CPAP, continuous positive airway pressure; ECMO, extracorporeal membrane oxygenation; HFV, high-frequency ventilation; iNO, inhaled nitric oxide; IV, intravenous; OI, oxygenation index; PGE<sub>1</sub>, prostaglandin E<sub>1</sub>; subQ, subcutaneous. (From Sharma M, Callan E, Konduri GG. *Pulmonary vasodilator therapy in persistent pulmonary hypertension of the newborn.* *Clin Perinatol.* 2022;49:103–105, Fig. 3.)

cannula. A Pao<sub>2</sub> or Sao<sub>2</sub> gradient between a preductal (right radial artery) and a postductal (umbilical artery) site of blood sampling suggests right-to-left shunting through the ductus arteriosus. Intracardiac shunting through the patent foramen ovale does not lead to a Pao<sub>2</sub> or Sao<sub>2</sub> gradient.

Real-time echocardiography combined with Doppler flow imaging is very helpful in evaluating PPHN. Systolic flattening of the interventricular septum as the right ventricular systolic pressure approaches the left ventricular systolic pressure can be used to estimate the degree of pulmonary hypertension. The peak velocity of the tricuspid valve regurgitation jet, when present, yields a quantitative estimate of the right ventricular systolic pressure. Likewise, the direction and velocity of a shunt across the PDA provides a quantitative comparison between the aortic and pulmonary artery pressures. In advanced cases, right-to-left or bidirectional shunting across a PDA and a patent foramen ovale can be observed.

**The differential diagnosis** of PPHN includes cyanotic heart disease (especially obstructed TAPVR), idiopathic pulmonary vein stenosis, congenital surfactant (protein) deficiency syndromes, pulmonary artery thrombosis, and congenital diffuse development disorders of acinar lung development (acinar dysplasia, congenital alveolar dysplasia, and alveolar capillary dysplasia with misalignment of the pulmonary veins).

**Alveolocapillary dysplasia (ACD)** is a rare, lethal autosomal recessive disorder of distal lung development characterized by immature lobular development and reduced capillary density. Infants with ACD

present with idiopathic PPHN, demonstrating little or no parenchymal lung disease and profound hypoxemia. Over 60% of infants with ACD manifest hypoxemia and respiratory failure within 48 hours of birth, while some with milder disease present beyond 6 months of age. The diagnosis is made on autopsy in 90% of cases, and the constellation of findings include thickened alveolar septa, increased muscularization of the pulmonary arterioles, a reduced number of capillaries, with the remaining capillaries demonstrating abnormal apposition to the air interface, and misalignment of the intrapulmonary veins. In up to 80% of cases, extrapulmonary malformations of the genitourinary, gastrointestinal, or cardiovascular system are present. Pathogenic variants in the transcription factor gene *FOXF1* have been identified in up to 40% of cases, but the diagnosis continues to rest on clinical and histopathologic features. There also may be associated gastrointestinal (malrotation), genitourinary, and cardiac (hypoplastic left heart syndrome) malformations. ACD is uniformly lethal and should be suspected in infants with idiopathic PPHN who fail to respond to maximal medical therapy, or when symptoms recur after successful weaning from extracorporeal membrane oxygenation (ECMO). In a UK ECMO report, up to 14% of infants who failed ECMO ultimately were diagnosed with ACD. Regardless of the timing of presentation, ACD is uniformly fatal, and lung transplantation remains the sole, experimental therapy.

## TREATMENT

Therapy for PPHN is directed toward correcting any predisposing condition (e.g., hypoglycemia, polycythemia) and improving poor tissue oxygenation by addressing the underlying pathology (Fig. 130.2). Initial management includes O<sub>2</sub> administration and correction of acidosis, hypotension, and hypercapnia. Persistent hypoxemia should be managed with intubation and mechanical ventilation.

Infants with PPHN are usually managed *without* hyperventilation or alkalinization. Gentle ventilation with normocarbica or permissive hypercarbia and avoidance of hypoxemia result in excellent outcomes and a low incidence of chronic lung disease and ECMO use.

Because of their instability and ability to fight the ventilator, newborns with PPHN usually require sedation. Nonpharmacologic measures such as minimal noise, light, and tactile stimulation are also employed. The use of paralytic agents is controversial and reserved for the newborn who cannot be treated with sedatives alone. Muscle relaxants may promote atelectasis of dependent lung regions and ventilation-perfusion mismatch and may be associated with an increased risk of death.

**Inotropic therapy** is frequently needed to support blood pressure and perfusion. Whereas epinephrine is frequently used as a first-line agent, other agents, such as dobutamine and milrinone, may be helpful when myocardial contractility is poor. Many centers use echo-guided assessment of cardiac function to choose appropriate inotropic therapy. Dopamine is typically avoided due to its ability to increase PVR. Some of the sickest newborns with PPHN demonstrate hypotension refractory to vasopressor administration. This results from desensitization of the cardiovascular system to catecholamines by overwhelming illness and relative adrenal insufficiency. Hydrocortisone rapidly upregulates cardiovascular adrenergic receptor expression and serves as a hormone substitute in cases of adrenal insufficiency.

**Inhaled nitric oxide (iNO)** is an endothelium-derived signaling molecule that relaxes vascular smooth muscle and can be delivered to the lung by inhalation. *Use of iNO reduces the need for ECMO support by approximately 40%.* The optimal starting dose is 20 ppm. Higher doses have not been shown to be more effective and are associated with side effects, including methemoglobinemia and increased levels of nitrogen dioxide, a pulmonary irritant. Most newborns require iNO for <5 days. Although iNO has been used as long-term therapy in

children and adults with primary pulmonary hypertension, prolonged dependency is rare in neonates and suggests the presence of lung hypoplasia, congenital heart disease, or ACD. The maximal safe duration of iNO therapy is unknown. The infant can be weaned to 5 ppm after 6–24 hours of therapy. The dose can then be reduced slowly and discontinued when  $F_{iO_2}$  is <0.6 and the iNO dose is 1 ppm. Abrupt discontinuation should be avoided because it may cause rebound pulmonary hypertension. iNO should be used only at institutions that offer ECMO support or have the capability of transporting an infant on iNO therapy if a referral for ECMO is necessary. Some infants with PPHN do not respond adequately to iNO. Therapy with continuous inhaled or intravenous (IV) prostacyclin (prostaglandin I<sub>2</sub>) can improve oxygenation in infants with PPHN. The safety and efficacy of sildenafil (type 5 phosphodiesterase inhibitor) in newborns with PPHN is under investigation; initial results are promising.

In 5–10% of patients with PPHN, the response to 100% O<sub>2</sub>, mechanical ventilation, and drugs is poor, and many of these infants benefit from ECMO. In such patients, two parameters have been used to predict mortality: the alveolar-arterial oxygen gradient (PA-aO<sub>2</sub>), and the oxygenation index (OI), calculated as  $F_{iO_2}$  (as %) × MAP/PaO<sub>2</sub>. A PA-aO<sub>2</sub> >600 for 8–12 hours and an OI >40 unresponsive to iNO predict a high mortality rate (>80%) and are indications for ECMO. In carefully selected, severely ill infants with hypoxemic respiratory failure caused by RDS, meconium aspiration pneumonia, congenital diaphragmatic hernia, PPHN, or sepsis, ECMO significantly improves survival.

**ECMO** is a form of cardiopulmonary bypass that augments systemic perfusion and provides gas exchange. Most experience has been with *venoarterial bypass*, which requires carotid artery ligation and the placement of large catheters in the right internal jugular vein and carotid artery. *Venovenous bypass* avoids carotid artery ligation and provides gas exchange, but it does not support cardiac output. Blood is initially pumped through the ECMO circuit at a rate that approximates 80% of the estimated cardiac output (150–200 mL/kg/min). Venous return passes through a membrane oxygenator, is rewarmed, and returns to the aortic arch in venoarterial ECMO and to the right atrium in venovenous ECMO. Venous O<sub>2</sub> saturation values are used to monitor tissue O<sub>2</sub> delivery and subsequent extraction for infants undergoing venoarterial ECMO, whereas arterial O<sub>2</sub> saturation values are used to monitor oxygenation for infants receiving venovenous ECMO.

Because ECMO requires complete heparinization to prevent clotting in the circuit, its use is generally avoided in patients with existing intracranial hemorrhage or who are at high risk of developing intraventricular hemorrhage (weight <2 kg, gestational age <34 weeks). In addition, infants being considered for ECMO should have reversible lung disease, no signs of systemic bleeding, and no severe asphyxia or lethal malformations, and they should have been ventilated for <10 days. Complications of ECMO include thromboembolism, air embolization, bleeding, stroke, seizures, atelectasis, cholestatic jaundice, thrombocytopenia, neutropenia, hemolysis, infectious complications of blood transfusions, edema formation, and systemic hypertension.

## PROGNOSIS

Survival in patients with PPHN varies with the underlying diagnosis but is generally ~90%. Long-term, survivors of PPHN are at risk for neurodevelopmental impairment and sensorineural deafness, which can occur in about 25% of patients. The outcome for infants with PPHN who are treated with ECMO is also favorable; >80–90% survive, and 60–75% of survivors appear normal at 1–3.5 years of age.

Visit Elsevier eBooks+ at [eBooks.Health.Elsevier.com](http://eBooks.Health.Elsevier.com) for Bibliography.



## Chapter 131

## Diaphragmatic Hernia

Krishna K. Acharya, Alicia J. Sprecher, and Susan S. Cohen

A diaphragmatic hernia is defined as a communication between the abdominal and thoracic cavities with or without abdominal contents in the thorax (Fig. 131.1). The etiology is rarely traumatic and usually congenital. The symptoms and prognosis depend on the location of the defect and associated anomalies. The defect may be at the esophageal hiatus (**hiatal hernia**); paraesophageal, adjacent to the hiatus (**paraesophageal hernia**; see Chapter 131.2); retrosternal (**foramen of Morgagni hernia**; see Chapter 131.1); or at the posterolateral portion of the diaphragm (**Bochdalek hernia**). In **congenital diaphragmatic hernia (CDH)**, the Bochdalek hernia accounts for up to 90% of the hernias seen, with 80–90% occurring on the left side. The Morgagni hernia accounts for 2–6% of CDH. The size of the defect is highly variable, ranging from a small hole to complete agenesis of this area of the diaphragm. These lesions may cause significant respiratory distress at birth, can be associated with other congenital anomalies, and have significant mortality and long-term morbidity.

### CONGENITAL DIAPHRAGMATIC HERNIA (BOCHDALEK)

#### Pathology and Etiology

Although CDH is characterized by a structural diaphragmatic defect, a major limiting factor for survival is the association with other anomalies, syndromes, and primarily with pulmonary hypoplasia. Lung hypoplasia was initially thought to be solely caused by the compression of the lung from the herniated abdominal contents, which impaired lung growth. However, evidence indicates that pulmonary hypoplasia, at least in some cases, may precede the development of the diaphragmatic defect.

Pulmonary hypoplasia is characterized by a reduction in pulmonary mass and the number of bronchial divisions, respiratory bronchioles, and alveoli. The pathology of pulmonary hypoplasia and CDH includes abnormal septa in the terminal sacculles, thickened alveoli, and thickened pulmonary arterioles. Biochemical abnormalities include relative

surfactant deficiencies, increased glycogen in the alveoli, and decreased levels of phosphatidylcholine, total DNA, and total lung protein, all of which contribute to limited gas exchange.

#### Epidemiology

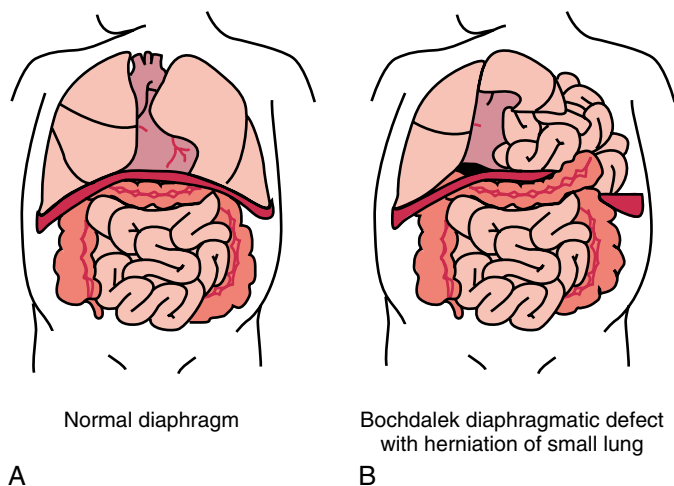
The incidence of CDH is between 1 in 2,000 and 1 in 3,000 live births, with males affected more often than females. Defects are more common on the left (85%) and are occasionally bilateral (<5%). Pulmonary hypoplasia and malrotation of the intestine are part of the lesion, not associated anomalies. Most cases of CDH are nonsyndromic (sporadic; 60%), but familial and syndromic cases have been reported. Associated anomalies in nonsyndromic patients have been reported in up to 30% of cases, including hypoplastic left heart syndrome and accessory spleens. CDH is recognized as part of several aneuploidy syndromes: trisomies 21, 13, and 18 and those with copy number variation: del 15q26.1-q26.2, del 8p23.1, del 1q41-q42, and del 4p16.3 as well as definable single gene syndromes including Cornelia de Lange, Donnai-Barrow, Cutis Laxa, cardiac-urogenital, and Matthew-Wood syndromes.

#### Diagnosis and Clinical Presentation

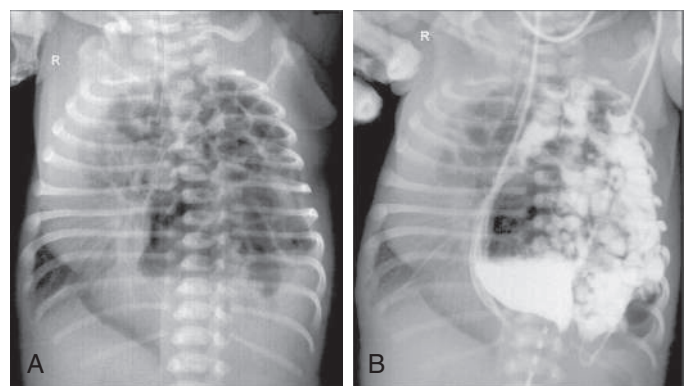
In >50% of cases, CDH can be diagnosed on prenatal ultrasonography (US) between 16 and 24 weeks of gestation. High-speed fetal MRI can further define the lesion. US findings may include polyhydramnios, chest mass, mediastinal shift, gastric bubble or a liver in the thoracic cavity, and fetal hydrops. Certain imaging features may predict outcome including liver position in the chest, observed-to-expected total lung volume (O/E TLV), and observed-to-expected lung-to-head ratio (O/E LHR). Nonetheless, no definitive characteristic reliably predicts outcome. After delivery, a chest radiograph is needed to confirm the diagnosis (Fig. 131.2). In some infants with an echogenic chest mass, further imaging is required. The differential diagnosis may include other diaphragm disorders, such as eventration or a cystic lung lesion (pulmonary sequestration, cystic adenomatoid malformation).

Arriving at the diagnosis early in pregnancy allows for prenatal counseling, possible fetal interventions (see Chapter 118), and planning for postnatal care. A referral to a center providing high-risk obstetrics, pediatric surgery, and tertiary care neonatology is advised. Careful evaluation for other anomalies should include echocardiography and amniocentesis. To avoid unnecessary pregnancy termination and unrealistic expectations, an experienced multidisciplinary group must carefully counsel the parents of a child diagnosed with a diaphragmatic hernia.

Respiratory distress is a cardinal sign in babies with CDH. It may occur immediately after birth, or there may be a period of up to 48 hours during which the baby is relatively stable. Respiratory distress



**Fig. 131.1** A, Normal diaphragm separating the abdominal and thoracic cavity. B, Diaphragmatic hernia with a small lung and abdominal contents in the thoracic cavity.



**Fig. 131.2** Bochdalek hernia. A, Chest radiograph showing herniated bowel loops in the left hemithorax, displacement of the mediastinum to the contralateral side, severely reduced lung space, and unclear lung fields bilaterally. B, Upper gastrointestinal tract radiograph showing the stomach and bowel loops stained with contrast in the left hemithorax. (From Hu X, Liu B. Bochdalek hernia. *Lancet*. 2018;392:60.)



is characterized clinically by tachypnea, grunting, use of accessory muscles, and cyanosis. Children with CDH may also have a scaphoid abdomen and increased chest wall diameter. Bowel sounds may also be heard in the chest with decreased breath sounds bilaterally. The point of maximal cardiac impulse may be displaced away from the side of the hernia if mediastinal shift has occurred. A chest radiograph and passage of a gastric tube are usually sufficient to confirm the diagnosis.

A small group of infants with CDH present beyond the neonatal period. Patients with a delayed presentation may experience vomiting as a result of intestinal obstruction or mild respiratory symptoms. Occasionally, incarceration of the intestine proceeds to ischemia with sepsis and shock. Unrecognized diaphragmatic hernia is a rare cause of sudden death in infants and toddlers. Group B streptococcal sepsis has been associated with delayed onset of symptoms and a CDH (often right side).

## Treatment

### Initial Management

Delivery at a tertiary center with experience in the management of CDH is required to provide early, appropriate respiratory support. In the delivery room, infants with respiratory distress should be rapidly stabilized with endotracheal intubation. *Prolonged mask ventilation in the delivery room, which enlarges the stomach and small bowel and thus makes oxygenation more difficult, must be avoided and a nasogastric or orogastric tube placed immediately for decompression.* Once in the neonatal intensive care unit (NICU), central arterial and venous (umbilical) lines are placed, pre- and postductal saturations monitored, and gastric contents intermittently decompressed to prevent enlargement. A preductal arterial oxygen saturation (SpO<sub>2</sub>) value  $\geq 85\%$  should be the minimum goal. An initial arterial PCO<sub>2</sub>  $> 80$  mm Hg is predictive of mortality in infants with CDH. Volutrauma is a significant problem. *Gentle ventilation with permissive hypercapnia reduces lung injury, need for extracorporeal membrane oxygenation (ECMO), and mortality.* Factors that contribute to persistent pulmonary hypertension of the newborn (PPHN; hypoxia, acidosis, hypothermia) should be avoided (see Chapter 130). Echocardiography is important to guide therapeutic decisions by measuring pulmonary and system vascular pressures and defining the presence of cardiac dysfunction. Routine use of inotropes is indicated in the presence of left ventricular dysfunction. Neonates with CDH may be surfactant deficient. Although surfactant is frequently used, no study has proved that it is beneficial in treatment of CDH, and it may precipitate decompensation. In infants with severe respiratory failure and hypoxemia, sedation and paralysis may be required.

### Ventilation Strategies

Conventional mechanical ventilation, high-frequency oscillatory ventilation (HFOV), and ECMO are the three main strategies to support respiratory failure in the newborn with CDH. The goal is to maintain oxygenation and CO<sub>2</sub> elimination without inducing volutrauma. Conventional ventilation using a gentle, lung protective strategy (peak inspiratory pressure [PIP]  $< 25$ , positive end-expiratory pressure [PEEP] 3–5 cm H<sub>2</sub>O) that allows for permissive hypercapnia (PaCO<sub>2</sub>  $< 65$  mm Hg) is recommended. Permissive hypercapnia (as opposed to hyperventilation with high PIP) has reduced lung injury and improved survival. HFOV as a rescue therapy is indicated if a PIP  $> 25$  is required to maintain appropriate ventilation or if hypoxemia persists.

Inhaled nitric oxide (iNO) is a selective pulmonary vasodilator. Its use reduces ductal shunting and pulmonary pressures and results in improved oxygenation. Although iNO has been helpful in PPHN, randomized trials have not demonstrated improved survival or reduced need for ECMO when iNO is used in newborns with CDH. Nonetheless, iNO is used in patients with CDH as a bridge to ECMO.

### Extracorporeal Membrane Oxygenation

The availability of ECMO and the utility of preoperative stabilization has improved survival of babies with CDH. ECMO is the therapeutic option for children in whom conventional ventilation or HFOV fails. ECMO is most often used before repair of the defect. Several objective

criteria for ECMO have been developed. Birthweight and the 5-minute Apgar score may be the best predictors of outcome in patients treated with ECMO. There is no strict lower weight limit for ECMO, but generally, vessels in infants  $< 1,800$  g are too small to cannulate.

The duration of ECMO for neonates with diaphragmatic hernia is longer (than for those with isolated PPHN or meconium aspiration and may last up to 2–4 weeks). Timing of repair of the diaphragm while the infant receives ECMO is controversial; some experts prefer early repair to allow a greater duration of ECMO after the repair, whereas many defer repair until the infant has demonstrated the ability to tolerate weaning from ECMO. The recurrence of pulmonary hypertension is associated with high mortality and weaning from ECMO support should be cautious. If the patient cannot be weaned from ECMO after repair of CDH, redirection of care toward comfort is usually offered to families.

### Prenatal Markers of Severity and Fetal Treatment

The most studied prenatal predictor of outcome in children with CDH studied is fetal US. A prospective study of US at 24–26 weeks compared fetal LHR with mortality. There were no survivors with LHR  $< 1$ , but all babies with LHR  $> 1.4$  survived. A second important consideration is the presence of liver in the thoracic cavity, which is a poor prognostic feature. Because LHR measurements increase with gestation, an O/E LHR is considered a more reliable predictor of severity irrespective of GA. O/E LHR of  $\geq 45\%$  is considered a good prognostic sign, whereas  $< 25\%$  is considered a poor prognostic sign. Fetal MRI is used at many fetal centers at 28–32 weeks for prognostication. The advantages of fetal MRI are that they are operator independent, allow measurement of both lungs, and allow better tissue contrast and better images. Normal reference values for fetal lung volumes on MRI have been published and TLV can be compared with the referent fetus. O/E TLV  $\geq 45\%$  is a good prognostic sign, whereas  $< 25\%$  is considered a poor prognostic sign.

Based on the observation that hydrostatic pressure exerted by fetal lung fluid plays a critical role in lung growth and maturity, a promising fetal therapy is in utero tracheal occlusion (**fetoscopic endoluminal tracheal occlusion [FETO]**). FETO therapy at 27–29 weeks' gestation improves survival from 15% to 40% in fetuses with severe left CDH with O/E LHR of  $< 25\%$ ; preterm birth is a risk factor. FETO therapy is only offered at a select few centers across the United States (see Chapter 118).

### Surgical Repair

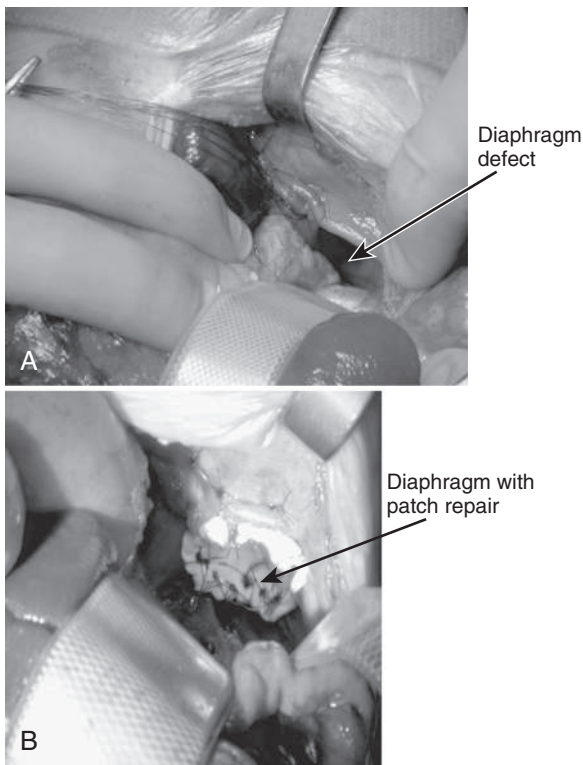
Most experts plan surgery at least 48 hours after stabilization and resolution of the pulmonary hypertension. Good relative indicators of stability are the requirement for conventional ventilation only, a low PIP, and FiO<sub>2</sub>  $< 50\%$ . If the newborn is receiving ECMO, an ability to be weaned from this support should be a consideration before surgical repair. In some centers, the repair is done with the cannulas in place; in other centers the cannulas are removed. A subcostal approach is most frequently used (Fig. 131.3). This allows for good visualization of the defect, and if the abdominal cavity cannot accommodate the herniated contents, a polymeric silicone (Silastic) patch can be placed, commonly known as a silo. Both laparoscopic and thoracoscopic repairs have been reported, but these should be reserved for only the most stable infants.

The defect size and amount of native diaphragm present are variable. Whenever possible, a primary repair using native tissue is performed. If the defect is too large, a porous polytetrafluoroethylene (Gore-Tex) patch is used.

Following surgical repair, the infant must be carefully monitored for worsening pulmonary hypertension. In some patients, a postoperative course of ECMO is needed. Other recognized complications include bleeding, chylothorax, and bowel obstruction. CDH recurrence can occur in about 10% of cases, usually during the first year of life, but can occur up to the first 5 years of life. There is a higher recurrence rate of CDH in children with patches (the patch does not grow as the child grows) than in those with native tissue repairs, those with larger defects, and those with liver in the defect. A loosely fitted patch may reduce the recurrence rates.

### Outcome and Long-Term Survival

Overall survival of liveborn infants with CDH is 75%. Relative predictors of a poor prognosis include an associated major anomaly and syndromes,



**Fig. 131.3** A, Intraoperative photo of congenital diaphragmatic hernia (CDH) before repair. B, Intraoperative photo of patch repair of CDH.

severe pulmonary hypoplasia, herniation to the contralateral lung, and the need for ECMO. The size of the defect appears to be the strongest predictor of morbidity.

Pulmonary problems continue to be a source of morbidity for long-term survivors of CDH. Children receiving CDH repair who were studied at 6–11 years of age demonstrated significant decreases in forced expiratory flow at 50% of vital capacity and decreased peak expiratory flow. Chronic lung disease can occur in about 15% of patients. Both obstructive and restrictive patterns can occur. Those without severe pulmonary hypertension and volutrauma do the best. Those at highest risk include children who required ECMO and patch repair, but the data clearly show that CDH survivors who did not require ECMO also need frequent attention to pulmonary issues. At discharge, up to 20% of infants require oxygen, but only 1–2% require oxygen past 1 year of age.

**Gastroesophageal reflux disease (GERD)** is reported in >50% of children with CDH. GERD is more common in children whose diaphragmatic defect involves the esophageal hiatus. **Intestinal obstruction** is reported in up to 20% of children and may result from a midgut volvulus, adhesions, or a recurrent hernia that became incarcerated.

Children with CDH typically have delayed growth in the first 2 years of life. Contributing factors include poor intake, GERD, and a caloric requirement that may be higher because of the energy required to breathe. Many children normalize and “catch up” in growth by the time they are 2 years old.

**Neurocognitive defects** are common and may result from the disease or the interventions. The incidence of neurologic abnormalities is higher in infants who require ECMO (67% vs 24% of those who do not). The abnormalities are similar to those seen in neonates treated with ECMO for other diagnoses and include transient and permanent developmental delay, abnormal hearing or vision, and seizures. Serious hearing loss may occur in up to 28% of children who underwent ECMO. The majority of neurologic abnormalities are classified as mild to moderate.

Other long-term problems include pectus excavatum and scoliosis. Survivors of CDH repair, particularly those requiring ECMO support, have a variety of long-term abnormalities that appear to improve with time but require close monitoring and multidisciplinary support.

**Health-related quality of life (HRQoL)** of school-age children born with CDH is overall good and comparable to healthy children,

although some children report lower quality of life. The burden of the child’s diagnosis on families long-term is also reportedly low. ECMO use is associated with a lower HRQoL in certain domains, as is the need for special education services in school, and chronic respiratory problems.

Visit Elsevier eBooks+ at [eBooks.Health.Elsevier.com](http://eBooks.Health.Elsevier.com) for Bibliography.

### 131.1 Foramen of Morgagni Hernia

Krishna K. Acharya, Alicia J. Sprecher, and Susan S. Cohen

Failure of the sternal and crural portions of the diaphragm to meet and fuse produces the foramen of Morgagni hernia. These defects are usually small, with a greater transverse than anteroposterior diameter, and are more often right sided (90%) but may be bilateral. The transverse colon, small intestine, or liver is usually contained in the hernial sac. Most children with these defects are asymptomatic and are diagnosed beyond the neonatal period, often by chest radiograph performed for evaluation of another condition. The anterolateral radiograph shows a structure behind the heart, and a lateral film localizes the mass to the retrosternal area. Chest CT or MRI confirms the diagnosis. When symptoms occur, they can include recurrent respiratory infections, cough, vomiting, or reflux; in rare cases, incarceration may occur. Repair is recommended for all patients, in view of the risk of bowel strangulation, and can be accomplished laparoscopically. Prosthetic material is rarely required.

### 131.2 Paraesophageal Hernia

Shawn K. Ahlfeld

Paraesophageal hernia is differentiated from the hiatal hernia in that the gastroesophageal junction is in the normal location. The herniation of the stomach alongside or adjacent to the gastroesophageal junction is prone to incarceration with strangulation and perforation. A previous Nissen fundoplication and other diaphragmatic procedures are risk factors. This unusual diaphragmatic hernia should be repaired promptly after identification.

### 131.3 Eventration

Krishna K. Acharya, Alicia J. Sprecher, and Susan S. Cohen

Eventration of the diaphragm is an abnormal elevation consisting of a thinned diaphragmatic muscle that causes elevation of the entire hemidiaphragm or more often the anterior aspect of the hemidiaphragm. This elevation produces a paradoxical motion of the affected hemidiaphragm. Most eventrations are asymptomatic and do not require repair. A congenital form is the result of either incomplete development of the muscular portion or central tendon or abnormal development of the phrenic nerves. Congenital eventration may affect lung development, but it has not been associated with pulmonary hypoplasia. The differential diagnosis includes diaphragmatic paralysis, diaphragmatic hernia, traction injury, and iatrogenic injury after heart surgery. Eventration is also associated with pulmonary sequestration, congenital heart disease, spinal muscular atrophy with respiratory distress, and chromosomal trisomies. Most eventrations are asymptomatic and do not require repair. The indications for surgery include continued need for mechanical ventilation, recurrent infections, and failure to thrive. Large or symptomatic eventrations can be repaired by plication through an abdominal or thoracic approach that is minimally invasive.

Visit Elsevier eBooks+ at [eBooks.Health.Elsevier.com](http://eBooks.Health.Elsevier.com) for Bibliography.

## Chapter 132

# Pulmonary Air Leaks: Pneumothorax, Pneumomediastinum, Pulmonary Interstitial Emphysema, Pneumopericardium

Alicia J. Sprecher, Krishna K. Acharya, and  
Susan S. Cohen

Pulmonary air leaks represent air breaching the alveolus and entering potential cavities within the chest. *Asymptomatic* pneumothorax, usually unilateral, is estimated to occur in 1–2% of all newborn infants; *symptomatic* pneumothorax and pneumomediastinum are less common. The incidence of pneumothorax is increased in infants with lung diseases such as meconium aspiration and respiratory distress syndrome (RDS); in those who receive assisted ventilation, especially if high-frequency ventilation (HFV) support is necessary; and in infants with pulmonary hypoplasia.

## ETIOLOGY AND PATHOPHYSIOLOGY

The most common cause of pneumothorax is overdistention resulting in alveolar rupture. Alveolar overdistention can occur with positive pressure ventilation during neonatal resuscitation, or it may occur in association with the “ball-valve” phenomenon that results from aspiration (classically meconium) and bronchial/bronchiolar obstruction. Although spontaneous rupture of an underlying pulmonary malformation (e.g., lobar emphysema, congenital lung cyst, pneumatocele) occurs, pneumothorax usually occurs in an otherwise normal lung, and no underlying etiology is identified.

Pneumothorax associated with **pulmonary hypoplasia** is common, tends to occur during the first few hours after birth, and is caused by reduced alveolar surface area and poorly compliant lungs. It is associated with disorders of decreased amniotic fluid volume (Potter syndrome, renal agenesis, renal dysplasia, chronic amniotic fluid leak), decreased fetal breathing movement (oligohydramnios, neuromuscular disease, fetal akinesia syndrome), pulmonary space-occupying lesions (diaphragmatic hernia, pleural effusion, chylothorax), and thoracic abnormalities (thoracic dystrophies).

Gas from a ruptured alveolus escapes into the interstitial spaces of the lung, where it tracks along small conducting airways and dissects along the peribronchial and perivascular connective tissue sheaths to the hilum of the lung (**pulmonary interstitial emphysema, PIE**). If the volume of escaped air is great enough, it may collect in the mediastinal space (pneumomediastinum) or rupture into the pleural space (pneumothorax), subcutaneous tissue (**subcutaneous emphysema**), and/or pericardial sac (**pneumopericardium**).

**Tension pneumothorax** occurs if an accumulation of air within the pleural space is sufficient to elevate intrapleural pressure above atmospheric pressure. Unilateral **tension pneumothorax** results in impaired ventilation not only in the ipsilateral lung but also in the contralateral

lung because of a shift in the mediastinum toward the contralateral side. Compression of the vena cava and torsion of the great vessels may interfere with venous return.

## CLINICAL MANIFESTATIONS

The physical findings of a clinically asymptomatic pneumothorax are hyperresonance and diminished ipsilateral breath sounds with or without tachypnea. Symptomatic pneumothorax is characterized by respiratory distress, which varies from merely high respiratory rate to severe dyspnea, tachypnea, and cyanosis. Irritability and restlessness or apnea may be the earliest signs. The onset is usually sudden but may be gradual; an infant may rapidly become critically ill. Physical exam findings include chest asymmetry with an increased anteroposterior diameter, hyperresonance, and diminished or absent breath sounds. The heart is displaced toward the contralateral side, resulting in displacement of the cardiac apex and point of maximal impulse. The diaphragm is displaced downward, as is the liver with right-sided pneumothorax, and may result in abdominal distention. Because pneumothorax may be bilateral in approximately 10% of patients, symmetry of findings does not rule it out. In tension pneumothorax, signs of shock are typical.

Pneumomediastinum can occur with or without a pneumothorax and itself is usually asymptomatic. The degree of respiratory distress depends on the amount of trapped gas; if great, bulging of the mid-thoracic area is observed, the neck veins are distended, and blood pressure is low. The last two findings are a result of tamponade of the systemic and pulmonary veins. Although often asymptomatic, **subcutaneous emphysema** in newborn infants is almost pathognomonic of pneumomediastinum. Rarely, air may embolize into the circulation (pulmonary air embolism) and cause cutaneous blanching, air in intravascular catheters, an air-filled heart and vessels on chest radiographs, and death.

**PIE** may precede the development of a pneumothorax or may occur independently and lead to increasing respiratory distress as a result of decreased compliance, hypercapnia, and hypoxemia. Hypoxemia is caused by an increased PA-aO<sub>2</sub> gradient and intrapulmonary shunting. Progressive enlargement of blebs of gas may result in cystic dilation and respiratory deterioration resembling pneumothorax. In severe cases, PIE precedes the development of bronchopulmonary dysplasia (BPD). Avoidance of high inspiratory or mean airway pressures may prevent the development of PIE.

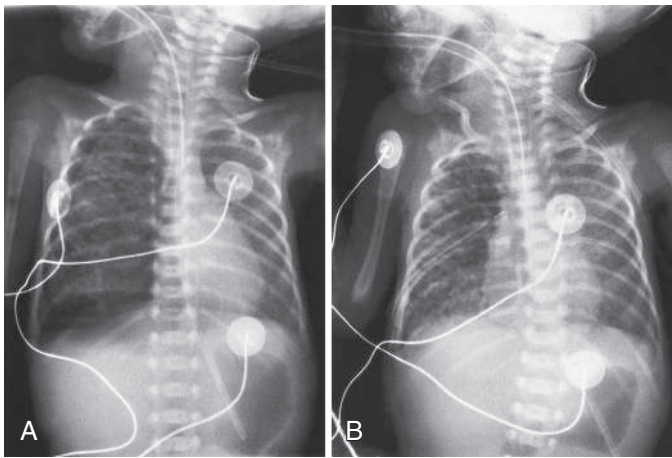
**Pneumopericardium** is generally associated with pneumothorax with air moving into the pericardium via areas of weakness in the pericardial sac or via embryonic connections between the pleura and pericardium. Pneumopericardium may be asymptomatic, requiring only general supportive treatment, but it usually manifests as sudden shock with tachycardia, muffled heart sounds, and poor pulses suggesting tamponade. Air pressure within the pericardium can cause cardiac tamponade.

Preterm infants whose course is complicated by pulmonary air leaks are at increased risk for mortality, BPD (see [Chapter 127](#)), severe intracranial hemorrhage, and prolonged NICU stays.

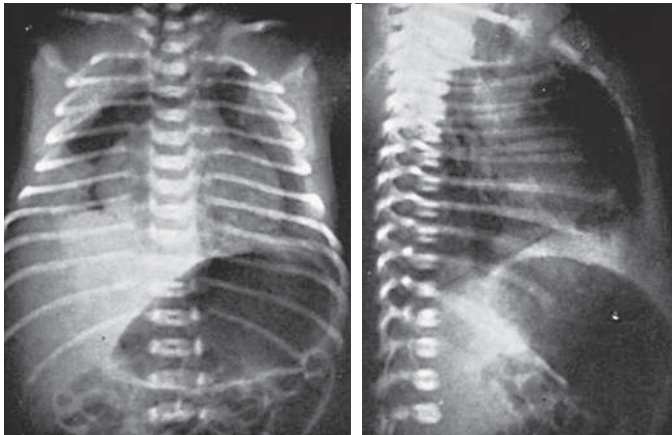
## DIAGNOSIS

Pneumothorax and other air leaks should be suspected in newborn infants who show signs of respiratory distress, are restless or irritable, or have a sudden change in condition. The diagnosis of pneumothorax is established by chest radiography, with the edge of the collapsed lung standing out in relief against the pneumothorax ([Fig. 132.1](#)). Pneumomediastinum is signified by hyperlucency around the heart border and between the sternum and the heart border and the displacement of the thymus by air, typically referred to as the “spinnaker sail” sign ([Fig. 132.2](#)). *Transillumination* of the thorax is often helpful in the emergency diagnosis of pneumothorax; the affected side transmits excessive light. In pneumopericardium, chest radiography demonstrates a halo of air around the cardiac silhouette. PIE appears as small cystic





**Fig. 132.1** A, Right-sided tension pneumothorax and widespread right lung pulmonary interstitial emphysema (PIE) in a preterm infant receiving intensive care. B, Resolution of pneumothorax with a chest tube in place; PIE persists. (From Meerstadt PWD, Gyll C. *Manual of Neonatal Emergency X-Ray Interpretation*. Philadelphia: Saunders; 1994. p. 73.)



**Fig. 132.2** Pneumomediastinum in newborn infant. Anteroposterior view (left) demonstrates compression of the lungs, and lateral view (right) shows bulging of the sternum, each resulting from distention of the mediastinum by trapped air.

radiolucencies along the interstitium often with hyperexpansion and is typically only seen in premature infants with preexisting lung disease.

### PREVENTION

Early recognition of patients at risk for air leak is essential. Infants with oligohydramnios, extreme prematurity, or congenital pulmonary malformations are at increased risk. Surfactant therapy for RDS (see Chapter 126) reduces the incidence of **pneumothorax**. Avoidance of high inspiratory or mean airway pressures may prevent the development of air leaks.

### TREATMENT

Without a continued air leak, small asymptomatic and mildly symptomatic pneumothorax, pneumomediastinum, and pneumopericardium require only close observation. Conservative management of a pneumothorax is effective even in selected infants requiring ventilatory support. Frequent small feedings may prevent gastric dilation and minimize crying, which can further compromise ventilation and worsen the pneumothorax. Breathing 100% oxygen in term infants may accelerate the resorption of free pleural air into blood by reducing the nitrogen tension in blood and producing a resultant nitrogen pressure gradient from the trapped gas in the blood; however, this is no longer practiced given the risks of oxygen toxicity.

When a pneumothorax is large, expanding, or with severe respiratory or circulatory embarrassment, emergency decompression by needle thoracentesis and/or chest tube placement is indicated. Needle thoracentesis is typically accomplished with the use of an angiocath or a 23-gauge butterfly needle attached to a stopcock and syringe to withdraw air. It can be inserted into the second intercostal space of the anterior chest. After the needle thoracentesis a chest radiograph should be obtained to evaluate and monitor for reaccumulation.

Chest tube placement should be undertaken in cases of recurrent pneumothorax after needle decompression or as a primary intervention in select patients at risk for ongoing air leak (i.e., on high-pressure invasive ventilation). In studies comparing needle decompression with primary chest tube placement there are no differences in mortality; however, approximately 30% of patients receiving a needle thoracentesis eventually required chest tube placement. **Chest tube placement** should occur under sterile conditions whenever possible and be preceded by appropriate analgesia. Pigtail catheters are the preferred type of chest tube in infants because of higher success rates and low complication rates. These catheters are placed using the Seldinger technique by introducing a needle, aspirating free air, and subsequently introducing a guidewire over which a pigtail catheter is advanced. Ideally the chest tube should be introduced into the fourth intercostal space (generally at the level of the nipple) in the anterior axillary line. Following placement, the chest tube should be attached to underwater seal drainage or continuous suction (−5 to −20 cm H<sub>2</sub>O). Serial chest radiographs should be obtained for all infants with a chest tube in place.

*Pneumopericardium with clinical symptoms (tamponade) requires prompt evacuation of entrapped air via pericardiocentesis.* **Pericardiocentesis** should be performed using sterile technique and analgesia whenever possible. Ideally an echocardiogram should be completed before undertaking the procedure and cardiology or cardiothoracic surgery involvement is encouraged. Continuous cardiopulmonary monitoring is essential during the procedure. A 20–23-gauge butterfly needle is introduced into the chest to the left of the subxiphoid process at a 30–45-degree angle pointing toward the right shoulder. The needle is advanced until air returns and the pericardium is subsequently evacuated of air. The provider should stop aspirating once air no longer returns, if there is blood return, or if ectopy is observed. Following the procedure an echocardiogram should be obtained.

Treatment of PIE may include bronchoscopy in patients with evidence of mucous plugging, selective intubation and ventilation of the uninvolved bronchus, oxygen, general respiratory care, and use of HFV.

Visit Elsevier eBooks+ at [eBooks.Health.Elsevier.com](http://eBooks.Health.Elsevier.com) for Bibliography.



## Chapter 133

## Pulmonary Hemorrhage

Alicia J. Sprecher, Krishna K. Acharya, and Susan S. Cohen

Massive pulmonary hemorrhage is a relatively uncommon, but catastrophic complication with a high risk of morbidity and mortality. Some degree of pulmonary hemorrhage occurs in about 10% of extremely preterm infants. However, massive pulmonary hemorrhage is less common and can be fatal. Autopsy demonstrates massive pulmonary hemorrhage in 15% of neonates who die in the first 2 weeks of life. The reported incidence at autopsy varies from 1-4 per 1,000 live births. Approximately 75% of affected patients weigh <2,500 g at birth. Prophylactic indomethacin in extremely low birthweight (ELBW) infants reduces the incidence of pulmonary hemorrhage.

Most infants with pulmonary hemorrhage have had symptoms of respiratory distress that are indistinguishable from those of respiratory distress syndrome (RDS). The onset may occur at birth or may be delayed several days. **Hemorrhagic pulmonary edema** is the source of blood in many cases and is associated with significant ductal shunting and high pulmonary blood flow or severe left-sided heart failure resulting from hypoxia. In severe cases, sudden cardiovascular collapse, poor lung compliance, profound cyanosis, and hypercapnia may be present. Radiographic findings are varied and nonspecific, ranging from minor streaking or patchy infiltrates to massive consolidation.

The risk of pulmonary hemorrhage is increased in association with acute pulmonary infection, severe asphyxia, RDS, assisted ventilation, patent ductus arteriosus (PDA), congenital heart disease, erythroblastosis fetalis, hemorrhagic disease of the newborn, thrombocytopenia, inborn errors of ammonia metabolism, and cold injury. Pulmonary hemorrhage is the only severe complication in which the rate is *increased* with surfactant treatment. Pulmonary hemorrhage is seen with all surfactants; the incidence ranges from 1-5% of treated infants and is higher with natural surfactant. Bleeding is predominantly alveolar in approximately 65% of cases and interstitial in the rest. Bleeding into other organs is observed at autopsy of severely ill neonates, suggesting an additional bleeding diathesis, such as disseminated intravascular coagulation. In preterm infants, often intraventricular hemorrhage can occur at the same time. Acute pulmonary hemorrhage may rarely occur in previously healthy full-term infants. The cause is unknown. Pulmonary hemorrhage may manifest as hemoptysis or blood in the nasopharynx or airway with no evidence of upper respiratory or gastrointestinal bleeding. Patients present with acute, severe respiratory failure requiring mechanical ventilation. Chest radiographs usually demonstrate bilateral alveolar infiltrates. The condition usually responds to intensive supportive treatment (see [Chapter 458](#)).

**Treatment** of pulmonary hemorrhage includes blood replacement, suctioning to clear the airway, intratracheal administration of epinephrine, and tamponade with increased mean airway pressure (often requiring high-frequency ventilation [HFV]). Although surfactant treatment has been associated with the development of pulmonary hemorrhage, administration of exogenous surfactant after the bleeding has occurred can improve lung compliance, because the presence of intraalveolar blood and protein can inactivate surfactant.

Visit Elsevier eBooks+ at [eBooks.Health.Elsevier.com](http://eBooks.Health.Elsevier.com) for Bibliography.

## Chapter 134

## Digestive System Disorders

Robert M. Kliegman

Signs and symptoms suggestive of gastrointestinal (GI) tract pathology in the newborn may reflect immaturity, disorders specific to the GI tract, or systemic diseases affecting the GI tract as part of a multisystem disorder ([Table 134.1](#); see [Chapter 121](#)).

Feeding intolerance in the very low birthweight neonate may be due to immaturity of GI motility but also to anatomic lesions from the esophagus to the anus, as well as systemic, metabolic (galactosemia, etc.), or inflammatory processes (sepsis, hemophagocytic lymphohistiocytosis). Recognizing other organ system abnormalities and abnormal laboratory findings (anemia, thrombocytopenia, leukocytosis, neutropenia, elevated inflammatory markers, acidosis, hypoglycemia) may help identify the specific disease.

**Table 134.1** Differential Diagnosis of Gastrointestinal Symptoms

SYMPTOM	GI DISORDERS	SYSTEMIC DISORDERS
Emesis	Reflux Volvulus Pyloric stenosis Hirschsprung disease Imperforate anus NEC Meconium plug	Sepsis Inborn error of metabolism Congenital adrenal hyperplasia Increased intracranial pressure
Jaundice	Hepatitis Biliary atresia GALD PFIC Alagille syndrome	Physiologic Hemolysis HLH Sepsis HSV Inborn error of metabolism
Abdominal distention	Feeding intolerance GI obstruction Meconium plug Ileus Meconium ileus NEC Pseudoobstruction Inguinal hernia	Sepsis Hypokalemia Hydronephrosis Ascites Hypermagnesemia

GALD, Gestational alloimmune liver disease; PFIC, progressive familial intrahepatic cholestasis; GI, gastrointestinal; NEC, necrotizing enterocolitis; HLH, hemophagocytic lymphohistiocytosis; HSV, herpes simplex virus.

## Chapter 133

## Pulmonary Hemorrhage

Alicia J. Sprecher, Krishna K. Acharya, and Susan S. Cohen

Massive pulmonary hemorrhage is a relatively uncommon, but catastrophic complication with a high risk of morbidity and mortality. Some degree of pulmonary hemorrhage occurs in about 10% of extremely preterm infants. However, massive pulmonary hemorrhage is less common and can be fatal. Autopsy demonstrates massive pulmonary hemorrhage in 15% of neonates who die in the first 2 weeks of life. The reported incidence at autopsy varies from 1-4 per 1,000 live births. Approximately 75% of affected patients weigh <2,500 g at birth. Prophylactic indomethacin in extremely low birthweight (ELBW) infants reduces the incidence of pulmonary hemorrhage.

Most infants with pulmonary hemorrhage have had symptoms of respiratory distress that are indistinguishable from those of respiratory distress syndrome (RDS). The onset may occur at birth or may be delayed several days. **Hemorrhagic pulmonary edema** is the source of blood in many cases and is associated with significant ductal shunting and high pulmonary blood flow or severe left-sided heart failure resulting from hypoxia. In severe cases, sudden cardiovascular collapse, poor lung compliance, profound cyanosis, and hypercapnia may be present. Radiographic findings are varied and nonspecific, ranging from minor streaking or patchy infiltrates to massive consolidation.

The risk of pulmonary hemorrhage is increased in association with acute pulmonary infection, severe asphyxia, RDS, assisted ventilation, patent ductus arteriosus (PDA), congenital heart disease, erythroblastosis fetalis, hemorrhagic disease of the newborn, thrombocytopenia, inborn errors of ammonia metabolism, and cold injury. Pulmonary hemorrhage is the only severe complication in which the rate is *increased* with surfactant treatment. Pulmonary hemorrhage is seen with all surfactants; the incidence ranges from 1-5% of treated infants and is higher with natural surfactant. Bleeding is predominantly alveolar in approximately 65% of cases and interstitial in the rest. Bleeding into other organs is observed at autopsy of severely ill neonates, suggesting an additional bleeding diathesis, such as disseminated intravascular coagulation. In preterm infants, often intraventricular hemorrhage can occur at the same time. Acute pulmonary hemorrhage may rarely occur in previously healthy full-term infants. The cause is unknown. Pulmonary hemorrhage may manifest as hemoptysis or blood in the nasopharynx or airway with no evidence of upper respiratory or gastrointestinal bleeding. Patients present with acute, severe respiratory failure requiring mechanical ventilation. Chest radiographs usually demonstrate bilateral alveolar infiltrates. The condition usually responds to intensive supportive treatment (see [Chapter 458](#)).

**Treatment** of pulmonary hemorrhage includes blood replacement, suctioning to clear the airway, intratracheal administration of epinephrine, and tamponade with increased mean airway pressure (often requiring high-frequency ventilation [HFV]). Although surfactant treatment has been associated with the development of pulmonary hemorrhage, administration of exogenous surfactant after the bleeding has occurred can improve lung compliance, because the presence of intraalveolar blood and protein can inactivate surfactant.

Visit Elsevier eBooks+ at [eBooks.Health.Elsevier.com](http://eBooks.Health.Elsevier.com) for Bibliography.

## Chapter 134

## Digestive System Disorders

Robert M. Kliegman

Signs and symptoms suggestive of gastrointestinal (GI) tract pathology in the newborn may reflect immaturity, disorders specific to the GI tract, or systemic diseases affecting the GI tract as part of a multisystem disorder ([Table 134.1](#); see [Chapter 121](#)).

Feeding intolerance in the very low birthweight neonate may be due to immaturity of GI motility but also to anatomic lesions from the esophagus to the anus, as well as systemic, metabolic (galactosemia, etc.), or inflammatory processes (sepsis, hemophagocytic lymphohistiocytosis). Recognizing other organ system abnormalities and abnormal laboratory findings (anemia, thrombocytopenia, leukocytosis, neutropenia, elevated inflammatory markers, acidosis, hypoglycemia) may help identify the specific disease.

**Table 134.1** Differential Diagnosis of Gastrointestinal Symptoms

SYMPTOM	GI DISORDERS	SYSTEMIC DISORDERS
Emesis	Reflux Volvulus Pyloric stenosis Hirschsprung disease Imperforate anus NEC Meconium plug	Sepsis Inborn error of metabolism Congenital adrenal hyperplasia Increased intracranial pressure
Jaundice	Hepatitis Biliary atresia GALD PFIC Alagille syndrome	Physiologic Hemolysis HLH Sepsis HSV Inborn error of metabolism
Abdominal distention	Feeding intolerance GI obstruction Meconium plug Ileus Meconium ileus NEC Pseudoobstruction Inguinal hernia	Sepsis Hypokalemia Hydronephrosis Ascites Hypermagnesemia

GALD, Gestational alloimmune liver disease; PFIC, progressive familial intrahepatic cholestasis; GI, gastrointestinal; NEC, necrotizing enterocolitis; HLH, hemophagocytic lymphohistiocytosis; HSV, herpes simplex virus.

## Chapter 135

# Meconium Ileus, Peritonitis, Intestinal Obstruction, and Gastroschisis

Eric C. Eichenwald

*Meconium* consists of bile salts, bile acids, and debris shed from the intestinal mucosa in the intrauterine period. More than 90% of full-term newborn infants and 80% of very low birthweight (VLBW) infants pass meconium within the first 24 hours. The possibility of intestinal obstruction should be considered in any infant who does not pass meconium by 24–36 hours.

## MECONIUM PLUGS

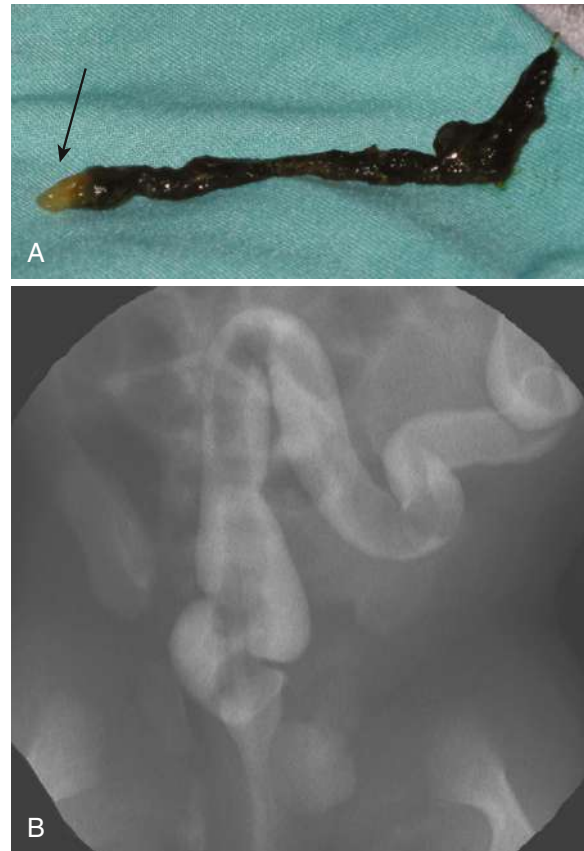
**Meconium plugs syndrome** refers to intestinal obstruction, usually in the distal colon, rectum, and anal canal, caused by meconium plugs (Fig. 135.1). Resulting from a disproportionately low amount of water in the intestinal lumen, meconium plugs are a rare cause of intrauterine intestinal obstruction and meconium peritonitis unrelated to cystic fibrosis (CF). **Anorectal plugs** may also cause mucosal ulceration from bowel wall erosion and subsequent intestinal perforation. **Meconium plugs** are associated with small left colon syndrome in infants of diabetic mothers, infants with CF (40%) and Hirschsprung disease (40%), maternal opiate use, and magnesium sulfate therapy for preeclampsia and tocolysis. Up to 30% of patients can have spontaneous resolution. Initial treatment may include administration of a glycerin suppository or rectal irrigation with isotonic saline. In up to 95% of patients, a Gastrografin enema (meglumine diatrizoate, a hyperosmolar, water-soluble, radiopaque solution containing 0.1% polysorbate 80 [Tween 80] and 37% organically bound iodine) will be both diagnostic and therapeutic, inducing passage of the plug, presumably because the high osmolarity (1,900 mOsm/L) of the solution draws fluid rapidly into the intestinal lumen and loosens the inspissated material. Such rapid loss of fluid into the bowel may result in acute fluid shifts with dehydration and shock, so it is advisable to dilute the contrast material with an equal amount of water and provide intravenous (IV) fluids, during and for several hours after the procedure, sufficient to maintain normal vital signs, urine output, and electrolytes. After removal of a meconium plug, the infant should be observed closely, and consideration given to performing diagnostic testing to identify **Hirschsprung disease** (congenital aganglionic megacolon; see Chapter 378.4) and CF (see Chapter 454).

## MECONIUM ILEUS

Meconium ileus, or impaction of inspissated meconium in the distal small bowel, accounts for up to 30% of cases of neonatal intestinal obstruction. It is common in patients with CF in whom the lack of fetal pancreatic enzymes inhibits digestive mechanisms, and meconium becomes viscid and mucilaginous. Clinically, neonates present with intestinal obstruction with or without perforation. Abdominal distention is prominent, and vomiting, often bilious, becomes persistent, although occasionally inspissated meconium stools may be passed shortly after birth. Meconium ileus can present as early as in utero, in which the fetus develops acute intestinal obstruction resulting in volvulus or perforation, peritoneal ascites, meconium peritonitis, and hydrops; if untreated, fetal loss may occur.

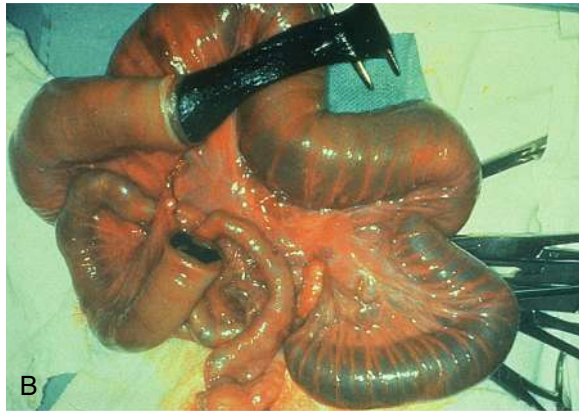
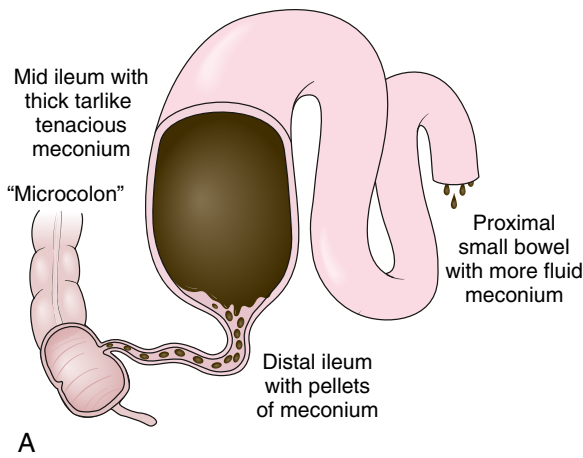
Meconium ileus is primarily associated with cystic fibrosis transmembrane regulator (CFTR) pathologic variants F508del, G542X, W1282X, R553X, and G551D. Patients with two copies of the F508del variant have a 25% chance of presenting with meconium ileus. F508del plus any other CF mutation confers 17% risk, and two other CF variants confer a 12% risk of meconium ileus. In addition, non-CFTR genetic modifier genes influence meconium ileus. In families who already have at least one child with CF complicated by meconium ileus, there is a 39% risk for meconium ileus in subsequent children, which is more than the rates expected with autosomal recessive inheritance. In a twin study, 82% of monozygotic twins showed concordance for meconium ileus, whereas only 22% of dizygotic and 24% of two affected siblings showed concordance. Positive newborn screening for CF should prompt sweat testing when the infant weighs >2 kg and is at least 36 weeks of corrected gestational age. Genetic testing confirms the diagnosis of CF (see Chapter 454). In ~20% of patients with meconium ileus, there is no evidence of CF; in some of these patients, pathogenic variants in *GUCY2C* are identified.

The differential diagnosis involves other causes of intestinal obstruction, including intestinal pseudoobstruction, and other causes of pancreatic insufficiency (see Chapter 398). Prenatal diagnosis is readily achieved by ultrasound with identification of enlarged bowel loops or a mass with distention of the proximal small bowel. Clinically the diagnosis can be made with a history of CF in



**Fig. 135.1** Meconium plug. **A**, Meconium plug evacuated after a diagnostic contrast enema demonstrated the distinctive white tip (arrow). **B**, Image from a contrast enema in a term neonate with vomiting and bowel distention demonstrates the long filling defect characteristic of meconium plug syndrome. The child was relieved of the obstruction after evacuation of the plug, without recurrence of symptoms. (From Hernanz-Schulman M. *Congenital and neonatal disorders*. In Coley BD, ed. *Caffey's Pediatric Diagnostic Imaging*. 12th ed. Philadelphia: Elsevier; 2013: Fig. 106-14.)



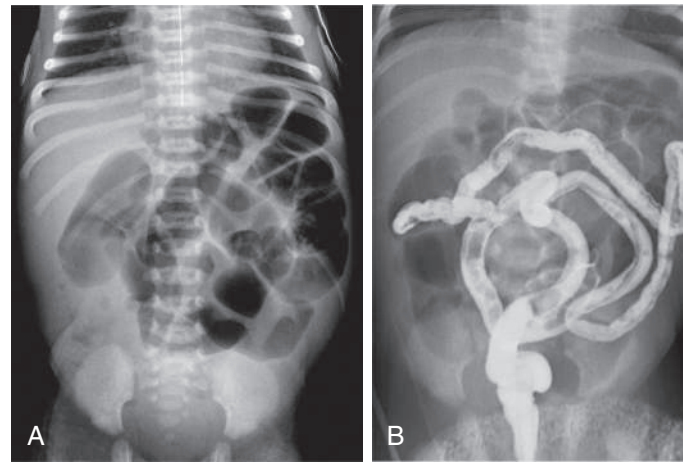


**Fig. 135.2** Meconium ileus. A, Schematic drawing of uncomplicated meconium ileus. Pellets of inspissated meconium fill the terminal ileum proximal to a microcolon. Several loops of more proximal ileum contain thick, tenacious meconium. B, Enterotomy of proximal bowel and the nature of the thick and tenacious meconium. Note the dilated proximal loops of bowel filled with meconium and the progressively small caliber of the distal bowel leading to the microcolon. (A from Leonidas JC, Berdon WE, et al. *Meconium ileus and its complications: a reappraisal of plain film roentgen diagnostic criteria*. *Am J Roentgenol Radium Ther Nucl Med*. 1970;108[3]:598–609; B courtesy Dr. Wallace W. Neblett III, Nashville, TN.)

a sibling, by palpation of doughy or cordlike masses of intestines through the abdominal wall, and from the radiographic appearance. Plain radiographs reveal small bowel obstruction. Air-fluid levels may not be apparent because of the thickened meconium.

In contrast to the generally evenly distended intestinal loops above an atresia, the loops may vary in width and are not as evenly filled with gas. At points of heaviest meconium concentration, the infiltrated gas may create a bubbly, granular appearance (Figs. 135.2 and 135.3).

Treatment for simple meconium ileus is a high-osmolarity Gastrografin enema, as described for meconium plugs. If the procedure is unsuccessful or perforation of the bowel wall is suspected, a laparotomy is performed and the ileum opened at the point of largest diameter of the impaction. Approximately 50% of these infants have associated intestinal atresia, stenosis, or volvulus that requires surgery. The inspissated meconium is removed by gentle and patient irrigation with warm isotonic sodium chloride or *N*-acetylcysteine (Mucosyst) solution through a catheter passed between the impaction and



**Fig. 135.3** Uncomplicated meconium ileus. A, Abdominal radiograph in 3-day-old infant with abdominal distention and bilious aspirates shows dilation of multiple loops of bowel. No calcifications are seen on the radiograph to suggest complicated meconium ileus. Orogastric tube near the gastroesophageal junction was subsequently advanced. B, Contrast enema demonstrates a microcolon, with multiple meconium plugs, consistent with the diagnosis of meconium ileus. (From Hernanz-Schulman M. *Congenital and neonatal disorders*. In Coley BD, ed. *Caffey's Pediatric Diagnostic Imaging*. 13th ed. Philadelphia: Elsevier; 2019: Fig. 102-36)

the bowel wall. Some patients will require bowel resection with a temporary double-barrel enterostomy followed by serial irrigations and distal refeeding, or primary anastomosis at the initial operation. Most infants with meconium ileus survive the neonatal period. If meconium ileus is associated with CF, the long-term prognosis depends on the severity of the underlying disease (see Chapter 454). In ~20% of patients with meconium ileus, there is no evidence of CF; in some of these patients pathogenic variants in *GUCY2C* are identified.

### MECONIUM PERITONITIS

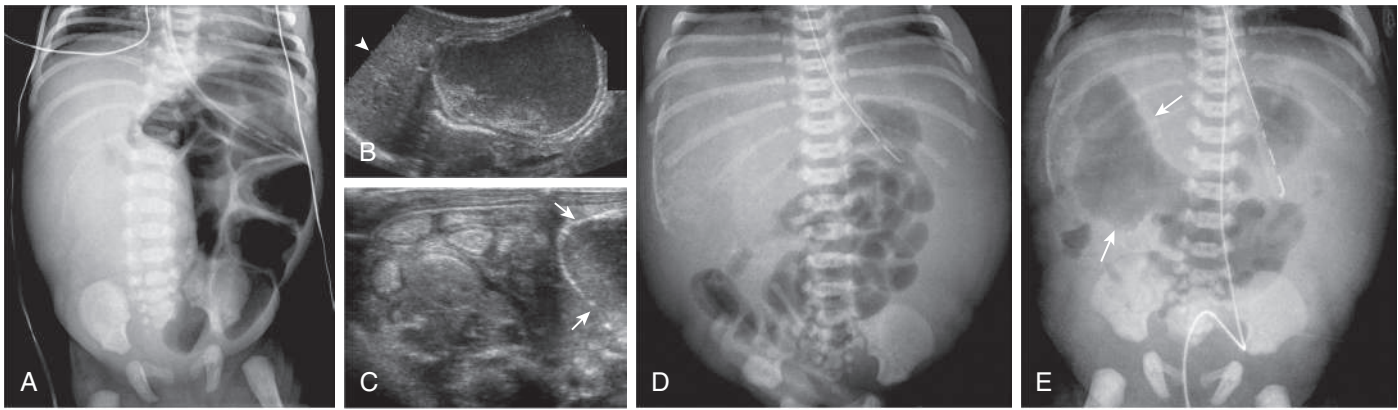
Perforation of the intestine may occur in utero or shortly after birth. Frequently, the intestinal perforation seals naturally with relatively little meconium leakage into the peritoneal cavity. Perforations occur most often as a complication of meconium ileus in infants with CF but occasionally result from a meconium plug or in utero intestinal obstruction of another cause.

Cases at the most severe end of the spectrum may be diagnosed on prenatal ultrasound with fetal ascites, polyhydramnios, bowel dilation, intraabdominal speckled calcifications, and hydrops fetalis (Fig. 135.4). At the other end are cases in which an intestinal perforation may seal spontaneously and patients remain asymptomatic, except when meconium becomes calcified and is later discovered on radiographs. Alternatively, the clinical picture may be dominated by signs of intestinal obstruction (as in meconium ileus) with abdominal distention, vomiting, and absence of stools or chemical peritonitis presenting with sepsis. Treatment consists primarily of elimination of the intestinal obstruction and drainage of the peritoneal cavity with a timely surgical intervention proved to result in high survival rate and favorable outcome even in complicated meconium peritonitis.

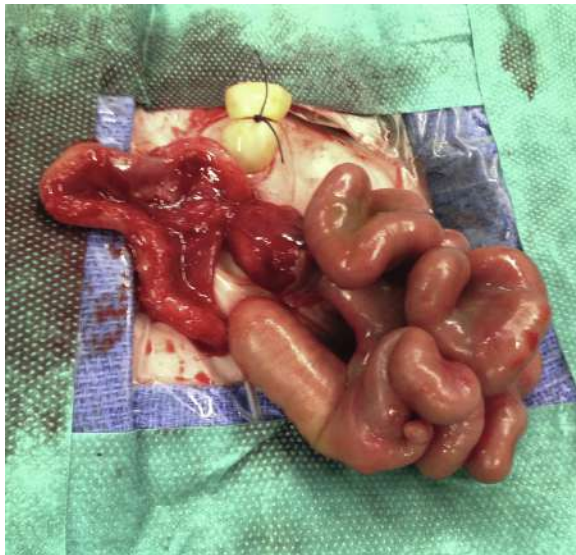
### GASTROSCHISIS

Gastroschisis is the herniation of abdominal contents (usually small intestine) through a defect in the anterior abdominal wall lateral to the umbilical cord (Fig. 135.5). The etiology is unknown, but it has been





**Fig. 135.4** Complicated meconium ileus. A, Abdominal radiograph in 2-day-old girl with abdominal distention and bilious aspirates shows absence of bowel gas in the right abdomen with a partly calcified mass displacing gas-filled dilated loops of bowel to the left. B, Ultrasound image demonstrates the subhepatic, partly calcified mass with internal debris and fluid-fluid level (arrowhead). C, Additional ultrasound image shows a portion of the cyst wall (arrows) and multiple, abnormal, hyperechoic loops of bowel. D, Abdominal radiograph in different 1-day-old infant shows a calcified mass in right upper quadrant, shown at sonography to represent a loculated complex meconium collection. E, Radiograph a few hours later of the same infant shown in D shows a persistent perforation with gas entering into the right upper quadrant collection (arrows). (From Hernanz-Schulman M. *Congenital and neonatal disorders*. In Coley BD, ed. *Caffey's Pediatric Diagnostic Imaging*. 13th ed. Philadelphia: Elsevier; 2019: Fig. 102-37)



**Fig. 135.5** Intraoperative view of a complex gastroschisis with intestinal atresia. Note the severe bowel matting in the complex gastroschisis. (Modified from Vinit N, Talbotec C, De Tristan MA, et al. *Predicting factors of protracted intestinal failure in children with gastroschisis*. *J Pediatr*. 2022;243:122–129. Fig. 1B.)

associated with young maternal age and possible opioid use; the incidence is ~2-5 infants in 10,000 births.

Gastroschisis is usually an isolated anomaly but has a high morbidity and mortality especially in complex lesions associated with intestinal atresias and necrosis resulting in short bowel syndrome and intestinal failure (see Chapter 385.6). Treatment requires resection of atretic or necrotic tissue and long-term parenteral alimentation until enteral nutrition can be established.

Visit Elsevier eBooks+ at [eBooks.Health.Elsevier.com](https://eBooks.Health.Elsevier.com) for Bibliography.

## Chapter 136

# Necrotizing Enterocolitis

Sagori Mukhopadhyay and Misty Good

Necrotizing enterocolitis (NEC) is the most common life-threatening emergency of the gastrointestinal (GI) tract in the newborn period. The disease is characterized by various degrees of mucosal or transmural necrosis of the intestine followed by local and systemic inflammation. The cause of NEC remains unclear but is most likely multifactorial.

### DEFINITION

NEC is clinically identified using a combination of clinical and radiographic signs and staged by categorizing NEC into suspected (stage I), definite (stage II, clinical signs of abdominal pathology with an abnormal abdominal radiograph showing pneumatosis intestinalis, portal venous gas, or ileus), and advanced (stage III, signs of stage II plus severe systemic signs of inflammation and acidosis with or without signs of intestinal perforation). In addition, NEC is also categorized into *medical and surgical NEC* defined by the type of acute intervention required. These criteria have been criticized for categorizing conditions with heterogeneous origins as the same disease. For example, conditions such as spontaneous intestinal perforation, septic ileus, and allergic enterocolitis can present with signs similar to NEC, but they arise from differing pathogenesis and may have differing outcomes. Similarly, term infants often present with NEC attributable to coexisting conditions such as congenital heart disease or gastroschisis, and likely do not share identical pathogenesis with NEC occurring in preterm infants. To minimize the heterogeneity of presentations that get diagnosed as NEC, a definition of “preterm NEC” has been proposed for use in clinical research. **Preterm NEC** in clinical research is defined by the presence of (1) clinical sign of abdominal distention and/or hematochezia; (2) onset between 10 days after birth to 36 weeks’ postmenstrual age with the highest risk period being 30-32 weeks’

postmenstrual age; and (3) one of the following—pneumatosis intestinalis or portal venous gas by radiograph or ultrasound, histopathologic evidence of intestinal necrosis, or evidence of vasculitis, coagulopathy, or inflammation in the absence of infection.

## EPIDEMIOLOGY

Epidemiologic studies have reported changes in NEC incidence in the past decade. Among 473,895 very low birthweight infants (VLBW, birthweight <1,500 g) admitted to one of 820 centers in the United States (2006–2017), the overall rate of NEC was 7.6%. From 2006–2017, there was a significant reduction in the prevalence of medical but not surgical NEC; mortality with NEC also decreased from 20.7% to 16.8% among infants with medical NEC, and 36.6% to 31.6% for neonates with surgical NEC.

## PATHOLOGY AND PATHOGENESIS

Many factors contribute to the development of the pathologic findings of NEC, including mucosal ischemia and subsequent necrosis; gas accumulation in the submucosa of the bowel wall (**pneumatosis intestinalis**); and progression of the necrosis to perforation, peritonitis, sepsis, and death. An overview of common hypothesized pathogenic mechanisms, related clinical presentation, and management is shown in [Figure 136.1](#). The distal part of the ileum and the proximal segment of the colon are involved most frequently; in fatal cases, transmural necrosis may extend from the stomach to the rectum (**NEC totalis**). The pathogenesis of NEC is not fully understood, but three major risk factors have been implicated: prematurity, bacterial colonization of the gut, and enteral feeding. NEC develops primarily in premature infants with exposure to a nutritional substrate in the context of immature intestinal motility, and immunity, microbial dysbiosis, and mucosal ischemia. An underlying genetic predisposition is recognized with variants in genes regulating immunomodulation and inflammation (e.g., toll-like receptor-4, interleukin [IL]-4 receptor  $\alpha$  chain, IL-6), apoptosis and cellular repair (e.g., platelet-activating factor), and

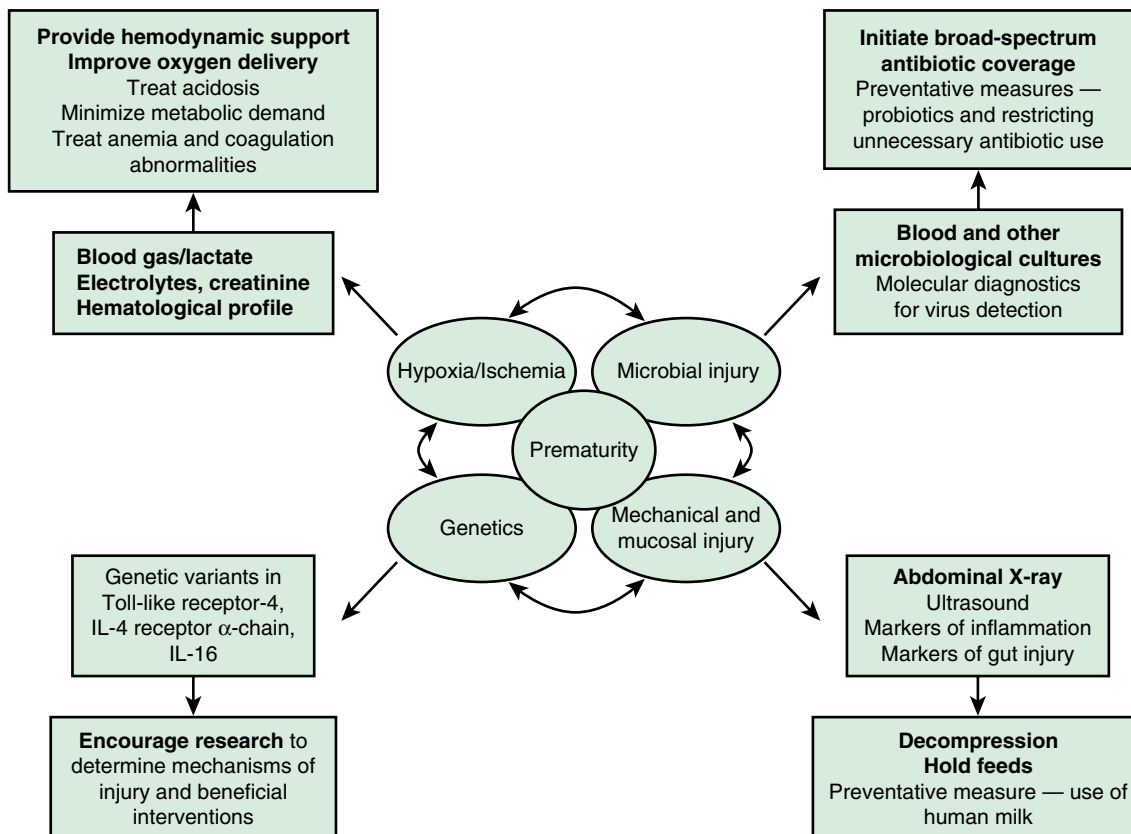
oxidant stress (e.g., vascular endothelial growth factor, arginine, nitric oxide). *The greatest risk factor for NEC is prematurity, with a mean onset between 30 and 32 weeks' postmenstrual age.* Other risk factors include small for gestational age, polycythemia, and conditions resulting in in utero hypoxia. NEC rarely occurs before the initiation of enteral feeding and is much less common in infants fed human milk.

## CLINICAL MANIFESTATIONS

Infants with NEC have a variety of signs and symptoms and may have an insidious or sudden catastrophic onset ([Table 136.1](#)). Age of onset is inversely related to gestational age. The first signs of impending disease may be nonspecific, including lethargy and temperature instability, or related to GI pathology, such as abdominal tenderness and distention, feeding intolerance, and bloody stools. Because of nonspecific signs, sepsis may be suspected before NEC. The spectrum of illness is broad, ranging from mild disease with only guaiac-positive stools to severe illness with bowel perforation, peritonitis, systemic inflammatory response syndrome, shock, and death. Laboratory findings may include neutropenia, anemia, thrombocytopenia, coagulopathy, and metabolic acidosis. Hypotension and respiratory failure are common. Progression may be rapid, but it is unusual for the disease to progress from mild to severe after 72 hours.

## DIAGNOSIS

A very high index of suspicion in treating preterm at-risk infants is crucial. Plain abdominal radiographs are essential to make a diagnosis of NEC. The finding of pneumatosis intestinalis confirms the clinical suspicion of NEC and is diagnostic; 50–75% of patients have pneumatosis when treatment is started ([Fig. 136.2](#)). Portal venous gas is a sign of severe disease, and pneumoperitoneum indicates a perforation ([Figs. 136.3 and 136.4](#)). Ultrasound may be useful to evaluate for free fluid, abscess, pneumatosis intestinalis, and bowel wall thickness, peristalsis, and perfusion ([Fig. 136.5](#)). Doppler flowmetry studies can be used to assess flow in superior mesenteric artery and portal vein.



**Fig. 136.1** Overview of risk factors and mechanisms of injury in necrotizing enterocolitis-associated presentation and management approaches. Bold indicates interventions that are common first-line interventions for NEC. IL, Interleukin. (Figure created by authors using BioRender.com.)

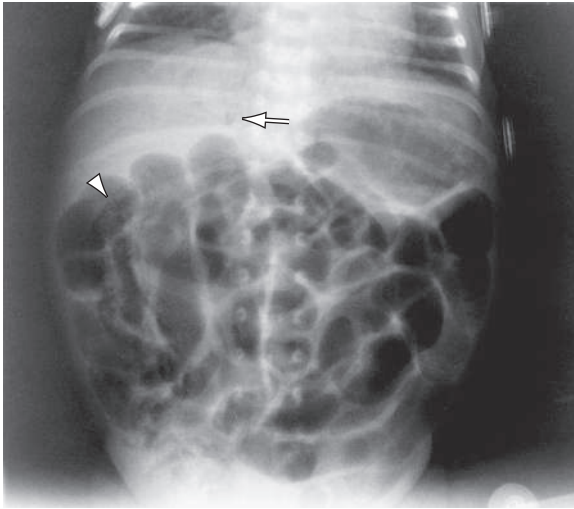
**Table 136.1** Signs and Symptoms Associated with Necrotizing Enterocolitis**GASTROINTESTINAL**

Abdominal distention  
 Abdominal tenderness  
 Feeding intolerance  
 Delayed gastric emptying  
 Emesis  
 Occult/gross blood in stool  
 Change in stool pattern/diarrhea  
 Abdominal mass  
 Erythema of abdominal wall

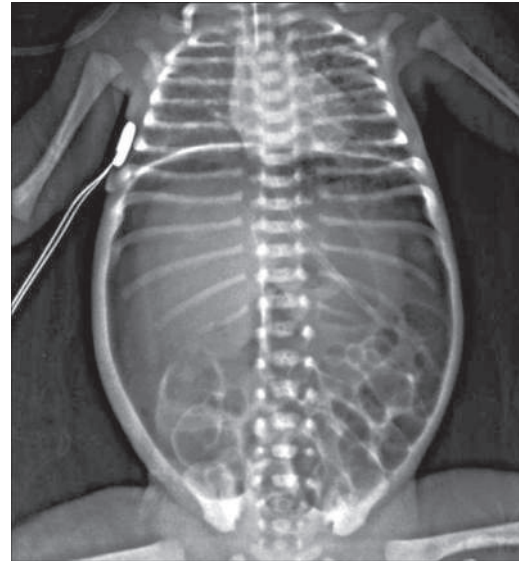
**SYSTEMIC**

Lethargy  
 Apnea/respiratory distress  
 Temperature instability  
 Acidosis (metabolic and/or respiratory)  
 Glucose instability  
 Poor perfusion/shock  
 Thrombocytopenia  
 Disseminated intravascular coagulopathy

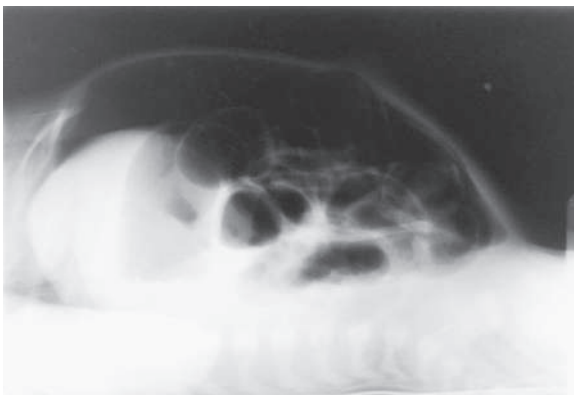
From Kanto WP Jr, Hunter JE, Stoll BJ. Recognition and medical management of necrotizing enterocolitis. *Clin Perinatol.* 1994;21:335–346.



**Fig. 136.2** Necrotizing enterocolitis (NEC). Kidney-ureter-bladder film demonstrates abdominal distention, hepatic portal venous gas (arrow), and a bubbly appearance of pneumatosis intestinalis (arrowhead; right lower quadrant). The latter two signs are thought to be pathognomonic for neonatal NEC.



**Fig. 136.4** Necrotizing enterocolitis (NEC). Plain abdominal x-ray film of an infant with perforated NEC showing pneumoperitoneum. (From Tam PKH, Chung PHY, St Peter SD, et al. *Advances in paediatric gastroenterology.* Lancet. 2017;390:1072–1082. Fig. 4)



**Fig. 136.3** Intestinal perforation. Cross-table abdominal radiograph in patient with neonatal necrotizing enterocolitis demonstrates marked distention and massive pneumoperitoneum, as evidenced by the free air below the anterior abdominal wall.

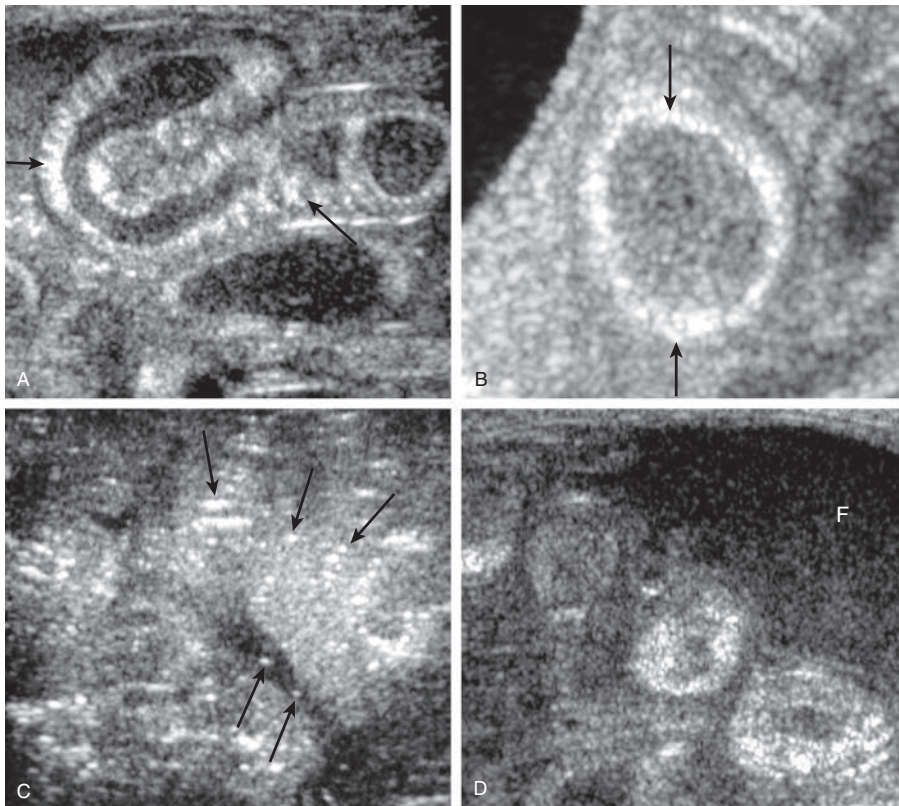
The differential diagnosis of NEC includes septic ileus, GI obstruction, volvulus, and isolated intestinal perforation. **Idiopathic focal intestinal perforation** can occur spontaneously or can be associated with the early use of postnatal corticosteroids and indomethacin. Pneumoperitoneum develops in such patients, but they are usually less ill than those with NEC. Occasional clusters of NEC cases have been attributed to viral infections, specifically norovirus, enterovirus, and rotavirus. Stool viral testing and infectious disease consultation should be considered when multiple cases occur together.

**TREATMENT**

Rapid initiation of therapy is required for infants with suspected, as well as proven NEC. There is no specific treatment for established NEC, so therapy is directed at providing supportive care and preventing further injury with cessation of feeding, nasogastric decompression, and administration of intravenous fluids and antibiotics (see Fig. 136.1). Careful attention to the respiratory status, coagulation profile, and acid-base and electrolyte balances are important. Ventilation should be assisted in the presence of apnea or if abdominal distention is contributing to hypoxia and hypercapnia. Intravascular volume replacement with crystalloid or blood products, cardiovascular support with fluid boluses and/or inotropes, and correction of hematologic, metabolic, and electrolyte abnormalities are essential to stabilize the infant with NEC. Umbilical arterial catheters are reported to reduce blood flow in the mesenteric blood vessels and should be removed if they remain in place after a diagnosis of NEC. Maintaining reliable intravenous access for ongoing hemodynamic support and medication administration is critical.

Approximately 16% of definite NEC cases may be associated with bacteremia detected within 72 hours of its diagnosis, most frequently with a gram-negative organism. NEC with associated bacteremia has a higher risk for requiring surgical intervention and mortality. Once blood has been drawn for culture, systemic antibiotics (with broad coverage based on the antibiotic sensitivity patterns in the particular neonatal ICU) should be started immediately. The addition of anaerobic coverage with antibiotics such as metronidazole or clindamycin is variably practiced. Management of NEC with anaerobic coverage is





**Fig. 136.5** Necrotizing enterocolitis. A, Mucosal and submucosal thickening (arrows). B, Intramural gas (pneumatosis intestinalis) creates an echogenic ring (arrows). C, Widespread echogenic bubbles of gas in the portal veins (arrows). D, Fluid with echogenic debris (F) lies adjacent to thick loops. (From John SD, Hollingsworth C: *The pediatric gastrointestinal tract*. In Levine D, Rumack CM, Wilson SR, Charboneau JW, eds. *Diagnostic Ultrasound*, 4th ed. Philadelphia: Elsevier, 2014. Fig 55.29.)

associated with slightly lower risk of mortality and higher risk of subsequent strictures.

The patient's course should be monitored closely by means of frequent physical assessments in the NICU; sequential anteroposterior and cross-table lateral or lateral decubitus abdominal radiographs to detect intestinal perforation; and serial determinations of hematologic, electrolyte, and acid-base status. A surgeon should be consulted early in the course of treatment. The only *absolute* indication for surgery is evidence of perforation on an abdominal radiograph (pneumoperitoneum). However, this is present in less than half of infants with perforation or necrosis at operative exploration. Progressive clinical deterioration despite maximum medical management, a single fixed bowel loop on serial radiographs, and abdominal wall erythema are relative indications for exploratory laparotomy. Ideally, surgery should be performed after intestinal necrosis develops but before perforation and peritonitis occur. The optimal surgical approach, however, remains controversial. The options for surgical treatment include primary peritoneal drainage (PPD) or exploratory laparotomy with resection of the necrotic intestine and usually stoma creation. Laparotomy is usually the initial therapy in the majority of VLBW infants with surgical NEC, even in those <1,000 g. Randomized clinical trials comparing these approaches failed to demonstrate significant differences in survival, nutritional outcomes, or length of stay. However, among those with a diagnosis of NEC (*as opposed to intestinal perforation*), 69% died or had neurodevelopmental impairment (NDI) when managed with initial laparotomy versus 85% when managed with PPD. In contrast, among infants with a diagnosis of *intestinal perforation*, death or NDI occurred 69% and 63% after initial management with laparotomy or PPD, respectively. When the diagnosis is confirmed NEC, initial management with laparotomy is more likely to reduce risk of death or NDI compared to PPD. However, the ultimate surgical approach for an individual case also depends on the surgeon's assessment and physiologic status of the patient.

### PROGNOSIS

In patients with pneumatosis intestinalis at NEC diagnosis, disease progression is nonresponsive to medical management alone in

approximately 20–40%; of these that require surgery, 20–50% die. Early postoperative complications include wound infection, dehiscence, and stomal problems (prolapse, necrosis). Later complications include intestinal strictures, which occur in approximately 25–35% of surgically or medically managed patients. After massive intestinal resection, complications from postoperative NEC include short bowel syndrome (malabsorption, growth failure, malnutrition), complications related to central venous catheters (sepsis, thrombosis), and cholestatic jaundice. Preterm infants with NEC who require surgical intervention are at increased risk for adverse growth and neurodevelopmental outcomes.

### PREVENTION

The most effective preventive strategy for NEC is the use of human milk (maternal or donor); newborns exclusively fed breast milk have a reduced risk of NEC. However, because human milk does not provide complete nutritional support for very preterm infants, nutritional fortification is usual practice. Some studies have suggested that an “exclusive human milk diet” using human rather than bovine fortifiers may further reduce the risk of NEC. An optimal feeding protocol (rapid vs slow volume increments) has not been discovered; it is important to note that strict adherence to a NICU-specific feeding protocol reduces the risk of NEC. Additionally, while extensive data and meta-analyses would support the use of probiotics to prevent NEC, there is no clear consensus on the safest, most effective formulation, timing of administration, or length of therapy. Other preventive strategies using prebiotics and synbiotics have also been studied, with variable outcomes. Inhibitors of gastric acid secretion ( $H_2$ -receptor blockers, proton pump inhibitors), high osmolality enteral fluids, or prolonged empirical antibiotics in the early neonatal period have been associated with increased risk of NEC and should be avoided.



## Chapter 137

# Jaundice and Hyperbilirubinemia in the Newborn

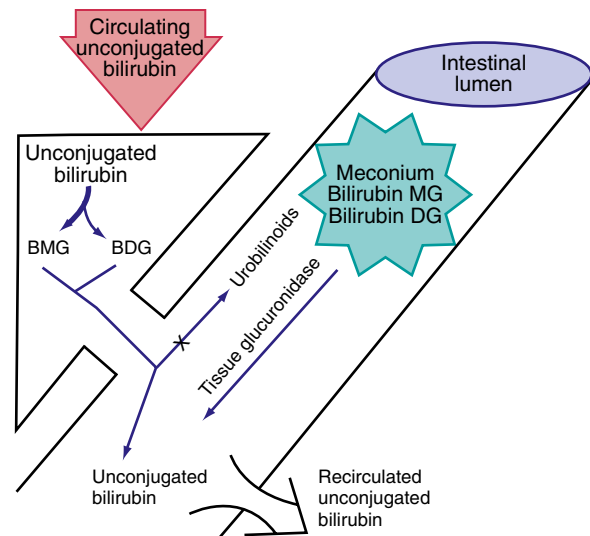
Kelsey S. Ryan and Robert M. Kliegman

**Hyperbilirubinemia** is a common and, in most cases, benign problem in neonates. **Jaundice** is observed during the first week after birth in approximately 60% of term infants and 80% of preterm infants. The yellow color usually results from the accumulation of unconjugated, nonpolar, lipid-soluble bilirubin pigment in the skin. This unconjugated bilirubin (designated **indirect-acting** by nature of the van den Bergh reaction) is an end product of heme-protein catabolism from a series of enzymatic reactions by heme-oxygenase and biliverdin reductase and nonenzymatic reducing agents in the reticuloendothelial cells. It may also be partly caused by deposition of pigment from conjugated bilirubin, the end product from indirect, unconjugated bilirubin that has undergone conjugation in the liver cell microsome by the enzyme uridine diphosphoglucuronic acid (UDP)-glucuronyl transferase to form the polar, water-soluble glucuronide of bilirubin (**direct-reacting**). Although bilirubin may have a physiologic role as an antioxidant, elevations of indirect, unconjugated bilirubin are potentially neurotoxic. Even though the conjugated form is not neurotoxic, direct hyperbilirubinemia indicates potentially serious hepatic disorders or a systemic illness.

## ETIOLOGY

During the neonatal period, metabolism of bilirubin is in transition from the *fetal stage*, during which the placenta is the principal route of elimination of the lipid-soluble, unconjugated bilirubin, to the *adult stage*, during which the water-soluble conjugated form is excreted from hepatic cells into the biliary system and gastrointestinal tract. **Unconjugated hyperbilirubinemia** may be caused or increased by any factor that (1) increases the load of bilirubin to be metabolized by the liver (hemolytic anemias, polycythemia, bruising or internal hemorrhage, shortened RBC life as a result of immaturity or transfusion of cells, increased enterohepatic circulation, infection), (2) damages or reduces the activity of the transferase enzyme or other related enzymes (genetic deficiency, hypoxia, infection, thyroid deficiency), (3) competes for or blocks the transferase enzyme (drugs and other substances requiring glucuronic acid conjugation), or (4) leads to an absence or decreased amounts of the enzyme or to reduction of bilirubin uptake by liver cells (genetic defect, prematurity). Gene polymorphisms in the hepatic uridine diphosphate glucuronosyltransferase isoenzyme 1A1 (*UGT1A1*) and the solute carrier organic anion transporter 1B1 (*SLCO1B1*), alone or in combination, influence the incidence of neonatal hyperbilirubinemia.

The toxic effects of elevated serum concentrations of unconjugated bilirubin are increased by factors that reduce the retention of bilirubin in the circulation (hypoproteinemia, displacement of bilirubin from its binding sites on albumin by competitive binding of drugs such as sulfisoxazole and moxalactam, acidosis, and increased free fatty acid concentration secondary to hypoglycemia, starvation, or hypothermia). Neurotoxic effects are directly related not only to the permeability of the blood-brain barrier (BBB) and nerve cell membranes but also to neuronal susceptibility to injury, all of which are adversely influenced by asphyxia, prematurity, hyperosmolality, and infection. Early and frequent feeding decreases, whereas suboptimal feedings and dehydration increases serum levels of bilirubin. Delay in passage of meconium, which contains 1 mg bilirubin/dL, may contribute to jaundice by enterohepatic recirculation after deconjugation by intestinal



**Fig. 137.1** Metabolism of bilirubin in the neonatal period. Neonatal production rate of bilirubin is 6-8 mg/kg/24 hr (in contrast to 3-4 mg/kg/24 hr in adults). Water-insoluble bilirubin is bound to albumin. At the plasma-hepatocyte interface, a liver membrane carrier (bilitranslocase) transports bilirubin to a cytosolic binding protein (ligandin or Y protein, now known to be glutathione S-transferase), which prevents back-absorption to plasma. Bilirubin is converted to bilirubin monoglucuronide (BMG). Neonates excrete more BMG than adults. In the fetus, conjugated lipid-insoluble BMG and bilirubin diglucuronide (BDG) must be deconjugated by tissue  $\beta$ -glucuronidases to facilitate placental transfer of lipid-soluble unconjugated bilirubin across the placental lipid membranes. After birth, intestinal or milk-containing glucuronidases contribute to the enterohepatic recirculation of bilirubin and possibly to the development of hyperbilirubinemia.

glucuronidase (Fig. 137.1). Drugs such as oxytocin (in the mother) and chemicals used in the nursery such as phenolic detergents may also produce unconjugated hyperbilirubinemia.

## CLINICAL MANIFESTATIONS

Jaundice usually appears during the early neonatal period, depending on etiology. Whereas jaundice from deposition of indirect bilirubin in the skin tends to appear bright yellow or orange, jaundice of the obstructive type (direct bilirubin) has a greenish or muddy yellow cast. Jaundice usually becomes apparent in a cephalocaudal progression, starting on the face and progressing to the abdomen and then the feet, as serum levels increase. Dermal pressure may reveal the anatomic progression of jaundice (face, approximately 5 mg/dL; mid-abdomen, 15 mg/dL; soles, 20 mg/dL), *but clinical examination cannot reliably estimate serum levels*. Noninvasive techniques for transcutaneous measurement of bilirubin that correlate with serum levels may be used to *screen* infants, but determination of the serum bilirubin level is indicated in patients with elevated age-specific transcutaneous bilirubin measurement, progressing jaundice, or risk for hemolysis or sepsis. Infants with severe hyperbilirubinemia may present with lethargy and poor feeding and, without treatment, can progress to acute bilirubin encephalopathy (kernicterus) (see Chapter 137.1).

## DIFFERENTIAL DIAGNOSIS

The distinction between *physiologic* and *pathologic* jaundice relates to the timing, rate of rise, and extent of hyperbilirubinemia, because some of the same causes of physiologic jaundice (e.g., large RBC mass, decreased capacity for bilirubin conjugation, increased enterohepatic circulation) can also result in pathologic jaundice. Evaluation should be determined on risk factors, clinical appearance, and severity of the hyperbilirubinemia (Tables 137.1-137.3). Jaundice that is present at birth or appears within the first 24 hours after birth should be considered **pathologic** and requires immediate attention. Potential diagnoses would include erythroblastosis fetalis, concealed hemorrhage, sepsis, or congenital

**Table 137.1** Risk Factors for Severe Neonatal Hyperbilirubinemia**GENETIC FACTORS**

- Gilbert syndrome
- Crigler-Najjar syndrome
- Alagille syndrome
- $\beta$  thalassemia
- Glucose-6-phosphate dehydrogenase deficiency
- Bilirubin glucuronosyltransferase polymorphism
- Pyruvate kinase deficiency
- Erythrocyte structural defects (including hereditary spherocytosis and elliptocytosis)
- Galactosemia

**MATERNAL FACTORS**

- Family history of severe jaundice, splenectomy, or cholecystectomy
- Primiparity
- Teenage pregnancy
- Diabetes
- Rhesus incompatibility
- ABO incompatibility
- Other blood group isoimmunization
- Use of drugs during labor (including oxytocin, promethazine, and bupivacaine)
- Exclusive breastfeeding

**PERINATAL FACTORS**

- Mode of deliver (breech vs vertex, instrumentation)
- Birth trauma (cephalohematoma or substantial bruising, extravasation)
- Birth asphyxia
- Congenital infections (including cytomegalovirus and syphilis)
- Sepsis

**NEONATAL FACTORS**

- Male sex
- Prematurity or low birthweight and small-for-gestational age
- Hypothyroidism
- Polycythemia
- Hypoglycemia
- Low intake of breast milk, dehydration, or weight loss
- Breast milk jaundice
- Jaundice in the first day of life
- Trisomy 21
- Infant of diabetic mother
- Cephalohematoma, other bruising

**OTHER RISK FACTORS AND MARKERS**

- Previous sibling received phototherapy or exchange transfusion
- Pre-discharge total serum bilirubin or transcutaneous bilirubin concentration in the high zone
- Use of hemolytic agents (e.g., naphthalene or menthol-based products) in glucose-6-phosphate dehydrogenase deficient population groups
- Folate deficiency
- Aflatoxins
- Hypothermia
- Birth outside of a healthcare facility

Modified from Olusanya BO, Kaplan M, Hansen TWR. Neonatal hyperbilirubinemia: a global perspective. *Lancet Child Adolesc.* 2018;2:610–618. Panel 2, p. 612.

infections, including syphilis, cytomegalovirus (CMV), rubella, and toxoplasmosis. Significant hemolysis is suggested by a rapid rise in serum bilirubin concentration ( $>0.5$  mg/dL/hr), anemia, pallor, reticulocytosis, hepatosplenomegaly, and a positive family history. An unusually high proportion of direct-reacting bilirubin may characterize jaundice in infants who have received intrauterine transfusions for erythroblastosis fetalis. Jaundice that first appears on the second or third day is usually

**Table 137.2** Evaluation of the Neonate with Significant Jaundice

CONCERN	POSSIBLE DIAGNOSIS	INITIAL LABORATORY TESTS
Jaundice on day 1	Hemolysis* TORCH/sepsis Hepatic failure syndromes <sup>†</sup> Internal hemorrhage	CBC, smear Total and direct bilirubin Blood type and Coombs test
Jaundice requiring phototherapy	Hemolysis* TORCH/sepsis	As above
Direct/conjugated hyperbilirubinemia	TORCH/sepsis Biliary atresia Other causes of cholestasis <sup>‡</sup> Hepatic failure syndromes <sup>†</sup>	Hepatic enzymes, INR, check newborn screen for metabolic disease, blood glucose, blood ammonia and lactate, urine and blood cultures, CMV and HSV PCR

\*Hemolysis may be immune or nonimmune (RBC membrane or enzyme defects).

<sup>†</sup>Hepatic failure syndromes: HSV, CMV, gestational alloimmune liver disease, mitochondrial liver disease, familial hemophagocytic syndrome.

<sup>‡</sup>See Chapter 404.

CMV, Cytomegalovirus; CBC, complete blood count; HSV, herpes simplex virus; PCR, polymerase chain reaction; INR, international normalized ratio; TORCH, toxoplasmosis, other, rubella, CMV, herpes.

physiologic but may represent a more severe form. Familial nonhemolytic icterus (**Crigler-Najjar syndrome**) and early-onset breastfeeding (suboptimal intake) jaundice are seen initially on the second or third day. Jaundice appearing after the third day and within the first week suggests bacterial sepsis or urinary tract infection; it may also be caused by other infections, notably syphilis, toxoplasmosis, CMV, herpes simplex virus (HSV), and enterovirus. Jaundice secondary to extensive ecchymosis or blood extravasation may occur during the first day or later, especially in premature infants. Polycythemia may also lead to early jaundice.

There is a long differential diagnosis for jaundice first recognized after the first week of life, including breast milk jaundice, septicemia, congenital atresia or paucity of the bile ducts, hepatitis, galactosemia, hypothyroidism, cystic fibrosis (CF), pyloric stenosis, and congenital hemolytic anemia crises related to RBC morphology and enzyme deficiencies (Fig. 137.2). The differential diagnosis for persistent jaundice during the first month of life includes hyperalimentation-associated cholestasis, hepatitis, CMV, syphilis, toxoplasmosis, familial nonhemolytic icterus, biliary atresia, galactosemia and other inborn errors of metabolism, and inspissated bile syndrome following hemolytic disease of the newborn. Rarely, physiologic jaundice may be prolonged for several weeks, as in infants with hypothyroidism or pyloric stenosis.

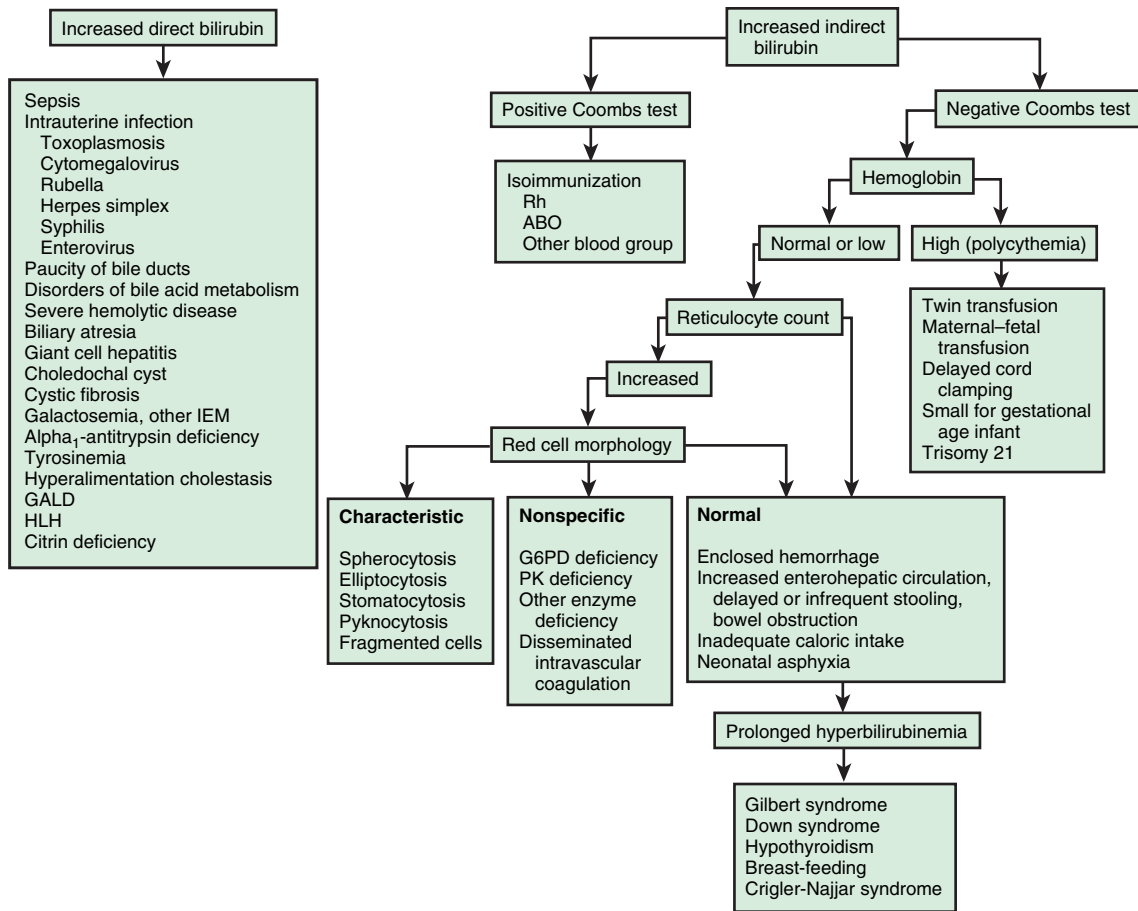
Regardless of gestation or time of appearance of jaundice, patients with significant hyperbilirubinemia and those with symptoms or signs require a complete diagnostic evaluation, which includes review of risks (Table 137.1), determination of direct and indirect bilirubin fractions, hemoglobin, reticulocyte count, blood type, direct antiglobulin/antibody test (DAT) (Coombs test), and examination of a peripheral blood smear. Indirect hyperbilirubinemia, reticulocytosis, and a smear with evidence of RBC destruction suggest hemolysis (see Table 137.2). In the absence of blood group incompatibility, non-immunologically-induced hemolysis should be considered. If the reticulocyte count, Coombs test result, and direct bilirubin value are normal, physiologic or pathologic indirect hyperbilirubinemia may be present (see Fig. 137.2). If direct hyperbilirubinemia is present, diagnostic possibilities include hepatitis, congenital bile duct disorders (biliary atresia, paucity of bile ducts, Byler disease), cholestasis, inborn errors of metabolism, CF, congenital hemosiderosis, sepsis, and neonatal hepatic failure syndromes (Table 137.4).

**Table 137.3** Diagnostic Features of the Various Types of Neonatal Jaundice

DIAGNOSIS	VAN DEN BERGH REACTION	JAUNDICE		PEAK BILIRUBIN CONCENTRATION		BILIRUBIN RATE OF ACCUMULATION (mg/dL/day)	COMMENTS
		APPEARS	DISAPPEARS	MG/DL	AGE IN DAYS		
"Physiologic jaundice"							Usually relates to degree of maturity
Full-term	Indirect	2-3 days	4-5 days	10-12	2-3	<5	
Premature	Indirect	3-4 days	7-9 days	15	6-8	<5	
<b>Hyperbilirubinemia caused by metabolic factors</b>							Metabolic factors: hypoxia, respiratory distress, lack of carbohydrate
Full-term	Indirect	2-3 days	Variable	>12	First wk	<5	Hormonal influences: hypothyroidism, hormones, Gilbert syndrome
Premature	Indirect	3-4 days	Variable	>15	First wk	<5	Genetic factors: Crigler-Najjar syndrome, Gilbert syndrome
<b>Hemolytic states and hematoma</b>	Indirect	May appear in first 24 hr	Variable	Unlimited	Variable	Usually >5	Erythroblastosis: Rh, ABO, Kell congenital hemolytic states: spherocytic, nonspherocytic Infantile pyknocytosis Drug: vitamin K Enclosed hemorrhage—hematoma
<b>Mixed hemolytic and hepatotoxic factors</b>	Indirect and direct	May appear in first 24 hr	Variable	Unlimited	Variable	Usually >5	Infection: bacterial sepsis, pyelonephritis, hepatitis, toxoplasmosis CMV HSV Rubella, syphilis
<b>Hepatocellular damage</b>	Indirect and direct	Usually 2-3 days; may appear by second wk	Variable	Unlimited	Variable	Variable, can be >5	Biliary atresia; paucity of bile ducts, familial cholestasis, galactosemia; hepatitis, infection, hepatic failure syndromes*

\*Gestational alloimmune liver disease, hemophagocytic lymphocytosis, mitochondrial hepatic disorders, inborn errors of metabolism  
CMV, Cytomegalovirus; HSV, herpes simplex virus.

From Brown AK. Neonatal jaundice. *Pediatr Clin North Am.* 1962;9:575-603.



**Fig. 137.2** Algorithmic approach to the diagnosis of neonatal jaundice. G6PD, Glucose-6-phosphate dehydrogenase; GALD, gestational alloimmune liver disease; HLH, hemophagocytic lymphohistiocytosis; IDM, infants of diabetic mothers; IEM, inborn error of metabolism; PK, pyruvate kinase. (From Oski FA. *Differential diagnosis of jaundice*. In Taeusch HW, Ballard RA, Avery MA, eds. *Schaffer and Avery's Diseases of the Newborn*. 6th ed. Philadelphia: Saunders; 1991.)

	<b>GALD</b>	<b>HLH</b>	<b>MITOCHONDRIAL</b>	<b>VIRAL</b>	<b>ISCHEMIC</b>
Transaminase levels (IU/L)	Normal/mild increase <100	Moderate/significant increase (>1,000)	Moderate increase (100-500)	Significant increase (>1,000)	Significant increase (>1,000-6,000)
INR	Significant increase	Moderate/significant increase	Moderate/significant increase	Moderate/significant increase	Moderate/significant increase
Ferritin level (ng/mL)	800-7,000	Significant increase (>20,000)	Variable	Significant increase (>20,000)	Variable depending on underlying cause of ischemia
Triglyceride levels	Normal	Increased	Normal	Normal	Normal
Hypoglycemia	Yes	Often	Yes	Often	Variable
Lactic acidosis	Normal	Normal	Increased	Normal	Often
α-Fetoprotein level (for age)	Increased	Normal	Normal/increased	Normal	Normal
Cholestasis	Progressive after birth	Moderate/significant	Moderate	None/mild at presentation	Mild/moderate

HLH, Hemophagocytic lymphohistiocytosis; GALD, gestational alloimmune liver disease; INR, international normalized ratio. From Larson-Nath C, Vitola BE. Neonatal acute liver failure. *Clin Perinatol*. 2020;47:25–39. Table 2 with data from Sundaram SS, Alonso EM, Narkewicz, MR, et al. *J Pediatr* 2011;159:813–818; Taylor SA, Whittington, PF. *Liver Transpl*. 2016;22(5):677–685; Bitar R, Thwaites R, Davison S, et al. *J Pediatr Gastroenterol Nutr*. 2017;64(1):70–75; Fellman V, Kotarsky H. *Semin Fetal Neonatal Med*. 2011;16(4):222–228.

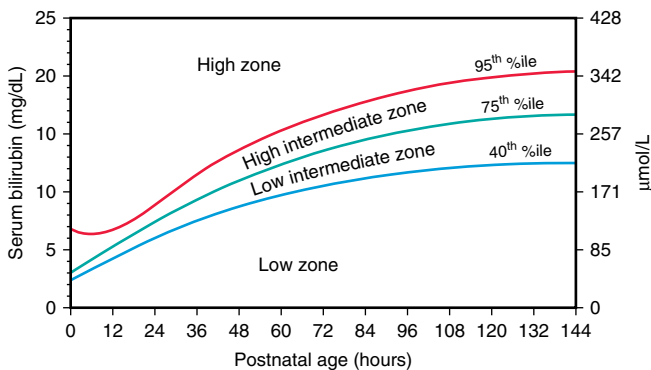


**PHYSIOLOGIC JAUNDICE (ICTERUS NEONATORUM)**

Under normal circumstances, the level of indirect bilirubin in umbilical cord serum is 1-3 mg/dL and rises at a rate of <5 mg/dL/24 hr; thus jaundice becomes visible on the second or third day, usually peaking between the second and fourth days at 5-6 mg/dL and decreasing to <2 mg/dL between the fifth and seventh days after birth. Jaundice associated with these changes is designated *physiologic* and is believed to be the result of increased bilirubin production from the breakdown of fetal RBCs combined with transient limitation in the conjugation of bilirubin by the immature neonatal liver.

Overall, 6-7% of full-term infants have indirect bilirubin levels >13 mg/dL, and <3% have levels >15 mg/dL. Risk factors for elevated indirect bilirubin include maternal age, ethnicity (Chinese, Japanese, Korean, Native American), maternal diabetes, prematurity, drugs, altitude, polycythemia, male, trisomy 21, cutaneous bruising, blood extravasation (cephalohematoma), oxytocin induction, breastfeeding, weight loss (dehydration or caloric deprivation), delayed bowel movement, and a family history of, or a sibling who had, physiologic jaundice (see Table 137.1). In infants without these variables, indirect bilirubin levels rarely rise >12 mg/dL, whereas infants with several risk factors are more likely to have higher bilirubin levels. A combination of breastfeeding, variant-glucuronosyltransferase activity (1A1), subclinical glucose-6-phosphate dehydrogenase (G6PD) deficiency, and alterations of the organic anion transporter-2 gene increases the risk of hyperbilirubinemia. Predicting which neonates are at risk for exaggerated physiologic jaundice can be based on *hour-specific* bilirubin levels in the first 24-72 hours of life (Fig. 137.3). Transcutaneous measurements of bilirubin are linearly correlated with serum levels and can be used for screening. Indirect bilirubin levels in full-term infants decline to adult levels (1 mg/dL) by 10-14 days of life. Persistent indirect hyperbilirubinemia beyond 2 weeks suggests hemolysis, hereditary glucuronyl transferase deficiency, breast milk jaundice, hypothyroidism, or intestinal obstruction. Jaundice associated with pyloric stenosis may be the result of caloric deprivation, relative deficiency of hepatic UDP-glucuronyl transferase, or an increase in the enterohepatic circulation of bilirubin from an ileus. In premature infants, the rise in serum bilirubin tends to be the same or somewhat slower but of longer duration than in term infants. Peak levels of 8-12 mg/dL are not usually reached until the fourth to seventh day, and jaundice is infrequently observed after the 10th day, corresponding to the maturation of mechanisms for bilirubin metabolism and excretion.

The diagnosis of physiologic jaundice in term or preterm infants can be established only by excluding known causes of jaundice based on the history, clinical findings, and laboratory data (see Table 137.3). In general, a search to determine the cause of jaundice should be made



**Fig. 137.3** Neonatal bilirubin nomogram. Percentile designation of well newborns  $\geq 35$  weeks' gestational age based on their hour-specific serum bilirubin values. The high zone is subdivided by the 95th percentile track. The intermediate zone is subdivided into upper and lower zones by the 75th percentile track. The low zone has been electively and statistically defined by the 40th percentile track. (Modified from Bahr TM, Henry E, Christensen RD, et al. A new hour-specific serum bilirubin nomogram for neonates  $\geq 35$  weeks of gestation. *J Pediatr*. 2021;236:28-33. Fig. 2.)

if (1) it appears in the first 24-36 hours after birth, (2) serum bilirubin is rising at a rate faster than 5 mg/dL/24 hr, (3) serum bilirubin is >12 mg/dL in a full-term infant (especially in the absence of risk factors) or 10-14 mg/dL in a preterm infant, (4) jaundice persists after 10-14 days after birth, or (5) direct bilirubin fraction is >2 mg/dL at any time. Other factors suggesting a pathologic cause of jaundice are family history of hemolytic disease, pallor, hepatomegaly, splenomegaly, failure of phototherapy to lower the bilirubin level, vomiting, lethargy, poor feeding, excessive weight loss, apnea, bradycardia, abnormal vital signs (including hypothermia), light-colored stools, dark urine positive for bilirubin, bleeding disorder, and signs of kernicterus (see Chapter 137.1).

**PATHOLOGIC HYPERBILIRUBINEMIA**

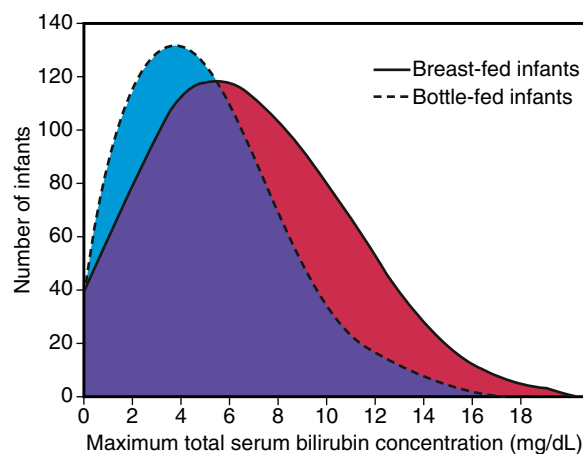
Jaundice and its underlying hyperbilirubinemia are considered pathologic if the time of appearance, duration, or pattern varies significantly from that of physiologic jaundice, or if the course is compatible with physiologic jaundice but other reasons exist to suspect that the infant is at special risk for neurotoxicity. It may not be possible to determine the precise cause of an abnormal elevation of unconjugated bilirubin, but many infants with this finding have associated risk factors such as ethnicity, prematurity, breastfeeding, and weight loss. Frequently, the terms *exaggerated physiologic jaundice* and *hyperbilirubinemia of the newborn* are used in infants whose primary problem is probably a deficiency or inactivity of bilirubin glucuronyl transferase (**Gilbert syndrome**) rather than an excessive load of bilirubin for excretion (see Table 137.1). *The combination of G6PD deficiency and a pathogenic variant of the promoter region of UDP-glucuronyl transferase-1 produces indirect hyperbilirubinemia in the absence of signs of hemolysis.*

The greatest risk associated with indirect hyperbilirubinemia is the development of bilirubin-induced neurologic dysfunction, which typically occurs with high indirect bilirubin levels (see Chapter 137.1). The development of kernicterus (**bilirubin encephalopathy**) depends on the level of indirect bilirubin, duration of exposure to bilirubin elevation, the cause of jaundice, and the infant's well-being. Neurologic injury including kernicterus may occur at lower bilirubin levels in preterm infants and in the presence of asphyxia, sepsis, meningitis, intraventricular hemorrhage, hemolysis, or drugs that displace bilirubin from albumin. *The exact serum indirect bilirubin level that is harmful for very low birthweight (VLBW) infants is unclear.*

**JAUNDICE ASSOCIATED WITH BREASTFEEDING**

Significant elevation in unconjugated bilirubin (**breast milk jaundice**) develops in an estimated 2% of breastfed term infants after the seventh day, with maximal concentrations as high as 10-30 mg/dL reached during the second to third week. If breastfeeding is continued, the bilirubin gradually decreases but may persist for 3-10 weeks at lower levels. Phototherapy may be of benefit (see Chapter 137.1). Although very uncommon, kernicterus can occur in patients with breast milk jaundice. The etiology of breast milk jaundice is not entirely clear, although intestinal  $\beta$ -glucuronidase resulting in deconjugation of bilirubin and increased enterohepatic circulation and other factors in breast milk that might interfere with bilirubin conjugation (e.g., pregnanediol, free fatty acids) have been implicated.

The late jaundice associated with breast milk should be distinguished from an *early onset*, accentuated unconjugated hyperbilirubinemia known as suboptimal intake hyperbilirubinemia or **breastfeeding jaundice**, which occurs during the first week after birth in breastfed infants, who normally have higher bilirubin levels than formula-fed infants (Fig. 137.4). Lower milk intake before breast milk production is established can result in various degrees of dehydration, which hemoconcentrates bilirubin, while also causing fewer bowel movements, which in turn increases the enterohepatic circulation of bilirubin. Prophylactic supplements of glucose water to breastfed infants are associated with higher bilirubin levels, in part because of reduced intake of the higher-caloric density breast milk and *are not indicated*. Frequent breastfeeding (>10 in 24 hours), rooming-in with night feeding, and ongoing lactation support may reduce the incidence of



**Fig. 137.4** Distribution of maximal bilirubin levels during the first week of life in breastfed and formula-fed White infants weighing >2,500 g. (From Maisels MJ, Gifford K. Normal serum bilirubin levels in the newborn and the effect of breast-feeding. *Pediatrics*. 1986;78:837–843.)

early breastfeeding jaundice. In addition, supplementation with formula or more preferred expressed breast milk is appropriate if the intake seems inadequate, weight loss is excessive, or the infant appears dehydrated.

## NEONATAL CHOLESTASIS

See Chapter 404.

## CONGENITAL ATRESIA OF THE BILE DUCTS

See Chapter 404.1.

Jaundice persisting for >2 weeks or associated with acholic stools and dark urine suggests biliary atresia. All infants with such findings require immediate diagnostic evaluation, including determination of direct bilirubin.

Visit Elsevier eBooks+ at eBooks.Health.Elsevier.com for Bibliography.

## 137.1 Kernicterus and Therapy of Hyperbilirubinemia

Kelsey S. Ryan and Robert M. Kliegman

Kernicterus, or **bilirubin encephalopathy**, is a neurologic syndrome resulting from the deposition of unconjugated (indirect) bilirubin in the basal ganglia and brainstem nuclei. The pathogenesis of kernicterus is multifactorial and involves an interaction between unconjugated bilirubin levels, albumin binding and unbound bilirubin levels, passage across the BBB, and neuronal susceptibility to injury. Disruption of the BBB by disease, asphyxia, infection, and other factors and maturational changes in BBB permeability affect risk.

The precise blood level above which indirect-reacting bilirubin or free bilirubin will be toxic for an individual infant is unpredictable. In a large series, however, kernicterus occurred only in infants with a bilirubin >20 mg/dL (more often >25–30 mg/dL), 90% of whom were previously healthy, predominantly breastfed, term and near-term infants. The duration of exposure to high bilirubin levels needed to produce toxic effects is unknown; the more immature the infant, and possibly age (day 1 vs day of life  $\geq 4$ ), the greater the susceptibility to kernicterus.

### CLINICAL MANIFESTATIONS

Signs and symptoms of kernicterus usually appear 2–5 days after birth in term infants and as late as the seventh day in preterm infants, but hyperbilirubinemia may lead to encephalopathy at any time during the neonatal period. The early signs may be subtle and indistinguishable from those of sepsis, asphyxia, hypoglycemia, intracranial hemorrhage,

### Table 137.5 Clinical Features of Kernicterus

#### ACUTE FORM

Phase 1 (first 1–2 days): poor suck, stupor, hypotonia, seizures  
Phase 2 (middle of first week): hypertonia of extensor muscles, opisthotonos, retrocollis, fever  
Phase 3 (after the first week): hypertonia

#### CHRONIC FORM

First year: hypotonia, active deep tendon reflexes, obligatory tonic neck reflexes, delayed motor skills  
After first year: movement disorders (choreoathetosis, ballismus, tremor), upward gaze, sensorineural hearing loss

From Denney PA, Seidman DS, Stevenson DK. Neonatal hyperbilirubinemia. *N Engl J Med* 2001;344:581–590.

apnea, and other acute systemic illnesses in a neonate. Lethargy, poor feeding, and loss of the Moro reflex are common initial signs. Subsequently, the infant may appear gravely ill and prostrate, with diminished tendon reflexes and respiratory distress. Opisthotonos with a bulging fontanel, twitching of the face or limbs, and a shrill, high-pitched cry may follow. In advanced cases, convulsions and spasm occur, with affected infants stiffly extending their arms in an inward rotation with the fists clenched (Table 137.5). Rigidity is rare at this late stage.

Many infants who progress to these severe neurologic signs die; the survivors usually have serious sequelae but may appear to recover and for 2–3 months show few abnormalities. Later in the first year, opisthotonos, muscle rigidity, irregular movements, and convulsions tend to recur. In the second year the opisthotonos and seizures abate, but irregular, involuntary movements, muscle rigidity, or, in some infants, hypotonia increase steadily. By 3 years of age, the complete neurologic syndrome is often apparent: bilateral choreoathetosis with involuntary muscle spasms, extrapyramidal signs, seizures, mental deficiency, dysarthric speech, high-frequency hearing loss, squinting, and defective upward eye movements. Pyramidal signs, hypotonia, and ataxia occur in a few infants. In mildly affected infants, the syndrome may be characterized only by mild to moderate neuromuscular incoordination, partial deafness, or “minimal brain dysfunction,” occurring singly or in combination; these problems may be unapparent until the child enters school (see Table 137.5).

### INCIDENCE AND PROGNOSIS

By pathologic criteria, kernicterus develops in 30% of infants (all gestational ages) with untreated hemolytic disease and bilirubin levels >25–30 mg/dL. The incidence at autopsy in hyperbilirubinemic preterm infants is 2–16% and is related to the risk factors discussed in this chapter. Reliable estimates of the frequency of the clinical syndrome are not available because of the wide spectrum of manifestations. Overt neurologic signs carry a grave prognosis; >75% of infants die, and 80% of affected survivors have bilateral choreoathetosis with involuntary muscle spasms. Developmental delay, deafness, and spastic quadriplegia are common.

### PREVENTION

The aim of bilirubin management is prevention of kernicterus. Although kernicterus has been thought to be a disease of the past, there are reports of neurotoxic effects of bilirubin in term and near-term infants who were discharged as healthy newborns. Effective prevention requires ongoing vigilance and a practical, system-based approach to distinguish infants with benign newborn jaundice from those whose course may be less predictable and potentially harmful. Predischarge universal screening for hyperbilirubinemia and assessment of clinical risk factors for severe jaundice and bilirubin-induced neurologic dysfunction include either total serum bilirubin or transcutaneous bilirubin measurement (interchangeably), although transcutaneous instruments may be less accurate at higher bilirubin levels (>15 mg/dL) or for infants with darker skin or if phototherapy has been used. If transcutaneous levels are documented as  $\geq 15$  mg/dL or rising rapidly, confirmation with a total serum bilirubin is recommended. Serum

values should also be measured once infants begin phototherapy, because transcutaneous measurement may falsely underestimate total bilirubin in this setting.

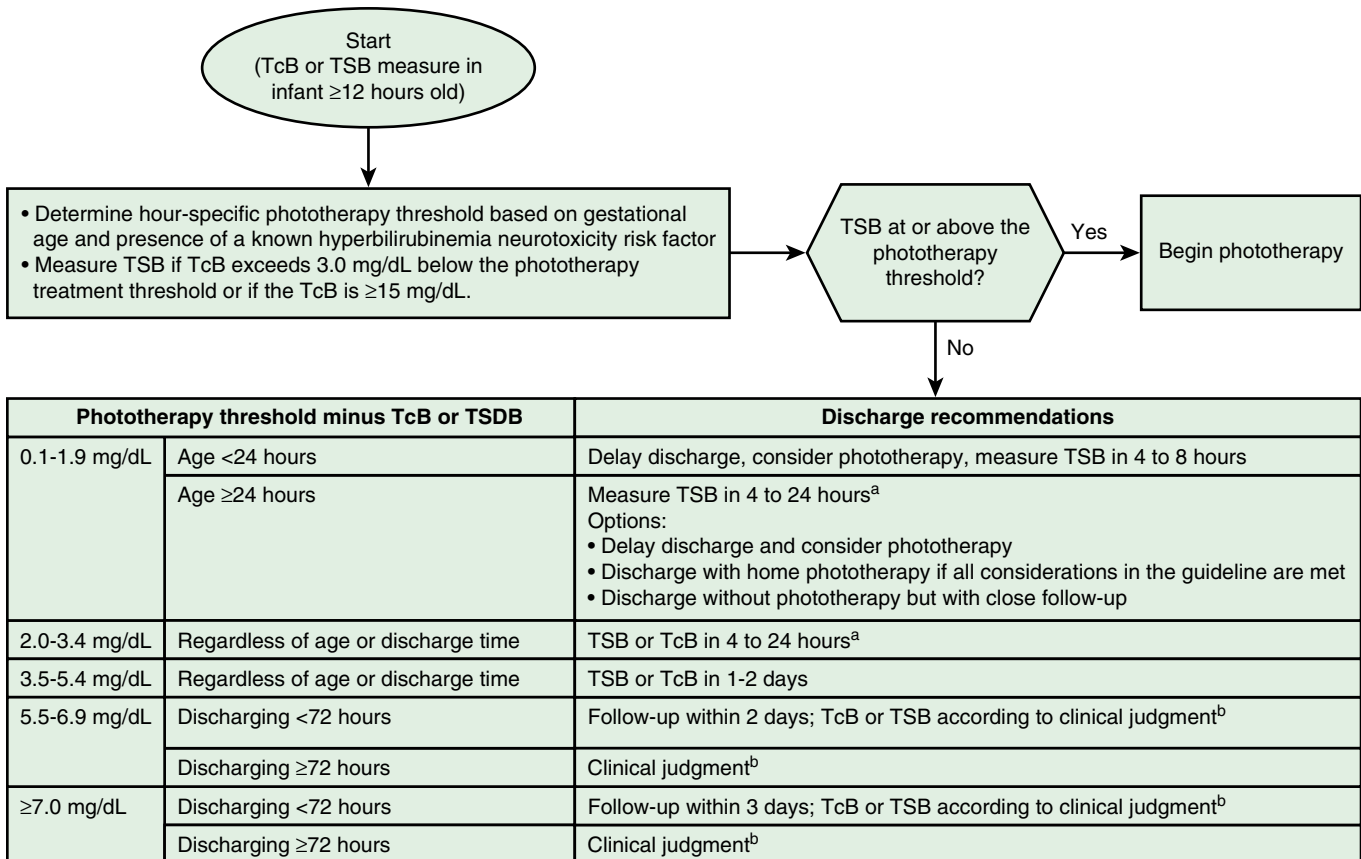
Protocols using the hour-specific bilirubin nomogram (see Fig. 137.3), physical examination, and clinical risk factors have been successful in identifying patients at risk for hyperbilirubinemia and candidates for targeted management. Potentially preventable causes of kernicterus include (1) early discharge (<48 hours) with no early follow-up (within 48 hours of discharge), a problem that is particularly important in near-term infants (35-37 weeks of gestation); (2) failure to check the bilirubin level in an infant noted to be jaundiced in the first 24 hours; (3) failure to recognize the presence of risk factors for hyperbilirubinemia, especially hemolysis; (4) underestimation of the severity of jaundice by clinical (visual) assessment, which is inaccurate; (5) lack of concern regarding the presence of jaundice; (6) delay in measuring the serum bilirubin level despite marked jaundice or delay in initiating phototherapy in the presence of elevated bilirubin levels; and (7) failure to respond to parental concern regarding jaundice, poor feeding, or lethargy. Figure 137.5 provides a consensus-based (expert opinion) management plan for neonates with significant hyperbilirubinemia that relies on consensus-recommended (expert opinion) phototherapy thresholds for gestational ages  $\geq 35$  weeks (Figs. 137.6 and 137.7) in well appearing neonates.

The following approach is further recommended: (1) any infant who is jaundiced before 24 hours requires measurement of total and direct serum bilirubin levels and, if elevated, evaluation for possible hemolytic or primary hepatic diseases, and (2) follow-up should be

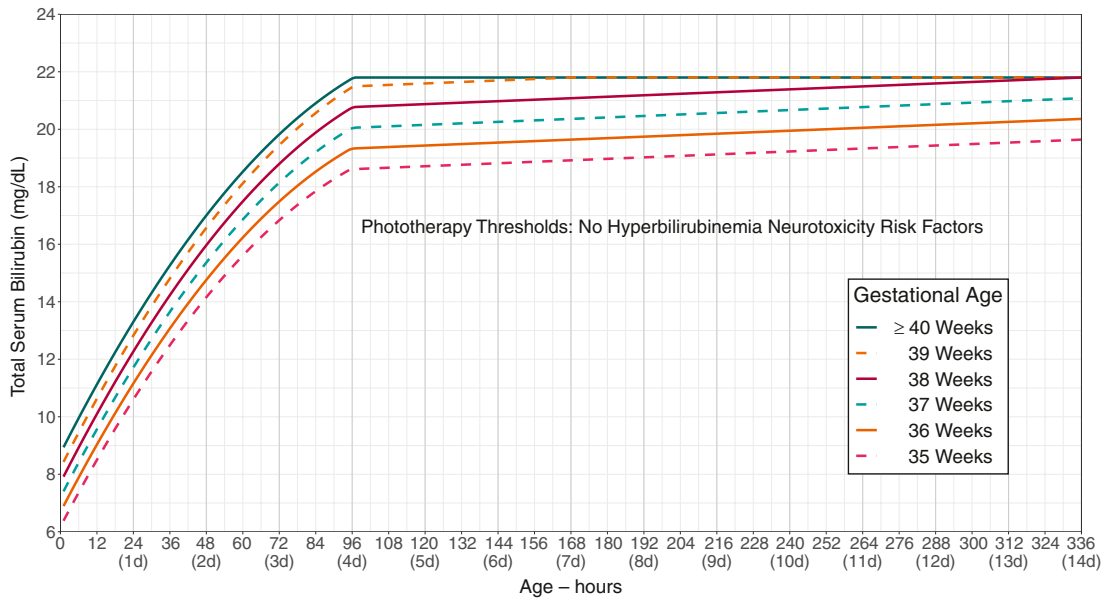
provided within 2-3 days of discharge to all neonates discharged earlier than 48 hours after birth. Early follow-up is particularly important for infants <38 weeks of gestation. The timing of follow-up depends on the age at discharge and the presence of risk factors. In some cases, follow-up within 24 hours is necessary. Postdischarge follow-up is essential for early recognition of problems related to hyperbilirubinemia and disease progression. Parental communication with regard to concerns about the infant's skin color and behavioral activities should be addressed early and frequently, including education about potential risks and neurotoxicity. Ongoing lactation promotion, education, support, and follow-up services are essential throughout the neonatal period. Parents should be advised to nurse their infants 8-12 times in 24 hours and to avoid supplementation with water or glucose water to ensure adequate hydration and caloric intake.

### TREATMENT OF HYPERBILIRUBINEMIA

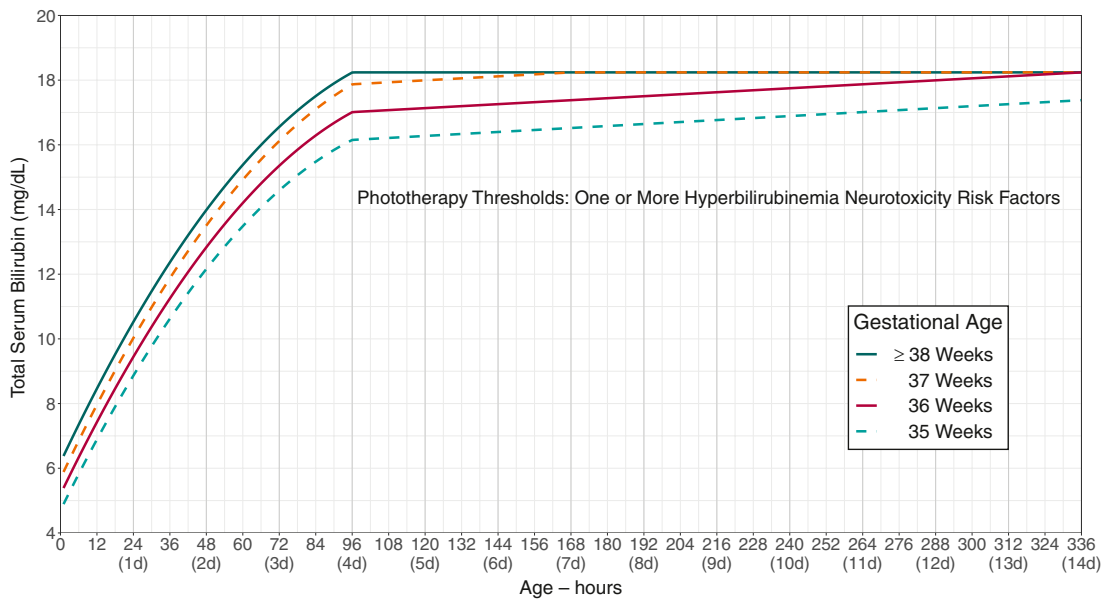
Regardless of the cause, the goal of therapy is to prevent neurotoxicity related to indirect-reacting bilirubin while causing no undue harm. Phototherapy and, if unsuccessful, exchange transfusion remain the primary treatment modalities used to keep the maximal total serum bilirubin below pathologic levels (Table 137.6; see Figs. 137.6 and 137.7). The risk of injury to the central nervous system from bilirubin must be balanced against the potential risk of treatment. Because phototherapy may require 6-12 hours to have a measurable effect, it must be started at bilirubin levels below those indicated for exchange transfusion. When identified, underlying



**Fig. 137.5** Algorithm to determine postdischarge follow-up for infants who have not received phototherapy during the birth hospitalization. <sup>a</sup>Use clinical judgment and shared decision-making to determine when to repeat the bilirubin measure within this 4–24-hour time window. <sup>b</sup>Clinical judgment decisions should include physical examination, the presence of risk factors for the development of hyperbilirubinemia or hyperbilirubinemia neurotoxicity risk factors, feeding adequacy, weight trajectory, and family support. TcB, Transcutaneous bilirubin; TSB, total serum bilirubin. (From Kemper AR, Newman TB, Slaughter JL, et al. Clinical practice guideline revision: management of hyperbilirubinemia in the newborn infant 35 or more weeks of gestation. *Pediatrics*. 2022; 150[3]:e2022058859. Fig. 7.)



**Fig. 137.6** Phototherapy thresholds by gestational age and age in hours for infants with no recognized hyperbilirubinemia neurotoxicity risk factors other than gestational age. These thresholds are based on expert opinion rather than strong evidence on when the potential benefits of phototherapy exceed its potential harms. Use total serum bilirubin concentrations; do not subtract direct-reacting or conjugated bilirubin from the total serum bilirubin. In rare cases of severe hyperbilirubinemia in which the direct-reacting or conjugated bilirubin exceeds 50% of the TSB, consult an expert. Note that infants <24 hours old with a TSB at or above the phototherapy threshold are likely to have a hemolytic process and should be evaluated for hemolytic disease. Hyperbilirubinemia neurotoxicity risk factors include gestational age <38 weeks; albumin <3.0 g/dL; isoimmune hemolytic disease, glucose-6-phosphate dehydrogenase (G6PD) deficiency, or other hemolytic conditions; sepsis; or any significant clinical instability in the previous 24 hours. (From Kemper AR, Newman TB, Slaughter JL, et al. *Clinical practice guideline revision: management of hyperbilirubinemia in the newborn infant 35 or more weeks of gestation*. *Pediatrics*. 2022;150[3]:e2022058859. Fig. 2.)



**Fig. 137.7** Phototherapy thresholds by gestational age and age in hours for infants with any recognized hyperbilirubinemia neurotoxicity risk factors other than gestational age. These thresholds are based on expert opinion rather than strong evidence on when the potential benefits of phototherapy exceed its potential harms. Use total serum bilirubin concentrations; do not subtract the direct-reacting or conjugated bilirubin from the total serum bilirubin. In rare cases of severe hyperbilirubinemia in which the direct-reacting or conjugated bilirubin exceeds 50% of the TSB, consult an expert. Hyperbilirubinemia neurotoxicity risk factors include gestational age <38 weeks; albumin <3.0 g/dL; isoimmune hemolytic disease, glucose-6-phosphate dehydrogenase (G6PD) deficiency, or other hemolytic conditions; sepsis; or any significant clinical instability in the previous 24 hours. (From Kemper AR, Newman TB, Slaughter JL, et al. *Clinical practice guideline revision: management of hyperbilirubinemia in the newborn infant 35 or more weeks of gestation*. *Pediatrics*. 2022;150[3]:e2022058859. Fig. 3.)



medical causes of elevated bilirubin and physiologic factors that contribute to neuronal susceptibility should be treated, such as antibiotics for sepsis, correction of acidosis, and dehydration (Fig. 137.8).

**Phototherapy**

Clinical jaundice and indirect hyperbilirubinemia are reduced by exposure to high-intensity light in the visible spectrum. Bilirubin absorbs light maximally in the blue range (420-470 nm). Broad-spectrum white, blue, and special narrow-spectrum (super) blue lights have been effective in reducing bilirubin levels. Bilirubin in the skin absorbs light energy, causing several photochemical reactions. One major product from phototherapy is a result of a reversible photoisomerization reaction converting the toxic native unconjugated 4Z,15Z-bilirubin into an unconjugated configurational isomer, 4Z,15E-bilirubin, which can then be excreted in bile without conjugation. The other major product from phototherapy is lumirubin, which is an irreversible structural isomer converted from native bilirubin that can be excreted by the kidneys in the unconjugated state.

The therapeutic effect of phototherapy depends on the light energy emitted in the effective range of wavelengths, the distance between the lights and the infant, and the surface area of exposed skin, as well as the

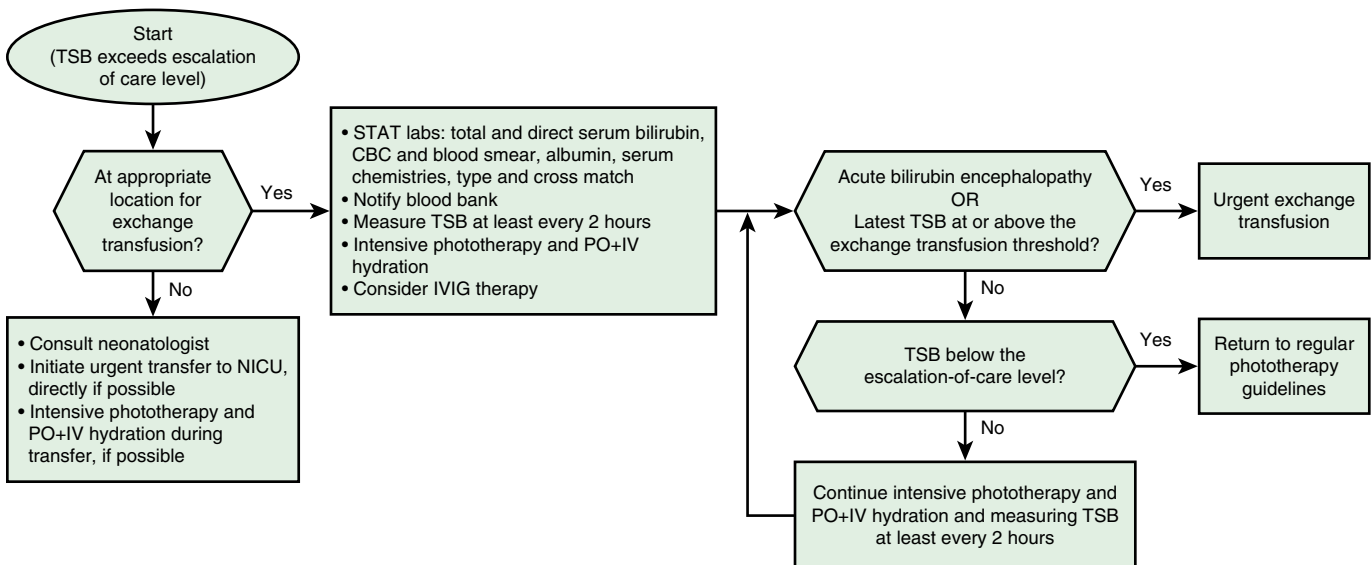
rate of hemolysis and in vivo metabolism and excretion of bilirubin. Available commercial phototherapy units vary considerably in spectral output and the intensity of radiance emitted; therefore the wattage can be accurately measured only at the patient's skin surface. Dark skin does not reduce the efficacy of phototherapy. Maximal intensive phototherapy should be used when indirect bilirubin levels approach those noted in Figures 137.6 and 137.7. Such therapy includes using LED lamps and/or putting a fiberoptic phototherapy blanket under the infant's back to increase the exposed surface area.

The use of phototherapy has decreased the need for exchange transfusion in term and preterm infants with hemolytic and nonhemolytic jaundice. When indications for exchange transfusion are present, phototherapy should not be used as a substitute; however, phototherapy may reduce the need for repeated exchange transfusions in infants with hemolysis. Conventional phototherapy is applied continuously (except for breastfeeding). It should be discontinued as soon as the indirect bilirubin concentration has reduced to levels considered safe with respect to the infant's age and condition. Serum bilirubin levels and hematocrit should be monitored every 4-8 hours in infants with hemolytic disease and those with bilirubin levels near toxic range. Serum bilirubin monitoring should continue for at least 24 hours after cessation of phototherapy in patients with hemolytic disease, because unexpected rises in bilirubin may occur, requiring further treatment. Skin color, visual assessment, or transcutaneous bilirubin levels cannot be relied on for evaluating the effectiveness of phototherapy; the skin of babies exposed to light may appear to be almost without jaundice in the presence of marked hyperbilirubinemia. Although not necessary for all affected infants, intravenous fluid supplementation added to oral feedings are beneficial in dehydrated patients or infants with bilirubin levels nearing those requiring exchange transfusion.

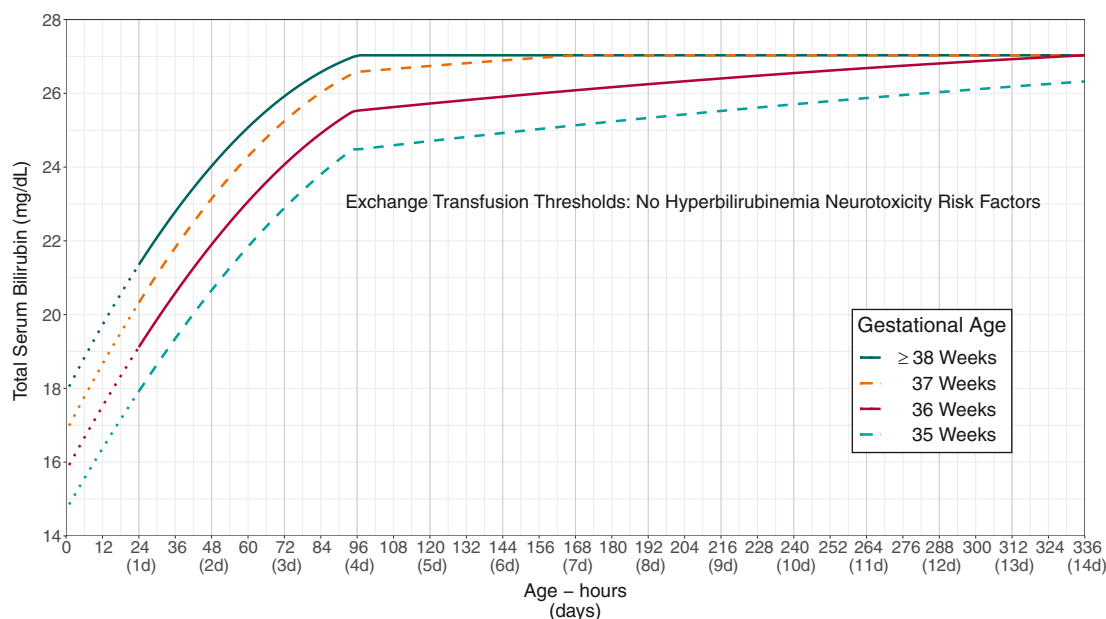
**Complications** associated with phototherapy include loose stools, erythematous macular rash, purpuric rash associated with transient porphyrinemia, hypothermia from exposure, and a benign condition called "bronze baby syndrome," which occurs in the presence of direct hyperbilirubinemia. Phototherapy is contraindicated in the presence of porphyria. Before phototherapy is initiated, the infant's eyes should be closed and adequately covered to prevent light exposure and corneal damage. Body temperature should be monitored, and the infant should be shielded from bulb breakage and fluorescent bulb use. Irradiance should be measured directly. In infants with hemolytic disease, care must be taken to monitor for the development

BIRTHWEIGHT (g)	UNCOMPLICATED*	COMPLICATED*
<1,000	12-13	10-12
1,000-1,250	12-14	10-12
1,251-1,499	14-16	12-14
1,500-1,999	16-20	15-17
2,000-2,500	20-22	18-20

\*Complications include perinatal asphyxia, acidosis, hypoxia, hypothermia, hypoalbuminemia, meningitis, intraventricular hemorrhage, hemolysis, hypoglycemia, or signs of kernicterus. Phototherapy is usually started at 50-70% of the maximal indirect level. If values greatly exceed this level, if phototherapy is unsuccessful in reducing the maximal bilirubin level, or if signs of kernicterus are evident, exchange transfusion is indicated.



**Fig. 137.8** Approach to escalation of care. The escalation-of-care threshold is 2 mg/dL below the exchange transfusion threshold. IVIG, Intravenous immunoglobulin; NICU, neonatal intensive care unit; PO, orally; TSB, total serum bilirubin. (Modified from Kemper AR, Newman TB, Slaughter JL, et al. Clinical practice guideline revision: management of hyperbilirubinemia in the newborn infant 35 or more weeks of gestation. Pediatrics. 2022;150[3]:e2022058859. Fig. 4.)



**Fig. 137.9** Exchange transfusion thresholds by gestational age for infants with no recognized hyperbilirubinemia neurotoxicity risk factors other than gestational age. These thresholds are based on expert opinion rather than strong evidence on when the potential benefits of escalation of care exceed its potential harms. The stippled lines for the first 24 hours indicate uncertainty because of the wide range of clinical circumstances and responses to intensive phototherapy. Use total serum bilirubin concentrations; do not subtract direct bilirubin from the total serum bilirubin. In rare cases of severe hyperbilirubinemia in which the direct-reacting or conjugated bilirubin exceeds 50% of the TSB, consult an expert. Hyperbilirubinemia neurotoxicity risk factors include albumin <3.0 g/dL; isoimmune hemolytic disease, glucose-6-phosphate dehydrogenase (G6PD) deficiency, or other hemolytic conditions; sepsis; or any significant clinical instability in the previous 24 hours. (From Kemper AR, Newman TB, Slaughter JL, et al. *Clinical practice guideline revision: management of hyperbilirubinemia in the newborn infant 35 or more weeks of gestation*. *Pediatrics*. 2022;150[3]:e2022058859. Fig. 5.)

of anemia, which may require transfusion; *anemia may develop despite lowering of bilirubin levels*. Clinical experience suggests that long-term adverse biologic effects of phototherapy are absent, minimal, or unrecognized.

The term **bronze baby syndrome** refers to a dark, grayish brown skin discoloration sometimes noted in infants undergoing phototherapy. Almost all infants observed with this syndrome have had significant elevation of direct-reacting bilirubin and other evidence of obstructive liver disease. The discoloration may result from photo-induced modification of porphyrins, which are often present during cholestatic jaundice and may last for many months. Despite the bronze baby syndrome, phototherapy can continue if needed.

### Intravenous Immunoglobulin

The administration of intravenous immunoglobulin (IVIG) is an adjunctive treatment for hyperbilirubinemia caused by *isoimmune hemolytic disease*. It has been used when serum bilirubin is approaching exchange levels despite maximal interventions, including phototherapy. IVIG (0.5-1.0 g/kg/dose; repeat in 12 hours) may reduce the need for exchange transfusion in both ABO and Rh hemolytic disease, presumably by reducing hemolysis. The effectiveness is unclear.

### Exchange Transfusion

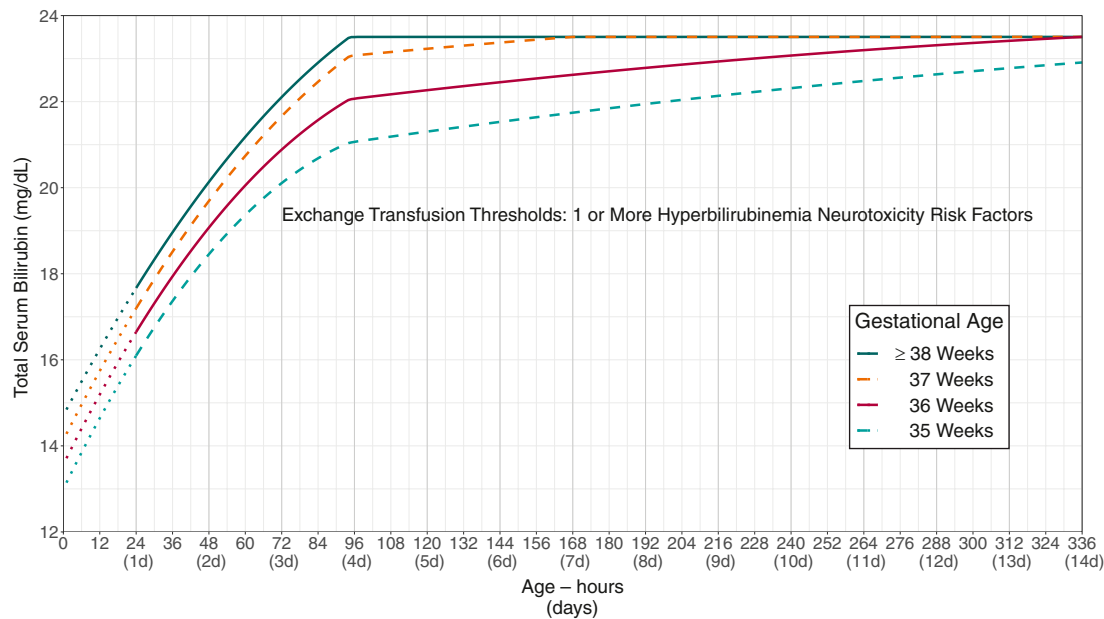
Double-volume exchange transfusion is performed if intensive phototherapy has failed to reduce bilirubin levels to a safe range and the risk of kernicterus exceeds the procedural risk. Potential complications from exchange transfusion are not trivial and include metabolic acidosis, electrolyte abnormalities, hypoglycemia, hypocalcemia,

thrombocytopenia, volume overload, arrhythmias, necrotizing enterocolitis (NEC), infection, graft versus host disease, and death. This widely accepted treatment is repeated if necessary to keep indirect bilirubin levels in a safe range (Fig. 137.9). Ideally the exchange transfusion should be performed with leukocyte-depleted, washed fresh-packed RBC's, reconstructed with fresh-frozen plasma to a hematocrit of ~40%. It should be cross matched against the neonate and the mother.

Various factors may influence the decision to perform a double-volume exchange transfusion in an individual patient (see Fig. 137.8). The appearance of clinical signs suggesting kernicterus is an absolute indication for exchange transfusion at any level of serum bilirubin. A hydropic jaundiced neonate with erythroblastosis from Rh disease will be critically ill and requires exchange transfusion at much lower levels than recommended in Figures 137.9 and 137.10. See other risk factors affecting exchange transfusion threshold in Figure 137.10.

A healthy full-term infant with physiologic or breast milk jaundice may tolerate a bilirubin concentration slightly higher than 25 mg/dL with no apparent ill effect, whereas kernicterus may develop in a sick premature infant at a significantly lower level. A level approaching that considered critical for the individual infant may be an indication for exchange transfusion during the first or second day after birth, when a further rise is anticipated, but not typically after the fourth day in a term infant or after the seventh day in a preterm infant, because an imminent decrease in bilirubin levels may be anticipated as the hepatic conjugating mechanism becomes more effective.

Visit Elsevier eBooks+ at [eBooks.Elsevier.com](https://www.elsevier.com/ebooks) for Bibliography.



**Fig. 137.10** Exchange transfusion thresholds by gestational age for infants with any recognized hyperbilirubinemia neurotoxicity risk factors other than gestational age. These thresholds are based on expert opinion rather than strong evidence on when the potential benefits of escalation of care exceed its potential harms. The stippled lines for the first 24 hours indicate uncertainty because of the wide range of clinical circumstances and responses to intensive phototherapy. Use total serum bilirubin concentrations; do not subtract direct bilirubin from the total serum bilirubin. In rare cases of severe hyperbilirubinemia in which the direct-reacting or conjugated bilirubin exceeds 50% of the TSB, consult an expert. Hyperbilirubinemia neurotoxicity risk factors include albumin <3.0 g/dL; isoimmune hemolytic disease, glucose-6-phosphate dehydrogenase (G6PD) deficiency, or other hemolytic conditions; sepsis; or any significant clinical instability in the previous 24 hours. (From Kemper AR, Newman TB, Slaughter JL, et al. *Clinical practice guideline revision: management of hyperbilirubinemia in the newborn infant 35 or more weeks of gestation*. *Pediatrics*. 2022;150[3]:e2022058859. Fig. 6.)

## Chapter 138

# Blood Disorders

Christopher S. Thom and Michele P. Lambert

### NORMAL ERYTHROPOIESIS AND HEMOGLOBIN FUNCTIONS

The diagnosis of anemia or polycythemia, and interpretation of laboratory values, requires understanding normal hemoglobin-oxygen binding and delivery physiology. Heterotetrameric **hemoglobin**, comprising two  $\alpha$ -globin and two  $\beta$ -globin monomers, has an exquisite ability to cooperatively bind and release oxygen molecules in response to environmental conditions. Hemoglobin switching refers to the normal transitions in gene expression among embryonic, fetal, and adult globins that occur before and after birth (Fig. 138.1). Fetal hemoglobin (HbF) is the predominant hemoglobin molecule produced during late gestation. Its increased oxygen affinity compared with maternal adult hemoglobin (HbA) facilitates oxygen transfer in the hypoxic in utero environment, which lacks direct atmospheric gas exchange. Relative in utero hypoxia explains the elevated hemoglobin levels normally seen in newborns, which can be exacerbated by pathologic chronic intrauterine hypoxia.

### NORMAL RED BLOOD CELL INDICES IN NEONATES AND INFANTS

Diagnosing anemia or polycythemia in infants also relies on comparisons to normal reference ranges, which vary based on gestational and postnatal age. Normal reference ranges for hemoglobin, hematocrit, and other erythrocyte indices are based on measurements from more

than 25,000 preterm and term infants through the first 28 days of life (Fig. 138.2). Hemoglobin and hematocrit levels exhibit linear increases between 22 and 40 weeks of gestation.

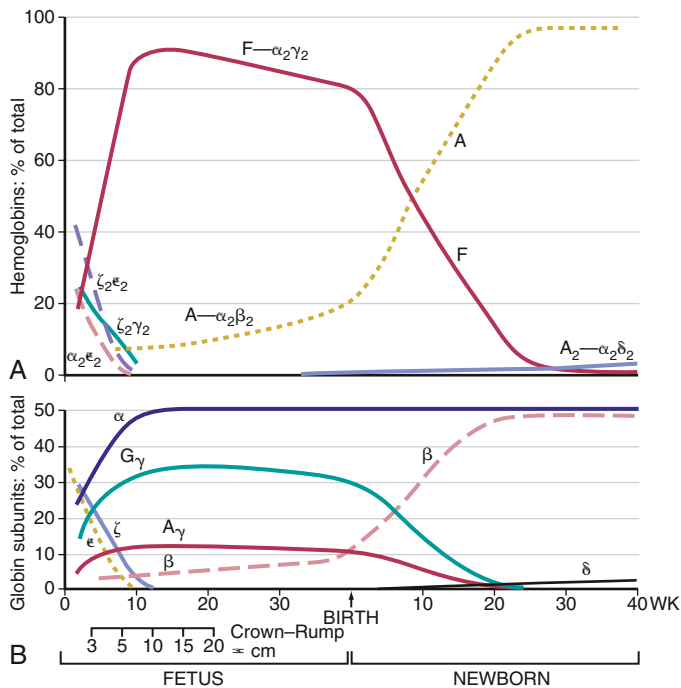
Erythrocyte mean corpuscular volume (MCV) in neonates is typically higher than toddlers or older children, with normal values ranging from approximately 100–115 fL at birth (see Fig. 138.2C). Reasons for this finding are multifactorial. An elevated MCV can reflect an increase in circulating reticulocytes (immature erythrocytes), although a relative reticulocytosis in neonates is inadequate to fully explain the MCV elevation. Indeed, mature erythrocytes are larger in neonates than in adults. The size discrepancy may be related to the presence of different hemoglobin molecules, as mature erythrocytes containing HbF (termed F cells) may be larger than HbA-containing cells. Conversely, MCV <100 fL in a neonate should prompt suspicion for underlying  $\alpha$ -thalassemia/thalassemia trait, maternal iron deficiency, or chronic fetal to maternal blood loss.

At any age, increased MCV can indicate hemolysis or other processes that enhance erythropoietic drive. Persistent microcytic anemia can result from thalassemia or iron deficiency.

### Platelet Count Abnormalities in Pediatric Patients

Hematopoiesis, megakaryopoiesis, and thrombopoiesis produce  $\sim 10^{11}$  platelets per day to facilitate normal blood clotting and fulfill important vascular functions (see Chapter 495). Processes that disrupt platelet production or consumption can significantly alter steady-state platelet quantities in circulation. This can be clinically relevant and require intervention, although many etiologies are transient and/or benign. Here we describe common etiologies that increase or decrease platelet counts. Chapter 533 includes a full description of these and other platelet defects.

**Thrombocytosis** is defined as  $>450 \times 10^9$  platelets/L blood, although for neonates this limit can be raised to  $>600 \times 10^9$  platelets/L. Thrombocytosis can be stratified from mild to extreme, the latter defined as  $>1,000 \times 10^9$



**Fig. 138.1** Developmental changes in (A) hemoglobin tetramers and (B) globin subunit expression from early gestation through infancy. (From Polin RA, Fox WW. *Fetal and Neonatal Physiology*. 2nd ed. Philadelphia: Saunders; 1998. p. 1769.)

platelets/L. Immature immune or hematopoietic systems may underlie an increased rate of thrombocytosis in infants and young children.

Myeloproliferative disorders can cause primary thrombocytosis, but this is rare in children. More often, thrombocytosis reflects a secondary or reactive process as part of an acute phase response. This is usually due to an inflammatory process and does not increase thrombotic risk in children. Extreme thrombocytosis is rare, and it can be more worrisome for infection, iron deficiency, or other inflammatory pathology. However, even extremely elevated platelet counts do not seem to increase risk of hemorrhage or thrombosis. Thus most often, thrombocytosis will resolve spontaneously, or after treatment of the inciting etiology, without adverse sequelae.

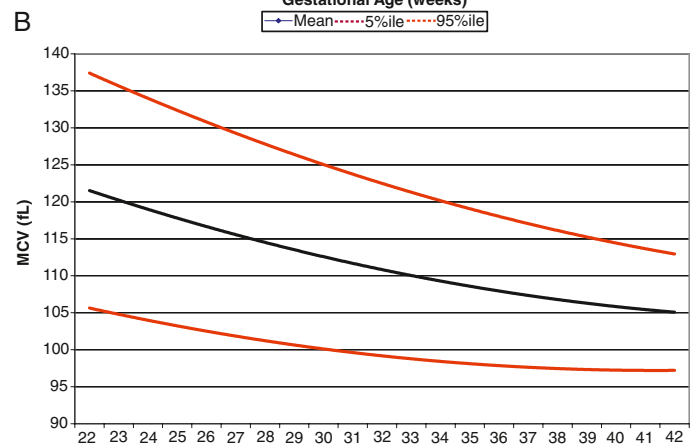
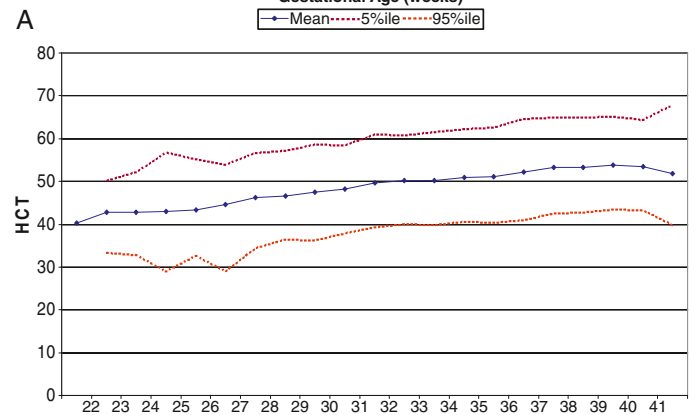
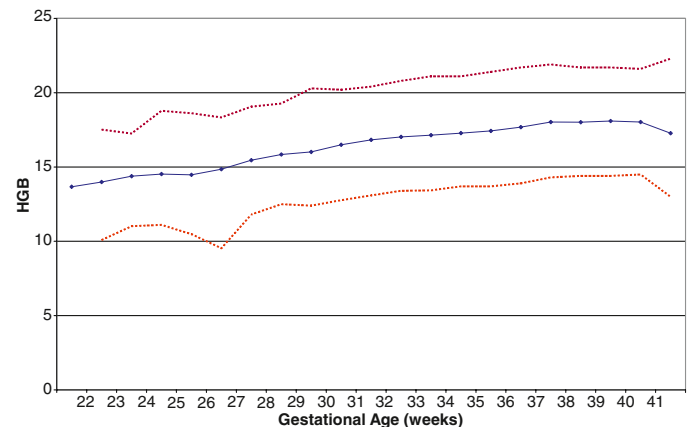
**Thrombocytopenia** is defined as platelets count  $<150 \times 10^9$  platelets/L blood. However, increased bleeding risk does not typically occur unless platelet counts decline to  $<20 \times 10^9$  platelets/L. Congenital and acquired processes underlie a broad differential diagnosis for thrombocytopenia that is described in [Chapter 533](#). Different immune and nonimmune processes can cause thrombocytopenia at different stages of infancy or later childhood, with wide-ranging health implications.

## NEUTROPENIA

White blood cells provide innate and adaptive immune functions. The neutrophil is a key component of innate immune surveillance, and disorders that affect neutrophil number and function can result in varied clinical consequences (see [Chapter 168](#)).

**Neutropenia** is defined as an absolute neutrophil count (ANC)  $<1,500/\mu\text{L}$  blood, but typically increases infection risk only when ANC falls  $<500/\mu\text{L}$ . Many processes affecting the survival of neutrophils and their precursor cells can cause neutropenia, including situations wherein antineutrophil antibodies increase neutrophil destruction and clearance.

Autoimmune neutropenia results from a patient's own neutrophil-targeted antibodies. It is among the most common etiologies of neutropenia in infants and toddlers, rarely results in significant infections or complications, and generally resolves by the time the child is school age. Neonatal isoimmune neutropenia results from transplacental passage of maternal antineutrophil antibodies in a process akin to red blood cell (RBC) antigen-targeted antibodies in hemolytic disease of the fetus and newborn (see [Chapter 140](#)). Importantly, these scenarios do not typically incur additional infection risks for patients. In fact,



**Fig. 138.2** Reference range for hematocrit (HCT) and hemoglobin (HGB) concentration according to gestational age. A and B, Reference ranges (5th percentile, mean, and 95th percentile) are shown for blood HGB (A) and HCT (B). Concentrations were obtained during the first 6 hours after birth, among patients at 22–42 weeks of gestation. Values were excluded if the diagnosis included abruption, placenta previa, or known fetal anemia, or if a blood transfusion was given before the first HGB was measured. C, Reference ranges for mean corpuscular volume (MCV) in neonates on first day after birth. The lower line shows the 5th percentile values, the middle line shows the mean values, and the upper line shows the 95th percentile values. (From Christensen RD, Jopling HE, Jopling J, Wiedmeier SE. *The CBC: Reference ranges for neonates*. *Semin Perinatol*. 2009;33[1]:3–11.)

they are typically diagnosed incidentally after noting abnormalities on a complete blood count obtained for other reasons. Reassurance, with or without repeat laboratory testing, is typically all that is required. Counts will virtually always normalize spontaneously.

Visit Elsevier eBooks+ at [eBooks.Health.Elsevier.com](http://eBooks.Health.Elsevier.com) for Bibliography.



## Chapter 139

## Anemia in the Newborn Infant

Christopher S. Thom and Michele P. Lambert

Anemia is extremely common worldwide, affecting an estimated 25% of the global population, and carries a broad differential diagnosis in infants and children. Etiologies may be acute or chronic, with clinical manifestations ranging from an asymptomatic laboratory finding to life-threatening signs and symptoms. Because anemia can result from decreased erythrocyte production, increased erythrocyte destruction, erythrocyte dysfunction, or blood loss, the differential diagnosis of anemia can be complex (Table 139.1). Careful consideration of details related to the patient's history and presentation can facilitate rapid diagnosis. Additional relevant details in neonates include gestational age and general health, perinatal course and delivery, and maternal health from early pregnancy through delivery and the postpartum period.

## THE PHYSIOLOGIC NADIR DURING INFANCY

An abrupt increase in oxygen tension and arterial hemoglobin saturation, a shift in the oxygen dissociation curve due to a switch from high oxygen affinity fetal hemoglobin (HbF) to low oxygen affinity adult hemoglobin (HbA), increased postnatal 2,3-diphosphoglycerate (increasing oxygen delivery through cooperativity), and adaptive cardiovascular mechanisms all contribute to increased oxygen delivery to tissues and can rapidly reduce erythropoietin levels postnatally. These mechanisms result in reduced erythropoiesis in the bone marrow after a week of life. Combined with the shorter half-life of neonatal erythrocytes compared to adult erythrocytes (60 days vs 120 days), full-term infants normally experience a slow decline in hemoglobin to 9–11 g/dL over 6–10 weeks (Fig. 139.1). Eventually, the reduction in hemoglobin concentration reduces oxygen delivery enough to stimulate erythropoietic drive, and hemoglobin levels subsequently rebound to “normal” levels for later life (see Fig. 139.1). These typical developmental and physiologic processes culminating in a decreased hemoglobin level are termed the **physiologic nadir**.

Preterm infants experience a more pronounced, earlier nadir, with hemoglobin levels falling to 8–9 g/dL over 4–8 weeks. One reason for the more dramatic nadir in preterm infants is reduced iron stores, because most iron is normally transferred to the fetus during the third trimester. The nadir in preterm infants is also a consequence of a reduced starting hemoglobin at birth; iatrogenic blood loss; and more significant cardiopulmonary disease, inadequate nutrition, and infections. Still, a hemoglobin level <8 typically prompts a transfusion and/or hematologist consultation.

Normal physiologic changes in hemoglobin concentration should be considered when diagnosing anemia in neonates and early infants. For example, a neonate may be considered anemic if the hemoglobin level declines below the 5th percentile for age (see Fig. 139.1, lower dashed lines). *Interventions should occur only in response to clinical signs and symptoms that occur as disease sequelae with referral to subspecialty care for further evaluation and management as appropriate.*

## ANEMIA CLASSIFICATIONS AND KEY DIAGNOSTIC MODALITIES

Anemia can result from blood loss, erythrocyte destruction (hemolysis), or underproduction of erythrocytes. Common etiologies are summarized in Table 139.1. In many cases, the clinical context, physical examination, and medical history, including review of the patient's history and clinical course, can be diagnostic. However, a simple and efficient laboratory workup can facilitate rapid definitive diagnosis and suggest an effective treatment strategy (Fig. 139.2).

In many cases, a CBC and the reticulocyte count can identify the diagnosis. Additional testing that is particularly helpful in neonatal diagnosis includes a direct antiglobulin test, serum bilirubin, infant blood type, and maternal blood type (ABO and Rh). Prenatal screening routinely includes indirect (serum) antiglobulin testing for maternal erythrocyte alloantibodies. The infant's peripheral blood smear can identify nucleated erythrocytes secondary to compensatory active erythropoiesis, as well as distinct erythrocyte morphologies (e.g., elliptocytes, acanthocytes) reflecting hemolytic anemia. Spherocytes and microspherocytes can suggest immune-mediated hemolysis or hereditary spherocytosis (HS), which can be differentiated by the direct antiglobulin test (DAT; formerly the direct Coombs test; Fig. 139.3). Importantly, neonatal blood smears often include atypical erythrocyte morphology with macrocytosis, poikilocytosis, and anisocytosis, which can result from normal erythropoiesis at that age and preclude definitive diagnosis. An experienced hematology-pathologist is needed to identify truly pathologic features (Table 139.2; see Chapter 496).

Specialized testing to diagnose various red cell membrane disorders and enzyme deficiencies, as well as hemoglobin quantitation for evaluation for specific hemoglobin disorders, may be performed in consultation with a specialist. Some states routinely screen newborns for glucose-6-phosphate-dehydrogenase (G6PD) deficiency. Further, universal screening in the United States for sickle cell disease has markedly improved health outcomes by facilitating early penicillin prophylaxis, although much work remains to be done.

## Inadequate Red Blood Cell Production

Whereas normal RBC underproduction after birth results in the **physiologic nadir**, this process can be more significant in preterm infants, requiring transfusions and other supportive therapy. **Anemia of prematurity** is largely due to iatrogenic losses (phlebotomy) and is exacerbated by acute or chronic illness, comorbidities of prematurity, and decreased iron stores.

**Iron-deficiency anemia** is the most common cause of anemia worldwide, and can occur during infancy or in older children. Iron is required

Table 139.1 Differential Diagnosis of Neonatal Anemia

## BLOOD LOSS

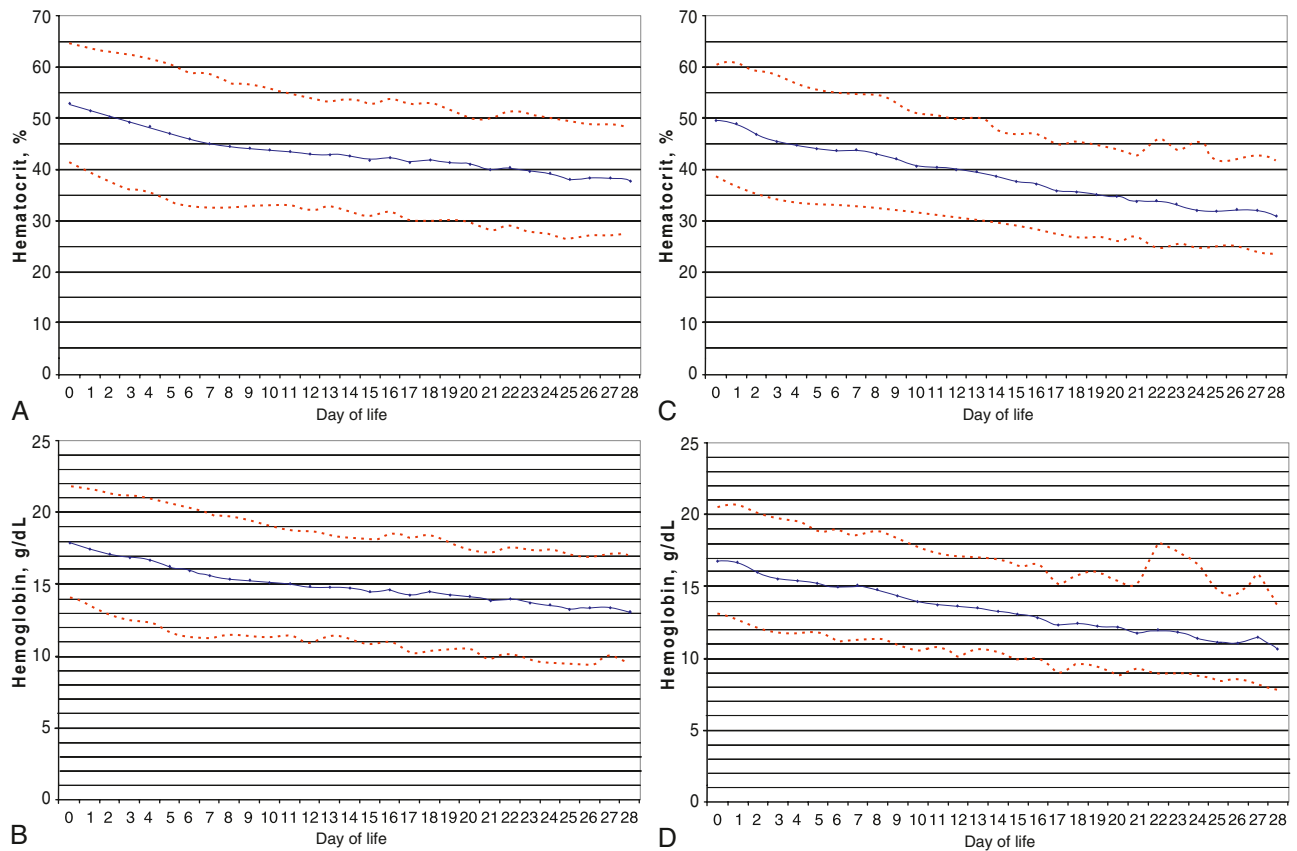
- Iatrogenic blood loss (phlebotomy)
- Placental hemorrhage
- Placental previa
- Injury of umbilical or placental vessels
- Fetomaternal transfusion
- Fetoplacental transfusion
- Twin-twin transfusion
- Acute perinatal hemorrhage (e.g., cesarean birth, other obstetric trauma)
- Chronic in utero blood loss

## ↑ RBC DESTRUCTION

- Immune-Mediated Hemolysis*
- Rh incompatibility
  - ABO incompatibility
  - Minor antigen incompatibility
- RBC Membrane Disorders*
- Hereditary spherocytosis
  - Hereditary elliptocytosis
  - Hereditary pyropoikilocytosis
  - Hereditary stomatocytosis
- RBC Enzyme Disorders*
- G6PD deficiency
  - Pyruvate kinase deficiency

## ↓ RBC PRODUCTION

- Physiologic anemia and anemia of prematurity
- Infection (rubella, CMV, parvovirus B19)
- Bone marrow suppression (acute stress in perinatal period)
- Hemoglobinopathy (γ-globin mutation, unstable β-hemoglobinopathy, α-thalassemia major)
- Bone marrow suppression (CMV, EBV)
- Diamond-Blackfan anemia
- Schwachman-Diamond syndrome
- Congenital dyserythropoietic anemia
- Fanconi anemia
- Pearson syndrome
- Congenital leukemia



**Fig. 139.1** Reference range for hematocrit and hemoglobin concentration during the first 28 days of life. A and B, Late preterm and term infants (35–42 weeks' gestation). C and D, Preterm infants (29–34 weeks' gestation). The reference ranges are shown for hematocrit (A and C) (41,957 patients) and blood hemoglobin (B and D) (39,559 patients) during the 28 days after birth. Values were divided into two groups (A/B and C/D) on the basis of gestational age at delivery. Patients were excluded when their diagnosis included abruption, placenta previa, or fetal anemia, or when a blood transfusion was given. Analysis was not possible for patients <29 weeks' gestation because virtually all these had repeated phlebotomy and erythrocyte transfusions. (From Jopling J, Henry E, Wiedmeier SE, Christensen RD. Reference ranges for hematocrit and blood hemoglobin concentration during the neonatal period: data from a multihospital health care system. *Pediatrics*. 2009;123[2]:e333–e337.)

for hemoglobin tetramer construction, so erythropoiesis demands ample iron be present to form hemoglobinized RBCs. Insufficient iron stores, either through chronic blood loss or inadequate iron intake, hinder erythropoiesis. RBCs will be uniformly microcytic (mean corpuscular volume [MCV] <80 fL) and hypochromic on the blood smear. Ferritin, transferrin, and reticulocyte quantities will be low. In addition to anemia, iron deficiency predisposes to thrombocytosis. This is a result of effects on hematopoietic progenitor cell lineage commitment, among potential mechanisms. Iron supplementation at doses of 3–6 mg/kg/day can effectively treat this condition; once-daily treatment is better than divided doses due to potential induction of hepcidin with frequent iron supplementation.

Acquired conditions may also suppress bone marrow erythrocyte production in neonates and older children (Table 139.3). Numerous bacterial and viral infections may suppress erythropoiesis and contribute to anemia, from prenatal TORCH (toxoplasmosis, other viral agents, rubella, cytomegalovirus [CMV], herpes simplex) infections and parvovirus B19 to sepsis. Congenital conditions may result in anemia due to decreased red cell production. These rare disorders may manifest early in the neonatal period, but more commonly present in later infancy or early childhood. Etiologies include the bone marrow failure syndromes (Fanconi anemia, Schwachman-Diamond syndrome, Diamond-Blackfan anemia, Aase syndrome congenital dyserythropoietic anemia, dyskeratosis congenita, Pearson syndrome), the thalassemias ( $\alpha$ ,  $\beta$ , or HbE), and infant leukemias, among others (see Tables 139.1 and 139.3).

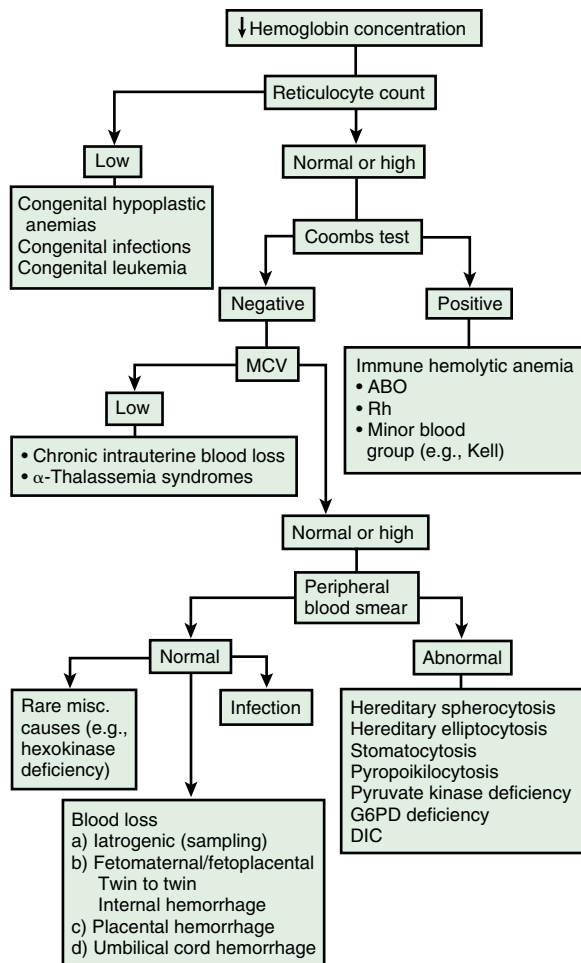
### Increased Red Cell Destruction: The Hemolytic Anemias

Increased rates of RBC destruction cause hemolytic anemia. This most often occurs via immune-mediated mechanisms, when RBC antigen incompatibilities exist between infants and mothers, or as a result of

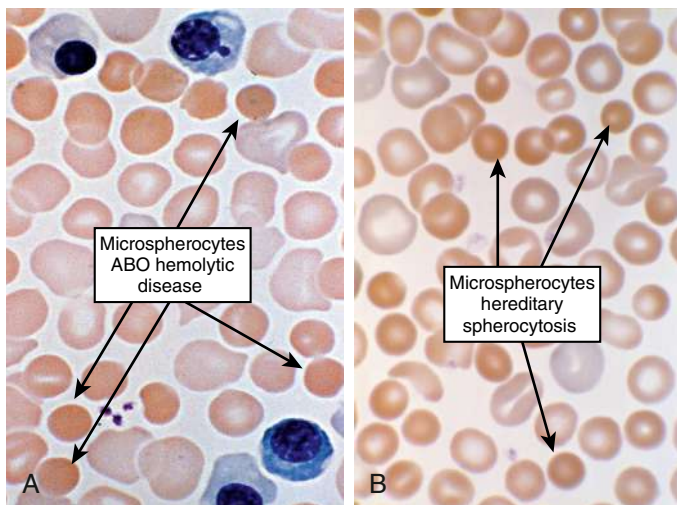
autoimmune disease in later childhood. However, intrinsic abnormalities in the erythrocyte membrane, hemoglobin, or other enzymes can also increase hemolysis. Severe hemolytic anemias can cause hyperbilirubinemia necessitating intervention (Fig. 139.4). For example, **hemolytic disease of the fetus and newborn (HDFN)**, also known as erythroblastosis fetalis, results in often severe alloimmune hemolysis from maternal antibodies targeting paternally derived RBC antigens (see Chapter 140).

**Congenital erythrocyte membrane disorders** can cause clinically significant hemolytic anemia and jaundice in the neonatal period and beyond. Key structural proteins and lipid components are necessary to produce durable, flexible, biconcave erythrocyte membranes capable of deforming and squeezing through tiny capillaries. Genetic abnormalities in integral membrane proteins (e.g., ankyrin, band 3,  $\alpha$ -spectrin,  $\beta$ -spectrin, protein 4.2) destabilize the RBC membrane and decrease cellular deformability, increasing splenic entrapment. HS is the most common RBC membrane disorder, affecting 1 in 2,500–5,000 individuals of European descent. HS is most often caused by pathogenic variants in genes coding for ankyrin or spectrin and is characterized by spherical erythrocytes on the blood smear (see Fig. 139.3; see Chapter 507). Most infants born with HS will develop jaundice early in the newborn period. *Treatment is largely supportive. Most patients with mild disease require little intervention, whereas those with more severe hemolysis sometimes require RBC transfusions or splenectomy.* Hereditary elliptocytosis (HE), another erythrocyte membranopathy, is typically less severe than HS. HE is characterized by elliptical-shaped erythrocytes on the peripheral blood smear and may be underdiagnosed given the extremely mild clinical presentation.

A more clinically significant membranopathy is hereditary pyropoikilocytosis (HPP), an autosomal recessive disorder with striking dysmorphology (poikilocytosis) on the peripheral blood smear. HPP is most common



**Fig. 139.2** Diagnostic algorithm showing the approach to anemia in newborn infants. DIC, Disseminated intravascular coagulation; G6PD, glucose-6-phosphate dehydrogenase; MCV, mean corpuscular volume. (Modified from Blanchette VS, Zipursky A. Assessment of anemia in newborn infants. *Clin Perinatol*. 1984;11:489–510.)



**Fig. 139.3** Microspherocytes. A, Neonate with ABO hemolytic disease. B, Neonate with hereditary spherocytosis. (From Christensen RD. Neonatal erythrocyte disorders. In Gleason CA, Jul SE, eds. *Avery's Diseases of the Newborn*. 10th ed. Philadelphia: Elsevier; 2018: Fig. 81-8.)

in infants of African descent and can be associated with severe anemia and hemolysis during infancy and throughout life. There is substantial clinical and genetic overlap between HPP and HE, because infants with HPP often have a family history of HE and may develop a milder condition resembling HE later in childhood (see Chapter 508).

In infants with significant jaundice in the first day of life without a blood type mismatch, a family history of hemolytic anemia should prompt clinical suspicion for an erythrocyte membranopathy. Beyond a negative DAT, diagnostic evaluation should include serial bilirubin and reticulocyte monitoring, along with a peripheral blood smear. Previously, osmotic fragility testing was the only way to establish the diagnosis, but it is significantly impacted by hemoglobin F concentrations. Some laboratories can instead diagnose certain membranopathies by flow cytometry based on binding of eosin-5-maleimide (EMA). Treatment is directed by the degree of anemia and hyperbilirubinemia, which can be highly variable.

**Erythrocyte enzymopathies** can also cause neonatal anemia. Circulating RBC survival relies on critical metabolic pathways to limit oxidative stress. Inadequate antioxidant systems can result in membrane instability and cell lysis that manifest clinically as hemolytic anemia. For example, G6PD is abundant in RBCs to limit oxidative stress. G6PD deficiency, the most common RBC enzymopathy, is an X-linked disorder affecting >400 million people worldwide. Different classes of G6PD deficiency vary in clinical severity. Although affected individuals are generally asymptomatic, some are prone to develop acute hemolytic anemia in the setting of oxidative stress triggered by sulfa drugs, infections, or certain foods like fava beans. There is an increased incidence of clinically significant jaundice in G6PD deficient neonates, who sometimes have severe and prolonged hyperbilirubinemia that can present in the first few days of life. Although severe anemia with reticulocytosis is uncommon, many infants require increased monitoring or therapy. Newborn screening for G6PD deficiency varies across the United States. G6PD activity can be tested in erythrocytes (<1–2% suggests G6PD deficiency). However, testing may be inaccurate during acute hemolysis or reticulocytosis because, for the most common variants, reticulocytes have higher enzyme activity.

Another common RBC enzymopathy is pyruvate kinase deficiency (PKD), which affects an estimated 3.2–8.5 per million individuals of European descent. Pyruvate kinase is a critical glycolytic enzyme. In its absence, metabolic derangements can cause RBC lysis and hemolytic anemia. Though clinical severity varies, PKD may be associated with sometimes life-threatening complications, prolonged jaundice, and lifelong blood transfusions.

## HEMOGLOBINOPATHIES

Hemoglobinopathies result from genetic variants in  $\gamma$ -globin,  $\beta$ -globin, or  $\alpha$ -globin genes. The clinical presentation of hemoglobin variants reflects aberrant biochemical properties of the mutated hemoglobin molecule. Individuals can be anemic (most commonly), cyanotic, polycythemic, prone to hemolysis, have high methemoglobin levels, or asymptomatic. Thousands of variants have been identified, with wide-ranging clinical severity.

Hemoglobin variants can also clinically manifest at different times according to when the affected globin chain is produced (see Fig. 138.1). The common  $\beta$ -hemoglobinopathies, sickle cell disease and  $\beta$ -thalassemia, do not typically present in the neonatal period due to protective effects from high HbF levels. In fact, novel therapeutic approaches aim to maintain HbF persistence in sickle cell patients. In contrast, infants with rare  $\gamma$ -globin variants can present with complications in the neonatal period that resolve in the first few months of life as normal gene expression changes to reduce or abrogate  $\gamma$ -globin expression.

### Hemorrhage and Red Blood Cell Loss

Blood loss or hemorrhage in utero or in the newborn period can also result in anemia. In fact, iatrogenic or pathologic blood loss is the most common cause of neonatal anemia. For critically ill and/or premature infants in the neonatal intensive care unit (NICU), laboratory monitoring can require phlebotomy of 15–30% of an infant's blood volume every week (~11–22 mL/kg/week). Most other blood loss etiologies occur just before or during delivery, often from placental abruption or fetal hemorrhage (see Table 139.1). Infants can also become anemic from occult gastrointestinal blood losses due to milk protein allergy. Other causes of blood loss are restricted

**Table 139.2** Morphologic Abnormalities of Erythrocytes in Neonates with Jaundice

ABNORMAL ERYTHROCYTE MORPHOLOGY	MOST LIKELY CAUSES	SUGGESTED LABORATORY TESTING/FINDINGS	OTHER FEATURES
Microspherocytes	Hereditary spherocytosis	DAT (–) EMA flow (+) Persistent spherocytosis Reticulocytosis	MCHC/MCV elevated (>36, likely >40)
	ABO hemolytic disease	DAT (+) Transient spherocytosis Reticulocytosis	MCHC/MCV normal (<36, likely <34)
Elliptocytes	Hereditary elliptocytosis	DAT (–)	MCHC normal MCV normal
Bite and blister cells	G6PD deficiency Unstable hemoglobin	G6PD enzyme activity Heinz body preparation	Typically affects males, but rarely females are also affected Ethnicity of equatorial origin
Echinocytes	PK deficiency Other glycolytic enzyme deficiency	PK enzyme activity Quantify activity of other glycolytic enzymes	Autosomal recessive, likely to have no family history
Schistocytes	DIC and/or perinatal asphyxia	Low levels of FV and FVIII, elevated levels of D-dimers	Low or falling platelet count Normal to high IPF
	Heinz body HA	Positive result of Heinz body preparation	Normal to high MPV DIC, perinatal asphyxia
	ADAMTS-13 deficiency (TTP)	Severely decreased ADAMTS-13 activity (<0.1 U/mL) high levels of LDH	ADAMTS-13 deficiency, early neonatal HUS, and giant hemangiomas all involve platelet consumption from endothelial injury and all have a similar neonatal presentation
	Neonatal hemolytic-uremic syndrome	Acute renal failure	
	Homozygous protein C deficiency	Severely decreased functional protein C activity (<1%)	
	Giant hemangioma	May be internal or external	

DAT, Direct antiglobulin test; DIC, disseminated intravascular coagulation; EMA, eosin 5-maleimide; FV, factor V; FVIII, factor VIII; G6PD, glucose-6-phosphate dehydrogenase; HA, hemolytic anemia; HUS, hemolytic uremic syndrome; IPF, immature platelet fraction; LDH, lactic dehydrogenase; MCHC, mean corpuscular hemoglobin concentration; MCV, mean corpuscular volume; MPV, mean platelet volume; PK, pyruvate kinase; TTP, thrombotic thrombocytopenic purpura.

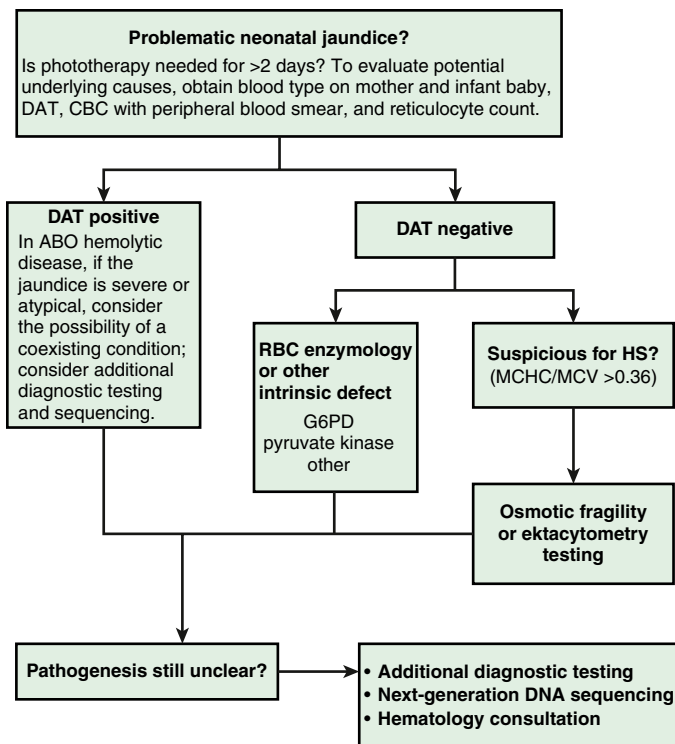
From Christensen RD, Yaish HM. Hemolytic disorders causing severe neonatal hyperbilirubinemia. *Clin Perinatol*. 2015;42:515–527. Table 3.

**Table 139.3** Syndromes Associated with Congenital Hyporegenerative Anemia

SYNDROME	PHENOTYPIC FEATURES	GENOTYPIC FEATURES
Adenosine deaminase deficiency	Autoimmune hemolytic anemia, reduced erythrocyte adenosine deaminase activity	AR, 20q13.11
Congenital dyserythropoietic anemias	<i>Type I (rare)</i> : megaloblastoid erythroid hyperplasia and nuclear chromatin bridges between nuclei <i>Type II (most common)</i> : hereditary erythroblastic multinuclearity with positive acidified serum test result, increased lysis to anti-I antibodies <i>Type III</i> : erythroblastic multinuclearity ("gigantoblasts"), macrocytosis	<i>Type I</i> : 15q15.1-q15.3 <i>Type II</i> : 20q11.2 <i>Type III</i> : 15q21
Diamond-Blackfan syndrome	Steroid-responsive hypoplastic anemia, often macrocytic after 5 mo of age	AR; sporadic gene variants and AD inheritance described; 19q13.2, 8p23.3-p22
Dyskeratosis congenita	Hypoproliferative anemia usually presenting between 5 and 15 yr of age	X-linked recessive, locus on Xq28; some cases with AD inheritance
Fanconi syndrome	Steroid-responsive hypoplastic anemia, reticulocytopenia, some macrocytic RBCs, shortened RBC life span Cells are hypersensitive to DNA cross-linked agents	AR, multiple genes: complementation; group A 16q24.3; group B Xp22.3; group C 9q22.3; group D2 3p25.3; group E 6p22-p21; group F 11p15; group G 9p13
Osler hemorrhagic telangiectasia syndrome	Hemorrhagic anemia	AD, 9q34.1
Osteopetrosis	Hypoplastic anemia from marrow compression; extramedullary erythropoiesis	AR, 16p13, 11q13.4-q13.5; AD, 1p21; lethal, reduced levels of osteoclasts
Pearson syndrome	Hypoplastic sideroblastic anemia, marrow cell vacuolization	Pleioplasmatic rearrangement of mitochondrial DNA; X-linked or AR
Peutz-Jeghers syndrome	Iron-deficiency anemia from chronic blood loss	AD, 19p13.3
ATR-X and ATR-16 syndromes	ATR-X: hypochromic, microcytic anemia; mild form of hemoglobin H disease ATR-16: more significant hemoglobin H disease and anemia are present	ATR-16, 16p13.3, deletions of $\alpha$ -globin locus

AD, Autosomal dominant; AR, autosomal recessive; ATR-16, chromosome 16–related  $\alpha$ -thalassemia/mental retardation; ATR-X, X-linked  $\alpha$ -thalassemia/mental retardation.  
From Christensen RD. Neonatal erythrocyte disorders. In: Gleason CA, Juul SE, eds. *Avery's Diseases of the Newborn*. 10th ed. Philadelphia: Elsevier; 2018: Table 81-2.





**Fig. 139.4** Algorithm for the evaluation of the neonate with problematic jaundice of unclear cause. Not all neonates who receive phototherapy for 2 days or more have hemolytic jaundice. However, if hemolytic jaundice is suspected, this algorithm for stepwise evaluation of the cause might be useful. DAT, Direct antiglobulin test; G6PD, glucose 6-phosphate dehydrogenase; HS, hereditary spherocytosis; MCHC, mean corpuscular hemoglobin concentration; MCV, mean corpuscular volume. (From Christensen RD. Neonatal erythrocyte disorders. In Gleason CA, Juul SE, eds. *Avery's Diseases of the Newborn*. 10th ed. Philadelphia: Elsevier; 2018: Fig. 81-15.)

to older children, including celiac disease or menstrual bleeding. Diagnosis and treatment of hemorrhage in the newborn period are discussed in [Chapter 142](#).

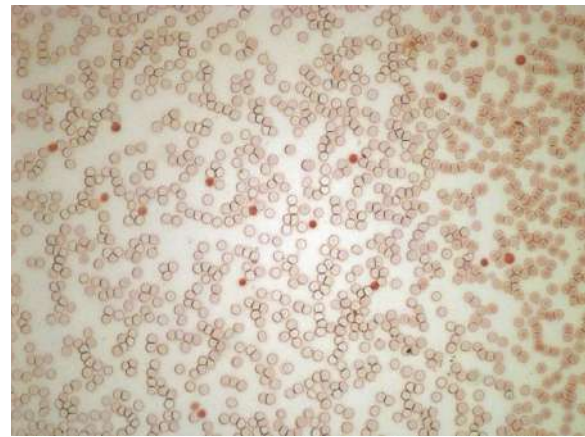
**Fetomaternal hemorrhage (FMH)** is caused by abnormal bleeding from fetal to maternal circulation before or during delivery. Although small amounts of FMH can be normal, more substantial pathologic FMH (>30 mL of fetal blood) occurs in 3 per 1,000 births. In comparison, large (>80 mL) or massive (>150 mL) FMH occurs in 0.9 and 0.2 per 1,000 births, respectively. Clinical signs of FMH vary due to differential fetal compensation. Decreased or absent fetal movement is the most common antenatal presentation and should prompt clinical suspicion. Postnatally, infant pallor, tachycardia, hypotension, and poor perfusion can indicate clinically significant anemia.

A standard diagnostic modality for FMH is the Kleihauer-Betke test, which leverages the differential stability of HbF vs HbA on acid exposure to identify fetal erythrocytes in the maternal circulation from a maternal blood smear ([Fig. 139.5](#)). However, this test requires technical skill, expert interpretation, and may not be available in a timely manner. Some laboratories now offer flow cytometry–based assays to quantify fetal RBCs in maternal circulation.

## ANEMIA MANAGEMENT PRINCIPALS

### Red Blood Cell Transfusions

The decision to transfuse packed RBC for anemia depends on the severity of symptoms, the hemoglobin concentration, and the presence of comorbidities that can alter oxygen delivery, such as pulmonary hypertension, bronchopulmonary dysplasia, cyanotic congenital heart disease, or other respiratory pathology. Benefits should be balanced against risks, including volume overload, hemolytic and nonhemolytic reactions, exposure to blood product preservatives and toxins, graft-versus-host reaction, and transfusion-acquired infections such as



**Fig. 139.5** Acid elution technique of Kleihauer (Kleihauer-Betke test). Fetal red blood cells stain with eosin and appear dark. Adult RBCs do not stain and appear as “ghosts.” (From Liley HG, Gardener G, Lopriore E, Smits-Wintjens V. Immune hemolytic disease. In Orkin SH, Nathan DG, Ginsburg D, et al., eds. *Nathan and Oski's Hematology and Oncology of Infancy and Childhood*. 8th ed. Philadelphia: Elsevier; 2015: Fig. 3-2.)

**Table 139.4** Suggested Transfusion Thresholds

POSTNATAL AGE	PRESENCE OF RESPIRATORY SUPPORT	ABSENCE OF RESPIRATORY SUPPORT
	HEMOGLOBIN CONCENTRATION g/dL (HEMATOCRIT %)	
Week 1	11.0 (33%)	10.0 (30%)
Week 2	10.0 (30%)	8.5 (25%)
Week 3	8.5 (25%)	7.0 (21%)

Values based on thresholds described in Kirpalani H, Bell EF, Hintz SR, et al. Higher or lower hemoglobin transfusion thresholds for preterm infants. *N Engl J Med*. 2020;383(27):2639–2651.

CMV, HIV, parvovirus, hepatitis B, and hepatitis C (see [Chapter 523](#)). Transfusion decisions should also consider the time course in which anemia developed, whether ongoing blood loss or hemolysis are anticipated, and if there are any planned surgical interventions.

Many neonates in the NICU require RBC transfusions, particularly among premature and very low birthweight (VLBW) infants. Several trials to compare restrictive (lower) to liberal (higher) transfusion thresholds have shown no significant differences in death or serious morbidity, with restrictive thresholds modestly reducing blood product exposure. These studies provide the basis for neonatal transfusion guidelines based on postnatal age and respiratory support needs ([Table 139.4](#)). *In full-term anemic infants, RBC transfusions should be similarly based on hemodynamic stability, respiratory status, clinical status, and expected clinical trajectory.*

To reduce blood product-associated CMV transmission to vulnerable infants, it is important that transfused RBCs are leukocyte reduced or CMV seronegative. There remains a small risk of transfusion-associated graft versus host disease even after RBC irradiation. Although data do not support specific transfusion volumes, the typical range is from 10–20 mL/kg. Infants at risk of volume overload, including neonates with congenital cardiac disease or who were born in the setting of chronic abruption, are typically given smaller volume transfusions (often 5 mL/kg). *One logical goal of RBC transfusions is to target a specific goal hemoglobin concentration.* Each 5 mL/kg of transfused RBCs is expected to raise the hemoglobin concentration by 1 g/dL.

Transfusion of RBCs is typically delivered at a rate of 3–5 mL/kg/hr, with a slower rate preferred for very small, acutely ill infants with a tenuous fluid status. Each transfusion should be completed within 4 hours, or before a given blood product expires.

Visit Elsevier eBooks+ at [eBooks.Health.Elsevier.com](https://eBooks.Health.Elsevier.com) for Bibliography.

## Chapter 140

## Hemolytic Disease of the Fetus and Newborn

Christopher S. Thom and Michele P. Lambert

Hemolytic disease of the fetus and newborn (HDFN), also known as **erythroblastosis fetalis**, is a broad diagnosis that applies to any fetus or neonate who develops alloimmune hemolysis caused by the transplacental passage of maternal antibodies directed against paternally derived red blood cell (RBC) antigens. Although more than 60 different RBC antigens can elicit a maternal antibody response, clinically significant disease is most often associated with incompatibility in ABO blood groups or rhesus (Rh) antigen (Table 140.1). HDFN caused by anti-RhD antibodies, occurring in RhD-positive infants born to RhD-negative mothers, is the most severe form because of the highly immunogenic nature of the RhD antigen. Less frequently, hemolytic disease may be caused by differences in other Rh system antigens, or by other RBC antigens such as C<sup>w</sup>, C<sup>x</sup>, D<sup>u</sup>, K (Kell), M, Duffy, S, P, MNS, Xg, Lutheran, Diego, and Kidd. *Early recognition and diagnosis facilitate timely interventions to prevent adverse sequelae.*

## HDFN CAUSED BY Rh INCOMPATIBILITY

## Pathogenesis

Rh antigenic determinants are genetically transmitted from each parent and determine Rh blood type by directing the production of Rh C, c, D, E, or e proteins to be expressed on the RBC surface. RhD alloimmunization is responsible for 90% of HDFN cases involving the Rh antigen system, but other Rh antigens, particularly E and c, can be causal. Rh sensitization usually occurs in the first pregnancy when small amounts of blood (usually >1 mL) enter maternal circulation so that most instances of sensitization occur around the time of delivery. Although sensitization may occur earlier in the first pregnancy resulting in some hemolysis, HDFN rarely occurs during a first pregnancy. After sensitization, smaller doses of antigen can stimulate antibody production, so all subsequent infants

expressing the cognate antigen are at risk for HDFN. For this reason, the severity of HDFN also typically worsens with successive pregnancies. *Routine administration of Rh immunoglobulin (RhoGAM) to mothers at risk for Rh alloimmunization, both at 28 and 32 weeks' gestation and within 72 hours after delivery of Rh-positive infants, has reduced initial sensitization to an estimated <0.1% of at-risk pregnancies in high-income countries.*

## Clinical Manifestations

The severity of HDFN is variable, ranging from mild hemolysis without overt symptoms to severe anemia with compensatory hyperplasia of erythropoietic tissues, including massive hepatosplenomegaly. When hemolysis exceeds the compensatory regenerative capacity of the hematopoietic system, profound anemia, thrombocytopenia, coagulopathy, cardiomegaly, respiratory distress, massive anasarca, and circulatory collapse can result. Perinatal hemoglobin concentrations may be as low as 3–4 g/dL.

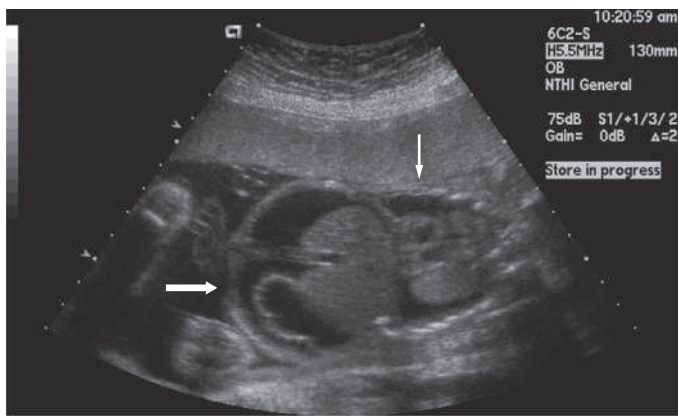
HDFN can also cause abnormal fluid collection in two or more fetal compartments (skin, pleura, pericardium, placenta, peritoneum, amniotic fluid), a clinical scenario termed **hydrops fetalis**, which frequently results in significant clinical morbidity or death in utero or shortly after birth. Hydrops results from heart failure along with subsequent hepatic congestion and dysfunction. This leads to reduced serum albumin and loss of intravascular oncotic pressure. Consequent edema can lead to extravascular fluid accumulation in the lungs (pleural effusion), abdomen (ascites), and elsewhere, which can compromise ventilation and lead to a range of life-threatening complications (Fig. 140.1). Hydrops is typically present when the fetal hemoglobin level is <5 g/dL but can occur when hemoglobin levels are between 7 and 9 g/dL. Hydrops does not invariably occur with low hemoglobin concentration, instead depending on the duration of anemia and the gestational age when anemia developed.

Infants affected by HDFN may not be jaundiced at birth because of effective placental clearance of lipid-soluble unconjugated bilirubin. However, in severe cases, bilirubin pigments can stain the amniotic fluid, cord, and vernix. In either case, hyperbilirubinemia is generally evident within 24 hours of birth, as hemolysis overwhelms the infant's bilirubin clearance system. Extremely high levels of unconjugated bilirubin levels present a risk of bilirubin encephalopathy (**kernicterus**), which is worsened in patients with concomitant hypoxia or acidosis.

Hypoglycemia may further complicate clinical management of infants with severe HDFN. This may be related to islet cell hypertrophy and hyperinsulinism due to growth stimulatory effects of anti-RhD antibodies on the pancreas.

Table 140.1 Etiologies of Hemolytic Disease of the Fetus and Newborn

	Rh	ABO	KELL
<b>BLOOD GROUPS</b>			
Mother	Rh-negative	O (occasionally B)	K1-negative
Infant	Rh-positive (D is most common)	A (sometimes B)	K1-positive
<b>CLINICAL FEATURES</b>			
Occurrence in firstborn	5%	40–50%	Rare
Severity in subsequent pregnancies:	Predictable	Difficult to predict	Somewhat predictable
Stillbirth/hydrops	Frequent (less with Rh-immunoglobulin use)	Rare	10%
Severe anemia	Frequent	Rare	Frequent
Jaundice	Prominent, severe	Mild-moderate	Mild
<b>LABORATORY TESTS</b>			
Direct antiglobulin test (infant)	Positive	Positive or negative	Positive or negative
Reticulocyte count	Elevated	Elevated	Variable
RBC antibodies (mother)	Usually detectable Antibody titers may help predict severity of fetal disease	May not be detectable Antibody titers may not correlate with fetal disease	Usually detectable Antibody titers may not correlate with fetal disease; fetus can be affected at titers lower than for Rh-mediated hemolysis



**Fig. 140.1** Hydrops fetalis. Longitudinal sonographic image of the fetus, with ascitic fluid outlining the liver (large arrow). The small arrow shows pleural effusion above the diaphragm. (From Wilkins I: *Nonimmune hydrops*. In Creasy RK, Resnick R, Iams JD, et al., eds. *Creasy & Resnik's Maternal-Fetal Medicine*. 7th ed. Philadelphia: Elsevier; 2014: Fig. 37-2.)

### Diagnosis, Prevention, and Treatment

Definitive diagnosis of HDFN requires demonstration of blood group incompatibility between mother and infant, and corresponding maternal antibody bound to the infant's RBCs. However, severe clinical presentations strongly suggest the diagnosis. Emergent interventions may be required before definitive test results become available.

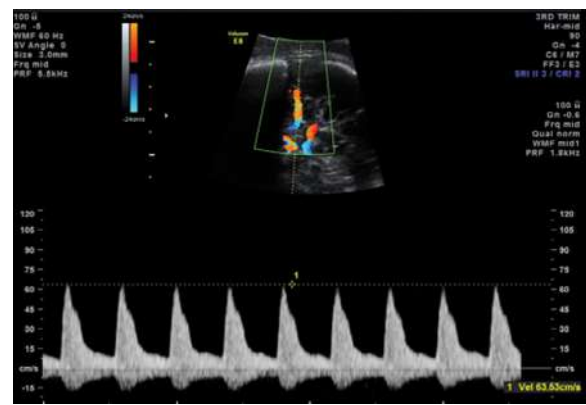
During pregnancy, expectant parents should have blood tested for potential blood type incompatibility, including ABO and Rh antigens. If RhD incompatible, maternal anti-RhD IgG titers should be measured early in pregnancy. Paternal blood can be tested to determine the fetal risk of inheriting the cognate antigen, typically either 50% or 100% depending on whether the father is heterozygous or homozygous. However, as paternal serologic testing alone is not fully accurate, molecular genotyping may be recommended for both parents.

Fetal genotyping provides an accurate prediction for the development of HDFN in sensitized mothers. Fetal Rh status is available by isolating fetal cells or cell-free fetal DNA from the maternal circulation. These methods are replacing amniocentesis and chorionic villus sampling methods and associated risks. Elevated antibody titers, or rising titers, correspond to increased HDFN risk.

Without Rh immunoglobulin prophylaxis, any Rh-negative woman with a previous pregnancy or abortion, prior exposure to transfused blood products, or receipt of an organ transplant is at risk for Rh sensitization. If a mother has had a previously affected infant or stillbirth, the Rh-positive infant is usually equally or more severely affected than the previous infant. Although there can be poor correlation between the anti-RhD titer level and disease severity, Rh-negative mothers found to have RhD antibody titers of  $\geq 1:16$  (15 IU/mL in Europe) at any time during a subsequent pregnancy warrant close monitoring for fetal anemia.

Pregnancies at risk for HDFN should be managed by maternal-fetal specialists. In some cases, monitoring must begin at 16-24 weeks' gestation. This is typically done via noninvasive Doppler ultrasonography of middle cerebral artery (MCA) flow velocity, which can be used to monitor for increased vascular resistance in fetal arteries indicative of fetal anemia (Fig. 140.2). Moderate to severe anemia increases MCA blood flow, so peak MCA flow velocity can be a quantitative correlate for anemia severity. Real-time ultrasound is used to detect signs of hydrops (skin or scalp edema, pleural or pericardial effusions, and ascites) and fetal heart rate monitoring. Early ultrasonographic signs of hydrops include organomegaly (liver, spleen, heart), the double-bowel wall sign (bowel edema), and placental thickening. Progression to polyhydramnios, ascites, pleural or pericardial effusions, and skin or scalp edema may then follow. *In the setting of concerning ultrasonographic findings, percutaneous umbilical blood sampling (PUBS) can provide more direct assessment of fetal hemoglobin level and facilitate intrauterine transfusions.*

Although cord blood hemoglobin content typically varies in proportion to disease severity, hemoglobin may be within the normal range due to



**Fig. 140.2** Middle cerebral artery (MCA) Doppler study of elevated peak systolic velocity (PSV). MCA-PSV can predict fetal anemia with sufficient accuracy to determine management, including the need for intrauterine transfusion or, in the mid to late third trimester, early delivery. Fetal hemoglobin is typically measured at the start and end of intravascular transfusion to validate the prediction from MCA-PSV results. The reliability of MCA-PSV can decrease after intrauterine transfusion because of the altered rheostatic characteristics of transfused adult blood. This is now the method of choice for detecting fetal anemia. (From Liley HG, Gardener G, Lopriore E, Smits-Wintjens V. *Immune hemolytic disease*. In Orkin SH, Nathan DG, Ginsburg D, et al., eds. *Nathan and Oski's Hematology and Oncology of Infancy and Childhood*. 8th ed. Philadelphia: Elsevier; 2015: Fig. 3-6.)

compensatory bone marrow and extramedullary hematopoiesis. Reticulocytosis will be present and a peripheral blood smear will show polychromasia with abundant nucleated RBCs. Thrombocytopenia may develop in severe cases. Umbilical cord bilirubin levels are generally between 3 and 5 mg/dL, including elevated direct bilirubin levels from cholestasis. Indirect-reacting bilirubin content rises rapidly in the first 6-12 hours of life.

Indications for delivery include fetal distress, complications during in utero interventions, and pulmonary maturity. Many affected infants are delivered preterm due to concerns for fetal well-being, after balancing risks of prematurity. The birth should be attended by a skilled neonatal resuscitation team familiar with the infant's prenatal course. *Because severe hemolytic anemia can cause rapid cardiovascular compromise, a team skilled in evaluation in management of HDFN should be involved when the diagnosis is suspected or confirmed, especially when there is a history of prior infants affected by HDFN.* Small packed RBC (PRBC) transfusions can be used to partially correct anemia, although volume expansion (e.g., large transfusions) risks worsening cardiac failure. Phototherapy may be necessary to treat hyperbilirubinemia in the first 24 hours of life if bilirubin levels exceed safe limits on an age-based nomogram (see Chapter 137). Although it is the indirect bilirubin fraction that crosses the blood-brain barrier to cause kernicterus, clinical decision-making is often based on total serum bilirubin levels.

Despite adequate resuscitation, phototherapy, and/or other empiric treatments, some infants with HDFN require exchange transfusions to treat anemia and/or hyperbilirubinemia. The decision to proceed with exchange transfusion is typically based on clinical status and trajectories in hemoglobin or serum bilirubin values, specifically the likelihood that serum bilirubin, plotted against postnatal hours of life, will reach a dangerous level (see Chapter 137). Signs and symptoms of kernicterus are absolute indications for exchange transfusion. Previous kernicterus or severe HDFN in a sibling, severe reticulocytosis  $>15\%$ , or prematurity (with increased kernicterus risk) are additional factors to be considered in the decision to proceed with exchange transfusion (see Chapter 137).

Complications related to HDFN can also present weeks after birth, irrespective of the prenatal or perinatal course. Late anemia can present after 4-6 weeks of life, sometimes clinically manifesting as poor feeding or growth. This can result from ongoing hemolysis caused by persistent circulating maternal alloantibodies, or from hyporegenerative anemia caused by suppression of bone marrow erythropoiesis. These etiologies can be distinguished by reticulocyte count and bilirubin level, with ongoing hemolysis driving reticulocytosis and hyperbilirubinemia.



Neutropenia may also be observed in association with hyporegenerative anemia. Outpatient blood and reticulocyte counts should be monitored serially under the supervision of an expert hematologist to determine the need for interventions through bone marrow recovery. Iron supplementation or erythropoietin therapy can be helpful. In some cases, PRBC transfusions can be required for months after birth, until the infant's own erythropoietic system becomes more robust.

Hemolysis and hyperbilirubinemia can also cause late-onset complications. Jaundice typically resolves spontaneously within a few weeks or months with conservative management. Portal vein thrombosis and portal hypertension may occur in children who have been subjected to exchange transfusion as newborn infants. This complication is thought to be seen in infants with prolonged, traumatic, or septic umbilical vein catheterization. Inspissated bile syndrome is another rare complication, associated with persistent icterus and significant elevations in both direct and indirect bilirubin levels.

The outcome for Rh-incompatible fetuses varies greatly, depending on the characteristics of both the RBC antigen and the maternal antibodies. Although fetal transfusions and prenatal interventions can ameliorate some complications, those with severe hydrops remain at risk for cerebral palsy, developmental delay, and deafness, requiring medical and procedural interventions for hydrops prenatally or after birth. Infants should be monitored closely for late complications by pediatric hematologists in the outpatient setting.

### HDFN CAUSED BY ABO INCOMPATIBILITY

ABO incompatibility is the most common cause of HDFN, with approximately 20% of live births at theoretical risk. Of at-risk infants, clinical manifestations develop in 1–10% and are usually less severe than Rh disease, rarely requiring aggressive clinical management or therapeutic intervention aside from phototherapy. This is because naturally occurring maternal antibodies against ABO blood group antigens are mostly IgM and therefore do not cross the placenta. However, some group O mothers will naturally produce anti-A or anti-B IgG antibodies that can cross the placenta to cause immune-mediated hemolysis. For this reason, ABO incompatibility can cause hemolysis even in a firstborn infant. Another reason for mild disease manifestations is that fetal and neonatal RBCs have relatively low ABO expression, limiting binding sites for maternal antibodies.

### Clinical Manifestations

Affected infants will typically develop jaundice in the first day of life. Severe clinical manifestations, such as hydrops, severe anemia, or hepatosplenomegaly, are rare. Diagnosis requires serologic ABO

incompatibility between the mother and infant, a positive DAT, and hyperbilirubinemia with or without anemia. Affected infants often have mild anemia and reticulocytosis, with peripheral blood smears showing polychromasia, nucleated RBCs, and spherocytes. *Phototherapy may be required based on bilirubin level and postnatal age, and is typically effective in lowering serum bilirubin levels* (see Chapter 137). In some cases, hemolysis can persist for weeks until maternal antibodies are cleared. Intravenous immunoglobulin (IVIG) administration can help to limit hemolysis and potentially avoid exchange transfusion and/or PRBC transfusions in cases with dangerous levels of hyperbilirubinemia or anemia, respectively. Rarely, affected infants who also have hyporegenerative anemia can require PRBC transfusions several weeks after birth. For this reason, outpatient monitoring is essential for newborns with ABO hemolytic disease. However, the persistence of hemolytic anemia or spherocytosis beyond 2 weeks of age can indicate an alternative diagnosis, such as hereditary spherocytosis (see Fig. 139.3).

### OTHER ETIOLOGIES OF HDFN

Incompatibility in blood group antigens other than Rh or ABO account for <5% of HDFN. Minor RBC antigen mismatch is emerging as a common cause of HDFN in the developed countries in which anti-RhD immune globulin is routinely used. The likelihood of minor antigen mismatches is a function of population frequency, antigen surface density on RBCs, and immunogenicity in the mother. In most cases, the infant's direct antiglobulin test (DAT) will be positive and maternal serum will have alloantibodies against infant (and paternal) erythrocytes. Elution techniques can identify the antigen specificity.

Common RBC antigens that can lead to clinically relevant incompatibility include those in the Kell, Duffy, and MNS blood groups. Kell incompatibility can be the most clinically relevant, as the severity of the hemolytic anemia is difficult to predict based on previous obstetric history, amniotic fluid bilirubin determinants, or maternal antibody titer (Table 140.2). Kell-alloimmunized infants often have inappropriately low numbers of circulating reticulocytes caused by erythroid suppression, and even low maternal titers of anti-Kell antibodies may cause significant anemia due to loss of precursors expressing the antigen as well as mature erythrocytes. No pharmacologic therapies are available to prevent sensitization with these minor antigens. As with cases of Rh and ABO incompatibility, treatment is supportive, including exchange transfusion for severe presentations.

Visit Elsevier eBooks+ at [eBooks.Health.Elsevier.com](https://eBooks.Health.Elsevier.com) for Bibliography.

**Table 140.2** Red Cell Antigens That Cause Hemolytic Disease of the Fetus and Newborn (HDFN)

MILD HDFN	MODERATE HDFN	SEVERE HDFN
ABO (A, B)	Rh (EW, hrs, Tar, Rh32, HrBE, Hr <sub>c</sub> )	Rh (D, c, f, Ce, C <sup>w</sup> , cE)
Rh (C, e, C <sup>x</sup> , VS, CE, Be <sup>a</sup> , JAL)	Diego (Di <sup>a</sup> , Di <sup>b</sup> , Wr <sup>a</sup> , ELO)	Kell (K, k, Ku, Js <sup>b</sup> )
Kell (Kp <sup>a</sup> , Js <sup>a</sup> , Ul <sup>a</sup> )	Duffy (Fy <sup>a</sup> )	Globoside (PP <sub>1</sub> P <sub>k</sub> )
Junior (Jra)	Gerbich (Ge3)	MNSs (Vw, Mur, MUT)
Kidd (Jk <sup>a</sup> , Jk <sup>b</sup> , Jk3)	H (H)	Mittenberger (Mi <sup>a</sup> )
Duffy (Fy <sup>b</sup> )	Kell (K, k, Ku, Js <sup>b</sup> )	MNSs (Vw, Mur, MUT)
Langereis (Lan)	MNSs (U, Ss S, s, Mt <sup>a</sup> , M <sup>y</sup> )	Gerbich (PP1Pk)
MNSs (M, N, Hil, Or)	Colton (Co <sup>a</sup> )	(HJK)
Colton (Co <sup>b</sup> , Co <sup>3</sup> )	(Kg)	—
Scianna (Rd, SC2)	(Sara)	—
Xg (Xg <sup>a</sup> )	—	—
(At <sup>a</sup> )	—	—

*Mild HDFN*, published reports of needing phototherapy for postnatal jaundice; *moderate HDFN*, published reports of needing postnatal exchange transfusion; *severe HDFN*, published reports of hydrops fetalis or intrauterine transfusions.

Note that some antigens have no system as per International Society of Blood Transfusion classification.

From Jackson ME, Baker JM. Hemolytic disease of the fetus and newborn. *Clin Lab Med*. 2021;41:133–151. Table 1.



## Chapter 141

## Neonatal Polycythemia

Christopher S. Thom and Michele P. Lambert

Neonatal polycythemia is broadly defined as an elevated hemoglobin or hematocrit level. This can be due to primary myeloproliferative disorders (e.g., polycythemia vera) or reactive processes, such as from chronic hypoxemia or living at high altitudes.

In infants, polycythemia is inferred from a hematocrit level >2 standard deviations above the normal value for gestational and postnatal age (Figs. 138.2 and 139.1). Full-term infants are therefore considered polycythemic with a hemoglobin level above ~22 g/dL or hematocrit >65%. It is important that these values are obtained from a “central” venous or arterial puncture, as heelstick or capillary samples can report artificially elevated values. Due to fluid shifts in the newborn period, hematocrit levels typically peak at 2–3 hours of life.

Although most polycythemic individuals are asymptomatic, symptomatic blood **hyperviscosity** from polycythemia can cause sluggish blood flow that decreases tissue perfusion and leads to metabolic disturbances. Signs and symptoms are vague, including irritability, lethargy, tachypnea, respiratory distress, cyanosis, feeding disturbances, hyperbilirubinemia, hypoglycemia, and thrombocytopenia. Thus a high index of suspicion is often required for diagnosis and coincident respiratory, cardiovascular, and neurologic disorders should be investigated. Severe complications include seizures, stroke, pulmonary hypertension, necrotizing enterocolitis (NEC), renal vein thrombosis, and renal failure in newborns. Related symptoms often appear in the first hours of life but can be delayed by up to 2–3 days depending on clinical context.

Dehydration should be considered as a potential contributing cause in symptomatic polycythemic infants. Neonatal polycythemia can also result from processes that lead to passive RBC transfusion into the fetus or increased intrauterine erythropoiesis. Passive fetal RBC transfusions may occur from prolonged delayed umbilical cord clamping but can also present in recipients of twin-twin transfusions or unrecognized maternal-fetal transfusions from the placenta.

Most cases of increased fetal erythropoiesis are thought to result from chronic intrauterine hypoxia, which stimulates erythropoietin and RBC production. Increased fetal erythropoiesis is associated with polycythemia in postterm (3%) and term (1–2%) infants; small-for-gestational-age (8%) or large-for-gestational-age (3%) infants; infants of diabetic mothers; infants of hypertensive mothers or those taking propranolol; and infants with trisomy 13, 18, or 21, adrenogenital syndrome, neonatal Graves disease, hypothyroidism, or Beckwith-Wiedemann syndrome. Delayed cord clamping does not increase the incidence of polycythemia. Contraindications to delayed cord clamping include suspected chronic intrauterine hypoxia (e.g., severe growth restriction) and maternal diabetes, which independently increase RBC production. The frequency of neonatal polycythemia is also increased for births at higher altitudes (5% at high altitude vs 1–2% at sea level).

Asymptomatic polycythemia can be treated conservatively, with consideration for supplemental enteral or intravenous hydration. Treatment for symptomatic infants should also begin with supplemental hydration, after considering potential comorbidities (e.g., heart failure). All polycythemic infants should have intake and output, blood glucose, and bilirubin levels followed closely. Infants with hyperviscosity symptoms may benefit from partial exchange transfusions, particularly if the hematocrit reaches  $\geq 75\%$  and symptoms worsen despite aggressive intravenous hydration.

Outcomes are more closely determined by etiologies contributing to chronic intrauterine hypoxia than polycythemia per se. Although infants treated with partial exchange transfusion may be at increased risk of NEC, it is unclear whether adverse long-term speech, fine motor, cognitive, and behavioral outcomes are affected.

Visit Elsevier eBooks+ at [eBooks.Elsevier.com](http://eBooks.Elsevier.com) for Bibliography.

## Chapter 142

## Hemorrhage in the Newborn Infant

Christopher S. Thom and Michele P. Lambert

Congenital and acquired bleeding disorders can manifest at varying times in infants and older children. Hemorrhage in an otherwise healthy newborn may suggest an inherited coagulation defect (e.g., hemophilia) or concurrent thrombocytopenia. Bleeding in otherwise sick neonates is frequently caused by underproduction or consumption of coagulation factors and/or platelets. Common acquired hemorrhagic disorders include hemorrhage due to vitamin K deficiency (see Chapter 71 and below), disseminated intravascular coagulation (DIC: see Chapter 532), or immune-mediated thrombocytopenia (see Chapter 533).

The neonatal hemostatic system differs from older children and adults. This impacts bleeding risk and laboratory assessment, and should enter into management considerations. Plasma levels of vitamin K–dependent coagulation factors (II, VII, IX, X, protein C, protein S) and antithrombin are initially low at birth and do not reach adult ranges until approximately 6 months of age. Note that overall the neonatal hemostatic system tends toward hypercoagulability, given low levels of protein C, protein S, and antithrombin. This may explain why neonatal platelets are hypofunctional in response to some agonists, and why neonatal platelet content differs from adults (Chapters 525 and 526).

## HEMORRHAGIC DISEASE OF THE NEWBORN

Bleeding from vitamin K deficiency, otherwise known as **hemorrhagic disease of the newborn**, results from transient but profound deficiencies in vitamin K–dependent coagulation factors. Vitamin K normally facilitates carboxylation of factors II, VII, IX, and X, which is necessary for enzymatic activities. Decarboxylated factors are biologically inactive. Without vitamin K, decarboxylated *proteins induced in vitamin K absence (PIVKA)* are secreted. The classic form of this disease can be prevented with intramuscular injection of vitamin K (phytonadione) just after birth.

The disease process most often affects exclusively breastfed infants who did not receive intramuscular vitamin K prophylaxis at birth. Maternal breastmilk lacks free vitamin K, and newborns lack the intestinal flora normally responsible for vitamin K synthesis. Premature infants with nutritional deficiencies are also at risk of vitamin K deficiency and bleeding.

Laboratory testing typically reveals prolonged prothrombin time (PT) and partial thromboplastin time (PTT) in affected infants, with low plasma levels of prothrombin (II) and factors VII, IX, and X. Soluble **PIVKA** measurement can also act as a laboratory marker for vitamin K status. Factors V and VIII, fibrinogen, bleeding time, clot retraction, platelet count, and platelet function will be within normal newborn ranges.

Intramuscular administration of 1 mg vitamin K<sub>1</sub> (phytonadione) soon after birth can prevent bleeding complications from vitamin K deficiency in most full-term infants. Low birthweight infants may be given 0.5 mg phytonadione, although weight-based dosing varies between institutions. Phytonadione is the only form of vitamin K available in the United States. Vitamin K<sub>2</sub>, also known as menaquinones, constitutes a minority of the vitamin K consumed by humans or produced by intestinal flora. Vitamin K prophylaxis does not prevent all hemorrhagic disease of the newborn. Although rare, cases can occur in full-term infants, preterm infants with significant nutritional deficiencies, and infants with malabsorption.

## Chapter 141

## Neonatal Polycythemia

Christopher S. Thom and Michele P. Lambert

Neonatal polycythemia is broadly defined as an elevated hemoglobin or hematocrit level. This can be due to primary myeloproliferative disorders (e.g., polycythemia vera) or reactive processes, such as from chronic hypoxemia or living at high altitudes.

In infants, polycythemia is inferred from a hematocrit level >2 standard deviations above the normal value for gestational and postnatal age (Figs. 138.2 and 139.1). Full-term infants are therefore considered polycythemic with a hemoglobin level above ~22 g/dL or hematocrit >65%. It is important that these values are obtained from a “central” venous or arterial puncture, as heelstick or capillary samples can report artificially elevated values. Due to fluid shifts in the newborn period, hematocrit levels typically peak at 2–3 hours of life.

Although most polycythemic individuals are asymptomatic, symptomatic blood **hyperviscosity** from polycythemia can cause sluggish blood flow that decreases tissue perfusion and leads to metabolic disturbances. Signs and symptoms are vague, including irritability, lethargy, tachypnea, respiratory distress, cyanosis, feeding disturbances, hyperbilirubinemia, hypoglycemia, and thrombocytopenia. Thus a high index of suspicion is often required for diagnosis and coincident respiratory, cardiovascular, and neurologic disorders should be investigated. Severe complications include seizures, stroke, pulmonary hypertension, necrotizing enterocolitis (NEC), renal vein thrombosis, and renal failure in newborns. Related symptoms often appear in the first hours of life but can be delayed by up to 2–3 days depending on clinical context.

Dehydration should be considered as a potential contributing cause in symptomatic polycythemic infants. Neonatal polycythemia can also result from processes that lead to passive RBC transfusion into the fetus or increased intrauterine erythropoiesis. Passive fetal RBC transfusions may occur from prolonged delayed umbilical cord clamping but can also present in recipients of twin-twin transfusions or unrecognized maternal-fetal transfusions from the placenta.

Most cases of increased fetal erythropoiesis are thought to result from chronic intrauterine hypoxia, which stimulates erythropoietin and RBC production. Increased fetal erythropoiesis is associated with polycythemia in postterm (3%) and term (1–2%) infants; small-for-gestational-age (8%) or large-for-gestational-age (3%) infants; infants of diabetic mothers; infants of hypertensive mothers or those taking propranolol; and infants with trisomy 13, 18, or 21, adrenogenital syndrome, neonatal Graves disease, hypothyroidism, or Beckwith-Wiedemann syndrome. Delayed cord clamping does not increase the incidence of polycythemia. Contraindications to delayed cord clamping include suspected chronic intrauterine hypoxia (e.g., severe growth restriction) and maternal diabetes, which independently increase RBC production. The frequency of neonatal polycythemia is also increased for births at higher altitudes (5% at high altitude vs 1–2% at sea level).

Asymptomatic polycythemia can be treated conservatively, with consideration for supplemental enteral or intravenous hydration. Treatment for symptomatic infants should also begin with supplemental hydration, after considering potential comorbidities (e.g., heart failure). All polycythemic infants should have intake and output, blood glucose, and bilirubin levels followed closely. Infants with hyperviscosity symptoms may benefit from partial exchange transfusions, particularly if the hematocrit reaches  $\geq 75\%$  and symptoms worsen despite aggressive intravenous hydration.

Outcomes are more closely determined by etiologies contributing to chronic intrauterine hypoxia than polycythemia per se. Although infants treated with partial exchange transfusion may be at increased risk of NEC, it is unclear whether adverse long-term speech, fine motor, cognitive, and behavioral outcomes are affected.

Visit Elsevier eBooks+ at [eBooks.Elsevier.com](http://eBooks.Elsevier.com) for Bibliography.

## Chapter 142

## Hemorrhage in the Newborn Infant

Christopher S. Thom and Michele P. Lambert

Congenital and acquired bleeding disorders can manifest at varying times in infants and older children. Hemorrhage in an otherwise healthy newborn may suggest an inherited coagulation defect (e.g., hemophilia) or concurrent thrombocytopenia. Bleeding in otherwise sick neonates is frequently caused by underproduction or consumption of coagulation factors and/or platelets. Common acquired hemorrhagic disorders include hemorrhage due to vitamin K deficiency (see Chapter 71 and below), disseminated intravascular coagulation (DIC: see Chapter 532), or immune-mediated thrombocytopenia (see Chapter 533).

The neonatal hemostatic system differs from older children and adults. This impacts bleeding risk and laboratory assessment, and should enter into management considerations. Plasma levels of vitamin K–dependent coagulation factors (II, VII, IX, X, protein C, protein S) and antithrombin are initially low at birth and do not reach adult ranges until approximately 6 months of age. Note that overall the neonatal hemostatic system tends toward hypercoagulability, given low levels of protein C, protein S, and antithrombin. This may explain why neonatal platelets are hypofunctional in response to some agonists, and why neonatal platelet content differs from adults (Chapters 525 and 526).

## HEMORRHAGIC DISEASE OF THE NEWBORN

Bleeding from vitamin K deficiency, otherwise known as **hemorrhagic disease of the newborn**, results from transient but profound deficiencies in vitamin K–dependent coagulation factors. Vitamin K normally facilitates carboxylation of factors II, VII, IX, and X, which is necessary for enzymatic activities. Decarboxylated factors are biologically inactive. Without vitamin K, decarboxylated *proteins induced in vitamin K absence (PIVKA)* are secreted. The classic form of this disease can be prevented with intramuscular injection of vitamin K (phytonadione) just after birth.

The disease process most often affects exclusively breastfed infants who did not receive intramuscular vitamin K prophylaxis at birth. Maternal breastmilk lacks free vitamin K, and newborns lack the intestinal flora normally responsible for vitamin K synthesis. Premature infants with nutritional deficiencies are also at risk of vitamin K deficiency and bleeding.

Laboratory testing typically reveals prolonged prothrombin time (PT) and partial thromboplastin time (PTT) in affected infants, with low plasma levels of prothrombin (II) and factors VII, IX, and X. Soluble **PIVKA** measurement can also act as a laboratory marker for vitamin K status. Factors V and VIII, fibrinogen, bleeding time, clot retraction, platelet count, and platelet function will be within normal newborn ranges.

Intramuscular administration of 1 mg vitamin K<sub>1</sub> (phytonadione) soon after birth can prevent bleeding complications from vitamin K deficiency in most full-term infants. Low birthweight infants may be given 0.5 mg phytonadione, although weight-based dosing varies between institutions. Phytonadione is the only form of vitamin K available in the United States. Vitamin K<sub>2</sub>, also known as menaquinones, constitutes a minority of the vitamin K consumed by humans or produced by intestinal flora. Vitamin K prophylaxis does not prevent all hemorrhagic disease of the newborn. Although rare, cases can occur in full-term infants, preterm infants with significant nutritional deficiencies, and infants with malabsorption.

**Table 142.1** Vitamin K Deficiency Bleeding (Hemorrhagic Disease of the Newborn)

	EARLY-ONSET DISEASE	CLASSIC DISEASE	LATE-ONSET DISEASE
Age	0-24 hr	2-7 days	1-6 mo
Potential sites of hemorrhage	Cephalohematoma Subgaleal Intracranial Gastrointestinal Umbilicus Intraabdominal	Gastrointestinal Ear-nose-throat-mucosal Intracranial Post circumcision Cutaneous Injection sites	Intracranial Gastrointestinal Cutaneous Ear-nose-throat-mucosal Injection sites Thoracic
Etiology/risks	Maternal drugs (phenobarbital, phenytoin, warfarin, rifampin, isoniazid) that interfere with vitamin K levels or absorption Inherited coagulopathy	Vitamin K deficiency Exclusive breastfeeding	Cholestasis: malabsorption of vitamin K (biliary atresia, cystic fibrosis, hepatitis) Abetalipoprotein deficiency Idiopathic in Asian breastfed infants Warfarin ingestion
Prevention	Avoidance of high-risk medication Possibly antenatal vitamin K to treatment of mother (20 mg) before birth and postnatal administration to infant soon after birth	Prevented by parenteral vitamin K at birth Oral vitamin K regimens require repeated dosing	Prevented by parenteral and high-dose oral vitamin K during periods of malabsorption or cholestasis
Incidence	Very rare	~2% if infant not given vitamin K soon after birth	Dependent on primary disease

Infants who present with hemorrhage should be given 1-5 mg of vitamin K<sub>1</sub> intravenously, typically on 3 consecutive days. This regimen generally improves coagulation defects and bleeding ceases within hours. Serious bleeding, particularly in premature infants or those with liver disease, may also require intravenous transfusion of fresh-frozen plasma to correct coagulopathy. Packed RBCs (PRBCs) or whole blood transfusions may also be required to correct anemia.

Bleeding episodes most frequently occur between days of life 2 and 7. Mild bleeding may precede more severe manifestations, which are most frequently gastrointestinal, nasal, subgaleal, intracranial, or occur after circumcision.

**Early-onset vitamin K deficiency** bleeding can occur in the first day of life in infants born to mothers chronically treated with drugs that interfere with vitamin K absorption or function, including warfarin, phenytoin, phenobarbital, or some cholesterol-lowering medications. Usually, bleeding is promptly ameliorated by vitamin K administration, although some infants can have poor or delayed improvements in bleeding. Thus infants born to mothers who took these medications late in gestation should be given 1-2 mg intravenous vitamin K immediately after birth, and serial newborn PT monitoring should begin using cord blood. If the PT is greatly prolonged and fails to improve, or significant hemorrhage presents, fresh-frozen plasma administration can temporarily correct factor deficiencies.

**Late-onset vitamin K deficiency** bleeding after 2 weeks of life is most often associated with conditions that cause fat-soluble vitamin malabsorption, including cystic fibrosis, neonatal hepatitis, or biliary atresia (Table 142.1). Bleeding can be severe and is not responsive to vitamin K treatment if there is hepatocellular injury; bleeding will respond to intravenous vitamin K if there is malabsorption.

Bleeding unresponsive to vitamin K should prompt consideration for congenital clotting factor deficiencies (see Chapter 525). These conditions may present with hematomas, melena, post circumcision bleeding, or bleeding from the umbilicus. Up to 70% cases of hemophilia (factor VIII or IX deficiency) are clinically apparent in the newborn period. Congenital factor deficiency treatment requires specific factor replacement, or fresh-frozen plasma if factor concentrate is not available.

Although oral vitamin K administration has been investigated as an alternative to intramuscular prophylaxis, oral regimens do not prevent late-onset vitamin K deficiency bleeding. Thus intramuscular vitamin K prophylaxis remains the method of choice.

Prompt recognition of infants who do present with bleeding from vitamin K deficiency is critical. A presumptive diagnosis can often be made based on a complete history, even before laboratory confirmation, facilitating rapid treatment initiation. With timely therapy and supportive care, the associated mortality rate is low.

### DISSEMINATED INTRAVASCULAR COAGULOPATHY

Critical illness that results in consumption of circulating coagulation factors and platelets is termed disseminated intravascular coagulation. In neonates and other patients, DIC can result in either bleeding or thrombosis. DIC occurs secondary to an array of primary processes, including but not limited to sepsis or asphyxia. Rarely, hemangiomas will cause consumption of coagulation factors and initiate this process. In addition to clinical context, coagulation studies, factor levels, and platelet counts can provide evidence of ongoing DIC. Management centers on treatment of the underlying etiology, although supportive care may include blood, plasma, vitamin K, or platelet transfusions to replace consumed factors. Usually, affected infants are critically ill, with evidence of end-organ damage. Those with DIC can have high rates of morbidity and mortality, dependent on the underlying etiology (see Chapter 532).

### Diagnosis and Treatment

Diagnostic modalities for hemorrhage in neonates vary based on clinical suspicion. For example, noninvasive imaging can be used to identify hemorrhage or bleeding sequelae. Premature infants who become acutely anemic out of proportion to phlebotomy are frequently monitored for intraventricular hemorrhage or investigated for bleeding elsewhere. These diagnostic measures can help to explain the pathology leading to anemia and any related risks. In turn, diagnosis can facilitate prognostication, and in rare cases lead to potentially definitive interventions (e.g., for some vascular malformations).

Treatment for blood loss typically includes transfusion of cross-matched PRBCs, which should be given more slowly in the setting of chronic blood loss or in patients at risk of volume overload. Therapies and interventions should also focus on correcting coexisting coagulopathy and/or comorbidities that increase further bleeding risk.

Visit Elsevier eBooks+ at eBooks.Health.Elsevier.com for Bibliography.



## Chapter 143

## Nonimmune Hydrops

Dalal Taha

Nonimmune hydrops, a significant contributor to neonatal morbidity and mortality, is the leading cause of fetal hydrops. **Hydrops fetalis** is defined by  $\geq 2$  abnormal fetal fluid collections, such as ascites, pleural, pericardial, or cutaneous edema ( $>5$  mm) (Fig. 143.1). In addition, there may be associated placental edema ( $>6$  mm), polyhydramnios (50%), and the rare occurrence of **mirror syndrome**, in which the mother becomes edematous. In cases in which hydrops is not caused by red cell alloimmunization, it is referred to as nonimmune hydrops. Non-immune hydrops is the result of a range of underlying etiologies, such as high-output cardiac failure secondary to anemia or fetal arrhythmia, alterations in lymphatic development, fetal inflammation, and capillary leak or elevated central venous pressure due to structural cardiac disease. Despite advances in recognition of the underlying cause, mortality remains high with prognosis dependent on the underlying cause, degree of prematurity, and extent of disease burden at birth.

## INCIDENCE AND ETIOLOGY

Estimates of incidence range between 1 in 1,700 pregnancies and 1 in 4,000 pregnancies. Population studies provide lower estimates, but this may be an underrepresentation due to a lack of information on fetuses who died in utero.

The etiologies are broad; cardiovascular, lymphatic, hematologic, and chromosomal disorders are the most common identifiable underlying causes (Table 143.1). The etiology is unknown in approximately 10–20% of cases. However, improved understanding of the lymphatic system and its contribution to the development of nonimmune hydrops has led to increased identification of the underlying etiology. Lymphatic causes of nonimmune hydrops are congenital lymphovenous atresia, in which the thoracic duct outlet is not connected to the venous circulation, and complete absence of the thoracic duct or pulmonary lymphatic perfusion syndrome, in which the pulmonary lymphatic channels abnormally conduct to the pleural space resulting in chylothorax. Other mechanisms for the development of nonimmune hydrops are not well established (Fig. 143.2).

## PRENATAL DIAGNOSIS AND TREATMENT

Hydrops fetalis is identified in utero by ultrasonographic findings of excess fluid. After ruling out immune-mediated hydrops (Rh

alloimmunization), other diagnostic testing may include screening for hemoglobinopathies, testing for fetal-maternal hemorrhage (Kleihauer-Betke test), and testing for infection (i.e., TORCH infections, syphilis, and parvovirus B19). Fetal echocardiography should be performed to assess for structural heart defect or arrhythmia. Commonly diagnosed causes of nonimmune hydrops in fetuses greater than 24 weeks' gestation are cardiac disorders. Amniotic fluid can be obtained for fetal genetic testing to evaluate for chromosomal and specific gene abnormalities. In cases with fetal pleural effusions, a fluid sample may be collected via thoracentesis and tested for lymphocyte count to determine whether the underlying cause of hydrops is due to lymphatic dysfunction.

In utero treatment has been successful for fetal supraventricular tachycardia (SVT), twin-twin transfusion syndrome, nonimmune fetal anemias, large vascular masses, congenital diaphragmatic hernia, and other chest occupying lesions, such as congenital cystic adenomatoid malformation (CCAM) and pulmonary sequestration. In cases in which initial ultrasound is not useful in identifying a cause, repeat ultrasound or fetal magnetic resonance imaging (MRI) can be used to reassess fetal anatomy, monitor progression of hydrops, determine an underlying diagnosis, and direct fetal intervention. The finding of nutmeg lung on fetal MRI signifies abnormal pulmonary lymphatic flow that results in chylothorax. To treat fetal pleural effusions, in the absence of an infectious etiology, fetal thoracentesis and/or thoracoamniotic shunt placement can be performed.

## POSTNATAL DIAGNOSIS AND TREATMENT

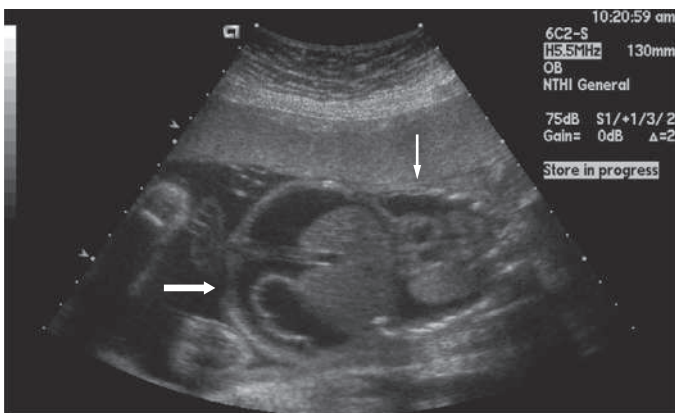
Postnatal therapy includes a team approach to the delivery room management that often requires immediate endotracheal tube intubation for predicted respiratory failure secondary to pleural, peritoneal, or pericardial effusions, pulmonary hypoplasia, surfactant deficiency, pulmonary edema, or poor chest wall compliance due to soft tissue edema. Immediate transfusion of packed red blood cells (RBCs) may also be required in the delivery room in the presence of anemias. Drainage of large pleural, peritoneal, or pericardial effusions may aid in achieving effective mechanical ventilation and ensure successful resuscitation. High ventilatory pressures may be needed to overcome poor chest compliance but may result in pneumothoraces or pulmonary interstitial emphysema, especially in cases with pulmonary hypoplasia.

Once the infant is stabilized, additional intensive care includes fluid and electrolyte management. Maintenance fluids should be restricted as much as possible with the goal of resolving or improving the degree of hydrops. In cases with ongoing drainage of pleural or peritoneal fluid, fluid replacement may be necessary to replete serum sodium levels and maintain hemodynamic stability. If the fluid drained is secondary to a lymphatic disorder, albumin may need to be administered to maintain adequate serum levels.

Diagnostic testing should be performed if an underlying etiology of hydrops is unknown at the time of birth to direct additional therapies. Whole exome (or genome) sequencing and microarray duplication/deletion studies are recommended to establish a diagnosis. Analysis of fluid from the pericardial, pleural, or peritoneal space may confirm an underlying lymphatic disorder if there is a lymphocyte predominance. Hypoalbuminemia and the presence of soft tissue edema is also suggestive of a lymphatic disorder. Additional evaluation of the lymphatic system includes the use of T2 weighted MRI, dynamic contrast-enhanced magnetic resonance lymphangiogram (DCMRL), and direct or conventional lymphangiogram. Interventions for congenital lymphatic disorders include ethiodized oil injection to treat pulmonary lymphatic perfusion syndrome and lymphovenous anastomosis for lymphovenous atresia.

## OUTCOMES

Mortality from nonimmune hydrops remains high at approximately 50% despite recent advances in diagnosis and treatment. Predictors of survival include gestational age at birth and degree of illness at the time of birth. Infants with parvovirus, isolated neonatal chylothorax, and SVT have the highest survival.



**Fig. 143.1** Hydrops fetalis. Longitudinal sonographic image of the fetus, with ascitic fluid outlining the liver (large arrow). The small arrow shows pleural effusion above the diaphragm. (From Wilkins I. *Nonimmune hydrops*. In Creasy RK, Resnick R, Iams JD, et al., eds. *Creasy & Resnik's Maternal-Fetal Medicine, 7th ed.* Philadelphia: Elsevier; 2014: Fig. 37-2.)

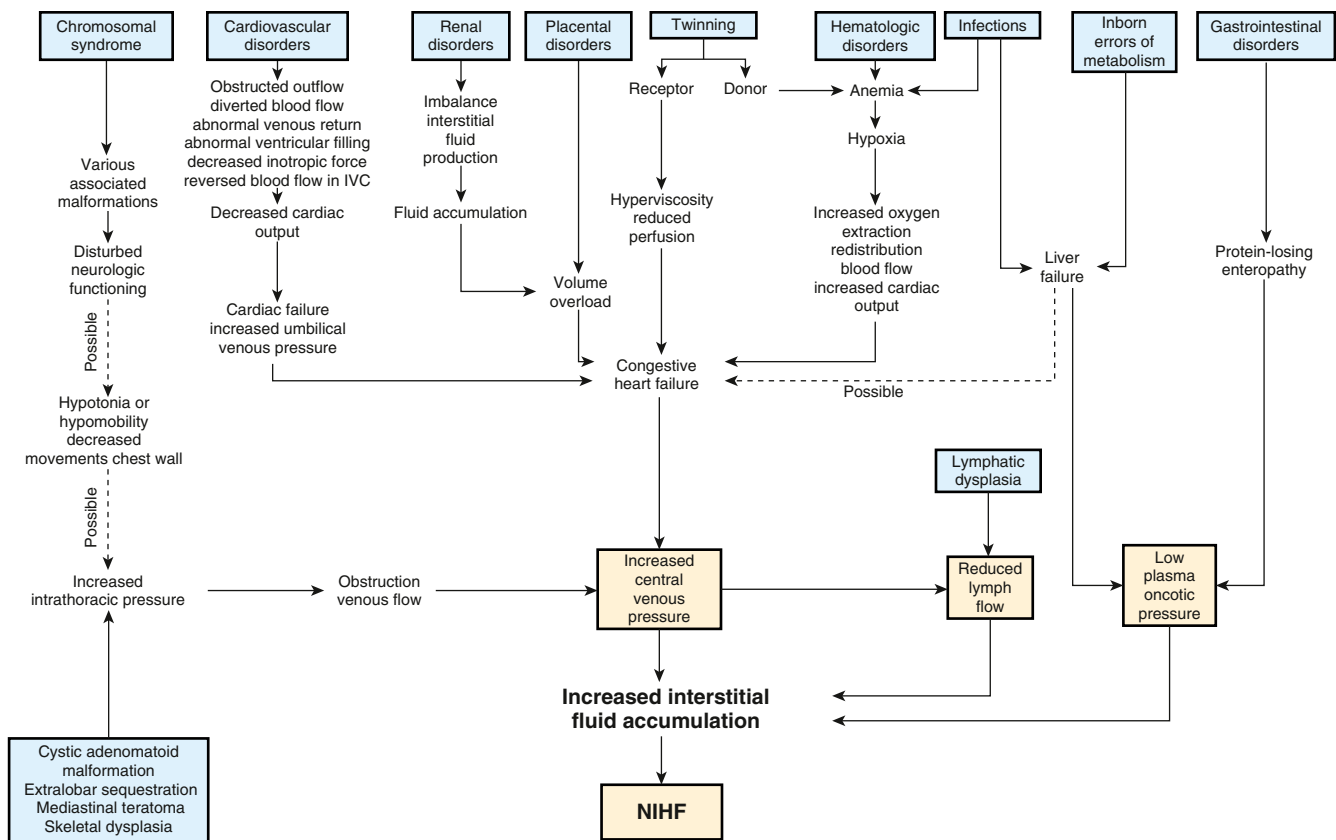


**Table 143.1** Principal Diagnoses Associated with Nonimmune Hydrops Fetalis

<p><b>CARDIOVASCULAR (21%)</b></p> <p><b>STRUCTURAL</b></p> <ul style="list-style-type: none"> <li>• Hypoplasias (left or right heart)</li> <li>• AV canal defect</li> <li>• Single ventricle</li> <li>• Transposition of great arteries</li> <li>• Septal defects (VSD/ASD)</li> <li>• Tetralogy of Fallot</li> <li>• Ebstein anomaly</li> <li>• Ductus arteriosus closure</li> <li>• Truncus arteriosus</li> <li>• Valvular (stenosis/insufficiency)</li> </ul> <p><b>ARRYTHMIAS</b></p> <ul style="list-style-type: none"> <li>• Atrial (flutter/tachyarrhythmia)</li> <li>• Wolff-Parkinson-White</li> <li>• Supraventricular tachycardia</li> <li>• Long QT interval</li> <li>• Heart block</li> </ul> <p><b>CARDIOMYOPATHY</b></p> <ul style="list-style-type: none"> <li>• Tumors</li> <li>• Neoplasias</li> <li>• Myopathies</li> <li>• Cardiosplenic syndromes</li> <li>• Hereditary cardiomyopathies</li> </ul> <p><b>INFECTION (6.7%)</b></p> <ul style="list-style-type: none"> <li>• Cytomegalovirus</li> <li>• Parvovirus B19</li> <li>• Syphilis</li> <li>• Herpes simplex</li> <li>• Rubella</li> <li>• Coxsackievirus</li> <li>• Leptospirosis</li> <li>• <i>Trypanosoma cruzi</i></li> </ul> <p><b>INBORN STORAGE DISEASE (1.1%)</b></p> <ul style="list-style-type: none"> <li>• Gaucher disease</li> <li>• GM1 gangliosidosis</li> <li>• Sialidosis</li> <li>• MPS IVA and VII</li> <li>• Mucopolidosis type I+II</li> <li>• Galactosialidosis</li> <li>• Niemann-Pick type C</li> </ul> <p><b>TTTS-PLACENTAL (5.6%)</b></p> <p><i>Twin</i></p> <ul style="list-style-type: none"> <li>• TTTS</li> <li>• Acardiac twin</li> </ul> <p><i>Placental</i></p> <ul style="list-style-type: none"> <li>• Umbilical vein thrombosis</li> <li>• Umbilical cord angiomyxoma</li> <li>• True cord knot</li> <li>• Chorionic vein thrombosis</li> <li>• Rare placenta disorders</li> </ul>	<p><b>THORACIC/EXTRATHORACIC MASS/LYMPHATIC (12.4%)</b></p> <p><i>Mass Effect</i></p> <ul style="list-style-type: none"> <li>• Diaphragmatic hernia</li> <li>• Congenital pulmonary adenomatoid malformation</li> <li>• Intrathoracic mass</li> <li>• Pulmonary sequestration</li> <li>• Chylothorax</li> <li>• Airway obstruction</li> <li>• Pulmonary lymphangiectasia</li> <li>• Bronchogenic cyst</li> </ul> <p><i>Other</i></p> <ul style="list-style-type: none"> <li>• Milroy syndrome</li> <li>• Generalized lymphatic dysplasia</li> <li>• Lymphedema-distichiasis syndrome</li> </ul> <p><i>Skeletal Dysplasias</i></p> <ul style="list-style-type: none"> <li>• Thanatophoric dysplasia</li> <li>• Short rib polydactyly</li> <li>• Hypophosphatasia</li> <li>• Osteogenesis imperfecta chondrogenesis</li> <li>• Campomelic dysplasia</li> <li>• Lethal achondroplasia</li> <li>• Nager syndrome</li> </ul> <p><b>IDIOPATHIC (17.8%)</b></p> <p><b>CHROMOSOMAL (13.4%)</b></p> <p><b>TRISOMY</b></p> <ul style="list-style-type: none"> <li>• 21</li> <li>• 18</li> <li>• 13</li> </ul> <p><b>MONOSOMY</b></p> <ul style="list-style-type: none"> <li>• 45, X</li> <li>• 45, X (mosaic)</li> </ul> <p><b>DUPLICATIONS</b></p> <ul style="list-style-type: none"> <li>• 18 q +</li> <li>• 11p</li> </ul> <p><b>DELETIONS</b></p> <ul style="list-style-type: none"> <li>• 13 q –</li> <li>• 17 q –</li> </ul> <p><b>TRIPLOIDY</b></p>	<p><b>HEMATOLOGIC (10.4%)</b></p> <ul style="list-style-type: none"> <li>• Alpha-thalassemia</li> <li>• Hereditary stomatocytosis</li> <li>• Fetomaternal hemorrhage</li> <li>• Glucose-6-phosphate deficiency</li> <li>• Leukemia</li> <li>• Pyruvate kinase deficiency</li> <li>• Red blood cell aplasias</li> <li>• Diamond-Blackfan syndrome</li> </ul> <p><b>GASTROINTESTINAL (0.5%)</b></p> <ul style="list-style-type: none"> <li>• Duodenal atresia</li> <li>• Duodenal diverticulum</li> <li>• Jejunoileal atresia</li> <li>• Volvulus</li> <li>• Imperforate anus</li> <li>• Meconium peritonitis</li> <li>• Intestinal malrotation</li> <li>• Intestinal duplication</li> <li>• Hepatic fibrosis</li> <li>• Cholestasis</li> <li>• Biliary atresia</li> <li>• Hepatic vascular malformations</li> <li>• Hepatitis</li> <li>• Hepatic necrosis</li> <li>• Liver tumor or cysts</li> </ul> <p><b>SYNDROMIC/MISCELLANEOUS (8.1%)</b></p> <ul style="list-style-type: none"> <li>• Noonan syndrome and other RASopathies</li> <li>• Arthrogyrosis</li> <li>• Multiple pterygium syndrome</li> <li>• Neu-Laxova syndrome</li> <li>• Pena-Shokeir syndrome</li> <li>• Myotonic dystrophy</li> <li>• Saldino-Noonan syndrome</li> <li>• Francois syndrome, type III</li> <li>• Familial nuchal bleb</li> <li>• Elejalde syndrome</li> <li>• Thoracoabdominal syndrome</li> </ul> <p><b>URINARY TRACT MALFORMATION (2.3%)</b></p> <ul style="list-style-type: none"> <li>• Urethral stenosis</li> <li>• Urethral atresia</li> <li>• Posterior urethral valve</li> <li>• Finnish type nephrosis</li> <li>• Edwards (prune belly) syndrome</li> </ul> <p><b>OTHER</b></p> <ul style="list-style-type: none"> <li>• HLH</li> <li>• IPEX</li> <li>• Nemaline myopathy</li> <li>• Multiple pterygium syndrome</li> <li>• Hyper IgE syndrome</li> </ul>
---	--	--

ASD, Atrial septal defect; AV, arteriovenous; HLH, hemophagocytic lymphohistiocytosis; IPEX, immune dysregulation polyendocrinopathy enteropathy X-linked; MPS, mucopolysaccharide; TTTS, twin-twin transfusion syndrome; VSD, ventricular septal defect.

Modified from Martin RJ, Fanaroff AA, Walsh MC, eds. *Fanaroff & Martin's Neonatal-Perinatal Medicine Diseases of the Fetus and Infant*, 11th ed. Philadelphia: Elsevier; 2020: Table 23.4, p 381.



**Fig. 143.2** Impact of various etiologies for nonimmune hydrops on fluid homeostasis. IVC, Inferior vena cava; NIHF, nonimmune hydrops fetalis. (Adapted from Bellini C, Hennekam RCM. *Non-immune hydrops fetalis: a short review of etiology and pathophysiology.* Am J Med Genet. 2012;158A:597–605.)

## Chapter 144

# The Umbilicus

Eric C. Eichenwald

The umbilical cord typically consists of two umbilical arteries, the umbilical vein, and a gelatinous substance called Wharton jelly, all contained within a sheath derived from the amnion and coiled into a helical shape. The muscular umbilical arteries carry deoxygenated blood from the fetus to the placenta and are contiguous with the fetal internal iliac arteries. The umbilical vein carries oxygenated blood from the placenta back to the fetus, where it flows into the inferior vena cava by way of the ductus venosus. The placenta contains an estimated 20 mL/kg of blood; current recommendations are to delay clamping of the cord at delivery for 30–60 seconds in both term and preterm infants, to facilitate placental transfusion. At term, a normal umbilical cord is approximately 55 cm long. Abnormally short cords are associated with conditions causing decreased fetal movement, including fetal hypotonia, oligohydramnios, and uterine constraint, and lead to increased risk for complications during labor and delivery for both mother and infant. Long cords (>70 cm) increase the risk for true knots, wrapping around the fetus, and/or prolapse. Straight uncoiled cords are associated with anomalies, fetal distress, and intrauterine fetal demise.

When the cord is cut after birth, portions of these structures remain in the base but gradually become obliterated. The blood vessels are functionally closed but anatomically patent for 10–20 days. The umbilical arteries become the lateral umbilical ligaments; the umbilical vein, the ligamentum teres; and the ductus venosus, the ligamentum venosum. The umbilical

cord stump usually sloughs within 2 weeks. Delayed separation of the cord, after more than 1 month, has been associated with neutrophil chemotactic defects and overwhelming bacterial infection (see Chapter 168).

A single umbilical artery is present in approximately 5–10/1,000 births; the frequency is higher (35–70/1,000) in twin births. It is estimated that 20–30% of infants with a single umbilical artery have other (and often multiple) congenital structural abnormalities. The presence of multiple anomalies is suggestive of an abnormal karyotype, including trisomies. Infants with an isolated single umbilical artery are not thought to be at increased risk of having a chromosomal anomaly, and no specific evaluation is indicated for these infants aside from a thorough physical examination.

The **omphalomesenteric duct (OMD)** is an embryonic connection between the developing midgut and the primitive yolk sac. It typically involutes at 8–9 weeks' gestation, but failure of this process can leave an abnormal connection between the umbilical cord and the gastrointestinal (GI) tract. The most common remnant of the OMD is a **Meckel diverticulum** (see Chapter 377), whereas abnormalities that would become symptomatic in the neonatal period include a **sinus** or **fistula** that would drain mucus or intestinal contents through the umbilicus. An umbilical **polyp** is one of the least common OMD remnants and represents exposed GI mucosa at the umbilical stump. The tissue of the polyp is bright red, firm, and has a mucoid secretion. Therapy for all OMD remnants is surgical excision of the anomaly.

A **persistent urachus** (urachal cyst, sinus, patent urachus, or diverticulum) is a result of failure of closure of the allantoic duct and may be associated with bladder outlet obstruction. Patency should be suspected if a clear, light-yellow, urine-like fluid is being discharged from the umbilicus. Symptoms include drainage, a mass or cyst, abdominal pain, local erythema, and infection. Urachal anomalies should be investigated by ultrasonography and a cystogram. Therapy for a persistent urachus is surgical excision of the anomaly and correction of any bladder outlet obstruction if present.

### UMBILICAL HEMORRHAGE

Hemorrhage from the umbilical cord may be the result of trauma, inadequate ligation of the cord, or failure of normal thrombus formation. It may also indicate hemorrhagic disease of the newborn or other coagulopathies (especially factor XIII deficiency), septicemia, or local infection. The infant should be observed frequently during the first few days of life so that if hemorrhage does occur, it will be detected promptly.

### UMBILICAL GRANULOMA

The umbilical cord stump usually dries and separates within 1-2 weeks after birth. The raw surface becomes covered by a thin layer of skin; scar tissue forms, and the wound is usually healed within 12-15 days. The presence of saprophytic organisms delays separation of the cord and increases the possibility of invasion by pathogenic organisms. Mild infection or incomplete epithelialization may result in a moist, granulating area at the base of the cord with a slight mucoid or mucopurulent discharge. Good results are usually obtained by cleansing with alcohol several times daily.

Persistence of granulation tissue at the base of the umbilicus is common. The tissue is soft, 3-10 mm in size, vascular and granular, colored dull red or pink, and may have a seropurulent discharge. Granulation tissue is treated by cauterization with silver nitrate, repeated at intervals of several days until the base is dry.

### UMBILICAL INFECTIONS

The devitalized umbilical cord provides an ideal medium for bacterial growth and a potential portal of entry for microbes. The term **omphalitis** refers to infection of the umbilical cord stump, navel, or the surrounding abdominal wall. Omphalitis must be distinguished from local irritation from the umbilical cord clamp. Erythema that extends to the abdominal wall, particularly tracking superiorly is concerning. Most term infants with mild localized omphalitis appear well and are afebrile. However, ~10-15% are acutely ill and at risk for bacteremia, spreading cellulitis, necrotizing fasciitis, and extension into the portal vein and liver. **Necrotizing fasciitis** (which is often polymicrobial) is associated with a high mortality rate and is often associated with neutropenia. Treatment of omphalitis includes prompt antibiotic therapy with agents effective against *Staphylococcus aureus* and *Escherichia coli*, such as an antistaphylococcal penicillin or vancomycin in combination with an aminoglycoside. If abscess formation or necrotizing fasciitis has occurred, surgical consultation for incision and drainage or debridement may be required.

In community and primary care settings in developing countries, topical application of chlorhexidine to the umbilical cord has been shown to reduce omphalitis and neonatal mortality. In hospital settings in developed countries, there is no convincing evidence that application of antiseptics (including triple dye, alcohol, or chlorhexidine) is superior to *dry cord care* in minimizing the risk of omphalitis for infants in these settings, although these treatments do reduce bacterial colonization.

### UMBILICAL HERNIA

Often associated with **diastasis recti**, an umbilical hernia is caused by incomplete closure or weakness of the muscular umbilical ring. Predisposing factors include Black race and low birthweight. The hernia appears as a soft swelling covered by skin that protrudes during crying, coughing, or straining and can be reduced easily through the fibrous ring at the umbilicus. The hernia consists of omentum or portions of the small intestine. The size of the defect varies from <1 cm in diameter to as much as 5 cm (2 inches), but larger defects are rare. Most umbilical hernias that appear before age 6 months disappear spontaneously by 1 year. Even large hernias (5-6 cm in all dimensions) have been known to disappear spontaneously by 5-6 years. Strangulation of intestinal contents is *extremely rare*. Surgery is not advised unless the hernia persists to age 4-5 years, causes symptoms, becomes strangulated, or becomes progressively larger after age 1-2 years. Defects exceeding 2 cm are less likely to close spontaneously.

### CONGENITAL OMPHALOCELE

An **omphalocele** is a herniation or protrusion of the abdominal contents into the base of the umbilical cord (Fig. 144.1). In contrast to the more common umbilical hernia, the sac is covered with peritoneum without overlying skin, and the insertion of the distal umbilical cord into the sac itself distinguishes this condition from other abdominal wall defects such as gastroschisis. The size of the



**Fig. 144.1** A, Omphalocele with umbilical cord insertion into the sac and intestine visible. B, Omphalocele with sac containing liver. (Courtesy Dr. Foong Lim, Cincinnati Fetal Center at Cincinnati Children's Hospital Medical Center.)

sac that lies outside the abdominal cavity depends on its contents. Herniation of intestines into the cord occurs in approximately 1/5,000 births, and herniation of liver and intestines in 1/10,000 births. The abdominal cavity may be proportionately small because of the lack of space-occupying viscera. Treatment for an omphalocele consists of covering the sac with moist, sterile dressings, then initiating prompt surgical repair if the abdomen is able to accommodate the eviscerated organs. If the omphalocele is too large to allow immediate repair, continued dressings may temporize and encourage epithelialization of the sac. Occasionally, mesh or similar synthetic material may be used to cover the viscera if the sac has ruptured or if excessive mobilization of the tissues would be necessary to cover the mass and its intact sac.

Many infants with omphalocele (50-70%) have associated malformations, and about 30% have chromosomal abnormalities. The likelihood of an abnormal karyotype is increased when the liver is *intracorporeal* (not within the sac). Omphalocele can be part of well-defined syndromes, including **Beckwith-Wiedemann syndrome**, characterized by omphalocele, macrosomia, and hypoglycemia. The survival rate for affected infants is largely determined by the presence of associated malformations or chromosomal abnormalities. For patients with isolated omphalocele, the survival rate is >90%.

### UMBILICAL TUMORS

Tumors of the umbilicus are rare and include angioma, enteroteratoma, dermoid cyst, myxosarcoma, and cysts of urachal or OMD remnants.

Visit Elsevier eBooks+ at [eBooks.Health.Elsevier.com](http://eBooks.Health.Elsevier.com) for Bibliography.



Chapter 145

# Neonatal Abstinence Syndrome

Stephen W. Patrick

Neonatal abstinence syndrome (NAS) is a drug withdrawal syndrome that occurs among some substance-exposed infants shortly after birth. The syndrome most commonly occurs after in utero exposure to opioids and is also called neonatal opioid withdrawal syndrome (NOWS). Between 2000 and 2017, the rate of NAS in the United States increased sixfold reaching 7.2 per 1,000 hospital births, which mirrors the rise of other population-wide opioid-related complications including overdose deaths. The opioid overdose crisis in the United States was first driven by prescription opioids (e.g., oxycontin), then heroin, and more

currently by illicitly produced fentanyl. For pregnant women opioid use disorder (OUD), or continued use of an opioid despite adverse consequences, often begins before pregnancy and is associated with myriad social risks including trauma and physical abuse. Treatment of OUD, especially with medications for OUD (MOUD), is effective in improving pregnancy outcomes. MOUD, including buprenorphine and methadone, has been shown to reduce risk of relapse, overdose death, HIV and hepatitis C virus (HCV), and preterm birth. **Methadone** is a full  $\mu$ -opioid agonist, generally given once daily, and is administered through highly regulated opioid treatment programs. **Buprenorphine** is a partial  $\mu$ -opioid agonist and a partial  $\kappa$ -antagonist, can be prescribed in the outpatient setting, and is more widely available. Accessing treatment can be challenging for pregnant women, with studies showing they are nearly 20% less likely to be accepted for treatment than nonpregnant women. Notably, MOUD such as methadone and buprenorphine can cause NAS; however, this is generally thought of as a preferable outcome when compared to preterm birth or overdose.

The clinical signs of NAS are generally associated with neurologic (e.g., tremor), gastrointestinal (e.g., poor feeding), and autonomic signs (e.g., tachypnea) and can be documented using the NAS score (Fig. 145.1) as well as the Eat, Sleep, Console (ESC) assessment tool (Table 145.1).

### NEONATAL ABSTINENCE SCORE

Date: \_\_\_\_\_ Weight: \_\_\_\_\_

System	Signs & Symptoms	Score	Time		Comments
			AM	PM	
Central Nervous System Disturbances	Excessive High Pitched Cry	2			
	Continuous High Pitched Cry	3			
	Sleeps < 1 Hour After Feeding	3			
	Sleeps < 2 Hours After Feeding	2			
	Sleeps < 3 Hours After Feeding	1			
	Hyperactive Moro Reflex	2			
	Markedly Hyperactive Moro Reflex	3			
	Mild Tremors Disturbed	1			
	Moderate - Severe Tremors Disturbed	2			
	Mild Tremors Undisturbed	3			
	Moderate - Severe Tremors Undisturbed	4			
	Increased Muscle Tone	2			
	Excoriation (Specific Area)	1			
	Myoclonic Jerks	3			
Generalized Convulsions	5				
Metabolic / Vasomotor / Respiratory Disturbances	Sweating	1			
	Fever < 101° F (37.2° - 38.2° C)	1			
	Fever ≥ 101.1° F (≥38.4° C)	2			
	Frequent Yawning (> 3 - 4 Times/Interval)	1			
	Mottling	1			
	Nasal Stuffiness	1			
	Sneezing (> 3 - 4 Times/Interval)	1			
	Nasal Flaring	2			
	Respiratory Rate - 60/min	1			
	Respiratory Rate - 60/min with Retractions	2			
Gastrointestinal Disturbances	Excessive Sucking	1			
	Poor Feeding	2			
	Regurgitation	2			
	Projectile Vomiting	3			
	Loose Stools	2			
	Watery Stools	3			
<b>TOTAL SCORE</b>					
Initials of Scorer					

**Fig. 145.1** Data from Amin A, Frazie M, Thompson S, Patel A. Assessing the Eat, Sleep, Console model for neonatal abstinence syndrome management at a regional referral center. *J Perinatol.* 2023 Apr 25:1-7; Blount T, Painter A, Freeman E, et al. Reduction in length of stay and morphine use for NAS with the "Eat, Sleep, Console" Method. *Hosp Pediatr.* 2019;9:615-623; Glait M, Moyer A, Saudek K, et al. Addressing drivers of health-care utilization for neonatal opioid withdrawal syndrome. *J Perinatol.* 2023;43:392-401; Grossman M. Eat, Sleep, Console (ECS) care tool. 2017 ESC 3rd ed. 1.30.20; Young LW, Ounpraseuth ST, Merhar SL, et al. Eat, sleep, console approach or usual care for neonatal opioid withdrawal. *N Engl J Med.* 2023;388:2326-2336.)



**Table 145.1** Eat, Sleep, Console (ESC) Assessment Approach to Neonatal Opioid Withdrawal

**EATS**

Takes > 10 min to coordinate feeding with hunger cues  
< 10 min for breastfeeds  
< 10 mL of a feed

**SLEEPS**

< 1 hr after a feed

**CONSOLES**

Takes > 10 min to be consoled  
Cannot stay consoled for 10 min

**Nonpharmacologic interventions include** rooming in, caregiver presence, skin to skin contact, holding/cuddling, safe swaddling (avoid face), feed on demand after hunger cues, breastfeeding, non-nutritive sucking, quiet low stimulation low-light environment, rhythmic motion, additional caregiver support, minimal disruptions in environment, cluster care to awake times, safe sleep, caregiver self-care and rest.

These parameters suggest withdrawal.

Data from Amin A, Frazie M, Thompson S, Patel A. Assessing the Eat, Sleep, Console model for neonatal abstinence syndrome management at a regional referral center. *J Perinatol.* 2023 Apr 25:1–7; Blount T, Painter A, Freeman E, et al. Reduction in length of stay and morphine use for NAS with the “Eat, Sleep, Console” Method. *Hosp Pediatr.* 2019;9:615–623; Glait M, Moyer A, Saudek K, et al. Addressing drivers of healthcare utilization for neonatal opioid withdrawal syndrome. *J Perinatol.* 2023;43:392–401; Grossman M. Eat, Sleep, Console (ECS) care tool. 2017 ESC 3rd ed. 1.30.20; Young LV, Ounpraseuth ST, Merhar SL, et al. Eat, sleep, console approach or usual care for neonatal opioid withdrawal. *N Engl J Med.* 2023;388:2326–2336.

The timing of NAS onset can be related to several factors, including the last maternal use and half-life of the opioid. NAS signs can rarely begin within 24 hours of birth but more commonly occur within 48 hours after short-acting opioids, and 72–96 hours after exposure to long-acting or maintenance opioids (e.g., methadone). For these reasons, it is recommended to observe opioid-exposed infants for at least 3 days after birth for an infant exposed to short-acting opioids and 5 days for longer half-life opioids such as buprenorphine. Tremors, poor feeding, excessive crying, poor sleeping, and hyperirritability are the most prominent signs of NAS. Other signs include sneezing, yawning, hiccups, myoclonic jerks, skin breakdown and abrasions, vomiting, loose stools, nasal stuffiness, and seizures. Many prenatal and postnatal factors can influence the severity and duration of withdrawal. Polysubstance use, particularly with cigarettes, gabapentin, benzodiazepines, and selective serotonin reuptake inhibitors, has been associated with a higher risk or more severe NAS, whereas breastfeeding after delivery, rooming-in, and standardizing care processes (i.e., following protocols) have been associated with lower risk or less severe NAS (see Table 145.1 for nonpharmacologic interventions).

Identifying substance use as early as possible in pregnancy is critical to improving pregnancy outcomes. For that reason, it is recommended to perform universal screening for substance use using a standardized and validated tool such as the four Ps:

- **Parents:** Did any of your parents have problems with alcohol or other drug use?
- **Partner:** Does your partner have a problem with alcohol or drug use?
- **Past:** In the past, have you had difficulties in your life because of alcohol or other drugs, including prescription medications?
- **Present:** In the past month, have you drunk any alcohol or used other drugs?

Screening can be augmented with toxicology testing of the mother or infant; it is important to recognize that toxicology testing has limitations and for some substances may only capture a short window of exposure. Toxicology testing of pregnant women requires informed consent but is not needed for infants if done as part of routine care.

Testing urine of mothers or infants can capture recent exposures, whereas umbilical cord and meconium testing will capture a longer window of substance use. Toxicology testing may not be

needed if women are in treatment and receive routine testing in pregnancy.

**TREATMENT AND SETTING**

Hospitals should have standardized protocols for the observation, scoring, and treatment of the opioid-exposed infant. The first line of treatment for all opioid-exposed infants is **nonpharmacologic support**, including rooming-in, breastfeeding, and tailoring the environment to not overstimulate the infant. Importantly, care for opioid-exposed infants and those diagnosed with NAS does not require admission to a neonatal intensive care unit (NICU); admission to a NICU may cause undue separation of the maternal–infant dyad as well as exacerbate clinical signs of withdrawal by placing the infant in a loud environment. Breastfeeding, in addition to its well-documented benefits, can also reduce NAS severity and can safely occur with maternal treatment using MOUD. Although there are no evidence-based guidelines, consensus guidelines suggest breastfeeding can be encouraged if there has been no relapse within 30 days of birth and should be encouraged if there has been no relapse within 90 days of birth. Untreated HIV is a contraindication to breastfeeding; however, breastfeeding is safe with HCV unless there are cracked or bleeding nipples.

The decision for pharmacologic treatment has been traditionally based on the nursing scoring assessment tool, and the most widely used tool is a modification of the Finnegan scoring tool (see Fig. 145.1). Other scoring tools include the Neonatal Narcotic Withdrawal Index, Neonatal Withdrawal Inventory, and MOTHER NAS Scale.

The **ESC model** is very useful and is an evidenced-based approach for improved outcomes and fewer pharmacologic interventions (Table 145.1). An inability to eat, sleep, or be consoled in at least two of the three parameters in the presence of nonpharmacologic interventions warrants pharmacologic therapy, usually with oral liquid morphine plus continued nonpharmacologic interventions. Other etiologies of poor eating, sleeping, and consolability must be evaluated. The main objectives when initiating pharmacologic treatment is to control clinical signs of withdrawal and to prevent adverse events (e.g., seizure). Excessive weight loss may be an indication for pharmacotherapy regardless of other clinical signs.

Pharmacologic treatment for NAS, when necessary, should be done with an opioid, and the most commonly used are morphine or methadone (Table 145.2). **Morphine** is a short-acting opioid given every 3 hours as a weight-based or clinical sign-based regimen. **Methadone** is a long-acting opioid that can generally be given twice a day after loading doses. **Buprenorphine** is an effective agent that may be superior to morphine; its use may be associated with a short duration of treatment and length of stay, as well as few adverse effects and less use of additional medications. Clinical trials have shown methadone and buprenorphine to decrease length of treatment when compared with morphine. Buprenorphine and some methadone formulations contain high ethanol levels, which may be deleterious to the infant and should be avoided. Closely adhering to NAS treatment protocols with guidelines on initiation and weaning have been shown to decrease both length of treatment and length of stay.

**Adjuvant therapy** is generally initiated in the unusual situation when the primary opioid is not effective in controlling the signs of NAS. The two medications used as adjuvant therapy are **phenobarbital** and **clonidine**. American Academy of Pediatrics (AAP) guidelines suggest clonidine be used as adjuvant therapy; phenobarbital should be avoided if possible as some studies suggest long-term use can be associated with developmental delay.

Long-term studies of opioid-exposed infants are lacking, and many are confounded by co-exposures (e.g., alcohol), maternal health (e.g., poor nutrition), or social risk (e.g., trauma), all of which could influence developmental outcomes. Still, infants should be closely monitored to optimize developmental trajectory. In many states a diagnosis of NAS qualifies for early intervention services, which are part of the Individuals with Disability and Education Act Part C, and infants should be referred to this service. Other supportive referrals should be

**Table 145.2** Medications Used in Pharmacologic Treatment of Neonatal Abstinence Syndrome

DRUG	INITIAL DOSING	DOSING INCREASES	WEANING SCHEDULE	ADD ADJUVANT THERAPY
Morphine	0.05 mg/kg/dose q3h	Increase dose 10–20%	10% of stabilizing dose q24h	>1 mg/kg/day of morphine Unable to wean for 2 days
Methadone	0.1 mg/kg/dose q6h for 4 doses	Increase to q4h if unable to capture	0.7 mg/kg/dose q12h × 2 doses, then 0.05 mg/kg/dose q12h × 2 0.04 mg/kg/dose q12h × 2 0.03 mg/kg/dose q12h × 2 0.02 mg/kg/dose q12h × 2 0.01 mg/kg/dose q12h × 2 0.01 mg/kg/dose q24h × 1	Unable to wean for 2 days
Buprenorphine	4 μg/kg q8h	2 μg/kg until maximum of 15 μg/kg	3 μg/kg/dose q8h × 3 doses 2 μg/kg/dose q8h × 3 2 μg/kg/dose q8h × 2 2 μg/kg/dose q24h × 1	Unable to wean for 2 days
Phenobarbital	20 mg/kg	—	5 mg/kg daily	N/A
Clonidine	1.5 μg/kg/dose q3h	25% dose escalation q24h	10% every day	N/A

N/A, Not available; q24h, every 24 hours.

considered, including home visitation programs and Early Head Start. Further, in the discharge process clinicians should also assess other risk, including HIV and HCV exposure, which must be followed in the outpatient setting. Hospitals should standardize the discharge process for opioid-exposed infants to ensure connection to postdischarge services.

Visit Elsevier eBooks+ at [eBooks.Health.Elsevier.com](http://eBooks.Health.Elsevier.com) for Bibliography.

## Chapter 146

# Fetal Alcohol Spectrum Disorder

*Susan A. Friedman and Hallam Hurt*

Alcohol is a known teratogen that can cause irreversible central nervous system (CNS) damage. Injury can include reduced brain volume, particularly for the frontal lobe, and thinning of the corpus callosum. These injuries can lead to CNS dysfunction that can range from relatively mild to severe. Prenatal alcohol exposure (PAE) affects all stages of brain development from neurogenesis to myelination, through mechanisms that include disrupted cell-cell interactions, altered gene expression, and oxidative stress leading to abnormalities such as reduced brain volume in the frontal lobe, striatum and caudate nucleus, thalamus, and cerebellum; thinning of the corpus callosum; and abnormal functioning of the amygdala.

PAE can result in a spectrum of outcomes. The term fetal alcohol spectrum disorder (FASD) is the umbrella term that encompasses a group of conditions associated with PAE. The FASD group of disorders includes fetal alcohol syndrome (FAS), partial fetal alcohol syndrome (pFAS), alcohol-related neurodevelopmental disorder (ARND), alcohol-related birth defect (ARBD), and neurobehavioral disorder associated with prenatal alcohol exposure (ND-PAE).

## EPIDEMIOLOGY

According to the CDC, approximately 1 in 7 pregnant women report consuming alcohol within the past 30 days. Approximately 20–30% report drinking at some point during the pregnancy, and more than 5% report binge drinking, consuming alcohol within the last 30 days, with ~20% reporting binge drinking. Because almost 50% of pregnancies in the United States are unplanned, unintentional PAE can occur before a woman knows she is pregnant.

## PREVALENCE

FASDs are the most common causes of preventable developmental delay and intellectual disability. Prevalence rates vary across reports. The US Centers for Disease Control and Prevention (CDC) FAS Surveillance Network reported prevalence rate across several populations of 0.3 out of 1,000 children from 7 to 9 years of age. This prevalence rate is much lower than that obtained by active case ascertainment studies in the United States and Western Europe, which have estimated prevalence rates of 2–5%. Another study reported similar rates, 24–48 cases per 1,000 children (2.4–4.8%) for all FASDs, and 6–9 cases per 1,000 (0.6–0.9%) for FAS specifically. Studies that have examined PAE by anonymous meconium testing demonstrate 4.26 times greater identification of alcohol use during pregnancy compared with maternal self-report. Rates of FASDs have been reported to be higher in children living in poverty, in Indigenous populations, and in children living in foster care. The rate of FASDs for children in foster care has been found to be 10 to 15 times higher than that for children in the general population. FASDs often go undetected in these children, and as many as 86.5% of foster and adopted youth with FASDs go undiagnosed or are diagnosed incorrectly within the FASD spectrum. Children adopted internationally represent another high-risk group, particularly those adopted from Eastern Europe. Children adopted from orphanages and other children with a history of early trauma, such as those in foster care, may also exhibit symptoms of posttraumatic stress disorder (PTSD) and other neurobehavioral and developmental issues that can overlap with those of FASD, including those without physical features (ARND or ND-PAE). The impairments seen in children with an FASD may also include the negative impact of additional prenatal and postnatal risk factors.

## DIAGNOSTIC SYSTEMS

The most widely used diagnostic guidelines are the Hoyme FASD diagnostic guidelines (revised 2016), the University of Washington 4-Digit Diagnostic Code (2004), the CDCFAS guidelines (revised

2004, only includes FAS), and the Canadian FASD guidelines (revised 2016).

These FASD diagnostic guidelines overlap but also have important distinctions. The Hoyme system uses more stringent alcohol exposure criteria than the 4-Digit Diagnostic Code. Both the Hoyme system (2016), and the 4-Digit Diagnostic Code system use the three diagnostic criteria of facial findings, growth restriction, and CNS abnormalities and both include a spectrum of disorders under the umbrella term of *fetal alcohol spectrum disorder* (FASD). However, they do differ in diagnostic tools, specific criteria used to define each category, and in diagnostic nomenclature. The result of these differences and others is that there may not be total agreement between the two in the diagnosis of a given patient. The CDC guidelines establish criteria only for FAS and require the three diagnostic criteria of facial findings, growth restriction, and CNS abnormalities, with or without documented PAE. In the updated Canadian guidelines, “fetal alcohol spectrum disorder” is considered a diagnostic term with two categories: FASD with sentinel facial features and FASD without sentinel facial features. These guidelines eliminate growth restriction as a required diagnostic criterion. They include an at-risk category for children with confirmed PAE who were too young to meet the criteria for neurodevelopmental deficits, or in whom assessment was incomplete. They also include a category for children with cardinal facial features without documentation or evidence of severe impairment in neurodevelopmental domains. There is no universal acceptance of one system. If less stringent criteria are used, the sensitivity increases, which may lead to overdiagnosis. Additional expert evaluation is then needed to confirm a diagnosis. In contrast, using more stringent criteria leads to greater specificity but may underdiagnose FASD.

### Historical and Clinical Features

The historical and clinical features shared by all previously described diagnostic systems (although not required by all of the disorders) include five categories: (1) PAE, (2) three key facial features, (3) prenatal/postnatal growth restriction, (4) deficient brain growth and/or significant structural brain abnormalities, and (5) neurobehavioral impairment.

### Prenatal Alcohol Exposure

A safe threshold or pattern of alcohol consumption during pregnancy has not been identified, and any PAE at any stage of gestation is believed to present a risk to a developing fetus. Significant alcohol exposure has been carefully defined in the 2016 updated Hoyme guidelines as follows.

One or more of the following exposures, beginning 3 months before pregnancy and continuing until delivery, with a standard drink defined as 1.5 oz of hard liquor, 5 oz of wine, or 12 oz of beer or wine cooler:

- $\geq 6$  drinks/week for  $\geq 2$  weeks during pregnancy
- $\geq 3$  drinks per occasion on  $\geq 2$  occasions

- Documented alcohol-related social or legal problems before or during pregnancy or a history of treatment for an alcohol-related condition
- Documentation of intoxication of blood, breath, or urine alcohol testing
- Positive testing with an established biomarker of alcohol exposure during pregnancy or at birth
- Positive finding on a validated screening tool for drinking during pregnancy

Information can be obtained from a variety of sources in addition to the birth mother, including family members, foster or adoptive parents, social service agencies who observed maternal alcohol consumption during pregnancy, or medical records that document PAE, alcohol treatment, or social, legal, or medical problems related to drinking during pregnancy. Binge drinking (4 or more drinks per occasion) has been shown to be the most harmful to fetal development. PAE in the first trimester leads to the classic facial dysmorphia associated with FAS and other structural defects. PAE can have other deleterious effects (e.g., spontaneous abortion, growth defect, CNS effects) on the fetus throughout the pregnancy.

Several well-validated screens are used to identify alcohol use in pregnant and nonpregnant women of childbearing years, including the assessments of Tolerance, Annoyance, Cut Down, Eye-Opener (T-ACE), Cut Back, Annoyed, Guilty, Eye-Opener (CAGE); Car; Relax; Alone; Forget; Friends; Trouble (CRAFFT); Alcohol Use Disorders Identification Test (Audit-C); and Tolerance, Worried, Eye-Opener, Amnesia, Kut Down (TWEAK). There are, however, no well-validated screens designed to ask about past consumption of alcohol. Pediatricians can ask the following two questions to determine the likelihood of significant PAE: “In the 3 months before you knew you were pregnant, how many times did you have 4 or more alcohol drinks in a day?” and “During your pregnancy, how many times did you have any alcohol?” If a positive response is given to either question, the clinician can follow up to determine the level of PAE by asking the following: (1) “During your pregnancy, on average, how many days per week did you have any alcohol?”; (2) “During your pregnancy, on a typical day when you had an alcoholic beverage, how many drinks did you have?”; and (3) “During your pregnancy, what was the maximum number of drinks that you had in a day?”

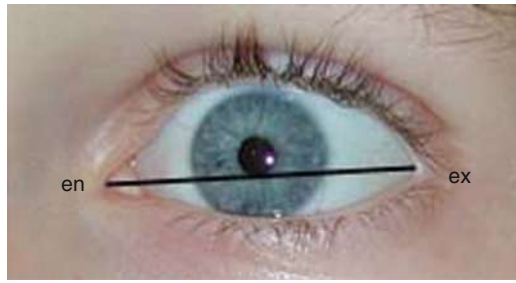
### Dysmorphic Facial Features

The three key, facial dysmorphic features include short palpebral fissures, a thin vermilion border of the upper lip, and a smooth philtrum (Fig. 146.1). Measurement of the **palpebral fissure length (PFL)** is shown in Figure 146.2. There are several different PFL charts that can be used to plot this measurement. That of Hall is included here (Fig. 146.3), with additional charts listed under Additional Resources for Healthcare Providers. In addition, different diagnostic systems have different cutoffs to define the criteria. Evaluation of the philtrum and upper lip utilizes the Lip-Philtrum

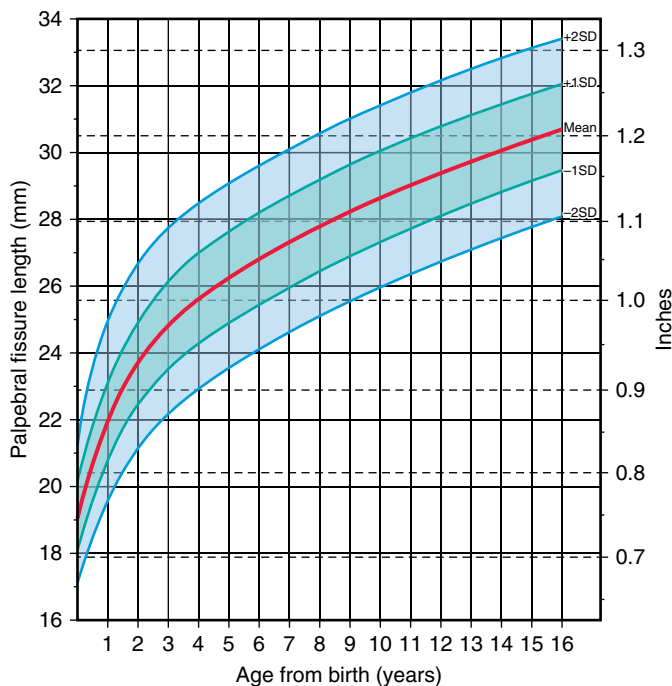


**Fig. 146.1** Examples of facial features of FAS in children of different ethnicities. A, White. B, Native American. C, Black. D, Asian. (Copyright 2021 Susan (Astley) Hemingway PhD, University of Washington.)





**Fig. 146.2** The palpebral fissure length is defined by the distance between the endocanthion (*en*) and exocanthion (*ex*) landmarks. (Copyright 2021 Susan (Astley) Hemingway PhD, University of Washington.)



**Fig. 146.3** Palpebral fissure measurements. (From Hall JG, Froster-Iskenius UG, Allanson J, eds. *Handbook of Normal Physical Measurements*. Oxford: Oxford University Press; 1989: p. 150.)

Guide developed at the University of Washington (Fig. 146.4), which can be obtained on request in digital format or as a laminated card from the University of Washington. Although this guide includes norms for White and Black children, additional work is needed on establishing norms for the three facial features across a wider range of racial groups.

Additional minor anomalies may also occur in association with PAE but are not included in the diagnostic criteria: mid-face hypoplasia, epicanthal folds, ptosis, strabismus, altered palmar crease (“hockey stick” and clinodactyly of the fifth finger [Fig. 146.5], “railroad track ears” [Fig. 146.6], hypoplastic nails, limited elbow supination, camptodactyly, hypertrichosis).

### Prenatal/Postnatal Growth Deficiency

This is defined as  $\leq 10$ th percentile for age (Hoyme and CDC) or  $\leq 3$ rd percentile (4-Digit Diagnostic Code) for *either* height or weight. The systems also vary in the timing of the growth problems (prenatal/at birth, or at any point in life).

### Deficient Brain Growth and Significant Structural Brain Abnormalities

Deficient brain growth is defined as an occipitofrontal head circumference (OFC)  $< 10$ th for age, abnormal morphogenesis, or abnormal neurophysiology. The criteria additionally state that if the child has weight and height  $< 10$ th percentile, then the OFC should be at or below the 3rd percentile. Structural brain abnormalities seen on brain imaging may include abnormalities of the corpus callosum, the cerebellum, or basal ganglia.

### Neurobehavioral/Neurodevelopmental Impairment

These criteria can include abnormal findings on neurologic exam or seizures, and/or functional neurobehavioral or neurodevelopmental abnormalities. There is tremendous variability in the presentation of the neurobehavioral and neurocognitive features of children with FASD due to the timing and amount of PAE and unique characteristics of the birth mother and the child. The assessment of neurobehavioral impairment is also different for children under 3 years of age than for children 3 years or older.

The degree of developmental impairment can range from relatively mild delays to severe intellectual disability, although approximately 75% of individuals with an FASD *do not* have intellectual disability. In *infants*, the symptoms can be nonspecific and may include irritability, poor feeding, sleep difficulties, a tendency to become easily overstimulated, or difficulty forming attachments with caregivers. *Young children* may demonstrate developmental delays, inattention, impulsivity, internalizing and externalizing problems, social impairments and difficulty with peers, and behavioral difficulties such as mood lability, frequent tantrums, or aggression. The neurocognitive profile of children with an FASD that emerges at *elementary or middle school age* includes challenges with processing speed, memory, visual-spatial reasoning, math, auditory comprehension, use of pragmatic language, and executive functioning skills. In *adolescents*, difficulties with abstract reasoning, time and money management, and social and adaptive skills may become more pronounced.

The most common comorbid mental health condition seen in children with an FASD is attention-deficit/hyperactivity disorder (ADHD; see Chapter 50), which occurs in  $> 50$ % of children. Individuals with FASD may also present with problems of self-regulation, impulse control, and adaptive functioning. Additional mental health disorders typically seen in children and adolescents include oppositional defiant and conduct disorder, anxiety disorder, adjustment disorder, sleep disorder, mood disorders (e.g., depression, bipolar disorder), and disinhibited social engagement disorder. FASD may increase the severity or complexity of these conditions.

### DIAGNOSTIC CRITERIA

Five diagnoses included under the FASD umbrella include the following:

1. Fetal alcohol syndrome (FAS)
2. Partial fetal alcohol syndrome (pFAS)
3. Alcohol related neurodevelopmental disorder (ARND)
4. Neurobehavioral disorder associated with prenatal alcohol exposure (ND-PAE)
5. Alcohol related birth defects (ARBD)

The previously described clinical features with or without a history PAE are used to define the disorders within the FASD spectrum (Tables 146.1-146.5). As noted earlier, the criteria do vary somewhat depending upon which diagnostic system is used.

### DIFFERENTIAL DIAGNOSIS

It is important to consider other causes of the facial features of FAS and pFAS, as each of these can be seen in certain genetic and teratogenic exposure conditions. Genetic conditions can include Williams syndrome, Dubowitz syndrome, Noonan syndrome, 22q11.2 deletion (velocardiofacial syndrome), Cornelia de Lange syndrome, chromosome 15q duplication syndrome, and others. Teratogenic exposure conditions include fetal valproate syndrome, fetal hydantoin syndrome, maternal phenylketonuria



FASD 4-Digit Diagnostic Code  
© 2014 Susan Astley, University of Washington [fasdpu.org](http://fasdpu.org)



**Fig. 146.4** University of Washington Lip-Philtrum Guides 1 (A) and 2 (B) are used to rank upper lip thinness and philtrum smoothness. The philtrum is the vertical groove between the nose and upper lip. The guides reflect the full range of lip thickness and philtrum depth with Rank 3 representing the population mean. Ranks 4 and 5 reflect the thin lip and smooth philtrum that characterize the FAS facial phenotype. Guide 1 is used for Whites and all other races with lips like Whites. Guide 2 is used for Blacks and all other races with lips like Blacks. Free digital images of these guides for use on smartphones are available from [astley@uw.edu](mailto:astley@uw.edu). (Copyright 2021 Susan (Astley) Hemingway PhD, University of Washington.)

(PKU) effects, toluene embryopathy, and others. Therefore a genetics evaluation may be warranted, especially when there is unconfirmed PAE.

The neurobehavioral issues associated with FASD can be difficult to distinguish from those of other behavioral health disorders, such as autism spectrum disorder, ADHD, intellectual disability, reactive attachment disorder, PTSD, exposure to other maternal substance use during pregnancy, and others. This is particularly the case when the FASD facial features are not present. Children who experience “adverse childhood experiences” (ACEs), such as neglect, abuse, poverty, and parental substance abuse, can have similar findings of hyperactivity, poor impulse control, emotional dysregulation, deficits in executive function, and memory weaknesses as children with FASD. Furthermore, these disorders are not mutually exclusive and more than one underlying disorder can result in the neurobehavioral issues found.

## OUTCOMES

Children with an FASD are at higher risk for victimization and bullying, often due to poor social judgment. Children and adolescents

who are not identified early and treated aggressively are significantly more likely to have secondary disabilities, including encounters with juvenile justice and incarceration, substance abuse problems, severe mental health problems, sexual promiscuity and other inappropriate sexual behaviors, high rates of school failure, dropout and under- or unemployment, health problems, and premature death. Children and adolescents with an FASD have a 95% lifetime likelihood of having a mental health diagnosis and are at higher risk for suicide. Although an FASD cannot be cured, the long-term negative effects of the brain injury caused by PAE can be reduced through aggressive, sustained intervention initiated early. Factors associated with a better outcome include early diagnosis (under age 6 years), a stable and nurturing home, lack of exposure to violence, full assessment for disabilities and adequate provision of appropriate education, therapies, and social services. Prevention of FASD and early identification and interventions for children with an FASD is essential and has become an important goal of the CDC and other organizations.



**Fig. 146.5** Characteristic hand findings that can be seen in a child with an FASD: curved fifth finger (clinodactyly) and upper palmar crease that widens after the bend and ends between the second and third fingers ("hockey stick" crease). (Courtesy Darryl Leja, NHGRI, National Institutes of Health.)



**Fig. 146.6** Ear findings that can be seen in a child with an FASD: "railroad track" appearance of ear creases. (Courtesy Darryl Leja, NHGRI, National Institutes of Health.)

## INTERVENTIONS AND TREATMENTS

Given the heterogeneity of presenting problems associated with the FASDs, interventions need to be tailored to address each individual child's or adolescent's profile of strengths and difficulties. Studies support that the most successful interventions begin early and continue across the life span, include a preventive focus, are intensive and individualized, address multiple domains of functioning, include parent education and training, and are coordinated across systems of care.

Behavioral issues seen in children with FASD can be difficult for parents to manage and can cause significant stress within the home. These children often have impaired cause-and-effect understanding and therefore may not respond to traditional behavior modification strategies. Pediatricians can help support families by providing parenting tips suggested by the CDC, such as providing a structured environment and stable routines, using simple concrete language

**Table 146.1** Diagnostic Criteria for Fetal Alcohol Syndrome

<p>ALL of the following, with or without documented prenatal alcohol exposure:</p> <p>Facial features (Hoyme system requires two or more, 4-Digit Diagnostic Code requires all three):</p> <ul style="list-style-type: none"> <li>• Palpebral fissures <math>\leq</math>10th percentile (Hoyme system) or <math>\leq</math>3rd percentile (4-Digit code)</li> <li>• Thin upper lip (ranking of 4 or 5 on racially normed Lip-Philtrum Guide*)</li> <li>• Smooth philtrum (ranking of 4 or 5 on racially normed Lip-Philtrum Guide*)</li> </ul> <p>Prenatal and/or postnatal growth deficiency:</p> <ul style="list-style-type: none"> <li>• Height and/or weight <math>\leq</math>10% for age and sex at any point of time (prenatal or postnatal)</li> <li>• Adjust for gestational age if preterm. (4-Digit Diagnostic Code puts emphasis on short stature)</li> </ul> <p>Deficient brain growth, abnormal brain formation or neurophysiology: one or more of the following:</p> <ul style="list-style-type: none"> <li>• Head circumference <math>\leq</math>10th % (Hoyme system) or <math>\leq</math>3rd percentile (4-Digit Diagnostic Code)</li> <li>• Structural brain abnormalities</li> <li>• Recurrent nonfebrile seizures with other causes excluded (Hoyme system)</li> </ul> <p>Neurobehavioral impairment:</p> <ul style="list-style-type: none"> <li>• For children &lt;3 y/o: Developmental delay <math>\geq</math>1.5 SD below the mean</li> <li>• For children 3 y/o or older (either of the following): <ul style="list-style-type: none"> <li>• Cognitive impairment: Scores <math>\geq</math>1.5 SD below mean (Hoyme) or <math>\geq</math>2 SD below mean (4-Digit Diagnostic Code) either for global abilities or for at least one neurobehavioral domain (executive function, specific learning impairment, memory impairment, or visual-spatial impairment). The Hoyme system defines impairment domain as normal or abnormal. The 4-Digit Diagnostic Code has three domains defined: normal, moderate, severe.</li> <li>• Behavioral impairment without cognitive impairment: <math>\geq</math>1.5SD below mean in self-regulation (mood or behavioral regulation), attention deficit, or impulse control.</li> </ul> </li> </ul>
--

\*The Hoyme system and the 4-Digit Diagnostic Code have different Lip-Philtrum Guides.  
SD, Standard deviation.

and lots of repetition, viewing the difficult behaviors as brain based rather than willful misbehavior, focusing on strengths, and providing an abundance of positive reinforcement. Specific programs include *Families Moving Forward* and *Parents and Children Together* teaching parents strategies designed to improve self-regulation and executive function, and decreasing child behavior problems. Children with FASD often have significant difficulties with social functioning, such as interpreting social cues and communicating in social settings. Programs such as *Children's Friendship Training* provides group-based, parent-assisted intervention that teaches social skills, which have been shown to improve standardized rating of social skills. Programs such as *Good Buddies* provide classes that address issues related to impaired social skills. Children with FASD may have decreased safety awareness, poor judgement, and impulsivity, which can place them at increased risk for unintentional injuries. A video-based intervention, *Fire and Street Safety*, was developed to address this. Children who participated showed significant improvement in safety-related knowledge and appropriate behavioral responses following the training and were also able to apply this training to real-world situations.

Young children with FASD are generally eligible for early intervention therapies (occupational therapy, physical therapy, speech therapy, and developmental instruction) and should be referred for these services as needed. Older children with an FASD often have difficulties with verbal and spatial learning, executive functioning, adaptive skills, social skills and peer relations, and mental health, which can interfere with academic performance. High rates of school failure and disruption are reported for this population. Difficulties with memory often require simplification of instructions, repetition, and patience. A home and school environment that is structured and predictable can also help to address this issue. To enhance generalizability of skills and to ensure they are encoded into memory, children with an FASD require consistent and predictable interventions, simplified directions, repeated instructions, and reduced distractions in the classroom. Classroom intervention programs such as *Cognitive Control Therapy* have been found to result in significant improvements in classroom behavior and academic achievement. Programs have also been developed that

**Table 146.2** Diagnostic Criteria for Partial Fetal Alcohol Syndrome

- WITH documented prenatal alcohol exposure (requires A and B):
  - A. Facial features (at least two of three)
  - B. Neurobehavioral impairment (same as for FAS), i.e., leaves out brain abnormalities and growth deficiency
- WITHOUT documented prenatal alcohol exposure (requires A, B, and C):
  - A. Facial features (at least two of three)
  - B. Growth deficiency OR deficient brain growth/structural brain abnormalities/recurrent seizures (at least one of these)
  - C. Neurobehavioral impairment (same as for FAS), i.e., same as FAS except it is EITHER growth deficiency OR brain growth/structural brain abnormalities/recurrent seizures (does not require both)

Note that the diagnosis of FAS and pFAS are the only FASDs that can be diagnosed in the absence of a confirmed maternal history of PAE.

FAS, Fetal alcohol syndrome; FASD, fetal alcohol spectrum disorder; pFAS, partial fetal alcohol syndrome.

**Table 146.3** Diagnostic Criteria for Alcohol-Related Neurodevelopmental Disorder

Requires A and B:

Note: *Cannot* be diagnosed definitively in children <3 yr old

- A. Documented prenatal alcohol exposure
- B. Neurobehavioral impairment:
  - WITH cognitive impairment: Global delay OR deficit in at least TWO neurobehavioral domains (executive function, specific learning impairment, memory impairment, visual-spatial impairment)
  - WITHOUT cognitive impairment: Behavioral deficit in at least TWO domains (behavioral regulation, attention, impulse control)

**Table 146.4** Diagnostic Criteria for Neurobehavioral Disorder Associated with Prenatal Alcohol Exposure

ND-PAE is a mental health disorder (rather than a medical disorder) included in the DSM-5 (2013) as a “new clarifying term” that encompasses the range of developmental disabilities associated with PAE that affect function and are not due to other conditions.

This diagnosis requires:

- ≥1 deficit in neurocognition
- ≥2 deficits in adaptive functioning (at least one in communication or social communication and interaction)
- ≥1 deficit in self-regulation
- History of maternal consumption of more than 13 alcoholic drinks in any 30-day period of the pregnancy or more than 2 alcoholic drinks in one sitting
- Onset of the disorder in childhood
- The findings cause clinically significant distress or impairment in important areas of functioning and are not better explained by other causes (medication, medical conditions, genetic disorders, or environmental neglect)

Although the diagnosis of ND-PAE overlaps with ARND, ND-PAE aims to describe the *behavioral and mental health effects* on an individual with PAE. Unlike ARND, a diagnosis of ND-PAE can be given with or without the physical characteristics of FAS (ARND does not include physical characteristics) and the diagnosis of ND-PAE can be given in addition to FAS or pFAS.

ARND, Alcohol-related neurodevelopmental disorder; DSM, *Diagnostic and Statistical Manual of Mental Disorders, Fifth Edition*; FAS, fetal alcohol syndrome; ND-PAE, neurobehavioral disorder associated with prenatal alcohol exposure; pFAS, partial fetal alcohol syndrome.

address specific areas of learning, such as *Language and Literacy Training Math Interactive Learning Experience*. A cognitive-based intervention, the *Alert Program* has been adapted to address self-regulation and executive function difficulties in children with FAS or ARND living in foster care or adoptive homes. A video game, *GoFar*, was developed by to address issues of self-regulation. An intervention that uses rehearsal training interventions has been shown to result in improvement in working memory. Children with FASD have been found to show deficits in adaptive functioning more significant than expected

**Table 146.5** Alcohol-Related Birth Defects

This diagnosis refers to a pattern of structural birth defects and other congenital abnormalities that can be characteristic of FASD.

Requires both A and B

- A. Documented prenatal alcohol exposure
- B. One or more specific major malformations found to be the result of prenatal alcohol exposure:
  - Cardiac: ASD, VSD, aberrant great vessels, conotruncal heart defects
  - Skeletal: radioulnar synostosis, vertebral segmentation defects, large joint contractures, scoliosis
  - Renal: kidney/ureteral malformations
  - Eyes: strabismus, ptosis, retinal vascular abnormalities, optic nerve hypoplasia
  - Ears: conductive or neurosensory hearing loss

ASD, Atrial septal defect; FASD, fetal alcohol spectrum disorder; VSD, ventricular septal defect.

based on their cognitive testing. Occupational therapy to address this issue can help to decrease the significant level of supervision and support required of parents and caregivers.

There are no medications that are approved specifically for FASDs, but some medications may be used for symptom management. These can include stimulants (for hyperactivity, inattention, and poor impulse control), antidepressants, neuroleptics, and anti-anxiety drugs. Children with an FASD are often treated with a higher number of drugs and at higher doses, likely because of atypical or less favorable responses. Such atypical responses may require an adjustment in medication or discontinuation. Stimulant medication use in patients with FASD is controversial but is often considered, since there is a high prevalence of ADHD-like symptoms in this population. Stimulants can lead to some improvement in hyperactivity but may be less helpful for impulsivity and attention, and the rate of efficacy in general is not as high as in idiopathic ADHD. A diagnosis in the FASD spectrum should, in fact, be considered in a child with ADHD who has an atypical response to such medications. The efficacy of non-stimulant medications used for ADHD, such as alpha-2 agonists is being studied and may be shown to be helpful. Studies are also underway for use of choline supplementation and treatment with atomoxetine (a selective norepinephrine reuptake inhibitor). Data regarding the use of SSRI (selective serotonin reuptake inhibitors) medications, antipsychotics, and mood stabilizers are limited in terms of efficacy and safety.

## THE PEDIATRICIAN/PRIMARY CARE PROVIDER'S ROLE

Pediatricians and other primary care providers need to document findings related to PAE and refer the child for a full evaluation. Indications for referral for further evaluation for FASD include confirmed history of significant PAE, concern raised by the caregiver about the possibility of FASD, all three facial features present, one or more facial features plus growth deficits, and one or more facial features along with one or more CNS abnormalities ± growth deficits. Evaluation for an FASD is best done by a multidisciplinary team that can provide a medical, genetic, and neuropsychologic assessment. This team might include a developmental behavioral pediatrician, psychologist/psychiatrist, geneticist, social worker, speech therapist, occupational therapist, physical therapist, and educational therapist/special education teacher. Evaluations by audiology and ophthalmology should be included if not already completed.

Once a diagnosis of an FASD is made, the pediatrician's/primary care providers role is important in establishing a medical home for the child that provides coordinated care between medical and mental health professionals, therapists, and educators who can help and support the child and family. The American Academy of Pediatrics (AAP) has developed an FASD toolkit (<https://www.aap.org/en-us/advocacy-and-policy/aap-health-initiatives/fetal-alcohol-spectrum-disorders-toolkit/Pages/default.aspx>) that includes a “Flow Diagram for Medical Home Evaluation of Fetal Alcohol Spectrum Disorders” to assist primary care providers in identifying children with an FASD and managing their challenges in an effort to reduce the lifelong adverse consequences.

Visit Elsevier eBooks+ at [eBooks.Elsevier.com](https://www.elsevier.com) for Bibliography.



## Chapter 147

## Infants of Diabetic Mothers

Kesi C. Yang

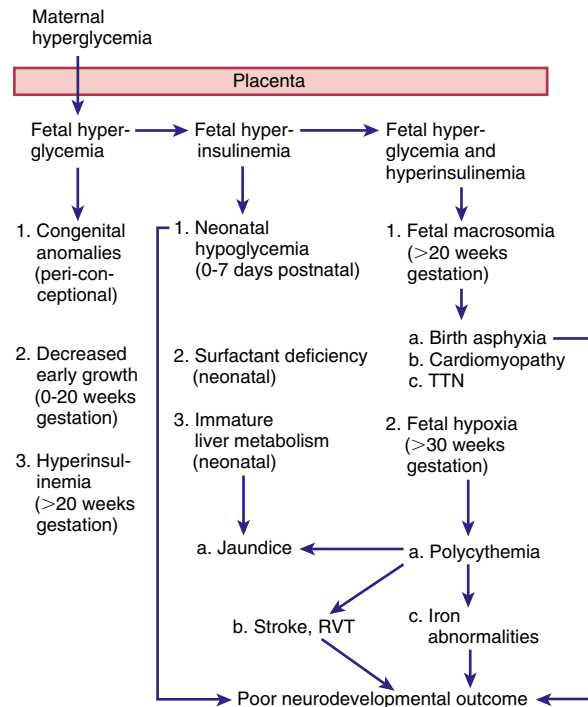
Diabetes (type 1, type 2, or gestational) in pregnancy increases the risk of complications and adverse outcomes in the mother and the baby. Complications related to diabetes are milder in gestational vs pregestational (preexisting type 1 or type 2) diabetes. Pregnancy outcomes are correlated with onset, duration, and severity of maternal hyperglycemia. Preconception planning and tight glycemic control (hemoglobin A<sub>1c</sub> [HbA<sub>1c</sub>] <6.5%) is crucial in pregestational diabetes to achieve the best outcomes for the mother and the baby. The risk of **diabetic embryopathy** (neural tube defects, cardiac defects, caudal regression syndrome) and spontaneous abortions is highest in those with pregestational diabetes who have poor control (HbA<sub>1c</sub> >7%) in the first trimester. The risk of congenital malformations in **gestational diabetes** is only slightly increased compared to the general population, because the duration of diabetes is less and hyperglycemia occurs later in gestation (typically >25 weeks).

Mothers with pregestational and gestational diabetes have a high incidence of complications during the pregnancy. Polyhydramnios, preeclampsia, preterm labor (induced and spontaneous), and chronic hypertension occur more frequently in mothers with diabetes. Accelerated fetal growth is also common, and 36–45% of **infants of diabetic mothers (IDMs)** are born large for gestational age (LGA). Restricted fetal growth is seen in mothers with pregestational diabetes and vascular disease, but it is less common. Fetal mortality rate is greater in both pregestational and gestational diabetic mothers than in nondiabetic mothers, but the rates have dropped precipitously over the years. Fetal loss throughout pregnancy is associated with poorly controlled maternal diabetes, especially **diabetic ketoacidosis**. The neonatal mortality rate of IDMs is >5 times that of infants of nondiabetic mothers and is higher at all gestational ages and in every birthweight for gestational age category. The rate is higher in women with pregestational diabetes, smoking, obesity, hypertension, and poor prenatal care.

## PATHOPHYSIOLOGY

The probable pathogenic sequence is that maternal hyperglycemia causes fetal hyperglycemia, and the fetal pancreatic response leads to fetal hyperinsulinemia, or hyperinsulinism. It is important to recognize that while maternal glucose crosses the placenta, maternal and exogenous insulin does not. Fetal hyperinsulinemia and hyperglycemia then cause increased hepatic glucose uptake and glycogen synthesis, accelerated lipogenesis, and augmented protein synthesis (Fig. 147.1). Related pathologic findings are hypertrophy and hyperplasia of the pancreatic  $\beta$  cells, increased weight of the placenta and infant organs (except the brain), myocardial hypertrophy, increased amount of cytoplasm in liver cells, and extramedullary hematopoiesis. Hyperinsulinism and hyperglycemia produce fetal acidosis, which may result in an increased rate of stillbirth. Separation of the placenta at birth suddenly interrupts glucose infusion into the neonate without a proportional effect on hyperinsulinism, leading to hypoglycemia during the first few hours after birth. The risk of rebound hypoglycemia can be diminished by tight blood glucose control during labor and delivery.

Hyperinsulinemia has been documented in infants of mothers with pregestational and gestational diabetes. The infants of mothers with *pregestational* diabetes have significantly higher fasting plasma insulin levels than normal newborns, despite similar glucose levels, and respond to glucose with an abnormally prompt elevation in plasma insulin. After arginine administration, they also have an enhanced insulin response and increased disappearance rates of glucose compared with



**Fig. 147.1** The fetal and neonatal events attributable to fetal hyperglycemia (column 1), fetal hyperinsulinemia (column 2), or both in synergy (column 3). Time of risk is denoted in parentheses. RVT, Renal vein thrombosis; TTN, transient tachypnea of the newborn. (From Nold JL, Georgieff MK. *Infants of diabetic mothers*. *Pediatr Clin North Am*. 2004;51:619–637.)

normal infants. In contrast, fasting glucose production and utilization rates are diminished in infants of mothers with *gestational* diabetes. Although hyperinsulinism is probably the main cause of hypoglycemia, the diminished epinephrine and glucagon responses that occur may be contributing factors. Infants of mothers with pregestational and gestational diabetes are at risk for neonatal hypoglycemia in the first hours of life, with an increased risk in both large- and small-for-gestational-age infants. Aggressive screening and treatment is recommended as outlined later.

## CLINICAL MANIFESTATIONS

Infants of mothers with pregestational diabetes and those of mothers with gestational diabetes often bear a surprising resemblance to each other (Fig. 147.2). They tend to be macrosomic as a result of increased body fat and enlarged viscera, with puffy, plethoric facies resembling those of patients who have been receiving corticosteroids. These infants may also be of normal birthweight if diabetes is well controlled or low birthweight if they are delivered before term or if their mothers have associated diabetic vascular disease. Infants that are macrosomic or LGA are at high risk of birth trauma (brachial plexus injury) and birth asphyxia because of not only their large size but also their decreased ability to tolerate stress, especially if they have cardiomyopathy and other effects of fetal hyperinsulinemia (Table 147.1).

**Hypoglycemia** develops in approximately 25–50% of infants of mothers with pregestational diabetes and 15–25% of infants of mothers with gestational diabetes, but only a small percentage of these infants become symptomatic. The probability that hypoglycemia will develop in such infants increases with higher cord or maternal fasting blood glucose levels. The nadir in an infant's blood glucose concentration is usually reached between 1 and 3 hours of age. Hypoglycemia can persist for 72 hours and in rare cases last up to 7 days. Frequent feedings can be used to treat the hypoglycemia, but some infants require intravenous (IV) dextrose.





**Fig. 147.2** Macrosomic, plethoric infant of a mother with gestational diabetes. The baby was born at 38 weeks of gestation but weighed 9 lb, 11 oz (4,408 g). Mild respiratory distress was the only symptom other than appearance.



**Fig. 147.3** Caudal dysplasia sequence. Newborn male infant with a normal upper body and a short lower segment. (Modified from Jones KL, Jones MC, Del Campo M, eds. *Smith's Recognizable Patterns of Human Malformation*, 8th ed. Philadelphia: Elsevier; 2022: Fig. 1, p. 897.)

**Table 147.1** Morbidity in Infants of Diabetic Mothers

Congenital anomalies
Heart failure and septal hypertrophy of heart
Surfactant deficiency, respiratory distress syndrome, transient tachypnea of the newborn, persistent pulmonary hypertension
Hyperbilirubinemia
Hypoglycemia, hypocalcemia, hypomagnesemia
Macrosomia, nerve injury related to birth trauma
Renal vein thrombosis
Small left colon
Unexplained intrauterine demise
Polycythemia
Visceromegaly
Predisposition to later-life obesity, insulin resistance, and diabetes

From Devaskar SU, Garg M. Disorders of carbohydrate metabolism in the neonate. In: Martin RJ, Fanaroff AA, Walsh MC, eds. *Fanaroff & Martin's Neonatal-Perinatal Medicine*, 10th ed. Philadelphia: Elsevier; 2015: Box 95-3.

The infants tend to be jittery, tremulous, and hyperexcitable during the first 3 days after birth, although hypotonia, lethargy, and poor feeding may also occur. Early appearance of these signs is more likely to be related to hypoglycemia but can also be caused by hypocalcemia and hypomagnesemia, which also occur in the first 24-72 hours of life due to delayed response of the parathormone system. Perinatal asphyxia is associated with increased irritability and also increases the risk of hypoglycemia, hypomagnesemia, and hypocalcemia.

**Tachypnea** develops in many IDMs during the first 2 days after birth and may be a manifestation of hypoglycemia, hypothermia, polycythemia, cardiac failure, transient tachypnea, or cerebral edema from birth trauma or asphyxia. IDMs have a higher incidence of **respiratory distress syndrome** (RDS) than do infants of nondiabetic mothers born at comparable gestational age. The greater incidence is likely related to an inhibitory effect of insulin on surfactant protein expression. **Polycythemia** often occurs with RDS as they are both a result of fetal hyperinsulinism.

**Cardiomegaly** is common, and heart failure occurs in 5–10% of IDMs. Interventricular septal hypertrophy may occur and may

manifest as **transient idiopathic hypertrophic subaortic stenosis**. This is thought to result from chronic hyperglycemia and chronic hyperinsulinism leading to glycogen loading in the heart. Inotropic agents worsen the obstruction and are contraindicated.  $\beta$ -Adrenergic blockers have been shown to relieve the obstruction, but ultimately the condition resolves spontaneously over time.

**Acute neurologic abnormalities** (lethargy, irritability, poor feeding) can be seen immediately after birth. The symptoms will resolve with treatment of the underlying cause but may persist for weeks if caused by birth asphyxia. Neurologic development and ossification centers tend to be immature and to correlate with brain size (which is not increased) and gestational age rather than total body weight in infants of mothers with gestational and pregestational diabetes. In addition, IDMs have an increased incidence of hyperbilirubinemia, polycythemia, iron deficiency, and renal vein thrombosis. Renal vein thrombosis should be suspected in the infant with a flank mass, hematuria, and thrombocytopenia.

There is a fourfold increase in **congenital anomalies** in infants of mothers with pregestational diabetes, and the risk varies with  $HbA_{1c}$  during the first trimester when organogenesis occurs. The recommended goal for periconceptual  $HbA_{1c}$  is  $<6.5\%$ . Although the risk of congenital malformations increases with increasing  $HbA_{1c}$  levels, there may still be an increased risk in the therapeutic goal range. Congenital anomalies of the central nervous system and cardiovascular system are most common, including failure of neural tube closure (encephalocele, meningomyelocele, and anencephaly), transposition of great vessels, ventricular septal defect (VSD), atrial septal defect (ASD), hypoplastic left heart, aortic stenosis, and coarctation of the aorta. Other less common anomalies include caudal regression syndrome (Fig. 147.3), intestinal atresia, renal agenesis, hydronephrosis, and cystic kidneys. **Small left colon syndrome** is a rare anomaly that develops in the second and third trimester because of rapid fluctuations in maternal and therefore fetal glucose, leading to impaired intestinal motility and subsequent intestinal growth. Prenatal ultrasound and a thorough newborn physical examination will identify most of these anomalies. High clinical

suspicion and a good prenatal history will help identify needed screening for subtle anomalies.

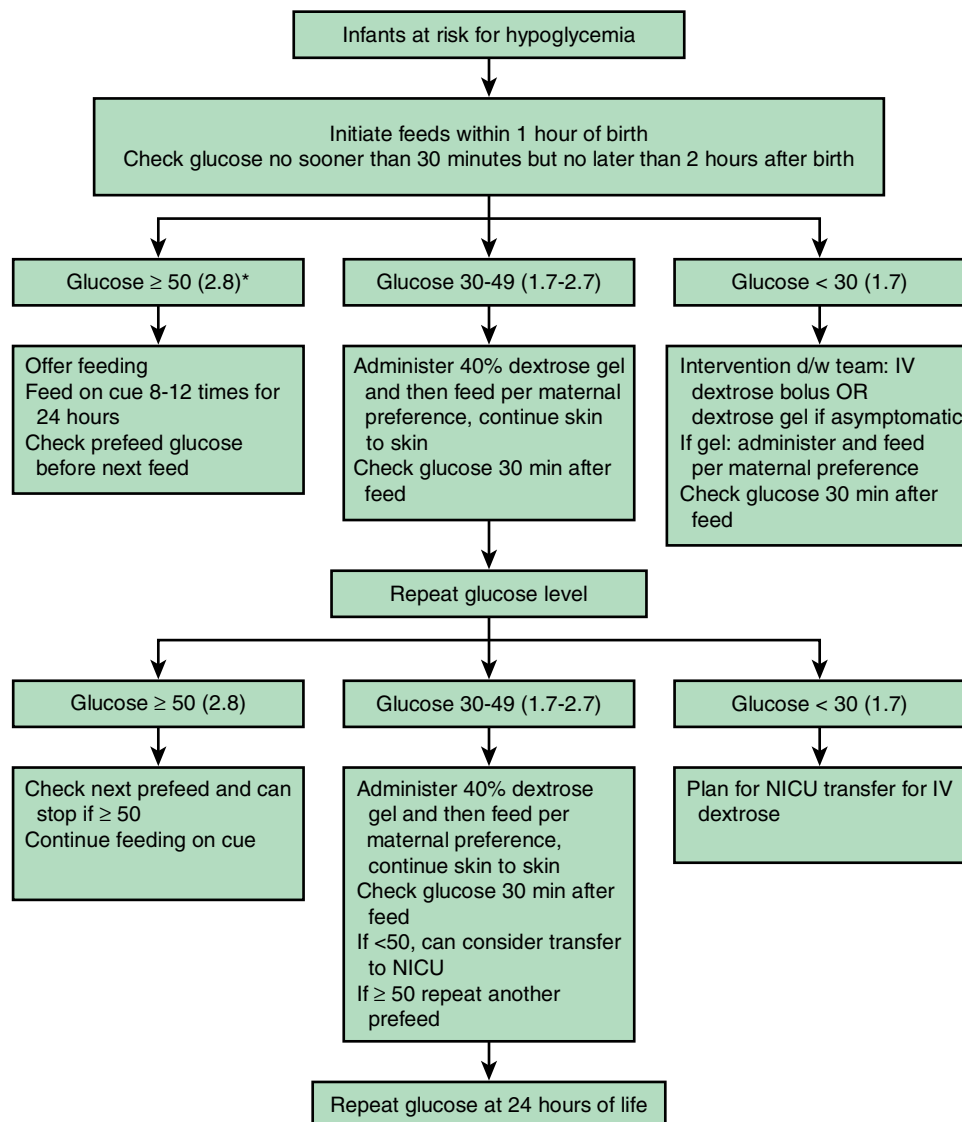
## TREATMENT

Preventive treatment of IDMs should be initiated before birth by means of preconception and frequent prenatal evaluations of all women with preexisting diabetes and pregnant women with gestational diabetes. This involves evaluation of fetal maturity, biophysical profile with non-stress testing (NST), Doppler velocimetry, and planning of the delivery of IDMs in hospitals where expert obstetric and pediatric care is continuously available. Preconception glucose control reduces the risk of anomalies and other adverse outcomes in women with pregestational diabetes, and glucose control during labor reduces the incidence of neonatal hypoglycemia. Women with type 1 diabetes who have tight glucose control during pregnancy (average daily glucose levels <95 mg/dL and HgbA<sub>1c</sub> <6.5%, if safely achievable without hypoglycemia) deliver infants with birthweight and anthropomorphic features similar to those of infants of nondiabetic mothers. Treatment of gestational diabetes (diet, glucose monitoring, insulin, and oral antihyperglycemic treatment with metformin or glyburide as needed) decreases the rate of serious perinatal outcomes (death, shoulder dystocia, bone fracture,

or nerve palsy). Continuous glucose monitoring has been increasingly used in pregnancy to achieve these purposes. In these mothers, the incidence of macrosomia and neonatal hypoglycemia is similar to that in mothers with insulin-treated gestational diabetes.

Regardless of size, IDMs should initially receive close observation and care. All infants should initiate feedings within 1 hour after birth. A screening glucose test should be performed no sooner than 30 minutes of life but no later than 2 hours and should be performed immediately in symptomatic infants. Defining precise glucose thresholds in neonates remains a challenge. The American Academy of Pediatrics (AAP) and the Pediatric Endocrine Society (PES) have both published guidelines based on observational data and expert opinion. These guidelines are adapted within individual institutions, with one example included in Figure 147.4. The AAP recommends maintaining a blood glucose level greater than 40 mg/dL (2.2 mmol/L) in the first 4 hours of life and greater than 45 mg/dL in the first 4 to 24 of life (2.5 mmol/L). In comparison, the PES recommends maintain a threshold of greater than 50 mg/dL (2.8 mmol/L) in the first 48 hours.

Feeding is the initial treatment for *asymptomatic* hypoglycemia. Oral or gavage feeding with breast milk or formula per maternal preference can be given. **Dextrose gel** has been shown to be a safe and



**Fig. 147.4** Neonatal hypoglycemia algorithm at the Hospital of the University of Pennsylvania. This was derived from institutional consensus and meant to serve as a sample management protocol as there is no defined threshold for neonatal hypoglycemia in the first day of life. IV, Intravenous; NICU, neonatal intensive care unit. \*Units are mg/dL (mmol/L).

effective adjunct to feeding and should be administered if available. Infants with *persistent* (and unresponsive to oral therapy) hypoglycemia should be treated with IV glucose (bolus followed by continuous infusion), especially if symptomatic. If question arises about an infant's ability to tolerate oral feeding, a continuous peripheral IV infusion at a rate of 4–8 mg/kg/min should be given. Neurologic symptoms of hypoglycemia *must* be treated with IV glucose. Bolus injections of hyper-tonic (25%) glucose should be avoided because they may cause further hyperinsulinemia and potentially produce rebound hypoglycemia (see [Chapter 113](#)). For treatment of hypocalcemia and hypermagnesemia, see [Chapters 121.4 and 121.5](#); for RDS treatment, see [Chapter 126](#); and for treatment of polycythemia, see [Chapter 141](#).

## PROGNOSIS

The subsequent incidence of diabetes mellitus in IDMs is higher than that in the general population because of genetic susceptibility in all types of diabetes. Infants of mothers with either pregestational diabetes or gestational diabetes are at risk for obesity and impaired glucose metabolism in later life as a result of intrauterine exposure to hyperglycemia. Disagreement persists about whether IDMs have a slightly increased risk of impaired intellectual development because of the many confounding factors (e.g., parental education, maternal age, neonatal complications). In general, the outcomes have improved over the last several decades due to increased awareness, screening, and improved prenatal care for pregnant women with diabetes.

Visit Elsevier eBooks+ at [eBooks.Health.Elsevier.com](http://eBooks.Health.Elsevier.com) for Bibliography.

## Chapter 148

# Epidemiology of Infections

Dustin D. Flannery

Neonatal infections are often classified by their timing relative to birth and include congenital, perinatal, early-onset, and late-onset disease. This categorization is clinically useful because infectious mechanisms, etiologies, and outcomes are fairly distinct for each, although there is some overlap between the different types. **Congenital infection** denotes infection acquired in utero. Such infections are often associated with injury to developing organs, depending on the timing of infection during gestation (see [Chapter 149](#)). **Perinatal infection** indicates acquisition around the time of delivery. Perinatally acquired organisms include both bacteria and viruses, some of which are the same as those causing congenital infection, but often manifest with different features. **Early-onset infection** occurs in the first 3 days after birth and is generally the consequence of infection caused by organisms acquired during the perinatal period. **Late-onset infection** occurs after 3 days and is caused by organisms that are typically acquired in the postnatal period. Notably, some studies categorize early-onset and late-onset infections as within the first 7 days of age and after 7 days, respectively, particularly for infants not continuously admitted to the hospital from birth, who are exposed to pathogens in the community.

Neonates are prone to infection for multiple reasons, namely because of their lack of fully responsive innate immunity ([Fig. 148.1](#)). Attenuated immune responses often result in minimal or nonspecific clinical manifestations, and effective treatment requires attention to subtle signs of infection and known risk factors. Compared with older infants, neonates are often treated empirically with systemic antimicrobials while awaiting results of laboratory investigations. Preterm infants are

particularly susceptible to infection because of their decreased innate immune and barrier defenses, need for invasive medical devices such as central venous catheters, and prolonged hospitalizations. The term “neonatal sepsis” typically refers to culture-confirmed infection of the blood, cerebrospinal fluid, and/or urine, though definitions vary across studies.

## INCIDENCE

Despite advances in maternal and neonatal care, infections remain a frequent and important cause of neonatal and infant morbidity and mortality. Neonatal infections are more common in areas with limited access to healthcare than in areas with a well-established healthcare infrastructure. Estimated incidence rates vary based on the case definition, geographical region, and the population studied. The overall global incidence of neonatal sepsis and other severe infections remains unknown given the lack of data from many countries, though the disease is common and often fatal. The global incidence is estimated at 2,824 cases per 100,000 live births; ~18% are fatal. For congenital infections, the incidence varies greatly depending on the specific infectious etiology and geographic region, though low- and middle-income countries have the greatest burden of disease.

The overall incidence of early-onset infection in the United States is approximately 1 per 1,000 live births and is dramatically higher among infants born preterm. The incidence varies significantly by gestational age (GA) and is highest among infants with a GA of 22 to 28 weeks (18.5 cases per 1,000 births). A 2021 report of over 84,000 very preterm infants at centers in the United States estimated the incidence of early-onset infection at 13.5 per 1,000 births; the incidence again varied substantially by GA ([Table 148.1](#)) and was highest for infants born <24 weeks (45.4 per 1,000 births). Similar to early-onset infection, late-onset infection incidence is inversely related to the degree of prematurity with significant variation across centers and geography. Among hospitalized newborns, 0.6–14% develop late-onset infection, with up to 40% of very preterm infants suffering from at least one episode.

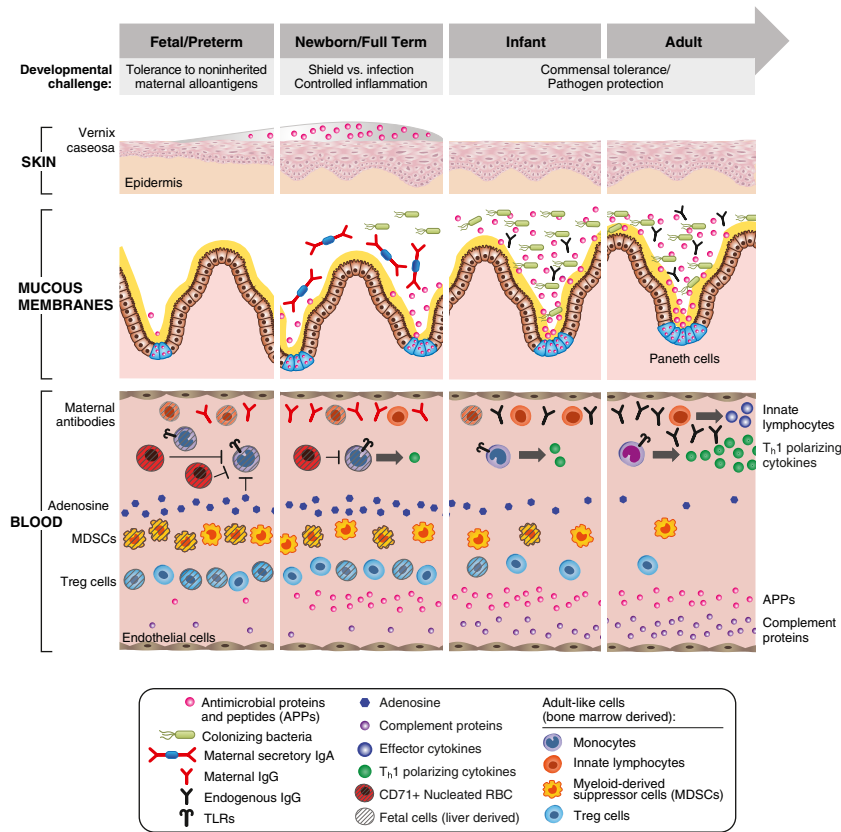
## MICROBIOLOGY

Infection microbiology is critically important to inform preventative strategies, as well as empiric and targeted antimicrobial therapies. A number of bacterial and nonbacterial pathogens can infect fetuses and newborns. Although there is overlap, pathogen types may be distinguished by timing of infection ([Table 148.2](#)).

The TORCH pneumonic, although not all-encompassing, is used to describe common causes of most often congenital or perinatal but also postnatal infection (see [Table 148.2](#)): toxoplasmosis, *Treponema pallidum* (syphilis), rubella, cytomegalovirus (CMV), herpes simplex virus (HSV), hepatitis B virus (HBV), hepatitis C virus (HCV), HIV, and other pathogens including parvovirus B19, varicella, and tuberculosis (TB). For pathogens causing congenital (prenatal), perinatal, and postnatal infection, modes of transfer include transplacental infection, exposure during labor and delivery through an infected or colonized birth canal, or from contact with an infected caretaker and/or infected breast milk (see [Chapter 149](#)). Some viral infections (e.g., CMV) can be substantial causes of disease whether acquired during gestation or acquired postpartum, whereas others (e.g., respiratory syncytial virus) are typically acquired only in the postnatal period ([Fig. 148.2](#)).

The two most common bacterial causes of **early-onset infection** are group B *Streptococcus* (GBS) and *Escherichia coli*; GBS is most common among term infants, whereas *E. coli* is the predominant pathogen among preterm infants. Approximately 30% of early-onset infections are caused by organisms other than GBS or *E. coli* (see [Table 148.2](#)). Coagulase-negative staphylococci (CONS) are the predominant cause of **late-onset infection** in hospitalized neonates, often accounting for 50–80%. Other common causes (see [Table 148.2](#)) include *Staphylococcus aureus*, gram-negative bacilli (*E. coli*, *Klebsiella* spp., *Enterobacter* spp., *Pseudomonas* spp.), and fungi (*Candida* spp.). In Asia and Africa additional pathogens cause early-onset sepsis (*Acinetobacter* spp., *Klebsiella pneumoniae*); these pathogens are often resistant to first-line antibiotics.

Microorganisms causing pneumonia acquired during labor and delivery include GBS, gram-negative enteric aerobes, *Listeria monocytogenes*,



**Fig. 148.1** Ontogeny of skin, soluble, and cellular innate defense systems. Host-protective barrier functions include physical, chemical, and functional components of the skin and mucous membrane epithelia of the fetus, neonate (birth to 28 days of age), and infant (1 month to 1 year of age). Skin: while physical and chemical barriers are impaired in early in life, especially in the preterm newborn, the vernix caseosa and skin epithelia of full-term newborns robustly express antimicrobial proteins and peptides (APPs). Mucous membranes: in parallel with and induced by an increasingly complex microbiota, the newborn intestinal mucosal epithelium rapidly changes structurally, with an increase in the population of crypts and crypt-based Paneth cells, as well as functionally with increasing APP expression. Blood: the composition of neonatal blood is distinct, with relatively low concentrations of complement components and APPs and high concentrations of the immunosuppressive purine metabolite adenosine. Plasma also contains maternal antibodies that are transferred beginning midgestation and supplemented by postnatal factors derived from breast milk. Innate immunity is detectable from the end of the first month of gestation, with changes driven largely by the increasing exposure to environmental microbes. Neonatal antigen-presenting cells such as blood monocytes express pattern recognition receptors (e.g., toll-like receptors [TLRs]) with distinct functional responses, including limited Th1-polarizing cytokine production, to most stimuli. Adaptive immunity develops from 4 weeks of gestation onward, with changes driven by an evolving chimerism reflecting fetal (liver-derived, shaded cells) regulatory T (Treg)-cell-rich lymphocytes, and more adultlike (bone marrow derived, unshaded cells) lymphocytes with distinct, epigenetically encoded functional programs. Ig, Immunoglobulin; RBC, red blood cell. (Modified from Kollmann TR, Kampmann B, Mazmanian SK, et al. Protecting the newborn and young infant from infectious diseases: lessons from immune ontogeny. *Immunity*. 2007;46:350–363.)

<b>Table 148.1</b> Incidence of Early-Onset Infection Among Very Preterm Infants	
<b>CATEGORY</b>	<b>INCIDENCE RATE PER 1,000 BIRTHS (99% CI)</b>
Overall	13.5 (12.5-14.6)
Gestational age, completed weeks	
≤23	45.4 (38.3-53.7)
24-25	26.0 (22.6-29.9)
26-27	15.5 (13.2-18.2)
28-29	10.1 (8.5-11.9)

Adapted from Flannery DD, Edwards EM, Puopolo KM, et al. Early-onset sepsis among very preterm infants. *Pediatrics*. 2021;148(4):e2021052456.

*Mycoplasma*, *Chlamydia trachomatis*, CMV, HSV, and *Candida* spp. (Table 148.3). The most common bacterial causes of neonatal meningitis are GBS, *E. coli*, *L. monocytogenes*, *Streptococcus pneumoniae*, other streptococci, *Haemophilus influenzae*, both coagulase-positive and coagulase-negative staphylococci, and other gram-negative bacilli. *Treponema pallidum* and TB infection involving the central nervous system (CNS) may also result in meningitis.

### PATHOGENESIS Early-Onset Infections

In most cases, the fetus or neonate is not exposed to potentially pathogenic bacteria until the membranes rupture and the infant passes through the birth canal and/or enters the extrauterine environment. The human birth canal is colonized with aerobic and anaerobic organisms that may result in ascending amniotic infection and/or



**Table 148.2** Most Common Pathogens Causing Neonatal Infections, Grouped by Timing of Infection

<p><b>CONGENITAL/PERINATAL</b></p> <ul style="list-style-type: none"> <li>• Toxoplasmosis</li> <li>• <i>Treponema pallidum</i> (syphilis)</li> <li>• Rubella</li> <li>• Cytomegalovirus</li> <li>• Herpes simplex virus</li> <li>• Hepatitis B and C</li> <li>• Human immunodeficiency virus</li> <li>• Varicella</li> <li>• Parvovirus B19</li> <li>• Tuberculosis</li> <li>• Zika virus</li> </ul> <p><b>EARLY-ONSET</b></p> <ul style="list-style-type: none"> <li>• Group B <i>Streptococcus</i></li> <li>• <i>Escherichia coli</i></li> <li>• <i>Haemophilus</i> species</li> <li>• <i>Staphylococcus aureus</i></li> <li>• <i>Klebsiella</i> species</li> <li>• <i>Enterococcus</i> species</li> <li>• Herpes simplex virus</li> <li>• <i>Streptococcus anginosus</i></li> <li>• <i>Listeria monocytogenes</i></li> </ul>	<ul style="list-style-type: none"> <li>• <i>Enterobacter</i> species</li> <li>• <i>Citrobacter</i> species</li> <li>• <i>Streptococcus pneumoniae</i></li> <li>• <i>Morganella morganii</i></li> <li>• <i>Pseudomonas</i> species</li> <li>• <i>Serratia</i> species</li> <li>• <i>Bacteroides</i> species</li> </ul> <p><b>LATE-ONSET</b></p> <ul style="list-style-type: none"> <li>• Coagulase-negative staphylococci</li> <li>• <i>Staphylococcus aureus</i></li> <li>• <i>Escherichia coli</i></li> <li>• <i>Candida</i> species</li> <li>• <i>Enterococcus</i> species</li> <li>• Group B <i>Streptococcus</i></li> <li>• <i>Klebsiella</i> species</li> <li>• <i>Enterobacter</i> species</li> <li>• <i>Pseudomonas</i> species</li> <li>• Respiratory syncytial virus</li> <li>• Herpes simplex virus</li> <li>• Enteroviruses</li> <li>• <i>Listeria monocytogenes</i></li> </ul>
---	--

Prenatal	Perinatal/intrapartum	Postnatal
Cytomegalovirus Zika virus Parvovirus B19 Varicella-zoster Rubella LCMV HSV HIV Parechovirus EBV HHV-6, HHV-7 Hepatitis B, C	HSV HIV Hepatitis B, C Enterovirus Varicella-zoster Cytomegalovirus Adenovirus Parechovirus	Respiratory syncytial virus Enterovirus Rotavirus Cytomegalovirus Varicella-zoster virus Hepatitis Adenovirus Influenza

**Fig. 148.2** Relative importance of neonatal viral infections related to the timing of acquisition of infection. Viruses are listed in declining order of importance relative to prenatal, perinatal (intrapartum), and postnatal timing of typical infection. Some neonatal virus infections (e.g., cytomegalovirus) can be substantial causes of disease whether acquired during gestation or acquired postpartum, whereas others (e.g., respiratory syncytial virus) are typically acquired in the postnatal period. EBV, Epstein-Barr virus; HHV, human herpesvirus; HSV, herpes simplex virus; LCMV, lymphocytic choriomeningitis virus. (From Schleiss MR, Marsh KJ. *Viral infections of the fetus and newborn*. In: Gleason CA, Juul SE, eds. *Avery's Diseases of the Newborn*. 10th ed. Philadelphia: Elsevier; 2018: Fig. 37.1.)

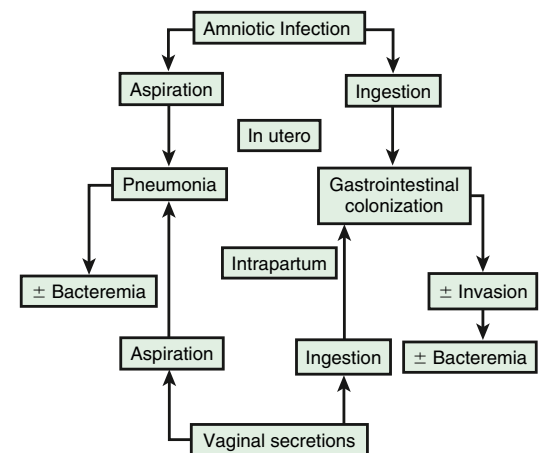
colonization of the neonate at birth. Vertical transmission of agents that infect the amniotic fluid and vaginal canal, and contamination from the gastrointestinal tract, may occur in utero or, more often, during labor and delivery (Fig. 148.3).

**Chorioamnionitis** results from microbial invasion of amniotic fluid, often as a result of prolonged rupture of the chorioamniotic membrane. Amniotic infection may also occur with apparently intact membranes or with a relatively brief duration of membrane rupture. The term *chorioamnionitis* refers to the clinical syndrome of intrauterine infection, which includes maternal fever, with or without local or systemic signs of chorioamnionitis (uterine tenderness, foul-smelling vaginal discharge/amniotic fluid, maternal leukocytosis, maternal and/or fetal tachycardia). Chorioamnionitis may also be asymptomatic, diagnosed only by amniotic fluid analysis or pathologic examination of the placenta. The rate of histologic chorioamnionitis is inversely related to GA at birth (Fig. 148.4) and directly related to duration of membrane

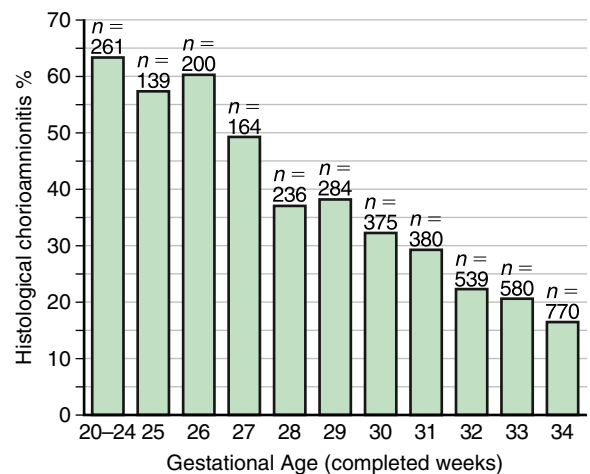
**Table 148.3** Etiologic Agents of Neonatal Pneumonia According to Timing of Acquisition

<p><b>TRANSPLACENTAL</b></p> <ul style="list-style-type: none"> <li>Cytomegalovirus (CMV)</li> <li>Herpes simplex virus (HSV)</li> <li><i>Mycobacterium tuberculosis</i></li> <li>Rubella virus</li> <li><i>Treponema pallidum</i></li> <li>Varicella-zoster virus (VZV)</li> <li><i>Listeria monocytogenes</i></li> </ul> <p><b>PERINATAL</b></p> <ul style="list-style-type: none"> <li>Anaerobic bacteria</li> <li>Chlamydia</li> <li>CMV</li> <li>Enteric bacteria</li> <li>Group B <i>Streptococci</i></li> <li><i>Haemophilus influenzae</i></li> <li>HSV</li> <li><i>Listeria monocytogenes</i></li> <li><i>Mycoplasma</i></li> </ul>	<p><b>POSTNATAL</b></p> <ul style="list-style-type: none"> <li>Adenovirus</li> <li><i>Candida</i> spp.*</li> <li>Coagulase-negative staphylococci</li> <li>CMV</li> <li>Enteric bacteria*</li> <li>Enteroviruses</li> <li>Influenza viruses A, B</li> <li>Parainfluenza</li> <li><i>Pseudomonas</i>*</li> <li>Respiratory syncytial virus (RSV)</li> <li><i>Staphylococcus aureus</i></li> <li><i>Mycobacterium tuberculosis</i></li> <li><i>Legionella</i></li> </ul>
--	--

\*More likely with mechanical ventilation or indwelling catheters, or after abdominal surgery.



**Fig. 148.3** Pathways of ascending or intrapartum infection.



**Fig. 148.4** Histologic chorioamnionitis in liveborn preterm babies by gestational age (n = 3,928 babies). (From Lahra MM, Jeffery HE. A fetal response to chorioamnionitis is associated with early survival after preterm birth. *Am J Obstet Gynecol*. 2004;190:147-151.)

rupture. Chorioamnionitis increases the risk of neonatal sepsis; however, most infants exposed to chorioamnionitis do not develop sepsis.

Chorioamnionitis was thought to result from infection of the amniotic fluid but is now better defined by the term *intrauterine inflammation* or *infection* at birth (*Triple I*). This is defined by fetal tachycardia, maternal leukocytosis (>15,000 cells in the absence of corticosteroids), purulent fluid from the cervical os, biochemical or microbiologic amniotic fluid changes consistent with infection, and fever ( $\geq 39.0^{\circ}\text{C}$ ) (see Chapter 149.2).

Bacterial colonization does not always result in fetal or neonatal disease. Factors influencing which colonized infant will experience disease are not well understood but include prematurity, underlying illness, invasive procedures, inoculum size, virulence of the infecting organism, genetic predisposition, the innate immune system, host response, and transplacental maternal antibodies (Fig. 148.5). Aspiration or ingestion of bacteria in amniotic fluid may lead to congenital pneumonia or systemic infection, with manifestations becoming apparent before delivery (fetal distress, tachycardia), at delivery (apnea, respiratory distress, shock), or after a latent period of a few hours (respiratory distress, shock). Aspiration or ingestion of bacteria during the birth process may lead to infection after an interval of 1-2 days.

Resuscitation at birth, particularly if it involves endotracheal intubation, insertion of an umbilical vessel catheter, or both, is associated with an increased risk of bacterial infection. Explanations include the presence of infection at the time of birth or acquisition of infection during the invasive procedures associated with resuscitation.

**Late-Onset Infections**

After birth, neonates are exposed to infectious agents in the hospital or in the community (including family and caretakers). Postnatal infections may be transmitted by direct contact with hospital personnel, the mother, or other caretakers; from breast milk (e.g., HIV, CMV); or from inanimate sources such as contaminated equipment or surfaces. The most common source of postnatal infections in hospitalized newborns is *hand contamination* of healthcare personnel, underscoring the importance of hand hygiene. Contaminated milk, especially powdered formula (*Cronobacter sakazakii*, *Salmonella*), equipment, other objects, or the environment are rare sources of neonatal infections but should be suspected during outbreaks of single organism disease.

Most cases of meningitis result from hematogenous dissemination. Less often, meningitis results from contiguous spread as a result of contamination of open neural tube defects, congenital sinus tracts, or

penetrating wounds from fetal scalp sampling or internal fetal electrocardiographic monitors. Cerebral abscess formation, ventriculitis, septic infarcts, hydrocephalus, and subdural effusions are complications of meningitis that occur more often in newborn infants than in older children. Metabolic factors, including hypoxia, acidosis, hypothermia, and inherited metabolic disorders (e.g., galactosemia), are likely to contribute to risk for and severity of neonatal infection.

**Infection in Premature Infants**

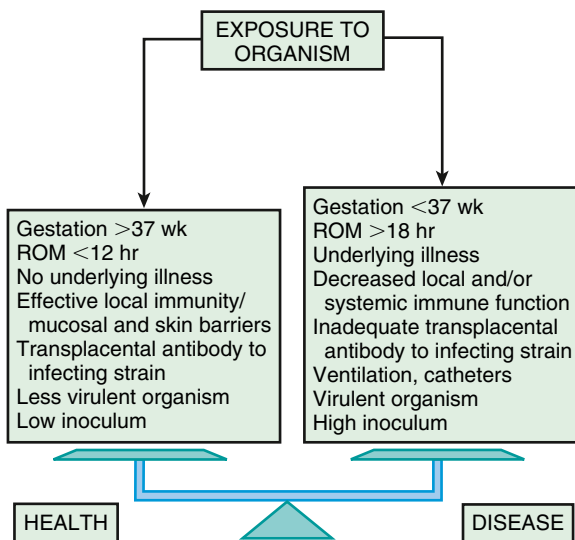
The most important neonatal factors predisposing to infection are prematurity and low birthweight. Premature infants have a 3- to 10-fold higher incidence of infection than full-term normal birthweight infants. Possible explanations include the following: (1) maternal genital tract infection is considered to be an important cause of preterm labor, with an increased risk of vertical transmission to the newborn; (2) the frequency of intraamniotic infection is inversely related to GA (see Figs. 148.1 and 148.5); (3) premature infants have documented immune dysfunction; and (4) premature infants often require prolonged intravenous access, endotracheal intubation, or other invasive procedures that provide a portal of entry or impair barrier and clearance mechanisms, putting them at continued risk for hospital-acquired infections.

**CLINICAL MANIFESTATIONS**

The maternal history and circumstances of delivery provide important information about maternal exposures to infectious diseases, bacterial colonization, immunity (natural and acquired), and obstetric risk factors (prematurity, prolonged ruptured membranes, maternal chorioamnionitis). Signs and symptoms in the neonate are often subtle and nonspecific. Temperature instability, tachypnea, lethargy, apnea, and poor feeding are common initial signs and should raise suspicion for systemic or focal infection (Table 148.4).

**Bacterial Sepsis**

Neonates with bacterial sepsis may have either nonspecific manifestations or focal signs of infection (see Table 148.4), including temperature instability, hypotension, poor perfusion with pallor and mottled skin, metabolic acidosis, tachycardia or bradycardia, apnea, respiratory distress, grunting, cyanosis, irritability, lethargy, seizures, feeding intolerance, abdominal distention, jaundice, petechiae, purpura, and bleeding. Table 148.5 lists World Health Organization *international criteria* for sepsis. The initial manifestation may involve only limited symptomatology and only one system, such as apnea alone or tachypnea with retractions, or tachycardia, or the infant may present with an acute catastrophic manifestation



**Fig. 148.5** Factors influencing the balance between health and disease in neonates exposed to a potential pathogen. ROM, Rupture of membranes. (Adapted from Baker CJ. *Group B streptococcal infections*. *Clin Perinatol* 1997;24:59–70.)

**Table 148.4** Initial Signs and Symptoms of Infection in Newborn Infants

<p><b>GENERAL</b> Fever, temperature instability Hypothermia "Not doing well" Poor feeding Edema</p>	<p><b>CARDIOVASCULAR</b> Pallor; mottling; cold, clammy skin Tachycardia Hypotension Bradycardia</p>
<p><b>GASTROINTESTINAL</b> Abdominal distention Vomiting Diarrhea Hepatomegaly</p>	<p><b>CENTRAL NERVOUS</b> Irritability, lethargy Tremors, seizures Hyporeflexia, hypotonia Abnormal Moro reflex Irregular respirations Full fontanel High-pitched cry</p>
<p><b>RESPIRATORY</b> Apnea, dyspnea Tachypnea, retractions Flaring, grunting Cyanosis</p>	<p><b>HEMATOLOGIC</b> Jaundice Splenomegaly Pallor Petechiae, purpura Bleeding</p>
<p><b>RENAL SYSTEM</b> Oliguria</p>	

**Table 148.5** Clinical Criteria for the Diagnosis of Sepsis in the International Setting: IMCI and WHO Criteria for Severe Infections in Children

- *Neurologic*: Convulsions, drowsy or unconscious, decreased activity, bulging fontanel
- *Respiratory*: Respiratory rate >60 breaths/min, grunting, severe chest indrawing, central cyanosis
- *Cardiac*: Poor perfusion, rapid and weak pulse
- *Gastrointestinal*: Jaundice, poor feeding, abdominal distention
- *Dermatologic*: Skin pustules, periumbilical erythema or purulence
- *Musculoskeletal*: Edema or erythema overlying bones or joints
- *Other*: Temperature >37.7°C (99.9°F; or feels hot) or <35.5°C (95.9°F; or feels cold)

IMCI, Integrated Management of Childhood Illness; WHO, World Health Organization. Adapted from WHO. *Pocket Book Of Hospital Care for Children: Guidelines for the Management of Common Childhood Illnesses*. 2nd ed. Geneva: WHO. 2013. p 45–69. [http://www.who.int/maternal\\_child\\_adolescent/documents/child\\_hospital\\_care/en/](http://www.who.int/maternal_child_adolescent/documents/child_hospital_care/en/).

with multiorgan dysfunction and shock. Infants should be reevaluated over time to determine whether the symptoms have progressed from mild to severe. Later complications of sepsis include respiratory failure, pulmonary hypertension, cardiac failure, shock, renal failure, liver dysfunction, cerebral edema or thrombosis, adrenal hemorrhage and/or insufficiency, bone marrow dysfunction (neutropenia, thrombocytopenia, anemia), and disseminated intravascular coagulopathy (DIC).

A variety of noninfectious conditions can occur together with neonatal infection or can make the diagnosis of infection more difficult. Respiratory distress syndrome (RDS) secondary to surfactant deficiency can mimic and/or coexist with bacterial pneumonia in premature infants. Because bacterial sepsis can be rapidly progressive, the physician must be alert to the signs and symptoms of possible infection and must initiate diagnostic evaluation and empirical therapy in a timely manner for infants at risk. The differential diagnosis of many of the signs and symptoms that suggest infection is extensive; noninfectious disorders must also be considered (Table 148.6).

### Systemic Inflammatory Response Syndrome

The clinical manifestations of infection depend on the virulence of the infecting organism and the body's inflammatory response. The term *systemic inflammatory response syndrome* (SIRS) is most frequently used to describe this unique process of infection and the subsequent systemic response (see Chapter 85). In addition to infection, SIRS may result from trauma, hemorrhagic shock, other causes of ischemia and inflammation, necrotizing enterocolitis, and pancreatitis.

Patients with SIRS have a spectrum of clinical symptoms that represent progressive stages of the pathologic process. In adults, SIRS is defined by the presence of two or more of the following: (1) fever or hypothermia, (2) tachycardia, (3) tachypnea, and (4) abnormal white blood cell (WBC) count or an increase in immature forms. In neonates and pediatric patients, SIRS manifests as temperature instability, respiratory dysfunction (altered gas exchange, hypoxemia, acute RDS), cardiac dysfunction (tachycardia, delayed capillary refill, hypotension), and perfusion abnormalities (oliguria, metabolic acidosis) (Table 148.7). Increased vascular permeability results in capillary leak into peripheral tissues and the lungs, with resultant peripheral and pulmonary edema. DIC results in the more severely affected cases. The cascade of escalating tissue injury may lead to multisystem organ failure and death.

There are neonates who appear to have sepsis or SIRS but no bacterial or viral pathogen has been recovered. Culture negative sepsis may be due to a hard-to-culture bacteria (anaerobes) or virus, as well as noninfectious inflammatory conditions. In addition, an undetected localized source with transient bacteremia (osteomyelitis), prior antibiotic treatment, and poor culture technique (too small blood sample for culture may miss bacteremia) may be responsible.

**Table 148.6** Serious Systemic Illness in Newborns: Differential Diagnosis of Neonatal Sepsis

#### CARDIAC

Congenital: hypoplastic left heart syndrome, other structural disease, persistent pulmonary hypertension of the newborn (PPHN)  
Acquired: myocarditis, hypovolemic or cardiogenic shock, PPHN

#### GASTROINTESTINAL

Necrotizing enterocolitis  
Spontaneous gastrointestinal perforation  
Midgut volvulus  
Hepatic failure (inborn errors of metabolism, neonatal iron storage disease)

#### HEMATOLOGIC

Neonatal purpura fulminans  
Immune-mediated thrombocytopenia  
Immune-mediated neutropenia  
Severe anemia  
Malignancies (congenital leukemia)  
Langerhans cell histiocytosis  
Hereditary clotting disorders  
Familial hemophagocytic lymphohistiocytosis

#### METABOLIC

Hypoglycemia  
Adrenal disorders: adrenal hemorrhage, adrenal insufficiency, congenital adrenal hyperplasia  
Inborn errors of metabolism: organic acidurias, lactic acidoses, urea cycle disorders, galactosemia

#### NEUROLOGIC

Intracranial hemorrhage: spontaneous, caused by child abuse  
Hypoxic-ischemic encephalopathy  
Neonatal seizures  
Infant botulism

#### RESPIRATORY

Respiratory distress syndrome  
Aspiration pneumonia: amniotic fluid, meconium, or gastric contents  
Lung hypoplasia  
Tracheoesophageal fistula  
Transient tachypnea of the newborn

**Table 148.7** Definitions of Systemic Inflammatory Response Syndrome (SIRS) and Sepsis in Pediatric Patients

**SIRS:** The systemic inflammatory response to a variety of clinical insults, manifested by two or more of the following conditions:  
Temperature instability <35°C (95°F) or >38.5°C (101.3°F)

Respiratory dysfunction:

- Tachypnea >2 SD above the mean for age
- Hypoxemia (PaO<sub>2</sub> <70 mm Hg on room air)

Cardiac dysfunction:

- Tachycardia >2 SD above the mean for age
- Delayed capillary refill >3 sec
- Hypotension >2 SD below the mean for age

Perfusion abnormalities:

- Oliguria (urine output <0.5 mL/kg/hr)
- Lactic acidosis (elevated plasma lactate and/or arterial pH <7.25)
- Altered mental status

**Sepsis:** The systemic inflammatory response to an infectious process

SD, Standard deviation.

From Adams-Chapman I, Stoll BJ. Systemic inflammatory response syndrome. *Semin Pediatr Infect Dis*. 2001;12:5–16.

### Temperature Instability

Fever or hypothermia may be the only initial manifestation of serious infection in newborns. However, only approximately 50% of infected newborn infants have a temperature >37.8°C (see Chapter 220). Fever in newborn infants does not always signify infection; it may be caused

by increased ambient temperature, isolette or radiant warmer malfunction, dehydration, CNS disorders, hyperthyroidism, familial dysautonomia, or ectodermal dysplasia. A single temperature elevation is infrequently associated with infection; sustained fever is more likely to be caused by infection. Most febrile infected infants have additional signs compatible with infection, although a focus of infection is not always apparent. Acute febrile illnesses occurring later in the neonatal period may be caused by urinary tract infection, meningitis, pneumonia, osteomyelitis, or gastroenteritis and viral infections (enteroviruses, others) in addition to sepsis, thus underscoring the importance of a diagnostic evaluation that includes blood culture, urine culture, lumbar puncture (LP), and other studies as indicated. Numerous pathogens may cause these late infections (see Table 148.2), including HSV, enteroviruses, respiratory syncytial virus, and bacterial organisms. In premature infants, hypothermia or temperature instability requiring increasing ambient (isolette, warmer) temperatures is more likely to accompany infection.

### Respiratory and Cardiovascular Symptoms

Early signs and symptoms of pneumonia may be nonspecific, including poor feeding, lethargy, irritability, cyanosis, temperature instability, and the overall impression that the infant is not well. Respiratory symptoms of increasing severity include grunting, tachypnea, retractions, nasal flaring, cyanosis, apnea, and progressive respiratory failure. If the infant is premature, signs of progressive respiratory distress may be *superimposed* on RDS or bronchopulmonary dysplasia (BPD). For mechanically ventilated infants, the need to increase ventilator support may indicate infection. Although a common finding in neonatal sepsis, tachycardia is nonspecific. Bradycardia may also occur. Poor perfusion and hypotension are more sensitive indicators of sepsis but tend to be late findings. In a prospective national surveillance study, 40% of neonates with sepsis required volume expansion, and 29% required vasopressor support.

Signs of pneumonia on physical examination, such as dullness to percussion, change in breath sounds, and the presence of rales or rhonchi, are very difficult to appreciate in a neonate. Radiographs of the chest may reveal new infiltrates or an effusion, but if the neonate has underlying RDS or BPD, it is very difficult to determine whether the radiographic changes represent a new process or worsening of the underlying disease.

The progression of neonatal pneumonia can be variable. Fulminant infection is most frequently associated with pyogenic organisms such as GBS (see Chapter 230). Onset may occur during the first hours or days of life, with the infant often manifesting rapidly progressive circulatory collapse and respiratory failure. With early-onset pneumonia in premature infants, the clinical course and chest radiographs may be indistinguishable from those with severe RDS, particularly for GBS pneumonia.

In contrast to the rapid progression of pneumonia caused by pyogenic organisms, an indolent course may be seen in nonbacterial infection. The onset can be preceded by upper respiratory tract symptoms or conjunctivitis. The infant may demonstrate a nonproductive cough, and the degree of respiratory compromise is variable. Fever is usually absent or low grade, and radiographic examination of the chest shows focal or diffuse interstitial pneumonitis or hyperinflation. Infection can be caused by *C. trachomatis*, CMV, *Ureaplasma urealyticum*, and other respiratory viruses. Rhinovirus has been reported to cause severe respiratory compromise in infants, particularly those who are preterm.

### Conjunctivitis

Conjunctival infection is relatively common and may be caused by a variety of organisms. The presentation includes periorbital swelling, conjunctival injection, and purulent conjunctival drainage. *C. trachomatis* and *Neisseria gonorrhoeae* are common causes; other gram-positive and gram-negative organisms are occasionally involved. *Pseudomonas aeruginosa* is an important pathogen in hospitalized preterm infants and may be a precursor to invasive disease. Viral infections (e.g., HSV, adenovirus) are occasionally seen. Recognition of

HSV infection is important to prevent corneal injury and dissemination to systemic sites.

### Skin and Soft Tissue Infection

Cutaneous manifestations of infection include omphalitis, cellulitis, mastitis, and subcutaneous abscesses. Pustules likely indicate the presence of staphylococcal infection but must be distinguished from the vesicular rash of HSV infection. Staphylococcal pustulosis results in larger, pus-filled lesions often scattered around the umbilicus, whereas HSV infection often appears as tiny vesicles in crops, often on the scalp. The presence of small, salmon-pink papules suggests *L. monocytogenes* infection. Mucocutaneous lesions suggest *Candida* spp. (see Chapter 280.1). Petechiae and purpura may be the result of systemic viral or bacterial infection. Neonatal **mastitis** is caused by *S. aureus* and in an otherwise well appearing afebrile neonate is a localized infection.

### Omphalitis

Omphalitis is a neonatal infection resulting from unhygienic care of the umbilical cord, which continues to be a problem, particularly in developing countries. The umbilical stump is colonized by bacteria from the maternal genital tract and the environment (see Chapter 144). The necrotic tissue of the umbilical cord is an excellent medium for bacterial growth. Omphalitis may remain a localized infection or may spread to the abdominal wall, the peritoneum, the umbilical or portal vessels, and the liver. Abdominal wall cellulitis or necrotizing fasciitis, with associated sepsis and a high mortality rate, may develop in infants with omphalitis. Prompt diagnosis and treatment are necessary to avoid serious complications. *S. aureus* and gram-negative organisms are common involved pathogens.

### Tetanus

Neonatal tetanus remains a serious infection in resource-limited countries (see Chapter 257). It results from unclean delivery and unhygienic management of the umbilical cord in an infant born to a mother who has not been immunized against tetanus. The surveillance case definition of neonatal tetanus requires the ability of a newborn to suck at birth and for the first few days of life, followed by an inability to suck. Neonatal tetanus typically occurs in infants 5-7 days after birth (range: 3-24 days) and is complicated by difficulty swallowing, spasms, stiffness, seizures, and death. Bronchopneumonia, presumably resulting from aspiration, is another complication and cause of death. Neonatal tetanus can be prevented by immunizing mothers before or during pregnancy and by ensuring a clean delivery, sterile cutting of the umbilical cord, and proper cord care after birth.

### LABORATORY FINDINGS

Maternal history and infant signs should guide diagnostic evaluation (Table 148.8). Additionally, signs of systemic infection in newborn infants may be unrevealing, so laboratory investigation plays a particularly important role in diagnosis. Cultures and cell counts are obtained from blood and urine. Cerebrospinal fluid (CSF) should be sent for Gram stain, routine culture, cell count with differential, and protein/glucose concentrations. Surface swabs, blood, and CSF are often obtained for HSV testing. Except for culture and directed pathogen testing, no single laboratory test is completely reliable for diagnosis of invasive infection in the newborn. CBC may demonstrate elevated or decreased WBC count, often with a shift toward more immature forms. Thrombocytopenia can be seen in systemic bacterial, fungal, or viral infection. Hyponatremia, acidosis, and other electrolyte abnormalities can be seen. Hyperbilirubinemia is nonspecific but may be an indication of systemic infection, particularly of the urine tract. Elevated serum transaminases may be a clue to systemic HSV, enterovirus, or other viral infection.

Various **serum biomarkers** have been investigated for their ability to identify infants with serious bacterial infection (SBI). An immature-to-total phagocyte count (I/T ratio) ( $\geq 0.2$ ) has the best sensitivity of the neutrophil indices for predicting neonatal sepsis. After the newborn period, serum C-reactive protein (CRP), procalcitonin, and ferritin have demonstrated reasonable sensitivity and specificity for SBI.



**Table 148.8** Evaluation of a Newborn for Infection or Sepsis**HISTORY (SPECIFIC RISK FACTORS)**

Maternal infection during gestation or at parturition (type and duration of antimicrobial therapy):  
 Urinary tract infection  
 Chorioamnionitis  
 Maternal colonization with group B *Streptococci*, *Neisseria gonorrhoeae*, herpes simplex  
 Low gestational age/birthweight  
 Multiple birth  
 Duration of membrane rupture  
 Complicated delivery  
 Fetal tachycardia (distress)  
 Age at onset (in utero, birth, early postnatal, late)  
 Location at onset (hospital, community)  
 Medical intervention:  
 Vascular access  
 Endotracheal intubation  
 Parenteral nutrition  
 Surgery

**EVIDENCE OF OTHER DISEASES\***

Congenital malformations (heart disease, neural tube defect)  
 Respiratory tract disease (respiratory distress syndrome, aspiration)  
 Necrotizing enterocolitis  
 Metabolic disease (e.g., galactosemia)

**EVIDENCE OF FOCAL OR SYSTEMIC DISEASE**

General appearance, neurologic status  
 Abnormal vital signs  
 Organ system disease  
 Feeding, stools, urine output, extremity movement

**LABORATORY STUDIES****Evidence of Infection**

Culture from a normally sterile site (blood, CSF, other)  
 Demonstration of a microorganism in tissue or fluid  
 Molecular detection (blood, urine, CSF) by specific PCR and/or 16S ribosomal DNA  
 Maternal or neonatal serology (syphilis, toxoplasmosis)

**Evidence of Inflammation**

Leukocytosis, increased immature/total neutrophil count ratio  
 Acute-phase reactants: C-reactive protein, erythrocyte sedimentation rate, procalcitonin, ferritin  
 Cytokines: interleukin-6, interleukin-B, tumor necrosis factor  
 Pleocytosis in CSF or synovial or pleural fluid  
 Disseminated intravascular coagulation: fibrin degradation products, D-dimer

**Evidence of Multiorgan System Disease**

Metabolic acidosis: pH,  $P_{CO_2}$   
 Pulmonary function:  $PO_2$ ,  $P_{CO_2}$   
 Renal function: blood urea nitrogen, creatinine  
 Hepatic injury/function: bilirubin, alanine transaminase, aspartate transaminase, ammonia, prothrombin time, partial thromboplastin time  
 Bone marrow function: neutropenia, anemia, thrombocytopenia

\*Diseases that increase the risk of infection or may overlap with signs of sepsis. CSF, Cerebrospinal fluid; PCR, polymerase chain reaction.

CRP may be monitored serially in newborn infants to assess response to therapy. Their value in the initial diagnosis of sepsis in the newborn period has yet to be clarified. The American Academy of Pediatrics (AAP) Committee on the Fetus and Newborn reiterated in a 2018 early-onset sepsis guideline update that lab tests alone should not be used to diagnose sepsis. Cytokines (both proinflammatory cytokines such as interleukin [IL]-6 and tumor necrosis factor- $\alpha$  and antiinflammatory cytokines such as IL-4 and IL-10), chemokines, and other biomarkers are increased in infected infants.

Tables 148.8 and 148.9 list clinical features and laboratory parameters that are useful in the diagnosis of neonatal infection or sepsis.

**GENERAL APPROACH TO MANAGEMENT**

In the absence of specific signs of focal infection, therapy for presumed infection in the neonate is often empirical and initiated on the basis of fever or hypothermia, listlessness, irritability, or apneic episodes. Antibiotics are chosen to cover the organisms typically causing neonatal sepsis, including GBS, gram-negative organisms, *Listeria*, and *Enterococcus*. Because the latter two organisms are intrinsically resistant to cephalosporins, ampicillin is generally included in the empirical treatment of infants with presumed neonatal infection (Table 148.10). Initiation of antibiotics within 1 hour of onset is recommended and has a survival advantage.

An empirical regimen for suspected **early-onset infection** in a term or late preterm infant includes ampicillin and gentamicin. This has long been a standard regimen for early-onset sepsis and provides coverage for the most prevalent organisms, predominantly GBS and *E. coli*. Resistance of *E. coli* to ampicillin or gentamicin has been reported; approximately 1 in 10 isolates are resistant to both ampicillin and gentamicin. Ampicillin plus cefotaxime (if available) or cefepime may be substituted if the patient presents with infection after discharge from the nursery, or when infection with resistant *E. coli* is suspected. Ceftriaxone is typically not used in the neonatal period due to precipitation with intravenous calcium and displacement of bound bilirubin causing hyperbilirubinemia. There is concern that cephalosporins may be associated with higher rates of mortality in neonates compared to ampicillin and gentamicin. Alterations to the standard regimen may be appropriate in some circumstances, such as for critically ill newborns, with illness out of proportion to degree of prematurity, at highest risk of infection given maternal risk factors and delivery characteristics.

HSV infection may present without cutaneous signs, in the absence of maternal history of infection, and in mothers receiving suppressive antiviral therapy. Therefore management of the ill newborn requires a high index of suspicion for HSV infection. Surface swabs, blood, and CSF are obtained for HSV culture or polymerase chain reaction (PCR), and empirical acyclovir is often recommended while the results of these studies are pending (see Chapters 220 and 299).

Systemic infection caused by *Candida* spp. is a concern in hospitalized infants, particularly extremely preterm infants with central venous access catheters and prior antibiotic and steroid exposure. Empirical therapy for fungal infection may be indicated for those at highest risk, as well as those with specific clinical signs such as erythematous rash, thrombocytopenia, hyperglycemia, and invasive devices.

Definitive therapy is based on identification and susceptibility of the offending organism. In almost all circumstances, the *narrowest* antibiotic with activity against the organism is chosen. Duration of therapy depends on the organism and the site of infection. In neonates with culture-proven sepsis, the usual course of therapy is typically 7–10 days. Longer treatment courses may be warranted if a specific focus of infection is identified (e.g., meningitis, osteomyelitis, septic arthritis). Antimicrobial therapy should be altered based on the susceptibility profile of the pathogen isolated. In infants with a negative blood culture but a clinical status that remains concerning for a systemic inflammation, other etiologies and potential focal sources of infection should be investigated. Sepsis is unlikely in these infants if appropriately obtained blood cultures are sterile by 48 hours.

**PREVENTION**

Intrapartum antibiotics are used to reduce vertical transmission of GBS (Table 148.11), as well as to lessen neonatal morbidity associated with preterm labor and preterm premature rupture of membranes (see Chapter 230). With introduction of selective intrapartum antibiotic prophylaxis to prevent perinatal transmission of GBS, rates of early-onset neonatal GBS infection in the United States declined from 1.7/1,000 live births to 0.25/1,000. Intrapartum chemoprophylaxis does *not* reduce the rates of late-onset GBS disease and has no effect on the rates of infection with non-GBS pathogens. Of concern is a possible increase in gram-negative infections (especially *E. coli*) despite a reduction in early GBS sepsis by intrapartum antibiotics.

**Table 148.9** Culture-Based and Non-Culture-Based Diagnostics for Neonatal Sepsis

CATEGORY	PARAMETER	OPTIMAL TIMING, VOLUME OF SPECIMEN, ROUTINE/INVESTIGATIONAL*	APPLICABILITY FOR NEONATAL SEPSIS
<b>CULTURE BASED</b>			
Blood	Culture	>1 mL of whole blood, from two sites	Gold standard for bacteremia
CSF	Culture	When clinically feasible	Gold standard for bacterial meningitis
Urine	Culture	>72 hr of life	Not useful for EOS; indicated for LOS evaluation
Tracheal aspirate	Culture	Neonates with endotracheal tube in place and signs of progressive respiratory distress	Usually reflects colonization
<b>NON-CULTURE BASED</b>			
Neutrophil indices	Neutropenia	After 12 hr of life	Neutropenia better predictor for sepsis than leukocytosis
	Absolute neutrophil count	Consider GA, delivery mode, altitude, arterial versus venous sampling, time since birth	
	Absolute immature neutrophil count		
Neutrophil markers	CD64	Elevated for 24 hr after infection Requires 50 $\mu$ L blood Results within hours Investigational	Cut points between 2.38 and 3.62 optimal sensitivity, specificity, and NPV for EOS
Platelet count	Thrombocytopenia and thrombocytosis	Late findings; slow to respond	Thrombocytopenia associated with fungal infection
CSF cell count	CSF WBC	Uninfected neonates: mean 10 cells/mm <sup>3</sup> ; range up to 20 cells/mm <sup>3</sup>	Does not predict culture-proven meningitis
CSF chemistries	CSF protein	Term <100 mg/dL	Elevated in fungal meningitis
	CSF glucose	Preterm higher; 70–80% of serum glucose	Low glucose specific for bacterial meningitis
Acute phase reactants	CRP	8–24 hr after infection	Good NPV
	Procalcitonin	2–12 hr after infection	Better sensitivity but less specificity than CRP

\*Investigational refers to an assay or parameter that is undergoing evaluation for clinical use and applicability.

CSF, Cerebrospinal fluid; EOS, early-onset sepsis; GA, gestational age; LOS, late-onset sepsis; MHC II, major histocompatibility complex class II; NPV, negative predictive value; TNF, tumor necrosis factor; WBC, white blood cell count.

From Shane AL, Stoll BJ. Recent developments and current issues in the epidemiology, diagnosis, and management of bacterial and fungal neonatal sepsis. *Am J Perinatol.* 2013;30(2):131–141.

Aggressive management of suspected maternal chorioamnionitis with antibiotic therapy during labor, along with rapid delivery of the infant, reduces the risk of early-onset neonatal sepsis. Vertical transmission of GBS and early-onset GBS disease is significantly reduced by selective intrapartum chemoprophylaxis (see Fig. 230.4) but does still occur. Neonatal infection with *Chlamydia* can be prevented by identification and treatment of infected pregnant women (see Chapter 272). Mother-to-child transmission of HIV is significantly reduced by maternal antiretroviral therapy during pregnancy, labor, and delivery, by cesarean delivery before rupture of membranes, and by antiretroviral treatment of the infant after birth (see Chapter 322).

Prevention of congenital and perinatal infections predominantly focuses on maternal health. The Centers for Disease Control and Prevention (CDC) recommends the following screening tests and treatment when indicated:

1. All pregnant women should be offered voluntary and confidential HIV testing at the first prenatal visit, as early in pregnancy as possible. HIV screening should be part of routine prenatal testing, unless the mother declines testing (opt-out screening). For women at high risk of infection during pregnancy (multiple sexual partners or STIs during pregnancy, intravenous drug use, HIV-infected partners), repeat testing in the third trimester is recommended. Rapid HIV screening is indicated for any women who presents in labor with an undocumented HIV status, unless she declines testing.
2. A serologic test for syphilis should be performed on all pregnant women at the first prenatal visit. Repeat screenings early in the third trimester and again at delivery are recommended for women in whom syphilis test results in the first trimester were positive and for those at high risk for infection during pregnancy. Infants should not be discharged from the hospital unless the syphilis

status of the mother has been determined at least once during pregnancy and preferably again at delivery.

3. Serologic testing for hepatitis B surface antigen (HBsAg) should be performed at the first prenatal visit, even if the woman has been previously vaccinated or tested. Women who were not screened prenatally, those who are at high risk for infection (multiple sexual partners, intravenous drug use, HBsAg-positive sex partner), and those with clinical hepatitis should be retested at the time of delivery.
4. A maternal genital culture for *C. trachomatis* should be performed at the first prenatal visit. Young women (<25 years) and those at increased risk for infection (new or multiple partners during pregnancy) should be retested during the third trimester.
5. A maternal culture for *N. gonorrhoeae* should be performed at the first prenatal visit. Those at high risk for infection should be retested in the third trimester.
6. All pregnant women at high risk for hepatitis C infection (intravenous drug use, blood transfusion or organ transplantation before 1992) should be screened for hepatitis C antibodies at the first prenatal visit.
7. Evidence does not support routine testing for bacterial vaginosis in pregnancy. For asymptomatic women at high risk for preterm delivery, testing may be considered. Symptomatic women should be tested and treated.
8. The CDC recommends universal screening for vaginorectal GBS colonization of all pregnant women at 36 0/7 and 37 6/7 weeks of gestation and a screening-based approach to selective intrapartum antibiotic prophylaxis against GBS (see Table 148.11) (see Figs. 230.2 and 230.3).

Visit Elsevier eBooks+ at [eBooks.Health.Elsevier.com](http://eBooks.Health.Elsevier.com) for Bibliography.

**Table 148.10** Management and Prevention of Neonatal Sepsis

CONDITION	THERAPY	ADDITIONAL CONSIDERATIONS
<b>EMPIRICAL MANAGEMENT</b>		
Early-onset sepsis	Ampicillin + aminoglycoside 10 days for bacteremia; 14 days for GBS and uncomplicated meningitis; extend to 21-28 days for complicated infections	<ul style="list-style-type: none"> <li>Consider a third-generation cephalosporin or carbapenem for meningitis or severe illness with high suspicion for gram-negative infection</li> <li>Tailor therapy to pathogen</li> <li>Should discontinue empiric therapy if pathogen not isolated</li> </ul>
Late-onset sepsis	Vancomycin or antistaphylococcal penicillin (i.e., nafcillin, oxacillin) + aminoglycoside Duration dependent on pathogen and site	<ul style="list-style-type: none"> <li>Gram-positive coverage should be based on local epidemiology, MRSA colonization, CONS risk factors, and clinical presentation</li> <li>Aminoglycoside-based regimen preferred to cephalosporin given reduced risk of resistance</li> <li>Consider cephalosporin if meningitis suspected</li> <li>Consider a carbapenem if third-generation cephalosporin recently received</li> <li>Consider amphotericin for fungal etiologies</li> <li>Tailor therapy to pathogen</li> <li>Consider discontinuation of therapy if pathogen not isolated</li> </ul>
<b>NONANTIMICROBIAL TREATMENT STRATEGIES</b>		
Recombinant G-CSF Recombinant GM-CSF	Enhance neutrophil number and function, but no reduction in infection when administered as prophylaxis or improvement in survival when administered as therapy	Insufficient evidence to support the clinical use of G-CSF or GM-CSF either as treatment or prophylaxis to prevent systemic infections
IVIG	Augments antibody-dependent cytotoxicity and improves neutrophilic function, but no evidence that IVIG in suspected or proven sepsis reduces death	Insufficient evidence from 10 RCTs or quasi-RCTs to support use in neonates with confirmed or suspected sepsis
<b>PREVENTION STRATEGIES</b>		
IAP	Administration of penicillin or ampicillin 4 hr before parturition	Successfully reduces rates of EOS caused by GBS No effect on LOS GBS
Fluconazole prophylaxis	Administration of weight-based dosing to neonates <1,500 g	Most beneficial in NICUs with high baseline rates of invasive candidiasis
BLF supplementation with a probiotic, <i>Lactobacillus rhamnosus</i> (GG)	BLF is a human milk glycoprotein with a role in innate immune response LGG enhances the activity of lactoferrin	BLF supplementation with and without LGG reduced the incidence of 1st LOS in 472 VLBW neonates in large randomized, double-blind RCT Additional confirmatory studies warranted

BLF, Bovine lactoferrin supplementation; CONS, coagulase-negative staphylococci; EOS, early-onset sepsis; GBS, group B *Streptococcus*; G-CSF, granulocyte colony-stimulating factor; GM-CSF, granulocyte-macrophage colony-stimulating factor; IAP, intrapartum antimicrobial prophylaxis; IVIG, intravenous immunoglobulin, LGG, *Lactobacillus rhamnosus* GG; LOS, late-onset sepsis; MRSA, methicillin-resistant *Staphylococcus aureus*; NICU, neonatal intensive care unit; RCTs, randomized controlled trials; VLBW, very low birthweight. Data from Carr R, Modi N, Doré C. G-CSF and GM-CSF for treating or preventing neonatal infections. *Cochrane Database Syst Rev.* 2003;(3):CD003066. Brocklehurst P, Farrell B, King A, et al. INIS Collaborative Group: Treatment of neonatal sepsis with intravenous immune globulin. *N Engl J Med.* 2011;365:1201–1211. Manzoni P, Decembrino L, Stolfi I, et al. Italian Task Force for the Study and Prevention of Neonatal Fungal Infections; Italian Society of Neonatology: Lactoferrin and prevention of late-onset sepsis in the pre-term neonates. *Early Hum Dev.* 2010;86(Suppl 1):59–61.  
From Shane AL, Stoll BJ. Recent developments and current issues in the epidemiology, diagnosis, and management of bacterial and fungal neonatal sepsis. *Am J Perinatol.* 2013;30(2):131–141.

**Table 148.11** Indications for Intrapartum Antibiotic Prophylaxis to Prevent Early-Onset Group B *Streptococcus* Disease

INTRAPARTUM GBS PROPHYLAXIS INDICATED	INTRAPARTUM GBS PROPHYLAXIS NOT INDICATED
Previous infant with invasive GBS disease	Colonization with GBS during a previous pregnancy (unless an indication for GBS prophylaxis is present for current pregnancy)
GBS bacteriuria during any trimester of the current pregnancy	GBS bacteriuria during previous pregnancy (unless another indication for GBS prophylaxis is present for current pregnancy)
Positive GBS screening culture during current pregnancy (unless a cesarean delivery is performed before onset of labor or amniotic membrane rupture)	Cesarean delivery before onset of labor or amniotic membrane rupture, regardless of GBS colonization status or gestational age
Unknown GBS status at the onset of labor (culture not done, incomplete, or results unknown) and any of the following: Delivery at <37 weeks' gestation* Amniotic membrane rupture ≥18 hr Intrapartum temperature ≥38.0°C (100.4°F)† Intrapartum NAAT‡ positive for GBS	Negative vaginal and rectal GBS screening culture in late gestation during the current pregnancy, regardless of intrapartum risk factors

\*Recommendations for the use of intrapartum antibiotics for prevention of early-onset GBS disease in the setting of threatened preterm delivery are presented in Chapter 230.

†If amnionitis is suspected, broad-spectrum antibiotic therapy that includes an agent known to be active against GBS should replace GBS prophylaxis.

‡If intrapartum NAAT is negative for GBS but any other intrapartum risk factor (delivery at <37 wk gestation, amniotic membrane rupture ≥18 hr, or temperature ≥38.0°C/100.4°F) is present, intrapartum antibiotic prophylaxis is indicated.

GBS, Group B streptococcus; NAAT, nucleic acid amplification test.

From Verani J, McGee L, Schrag S. Prevention of perinatal group B streptococcal disease—revised guidelines from CDC, 2010. *MMWR Recomm Rep.* 2010;59(RR-10):1–36.

## Chapter 149

## Congenital and Perinatal Infections

Sallie R. Permar and Emma L. Mohr

Infections are a frequent and important cause of neonatal morbidity and mortality. **Congenital** or **intrauterine** infections (i.e., those transmitted across the placenta) and **perinatal** infections (i.e., those transmitted from the mother to the fetus or newborn infant during the birth process) represent two major routes of neonatal infection.

## 149.1 Congenital Infections

Sallie R. Permar and Emma L. Mohr

In utero infections are caused by a variety of etiologic agents, including bacteria, viruses, fungi, and protozoa. Clinical manifestations of congenital infectious diseases in neonates can range from asymptomatic or subclinical to life-threatening disease. History and physical examination findings, in addition to laboratory testing and/or radiologic imaging, provide insight into the best approach for prevention and treatment of congenital infectious diseases in this immunologically immature population (see Fig. 148.2 and Table 148.2).

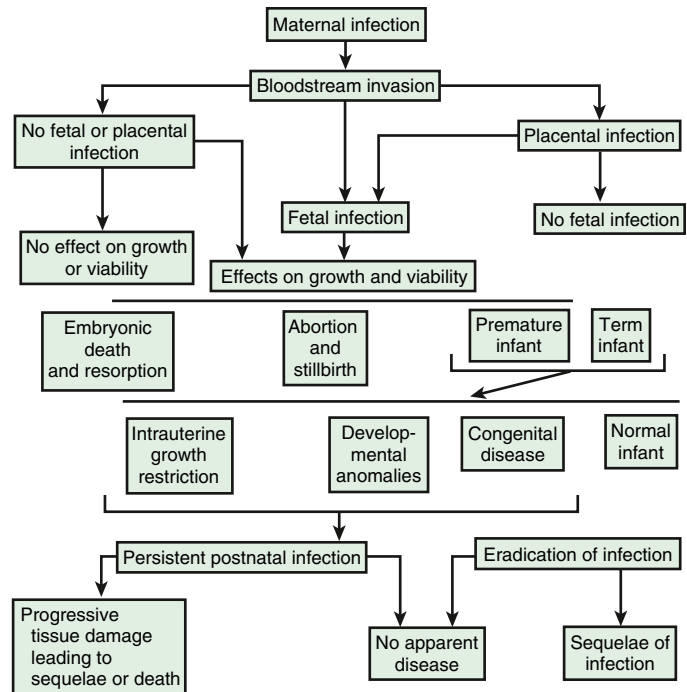
## GENERAL APPROACH

Prenatal counseling on methods to prevent congenital infections is the best approach for improving infant outcomes. Once a fetus or infant is suspected of having a congenital or perinatal infection, infectious as well as noninfectious processes, such as underlying congenital heart disease, genetic disorders, and inborn errors of metabolism, should be considered in the differential diagnosis. Because maternal infection is a prerequisite for infection in the fetus, a thorough history is essential to assess the mother for her symptoms, travel, diet, medication use, occupational exposures, and any **sexually transmitted infections (STIs)** during pregnancy. Clinical manifestations are varied and overlap for many of the pathogens causing intrauterine infection. Laboratory testing and/or radiologic imaging is often required to confirm the diagnosis. Treatment depends on the specific pathogen and can range from symptomatic management with close follow-up for long-term sequelae to targeted antimicrobial therapy.

## PATHOGENESIS

The route and timing of infection can provide helpful clues as to the potential infectious etiology (Fig. 149.1 and Table 149.1). First-trimester infection may alter embryogenesis and result in malformations of the heart and eyes, as seen in congenital rubella syndrome. Third-trimester infection (e.g., congenital toxoplasmosis) can result in active infection with signs of hepatomegaly, splenomegaly, and generalized lymphadenopathy at birth. Infections that occur late in gestation (e.g., congenital syphilis) may lead to a delay in clinical manifestations until weeks to years after birth.

Intrauterine infection from cytomegalovirus (CMV), *Treponema pallidum*, *Toxoplasma gondii*, rubella virus, varicella-zoster virus (VZV), and human parvovirus B19 may cause minimal or no symptoms in the mother but still may be transmitted across the placenta to the fetus. The presence of maternal antibodies to rubella prevents maternal infection and congenital transmission, but transmission across the placenta of CMV can occur despite preexisting immunity, albeit at a lower rate compared to primary maternal CMV infection. Regardless of the mother's immune status, the placenta may act as a



**Fig. 149.1** Pathogenesis of hematogenous transplacental infections. (Adapted from Klein JO, Remington JS. *Current concepts of infections of the fetus and newborn infant*. In: Remington JS, Klein JO, eds. *Infectious Diseases of the Fetus and Newborn Infant*, 8th ed. Philadelphia: Saunders; 2002.)

barrier, and the fetus may or may not be infected. If infection occurs, signs may or may not be noted in the fetus during pregnancy. Infection can result in spontaneous abortion, congenital malformation, intrauterine growth restriction (IUGR), premature birth, stillbirth, acute or delayed disease in the neonate, or asymptomatic persistent infection with sequelae later in life.

## PREVENTION

Prevention of congenital infections includes behavioral and therapeutic interventions. Counseling-based interventions are effective in reducing CMV infection, but few healthcare providers report counseling their patients on CMV prevention. Counseling on hygienic practices, such as washing hands after diaper changes and avoiding contact with saliva, decreases CMV transmission risk. Safer sex practices, safe food preparation practices, and preventing mosquito bites are some of the recommendations that prevent congenital and perinatal infections. Prenatal and maternal vaccination and control of existing maternal infections are other strategies of preventing congenital infection. Prevention recommendations are presented in Table 149.2.

## CLINICAL MANIFESTATIONS

The clinical manifestations of intrauterine infections can range from asymptomatic to severe multiorgan system complications. For some agents (e.g., CMV, *T. pallidum*), ongoing injury after birth can lead to late sequelae as well. The specific clinical signs in the newborn period are usually not sufficient to make a definitive diagnosis but are useful to guide more specific laboratory testing. Symptomatic congenital infections often affect the central nervous system (CNS; brain and eyes) and the reticuloendothelial system (RES; bone marrow, liver, and spleen). Table 149.3 presents the clinical manifestations of some specific congenital infections. Congenital Zika virus infection has features that are rarely seen with other congenital infections (Table 149.4). For example, no hematologic or hepatic laboratory abnormalities have been documented in infants with congenital Zika virus infection. Table 149.5 provides late sequelae of some congenital infections.



**Table 149.1** Specific Agents in Effects of Transplacental Fetal Infection on the Fetus and Newborn Infant

ORGANISM	DISEASE				
	PREMATURITY	INTRAUTERINE GROWTH RESTRICTION/LOW BIRTHWEIGHT	DEVELOPMENTAL ANOMALIES	CONGENITAL DISEASE	PERSISTENT POSTNATAL INFECTION
Viruses	CMV HSV Rubeola Smallpox HBV HIV* SARS-CoV-2 Zika	CMV Rubella VZV* HIV Zika	CMV Rubella VZV Coxsackievirus B* HIV Zika	CMV Rubella VZV HSV Mumps* Rubeola Vaccinia Smallpox Coxsackievirus B Poliovirus HBV HIV LCV Parvovirus Zika	CMV Rubella VZV HSV HBV HIV Zika
Bacteria	<i>Treponema pallidum</i> <i>Mycobacterium tuberculosis</i> <i>Listeria monocytogenes</i> <i>Campylobacter fetus</i> <i>Salmonella typhi</i>			<i>T. pallidum</i> <i>M. tuberculosis</i> <i>L. monocytogenes</i> <i>C. fetus</i> <i>S. typhi</i> <i>Borrelia burgdorferi</i>	<i>T. pallidum</i> <i>M. tuberculosis</i>
Protozoa	<i>Toxoplasma gondii</i> <i>Plasmodium*</i> <i>Trypanosoma cruzi</i>	<i>T. gondii</i> <i>Plasmodium</i> <i>T. cruzi</i>		<i>T. gondii</i> <i>Plasmodium</i> <i>T. cruzi</i>	<i>T. gondii</i> <i>Plasmodium</i>

\*Association of effect with infection has been suggested and is under consideration.

CMV, Cytomegalovirus; HBV, hepatitis B virus; HSV, herpes simplex virus; LCV, lymphocytic choriomeningitis virus; SARS-CoV-2, severe acute respiratory syndrome coronavirus 2; VZV, varicella-zoster virus.

From Maldonado YA, Nizet V, Klein JO, et al. Current concepts of infections of the fetus and newborn infant. In: Wilson CB, Nizet V, Maldonado Y, et al., eds. *Remington and Klein's Infectious Diseases of the Fetus and Newborn*, 8th ed. Philadelphia: Elsevier; 2016. Tables 1–5; and from Woodworth KR, Olsen EO, Neelam V, et al. Birth and Infant Outcomes Following Laboratory-Confirmed SARS-CoV-2 Infection in Pregnancy - SET-NET, 16 Jurisdictions, March 29-October 14, 2020. *MMWR Morb Mortal Wkly Rep* 2020;69:1635–40.

## DIAGNOSIS

### During Pregnancy

The presence of IUGR or a physical abnormality on a prenatal fetal ultrasound raises concern for a congenital infection. The well-known acronym **TORCH**—*T. gondii*, **O**ther (*T. pallidum*, human parvovirus B19, HIV, Zika virus, others), **R**ubella, **C**ytomegalovirus, and **H**erpes simplex virus (HSV)—is a historical mnemonic but is less useful given the number of other infections that need to be considered. The routine ordering of TORCH serology panels is not recommended because the presence of a pathogen-specific IgG response in the mother indicates past infection but does not establish if the infection occurred during pregnancy. Maternal IgM titers to specific pathogens are only moderately sensitive, and a negative result cannot be used to exclude infection. Testing the mother for the pathogen of concern itself, such as testing for CMV, HIV, or Zika viremia, can shed some light onto the potential congenital pathogens of concern.

In certain cases, a fetal blood sample with cordocentesis can be obtained and tested for total and pathogen-specific IgM assays, polymerase chain reaction assays (PCRs), or cultures. A positive pathogen-specific IgM test is strongly suggestive of infection, but a negative test does not rule out the organism as the cause of the fetopathy. Amniotic fluid can also be obtained and sent for PCR or culture. The presence of CMV, *T. gondii*, or human parvovirus B19 in amniotic fluid indicates the fetus likely is infected but cannot establish the severity of disease. Although HSV is included in the TORCH acronym, it is rarely isolated from amniotic fluid and is rarely transmitted across the placenta from mother to fetus. Fetal blood can be collected to test for human parvovirus B19 IgM and PCR.

### Newborn Infant

When a congenital infection is suspected because clinical signs are present at birth, a complete blood count with differential and platelet

count along with measurements of transaminases and total/direct bilirubin are routinely performed. Additional evaluations may include a dilated funduscopic examination for retinopathy, auditory brainstem response (ABR) for those failing the newborn hearing screen, and CNS imaging. If available, pathologic examination of the placenta and/or cord may be informative. Infectious diseases consultation is valuable in guiding the evaluation.

Neonatal antibody titers for specific pathogens are often difficult to interpret because IgG is acquired from the mother by transplacental passage, and a positive result may reflect the mother's past infection and not infection of the newborn. Neonatal IgM antibody titers to specific pathogens have high specificity and only moderate sensitivity; a negative result cannot be used to exclude infection. Paired maternal and fetal-neonatal IgG antibody titers showing higher or rising infant IgG antibodies can diagnose some congenital infections (e.g., syphilis). Total cord blood IgM and IgA are not actively transported across the placenta to the fetus yet are not specific or sensitive enough for intrauterine infection.

PCR testing of infant saliva, urine, and/or blood for CMV and other viral infections is sensitive, specific, and widely accepted over virus cultures, yet should be performed within the first 2 weeks of life to distinguish congenital infection from perinatal or postnatal infection. The Palo Alto Medical Foundation Toxoplasma Serology Laboratory (PAMF-TSL; Palo Alto, CA: [www.pamf.org/serology/](http://www.pamf.org/serology/); telephone: (650) 853-4828; e-mail: [remingtonlab@sutterhealth.org](mailto:remingtonlab@sutterhealth.org)) offers specialized tests and physician experts to aid in the diagnosis of congenital toxoplasmosis. Testing for Zika virus with real-time reverse-transcription PCR (rRT-PCR) from neonatal urine and serum and IgM enzyme-linked immunosorbent assay (ELISA) from neonatal serum is recommended. However, the most reliable method of testing has not been established. In endemic areas, this workup

**Table 149.2** Prevention Strategies for Congenital and Perinatal Infections

<b>PATHOGEN</b>	<b>PREVENTION STRATEGY</b>
CMV	Hygienic education to avoid direct contact with toddler urine/saliva, avoid new sexual partners
HSV	Prevention of maternal STI near delivery and exposure of newborn to active maternal lesions
VZV	Vaccination of nonpregnant women of childbearing age with a negative varicella history or vaccine immunity
Rubella virus	Vaccination of nonpregnant women of childbearing age with no immunization history
HIV	Safe sex practices; maternal treatment with HAART on infection
SARS-CoV-2	Prenatal and maternal vaccination, masking, and social distancing
Zika virus	Prevention of mosquito bites and safe sex practices with persons who have recently traveled to endemic areas
<i>Toxoplasma gondii</i>	Avoiding undercooked meat, avoiding unpasteurized goat milk, avoiding raw mollusks, avoid contact with litter or soil potentially contaminated with cat feces
<i>Treponema pallidum</i>	Safe sex practices; screening in nonpregnant populations

HSV, Herpes simplex virus; CMV, cytomegalovirus; VZV, varicella-zoster virus; SARS-CoV-2, severe acute respiratory syndrome coronavirus 2; STI, sexually transmitted infection; HAART, highly active antiretroviral therapy.

From Auriti C, De Rose DU, Santisi A, et al. Pregnancy and viral infections: Mechanisms of fetal damage, diagnosis and prevention of neonatal adverse outcomes from cytomegalovirus to SARS-CoV-2 and Zika virus. *Biochim Biophys Acta Mol Basis Dis.* 2021;1867:1–17; Maldonado YA, Read JS. American Academy of pediatrics committee on infectious diseases: diagnosis, treatment, and prevention of congenital toxoplasmosis in the United States. *Pediatrics.* 2017;139(2):e20163860; US Preventive Services Task Force: Screening for syphilis infection in pregnant women, February 2018.

should be done soon after delivery because it is difficult to distinguish congenital from perinatal and postnatal infection if testing is done later.

### SPECIFIC INFECTIOUS AGENTS

Important congenital infections include more than the TORCH agents. The following is a list of pathogens that may be transmitted across the placenta and the respective chapters where they are discussed in more detail, including treatment.

#### Bacteria

*Listeria monocytogenes* (Chapter 234)

Syphilis (*Treponema pallidum*) (Chapter 264)

#### Viruses

Cytomegalovirus (Chapter 302)

Hepatitis B (Chapter 406)

Hepatitis C (Chapter 406)

Herpes simplex virus (Chapter 299)

Human immunodeficiency virus (Chapter 322)

Human parvovirus B19 (Chapter 298)

Lymphocytic choriomeningitis virus (Chapter 318)

Rubella (Chapter 294)

Varicella-zoster virus (Chapter 300)

Zika virus (Chapter 314.12)

Parasite

Toxoplasmosis (*Toxoplasma gondii*) (Chapter 336)

## 149.2 Perinatal Infections

Sallie R. Permar and Emma L. Mohr

Perinatal infections are defined as those that are transmitted from the mother to the fetus or newborn infant during the birth process. Despite recommended universal screening of pregnant women for *Chlamydia trachomatis*, gonorrhea, and group B streptococcus (GBS), transmission to the newborn still occurs. In addition to these STIs, other bacteria, viruses, and *Candida* spp. may cause perinatal infections. Similar to congenital infections, their presentation can range from asymptomatic to a sepsis-like syndrome.

### GENERAL APPROACH

The general approach is like that for congenital infections and includes a detailed maternal history and a careful examination of the newborn (see Chapter 148). Many clinical syndromes overlap; therefore laboratory testing is usually required to establish a specific microbiologic etiology and guide management decisions.

### PATHOGENESIS

The human birth canal is colonized with aerobic and anaerobic bacteria. **Ascending amniotic infection** may occur with either apparently intact membranes or relatively brief duration of membrane rupture. Infectious agents can also be acquired as the newborn infant passes through the vaginal canal. This acquisition may result in either colonization or disease. Factors influencing which colonized infants will experience disease are not well understood but include prematurity, underlying illness, invasive procedures, inoculum size, virulence of the infecting organism, genetic predisposition, the innate immune system, host response, and transplacental maternal antibodies.

**Chorioamnionitis** has been historically used to refer to microbial invasion of the amniotic fluid, often as a result of prolonged rupture of the chorioamniotic membrane for >18 hours. The term *chorioamnionitis* is confusing because it does not convey the spectrum of inflammatory or infectious diseases, it leaves out other intrauterine components that can be involved (e.g., decidua), and it results in significant variability in clinical practice, with the potential for a significant number of well newborns being exposed to antimicrobial agents. The term **intrauterine inflammation or infection at birth**, abbreviated as **Triple I**, is preferred because of the heterogeneous nature of conditions that can affect the mother and neonate (Table 149.6). Regardless of the definition used, prematurity (<37 weeks) is associated with a greater risk of early-onset sepsis, especially with GBS.

Aspiration or ingestion of bacteria in amniotic fluid may lead to congenital pneumonia or systemic infection, with manifestations becoming apparent before delivery (fetal distress, tachycardia), at delivery (failure to breathe, respiratory distress, shock), or after a latent period of a few hours (respiratory distress, shock). Aspiration or ingestion of bacteria during the birth process may lead to infection after an interval of 1–2 days.

### CLINICAL MANIFESTATIONS

Most perinatal infections present clinically during the first month of life. Initial signs and symptoms may be either nonspecific or focal (see Chapter 148). Additional information on specific infectious agents and their management are reviewed in the chapters indicated below.

### SPECIFIC INFECTIOUS AGENTS

#### Bacteria

*Chlamydia trachomatis* (Chapter 272)

*Escherichia coli* (Chapter 246)

Genital mycoplasmas (Chapter 270)

Group B streptococci (Chapter 230)

*Neisseria gonorrhoeae* (Chapter 238)

Syphilis (*Treponema pallidum*) (Chapter 264)

RUBELLA VIRUS	CYTOMEGALOVIRUS	TOXOPLASMA GONDII	HERPES SIMPLEX VIRUS	TREPONEMA PALLIDUM	ENTEROVIRUSES	ZIKA VIRUS
Hepatosplenomegaly	Hepatosplenomegaly	Hepatosplenomegaly	Hepatosplenomegaly	Hepatosplenomegaly	Hepatosplenomegaly	Fetal brain disruption
Jaundice	Jaundice	Jaundice	Jaundice	Jaundice	Jaundice	sequence*
Pneumonitis	Pneumonitis	Pneumonitis	Pneumonitis	Pneumonitis	Pneumonitis	Cortical thinning
Petechiae	Petechiae	Petechiae	Petechiae	Petechiae	Petechiae	Ventriculomegaly
or purpura	or purpura	or purpura	or purpura	or purpura	or purpura	Microcephaly
Meningoencephalitis	Meningoencephalitis	Meningoencephalitis	Meningoencephalitis	Meningoencephalitis	Meningoencephalitis	Microphthalmia
Hydrocephalus	Hydrocephalus	Hydrocephalus*	Hydrocephalus	Adenopathy	Adenopathy	or coloboma
Adenopathy	Microcephaly*	Microcephaly	Microcephaly	Maculopapular	Maculopapular	Cataracts
Hearing deficits	Intracranial calcifications*	Maculopapular exanthems	Maculopapular exanthems	Bone lesions*	exanthems	Contractures
Myocarditis	Hearing deficits	Intracranial calcifications*	Vesicles*	Glaucoma	Myocarditis*	Hearing deficits
Congenital defects*	Chorioretinitis or retinopathy	Myocarditis	Myocarditis	Chorioretinitis or retinopathy	Conjunctivitis	Epilepsy
Bone lesions*	Optic atrophy	Bone lesions	Chorioretinitis	Uveitis	Keratoconjunctivitis	Hyper/hypotonia
Glaucoma*		Chorioretinitis or retinopathy*	Cataracts			
Chorioretinitis or retinopathy*		Cataracts	Conjunctivitis			
Cataracts*		Optic atrophy	or keratoconjunctivitis*			
Microphthalmia		Microphthalmia				
		Uveitis				
		Sensorineural hearing loss*				

\*Has diagnostic significance for this infection.

Adapted from Maldonado YA, Nizet V, Klein JO, et al. Current concepts of infections of the fetus and newborn infant. In: Wilson CB, Nizet V, Maldonado Y, et al., eds. *Remington and Klein's Infectious Diseases of the Fetus and Newborn*, 8th ed. Philadelphia: Elsevier; 2016: Tables 1–6; with data from Moore CA, Staples JE, Dobyns WB, et al. Characterizing the pattern of anomalies in congenital zika syndrome for pediatric clinicians. *JAMA Pediatr.* 2017;171(3):288–295.

ORGANISM	SIGNS
<i>Toxoplasma gondii</i>	Hydrocephalus, diffuse intracranial calcification, chorioretinitis
Rubella virus	Cardiac defects, sensorineural hearing loss, cataracts, microcephaly, “blueberry muffin” skin lesions, hepatomegaly, interstitial pneumonitis, myocarditis, disturbances in bone growth, intrauterine growth restriction
CMV	Microcephaly, periventricular calcifications, jaundice, petechiae or purpura, hepatosplenomegaly, intrauterine growth restriction, sensorineural hearing loss
HSV	Skin vesicles or scarring, eye scarring, microcephaly or hydranencephaly, vesicular skin rash, keratoconjunctivitis, meningoencephalitis, sepsis with hepatic failure
<i>Treponema pallidum</i>	Bullous, macular, or eczematous skin lesions involving palms and soles; rhinorrhea; dactylitis and other signs of osteochondritis and periostitis; hepatosplenomegaly; lymphadenopathy
VZV	Limb hypoplasia, cicatricial skin lesions, ocular abnormalities, cortical atrophy
Parvovirus B19	Nonimmune hydrops fetalis
HIV	Severe thrush, failure to thrive, recurrent bacterial infections, calcification of basal ganglia
Zika virus	Microcephaly, lissencephaly, cerebellar hypoplasia, akinesia syndrome, macular scarring, retinal mottling, subcortical calcifications, hypertonia

HSV, Herpes simplex virus; CMV, cytomegalovirus; VZV, varicella-zoster virus.

From Maldonado YA, Nizet V, Klein JO, et al. Current concepts of infections of the fetus and newborn infant. In: Wilson CB, Nizet V, Maldonado Y, et al., eds. *Remington and Klein's Infectious Diseases of the Fetus and Newborn*, 8th ed. Philadelphia: Elsevier; 2016: Tables 1–7.

CLINICAL SIGN	INFECTION				
	CMV	RUBELLA VIRUS	TOXOPLASMA GONDII	TREPONEMA PALLIDUM	ZIKA VIRUS
Hearing loss	+	+	+	+	+
Dental/skeletal problems	(–)	+	(–)	+	+
Developmental delays	+	+	+	+	+
Seizures	+	+	+	+	+

+, Present; (–), rare or absent; CMV, cytomegalovirus.

Table 149.6 Classification of Triple I and Isolated Maternal Fever	
TERMINOLOGY	FEATURES
Isolated maternal fever	Maternal oral temperature $\geq 39^{\circ}\text{C}$ is considered a “documented fever” If the oral temperature is $\geq 38^{\circ}\text{C}$ but $\leq 39^{\circ}\text{C}$ , repeat the measurement in 30 min If the repeat value is $\geq 38^{\circ}\text{C}$ , it is considered a “documented fever”
Suspected Triple I	Fever without a clear source with any of the following: 1. Baseline fetal tachycardia ( $>160$ beats/min for 10 min) 2. Maternal WBC $>15,000/\text{mm}^3$ in the absence of corticosteroids 3. Purulent fluid from the cervical os
Confirmed Triple I	All the above (from suspected Triple I) with any of the following: 1. Amniocentesis-proven infection through positive Gram stain 2. Low glucose of amniotic fluid or positive amniotic fluid culture 3. Placental pathology consistent with infection

Triple I, Intrauterine inflammation or infection at birth; WBC, white blood cell count.

Adapted from Higgins RD, Saade G; Chorioamnionitis Workshop participants: Evaluation and management of women and newborns with a maternal diagnosis of chorioamnionitis: summary of a workshop. *Obstet Gynecol* 2016;127(3):426–436.

Table 149.7 Laboratory Tests in the Diagnosis of Specific Perinatal Infections		
INFECTIOUS AGENT	ACCEPTABLE SPECIMEN(S) FROM INFANT UNLESS OTHERWISE INDICATED	LABORATORY TEST
<i>Chlamydia trachomatis</i>	Conjunctiva, nasopharyngeal swab, tracheal aspirate	DFA or culture using special transport media NAATs are not FDA-approved for specimens from neonates*
Genital mycoplasmas ( <i>Mycoplasma hominis</i> , <i>M. genitalium</i> , <i>Ureaplasma urealyticum</i> )	Tracheal aspirate, blood, CSF	Culture using special transport media NAATs
<i>Neisseria gonorrhoeae</i>	Conjunctiva, blood, CSF, synovial fluid	Finding gram-negative intracellular diplococci on Gram stain is suggestive Culture on special media establishes the diagnosis
Syphilis ( <i>Treponema pallidum</i> )	Serum (mother)  Serum CSF	A nontreponemal test (RPR or VDRL) and if reactive, a specific treponemal test <sup>†</sup> or reverse-sequence screening: specific treponemal test and if reactive, a quantitative nontreponemal test RPR/VDRL VDRL
Cytomegalovirus	Urine, saliva (with confirmational urine), blood, or CSF (if CNS involvement)	CMV DNA PCR Obtained within 3 wk of birth
Enteroviruses	Blood, nasopharyngeal swab, throat swab, conjunctival swab, tracheal aspirate, urine, stool, rectal swab, vesicle fluid, CSF	PCR Cell culture (sensitivity depends on serotype and cell lines used)
Hepatitis B	Serum (mother) Serum	HBsAg If mother’s HBsAg is positive, at age 9 mo, test the infant for HBsAg and hepatitis B surface antibody
Herpes simplex viruses 1 and 2	Conjunctiva, skin vesicle scraping, whole blood, mouth vesicles CSF “Surface cultures” (mouth, nasopharynx, conjunctiva, and anus)	PCR or cell culture  PCR PCR or cell culture
HIV	Serum (mother) Whole blood (infant)	Fourth-generation HIV antigen/antibody test HIV DNA PCR (performed on peripheral blood mononuclear cells) or RNA PCR (performed on plasma)
<i>Candida</i> species	Blood, skin biopsy, or CSF	Culture
Zika virus	Blood, urine  Blood	RNA PCR Also assay CSF for RNA if obtained for other reasons IgM antibodies Also assay CSF for IgM if obtained for other reasons
SARS-CoV-2	Nasopharynx, oropharynx, nose, saliva, trachea	RT-PCR or direct antigen testing

\*Published evaluations of NAATs for these indications are limited, but sensitivity and specificity is expected to be at least as high as those for culture.

<sup>†</sup>Treponemal tests include the *T. pallidum* particle agglutination (TP-PA) test, *T. pallidum* enzyme immunoassay (TP-EIA), *T. pallidum* chemiluminescent assay (TP-CIA), and fluorescent treponemal antibody absorption (FTA-ABS) test.

DFA, Direct immunofluorescence assay; NAAT, Nucleic acid amplification test; FDA, U.S. Food and Drug Administration; CSF, Cerebrospinal fluid; VDRL, Venereal Disease Research Laboratories; RPR, rapid plasma reagin; HBsAg, hepatitis B surface antigen; PCR, polymerase chain reaction; SARS-CoV-2, severe acute respiratory syndrome coronavirus 2; RT-PCR, reverse-transcription polymerase chain reaction.

Created with data from pathogen-specific chapters within Kimberlin DW, Barnett ED, Lynfield R, Sawyer MH, eds. *Redbook: 2021-2024 Report of the Committee on Infectious Diseases*, 32nd ed. Itasca, IL: American Academy of Pediatrics; 2018; p. 729–744.



**Viruses**

Cytomegalovirus (Chapter 302)  
Enteroviruses (Chapter 297)  
Hepatitis B (Chapter 406)  
Herpes simplex virus (Chapter 299)  
Human immunodeficiency virus (Chapter 322)  
Severe acute respiratory syndrome coronavirus 2 (Chapter 311)

**Fungi**

*Candida* spp. (Chapter 280)

**DIAGNOSIS**

The maternal history provides important information about maternal exposures to infectious diseases, bacterial colonization, immunity

(natural and acquired), and obstetric risk factors (prematurity, prolonged ruptured membranes, chorioamnionitis). STIs acquired by a pregnant woman, including syphilis, *N. gonorrhoeae*, and *C. trachomatis*, have the potential for perinatal transmission.

Neonates with perinatal infections often present with nonspecific symptoms and signs; therefore the general diagnostic evaluation for the ill neonate as discussed in Chapter 202 should be followed. Table 149.7 provides a summary of laboratory tests that are useful to diagnose specific perinatal infections.

Visit Elsevier eBooks+ at [eBooks.Health.Elsevier.com](http://eBooks.Health.Elsevier.com) for Bibliography.

Chapter 150

## Adolescent Physical and Social Development

Cynthia M. Holland-Hall and  
Maria D. Brown

Hormonally driven physiologic changes and ongoing neurologic development occur in the setting of social structures that foster the transition from childhood to adulthood. This period of development comprises **adolescence**, which is divided into three phases—early, middle, and late adolescence—each marked by a characteristic set of biologic, cognitive, and psychosocial milestones (Table 150.1). Although individual variations in the timing and pace of development undoubtedly exist, these changes follow a predictable pattern of occurrence. Gender and culture profoundly affect the developmental course, as do physical, social, and environmental influences (Fig. 150.1). Given the interaction of these domains, a biopsychosocial perspective is best suited to approach the healthcare of the adolescent.

### PHYSICAL DEVELOPMENT

**Puberty** is the biologic transition from childhood to adulthood. Pubertal changes include the appearance of the secondary sexual characteristics, increase in height, change in body composition, and development

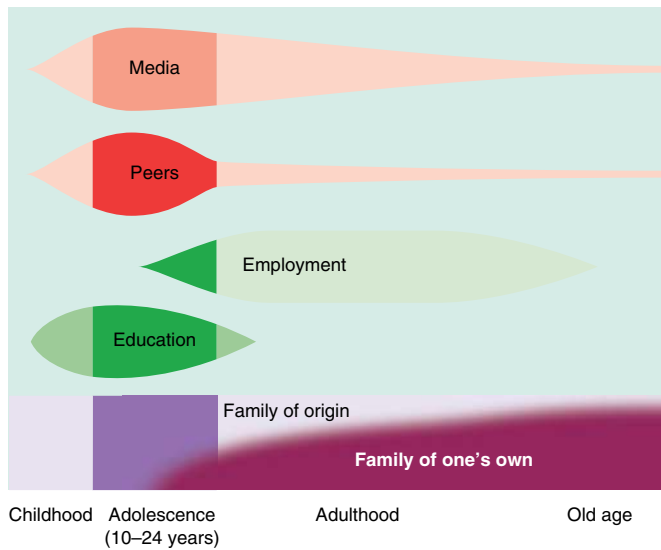
See also Part XXIV and Chapters 599 and 600.

During the preteen, teenage, and young adult years, young people undergo not only dramatic changes in physical appearance but also rapid changes in physiologic, psychological, and social functioning.

**Table 150.1** Milestones in Early, Middle, and Late Adolescent Development

VARIABLE	EARLY ADOLESCENCE	MIDDLE ADOLESCENCE	LATE ADOLESCENCE
Approximate age range	10-13yr	14-17yr	18-21yr
Sexual maturity rating*	1-2	3-5	5
Physical	<ul style="list-style-type: none"> <li>• <i>Females</i>: secondary sex characteristics (breast, pubic, axillary hair), start of growth spurt</li> <li>• <i>Males</i>: testicular enlargement, start of genital growth</li> </ul>	<ul style="list-style-type: none"> <li>• <i>Females</i>: peak growth velocity, menarche (if not already attained)</li> <li>• <i>Males</i>: growth spurt, secondary sex characteristics, nocturnal emissions, facial and body hair, voice changes</li> <li>• Change in body composition</li> <li>• Acne</li> </ul>	<ul style="list-style-type: none"> <li>• Physical maturation slows</li> <li>• Increased lean muscle mass in males</li> </ul>
Cognitive and moral	<ul style="list-style-type: none"> <li>• Concrete operations</li> <li>• Egocentricity</li> <li>• Unable to perceive long-term outcome of current decisions</li> <li>• Follow rules to avoid punishment</li> </ul>	<ul style="list-style-type: none"> <li>• Emergence of abstract thought (formal operations)</li> <li>• May perceive future implications, but may not apply in decision-making</li> <li>• Strong emotions may drive decision-making</li> <li>• Sense of invulnerability</li> <li>• Growing ability to see others' perspectives</li> </ul>	<ul style="list-style-type: none"> <li>• Future-oriented with sense of perspective</li> <li>• Idealism</li> <li>• Able to think things through independently</li> <li>• Improved impulse control</li> <li>• Improved assessment of risk vs reward</li> <li>• Able to distinguish law from morality</li> </ul>
Self-concept/identity formation	<ul style="list-style-type: none"> <li>• Preoccupied with changing body</li> <li>• Self-consciousness about appearance and attractiveness</li> </ul>	<ul style="list-style-type: none"> <li>• Concern with attractiveness</li> <li>• Increasing introspection</li> </ul>	<ul style="list-style-type: none"> <li>• More stable body image</li> <li>• Attractiveness may still be of concern</li> <li>• Consolidation of identity</li> </ul>
Family	<ul style="list-style-type: none"> <li>• Increased need for privacy</li> <li>• Exploration of boundaries of dependence vs independence</li> </ul>	<ul style="list-style-type: none"> <li>• Conflicts over control and independence</li> <li>• Struggle for greater autonomy</li> <li>• Increased separation from parents</li> </ul>	<ul style="list-style-type: none"> <li>• Emotional and physical separation from family</li> <li>• Increased autonomy</li> <li>• Reestablishment of "adult" relationship with parents</li> </ul>
Peers	<ul style="list-style-type: none"> <li>• Same-gender peer affiliations</li> </ul>	<ul style="list-style-type: none"> <li>• Intense peer group involvement</li> <li>• Preoccupation with peer culture</li> <li>• Conformity</li> </ul>	<ul style="list-style-type: none"> <li>• Peer group and values recede in importance</li> </ul>
Sexual	<ul style="list-style-type: none"> <li>• Increased interest in sexual anatomy</li> <li>• Anxieties and questions about pubertal changes</li> <li>• Limited capacity for intimacy</li> </ul>	<ul style="list-style-type: none"> <li>• Testing ability to attract partner</li> <li>• Initiation of relationships and sexual activity</li> <li>• Exploration of sexual identity</li> </ul>	<ul style="list-style-type: none"> <li>• Consolidation of sexual identity</li> <li>• Focus on intimacy and formation of stable relationships</li> <li>• Planning for future and commitment</li> </ul>

\*See text and Figures 150.2 and 150.3.



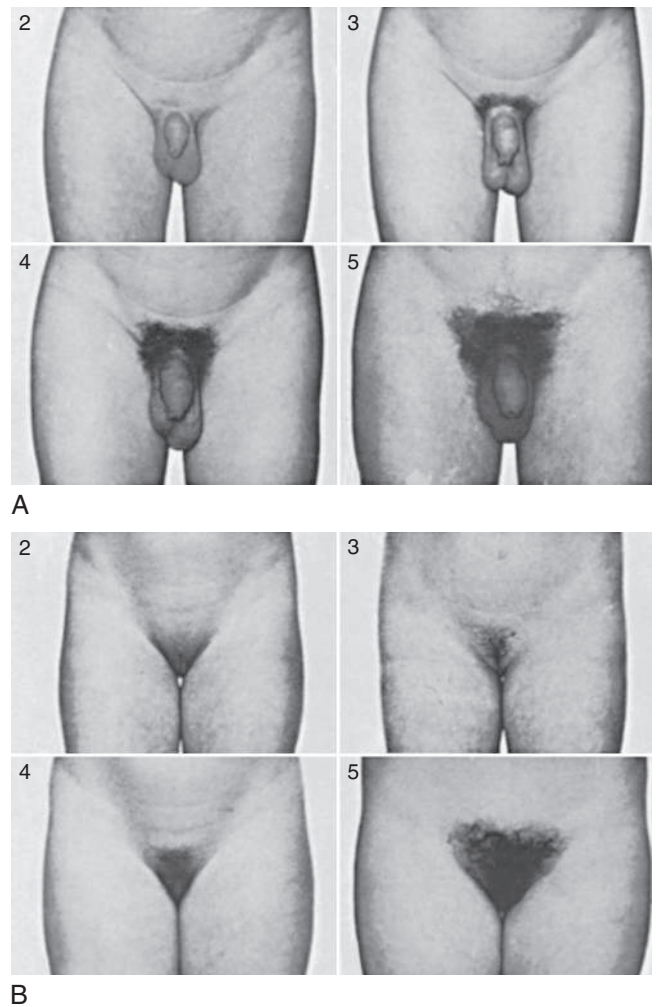
**Fig. 150.1** Changing proximal social determinants of health across the life course. During adolescence, social determinants from outside the family become greater, with major influences of peers, media, education, and the beginning of workplace influences. Community and structural determinants remain consistently influential, as shown by the background shading. (From Patton GC, Sawyer SM, Santelli JS, et al. *Our future: a Lancet commission on adolescent health and wellbeing*. *Lancet*. 2016;387:2423–2478, Fig. 2.)

of reproductive capacity. Two principal physiologic events occur during puberty: adrenarche and gonadarche. Adrenal androgen production, chiefly dehydroepiandrosterone sulfate (DHEAS), rises in response to adrenocorticotropic hormone (ACTH). Increases in serum concentrations of DHEAS result in the development of adult-like body odor and faint genital hair (**adrenarche**), occurring as early as 6–8 years of age. Gonadal sex steroid production occurs with activation of the hypothalamic-pituitary-gonadal (HPG) axis (**gonadarche**). Maturation of the gonadotropin-releasing hormone (GnRH) pulse generator is among the earliest neuroendocrine changes associated with the onset of puberty. Under the influence of GnRH, the pituitary gland secretes luteinizing hormone (LH) and follicle-stimulating hormone (FSH); initially this occurs in a pulsatile fashion primarily during sleep, but this diurnal variation diminishes throughout puberty. LH and FSH stimulate corresponding increases in gonadal androgens and estrogens. The triggers for these changes are incompletely understood. The activation of the HPG axis may be mediated by increasing adiposity and associated insulin resistance, hyperinsulinemia, elevated androgens, and leptin. Both genetic and environmental (epigenetic) factors contribute to the regulation of pubertal timing.

### Sexual Development

The progression of the development of the secondary sex characteristics may be described using the **sexual maturity rating (SMR)** scale (ranging from 1, prepubertal, to 5, fully mature adolescent) or **Tanner stages**. **Figures 150.2 and 150.3** depict the physical findings of breast and pubic hair maturation at each SMR (**Tables 150.2 and 150.3**). Although the ages at which individual pubertal changes occur may vary, the timing and sequence of these changes relative to one another is predictable (**Figs. 150.4 and 150.5**). The wide range of normal progress through sexual maturation is affected by genetics, the psychosocial environment, nutrition, and overall health status. Environmental exposures may also play a role.

In **males** the first visible sign of puberty and the hallmark of SMR 2 is testicular enlargement, beginning as early as 9.5 years, followed by the development of pubic hair. This is followed by penile growth during SMR 3. Peak growth occurs when testis volumes reach approximately 9–10 cm<sup>3</sup> during SMR 4. Under the influence of LH and testosterone, the seminiferous tubules, epididymis, seminal vesicles, and prostate

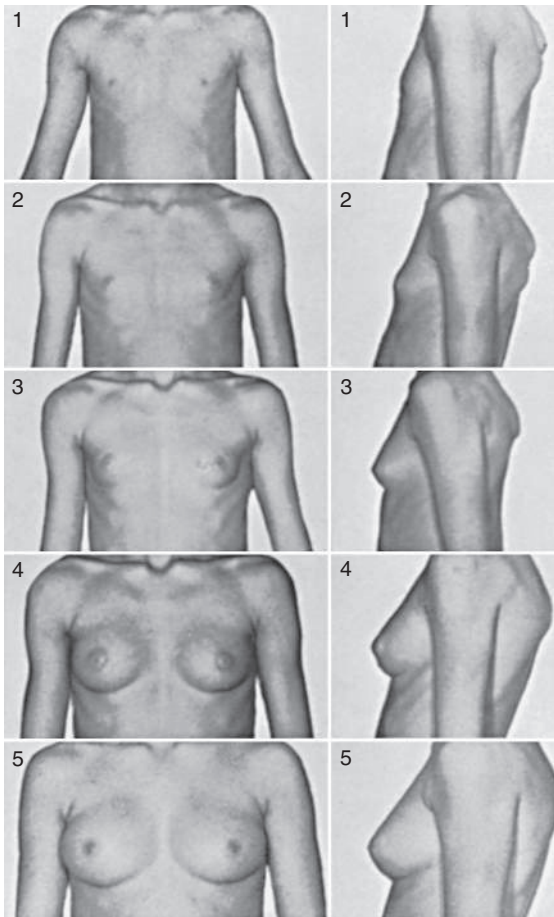


**Fig. 150.2** Sexual maturity ratings (2–5) of pubic hair changes in adolescent males (A) and females (B) (see **Tables 150.2 and 150.3**). (Courtesy J.M. Tanner, MD, Institute of Child Health, Department for Growth and Development, University of London.)

enlarge. Sperm may be found in the urine by SMR 3; nocturnal emissions may be noted at this time as well. Some degree of breast tissue growth, typically bilateral, occurs in 40–65% of males during SMR 2–4 as a presumed consequence of a relative excess of estrogenic stimulation. This usually resolves with ongoing maturation.

In **females**, typically the first visible sign of puberty and the hallmark of SMR 2 is the appearance of breast buds (**thelarche**), between 7 and 12 years of age. A significant minority of females develops pubic hair (**pubarche**) prior to thelarche. Less visible changes include enlargement of the ovaries, uterus, labia, and clitoris and thickening of the endometrium and vaginal mucosa. A clear vaginal discharge may be present before menarche (physiologic leukorrhea). Menses typically begins within 3 years of thelarche, during SMR 3–4 (average age 12.5 years; normal range 9–15 years) (see **Fig. 150.5**). The timing of **menarche** is determined largely by genetics; contributing factors likely include adiposity, chronic illness, nutritional status, and the physical and psychosocial environment. Early menstrual cycles often are anovulatory and thus somewhat irregular, but typically occur every 21–45 days and include 3–7 days of bleeding, even during the first year after menarche.

The **onset of puberty** and menarche appear to be occurring at earlier ages than previously reported in the United States (see **Chapter 599**). Several studies from 1948 to 1981 identified the average age for the onset of breast development as ranging from 10.6 to 11.2 years of age. A subsequent prospective study suggests an earlier average age of onset of 8.8 years in Black females and 9.6 years in White females. Almost 25% of Black females and 10% of White females initiate breast development



**Fig. 150.3** Sexual maturity ratings (1-5) of breast changes in adolescent females. (Courtesy J.M. Tanner, MD, Institute of Child Health, Department for Growth and Development, University of London.)

by 7 years of age. A 2020 systematic review and meta-analysis demonstrated an almost 3 months per decade decrease in age of thelarche between 1977 and 2013 worldwide. Early breast development may be associated with a slower tempo of puberty (i.e., longer time to menarche). There also appears to be a trend toward decreasing ages for the onset of pubic hair development and menarche. Data from the National Health and Nutrition Examination Survey (NHANES), a nationally representative, longitudinal survey in the United States, show a decline in the average age of menarche of 4.9 months between the 1960s and 2002. This may be partially explained by changes in the ethnic makeup of the sample. Changes in the timing of menarche *within* ethnic groups were significantly smaller. The reasons for the larger decrease in age for breast development have been postulated to include the epidemic of childhood obesity and exposure to estrogen-like environmental agents (endocrine disruptors), but further research in this area is needed.

Although fewer data are available on changes in the timing of puberty in males, they appear to be experiencing a similar trend. Although the method of assessing the onset of puberty (i.e., inspection vs palpation of the testes) varies between studies, it appears that the average age for the onset of genital and pubic hair development may have decreased by 1-2 years over the past several decades in many industrialized countries. Evidence for an association of obesity with the timing of puberty in males has been inconsistent.

**Somatic Growth**

Linear growth acceleration begins in early adolescence for all genders, with 15–20% of adult height accrued during puberty. Females attain a **peak height velocity (PHV)** of 8-9 cm/year at SMR 2-3, approximately 6 months before menarche. Males typically begin their growth acceleration at a later SMR stage and achieve a PHV of 9-10 cm/year later in the course of puberty (SMR 3-4). Males continue their linear growth for approximately 2-3 years after females have stopped growing, accounting for an average difference of 11-13 cm in height between adult males and females (Fig. 150.6). The growth spurt begins distally, with enlargement of the hands and feet, followed by the arms and legs, and finally the trunk and chest. This growth pattern imparts a characteristic “awkward” appearance to some early adolescents. Body

**Table 150.2** Sexual Maturity Rating (SMR) Stages in Females

SMR STAGE	PUBIC HAIR	BREASTS
1	Preadolescent	Preadolescent
2	Sparse, lightly pigmented, straight, medial border of labia	Breast and papilla elevated as small mound; diameter of areola increased
3	Darker, beginning to curl, increased amount	Breast and areola enlarged, no contour separation
4	Coarse, curly, abundant, but less than in adult	Areola and papilla form secondary mound
5	Adult feminine triangle, spread to medial surface of thighs	Mature, nipple projects, areola part of general breast contour

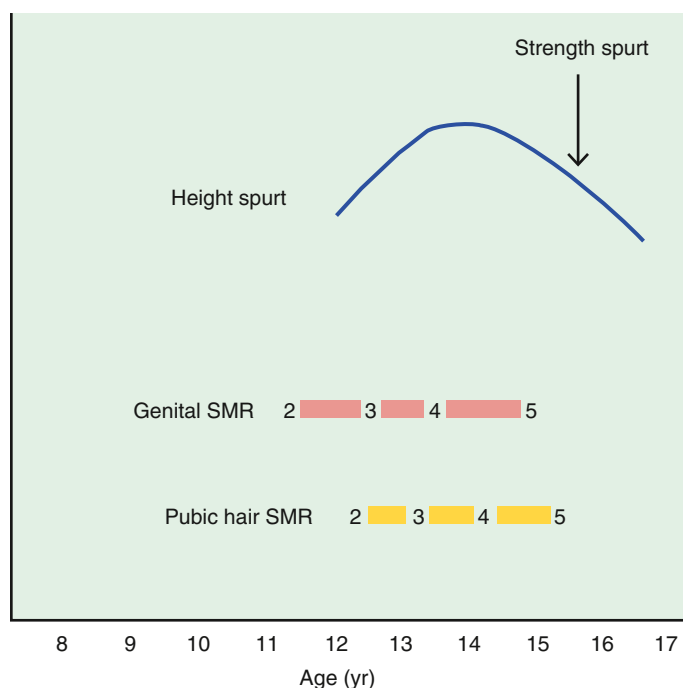
From Tanner JM. *Growth at Adolescence*, 2nd ed. Oxford, England: Blackwell Scientific; 1962.

**Table 150.3** Sexual Maturity Rating (SMR) Stages in Males

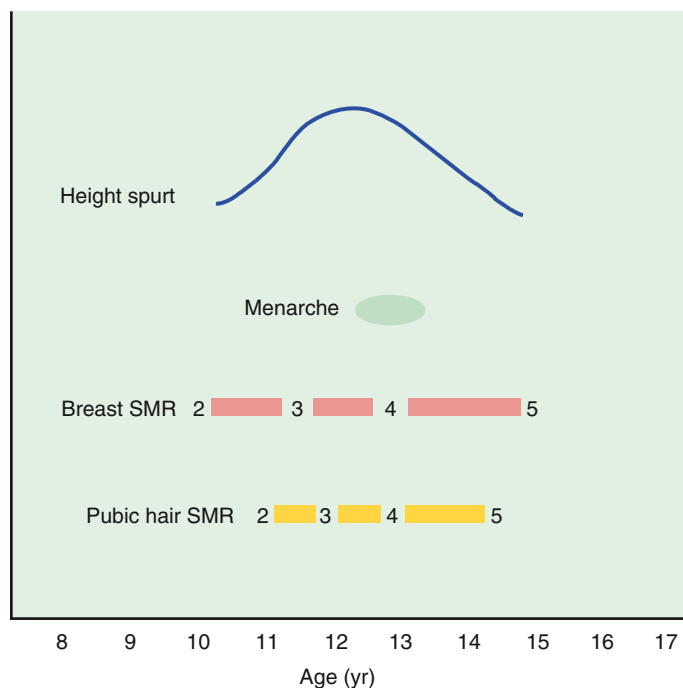
SMR STAGE	PUBIC HAIR	PENIS	TESTES
1	None	Preadolescent	Preadolescent
2	Scant, long, slightly pigmented	Minimal change/enlargement	Enlarged scrotum, pink, texture altered
3	Darker, starting to curl, small amount	Lengthens	Larger
4	Resembles adult type, but less quantity; coarse, curly	Larger; glans and breadth increase in size	Larger, scrotum dark
5	Adult distribution, spread to medial surface of thighs	Adult size	Adult size

From Tanner JM. *Growth at Adolescence*, 2nd ed. Oxford, England: Blackwell Scientific; 1962.



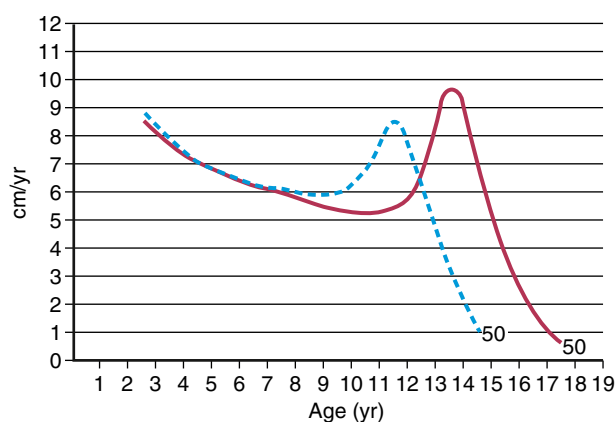


**Fig. 150.4** Sequence of pubertal events in males. Although the age of onset of puberty is variable, the sequence of events relative to one another is predictable. SMR, Sexual maturity rating.



**Fig. 150.5** Sequence of pubertal events in females. Although the age of onset of puberty is variable, the sequence of events relative to one another is predictable. SMR, Sexual maturity rating.

composition changes as well after attainment of PHV. Males undergo an increase in lean body mass (“strength spurt”), whereas females develop a higher proportion of body fat. Scoliosis, if present, may progress with rapid axial skeleton growth (see Chapter 720.1). From 50% to 65% of total body calcium is laid down during puberty. Bone growth precedes increases in bone mineralization and bone density, which may increase the adolescent’s risk of fracture during times of rapid growth.



**Fig. 150.6** Height velocity curves for American males (solid line) and females (dashed line) who have their peak height velocity at the average age (i.e., average growth tempo). (From Tanner JM, Davies PSW. *Clinical longitudinal standards for height and height velocity for North American children*. *J Pediatr*. 1985;107:317.)

Because skeletal growth precedes muscle and tendon growth, sprains and strains may be more common during this time as well.

Cardiovascular changes in middle adolescence include increased heart size, higher blood pressure, and increases in blood volume and hematocrit, particularly in males. Coupled with an increase in lung vital capacity, these changes lead to greater aerobic capacity. Androgenic stimulation of sebaceous and apocrine glands may result in acne and body odor. Rapid enlargement of the larynx, pharynx, and lungs leads to changes in vocal quality in males, typically preceded by vocal instability (voice cracking). Elongation of the optic globe may result in the development of myopia (see Chapter 660). Dental changes include jaw growth, loss of the final deciduous teeth, and eruption of the permanent cuspids, premolars, and finally, molars (see Chapter 353). Orthodontic appliances may be needed, secondary to growth exacerbations of bite disturbances. Physiologic changes in sleep patterns and increased sleep requirements occur, causing many adolescents to delay sleep onset at night, with subsequent difficulty awakening for early school start times in the morning (see Chapter 31). The mechanism of delayed circadian rhythm has not been elucidated but likely involves changes in both circadian and homeostatic sleep regulatory processes.

## NEUROLOGIC, COGNITIVE, AND MORAL DEVELOPMENT

As children progress through adolescence, they develop and refine their ability to use formal operational thought processes. Abstract, symbolic, and hypothetical thinking replaces the need to manipulate concrete objects. Middle and late adolescents develop the ability to consider multiple options and to assess the long-term consequences of their actions. The capacity for verbal expression is enhanced. Because adolescents’ decision-making and subsequent behaviors are the primary determinants of their mortality and morbidity, understanding these cognitive processes is of critical importance.

Both structural and functional brain development continue throughout adolescence. Cortical gray matter volume peaks in preadolescence, then decreases because of selective “pruning” of rarely used synaptic connections, slowly declining as the third decade of life is approached. Cerebral white matter volume increases until mid-to-late adolescence, reflecting increasing myelination and subsequent facilitation of integrated brain activity and more efficient transmission of information between different regions of the brain, enhancing the “signal-to-noise” ratio. Although the frontal lobes and prefrontal cortex, regions of the brain associated with executive function, have been considered to be among the last regions to mature, other cortical regions show similarly prolonged trajectories of maturation. Without question, adolescents are capable of the complex cognitive processes attributed to frontal lobe function. *Cognitive control*, however, continues to improve into adulthood, with progressive maturation and *integration* of component

processes such as working memory, inhibition and impulse control, performance monitoring, and motivational circuitry.

The behavioral correlates of adolescent neurodevelopment remain speculative but are increasingly supported by a rapidly expanding body of research. Adolescents appear to demonstrate a unique sensitivity to the effects of dopamine on reward-relevant subcortical structures such as the ventral striatum and the ventral tegmental area, with some studies demonstrating increased activation in this region when receiving rewards relative to children or adults. Other studies show reduced responsiveness to aversive stimuli in adolescents. This altered responsiveness to risk vs reward, paired with incomplete frontal lobe myelination and thus immature impulse control, may underlie the increased risk taking and novelty seeking seen in adolescents. Early maturation and distinct patterns of neural reactivity in the amygdala and other limbic structures may explain the strong role that social and emotional stimuli play in adolescents, sometimes overwhelming the frontal executive function systems that facilitate the interpretation and regulation of those social and emotional experiences. This may explain why adolescents are more likely to make poor decisions in highly emotionally charged situations relative to mature adults. These “hot cognition” processes may result in the adolescent making a different decision in the context of a strong affective experience than he or she would in a less emotional state (“cool cognition”). These two types of cognitive processes may not develop at the same rate; the adolescent may be able to use higher brain structures and functions more effectively when in states of lower emotional arousal.

**Early adolescents** often continue to employ the concrete operational cognitive processes of childhood. Although formal operational cognition is developing, it may be applied inconsistently across different domains. A young adolescent may be able to use abstract thought when completing schoolwork, but not when working through a personal dilemma. Early adolescence also is characterized by egocentricity—the belief of some adolescents that they are the center of everyone’s attention. Despite being largely imagined, this perception of always being “on stage” can be stressful for adolescents, who may feel that others are constantly judging or evaluating them. Early adolescents express a greater need for privacy than they did in childhood and begin to appreciate the privacy of their own thoughts. With ongoing cognitive development, **middle adolescents** are more able to consider the needs and feelings of other people. Their creativity and intellectual abilities are enhanced. Because of their increased capacity for abstract thought in combination with a persistent perception of uniqueness, middle adolescents may feel a sense of immortality and immunity to the consequences of risky behaviors. **Late adolescents** are more future oriented and able to delay gratification. They can think more independently, consider others’ views, and compromise. They have a stronger sense of self and more stable interests. Under times of stress, adolescents may temporarily revert to the cognitive processes and coping strategies used at younger ages.

**Moral development** generally accompanies cognitive development. Preadolescents, concrete and individualistic, follow rules to please authority figures and avoid punishment. As they move into early adolescence, they develop a stronger sense of right and wrong but are likely to perceive these as absolute and unquestionable. Middle and late adolescents may establish a sense of morality driven by their desire to be seen as a good person, to behave in a manner according to their perceived place in society, or by their sense of obligation to care for others. Moral decision-making, however, still may be highly subject to emotional context. Late adolescents may develop a rational conscience and an independent system of values, although these often are largely consistent with parental values. While going through this complex developmental process, religious or political organizations that promote simple answers to complex social or moral questions may hold great appeal to the adolescent.

## PSYCHOSOCIAL DEVELOPMENT

In contrast to cognitive development, psychosocial development correlates more strongly with pubertal status and physical maturation than with chronological age. Whereas cognitive development

is more biologically determined, psychosocial development is subject to greater environmental and cultural influences. Indeed, cultural variation can be dramatic. Some late adolescents move immediately from high school into marriage, childbearing, working, and financial independence; others remain dependent on the parents while pursuing their own education for several more years, in a period sometimes referred to as *emerging adulthood*. Psychosocial development also may be nonlinear, with different domains of growth progressing along different timelines. An overriding theme of psychosocial development is the concept of identity formation and consolidation as the adolescent moves away from the nurturing protection of the family, develops an increased affiliation with the peer group(s), and ultimately defines himself or herself as an individual.

**Separation from the parents** is a hallmark of adolescent development. Early adolescents start to seek out more privacy at home, spending less time with the parents. They begin to reject parental advice and involvement in their decision-making as they explore the boundaries of their dependence on, and independence from, their parents. With evolving cognitive skills, an adolescent can conceive of an ideal parent and contrast this ideal with his or her own parents. Adolescents may seek out alternative adult role models, such as teachers, coaches, or parents of friends. Parent-child conflict often peaks during middle adolescence, with disagreements over privileges, independence, and other limits set by the parents. Adolescents may appear intermittently to seek and reject parental acceptance. It is theorized that perhaps the adolescent *needs* to conceive of the parents as “wrong” in order to ameliorate the pain of separating from them. Throughout this time, however, the parents remain a critical source of nurturing and support for the adolescent and continue to exert significant influence over the adolescent’s decision-making. Paradoxically, frequent arguments and conflict may coexist with strong emotional bonds and closeness. The late adolescent may reestablish a more “adult-adult” type of relationship with the parents, once again seeking out and considering parental advice and guidance as they enter adulthood.

Increasing importance of the **peer group** also may buffer the emotional trauma of separating from the parents (see Fig. 150.1). Early adolescents tend to socialize largely with same-gender peers, both in their individual friendships and larger groups. Females’ peer groups tend to be more relationship oriented, whereas males’ peer groups are more likely to be centered around a particular interest or activity. In both cases, group cohesion and a sense of belonging become important. Peers become increasingly important in middle adolescence, during which time the adolescent may experiment with being a part of different groups and “try on” different identities. These groups may include all genders. Peer groups may arise from organized activities, such as sports or clubs, or may simply be friendship based. Gang membership is another form of peer acceptance. **Conformity** with the peers in manners of dress, speech, and behavior is a normal part of this process and should not necessarily be viewed negatively. Similarly, **peer pressure** may exist, but its influence over the adolescent’s decision-making may be positive, negative, or negligible. Acceptance and successful navigation of peer groups during adolescence may give the individual more confidence to move into and out of various social, academic, and professional groups in the future. Late adolescents are less vulnerable to peer group influence, having moved closer to establishing their own stable identity. Their cognitive skills allow them to choose selectively among different peer groups, endorsing and adopting individual values and behaviors that best reflect who they are becoming.

Early adolescents have increased **sexual awareness and interest**, which may manifest as sexual talk and gossip, and often is focused on sexual anatomy. Masturbation and other sexual exploration, sometimes with same-sex peers, are common. The prevalence of other forms of sexual behavior varies by culture; in general, these behaviors are less common in early adolescents. Romantic relationships, if they exist at all, lack emotional depth. Sexual curiosity, experimentation, and activity become more common among

middle adolescents. Same-sex attraction is common; sexual orientation may become clear to some adolescents, but still may be evolving in others during this time. Dating behaviors may be seen, but this is culture dependent and may not be a popular construct for all adolescents. Individual relationships often continue to emphasize sexual attraction over emotional intimacy. Relationships that occur during middle adolescence may be short and intense. Emotional intimacy and more permanent relationships may not be seen until late adolescence. At that time, relationships increasingly involve love and commitment and demonstrate greater stability.

**Body image** may affect (and be affected by) adolescents' psychosocial development as well. Early and middle adolescence are usually the ages during which poor or distorted body image and eating disorders develop. Early adolescents undergo rapid physical changes and may experience uncertainty about whether all these anatomic and physiologic changes are progressing normally. Reassurance from adults, including their healthcare providers, may be comforting. As puberty comes to an end and these changes slow, the middle adolescent's preoccupation may shift to whether they are attractive to others. A strong emphasis on physical appearance during this time is common. Although this focus on physical appearance may continue into adulthood, late adolescence generally is characterized by a shifting balance toward introspection, with somewhat less emphasis placed on external characteristics.

The **timing of pubertal changes** also can affect psychosocial development and well-being. The progression of pubertal changes in males is generally associated with a positive self-image. Early-maturing males tend to have greater self-confidence, social, and academic success, whereas later-maturing males are at risk for more internalizing behaviors and diminished self-esteem. Females may initially perceive changes in their physical appearance more negatively. This appears to be especially true for early-maturing females, some of whom experience greater decreases in self-esteem, engage in more disruptive behaviors, and have more conflict with their parents than do on-time or late-maturing females. Early-maturing females may be more comfortable associating with older peers and may subsequently be exposed to peer pressure around things like sexual activity and substance use at younger ages. Still lacking the cognitive skills to effectively navigate these situations, they may be vulnerable to making poor decisions that place their health and safety at risk. Many other factors influence how adolescents experience puberty, and supportive peers and adults can have a positive impact on psychosocial development at any maturational stage. With successful navigation of these domains, emerging adults move into the world with a strong sense of personal identity and their place in society. They are able to work toward a vocation and financial independence and to manage the responsibilities of adulthood.

### IMPLICATIONS FOR PROVIDERS, PARENTS, AND POLICYMAKERS

Providers can help parents approach their child's adolescent years by reframing some of the "challenges" of adolescence as normal developmental milestones that should be anticipated and accepted. Puberty and emerging sexuality should be approached as positive and health-affirming life changes, rather than focusing discussions only on the negative reproductive risks and outcomes. Even good-natured teasing about bodily changes can be detrimental to the adolescent's self-image. Early-maturing females and late-maturing males should be supported, recognizing their potential increased exposure to psychosocial challenges. Identification of strengths and emerging positive coping strategies should be promoted in all youth, particularly those with chronic illness or other challenges. Providers need to determine the young adolescent's cognitive development and capacity for abstract thought and tailor their communication and counseling style accordingly. Physical examinations should be performed in private with the parent outside the exam room (provided the adolescent is comfortable with this), which also affords the adolescent and provider an opportunity to discuss confidential issues. Reassurance of normal development should be provided.

As adolescents develop more independence and parent-child conflict peaks, providers should remind parents that this is typical and that arguing does not mean the adolescent does not value the parents' input and perspectives. Although some may rebel initially, most adolescents ultimately adopt a value system very similar to that of their parents. Even if discussions feel ineffective to parents, they should continue to demonstrate and model these values to their child. Similarly, rather than categorically dismissing their child's "negative" interests, such as playing a violent video game, parents should be encouraged to use these opportunities to model critical thinking about the impact of such an activity. Potentially negative peer groups may be approached the same way, while fostering the development of positive peer networks. **Authoritative parenting**, in which clear and appropriate negotiated limits are set in the context of a caring and mutually respectful parent-child relationship, is most strongly associated with positive psychosocial development. Parental connectedness and close supervision or monitoring of the youth's activities and peer group can be protective against early onset of sexual activity and involvement in behaviors that may threaten their safety and can foster positive youth development. Parents should also assume an active role in their adolescent's transition to adulthood to ensure that their child receives appropriate preventive health services.

Parents and providers may each work with adolescents to foster good decision-making. In addition to providing adolescents with accurate and complete health information, the adolescent's cognitive ability to use this information in various contexts must be considered. Visits with providers can be used to promote independence among adolescents by spending time separately with both caregivers and the adolescent, allowing the adolescent space to voice concerns and receive appropriate information about making healthy decisions and recognizing behaviors that may be placing their health at risk.

Adolescents may find themselves needing to make important decisions in highly charged situations where they may be unable to manage their emotions and use their higher cognitive functions to examine the consequences of their decision. For example, a couple in a sexual situation with high emotional arousal may make the decision to proceed with unprotected intercourse. By anticipating this situation ahead of time, under conditions of lower emotional arousal, and making a plan to deal with this, they may make a different decision (e.g., stick with their prior decision never to have sex without protection) when the time comes. Parents and healthcare providers are in a position to encourage and foster this anticipation and planning under conditions of "cool cognition."

Providers may need to help parents distinguish normal adolescent development and risk-taking behaviors from possible signs of a more serious mental health or conduct problem. Bids for **autonomy**, such as avoiding family activities, demanding privacy, and increasing argumentativeness, are normal; extreme **withdrawal** or **antagonism** may be dysfunctional, signaling a mental health or substance use concern. Bewilderment and dysphoria at the start of middle school are normal; continued failure to adapt several months later suggests a more serious problem. Although some degree of risk taking is normal, progressive escalation of risk-taking behaviors is problematic. In general, when the adolescent's behaviors cause significant dysfunction in the domains of home life, academics, or peer relationships, they should be addressed by the parents and healthcare provider, and referral to a mental health provider may be considered. In most cases, parents can be reassured that although adolescence can pose unique challenges, their adolescent, like most adolescents, will come through it to become a successful and happy adult.

At national and international levels, adolescents are at risk for environmental, health, behavioral, and societal challenges. [Table 150.4](#) provides suggestions to address these issues.

Visit Elsevier eBooks+ at [eBooks.Health.Elsevier.com](http://eBooks.Health.Elsevier.com) for Bibliography.

**Table 150.4** Recommended Action Bundles\* for Adolescent and Young Adult Health Problems and Risks

PROBLEM/ RISK AREA	STRUCTURAL	SOCIAL MARKETING	COMMUNITY INTERVENTIONS, INCLUDING FAMILY	ELECTRONIC HEALTH, MOBILE HEALTH	SCHOOLS	HEALTH SERVICE SECTOR
Sexual and reproductive health, including HIV	<b>Legislation</b> 18 yr as the minimum age of marriage Allow provision of contraception to legal minors Legalize abortion	Promote community support for sexual and reproductive health and HIV health access for adolescents	Cash transfer programs, with payments linked to staying in school Positive youth development Peer education	Target knowledge, attitudes, and risk behaviors	Quality secondary education Comprehensive sexuality education Safe schools with clean toilets and facilities for menstrual care School-based health services with condoms and modern contraceptives	Condoms and affordable modern contraception, including long-acting reversible contraception Early HIV and STI diagnosis and treatment Male circumcision Antenatal, delivery, and postnatal care Transition to adult care for HIV
Undernutrition	Fortification of foods (e.g., iron, folate)		Micronutrient supplements (particularly in pregnancy) Protein-energy supplementation Deworming Cash transfer program Nutrition education		Micronutrient supplements Healthy school meals	Screening and micronutrient supplementation
Infectious diseases			Deworming Bed net distribution		HPV vaccination Deworming	Early identification and treatment Adolescent vaccinations (HPV, childhood catch-up) Deworming Bed net distribution Seasonal malaria chemoprevention
Violence	<b>Gun control</b> Legalize homosexuality and protect women from violence and sexual coercion Youth justice reforms to promote second chances and diversion from custody 16 yr as the minimum age for criminal responsibility	Promote knowledge of the effects of violence and available services	Promote parent skills and parent-child communication Positive youth development Promote gender equality Economic empowerment Group training for awareness, knowledge, and skills		Multicomponent interventions that target violent behavior and substance use	Trauma care
Unintentional injury	<b>Graduated licensing</b> Mandatory helmet wearing Multicomponent traffic injury control	Promote knowledge of risks	Police enforcement of traffic injury control			Trauma care, including first responders (e.g., ambulances)
Alcohol and illicit drugs	Limit alcohol sales to underage adolescents Taxation on alcohol Drunk-driving legislation Restrict illicit alcohol Interventions in licensed premises Diversion from youth justice and custody Graduated drinking	<b>Advertising restrictions</b> Campaigns to build community awareness	Promote parent-child communication and parenting skills Needle-syringe exchange access Mentoring	Target knowledge, attitudes, and risk behaviors	Alcohol-free policies	Risk screening and motivational interviewing

Continued



**Table 150.4** Recommended Action Bundles for Adolescent and Young Adult Health Problems and Risks—cont'd

PROBLEM/ RISK AREA	STRUCTURAL	SOCIAL MARKETING	COMMUNITY INTERVENTIONS, INCLUDING FAMILY	ELECTRONIC HEALTH, MOBILE HEALTH	SCHOOLS	HEALTH SERVICE SECTOR
Tobacco	Tobacco control, including taxation, pricing, and advertising control Youth access restrictions Legislation for smoke-free air	Anti-tobacco campaigns	<i>Interventions to promote parent skills and parent-child communication</i>	<i>Text messaging adjunct to quitting</i>	<i>Smoke-free policies Multicomponent</i>	<i>Routine screening and motivation interviewing to promote cessation</i>
Mental disorders and suicide	Restriction of access to means	<i>Promote adolescent mental health literacy</i>	<i>Gatekeeper training</i>	<i>Electronic mental health interventions</i>	<i>Educational interventions Gatekeeper training School-based mental health services</i>	<b>Practitioner training in depression recognition and treatment</b> <i>Routine assessment of mental health, including self-harm and suicide risk</i>
Chronic physical disorders			<i>Peer support initiatives</i>		<i>School-based health services</i>	<i>Promote self-management Promote transition to adult healthcare</i>
Overweight and obesity	<b>Taxation of high-sugar, high-salt, and high-fat foods</b> <i>Front-of-pack nutrition labels Restriction of fast-food advertising</i>	<i>Promote physical activity</i>	<i>Create opportunities for maintenance of physical activity in daily life</i>	<i>Interactive or personalized feedback interventions</i>	<i>Multicomponent interventions involving education about healthy diet and increasing opportunities for physical education</i>	<b>Manage comorbidities of obesity</b>

\*Actions in **bold** have an evidence base in adolescents and young adults; actions in *italics* are promising but without yet a strong evidence base in adolescents and young adults. HIV, Human immunodeficiency virus; HPV, human papillomavirus; STI, sexually transmitted infection. From Patton GC, Sawyer SM, Santelli JS, et al. Our future: a Lancet commission on adolescent health and wellbeing. *Lancet*. 2016;387:2423–2478, p. 2458.

## Chapter 151

# Delivery of Healthcare to Adolescents

Samantha V. Hill and  
Tamera Coyne-Beasley

Healthcare providers play an important role in nurturing healthy behaviors among adolescents, because the leading causes of death and disability among adolescents are preventable. Adolescence provides a unique opportunity to prevent or modify health conditions arising from behaviors that develop in the second decade of life and that can lead to substantial morbidity and mortality, such as trauma, suicide, cardiovascular and pulmonary disease, type 2 diabetes, reproductive health issues, and cancer (see [Chapter 150](#), Table 150.4).

Health systems in each community should be in place to ensure comprehensive and high-quality care to adolescents. **Health insurance coverage** that is affordable, continuous, confidential, and not subject to exclusion for preexisting conditions should be available for all adolescents and young adults. **Comprehensive, coordinated benefits** should meet the developmental needs of adolescents, particularly for reproductive, mental health, dental, and substance use services. **Safety net providers and programs** that provide confidential services, such as school-based health centers, federally qualified health centers, family planning services, and clinics that treat sexually transmitted infections (STIs) in adolescents and

young adults, need to have assured funding for viability and sustainability. **Quality-of-care** data should be collected and analyzed by age so that the performance measures for age-appropriate healthcare needs of adolescents are monitored. **Affordability** is important for access to preventive services. Family involvement should be encouraged, but **confidentiality** and adolescent consent are critically important and should be addressed with intentionality at each visit.

Healthcare providers, trained and experienced in adolescent care, should be available in all communities. Healthcare providers should be adequately compensated to support the range and intensity of services required to address the developmental and health service needs of adolescents. The development and dissemination of provider education about **adolescent preventive health guidelines** have been demonstrated to improve the content of recommended care (Table 151.1). The ease of recognition or expectation that an adolescent's needs can be addressed in a setting relates to the visibility and flexibility of sites and services. Staff at sites should be approachable, linguistically capable, culturally humble, and able to balance trauma-informed care with healing-centered engagement approaches with attention to equity and social determinants of health. Health services should be coordinated to respond to goals for adolescent health at the local, state, and national levels. The coordination should address service financing and delivery in a manner that reduces disparities in care.

Although most adolescents in the United States have seen a healthcare provider in the past year and report a usual source of healthcare, adolescents are less likely to receive preventive care services. According to the 2019 National Health Interview Survey, an estimated 92% of 12- to 17-year-old U.S. adolescents had a well child visit within the past year. Uninsured adolescents are the least likely to receive care. The National Health Interview Survey found that 8% of 15- to 18-year-olds were uninsured, whereas 61% and 31% had private and public insurance in 2016, respectively.

**Table 151.1** Bright Futures/American Academy of Pediatrics Recommendations for Preventive Healthcare for 11- to 21-Year-Olds

PERIODICITY AND INDICATIONS	
HISTORY	Annual
MEASUREMENTS	
Body mass index	Annual
Blood pressure	Annual
SENSORY SCREENING	
Vision	At 12yr and 15yr visits or if risk assessment positive
Hearing	Screen with audiometry, including 6,000- and 8,000-Hz high frequencies once at 11-14yr, once at 15-17yr, and once at 18-21yr.
DEVELOPMENTAL/BEHAVIORAL ASSESSMENT	
Developmental surveillance	Annual
Psychosocial/behavioral assessment	Annual
Depression screening	Annual for 12yr and older
Tobacco, alcohol, and drug use assessment	If risk assessment positive
PHYSICAL EXAMINATION	Annual
PROCEDURES	
Immunization*	Annual
Hematocrit or hemoglobin	If risk assessment positive
Tuberculin test	If risk assessment positive
Dyslipidemia screening	Once at 9-11yr, and once at 17-21yr
STI screening	If sexually active
HIV screening†	Once between ages 15 and 18yr Discuss and offer at earlier age and annually if risk assessment positive.
Cervical dysplasia screening‡	Beginning at age 21yr
ORAL HEALTH	Annual; refer to dental home
ANTICIPATORY GUIDANCE	Annual§

\*Schedules per the Advisory Committee on Immunization Practices, published annually at <http://www.cdc.gov/vaccines/schedules/hcp/index.html> and [http://redbook.solutionns.aap.org/SS/Immunization\\_Schedules.aspx](http://redbook.solutionns.aap.org/SS/Immunization_Schedules.aspx).

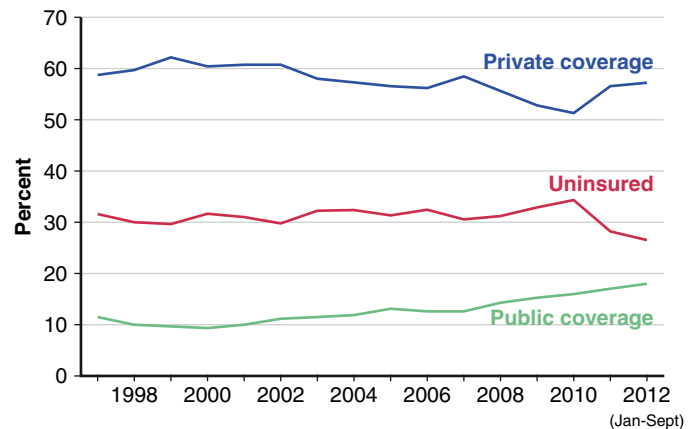
†The CDC recommends universal, voluntary HIV screening of all sexually active people beginning at age 13 yr. The American Academy of Pediatrics recommends offering routine HIV screening to all adolescents at least once by 16-18 yr of age and to those younger if at risk. The U.S. Preventive Services Task Force recommends offering routine HIV screening to all adolescents age 15 yr and older at least once and to those younger if at risk. Patients who test positive for HIV should receive prevention counseling and referral to care before leaving the testing site.

‡Screening for cervical cancer, April 2012, U.S. Preventive Services Task Force. <http://www.uspreventiveservicestaskforce.org/uspstf/uspscerv.htm>.

§Refer to specific guidance by age as listed in *Bright Futures* guidelines. HIV, Human immunodeficiency virus; STI, sexually transmitted infection.

Adapted from Hagan JF, Shaw JS, Duncan PM, eds. *Bright Futures: Guidelines for Health Supervision of Infants, Children, and Adolescents*, 4th ed. Elk Grove Village, IL: American Academy of Pediatrics; 2017.

The **Patient Protection and Affordable Care Act (ACA)** has expanded access to both commercial health plans and Medicaid for young adults age 19-26 years (Fig. 151.1); the proportion of young adults with insurance increased from 65.7% to 73.8%. ACA provisions require that commercial health plans continue dependent coverage to 26 years, regardless of the young adult's financial or dependent status, marriage, or educational enrollment; mandate university and college student health plans enhance consumer protections for students; provide financial assistance for young adults to enroll into health insurance exchanges with incomes ranging from 133% to 399% of



**Fig. 151.1** Percentage of adults 19-25 years of age with health insurance by coverage type and percentage uninsured at the time of the interview: United States, 1997 to September 2012. Note: Estimates for 2012 are based on data collected in January through September. Data are based on household interviews of a sample of the civilian noninstitutionalized population. (Data from CDC/NCHS, *National Health Interview Survey, 1997-2012, Family Core Component*.)

the federal poverty level in Medicaid expansion states; and offer preventive healthcare services (to include contraceptive care) free of any cost sharing, deductibles, or copayments. In states that have expanded Medicaid coverage, all adults with incomes <133% of the federal poverty level are eligible to enroll. After passage of the ACA, 14% of 18- to 24-year-olds still remained uninsured.

The complexity and interaction of physical, cognitive, and psychosocial developmental processes during adolescence require sensitivity and skill on the part of the health professional (see Chapter 150). Health education and promotion, as well as disease prevention, should be the focus of every visit (Table 151.2).

The Centers for Disease Control and Prevention (CDC) Advisory Committee on Immunization Practices (ACIP) currently recommends routine adolescent vaccines for universal administration beginning at the 11- to 12-year-old visit or as soon as possible: (1) tetanus-diphtheria-acellular pertussis vaccine (Tdap), (2) the meningococcal conjugate vaccine (MCV4) with a booster at age 16 years, (3) the human papillomavirus vaccine (HPV) series, and (4) the COVID-19 vaccine (see Chapter 215). ACIP recommends annual influenza vaccination and hepatitis A virus (HAV) vaccination to adolescents and young adults who have not previously received the HAV vaccine series if immunity against HAV is desired or for those at increased risk for infection, such as men who have sex with men (MSM), injection drug users (IDUs), and those with chronic liver disease or clotting factor disorders, or those who live in endemic areas. Although another meningococcal vaccine (MenB) is not routinely recommended for all adolescents, the ACIP recommends a MenB vaccine series for people ages 16-23 based on shared clinical decision-making with the patient (or parent/guardian) to provide short-term protection against serogroup B meningococcal disease.

The time spent on various elements of the screening will vary with the issues that surface during the assessment. However, time for screening and assessment is important for all adolescents, and the ideal model of adolescent care requires a minimum of 20 minutes per visit. For lesbian, gay, bisexual, trans, intersex, and asexual youth (see Chapters 153 and 154), emotional and psychologic concerns related to their experiences, from fear of disclosure to the trauma of discrimination or bullying or violence, may direct the clinician to spend more time assessing emotional and psychologic supports in the young person's environment. For youth with chronic illnesses or special needs, the assessment of at-risk behaviors should not be omitted or deemphasized by assuming they do not experience the "normal" adolescent vulnerabilities.

Visit Elsevier eBooks+ at [eBooks.Health.Elsevier.com](http://eBooks.Health.Elsevier.com) for Bibliography.

**Table 151.2** Adolescent Screening Recommendations

UNIVERSAL SCREENING	11- TO 14-YR-OLD VISIT	15- TO 17-YR-OLD VISIT	18- TO 21-YR-OLD VISIT	
	ACTION	ACTION	ACTION	
Cervical dysplasia*	N/A	N/A	Pap smear all young women at 21 yr visit	
Depression	Annual adolescent depression screen beginning at 12yr visit	Annual adolescent depression screen	Annual adolescent depression screen	
Dyslipidemia	Lipid screen once at 9-11 yr	Lipid screen once at 17-21 yr	Lipid screen once at 17-21 yr	
Hearing	Once at 11-14yr Audiometry, including 6,000- and 8,000-Hz high frequencies	Once at 15-17 yr Audiometry, including 6,000- and 8,000-Hz high frequencies	Once at 18-21 yr Audiometry, including 6,000- and 8,000-Hz high frequencies	
HIV†	Selective screening (see later)	HIV test once at 15-18yr	HIV test once at 15-18yr	
Tobacco, alcohol, or drug use	Annual tobacco, alcohol, or drug use screen	Annual tobacco, alcohol, or drug use screen	Annual tobacco, alcohol, or drug use screen	
Vision	At 12yr visit Objective measure with age-appropriate visual acuity measurement using HOTV or Lea symbols, Sloan letters, or Snellen letters	At 15yr visit Objective measure with age-appropriate visual acuity measurement using HOTV or Lea symbols, Sloan letters, or Snellen letters	N/A	
SELECTIVE SCREENING	RISK ASSESSMENT (RA)	11-14 YR OLD VISIT	15-17 YR OLD VISIT	18-21 YR OLD VISIT
		ACTION IF RA+	ACTION IF RA+	ACTION IF RA+
Anemia	Positive on risk screening questions	Hemoglobin or hematocrit	Hemoglobin or hematocrit	Hemoglobin or hematocrit
Dyslipidemia (if not universally screened at this visit)	Positive on risk screening questions and not previously screened with normal results	Lipid profile	Lipid profile	Lipid profile
HIV†	Positive on risk screening questions	HIV test	HIV test (if not universally screened at this visit)	HIV test (if not universally screened at this visit)
Oral health (through 16yr visit)	Primary water source fluoride deficient	Oral fluoridation supplementation	Oral fluoridation supplementation	N/A
<b>STIs</b>				
Chlamydia	Sexually active females	Chlamydia and gonorrhea NAAT (test at all sites where patient engages in sex)	Chlamydia and gonorrhea NAAT (test at all sites where patient engages in sex)	Chlamydia and gonorrhea NAAT (test at all sites where patient engages in sex)
Gonorrhea	Sexually active females			
Syphilis	Sexually active and positive on risk screening questions	Syphilis test	Syphilis test	Syphilis test
Tuberculosis	Positive on risk screening questions	Tuberculin skin test	Tuberculin skin test	Tuberculin skin test
Vision at other ages	Positive on risk screening questions at 11, 13, and 14yr visits	Objective measure with age-appropriate visual acuity measurement using HOTV or Lea symbols, Sloan letters, or Snellen letters	Objective measure with age-appropriate visual acuity measurement using HOTV or Lea symbols, Sloan letters, or Snellen letters	Objective measure with age-appropriate visual acuity measurement using HOTV or Lea symbols, Sloan letters, or Snellen letters

\*Screening for Cervical Cancer. April 2012. U.S. Preventive Services Task Force.

†The Centers for Disease Control and Prevention recommends universal, voluntary HIV screening of all sexually active people beginning at age 13 yr. The American Academy of Pediatrics recommends routine HIV screening offered to all adolescents at least once by 16-18 yr of age and to those younger if at risk. The U.S. Preventive Services Task Force recommends routine HIV screening offered to all adolescents age 15 yr and older at least once and to those younger if at risk. Patients who test positive for HIV should receive prevention counseling and referral to care before leaving the testing site.

NA, Not applicable; NAAT, nucleic acid amplification test; STIs, sexually transmitted infections.

Adapted from Hagan JF, Shaw JS, Duncan PM, eds. *Bright Futures: Guidelines for Health Supervision of Infants, Children, and Adolescents*, 4th ed. Elk Grove Village, IL: American Academy of Pediatrics; 2017 and Bright Futures/American Academy of Pediatrics: Recommendations for Preventive Pediatric Health Care (Periodicity Schedule), 2017. [https://www.aap.org/en-us/Documents/periodicity\\_schedule.pdf](https://www.aap.org/en-us/Documents/periodicity_schedule.pdf).

## 151.1 Legal Issues

Samantha V. Hill and Tamera Coyne-Beasley

The rights of an individual, including those of adolescents, vary widely between nations. In the United States, the right of a minor to consent to treatment without parental knowledge differs between states and is governed by **state-specific minor consent laws**. Some consent laws are based on a minor's status, such as minors who are emancipated, parents, married, pregnant, in the armed services, or mature. In some states, minors can be considered *emancipated* if they are or have served in the armed services or are living apart from parents and are economically independent through gainful employment. A *mature minor* is a minor who is emotionally and intellectually mature enough to give informed consent and who lives under the supervision of a parent or guardian. Courts have held that if a minor is mature, a physician is not liable for providing beneficial treatment. There is no formal process for recognition of a mature minor. The determination is made by the healthcare provider.

Some minor consent laws are based on services a minor is seeking, such as emergency care, sexual healthcare, substance abuse, or mental healthcare (Table 151.3). All 50 states and the District of Columbia explicitly allow minors to consent for their own health services for **STIs**. Approximately 25% of states require that minors be a certain age (generally 12-14 years) before they can consent for their own care for STIs. No state requires parental consent for STI care or requires that providers notify parents that an adolescent minor child has received STI services, except in limited or unusual circumstances.

Minors' right to consent for **contraceptive services** varies from state to state. Almost 50% of states and the District of Columbia explicitly authorize all minors to consent for their own contraceptive services, and 50% of states permit minors to consent for their own contraceptive services under specific circumstances, such as being married, a parent, currently or previously pregnant, over a certain age, or a high school graduate, or per physician's discretion. The FDA has approved a non-prescription daily oral contraceptive (norgestrel) intended to reduce barriers to access to an effective birth control measure.

A minor's right to consent for **mental healthcare** and **substance use** treatment services varies by state and age of the minor, whether care is medical vs nonmedical (e.g., counseling), and whether care is delivered

as an inpatient vs outpatient basis. Minor consent laws often contain provisions regarding confidentiality and disclosure, even when general state consent laws do not have such provisions.

The **confidentiality** of medical information and records of a minor who has consented for his or her own *reproductive healthcare* is governed by numerous federal and state laws. Laws in some states explicitly protect the confidentiality of STI or contraceptive services for which minors have given their own consent and do not allow disclosure of the information without the minor's consent. In other states, laws grant physicians discretion to disclose information to parents.

The confidentiality of medical information and records of a minor who has consented for their own healthcare is also governed by numerous federal and state laws. Laws in some states explicitly protect the confidentiality of STI, contraceptive, or mental health services for which minors have given their own consent and do not allow disclosure of the information without the minor's consent. In other states, laws grant physicians discretion to disclose information to parents. Title X and Medicaid both provide confidentiality protection for family planning services provided to minors with funding from these programs.

Federal regulations issued under the Federal Health Insurance Portability and Accountability Act, known as the **HIPAA Privacy Rule**, defer to state and "other applicable laws" with respect to the question of whether parents have access to information about care for which a minor has given consent. Thus both the state laws that either prohibit or permit disclosure of confidential information and the federal Title X and Medicaid laws that protect the confidentiality of care for adolescents are important under the HIPAA Privacy Rule in determining when confidential information about health services for minors can be disclosed to parents.

Billing for confidential services is complex. Commercial health plans send home an *explanation of benefit (EOB)* to the primary insured or the primary beneficiary, listing services rendered by the provider and reimbursed by the health plan. An EOB documenting that confidential health services were rendered to their adolescent dependent that is received by a parent may disclose those services. In addition, copayments automatically generated with certain billing codes for office visits and medications can be a barrier for adolescents receiving care, including treatment. One way to circumvent a breach of confidentiality from EOBs is to have the adolescent call the insurance company; however, this can be a time-consuming process.

**Table 151.3** Types of Minor Consent Statutes or Rules of Common Law That Allow for Medical Treatment of a Minor Patient Without Parental Consent

LEGAL EXCEPTIONS TO INFORMED CONSENT REQUIREMENT	MEDICAL CARE SETTING
The "emergency" exception	<ul style="list-style-type: none"> <li>The child is suffering from an emergent condition that places his or her life or health in danger</li> <li>The child's legal guardian is unavailable or unable to provide consent for treatment or transport</li> <li>Treatment or transport cannot be safely delayed until consent can be obtained</li> <li>The professional administers only treatment for emergent conditions that pose an immediate threat to the child</li> </ul>
The "emancipated minor" exception	<ul style="list-style-type: none"> <li>Married</li> <li>Economically self-supporting and not living at home</li> <li>Active-duty status in the military</li> <li>In some states, a minor who is a parent or pregnant</li> <li>Some states might require a court to declare the emancipation of a minor</li> </ul>
The "mature minor" exception	Most states recognize a mature minor, in which a minor, usually $\geq 14$ yr, displays sufficient maturity and intelligence to understand and appreciate the benefits, risks, and alternatives of the proposed treatment and to make a voluntary and reasonable choice on the basis of that information; states vary or whether a judicial determination is required
Exceptions based on specific medical condition (state laws vary)	Minor seeks: <ul style="list-style-type: none"> <li>Mental health services</li> <li>Pregnancy and contraceptive services</li> <li>Testing or treatment for HIV infection or AIDS</li> <li>Sexually transmitted infection testing and treatment</li> <li>Drug and alcohol addiction treatment</li> </ul>

Data from American Academy of Pediatrics: consent for emergency medical services for children and adolescents. *Pediatrics* 2011;128:427-433.



In March 2020, in response to the COVID-19 pandemic, the Coronavirus Aid, Relief, and Economic Security Act (CARES Act) was passed. Part of this act requires rapid release of all patient documentation (e.g., notes, laboratory results, problem and medication lists) and poses a new challenge to the provision of confidential health services to adolescents.

Providers may elect to establish a policy of discussing with their adolescent patients when medical records and other information will be disclosed and developing a mechanism to alert office staff as to what information in the chart is confidential. For legal and other reasons, a chaperone should be present whenever an adolescent patient's genitalia is examined.

Visit Elsevier eBooks+ at [eBooks.Health.Elsevier.com](https://eBooks.Health.Elsevier.com) for Bibliography.

## 151.2 Screening Procedures

Samantha V. Hill and Tamera Coyne-Beasley

### INTERVIEWING THE ADOLESCENT

The preparation for a successful interview with an adolescent patient varies based on the history of the relationship with the patient. Patients (and their parents) who are going from preadolescence to adolescence while seeing the same provider should be guided through the transition. Although the rules for confidentiality are the same for new and continuing patients, the change in the **physician-patient relationship**, allowing more privacy during the visit and more autonomy in the health process, may be threatening for the parent and the adolescent. For new patients, the initial phases of the interview are more challenging given the need to establish rapport rapidly with the patient in order to meet the goals of the encounter. Issues of **confidentiality and privacy** should be explicitly stated along with the conditions under which that confidentiality may need to be altered, that is, in life- or safety-threatening situations. For new patients, the parents should be interviewed with the adolescent or before the adolescent to ensure that the adolescent does not perceive a breach of confidentiality. The clinician who takes time to listen, avoids judgmental statements and the use of street jargon, and shows respect for the adolescent's emerging maturity will have an easier time communicating with the adolescent. The use of *open-ended questions*, rather than closed-ended questions, will further facilitate history taking. (The closed-ended question, "Do you get along with your father?" leads to the answer "yes" or "no," in contrast to the question, "What might you like to be different in your relationship with your mother?" which may lead to an answer such as, "I would like her to stop always worrying about me.")

The goals of the interview or clinical encounter are to establish an information base, identify problems and issues from the patient's perspective, and identify problems and issues from the perspective of the clinician, based on knowledge of the health and other issues relevant to the adolescent age-group. The adolescent should be given an opportunity to express concerns and the reasons for seeking medical attention. The adolescent and the parent should be allowed to express the strengths and successes of the adolescent, in addition to communicating problems.

The effectiveness of an interview can be compromised when the interviewer is distracted by other events or individuals in the office, when extreme time limitations are obvious to either party, or when there is expressible discomfort with either the patient or the interviewer. The need for an **interpreter** when a patient is hearing impaired or a **translator** if the patient and interviewer are not language compatible provides a challenge, but not necessarily a barrier, under most circumstances (see Chapter 12). Observations during the interview can

be useful to the overall assessment of the patient's maturity, presence or absence of depression, and the parent-adolescent relationship. Given the key role of a successful interview in the screening process, excellent training and experience should be sought by clinicians providing comprehensive care to adolescent patients.

### PSYCHOSOCIAL ASSESSMENT

A few questions should be asked to identify the adolescent who is having difficulty with **peer relationships** (Do you have a best friend with whom you can share even the most personal secret?), **self-image** (Is there anything you would like to change about yourself?), **depression** (In the past year have you felt depressed or sad most days, even if you felt okay sometimes?), **school** (How are your grades this year compared with last year?), **personal decisions** (Are you feeling pressured to engage in any behavior for which you do not feel you are ready?), **substance use** (Have you ever tried smoking, vaping, alcohol, weed, or prescription drugs that were not prescribed for you?), and an **eating disorder** (Do you ever feel that food controls you, rather than vice versa?). Standardized screening for depression with validated tools such as the PH-Q9 modified for teens is also helpful. The **HEADS/SF/FIRST** mnemonic, basic or expanded, can be useful in guiding the interview if encounter forms are not available (Table 151.4). Based on the assessments,

**Table 151.4** Adolescent Psychosocial Assessment: HEADS/SF/FIRST Mnemonic

<b>Home.</b> Space, privacy, frequent geographic moves, neighborhood
<b>Education/School.</b> Frequent school changes, repetition of a grade/in each subject, teachers' reports, vocational goals, after-school educational clubs (e.g., language, speech, math), learning disabilities
<b>Abuse.</b> Physical, sexual, emotional, verbal abuse; parental discipline
<b>Drugs.</b> Tobacco, electronic cigarettes or vaping devices, alcohol, marijuana, inhalants, "club drugs," "rave" parties, others; drug of choice, age at initiation, frequency, mode of intake, rituals, alone or with peers, quit methods, number of attempts
<b>Safety.</b> Seat belts, helmets, sports safety measures, hazardous activities, driving while intoxicated
<b>Sexuality/Sexual Identity.</b> Reproductive health (use of contraceptives, presence of sexually transmitted infections, feelings, pregnancy)
<b>Family and Friends</b>
<i>Family:</i> Family constellation; genogram; single/married/separated/divorced/blended family; family occupations and shifts; history of addiction in first- and second-degree relatives; parental attitude toward alcohol and drugs; parental rules; chronically ill, physically or mentally challenged parent
<i>Friends:</i> Peer cliques and configuration ("preppies," "jocks," "nerds," "computer geeks," cheerleaders), gang or cult affiliation
<b>Image.</b> Height and weight perceptions, body musculature and physique, appearance (including dress, jewelry, tattoos, body piercing as fashion trends or other statement)
<b>Recreation.</b> Sleep, exercise, organized or unstructured sports, recreational activities (television, video games, computer games, internet and chat rooms, church or community youth group activities [e.g., Boy (BSA)/Girl Scouts; Big Brother/Sister groups, campus groups]). How many hours per day, days per week involved?
<b>Spirituality and Connectedness.</b> Use HOPE* or FICA† acronym; adherence, rituals, occult practices, community service or involvement
<b>Threats and Violence.</b> Self-harm or harm to others, running away, cruelty to animals, guns, fights, arrests, stealing, fire setting, fights in school

\*HOPE, Hope or security for the future; organized religion; personal spirituality and practices; effects on medical care and end-of-life issues.

†FICA, Faith beliefs; importance and influence of faith; community support.

From Dias PJ: Adolescent substance abuse: assessment in the office. *Pediatr Clin North Am* 2002;49:269-300.

appropriate counseling or referrals are recommended for more thorough probing or for in-depth interviewing.

## PHYSICAL EXAMINATION

### Vision Testing

The pubertal growth spurt may involve the optic globe, resulting in its elongation and myopia in genetically predisposed individuals (see [Chapter 658](#)). Vision testing should therefore be performed to detect this problem before it affects school performance.

### Audiometry

Highly amplified music of the kind enjoyed by many adolescents may result in hearing loss or tinnitus (see [Chapter 676](#)). A hearing screening is recommended by the *Bright Futures* guidelines for adolescents who are exposed to loud noises regularly, have had recurring ear infections, or report problems.

### Blood Pressure Determination

Criteria for a diagnosis of hypertension are based on age-specific norms that increase with pubertal maturation (see [Chapter 471](#)). Individuals younger than 13 years old whose blood pressure (BP) exceeds the 95th percentile for their age are suspect for having hypertension, regardless of the absolute reading, and a BP between the 90th and 95th percentiles should receive appropriate counseling relative to weight and have a follow-up examination in 6 months. Individuals 13–18 years old with a BP of 130–139/80–89 are suspect for having hypertension, and those with a BP of 120–129/80 should receive appropriate counseling relative to weight and have a follow-up examination in 6 months. Those with elevated BPs should have their BP measured on three separate occasions to determine the stability of the elevation before moving forward with an intervention strategy. The technique is important; false-positive results may be obtained if the cuff covers less than two thirds of the upper arm. The patient should be seated, and an average should be taken of the second and third consecutive readings, using the change rather than the disappearance as the diastolic pressure. Most adolescents with BP elevation have labile hypertension. If BP is below 2 standard deviations (SD) for age, anorexia nervosa and Addison disease should be considered.

### Scoliosis

See [Chapter 720](#).

Approximately 5% of male and 10–14% of female adolescents have a mild curvature of the spine. This is 2–4 times the rate in younger children. Scoliosis is typically manifested during the peak of the height velocity curve, at approximately 12 years in females and 14 years in males. Females should be screened twice, once between 11 and 12 and again between 13 and 14, and males should be screened between 12 and 13. Curves measuring >10 degrees should be monitored by an orthopedist until growth is complete.

### Breast Examination

See [Chapters 158 and 588](#).

Visual inspection of the young and middle adolescent female's breasts is performed to evaluate progression of sexual maturation and provide reassurance about development. The American Cancer Society no longer recommends a clinical breast exam as a screening method for women in the United States. Breast self-exam is also no longer recommended as an option for women of any age.

### Scrotum Examination

Visual inspection of the young and middle adolescent male testicles is performed to evaluate progression of sexual maturation and

provide reassurance about development. The peak incidence of germ cell tumors of the testes is in late adolescence and early adulthood. Because varicoceles often appear during puberty, the examination also provides an opportunity to explain and reassure the patient about this entity (see [Chapter 582](#)). Self-examination is no longer recommended because of the low incidence and high recovery rates of testicular cancer in this age-group. Palpation of the scrotum along with visual inspection should be performed to document bilaterally descended testicles.

### Pelvic Examination

See [Chapter 585](#).

### Laboratory Testing

The increased incidence of iron-deficiency anemia after menarche directs the performance of a hematocrit annually in females with moderate to heavy menses. The reference standard for this test changes with progression of puberty, as estrogen suppresses erythropoietin (see [Chapter 496](#)). Populations with nutritional risk should also have the hematocrit monitored. Androgens have the opposite effect, causing the hematocrit to rise during male puberty; sexual maturity rating (SMR) 1 males have an average hematocrit of 39%, whereas those who have completed puberty (SMR 5) have an average value of 43%. **Tuberculosis (TB)** testing is important in adolescents with risk factors, such as an adolescent with HIV, living in a household with someone with HIV, incarcerated, homeless, from a country where TB is common, or those with other risk factors, because puberty has been shown to activate this disease in those not previously treated. **Hepatitis C virus (HCV)** screening should be offered to all adolescents 18 years and older regardless of their risks. It should also be offered to adolescents who report risk factors, such as IDU, received blood products or organ donation before 1992, or long-term hemodialysis. The rate of acute hepatitis C has remained the highest among persons age 20–39 years, similar to age-groups at highest risk for fatal overdose in the United States and age at initiation of IDU among certain U.S. populations. Compared with 2018, the greatest increase in the rates of acute hepatitis C were observed among those age 40–49 years (31% increase), followed by those age 30–39 years (23% increase). For the first time in more than a decade, the rate of acute hepatitis C decreased slightly among those age 20–29 years. Rates have consistently been lowest among those age <20 years or ≥60 years. Sexually active adolescents should undergo screening for **STIs** per CDC guidelines, regardless of symptoms (see [Chapter 163](#)). There are clear indications for chlamydia and gonorrhea screening of females ≤24 years old, but less sufficient evidence to support routine screening in young men. Based on feasibility, efficacy, and cost-effectiveness, evidence is insufficient to recommend routine chlamydia screening in all sexually active young men. However, screening of sexually active young males should be considered in clinical settings associated with a high prevalence of chlamydia (e.g., adolescent clinics, correctional facilities, sexually transmitted disease clinics) and should be offered to all young MSM. **HIV** screening should be discussed and offered at least once to all adolescents age 15–18 years and to younger and older adolescents who are at increased risk. Routine screening of adolescents who are asymptomatic for certain STIs (e.g., syphilis, trichomoniasis, herpes simplex virus, HPV) is not recommended. However, young MSM and pregnant adolescent females might require more thorough evaluation for all sexually transmitted diseases. Because cervical cancer incidence is low and complications from procedures may outweigh benefits of screening adolescent females, cervical cancer screening should not begin until age 21 years.

Visit Elsevier eBooks+ at [eBooks.Health.Elsevier.com](http://eBooks.Health.Elsevier.com) for Bibliography.

## Chapter 152

# Transitioning to Adult Care

Joseph M. Truglio and Nikita Barai

The importance of thoughtfully and intentionally transitioning care of adolescents from pediatric to adult services, particularly for adolescents with **special healthcare needs (SHCN)**, has been recognized for more than 2 decades. The Society of Adolescent Health and Medicine defines health care transitions as “the purposeful, planned movement of adolescents and young adults (AYA) with chronic physical and medical conditions from child-centered to the adult-oriented health care system.” For adolescents with SHCN, successful transition is associated with improved health outcomes and quality of life, whereas poorly managed transitions may lead to loss of a medical home and worsening of chronic disease control. All adolescents, regardless of SHCN, are likely to benefit from the autonomy, continuity of care, and self-management skills that are facilitated by a successful transition.

Guidelines emphasize that **transition** is a process, not an event, and encompasses much more than simply the transfer of care from one clinician to another. The guidelines make recommendations and provide practice-based resources for implementing elements of transition support in pediatric, family medicine, internal medicine, and combined internal medicine–pediatric practices. This includes providing assistance for the patient in adapting to an adult model of healthcare delivery as they transition from one practice/clinician to another or as they transition between models of care within the same practice. It also emphasizes the importance of the many members of the patient’s care team (primary and specialty care, physical and occupational therapy, school and/or vocational support, mental health clinicians, and so on) that support the patient before, during, and after the transition process. **Table 152.1** represents the key elements of healthcare transition. Tools to assist providers with these steps are available online from the National Center for Health Care Transition Improvement ([www.gottransition.org](http://www.gottransition.org)).

The process begins with the development of a transition policy and its dissemination to all families of young adolescents, ensuring families understand that transition planning will be an element of health maintenance and chronic care management visits throughout the adolescent years. By middle adolescence, a transition plan should be developed with the youth and family caregivers and updated at subsequent visits until the patient is ready for implementation of the adult care model in early adulthood. Periodic **readiness assessments** are key to planning and anticipating challenges. Critical to the transition process is **skills training** for the adolescent in communication, self-advocacy, and self-care. Some youth with SHCN depend on caregivers for navigating the healthcare system on their behalf, and it is not realistic to expect increased independence. For these youth, addressing guardianship, long-term care planning, and advance directives are important. **Care coordination** facilitates navigation and engagement in an adult-oriented health system, especially for adolescents with SHCN. The goal is to help all youth maximize their potential as they become young adults.

Visit Elsevier eBooks+ at [eBooks.Health.Elsevier.com](http://eBooks.Health.Elsevier.com) for Bibliography.

**Table 152.1** Key Elements of the Transition of Healthcare Process

- **Written transition policy** to be shared with youth, families, providers, and staff, explaining the process and the responsibilities of all team members
- **Transitioning youth registry** to track the progress of each patient through the transition process
- **Longitudinal readiness checklists** assessing the youth’s ability for independence, self-management, and communicating with the adult healthcare system, as well as the family’s readiness to assist the patient in achieving these goals
- **Written transition plan** documenting the steps to be conducted to meet the needs identified in the readiness assessment and identifying appropriate adult care resources
- For youth with SHCN, expanded transition services, including attention to insurance, entitlements, guardianship, and vocational needs, in addition to adult subspecialty care
- Appropriate communication between the pediatric and adult medical home and subspecialists, including a **portable medical summary** and care plan delivered to the patient and caregivers
- Transfer of care, within the 18- to 21-yr-old range, to adult providers, to whom pediatric providers continue to serve as a resource until transition is complete

## Chapter 153

# Gender Identity and Transgender Care

Abby Walch and Stephen M. Rosenthal

## TERMINOLOGY

**Sex** refers to the physical or genetic characteristics that differentiate between biologic maleness or femaleness (e.g., sex chromosomes, gonads, internal and external genital structures). **Sex designated (assigned) at birth** is typically based on the appearance of the external genitalia. In the absence of atypical genitalia, which may indicate a difference of sexual development requiring further evaluation, sex is designated at birth as either male or female.

**Gender identity** refers to one’s internal core sense of gender. Gender is not binary, and although most people identify their gender as being male (boy or man) or female (girl or woman), others may identify as both, neither, or another gender completely. The gender identity of an individual cannot be known until they reach a certain level of psychosocial development and self-awareness to identify it themselves. Development of gender identity likely results from a complex interplay of biologic, environmental, and cultural factors. This concept is supported by compelling studies in several biomedical disciplines including genetics, endocrinology, and neurology. **Gender expression** refers to one’s external manifestations of gender (e.g., choice of name, pronouns, clothing, hairstyle), whereas **gender role** describes the behaviors, attitudes, and personality traits considered to be masculine or feminine by a society or culture during a particular period.

Many cultures recognize and accept as normal more than two genders. In the Philippines, *Bakla* is considered a third gender; many are community leaders. In India, the third gender is *Hijras*, and Aboriginal (Australian) terms such as *brotherboy* and *sistergirl* are used to refer to transgender and gender-diverse people.



Indigenous Nations (America) peoples may have three to five genders: male, female, Two Spirits female, Two Spirits male, and transgender. Navajo refer to Two Spirits as *Nádleehí* (transformed), and the Cheyenne term for Two Spirits is *Hemaneh* (half man, half woman). In all these societies, Two Spirits people are honored and often leaders in their tribe.

**Cisgender** refers to people who have a gender identity that aligns with their sex designated at birth. **Gender incongruence** is the term used when gender identity does not align with the sex designated at birth. **Transgender and gender diverse (TGD)** is an umbrella term used to describe a diverse group of people with gender incongruence. *All TGD gender identities are normal, healthy variations within the spectrum of possible gender identities.* Individuals with gender identities that are not exclusively male or female may describe themselves as **gender nonbinary**, **genderqueer**, or **genderfluid**. Some of these individuals may also identify as transgender while others may not.

**Gender dysphoria** refers to the distress experienced by TGD individuals caused by gender incongruence. This term replaced “gender identity disorder” in the most recent *Diagnostic and Statistical Manual of Mental Disorders (DSM)-5* published in 2013, focusing the clinical concern on the distress an individual may experience because of gender dysphoria and underscoring the *nonpathologic* nature of TGD gender identities. Not all TGD individuals experience gender dysphoria, and use of this term, although sometimes necessary to obtain gender-affirming therapies, may be considered offensive and stigmatizing by some.

It is important to distinguish gender identity as separate from **sexual orientation**, which refers to an individual’s sexual attraction to another person. Gender identity does not predict sexual orientation, and a person with any gender identity may have any sexual orientation.

## EPIDEMIOLOGY

Early studies likely underestimated the size of the TGD population due to reliance on reports of individuals who accessed gender-related mental health or medical care and because of the lack of questions related to gender identity on population-based surveys. With newer study methods and increased societal recognition and acceptance of the diverse spectrum of genders, it is now evident that the prevalence of TGD persons is higher than previously thought. With improved access to multidisciplinary gender clinics, TGD youth are seeking gender-affirming medical treatment at increasing rates.

In 2022, a report from the Williams Institute of the University of California Los Angeles School of Law, informed by the Center for Disease Control and Prevention’s (CDC’s) Behavior Risk Factor Surveillance System and the Youth Risk Behavior Survey carried out from 2017 to 2020 and 2017 to 2019, respectively, revealed that 0.5% of U.S. adults (18 years and older) and 1.4% of adolescents and young adults (13–17 years) identify as transgender. A population-based study of self-reported gender identity in high school students carried out in Minnesota in 2016 reported a 2.7% prevalence of TGD individuals. An international review in 2016 estimated the TGD population worldwide to be 25 million with 0.5–1.3% of birth-designated males and 0.4–1.2% of birth-designated females having TGD gender identities.

There has been a striking inversion in the sex ratio of TGD youth seeking services for gender dysphoria. Reports from Europe and North America prior to 2005–2006 revealed a predominance of birth-designated males. Since then, and for unclear reasons, there has been a predominance of birth-designated females. A 2017 survey of 25 gender centers in the United States, Europe, and Chile demonstrated that 63% of youth being treated were transitioning from female to male.

## Clinical Presentation

TGD youth may recognize and reveal their gender identity to others at any age. Some will communicate their identity in early childhood as soon as they are able to talk. Others may not acknowledge or share their identity until adulthood, largely influenced by a cis-heteronormative society in

which TGD individuals encounter significant oppression and discrimination. What is evident is the importance of accepting and valuing the gender identities as reported by TGD children at any point in time and the recognition that gender may not be binary and may change over time.

Gender incongruence that occurs in young children does not invariably persist into adolescence and adulthood. Studies based on earlier versions of the DSM demonstrate that gender dysphoria or gender incongruence in prepubertal children persists in a minority of these individuals. Future studies may reveal different persistence rates, as DSM-5 criteria for the diagnosis of gender dysphoria are narrower compared to previous versions. Although it is currently not possible to predict which children will persist in their asserted TGD identity, certain factors are associated with persistence of a TGD identity. Receipt of a gender dysphoria diagnosis in childhood, increased intensity of gender dysphoria as measured on gender dysphoria scales, social gender transition in childhood, sex designated as female at birth, and older age at clinic intake have been associated with higher persistence rates of TGD identities. Although not well studied, the assigned male at birth verbal toddler who asserts “I am a girl” (rather than “I want to be a girl”) has a high likelihood of persistence.

Recognition that social gender transition in prepubertal children is associated with a higher likelihood of persistence should not prevent children from making this transition. Social transition, when completed early, may result in more favorable outcomes for some TGD children and should be done with input from a qualified mental health provider. Currently, persistence of gender incongruence and gender dysphoria can only reliably be assessed after the onset of puberty. Gender dysphoria that emerges or worsens with puberty onset is associated with a very high rate of persistence of that individual’s TGD identity into adulthood, an observation that is fundamental to the rationale for the provision of medical interventions in TGD youth who meet criteria for treatment.

## Diagnostic Evaluation

Optimally, the diagnostic evaluations of TGD youth are performed by a multidisciplinary team comprising medical and mental health professionals. Current clinical practice guidelines recommend that gender incongruence and gender dysphoria be diagnosed by a qualified mental health gender specialist after a thorough psychodiagnostic evaluation. Specific criteria for the mental health gender specialist in their role providing care for TGD youth are outlined elsewhere, whereas the recommendations in this chapter are intended for medical providers.

Although the involvement of a mental health gender specialist in the diagnostic evaluation of TGD youth is recommended by current clinical practice guidelines prior to initiating any medical therapies, it is recognized that this may not always be possible. Mental health gender specialists may be inaccessible in certain areas, and the insistence that a TGD child establish mental healthcare in this circumstance could delay care indefinitely. Additionally, if an early pubertal TGD child presents with significant gender dysphoria, and if requiring input from a mental health gender specialist before initiating puberty blockers would create a significant delay in care, resulting in the development of irreversible secondary sexual characteristics, this could be harmful. Therefore in limited circumstances it may be reasonable to initiate gender-affirming medical therapies without input from a mental health gender specialist, though with the increasing use of telehealth, there may be greater access to mental health gender specialists. Providers involved in the diagnostic evaluation of TGD youth should be thoughtful about their strengths and limitations and refer for further evaluation as needed to provide optimal care.

At the initial clinic visit, medical providers should obtain information from TGD youth and their families about the child’s gender journey. This information should include their current understanding of their gender identity, challenges faced in addition to support received in their families and surrounding communities, any distress associated with their body and if so whether it changed with puberty, and a full medical and mental health history. After obtaining this information, in TGD youth seeking gender-affirming medical therapies, the medical provider then must decide whether the individual fulfills criteria for treatment (Table 153.1) for gender dysphoria/gender incongruence according to the DSM-5 (Table 153.2).



**Table 153.1** Criteria for Gender-Affirming Hormone Therapy for Adolescents

Adolescents are eligible for GnRH agonist treatment if:

1. A QUALIFIED MHP HAS CONFIRMED THAT:

- The adolescent has demonstrated a long-lasting and intense pattern of gender nonconformity or gender dysphoria (whether suppressed or expressed)
- Gender dysphoria worsened with the onset of puberty
- Any coexisting psychologic, medical, or social problems that could interfere with treatment (e.g., that may compromise treatment adherence) have been addressed, such that the adolescent's situation and functioning are stable enough to start treatment
- The adolescent has sufficient mental capacity to give informed consent/assent to this (reversible) treatment

2. AND THE ADOLESCENT:

- Has been informed of the effects and side effects of treatment (including potential loss of fertility if the individual subsequently continues with sex hormone treatment) and options to preserve fertility
- Has given informed consent/assent and (particularly when the adolescent has not reached the age of legal medical consent, depending on applicable legislation) the parents or other caretakers or guardians have consented to the treatment and are involved in supporting the adolescent throughout the treatment process

3. AND A PEDIATRIC ENDOCRINOLOGIST OR OTHER CLINICIAN EXPERIENCED IN PUBERTAL ASSESSMENT:

- Agrees with the indication for GnRH agonist treatment
- Has confirmed that puberty has started in the adolescent (Tanner stage  $\geq$ G2/B2)
- Has confirmed that there are no medical contraindications to GnRH agonist treatment

Adolescents are eligible for subsequent sex hormone treatment if:

1. A QUALIFIED MHP HAS CONFIRMED:

- The persistence of gender dysphoria
- Any coexisting psychologic, medical, or social problems that could interfere with treatment (e.g., that may compromise treatment adherence) have been addressed, such that the adolescent's situation and functioning are stable enough to start sex hormone treatment
- The adolescent has sufficient mental capacity (which most adolescents have by age 16 years) to estimate the consequences of this (partly) irreversible treatment, weigh the benefits and risks, and give informed consent/assent to this (partly) irreversible treatment

2. AND THE ADOLESCENT:

- Has been informed of the (irreversible) effects and side effects of treatment (including potential loss of fertility and options to preserve fertility)
- Has given informed consent/assent and (particularly when the adolescent has not reached the age of legal medical consent, depending on applicable legislation) the parents or other caretakers or guardians have consented to the treatment and are involved in supporting the adolescent throughout the treatment process

3. AND A PEDIATRIC ENDOCRINOLOGIST OR OTHER CLINICIAN EXPERIENCED IN PUBERTAL INDUCTION:

- Agrees with the indication for sex hormone treatment
- Has confirmed that there are no medical contraindications to sex hormone treatment

MHP, mental health professional.

Data from Coleman E, Radix AE, Bouman WP, et al. Standards of care for the health of transgender and gender diverse people, Version 8. *Int J Transgend Health*. 2022;23(Suppl 1):S1-S259.

### Gender-Affirmative Care

TGD youth have historically faced high rates of discrimination and barriers in medical care settings. Pediatric primary care providers play a vital role in assessing the gender identities of their patients during routine well child checks, and they should be relied upon as a trusted source of validation, support, and reassurance to TGD youth and their families (Table 153.3). If a provider feels unable to address gender-related issues, then referral to another provider who can is recommended. If additional information on gender-affirming medical therapies is desired, referral to

**Table 153.2** DSM-5 Criteria for Gender Dysphoria in Adolescents and Adults

A. A marked incongruence between one's experienced/expressed gender and natal gender of at least 6 mo in duration, as manifested by at least two of the following:

1. A marked incongruence between one's experienced/expressed gender and primary and/or secondary sex characteristics (or in young adolescents, the anticipated secondary sex characteristics)
2. A strong desire to be rid of one's primary and/or secondary sex characteristics because of a marked incongruence with one's experienced/expressed gender (or in young adolescents, a desire to prevent the development of the anticipated secondary sex characteristics)
3. A strong desire for the primary and/or secondary sex characteristics of the other gender
4. A strong desire to be of the other gender (or some alternative gender different from one's designated gender)
5. A strong desire to be treated as the other gender (or some alternative gender different from one's designated gender)
6. A strong conviction that one has the typical feelings and reactions of the other gender (or some alternative gender different from one's designated gender)

B. The condition is associated with clinically significant distress or impairment in social, occupational, or other important areas of functioning

Specify if:

1. The condition exists with a disorder of sex development
2. The condition is posttransitional, in that the individual has transitioned to full-time living in the desired gender (with or without legalization of gender change) and has undergone (or is preparing to have) at least one sex-related medical procedure or treatment regimen—namely, regular sex hormone treatment or gender reassignment surgery confirming the desired gender (e.g., penectomy, vaginoplasty in natal males; mastectomy or phalloplasty in natal females)

From the *Diagnostic and Statistical Manual of Mental Disorders*, 5th ed. Copyright 2013. American Psychiatric Association.

a provider with expertise in the care of TGD youth is appropriate. Available resources for youth, family, and providers are noted in Table 153.4.

Pediatric providers should follow a gender-affirmative care model (GACM) in their practices. In a GACM, providers offer a supportive, open-minded environment while facilitating discussion and exploration of their patients' gender identities. Within this care model, the following messages are relayed: (1) TGD identities and diverse gender expressions are normal, healthy variations, (2) gender identity develops through a complex interplay of biologic, environmental, and cultural factors, and (3) coexisting mental health issues are more often *caused* by stigma and discrimination than by internal psychologic disturbances within the TGD child. Key components of gender-affirming clinics are highlighted in Figure 153.1.

Pediatric providers should help TGD youth explore the various options available for gender affirmation. Some TGD youth will require medical or surgical interventions for affirmation of their gender, whereas others will not. Social transition is a nonmedical intervention that may occur gradually or all at once. It may occur in only some environments and not in others, or it may occur in all spaces in which TGD individuals find themselves. Social transition may include adaptations to name and/or pronouns, changes to hairstyle and/or clothing, use of devices to hide unwanted physical features (e.g., binders to create a smoother contour of the chest) or to create the appearance of desired physical features (e.g., packers to achieve the appearance of a genital bulge), and steps to access appropriate restroom facilities at school, work, or other public locations. Social transition may also include legal

Table 153.3 Strategies for Supporting TGD Youth	
DOMAIN	STRATEGIES
Clinical settings	Use of affirmed name and pronouns in clinical spaces and inclusion of this information in the electronic medical record (EMR) Training for clinical staff Use of affirming imagery, inclusive intake forms Gender-neutral bathroom spaces Open-ended, nonjudgmental discussion about gender identity Sensitive, trauma-informed care History taking using nongendered language
Relationships with family/caregivers	Assistance with disclosure of identity to family when desired by the youth Psychoeducation on gender development and the benefits of supporting TGD youth Promoting practices such as use of affirmed name and pronouns Education about social transitioning Providing space and support for parents to express concerns without youth present Support for disclosure to extended family or other important people Referrals to support groups or family counseling
Educational settings	Education for school staff on gender concepts and zero tolerance for transphobia Advocating for the use of affirmed name and pronouns Advocacy for inclusive sexual education curriculum Advocacy for youth to use preferred bathrooms, locker rooms, and dorms and participate with desired sports teams
Public identification	Assistance with documentation for changing legal name and/or gender marker Documentation of the patient's gender identity to ensure safe passage during travel

From Voss RV, Simons L. Supporting the health of transgender and gender-diverse youth in primary care settings. *Prim Care Clin Office Pract.* 2021;48:259–270, Table 2; with data from Guss CE, Woolverton GA, Borus J, et al. Transgender adolescents' experiences in primary care: a qualitative study. *J Adolesc Health.* 2019;65:344–349.

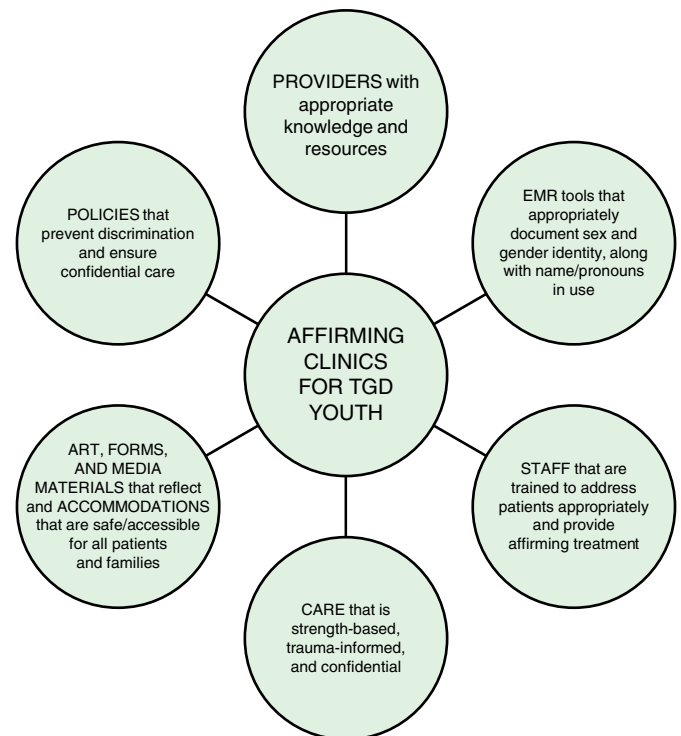
Table 153.4 Resources for Youth, Parents, and Providers	
ONLINE RESOURCE	
Resources for youth	Gender Spectrum (genderspectrum.org) The Trevor Project (thetrevorproject.org) Transgender Law Center (transgenderlawcenter.org) TransAthlete (transathlete.com) TransLifeline (translifeline.org)
Resources for families and caregivers	PFLAG/PTI (pflag.org) Family Acceptance Project (familyproject.sfsu.edu) Gender Spectrum (genderspectrum.org) National Center for Transgender Equality (transequality.org) Trans Youth Family Allies (imatyfa.org)
Resources for providers	World Professional Association for Transgender Health Standards of Care (wpath.org) Endocrine Society Gender Dysphoria/Gender Incongruence Practice Guidelines (www.endocrine.org) UCSF Transgender Center for Excellence (transcare.ucsf.edu/guidelines) National LGBTQIA + Health Education Center (lgbtqihealtheducation.org)

From Voss RV, Simons L. Supporting the health of transgender and gender-diverse youth in primary care settings. *Prim Care Clin Office Pract.* 2021;48:259–270, Table 3.

affirmation in which an individual updates their name and/or gender marker on legal documents.

### MENTAL HEALTH CONSIDERATIONS

Although the vast majority of TGD youth do not have any underlying severe psychiatric illnesses, they are at increased risk of internalizing disorders and life-threatening behaviors. Studies have demonstrated an increased prevalence of anxiety, depression, obsessive-compulsive disorder, posttraumatic stress disorder, eating disorder, self-harm



**Fig. 153.1** Key components of an affirming clinic for TGD youth. (Adapted from Allen BJ, Rosenthal SM. *Care of transgender, nonbinary, and gender diverse youth.* In Allen DB, Nadeau K, Kappy MS, Geffner ME, eds. *Pediatric Endocrinology: Principles and Practice*, 3rd ed. New York: McGraw Hill; 2020: Fig. 7-2.)

behavior, suicidal ideation, and suicide attempts in TGD youth compared to cisgender controls. These conditions and behaviors are not inherent to an individual's gender identity, but rather often occur secondary to a lack of societal acceptance, stigma, discrimination, and poor

access to gender-affirming mental health and medical care. A higher co-occurrence of autism spectrum disorder among individuals with gender dysphoria and vice versa has also been demonstrated in addition to higher rates of homelessness, physical violence, substance abuse, and high-risk sexual behaviors compared to the general population.

In addition to determining the presence or absence of gender dysphoria as part of the psychodiagnostic evaluation, there are many important reasons to consider involving a mental health gender specialist in the evaluation and care of TGD youth *before* and *during* the provision of gender-affirming medical care. Mental health gender specialists may (1) evaluate for the presence of and provide treatment for coexisting mental health concerns, (2) provide family counseling and supportive psychotherapy to assist youth with the exploration of their gender identity and alleviate any distress secondary to gender dysphoria, (3) provide education, assist in decision-making, and refer as indicated for gender-affirming medical therapies, (4) educate and advocate for TGD youth and their families in their community, and (5) provide TGD youth and their families with information for support groups. An emphasis should be placed on the nonpathologic nature of TGD gender identities, and conversion or reparative therapies aimed at changing an individual's gender identity are ineffective and unethical (and illegal in certain places) practices that should not be pursued.

Despite the increased risk for mental health comorbidities in TGD youth, studies have provided evidence of protective factors resulting in positive mental health outcomes. Education regarding and access to gender-affirming medical interventions at early pubertal stages resulted in less gender dysphoria and better mental health and well-being in TGD youth. Additionally, TGD youth with supportive family environments have better mental health outcomes and quality of life. This knowledge underscores the importance of involving a qualified mental health professional to facilitate supportive home environments as needed and educating TGD youth and their families on options for gender-affirming medical therapies.

Another aspect of support is to provide access to other children/adolescents who are TGD. Many have identified like-minded friends in their own community, but others may develop a community through summer camps, group meetings associated with a treatment center, or the internet.

### Gender-Affirming Medical Care

Affirming medical and surgical options in TGD individuals who require them to bring their body into alignment with their gender identity are essential, medically necessary interventions that have clear mental health benefits, some of which might even be lifesaving. Mental health benefits of gender-affirming medical therapies include the alleviation of gender dysphoria and the avoidance of worsening of any underlying psychological distress. Options available to TGD youth vary depending on their pubertal and developmental stage, and care should be individualized based on the goals of the child rather than applied as a blanket algorithm. At each decision point, careful consideration should be given to the potential risks, benefits, and likely outcomes of each treatment, and use of signed consent forms, or informed assent forms in the case of individuals <18 years of age, attesting to an understanding of these considerations are advised before initiating any gender-affirming medical therapies. Medical care for TGD youth is based primarily on the World Professional Association for Transgender Health (WPATH) Standards of Care (SOC) published in 2022 and the Endocrine Society's clinical practice guidelines, last published in 2017. TGD seeking gender-affirming hormone therapy must satisfy certain criteria before proceeding (see [Table 153.1](#)).

Current standards of care and clinical practice guidelines for the gender-affirming medical care of TGD youth are based on compelling research from short- to medium-term studies, a 22-year follow-up case report, and expert opinion. Although large longitudinal observational outcome studies are ongoing, there remains a paucity of long-term outcome data currently available. Nevertheless, refusing to deliver timely medical interventions for TGD youth is not a neutral option. A delay or withholding of care may prolong or worsen gender dysphoria and

mental health and lead to the development of irreversible physical changes that may require invasive surgical interventions in the future.

## PUBERTY BLOCKERS

### Treatment Criteria and Timing

Pubertal hormone suppression is recommended in TGD youth who meet criteria for treatment (see [Table 153.1](#)). No medical interventions are recommended before the onset of puberty. TGD youth are eligible for treatment *only after* the onset of puberty. Medical providers should monitor for physical exam findings consistent with Tanner stage 2, including breast buds in youth designated female at birth and testicular volume  $\geq 4$  mL in youth designated male at birth. Laboratory assays, including ultrasensitive gonadotropin and sex steroid levels obtained in the early morning, can be used to confirm the onset of puberty. However, gonadotropin-releasing hormone (GnRH) is released from the hypothalamus in a pulsatile manner, and in early puberty, gonadotropin and sex steroid hormone levels may overlap with prepubertal ranges if checked at random times.

### Goals of Therapy

When initiated early in puberty, pubertal suppression allows for expansion of the diagnostic phase with additional time for gender identity exploration before deciding whether or not to proceed with gender-affirming sex hormone (GAH) therapy. Pubertal suppression also prevents the development of undesirable, irreversible secondary sex characteristics not aligned with the individual's gender identity. These irreversible characteristics include breast development, female body habitus, and possibly short stature in individuals designated female at birth and low voice, laryngeal prominence, male bone configuration, tall stature, and male hair pattern on the face and extremities in individuals designated male at birth. Some, but not all, of these features can only be addressed later with surgery, but pubertal suppression is preferred. Pubertal suppression initiated in early puberty is thought to be fully reversible; if suspended or discontinued, endogenous puberty will resume.

Pubertal suppression can also be considered in TGD youth in later stages of puberty with the goal of achieving menstrual suppression in individuals designated female at birth or the goal of blocking androgen effects in individuals designated male at birth. However, studies do not currently exist that inform whether pubertal blockers can be used as a monotherapy (and for how long) in adolescents older than 14 without posing a risk to skeletal health, given that prolonged deficiency of sex steroids could result in impaired bone mineral density (BMD) during later adolescence and adulthood.

### Treatment Options

**GnRH agonists are the preferred agents for pubertal suppression in TGD youth.** GnRH agonists are long-acting medications that are highly effective in suppressing gonadotropin release through GnRH receptor desensitization. Once started, GnRH agonists may result in some regression of previously developed secondary sex characteristics, including atrophy of breast tissue and a reduction in testicular size. GnRH agonists are available as injectables given every 1-6 months or as subcutaneous implants that last 1-2 years.

Although GnRH agonists are the most effective and preferred option for pubertal suppression, they are costly and may be inaccessible to TGD individuals without insurance coverage. Antiandrogens and progestins with antiandrogen properties, including spironolactone, cyproterone, bicalutamide, and medroxyprogesterone, provide additional options for pubertal suppression. These medications are not as efficacious in suppressing the HPG axis as compared to GnRH agonists, and concern regarding potential side effects have limited their use. The various medications available for pubertal suppression can be found in [Table 153.5](#).

### Potential Adverse Effects

Before initiating treatment for pubertal suppression, it is important to discuss potential adverse effects with TGD youth and their guardians. The primary risks of treatment with GnRH agonists

**Table 153.5** Available Formulations of Medications Used for Pubertal Blockade

	MEDICATION	ROUTE OF ADMINISTRATION	DOSING FREQUENCY	DOSE
GnRH agonists	Leuprolide acetate	Intramuscular	Every 1-3 mo	11.25-30 mg
	Triptorelin	Intramuscular	Every 24 wk	22.5 mg
	Histrelin	Subcutaneous implant	Every 1-2 yr	50 mg
Progestins	Medroxyprogesterone	Oral	Daily	Up to 40 mg
		Intramuscular	Every 3 mo	150 mg
Antiandrogens	Spironolactone	Oral	1-2 times/day	25 mg initially, up to 100-300 mg divided twice daily
	Cyproterone acetate	Oral	Daily	Up to 100 mg
	Bicalutamide	Oral	Daily	50 mg

GnRH, Gonadotropin-releasing hormone.

Adapted from Allen BJ, Rosenthal SM. Care of transgender, nonbinary, and gender diverse youth. In: Allen DB, Nadeau K, Kappy MS, Geffner ME, eds. *Pediatric Endocrinology: Principles and Practice*, 3rd ed. New York: McGraw Hill; 2020.

**Table 153.6** Baseline and Follow-Up Protocol During Suppression of Puberty**EVERY 3-6 MO**

Anthropometry: height, weight, sitting height, blood pressure, Tanner stages

**EVERY 6-12 MO**

Laboratory: LH, FSH, E2/T, 25-OH vitamin D

**EVERY 1-2 YR**

Bone density using DXA

Bone age on x-ray of the left hand (if clinically indicated)

DXA, Dual-energy x-ray absorptiometry; E2, estradiol; FSH, follicle-stimulating hormone; LH, luteinizing hormone; T, testosterone.

Adapted from Hembree WC, Cohen-Kettenis PT, Delemarre-van de Waal HA, Gooren LJ, et al; Endocrine Society. Endocrine treatment of transsexual persons: an Endocrine Society clinical practice guideline. *J Clin Endocrinol Metab*. 2009;94(9):3132–3154.

include impaired bone mineralization, compromised fertility (if followed by GAH therapy), and unknown effects on brain development and metabolism.

**Bone Health**

GnRH agonist treatment initiated early in puberty is associated with an increased risk of compromised BMD. Assessment of BMD in TGD individuals is challenging in part because it is not clear whether scores should be compared to norms for the individual's sex designated at birth or to norms for their gender identity. Previous studies have demonstrated an expected stabilization or decline in BMD Z-scores during treatment with GnRH agonists without recovery to baseline after treatment with GAH therapy in all instances. In one study, BMD Z-scores normalized in transmales but remained below zero in transfemales 3 years after the addition of GAH therapy. Potential explanations for differences include differences in lifestyle, exercise, and vitamin D levels. In early pubertal TGD youth treated with GnRH agonists, vitamin D status should be monitored and supplemented, if necessary, and adequate dietary calcium intake and weight-bearing exercise should be encouraged to optimize bone health. BMD should also be monitored every 1-2 years during GnRH agonist treatment and, if the individual undergoes phenotypic transition with gender-affirming sex hormones, should continue to be monitored as described in the Endocrine Society's clinical practice guideline (Tables 153.6 and 153.7).

**Fertility**

Before initiating treatment for pubertal suppression, counseling must be provided regarding options for fertility preservation. TGD adolescents and their families should be given the opportunity to meet with a specialist in reproductive endocrinology before initiating therapy or at any point during gender-affirming medical therapy as desired. When initiated early in puberty, GnRH agonists inhibit gonadal tissue maturation. If discontinued, the effects of GnRH agonists on fertility are reversible, and gamete maturation will resume. However, if followed by GAH therapy, fertility is likely to be compromised. If TGD youth desire fertility preservation, delaying or temporarily discontinuing pubertal suppression to promote spermatogenesis and oocyte maturation to allow for gamete collection is an option. The attainment of mature gametes occurs during the later stages of puberty when irreversible secondary sexual characteristics have developed, however, features that are undesirable for many TGD youth. Individuals who decide to continue pubertal suppression may elect to preserve immature gonadal tissue in the hopes that ongoing studies and future preservation techniques will allow for the maturation and preservation of viable gametes. Although in vitro maturation of human germ cells has not yet been accomplished, a report described in vivo maturation and subsequent cryopreservation of oocytes in a transgender male adolescent treated with a GnRH agonist starting in early puberty. This was achieved 2 years after the initiation of GnRH agonist therapy and without the discontinuation of pubertal suppression.

In contrast to TGD youth who initiate GnRH agonist therapy in early puberty, cryopreservation of mature sperm or eggs is an option before initiating gender-affirming medical therapy in late puberty or postpuberty (Table 153.8). If GAH therapy is initiated without fertility preservation in these individuals, it may be possible to discontinue hormone therapy in the future to allow for recovery of the hypothalamic-pituitary-gonadal (HPG) axis and subsequent gamete maturation. Stopping estrogen in individuals designated male at birth may allow for recovery of testicular function and collection of sperm. Discontinuation of testosterone in individuals designated female at birth may allow for ovarian recovery and release of eggs, and some who have desired this have had successful pregnancies. Unfortunately, even when counseling is provided, very few TGD youth pursue fertility preservation because of the high associated costs and invasiveness of some procedures and concerns regarding potential delays to medical transition.

**Brain Development**

Very few studies thus far have assessed the impact of GnRH agonist therapy on brain development. Attainment of executive functioning is a milestone that is typically achieved during puberty. A single cross-sectional study comparing TGD adolescents treated with GnRH agonists



**Table 153.7** Baseline and Follow-Up Protocol During Induction of Puberty

Anthropometry	Height,* sitting height,* weight, blood pressure, Tanner stages*	Every 3-6 mo
Laboratory studies	Testosterone: testosterone, hemoglobin/hematocrit, lipids, 25-OH vitamin D* Estrogen: estradiol, prolactin, 25-OH vitamin D*	Every 3-12 mo
Imaging*	DXA to evaluate bone mineral density† Left hand radiograph to evaluate bone age (as clinically indicated)	Every 1-2 yr

\*Only indicated in individuals previously treated with pubertal blockers.

†BMD should be monitored into adulthood (until the age of 25-30 yr or until peak bone mass has been reached).

DXA, Dual-energy x-ray absorptiometry.

Adapted from Hembree WC, Cohen-Kettenis PT, Delemarre-van de Waal HA, Gooren LJ, et al; Endocrine Society. Endocrine treatment of transsexual persons: an Endocrine Society clinical practice guideline. *J Clin Endocrinol Metab.* 2009;94(9):3132-3154.

**Table 153.8** Fertility Preservation Options for Transgender Patients

FERTILITY PRESERVATION METHOD	PROCEDURE	TIMING OF INTERVENTION
<b>ASSIGNED MALE AT BIRTH</b>		
Sperm cryopreservation	Sperm is collected from ejaculated semen ± electrical or vibratory stimulation	1. Before initiation of gender-affirming hormone therapy or surgery 2. If gender-affirming hormone therapy already initiated, consider 3-mo cessation of estrogen
Surgical sperm extraction	Sperm is obtained surgically from the testis (TESE) or epididymis (PESA)	1. Before initiation of gender-affirming hormone therapy or surgery 2. If gender-affirming hormone therapy already initiated, consider 3-mo cessation of estrogen
<b>ASSIGNED FEMALE AT BIRTH</b>		
Oocyte cryopreservation	Ovarian stimulation followed by surgical egg retrieval and egg freezing	1. Before initiation of gender-affirming hormone therapy or surgery 2. If gender-affirming hormone therapy already initiated, consider 3-mo cessation of testosterone
Embryo cryopreservation	Ovarian stimulation followed by surgical egg retrieval, IVF, and embryo freezing	1. Before initiation of gender-affirming hormone therapy or surgery 2. If gender-affirming hormone therapy already initiated, consider 3-mo cessation of testosterone
Ovarian tissue cryopreservation	Surgical removal and freezing of ovarian tissue	Before gender-affirming surgery involving removal of ovaries

PESA, Percutaneous epididymal sperm aspiration; TESE, testicular sperm extraction; IVF, in vitro fertilization.

From Montoya MN, Peipert BJ, Whicker D, Gray B. Reproductive considerations for the LGBTQ+ community. *Prim Care Clin Office Pract.* 2021;48:283-297, Table 2.

to untreated TGD adolescents found no significant differences in executive functioning. However, animal studies have suggested that GnRH agonists may affect cognitive function, and one transgender adolescent was reported to demonstrate a lack of expected variation in white matter fractional anisotropy (a measure of brain maturation thought to typically occur during puberty) and a 9-point drop in operational memory testing after approximately 2 years of treatment with a GnRH agonist. A subsequent systematic review and meta-analysis found no adverse impacts of hormone therapy on cognitive function in transgender young adults. Additional long-term studies are necessary to assess the impact of GnRH agonist therapy more fully on brain development in TGD youth.

### Metabolism and Other Effects

A few studies have evaluated the effects of GnRH agonists on various metabolic and physiologic parameters and future surgical outcomes. A decrease in lean body mass, an increase in fat percentage, and weight gain have been reported in studies of TGD adolescents treated with GnRH agonists. TGD youth designated female at birth who start GnRH agonist therapy may also experience hot flashes, especially if this treatment is initiated in the later stages of puberty. TGD youth designated male at birth who initiate pubertal suppression in early puberty will have limited growth of their genitalia, which may require alternative techniques for penile inversion-vaginoplasty if gender-affirming genital surgery is desired in the future, and counseling should be provided in this regard before initiating treatment with a pubertal blocker.

### Alternative Therapy Side Effects

GnRH agonist therapy for pubertal suppression may not be an option for all TGD youth, and alternative therapies are also associated with potential adverse effects. Spironolactone may cause electrolyte abnormalities, polyuria, and orthostasis. Concern for potential hepatotoxicity associated with cyproterone acetate and bicalutamide treatment has limited their use. Progestin treatment may cause hot flashes, headaches, acne, depression, weight gain, lipid changes, and irregular menstrual bleeding in individuals designated female at birth.

### Monitoring Protocol

Efficacy and potential adverse effects of treatment should be monitored closely in TGD youth treated with pubertal suppression according to the protocol outlined in [Table 153.6](#). For individuals treated with spironolactone, serum electrolytes should be monitored every 3 months for the first year of therapy and then annually.

A clear endpoint for pubertal suppression can be difficult to determine. It is generally recommended that GnRH agonists not be continued as monotherapy past age 14 years (nor initiated as a monotherapy past age 14 years) because of the potential adverse effects on bone health. The decision must ultimately be made to discontinue pubertal suppression all together or to initiate concurrent treatment with GAH therapy. It is recognized that this decision point can be difficult for TGD adolescents, particularly for some with nonbinary gender identities who may not desire certain physical changes that may occur with sex hormone therapy. Although current guidelines suggest that GnRH

**Table 153.9** Protocol Induction of Puberty

	MEDICATION	ROUTE OF ADMINISTRATION	DOSING FREQUENCY	INITIAL DOSE	DOSE ESCALATION	ADULT DOSE
Estrogen	17β-estradiol	Oral/sublingual	Daily	PB: 5 μg/kg/day	5 μg/kg every 6 mo	2-6 mg/day
				PP: 1 mg	1 mg every 6 mo	
		Transdermal	Every 3-5 days	PB: 6.25-12.5 μg/24 hr	12.5 μg/24 hr every 6 mo	50-200 μg/24 hr
				PP: 25-50 μg/24 hr	25 μg/24 hr every 6 mo	
Testosterone	Testosterone enanthate/cypionate	Subcutaneous	Weekly	PB: 12.5 mg/m <sup>2</sup>	12.5 mg/m <sup>2</sup> every 6 mo	30-100 mg/wk
				PP: 37.5 mg	37.5 mg every 6 mo	
		Intramuscular	Every 2 wk	PB: 25 mg/m <sup>2</sup>	25 mg/m <sup>2</sup> every 6 mo	60-200 mg every 2 wk
				PP: 75 mg	75 mg every 6 mo	

PB, Pubertal blocker initiated in early puberty; PP, postpuberty.

Adapted from Hembree WC, Cohen-Kettenis PT, Gooren L, et al. Endocrine treatment of gender-dysphoric/gender-incongruent persons: an Endocrine Society clinical practice guideline. *J Clin Endocrinol Metab.* 2017;102:3869–3903, Table 8; and from Allen BJ, Rosenthal SM. Care of transgender, nonbinary, and gender diverse youth. In: Allen DB, Nadeau K, Kappy MS, Geffner ME, eds. *Pediatric Endocrinology: Principles and Practice*, 3rd ed. New York: McGraw Hill; 2020, Fig. 7-2.

agonist therapy may be continued in conjunction with sex hormone therapy until gonadectomy (if pursued), it is often possible to discontinue this therapy in individuals designated female at birth who initiate treatment with testosterone once adult levels of testosterone have been reached.

## GENDER-AFFIRMING SEX HORMONE THERAPY

### Treatment Criteria and Timing

GAH therapy is a medically necessary intervention for many TGD adolescents. GAH therapy is partially reversible, and it is the responsibility of the medical provider to ensure the adolescent meets criteria for treatment before initiating therapy (see [Table 153.1](#)). *GAH treatment may be initiated in TGD adolescents who request this therapy after a multidisciplinary team of medical and mental health providers has confirmed the persistence of gender dysphoria/gender incongruence and if the adolescent has sufficient mental capacity to give informed consent/assent.* Most adolescents are felt to have sufficient mental capacity to provide informed consent by age 16 years; however, there may be compelling reasons to initiate therapy earlier. TGD youth treated with pubertal suppression at Tanner stage 2, which may occur as early as 8-9 years of age, may incur certain risks if this treatment is continued as monotherapy until 16 years of age. Prolonged pubertal suppression may be detrimental to bone health, and it may have detrimental effects on mental health if puberty is delayed well beyond the majority of an individual's peers. Treatment with GAH therapy therefore should be individualized with consideration given to earlier initiation as clinically indicated. Initiation of GAH should follow an evaluation by a qualified mental health gender specialist (separate from any evaluation focused on prior use of pubertal suppression), the signing of consent/assent forms, the obtaining of baseline labs, and consideration of fertility preservation.

### Goals of Therapy

The goals of GAH therapy are (1) to reduce *endogenous* sex hormone levels to prevent the development of secondary sex characteristics in individuals previously treated with pubertal blockers or to reduce secondary sex characteristics in those who have already progressed through any degree of puberty and (2) to provide *exogenous* sex hormones to allow for phenotypic changes aligned with an individual's gender identity. GAH therapy must be individualized based on the adolescent's goals rather than applying a one-size-fits-all approach, though it is important to achieve a level of either testosterone or estrogen that is in the normal range for a person's developmental stage.

### Treatment Options

In TGD adolescents whose puberty was blocked in early Tanner stages, puberty induction with GAH treatment should be initiated using a gradually increasing dose schedule ([Table 153.9](#)). Initial exogenous sex hormone levels are insufficient to suppress endogenous sex hormone secretion, and pubertal blockade should be continued. As sex hormone doses increase, GnRH agonist treatment may often be discontinued in individuals designated female at birth who are treated with testosterone therapy. Adult doses of exogenous testosterone therapy are often sufficient to suppress the HPG axis. In contrast, pubertal suppression must often be continued in individuals designated male at birth who are treated with estrogen therapy. Adult doses of estrogen therapy are insufficient in suppressing the HPG axis and testosterone release. Ongoing adjunctive therapy with a GnRH agonist or antiandrogen therapy (e.g., spironolactone) to block testosterone secretion and/or action is required indefinitely or until gonadectomy, if pursued. Not all TGD adolescents will pursue gonadectomy, and long-term studies are needed to determine the potential risks of prolonged treatment with GnRH agonists.

In TGD adolescents who present for gender-affirming medical therapy in late puberty or after completion of puberty, pubertal induction with sex hormones can start at higher doses and can occur more rapidly (see [Table 153.9](#)).

At this time, no evidence has demonstrated that any of the following medically approved types or methods of administering hormones is superior to others in yielding the desired phenotypic changes. Protocols for some formulations of estrogen and testosterone are not available. Protocols that do exist are outlined in [Table 153.9](#). It is important to emphasize to patients that individual variations in outcomes will occur based on several factors including genetics, body type, and compliance.

### Estrogen

Estrogen can be given via transdermal, oral, or injectable routes. The naturally occurring form, 17β-estradiol, is preferred to synthetic (e.g., ethinyl estradiol) and conjugated estrogens (e.g., Premarin), which cannot easily be monitored in the serum. Compared to synthetic estrogens, 17β-estradiol is also associated with a lower risk of venous thromboembolism (VTE). Serum estradiol levels can be monitored, with the eventual goal of achieving values in the normal range for premenopausal females (100-200 pg/mL).

TGD individuals who pursue estrogen therapy should be educated on the expected timeline of physical changes ([Table 153.10](#)).

**Table 153.10** Timeline of Effects from Gender-Affirming Sex Hormone Therapy

	EFFECT	ONSET	MAXIMUM	REVERSIBILITY
Estrogen	Redistribution of body fat	3-6 mo	2-3 yr	Likely
	Decreased muscle mass/strength	3-6 mo	1-2 yr	Likely
	Softening of skin/decreased oiliness	3-6 mo	Unknown	Likely
	Decreased sexual desire	1-3 mo	3-6 mo	Likely
	Decreased spontaneous erections	1-3 mo	3-6 mo	Likely
	Breast growth	3-6 mo	2-3 yr	Not possible without surgery
	Decreased testicular volume	3-6 mo	2-3 yr	Unknown
	Decreased sperm production	Unknown	>3 yr	Unknown
	Decreased terminal hair growth	6-12 mo	>3 yr	Possible
Scalp hair	Variable			
Testosterone	Skin oiliness/acne	1-6 mo	1-2 yr	Likely
	Facial/body hair growth	6-12 mo	4-5 yr	Unlikely without electrolysis
	Scalp hair loss	6-12 mo		Unlikely
	Increased muscle mass/strength	6-12 mo	2-5 yr	Likely
	Fat redistribution	1-6 mo	2-5 yr	Likely
	Cessation of menses	1-6 mo		Likely
	Clitoral enlargement	1-6 mo	1-2 yr	Unknown
	Vaginal atrophy	1-6 mo	1-2 yr	Unknown
	Deepening of voice	6-12 mo	1-2 yr	Not possible without surgery

Adapted from Hembree WC, Cohen-Kettenis PT, Gooren L, et al. Endocrine treatment of gender-dysphoric/gender-incongruent persons: an Endocrine Society clinical practice guideline. *J Clin Endocrinol Metab*. 2017;102:3869–3903, Table 12; and from Allen BJ, Rosenthal SM. Care of transgender, nonbinary, and gender diverse youth. In Allen DB, Nadeau K, Kappy MS, Geffner ME, eds. *Pediatric Endocrinology: Principles and Practice*, 3rd ed. New York: McGraw Hill; 2020, Tables 7-11 and 7-12.

Treatment will lead to some changes that are likely reversible and others, such as breast development, that are irreversible without surgery.

### Testosterone

Naturally occurring testosterone may be given transdermally via gels or patches, through subcutaneous or intramuscular injections, or via implantation of subcutaneous pellets. Oral testosterone undecanoate is Food and Drug Administration (FDA)-approved for use in the United States but is not currently in wide use. It is important to counsel patients on the potential transfer to others via direct contact when transdermal formulations are used. Testosterone levels can be monitored in the serum, with the eventual goal of achieving values in the normal male range (typically 320-1,000 ng/dL, depending on the specific assay).

TGD individuals treated with testosterone should be educated on the expected timeline of physical changes (see Table 153.10). Treatment will lead to some changes that are likely reversible and others that are not, such as facial hair growth, which is irreversible without electrolysis. Adult levels of testosterone are typically sufficient to suppress the HPG axis and induce amenorrhea in TGD individuals designated female at birth. However, unplanned pregnancies have been reported, emphasizing the need for *ongoing contraceptive counseling* in these individuals. If undesired uterine bleeding persists, or if menstruation is causing significant dysphoria before the initiation of testosterone therapy, a progestin or other agent may be used for menstrual suppression. If estrogen is tolerable, combined continuous oral contraceptives (with limited intervals for breakthrough menses) are more effective in achieving menstrual suppression and are better for maintaining bone health than progestin-only options. For TGD adolescents who prefer nonestrogen-containing medications, progesterone-only pills, medroxyprogesterone acetate shots,

and progesterone-containing intrauterine or implantable devices are available.

### Potential Adverse Effects

Clinicians should inform TGD adolescents of the potential for adverse effects of GAH treatment. Risk for adverse effects is higher when supraphysiologic or inadequate doses of sex hormones are used, which should be avoided. Before initiating therapy, risk factors for adverse effects should be assessed and minimized when possible. GAH treatment has implications for fertility, which must be discussed before initiating therapy as noted previously.

### Risks with Estrogen

The most serious risks associated with estrogen therapy include VTE, cardiovascular disease, and cerebrovascular accident. The risk increases with higher estrogen doses and supraphysiologic estradiol levels. Risk factors for these conditions should be assessed and addressed before initiating estrogen therapy. Tobacco cessation counseling should be provided as indicated. Oral ethinyl estradiol in particular appears to increase the risk of VTE, and it should not be used for GAH therapy in individuals at high risk. Estrogen may also cause growth of pituitary lactotroph cells and hyperprolactinemia, which resolves with a reduction or discontinuation of therapy in most individuals. Other potential adverse effects include weight gain, cholelithiasis, and hypertriglyceridemia. TGD adults treated with estrogen therapy have been shown to have an increased risk for developing breast cancer compared with a general population of men in a retrospective Dutch study, although the risk was still lower than in the general population of women. Another retrospective Dutch study spanning five decades demonstrated an increased mortality risk in TGD individuals treated with estrogen therapy compared with a general population of men and general population of women with high risks of death because of cardiovascular

disease, lung cancer, HIV-related disease, and suicide; however, the study was not designed to attribute the cause of the increased mortality risk to a specific effect of estrogen therapy. Absolute contraindications to estrogen therapy include previous VTE related to an underlying hypercoagulable condition, history of estrogen-sensitive neoplasm, and end-stage chronic liver disease.

**Risks with Testosterone**

Testosterone therapy is primarily associated with potential risks of developing acne, weight gain, hypertension, polycythemia, and a more atherogenic lipid profile (i.e., elevated low-density lipoprotein, elevated triglyceride, and decreased high-density lipoprotein cholesterol levels). Risk increases with sustained, supraphysiologic testosterone levels. Risk factors for these conditions should be assessed and addressed before initiating testosterone therapy. Despite being associated with a more atherogenic lipid profile, numerous studies have shown no increased risk of cardiovascular disease in individuals treated with testosterone. Additional studies are needed to determine if therapy is associated with an increased risk for cerebrovascular disease. Historically, oral testosterone formulations have been associated with increased risk for transaminitis and severe liver dysfunction, whereas injectable formulations are not. Because of the concern that aromatization of testosterone to estradiol may increase risk in patients with a history of estrogen-sensitive malignancies, consultation with an oncologist should be considered before initiating therapy in such patients. Absolute contraindications to testosterone therapy include current pregnancy, unstable coronary artery disease, and untreated polycythemia (hematocrit ≥55%).

**Monitoring Protocol**

Efficacy and potential adverse effects of treatment should be monitored closely in TGD youth treated with GAH therapy at baseline and follow-up

according to the protocol outlined in Table 153.7. Clinical evaluation and laboratory monitoring are recommended every 3 months during the first year of GAH therapy and then 1-2 times annually thereafter. All evaluations should include a physical exam, including measurement of weight and blood pressure. Chest and genitourinary exams may be sensitive issues for TGD youth and should only be conducted as needed to guide management. Evaluations should include questions regarding occurrence of potential adverse events and satisfaction with phenotypic changes on medical therapies. Medication dosing adjustments should occur as needed with the goal of avoiding supraphysiologic and sub-physiologic hormone levels that may increase the risk for adverse effects.

**Surgical Therapy**

Gender-affirming surgeries may be pursued by some TGD individuals to better align their bodies with their gender identities. In these individuals, surgery is medically necessary and an essential step to alleviate their gender dysphoria. Surgeries are irreversible interventions, and most, including those that directly affect fertility such as gonadectomy and/or hysterectomy, are not recommended until an individual reaches age 18 years or the age of legal majority in their country. The Endocrine Society clinical practice guideline and WPATH SOC acknowledge that mastectomy may be considered in TGD adolescents before age 18 years, taking into consideration the physical and mental health status of the individual. Hormone therapy should not be considered a prerequisite to accessing gender-affirming surgical procedures in individuals who do not desire hormone therapy nor in those in whom it is medically contraindicated. Surgeries may occur after the appropriate assessments by qualified medical and mental health professionals responsible for the care of the TGD individual have been performed and confirm that criteria for surgery are met. Individuals who undergo gonadectomy will require ongoing hormone replacement therapy to prevent adverse effects, including osteoporosis.

**Table 153.11** Recommendations for Breast and Reproductive Tract Cancer Screening

ORGAN	TRANSGENDER WOMEN	TRANSGENDER MEN
Breast/chest	Discuss mammography in transwomen age >50 yr with additional risk factors for breast cancer (body mass index >35 kg/m <sup>2</sup> , estrogen and/or progestin use >5 yr, family history) <ul style="list-style-type: none"> <li>Family history of BRCA mutations: prophylactic mastectomy could be recommended, with consecutive primary reconstruction</li> </ul>	Patients who have not undergone bilateral mastectomy should follow cisgender women recommendations for breast cancer screening Patients who have undergone chest reconstructive surgery should be offered physical examination and/or chest ultrasound
Cervix	Not recommended (transwomen do not have a cervix) <ul style="list-style-type: none"> <li>Patients should be routinely examined to detect HPV-related lesions</li> </ul>	Patients with an intact cervix should follow the recommendations for cisgender women <ul style="list-style-type: none"> <li>Consider self-collected vaginal swabs to test for high-risk HPV DNA</li> <li>Pathologists should be aware if patient is taking testosterone</li> <li>Patients who have undergone total hysterectomy and have no history of high-grade cervical precancerous lesion or cervical cancer can discontinue cervical cancer screening</li> </ul>
Ovarian	N/A	Do not routinely screen <ul style="list-style-type: none"> <li>Transmen at increased risk (identified BRCA gene mutation and family history) should be referred for genetic counseling</li> <li>Consider risk-reduction salpingo-oophorectomy</li> </ul>
Endometrial	N/A	Do not routinely screen <ul style="list-style-type: none"> <li>Unexplained bleeding (in patients under testosterone who had reached amenorrhea) should be evaluated</li> </ul>
Prostate	Monitor the following framework for cisgender men <ul style="list-style-type: none"> <li>PSA cutoffs may be lower in transgender men receiving antiandrogens</li> <li>Consider transvaginal digital examination and ultrasound</li> </ul>	N/A

N/A, Not applicable; PSA, prostate-specific antigen.

From Labanca T, Manero I, Pannunzio M. Transgender patients: considerations for routine gynecologic care and cancer screening. *J Gynecol Cancer*. 2020;30:1990–1996, Table 4.



### Primary Care: Screening

Not all TGD adults have had gender-affirming chest or reproductive organ surgery. Because of this, they may be at risk for cancers not typically screened for based on their affirmed or biologic gender. Suggested breast and reproductive cancer screening recommendations are noted in Table 153.11.

### THERAPY FOR NONBINARY YOUTH

Youth with nonbinary gender identities are increasingly presenting for gender-affirming medical care. Although current clinical care guidelines recognize that gender exists on a spectrum and may not always be binary, research and guidelines to date have been largely grounded in the binary gender narrative. Some individuals with nonbinary gender identities will seek treatment as outlined in current clinical practice guidelines, but not all will. The Endocrine Society clinical practice guidelines state that tailoring of current protocols to the individual may be acceptable if done within the context of accepted safety guidelines using a multidisciplinary approach including mental health support. Additionally, the WPATH SOC state they are intended to be flexible to meet the diverse health-care needs of the individual, and health professionals may modify them in consultation with their TGD patients. However, evidence-based protocols are not yet available for nonbinary individuals, and neither the Endocrine Society nor the WPATH provide guidelines specific to the care of nonbinary youth. Nonbinary individuals have been shown to have higher rates of depression, anxiety, and self-harm compared to their binary transgender peers. In addition, they often encounter more barriers in their attempts to access gender-affirming medical care, even when care is accessed at specialized gender clinics. As a result, some feel forced to identify within the gender binary to obtain desired medical therapies or choose to not seek care.

Until future studies inform clinical practice guidelines outlining therapeutic approaches specific to nonbinary youth, gender-affirming care for nonbinary youth should be individualized. Providers should frame care using the concept of *embodiment rather than transition*, the latter implying a linear path within the gender binary. Ongoing dialogue and support are essential in helping nonbinary youth navigate a potentially nonlinear path. Providers should explore the individual's internal awareness of self, specific areas of gender dysphoria, and their embodiment goals to offer specific therapies toward affirming the individual's gender. Specific expected outcomes of the possible interventions (e.g., increased facial hair with testosterone or chest growth with estrogen) should be discussed rather than describing therapies as masculinizing or feminizing in nature. Difficult decisions may need to be made, particularly for nonbinary youth treated with pubertal suppression who do not desire any secondary sex characteristics. There is the potential for negative impacts on bone health from prolonged monotherapy with pubertal blocking agents, and this should be avoided. Providers should expect to have conversations about balancing the individual's priorities in their specific embodiment goals and to discuss the known potential risks and benefits of various treatment options in order to provide optimal care to their nonbinary patients. Patients should be counseled about the importance of maintaining a minimum threshold level of sex steroids—typically a normal adult range of either estrogen or testosterone—to preserve general health.

Like TGD youth with binary gender identities, available medical interventions for nonbinary youth may include pubertal suppression, sex hormones, and surgeries. Desired and unwanted effects should be discussed and balanced in decision-making regarding

therapies. Existing treatment protocols may be modified to achieve patient embodiment goals if deemed safe with a plan for close follow-up monitoring. Potential modifications may include gradual titration or tapering of doses, low-dose or limited testosterone therapy, lower doses of estrogen therapy, intermittent hormone dosing, use of both estrogen and testosterone, and use of adjunctive medications. After initiating a new treatment, follow-up visits should include a discussion of physical changes noted and whether they are in alignment with the patient's embodiment goals, with adjustments made as needed.

### Mental Health Outcomes of Treatment

Multiple studies have demonstrated the positive impact of gender-affirming medical and surgical interventions on mental health outcomes in TGD adolescents. A prospective study of 55 TGD adolescents and young adults in the Netherlands published in 2014 demonstrated resolution of gender dysphoria and improvement in general psychologic functioning after sequential treatment with GnRH agonist therapy, GAH treatment, and gender reassignment surgery. These individuals were also shown to have a sense of well-being equivalent or superior to that seen in age-matched controls from the general population, and none regretted treatment. A cross-sectional survey administered by the National Center for Transgender Equality to more than 20,000 U.S. TGD adults age 18-36 years demonstrated that those treated with GnRH agonists for pubertal suppression during adolescence had a significantly lower odds of lifetime suicidal ideation compared to those who wanted, but did not receive, such treatment. The largest observational study assessing the impact of gender-affirming medical care on the mental health of TGD adolescents and young adults in the United States (n = 315, age 12-20 years) demonstrated significant improvements in psychosocial functioning, decreases in depression and anxiety, and increases in appearance congruence, positive affect, and life satisfaction. Other studies have also reported on improvement of mental health measures, quality of life, global psychosocial functioning, and body image in response to treatment with gender-affirming medical care.

### Challenges to Care

TGD youth not only face high levels of discrimination in their lived environments, but those who succeed in accessing medical care often encounter stigma and discrimination within healthcare settings. Research on the experiences of TGD persons of color, a group that faces startlingly high rates of violence and homicide, is an area in need of much attention. In the United States, gender-affirming medical therapies are currently not FDA-approved for use in TGD youth, and insurance companies often deny coverage of these medically necessary, essential, and even lifesaving interventions. Some families can pay out-of-pocket for treatments when coverage is denied, whereas others cannot, furthering the socioeconomic divide between wealthy and impoverished. Efforts in multiple U.S. states to criminalize the medical care of TGD youth are ongoing and in need of significant advocacy and education. In addition, participation in same-gender sporting activities has created significant barriers among TGD athletes. Some athletic bodies have placed barriers to same-gender participation, requiring transfemales to start suppressive therapy early in puberty or to monitor testosterone levels, with a cutoff level prohibiting participation.

Visit Elsevier eBooks+ at [eBooks.Elsevier.com](https://eBooks.Elsevier.com) for Bibliography.

## Chapter 154

## Gay, Lesbian, and Bisexual Adolescents

Stewart L. Adelson and Mark A. Schuster

Understanding a child's or adolescent's sexual and emotional development is an essential part of any comprehensive pediatric evaluation. For youth who are or might be gay, lesbian, or bisexual (**GLB also noted as LGB in the LGBT abbreviation**), such understanding is particularly important. GLB youth as a group have the same health and developmental needs typical of youth in general, and their sexual orientation is part of the normal spectrum of human sexuality. However, they encounter distinct developmental challenges and can have additional physical and mental health needs related to their orientation and others' reaction to it. Their sexual orientation may be different from that expected by some families, peers, and society; they are at risk of peer rejection, bullying, violence, or family nonacceptance more frequently than most youth. Although the majority of GLB adolescents grow up physically and mentally healthy, they are at increased risk for certain health problems as a result of these stresses and the epidemiology of health threats such as HIV and other sexually transmitted infections (STIs). In addition, healthcare providers may also have biases and assumptions about the GLB community (Table 154.1).

**Sexual orientation** refers to an individual's attraction to others based on sex or gender. It encompasses emotional and erotic desires, physiologic arousal, sexual behavior, sexual identity, and social role. As sexuality develops, youth can be oriented entirely toward

a particular sex or gender, or more than one, to various degrees on a continuum. **Homosexuality** involves orientation toward people of one's same sex or gender, and **bisexuality** involves orientation toward males and females. **Gay** is a common term for both males and females who have same-sex attractions; **lesbian** refers to gay females. Increasing numbers of youth describe themselves as having a nonbinary gender identity (see Chapter 153). Accordingly, some do not fit binary categories of sexual orientation and use other terms to describe themselves, such as **pansexual** (attracted to all genders). Those unsure of their orientation are **curious** or **questioning**. The term **young men who have sex with men (YMSM)** is sometimes used in the research literature to denote male youth who engage in sexual activity with other males, regardless of how they identify themselves.

### PREVALENCE OF HOMOSEXUALITY AND BISEXUALITY IN YOUTH

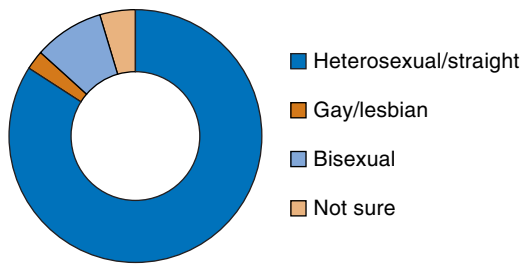
Some junior high and high school students self-identify as gay, lesbian, or bisexual (Fig. 154.1). Some who do not identify as GLB report same-sex attraction, fantasies, or behavior. Some are unsure of their sexual orientation. Certainty about sexual orientation tends to increase through adolescence with sexual experience, although one can be aware of one's orientation without having had sexual partners. Those who fear nonacceptance may try to suppress or deny their orientation. Consequently, various aspects of an individual's orientation—attraction, behavior, and identity—may not always be consistent with each other throughout development. Not all youth with homosexual attraction or experience identify as *gay*, consistent in part with reluctance about having or revealing a gay identity and underscoring the differences among attraction, behavior, and identity. A report providing national estimates of the number of high school students with GLB identity in 2019 found that 2.5% said they were gay or lesbian, 8.7% said they were bisexual, and 4.5% reported being unsure of their sexual orientation (see Fig. 154.1).

**Table 154.1** Common Assumptions to Avoid When Caring for Lesbian, Gay, Bisexual, and Queer Patients

ASSUMPTION TYPE	DO NOT ASSUME THAT...
Identity	<ul style="list-style-type: none"> <li>• Lesbian, gay, or bisexual people are cisgender</li> <li>• A person has to identify as either male or female</li> <li>• A person's gender or sexual orientation is a major aspect of a person's identity</li> <li>• Being lesbian, gay, bisexual, or queer is always hard</li> <li>• LGBQ people cannot adjust to stressors</li> </ul>
Sexual orientation	<ul style="list-style-type: none"> <li>• All patients are heterosexual</li> <li>• People exploring their sexuality have a need to categorize into established sexual orientations</li> <li>• Bisexuality is a phase or that bisexual people are confused</li> <li>• Sexual orientation aligns with sexual behavior</li> </ul>
Sexual behavior	<ul style="list-style-type: none"> <li>• All LGBQ people are sexually active (some are celibate or asexual)</li> <li>• Gay men do not have sex with women or lesbian women do not have sex with men</li> <li>• All gay men have multiple partners and engage in high-risk behavior</li> <li>• Sexual behavior will remain stable over time</li> <li>• Lesbians are not at risk of HPV or other STIs</li> <li>• Bisexual people are promiscuous or are always unfaithful</li> </ul>
Relationships and family	<ul style="list-style-type: none"> <li>• Lesbian women do not want to be pregnant or are not at risk of pregnancy</li> <li>• Interpersonal violence does not occur in LGBQ couples</li> <li>• LGBQ patients do not have children or do not wish to have children</li> <li>• All adults of reproductive age have an interest in parenting</li> <li>• LGBQ people do not have strong family ties</li> <li>• LGBQ patients have ties to their families of origin</li> </ul>
Anatomy	<ul style="list-style-type: none"> <li>• Queer people all want to change their bodies with surgeries or hormones</li> <li>• Anything about the body of an LGBQ patient</li> </ul>

HPV, Human papillomavirus; STI, sexually transmitted illness.

Adapted from Makadon HJ, Mayer KH, Potter J, Goldhammer H. *The Fenway Guide to Lesbian, Gay, Bisexual, and Transgender Health*, 2nd ed. Philadelphia: American College of Physicians, 2015; and Suarez Lupez E, Siegel J, Streed Jr C. The annual examination for lesbian, gay, and bisexual patients. *Prim Care Clin Office Pract*. 2021;48:191–212, Table 1.



YRBS 2019 - students were restricted to these choices

**Fig. 154.1** Sexual identities among high school students. YRBS; Youth Risk Behavior Study. (From HHS Youth Risk Behavior Survey from 2019: US Department of Health and Human Services, Centers for Disease Control and Prevention. (2020, Aug 21). Youth Risk Behavior Surveillance -- United States, 2019. MMWR Supplement, 69(1) <https://www.cdc.gov/healthyyouth/data/yrbs/pdf/2019/su6901-H.pdf>.)

## DEVELOPMENT OF SEXUAL ORIENTATION IN CHILDHOOD AND ADOLESCENCE

Sexual orientation development appears to begin prenatally and continue through childhood and adolescence and into adulthood. Both gender role behavior in childhood and sexual orientation in puberty and adolescence are partly influenced by prenatal genetic and neuroendocrine factors. Sociocultural and psychologic factors also influence sexual development. A gay or lesbian sexual orientation is sometimes preceded developmentally in childhood by nonconforming gender expression or variation from population averages in expression of gender-related behavior such as activities, interests, styles, and other attributes recognized as masculine or feminine, like toy preferences and preference for playmates of a particular gender. Childhood gender nonconformity is significantly associated with nonheterosexual orientation, especially in males. However, it is not experienced by all gay or lesbian people, and not all children with nonconforming gender role behavior are gay or lesbian. When present, however, nonconformity causes many gay people to feel different from peers during childhood, even before sexual desire or identity emerges. Depending on the setting, gender-nonconforming children may experience ostracism, bullying, or family nonacceptance. These reactions to gender nonconformity can lead to later difficulty with gender-related self-esteem and long-term mental health problems.

Less frequently, gay or lesbian sexual orientation in adolescence is preceded by childhood **gender variant identity**, a phenomenon in which the gender identity of an individual at any age differs from phenotypic sex and assigned sex at birth (see Chapter 153).

## STIGMA, RISK, AND RESILIENCE

People experiencing same-sex attraction and behavior exist in all societies. The meaning, acceptance, and legality of non-heterosexual attraction vary greatly with cultural, historical, and social contexts. Although gay people are more visible and accepted in some societies, youth are often exposed to antigay attitudes. For many GLB youth, revealing their sexual orientation (*coming out*) to family, peers, healthcare providers, and others is a significant step. Specific racial, ethnic, religious, and other demographic groups may experience distinct developmental stressors. A comprehensive understanding of a youth's sexual development and health must consider intersecting sociodemographic factors influencing a youth's experience of a nonheterosexual orientation. For example, race, ethnicity, and religious affiliation—and the reactions of others to one's demographic characteristics—can influence comfort disclosing an GLB identity, involvement in GLB socialization, access to religious affirmation, and processes of coming out.

Some GLB youth experience difficulty coping with **stigma**. A longitudinal study that investigated **bullying and victimization** among youth from 5th through 10th grade found that the females and males who identified as GLB in 10th grade were more likely than their peers to report that they had been bullied and victimized across grades. GLB youth may be perceived by others as different before they themselves have any GLB attraction or experience or identify as GLB. Even when not overtly threatened, GLB youth frequently encounter negative attitudes that force them to hide at a time when family and peer acceptance holds great developmental significance. Family nonacceptance, feeling unsafe due to school harassment, and peer bullying related to sexual orientation elevate risk in GLB adolescents for depression, anxiety, substance abuse, suicidal thoughts and attempts, and social problems such as truancy, dropping out, running away, and homelessness. Mental health problems, sexual risk-taking, or substance use may increase exposure to HIV and other STIs. Stigma may also impede access to healthcare in some communities.

Nevertheless, most GLB youth are resilient, with good physical and mental health despite possible pervasive stresses. Family connectedness and school support and safety are important protective factors against depression, suicidal thoughts and attempts, and substance abuse. GLB antiharassment policies and organizations such as **genders and sexualities alliances** (also sometimes called gay-straight alliances) and antibullying programs are associated with increased school safety for GLB youth. It is therefore important to reduce stigma, support acceptance, and promote resilient coping.

## HEALTH

### Depression and Suicidality

Compared to their heterosexual peers, GLB youth and those who are not sure of their sexual orientation have a higher prevalence of suicidality. Family rejection, bullying, and other victimization motivated by homophobia account statistically for increased depression and suicidal thoughts and attempts in GLB adolescents. Suicidal thoughts or attempts are highest during the interval after recognition of same-sex attraction or a same-sex sexual experience but before self-acceptance as gay.

### Sexually Transmitted Infections

The epidemiology of STIs, related to specific sexual practices and prevalence of certain STIs in GLB communities, informs recommended counseling, screening, and treatment strategies (Table 154.2). Anal intercourse has been shown to be the most efficient route of infection by hepatitis B (see Chapter 406), cytomegalovirus (see Chapter 302), and HIV (see Chapter 322). Oral-anal and digital-anal contact can transmit enteric pathogens, such as hepatitis A. Unprotected oral sex also can lead to oropharyngeal disease in the receptive partner and gonococcal and nongonococcal urethritis in the insertive partner. Certain STIs, particularly ulcerative diseases, such as syphilis and herpes simplex virus infection, facilitate spread of HIV. YMSM are also at risk for infections with *Shigella* spp. and Mpox (see Chapter 163).

Among U.S. adolescents and young adults, YMSM, and especially Black YMSM, continue to face the greatest prevalence of HIV/AIDS. Although possible, female-to-female sexual transmission of HIV is inefficient, and females who only engage in sex with females are less likely than other youth to acquire an STI. However, males and females who identify as gay or lesbian may engage in sexual activity with partners who are not of the same gender; counseling and screening for all types of STIs are still relevant.

### Substance Abuse

Compared with their heterosexual peers, GLB youth appear to use alcohol and other substances at higher rates, including more binge drinking and earlier onset and more rapid trajectory of substance use.

More substantial substance use may be greatest in youth who, although they do not identify as GLB, have attraction to or engage in sexual behavior with others of their gender.

**Obesity and Disordered Eating**

Compared with heterosexual females, lesbian and bisexual females are generally more likely to be obese or overweight. In contrast, young gay and bisexual males are more likely to have body image concerns and to restrict eating or engage in compensatory weight loss strategies

compared to heterosexual boys. Binge eating may also be more common in GLB youth.

**Psychosocial Problems**

Academic underachievement, truancy, and dropping out of school are frequently associated in GLB adolescents with homophobic victimization, harassment, violence, and feeling unsafe at school. Studies suggest that youth who eventually identify as GLB have higher rates than other youth of experiencing child abuse and of running away or being kicked

**Table 154.2** The 6 Ps of a Complete Sexual History

P	OBJECTIVES	QUESTIONS
Partners	<ul style="list-style-type: none"> <li>Determine the number and gender/sex of partners</li> <li>Determine partner risk factors (other partners, drug use)</li> </ul>	"Are you currently sexually active?" "Have you ever been sexually active?" "When you have sex, what is the gender of your partners? What anatomy is used for sex?" "How do you describe your sexual orientation?" "How many partners have you had in the past 6 (or 12) months?" "Has anyone ever forced themselves on you sexually or touched you sexually in an unwanted way?"* Remember to ask about opposite-sex partners
Practices	<ul style="list-style-type: none"> <li>If a patient has had more than one partner in the past 12 mo (or has a partner who has other sex partners)</li> <li>Explore their sexual practices and behaviors, because they will guide assessment of risk and determination of testing</li> </ul>	"What types of sex are you having?" "When having sex, do you have vaginal, anal, and/or oral sex?" "If you have anal sex, do you have insertive sex, receptive sex, or both?" In colloquial words, "Are you a top, a bottom, or vers?" "Do you have any alternative sexual practices?" (i.e., kinks, BDSM, fisting) "Do you use alcohol or drugs during sex?" "Have you ever exchanged sex for money, drugs, food, or shelter?" "Do you use lubricants during sex? What kind?" "Do you use sex toys? How often? Do you share them? Do you clean them?" Put bluntly, questions should aim to answer who is putting what, where, when, and how
Protection from STI	<ul style="list-style-type: none"> <li>If a patient has had more than one partner in the past 12 mo (or has a partner who has other sex partners)<sup>†</sup></li> <li>Based on patient risk profile, ask these questions accordingly</li> <li>Explore the patient's use of barrier methods</li> <li>Explore the patient's use of PrEP</li> </ul>	"How do you keep yourself safe during sex?" "Do you use condoms/dental dams when having vaginal, anal, and/or oral sex? How often? All the time? Most of the time? About half of the time? Rarely?" If no, "Why not?" "Do you and your partners use any other protection against STI?" "Do you or your partner use PrEP? "Are you interested in starting PrEP?"
Past history of STI	<ul style="list-style-type: none"> <li>Explore patient STI history as a risk factor for future STI</li> </ul>	"Have you ever been tested for HIV or other STIs?" "Have you ever been diagnosed with an STI?" If yes, "When were you diagnosed? How were you treated?" "Would you like to be tested? And which parts of your body should we check?" "Has your current or any former partners ever been diagnosed with an STI?" If yes, "Have you been tested for the same STI?"
Pleasure/pain	<ul style="list-style-type: none"> <li>Recognize the importance of pleasure in sexual intimacy and well-being</li> </ul>	"Are you satisfied with your sexual life?" "Do you have any pain with sex?" "Do you have any problems with erection, lubrication, ejaculation, or orgasm?"
Prevention/planning of pregnancy	<ul style="list-style-type: none"> <li>Evaluate desire for/risk of pregnancy</li> </ul>	"Are you concerned about getting pregnant or getting your partner pregnant?" "Are you using contraception or practicing any form of birth control?" "Do you need any information on birth control?"

\*For more information, please see, "Sexual Health and the LGBTQ+ Community," by Taylor NM, King CK.. *Prim Care Clin Office Pract.* 2021;48:271-282.

<sup>†</sup>For patients who report one or fewer partners in the last 12 mo, ask whether they have any concerns about STI.

BDSM, Bondage and discipline, dominance and submission, sadism and masochism; HIV, human immunodeficiency virus; PrEP, preexposure prophylaxis.

From Suarez S, Lupez E, Siegel J, Streed Jr C. The annual examination for lesbian, gay, and bisexual patients. *Prim Care Clin Office Pract.* 2021;48:191-212, Table 2.



out of their homes. GLB young people are overrepresented among homeless and runaway populations across the United States, which can expose them to drugs, sexual abuse, and other health risks.

## RECOMMENDATIONS FOR CARE

### Evaluation

The goal of GLB pediatric care is physical health, social and emotional well-being, and healthy development. Physicians should provide nonjudgmental care to all adolescents, including those who are GLB or questioning (see [Chapter 153](#), [Table 153.1](#), and [Table 154.1](#)). They should receive the age-appropriate history, examination, and anticipatory guidance recommended for adolescents in general. The physical examination and laboratory evaluation of GLB and questioning adolescents are the same as for any teenager. However, providers should appropriately screen for special potential medical and psychosocial threats to GLB teenagers' health.

A nonjudgmental healthcare environment is important, with open communication and a positive relationship with youth and families. In the waiting room, written material about sexual orientation, support groups, and community resources will signal openness to discussing sexuality. Registration forms recognizing the possibility of same-gender parents signal a safe setting (e.g., forms can list parent/guardian #1, parent/guardian #2). Sexual history questions should avoid heterosexual assumptions (e.g., ask "Are you dating someone?" vs "Do you have a boyfriend/girlfriend?"). This is important at all ages. For example, asking a 6-year-old male if he has a girlfriend may convey an unsupportive message if he discovers later that he would like a boyfriend. Explaining confidentiality and incorporating into each adolescent visit private time with no parent in the room (see [Chapter 137](#)) may facilitate discussing sexual orientation, as may use of appropriate health history forms such as the American Medical Association's Guidelines for Adolescent Prevention Services Questionnaire.

Clinicians should remember that any youth might be GLB whether or not they are identified or perceived as such, so clinicians should not presuppose a particular orientation (see [Table 154.1](#)). Competency in conveying sensitivity, acceptance, and respectfulness; effective communication skills; and appropriate attention to privacy and confidentiality (including practices related to billing and record requests) are fundamental to providing high-quality care. While remaining attuned to youth's preferences, explicit or implied, for discussing sexual orientation, providers can tactfully take the lead, if necessary, regarding any pressing areas of clinical concern.

### Medical and Sexual Health

STIs are covered in [Chapter 163](#), but issues specific to GLB youth are included here. Use of latex condoms for fellatio, and dental dams and cut-open latex condoms for anilingus and cunnilingus, should be discussed with adolescents. Recommendations also include use of latex condoms for sexual appliances. In addition, it is important to emphasize that people who have been using alcohol or other drugs are at increased likelihood for engaging in riskier sexual activity. It is important not to assume that a gay male or female who does not identify as bisexual has not had sex with someone of a different sex or gender; lesbians can still have an unplanned pregnancy. Therefore prevention counseling about unintended pregnancy is relevant

to all adolescents. Similarly, youth who identify as heterosexual and whose attractions are not to those of the same sex or gender may still have sexual activity with a partner of the same sex or gender.

Although vaccination against hepatitis A and B is recommended for all children, it is particularly recommended that nonvaccinated adolescent males who are having (or are likely to have) sex with males receive catch-up vaccines. The same recommendation applies to the human papillomavirus (HPV) vaccine for males. The Centers for Disease Control and Prevention (CDC) recommends that males who are engaging in sexual activity with males have annual testing for HIV, hepatitis A, hepatitis B, syphilis, urethral gonorrhea, and chlamydia (if engaging in insertive oral or anal intercourse), oral gonorrhea (if engaging in receptive oral intercourse), and rectal gonorrhea and chlamydia (if engaging in receptive anal intercourse). The CDC also recommends HIV pre-exposure prophylaxis (PrEP) for adolescents who are engaging in or plan to engage in sexual behavior placing them at "substantial ongoing risk of HIV exposure and acquisition."

### Mental Health

Awareness of mental health and social problems is important when caring for GLB youth, as for all youth. Clinicians should monitor for depression, suicidality, anxiety, and substance abuse and know their community's mental health resources. Minor psychosocial problems might be handled by referral to a support group for patients (e.g., a school gay-straight or genders-sexualities alliance, other community support group) or for parents and others (e.g., Parents, Families and Friends of Lesbians and Gays). In some communities, agencies and organizations serving the GLB community can help with social, educational, vocational, housing, and other needs.

Individuals or families who harbor negative attitudes may inquire about mental health treatment to avert or change a gay or bisexual orientation (conversion therapy). However, a GLB orientation is not an illness, and all leading health organizations have concluded that such change is neither possible nor warranted. Conversion therapy is illegal in 18 states; 22 states have no law or policy.

It is important to distinguish between a GLB orientation, which is not a mental illness, and mental health problems (e.g., depression) for which GLB youth are at elevated risk. While understanding different families' values, clinicians must recognize the morbidity and mortality associated with stigma and attempt to foster physical and emotional health. Individual or family therapy might be indicated.

Clinicians should also monitor for specific stressors, such as bullying and other homophobic victimization, family nonacceptance, and abuse. Failure to confront harassment constitutes tacit assent. Anticipatory guidance, referral, and substance abuse treatment should be considered for the subset of GLB youth who use alcohol, drugs, or tobacco, some of whom may be using these to manage painful feelings related to conflicts over their sexuality.

Adolescents with serious psychiatric symptoms, such as suicidality, depression, and substance abuse, should be referred to mental health specialists with competency in treating GLB adolescents (see [Chapter 40](#)).

Visit Elsevier eBooks+ at [eBooks.Health.Elsevier.com](http://eBooks.Health.Elsevier.com) for Bibliography.

## Chapter 155

# The Epidemiology of Adolescent Health Problems

Samantha V. Hill and Tamera Coyne-Beasley

Adolescence is the first period of life where the major determinants of morbidity and mortality are *behavioral* rather than congenital or infectious. As adolescents make the transition from childhood to adulthood, they establish behaviors that affect both their current and future health. Adolescence is a time of immense biologic, psychologic, and social change (see Chapter 150). Many of the psychologic changes have a biologic substrate in the development and eventual maturation of the central nervous system, particularly the frontal lobe areas responsible for executive functioning (Fig. 155.1). In addition to cognitive development, there are both risk and protective factors for adverse adolescent health behaviors that are dependent on the social environment and the mental health of an adolescent (Table 155.1).

Many adolescents continually confront the task of making healthy choices while struggling with impulsivity that can lead to unintentional consequences, such as injuries, sexually transmitted infections (STIs), or drug overdoses. Adolescents are also challenged with adopting behaviors that will affect their future adult health, such as eating nutritiously; engaging in physical activity; and choosing not to use tobacco (including vapes and e-cigarettes), alcohol, cannabis, or illicit substances. Environmental factors and social determinants of health in and among an individual's family, peers, school, and community also contribute to adolescents' health and risk behaviors. The U.S. Centers for Disease Control and Prevention (CDC) **Youth Risk Behavior Surveillance Survey**, a school-based survey of a nationally representative sample of U.S. high school students, demonstrates that youth begin engaging in behaviors that place their health at risk during adolescence (Fig. 155.2).

Although according to the 2018 CDC National Health Interview Survey (<https://www.cdc.gov/nchs/nhis/shs/tables.htm>), a probability sample survey conducted annually, an estimated 83% of 12- to 17-year-olds report excellent or very good health, 11% reported limitation in usual activities because of one or more chronic conditions, 10% missed 6-10 school days in the past year, 6% are uninsured, 5% have no usual place of healthcare, 10% have asthma, 12% have respiratory

allergies, 10% have a learning disability, 13% have attention-deficit/hyperactivity disorder, and 18% take prescription medications routinely. In 2018 the mortality rate among adolescents 15-19 years of age was 49 deaths per 100,000 population. Although varying by gender, the leading causes of death overall among adolescents 15-19 years of age are (1) unintentional injuries, (2) suicide, and (3) homicide (Table 155.2).

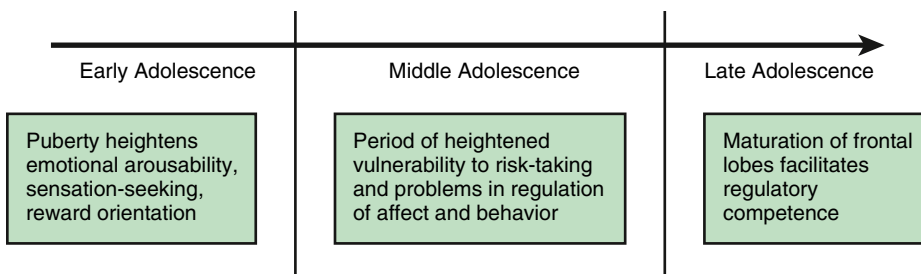
Within the adolescent population, **disparities in health** occur. Adolescent health outcomes and behaviors vary among populations that can be defined by being Black, ethnicity, gender, education, income, disability, geographic location (e.g., rural or urban), or sexual orientation. Health disparities result from multiple factors affecting social determinates of health, including poverty, environmental threats, inadequate access to healthcare, individual and behavioral factors, racism and other systemic biases, and educational and other inequalities (Table 155.3).

## ACCESS TO HEALTHCARE

Adolescents in the United States make fewer visits to physicians for ambulatory office visits than any other age-group; school-age children and adolescents are more likely than younger children to have unmet health needs and delayed medical care. Adolescents who actually receive preventive care may still not have access to time alone with their provider to discuss confidential health issues such as STIs, HIV, or pregnancy prevention. Less than half (22% of 13- to 14-year-olds and 43% of 15- to 18-year-olds) of adolescents have time alone with their healthcare provider during a preventive healthcare visit; sexually experienced teens report sexual health discussions more often than nonsexually experienced teens, but the frequency is still low at 81% and 65% for sexually experienced young women and men, respectively.

The 2010 Patient Protection and Affordable Care Act (ACA) has improved access to care for young adults 18 to 24 years old. The ACA permits children to receive benefits from their parents' health plans through age 26 years. Although accomplishments have been made in improving adolescent health, *Healthy People* provides science-based, 10-year national objectives for measuring and improving the health of all Americans by establishing benchmarks and monitoring progress over time. The *Healthy People 2030* agenda includes 24 adolescent-specific objectives with a goal of improving the healthy development, health, safety, and well-being of adolescents and young adults over the next 10 years (Table 155.4). This science-based initiative is centered around a framework for public health prevention priorities and actions to improve the health status of U.S. youth.

Visit Elsevier eBooks+ at [eBooks.Health.Elsevier.com](https://eBooks.Health.Elsevier.com) for Bibliography.



**Fig. 155.1** It has been speculated that the impact of puberty on arousal and motivation occurs before the maturation of the frontal lobes is complete. This gap may create a period of heightened vulnerability to problems in the regulation of affect and behavior, which might help to explain the increased potential in adolescence for risk-taking, recklessness, and the onset of emotional and behavioral problems. (From Steinberg L. *Cognitive and affective development in adolescence*. *Trends Cogn Sci*. 2005;9:69-74.)

Table 155.1 Identified Risk and Protective Factors for Adolescent Health Behaviors		
BEHAVIOR	RISK FACTORS	PROTECTIVE FACTORS
Smoking	Depression and other mental health problems, alcohol use, disconnectedness from school or family, difficulty talking with parents, minority ethnicity, low school achievement, peer smoking	Family connectedness, perceived healthiness, higher parental expectations, low prevalence of smoking in school
Alcohol and drug misuse	Depression and other mental health problems, low self-esteem, easy family access to alcohol, working outside school, difficulty talking with parents, risk factors for transition from occasional to regular substance misuse (smoking, availability of substances, peer use, other risk behaviors)	Connectedness with school and family, religious affiliation
Teenage pregnancy	Deprivation, city residence, low educational expectations, sexual intercourse, lack of access to sexual health services, drug and alcohol use	Connectedness with school and family, religious affiliation
Sexually transmitted infections	Mental health problems, substance misuse, exploration of sexuality and sexual identity (sexual activity)	Connectedness with school and family, religious affiliation

Adapted from McIntosh N, Helms P, Smyth R, eds. *Fofar and Arneil's Textbook of Pediatrics*, 6th ed. Edinburgh: Churchill Livingstone; 2003:1757–1768; and Viner R, Macfarlane A. Health promotion. *BMJ*. 2005;330:527–529.

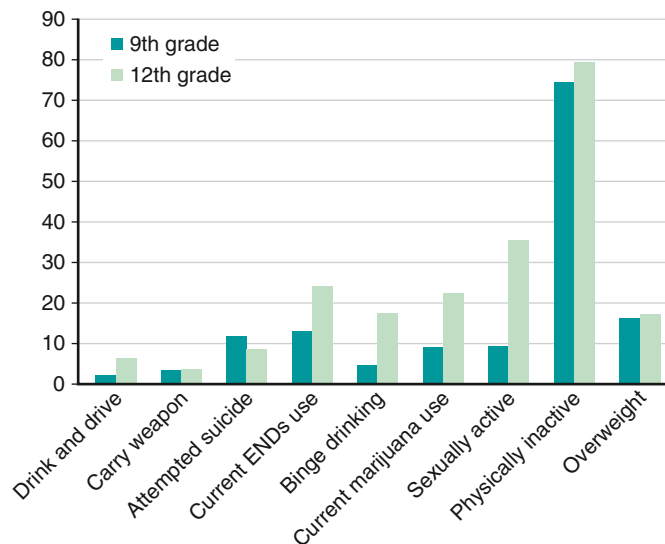


Fig. 155.2 Selected health behaviors among 9th and 12th-grade high school students. ENDS, Electronic nicotine delivery systems. (Data from Centers for Disease Control and Prevention: 1991-2021 High school youth risk behavior survey data. <http://nccd.cdc.gov/youthonline>.)

Table 155.2 Leading Causes of Death Among 15- to 19-Year-Olds by Gender, United States, 2018-2021*				
LEADING CAUSES OF DEATH	MALE		FEMALE	
	CAUSE OF DEATH	MORTALITY RATE PER 100,000 POPULATION	CAUSE OF DEATH	MORTALITY RATE PER 100,000 POPULATION
#1	Unintentional injuries	32.4	Accidents (unintentional injuries)	14.3
#2	Assault (homicide)	21.6	Intentional self-harm (suicide)	5.2
#3	Intentional self-harm	16.1	Malignant neoplasms	3.6

\*Based on data from Heron M. Deaths: leading causes for 2018-2019, CDC WONDER Online Database 2021. <https://wonder.cdc.gov/>

**Table 155.3** Adolescent Health Outcomes by Ethnicity, United States, 2018-2019

OUTCOME	WHITE	BLACK	AI/AN	API	HISPANIC
Deaths*	45.4	79.8	62.8	23.4 <sup>§</sup>	29.3
Births <sup>†</sup>	11.4	25.8	29.2	2.7 <sup>§</sup>	18.2
Obese <sup>‡‡</sup>	12.5	18.2	7.9	33.3 <sup>§</sup>	37.1
Asthma <sup>‡</sup>	10.1	18.0	17.8	8.2 <sup>§</sup>	12.5
Depressed <sup>**</sup>	14.0	9.5	16.3	11.5 <sup>§</sup>	13.8
Chlamydia*	857.5	4,894.0	2343.1	310.3 <sup>§</sup>	1080.4
Gonorrhea*	134.5	1506.1	559.9	44.9 <sup>§</sup>	179.8
HIV*	2.1	34.8	5.6	12.2 <sup>§</sup>	7.4

\*2019 rates per 100,000 15- to 19-yr-old population by race/ethnicity.

<sup>†</sup>2019 rates of births in per 1,000 15- to 19-yr-old females by race/ethnicity.

<sup>‡</sup>Percent high school students reporting health outcome in 2018.

<sup>\*\*</sup>Prevalence of 12- to 17-yr-olds reporting health outcome in 2017.

<sup>‡‡</sup>Percent high school students reporting health outcome in 2017.

<sup>§</sup>Rates of Asian-only race.

AI/AN, American Indian or Alaska Native; API, Asian or Pacific Islander; HIV, human immunodeficiency virus.

**Table 155.4** Healthy People 2030 Adolescent Health (AH) Objectives

- **AH-01:** Increase the proportion of adolescents who had a preventive healthcare visit in the past year.
- **AH-02:** Increase the proportion of adolescents who speak privately with a provider at a preventive medical visit.
- **AH-03:** Increase the proportion of adolescents who have an adult they can talk to about serious problems.
- **AH-04:** Increase the proportion of students participating in the School Breakfast Program.
- **AH-05:** Increase the proportion of 4th-graders with reading skills at or above the proficient level.
- **AH-06:** Increase the proportion of 4th-graders with math skills at or above the proficient level.
- **AH-07:** Reduce chronic school absence among early adolescents.
- **AH-08:** Increase the proportion of high school students who graduate in 4 years.
- **AH-09:** Reduce the proportion of adolescents and young adults who are not in school or working.
- **AH-10:** Reduce the rate of minors and young adults committing violent crimes.
- **AH-D01:** Increase the proportion of trauma-informed early childcare settings and elementary and secondary schools.
- **AH-D02:** Increase the proportion of children and adolescents with symptoms of trauma who get treatment.
- **AH-D03:** Reduce the proportion of public schools with a serious violent incident.
- **AH-R01:** Increase the proportion of adolescents who get support for their transition to adult healthcare.
- **AH-R02:** Increase the proportion of adolescents in foster care who show signs of being ready for adulthood.
- **AH-R03:** Increase the proportion of eligible students participating in the Summer Food Service Program.
- **AH-R04:** Increase the proportion of 8th-graders with reading skills at or above the proficient level.
- **AH-R0:** Increase the proportion of 8th-graders with math skills at or above the proficient level.
- **AH-R06:** Increase the proportion of schools requiring students to take at least two health education courses from 6 to 12.
- **AH-R07:** Increase the proportion of secondary schools with a start time of 8:30 AM or later.
- **AH-R08:** Increase the proportion of secondary schools with a full-time registered nurse.
- **AH-R09:** Increase the proportion of public schools with a counselor, social worker, and psychologist.
- **AH-R10:** Increase the proportion of students served under the Individuals with Disabilities Education Act who earn a high school diploma.
- **AH-R11:** Reduce the rate of adolescents and young adult victimization from violent crimes.

From U.S. Department of Health and Human Services: *Healthy People 2030*, available at: <https://health.gov/healthypeople/about/workgroups/adolescent-health-workgroup>.



## Chapter 156

## Violent Behavior

Michael N. Levas and  
Marlene D. Melzer-Lange

Violence is recognized by the World Health Organization (WHO) as a leading worldwide public health problem. The WHO defines violence as “the *intentional* use of physical force or power, threatened or actual, against oneself, another person, or against a group or community that either results in or has a high likelihood of resulting in *injury*, death, psychological harm, maldevelopment or deprivation” (see Chapter 15). Youths may be perpetrators, victims, or observers of violence (or any combination of the three roles, wherein the roles are unclear), with varying severity of impact on the individual, family, and larger community. Risk factors for youth violence include poverty, socially disorganized communities, war and other regional conflicts, substance misuse (in the child or family), behavioral health disorders (attention-deficit, hyperactivity, conduct disorder), poor school performance, social isolation, child trafficking, runaway youth, criminal or gang involvement (child or family), bullying, and low parental involvement.

### EPIDEMIOLOGY

In 2019 (and 2021), **homicide** in the United States was the third leading cause of death for 10- to 24-year-olds, totaling 4,965 deaths, which were largely males (85%) killed by a handgun (79%). The 2019 homicide rate for teens age 12–17 years was 3.43/100,000 youth, down 63% from 8.4/100,000 youth in 1993. The WHO reports that other than the United States, where the youth and young adult homicide rate was 11/100,000, most countries with homicide rates above 10/100,000 are developing nations or countries with socioeconomic instability. In the United States the prevalence of behaviors that contribute to violence has not decreased, as fighting, weapon carrying, and cyberbullying remain prevalent among youth. Furthermore, the rate of homicide in youth had been declining since the peak in the 1990s but showed an increase in 2017 that has continued (Fig. 156.1). Adolescent reports of **physical fighting** have decreased from 42% in 1991 to 22% in 2019.

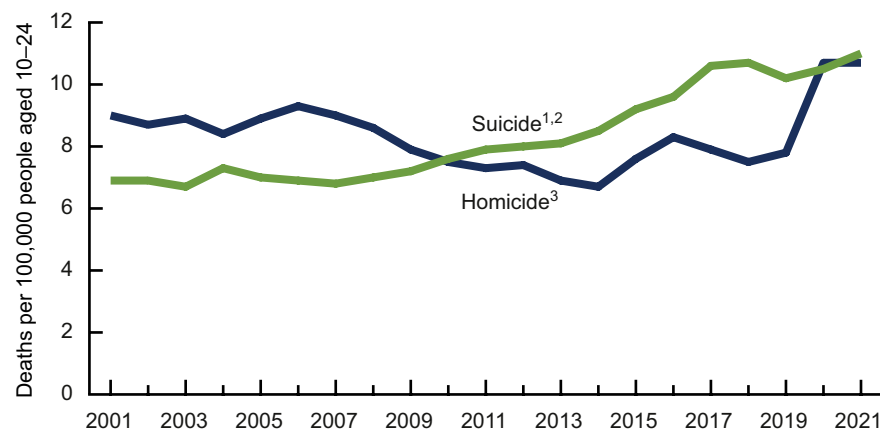
Violence at U.S. schools remains a significant problem, with 8.1% of students reporting being in a physical fight on school property one

more times in the preceding 12 months in 2019. The 2019 Youth Risk Behavior Surveillance System reported 13.1% of youths overall carried a weapon such as a gun, knife, or club in the last 30 days; 2.8% carried the weapon to school; and 7.4% reported being threatened or injured with a type of weapon on school property. Males are more likely than females to carry a gun or weapon and therefore may need more support and engagement at home and at school. These **violence-related behaviors** at school affect the general students' perception of safety. More than 8.7% of students did not go to school on one or more days in the preceding 30 days because they felt it was unsafe. School-based prevention programs initiated at the elementary school level have been found to decrease violent behaviors in students. Increased surveillance of students is warranted both on and around school property to improve student safety.

**Adolescent relationship abuse (dating violence/reproductive coercion)** occurs between two people in a close relationship and can be physical (punching, kicking, hitting, shoving), emotional (shaming, bullying, controlling, stalking), or sexual (forcing a partner to engage in a sexual act when he or she does not consent to it). Incidents of adolescent relationship abuse are not uncommon, with 22.4% of females and 15% of males experiencing some type of partner violence between the ages of 11 and 17 years. It may start with teasing, name calling, or shaming but often progresses electronically, with frequent calls, texting, or posting sexual pictures of a partner on social media. Risk factors for being a victim of adolescent relationship abuse include those who use alcohol, believe violence is acceptable, have a lack of adult supervision, or have a peer who is in a violent relationship. Most teens do not report the behaviors because of fear of retaliation from the partner. Teens who are victims of adolescent relationship abuse are more likely to experience decreased school performance, have thoughts about suicide, use drugs and alcohol, develop an eating disorder, experience depression, and are more likely to be victimized during college and into adulthood. School-based prevention programs that address attitudes and behaviors linked with adolescent relationship abuse, such as **Safe Dates** and **Dating Matters**, offer training experiences to change social norms among teens.

### ETIOLOGY

The WHO places youth violence in a model within the context of three larger types of violence: self-inflicted, interpersonal, and collective. **Interpersonal violence** is subdivided into violence largely between family members or partners and includes child abuse. **Community violence** occurs between individuals who are unrelated. **Collective violence** incorporates violence by people who are members of an identified group



**Fig. 156.1** Suicide and homicide death rates among people aged 10–24, United States, 2001–2021. <sup>1</sup>No statistically significant trend from 2001–2007, then significant increasing trend from 2007–2021 ( $p < 0.05$ ). <sup>2</sup>Rate significantly lower than the rates for homicide from 2001–2009 and significantly higher from 2011–2019 ( $p < 0.05$ ). <sup>3</sup>No statistically significant trend for homicides from 2001–2006, then significant decreasing trend from 2006–2014, and a significant increasing trend from 2014–2021 ( $p < 0.05$ ). The rate in 2021 was not significantly different than the rate in 2020 ( $p < 0.05$ ). NOTES: Suicides are identified with International Classification of Diseases, 10th Revision codes U03, X60–X84, and Y87.0, and homicides with codes U01–U02, X85–Y09, and Y87.1. Access data table at: <https://www.cdc.gov/nchs/data/databriefs/db471-tables.pdf#1>. SOURCE: National Center for Health Statistics, National Vital Statistics System, Mortality data file. (From Curtin SC, Garnett MF. Suicide and Homicide Death Rates Among Youth and Young Adults Aged 10–24: United States, 2001–2021. NCHS Data Brief. 2023 Jun;(471):1–8. Fig 1.)

against another group of individuals with social, political, or economic motivation. The types of violence in this model have behavioral links, such that child abuse victims are more likely to experience violent and aggressive interpersonal behavior as adolescents and adults. Overlapping risk factors for the types of violence include firearm availability, alcohol use, and socioeconomic inequalities. The benefit to identifying common risk factors for the types of violence lies in the potential for intervening with prevention efforts and gaining positive outcomes for more than one type of violent behavior. The model further acknowledges four categories that explore the potential nature of violence as involving physical, sexual, or psychologic force and deprivation.

The social-ecologic model of public health focuses on both population-level and individual-level determinants of health and their respective interventions. On the individual level, there may be two types of antisocial youth: life course persistent and limited. **Life course-limited offenders** have no childhood aberrant behaviors and are more likely to commit *status* offenses such as vandalism, running away, and other behaviors symbolic of their struggle for autonomy from parents. **Life course-persistent offenders** exhibit aberrant behavior in childhood, such as problems with temperament, behavioral development, and cognition; as adolescents they participate in more *victim-oriented* crimes. The existence of **adverse childhood experiences** foretells future health issues and subsequent violence. This hypothesis proposes that precursors such as child abuse and neglect, a child witnessing violence, adolescent sexual and physical abuse, and adolescent exposure to violence and violent assaults predispose youths to outcomes of violent behavior, violent crime, delinquency, violent assaults, suicide, or premature death. This public health model also emphasizes the community environment and resiliency of the individual and family. An additional common paradigm for high-risk violence behavior poses a balance of risk and protective factors at the individual, family, and community levels.

## CLINICAL MANIFESTATIONS

The identified risk factors for youth violence include poverty, association with delinquent peers, poor school performance or low education status, disconnection from adult role models or mentors, prior history of violence or victimization, poor family functioning, childhood abuse, substance misuse, and certain mental health disorders. The most common disorders associated with **aggressive behavior** in adolescents are intellectual disabilities, learning disabilities, moderately severe language disorders, and mental health disorders such as attention-deficit/hyperactivity disorder (ADHD) and mood disturbances. In general, youth with mental health disorders are not violent. However, the link between severe mental illness and violent behaviors is strongest for those with coexisting alcohol or substance abuse or dependence.

Inability to master prosocial skills such as the establishment and maintenance of positive family/peer relations and poor resolution of conflict may put adolescents at higher risk of physical violence and other risky behaviors. The single, most protective factor is the existence of one or more significant adult mentors in the child's life. **Conduct disorder** and **oppositional defiant disorder** are specific psychiatric diagnoses whose definitions are associated with violent behavior (Table 156.1). They occur with other disorders such as ADHD (see Chapter 50) and increase an adolescent's vulnerability for juvenile delinquency, substance use or abuse, sexual promiscuity, adult criminal behavior, incarceration, and antisocial personality disorder. Other co-occurring risk factors for youth violence include use of anabolic steroids, gang tattoos, belief in one's premature death (inability to see oneself as surviving to adulthood), preteen alcohol use, and placement in a juvenile detention center.

## DIAGNOSIS

The assessment of an adolescent at risk or with a history of violent behavior or victimization should be a part of the health maintenance visit of all adolescents. The answers to questions about recent history of involvement in a physical fight, carrying a weapon, or firearms in the household, as well as concerns that the adolescent may have about personal safety, may suggest a problem requiring a more in-depth evaluation. The **FISTS** mnemonic provides guidance for structuring the assessment (Table 156.2). Another screening tool, **Violence Injury**

**Table 156.1** Oppositional Defiant Disorder and Conduct Disorder

OPPOSITIONAL DEFIANT DISORDER	CONDUCT DISORDER
<ul style="list-style-type: none"> <li>• Often being angry or losing one's temper</li> <li>• Often arguing with adults or refusing to comply with adults' rules or requests</li> <li>• Often resentful or spiteful</li> <li>• Deliberately annoying others or becoming annoyed with others</li> <li>• Often blaming other people for one's own mistakes or misbehavior</li> </ul>	<ul style="list-style-type: none"> <li>• Breaking serious rules, such as running away, staying out at night when told not to, or skipping school</li> <li>• Being aggressive in a way that causes harm, such as bullying, fighting, or being cruel to animals</li> <li>• Lying, stealing, or damaging other people's property on purpose</li> </ul>

Courtesy Centers for Disease Control and Prevention: Children's Mental Health, <https://www.cdc.gov/childrensmentalhealth/behavior.html>, accessed August 4, 2021.

**Table 156.2** FISTS Mnemonic to Assess an Adolescent's Risk of Violence

<b>F: Fighting</b> (How many fights were you in last year? What was the last?)
<b>I: Injuries</b> (Have you ever been injured? Have you ever injured someone else?)
<b>S: Sex</b> (Has your partner hit you? Have you hit your partner? Have you ever been forced to have sex?)
<b>T: Threats</b> (Has someone with a weapon threatened you? What happened? Has anything changed to make you feel safer?)
<b>S: Self-defense</b> (What do you do if someone tries to pick a fight? Have you carried a weapon in self-defense?)

Adapted with permission from the Association of American Medical Colleges. Alpert EJ, Sege RD, Bradshaw YS. Interpersonal violence and the education of physicians. *Acad Med.* 1997;72:S41–S50.

**Protection and Risk Screen (VIPRS)**, has been validated to predict *future* violence among youth in the primary care setting (Table 156.3). The additional factors of physical or sexual abuse, serious problems at school, poor school performance and attendance, multiple incidents of trauma, substance use, and symptoms associated with behavioral disorders are indications for evaluation by a behavioral health professional. In a situation of acute trauma, assault victims are not always forthcoming about the circumstances of their injuries for fear of retaliation or police involvement. Stabilization of the injury or the gathering of forensic evidence in sexual assault is the treatment priority; however, once this is achieved, addressing a more comprehensive set of issues surrounding the assault is appropriate.

## TREATMENT

In the patient with acute injury secondary to violent assault, the treatment plan should follow standard protocols, which include the stabilization of the injury, evaluation and treatment of the injury, evaluation of the assault circumstance, psychologic evaluation and support, social service evaluation of the circumstances surrounding the assault, and a treatment plan on discharge that is designed to protect the adolescent from subsequent injury episodes, prevent retaliation, and minimize the development of psychologic disability. Victims and *witnesses* of violence are at risk for posttraumatic stress disorder and future aggressive or violent behavior. Using a **trauma-informed care** approach enables providers to help these victims and witnesses so that they can develop linkages to recovery and resilience. **Hospital-based violence intervention programs** have shown success by supporting violently injured youth and their families in the emergency department, hospital, or community. Credible messenger and violence interrupter programs have shown promise in decreasing the cycle of violence and retaliation in the community after violent events.

**Table 156.3** Violence Injury and Perpetration Risk Screen (VIPRS Scale): Percent and Odds of Future Violence Perpetration by Question Type

<b>PROTECTIVE FACTORS</b>	<b>%</b>	<b>ODDS OF ASSOCIATION WITH VIOLENCE PERPETRATION IF PROTECTIVE FACTOR NOT PRESENT OR (95% CI)</b>
1. Do your parents expect you to do well at school?		6.1(1.1-33.83)
Most of the time	93	
Sometimes	6.1	
Rarely/never	0.6	
2. Are your grades mostly		5.8(1.7-19.2)
A/B average	77.9	
C average	16.6	
D/F average	5.5	
<b>RISK FACTORS</b>	<b>% POSITIVE</b>	<b>ODDS OF ASSOCIATION WITH FUTURE VIOLENCE PERPETRATION IF RISK FACTOR PRESENT (OR 95% CI)</b>
3. Have you been suspended from school in the last year?		
Yes	17	47(11.1-201)
4. How many fights have you been in during the last year?		
0	82	
1-5	18	10.7(3.2-35.6)
5. Have you ever smoked marijuana or used other drugs?		
Yes	23	4.6(1.5-14.2)
6. Have you or your friends ever been in trouble with the law?*		
Yes	38.2	2.1(0.72-6.2)
Males	40.8	8.6(1.4-54.2)
Females	36.2	0.85(0.19-3.8)
7. Are you or your friends involved with a gang or tagging crew?		
Yes	7.0	4.6(0.93-23.0)
8. Do you feel you are hyperactive, or have you ever been diagnosed with ADHD*		
Yes	14.8	3.0(0.88-10.3)
Males	15.9	0.83(0.08-8.5)
Females	14.0	6.4(1.3-30.7)
9. Have you had any friends who have committed suicide?		
Yes	11	3.7(0.93-14.4)
10. Have you ever been injured in a fight?		
Yes	10	4.3(1.1-17.6)
11. When was the last time you hurt someone else in a fight?		
In the past month	4.3	
Between 1 and 6 mo ago	6.7	
Between 6 and 12 mo ago	3.7	
Over 1 yr ago	11.6	
Never	73.8	
Positive if ≤12 mo ago	14.6	24.6(4.3-138.7)
12. When was the last time you watched a fight?		
In the past month	25	
Between 1 and 6 mo ago	13.4	
Between 6 and 2 mo ago	11.6	
Over 1 yr ago	22.6	
Never	27.4	
Positive if ≤12 mo ago	50	6.1(1.6-22)

Continued

Table 156.3 Violence Injury and Perpetration Risk Screen (VIPRS Scale): Percent and Odds of Future Violence Perpetration by Question Type—cont'd		
RISK FACTORS	% POSITIVE	ODDS OF ASSOCIATION WITH FUTURE VIOLENCE PERPETRATION IF RISK FACTOR PRESENT (OR 95% CI)
13. How many times has someone beat you up in the last 6 mo?		
0	91.2	
1-6	9.8	6.2(1.1-34.2)
14. How many times has someone asked you to fight in the last 6 mo?		
0	75	
1-6	25	3.6(1.1-11.7)

\*Questions 6 and 8 display gender differences, because these two questions reveal statistically significant differences between genders. Modified from Sigel EJ, Hoffenberg A, Hart J, Dodge M. Development and psychometric properties of a violence screening tool for primary care. *J Adolesc Health*. 2011;48:358–365, Table 4.

Table 156.4 Preventing Youth Violence (CDC)	
STRATEGY	APPROACH
Promote family environments that support healthy development	Early childhood home visitation Parenting skill and family relationship programs
Provide quality education early in life	Preschool enrichment with family engagement
Strengthen youth skills	Universal school-based programs
Connect youth to caring adults and activities	Mentoring programs After-school programs
Create protective community environments	Modify the physical and social environment Reduce exposure to community-level risks Street outreach and community norm change
Intervene to lessen harms and prevent future risk	Treatment to lessen the harms of violence exposures Treatment to prevent problem behavior and further involvement in violence Hospital-community partnerships

From David-Ferdon, C, Vivolo-Kantor AM, Dahlberg LL, et al. *A Comprehensive Technical Package for the Prevention of Youth Violence and Associated Risk Behaviors*. Atlanta, GA: National Center for Injury Prevention and Control, Centers for Disease Control and Prevention; 2016.

Multiple treatment modalities are used simultaneously in managing adolescents with persistent violent and aggressive behavior and range from cognitive-behavioral therapy involving the individual and family to specific family interventions (parent management training, multi-systemic treatment) and pharmacotherapy. Treatment of comorbid conditions, such as ADHD, depression, anxiety, and substance abuse, appears to reduce aggressive behavior.

**PREVENTION**

The WHO recognizes a multifactorial approach to prevention: parenting and early childhood development strategies, school-based academic and social skills development strategies, strategies for young people at higher risk of or already involved in violence, and community- and society-level strategies (Tables 156.4 and 156.5). **Parenting and early childhood development approaches** concentrate on working with families to provide nonviolent parenting through home visitation and parent groups as well as teaching coping strategies and nonviolent conflict resolution for all children and families. **School-based social skills development strategies** focus on students' families and peer

Table 156.5 Prevention of Youth Violence (WHO)	
Promising prevention programs include:	
<ul style="list-style-type: none"> <li>• Life skills and social development programs designed to help children and adolescents manage anger, resolve conflict, and develop the necessary social skills to solve problems</li> <li>• Whole-school approaches to violence prevention in educational facilities</li> <li>• Programs that support parents and teach positive parenting skills</li> <li>• Preschool programs that provide children with academic and social skills at an early age</li> <li>• Therapeutic approaches for youths at high risk of being involved in violence</li> <li>• Reducing access to alcohol</li> <li>• Interventions to reduce the harmful use of drugs</li> <li>• Restrictive firearm licensing</li> <li>• Community and problem-oriented policing</li> <li>• Interventions to reduce concentrated poverty and to upgrade urban environments</li> </ul>	

Preventing youth violence requires a comprehensive approach that addresses the social determinants of violence, such as income inequality, rapid demographic and social change, and low levels of social protection. Courtesy World Health Organization: Youth Violence. <https://www.who.int/news-room/fact-sheets/detail/youth-violence>, accessed August 11, 2022.

relationships, especially those with the potential to trigger aggressive or violent responses. Solutions include improving coping or problem-solving skills, anti-bullying campaigns, peer mediation, adolescent relationship abuse prevention, and after-school programs. **Strategies for young people at higher risk of, or already involved in, violence** include therapeutic behavioral health approaches, crime victim services, vocational training, mentoring, and gang intervention. These youth are at highest risk for repeat injury or incarceration. **Community- and societal-level approaches** include broader advocacy and legislative actions and changing the cultural norm toward violent behaviors.

A specific prevention strategy can incorporate several approaches, such as the handgun/firearm prevention recommendations that include gun-lock safety, public education, and legislative advocacy. Other efforts are directed toward establishing a national database to track and define the problem of youth violence. The **National Violent Death Reporting System** collects and analyzes violent death data from all 50 states, the District of Columbia, and Puerto Rico and aims to improve surveillance of current trends, to share information state to state, to build partnerships among state and community organizations, and to develop and implement prevention and intervention programs. The Centers for Disease Control and Prevention characterizes specific successful prevention programs, including Striving to Reduce Youth Violence Everywhere (STRYVE), and summarizes program content on its website ([www.cdc.gov](http://www.cdc.gov)).

Visit Elsevier eBooks+ at [eBooks.Health.Elsevier.com](http://eBooks.Health.Elsevier.com) for Bibliography.



## Chapter 157

## Substance Use Disorder

Cora Collette Breuner

Many adolescents engage in the use of a wide range of substances, including alcohol, tobacco products, natural marijuana and synthetic cannabinoids, opiates, psychoactive agents (amphetamine, cocaine, MDMA, 3,4-methylenedioxymethamphetamine), hallucinogens, inhaled products (glue, organic solvents, nitrous oxide), and stimulants. Their reactions to and the consequences of these exposures are influenced by a complex interaction among biologic and psychosocial development, environmental messages, legality, and societal attitudes. The potential for adverse outcome with occasional use, such as motor vehicle crashes, violence, and other injuries, is sufficient justification to consider any substance use in adolescents a considerable risk.

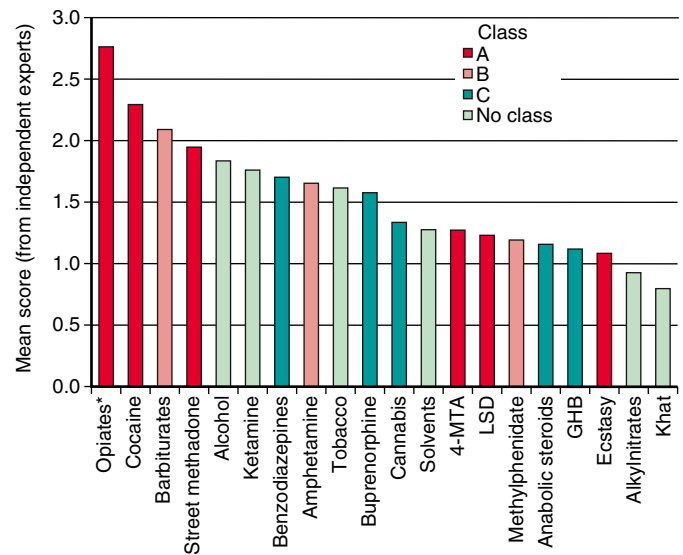
Individuals who initiate substance use at an early age are at a greater risk for developing a **substance use disorder** than those who begin using substances in early adulthood. Substance use disorder is diagnosed when the recurrent use of the substance causes clinically significant impairment, including health problems, disability, and failure to meet major responsibilities at work, school, or home. Substance use in younger adolescents may act as a substitute for developing age-appropriate coping strategies and enhance vulnerability to poor decision-making. Most (88%) people report that their age of first alcohol use was <21 years old, the legal drinking age in the United States. Inhalants have been identified as a popular first substance for youth in eighth grade (age 13–14 years).

Substance use disorder is a pervasive phenomenon and infiltrates every socioeconomic and cultural segment of the population. It is one of the costliest and most challenging public health problems facing all societies and cultures. The challenge to the clinician is to identify youth at risk for substance use disorder and offer early intervention. The challenge to the community and society is to create norms that decrease the likelihood of adverse health outcomes for adolescents and promote and facilitate opportunities for adolescents to choose healthier and safer options. Recognizing those substances with the greatest harm, and at times focusing on harm reduction with or without abstinence, is essential in the approach to the adolescent with substance use disorder (Fig. 157.1).

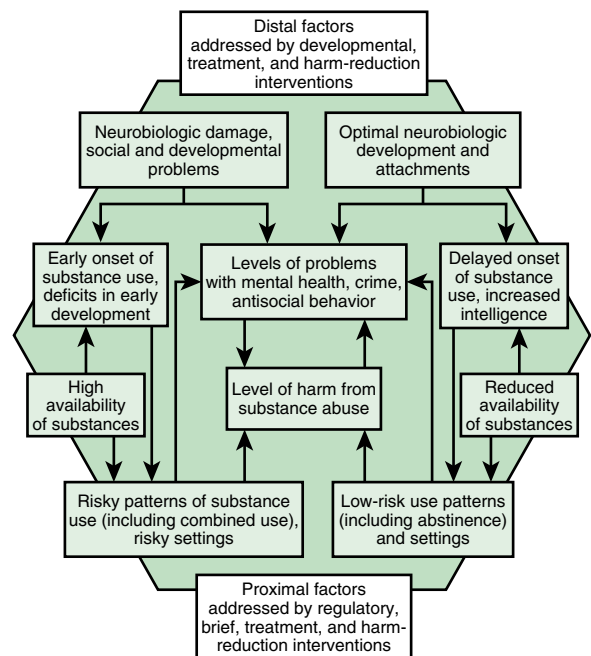
## ETIOLOGY

Substance use disorder has multifactorial origins (Fig. 157.2). Social determinants of health, including economic stability, education, health and healthcare, neighborhood environment, and social and community context, all have an impact on adolescents and can lead to substance use disorder and use. Biologic factors, including genetic predisposition, are established contributors. Behaviors such as ineffective self-control, poor school performance, involvement with the juvenile justice system, and emotional trends such as low self-esteem are frequently associated with or predate the onset of substance use. Psychiatric disorders often coexist with adolescent substance use. Conduct disorders and antisocial personality disorders are the most common diagnoses coexisting with substance use, particularly in males. Teens with depression (see Chapter 39.1), attention-deficit disorder (Chapter 50), anxiety (Chapter 38), and eating disorders (Chapter 41) have high rates of substance use. The determinants of adolescent substance use disorder and substance use are explained using numerous theoretical models and include factors at the individual level, the level of significant relationships with others, and the level of the setting or environment. These models include a balance of risk and protective or coping factors contributing to individual differences among adolescents with similar risk factors who escape adverse outcomes.

Risk factors for adolescent *substance use disorder* may differ from those associated with adolescent substance use. Adolescent substance



**Fig. 157.1** Mean harm scores for 20 substances as determined by an expert panel based on three criteria: physical harm to user, potential for dependence, and effect on family, community, and society. Classification under the Misuse of Substances Act, when appropriate, is shown by the color of each bar. Class A substances are deemed potentially most dangerous; class C least dangerous. \*Heroin, fentanyl, fentanyl derivatives. (From Nutt D, King LA, Saulsbury W, et al. *Development of a rational scale to access the harm of substances of potential misuse. Lancet* 2007;369:1047–1053.)



**Fig. 157.2** Protection and risk model for distal and proximal determinants of risky substance use disorder and related harms. (From Toumbourou JW, Stockwell T, Neighbors C, et al. *Interventions to reduce harm associated with adolescent substance use. Lancet* 2007;369:1391–1571.)

use is more commonly related to social and peer factors, whereas *use disorder* is more often a function of psychologic and biologic factors. The likelihood that an otherwise normal adolescent would experiment with substances may depend on the availability of the substance to the adolescent, the perceived positive or otherwise functional value to the adolescent, the perceived risk associated with use, and the presence or absence of restraints, as determined by the adolescent's cultural or other important value systems.

Specific historical questions can assist in determining the severity of the substance problem through a rating system (Table 157.1). The type of substance used (marijuana vs cocaine), the circumstances of use (alone or in a group setting), the frequency and timing of use (daily before school vs occasionally on a weekend), current mental health status, and general functional status, including sleep habits and screen use, should all be considered in evaluating any adolescent found to be using a substance. The stage of substance use should also be considered (Table 157.2). A teen may spend months or years in the experimentation phase trying a variety of illicit substances, including the most common substances: alcohol, tobacco products, and marijuana. Often it is not until regular use of substances results in negative consequences (problem use) that the adolescent is identified as having a problem, either by parents, friends, teachers, or a healthcare provider. Having emotionally supportive parents with open communication styles, involvement in organized school activities, having mentors or role models outside the home, and recognition of the importance of academic achievement are examples of important protective factors against developing problematic use.

**EPIDEMIOLOGY**

Alcohol, tobacco products, and marijuana are the most commonly reported substances used among U.S. teens (Table 157.3). The prevalence of substance use and associated risky behaviors vary by age, gender, race/ethnicity, and other sociodemographic factors. Younger teenagers tend to report less use of substances than do older teenagers, except for inhalants (in 2016, 4.4% in 8th grade, 2.8% in 10th grade, 1.0% in 12th grade). In 2019, a total of 50.1% of U.S. high school students had ever used electronic vapor products, and 24.1% had ever tried cigarette smoking. Current electronic vapor product use was 32.7%, current cigarette smoking was 6.0%, current cigar smoking was 5.7%, and current smokeless tobacco use was 3.8%. Approximately 36.5% of students were current users of any tobacco product, and 8.2% were current users of two or more tobacco products. Males have higher rates of substances use than females, with greatest differences seen in their higher rates of use of tobacco products including vaping, chewing and cigarettes/cigars, and anabolic steroids.

Fewer students engaged in some high-risk substance use-related behaviors from 2009 through 2019. However, approximately one in seven students are still reporting lifetime use of any illicit drug or misuse of prescription medicine.

**Marijuana** use has been trending down over the past several years among adolescents, though there is variation in the extent and rate of use in different racial/ethnic groups. Use also depends on grade level, urban vs rural location, class size, and state laws regarding legalization

of recreational or medical marijuana. The magnitude of the increase was greater in states with legal medical or recreational marijuana. Synthetic cannabinoids have significant psychotropic effects and addictive potential. Severe neuropsychiatric toxicity is often different from and more severe than marijuana.

The number of 12th graders who report using any of the **prescription psychotherapeutic** substances, including amphetamines, sedatives (barbiturates), tranquilizers, and narcotics other than heroin, decreased in 2019. Prevalence was 14% for ever used and 7.0% for 30-day use, indicating that a substantial portion of adolescents still misuse prescription substances including opioids. Rural adolescents are also more likely than urban adolescents to misuse prescription substances. In a large-scale study of 16,209 adolescent exposures to prescription substances, 52.4% were females, and the mean age was 16.6 years. The five most frequently misused substances were hydrocodone (32%),

**Table 157.2** Stages of Adolescent Substance Use

STAGE	DESCRIPTION
1	<b>Potential for use</b> <ul style="list-style-type: none"> <li>Decreased impulse control</li> <li>Need for immediate gratification</li> <li>Available substances, alcohol, inhalants</li> <li>Need for peer acceptance</li> </ul>
2	<b>Experimentation: learning the euphoria</b> <ul style="list-style-type: none"> <li>Use of inhalants, tobacco, marijuana, and alcohol with friends</li> <li>Few, if any, consequences</li> <li>Use may increase to weekends regularly</li> <li>Little change in behavior</li> </ul>
3	<b>Regular use: seeking the euphoria</b> <ul style="list-style-type: none"> <li>Use of other substances (e.g., stimulants, LSD, sedatives)</li> <li>Behavioral changes and some consequences</li> <li>Increased frequency of use; use disorder alone</li> <li>Buying or stealing substances</li> </ul>
4	<b>Regular use: preoccupation with the “high”</b> <ul style="list-style-type: none"> <li>Daily use of substances</li> <li>Loss of control</li> <li>Multiple consequences and risk taking</li> <li>Estrangement from family and “straight” friends</li> </ul>
5	<b>Burnout: use of substances to feel normal</b> <ul style="list-style-type: none"> <li>Polysubstance use/cross-addiction</li> <li>Guilt, withdrawal, shame, remorse, depression</li> <li>Physical and mental deterioration</li> <li>Increased risk taking, self-destructive, suicidal</li> </ul>

**Table 157.1** Assessing the Seriousness of Adolescent Substance Use

VARIABLE	0	+1	+2
Age (yr)	>15	<15	
Sex	Male	Female	
Family history of substance use		Yes	
Setting of substance use	In group		Alone
Affect before substance use	Happy	Always poor	Sad
School performance	Good, improving		Recently poor
Use disorder before driving	None		Yes
History of accidents	None		Yes
Time of week	Weekend	Weekdays	
Time of day		After school	Before or during school
Type of substance	Marijuana, beer, wine	Hallucinogens, amphetamines	Whiskey, opiates, cocaine, barbiturates

Total score: 0-3, less worrisome; 3-8, serious; 8-18, very serious.

**Table 157.3** Trends in Annual Prevalence (%) of Use Disorder of Various Substances for Grades 8, 10, and 12 Combined

																PEAK YEAR–2021 CHANGE		LOW YEAR–2021 CHANGE		
	2007	2008	2009	2010	2011	2012	2013	2014	2015	2016	2017	2018	2019 <sup>E</sup>	2020	2021	2020–2021 CHANGE	ABSOLUTE CHANGE	PROPORTIONAL CHANGE (%) <sup>a</sup>	ABSOLUTE CHANGE	PROPORTIONAL CHANGE (%) <sup>a</sup>
Any illicit drug <sup>c</sup>	24.8	24.9	25.9	27.3	27.6	27.1	28.6 <sup>†</sup>	27.2	26.8	25.3	26.5	27.1	27.7	27.3	19.9	-7.4 sss	-7.8 sss	-28.1	—	—
Any illicit drug other than marijuana <sup>c</sup>	12.4	11.9	11.6	11.8	11.3	10.8	11.4 <sup>†</sup>	10.9	10.5	9.7	9.4	9.3	9.0	9.2	5.6	-3.6 sss	-5.3 sss	-48.7	—	—
Any illicit drug including inhalants <sup>c</sup>	27.6	27.6	28.5	29.7	29.8	29.0	30.5 <sup>†</sup>	28.5	28.4	26.3	28.3	28.8	29.0	29.2	21.5	-7.8 sss	-7.8 sss	-26.6	—	—
Marijuana/hashish	21.4	21.5	22.9	24.5	25.0	24.7	25.8	24.2	23.7	22.6	23.9	24.3	25.2	2	17.9	-6.7 sss	-12.1 sss	-40.3	—	—
Synthetic marijuana	—	—	—	—	—	8.0	6.4	4.8	4.2	3.1	2.8	2.6	2.9	2.2	1.6	-0.6 ss	-6.4 sss	-80.3	—	—
Inhalants	6.4	6.4	6.1	6.0	5.0	4.5	3.8	3.6	3.2	2.6	2.9	2.9	2.9	3.4	2.9	-0.5	-7.3 sss	-71.6	+0.2	+0.3
Hallucinogens	3.8	3.8	3.5	3.8	3.7	3.2	3.1	2.8	2.8	2.8	2.7	2.7	2.9	3.4	2.4	-1.0 s	-3.6 sss	-60.4	—	—
LSD	1.7	1.9	1.6	1.8	1.8	1.6	1.6	1.7	1.9	2.0	2.1	2.0	2.2	2.5	1.5	-0.9 ss	-4.8 sss	-75.6	+0.1	+0.6
Hallucinogens other than LSD	3.3	3.2	3.0	3.3	3.1	2.7	2.5	2.1	1.9	1.8	1.8	1.7	1.9	2.0	1.7	-0.3	-2.4 sss	-58.3	—	—
Ecstasy (MDMA) <sup>d</sup>	3.0	2.9	3.0	3.8	3.7	2.5	2.8 <sup>†</sup>	3.4	2.4	1.8	1.7	1.5	1.6	1.3	0.8	-0.5 s	-2.6 sss	-76.0	—	—
Salvia	—	—	—	3.5	3.6	2.7	2.3	1.4	1.2	1.2	0.9	0.8	0.8	0.8	0.5	-0.3 s	-3.1 sss	-85.1	—	—
Cocaine	3.4	2.9	2.5	2.2	2.0	1.9	1.8	1.6	1.7	1.4	1.6	1.5	1.4	1.4	0.7	-0.8 ss	-3.8 sss	-85.0	—	—
Crack	1.5	1.3	1.2	1.1	1.0	0.9	0.8	0.7	0.8	0.6	0.7	0.6	0.7	0.6	0.4	-0.2	-2.0 sss	-82.6	—	—
Other cocaine	2.9	2.6	2.1	1.9	1.7	1.7	1.5	1.5	1.5	1.2	1.3	1.3	1.3	1.4	0.5	-0.9 sss	-3.5 sss	-86.6	—	—
Heroin	0.8	0.8	0.8	0.8	0.7	0.6	0.6	0.5	0.4	0.3	0.3	0.3	0.3	0.2	0.2	-0.1	-1.1 sss	-85.5	—	—
With a needle	0.5	0.5	0.5	0.6	0.5	0.4	0.4	0.4	0.3	0.3	0.2	0.2	0.2	0.2	0.1	0.0	-0.6 sss	-84.3	—	—
Without a needle	0.7	0.6	0.5	0.6	0.5	0.4	0.4	0.3	0.3	0.2	0.2	0.2	0.2	0.1	0.1	0.0	-1.0 sss	-92.7	—	—
OxyContin	3.5	3.4	3.9	3.8	3.4	2.9	2.9	2.4	2.3	2.1	1.9	1.7	1.7	1.4	0.9	-0.5	-3.0 sss	-77.3	—	—
Vicodin	6.2	6.1	6.5	5.9	5.1	4.3	3.7	3.0	2.5	1.8	1.3	1.1	1.0	0.9	0.6	-0.2	-5.9 sss	-90.6	—	—
Amphetamines <sup>c</sup>	6.5	5.8	5.9	6.2	5.9	5.6	7.0 <sup>†</sup>	6.6	6.2	5.4	5.0	5.0	4.6	4.6	2.7	-1.9 sss	-3.9 sss	-59.5	—	—
Ritalin	2.8	2.6	2.5	2.2	2.1	1.7	1.7	1.5	1.4	1.1	0.8	0.8	0.9	1.0	0.5	-0.6	-3.7 sss	-88.3	—	—
Adderall	—	—	4.3	4.5	4.1	4.4	4.4	4.1	4.5	3.9	3.5	3.5	3.1	3.3	1.7	-1.6 sss	-2.8 sss	-61.3	—	—
Methamphetamine	1.4	1.3	1.3	1.3	1.2	1.0	1.0	0.8	0.6	0.5	0.5	0.5	0.5	0.7	0.2	-0.5 ss	-3.9 sss	-96.1	—	—
Bath salts (synthetic stimulants)	—	—	—	—	—	0.9	0.9	0.8	0.7	0.8	0.5	0.7	—	—	—	—	—	—	—	—
Tranquilizers	4.5	4.3	4.5	4.4	3.9	3.7	3.3	3.4	3.4	3.5	3.6	3.2	3.1	2.7	1.2	-1.4 sss	-4.3 sss	-77.8	—	—
OTC cough/cold medicines	5.0	4.7	5.2	4.8	4.4	4.4	4.0	3.2	3.1	3.2	3.0	3.2	2.8	3.7	2.7	-1.1 s	-2.7 sss	-50.3	—	—
Rohypnol	0.8	0.7	0.6	0.8	0.9	0.7	0.6	0.5	0.5	0.7	0.5	0.4	0.5	1.0	0.2	-0.7 sss	-0.7 sss	-71.3	—	—
GHB <sup>b</sup>	0.7	0.9	0.9	0.8	0.8	—	—	—	—	—	—	—	—	—	—	—	—	—	—	—
Ketamine <sup>b</sup>	1.0	1.2	1.3	1.2	1.2	—	—	—	—	—	—	—	—	—	—	—	—	—	—	—

Continued

**Table 157.3** Trends in Annual Prevalence (%) of Use Disorder of Various Substances for Grades 8, 10, and 12 Combined—cont'd

																	PEAK YEAR–2021 CHANGE		LOW YEAR–2021 CHANGE	
	2007	2008	2009	2010	2011	2012	2013	2014	2015	2016	2017	2018	2019 <sup>E</sup>	2020	2021	2020–2021 CHANGE	ABSOLUTE CHANGE	PROPORTIONAL CHANGE (%) <sup>a</sup>	ABSOLUTE CHANGE	PROPORTIONAL CHANGE (%) <sup>a</sup>
Alcohol	50.2	48.7	48.4	47.4	45.3	44.3	42.8	40.7	39.9	36.7	36.7	36.1	35.9	38.3	30.2	-8.1 sss	-31.1 sss	-50.7	—	—
Been drunk	29.7	28.1	28.7	27.1	25.9	26.4	25.4	23.6	22.5	20.7	20.4	20.0	19.5	22.1	15.5	-6.6 sss	-21.4 sss	-57.9	—	—
Flavored alcoholic beverages	40.8	39.0	37.8	35.9	33.7	32.5	31.3	29.4	28.8	25.3	25.9	26.1	24.6	26.5	20.0	-6.5 sss	-24.5 sss	-55.1	—	—
Alcoholic beverages containing caffeine	—	—	—	—	19.7	18.6	16.6	14.3	13.0	11.2	10.6	10.1	9.2	8.6	7.8	-0.8 sss	-11.9 sss	-60.3	—	—
Any vaping	—	—	—	—	—	—	—	—	—	—	21.5	28.9	<b>31.9</b>	30.7	22.1	-8.6 sss	-9.9 sss	-30.9	+0.6	+2.6
Vaping nicotine	—	—	—	—	—	—	—	—	—	—	13.9	21.6	<b>27.3</b>	27.1	19.2	-7.9 sss	-8.1 sss	-29.7	+5.3 sss	+37.7
Vaping marijuana	—	—	—	—	—	—	—	—	—	—	6.8	9.9	15.6	<b>16.3</b>	11.6	-4.7 ss	-4.7 ss	-28.9	+4.8 sss	+69.7
Vaping just flavoring	—	—	—	—	—	—	—	—	—	—	17.2	<b>21.8</b>	18.6	15.8	10.0	-5.8 sss	-11.8 sss	-54.3	—	—
Juul	—	—	—	—	—	—	—	—	—	—	—	—	<b>23.8</b>	20.6	9.1	-11.5 sss	-14.7 sss	-61.7	—	—
Dissolvable tobacco products	—	—	—	—	—	1.4	1.4	1.2	1.1	0.9	0.9	1.0	1.0	0.9	0.7	-0.2	-0.7 s	-48.7	—	—
Snus	—	—	—	—	—	5.6	4.8	4.1	3.8	3.6	2.6	3.0	2.2	2.7	1.6	-1.1 ss	-4.0 sss	-72.0	—	—
Steroids	1.1	1.1	1.0	0.9	0.9	0.9	0.9	0.9	1.0	0.8	0.8	0.8	0.9	1.1	0.4	-0.7 sss	-1.6 sss	-79.5	—	—

<sup>a</sup>The proportional change is the percent by which the most recent year deviates from the peak year (or the low year) for the drug in question. So, if a drug was at 20% prevalence in the peak year and declined to 10% prevalence in the most recent year, that would reflect a proportional decline of 50%.

<sup>b</sup>Question was discontinued among 8th and 10th graders in 2012.

<sup>c</sup>In 2013, for the questions on the use of amphetamines, the text was changed on two of the questionnaire forms for 8th and 10th graders and four of the questionnaire forms for 12th graders. This change also affected the any illicit drug indices. Data presented here include only the changed forms beginning in 2013.

<sup>d</sup>In 2014, the text was changed on one of the questionnaire forms for 8th, 10th, and 12th graders to include “molly” in the description. The remaining forms were changed in 2015. Data for both versions of the question are presented here.

<sup>e</sup>Drug prevalence results in 2019 combine results from paper-and-pencil surveys with those completed using electronic tablets. In 2019, students in a randomly selected half of schools completed MTF surveys on paper-and-pencil and students in the other half completed the surveys using electronic tablets. Analysis of this randomized controlled trial demonstrated that these results did not significantly differ across survey mode (Miech RA, Couper MP, Heeringa SG, et al. The impact of survey mode on US national estimates of adolescent drug prevalence: results from a randomized controlled study, *Addiction*). Results for student attitudes and beliefs in 2019 are based on answers from paper-and-pencil surveys only because these appear more susceptible to survey mode effects.

Notes: — indicates data not available. ‡ indicates a change in the question text. When a question change occurs, peak levels after that change are used to calculate the peak year to current year difference. Values in bold equal peak levels since 1991. Values in italics equal peak level before wording change. Level of significance of difference between classes: s = 0.05, ss = 0.01, sss = 0.001. Any apparent inconsistency between the change estimate and the prevalence estimates for the two most recent years is the result of rounding.

Modified from Miech RA, Johnston LD, O'Malley PM, et al. *Monitoring the Future National Survey Results on Drug Use, 1975–2021: Volume I, Secondary School Students*. Ann Arbor, MI: Institute for Social Research, The University of Michigan; 2022.

Available <https://monitoringthefuture.org/wp-content/uploads/2022/12/mtf2022.pdf>



amphetamines (18%), oxycodone (15%), methylphenidate (14%), and tramadol (11%). Many of these substances can be found in the home of friends; some are over-the-counter (OTC) substances (dextromethorphan, pseudoephedrine), whereas others are purchased from substance dealers at schools and colleges. Adolescents often combine opioids with marijuana, alcohol, cocaine, and tranquilizers, putting them at risk for serious complications and overdose.

### CLINICAL MANIFESTATIONS

Although manifestations vary by the specific substance of use, adolescents who use substances often present in an office setting with no obvious physical findings. Substance use disorder is more frequently detected in adolescents who experience trauma such as motor vehicle crashes, bicycle injuries, or violence. Eliciting appropriate historical information regarding substance use, followed by blood alcohol and urine substance screens, is recommended in emergency settings. Although waning in popularity, the illicit substances known as “club drugs” still need to be considered in the differential diagnosis of a teen with an altered sensorium. An adolescent presenting to an emergency setting with an impaired sensorium should be evaluated for substance use as a part of the differential diagnosis (Table 157.4). Screening for substance use is recommended for patients with psychiatric and behavioral diagnoses. Other clinical manifestations of substance use are associated with the route of use; intravenous substance use is associated with venous “tracks” and needle marks, and nasal mucosal injuries are associated with nasal insufflation of substances. Seizures can be a direct effect of substances such as cocaine, synthetic marijuana, and amphetamines or an effect of substance withdrawal in the case of barbiturates or tranquilizers.

### SCREENING FOR SUBSTANCE USE DISORDERS

In a primary care setting the annual health maintenance examination provides an opportunity for identifying adolescents with substance use disorder. The direct questions and the assessment of school performance, family relationships, and peer activities may necessitate a more in-depth interview if there are suggestions of difficulties in those areas. Several self-report screening questionnaires also are available, with varying degrees of standardization, length, and reliability. The **CRAFFT mnemonic** is specifically designed to screen for adolescents’ substance use in the primary care setting (Table 157.5). Privacy and confidentiality must be established when asking the teen about specifics of their substance experimentation or use. Interviewing the parents can provide additional perspective on early warning signs that go unnoticed or disregarded by the teen. Examples of early warning signs of teen substance use disorder are change in mood, appetite, or sleep pattern; decreased interest in school or school performance; loss of weight; secretive behavior about social plans; or valuables such as money or jewelry missing from the home. The use of urine substance screening is recommended when select circumstances are present: (1) psychiatric symptoms to rule out comorbidity or dual diagnoses, (2) significant changes in school performance or other daily behaviors, (3) frequently occurring accidents, (4) frequently occurring episodes of respiratory problems, (5) evaluation of serious motor vehicular or other injuries, and (6) as a monitoring procedure for a recovery program. Most initial screening uses an immunoassay method, such as the enzyme-multiplied immunoassay technique, followed by a confirmatory test using highly sensitive, highly specific gas chromatography-mass spectrometry. The substances that can cause false-positive results should be considered, especially when there is a discrepancy between

**Table 157.4** Most Common Toxic Syndromes

<b>ANTICHOLINERGIC SYNDROMES</b>	
Common signs	Delirium with mumbling speech, tachycardia, dry, flushed skin, dilated pupils, myoclonus, slightly elevated temperature, urinary retention, and decreased bowel sounds. Seizures and dysrhythmias may occur in severe cases.
Common causes	Antihistamines, antiparkinsonian medication, atropine, scopolamine, amantadine, antipsychotic agents, antidepressant agents, antispasmodic agents, mydriatic agents, skeletal muscle relaxants, and many plants (notably jimsonweed and <i>Amanita muscaria</i> ).
<b>SYMPATHOMIMETIC SYNDROMES</b>	
Common signs	Delusions, paranoia, tachycardia (or bradycardia if the substance is a pure $\alpha$ -adrenergic agonist), hypertension, hyperpyrexia, diaphoresis, piloerection, mydriasis, and hyperreflexia. Seizures, hypotension, and dysrhythmias may occur in severe cases.
Common causes	Cocaine, amphetamine, methamphetamine (and its derivatives 3,4-methylenedioxymphetamine, 3,4-methylenedioxyamphetamine, 3,4-methylenedioxyethamphetamine, and 2,5-dimethoxy-4-bromoamphetamine), some synthetic marijuana, and OTC decongestants (phenylpropanolamine, ephedrine, and pseudoephedrine). In caffeine and theophylline overdoses, similar findings, except for the organic psychiatric signs, result from catecholamine release.
<b>OPIATE, SEDATIVE, OR ETHANOL INTOXICATION</b>	
Common signs	Coma, respiratory depression, miosis, hypotension, bradycardia, hypothermia, pulmonary edema, decreased bowel sounds, hyporeflexia, and needle marks. Seizures may occur after overdoses of some narcotics, notably propoxyphene.
Common causes	Narcotics, barbiturates, benzodiazepines, ethchlorvynol, glutethimide, methyprylon, methaqualone, meprobamate, ethanol, clonidine, and guanabenz.
<b>CHOLINERGIC SYNDROMES</b>	
Common signs	Confusion, central nervous system depression, weakness, salivation, lacrimation, urinary and fecal incontinence, gastrointestinal cramping, emesis, diaphoresis, muscle fasciculations, pulmonary edema, miosis, bradycardia or tachycardia, and seizures.
Common causes	Organophosphate and carbamate insecticides, physostigmine, edrophonium, and some mushrooms.

From Kulig K. Initial management of ingestions of toxic substances. *N Engl J Med* 1992;326:1677–1681.

**Table 157.5** CRAFFT Mnemonic Tool

<ul style="list-style-type: none"> <li>• Have you ever ridden in a Car driven by someone (including yourself) who was high or had been using alcohol or substances?</li> <li>• Do you ever use alcohol or substances to Relax, feel better about yourself, or fit in?</li> <li>• Do you ever use alcohol or substances while you are by yourself (Alone)?</li> </ul>	<ul style="list-style-type: none"> <li>• Do you ever Forget things you did while using alcohol or substances?</li> <li>• Do your Family or Friends ever tell you that you should cut down on your drinking or substance use?</li> <li>• Have you ever gotten into Trouble while you were using alcohol or substances?</li> </ul>
--	--

From the Center for Adolescent Substance Use Research (CeASAR). *The CRAFFT Screening Interview*. (Copyright John R. Knight, MD, Boston Children’s Hospital, 2015.)

the physical findings and the urine substance screen result. Current guidelines strongly discourage routine home-based or school-based testing.

## DIAGNOSIS

The *Diagnostic and Statistical Manual of Mental Disorders* (DSM-5) no longer identifies substance use disorder as those of *abuse* or of *dependence*. A substance use disorder is defined by a cluster of cognitive, behavioral, and physiologic symptoms that indicate that an adolescent is using a substance even though there is evidence that the substance is harming the adolescent. Even after detoxification, a substance use disorder may leave persistent changes in brain circuits with resulting behavioral changes. There are 11 criteria that describe a pathologic pattern of behaviors related to use of the substance, falling into four categories: impaired control, social impairment, increased risk, and pharmacologic criteria. The first category, **impaired control**, describes an individual taking increasing amounts of the substance who expresses a persistent desire to decrease use, with unsuccessful efforts. The individual may spend a great deal of time obtaining the substance, using the substance, or recovering from its effects and expresses an intense desire for the substance, usually in settings where the substance had been available, such as a specific type of social situation. The second cluster of criteria (5-7) reflects **social impairment**, including the inability to perform as expected in school, at home, or at a job; increasing social problems; and withdrawing from the family. The third cluster addresses **increased risk** associated with use of the substance, and the fourth cluster addresses **pharmacologic responses** (tolerance and/or withdrawal). The total number of criteria present is associated with a determination of a *mild, moderate, or severe* disorder.

These criteria may have limitations with adolescents because of differing patterns of use, developmental implications, and other age-related consequences. Adolescents who meet diagnostic criteria should be referred to a program for substance use disorder treatment unless the primary care physician has additional training in addiction medicine.

## COMPLICATIONS

Substance use disorder in adolescence is associated with significant comorbidities and acts of juvenile delinquency. Youth may engage in other high-risk behaviors such as robbery, burglary, substance dealing, or prostitution for the purpose of acquiring the money necessary to buy substances. Regular use of any substance eventually diminishes judgment and is associated with unprotected sexual activity with its consequences of pregnancy and sexually transmitted infections, including HIV, as well as physical violence. Substance use disorder is closely associated with trauma in the adolescent population. Several studies of adolescent trauma victims have identified cannabinoids and cocaine in blood and urine samples in significant proportions (40%), in addition to the more common identification of alcohol. Any use of injected substances involves the risk of hepatitis B and C viruses and HIV (see Chapter 322).

## TREATMENT

Adolescent substance use disorder is a complex condition requiring a multidisciplinary approach that attends to the needs of the individual, not just substance use. Fundamental principles for treatment include accessibility to treatment, using a multidisciplinary approach, employing individual or group counseling, offering mental health services, monitoring of substance use while in treatment, and understanding that recovery from substance use/addiction may involve multiple relapses. For most patients, remaining in treatment for a minimum period of 3 months may result in a significant improvement.

## PROGNOSIS

For adolescent substance users who have been referred to a substance treatment program, positive outcomes are directly related to regular attendance in posttreatment groups. Outcomes are worse for males with learning problems or conduct disorder than for those without such disorders. Peer use patterns and parental use have a major influence on outcome for males. The chronicity of a substance use disorder

**Table 157.6** Domains of Risk and Protective Factors for Substance Use Prevention

RISK FACTORS	DOMAIN	PROTECTIVE FACTORS
Early aggressive behavior	Individual	Self-control
Lack of parental supervision	Family	Parental monitoring
Substance use	Peer	Academic competence
Substance availability	School	Anti-substance use disorder policies
Poverty	Community	Strong neighborhood attachment

From National Institute on Substance Use. Preventing Substance Use Disorder Among Children and Adolescents: A Research-Based Guide for Parents, Educators, and Community Leaders, NIH Pub No 04-4212(B), 2nd ed. Bethesda, MD: NIDA; 2003.

makes **relapse** an issue that must always be considered when managing patients after treatment, and appropriate assistance from a healthcare professional qualified in substance use disorder treatment should be obtained.

## PREVENTION

Preventing substance use disorder among adolescents requires prevention efforts aimed at the individual, family, school, and community levels. The National Institute on Drug Abuse (NIDA) of the U.S. National Institutes of Health has identified essential principles of successful prevention programs. Programs should enhance *protective factors* (parent support) and reduce *risk factors* (poor self-control), should address all forms of substance use (legal and illegal), should address the specific type(s) of substance use within an identified community, and should be culturally competent to improve effectiveness (Table 157.6). Prevention programs need to target emotionally and socially intense times such as life/school transitions for adolescents to adequately anticipate potential substance use disorder. Examples of effective research-based substance use prevention programs featuring a variety of strategies are listed on the NIDA website ([www.drugabuse.gov](http://www.drugabuse.gov)) and on the Center for Substance Abuse Prevention website ([www.prevention.samhsa.gov](http://www.prevention.samhsa.gov)).

Visit Elsevier eBooks+ at [eBooks.Health.Elsevier.com](http://eBooks.Health.Elsevier.com) for Bibliography.

## 157.1 Alcohol

Cora Collette Breuner

Alcohol is the most widely used substance of abuse among America's youth, and a higher proportion use alcohol than use tobacco or other substances, but the numbers are trending down. According to the 2020 *Monitoring the Future (MTF)* study, by the end of high school, 61.5% of students had reported ever using alcohol and 26% of eighth graders had reported ever using alcohol. Early initiation of alcohol use increases the risk for a variety of developmental problems during adolescence and is frequently an indicator of future substance use. Drinking by children, adolescents, and young adults has serious negative consequences for the individuals, their families, their communities, and society as a whole. Underage drinking contributes to a wide range of costly health and social problems, including motor vehicle crashes (the greatest single mortality risk for underage drinkers); suicide; interpersonal violence (e.g., homicides, assaults, rapes); unintentional injuries such as burns, falls, and drowning; brain impairment; alcohol dependence; risky sexual activity; academic problems; and alcohol and other drug poisoning.

Multiple factors can affect a young teen's risk of developing a drinking problem at an early age (Table 157.7). One third of high school seniors admit to combining drinking behaviors with other risky behaviors, such as driving or taking additional substances. **Binge drinking**

**Table 157.7** Risk Factors for a Teen Developing a Drinking Problem**FAMILY RISK FACTORS**

- Low parental supervision
- Poor parent to teen communication
- Family conflicts
- Severe or inconsistent family discipline
- Having a parent with an alcohol or substance problem

**INDIVIDUAL RISK FACTORS**

- Poor impulse control
- Emotional instability
- Thrill-seeking behaviors
- Behavioral problems
- Perceived risk of drinking is low
- Begins drinking before age 14 yr

remains especially problematic among older teens and young adults; 31% of high school seniors report having five or more drinks in a row in the last 30 days. Higher rates of alcohol use disorder are seen in males (23.8%) than in females (19.8%). Teens with binge-drinking patterns are more likely to be assaulted, engage in high-risk sexual behaviors, have academic problems, and be injured than those teens without binge-drinking patterns.

Alcohol contributes to more deaths in young individuals in the United States than all the illicit substances combined. Among studies of adolescent trauma victims, alcohol is reported to be present in 32–45% of hospital admissions. Motor vehicle crashes are the most frequent type of event associated with alcohol use, but the injuries span several types, including self-inflicted wounds.

Alcohol is often mixed with energy drinks (caffeine, taurine, sugars), which can result in a spectrum of alcohol-related negative behaviors. Caffeine may counter the sedative effects of alcohol, resulting in more alcohol consumption and a perception of not being intoxicated, thus leading to risk-taking behavior such as driving while intoxicated. In addition, aggressive behavior, including sexual assaults and motor vehicle or other injuries, has been reported. Both alcohol and caffeine overdoses have also been reported.

**PHARMACOLOGY AND PATHOPHYSIOLOGY**

Alcohol (ethyl alcohol or ethanol) is rapidly absorbed in the stomach and is transported to the liver and metabolized by two pathways. The primary metabolic pathway contributes to the excess synthesis of triglycerides, a phenomenon that is responsible for producing a **fatty liver**, even in those who are well nourished. Engorgement of hepatocytes with fat causes necrosis, triggering an inflammatory process (**alcoholic hepatitis**), later followed by fibrosis, the hallmark of **cirrhosis**. Early hepatic involvement may result in elevation in  $\gamma$ -glutamyltransferase (GGT) and serum glutamic-pyruvic transaminase (alanine transaminase). The second metabolic pathway, which is used at high serum alcohol levels, involves the microsomal enzyme system of the liver, in which the cofactor is reduced to nicotinamide-adenine dinucleotide phosphate. The net effect of activation of this pathway is to decrease metabolism of substances that share this system and to allow for their accumulation, enhanced effect, and possible toxicity.

**CLINICAL MANIFESTATIONS**

Alcohol acts primarily as a central nervous system (CNS) depressant. It produces euphoria, grogginess, talkativeness, impaired short-term memory, and an increased pain threshold. Alcohol's ability to produce vasodilation and hypothermia is also centrally mediated. At very high serum levels, respiratory depression occurs. Its inhibitory effect on pituitary antidiuretic hormone release is responsible for its diuretic effect. The gastrointestinal (GI) complications of alcohol use can occur from a single large ingestion. The most common is acute **erosive gastritis**, manifesting as epigastric pain, anorexia, vomiting, and heme-positive stools. Less frequently, vomiting and mid-abdominal pain may

be caused by acute alcoholic **pancreatitis**; the diagnosis is confirmed by the finding of elevated serum amylase and lipase levels.

**DIAGNOSIS**

Primary care settings provide the opportunity to screen teens for alcohol use disorder or problem behaviors. Brief alcohol screening instruments such as CRAFFT (see Table 157.5) perform well in a clinical setting as techniques to identify alcohol use disorders. A score of 2 or higher is a positive screen, indicating a need for additional assessment.

Teenagers in the early phases of alcohol use exhibit few physical findings. Recent use of alcohol may be reflected in elevated GGT and aspartate transaminase levels.

In acute care settings the **alcohol overdose syndrome** should be suspected in any teenager who appears disoriented, lethargic, or comatose. Although the distinctive aroma of alcohol may assist in diagnosis, confirmation by analysis of blood is recommended. At levels >200 mg/dL, the adolescent is at risk of death, and levels >500 mg/dL (median lethal dose) are usually associated with a fatal outcome. *When the level of obtundation appears excessive for the reported blood alcohol level, head trauma, hypoglycemia, or ingestion of other substances should be considered as possible confounding factors.*

**TREATMENT**

The usual mechanism of death from alcohol overdose syndrome is **respiratory depression**; artificial ventilatory support must be provided until the liver can eliminate sufficient amounts of alcohol from the body. In a patient *without* chronic alcohol use, it generally takes 20 hours to reduce the blood level of alcohol from 400 mg/dL to zero. Dialysis should be considered when the blood level is >400 mg/dL. As a follow-up to acute treatment, referral for treatment of the alcohol use disorder is indicated. Group counseling, individualized counseling, and multifamily educational intervention have proved to be effective interventions for teens.

Visit Elsevier eBooks+ at [eBooks.Health.Elsevier.com](http://eBooks.Health.Elsevier.com) for Bibliography.

**157.2 Tobacco, E-Cigarettes, and Other Tobacco Products**

Brian P. Janssen

**CIGARETTES**

Tobacco use and addiction often start in childhood or adolescence, a period when the brain has heightened susceptibility to nicotine addiction. Nearly 90% of adult cigarette smokers began smoking before age 18. Factors associated with youth tobacco use include exposure to smokers (friends, parents), tobacco availability, low socioeconomic status, poor school performance, low self-esteem, lack of perceived risk of use, and lack of skills to resist influences to use tobacco.

The landscape of tobacco product use among youth has shifted dramatically over the past decade. Various sources are used to capture data on tobacco use. Similar trends have been observed across cross-sectional surveys with data on youth use, including, for example, the National Youth Tobacco Survey, Monitoring the Future, and the Youth Risk Behavior Surveillance system.

Based on 2022 data, current use of any tobacco product was reported by 11.3% (3.08 million) of all students, including 16.5% (2.51 million) of high school and 4.5% (530,000) of middle school students. E-cigarettes were the most used tobacco product among high school (14.1%; 2.14 million) and middle school (3.3%; 380,000) students. Among high school students, 5.2% reported current use of any combustible tobacco product. By product, current use among high school students was highest for e-cigarettes (14.1%), followed by cigars (2.8%), cigarettes (2.0%), smokeless tobacco (1.6%), hookahs (1.5%), nicotine pouches (1.4%), heated tobacco products (1.1%), and pipe tobacco (0.7%). Among middle school students, 1.6% reported current use of any combustible tobacco product. By type of product, current use among middle school students



was highest for e-cigarettes (3.3%), followed by cigarettes (1.0%), smokeless tobacco (0.7%), heated tobacco products (0.7%), cigars (0.6%), hookahs (0.5%), nicotine pouches (0.5%), and pipe tobacco (0.3%).

Tobacco use tends to be higher among males compared to females and by those identifying as lesbian, gay, or bisexual compared to heterosexual or uncertain sexual identity. Tobacco is used by teens in all regions of the world, although the form of tobacco used differs. In the Americas and Europe, cigarette smoking is the predominant form of tobacco use, followed by cigars and smokeless tobacco; in the Eastern Mediterranean, hookah use is prevalent; in Southeast Asia, smokeless tobacco products are used; in the Western Pacific, betel nut is chewed with tobacco; and pipe, snuff, and rolled tobacco leaves are used in Africa. Cigarette use by teens in low- and middle-income nations is increasing.

## PHARMACOLOGY

**Nicotine**, the primary active ingredient in cigarettes, is addictive. Nicotine is absorbed by multiple sites in the body, including the lungs, skin, GI tract, and buccal and nasal mucosa. The action of nicotine is mediated through nicotinic acetylcholine receptors located on noncholinergic presynaptic and postsynaptic sites in the brain and causes increased levels of dopamine. Nicotine also stimulates the adrenal glands to release epinephrine, causing an immediate elevation in blood pressure, respiration, and heart rate. The dose of nicotine delivered to the user in a cigarette depends on a variety of factors, including puffing characteristics. A smoker typically takes 10 puffs within the span of 5 minutes and absorbs 1–2 mg of nicotine (range: 0.5–3 mg). The Food and Drug Administration (FDA) is planning to reduce the permissible amount of nicotine in cigarettes. **Cotinine**, the major metabolite of nicotine, has a biologic half-life of 19–24 hours and can be detected in urine, serum, and saliva.

## CLINICAL MANIFESTATIONS

Cigarettes are addictive by design and result in life-shortening diseases in half of their long-term users. Each year, approximately 480,000 deaths are attributable to smoking, responsible for 1 of every 5 deaths and 1 of every 3 cancer deaths in the United States. Cigarette smoking has severe adverse health consequences for youth and young adults, including increased prevalence of chronic cough, sputum production, wheezing, and worsening asthma. Smoking during pregnancy increases prenatal and perinatal morbidity and mortality, either causing or exacerbating the risks of preterm birth, low birthweight, congenital malformations, stillbirth, and sudden infant death syndrome (SIDS) and sudden unexplained infant death (SUID). **Withdrawal** symptoms, including irritability, decreased concentration, increased appetite, and strong cravings for tobacco, can occur when adolescents try to quit.

## ELECTRONIC CIGARETTES (E-CIGARETTES)

E-cigarettes are handheld devices that produce an aerosol created from a solution of nicotine, flavoring chemicals, humectants such as propylene glycol, and often other constituents unknown and unadvertised to the consumer. There is wide variability in terminology, product design, and engineering of these products, with alternative names including e-cigs, electronic cigars, electronic hookah, e-hookah, and vaping devices. The tobacco industry continues to develop new products that contain nicotine but may not be recognized as a tobacco product by teens. The unique flavors offered in e-cigarette solutions, the majority of which are confectionary in nature and appealing to children, have been shown to encourage youth experimentation, regular use, and addiction.

Known harmful toxicants and carcinogens have been found in e-cigarette solutions, in device emissions, and within the bodies of adolescent users. Multiple systematic reviews and meta-analyses have found e-cigarette use is associated with an increased risk of subsequent cigarette smoking initiation and current cigarette smoking in young people. There is a critical need for e-cigarette regulation,

legislative action, and counter-promotion to prevent children, adolescents, and young adults from transitioning from e-cigarettes to traditional cigarettes and minimize the potential public health harm from e-cigarette use. The FDA should regulate all tobacco and nicotine products to protect public health.

## HOOHAH

Hookah (water pipe) smoking uses specially treated tobacco that comes in a variety of flavors. Many teens believe incorrectly that hookah does not contain nicotine. Emerging evidence indicates that hookah may involve comparable health risks to cigarettes, including nicotine dependence. Both human and machine simulation studies of hookah use consistently find that smoke content and user toxicant exposure, including carbon monoxide, tar, and nicotine, are at least comparable to that of cigarettes. Secondhand smoke from hookahs can be a health risk for nonsmokers exposed to harmful toxicants.

## TREATMENT

The 2020 U.S. Surgeon Report on smoking cessation emphasizes that smoking cessation is beneficial at any age, reducing the risk of premature death, adding as much as a decade to life expectancy, while also reducing the risk of many adverse health effects. More than half of adolescents who use tobacco products report that they want to quit, and more than half report making at least one quit attempt in the past year. Thus for adolescents who want to stop tobacco or e-cigarette use, it is reasonable to consider referral to behavioral cessation supports. Behavioral interventions for adults have significant evidence supporting their effectiveness, and many youth and young adult supports are modeled off of these programs.

Little research has been conducted assessing the effectiveness of pharmacologic therapies for combustible tobacco use among adolescents. The 2020 U.S. Preventive Services Task Force recommendation concluded there was inadequate evidence on the benefits and harms of medications for tobacco cessation in children and adolescents. Nonetheless, consensus panels recommend that for adolescents who want to stop tobacco or e-cigarette use with moderate to severe tobacco dependence, it is reasonable to consider pharmacotherapy, especially nicotine replacement therapy (NRT). Cessation medications are not approved by the FDA for use with children or adolescents, and NRT cannot be purchased OTC by persons younger than 18 years of age. However, cessation medications can be prescribed for and used by youth under the supervision of a physician. NRT is also available as a patch, gum, inhaler, nasal spray, lozenge, or microtab (Table 157.8). Tobacco dependence treatment for youth should be tailored to the patient's level of nicotine dependence and readiness for change. Given the very high rates of nonadherence during therapy and relapse after discontinuation of therapy among adolescents in the trials of these medications, close follow-up is recommended.

Pediatric clinicians can connect patients to effective behavioral interventions, including telephone, text message, smartphone app, internet, and community-based resources. Free telephone-based treatment (800-QUIT-NOW) has been shown to improve smoking cessation rates. Smoke-free TXT, offered by the National Cancer Institute, engages teens to quit smoking using free, daily text messaging. Teens can sign up online ([teen.smokefree.gov](http://teen.smokefree.gov)) or text QUIT to iQUIT (47848). A smartphone-based app, quitSTART, helps teens track cravings, monitor moods, use cessation tips, and follow quitting attempts. Truth Initiative has an evidence-based program, This Is Quitting, which is targeted to teens who want to stop using e-cigarettes (<https://truthinitiative.org/thisisquitting>). The American Academy of Pediatrics offers a brief, practical guide that is designed to support pediatric health clinicians in providing behavioral and pharmacologic support to help youth quit (<https://services.aap.org/en/patient-care/tobacco-control-and-prevention/youth-tobacco-cessation/>).

Visit Elsevier eBooks+ at [eBooks.Health.Elsevier.com](http://eBooks.Health.Elsevier.com) for Bibliography.



**Table 157.8** Smoking Cessation Pharmacotherapy Available in the United States\*

THERAPY BRAND	NAME	STRENGTHS	FDA-APPROVED ADULT DOSING	AVAILABILITY†	STUDIED IN ADOLESCENTS
<b>NICOTINE REPLACEMENT THERAPY</b>					
Gum‡	Nicorette	2 mg, 4 mg	The 4-mg strength should be used by patients who smoke $\geq 25$ cigarettes a day; otherwise, 2-mg strength should be used. Wk 1-6: 1 piece every 1-2 hr Wk 7-9: 1 piece every 2-4 hr Wk 10-12: 1 piece every 4-8 hr	OTC*	Yes
Inhaler	Nicotrol Inhaler	4 mg	6-16 cartridges a day for up to 12 wk	Rx	No
Lozenge	Commit, Nicorette mini	2 mg, 4 mg	The 4-mg strength should be used by patients who smoke their first cigarette within 30 min of waking; otherwise, 2-mg strength should be used. Wk 1-6: 1 lozenge every 1-2 hr Wk 7-9: 1 lozenge every 2-4 hr Wk 10-12: 1 lozenge every 4-8 hr	OTC	No
Nasal spray	Nicotrol NS	0.5 mg/spray	1-2 sprays/hr up to a maximum of 80 sprays per day	Rx	Yes
Transdermal patch‡	NicoDerm CQ	7, 14, 21 mg/24 hr	For patients who smoke >10 cigarettes daily: Step 1: one 21-mg patch daily for wk 1-6 Step 2: one 14-mg patch daily for wk 7-8 Step 3: one 7-mg patch daily for wk 9-10 For patients who smoke <10 cigarettes daily: Begin with 14-mg patch daily for 6 wk, followed by 7-mg patch for 2 wk.	OTC	Yes
<b>NONNICOTINE THERAPY</b>					
Bupropion SR‡	Zyban	150-mg sustained-release tablets	150 mg PO in morning for 3 days, then increase to 150 mg PO bid	Rx	Yes
Varenicline	Chantix	0.5-, 1-mg tablets	0.5 mg PO in morning for 3 days; increase to 0.5 mg PO bid for 4 days, then increase to 1 mg PO bid	Rx	Yes

\*None are FDA approved for use in patients younger than 18 years of age.

†OTC, Over the counter; Rx, prescription product; PO, by mouth (orally); bid, twice daily.

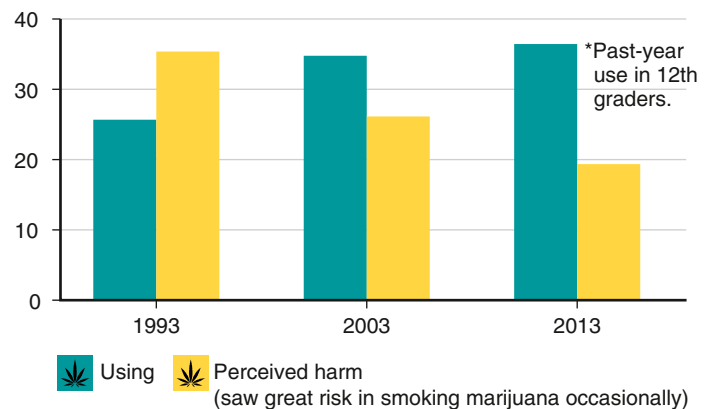
‡Generics are available.

From JP Karpinski et al: Smoking cessation treatment for adolescents. *J Pediatr Pharmacol Ther* 2010;15:249–260

### 157.3 Marijuana

Cora Collette Breuner

Marijuana (cannabis, pot, weed, hash, grass), derived from the *Cannabis sativa* hemp plant, is the most commonly used illicit substance. The main active chemical, tetrahydrocannabinol (THC), is responsible for its hallucinogenic properties. THC is absorbed rapidly by the nasal or oral routes, producing a peak of subjective effect at 10 min and 1 hour, respectively. Marijuana is generally smoked as a cigarette (reefer, joint), in a pipe, or ingested (edibles). Although there is much variation in content, each cigarette contains 8–10% THC. Another popular form that is smoked, a “blunt,” is a hollowed-out small cigar (tobacco leaf) refilled with marijuana, and thus also contains nicotine. Marijuana products (hash oil or leaf) can also be used in some vaping devices or hookah pens. **Hashish** is the concentrated THC resin in a sticky black liquid or oil. Although marijuana use by U.S. teens has declined in the last decade, ~25% of high school students have used marijuana at least once during the previous 30 days. About 8% of students report having tried marijuana before age 13, with a range of 4.3–18.5% across various states, indicating the need for early prevention efforts. Adolescents living in states where medical marijuana is legal report a higher use



**Fig. 157.3** As the perceived harm of marijuana drops, use disorder goes up. The 36.4% using in 2013 equates to about 11 students in the average class. (From NIH National Institute on Substance Use.)

of cannabis edibles. It is important to recognize that as perceived harm drops, marijuana use increases. (Fig. 157.3). In addition, the potency of cannabis has increased substantially in part to marketing and legal sales.

**Table 157.9** Acute and Chronic Adverse Effects of Cannabis Use**ACUTE ADVERSE EFFECTS**

- Anxiety and panic, especially in naïve users
- Psychotic symptoms (at high doses)
- Road crashes if a person drives while intoxicated
- Cannabis hyperemesis syndrome

**CHRONIC ADVERSE EFFECTS**

- Cannabis dependence syndrome (in about 1 in 10 users)
- Chronic bronchitis and impaired respiratory function in regular smokers
- Psychotic symptoms and disorders in heavy users, especially those with a history of psychotic symptoms or a family history of these disorders
- Impaired educational attainment in adolescents who are regular users
- Subtle cognitive impairment in those who are daily users for 10 yr or more
- Impaired tasks of sequencing ability, cognitive processing speed, inhibition, and sustained attention

Modified from Hall W, Degenhardt L. Adverse health effects of non-medical cannabis use. *Lancet*. 2009;374:1383–1390.

**Table 157.10** Rome IV Criteria for CHS Diagnosis

CATEGORY	FEATURES
Essential	Stereotypical episodic vomiting resembling CVS in terms of onset, duration, and frequency Presentation after prolonged, excessive cannabis use Relief of vomiting episodes by sustained cessation of cannabis use
Supportive remarks	May be associated with pathologic bathing behavior (prolonged hot baths or showers)

CHS, Cannabinoid hyperemesis syndrome; CVS, cyclic vomiting syndrome.

From Zhu JW, Gonsalves CL, Issenman RM, Kam AJ. Diagnosis and acute management of adolescent cannabinoid hyperemesis syndrome: a systematic review. *J Adolesc Health*. 2021;68:246–254, Table 1, p. 248.

**CLINICAL MANIFESTATIONS**

In addition to the desired effects of elation and euphoria, marijuana may cause impairment of short-term memory, poor performance of tasks requiring divided attention (e.g., those involved in driving), loss of critical judgment, decreased coordination, and distortion of time perception (Table 157.9). Visual hallucinations and perceived body distortions occur rarely, but “flashbacks” or recall of frightening hallucinations experienced under marijuana’s influence may occur, usually during stress or with fever.

Smoking marijuana for a minimum of 4 days/week for 6 months appears to result in dose-related suppression of plasma testosterone levels and spermatogenesis, prompting concern about the potential deleterious effect of smoking marijuana before completion of pubertal growth and development. There is an antiemetic effect of oral THC or smoked marijuana, often followed by appetite stimulation, which is the basis of the substance’s use in patients receiving cancer chemotherapy.

An **amotivational syndrome** has been described in long-term marijuana users who lose interest in age-appropriate behavior; proof of the causative relationship remains equivocal. Chronic use is associated with increased anxiety and depression, learning problems, poor job performance, hyperemesis, and respiratory problems such as pharyngitis, sinusitis, bronchitis, and asthma (see Table 157.9).

**Cannabinoid hyperemesis syndrome (CHS)** is characterized by recurrent episodes of vomiting associated with abdominal pain and nausea; patients often find relief by taking a hot shower or bath (Table 157.10). Cannabis use typically has been chronic (>1-2 year) and frequent (multiple times per week). There is considerable similarities between CHS and cyclic vomiting syndrome (see Chapter 390). Treatment of CHS includes stopping marijuana use, antiemetics, and topical capsaicin.

The increased THC content of marijuana of 5- to 15-fold compared to that of the 1970s is related to the observation of a **withdrawal syndrome** occurring 24-48 hours after discontinuing the substance. Heavy users experience malaise, irritability, agitation, insomnia, substance craving, shakiness, diaphoresis, night sweats, and GI disturbance. The symptoms peak by the fourth day and resolve in 10-14 days. Certain substances may interact with marijuana to potentiate sedation (alcohol, diazepam) and stimulation (cocaine, amphetamines) or may be antagonistic (propranolol, phenytoin).

Behavioral interventions, including **cognitive-behavioral therapy (CBT)** and motivational incentives, have shown to be effective in treating marijuana dependency.

Visit Elsevier eBooks+ at eBooks.Health.Elsevier.com for Bibliography.

**157.4 Inhalants**

Cora Collette Breuner

Inhalants, found in many common household products, comprise a diverse group of volatile substances whose vapors can be inhaled to produce psychoactive effects. The practice of inhalation is popular among younger adolescents and decreases with increasing age. Young adolescents are attracted to these substances because of their rapid action, easy availability, and low cost. Products that are abused as inhalants include *volatile solvents* (paint thinners, glue, e-cigarette solvents known as “dripping,” toluene, acetone, refrigerants, gasoline, cleaning fluids, correction fluids), *aerosols* (spray paint, nitrous oxide, hair spray), *gases* (propane tanks, lighter fluid), *nitrites* (“poppers” or “video head cleaner”), and *propellants* used in whipped cream dispensers. The most popular inhalants among young adolescents are glue, shoe polish, and spray paint. The various products contain a wide range of chemicals with serious adverse health effects (Table 157.11). **Huffing**, the practice of inhaling fumes, can be accomplished using a paper bag containing a chemical-soaked cloth; spraying aerosols directly into the nose/mouth; or using a balloon, plastic bag, or soda can filled with fumes. The percentage of adolescents using inhalants has remained stable, with 5.8% of high school students reporting having ever used inhalants. Eighth and ninth graders report highest use, suggesting targeted prevention strategies for this age-group.

**CLINICAL MANIFESTATIONS**

The major effects of inhalants are psychoactive (Table 157.12). The intoxication lasts only a few minutes, so a typical user will huff repeatedly over an extended period (hours) to maintain the high. The immediate effects of inhalants are similar to alcohol: euphoria, slurred speech, decreased coordination, and dizziness. **Toluene**, the main ingredient in model airplane glue and some rubber cements, causes relaxation and pleasant hallucinations for up to 2 hours. Euphoria is followed by violent excitement; coma may result from prolonged or rapid inhalation. **Volatile nitrites**, such as amyl nitrite, butyl nitrite, and related compounds marketed as room deodorizers, are used as euphorants, enhancers of musical appreciation, and sexual enhancers among older adolescents and young adults. They may result in headaches, syncope, and lightheadedness; profound hypotension and cutaneous flushing followed by vasoconstriction and tachycardia; transiently inverted T waves and depressed ST segments on electrocardiography; methemoglobinemia; increased bronchial irritation;

**Table 157.11** Hazards of Chemicals Found in Commonly Used Inhalants

<b>Amyl nitrite, butyl nitrite</b> (“poppers,” “video head cleaner”): sudden sniffing death syndrome, suppressed immunologic function, injury to red blood cells (interfering with oxygen supply to vital tissues)
<b>Benzene</b> (found in gasoline): bone marrow injury, impaired immunologic function, increased risk of leukemia, reproductive system toxicity
<b>Butane, propane</b> (found in lighter fluid, hair and paint sprays): sudden sniffing death syndrome via cardiac effects, serious burn injuries (because of flammability)
<b>Freon</b> (used as a refrigerant and aerosol propellant): sudden sniffing death syndrome, respiratory obstruction and death (from sudden cooling/cold injury to airways), liver damage
<b>Methylene chloride</b> (found in paint thinners and removers, degreasers): reduction of oxygen-carrying of blood, changes to the heart muscle and heartbeat
<b>Nitrous oxide</b> (“laughing gas, Whippits, i.e., whipped cream dispensers), <b>hexane</b> : death from lack of oxygen to the brain, altered perception and motor coordination, loss of sensation, limb spasms, blackouts caused by blood pressure changes, depression of heart muscle functioning; vitamin B <sub>12</sub> deficiency
<b>Toluene</b> (found in gasoline, paint thinners and removers, correction fluid): brain damage (loss of brain tissue mass, impaired cognition, gait disturbance, loss of coordination, loss of equilibrium, limb spasms, hearing and vision loss), liver and kidney damage
<b>Trichloroethylene</b> (found in spot removers, degreasers): sudden sniffing death syndrome, cirrhosis of the liver, reproductive complications, hearing and vision damage

**Table 157.12** Stages in Symptom Development After Use of Inhalants

STAGE	SYMPTOMS
1: Excitatory	Euphoria, excitation, exhilaration, dizziness, hallucinations, sneezing, coughing, excess salivation, intolerance to light, nausea and vomiting, flushed skin and bizarre behavior
2: Early CNS depression	Confusion, disorientation, dullness, loss of self-control, ringing or buzzing in the head, blurred or double vision, cramps, headache, insensitivity to pain, and pallor or paleness
3: Medium CNS depression	Drowsiness, muscular incoordination, slurred speech, depressed reflexes, and nystagmus or rapid involuntary oscillation of the eyeballs
4: Late CNS depression	Unconsciousness that may be accompanied by bizarre dreams, epileptiform seizures, and EEG changes

CNS, Central nervous system; EEG, electroencephalogram.

From Harris D. Volatile substance use. *Arch Dis Child Educ Pract Ed.* 2006;91:ep93–ep100.

and increased intraocular pressure. There may be dermatologic findings, including perianal/perioral dermatitis (“huffer rash”), frostbite, and contact dermatitis, as well as epistaxis, nasal ulcers, and conjunctivitis.

## COMPLICATIONS

Model airplane glue is responsible for a wide range of complications related to chemical toxicity, to the method of administration (in plastic bags, with resultant suffocation), and to the dangerous setting in which the inhalation occurs (roof tops). Common neuromuscular changes reported in chronic inhalant users include difficulty coordinating movement, gait disorders, muscle tremors, and spasticity, particularly in the legs (Table 157.13). Chronic use may

**Table 157.13** Documented Clinical Presentations of Acute and Chronic Volatile Substance Use

Ventricular fibrillation	Muscle weakness
Asystolic cardiac arrest	Abdominal pain
Myocardial infarction	Cough
Ataxia	Aspiration pneumonia
Agitation	Chemical pneumonitis
Limb and trunk incoordination	Coma
Tremor	Visual and auditory hallucinations
Visual loss	Acute delusions
Tinnitus	Nausea and vomiting
Dysarthria	Pulmonary edema
Vertigo	Photophobia
Hyperreflexia	Rash
Acute confusional state	Jaundice
Conjunctivitis	Anorexia
Acute paranoia	Slurred speech
Depression	Diarrhea
Oral and nasal mucosal ulceration	Weight loss
Halitosis	Epistaxis
Convulsions/fits	Rhinitis
Headache	Cerebral edema
Peripheral neuropathy	Visual loss
Methemoglobinemia	Burns
Acute trauma	Renal tubular acidosis

cause pulmonary hypertension, restrictive lung defects or reduced diffusion capacity, peripheral neuropathy, hematuria, tubular acidosis, and possibly cerebral and cerebellar atrophy. Chronic inhalant use has long been linked to widespread brain damage and cognitive abnormalities that can range from mild impairment (poor memory, decreased learning ability) to severe dementia. High-frequency inhalant users were significantly more likely than moderate- and low-frequency users to experience adverse consequences of inhalant intoxication, such as behavioral, language, and memory problems. Certain risky behaviors and consequences, such as engaging in unprotected sex or fighting while high on inhalants, were dramatically more common among high-frequency than low-frequency inhalant users. Death in the acute phase may result from cerebral or pulmonary edema or myocardial involvement (see Table 157.13).

## DIAGNOSIS

Diagnosis of inhalant abuse is difficult because of the ubiquitous nature of the products and decreased parental awareness of the dangers. In the primary care setting, providers need to ask parents if they have witnessed any unusual behaviors in their teen; noticed high-risk products in the teen’s bedroom; seen paint on the teen’s hands, nose, or mouth; or found paint- or chemical-coated rags. Complete blood count, coagulation studies, and hepatic and renal function studies may identify the complications. In extreme intoxication, a user may manifest symptoms of restlessness, general muscle weakness, dysarthria, nystagmus, disruptive behavior, and occasionally hallucinations. Toluene is excreted rapidly in the urine as hippuric acid, with the residual detectable in the serum by gas chromatography.

## TREATMENT

Treatment is generally supportive and directed toward control of arrhythmia and stabilization of respirations and circulation. Withdrawal symptoms do not usually occur.

Visit Elsevier eBooks+ at eBooks.Health.Elsevier.com for Bibliography.

## 157.5 EVALI

E-cigarette or vaping use–associated lung injury.  
See Chapter 450.

## 157.6 Hallucinogens

Cora Collette Breuner

Several naturally occurring and synthetic substances are used by adolescents for their hallucinogenic properties. They have chemical structures similar to neurotransmitters such as serotonin, but their exact mechanism of action remains unclear. Lysergic acid diethylamide (LSD), methylenedioxyamphetamine (ecstasy, MDMA), and hallucinogenic magic mushrooms (psilocybins) are the most commonly reported hallucinogens used. Peyote (mescaline) derived from a cactus flower is chemically related to MDMA. Ayahuasca is another plant-derived hallucinogen found in South America whose active agents are N,N-dimethyltryptamine (DMT) and harmala alkaloids, which act as a monoamine oxidase inhibitor. Another hallucinatory agent is derived from a poisonous toad (*Bufo alvarius*), native to the Sonoran Desert, which produces 5-MeO-DMT in its venom gland. 251-NBOMe (N-Bomb) is a designer substance that interacts with the 5HT-2a receptor and has sympathomimetic and hallucinogenic properties (Table 157.14).

### LYSERGIC ACID DIETHYLAMIDE

LSD (acid, big “d,” blotters) is a very potent hallucinogen that is made from lysergic acid found in ergot, a fungus that grows on rye and other grains. Its high potency allows effective doses to be applied to absorbent paper, or it can be taken as a liquid or a tablet. The onset of action can be 30–60 minutes, and it peaks at 2–4 hours. By 10–12 hours, individuals return to the preingestion state. Among U.S. 12th graders, 4% report trying LSD at least once.

### Clinical Manifestations

The effects of LSD can be divided into three categories: somatic (physical effects), perceptual (altered changes in vision and hearing), and psychic (changes in sensorium). The common somatic symptoms are dizziness, dilated pupils, nausea, flushing, elevated temperature, and tachycardia. The sensation of *synesthesia*, or “seeing” smells and “hearing” colors, as well as major distortions of time and self, have been reported with high doses of LSD. Delusional ideation, body distortion, and suspiciousness to the point of toxic psychosis are the more serious of the psychic symptoms. LSD is not considered to be an addictive substance because it does not typically produce substance-seeking behavior.

### Treatment

An individual is considered to have a “bad trip” when the sensory experiences cause the user to become terrified or panicked. These episodes should be treated by removing the individual from the aggravating situation and placing them in a quiet room with a calming friend. In situations of extreme agitation or seizures, use of benzodiazepines may be warranted. “Flashbacks,” or LSD-induced states after the drug has worn off, and tolerance to the effects of the drug are additional complications of its use.

### METHYLENEDIOXYMETHAMPHETAMINE

MDMA (“X,” ecstasy, Molly), a phenylisopropylamine hallucinogen, is a synthetic compound similar to hallucinogenic cactus-derived mescaline and the stimulant methamphetamine. Like other hallucinogens, this substance is proposed to interact with serotonergic neurons in the CNS. It is the preferred substance at “raves,” all-night dance parties, and is also known as one of the “club substances” along with  $\gamma$ -hydroxybutyrate (GHB) and ketamine. Nationwide, the prevalence of

having ever used MDMA was 8.4% of college students; 12th-grade lifetime use was 2.8% in 2021.

### Clinical Manifestations

Euphoria, a heightened sensual awareness, and increased psychic and emotional energy are acute effects. Compared to other hallucinogens, MDMA is less likely to produce emotional lability, depersonalization, and disturbances of thought. Nausea, jaw clenching, teeth grinding, and blurred vision are somatic symptoms, whereas anxiety, panic attacks, and psychosis are the adverse psychiatric outcomes. A few deaths have been reported after ingestion of the substance. In high doses, MDMA can interfere with the body’s ability to regulate temperature. The resultant hyperthermia in association with vigorous dancing at a “rave” has resulted in severe liver, kidney, and cardiovascular system failure and death. No specific treatments are recommended for acute toxicity.

Chronic MDMA use can lead to changes in brain function, affecting cognitive tasks and memory. These symptoms may occur because of MDMA’s effects on neurons that secrete serotonin as a neurotransmitter. The serotonin system plays an important role in regulating mood, aggression, sexual activity, sleep, and sensitivity to pain. A high rate of dependence has been found among MDMA users. MDMA exposure may be associated with long-term neurotoxicity and damage to serotonin-containing neurons. In nonhuman primates, exposure to MDMA for only 4 days caused damage to serotonin nerve terminals that was evident 6–7 years later. There are no specific pharmacologic treatments for MDMA addiction. Substance use recovery groups are recommended.

### PHENCYCLIDINE

Phencyclidine (PCP) (Sernyl, angel dust, hog, peace pill, sheets) is an arylcyclohexylamine whose popularity is related in part to its ease of synthesis in home laboratories. One of the by-products of home synthesis can cause cramps, diarrhea, and hematemesis. It is a “dissociative substance” that produces feelings of detachment from the surrounding environment and self. The substance is thought to potentiate adrenergic effects by inhibiting neuronal reuptake of catecholamines. PCP is available as a tablet, liquid, or powder, which may be used alone or sprinkled on cigarettes (joints). The powders and tablets generally contain 2–6 mg of PCP, whereas joints average 1 mg for every 150 mg of tobacco leaves, or approximately 30–50 mg per joint. The prevalence of PCP use (a hallucinogenic substance) among U.S. 12th graders is approximately 1%.

### Clinical Manifestations

The clinical manifestations are dose related and produce alterations of perception, behavior, and autonomic functions. Euphoria, nystagmus, ataxia, and emotional lability occur within 2–3 minutes after smoking 1–5 mg and last for 4–6 hours. At these low doses the user is likely to experience shallow breathing, flushing, generalized numbness of extremities, and loss of motor coordination. Hallucinations may involve bizarre distortions of body image that often precipitate panic reactions. With doses of 5–15 mg, a toxic psychosis may occur, with disorientation, hypersalivation, and abusive language lasting for >1 hour. Hypotension, generalized seizures, and cardiac arrhythmias typically occur with plasma concentrations of 40–200 mg/dL. Death has been reported during psychotic delirium from hypertension, hypotension, hypothermia, seizures, and trauma. The coma of PCP may be distinguished from that of the opiates by the absence of respiratory depression; the presence of muscle rigidity, hyperreflexia, and nystagmus; and lack of response to naloxone. PCP psychosis may be difficult to distinguish from schizophrenia. In the absence of a history of use, the diagnosis depends on urinalysis.

### Treatment

Management of the PCP-intoxicated patient includes placement in a darkened, quiet room on a floor pad, safe from injury. Acute alcohol intoxication may also be present. For recent oral ingestion, gastric absorption is poor, and induction of emesis or gastric lavage is useful. Diazepam, in a dose of 5–10 mg orally or 2–5 mg intravenously, may



Table 157.14 Classes of Hallucinogens

CHEMICAL NAMES	PLANTS OR NATURAL SOURCES; SYNTHETIC AGENTS; "SLANG NAMES"
<b>INDOLEAMINES</b>	
<i>Lysergamides (Ergolines)</i>	
d-Lysergic acid diethylamide	LSD; Delysid; "acid," "blotter," "stamps," "dots," "trips," "paper," "a-bombs," "pyramids"
d-Lysergic acid amide	<i>Ipomoea violacea</i> (morning glory), <i>Rivea corymbosa</i> (Mexican ololiuqui), <i>Argyrea nervosa</i> (Hawaiian baby woodrose), <i>Merremia tuberosa</i> (Hawaiian woodrose)
<i>Alkytryptamines</i>	
$\alpha$ -Methyltryptamine	AMT; "alpha"
N,N-dimethyltryptamine (DMT)	<i>Piptadenia peregrina</i> , <i>Anadenanthera peregrina</i> , <i>Prestonia amazenicum</i> , <i>Mimosa hostilis</i> , <i>Vivola calophylla</i> ; "businessman's trip"
5-Methoxy-N,N-dimethyltryptamine (5-MeO-DMT)	<i>Bufo alvarius</i>
Psilocybin (4-phosphoryloxy-DMT)	<i>Psilocybesp</i> , <i>Panaeolus</i> sp., <i>Conocybesp</i> , <i>Inocybesp</i> , <i>Gymnopilus</i> sp., <i>Lycoperdon</i> sp., <i>Pluteus</i> genus; "magic mushrooms," "shrooms," "alice"
Psilocin (4-OH-DMT)	
5-Methoxy-N,N-diisopropyltryptamine (5-MeO-DIPT)	"Foxy methoxy," "foxy"
Bufofenine (5-OH-DMT)	Ch'an Su
Diethyltryptamine	DET
Ibogaine	<i>Tabernanthe iboga</i>
<b>PHENYLETHYLAMINES</b>	
Mescaline (3,4,5-trimethoxyphenethylamine)	Peyote cactus ( <i>Lophophora williamsii</i> )
3,4-methylenedioxyamphetamine (MDMA)	Ecstasy; "XTC," "X," "E," "Adam," "the hug drug"
3,4-methylenedioxyamphetamine (MDEA)	"Eve"
Methylenedioxyamphetamine (MDA)	
4-Bromo-2,5-dimethoxyamphetamine (DOM)	"Serenity, tranquility, and peace" [STP]
Paramethoxyamphetamine (PMA)	
<b>ARYLCYCLOHEXYLAMINES (PIPERIDINE DERIVATIVES)</b>	
Phencyclidine (PCP)	Angel dust; "hog," "wacky weed," "T," "killer weed"
Ketamine	Ketalar, ketaject, ketanest, "special K," "K," "K-hole," "vitamin K"
Dextromethorphan	"DXM," "dex," "robotripping," "CCC," "skittles," "red devils"
<b>PIPERAZINES</b>	
Benzylpiperazine (BZP)	"Legal E," "Legal X," "A2"
Trifluoromethylphenylpiperazine (TFMPP)	
Methylenedioxybenzylpiperazine (MDBP)	
m-Chlorophenylpiperazine (mCPP)	
p-Methoxyphenylpiperazine (MeOPP)	
<b>TETRAHYDROCANNABINOIDS</b>	
Tetrahydrocannabinol ( $\Delta^9$ -THC, $\Delta^1$ -THC)	Dronabinol (Marinol); <i>Cannabis sativa</i> (marijuana, hashish)
<b>DITERPENE ALKALOIDS</b>	
Salvinorin A, C	<i>Salvia divinorum</i> ; sage
Myrsicin, saffron	<i>Myristica fragrans</i> (nutmeg, mace)
<b>ANTICHOLINERGIC AGENTS</b>	
Atropine (d,l-hyoscyamine)	<i>Atropa belladonna</i> (deadly nightshade), <i>Datura stramonium</i> (jimson weed)
Scopolamine (L-hyoscyne)	Transderm Scop; <i>Datura stramonium</i> (jimson weed), <i>Hyoscyamus niger</i> (henbane)

From Traub SJ. Hallucinogens. In Shannon MW, Borron SW, Burns MJ, eds. *Haddad and Winchester's Clinical Management of Poisoning and Drug Overdose*, 4th ed. Philadelphia: Elsevier, 2007: Table 45.1.

be helpful if the patient is agitated and not comatose. Rapid excretion of the substance is promoted by acidification of the urine. Supportive therapy of the comatose patient is indicated with particular attention to hydration, which may be compromised by PCP-induced diuresis. Inpatient and/or behavioral treatments can be helpful for chronic PCP users.

Visit Elsevier eBooks+ at [eBooks.Health.Elsevier.com](http://eBooks.Health.Elsevier.com) for Bibliography.

## 157.7 Cocaine

Cora Collette Breuner

Cocaine, an alkaloid extracted from the leaves of the South American *Erythroxylum coca*, is supplied as the hydrochloride salt in crystalline form. With **snorting**, it is rapidly absorbed into the bloodstream from the nasal mucosa, detoxified by the liver, and excreted in the urine as benzoylecgonine. Smoking the cocaine alkaloid (**freebasing**) involves inhaling the cocaine vapors in pipes or cigarettes mixed with tobacco

or marijuana. Accidental burns are potential complications of this practice. With **crack** cocaine, the crystallized rock form, the smoker feels “high” in <10 seconds. The risk of addiction with this method is higher and more rapidly progressive than from snorting cocaine. Tolerance develops, and the user must increase the dose or change the route of administration, or both, to achieve the same effect. To sustain the high, cocaine users repeatedly use cocaine in short periods known as “binges.” Substance dealers often place cocaine in plastic bags or condoms and swallow these containers during transport. Rupture of a container produces a sympathomimetic crisis (see [Table 157.4](#)). Cocaine use disorder among U.S. high school students has decreased in the last decade, with 2.5% of 12th graders having tried the substance (any route) at least once.

### CLINICAL MANIFESTATIONS

Cocaine is a strong CNS stimulant that increases dopamine levels by preventing reuptake. Cocaine produces euphoria, increased motor activity, decreased fatigability, and mental alertness. Its sympathomimetic properties are responsible for pupillary dilation, tachycardia, hypertension, and hyperthermia. Snorting cocaine chronically results in loss of sense of smell, nosebleeds, and chronic rhinorrhea. Injecting cocaine increases risk for HIV infection. Chronic users experience anxiety, irritability, and sometimes paranoid psychosis. Lethal effects are possible, especially when cocaine is used in combination with other substances, such as heroin, in an injectable form known as a “speed-ball.” When taken with alcohol, cocaine is metabolized by the liver to produce cocaethylene, a substance that enhances the euphoria and is associated with a greater risk of sudden death than with cocaine alone. Pregnant adolescents who use cocaine place their fetus at risk of premature delivery, complications of low birthweight, and possibly developmental disorders.

### TREATMENT

There are no FDA-approved medications for treatment of cocaine addiction. CBT has been shown to be effective when provided in combination with additional services and social support. Oral sustained-release dexamphetamine has been shown to be partially effective in adults with cocaine dependence.

Visit Elsevier eBooks+ at [eBooks.Health.Elsevier.com](http://eBooks.Health.Elsevier.com) for Bibliography.

## 157.8 Amphetamines

Cora Collette Breuner

Methamphetamine, commonly known as **meth**, is a nervous system stimulant and Schedule II substance with a high potential for abuse. Most of the methamphetamine currently used is produced in illegal laboratories. It is a white, odorless, bitter-tasting powder that is particularly popular among adolescents and young adults because of its potency and ease of absorption. It can be ingested orally, smoked, needle-injected, or absorbed across mucous membranes. Amphetamines have multiple CNS effects, including release of neurotransmitters and an indirect catecholamine agonist effect. Approximately 0.6% of 12th graders reported using methamphetamine at least once.

### CLINICAL MANIFESTATIONS

Methamphetamine rapidly increases the release and blocks the reuptake of dopamine, a powerful “feel good” neurotransmitter ([Table 157.15](#)). The effects of amphetamines can be dose related. In small amounts, amphetamine effects resemble other stimulants: increased physical activity, rapid and/or irregular heart rate, increased blood pressure, and decreased appetite. High doses produce slowing of cardiac conduction in the face of ventricular irritability. Hypertensive and hyperpyrexia episodes can occur, as can seizures (see [Table 157.4](#)). Binging may result in the development of psychotic ideation with the potential for sudden violence. Cerebrovascular damage, psychosis, severe receding of the gums with tooth decay, and infection with HIV and hepatitis B and C can result from long-term use. A withdrawal syndrome is associated with amphetamine use, with early, intermediate, and late phases (see [Table 157.15](#)). The early phase is characterized as a “crash” phase with depression, agitation, fatigue, and desire for more of the substance. Loss of physical and mental energy, limited interest in the environment, and anhedonia mark the intermediate phase. In the final phase, substance craving returns, often triggered by particular situations or objects.

### TREATMENT

Acute agitation and delusional behaviors can be treated with haloperidol or droperidol. Phenothiazines are contraindicated and may cause

**Table 157.15** Signs and Symptoms of Intoxication and Withdrawal

	OPIATES	AMPHETAMINES/COCAINE	BENZODIAZEPINES
<b>INTOXICATION</b>			
Behavior	Apathy and sedation; disinhibition; psychomotor retardation; impaired attention and judgment	Euphoria and sensation of increased energy; hypervigilance; grandiosity, aggression, argumentative; labile mood; repetitive stereotyped behaviors; hallucinations, usually with intact orientation; paranoid ideation; interference with personal functioning	Euphoria; apathy and sedation; abusiveness or aggression; labile mood; impaired attention; anterograde amnesia; impaired psychomotor performance; interference with personal functioning
Signs	Drowsiness; slurred speech; pupillary constriction (except anoxia from severe overdose—dilation); decreased level of consciousness	Dilated pupils; tachycardia (occasionally bradycardia, cardiac arrhythmias); hypertension; nausea/vomiting; sweating and chills; evidence of weight loss; dilated pupils; chest pain; convulsions	Unsteady gait; difficulty in standing; slurred speech; nystagmus; decreased level consciousness; erythematous skin lesions or blisters
Overdose	Respiratory depression; hypothermia	Sympathomimetic symptoms	Hypotension; hyperthermia; depression of gag reflex; coma
Withdrawal	Craving to use; lacrimation; yawning; rhinorrhea/sneezing; muscle aches or cramps; abdominal cramps; nausea/vomiting/diarrhea; sweating; dilated pupils; anorexia; irritability; tremor; piloerection/chills; restlessness; disturbed sleep	Dysphoric mood (sadness/anhedonia); lethargy and fatigue; psychomotor retardation or agitation; craving; increased appetite; insomnia or hypersomnia; bizarre or unpleasant dreams	Tremor of tongue, eyelids, or outstretched hands; nausea or vomiting; tachycardia; postural hypotension; psychomotor agitation; headache; insomnia; malaise or weakness; transient visual, tactile, or auditory hallucinations or illusions; paranoid ideation; grand mal convulsions

From Haber PS, Demirkol A, Lange K, et al. Management of injecting substance users admitted to hospital. *Lancet*. 2009;374:1284–1292.

a rapid drop in blood pressure or seizure activity. Other supportive treatment consists of a cooling blanket for hyperthermia and treatment of the hypertension and arrhythmias, which may respond to sedation with lorazepam or diazepam. For the chronic user, comprehensive CBT interventions have been demonstrated as effective treatment options.

Visit Elsevier eBooks+ at [eBooks.Health.Elsevier.com](https://eBooks.Health.Elsevier.com) for Bibliography.

## 157.9 Stimulant Use and Diversion

Cora Collette Breuner

In MTF 2021, 4.6% of 12th graders reported using OTC diet pills in their lifetime and 1.1% in the past 30 days. These include nonprescription stimulants of two general types: pseudoamphetamines, usually sold by internet/mail order, and OTC stimulants, primarily diet and “stay-awake” pills. These substances usually contain caffeine, ephedrine, and/or phenylpropanolamine.

The *misuse* of a stimulant medication, defined as taking a stimulant not prescribed by a healthcare provider and not in accordance with healthcare provider guidance, has been growing over the past two decades, with an increase in prevalence rates of nonprescription stimulant use among both adolescents and young adults in the past 10 years. Nonprescription use of methylphenidate (MPH) in 2000 was 1.2%, increasing to 2% for MPH and 7.5% for nonprescription mixed amphetamine salts (AMPs) in 2015.

The majority of nonprescription stimulant users reported obtaining the substances by **diversion**, a process for obtaining the substance from peers. Diversion occurs quite often and can begin in childhood, adolescence, or young adulthood. Lifetime rates of diversion ranged from 16–29% of students with stimulant prescriptions. One survey reported that 23.3% of middle and high school students taking prescribed stimulants had been solicited to divert their medication to others at a rate that increased from middle to high school. It has been shown that 54% of college students prescribed stimulants for attention-deficit/hyperactivity disorder (ADHD) had been approached to divert their medication.

In U.S. college students, nonprescription use of stimulants is more prevalent among particular subgroups (males; members of fraternities/sororities; with lower grade point averages; more likely to use alcohol, cigarettes, marijuana, MDMA, or cocaine) and types of colleges (northeastern region, with more competitive admission standards). Lifetime prevalence of nonprescription stimulant use was 6.9% and past-month prevalence 2.1%. According to a survey of 334 ADHD-diagnosed college students taking prescription stimulants, 25% misused their own prescription medications. Scholastic pressures, including the need to succeed academically, and persistent social and financial demands place many students at an increased risk for misuse of various substances, especially at the end of school terms. A web-based survey of medical and health profession students found that the most common reason for nonprescription stimulant use was to focus and concentrate during studying.

### CLINICAL MANIFESTATIONS

Misuse of stimulants is associated with psychosis, seizures, dysrhythmias, myocardial infarction, cardiomyopathy, and even sudden death. Intentional misuse of MPH or AMPs in combination with other substances leads to adverse medical consequences. Importantly, 14% of the emergency department (ED) visits for stimulant use were associated with cardiovascular (CV) events. Psychosis includes visual hallucinations, delusions, anorexia, flattening of affect, and insomnia mediated by dopaminergic excess. The CV effects include hypertension, arrhythmias, tachycardia, cardiomyopathy, cardiac dysrhythmias, necrotizing vasculitis, and CV accidents. Case reports include serious CV adverse drug reactions (ADRs), sudden death, and psychiatric disorders. Many patients report sleep difficulties (72%), irritability (62%), dizziness and lightheadedness (35%), headaches (33%), stomachaches (33%), and sadness (25%). Other health risks include loss of appetite, weight loss, and nervousness. Many users are involved in heavy episodic alcohol use while using MPH

or AMPs. Most users of MPH or AMPs are unaware of these adverse effects and predominantly “feel good” about taking these medications.

Despite reports that MPH misuse is a healthcare issue, >82% of primary care physicians did not suspect misuse of prescribed ADHD medication in one report, and <1% thought that their patients were diverting prescribed ADHD medication. Improved monitoring for malingering and patient misuse may assist stopping diversion of these medications. An ADHD diagnosis should be confirmed in those requesting ADHD medication, and they should be screened for use of other substances.

### TREATMENT

Treatment for nonprescription stimulant overdose is similar as that for amphetamine overdose. Haloperidol or droperidol is recommended for acute agitation and delusional behaviors. Phenothiazines are contraindicated and may cause a rapid drop in blood pressure or seizure activity. Hyperthermia may require use of a cooling blanket, and sedation with a benzodiazepine is recommended for treatment of the hypertension and arrhythmias. In those with chronic use, inpatient or outpatient substance use interventions using CBT have been shown to be the most effective treatment option.

Monitoring of the diversion and misuse of pharmaceutical stimulants must be a priority. More data need to be obtained on the prevalence, patterns, and harmful effects in adolescents and young adults.

Visit Elsevier eBooks+ at [eBooks.Health.Elsevier.com](https://eBooks.Health.Elsevier.com) for Bibliography.

## 157.10 Opiates/Opioids

Cora Collette Breuner

Opiates refers to natural derived drugs (morphine, codeine, opium), whereas opioids refers to natural, semisynthetic, and synthetic agents. **Heroin** is a highly addictive synthetic opiate substance made from a naturally occurring substance (**morphine**) in the opium poppy plant. It is a white or brown powder that can be injected (intravenously or subcutaneously), snorted/sniffed, or smoked. Intravenous (IV) injection produces an immediate effect, whereas effects from the subcutaneous route occur in minutes, and from snorting, in 30 minutes. After injection, heroin crosses the blood-brain barrier, is converted to morphine, and binds to opiate receptors. Tolerance develops to the euphoric effect, and the chronic user must take more heroin to achieve the same intense effect. Heroin use among U.S. teens peaked in the mid-1990s but is resurgent in some suburban communities, as is the use of **prescription opioids** found in the home. Nationwide, 2.9% of high school students report having tried heroin at least once. **Fentanyl** is a more potent opiate and is responsible for many opiate overdoses. Other opiate drugs are noted in [Table 157.16](#). Synthetic opiate fentanyl-derived analogues or nitrazene drugs (novel potent opioids:NPO) are much more potent than fentanyl and require higher and multiple doses of naloxone to reverse an overdose. NPOs include broprhine, isotonitazene, metonitazene, and N-piperidinyl etonitazene. Fentanyl is often illicitly manufactured and may be mixed with other substances, including xylazine, a nonopioid sedative. Xylazine, also known as *tranq*, is a veterinary drug that in humans produces central nervous system and respiratory depression, as well as bradycardia and hypotension. Xylazine also produces poorly healing cutaneous ulcerations at the site of injection and at distal sites. In 2022, fentanyl-xylazine combinations have been responsible for a significant number of overdose deaths; there is no antidote for xylazine.

### CLINICAL MANIFESTATIONS

The clinical manifestations are determined by the purity of the heroin or its adulterants, combined with the route of administration (oral vs injection). The immediate effects include euphoria, diminution in pain, flushing of the skin, and pinpoint pupils (see [Table 157.15](#)). An effect on the hypothalamus is suggested by the lowering of body temperature. The most common dermatologic lesions are the “tracks,” the hypertrophic linear scars that follow the course of large veins. Smaller, discrete peripheral scars, resembling healed insect bites, may be easily overlooked. The adolescent who injects heroin subcutaneously may have fat necrosis, lipodystrophy, and atrophy over portions

**Table 157.16** Types and Actions of the Most Commonly Prescribed and Used Opioids

	TYPE OF OPIOID	ACTION ON OPIOID RECEPTOR
Alfentanil	Fully synthetic	Agonist of $\mu$ -receptors
Buprenorphine	Semisynthetic	Partial agonist of $\mu$ -receptors and NOP receptors; antagonist of $\kappa$ -receptors
Codeine	Natural	Weak agonist of $\mu$ -receptors
Diamorphine (heroin)	Semisynthetic	Agonist of $\mu$ -receptors, $\delta$ -receptors, and $\kappa$ -receptors; predominant binding to $\mu$ -receptors
Dihydrocodeine	Semisynthetic	Agonist of $\mu$ -receptors
Fentanyl	Fully synthetic	Agonist of $\mu$ -receptors, $\delta$ -receptors, and $\kappa$ -receptors; predominant binding to $\mu$ -receptors
Hydromorphone	Semisynthetic	Agonist of $\mu$ -receptors and $\kappa$ -receptors; predominant binding to $\mu$ -receptors
Methadone	Fully synthetic	Agonist of $\mu$ -receptors
Morphine	Natural	Agonist of $\mu$ -receptors, $\delta$ -receptors, and $\kappa$ -receptors; predominant binding to $\mu$ -receptors
Oxycodone	Semisynthetic	Weak agonist of $\mu$ -receptors, $\delta$ -receptors, and $\kappa$ -receptors; predominant binding to $\mu$ -receptors
Pentazocine	Fully synthetic	Partial agonist of $\delta$ -receptors and $\kappa$ -receptors; antagonist of $\mu$ -receptors
Pethidine (meperidine)	Fully synthetic	Agonist of $\kappa$ -receptors
Tramadol	Fully synthetic	Weak agonist of $\mu$ -receptors

Information presented is from the DrugBank and PubChem databases.

NOP, Nociceptin opioid peptide.

From Fountas A, Van Uum S, Karavitiaki N. Opioid-induced endocrinopathies. *Lancet Diabetes Endocrinol.* 2020;8:68–80.

of the extremities. Attempts to conceal these stigmata may include amateur tattoos in unusual sites. Skin abscesses secondary to unsterile techniques of substance administration are usually found. There is a loss of libido; the mechanism is unknown. The chronic heroin user may resort to prostitution to support the habit, thus increasing the risk of sexually transmitted diseases (including HIV), pregnancy, and other infectious diseases. Constipation results from decreased smooth muscle propulsive contractions and increased anal sphincter tone. The absence of sterile technique in injection may lead to cerebral microabscesses or endocarditis, usually caused by *Staphylococcus aureus* or *Pseudomonas aeruginosa*. Abnormal serologic reactions are also common, including false-positive Venereal Disease Research Laboratories and latex fixation tests. Infectious complications are usually not seen with oral prescription opioid use unless the pills are dissolved and injected.

## WITHDRAWAL

After  $\geq 8$  hours without heroin, the addicted individual undergoes a series of physiologic disturbances over 24–36 hours, referred to collectively as “withdrawal” or **abstinence syndrome** (see [Table 157.15](#)). The earliest sign is yawning, followed by lacrimation, mydriasis, restlessness, insomnia, “goose flesh,” cramping of the voluntary musculature, bone pain, hyperactive bowel sounds and diarrhea, tachycardia, and systolic hypertension. Although the administration of **methadone** is the most common method of detoxification, **buprenorphine**, an opiate agonist-antagonist, is available for detoxification and maintenance treatment of heroin and other opiates. Buprenorphine has the advantage of offering less risk of addiction, overdose, and withdrawal effects and can be dispensed in the privacy of a physician’s office. Combined with behavioral interventions, it has a greater success rate of detoxification. A combination substance, buprenorphine plus naloxone, has been formulated to minimize use during detoxification. Clonidine and tramadol have also been used to manage opioid withdrawal.

Substances used to treat **opioid use disorder**, a chronic relapsing problem, traditionally include methadone maintenance and buprenorphine. Use-deterrent opioid pill formulations (when pain control requires an opioid) include pills resistant to crushing that form a viscous gel when dissolved or pills with a sequestered opioid antagonist (naltrexone).

## OVERDOSE SYNDROME

Overdose syndrome is an acute reaction after administration of an opiate. It is the leading cause of death among substance users. Many opiate overdoses are complicated by polydrug use ([Fig. 157.4](#)). The clinical signs include stupor or coma, seizures, miotic pupils (unless severe anoxia has occurred), respiratory depression, cyanosis, and pulmonary edema. The differential diagnosis includes CNS trauma, diabetic coma, hepatic (and other) encephalopathy, Reye syndrome, and overdose of alcohol, barbiturates, PCP, or methadone. Diagnosis of opiate toxicity is facilitated by IV administration of naloxone 0.1 mg/kg, not to exceed 2 mg, which causes dilation of pupils constricted by the opiate. Diagnosis is confirmed by the finding of opiates in the urine and/or serum.

## TREATMENT

Treatment of acute heroin overdose consists of maintaining adequate oxygenation and continued administration of **naloxone**, a pure opioid antagonist (see [Chapter 94](#)). It may be given intravenously, intramuscularly, subcutaneously, as a nasal spray, or by endotracheal tube. Naloxone has an ultra-rapid onset of action (1 minute) and duration of action of 20–60 minutes. Naloxone is often available in the field, carried by first responders. Take-home naloxone may also be given to substance users, their family, or friends; such programs have been effective in treating overdoses. If there is no response, other etiologies for the respiratory depression must be explored. Naloxone may have to be repeated if given by nasal route or continued for 24 hours if methadone, rather than shorter-acting heroin, has been taken. Higher and prolonged naloxone dosing is required for novel potent opioid overdoses. Admission to the intensive care unit is indicated for patients who require continuous naloxone infusions (rebound coma, respiratory depression) and for those with life-threatening arrhythmias, shock, and seizures.

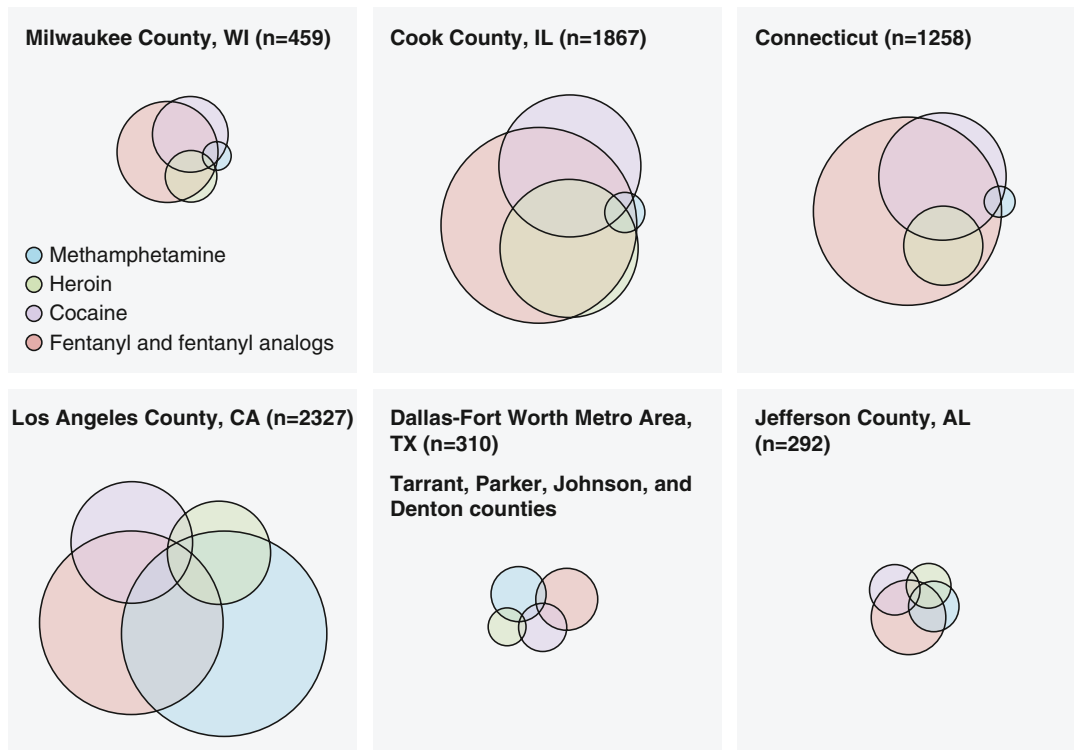
Visit Elsevier eBooks+ at [eBooks.Health.Elsevier.com](#) for Bibliography.

## 157.11 Synthetic Cannabinoids

Cora Collette Breuner

**Bath salts** refers to a group of previously OTC, but now illicit, often home synthesized, substances containing one or more chemicals similar to **cathinone**, an amphetamine-like stimulant found in the khat





**Fig. 157.4** Proportional drug combinations involved in fatal overdoses in U.S. jurisdictions with detailed medical examiner data available, 2020. Based on death investigations that were completed at the time of data request. Official counts by jurisdictions may differ as all investigations are completed. These areas were chosen to provide a country-wide view. (From Humphreys K, Shover CL, Andrews CM, et al. *Responding to the opioid crisis in North America and beyond: recommendations of the Stanford-Lancet commission*. *Lancet*. 2022;399:555–604, Fig. 5.)

plant. The bath salts, marketed under ever-changing brand names (e.g., Lunar Wave, Cloud Nine, Vanilla Sky), are sold online or in substance paraphernalia stores as a white or brown crystalline powder and can be ingested, inhaled, or injected. The most current information about teen use of bath salts is from the 2016 MTF survey of 8th, 10th, and 12th graders, who report use of 0.9%, 0.8%, and 0.8%, respectively. The synthetic cathinones found in bath salts include methylone, mephedrone, and 3,4-methylenedioxypyrovalerone (MDPV), all of which are chemically similar to amphetamines and MDMA (ecstasy).

### CLINICAL MANIFESTATIONS

The chemicals in bath salts raise brain dopamine levels, causing the user to feel a surge of euphoria, with increased sociability and sex drive. In addition, the user may experience a surge in norepinephrine, causing reactions such as an elevated heart rate, chest pain, vasoconstriction, diaphoresis, hyperthermia, dilated pupils, seizures, arrhythmias, and high blood pressure. Users also experience psychiatric symptoms such as aggressive behavior, panic attacks, paranoia, psychosis, delirium, self-mutilation, and hallucinations caused by elevated serotonin levels. Intoxication from bath salts may cause **excited delirium syndrome**, which includes dehydration, rhabdomyolysis, and kidney failure.

### TREATMENT

Treatment of overdose should be directed at specific complications but often includes benzodiazepines or propofol for agitation and other neuropsychiatric manifestations. The synthetic cathinones in bath salts are highly addictive, triggering intense cravings in those who consume them frequently. This may result in dependence, tolerance, and strong withdrawal symptoms, as seen in other highly addictive substances. The sale of two of the synthetic cathinones, mephedrone and MDPV, is illegal in the United States.

### SYNTHETIC CANNABINOIDS (MARIJUANA)

Spice, K2, crazy clown, aroma, black mamba, blaze, dream, and funky monkey are some of the common street names for synthetic

marijuana, which is a mixture of herbs or plant materials that have been sprayed with artificial chemicals similar to THC, the psychoactive ingredient in marijuana. One active group of chemicals is the **carboxamides**, which *are not detected* by standard assays to detect THC. In the United States the chemicals in “spice” are designated a Schedule I controlled substance (as is marijuana) by the Drug Enforcement Administration (DEA), thereby making it illegal to sell, buy, or possess them. Nonetheless, synthetic marijuana is the second most common illicit substance used by high school seniors. More than 10% of high school seniors used synthetic marijuana in the last year.

Synthetic marijuana is mainly used by smoking, or mixed with marijuana, or brewed as a tea for drinking. The chemicals in synthetic marijuana affect the same receptors as THC and produce similar effects as seen in cannabis use, such as relaxation, elevated mood, and altered perception. In addition, sympathomimetic symptoms are quite common and are the cause of significant toxicity. Symptoms of **intoxication** depend on the individual compounds in the community and include vomiting, tachycardia, hypertension, hyperthermia, confusion, extreme anxiety, profuse sweating, agitation, aggression, dysphoria, hallucinations, seizures, rhabdomyolysis, dystonia, unresponsiveness, confusion, catatonia, “zombie-like” behaviors, psychosis, coma, and myocardial ischemia. Some of the neuropsychiatric manifestations may last for 1–4 weeks and at times resemble autoimmune encephalitis syndromes. Patients often require psychopharmacology for agitation or frank psychosis. In response to legislation to ban the chemicals in OTC synthetic marijuana products, manufacturers alter and substitute the chemicals in the product, keeping it on the legal market and leaving teens particularly vulnerable to potential health effects.

Synthetic marijuana is not detected by standard toxicology screening but can be identified in specialized laboratories.

Visit Elsevier eBooks+ at [eBooks.Elsevier.com](https://eBooks.Elsevier.com) for Bibliography.

## Chapter 158

## The Breast

Cynthia M. Holland-Hall

Breast development is often the first visible sign of puberty in the adolescent female. Pediatric practitioners must be able to distinguish normal breast development, including normal variants, from pathologic breast disorders. Visual inspection of the breast tissue should routinely be a component of the adolescent's general physical examination. Breast development during puberty is described using the **Sexual Maturity Rating (SMR)** scale, progressing from SMR 1 to SMR 5 as the breast becomes more mature (see [Chapter 150](#), [Fig. 150.2](#)).

**FEMALE DISORDERS**

See Chapter 588.

**MALE DISORDERS**

**Pubertal gynecomastia**, benign glandular proliferation in the male breast, occurs in up to 65% of healthy adolescent males (see [Chapter 625](#)). The incidence of gynecomastia has increased over the past 20 years, suggesting that changes in the endogenous or exogenous sex-steroid environment have occurred. It is thought that an imbalance of estrogen and androgen concentrations contributes, at least in part, to the development of gynecomastia. Elevations of insulin-like growth factor (IGF)-1 have also been demonstrated. The onset of physiologic gynecomastia typically is between 10 and 13 years, peaking at SMR 3-4. Careful physical examination is essential to distinguish between **true gynecomastia**, characterized by a discrete disk of palpable glandular tissue under the nipple-areolar complex, and **pseudogynecomastia**, characterized by more diffuse, bilateral adiposity of the anterior chest wall. Physiologic gynecomastia regresses spontaneously in up to 90% of adolescents within 18-24 months but may transition into lipomastia. Reassurance and continued observation are recommended in most patients; surgery may be indicated in severe or persistent cases. No medical therapies for gynecomastia have been approved for use in adolescents by the U.S. Food and Drug Administration. Small, noncontrolled trials of antiestrogens, such as tamoxifen, appear promising, but more evidence is needed. Conditions associated with nonphysiologic gynecomastia include endocrine disorders, liver disease, neoplasms, chronic disease, and trauma. It can also be seen as a late effect in childhood cancer survivors. Although dozens of medications are implicated as possible causes of gynecomastia, convincing evidence exists only for a few, including several antiandrogens and other exogenous hormones, isoniazid, antiretrovirals, and histamine-2 receptor blockers. Calcium channel blockers, isotretinoin, statins, certain antipsychotics, proton pump inhibitors, lavender, and tea tree oil may be causative. Among drugs of misuse, alcohol, opioids, and anabolic steroids may be associated with gynecomastia, but minimal evidence supports an association with marijuana or amphetamines.

Other breast pathology in males is uncommon. Benign masses such as neurofibromas, lipomas, and dermoid cysts have been reported in the male breast. Males with Klinefelter syndrome have an elevated risk of breast cancer (see [Chapter 623](#)), but this malignancy is otherwise exceedingly rare in adolescents.

Visit Elsevier eBooks+ at [eBooks.Health.Elsevier.com](#) for Bibliography.

## Chapter 159

## Menstruation-Related Disorders

Fareeda Haamid and Gina S. Sucato

See also [Chapter 587](#).

At least 400 lifetime episodes of menstruation are predicted in those who menstruate, yet many adolescents consistently report stigma, inadequate health education, and hesitance to discuss their menses with trusted adults. Clinicians should normalize menstruation and avoid unnecessarily medicalizing this natural process. Menstrual disturbances, including delayed onset, irregularity, heavy flow, and pain, occur in 75% of adolescent females. For adolescents with minor variations from normal ([Table 159.1](#)), an explanation of symptoms and reassurance may be all that is needed. Severe dysmenorrhea or prolonged menstrual bleeding can be not only frightening but a cause of persistent morbidity requiring more intensive management, potentially including referral to a specialist in adolescent gynecology.

**NORMAL MENSTRUATION**

The average age of **menarche**, or first menses, was thought to vary according to ethnic origin and socioeconomic status (SES). A prospective U.S. study of nearly 1,100 diverse females demonstrated no correlation between SES and menarche yet a statistically significant correlation with SES and thelarche; lower SES was associated with earlier pubertal onset. There is often a close concordance of the age at menarche between mother and daughter, which suggests genetic factors are determinants in addition to individual factors such as weight, exercise level, and chronic medical conditions. The age of menarche has declined in countries and populations experiencing improved nutritional standards and other living conditions. In U.S. females, the average age of menarche, 12.5 years, has been relatively stable over the last few decades. Higher body mass index (BMI) is associated with earlier onset of menarche.

The onset of breast budding (**thelarche**) is the first sign of puberty in most females, though it has decreased worldwide by a mean of roughly 3 months per decade from 1977 to 2013. Menarche typically occurs within 2-3 years of thelarche during breast **sexual maturity rating (SMR)**; i.e., Tanner stage) 4. Longer cycle lengths ranging between 21 and 45 days occur initially then periods gradually become more regular. However, for most adolescents, by 3 years postmenarche, menstrual cycle patterns are similar to adults, occurring every 21-35 days.

**MENSTRUAL IRREGULARITIES**

In young adolescents, many menstrual variations are explained by **anovulation** caused by immaturity of the hypothalamic-pituitary-ovarian

**Table 159.1** Characteristics of Normal Menses\*

Cycle length**	21-35 days 21-45 days during first 3 yr after menarche
Duration of menses	7 or fewer days
Blood flow	6 or fewer soaked menstrual products per day Infrequent overflow of menstrual cups

\*Adolescents with two or more cycles outside this range or who skip their period for 3 consecutive months warrant evaluation.

\*\*A cycle begins with the first day of one period and extends to the first day of the next.

axis governing the menstrual cycle. Significant deviations from normal should prompt a search for organic pathology in a logical and cost-effective manner. An accurate menstrual history is an important, but often lacking, first step toward a diagnosis. At menarche, all patients should be encouraged to track their periods.

A range of terms has previously been used to describe abnormal menstrual bleeding. Terms such as “menorrhagia and metrorrhagia” are imprecise, confusing, and not linked to any specific underlying pathology. **Abnormal uterine bleeding (AUB)** is the preferred term for uterine bleeding that is abnormal in regularity, volume, frequency, or duration. AUB is further specified by adding descriptive terms such as *heavy menstrual* bleeding or *intermenstrual* bleeding. A qualifier is added to categorize the etiology of abnormal bleeding. Of the nine categories, the three most relevant to adolescents are **ovulatory dysfunction (AUB-O)**, previously referred to as *dysfunctional uterine bleeding* and discussed in Chapter 159.2; **coagulopathy (AUB-C)**; and **not otherwise classified (AUB-N)**.

In addition to a standard medical history noting hospitalizations, chronic illness, and medication and supplement use, a complete history for evaluating a patient with menstrual irregularity should include the timing of pubertal milestones, such as onset of pubic and axillary hair and breast development; a detailed patient menstrual history; age of menarche and overall menstrual pattern of mother and sisters; and a family history of gynecologic problems. The complete review of systems should elicit any changes in headache pattern or vision; the presence of galactorrhea; and any changes in skin, hair, or bowel patterns. Changes in diet, level of exercise, and sports participation are also important factors when generating a differential diagnosis. The patient should be interviewed alone, and the confidential history should assess substance use, consensual sexual activity, forced sexual behavior, abuse, and other psychosocial stressors.

Assessment of basic growth parameters should include weight, height, and BMI and a thorough review of the growth chart. Physical examination should document heart rate, blood pressure, SMR, signs of androgen excess, such as hirsutism or severe acne, and signs suggestive of an eating disorder (see Chapter 41), such as bradycardia, cachexia, lanugo, or knuckle calluses. A careful external genital examination should be performed. An internal pelvic examination is rarely necessary in the absence of sexual activity. Any internal exam being considered for young adolescents should be performed with proper equipment and technique by a clinician with expertise in this age-group. Transabdominal pelvic ultrasound can be a useful adjunct for evaluating anatomic abnormalities in the adolescent; when indicated, MRI can provide greater detail of pelvic anatomy.

Visit Elsevier eBooks+ at [eBooks.Health.Elsevier.com](http://eBooks.Health.Elsevier.com) for Bibliography.

## 159.1 Amenorrhea

Fareeda Haamid and Gina S. Sucato

**Amenorrhea**, the absence of menstruation, generally requires evaluation at age 15 years, or if there has been no menstruation within 3 years of the onset of puberty (**primary amenorrhea**), or if there has been no menstruation for the length of three previous cycles in a postmenarchal patient (**secondary amenorrhea**). However, the following caveats exist: lack of any pubertal signs by age 13 years in a female should prompt evaluation for pubertal delay; in sexually active patients, or those with other symptoms suggesting pathology, evaluation should be initiated without waiting for three missed cycles; in patients whose breast development started between age 8 and 9 years, observation for >3 years may be warranted in some cases, given data suggesting that the age of thelarche has decreased but the age of menarche has not. Conversely, expectant management with close follow-up can be

**Table 159.2** Causes of Primary or Secondary Amenorrhea

Pregnancy (regardless of history can cause primary or secondary amenorrhea)
Functional hypothalamic states (stress, weight loss, undernutrition, high levels of exercise, energy deficit even at normal weight)
Relative energy deficiency in sport (RED-S) (inadequate energy intake causing impaired physiologic function, including amenorrhea, bradycardia, and low bone density)
Eating disorders
Premature ovarian insufficiency (autoimmune, idiopathic, galactosemia, or secondary to radiation or chemotherapy)
Hypothalamic and/or pituitary damage (e.g., irradiation, tumor, traumatic brain injury, surgery, hemochromatosis, midline central nervous system defects such as septooptic dysplasia, autoimmune pituitary hypophysitis)
Thyroid disease (hyper- or hypo-; hypothyroidism more likely to be associated with increased bleeding)
Prolactinoma
Systemic disease (e.g., inflammatory bowel disease, cyanotic congenital heart disease, sickle cell disease, cystic fibrosis, celiac disease)
Hyperandrogenism (polycystic ovary syndrome, nonclassic congenital adrenal hyperplasia, adrenal tumor or dysfunction)
Drugs and medications (e.g., illicit drugs, atypical antipsychotics, hormones)
Turner syndrome (including mosaicism)

**Table 159.3** Additional Causes of Primary Amenorrhea

Physiologic/constitutional delay
Anatomic abnormalities
Müllerian agenesis
Imperforate hymen
Transverse vaginal septum
Genetic disorders
46,XY disorders of sexual development (e.g., androgen insensitivity syndrome, 5 $\alpha$ -reductase deficiency, 17 $\alpha$ -hydroxylase deficiency)
Mixed gonadal dysgenesis (associated with various chromosome patterns)
Turner syndrome (resulting from 45,X or a variety of mosaic or other abnormal karyotypes)
Genetic hypogonadotropic hypogonadism (e.g., X-linked Kallmann syndrome)

considered in a patient whose history, physical examination showing some pubertal development, and family history suggest constitutional delay of puberty.

The differential diagnosis of amenorrhea is broad (Table 159.2) and requires a careful history and physical exam to guide any necessary diagnostic studies. Understanding the timing and tempo of the patient's pubertal milestones is key to the evaluation. The first step in the amenorrhea evaluation is to ascertain whether the patient has ever had any menstrual bleeding. Conditions that can interrupt the menstrual cycle can also prevent menarche; therefore some aspects of the evaluation of primary and secondary amenorrhea are identical. In females with primary amenorrhea, genetic and anatomic conditions must also be considered (Table 159.3).

### HISTORY AND PHYSICAL EXAMINATION

Important historical elements include dietary intake, exercise level, and a thorough review of any ongoing symptoms, including fever, headache, vision changes, chronic respiratory or gastrointestinal (GI) complaints, bowel habit changes, galactorrhea, changes in hair or nails, excessive body hair, severe acne, unexplained musculoskeletal complaints, and changes in

vaginal discharge, which may decrease in females who are hypoestrogenic. Any underlying medical conditions and the adequacy of their control should be noted, as well as the presence of any renal or skeletal anomalies, some of which may have associated reproductive system anomalies. Clinicians should document medications, particularly those for psychiatric conditions. Family history of menarcheal age, eating disorders (see [Chapter 41](#)), and **polycystic ovary syndrome (PCOS)** (see [Chapter 589](#)) should be elicited. A thorough social history is necessary, especially concerning the presence or absence of sexual activity or abuse (see [Chapter 16.1](#)).

Physical examination should begin with careful attention to growth chart trajectories. In addition to a search for undiagnosed systemic disease, clues to an eating disorder, thyroid disease, or hyperandrogenism should be sought. The exam should assess for BMI, orthostatic pulses, blood pressure, abnormal dentition, anosmia or hyposmia (suggestive of Kallmann syndrome; see [Chapter 623.2](#)), parotid enlargement, thyroid gland palpation, hepatosplenomegaly, abdominal mass, lymphadenopathy, and SMR (see [Chapter 150](#)). Skin examination should note any lanugo, dry or doughy skin, loss of hair from scalp or eyebrows, striae, acanthosis nigricans, or acne. Clinicians should assess for glandular breast tissue via palpation in patients with primary amenorrhea. The external genital exam should note SMR and appearance of the vagina, which should be pink and moist; thin, dry, reddened mucosa suggests estrogen deficiency. The clitoral width should be <1 cm. In the patient with primary amenorrhea, vaginal patency can be painlessly assessed using a slender saline-moistened swab and careful avoidance of the hymen. If physical assessment of the cervix and uterus is not tolerated, a transabdominal pelvic ultrasound is advisable in patients with primary amenorrhea, followed by MRI if more detail is needed.

## LABORATORY STUDIES

A urine pregnancy test, serum prolactin levels, thyroid-stimulating hormone, and follicle-stimulating hormone (FSH) are reasonable to measure in all patients presenting with amenorrhea ([Fig. 159.1](#)). Elevation of FSH (>30 mIU/mL) in an amenorrheic female suggests ovarian insufficiency, and if confirmed with repeat testing, should be followed with a

pelvic ultrasound, karyotype, and specialist referral. Diagnostic tests in the patient presenting with amenorrhea should be tailored to the history and physical exam.

In patients with signs of androgen excess (e.g., severe acne or hirsutism) or other physical stigmata associated with PCOS (rapid pubertal weight gain, acanthosis nigricans) consider measuring levels of 17-hydroxyprogesterone (17-OHP), free and total testosterone, dehydroepiandrosterone sulfate (DHEAS), and androstenedione; all preferably collected in the morning. PCOS affects up to 15% of females; diagnostic criteria for adolescents are controversial but include variations of menstrual irregularity (ranging from amenorrhea to AUB) and clinical or biochemical hyperandrogenism. The interpretation of polycystic ovarian morphology identified on ultrasound in adolescents can be challenging, and an ultrasound is not necessary for diagnosis in adolescents.

With the exceptions of pregnancy, constitutional delay, and imperforate hymen, conditions causing primary amenorrhea are associated with reduced fertility; thus their diagnosis may cause profound emotional responses in patients and families. Therefore before ordering studies to confirm these diagnoses (e.g., karyotype, MRI of reproductive anatomy), the clinician should carefully consider the implications and be prepared to refer to specialists with experience managing the long-term treatment of such diagnoses.

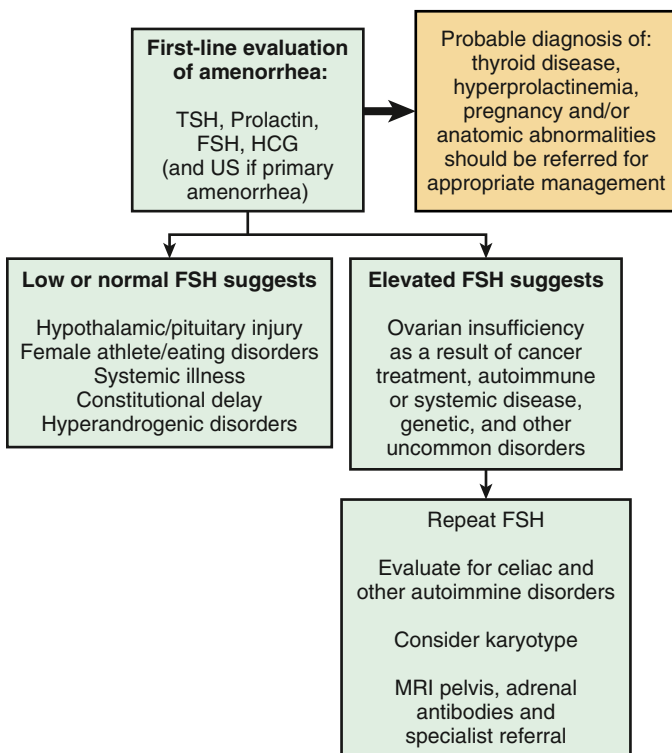
In patients presumed to have hypothalamic amenorrhea, based on prepubertal luteinizing hormone (LH) and low FSH levels using an ultrasensitive assay and consistent history and physical exam, MRI of the brain is not necessary in all patients. However, MRI should be considered for patients presenting with a headache history that has changed from baseline; persistent emesis; change in thirst, urination, or vision; elevated prolactin or galactorrhea; or other neurologic symptoms.

## TREATMENT

Treatment for amenorrhea widely varies depending on the underlying cause. Many diagnoses require referral to clinicians in specialties such as endocrinology, adolescent medicine, and gynecology; often, collaboration with other disciplines such as psychology or nutrition is indicated. The mainstay of PCOS treatment is suppression of ovarian androgens, typically with **combined hormonal contraception** (i.e., estrogen and progestin) and **lifestyle modifications** to decrease obesity and insulin resistance. Patients with abnormal glucose tolerance may benefit from the addition of **metformin**. **Spirolactone**, an androgen receptor blocker, can also be used to reduce androgen effects, including hirsutism. **Metabolic syndrome** is highly prevalent in PCOS; thus clinicians should evaluate for comorbid diabetes and hyperlipidemia with periodic lipid and hemoglobin A<sub>1c</sub> screening. It is crucial to normalize weight and improve nutritional status for patients with eating disorders or other hypoestrogenic conditions of energy imbalance. It is not routinely recommended to initiate hormonal therapy in these patients. However, short-term use of **transdermal estrogen therapy (E2)** to protect bone health may be considered for those who remain amenorrheic after a trial of nutritional and activity modification. For females with amenorrhea due to partial or total ovarian insufficiency, exogenous hormones are required for all pubertal development. Experts recommend starting at age 10-12 years with low-dose transdermal estrogen, progressing to increased doses of estrogen and cyclic progestin. Continued maintenance therapy can be accomplished with higher-dose combination products, as found in typical combined hormonal contraceptive pills, patches, and vaginal rings.

In the absence of a clear indication such as PCOS, hormonal medications (e.g., combined hormonal methods) to produce monthly bleeding are not recommended for patients with **secondary amenorrhea** because it will mask the patient's subsequent menstrual pattern. However, in patients with normal postpubertal estrogen levels, progesterone can be useful to periodically (every 4-12 weeks) induce shedding of the endometrial lining to avoid buildup and subsequent heavy menses. One commonly used regimen is **medroxyprogesterone 10 mg PO daily** for the first 7-14 days of the month.

Visit Elsevier eBooks+ at [eBooks.Health.Elsevier.com](http://eBooks.Health.Elsevier.com) for Bibliography.



**Fig. 159.1** Initial diagnostic testing algorithm to evaluate amenorrhea. FSH, Follicle-stimulating hormone; HCG, human chorionic gonadotropin; LH, luteinizing hormone; MRI, magnetic resonance imaging; US, ultrasound.



## 159.2 Abnormal Uterine Bleeding

Fareeda Haamid and Gina S. Sucato

Abnormal uterine bleeding (AUB) is a broad term used to describe any menstrual bleeding pattern that deviates from physiologic patterns. Clinicians are encouraged to categorize the abnormal pattern based on the patient's complaint, which is typically irregular (AUB/IMB: **intermenstrual bleeding**) or heavy (AUB/HMB: **heavy menstrual bleeding**).

### IRREGULAR MENSTRUAL BLEEDING

Menstrual status should be treated as a *vital sign*; at every preventative care or comprehensive visit clinicians should document the first day of the last menstrual period and the menstrual pattern. Although menses are frequently irregular in the early postmenarcheal years, further evaluation is necessary when menstrual patterns vary too widely from what is normal for age. Even in the first postmenarcheal year, menses are usually not less frequent than every 45 days. Menses become increasingly regular with age, and by 3 years after menarche typically occur every 21-35 days, lasting 3-7 days. Personal cycle duration is usually established by age 19 or 20 years.

In the early postmenarcheal years, the most common cause of AUB in adolescents is anovulation caused by immaturity of the hypothalamic-pituitary-ovarian axis. In the absence of a mid-cycle LH surge to stimulate ovulation, there is no corpus luteum production of progesterone. Without the stabilizing effects of progesterone on the endometrial lining, there is increased risk of irregular bleeding. **AUB caused**

**by ovulatory dysfunction (AUB-O;** previously termed *dysfunctional uterine bleeding*), describes irregular bleeding in the absence of specific anatomic, systemic, or endocrinologic disease. Although it is the most common cause of abnormal menstrual bleeding in adolescents, AUB-O is a diagnosis of exclusion. It is important to remember that most conditions that cause amenorrhea can first cause anovulation, which is a key risk for heavy irregular bleeding. [Table 159.4](#) lists the causes of AUB and vaginal bleeding. Adolescents rarely present with complaints of unusually short or light menses. However, short, light, or infrequent menstrual patterns that have changed from a previously established pattern may need to be evaluated similarly to secondary amenorrhea.

Unscheduled bleeding during the use of hormonal contraception frequently occurs, particularly with progestin-only methods. Common causes include medication nonadherence, interactions with prescribed or over-the-counter medications, and smoking. Patients should be reassured such bleeding is benign and not an indication to stop an otherwise satisfactory contraceptive method.

### HEAVY AND PROLONGED MENSTRUAL BLEEDING

Irregular bleeding, particularly from anovulation, can be long and heavy (see [Table 159.4](#)). However, a hematologic cause (**AUB-C**) should be strongly considered in patients with regular, cyclic menses that are long and/or heavy, especially if heavy menses occurs at the onset of menarche and bleeding disorder symptoms are present. **von Willebrand disease** and other coagulation disorders are found in up to 13% and 20%, respectively, of patients with heavy menstrual bleeding. Other symptoms suggestive of bleeding disorders include changing

**Table 159.4** Causes of Vaginal Bleeding in Adolescence

CAUSES OF VAGINAL BLEEDING	EXAMPLES	FEATURES
Immature hypothalamic-pituitary-ovarian axis ( <b>AUB-O</b> )	Patient within 2yr of menarche	Patient responds to hormonal treatment.
Weight changes, disordered eating, or excessive exercise	Anorexia nervosa, bulimia, weight gain or loss of more than 10 pounds from any etiology	Weight loss more frequently results in lighter, less frequent menses.
Endocrinologic causes	Thyroid disease, polycystic ovary syndrome (PCOS)	Bleeding typically increases with hypothyroidism and decreases with PCOS and hyperthyroidism.
Pregnancy complication	Threatened abortion, postpartum or postabortal endometritis	History of sexual activity and/or pregnancy
Infection	Cervicitis, condyloma, pelvic inflammatory disease	Bleeding is usually not heavy and may occur during or after sexual intercourse.
Trauma	Sexual assault, straddle injuries	History will be evident in patients of menstruating age unless there is cognitive disability.
Vaginal foreign body	Toilet paper, broken condoms, tampons	Associated with odor and vaginal discharge, but usually not heavy bleeding.
Hematologic causes ( <b>AUB-C</b> )	Type 1, 2, 3 von Willebrand disease, platelet function disorders, thrombocytopenia (idiopathic thrombocytopenic purpura, drug induced), symptomatic hemophilia carrier, clotting factor deficiency, leukemia, aplastic anemia	Bleeding is heavy and/or long and frequently regular, may present at menarche, and may be accompanied by a suggestive personal or family history (hysterectomy, uterine ablation, cautery for epistaxis) or physical exam (ecchymoses, petechiae).
Medications	Estrogens and progestins in combined hormonal contraception Androgens Drugs that affect prolactin (estrogens, phenothiazines, tricyclic antidepressants, metoclopramide) Anticoagulants (heparin, warfarin, aspirin, NSAIDs) SSRIs	Affect the hypothalamic-pituitary-ovarian axis, endometrial lining, platelets, or coagulation pathway.
Anatomic	Partial obstruction of vagina or uterus causing asynchronous bleeding; cervical or endometrial polyps or myomas; hemangioma; uterine vascular malformation; genital/reproductive tract cancer	Most of these entities are extremely rare, especially reproductive tract cancers.
Systemic disease	Celiac disease, rheumatoid arthritis, Ehlers-Danlos syndrome and other connective tissue disorders	Accompanied by other condition-specific signs.

a pad or tampon more than hourly, passing clots larger than 1 inch in diameter, iron deficiency, menses longer than 7 days, a history of hemorrhagic ovarian cysts, excessive bleeding from wounds or post-operatively, mucosal bleeding (epistaxis or GI tract), and first-degree relatives with heavy menses or epistaxis requiring medical treatment. Inherited collagen disorders such as Ehlers-Danlos syndrome are associated with vascular collagen abnormalities; thus patients with heavy menses and manifestations of joint hyperflexibility may require a hematology referral.

## LABORATORY FINDINGS

Table 159.5 lists laboratory tests to consider in patients with long, heavy bleeding. Females with persistent heavy bleeding despite negative first-line testing should be referred to a hematologist for testing for platelet function disorders, factor deficiencies, and other less common disorders. In the initial evaluation, rapidity of blood loss in conjunction with the hemoglobin establishes the **bleeding severity**: **mild** (hemoglobin 10-11 g/dL), **moderate** (hemoglobin 7-10 g/dL), or **severe** (hemoglobin <7 g/dL). Iron deficiency is defined as serum ferritin of <15 µg/mL.

## TREATMENT

In bleeding that has resulted in **mild** anemia, the patient should keep a menstrual calendar to follow the subsequent flow patterns. **Nonsteroidal antiinflammatory drugs** (NSAIDs; e.g., naproxen) are more effective than placebo in treating heavy bleeding and can also treat concurrent dysmenorrhea. Clinicians may need to educate patients and families about the noncontraceptive medical indications for hormonal contraception given the unnecessary stigma commonly associated with these medications. Active bleeding typically responds well to cycling with any **combined hormonal contraceptive method** containing estrogen and progestin starting with once-daily dosing; up to twice-daily dosing may be considered until bleeding stops. Patients with estrogen contraindications such as migraine with aura, uncontrolled hypertension, or thrombotic risks can be treated with progestins alone, such as medroxyprogesterone 10 mg orally daily or norethindrone acetate 5-10 mg PO daily, either continuously or for 10-14 days per month. The latter regimen will be followed by monthly bleeding.

Iron deficiency with or without anemia should be treated with **65 mg elemental oral iron** once daily until serum ferritin >30 µg/mL. Dosing more frequently than daily has not been shown to be beneficial. Ferritin and hemoglobin should be repeated 4 weeks after treatment

**Table 159.5** Laboratory Tests to Evaluate Patients with Abnormal Uterine Bleeding

Complete blood count with platelets
Ferritin
Urine pregnancy test (regardless of history)
Thyroid function studies
Total and free testosterone*
Liver and kidney function studies
Nucleic acid amplification test (NAAT) or equivalent testing for <i>Chlamydia trachomatis</i> , <i>Neisseria gonorrhoeae</i> , and <i>Trichomonas vaginalis</i>
Prothrombin time and partial thromboplastin time
von Willebrand factor antigen, vWF activity (such as ristocetin cofactor), and factor VIII <sup>I</sup> activity
Pelvic ultrasound (if palpable mass or bleeding persists despite treatment)

\*In patients with signs or symptoms suggestive of polycystic ovary syndrome, such as acne, hirsutism, obesity, acanthosis nigricans, and a history of infrequent menses.

†Any abnormalities should be referred to a hematologist. False-negative von Willebrand tests and false-positive platelet function studies have been observed in the setting of anemia. It is preferable to obtain tests before estrogen treatment is started to minimize false-negative results. Repeat testing is common in patients for whom there is a high pretest suspicion.

is initiated. Once anemia is corrected, iron should be continued once daily for 3 months to replenish iron stores. A referral to hematology may be warranted for insufficient response or intolerance of oral iron for consideration of **intravenous (IV) iron therapy**.

With **moderate** anemia, any of the hormonal regimens noted earlier can be used. However, it may be necessary in patients with more brisk bleeding to start with three to four **combined oral contraceptive (COC) pills** (or three to four doses of **medroxyprogesterone** 10 mg) per day, with additional medication to control nausea. The dose can usually be tapered to daily dosing over the next 2 weeks. Patients with ongoing rapid bleeding, syncope or lightheadedness, hemodynamic instability, or hemoglobin of <7 g/dL should be treated in the hospital.

Patients with **severe** anemia should be treated with one of the hormone tapers described earlier, in addition to **IV fluid or blood products** as indicated; it is advisable to draw necessary hematologic laboratory studies before transfusion. Patients with emesis or other significant symptoms may be initially treated with **conjugated estrogens** 25 mg IV every 4-6 hours for 1-2 days. A COC or progestin regimen should be added within 24-48 hours because progestin is needed to stabilize the endometrial lining and can be used as maintenance therapy after hospital discharge. In the exceptionally rare case of a patient whose bleeding cannot be controlled hormonally, options for gynecologic interventions include **intrauterine Foley balloon placement** or **uterine packing** to tamponade the uterus mechanically. Dilation and curettage, performed frequently in adults, is almost never indicated in adolescents and can increase blood loss in patients with bleeding disorders.

Hormonal AUB treatment should continue for at least 3-6 months, depending on the patient's age, prior menstrual history, and severity of presentation, before reassessing the need for ongoing therapy. Additional options for maintenance therapy include **combined hormonal transdermal patches and vaginal rings**; **depot medroxyprogesterone acetate** 150 mg intramuscularly (IM) or 104 mg subcutaneously (SC) every 3 months; and placement of a **levonorgestrel intrauterine device (IUD)**, depending on the patient's preference and/or concurrent need for long-term contraception. For patients who need or choose to avoid hormonal therapy, **antifibrinolytics such as tranexamic acid** 1,300 mg PO 3 times daily can be used for up to 5 days during monthly menstruation in patients who do not have an increased risk of thrombosis.

Females with a known bleeding disorder may be up to 5 times more likely to develop heavy menstrual bleeding. Therefore it can be helpful while the patient is premenarcheal to devise a proactive plan in collaboration with the patient's hematology team in the event of acute heavy menstrual bleeding, which can occur at menarche.

Visit Elsevier eBooks+ at [eBooks.Health.Elsevier.com](http://eBooks.Health.Elsevier.com) for Bibliography.

## 159.3 Dysmenorrhea

Fareeda Haamid and Gina S. Sucato

Dysmenorrhea, painful uterine cramps that precede and accompany menses, occur in up to 90% of 17- to 24-year-olds. Although dysmenorrhea is frequently severe enough to interfere with school and other activities, many adolescents undertreat their symptoms, and fewer seek medical care.

Dysmenorrhea may be primary or secondary. **Primary dysmenorrhea**, characterized by the absence of any specific pelvic pathologic condition, is the more commonly occurring form, accounting for approximately 90% of cases. After ovulation, withdrawal of progesterone results in synthesis of prostaglandins by the endometrium, which stimulates local vasoconstriction, uterine ischemia and pain, and smooth muscle contraction, explaining uterine and GI symptoms.

**Secondary dysmenorrhea** results from underlying pathology, such as anatomic abnormality, or infection, such as pelvic inflammatory disease. However, the most common cause of secondary dysmenorrhea in adolescents is **endometriosis**, a condition in which implants of endometrial tissue are found outside the uterus, usually near the fallopian tubes and ovaries. Often, other family members have endometriosis. Severe menstrual pain is characteristic of endometriosis; however, adolescents may also have noncyclic pain. Although primary dysmenorrhea is almost always the cause, a careful history and physical examination are required for adolescents who present with **pelvic pain**. An internal pelvic exam is not required in

females who are not sexually experienced and whose presentation is consistent with primary dysmenorrhea. Constipation can vary cyclically in many females, especially those with irritable bowel syndrome, and often significantly contributes to the pain. **Mittelschmerz**, brief severe pain with ovulation, occurs at mid-cycle. **Table 159.6** lists the differential diagnosis and “red flags” for secondary dysmenorrhea. Ovarian cysts, a frequent concern of families, are usually transient and painless.

Treatment for primary dysmenorrhea is aimed at preventing or decreasing prostaglandin production. The mainstay of first-line treatment is prostaglandin synthetase inhibition with NSAIDs (**Table 159.7**) beginning at,

Table 159.6 Differential Diagnosis of Dysmenorrhea in Adolescents*		
	PRESENTATION	DIAGNOSIS
Primary	Crampy pelvic pain may be accompanied by aching/heaviness in lower back and upper thighs, nausea, emesis, diarrhea, headache, mastalgia, fatigue, and dizziness; symptoms begin at or shortly before menstrual flow onset and last 1-3 days.	Normal physical exam; internal exam only for sexually active adolescents. Ultrasound can be reserved for patients with atypical presentations (e.g., onset at menarche) or pain despite NSAIDs and hormonal therapy.
Endometriosis and adenomyosis†	<b>Increasingly severe dysmenorrhea despite adequate therapy</b> ; pain exacerbated during menses or noncyclical pain.	Increased risk in patients with obstructive anomalies and possibly bleeding disorders; however, most adolescents with endometriosis have normal anatomy and bleeding indices; visual diagnosis is made during surgery and confirmed by tissue sample.
Müllerian anomalies with partial outflow obstruction	<b>Pain begins at or shortly after menarche</b> and occurs with bleeding; presence of <b>known renal tract anomaly</b> (often coexists with müllerian anomaly).	Pelvic ultrasound will demonstrate uterine anomalies (e.g., rudimentary uterine horn); MRI may be required to identify some lesions (e.g., obstructed hemivagina).
Pelvic inflammatory disease	Abrupt onset of dysmenorrhea more severe than baseline in a sexually active adolescent; presentation can range from mild discomfort to acute abdomen.	Clinical diagnosis made by finding <b>lower abdominal tenderness plus cervical motion tenderness, uterine or adnexal tenderness</b> on bimanual pelvic examination (see <b>Chapter 146</b> ); supporting features include dysuria, dyspareunia, <b>vaginal discharge</b> , fever, and increased white blood cell count.
Pregnancy complication	Coincident pain and bleeding may be misdiagnosed as dysmenorrhea.	Urine test positive for human chorionic gonadotropin.

\***Bold** entries indicate “red flags” for diagnosis.

†Adenomyosis is the presence of endometrial tissue within the uterine myometrium.

Table 159.7 Treatment for Dysmenorrhea			
	MEDICATION	REGIMEN	COMMENTS
NSAIDs (for up to 5 days)	Ibuprofen 200 mg	2 tablets PO q4-6h	Over-the-counter
	Naproxen sodium 275 mg	550 mg loading dose, then 275 mg PO q6h	Patients may prefer the equivalent 550 mg PO q12h dosing regimen.
	Celecoxib (cyclooxygenase [COX]-2 inhibitor)*	400 mg loading dose, then 200 mg PO q12h prn pain	Can be used for patients with bleeding disorders.
Hormonal contraception	Combined hormonal contraceptive	Continuous hormone regimens vs standard 21 hormone days followed by 7 placebo days may offer better relief but may increase the risk of unscheduled intermenstrual bleeding.	Treatment can be based on patient preference.
	Progestin-only methods	DMPA 150 mg IM or 104 mg SC q3mo; levonorgestrel intrauterine device for up to 8yr; etonogestrel implant	DMPA has potential side effects of weight gain, interference with expected bone density increase during adolescence, and higher discontinuation rates than LARC methods.
Gonadotropin-releasing hormone agonist	Depot leuprolide	11.25 mg IM q3mo	Consider for presumed endometriosis unresponsive to hormonal methods; add-back hormones advised to prevent bone loss.

\*This medication may cause serious cardiovascular and gastrointestinal events. Use with caution in patients with impaired renal or liver dysfunction, heart failure, or a history of GI bleeding or ulcer. Full prescribing information can be found at [https://www.accessdata.fda.gov/drugsatfda\\_docs/label/2018/020998s050lbl.pdf](https://www.accessdata.fda.gov/drugsatfda_docs/label/2018/020998s050lbl.pdf)

DMPA, Depot medroxyprogesterone acetate; LARC, long-acting reversible contraceptive; NSAIDs, nonsteroidal antiinflammatory drugs.

**Table 159.8** Criteria for Premenstrual Dysphoric Disorder

- A. In the majority of menstrual cycles, at least five symptoms must be present in the final week before the onset of menses, start to improve with a few days after the onset of menses, and become minimal or absent in the week post menses.
- B. One (or more) of the following symptoms must be present:
1. Marked affective lability (e.g., mood swings; feeling suddenly sad or tearful, or increased sensitivity to rejection).
  2. Marked irritability or anger or increased interpersonal conflicts.
  3. Marked depressed mood, feelings of hopelessness, or self-deprecating thoughts.
  4. Marked anxiety, tension, and/or feelings of being keyed up or on edge.
- C. One (or more) of the following symptoms must additionally be present, to reach a total of five symptoms when combined with symptoms from criterion B.
1. Decreased interest in usual activities (e.g., work, school, friends, and hobbies).
  2. Subjective difficulty in concentration.
  3. Lethargy, easy fatigability, or marked lack of energy.
  4. Marked change in appetite, overeating, or specific food cravings.
  5. Hypersomnia or insomnia.
  6. A sense of being overwhelmed or out of control.
  7. Physical symptoms such as breast tenderness or swelling, joint or muscle pain, a sensation of "bloating," or weight gain.
- Note: The symptoms in criteria A-C must have been met for most menstrual cycles that occurred in the preceding year.
- D. The symptoms are associated with clinically significant distress or interference with work, school, usual social activities, or relationships with others (e.g., avoidance of social activities; decreased productivity and efficiency at work, school, or home).
- E. The disturbance is not merely an exacerbation of the symptoms of another disorder, such as major depressive disorder, panic disorder, persistent depressive disorder (dysthymia), or a personality disorder (although it may co-occur with any of these disorders).
- F. Criterion A should be confirmed by prospective daily ratings during at least two symptomatic cycles. (Note: The diagnosis may be made provisionally prior to this confirmation.)
- G. The symptoms are not attributable to the physiologic effects of a substance (e.g., a drug of abuse, a medication, other treatment) or another medical condition (e.g., hyperthyroidism).

From the *Diagnostic and Statistical Manual of Mental Disorders*, 5th ed., pp. 171–172. Copyright 2013. American Psychiatric Association.

or preferably the day before, menstruation. High doses of around-the-clock treatment are rarely needed for more than the first 2 days. More data are needed to make specific treatment recommendations regarding exercise, but females should be reassured that participation in usual sports and extracurricular activities is not only permissible but a benchmark of adequate treatment.

For those adolescents whose pain does not optimally respond to dosed NSAIDs, or who also require contraception, the currently available forms of **hormonal contraception** will improve dysmenorrhea. Up to three cycles may be required to appreciate the full benefit. Methods and regimens that eliminate a placebo interval may provide better relief. Despite various studies of adjuvant treatments including heat, aromatherapy, acupressure, acupuncture,

transcutaneous nerve stimulation, herbal remedies, yoga, and dietary supplements, hormonal medications are the mainstay of second-line treatment. Females whose pain persists despite more than 3 months of adequate hormonal therapy require further evaluation and treatment and referral to a specialist, as endometriosis has been found in up to 69% of adolescents who underwent laparoscopy for persistent pelvic pain.

Visit Elsevier eBooks+ at [eBooks.Health.Elsevier.com](http://eBooks.Health.Elsevier.com) for Bibliography.

## 159.4 Premenstrual Syndrome and Premenstrual Dysphoric Disorder

Fareeda Haamid and Gina S. Sucato

**Premenstrual syndrome (PMS)**, which occurs in up to 30% of adolescents, is marked by symptoms such as mood changes, bloating, and breast tenderness that begin in the luteal phase of the menstrual cycle (i.e., the time between ovulation and the first day of bleeding) and improve within a few days after the onset of menses. Adolescents are often reassured by education about the relationship of symptoms to the menstrual cycle. Lifestyle interventions such as exercise and stress reduction sometimes provide adequate relief. For more severe symptoms, cognitive-behavioral therapy may be useful. Current data do not support routine recommendations for any vitamin, mineral, or other dietary supplements in the absence of documented deficiency. There is not strong evidence supporting the effectiveness of combined hormonal contraceptive methods for PMS. However, some experts suggest this treatment option for adolescents who also have dysmenorrhea, acne, or contraceptive needs.

**Premenstrual dysphoric disorder (PMDD)** is distinguished from other depressive disorders by its timing; mood symptoms are precipitated by ovulation, recur in the luteal phase, and disappear at the end of menstruation. It is distinguished from PMS by the severity and consequences of the affective symptoms. PMDD causes significant distress and functional impairment and may be accompanied by physical and behavioral symptoms (Table 159.8). It is a distinct, treatment-responsive depressive disorder. PMDD occurs in 2–6% of menstruating females worldwide. Accurate diagnosis requires use of a menstrual calendar to prospectively document cyclic symptoms. Other mental health conditions such as depression and anxiety disorders may be exacerbated before or during menses, but symptoms will occur throughout the cycle.

**Selective serotonin reuptake inhibitors (SSRIs)** are first-line therapy for PMDD and severe PMS. In contrast to the treatment of depression, SSRIs can be rapidly effective for premenstrual symptoms and thus can be prescribed either continuously or intermittently, beginning at ovulation (or whenever in the luteal phase symptoms begin) and ending when symptoms resolve. Adolescents can be prescribed the standard regimens used for adults, such as fluoxetine 20 mg PO daily. For adolescents who also need contraception, the drospirenone 3 mg and ethinyl estradiol 0.02 mg combination pill delivered for 24 days followed by 4 inactive days has been approved by the Food and Drug Administration for PMDD.

Visit Elsevier eBooks+ at [eBooks.Health.Elsevier.com](http://eBooks.Health.Elsevier.com) for Bibliography.



## Chapter 160

## Contraception

Mary E. Romano and Elizabeth M. Alderman

The consequences of sexual activity, including unintended pregnancy (see Chapter 161) and sexually transmitted infections (STIs; Chapter 163), occur in adolescents at higher rates than in adults. Significant barriers, including access to confidential care, may delay an adolescent's ability to access reproductive healthcare until after initiation of sexual activity, and many may become pregnant and/or acquire an STI during this interval. Early and appropriate counseling and education with adolescents, including direct discussion of the risks of unintended pregnancy and STI prevention, can help to mitigate these risks; adolescents who plan sexual initiation are 75% more likely to use contraception at sexual debut. Therefore appropriate patient-centered counseling and provision of contraception as warranted are an essential component of comprehensive healthcare for adolescents. *Female* refers to cis-female but theoretically would include all those with a uterus engaging in sexual behaviors that put them at risk for pregnancy.

## CONTRACEPTIVE EFFECTIVENESS

To decrease rates of unintended pregnancy, the American Academy of Pediatrics (AAP) and American College of Obstetricians and Gynecologists (ACOG) recommend that healthcare providers counsel about and ensure access to all contraceptive methods for their adolescent

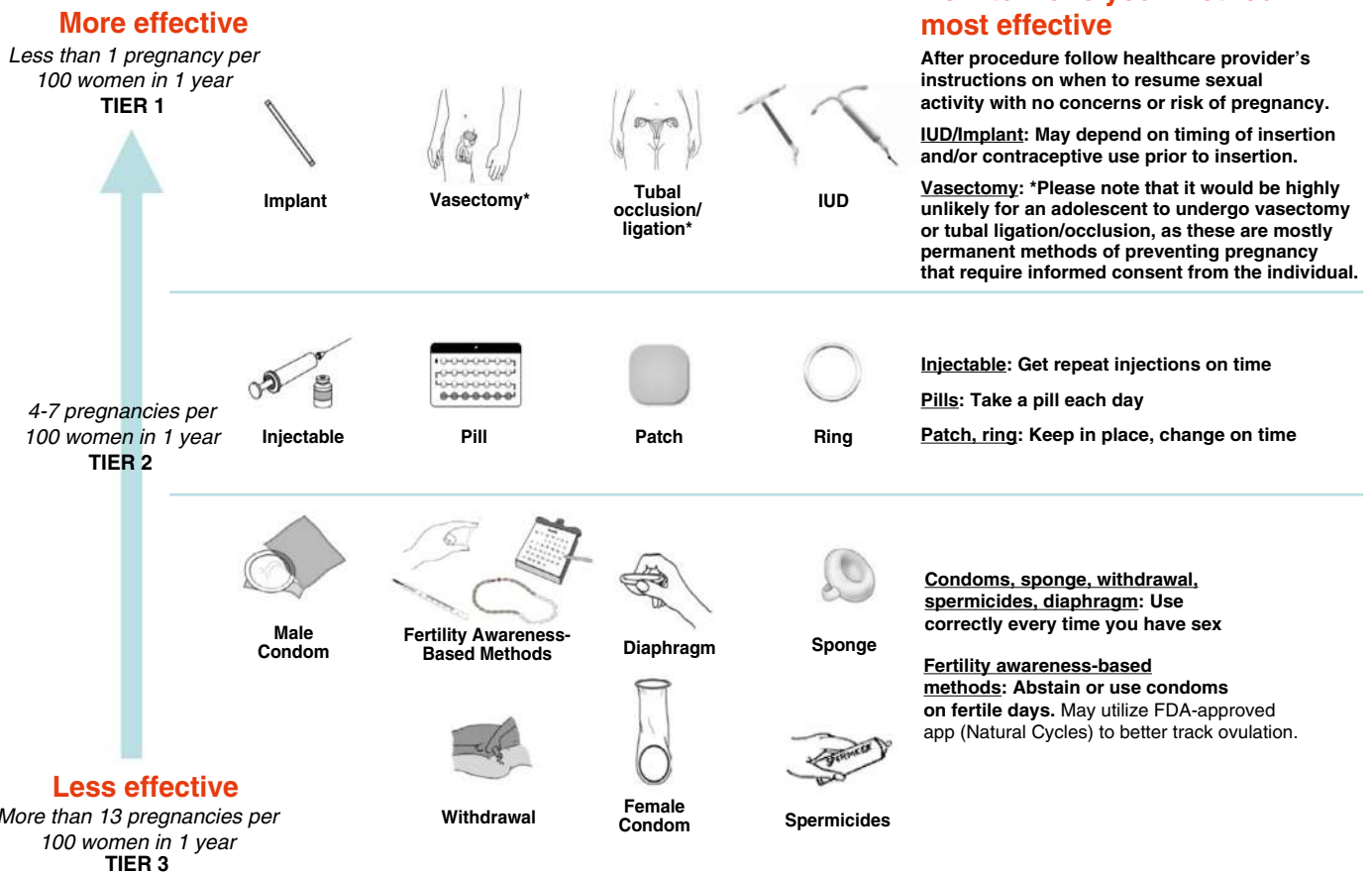
patients. Comparing typical effectiveness of contraceptive methods, Figure 160.1 illustrates a tiered system of contraceptive methods ranging from more effective to least effective. These tiers are categorized by **typical-use failure rates**, which reflect the effectiveness of a method for the average person who may not always use the method consistently or correctly (Table 160.1). For example, for oral contraceptive pills, the typical-use failure rate is 7%, whereas the *perfect-use* failure rate is <1%. **Tier 1** methods, the most effective, include those with failure rates of <1 pregnancy per 100 women in a year of typical use, and reversible Tier 1 methods include intrauterine devices (IUDs) and implants. **Tier 2** methods have failure rates of 4-7 pregnancies per 100 women in a year of typical use and include injectable contraception, oral contraceptive pills, contraceptive patches, and the vaginal ring. **Tier 3** methods have failure rates of >13 pregnancies per 100 women per year of typical use and include the male and female condom, the diaphragm, withdrawal, the sponge, fertility awareness-based methods, and spermicides.

## 160.1 Contraceptive Use

Mary E. Romano and Elizabeth M. Alderman

## SEXUAL ACTIVITY

According to the 2021 Youth Risk Behavior Surveillance System, 30% of U.S. high school students had ever had sexual intercourse and approximately 22% reported being currently sexually active. These numbers have been decreasing since 2015. However, significant decreases noted from 2019 to 2021 may be attributable to the effect of the COVID pandemic on behaviors.



**Fig. 160.1** Effectiveness of contraceptive methods. (Modified from Trussell J, Aiken ARA, Micks E, Guthrie K. Contraceptive efficacy, safety, and personal considerations. In: Hatcher RA, Nelson AL, Trussell J, et al., eds. *Contraceptive Technology*, 21st ed. New York: Ayer Company Publishers; 2018:102.)

Table 160.1		Efficacy of Contraceptives			
METHOD	FAILURE RATE (%)*		SOME ADVANTAGES	SOME ADVERSE EFFECTS AND DISADVANTAGES	
	TYPICAL USE	PERFECT USE			
Implant Nexplanon	0.1	0.1	Convenience; long-term contraception; efficacy not dependent on patient adherence; rapid return of fertility after removal	Irregular bleeding; amenorrhea, insertion and/or removal complications	
Intrauterine Devices (IUDs)			Convenience; long-term contraception; efficacy not dependent on patient adherence; rapid return of fertility after removal	Rare uterine perforation; risk of infection with insertion	
ParaGard T380A	0.8	0.6	Effective for 10yr; nonhormonal	Irregular/heavy bleeding and dysmenorrhea	
Mirena	0.1	0.1	Effective for 8 yr; decreased menstrual bleeding and improved symptoms of dysmenorrhea	Irregular bleeding in first 3-6 mo, followed by amenorrhea; unpredictable suppression of ovulation and potential ovulatory SE (ovarian cysts, PMS, dysmenorrhea)	
Liletta	0.1	0.1	Decreased menstrual bleeding and improved symptoms of dysmenorrhea	Irregular bleeding in first 3-6 mo; unpredictable suppression of ovulation and potential ovulatory SE (ovarian cysts, PMS, dysmenorrhea)	
Kyleena	0.2	0.2	Smaller T-frame and narrower insertion tube	Irregular bleeding in first 3-6 mo; unpredictable suppression of ovulation and potential ovulatory SE (ovarian cysts, PMS, dysmenorrhea), unpredictable bleeding pattern for the duration of use	
Skylla	0.4	0.3	Smaller T-frame and narrower insertion tube	Irregular bleeding in first 3-6 mo; unpredictable suppression of ovulation and potential ovulatory SE (ovarian cysts, PMS, dysmenorrhea), unpredictable bleeding pattern for the duration of use	
Injectable Depo-Provera	4	0.2	Convenience of q3mo injections; same as progestin-only oral contraceptives	Delayed return to fertility, irregular bleeding, and amenorrhea; weight gain; decreased bone mineral density while receiving injections	
Combination Oral Contraceptives	7	0.3	Protection against ovarian and endometrial cancer; suppresses ovulation, which can improve symptoms of PMS, PMDD, and dysmenorrhea; quick return to fertility upon discontinuation	Increased rate of thromboembolism, which increases with age and in those with underlying risks for blood clots, nausea; headache; contraindicated with breastfeeding	
Progestin-Only Oral Contraceptives	7	0.3	Safe in breastfeeding women and those with underlying risk of blood clots	Irregular, unpredictable bleeding; must take at same time every day, unpredictable suppression of ovulation	
Transdermal Patch	7	0.3	Convenience of once-weekly application; same benefits as combination oral contraceptives	Application site reactions; detachment; increased estrogen exposure as compared with oral contraceptives	
Vaginal Ring	7	0.3	Convenience of once-monthly application, benefits similar to combination oral contraceptive pills	Discomfort of ring or with insertion; vaginal discharge	
Diaphragm with Spermicide	17	16	Low cost	High failure rate; cervical irritation; there can be increased risk of urinary tract infection and toxic shock syndrome with improper and prolonged use; some require fitting by healthcare professional; may be difficult to obtain; available only by prescription	
Condoms Only Female	21	5	Protection against STIs; covers external genitalia; OTC	High failure rate; difficult to insert; may be less appealing because of need to stop during sexual activity	
Male	13	2	Protection against STIs, OTC, male participation	High failure rate; allergic reactions; may be less appealing because of need to stop during sexual activity; breakage possible	
Cervical Cap	16–32	9–26	Effective for 48 hr; can be used for ~2 yr	High failure rate, cervical irritation, risk of toxic shock, limited sizes, requires prescription	
Withdrawal	20	4	No drugs or devices	High failure rate	
Sponge	14–27	9–20	OTC; low cost; no fitting required; provides 24 hr of protection	High failure rate; contraindicated during menses; increased risk of toxic shock syndrome with improper and prolonged use	

Continued

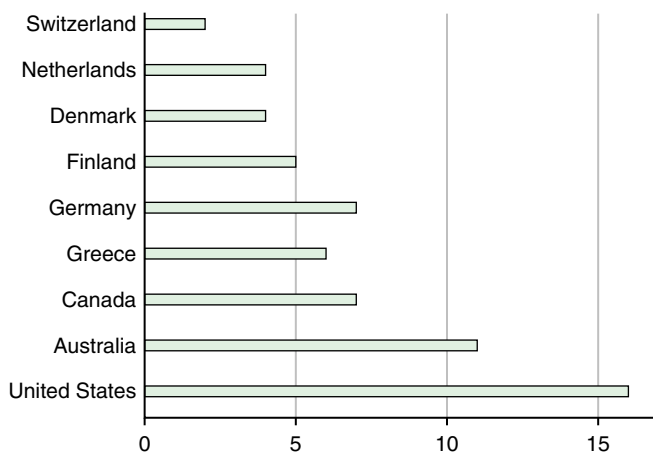
**Table 160.1** Efficacy of Contraceptives—cont'd

METHOD	FAILURE RATE (%)*		SOME ADVANTAGES	SOME ADVERSE EFFECTS AND DISADVANTAGES
	TYPICAL USE	PERFECT USE		
Fertility Awareness–Based Methods	15	—	Low cost; no drugs or devices	High failure rate; can be difficult to use properly if periods/ovulation are not well established/regular, requires periods of abstinence
Spermicide Nonoxynol-9	21	16	Available OTC —	High failure rate; local irritation; must be reapplied with repeat intercourse; unknown effect on HIV transmission, cost
Phexxi	14	5	Microbicidal effect, increased viscosity as compared to other spermicides	Requires a prescription, local irritation; must be reapplied with repeat intercourse; cannot be used with vaginal ring, cost/insurance coverage
No Method	85	85	—	—

\*Risk of unintended pregnancy during first year of use; data from Trussel J et al: In: Hatcher RA, Nelson AL, Trussell J, et al., eds. *Contraceptive Technology*, 21st ed. New York: Ayer Company Publishers; 2018.

STIs, Sexually transmitted infections; OTC, over the counter; N-9, Nonoxynol 9.

Adapted from Choice of contraceptives. *Med Lett* 2018;60(1557):161.



**Fig. 160.2** Teen birthrates in high-income countries, 2020. Live births per 1,000 females age 15-19 yr. (Data from *The World Bank Group. United Nations Population Division, World Population Prospects*. <https://data.worldbank.org/indicator/SP.ADO.TFRT>.)

Although U.S. teens and European teens have similar levels of **sexual activity** and ages of **sexual debut**, U.S. teens are less likely to use contraception and less likely to use the most effective methods. Teen pregnancy rates have been declining worldwide—a result of delayed initiation of sexual activity and increased contraceptive use. Despite this decline, the United States still had the highest teen birthrate in the Western industrialized world as of 2020, with 16.7 live births per 1,000 females age 15-19 years (Fig. 160.2). This is 8 times higher than the teen birthrate in Switzerland, which has the lowest rate in Western Europe. As of 2020 the teenage pregnancy rate in the United States is 31 pregnancies per 1,000 women, with a rate of 13.6/1,000 in those 15-17 years and 56.9/1,000 in those 18-19 years. The majority of these pregnancies are unintended, and one in five births are a repeat birth, indicating an unmet need for reliable, effective contraception that teens will correctly and consistently use.

### USE OF CONTRACEPTION AMONG TEENS

According to the 2017–2019 National Survey of Family Growth, 78% of females and 89% of males who had their first sexual intercourse before age 20 years used a contraceptive method at first intercourse. The method most used by teenage females is the condom, followed by withdrawal (both least effective methods) and then the pill (a moderately effective method). IUDs and implants, the most effective reversible methods, are used by 20% of females 15-19 years, with the implant being more commonly used (15%). Use of contraception at first sex has

greatly increased over the last 50 years. Factors associated with contraceptive use at first sex include increasing age among teens up to age 17 years, time spent in college, and planning their sexual debut.

More than half of sexually experienced female teens are currently using the most effective reversible contraceptives or moderately effective contraceptive methods. U.S. teens' use of hormonal methods at last intercourse is less frequent compared with teens in other developed countries. A higher likelihood of female current contraceptive use is associated with older age at sexual initiation, aspirations for higher academic achievement, acceptance of one's own sexual activity, and a positive attitude toward contraception. Despite the importance of dual-method use to protect against both unwanted pregnancy and STIs, only 33% of sexually active female U.S. teens report using a barrier method (condoms) plus another method of contraception at last sexual activity.

Visit Elsevier eBooks+ at [eBooks.Elsevier.com](https://eBooks.Elsevier.com) for Bibliography.

## 160.2 Contraceptive Counseling

Mary E. Romano and Elizabeth M. Alderman

The adolescent preventive health visit offers opportunities for confidential discussions with all adolescents and the opportunity to identify and discuss sexual practices that may be putting the adolescent at risk for STIs or unintended pregnancy. It is also a time to discuss safe sexual behaviors, including abstinence (see Chapter 151). It is important to ask specifically about adolescents' sexual behaviors to make sure your counseling is appropriate for their sexual activity. Adolescents with medical conditions, either chronic or acute, are particularly vulnerable to having sexual and reproductive health omitted from their visits, although they have similar sexual health and contraceptive needs (see Chapter 756). Their comorbidities or concurrent medication use may make STIs and unintended pregnancy an increased health risk and may affect contraceptive counseling/options. The **U.S. Medical Eligibility Criteria for Contraceptive Use (MEC)** outlines medical conditions associated with increased risk for adverse health events with pregnancy and provides recommendations for who can safely use specific contraceptive methods.

The goals of adolescent contraceptive counseling are to (1) understand adolescent experiences, preferences, perceptions, and misperceptions about pregnancy and use of contraceptives; (2) help adolescents understand the risks of unprotected sexual intercourse, including STIs and unintended pregnancy; (3) educate adolescents about the various contraceptive methods available using information that is medically accurate, balanced, and provided in a nonjudgmental manner; and (4) engage in patient-centered counseling so the adolescent feels empowered to choose a safe and effective method that can either be

provided on site or be easily obtained through prescription or by referral. If adolescents are comfortable and willing to include their parents in this discussion, it is also always helpful to engage parents in the decision-making process and address any parental questions and concerns. Providers should be aware of state laws affecting confidentiality and an adolescent's ability to access confidential contraceptive services (see [Chapter 151](#)). Most states allow adolescents confidential access to contraceptive services, but given that many adolescents are under their parents' insurance plan, confidentiality may be unintentionally breached through billing and explanation of benefit statements, as well as through the open notes mandate. This should be discussed with adolescents, especially those who are very concerned about disclosing sexual health information to their parents or guardians.

Counseling should include a review of all contraceptive methods available that the adolescent can use safely (see U.S. MEC). **Long-acting reversible contraception** (LARC/IUDs and implants) is a safe and effective option for many adolescents, including those who have not been pregnant or given birth. The adolescent should be counseled about method effectiveness using typical-use failure rates. Although it is important to highlight the methods most effective at preventing pregnancy, it is also imperative to provide contraceptive counseling within the framework of reproductive justice and to avoid any coercion due to provider preference or bias. The focus of contraceptive counseling should be on the priorities of the adolescent, and the adolescent should be allowed to explore all options and determine which method is most appropriate for their contraceptive needs and priorities. It is important to ask about use of **withdrawal** and discuss its risks given that 60% of female teens have used it for contraception and it has a typical-use failure rate of 20%. **Abstinence** should also be discussed as an option even if teens have engaged in sexual intercourse in the past. Abstinence may be the best option if adolescents do not have another method available at a particular time.

Necessary concepts to address while discussing individual methods include how effective the method is, how long the method works, what behaviors are required for correct and consistent use, what side effects may be seen, any noncontraceptive benefits of the method (e.g., reduced menstrual bleeding, protection from STIs), and what signs or symptoms of complications should prompt a return visit. Reviewing common side effects allows teens to anticipate and cope with any changes with reassurance and may avoid method discontinuation. Weighing the possibility of certain side effects with the possibility of an unintended pregnancy may also help with the conversation. It is also important to address any specific misperceptions teens may have for certain contraceptives regarding side effects, effectiveness, or effect on future fertility.

Once an adolescent chooses a method, the provider and adolescent should discuss clear plans on correct and consistent use of the chosen method and strategies for appropriate follow-up (see [Table 160.1](#)). Providers should help the adolescent consider potential barriers to correct and consistent use (e.g., forgetting to take a pill daily) and develop strategies to deal with each barrier (e.g., use of reminder systems such as daily text messages or phone alarms). The provider should assess whether the teen understood the information discussed and may confirm by asking the teen to repeat back key concepts.

The U.S. Selected Practice Recommendations for Contraceptive Use provides guidance for providers regarding when to start contraception, how to be certain the woman is not pregnant at contraception initiation, and what examinations and tests are recommended before initiating contraception. Generally, women may start a contraceptive method other than an IUD at any time, and an IUD may be placed when a provider is reasonably certain that a woman is not pregnant. The Centers for Disease Control and Prevention (CDC) defines this as a patient who has no symptoms or signs of pregnancy, is  $\leq 7$  days after the start of normal menses, has not had sexual intercourse since the start of last normal menses, and has been correctly and consistently using a reliable method of contraception.

Most women do not require any special exam or additional screening for STIs before initiating contraception if they have been recently screened according to the CDC's STI treatment guidelines. A blood

pressure reading is advisable. A pelvic examination is only required for placement of an IUD, unless otherwise indicated. STI screening is appropriate at and/or before IUD placement, even if a patient does not report sexual activity, as some patients may choose to not disclose this information to their provider. Gonorrhea and chlamydia screening using a self- or provider-collected vaginal swab or urine sample is recommended unless symptoms require a pelvic exam. IUD placement should not be delayed to receive screening results. Cervical cancer screening is not recommended until age 21.

Providers should offer confidential services to adolescents and observe all relevant state laws and legal obligations (e.g., notification or reporting of sexual abuse). [Chapter 151](#) discusses confidentiality and consent issues related to contraceptive management. Providers should also encourage adolescents to involve parents or guardians in their healthcare decisions, while giving parents clear information on their teen's right to confidentiality, privacy, and informed consent. All services should be provided in a youth-friendly manner, meaning that they are accessible, equitable, acceptable, appropriate, comprehensive, effective, and efficient. Resources are available that describe ways to ensure a **teen-friendly** reproductive health visit.

Visit Elsevier eBooks+ at [eBooks.Health.Elsevier.com](http://eBooks.Health.Elsevier.com) for Bibliography.

### 160.3 Long-Acting Reversible Contraception

Mary E. Romano and Elizabeth M. Alderman

Long-acting reversible contraception (LARC) includes four **levonorgestrel (LNG)** IUDs, the **copper (Cu)** IUD, and the etonogestrel subdermal implant. LARC methods are the only Tier 1 methods that are reversible (see [Fig. 160.1](#)). Their efficacy is the result of the fact that LARC does not require frequent office or pharmacy visits and does not depend on user adherence for effectiveness. In the Contraceptive CHOICE Project in St. Louis, Missouri, >9,000 women were given the contraceptive method of their choice at no cost and were followed for 2-3 years. The failure rates among women of all ages, including adolescents who used oral contraceptive pills, transdermal patch, or vaginal ring, were >20 times higher than the failure rates for those using a LARC method. Acceptance, continuation, and satisfaction in this project were also higher among adolescents using LARC compared with adolescents using non-LARC methods. *ACOG and AAP support the use of LARC methods for adolescents*. The U.S. MEC supports safe use of both IUDs and implants for adolescents and nulliparous women. Implants are considered Category 1 for all ages, and IUDs are considered Category 2 for women <20 years old and for nulliparous women ([Table 160.2](#)).

#### INTRAUTERINE DEVICES

IUDs are small, flexible, plastic objects introduced into the uterine cavity through the cervix. They differ in size, shape, presence or absence of hormone, and dose of hormone delivered daily. In the United States, five IUDs are currently approved by the Food and Drug Administration (FDA): the CuT380A (Paragard) and four LNG IUDs (Liletta, Kyleena, Mirena, and Skyla).

The LNG IUDs also have various actions, from thickening of cervical mucus and inhibiting sperm survival to suppressing the endometrium. LNG IUDs are effective and approved for use from 3 to 8 years. The Cu IUD releases copper ions into the uterine cavity, which induces an inflammatory response within the endometrium. Copper also impairs sperm motility/migration, inhibits the acrosomal reaction, and impairs implantation. As with the other IUDs, the Cu IUD is reversible, safe for use in nulliparous women, and effective for at least 10 years. All IUDs have typical-use failure rates of <1% (see [Fig. 160.1](#)). All LARC methods are appropriate and safe to use in the postpartum period.

Mirena is FDA approved for the treatment of heavy menstrual bleeding, and studies in adults have demonstrated an 80% reduction in menstrual blood loss in Mirena users, with 50% of users reporting amenorrhea after 2 years of use. Among the other LNG IUDs,



**Table 160.2** Categories of Medical Eligibility Criteria for Contraceptive Use

<b>Category 1:</b> A condition for which there is no restriction for the use of the contraceptive method
<b>Category 2:</b> A condition for which the advantages of using the method generally outweigh the theoretical or proven risks
<b>Category 3:</b> A condition for which the theoretical or proven risks usually outweigh the advantages of using the method
<b>Category 4:</b> A condition that represents an unacceptable health risk if the contraceptive method is used

**Table 160.3** Conditions Classified as Category 3 and 4 for Combined Hormonal Contraceptive Use

<b>Category 4</b> (a condition that represents an unacceptable health risk if the contraceptive method is used)
Complicated valvular heart disease
Current breast cancer
Severe decompensated cirrhosis
Deep venous thrombosis/pulmonary embolism (acute; history, not on anticoagulation or on established therapy for at least 3 mo with higher risk recurrence; major surgery with prolonged immobilization)
Complicated diabetes with nephropathy, retinopathy, neuropathy, or other vascular disease or duration of diabetes >20yr
Migraine with aura
Poorly controlled hypertension (blood pressure >160/100 mm Hg) or hypertension with vascular disease
Ischemic heart disease (history of or current)
Hepatocellular adenoma
Malignant liver tumor
Peripartum cardiomyopathy (diagnosed <6 mo before or with moderately or severely impaired cardiac function)
Postpartum <21 days
History of cerebrovascular accident
Systemic lupus erythematosus with positive antiphospholipid antibodies
Thrombogenic pathogenic variants
Viral hepatitis (acute or flare)
<b>Category 3</b> (a condition for which the theoretical or proven risks usually outweigh the advantages of using the method)
Past breast cancer with no evidence of disease for 5 yr
Breastfeeding and <1 mo postpartum
Deep venous thrombosis/pulmonary embolism (history of DVT/PE with lower risk recurrence)
Gallbladder disease (current, medically treated)
History of malabsorptive bariatric surgery
History of cholestasis and past combined oral contraceptive–related
Hypertension (adequately controlled or blood pressure <160/100 mm Hg)
Peripartum cardiomyopathy with mild impairment or >6 mo
Postpartum 21–42 days with other risk factors for venous thromboembolism
Drug interactions (ritonavir-boosted protease inhibitors; certain anticonvulsants; rifampin or rifabutin)
First-degree family member with a history of a blood clot/clotting disorder/thromboembolic event

From Curtis KM, Tepper NK, Jatlaoui TC, et al. U.S. medical eligibility criteria for contraceptive use, 2016. *MMWR Recomm Rep* 2016;65(RR-3):1–104.

amenorrhea at 2 years is reported at 26% for Liletta users, and Kyleena and Skyla report prolonged and irregular bleeding at 1 year in 5–20% of users. Heavier bleeding patterns and increased dysmenorrhea are reported in users of the Cu-IUD. Patients should be counseled on bleeding patterns and expected changes to their menstrual bleeding after IUD insertion (Table 160.3).

Common misconceptions of IUDs among healthcare providers are that IUDs can cause or increase the risks of infections, cause infertility,

and generally are not safe or tolerated by teens or nulliparous women; these misconceptions can be a barrier for teens desiring an IUD to access these highly effective and safe methods. IUDs do not increase risk of infertility and may be inserted safely in teenagers regardless of parity (Category 2; see Table 160.2).

Although early studies suggested an increased risk for upper genital tract infection, because of the passing of a foreign body through the cervix, new studies have refuted these concerns. Therefore clinicians are encouraged to consider the use of IUDs in adolescents despite relatively high prevalence rates of STIs in this population. Teens should be screened for gonorrhea and chlamydia at and/or before IUD placement, although placement should not be delayed if results have not returned and there are no signs of current infection (e.g., purulent discharge, erythematous cervix). If STI testing is positive with an IUD in place, the patient may be treated without removing the IUD if she wants to continue the method.

There has been evidence that rates of IUD expulsion are higher in adolescents as compared to older women. The data are limited, but the risk seems to be higher with Cu-IUD vs hormonal IUD, previous IUD expulsion, and concomitant use of the menstrual cup. A paracervical block with lidocaine may reduce patient discomfort during placement and, along with other medications (e.g., NSAIDs, anxiolytics), may be considered on an individual patient basis, but these are not routinely recommended.

## IMPLANTS

One contraceptive implant is available in the United States. The single rod that releases 60 µg/day of **etonogestrel** has been updated to a radiopaque rod with a new inserter. This **progestin-only method** keeps etonogestrel at steady serum levels for at least 3 years and primarily works to inhibit ovulation. Similar to the levonorgestrel IUD, the progestin acts on the uterus to cause an atrophic endometrium and thicken cervical mucus to block sperm penetration; its typical-use failure rate is also <1% (see Fig. 160.1). Unlike the IUD, no pelvic exam is required for insertion. A trained provider can quickly place or remove the implant in the upper arm under local anesthesia. The most common side effect of the contraceptive implant is irregular and unscheduled/unpredictable bleeding. This can include irregular or infrequent bleeding, amenorrhea, and less often, prolonged or frequent bleeding. Although the continuation rates are favorable and comparable to the IUD, the most common reason for discontinuation is dissatisfaction with bleeding patterns. It is important that adolescents be appropriately counseled on the potential for changes to their bleeding pattern before insertion of the implant. Adolescents who present with troublesome bleeding should be evaluated for any underlying gynecologic abnormalities, bleeding or blotting disorders, and the presence of an STI. If these are not present and adolescents desire treatment, they can be treated with a short course of NSAIDs (5–7 days) or low-dose combined oral contraceptives (COCs) if no contraindications to estrogen exist (10–20 days). Any and all adolescents desiring implant removal because of side effects should be offered prompt removal as indicated.

One potential unique complication of this method relates to localized infection and other side effects after implantation, such as bleeding, hematoma, or scarring, and if inserted too deeply into the muscle, neural damage or migration; however, these events are rare, occurring in <1% of patients. Minor side effects, such as bruising or skin irritation, are more common but most often resolve without treatment.

Visit Elsevier eBooks+ at [eBooks.Elsevier.com](http://eBooks.Elsevier.com) for Bibliography.

## 160.4 Other Progestin-Only Methods

Mary E. Romano and Elizabeth M. Alderman

Several progestin-only contraceptive methods are available and include the LNG IUDs and implant (see Chapter 160.3), as well as an injectable and progestin-only pills. These methods do not contain estrogen and may be useful for teens with contraindications to estrogen use or in

**Table 160.4** Hormonal Intrauterine Devices

	MIRENA	KYLEENA	LILETTA	SKYLA
Duration of use	FDA approved 8 yr	FDA approved 5 yr	FDA approved 8 yr	FDA approved 3 yr
Daily hormone delivery over time	20 mcg LNG/day → 9 mcg/day (52 mcg total)	17.5 mcg LNG/day → 7.4 mcg/day (19.5 mcg total)	19.5 mcg LNG/day → 9.8 mcg/day (52 mcg total)	14 mcg LNG/day → 5 mcg/day (13.5 mcg total)
Device size	32 mm × 32 mm	28 mm × 30 mm	32 mm × 32 mm	28 mm × 30 mm
Diameter of insertion rod	4.4 mm	3.8 mm diameter	4.4 mm diameter	3.8 mm diameter

FDA, Food and Drug Administration; LNG, levonorgestrel.

patients who prefer a method without estrogen such as gender-diverse adolescents and young adults (Table 160.4). They are considered safe for use in teens (Category 1 or 2; see Table 160.2). Progestins thicken cervical mucus to block sperm entry into the uterine cavity and induce an atrophic endometrium leading to either amenorrhea or less menstrual blood loss; the implant and injectable also suppress ovulation, whereas the progestin-only pills and LNG IUDs may affect the frequency of ovulation but do not suppress it completely. Teens should be provided anticipatory counseling regarding bleeding irregularities that may normally occur in the first 3-6 months of any hormonal contraception use.

### DEPO-PROVERA

An *injectable progestin*, depot **medroxyprogesterone acetate (DMPA, Depo-Provera)** is a Tier 2 contraceptive method available as a deep intramuscular (IM) injection (150 mg) or as a subcutaneous (SC) injection (104 mg) with typical-use failure rates of 4% (see Table 160.1). Both preparations must be readministered every 3 months (13 weeks). When appropriate, DMPA can be given up to 3 weeks before or 7 days after the 13 weeks scheduled interval without any effect on contraceptive efficacy. DMPA works by inhibiting ovulation and thickening cervical mucus. DMPA may be preferred by patients or parents who are caring for a child with intellectual disabilities. Common concerns with DMPA include bleeding changes, bone effects, and weight gain. After 1 year of use, 50% of DMPA users develop amenorrhea, which may be an added advantage for teens with heavy menstrual bleeding, dysmenorrhea, anemias, or blood dyscrasias. It may also be advantageous for those desiring menstrual suppression because of physical or developmental disabilities that make hygiene difficult or those in whom menstruation causes gender dysphoria. Studies have demonstrated bone mineral density (BMD) loss in adolescents with DMPA use, but this has not been shown to directly increase fracture risk. It is unclear how this decrease in BMD affects the risk for osteoporosis later in life. Other studies have found that BMD is recovered after discontinuation of this method, and it is thus considered safe for use in this population with appropriate counseling and consideration of other risk factors for bone health. Healthcare providers should speak at length with teens and parents, when appropriate, who are already at high risk for low BMD, such as those receiving chronic corticosteroid therapy or those with eating disorders (see Chapter 749). They should discuss and decide together if DMPA is an appropriate contraceptive choice. Patients and providers need to balance the potential bone effects of DMPA with the bone effects that can occur with a teenage pregnancy. Although the FDA issued a black box warning in 2004 because of Depo's BMD effects, the AAP and ACOG do not recommend limiting duration of DMPA use and do not recommend routine BMD screening for females using it. Early weight gain may be predictive of progressive gain over time; thus those teens gaining weight in the first 3-6 months after the initiation of DMPA should be monitored and continue to engage in discussions about healthy eating and exercise habits.

### PROGESTIN-ONLY PILLS

Progestin-only oral contraceptive pills (POPs) are available and safe for use in adolescents. POPs (**mini pills**) are quickly effective after 2 days of initiation in thickening cervical mucus, but do not reliably

inhibit ovulation. Prior to 2019, the only progestin pill available in the United States contained 0.35 mg of norethindrone. Norethindrone has a short half-life, and it is important that this pill is taken at the same time every day, which can make adherence difficult. If a pill is >3 hours late from normal time, an unintended pregnancy may occur. POPs have a typical-use failure rate of 7% (see Table 160.1). Norethindrone POPs are taken continuously, and as a result, the bleeding pattern is variable—ranging from amenorrhea to irregular and unpredictable breakthrough bleeding. Acceptance by adolescents is limited by the necessity of taking the pill at the same time daily, and bleeding irregularities

In 2019 the FDA approved a new POP—Slynd—which contains 4 mg of drospirenone. This is higher than the dose found in COCs. Drospirenone is an analog of spironolactone with a longer half-life of ~25-30 hours, which allows for more flexibility with timing of pills. It also has some antiminerlocorticoid activity and therefore should be used with caution in those who may take other medications or have medical comorbidities that can put them at risk for hyperkalemia. Slynd comes in a 28-day pill pack with four inactive pills intended to cause a scheduled withdrawal bleed. Slynd primarily suppresses ovulation. Studies have demonstrated its safety and efficacy along with high rates of satisfaction among users (85%). There may still be unscheduled bleeding, but it seems to be more favorable than what is experienced with norethindrone use.

Visit Elsevier eBooks+ at [eBooks.Health.Elsevier.com](https://ebooks.health.elsevier.com) for Bibliography.

## 160.5 Combined Hormonal Contraceptives

Mary E. Romano and Elizabeth M. Alderman

Combined hormonal contraceptives (CHCs) are methods that include an estrogen in combination with a progestin that has progestational, estrogenic, and androgenic properties. Methods available in the United States include several formulations of COCs, a transdermal patch, and a vaginal ring. The major mechanism of action of the **estrogen-progestin** combination is to prevent the surge of luteinizing hormone and thereby inhibit ovulation. Additional effects to the reproductive tract include thickening of the cervical mucus, which prevents sperm penetration, and thinning of the endometrial lining, which may decrease menstrual blood loss. Typical-use failure rates for all CHCs are the same at 7%.

The COCs, patch, and vaginal ring are classified together as CHCs in the U.S. MEC for Contraceptive Use, and recommendations mostly consider estrogen exposure for a given condition or characteristic (see Tables 160.3 and 160.4). Thromboembolic events such as venous thromboembolism (VTE), pulmonary embolism, or stroke are some of the more serious potential complications of exogenous estrogen use. These serious adverse events are exceedingly rare in adolescents who do not have other risk factors for thromboembolic events. Although the risk of blood clots is increased in those who smoke cigarettes, the likelihood of its occurrence is very small in adolescents, and thus clinically insignificant, compared to the risk of morbidity and mortality from other pregnancy-related complications, including blood clots

associated with the high estrogen levels that occur during pregnancy and in the postpartum period.

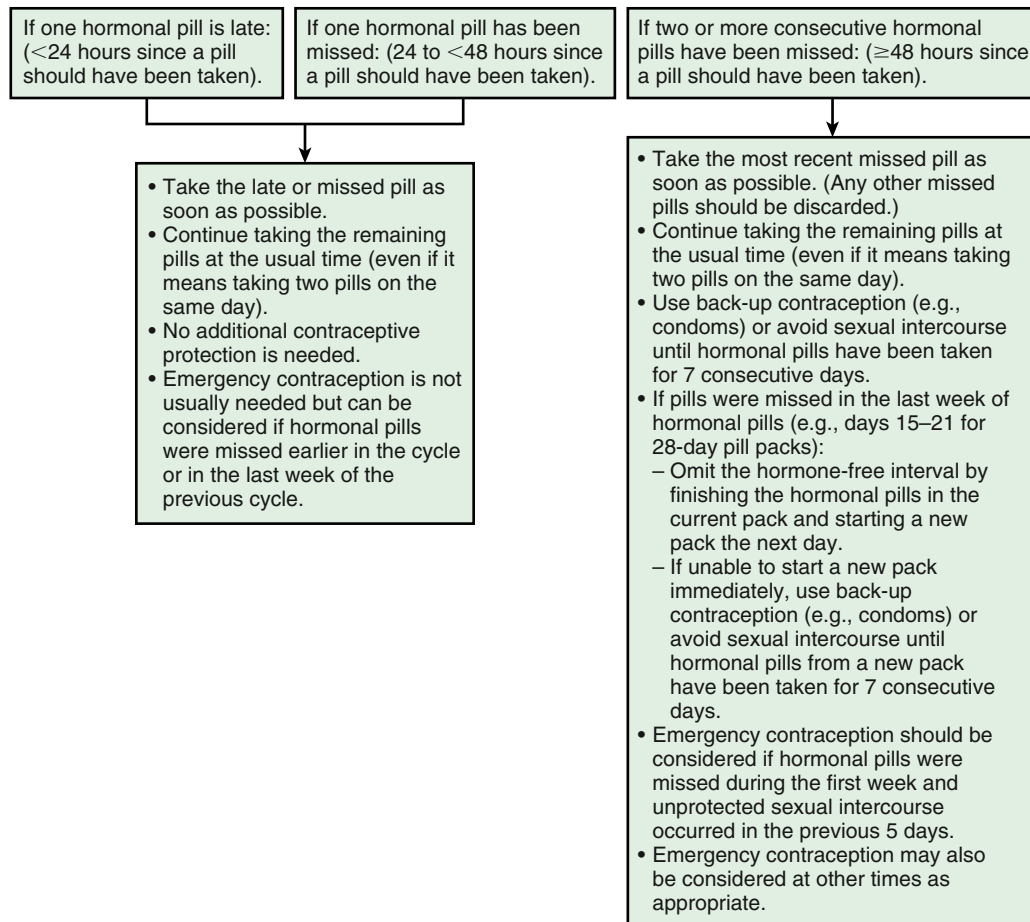
### COMBINED ORAL CONTRACEPTIVES

Oral contraceptive pills (OCs) can be either COCs or POPs and are commonly referred to as “the pill.” The pill is one of the most common contraceptive methods used among women of all ages. To decrease risk of pregnancy and increase continuation, providers are encouraged to provide OCs at the time of patient presentation to start immediately rather than waiting for next menses, as long as the provider is reasonably sure that the patient is not pregnant. Providers are also encouraged to provide up to 13 pill packs at a time, based on evidence that more pill packs provided is associated with higher continuation rates. However, it is important to see an adolescent in follow-up once starting contraception to discuss adherence and satisfaction with the method selected. Advanced provision of emergency contraceptive pills is also recommended should patients miss pills and have unprotected sex. The effectiveness of COCs depends on adherence, and it can be difficult for any patient to remember to take a pill each day. [Figures 160.3 and 160.4](#) list the rules for missed pills or after vomiting or diarrhea.

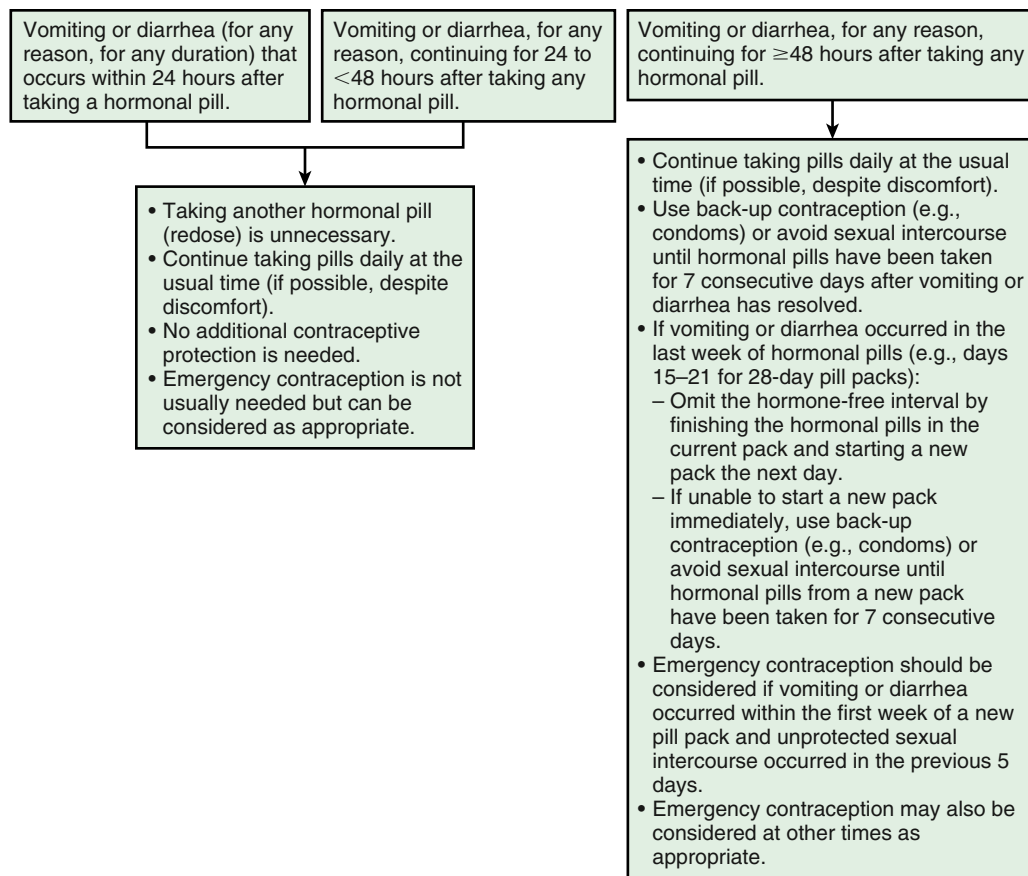
COCs contain between 50 µg and 10 µg of an estrogenic substance, typically **ethinyl estradiol**, and as many as 10 progestins are available in the United States for combined pills. Multiple preparations are available to help select the formulation that satisfies an individual patient, with minimal side effects. Studies looking at the effects of estrogen dosing on bone health have found lower rates of bone accrual in those taking COCs containing 20 mcg as compared with nonusers. It is recommended that adolescents start on a COC containing 30–35 µg of an estrogenic substance.

COCs can be packaged as 28-day *monophasic* pills, which contain the same dose of active pills for 21 or 24 days, followed by 7 or 4 days of placebo pills, respectively. Monophasic formulations are also available for extended cycles of 91 days or 1 year so that withdrawal bleeding does not occur each month, but at the end of each extended cycle. **Extended cycling** of monophasic COCs for adolescents has some anticipated benefits associated with increased ovarian activity suppression and may decrease failure rates. Other advantages include menstrual suppression in those patients in whom that is a priority and diminished frequency of hormonal withdrawal (premenstrual) effects, including headaches and migraines, mood changes, and heavy monthly bleeding. The most common side effect of extended-cycle OCs is intermenstrual bleeding and/or spotting, with the total days of bleeding over the first year of treatment being similar for extended-cycle users and users following a 28-day-cycle regimen. The unscheduled bleeding pattern diminishes over time. *Multiphasic* pill packs contain various levels of estrogen and progestin for 21 active pills and contain 7 placebo pills. Multiphasic formulations are not available for extended-cycle use. Providers can refer to the U.S. Selected Practice Recommendations for Contraceptive Use to counsel patients on how to manage late or missed COCs.

The short-term adverse effects of COCs, such as nausea and weight gain, often interfere with compliance in adolescent patients. These effects are usually transient and may be overlooked by the beneficial effects of a shortened menses and the relief of dysmenorrhea. The inhibition of ovulation or the suppressant effect of estrogens on prostaglandin production by the endometrium makes COCs effective in preventing dysmenorrhea (see [Chapter 159](#)). Acne is typically improved by COCs, as estrogen can reduce the effects of circulating androgens. There is no evidence that one particular COC is superior to



**Fig. 160.3** Algorithm showing recommended actions after late or missed combined oral contraceptives. (From Curtis KM, Jatlaoui TC, Tepper NK, et al. U.S. selected practice recommendations for contraceptive use, 2016. *MMWR Recomm Rep* 2016;65[RR-4]:1–66, Fig. 2, p. 28.)



**Fig. 160.4** Algorithm showing recommended steps after vomiting or diarrhea while using combined oral contraceptives. (From Curtis KM, Jatlaoui TC, Tepper NK, et al. U.S. selected practice recommendations for contraceptive use, 2016. *MMWR Recomm Rep* 2016;65[RR-4]:1–66, Fig. 5, p. 30.)

another in targeting acne, but theoretically it would be better to use a pill with nonandrogenic progestins (see [Chapter 710](#)). **Drospirenone**, a progestin with antimineralocorticoid activity, has been shown to reduce premenstrual symptomatology, but the potential for hyperkalemia as a side effect eliminates patients with renal, liver, or adrenal diseases and patients taking certain medications.

The FDA has concluded that drospirenone-containing OCs may be associated with a higher risk of VTE than other progestin-containing pills. Although no studies have provided consistent estimates of the comparative risk of VTE between OCs that contain drospirenone and those that do not, or accounted for patient characteristics that may affect VTE risk, there has been a threefold increased risk of VTE reported for drospirenone-containing pills as compared with products containing levonorgestrel or other progestins. As a result, the FDA requires that labeling be revised for the OCs marketed under the Beyaz, Safyral, Yasmin, and Yaz brands. This clot risk has not been established for Slynd, which contains 4 mg of drospirenone and no estrogenic component. Despite the risk of VTE with all OCs, the absolute risk remains lower than the risk of developing VTE during pregnancy or the postpartum period.

## TRANSDERMAL PATCH

The transdermal patch releases a combination of ethinyl estradiol and a progestin daily. It is applied to the lower abdomen, buttocks, or upper body, excluding the breasts. It is worn continuously for 1 week and changed weekly for a total of 3 weeks, then no patch is worn for the fourth week, at which time bleeding occurs (see [Table 160.1](#)). Limited studies in adolescents suggest higher rates of partial or full detachment compared with adults, with high patient satisfaction and 50–83% continuation rates from 3 to 18 months of use ([Fig. 160.5](#)). As with other combined hormonal methods, the patch is a Tier 2 contraceptive. Providers can refer to the U.S. Selected Practice Recommendations to

counsel patients on how to manage delayed application or detachment of the patch.

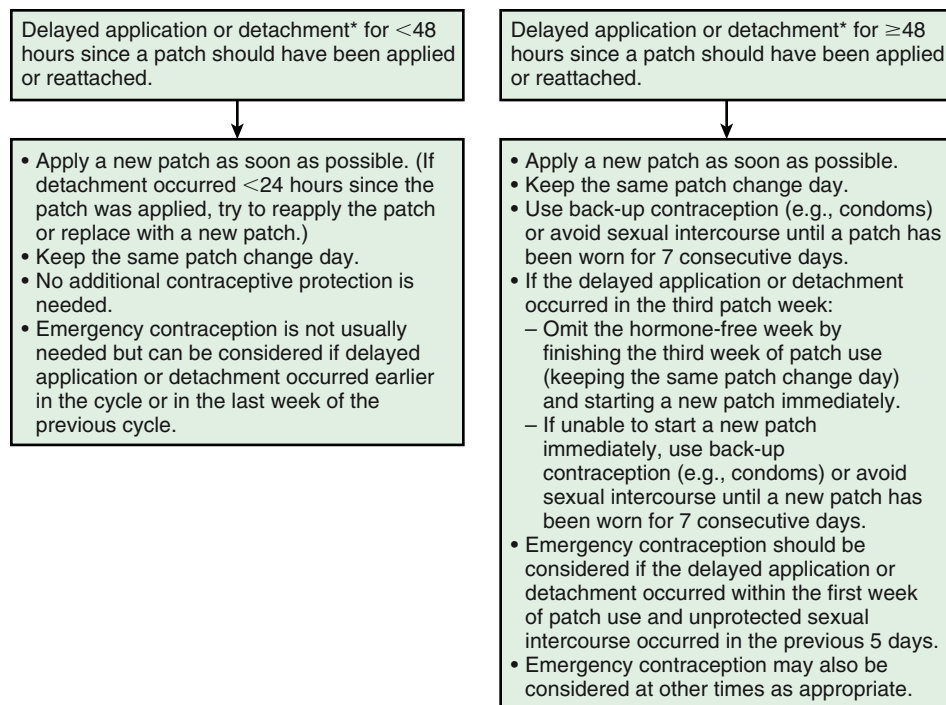
The first patch available was Ortho Evra, now available only in a generic version called Xulane. It releases 35 µg ethinyl estradiol and 150 µg norelgestromin daily. Compared with the pharmacokinetics of COCs, the area under the curve for the patch is about 55% higher for patch users. This caused concerns about increased risk of clots with higher estrogen exposure, although there have been no data to confirm this risk. Studies to date have had conflicting data on the risk of VTE in patients using nonoral combined hormonal contraception. There is also concern for efficacy of the patch in those whose weight was >90 kg, and this should be discussed with patients in consideration of use. The Xulane patch can be used to extend cycles similar to COC extended-cycle pills. Patients may choose to wear patches consecutively without any “patch-free week” but should be aware that this can carry a risk of breakthrough bleeding, as occurs with extended-cycle COC use.

In 2020 Twirla was developed to address the need for a lower-dose product to reduce the cumulative estrogen exposure from patch use. Twirla releases 30 µg ethinyl estradiol (EE) and 120 µg levonorgestrel (LNG) daily, and the maximum steady-state concentrations were 60% (EE) and 18% (LNG) as compared with Xulane. Initial studies did not demonstrate a significantly decreased clot risk as compared to other methods of combined hormonal contraception, but as with Xulane, efficacy seemed to be affected by body mass index (BMI), in particular in those who were categorized by BMI as obese. Twirla was not studied for extended use.

## VAGINAL RING

The vaginal contraceptive ring is a flexible, transparent, colorless vaginal ring that is inserted into the vagina by the patient. It releases a daily dose of ethinyl estradiol and a progestin. It remains in place for 3 weeks, during which time these hormones are absorbed. It is then typically





\*If detachment takes place but the woman is unsure when the detachment occurred, consider the patch to have been detached for  $\geq 48$  hours since a patch should have been applied or reattached.

**Fig. 160.5** Algorithm showing recommended actions after delayed application or detachment with combined hormonal patch. (From Curtis KM, Jatlaoui TC, Tepper NK, et al. U.S. Selected practice recommendations for contraceptive use, 2016. *MMWR Recomm Rep* 2016;65[RR-4]:1–66, Fig. 3, p. 28.)

removed for 7 days during which time a withdrawal bleed should occur. If the ring is accidentally expelled or removed for intercourse, it should be reinserted; however, if it is out of place  $\geq 48$  hours or the ring is not replaced within 7 days after removal, a backup method of contraception should be used (Fig. 160.6). The vaginal ring is a Tier 2 contraceptive. Providers can refer to the U.S. Selected Practice Recommendations to counsel patients on how to manage delayed insertion or reinsertion with the vaginal ring.

The first contraceptive ring available was NuvaRing, which measures about 2.1 inches in diameter and releases 1  $\mu\text{g}$  ethinyl estradiol and 120  $\mu\text{g}$  etonogestrel daily. Users use one ring per 4-week cycle with 3 weeks in and 1 week out and a scheduled withdrawal bleed. It should be noted that although it is labeled for 28 days of use, it contains enough hormones to be used for up to 35 days and can be replaced once every calendar month. The ring can be used to extend cycles similar to COC extended-cycle pills. Patients may choose to use the Nuva Ring consecutively without any “ring-free week” but should be aware that this can carry a risk of breakthrough bleeding, as occurs with extended-cycle COC use. Annovera is FDA approved and offers a single ring, which can be reused for 13 consecutive cycles and does not require refrigeration when not in use. Annovera has a diameter of about 2.2 inches and releases 13  $\mu\text{g}$  of EE and 150  $\mu\text{g}$  of segesterone acetate daily. It has not been studied for extended use, and initial studies did not include those with a BMI  $>29$  kg/m<sup>2</sup>.

## CONTRAINDICATIONS

Contraceptive counseling should include a discussion and assessment for any absolute or relative contraindications to estrogen use. Contraindications to the use of estrogen-containing methods include those conditions for which CHCs pose an unacceptable health risk (Category 4) in the U.S. MEC for Contraceptive Use (see Table 160.3); current breast cancer; severe cirrhosis, acute deep venous thrombosis/pulmonary embolism (DVT/PE) or history of DVT/PE with higher risk for recurrence, major surgery with prolonged immobilization, diabetes with nephropathy, retinopathy, or neuropathy, migraines with focal

neurologic aura, stage II hypertension, vascular disease, ischemic heart disease, hepatocellular adenoma or malignant liver tumors, multiple risk factors for cardiovascular disease, peripartum cardiomyopathy, postpartum  $<21$  day, complicated solid-organ transplantation, history of cerebrovascular accident, systemic lupus erythematosus with positive antiphospholipid antibodies, thrombogenic pathogenic variants, and complicated valvular heart disease. The initial history taken before prescribing CHCs should specifically address these risks. The U.S. MEC provides contraceptive safety guidance with  $>1,800$  recommendations for  $>120$  medical conditions or characteristics. According to the MEC, obesity is not a contraindication to estrogen or contraceptive use, and these adolescents would be considered at high risk for pregnancy complications. Therefore adolescents with obesity should be counseled on and offered contraception when indicated and if desired by the patient.

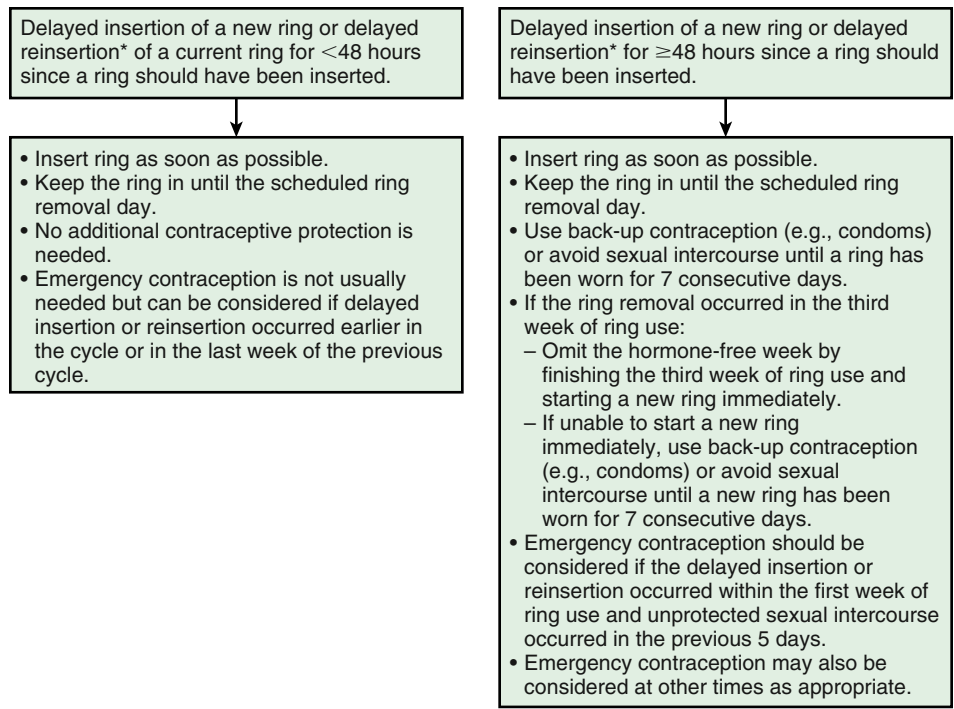
Other things to discuss and consider when evaluating an adolescent for COC use are a family history of blood clots or clotting disorders and any medications that might interact with COCs. If a patient has a first-degree relative with history of VTE, evaluation for a familial thrombophilia is advisable. There are few medication interactions for progestin-only methods, but there are medications that may be affected by or affect levels of COCs. This includes certain anticonvulsants and psychotropic medications as well as herbal supplements, which may affect COC levels. The CDC has a resource for antiretrovirals and their potential for interactions with hormonal contraception. Lexicomp and UpToDate provide additional information on interactions with COCs.

Visit Elsevier eBooks+ at eBooks.Elsevier.com for Bibliography.

## 160.6 Emergency Contraception

Mary E. Romano and Elizabeth M. Alderman

Unprotected intercourse at mid-cycle carries a pregnancy risk of 20–30%. At other times during the cycle, the risk is 2–4%. Emergency



\*If removal takes place but the woman is unsure of how long the ring has been removed, consider the ring to have been removed for ≥48 hours since a ring should have been inserted or reinserted.

**Fig. 160.6** Algorithm showing recommended actions after delayed insertion or reinsertion with combined vaginal ring. (From Curtis KM, Jatlaoui TC, Tepper NK, et al. U.S. selected practice recommendations for contraceptive use, 2016. *MMWR Recomm Rep* 2016;65[RR-4]:1–66, Fig. 4, p. 29.)

<b>Table 160.5</b> Possible Indications for Emergency Contraception	
<b>SEXUAL ASSAULT</b>	
HIGH-RISK SEXUAL ACTIVITY	
No contraception during intercourse	
Intoxication (alcohol, drugs)	
Coitus interruptus	
<b>CONTRACEPTION FAILURES</b>	
Condom breaking, spillage, leaks, intentional removal	
Dislodgement and/or breaking of diaphragm, female condom, cervical cap	
Expulsion of IUD	
Spermicide failure to melt before coitus	
<b>DELAYED OR MISSED CONTRACEPTION</b>	
2 consecutive missed days of combined oral contraceptive	
1 missed day of progestin-only oral contraceptives	
>2-wk late injection of depot medroxyprogesterone	
≥2 days late start of vaginal ring or patch cycle	
Incorrect timing of spermicide/gel before sexual activity	
<b>OTHER</b>	
Exposure to teratogens in the absence of contraception	

IUD, Intrauterine device.

contraception (EC) refers to methods of contraception that are used after sexual intercourse to reduce the risk of pregnancy but do not interrupt an existing pregnancy. EC may be used up to 120 hours after unprotected intercourse or contraceptive failure. Table 160.5 lists the indications for use of EC. EC methods include the Cu IUD, LNG 52-mg IUD, and emergency contraceptive pills, which include ulipristal acetate, LNG, and COCs following the Yuzpe method. Although

the mechanism of action of the IUD as EC is unclear, all emergency contraceptive pills work to delay ovulation and are effective only for intercourse that occurs before administration. Initiation of a regular contraceptive method is necessary to prevent pregnancy for any intercourse that occurs for the remainder of the cycle and for future cycles. If pregnancy has already occurred, emergency contraceptive pills will not terminate an existing pregnancy or have teratogenic effects on the fetus.

Teens can access EC information through a hotline at 888-NOT-2-LATE to obtain EC pills over the counter (OTC). The Guttmacher Institute maintains an up-to-date listing on EC. The ACOG and AAP recommend advance provision of EC pills for at-risk adolescents to remove barriers to access and increase awareness of the utility of EC. No examination or testing is required before use of EC, but a follow-up appointment is recommended to determine the effectiveness of treatment and to diagnose a possible early pregnancy. The visit also provides an opportunity to counsel the adolescent, explore the situation leading up to the unprotected intercourse or contraceptive failure, test for STIs, offer HIV testing, and engage in a discussion about contraception when appropriate. It is also important to engage adolescent males in discussions about the availability and use of EC if they have engaged in unprotected intercourse, especially when and how to access Plan B, which is available OTC.

**COPPER IUD**

The CuT380A (Paragard) is not FDA approved for EC, but it has been shown to be >99% effective if used within 5 days (120 hours) after unprotected sex. The additional benefit of using the Cu IUD for EC is that it also provides long-term reversible contraception. Efficacy of the Cu-IUD is not affected by BMI.

**LNG 52-mg IUD**

The Mirena IUD is not FDA approved for EC, but studies have shown it is as effective/noninferior to the Cu-IUD for EC if used within 5 days (120 hours) after unprotected sex. Similar to the Cu-IUD, it also provides long-term reversible contraception and efficacy is not affected by BMI.

## ULIPRISTAL ACETATE

Ulipristal acetate (UPA) is available for EC and is FDA approved for use up to 120 hours after unprotected sex. UPA is available only by prescription regardless of age. A few studies have shown it to be more effective than LNG at and beyond 72 hours. If starting OC pills after taking UPA, it is recommended to start or resume pills no sooner than 5 days after taking UPA to avoid decreased efficacy of contraceptive pills as a result of its antiestrogenic effect. Studies have shown an increased risk of ovulation if COC pills are started immediately after UPA use. Studies have not looked at UPA efficacy when Depo or a progestin-containing LARC is initiated immediately after UPA use. If starting a method requires an extra visit (e.g., IUDs, implant, Depo-Provera), starting the method at the time of ulipristal use may be considered, weighing the risk of decreasing the effectiveness of ulipristal with the risk of not starting a contraceptive method. Patients should be encouraged to take a pregnancy test within 3 weeks after UPA use either in the office or on their own. Studies have suggested UPA is less effective in overweight and obese women (BMI >25). This should be discussed with patients, and all attempts should be made to provide UPA as soon as possible after unprotected sexual activity.

## LEVONORGESTREL

In 2013 the FDA approved the emergency contraceptive drug **Plan B One-Step** as an OTC option for all persons of childbearing potential. Experience with adolescents has demonstrated more effective use of EC with advance provision, and this is not associated with more frequent unprotected intercourse or less condom and/or pill use. Nausea and vomiting are uncommon side effects, and LNG has been shown to be more effective at preventing pregnancy than the Yuzpe method. However, LNG has been shown to be less effective than UPA when taken  $\geq 72$  hours and in women who are obese and overweight (BMI >25). This should be discussed with women in deciding with EC method is most appropriate for use. Patients should be encouraged to take a pregnancy test within 3 weeks after EC use either in the office or on their own.

### Yuzpe Method

The **Yuzpe method** has been replaced by the more effective methods of EC, but may be useful for women who do not have access to other methods and/or already have COCs at home and desire EC. It is most effective when taken up to 72 hours after unprotected intercourse. For EC, COC pills with 200  $\mu\text{g}$  ethinyl estradiol and 2 mg norgestrel or 1 mg levonorgestrel should be taken in two doses, 12 hours apart. This method is effective in reducing the risk of pregnancy by 75%. The most common side effects are nausea (50%) and vomiting (20%), prompting some clinicians to prescribe or recommend antiemetics along with the COCs.

Visit Elsevier eBooks+ at [eBooks.Health.Elsevier.com](http://eBooks.Health.Elsevier.com) for Bibliography.

## 160.7 Condoms

Mary E. Romano and Elizabeth M. Alderman

The use of condoms is the only contraceptive method that protects against pregnancy and STIs, including HIV. Condoms, also referred to as *barrier contraception*, prevent sperm from being deposited in the vagina. The use of condoms in conjunction with hormonal contraception (or Cu IUD) is always recommended to reduce the risk of pregnancy and protect against STIs. This is sometimes referred to as *dual protection*. Although correct and consistent condom use with every act of sexual intercourse theoretically protects against pregnancy and STIs, providers should encourage adolescents to use condoms for STI/HIV protection along with a more effective method for pregnancy protection.

No major medical side effects are associated with condom use, and condoms are available for use by males and females. Nonlatex condoms are available for those with a latex allergy, and these include lambskin and synthetic polyurethane condoms. Lambskin condoms do not protect against HIV and other viral infections, although they do work to

prevent pregnancy. Although condom use at last sexual intercourse had steadily increased from the early 1990s to the mid-2000s, the percentage of students reporting condom use at last intercourse has remained stable, with 54% of adolescents reporting condom use at last intercourse. Earlier increases in condom use were thought to be the result of increased awareness of HIV risks. Only 9% of high school students reported using dual methods of contraception (condom plus something else) at last intercourse. The main advantages of condoms are their low price, availability without prescription, male involvement in the responsibility for contraception, and effectiveness in preventing transmission of STIs, including HIV and human papillomavirus (HPV). The typical-use failure rate for male condoms is 18% for all users and is thought to be higher in adolescents. For the most effective dual protection, male latex condoms are recommended as protection against STIs and should be used in conjunction with another method of contraception. According to the National Survey of Family Growth, only 21.3% of females used another contraceptive method along with a condom at last sex during the past 12 months.

There is only one female condom available in the United States. It is available OTC or can be ordered online. It is nonlatex. It can be harder to use properly and has a higher typical-use failure rate (21%) than the male condoms. There are no human studies demonstrating its effectiveness against STIs. Adolescents intending to use this method should be provided education on proper use and hands-on practice to ensure effective use.

Visit Elsevier eBooks+ at [eBooks.Health.Elsevier.com](http://eBooks.Health.Elsevier.com) for Bibliography.

## 160.8 Other Barrier Methods

Mary E. Romano and Elizabeth M. Alderman

Although these methods are not widely available or used, they are important to know about for patients who wish to use nonhormonal contraception at the time of intercourse.

### DIAPHRAGM, CERVICAL CAP, AND SPONGE

These methods have few side effects but are much less likely to be used by teenagers. Typical-use failure rates exceed 14%. The sponge has limited OTC availability in the United States, and the cervical cap and diaphragm require a visit with a healthcare provider for fitting. The **cervical cap** and **sponge** have lower failure rates in nulliparous women, whereas the **diaphragm** has similar rates among nulliparous and parous women. The sponge is used with water, whereas the cervical cap and diaphragm are used with spermicide before being placed over the cervix. Adolescents may feel less comfortable and be less likely to use these methods because of the messiness of the jelly or the need for insertion and removal interrupting the spontaneity of sex (to be inserted before sex and left in for several hours afterward). Spermicide must be reapplied before every act of intercourse. Adolescents may also be less comfortable touching their genitals.

## 160.9 Other Contraceptive Methods

Mary E. Romano and Elizabeth M. Alderman

The only OTC spermicide available in the United States is Nonoxonyl-9 (N-9). It is available as a foam, film, gel, cream, suppository, and tablet. It must be placed in the vagina no more than 1 hour before intercourse and again before each act of intercourse/ejaculation. Side effects, although rare, include local irritation or contact vaginitis. There have been concerns about the vaginal and cervical mucosal damage observed with N-9 and its impact on HIV transmission. Results thus far have been inconclusive. There were some studies that suggested that N-9 is gonococcidal and spirocheticidal, but this has not been substantiated in randomized clinical trials. Spermicides should be used in combination with barrier methods because their typical-use failure rate alone is 21%

Phexxi is a prescription vaginal gel that is FDA approved. It is non-hormonal and user controlled. It can be used alone or in conjunction with other methods, although it is not recommended for use with the intravaginal ring. It is prepackaged in a single-dose applicator and must be inserted intravaginally up to 1 hour before vaginal intercourse. It works to maintain vaginal pH in an acidic range (~3.5 to 4.5) despite the presence of alkaline semen/sperm, which limits motility and incapacitates sperm. When compared with other OTC spermicidal gels, Phexxi has a higher viscosity, which minimizes vaginal leakage of the product and is thought to further affect sperm motility and provide an additional barrier to cervical penetration. Data also suggest Phexxi may have microbicidal effects in that by maintaining an acidic vaginal pH, Phexxi may enhance the vagina's natural microbicidal mechanisms. This effect seems more consistent and reliable than what has been found with the use of N-9. As with N-9, the most commonly reported side effect was vaginal discomfort and irritation. There has been no evidence that it affects HIV transmission. It should not be used in women with recurrent urinary tract infections (UTIs) or any urinary tract abnormalities.

### WITHDRAWAL

The pregnancy risk with use of withdrawal as a contraceptive method is probably underestimated in adolescents, and a high typical-use failure rate of 20% should be specifically addressed with all adolescents, given that up to 60% of teens have reported using withdrawal for contraception.

### FERTILITY AWARENESS–BASED METHODS

Fertility awareness methods require that one be aware of the fertile days of their menstrual cycle and either avoid intercourse during that time or use barrier contraception. Methods typically involve calculating the length of one's menstrual cycle, observing changes in body temperature and/or cervical secretions. Fertility awareness methods are based on regular ovulatory cycles, which are less common in teens, and therefore fertility awareness methods may be difficult for a teenager to use effectively. Methods include the Standard Days method, basal body temperature method, Billings method, and lactational amenorrhea. Be aware that the lactational amenorrhea method may be a highly effective, temporary contraceptive method if the following criteria are met: (1) no return of menses, (2) the infant is <6 months old, and (3) the woman is exclusively breastfeeding. There is an FDA-approved mobile application—Natural Cycles—that may be used to best predict fertility days to plan for abstinence or barrier contraceptive use. Other apps do exist, but they are not FDA approved.

Visit Elsevier eBooks+ at [eBooks.Elsevier.com](https://www.elsevier.com/ebooksplus) for Bibliography.

## Chapter 161

# Adolescent Pregnancy

Cora Collette Breuner

### EPIDEMIOLOGY

There has been a trend of decreasing teen births and pregnancies since 1991 (Fig. 161.1). Teen birthrates in the United States are at a historic low secondary to increased use of contraception at first intercourse, use of dual methods of condoms and hormonal contraception among sexually active teenagers, and access to abortion (see Chapter 161.1). Despite these data, the United States continues to lead other industrialized countries in having high rates of adolescent pregnancy, with >700,000 pregnancies per year. Nonetheless, the National Survey of Family Growth (NSFG) 2006–2010 revealed that less than one third of

15- to 19-year-old females consistently used contraceptive methods at last intercourse.

The improvement in U.S. female teen birthrates is attributed to three factors: more teens are delaying the onset of sexual intercourse, are using some form of contraception when they begin to have sexual intercourse, and are using long-lasting contraceptive agents such as injections, implants, and intrauterine devices (IUDs).

Most pregnancies among U.S. adolescents are **unintended** (unwanted or mistimed); 88% of births to teenagers 15-17 years old were the result of unintended pregnancies. Birthrate statistics underestimate actual adolescent pregnancy rates because the birthrate numerator includes the number of actual births per 1,000 individuals in that age-group, but the pregnancy rate includes actual births, abortions, and best estimates of fetal loss per 1,000 adolescents in that age-group.

The *reported* **abortion** rate among adolescents in 2019 for those <15 years of age was 0.4 per 1,000 females (of the same age-group), and for those 15-19 years, it was 6.0 per 1,000; this compares to the most common age for having an abortion (20-29) of 18-19 per 1,000 females. It is unknown how many abortions go unreported (see Chapter 161.1).

### ETIOLOGY

In industrialized countries with policies supporting access to protection against pregnancy and sexually transmitted infections (STIs), older adolescents are more likely to use hormonal contraceptives and condoms, resulting in a lowered risk of unplanned pregnancy. Younger teenagers are likely to be less deliberate and logical about their sexual decisions, and their sexual activity is likely to be sporadic or even coercive, contributing to inconsistent contraceptive use and a greater risk of unplanned pregnancy. Better personal hopes for employment and higher educational goals are associated with lowered probability of childbearing in most groups. In nonindustrialized countries, laws permitting marriage of young and mid-teens, poverty, and limited female education are associated with increased adolescent pregnancy rates.

### CLINICAL MANIFESTATIONS

Adolescents may experience the traditional symptoms of pregnancy: morning sickness (vomiting, nausea that may also occur *any* time of the day), swollen tender breasts, weight gain, and amenorrhea. Often the presentation is less classic; headache, fatigue, abdominal pain, dizziness, and scanty or irregular menses are common presenting complaints.

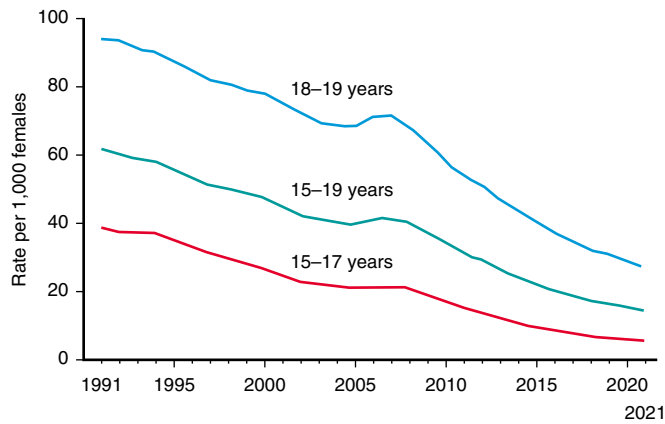
In the pediatric office, some teens are reluctant to divulge concerns of pregnancy. Denial of sexual activity and menstrual irregularity should not preclude the diagnosis in face of other clinical or historical information. An unanticipated request for a complete checkup or a visit for contraception may uncover a suspected pregnancy. *Pregnancy is still the most common diagnosis when adolescents present with secondary amenorrhea.*

### DIAGNOSIS

Table 161.1 provides classic symptoms, laboratory tests, and physical changes in the diagnosis of pregnancy.

On physical examination, the findings of an enlarged uterus, cervical cyanosis (**Chadwick sign**), a soft uterus (**Hegar sign**), or a soft cervix (**Goodell sign**) are highly suggestive of an intrauterine pregnancy. A confirmatory pregnancy test is always recommended, either *qualitative* or *quantitative*. Modern **qualitative** urinary detection methods are efficient at detecting pregnancy, whether performed at home or in the office. These tests are based on detection of the beta subunit of human chorionic gonadotropin (**hCG**). Although claims for nonprescription home pregnancy tests may indicate 98% detection on the day of the first missed menstrual period, sensitivity and accuracy vary considerably. Office or point-of-care tests have increased standardization and generally have increased sensitivity, with the possibility of detecting a pregnancy within 3-4 days after implantation. However, in any menstrual cycle, ovulation may be delayed, and in any pregnancy, the day of implantation may vary considerably, as may rate of production of hCG. This variability, along with variation of urinary concentration, may affect test sensitivity. *Consequently, each negative test should be*





**Fig. 161.1** Birth rates for teenagers by age of mother: United States, final 1991–2020 and provisional 2021. Source: National Center for Health Statistics, National Vital Statistics System, Natality. (From Hamilton BE, Martin JA, Osterman JA, Division of Vital Statistics, National Center for Health Statistics. Births: provisional data for 2021. Nat Vital Stats Rapid Release. 2022;20, Fig. 2.)

**Table 161.1** Diagnosis of Pregnancy Dated from First Day of Last Menstrual Cycle

#### CLASSIC SYMPTOMS

Missed menses, breast tenderness, nipple sensitivity, nausea, vomiting, fatigue, abdominal and back pain, weight gain, urinary frequency.

Teens may present with unrelated symptoms that enable them to visit the doctor and maintain confidentiality.

#### LABORATORY DIAGNOSIS

Tests for human chorionic gonadotropin in urine or blood may be positive 7–10 days after fertilization, depending on sensitivity. Irregular menses make ovulation/fertilization difficult to predict. Home pregnancy tests have a high error rate.

#### PHYSICAL CHANGES

2–3 wk after implantation: cervical softening and cyanosis.

8 wk: uterus size of orange.

12 wk: uterus size of grapefruit and palpable suprapubically.

20 wk: uterus at umbilicus.

If physical findings are not consistent with dates, ultrasound will confirm.

repeated in 1–4 weeks if there is a heightened suspicion of pregnancy. The most sensitive pregnancy detection test is a serum **quantitative  $\beta$ hCG radioimmunoassay**, with reliable results within 7 days after fertilization. This more expensive test is used primarily during evaluations for ectopic pregnancy, to detect retained placenta after pregnancy termination, or in the management of a molar pregnancy. It is used when serial measurements are necessary in clinical management.

Although not used for primary diagnosis of pregnancy, pelvic or vaginal **ultrasound** can be helpful in detecting and dating a pregnancy. Pelvic ultrasound will detect a gestational sac at about 5–6 weeks (dated from last menstrual period) and vaginal ultrasound at 4.5–5 weeks. This tool may also be used to distinguish diagnostically between intrauterine and ectopic pregnancies.

### PREGNANCY COUNSELING AND INITIAL MANAGEMENT

Once the diagnosis of pregnancy is made, it is important to begin addressing the psychosocial and the medical aspects of the pregnancy.

The patient's response to the pregnancy should be assessed and her emotional issues addressed. It should not be assumed that the pregnancy was unintended. Discussion of the patient's options should be initiated. These options include (1) releasing the child to an adoptive family, (2) electively terminating the pregnancy, and (3) raising the child herself with the help of family, father of the baby, friends, and/or other social resources. Options should be presented in a supportive, informative, nonjudgmental fashion; for some young women, they may need to be discussed over several visits. Physicians who are uncomfortable in presenting options to their young patients should refer their patients to a provider who can provide this service expeditiously. Pregnancy terminations implemented early in the pregnancy are generally less risky and less expensive than those initiated later. These include the prescription use of mifepristone and misoprostol within 10 weeks (the World Health Organization [WHO] recommends 12 weeks) of the pregnancy (see Chapter 161.1).

Other issues that may need discussion are how to inform and involve the patient's parents and the father of the infant; implementing strategies for ensuring continuation of the young mother's education; discontinuation of tobacco, alcohol, and illicit drug use; discontinuance and avoidance of any medications that may be considered teratogenic; starting folic acid, calcium, and iron supplements; proper nutrition; and testing for STIs. Especially in younger adolescents, the possibility of **coercive sex** (see Chapter 162) must be considered and appropriate social work/legal referrals made if abuse has occurred, although most pregnancies are not a result of coercive sex. Patients who elect to continue their pregnancy should be referred as soon as possible to an adolescent-friendly obstetric provider.

Risk factors for teen pregnancy include growing up in poverty, having parents with low levels of education, growing up in a single-parent family, fewer opportunities in their community for positive youth involvement, neighborhood physical disorder, foster care (such teens are more than twice as likely to become pregnant than those not in foster care), and having poor performance in school (see "Psychosocial Outcomes/Risks for Mother and Child" later).

### The Importance of Prevention

Teen pregnancy and childbearing bring substantial social and economic costs through immediate and long-term impacts on teen parents and their children. In 2010, teen pregnancy and childbirth accounted for at least \$9.4 billion in costs for increased healthcare and foster care, increased incarceration rates among children of teen parents, and lost tax revenue because of lower educational attainment and income among teen mothers.

### ADOLESCENT FATHERS

Those who become fathers as adolescents also have poorer educational achievement than their age-matched peers. They are more likely than other peers to have been involved with illegal activities and with the use of illegal substances. Adult men who father the children of teen mothers are poorer and educationally less advanced than their age-matched peers and tend to be 2–3 years older than the mother, but any combination of age differences may exist. Younger teen mothers are more likely to have a greater age difference between themselves and the father of their child, raising the issue of coercive sex or statutory rape (see Chapter 162).

Male partners have a significant influence on the young woman's decision/desire to become pregnant and to parent her child. Sensitively and appropriately including the male partner in discussions of family planning, contraception, and pregnancy options may be a useful strategy in improving outcomes for all. This can only be successful if the young female patient is willing to have her partner involved in such discussions.

### MEDICAL COMPLICATIONS OF MOTHERS AND BABIES

Although pregnant teens are at higher-than-average risk for some complications of pregnancy, most teenagers have pregnancies that are without major medical complications, delivering healthy infants. The

miscarriage/stillbirth risk for adolescents is estimated at 15–20%. In the United States, elective pregnancy termination rates peaked from 1985 to 1988 at 41–46%, decreasing since then to approximately 30% in 2008. Teen mothers have low rates of age-related chronic disease (diabetes or hypertension) that might affect the outcomes of a pregnancy. They also have lower rates of twin pregnancies than older women. They tolerate childbirth well with few operative interventions. However, compared with 20- to 39-year-old mothers, teens have higher incidences of low birthweight infants, preterm infants, neonatal deaths, passage of moderate to heavy fetal meconium during parturition, and infant deaths within 1 year after birth. The highest rates of poor outcomes occur in the youngest and most economically disadvantaged mothers. *Gastroschisis*, although rare, has a much higher incidence in infants of teen mothers, for reasons that are unclear. Teen mothers also have higher rates of anemia, pregnancy-associated hypertension, and eclampsia, with the youngest teens having rates of pregnancy-associated hypertension higher than the rates of women in their 20s and 30s. The youngest teens also have a higher incidence of poor weight gain (<16 lb) during their pregnancy. This correlates with a decrease in the birthweights of their infants. Poor maternal weight gain also has correlated strongly with teens' late entrance into prenatal care and with inadequate use of prenatal care. Sexually active teens have higher rates of STIs than older sexually active women.

Globally, many young women who become pregnant have been exposed to violence or abuse in some form during their lives. There is some evidence that teenage women have the highest rates of **violence** during pregnancy of any group. Violence has been associated with injuries and death as well as preterm births, low birthweight, bleeding, substance abuse, and late entrance into prenatal care. An analysis of the Pregnancy Mortality Surveillance System indicates that in the United States 1991–1999, homicide was the second leading cause of injury-related deaths in pregnant and postpartum women. Women age 19 years and younger had the highest pregnancy-related homicide rate (see [Chapter 156](#)).

**Ectopic pregnancy** occurs in 1–2% of conceptions and is more common in women with a previous history of an ectopic pregnancy, pelvic inflammatory disease, prior appendicitis, infertility, in utero exposure to diethylstilbestrol, and possibly an IUD. Most ectopic pregnancies are in the fallopian tube (tubal pregnancy). Manifestations include vaginal spotting after a missed menstrual period that may progress to more intense vaginal bleeding (suggestive of spontaneous abortion); vaginal bleeding is absent in 10–20%. Abdominal pain is associated with distention of the fallopian tube; tubal rupture results in more intense pain, hemorrhagic shock, and peritonitis. Some women have nonspecific abdominal complaints and are misdiagnosed with gastroenteritis. Cervical motion and adnexal tenderness (and adnexal mass) may be present. **Transvaginal sonography** (not transabdominal) is the diagnostic test of choice to detect an ectopic pregnancy and reveals an adnexal mass and no uterine pregnancy. Nonetheless, some women will have pregnancy of unknown location by transvaginal sonography; approximately 20% of these will have an ectopic pregnancy. Measurement of sensitive quantitative serum  $\beta$ hCG levels together with transvaginal sonography has value in diagnosing an ectopic pregnancy. If the initial  $\beta$ hCG is above the *discriminatory zone* (level at which one expects an intrauterine pregnancy) but on transvaginal sonography there is no intrauterine pregnancy, there may be an ectopic pregnancy or an abnormal uterine pregnancy. In addition, if the  $\beta$ hCG is below the discriminatory level (usually <3,000 mIU/mL) with no definitive diagnosis by sonography, serial  $\beta$ hCG testing should be performed every 48 hours. In a normal uterine pregnancy,  $\beta$ hCG levels should increase approximately 50% every 48 hours; declining levels may suggest a miscarriage or an ectopic pregnancy. Some would perform a dilation and curettage and check for products of conception or follow serial  $\beta$ hCG levels. If there are no products of conception or if  $\beta$ hCG levels plateau or increase, an ectopic pregnancy is present. Treatment of unstable or advanced patients is usually by laparoscopic surgery or by laparotomy. Because of early detection, many patients remain stable (*unruptured*). Stable patients with an unruptured ectopic pregnancy may be treated with single-dose, or more often, multidose methotrexate to induce

abortion. Contraindications to methotrexate in a stable patient include size of the ectopic mass (>3.5 cm) and embryonic cardiac motion.

Prematurity and low birthweight increase the perinatal morbidity and mortality for infants of teen mothers. These infants also have higher-than-average rates of sudden infant death syndrome (see [Chapter 423](#)), possibly because of less use of the supine sleep position or cosleeping, and are at higher risk of both intentional and unintentional injury (see [Chapter 17](#)). One study showed that the risk of homicide is 9–10 times higher if a child born to a teen mother is not the mother's firstborn compared with the risk to a firstborn of a woman age 25 years or older. The perpetrator is often the father, stepfather, or boyfriend of the mother.

After childbirth, **depressive symptoms** may occur in as many as 50% of teen mothers. Depression seems to be greater with additional social stressors and with decreased social supports. Support from the infant's father and the teen's mother seems to be especially important in preventing depression. Pediatricians who care for parenting teens should be sensitive to the possibility of depression, as well as to inflicted injury to mother or child; appropriate diagnosis, treatment, and referral to mental health or social agencies should be offered and facilitated.

## PSYCHOSOCIAL OUTCOMES/RISKS FOR MOTHER AND CHILD

### Educational Issues

Pregnancy and birth are significant contributors to high school dropout rates among girls. Only about 50% of teen mothers receive a high school diploma by age 22, whereas approximately 90% of women who do not give birth during adolescence graduate from high school. Mothers who have given birth as teens generally remain 2 years behind their age-matched peers in formal educational attainment at least through their third decade. Maternal lack of education limits the income of many of these young families (see [Chapter 1](#)).

The children of teenage mothers are more likely to have lower school achievement and to drop out of high school, have more health problems, and face unemployment as a young adult.

### Substance Use

See also [Chapter 157](#).

Teenagers who abuse drugs, alcohol, and tobacco have higher pregnancy rates than their peers. Most substance-abusing mothers appear to decrease or stop their substance use while pregnant. Use begins to increase again about 6 months postpartum, complicating the parenting process and the mother's return to school.

### Repeat Pregnancy

In the United States, approximately 20% of all births to adolescent mothers (age 15–19) are second order or higher. Prenatal care is begun even later with a second pregnancy, and the second infant is at higher risk of poor outcome than the first birth. Mothers at risk of early repeat pregnancy (<2 years) include those who do not initiate long-acting contraceptives after the index birth, those who do not return to school within 6 months of the index birth, those with mood disorders, those receiving major childcare assistance from the adolescent's mother, those who are married or living with the infant's father, those having peers who were adolescent parents, and those who are no longer involved with the baby's father and who meet a new boyfriend who wants to have a child. To reduce repeat pregnancy rates in these teens, programs must be tailored for this population, preferably offering comprehensive healthcare for both the young mother and her child. Healthcare providers should remember to provide positive reinforcement for teen parenting successes (i.e., compliment teen parents when they are doing a good job).

### Children Born to Teen Mothers

Many children born to teen mothers have behavioral problems that may be seen as early as the preschool period. Many drop out of school early (33%), become adolescent parents (25%), or, if male, are incarcerated (16%). Explanations for these poor outcomes include poverty, parental learning difficulties, negative parenting styles of teen parents,

maternal depression, parental immaturity, poor parental modeling, social stress, exposure to surrounding violence, and conflicts with grandparents, especially grandmothers. Continued positive paternal involvement throughout the child's life may be somewhat protective against negative outcomes. Many of these poor outcomes appear to be attributable to the socioeconomic/demographic situation in which the teen pregnancy has occurred, not solely to maternal age. Even when socioeconomic status and demographics are controlled, infants of teen mothers have lower achievement scores, lower high school graduation rates, increased risk of teen births themselves, and, at least in Illinois (where records include age of birth mother), a higher probability of abuse and neglect.

Comprehensive programs focused on supporting adolescent mothers and infants using life skills training, medical care, and psychosocial support demonstrate higher employment rates, higher income, and less welfare dependency in participating adolescents.

## PREVENTION OF TEEN PREGNANCIES

Adolescent pregnancy is a multifaceted problem that requires multifactorial solutions. The provision of contraception and education about fertility risk from the primary care physician is important but insufficient to address the problem fully. Family and community involvement are essential elements for teen pregnancy prevention. Strategies for primary prevention (preventing first birth) are different from the strategies needed for secondary prevention (preventing second or more births). Over the past 30 years, many models of teen pregnancy prevention programs have been implemented and evaluated. Table 161.2 lists the common components of successful evidence-based programs.

**Abstinence-only** sexual education aims to teach adolescents to wait until marriage to initiate sexual activity but, unfortunately, does not mention contraception. Abstinence education is sometimes coupled with “virginity pledges” in which teenagers pledge to remain abstinent until they marry. Other educational programs emphasize HIV and STI prevention and in the process prevent pregnancy, whereas others include both abstinence and contraception in their curricula. Sex education and teaching about contraception do not lead to an increase in sexual activity. Teenagers who participate in programs with **comprehensive** sex education components generally have lower rates of pregnancy than those exposed solely to abstinence-only programs or no sex education at all.

In many U.S. communities, programs that engage youth in community service and that combine sex education and youth development are also successful in deterring pregnancy. Programs vary in their sites of service from schools to social agencies, health clinics, youth organizations, and churches. Programs must be tailored to the cultural background, ethnicity, age-group, and gender of the group being targeted for the prevention services.

**Table 161.2** Common Components of Most Successful Evidence-Based Programs to Prevent Teen Pregnancy

- Information is provided about the benefits of abstinence.
- Information is provided about contraception for those who are already sexually active.
- Information is provided about the signs and symptoms of STIs and how to prevent STIs.
- Interactive sessions on peer pressure are presented.
- Teenagers are taught communication skills.
- Programs are tailored to meet the needs of specific groups of young people (e.g., young men or young women, cultural groups, younger or older teens).

STI, Sexually transmitted infection.

Adapted from Suellentrop K. *What Works 2011–2012: Curriculum-Based Programs That Help Prevent Teen Pregnancy*. Washington, DC: National Campaign to Prevent Teen and Unplanned Pregnancy, [http://www.c-hubonline.org/sites/default/files/resources/m-ain/What\\_Works\\_0.pdf](http://www.c-hubonline.org/sites/default/files/resources/m-ain/What_Works_0.pdf).

Secondary prevention programs are fewer in number. In the United States, some communities have tried to “pay” young mothers not to become pregnant again, but these efforts have not always been fruitful. **Home visiting** by nurses has been successful in some areas, and many communities have developed “Teen Tot” clinics that provide a “one-stop shopping model” for healthcare for both the teen mother and the baby in the same site at the same time. Both programs have reported some successes.

In the practice setting, the identification of the sexually active adolescent through a confidential clinical interview is a first step in pregnancy prevention. The primary care physician should provide the teenager with factual information in a nonjudgmental manner and then guide the teenager in the decision-making process of choosing a contraceptive (see Chapter 160). The practice setting is an ideal setting to support the teenager who chooses to remain abstinent. When a teenager does become pregnant and requires prenatal care services, healthcare providers should remember that the pregnant teenager is an adolescent who has become pregnant, not a pregnant woman who happens to be an adolescent.

Visit Elsevier eBooks+ at [eBooks.Health.Elsevier.com](http://eBooks.Health.Elsevier.com) for Bibliography.

## 161.1 Abortion

Alison S. Kliegman and Robert M. Kliegman

Abortion is a safe, common, and essential reproductive healthcare evidence-based intervention. Worldwide ~30% of all pregnancies and ~60% of all unintended pregnancies are voluntarily terminated. In the past by age 45 ~25% of U.S. pregnant persons had an abortion. The WHO defines abortion as the termination of pregnancy before 20 weeks' gestation. Abortions can be voluntary or spontaneous (miscarriages). Access to reproductive care, including abortion care, is considered by all health organizations as a basic human right. The American Academy of Pediatrics supports a young person's right of “access to comprehensive, evidence-based reproductive healthcare services, including abortion.” Abortion should be available to any person requesting it without a specific indication. The most common indication is unintended (unplanned) pregnancy, which includes not being able to afford a child, poorly timed pregnancy, and not having a suitable partner; additional indications include being subjected to coercive sexual encounters, as well as medical conditions that place the pregnant person at risk and certain fatal fetal conditions.

### EPIDEMIOLOGY

Most abortions occur in patients between 20 and 30 years of age (Table 161.3). In addition, the majority of abortions occur in the first trimester (Fig. 161.2). The highest ratio of abortion (number of abortions per 1,000 live births) is noted in persons <15 years (Fig. 161.3). Among 15- to 19-year-olds, the United States has one of the highest rates of adolescent pregnancy but among one of the lowest rates of adolescent pregnancies ending in abortion when compared to other developed countries (Fig. 161.4). Seventy-five percent of adolescent pregnancies in the United States are unplanned, while ~30% end with an abortion (among those 15-17 years).

### Abortion Care

The WHO 2022 report recommends that:

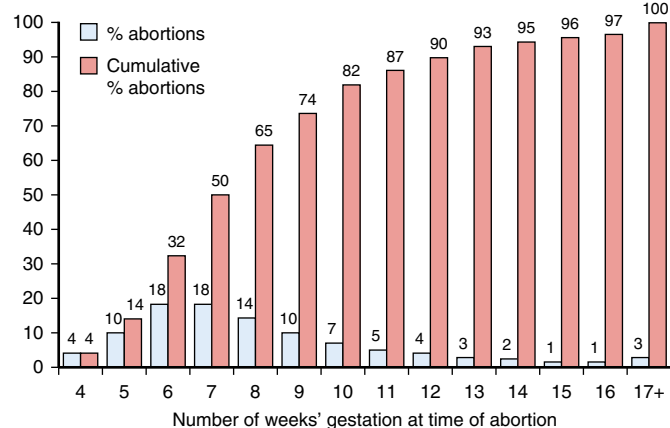
- Abortions must be decriminalized
- Be made available at request
- Be made available by telemedicine
- Be made available for self-management, not just in clinic
- Have a wide range of eligible providers
- Provide an enabling environment (Fig. 161.5)

The National Academies of Sciences, Engineering and Medicine provides an outline for continuum of abortion care; preabortion, pregnancy termination, and post-abortion care (Fig. 161.6).

**Table 161.3** Characteristics of Persons Who Had an Abortion in an Outpatient Setting in 2014, by Percent

CHARACTERISTIC	PERCENT
<b>Age*</b>	
<15-17	3.6
18-19	8.2
20-24	33.6
25-29	26.3
30-34	16.0
35+	12.2
<b>Prior Pregnancies*</b>	
No prior pregnancies	29.2
Prior birth only	26.0
Prior abortion only	11.7
Prior birth and abortion	33.1
<b>Education*</b>	
Not a high school graduate	12.2
High school graduate or GED	29.0
Some college or associate's degree	39.2
College graduate	19.7
<b>Family Income as a Percentage of Federal Poverty Level†</b>	
<100	49.3
100-199	25.7
≥200	25.0

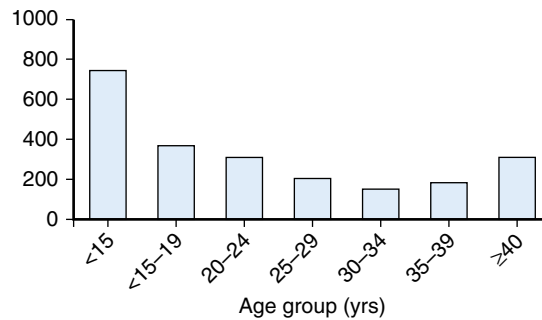
Note: Percentages may not sum to 100 because of rounding.  
 Sources: \*Jones RK, Jerman J. Characteristics and circumstances of U.S. women who obtain very early and second trimester abortions. *PLoS One*. 2017b;12:e0169969 (n = 8,098); †Jerman J, Jones RK, Onda T. Characteristics of U.S. abortion patients in 2014 and changes since 2008. 2016. [October 17, 2016]. [https://www.guttmacher.org/sites/default/files/report\\_pdf/characteristics-us-abortion-patients-2014.pdf](https://www.guttmacher.org/sites/default/files/report_pdf/characteristics-us-abortion-patients-2014.pdf) (n = 8,380).  
 Modified from National Academies of Sciences, Engineering, and Medicine; Health and Medicine Division; Board on Health Care Services; Board on Population Health and Public Health Practice; Committee on Reproductive Health Services. *Assessing the Safety and Quality of Abortion Care in the U.S.* Washington, DC: National Academies Press; 2018: Table 1-2.



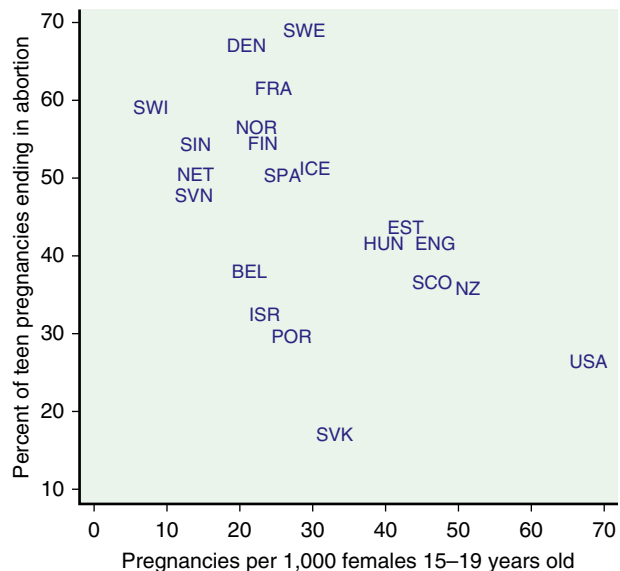
**Fig. 161.2** Percentage and cumulative percentage of outpatient abortions by weeks' gestation, 2014–2015. (From Jones RK, Jerman J. *Characteristics and circumstances of US women who obtain very early and second trimester abortions.* *PLoS One* 2017; 12(1):e0169969.)

**Methods**

Abortion methods vary depending on gestational age, location (in clinic vs self-managed), and procedure (medical vs surgical). Medically managed abortion (“abortion pill”) is FDA approved up to 10 weeks, although the WHO suggests up to 12 weeks and has also been used “off label” at later gestational ages. It consists of mifepristone



**Fig. 161.3** Abortion ratio by age-group of persons who obtained a legal abortion in selected states of the United States in 2001. Abortion ratio refers to number of abortions per 1,000 live births. (From Strauss LT, Herndon J, Chang J, et al. *Abortion surveillance—United States, 2001.* *MMWR Surveill Summ.* 2004;53:1–32.)

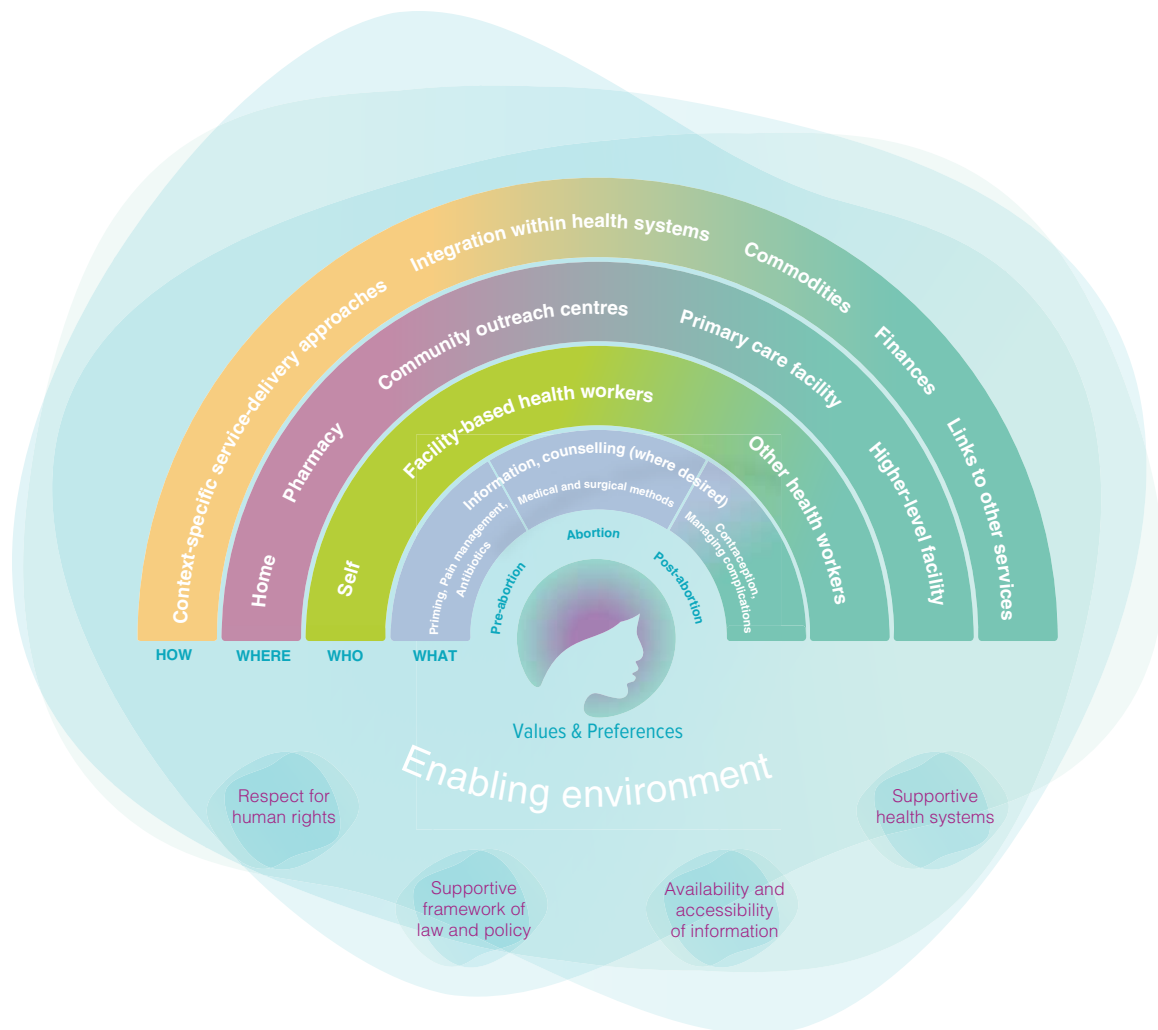


**Fig. 161.4** Percentage of teen pregnancies ending in abortion is inversely correlated with teen pregnancy rate. BEL, Belgium; DEN, Denmark; ENG, England and Wales; EST, Estonia; FIN, Finland; FRA, France; HUN, Hungary; ICE, Iceland; ISR, Israel; NET, The Netherlands; NOR, Norway; NZ, New Zealand; POR, Portugal; SCO, Scotland; SIN, Singapore; SPA, Spain; SVK, Slovakia; SVN, Slovenia; SWE, Sweden; SWI, Switzerland; USA, United States. (From Sedgh G, Finer LB, Bankole A, et al. *Adolescent pregnancy, birth, and abortion rates across countries: levels and recent trends.* *J Adolesc Med.* 2010;56:223–230, Fig. 1.)

(a potent progesterone antagonist) 200 mg PO × one dose, followed within 24–48 hours by misoprostol 800 µg (a prostaglandin to induce uterine contractions) by buccal, sublingual, or vaginal routes. Medical abortion represents ~50% of abortions in the United States (Fig. 161.7). This treatment is available in clinic but also via telehealth, where a prescriber then mails the medication to be taken at home (self-managed medical abortion). This latter mail order availability is FDA-approved. Self-managed medical abortion is safe and ~96% effective; complications are rare (~1%) and include hemorrhage or infection; no deaths have been reported from self-managed medical abortion. Contraindications include porphyria, a bleeding disorder, taking anticoagulants, adrenal insufficiency, long-term systemic steroid use, ectopic pregnancy, and the presence of an IUD.

Acute side effects during a self-managed abortion are to be expected and include nausea and vomiting, headaches, diarrhea, and flu-like symptoms and, once the abortion starts, cramping and bleeding. Excessive bleeding (two or more pads per hour for >2 hours), fever (>100°F), or severe abdominal pain requires medical attention. After





**Fig. 161.5** Conceptual framework of the WHO abortion care guidelines. (From World Health Organization. *Abortion Care Guideline*. Geneva: World Health Organization; 2022. License: CC BY-NC-SA 3.0 IGO. Fig.1 <https://www.who.int/publications/i/item/9789240039483>.)

the abortion, do not use tampons for ~5 days and get a pregnancy test ~3 weeks later to ensure a complete abortion. After that, a contraceptive should be started in sexually active individuals (may not be indicated in cases of rape or incest). Medical abortion has an exceptional safety record; long-term studies demonstrate no adverse effect on fertility, premature birth, breast cancer, or mental health issues.

The medications can be available by online consultation from Aid Access ([aidaccess.org](http://aidaccess.org)); pills will be mailed directly from Aid Access to persons in all states permitting self-managed abortion. “Shield laws” protect telemedicine providers serving patients in states where abortion is illegal.

Surgical methods for abortion require in-clinic presence and a skilled provider. These include suction curettage (aspiration method) used between ~6 and 16 weeks’ gestation, dilation, and evacuation (~12–24 weeks); induction of labor; and, if necessary, rarely a hysterotomy (C-section) at >24 weeks. Anesthesia (local or general) is needed for these procedures.

Restricting access to or banning legal abortions will not reduce the total number of abortions but increases the risk of criminalization and potentially the number of unsafe procedures. On a global basis, unsafe abortions represent ~45% of all abortions. Unsafe abortion increases the risk of incomplete abortion (retained products of conception), hemorrhage, infection, uterine perforation, other organ injury, and infertility. Restricting access to abortion with resultant pregnancy will have adverse economic and educational consequences for the pregnant adolescent (see Chapter 161). In addition, the United States has one of the highest maternal mortality rates

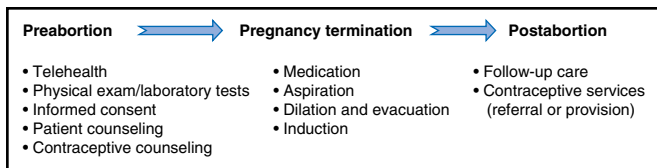
(23.8 deaths per 100,000 live births in 2020) of developed countries. The risk of death from pregnancy is much higher than from any form of legal abortion.

### Challenges and Barriers

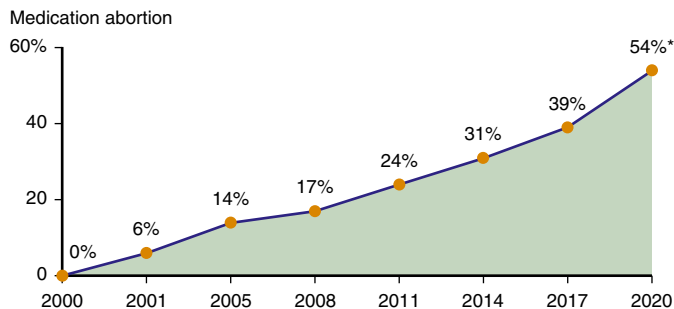
There are multiple logistic and legal challenges to obtaining an abortion. Some are generalizable to all ages, whereas others are specific to adolescent patients.

Some states have a complete ban against abortions, necessitating travel to another state or country. In other states, there is a limit to gestational age (usually first trimester). Many are limiting abortion to 6 weeks or when fetal heart beats are detected. The majority of states require a physician to perform an abortion. Some states restrict the use of public funding, and others restrict private insurance use for abortions. In one study, ~45% of fees were paid by the pregnant person; in states that ban Medicaid funding for abortion, the patient pays the full cost. States vary in the requirement for preabortion “counseling” and a waiting period. If “counseling” is needed, it should be from an abortion provider, not a state mandated program, which may be biased against abortion.

The criminalization of abortion (the pregnant person, the provider, others involved) has created a climate of enhanced surveillance and added barriers. Laws have been proposed to require abortion providers to register all patients requesting an abortion. These reporting mandates will compromise patient-provider confidentiality and possibly violate Health Insurance Portability and Accountability Act (HIPAA) regulations. Nonetheless HIPAA may not be applicable if legal action is filed against a patient and/or provider. Other laws will



**Fig. 161.6** Continuum of abortion care. (Modified from National Academies of Sciences, Engineering, and Medicine; Health and Medicine Division; Board on Health Care Services; Board on Population Health and Public Health Practice; Committee on Reproductive Health Services. *Assessing the Safety and Quality of Abortion Care in the U.S.* Washington, DC: National Academies Press; 2018: Fig.1-1.)



**Fig. 161.7** As of 2020, medication abortions account for the majority of all U.S. abortions. \*Based on preliminary data. (From Guttmacher Institute. *Medication abortion now accounts for more than half of all US abortions, 2022.* <https://www.guttmacher.org/print/article/2022/02/medication-abortion-now-accounts-more-half-all-us-abortions>.)

permit private citizens to sue pregnant persons having an abortion or those who help (even those transporting the pregnant person to another state). With these legal obstacles in place, patients seeking an abortion must be vigilant in keeping abortion-seeking behaviors private and unavailable to litigious prosecution. This should include internet browsing and searches, text messages, period tracking apps, payments, and travel plans, all of which may be used as evidence. Although a self-managed medically induced abortion is clinically indistinguishable from a spontaneous miscarriage, a prosecutor may use electronic information as evidence to identify an induced abortion.

The concept of fetal personhood and laws defining this as starting at conception add another legal concern. Fetal personhood proponents suggest that the unborn fetus has rights similar to a child after birth and that any action thought to harm the fetus will be considered illegal. Pregnant persons can thus be detained or arrested for actions perceived as harmful to the fetus (beginning in the first trimester). Most of the cases have been related to a pregnant person's use of drugs; such patients have been accused of child abuse or even distributing drugs to a minor. In addition to the effects that the concept of fetal personhood will have on abortions, it may have implications for persons with an IUD, those using emergency contraception, embryos created for IVF, and those experiencing an ectopic pregnancy.

In addition to challenges experienced by all persons seeking an abortion, adolescents who are minors have age-specific barriers. Minors may not be able to travel to locations providing abortion (finances, driver's license, purchase airline ticket) and in most states, they are required to have some form of parental (grandparent or other adult relative in some states) involvement by notification or actual consent (PNA). PNA can be avoided by using a judicial bypass after appealing to a judge. In this case, the judge will determine if the adolescent requesting an abortion is "mature and informed." States with legal access to abortion may eliminate PNA altogether (e.g., Illinois).

Various organizations have facilitated access to self-managed abortions or to provide referrals to the nearest abortion provider. Aid Access

(<http://www.aidaccess.org>) is an online international abortion consult service that will make mifepristone/misoprostol available by mail (including minors). Another site (<http://www.ineedana.com>) helps locate the nearest abortion provider, and <http://www.elevatedaccess.org> helps arrange flights to legal abortion sites.

Other resources include Women on Web <http://www.womenonweb.org/en/> and Planned Parenthood as a patient navigator or provider of abortions.

To get help with funding: National Network of Abortion Funds <https://abortionfunds.org/> or <https://prochoice.org/>

Locating Plan C pills: [https://www.plancpills.org/?gclid=CjwKCAjw\\_b6WBhAQEiwAp4HyIKGkcL2gncj28MXzfN1eONGC4a3p\\_I9FLRx\\_f\\_4I\\_v8NZ5HqDD04JwxC6LQQAvD\\_BwE](https://www.plancpills.org/?gclid=CjwKCAjw_b6WBhAQEiwAp4HyIKGkcL2gncj28MXzfN1eONGC4a3p_I9FLRx_f_4I_v8NZ5HqDD04JwxC6LQQAvD_BwE)

Help with a self-managed abortion: <https://www.mahotline.org/>

Visit Elsevier eBooks+ at [eBooks.Elsevier.com](https://ebooks.elsevier.com) for Bibliography.

## Chapter 162

# Adolescent Sexual Assault

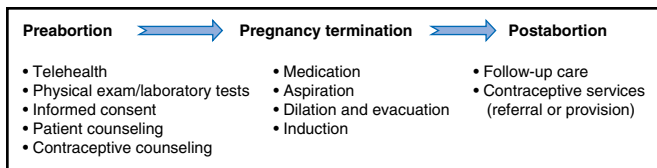
Allison M. Jackson, Adrienne R. Artis, and Norrell K. Atkinson

*Rape is an act of violence, not an act of sex.* Rape is historically defined as coercive sexual intercourse involving physical force or psychological manipulation of a female or a male. Recognizing that sexual intercourse is not a requirement for the definition, the U.S. Department of Justice (DOJ) defines rape as "the penetration, no matter how slight, of the vagina or anus with any body part or object, or oral penetration by a sex organ of another person, without the consent of the victim." Though definitions may vary by state, **sexual assault** is a more inclusive term that according to the U.S. DOJ "means any nonconsensual sexual act proscribed by Federal, tribal, or State law, including when the victim lacks capacity to consent."

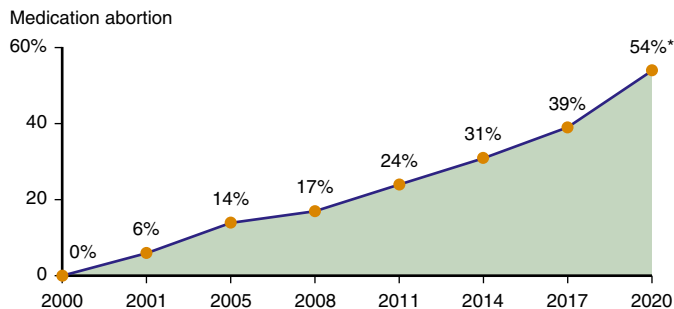
## EPIDEMIOLOGY

Exact figures on the incidence of rape are unavailable because sexual assault is underreported. In the 2019 National Crime Victimization Survey, only 0.56 per 1,000 persons over 12 years of age reported sexual assault to police. According to the National Intimate Partner and Sexual Violence Survey of 2015 (NISVS 2015), over 43% women and nearly 25% of men experienced some form of **sexual violence** in their lifetime. Females exceed males as reported rape victims, but male rape may be more underreported than female rape.

Adolescence is a high-risk age-group for sexual assault, with 43.2% of females and 51.3% of males experiencing their first sexual assault before the age of 18 years, and 81.3% of females and 70.8% males experiencing their first sexual assault before the age of 25 years (NISVS 2015). Between 1995 and 2013 the rate of rape and sexual assault was highest for adolescent females between ages 18 and 24 years. The National Survey of Children's Exposure to Violence (NatSCEV 2014) revealed that 12.9% of 14- to 17-year-olds experienced any sexual victimization in the past year, 21.7% had experienced any sexual victimization in their lifetime, 4.2% experienced sexual assault in the past year, and 10.2% in their lifetime. This survey also demonstrated how other experiences with violence compound the risk for sexual victimization. Youth with a history of maltreatment by a caregiver were four times more likely to experience sexual victimization and more than four times more likely to experience sexual victimization if they were a witness to violence. Among older adolescents age 18-24 years, the rate of rape and sexual



**Fig. 161.6** Continuum of abortion care. (Modified from National Academies of Sciences, Engineering, and Medicine; Health and Medicine Division; Board on Health Care Services; Board on Population Health and Public Health Practice; Committee on Reproductive Health Services. *Assessing the Safety and Quality of Abortion Care in the U.S.* Washington, DC: National Academies Press; 2018: Fig.1-1.)



**Fig. 161.7** As of 2020, medication abortions account for the majority of all U.S. abortions. \*Based on preliminary data. (From Guttmacher Institute. *Medication abortion now accounts for more than half of all US abortions, 2022.* <https://www.guttmacher.org/print/article/2022/02/medication-abortion-now-accounts-more-half-all-us-abortions>.)

permit private citizens to sue pregnant persons having an abortion or those who help (even those transporting the pregnant person to another state). With these legal obstacles in place, patients seeking an abortion must be vigilant in keeping abortion-seeking behaviors private and unavailable to litigious prosecution. This should include internet browsing and searches, text messages, period tracking apps, payments, and travel plans, all of which may be used as evidence. Although a self-managed medically induced abortion is clinically indistinguishable from a spontaneous miscarriage, a prosecutor may use electronic information as evidence to identify an induced abortion.

The concept of fetal personhood and laws defining this as starting at conception add another legal concern. Fetal personhood proponents suggest that the unborn fetus has rights similar to a child after birth and that any action thought to harm the fetus will be considered illegal. Pregnant persons can thus be detained or arrested for actions perceived as harmful to the fetus (beginning in the first trimester). Most of the cases have been related to a pregnant person's use of drugs; such patients have been accused of child abuse or even distributing drugs to a minor. In addition to the effects that the concept of fetal personhood will have on abortions, it may have implications for persons with an IUD, those using emergency contraception, embryos created for IVF, and those experiencing an ectopic pregnancy.

In addition to challenges experienced by all persons seeking an abortion, adolescents who are minors have age-specific barriers. Minors may not be able to travel to locations providing abortion (finances, driver's license, purchase airline ticket) and in most states, they are required to have some form of parental (grandparent or other adult relative in some states) involvement by notification or actual consent (PNA). PNA can be avoided by using a judicial bypass after appealing to a judge. In this case, the judge will determine if the adolescent requesting an abortion is "mature and informed." States with legal access to abortion may eliminate PNA altogether (e.g., Illinois).

Various organizations have facilitated access to self-managed abortions or to provide referrals to the nearest abortion provider. Aid Access

(<http://www.aidaccess.org>) is an online international abortion consult service that will make mifepristone/misoprostol available by mail (including minors). Another site (<http://www.ineedana.com>) helps locate the nearest abortion provider, and <http://www.elevatedaccess.org> helps arrange flights to legal abortion sites.

Other resources include Women on Web <http://www.womenonweb.org/en/> and Planned Parenthood as a patient navigator or provider of abortions.

To get help with funding: National Network of Abortion Funds <https://abortionfunds.org/> or <https://prochoice.org/>

Locating Plan C pills: [https://www.plancpills.org/?gclid=CjwKCAjw\\_b6WBhAQEiwAp4HyIKGkcL2gncj28MXzfN1eONGC4a3p\\_I9FLRx\\_f\\_4I\\_v8NZ5HqDD04JwxC6LQQAvD\\_BwE](https://www.plancpills.org/?gclid=CjwKCAjw_b6WBhAQEiwAp4HyIKGkcL2gncj28MXzfN1eONGC4a3p_I9FLRx_f_4I_v8NZ5HqDD04JwxC6LQQAvD_BwE)

Help with a self-managed abortion: <https://www.mahotline.org/>

Visit Elsevier eBooks+ at [eBooks.Health.Elsevier.com](https://www.elsevier.com/ebooksplus) for Bibliography.

## Chapter 162

# Adolescent Sexual Assault

Allison M. Jackson, Adrienne R. Artis, and Norrell K. Atkinson

*Rape is an act of violence, not an act of sex.* Rape is historically defined as coercive sexual intercourse involving physical force or psychological manipulation of a female or a male. Recognizing that sexual intercourse is not a requirement for the definition, the U.S. Department of Justice (DOJ) defines rape as "the penetration, no matter how slight, of the vagina or anus with any body part or object, or oral penetration by a sex organ of another person, without the consent of the victim." Though definitions may vary by state, **sexual assault** is a more inclusive term that according to the U.S. DOJ "means any nonconsensual sexual act proscribed by Federal, tribal, or State law, including when the victim lacks capacity to consent."

## EPIDEMIOLOGY

Exact figures on the incidence of rape are unavailable because sexual assault is underreported. In the 2019 National Crime Victimization Survey, only 0.56 per 1,000 persons over 12 years of age reported sexual assault to police. According to the National Intimate Partner and Sexual Violence Survey of 2015 (NISVS 2015), over 43% women and nearly 25% of men experienced some form of **sexual violence** in their lifetime. Females exceed males as reported rape victims, but male rape may be more underreported than female rape.

Adolescence is a high-risk age-group for sexual assault, with 43.2% of females and 51.3% of males experiencing their first sexual assault before the age of 18 years, and 81.3% of females and 70.8% males experiencing their first sexual assault before the age of 25 years (NISVS 2015). Between 1995 and 2013 the rate of rape and sexual assault was highest for adolescent females between ages 18 and 24 years. The National Survey of Children's Exposure to Violence (NatSCEV 2014) revealed that 12.9% of 14- to 17-year-olds experienced any sexual victimization in the past year, 21.7% had experienced any sexual victimization in their lifetime, 4.2% experienced sexual assault in the past year, and 10.2% in their lifetime. This survey also demonstrated how other experiences with violence compound the risk for sexual victimization. Youth with a history of maltreatment by a caregiver were four times more likely to experience sexual victimization and more than four times more likely to experience sexual victimization if they were a witness to violence. Among older adolescents age 18-24 years, the rate of rape and sexual

assault was 1.2 times higher for those not enrolled in college than those in college. Further, several studies of youth in the juvenile justice system demonstrate a particularly high prevalence of prior sexual victimization of young females in that setting. Rape occurs worldwide and is especially prevalent in war and armed conflicts. The World Health Organization estimates that rape and domestic violence are responsible for 5–16% of healthy years of life lost by females of reproductive age.

Female adolescents and young adults have the highest rates of rape compared to any other age-group. The normal developmental growth tasks of adolescence may contribute to this vulnerability in the following ways: (1) the emergence of independence from parents and the establishment of relationships outside the family may expose adolescents to environments with which they are unfamiliar and situations that they are unprepared to handle; (2) dating and becoming comfortable with one's sexuality may result in activities that are unwanted, but the adolescent is too inexperienced to avoid the unwanted actions; and (3) young adolescents may be naïve and more trusting than they should be (see Chapter 150). Many teens are technologically competent, which gives sexual perpetrators access to unsuspecting vulnerable populations who were previously beyond their reach. Social media and online dating sites represent a major risk for adolescents, as they facilitate correspondence with individuals unknown to them or protective family members, while simultaneously providing a false sense of security because of remote electronic communications. A determined perpetrator can obtain specific information to identify the adolescent and arrange for a meeting that is primed for sexual victimization.

Some adolescents are at higher risk of being victims of rape than others (Table 162.1).

## TERMINOLOGY

**Sexual violence** is a term that broadly encompasses criminal acts including **sexual assault**, **rape** and **sexual abuse**, and which disproportionately affects adolescents and young adults. Because of the prevalence of sexual violence in the adolescent population, it is important for healthcare providers to have a general understanding of the types of sexual violence that may affect children and adolescents. Providers should also be aware that every state carries their own legal definition of these crimes. These definitions dictate if or how a crime is prosecuted, which could affect survivors who have disclosed sexual violence.

Delayed disclosures of sexual violence are common. The circumstances and relationship of the assailant to the survivor can often affect if, when, and how a child or youth discloses an assault. Sexual violence is typically perpetrated by someone who knows their victim; less frequently the assailant is a stranger. The gender of the survivor may also affect the disclosure process. Males are less likely to disclose sexual violence compared with females. Individuals who are transgender, gender nonconforming, nonbinary, or other noncisgender identities are less likely to disclose sexual assault than those who identify as cisgender.

**Table 162.1** Adolescents at High Risk of Rape Victimization

### MALE, FEMALE, NONBINARY ADOLESCENTS

Drug and alcohol users  
Runaways  
Those with intellectual disability or developmental delay  
Street youths  
Transgender youth  
Youths with a history of sexual abuse

### PRIMARILY FEMALES

Survivors of prior sexual assault  
Newcomers to a town or college

### PRIMARILY MALES

Those in institutionalized settings (detention centers, prison)  
Gay males

In any scenario where rape is facilitated by threats, coercion, physical force, or illicit and/or legal substances, the disclosure process for a survivor of sexual assault can be impacted.

## TYPES OF SEXUAL VIOLENCE

**Sexual assault** is defined as sexual contact or behavior that occurs without explicit consent of the victim. It can include things such as attempted rape, rape, fondling, or forcing a person to perform sexual acts. It is important to remember that force is not always physical, but it can also be intimidation or coercive control of the person. Force may also include threatening to hurt the person or those close to them.

**Rape** is a form of sexual assault involving penetration. Not all sexual assaults are rape. Rape can further be defined as **stranger rape vs acquaintance rape**. **Intimate partner sexual violence** is a form of acquaintance rape. An intimate partner is defined as a person with which the survivor has had a close personal or sexual relationship; thus this form of sexual violence can be prevalent among adolescents. Intimate partner sexual violence can often start with controlling or emotionally abusive behaviors, which then escalate to assault.

Rape can frequently involve illicit and/or legal substances to facilitate the assault. Drug-facilitated rape involves perpetrators administering substances such as  $\gamma$ -hydroxybutyric acid (GHB), flunitrazepam (Rohypnol), and ketamine hydrochloride to their victim. More commonly, substances such as alcohol, tetrahydrocannabinoids (THC), benzodiazepines, stimulants, barbiturates, opioids, or other drugs are used during the course of an assault. Detection of these drugs requires a high index of suspicion, and a medical evaluation within 8-12 hours is necessary for prompt detection of these substances. Specific testing is used that is more sensitive than routine toxicology screens, which are often insufficient.

**Sexual abuse** is a type of child abuse (see Chapter 17). The American Academy of Pediatrics defines child sexual abuse as a child or adolescent who engages in sexual activities that they cannot comprehend, for which they are developmentally unprepared and unable to give informed consent, and/or when there is a violation of the legal or social taboos of society. It includes many things ranging from oral, genital, or anal contact and fondling by or of the child, to noncontact abuses, such as exhibitionism, voyeurism, or various forms of child exploitations such as pornography.

The **commercial sexual exploitation of children (CSEC)**, also known as **sex trafficking**, is a more complex form of sexual violence and is considered a form of child abuse (see Chapter 16). Sex trafficking is federally defined as the recruiting, harboring, transporting, providing, obtaining, patronizing, or soliciting of an individual through the means of force, fraud, or coercion for commercial sex. Although a pimp often personally recruits victims, they may use others to recruit. These youth may experience physical and sexual assault by the pimp as well as the “johns.” Many of these youth have a history of child maltreatment, increasing their vulnerability to this form of abuse. Fear of the consequences of disclosure and the survival skills acquired often yield a very guarded presentation in the healthcare setting.

Survivors of sexual violence often experience long-term symptoms related to the trauma they have sustained. Untreated trauma can negatively affect the physical and emotional health of an adolescent into adulthood. Engagement in trauma-focused therapy, combined with a supportive environment for the adolescent to grow, can help to mitigate the effects of the trauma that they have sustained. Providers should be knowledgeable of trauma-focused therapists in their community where adolescent survivors of sexual violence can receive care.

## CLINICAL MANIFESTATIONS

The adolescent's acute presentation after a rape may vary considerably, from histrionics to near-mute withdrawal. Even if they do not appear afraid, most victims are extremely fearful and very anxious about the incident, the rape report, the examination, and the entire process, including potential repercussions. Because adolescents are between the developmental lines of childhood and adulthood, their responses to rape may have elements of both child and adult behaviors. Many teens,



particularly young adolescents, may experience some level of cognitive disorganization.

Adolescents may be reluctant to report rape for a variety of reasons, including self-blame, fear, embarrassment, or in the circumstances of drug-facilitated rape, uncertainty of event details. Adolescent victims, unlike child victims who elicit sympathy and support, often face intense scrutiny regarding their credibility and inappropriately misplaced societal blame for the assault. This view is baseless and should not be used during an evaluation of any teenage victim of sexual violence. When adolescents do not report a rape, they may present at a future date with concerns for pregnancy; symptoms of or concerns for a sexually transmitted infection (STI); and symptoms of posttraumatic stress disorder (see [Chapter 38](#)), such as sleep disturbances, nightmares, mood swings, and flashbacks. Other teens may present with psychosomatic complaints or difficulties with schoolwork. All adolescents should be screened for possible sexual victimization at health examination visits.

## INTERVIEW AND PHYSICAL EXAMINATION

The purpose of the adolescent medical evaluation after a sexual assault is to provide medical care for the teen and to collect and document evidence of the assault when applicable. Although many teens delay seeking medical care, others present to a medical facility within 72 hours (or up to 96 hours depending on the protocol used) of the rape, at which time forensic evidence collection should be offered to the patient. Whether presenting acutely or more remotely, a comprehensive physical exam is recommended to the extent that the patient allows. Experienced clinicians with training and knowledge of forensic evidence collection and medical-legal procedures should complete the rape evaluation or supervise the evaluation when possible.

The clinician's responsibilities are to provide support, obtain the history in a nonjudgmental and noncoercive manner, conduct a complete examination without retraumatizing the victim, and collect forensic evidence. The clinician must complete laboratory testing, administer prophylaxis treatment for STIs and emergency contraception, arrange for counseling services, and file a report to appropriate authorities in accordance with the law. In some jurisdictions, healthcare professionals are required to report all sexual assaults of minors regardless of the relationship of the victim to the perpetrator. Although healthcare professionals are legally mandated to report sexual abuse, when the perpetrator is an acquaintance or stranger, some jurisdictions leave the decision of reporting up to the victim, requiring the victim to report the sexual assault. It is not the clinician's responsibility to decide whether a sexual assault has occurred; the legal system will make that determination. Furthermore, absence of injury does not exclude the possibility that sexual assault occurred.

Ideally, a clinician trained in forensic interviewing should obtain the history. In all cases, the history should be obtained by asking *only* open-ended questions to obtain information about (1) what happened, (2) where it happened, (3) when it happened, and (4) who did it. After obtaining a concise history, including details of the type of physical contact that occurred between the victim and the assailant, the clinician should conduct a thorough and complete physical examination and document all injuries (nongenital and genital). Clinicians should provide sensitive, nonjudgmental support during the entire evaluation, as the adolescent victim has experienced a major trauma and is susceptible to retraumatization during this process. Each component of the evaluation should be explained in detail to the victim, allowing the adolescent as much control as possible, including refusal to complete any part or all of the forensic evidence collection process. For sensitive examinations like these, a chaperone should be offered. Additionally, it is often useful to permit a trusted supportive person, such as a family

member, friend, or rape crisis advocate, to be present during the evaluation if that is the adolescent's wish.

The examining clinician should be familiar with **forensic evidence collection** and the physical evidence recovery kit (PERK) before initiating the examination. In the United States, each state's PERK is different, but most include some or all of the following components: swabs of suspected semen deposits, swabs of bite mark impressions to collect genetic markers (DNA, ABO group); swabs of any penetrated orifice or body surface where saliva may be present; and documentation of acute cutaneous injuries using body diagram charts and photographs with visible standard measurements. Areas of restraint should be carefully inspected for injuries; these areas include the extremities and neck. Inspection of the skin may also reveal suction injuries or bite impressions. Inspection of the mouth, with particular attention to the oral frenula and palate, may reveal mucosal injury. Although use of alternative light sources, such as the Wood lamp or blue light, enhance detection of semen and saliva, other common substances such as urine and lotion also fluoresce with alternative light sources. Swabs of sites that fluoresce under such light should be obtained for further forensic analysis.

The genital examination of a female rape victim should be undertaken with the patient in the lithotomy position. The prone knee-chest position may be used as an exam-clarifying technique, specifically to evaluate the posterior rim of the hymen and perianal area. The genital exam of a male rape victim should be undertaken with the patient in the supine position. The clinician's exam should include careful inspection of the entire pelvic, genital, and perianal areas. The clinician should document any acute injuries such as edema, erythema, petechiae, bruising, hemorrhage, or tearing. Aqueous solution of toluidine blue (1%), which adheres to nucleated cells, may be used during the acute examination to improve visualization of microtrauma in the perianal area. Any disruption to the superficial epidermis will allow for dye uptake and thus cannot differentiate between disruption of the skin from trauma, irritation, or infection. Additionally, a colposcope may be used to provide magnification and photo documentation of injuries.

## LABORATORY DATA

When adolescents present for medical care within 72-120 hours of a sexual assault, a forensic evidence collection kit should be offered to the patient. The time frames of eligibility for forensic evidence collection vary according to jurisdiction, so it is important to know the criteria of the jurisdiction investigating the assault. Regardless of an adolescent's decision to have evidence collection completed, medical care, including physical examination, laboratory testing ([Table 162.2](#)), and prophylactic therapies, should be offered to the patient. Follow-up evaluations should be scheduled to repeat these laboratory studies.

## TREATMENT

Treatment includes **prophylactic antimicrobials** for STIs (see [Chapter 163](#)) and emergency contraception (see [Chapter 160.6](#)). The Centers for Disease Control and Prevention (CDC) reports that trichomoniasis, bacterial vaginosis, gonorrhea, and chlamydia are the most frequently diagnosed infections among women who have been sexually assaulted. Antimicrobial prophylaxis is recommended for adolescent rape victims because of the risk of acquiring an STI and the risk of pelvic inflammatory disease ([Table 162.3](#)). HIV **postexposure prophylaxis (PEP)** must be considered and an infectious disease specialist consulted if higher transmission risk factors are identified (e.g., knowing that the perpetrator is HIV-positive, significant mucosal injury of the victim) to prescribe a triple-antiretroviral regimen ([Fig. 162.1](#)). Hepatitis B infection can be prevented with immunoglobulin and/or vaccination depending on the victim's immunization status and the perpetrators status; thus similar considerations should be made for possible exposure

**Table 162.2** Laboratory Evaluation of Sexual Assault

<b>Within 8-12 hr (if Indicated by History)</b>
Urine and blood for date rape drugs (GHB, Rohypnol, and ketamine)
<b>Within 24 hr (if Indicated by History)</b>
Blood for comprehensive toxicology screen (for other classes of drugs)
<b>Within 72 hr (or up to 96 hr Depending on Protocol Used)</b>
Forensic evidence kit
Pregnancy test
Hepatitis B screen (hepatitis B surface antigen, surface antibody, and core antibody)
Syphilis (rapid plasma reagin [RPR] or Venereal Disease Research Laboratory [VDRL])
HIV (HIV 1/2 Ag/Ab immunoassay, point-of-care testing can be useful in persons unlikely to follow up with a provider)
Bacterial vaginosis (BV) and candidiasis: point-of-care testing and/or wet mount of vaginal secretions with measurement of pH and KOH application for whiff test
Trichomonas vaginalis: nucleic acid amplification tests (NAATs) by urine or vaginal specimen or point-of-care testing (i.e., DNA probes) from vaginal specimen
Chlamydia and <i>Neisseria gonorrhoeae</i> : NAATs at sites of penetration or attempted penetration:
<ul style="list-style-type: none"> <li>• <i>N. gonorrhoeae</i>: oropharynx (*), rectum (*), urine (**)</li> <li>• <i>Chlamydia</i>: rectum (*), urine (**)</li> </ul>

\*Men who have sex with men (MSM) should be offered screening of gonorrhea and chlamydia if they report receptive oral or anal sex during the preceding year even if there was not contact at these sites during the assault.

\*\*NAAT can be obtained on a dirty urine sample as an alternative to a genital swab. From Centers for Disease Control and Prevention. Sexually transmitted diseases: treatment guidelines 2015, *MMWR Recomm Rep*. 2015;64(RR-3):1-140; and Updated guidelines for antiretroviral postexposure prophylaxis after sexual, injection drug use, or other nonoccupational exposure to HIV—United States, 2016. *MMWR Morb Mortal Wkly Rep*. 2016;65:458.

to the hepatitis B virus in vaccinated/unvaccinated individuals. Human papilloma virus (HPV) vaccination is also recommended because persons who have been sexually assaulted are also at risk for infection, and the efficacy of the HPV vaccine is high. Clinicians should review the importance for the patient's compliance with medical treatment, psychologic treatment, and follow-up care. Counseling should be provided about the symptoms of STIs and the need for urgent follow-up if symptoms develop. Abstinence from sexual intercourse should be recommended until the completion of the STI prophylactic course.

At the time of presentation, the clinician should address the need for follow-up care, including psychologic counseling. Adolescent victims are at increased risk of posttraumatic stress disorder, depression, self-abusive behaviors, suicidal ideation, delinquency, substance abuse, eating disorders, and sexual revictimization. It is important for the adolescent victim and parents to understand the value of timely counseling services to decrease these potential long-term sequelae. Counseling services should be arranged during the initial evaluation, with follow-up arranged with the primary care physician to improve compliance.

## FOLLOW-UP

Follow-up evaluation should be arranged within 1 week of the initial evaluation with a child abuse pediatrician or a Child Advocacy Center to provide an opportunity for prompt review of STI test results, to monitor for medication adherence and possible side effects, to ensure healing and documentation of injuries, and to evaluate for the resolution of symptoms initially present, the development of new physical symptoms, or emerging mental health concerns. If no STI prophylaxis was given, follow-up

**Table 162.3** Postexposure Prophylaxis (PEP) for Acute Sexual Assault Victims

<b>ROUTINE</b>	
Recommended regimen for STI prophylaxis	<ul style="list-style-type: none"> <li>• Ceftriaxone 500 mg IM once in a single dose*</li> </ul> <b>PLUS</b> <ul style="list-style-type: none"> <li>• Doxycycline 100 mg orally twice a day for 7 days (azithromycin 1 g orally in a single dose should be considered in persons at high risk for noncompliance)</li> </ul> <b>PLUS (for females)</b> <ul style="list-style-type: none"> <li>• Metronidazole 500 mg orally twice a day for 7 days (2 g orally in a single dose should be considered in persons at high risk for noncompliance)</li> </ul>
Pregnancy prophylaxis	Levonorgestrel (Plan B) 1.5 mg orally in a single dose ** <i>Ulipristal acetate (Ella) 30 mg is effective for up to 120 hr</i>
HPV	Assess HPV vaccination history; vaccine should be provided at initial evaluation if unimmunized or partially immunized <ul style="list-style-type: none"> <li>• If unimmunized and &gt;15 yr at the time of the initial exam, give first dose and, two follow-up doses at 1-2 mo and 6 mo</li> <li>• If &lt;15 yr, a single follow-up dose at 6-12 mo</li> <li>• If partially immunized, a follow-up dose if &gt;5 mo since the first dose or &gt;12 wk since the second dose</li> </ul>
<b>AS INDICATED</b>	
HIV†	<b>Preferred regimen</b> <ul style="list-style-type: none"> <li>• Tenofovir 300 mg and fixed-dose combination emtricitabine 200 mg (Truvada) once daily</li> </ul> <b>PLUS</b> <ul style="list-style-type: none"> <li>• Raltegravir 400 mg orally twice a day</li> </ul> <b>OR</b> <ul style="list-style-type: none"> <li>• Dolutegravir 50 mg orally once a day</li> </ul> All persons with a potential exposure within 72 hours should be offered PEP, which includes a 28-day course of a three-drug antiretroviral regimen.
Hepatitis B	<i>Alternative regimens available.</i> Specific indications for vaccine, immunoglobulin, and/or booster depend on assailant's status

\*If ≥150 kg, give 1 g of ceftriaxone IM once.

\*\*Provided for patients with negative urine pregnancy screen. In addition, an antiemetic (Compazine, Zofran) can be prescribed for patients receiving emergency contraception.

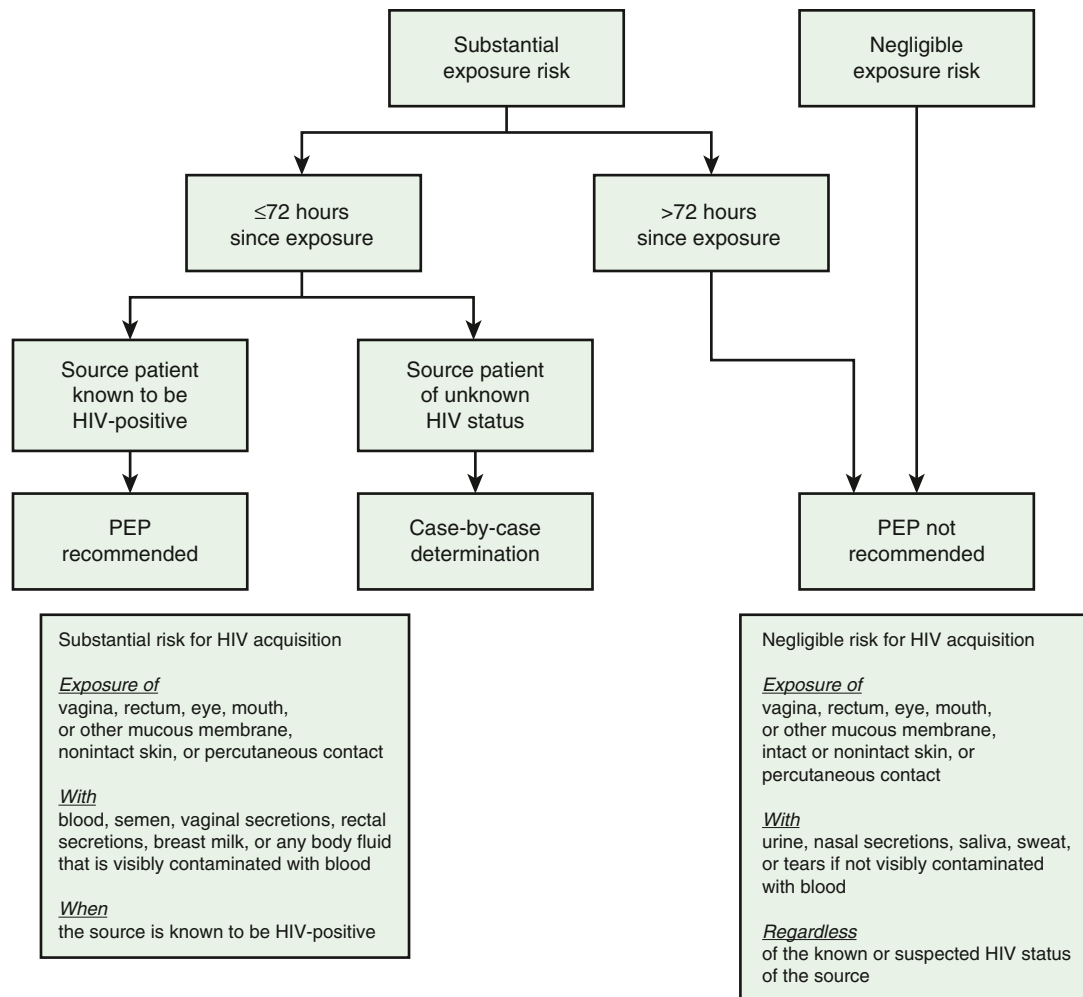
†HIV PEP is provided for patients with penetration and when the assailant is known to be HIV-positive or at high risk because of a history of incarceration, intravenous drug use, or multiple sexual partners. If provided, laboratory studies must be drawn before administration of medication (HIV, CBC, LFTs, BUN/Cr, amylase, lipase), and follow-up must be arranged.

Data from Workowski, KA, Bachmann, LH, Chan, PA Sexually Transmitted Infections Treatment Guidelines, 2021. *MMWR Recomm Rep* 2021;70:128-135.

testing for gonorrhea, chlamydia, and trichomonas can be repeated in 1-2 weeks after the assault. If prophylaxis was provided, follow-up testing is not needed unless symptoms develop. If infection in the assailant cannot be ruled out, serologic testing for syphilis can be repeated in 4-6 weeks and 3 months, and for HIV in 6 weeks and 3 months.

## PREVENTION

**Primary prevention** may be accomplished through education of pre-adolescents and adolescents on the issues of consent, rape, healthy



**Fig. 162.1** Algorithm to evaluate the need for nonoccupational HIV postexposure prophylaxis among adult and adolescent survivors of sexual assault. (From Workowski, KA, Bachmann, LH, Chan, PA. Sexually transmitted infections treatment guidelines, 2021. *MMWR Recomm Rep.* 2021;70:128–135; adapted from Announcement: updated guidelines for antiretroviral postexposure prophylaxis after sexual, injection-drug use, or other nonoccupational exposure to HIV—United States, 2016. *MMWR Morb Mortal Wkly Rep.* 2016;65:458.)

relationships, internet dangers, and drug- and alcohol-facilitated rape. Prevention messages should be targeted at males, females, and nonbinary youth at high schools and colleges. Particular emphasis on prevention efforts during college orientation is highly recommended. High-risk situations that may increase the likelihood of a sexual assault should be discouraged, such as the use of drugs or alcohol, drinking from a container that has been left unattended, and accepting drinks from strangers. **Secondary prevention** includes informing adolescents of the benefits of timely medical evaluations when rape has occurred. Individual clinicians should ask adolescents about past experiences of forced and unwanted sexual behaviors and offer help

in dealing with those experiences. The importance of prevention cannot be overstated because adolescents are disproportionately affected by sexual assault, and they are particularly vulnerable to long-term consequences.

Counseling services for family members of the victim may improve their ability to provide appropriate support to the adolescent victim. Caution parents not to use the assault as a validation of their parental guidance, as it will only serve to place blame inappropriately on the adolescent victim.

Visit Elsevier eBooks+ at [eBooks.Health.Elsevier.com](https://eBooks.Health.Elsevier.com) for Bibliography.

## Chapter 163

## Sexually Transmitted Infections

Tamera Coyne-Beasley, Nefertiti H. Durant, and Samantha V. Hill

Age-specific rates of many sexually transmitted infections (STIs) are highest among sexually experienced adolescents and young adults, after controlling for sexual activity. Although some STI pathogens present as STI syndromes with a specific constellation of symptoms, most are asymptomatic and only detected by a laboratory test. The approach to prevention and control of these infections lies in education, screening, and early diagnosis and treatment.

## ETIOLOGY

Any adolescent who has had oral, vaginal, or anal sexual intercourse is behaviorally vulnerable to acquiring an STI. Not all adolescents are at equal risk; physical, behavioral, and social factors contribute to an adolescent's risk. Adolescents who initiate sex at a younger age; youth residing in detention facilities; youth attending STI clinics; youth involved in commercial sex exploitation or survival sex and exchange sex for drugs, money, food, or housing; young males having sex with males (YMSM); adolescent women and young adult women having sex with older men; transgender youth; youth with disabilities; and youth who are injection drug users are at higher risk for STIs. Risky behaviors, such as sex with multiple concurrent partners or multiple sequential partners of limited duration, failure to use barrier protection consistently and correctly, and increased biologic susceptibility to infection also contribute to risk (Table 163.1). Although all 50 states and the District of Columbia explicitly allow minors to consent for their own

**Table 163.1** Circumstances Contributing to Adolescents' Susceptibility to Sexually Transmitted Infections

## PHYSICAL

Younger age at puberty  
Cervical ectopy  
Smaller introitus leading to traumatic sex  
Asymptomatic nature of sexually transmitted infection  
Uncircumcised penis

## BEHAVIOR INFLUENCED BY DEVELOPMENTAL STAGES

Early adolescence: Lack ability to think abstractly  
Middle adolescence: Believe in uniqueness and lack of vulnerability

## SOCIAL FACTORS

Poverty  
Limited access to "adolescent-friendly" healthcare services  
Adolescent health-seeking behaviors (forgoing care because of confidentiality concerns or denial of health problem)  
Sexual abuse, trafficking, and violence  
Lower levels of condom use  
Mental health issues and substance use/abuse  
Decreased access to confidential medical care leading complexity in seeking care  
Homelessness  
Young adolescent females with older partners  
Young men having sex with men

Data from Wangu, G Burstein. Adolescent sexuality: updates to the Sexually Transmitted Infection Guidelines. *Ped Clin North Am.* 2017;64:389–341; and Spear LP. Adolescent neurodevelopment. *J Adolesc Health.* 2013;52:S7–S13.

sexual health services (at varying ages), many adolescents encounter multiple obstacles to accessing this care, including poverty, insurance coverage, and fears of lack of confidentiality (see Table 163.1). Adolescents who are survivors of sexual assault need reassurance, protection, and appropriate intervention when these circumstances are uncovered (see Chapter 162).

## EPIDEMIOLOGY

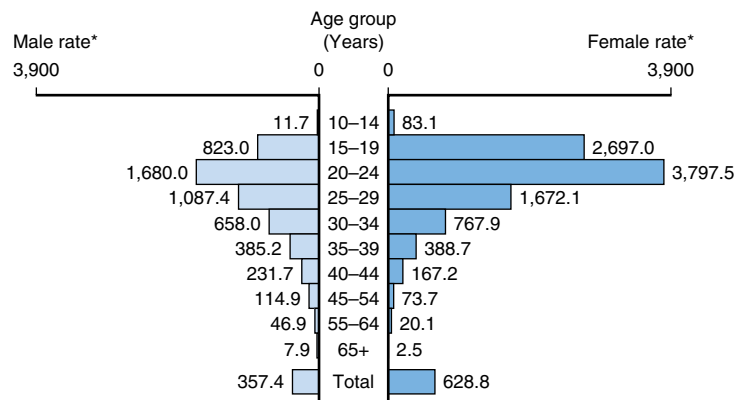
STI prevalence varies by age, gender, race, and ethnicity. In the United States, although adolescents and young adults ages 15–24 represent 25% of the sexually experienced population, this age-group accounts for almost 50% of all incident STIs each year.

**Chlamydia** is the most frequently reported infectious disease in the United States and is the second most common STI in U.S. adolescents and young adults after human papillomavirus (HPV). In 2019, young adult females ages 20–24 (3,797.8 cases per 100,000 females) followed by females ages 15–19 (2,697.0 cases per 100,000 females) had the highest rates of chlamydia in the United States (Fig. 163.1). Notably age-specific rates of reported cases of chlamydia among males, although substantially lower than rates among females, were still highest in young adult males 20–24 years (1,680.0 cases per 100,000 males). Chlamydia remains common among all races and ethnic groups. In 2021, a total of 1,644,416 cases of *Chlamydia trachomatis* infection were reported to the CDC, making it the most common notifiable sexually transmitted infection in the United States for that year. This case count corresponds to a rate of 495.5 cases per 100,000 population, an increase of 3.9% compared with the rate in 2020. During 2020 to 2021, rates of reported chlamydia increased among both males and females, in all regions of the United States, among most age groups, and among all race/Hispanic ethnicity groups. Rates of reported chlamydia are highest among adolescents and young adults. In 2021, almost two-thirds (58%) of all reported chlamydia cases were among persons aged 15–24 years.

Reported rates of other bacterial STIs are also high among adolescents and young adults. In 2021, gonorrhea rates among adolescents were 360.1/100,000 for males ages 15–19 compared to 587.8/100,000 for young women ages 15–19. Gonorrhea rates for young adult males ages 20–24 years old (844.2/100,000) were significantly higher than rates for males at any other age/sex group and slightly lower than for young women ages 20–24 (873.2/100,000).

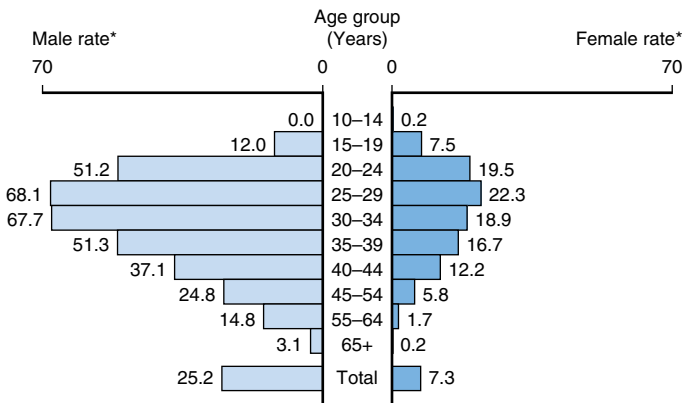
**Pelvic inflammatory disease (PID)** is a clinical syndrome that results from the ascension of microorganisms from the cervix and vagina to the upper genital tract. PID is a serious complication of chlamydia and gonorrhea, two of the most common reportable infectious diseases and STIs in the United States. PID rates are highest among females ages 15–24 compared with older women.

**Syphilis rates** have increased at an alarming rate, especially among males, since 2000. In 2021, young adult males age 20–24 had the third highest rate of primary and secondary syphilis at 51.2 per 100,000. Rates among adolescent males ages 15–19 were lower at 12.0 per 100,000.



**Fig. 163.1** Chlamydia: Rates of reported cases by age group and sex, United States, 2021. (Data from the Centers for Disease Control and Prevention: [www.cdc.gov/std/statistics/2021/data.zip](http://www.cdc.gov/std/statistics/2021/data.zip).)





**Fig. 163.2** Primary and secondary syphilis—Rates of reported cases by age group and sex, United States, 2021. (Data from the Centers for Disease and Control and Prevention: [www.cdc.gov/std/statistics/2021/data.zip](http://www.cdc.gov/std/statistics/2021/data.zip))

Rates of female primary and secondary syphilis are much lower than male rates (7.5/100,000 among 15-19 year olds; 19.5/100,000 among 20-24 year olds).

Adolescents also carry a large burden of viral STIs. U.S. youth are at persistent risk for **HIV infection**. However, according to the 2021 Youth Risk Behavior Survey, only 6% of high school students have ever been tested for HIV. Adolescents (persons aged 13–19 years) and young adults (persons aged 20–24 years) accounted for 21% of the 36,801 diagnoses of HIV infection in 2019 in the United States and 6 dependent areas. They are the least likely of any age group to be aware of their HIV infection, retained in care, or have a suppressed viral load. From 2015 through 2019 in the United States and 6 dependent areas, the number of diagnoses of HIV infection among adolescents and young adults for males, females, and transgender MTF decreased. In 2019, diagnoses of HIV infection among adolescent and young adult males (85%) and females (12%) accounted for approximately 97% of HIV diagnoses. Transgender MTF adolescents and young adults accounted for 3% of annual diagnoses. From 2015 through 2019 in the United States, the rate of diagnosis of HIV infection for Asian, Black/African American, and multiracial adolescents decreased. The rates of diagnosis of HIV infection for Hispanic/Latino and White adolescents remained stable. In 2019, the highest rate was 23.5 for Black/African American adolescents, followed by 6.3 for Hispanic/Latino, and 4.2 for multiracial adolescents. Racial and ethnic disparities persist.

**Human papillomavirus (HPV)** is the most frequently acquired STI in the United States. According to the National Health and Nutrition Examination Survey (NHANES), prevalence of HPV vaccine types 6, 11, 16, and 18 (**4vHPV**) declined between the pre-vaccine (2003–2006) and vaccine (2009–2012) eras: from 11.5% to 4.3% among females ages 14-19 and from 18.5% to 12.1% among females ages 20-24. Within 6 years of introduction of the HPV vaccine, there was a 64% decrease in 4vHPV-type prevalence among female youth ages 14-19 and a 34% decrease among young adult women ages 20-24. Efforts are ongoing to improve vaccination among all youth.

**Herpes simplex virus type 2 (HSV-2)** is the most prevalent viral STI (see Chapter 299). According to NHANES data, prevalence of both HSV-1 and HSV-2 decreased from 1999–2000 to 2015–2016 (from 59.4% to 48.1% and from 18.0% to 12.1%, respectively). According to Centers for Disease Control and Prevention (CDC) data, seroprevalence for HSV-2 for adolescents ages 14-19 was low, at 0.8. It is important to note that among young adults ages 20-29, HSV-2 prevalence is higher, at 7.6%. Prevalence of HSV-1 among 14- to 19-year-olds was 27% compared to 41% among those ages 20-29. There are notable ethnic, racial, and gender disparities in HSV prevalence. Prevalence of HSV-1 was highest among Mexican American persons and lowest among non-Hispanic White persons. HSV-2 prevalence was highest among Hispanic Black persons



**Fig. 163.3** Cervical ectopy. (From Seattle STD/HIV Prevention Training Center, University of Washington, Claire E. Stevens.)

and lowest among non-Hispanic Asian persons. Both HSV-1 and HSV-2 were higher among females than males.

## PATHOGENESIS

During puberty, increasing levels of estrogen cause the vaginal epithelium to thicken and cornify and the cellular glycogen content to rise, with the latter causing the vaginal pH to fall. These changes increase the resistance of the vaginal epithelium to penetration by certain organisms (including *Neisseria gonorrhoeae*) and increase the susceptibility to others (*Candida albicans* and *Trichomonas*; see Chapter 330). The transformation of the vaginal cells leaves columnar cells on the ectocervix, forming a border of the two cell types on the ectocervix known as the *squamocolumnar junction*. The appearance is referred to as *ectopy* (Fig. 163.3). With maturation, this tissue involutes. Before involution, it represents a unique vulnerability to infection for adolescent females. The association of early sexual debut and younger gynecologic age with increased risk of STIs supports this explanation of the pathogenesis of infection in young adolescents.

## SCREENING

Early detection and treatment are primary *STI control strategies*. Some of the most common STIs in adolescents, including HPV, HSV, chlamydia, and gonorrhea, are usually asymptomatic and, if undetected, can be spread inadvertently by the infected host. **Screening** initiatives for chlamydial infections have demonstrated reductions in PID cases by up to 40%. Federal and professional medical organizations recommend annual chlamydia and gonorrhea screening for sexually active females <25 years old (Table 163.2). The lack of a dialog about STIs or the provision of STI services at annual preventive service visits to sexually experienced adolescents is a missed opportunity for screening and education. Comprehensive, confidential, reproductive health services, including STI screening, should be offered to all sexually experienced adolescents (see Table 163.2).

## COMMON INFECTIONS AND CLINICAL MANIFESTATIONS

**STI syndromes** are generally characterized by the location of the manifestation (vaginitis, enteritis) or the type of lesion (genital ulcer). Certain constellations of presenting symptoms suggest the inclusion of a possible STI in the differential diagnosis.

### Urethritis

Urethritis is an STI syndrome characterized by inflammation of the urethra, usually caused by an infectious etiology. Urethritis may present with urethral discharge, dysuria, urethral irritation, or meatal pruritus. Urgency, frequency of urination, erythema of the urethral meatus, and urethral pain or burning are less common clinical presentations. Approximately 30–50% of males are asymptomatic but may have signs of discharge on diagnosis. On examination, the classic finding is mucoid or purulent discharge from the urethral meatus (Fig. 163.4). If no discharge is evident on exam, providers may attempt to

**Table 163.2** Routine Laboratory Screening Recommendations for Sexually Transmitted Infections in Sexually Active Adolescents and Young Adults**CHLAMYDIA TRACHOMATIS AND NEISSERIA GONORRHOEAE**

- Routine screening for *C. trachomatis* and *N. gonorrhoeae* of all sexually active females age <25 yr is recommended annually.
- Extragenital chlamydia and gonorrhea screening (pharyngeal or rectal) can be considered on the basis of reported sexual behaviors and exposure, through shared clinical decision-making between the patient and the provider.
- Routinely screen sexually active adolescent and young adult MSM at sites of contact for chlamydia (urethra, rectum) and gonorrhea (urethra, rectum, pharynx) at least annually regardless of condom use. NAAT is preferred for provider or self-collected specimens. More frequent screening (i.e., at 3- to 6-mo intervals) is indicated for MSM, including those taking PrEP and those with HIV infection, if risk behaviors persist or if they or their sex partners have multiple partners or anonymous partners or have sex with illicit drug use.
- Consider screening for *C. trachomatis* of sexually active adolescent and young adult males annually who have a history of multiple partners in clinical settings with high prevalence rates, such as jails or juvenile correction facilities, national job training programs, STD clinics, high school clinics, or adolescent clinics.

**HUMAN IMMUNODEFICIENCY VIRUS (HIV)**

The following recommendations apply to testing for HIV:

- HIV testing is recommended for all adolescents and young adults seeking STI evaluation and/or treatment who are not already known to have HIV infection. Testing should be routine at the time of the STI evaluation, regardless of whether the patient reports any specific behavioral risks for HIV.
- The CDC and USPSTF recommend HIV screening at least once for all persons age 13-64 yr or 15-65, respectively.
- Persons at higher risk for HIV acquisition, including sexually active gay, bisexual, and other MSM, should be screened for HIV at least annually. Providers can consider the benefits of offering more frequent screening (e.g., every 3-6 months) among MSM at increased behavioral risk for acquiring HIV.
- All pregnant adolescents should be tested for HIV during the first prenatal visit. A second test during the third trimester, preferably at <36 weeks' gestation, should be considered and is recommended for adolescents and young adults who are at high risk for acquiring infection.
- HIV screening should be voluntary and free from coercion. Patients should not be tested without their knowledge.
- Providers should use a laboratory-based antigen/antibody (Ag/Ab) combination assay as the first test for HIV, unless persons are unlikely to follow up with a provider to receive their HIV test results; in those cases screening with a rapid POC test can be useful.
- Providers should test for HIV RNA if initial testing according to the HIV testing algorithm recommended by the CDC is negative or indeterminate when concerned about acute HIV infection (<https://stacks.cdc.gov/view/cdc/50872>).
- HIV screening should be discussed and offered to all adolescents at least once by age 16-18 yr and throughout young adulthood in healthcare settings. HIV risk should be assessed annually for >13 yr and offered if HIV risk factors are identified.

- Routinely screen sexually active adolescent and young adult MSM at least annually regardless of condom use. More frequent screening (i.e., at 3- to 6-mo intervals) is indicated for MSM who have multiple or anonymous partners or who have sex with illicit drug use.

**SYPHILIS**

- Syphilis screening should be offered to sexually active adolescents reporting risk factors, including MSM.
- Routinely screen sexually active adolescent and young adult MSM at least annually regardless of condom use. More frequent screening (i.e., at 3- to 6-mo intervals) is indicated for MSM who have multiple or anonymous partners or who have sex with illicit drug use.
- Screen women at 1st prenatal visit, at 28 weeks, at delivery if at greater behavioral risk.
- Screen asymptomatic women who may have increased behavioral vulnerability (history of incarceration, transactional sex, higher rate in community).
- Providers should consult with their local health department regarding local syphilis prevalence and associated risk factors that are associated with syphilis acquisition.

**HEPATITIS B VIRUS**

- All MSM should be screened with HBsAg, HBV core antibody, and HBV surface antibody.
- Vaccination against both HAV and HBV is recommended for all MSM when a previous infection or vaccination cannot be documented.

**HEPATITIS C VIRUS AND UNIVERSAL HEPATITIS C SCREENING**

- The CDC recommends hepatitis C screening at least once in a lifetime for all adults age 18 yr and older, except in settings where the prevalence of HCV infection (HCV RNA positivity) is <0.1%.
- Hepatitis C screening for all pregnant women during each pregnancy, except in settings where the prevalence of HCV infection (HCV RNA positivity) is less than 0.1%.
- Screening adolescents younger than 18 yr old for HCV who report risk factors, that is, injection drug use, receipt of an unregulated tattoo, received blood products or organ donation before 1992, received clotting factor concentrates before 1987, or long-term hemodialysis.
- Given the high HCV prevalence among young injection drug users, screening should be strongly considered.
- All people living with HIV should be screened during the initial HIV evaluations and at least annually thereafter.
- Screening should be performed using HCV antibody assays followed by HCV RNA testing for those with a positive antibody test.
- Routine screening of adolescents and young adults who are asymptomatic for certain STIs (i.e., syphilis, trichomoniasis, BBV, HSV, HAV, and HB) is not typically recommended.

From Centers for Disease Control and Prevention: <https://www.cdc.gov/std/treatment-guidelines/screening-recommendations.htm> and <https://www.cdc.gov/hepatitis/hcv/guideline.sc.htm>.

express discharge by applying gentle pressure to the urethra from the base distally to the meatus 3-4 times. *Chlamydia trachomatis* and *N. gonorrhoeae* are the most commonly identified pathogens. *Mycoplasma genitalium* has been associated with urethritis, but data supporting *Ureaplasma urealyticum* have been inconsistent. *Trichomonas vaginalis* can cause nongonococcal urethritis (NGU), but the prevalence varies. HSV-1, HSV-2, and Epstein-Barr virus (EBV) are also potential urethritis pathogens in some cases. Sensitive diagnostic *C. trachomatis* and *N. gonorrhoeae* tests are available for the evaluation of urethritis. However, other pathogens can be considered when NGU is not responsive to treatment. Noninfectious causes of urethritis include urethral trauma or foreign body. Unlike in females, urinary tract infections (UTIs) are rare in males who have no genitourinary medical history.

In the typical sexually active adolescent male, dysuria and urethral discharge suggest the presence of an STI unless proven otherwise.

**Epididymitis**

The inflammation of the epididymis in adolescent males is most often associated with an STI, most frequently *C. trachomatis* or *N. gonorrhoeae*. The presentation of unilateral scrotal swelling and tenderness, often accompanied by a hydrocele and palpable swelling of the epididymis, associated with the history of urethral discharge constitute the presumptive diagnosis of epididymitis. Males who practice insertive anal intercourse are also vulnerable to *Escherichia coli* infection. **Testicular torsion**, a surgical emergency usually presenting with sudden onset of severe testicular pain, should be considered in the differential



**Fig. 163.4** Gonococcal urethral discharge. (From Seattle STD/HIV Prevention Training Center, University of Washington, Connie Celum and Walter Stamm.)

diagnosis (see Chapter 582). The evaluation for epididymitis should include obtaining evidence of urethral inflammation by physical exam, Gram stain of urethral secretions, urine leukocyte esterase test, or urine microscopy. A *C. trachomatis* and *N. gonorrhoeae* nucleic acid amplification test (NAAT) should be performed.

### Vaginitis

Vaginitis is a superficial infection of the vaginal mucosa frequently presenting as vaginal discharge, with or without vulvar involvement (see Chapter 586). **Bacterial vaginosis, vulvovaginal candidiasis, and trichomoniasis** are the predominant infections associated with vaginal discharge. Bacterial vaginosis is caused by replacement of the normal hydrogen peroxide ( $H_2O_2$ )–producing *Lactobacillus* species vaginal flora by an overgrowth of anaerobic microorganisms, as well as *Gardnerella vaginalis*, *Ureaplasma*, and *Mycoplasma*. It is diagnosed based on an individual having at least three out of four of **Amsel's criteria**: (1) thin, gray, homogenous discharge, (2) vaginal pH >4.5, (3) fishy odor after the addition of potassium hydroxide (KOH) to discharge, and (4) at least 20% clue cells present on wet prep. It is important to note that research has shown there to be significant variability in providers' abilities to read wet preps; thus standardization of wet prep analysis via laboratories is recommended. BV NAATs are also available but should be used only by symptomatic women because accuracy has not been determined for asymptomatic women. Researchers do not know the cause of bacterial vaginosis or how some women acquire it. We do know the condition typically occurs in sexually active women. We also know that sexual activity is associated with increased frequency of bacterial vaginosis. Additionally, history of a diagnosis of bacterial vaginosis increases the risk of acquisition of other STIs. Vulvovaginal candidiasis, usually caused by *C. albicans*, can trigger vulvar pruritus, pain, swelling, redness, and dysuria. Findings on vaginal examination include vulvar edema, fissures, excoriations, or thick curdy vaginal discharge. Trichomoniasis is caused by the protozoan *T. vaginalis*. Infected females may present with symptoms characterized by a diffuse, malodorous, yellow-green vaginal discharge with vulvar irritation or may be diagnosed by screening an asymptomatic patient. Cervicitis can sometimes cause a vaginal discharge. Laboratory confirmation is recommended because clinical presentations may vary and patients may be infected with more than one pathogen.



**Fig. 163.5** Mucopurulent cervical discharge positive swab test. (From Seattle STD/HIV Prevention Training Center, University of Washington, Claire E. Stevens and Ronald E. Roddy. <http://www2a.cdc.gov/stdtraining/ready-to-use/pid.htm>.)



**Fig. 163.6** Inflamed cervix caused by gonococcal cervicitis. (From Centers for Disease Control and Prevention: STD clinical slides. <http://www.cdc.gov/std/training/clinicalslides/slides-dl.htm>.)

### Cervicitis

The inflammatory process in cervicitis involves the deeper structures in the mucous membrane of the cervix uteri. Vaginal discharge can be a manifestation, but cervicitis is frequently asymptomatic. Patients also present with complaints of irregular or postcoital bleeding. Two major diagnostic signs characterize cervicitis: (1) a purulent or mucopurulent endocervical exudate visible in the endocervical canal or on an endocervical swab specimen (e.g., swab sign; Fig. 163.5), called **mucopurulent cervicitis** or cervicitis, and (2) sustained endocervical bleeding easily induced by gentle passage of a cotton swab through the cervical os, signifying friability. Cervical changes associated with cervicitis must be distinguished from cervical ectopy in the younger adolescent to avoid the overdiagnosis of inflammation (Fig. 163.6 and see Fig. 163.3). The pathogens identified most frequently with cervicitis are *C. trachomatis* and *N. gonorrhoeae*, although no pathogen is identified in most cases. HSV is a less common pathogen associated with ulcerative and necrotic lesions on the cervix.

### Pelvic Inflammatory Disease

PID encompasses a spectrum of inflammatory disorders of the female upper genital tract, including **endometritis, salpingitis, tuboovarian abscess, and pelvic peritonitis**, usually in combination rather than as separate entities. *N. gonorrhoeae* and *C. trachomatis* predominate as the involved pathogenic organisms in younger adolescents (see Chapters 238 and 271), although PID should be approached as having



a multiorganism etiology, including pathogens such as anaerobes, *G. vaginalis*, *Haemophilus influenzae*, enteric gram-negative rods, and *Streptococcus agalactiae*. In addition, cytomegalovirus, *Mycoplasma hominis*, *U. urealyticum*, and *M. genitalium* may be associated with PID. PID (tuboovarian abscess) has rarely been reported in virgins and is usually caused by *E. coli* and associated in some patients with obesity and possible pooling of urine in the vagina.

PID is difficult to diagnose because of the wide variation in symptoms and signs. Many females with PID have subtle or mild symptoms, resulting in many unrecognized cases. Healthcare providers should consider the possibility of PID in young, sexually active females presenting with vaginal discharge or abdominal pain.

The clinical diagnosis of PID is based on the presence of at least one of the minimal criteria, either cervical motion tenderness, uterine tenderness, or adnexal tenderness, to increase the diagnostic sensitivity and reduce the likelihood of missed or delayed diagnosis. Providers should also consider that adolescents are the population in whom PID is typically diagnosed and thus should have a low threshold for initiating empirical treatment. In addition, the majority of females with PID have either mucopurulent cervical discharge or evidence of white blood cells (WBCs) on a microscopic evaluation of a vaginal fluid–saline preparation. If the cervical discharge appears normal and no WBCs are observed on the wet prep of vaginal fluid, the diagnosis of PID is unlikely, and alternative causes of pain should be investigated. Specific, but not always practical, criteria for PID include evidence of endometritis on biopsy, transvaginal sonography or MRI evidence of thickened, fluid-filled tubes, or Doppler evidence of tubal hyperemia or laparoscopic evidence of PID.

### Enteritis

Among men who have sex with men (MSM), both *Chlamydia* and the gonococcus can cause enteric (colitis, proctitis) symptoms. In addition, infections with enteric pathogens (*Shigella*, *Campylobacter*, *Ameba*) have been noted.

### Sepsis

Although there are rare urogenital tract cases of meningococcal infections with heterosexual intercourse (similar to gonococcus), men who have sex (particularly oral sex) with men are at increased risk

for invasive meningococcal infections, which often occur as an outbreak. Meningococcus may colonize the pharyngeal, anal, or urethral mucosa. Meningococcemia must be distinguished from disseminated gonococcal infection (DGI), which will manifest with a gram-negative diplococci-positive blood culture along with tenosynovitis, septic arthritis, petechial/pustular rash, and less often, endocarditis.

### Genital Ulcer Syndromes

An **ulcerative lesion** in a mucosal area exposed to sexual contact is the unifying characteristic of infections associated with genital ulcer syndromes. Genital ulcer lesions are most frequently seen on the penis and vulva, but also occur on oral and rectal mucosa, depending on the adolescent's sexual practices. HSV and *Treponema pallidum* (syphilis) are the most common organisms associated with genital ulcer syndromes. Table 163.3 presents the clinical characteristics differentiating the lesions of the most common infections associated with genital ulcers, along with the required laboratory diagnosis to identify the causative agent accurately.

**Genital herpes**, the most common ulcerative STI among adolescents, is a chronic, lifelong viral infection. Two sexually transmitted HSV types have been identified: HSV-1 and HSV-2. The majority of cases of recurrent genital herpes are caused by HSV-2. However, among young women and MSM, an increasing proportion of anogenital herpes has been HSV-1. Most HSV-2–infected persons are unaware of their diagnosis because they experience mild or unrecognized infections but continue to shed virus intermittently in the genital tract. Therefore most genital herpes infections are transmitted by asymptomatic persons who are unaware of their infection.

Although the initial herpetic lesion is a vesicle, by the time the patient presents clinically, the vesicle often has ruptured spontaneously, leaving a shallow, painful ulcer (Fig. 163.7A). Recurrences are generally less intense and painful (see Fig. 163.7B). Up to 50% of first genital herpes episodes are caused by HSV-1. However, recurrences and subclinical shedding are much more frequent for genital HSV-2 infection.

**Syphilis** is a less common cause of genital ulcers in adolescents than in adults. Syphilis is caused by *T. pallidum*. Primary syphilis presents as a single painless ulcer or chancre at the site of infection. However, it can also present with multiple atypical or painful lesions. Secondary syphilis manifestations include skin rash,

**Table 163.3** Signs, Symptoms, and Presumptive and Definitive Diagnoses of Genital Ulcers

SIGNS/SYMPTOMS	HERPES SIMPLEX VIRUS	SYPHILIS (PRIMARY)	CHANCROID
Ulcers	Vesicles rupture to form shallow ulcers	Ulcer with well-demarcated, indurated borders and a clean base (chancre)	Nonindurated and undermined borders and a purulent base
Painful	Painful	Painless*	Painful
Number of lesions	Usually multiple	Usually single	Multiple
Inguinal lymphadenopathy	First-time infections may cause constitutional symptoms and lymphadenopathy	Usually mild and minimally tender	Unilateral or bilateral painful adenopathy in >50% Inguinal bubo formation and rupture may occur
Clinical suspicion	Typical lesions; positive HSV-2 type-specific virologic test from the lesion by NAAT or culture OR Type-specific serologic testing	A presumptive diagnosis requires two laboratory serologic tests, a nontreponemal test (i.e., VDRL or RPR), and a treponemal test (TP-PA) assay, various EIAs, chemiluminescence assays [CIA], and immunoblots or rapid treponemal assay)	If all four criteria are met: 1. ≥1 Painful genital ulcers 2. Typical ulcers and regional lymphadenopathy 3. No evidence of <i>T. pallidum</i> 4. HSV-1 or HSV-2 NAAT or HSV culture performed on the ulcer exudate or fluid are negative
Definitive diagnosis	Detection of HSV by culture or PCR from ulcer scraping or aspiration of vesicle fluid	Identification of <i>Treponema pallidum</i> from a chancre or lymph node aspirate on dark-field microscopy	Detection of <i>Haemophilus ducreyi</i> by culture

\*Primary syphilitic ulcers may be painful if they become coinfecting with bacteria or one of the other organisms responsible for genital ulcers.

EIA, Enzyme immunoassay; HSV, herpes simplex virus; PCR, polymerase chain reaction; RPR, rapid plasma reagin; VDRL, Venereal Disease Research Laboratories.

From <https://www.cdc.gov/std/treatment-guidelines/default.htm>





**Fig. 163.7** A, Initial herpes infection showing multiple erosions with polycyclic outlines surrounded by an erythematous halo and associated with intense pain. B, Erosions surrounded by an erythematous halo. Clinical signs and symptoms of recurrences are usually less intense than those of initial infection. (From Martín JM, Villalón G, Jordá E. Update on treatment of genital herpes. *Actas Dermosifiliogr.* 2009;100:22–32, Figs. 1 and 2.)

mucocutaneous lesions, and lymphadenopathy in addition to other nonspecific symptoms (e.g., sore throat, malaise), gastrointestinal symptoms (e.g., hepatitis), and renal symptoms. Tertiary syphilis presents with cardiac involvement, gummatous lesions, tabes dorsalis, and general paresis. Latent syphilis lacks clinical manifestations and is detected by serologic testing. Latent syphilis acquired within the preceding year is referred to as *early latent syphilis*. Latent syphilis acquired at least 1 year prior is referred to as *late latent syphilis*. Infections of the central nervous system (CNS) (neurosyphilis), of the visual system (ocular syphilis), or auditory system (otosyphilis) can occur at any stage.

**Lymphogranuloma venereum** caused by *C. trachomatis* serovars L1–L3 is uncommon, although outbreaks do occur in MSM. In these circumstances, proctitis or proctocolitis is the usual manifestation. HIV is often present in affected men. Unusual infectious causes of genital, anal, or perianal ulcers in the United States and other industrialized countries include chancroid and donovanosis.

**Monkeypox** (see Chapter 767) has been reported after sexual contact, particularly among MSM.

The differential diagnosis of genital ulcers also includes Behçet disease (see Chapter 202), Crohn disease (see Chapter 382.2), aphthous ulceration, and acute genital ulcers caused by cytomegalovirus (see Chapter 302) or EBV (see Chapter 301). Acute genital ulcers often follow a flu or mononucleosis-like illness in an immunocompetent person and are unrelated to sexual activity. The lesions are 0.5–2.5 cm in size, bilateral, symmetric, multiple, painful, and necrotic and are associated with inguinal lymphadenopathy. This primary infection is also associated with fever and malaise. The diagnosis may require EBV titers or polymerase chain reaction (PCR) testing. Treatment is supportive care, including pain management.

### Genital Lesions and Ectoparasites

Lesions that present as outgrowths on the surface of the epithelium and other limited epidermal lesions are included under this categorization of syndromes. HPV can cause genital warts and genital-cervical abnormalities that can lead to cancer (see Chapter 313). **Genital HPV** types are classified according to their association with cancer. Infections with low-risk types, such as **HPV types 6 and 11**, can cause benign or low-grade changes in cells of the cervix, genital warts, and recurrent respiratory papillomatosis. High-risk HPV types can cause cervical, anal, vulvar, vaginal, head, and neck cancers. **High-risk HPV types 16 and 18** are detected in approximately

70% of **cervical cancers**. Persistent infection increases the risk of cervical cancer. **Molluscum contagiosum** and **condyloma latum** associated with secondary syphilis complete the classification of genital lesion syndromes.

As a result of the close physical contact during sexual contact, common ectoparasitic infestations of the pubic area occur as **pediculosis pubis** or the papular lesions of **scabies** (see Chapter 709.2).

### HIV, Hepatitis B, and Hepatitis C

HIV and hepatitis B virus (HBV) present as asymptomatic, unexpected occurrences in most infected adolescents. High vaccination coverage rates among infants and adolescents have resulted in substantial declines in acute HBV incidence among U.S.-born adolescents. Risk factors identified in the history or routine screening during prenatal care are much more likely to result in suspicion of infection, leading to the appropriate laboratory screening, than are clinical manifestations in this age-group (see Chapters 322 and 406). HIV incidence among adolescents has also declined, though disparities based on race, ethnicity, gender, and region persist. Young adults continue to be affected by HIV as well. The US Preventive Services Task Force (USPSTF) recommends all individuals between ages 15 and 65 be tested for HIV at least once in their life, and the CDC recommends HIV testing once between 13 and 64 and once a year based on behaviors. Hepatitis C virus (HCV) incidence continues to be on the rise not only among individuals known to be part of the “baby boomer” generation but also among young adults. Because of the rise in injection opioid use and HCV, the American Association for the Study of Liver Disease and Infectious Disease Society of America (AASLD–IDSA), and CDC recommend HCV screening among all individuals 18 years old and older. They also recommend screening based on risk behaviors among individuals younger than age 18 (see Table 163.2).

### DIAGNOSIS

Most often, adolescents infected with bacterial and viral STI pathogens do not report symptoms suggestive of infection. With the use of very sensitive, noninvasive chlamydia and gonorrhea NAAT, providers are finding that most genital infections in females and many males are asymptomatic. A thorough sexual history is key to identifying adolescents who should be screened for STIs and for identifying those who require a laboratory diagnostic evaluation for an STI syndrome.

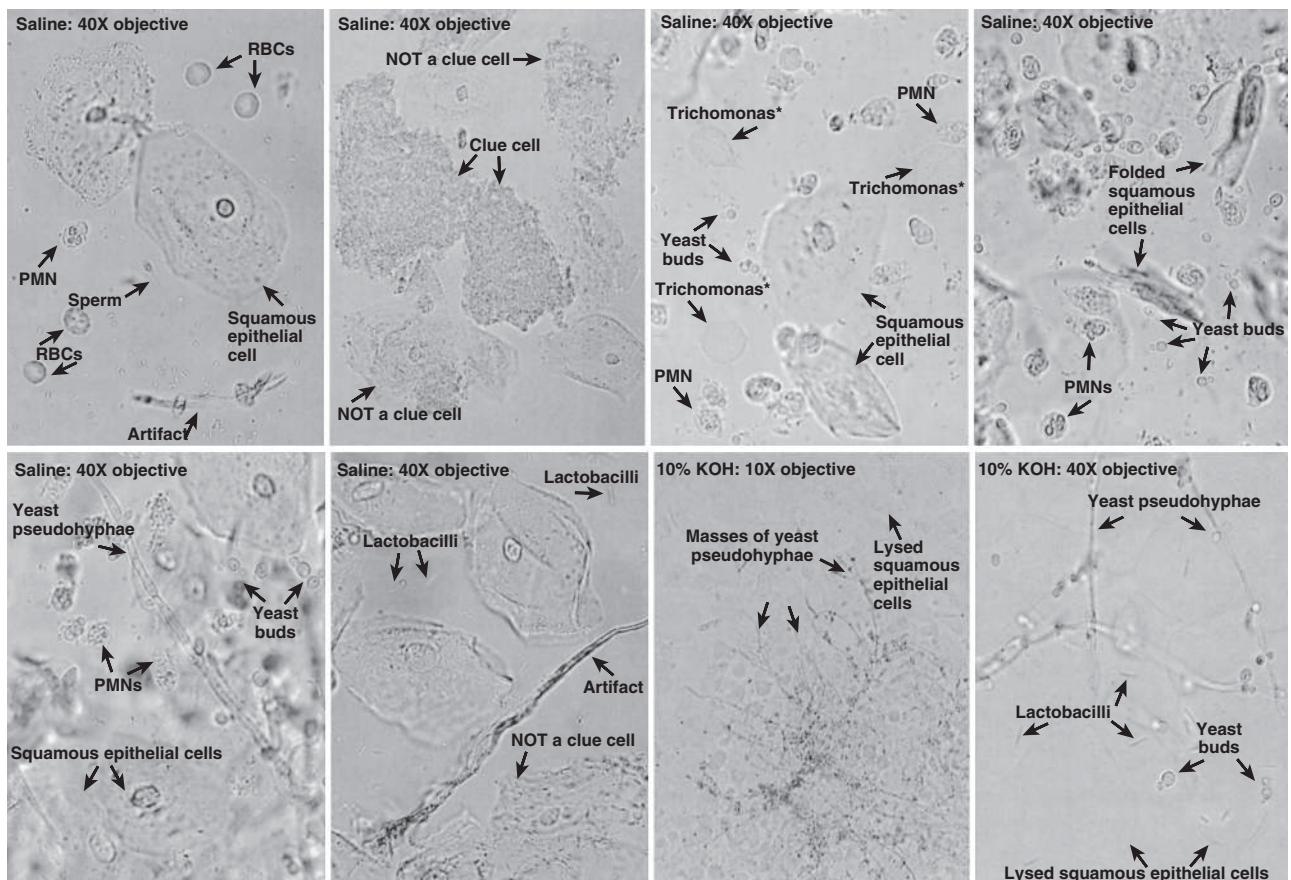
When eliciting a sexual health history, discussions should be appropriate for the patient's developmental level. In addition to questions regarding vaginal or urethral discharge, genital lesions, and lower abdominal pain among females, one should ask about prior treatment of any STI symptoms, including self-treatment using nonprescription medications. **Dyspareunia** is a consistent symptom in adolescents with PID. Providers must ask about oral or anal sexual activity to determine sites for specimen collection.

**Urethritis** should be objectively documented by evidence of inflammation or infectious etiology. Patient complaint without objective clinical or laboratory evidence does not fulfill diagnostic criteria. Inflammation can be documented by (1) observing urethral mucopurulent discharge, (2)  $\geq 2$  WBCs per high-power field on microscopic examination of Gram stain urethral secretions, (3) urine microscopic findings of  $\geq 10$  WBCs per high-power field of first-void urine specimen, or (4) a positive urine leukocyte esterase test of a first-void specimen. Laboratory evaluation is essential to identify the involved pathogens to determine treatment, partner notification, and disease control. *C. trachomatis* and *N. gonorrhoeae* NAATs of a urine specimen are recommended. The presence of gram-negative intracellular diplococci on microscopy obtained from a male urethral specimen confirms the diagnosis of gonococcal urethritis.

An essential component of the diagnostic evaluation of vaginal, cervical, or urethral discharge is a chlamydia and gonorrhea NAAT. NAATs are the most sensitive tests available in such cases and are licensed for use with urine, urethral, vaginal, and cervical specimens. Many of the chlamydia NAATs are approved by the U.S. Food and Drug Administration (FDA) to test patient-collected vaginal swabs in the clinical setting and liquid cytology specimens. Female vaginal swab specimens and male first-void urine are considered the optimal specimen types. Female urine remains an acceptable chlamydia and

gonorrhea NAAT specimen, but it may have slightly reduced performance when compared with cervical or vaginal swab specimens. Urine is the recommended specimen for male urethral infection. Gonorrhea and chlamydia NAATs perform well on rectal and oropharyngeal specimens and can be performed by clinical laboratories that have completed the appropriate verification studies to obtain Clinical Laboratory Improvement Amendments (CLIA) approval.

Evaluation of adolescent females with **vaginitis** includes laboratory data. Traditionally, the cause of vaginal symptoms was determined by pH and microscopic examination of the discharge. However, CLIA-waived point-of-care vaginitis tests are available. Using pH paper, an elevated pH (i.e.,  $>4.5$ ) is common with bacterial vaginosis and trichomoniasis. Because pH testing is not highly specific, discharge should be further examined. For microscopic exam, a slide can be made with the discharge diluted in 1–2 drops of 0.9% normal saline solution and another slide with discharge diluted in 10% KOH solution. Examining the saline specimen slide under a microscope may reveal motile or dead *T. vaginalis* or clue cells (epithelial cells with borders obscured by small bacteria), which are characteristic of **bacterial vaginosis**. WBCs without evidence of trichomonads or yeast are usually suggestive of cervicitis. This evaluation has been consistently shown to be highly subjective, which is why there are more NAAT tests available for diagnosis. The yeast or pseudohyphae of *Candida* species are more easily identified in the KOH specimen (Fig. 163.8). The sensitivity of microscopy is approximately 50% and requires immediate evaluation of the slide for optimal results. Therefore lack of findings does not eliminate the possibility of infection. More sensitive point-of-care vaginitis tests include the OSOM Trichomonas Rapid Test (Sekisui Diagnostics, Lexington, MA), an immunochromatographic capillary flow dipstick technology with reported 83% sensitivity. The OSOM BVBLUE Test (Sekisui) detects



**Fig. 163.8** Common normal and abnormal microscopic findings during examination of vaginal fluid. KOH, Potassium hydroxide solution; PMN, polymorphonuclear leukocyte; RBCs, red blood cells. (From *Adolescent Medicine: State of the Art Reviews*, vol. 14, no. 2. Philadelphia: Hanley & Belfus; 2003:350–351.)



**Table 163.4** Pathologic Vaginal Discharge

INFECTIVE DISCHARGE	OTHER REASONS FOR DISCHARGE
<b>COMMON CAUSES</b> <b>Organisms</b> <i>Candida albicans</i> <i>Trichomonas vaginalis</i> <i>Chlamydia trachomatis</i> <i>Neisseria gonorrhoeae</i> <i>Mycoplasma genitalium</i> <b>Conditions</b> Bacterial vaginosis Acute pelvic inflammatory disease Postoperative pelvic infection Postabortal sepsis Puerperal sepsis <b>LESS COMMON CAUSES</b> <i>Ureaplasma urealyticum</i> Syphilis <i>Escherichia coli</i>	<b>COMMON CAUSES</b> Retained tampon or condom Chemical irritation Allergic responses Ectropion Endocervical polyp Intrauterine device Atrophic changes <b>LESS COMMON CAUSES</b> Physical trauma Vault granulation tissue Vesicovaginal fistula Rectovaginal fistula Neoplasia Cervicitis

From Mitchell H. Vaginal discharge—causes, diagnosis, and treatment. *BMJ*. 2004;328:1306–1308; and Sexually Transmitted Infections Treatment Guidelines, 2021: Vulvovaginal Itching, Burning, Irritation, Odor or Discharge: <https://www.cdc.gov/std/treatment-guidelines/vaginal-discharge.htm>.

**Table 163.5** Evaluation for Pelvic Inflammatory Disease (PID)**2021 CDC DIAGNOSTIC CRITERIA****Minimal Criteria**

- Cervical motion tenderness

or

- Uterine tenderness

or

- Adnexal tenderness

**Additional Criteria to Enhance Specificity of the Minimal Criteria**

- Oral temperature >38.3°C (101°F)
- Abnormal cervical or vaginal mucopurulent discharge\*
- Presence of abundant numbers of WBCs on saline microscopy of vaginal secretions\*
- Elevated ESR or C-reactive protein
- Laboratory documentation of cervical *Neisseria gonorrhoeae* or *Chlamydia trachomatis* infection

**Most Specific Criteria to Enhance the Specificity of the Minimal Criteria**

- Transvaginal sonography or MRI techniques showing thickened, fluid-filled tubes, with or without free pelvic fluid or tuboovarian complex, or Doppler studies suggesting pelvic infection (e.g., tubal hyperemia)
- Endometrial biopsy with histopathologic evidence of endometritis
- Laparoscopic abnormalities consistent with PID

**Differential Diagnosis (Partial List)**

- Gastrointestinal: appendicitis, constipation, diverticulitis, gastroenteritis, inflammatory bowel disease, irritable bowel syndrome
- Gynecologic: ovarian cyst (intact, ruptured, or torsed), endometriosis, dysmenorrhea, ectopic pregnancy, mittelschmerz, ruptured follicle, septic or threatened abortion, tuboovarian abscess
- Urinary tract: cystitis, pyelonephritis, urethritis, nephrolithiasis
- ESR, Erythrocyte sedimentation rate; WBCs, white blood cells

\*If the cervical discharge appears normal and no WBCs are observed on the wet prep of vaginal fluid, the diagnosis of PID is unlikely and alternative causes of pain should be investigated.

Adapted from Centers for Disease Control and Prevention (CDC): <https://www.cdc.gov/std/treatment-guidelines/pid.htm>.

elevated vaginal fluid sialidase activity, an enzyme produced by bacterial pathogens associated with bacterial vaginosis, including *Gardnerella*, *Bacteroides*, *Prevotella*, and *Mobiluncus*, and has a reported

90% sensitivity. Both tests are CLIA waived, with results available in 10 minutes.

Clinical laboratory-based vaginitis tests are also available. The Affirm VPIII (Becton Dickinson) is a moderate-complexity nucleic acid probe test that evaluates for *T. vaginalis*, *G. vaginalis*, and *C. albicans* and has a sensitivity of 63% and specificity of >99.9%, with results available in 45 minutes. Some gonorrhea and chlamydia NAATs also offer an assay for *T. vaginalis* testing of female specimens tested for *N. gonorrhoeae* and *C. trachomatis*, considered the gold standard for *Trichomonas* testing.

Objective signs of vulvar inflammation in the absence of vaginal pathogens, along with a minimal amount of vaginal discharge, suggest the possibility of mechanical, chemical, allergic, or other noninfectious irritation of the vulva (Table 163.4).

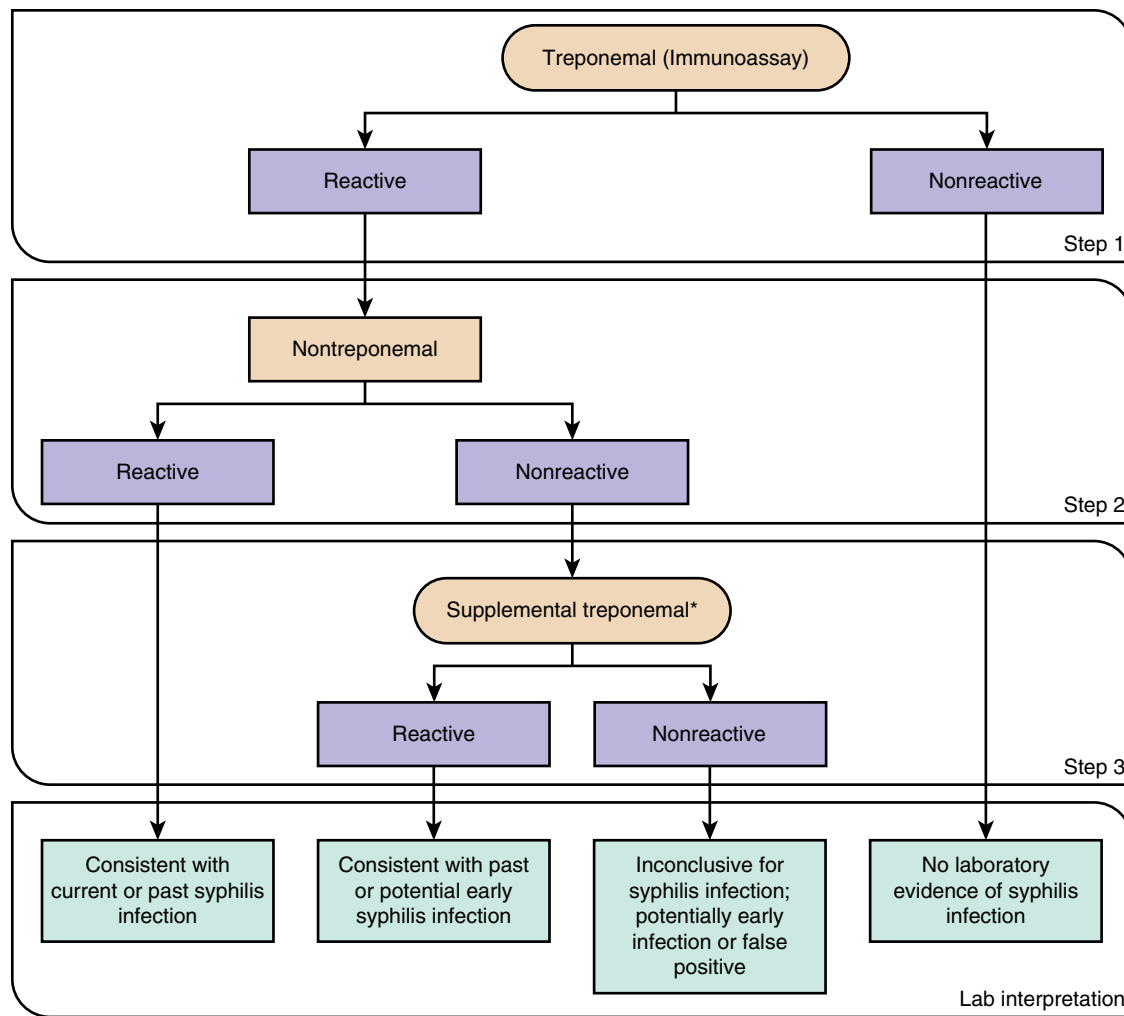
The **definitive diagnosis of PID** is difficult based on clinical findings alone. Clinical diagnosis is imprecise, and no single historical, physical, or laboratory finding is both sensitive and specific for the diagnosis of acute PID. Clinical criteria have a positive predictive value of only 65–90% compared with laparoscopy. Although healthcare providers should maintain a low threshold for the diagnosis of PID, additional criteria to enhance the specificity of diagnosis, such as transvaginal ultrasonography, can be considered (Table 163.5).

Cell culture and PCR are the preferred **HSV tests**. Viral culture sensitivity is low, and intermittent viral shedding causes false-negative results. NAATs, including PCR assays for HSV DNA, are more sensitive and increasingly available for diagnosing genital HSV. The Tzanck test is insensitive and nonspecific and should not be considered reliable.

Accurate type-specific **HSV serologic assays** are based on the HSV-specific glycoproteins G2 (HSV-2) and G1 (HSV-1). Both laboratory-based point-of-care tests are available. Because almost all HSV-2 infections are sexually acquired, the presence of type-specific HSV-2 antibody implies anogenital infection. The presence of HSV-1 antibody alone is more difficult to interpret because of the frequency of oral HSV infection acquired during childhood. Type-specific HSV serologic assays might be useful in the following scenarios: (1) recurrent genital symptoms or atypical symptoms with negative HSV cultures; (2) a clinical diagnosis of genital herpes without laboratory confirmation; and (3) a patient with a partner with genital herpes, especially if considering suppressive antiviral therapy to prevent transmission.

For **syphilis testing**, nontreponemal tests, such as the rapid plasma reagin (RPR) or Venereal Disease Research Laboratories (VDRL), and treponemal testing, such as fluorescent treponemal antibody absorbed tests, the *T. pallidum* passive particle agglutination (TP-PA) assay, and various enzyme and chemiluminescence immunoassays (EIA/CIA), are recommended. However, many clinical laboratories have adopted a *reverse sequence* of screening in which a treponemal EIA/CIA is performed first, followed by testing of reactive sera with a nontreponemal test (e.g., RPR). Treponemal tests often remain positive for life, with only 15–25% becoming serologically nonreactive, if treated early in primary syphilis. A positive treponemal EIA or CIA test can identify both *previously treated and untreated or incompletely treated syphilis*. False-positive results can occur, particularly among populations with low syphilis prevalence. Persons with a positive treponemal screening test should have a standard nontreponemal test with titer (RPR or VDRL) to guide patient management decisions. If EIA/CIA and RPR/VDRL results are discordant, the laboratory should perform a different treponemal test to confirm the results of the initial test. Patients with discordant serologic results by EIA/CIA and RPR/VDRL testing whose sera are reactive by TP-PA testing are considered to have past or present syphilis; if sera are TP-PA nonreactive, syphilis is unlikely (Fig. 163.9).

**Rapid HIV testing** with third- and fourth-generation test results available in 10–20 minutes can be useful when the likelihood of adolescents returning for their results is low. Point-of-care CLIA-waived tests for whole blood finger stick (fourth generation) and oral fluid specimens (third generation) testing are available. Clinical studies have demonstrated that the rapid HIV test performance is comparable to those of EIAs. Because some reactive test results may be false positive, every reactive rapid test must be confirmed.



**Fig. 163.9** Centers for Disease Control and Prevention (CDC)–recommended algorithm for reverse-sequence syphilis screening: Treponemal test screening followed by nontreponemal test confirmation. \*The supplemental treponemal test should use a unique platform and/or antigen different from the first treponemal test. (From Association of Public Health Laboratories. *Suggested Reporting Language for Syphilis Serological Testing*. Association of Public Health Laboratories August 2020 [https://www.aphl.org/programs/infectious\\_disease/std/Documents/ID-2020Aug-Syphilis-Reporting-Language.pdf](https://www.aphl.org/programs/infectious_disease/std/Documents/ID-2020Aug-Syphilis-Reporting-Language.pdf).)

Table 163.6 Management Guidelines for Uncomplicated Bacterial STIs in Adolescents and Adults		
PATHOGEN	RECOMMENDED REGIMENS	ALTERNATIVE REGIMENS AND SPECIAL CONSIDERATIONS
<i>Chlamydia trachomatis</i>	Doxycycline 100 mg orally 2×/day for 7 days <b>For pregnancy:</b> Azithromycin 1 g orally in a single dose	Azithromycin 1 g orally in a single dose <b>OR</b> Levofloxacin 500 mg orally 1×/day for 7 days <b>For pregnancy:</b> Amoxicillin 500 mg orally 3×/day for 7 days
<i>Neisseria gonorrhoeae</i> (cervix, urethra, and rectum)	Ceftriaxone 500 mg IM in a single dose for persons weighing <150 kg If chlamydial infection has not been excluded, treat for chlamydia with doxycycline 100 mg orally 2×/day for 7 days For person weighing >150 kg, ceftriaxone 1 g should be administered	<b>If cephalosporin allergy or unavailable:</b> Gentamicin 240 mg IM in a single dose <b>PLUS</b> Azithromycin 2 g orally in a single dose <b>OR</b> Cefixime 800 mg orally in a single dose
<i>Neisseria gonorrhoeae</i> (pharynx)	Ceftriaxone 500 mg IM in a single dose for person weighing <150 kg Ceftriaxone 1 g IM for a person weighing ≥150 kg	
<i>Treponema pallidum</i> (primary and secondary syphilis or early latent syphilis, i.e., infection <12 mo)	Benztamine penicillin G 2.4 million units IM in a single dose	<b>Penicillin allergy:</b> Doxycycline 100 mg orally twice daily for 14 days or tetracycline 500 mg orally 4 times daily for 14 days; limited data suggest ceftriaxone 1-2 g daily either IM or IV for 10-14 days <b>OR</b> Azithromycin 2 g orally in a single dose has been effective, but treatment failures have been documented

Continued



**Table 163.6** Management Guidelines for Uncomplicated Bacterial STIs in Adolescents and Adults—cont'd

<b>PATHOGEN</b>	<b>RECOMMENDED REGIMENS</b>	<b>ALTERNATIVE REGIMENS AND SPECIAL CONSIDERATIONS</b>
<i>Treponema pallidum</i> (late latent syphilis or syphilis of unknown duration)	Benzathine penicillin G 7.2 million units total, administered as three doses of 2.4 million units IM each at 1-wk intervals	<b>Penicillin allergy:</b> Doxycycline 100 mg orally twice daily for 28 days or tetracycline 500 mg orally 4 times daily for 28 days, with close serologic and clinical follow-up
<i>Treponema pallidum</i> (neurosyphilis, ocular syphilis, and otosyphilis)	Aqueous crystalline penicillin G 18-24 million units per day, administered as 3-4 million units by IV every 4 hr or continuous infusion, for 10-14 days	Procaine penicillin G 2.4 million units IM 1×/day for 10-14 days <b>PLUS</b> Probenecid 500 mg orally 4×/day for 10-14 days
<i>Haemophilus ducreyi</i> (chancroid: genital ulcers, lymphadenopathy)	Azithromycin 1 g orally in a single dose <b>OR</b> Ceftriaxone 250 mg IM in a single dose <b>OR</b> Ciprofloxacin 500 mg orally 2× daily for 3 days <b>OR</b> Erythromycin base 500 mg orally 3× daily for 7 days	
<i>Chlamydia trachomatis</i> serovars L1, L2, or L3 (lymphogranuloma venereum)	Doxycycline 100 mg orally 2× daily for 21 days	<b>Alternative:</b> Erythromycin base 500 mg orally 4× daily for 21 days <b>OR</b> Azithromycin 1 g orally once weekly for 3 wk

IM, Intramuscularly; IV, intravenously; NAAT, nucleic acid amplification test.

Adapted from Centers for Disease Control and Prevention. Sexually transmitted diseases: treatment guidelines, 2021. *MMWR Recomm Rep.* 2021;70:1–187, <https://www.cdc.gov/std/treatment-guidelines/default.htm>.

**Table 163.7** Management Guidelines for Uncomplicated Miscellaneous Sexually Transmitted Infections in Adolescents and Adults

<b>PATHOGEN</b>	<b>RECOMMENDED REGIMENS</b>	<b>ALTERNATIVE REGIMENS AND SPECIAL CONSIDERATIONS</b>
Trichomoniasis	<b>Women:</b> Metronidazole 500 mg orally 2×/day for 7 days <b>Men:</b> Metronidazole 2 g orally in a single dose	For women and men: Tinidazole 2 g orally in a single dose
<i>Phthirus pubis</i> (pediculosis pubis, e.g., pubic lice)	Permethrin 1% cream rinse applied to affected areas and washed off after 10 min <b>OR</b> Pyrethrins with piperonyl butoxide applied to affected areas and washed off after 10 min Launder clothing and bedding	Malathion 0.5% lotion applied for 8-12 hr and washed off <b>OR</b> Ivermectin 250 µg/kg orally, repeat in 7-14 days
<i>Sarcoptes scabiei</i> (scabies)	Permethrin 5% cream applied to all areas of the body (from neck down), wash after 8-14 hr <b>OR</b> Ivermectin 200 µg/kg body weight orally, repeated in 14 days Launder clothing and bedding	Lindane (1%) 1 oz of lotion or 30 g of cream in thin layer to all areas of body from neck down; wash off after 8 hr

Adapted from Centers for Disease Control and Prevention. Sexually transmitted diseases: treatment guidelines. *MMWR.* 2021;64(RR-3); <https://www.cdc.gov/std/treatment-guidelines/STI-Guidelines-2021.pdf>.

## TREATMENT

See Part XV for chapters on the treatment of specific microorganisms and [Tables 163.6-163.8](#). Treatment regimens using nonprescription products for candidal vaginitis and pediculosis reduce financial and access barriers to rapid treatment for adolescents, but potential risks for inappropriate self-treatment and complications from untreated, more serious infections must be considered before using this approach. Minimizing noncompliance with treatment, notifying and treating the sexual partners, addressing prevention and contraceptive issues, offering available vaccines to prevent STIs, and making every effort to preserve fertility are additional physician responsibilities.

Chlamydia- and gonorrhea-infected males and females should be retested approximately 3 months after treatment, regardless of whether they believe that their sex partners were treated, or whenever persons next present for medical care in the 12 months after initial treatment. Adolescents who are pregnant with chlamydia and gonorrhea infections should be retested in approximately 1 month after treatment. Adolescents with oral gonorrhea should be retested in 7-14 days. Once an infection is diagnosed, partner evaluation, testing, and treatment are recommended for sexual contacts within 60 days of symptoms or diagnosis, or the most recent partner if sexual contact was >60 days, even if the partner is asymptomatic. Abstinence is recommended for at least 7 days

**Table 163.8** Management Guidelines for Uncomplicated Genital Warts and Genital Herpes in Adolescents and Adults

PATHOGEN	RECOMMENDED REGIMENS	ALTERNATIVE REGIMENS AND SPECIAL CONSIDERATIONS
<b>HUMAN PAPILLOMAVIRUS (HPV)</b>		
External anogenital warts (penis, groin, scrotum, vulva, perineum, external anus, and perianus)	<p><b>Patient applied:</b> Imiquimod 3.75–5% cream self-applied to warts at bedtime nightly for up to 16 wk; wash off after 6–10 hr</p> <p><b>OR</b></p> <p>Podofilox 0.5% solution or gel self-applied to warts twice daily for 3 consecutive days each wk followed by 4 days of no therapy. May be repeated for up to four cycles.</p> <p><b>OR</b></p> <p>Sinecatechins 15% ointment self-applied 3 times daily for up to 16 wk. Do not wash off after use, and avoid genital, anal, and oral sexual contact while ointment is on skin.</p> <p><b>Provider-administered:</b> Cryotherapy with liquid nitrogen or cryoprobe. Repeat applications every 1–2 wk.</p> <p><b>OR</b></p> <p>Surgical removal either by tangential scissor excision, electrocautery, tangential shave excision, curettage, laser or electrosurgery.</p> <p><b>OR</b></p> <p>Trichloroacetic acid (TCA) or bichloroacetic acid (BCA) 80–90%; small amount applied only to warts and allowed to dry, when white “frosting” develops; can be repeated weekly.</p>	<p><b>Provider administered:</b> Podophyllin resin 10–25% in a compound tincture of benzoin applied to each wart and then allowed to air-dry; thoroughly wash off after 1–4 hr; can be repeated weekly. Systemic toxicity has been reported when podophyllin resin was applied to large areas of friable tissue and was not washed off within 4 hr.</p> <p>Many persons with external anal warts also have <b>intraanal warts</b> and might benefit from inspection of anal canal by digital examination, standard anoscopy, or high-resolution anoscopy.</p>
Cervical warts	<p>Cryotherapy with liquid nitrogen</p> <p><b>OR</b></p> <p>Surgical removal</p> <p><b>OR</b></p> <p>TCA or BCA 80–90% solution</p> <p>Management should include consultation with a specialist.</p>	
Vaginal warts	<p>Cryotherapy with liquid nitrogen; avoid cryoprobe use because of risk for vaginal perforation and fistula formation.</p> <p><b>OR</b></p> <p>Surgical removal</p> <p><b>OR</b></p> <p>TCA or BCA 80–90%; small amount applied only to warts and allowed to dry, when white “frosting” develops; can be repeated weekly.</p>	
Urethral meatal warts	<p>Cryotherapy with liquid nitrogen</p> <p><b>OR</b></p> <p>Surgical removal</p>	
Intraanal warts	<p>Cryotherapy with liquid nitrogen</p> <p><b>OR</b></p> <p>Surgical removal</p> <p><b>OR</b></p> <p>TCA or BCA 80–90% applied to warts. A small amount should be applied only to warts and allowed to dry, at which time a white “frosting” develops. Can be repeated weekly.</p>	Management of intraanal warts should include consultation with a specialist.
<b>HERPES SIMPLEX VIRUS (HSV; GENITAL HERPES)</b>		
First clinical episode	<p><b>Treat for 7–10 days with one of the following:</b> Acyclovir 400 mg orally 3× daily Valacyclovir 1 g orally 2× daily Famciclovir 250 mg orally 3× daily</p>	Consider extending treatment if healing is incomplete after 10 days of therapy.
Episodic therapy for recurrences	<p><b>Treat with one of the following:</b> Acyclovir 800 mg orally 2× daily for 5 days Acyclovir 800 mg orally 3× daily for 2 days Valacyclovir 500 mg orally 2× daily for 3 days Valacyclovir 1,000 mg orally once daily for 5 days Famciclovir 1,000 mg orally 2× daily for 1 day Famciclovir 500 mg orally once, then 250 mg 2× daily for 2 days Famciclovir 125 mg orally twice daily for 5 days</p>	Effective episodic treatment of recurrences requires initiation of therapy within 1 day of lesion onset or during the prodrome that precedes some outbreaks. The patient should be provided with a supply or a prescription for the medication with instructions to initiate treatment immediately when symptoms begin.
Suppressive therapy to reduce frequency of recurrences	<p><b>Treat with one of the following:</b> Acyclovir 400 mg orally 2× daily Valacyclovir 500 mg orally once daily* or 1 g orally once daily Famciclovir 250 mg orally 2× daily</p>	All patients should be counseled regarding suppressive therapy availability, regardless of number of outbreaks per year. Because the frequency of recurrent outbreaks diminishes over time in many patients, providers should periodically discuss the need to continue therapy.

Continued

**Table 163.8** Management Guidelines for Uncomplicated Genital Warts and Genital Herpes in Adolescents and Adults—cont'd

PATHOGEN	RECOMMENDED REGIMENS	ALTERNATIVE REGIMENS AND SPECIAL CONSIDERATIONS
Daily suppressive therapy in persons with HIV infection	Acyclovir 400-800 mg orally 2-3× daily <b>OR</b> Famciclovir 500 mg orally 2× daily <b>OR</b> Valacyclovir 500 mg orally 2× daily	If lesions persist or recur in a patient receiving antiviral treatment, acyclovir resistance should be suspected and a viral culture obtained for phenotypic sensitivity testing. Consultation with an infectious disease specialist is recommended.
Episodic infection in persons with HIV	Acyclovir 400 mg orally 3× daily for 7-10 days <b>OR</b> Famciclovir 250 mg orally 3×/day for 7-10 days <b>OR</b> Valacyclovir 1g orally 2× for 7-10 days	If lesions persist or recur in a patient receiving antiviral treatment, acyclovir resistance should be suspected and a viral culture obtained for phenotypic sensitivity testing. Consultation with an infectious disease specialist is recommended.
Daily suppressive therapy of recurrent genital herpes in pregnant women	<b>Treatment is recommended to start at 36 wk gestation:</b> Acyclovir 400 mg orally 3× daily <b>OR</b> Valacyclovir 500 mg orally 2× per day	

\*Valacyclovir 500 mg once daily might be less effective than other valacyclovir or acyclovir dosing regimens in patients who have very frequent recurrences (i.e., ≥10 episodes per yr). Adapted from Centers for Disease Control and Prevention. Sexually transmitted diseases: treatment guidelines, *MMWR* 2021;64(RR-3): <https://www.cdc.gov/std/treatment-guidelines/STI-Guidelines-2021.pdf>.

**Table 163.9** Option for Pre-Exposure Prophylaxis (PrEP) for HIV Prevention

GENERIC	DOSE	FREQUENCY	POPULATION
Tenofovir disoproxil fumarate + emtricitabine (F/TDF)*	200 mg/300 mg	Daily pill	Any person weighing at least 35 kg
Tenofovir alafenamide + emtricitabine (F/TAF)	200 mg/25 mg	Daily pill	Individuals engaging in anal sex who are cis male, transwomen weighing at least 35 kg
Cabotegravir	200 mg/mL	Every 2 month injection	Any person weighing at least 35 kg

\*F/TDF is also available by brand name and generic depending on insurance. It can also be used as intermittent dosing for cis-men and transwomen engaging in anal sex.

after both patient and partner have completed treatment. A test for pregnancy should be performed for all females with suspected PID because the test outcome will affect management. Repeat testing 3 months after treatment is also recommended for *Trichomonas* infection.

Diagnosis and therapy are often carried out within the context of a **confidential** relationship between the physician and the patient. Therefore the need to report certain STIs to health department authorities should be clarified at the outset. Health departments are Health Insurance Portability and Affordability Act (HIPAA) exempt and will not violate confidentiality. The health department's role is to ensure that treatment and case finding have been accomplished and that sexual partners have been notified of their STI exposure. **Expedited partner therapy (EPT)**, the clinical practice of treating sex partners of patients diagnosed with chlamydia or gonorrhea by providing prescriptions or medications to the patient to take to the partner without the health-care provider first examining the partner, is a strategy to reduce further transmission of infection. In randomized trials, EPT has reduced the rates of persistent or recurrent gonorrhea and chlamydia infection. Serious adverse reactions are rare with recommended chlamydia and gonorrhea treatment regimens, such as doxycycline, azithromycin, and ceftriaxone. Transient gastrointestinal side effects are more common but rarely result in severe morbidity. Most states expressly permit EPT or may allow its practice. Resources for information regarding EPT and state laws are available at the CDC website.

## PREVENTION

Healthcare providers should integrate comprehensive **sexuality education** into clinical practice with children from early childhood

through adolescence. Providers should counsel adolescents regarding sexual behaviors associated with risk of STI acquisition and should educate using evidence-based prevention strategies, which include a discussion of abstinence and other risk reduction strategies, such as consistent and correct condom use, and distribution of educational materials for reinforcement. The USPSTF recommends **high-intensity behavioral counseling** to prevent STIs for all sexually active adolescents.

The following recommendations for the primary prevention of STIs through vaccination are based on published guidelines from the Advisory Committee on Immunization Practices:

- HPV vaccination is recommended through age 26 years for males and females not vaccinated previously at the routine age of 11 or 12 years. Vaccination can be started at age 9. Two doses of HPV vaccine are recommended for most persons starting the series before their 15th birthday; three doses are recommended at ≥ 15 years.
- The HBV vaccination series is recommended for all adolescents and young adults who have not previously received the universal HBV vaccine series during childhood.
- Mpox vaccination is recommended for gay, bisexual, transgender persons and if the patient has had sexual or intimate contact with someone who may have mpox. Mpox vaccination is a two-dose schedule separated by 4 weeks.

Preexposure prophylaxis (PrEP) offers another strategy to specifically prevent HIV infection (Table 163.9).

The CDC and USPSTF recommend offering HIV PrEP to adolescents weighing ≥35 kg and young adults who are HIV negative and

Section 1

## Evaluation of the Immune System

Chapter 164

### Orientation to the Consideration of Inborn Errors of Immunity

Soma Jyonouchi and Kathleen E. Sullivan

**Primary immune deficiency diseases (PIDDs)** comprise more than 450 disorders that impair the development or function of the immune system. Most these disorders result from a single gene pathogenic variant, although more complex inheritance patterns can also occur.

The initial diagnosis and subsequent treatment of PIDDs are often delayed due to a low index of suspicion, a rare individual disease incidence, protein manifestations including infection, autoimmunity, cutaneous lesions, and failure to thrive all in the background of a higher frequency of more common childhood illnesses (nonspecific viral illness, allergy). This diagnostic delay can lead to irreversible end-organ damage or death.

Newborn screening for severe combined immune deficiency (SCID) has helped the early detection of SCID and other immune deficiencies associated with very low T cells. However, the vast majority of immune deficiencies will not be detected by this method. Physicians must be aware of concerning manifestations or events that suggest an underlying PIDD. The varied presentations and complex phenotypes,

some of which have minimal or no infectious manifestations, make the initial diagnosis of PIDDs difficult (Table 164.1). Manifestations of PIDD include recurrent and/or sentinel infections, fever without a focus, periodontitis, poor formation of pus at a site of infection, and unusual inflammatory (including autoimmune) diseases. PIDDs may involve defects in one or more host defense mechanism, or they may be an independent isolated disorder or part of a recognizable syndrome (Table 164.2).

The immune system is primarily responsible for protecting the body against invading infectious pathogens. Recurrent (often in multiple sites), severe, or unusual infections are typical presentations of PIDDs. Viral, bacterial, fungal, and mycobacterial infections each require distinct arms of the immune system for eradication; identification of the microbe causing an infection is helpful in directing the evaluation of a patient with suspected PIDD (see Table 164.1; Table 164.3). Children who exceed the normal frequency of infections or who have very prolonged symptoms suggesting failure of pathogen clearance may also warrant evaluation. The typical preschool child can have 6-10 viral respiratory infections per year, making this assessment less than straightforward. Patients with PIDD are significantly more likely to have severe infections requiring hospitalization and prolonged or unsuccessful treatment with IV antibiotics. Infections with unusual pathogens (opportunistic organisms) or infections resulting from live attenuated virus vaccines (rotavirus, varicella, MMR) are important warning signs. Neutropenia or lymphocytopenia may be present.

In addition to pathogen defense, the immune system must demonstrate tolerance to the host and prevent excessive inflammation that can result in tissue damage. In addition to infections, patients can present with autoimmune disease and/or autoinflammatory conditions. The presence of a family history of PIDD or consanguinity should increase suspicion for these conditions.

The patient's clinical presentation can help guide the initial laboratory evaluation (Fig. 164.1).

#### INFECTION RED FLAGS

Infections are one of the more common reasons to initiate an immunologic evaluation. The pattern and etiology of the infections dictate the appropriate diagnostic evaluation. A high burden of infections in a child is the most common reason for referral to an immunology

**Table 164.1** Patterns of Infections and Other Conditions in Primary Immunodeficiency

DISORDER	ILLNESSES	
	TYPE OF INFECTION	OTHER CONDITIONS
Antibody defects	Sinopulmonary infections ( <i>Streptococcus pneumoniae</i> , <i>Haemophilus influenzae</i> , or <i>Mycoplasma sp.</i> ) Gastrointestinal (enteroviruses, <i>Salmonella</i> , <i>Campylobacter</i> , <i>Giardia</i> , norovirus)	Autoimmune disease (thrombocytopenia, hemolytic anemia, neutropenia) Inflammatory bowel disease Lymphadenopathy, splenomegaly Otitis, mastoiditis
Cell-mediated immunity defects	Pneumonia ( <i>Pneumocystis jirovecii</i> ), <i>Mycobacterium avium-intracellulare</i> Severe Epstein-Barr infection Gastrointestinal disease (viruses, cytomegalovirus) Fungi of the skin, nails, mucous membranes	Failure to thrive Splenomegaly, lymphadenopathy
Defects of phagocytosis	Skin, liver, lymph nodes, abscesses ( <i>Staphylococcus</i> , gram-negative bacteria, fungi)	Inflammatory bowel disease Granulomatous infiltrations
Defects of complement	Sepsis and other blood-borne encapsulated bacteria; meningitis, ( <i>Streptococcus</i> , <i>Pneumococcus</i> , <i>Neisseria</i> )	Autoimmune disease (systemic lupus erythematosus, ANA+, glomerulonephritis)

ANA, Antinuclear antibodies.

From Leung DYM, Akdis CA, Bacharier LB, et al., eds. *Pediatric Allergy Principles and Practice*. 4th ed. Philadelphia: Elsevier; 2021. Table 4.1, p. 32.



**Table 164.2** Types of Primary Immune Defects

<b>IMMUNODEFICIENCIES AFFECTING CELLULAR AND HUMORAL IMMUNITY</b>	
T-B <sup>+</sup> NK- SCID	Common gamma chain (IL2RG, X-linked), JAK3
T-B <sup>+</sup> NK <sup>+</sup> SCID	IL7- $\alpha$ , T-cell receptor defects, CD45, PNP deficiency
T-B <sup>-</sup> SCID	RAG1, RAG2 defects, adenosine deaminase deficiency
<b>COMBINED IMMUNODEFICIENCIES, GENERALLY LESS SEVERE</b>	
MHC class I and II defects; T-cell receptor defects; DOCK8, IL21, and IL21R, and others	
<b>COMBINED IMMUNODEFICIENCIES WITH SYNDROMIC OR OTHER FEATURES</b>	
With thrombocytopenia	Wiskott-Aldrich syndrome
DNA repair defects	Ataxia telangiectasia, Nijmegen breakage syndrome; Bloom syndrome, dyskeratosis congenital, LIG-4
Hyper-IgE syndromes	STAT3 loss of function, and others
Immuno-osseous dysplasias	Cartilage hair hypoplasia Schimke immuno-osseous dysplasia
Ectodermal dysplasia	IKBKG deficiency (NEMO)
<b>THYMIC DEFECTS WITH ADDITIONAL CONGENITAL ANOMALIES</b>	
DiGeorge, velocardiofacial syndrome CHARGE syndrome	
<b>ANTIBODY DEFECTS</b>	
Agammaglobulinemias	X-linked and autosomal forms of agammaglobulinemia
Hyper-IgM syndromes	X-linked and autosomal forms
IgG or IgA deficiency	IgG subclass and IgA deficiency
IgG, and IgA and or IgM deficiency	Common variable immunodeficiency
<b>DISEASES OF IMMUNE DYSREGULATION</b>	
Familial hemophagocytic lymphohistiocytosis	Perforin deficiency; UNC13D.
With hypopigmentation	Chédiak-Higashi, Griscelli, Hermansky-Pudlak syndromes
With autoimmunity	Autoimmune polyendocrinopathy with candidiasis and ectodermal dystrophy, autoimmune lymphoproliferative syndrome
With defects of regulatory T cells	X-linked immune dysregulation, polyendocrinopathy enteropathy (IPEX), defects of CTLA4, STAT3
Leading to severe Epstein-Barr virus	X-linked autoimmune lymphoproliferative syndrome, XIAP deficiency, magnesium transporter 1 (MAGT1)
With colitis	IL-10 defects
<b>CONGENITAL DEFECTS OF PHAGOCYTE NUMBER OR FUNCTION</b>	
Neutropenia	Elastase deficiency, HAX1 deficiency, and others
Defects of motility	Leukocyte adhesion deficiency
Defects of respiratory burst	Chronic granulomatous disease
Other nonlymphoid defects	GATA2 deficiency
<b>DEFECTS IN INTRINSIC AND INNATE IMMUNITY</b>	
Mycobacterial disease	IL-12, IL-23, INF- $\gamma$ , STAT1 defects, and others
Warts	Epidermodysplasia verruciformis (EVER), hypogammaglobulinemia, infections, myelokathexis syndrome (WHIM)
Viral infections	STAT1, STAT2, IRF7, and others
Herpes simplex encephalitis	TLR3, UNC93B1
Fungal diseases	CARD9, IL17 defects, STAT1
Bacterial susceptibility	IRAK4, MYD88, IRAK1, and others
<b>COMPLEMENT DEFICIENCY</b>	
Classical pathway	C1q-C9 defects
Alternative pathway	Factors B, D, I, H, properdin, and others
Regulatory and membrane controls	Co-factor proteins

CHARGE defect, Disorder with coloboma, heart defects, atresia choanae (also known as choanal atresia), growth retardation, genital abnormalities, and ear abnormalities; Ig, immunoglobulin; MHC, major histocompatibility complex; NK, natural killer; PNP, purine nucleoside phosphorylase; SCID, severe combined immunodeficiency. From Leung DYM, Akdis CA, Bacharier LB, et al., eds. *Pediatric Allergy Principles and Practice*. 4th ed. Philadelphia: Elsevier; 2021. Table 4.2, p. 33-34.

center; there are certain patterns that can collectively be thought of as **red flags**, mandating an immunologic evaluation.

### Recurrent Sinopulmonary Infections

Recurrent bacterial sinopulmonary infections (ear, sinus, pneumonia) with encapsulated organisms are a common presentation for PIDDs. It can be challenging to define a number of infections that represent a

threshold to begin an immunologic evaluation. Typically, most patients with a PIDD will have a diversity of sites impacted by infection; the frequency will be higher or the severity more severe than the clinician would expect. Recurrent sinopulmonary infections are highly suggestive of patients with antibody deficiencies, such as common variable immunodeficiency (CVID; see [Chapter 165](#)) or X-linked agammaglobulinemia (XLA; see [Chapter 166](#)). Patients often require *longer courses*

**Table 164.3** Sentinel Infections and Related Genes

INFECTIONS	RECOGNIZED GENE DEFECTS AND WELL-CHARACTERIZED SYNDROMES
<b>VIRUSES</b>	
Herpes simplex encephalitis	<i>TBK1, TLR3, TRAF3, TRIF, UNC93B</i>
Cutaneous herpes simplex	Severe T-cell defects, <i>DOCK8, GATA2, WAS</i>
EBV—chronic	<i>CD21, CD27, CORO1A, ITK, MAGT1, PRKCD, CXCR4</i>
EBV—HLH	<i>AP3B1, LYST1, PRF1, RAB27A, SH2D1A, STX11, UNC13D, XIAP</i>
CMV	Severe T-cell defects, Good syndrome, <i>DOCK8, GATA2, STIM1, WAS</i>
Papilloma virus	Idiopathic CD4 lymphopenia, <i>ATM, CD40L, EVER1, EVER2, DOCK8, GATA2, IKBKG, MST1, RORH, STK4, CXCR4</i>
<b>FUNGI</b>	
<i>Candida</i>	<i>AIRE, CARD9, IL17F, IL17RA, STAT1</i>
<i>Aspergillus</i>	Idiopathic CD4 lymphopenia, <i>CYBA, CYBB, DOCK8, GATA2, ITGB2, NCF1, NCF2, NCF4, STAT3</i>
<b>BACTERIA</b>	
<i>Pseudomonas</i>	Congenital neutropenia, <i>IRAK4, ITGB2, MYD88, BTK</i> (neutropenia), <i>CD40LG</i> (neutropenia)
<i>Salmonella</i>	<i>CYBB, IFNGR1, IFNGR2, IL12B, IL12RB1</i>
<i>Serratia</i>	<i>CYBA, CYBB, NCF1, NCF2, NCF4</i>
<i>Neisseria</i>	<i>C5, C6, C7, C8A, C8B, C8G, C9, CFD, CFH, CFI, CFP</i>
<i>Streptococcus pneumoniae</i>	<i>C1QA, C1QB, C1QC, C4A + C4B, C2, C3, IRAK4, MYD88</i>
<b>MYCOBACTERIA</b>	
<i>Mycobacteria</i>	<i>CYBA, CYBB, GATA2, IFNGR1, IFNGR2, IKBKG, IL12, IL12RB1, IRF8, NCF1, NCF2, NCF4, STAT1, TYK2</i>

CMV, Cytomegalovirus; EBV, Epstein-Barr virus; HLH, hemophagocytic lymphohistiocytosis. From Sullivan KE, Stiehm ER, eds. *Stiehm's Immune Deficiencies*. 2nd ed. London: Elsevier; 2020. Table 1.2.

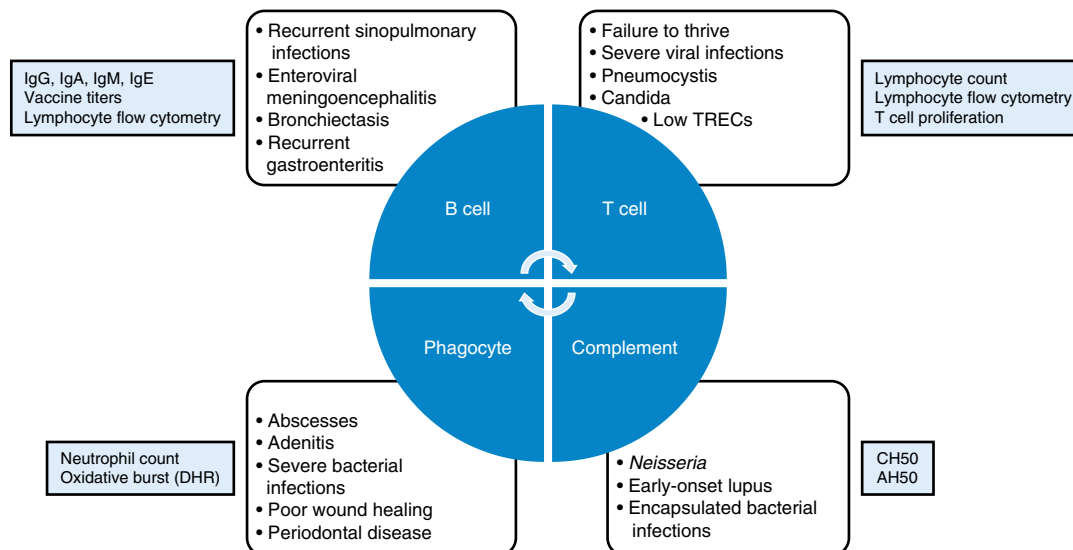
of antibiotics to clear infections and may not have improvement with standard interventions such as bilateral myringotomy tubes or sinus surgery.

### Recurrent Invasive Pneumococcal Infections

Invasive pneumococcal infections (sepsis, septic arthritis, meningitis) may occur in patients with antibody deficiency (Table 164.4). A single episode need not imply a PID. Recurrent invasive pneumococcal infections should elicit an evaluation. Pneumococcus has a polysaccharide capsule that permits it to evade the immune system. Antibodies bind to these bacteria (opsonization), which facilitates phagocytosis and bacterial killing. The early complement fragment C3b also opsonizes bacteria, labeling it for destruction. Patients with **early classical complement component deficiencies** (see Chapter 173) have an increased risk of invasive infections with encapsulated bacteria such as pneumococcus. The spleen plays a key role in the phagocytosis and clearance of nonopsonized bacteria. Thus **primary or secondary asplenia** is associated with an increased risk of disseminated infections with pneumococcus (and meningococcus) requiring patients to take antibiotic prophylaxis. Patients with **toll-like receptor (TLR) defects** (IRAK4, MyD88, and NEMO deficiency) develop invasive pneumococcal and *Staphylococcus aureus* infections. These patients uniquely fail to (or minimally) manifest signs of inflammation (fevers, elevated CRP, ESR) despite having invasive infections; this is the result of a block in the pathway that produces inflammatory cytokines such as interleukin (IL)-6 and tumor necrosis factor (TNF)- $\alpha$ , critical for recruitment of neutrophils and fever generation.

### Severe Papillomavirus

A number of PIDDs are characterized by recurrent, severe human papillomavirus (HPV) infections (see Table 164.3). Warts are common in the general population but high numbers should suggest a PID. Patients with WHIM syndrome (warts, hypogammaglobulinemia, immunodeficiency, myelokathexis) have a unique susceptibility to HPV-induced warts in addition to bacterial sinopulmonary infections and cutaneous abscesses (immunity to other viral infections is intact) (see Fig. 708.6). One of the hallmarks of **DOCK8 deficiency** is severe cutaneous viral infections with HPV, molluscum contagiosum, herpes simplex, and varicella zoster. Patients with **epidermodysplasia verruciformis** have markedly increased susceptibility to cutaneous HPV infections. Patients with **GATA2 deficiency** can suffer from severe disseminated HPV, including genital locations, and molluscum contagiosum infections. Treatment is distinct for each condition, but knowing



**Fig. 164.1** When infections are the major manifestation of the inborn error of immunity, several types of laboratory tests can yield a diagnosis. The specific type of infection suggests the effector arm of the immune system that may be dysfunctional, and the testing can be applied in a targeted fashion. Laboratory evaluation is noted in the light blue boxes. DHR, dihydrorhodamine, Ig, immunoglobulin; TRECs, T cell receptor excision circles.

**Table 164.4** Recurrent Invasive Pneumococcal Infections

CONDITION	GENE/CONDITION SUBSET	INHERITANCE	OTHER FEATURES
Asplenia	<i>ATRX</i>	XL	Developmental delay, low-set ears, single palmar crease
Asplenia	<i>HMOX1</i>	AR	Hemolysis, nephritis
Asplenia	<i>NKX2-5</i>	AD	
Asplenia	<i>RPSA</i>	AD	
Asplenia	<i>ZEB2</i>	AD	Mowat-Wilson syndrome, microcephaly, Hirschsprung disease, defects in corpus callosum
Asplenia	Gene unknown/syndromic		Can occur in heterotaxy syndromes
Antibody deficiency	<i>BTK</i>	XL	
Antibody deficiency	Hypogammaglobulinemia	Various	
Antibody deficiency	Specific antibody deficiency	Various	
Antibody deficiency	IgG subclass deficiency	Various	
Antibody deficiency	CVID	Various	
Innate immune deficiency	<i>MYD88</i>	AR	Poor fever formation
Innate immune deficiency	<i>IRAK4</i>	AR	Poor fever formation
Innate immune deficiency	<i>IKBKG</i>	XL	Peg teeth, ectodermal dysplasia
Complement deficiency	C2	AR	Can have lupus
Complement deficiency	C1	AR	Can have lupus
Complement deficiency	C4	AR	Can have lupus
Complement deficiency	C3	AR	Glomerulonephritis

AD, Autosomal dominant; AR, autosomal recessive; CVID, common variable immunodeficiency; XL, X-linked.

the immune etiology is critical because of the substantial morbidity associated with continually spreading warts.

### Herpes Simplex Virus Encephalitis

Several innate PIDDs uniquely present with recurrent herpes simplex virus (HSV) encephalitis (without mucosal HSV infections) due to disruption of the signaling pathways regulating antiviral cytokines interferon (IFN)- $\alpha$  and - $\beta$ , which are critical for control of HSV infections (see Table 164.3). Examples of these PIDDs include TLR3 deficiency, UNC93b deficiency, and interferon regulatory factor 3 (IRF3) deficiency. The importance of recognition relates to the likelihood of recurrence, with the attendant central nervous system (CNS) dysfunction that can result.

### Epstein-Barr Virus

Severe life-threatening infections with fulminant Epstein-Barr virus (EBV) are a hallmark of certain PIDDs, whereas typical outpatient infectious mononucleosis infections are not concerning (see Chapter 301) (see Table 164.3). Patients with **familial hemophagocytic lymphohistiocytosis (HLH)** have a block in the cytotoxic lymphocyte (NK and CD8 T cell) pathway necessary to control EBV infections (see Chapter 556). Patients develop uncontrolled immune hyperactivation (cytokine storm) from unchecked EBV infections resulting in life-threatening HLH. Clinical symptoms include fever, hepatosplenomegaly, pancytopenia, and multi-system organ failure. There may be evidence of hemophagocytosis activated by macrophages in a bone marrow biopsy. Patients with **X-linked lymphoproliferative syndrome (XLP)** are predisposed to fatal fulminant EBV with or without HLH, as well as lymphoma. Patients with XLP who survive acute EBV infections will often go on to develop hypogammaglobulinemia. Multiple PIDD disorders have an increased risk of HLH (Table 164.5). These conditions are more likely to require hematopoietic cell transplantation (see Chapter 176) than HLH occurring in the non-PIDD community.

### Severe Candida

Severe oral thrush from *Candida albicans* (as well as other opportunistic infections such as *Pneumocystis jiroveci*) can be seen in patients with SCID who have very low CD3 T cells (classically <300) and poor T-cell function; this mirrors the clinical phenotype of infants with HIV who also have low T cells (see Table 164.3). Intact T-cell IL-17 immunity is essential for control of *Candida* infections and overall decrements in the entire T-cell population or selective defects in the Th17 population are strongly associated with *Candida*. Patients with specific gene pathogenic variants in IL-17 signaling (IL-17RA, IL-17RC, IL-17E, and ACT1) present with **chronic mucocutaneous candidiasis (CMCC; Candida infections of the skin, nails, mucosa)**. *STAT1* gain-of-function pathogenic variants result in decreased IL-17 production that also predisposes patients to skin and mucosal *Candida* infections. Autoimmune polyendocrinopathy candidiasis ectodermal dystrophy (APECED) is an autosomal recessive disease caused by mutations in the autoimmune regulator (AIRE) gene. Patients develop CMCC and autoimmune endocrine disorders such as hypoparathyroidism and adrenal insufficiency.

### Aspergillus

Neutrophils are responsible for engulfing and killing fungal organisms. *Aspergillus* species are a major cause of infections in chronic granulomatous disease (CGD), a PIDD characterized by defective neutrophil function (see Table 164.3). CGD patients most commonly develop *Aspergillus* pneumonia or osteomyelitis, although all sites are susceptible to fungal infection. *Aspergillus nidulans* infections occur almost exclusively in CGD and result in a much higher rate of osteomyelitis and mortality than *A. fumigatus*. Exposure to *Aspergillus* through handling of mulch with gardening or exposure to hay can cause fulminant pneumonitis in CGD patients. Patients with **GATA2 deficiency** and *STAT1* gain-of-function pathogenic variants can develop fungal infections such as aspergillus and histoplasmosis as well as atypical mycobacteria. Patients with autosomal dominant **hyper-IgE syndrome**

**Table 164.5** Primary Immune Deficiency Disease and Risk of Hemophagocytic Lymphohistiocytosis\*

CONDITION	GENE/CONDITION SUBSET	INHERITANCE	RISK OF HLH	OTHER FEATURES
CD48 deficiency	<i>CD48</i>	AD	High	
Chédiak-Higashi syndrome	<i>LYST</i>	AR	High	Pigmentary dilution
NLRC4	<i>NLRC4</i>		High	IBD
Perforin deficiency (FHL2)	<i>PRF1</i>	AR	High	
Griselli syndrome, type 2	<i>RAB27A</i>	AR	High	Pigmentary dilution
X-linked lymphoproliferative disease 1	<i>SH2D1A</i>	XL	High	
Syntaxin 11 deficiency (FHL4)	<i>STX11</i>	AR	High	
STXBP2/Munc18-2 deficiency (FHL5)	<i>STXBP2</i>	AR or AD	High	Hypogammaglobulinemia, IBD
UNC13D/Munc13-4 deficiency (FHL3)	<i>UNC13D</i>	AR	High	
X-linked lymphoproliferative disease 2	<i>XIAP</i>	XL	High	
CD27 deficiency	<i>CD27</i>	AR	Medium	Unable to control EBV
Chronic granulomatous disease	<i>All genetic types</i>	XL, AR	Low	Infections, granulomas
Hermansky-Pudlak syndrome, type 2	<i>AP3B1</i>	AR	Low	Pigmentary dilution
Hermansky-Pudlak syndrome, type 10	<i>AP3D1</i>	AR	Low	Pigmentary dilution
Lysinuric protein intolerance SLC7A7 deficiency	<i>SLC7A7</i>	AR	Low	Lung disease, feeding intolerance

\*Other primary immune deficiency diseases, including most T-cell deficiencies have been associated with HLH in rare patients. AD, Autosomal dominant; AR, autosomal recessive; HLH, Hemophagocytic lymphohistiocytosis; IBD, inflammatory bowel disease.

(STAT3 deficiency) commonly develop lung pneumatoceles (cavities), which can then become superinfected with *Aspergillus*.

### Sentinel Bacterial Infections

Certain bacterial infections are considered *sentinel infections* because the pathogen is highly associated with specific PIDDs. The following bacteria are considered highly suspicious for CGD: *Burkholderia cepacia*, *Nocardia*, *Serratia marcescens*, *Chromobacterium violaceum*, and *Granulibacter bethesdensis*. Unlike patients with cystic fibrosis, *B. cepacia* in CGD can cause pneumonia but also rapidly fatal sepsis. Terminal complement (C5-C9) and alternative complement defects (properdin or factor D deficiency) have increased susceptibility to recurrent invasive *Neisseria* species (recurrent meningococcal and disseminated gonococcal infections). Complement deficiencies are also found more frequently in patients with meningitis due to unusual serotypes of *Neisseria*.

### Mycobacterial Infections

Intact IL-12 and IFN- $\gamma$  signaling is required to activate phagocytes such as macrophages to clear intracellular pathogens such as mycobacteria (see Table 164.3). Patients who have defects along this pathway such as IL-12 p40, IL-12 receptor, and IFN- $\gamma$  receptor deficiency present with atypical mycobacterial infections; these infections can spread to bones and visceral organs (rather than isolated uncomplicated cervical lymphadenitis, which does not suggest a PIDD). STAT1 deficiency is associated with mycobacterial infections because STAT1 is required for IFN- $\gamma$  signaling. Patients with NEMO deficiency due to pathogenic variants in *IKBKG* develop mycobacterial disease due to impaired IL-12 production in response to infection and impaired TLR signaling. Atypical mycobacteria also cause pulmonary disease in patients with CGD. Patients with the PIDDs mentioned previously born outside of the United States who receive the bacilli Calmette-Guérin (BCG) attenuated vaccine can present with disseminated BCG strain mycobacterial infection often complicating subsequent hematopoietic cell transplantation.

### Severe Cryptosporidia

*Cryptosporidium* is a protozoan parasite that causes diarrheal disease in humans. Exposure occurs from contaminated drinking water

sources as well as fresh water and public swimming pools. Patients with PIDD can develop infections outside of the GI tract such as the lungs, biliary tract, and pancreas. Intact T-cell immunity appears to play a critical role in resolution of *Cryptosporidium* infection as evidenced by the high incidence of this infection in patients with HIV. PIDDs with impaired T-cell immunity are characterized by increased risk for developing *Cryptosporidium*. In X-linked hyper-IgM syndrome, major histocompatibility complex (MHC) class II deficiency, DOCK8 deficiency, IL-21 receptor deficiency, sclerosing cholangitis, and cirrhosis from chronic *Cryptosporidium* infection can occur. The presence of liver disease from *Cryptosporidium* appears to increase the risk of mortality from curative hematopoietic cell transplantation.

### SCHEMA FOR DIAGNOSIS

Clues to the diagnosis of a PIDD may be obtained by the past and current history and the physical exam (Tables 164.6 and 164.7)

Laboratory studies typically used in the diagnosis of PIDD are rudimentary. Typical laboratory studies measure the amount of antibody or count the numbers of a given cell type (T cells as an example). There is a relatively limited ability to test function. Figures 164.1 and 164.2 outline a strategy to approach the diagnostic testing for PIDDs.

### NONINFECTIOUS PRESENTATIONS SUGGESTING PIDD

Autoimmunity and inflammation can be indicators of a possible PIDD. Infections may be falsely attributed to the medications used to control the autoimmunity or inflammation. Often the usual immunologic testing is normal. Many of the autoimmune or autoinflammatory disorders associated with PIDD may need to be identified through genetic sequencing.

### Autoimmunity

Autoimmunity can be the presenting manifestation of a PIDD. Rather than having the more familiar infectious phenotype, these patients have defects in tolerance or lymphocyte function that compromise their homeostasis. HLH is a profound form of immune dysregulation (see Chapter 556.2). These conditions are important to recognize because *targeted* therapies can be beneficial and because they can evolve to complex phenotypes with severe morbidity. The typical laboratory



**Table 164.6** Clinical Aids to the Diagnosis of Immunodeficiency**SUGGESTIVE OF B-CELL DEFECT (HUMORAL IMMUNODEFICIENCY)**

Recurrent bacterial infections of the upper and lower respiratory tracts  
 Recurrent skin infections, meningitis, osteomyelitis secondary to encapsulated bacteria (*Streptococcus pneumoniae*, *Haemophilus influenzae*, *Staphylococcus aureus*, *Neisseria meningitidis*)  
 Severe *Giardia lamblia* infections  
 Paralysis after vaccination with live attenuated poliovirus  
 Reduced levels of immunoglobulins

**SUGGESTIVE OF T-CELL DEFECT (COMBINED IMMUNODEFICIENCY)**

Systemic illness after vaccination with any live virus or BCG  
 Unusual life-threatening complication after infection with benign viruses (giant cell pneumonia with measles; varicella pneumonia)  
 Chronic oral candidiasis after 6 mo of age  
 Chronic mucocutaneous candidiasis  
 Graft versus host disease after blood transfusion  
 Reduced lymphocyte counts for age  
 Low level of immunoglobulins  
 Absence of lymph nodes and tonsils  
 Small thymus  
 Chronic diarrhea  
 Failure to thrive  
 Recurrent infections with opportunistic organisms  
 Generalized, recurrent, recalcitrant warts

**SUGGESTIVE OF MACROPHAGE DYSFUNCTION**

Disseminated atypical mycobacterial infection, recurrent *Salmonella* infection  
 Fatal infection after BCG vaccination

**CONGENITAL SYNDROMES WITH IMMUNODEFICIENCY**

Ataxia-telangiectasia: ataxia, telangiectasia  
 Autoimmune polyglandular syndrome: hypofunction of one or more endocrine organs, chronic mucocutaneous candidiasis  
 Cartilage-hair hypoplasia: short-limbed dwarfism, sparse hair, neutropenia  
 Wiskott-Aldrich syndrome: thrombocytopenia, male gender, eczema  
 Chédiak-Higashi syndrome: oculocutaneous albinism, nystagmus, recurrent bacterial infections, peripheral neuropathies  
 DiGeorge syndrome (22q deletion syndrome): unusual facies, heart defect, hypocalcemia  
 CHARGE syndrome: coloboma, heart defects, atresia choanae, retarded growth, genital hypoplasia, ear anomalies/deafness  
 Short-limb skeletal dysplasia with combined immune deficiency: metaphyseal dysplasia, ADA deficiency, or Omenn syndrome  
 X-linked agammaglobulinemia with growth hormone deficiency: hypogammaglobulinemia, growth hormone deficiency  
 Kabuki syndrome: long palpebral fissures, prominent eyelashes, congenital heart disease  
 Timothy syndrome: prolonged QT, congenital heart disease, developmental delay  
 PTEN tumor hamartoma syndrome: multiple hamartomas, cancer

**SUGGESTIVE OF ASPLENIA**

Heterotaxia, complex congenital heart disease, Howell-Jolly bodies on blood smear, sickle cell anemia

ADA, Adenosine deaminase; BCG, bacille Calmette-Guérin.  
 From Verbsky JW, Routes JM. Recurrent fever, immune deficiency, and autoinflammatory disorders. In: Kliegman RM, Toth H, Bordini BJ, Basel D, eds. *Nelson Pediatric Symptom-Based Diagnosis*. 2nd ed. Philadelphia: Elsevier, 2023. Table 54.7, p. 1028.

evaluations used in the diagnosis of the PIDD are often unrevealing or minimally abnormal, leading to delay in diagnosis and implementation of appropriate therapy. The prognosis may be poor; hematopoietic cell transplantation is recommended.

**Early-Onset Systemic Lupus Erythematosus**

Prepubertal systemic lupus erythematosus (SLE) is uncommon and onset of SLE before 5 years of age is exceptionally unusual (Table 164.8);

onset before 5 years of age suggests a monogenic condition such as early complement component deficiencies (see Chapter 173). Complement deficiencies also have an infection phenotype. SLE is the dominant phenotype for C1 and C4 deficiencies. The mechanism by which these complement deficiencies lead to susceptibility to SLE is through impaired clearance of apoptotic material and compromised tolerance. SLE may present in infancy in C1 and C4 deficiencies and it is typically severe. C2 deficiency, in contrast, is associated with a milder susceptibility to SLE and proportionally higher susceptibility to infection. Other gene defects associated with early-onset SLE include lymphocyte defects such as *PRKCD*, *FAS*, and *FASL*. Manifestations of the **interferonopathies** such as Aicardi Goutières can resemble SLE and may have a high rate of antinuclear antibodies (ANA). CNS involvement and a cutaneous vasculopathy are hallmarks of interferonopathies (see Chapter 205).

**Early-Onset Enteropathy**

Small bowel enteropathy in these conditions is defined as non-gluten sensitive and associated with villous blunting or atrophy (Table 164.9). A key component of the differential diagnosis is the congenital diarrheas associated with either solute carrier defects or altered epithelial function (see Chapter 385). However, many of the solute carrier defects do not have villous blunting or atrophy. The early-onset enteropathy conditions are most often related to T-cell defects in intolerance and are classically associated with dysfunctional regulatory T cells such as in **IPEX** (immune dysregulation enteropathy X-linked). Identical but milder enteropathy is also seen in patients with **STAT5B deficiency** and **IL2RA deficiency**. Both of these molecules are required for critical signal transduction in regulatory T cells. Although enteropathy is often the presenting manifestation in these regulatory T-cell deficiency states, many of these patients will develop additional autoimmune features. The progression of autoimmune involvement of different organ systems can only be altered through hematopoietic cell transplantation. Enteropathy can also be seen in older individuals with one of the immune dysregulation conditions associated with **CVID**. In these conditions, the enteropathy may appear in early childhood or as late as middle age. The key to suspecting a monogenic immune dysregulation condition is the finding of villous atrophy that is not gluten-restriction responsive. Expanded populations of intraepithelial lymphocytes are also common.

**Pleomorphic Autoimmunity**

Autoimmunity in children usually does not imply an inherited monogenic condition (Table 164.10). In a setting where there is a strong family history and a suspected autosomal dominant condition, the first onset of autoimmunity may prompt a genetic evaluation; a single organ autoimmune disease does not strongly suggest that there is a monogenic condition underlying that autoimmune disease.

Pleomorphic autoimmunity refers to autoimmune disease affecting multiple organs in a pattern that is not typical for either age of onset or evolution. SLE can affect a number of organs as can mixed connective tissue disease, but it would be unusual for those conditions to also be associated with diabetes mellitus or autoimmune hepatitis. When autoimmunity does not fall cleanly into a particular diagnosis, it is suggestive of pleomorphic autoimmunity.

There is a broad range of defects in T- and B-cell tolerance and conditions associated with impaired regulation of T-cell behavior that can lead to an array of autoimmune conditions. The organs affected by autoimmunity typically accrue over time and in a pattern that is not standard for the known sporadic systemic autoimmune conditions. In some cases, these conditions may also have peculiar pathologic features that represent a clue that the underlying diagnosis is something other than a standard autoimmune disease of childhood. Table 164.10 attempts to categorize conditions according to the pathway implicated. There is wide heterogeneity in the timing of the autoimmune disease, the penetrance of the disease, and the end organs affected. This combination makes this particular subset of PIDD extraordinarily difficult to conceptualize. Only a high index of suspicion and the use of genetic evaluations can identify these patients who will often benefit from targeted therapeutics.

**Table 164.7** Special Physical Features Associated with Immunodeficiency Disorders

CLINICAL FEATURES	DISORDERS
<b>DERMATOLOGIC</b>	
Eczema	Wiskott-Aldrich syndrome, IPEX, hyper-IgE syndromes, hypereosinophilia syndromes, IgA deficiency
Sparse and/or hypopigmented hair	Cartilage-hair hypoplasia, Chédiak-Higashi syndrome, Griscelli syndrome
Ocular telangiectasia	Ataxia-telangiectasia
Oculocutaneous albinism	Chédiak-Higashi syndrome
Severe dermatitis	Omenn syndrome
Erythroderma	Omenn syndrome, SCID, graft versus host disease, Comèl-Netherton syndrome
Recurrent abscesses with pulmonary pneumatoceles	Hyper-IgE syndromes
Recurrent organ granulomas or abscesses, lung, liver, and rectum especially	CGD
Recurrent abscesses or cellulitis	CGD, hyper-IgE syndrome, leukocyte adhesion defect
Cutaneous granulomas	Ataxia telangiectasia, SCID, CVID, RAG deficiency
Oral ulcers	CGD, SCID, congenital neutropenia
Periodontitis, gingivitis, stomatitis	Neutrophil defects
Oral or nail candidiasis	T-cell immune defects, combined defects (SCIDs); mucocutaneous candidiasis; hyper-IgE syndromes; IL-12, IL-17, and IL-23 deficiencies; <i>CARD9</i> deficiency; <i>STAT1</i> deficiency
Vitiligo	B-cell defects, mucocutaneous candidiasis
Alopecia	B-cell defects, mucocutaneous candidiasis
Chronic conjunctivitis	B-cell defects
<b>EXTREMITIES</b>	
Clubbing of nails	Chronic lung disease caused by antibody defects
Arthritis	Antibody defects, Wiskott-Aldrich syndrome, hyper-IgM syndrome
<b>ENDOCRINOLOGIC</b>	
Hypoparathyroidism	DiGeorge syndrome, mucocutaneous candidiasis
Endocrinopathies (autoimmune)	Mucocutaneous candidiasis
Diabetes, hypothyroid	IPEX and IPEX-like syndromes
Growth hormone deficiency	X-linked agammaglobulinemia
Gonadal dysgenesis	Mucocutaneous candidiasis
<b>HEMATOLOGIC</b>	
Hemolytic anemia	B- and T-cell immune defects, ALPS
Thrombocytopenia, small platelets	Wiskott-Aldrich syndrome
Neutropenia	Hyper-IgM syndrome, Wiskott-Aldrich variant, CGD
Immune thrombocytopenia	B-cell immune defects, ALPS
<b>SKELETAL</b>	
Short-limb dwarfism	Short-limb dwarfism with T-cell and/or B-cell immune defects
Bony dysplasia	ADA deficiency, cartilage-hair hypoplasia

ADA, Adenosine deaminase; ALPS, autoimmune lymphoproliferative syndrome; CGD, chronic granulomatous disease; CVID, common variable immunodeficiency; IPEX, X-linked immune dysfunction enteropathy polyendocrinopathy; SCID, severe combined immunodeficiency.

From Goldman L, Ausiello D, ed. *Cecil Textbook of Medicine*. 22nd ed. Philadelphia: Saunders; 2004. p 1599.

## Inflammatory Diseases

Many of the recognized inflammatory diseases are the periodic fever (autoinflammatory) syndromes (see Chapter 204). Distinguishing fevers related to infection and those fevers that are driven by endogenous immune dysfunction is often initially difficult. The first contact with the healthcare system may be by a subspecialist who may only recognize the initial presenting manifestation. The inflammatory diseases are typically managed according to the pathway that is defective; therefore the distinction between these conditions and the autoimmune conditions is critically important.

### Very Early Onset Inflammatory Bowel Disease

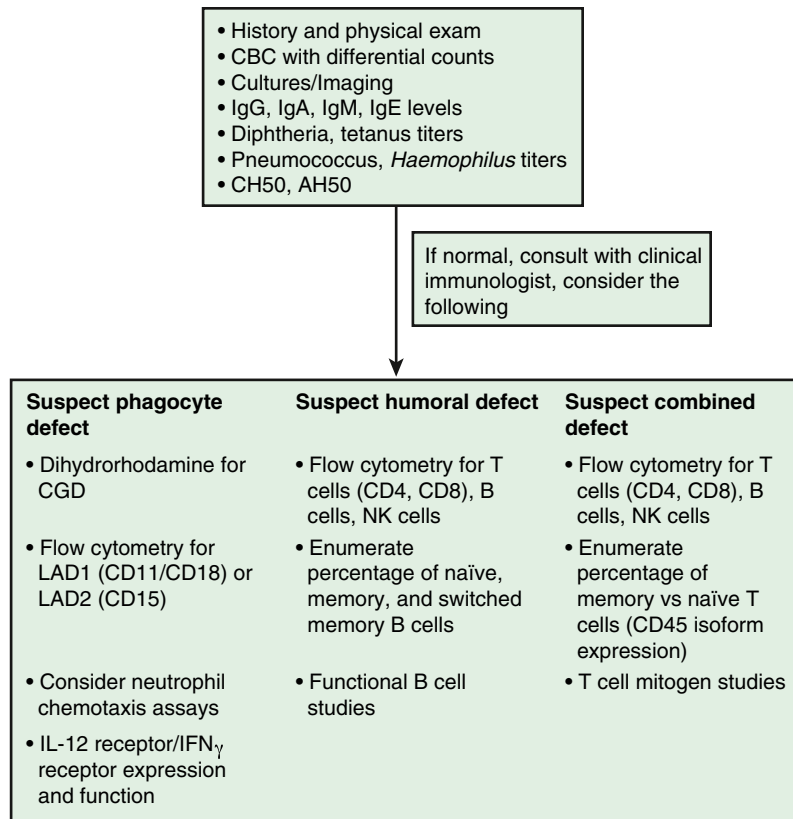
A key setting where a monogenic inflammatory condition should be considered is infantile-onset inflammatory bowel disease or early-onset inflammatory bowel disease with additional autoimmune features (see Chapter 382.1). Overall, approximately 20% of children who develop inflammatory bowel disease prior to 6 years of age will have a monogenic immune-based condition. The frequency increases with infantile onset or with panenteric disease. The diagnosis is most often established through genetic sequencing because the implicated genes are

numerous and diverse (see Chapters 174 and 382.3). These conditions are managed with targeted biologic or small molecule agents with a few select patient subsets requiring hematopoietic cell transplantation.

### Fever Syndromes

The central feature of the inherited fever syndromes is fever arising in the absence of infectious trigger (see Chapter 204). Infants and toddlers may have infections with a frequency of one per month and take as long as 2 weeks to recover. Nevertheless, the parents will often remark that the fevers “came out of the blue” or no one else in the household was ill at the time and express surprise at the frequency with which their child has been diagnosed with a viral infection with no viral symptoms. Some of the fever syndromes have fever that is typically isolated with no additional end-organ effects, whereas others have fever as a component of a much larger systemic inflammatory picture.

The most familiar inherited fever syndromes are those associated with inflammasome activation and typically treated with IL-1 inhibitors. A key consideration in the differential diagnosis for these conditions is the nongenetic condition called periodic fever aphthous stomatitis pharyngitis adenitis (PFAPA; see Chapter 204).



**Fig. 164.2** Initial work-up and follow-up studies of patients with suspected immune deficiency. Consultation with a clinical immunologist is recommended to guide advanced testing and interpret results. CGD, Chronic granulomatous disease; Ig, immunoglobulin; LAD, leukocyte adhesion defect; NK, natural killer; IL, interleukin; IFN, interferon. (From Verbsky JW, Routes JM. *Recurrent fever, immune deficiency, and autoinflammatory disorders*. In Kliegman RM, Toth H, Bordini BJ, Basel D, eds. *Nelson Pediatric Symptom-Based Diagnosis*. 2nd ed. Philadelphia: Elsevier; 2023. Fig. 54.9, p. 1029.)

<b>Table 164.8</b> Early-Onset Monogenic Systemic Lupus Erythematosus				
PATHWAY	GENE	INHERITANCE	SLE FREQUENCY	OTHER FEATURES
Complement	<i>C1QA</i>	AR	High	Infections
Complement	<i>C1QB</i>	AR	High	Infections
Complement	<i>C1QC</i>	AR	High	Infections
Complement	<i>C1R</i>	AR	High	Infections
Complement	<i>C1S</i>	AR	High	Infections
Complement	<i>C2</i>	AR	Low	Infections
Complement	<i>C3</i>	AR	Low	Infections, GN
Complement	<i>C4</i>	AR	High	Infections
Type I Interferon-AGS	<i>ADAR</i>	AR or AD (DN)	Low	AGS, CNS
Type I Interferon-AGS	<i>IFIH1</i>	AD (GOF)	Low	AGS, arthropathy, CNS
Type I Interferon-AGS	<i>RNASEH2A/B/C</i>	AR	Low	AGS
Type I Interferon-AGS	<i>SAMHD1</i>	AR	Low	AGS, FCL, CNS
Type I Interferon-AGS	<i>TREX1</i>	AR or AD (DN)	Low	AGS, FCL
Type I Interferon	<i>ACP5</i>	AR	High	Bone, CNS
Type I Interferon	<i>DNASE1</i>	AR	High	
Type I Interferon	<i>DNASE2</i>	AR	High	GN
Type I Interferon	<i>DNASE1L3</i>	AR	High	HUVS
Type I Interferon	<i>OTUD1</i>	AD	Medium	Arthritis, IBD
Type I Interferon	<i>STING</i>	AD (GOF)	Medium	Vasculopathy, arthritis, ILD

Continued

**Table 164.8** Early-Onset Monogenic Systemic Lupus Erythematosus—cont'd

<b>PATHWAY</b>	<b>GENE</b>	<b>INHERITANCE</b>	<b>SLE FREQUENCY</b>	<b>OTHER FEATURES</b>
RAS/MAPK	<i>KRAS</i>	AD	Low	Short stature
RAS/MAPK	<i>PTPN1</i>	AD	Low	Short stature
RAS/MAPK	<i>SHOC2</i>	AD	Low	Noonan-like syndrome
Proteasome	<i>PSMA3</i>	AD	Low	Dermatosis, lipodystrophy
Proteasome	<i>PSMB4</i>	AD	Low	Dermatosis, lipodystrophy
Proteasome	<i>PSMB8</i>	AD	Low	Dermatosis, lipodystrophy
Proteasome	<i>PSMB9</i>	AD	Low	Dermatosis, lipodystrophy
Apoptosis	<i>FASLG</i>	AD	Medium	ALPS
Apoptosis	<i>TNFRSF6</i>	AD	Medium	ALPS
Tolerance	<i>PRKCD</i>	AR	High	Infections
Tolerance	<i>RAG1/2</i>	AR	Medium	Infections, granulomas
Oxidase	<i>CYBB</i>	XL	Low	Males, CGD; females, discoid SLE
AKT	<i>PTEN</i>	AD	Medium	Malignancy risk
Collagen	<i>PEPD</i>	AR	Low	Leg ulcers
Amino acids	<i>SLC7A7</i>	AR	Low	Lysinuric protein intolerance
Carbohydrate	<i>MAN2B1</i>	AR	Low	Mannosidase
NFKappaB	<i>TNFAIP3</i>	AD	Medium	Vasculitis, ALPS
Adenosine	<i>ADA2</i>	AR	Low	Vasculitis, CNS, ALPS
Transcription factor	<i>IKZF1</i>	AD	Low	Leukemia, infections

AD, Autosomal dominant; AGS, Aicardi Goutières syndrome; ALPS, autoimmune lymphoproliferative syndrome; AR, autosomal recessive; CNS, central nervous system; DN, dominant negative; FCL, familial chilblains lupus; GOF, gain of function; GN, glomerulonephritis; HUVS, hypocomplementemic urticarial vasculitis; IBD, inflammatory bowel disease; ILD: interstitial lung disease; SLE, systemic lupus erythematosus; XL, X-linked.

**Table 164.9** Early-Onset Enteropathy (Not Gluten Sensitive)

<b>CONDITION</b>	<b>GENE</b>	<b>INHERITANCE</b>	<b>ENTEROPATHY FREQUENCY</b>	<b>OTHER FEATURES</b>
Microvillous inclusion disease	<i>MYO5B</i>	AR	Always	Neonatal onset
Microvillous inclusion disease	<i>STX3</i>	AR	Always	Neonatal onset
Tufting enteropathy	<i>EPCAM</i>	AR	Always	Neonatal onset
Tufting enteropathy	<i>SPINT2</i>	AR	Always	Keratitits, anal/choanal atresia
Trichohepatoenteric syndrome	<i>SKIV2L</i>	AR	Always	Trichorrhexis nodosa, IUGR
Trichohepatoenteric syndrome	<i>TTC37</i>	AR	Always	Trichorrhexis nodosa, IUGR
Multiple intestinal atresia	<i>TTC7A</i>	AR	High	Lymphopenia, IA
Immune dysregulation	<i>CARD11</i>	AD	Low	CVID, alopecia, atopy
Immune dysregulation	<i>CTLA4</i>	AD	Medium (broad age of onset)	LP, CVID, infections
Immune dysregulation	<i>DEF6</i>	AR	Medium	Cardiomyopathy, infections
Immune dysregulation	<i>FOXP3</i>	XL	Always	Diabetes
Immune dysregulation	<i>ICOS</i>	AR	Medium (broad age of onset)	LP, CVID, infections
Immune dysregulation	<i>IL2RA</i>	AR	Low	Lymphopenia, infections, LP
Immune dysregulation	<i>LRBA</i>	AR	Medium (broad age of onset)	LP, CVID, infections
Immune dysregulation	<i>MALT1</i>	AR	High	Infections, LP, eczema
Immune dysregulation	<i>RLTPR</i>	AR	Medium	Infections, EBV
Immune dysregulation	<i>STAT1</i>	AD (GOF)	High	<i>Candida</i> , diabetes
Immune dysregulation	<i>STAT3</i>	AD (GOF)	High	Short, LP
Immune dysregulation	<i>XIAP</i>	XL	High	EBV, HLH
MHC class II deficiency	<i>RFXANK</i>	AR	Low	Infection, cytopenias
MHC class II deficiency	<i>CIITA</i>	AR	Low	Infection, cytopenias
MHC class II deficiency	<i>RFX5</i>	AR	Low	Infection, cytopenias
MHC class II deficiency	<i>RFXAP</i>	AR	Low	Infection, cytopenias

AD, Autosomal dominant; AR, autosomal recessive; CVID, Common variable immune deficiency; EBV, Epstein-Barr virus; GOF, gain of function; HLH, hemophagocytic lymphohistiocytosis; IA, intestinal atresia and fibrosis; IUGR, intrauterine growth retardation; LP, lymphocytic infiltrates in multiple organs; MHC, major histocompatibility complex; XL, X-linked.



**Table 164.10** Pleomorphic Autoimmunity (Autoimmunity Not Limited to a Single Organ)

PATHWAY	GENE	INHERITANCE	MAIN ORGANS INVOLVED	NONIMMUNE FEATURES	INFECTIONS
B-cell tolerance	<i>AID</i>	AR	Lymphoid hyperplasia, cytopenias, GI		High IgM, frequent infections
T-cell tolerance	<i>AIRE</i>	AR/AD	Endocrine organs, lung, skin	Nail dystrophy	<i>Candida</i>
T-cell tolerance	<i>ARPC1B</i>	AR	Cytopenias, GI	Thrombocytopenia	Frequent infections
T-cell tolerance	<i>CTLA4</i>	AD	GI, lung, CNS		Frequent infections
T-cell tolerance	<i>COPA</i>	AD	Lung, joint, renal		
T-cell tolerance	<i>FOXP3</i>	XL	GI, endocrine, skin		
T-cell tolerance	<i>HAVCR2</i>	AR	HLH, panniculitis, SLE-like, joint	Lymphoma	
T-cell tolerance	<i>IL2RA</i>	AR	Skin, GI, endocrine		Viral
T-cell tolerance	<i>IL2RB</i>	AR	GI, skin		Viral
T-cell tolerance	<i>ITCH</i>	AR	Joints, lung, enteropathy	Developmental delay	
T-cell tolerance	<i>JAK1</i>	AD (GOF)	Skin, renal, GI		
T-cell tolerance	<i>LRBA</i>	AR	GI, lung, CNS		
T-cell tolerance	<i>ORAI1</i>	AR	Cytopenias, vasculitis	Myopathy, poor dental enamel	Frequent infections
T-cell tolerance	<i>PRKCD</i>	AR	SLE-like		Frequent infections
T-cell tolerance	<i>PTEN</i>	AD	Cytopenias, GI, endocrine	Malignancy, macrocephaly, developmental delay	
T-cell tolerance	<i>STAT1</i>	AD (GOF)	GI, endocrine		<i>Candida</i>
T-cell tolerance	<i>STAT3</i>	AD (GOF)	GI, lung, endocrine	Short stature	
T-cell tolerance	<i>STIM1</i>	AR	Cytopenias, Sjögren syndrome	Myopathy, poor dental enamel	Frequent infections
T-cell tolerance	<i>TPP2</i>	AR	Hematopoietic	CNS	Viral
T-cell tolerance	<i>WAS</i>	XL	Cytopenias, GI	Thrombocytopenia	Frequent infections
T-cell tolerance	<i>WIP</i>	AR	Cytopenias, GI	Thrombocytopenia	Frequent infections
Inflammatory pathway	<i>RBCK1</i>	AR	Joints, skin, GI	Amylopectin deposits in muscle	Frequent infections
Inflammatory pathway	<i>RIPK1</i>	AD	GI, joint	HSM episodic	Fevers
Inflammatory pathway	<i>RNF31</i>	AR	Joints, skin	Amylopectin deposits in muscle	Frequent infections, CVID-like
Inflammatory pathway	<i>TNFAIP3</i>	AD	Mucosal ulcers, GI, arthritis, skin		Fevers
Lysinuric protein intolerance	<i>SLC7A7</i>	AR	HLH, SLE, PAP	HSM, poor growth, osteoporosis, renal	Infections trigger metabolic decompensation

AD, Autosomal dominant; AR, autosomal recessive; CNS, central nervous system; CVID, common variable immune deficiency; GI, gastrointestinal, GOF, gain of function; HLH, hemophagocytic lymphohistiocytosis; HSM, hepatosplenomegaly; PAP, pulmonary alveolar proteinosis; SLE, systemic lupus erythematosus; XL, X-linked.

Although genetic fever syndromes may have a cutaneous component, abdominal pain, or nausea, fever is by far the dominant manifestation. There may be a family history or there may be an ethnic background that suggests the diagnosis (e.g., familial Mediterranean fever).

Other fever syndromes are related to proteasome dysfunction. These often have a very strong cutaneous component that can be a neutrophilic dermatosis or more of a vasculopathic picture with chilblains affecting the ears, fingers, and toes. Over time, these conditions may develop lipodystrophy. Fever is often seen in these

conditions before 5 years of age. Treatment often includes a Jak inhibitor.

In their most severe form, interferonopathies present with the infantile-onset leukoencephalopathy called **Aicardi Goutières syndrome**. There are milder variants leading to interferon production that can be associated with later onset and a picture more typical for SLE. The earlier the onset the more likely there is to be significant brain involvement. These conditions are treated with Jak inhibitors.

Visit Elsevier eBooks+ at [eBooks.Health.Elsevier.com](http://eBooks.Health.Elsevier.com) for Bibliography.

## Section 2

# The T-, B-, and NK-Cell Systems

## Chapter 165

## T-Cell and Combined Deficiencies

Ramsay L. Fuleihan

### T-CELL AND COMBINED DEFICIENCIES

T lymphocytes (T cells) play a central role in the orchestration and regulation of the adaptive immune response. CD4 T cells help B cells synthesize specific IgG, IgA, and IgE antibodies and develop into memory B cells, help macrophages kill intracellular pathogens, and regulate the immune response. CD8 T cells kill virus-infected or malignant cells. Immune deficiency diseases that disrupt T-cell development or function are usually severe, affecting multiple aspects of adaptive immunity, and are thus *combined immune deficiency diseases*. A hallmark of the adaptive immune response is specific recognition of pathogen proteins via antigen receptors, the T-cell receptor (TCR) in T cells and immunoglobulin in B cells. Antigen receptors have a variable region that is formed by random rearrangement of two to three gene segments, V(D)J, allowing a large variety of antigen recognition. TCRs recognize a fragment of a protein that is presented by

the major histocompatibility complex (MHC) molecules; therefore the randomly generated variable region of the TCR needs to be able to interact with the individual's MHC molecules. During T-cell development in the thymus, only thymocytes with TCRs that recognize the individual's MHC molecules are selected to survive (positive selection) and all other thymocytes die (by neglect). Among the thymocytes that survive, those with self-reactive TCRs are eliminated (negative selection) or develop into regulatory T cells to prevent autoimmune disease (Fig. 165.1). There is a symbiotic relationship between the thymus and developing thymocytes, where the absence of a thymus affects T-cell development and the absence of thymocytes leads to disruption of the thymic architecture. Pathogenic gene variants affecting any of the signaling pathways, DNA recombination, and repair enzymes as well as the thymic environment can lead to T-cell and combined immune deficiency diseases.

Visit Elsevier eBooks+ at [eBooks.Health.Elsevier.com](http://eBooks.Health.Elsevier.com) for Bibliography

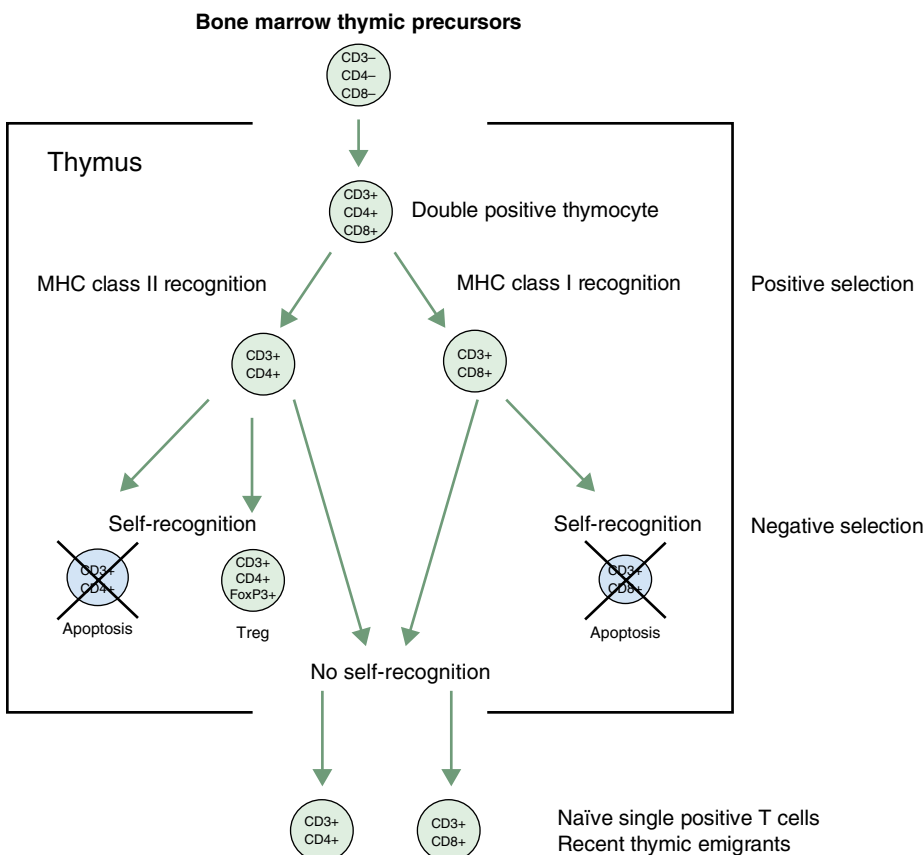
### 165.1 Severe Combined Immunodeficiencies

Ramsay L. Fuleihan

Severe combined immunodeficiency (SCID) is caused by diverse pathogenic gene variants that lead to absence of T- and B-cell function. Patients with this group of disorders have the most severe immunodeficiency.

#### GENETICS AND PATHOGENESIS

SCID is caused by pathogenic variants in genes crucial for lymphoid cell development or function (Table 165.1 and Fig. 165.2). All patients with SCID have very small thymuses that contain no thymocytes and lack corticomedullary distinction and lack Hassall's corpuscles. The thymic epithelium appears histologically normal. Both the follicular and the paracortical areas of the spleen are depleted of lymphocytes. Lymph nodes, tonsils, adenoids, and Peyer patches are absent or extremely underdeveloped.



**Fig. 165.1** Schematic representation of T-cell development in the thymus. Thymocyte precursors leave the bone marrow and enter the thymus with no expression of CD3, CD4, or CD8 (double negative T cells). Later the thymocytes express CD3 and both CD4 and CD8. If the newly formed T-cell receptor (TCR) recognizes major histocompatibility complex (MHC) class I or class II molecules, the thymocytes receive a positive selection signal and develop into CD8 or CD4 single positive thymocytes, respectively. Single positive thymocytes with TCR that recognize self-proteins will be killed by apoptosis or develop into regulatory T cells (Treg) to prevent autoimmune disease. Single positive thymocytes that are non-self-reactive leave the thymus as naïve single positive T cells ready to engage in the immune response when needed.

**Table 165.1** Genetic Basis of Severe Combined Immunodeficiency and SCID Variants

DISEASE	INHERITANCE	PATHOGENESIS	ADDITIONAL FEATURES	TREATMENT
<b>T-B<sup>-</sup> SCID</b>				
Reticular dysgenesis	AR	Impaired mitochondrial energy metabolism and leukocyte differentiation	Severe neutropenia, deafness Pathogenic variants in adenylate kinase 2	GCSF, HSCT
Reticular dysgenesis	AD	Impaired hematopoiesis	Severe neutropenia but no deafness, gain-of-function variant in RAC2	HSCT
Adenosine deaminase deficiency	AR	Accumulation of toxic purine nucleosides	Neurologic, hepatic, renal, lung, skeletal, bone marrow abnormalities	HSCT, PEG-ADA, gene therapy
RAG1 and RAG2 deficiency	AR	Defective V(D)J recombination	None	HSCT
Artemis deficiency	AR	Defective V(D)J recombination, radiation sensitivity	<i>DCLERE1C</i> pathogenic gene variants	HSCT
DNA-PK deficiency	AR	Defective V(D)J recombination	None	HSCT
DNA ligase IV deficiency	AR	Defective V(D)J recombination, radiation sensitivity	Growth delay, microcephaly, bone marrow abnormalities, lymphoid malignancies	HSCT
Cernunnos-XLF	AR	Defective V(D)J recombination, radiation sensitivity	Growth delay, microcephaly, birdlike facies, bone defects	HSCT
<b>T-B<sup>+</sup> SCID</b>				
$\gamma_c$ (CD132) deficiency	XL	Abnormal signaling via $\gamma_c$ -ILRs (IL-2, 4, 7, 9, 15, 21)	None	HSCT, gene therapy
Jak3 deficiency	AR	Abnormal signaling downstream of $\gamma_c$	None	HSCT
IL-7R $\alpha$ deficiency	AR	Abnormal IL-7R signaling	Thymus absent	HSCT
CD45 deficiency	AR		None	HSCT
CD3 $\delta$ deficiency	AR	Arrest of thymocytes differentiation at CD4 <sup>-</sup> CD8 <sup>-</sup> stage	Thymus size may be normal	HSCT
CD3 $\epsilon$ deficiency	AR	Arrest of thymocytes differentiation at CD4 <sup>-</sup> CD8 <sup>-</sup> stage	$\gamma/\delta$ T cells absent	HSCT
CD3 $\zeta$ deficiency	AR	Abnormal signaling	None	HSCT
Coronin-1A deficiency	AR	Abnormal T-cell egress from thymus and lymph nodes	Normal thymus size Attention deficit disorder	HSCT
LAT deficiency	AR	Defective T-cell development in the thymus	Autoimmune disease	HSCT
SLP76	AR	Abnormal signaling	Neutrophil defect, skin abscesses, rash, autoimmunity	HSCT attempted

$\gamma_c$ , Common gamma chain; AD, Autosomal dominant; AR, Autosomal recessive; GCSF, granulocyte colony-stimulating factor; HSCT, hematopoietic stem cell transplantation; IL, interleukin; Jak3, Janus kinase 3; PEG-ADA, polyethylene glycol-modified adenosine deaminase; R, receptor; RAG1, RAG2, recombinase-activating genes 1 and 2; SCID, severe combined immune deficiency; V(D)J, variable, diversity, joining domains; XL, X-linked.

Adapted from Roifman CM, Grunebaum E. Primary T-cell immunodeficiencies. In: Rich RR, Fleisher TA, Shearer WT, et al., eds. *Clinical Immunology*. 4th ed. Philadelphia: Saunders; 2013. pp. 440-441.

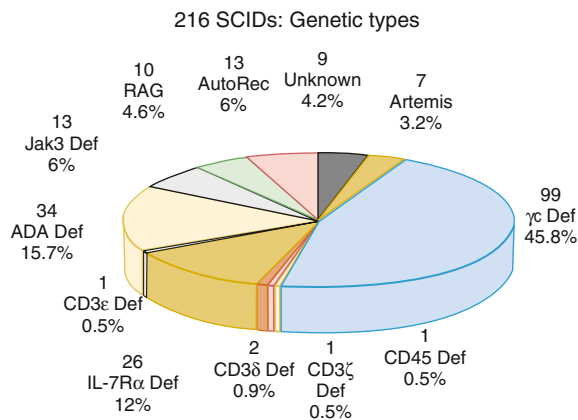
The 4 most common types of SCID are the X-linked forms caused by pathogenic variants in *CD132*, autosomal recessive *RAG1* and *RAG2* deficiencies, and adenosine deaminase (ADA) deficiency. Additional forms are listed in Table 165.1. For X-linked SCID and ADA deficiency, gene therapy exists, but genetic counseling is the most compelling reason for genetic sequencing to identify the pathogenic gene variant. Several specific pathogenic gene variants are associated with increased sensitivity to radiation and chemotherapy, and their early identification can lead to a better transplant experience by avoiding or reducing dosages of conditioning agents.

### CLINICAL MANIFESTATIONS

SCID is included in the newborn screening program in all states in the United States and in several countries around the world. Thus infants can be identified and treated prior to development of symptoms, which has dramatically improved the survival of infants with SCID. A few genetic types of SCID are not detected by newborn screening, and there are many countries where newborn screening for SCID is not yet

performed. Therefore an awareness of the clinical presentation of SCID remains important in the early diagnosis and treatment of patients.

When infants with SCID are not detected through newborn screening, they most often present with **infection** during infancy. Diarrhea, pneumonia, otitis media, sepsis, and cutaneous infections are common presentations. Infections with a variety of opportunistic organisms, either through direct exposure or immunization, can lead to death. Potential infectious threats include *Candida albicans*, *Pneumocystis jiroveci* (PJP), parainfluenza 3 virus, adenovirus, respiratory syncytial virus (RSV), cytomegalovirus (CMV), Epstein-Barr virus (EBV), varicella-zoster virus, measles virus, and attenuated organisms from the MMRV (measles, mumps, rubella, varicella), rotavirus, oral polio, nasal influenza, yellow fever, or bacille Calmette-Guérin (BCG) vaccines. Disseminated BCG infection may be the presenting feature of SCID in countries where the vaccine is given at birth. Infants with SCID also lack the ability to reject foreign tissue and are therefore at risk for severe or fatal **graft versus host disease (GVHD)** from T lymphocytes in nonirradiated blood products or maternal immunocompetent T cells



**Fig. 165.2** Relative frequencies of the different genetic types of severe combined immunodeficiency (SCID) among 216 patients seen consecutively. (From Buckley RH, Orange JS. *Primary immunodeficiency diseases*. In: Burks AW, Holgate ST, O’Hehir RE, et al., eds. *Middleton’s Allergy: Principles and Practice*. 9th ed. Philadelphia: Elsevier; 2020. Fig. 69.2, p. 1126.)



**Fig. 165.3** Typical clinical features in an infant with Omenn syndrome. Note generalized erythroderma with scaly skin, alopecia, and edema. (From Notarangelo LD. *T cell immunodeficiencies*. In: Leung DYM, Akdis CA, Bacharier LB, et al., eds. *Pediatric Allergy Principles and Practice*. 4th ed. Philadelphia: Elsevier; 2021. Fig 6.1.)

that crossed the placenta during pregnancy. The latter is usually not fatal but can be severe. This devastating presentation is characterized by expansion of the allogeneic cells, rash, hepatosplenomegaly, and diarrhea. A third presentation is often called **Omenn syndrome**, caused by hypomorphic pathogenic variants in SCID-causing genes, which allow few T cells to be generated in the infant that then expand, unregulated, and cause a clinical picture similar to GVHD (Fig. 165.3) with a severe dermatitis, lymphadenopathy, and diarrhea. The difference in this case is that the cells are the infant’s own cells. Dermatitis, especially if it is difficult to treat, failure to thrive, and infection in the first 6 months of life, particularly severe infections from commonly mild pathogens or opportunistic organisms, should raise the suspicion of SCID.

All genetic types of SCID are associated with profound immunodeficiency. A small number have other associated features or atypical features that are important to recognize. ADA deficiency can be associated with pulmonary alveolar proteinosis and chondroosseous dysplasia. Adenylate kinase 2 (AK2) deficiency causes a picture referred to

as **reticular dysgenesis** where neutrophils, myeloid cells, and lymphocytes are all low. This condition is also often associated with deafness.

## DIAGNOSIS

A high index of suspicion is very important in the diagnosis of SCID. A key feature of SCID is that almost all patients will have a low lymphocyte count. Some patients may have a normal lymphocyte count from proliferation of B cells and/or natural killer (NK) cells. A combination of infection and a persistently low lymphocyte count is an indication to test for SCID. The diagnostic strategy both for symptomatic infants and those detected by newborn screening or with a family history of SCID is to perform flow cytometry to quantitate the T, B, and NK cells in the infant (Fig. 165.4). The CD45RA (naïve T-cell) and CD45RO (memory T-cell) markers can be helpful to identify patients with maternal engraftment or Omenn syndrome with predominantly memory T cells. Identification of a limited TCR repertoire is also helpful in the diagnosis of Omenn syndrome. T-cell function is often assessed by measuring proliferative responses to stimulation with mitogens.

Gene sequencing is often done by requesting a SCID gene panel or a more extensive primary immunodeficiency (PID) gene panel. There are certain laboratory features that predict specific gene defects. When both T and B cells are low with normal numbers of NK cells, often a gene encoding a protein involved in V(D)J recombination is the cause such as *RAG1* and 2. Similarly, certain cytokine receptor defects are associated with specific SCID lymphocyte phenotypes, such as absent T cells and NK cells, but normal or elevated numbers of B cells in X-SCID caused by pathogenic variants in the common gamma chain (CD132) of cytokine receptors. Pathogenic variants in Janus kinase (*JAK*)3, which signal downstream of CD132, cause an autosomal recessive form of SCID affecting both females and males, with an identical lymphocyte phenotype as X-SCID.

The diagnosis of SCID can be established by the presence of a known pathogenic gene variant, low T-cell counts with proliferative response to the mitogen phytohemagglutinin (PHA) less than 10% of a normal control, or the identification of maternal T cells in the child. In male infants, this can be determined by fluorescence in situ hybridization (FISH) for the X and Y chromosomes.

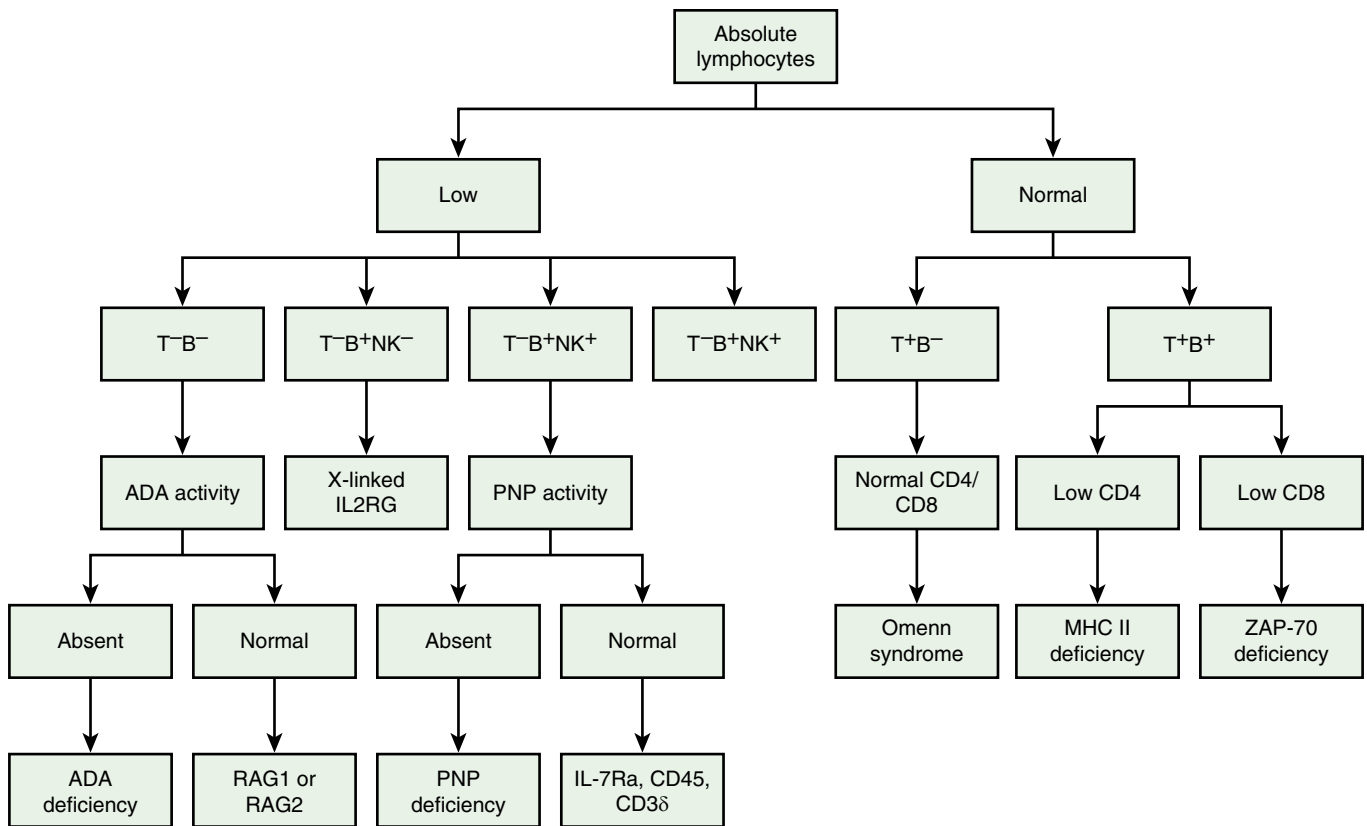
## Newborn Screening

Newborn screening for SCID has allowed the early diagnosis and treatment of SCID, improving the outcome of therapy and changing the natural history of the disease. Newborn screening is based on quantitative polymerase chain reaction (PCR) of T-cell receptor excision circles (TRECs), which are formed during V(D)J rearrangement of the variable region of the TCR chains. These TRECs do not replicate during cell division; they are thus present in most or all recent thymic emigrants but get diluted out as T cells divide in the periphery. The TREC assay identifies low numbers of recent thymic emigrants, which is not diagnostic of SCID, but raises suspicion to proceed with an evaluation of lymphocyte subsets and function followed by confirmation with genetic testing. Other diseases with low T-cell counts may also be identified by newborn screening and include 22Q11.2 deletion syndrome, *Rac2* deficiency, trisomy 21, and idiopathic lymphopenia, which was not well appreciated until newborn screening was implemented. In many countries, kappa excision circles (KRECs), generated during B-cell development, are assayed simultaneously with TRECs allowing a larger number of types of SCID to be identified as well as allowing identification of infants with agammaglobulinemia.

## TREATMENT

SCID is a true pediatric immunologic emergency. Unless immunologic reconstitution is achieved through hematopoietic stem cell transplantation (HSCT) or gene therapy, death usually occurs during the first year of life and almost invariably before 2 years of age. HSCT in the first 100 days of life or in an infant prior to infection is associated with a 95% survival rate. In patients with SCID, 92% have survived after T-cell-depleted parental marrow is given soon after birth when the infant is healthy, without pretransplant chemotherapy or posttransplant GVHD prophylaxis, although T-cell reconstitution is improved with pretransplant conditioning including reduced-intensity protocols.





**Fig. 165.4** Using the absolute lymphocytes count as a starting place to suggest the type of severe combined immunodeficiency (SCID) that may be present. ADA, Adenosine deaminase; MHC, major histocompatibility complex; PNP, purine nucleoside phosphorylase. (From Cunningham-Rundles C. Approach to the child with recurrent infections and molecular diagnosis. In: Leung DYM, Akdis CA, Bacharier LB, et al., eds. *Pediatric Allergy Principles and Practice*. 4th ed. Philadelphia: Elsevier; 2021. Fig. 4.2.)

Bone marrow transplantation remains the most important and effective therapy for SCID. In ADA-deficient and X-linked SCID, there has been success in correcting the immune defects with ex vivo gene transfer to autologous hematopoietic stem cells. Initial protocols of gene therapy for X-linked SCID resulted in **insertional mutagenesis** with the development of leukemic-like clonal T cells or lymphoma in some patients. Modification of the gene therapy protocol has greatly reduced the risk of insertional mutagenesis. ADA-deficient SCID can also be treated with enzyme replacement by repeated injections of polyethylene glycol-ADA (PEG-ADA), although the immune reconstitution achieved is not as effective as with HSCT or gene therapy. Until definitive therapy can be achieved, SCID patients should be treated with supportive care for prevention and treatment of infections with immunoglobulin replacement and microbial prophylaxis starting at 4-6 weeks of age including PJP prophylaxis as well as viral and fungal prophylaxis. Breastfeeding should be avoided if the mother is CMV or EBV positive as infection can be transmitted via breast milk.

Visit Elsevier eBooks+ at eBooks.Health.Elsevier.com for Bibliography.

## 165.2 Combined Immunodeficiencies

Ramsay L. Fuleihan

Combined immunodeficiency (CID) is distinguished from SCID by the presence of low but not absent T-cell function. CID is a syndrome of diverse genetic causes and, therefore, diverse clinical and laboratory characteristics. Patients with CID may have recurrent or chronic pulmonary infections, opportunistic infections, failure to thrive, oral or cutaneous candidiasis, chronic diarrhea, recurrent skin infections, gram-negative bacterial sepsis, urinary tract infections, or severe varicella in infancy. Although they usually survive longer than infants with SCID, patients with CID fail to thrive and often die before reaching adulthood. Neutropenia

and eosinophilia are common. Serum immunoglobulins may be normal or elevated for all classes; selective IgA deficiency, marked elevation of IgE, and elevated IgM levels occur in some cases. Although antibody-forming capacity is impaired in most patients, it may not be absent.

Studies of cellular immune function may show lymphopenia, deficiencies of T cells, specific T-cell subsets, or switched memory B cells, and extremely low but not absent lymphocyte proliferative responses to mitogens, antigens, or allogeneic cells in vitro. Peripheral lymphoid tissues may demonstrate paracortical lymphocyte depletion. The thymus is usually small, with a paucity of thymocytes and usually no Hassall's corpuscles.

There is a large number and variety of CIDs caused by pathogenic variants in many different genes. A list of known causes of CID with some of their characteristic features can be found in Tables 165.2 to 165.7.

### COMBINED IMMUNODEFICIENCIES THAT ARE GENERALLY LESS PROFOUND THAN SCID

Several types of CID are characterized by a severe immunodeficiency but affected patients tend to survive longer than patients with SCID (see Table 165.2). These patients are susceptible to severe viral, opportunistic, and/or fungal infections. Their laboratory features are variable from normal lymphocyte subsets to a severe deficiency of CD4, CD8, or both cell types. Invariably, T-cell function is decreased but proliferative responses to mitogens and, in some cases, to antigens may be normal, making it difficult to have unifying laboratory characteristics for this group of diseases. The severity of clinical infection and/or the presence of a family history of CID should raise suspicion and initiate a laboratory evaluation for these diseases.

### COMBINED IMMUNODEFICIENCY FROM DEFICIENCY IN CD4 T-CELL HELPER FUNCTION

CD4 T cells play an important role in orchestrating the immune response. Helper function from CD4 T cells is critical for immunoglobulin isotype switching, somatic hypermutation, and B-cell memory

**Table 165.2** Combined Immunodeficiencies Generally Less Profound Than SCID

DISEASE (DEFICIENCY)	INHERITANCE	PATHOGENESIS	ADDITIONAL FEATURES	TREATMENT
CD40 Ligand (CD154)	XL	Defective CD40 ligand:CD40 signaling	Opportunistic infections, neutropenia, biliary tract and liver disease/cancer, neuroectodermal cancer	HSCT
CD40	AR	Defective CD40 ligand:CD40 signaling	Opportunistic infections, neutropenia, biliary tract and liver disease	HSCT
ICOS	AR		Autoimmunity, gastroenteritis, granulomas	
ICOS Ligand	AR	Decreased T and B cells	Neutropenia	
CD3 $\gamma$	AR	Low TCR expression	Autoimmunity of variable severity	
CD8	AR	Absent CD8 T cells	May be asymptomatic	
ZAP-70 LOF	AR	Low CD8 T cells, poor CD4 T-cell function	May have immune dysregulation, autoimmunity	HSCT
ZAP-70 LOF/GOF	AR	Low CD8 T cells	Severe autoimmunity, bullous pemphigoid, inflammatory colitis	HSCT
MHC class I (TAP1, TAP2, TAPBP, $\beta_2$ -microglobulin)	AR	Low CD8 T cells, absent MHC I on lymphocytes and thymic epithelium	Vasculitis, pyoderma gangrenosum	
MHC class II (CIITA, RFX5, RFXANK, RFXAP)	AR	Low CD4 T cells absent MHC II on lymphocytes and thymic epithelium	Failure to thrive, liver biliary tract disease	HSCT
IKAROS	AD	No memory T cells or B cells	Opportunistic infections, early CID onset	
DOCK2	AR	Low T cells and poor NK cell function	Invasive herpesvirus infections, poor interferon responses	
Polymerase and (POLD1, POLD2)	AR	Low CD4 T cells	Skin infections, warts and molluscum, short stature, intellectual disability	
RHOH	AR	Restricted TCR repertoire	HPV infection, lung granulomas, molluscum, lymphoma	
STK4	AR	Low CD4 T cells	Intermittent neutropenia, viral and <i>Candida</i> infection, lymphoproliferation, autoimmune cytopenias, lymphoma, congenital heart disease	
TCR $\alpha$	AR	Absent TCR $\alpha\beta$	Immune dysregulation, autoimmunity, diarrhea	
LCK	AR	Poor TCR signaling, low CD4 T cells and low regulatory T cells, restricted TCR repertoire	Immune dysregulation, autoimmunity	
ITK	AR	Decreased T-cell activation, progressive decline in CD4 T cells	EBV-associated B-cell lymphoproliferation, immune dysregulation	
MALT1	AR	Poor T-cell proliferation		
CARD11 LOF	AR	Poor T-cell proliferation	Opportunistic infections	
BCL10	AR	Poor T-cell antigen or anti-CD3 proliferation, few memory T cells and Tregs	Candidiasis, gastroenteritis	
IL-21	AR	Low T-cell function, low memory/switched B cells	Opportunistic infections, liver disease	
IL-21R	AR	Low cytokine production, low T-cell antigen proliferation		
OX40	AR	Low Ag-specific memory CD4 T cells	Impaired immunity to HHV8, Kaposi's sarcoma	
IKBKB	AR	Impaired TCR activation, absent Treg and $\gamma/\delta$ T cells	Opportunistic infections	HSCT
NIK	AR	Poor T-cell antigen proliferation, low switched memory B cells	<i>Cryptosporidium</i> infection	
RelB	AR	Reduced TCR diversity with poor proliferation to mitogens and absent to antigens		

Continued

**Table 165.2** Combined Immunodeficiencies Generally Less Profound Than SCID—cont'd

DISEASE (DEFICIENCY)	INHERITANCE	PATHOGENESIS	ADDITIONAL FEATURES	TREATMENT
RelA haploinsufficiency	AD	Impaired NFκB activation with decreased inflammatory cytokines	Chronic mucocutaneous ulceration	
Moesin	XL	Defective T-cell migration and proliferation	Varicella infections, neutropenia	
TFRC	AR	Poor T-cell proliferation, low memory B cells	Neutropenia, thrombocytopenia	
c-Rel	AR	Poor T- and B-cell proliferation, low memory CD4 and low memory B cells	<i>Mycobacteria</i> and <i>Salmonella</i> infections, opportunistic infections, defective innate immunity	
FCHO1	AR	Poor T-cell proliferation	Mycobacterial infections, lymphoproliferation, failure to thrive	

Ag, antigen; AD, Autosomal dominant; AR, autosomal recessive; CID, combined immune deficiency; EBV, Epstein-Barr virus; HHV8, human herpesvirus-8; HPV, human papillomavirus; HSCT, hematopoietic stem cell transplantation; IL, interleukin; GOF, gain of function; LOF, loss of function; MHC, major histocompatibility complex; NK, natural killer; R, receptor; TCR, T-cell receptor; Treg, regulatory T cell; XL, X-linked.

Adapted from Tangye SG, Al-Herz W, Bousfiha A, et al. Human inborn errors of immunity: 2022 update on the classification from the International Union of Immunological Societies Expert Committee. *J Clin Immunol* 2022;42:1473–1507.

**Table 165.3** DNA Repair Defects Other Than Causing SCID

DISEASE	GENE	INHERITANCE	PATHOGENESIS	ADDITIONAL FEATURES	TREATMENT
Ataxia-telangiectasia	<i>ATM</i>	AR	Progressive decrease in T cells, poor T-cell proliferation	Ataxia, telangiectasia, elevated IgM, lymphoreticular malignancy, increased radiosensitivity, chromosomal instability and translocations	Ig replacement, supportive care, avoid ionizing radiation
Nijmegen breakage syndrome	<i>NBS1</i>	AR	Progressive decrease in T cells	Microcephaly, dysmorphic features, lymphomas and solid tumors, hyper-IgM	Ig replacement, supportive care, avoid ionizing radiation
Bloom syndrome	<i>BLM</i>	AR	Marrow failure, low Ig	Short stature, dysmorphic facies, sun-sensitive erythema, leukemia, lymphoma, chromosomal instability	Ig replacement, supportive care, avoid ionizing radiation
Immunodeficiency with centromeric instability and facial anomalies (ICF types 1, 2, 3, 4)	<i>DNMT3B</i> <i>ZBTB24</i> <i>CDCA7</i> <i>HELLS</i>	AR	Decreased T cells, decreased response to PHA, hypogammaglobulinemia with variable antibody deficiency	Facial dysmorphism, developmental delay, macroglossia, opportunistic infections, malabsorption, cytopenias, malignancies, multiradial configurations of chromosomes 1, 9, 16	Ig replacement, supportive care, avoid ionizing radiation
PMS2 deficiency	<i>PMS2</i>	AR	Low B cells, abnormal antibody responses	Café-au-lait spots, hyper-IgM, lymphoma, colorectal carcinoma, brain tumors	Ig replacement, supportive care, avoid ionizing radiation
Radiosensitivity, immune deficiency, dysmorphic features, learning difficulties (RIDDLE) syndrome	<i>RNF168</i>	AR	Low IgG or IgA	Short stature, mild defects of motor control to ataxia, may have learning difficulties	Ig replacement, supportive care, avoid ionizing radiation
MCM4 deficiency	<i>MCM4</i>	AR	Low number and function of NK cells	Short stature, B-cell lymphoma, adrenal failure	Supportive care, avoid ionizing radiation
Polymerase ε subunit 1 deficiency (FILS syndrome)	<i>POLE1</i>	AR	Decreased T-cell proliferation	Short stature, facial dysmorphism, livedo	Ig replacement, supportive care, avoid ionizing radiation

Continued

Table 165.3 DNA Repair Defects Other Than Causing SCID—cont'd					
DISEASE	GENE	INHERITANCE	PATHOGENESIS	ADDITIONAL FEATURES	TREATMENT
Polymerase ε subunit 2 deficiency	<i>POLE2</i>	AR	Lymphopenia, absent T-cell proliferation to Ags, hypogammaglobulinemia	Disseminated BCG, autoimmunity (type 1 diabetes), hypothyroidism, facial dysmorphism	Ig replacement, supportive care, avoid ionizing radiation
Ligase 1 deficiency	<i>LIG1</i>	AR	Lymphopenia, increased γ/δ T cells, decreased T-cell proliferation, hypogammaglobulinemia antibody deficiency	Growth restriction, sun sensitivity, radiation sensitivity, macrocytic RBC	Ig replacement, supportive care, avoid ionizing radiation
NSMCE3 deficiency	<i>NSMCE3</i>	AR	Decreased T cells and T-cell response to mitogens and antigens	Thymic hypoplasia, severe lung disease, chromosomal breakage, radiation sensitivity	Ig replacement, supportive care, avoid ionizing radiation
ERCC6L2 deficiency	<i>ERCC6L2</i>	AR	Lymphopenia	Facial dysmorphism, microcephaly, bone marrow failure	Supportive care, avoid ionizing radiation
GIN51 deficiency	<i>GIN51</i>	AR	Low NK cells, high IgA with low IgM and IgG	Neutropenia, IUGR	Supportive care, avoid ionizing radiation

Ag, Antigen; AR, Autosomal recessive; BCG, bacilli Calmette-Guérin; FILS, facial dysmorphism, immunodeficiency, livedo, and short stature; ICF, instability, centromeric, facial anomalies; Ig, immunoglobulin; IUGR, intrauterine growth retardation; NK, natural killer; PHA, phytohemagglutinin; RBC, red blood cell.

Adapted from Tangye SG, Al-Herz W, Bousfiha A, et al. Human inborn errors of immunity: 2022 update on the classification from the International Union of Immunological Societies Expert Committee. *J Clin Immunol* 2022;42:1473–1507.

Table 165.4 Immunoosseous Dysplasias					
DISEASE	GENE	INHERITANCE	PATHOGENESIS	ADDITIONAL FEATURES	TREATMENT
Cartilage hair hypoplasia	<i>RMRP</i>	AR	Normal to severely decreased T-cell counts Decreased T-cell proliferation	Short-limbed dwarfism with metaphyseal dysostosis, sparse hair, bone marrow failure, autoimmunity, susceptibility to lymphoma and other cancers, impaired spermatogenesis, neuronal dysplasia of the intestine	HSCT for the immunodeficiency
Schimke immunoosseous dysplasia	<i>SMARCAL1</i>	AR	Decreased T cells	Short stature, spondyloepiphyseal dysplasia, intrauterine growth restriction; nephropathy; bacterial, viral, fungal infections; may present as SCID; bone marrow failure	HSCT for the immunodeficiency
<i>MYSM1</i> deficiency	<i>MYSM1</i>	AR	Decreased T cells, naïve T cells, and NK cells B-cell deficiency with hypogammaglobulinemia	Short stature; recurrent infections; congenital bone marrow failure, myelodysplasia; immunodeficiency affecting B cells and granulocytes; skeletal anomalies; cataracts; developmental delay	HSCT for the immunodeficiency
MOPD1 deficiency (Roifman syndrome)	<i>RNU4ATAC</i>	AR	Decreased NK cell function Decreased total and memory B cells Hypogammaglobulinemia, variably decreased specific antibodies	Recurrent bacterial infections; lymphadenopathy; spondyloepiphyseal dysplasia, extreme intrauterine growth restriction; retinal dystrophy; facial dysmorphism; may present with microcephaly; short stature	HSCT for the immunodeficiency
Immunoskeletal dysplasia with neurodevelopmental abnormalities ( <i>EXTL3</i> deficiency)	<i>EXTL3</i>	AR	Decreased T cells, decreased to normal Ig levels	Short stature; cervical spinal stenosis, neurodevelopmental impairment; eosinophilia; may have early infant mortality	HSCT for the immunodeficiency

AR, Autosomal recessive; HSCT, hematopoietic stem cell transplantation; Ig, immunoglobulin; NK, natural killer; SCID, severe combined immune deficiency.

Adapted from Tangye SG, Al-Herz W, Bousfiha A, et al. Human inborn errors of immunity: 2022 update on the classification from the International Union of Immunological Societies Expert Committee. *J Clin Immunol* 2022;42:1473–1507.



Table 165.5		Other Combined Immunodeficiencies			
DISEASE	GENE	INHERITANCE	PATHOGENESIS	ADDITIONAL FEATURES	TREATMENT
PNP deficiency	<i>PNP</i>	AR	Progressive decrease in T cells	Autoimmune hemolytic anemia, neurologic impairment	HSCT
Immunodeficiency with multiple intestinal atresias	<i>TTC7A</i>	AR	Variable T-cell counts but may be as low as SCID with low TRECs at NBS	Multiple intestinal atresias, intrauterine polyhydramnios, early demise, bacterial (sepsis), viral and fungal infections	HSCT for severe T-cell deficiency
Trichohepatoenteric syndrome (THES)	<i>TTC37</i> <i>SKIV2L</i>	AR	Impaired IFN $\gamma$ production, variably low switched memory B cells, hypogammaglobulinemia, may have low antibody responses	Respiratory infections; IUGR; facial dysmorphic features, wooly hair; early-onset intractable diarrhea, liver cirrhosis; platelet abnormalities	
Hepatic venoocclusive disease with immunodeficiency (VODI)	<i>SP110</i>	AR	Decreased memory T and B cells; low IgG, IgA, and IgM; absent germinal centers and tissue plasma cells	Hepatic venoocclusive disease Susceptibility to opportunistic infections: PJP, CMV, <i>Candida</i> Thrombocytopenia, hepatosplenomegaly, cerebrospinal leukodystrophy	
BCL11B deficiency	<i>BCL11B</i>	AD	Decreased T-cell counts with poor proliferation	Congenital abnormalities, neonatal teeth, dysmorphic facies; absent corpus callosum, neurocognitive deficits	
EPG5 deficiency (Vici syndrome)	<i>EPG5</i>	AR	Very low CD4 T cells, decreased Ig levels especially IgG2, defective B cells	Chronic mucocutaneous candidiasis, recurrent infections, agenesis of the corpus callosum, microcephaly, cataracts; cardiomyopathy, skin hypopigmentation, intellectual disability	
HOIL1 deficiency	<i>RBCK1</i>	AR	Decreased memory B cells with poor antibody response to polysaccharide antigens	Bacterial infections, autoinflammation, amylopectinosis	
HOIP deficiency	<i>RNF31</i>	AR	Decreased memory B cells with decreased Ig levels	Bacterial infections, autoinflammation, amylopectinosis, lymphangiectasia	
Hennekam lymphangiectasia-lymphedema syndrome	<i>CCBE1</i> <i>FAT4</i>	AR	Variably decreased T- and B-cell counts, decreased Ig levels	Facial anomalies and other dysmorphic features, lymphangiectasia and lymphedema	
Activating de novo mutations in nuclear factor, erythroid 2-like (NFE2L2)	<i>NFE2L2</i>	AD	Decreased switched memory B cells, hypogammaglobulinemia and decreased antibody responses	Recurrent respiratory and skin infections; growth restriction, developmental delay; white matter cerebral lesions; increased level of homocysteine; increased expression of stress response genes	
STAT5b deficiency	<i>STAT5B</i>	AR	Slightly decreased T cells, decreased Treg number and function, hypogammaglobulinemia with elevated IgE	Growth-hormone insensitive dwarfism, dysmorphic features, eczema, lymphocytic interstitial pneumonitis, autoimmunity	
STAT5b deficiency	<i>STAT5B</i>	AD (dominant negative variants)	Increased IgE	Growth failure, eczema, lack immune defects of AR STAT5b deficiency	
Kabuki syndrome (type 1 and 2)	<i>KMT2D</i> <i>KDM6A</i>	AD XL (females may be affected)	Low IgA, occasionally low IgG	Typical facial abnormalities, cleft or high arched palate, skeletal abnormalities, short stature; intellectual disability; congenital heart defects; recurrent infections (otitis media, pneumonia); autoimmunity	

Continued

**Table 165.5** Other Combined Immunodeficiencies—cont'd

DISEASE	GENE	INHERITANCE	PATHOGENESIS	ADDITIONAL FEATURES	TREATMENT
KMT2A deficiency (Wiedemann-Steiner syndrome)	KMT2A	AD	Decreased memory B cells, hypogammaglobulinemia with decreased antibody responses	Respiratory infections; short stature; hypertelorism; hairy elbows; developmental delay, intellectual disability	

AD, Autosomal dominant; AR, Autosomal recessive; CMV, cytomegalovirus; HSCT, hematopoietic stem cell transplantation; IFN, interferon; Ig, immunoglobulin; IUGR, intrauterine growth retardation; NBS, newborn screening; PJP, *Pneumocystis jirovecii*; PNP, purine nucleoside phosphorylase; SCID, severe combined immune deficiency; TREC, T-cell receptor excision circle; Treg, regulatory T cells; XL, X-linked.

Adapted from Tangye SG, Al-Herz W, Bousfiha A, et al. Human inborn errors of immunity: 2022 update on the classification from the International Union of Immunological Societies Expert Committee. *J Clin Immunol* 2022;42:1473–1507.

**Table 165.6** Thymic Disorders

DISEASE	GENE	INHERITANCE	PATHOGENESIS	ADDITIONAL FEATURES	TREATMENT
DiGeorge/Velocardio-facial syndrome/ chromosome 22Q11.2 deletion syndrome <i>TBX1</i> deficiency	22Q11.2del including <i>TBX1</i> , <i>TBX1</i> Unknown	AD (Unknown defects are sporadic)	Variable T-cell counts, may have low TRECs at NBS, may have hypogammaglobulinemia	Conotruncal cardiac defects, hypoparathyroidism, abnormal facies, velopalatal insufficiency, intellectual disability, autoimmunity	Thymic transplant for severe T-cell deficiency
CHARGE syndrome	<i>CHD7</i> <i>SEMA3E</i> Unknown	AD AD	Variable T-cell counts, may have low TRECs at NBS, may have hypogammaglobulinemia	Coloboma of eye; heart anomaly; choanal atresia; intellectual disability; genital and ear anomalies (CHARGE), CNS malformation	Thymic transplant for severe T-cell deficiency
Winged helix nude <i>FOXP1</i> deficiency	<i>FOXP1</i>	AR	Very low T cells, decreased Ig levels	Severe infections, abnormal thymic epithelium, congenital alopecia, nail dystrophy, neural tube defect	Thymic transplant attempted
<i>FOXP1</i> haploinsufficiency	<i>FOXP1</i>	AD	Severe T-cell lymphopenia at birth, normal by adulthood	Recurrent, viral and bacterial respiratory tract infections; (eczema, dermatitis), nail dystrophy	
Chromosome 10p13-p14 deletion syndrome (10p13-p14DS)	10p13-p14del	AD	T-cell lymphopenia rarely with decreased proliferation to mitogens and antigens, may have hypoplastic thymus	Hypoparathyroidism, renal disease, deafness, growth retardation, facial dysmorphism, cardiac defects may be present, may have recurrent infections	
Chromosome 11q deletion syndrome (Jacobsen syndrome)	11q23del	AD	T-, B-, and NK cell lymphopenia, low switched memory B cells, variable Ig levels and antibody responses	Recurrent respiratory infections; multiple warts; facial dysmorphism, growth retardation	Ig replacement for antibody deficiency
<i>PAX1</i>	<i>PAX1</i>	AR	Absent thymus	Omenn-like syndrome	HSCT attempted, thymic transplantation attempted

AD, Autosomal dominant; AR, Autosomal recessive; del, deletion; CNS, central nervous system; HSCT, hematopoietic stem cell transplantation; TREC, T-cell receptor excision circle; NBS, newborn screening; Ig, immunoglobulin.

Adapted from Tangye SG, Al-Herz W, Bousfiha A, et al. Human inborn errors of immunity: 2022 update on the classification from the International Union of Immunological Societies Expert Committee. *J Clin Immunol* 2022;42:1473–1507.

Table 165.7 Hyper IgE Syndromes					
DISEASE	GENE	INHERITANCE	PATHOGENESIS	ADDITIONAL FEATURES	TREATMENT
HIE (Job syndrome)	<i>STAT3</i>	AD (DN LOF)	Decreased response to <i>STAT3</i> -activating cytokines; decreased Th17, T follicular helper, MAIT, NKT cells, reduced memory B cells, elevated IgE	Coarse facial features, broad nasal bridge; staphylococcal abscesses, eczema, pneumatoceles, pulmonary <i>Aspergillus</i> , PJP, mucocutaneous candidiasis; hyperextensible joints, osteoporosis and bone fractures, scoliosis, retained primary teeth; coronary and cerebral aneurysms	Bacterial and fungal prophylaxis
DOCK8 deficiency	<i>DOCK8</i>	AR	T-cell lymphopenia with poor proliferation, few Tregs with poor function, reduced MAIT and NKT cells, very high IgE	Low NK cells with poor function Eosinophilia, recurrent infections, cutaneous viral, fungal and staphylococcal infections, severe atopy/allergic disease, cancer diathesis	HSCT
IL-6 receptor deficiency	<i>IL6R</i>	AR	Decreased switched memory B cells, very high IgE	Recurrent pyogenic infections, cold abscesses, elevated IL-6 levels	Bacterial prophylaxis
IL-6 signal transducer (IL6ST) deficiency	<i>IL6ST</i>	AR	Decreased Th17 cells, reduced memory B cells, high IgE, variable antibody responses	Bacterial infections, abscesses, eczema, pulmonary abscesses, pneumatoceles; bone fractures; scoliosis; retention of primary teeth; craniostenosis	Bacterial prophylaxis
IL6ST	<i>IL6ST</i>	AD (DN)	Increased Th2, naïve T cells, low memory T and B cells, low to normal NK cell counts, elevated IgE with normal or low IgG	Similar to AD HIE syndrome: dermatitis/eczema, eosinophilia, recurrent skin infections, pneumonia, bronchiectasis, pneumatoceles, pulmonary aspergillosis, connective tissue defects (scoliosis, face, joints, fractures, palate, tooth retention)	Bacterial and fungal prophylaxis
IL6ST	<i>IL6ST</i>	AR (LOF)	Death in utero or in neonatal period	Fatal Stuve-Wiedemann-like syndrome; skeletal dysplasia, lung dysfunction, renal abnormalities, thrombocytopenia, dermatitis, eczema, defective acute phase response, complete unresponsiveness to IL-6 family cytokines	None
ZNF341 deficiency	<i>ZNF341</i>	AR	Decreased Th17 and NK cells, reduced memory B cells, decreased response to <i>STAT3</i> -activating cytokines	Similar to AD-HIE: mild facial dysmorphism; early-onset eczema, mucocutaneous candidiasis, bacterial skin infections, <i>Staphylococcus aureus</i> abscesses, recurrent bacterial respiratory infections, pneumatoceles; hyperextensible joints; bone fractures and retention of primary teeth	Bacterial and fungal prophylaxis
ERBIN deficiency	<i>ERBB2IP</i>	AD	Increased Treg, moderate increased IgE	Susceptibility to <i>S. aureus</i> , eczema, recurrent respiratory infections, hyperextensible joints, scoliosis, arterial dilatation in some patients	Bacterial prophylaxis
Loeys-Dietz syndrome	<i>TGFBR1, TGFBR2</i>	AD	Elevated IgE	Recurrent respiratory infections; eczema, food allergies; hyperextensible joints, scoliosis, retention of primary teeth; aortic aneurysms	Bacterial prophylaxis
Comèl-Netherton syndrome	<i>SPINK5</i>	AR	Low memory B cells, elevated IgE and IgA, variable antibody responses	Congenital ichthyosis, bamboo hair, atopic diathesis, bacterial infections, failure to thrive	Bacterial prophylaxis; Ig replacement for antibody deficiency
PGM3 deficiency	<i>PGM3</i>	AR	May have low T cells, B cells, memory B cells, normal or elevated IgG, IgA, and high IgE, eosinophilia	Severe atopy; autoimmunity; bacterial and viral infections; short stature, brachydactyly, dysmorphic facial features; intellectual disability and cognitive impairment, delayed CNS myelination in some patients	
CARD11 deficiency	<i>CARD11</i> DN LOF	AD	Defective T-cell activation and proliferation, high IgE, Th2 skewing, poor specific antibody production, impaired activation of the NF- $\kappa$ B and mTORC1 pathways	Variable atopy, eczema, food allergy, eosinophilia; cutaneous viral infections, recurrent respiratory infections; lymphoma; CID	Ig replacement for antibody deficiency

AD, Autosomal dominant; AR, Autosomal recessive; CID, combined immunodeficiency; CNS, central nervous system; DN, dominant negative; HIE, hyper-IgE; Ig, immunoglobulin; IL, interleukin; IL6ST, gp130 common signal transducer of the IL-6 cytokine family; LOF, loss of function; MAIT, mucosal-associated invariant T cells; NKT, natural killer T cells; PJP, *Pneumocystis jirovecii*; Th, T helper; Treg, regulatory T cells.

Adapted from Tangye SG, Al-Herz W, Bousfiha A, et al. Human inborn errors of immunity: 2022 update on the classification from the International Union of Immunological Societies Expert Committee. *J Clin Immunol* 2022;42:1473–1507.

formation as well as helping macrophages kill intracellular pathogens. In addition, patients with poor or absent CD4 T-cell helper function are susceptible to opportunistic infection. The consequences of defects in CD40 ligand and CD40 highlight the role CD4 T-cell-dependent helper function plays in immunity.

### CD40 LIGAND AND CD40 DEFICIENCY

CD40 ligand (CD154) deficiency (X-linked) and similarly, CD40 deficiency (autosomal recessive), cause a severe form of **hyper-IgM syndrome** that is a CID.

#### Genetics and Pathogenesis

Pathogenic variants in the CD40 ligand or CD40 genes, disrupt the interaction between CD4 T cells and antigen-presenting cells (APCs): dendritic cells, monocytes/macrophages, and B cells. CD40 ligand is expressed on activated CD4 T cells and delivers signals to APC via CD40 to stimulate expression of co-stimulatory molecules that help T-cell activation and differentiation, immunoglobulin isotype switching and somatic hypermutation in B cells as well as memory B-cell development, and signals to macrophages to kill intracellular pathogens. Therefore disruption of the CD40 signaling pathway affects several key elements of the adaptive immune response leading to a CID disease characterized by failure of immunoglobulin isotype switching, a process important for synthesis of IgG, IgA, and IgE antibodies; failure of somatic hypermutation, a process by which B cells generate antibodies of higher affinity; and absent B-cell memory, susceptibility to opportunistic infections including PJP, and *Cryptosporidium* and enhanced susceptibility to some cancers especially of the liver or of neuroectodermal origin.

#### Clinical Manifestations

Recurrent and opportunistic infections usually develop in the first year of life. About half the patients present with PJP pneumonia. Recurrent bacterial sinopulmonary infections are also common as well as *Cryptosporidium* infection and sclerosing cholangitis. Chronic or recurrent neutropenia is also a feature of this disease, although the pathogenesis of neutropenia is not well known. Patients have a higher susceptibility to cancer of the liver or biliary tree as well as primitive neuroectodermal carcinoma, which usually develop after the first 10 years of life. Few patients survive beyond 30 years of age. Some patients with milder genetic variations present in adolescence with parvovirus-induced aplastic anemia.

#### Diagnosis

Serum immunoglobulin levels show very low or absent IgG, IgA, and IgE, with normal or elevated IgM. Some patients have normal serum IgA levels, likely the result of a non-CD40-dependent isotype switching mechanism. The term hyper-IgM is a misnomer because most patients are identified before they have elevation of serum IgM levels. Lymphocyte subsets as well as lymphocyte proliferation to mitogens are usually normal. Characteristically, there is an absence or paucity of switched memory B cells. Patients may or may not have neutropenia, which can be severe. Flow cytometry for expression of CD40 on resting B cells or CD40 ligand on activated T cells can identify patients with these defects. Staining for CD40 ligand expression with soluble CD40 will identify all CD40 ligand variants that prevent binding to CD40. Gene sequencing of CD40 and CD40 ligand can be done separately or within a larger PID gene panel with known pathogenic variants confirming the disease.

#### Treatment

Patients should be treated with immunoglobulin replacement therapy and PJP prophylaxis as soon as the diagnosis is suspected. Attention to hygiene and clean drinking water as well as avoiding swimming in lakes will help prevent exposure to opportunistic organisms such as *Cryptosporidium*. HSCT can be curative and is recommended if the patient has a matched related or unrelated donor. Outcomes after stem cell transplantation have a trend toward improved survival and a reduced risk for cancer and improved quality of life.

### MHC CLASS II DEFICIENCY AND OTHER CAUSES OF CD4 T-CELL DEFICIENCY

MHC class I and II molecules play an important role in T-cell development and function by presenting a peptide fragment from a pathogen-derived protein to the TCR of CD8 or CD4 T cells, respectively. MHC class II molecules are required for processing and presentation of peptides derived from exogenous antigens to CD4 T cells and for positive selection of CD4 T cells in the thymus. Therefore MHC class II deficiency is a severe form of **bare lymphocyte syndrome** resulting in decreased CD4 T cells and impairment in their function.

#### Clinical Manifestations

Patients with low, or occasionally normal, CD4 T-cell numbers from MHC class II deficiency are susceptible to bacterial, viral, fungal, and opportunistic infections. Patients usually present in the first year of life with respiratory infections, chronic diarrhea, and failure to thrive. *Cryptosporidium* infections may be associated with sclerosing cholangitis and liver failure.

#### Genetics and Pathogenesis

MHC class II deficiency results from defects in genes encoding for transcription factors necessary for expression of MHC class II molecules from the HLA-DR, HLA-DP, and HLA-DQ loci including CIITA, RFXANK, RFX5, and RFXAP, which explains the concomitant loss of expression from all three loci.

#### Diagnosis

Immunodeficiencies with MHC class II deficiency can be identified by absent or low CD4 T cells on lymphocyte phenotyping by flow cytometry and absent MHC class II molecules. In some cases, CD8 T-cell numbers are also decreased. Lymphocyte proliferation to mitogens is normal but absent in response to antigens.

#### Treatment

The prognosis for MHC class II deficiency is poor with most patients dying in the first decade of life. HSCT has been performed and improves CD4 T-cell proliferation but not numbers because it does not correct the expression of MHC class II molecules on thymic epithelial cells. The outcome of HSCT in MHC class II deficiency is not as good as in SCID and other severe immunodeficiency diseases.

### MHC CLASS I DEFICIENCY AND OTHER CAUSES OF CD8 T-CELL DEFICIENCY

MHC class I molecules play an important role in T-cell development and function by presenting a peptide fragment from an intracellular pathogen, such as viruses, or cancer-derived proteins to the TCR of CD8 T cells. In the thymus, MHC class I molecules provide the positive selection signal for thymocytes to develop into CD8 T cells. Therefore the absence of MHC class I molecules in the thymus (and on all nucleated cells) is associated with very low or absent CD8 T cells. There are several other pathogenic gene variants that cause a deficiency in CD8 T cells.

#### Genetics and Pathogenesis

MHC class I deficiency results from pathogenic variants in the transporter associated with antigen processing (TAP) 1 or 2, TAP binding protein, or  $\beta_2$ -microglobulin genes. The TAP proteins play an important role in allowing the expression of MHC class I molecules on the surface of all nucleated cells and  $\beta_2$ -microglobulin associates with MHC class I molecules on the surface of cells.

#### Clinical Manifestations

Patients with low CD8 T cells from MHC class I deficiency may be asymptomatic in some cases but may present with chronic respiratory infections including bronchiectasis and granulomatous skin ulcers.

#### Diagnosis

Immunodeficiency patients with MHC class I deficiency can be identified by absent or low CD8 T cells on lymphocyte phenotyping by flow



cytometry and absent MHC class I molecules. Lymphocyte proliferation is normal.

### Treatment

MHC class I deficiency is treated with supportive therapy and avoidance of immunosuppression if possible.

## OTHER FORMS OF CD8 DEFICIENCY

### CD8 $\alpha$ Gene Defects

CD8 deficiency also results from pathogenic variants in the CD8  $\alpha$  gene. Patients are susceptible to bacterial and viral respiratory infections. CD8 T-cell numbers are low and there is an increase in CD4-CD8- T cells. Lymphocyte proliferation is normal. CD8  $\alpha$  deficiency is also treated with supportive therapy and avoidance of immunosuppression if possible.

### Defects in the Zeta-Associated Protein 70

The zeta-associated protein (ZAP-70) is a severe immunodeficiency similar to SCID with absent or very low numbers of CD8 T cells. Although CD4 T cells develop in adequate numbers, they are defective in proliferation and function. Patients with ZAP-70 deficiency are susceptible to all types of infection including opportunistic infections, disseminated varicella, and mucocutaneous candidiasis with failure to thrive and diarrhea. The diagnosis of ZAP-70 deficiency can be made by low CD8 T-cell counts and deficient T-cell proliferation to mitogens that can be rescued by bypassing ZAP-70 signaling with phorbol ester and ionomycin, helping confirm that the defect is in the proximal signaling pathway in T cells. The diagnosis is confirmed by identification of a homozygous or combined heterozygous pathogenic variant in the ZAP-70 gene. Treatment of ZAP-70 deficiency requires HSCT. Immunoglobulin replacement and microbial prophylaxis should be initiated until immune reconstitution after HSCT is achieved.

## COMBINED IMMUNODEFICIENCIES WITH CONGENITAL THROMBOCYTOPENIA

### Wiskott-Aldrich Syndrome

Wiskott-Aldrich syndrome (WAS) is an X-linked recessive disorder characterized by atopic dermatitis, thrombocytopenic purpura with normal-appearing megakaryocytes but small defective platelets, and susceptibility to infection.

### Genetics and Pathogenesis

The Wiskott-Aldrich syndrome protein (WASP) controls the assembly of actin filaments required for cell migration and cell-cell interactions. Specific pathogenic variants in the WASP gene cause X-linked thrombocytopenia (XLT) without immunodeficiency and gain-of-function variants cause X-linked severe congenital neutropenia. A similar phenotype to WAS occurs with pathogenic variants in the WASP interactive Protein (WIP) that is an autosomal recessive disease affecting both females and males.

### Clinical Manifestations

Patients often have prolonged bleeding from the circumcision site or bloody diarrhea during infancy. The thrombocytopenia is not caused initially by antiplatelet antibodies, although autoimmunity may develop later in life. **Atopic dermatitis** and **recurrent infections** usually develop during the first year of life. *Streptococcus pneumoniae* and other bacteria having polysaccharide capsules cause otitis media, pneumonia, meningitis, and sepsis. Later, infections with agents such as *P. jiroveci* and the herpesviruses become more frequent. Infections, bleeding, and EBV-associated malignancies are major causes of death.

### Diagnosis

The predominant immunoglobulin pattern is a low serum level of IgM, elevated IgA and IgE, and a normal or slightly low IgG. Percentages of T cells are moderately reduced, and lymphocyte responses to mitogens are variably depressed. The presence of low numbers of platelets that are small in size is typical. Immunologically, patients with this defect uniformly have an impaired humoral immune response to

polysaccharide antigens, as evidenced by absent or greatly diminished isoagglutinins, and poor or absent antibody responses after immunization with polysaccharide vaccines. In addition, antibody responses to protein and conjugate vaccines may also be diminished.

### Treatment

Good supportive care includes appropriate nutrition, immunoglobulin replacement, use of killed vaccines, and aggressive management of eczema and associated cutaneous infections. Because of their profound antibody deficiency, these patients should be given immunoglobulin replacement regardless of their serum levels of the different immunoglobulin isotypes. HSCT is the treatment of choice when a high-quality matched donor is available and is usually curative. Gene therapy has resulted in sustained benefits in several patients. As in X-SCID, early trials of gene therapy were associated with the development of malignancy.

In addition to WAS and WIP deficiency, there is a third cause of immunodeficiency with thrombocytopenia from pathogenic variants in the *ARPC1B* gene affecting Arp2/3-mediated filament branching presenting with mild thrombocytopenia but normal-sized platelets and recurrent infections. Patients have high IgA and IgE as in WAS.

## DNA REPAIR DEFECTS OTHER THAN THOSE CAUSING SCID

DNA repair plays an important role during lymphocyte development and differentiation including V(D)J recombination and immunoglobulin isotype switching. Therefore defects in DNA repair enzyme are frequently associated with CID and many have other characteristic features to identify them (see Table 165.3).

### ATAXIA-TELANGIECTASIA

Ataxia-telangiectasia is a complex syndrome with immunologic, neurologic, endocrinologic, hepatic, and cutaneous abnormalities.

### Genetics and Pathogenesis

The ataxia-telangiectasia pathogenic variant (*ATM*) gene encodes a protein critical for responses to DNA damage. Cells from patients, as well as from heterozygous carriers, have increased sensitivity to ionizing radiation, defective DNA repair, and frequent chromosomal abnormalities.

In vitro tests of lymphocyte function have generally shown moderately depressed proliferative responses to T- and B-cell mitogens. Percentages of CD3 and CD4 T cells are moderately reduced, with normal or increased percentages of CD8 T cells and elevated numbers of  $\gamma/\delta$  T cells. The thymus is very hypoplastic, exhibits poor organization, and lacks Hassall's corpuscles.

### Clinical Manifestations

The most prominent clinical features are progressive cerebellar ataxia, oculocutaneous telangiectasias, chronic sinopulmonary disease, a high incidence of malignancy, and variable humoral and cellular immunodeficiency. Ataxia typically becomes evident soon after these children begin to walk and progresses until they are confined to a wheelchair, usually by age 10-12 years. The telangiectasias begin to develop at 3-6 years of age, contributing to a delay in diagnosis. Recurrent sinopulmonary infections occur in approximately 80% of patients. Although common viral infections have not usually resulted in untoward sequelae, fatal varicella has occurred. The malignancies associated with ataxia-telangiectasia are usually of the lymphoreticular type, but adenocarcinomas also occur. Carriers of pathogenic variants have an increased incidence of malignancy.

### Diagnosis

Patients have elevated serum  $\alpha$ -fetoprotein levels. The most frequent humoral immunologic abnormality is the selective absence of IgA, which occurs in 50-80% of these patients. IgG2 or total IgG levels may be decreased, and specific antibody levels may be decreased or normal. Some patients have an elevated serum IgM level. Identification of homozygous or compound heterozygous pathogenic variants in the *ATM* gene confirms the diagnosis.

### Treatment

Therapy in ataxia-telangiectasia is supportive but includes immunoglobulin replacement and avoidance of ionizing radiation unless absolutely necessary to establish a clinical diagnosis and initiate appropriate treatment.

### Immunoosseous Dysplasias

Immunoosseous dysplasias are a group of combined immune deficiency diseases affecting bone development as well as T-cell development or function. They are characterized by skeletal abnormalities and recurrent infections (see Table 165.4).

### CARTILAGE-HAIR HYPOPLASIA

Cartilage-hair hypoplasia (CHH) is an unusual form of **metaphyseal dysplasia** with frequent and severe infections. It occurs with a high frequency among the Amish and Finnish people (Chapter 741).

### Genetics and Pathogenesis

CHH is an autosomal recessive condition. Numerous pathogenic variants that cosegregate with the CHH phenotype have been identified in the untranslated RNase MRP (*RMRP*) gene. The RMRP endoribonuclease consists of an RNA molecule bound to several proteins and has at least two functions: cleavage of RNA in mitochondrial DNA synthesis and nucleolar cleaving of pre-RNA. Defects in *RMRP* cause CHH by disrupting a function of *RMRP* RNA that affects multiple organ systems. In vitro studies show decreased numbers of T cells and defective T-cell proliferation because of an intrinsic defect related to the G1 phase, resulting in a longer cell cycle for individual cells. NK cells are increased in number and function.

### Clinical Manifestations

Clinical features include short, pudgy hands; redundant skin; hyperextensible joints of hands and feet but an inability to extend the elbows completely; and fine, sparse, light hair and eyebrows. Infections range from mild to severe (Fig. 165.5). Associated conditions include deficient erythropoiesis, Hirschsprung disease, and an increased risk of malignancies. The bones radiographically show scalloping and sclerotic or cystic changes in the metaphysis and flaring of the costochondral junctions of the ribs.

### Diagnosis

The diagnosis of CHH is suspected by the clinical constellation of skeletal dysplasia and immune deficiency and supporting laboratory findings. Homozygous or compound heterozygous pathogenic variants in the *RMRP* gene confirms the diagnosis.

### Treatment

Treatment of CHH is supportive. Some patients have been treated with HSCT, which will correct the T-cell immunodeficiency and erythropoiesis but will not affect other organ systems.

### ANHIDROTIC ECTODERMAL DYSPLASIA WITH IMMUNODEFICIENCY

Anhidrotic ectodermal dysplasia with immunodeficiency (EDA-ID) is a CID characterized by susceptibility to infection, thin sparse hair, abnormal dentition (conical teeth), and absence of salivary gland (Chapter 690).

### Genetics and Pathogenesis

X-linked EDA-ID results from hypomorphic gene variants in the *IKK $\gamma$*  gene that encodes the NF- $\kappa$ B essential modulator (NEMO). Complete loss-of-function (LOF) variants are deleterious early in embryogenesis. Carriers of LOF variants have features of incontinentia pigmenti. NEMO is a member of the IKK complex that phosphorylates the inhibitor of NF- $\kappa$ B (I $\kappa$ B), which then allows NF- $\kappa$ B to translocate to the nucleus and turn on gene expression. In lymphocytes, NF- $\kappa$ B is involved in signaling via the antigen receptors, the tumor necrosis factor (TNF) receptor family, and toll-like receptors as well as the interleukin (IL)-1 receptor. Defects in NEMO affect both the innate and adaptive immune systems and can be severe. Autosomal dominant gain-of-function variants in I $\kappa$ B $\alpha$  also result in a similar phenotype



**Fig. 165.5** Metaphyseal dysplasia, McKusick type. Note the fine, sparse hair and short limbs. (From Jones KL, Jones MC, Del Campo M. *Smith's Recognizable Patterns of Human Malformation*. 8th ed. Philadelphia: Elsevier; 2022. Fig.1, p. 529.)

that affects both females and males as well as gain-of-function variants in I $\kappa$ BK $\beta$ . The latter is also associated with recurrent bacterial, viral, and fungal infections, but the ectodermal defects are variable.

### Clinical Manifestations

Patients with EDA-ID suffer from recurrent and severe infections from gram-positive and gram-negative bacteria, mycobacteria, viruses, and fungi. Patients have thin sparse hair and conical teeth and may have colitis. More severe variants may be associated with osteopetrosis and lymphedema; their disease is termed OL-EDA-ID (osteopetrosis, lymphedema, EDA-ID).

### Diagnosis

The diagnosis can be suspected from the clinical features of anhidrosis, ectodermal dysplasia, and recurrent infections. Patients frequently present with hypogammaglobulinemia as in the hyper-IgM syndrome because CD40 signaling involves NF- $\kappa$ B, with elevated IgM in some patients. Most if not all patients have poor NK cell function. The diagnosis can be confirmed by identification of hypomorphic variants in the *IKK $\gamma$*  gene or gain-of-function variants in the I $\kappa$ B $\alpha$  gene.

### Treatment

Patients are usually treated with immunoglobulin replacement and close monitoring. The outcome is dependent on the severity of the phenotype. HSCT has been successful in some patients, but it may not correct the colitis or other features of the disease.

### Calcium Channel Defects

Calcium signaling plays an important role in T-cell activation, where initially calcium is released from the endoplasmic reticulum into the cytoplasm, which is sensed by STIM1 that in turn activates calcium release activated channels (CRACs), which are made up of the pore-forming subunit ORAI-1, to bring in additional calcium from outside the cell. Intracellular calcium activates calcium-dependent enzymes including calcineurin, which activates the nuclear factor of activated T cells (NFAT), which

translocates to the nucleus and activates gene transcription including IL-2 and the CD40 ligand. Pathogenic variants in *ORAI-1* or *STIM1* result in a CID associated with hypotonia because calcium is also important for muscle function.

### Clinical Manifestations

Patients with calcium channel defects have recurrent and severe infections with bacteria, viruses, and fungi. They typically have pneumonia but may present with a variety of infections including BCG lymphadenitis, chronic rotavirus diarrhea, and mucocutaneous candidiasis. They may also present with failure to thrive, ectodermal dysplasia defective dental enamel, and mydrasis. Patients also have a nonprogressive hypotonia.

### Diagnosis

Patients have normal numbers of T cells, but the T cells have decreased or have absent proliferation to mitogens, antigens, or anti-CD3. Although serum immunoglobulins are normal or increased, specific antibody levels are diminished and NK cell function may also be decreased as B cells and NK cells also depend on calcium signaling for their activation. The clinical features and laboratory test results are similar for both *ORA-1* and *STIM1* deficiency. Therefore genetic testing is required to identify the specific pathogenic variants, which will aid in genetic counseling and prenatal diagnosis.

### Treatment

HSCT is the optimal treatment for the immunodeficiency; however, it does not correct the hypotonia, which may contribute to recurrent pneumonia.

Visit Elsevier eBooks+ at [eBooks.Elsevier.com](https://ebooks.elsevier.com) for Bibliography.

## 165.3 Thymic Disorders

Ramsay L. Fuleihan

The thymus is the organ where T-cell development occurs and central T-cell tolerance to self-proteins develops by negative selection of self-reactive thymocytes or development of regulatory T cells. Defects in thymic development affect T-cell development causing a variable degree of T-cell immunodeficiency and are associated with higher risk for the development of autoimmunity.

### DIGEORGE/VELOCARDIOFACIAL SYNDROME/ CHROMOSOME 22Q11.2 DELETION SYNDROME (22Q11.2DS)

Chromosome 22q11.2 deletion syndrome is the most common of the T-cell disorders, occurring in about 1 in 3,000 births in the United States. Chromosome 22q11.2 deletions disrupt development of the third and fourth pharyngeal pouches during early embryogenesis, leading to hypoplasia or aplasia of the thymus and parathyroid glands. Other structures forming at the same age are also frequently affected, resulting in anomalies of the great vessels (right-sided aortic arch), esophageal atresia, bifid uvula, congenital heart disease (conotruncal, atrial, and ventricular septal defects), a short philtrum of the upper lip, hypertelorism, an antimongoloid slant to the eyes, mandibular hypoplasia, and posteriorly rotated ears (see [Chapter 99](#)) ([Fig. 165.6](#)). With advanced fetal ultrasound and fetal echocardiography, the diagnosis is often identified prenatally. Other patients may be identified by low TREC counts on newborn screening for SCID or sometimes by the development of hypocalcemic seizures during the neonatal period.

### Genetics and Pathogenesis

Chromosome 22q11.2 deletions occur with high frequency because complex repeat sequences that flank the region represent a challenge for DNA polymerase. This condition is inherited in an autosomal dominant fashion and occurs with comparable frequency in all populations. Within the deleted region, haplosufficiency for the *TBX1* transcription factor appears to underlie the majority of the phenotype. The phenotype is highly variable; a subset of patients has a phenotype that has



**Fig. 165.6** Typical facial appearance of a child with DiGeorge syndrome. Notice the microstomia, hypertelorism, upturned nose, and posteriorly rotated and small, low-set ears. (From Chinn IK, Chinen J, Shearer WT. Primary immunodeficiency diseases. In: Cherry JD, Harrison GJ, Kaplan SL, et al., eds. *Feigin and Cherry's Textbook of Pediatric Infectious Diseases*. 8th ed. Philadelphia: Elsevier; 2019. Fig. 67.1, p. 641.)

also been called **DiGeorge syndrome**, **velocardiofacial syndrome**, or **conotruncal anomaly face syndrome**.

Variable hypoplasia of the thymus occurs in 75% of the patients with the deletion, which is more frequent than total aplasia; aplasia is present in <1% of patients with 22q11.2 deletion syndrome. Slightly less than half of patients with complete thymic aplasia are hemizygous at chromosome 22q11.2. Approximately 15% are born to diabetic mothers. Another 15% of infants have no identified risk factors. Approximately 30% of infants with complete DiGeorge syndrome have **CHARGE association** (coloboma, heart defect, choanal atresia, growth or developmental retardation, genital hypoplasia, and ear anomalies including deafness). Pathogenic variants in the chromodomain helicase DNA-binding protein 7 (*CHD7*) gene on chromosome 8q12.2 are found in approximately 60–65% of individuals with CHARGE syndrome; some have pathogenic variants in *SEMA3E*.

### Clinical Manifestations

Children with partial thymic *hypoplasia* may have little trouble with infections and grow normally. Patients with thymic *aplasia* (complete DiGeorge syndrome) resemble patients with SCID in their susceptibility to infections with low-grade or opportunistic pathogens, including fungi, viruses, and *P. jiroveci*, and to GVHD from nonirradiated blood transfusions. Patients with thymic aplasia can develop an atypical phenotype in which oligoclonal T-cell populations appear in the blood associated with rash and lymphadenopathy. These atypical patients appear phenotypically similar to patients with **Omenn syndrome** or maternal T-lymphocyte engraftment.

It is critical to ascertain in a timely manner whether an infant has thymic aplasia, because this disease is fatal without treatment. A T-cell count should be obtained on all infants born with primary hypoparathyroidism, CHARGE syndrome, and conotruncal cardiac anomalies with syndromic features. Some but not all infants are identified by newborn screening for SCID and when 22q11.2 deletion is suspected, a calcium level should be obtained at the time of T-cell evaluation. The three manifestations with the highest morbidity in early infancy are profound immunodeficiency, severe cardiac anomaly, and seizures from hypocalcemia. Thus an early focus on these concerns is warranted even before the diagnosis is confirmed. Affected patients may also develop autoimmune cytopenias, juvenile idiopathic arthritis, atopy, and malignancies (lymphomas).



### Diagnosis

The clinical features of DiGeorge/CHARGE/22Q11.2DS will help in establishing the diagnosis, but there is a wide variety of clinical phenotypes. In most patients, absolute lymphocyte counts are usually only moderately low for age. The CD3 T-cell counts are variably decreased in number, corresponding to the degree of thymic hypoplasia. Lymphocyte responses to mitogen stimulation are absent, reduced, or normal, depending on the degree of thymic deficiency. Immunoglobulin levels are often normal, but there is an increased frequency of IgA deficiency, low IgM levels, and some patients develop progressive hypogammaglobulinemia. FISH for 22Q11.2 may identify patients with 22Q11.2DS as well as the more sensitive DNA microarray. Pathogenic variants in *TBX1* may be found in DiGeorge syndrome, and pathogenic variants in *CHD7* or *SEMA3E* in CHARGE syndrome.

### Treatment

The immunodeficiency in thymic aplasia is correctable by cultured allogenic (donor derived) thymic tissue transplants. Following thymic tissue transplantation, a cytokine release syndrome may develop. Some infants with thymic aplasia have been given nonirradiated unfractionated bone marrow or peripheral blood transplants from a human leukocyte antigen-identical sibling, with subsequent improved immune function because of adoptively transferred T cells. Infants and children with low T-cell counts but not low enough to consider transplantation should be monitored for evolution of immunoglobulin defects as well as autoimmunity. Infections in these patients are multifactorial. Their anatomy may not favor drainage of secretions; they have a higher rate of atopy, which may complicate infections; and their host defense may allow persistence of infections. Interventions range from hand hygiene, probiotics, prophylactic antibiotics, and risk management to immunoglobulin replacement for those who have demonstrated defective humoral immunity. Live-viral vaccines should be avoided until adequate CD4 and CD8 T-cell counts are confirmed and normal response to antigens is documented with T-cell proliferation to antigens or a protective antibody response to a protein vaccine such as tetanus.

Visit Elsevier eBooks+ at [eBooks.Health.Elsevier.com](http://eBooks.Health.Elsevier.com) for Bibliography.

## 165.4 Inborn Errors of Immunity with a Strong Atopic Diathesis

Ramsay L. Fuleihan

### AUTOSOMAL DOMINANT HYPER-IgE SYNDROME STAT3 DEFICIENCY (JOB SYNDROME)

This syndrome is associated with early-onset atopy and recurrent skin and lung infections.

#### Genetics and Pathogenesis

The autosomal dominant hyper-IgE syndrome is caused by heterozygous pathogenic variants in the gene encoding signal transducer and activator of transcription 3 (*STAT3*). These pathogenic variants result in a dominant negative effect. The many clinical features are caused by compromised signaling downstream of the IL-6, type I interferon, IL-22, IL-10, and epidermal growth factor (EGF) receptors.

#### Clinical Manifestations

The characteristic clinical features are staphylococcal abscesses, pneumatoceles, osteopenia, and unusual facial features. There is a history from infancy of recurrent staphylococcal abscesses involving the skin, lungs, joints, viscera, and other sites. Persistent pneumatoceles develop as a result of recurrent pneumonia. Patients often have a history of sinusitis and mastoiditis. *C. albicans* is the second most common pathogen. Allergic respiratory symptoms are usually absent. The pruritic dermatitis that occurs is not typical of atopic eczema and does not always persist. There can be a prominent forehead, deep-set wide-spaced eyes, a broad nasal bridge, a



**Fig. 165.7** Mucocutaneous inflammation and infections in DOCK8-HIES. Severe eczema, molluscum contagiosum and fungal skin infections, and benign tumorous mucosa proliferations progressing from the inner eyelid and from oral mucosa are clinical signs of DOCK8-HIES. (From Hagl B, Heinz V, Schlesinger A, et al. Key findings to expedite the diagnosis of hyper-IgE syndromes in infants and young children. *Pediatr Allergy Immunol.* 2016;27[2]:177-184. Fig. 1)

wide fleshy nasal tip, mild prognathism, facial asymmetry, and hemihypertrophy, although these are most evident in adulthood. In older children, delay in shedding primary teeth, recurrent fractures, and scoliosis occur.

These patients demonstrate an *exceptionally high serum IgE concentration*; usually normal concentrations of IgG, IgA, and IgM; pronounced blood and sputum eosinophilia; and poor antibody and cell-mediated responses to neoantigens. Although IgE levels >2,000 IU/mL are characteristic, IgE levels may fluctuate and even decrease in adulthood. In neonates and infants with the pruritic pustular dermatosis, IgE levels will be elevated *for age* and are usually in the 100s. In vitro studies show normal percentages of blood T, B, and NK lymphocytes, except for a decreased percentage of T cells with the memory (CD45RO) phenotype and an absence or deficiency of T-helper type 17 (Th17) cells. Most patients have normal T-lymphocyte proliferative responses to mitogens but very low or absent responses to antigens or allogeneic cells from family members. Blood, sputum, and histologic sections of lymph nodes, spleen, and lung cysts show striking eosinophilia. Hassall's corpuscles and thymic architecture are normal.

#### Treatment

Therapy is generally directed at prevention of infection using antimicrobials including antibiotics and antifungals as well as immunoglobulin replacement.

### DOCK8 DEFICIENCY

Deficiency of DOCK8 (dedicator of cytokinesis 8) is an autosomal recessive severe immunodeficiency that most often presents with impressively severe eczema in infancy and toddlerhood, food allergy, and eosinophilic esophagitis. Patients commonly have cutaneous viral infections with herpes simplex virus (HSV), varicella, or molluscum contagiosum; susceptibility to infection by CMV and EBV; recurrent pneumonia leading to bronchiectasis; and opportunistic infections with PJP. In some patients, cryptosporidia causes sclerosing cholangitis (Fig. 165.7). The infectious susceptibility tends to worsen over time, as do the laboratory features of immune dysfunction, most often low T-cell counts and poor proliferative function. Serum IgE levels tend to be elevated with eosinophilia, whereas other immunoglobulin levels may be decreased, especially IgM. Specific antibody levels are variably decreased. Patients are also susceptible to autoimmune disease as well as cancer. Although these patients can survive to adulthood without transplantation, they suffer many complications and their quality of life is often poor. For this reason, most patients are now transplanted early in life to avoid the later complications.

Visit Elsevier eBooks+ at [eBooks.Health.Elsevier.com](http://eBooks.Health.Elsevier.com) for Bibliography.



## Chapter 166

## B-Cell and Antibody Deficiencies

Vivian P. Hernandez-Trujillo and Camile Ortega

Of the primary immunodeficiency diseases (PIDDs), those affecting antibody production are the most prevalent. Selective absence of IgA is the most common defect, with rates ranging from 1 in 333 to 1 in 18,000 persons among different races and ethnicities. Patients with antibody deficiency are usually recognized because they have recurrent infections with encapsulated bacteria, predominantly in the upper and lower respiratory tracts. Some individuals with selective IgA deficiency or infants with transient hypogammaglobulinemia may have few or no infections. These conditions have a complex and likely polygenic inheritance, as do the common variable immunodeficiency (CVID) syndromes. The gene defects for many primary antibody deficiency disorders have been identified (Table 166.1). Sometimes the defect is not in the B cell itself but in T cells, which are required for complete B-cell function. Some disorders are caused by unknown factors or are secondary to an underlying disease or its treatment.

## 166.1 Agammaglobulinemia

Vivian P. Hernandez-Trujillo and Camile Ortega

## X-LINKED AGAMMAGLOBULINEMIA

Patients with X-linked agammaglobulinemia (XLA), or **Bruton agammaglobulinemia**, have a profound defect in B-lymphocyte development resulting in severe hypogammaglobulinemia, an absence of circulating B cells, small to absent tonsils, and no palpable lymph nodes. These patients present with an increased susceptibility to infection (Fig. 166.1) and have increased risk of neutropenia and autoimmunity, particularly presenting as colitis.

## Genetics and Pathogenesis

The variant gene in XLA maps to q22 on the long arm of the X chromosome and encodes the B-cell protein tyrosine kinase Btk (Bruton tyrosine kinase). Btk is a member of the Tec family of cytoplasmic protein tyrosine kinases and is expressed at high levels in all B-lineage cells, including pre-B cells. Some pre-B cells are found in the bone marrow, but the percentage of peripheral blood B lymphocytes is <1%. The percentage of T cells is increased, ratios of T-cell subsets are normal, and T-cell function is intact. The thymus is normal.

Several autosomal recessive defects have also been shown to result in agammaglobulinemia with an absence of circulating B cells (see Table 166.1; Table 166.2), including pathogenic variants in the genes encoding the (1)  $\mu$  heavy chain gene; (2)  $Ig\alpha$  and (3)  $Ig\beta$  signaling molecules; (4) B-cell linker adaptor protein (BLNK); (5) surrogate light chain,  $\lambda 5/14.1$ ; (6) leucine-rich repeat-containing 8 (LRRC8); (7) p85 $\alpha$  subunit of phosphatidylinositol-3 kinase; (8) p110  $\delta$  subunit of phosphatidylinositol-3 kinase; (9) TCF3; (10) SLC39A7; and (11) TOP2B. These are rare but are clinically indistinguishable from the X-linked form (see Fig. 166.1).

## Clinical Manifestations/Complications

Most males afflicted with XLA remain well during the first 6-9 months of life by virtue of maternally transmitted IgG antibodies. Thereafter they acquire infections with extracellular pyogenic organisms, such as *Streptococcus pneumoniae* and *Haemophilus influenzae*, unless they are

given prophylactic antibiotics or immunoglobulin therapy. Infections include sinusitis, otitis media, pneumonia, or, less often, sepsis or meningitis (Fig. 166.2). Infections with *Mycoplasma* are also particularly problematic, specifically as they can affect the joints. Chronic fungal infections are seen; *Pneumocystis jirovecii* pneumonia rarely occurs. Viral infections are usually handled normally, with the exceptions of hepatitis viruses and enteroviruses. There are examples of paralysis when live polio vaccine was administered to these patients, and chronic, eventually fatal, central nervous system (CNS) infections with various echoviruses and coxsackieviruses have occurred in a significant number of patients. An enterovirus-associated myositis resembling dermatomyositis has also been observed. Enteroviral encephalitis can also be life-threatening in patients with XLA. **Neutropenia**, typically seen at diagnosis when infected, can be associated with *Pseudomonas* or staphylococcal infections. In addition, *Pseudomonas* can lead to severe and life-threatening invasive infections. *Giardia* can also lead to diarrhea and weight loss. A sudden decrease in serum IgG level should prompt an evaluation for *Giardia*.

Long-term complications include bronchiectasis and colitis, presenting like an inflammatory bowel disease. Gastrointestinal (GI) disease has been increasingly reported in patients with XLA. Although immune globulin replacement decreased severe infectious complications, the chronic lung disease persisted in a recent cohort study. In addition, in a separate cohort, infections were highest before initiation of antibody replacement; however, patients continued to have infections despite adequate IgG levels.

## Diagnosis

The diagnosis of XLA should be suspected if lymphoid hypoplasia is found on physical examination (minimal or no tonsillar tissue and no palpable lymph nodes), and serum concentrations of IgG, IgA, IgM, and IgE are far below the 95% confidence limits for appropriate age- and race-matched controls; total immunoglobulins are usually <100 mg/dL. Levels of natural antibodies to type A and B red blood cell polysaccharide antigens (isohemagglutinins) and antibodies to antigens given during routine immunizations are abnormally low in XLA, whereas they are typically normal in transient hypogammaglobulinemia of infancy. In infants below the age of 6 months, care should be taken when interpreting normal IgG, which can represent maternal IgG passed in utero. In this case, flow cytometry is essential in making the diagnosis of XLA. Flow cytometry is an important test to demonstrate the absence of circulating B cells, which will distinguish XLA from most types of CVID, the hyper-IgM syndrome, and transient hypogammaglobulinemia of infancy (Fig. 166.3). Genetic testing is also available to detect absence of Btk.

## AUTOSOMAL RECESSIVE AGAMMAGLOBULINEMIA

Autosomal recessive agammaglobulinemia (ARA) is a clinically indistinguishable disorder from XLA presenting in males and females. The successful assembly and subsequent signaling capacity of the pre-B cell receptor complex (pre-BCR) in the bone marrow is central to the production of B cells and antibody-secreting plasma cells. A pathogenic variant in any of the components of the pre-BCR, or in the downstream signaling cascade, results in these rare forms of agammaglobulinemia (see Fig. 166.1).

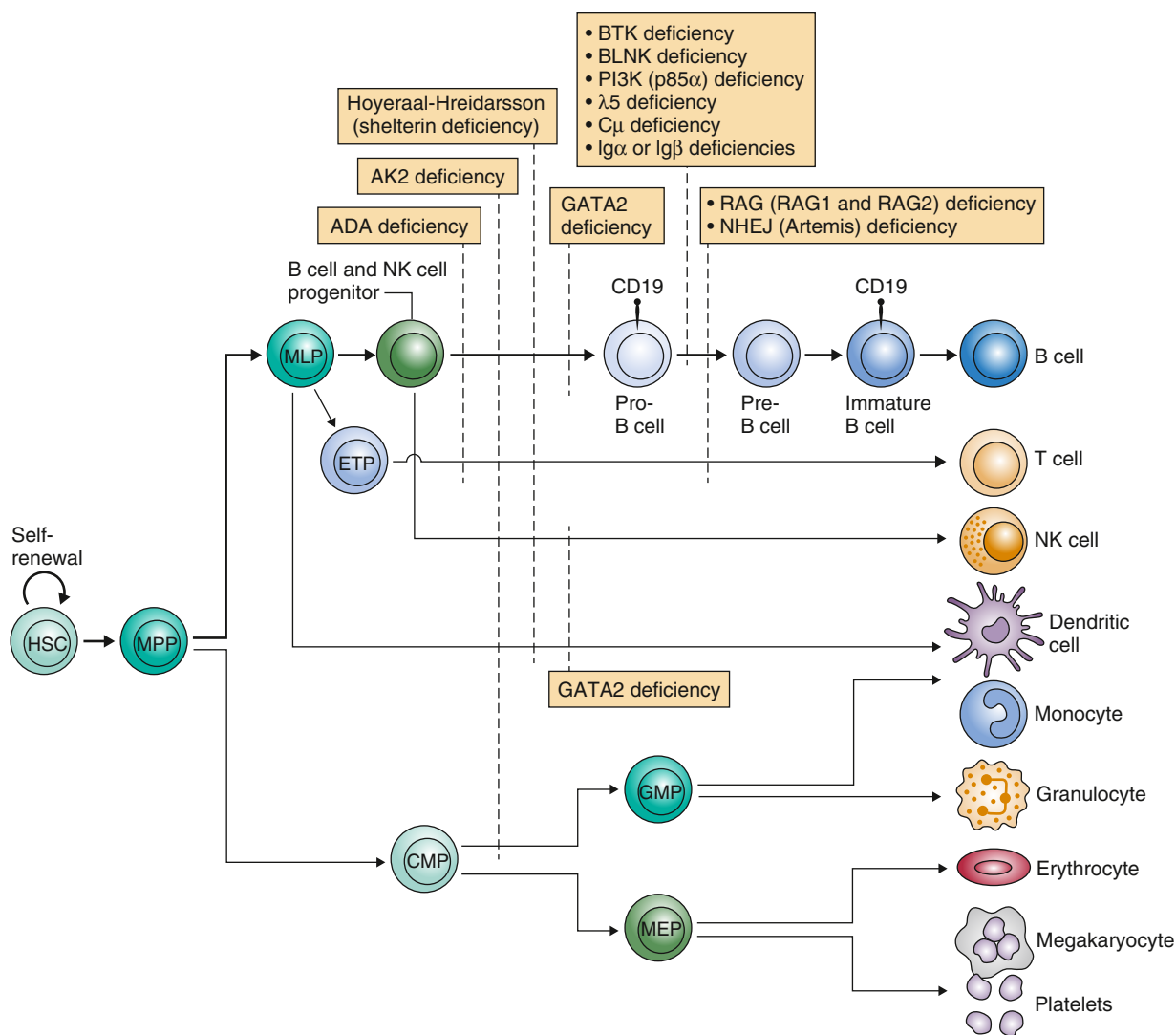
## Genetics and Pathogenesis

Hematopoietic stem cells develop into B cells in the bone marrow. The maturation into antibody-secreting plasma cells occurs in peripheral lymphoid tissues. B-cell development relies on a tightly regulated sequence of events from the pro-B cell stage to the formation of the pre-BCR and onward (see Fig. 166.1).

The pre-BCR is composed of the membrane form of the  $\mu$  heavy chain, the surrogate light chain composed of VpreB and  $\lambda 5/14.1$  and the immunoglobulin-associated signal transducing chains,  $Ig\alpha$  and  $Ig\beta$ . An autosomal pattern of inheritance occurs in approximately 10% of agammaglobulinemic syndromes, and, in some affected families, there is known consanguinity. Approximately half of these pathogenic variants are in  $\mu$  heavy (IGHM) and have a clinical picture that

<b>Table 166.1 Genetic Basis of the Most Common Primary Antibody Deficiency Disorders</b>		
<b>GENE</b>	<b>PHENOTYPE</b>	<b>DISORDER</b>
<i>BAFFR</i>	CVID	Hypogammaglobulinemia
<i>CD19</i>	CVID	Hypogammaglobulinemia
<i>CD20</i>	CVID	Hypogammaglobulinemia
<i>CD21</i>	CVID	Hypogammaglobulinemia
<i>CD81</i>	CVID	Hypogammaglobulinemia
<i>CTLA4</i>	CVID	Hypogammaglobulinemia, pronounced lymphoproliferation and autoimmunity
<i>ICOS</i>	CVID	Hypogammaglobulinemia, autoimmunity, neoplasia
<i>LRBA</i>	CVID	Hypogammaglobulinemia, pronounced lymphoproliferation and autoimmunity
<i>NFKB2</i>	CVID	Hypogammaglobulinemia, autoimmunity
<i>NFKB1</i>	CVID	Hypogammaglobulinemia, autoimmunity
<i>PIK3CD</i> (AD)	CVID	Hypogammaglobulinemia, adenopathy
<i>PI3KR1</i> (AD)	CVID	Hypogammaglobulinemia
<i>TNFRSF13B</i>	CVID	Hypogammaglobulinemia, low penetrance of disease
Unknown	CVID	Hypogammaglobulinemia, autoimmunity Majority of patients with CVID have no known gene variant
Unknown	IgG subclass deficiency	Variable association with infection
Unknown	Specific antibody deficiency	Normal immunoglobulin levels with poor vaccine responses
Unknown	Transient hypogammaglobulinemia of infancy	Vaccine responses are usually preserved, and most children outgrow this by age 3yr
Unknown	Selective IgA deficiency	Low or absent IgA; low concentrations of all immunoglobulins and of switched memory B cells in CVID
<i>BLNK</i>	Agammaglobulinemia	Absence of antibody production, lack of B cells
<i>BTK</i>	Agammaglobulinemia	Absence of antibody production, lack of B cells, X-linked agammaglobulinemia
<i>CD79A</i>	Agammaglobulinemia	Loss of the Ig $\alpha$ required for signal transduction, absence of antibody production, lack of B cells
<i>CD79B</i>	Agammaglobulinemia	Loss of the Ig $\beta$ required for signal transduction, absence of antibody production, lack of B cells
<i>IGHM</i>	Agammaglobulinemia	Loss of the Ig heavy chain, absence of antibody production, lack of B cells
<i>IGLL1</i>	Agammaglobulinemia	Loss of the surrogate light chain, absence of antibody production, lack of B cells
<i>PI3KR1</i> (AR)	Agammaglobulinemia	Loss of signal transduction through the B-cell receptor, absence of antibody production, lack of B cells
<i>PIK3CD</i> $\delta$ (AR)	Agammaglobulinemia	Severely impaired signal transduction through B-cell receptor, absence of antibody production, lack of B cells
<i>SLC39A7</i>	Agammaglobulinemia	Impaired signal transduction through the B-cell receptor, absence of antibody production, lack of B cells
<i>TCF3</i>	Agammaglobulinemia	Loss of a key transcription factor for B-cell development, absence of antibody production, lack of B cells
<i>AID</i>	Class switch defect	Failure to produce IgG, IgA, and IgE antibodies
<i>CD40</i>	Class switch defect	Failure to produce IgG, IgA, and IgE antibodies, <i>Pneumocystis</i> and <i>Cryptosporidium</i> susceptibility
<i>CD154</i>	Class switch defect	Failure to produce IgG, IgA, and IgE antibodies, <i>Pneumocystis</i> and <i>Cryptosporidium</i> susceptibility
<i>INO80</i>	Class switch defect	Failure to produce IgG, IgA, and IgE antibodies
<i>MSH6</i>	Class switch defect	Failure to produce IgG, IgA, and IgE antibodies, malignancy
<i>UNG</i>	Class switch defect	Failure to produce IgG, IgA, and IgE antibodies
<i>CD27</i>	EBV lymphoproliferation	Memory B-cell deficiency Hypogammaglobulinemia
<i>NEMO</i>	Anhidrotic ectodermal dysplasia with immunodeficiency	Phenotype highly variable but includes specific antibody deficiency and CVID

AD, autosomal dominant; AR, autosomal recessive; CVID, common variable immunodeficiency; EBV, Epstein-Barr virus.



**Fig. 166.1** B-cell development defects in primary antibody deficiencies (PADs) result from developmental defects that are either B-cell specific or affect several hematopoietic cell lineages. B-cell development occurs in the bone marrow, where hematopoietic stem cells (HSCs) undergo B-cell lineage specification. Some autosomal-recessive forms of severe combined immunodeficiency (SCID) are associated with an early defect in both B and T cells and are diagnosed in the first few months or years of life. For example, adenosine deaminase (ADA) deficiency leads to an accumulation of adenosines and thus the death of the lymphocytes. Moreover, adenylate kinase 2 (AK2) deficiency (also known as reticular dysgenesis) is a metabolic defect that mostly affects T cells, natural killer (NK) cells, neutrophils, and (in some cases) B cells. It is associated with very early onset hypogammaglobulinaemia or even agammaglobulinaemia. Dyskeratosis congenita is caused by mutations in genes encoding components of the telomerase or shelterin complexes; it is a rare inherited bone-marrow failure syndrome that leads to progressive B- and T-cell lymphopenia and hypogammaglobulinaemia. Finally, mutations in GATA2 (which encodes a transcription factor required for early differentiation of hematopoietic cells in the bone marrow) also lead to B-cell, dendritic cell, monocyte, and NK cell deficiencies. Successive B-cell differentiation stages are characterized by ordered gene expression and stochastic immunoglobulin gene rearrangements. The V(D)J recombination of the immunoglobulin locus is achieved by the lymphocyte-specific RAG molecules and the non-lymphocyte-specific nonhomologous end joining (NHEJ) complex and leads to the expression of the pre-B cell receptor (BCR). Defects in V(D)J recombination (as observed in RAG deficiency and NHEJ deficiency) typically result in the absence of mature B and T cells. The pre-BCR is affected in these cases, leading to PADs as V(D)J recombination is required for heavy chain expression. The dashed lines indicate a block of differentiation. BLNK, B-cell linker; Btk, Bruton tyrosine kinase; CMP, common myeloid progenitor; ETP, early T-cell precursor; GMP, granulocyte/macrophage progenitor; MEP, megakaryocyte/erythrocyte progenitor; MLP, multi-lymphoid progenitor; MPP, multipotent progenitor; PI3K, phosphoinositide 3-kinase. (From Durandy A, Kracker S, Fischer A. *Primary antibody deficiencies*. *Nat Rev Immunol*. 2013;13:519-533. Box 1, p. 520.)

is similar to XLA. Variants in the genes encoding for Ig $\alpha$  (CD79a), Ig $\beta$  (CD79b),  $\lambda$ 5 (IGLL1), BLNK, and p85 $\alpha$  (PI3KR1) have been identified as other, more rare, causes for ARA in humans (see Fig. 166.1). Autosomal dominant forms of agammaglobulinemia have also been identified in patients with an unusual phenotype characterized by an increased expression of CD19, but with the absence of the BCR. Genetic studies demonstrated a *de novo* variant in the broadly expressed transcription factor E47, which functions as a quality control mechanism of enforcing a block to prevent cells that lack a pre-BCR from further development.

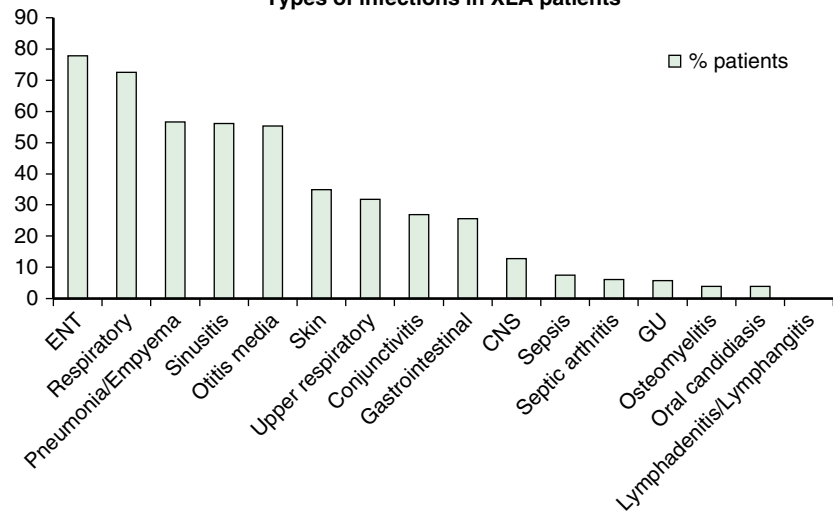
### Clinical Manifestations

Absent peripheral B cells and severe hypogammaglobulinemia due to a developmental arrest at the pro-B stage to pre-B stage is characteristic of ARA. Although these patients generally have clinical findings that are indistinguishable from Btk mutations, patients with the pathogenic variants in any of the components of the BCR leading to ARA tend to have a more severe phenotype. ARA is diagnosed at a mean age of 11 months, rather than 35 months in patients with XLA. There is also a higher incidence of enteroviral infections and *Pseudomonas* sepsis with neutropenia. These differences suggest there is protective value in

**Table 166.2** Patterns of Inheritance for Different Forms of Agammaglobulinemia

DISEASE	GENE/PROTEIN AFFECTED	PATTERN OF INHERITANCE
XLA	Btk	X-linked
IGHM	$\mu$ heavy chain	Autosomal recessive
Ig $\alpha$	CD79a	Autosomal recessive
Ig $\beta$	CD79b	Autosomal recessive
$\lambda 5$	IGLL1	Autosomal recessive
BLNK	BLNK scaffolding protein	Autosomal recessive
PIK3R1	PIK3 regulatory subunit	Autosomal recessive
PIK3CD	PIK3 regulatory subunit	Autosomal recessive
SLC39A7	Zinc transporter protein ZIP7	Autosomal recessive
TCF3	Transcription factors E12 and E47	Autosomal recessive or autosomal dominant
LRR8	LRR8 deficiency	Autosomal dominant
Hoffman syndrome	TOP2B	Autosomal dominant

XLA, X-linked agammaglobulinemia.

**Types of infections in XLA patients**

**Fig. 166.2** Types of Infections in a cohort of X-linked agammaglobulinemia (XLA) patients. USIDNET Registry. Infections affect many body systems in XLA patients. CNS, Central nervous system; ENT, ear, nose, and throat; GU, genitourinary. (Data from Groth D, Wright H, Marsh R, et al. X-linked agammaglobulinemia: Infection frequencies in 226 patients from the USIDNET Registry. *J Allergy Clin Immunol.* 2020;145[2 Supplement]:AB80.)

the small amount of immunoglobulins produced by patients with XLA. Treatment using immunoglobulin and aggressive use of antibiotics is identical to that for patients with XLA.

### Diagnosis

Due to the early B-cell developmental arrest, ARA variants have been associated with the complete absence of CD19<sup>+</sup> B cells in the peripheral circulation and profound hypogammaglobulinemia. Identifying a genetic cause of ARA is challenging, and there is a need for a better understanding of susceptibility genes and modifying genetic factors. The goal of further areas of investigation should include the identification of variant genes in patients who do not appear to have defects in the genes already associated with immunodeficiency.

Whole genome sequencing will greatly facilitate the molecular diagnosis of abnormalities in additional genes that can cause ARA.

### Inheritance Patterns

XLA affects males, as it is an X-linked disorder. The inheritance patterns include all female offspring as carriers, and none of the male offspring will be affected. Autosomal recessive forms of agammaglobulinemia result in both males and females affected, as each parent passes on the affected gene. Patients with agammaglobulinemia tend to have more severe disease, often presenting earlier in life compared with

patients with hypogammaglobulinemia, specific antibody deficiency (SAD), or CVID.

Treatment with antibody replacement and prophylactic antibiotics for patients with any form of agammaglobulinemia is essential in preventing infections and will be further reviewed later.

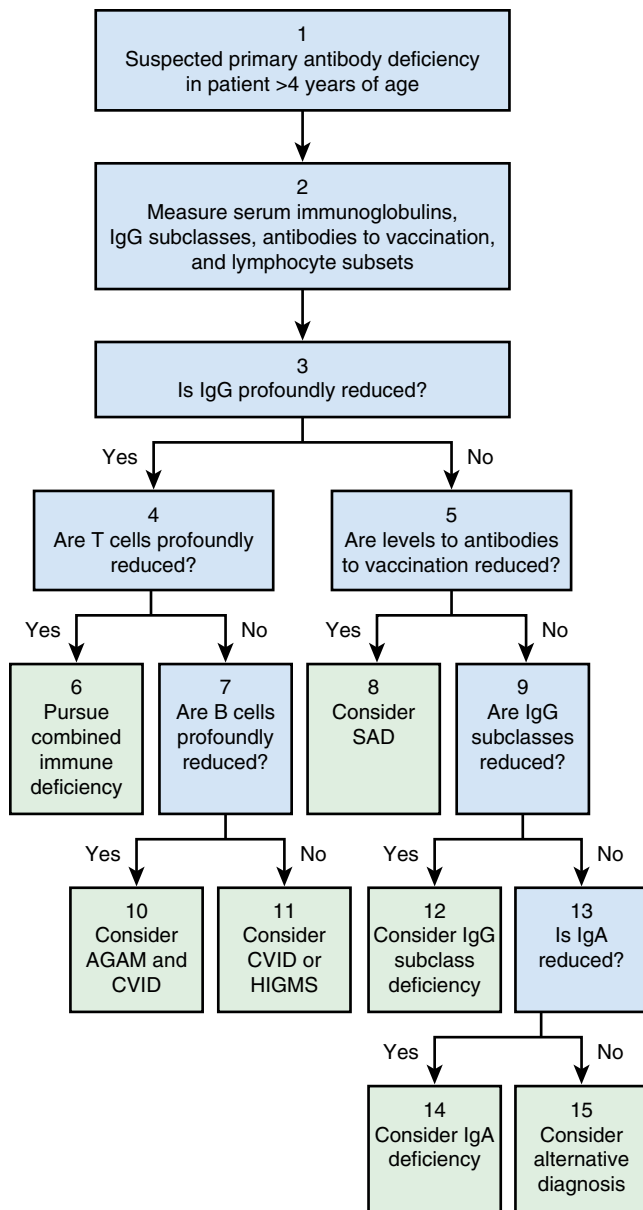
Visit Elsevier eBooks+ at [eBooks.Health.Elsevier.com](https://eBooks.Health.Elsevier.com) for Bibliography.

## 166.2 Hypogammaglobulinemia, Transient Hypogammaglobulinemia of Infancy, Specific Antibody Deficiency, and Common Variable Immunodeficiency

Vivian P. Hernandez-Trujillo and Camile Ortega

Patients with low IgG may present at different ages. Hypogammaglobulinemia results from low, but not absent, levels of serum immunoglobulins. If a patient is diagnosed with a specific pathologic genetic variant, this aids in making a specific diagnosis. Otherwise, in patients with a low IgG, the diagnosis may be arbitrary when considering the differential of hypogammaglobulinemia, SAD, and CVID (Tables 166.3 and 166.4).





**Fig. 166.3** Algorithm for evaluation of a patient with suspected primary antibody deficiency. AGAM, Congenital agammaglobulinemia; CVID, common variable immunodeficiency; HIGMS, hyperIgM syndrome; SAD, specific antibody deficiency. (From Maglione PJ. Primary antibody deficiency. In: Leung DYM, Akdis CA, Bacharier LB, et al., eds. *Pediatric Allergy Principles and Practice*. 4th ed. Philadelphia: Elsevier, 2021. Fig. 5.1.)

## HYPOGAMMAGLOBULINEMIA

The most common types of PID are antibody deficiencies characterized by hypogammaglobulinemia and recurrent infections and are usually present in childhood. Primary hypogammaglobulinemia represents a spectrum of disease, with more severe phenotypes characterized by profound hypogammaglobulinemia or agammaglobulinemic states, as was described in the previous section. SAD and CVID are presented in the following sections, and onset may occur later in childhood and adolescence. This is in contrast to transient hypogammaglobulinemia of infancy, which presents in the first few months of life.

The secondary forms are more common in adults and are a result of decreased production or increased loss. Decreased production can be drug induced (rituximab, glucocorticoids, and antiepileptics), from malignancy or premalignant disorders (chronic lymphocytic leukemia, lymphoma, multiple myeloma, or Waldenström macroglobulinemia), and from Good syndrome (thymoma with hypogammaglobulinemia).

Increased loss can result from protein-losing enteropathies, intestinal lymphangiectasia, nephrotic syndrome, burns, and trauma.

## Specific Antibody Deficiency

SAD is defined as patients, 2 years old and older, with recurrent infections and normal immunoglobulin isotypes who lack antibody response to purified *S. pneumoniae* capsular polysaccharide antigens, while responding normally to protein antigens.

## Genetics and Pathogenesis

Infants demonstrate robust antibody responses to protein antigens through T-cell–dependent activation. Response to purified polysaccharide vaccines (PPVs) does not involve T-cell activation, and is only considered to be fully developed by 2 years of age. The response to protein antigens, including those contained in the protein conjugated vaccines (PCVs), typically remains intact in patients with SAD. In SAD, some patients' lack of response to PPV may represent physiologic immaturity of the immune system, and may resolve over time. In SAD patients with recurrent infections requiring antibiotics, there is likely an underlying immunologic abnormality. The cause for this delay in maturation remains unknown. Abnormalities in a specific pathogen-associated molecular pathway may be responsible for the variability in which individuals respond to specific protein or polysaccharide antigens despite normal total immunoglobulin levels. A number of cellular pathways produce antibodies against purified or conjugate polysaccharides and are likely to be altered by different defects. The response seen to PPV, which can occur in patients who lack a response to PCV, demonstrates how conjugate and purified polysaccharides induce antibodies through different activation pathways. The variation in phenotypes of SAD also supports the likelihood of different pathogenic mechanisms resulting in polysaccharide antibody deficiencies. The use of large-scale DNA studies, along with IgM memory and class-switched memory B cells as immunologic markers, is expected to provide useful information for the evaluation and management of patients with SAD in the future.

## Clinical Manifestations

Patients with SAD present in a manner consistent with those with defects of humoral immunity. Frequent, severe, or prolonged sinopulmonary infections are most common. Rapid recurrence of infection on discontinuation of antibiotics, following initial improvement, is also common. Invasive and life-threatening infections are not frequent. Approximately half of children show resolution of SAD in 3 years and treatment may be temporary. A new diagnosis of SAD during adolescence or adulthood could indicate a previously missed diagnosis or progression of a mild phenotype. Pathogen susceptibility is not specific and not limited to *S. pneumoniae*. Other encapsulated bacteria, (*H. influenzae* and *Moraxella catarrhalis*), *Staphylococcus aureus* and respiratory viruses cause significant disease in SAD.

SAD patients with allergic disease are among the most challenging to identify due to increased risk of sinopulmonary infections resulting from persistent inflammation and anatomic dysfunction associated with asthma and rhinitis. It is important to consider underlying SAD in this population, as IgE-mediated sensitization is only present in some of these patients. Mucociliary or anatomic defects should also be considered in those who have developed high titers in response to natural infection, but maintain an abnormal pattern of infections.

Although lack of antibody response to polysaccharide antigens is found frequently in patients without any associated immune deficiency, selective antibody deficiencies are also common in patients with known PID with normal total immunoglobulin levels such as ataxia telangiectasia, asplenia, hyper-IgE syndrome, selective IgA deficiency, IgG subclass deficiencies, Wiskott-Aldrich syndrome, and partial DiGeorge syndrome. A subset of adolescents and adults with SAD may progress to more severe forms of PID, including other forms of hypogammaglobulinemia and CVID.

## Diagnosis

The gold standard for the diagnosis of SAD involves evaluating the response to the 23-valent pneumococcal polysaccharide vaccine (PPV23). In patients immunized with protein conjugated

**Table 166.3** Main Phenotypes of Primary Antibody Deficiencies

PHENOTYPE	MAIN CLINICAL FEATURES	MAIN B-CELL FEATURES
Agammaglobulinemia	Bacterial infections (in respiratory tract) and enterovirus infections	Absence of CD19 B cells
Common variable immunodeficiency	Bacterial infections (in respiratory tract and gut), autoimmunity, cancer, and increased risk of granuloma	Highly variable; may see decreased memory B cells
Class switch defects	Bacterial and opportunistic infections	Decreased frequency of memory B cells
Selective IgA deficiency	Most often asymptomatic	Normal
IgG subclass deficiency	Frequent bacterial infections; diagnosis after age 2yr	B-cell subsets normal
Selective polysaccharide antibody deficiency	Bacterial infections (after age 2yr)	Normal IgG (including IgG2 and IgG4) levels, normal B-cell subsets

**Table 166.4** Antibody Deficiency Disorders with Laboratory Evaluation

LABORATORY VALUES	XLA/AR AGAMMA	SELECTIVE IgA	SPECIFIC ANTIBODY DEFICIENCY	COMMON VARIABLE IMMUNODEFICIENCY	TRANSIENT HYPOGAMMA-GLOBULINEMIA
IgG	Decreased	Normal	Normal	Decreased to normal	Decreased
IgA	Decreased	Decreased	Normal	Decreased to normal	Normal
IgM	Decreased	Normal	Normal	Varies	Normal
LYMPHOCYTES					
B CD19 <sup>+</sup>	Decreased to absent	Normal	Normal	Decreased to normal memory B cells	Normal
T CD4 <sup>+</sup> /CD3 <sup>+</sup>	Normal to increased	Normal	Normal	Normal	Normal
CD8 <sup>+</sup> /CD3 <sup>+</sup>	Normal to increased	Normal	Normal	Normal	Normal
NK 16 <sup>+</sup> /56 <sup>+</sup>	Normal to increased	Normal	Normal	Normal	Normal
SPECIFIC ANTIBODY TITERS					
Protein	Decreased	Normal	Normal	Decreased to normal	Normal
Polysaccharide	Decreased	Normal	Decreased	Decreased to normal	Normal

AR, Autosomal recessive; NK, natural killer; XLA, X-linked agammaglobulinemia.

pneumococcal vaccines (PCV-7, PCV-13, PCV-10, PCV-15, PCV-20), the evaluation must be based on the serotypes not present in conjugate vaccines. In unimmunized patients, a complete absence of protective titers to all serotypes is unusual, as most individuals would be expected to have developed some in response to natural infection by 2 years of age. The standard and reproducible method used for analysis is the third-generation World Health Organization enzyme-linked immunosorbent assay (ELISA) and the antigens are individual serotype specific capsular polysaccharides of pneumococci. Antibody titers are expressed as mg/mL and although titers as low as 0.35 mg/mL have been considered protective against invasive infections, a titer of 1.3 mg/mL is used as the threshold of response to PPV23 and generally considered protective against mucosal infections. **Four different phenotypes of SAD** have been described based on the response to the available pneumococcal vaccines: mild, moderate, severe, and memory. Although all phenotypes presume an abnormal pattern of infection, severity or susceptibility to infection may or may not correlate clinically. The severe phenotype is defined as nearly absent protective titers to  $\leq 2$  serotypes following PPV23. The moderate phenotype is based on age: for those less than 6 years old, less than 50% protective serotypes and those age 6 years old and greater, less than 70% protective serotypes. Many patients fall in the mild phenotype, which is less well defined as a failure of response to multiple phenotypes. The

memory phenotype, also dependent on age, is defined as an adequate initial response and subsequent loss of protective titers within 6 months. The evaluation of specific antibodies against *S. pneumoniae* polysaccharides provides guidance in determining the need for additional immunization, antibiotic therapy, or IgG replacement therapy in SAD patients. Children and adults who have not been immunized and have not developed protective titers in response to natural infection should be immunized with PCV followed by PPV23, as they have been shown to respond both clinically and serologically. Patients who fail to respond to the initial challenge with PPV23 may respond to the conjugated vaccine, when given  $\geq 1$  year after PPV23. Most patients have an excellent prognosis with appropriate treatment.

### COMMON VARIABLE IMMUNODEFICIENCY

CVID is a syndrome characterized by hypogammaglobulinemia after an initial period of apparent normal immune function. Serum IgG must be  $< 2$  standard deviations below the *age-adjusted* norms, with low IgA and/or IgM levels. CVID patients may appear similar clinically to those with XLA in the types of infections experienced and bacterial etiologic agents involved, except that enterovirus meningoencephalitis is rare in patients with CVID. In contrast to XLA, the sex distribution in CVID is almost equal, the age at onset is later, and infections may be less severe. CVID is the most common of the antibody defects.

### Genetics and Pathogenesis

CVID is a phenotypic diagnosis with a polygenic inheritance in most cases. Genes known to produce the CVID phenotype when pathogenic variants occur include *ICOS* (inducible co-stimulator) deficiency, *SH2DIA* (responsible for X-linked lymphoproliferative disease [XLP]), *CD19*, *CD20*, *CD21*, *CD81*, *BAFF-R* (B-cell-activating factor of the tumor necrosis factor family of receptors), *NFKB1* and *NFKB2*, *IKZF1*, *ATP6AP1*, *MOGS*, *TACI*, and *TRNT1* (Fig. 166.4). With rare exceptions, management of CVID does not depend on a genetic diagnosis. In the setting of atypical infections or autoimmunity, pursuing a genetic diagnosis can be useful because some genetic etiologies can have a poor prognosis and transplantation should be considered. Targeted treatment options may also be available to treat some forms of CVID related to *LRBA* or *CTLA4* pathogenic variants.

Despite normal numbers of circulating B cells in many patients and the presence of lymphoid cortical follicles, blood B cells from CVID patients do not differentiate normally into immunoglobulin-producing cells. They may have a deficiency of switched memory B cells.

### Clinical Manifestations

The serum immunoglobulin and antibody deficiencies in CVID are associated with recurrent sinopulmonary infections (sinusitis, otitis, pneumonia). Most patients present before age 20. Close monitoring for the development of chronic lung disease is needed. Repeated pulmonary infections may produce bronchiectasis; interstitial lung disease is common (Fig. 166.5). Sepsis and meningitis with encapsulated bacteria occur more frequently than in the general population. Patients with recurrent infections as their only manifestation typically have a normal life expectancy and do well with immunoglobulin replacement. The presence of autoimmune disease or lymphoproliferation confers a poor prognosis, as antibody replacement does not improve these conditions. Patients with CVID often have autoantibody formation and normal-sized or enlarged tonsils and lymph nodes; about 25% of patients have splenomegaly. CVID has also been associated with a spruelike enteropathy with or without nodular lymphoid hyperplasia of the intestine. Other autoimmune diseases include alopecia areata, hemolytic anemia, thrombocytopenia, gastric atrophy, achlorhydria, and pernicious anemia. Lymphoid interstitial pneumonia, intestinal lung disease, pseudolymphoma, B-cell lymphomas, amyloidosis, and noncaseating sarcoid-like granulomas of the lungs (**granulomatous and lymphocytic interstitial lung disease [GLILD]**), spleen, skin, and liver also

occur. Patients should be monitored closely over time for symptoms involving multiple tissues.

### 166.3 Class Switch Defects

Vivian P. Hernandez-Trujillo and Camile Ortega

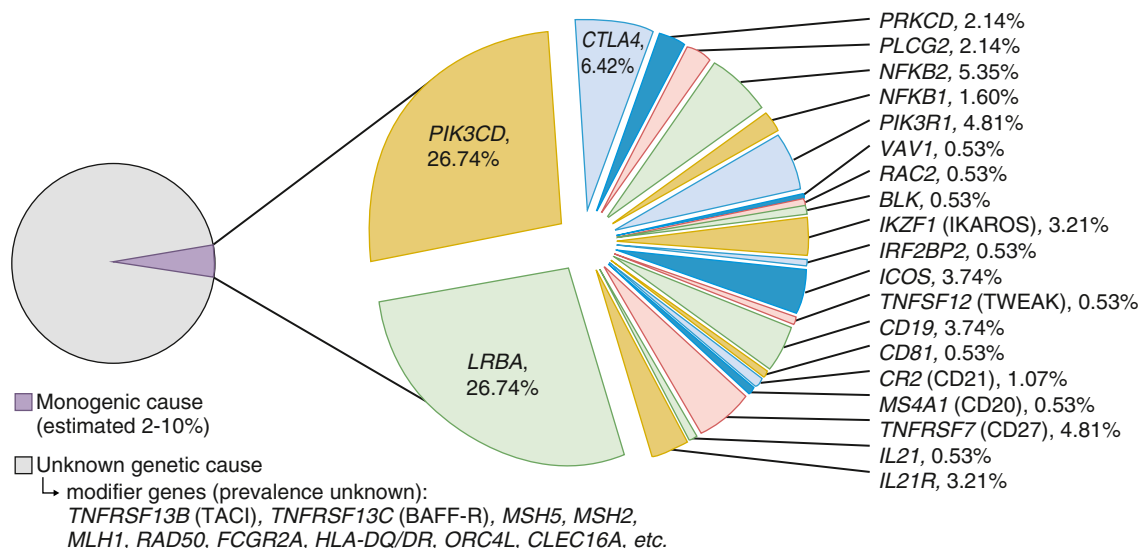
The **hyper-IgM syndrome** is genetically heterogeneous and characterized by normal or elevated serum IgM levels associated with low or absent IgG, IgA, and IgE serum levels, indicating a defect in the class switch recombination (CSR) process. Causative pathogenic variants have been identified in the CD40 ligand gene on the X chromosome and three genes on autosomal chromosomes: the activation-induced cytidine deaminase (*AID*) gene, the uracil DNA glycosylase gene (*UNG*), and the CD40 gene on chromosome 20. Distinctive clinical features permit presumptive recognition of the type of pathogenic variants in these patients, thereby aiding proper choice of therapy. All such patients should undergo molecular analysis to ascertain the affected gene for purposes of genetic counseling, carrier detection, and decisions regarding definitive therapy.

### X-LINKED HYPER-IgM CAUSED BY MUTATIONS IN CD40 LIGAND GENE

X-linked hyper-IgM is caused by pathogenic variants in the gene that encodes the CD40 ligand (*CD154*, *CD40L*), which is expressed on activated T-helper (Th) cells. Males with this syndrome have very low serum concentrations of IgG and IgA, with a usually normal or sometimes elevated concentration of polyclonal IgM; may or may not have small tonsils; usually have no palpable lymph nodes; and often have profound neutropenia. This disease, unlike the autosomal recessive forms of hyper-IgM, affects both B and T cells.

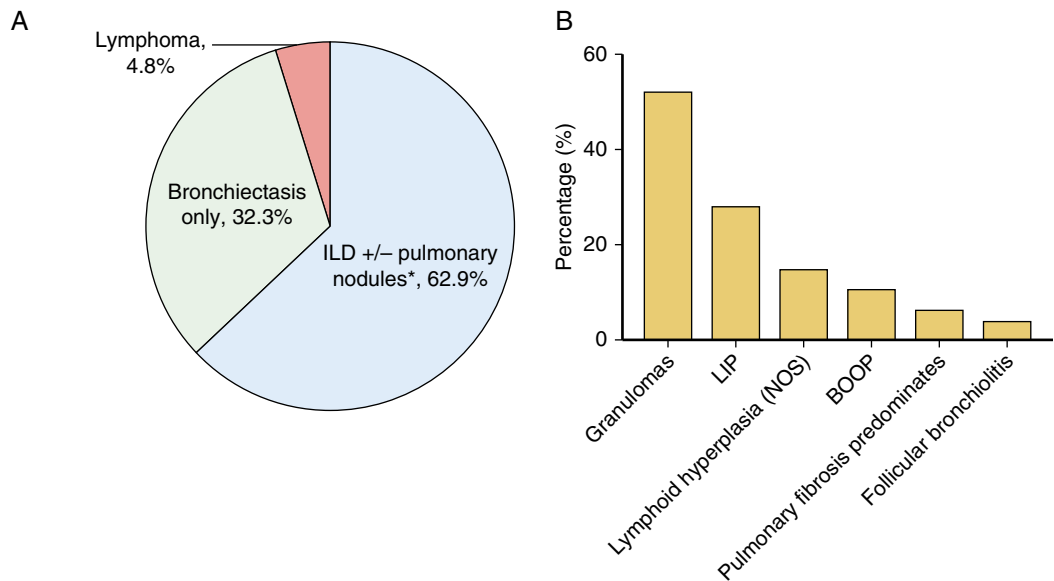
### Genetics and Pathogenesis

The B cells are normal in this condition; the defect is in the T cells. *CD40L* is the ligand for *CD40*, which is present on B cells and monocytes. *CD40L* is upregulated on activated T cells. Mutations result in an inability to signal B cells to undergo isotype switching, and thus the B cells produce only IgM. The failure of T cells to interact with B cells through this receptor-ligand pair also causes a failure of upregulation of the B-cell and monocyte surface molecules *CD80* and *CD86* that



**Fig. 166.4** Known genetic etiology of common variable immunodeficiency (CVID). The majority of cases of CVID do not have a defined genetic cause. Many of these are likely to be multifactorial, and the genomic duplication and deletion burden in CVID suggests this to be the case; 115 of the mutations have been identified. The colored pie chart represents their breakdown and relative frequency. (From Bogaert DJ, Dullaers M, Lambrecht BN, et al. Genes associated with common variable immunodeficiency: One diagnosis to rule them all? *J Med Genet.* 2016;53[9]:575-590. Fig 1.)

**Fig. 166.5** Chronic lung disease in common variable immunodeficiency. **A**, Lung disease types by radiographs and/or pathology reports ( $n = 124$ ). **B**, Interstitial lung disease pathologies ( $n = 46$ ). \*Thirteen of 65 subjects with ILD had concurrent bronchiectasis. BOOP, bronchiolitis obliterans organizing pneumonia; ILD, interstitial lung disease; LIP, lymphoid interstitial pneumonia. (From Ho HE, Cunningham-Rundles C. Non-infectious complications of common variable immunodeficiency: Updated clinical spectrum, sequelae, and insights to pathogenesis. *Front Immunol.* 2020;11:149. Fig. 1)



interact with CD28/CTLA4 on T cells, resulting in failure of “crosstalk” between immune system cells.

### Clinical Manifestations

Males with the CD40 ligand defect become symptomatic during the first or second year of life with recurrent pyogenic infections, including otitis media, sinusitis, pneumonia, and tonsillitis. They have marked susceptibility to *P. jirovecii* pneumonia and can be neutropenic. Lymph node histology shows only abortive germinal center formation with severe depletion and phenotypic abnormalities of follicular dendritic cells. These patients have normal numbers of circulating B lymphocytes, but a decreased frequency of CD27<sup>+</sup> memory B cells. Circulating T cells are also present in normal numbers and in vitro responses to mitogens are normal, but there is decreased antigen-specific T-cell function. In addition to opportunistic infections such as *P. jirovecii* pneumonia, there is an increased incidence of extensive verruca vulgaris lesions, *Cryptosporidium* enteritis, subsequent liver disease, and an increased risk of malignancy.

### Treatment

Because of the poor prognosis, the treatment of choice is an HLA-identical hematopoietic stem cell transplant at an early age. Alternative treatment for this condition is lifelong infusions of immune globulin. In patients with severe neutropenia, the use of granulocyte colony-stimulating factor has been beneficial.

## AUTOSOMAL RECESSIVE HYPER-IgM

### Genetics and Pathogenesis

In contrast to patients with the CD40L defect, B cells from these patients are not able to switch from IgM-secreting to IgG-, IgA-, or IgE-secreting cells, even when co-cultured with normal T cells. The defects are all B-cell intrinsic. The most common autosomal recessive defect is in a gene that encodes AID. AID deaminates cytosine into uracil in targeted DNA, which is followed by uracil removal by UNG. Severely impaired CSR was found in three hyper-IgM patients reported to have UNG deficiency. Their clinical characteristics were similar to those with AID deficiency, with increased susceptibility to bacterial infections and lymphoid hyperplasia. Histologic examination of the enlarged lymph nodes reveals the presence of giant germinal centers (5-10 times > normal) filled with highly proliferating B cells. Autosomal recessive hyper-IgM can be caused by defects in CD40. Clinical manifestations included recurrent sinopulmonary infections, *P. jirovecii* pneumonia, and *Cryptosporidium parvum* infections, very similar to the manifestations seen in X-linked hyper-IgM syndrome. Patients with *INO80* deficiency may present with severe bacterial infections;

whereas in *MSH6* deficiency patients may have increased IgM, family or personal history of cancer, and low switch memory B cells.

### Clinical Manifestations

Concentrations of serum IgG, IgA, and IgE are very low in AID, UNG, and CD40 deficiencies. In contrast to the CD40 ligand defect, however, the serum IgM concentration in patients with AID deficiency is usually markedly elevated and polyclonal. Patients with AID and UNG mutations have lymphoid hyperplasia, are generally older at age at onset, do not have susceptibility to *P. jirovecii* pneumonia, often do have iso-hemagglutinins, and are much less likely to have neutropenia unless it occurs on an autoimmune basis. The lymphoid hyperplasia distinguishes these patients from many others with antibody deficiency, particularly agammaglobulinemia, which leads to a paucity of lymphoid tissue. They have a tendency, however, to develop autoimmune and inflammatory disorders, including diabetes mellitus, polyarthritis, autoimmune hepatitis, hemolytic anemia, immune thrombocytopenia, Crohn disease, and chronic uveitis.

### Treatment and Prognosis

With early diagnosis and antibody replacement, as well as good management of infections with antibiotics, patients with AID and UNG mutations generally have a more benign course than do those with the CD40L or CD40 defects. CD40 deficiency is rare but appears to mimic the manifestations of CD40L quite closely.

### Treatment of Antibody Deficiency

Except for the CD40 ligand defect, for which stem cell transplantation is recommended, judicious use of antibiotics to treat documented infections and regular administration of immunoglobulin are the only effective treatments for primary B-cell disorders. The most common forms of replacement therapy are either intravenous or subcutaneous immune globulin (IVIG or SCIG). Broad antibody deficiency should be carefully documented before such therapy is initiated. The rationale for the use of IVIG or SCIG is to provide missing antibodies, not to raise the serum IgG or IgG subclass level. The development of safe and effective immunoglobulin preparations is a major advancement in the treatment of patients with severe antibody deficiencies, although it is expensive and there have been national shortages.

Almost all commercial preparations are isolated from normal plasma by the Cohn alcohol fractionation method or a modification of it. Cohn fraction II is then further treated to remove aggregated IgG. Additional stabilizing agents such as sugars, glycine, and albumin are added to prevent reaggregation and protect the IgG molecule during lyophilization. The ethanol used in preparation of immunoglobulin inactivates



HIV, and an organic solvent/detergent step inactivates hepatitis B and C viruses. Some preparations are also nanofiltered to remove infectious agents. Most commercial lots are produced from plasma pooled from 10,000 to 60,000 donors and therefore contain a broad spectrum of antibodies. Each pool must contain adequate levels of antibody to antigens in various vaccines, such as tetanus and measles. However, there is no standardization based on titers of antibodies to more clinically relevant organisms, such as *S. pneumoniae* and *H. influenzae* type b.

The IVIG and SCIG preparations available in the United States have similar efficacy and safety. Rare transmission of hepatitis C virus has occurred in the past, but this has been resolved by the additional treatment step. There has been no documented transmission of HIV by any of these preparations. IVIG or SCIG at a dose of 400-600 mg/kg per month achieves trough IgG levels close to the normal range. Higher doses are indicated in patients with chronic or severe respiratory infections. Systemic reactions may occur, but rarely are these true anaphylactic reactions. Neutropenia associated with B-cell defects has responded to granulocyte colony-stimulating factor. Treatment of inflammatory bowel disease is essential in maintaining adequate IgG levels.

Visit Elsevier eBooks+ at [eBooks.Health.Elsevier.com](http://eBooks.Health.Elsevier.com) for Bibliography.

## 166.4 Isotype Defects

Vivian P. Hernandez-Trujillo and Camile Ortega

### SELECTIVE IgA DEFICIENCY

An isolated absence or near absence (<5 mg/dL) of serum and secretory IgA is the most common well-defined immunodeficiency disorder, with a disease frequency as high as 0.33% in some populations. Patients may be asymptomatic or may develop sinopulmonary or gastrointestinal (GI) infections (especially *Giardia*). IgA deficiency is also associated with celiac disease and other autoimmune disorders. The diagnosis cannot be made until about 4 years of age, when IgA levels should be matured to adult levels.

The basic defect resulting in IgA deficiency is unknown. Phenotypically normal blood B cells are present. In these patients, normal levels of other isotypes and normal specific antibody levels are seen. This defect also often occurs in pedigrees containing individuals with CVID. Indeed, IgA deficiency may evolve into CVID over time. IgA deficiency is noted in patients treated with the same drugs associated with producing CVID (phenytoin, D-penicillamine, gold, and sulfasalazine), suggesting that environmental factors may trigger this disease in a genetically susceptible person.

### Clinical Manifestations

Infections occur predominantly in the respiratory, GI, and urogenital tracts. Bacterial agents responsible are the same as in other antibody deficiency syndromes. Intestinal giardiasis is common. Serum concentrations of other immunoglobulins are usually normal in patients with selective IgA deficiency, although IgG2 (and other) subclass deficiency has been reported.

Serum antibodies to IgA are reported in as many as 44% of patients with selective IgA deficiency. These antibodies can cause nonhemolytic transfusion reactions. Washed erythrocytes (frozen blood would have

this done routinely) or blood products from other IgA-deficient individuals should be administered to patients with IgA deficiency. Many immune globulin preparations contain sufficient IgA to cause reactions. It is important to note that administration of immune globulin, which is >99% IgG, is not indicated because most IgA-deficient patients make IgG antibodies normally.

### IgG Subclass Deficiencies

Some patients have deficiencies of one or more of the four subclasses of IgG despite normal or elevated total IgG serum concentration. Most patients may be asymptomatic. Some patients with absent or very low concentrations of IgG2 also have IgA deficiency. They may present with bacterial infections. Other patients with IgG subclass deficiency have gone on to develop CVID, suggesting that the presence of IgG subclass deficiency may be a marker for more generalized immune dysfunction. The biologic significance of the numerous moderate deficiencies of IgG subclasses that have been reported is difficult to assess. IgG subclass measurement is not cost-effective in evaluating immune function in the child with recurrent infections. The more relevant issue is a patient's capacity to make specific antibodies to protein and polysaccharide antigens, because profound deficiencies of antipolysaccharide antibodies have been noted even in the presence of normal concentrations of IgG2. For this reason, immune globulin should not be administered to patients with IgG subclass deficiency unless they are shown to have a deficiency of antibodies to a broad array of antigens.

### Immunoglobulin Heavy- and Light-Chain Deletions

Some completely asymptomatic individuals have been documented to have a total absence of IgG1, IgG2, IgG4, and/or IgA1 as a result of gene deletions. These patients illustrate the importance of assessing specific antibody formation before deciding to initiate immune globulin therapy in IgG subclass-deficient patients. Low or undetectable levels of IgG subclasses alone is, therefore, not an indication for antibody replacement.

Visit Elsevier eBooks+ at [eBooks.Health.Elsevier.com](http://eBooks.Health.Elsevier.com) for Bibliography.

## 166.5 Transient Hypogammaglobulinemia of Infancy

Vivian P. Hernandez-Trujillo and Camile Ortega

A common laboratory finding in infants, transient hypogammaglobulinemia represents developmental delay in the production of immunoglobulin. It is thought to occur in as many as 1:1,000 children. Most infants begin to produce IgG in the first 3 months of life, and the quantity produced increases throughout infancy. For reasons incompletely understood, a small number of infants either begin late or do not increase their production as expected. This condition will resolve with no intervention, but represents a source of diagnostic confusion. A key distinction is that responses to vaccines are usually preserved in this condition, whereas in the others, including SAD, antibody responses will be low to absent.

Visit Elsevier eBooks+ at [eBooks.Health.Elsevier.com](http://eBooks.Health.Elsevier.com) for Bibliography.

## Chapter 167

## Natural Killer Cells

Jessica M. Palmieri\*, Vibha A. Szafron\*, and Lisa Forbes Satter

Natural killer (NK) cells are lymphocytes that have a critical role in the innate immune response to pathogenic challenge and cellular stress. NK cells are capable of rapid target cell killing and can quickly secrete large amounts of preformed granzymes and perforins in response to viral infections, especially those of the herpesvirus family. They are also crucial in tumor surveillance. NK cells are found in the circulating blood as approximately 3–15% of lymphocytes and are also found in both primary and secondary lymphoid tissues where they are in a constant state of surveillance for cellular abnormalities. NK cells use a detection system composed of a wide range of germline-encoded cell surface receptors that contribute to simultaneous NK activating and inhibitory signals. NK cells are constantly receiving both activating and inhibitory signals with the balance of signals tilted toward inactivation until NK cell recognition of a target cell occurs. With target cell recognition, the balance between inhibitory and activating signals leans in favor of activation and NK cell killing is initiated.

NK cells are defined as *innate immune lymphocytes* because unlike B and T lymphocytes, they do not utilize recombination-activating gene (RAG) proteins required for DNA rearrangement and assemblage of diverse antigen-specific receptors in response to antigen exposure. However, they can develop long-lived and highly antigen-specific immunologic memory responses to different antigens through *RAG-independent adaptive immunity*, which provides life-long immune memory responses. This means that despite a lack of receptor diversity accrued via DNA rearrangement like B cells and T cells, NK cells do have characteristics associated with the adaptive immune system; distinguishing healthy from diseased cells, producing robust antiviral responses, and maintaining a collection of long-lived cells that expand during cellular stress responses.

### NK CELL MARKERS, SUBSETS, AND MATURATION

Mature NK cells are traditionally defined as non-T, non-B lymphocytes that can rapidly produce interferon gamma (IFN- $\gamma$ ) and can mediate cellular cytotoxicity. Like all lymphocytes, they express clusters of differentiation (CD) markers that identify their cell type and stage of development that are also upregulated or downregulated for cell homing purposes. However, there are no surface markers that are unique and specific for NK cells. NK cells have been traditionally identified by using flow cytometry to exclude the cellular surface presence of leukocyte expressing markers specific to other leukocytes, such as CD3 and CD5 (T cells), CD19 and CD20 (B cells), and CD13 and CD14 (myelomonocytic cells). Further identification of NK cells follows via their expression of CD56 (neural cell adhesion molecule-1) and/or CD16, their low-affinity Fc gamma receptor that mediates **antibody-dependent cellular cytotoxicity** (ADCC). Neither CD56 nor CD16 is specific or unique to the NK cell lineage; however, these CD markers are functionally important and thus used to characterize major subsets of NK cells.

NK cells develop from CD34 hematopoietic stem cells (HSCs) in the bone marrow and then undergo maturation in secondary lymphoid tissues. NK cell development occurs through a series of six functionally distinct developmental stages distinguishable by cellular expression of cell surface markers including CD34, CD117, CD94/NKG2A (surface inhibitory receptor), Nkp80 (surface

activating receptor), CD16, and CD57. Once mature, NK cells then circulate through the peripheral blood (PB) or are found in organ tissues such as the secondary lymphoid tissues, liver, lungs, uterus, kidneys, or gut. For example, stage 1 cells found in the bone marrow are marked by the presence of only CD34, and subsequent stages occur through the upregulation and downregulation of previously mentioned cell surface markers; whereas, stage 6 mature NK cells in the PB express Nkp80, CD16, and CD57 (Fig. 167.1).

NK cells express CD56 at different levels of development. CD56<sup>bright</sup> NK cells that express high levels of CD56, without expressing much CD16, are considered stage 4b and are approximately 3–10% of circulating PB NK cells. Most PB NK cells express CD16 and low levels of CD56 and are referred to as CD56<sup>dim</sup> NK cells. Distinguishing cells as CD56<sup>bright</sup> and CD56<sup>dim</sup> refers to the increased fluorescent intensity for CD56<sup>+</sup> cells seen in comparison to cells negative for CD56. CD56<sup>bright</sup> and CD56<sup>dim</sup> cells are functionally different. CD56<sup>bright</sup> NK cells are considered to be developmentally immature and produce higher levels of cytokines such as IFN- $\gamma$  with less cytotoxic capacity. They can rapidly produce large amounts of cytokines and chemokines; however, they contain low levels of perforin and granzymes and have low or absent CD16, making them poor mediators of direct cytotoxicity and ADCC. In contrast, CD56<sup>dim</sup> cells are developmentally more mature, contain high levels of perforin, are cytotoxic, and recognize antibody-coated cells through CD16. CD56<sup>dim</sup> cells are able to produce large amounts of cytokines but not to the degree of CD56<sup>bright</sup> cells.

The cell surface marker expression for NK cells in the PB and tissues are phenotypically distinct due to the influence of each tissue's unique microenvironment. Similarly, the ratio of CD56<sup>bright</sup> and CD56<sup>dim</sup> NK subsets in the tissues is not the same as the ratios found in the PB. In the bone marrow, lung, spleen, subcutaneous adipose tissue, and breast tissue, CD56<sup>dim</sup> NK cells predominate, whereas CD56<sup>bright</sup> NK cells predominate in the mucosa-associated lymphoid tissues (MALTs; e.g., gastric and intestinal mucosa), liver, uterus, visceral adipose tissue, adrenal gland, and kidney.

### NK Cell Functions

NK cells have a critical role in the control of tumor growth and metastasis and are vital for the innate immune response against infections, particularly certain viruses. Additionally, there is increasing recognition of the importance of NK cells in immunoregulation, coordination of immunity, and modulation of autoreactivity.

NK cell activity is a balance between inhibitory and activating signals. NK cell surfaces contain a wide range of receptors that affect NK cell expression. Healthy host cells express high amounts of major histocompatibility complex class I (MHC I) molecules that ligate NK cell inhibitory receptors and prevent unwanted killing of healthy cells. Infected or malignant host cells downregulate their MHC I expression and express ligands for NK cell activating receptors, which triggers NK cell killing of the diseased cell. The balance of signals for NK cell inhibition by MHC I expression in healthy cells and NK cell activation by MHC I downregulation during cellular stress allows NK cells to defend against viruses and tumors and have protective roles in fungal, extracellular bacterial, intracellular bacterial, and parasitic infections. Many viruses have evolved to specifically downregulate MHC I in cells they infect to prevent the host cell from presenting antigenic peptides to virus-specific cytotoxic T lymphocytes (CTLs). Although this strategy does allow virus-infected cell evasion from CTLs, it makes the infected cell more susceptible to recognition by NK cells.

The three main functions of NK cells include cytokine/chemokine production, contact-dependent co-stimulation, and cytotoxicity. Additionally, NK cells are capable of interfacing with the adaptive immune system through their IgG Fc receptor, CD16, which allows them to engage in antibody-dependent killing.

### Cytokine/Chemokine Production

Activated NK cells secrete a wide variety of cytokines and chemokines in response to stimulation by interleukin (IL)-12, IL-15, and IL-18. IFN- $\gamma$  is one of the most potent cytokines released by

\* These authors contributed equally to this work.

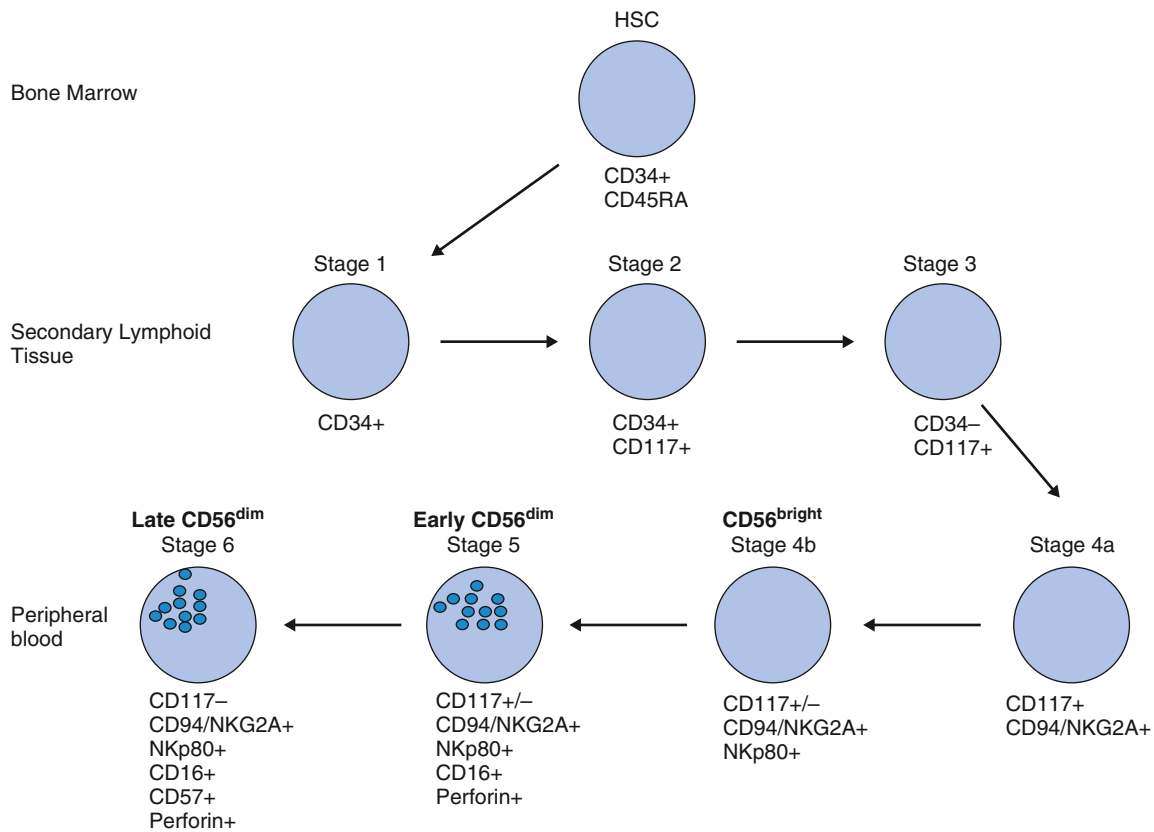


Fig. 167.1 Stages of NK cell development. HSC, Hematopoietic stem cell.

NK cells. It is crucial for the antiviral, antibacterial, and antitumor activity of NK cells through modulating death ligand expression of caspase, FasL, and TRAIL. NK cells are thus able to target cells for death through expression of these death ligands. Death ligand killing is not as rapid as lytic granule killing. Additional NK cell-released cytokines include TNF- $\alpha$ , IL-10, IL-5, and IL-13. NK cells also produce chemokines (chemotactic agents) such as MIP-1 $\alpha$ , MIP-1 $\beta$ , IL-8, and RANTES. It is important to note that cytokines and chemokines in NK cells are compartmentalized separately from the lytic granules allowing them to be accessed separately from their cytotoxicity function.

### Contact-Dependent Co-Stimulation

NK cells can promote and regulate immunity through direct receptor-ligand interactions with other cells, or contact-dependent co-stimulation. NK cells express or can be induced to express a variety of co-stimulatory and inhibitory ligands including the CD40 ligand, CD28, and PD-1, which can then interact with other types of immune cells to alter immune responses.

### NK CELL SPONTANEOUS CYTOTOXICITY

Similar to cytotoxic T cells, NK cells secrete specialized lysosome-related organelles known as **lytic granules**. However, unlike CTLs, the lytic granules inside NK cells are preformed and abundant while the cell is at rest, which allows for their rapid killing response on recognition of cellular distress/disease. Lytic granule contents include **perforin** (pore-forming molecule) and pro-apoptotic enzymes such as **granzymes**. Once an NK cell recognizes an activation signal from a distressed cell, the NK cell will polarize its lytic granules toward the portion of the NK cell membrane in contact with the target cell where the lytic granules will then dock. This is followed by fusion of the secretory lysosome with the plasma membrane of the target cells. The site of NK cell connection with the target cell is called the **lytic immunologic synapse**.

Once a stable connection is formed at the lytic immunologic synapse, cellular killing by the lytic granules will be completed in less than 2 hours. Perforin will insert into the target cell membrane, which will allow for pro-apoptotic granzymes to travel to the target cell and initiate cellular killing.

### NK CELL ANTIBODY-DEPENDENT KILLING

NK cells are also able to kill target cells via ADCC. NK cells have an IgG Fc receptor, CD16, expressed on their cell surfaces that allows them to recognize IgG-opsonized targets to promote killing without priming via lysing of the target cell. ADCC also causes NK cell secretion of cytokines like INF- $\gamma$  for recruitment of adaptive immune cells.

### Etiologies of NK Cell Deficiency

NK cells are lymphocytes that are critical for the immune response to viral infections. Patients with recurrent severe and refractory cutaneous viral and herpes viral infections should be evaluated for **NK cell deficiency (NKD)** with both enumeration and functional studies. However, ultimate evaluation should be completed with immunogenetic analysis as patients with diagnosed NKD may benefit from antiviral prophylaxis and eventual HSC transplant.

**NKD** accounts for a small subset of primary immunodeficiencies (PIDs) that often present as clinical and diagnostic challenges. In general, NKD is suspected in patients who appear to have increased susceptibility to herpesvirus infections as well as select other viral pathogens such as a human papillomavirus (HPV).

NK cells can be decreased in number or function for many reasons. More commonly, severe illness and emotional stress can cause decreases of these cells. In addition, immunosuppressive medications such as corticosteroids, mycophenolate, cyclosporine, azathioprine, and 6-mercaptopurine can depress NK cells. Given many factors are known to affect the stability of NK cells, repetition of the test is required to document true deficiency. If a patient is found to have abnormal NK cell studies 3 times, drawn at least 1 month

apart, inborn errors in immunity should be also considered, as described next.

More than 50 PIDs include abnormalities in NK cells as part of their immunophenotypes. This occurs secondary to disruption in maturation, proliferation, or survival of NK cells. Forms of **severe combined immune deficiency (SCID)** including *IL2RG*, *JAK3*, and *AK2* deficiency are known to present with low or absent NK cell numbers. In addition, given the importance of lytic granule secretion to NK cytotoxicity, conditions with abnormal granule secretion, such as primary **hemophagocytic lymphohistiocytosis**, or abnormal cytoskeletal function, such as **Wiskott-Aldrich syndrome**, also can lead to NK cell aberrations.

NKDs are classified as classical or functional. In **classical NKD**, there is a significantly decreased or absent number of CD3<sup>+</sup>CD56<sup>+</sup> cells, making up less than 1% of the total peripheral lymphocytes. Alternatively, although the number of NK cells can be normal in **functional NKD**, these cells are functionally impaired.

### Classical NK Cell Deficiency

Classical NKDs include pathogenic variants in *MCM4*, *MCM10*, *GINS1*, *GATA2*, *RTEL1*, and *IRF8*.

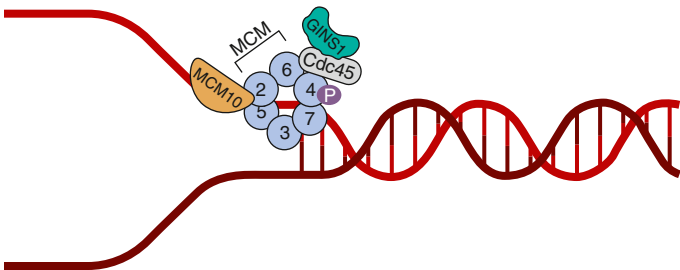
#### *MCM4* and *MCM10*

*MCM* (mini-chromosome maintenance complex member) 4 and 10 are a part of the MCM replisome progression complex important for DNA replication. *MCM4* is part of the *Cdc45-MCM2-7-GINS1* (CMG) helicase complex and *MCM10* is a replication factor associated with this complex. In times of cellular stress, variant complexes have resulted in abnormal DNA breakage (Fig. 167.2). These patients have a decreased number of NK cells, specifically CD56<sup>dim</sup> NK cells. CD56<sup>dim</sup> NK cells are mature NK cells that express CD16 (Fc receptor) and are important for ADCC. It is possible that CD56<sup>dim</sup> NK cells are particularly reliant on the MCM complex for survival. Alternatively, the pathogenic variant may cause an interruption along development before mature NK cell expansion. Patients with biallelic pathogenic variants in *MCM4* have Epstein-Barr virus (EBV)-driven lymphoproliferation and viral pneumonitis. As *MCM4* is widely expressed in many cells, these patients can also have adrenal insufficiency, short stature, and development delay.

*MCM10*-deficient patients have a similar immunologic phenotype related to their NK cell abnormalities and the patients reported were found to have severe cytomegalovirus (CMV) infection.

#### *GINS1*

Go-Ichi-Ni-San complex subunit 1 (*GINS1*) is a protein involved in the CMG helicase complex that is important for DNA replication. Biallelic pathogenic variants in *GINS* have been seen to cause growth retardation, neutropenia, and NKD. It is important to note



**Fig. 167.2** Cell division cycle complex pathogenic variants associated with NK cell deficiency: *MCM4*, *MCM10*, and *GINS1*. Schematic illustration of the cell division cycle complex including the CMG (Cdc45, mini-chromosome maintenance [MCM 2-7], *GINS1*) helicase complex and *MCM10*.

that both CD56<sup>dim</sup> and CD56<sup>bright</sup> cells are affected in this disorder. *MCM4*, *MCM10*, and *GINS1* defects causing classical NKD suggests that chromosomal maintenance is critical to NK cell development and function.

#### *GATA2*

Pathogenic variants in *GATA2* (GATA-binding protein-2), inherited in an autosomal dominant manner, can cause immune aberrations affecting many different cell lines. The pathogenic variant prevents appropriate NK cell development with specific deficiency of immature CD56<sup>bright</sup> NK cells causing an absence of the CD56<sup>bright</sup> population, leaving a functionally impaired CD56<sup>dim</sup> population. These patients are known to have refractory HPV infections, among other cutaneous viral infections, myelodysplasias, cytopenias, and a risk of acute and chronic myeloid leukemias.

#### *RTEL1*

Biallelic pathogenic variants in regulator of telomerase elongation (*RTEL1*), a DNA helicase, cause a form of **dyskeratosis congenita**, bone marrow failure, and immunodeficiency known as **Hoyeraal-Hreidarsson syndrome**. One patient reported with a history of disseminated varicella infection was found to have abnormal NK cells in number and function.

#### *IRF8*

Interferon regulatory factor 8 (*IRF8*) is a transcription factor involved in B-cell, dendritic cell, granulocyte, monocyte, and NK cell production. *IRF8* is vital for the NK cell response to viral infections and patients have been found to have severe EBV infections. Terminal NK cell maturation is disrupted and CD56<sup>dim</sup> cells are decreased in patients with biallelic *IRF8* pathogenic variants.

### FUNCTIONAL NK CELL DEFICIENCY (FNKCD)

#### *CD16* Deficiency

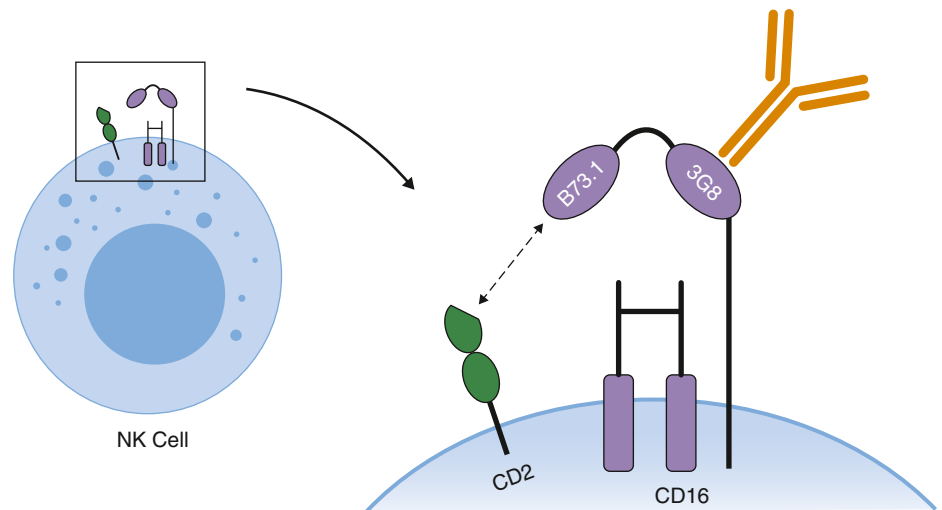
Patients with CD16 deficiency have severe infections with herpes viral pathogens such as varicella-zoster virus (VZV), herpes simplex virus (HSV) and EBV. One patient was reported to have EBV-driven Castleman disease. The deficiency is caused by a homozygous pathogenic variant in the *FCGR3A* gene, which encodes CD16. CD16 is the Fc receptor on NK cells required for ADCC. As CD16 deficiency is an FNKCD, patients have normal levels of NK cells, but abnormal function. Although CD16's main function is to facilitate ADCC, patients with CD16 deficiency have been found to have abnormal spontaneous cytotoxicity with normal antibody-dependent cytotoxicity (Fig. 167.3). Further analysis helped uncover a new function of the CD16 protein related to spontaneous cytotoxicity, which clarifies this unexpected finding. The variant sequence in CD16 deficiency encodes for the distal B73.1 domain of the CD16 molecule. Studies from patients with this pathogenic variant revealed that this region is needed for co-activation of the NK cell CD2 stimulatory receptor, which is required for spontaneous cytotoxicity. Alternatively, immunoglobulin binding, which is integral to ADCC, occurs at the proximal 3G8 domain of CD16, which is not affected by the variant. For diagnostic purposes, two anti-CD16 monoclonal antibodies are utilized against the distal B73.1 and proximal 3G8 domains. Therefore patients with CD16 deficiency will have absent B73.1 expression and normal 3G8 expression. These diagnostic tests can help identify patients with CD16 deficiency in addition to genetic analysis of *FCGR3A*.

#### *ELF4*

E74-like ETS transcription factor 4 (*ELF4*) is a protein involved in transactivation of gene promoters through DNA binding. Perforin expression, an important component of NK cell activity, has been shown to be dependent on *ELF4*-regulated promoters. Pathogenic variants in *ELF4* can result in poor terminal NK cell maturation



**Fig. 167.3** Functional natural killer (NK) cell deficiency secondary to CD16 pathologic variants. Schematic of the CD16 (Fc) NK cell receptor. The proximal domain of the CD16 receptor, 3G8, binds the Fc portion of immunoglobulin, which is important for antibody-dependent cytotoxicity. The distal domain of the CD16 receptor, B73.1, co-localizes with the CD2 stimulatory receptor facilitating spontaneous cytotoxicity. In *CD16* deficiency, the B73.1 domain of the CD16 receptor is not adequately expressed causing impaired spontaneous cytotoxicity.



from CD56<sup>bright</sup> to CD56<sup>dim</sup> (cytotoxic) NK cells. A rare, hemizygous variant in *ELF4*, located on the X chromosome, has been described as a novel cause of NK cell deficiency. Patients with this variant can present with recurrent sinopulmonary and varicella zoster infections, as well as lymphoproliferative and malignant disease. Laboratory analysis has shown decreased number and function of NK cells, specifically with an abnormal immature NK cell CD56<sup>bright</sup> to mature CD56<sup>dim</sup> NK cell ratio. Because these patients also can present with decreased B cells and hypogammaglobulinemia, further work is needed to elucidate the role of *ELF4* in B cell development and function.

### NK Cell Diagnostic Tests

When evaluating for possible NK cell defects, it is important to examine the total NK cell count and percentage, the distribution of NK cell subsets, and NK cell function.

### NK Cell Count and Percentage

The absolute NK cell count and NK cell percentage of total lymphocytes is often calculated using a lymphocyte subset analysis or enumeration assay. This test is performed using flow cytometry and will identify the CD16 and CD56 markers of NK cells. The majority of lymphocyte enumeration assays use a combined CD56/16 antibody and cannot distinguish between CD56<sup>bright</sup> and CD56<sup>dim</sup> NK cells. Further delineation of NK cell subsets (CD56<sup>dim</sup>, CD56<sup>bright</sup>, etc.) can be obtained with further flow cytometry for additional NK cell markers. Evaluation of NK cell phenotypes and ratios such as the CD56 bright to dim ratio becomes important in evaluating for NK cell defects such as *GATA2* deficiency.

## FUNCTIONAL ASSAYS AVAILABLE FOR CLINICAL EVALUATION

### NK Cell Cytotoxicity Assay

NK cytotoxic killing ability can be evaluated using a flow cytometry-based assay to quantify NK cell cytotoxic activity or a chromium release (<sup>51</sup>Cr) cytotoxicity assay. The <sup>51</sup>Cr is technician dependent and requires the use of radioactive material. Many laboratories are doing the flow cytometry-based assay.

Individual clinical laboratories have normal ranges that are particular to their specific assay; however, the values for this assay are dependent

on the percentage of NK cells present in the sample. A peripheral blood mononuclear cell (PBMC) sample with lower numbers of NK cells may not identify as much NK cell cytotoxicity as a sample with higher levels of NK cells, thus it is essential to take the percentage of NK cells into account when interpreting these assays.

### CD107a Degranulation

Lysosomal-associated membrane protein-1 (LAMP-1) or CD107a is contained in NK cell lytic granules. CD107a is significantly upregulated on the surface of NK cells following lytic granule fusion with the NK cell membrane after activation by MHC I downregulated target cells. CD107a is thus often used as a way to evaluate activation-induced NK cell degranulation. In this test, NK cells are stimulated and the upregulation of CD107a is measured using flow cytometry.

CD107a degranulation has advantages and disadvantages when compared to the NK cell cytotoxicity assay. The main advantage is that CD107a degranulation can be measured in individual cells and is therefore independent of the NK cells percentage. The disadvantage is that it does not directly measure NK cell killing ability. NK cell killing can be impaired despite appropriate degranulation for reasons such as abnormal lytic effector molecules. Ten to 30% of resting NK cells can be induced to degranulate when measured by flow cytometry, and in normal individuals CD107a degranulation reasonably correlates with killing ability.

## NK CELL DEFICIENCY TREATMENT

Primarily, treatment of NKD targets the infectious complications that occur in these patients. Specifically, HSV infections should be treated with antiviral therapy such as acyclovir. Long-term prophylaxis should be considered after completion of treatment. HPV infections can be significant and recurrent, and patients should be referred to dermatology for medical and surgical management.

Additional therapies such as immunoglobulin replacement and antimycobacterial prophylaxis can be utilized depending on the genetic cause of NKD. The only curative therapy for classical NKDs at this time is HSC transplantation.

Visit Elsevier eBooks+ at [eBooks.Health.Elsevier.com](http://eBooks.Health.Elsevier.com) for Bibliography.

## Section 3

## The Phagocytic System

## Chapter 168

## Neutrophils

Thomas D. Coates

## THE PHAGOCYtic INFLAMMATORY RESPONSE

The phagocyte system includes both granulocytes (neutrophils, eosinophils, and basophils) and mononuclear phagocytes (monocytes and tissue macrophages). Neutrophils and mononuclear phagocytes share primary functions, including the defining properties of large-particle ingestion and microbial killing. Phagocytes participate primarily in the innate immune response but also help initiate acquired immunity.

Neutrophils provide the rapid effector arm of the innate immune system. They circulate in the bloodstream for only about 6 hours (Table 168.1), but on encountering specific chemotactic signals, they adhere to the vascular endothelium and transmigrate into tissues. There they ingest and kill microbes and release chemotactic signals to recruit more neutrophils and to attract dendritic cells and other initiators of the acquired immune response.

## HEMATOPOIESIS

The hematopoietic progenitor system can be viewed as a continuum of functional compartments, with the most primitive compartment composed of very rare **pluripotential stem cells**, which have high self-renewal capacity and give rise to more mature stem cells, including cells that are committed to either lymphoid or myeloid development

Table 168.1 Neutrophil and Monocyte Kinetics

NEUTROPHILS	
Average time in mitosis (myeloblast to myelocyte)	7-9 days
Average time in postmitosis and storage (metamyelocyte to neutrophil)	3-7 days
Average half-life in the circulation	6 hr
Average total body pool	$6.5 \times 10^8$ cells/kg
Average circulating pool	$3.2 \times 10^8$ cells/kg
Average marginating pool	$3.3 \times 10^8$ cells/kg
Average daily turnover rate	$1.8 \times 10^8$ cells/kg
MONONUCLEAR PHAGOCYTES	
Average time in mitosis	30-48 hr
Average half-life in the circulation	36-104 hr
Average circulating pool (monocytes)	$1.8 \times 10^7$ cells/kg
Average daily turnover rate	$1.8 \times 10^9$ cells/kg
Average survival in tissues (macrophages)	Months

From Boxer LA. Function of neutrophils and mononuclear phagocytes. In: Bennett JC, Plum F, eds. *Cecil Textbook of Medicine*. 20th ed. Philadelphia: Saunders; 1996.

(Fig. 168.1). Common lymphoid progenitor cells give rise to T- and B-cell precursors and their mature progeny. Common myeloid progenitor cells eventually give rise to committed single-lineage progenitors of the recognizable precursors through a random process of lineage restriction in a stepwise process (see Chapter 495). The capacity of lineage-specific committed progenitors to proliferate and differentiate in response to demand provides the hematopoietic system with a remarkable range of response to changing requirements for mature blood cell production.

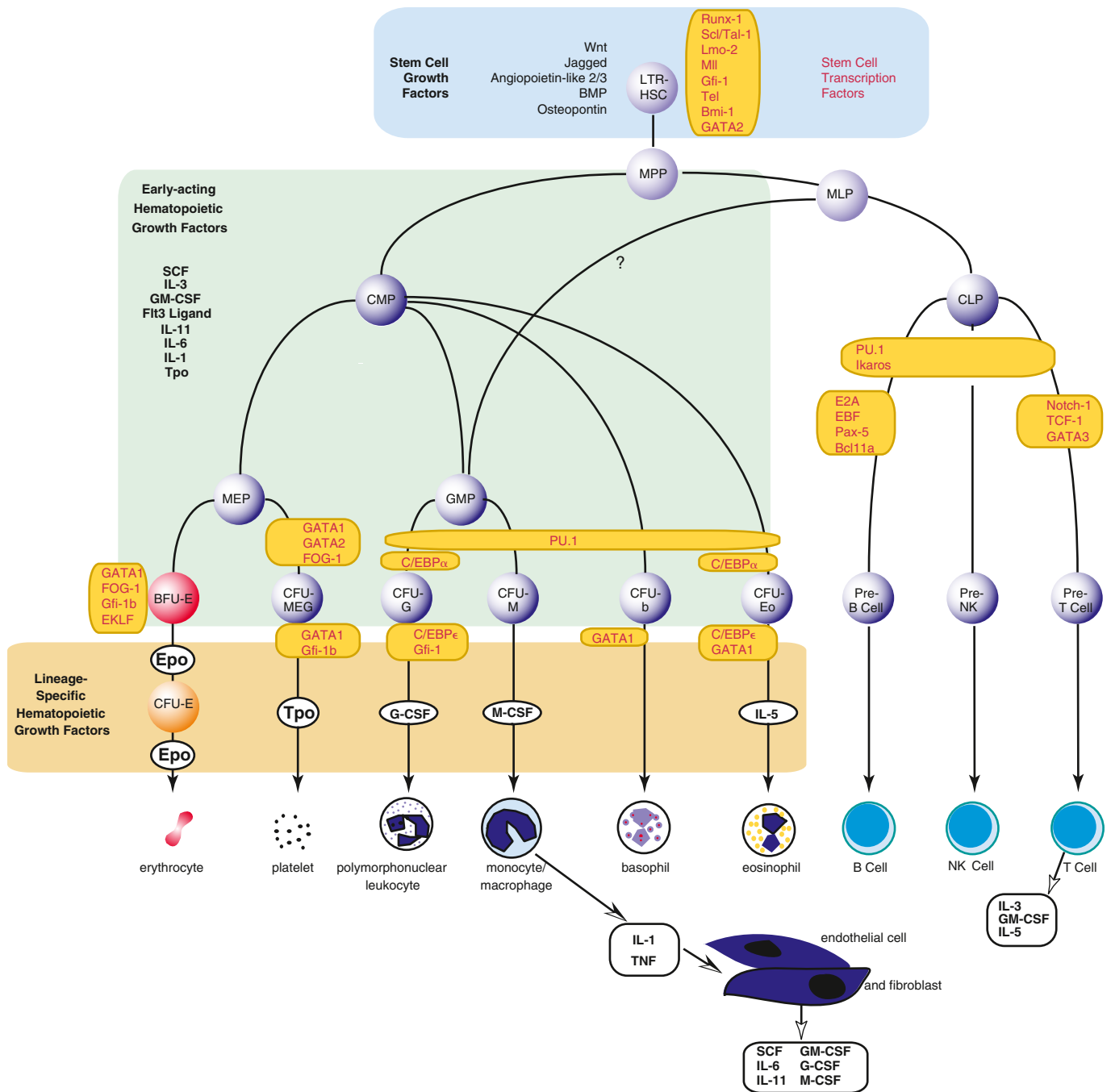
The proliferation, differentiation, and survival of immature hematopoietic progenitor cells are governed by hematopoietic growth factors, a family of glycoproteins (see Chapter 495). Along with regulating proliferation and differentiation of progenitors, these factors influence the survival and function of mature blood cells. During granulopoiesis and monopoiesis, multiple cytokines regulate the cells at each stage of differentiation from pluripotent stem cells to nondividing, terminally differentiated cells (monocytes, neutrophils, eosinophils, and basophils). As cells mature, they lose receptors for most cytokines, especially those that influence early cell development; however, they retain receptors for cytokines that affect their mobilization and function, such as granulocyte and macrophage colony-stimulating factors. Mature phagocytes also express receptors for chemokines, which help direct the cells to sites of inflammation. Chemokine receptors such as CXCR4 and its ligand SDF-1 play a key role in retention of developing myeloid cells within bone marrow.

## NEUTROPHIL MATURATION AND KINETICS

The process of intramedullary granulocyte maturation involves changes in nuclear configuration and accumulation of specific intracytoplasmic granules. The bone marrow microenvironment supports the normal steady-state renewal of peripheral blood neutrophils through the generation of growth and differentiation factors by stromal cells. Growth factors such as granulocyte colony-stimulating factor (G-CSF) and granulocyte-macrophage colony-stimulating factor (GM-CSF) not only stimulate cell division, but also induce the expression of transcription factors that regulate the biosynthesis of functional components of the neutrophil, such as granule proteins. The transcription factor PU.1 is essential for myelopoiesis, both as a positive regulatory element and as a suppressor of GATA1, a transcription factor that directs nonmyeloid differentiation. Other transcription factors, such as Runx1 (AML1), c-myb, CDP, C/EBP $\alpha$ , C/EBP $\gamma$ , and MEF, are expressed in the myeloblast and promyelocyte, and some of these are required for azurophil granule protein expression. As cells enter the myelocyte stage, Runx1 and myb are downregulated, whereas PU.1 and C/EBP $\epsilon$  expression rise to initiate terminal differentiation.

**Granulocytes** survive for only 6-12 hours in the circulation; therefore daily production of  $2 \times 10^4$  granulocytes/ $\mu$ L of blood is required to maintain a level of circulating granulocytes of  $5 \times 10^3$ / $\mu$ L (see Table 168.1). The relatively small peripheral blood pool includes the rapidly interchanging circulating and marginating pools; the latter provides entrance into the tissue phase, where neutrophils may survive for hours or days. The circulating pool is fed and buffered by a much larger marrow population of mature neutrophils and myeloid precursors, representing the marrow reserve and proliferating pools, respectively. Proliferation of myeloid cells, encompassing approximately five mitotic divisions, takes place only during the first three stages of neutrophil development, in myeloblasts, promyelocytes, and myelocytes. After the myelocyte stage, the cells terminally differentiate into nondividing, maturing metamyelocytes, bands, and neutrophils.

Neutrophil maturation is associated with nuclear condensation and lobulation and the sequential production of characteristic granule populations. A **myeloblast** is a relatively undifferentiated cell with a large oval nucleus, a sizable nucleolus, and a deficiency of granules. **Promyelocytes** acquire peroxidase-positive azurophilic (primary) granules, and then **myelocytes** and **metamyelocytes** acquire specific (secondary) granules; tertiary granules and secretory vesicles develop in the final stage of neutrophil maturation.

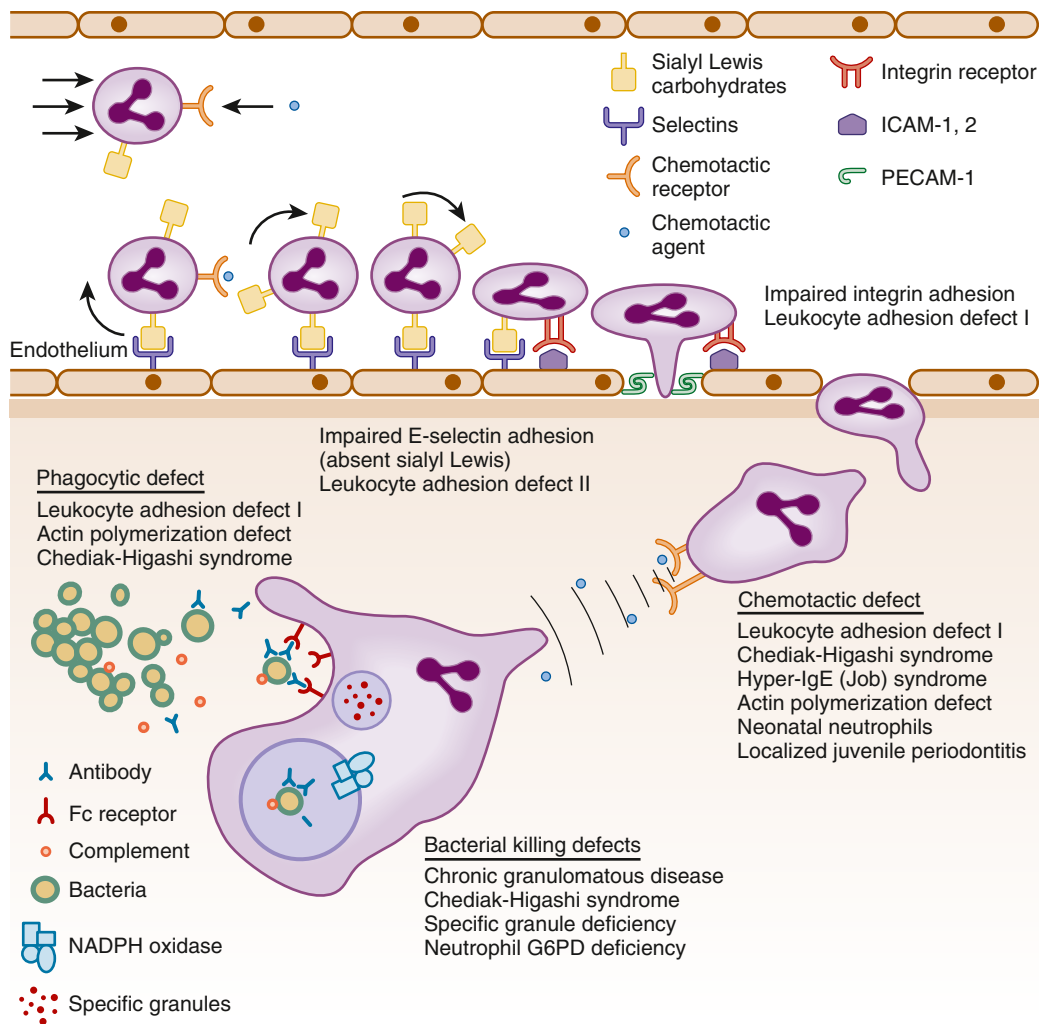


**Fig. 168.1** Major cytokine sources and actions and transcription factor requirements for hematopoietic cells. Cells of the bone marrow microenvironment, such as macrophages, endothelial cells, and reticular fibroblastoid cells, produce macrophage, granulocyte-macrophage, and granulocyte colony-stimulating factors (M-CSF, GM-CSF, G-CSF), interleukin-6 (IL-6), and probably stem cell factor (SCF) (cellular sources not precisely determined) after induction with endotoxin (macrophage) or IL-1/tumor necrosis factor (TNF) (endothelial cells and fibroblasts). T cells produce IL-3, GM-CSF, and IL-5 in response to antigenic and IL-1 stimulation. These cytokines have overlapping actions during hematopoietic differentiation, as indicated, and for all lineages, optimal development requires a combination of early-acting and late-acting factors. Transcription factors important for survival or self-renewal of stem cells are shown in red at the top, whereas stages of hematopoiesis blocked after the depletion of indicated transcription factors are shown in red for multipotent and committed progenitors. (From Sieff CA, Daley GQ, Zon LI. *Anatomy and physiology of hematopoiesis*. In: Orkin SH, Fisher DE, Ginsburg D, et al., eds. *Nathan and Oski's Hematology and Oncology of Infancy and Childhood*. 8th ed. Philadelphia: Elsevier; 2015. Fig 1.7.)

## NEUTROPHIL FUNCTION

Neutrophil responses are initiated as circulating neutrophils flowing through the postcapillary venules detect low levels of chemokines and other chemotactic substances released from a site of infection. The sequence of events as the neutrophil moves from circulating in the blood to the encounter and destruction of bacteria is carefully orchestrated by a series of biochemical events, defects

of which are associated with genetic disorders of neutrophil function (Fig. 168.2). In fact, these disorders of neutrophil function lead to our understanding of the cell biology of phagocyte function. A subset of circulating neutrophils loosely adheres to the endothelium through low-affinity receptors called **selectins** and rolls along the endothelium, forming the marginated pool. Soluble effectors of inflammation trigger subtle changes in surface adhesion molecules



**Fig. 168.2** The neutrophil-mediated inflammatory response and associated neutrophil dysfunction syndromes. Circulating neutrophils loosely attach to endothelium via selectins and roll along the vessel wall until they arrive at the site of infection. Inflammatory monokines, interleukin-1 (IL-1), and tumor necrosis factor (TNF) activate endothelial cells to express E- and P-selectins. E- and P-selectins serve as counter-receptors for neutrophils sialyl Lewis X and Lewis X to cause low-avidity neutrophil rolling. Activated endothelial cells express intracellular adhesion molecule (ICAM)-1, which serves as a counter-receptor for neutrophil  $\beta_2$ -integrin molecules, leading to high-avidity leukocyte spreading and the start of transendothelial migration at the infection site. Neutrophils invade through the vascular basement membrane with the release of proteases and reactive oxidative intermediates, causing local destruction of surrounding tissue at sites of high concentrations of chemotactic factors, and migrate to the site of infection, where they ingest and kill the bacteria. NADPH, Nicotinamide-adenine dinucleotide phosphate; PECAM, platelet endothelial cell adhesion molecule. (Modified from Kyono W, Coates TD. A practical approach to neutrophil disorders. *Pediatr Clin North Am.* 2002;49:929.)

on endothelial cells at the site of infection. The rolling of neutrophils allows more intense exposure of neutrophils to activating factors such as tumor necrosis factor or interleukin-1 (see Fig. 168.2). Exposure of neutrophils to these same activating factors induces qualitative and quantitative changes in the family of  $\beta_2$ -integrin adhesion receptors (the CD11/CD18 group of surface molecules), leading to tight adhesion between neutrophils and endothelial cells at the site of inflammation and ultimately to transmigration of the neutrophil into the tissue.

Once through the endothelium, the neutrophil senses the gradient of chemokines or other chemoattractants and migrates to sites of infection. **Neutrophil migration** is a complex process involving rounds of receptor engagement, signal transduction, and remodeling of the actin microfilaments composing in part the cytoskeleton. Actin polymerization-depolymerization occurs in approximately 8-second cycles and drives cyclic extension and retraction of the actin-rich lamella at the front of the neutrophil. Receptors at the leading edge of the lamella detect the gradient of attractant and follow microorganisms,

then ingest and destroy them. When the neutrophil reaches the site of infection, it recognizes pathogens by means of Fc immunoglobulin and complement receptors, toll-like receptors, fibronectin receptors, and other adhesion molecules.

The neutrophil ingests microbes that are coated by **opsonins**, serum proteins such as immunoglobulin and complement component C3. The pathogens are engulfed into a closed vacuole, the **phagosome** (Fig. 168.3), where two cellular responses essential for optimal microbicidal activity occur concomitantly: degranulation and activation of nicotinamide-adenine dinucleotide phosphate (NADPH)-dependent oxidase. Fusion of neutrophil granule membranes with the phagosome membrane delivers potent antimicrobial proteins and small peptides into the phagosome.

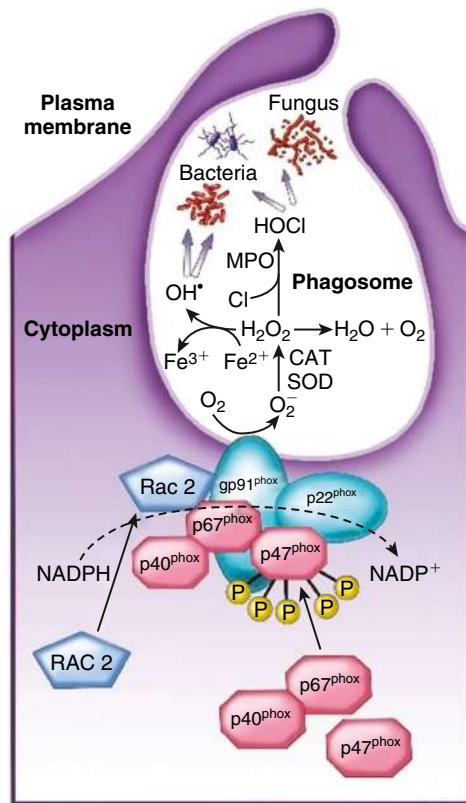
Assembly and activation of NADPH oxidase occur at the phagosome membrane as well (see Fig. 168.3), generating large amounts of superoxide ( $O_2^-$ ) from molecular oxygen, which in turn decomposes to produce hydrogen peroxide ( $H_2O_2$ ) and singlet oxygen. **Myeloperoxidase**, a major azurophilic granule component, catalyzes the reaction



## Chapter 169

## Eosinophils

Benjamin L. Wright and Brian P. Vickery



**Fig. 168.3** Nicotinamide adenine dinucleotide phosphate (NADPH) oxidase components and activation. On activation of phagocytic cells, the 3 cytosolic components (red) of the NADPH oxidase (p67<sup>phox</sup>, p47<sup>phox</sup>, and p40<sup>phox</sup>), plus the small guanosine triphosphatase (GTPase) protein Rac2, are translocated to the membrane of the phagocytic vacuole. The p47<sup>phox</sup> subunit binds to the flavocytochrome<sub>b558</sub> membrane component (blue-green) of the NADPH oxidase (gp91<sup>phox</sup> plus p22<sup>phox</sup>). The NADPH oxidase catalyzes the formation of superoxide by transferring an electron from NADPH to molecular oxygen (O<sub>2</sub>), thereby forming the superoxide free radical. The unstable superoxide anion is converted to hydrogen peroxide, either spontaneously or by superoxide dismutase (SOD). H<sub>2</sub>O<sub>2</sub> can follow different metabolic pathways into more potent reactive oxidants, such as OH<sup>•</sup> or HOCl) or degradation to H<sub>2</sub>O + O<sub>2</sub>. (Adapted from Stiehm ER, Ochs HD, Winkelstein JA. *Immunologic Disorders in Infants and Children*, 5th ed. Philadelphia: Saunders; 2004, p. 622.)

of H<sub>2</sub>O<sub>2</sub> with ubiquitously present chloride ions to create hypochlorous acid (HOCl) in the phagosome. H<sub>2</sub>O<sub>2</sub> and HOCl are potent microbicidal agents that break down and clear pathogens from sites of infection.

In addition, neutrophils secrete a wide variety of cytokines and chemokines that recruit more neutrophils to fight the infection, attract monocytes and macrophages that possess both microbicidal and scavenger functions, and promote antigen presentation to help initiate the adaptive immune response. Also, the reactive oxidants can inactivate chemotactic factors and may serve to terminate the process of neutrophil influx, thereby attenuating the inflammatory process. Finally, the release of reactive oxygen species, granule proteins, and cytokines can also damage local tissues, leading to the classic signs of inflammation or to more permanent impairment of tissue integrity and function. In addition to the role of neutrophils in tissue damage, they are now known to play a significant role in regulation of inflammation and promoting tissue repair. Turning off inflammation and removing tissue debris is an important role and, like seeking and destroying bacteria, this process is highly regulated as well.

Visit Elsevier eBooks+ at [eBooks.Health.Elsevier.com](http://eBooks.Health.Elsevier.com) for Bibliography.

Eosinophils are nondividing, fully differentiated cells with a diameter of approximately 8 μm and a bilobed nucleus that are distinguished from other leukocytes by their morphology, constituent products, and association with specific diseases. Their characteristic membrane-bound specific granules stain bright pink with eosin and are cytotoxic for the larval stages of helminthic parasites and are also thought to contribute to much of the inflammation associated with chronic allergic diseases such as asthma (see [Chapter 185](#)). Eosinophil granule proteins including major basic protein, eosinophil cationic protein, eosinophil-derived neurotoxin, and eosinophil peroxidase are thought to inflict epithelial cell damage, although recent studies indicate their role may be more nuanced and not purely destructive. Eosinophil granule contents activate other proinflammatory cells, including mast cells, basophils, neutrophils, and platelets and have the capacity to generate large amounts of the lipid mediators, which can cause vasoconstriction, smooth muscle contraction, and mucus hypersecretion ([Fig. 169.1](#)). Eosinophils are a source of several proinflammatory cytokines and have also been shown to influence T-cell recruitment and immune polarization in inflammatory settings. Thus eosinophils have considerable potential to initiate and sustain the inflammatory response of the innate and acquired immune systems.

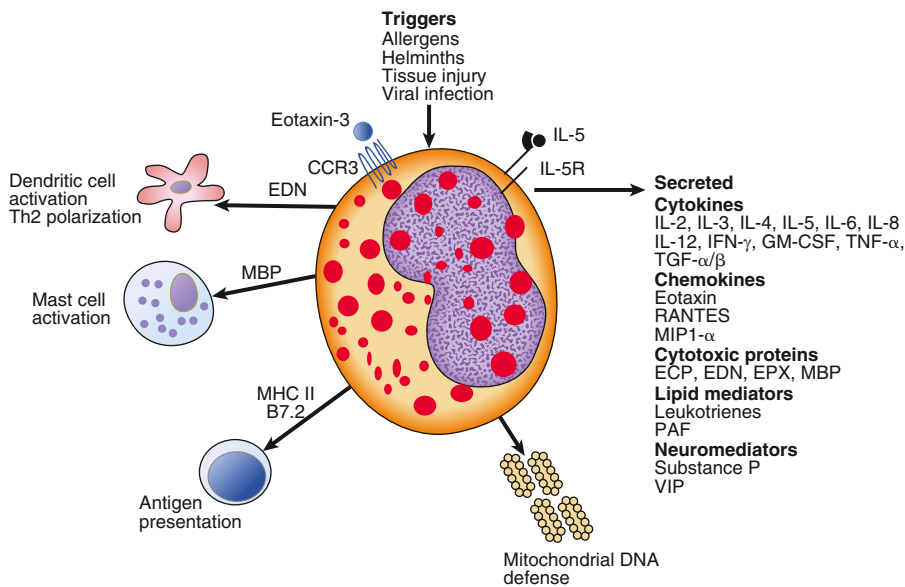
Eosinophil migration from the vasculature into the extracellular tissue is mediated by the binding of leukocyte adhesion receptors (e.g., VLA-4) to their ligands or counterstructures (VCAM-1) on the post-capillary endothelium. Eosinophils are recruited to tissues in inflammatory states by a group of chemokines known as **eotaxins** (eotaxin 1, 2, and 3). These unique pathways account for selective accumulation of eosinophils in allergic and inflammatory disorders. Eosinophils normally dwell primarily in tissues, especially tissues with an epithelial interface with the environment, including the respiratory, gastrointestinal (GI), and lower genitourinary tracts. The life span of eosinophils may extend for weeks within tissues.

**Interleukin (IL)-5** selectively enhances eosinophil production, adhesion to endothelial cells, and function. Considerable evidence shows that IL-5 has a pivotal role in promoting eosinophilopoiesis. It is the predominant cytokine in allergen-induced pulmonary late-phase reaction, and antibodies against IL-5 (mepolizumab, reslizumab, benralizumab) decrease sputum eosinophils and reduce exacerbations in a subset of patients with asthma. Eosinophils also bear unique receptors for several chemokines, including RANTES (regulated on activation, normal T-cell expressed and secreted), eotaxin, and monocyte chemoattractant proteins 3 and 4. These chemokines appear to be key mediators in the induction of tissue eosinophilia.

### DISEASES ASSOCIATED WITH EOSINOPHILIA

The **absolute eosinophil count (AEC)** is used to quantify peripheral blood eosinophilia. Calculated as the white blood cell (WBC) count/μL × percentage of eosinophils, it is usually <450 cells/μL and varies diurnally, with eosinophil numbers higher in the early morning and diminishing as endogenous glucocorticoid levels rise.

Many diseases with allergic, infectious, hematologic, autoimmune, or idiopathic origins are associated with moderate (AEC 1,500-5,000 cells/μL) or severe (AEC >5,000 cells/μL) eosinophilia in peripheral blood ([Table 169.1](#)). These disorders may range from mild and transient to chronic and life-threatening. Importantly, blood eosinophil numbers do not always reflect the extent of eosinophil involvement in tissues and degranulation products may more accurately reflect disease activity. Because prolonged eosinophilia is associated with end-organ



**Fig. 169.1** Schematic diagram of an eosinophil and its diverse properties. Eosinophils are bilobed granulocytes that respond to diverse stimuli, including allergens, helminths, viral infections, allografts, and nonspecific tissue injury. Eosinophils express the receptor for interleukin (IL)-5, a critical eosinophil growth and differentiation factor, as well as the receptor for eotaxin and related chemokines (CCR3). The secondary granules contain four primary cationic proteins designated eosinophil peroxidase (EPX), major basic protein (MBP), eosinophil cationic protein (ECP), and eosinophil-derived neurotoxin (EDN). All four proteins are cytotoxic molecules; also, ECP and EDN are ribonucleases. In addition to releasing their preformed cationic proteins, eosinophils can release a variety of cytokines, chemokines, and neuromediators and generate large amounts of leukotriene C4 (LTC<sub>4</sub>). Last, eosinophils can be induced to express major histocompatibility complex (MHC) class II and co-stimulatory molecules and may be involved in propagating immune responses by presenting antigen to T cells. PAF, platelet activating factor; VIP, vasoactive intestinal peptide. (From Leung YM, Szeffler SJ, Bomilla FA, Akdis CA, Sampson HA. *Pediatric Allergy: Principles and practice*. 3rd ed. Philadelphia: Elsevier; 2016. p. 42.)

damage, especially involving the heart, patients with persistently elevated AECs should undergo a thorough evaluation to search for an underlying cause.

### Allergic Diseases

Allergy is the most common cause of eosinophilia in children in the United States. Patients with allergic asthma typically have eosinophils in the blood, sputum, and/or lung tissue. **Hypersensitivity drug reactions** can elicit eosinophilia, and when associated with organ dysfunction (e.g., DRESS [drug rash with eosinophilia and systemic symptoms]), these reactions can be serious (see Chapter 193). If a drug is suspected of triggering eosinophilia, biochemical evidence of organ dysfunction should be sought, and if found, the drug should be discontinued. Various skin diseases have also been associated with eosinophilia, including atopic dermatitis/eczema, pemphigus, urticaria, and toxic epidermal necrolysis.

**Eosinophilic gastrointestinal diseases** (EGIDs) are important emerging allergic causes of eosinophilia in tissue and, in some cases, peripheral blood (see Chapter 383). In these conditions, eosinophils are recruited to the esophagus, stomach, and/or intestine, where they may cause tissue inflammation and clinical symptoms such as dysphagia, food aversion, abdominal pain, vomiting, or diarrhea. Eosinophilic esophagitis is the most common EGID. Treatment options include proton pump inhibitors, allergen elimination diets, topical corticosteroids, and biologics (e.g. dupilumab). Patients with nonesophageal EGIDs often require treatment with systemic steroids.

### Infectious Diseases

Eosinophilia is often associated with invasive infection with multicellular helminthic parasites, which are the most common cause in developing countries. Table 169.1 includes examples of specific organisms. The level of eosinophilia tends to parallel the magnitude and extent of tissue invasion, especially by larvae such as **visceral larva migrans** (see Chapter 344). Eosinophilia often *does not* occur in established parasitic infections that are well contained within tissues or are solely intraluminal in the GI tract, such as *Giardia lamblia* and *Enterobius vermicularis* infection.

In evaluating patients with unexplained eosinophilia, the dietary history and geographic or travel history may indicate potential exposures to helminthic parasites. It is frequently necessary to examine the stool for ova and larvae at least three times. Additionally, the diagnostic parasite stages of many of the helminthic parasites that cause

eosinophilia never appear in feces. Thus normal results of stool examinations do not absolutely preclude a helminthic cause of eosinophilia; diagnostic blood tests or tissue biopsy may be needed. *Toxocara* causes visceral larva migrans usually in toddlers with pica (see Chapter 344). Most young children are asymptomatic, but some develop fever, pneumonitis, hepatomegaly, and hypergammaglobulinemia accompanied by severe eosinophilia. Isohemagglutinins are frequently elevated, and serology can establish the diagnosis.

Two fungal diseases may be associated with eosinophilia: aspergillosis in the form of **allergic bronchopulmonary aspergillosis** (see Chapter 283) and **coccidioidomycosis** (see Chapter 286) following primary infection, especially in conjunction with erythema nodosum. HIV infection can also be associated with peripheral eosinophilia.

### Hypereosinophilic Syndrome

The idiopathic hypereosinophilic syndrome is a heterogeneous group of disorders characterized by sustained overproduction of eosinophils. The three diagnostic criteria for this disorder are (1) AEC >1,500 cells/ $\mu$ L persisting for 6 months or longer or at least on two occasions or with evidence of tissue eosinophilia; (2) absence of another diagnosis to explain the eosinophilia; and (3) signs and symptoms of organ involvement. The clinical signs and symptoms of hypereosinophilic syndrome can be heterogeneous because of the diversity of potential organ (pulmonary, cutaneous, neurologic, serosal, GI) involvement. Organ-specific signs and symptoms direct the diagnostic evaluation, but common initial tests used to evaluate hypereosinophilia and potential end-organ complications include a comprehensive metabolic panel, inflammatory markers, troponin level, urinalysis, antineutrophil cytoplasmic antibodies, immunoglobulin levels, vitamin B<sub>12</sub> level, tryptase level, stool examination for ova and parasites, parasite serologies, HIV testing, and a chest x-ray. Eosinophilic endomyocardial disease, one of the most serious and life-threatening complications, can cause heart failure from endomyocardial thrombosis and fibrosis. Screening for cardiac involvement should also include an electrocardiogram, an echocardiogram, and in some cases a cardiac MRI. Evaluation of the hypereosinophilic syndrome requires morphologic review of the blood and marrow, cytogenetics, fluorescence in situ hybridization, immunophenotyping by flow cytometry, and T-cell clonality assessment to detect histopathologic or clonal evidence for hematolymphoid neoplasm. Eosinophilic leukemia, a clonal myeloproliferative variant, may be distinguished from idiopathic hypereosinophilic syndrome

**Table 169.1** Causes of Eosinophilia**ALLERGIC DISORDERS**

Allergic rhinitis  
 Asthma  
 Acute and chronic urticaria  
 Atopic dermatitis  
 Angioedema  
 Hypersensitivity drug reactions (drug rash with eosinophilia and systemic symptoms [DRESS])  
 Eosinophilic gastrointestinal disorders  
 Interstitial nephritis  
 Mastocytosis

**INFECTIOUS DISEASES****Tissue-Invasive Helminth Infections and Other Infections**

Trichinosis  
 Toxocariasis  
 Strongyloidiasis  
 Ascariasis  
 Filariasis  
 Schistosomiasis  
 Echinococcosis  
 Amebiasis  
 Malaria  
 Scabies  
 Toxoplasmosis  
*Pneumocystis jirovecii*  
 Scarlet fever  
 Allergic bronchopulmonary aspergillosis (ABPA)  
 Coccidioidomycosis  
 Human immunodeficiency virus (HIV)

**MALIGNANT DISORDERS**

Hodgkin disease and T-cell lymphoma  
 Acute myelogenous leukemia  
 Myeloproliferative disorders  
 Eosinophilic leukemia  
 Brain tumors

**GASTROINTESTINAL DISORDERS**

Inflammatory bowel disease  
 Peritoneal dialysis  
 Chronic active hepatitis

**Eosinophilic Gastrointestinal Disorders**

Eosinophilic esophagitis  
 Eosinophilic gastritis  
 Eosinophilic enteritis  
 Eosinophilic colitis

**RHEUMATOLOGIC DISEASE**

Rheumatoid arthritis  
 Eosinophilic fasciitis  
 Scleroderma  
 Dermatomyositis  
 Systemic lupus erythematosus  
 IgG4-related disease  
 Eosinophilic granulomatosis with polyangiitis (Churg-Strauss vasculitis)

**IMMUNODEFICIENCY/IMMUNE DYSREGULATION DISEASE**

Hyperimmunoglobulin E syndromes  
 Wiskott-Aldrich syndrome  
 Graft-versus-host disease  
 Omenn syndrome  
 Severe congenital neutropenia  
 Autoimmune lymphoproliferative syndromes (ALPS)  
 Immune dysregulation, polyendocrinopathy, X-linked (IPEX) and IPEX-like syndrome  
 Transplant rejection (solid organ)

**MISCELLANEOUS**

Thrombocytopenia with absent radii  
 Hypersensitivity pneumonitis  
 Adrenal insufficiency  
 Postirradiation of abdomen  
 Histiocytosis with cutaneous involvement  
 Hypereosinophilic syndromes  
 Cytokine infusion  
 Pemphigoid

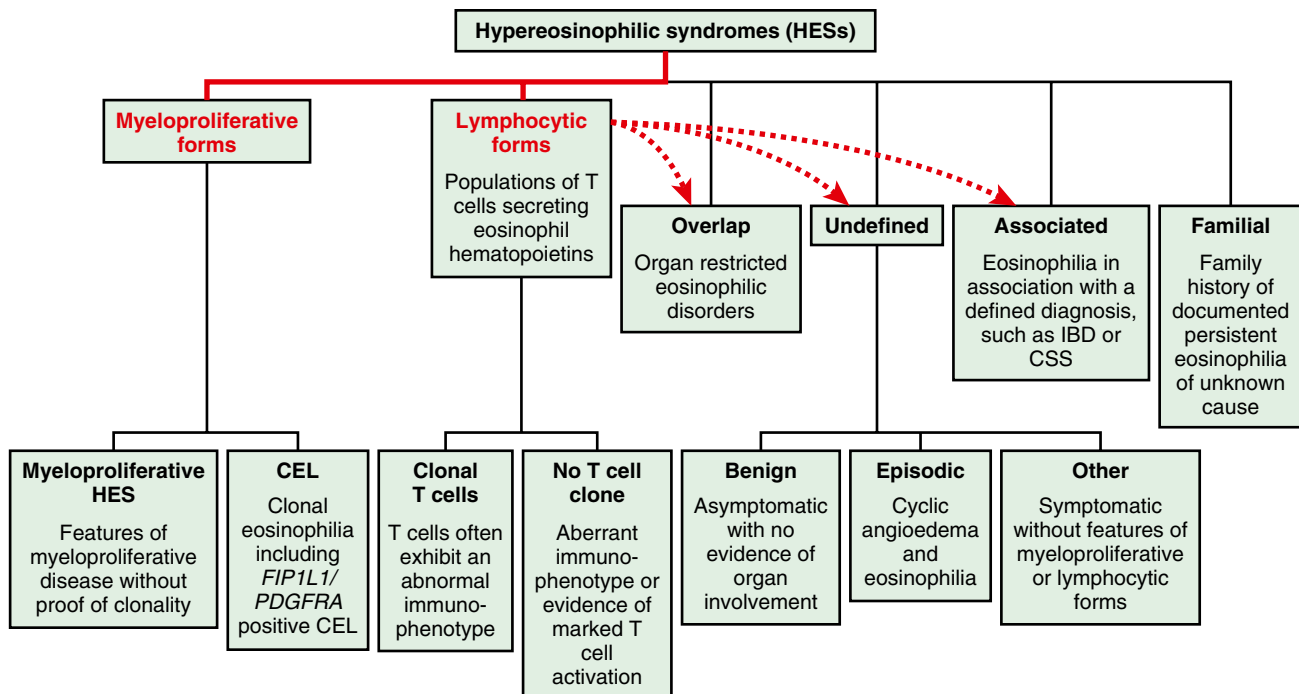
by demonstrating a clonal interstitial deletion on chromosome 4q12 that fuses the platelet-derived growth factor receptor- $\alpha$  (*PDGFRA*) and FIP1-like-1 (*FIP1L1*) genes; this disorder is treated with imatinib mesylate, a tyrosine kinase inhibitor, which helps target the fusion oncoprotein (Fig. 169.2).

Therapy is aimed at suppressing eosinophilia and is initiated with corticosteroids. Patients with possible exposure to *Strongyloides* should receive concomitant empiric treatment with ivermectin to prevent corticosteroid-associated hyperinfection syndrome. Imatinib mesylate may be effective in FIP1L1-PDGFRA-negative patients. Hydroxyurea or interferon- $\alpha$  may be beneficial in patients unresponsive to corticosteroids. Specific anti-IL-5 monoclonal antibodies (mepolizumab) target this cytokine, which has a central role in eosinophil differentiation, mobilization, and activity. With therapy, the eosinophil count declines and corticosteroid doses may be reduced. For patients with prominent organ involvement who fail to respond to therapy, the mortality is about 75% after 3 years.

**Miscellaneous Diseases**

Eosinophilia is observed in many patients with primary immunodeficiency syndromes, especially hyper-IgE syndrome, Wiskott-Aldrich syndrome, and Omenn syndrome (see Chapter 165). Eosinophilia is also frequently present in the syndrome of thrombocytopenia with absent radii and in familial reticuloendotheliosis with eosinophilia. Eosinophilia can be found in patients with Hodgkin disease, as well as in acute lymphoid and myeloid leukemia. Other considerations include GI disorders such as ulcerative colitis, Crohn disease during symptomatic phases, chronic hepatitis, eosinophilic granulomatosis with polyangiitis (Churg-Strauss vasculitis), mastocytosis, and adrenal insufficiency.

Visit Elsevier eBooks+ at [eBooks.Health.Elsevier.com](http://eBooks.Health.Elsevier.com) for Bibliography.



**Fig. 169.2** Revised classification of hypereosinophilic syndromes. Changes from the previous classification are indicated in red. Dashed arrows identify hypereosinophilic syndrome (HES) forms for which at least some patients have T-cell-driven disease. Classification of myeloproliferative forms has been simplified, and patients with HES and eosinophil hematopoietin-producing T cells in the absence of a T-cell clone are included in the lymphocytic forms of HES. CEL, Chronic eosinophilic leukemia; CSS, Churg-Strauss syndrome; IBD, inflammatory bowel disease. (From Simon HU, Rothenberg ME, Bochner BS, et al. Refining the definition of hypereosinophilic syndrome. *J Allergy Clin Immunol.* 2010;126:45-49.)

## Chapter 170

# Disorders of Phagocyte Function

Thomas D. Coates

Neutrophils are the first line of defense against microbial invasion. They arrive at the site of inflammation during the critical 2-4 hours after microbial invasion to contain the infection and prevent hematogenous dissemination. Much of our knowledge about neutrophil function derives from studies done in patients with genetic errors in neutrophil function. These critical functions and their associated disorders are depicted in [Figure 168.2](#). Children with phagocytic dysfunction present at a young age with recurrent infections that often involve unusual organisms and are poorly responsive to treatment.

Primary defects of phagocytic function comprise <20% of immunodeficiencies, and there is significant overlap in the presenting signs and symptoms between phagocytic disorders and lymphocyte and humeral disorders. Children with phagocytic defects present with deep tissue infection, pneumonia, adenitis, cutaneous lesions, or osteomyelitis rather than bloodstream infections ([Tables 170.1 and 170.2](#); [Fig. 170.1](#)). In the past, diagnosis of these disorders relied on very specialized

biologic assays. Because the genes for most of these disorders have been identified, the first step in diagnosis for all of these disorders is to obtain DNA analysis through commercially available genetic panels for immunodeficiency.

**Chemotaxis**, the direct migration of cells into sites of infection, involves a complex series of events (see [Chapter 168](#)). Disorders of adhesion or granule abnormalities can have intermediate or profound motility defects, and the propensity to infections is related to a combination of these functional deficits. One family with recessively inherited neutrophil actin dysfunction demonstrated that a pure severe chemotactic defect can result in fatal recurrent infection. Defective *in vitro* chemotaxis of neutrophils can be detected in children with various clinical conditions. However, unless chemotaxis is essentially absent, it is difficult to establish whether frequent infections arise from a primary chemotactic abnormality or occur as secondary medical complications of the underlying disorder. Dental infection with *Capnocytophaga* is associated with a clear neutrophil motility defect that resolves when the infection is eliminated.

Motility defects present with significant skin and mucosal infections. Tender cutaneous nodular lesions may also be present and characteristically do not contain neutrophils. In fact, the presence of a true abscess makes the diagnosis of a significant chemotactic defect less likely.

Laboratory tests of chemotaxis are biologic assays and have high variability except in the most experienced hands. The assays must be done on freshly obtained blood and are affected by many factors related to the blood sampling. It is best to assay other features of the suspected disorder, such as surface marker expression, to establish a specific diagnosis.



**Table 170.1** Infections and White Blood Cell Defects: Features That Can Be Seen in Phagocyte Disorders

SEVERE INFECTIONS		RECURRENT INFECTIONS		SPECIFIC INFECTIONS		UNUSUALLY LOCATED INFECTIONS	
TYPE OF INFECTION	DIAGNOSIS TO CONSIDER	SITE OF INFECTION	DIAGNOSIS TO CONSIDER	MICRO-ORGANISM	DIAGNOSIS TO CONSIDER	SITE OF INFECTION	DIAGNOSIS TO CONSIDER
Cellulitis	Neutropenia, LAD, CGD, HIES	Cutaneous	Neutropenia, CGD, LAD, HIES	<i>Staphylococcus epidermidis</i>	Neutropenia, LAD	Umbilical cord	LAD
Colitis	Neutropenia, CGD	Gums	LAD, neutrophil motility disorders	<i>Serratia marcescens</i> , <i>Nocardia</i> , <i>Burkholderia cepacia</i>	CGD	Liver abscess	CGD
Osteomyelitis	CGD, MSMD pathway defects	Upper and lower respiratory tract	Neutropenia, HIES, functional neutrophil disorders	<i>Aspergillus</i>	Neutropenia, CGD, HIES	Gums	LAD, neutrophil motility disorders
		Gastrointestinal tract	CGD, MSMD pathway defects (salmonella)	Nontuberculous mycobacteria, BCG	MSMD pathway defects, SCID, CGD		
		Lymph nodes	CGD, MSMD pathway defects (mycobacteria)	<i>Candida</i>	Neutropenia, CGD, MPO		
		Osteomyelitis	CGD, MSMD				

BCG, Bacille Calmette-Guérin; CGD, chronic granulomatous disease; HIES, hyper-IgE syndrome; LAD, leukocyte adhesion deficiency; MPO, myeloperoxidase; MSMD, mendelian susceptibility to mycobacterial disease; SCID, severe combined immunodeficiency.

From Leung DYM. *Pediatric Allergy: Principles and Practice*. 2nd ed. Philadelphia: Saunders; 2010. p. 134.

**Table 170.2** Clinical Disorders of Neutrophil Function

DISORDER	ETIOLOGY	IMPAIRED FUNCTION	CLINICAL CONSEQUENCE
<b>DEGRANULATION ABNORMALITIES</b>			
Chédiak-Higashi syndrome (CHS)	Autosomal recessive; disordered coalescence of lysosomal granules; responsible gene is <i>CHSI/LYST</i> , which encodes a protein hypothesized to regulate granule fusion	Decreased neutrophil chemotaxis, degranulation, and bactericidal activity; platelet storage pool defect; impaired NK function, failure to disperse melanosomes	Neutropenia; recurrent pyogenic infections; propensity to develop marked hepatosplenomegaly as a manifestation of hemophagocytic syndrome
Specific granule deficiency	Autosomal recessive; functional loss of myeloid transcription factor arising from a pathogenic variant or arising from reduced expression of <i>Gfi-1</i> or <i>C/EBP<math>\epsilon</math></i> , which regulates specific granule formation	Impaired chemotaxis and bactericidal activity; bilobed nuclei in neutrophils; defensins, gelatinase, collagenase, vitamin B <sub>12</sub> -binding protein, and lactoferrin	Recurrent deep-seated abscesses
<b>ADHESION ABNORMALITIES</b>			
Leukocyte adhesion deficiency 1 (LAD-1)	Autosomal recessive; absence of CD11/CD18 surface adhesive glycoproteins ( $\beta_2$ -integrins) on leukocyte membranes most commonly arising from failure to express CD18 messenger RNA	Decreased binding of iC3b to neutrophils and impaired adhesion to ICAM-1 and ICAM-2	Neutrophilia; recurrent bacterial infection associated with a lack of pus formation
Leukocyte adhesion deficiency 2 (LAD-2)	Autosomal recessive; loss of fucosylation of ligands for selectins and other glycol conjugates arising from pathogenic variants of GDP-fucose transporter	Decreased adhesion to activated endothelium expressing ELAM	Neutrophilia; recurrent bacterial infection without pus
Leukocyte adhesion deficiency 3 (LAD-1 variant syndrome)	Autosomal recessive; impaired integrin function arising from pathogenic variants of <i>FERMT3</i> , which encodes kindlin-3 in hematopoietic cells; kindlin-3 binds to $\beta$ -integrin and thereby transmits integrin activation	Impaired neutrophil adhesion and platelet activation	Neutrophilia, recurrent infections, bleeding tendency

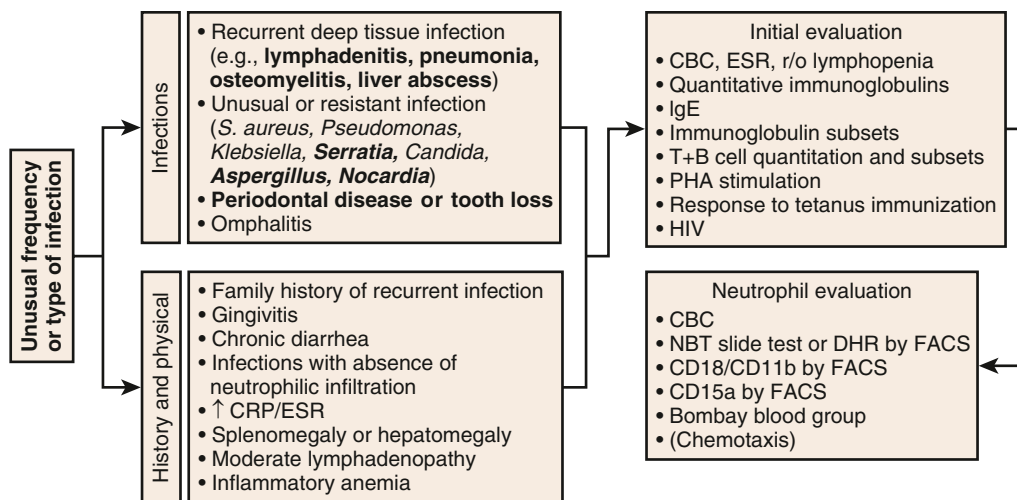
*Continued*

**Table 170.2** Clinical Disorders of Neutrophil Function—cont'd

DISORDER	ETIOLOGY	IMPAIRED FUNCTION	CLINICAL CONSEQUENCE
<b>DISORDERS OF CELL MOTILITY</b>			
Enhanced motile responses; FMF	Autosomal recessive gene responsible for FMF on chromosome 16, which encodes for a protein called pyrin; pyrin regulates caspase-1 and thereby IL-1 $\beta$ secretion; mutated pyrin may lead to heightened sensitivity to endotoxin, excessive IL-1 $\beta$ production, and impaired monocyte apoptosis	Excessive accumulation of neutrophils at inflamed sites, possibly the result of excessive IL-1 $\beta$ production	Recurrent fever, peritonitis, pleuritis, arthritis, amyloidosis
<b>DEPRESSED MOTILE RESPONSES</b>			
Defects in the generation of chemotactic signals	IgG deficiencies; C3 and properdin deficiency can arise from genetic or acquired abnormalities; mannose-binding protein deficiency predominantly in neonates	Deficiency of serum chemotaxis and opsonic activities	Recurrent pyogenic infections
Intrinsic defects of the neutrophil, e.g., LAD, CHS, specific granule deficiency, neutrophil actin dysfunction, neonatal neutrophils	In the neonatal neutrophil there is diminished ability to express $\beta_2$ -integrins, and there is a qualitative impairment in $\beta_2$ -integrin function	Diminished chemotaxis	Propensity to develop pyogenic infections
Direct inhibition of neutrophil mobility, e.g., drugs	Ethanol, glucocorticoids, cyclic AMP	Impaired locomotion and ingestion; impaired adherence	Possible cause for frequent infections; neutrophilia seen with epinephrine arises from cyclic AMP release from endothelium
Immune complexes	Bind to Fc receptors on neutrophils in patients with rheumatoid arthritis, systemic lupus erythematosus, and other inflammatory states	Impaired chemotaxis	Recurrent pyogenic infections
Hyper-IgE syndrome	Autosomal dominant; responsible gene is <i>STAT3</i>	Impaired chemotaxis at times; impaired regulation of cytokine production	Recurrent skin and sinopulmonary infections, eczema, mucocutaneous candidiasis, eosinophilia, retained primary teeth, minimal trauma fractures, scoliosis, and characteristic facies
Hyper-IgE syndrome—AR	Autosomal recessive; more than one gene likely contributes to its etiology	High IgE levels, impaired lymphocyte activation to staphylococcal antigens	Recurrent pneumonia without pneumatoceles sepsis, enzyme, boils, mucocutaneous candidiasis, neurologic symptoms, eosinophilia
<b>MICROBICIDAL ACTIVITY</b>			
Chronic granulomatous disease (CGD)	X-linked and AR; failure to express functional gp91 <sup>phox</sup> in the phagocyte membrane in p22 <sup>phox</sup> (AR) Other AR forms of CGD arise from failure to express protein p47 <sup>phox</sup> or p67 <sup>phox</sup>	Failure to activate neutrophil respiratory burst, leading to failure to kill catalase-positive microbes	Recurrent pyogenic infections with catalase-positive microorganisms
G6PD deficiency	<5% of normal activity of G6PD	Failure to activate NADPH-dependent oxidase; hemolytic anemia	Infections with catalase-positive microorganisms
Myeloperoxidase deficiency	Autosomal recessive; failure to process modified precursor protein arising from missense variant	H <sub>2</sub> O <sub>2</sub> -dependent antimicrobial activity not potentiated by myeloperoxidase	None
Rac2 deficiency	Autosomal dominant; dominant negative inhibition by variant protein of Rac2-mediated functions	Failure of membrane receptor-mediated O <sub>2</sub> <sup>-</sup> generation and chemotaxis	Neutrophilia, recurrent bacterial infections
Deficiencies of glutathione reductase and glutathione synthetase	AR; failure to detoxify H <sub>2</sub> O <sub>2</sub>	Excessive formation of H <sub>2</sub> O <sub>2</sub>	Minimal problems with recurrent pyogenic infections

AMP, Adenosine monophosphate; AR, autosomal recessive; C, complement; CD, cluster of differentiation; ELAM, endothelial-leukocyte adhesion molecule; FMF, familial Mediterranean fever; G6PD, glucose-6-phosphate dehydrogenase; GDP, guanosine diphosphate; ICAM, intracellular adhesion molecule; IL-1, interleukin-1; NADPH, nicotinamide adenine dinucleotide phosphate; NK, natural killer.

Adapted from Curnutte JT, Boxer LA. Clinically significant phagocytic cell defects. In: Remington JS, Swartz MN, eds. *Current Clinical Topics in Infectious Disease*. 6th ed. New York: McGraw-Hill; 1985. p. 144.



**Fig. 170.1** Algorithm for clinical evaluation of patients with recurrent infections. Shown are the evaluations that can be done in a routine clinical laboratory. The complete blood count (CBC) can detect marked leukocytosis in leukocyte adhesion deficiency (LAD) and giant granules of Chédiak-Higashi syndrome may be seen on the smear. Chemotaxis and all other neutrophil function assays require highly specialized research laboratories. CD, Cluster of differentiation; CRP, C-reactive protein; DHR, dihydrorhodamine; ESR, erythrocyte sedimentation rate; FACS, fluorescence-activated cell sorter; HIV, human immunodeficiency virus; IgE, immunoglobulin E; NBT, nitroblue tetrazolium; PHA, phytohemagglutinin. (Adapted from Dinauer, MC, Coates TD: *Disorders of neutrophil function*. In: Hoffman R, Benz EJ, Silberstein LE, et al., eds. *Hematology: Basic Principles and Practice*. 6th ed. Philadelphia: Saunders; 2012.)

## LEUKOCYTE ADHESION DEFICIENCY

Leukocyte adhesion deficiency types 1 (LAD-1), 2 (LAD-2), and 3 (LAD-3) are rare autosomal recessive disorders of leukocyte function. LAD-1 affects about 1 per 10 million individuals and is characterized by recurrent bacterial and fungal infections and depressed inflammatory responses despite striking blood neutrophilia (Table 170.3).

### Genetics and Pathogenesis

LAD-1 results from pathogenic variants of the gene on chromosome 21q22.3 encoding CD18, the 95-kDa  $\beta_2$ -leukocyte transmembrane integrin subunit. Normal neutrophils express four heterodimeric adhesion molecules: LFA-1 (CD11a/CD18), Mac-1 (CD11b/CD18, also known as CR3 or iC3b receptor), p150,95 (CD11c/CD18), and  $\alpha_{1\beta_2}$  (CD11d/CD18). These four transmembrane adhesion molecules are composed of unique extracellular  $\alpha_1$  encoded on chromosome 16, and they share a common  $\beta_2$  subunit (CD18) that links them to the membrane and connects them to intracellular signal transduction machinery. This group of leukocyte integrins is responsible for the tight adhesion of neutrophils to the endothelial cell surface, egress from the circulation, and adhesion to iC3b-coated microorganisms, which promotes phagocytosis and particulate activation of the phagocyte nicotinamide adenine dinucleotide phosphate (NADPH) oxidase. Some pathogenic variants of CD11/CD18 allow a low level of assembly and activity of integrin molecules, resulting in retention of some neutrophil integrin adhesion function and a moderate phenotype.

Because of their inability to adhere firmly to intercellular adhesion molecules 1 (ICAM-1) and 2 (ICAM-2) expressed on inflamed endothelial cells (see Chapter 168), neutrophils cannot transmigrate through the vessel wall and move to the site infection. Furthermore, neutrophils that do arrive at inflammatory sites fail to recognize microorganisms opsonized with complement fragment iC3b, an important stable opsonin formed by the cleavage of C3b. Therefore other neutrophil functions such as degranulation and oxidative metabolism normally triggered by iC3b binding are also greatly compromised in LAD-1 neutrophils, resulting in impaired phagocytic function and high risk for serious and recurrent bacterial infections.

Monocyte function is also impaired, with poor fibrinogen-binding function, an activity that is promoted by the CD11/CD18 complex. Consequently, such cells are unable to participate effectively in wound healing.

Children with LAD-2 share the clinical features of LAD-1 but have normal CD11/CD18 integrins. Features unique to LAD-2 include neurologic defects, cranial facial dysmorphism, and absence of the erythrocyte ABO blood group antigen (**Bombay phenotype**). LAD-2 (also known as **congenital disorder of glycosylation IIc (CDG-IIc)**) derives from pathogenic variants in the gene encoding a specific guanosine diphosphate (GDP)-L-fucose transporter of the Golgi apparatus. This abnormality prevents the incorporation of fucose into various cell surface glycoproteins, including the carbohydrate structure sialyl Lewis X that is critical for low-affinity rolling adhesion of neutrophils to vascular endothelium. This is an important initial step necessary for subsequent integrin-mediated activation, spreading, and transendothelial migration. Infections in LAD-2 are milder than that in LAD-1.

LAD-3 is characterized by a **Glanzmann thrombasthenia-like** bleeding disorder, delayed separation of the umbilical cord, and serious skin and soft tissue infections similar to those seen in LAD-1, and failure of leukocytes to undergo  $\beta_2$ - and  $\beta_1$ -integrin-mediated adhesion and migration. Pathogenic variants in *KINDLIN3* affect integrin activation.

### Clinical Manifestations

Patients with the severe clinical form of LAD-1 express <0.3% of the normal amount of the  $\beta_2$ -integrin molecules, whereas patients with the moderate phenotype may express 2–7% of the normal amount. Children with severe forms of LAD present in infancy with recurrent, indolent bacterial infections of the skin, mouth, respiratory tract, lower intestinal tract, and genital mucosa. Significant neutrophilic leukocytosis, often  $>25,000/\text{mm}^3$ , is a prominent feature. They may have a history of delayed separation of the umbilical cord, usually with associated infection of the cord stump. The presence of significant omphalitis is an important feature that distinguishes these rare patients from the 10% of healthy infants who can have cord separation at age 3 weeks or later. Skin infection may progress to large chronic ulcers with polymicrobial infection, including anaerobic organisms (Fig. 170.2). The ulcers heal slowly, need months of antibiotic treatment, and often require plastic surgery grafting. Severe gingivitis can lead to early loss of primary and secondary teeth (Fig. 170.3). Infected areas characteristically have very little neutrophilic infiltration (absent pus).

The pathogens infecting patients with LAD-1 are similar to those affecting patients with severe neutropenia (see Chapter 171) and

**Table 170.3** Leukocyte Adhesion Deficiency Syndromes

LEUKOCYTE ADHESION DEFICIENCY (LAD)	TYPE 1 (LAD-1)	TYPE 2 (LAD-2 OR CDG-IIc)	TYPE 3 (LAD-3)	E-SELECTIN DEFICIENCY	Rac2 DEFICIENCY
OMIM	116920	266265	612840	131210	602049
Inheritance pattern	Autosomal recessive	Autosomal recessive	Autosomal recessive	Unknown	Autosomal dominant
Affected protein(s)	$\beta_2$ -Integrin common chain (CD18)	Fucosylated proteins (e.g., sialyl-Lewis X, CD15s)	Kindlin 3	Endothelial E-selectin expression	Rac2
Neutrophil function affected	Chemotaxis, tight adherence	Rolling, tethering	Chemotaxis, adhesion, superoxide production	Rolling, tethering	Chemotaxis, superoxide production
Delayed umbilical cord separation	Yes (severe phenotype only)	Yes	Yes	Yes	Yes
Leukocytosis/neutrophilia	Yes	Yes	Yes	No (mild neutropenia)	Yes

CDG-IIc, Congenital disorder of glycosylation IIc; OMIM, Online Mendelian Inheritance in Man. From Leung DYM. *Pediatric Allergy: Principles and Practice*. 2nd ed. Philadelphia: Saunders; 2010. p. 139.



**Fig. 170.2** Skin infection of a patient with leukocyte adhesion deficiency type 1. Failure to form pus, inability to demarcate the fibrotic skin debris, and limited inflammation. *Enterococcus gallinarum* was cultured from the wound. (From Rich RR. *Clinical Immunology: Principles and Practice*. 4th ed. Philadelphia: Saunders; 2013, p. 273.)



**Fig. 170.3** Oral pathology in a patient with leukocyte adhesion deficiency type 1 (LAD-1). Gingivitis and severe periodontitis are hallmarks of LAD-1. (From Rich RR. *Clinical Immunology: Principles and Practice*. 4th ed. Philadelphia: Saunders; 2013, p. 273.)

include *Staphylococcus aureus* and enteric gram-negative organisms such as *Escherichia coli*. These patients are also susceptible to opportunistic infection by fungi such as *Candida* and *Aspergillus*. Typical signs of inflammation, such as swelling, erythema, and warmth, may be absent. Pus does not form, and few neutrophils are identified microscopically in biopsy specimens of infected tissues. Despite the paucity of neutrophils within the affected tissue, the circulating neutrophil count during infection typically exceeds 30,000/ $\mu$ L and can surpass 100,000/ $\mu$ L. During intervals between infections, the peripheral blood neutrophil count may chronically exceed 12,000/ $\mu$ L. LAD-1 genotypes with only moderate, rather than absent, amounts of functional integrins at the surface of the neutrophil have significantly reduced severity and frequency of infections compared with children with the severe form, although gingival disease is still a prominent feature.

### Laboratory Findings

The diagnosis of LAD-1 is established most readily by flow cytometric measurements of surface CD11b/CD18 in stimulated and unstimulated neutrophils. Neutrophil and monocyte adherence, aggregation, chemotaxis, and iC3b-mediated phagocytosis demonstrate striking abnormalities. However, these assays are not clinically available. Delayed-type hypersensitivity reactions are normal, and most individuals have normal specific antibody synthesis, although some patients have impaired T-lymphocyte-dependent antibody responses. The diagnosis of LAD-2 is established by flow cytometric measurement of sialyl Lewis X (CD15) on neutrophils. It is important to note that the flow cytometric assays are not done the same as the more common lymphocyte subset analysis and require specialized approaches to detect levels of surface expression, especially to detect milder phenotypes.

### Treatment

Treatment of LAD-1 depends on the phenotype, as determined by the level of expression of functional CD11/CD18 integrins. Early allogeneic hematopoietic stem cell transplantation (HSCT) is the treatment of choice for severe LAD-1 (and LAD-3). One patient was successfully treated with ustekinumab, an inhibitor of interleukins 12 and 23. Other treatment is largely supportive. Patients can be maintained on prophylactic trimethoprim/sulfamethoxazole (TMP/SMX) and should have close surveillance for early identification of infections and initiation of empirical treatment with broad-spectrum antibiotics. Specific determination of the etiologic agent by culture or biopsy is important because of the prolonged antibiotic treatment required in the absence of neutrophil function.

Some LAD-2 patients have responded to fucose supplementation, which induced a rapid reduction in the circulating leukocyte count and appearance of the sialyl Lewis X molecules, accompanied by marked improvement in leukocyte adhesion.



### Prognosis

The severity of infectious complications correlates with the degree of  $\beta_2$ -integrin deficiency. Patients with severe deficiency may die in infancy, and those surviving infancy have a susceptibility to severe life-threatening systemic infections. Patients with moderate deficiency have infrequent life-threatening infections and relatively long survival.

### CHÉDIAK-HIGASHI SYNDROME

Chédiak-Higashi syndrome (CHS) is a rare autosomal recessive disorder characterized by increased susceptibility to infection caused by defective degranulation of neutrophils, a mild bleeding diathesis, partial oculocutaneous albinism, progressive peripheral neuropathy, and a tendency to develop a life-threatening form of **hemophagocytic lymphohistiocytosis** (see Chapter 556.2). CHS is caused by a fundamental defect in granule morphogenesis that results in abnormally large granules in multiple tissues. Pigmentary dilution involving the hair, skin, and ocular fundi results from pathologic aggregation of melanosomes. Neurologic deficits are associated with a failure of decussation of the optic and auditory nerves. Patients exhibit an increased susceptibility to infection that can be explained only in part by defects in neutrophil function. The patients have progressive neutropenia as well as abnormalities in natural killer (NK) function, again related to granule dysfunction.

### Genetics and Pathogenesis

*LYST* (for lysosomal traffic regulator), the gene variant in CHS, is located at chromosome 1q2-q44. The *LYST*/CHS protein is thought to regulate vesicle transport by mediating protein-protein interaction and protein-membrane associations. Loss of function may lead to indiscriminate interactions with lysosomal surface proteins, yielding giant granules through uncontrolled fusion of lysosomes with each other.

Almost all cells of patients with CHS show some oversized and dysmorphic lysosomes, storage granules, or related vesicular structures. Melanosomes are oversized, and delivery to the keratinocytes and hair follicles is compromised, resulting in hair shafts devoid of pigment granules. This abnormality in melanosomes leads to the macroscopic impression of hair and skin that is lighter than expected from parental coloration. The same abnormality in melanocytes leads to the partial ocular albinism associated with light sensitivity.

Beginning early in neutrophil development, spontaneous fusion of giant primary granules with each other or with cytoplasmic membrane components results in huge secondary lysosomes with reduced contents of hydrolytic enzymes, including proteinases, elastase, and cathepsin G. This deficiency of proteolytic enzymes may be responsible for the impaired killing of microorganisms by CHS neutrophils.

### Clinical Manifestations

Patients with CHS have light skin and silvery hair and frequently complain of solar sensitivity and photophobia that is associated with rotary nystagmus. Other signs and symptoms vary considerably, but frequent infections and neuropathy are common. The infections involve mucous membranes, skin, and respiratory tract. Affected children are susceptible to gram-positive bacteria, gram-negative bacteria, and fungi, with *S. aureus* being the most common offending organism. The **neuropathy** may be sensory or motor in type, and ataxia may be a prominent feature. Neuropathy often begins in the teenage years and becomes the most prominent problem.

Patients with CHS have prolonged bleeding times with normal platelet counts, resulting from impaired platelet aggregation associated with a deficiency of the dense granules containing adenosine diphosphate and serotonin.

The most life-threatening complication of CHS is the development of an accelerated phase characterized by pancytopenia, high fever, and lymphohistiocytic infiltration of liver, spleen, and lymph nodes. The onset of the accelerated phase, which can occur at any age, is now recognized to be a genetic form of hemophagocytic lymphohistiocytosis. This occurs in 85% of patients and usually results in death.

### Laboratory Findings

The diagnosis of CHS is established by finding large inclusions in all nucleated blood cells. These can be seen on Wright-stained blood films and are accentuated by a peroxidase stain. Because of impaired egress from the bone marrow, cells containing the large inclusions may be missed on peripheral blood smear but readily identified on bone marrow examination. The patients have progressive neutropenia and abnormal platelet, neutrophil, and NK function.

### Treatment

High-dose ascorbic acid (200 mg/day for infants; 2,000 mg/day for adults) may improve the clinical status of some children in the stable phase. Although controversy surrounds the efficacy of ascorbic acid, given the safety of the vitamin, it is reasonable to administer ascorbic acid to all patients.

The only curative therapy to prevent the accelerated phase is HSCT. Normal stem cells reconstitute hematopoietic and immunologic function, correct the NK cell deficiency, and prevent conversion to the accelerated phase, but cannot correct or prevent the neuropathy. If the patient is in the accelerated phase with active hemophagocytic lymphohistiocytosis, HSCT often fails to prevent death. While HSCT can cure the neutrophil defect and hemophagocytic lymphohistiocytosis, it does nothing for neurologic complications.

### MYELOPEROXIDASE DEFICIENCY

Myeloperoxidase (MPO) deficiency is an autosomal recessive disorder of oxidative metabolism and is one of the most common inherited disorders of phagocytes, occurring at a frequency approaching 1 per 2,000 individuals. MPO is a green heme protein located in the azurophilic lysosomes of neutrophils and monocytes and is the basis for the greenish tinge to pus accumulated at a site of infection.

### Clinical Manifestations

MPO deficiency is usually clinically silent. Rarely, patients may have disseminated candidiasis, usually in conjunction with diabetes mellitus. Acquired partial MPO deficiency can develop in acute myelogenous leukemia and in myelodysplastic syndromes.

### Laboratory Findings

Deficiency of neutrophil and monocyte MPO can be identified by histochemical analysis. Severe MPO deficiency can cause the dihydrorhodamine (DHR) flow cytometric assay for chronic granulomatous disease (CGD) to be falsely positive. Unlike CGD, eosinophils in severe MPO deficiency will still reduce DHR and yield a normal reaction.

### Treatment

There is no specific therapy for MPO deficiency. Aggressive treatment with antifungal agents should be provided for candidal infections. The prognosis is usually excellent.

### CHRONIC GRANULOMATOUS DISEASE

CGD is characterized by neutrophils and monocytes capable of normal chemotaxis, ingestion, and degranulation, but unable to kill **catalase-positive microorganisms** because of a defect in the generation of microbicidal oxygen metabolites. CGD is a rare disease, affecting 4-5 per 1 million individuals; it is caused by four genes: one X-linked and three autosomal recessive inheritance (Table 170.4).

### Genetics and Pathogenesis

Activation of the phagocyte NADPH oxidase requires stimulation of the neutrophils and involves assembly from cytoplasmic and integral membrane subunits (see Fig. 168.3). Oxidase activation initiates with phosphorylation of a cationic cytoplasmic protein, p47<sup>phox</sup> (47-kDa phagocyte oxidase protein). Phosphorylated p47<sup>phox</sup>, together with two other cytoplasmic components of the oxidase, p67<sup>phox</sup> and the low-molecular-weight guanosine triphosphatase Rac2, translocates to the membrane, where they combine with the cytoplasmic domains of the transmembrane flavocytochrome b<sub>558</sub> to form the active oxidase complex. The flavocytochrome is a heterodimer composed of p22<sup>phox</sup> and highly glycosylated gp91<sup>phox</sup>. The

**Table 170.4** Classification of Chronic Granulomatous Disease

COMPONENT AFFECTED	INHERITANCE	SUBTYPE*	FLAVOCYTOCHROME b SPECTRUM	NBT SCORE (% POSITIVE)	INCIDENCE (% OF CASES)
gp91 <sup>phox</sup>	X	X91 <sup>0</sup>	0	0	60
		X91 <sup>-</sup>	Low	80-100 (weak)	5
		X91 <sup>-</sup>	Low	5-10	<1
		X91 <sup>+</sup>	0	0	1
p22 <sup>phox</sup>	A	A220	0	0	4
		A22 <sup>+</sup>	N	0	<1
p47 <sup>phox</sup>	A	A470	N	0 <sup>†</sup>	25
p67 <sup>phox</sup>	A	A670	N	0	5
		A67 <sup>+</sup>	N	0	<1
p40 <sup>phox</sup>	A	A40 <sup>-</sup>	N	100	<1

\*In this nomenclature, the first letter represents the mode of inheritance (X-linked [X] or autosomal recessive [A]), whereas the number indicates the *phox* component that is genetically affected. The superscript symbols indicate whether the level of protein of the affected component is undetectable (<sup>0</sup>), diminished (<sup>-</sup>), or normal (<sup>+</sup>), as measured by immunoblot analysis.

<sup>†</sup>Can be weakly positive.

NBT, Nitroblue tetrazolium.

From Dinayer MC, Newburger PE, Borregaard N. Phagocyte system and disorders of granulopoiesis and granulocyte function. In: Orkin SH, Fisher DE, Ginsburg D, et al., eds. *Nathan and Oski's Hematology and Oncology of Infancy and Childhood*. 8th ed. Philadelphia: Elsevier; 2015. Table 22.12, p. 833.

gp91<sup>phox</sup> glycoprotein catalyzes electron transport through its NADPH-binding, flavin-binding, and heme-binding domains. Defects in any of these NADPH oxidase components can lead to CGD.

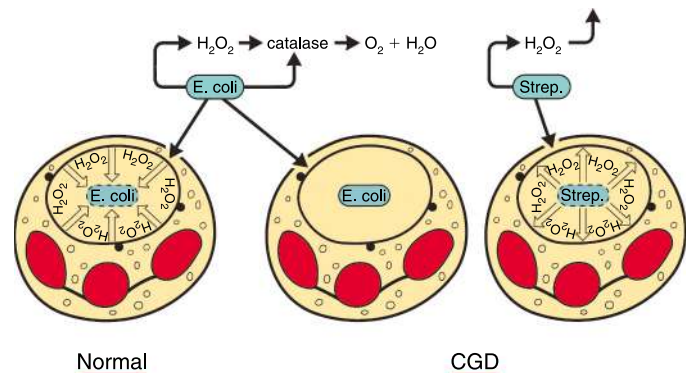
Approximately 65% of patients with CGD are males who inherit their disorder as a result of pathogenic variants in *CYBB*, an X-chromosome gene encoding gp91<sup>phox</sup>. Approximately 35% of patients inherit CGD in an autosomal recessive fashion resulting from pathogenic variants in the *NCF1* gene on chromosome 7, encoding p47<sup>phox</sup>. Defects in the genes encoding p67<sup>phox</sup> (*NCF2* on chromosome 1) and p22<sup>phox</sup> (*CYBA* on chromosome 16) are inherited in an autosomal recessive manner and account for approximately 5% of cases of CGD.

The CGD phagocytic vacuoles lack microbicidal reactive oxygen species and remain acidic, so bacteria are not killed or digested properly (Fig. 170.4). Hematoxylin-eosin-stained sections from patients' tissues show multiple granulomas that give CGD its descriptive name.

### Clinical Manifestations

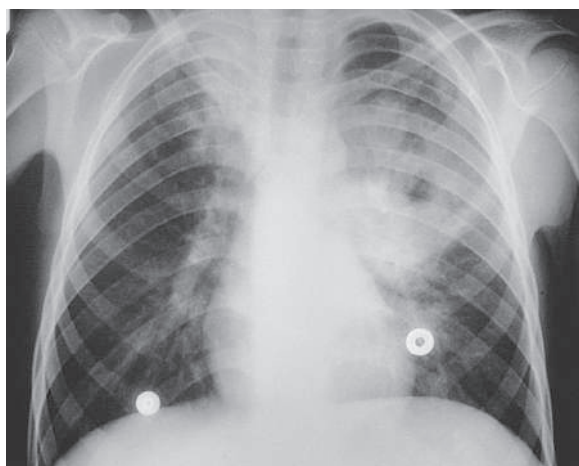
Although the clinical presentation is variable, several features suggest the diagnosis of CGD. These include any patient with recurrent pneumonia, lymphadenitis, hepatic, subcutaneous, or other abscesses, osteomyelitis at multiple sites, family history of recurrent infections, or any infection with an unusual catalase-positive organism requires evaluation (Fig. 170.5). Other clinical features include chronic colitis or enteritis, gastric outlet or ureteral obstruction from granulomas, or bloodstream infection caused by *Salmonella*, *Burkholderia cepacia*, or *Candida*.

The onset of clinical signs and symptoms usually occurs in early infancy, although a few patients with very rare CGD subtypes have presented later in life. The attack rate and severity of infections are exceedingly variable; however, the infection incidence decreases in the second decade, coincident with maturation of the lymphocyte and humoral immunity. The most common pathogen is *S. aureus*, but any catalase-positive microorganism may be involved. Other organisms frequently causing infections include *Serratia marcescens*, *B. cepacia*, *Aspergillus*, *Candida albicans*, *Nocardia*, and *Salmonella*. There may also be increased susceptibility to mycobacteria, including the bacille Calmette-Guérin vaccine. Pneumonia, lymphadenitis, osteomyelitis, and skin infections are the most common illnesses encountered. Bacteremia or fungemia occurs but is much less common than focal infections and usually only occurs when local infections have been inappropriately treated for long periods. Patients may have sequelae of chronic infection, including anemia of chronic disease, poor growth,



**Fig. 170.4** Pathogenesis of chronic granulomatous disease (CGD). The manner in which the metabolic deficiency of the CGD neutrophil predisposes the host to infection is shown schematically. Normal neutrophils stimulate hydrogen peroxide (H<sub>2</sub>O<sub>2</sub>) in the phagosome containing ingested *Escherichia coli*. Myeloperoxidase is delivered to the phagosome by degranulation, as indicated by the closed circles. In this setting, H<sub>2</sub>O<sub>2</sub> acts as a substrate for myeloperoxidase to oxidize halide to hypochlorous acid and chloramines that kill the microbes. The quantity of H<sub>2</sub>O<sub>2</sub> produced by the normal neutrophil is sufficient to exceed the capacity of catalase, an H<sub>2</sub>O<sub>2</sub>-catabolizing enzyme of many aerobic microorganisms, including *Staphylococcus aureus*, most gram-negative enteric bacteria, *Candida albicans*, and *Aspergillus*. When organisms such as *E. coli* gain entry into CGD neutrophils, they are not exposed to H<sub>2</sub>O<sub>2</sub> because the neutrophils do not produce it, and the H<sub>2</sub>O<sub>2</sub> generated by microorganisms themselves is destroyed by their own catalase. When CGD neutrophils ingest streptococci, which lack catalase, the organisms generate enough H<sub>2</sub>O<sub>2</sub> to result in a microbicidal effect. As indicated (middle), catalase-positive microbes such as *E. coli* can survive within the phagosome of the CGD neutrophil. (Adapted from Boxer LA. *Quantitative abnormalities of granulocytes*. In: Beutler E, Lichtman MA, Coller BS, et al., eds. *Williams Hematology*. 6th ed. New York: McGraw-Hill; 2001. p. 845.)

lymphadenopathy, hepatosplenomegaly, chronic purulent dermatitis, restrictive lung disease, gingivitis, hydronephrosis, esophageal dysmotility, and pyloric outlet narrowing. Perirectal abscesses and recurrent skin infections, including folliculitis, cutaneous granulomas, and discoid lupus erythematosus, also suggest CGD.



**Fig. 170.5** Chest radiograph of a 10-year-old boy with chronic granulomatous disease shows a left-sided pulmonary infiltrate and cavitary lung lesion. Biopsy revealed an *Aspergillus fumigatus* infection. (From Chinn IK, Chinen J, Shearer WT. *Primary immunodeficiency diseases*. In Cherry JD, Harrison GJ, Kaplan SL, et al., eds. *Feigin and Cherry's Textbook of Pediatric Infectious Diseases*. 8th ed. Philadelphia: Elsevier; 2019. Fig. 67.6, p. 652.)

**Granuloma formation** and inflammatory processes are a hallmark of CGD and may be the presenting symptoms that prompt testing for CGD if they cause pyloric outlet obstruction, bladder outlet or ureter obstruction, or rectal fistulas and granulomatous colitis simulating Crohn disease. More than 80% of CGD patients have positive serology for Crohn disease. Persistent fever, especially with splenomegaly and cytopenia, warrants an evaluation for secondary macrophage activation syndrome. This has been seen in CGD and may require treatment with corticosteroids and discontinuation of interferon- $\gamma$  treatment.

### Laboratory Findings

The diagnosis is most often made by performing flow cytometry using DHR to measure oxidant production through its increased fluorescence when oxidized by hydrogen peroxide ( $H_2O_2$ ). The nitroblue tetrazolium dye test is frequently cited in the literature but is only rarely used clinically. The X-linked carrier state is usually easily diagnosed in the mother by DHR fluorescence through a bimodal response to stimulation. It is important to test the mother as some extremely lyonized carriers with <5% positive cells may have chronic clinical problems as well. Ideally, at least the first patient in a kindred should have DNA analysis to facilitate prenatal diagnosis and for genetic counseling purposes.

A few individuals have been described with apparent CGD caused by severe glucose-6-phosphate dehydrogenase deficiency, leading to insufficient NADPH substrate for the phagocyte oxidase. The erythrocytes of these patients also lack the enzyme, leading to chronic hemolysis.

### Treatment

HSCT is the only known cure for CGD, although gene therapy has been transiently successful in a few patients and is the topic of active research. HSCT transplant for all patients with CGD is strongly recommended if a suitable sibling or unrelated donor can be identified. The long-term outcome for survival late into adulthood is not good, even in the hands of experienced CGD physicians. Curative therapy at an early age is strongly recommended by many experts.

Patients with CGD should be given daily oral TMP/SMX because it reduces the number of bacterial infections. A placebo-controlled study found that interferon- $\gamma$  50  $\mu\text{g}/\text{m}^2$  three times per week significantly reduces the number of hospitalizations and serious infections, although the mechanism of action is unclear. Itraconazole (200 mg/day for patients weighing >50 kg and 100 mg/day for patients <50 kg and  $\leq 5$  years old) administered prophylactically reduces the frequency of fungal infections.

Management of infection is dramatically different than in normal children. CGD patients are always at risk for deep-seated, indolent bacterial infections that can become widespread if not treated properly. They also

develop the same kinds of infections that occur in normal children, so determination of the appropriate treatment can be difficult. The ESR can be quite helpful. If the child does not have a deep-seated infection, the ESR will be normal or will normalize within several days with standard management. If it does not, however, a search for deep tissues is warranted, as is consideration of empirical antibiotics. Cultures should be obtained, but are usually negative. Because all neutrophil functions in CGD except killing are normal, there is often an exuberant inflammatory reaction to a very small number of organisms. Thus blood cultures and direct cultures of biopsy samples are usually negative unless there are many organisms. Most abscesses require surgical drainage for therapeutic and diagnostic purposes. Prolonged use of antibiotics is required even for common bacterial infections. A simple pneumonia may require 6-8 weeks or more of parenteral antibiotics. Infections should be treated for at least 1 week past normalization of ESR to prevent recurrence. Severe pneumonias can be cleared completely but may require many months of parenteral antibiotics. Especially because cultures are often not helpful, many support an "antibiotic sensitivity by sedimentation rate response" approach to treatment. The ESRs are often 40-80 mm/hr or more with severe infection and will decrease monotonically over a week or so after starting antibacterial drugs. It is important to check the ESR daily or every other day because of moderate variability in this test, and changes in treatment need to be based on trends rather than individual values. If there is a clear downward trend over 3-10 days, continue with antibacterials alone. If this is not the case, parenteral voriconazole should be added to cover *Aspergillus*. Failure of the ESR to decrease suggests another antimicrobial approach needs to be tried. This sequential addition of antimicrobials offers some insight into the nature of the infection. If both antibacterials and antifungal are started at the same time, one cannot know what caused a response.

Because of the rarity of this disorder, it is critical to seek counsel from someone with significant direct experience with management of several CGD patients. Granulocyte transfusions have been used, but their benefit is unclear. The ESR should be regularly monitored in well patients and whenever they appear ill. A high ESR itself is usually not enough to trigger treatment. However, in the presence of symptoms, one should search for sources at least by contrast CT of the sinus, chest, and abdomen. If the patient is unstable or has very high fevers, *B. cepacia* should be considered and empirically covered. This organism can cause septic shock quickly, unlike the usual smoldering infections seen in CGD. The patient can be treated with antibiotics until the ESR is normal and radiographic evidence of infection has been cleared, if possible. The overall incidence of infection decreases in the second decade of life as nonneutrophil immunity matures, but increased risk of infection is lifelong.

Corticosteroids may be useful for the treatment of children with antral and urethral obstruction or severe granulomatous colitis. Corticosteroids can also be helpful in pneumonia to shrink granulomas in the lung and promote drainage. Short (4-6 days) pulses of 1-2 mg/kg of prednisone are recommended, with rapid taper to avoid long-term side effects and risk of fungus. Pulses can be repeated if clinical effect has not been achieved.

### Genetic Counseling

Identifying a patient's specific genetic subgroup by DNA analysis is useful primarily for genetic counseling and prenatal diagnosis. In X-linked CGD, all possibly affected females should be tested by DHR to exclude carrier state. Diagnosis by DNA is strongly recommended in suspected carriers with normal DHR who are related to a known proband, because rarely DHR testing is normal in obligate carriers and may indicate that the patient has a spontaneous mutation and the mother may not be a carrier at all. Counseling is best done by a physician who has direct knowledge of the clinical manifestations of CGD.

### Prognosis

The overall mortality rate for CGD is about two patient deaths per year per 100 cases, with the highest mortality among young children. The development of effective infection prophylaxis regimens, close surveillance for signs of infections, and aggressive surgical and medical interventions have improved the prognosis.

Visit Elsevier eBooks+ at [eBooks.Health.Elsevier.com](http://eBooks.Health.Elsevier.com) for Bibliography.



## Chapter 171

## Leukopenia

Thomas F. Michniacki and  
Kelly J. Walkovich

Leukopenia refers to an abnormally low number of white blood cells (WBCs) in the circulating blood secondary to a paucity of lymphocytes, granulocytes, or both. Because there are marked developmental changes in normal values for WBC counts during childhood, normal ranges must be considered in the context of age. For newborns, the mean WBC count at birth is high, followed by a rapid fall beginning at 12 hours through the first week of life. Thereafter, values are stable until 1 year of age, after which a slow, steady decline in the WBC count continues throughout childhood until adult values are reached during adolescence. Evaluation of patients with leukopenia begins with a thorough history, physical examination, and at least one confirmatory complete blood count with differential. Further evaluation then depends on whether the leukopenia represents a decreased number of neutrophils, lymphocytes, or both cell populations (Table 171.1). Treatment depends on the etiology and clinical manifestations of the leukopenia.

### NEUTROPENIA

Neutropenia is defined as a decrease in the absolute number of circulating segmented neutrophils and bands in the peripheral blood. The **absolute neutrophil count (ANC)** is determined by multiplying the total WBC count by the percentage of segmented neutrophils plus bands. Normal neutrophil counts must be stratified for age and race. Neutrophils predominate at birth but rapidly decrease in the first few days of life. During infancy, neutrophils constitute 20–30% of circulating leukocyte populations. Near-equal numbers of neutrophils and lymphocytes are found in the peripheral circulation at 5 years of age, and the characteristic 70% predominance of neutrophils that occurs in adulthood is usually attained during puberty. For White children >12 months old, the lower limit of normal for the ANC is 1,500/ $\mu\text{L}$ ; for Black children >12 months old, the lower limit of normal is 1,200/ $\mu\text{L}$ . The relatively lower limit of normal in Black individuals likely reflects the prevalence of the **Duffy negative** (Fy $^{-/-}$ ) blood group, which is enriched in populations in the malarial belt of Africa and is associated with ANCs 200–600/ $\mu\text{L}$  less than those who are Duffy positive.

Neutropenia may be characterized as **mild** (ANC 1,000–1,500/ $\mu\text{L}$ ), **moderate** (ANC 500–1,000/ $\mu\text{L}$ ), or **severe** (ANC <500/ $\mu\text{L}$ ). ANC <200 is also termed **agranulocytosis**. This stratification aids in predicting the risk of pyogenic infection in patients who have neutropenia resulting from disorders of bone marrow production, because only patients with severe neutropenia have a significantly increased susceptibility to life-threatening infections. Neutropenia associated with monocytopenia, lymphocytopenia, or hypogammaglobulinemia increases the risk for infection compared with isolated neutropenia. *Patients with neutropenia caused by increased destruction (e.g., autoimmune) may tolerate very low ANCs without increased frequency of infection*, because of their often robust ability to generate additional neutrophils from their functioning marrow when needed.

**Acute neutropenia** evolves over a few days and is often a result of rapid neutrophil use and compromised neutrophil production. **Chronic neutropenia** by definition lasts longer than 3 months and arises from reduced production, increased destruction, or excessive splenic sequestration of neutrophils. The etiology of

neutropenia can be classified as either an acquired disorder or extrinsic insult (Table 171.2) or more rarely an inherited, intrinsic defect (Table 171.3).

### Clinical Manifestations of Neutropenia

Individuals with neutrophil counts <500/ $\mu\text{L}$  are at substantial risk for developing infections, primarily from their endogenous flora as well as from nosocomial organisms. However, some patients with isolated chronic neutropenia may not experience many serious infections, probably because the remainder of the immune system remains intact or because neutrophil delivery to tissues is preserved, as in autoimmune neutropenias (AINs). In contrast, children whose neutropenia is secondary to acquired disorders of production, as occurs with cytotoxic therapy, immunosuppressive drugs, or radiation therapy, are likely to develop serious bacterial infections because many arms of the immune system are markedly compromised and the ability of the marrow to robustly generate new phagocytes is impaired. Neutropenia associated with additional monocytopenia or lymphocytopenia is more highly associated with serious infection than neutropenia alone. The integrity of skin and mucous membranes, the vascular supply to tissues, and nutritional status also influence the risk of infection.

The most common clinical presentation of profound neutropenia includes fever, frequent infections, aphthous stomatitis, and gingivitis. Infections frequently associated with neutropenia include cellulitis, furunculosis, perirectal inflammation, colitis, sinusitis, warts, and otitis media, as well as more serious infections such as pneumonia, deep tissue abscess, and sepsis. The most common pathogens causing infections in neutropenic patients are *Staphylococcus aureus* and gram-negative bacteria. Isolated neutropenia does not heighten a patient's susceptibility to parasitic or viral infections or to bacterial meningitis but does increase the risk of fungal pathogens causing disease. The usual signs and symptoms of local infection and inflammation (e.g., exudate, fluctuance, regional lymphadenopathy) may be diminished in the absence of neutrophils because of the inability to form pus, but patients with agranulocytosis still experience fever and feel pain at sites of inflammation.

### Laboratory Findings

Isolated absolute neutropenia has a limited number of causes (see Tables 171.2 to 171.6). The duration and severity of the neutropenia greatly influence the extent of laboratory evaluation. Patients with chronic neutropenia since infancy and a history of recurrent fevers and chronic gingivitis should have WBC counts and differential counts determined 3 times a week for 6–8 weeks to evaluate for periodicity suggestive of **cyclic neutropenia**. Bone marrow aspiration and biopsy should be performed on select patients to assess cellularity and myeloid maturation. Additional marrow studies, such as cytogenetic analysis and flow cytometry for detecting leukemia and other malignant disorders, should be obtained for patients with suspected intrinsic defects in the myeloid progenitors and for patients with suspected malignancy. Children of African or Arabic descent with mild to moderate neutropenia should have Duffy null, Fy(a-b-) variant, screening completed. Selection of further laboratory tests is determined by the duration and severity of the neutropenia and the associated findings on physical examination (see Table 171.1).

### Acquired Neutropenia Infection-Related Neutropenia

Transient neutropenia often accompanies or follows **viral infections** and is the most frequent cause of neutropenia in childhood (Table 171.4). Viruses causing acute neutropenia include influenza A and B, SARS-CoV-2, adenovirus, respiratory syncytial virus, enteroviruses, human herpesvirus 6, measles, rubella, and varicella. Parvovirus B19 and hepatitis A or B may also cause neutropenia,



**Table 171.1** Diagnostic Approach for Patients with Leukopenia

EVALUATION	ASSOCIATED CLINICAL DIAGNOSES
<b>INITIAL EVALUATION</b>	
History of acute or chronic leukopenia	
General medical history including prior serious, recurrent or unusual infections and malignancy	Congenital syndromes (severe congenital neutropenia, cyclic neutropenia, Shwachman-Diamond, Wiskott-Aldrich, Fanconi anemia, dyskeratosis congenita, glycogen storage disease type Ib, disorders of vesicular transport, GATA2 haploinsufficiency, and primary immunodeficiencies)
Physical examination: stomatitis, gingivitis, dental defects, warts, lymphedema, congenital anomalies	
Spleen size	Hypersplenism
History of drug exposure	Drug-associated neutropenia
Complete blood count with differential and reticulocyte counts	Neutropenia, aplastic anemia, autoimmune cytopenias
<b>IF ANC &lt;1,000/<math>\mu</math>L</b>	
<i>Evaluation of Acute-Onset Neutropenia</i>	
Repeat blood counts in 3-4 wk	Transient myelosuppression (e.g., viral)
Serology and cultures for infectious agents	Active or chronic infection with viruses (e.g., EBV, CMV), bacteria, mycobacteria, rickettsia
Discontinue drug(s) associated with neutropenia	Drug-associated neutropenia
Test for antineutrophil antibodies	Autoimmune neutropenia
Measure quantitative immunoglobulins (IgG, IgA, IgM, IgE), lymphocyte subsets	Neutropenia associated with disorders of immune function
<b>IF ANC &lt;500/<math>\mu</math>L ON THREE SEPARATE TESTS</b>	
Bone marrow aspiration and biopsy, with cytogenetics	Severe congenital neutropenia, cyclic neutropenia, Shwachman-Diamond syndrome, myelokathexis; chronic benign or idiopathic neutropenia; reticular dysgenesis
Glucocorticoid stimulation test	Chronic benign or idiopathic neutropenia, some autoimmune neutropenias
Serial CBCs (3/wk for 6wk)	Cyclic neutropenia
Exocrine pancreatic function	Shwachman-Diamond syndrome
Skeletal radiographs	Shwachman-Diamond syndrome, cartilage-hair hypoplasia, Fanconi anemia
<b>IF ALC &lt;1,000/<math>\mu</math>L</b>	
Repeat blood counts in 3-4 wk	Transient leukopenia (e.g., viral)
<b>IF ALC &lt;1,000/<math>\mu</math>L THREE SEPARATE TESTS</b>	
HIV antibody or RNA test	HIV infection, AIDS
Quantitative immunoglobulins (IgG, IgA, IgM, IgE), vaccine titers, lymphocyte subsets; qualitative lymphocyte proliferation to mitogens/antigens	Congenital or acquired disorders of immune function
<b>IF THERE IS PANCYTOPENIA</b>	
Bone marrow aspiration and biopsy	Bone marrow replacement by malignancy, fibrosis, granulomata, storage cells; aplastic anemia
Bone marrow cytogenetics and flow cytometry	Myelodysplasia, leukemia
Copper, vitamin B12 and folate levels	Vitamin deficiencies

ALC, Absolute lymphocyte count; ANC, absolute neutrophil count; CBC, complete blood count; CMV, cytomegalovirus; EBV, Epstein-Barr virus.

but are more often associated with pure red cell aplasia or multiple cytopenias, respectively. Viral-associated acute neutropenia often occurs during the first 24-48 hours of illness and usually persists for 3-8 days, which generally corresponds to the period of viremia. The neutropenia is related to virus-induced redistribution of neutrophils from the circulating to the marginating pool. In addition, neutrophil sequestration may occur after virus-induced tissue damage or splenomegaly.

Significant neutropenia also may be associated with severe bacterial, protozoal, rickettsial, or fungal infections (see Table 171.4). **Bacterial sepsis** is a particularly serious cause of neutropenia, especially among younger infants and children. Premature neonates are especially prone to exhausting their marrow reserve and rapidly succumbing to bacterial sepsis.

Chronic neutropenia often accompanies infection with Epstein-Barr virus, cytomegalovirus, or HIV and certain immunodeficiencies

**Table 171.2** Causes of Neutropenia Extrinsic to Marrow Myeloid Cells

CAUSE	ETIOLOGIC FACTORS/AGENTS	ASSOCIATED FINDINGS
Infection	Viruses, bacteria, protozoa, rickettsia, fungi	Clinical features and laboratory findings of the infectious agent
Drug induced	Phenothiazines, sulfonamides, anticonvulsants, penicillins, aminopyrine	Usually none; occasional hypersensitivity reaction (fever, lymphadenopathy, rash, hepatitis, nephritis, pneumonitis, aplastic anemia) or antineutrophil antibody
Immune neutropenia	Alloimmune, autoimmune	Myeloid hyperplasia with left shift in bone marrow (may appear to be “arrested” at metamyelocyte or band stage)
Reticuloendothelial sequestration	Hypersplenism	Anemia, thrombocytopenia
Bone marrow replacement	Myelofibrosis, malignancy (leukemia, lymphoma, metastatic solid tumor, etc.)	Anemia, thrombocytopenia, marrow fibrosis, malignant cells in bone marrow sites of extramedullary hematopoiesis
Cancer chemotherapy or radiation therapy	Suppression of myeloid cell production	Anemia, thrombocytopenia, bone marrow hypoplasia

**Table 171.3** Acquired Disorders of Myeloid Cells

CAUSE	ETIOLOGIC FACTORS/AGENTS	ASSOCIATED FINDINGS
Aplastic anemia	Stem cell destruction and depletion	Pancytopenia
Vitamin B <sub>12</sub> , copper, or folate deficiency	Malnutrition; congenital deficiency of B <sub>12</sub> absorption, transport, and storage; vitamin avoidance	Megaloblastic anemia, hyper-segmented neutrophils
Acute leukemia, chronic myelogenous leukemia	Bone marrow replacement with malignant cells	Pancytopenia, leukocytosis
Myelodysplasia	Dysplastic maturation of stem cells	Bone marrow hypoplasia with megaloblastoid red cell precursors, thrombocytopenia
Prematurity with birthweight <2kg	Impaired regulation of myeloid proliferation and reduced size of postmitotic pool	Maternal preeclampsia
Chronic idiopathic neutropenia	Impaired myeloid proliferation and/or maturation	None
Paroxysmal nocturnal hemoglobinuria	Acquired stem cell defect secondary to <i>PIGA</i> gene variant	Pancytopenia, thrombosis (hepatic vein thrombosis)

**Table 171.4** Infections Associated with Neutropenia

Viral	Cytomegalovirus, dengue, Epstein-Barr virus, hepatitis viruses, HIV, influenza, measles, parvovirus B19, rubella, varicella, HHV-6, SARS-CoV-2
Bacterial	<i>Brucella</i> , paratyphoid, pertussis, tuberculosis (disseminated), tularemia, <i>Shigella</i> , typhoid; any form of sepsis
Fungal	Histoplasmosis (disseminated)
Protozoan	Malaria, leishmaniasis (kala-azar)
Rickettsial	<i>Anaplasma</i> (formerly <i>Ehrlichia</i> ) <i>phagocytophilum</i> , psittacosis, Rocky Mountain spotted fever, typhus, rickettsialpox

HHV-6, Human herpesvirus-6.

such as X-linked agammaglobulinemia (XLA), hyper-IgM syndrome and AIDS. The neutropenia associated with AIDS likely arises from a combination of viral bone marrow suppression, antibody-mediated destruction of neutrophils, and effects of antiretroviral or other drugs.

### Drug-Induced Neutropenia

Drugs constitute a common cause of neutropenia (Table 171.5). The incidence of drug-induced neutropenia increases dramatically with age; only 10% of cases occur among children and young adults. The majority of cases occur among adults >65 years, likely reflecting the more frequent use of multiple medications in that age-group. Almost any drug can cause neutropenia. The most common offending drug classes are antimicrobial agents, antithyroid drugs, antipsychotics, antiepileptics, antipyretics, and antirheumatics. **Drug-induced neutropenia** has several underlying mechanisms (immune-mediated, toxic, idiosyncratic, hypersensitivity, idiopathic) that are distinct from the severe neutropenia that predictably occurs after administration of antineoplastic drugs or radiotherapy.

Drug-induced neutropenia from immune mechanisms usually develops abruptly, is accompanied by fever, and lasts for about 1 week after the discontinuation of the drug. The process likely arises from effects of drugs such as propylthiouracil or penicillin that act as haptens to stimulate antibody formation, or drugs such as quinine that induce immune complex formation. Other drugs, including the antipsychotic drugs such as the phenothiazines, can cause neutropenia when given in toxic amounts, but some individuals, such as those with preexisting neutropenia, may be susceptible to levels at the high end of the usual therapeutic range. Late-onset neutropenia can occur after rituximab therapy. Idiosyncratic reactions,

**Table 171.5** Forms of Drug-Induced Neutropenia

	IMMUNOLOGIC	TOXIC	HYPERSENSITIVITY
Paradigm drugs	Aminopyrine, propylthiouracil, penicillins	Phenothiazines, clozapine	Phenytoin, phenobarbital
Time to onset	Days to weeks	Weeks to months	Weeks to months
Clinical appearance	Acute, often explosive symptoms	Often asymptomatic or insidious onset	May be associated with fever, rash, nephritis, pneumonitis, or aplastic anemia
Rechallenge	Prompt recurrence with small test dose	Latent period; high doses required	Latent period; high doses required
Laboratory findings	Antineutrophil antibody may be positive; bone marrow myeloid hyperplasia	Bone marrow myeloid hypoplasia	Bone marrow myeloid hypoplasia

for example to chloramphenicol, are unpredictable with regard to dose or duration of use. Hypersensitivity reactions are rare and may involve arene oxide metabolites of aromatic anticonvulsants. Fever, rash, lymphadenopathy, hepatitis, nephritis, pneumonitis, and aplastic anemia are often associated with hypersensitivity-induced neutropenia. Acute hypersensitivity reactions such as those caused by phenytoin or phenobarbital may last for only a few days if the offending drug is discontinued. Chronic hypersensitivity may last for months to years.

Once neutropenia occurs, the most effective therapeutic measure is withdrawal of nonessential drugs, particularly drugs most commonly associated with neutropenia. Usually, the neutropenia will resolve soon after withdrawal of the offending drug. If the neutropenia fails to improve with drug withdrawal and the patient is symptomatic with infection or stomatitis, subcutaneous administration of recombinant human granulocyte colony-stimulating factor (G-CSF; filgrastim, 5 µg/kg/day) should be considered. Drug-induced neutropenia may be asymptomatic and noted only as an incidental finding or because of regular monitoring of WBC counts during drug therapy. For patients who are asymptomatic, continuation of the suspected offending drug depends on the relative risks of neutropenia vs discontinuation of a possibly essential drug. If the drug is continued, blood counts should be monitored for possible progression to agranulocytosis.

Neutropenia usually and predictably follows the use of anticancer drugs or radiation therapy, especially radiation directed at the pelvis or vertebrae, secondary to cytotoxic effects on rapidly replicating myeloid precursors. A decline in the WBC count typically occurs 7-10 days after administration of the anticancer drug and may persist for 1-2 weeks. The neutropenia accompanying malignancy or following cancer chemotherapy is frequently associated with compromised cellular immunity and barrier compromise secondary to central venous lines and mucositis, thereby predisposing patients to a much greater risk of infection than found in disorders associated with isolated neutropenia. Patients with chemotherapy/radiation-related neutropenia and fever must be treated aggressively with broad-spectrum antibiotics.

### Nutrition-Related Neutropenia

Poor nutrition can contribute to neutropenia. Ineffective myelopoiesis may result in neutropenia caused by acquired dietary **copper, vitamin B<sub>12</sub>, or folic acid deficiency**. In addition, megaloblastic pancytopenia also can result from extended use of antibiotics such as trimethoprim/sulfamethoxazole that inhibit folic acid metabolism and from the use of phenytoin, which may impair folate absorption in the small intestine, or from surgical resection of the small intestine. Neutropenia also occurs with starvation and marasmus in infants, with anorexia nervosa, and occasionally among patients receiving prolonged parenteral nutrition without vitamin supplementation. Patients receiving prolonged parenteral nutrition and supplemental lipids are additionally at risk for neutropenia given hepatosplenomegaly-related sequestration and marrow infiltration

by abnormal macrophages filled with blue-staining pigment granules and atypical lipid vacuoles; these cells are termed **sea-blue histiocytes**.

### Immune-Mediated Neutropenia

Immune-mediated neutropenia is usually associated with the presence of circulating antineutrophil antibodies, which may mediate neutrophil destruction by complement-mediated lysis or splenic phagocytosis of opsonized neutrophils, or by accelerated apoptosis of mature neutrophils or myeloid precursors.

**Alloimmune neonatal neutropenia** occurs after transplacental transfer of maternal alloantibodies directed against antigens on the infant's neutrophils, analogous to Rh-hemolytic disease. Prenatal sensitization induces maternal IgG antibodies to neutrophil antigens on fetal cells. The neutropenia is often severe and infants may present within the first 2 weeks of life with skin or umbilical infections, fever, and pneumonia caused by the usual microbes that cause neonatal disease. By 7 weeks of age, the neutrophil count usually returns to normal, reflecting the decay of maternal antibodies in the infant's circulation. Treatment consists of supportive care and appropriate antibiotics for clinical infections, plus G-CSF for severe infections without neutrophil recovery.

Mothers with autoimmune disease may give birth to infants who develop transient neutropenia, known as **neonatal passive AIN**. The duration of the neutropenia depends on the time required for the infant to clear the maternally transferred circulating IgG antibody. It persists in most cases for a few weeks to a few months. Neonates almost always remain asymptomatic.

**AIN of infancy** is a benign condition with an annual incidence of approximately 1 per 100,000 among children between infancy and 10 years of age. Antineutrophil antibodies are inappropriately created by the child during an inflammatory episode, most commonly a mild viral infection. Patients usually have severe neutropenia on presentation, with ANC <500/µL, but the total WBC count is generally within normal limits. Monocytosis or eosinophilia may occur but does not impact the low rate of infection. The median age of presentation is 8-11 months, with a range of 2-54 months. The diagnosis is often evident when a blood count incidentally reveals neutropenia in a child with a minor infection or when a routine complete blood count is obtained at the 12-month well-child visit. Occasionally, children may present with more severe infections, including abscesses, pneumonia, or sepsis. The diagnosis may be supported by the presence of antineutrophil antibodies in serum; however, the test has frequent false-negative and false-positive results, so the absence of detectable antineutrophil antibodies does not exclude the diagnosis, and a positive result does not exclude other conditions. Therefore the diagnosis is best made clinically based on a benign course and, if obtained, a normal or hyperplastic myeloid maturation in the bone marrow. There is considerable overlap between AIN of infancy and **"chronic benign neutropenia."**

Treatment is not generally necessary because the disease is only rarely associated with severe infection and usually remits spontaneously. Low-dose G-CSF may be useful for severe infections, to promote wound healing following surgery, or to avert emergency room visits or hospitalizations for febrile illnesses. Longitudinal studies of infants with AIN demonstrate median duration of disease ranging from 7-30 months. Affected children generally have no evidence or risk of other autoimmune diseases.

**AIN in older children** can occur as an isolated process, as a manifestation of other autoimmune diseases, or as a secondary complication of infection, drugs, or malignancy. In primary AIN, low circulating neutrophil counts are the only hematologic finding, and associated diseases or other factors that cause neutropenia are absent. Secondary AIN associated with immune dysregulation or other factors is more often identified in older children and is less likely to remit spontaneously. AIN is distinguished from other forms of neutropenia by the demonstration of antineutrophil antibodies (with caveats previously discussed) and myeloid hyperplasia on bone marrow examination. The most common antineutrophil antibody targets are human neutrophil antigens 1a, 1b, and 2.

Treatment of AIN relies on management of any underlying disorders. In addition, judicious use of appropriate antibiotics for bacterial infections is generally beneficial, as is family and primary care provider education. Regular dental hygiene, always strongly recommended, is even more important. Infections tend to be less frequent in AIN than with the corresponding degree of neutropenia from other causes, probably because tissue delivery of neutrophils is greater than that in conditions resulting from impaired production. Prophylactic antibiotics may be helpful for the management of recurrent minor infections. For patients with serious or recurrent infections, G-CSF is generally effective at raising the ANC and preventing infection. Very low doses (<1-2 µg/kg/day) are usually effective, and administration of standard doses can lead to severe bone pain from marrow expansion.

### Neutropenia Secondary to Bone Marrow Replacement

Various acquired bone marrow disorders lead to neutropenia, usually accompanied by anemia and thrombocytopenia. Hematologic malignancies, including leukemia, lymphoma, and metastatic solid tumors, suppress myelopoiesis by infiltrating the bone marrow with tumor cells. Neutropenia may also accompany aplastic anemia, myelodysplastic disorders, or preleukemic syndromes, which are characterized by multiple cytopenias and often macrocytosis. Treatment requires management of the underlying disease.

### Neutropenia Secondary to Reticuloendothelial Sequestration

**Splenic enlargement** resulting from intrinsic splenic disease (storage disease), portal hypertension, or systemic causes of splenic hyperplasia (inflammation or neoplasia) can lead to neutropenia. Most often the neutropenia is mild to moderate and is accompanied by corresponding degrees of thrombocytopenia and anemia. The reduced neutrophil survival corresponds to the size of the spleen, and the extent of the neutropenia is inversely proportional to bone marrow compensatory mechanisms. Usually, the neutropenia can be corrected by successfully treating the underlying disease. In select cases, splenectomy may be necessary to restore the neutrophil count to normal, but results in increased risk of infections by encapsulated bacterial organisms. Patients undergoing splenectomy should receive appropriate preoperative immunizations and may benefit from antibiotic prophylaxis after splenectomy to help mitigate the risk of sepsis. Splenectomy should be avoided in patients with common variable immunodeficiency (CVID), autoimmune lymphoproliferative disease, and other immunodeficiency syndromes because of the higher risk of sepsis.

### Inherited Neutropenia

Intrinsic disorders of proliferation or maturation of myeloid precursor cells are rare. Table 171.6 presents a classification based on genetics (Fig. 171.1) and molecular mechanisms; other organ involvement or physical features may suggest an etiology (Table 171.7).

### Primary Disorders of Granulopoiesis

**Cyclic neutropenia** is an autosomal dominant congenital granulopoietic disorder occurring with an estimated incidence of 0.5-1 cases per 1 million population. The disorder is characterized by regular, periodic oscillations, with the ANC ranging from normal to <200/µL, mirrored by reciprocal cycling of monocytes. Cyclic neutropenia is sometimes termed *cyclic hematopoiesis* because of the secondary cycling of other blood cells, such as platelets and reticulocytes. The mean oscillatory period of the cycle is 21 days (±4 days). During the neutropenic nadir, many patients develop malaise, fever, oral and genital ulcers, gingivitis, periodontitis, or pharyngitis, and occasionally lymph node enlargement. More serious infections occasionally occur, including pneumonia, mastoiditis, and intestinal perforation with peritonitis leading to life-threatening clostridial sepsis. Before the availability of G-CSF, approximately 10% of patients developed fatal clostridial or gram-negative infections. Cyclic neutropenia arises from a regulatory abnormality involving early hematopoietic precursor cells and is almost invariably associated with pathologic variants in the neutrophil elastase gene, *ELANE*, that lead to accelerated apoptosis as a result of abnormal protein folding. Many patients experience abatement of symptoms with age. The cycles tend to become less noticeable in older patients, and the hematologic picture often begins to resemble that of chronic idiopathic neutropenia.

Cyclic neutropenia is diagnosed by obtaining blood counts 3 times a week for 6-8 weeks. The requirement for repeated blood counts is necessary because some of the elastase variants overlap with those in patients who have **severe congenital neutropenia (SCN)**. Demonstrating oscillation or a lack thereof in the blood counts helps to identify patients' risks for progression to **myelodysplastic syndrome (MDS)/acute myelogenous leukemia (AML)**, a risk that is only associated with SCN. The diagnosis can be confirmed with genetic studies demonstrating a pathologic variant in *ELANE*. Affected patients with neutrophil nadirs <200/µL are treated with G-CSF, and their cycle of profound neutropenia changes from a 21-day period with at least 3-5 days of profound neutropenia to 9-11 days with 1 day of less profound neutropenia. The dose needed to maintain nadirs >500/µL is usually 2-4 µg/kg/day administered daily or every other day.

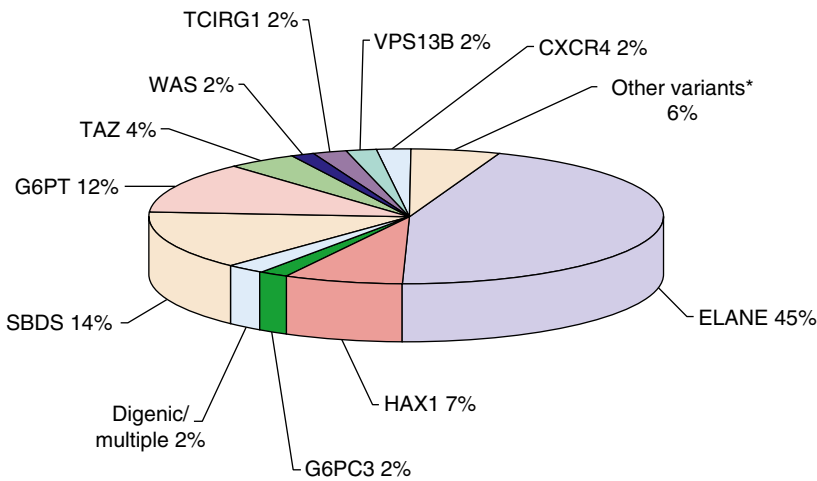
SCN is a rare, genetically heterogeneous, congenital granulopoietic disorder with an estimated incidence of 1-2 cases per 1 million population. The disorder is characterized by an arrest in myeloid maturation at the promyelocyte stage in the bone marrow, resulting in ANCs consistently <200/µL and may occur sporadically, with autosomal dominant or recessive inheritance. The **dominant** form is caused most often by pathologic variants in *ELANE*, which accounts for 60-80% of SCN cases, whereas **recessive** forms arise from variants in *HAX1* (the form also known as **Kostmann disease**) or *G6PC3* (encoding a myeloid-specific isoform of glucose-6-phosphatase). Pathologic alterations in *GFI1*, *CSF3R*, and *JAGN1* additionally may lead to the condition. *HAX1* variants may be associated with neurologic deficits, and *G6PC3* with heart defects, urogenital abnormalities, and venous angiectasia. In addition to severe neutropenia, peripheral blood counts generally show monocytosis and many also exhibit eosinophilia; chronic inflammation may lead to secondary anemia and thrombocytosis. Patients who have SCN experience frequent episodes of fever, skin infections (including omphalitis), oral ulcers, gingivitis, pneumonia, and perirectal abscesses, typically appearing in the first few months of life. Infections often disseminate to the blood, meninges, and peritoneum and are usually caused by *S. aureus*, *Escherichia coli*, and *Pseudomonas* species. Without filgrastim therapy, most patients die of infectious complications within the first 1-2 years of life despite prophylactic antibiotics.



**Table 171.6** Intrinsic Disorders of Myeloid Precursor Cells

SYNDROME	INHERITANCE (GENE)	CLINICAL FEATURES (INCLUDING STATIC NEUTROPENIA UNLESS OTHERWISE NOTED)
<b>PRIMARY DISORDERS OF MYELOPOIESIS</b>		
Cyclic neutropenia	AD ( <i>ELANE</i> )	Periodic oscillation (21-day cycles) in ANC
Severe congenital neutropenia	AD (primarily <i>ELANE</i> , also <i>GFI1</i> and others)	Risk of MDS/AML
	AR ( <i>G6PC3</i> , <i>HAX1</i> , <i>JAGN1</i> , <i>CSF3R</i> ) ( <i>HAX1</i> = Kostmann syndrome)	<i>G6PC3</i> : cardiac and urogenital anomalies, venous angioectasias; <i>HAX1</i> : neurologic abnormalities, risk of MDS/AML
	XL ( <i>WAS</i> )	Neutropenic variant of Wiskott-Aldrich syndrome
<b>DISORDERS OF MOLECULAR PROCESSING</b>		
Shwachman-Diamond syndrome	Ribosomal defect: AR ( <i>SBDS</i> , <i>DNAJC21</i> , <i>EFL1</i> , <i>SRP54</i> )	Pancreatic insufficiency, metaphyseal dysostosis, bone marrow failure, MDS/AML
Telomere biology disorders/ dyskeratosis congenita	Telomere length abnormality: XL ( <i>DKC1</i> ), AD or AR ( <i>ACD</i> , <i>RTEL1</i> , <i>TERC</i> , <i>TERT</i> ), AD ( <i>NAF1</i> , <i>TINF2</i> ), AR ( <i>CTC1</i> , <i>NHP2</i> , <i>NOP10</i> , <i>PARN</i> , <i>STN1</i> , <i>WRAP53</i> )	Nail dystrophy, leukoplakia, abnormal and carious teeth, lacey reticulated hyperpigmentation of the skin, bone marrow failure, various malignancies, Coats plus syndrome ( <i>CTC1</i> and <i>STN1</i> )
<b>DISORDERS OF VESICULAR TRAFFICKING</b>		
Chédiak-Higashi syndrome	AR ( <i>LYST</i> )	Partial albinism, giant granules in myeloid cells, platelet storage pool defect, impaired NK cell function, HLH
Griscelli syndrome, type II	AR ( <i>RAB27a</i> )	Partial albinism, impaired NK cell function, neurologic impairment, HLH
Cohen syndrome	AR ( <i>COH1</i> )	Partial albinism, pigmentary retinopathy, developmental delay, facial dysmorphism
Hermansky-Pudlak syndrome, type II	AR ( <i>AP3B1</i> )	Cyclic neutropenia, partial albinism, HLH
p14 deficiency	AR ( <i>MAPBP1P</i> )	Partial albinism, coarse facial features, decreased B and T cells
VPS45 defects	AR ( <i>VPS45</i> )	Neutrophil dysfunction, bone marrow fibrosis, nephromegaly
<b>DISORDERS OF METABOLISM</b>		
Glycogen storage disease, type 1b	AR ( <i>G6PT1</i> )	Hepatic enlargement, growth retardation, impaired neutrophil motility
Methylmalonic/propionic acidemia/ aciduria	AR ( <i>CLPB</i> ) Mutase or cobalamin transporters/ propionyl coenzyme A carboxylase	Ketoacidosis, metabolic stroke, depressed consciousness, megaloblastic anemia
3-Methylglutaconic aciduria	AR ( <i>CLPB</i> )	Nonspecific finding indicative of mitochondrial dysfunction or associated with known syndromes
Barth syndrome	XL ( <i>TAZ</i> )	Episodic neutropenia, dilated cardiomyopathy, methylglutaconic aciduria
Pearson syndrome	Mitochondrial (DNA deletions)	Episodic neutropenia, pancytopenia; defects in exocrine pancreas, liver, and kidneys
<b>NEUTROPENIA IN DISORDERS OF IMMUNE FUNCTION</b>		
Common variable immunodeficiency	Familial, sporadic ( <i>TNFRSF13B</i> )	Hypogammaglobulinemia, other immune system defects
IgA deficiency	Unknown (Unknown or <i>TNFRSF13B</i> )	Decreased IgA
Severe combined immunodeficiency	AR, XL (multiple loci)	Absent humoral and cellular immune function
Hyper-IgM syndrome	XL ( <i>HIGM1</i> )	Absent IgG, elevated IgM, autoimmune cytopenias
WHIM syndrome	AD ( <i>CXCR4</i> )	Warts, hypogammaglobulinemia, infections, myelokathexis
Cartilage-hair hypoplasia	AR ( <i>RMRP</i> )	Lymphopenia, short-limbed dwarfism, metaphyseal chondrodysplasia, fine sparse hair
Schimke immunoosseous dysplasia	AR ( <i>SMARCA1</i> )	Lymphopenia, pancytopenia, spondyloepiphyseal dysplasia, growth retardation, renal failure
X-linked agammaglobulinemia	XL (Bruton tyrosine kinase ( <i>BTK</i> ))	Agammaglobulinemia, neutropenia in ~25%
GATA2 haploinsufficiency	AD ( <i>GATA2</i> )	Pulmonary alveolar proteinosis, lymphedema, monocytopenia, decreased B and NK cells, risk for severe fungal/mycobacterial/viral infections, susceptibility to leukemia/MDS, MonoMAC syndrome

AD, Autosomal dominant; AML, acute myelogenous leukemia; ANC, absolute neutrophil count; AR, autosomal recessive; HLH, hemophagocytic lymphohistiocytosis; MDS, myelodysplastic syndrome; NK, natural killer; XL, X-linked.



**Fig. 171.1** Genes with germline variants associated with severe congenital neutropenia. Data based on 650 patients with severe congenital neutropenia registered in the European and North American Branches of the Severe Chronic Neutropenia International Registry. \*Pathogenic variants in *JAGN1*, *LAMTOR2*, *GFI1*, *LYST*, *USB1*, or mitochondrial DNA. (From Skokowa J, Dale DC, Touw IP, Zeidler C, Welte K. Severe congenital neutropenias. *Nat Rev Dis Primers*. 2017;3:17032. Fig. 3.)

More than 95% of SCN patients respond to filgrastim (G-CSF) treatment with an increase in the ANC and a decrease in infections. Doses required to achieve an ANC  $>1,000/\mu\text{L}$  vary greatly. A starting dose of filgrastim at  $5 \mu\text{g}/\text{kg}/\text{day}$  is recommended; the dose should be gradually increased, if necessary, to as high as  $100 \mu\text{g}/\text{kg}/\text{day}$  to attain an ANC of  $1,000\text{--}2,000/\mu\text{L}$ . The 5% of patients who do not respond to filgrastim or who require high doses ( $>8 \mu\text{g}/\text{kg}/\text{day}$ ) should be considered for hematopoietic stem cell transplantation (HSCT). Along with infections, patients with SCN are at risk for developing MDS associated with monosomy 7 and AML. For this reason, regular monitoring with blood counts and yearly bone marrow surveillance, including karyotyping and fluorescence in situ hybridization, should be performed on all SCN patients. Although clonal cytogenetic abnormalities may spontaneously remit, their appearance should be considered a strong indication for HSCT, which is much more likely to be successful before progression to MDS/AML.

### Disorders of Molecular Processing

**Shwachman-Diamond syndrome (SDS)** is an autosomal recessive disorder classically characterized by neutropenia, pancreatic insufficiency, and short stature with skeletal abnormalities. SDS is most commonly caused by pro-apoptotic pathologic variants of the *SBDS* gene, which encodes a protein that plays a role in ribosome biogenesis and RNA processing. The initial symptoms are usually steatorrhea and failure to thrive because of malabsorption secondary to pancreatic insufficiency, which usually develops by 4 months of age, although the gastrointestinal symptoms may be subtle in some patients and go unrecognized. Patients have also been reported to have respiratory problems with frequent otitis media, pneumonia, and eczema. Virtually all patients with SDS have neutropenia, with the ANC periodically  $<1,000/\mu\text{L}$ . Some children have hypogammaglobulinemia, defects in chemotaxis, or a reduction in the number or function of B, T, and natural killer (NK) cells that may contribute to the increased susceptibility to pyogenic infection. The diagnosis of SDS is based on clinical phenotype; approximately 90% of patients have pathologic variants identified in *SBDS* with additional disease-causing variants now recently discovered in *DNAJC21*, *EFL1*, and *SRP54*. SDS may progress to bone marrow hypoplasia or MDS/AML; identification of increasing *TP53* variants or cytogenetic abnormalities, particularly isochromosome i(7q) and del(20q), often precede conversion to MDS, so routine bone marrow monitoring is warranted. Treatment includes pancreatic enzyme replacement, plus G-CSF in patients with severe neutropenia.

**Telomere biology disorders (TBDs)**, including **dyskeratosis congenita**, are disorders of telomere length that most often present

as bone marrow failure rather than isolated neutropenia. Various pathologic variants have now been identified to cause such conditions (see [Table 171.6](#)), including alterations in *ACD*, *PARN*, *DKC1*, *RTEL1*, *TERC*, and *TERT*. Moreover, the classic phenotype includes nail dystrophy, leukoplakia, malformed teeth, and reticulated hyperpigmentation of the skin, although many patients, particularly young ones, do not exhibit these clinical features. Pulmonary and hepatic fibrosis is also a concern in individuals with TBDs. Patients are at risk for not only hematologic dysplasia/malignancy but additionally neoplasms involving the gastrointestinal tract, skin, and head and neck. Early and routine screening for these malignancies can be lifesaving.

### Vesicular Trafficking Disorders

This group of rare **primary immunodeficiency syndromes** (see [Table 171.6](#)) derives from autosomal recessive defects in the biogenesis or trafficking of lysosomes and related endosomal organelles. The syndromes share phenotypic characteristics, including defects in melanosomes contributing to partial albinism, abnormal platelet function, and immunologic defects involving not only neutrophil number, but also the function of neutrophils, B lymphocytes, NK cells, and cytotoxic T lymphocytes. The syndromes share a high risk of hemophagocytic lymphohistiocytosis (HLH) as a result of defects in T and NK cells.

**Chédiak-Higashi syndrome** has characteristic giant cytoplasmic granules in neutrophils, monocytes, and lymphocytes, and is a disorder of subcellular vesicular dysfunction caused by pathologic variants in the *LYST* gene, with resultant giant granules in all granule-bearing cells. Patients have increased susceptibility to infections, mild bleeding diathesis, progressive peripheral neuropathy, and predisposition to life-threatening HLH. The only curative treatment is HSCT, but transplant does not treat all aspects of the disorder.

**Griselli syndrome type II** also features neutropenia, partial albinism, and a high risk of HLH, but peripheral blood granulocytes do not show giant granules. Patients often have hypogammaglobulinemia. The disorder is caused by alterations in *RAB27a*, which encodes a small guanosine triphosphatase that regulates granule secretory pathways. The only curative treatment is HSCT.

### Disorders of Metabolism

Recurrent infections with neutropenia are a distinctive feature of **glycogen storage disease (GSD) type Ib**. As in classic von Gierke disease (GSDIa), glycogen storage in GSDIb causes massive hepatomegaly and severe growth retardation. Pathologic variants in glucose-6-phosphate transporter 1, *G6PT1*, inhibit glucose transport in GSDIb, resulting in both defective neutrophil motility and increased apoptosis associated with neutropenia and recurrent bacterial infections. Treatment with

**Table 171.7** Main Organ Associated Features and Genetic Subtypes of Congenital Neutropenia

SYSTEM	HEMATOLOGIC OR ASSOCIATED FEATURES	DISEASE	GENE
Blood/bone marrow maturation	Maturation arrest	Severe congenital neutropenia Severe congenital neutropenia Wiskott-Aldrich syndrome <i>Neutropenia G6PC3</i> <i>G-CSF receptor</i>	<i>ELANE</i> <i>HAX1</i> <i>WAS</i> <i>G6PC3</i> Extracellular domain of <i>CSF3R</i>
	No maturation arrest	<i>GSD1b</i> WHIM Shwachman Diamond disease Cohen disease Hermansky-Pudlak type 2	<i>G6PT1</i> <i>CXCR4</i> <i>SBDS</i> <i>VPS13B</i> <i>AP3B1</i>
	Myelokathexis	WHIM	<i>CXCR4</i>
Pancreas	External pancreatic insufficiency	Shwachman Diamond disease	<i>SBDS</i>
Eyes	Congenital cataract	Charcot-Marie-Tooth	<i>Dynamin 2</i>
	Retinochoroidal dystrophy	Cohen disease	<i>VPS13B</i>
Heart	Heart: arrhythmias	<i>Neutropenia G6PC3</i>	<i>G6PC3</i>
	Dilated cardiomyopathy	Barth diseases	<i>TAZ</i>
	Cardiomyopathy	Shwachman Diamond disease	<i>SBDS</i>
	Various cardiac abnormalities	Shwachman Diamond disease WHIM <i>Neutropenia G6PC3</i>	<i>SBDS</i> <i>CXCR4</i> <i>G6PC3</i>
Skin	Skin xerosis eczema	Shwachman Diamond disease	<i>SBDS</i>
	Skin: prominent superficial veins	<i>Neutropenia G6PC3</i>	<i>G6PC3</i>
	Skin poikiloderma	SCN with poikiloderma type Clericuzio	<i>16ORF57</i>
	Skin: Partial or complete albinism	Hermansky-Pudlak type 2 AP14 defect Chédiak Higashi disease Griscelli disease	<i>AP3B1</i> <i>AP14</i> <i>LYST</i> <i>RAB27A</i>
	Hair: fine, sparse, and light-colored	Cartilage-hair hypoplasia	<i>RMRP</i>
Bone	Metaphyseal dysplasia	Shwachman Diamond disease Cartilage-hair hypoplasia	<i>SBDS</i> <i>RMRP</i>
	Facial dysmorphism	Cohen disease	<i>VPS13B</i>
Central nervous system	Mental retardation	Kostmann disease Shwachman Diamond disease Cohen disease	<i>HAX1</i> <i>SBDS</i> <i>VPS13B</i>
Muscle	Weakness	<i>Neutropenia G6PC3</i> Axonal Charcot-Marie-Tooth disease	<i>G6PC3</i> <i>Dynamin 2</i>
Metabolic pathway	Fasting intolerance and glycogenosis	Glycogen storage disease type Ib	<i>SLC37A4</i>
Inner ear	Inner ear defect	GFI 1/severe chronic neutropenia Reticular dysgenesis	<i>GFI1</i> <i>AK2</i>
Urogenital tract	Uropathy	<i>Neutropenia G6PC3</i>	<i>G6PC3</i>
	Cryptorchidism	Cohen disease <i>Neutropenia G6PC3</i>	<i>VPS13B</i> <i>G6PC3</i>

G-CSF, Granulocyte colony-stimulating factor; SCN, severe congenital neutropenia; WHIM, warts, hypogammaglobulinemia, infections, myelokathexis.

From Donadieu J, Fenneteau O, Beaupain B, Mahlaoui N, Chantelot CB. Congenital neutropenia: diagnosis, molecular bases and patient management. *Orphanet J Rare Dis*. 2011;6:26. Table 2.

G-CSF can correct the neutropenia but does not correct the underlying functional neutrophil defects.

### Neutropenia in Disorders of Immune Dysfunction

Congenital immunologic disorders that have severe neutropenia as a clinical feature include XLA, CVID, the severe combined immunodeficiencies (SCIDs), autoimmune lymphoproliferative syndrome, hyperimmunoglobulin M syndrome, WHIM (warts, hypogammaglobulinemia, infections, myelokathexis) syndrome, GATA2

haploinsufficiency, and a number of even rarer immunodeficiency disorders (see Table 171.6).

### Unclassified Neutropenic Disorders

**Chronic benign neutropenia** of childhood represents a common group of disorders characterized by mild to moderate neutropenia that does not lead to an increased risk of pyogenic infections. Spontaneous remissions are often reported, although these may represent misdiagnosis of AIN of infancy, in which remissions often occur during

**Table 171.8** Causes of Lymphocytopenia

<b>ACQUIRED</b>	
Infectious diseases	AIDS, hepatitis, influenza, sepsis, tuberculosis, typhoid, COVID-19
Iatrogenic	Corticosteroids, cytotoxic chemotherapy, high-dose PUVA, immunosuppressive therapy, radiation, thoracic duct drainage/chylothorax
Systemic diseases	Hodgkin disease, lupus erythematosus, myasthenia gravis, protein-losing enteropathy, renal failure, sarcoidosis
Other	Aplastic anemia, dietary deficiencies, thermal injury
<b>INHERITED</b>	
Aplasia of lymphopoietic stem cells	Cartilage-hair hypoplasia, ataxia-telangiectasia, SCID, thymoma, Wiskott-Aldrich syndrome

PUVA, Psoralen and ultraviolet A irradiation; SCID, severe combined immunodeficiency.

childhood. Chronic benign neutropenia may be sporadic or inherited in either dominant or recessive form. Because of the relatively low risk of serious infection, patients usually do not require any therapy.

**Idiopathic chronic neutropenia** is characterized by the onset of neutropenia after 2 years of age, with no identifiable etiology. Patients with an ANC persistently  $<500/\mu\text{L}$  may have recurrent pyogenic infections involving the skin, mucous membranes, lungs, and lymph nodes. Bone marrow examination reveals variable patterns of myeloid formation with arrest generally occurring between the myelocyte and band forms. The diagnosis overlaps with chronic benign and AINs.

### Treatment

The management of acquired transient neutropenia associated with malignancies, myelosuppressive chemotherapy, or immunosuppressive chemotherapy differs from that of congenital or chronic forms of neutropenia. In the former situation, infections sometimes are heralded only by fever, and sepsis is a major cause of death. Early recognition and treatment of infections may be lifesaving. Therapy of severe chronic neutropenia is dictated by the clinical manifestations. Patients with benign neutropenia and no evidence of repeated bacterial infections or chronic gingivitis require no specific therapy. Superficial infections in children with mild to moderate neutropenia may be treated with appropriate oral antibiotics. In patients who have invasive or life-threatening infections, broad-spectrum intravenous antibiotics should be started promptly.

Subcutaneously administered G-CSF can provide effective treatment of severe chronic neutropenia, including SCN, cyclic neutropenia, and chronic symptomatic idiopathic neutropenias. Treatment leads to dramatic increases in neutrophil counts, resulting in marked attenuation of infection and inflammation. Doses range from 2-5  $\mu\text{g}/\text{kg}/\text{day}$  for cyclic, idiopathic, and AINs, to 5-100  $\mu\text{g}/\text{kg}/\text{day}$  for SCN. The long-term effects of G-CSF therapy include a propensity for the development of moderate splenomegaly, reduced bone density, thrombocytopenia, and rarely vasculitis; only patients with SCN are at risk for MDS/AML.

Patients with SCN or SDS who develop MDS or AML respond only to HSCT; chemotherapy is ineffective. HSCT is also the treatment of choice for aplastic anemia or familial HLH.

### LYMPHOPENIA

The definition of lymphopenia, as with neutropenia, is age dependent and can have acquired or inherited causes. **The absolute lymphocyte count (ALC)** is determined by multiplying the total WBC count by the percentage of total lymphocytes. For children  $<12$  months old, lymphopenia is defined as an ALC  $<3,000$  cells/ $\mu\text{L}$ . For older children and adults, an ALC  $<1,000$  cells/ $\mu\text{L}$  is considered lymphopenia. In isolation, mild to moderate lymphopenia is generally a benign condition often detected only in the evaluation of other illnesses. However, severe lymphopenia can result in serious, life-threatening illness. Lymphocyte subpopulations can be measured by flow cytometry, which uses the pattern of lymphocyte antigen expression to quantitate and classify T, B, and NK cells.

### Acquired Lymphopenia

Acute lymphopenia is most often a result of infection and/or is iatrogenic from lymphocyte-toxic medications and treatments (Table 171.8). Microbial causes include viruses (e.g., respiratory syncytial virus, cytomegalovirus, influenza, measles, hepatitis, COVID-19), bacterial infections (e.g., tuberculosis, typhoid fever, histoplasmosis, brucellosis), and malaria. The mechanisms behind infection-associated lymphopenia are not fully elucidated but probably include lymphocyte redistribution and accelerated apoptosis. Corticosteroids are a common cause of medication-induced lymphopenia, as are lymphocyte-specific immunosuppressive agents (e.g., antilymphocyte globulin, alemtuzumab, rituximab), chemotherapy drugs, and radiation. In most cases, infectious and iatrogenic causes of acute lymphopenia are reversible, although full lymphocyte recovery from chemotherapy and lymphocyte-specific immunosuppressive agents may take several months to years. Prolonged lymphopenia (see Table 171.8) may be caused by recurrent infection, persistent infections (mostly notably HIV), malnutrition, mechanical loss of lymphocytes through protein-losing enteropathy or thoracic duct leaks, or systemic diseases such as lupus erythematosus, rheumatoid arthritis, sarcoidosis, renal failure, lymphoma, and aplastic anemia.

### Inherited Lymphopenia

Primary immunodeficiencies and bone marrow failure syndromes are the main cause of inherited lymphopenia in children (see Table 171.8). Primary immunodeficiency may result in a severe quantitative defect, as in XLA and SCID, or a qualitative or progressive defect, as in Wiskott-Aldrich syndrome and CVID. XLA is characterized by a near-absence of mature B cells because of a pathologic alteration in *BTK* that results in a dysfunctional tyrosine kinase. SCIDs are a genetically heterogeneous group of disorders characterized by abnormalities of thymopoiesis and T-cell maturation. Newborn screening for severe T-cell deficiency, by analysis of T-cell receptor excision circles (TRECs) from dried blood spot Guthrie cards, aids in the rapid identification and treatment of infants with SCID and other T-cell disorders. Quantitative defects in lymphocytes can also be appreciated in select forms of inherited bone marrow failure such as reticular dysgenesis, SCN secondary to *GFI1* variants, and dyskeratosis congenita.

Visit Elsevier eBooks+ at [eBooks.Health.Elsevier.com](https://www.elsevier.com/ebooks-health) for Bibliography.



## Chapter 172

## Leukocytosis

Thomas F. Michniacki and  
Kelly J. Walkovich

Leukocytosis is an elevation in the total leukocyte or white blood cell (WBC) count that is 2 standard deviations (SDs) above the mean for age. It is most often caused by elevated numbers of neutrophils (i.e., neutrophilia), although marked increases in monocytes, eosinophils, basophils, and lymphocytes can be seen. Before extensive evaluation, it is important to assess for spurious elevations in the WBC count caused by platelet clumping (secondary to insufficient sample anticoagulation or the presence of EDTA-dependent agglutinins), high numbers of circulating nucleated red blood cells (RBCs), and the presence of cryoglobulins by review of the peripheral smear.

Malignancy, namely leukemia and lymphoma, is a primary concern for patients with leukocytosis. For discussion of WBC elevation caused by immature leukocytes in acute and chronic leukemias, see Chapter 544. Nonmalignant WBC counts exceeding 50,000/ $\mu\text{L}$  have historically been termed a **leukemoid reaction**. Unlike leukemia, leukemoid reactions show relatively small proportions of immature myeloid cells, consisting largely of band forms, occasional metamyelocytes, and progressively rarer myelocytes, promyelocytes, and blasts. Leukemoid reactions are most often neutrophilic and are frequently associated with severe bacterial infections, including shigellosis, salmonellosis, and meningococcemia; physiologic stressors; and certain medications.

The presence of a **left shift**, defined as having >5% immature neutrophils in the peripheral blood, is consistent with marrow stress. Higher degrees of left shift with more immature neutrophil precursors are indicative of serious bacterial infections and may be a dire sign of depletion of the bone marrow reserve pool of neutrophils. Marked left shift may occasionally be encountered with trauma, burns, surgery, acute hemolysis, or hemorrhage.

### NEUTROPHILIA

Neutrophilia is an increase in the total number of blood neutrophils that is 2 SD above the mean count for age. Elevated absolute neutrophil counts represent disturbances of the normal equilibrium involving bone marrow neutrophil production, migration out of the marrow compartments into the circulation, and neutrophil destruction. Neutrophilia may arise either alone or in combination with enhanced mobilization into the **circulating pool** from either the bone marrow storage compartment or the peripheral blood **marginating pool**, by impaired neutrophil egress into tissues, or by expansion of the circulating neutrophil pool secondary to increased granulopoiesis. Myelocytes are not released to the blood except under extreme circumstances.

### Acute Acquired Neutrophilia

Neutrophilia is usually an acquired, secondary finding associated with inflammation, infection, injury, or an acute physical or emotional stressor (Table 172.1). Bacterial infections, trauma (especially with hemorrhage), and surgery are among the most common causes encountered in clinical practice. Neutrophilia may also be associated with heat stroke, burns, diabetic ketoacidosis, vaccines, pregnancy, or cigarette use.

Drugs commonly associated with neutrophilia include epinephrine, corticosteroids, and recombinant growth factors such as recombinant human granulocyte colony-stimulating factor (G-CSF) and recombinant human granulocyte-macrophage colony-stimulating factor (GM-CSF). Epinephrine causes release into the circulation of a sequestered pool of neutrophils that normally marginate along the vascular endothelium. Corticosteroids accelerate the release of neutrophils and bands from a large storage pool within the bone marrow and impair

the migration of neutrophils from the circulation into tissues. G-CSF and GM-CSF cause acute and chronic neutrophilia by mobilizing cells from the marrow reserves and stimulating neutrophil production.

Acute neutrophilia in response to inflammation and infections occurs because of release of neutrophils from the marrow storage pool. The postmitotic marrow neutrophil pools are approximately 10 times the size of the blood neutrophil pool, and about half of these cells are bands and segmented neutrophils. Exposure of blood to foreign substances such as hemodialysis membrane activates the complement system and causes transient neutropenia, followed by neutrophilia secondary to release of bone marrow neutrophils. Reactive neutrophils often have toxic granulation and Döhle bodies present.

### Chronic Acquired Neutrophilia

Chronic acquired neutrophilia is usually associated with continued stimulation of neutrophil production resulting from persistent inflammatory reactions or chronic infections (e.g., tuberculosis), vasculitis, postsplenectomy states, Hodgkin disease, chronic myelogenous leukemia, chronic blood loss, sickle cell disease, some chronic hemolytic anemias, and prolonged administration of corticosteroids (see Table 172.1). Chronic neutrophilia can arise after expansion of cell production secondary to stimulation of cell divisions within the mitotic precursor pool, which consists of promyelocytes and myelocytes. Subsequently, the size of the postmitotic pool increases. These changes lead to an increase in the marrow reserve pool, which can be readily mobilized for release of neutrophils into the circulation. The neutrophil production rate can increase greatly in response to exogenously administered hematopoietic growth factors, such as G-CSF, with a maximum response taking at least 1 week to develop.

### Lifelong Neutrophilia

Congenital or acquired asplenia is associated with lifelong neutrophilia. Some patients with trisomy 21 also have neutrophilia. Uncommon genetic disorders that present with neutrophilia include leukocyte function disorders such as leukocyte adhesion deficiency and Rac2 deficiency (see Chapter 170) and systemic disorders such as familial cold urticaria, periodic fever syndromes, and familial myeloproliferative disease (see Table 172.1). Rare patients with an autosomal dominant hereditary neutrophilia have been reported.

Evaluation of persistent neutrophilia requires a careful history, physical examination, and laboratory studies to search for infectious, inflammatory, and neoplastic conditions. The leukocyte alkaline phosphatase score of circulating neutrophils can differentiate chronic myelogenous leukemia, in which the level is uniformly almost zero, from reactive or secondary neutrophilia, which features normal to elevated levels.

## ADDITIONAL FORMS OF LEUKOCYTOSIS

### Monocytosis

The average absolute blood monocyte count varies with age, which must be considered in the assessment of monocytosis. Given the role of monocytes in antigen presentation and cytokine secretion and as effectors of ingestion of invading organisms, it is not surprising that many clinical disorders give rise to monocytosis (Table 172.2). Typically, monocytosis occurs in patients recovering from myelosuppressive chemotherapy and is a harbinger of the return of the neutrophil count to normal. Monocytosis is occasionally a sign of an acute bacterial, viral, protozoal, or rickettsial infection and may also occur in some forms of chronic neutropenia and postsplenectomy states. Chronic inflammatory conditions can stimulate sustained monocytosis, as can preleukemia, chronic myelogenous leukemia, and lymphomas.

### Eosinophilia

Eosinophilia is defined as an absolute eosinophil count >1500 cells/ $\mu\text{L}$ . The majority of eosinophilic conditions are reactive, including infections (especially parasitic diseases), connective tissue disorders, allergic and hyperinflammatory diseases, pulmonary disorders, and dermatologic conditions (see Chapter 169). Drug reaction with eosinophilia and systemic symptoms (DRESS) is a particularly important condition

Table 172.1 Causes of Neutrophilia		
TYPE	CAUSE	EXAMPLE
Acute acquired	Bacterial infections	
	Neutrophil disorder	Leukocyte adhesion defects
	Surgery	
	Acute stress	Burns, diabetic ketoacidosis, heat stroke, postneutropenia rebound, exercise
	Drugs	Corticosteroids, epinephrine, hematopoietic growth factors, lithium
Chronic acquired	Chronic inflammation	Inflammatory bowel disease, rheumatoid arthritis, vasculitis, cigarette exposure
	Persistent infection	Tuberculosis
	Persistent stress	Chronic blood loss, hypoxia, sickle cell and other chronic hemolytic anemias
	Drugs	Corticosteroids, lithium; rarely ranitidine, quinidine
	Other	Postsplenectomy, tumors, Hodgkin disease, pregnancy, Sweet syndrome
Lifelong	Congenital asplenia	
	Hereditary disorders	Familial cold urticaria, hereditary neutrophilia, leukocyte adhesion deficiencies, periodic fever syndromes

Table 172.2 Causes of Monocytosis	
CAUSE	EXAMPLE
Infections	
Bacterial	Brucellosis, subacute bacterial endocarditis, syphilis, tuberculosis, typhoid
Nonbacterial	Fungal infections, kala-azar, malaria, Rocky Mountain spotted fever, typhus
Hematologic disorders	Congenital and acquired neutropenias, hemolytic anemias
Malignant disorders	Acute myelogenous leukemia, chronic myelogenous leukemia, juvenile myelomonocytic leukemia, Hodgkin disease, non-Hodgkin lymphomas, preleukemia
Chronic inflammatory diseases	Inflammatory bowel disease, polyarteritis nodosa, rheumatoid arthritis, sarcoidosis, systemic lupus erythematosus
Miscellaneous	Cirrhosis, drug reaction, postsplenectomy, recovery from bone marrow suppression

to consider in those with prominent eosinophilia as severe cases are associated with significant morbidity and mortality (see Chapter 686.2). Hypereosinophilic syndrome and systemic mastocytosis are additional important causes of an elevated eosinophil count. However, persistent eosinophilia can also herald a malignancy such as leukemia, lymphoma, or carcinoma.

### Basophilia

Basophilia is defined as an absolute basophil count  $>120$  cells/ $\mu\text{L}$ . Basophilia is a nonspecific sign of a wide variety of disorders and is usually of limited diagnostic importance. Basophilia is most often present in hypersensitivity reactions and frequently accompanies the leukocytosis of chronic myeloid leukemia.

### Lymphocytosis

The most common cause of lymphocytosis is an acute viral illness, as part of the normal T-cell response to the infection. In infectious mononucleosis, the B cells are infected with the Epstein-Barr virus, and the T cells react to the viral antigens present in the B cells, resulting in **atypical lymphocytes** with characteristic large, vacuolated morphology. Other viral infections classically associated with lymphocytosis are cytomegalovirus and viral hepatitis. Chronic bacterial infections such as tuberculosis and brucellosis may lead to a sustained lymphocytosis. Pertussis is accompanied by marked lymphocytosis in approximately 25% of infants infected before 6 months of age. Thyrotoxicosis and Addison disease are endocrine disorders associated with lymphocytosis. Persistent or pronounced lymphocytosis suggests acute lymphocytic leukemia.

Visit Elsevier eBooks+ at [eBooks.Health.Elsevier.com](http://eBooks.Health.Elsevier.com) for Bibliography

## Section 4

## Complement System

## Chapter 173

## Complement System

Anete Sevciovic Grumach

## 173.1 Complement Components, Pathways, and Evaluation

Anete Sevciovic Grumach

The complement system (CS) forms a network of soluble and cell surface-bound components, pattern-recognition proteins (PRPs), proteases, receptors, effectors, and regulators to perform multiple sensor and effector functions as part of the *innate* immune system (Tables 173.1 and 173.2). It represents an essential part of immunity, having a major role in host defense against pathogens, homeostasis, and inflammation, such as promoting phagocytic removal of senescent cells, molecular debris, and weak or superfluous synapses during brain formation. Complement acts not only in the extracellular space but also within cells and subcellular compartments, where it is involved in the regulation of basic processes of the cell, suggesting that complement directs both innate and adaptive immune responses. Cells are generally protected from amplification and effector insult by a group of complement regulators, which are expressed on their surface or mobilized from the circulation. However, if the equilibrium between complement activation and regulation is disturbed, complement can harm the host and precipitate or worsen adverse processes that result in diseases.

Circulating complement proteases are zymogens and, once activated, they initiate an amplification cascade through cleavage of specific targets and/or interaction with other proteins. Depending on the activating surface, the CS can be triggered by the **classical (CP)**, **lectin (LP)**, and **alternative (AP) pathways**. Each pathway is triggered by different interactions. The CP is initiated by immune complexes through binding of complement protein C1q to immune complexes containing IgM or IgG, in solution or bound to antigens on the cell surface. Certain bacteria, RNA viruses, and the lipid A component of bacterial endotoxin as **pathogen-associated molecular patterns (PAMPs)** on microbial surfaces can activate C1q directly and trigger the full complement cascade. The LP is activated when **mannose-binding lectin (MBL)**, or ficolins, recognize unique carbohydrate

structures present on the surface of pathogens or altered glycosylation patterns (DAMPs, danger-associated molecular patterns) on abnormal host cells. The **mannose-binding lectin-associated serine proteases (MASPs)** cleave C2 and C4, following the same sequence as CP.

The AP is rapidly activated after contact with pathogens, independent of antibody; however, antibody will accelerate the rate of activation. The fluid phase C3 convertase complex C3(H<sub>2</sub>O)Bb is generated with the spontaneous hydrolysis of C3, referred to as “tick over.” An amplification loop leads to rapid opsonization stabilized by properdin. Therefore each of these pathways converge toward the cleavage of the abundant plasma protein C3 by a C3 convertase, followed by the formation of a C5 convertase, which cleaves C5 into C5a and C5b, and induces the activation of the common lytic effector **terminal pathway (TP)**. The interaction among C5b, C6, C7, C8, and C9 is nonenzymatic and depends on changes in molecular configuration. The subsequent insertion of TP components into the cell wall leads to lysis via the **membrane attack complex (MAC)**, which is composed of complement proteins C5b to C9.

Cell membrane receptors bind complement components or fragments to mediate complement activity, and a large array of serum and membrane regulatory proteins control the activation of CS (Fig. 173.1). The circulating components and regulators together comprise approximately 15% of the globulin fraction and 4% of the total serum proteins. The normal concentrations of serum complement components vary by age; newborn infants have mild to moderate deficiencies of all components.

## CLASSICAL AND LECTIN PATHWAYS

The CP sequence begins with fixation of C1, by way of C1q, to the Fc non-antigen-binding part of the antibody molecule after antigen-antibody interaction. On binding, the C1 complex changes conformation, activating the C1r and C1s protease subunits; the C1s subcomponent becomes an active enzyme, **C1 esterase**. The activation leads to cleavage of C2 and C4 and the formation of the CP C3 convertase (C4bC2a).

As part of the **innate immune response**, broadly reactive “natural” antibodies and C-reactive protein (CRP), which react with carbohydrates from microorganisms and with dying cells, can substitute for specific antibodies in the fixation of C1q and initiate reaction of the entire sequence. Endogenous substances, including uric acid crystals, amyloid deposits, DNA, and components of damaged cells, such as apoptotic blebs and mitochondrial membranes, can activate C1q directly. In this case, however, the ligand-C1q complex interacts strongly with the inhibitor’s C4-binding protein and factor H, allowing some C3-mediated **opsonization** and **phagocytosis** but limiting the full inflammatory response typically triggered by microbes.

Table 173.1 Nomenclature for Complement Components

	EXAMPLES
Classical pathway components are labeled with a C and a number	C1, C2, C4
Alternative pathway components are lettered	B, P, D
Some components are called factors	Factor B, factor D
Activated components or complexes have a bar over to indicate activation	C4bC2a
Cleavage fragments are designated with a small letter	C3a, C3b
Cell membrane receptor	CR1, CR2, CR3, CR4

Table 173.2 Components of Complement System

## SERUM COMPONENTS THAT ARE THE CORE OF THE COMPLEMENT SYSTEM

Classical pathway: C1q, C1r, C1s, C4, C2, C3

Alternative pathway: factor B, factor D

Lectin pathway: Mannose-binding lectin (MBL), ficolins 1/2/3, MBL-associated serine proteases (MASPs) 1/2/3

Membrane attack complex: C5, C6, C7, C8, C9

Regulatory protein, enhancing: properdin

Regulatory proteins, downregulating: C1 inhibitor (C1-INH), C4-binding protein (C4-bp), factor H, factor I, vitronectin, clusterin, carboxypeptidase N (anaphylatoxin inactivator)

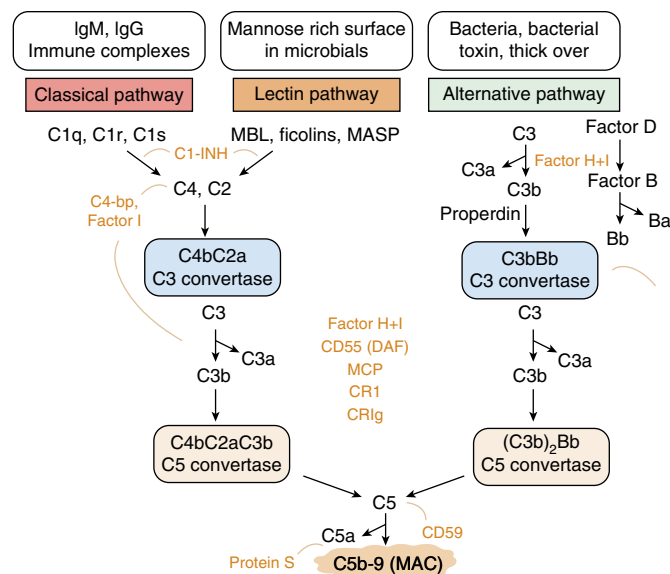
## MEMBRANE REGULATORY PROTEINS

CR1 (CD35), membrane cofactor protein (MCP; CD46), decay-accelerating factor (DAF, CD55), CD59 (membrane inhibitor of reactive lysis)

## MEMBRANE RECEPTORS

CR1 (CD35), CR2 (CD21), CR3 (CD11b/CD18), CR4 (CD11c/CD18)

C3a receptor, C5a receptor, C1q receptors, complement receptor of the immunoglobulin superfamily (CRIg)



**Fig. 173.1** Activation and control of the complement system. C1-INH, C1 inhibitor; C4-bp, C4-binding protein; CD59, cell membrane-associated protein; CR1 (CD35), complement receptor 1; CR1g, complement receptor of the immunoglobulin superfamily; DAF, CD55, decay-accelerating factor; MASP, mannose-binding lectin-associated serine protease; MAC, membrane attack complex; MCP, membrane cofactor protein.

C1q synthesized in the brain and retina fixes to superfluous synapses, which then can be cleared through C1q receptors on microglia, clearing the way for fresh synapses to populate the developing nervous system.

Recognition molecules in the LP are **MBL, ficolins, or collectins (CL-11 or kidney collectin or CL-K1; CL-10, collectin liver 1)**. MBL is the prototype of the collectin family of carbohydrate-binding proteins (**lectins**) that play an important part in innate, nonspecific immunity; its structure is homologous to that of C1q. Three ficolins have been identified in humans: **L-ficolin (ficolin-2)**, **H-ficolin (ficolin-3)**, and **M-ficolin (ficolin-1)**. Ficolins show specificity for *N*-acetylglucosamine residues in complex oligosaccharides, but not for mannose or high-mannose-type oligosaccharides. Individual members display additional specificities, e.g., H-ficolin binds to *N*-acetyl-*D*-galactosamine and *D*-fucose, M-ficolin binds to sialic acid, and L-ficolin recognizes lipoteichoic acid and 1,3- $\beta$ -*D*-glucan, the major component of yeast and fungal cell walls. These lectins, in association with **MASP-1, -2, and -3**, can bind to mannose, lipoteichoic acid, and other carbohydrates on the surface of bacteria, fungi, parasites, and viruses. There, MASPs then function like C1s to cleave C4 and C2 and activate the complement cascade. The peptide C4a has weak **anaphylatoxin** activity and reacts with mast cells to release the chemical mediators of immediate hypersensitivity, including histamine. The activation of C3 and C5 also liberates potent chemotactic fragments (i.e., the anaphylatoxins C3a and C5a) that recruit immune cells to the site of activation and prime them. Fixation of C4b to the complex permits it to adhere to neutrophils, macrophages, B cells, dendritic cells, and erythrocytes. MASP-2 can activate clotting by generating thrombin from prothrombin, which could prevent microbial spread.

Cleavage of C3 and generation of **C3b** is the next step in the sequence. The serum concentration of C3 is the highest of any component, and its activation is the most crucial step in terms of biologic activity. Cleavage of C3 can be achieved through the **C3 convertase** of the CP, C142, or of the AP, C3bBb. Once C3b is fixed to a complex or dead or dying host cell, it can bind to cells with receptors for C3b (complement receptor 1, **CR1**), including B lymphocytes, erythrocytes, and phagocytic cells (neutrophils, monocytes, and macrophages). Efficient **phagocytosis** of most microorganisms, especially by neutrophils, requires binding of C3 to the microbe. The severe pyogenic infections that frequently occur in C3-deficient patients illustrate this point. The biologic activity

of C3b is controlled by cleavage by **factor I** to iC3b, which promotes phagocytosis on binding to the **iC3b receptor (CR3)** on phagocytes. Further degradation of iC3b by factor I and proteases yields C3dg, then C3d; C3d binds to CR2 on B lymphocytes, thereby serving as a co-stimulator of antigen-induced B-cell activation.

## ALTERNATIVE PATHWAY

The AP can be activated by C3b generated through CP activity or proteases from neutrophils or the clotting system. It can also be activated by a form of C3 created by a low-grade, spontaneous reaction of native C3 with a molecule of water, or a tick over that occurs constantly in plasma. Once formed, C3b or the hydrolyzed C3 can bind to any nearby cell or to factor B. **Factor B** attached to C3b in the plasma or on a surface can be cleaved to Bb by the circulating protease **factor D**. The complex C3bBb becomes an efficient C3 convertase, which generates more C3b through an amplification loop. **Properdin** can bind to C3bBb, increasing stability of the enzyme and protecting it from inactivation by **factors I and H**, which modulate the loop and the pathway.

Certain activating surfaces promote AP activation if C3b is fixed to them, including bacterial teichoic acid and endotoxin, virally infected cells, antigen-immunoglobulin A complexes, and cardiopulmonary bypass and renal dialysis membranes. These surfaces act by protecting the C3bBb enzyme from the control otherwise exercised by factors I and H. Rabbit red blood cell (RBC) membrane is such a surface, which serves as the basis for an assay of serum AP activity. Conversely, sialic acid on the surface of microorganisms or cells prevents the formation of an effective AP C3 convertase by promoting the activity of factors I and H. Significant activation of C3 can occur through the AP, and the resultant biologic activities are qualitatively the same as those achieved through activation by C142.

## MEMBRANE ATTACK COMPLEX

The sequence leading to cytolysis begins with the attachment of C5b to the C5-activating enzyme from the CP, C4b2a3b, or from the AP, C3bBb3b. C6 is bound to C5b without being cleaved, stabilizing the activated C5b fragment. The C5b6 complex then dissociates from C423 and reacts with C7. C5b67 complexes must attach promptly to the membrane of the parent or a bystander cell, or they lose their activity. Next, C8 binds, and the C5b678 complex then promotes the addition of multiple C9 molecules. The C9 polymer of at least 3-6 molecules forms a transmembrane channel, and lysis ensues.

## CONTROL MECHANISMS

Without control mechanisms acting at multiple points, there would be unbridled consumption of components, which would generate severe, potentially lethal host damage. Cells are generally protected from amplification and effector insult by a panel of complement regulators, which are expressed on their surface or recruited from circulation. At the first step, **C1 inhibitor (C1-INH)** inhibits C1r and C1s enzymatic activity and thus the cleavage of C4 and C2. C1-INH also inhibits MASP-2, factors XIa and XIIa of the clotting system, and kallikrein of the contact system. Activated C2 has a short half-life, and this relative instability limits the effective life of C42 and C423. The AP enzyme that activates C3, C3bBb, also has a short half-life, although it can be prolonged by the binding of **properdin** to the enzyme complex. Properdin can also bind directly to microbes and promote assembly of the AP C3 convertase.

The serum contains the enzyme carboxypeptidase N, which cleaves the *N*-terminus arginine from C4a, C3a, and C5a, thereby limiting their biologic activity. Factor I inactivates C4b and C3b; factor H accelerates inactivation of C3b by factor I; and an analogous factor, **C4-binding protein (C4-bp)**, accelerates C4b cleavage by factor I, thus limiting assembly of the C3 convertase. Three protein constituents of cell membranes (**CR1, membrane cofactor protein [MCP], and decay-accelerating factor [DAF]**) promote the disruption of C3 and C5 convertases assembled on those membranes. Another **cell membrane-associated protein, CD59**, can bind C8 or both C8 and C9, thereby interfering with the insertion of the MAC (C5b6789). The serum proteins **vitronectin** and **clusterin** can inhibit attachment of the C5b67 complex to cell membranes, bind C8 or C9 in a full MAC, or



interfere with the formation or insertion of this complex. Vitronectin also promotes macrophage uptake of dying neutrophils. The genes for the regulatory proteins factor H, C4-bp, MCP, DAF, CR1, and CR2 are clustered on chromosome 1.

### PARTICIPATION IN HOST DEFENSE

Neutralization of virus by antibody can be enhanced with C1 and C4 and further enhanced by the additional fixation of C3b through the classical or alternative pathway. Complement may therefore be particularly important in the early phases of a viral infection when the antibody titer is limited. Antibody and the full complement sequence can also eliminate infectivity of at least some viruses by the production of typical complement “holes,” as seen by electron microscopy. Fixation of C1q can opsonize (promote phagocytosis) through binding to the phagocyte C1q receptor.

**C4a, C3a, and C5a** can bind to mast cells and thereby trigger the release of histamine and other mediators, leading to vasodilation and the swelling and redness of inflammation. C5a can enhance macrophage phagocytosis of C3b-opsonized particles and induce macrophages to release the cytokines tumor necrosis factor and interleukin-1. C5a is a major **chemotactic factor** for neutrophils, monocytes, and eosinophils, which can efficiently phagocytize microorganisms opsonized with C3b or cleaved C3b (iC3b). Further inactivation of cell-bound C3b by cleavage to C3d and C3dg removes its opsonizing activity, but it can still bind to B cells. Fixation of C3b to a target cell can enhance its lysis by natural killer cells or macrophages (Fig. 173.2).

Insoluble immune complexes can be solubilized if they bind C3b, apparently because C3b disrupts the orderly antigen-antibody lattice. Binding C3b to a complex also allows it to adhere to **C3 receptors (CR1)** on RBCs, which then transport the complexes to hepatic and splenic macrophages for removal. This phenomenon may at least partially explain the immune complex disease found in patients who lack C1, C4, C2, or C3.

The CS serves to link the innate and adaptive immune systems. C4b or C3b coupled to immune complexes promotes their binding to antigen-presenting macrophages, dendritic cells, and B cells. The coupling of antigens to C3d allows binding to CR2 on B cells, which greatly reduces the amount of antigen needed to trigger an antibody response.

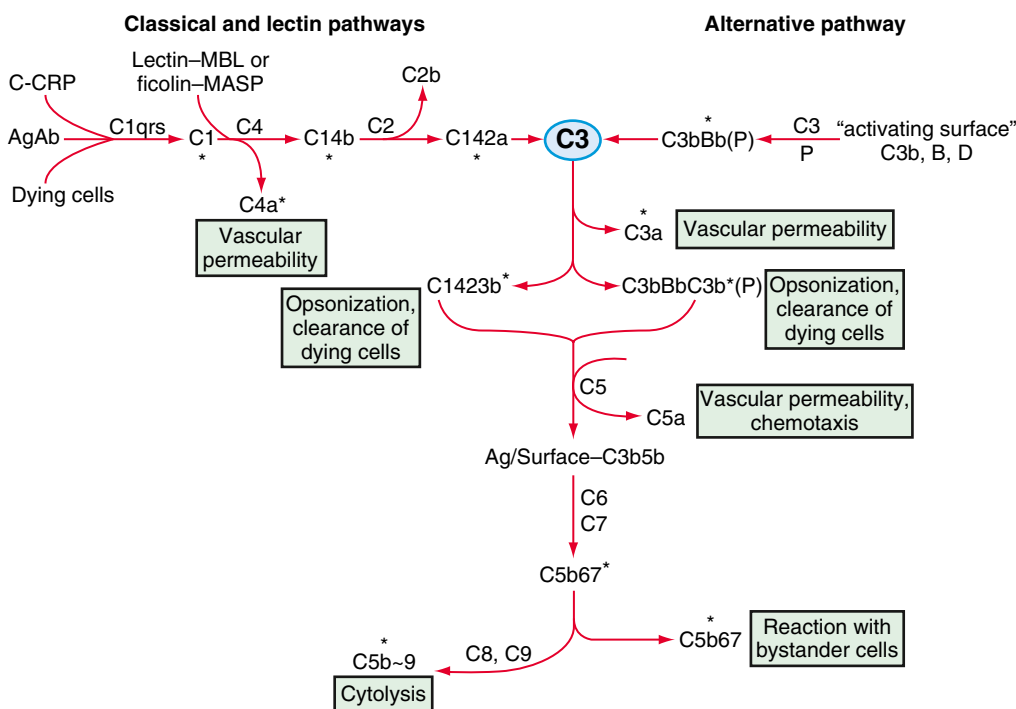
Neutralization of endotoxin in vitro and protection from its lethal effects in experimental animals require C1-INH and later-acting

components of complement, at least through C6. Activation of the entire complement sequence can result in lysis of virus-infected cells, tumor cells, and most types of microorganisms. **Bactericidal activity** of complement has not appeared to be important to host defense, except for the occurrence of *Neisseria* infections in patients lacking later-acting components of complement.

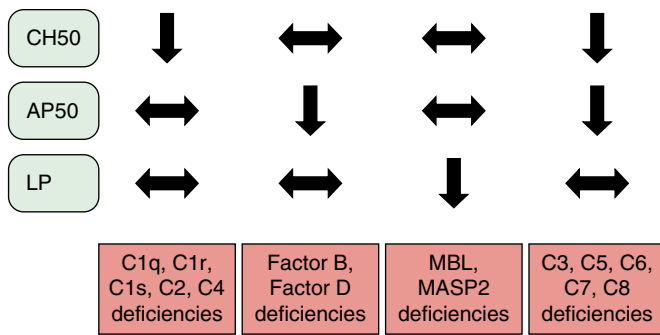
### Complement Evaluation

Good quality blood sampling requires that after clotting (about 20-120 minutes), the serum must be separated by centrifugation as soon as possible, and stored under controlled conditions. In case complement testing cannot be performed on the day of blood sampling, the serum and plasma samples must be stored in a deep freezer ( $-20^{\circ}\text{C}$ ) for up to 3 months or in an ultra-deep freezer ( $-70^{\circ}\text{C}$ ) for a longer storage until analysis. If the analysis will be done by a specialized laboratory, the samples must be shipped on dry ice by courier. Repeated freezing and thawing should be avoided because of the risk of in vitro activation. The serum is sufficient for the analysis of the total function of complement proteins and regulators as well as of autoantibodies. A quantitation of activation products requires the use of EDTA plasma because it blocks the in vitro activation of the CS by way of its  $\text{Mg}^{2+}$  and  $\text{Ca}^{2+}$  complexing properties. Heparin and citrate are less useful. The utilization of the less invasive dried blood spot (DBS)-based assays can also be used for diagnosis; enzyme activities could be retained, facilitating the samples' transportation.

The indication for using assays for complement evaluation is to detect genetic, acquired, or the effect of complement inhibitory therapy. Functional assays can screen and direct the following steps for the evaluation of specific protein deficiencies (Fig. 173.3). Assays including hemolysis of RBCs (**CH50, AP50**) check the activation of classical and alternative pathways. In both cases, CH50 and AP50, the functional result is the lytic destruction of erythrocytes on membrane insertion of C5b-9 (MAC). Low but not absent CH50 results could reflect complement consumption due to active immune complex disease, diminished hepatic production due to liver disease, and immaturity of hepatic production seen in young infants. *Screening with hemolytic assays is not adequate for C9, properdin, MBL, MASP-2, or ficolin deficiencies.* In patients with these defects, the hemolytic assay value may be minimally decreased or normal. An alternative assay, popular in Europe, is a plate-based activation assay, which more specifically detects complement



**Fig. 173.2** Sequence of activation of the components of the classical and lectin pathways of complement and interaction with the alternative pathway. Functional activities generated during activation are enclosed in boxes. The multiple sites at which inhibitory regulator proteins (not shown) act are indicated by asterisks. Ab, Antibody (immunoglobulin G or M class); Ag, antigen (bacterium, virus, tumor, or tissue cell); B, D, P, factors B, D, and properdin; C-CRP, carbohydrate-carbohydrate-reactive protein; MBL, mannose-binding lectin; MASP, MBL-associated serine protease.



**Fig. 173.3** Laboratory screening of complement system. LP, Lectin pathway; MBL, mannose-binding lectin; MASP, MBL-associated serine protease.

activation through CP, LP, and AP (“CS screen” test). Although the result target of these enzyme-linked immunosorbent assays (ELISAs) is principally the same as for the lytic assays, it is based on detecting full assembly of C5b-9 by using an antibody to a C9 neoantigen when serum is added to microtiter wells coated with the activation agent for the different pathways (e.g., IgM for CP, mannan for LP, and lipopolysaccharides for AP).

Once an abnormal CH50 or AP50 has been confirmed, immunochemical tests can be used to define the serum levels of specific components, the second step for defining complement deficiencies. Normal concentrations of single components do not exclude functional defects. The functional activity of a single component can be tested. Sera depleted of the actual component and patient’s fresh serum are mixed to see whether the activity can be restored by using hemolysis as a result. Reduced functional activity of individual complement components either reflects a deficiency state, or indicates consuming complement activation. To distinguish primary or acquired defects, activation products generated by CS activation could be measured. Different approaches can be applied for this aim: detection of split fragments, generated after enzymatic cleavage of certain components, e.g., C4 (C4a, C4b/c, C4d), C3 (C3a, C3b/c, iC3b, C3d), factor B (Ba, Bb), and C5 (C5a), or the identification of protein complexes where activated components are bound to their respective regulators, like C1rs-C1-inhibitor, the properdin-containing AP convertase, C3bBbP, and sC5b-9 (soluble terminal complement complex). Detection of complement activation products like C3d and C4d on red cells using *flow cytometry* has been used to evaluate *in vivo* complement activation in autoimmune diseases and trauma. The terminal **C5b-9 complement complex** exists in two forms, the MAC and the soluble form (sC5b-9). The *in vitro*-generated surface-bound C5b-9 must not be confused with sC5b-9, which is found in plasma and if increased is a useful marker of complement activation *in vivo* reflecting diseases with disturbed complement function. sC5b-9 can be quantified by ELISA and is based on the same C9 neoepitope principle. In the case of efficient C5 blockade, there should ideally be no sC5b-9 present.

C4 levels have been used as a screening test for **C1-INH deficiency in hereditary angioedema (HAE)**; this test does not substitute quantitative and/or functional evaluation of C1-INH. C4 concentrations can be within normal range between episodes in approximately 5–10% of the patients. Also, a defective C1-INH protein can reflect only a functional assay with normal quantitative values. **Deficiency of factor I or H** permits persistence of the classical and alternative pathway convertase and thus consumption of C3, with reduction in the CH50 value. If multiple components are decreased, it is possible that sample handling was improper, a regulatory protein was deficient, or autoantibodies were present. Flow cytometry is the standard technique for the diagnosis of **paroxysmal nocturnal hemoglobinuria (PNH)** by detecting reduced levels of CD55 and CD59 on blood cells.

Autoantibodies to complement components could simulate deficiencies and assays for their detection would be relevant according to clinical information. They are often associated with specific diseases, e.g., anti-C1q antibody is associated with hypocomplementemic

**Table 173.3** The Steps for Complement System Evaluation

COMPLEMENT EVALUATION	EXAMPLES
Total complement activity	CH50, AP50, lectin pathway
Quantification of single components	C3, C4, MBL, properdin
Functional activity of single components	Functional C1 inhibitor
Products of complement activation	C3d; C3dg
Autoantibodies to complement components	Anti-C1q; nephritic factor
Cell surface expression	CD55; CD59; CR3/4
Tissue deposition of complement proteins or fragments	Deposition of C3 or factor H in injury burns
Genetic evaluation	Next generation sequencing or specific gene panels

urticarial vasculitis and/or proliferative systemic lupus erythematosus (SLE) nephritis.

Assessment of cell surface expression of receptors and tissue deposition of complement proteins or fragments are further steps for complement evaluation. Specific gene panels are another accessible tool that could supply additional information (Table 173.3).

Visit Elsevier eBooks+ at [eBooks.Health.Elsevier.com](http://eBooks.Health.Elsevier.com) for Bibliography.

## 173.2 Complement Pathway Deficiencies

Anete Sevciovic Grumach

Most genetically determined complement deficiencies are inherited in an autosomal recessive fashion. Exceptions are properdin deficiency, which is X-linked, and C1-INH deficiency, which is autosomal dominant. In most cases, it is possible to predict the effects of a particular deficiency based on understanding the normal physiologic function of that protein. Increased susceptibility to **infections** caused by encapsulated bacteria and **autoimmunity** are the most common presentations of complement deficiencies. Deficiency of components of TP and properdin deficiency are associated with neisserial infections. When there is an imbalance between complement activation and regulation, complement can quickly attack the host and trigger and/or exacerbate adverse processes that result in diseases and clinical complications. Genetic variants in the **complement factor H (CFH)** and **complement factor I (CFI)** genes have been associated with **atypical hemolytic uremic syndrome (aHUS)** and **aging macular degeneration (AMD)**. A distinct clinical manifestation is described for deficiency of C1-INH causing recurrent **angioedema**.

### CLASSICAL PATHWAY DEFICIENCIES

Patients deficient in the initial components of the CP are prone to autoimmune connective tissue diseases (Table 173.4). Most patients with primary **C1q deficiency** have SLE; some have SLE-like syndrome without typical SLE serology, a chronic rash with underlying vasculitis, or membranoproliferative glomerulonephritis (MPGN). The association with SLE is due to compromised clearance of apoptotic debris and impaired B-cell tolerance. Some C1q-deficient children have serious infections, including septicemia and meningitis. Only a few patients with **inherited deficiencies of C1r and C1s** have been described. It is thought that neither component is stable without the other so that a pathogenic variant in one often leads to diminished levels of both. Glomerulonephritis and lupus have been reported in C1r/C1s-deficient patients.

**Table 173.4** Pathway Deficiencies of Complement System

DEFICIENCY	INHERITANCE	ASSOCIATED SYMPTOMS/DISORDERS
C1q, C1r/s (often combined), C2, C4 (total C4 deficiency)	AR	SLE, systemic infections with encapsulated organisms; heterozygous C2 deficiency may have a reduced CH50 but remain asymptomatic
C4A or C4B	Complex	Susceptibility to infections and/or autoimmunity (SLE); mostly asymptomatic
C3 GOF	AD	aHUS (2–10% of the cases)
C3	AR	Pyogenic infections, neisserial infections, glomerulonephritis, AMD
C5, C6, C7, C8 $\alpha$ - $\gamma$ /C8 $\beta$	AR	Neisserial infections; recurrent meningitis
C9	AR	Neisserial infections (mostly asymptomatic)
Factor B	AR*	Neisserial and pneumococcal infections, aHUS (1–4% of the cases)
Factor D	AR	Bacterial infections
MBL	Polymorphism	Bacterial infections (mostly asymptomatic) and susceptibility to autoimmunity in some cases
Ficolin-3 (H-ficolin)	Polymorphism	Various clinical phenotypes
MASP-1	AR	3MC syndrome
MASP-2	AR	Respiratory infections, mostly asymptomatic

\*AR, Autosomal recessive non-codominant.

AR, Autosomal recessive; AD, Autosomal dominant; C4A and C4B, isotypes encoded by C4A and C4B genes, respectively; GOF, gain of function; SLE, systemic lupus erythematosus; aHUS, atypical hemolytic uremic syndrome; AMD, aging macular degeneration; 3MC, Mingarelli, Malpuech, Michels and Carnevale.

Complement component **C4** is a central protein in the classical and lectin pathways within the CS. **C4A** and **C4B** genes encode the two isoforms of the component C4, an essential element for the effector arm of the humoral immune response. The two isotypes of C4, which differ by only four amino acids, demonstrate differential chemical reactivities: C4A displays a higher affinity for amino group-containing antigens or immune complexes, and C4B for hydroxyl group-containing antigens. The presence of one C4A or C4B gene is called *heterozygous* C4A or C4B deficiency, whereas the presence of no functional C4A or C4B genes causes *complete* C4A or C4B deficiency and is called **homozygous C4 deficiency**. Homozygous deficiencies of complement C4A or C4B are detected in 1–10% of populations. Homozygous deficiency of C4A is associated with an increased frequency of SLE; whereas homozygous C4B deficiency has been associated with increased susceptibility to bacterial and enveloped viral infections. Within each C4 gene, there can be deletions or duplications or simple inactivating variants; therefore interpretation of a serum level is difficult.

**C2 deficiency** is found with a frequency of 1/10,000 in the White population. The lowest frequency of autoimmunity (10–42%), among the proteins of the CP, is observed in C2-deficient patients. Individuals with C2 deficiency also carry the risk of life-threatening septicemic illnesses, usually caused by pneumococci; however, most have not had problems, presumably because of protective effects of other complement pathways. The genes for C2, factor B (AP), and C4 are situated close to each other on chromosome 6, and a partial depression of factor B levels can occur in conjunction with C2 deficiency.

Patients with C1, C2, or C4 deficiency have an increased occurrence of **autoantibodies**; antinuclear antibodies are present in 75% of patients with C1 or C4 deficiency and 25–55% of patients with C2 deficiency. Anti-dsDNA antibodies are present in 20% of patients with C1q/C4 deficiency and 33% of patients with C2 deficiency. Individuals with heterozygous C2 or C4 deficiency often remain asymptomatic. Also, there is an increased incidence of **bacterial infections** associated with deficiency of components in CP, including meningitis, pneumonia, arthritis, or septicemia. Other infections such as epiglottitis, and peritonitis have been described. The most common organisms identified in C2-deficient patients have been *Streptococcus pneumoniae* and *Haemophilus influenzae* type b.

### C3 Deficiency

C3 deficiency is rare and the disease manifests early in life. Severe infections (pneumonia, meningitis, osteomyelitis, or bacteremia) caused by encapsulated bacteria (*H. influenzae*, *Neisseria meningitidis*) occur. The infections reflect the impairment in the C3b opsonization, generation of chemotactic factor, influence in B-cell stimulation, and failure of complete complement activation. **MPGN** is noted in approximately 30% of the cases of C3 deficiency. Slightly more common is a partial deficiency of C3, termed *hypomorphic* C3. This partial deficiency has been seen in some autoimmune disorders. Rare C3 gain-of-function (GOF) variants may lead to **aHUS** and endothelial damage in the glomerulus. One common and several rare variants in C3 have been associated with increased risk of AMD. A unique feature of C3 deficiency is a vasculitic rash that may appear during infections; symptoms of serum sickness may occasionally be seen. These unusual findings are due to the lack of immune complex solubilization by C3. They typically are transient in nature but can cause confusion with lupus, particularly in the presence of glomerulonephritis.

### DEFICIENCY OF TERMINAL COMPONENTS (C5, C6, C7, C8, C9)

Terminal components are shared by the classical, lectin, and alternative pathways, and are ultimately responsible for the formation of the **MAC**. The risk of developing **meningococcal sepsis or meningitis** is markedly increased in people who have a deficiency of one terminal component. In contrast to the immunocompetent population (median age for meningococcal infection: 3 years), the onset of symptoms in patients with terminal deficiencies is 17 years. However, infections generally lead to lower mortality, may be recurrent, and have a milder course than in an immunocompetent person. Rarely, SLE or other autoimmune disorders has been identified in these defects. Disseminated *Neisseria gonorrhoeae* infections have also been described; an increased frequency of other bacterial infections is not observed. A terminal component deficiency should be suspected if there is a family history of meningococcal infections, repeated neisserial infections, or if the causative meningococcal serotype is W-135, X, Y, or Z, which less frequently cause infections in healthy individuals. Early vaccination of children could change the profile of serotypes causing infection in those patients.



**C6 deficiency** occurs more frequently in African Americans and in people from South Africa. Two variations of C6 deficiency have been described. In one case, a splice defect leads to a smaller than usual protein, C6SD. This protein functions less efficiently than wild-type C6; however, it is not clear whether bearing C6SD leads to compromised host defense. The other variation is combined C6 and C7 deficiency. **C7 deficiency** is rare and in the few reported cases, the clinical presentations have varied.

C8 is composed of three chains:  $\alpha$ ,  $\beta$ , and  $\gamma$ . **C8 $\beta$  deficiency** is more common in White people, whereas **C8 $\alpha$ - $\gamma$  deficiency** is more common among African Americans. Approximately 1 patient in 1000 carries a homozygous common nonsense variant causing **C9 deficiency** as described in Japan and Korea. It is more difficult to diagnose than most of the other complement deficiencies because the CH50 is diminished but not absent. Lytic activity can be generated in the absence of C9. The neisserial disease can occur, although the penetrance appears to be less than that with other terminal component deficiencies.

### ALTERNATIVE PATHWAY DEFICIENCIES

The AP is a highly conserved surveillance system that is continuously turning over (tick over) due to a labile thioester bond in C3 and thus does not require antibodies or lectins for activation. **Properdin** is a positive regulator of AP activity and works by stabilizing AP convertases. **Properdin deficiency** is rare, hereditary, and is the only X-linked complement deficiency. A small number of patients have been identified with properdin deficiency; these patients are unusually susceptible to **Neisseria infections**. There is a particularly high fatality rate for meningococcal disease in properdin-deficient patients, in contrast with the protection from early death seen in patients with terminal complement component deficiencies. It manifests with either complete absence of the molecule (type I), partial deficiency (type II), or a normal level of dysfunctional protein (type III). Properdin-deficient individuals are susceptible to **meningococcal disease**, which is frequently complicated by sepsis and most commonly occurs in adolescence. **Factor D** and **Factor B deficiencies** were described in few cases and the association with *Neisseria* infections was also identified. Systemic streptococcal infections have also been involved in factor D deficiency. GOF pathogenic variants in factor B are associated with the aHUS.

### LECTIN PATHWAY DEFICIENCIES

The LP is focused on the recognition of repetitive carbohydrate patterns found on the surface of microbial pathogens. Lectin **pattern recognition molecules (PRMs)**, which include MBL, ficolin-1, ficolin-2, ficolin-3, collectin-10, and collectin-11, activate the pathway in an analogous manner to antibodies in the CP. **MASPs**, which act in a similar fashion to C1r and C1s, associate with MBL and activate C4 and C2 by proteolytic cleavage (see Fig.173.1). Among White populations, approximately 5–7% of people have inherited MBL deficiency. LP impairment due to insufficient production of any of these components is common and may be associated with no clear clinical phenotype. However, MBL insufficiency is, in combination with other factors, associated with more severe forms of sepsis and fatal outcomes. The deficiency appears to represent a modest risk factor for infection, typically revealed in a high-risk setting. Similarly, it may subtly alter the course or contribute to the overall risk of developing several autoimmune diseases. MBL deficiency has been associated as an additional severity influence for common variable immunodeficiency, cystic fibrosis, and hepatitis. In contrast, low MBL levels have been described as protective for mycobacterial infection. MBL deficiency is not typically associated with absent levels, and it has been difficult to define the normal range in healthy people.

**MASP-1**, the most abundant protease of the LP, has a central role in pathway activation via MASP-2. MASP-1 may be involved in coagulation, renal, gastrointestinal, and myocardial ischemia/reperfusion-related pathology; there is no firm evidence for this type of pathology in humans.

The **Malpuech, Michels, Mingarelli, Carnevale (3MC) syndrome** is a rare, autosomal recessive genetic disorder associated with pathogenic variants in the **MASP1/3; COLEC11; or COLEC10** genes. The

number of 3MC patients with known pathogenic variants in these three genes reported so far remains very small. The clinical manifestations of the 3MC syndrome consist of developmental delay, facial dysmorphism, and various skeletal anomalies. Developmental defects include cleft lip and palate, postnatal growth deficiency, cognitive impairment, and hearing loss. Excess or unusual infections and autoimmunity have not yet been described in this syndrome. The proposed mechanism was revealed by an unexpected role for these proteins in cuing neural crest cell migration.

**MASP-2 deficiency** was initially described in a patient with serious infections and autoimmune disease. MASP-2 deficiency has been included in the classification of primary immunodeficiencies. Asymptomatic individuals have been described; the frequency is 6/10,000, suggesting that the phenotype is mild. Healthy individuals homozygous for p.D120G have also been found by chance in genetic association studies. These findings suggest that MASP-2 deficiency could no longer be associated to a specific clinical phenotype. In contrast, increased levels of MBL or MASP-2 may contribute to poor disease outcome associated with mycobacterial infections or pneumococcal meningitis.

Complete **ficolin-3 (or H-ficolin) deficiency** was initially associated with increased susceptibility to infections and necrotizing enterocolitis. A heterogeneous range of clinical manifestations have been described in patients with complete ficolin-3 deficiency, and the first case described was later diagnosed with Wiskott-Aldrich syndrome. Respiratory and nervous system involvement in the few reported cases of FCN3 deficiency raises awareness regarding the significance of ficolin-3 in respiratory and nervous immunity.

### DEFICIENCIES OF COMPLEMENT REGULATION

The CS has several levels of **regulation** at the initiation, amplification (formation of convertases), and membrane attack phases, thereby preventing inadvertent tissue damage. Deficiency of complement inhibitors leads to dysregulation either in the fluid phase or on cell surfaces and consequent recurrent infections (mostly bacterial), inflammatory disorders, and presentations with a broader clinical phenotype. These include angioedema (**C1-INH deficiency**), kidney and eye diseases (**factor H, factor I, or CD46/MCP deficiency**), **protein-losing enteropathy (CD55/DAF deficiency)**, and **PNH (CD55 + CD59 deficiency)**. In addition, there are seven complement receptors (C1qR, C3aR, C5aR, CR1, CR2, CR3, and CR4). The same disease spectrum may be caused and shaped by a broad variety of different alterations in complement activators and/or regulators. The individual complement profile of a patient (sometimes referred to as **complotype**) often determines the course and severity of the disease. Disorders such as AMD, aHUS, or C3 glomerulopathy (C3G) are among the most well-described examples in this context.

Approximately 50% of patients with aHUS have genetic pathogenic variants of factors H and I, C3, factor B, and/or MCP, and deletion of complement factor H-related proteins 1 and 3 (CFHR1/CFHR3). Approximately 20% of patients with aHUS have pathologic variants in more than one gene and patients with autoantibodies to regulatory proteins also comprise a significant subset. The majority of aHUS cases are sporadic and occur in the absence of prior family history. Furthermore, even in familial forms of aHUS, penetrance is incomplete.

Thrombomodulin (CD141) also has a regulatory role and binds to factor H and C3b, thereby inhibiting complement activation. Interestingly, pathologic variants in factor H, MCP, and factor I have also been reported in C3 MPGN, as well as preeclampsia and hemolysis, elevated liver enzyme levels, and low platelet levels (HELLP) syndrome.

Several complement proteins, their activation products, and regulators have also been related to **AMD**, particularly, C3 and factors H and I.

### Hereditary Angioedema

**HAE** comprises a group of diseases characterized by recurrent angioedema without wheals, showing an autosomal dominant inheritance pattern. It was first recognized in patients with heterozygous **deficiencies of C1-INH** and the estimated prevalence is 1:50,000 (**Chapter 189.1**). Patients with angioedema without wheals have also been described with normal C1-INH levels. Several pathogenic variants



were associated with this group of patients with **primary angioedema**: factor XII (FXII-HAE), plasminogen (PLG-HAE), angiotensin-converting enzyme (ACE-HAE), kininogen-1 (KNG1-HAE), myoferlin (MYOF-HAE), and heparan sulfate-glucosamine 3-O-sulfotransferase 6 (HS-HAE). However, a significant proportion do not have a defined molecular explanation.

The angioedema is self-limited and recurrent, affecting the deep layers of skin and mucosa, commonly causing swelling of extremities (hands, feet, limbs), face, lips, tongue, genitalia, bowels, and the upper airway. The involvement of the gastrointestinal tract causes severe abdominal pain, distension, vomiting, and, less frequently, diarrhea. The symptoms can be misdiagnosed, and unnecessary surgery may be performed. The obstruction of upper airways due to edema of the larynx is associated with asphyxia if the attacks are not prevented. Swelling attacks are transitory and usually last from 2-5 days, but their severity and frequency vary widely from patient to patient. Approximately 5% of people who carry a C1-INH pathologic variant are asymptomatic.

In the most frequent subtype, HAE with C1-INH deficiency (HAE-C1INH, OMIM #106100), the first HAE episodes occur at a mean age of 10 years; however, the onset of symptoms may occur at an early age (Chapter 189.1). This type of HAE is classified as **type I** when there is low quantitative and functional C1-INH levels (85% of the cases) and **type II** for decreased functional C1-INH values. A typical functional level is approximately 25–40% of normal in both types. Attacks, when identified, are triggered by stress, trauma, hormones (estrogen), infections, extreme temperatures, and alcohol. Although many patients can identify triggers, many episodes have no identifiable trigger, which increases anxiety and contributes to feelings of loss of control. The symptoms are preceded by prodromes, such as erythema marginatum, irritability, nausea, and flulike symptoms. Consumption of C2 and C4 increases the risk for the development of SLE. Positive family history occurs in 75% of the cases and de novo pathogenic variants are described in 25% of the cases.

The **third type** of HAE referred to as **HAE with normal C1-INH** (previously called type III), is not a complement deficiency. It is characterized by normal serum levels and functional activity of C1-INH. It has been described primarily in females; however, both sexes are affected.

**Acquired C1-INH deficiency** is rarer than HAE-C1-INH (1:9) and is clinically indistinguishable from inherited C1-INH deficiency except that onset is later in life (>40 years old). Patients with acquired C1-INH deficiency require careful surveillance for malignancy; B-cell malignancies, autoimmunity, and monoclonal gammopathies are the most common. The laboratory features are similar to those of hereditary C1-INH deficiency, except that C1q levels are diminished in these patients. Anti-C1-INH can be detected in approximately 70% of the cases.

### C4 Binding Protein Deficiency

C4 binding protein deficiency has been described in one family. The proband presented with angioedema, vasculitis, and arthritis. The manifestations were thought to relate to uncontrolled activation of the CP and the release of anaphylatoxins.

### Factor H Deficiency

Factor H (CFH), which is present at high concentrations (500 µg/mL) in plasma, works in both the liquid and solid phases and attenuates the activity of C3 convertase in the AP and acts as a cofactor for factor I in the cleavage of C3b and C4b. It is a multifunctional molecule that has the function of decay acceleration and plays a very important role in regulating complement activation. Infections, aHUS, glomerulonephritis, and macular degeneration are the main disease phenotypes seen in patients with factor H deficiency. Infections occur due to secondary consumption of C3 with consequent partial deficiency. Diagnosis is suggestive when C3 has diminished levels and low but not absent CH50 and AP50 is found. The antigenic levels of factor H are typically low.

Several people with **MPGN** were identified with factor H deficiency. CFH deficiency was found to be the underlying basis for the pathophysiologic changes in 15–30% of patients with **aHUS**. aHUS is a thrombotic microangiopathy characterized by hemolytic anemia,

thrombocytopenia, and renal failure, which occurs in the absence of its usual cause (infection with a Shiga toxin-producing organism). It is called “atypical” because it lacks the common trigger of infectious diarrhea. CFH deficiency probably affects the ability to protect the fenestrated endothelium in the glomerulus from complement-mediated damage. Recurrent aHUS also has been seen in patients with antibodies to factor H, defining an acquired form as well. This form may be slightly more amenable to therapy. Both autosomal recessive and heterozygous pathogenic variants have been seen. The age at onset is quite young in most cases, and the disease is recurrent. Mortality is not uncommon. These patients have a diminished C3 level, although the antigenic level of factor H typically is normal or elevated. Normal C3 levels are sometimes seen, and the only way in which this disorder can be identified is with direct genetic analysis.

A common tyrosine-histidine polymorphism of factor H was identified as a significant risk factor for **macular degeneration** with a higher risk of the development of macular degeneration and blindness subsequently. In macular degeneration, the central region of the retina is gradually destroyed by a process that leaves deposits of protein that contain factor H and terminal complement components. It has been hypothesized that the abnormal factor H provides less protection to the choroidal vessels, allowing smoldering complement activation with gradual damage to the endothelium.

### FACTOR I DEFICIENCY

Not only factor H but also factor I is a key regulator of the AP. Deficiency of factor I results in uncontrolled activation of the AP with subsequent secondary C3 deficiency and a reduction in circulating factor H levels. Distinct clinical manifestations have been associated with **factor I deficiency**. Marked susceptibility to infections relates to the role of factor I as a cofactor for C3bBb dissociation. When factor I is lacking, C3bBb continues to cleave C3 resulting in secondary C3 deficit. Both the CH50 and the AP50 are depressed but not absent, and C3 antigen levels are low. In factor I deficiency, infections are similar to those seen in true C3 deficiency. Neisserial disease has been reported, as well as infections with encapsulated organisms such as *S. pneumoniae* and *H. influenzae*. Partial factor I deficiency has been described. aHUS, or MPGN II, has also been associated with factor I deficiency, probably related to the capacity of complement regulatory proteins to protect vascular endothelium from activating complement after microtrauma. These cases of factor I deficiency are difficult to identify because complement studies often give normal results. C3 may be depressed but is not necessarily affected. The pathogenic variants inactivate certain binding sites like surface-bound C3b and polyanion surfaces such as the fenestrated endothelium of the glomerulus, which exposes the basement membrane. A third phenotype resembles an autoinflammatory process and has been described in a small number of patients. Central nervous system inflammation has been the hallmark. Partial factor I deficiency has also been previously associated with clinical manifestations including recurrent tonsillitis, urinary infections, otitis, pyelonephritis, severe meningitis, and sepsis.

### Membrane Cofactor Protein (CD46) Deficiency

MCP is a membrane protein, and its defect is intrinsic to the kidney. Deficiencies of MCP are associated with a later onset of atypical HUS compared with factor H and factor I deficiencies and it accounts for approximately 10% of all cases. There is no other known phenotype for MCP deficiency. Findings on traditional complement analysis are normal, although the mechanism is thought to be the same as for factor H and factor I deficiencies. Considering the local defect, renal transplantation can be successful.

### CD59 Deficiency

CD59 is the key membrane regulator of the TP that prevents insertion of the MAC into host tissue. It is expressed on most hematopoietic cells and endothelial cells, where it confers protection from intravascular complement-mediated lysis. Isolated CD59 deficiency manifests by chronic hemolytic anemia, recurrent stroke, and severe Guillain-Barré-like neurologic symptoms with hemolysis. This defect

**Table 173.5** Protein Regulators and Receptor Deficiencies of Complement System

DEFICIENCY	INHERITANCE	ASSOCIATED SYMPTOMS/DISORDERS
C1 inhibitor	AD	HAE with C1-INH deficiency
C4-binding protein	Unknown	Atypical Morbus Behçet, angioedema, protein S deficit
Properdin	X-linked recessive	Meningitis ( <i>Neisseria</i> )
Factor H	AR	Membranoproliferative glomerulonephritis, AMD, aHUS (20–30% of the cases)
Factor I	AR	Pyogenic infections, neisserial infections, glomerulonephritis, aHUS (5–10% of the cases), central nervous system inflammation
CFHR1 (FHR3)	Complex	aHUS, C3G, AMD, RA, SLE
Thrombomodulin (CD141)	AD	aHUS (3–5% of the cases)
CD46/MCP	Most often heterozygous or compound heterozygous pathogenic variants	aHUS (10–15% of the cases)
CD55/DAF	AR	Protein losing enteropathy
CD55 (DAF) or CD59	AR	PNH
CD59	AR	Chronic hemolysis and relapsing peripheral demyelinating disease, cerebral infarction
CR2 (CD21)	AR	Infections, associated with CVID
CR3 (CD18/CD11b); CR4 (CD18/CD11c, LFA-1)	AR	LAD

CFHR1, Complement factor H related 1; MCP, membrane cofactor protein; DAF, decay-accelerating factor; LFA-1, integrin called lymphocyte function-associated antigen 1; AR, autosomal recessive; AD, autosomal dominant; aHUS, atypical hemolytic uremic syndrome; C3G, C3 glomerulopathy; SLE, systemic lupus erythematosus; AMD, aging macular degeneration; RA, rheumatoid arthritis; SLE, systemic lupus erythematosus; PNH, paroxysmal nocturnal hemoglobinuria; CVID, common variable immunodeficiency; LAD, leukocyte adhesion deficiency.

in CD59 was suspected in cases of chronic hemolysis because of the phenotypic resemblance to PNH. PNH is caused by acquired somatic variants of phosphatidylinositol glycan class A (PIG-A) or phosphatidylinositol glycan class M (PIG-M) in a clone of bone marrow progenitor cells. The protein product of PIG-A is an anchoring structure for C8 binding protein, DAF (CD55), and CD59. Glycosylphosphatidylinositol (GPI)-anchored proteins protect hematopoietic cells from complement-mediated lysis. PNH is characterized by recurrent episodes of hemoglobinuria secondary to intravascular hemolysis and can be associated with thrombosis and aplastic anemia. The red cells are the most vulnerable because they have no ability to repair membrane damage. When the cells develop from the variant-bearing progenitor, they lack all GPI-anchored membrane proteins, although the major features relate to loss of CD59. The diagnosis of PNH is made by flow cytometry for CD59 or CD55 (DAF).

### Decay-Accelerating Factor (CD55) Deficiency

DAF (CD55) is a membrane-bound regulator that dissociates both classical and alternative C3 convertases. In certain kindreds, DAF deficiency has been associated with protein-losing enteropathy, whereas in others, all of the members have been completely healthy, with the deficiency being identified at the time of blood donation or cross matching for a transfusion. The *Cromer blood group* antigens reside on DAF. The RBCs of people with the Cromer-null phenotype, Inab, lack DAF but do not appear to show increased susceptibility to hemolysis. This finding suggests that CD59 is substantially more important in regulating red cell lysis by complement.

## DEFICIENCIES OF COMPLEMENT RECEPTORS

### CR1 Deficiency

CR1 (CD35) is a multiple modular protein that binds C3b/C4b-opsonized foreign antigens, mediating the immune adherence phenomenon. No cases of complete inherited CR1 deficiency have been reported; however, acquired mild C1R deficiency is quite common in patients with immune complex diseases and serum sickness. Similarly, a polymorphic variant of CR1 with diminished levels and function has

been described, although it does not appear to be a risk factor for autoimmune disease.

### CR3/CR4 Deficiency

CR3/CR4 deficiency (LFA-1) is a defect in the 3  $\beta_2$ -integrin adhesion molecules. Pathogenic variants in the common  $\beta$  chain (CD18) lead to failure to express adequate  $\alpha$  chains: CD11a, CD11b, and CD11c. **Leukocyte adhesion deficiency (LAD)** is an autosomal recessive disorder of neutrophil function resulting from a deficiency of  $\beta_2$ -integrin subunit of the leukocyte cell adhesion molecule (Table 173.5; see Chapter 170). The leukocyte cell adhesion molecule is present on the surface of peripheral blood mononuclear leukocytes and granulocytes and mediates cell-cell and cell-extracellular matrix adhesion. LAD is characterized by a delayed separation of the umbilical cord, recurrent bacterial and fungal infections, and impaired pus formation and wound healing associated with heavy mortality; bone marrow transplantation often is recommended. The infections are characteristic in that necrosis predominates, with little neutrophilic infiltrate. With some residual  $\beta_2$ -integrin expression, the patient may be able to survive without a bone marrow transplant and infections are common.

The manifestations of the disorder are due to the combined effects of ineffective opsonization and an inability to traverse the vascular endothelium to phagocytose bacteria.  $\beta_2$ -Integrins are essential for the firm adhesion step and diapedesis. Lacking  $\beta_2$ -integrins, the neutrophils remain in the vascular space, where they are unable to participate in the defense against bacteria. This explains the lack of pus at sites of active infection.

Two other forms of LAD are recognized: **LAD type II** is due to a defect in fucosylation of selectin ligands and **LAD type III** is due to an activation defect of integrins. The major manifestations are the infection pattern just described and a moderate to severe bleeding tendency secondary to impaired activation of platelet adhesion molecules. LAD-III results from pathogenic variants in FERMT3, or KINDLIN3, which encodes an intracellular protein that interacts with  $\beta$ -integrins in hematopoietic cells. In LAD-III, the adhesive functions of integrins on both leukocytes and platelets are disrupted, most likely due

to defects in activation-dependent alterations of surface integrins that enable high-avidity binding to ligands on target cells, a process termed inside-out signaling.

### MANAGEMENT OF COMPLEMENT DEFICIENCIES

Prophylactic antibiotics may offer additional protection from serious infection. With the onset of unexplained fever, cultures should be obtained and antibiotic therapy instituted rapidly and with less stringent indications than in an unaffected child. The parent or patient should be given a written action plan describing any predisposition to systemic bacterial infection or autoimmune disease associated with the patient's deficiency, along with the recommended initial approach to management, for possible use by school, camp, or emergency department physicians. Therapy for infection is not standardized, but it is usually directed to prevent infections caused by encapsulated bacteria. Early complement component deficiencies have major risks to acquire infections caused by *S. pneumoniae* and *H. influenzae*.

Patients should also be vaccinated against encapsulated organisms to maintain high titers. In the case of terminal component, factor D, and properdin deficiencies, high levels of antibody after vaccination may partially compensate for the complement deficiency. Effective vaccines are available; high titers of antibody may offer protection. Repeat immunization of patients is advisable because complement deficiency can be associated with a blunted or shorter-lived antibody response than normal. Immunization of household members may reduce the risk of exposing patients to these pathogens.

Patients under immunosuppression for rheumatologic disorders such as SLE will require more vigilance for severe infection. Individuals with SLE and a complement defect generally respond as well to therapy as do those without complement deficiency. Management of cardiac risk factors is of heightened importance in early complement component-deficient individuals because of their accelerated atherosclerosis. C1q deficiency has a poor prognosis and this protein is produced to a large extent by myeloid cells. Bone marrow transplantation has been curative and should be considered for C1q deficiency.

MBL purified from plasma or recombinant material has been administered in trials; however, no prospective study has been performed. In addition, the role of MBL deficiency in significant infections is not well established.

The treatment of **HAE with C1-INH deficiency** is noted in [Chapter 189.1](#). General guidance includes avoiding the use of estrogens or drugs that can induce angioedema, such as angiotensin-converting enzyme inhibitors (ACEis) and gliptins. If possible, trigger factors could be avoided. Vaccination is not contraindicated, and hepatitis A and B vaccinations are recommended. The approach includes long-term prophylaxis (LTP), short-term prophylaxis (STP), and on-demand therapy ([Table 173.6](#); see [Chapter 189.1](#)).

STP is used for dental procedures, surgical procedures, endoscopies, or other situations in which significant trauma may be expected. Attenuated androgens can be used for this indication; C1-INH concentrates have largely supplanted androgens in this setting. A recombinant C1-INH, conestat alfa, is effective for both HAE attacks and for STP. Fresh-frozen plasma (FFP) is another alternative in this setting.

Despite prophylaxis, breakthrough episodes do occur. **On-demand therapy** should also be an option for patients with sporadic attacks or who may not be on any active prophylaxis. There are several options to treat the attacks: C1-INH concentrate; ecallantide, a kallikrein inhibitor; and icatibant, a bradykinin  $\beta_2$ -receptor antagonist.

On-demand treatment and STP is the same for **HAE with normal C1-INH**. LTP shows improvement with tranexamic acid and progestins.

### PNH/aHUS Treatment

**Eculizumab**, a humanized monoclonal IgG2/4-antibody targeting C5, prevents the generation of the MAC C5b9 and is an effective treatment for PNH and aHUS.

Visit Elsevier eBooks+ at [eBooks.Health.Elsevier.com](http://eBooks.Health.Elsevier.com) for Bibliography.

**Table 173.6** Therapies for Hereditary Angioedema with C1 Inhibitor Deficiency

LONG-TERM PROPHYLAXIS	
Androgens (danazol, oxandrolone, stanozolol)	Avoid use If necessary: Danazol: 10 mg/kg/day (max 200 mg/day) Oxandrolone: $\leq 0.1$ mg/kg/day (no max) Stanozolol: 2-6 mg/day (dose and max) after puberty (Tanner 5) Oral
Antifibrinolytics (tranexamic acid, epsilon aminocaproic acid)	Tranexamic acid: 10 mg/kg/day bid to 25 mg/kg/day tid Limit dosage 3 g/day Oral
pdC1-INH nanofiltered*	Approved for $\geq 12$ yr in some countries, $\geq 6$ yr in others 1,000 IU in $\geq 12$ yr 6-12 yr 500 IU q 3-4 days IV
SC pdC1-INH nanofiltered	60 IU/kg twice weekly >12 yr SC
Lanadelumab	300 mg every 2 wk After 6 mo, if no attacks: 300 mg every 4 wk >12 yr SC
Berotrastat	Approved in some countries for 12 yr or older 150 mg/day Oral
SHORT-TERM PROPHYLAXIS	
pdC1-INH nanofiltered*	20 IU/kg IV (no age limits) 1-6 hr before procedure/trigger IV
rhC1-INH/conestat alfa	Approved for $\geq 12$ yr in some countries, $\geq 2$ yr in others 50 IU/kg, max. 4,200 IU (50 IU/kg <84 kg, 4,200 IU >85 kg) IV
Androgens (danazol, oxandrolone, stanozolol)	Avoid use Danazol: 10 mg/kg/day (max 200 mg/day) Oxandrolone: $\leq 0.1$ mg/kg/day (no max) Stanozolol: 2-6 mg/day (dose and max) 5 days before and 2-3 days after procedure/trigger Oral
Fresh-frozen plasma	May be used, if other STP medications not available 10 mL/kg IV No age limits
ON-DEMAND THERAPY	
Ecallantide	Approved in some countries for $\geq 12$ yr 30 mg SC Self-administration is not allowed due to anaphylaxis
Icatibant	Approved for $\geq 18$ yr in some countries, $\geq 2$ yr in others 30 mg/3 mL Dose adjustment is needed for adolescent/children <65 kg/ $\geq 2$ yr SC
pdC1-INH nanofiltered*	20 IU/kg IV (no age limits)
rhC1-INH/conestat alfa	Approved for $\geq 12$ yr in some countries, $\geq 2$ yr in others 50 IU/kg, max. 4,200 IU (50 IU/kg <84 kg, 4,200 IU >85 kg) IV
Fresh-frozen plasma	May be used if other on-demand medications are not available 10 mL/kg IV No age limits

\*Commercial name for pdC1-INH nanofiltered indicated for LTP is Cinryze and for STP is Bernert. IV, Intravenous; LTP, long-term prophylaxis; pd, plasma derived; rh, recombinant; SC, subcutaneous; STP, short-term prophylaxis.

## Section 5

## Immune Dysregulation

## Chapter 174

## Immune Dysregulation

Danielle E. Arnold and Jennifer W. Leiding

Primary immune dysregulatory diseases (PIRDs) are a recognized subset of primary immunodeficiencies that are characterized by hyperinflammation, organ-specific and systemic autoimmunity, endocrinopathy, enteropathy, and nonmalignant lymphoproliferation. Clinical manifestations of immune dysregulation should lead to a consideration of PIRD. Genetic testing can confirm a diagnosis. Targeted treatments are available for many PIRDs and hematopoietic cell transplant (HCT) is often curative.

## 174.1 Tregopathies

Danielle E. Arnold and Jennifer W. Leiding

Tregopathies are a subset of primary immunodeficiency diseases recognized by the International Union of Immunologic Societies. The clinical manifestations of these diseases are variable, but all involve some degree of immune dysregulation manifesting as autoimmunity, hyperinflammation, cancer predisposition, and/or lymphoproliferative disease.

## PATHOPHYSIOLOGY

T regulatory (Treg) cells are specialized T cells responsible for the maintenance and self-tolerance of immune responses (Fig. 174.1). These cells are responsible for suppressing production of proinflammatory cytokines and growth factors and suppressing T-cell proliferation. The transcription factor FOXP3 is essential for the regulatory function of Treg cells. Several subsets of Treg cells exist, each characterized by unique features. Thymic-derived Treg cells (tTreg) ( $CD4^+CD25^+FOXP3^+$ ) account for ~5% of total  $CD4^+$  T cells in the peripheral blood.  $FOXP3^+$  Treg cells can also differentiate outside of the thymus in peripheral tissues. These cells are known as peripherally induced regulatory (pTreg) cells. A number of monogenic diseases (Table 174.1) of the immune system that affect the number and/or function of Treg cells have been described. By reducing the effect of Treg cells, T-cell activation and proliferation are unrestrained. This lack

of regulation or inhibition manifests as immune dysregulation. Clinical symptoms of these disorders include early onset multiorgan autoimmunity, endocrinopathy, enteropathy, colitis, and lymphoproliferation.

## Diagnosis

In a patient with early-onset, severe, or difficult to control autoimmunity, endocrinopathy, colitis, or nonmalignant lymphoproliferative disease, a diagnosis of a Tregopathy should be considered. Next generation sequencing via a targeted panel and/or whole exome sequencing is necessary to establish a genetic diagnosis.

## Treatment

Targeted treatment is available for several Tregopathies (see Table 174.1). Abatacept, a CTLA4-Ig fusion protein, has been used successfully in the treatment of refractory cytopenias, interstitial lung disease, and lymphoproliferation in CTLA4 haploinsufficiency and lipopolysaccharide-responsive and beige-like anchor protein (LRBA) deficiency. Jakinibs are a class of medications that inhibit Janus kinase activation of certain STAT transcription factors. Jakinibs have been used successfully to treat immune dysregulatory and autoimmune symptoms in gain-of-function of STAT1 and STAT3 diseases. HCT can provide a curative option for many Tregopathies.

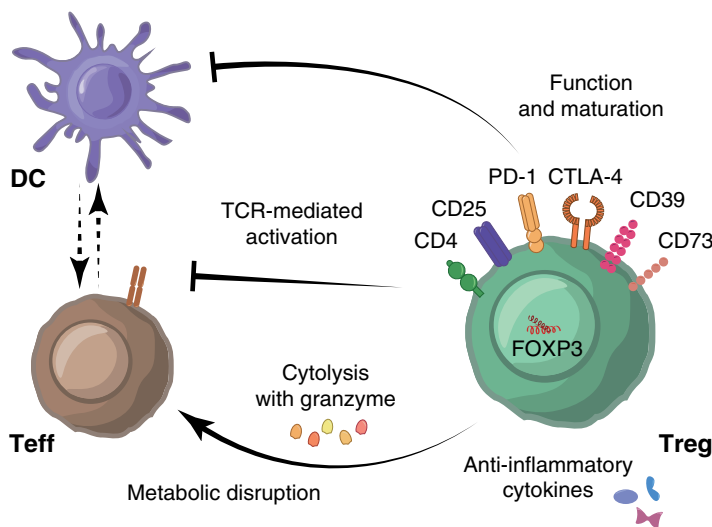
## IMMUNE DYSREGULATION POLYENDOCRINOPATHY, ENTEROPATHY, X-LINKED SYNDROME

This immune dysregulation syndrome is characterized by onset within the first few weeks or months of life with watery diarrhea (autoimmune enteropathy), an eczematous rash (erythroderma in neonates), insulin-dependent diabetes mellitus, hyperthyroidism or more often hypothyroidism, severe allergies, and other autoimmune disorders (Coombs-positive hemolytic anemia, thrombocytopenia, neutropenia). Psoriasisiform or ichthyosiform rashes and alopecia have also been reported.

Immune dysregulation, polyendocrinopathy, enteropathy, X-linked (IPEX) syndrome is caused by a pathogenic variant in the *FOXP3* gene, which encodes a forkhead-winged helix transcription factor (*scurfin*) involved in the function and development of  $CD4^+ CD25^+$  Tregs. The absence of Tregs may predispose to abnormal activation of effector T cells. Variants in multiple other genes also produce an IPEX-like syndrome (see Table 174.1; Fig. 174.2).

## Clinical Manifestations

Watery diarrhea with intestinal villous atrophy leads to failure to thrive in most patients. Cutaneous lesions (usually eczema) and insulin-dependent diabetes begin in infancy. Lymphadenopathy and splenomegaly are also present. Serious bacterial infections (meningitis, sepsis, pneumonia, osteomyelitis) may be related to neutropenia, malnutrition, or immune dysregulation. Laboratory features reflect the associated autoimmune diseases, dehydration, and malnutrition. In addition, serum IgE levels are elevated,



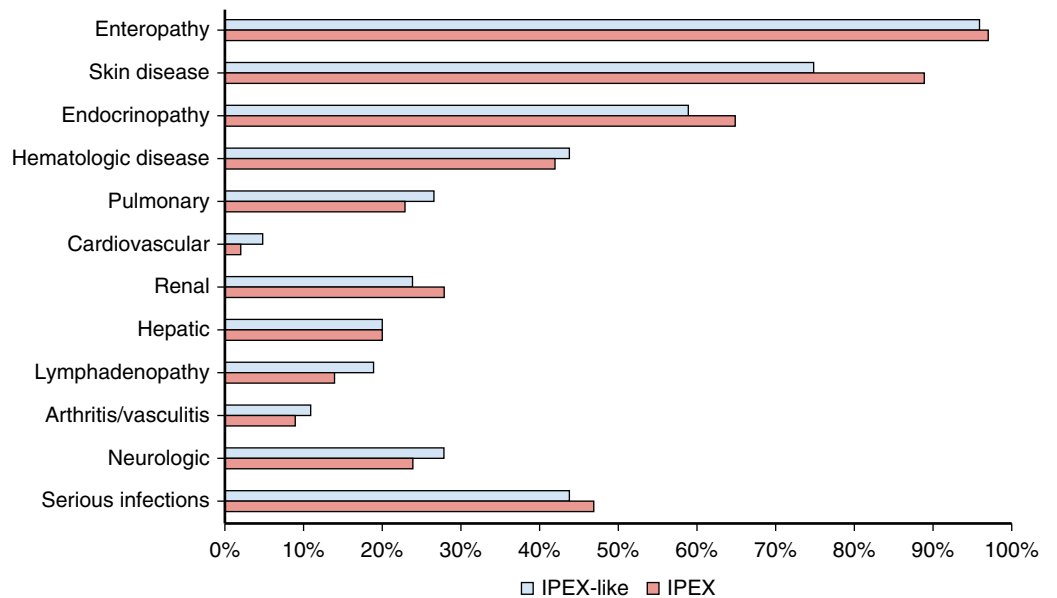
**Fig. 174.1** Immunosuppressive mechanisms underlying Treg-mediated immune suppression. Tregs are characterized by expression of the cell surface markers  $CD4^+$ ,  $CD25^{\text{high}}$  and  $CD127^{\text{low/-}}$ , and transcription factor FOXP3. Tregs modulate the immune system using their suppressive molecules PD-1, CTLA-4, and CD39, and various surface receptors through inhibition of dendritic cell (DC) function and maturation, through the secretion of anti-inflammatory cytokines such as IL-10, TGF- $\beta$ , and IL-35, and/or through direct inhibition of Teff via induction of cytotoxicity using granzyme and metabolic disruption. Moreover, Tregs can reduce Teff activation by limiting TCR-ligand binding. DC, dendritic cell; TCR, T cell receptor; Teff, effector T cell; Treg, regulatory T cell. (From Kempkes RWM, Joosten I, Koenen HJPM, He X. Metabolic pathways involved in regulatory T cell functionality. *Front Immunol.* 2019;10:2839. Fig. 1.)



**Table 174.1** Tregopathies

GENE (PROTEIN)	DISORDER	INHERITANCE	CLINICAL PHENOTYPE	DEFINITIVE OR DISEASE-SPECIFIC TREATMENT
<i>FOXP3</i>	IPEX syndrome	XL	Enteropathy, type 1 diabetes, eczema, FTT, autoimmune cytopenias, thyroiditis, hepatitis	Tacrolimus, cyclosporine Allogeneic HCT
<i>IL2RA</i>	CD25 deficiency	AR	Enteropathy, eczema, lymphoproliferation, recurrent infections	Allogeneic HCT
<i>CTLA-4</i> <i>ALPSV</i>	CTLA4 haploinsufficiency	AD	Enteropathy, type 1 diabetes, autoimmune cytopenias, interstitial lung disease	Sirolimus Abatacept, belatacept Allogeneic HCT
<i>LRBA</i>	LRBA deficiency	AR	Enteropathy, type 1 diabetes, autoimmune cytopenias, interstitial lung disease	Abatacept, belatacept Allogeneic HCT
<i>BACH2</i>	BACH2 deficiency	AD	Enteropathy, lymphoproliferation, recurrent respiratory tract infections, infections	Allogeneic HCT
<i>STAT3</i>	STAT3 GOF	AD, GOF	Enteropathy, autoimmune cytopenias, lymphoproliferation, type 1 diabetes, recurrent infections	Jakinibs Allogeneic HCT
<i>STAT5B</i>	STAT5B	AD, AR	Eczema, growth hormone deficiency, infections, enteropathy, JIA, ITP, chronic lung disease	Symptom specific therapy, HCT

IPEX, Immune dysregulation, polyendocrinopathy, enteropathy, X-linked; XL, X-linked; FTT, failure to thrive; HCT, hematopoietic cell transplant; AR, autosomal recessive; CTLA, cytotoxic T-lymphocyte protein; ALPSV, autoimmune lymphoproliferative disease V; AD, autosomal dominant; LRBA, lipopolysaccharide-responsive and beigelike anchor protein; BACH2, broad complex-tramtrack-bric a brac and Cap'n'collar homology; STAT, signal transducer and activator of transcription; GOF, gain of function; JIA, juvenile idiopathic arthritis; ITP, immune thrombocytopenic purpura.



**Fig. 174.2** Clinical manifestations in the IPEX-like cohorts. (Modified from Gambineri E, Ciullini Manurita S, Hagin D, et al. Clinical, immunological, and molecular heterogeneity of 173 patients with the phenotype of immune dysregulation, polyendocrinopathy, enteropathy, X-linked (IPEX) syndrome. *Front Immunol.* 2018;9:2411. Fig. 5.)

with normal levels of IgM, IgG, and IgA. The diagnosis is initially made clinically and confirmed by genetic testing (exome or panels).

### Treatment

Inhibition of T-cell activation by cyclosporine, tacrolimus, or sirolimus with corticosteroids is the treatment of choice, along with the specific care of the endocrinopathy and other manifestations of autoimmunity. These agents are typically used as a bridge to transplant. HCT is the only possibility for curing IPEX. Janus kinase inhibitors have been used in patients with IPEX-like syndromes.

Visit Elsevier eBooks+ at [eBooks.Health.Elsevier.com](https://ebooks.health.elsevier.com) for Bibliography.

## 174.2 Hemophagocytic Lymphohistiocytosis

Danielle E. Arnold and Jennifer W. Leiding

Hemophagocytic lymphohistiocytosis (HLH) is a severe systemic hyperinflammatory syndrome that can be aggressive and life-threatening. Classic features include fever, cytopenia, hepatosplenomegaly, coagulopathy, and elevations in inflammatory markers.

**Primary or genetic HLH** is due to pathogenic variants in genes that predispose patients to HLH by a variety of mechanisms and includes classic familial HLH due to pathogenic variants in *PRF1*, *UNC13D*, *STX11*, and *STXBP2*; certain pigmentary disorders; and other primary

immunodeficiencies or immune regulatory disorders (see Chapter 556.2; Fig. 174.3). Primary HLH is seen most frequently in pediatric patients but may occur at all ages.

**Secondary HLH** occurs in the setting of a medical condition that results in intense immune activation such as severe infection, malignancy, or rheumatologic disease. Many primary immune deficiencies (PIDs) are also associated with an increased risk of HLH, usually in the setting of infection. HLH has been reported in patients with severe combined immune deficiency and chronic granulomatous disease, but secondary HLH has been seen in a wide variety of PID. Several inborn errors of metabolism can also present with secondary HLH.

Of note, patients with primary or genetic HLH often present with HLH triggered by or “secondary” to infection or other immune activating events.

For more details see Chapter 556.2.

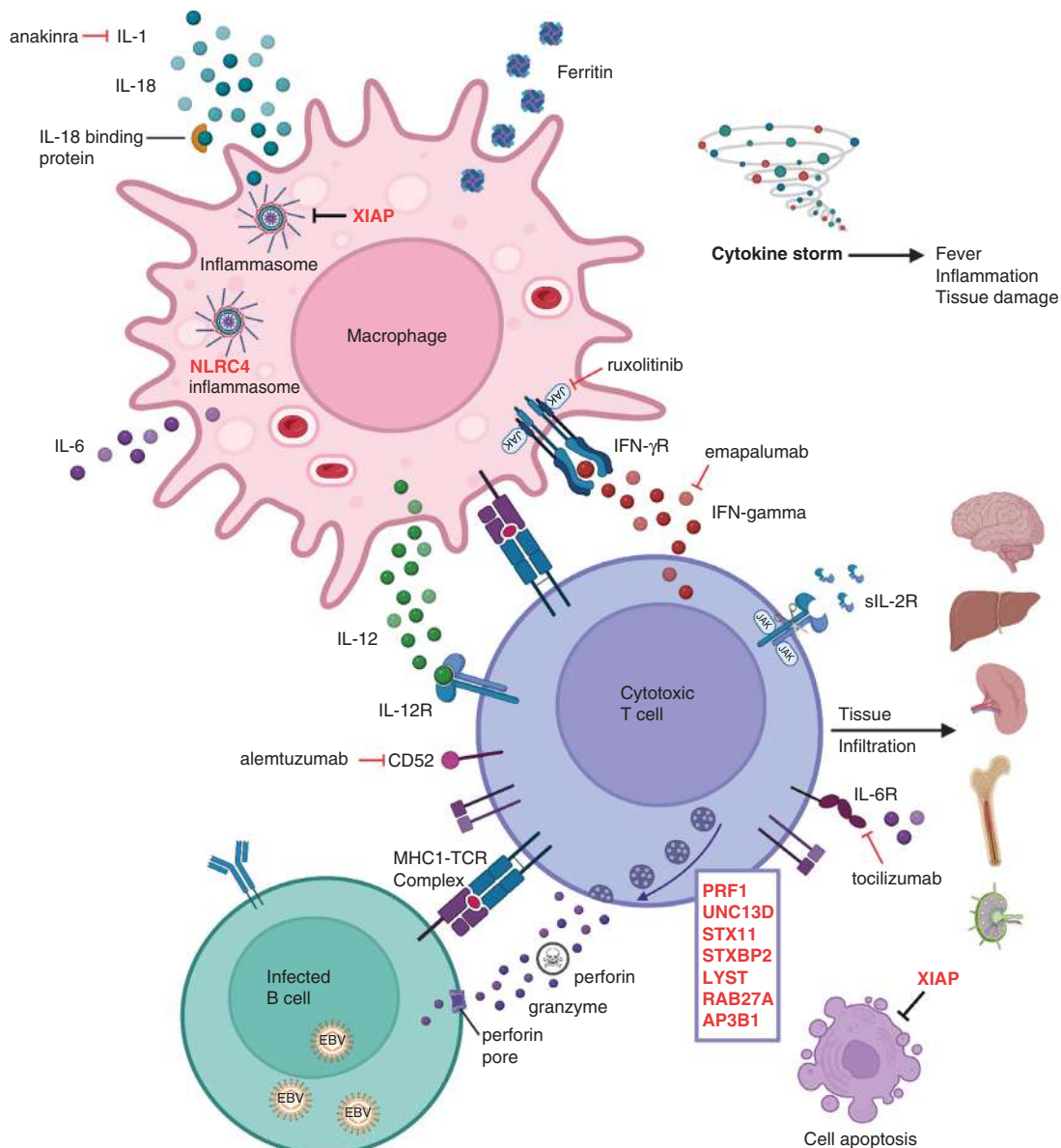
Visit Elsevier eBooks+ at [eBooks.Health.Elsevier.com](http://eBooks.Health.Elsevier.com) for Bibliography.

## 174.3 Epstein-Barr Virus Susceptibility Disorders

Danielle E. Arnold and Jennifer W. Leiding

Epstein-Barr virus (EBV) is a gamma-herpes family virus with a marked tropism for B cells. Most individuals experience asymptomatic infection or infectious mononucleosis, a self-limiting lymphoproliferative disease that is particularly common in adolescents. EBV is also an oncogenic virus and may induce several types of neoplasms, including B-cell, T-cell, and natural killer (NK) cell lymphomas; nasopharyngeal and gastric carcinomas; and EBV-associated smooth muscle cell tumors.

During primary infection, EBV-infected B cells are eliminated by EBV-specific cytotoxic T cells as well as other innate cytotoxic lymphocytes such as NK cells,  $\gamma\delta$  T cells, and invariant natural killer T (iNKT) cells. However, some EBV-infected B cells escape the immune response, establishing a reservoir for EBV that may reactivate



**Fig. 174.3** Hemophagocytic lymphohistiocytosis (HLH). HLH is a severe systemic inflammatory syndrome due to abnormal reciprocal macrophage and cytotoxic lymphocyte hyperactivation, resulting in cytokine storm, hemophagocytosis, and tissue infiltration by activated immune cells. Primary HLH genes associated with defective granule-mediated cytotoxicity or inflammasome dysregulation are shown in red. Common nonsteroidal immunosuppressive agents frequently used to treat HLH are also shown. EBV, Epstein-Barr virus; IFN, interferon; IL, interleukin; MHC, major histocompatibility complex; TCR, T-cell receptor; XIAP, X-linked inhibitor of apoptosis.

throughout an individual's life. These reactivations are typically asymptomatic in healthy individuals; however, in immunocompromised persons, EBV reactivations and persistence and expansion of latently infected B lymphoblasts may result in symptomatic and often severe disease.

### PATHOPHYSIOLOGY

There are several primary combined immunodeficiencies characterized by a very high predisposition to EBV infection, some of which are listed in Table 174.2. These disorders are due to defects in pathways involved in T- and B-cell interaction and crosstalk (Fig. 174.4). Disruption of these pathways results in aberrant cytotoxic T-cell activation, migration, proliferation, and/or cytolytic activity in response to antigenic stimulation and, thus, impaired immune surveillance of B cells by T cells. Marked decrease or absence of

iNKT cells, mucosal-associated invariant T (MAIT) cells, and/or NK cells and impaired NK cell function are also often observed.

### Clinical Manifestations, Diagnosis, and Treatment

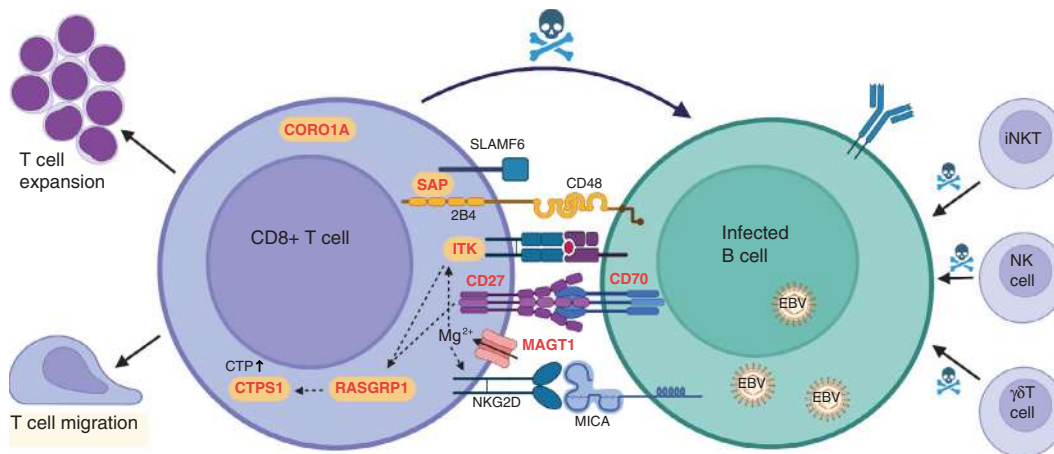
More than 50% of patients with EBV susceptibility disorders experience at least one episode of EBV lymphoproliferative disease. Patients are also susceptible to other EBV-driven pathologies, including HLH and both Hodgkin and non-Hodgkin lymphoma. Other severe viral infections (e.g., other herpesviruses, human herpesvirus 6 [HHV-6]), bacterial infections, particularly recurrent pulmonary infections, and hypogammaglobulinemia and/or dysgammaglobulinemia are also common. Diagnosis for these disorders is with a full immune evaluation and genetic testing. Treatment includes rituximab (anti-CD20 antibody) to eliminate EBV-infected B cells, treatment of infections, and immunoglobulin

**Table 174.2** Primary or Genetic EBV Susceptibility Disorders

GENE (PROTEIN)	DISORDER	INHERITANCE	PATHOGENESIS	ADDITIONAL FEATURES	DEFINITIVE OR DISEASE-SPECIFIC TREATMENT*
<i>MAGT1</i>	XMEN (X-linked immunodeficiency w/Mg <sup>2+</sup> defect, EBV infection and neoplasia)	XL	Defective Mg <sup>2+</sup> transporter; ↓ NKG2D expression results in defective cytotoxicity	Chronic EBV infection rather than full-scale HLH, viral infections, lung infections, autoimmune cytopenia, lymphoma	Allogeneic HCT
<i>ITK</i>	Lymphoproliferative syndrome 1	AR	Defective tyrosine kinase function; defective cytotoxic T-cell expansion, and cytolytic capacity; ↓ iNKT cells	Chronic EBV infection, lung infections, PJP, autoimmune cytopenia, lymphoma	Allogeneic HCT
<i>CD27</i>	Lymphoproliferative syndrome 2	AD	CD27 is a co-stimulatory molecule on T cells; required for normal T-cell proliferation and cytotoxicity against EBV-infected B cells; ↓ iNKT cells	Chronic EBV infection, lung infections, uveitis, oral and anal ulcers, hypogammaglobulinemia, lymphoma	Allogeneic HCT
<i>CD70</i>	Lymphoproliferative syndrome 3	AR	CD70 expressed by EBV-infected B cells interacts with CD27 on T cells; required for normal expansion and cytotoxicity of T cells; ↓ NKG2D and 2B4 expression; ↓ iNKT cells	Chronic EBV infection, lung infections, lymphoma	Allogeneic HCT
<i>CTPS1</i>	CTPS1 deficiency	AR	Enzyme involved in de novo synthesis of cytidine nucleotide triphosphate (CTP); deficiency leads to impaired T-cell proliferation; ↓ iNKT cells	Chronic EBV infection, viral infections, lung infections, meningitis, eczema, lymphoma	Allogeneic HCT
<i>CORO1A</i>	CORO1A deficiency	AR	Actin regulator; T lymphopenia, impaired immunologic synapse formation and intracellular signaling; ↓ iNKT cells	Chronic EBV infection rather than HLH, viral infections, lung infections, neurologic involvement, lymphoma	Allogeneic HCT
<i>RASGRP1</i>	RASGRP1 deficiency	AR	Activates RAS, which leads to MAPK pathway activation; defects in T-cell activation, proliferation, and migration; ↓ iNKT cells	Chronic EBV infection, viral infections, lung infections, autoimmune cytopenia, EBV negative lymphoproliferative disease, lymphoma	Allogeneic HCT

\*Treatment should include HLH-directed therapy, treatment of infections and malignancy, and other supportive care measures as appropriate.

EBV, Epstein-Barr virus; AR, autosomal recessive; XL, X-linked; AD, autosomal dominant; TNF, tumor necrosis factor; iNKT, invariant NK T cell; CNS, central nervous system; HSM, hepatosplenomegaly; PJP, *Pneumocystis jirovecii* pneumonia; HCT, hematopoietic cell transplantation.



**Fig. 174.4** Epstein-Barr virus (EBV) susceptibility disorders. Combined immunodeficiencies characterized by a very high predisposition to EBV lymphoproliferative disease are shown in red. These genes/proteins play essential roles in the recognition of EBV-infected B cells by T cells and in cytotoxic T-cell activation, migration, proliferation, and/or cytotoxic activity. As such, defects in any of these components allow for EBV-infected B-cell immune escape. Invariant natural killer T (iNKT) cell, NK cell, and  $\gamma\delta$ T-cell numbers and/or function may also be low or aberrant, respectively.

replacement when indicated. Allogeneic HCT is the only curative treatment available.

### Other Primary Immunodeficiencies Associated with Epstein-Barr Virus Lymphoproliferative Disease

Herpesvirus infections and EBV lymphoproliferative disease are also seen to a lesser extent in several other combined immunodeficiencies associated with T-cell defects, particularly those affecting T-cell survival and mobilization. Classic examples include Wiskott-Aldrich syndrome, DOCK8 deficiency, GATA2 haploinsufficiency, and activated PI3K-delta syndrome, among others. Severe EBV infections may also be seen in patients with hypomorphic or leaky severe combined immunodeficiency.

Any patient who presents with prolonged and/or severe EBV lymphoproliferative disease or EBV-positive lymphoma warrants evaluation for an underlying primary immunodeficiency.

Visit Elsevier eBooks+ at [eBooks.Health.Elsevier.com](http://eBooks.Health.Elsevier.com) for Bibliography.

## 174.4 Chronic Active Epstein-Barr Virus

Danielle E. Arnold and Jennifer W. Leiding

Chronic active EBV (CAEBV) is a rare systemic EBV lymphoproliferative disorder characterized by fever, persistent lymphadenopathy, hepatosplenomegaly, and hepatitis in the absence of an underlying primary or secondary immunodeficiency, malignancy, or autoimmune disorder.

### GENETIC PREDISPOSITION

CAEBV is seen primarily in persons of East Asian (Japan, Korea, China, and Taiwan) or Latin American (Indigenous people in Mexico and Central/South America) ancestry; in these patients, EBV is predominantly present in T cells or NK cells. Conversely, while rare, persons of Western European descent typically have B-cell CAEBV. The uneven geographic distribution of CAEBV suggests that underlying genetic factors may contribute to the development of CAEBV; heterozygous pathogenic variants in HLH predisposing genes (e.g., perforin) have been identified in patients with CAEBV. Causative genetic defects have not been identified in most cases.

### Pathophysiology

The mechanism of EBV entry into T cells or NK cells is unclear, but T cells and NK cells can express low levels of CD21, the EBV receptor, during primary infection. The pathogenesis of CAEBV is less clear. Evidence suggests that EBV infection directly induces T-cell or NK cell survival via activation of several survival-promoting molecules

**Table 174.3** Chronic Active EBV (CAEBV) Diagnostic Criteria

All 4 criteria must be present:

1. Sustained or recurrent infectious mononucleosis-like symptoms persisting for >3 mo
2. EBV PCR  $>10^{2.5}$  copies/ $\mu$ g DNA in the peripheral blood or tissue lesion
3. Evidence of EBV infection of T or NK cells in the peripheral blood or affected tissues
4. Exclusion of other diagnoses: primary EBV infection, primary or secondary immunodeficiency, malignancy, autoimmune disease

EBV, Epstein-Barr virus; NK, natural killer; PCR, polymerase chain reaction.

or pathways, including upregulation of co-stimulatory molecules that suppress apoptosis, activation of the NF- $\kappa$ B pathway, and upregulation of activation-induced cytidine deaminase, which acts as a genomic disruptor and has been shown to play a role in EBV-induced lymphomagenesis in B cells.

### Clinical Manifestations and Diagnosis

Clinical manifestations of CAEBV are heterogenous, ranging from a mild and indolent clinical course to a more aggressive and potentially fatal illness due to complications such as HLH, multisystem organ failure, and/or progression to leukemia or lymphoma. Clinical manifestations may be episodic, but patients typically have persistently and markedly elevated levels of EBV in the blood throughout their disease course. Infiltration of tissues by EBV-positive lymphocytes may result in organ failure (liver failure is commonly seen), and EBV-infected T cells and NK cells may undergo malignant transformation. The diagnostic criteria for CAEBV are listed in Table 174.3; CAEBV should be suspected in any patient with sustained inflammation of unknown origin and chronically elevated EBV polymerase chain reaction (PCR) levels.

Evaluations to determine whether EBV is predominantly present in T cells or NK cells should be undertaken, if possible, in patients with CAEBV. One method is EBV PCR on peripheral blood mononuclear cells that have been sorted by flow cytometry, although this test is not widely available. Histologic examination of tissue that has been infiltrated by EBV-infected lymphocytes by immune staining and in situ hybridization of EBV-encoded mRNA (EBER) is another approach.

### Treatment

Treatment options in severe cases are limited, and clinical responses are mostly transient. Some therapeutic approaches include



immunomodulatory therapy, combination bortezomib and ganciclovir, and EBV-specific T cells. Patients with HLH should receive HLH-directed therapy. Standard antiviral therapy is not effective. Cytotoxic chemotherapy is also used to reduce disease activity and burden of EBV-infected lymphocytes, primarily as a bridge to HCT. Allogeneic HCT is the only definitive therapy available with overall survival rates as high as 87% in some reports. Patients with progressive disease remain difficult to transplant. As such, some advocate rapidly proceeding to HCT early in the disease process, although the timing of HCT remains controversial.

Visit Elsevier eBooks+ at [eBooks.Health.Elsevier.com](https://eBooks.Health.Elsevier.com) for Bibliography.

## 174.5 Very Early Onset Inflammatory Bowel Disease

Danielle E. Arnold and Jennifer W. Leiding

Inflammatory bowel disease that presents in children less than 6 years of age is known as very early onset inflammatory bowel disease (VEO-IBD). Monogenic defects involved in primary immunodeficiency and intestinal barrier processes are enriched in children with VEO-IBD (Fig. 174.5). Targeted therapies in children with VEO-IBD with a monogenic defect have been successful in treating disease manifestations (see Chapter 382.3).

### DISEASE CLASSIFICATION AND CLINICAL PRESENTATION

Children diagnosed with IBD <2 years of age are referred to as *infantile-onset* IBD and those 2-6 years as VEO-IBD. Children present

with classic symptoms of IBD including weight loss, failure to thrive, abdominal pain, fever, constipation, diarrhea, hematochezia. The phenotype is heterogenous with some children having mild disease and others presenting with or developing more severe disease over time. Approximately 40% have extensive pancolonic disease at presentation. Extent, location, and histology can progress or change over time.

For more details see Chapter 382.3.

Visit Elsevier eBooks+ at [eBooks.Health.Elsevier.com](https://eBooks.Health.Elsevier.com) for Bibliography.

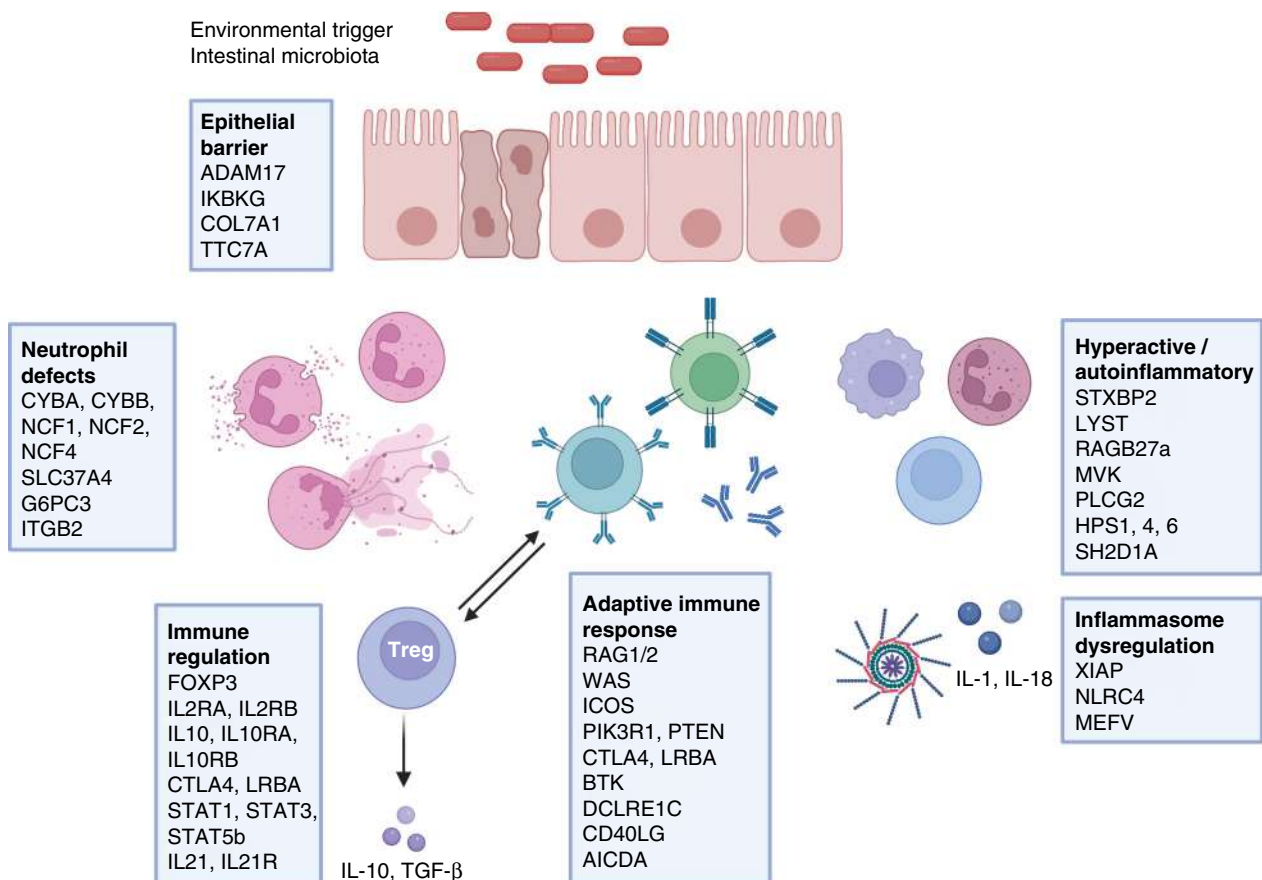
## 174.6 Autoimmune Cytopenias

Danielle E. Arnold and Jennifer W. Leiding

Autoimmune cytopenias are a group of disorders in which there is immune destruction of differentiated hematopoietic cells. Immune destruction can be autoantibody mediated or non-autoantibody mediated. Single lineage disease can affect red cells (autoimmune hemolytic anemia [AIHA]), platelets (idiopathic thrombocytopenia purpura [ITP]), or neutrophils (autoimmune neutropenia [AIN]). Bilineage or trilineage disease can affect any combination of these cell lines. **Evan disease** is a combination of AIHA and ITP.

### PATHOPHYSIOLOGY

The etiology of autoimmune cytopenias as a manifestation of an inborn error of immunity is often multifactorial with autoantibody-mediated destruction or cellular-mediated destruction of red blood cells, platelets, or neutrophils as the major causes of hemolysis (Table 174.4). In disorders with intrinsic B-cell defects and disrupted T- and B-cell interactions, autoantibody production toward hematopoietic cells can



**Fig. 174.5** Very early onset inflammatory bowel disease. Complex host interactions between the environment, intestinal microbiota, and immune-related genes maintain gut health. Mutations in genes involved in epithelial barrier, neutrophil function, control of inflammation, and T- and B-cell function can manifest as very early onset inflammatory bowel disease. IL, Interleukin; TGF, transforming growth factor; Treg, T regulatory cell.

**Table 174.4** Monogenic Causes of Autoimmune Cytopenias and Primary Immunodeficiency

GENE (PROTEIN)	DISORDER	MOI	CLINICAL PHENOTYPE	IMMUNE FEATURES	DEFINITIVE OR DISEASE-SPECIFIC TREATMENT
<i>PIK3</i> defects	Activated PI3K-delta syndrome	AD, LOF AD, GOF AD	Insulin resistance, short stature, nodular lymphoid hyperplasia, lymphoma, bronchiectasis	High IgM, low IgG, low CD4/CD45RA	Allogeneic HCT *Leniolisib, sirolimus
<i>STAT3</i>	STAT3 GOF	AD, GOF	Enteropathy, autoimmune cytopenias, lymphoproliferation, recurrent infections	Elevated DNTs Variable decreases in IgG, IgA, IgM, B- and T-cell quantities	Jakinibs Allogeneic HCT
<i>STAT1</i>	STAT1 GOF	AD, GOF	Chronic mucocutaneous candidiasis, cerebral aneurysms, interstitial lung disease, enteropathy, colitis	Variable decreases in IgG, IgA, IgM, B- and T-cell quantities	Jakinibs Allogeneic HCT
<i>CTLA-4</i>	CTLA4 haploinsufficiency	AD	Enteropathy, type 1 diabetes, autoimmune cytopenias, interstitial lung disease	Low IgG, low T-cell quantities	Sirolimus Abatacept, belatacept Allogeneic HCT
<i>LRBA</i>	LRBA deficiency	AR	Enteropathy, type 1 diabetes, autoimmune cytopenias, interstitial lung disease	Low IgG, low T-cell quantities	Abatacept, belatacept Allogeneic HCT
<i>TNFRSF6</i> <i>TNFSF6</i> <i>FADD</i> <i>CASP8</i> <i>CASP10</i>	ALPS	AR GOF	Lymphadenopathy, lymphoma	Elevated DNTs	Mycophenolate mofetil Sirolimus

PI3K, Phosphoinositide 3 kinase; AD, autosomal dominant; LOF, loss of function; AD, autosomal dominant; GOF, gain of function; HCT, hematopoietic cell transplant; STAT, signal transducer and activator of transcription; CTLA, cytotoxic T-lymphocyte protein; LRBA, lipopolysaccharide-responsive and beigelike anchor protein; ALPS, autoimmune lymphoproliferative syndrome; DNT, double negative T cell.

occur. When B-cell maturation is impaired, vital steps in the induction of tolerance are omitted. In addition to the humoral B-cell defects that can lead to autoimmune cytopenias, intrinsic defects in T-cell effector function can lead to cellular autoimmunity. Impaired T-cell development can cause a lack of functional effector cells against non-self or “dangerous” antigens while allowing production of autoreactive clones with T-cell receptors directed against self-antigens. Additionally, T-cell defects may lead to a reduction in FOXP3<sup>+</sup> Treg cells.

### Clinical Manifestations and Diagnosis

The clinical presentation of AIHA commonly includes dizziness, fatigue, pallor, jaundice, and exertional dyspnea (see Chapter 513). Complete blood count will show anemia and reticulocytosis. Additional features of hemolysis include hyperbilirubinemia, elevated lactate dehydrogenase, and decreased haptoglobin levels. Direct anti-globulin testing is most often positive. ITP typically presents with bleeding episodes that can range from mild bruising, petechiae, and epistaxis to oral purpura, hematuria, menorrhagia, gastrointestinal hemorrhage, or intracranial bleeding (see Chapter 533.1). Severe life-threatening bleeding is rare. Laboratory findings include acute thrombocytopenia. Mean platelet volume is elevated or variable indicating that large new platelets are being generated to compensate for loss. Autoantibodies against platelet glycoproteins may be positive but are not helpful in elucidating immune thrombocytopenia as they are positive in less than 65% of patients with immune thrombocytopenia and are not predictive, specific, or prognostic. AIN presents with low absolute neutrophil count (see Chapter 171). Clinical manifestations include aphthous stomatitis, periodontal disease, and increased frequency of soft tissue infections. Invasive infections and sepsis are rare. Antigranulocyte antibodies can be present.

### Immunodeficiencies Associated with Autoimmune Cytopenias

Autoimmune cytopenias, especially those that include bilineages and trilineages, are often a presenting symptom of or associated with primary immunodysregulatory disorders. Other organ-specific immunodysregulatory and autoimmune conditions are often present. Next generation sequencing via whole exome sequencing or panel-based sequencing can aid in establishing a diagnosis. When an inborn error of immunity is suspected with the presence of autoimmune cytopenias, a general immune screen should be performed including serum quantities of IgG, IgM, IgA, and IgE. Quantities of T cell, B cell, and NK cells should also be measured. Additional labs that may be helpful in narrowing a diagnosis of immunodeficiency include quantification of  $\alpha\beta$ <sup>+</sup>double negative T cells (CD4<sup>-</sup>CD8<sup>-</sup>), CD27<sup>+</sup>IgD<sup>+</sup> and CD27<sup>+</sup>IgD<sup>-</sup> memory B cells, serum ferritin, soluble interleukin (IL)-2 receptor, IL-18, soluble Fas ligand, vitamin B<sub>12</sub>, and folate.

### Treatment

Targeted treatment of the primary immunodysregulatory disorder can control or resolve autoimmune cytopenias. Standard treatment of autoimmune cytopenias with or without a primary immunodysregulatory disorder include corticosteroids, intravenous immunoglobulin (IVIG), and biologic therapies such as rituximab and daratumumab (monoclonal antibody against CD38 expressed on long-lived plasma cells). Control of symptoms is often more difficult and may increase the suspicion for an underlying primary immunodysregulatory disorder.

Visit Elsevier eBooks+ at [eBooks.Health.Elsevier.com](http://eBooks.Health.Elsevier.com) for Bibliography.

## 174.7 Autoimmune Lymphoproliferative Syndrome

Danielle E. Arnold and Jennifer W. Leiding

Autoimmune lymphoproliferative syndrome (ALPS), also known as Canale-Smith syndrome, is a disorder of abnormal lymphocyte apoptosis leading to polyclonal populations of T cells (double-negative T cells), which express CD3 and  $\alpha/\beta$  antigen receptors but do not have CD4 or CD8 co-receptors (CD3<sup>+</sup> T-cell receptor  $\alpha/\beta$ <sup>+</sup>, CD4<sup>-</sup>CD8<sup>-</sup>). These T cells respond poorly to antigens or mitogens and do not produce growth or survival factors (IL-2). The genetic deficit in most patients is a germline or somatic pathologic variant in the *FAS* gene, which produces a cell surface receptor of the tumor necrosis factor (TNF) receptor superfamily (TNFRSF6), which, when stimulated by its ligand, will produce programmed cell death (Table 174.5). Persistent survival of these lymphocytes leads to immune dysregulation and autoimmunity. ALPS is also caused by other genes in the Fas pathway (*FASLG* and *CASP10*). In addition, ALPS-like disorders are associated with other mutations: RAS-associated autoimmune lymphoproliferative disorder (RALD), caspase-8 deficiency, Fas-associated protein with death domain deficiency (FADD), and protein kinase C delta deficiency (PRKCD). These disorders have varying degrees of immunodeficiency, autoimmunity, and lymphoproliferation.

### CLINICAL MANIFESTATIONS

ALPS is characterized by **autoimmunity, chronic persistent or recurrent lymphadenopathy**, splenomegaly, hepatomegaly (in 50%), and hypergammaglobulinemia (IgG, IgA). Many patients present in the first year of life, and most are symptomatic by age 5 years. Lymphadenopathy can be striking (Fig. 174.6). Splenomegaly

**Table 174.5** Revised Diagnostic Criteria for Autoimmune Lymphoproliferative Syndrome\*

#### REQUIRED

1. Chronic (>6 mo), nonmalignant, noninfectious lymphadenopathy, splenomegaly or both
2. Elevated CD3<sup>+</sup> TCR $\alpha\beta$ <sup>+</sup> CD4<sup>-</sup>CD8<sup>-</sup> DNT cells ( $\geq 1.5\%$  of total lymphocytes or 2.5% of CD3<sup>+</sup> lymphocytes) in the setting of normal or elevated lymphocyte counts

#### ACCESSORY

##### Primary

1. Defective lymphocyte apoptosis (in two separate assays)
2. Somatic or germline pathogenic mutation in *FAS*, *FASLG*, or *CASP10*

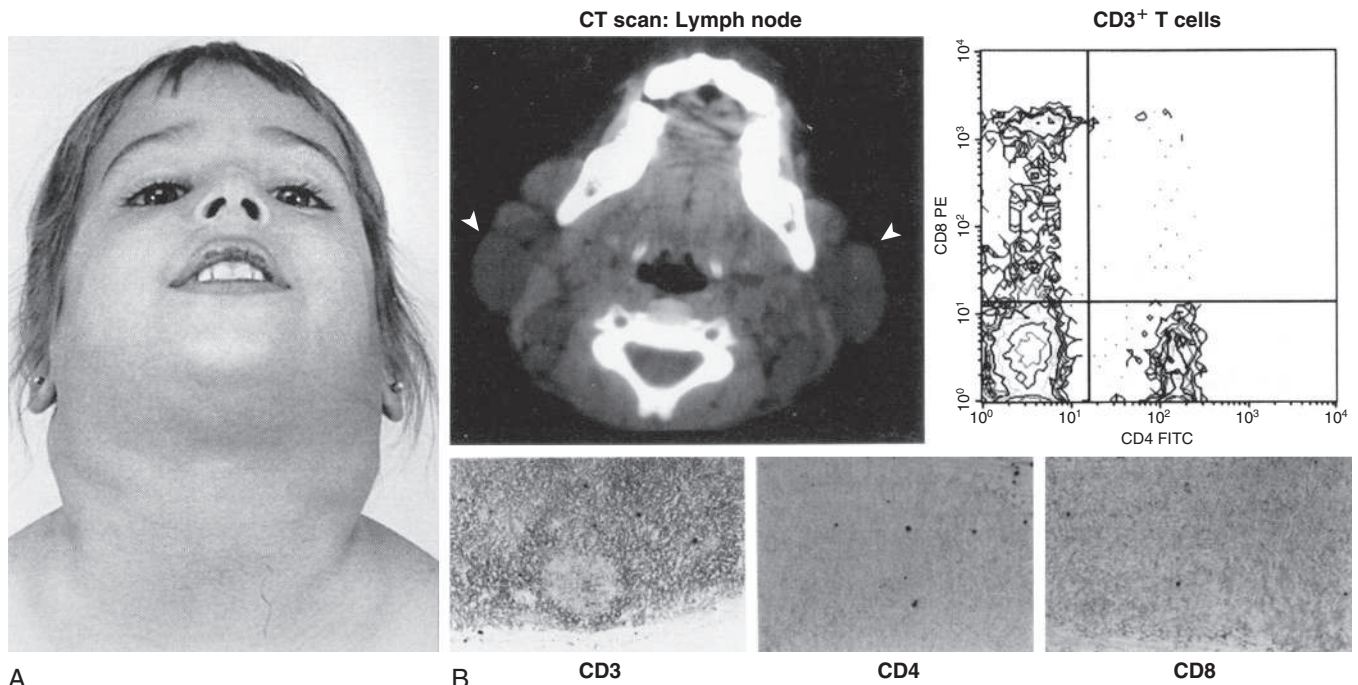
##### Secondary

1. Elevated plasma sFasL levels (>200 pg/mL) OR elevated plasma interleukin-10 levels (>20 pg/mL) OR elevated serum or plasma vitamin B<sub>12</sub> levels (>1500 ng/L) OR elevated plasma interleukin-18 levels >500 pg/mL
2. Typical immunohistologic findings as reviewed by an experienced hematopathologist
3. Autoimmune cytopenias (hemolytic anemia, thrombocytopenia, or neutropenia) AND elevated immunoglobulin G levels (polyclonal hypergammaglobulinemia)
4. Family history of a nonmalignant/noninfectious lymphoproliferation with or without autoimmunity

\*A definitive diagnosis is based on the presence of both required criteria plus one primary accessory criterion. A probable diagnosis is based on the presence of both required criteria plus one secondary accessory criterion.

DNT, Double-negative T cell; TCR, T-cell receptor.

From Petty RE, Laxer RM, Lindsley CB, Wedderburn LR, eds. *Textbook of Pediatric Rheumatology*. 7th ed. Philadelphia: Elsevier; 2016. Box 46-2.



**Fig. 174.6** Clinical, radiographic, immunologic, and histologic characteristics of the autoimmune lymphoproliferative syndrome. **A**, Front view of the National Institutes of Health patient. **B**, *Top left*, CT scan of the neck is shown demonstrating enlarged preauricular, cervical, and occipital lymph nodes. *Arrowheads* denote the most prominent lymph nodes. *Top right*, Flow cytometric analysis of peripheral blood T cells from a patient with autoimmune lymphoproliferative syndrome (ALPS), with CD8 expression on the vertical axis and CD4 on the horizontal axis. *Lower left quadrant*, Contains CD4<sup>-</sup>CD8<sup>-</sup> (double-negative) T cells, which are usually present at <1% of T cells expressing the  $\alpha\beta$  T-cell receptor. *Bottom*, CD3, CD4, and CD8 staining on serial sections of a lymph node biopsy specimen from a patient with ALPS. Large numbers of DNCD3<sup>+</sup> CD4<sup>-</sup>CD8<sup>-</sup> (double-negative) T cells are present in the interfollicular areas of the lymph node. (Adapted from Siegel RM, Fleisher TA. The role of Fas and related death receptors in autoimmune and other disease states. *J Allergy Clin Immunol*. 1999;103[5 Pt 1]:729-738.)

may produce hypersplenism. Autoimmunity also produces anemia (Coombs-positive hemolytic anemia) or thrombocytopenia or a mild neutropenia. The lymphoproliferative process (lymphadenopathy, splenomegaly) may regress over time, but autoimmunity does not regress and is characterized by frequent exacerbations and recurrences. Other autoimmune features include urticaria, uveitis, glomerulonephritis, hepatitis, vasculitis, panniculitis, arthritis, premature ovarian failure, thyroiditis, myocarditis, pancreatitis, and CNS involvement (seizures, headaches, encephalopathy, transverse myelitis, Guillain-Barré syndrome, ataxia).

Malignancies are also more common in patients with ALPS and include Hodgkin and non-Hodgkin lymphomas and solid-tissue

tumors of thyroid, skin, heart, or lung. ALPS is one cause of Evan syndrome (immune thrombocytopenia and immune hemolytic anemia).

### Diagnosis

Laboratory abnormalities depend on the lymphoproliferative organ response (hypersplenism) or the degree of autoimmunity (anemia, thrombocytopenia). There may be lymphocytosis or lymphopenia. Table 174.5 lists the criteria for the diagnosis. Flow cytometry helps identify the lymphocyte type (see Fig. 174.6). Functional genetic analysis for the *TNFRSF6* gene often reveals a heterozygous mutation. The differential diagnosis of ALP-related syndromes is noted in Table 174.6.

**Table 174.6** Autoimmune Lymphoproliferative Syndrome (ALPS)-Related Syndromes That Are Potentially Similar to But Genetically Distinct from ALPS or Meet Characteristics of ALPS with Undetermined Genetic Defects (ALPS-U)

DISEASE	NOMENCLATURE	MUTATION	CLINICAL FEATURES	LABORATORY BIOMARKERS	POTENTIAL TARGETED THERAPIES
Ras-associated autoimmune leukoproliferative disorder	RALD	Germline or somatic <i>NRAS</i> and <i>KRAS</i> pathogenic variants RAS markedly decreases Bim protein expression leading to impaired lymphoid withdrawal and T-cell receptor (TCR)-induced apoptosis	Primary immunodeficiency disorder of defective apoptosis leading to lymphadenopathy, massive splenomegaly, increased circulating B cells, hypergammaglobulinemia, and autoimmunity increased risk for hematopoietic malignancies	Persistent absolute or relative monocytosis, hypergammaglobulinemia, B lymphocytosis Does not exhibit elevated "double-negative T cells" (DNTs), vitamin B <sub>12</sub> Activating somatic mutations in <i>KRAS</i> or <i>NRAS</i>	Mitogen-activated pathway kinase (MAPK) inhibitors (for example, trametinib), mammalian target of rapamycin (mTOR) inhibitors (sirolimus, everolimus)
Danzani autoimmune lymphoproliferative disease	DALD	No causative genes identified Overexpression of the cytokine osteopontin Perforin	Exhibit autoimmunity, lymphoproliferation, splenomegaly, and defective Fas without expansion of DNT cells	Absent DNTs FAS resistance but without <i>FAS</i> or <i>FASL</i> mutations	
Caspase-8 deficiency state	CEDS	Loss-of-function pathogenic variants in <i>CASP8</i> thought to play a dual role in the induction of the nuclear factor-kappa B (NF-κB) transcription factor during lymphocyte activation as well as in apoptosis mediated by the Fas death-inducing signaling complex (DISC)	Exhibits lymphoproliferation and apoptosis defects observed in ALPS, but manifests immunodeficiency rather than autoimmunity; recurrent sinopulmonary infections Increased risk for malignancy	Serum Ig levels, antibody function, lymphocyte activation Defective activation of T, B and natural killer (NK) cells <i>CASP8</i> deficiency	
Fas-associated death domain deficiency	<i>FADD</i> deficiency	Autosomal recessive (AR) <i>FADD</i> deficiency	Characterized by severe bacterial and viral infections, congenital heart defects, and recurrent episodes of fever, liver dysfunction, and seizures	<i>FADD</i> deficiency	
Common variable immunodeficiency 9	Protein kinase C delta ( <i>PRKCD</i> ) deficiency	AR <i>PRKCD</i> primary immunodeficiency	Characterized by recurrent infections, lymphadenopathy, hepatosplenomegaly, autoimmunity, and NK cell dysfunction	IL-10 overexpression by B cells	



**Table 174.6** Autoimmune Lymphoproliferative Syndrome (ALPS)-Related Syndromes That Are Potentially Similar to But Genetically Distinct from ALPS or Meet Characteristics of ALPS with Undetermined Genetic Defects (ALPS-U)—cont'd

DISEASE	NOMENCLATURE	MUTATION	CLINICAL FEATURES	LABORATORY BIOMARKERS	POTENTIAL TARGETED THERAPIES
Activated PI3K delta syndrome	APDS, also known as PASLI	Heterozygous gain-of-function pathogenic variants in <i>PI3KCD</i> or <i>PI3KR1</i>	Recurrent respiratory infections and increased susceptibility to viral infections with both B- and T-cell defects	Decreased naïve T cells, low IgG, IgA, and normal or elevated IgM	mTOR inhibitors, PI3K inhibitors
X-linked immunodeficiency with magnesium defect, Epstein-Barr virus (EBV) infection and neoplasia	XMEN disease	Loss-of-function pathogenic variants in magnesium transporter 1 ( <i>MAGT1</i> ); X-linked	Chronic high-level EBV with increased EBV-infected B cells and increased susceptibility to EBV-associated lymphomas	Mg deficiency	Magnesium
Gain-of-function mutations in signal transducer and activator of transcription 1 defect	GOF <i>STAT1</i> defect	<i>STAT1</i> gain-of-function pathogenic variants	Chronic mucocutaneous candidiasis, recurrent <i>Staphylococcus aureus</i> infections, cerebral aneurysms, and multiple autoimmune features	Decreased TH17 response	JAK/STAT inhibitors (for example, ruxolitinib)
Gain-of-function mutations in signal transducer and activator of transcription 3	GOF <i>STAT3</i> -mutations	<i>STAT3</i> -gain of function pathogenic variants	Lymphoproliferation and childhood-onset autoimmunity thought to result from dysregulated cytokine signaling and interstitial lung disease		Anti-IL-6R monoclonal antibody (tocilizumab)
Cytotoxic T lymphocyte antigen ( <i>CTLA4</i> ) haploinsufficiency with autoimmune infiltration	CHAI	Heterozygous loss-of-function pathogenic variants in <i>CTLA4</i>	Hypogammaglobulinemia and autoantibody-mediated cytopenias, lymphadenopathy, splenomegaly, organ-specific autoimmunity, and lymphocytic infiltration of nonlymphoid organs CHAI more commonly seen in older children or young adults, whereas disease onset in LATAIE is typically earlier		CTLA4-Ig fusion drug (Abatacept) mTOR inhibitors
Common variable immune deficiency caused by defect in lipopolysaccharide-responsive and beigelike anchor protein LRBA deficiency with autoantibodies, regulatory T-cell defects, autoimmune infiltration, and enteropathy	<i>LRBA</i> deficiency LATAIE	<i>LRBA</i> encodes the lipopolysaccharide-responsive and beigelike anchor protein, thought to regulate <i>CTLA4</i>	Antibody deficiency, infection, autoimmunity, and lymphoproliferation, often linked with enteropathy or inflammatory bowel disease Lymphocyte infiltration also seen in lungs and brain		CTLA4-Ig fusion drugs Hydroxychloroquine or chloroquine mTOR inhibitors

Note: The majority of these syndromes have been defined based on the genomic defect with associated symptoms.

From Bride K, Teachey D. Autoimmune lymphoproliferative syndrome: more than a FAScinating disease. *F1000Res*. 2017;6:1928. Table 1.

**Treatment**

Rapamycin (sirolimus) will often control the adenopathy and autoimmune cytopenias. Malignancies can be treated with the usual protocols used in patients unaffected by ALPS. Stem cell transplantation is another possible option in treating the autoimmune manifestations of ALPS.

**174.8 Nuclear Factor- $\kappa$ B Pathway Defects**

Danielle E. Arnold and Jennifer W. Leiding

The NF- $\kappa$ B pathways consist of canonical (NF- $\kappa$ B1) and noncanonical (NF- $\kappa$ B2) pathways. On cellular activation, both pathways lead

to activation and translocation of NF- $\kappa$ B proteins into the nucleus, where they initiate downstream inflammatory responses. Defects in many proteins in both pathways have been described. Table 174.7 describes immune defects of the NF- $\kappa$ B pathways that cause symptoms of immune dysregulation or autoimmunity. Treatment of NF- $\kappa$ B defects includes prevention of infections and replacement of immunoglobulin and has included HSCT.

Visit Elsevier eBooks+ at [eBooks.Health.Elsevier.com](http://eBooks.Health.Elsevier.com) for Bibliography.

**Table 174.7** Defects of Nuclear Factor- $\kappa$ B Pathways Associated with Immune Dysregulation

PROTEIN	INHERITANCE	AUTOIMMUNE OR INFLAMMATORY COMPLICATIONS	OTHER MANIFESTATIONS	IMMUNOLOGIC PHENOTYPE
IKBKG (NEMO)	XL	Colitis	<ul style="list-style-type: none"> <li>Ectodermal dysplasia</li> <li>Osteopetrosis</li> <li>Lymphedema</li> <li>Bacterial infections</li> <li>Opportunistic infections</li> <li>DNA viral infections</li> </ul>	<ul style="list-style-type: none"> <li>Hypogammaglobulinemia</li> <li>Hyper-IgM</li> <li>Hyper-IgA</li> <li>Hyper-IgD</li> <li>Poor antibody responses</li> <li>Decreased NK cell function</li> <li>Decreased TLR responses</li> </ul>
NF- $\kappa$ B1	AD	<ul style="list-style-type: none"> <li>Pyoderma gangrenosum</li> <li>Lymphoproliferation</li> <li>Cytopenia</li> <li>Hypothyroidism</li> <li>Alopecia areata</li> <li>Enteritis</li> <li>LIP</li> <li>NRH</li> </ul>	<ul style="list-style-type: none"> <li>Atrophic gastritis</li> <li>Squamous cell carcinoma</li> <li>Respiratory tract infections</li> <li>Superficial skin infections</li> <li>Lung adenocarcinoma</li> <li>Respiratory insufficiency</li> <li>Aortic stenosis</li> <li>Non-Hodgkin lymphoma</li> </ul>	<ul style="list-style-type: none"> <li>Hypogammaglobulinemia</li> <li>IgA deficiency</li> </ul>
NF- $\kappa$ B2	AD	<ul style="list-style-type: none"> <li>Alopecia totalis</li> <li>Trachyonychia</li> <li>Vitiligo</li> <li>Autoantibodies: thyroid peroxidase, thyroglobulin</li> <li>Central adrenal insufficiency</li> </ul>	<ul style="list-style-type: none"> <li>Viral respiratory infections</li> <li>Pneumonias</li> <li>Sinusitis</li> <li>Otitis media</li> <li>Recurrent herpes</li> <li>Asthma</li> <li>Type 1 Chiari malformation</li> <li>Interstitial lung disease</li> </ul>	<ul style="list-style-type: none"> <li>Early-onset hypogammaglobulinemia</li> <li>Low vaccine responses</li> <li>Variable B-cell counts</li> <li>Low switched memory B cells (CD19<sup>+</sup>CD27<sup>+</sup>IgD<sup>-</sup>)</li> <li>Low marginal zone B cells (CD19<sup>+</sup>CD27<sup>+</sup>IgD<sup>+</sup>)</li> </ul>

XL, X-linked; AD, autosomal dominant; LIP, lymphocytic interstitial pneumonitis; NRH, nonregenerative hyperplasia; TLR, toll like receptor.

## Chapter 175

## Defects of Innate Immunity

Jenna R.E. Bergerson and  
Alexandra F. Freeman

The innate immune system is the body's first defense against pathogens, and includes barriers such as the skin as well as neutrophils, natural killer (NK) cells, the toll-like receptors (TLRs) for microbial pathogen recognition, cytokines, and the complement system. Breakdown of different parts of this system can predispose primarily to different pathogens, such as viruses, fungi, bacteria, and mycobacteria. The innate immune system also plays an important role in engaging the adaptive immune response.

## 175.1 Predisposition to Fungal Infections

Jenna R.E. Bergerson and Alexandra F. Freeman

Despite constant exposure to environmental fungi at sites like the respiratory and gastrointestinal tracts and the skin, immunocompetent individuals do not develop invasive fungal disease because highly sophisticated host defenses have evolved with time. The genetic basis for inborn errors of immunity (IEIs) presenting with mucocutaneous and/or invasive fungal disease have provided valuable insight into the immunologic mediators necessary for antifungal host defense. Certain IEIs whose phenotype includes fungal disease, such as chronic granulomatous disease (CGD), APECED, GATA2 deficiency, and dominant negative STAT3 pathogenic variants (Job syndrome), are examples.

*Candida* and *Aspergillus* are the two most commonly encountered opportunistic fungi in clinical practice; both of these fungi are recognized in host tissues by pattern recognition receptors (PRRs) on the cell surface. When triggered by a relevant ligand, activation of these receptors results in pathogen uptake and killing. Most relevant to antifungal immunity is the C-type lectin receptor (CLR) family, which recognizes specific fungal cell wall components called pathogen-associated molecular patterns, like  $\beta$ -glucans or mannans. When CLRs like Dectin-1 bind ligand, the CARD9/BCL10/MALT1 complex (BCM complex) is formed. Signaling via downstream pathways ultimately results in production of proinflammatory cytokines and promotes fungal uptake and killing by myeloid phagocytes.

The molecular mechanisms that protect against host mucosal infections with *Candida* spp. are vastly different than those that confer protection against systemic infection. Neutrophils, monocytes, and macrophages are seemingly dispensable for immunity to mucosal *Candida* infection; chronic mucocutaneous candidiasis (CMC) is not seen in neutropenic patients or those with CGD. Instead, mucocutaneous candidiasis seems to correlate with impairments in T-lymphocyte number or function. Interleukin (IL)-17 signaling is also a critical pathway for protection against CMC. On receptor activation, the adaptor molecule ACT1 is recruited to the IL-17 receptor and mediates the induction of signaling pathways that upregulate the transcription of cytokines and antimicrobial peptides (AMPs) that help clear *Candida* from the mucosal surfaces. Control of endemic fungi, such as *Histoplasma*, is dependent on the IL-12/IFN $\gamma$ /STAT1 pathway.

**Chronic mucocutaneous candidiasis** is characterized by severe, persistent, or recurrent symptomatic infection of the nails, skin, oral, or genital mucosa by the *Candida* genus. CMC has been associated with a number of IEIs, in which it is one of many disease features along with other infections and/or autoimmune manifestations. However,

CMC can also be a main feature of a primary immunodeficiency disease (PIDD) (Table 175.1).

Antifungal therapy is the hallmark of treatment in these diseases. Episodes of CMC typically respond to either topical or oral therapy. Recurrences are common without secondary prophylaxis. Prophylaxis should be initiated in those patients with frequent and early recurrences after discontinuation of antifungal therapy. Prophylaxis is important not only to reduce the morbidity associated with recurrent episodes of CMC, but also to prevent mucosal inflammation, which can increase the risk of squamous cell carcinoma. Repeated courses of antifungal therapy increase the risk of developing resistance to antifungal therapy. All cases of CMC should be confirmed with culture, and susceptibility testing should guide the choice of antifungal if a therapeutic response is not observed.

Systemic fungal disease should be guided by culture and susceptibility data with consideration of antifungal penetration in the affected tissue. Additional factors to consider include concomitant medications (triazoles are metabolized by P450 and prolong the QT interval with the exception of isavuconazole, which shortens it), liver function, and kidney function (amphotericin use). It is important to also consider that voriconazole is associated with additional toxicities including an increased risk of squamous cell carcinoma of the skin, fluorosis, peripheral neuropathy, and visual disturbances. Survival of life-threatening fungal infection should also mandate secondary antifungal prophylaxis unless the underlying immunodeficiency is cured by hematopoietic stem cell transplantation (HSCT).

## CARD9 DEFICIENCY

CARD9 deficiency is caused by biallelic loss-of-function (LOF) pathogenic variants in *CARD9*. CARD9 contributes to antifungal host defense in a pathogen- and organ-specific manner with a striking predilection for *Candida albicans* central nervous system (CNS) infections. CARD9 deficiency is the only known IEI in which patients are predisposed to both mucocutaneous and systemic candidiasis, with *C. albicans* typically isolated. The CNS is the most common site of systemic involvement, with CNS candidiasis often presenting as either meningoencephalitis or an intracranial abscess  $\pm$  obstructive hydrocephalus. The next most common site of systemic involvement is bone. Neutrophils are absent in all involved exudates and tissues.

Deep dermatophytosis and subcutaneous phaeohyphomycosis infections can also be seen in CARD9 deficiency. *Trichophyton rubrum* and *Trichophyton violaceum* were the most common dermatophyte species. Severe complications like lymphadenitis, extension into adjacent organs with fistula formation, and dissemination to the CNS have been seen. Dermal biopsies show necrotizing granulomatous inflammation, subcutaneous nodules, and severe ulceration of the superficial tissues. Subcutaneous phaeohyphomycosis with a predilection for facial involvement has also been reported. Granulomatous inflammation with scattered lymphocytes and eosinophils are seen on biopsy. Extrapulmonary aspergillosis and a variety of dematiaceous fungi have also been reported including *Phialophora verrucosa*, *Exophiala spinifera*, *Ochroconis musae*, and *Corynespora cassiicola*.

Clinical manifestations of CARD9 deficiency are fully penetrant by the fourth or fifth decade of life with about 40% of patients presenting in adulthood. Sequencing of *CARD9* is required to establish the diagnosis, and determination of functional consequences of *CARD9* variants is difficult. Lymphocyte phenotyping is usually normal, as are absolute neutrophil and monocyte counts despite a lack of neutrophils in infected CSF. Nearly 60% of affected patients have findings of elevated serum IgE and/or hypereosinophilia. Treatment of fungal infection follows the tenets outlined earlier, frequently with infectious diseases consultation followed by lifelong antifungal prophylaxis unless HSCT is successfully performed. Two patients with CARD9 deficiency have been successfully treated with HSCT leading to clinical remission. There is a potential role for treatment of fungal disease with granulocyte-macrophage colony-stimulating factor (GM-CSF) therapy in CARD9 deficiency, but there is variability in response that may relate to the underlying pathogenic variant(s) responsible for disease; thus seeking expert advice is recommended.

**Table 175.1** Medelian Susceptibility to Mycobacterial Disease Defects

	GENE/INHERITANCE	CLINICAL PHENOTYPE	TREATMENT
Complete IFN $\gamma$ R1/R2 deficiency	IFN $\gamma$ R1 or IFN $\gamma$ R2/AR	Early-onset disseminated NTM or BCG	Antimycobacterials; HSCT
Autosomal dominant IFN $\gamma$ R1 deficiency	IFN $\gamma$ R1/AD	NTM or BCG osteomyelitis, disseminated <i>Salmonella</i> , disseminated endemic mycoses	Antimycobacterials; adjuvant IFN- $\gamma$
IL-12RB1 deficiency	IL12RB1/AR	Disseminated NTM, BCG, <i>Salmonella</i> Mucocutaneous candidiasis Variable penetration	Antimycobacterials; consider IFN- $\gamma$ with careful monitoring
IL-12p40 deficiency	IL12B/AR	Disseminated NTM, BCG, <i>Salmonella</i> Variable penetration	Antimycobacterials; consider IFN- $\gamma$ with careful monitoring
IL-12Rb2 deficiency	IL12RB2/AR	NTM, BCG, and tuberculosis	Antimycobacterials
IL-23R deficiency	IL23R/AR	NTM, BCG, and tuberculosis	Antimycobacterials
STAT1 LOF	STAT1/AD	Disseminated BCG/NTM, often osteomyelitis	Antimycobacterials; consider IFN- $\gamma$
SPPL2a deficiency	SPPL2A/AR	Disseminated BCG	Antimycobacterials
TYK2 deficiency	TYK2/AR	Disseminated BCG, tuberculosis, viral infections	Antimycobacterials
Macrophage gp91 phox deficiency	CYBB/XL; distinct variants than those causing CGD	Disseminated BCG	Antimycobacterials
IRF8 deficiency (dominant)	IRF8/AD	Disseminated BCG, NTM	Antimycobacterials
IRF8 deficiency (recessive)	IRF8/AR	Viral, mycobacterial, mucocutaneous candidiasis	Antimicrobials, consider HSCT
ISG15 deficiency	ISG15/AR	Disseminated BCG	Antimycobacterials
ROR $\gamma$ t deficiency	RORC/AR	Disseminated BCG and mucocutaneous candidiasis	Antimicrobials
JAK1 LOF	JAK1/AR	Bacterial, viral, and disseminated NTM	Antimicrobials

AD, Autosomal dominant; AR, autosomal recessive; BCG, bacilli Calmette-Guérin; CGD, chronic granulomatous disease; HSCT, hematopoietic stem cell transplantation; IFN, interferon; LOF, loss of function; NTM, nontuberculous mycobacteria.

### STAT1 GOF

STAT1 gain-of-function (GOF) pathogenic variants present with CMC, autoimmunity, intracranial aneurysms, and/or squamous cell carcinoma. This condition likely accounts for more than 50% of CMC cases; CMC affects most patients with this diagnosis and typically presents in the first year of life. *Candida* involvement of the oropharynx is most common, but esophagitis, genital, and skin and nail disease are also common. *C. albicans* is the most common cause of CMC, but other *Candida* species have also been isolated. Azole resistance is a major challenge over time making treatment difficult.

Invasive fungal infections are less common in this disease but can be quite severe. Disseminated *Histoplasmosis*, *Cryptococcus*, *Coccidioides*, and *Paracoccidioides* can be difficult to treat and, in some cases, have been fatal. Pulmonary and disseminated mold infections have been reported infrequently and include organisms such as *Aspergillus*, *Nannizziopsis*, and *Mucorales*. *Pneumocystis jiroveci* pneumonia has been reported rarely.

A wide range of other types of pathogens cause infections in this patient population as well including recurrent bacterial sinopulmonary infections, typically due to *Streptococcus pneumoniae*, *Haemophilus influenzae*, and *Staphylococcus aureus*. Bronchiectasis, when present, may further produce susceptibility to pathogens such as *Pseudomonas*. Less commonly skin infections such as folliculitis or cellulitis are also observed. Mycobacterial infections are typically due to BCG in those from countries that routinely immunize against tuberculosis (TB), and nontuberculous mycobacteria (NTM) adenitis or TB, or NTM lung

infections. NTM infections do not usually disseminate widely in STAT1 GOF as they do in autosomal recessive or dominant STAT1 LOF.

Severe or recurrent viral infections, most commonly due to herpesviruses (herpes simplex virus [HSV], varicella-zoster virus [VZV], Epstein-Barr virus [EBV], cytomegalovirus [CMV], BK, and JC), are also troublesome in over 30% of patients. Recurrent oral mucocutaneous disease due to HSV or recurrent VZV infection are the most frequent viral disease manifestations. EBV and CMV viremias are commonly detected, but CMV disease is infrequent as is symptomatic EBV disease. Human papillomavirus (HPV)-driven warts and molluscum are seen in a small number of these patients and are difficult to treat. Although rare, progressive multifocal leukoencephalopathy (PML) from JC virus is of particular concern due to its high mortality. PML has been seen with and without additional immune modulation; therapies that are sometimes indicated for the autoimmunity seen in STAT1 GOF, such as rituximab, need to be used with caution.

Additional disease manifestations include autoimmunity, vasculopathy, and malignancy. Autoimmune thyroid disease is most common, but type 1 diabetes mellitus, vitiligo, alopecia, pernicious anemia, autoimmune cytopenias, inflammatory bowel disease, and lupus-like disease have all been observed and, in many cases, the autoimmune manifestations can be quite refractory and difficult to control. Aphthous ulcers are also especially common and can be very painful. Cerebral aneurysms are the most common vasculopathy seen, but extracerebral vascular abnormalities occur as well. These aneurysms may be the result of vasculitis, perhaps from pathogens like VZV; serial



prospective imaging should be a part of routine screening. The most common malignancy observed is squamous cell carcinoma, mainly of the skin, oropharynx, and esophagus. Chronic inflammation caused by mucosal *Candida* infections may play an important role, as well as inflammation driven by increased STAT1 activity.

Management has been largely targeted against the infections and treatment of autoimmunity when present. Many of the patients need antifungal prophylaxis, and azole resistance may emerge and limit therapeutic choices to topical nystatin or amphotericin washes, or IV echinocandins. It is worth highlighting that voriconazole is not recommended in this patient population due to its photosensitivity and long-term skin cancer risk. In those patients with recurrent sinopulmonary infections and/or bronchiectasis, antibiotic prophylaxis is likely to be beneficial. Azithromycin prophylaxis, if pulmonary NTM is not present, may be beneficial not only for prevention of recurrent airway infections, but also will yield some antiinflammatory benefits. Recurrent HSV or VZV infections suggest the need for prophylaxis with acyclovir or valacyclovir. The autoimmunity is typically treated with immune suppression, and many have received long courses of corticosteroids. However, there are positive reports of success controlling this inflammation and autoimmunity with JAK inhibition. Ruxolitinib has been used in STAT1 GOF to treat alopecia, enteropathy, autoimmune cytopenias, and hepatitis. There is one report of JAK inhibition being used early in the course of associated insulin-dependent diabetes, with resolution of the need for insulin and remission of the diabetes. JAK inhibition also can be highly effective in the treatment of CMC because there is growing evidence that the CMC observed in this disease is due to exuberant inflammation rather than infection susceptibility. *Severe or disseminated infections have progressed while on JAK inhibition, thus, it is best to start this treatment only when invasive infections are adequately controlled.* Some patients develop hypogammaglobulinemia over time; immune globulin replacement may be indicated. HSCT is not yet the preferred option for treatment of STAT1 GOF. HSCT in this population of patients has been difficult with high morbidity and mortality, although it is important to note that many of these transplants were done before the genetic diagnosis was known and a variety of conditioning regimens were used.

### IL-17F DEFICIENCY

A dominant-negative missense pathogenic variant in *IL17F* was reported in multiple patients from one kindred with CMC. About 65% of these patients had CMC manifesting as persistent thrush, vulvovaginal candidiasis, and interdigital intertrigo. Lymphocyte phenotyping and quantitative immunoglobulin levels were normal in the one patient who had such testing. Diagnosis relies on sequencing of IL-17F, but can also be suspected if flow cytometry shows absent intracellular IL-17F producing CD3<sup>+</sup> cells in patients with detectable IL-17A and IL-22 producing CD3<sup>+</sup> cells. Although there is insufficient clinical information to suggest ideal management of patients with IL-17F deficiency, we recommend a similar approach as outlined for management of CMC.

### IL-17RA DEFICIENCY

IL-17RA deficiency also presents with CMC, but usually with onset within the first year of life. Candidiasis involved the oropharynx in 95% of patients, the genitals in 38% (60% females), the skin or scalp in 67%, and the nails in 19%. Episodes of CMC seemed to respond to topical or oral therapy. Staphylococcal skin infections were seen in 65% of the cohort, with such lesions also manifesting in the first year of life. Bacterial recurrent sinopulmonary infections occur in just over one-third of these patients, and all responded to antibiotic therapy.

Lymphocyte phenotyping is normal, and diagnosis should be made by sequencing of the *IL17RA* gene, particularly when early-onset CMC and concurrent *S. aureus* skin infections are present.

As CMC is a presenting feature of all reported patients with IL-17RA deficiency, oral antifungal prophylaxis should be initiated. Strong consideration should be given to also initiating antibiotic prophylaxis in those who have culture-proven bacterial infections that are recurrent

or severe. In those with recurrent sinopulmonary infections, although the spectrum of organisms is not known, covering for common bacterial etiologies like *S. pneumoniae*, *H. influenzae*, and *Moraxella catarrhalis* should be sufficient to prevent disease.

Visit Elsevier eBooks+ at [eBooks.Health.Elsevier.com](http://eBooks.Health.Elsevier.com) for Bibliography.

## 175.2 Innate Immunity Defects with Predominant Susceptibility to Viral Infections

Jenna R.E. Bergerson and Alexandra F. Freeman

Defects in innate immunity that predispose to viral infections are divided into three main groups: those primarily predisposing to HPV, those predisposing primarily to HSV encephalitis, and those predisposing to other viruses, many of which interfere with interferon (IFN) signaling. Some of these defects are described in the following sections along with other rare defects highlighted in Table 175.2.

### PREDOMINANT HPV SUSCEPTIBILITY

**Epidermodysplasia verruciformis (EV)** is the main clinical presentation for diseases with autosomal recessive pathogenic variants in the transmembrane channel-like 6 and 8 (*TMC6* and *TMC8*) genes and more recently described in the calcium- and integrin-binding protein 1 (*CIB1*) gene, encoding for the proteins EVER1, EVER2, and CIB1, respectively. EVER1, EVER2, and CIB1 complex together for keratinocyte intrinsic immunity, and disruption of this complex leads to HPV susceptibility. The typical warts affecting healthy individuals are from  $\alpha$ -HPV types; however, in EV,  $\beta$ -HPV causes symptomatic disease, which is usually asymptomatic in healthy individuals but associated with cancer in some immune compromised individuals. The warts are frequently not the typical verrucous appearance seen in healthy children, but are usually flat warts, and can look like tinea versicolor with pigment changes. The warts appear in sun-exposed areas and have a high incidence of cancer transformation. Individuals with EV do not usually have increased risk of other infections; they have normal immune evaluations including normal lymphocyte number and function. Diagnosis is with genetic testing after suspicion with atypical widespread HPV disease. There is no specific treatment, although warts are treated with standard therapies (see Chapter 708). Patients needed to be counseled to avoid UV and radiation exposure, and these individuals need frequent screening for skin cancer.

**WHIM (wart, hypogammaglobulinemia, infections, myelokathexis) syndrome** is an autosomal dominant (AD) disease caused by GOF pathogenic variants in *CXCR4*. Increased responsiveness of the *CXCR4* receptor to its ligand CXCL12 (also known as SDF-1) results in increased retention of the neutrophils in the bone marrow and thus the finding of myelokathexis (neutropenia related to the inability of neutrophils to leave the marrow). Patients also have lymphopenia with decreased B-, T- and NK lymphocytes, along with hypogammaglobulinemia. Although recurrent infections are common, they tend not to be as severe as expected from the neutropenia because the neutrophils often are released from the bone marrow with infection; dental issues likely related to the neutropenia are common. Recurrent sinopulmonary infections likely relate more to the hypogammaglobulinemia, and some patients develop bronchiectasis. Warts typically start in childhood or adolescence and are often particularly severe with poor response to therapy. Evolution into squamous cell carcinomas can occur; patients require monitoring. Treatment traditionally has been supportive in treating infections and preventive with immune globulin therapy and G-CSF, which usually needs to be dosed at lower concentrations due to frequently experienced debilitating bone pain. Plerixafor, an antagonist of *CXCR4*, may provide a specific therapy.

There are several other PIDDs that primarily affect lymphocytes that have HPV susceptibility as a major component and are discussed in

other chapters. Many of these diseases, such as DOCK8 deficiency and GATA2 deficiency, have broader susceptibility than just HPV. CD28 deficiency has susceptibility specific for HPV resulting in warts and cutaneous horns. Compared to EV, those with CD28 deficiency have predisposition to the more common  $\alpha$ - and  $\gamma$ -HPV types.

### Predisposition to Severe Viral Infections

Host control of viral infections is predominately dependent on normal type 1 IFN signaling (Fig. 175.1; see Table 175.2). Type 1 IFNs, including the IFN- $\alpha$  subtypes and IFN- $\beta$ , bind to their heteroreceptor comprising IFNAR1 and IFNAR2 leading to phosphorylation of TYK2 and JAK1. Activation of TYK2 and JAK1 leads to phosphorylation of STAT1 and STAT2, which then cause upregulation of **interferon-stimulated genes (ISGs)**. There are multiple potential defects along this pathway that can lead to viral susceptibility. The role of this pathway has been highlighted with the COVID-19 pandemic, with not only genetic defects but also autoantibodies against type 1 IFNs leading to more severe disease.

Autosomal recessive pathogenic variants in *IFNAR1* and *IFNAR2* lead to a lack of TYK2 phosphorylation for IFNAR1 defects, and both TYK2 and JAK1 phosphorylation for IFNAR2 with subsequent downstream deficiency of ISG upregulation. Despite the severe *in vitro* findings, the viral infection susceptibility appears more limited. Both are rare diseases, with most patients developing severe or fatal illness after live viral vaccination with the measles mumps rubella (MMR) vaccine (largely measles component) or yellow fever vaccine. Herpes viral control is variable, with a fatal case of herpes encephalitis reported in IFNAR1 deficiency, and poor control of human herpesvirus 6 (HHV6) in IFNAR2. Variants have been described with severe SARS-CoV-2 infection. These diseases appear to have incomplete penetrance, with some affected individuals having better control of viral infections or vaccination. Naturally acquired viral infections have been controlled much more than live viral vaccinations. These diseases are rare and therapy remains unclear, but avoiding live viral vaccines, considering antiviral prophylaxis for HSV/VZV infections, and vaccination of affected individuals and close contacts for influenza and COVID-19 appears prudent.

Genetic defects in *STAT1* can be activating (STAT1 GOF) or can be heterozygous or recessive with LOF. Autosomal recessive complete STAT1 deficiency is the most severe defect with most cases being fatal early in life. As IFN- $\alpha$ , IFN- $\beta$ , and IFN- $\gamma$  all signal through STAT1, completely impaired signaling predisposes individuals to both severe

early-onset viral disease in addition to disseminated mycobacterial disease. Herpes family infections are common as well as live viral disseminated infection. The disease is fatal without HSCT early in life, but HSCT outcomes have been poor with several children having herpes family inflammatory complications after HSCT, such as with hemophagocytic lymphohistiocytosis (HLH) or severe CMV disease. There are also patients with autosomal recessive hypomorphic *STAT1* pathogenic variants who have some residual STAT1 disease that appears to have a less severe phenotype. Treatment is with aggressive antimicrobials to treat presenting infections and prevent new infections until HSCT is performed.

*Autosomal recessive complete STAT2 deficiency* presenting early in life with severe viral infections is not as severe as STAT1 deficiency due to maintenance of IFN- $\gamma$  signaling. Compared to IFNAR1 and IFNAR2 deficiency, there is more severe disease with naturally acquired viral infections such as respiratory syncytial virus (RSV) and enteroviruses, but similarly severe disease has been seen with MMR vaccine. Some children have been described to have a Kawasaki-like inflammatory presentation. The phenotype has been variable with some deaths early in life and some surviving to adulthood. Treatment remains uncertain with few patients reported, but live viral vaccines should be avoided, antiviral prophylaxis provided, and influenza vaccination given to those affected and close contacts.

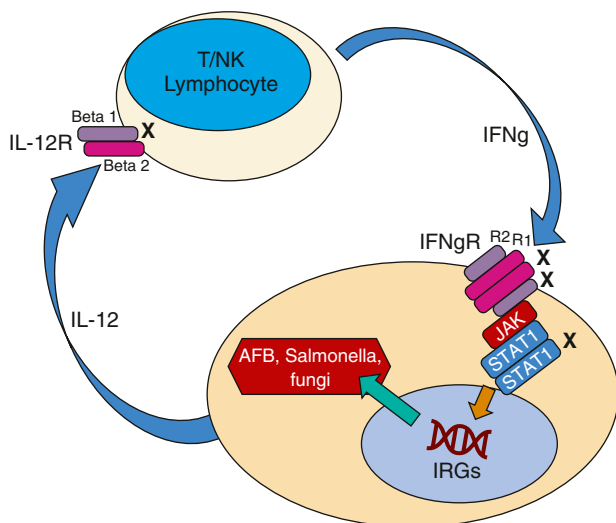
*Autosomal recessive IRF9 deficiency* appears to present similarly to STAT2 deficiency. After IFN- $\alpha$  or IFN- $\beta$  stimulation leads to STAT1 and STAT2 phosphorylation, these STAT proteins can heterodimerize with IRF9 to lead to ISG upregulation. This is a very rare defect presenting with naturally occurring or vaccine strain viruses. Life-threatening influenza and severe enterovirus infections have been described in addition to vaccine strain varicella and MMR dissemination. Treatment remains uncertain with few patients reported, but live viral vaccines should be avoided, antiviral prophylaxis considered, and influenza and COVID-19 vaccination given to those affected and close contacts.

Defects have been described in cytosolic sensors of viral DNA or RNA replication by-products that lead to fairly specific viral susceptibility. Melanoma differentiation-associated protein 5 (MDA5), encoded by the *IFIH1* gene, is a cytosolic sensor of double-stranded RNA by-products of RNA viral replication. Several patients have been described with LOF variants, either autosomal recessive or dominant, with presumed dominant negative effect, resulting in severe susceptibility to respiratory viruses including rhinovirus and influenza. Retinoic acid-inducible gene I (RIG-I), encoded by the *DDX58* gene, plays a similar role, and a patient has been described with LOF variants having severe influenza infection. RNA polymerase III deficiency (POL III) is a cytosolic DNA sensor detecting replication by-products of DNA viruses. AD pathogenic variants have been reported in POL III in children and adults with severe varicella-zoster disease causing pneumonitis, encephalitis, and CNS vasculitis. Treatment is not defined, but avoiding live viral vaccines, providing antiviral prophylaxis, and providing non-live annual influenza and COVID-19 vaccination to affected individuals and family members appear prudent.

NK functional and quantitative defects can occur on their own or as part of combined immune deficiencies and are associated with viral infections (see Chapter 167). Pathogenic variants in the *FCGR3A* gene, encoding CD16, which is a Fc receptor on NK cells, impair NK cytotoxicity. A few patients have been described who have susceptibility to herpes family viruses with EBV-related disease such as Castleman disease or HSV and VZV infections. Patients also develop significant warts from HPV infection. Antiviral prophylaxis should be given to prevent HSV/VZV infections, in addition to HPV vaccination.

### Predominant HSV Encephalitis

Defects that affect TLR3 signaling predispose quite specifically to HSV encephalitis due to their role in the activation of type 1 IFNs in the CNS (Fig. 175.2; see Table 175.2). Double-stranded RNA is detected by TLR3, which then recruits the adaptor TRIF to activate TRAF3 to induce IFN- $\alpha$ , IFN- $\beta$ , and inflammatory cytokines through TBK1 and IRF3 and other proteins. UNC93B1 acts as a transporter protein to



**Fig. 175.1** Host control of mycobacteria. Macrophages ingest mycobacteria leading to secretion of cytokine IL-12, which then binds to its heterodimer receptor on the T lymphocytes and NK cells leading to the secretion of IFN- $\gamma$ . IFN- $\gamma$  binds to its heterodimer receptor, IFN- $\gamma$ R1 and IFN- $\gamma$ R2, leading to JAK1 and JAK2 phosphorylation, and then STAT1 phosphorylation. Where defects lead to MSMD are marked by an X.

**Table 175.2** Defects with Predominant Susceptibility to Viral Infections

GENE/INHERITANCE	CLINICAL PHENOTYPE	SPECIFIC TREATMENT	GENE/INHERITANCE
Epidermodysplasia verruciformis	<i>EVER1, EVER2, CIB1/AR</i>	Diffuse flat warts, with increased skin cancers	Avoid UV/radiation exposure, skin cancer screening.
WHIM syndrome	<i>CXCR4/AD</i>	Warts, squamous cell cancer, sinopulmonary infections, neutropenia, hypogammaglobulinemia	G-CSF, IgRT, plerixafor
IFNAR1 deficiency	<i>IFNAR1/AR</i>	Severe disease after live viral vaccination (MMR, yellow fever), herpesviruses	Avoid live viral vaccination, consider HSV/VZV prophylaxis
IFNAR2 deficiency	<i>IFNAR2/AR</i>	Severe disease after live viral vaccination (MMR, yellow fever), herpesviruses	Avoid live viral vaccination, consider HSV/VZV prophylaxis
Complete STAT1 deficiency	<i>STAT1/AR</i>	Early-onset severe viral and disseminated <i>Mycobacteria</i>	Early HSCT
STAT2 deficiency	<i>STAT2/AR</i>	Severe respiratory viruses, enterovirus; some live viral vaccine disease	Avoid live viral vaccines
IRF9 deficiency	<i>IRF9/AR</i>	Severe respiratory viruses, enterovirus; some live viral vaccine disease	Avoid live viral vaccines
IRF7 deficiency	<i>IRF7/AR</i>	Severe influenza	Influenza vaccination*
MDA5 deficiency	<i>IFIH1/AR</i> or AD	Severe respiratory tract infections	Influenza vaccination
RNA polymerase III deficiency	<i>POL3A, POL3C, POL3F/AD</i>	Severe varicella-zoster	Antiviral prophylaxis
CD16 deficiency	<i>FCGR31/AR</i>	Herpes family infections, HPV	Antiviral prophylaxis
IL-18BP deficiency	<i>IL18BP/AR</i>	Fulminant hepatitis A	Hepatitis A vaccination
TLR3 deficiency	<i>TLR3/AD</i> and AR	HSV encephalitis, severe influenza, zoster	Antiviral prophylaxis
TRAF3 deficiency	<i>TRAF3/AD</i>	HSV encephalitis	Antiviral prophylaxis
TRIF deficiency	<i>TRIF/AD</i> and AR	HSV encephalitis	Antiviral prophylaxis
UNC93B1 deficiency	<i>UNC93B1/AR</i>	HSV encephalitis	Antiviral prophylaxis
TBANK1 deficiency	<i>TBANK1/AD</i>	HSV encephalitis	Antiviral prophylaxis
IRF3 deficiency	<i>IRF3/AD</i>	HSV encephalitis	Antiviral prophylaxis
DRB1 deficiency	<i>DRB1/AR</i>	Brainstem encephalitis	Antiviral prophylaxis

\*Although influenza vaccination is highlighted for certain inborn errors of immunity (IEIs), influenza vaccination should be given to all those with IEIs and their close contacts unless there is a contraindication. In addition, HPV vaccination should be given per the recommended schedule. Vaccination at an earlier age can be considered for certain defects with HPV predisposition.

AD, Autosomal dominant; AR, autosomal recessive; G-CSF, granulocyte colony-stimulating factor; HPV, human papillomavirus; HSCT, hematopoietic stem cell transplantation; HSV, herpes simplex virus; IFN, interferon; MMR, measles mumps rubella; UV, ultraviolet; VZV, varicella-zoster virus; WHIM, (wart, hypogammaglobulinemia, infections, myelokathexis) syndrome.

transport TLR3 and other TLRs from the endoplasmic reticulum to the endosome to allow RNA binding. The TLR3 pathway is redundant for leukocyte immunity, but it is essential for CNS host viral immunity; thus the infection susceptibility of these defects is primarily CNS HSV disease. The defects in signaling are not found in leukocytes but required fibroblasts and inducible pluripotent stem cell generation of CNS cells to demonstrate abnormal IFN- $\alpha$  responses with HSV infection.

Pathogenic variants in multiple genes along this pathway have similar presentations with HSV encephalitis including autosomal recessive and dominant LOF variants in *TLR3*, dominant pathogenic variants in *TRAF3*, dominant and recessive pathogenic variants in *TRIF*, recessive pathogenic variants in *UNC93B1*, and dominant pathogenic variants in *TBANK1* and *IRF3*. The HSV encephalitis tends to present in infancy and early childhood on HSV exposure, with frontal and temporal lobes predominantly affected. Dominant pathogenic variants in *TLR3* have also been associated with severe influenza and varicella-zoster encephalitis in a few adults. Genetic diagnosis is essential as routine immunologic

studies are normal. Treatment is supportive with acyclovir or similar prophylaxis.

Rarely children can have brainstem CNS infections, including HSV; defects in the TLR3 pathway have not been found in these cases. Autosomal recessive hypomorphic pathogenic variants in *DBR1* (debranching enzyme 1) have been identified in children with brainstem encephalitis caused by HSV, norovirus, and influenza virus. *DBR1* is an RNA lariat-debranching enzyme that degrades spliced RNA introns, which is ubiquitously expressed in humans but with highest amounts in the brainstem and peripheral nervous system. With decreased function, there is increased accumulation of lariat introns that presumably interfere with viral recognition and control. Genetic diagnosis can allow prophylaxis with antivirals such as acyclovir and influenza vaccination of the affected individual and close contacts.

Visit Elsevier eBooks+ at [eBooks.Elsevier.com](http://eBooks.Elsevier.com) for Bibliography.

### 175.3 Susceptibility to Invasive Bacterial Infections

Jenna R.E. Bergerson and Alexandra F. Freeman

Inborn errors of immunity (IEIs) with predominant susceptibility to invasive bacterial infections such as meningitis, sepsis, arthritis, osteomyelitis, and deep-seated abscesses are rare, and are mostly due to neutrophil defects or defects in innate immunity. Inherited disorders of the Toll and IL-1 receptor (TIR)-pathway are innate immunity defects with a very distinct phenotype with invasive pyogenic bacterial infections and usually the absence of fever and inflammatory markers. TLRs on white blood cell surfaces sense bacterial peptides leading to activation of the NF- $\kappa$ B and MAPK pathway leading to inflammatory mediators (Fig. 175.3). IEIs associated with impaired TLR signaling include pathogenic variants in *NEMO*, *IKBA*, *MyD88*, and *IRAK4* (Table 175.3).

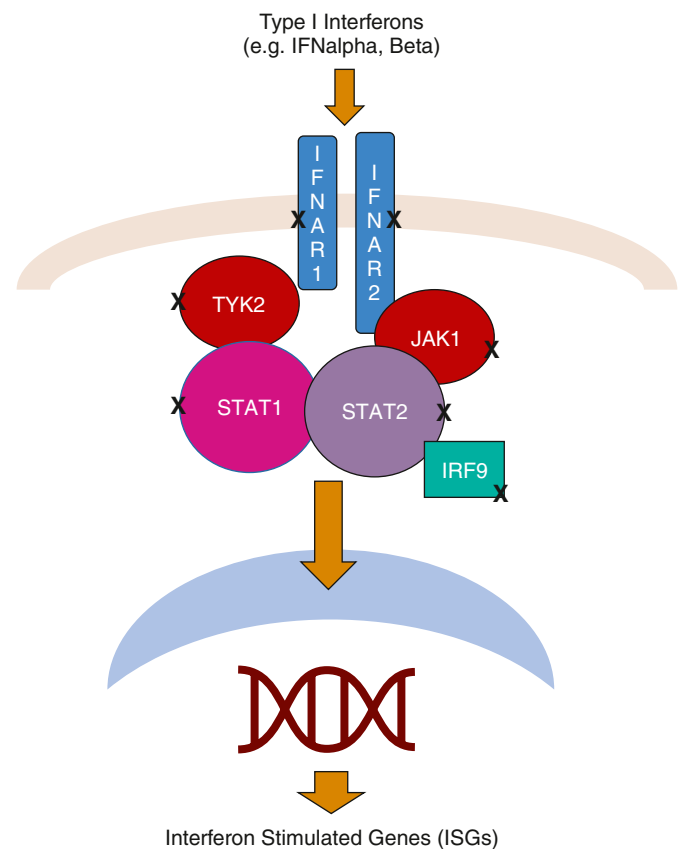
#### IRAK4 DEFICIENCY

IRAK4 deficiency presents in infancy and early childhood with severe, recurrent bacterial infections, specifically due to *S. pneumoniae*, *S. aureus*, and *Pseudomonas aeruginosa*. Unique to this disorder, clostridial infections have also been reported. An impairment in mounting a fever at the beginning of infection with a corresponding rise in CRP are also hallmark features of this disease. Most patients with IRAK4 deficiency present with their first bacterial infection before 2 years of age; there is a high mortality rate in the early years. However, the frequency and severity of infections in IRAK4 deficiency improves with age, with none of the reported patients having invasive bacterial infections after the onset of adolescence, even those not on prophylactic antibiotics. Approximately 50% of IRAK4-deficient patients continue to have noninvasive skin and upper respiratory infections after adolescence. Delayed separation of the umbilical cord has been reported in IRAK4-deficient patients due to an unclear mechanism.

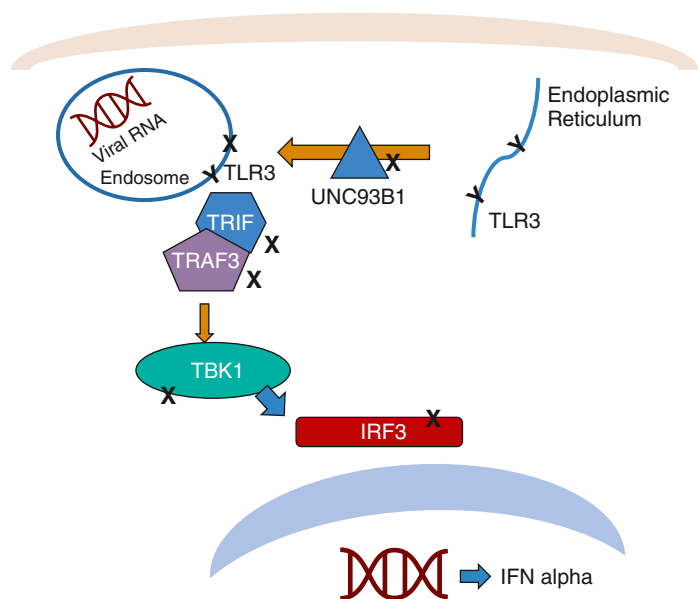
Diagnosis relies on clinical suspicion and genetic testing because other immunologic studies are variable or require research laboratory testing. All T- and B-cell and NK cell subsets are unremarkable, but there may be a deficiency of unswitched memory B cells with normal levels of switched memory B cells. Specific antibody levels to pneumococcal and allohemagglutinins of the ABO system are impaired in up to 30% of patients. Serum IgE and IgG4 concentrations are elevated in up to 65% and 30%, respectively. Defective IL-6 production leads to the inability to increase plasma CRP or mount fevers. Without the clinical findings of fever and inflammatory markers, there may be a low threshold for diagnostic imaging and initiating empiric parenteral antibiotic treatment against *S. pneumoniae*, *S. aureus*, and *P. aeruginosa*. Antibiotic prophylaxis should be implemented with agents like cotrimazole plus penicillin, and immunizations against pneumococcus serotypes, *H. influenzae*, and *Neisseria meningitidis* given. If patients have a poor response to vaccination, immunoglobulin replacement should be considered. There is a paucity of data to support the duration of antibiotic prophylaxis, but given that invasive pyogenic infections seem to resolve by adolescence a trial discontinuation could be considered at this time. Nonetheless these patients continue to have skin and upper respiratory infections and may benefit from lifelong antibiotic prophylaxis targeting pyogenic bacteria.

#### MYD88 DEFICIENCY

MyD88 deficiency resembles the clinical and laboratory findings in IRAK4 deficiency (Fig. 175.4; see Table 175.1). These patients have a susceptibility to serious bacterial infections due primarily to *S. pneumoniae*, *S. aureus*, and *P. aeruginosa*, including an inability to mount fever at the beginning of infection. CRP does not rise early during infection, likely due to impaired IL-6 production. Invasive bacterial infections begin before age 2 years and seem to improve with age, although noninvasive bacterial infections similarly persist after adolescence. Diagnosis is similar to IRAK4 deficiency relying on genetics, as routine immunologic testing is nondiagnostic. MyD88-deficient patients may have elevated serum IgE and IgG4 concentrations in up to 50% and



**Fig. 175.2** Defects along type 1 interferon (IFN) signaling lead to viral susceptibility. Type 1 IFNs bind to their heteroreceptor comprising IFNAR1 and IFNAR2 leading to TYK2 and JAK1 phosphorylation followed by phosphorylation of STAT1 and STAT2, which then cause upregulation of IFN-stimulated genes (ISGs). IRF9 can also heterodimerize with STAT2 leading to ISG upregulation. Multiple genetic defects along this pathway (marked with X) can lead to viral susceptibility.



**Fig. 175.3** Defects that affect toll-like receptor (TLR) 3 signaling predispose to HSV encephalitis by impairing type I interferon (IFN) activation. Double-stranded RNA is detected by TLR3, which then recruits the adaptor TRIF to activate TRAF3 and then through TBK1 and IRF3 to induce IFN- $\alpha$  and other inflammatory cytokines. UNC93B1 transports TLR3 from the endoplasmic reticulum to the endosome.



**Table 175.3** Innate Defects with Bacterial Susceptibility

DISEASE	GENE/INHERITANCE	CLINICAL PHENOTYPE	LABORATORY PARAMETERS
IRAK4 deficiency	IRAK4, AR	Early-onset invasive pyogenic bacterial infections resolving in adolescence Persistence of noninvasive skin and URT infections	↓ IL-6, undetectable CRP in setting of infection ↓ CSM B cells Poor specific antibody levels to pneumococcus
MyD88 deficiency	MYD88, AR	Early-onset invasive pyogenic bacterial infections resolving in adolescence Persistence of noninvasive skin and URT infections	↓ IL-6, undetectable CRP in setting of infection ↓ CSM B cells
IRAK1 deficiency	IRAK1, XL	Undefined as reported in only one patient with Rett syndrome	Unknown
TIRAP deficiency	TIRAP, AR	Undefined Identified in nine members of one family with only one affected (pneumonia and sepsis from PVL-associated <i>Staphylococcus aureus</i> )	Selectively ↓CSM B cells
Isolated congenital asplenia	RPSA, AD	Sepsis with encapsulated bacteria, absent spleen	HJB on blood smear
	PBX1, NKX2-5, BAPX1, POD1, AR	Sepsis with encapsulated bacteria, absent spleen	HJB on blood smear

AD, Autosomal dominant; AR, autosomal recessive; CSM; class switched memory; HJB; Howell-Jolly bodies; IL, interleukin; PVL, Panton-Valentine leukocidin; URT, upper respiratory tract; XL, X-linked.

33% of patients tested (respectively), as well as a specific deficiency of unswitched memory B cells. Treatment of MyD88 deficiency should follow the same principles as outlined previously for IRAK4 deficiency.

Other inherited disorders of the TIR pathway like IRAK1 deficiency and TIRAP deficiency will be addressed in Table 175.3.

### ISOLATED CONGENITAL ASPLENIA

Asplenia refers to the complete lack of splenic tissue and includes a heterogenous group of conditions ranging from surgical asplenia to congenital asplenia. Congenital asplenia can be part of a syndrome of multiple congenital anomalies (see Chapter 480.11) or, less often, it can be isolated (see Table 175.3).

A diagnosis of isolated congenital asplenia (ICA) is made on the basis of the presence of Howell-Jolly bodies (HJBs) on blood smear and the lack of a detectable spleen at ultrasound in the absence of cardiovascular malformations. Some cases are due to an AD inheritance; relatives of those with ICA should be evaluated because the outcome is typically poor without initiation of antibiotic prophylaxis and pneumococcal vaccination. Half of all isolated cases are due to pathogenic variants in *RPSA*, a protein component of the small ribosomal subunit. Involvement of related key spleen patterning genes involved during embryogenesis can also result in splenic agenesis.

Presentation is typically with overwhelming, refractory infections due to encapsulated bacteria, particularly *S. pneumoniae*, but also other encapsulated bacteria like *H. influenzae* and *N. meningitidis*. Diseases like malaria and babesiosis also affect asplenic patients more severely due to defective removal of intra-erythrocytic parasites. In all cases of pneumococcal sepsis, a blood smear should be evaluated for HJBs in addition to an abdominal ultrasound to identify patients with ICA.

Immunization against pneumococcal serotypes and meningococcal serotypes is essential. Conjugated vaccines are preferred to unconjugated vaccines. Influenza vaccination should also occur yearly due to the risk of pneumococcal superinfection. Long-term oral penicillin prophylaxis (amoxicillin 10 mg/kg twice daily to max 250 mg OR ≤3 years: penicillin V 125 mg twice daily, ≥3 years: penicillin 250 mg twice daily) is recommended, as is early initiation of IV antibiotics in the setting of febrile illnesses. Patient education is a critical part in management. Patients should recognize and react to fever as a life-threatening emergency with initiation of antibiotic therapy at home (pediatric dosage of amoxicillin-clavulanate 45 mg/kg twice daily or levofloxacin 10 mg/kg for penicillin

allergic patients) even before seeking medical care. Animal bites (risk of *Capnocytophaga*) also should be recognized as a medical emergency requiring local wound care and debridement, and a short course of antibiotic therapy (amoxicillin-clavulanate for 3-5 days). Lastly, when traveling patients should know what to do in case of fever, and if in a tropical area recognize the increased risk for malaria.

Visit Elsevier eBooks+ at [eBooks.Health.Elsevier.com](http://eBooks.Health.Elsevier.com) for Bibliography.

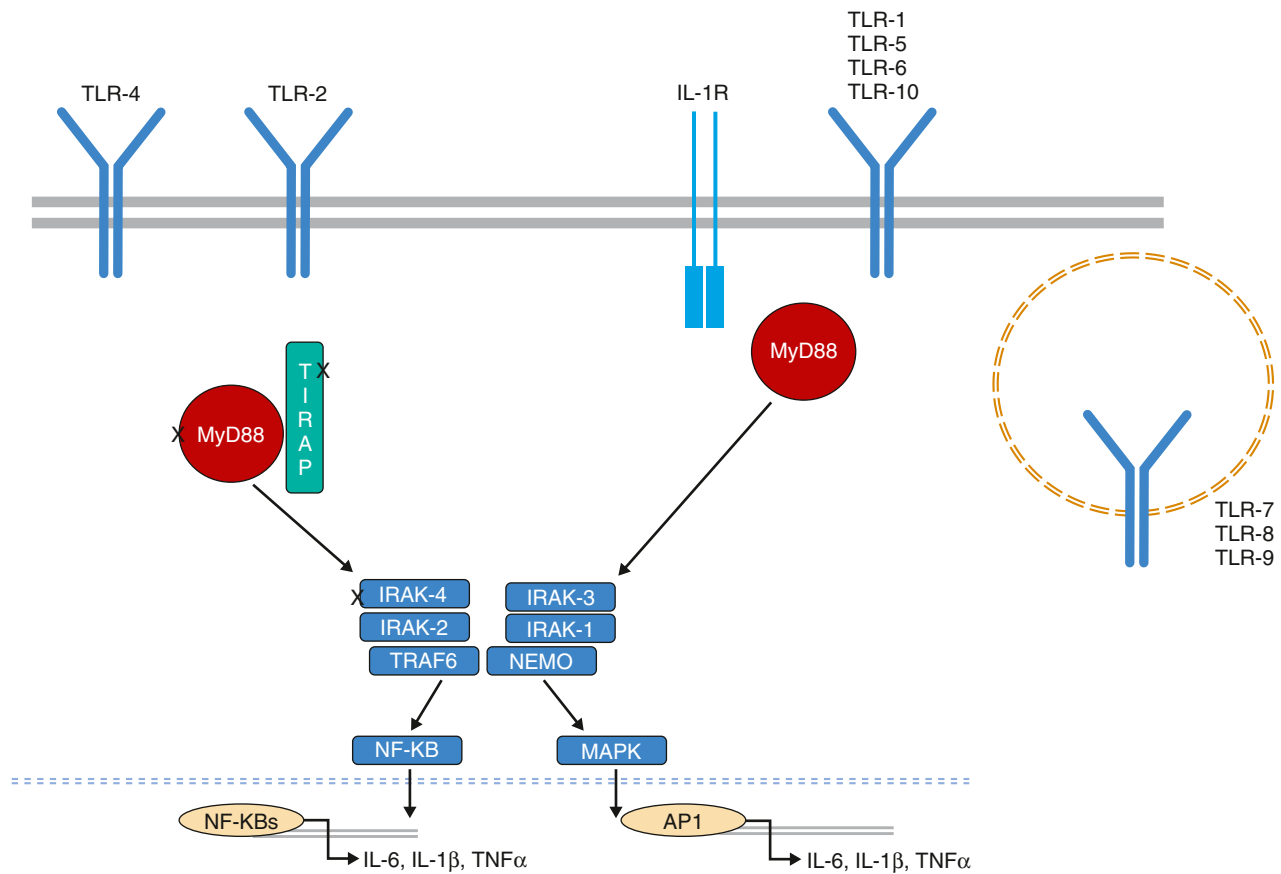
## 175.4 Mendelian Susceptibility to Mycobacterial Diseases

Jenna R.E. Bergerson and Alexandra F. Freeman

The group of diseases referred to as mendelian susceptibility to mycobacterial diseases (MSMDs) centers around the synthesis and signaling of IFN- $\gamma$  required for the ability of macrophages to control intracellular infections including mycobacteria as well as some other intracellular bacteria, fungi and viruses (see Table 175.1).

Control of mycobacterial infections relies on the IL-12/IFN- $\gamma$ /STAT1 pathway (see Fig. 175.4). When the macrophages ingest mycobacteria or other intracellular organisms, they secrete the cytokine IL-12, which binds to its receptor, a heterodimer comprising IL-12RB1 plus IL-21RB2, on the T lymphocytes and NK cells. This then leads to the secretion by the T/NK lymphocytes of IFN- $\gamma$ . IFN- $\gamma$  binds to its heterodimer receptor, IFN- $\gamma$ R1 and IFN- $\gamma$ R2, leading to JAK1 and JAK2 phosphorylation, and then STAT1 phosphorylation. STAT1 is a transcription factor that leads to the upregulation of IFN-regulated genes (IRGs), which leads to the clearance of these infections. Control of mycobacteria relies on this pathway, but also other intracellular microorganisms such as endemic fungi (e.g., *Histoplasma* and *Coccidioides*), *Salmonella*, leishmaniasis, and, in part, some viruses, such as those in the herpes virus family.

The MSMD defects typically present with disseminated BCG or with extrapulmonary nontuberculous and environmental mycobacteria (NTM); individuals with disseminated mycobacterial disease with either bone or visceral involvement should be evaluated. Depending on the type of defect, the infection may be more localized, such as the osteomyelitis seen frequently with dominant LOF defects in *IFN- $\gamma$ R1* or *STAT1*,



**Fig. 175.4** TLR/IL-1R pathways. MyD88 is a cytosolic adaptor protein that bridges TLRs and IL-1Rs to the IRAK complex and subsequently allows for the downstream production of cytokines and interferons (IFNs) through the NF- $\kappa$ B and MAPK pathways. All TLRs, except TLR3, as well as multiple IL-1Rs use MyD88 and IRAK4. Where defects lead to predominant susceptibility to invasive bacterial infections are marked by an X.

or with more disseminated disease often with lymph node, bowel, and hepatosplenic involvement. Extrapulmonary TB should also raise suspicion of MSMD in young BCG-vaccinated children. Mycobacterial disease restricted to the lungs is much less frequently associated with MSMD, but more often with diseases predisposing to bronchiectasis. In addition, young children with isolated cervical adenitis from NTM do not usually have MSMD; the evaluation can be limited to those with recurrent or difficult to treat disease.

Therapy relies on targeted antimicrobials, but cytokine adjuvants, such as IFN- $\gamma$ , and consideration of HSCT varies based on the defect. Related defects that predispose to CMC are noted in [Table 175.4](#).

### IFN- $\gamma$ R Defects

The IFN- $\gamma$  receptor is a heterodimer comprised of IFN- $\gamma$ R1 and IFN- $\gamma$ R2, and defects in both components lead to abnormal signaling. There are biallelic and heterozygous pathogenic variants that lead to differing presentations.

### Autosomal Recessive Complete IFN- $\gamma$ R1/IFN- $\gamma$ R2 Deficiency

The most severe defect of the IFN- $\gamma$ R defects are homozygous or compound heterozygous pathogenic variants that block all IFN- $\gamma$  signaling. The variants are in the extracellular domains of the protein and lead to no surface receptor expression. In countries where BCG is given, these patients typically present in infancy with disseminated BCG; in other countries affected patients present usually in early childhood with disseminated NTM, such as *Mycobacterium avium* complex (MAC). *Salmonella* and *Listeria* can also cause severe infection; there may be more severe disease with common respiratory viruses and herpes family viruses. Diagnosis is with genetic testing, but some laboratories can also suggest the diagnosis by performing flow cytometry showing no surface expression of the IFN- $\gamma$

on monocytes or lack of intracellular STAT1 phosphorylation after stimulation with IFN- $\gamma$ .

Treatment of complete IFN- $\gamma$ R1 deficiency is aggressive antimicrobial therapy until HSCT. Adjuvant IFN- $\gamma$  is not helpful because signaling is blocked; addition of IFN- $\alpha$  has been used successfully in some cases of disseminated MAC. These patients usually have disseminated NTM or BCG and require combination antibiotics through HSCT, with breakthrough infections being seen often if antibiotics are withdrawn. High serum IFN- $\gamma$  levels in the blood are typical when infection is present and has been correlated with a poor HSCT outcome; these levels can be followed and HSCT optimally performed when they decline.

### Autosomal Dominant IFN- $\gamma$ R1 Deficiency

Compared with complete  $\gamma$ 2 deficiency, AD IFN- $\gamma$ R1 deficiency allows partial IFN $\gamma$  signaling, and thus a typically less severe clinical course. Most pathogenic variants are small frameshift deletions in the intracellular domain of the *IFNGR1* gene, thus blocking both the JAK binding site as well as the receptor recycling domain, eliminating the removal of the nonfunctional receptor from the cell surface. Clinical presentation is usually later in childhood or adolescence with more focal NTM infections, which is usually osteomyelitis. BCG can present with osteomyelitis as well, at a younger age than is usually seen for the environmental NTM. Disseminated endemic fungi infections with *Histoplasma* and *Coccidioides* are seen, in addition to disseminated *Salmonella* infections. Diagnosis relies on genetic testing, but in laboratories able to perform flow cytometry for IFN- $\gamma$ R expression, diagnosis is suspected by increased IFN- $\gamma$ R expression due to the inability to recycle the receptor. Intracellular STAT1 phosphorylation is reduced after IFN- $\gamma$  stimulation, although not absent such as with the complete defects.

Treatment involves antimicrobials guided by the specific infection, with combination antibiotics needed for NTM/BCG. The addition of IFN- $\gamma$  is

**Table 175.4** Chronic Mucocutaneous Candidiasis Associated Inborn Errors of Immunity

SYNDROME	GENE	INHERITANCE	FUNGAL SPECIES	OTHER MANIFESTATIONS
CARD9 deficiency (30% CMC)	CARD9	AR	<i>Candida</i> spp. (often CNS involvement), CMC <i>Aspergillus</i> spp. (extrapulmonary), dermatophytes, phaeoohyphomycosis	Some with increased IgE and eosinophilia
IL-17F deficiency (67% CMC)	IL17F	AD	CMC	Asthma, folliculitis
IL-17RA deficiency (100% CMC)	IL17RA	AR	CMC	Folliculitis, susceptibility to <i>Staphylococcus aureus</i> (skin) bacterial infections
IL-17RC (100% CMC)	IL17RC	AR	CMC	None
ACT1 (100%)	TRAF3IP2	AR	CMC	Seborrheic dermatitis
STAT1 GOF (95% CMC)	STAT1	AD	CMC, <i>Histoplasma capsulatum</i> , <i>Coccidioides</i> spp., <i>Talaromyces marneffeii</i> , <i>Trichophyton</i> , <i>Cryptococcus</i> , <i>Aspergillus</i> , <i>Mucorales</i>	Herpes viral infections, bacterial sinopulmonary and skin infections, mycobacterial pulmonary and disseminated infections, CNS aneurysms, autoimmunity

AD, Autosomal dominant; AR, autosomal recessive; CMC, chronic mucocutaneous candidiasis; CNS, central nervous system; GOF, gain of function; IL, interleukin.

often helpful to clear the infection because some IFN- $\gamma$  signaling remains. After clearance of the infection, lifelong prophylaxis is suggested such as with azithromycin therapy, and consideration of fluconazole for *Coccidioides* endemic regions. IFN- $\gamma$  is not usually long term for prophylaxis. HSCT has been performed in rare cases but is typically not considered necessary.

### Autosomal Recessive IL-12 Receptor Beta 1 (IL-12RB1) Deficiency

Biallelic typically missense or nonsense pathogenic variants in *IL-12RB1* result in complete loss of IL-12 signaling leading to disseminated NTM or other intracellular infections. Compared with complete IFN- $\gamma$ R deficiency, the penetration and expressivity of IL-12RB1 deficiency is much more variable. Some patients are asymptomatic, even if BCG is given, whereas others develop severe disease early in life with early mortality; even within families the disease can have very different presentations. This defect is also more common than IFN- $\gamma$ R deficiency. Disseminated BCG is common in countries in which the vaccine is given and disseminated environmental NTM presents at much more variable ages in other countries. Although there is increased childhood mortality from this defect, patients who clear disseminated BCG infection have lower rates of subsequent NTM infection than those who did not have a BCG infection. Disseminated *Salmonella* is seen frequently. IL-12RB1 forms a heterodimer with IL-23R, so perturbation of this signaling cascade also results in an increased rate of mucocutaneous candidiasis. Diagnosis is confirmed with genetic testing, but some laboratories can test the lymphocyte response to IL-12 signaling, noting absence of STAT4 phosphorylation or IFN- $\gamma$  secretion.

Treatment is aimed at antimicrobials for the diagnosed infection. Secondary prophylaxis is suggested after clearance of mycobacterial infections, such as with azithromycin. Adjuvant IFN- $\gamma$  therapy has been used in cases where antimicrobials do not adequately clear the infection. Increased doses than are used in CGD may be needed, with prudence being to titrate up the dose slowly as hyperinflammatory presentations can complicate the therapy. There is very little experience with HSCT in IL-12RB1 deficiency.

### AD STAT1 Loss of Function

Although GOF and complete LOF *STAT1* defects can be associated with NTM infections, NTM infections occur with the highest frequency in AD *STAT1* LOF, which is to be expected because *STAT1* is downstream of the IL-12/IFN- $\gamma$  pathway. Presentation is typically with

more focal NTM or BCG infections, often with osteomyelitis, similar to that seen with AD IFN- $\gamma$ R1 deficiency. Diagnosis requires genetic testing. Patients typically respond well to combination antimicrobials and can then be placed on long-term prophylaxis. Infants with complete *STAT1* deficiency have had disseminated BCG; this defect also has severe viral infections.

### TYK2 Deficiency

JAK proteins and TYK2 are part of the JAK/STAT signal transduction pathway. TYK2 is downstream of IFN- $\alpha$  and - $\beta$ , as well as IL-12/IL-23, with its activation leading to *STAT1* phosphorylation. Patients have had disseminated BCG, TB, and viral infections.

### DIFFERENTIAL DIAGNOSIS FOR MSMD

MSMD centers around the control of intracellular organisms including *Mycobacteria* by the lymphocyte/macrophage interactions involving the IL-12/IFN- $\gamma$ /STAT1 pathway. However, other primary and secondary immune deficiencies should be included in the differential diagnosis of those presenting with disseminated NTM. Disseminated NTM is a common infection for those with **GATA2 deficiency**, which typically presents in adolescence or adulthood, and is often associated with monocytopenia and myelodysplasia, susceptibility to HPV, and pulmonary alveolar proteinosis. **Nuclear factor- $\kappa$ -B (NEMO) deficiency** and other genetic defects involved in NF- $\kappa$ B activation, such as defects in I $\kappa$ B $\alpha$ , are combined immune deficiencies that present with recurrent bacterial, viral, and disseminated mycobacterial disease; NEMO and I $\kappa$ B $\alpha$  may both have ectodermal dysplasia as part of the phenotype. Disseminated NTM is a less frequent complication for other myeloid and lymphocyte IEs such as CGD, NFKB1 deficiency, and severe combined immune deficiency (SCID). Disseminated NTM is also associated with **autoantibodies against IFN- $\gamma$** ; these should be considered for adult-onset disease. In the United States, anti-IFN- $\gamma$  autoantibody disease with disseminated NTM is much more common in Asian females but is seen in males and females in East Asian countries. HIV/AIDS should always be ruled out for those with disseminated NTM. Disseminated NTM can also be seen secondary to immune suppressive medications, with TNF- $\alpha$  blockade being the most common cause. Hairy cell leukemia has an increased incidence of disseminated NTM.

Visit Elsevier eBooks+ at [eBooks.Health.Elsevier.com](http://eBooks.Health.Elsevier.com) for Bibliography.

## Chapter 176

# Approaches to Treatment of Primary Immune Deficiency Diseases

Alissa McInerney, Stefani Su, and Artemio M. Jongco III

## GENERAL INFECTION PREVENTION AND MANAGEMENT STRATEGIES

Whenever possible, precautionary measures to reduce or minimize exposure to infection should be implemented. Whereas patients with severe immunologic defects (e.g., severe combined immunodeficiency [SCID]) would benefit from strict isolation, patients with other, less severe types of primary immunodeficiency disease (PID) usually do not require such restrictive measures. It is imperative to maximize the patient's quality of life while implementing appropriate infection mitigation strategies. Using shared decision-making, the clinician, patient, and caregivers should regularly discuss the risks, benefits, and alternatives of infection mitigation strategies, as the patient's clinical situation and risk change over time. Universal precautions, including but not limited to proper and thorough hand hygiene, should be frequently practiced by patients as well as their close contacts. The use of masks that cover the nose and mouth should be considered to avoid infection, especially when highly transmissible infections (e.g., SARS-CoV-2) are prevalent in the community. This is especially important in those PID patients before hematopoietic stem cell transplant (HSCT) while on immunosuppressive medications and afterward while awaiting immune reconstitution. *There is a low threshold to do further diagnostic testing to identify acute infections early and to start antimicrobial therapy or admit the patient to hospital for aggressive treatment if needed.*

It is also important to practice standard routine oral hygiene. Guidelines for antibiotic prophylaxis prior to dental procedures in PID patients has not been well established. Antibiotic prophylaxis is recommended for patients with PIDs requiring invasive dental procedures such as root canals and tooth extraction. In particular, those patients with PID with ongoing odontogenic infections require antibiotics before and during dental treatment. There is not enough evidence for antibiotic prophylaxis for noninvasive dental procedures such as oral examinations.

## IMMUNIZATIONS

Some PID patients *will not* mount an adequate immune response to vaccinations because of their underlying immunologic defect. Nonetheless, immunizations should be given to prevent infections to PID patients who are able to respond to vaccination. Specific immunization practices are covered in Chapter 215. Immunization with live viral or bacterial vaccines (BCG) is contraindicated in many PIDs due to the risk of acquiring the live vaccine-related disease. Specific recommendations for vaccines in PID are shown in Table 176.1.

Patients who are on immunoglobulin G (IgG) replacement therapy (IgRT) do not require routine vaccinations because they receive *passive* immunization. Protective levels of antibodies against tetanus toxoid, diphtheria toxoid, measles, varicella, pertussis, pneumococci, and three meningococcal serotypes are documented in patients receiving IgRT.

## GUIDANCE FOR CLOSE CONTACTS

Household members and other close contacts should not receive live oral polio virus or live influenza vaccine because they may shed the virus and transmit infection. Household members should generally be vaccinated to all recommended vaccines, including MMR and

varicella, to facilitate herd immunity. Transmission of MMR vaccine viruses has not been reported. The risk of transmission of varicella vaccine virus from a healthy person to an immunocompromised person is rare. If a close contact develops varicella rash after immunization with the varicella or zoster vaccines, isolation of the patient and administration of varicella-zoster immune globulin is recommended.

## COVID-19 VACCINE

The impact and severity of SARS-CoV-2 infection likely varies depending on the underlying immune defect. Small case series have suggested that B-cell lymphopenia (such as in X-linked agammaglobulinemia [XLA]) may actually be a protective factor and correlates with milder COVID-19 course. Meanwhile, patients with biallelic loss-of-function variants in *AIRE*, who have autoimmune polyendocrine syndrome type-1 (APS-1), appear to have higher risk for life-threatening COVID-19 pneumonia due to the presence of autoantibodies to type I interferons (IFNs). Although all PID patients will benefit from infection prevention and mitigation practices, it is becoming apparent that morbidity and mortality is variable among PID patients.

The most effective COVID prevention practices include the standard infection prevention strategies for all diseases including frequent handwashing, minimizing exposure to sick contacts, self-isolation/quarantining while ill, and mask wearing when in crowded public areas or areas with suboptimal ventilation. The most effective prevention strategy against COVID-19 is vaccination. Although this is a rapidly changing situation, a variety of organizations have created recommendations for immunodeficiency patients. The consensus is that PID patients should be vaccinated with non-live vaccines based on what has been approved for the age-group in their country. Patients with humoral deficiencies who do not respond with measurable antibody titers should still be considered for vaccination as vaccines can induce cellular immunity as well.

In the United States, the Centers for Disease Control and Prevention (CDC) recommends administration of a third or fourth dose in high-risk patients, such as immunocompromised patients, including PID patients with moderate to severe immunodeficiency and patients on chronic immunosuppressive therapy.

## PROPHYLAXIS

### Antimicrobial Prophylaxis

Prophylactic antibiotics are one of the mainstays for infection prevention in patients with PID. The specific antimicrobial prophylaxis recommended differs depending on the type of PID because patients with different PIDs are susceptible to different pathogens.

## IMMUNODEFICIENCIES AFFECTING CELLULAR AND HUMORAL IMMUNITY

### Severe Combined Immunodeficiency

Patients with SCID will require definitive treatment with allogeneic HSCT to correct the immune defect. It is crucial that patients remain infection free to maximize chances of long-term survival. With the implementation of newborn screening for SCID, infants with SCID are being detected before they develop infections. When SCID is suspected, the number of people in contact with the infant should be limited. Due to risk of transmission of cytomegalovirus (CMV) through breast milk, many PID transplant centers recommend cessation of breastfeeding until the CMV status of both the mother and infant is established.

Antimicrobial prophylaxis should be directed toward pneumonia caused by *Pneumocystis jirovecii* with a combination of sulfamethoxazole and trimethoprim. However, in infants under 2 months of age, there is a concern for bilirubin displacement from albumin and subsequent risk of kernicterus. In these young infants, close monitoring of bilirubin levels is recommended or alternatives such as atovaquone, dapsone, and pentamidine can be considered. Fluconazole to prevent mucocutaneous candidiasis and acyclovir for viral prophylaxis can be considered as well. In countries where BCG vaccine is commonly administered in early infancy, daily chemoprophylaxis until definitive treatment with HSCT and immune reconstitution is needed with isoniazid and rifampin due to the risk of disseminated BCG infection.



**Table 176.1** Immunizations in Patients with Primary Immunodeficiency Diseases

PRIMARY DEFECT	EXAMPLE OF SPECIFIC IMMUNODEFICIENCY	NOT RECOMMENDED	RECOMMENDED
Predominantly antibody deficiencies	Hypogammaglobulinemias (X-linked agammaglobulinemia, common variable immunodeficiency) Other antibody deficiencies (selective IgA deficiency, IgG subclass deficiencies, specific antibody deficiency with normal immunoglobulins)	Live-attenuated vaccines excluding BCG Live-attenuated influenza, OPV, adenovirus, typhoid, yellow fever	Inactivated vaccines All vaccines likely effective Pneumococcal and <i>Hib</i>
Combined immunodeficiencies	Complete defects (SCID, complete DiGeorge syndrome) Partial defects (partial DiGeorge syndrome, Wiskott-Aldrich syndrome, ataxia telangiectasia)	All live vaccines Live-attenuated influenza, OPV, rotavirus, adenovirus, smallpox, typhoid, yellow fever, BCG	All vaccines likely ineffective Inactivated vaccines, live-attenuated MMR, varicella, and herpes zoster if documentation of adequate T-cell number*
Complement		None	All routine vaccines, especially pneumococcal and meningococcal vaccines
Phagocytic function	Chronic granulomatous disease, leukocyte adhesion defects	Live-attenuated influenza, adenovirus, typhoid, BCG	All inactivated vaccines, other live-attenuated viral vaccines
IFN- $\gamma$ -IL-12 pathway defects		BCG	

\*Age-related levels of immunocompetence proposed by the CDC: <1 yr, 1500; 1-5 yr, 1,000; and >6 yr, 500 CD4<sup>+</sup> T cells/mm<sup>3</sup> for HIV may also be used. BCG, Bacille Calmette-Guérin; OPV, oral poliovirus vaccine; SCID, severe combined immune deficiency; MMR, measles, mumps, rubella; IFN- $\gamma$ , interferon gamma; IL-12, interleukin-12. Data from Medical Advisory Committee of the Immune Deficiency Foundation, Shearer WT, Fleisher TA, et al. Recommendations for live viral and bacterial vaccines in immunodeficient patients and their close contacts. *J Allergy Clin Immunol*. 2014;133(4):961-966.

Palivizumab, a humanized monoclonal antibody against respiratory syncytial virus (RSV), can be considered for children under 2 years of age with SCID during the RSV season to prevent serious disease. The specific RSV seasonal patterns differ between countries.

### HYPHER-IgM/CD40LG DEFICIENCY

Patients with hyper-IgM or CD40LG deficiency are especially susceptible to *P. jiroveci* pneumonia (PJP) and require prophylaxis with a combination of sulfamethoxazole and trimethoprim. These patients are also at special risk for developing sclerosing cholangitis, which can be associated with *Cryptosporidium parvum* infection. To prevent the risk of cryptosporidium infection, steps need to be taken to avoid drinking contaminated water and places where risk of infection is higher, such as at recreational water parks.

### COMBINED IMMUNODEFICIENCIES WITH ASSOCIATED OR SYNDROME FEATURES

#### DiGeorge Syndrome/22q11 Deletion Syndrome

Most patients with DiGeorge syndrome do not require antimicrobial prophylaxis as most patients do not have severe immunodeficiency (i.e., partial DiGeorge syndrome). Less than 1% of patients have significant thymic aplasia and profound T- and B-cell lymphopenia (i.e., complete DiGeorge syndrome), putting them at risk of PJP and CMV; PJP prophylaxis is recommended.

#### Wiskott-Aldrich Syndrome

Patients with Wiskott-Aldrich syndrome (WAS) are susceptible to a variety of viral and bacterial infections. *Prophylactic antimicrobials against infection by PJP and herpes simplex virus are often recommended.* If splenectomy is necessary for severe refractory thrombocytopenia, those patients would then require penicillin prophylaxis to protect against infection by encapsulated organisms.

#### Ataxia Telangiectasia

Opportunistic infections in patients with ataxia telangiectasia are infrequent; however, sinopulmonary infections are common. Prophylactic azithromycin is commonly used empirically, however, efficacy data are sparse.

### STAT3 HYPER-IgE SYNDROME (JOB SYNDROME)

These patients are susceptible to skin infections predominantly with *Staphylococcus aureus* causing “cold” abscesses with diminished inflammatory response. Chronic mucocutaneous candidiasis occurs in over 70% of patients. Pneumonia is a frequent infection with risk of leading to bronchiectasis and pneumatoceles. Common causative pathogens include *Staphylococcus*, *Streptococcus pneumoniae*, *Haemophilus influenzae*, and fungal organisms such as *Aspergillus* and *P. jiroveci*. *Antimicrobial prophylaxis with a combination of sulfamethoxazole and trimethoprim and antifungal medications such as itraconazole is recommended.*

### NF- $\kappa$ B ESSENTIAL MODULATOR (NEMO) DEFICIENCY

Patients with NF- $\kappa$ B essential modulator (NEMO) deficiency are susceptible to nontuberculous mycobacteria (NTM), similar to patients with IFN- $\gamma$  and interleukin (IL)-12 defects. Prophylaxis with azithromycin should be considered. However, these patients are also at risk for many bacterial infections, viral infections such as herpesviruses, and opportunistic infections such as PJP. *Acyclovir for viral prophylaxis and a combination of sulfamethoxazole and trimethoprim for PJP prophylaxis should be considered as well.*

### PREDOMINANTLY ANTIBODY DEFICIENCIES

#### Hypogammaglobulinemias

Lifelong IgRT is the mainstay of infection prevention for patients with major antibody deficiencies such as agammaglobulinemia and common variable immunodeficiency (CVID). Prophylactic antibiotics can be used in conjunction with IgRT for patients who develop recurrent respiratory tract infections, which can lead to severe complications of bronchiectasis. Macrolide antibiotics such as azithromycin are commonly used for prophylaxis due to their anti-inflammatory properties in chronic lung disease. Low-dose oral azithromycin reduces the number of exacerbation episodes per patient-year, with a consequent reduction in additional courses of antibiotics and risk of hospitalization.

#### Other Antibody Deficiencies

Patients with minor antibody deficiencies such as **transient hypogammaglobulinemia of infancy (THI)**, selective IgA deficiency, IgG

subclass deficiency, or specific antibody deficiency with normal immunoglobulins can usually be managed without need for IgRT. Patients who experience chronic or recurrent infections may benefit from prophylactic antibiotics. Prophylactic antibiotics and IgRT are equally effective as first-line treatment in preventing infections in specific antibody deficiency patients.

## CONGENITAL PHAGOCYTE DEFECTS

### Chronic Granulomatous Disease

Patients with chronic granulomatous disease (CGD) are susceptible to severe bacterial and fungal infections. The most common bacterial organisms include *S. aureus*, *Serratia marcescens*, *Burkholderia cepacia*, and *Nocardia* species. The majority of fungal infections in CGD are attributed to *Aspergillus* species causing invasive aspergillosis. *Prophylaxis with a combination of sulfamethoxazole and trimethoprim and itraconazole is recommended.*

### Leukocyte Adhesion Deficiency

Antibiotic prophylaxis to protect against infections with *S. aureus* or gram-negative bacilli is recommended.

## DEFECTS IN INTRINSIC AND INNATE IMMUNITY

### Interferon- $\gamma$ /IL-12 Pathway Defects

Patients with IFN- $\gamma$ /IL-12 pathway defects are at special risk for infections with intracellular pathogens such as nontuberculosis *Mycobacterium* species as well as *Salmonella*. *Prophylaxis with daily azithromycin or clarithromycin is recommended.*

## COMPLEMENT DEFICIENCIES

Deficiency of terminal pathway components can lead to recurrent neisserial infections. Antibiotic prophylaxis with penicillin can be considered. *Immunization against S. pneumoniae, H. influenzae, and Neisseria meningitidis is strongly recommended.*

## IMMUNOGLOBULIN G REPLACEMENT THERAPY

Human immunoglobulin preparations, derived from the plasma of paid donors, can be administered intravenously (IVIG), subcutaneously (SCIG), or intramuscularly (IMIG) to treat a variety of disorders, including inborn errors of immunity, acquired immunodeficiency, and autoimmune and inflammatory disorders. IgRT provides *passive immunity* through preformed antibodies against a wide range of pathogens that are encountered by the general population, leading to immediate but transient protection; IgRT has an integral role in the treatment of patients with defects in the humoral immune system. IgRT is also used for a variety of medical conditions because of its anti-inflammatory and immunomodulating effects.

### Products

Although most products are approved for a specific administration route, several 10% IVIG solutions can be administered subcutaneously with good patient tolerability. More concentrated 20% SCIG and 16% IMIG products should not be used intravenously. Available products and their key properties are summarized in [Table 176.2](#). IMIG is rarely used because of its inferior safety and tolerability profile. Injections are painful, the injectable volume is limited, and the risk of local injury and adverse reactions is higher. Both IVIG and SCIG products are effective in treating humoral immunodeficiencies, without significant differences in the infection rates between the two routes. Incidence of infection is inversely correlated with dose regardless of route.

## INDICATIONS FOR IgRT

IgRT is indicated for the treatment of primary immunodeficiencies characterized by absent or deficient antibody production, which comprises the majority of PIDs. The utility of IgRT in decreasing the frequency and severity of infection is well accepted for agammaglobulinemia (e.g., XLA) and hypogammaglobulinemia (e.g., CVID). There are six distinct phenotypes of primary immunodeficiency for which IgRT is or may be indicated: (1) agammaglobulinemia due to absence of B cells, (2) hypogammaglobulinemia with poor antibody function,

(3) normal immunoglobulin levels with impaired specific antibody production, (4) hypogammaglobulinemia with normal antibody function, (5) isolated IgG subclass deficiency with normal immunoglobulin levels and normal quality antibody responses, and (6) recurrent infections related to an unknown immune mechanism.

### Agammaglobulinemia Due to Absence of B cells

IgRT reduces both acute and chronic infections in this patient population; the number and severity of infectious complications are inversely correlated with IgRT dose. When IgG trough levels are maintained above 800 mg/dL, serious bacterial illness and enteroviral meningoencephalitis are prevented; increasing trough levels up to 1,000 mg/dL are associated with decreased risk for pneumonia. In the setting of SCID, IgRT is warranted at diagnosis because maternally derived IgG wanes after birth, during the posttransplant period, or gene therapy or enzyme replacement (for adenosine deaminase [ADA] deficiency) until B-cell function reconstitution, or indefinitely if B-cell function is not restored.

### Hypogammaglobulinemia with Poor Antibody Function

Patients with recurrent infections who demonstrate decreased immunoglobulin concentrations and/or impaired response to protein and/or polysaccharide vaccines benefit from IgRT. CVID falls in this category. Initiation of IgRT is associated with decreased infection rate compared with pretreatment. Adequate IgRT dosing is associated with decreased frequency of sinopulmonary infections, which can mitigate the development of lung inflammation, bronchiectasis, and chronic lung disease. Growing evidence and expert consensus support individualizing IgRT dosing to keep the patient relatively infection free, achieving a “biologic trough or biologic steady-state level,” and following clinical outcomes rather than using a standardized dose in all patients by disease. In addition to CVID, patients with class-switching defects, such as autosomal recessive and X-linked hyper-IgM syndromes, also demonstrate decreased infection rates from a variety of pathogens.

### NORMAL IMMUNOGLOBULIN LEVELS WITH IMPAIRED SPECIFIC ANTIBODY PRODUCTION

Determining whether and when IgRT is indicated for these patients can be challenging. Available evidence and expert consensus suggest that IgRT should be given when there is well-documented nonresponsiveness to polysaccharide vaccines and recurrent infections that are inadequately managed by antibiotic prophylaxis. Protective concentration of antibody to polysaccharide antigens is considered 1.3  $\mu\text{g/mL}$  and conversion from nonprotective to protective titers. In children 2-5 years, >50% of concentrations tested are considered protective, with an observed increase of at least twofold postvaccination, while the threshold is >70% in patients aged 6-65 years. Selective antibody deficiency has been categorized into four phenotypes—mild, moderate, severe, and memory (where the patient can mount an adequate initial response that wanes within 6 months). If an IgRT trial is started, it should be discontinued after a period of time so that antibody responses can be reevaluated a minimum of 3 months after discontinuation. Some children can demonstrate clinical improvement and improved response after pneumococcal polysaccharide vaccine challenge after a short trial of IgRT, whereas others continue to have recurrent infections and restart IgRT.

### Hypogammaglobulinemia with Normal Antibody Function

Age-specific normal ranges differ among laboratories and having IgG levels below the lower limit of normal for age without accompanying infections may not be clinically significant. The IgG levels of children experiencing **THI** normalize with time. THI may be exacerbated by pre-term birth. In the absence of significant infections, IgRT is not routinely recommended for these children. Acquired hypogammaglobulinemia arising from medication (e.g., seizure medications, B-cell depletion therapy) can also fall in this category. Severe hypogammaglobulinemia, conventionally defined as IgG levels  $\leq 150$  mg/day, is considered a risk

**Table 176.2** Available Immunoglobulin Replacement Therapy Products

ROUTE	PRODUCT	DOSAGE FORM	DILUENT	REFRIG-ERATION REQUIRED?	FILTRATION REQUIRED?	OSMOLALITY (mOsm/kg)	SODIUM	PH	IgA (mcg/mL)	STABILIZER OR REGULATOR*	PATHOGEN INACTIVATION/REMOVAL†
IV	Asceniv	10% liquid	NA	Yes	No	Not available	0.100-0.140 mol/L	4.0-4.6	<200	Glycine and polysorbate 80	FP, S/D, VF
	Bivigam	10% liquid	NA	Yes	No	<510	100-140 mM	4.0-4.6	≤200	Glycine	FP, S/D, NF
	Flebogamma DIF 5%	5% liquid	NA	No‡	Optional	240-370	Trace	5.0-6.0	<50	D-sorbitol	Past, S/D, dsNF, FP, PEG, pH 4
	Flebogamma DIF 10%	10% liquid	NA	No‡	No	240-370	Trace	5.0-6.0	<100	D-sorbitol	Past, S/D, dsNF, FP, PEG, pH 4
	Gammagard 5% S/D	Lyophilized	Sterile water	No	Yes	636	8.5 mg/mL	6.8	<1	2% glucose and glycine	CEF, CHROM, S/D
	Gammaplex	5% liquid	NA	No‡	15-20-μm filter preferred	420-500	30 to 50 mmol/L	4.8-5.0	<4	Sorbitol and glycine and polysorbate 80	S/D, VF, low pH
	Gammaplex	10% liquid	NA	No‡	No	≥280	<30 mM/L	4.9-5.2	<20	Glycine and polysorbate 80	S/D, VF, low pH
	Octagam	5% liquid	NA	No‡	Optional	310-380	0.03 mEq/mL	5.1-6.0	<200	Maltose	CEF, UF, CHROM, S/D, pH 4
	Octagam	10% liquid	NA	No‡	Optional	310-380	<30 mmol/L	4.5-5.0	106	Maltose	CEF, S/D, pH 4, UF, CHROM
	Panzyga	10% liquid	NA	No§	Optional	240-310	Trace	4.5-5.0	100	Glycine	S/D, CEF, NF, CHROM
Privigen	10% liquid	NA	No**	No	240-440	Trace	4.6-5.0	<25	L-proline	CEF, CHROM, pH 4, DF, NF, OAF	
IV or SC	Gammagard liquid	10% liquid	NA	No‡	Optional	240-300	None added	4.6-5.1	37	Glycine	CEF, CHROM, S/D, pH 4, NF
	Gammaked	10% liquid	NA, incompatible with saline	No**	No	258	None added	4.0-4.5	46	Glycine	CEF, pH 4.2, DF, CAP, CHROM, NF
	Gamunex-C	10% liquid	NA, incompatible with saline	No**	No	258	None added	4.0-4.5	46	Glycine	CEF, pH 4.2, DF, CAP, CHROM, NF

Continued

**Table 176.2** Available Immunoglobulin Replacement Therapy Products—cont'd

ROUTE	PRODUCT	DOSAGE FORM	DILUENT	REFRIG-ERATION REQUIRED?	FILTRATION REQUIRED?	OSMOLALITY (mOsm/kg)	SODIUM	PH	IgA (mcg/mL)	STABILIZER OR REGULATOR*	PATHOGEN INACTIVATION/REMOVAL†
SC	Cutaquig	16.5% liquid	NA	Yes <sup>¶</sup>	No	310-380	<30 mmol/L	5.0-5.5	≤600	Maltose	CEF, UF, CHROM, S/D, pH 4
	Cuvitru	20% liquid	NA	No <sup>***</sup>	No	208-290	None	4.6-5.1	80	Glycine	CEF, CHROM, NF, S/D
	Hizentra	20% liquid	NA	No	No	380	Trace, <10 mmol/L	4.6-5.2	≤50	Proline	CEF, CHROM, pH 4.2, DF, NF, VF, OAF
	HyQvia	10% liquid + recombinant human hyaluronidase	NA	No	No <sup>††</sup>	240-300	None added	4.6-5.1	37	Glycine	CEF, CHROM, S/D, pH 4, NF
	Xembify	20% liquid	NA	2-8°C	No	280-404	None	4.1-4.8	≤70	Glycine	CEF, CHROM, CAP, NF, DF, low pH
IM	GamaSTAN	16.5% liquid	NA	2-8°C	No	Not available	Not measured	4.1-4.8	Not measured	Glycine	CEF, CAP, CHROM, NF, low pH, DF
	GamaSTAN S/D <sup>‡‡</sup>	15–18% liquid	NA	2-8°C	No	Not available	0.4-0.5%	6.4-7.2	Not measured	Glycine	CEF, S/D, UF

\*Precautions and laboratory abnormalities associated with specific stabilizers include the following:

- Glucose: May alter glycemic control in patients with diabetes mellitus.
- L-proline: Cannot be used in patients with hyperprolinemia.
- Maltose: Falsely elevates glucose readings in certain blood glucose monitoring systems, may contain trace corn protein (potential allergen), and may increase plasma osmolality (usually not clinically important).
- Polysorbate 80: Some patients may be hypersensitive (also known as Tween 80); reactions can be delayed type.
- Sorbitol, D-sorbitol: Cannot be used in patients with hereditary fructose intolerance.
- Sucrose: Avoid in patients with renal impairment or increased risk of acute kidney injury.

†Pathogen inactivation/removal using CEF, DF, UF, CAP, CHROM, Nano, dsNF, VF, S/D, Past, FP, or OAF.

‡Not required (+2 to 25°C).

§Storage is 2-8°C for 24 months or 25°C for 9 months.

\*\*Storage is 2-8°C for 36 months or 25°C for 6 months.

¶Storage is 2-8°C for 24 months or 25°C for 6 months.

\*\*\*Storage is 2-8°C for 36 months or 25°C for 12 months.

††Storage is 2-8°C for 36 months or 25°C for 3 months.

‡‡GamaSTAN S/D has been discontinued in the United States.

Note: Brand names and descriptions refer to products available in the United States and some other countries; product availability, specific composition, and other details regarding individual products vary in other countries.

IgA, Immunoglobulin A; IV, intravenous; NA, not applicable; FP, fraction precipitation; S/D, solvent detergent; VF, virus filtration; Nano, NF, nanofiltration; DIF, dual inactivation and filtration; Past, pasteurization; dsNF, double sequential nanofiltration; PEG, polyethylene glycol precipitation; CEF, cold ethanol fractionation; DF, depth filtration; UF, ultrafiltration; CHROM, chromatography; SC, subcutaneous; CAP, caprylate; OAF, octanoic acid fractionation; IM, intramuscular.

Adapted from Perez EE, Orange JS, Bonilla F, et al. Update on the use of immunoglobulin in human disease: A review of evidence. *J Allergy Clin Immunol*. 2017;139(3S):S1–S46; with data from Immune Deficiency Foundation. Characteristics of Immunoglobulin Products Used to Treat Primary Immunodeficiencies. Accessed 8/10/21. [https://primaryimmune.org/sites/default/files/publications/IDF\\_IG%20Booklet%202020.pdf](https://primaryimmune.org/sites/default/files/publications/IDF_IG%20Booklet%202020.pdf)



factor for infection, and empiric trial of IgRT is reasonable. However, patients with levels between 150 and 250 mg/dL deserve further consideration of antibody function and individual clinical history.

### Isolated IgG Subclass Deficiency with Normal Immunoglobulin Levels and Normal Quality Antibody Responses

Most patients with subclass deficiency are asymptomatic, but a few may have recurrent infections and poor antibody responses to specific antigens. *First-line management includes prophylactic antibiotics and treatment of other comorbidities, such as allergic rhinitis, that can contribute to the development of sinopulmonary infections.* IgRT is not routinely recommended for these patients; some case studies have demonstrated reduced infection rate, decreased antibiotic use, and improved quality of life among patients on therapy.

### Recurrent Infections Related to an Unknown Immune Mechanism

There are defined immunodeficiencies, such as ataxia telangiectasia, WAS, and *STAT3* deficiency, as well as syndromic immunodeficiencies, such as Jacobsen syndrome, which can present with variable humoral immune defects. IgRT can prevent infections in select patients, and the decision to start IgRT and dosing considerations should be tailored to individual needs.

## INDIVIDUALIZING IgRT

Clinicians, patients, and caregivers need to consider each patient's specific clinical situation and comorbidities, incorporate patient and caregiver preferences, and consider flexibility in dosing route and frequency. Children and adolescents may object to the multiple and more frequent needlesticks associated with SCIG. Once the decision is made to start IgRT, the clinician, patient, and caregivers need to periodically reassess and adjust as needed. Available IgRT products differ from one another and are not interchangeable; the product used should be matched carefully to the patient characteristics to maximize patient safety. There are eight guiding principles on the safe, effective, and appropriate use of IgRT in patients with primary immunodeficiency (Table 176.3).

## CONSIDERATIONS FOR PRODUCT SELECTIONS

### IVIG

#### IgA Content

The amount of IgA in various products varies. Rarely, severe allergic reactions, including anaphylaxis, have been reported in patients with IgE anti-IgA or IgG anti-IgA. In these cases, use of low IgA-containing IVIG products or SCIG, which appears to be tolerated by these patients despite having higher IgA content, is recommended. Anaphylaxis due to IgA in SCIG has not been reported.

#### Adverse Reactions

All IgRT products are associated with a potential risk for adverse reactions, but historically IVIG is associated with higher risk. Most IVIG adverse reactions are rate related, mild, and occur in 5–15% of infusions. Slowing or stopping the infusion for 15–30 minutes usually leads to complete resolution. Premedication regimens can also help. Ensuring adequate hydration or switching to SCIG has been used successfully to mitigate this risk. Risk factors for experiencing adverse reactions include (1) having IVIG for the first time, (2) having or recently having a bacterial infection, (3) having underlying chronic inflammation, (4) using higher concentration products, (5) using lyophilized product, and (6) fast infusion rates. Future reactions become less likely after subsequent infusions with the same product. However, patients can develop adverse reactions at any point even to products they have tolerated previously; clinicians and patients need to remain vigilant. For enhanced safety, patients who have experienced prior adverse reactions may benefit from getting infusions at a medical facility, instead of at home with an infusion nurse.

Serious adverse events, including acute renal failure, neurodegeneration, and thromboembolic events, can occur during or soon after infusion. Thromboembolic events such as myocardial infarction,

**Table 176.3** Guiding Principles for Effective Use of IgRT for Patients with Primary Immunodeficiency

GUIDING PRINCIPLE	RATIONALE
Indication for IgRT	IgG is indicated as replacement therapy for patients with PI characterized by absent or deficient antibody production; PI is an FDA-approved indication for IgRT
Diagnoses	A large number of PI diagnoses exist for which IgRT is indicated and recommended; many diagnoses have low total IgG levels, but some have a normal level with documented specific antibody deficiency
Frequency of IgRT	Treatment is indicated as ongoing replacement therapy for PI; treatment should not be interrupted once a definitive diagnosis has been established
Dose	IVIG is indicated for PI patients at a starting dose of 400–600 mg/kg every 3–4 wk; SCIG is generally used at a starting dose of 100–200 mg/kg/wk; SCIG dosing frequency is flexible
IgG trough levels	IgG trough levels can be useful in some diagnoses to guide care but should not be a consideration in access to IgRT
Site of care	The decision to infuse IgRT in a hospital, outpatient infusion center, community office, or home-based setting must be based on patient clinical characteristics
Route	Administration route must be based on patient characteristics; throughout life, certain patients may be more appropriate for IV or SC therapy depending on many factors, and patients should have access to either route as needed
Product	IVIG/SCIG are not generic drugs and products are not interchangeable; a specific product needs to be matched to patient characteristics to ensure patient safety; product change should only occur with active participation of the prescribing physician

IgRT, Immunoglobulin replacement therapy; IgG, immunoglobulin G; PI, primary immunodeficiency; FDA, US Food and Drug Administration; SCIG, subcutaneous immunoglobulin; IV, intravenous; SC, subcutaneous; IVIG, intravenous immunoglobulin. Data from Perez EE, Orange JS, Bonilla F, et al. Update on the use of immunoglobulin in human disease: A review of evidence. *J Allergy Clin Immunol.* 2017;139(3S):S1–S46; with data from Yong PL, Boyle J, Ballou M, et al. Use of intravenous immunoglobulin and adjunctive therapies in the treatment of primary immunodeficiencies: A working group report of and study by the Primary Immunodeficiency Committee of the American Academy of Allergy Asthma and Immunology. *Clin Immunol.* 2010;135(2):255–263.

stroke, deep vein thrombosis, and pulmonary embolism are rare, but they need to be watched for and require timely intervention when they occur. Risk factors include preexisting cardiovascular disease, diabetes mellitus, dehydration, sepsis, increased blood viscosity, hypercholesterolemia, and hypertension. The use of indwelling venous catheters solely for IVIG administration is not recommended due to the increased risk for thromboembolism and infection with these devices.

### SCIG Products

Available products range from 10–20% concentration and offer much dosing flexibility for patients. Facilitated SCIG (fSCIG) involves recombinant human hyaluronidase to facilitate the SC administration of large volumes of IgG among multiple sites and a variety of dosing schedules. Many studies demonstrate equivalence and noninferiority of SCIG and IVIG for management of PIDs.

## Adverse Reactions

SCIG is well tolerated by many patients, including children and IgA-deficient patients, and its safety profile is well documented. The most common adverse reaction is local infusion site reactions that can range from mild to severe, but severe local reactions are rare. The prevalence of these local site reactions appears to diminish when infusions are continued. Carefully cleaning the skin of the infusion site with alcohol and using appropriately sized infusion needles or catheters can further decrease risk of local reactions. IV administration of 10% products that are approved for both IV and SC administration is unlikely to be problematic, but 20% products should not be used intravenously. Premedication is usually not needed for SCIG, but pretreatment of the infusion site with local anesthetic creams may improve tolerability in children.

In the United States, patients are routinely provided epinephrine autoinjectors as part of an anaphylaxis kit for home infusions, regardless of prior history of allergic reactions to IgRT.

## DOSING CONSIDERATIONS

The IgRT dose that keeps a patient relatively infection free varies between patients and can vary in the same patient over time, so the goal of IgRT should be to maximize clinical outcomes and not to achieve a specific IgG level.

## Conversion from IVIG to SCIG

The bioavailability of SCIG is approximately 67% lower compared to IVIG. Thus the monthly dose of SCIG required to achieve an equivalent monthly area under the curve (AUC) is 1.37 times the IVIG dose for 16% products and 1.53 for 20% products. No significant differences in infection incidence or outcome have been shown between studies that do not utilize this dose adjustment compared to studies with this dose adjustment. In clinical practice, AUC dose adjustment is rarely used.

## IVIG Dosing

For IVIG, many clinical immunologists use 400-600 mg/kg every 3-4 weeks as an acceptable starting point for maintenance therapy, while continuing to check annual trough levels. Infusion rates start slowly (e.g., 0.01 mL/kg/min) to minimize adverse reactions, and the rate can be increased as tolerated. Clinicians should monitor weight changes and adjust dosing accordingly. Also, IgG levels may need to be checked more frequently if the patient experiences breakthrough infections, develops new medical conditions (e.g., protein losing conditions), or is not responding to treatment as expected. Because pharmacokinetics also differs among patients, a specific IVIG dose can result in different trough levels in patients with similar body mass. There is insufficient evidence to routinely recommend higher loading IVIG doses in patients with low IgG levels at presentation; this practice has been associated with higher risk for adverse reactions at IgRT start. There is limited data on optimal dosing intervals for IVIG, and current practices vary widely.

## SCIG Dosing

For traditional SCIG, a starting dose of 100-200 mg/kg of body weight per week is commonly used. For hyaluronidase fSCIG, a starting dose of 400-600 mg/kg via one or two sites every 3-4 weeks is common. When fSCIG is given every 3-4 weeks, the initial peak will still be lower than that of IVIG given at the same intervals, but the trough serum levels will be similar. Patients have more dosing frequency flexibility because there are products approved for daily, weekly, biweekly, or monthly dosing. Infusion rates generally range from 10-35 mL/hr per site by pump with volumes of 15-40 mL per site. The number of sites depends on the total volume for the target dose, and typical infusion sites include abdomen, outer thigh, upper arm, and buttocks. Manual rapid-push protocols that do not require infusion pumps have been reported to be safe and tolerable by patients in small nonrandomized trials. Steady-state serum IgG levels should be monitored periodically after approximately 3 months and can be used to assess patient adherence.

## Facilitated SCIG

The dosing of hyaluronidase fSCIG is similar to IVIG. In the United States, fSCIG is approved for use in patients 2 years or older. Unlike

traditional SCIG, a four-dose/7-week “ramp-up” period is recommended when starting fSCIG, even in patients who have used other IgRT products successfully. Once established on therapy, fSCIG infusion rates can be increased as tolerated by the patient from 50 mL/hr up to 300 mL/hr. The IgG is infused via peristaltic pump or large volume battery-operated pump, similar to IVIG, which has been programmed to account for the higher pressure of fSCIG compared with IV.

## ADMINISTRATION DETAILS

### Premedication

Many patients tolerate IVIG infusions without premedication. Pediatric pretreatment regimens include oral acetaminophen or ibuprofen, oral or IV or IM diphenhydramine, or alternatively a non-sedating antihistamine and/or a glucocorticoid such as oral prednisolone or IV hydrocortisone. Maintaining adequate hydration before infusion orally or via IV fluids with normal saline may be beneficial, especially for patients with preexisting renal disease or other risk factors (e.g., concomitant use of nephrotoxic agents). *Premedication is usually not required for SCIG.*

### VACCINATION WHILE ON IgRT

Administration of IgRT may interfere with vaccination efficacy because the antibodies in the product might bind to the antigens in the vaccine and inhibit the immune response. The IgG in the IgRT product may hinder the viral replication that is needed to induce the desired immune response in live-virus vaccines such as MMR or varicella (varicella-zoster virus [VZV]). Antibody-containing blood products from the United States do not interfere with the immune response to yellow fever vaccine and are not believed to interfere with the response to live typhoid, live-attenuated influenza, rotavirus, or zoster vaccines. The duration of inhibition ranges from 3-11 months and is related to the amount of antigen-specific antibody contained in the immune globulin or blood product. *For patients on IgRT, 8 months since last IVIG infusion is the suggested waiting time before administering live vaccines.* Although no specific recommended waiting time has been suggested for SCIG, many clinicians will also wait for 8 months since last infusion.

- If the antibody-containing product is administered *before* the vaccine is scheduled, the vaccine should be delayed for the suggested interval. If a dose of MMR or VZV vaccine is administered after an antibody-containing product but at an interval shorter than the suggested interval, the vaccine dose should be repeated at the suggested interval unless an antibody response to the vaccine is documented.
- If the antibody-containing product is necessary within 14 days *after* administration of MMR or VZV vaccine, the vaccine dose should be repeated after the suggested interval, unless an antibody response to the vaccine is documented.

Caution is advised when checking and interpreting IgG-based serologies while on IgRT. Stopping IgRT to assess vaccine efficacy in immunodeficient patients is generally not recommended. Neoantigen vaccines such as *Salmonella typhi Vi* can be used to assess a patient's ability to make specific antibodies while on IgRT, but this is not widely available.

Annual inactivated influenza vaccine is generally recommended for immunodeficient patients, including those on IgRT, presumably to stimulate T-cell immunity, although data are lacking that demonstrate induction of protective antibodies. The influenza vaccine may be given simultaneously or at any time interval before or after IgRT infusion.

Clinical trials using gene therapy with retroviral vectors have been conducted for several inborn errors of immunity including ADA-SCID, X-linked SCID, X-linked CGD, and WAS in which immunity was restored but with leukoproliferative complications due to insertion of the vector into oncogenes, in all except for ADA-SCID. The use of lentiviral vectors represented a breakthrough in the field with clinical recovery and immune reconstitution while minimizing vector-related complications. For further details on HSCT and gene therapy/editing, see [Chapters 177 and 178](#).

Visit Elsevier eBooks+ at [eBooks.Health.Elsevier.com](http://eBooks.Health.Elsevier.com) for Bibliography.

## Section 6

# Hematopoietic Stem Cell Transplantation

## Chapter 177

## Principles and Clinical Indications of Hematopoietic Stem Cell Transplantation

Rachel A. Phelan and David Margolis

Allogeneic (from a donor) or autologous (from the same individual) hematopoietic stem cells have been used to cure both malignant and non-malignant disorders. **Autologous** transplantation is employed as a rescue strategy after delivering otherwise lethal doses of chemotherapy with or without radiotherapy in children with hematologic malignancies such as relapsed lymphoma or selected solid tumors (e.g., neuroblastoma, brain tumors). **Allogeneic** transplantation is used to treat children with genetic diseases of blood cells, such as hemoglobinopathies, primary immunodeficiency diseases, various inherited metabolic diseases, and bone marrow failure. Allogeneic transplant is also used as treatment for hematologic malignancies, such as leukemia and myelodysplastic syndromes. Bone marrow had originally represented the only source of hematopoietic progenitor cells. Growth factor (granulocyte colony-stimulating factor)-mobilized peripheral blood hematopoietic stem cells and umbilical cord blood hematopoietic progenitors have also been regularly used in clinical practice to perform hematopoietic stem cell transplantation (HSCT).

A **human leukocyte antigen (HLA)**-matched sibling was traditionally the only type of donor employed. Matched unrelated volunteers, full-haplotype mismatched family members, and unrelated cord blood donors have been largely utilized to transplant patients lacking an HLA-identical relative.

Protocols for allogeneic HSCT consist of two parts: the preparative regimen and transplantation itself. During the **preparative conditioning regimen**, chemotherapy, at times in conjunction with irradiation, is administered to eliminate the patient's hematopoietic system and to suppress the immune system, especially T cells, so that graft rejection is prevented. In patients with malignancies, the preparative regimen also serves to significantly reduce the tumor burden. The patient then receives an intravenous infusion of hematopoietic cells from the donor. Less aggressive conditioning regimens, known as **reduced-intensity conditioning regimens**, are also used in pediatric patients. These regimens are mainly immunosuppressive and aim at inducing a state of reduced immune competence of the recipient to avoid the rejection of donor cells.

The immunology of HSCT is distinct from that of other types of transplant because, in addition to stem cells, the graft contains mature blood cells of donor origin, including T cells, B cells, natural killer cells, and dendritic cells. These cells repopulate the recipient's lymphohematopoietic system and give rise to a new immune system, which helps eliminate residual leukemia cells that survive the conditioning regimen. This effect is known as the **graft-versus-leukemia (GVL) effect**.

The donor immune system exerts its T-cell-mediated GVL effect through alloreactions directed against histocompatibility antigens displayed on recipient leukemia cells. However, because some of these histocompatibility antigens are also displayed on tissues, unwanted T-cell-mediated alloreactions may ensue. Specifically, donor

alloreactive immune cells may attack recipient tissues, particularly the skin, gastrointestinal (GI) tract, and liver, causing acute or chronic **graft-versus-host disease (GVHD)**, a condition of varying severity that in some cases can be life-threatening or even fatal (see Chapter 179).

The success of allogeneic HSCT is undermined by diversity between donors and recipients in major and minor histocompatibility antigens. **HLA**, including HLA-A, HLA-B, and HLA-C major histocompatibility complex (MHC) class I molecules, present peptides to CD8<sup>+</sup> T cells, whereas the HLA-DR, HLA-DQ, and HLA-DP MHC class II molecules present peptides to CD4<sup>+</sup> T cells. There are hundreds of variant forms of each class I and class II molecule, and even small differences can elicit alloreactive T-cell responses that mediate graft rejection and/or GVHD. Disparities for HLA-A, HLA-B, HLA-C, or HLA-DRB1 alleles in the donor-recipient pair are independent risk factors for both acute and chronic GVHD. There is also increasing evidence that HLA-DQ and HLA-DP may play a role, prompting some transplant centers to also explore matching at these alleles.

Minor histocompatibility antigens derive from differences between the HLA-matched recipient and donor in peptides that are presented by the same HLA allotype. These antigens result from polymorphisms of non-HLA proteins, differences in the level of expression of proteins, or genetic differences between males and females. An example of the latter is represented by the H-Y antigens encoded by the Y chromosome, which can stimulate GVHD when a female donor is employed to transplant an HLA-identical male recipient. Thus, from this evidence, GVHD may occur even when the donor and recipient are HLA identical.

The preferred donor for any patient undergoing HSCT has traditionally been an HLA-identical sibling. Because polymorphic HLA genes are closely linked and usually constitute a single genetic locus, *any pair of siblings has a 25% chance of being HLA identical*. Thus, also in view of the limited family size in the developed countries, <25–30% of patients in need of an allograft can receive their transplant from an HLA-identical sibling. This percentage is even lower in patients with inherited disorders because affected siblings will not be considered donor candidates.

### HSCT FROM AN HLA-IDENTICAL SIBLING DONOR

Allogeneic HSCT from an HLA-compatible sibling is the treatment of choice for children with hematologic malignancies and various congenital or acquired diseases (Table 177.1). Best results are achieved in patients with congenital or acquired nonmalignant disorders because the risk of disease recurrence is low and the cumulative transplantation-related mortality is lower than in children receiving transplants for hematologic malignancies.

### ACUTE LYMPHOBLASTIC LEUKEMIA

Allogeneic HSCT is used for pediatric patients with acute lymphoblastic leukemia (ALL), either in the first complete remission when a child is considered at *high risk* of leukemia recurrence (e.g., those carrying poor-risk cytogenetic characteristics or with high levels of minimal residual disease), or in second or further complete remission after previous marrow relapse. ALL is the most common indication for HSCT in childhood. Several patient-, donor-, disease-, and transplant-related variables may influence the outcome of patients with ALL given an allogeneic HSCT. The probabilities of 3-year overall survival (OS) for US patients <18 years of age with ALL transplanted in the first or second complete remission is 70–80% and 60–70%, respectively. Inferior results are obtained in patients receiving transplants in more advanced disease phases (50–60%; Fig. 177.1). The use of total body irradiation (TBI) during the preparative regimen offers an advantage in terms of better event-free survival (EFS) compared to a regimen consisting of cytotoxic drugs alone, but it can induce more long-term side effects. This has prompted more investigation into TBI-sparing alternatives. Less intensive GVHD prophylaxis is also associated with a better outcome. Bone marrow is generally the preferred source of stem cells to be employed for transplantation, although this differs among transplant centers.

Although the main benefit for allogeneic HSCT recipients with leukemia derives from the GVL effect displayed by immunocompetent cells, disease recurrence remains the main cause of treatment



**Table 177.1** Indications for Allogeneic Hematopoietic Stem Cell Transplantation for Pediatric Diseases**MALIGNANCY****ALL**

First complete remission for patients at very high risk of relapse  
 T-cell immunophenotype and poor response to corticosteroid therapy  
 Not in remission at the end of the induction phase  
 Marked hypodiploidy (<43 chromosomes)  
 Minimal residual disease at the end of consolidation therapy

**High-risk infant ALL**

Second complete remission  
 Third or later complete remission

Acute myeloid leukemia in first complete remission or in advanced-disease phase

Philadelphia chromosome–positive chronic myeloid leukemia

Myelodysplastic syndromes

Hodgkin and non-Hodgkin lymphomas

Selected solid tumors

Metastatic neuroblastoma  
 Rhabdomyosarcoma refractory to conventional treatment  
 Very high risk Ewing sarcoma  
 High-risk CNS tumors

**ANEMIAS**

Severe acquired aplastic anemia  
 Fanconi anemia  
 Paroxysmal nocturnal hemoglobinemia  
 Congenital dyskeratosis  
 Diamond-Blackfan anemia  
 Thalassemia major  
 Sickle cell disease  
 Shwachman-Diamond syndrome

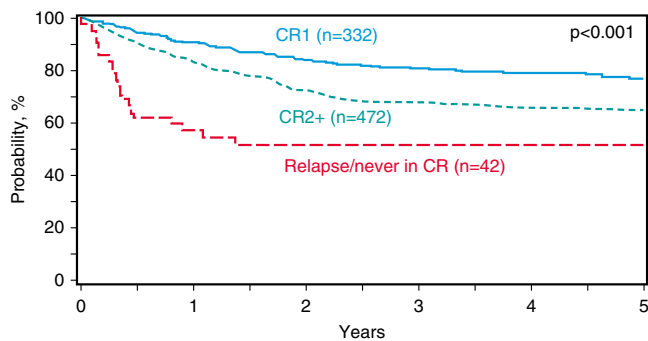
**IMMUNOLOGIC DISORDERS**

Variants of severe combined immunodeficiency  
 Hyper-IgM syndrome  
 Leukocyte adhesion deficiency  
 Omenn syndrome  
 Zap-70 kinase deficiency  
 Cartilage-hair hypoplasia  
 PNP deficiency  
 CD40 ligand deficiency  
 MHC class II deficiency  
 Wiskott-Aldrich syndrome  
 Chédiak-Higashi syndrome  
 Kostmann syndrome (infantile malignant agranulocytosis)  
 Chronic granulomatous disease  
 Autoimmune lymphoproliferative syndrome  
 X-linked lymphoproliferative disease (Duncan syndrome)  
 IPEX syndrome  
 Interleukin-10 receptor deficiency  
 Hemophagocytic lymphohistiocytosis  
 Interferon- $\gamma$  receptor deficiency  
 Griscelli disease  
 Granule deficiency

**OTHER DISORDERS**

Selected severe variants of platelet function disorders (e.g., Glanzmann thrombasthenia, congenital amegakaryocytic thrombocytopenia)  
 Selected types of mucopolysaccharidosis (e.g., Hurler disease) or other liposomal/peroxisomal disorders (e.g., Krabbe disease, adrenoleukodystrophy)  
 Infantile malignant osteopetrosis  
 Life-threatening cytopenia unresponsive to conventional treatments

ALL, Acute lymphoblastic leukemia; CNS, central nervous system; IPEX, immune dysregulation, polyendocrinopathy, enteropathy, X-linked; MHC, major histocompatibility complex; PNP, purine nucleoside phosphorylase.



**Fig. 177.1** Survival after matched related donor hematopoietic stem cell transplantation for acute lymphoblastic leukemia (ALL), age <18 years, 2008–2018. CR1, first complete remission; CR2+, second or greater remission. (From Phelan R, Arora M, Chen M. Current use and outcome of hematopoietic stem cell transplantation: CIBMTR US summary slides 2020. <http://www.cibmtr.org>.)

failure. The risk of failing to eradicate leukemia is influenced by many variables, including disease phase, molecular lesions of tumor cells, and disparity for major or minor histocompatibility antigens in the donor/recipient pairs. To overcome the hurdle of tumor elusion caused by HLA loss on malignant cells, the use of non–HLA-restricted **chimeric antigen receptors (CARs)** has also been used. This therapeutic strategy is based on genetic reprogramming of T cells through artificial immune receptors that reproducibly and efficiently redirect the antigen specificity of polyclonal T lymphocytes

toward target antigens expressed by leukemic cells. When expressed by T cells, CARs mediate antigen recognition and tumor cytotoxicity in an MHC-unrestricted fashion and can target any molecule (protein, carbohydrate, or glycolipid) expressed on the surface of tumor cells, thus bypassing one of the major tumor escape mechanisms based on the downregulation of MHC molecules. CARs are composed of an extracellular specific antigen-binding moiety, obtained from the variable regions of a monoclonal antibody, linked together to form a single-chain antibody (scFv), and of an intracellular signaling component derived from the  $\zeta$  chain of the T-cell receptor (TCR)-CD3 complex. The addition to the CAR gene construct of co-stimulation signals and cytokines promoting T-cell expansion and survival improves the antitumor efficiency of the engineered T cells and their survival in the tumor milieu. Gamma retrovirus and lentiviruses are usually used to transduce CARs into T lymphocytes to be employed in the clinical setting. These vectors have been shown to efficiently infect T lymphocytes, integrate into the host genome, and produce robust expression of the gene in human T cells and their progeny.

**ACUTE MYELOID LEUKEMIA**

Allogeneic HSCT is largely employed as postremission treatment of pediatric patients with acute myeloid leukemia (AML) who meet certain high-risk disease criteria. This subset of children with AML in first complete remission who are given allogeneic HSCT as consolidation therapy have a better probability of EFS than those treated with either chemotherapy alone or autologous transplantation. Results obtained in patients given HSCT after either a TBI-containing or a chemotherapy-based preparative regimen are similar. Therefore, for AML, conditioning regimens generally omit the use of TBI because of associated long-term side effects. Children with acute promyelocytic leukemia in



molecular remission at the end of treatment with chemotherapy and all-*trans*-retinoic acid, or with AML and translocation t(8;21) inversion of chromosome 16 (inv16), translocation t(16;16), or normal cytogenetics and presence of *NPM1* or *CEPBA* pathogenic variants are no longer considered eligible for allogeneic HSCT in first complete remission in view of their improved prognosis with alternative treatments. Studies suggest restricting the use of HSCT to those patients with poor molecular lesions, such as FLT3-internal tandem duplication or mixed-lineage leukemia abnormalities, or with high levels of minimal residual disease at the end of induction therapy. Approximately 40–60% of pediatric patients with AML in the second complete remission can be rescued by HSCT. The probabilities of 3-year OS for US patients <18 years of age with AML transplanted in the first or second complete remission is 60–70%. Similar to ALL, inferior results are obtained in patients receiving transplants in more advanced disease phases (30–40%).

### CHRONIC MYELOGENOUS LEUKEMIA

For many years, allogeneic HSCT has been considered the only proven curative treatment for children with Philadelphia-positive (Ph+) chronic myelogenous leukemia. Leukemia-free survival of chronic myelogenous leukemia patients after an allograft is 45–80%. The phase of disease (chronic phase, accelerated phase, blast crisis), recipient age, type of donor employed (related or unrelated), and time between diagnosis and HSCT are the main factors influencing the outcome. The best results are obtained in children transplanted during the chronic phase from an HLA-identical sibling within 1 year from diagnosis. Unlike other forms of pediatric leukemia, infusion of donor leukocytes can reinstate a state of complete remission in a large proportion of patients experiencing leukemia relapse.

Treatment with the specific BCR-ABL tyrosine protein kinase inhibitors (imatinib mesylate, dasatinib, nilotinib), targeting the enzymatic activity of the BCR-ABL fusion protein, has modified the natural history of the disease and thus the indications for transplantation. The indication for HSCT in this population is generally reserved for patients with a poor response to tyrosine kinase inhibitors or those who do not tolerate their side effects.

### JUVENILE MYELOMONOCYTIC LEUKEMIA

Juvenile myelomonocytic leukemia (JMML) is a rare hematopoietic malignancy of early childhood, representing 2–3% of all pediatric leukemias. JMML is characterized by hepatosplenomegaly and organ infiltration, with excessive proliferation of cells of monocytic and granulocytic lineages. Hypersensitivity to granulocyte-macrophage colony-stimulating factor (GM-CSF) and pathologic activation of the RAS-RAF-MAP (mitogen-activated protein) kinase signaling pathway play an important role in the pathophysiology. JMML usually runs an aggressive clinical course, with a median duration of survival for untreated children of <12 months from diagnosis. Rare patients with *CBL1* or *N-RAS* mutations can survive for years without an allograft.

HSCT can cure approximately 50–60% of patients with JMML. Patients who receive a transplant from an unrelated donor have comparable outcome to those given HSCT from an HLA-compatible related donor. Cord blood transplantation represents a suitable alternative option. Leukemia recurrence is the main cause of treatment failure in children with JMML after HSCT, with the relapse rate as high as 40–50%. Because children with JMML frequently have massive spleen enlargement, splenectomy has been performed before transplantation. Spleen size at the time of HSCT and splenectomy before HSCT do not appear to affect the posttransplantation outcome. Donor leukocyte infusion is not useful to rescue patients experiencing disease recurrence; a second allograft can induce sustained remission in approximately 30% of children with JMML relapsing after a first HSCT.

### MYELODYSPLASTIC SYNDROMES OTHER THAN JUVENILE MYELOMONOCYTIC LEUKEMIA

Myelodysplastic syndromes are a heterogeneous group of clonal disorders characterized by ineffective hematopoiesis leading to peripheral blood cytopenia and a propensity to evolve toward AML. HSCT is the treatment of choice for children with **refractory anemia with excess of blasts (RAEB)** and for those with RAEB in transformation (RAEB-t). The probability of survival without evidence of disease for these

children is 65–70%. It is still unclear whether patients with myelodysplastic syndromes and a blast percentage >20% benefit from pretransplantation chemotherapy. HSCT from an HLA-identical sibling is also the preferred treatment for all children with refractory cytopenia. Transplantation is also considered in children with refractory cytopenia associated with monosomy 7, GATA 2 deficiency, complex karyotype, life-threatening infections, profound neutropenia, or transfusion dependency. For children with **refractory cytopenia**, the probability of EFS after HSCT may be as high as 80%, and disease recurrence is rarely observed. This observation has provided the rationale for testing reduced-intensity regimens in these patients.

### NON-HODGKIN LYMPHOMA AND HODGKIN DISEASE

Childhood non-Hodgkin lymphoma (NHL) and Hodgkin disease (HD) are very responsive to conventional chemoradiotherapy; some patients have refractory disease or are at high risk for relapse. HSCT can cure a proportion of patients with relapsed NHL and HD and should be offered early after relapse, while the disease is still sensitive to therapy. If an HLA-matched donor is available, allogeneic transplantation can be offered to patients with NHL to take advantage of the GVL effect. Patients with sensitive disease and limited tumor burden have favorable outcomes, with EFS rates of 50–60%. Patients with relapsed or refractory HD do well after autologous HSCT, with EFS of 50–60%. HD patients may also benefit from a GVL effect when given an allograft.

### ACQUIRED APLASTIC ANEMIA

Because the probability of long-term survival for a matched-sibling bone marrow transplant (BMT) is reproducibly >80% for children and young adults, BMT is the treatment of choice for children and young adults with acquired severe aplastic anemia. Historically, the treatment of choice for children and young adults without an HLA-matched sibling has been intensive immunosuppression. Because the outcomes of matched unrelated donor transplant for children with acquired aplastic anemia have improved substantially over the years, the use of unrelated donor HSCT upfront *without* prior immunosuppressive therapy is being considered more frequently.

For patients who do not have a matched-sibling donor or well-matched unrelated donor, historically the transplant options were very disappointing. Fortunately, there is hope in using haploidentical transplant for this disease. The use of a reduced intensity conditioning regimen combined with GVHD prophylaxis, including posttransplant cyclophosphamide, have shown significant improvement over prior experiences with survival approaching transplants using well matched unrelated donors.

### INHERITED BONE MARROW FAILURE SYNDROMES

**Fanconi anemia (FA)** and dyskeratosis congenita are genetic disorders associated with a high risk of developing pancytopenia. FA is an autosomal recessive disease characterized by spontaneous chromosomal fragility, which is increased after exposure of peripheral blood lymphocytes to DNA crosslinking agents, including clastogenic compounds such as diepoxybutane, mitomycin C, and melphalan. Patients with FA, along with being at risk for pancytopenia, show a high propensity to develop clonal disorders of hematopoiesis, such as myelodysplastic syndromes and AML. HSCT can rescue aplastic anemia and prevent the occurrence of clonal hematopoietic disorders. In view of their defects in DNA repair mechanisms, which are responsible for the chromosomal fragility, FA patients have an exquisite sensitivity to alkylating agents and radiation therapy. Thus they must be prepared for the allograft with reduced doses of cyclophosphamide and only judicious use of radiation. Many FA patients were once successfully transplanted after receiving low-dose cyclophosphamide and thoracoabdominal irradiation. However, the use of this regimen is associated with an increased incidence of posttransplantation head and neck cancers. Low-dose cyclophosphamide combined with fludarabine has been very well tolerated in patients with FA who have a matched-related donor. The addition of low-dose TBI and antithymocyte globulin (ATG) for those with an unrelated donor has shown similar success. Currently, the 5-year OS is >90% in patients with FA who receive HSCT before the transformation to hematologic malignancy. Because of their underlying disorder, however, patients with FA must be monitored closely in

the years after transplant to assess for late effects, including secondary malignancies and endocrinopathies.

Allogeneic HSCT remains the only potentially curative approach for severe bone marrow failure associated with **dyskeratosis congenita**, a rare congenital syndrome characterized also by atrophy and reticular pigmentation of the skin, nail dystrophy, and leukoplakia of mucous membranes. Results of allograft in these patients have been relatively poor, with a 10-year survival of 20–30%, because of both early and late complications, reflecting increased sensitivity of endothelial cells to radiotherapy and alkylating agents.

### THALASSEMIA

Conventional treatment (i.e., regular blood transfusion and iron-chelation therapy) has dramatically improved both the survival and the quality of life of patients with thalassemia, changing a previously fatal disease with early death to a chronic, slowly progressive disease compatible with prolonged survival. However, HSCT remains the only curative treatment for patients with thalassemia. In these patients the risk of dying from transplant-related complications depends primarily on patient age, iron overload, and concomitant hepatic viral infections. Adults, especially with chronic active hepatitis, have a poorer outcome than children. Among children, three classes of risk have been identified on the basis of three parameters: regularity of previous iron chelation, liver enlargement, and presence of portal fibrosis. In pediatric patients *without* liver disease who have received regular iron chelation (class 1 patients), the probability of survival with transfusion independence is >90%, whereas for patients with low compliance with iron chelation and signs of severe liver damage (class 3 patients), the probability of survival has been 60%.

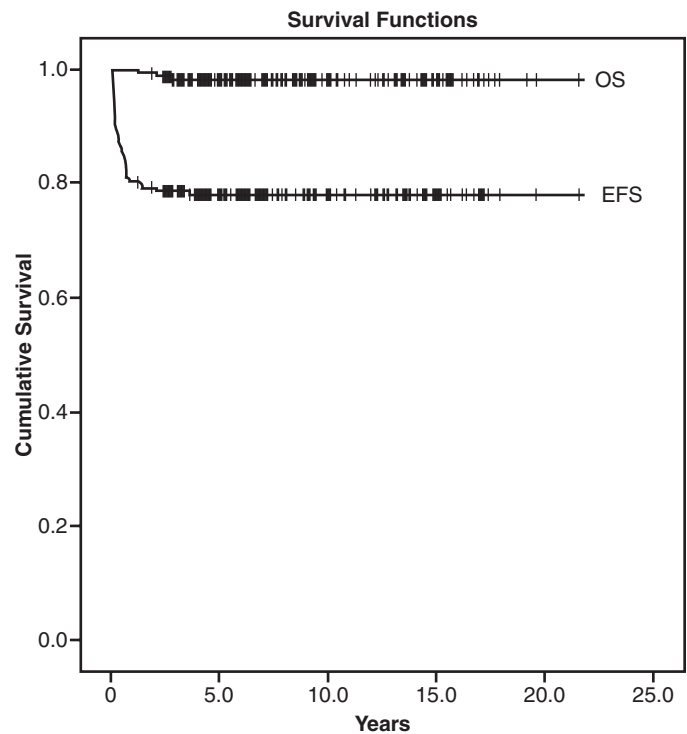
With improvements in supportive care and conditioning regimens, even patients with more advanced liver disease have had excellent outcomes (Fig. 177.2). The most effective pharmacologic combinations (e.g., including cyclosporine and methotrexate) should be employed to prevent GVHD. The outcome of patients transplanted from an unrelated donor has been reported similar to that of HLA-identical sibling recipients. The increased use of umbilical cord blood and haploidentical donors in this population is being explored to expand the number of patients eligible for HSCT. Also, advancements in gene therapy are being made in thalassemia in clinical trials, which may eventually change the approach to this disease.

### SICKLE CELL DISEASE

Disease severity varies greatly among patients with sickle cell disease, with 5–20% of the overall population suffering significant morbidity from vasoocclusive crises and pulmonary, renal, or neurologic damage. Hydroxyurea, an agent favoring the synthesis of fetal hemoglobin, reduces the frequency and severity of vasoocclusive crises and improves the quality of life for patients with sickle cell disease; however, allogeneic HSCT is the only curative treatment for this disease currently. Although HSCT can cure homozygous hemoglobin S, hemoglobin S $\beta$ 0, or hemoglobin sickle cell disease, selecting appropriate candidates for transplantation is difficult. Patients with sickle cell disease may survive for decades, but some patients have a poor quality of life, with repeated hospitalizations for painful vasoocclusive crises and central nervous system (CNS) infarcts. The main indications for performing HSCT in patients with sickle cell disease are history of strokes or abnormal transcranial Doppler ultrasound, recurrent acute chest syndrome, and/or recurrent vasoocclusive crises. The results of HSCT are best when performed in children with an HLA-identical sibling, with a probability of cure of 80–90%. However, the use of alternative donor transplants in this population, including matched unrelated donors and haploidentical donors, is being investigated through a number of clinical trials and may increase the number of patients eligible to undergo potentially curative HSCT. Reduced-intensity and reduced-toxicity regimens are also being explored to further decrease transplant-related morbidity and mortality, although graft failure remains an important issue in this patient population. Gene therapy for sickle cell disease is currently being investigated in clinical trials.

### IMMUNODEFICIENCY DISORDERS

HSCT is the treatment of choice for children affected by severe combined immunodeficiency (SCID), as well as for other inherited



**Fig. 177.2** Overall survival (OS) and event-free (graft failure) survival (EFS) after hematopoietic stem cell transplantation in children  $\geq 1$  year from transplant for  $\beta$ -thalassemia major. (From Chaudhury S, Ayas M, Rosen C, et al. A Multicenter Retrospective Analysis Stressing the Importance of Long-Term Follow-Up after Hematopoietic Cell Transplantation for  $\beta$ -Thalassemia. *Biol Blood Marrow Transplant.* 2017;23(10):1695–1700.)

immunodeficiencies, including Wiskott-Aldrich syndrome, leukocyte adhesion deficiency (LAD), and chronic granulomatous disease (see Table 177.1). With an HLA-identical sibling, the probability of survival approaches 100%, with less favorable results for patients transplanted from an HLA-partially matched relative. Some children with SCID, mainly those without residual natural killer activity or maternal T-cell engraftment, may be transplanted without receiving any preparative regimen; the donor lymphoid cells are usually the only elements that engraft. Sustained donor engraftment is more difficult to achieve in children with Omenn syndrome, hemophagocytic lymphohistiocytosis (HLD), or LAD. Life-threatening opportunistic fungal and viral infections occurring before the allograft adversely affect the patient's outcome after HSCT. Because of this, patients with the most severe immunodeficiencies must be transplanted as early as possible to prevent infectious complications.

### INHERITED METABOLIC DISEASES

Inherited metabolic diseases are a broad group of diseases that result from the accumulation of substrate within tissues caused by dysfunction of the lysosome or peroxisome. The use of HSCT has been established for a variety of inherited metabolic diseases, including mucopolysaccharidosis type 1 (Hurler syndrome) and adrenoleukodystrophy (ALD). Although some of these diseases are treatable with exogenous enzyme replacement therapy, the clinical manifestations of disease tend to progress over time, especially disease in the CNS, where enzyme is unable to be reliably delivered. It is thought that undergoing HSCT results in the engraftment of microglial cells that are able to provide new enzyme to the areas where enzyme replacement therapy, if available, cannot have a substantial impact. Multiple studies have shown significantly improved outcomes for patients who are diagnosed with their underlying conditions relatively early and are able to undergo HSCT expeditiously, before significant damage from accumulated substrate that may be irreversible.

## Chapter 178

# Hematopoietic Stem Cell Transplantation from Alternative Sources and Donors

Rachel A. Phelan and David Margolis

Two thirds of patients who need allogeneic hematopoietic stem cell transplantation (HSCT) do not have an available HLA-identical sibling. Alternative sources of hematopoietic stem cells (HSCs) are being increasingly used and include **matched unrelated donors**, **unrelated umbilical cord blood**, and **HLA-haploidentical relatives**. Each of these three options has advantages and limitations, but rather than being considered competing alternatives, they should be regarded as complementary strategies to be chosen after a careful evaluation of the relative risks and benefits in the patient's best interest. The choice of the donor will depend on various factors related to urgency of transplantation; patient-, disease-, and transplant-related factors; center experience; and physician preference.

## UNRELATED DONOR TRANSPLANTS

One of the most widely used strategies for children who need an allograft and do not have an available HLA-identical sibling is to identify an unrelated HLA-matched donor in a registry. Worldwide international registries include almost 27 million HLA-typed volunteer donors. HLA-A, HLA-B, HLA-C class I loci, and the DRB1 class II locus are the HLA loci that most influence outcome after HSCT from an unrelated volunteer. Other class II loci (namely, DQB1 and DP1 loci), as well as **killer cell immunoglobulin-like receptor (KIR)** haplotypes, are also increasingly considered when choosing a donor, although their impact on outcome is less well elucidated.

Although in the past serologic (low-resolution) typing was used for HLA-A and HLA-B loci, currently the unrelated donors are selected using high-resolution (allelic) molecular typing of loci HLA-A, HLA-B, HLA-C, and -DRB1. The chance of finding an HLA-matched unrelated donor depends on the frequency of the HLA phenotype, which is closely linked to the ethnic origin of the registry donors. Data from the National Marrow Donor Program (NMDP) donor registry and banked cord blood units estimated that essentially every patient in need of a transplant would be able to find a donor in a timely fashion, despite the recipient's race/ethnic group, donor availability, and cell dose. However, many of those patients may not have access to an "ideal" graft, defined as HLA matching of a minimum of 8/8 for bone marrow and 6/6 for cord blood.

Initially, HLA polymorphism and the intrinsic limitations of conventional (i.e., serologic) HLA-typing techniques unfavorably affected the accuracy of matching, thus increasing rejection rates and the incidence of acute and chronic graft-versus-host disease (GVHD). The advent of both high-resolution molecular HLA classes I and II loci typing coupled with progress in the prophylaxis and treatment of GVHD has resulted in a reduction of transplantation-related mortality and improvement in outcome. Indeed, outcomes from a fully matched unrelated volunteer donor are now similar to those of HSCT from an HLA-identical sibling. The outcomes of haploidentical transplantation are similarly reaching that of matched unrelated donors as well as matched sibling donors.

Although a single locus disparity in patients with leukemia may be seen as beneficial by a reduction in the relapse rate caused by the graft-versus-leukemia (GVL) effect, in patients with nonmalignant disorders in whom GVL is not beneficial, optimal results are obtained only when a donor matched at the allelic level with the recipient is selected. In general, a single HLA disparity in the donor-recipient pair, irrespective

of whether antigenic or allelic in nature, predicts a greater risk of non-leukemia mortality; multiple allelic disparities at different HLA loci have an additive detrimental effect and are associated with an even worse outcome. To reduce the risk of acute GVHD, *ex vivo T-cell depletion of the graft* has been employed, with variable efficacy. Studies are looking at selectively depleting donor  $\alpha/\beta$  T cells, which are the T cells that drive GVHD, while preserving the T cells and natural killer (NK) cells, which may be responsible for GVL and protection from infection.

Although the majority of patients who have required a matched unrelated donor transplant have received a bone marrow or peripheral stem cell graft, for patients who urgently need a transplant, the time required to identify a suitable donor from a potential panel, establish eligibility, and harvest the cells may lead to relapse and failure to transplant. For this subset of patients who urgently need a transplant, attention has focused on unrelated cord blood and HLA-haploidentical, mismatched family donors.

## UMBILICAL CORD BLOOD TRANSPLANTS

Umbilical cord blood transplantation (UCBT) is a viable option for children who need allogeneic HSCT. UCBT offers the advantages of absence of risks to donors, reduced risk of transmitting infections, and for transplants from unrelated donors, immediate availability of cryopreserved cells, with the median time from start of search to transplantation of only 3-4 weeks. Compared with bone marrow transplantation (BMT), the advantages of UCBT are also represented by lower incidence of chronic GVHD and the possibility of using donors showing HLA disparities with the recipient. Despite these advantages, the large experience gained over the last 2 decades has demonstrated that UCBT patients may be exposed to an increased risk of early fatal complications, mainly because of a lower engraftment rate of donor hematopoiesis, delayed kinetics of neutrophil recovery (risk of infection), and lack of adoptive transfer of pathogen-specific memory T cells. Transfer of donor-derived, memory T cells significantly contributes to early immunologic reconstitution of children after unmanipulated allogeneic bone marrow or peripheral blood stem cell transplantation.

Concerning the issues of engraftment and hematopoietic recovery, it has been demonstrated that an inverse correlation exists between the number of nucleated cord blood cells infused per kilogram recipient body weight and the risk of dying for transplantation-related causes. In particular, engraftment is a major concern when the nucleated cells are  $<2.5 \times 10^7/\text{kg}$  of recipient body weight. Because a cord blood unit usually contains between  $1 \times 10^9$  and  $1.8 \times 10^9$  cells, it is not surprising that UCBT has been less frequently employed for adolescents or adults with body weight  $>40$  kg. Indeed, it can be estimated that only 30% of the UCB units available in the bank inventory could suffice for a 75 kg patient, according to the recommended threshold cell dose. Efforts have focused on approaches capable of increasing the number of UCB cells to be transplanted. Selection of the richest cord blood units or infusion of 2 units in the same recipient (i.e., double UCBT) have been explored to improve the results of UCBT. The results of these studies have been mixed, with one large study demonstrating no survival advantage for children and adolescents that receive double UCBT. Preliminary studies of *ex vivo* expansion of a single umbilical cord sample with UM171, an HSC self-renewal agonist, have suggested improved engraftment, reduced infection, and low rates of severe acute GVHD.

The long-term results of UCB transplants are similar to those after transplantation from other sources of HSCs for pediatric hematologic malignancies. In patients with hematologic malignancies, recipients of UCBT may be transplanted from donors with greater HLA disparities, receive 1-log fewer nucleated cells, have delayed neutrophil and platelet recovery, and show reduced incidence of GVHD compared with children given BMT from unrelated donors. In one study, there were similar rates of acute GVHD, but significantly less chronic GVHD in patients who received UCBT. Nevertheless, both the relapse rate and the overall survival probability did not differ in unrelated UCBT or BMT pediatric recipients. Thus, in the absence of an HLA-identical family donor, unrelated UCBT can be considered a suitable option for children with malignant and non-malignant disorders. Results of UCBT have been of particular interest in children with certain nonmalignant disorders to proceed to transplant quickly and prevent further progression of disease.



## HAPLOIDENTICAL TRANSPLANTS

HSCT from an HLA-haploidentical (**haplo-HSCT**) donor offers an immediate source of HSCs to almost all patients who fail to find a matched donor, whether related or unrelated, or a suitable cord blood unit. Indeed, almost all children have at least one haploidentical-3 loci mismatched family member who is promptly available as donor. The few patients who reject the haploidentical transplant also have the advantage of another immediately available donor within the family. Moreover, this may represent an approach that would be attractive in the global health setting, where more sophisticated donor registries and cell-processing techniques are less unavailable.

Efficient T-cell depletion of the graft has been demonstrated to prevent acute and chronic GVHD even when using haploidentical parental grafts. This can be done *ex vivo* or *in vivo* with the use of chemotherapeutic agents before and after cell infusion. The use of post-transplant cyclophosphamide is one such *in vivo* technique now being widely incorporated into haploidentical transplant regimens. The benefits of T-cell depletion were first demonstrated in transplantation of children with severe combined immunodeficiency (SCID). More than 300 transplants in SCID patients using haploidentical donors have been performed worldwide, with a high rate of long-term partial or complete immune reconstitution.

The elimination of mature T cells from the graft, necessary for preventing GVHD in a context of great immune genetic disparity, results in recipients being unable to benefit from the adoptive transfer of donor memory T lymphocytes, through their peripheral expansion, are the main factor responsible for protection from infections in the first few months after transplantation. A state of profound immunodeficiency lasts for at least 4-6 months after transplantation in haplo-HSCT recipients. Sophisticated strategies of adoptive infusions of T-cell lines or clones specific for the most common and life-threatening pathogens (Epstein-Barr virus [EBV], human cytomegalovirus, *Aspergillus*, adenovirus) have been successfully tested in trials to protect the recipients in the early posttransplant period.

For many years the absence of the T-cell-mediated GVL effect has been considered as rendering the recipients of a T-cell-depleted allograft more susceptible to leukemia relapse. However, it has been demonstrated that a GVL effect displayed by donor NK cells can compensate for this lack of T-specific alloreactivity when an HLA-disparate NK-alloreactive relative is employed as a donor.

Selective approaches of graft manipulation in haploidentical and unrelated donor transplant have also been developed. In particular, promising results have been obtained through a negative depletion of T lymphocytes carrying the  $\alpha/\beta$  chains of the T-cell receptor, which are believed to be the mediators of GVHD. B lymphocytes are also depleted to prevent EBV-related lymphoproliferative disease. Through this approach the patient can benefit from the adoptive transfer of committed hematopoietic progenitors, mature NK cells and  $\gamma/\delta^+$  T cells, which can confer a protection against life-threatening infections as well as provide a GVL effect.

The outcomes of haplo-HSCT have been more extensively reported in adults than in children. The reported probability of survival at 3-4 yr after a haplo-HSCT in children with acute leukemia ranged from 18-48%. Survival was influenced by many factors, most importantly the state of remission at transplantation, with poorer outcomes in children with myeloid leukemias than in those with lymphoid leukemia. In haplotype-mismatched parent-to-child HSCT, patients with acute leukemia grafted from the mother had reduced relapse rates compared with recipients of paternal grafts, translating into better event-free survival.

## DONOR VERSUS RECIPIENT NK CELL ALLOREACTIVITY

NK cells are the first lymphocytes derived from the donor to recover after allogeneic HCT. Donor versus recipient NK cell alloreactivity derives from a mismatch between donor NK clones, carrying specific inhibitory receptors for self-major histocompatibility complex (MHC) class I molecules, and MHC class I ligands on recipient cells. NK cells are primed to kill by several activating receptors, which play an important role in the NK cell-mediated GVL effect. Human NK cells discriminate allelic forms of MHC molecules via **KIRs**, which are clonally distributed with each cell in the repertoire bearing at least one receptor that is specific for self-MHC class I molecules. Because NK cells co-express

**Table 178.1** Indications for Autologous Hematopoietic Stem Cell Transplantation for Pediatric Diseases

- Relapsed Hodgkin or non-Hodgkin lymphoma
- Stage IV or relapsed neuroblastoma
- High-risk, relapsed, or resistant brain tumors
- Stage IV Ewing sarcoma
- Life-threatening autoimmune diseases resistant to conventional treatments

inhibitory receptors for self-MHC class I molecules, autologous cells are not killed. When faced with mismatched allogeneic targets, NK cells sense the missing expression of self-class I alleles and mediate alloreactions. In mismatched transplants, there are many donor recipient pairs in which the donor NK inhibitory cells do not recognize the recipient's class I alleles as self. Consequently, the donor NK cells are not blocked and are activated to lyse the recipient's lymphohematopoietic cells.

Haplo-HSCT trials demonstrate that MHC class I mismatches, which generate an alloreactive NK cell response in the graft-versus-host direction, eradicate leukemia cells, improve engraftment, and protect from T-cell-mediated GVHD. The potential for donor versus recipient NK cell alloreactivity, which can be predicted by standard HLA typing, is increasingly being examined when selecting the donor of choice. The importance of KIR haplotype in transplants other than haploidentical transplantation in preventing GVHD as well as relapse has been shown to be increasingly beneficial.

## AUTOLOGOUS HEMATOPOIETIC STEM CELL TRANSPLANTATION

Autologous transplantation, using the patient's own stored marrow, is associated with a low risk of life-threatening transplant-related complications, although the main cause of failure is disease recurrence. Bone marrow was once the only source of stem cells employed in patients given an autograft. The majority of patients treated with autologous HSCT receive hematopoietic progenitors mobilized in peripheral blood by either cytokines alone (mainly granulocyte colony-stimulating factor) or by cytokines plus cytotoxic agents. A CXCR4 antagonist can be extremely effective in mobilizing hematopoietic progenitors in the periphery. Compared with bone marrow, the use of peripheral blood progenitors is associated with a faster hematopoietic recovery and a comparable outcome.

Autologous HSCT is employed primarily for selected children with relapsed lymphomas and select solid tumors (Table 178.1).

Patients with sensitive lymphomas and minimal tumor burden have favorable outcomes after autologous HSCT, with disease-free survival rates of 50-60%, whereas high-risk patients with bulky tumor or poorly responsive disease have a poor outcome, with survival rates of 10-20%.

Autologous HSCT in patients with high-risk neuroblastoma is associated with a better outcome than conventional chemotherapy. A Children's Oncology Group (COG) study demonstrated further survival advantage by performing two sequential, or tandem, transplants that use different chemotherapeutic agents. Because of these improved outcomes, tandem autologous transplants are now considered the standard recommended treatment. In these patients, posttransplantation infusion of a monoclonal antibody directed against a molecule (GD2) expressed on the surface of neuroblastoma cells confers a protection against the risk of tumor recurrence.

For children with brain tumors at high risk of relapse, or resistant to conventional chemotherapy and irradiation, the dose-limiting toxicity for intensifying therapy is myelosuppression, thus providing a role for stem cell rescue. Several studies provide encouraging results for patients with different histologic types of brain tumors treated with autologous HSCT.



## Chapter 179

# Graft-Versus-Host Disease, Rejection, and Venooclusive Disease

Rachel A. Phelan and David Margolis

A major cause of mortality and morbidity after allogeneic hematopoietic stem cell transplantation (HSCT) is **graft-versus-host disease (GVHD)**, which is caused by engraftment of immunocompetent donor T lymphocytes in an immunologically compromised host who shows histocompatibility differences with the donor. These differences between the donor and the host may result in donor T-cell activation against either recipient major histocompatibility complex (MHC) antigens or minor histocompatibility antigens. GVHD is usually subdivided in two forms: **acute GVHD**, which occurs within 3 months after transplantation, and **chronic GVHD**, which, although related, is a different disease, occurring later and displaying some clinical and pathologic features that resemble those observed in selected autoimmune disorders (e.g., systemic sclerosis, Sjögren syndrome).

## ACUTE GRAFT-VERSUS-HOST DISEASE

Acute GVHD is caused by the alloreactive, donor-derived T cells contained in the graft, which attack nonshared recipient's antigens on target tissues. A 3-step process generates the clinical syndrome. First, conditioning-induced tissue damage activates recipient antigen-presenting cells, which present recipient alloantigens to the donor T cells transferred with the graft and secrete **cytokines**, such as interleukin (IL)-12, favoring the polarization of T-cell response in the type 1 direction. Second, in response to recipient antigens, donor T cells become activated, proliferate, expand, and generate cytokines such as tumor necrosis factor (TNF)- $\alpha$ , IL-2, and interferon (IFN)- $\gamma$ . In the third step of the process, these cytokines cause tissue damage and promote differentiation of cytotoxic CD8<sup>+</sup> T cells, which, together with macrophages, kill recipient cells and further disrupt tissues.

Acute GVHD usually develops 2-8 weeks after transplantation. The primary manifestations depend on the sites of involvement and may include an erythematous maculopapular rash (Figs. 179.1 and 179.2), persistent anorexia, vomiting and/or diarrhea, and liver disease with increased serum levels of bilirubin, alanine transaminase (ALT), aspartate transaminase (AST), and alkaline phosphatase (ALP). Diagnosis may benefit from skin, liver, or gastrointestinal (GI) biopsy for confirmation. Endothelial damage and lymphocytic infiltrates are seen in all affected organs. The epidermis and hair follicles of the skin are damaged, the hepatic small bile ducts show segmental disruption, and there is destruction of the crypts and mucosal ulceration of the GI tract. Grade I acute GVHD (skin rash alone) has a favorable prognosis and often requires no treatment, or topical treatment alone. Grade II GVHD is a moderately severe multiorgan disease requiring immunosuppressive therapy. Grade III GVHD is a severe multiorgan disease, and grade IV GVHD is a life-threatening, often fatal condition (Table 179.1).

The standard pharmacologic prophylaxis of GVHD after an unmanipulated allograft relies mainly on posttransplant administration of immunosuppressive drugs, such as cyclosporine or tacrolimus or combinations of either with methotrexate or prednisone, anti-T-cell antibodies, mycophenolate mofetil (MMF), and other immunosuppressive agents. Infusion of cyclophosphamide on days +3 and +4 after transplantation has been used as a strategy to deplete alloreactive donor T lymphocytes that become activated

after exposure to recipient antigens. This approach has been successful in patients undergoing haploidentical transplantation. Pretransplantation infusion of either antithymocyte globulin (ATG) or monoclonal antibodies (mAbs) such as alemtuzumab is largely used to modulate alloreactivity of donor T cells, in particular in patients given the allograft from either an unrelated donor or a partially matched relative. An alternative approach is the removal of T lymphocytes from the graft (**T-cell depletion**). Other approaches are being used to selectively remove the  $\alpha/\beta$  T cells, which are thought to be responsible for the development of GVHD, while preserving the  $\gamma/\delta$  T cells in order to sustain graft-versus-leukemia (GVL) and the ability to fight infection. Any form of GVHD prophylaxis may impair posttransplantation immunologic reconstitution, increasing the risk of infection-related deaths. Traditional T-cell depletion of the graft is also associated with an increased risk of leukemia recurrence in patients transplanted from an HLA-identical sibling or an unrelated volunteer.

Despite prophylaxis, significant acute GVHD develops in approximately 30% of recipients of HSCT from matched siblings and in as many as 60% of HSCT recipients from unrelated donors. These numbers are estimates, and the actual risk of acute GVHD is highly variable depending on several factors. Risk for development of GVHD is increased by diagnosis of malignant disease, older donor and recipient age, and in patients given an unmanipulated allograft. The most important risk factor for acute GVHD is the presence of disparities for HLA molecules in the donor-recipient pair.

Acute GVHD is usually initially treated with glucocorticoids; approximately 40–50% of patients show a complete response to



**Fig. 179.1** Acute graft-versus-host disease. Involvement of the scalp, ears, palms, and soles is common. (From Paller AS, Mancini AJ, eds. *Hurwitz Clinical Pediatric Dermatology*. 5th ed. Philadelphia: Elsevier, 2016. p 577.)



**Fig. 179.2** Acute graft-versus-host disease. Almost confluent eruption of erythematous macules and papules in an immunodeficient neonate treated with extracorporeal membrane oxygenation (ECMO) and transfusion of nonirradiated blood. (From Paller AS, Mancini AJ, eds. *Hurwitz Clinical Pediatric Dermatology*. 5th ed. Philadelphia: Elsevier, 2016. p 577.)

**Table 179.1** Clinical Staging and Grading\* of Acute Graft-Versus-Host Disease

STAGE	SKIN (ACTIVE ERYTHEMA ONLY)	LIVER (BILIRUBIN)	UPPER GI	LOWER GI (STOOL OUTPUT/DAY)
0	No active (erythematous) GVHD rash	<2mg/dL	No or intermittent nausea, vomiting, or anorexia	Adult: <500mL/day or <3 episodes/day Child: <10 mL/kg/day or <4 episodes/day
1	Maculopapular rash <25% BSA	2-3mg/dL	Persistent nausea, vomiting or anorexia	Adult: 500-999mL/day or 3-4 episodes/day Child: 10-19.9 mL/kg/day or 4-6 episodes/day
2	Maculopapular rash 25–50% BSA	3.1-6mg/dL		Adult: 1,000-1,500mL/day or 5-7 episodes/day Child: 20-30 mL/kg/day or 7-10 episodes/day
3	Maculopapular rash >50% BSA	6.1-15mg/dL		Adult: >1,500mL/day or >7 episodes/day Child: >30 mL/kg/day or >10 episodes/day
4	Generalized erythroderma (>50% BSA) plus bullous formation and desquamation >5% BSA	>15mg/dL		Severe abdominal pain with or without ileus or grossly bloody stool (regardless of stool volume)

\*Overall clinical grade (based on most severe target organ involvement):

Grade 0: no stage 1-4 of any organ.

Grade I: stage 1-2 skin without liver, upper GI, or lower GI involvement.

Grade II: stage 3 rash and/or stage 1 liver and/or stage 1 upper GI and/or stage 1 lower GI.

Grade III: stage 2-3 liver and/or stage 2-3 lower GI, with stage 0-3 skin and/or stage 0-1 upper GI.

Grade IV: stage 4 skin, liver, or lower GI involvement, with stage 0-1 upper GI.

GI, Gastrointestinal; GVH, graft-versus-host; BSA, body surface area.

From Harris AC, Young R, Devine S, et al. International, Multicenter Standardization of Acute Graft-versus-Host Disease Clinical Data Collection: A Report from the Mount Sinai Acute GVHD International Consortium. *Biol Blood Marrow Transplant*. 2016;22(1):4–10.

corticosteroids. The risk of transplantation-related mortality is much higher in patients who do not respond to corticosteroids than in those showing a complete response. Ruxolitinib, targeting the JAK signaling pathway, or other drugs targeting molecules expressed on T cells or cytokines released during the inflammatory cascade (including infliximab and etanercept targeting TNF, vedolizumab targeting  $\alpha_4\beta_7$ -integrin, and tocilizumab targeting IL-6), which underlies the pathophysiology of GVHD, have been used in patients with steroid-resistant acute GVHD. Extracorporeal photopheresis is another second-line treatment for GVHD and is most efficacious for skin GVHD. A patient's peripheral blood is exposed to a photosensitive compound and then exposed to ultraviolet light. The cells are then reinfused into the patient. It is thought that this process results in an increase in apoptosis of lymphocytes responsible for GVHD as well as the upregulation of anti-inflammatory cytokines and regulatory T cells. Promising results in children with steroid-resistant acute GVHD have also been obtained using **mesenchymal stromal cells**, which are able to blunt the inflammatory response associated with acute GVHD.

### CHRONIC GRAFT-VERSUS-HOST DISEASE

Chronic GVHD develops or persists >3 months after transplantation and is the most frequent late complication of allogeneic HSCT with an incidence of approximately 25% in pediatric patients. Chronic GVHD is the major cause of nonrelapse mortality and morbidity in long-term HSCT survivors. Acute GVHD is recognized as the most important factor predicting the development of the chronic form of the disease. The use of matched unrelated volunteers as donors and use of unmanipulated peripheral blood as the stem cell source have increased the incidence and severity of chronic GVHD. Other factors that predict occurrence of chronic GVHD include older donor and recipient ages, female donor for male recipient, diagnosis of malignancy, and use of total body irradiation (TBI) as part of the preparative regimen.

Chronic GVHD is a disorder of immune regulation characterized by autoantibody production, increased collagen deposition and fibrosis, and clinical symptoms similar to those seen in patients with autoimmune diseases (Table 179.2). The predominant cytokines involved in the pathophysiology of chronic GVHD are usually

**Table 179.2** Clinical Findings in Chronic Graft-Versus-Host Disease

ORGAN SYSTEM	SYMPTOMS AND SIGNS
Systemic	Immunodeficiency and recurrent infections
Skin	Lichen planus, scleroderma, hyperpigmentation or hypopigmentation, erythema, freckling, ichthyosis, ulcerations Flexion contractures Vaginal scars Onycholysis Nail loss
Hair	Alopecia; scarring or nonscarring
Mouth	Sicca syndrome, lichen planus, depapillation of tongue with variegations, scalloping of lateral margins, xerostomia, mucocoele
Joints	Diffuse myositis/tendonitis, arthritis, contractures
Eyes	Decreased tearing, injected sclerae, scarring conjunctivitis, keratopathy
Liver	Increased enzymes, cholestasis, hepatomegaly, cirrhosis
Gastrointestinal	Failure to thrive, malabsorption, chronic diarrhea Esophageal strictures
Lung	Cough, dyspnea, wheezing Bronchiolitis obliterans, chronic rales, pneumothorax, fibrosis
Hematology	Thrombocytopenia, eosinophilia, Howell-Jolly bodies (splenic dysfunction)

type II cytokines such as IL-4, IL-5, and IL-13. IL-4 and IL-5 contribute to eosinophilia and B-cell hyperactivity with elevated IgM, IgG, and IgE titers. Associated monoclonal gammopathies indicate clonal dysregulation. Chronic GVHD is dependent on the development and persistence of donor T cells that are not tolerant to the recipient. Maturation of transplanted stem cells within a damaged thymus could lead to errors in negative selection and production of cells that have not been tolerized to recipient antigens and are therefore autoreactive or, more accurately, **recipient reactive**. This ongoing immune reactivity results in clinical features resembling a systemic autoimmune disease with lichenoid and sclerodermatous skin lesions, malar rash, sicca syndrome, arthritis, joint contractures, bronchiolitis obliterans, and bile duct degeneration with cholestasis.

Patients with chronic GVHD involving only the skin and liver have a favorable course (Figs. 179.3 and 179.4). Extensive multi-organ disease may be associated with a very poor quality of life, recurrent infections associated with prolonged immunosuppressive regimens to control GVHD, and a high mortality rate. Morbidity and mortality are highest in patients with a progressive onset of chronic GVHD that directly follows acute GVHD, intermediate in those with a **quiescent onset** after resolution of acute GVHD, and lowest in patients with **de novo onset** in the absence of acute GVHD. Chronic GVHD can be classified as mild, moderate, or severe depending on extent of involvement. Single-agent prednisone is the standard treatment, although other agents have been employed with variable success. Ruxolitinib, a Janus kinase inhibitor, has been a beneficial treatment for steroid-dependent or refractory chronic GVHD. In addition, ibrutinib, a Bruton tyrosine kinase inhibitor, has been approved by the FDA for the treatment of chronic GVHD. Treatment with imatinib mesylate, which inhibits the synthesis of collagen, has been effective in some patients with chronic GVHD and sclerotic features. As a consequence of prolonged immunosuppression, patients with chronic GVHD are particularly susceptible to infections and should receive appropriate antibiotic prophylaxis, including trimethoprim/sulfamethoxazole (TMP/SMX). Chronic GVHD resolves in most pediatric patients but may require 1-3 years of immunosuppressive therapy before the drugs can be withdrawn without the disease recurring. Chronic GVHD promotes the development of secondary neoplasms, in particular in patients with Fanconi anemia, and has a significant impact on quality of life.

### GRAFT FAILURE

Graft failure is a serious complication exposing patients to a high risk of fatal infection. **Primary graft failure** is defined as failure to achieve a neutrophil count of  $0.5 \times 10^9/L$  after transplantation. **Secondary graft failure** is loss of peripheral blood counts following initial transient engraftment of donor cells. Causes of graft failure after autologous and allogeneic transplantation include transplantation of an inadequate stem cell dose (more frequently observed in children given cord blood transplantation) and viral infections such as with cytomegalovirus or human herpesvirus type 6, which are often associated with activation of recipient macrophages. Graft failure after allogeneic transplantation, however, is mainly caused by immunologically mediated rejection of the graft by residual recipient-type T cells that survive the conditioning regimen.

Diagnosis of graft failure resulting from immunologic mechanisms is based on examination of peripheral blood and marrow aspirate and biopsy, along with molecular analysis of chimerism status. Persistence of lymphocytes of host origin in allogeneic transplant recipients with graft failure indicates immunologic rejection. The risk of immune-mediated graft rejection is higher in patients given HLA-disparate, T-cell-depleted grafts, reduced-intensity conditioning regimens, and transplantation of low numbers of stem cells, and in recipients who are sensitized toward major HLA antigens or, less frequently, minor histocompatibility



**Fig. 179.3** Chronic graft-versus-host disease (GVHD), lichenoid. After bone marrow transplantation, this patient had acute GVHD and subsequently developed cutaneous scaling papules and plaques typical of lichen planus. (From Paller AS, Mancini AJ, eds. Hurwitz Clinical Pediatric Dermatology. 5th ed. Philadelphia: Elsevier; 2016. p 577.)



**Fig. 179.4** Chronic graft-versus-host disease. Note the extensive alopecia of the scalp with dyschromia and numerous sclerodermatous plaques of the scalp and back. (From Paller AS, Mancini AJ, eds. Hurwitz Clinical Pediatric Dermatology. 5th ed. Philadelphia: Elsevier; 2016. p 579.)

antigens. Allosensitization develops as a consequence of preceding blood product transfusions and is observed particularly in recipients with aplastic anemia, sickle cell disease, and thalassemia. In HSCT for nonmalignant diseases, such as mucopolysaccharidoses, graft failure is also facilitated by the absence of previous treatment with cytotoxic and immunosuppressive drugs. In thalassemia, graft failure is promoted by expansion of recipient hematopoietic cells. GVHD prophylaxis with methotrexate, an antimetabolite, and anti-infective prophylaxis with TMP/SMX or ganciclovir may also delay engraftment.

**Treatment** of graft failure usually requires removing all potentially myelotoxic agents from the treatment regimen and attempting a short trial of hematopoietic growth factors, such as granulocyte colony-stimulating factor. A second transplant, usually preceded



**Table 179.3** Severity Grading Thresholds of Sinusoidal Obstructive Syndrome Among Children, Adolescents, and Young Adults

	MILD	MODERATE	SEVERE	VERY SEVERE
ALT, AST, GLDH (mg/dL)	<2× normal	2-5× normal	2-5× normal	>5× normal
Bilirubin (mg/dL)	<2	<2	≥2	Bilirubin doubles in 48 hr
Coagulopathy (not responsive to vitamin K administration; INR)	<1.5	1.5-1.9	>2	Need for replacement of coagulation factors
Ascites	Mild (minimal fluid by liver, spleen or pelvis)	Moderate (<1 cm fluid)	Severe (fluid in all 3 regions with >1 cm fluid in at least 2 regions)	Requires paracentesis
Weight gain (from baseline)	2.5%	5–10% despite diuretic use	>10%	Persistent rise
Renal function score	KDIGO 1: serum creatinine 1.5-1.9× baseline or ≥0.3 mg/dL (≥26.5 mmol/L) increase or urine output <0.5 mL/kg/hr for 6-12 hr	KDIGO 2: serum creatinine 2.0-2.9× baseline or urine output <0.5 mL/kg/hr for ≥12 hr	KDIGO 3: serum creatinine 3.0× baseline or increase in serum creatinine ≥4.0-mg/dL (≥353.6 mmol/L) or initiation of renal replacement therapy or decrease in eGFR to <35 mL/min per 1.73 m <sup>2</sup> (patients <18 years) or urine output <0.3 mL/kg/hr for ≥24 hr or anuria for ≥12 hr (patients <18 years)	Persistent need for renal replacement therapy
Encephalopathy	CAPD <9	CAPD <9	CAPD ≥9	CAPD ≥9
Persistent RT	<3 days	3-7 days	—	>7 days
Pulmonary function	<2 L	<2 L	NIV/IMV	IMV

ALT, Alanine aminotransferase; AST, aspartate aminotransferase; GLDH, glutamate dehydrogenase; INR, international normalized ratio; KDIGO, Kidney Disease: Improving Global Outcomes score; eGFR, estimated glomerular filtration rate; CAPD, Cornell Assessment of Pediatric Delirium; RT, refractory thrombocytopenia; NIV, noninvasive ventilation; IMV, invasive mechanical ventilation.

From Mahadeo KM, Bajwa R, Abdel-Azim H, et al. Diagnosis, grading, and treatment recommendations for children, adolescents, and young adults with sinusoidal obstructive syndrome: An international expert position statement. *Lancet Haematol*. 2020;7(1):e61–e72.

by a highly immunosuppressive regimen, is frequently employed to rescue patients experiencing graft failure. High-intensity regimens are generally tolerated poorly if administered within 100 days from a first transplant because of cumulative toxicities, but this risk must be balanced with the risk of infection from prolonged neutropenia and lymphocytopenia.

### VENOOCCLUSIVE DISEASE

Hepatic venoocclusive disease (VOD), also known as sinusoidal obstruction syndrome, presents with hepatomegaly, right upper quadrant tenderness, jaundice, coagulopathy, thrombocytopenia, and weight gain from fluid retention and ascites (Table 179.3). It results from endothelial damage within the liver, which can then progress to multiorgan dysfunction. Onset is usually within 30 days of transplantation, with an incidence of approximately 15%, depending on the intensity of the conditioning protocol. Risk factors include young age, prior hepatic disease (fibrosis, cirrhosis),

abdominal radiation, repeated transplantations, neuroblastoma, osteopetrosis, and familial hemophagocytic lymphohistiocytosis. The severe form of VOD has a high mortality rate (>80%) without treatment.

Prophylaxis has traditionally used ursodeoxycholic acid and occasionally heparin; only **defibrotide** has demonstrated efficacy in treating VOD. A phase 3 study demonstrated improvement in survival and response rate to VOD in patients treated with defibrotide. Defibrotide is a combination of porcine oligodeoxyribonucleotides that reduces procoagulant activity and enhances fibrinolytic properties of endothelial cells. Defibrotide is FDA approved for the treatment of VOD in adult and pediatric patients with renal or pulmonary dysfunction after HSCT. Defibrotide is often used as prophylaxis in Europe, with data showing efficacy, but this use is not yet approved in the United States.

Visit Elsevier eBooks+ at [eBooks.Elsevier.com](https://www.elsevier.com/ebooks) for Bibliography.



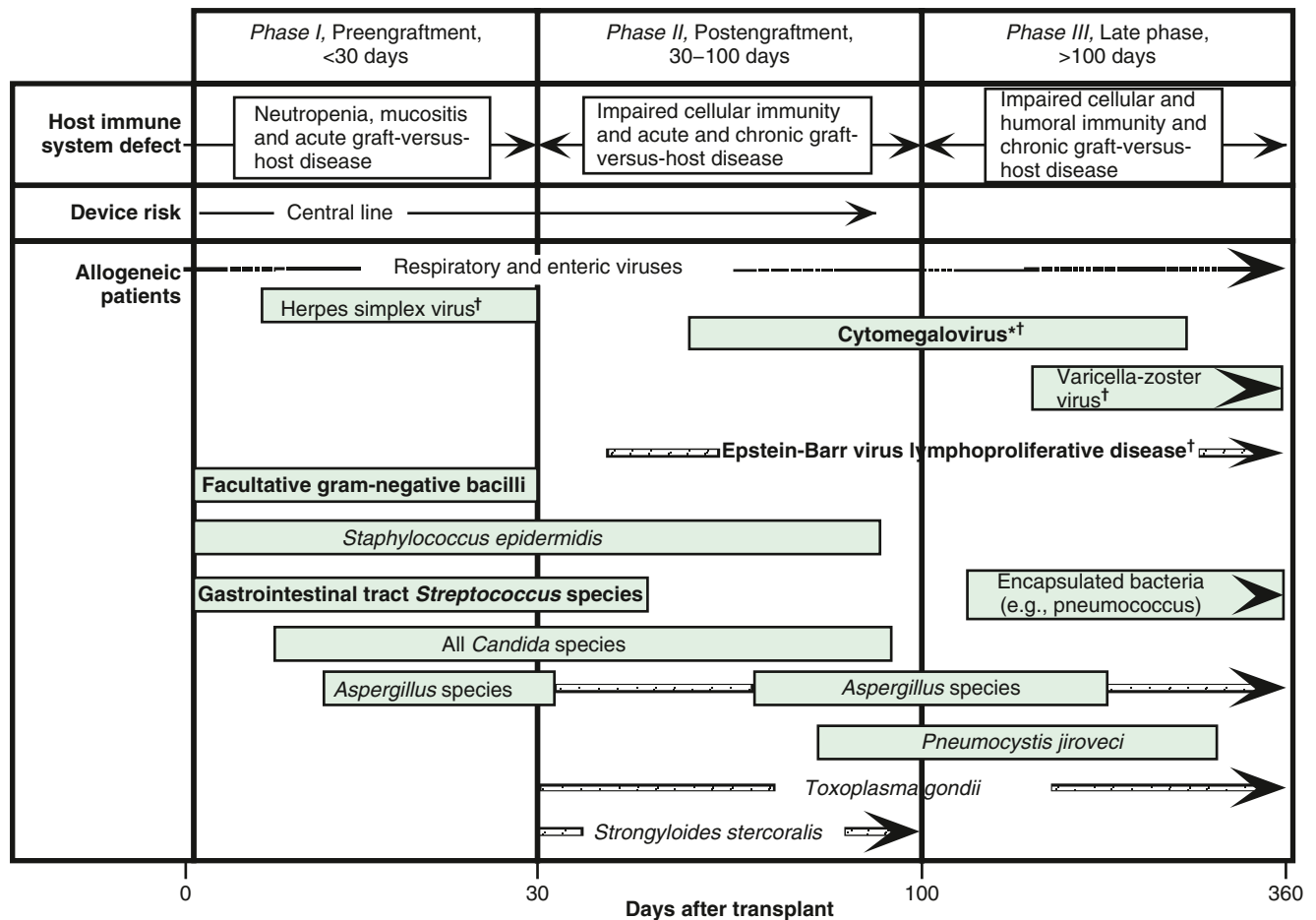
## Chapter 180

## Infectious Complications of Hematopoietic Stem Cell Transplantation

Anna R. Huppler

Hematopoietic stem cell transplantation (HSCT) recipients experience a transient but profound state of immune deficiency. The risk of infection depends on the stage after transplantation (pre- vs postengraftment), ongoing immunosuppression, disruption in barrier functions (indwelling catheters, graft-versus-host disease [GVHD]), mucositis, and preexisting infections (Fig. 180.1). Management approaches may include the use of prophylactic antimicrobials, preemptive antimicrobials for infection prior to symptomatic disease, or antimicrobial treatment of documented or suspected infection.

Immediately after transplantation, the absence or paucity of neutrophils (**neutropenia**) renders patients susceptible to bacterial and fungal infections. Consequently, consideration is given to the use of antipseudomonal and antifungal prophylaxis during the conditioning regimen. Evidence is moderate quality against systemic antibacterial prophylaxis and for systemic antifungal prophylaxis, which is reflected in published society guidelines. Even with the use of prophylactic measures, the majority of patients will develop fever and signs of infection in the early posttransplantation period. The common pathogens include enteric gram-negative bacteria and fungi. An indwelling central venous line, routinely employed in all children given HSCT, is a significant risk factor for infection. Staphylococcal species and *Candida* species are the most frequent pathogens in catheter-related infections (see Chapter 224). Multidrug-resistant strains of *Pseudomonas aeruginosa* and *Klebsiella pneumoniae* can cause infection, with prevalence highly variable among centers. Severe lower respiratory tract disease caused by seasonal respiratory viruses, such as influenza, respiratory syncytial virus (RSV), parainfluenza virus, and human metapneumovirus, can occur during the pre- or postengraftment phase. Emerging infections, such as SARS-CoV-2, can also cause severe or persistent infection in immunocompromised individuals. Published guidelines from the International Pediatric Fever and Neutropenia Guideline Panel address the management of fever and neutropenia after HSCT (Table 180.1).



\*Without standard prophylaxis

† Primarily among persons who are seropositive before transplant

□ High incidence (≥10%)

▬ Low incidence (&lt;10%)

⋯ Episodic and endemic

— Continuous risk

**Fig. 180.1** Phases of opportunistic infections among allogeneic HSCT recipients. (From Centers for Disease Control and Prevention; Infectious Disease Society of America; American Society of Blood and Marrow Transplantation. Guidelines for preventing opportunistic infections among hematopoietic stem cell transplant recipients [published correction appears in MMWR Recomm Rep. 2004 May 14;53(19):396]. MMWR Recomm Rep. 2000;49(RR-10):1–CE7.)

**Table 180.1** Overall Summary of Recommendations for Management of Fever and Neutropenia**INITIAL MANAGEMENT****Risk Stratification**

A1. Adopt a validated risk stratification strategy and incorporate it into routine clinical management (strong recommendation, low-quality evidence).

**Evaluation**

A2. Obtain blood cultures at the onset of FN from all lumens of central venous catheters (strong recommendation, low-quality evidence).

A3. Consider obtaining peripheral blood cultures concurrent with central venous catheter cultures (weak recommendation, moderate-quality evidence).

A4. Consider urinalysis and urine culture in patients in whom a clean-catch, midstream specimen is readily available (weak recommendation, low-quality evidence).

A5. Obtain chest radiography only in patients with respiratory signs or symptoms (strong recommendation, moderate-quality evidence).

**Treatment**

A6. In high-risk FN:

A6a. Use monotherapy with an antipseudomonal  $\beta$ -lactam, a fourth-generation cephalosporin, or a carbapenem as empirical therapy in pediatric high-risk FN (strong recommendation, high-quality evidence).

A6b. Reserve addition of a second gram-negative agent or a glycopeptide for patients who are clinically unstable, when a resistant infection is suspected, or for centers with a high rate of resistant pathogens (strong recommendation, moderate-quality evidence).

A7. In low-risk FN:

A7a. Consider initial or step-down outpatient management if the infrastructure is in place to ensure careful monitoring and follow-up (weak recommendation, moderate-quality evidence).

A7b. Consider oral antibiotic administration if the child is able to tolerate this route of administration reliably (weak recommendation, moderate-quality evidence).

**ONGOING MANAGEMENT****Modification of Treatment**

B1. In patients who are responding to initial empirical antibiotic therapy, discontinue double coverage for gram-negative infection or empirical glycopeptide (if initiated) after 24 to 72 hours if there is no specific microbiologic indication to continue combination therapy (strong recommendation, moderate-quality evidence).

B2. Do not modify the initial empirical antibacterial regimen based solely on persistent fever in children who are clinically stable (strong recommendation, low-quality evidence).

B3. In children with persistent fever who become clinically unstable, escalate the initial empirical antibacterial regimen to include coverage for resistant gram-negative, gram-positive, and anaerobic bacteria (strong recommendation, very low-quality evidence).

**Cessation of Treatment**

B4. In all patients, discontinue empirical antibiotics in patients who have negative blood cultures at 48 hours, who have been afebrile for at least 24 hours, and who have evidence of marrow recovery (strong recommendation, low-quality evidence).

B5. In patients with low-risk FN, consider discontinuation of empirical antibiotics at 72 hours in patients who have negative blood cultures and who have been afebrile for at least 24 hours, irrespective of marrow recovery status, as long as careful follow-up is ensured (weak recommendation, moderate-quality evidence).

**EMPIRICAL ANTIFUNGAL THERAPY****Risk Stratification**

C1. Patients at high risk of IFD are those with AML, high-risk ALL, or relapsed acute leukemia, and children undergoing allogeneic HSCT. Children with prolonged neutropenia and children receiving high-dose corticosteroids are also at high risk of IFD. All others should be categorized as IFD low risk (strong recommendation, low-quality evidence).

**Evaluation**

C2. In terms of biomarkers to guide empirical antifungal management for prolonged ( $\geq 96$  hours) FN in IFD high-risk patients:

C2a. Consider not using serum GM (weak recommendation, moderate-quality evidence).

C2b. Do not use  $\beta$ -d-glucan (strong recommendation, low-quality evidence).

C2c. Do not use fungal PCR testing in blood (strong recommendation, moderate-quality evidence).

C3. In terms of imaging for the evaluation of prolonged ( $\geq 96$  hours) FN in IFD high-risk patients:

C3a. Perform CT of the lungs (strong recommendation, low-quality evidence).

C3b. Consider imaging of abdomen in patients without localizing signs or symptoms (weak recommendation, low-quality evidence).

C3c. Consider not routinely performing CT of sinuses in patients without localizing signs or symptoms (weak recommendation, low-quality evidence).

**Table 180.1** Overall Summary of Recommendations for Management of Fever and Neutropenia—cont'd**Treatment**

C4. In IFD high-risk patients with prolonged ( $\geq 96$  hours) FN unresponsive to broad-spectrum antibacterial agents, initiate caspofungin or liposomal amphotericin B for empirical antifungal therapy (strong recommendation, high-quality evidence).

C5. In IFD low-risk patients with prolonged ( $\geq 96$  hours) FN, consider withholding empirical antifungal therapy (weak recommendation, low-quality evidence).

ALL, Acute lymphoblastic leukemia; AML, acute myeloid leukemia; FN, fever and neutropenia; GM, galactomannan; HSCT, hematopoietic stem cell transplantation; IFD, invasive fungal disease; PCR, polymerase chain reaction.

Modified from Lehnbecher T, Robinson P, Fisher B, et al. Guideline for the management of fever and neutropenia in children with cancer and hematopoietic stem-cell transplantation recipients: 2017 Update. *J Clin Oncol*. 2017;35(18):2082–2094. Table 1, p. 2084–2086.

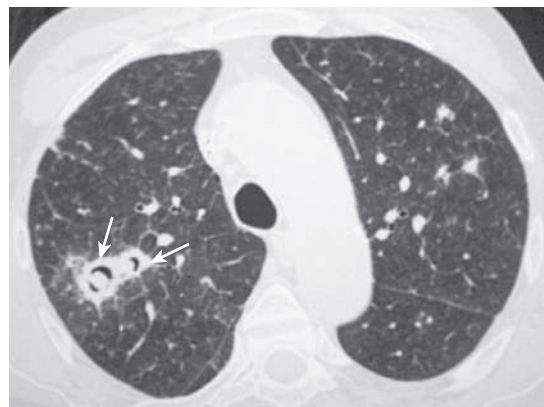
HSCT recipients remain at increased risk of developing severe infections even after the neutrophil count has normalized because of prolonged depression in T-cell number and function. The manifestations of GVHD, as well as the associated immunosuppressive therapy, are additional risk factors for fungal and viral opportunistic infections. After umbilical cord blood transplant (UCBT), infections are the consequence of both slow neutrophil engraftment and donor T-cell naïveté. In haploidentical transplantation, T-cell depletion results in an increased risk of infection in the first 4–6 months. Recipients of this type of transplantation, as well as those receiving UCBT, do not have the benefit of adoptive transfer of donor-derived, antigen-experienced T cells. For HSCT recipients after engraftment, **invasive fungal disease (IFD)**, herpesviruses, and adenovirus infections represent life-threatening complications that significantly affect outcomes. Additional pathogens to consider include nontuberculous mycobacteria, BK virus, *Clostridium difficile*, and norovirus.

**IFD** remains a significant cause of infectious morbidity and mortality in allogeneic HSCT recipients. Empirical treatment for IFD is considered for HSCT patients with persistent fever despite 96 hours of broad-spectrum antibiotic treatment. The most common organisms are *Aspergillus* and *Candida* species. Infections also occur with non-*Aspergillus* molds, including *Mucor* and *Rhizopus* species (among other agents of mucormycosis), *Fusarium*, and *Scedosporium* species. *Pneumocystis jirovecii* is a unique, noncultivable cause of fungal pneumonia in immunocompromised patients. Despite prompt and aggressive administration of potent antifungal agents, proven cases of IFD carry case fatality rates of 20–70%. IFD can present early after transplant, although there is a shift toward presentation of infection in the postengraftment period in the presence of GVHD. The risk of developing IFD is mainly influenced by history of previous fungal infection, duration of neutropenia, use of corticosteroid therapy, mucosal tissue damage (GVHD, posttransplant cytomegalovirus [CMV] infection, viral respiratory tract infections), and for candidiasis, presence of central venous catheters.

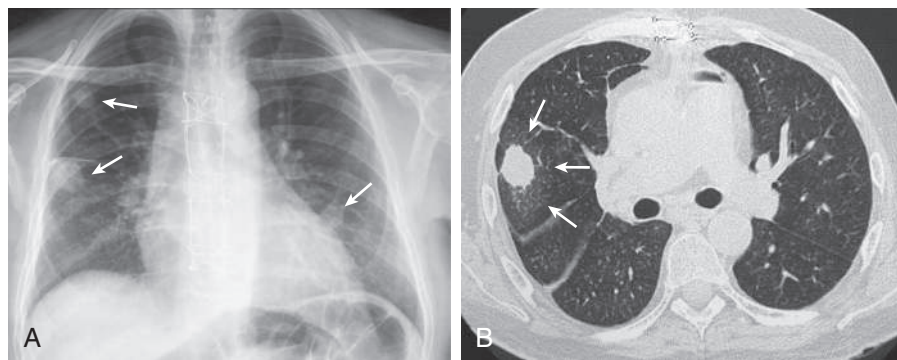
**Disseminated candidiasis** presents frequently as a central venous catheter-associated infection. However, up to 50% of patients with disseminated candidiasis do not present with positive blood cultures. Patients with and without candidemia can have infection of normally sterile organs, including liver, spleen, kidney, brain, heart, and eye. Mortality rates in pediatric series range from 10–25%. Echinocandins (micafungin,

caspofungin) are the initial drugs of choice for candidiasis in immunocompromised patients with pediatric data supporting reduced 14-day failure rates compared to initial triazole or amphotericin B therapy.

Pulmonary disease is the common presentation of invasive **aspergillosis**. The upper airway mucosa (nose and sinuses) can also be a site of initial infection. Infection progresses from lung or sinus sites by direct extension across tissue or angioinvasion resulting in hematogenous dissemination to brain and other organs. The earliest imaging finding is classically one or more small pulmonary nodules (Figs. 180.2 and 180.3). As a nodule enlarges, the dense central core of infarcted tissue may become surrounded by edema or hemorrhage, forming a hazy rim known as the *halo sign*. When bone marrow function recovers, the infarcted central core may cavitate, creating the *crescent sign*. Unfortunately, radiographic signs, including the halo sign, crescent sign, and cavitation, have low sensitivity in pediatric patients. Clinical criteria are used to diagnose proven or probable IFD, requiring direct or indirect microbiologic data. Direct, culture-based diagnosis requires invasive



**Fig. 180.3** Angioinvasive aspergillosis. CT section at the level of the lower trachea shows a consolidation with an eccentric cavitation and air crescent sign (arrows). This finding in this neutropenic patient is highly diagnostic of angioinvasive aspergillosis. (From Franquet T. *Nonneoplastic parenchymal lung disease*. In Haaga JR, Boll DT, eds. *CT and MRI of the Whole Body*, 6th ed. Philadelphia: Elsevier; 2017. Fig 36.14.)



**Fig. 180.2** Angioinvasive aspergillosis. A, Posteroanterior radiograph shows multiple nodules in the lungs (arrows). B, CT section at the level of the intermediary bronchus shows a nodule surrounded by a halo of ground-glass attenuation (arrows). (From Franquet T. *Nonneoplastic parenchymal lung disease*. In Haaga JR, Boll DT, eds. *CT and MRI of the Whole Body*, 6th ed. Philadelphia: Elsevier; 2017. Fig 36.13.)

procedures, such as sinus endoscopy or lung biopsy. Indirect measures, including *fungal biomarkers*, are used in HSCT patients to screen for or diagnose probable aspergillosis. Galactomannan from serum or bronchoalveolar lavage fluid is an adjunct to diagnostic strategies because of a high negative predictive value for aspergillosis; however, lack of detection of mucormycosis limits its utility as a single diagnostic test. Other limitations include poor positive predictive values due to false-positive test results and lack of validation in patients without neutropenia. Another widely available biomarker, (1→3)- $\beta$ -D-glucan, is insufficiently studied for routine use in pediatric patients.

Fungal infection prevention includes isolation of the patient in a laminar airflow or positive pressure room. Universal prophylaxis to prevent *Pneumocystis pneumonia* is advocated until the return of T-cell function in HSCT patients; the primary agent for prophylaxis is trimethoprim/sulfamethoxazole. Alternative agents are pentamidine, dapsone, and atovaquone. For prevention and treatment of other IFDs, liposomal amphotericin B, azole compounds (itraconazole, voriconazole, posaconazole, isavuconazole), and echinocandins (caspofungin, micafungin) are used. Voriconazole represents the treatment of choice for adult patients with invasive aspergillosis, but achieving adequate trough levels can be challenging in young children. The agents of mucormycosis are resistant to most azole and echinocandin medications, which makes liposomal amphotericin B the initial drug of choice. IFD often does not respond satisfactorily to antifungal agents alone, and infection may persist until adequate source control is achieved with surgical debridement and immune function recovers.

**Herpesviruses**, including CMV, Epstein-Barr virus (EBV), human herpesvirus 6 (HHV-6), herpes simplex virus (HSV-1 and HSV-2), and varicella-zoster virus (VZV) are pathogens that can cause significant disease after HSCT. Because herpesviruses can establish latency in the human host, symptomatic infection can occur from viral reactivation as well as acquisition from the donor or de novo infection. Baseline susceptibility to disease and viremia before symptom development can be established with laboratory monitoring (pretransplant donor-recipient serology, posttransplant viral load monitoring) and can inform decisions on prophylactic and preemptive antiviral treatment.

**CMV infection** remains the most common and potentially severe viral complication in patients receiving allogeneic HSCT. Risk factors for CMV viremia include recipient seropositivity, UCBT, and acute GVHD. The period of maximal risk for CMV disease is 1-4 months after transplantation. Late presentation of CMV disease is associated with GVHD. Until CMV-specific T-cell responses develop months after transplant, CMV infection may result in a variety of syndromes, including fever, leukopenia, thrombocytopenia, hepatitis, pneumonitis, retinitis, esophagitis, gastritis, and colitis. CMV pneumonia has been reported to occur in up to 15-20% of bone marrow transplant recipients, with a case fatality rate of 85% in the absence of early treatment. Tachypnea, hypoxia, and nonproductive cough signal respiratory involvement. Chest radiography often reveals bilateral interstitial or reticulonodular infiltrates, which begin in the periphery of the lower lobes and spread centrally and superiorly. Gastrointestinal CMV involvement may lead to ulcers of the esophagus, stomach, small intestine, and colon with complications of bleeding or perforation. Fatal CMV infections are often associated with persistent viremia and multiorgan involvement.

CMV disease has largely been prevented through prophylaxis or preemptive approaches. Prophylaxis is based on administration of antiviral drugs to at-risk transplanted patients for a median duration of 3 months after transplantation. The major drawbacks of this approach are drug toxicity, late CMV disease after withdrawal of prophylaxis, potential unnecessary treatment of patients who would not have reactivated CMV infection, and low cost-effectiveness. Preemptive therapy aims at treating only patients who experience CMV reactivation and thus are at risk of developing overt disease; it starts on detection of CMV in blood but before symptom development. The major drawback of this strategy is the need of serial monitoring of CMV by polymerase chain reaction (PCR) in blood. First-line therapy is usually ganciclovir, with foscarnet as an alternative for resistant strains or ganciclovir intolerance.

**EBV-related posttransplant lymphoproliferative disease (PTLD)** is a major complication in HSCT and solid-organ transplantation. In patients receiving HSCT, selective procedures of T-cell depletion-sparing B lymphocytes and use of HLA-partially matched family and unrelated donors are risk factors for the development of PTLD. PTLD usually presents in the first 4-6 months after transplantation as high-grade, diffuse, large-cell B-cell lymphomas that are oligoclonal or monoclonal. High EBV viral loads in blood by PCR predict development of PTLD. Standard treatment of PTLD includes the reduction of immunosuppression, monoclonal antibodies directed against CD20 on B cells (rituximab), or cytotoxic chemotherapy. Prophylactic strategies with rituximab for EBV-positive recipients during conditioning for HSCT have also been employed. Histologic diagnosis of PTLD is required to assess for the emergence of neoplasms in which cells are CD19<sup>+</sup> but CD20<sup>-</sup>, thus eliminating susceptibility to rituximab.

**Disseminated adenovirus infection** is a life-threatening complication of HSCT recipients. Clinical manifestations include fever, hepatitis, enteritis, meningoencephalitis, and pneumonia. Young children or recipients of donor cells naïve to adenovirus (T-cell-depleted grafts or UCBT) are at particular risk of developing this complication. Diagnosis is based on the demonstration of high viral loads by PCR in blood or recovery of virus in tissue biopsies. Pharmacologic treatment of adenovirus infections is with the antiviral **cidofovir**, which has significant renal toxicity and limited potency at controlling viral replication. The enterally available prodrug brincidofovir showed initial promise in allogeneic pediatric HSCT recipients with refractory adenovirus infection but is not available clinically for this indication. Recovery of immune system function is associated with improved survival with disseminated adenovirus infection.

In immunocompromised hosts, severe viral infections, including PTLD and adenovirus infection, originate from a deficiency of virus-specific **cytotoxic T lymphocytes** (CTLs). This finding provides the rationale for developing strategies of adoptive cell therapy to restore virus-specific immune competence. Multiple protocols are in clinical trials and available at some centers for the rapid generation of specific CTL lines of donor or third-party origin.

Visit Elsevier eBooks+ at [eBooks.Health.Elsevier.com](http://eBooks.Health.Elsevier.com) for Bibliography.



## Chapter 181

# Late Effects of Hematopoietic Stem Cell Transplantation

Rachel A. Phelan and David Margolis

Pediatric hematopoietic stem cell transplantation (HSCT) is considered standard-of-care treatment for several malignant and nonmalignant conditions. Treatment generally involves exposure to chemotherapy and occasionally radiation to encourage engraftment of donor stem cells and prevent donor and recipient rejection. The period immediately after transplant is associated with the risk for a number of serious acute complications, including profound immunosuppression and subsequent risk for infection, graft-versus-host disease (GVHD), and organ toxicities (see Chapters 179 and 180). Fortunately, significant progress has been made in supportive care strategies to reduce the risk of acute complications and treat them more effectively if they do arise. This has resulted in a growing number of pediatric patients who are now long-term survivors following HSCT. The estimated total number of HSCT survivors in 2009 was 108,900, and this is expected to increase 5 times by 2030 to over 500,000. Of these survivors, approximately 14% (64,000) in 2030 will have received a transplant in childhood (<18 years of age).

Exposure to chemotherapy, radiation, or a combination of both, places patients at similar long-term risks as the pediatric cancer population; the high doses and types of chemotherapy and radiation often amplify the risk for issues such as ovarian failure/infertility and neurocognitive difficulties. Total body irradiation (TBI) has been shown to increase dramatically the risk for late complications after transplant. In addition, late effects may be additive if the patient received therapy before HSCT for their underlying malignancy. Moreover, the indication for transplant in pediatric patients is not always related to malignancy, but rather an underlying immunodeficiency, bone marrow failure syndrome, or metabolic disorder. These patients are potentially at risk for late effects related to this underlying disease and require different types of monitoring.

Essentially, every organ system can be impacted by the long-term effects of therapy, and each must be considered when undergoing late effects surveillance (Table 181.1). As a result of growing evidence of the importance of lifelong care for HSCT survivors, multiple groups have published consensus guidelines to help in caring for this patient population. As the field of survivorship continues to expand, *we recommend the following reference for real-time evidence-based recommendations from the Children's Oncology Group* (see <http://survivorshipguidelines.org>).

## ENDOCRINE EFFECTS

Children given HSCT before puberty may develop **growth impairment**, precluding achievement of the genetic target for adult height. The decrease in growth velocity is similar for boys and girls and is more frequently observed in patients given TBI as part of the preparative regimen. Chronic GVHD and its treatment with corticosteroids may also contribute to growth impairment.

Growth impairment of patients given TBI is mainly a result of direct damage of cartilage plates and to the effect of TBI on the hypothalamic-pituitary axis, which leads to an inappropriately low production of growth hormone (GH). GH deficiency is susceptible to at least partial correction through administration of hormonal replacement therapy. Annual growth evaluation should be performed in all children after HSCT. Children showing a decreased growth velocity should be further investigated through evaluation of bone age and secretion of GH in response to pharmacologic stimulus.

The use of TBI during the preparative regimen involves the thyroid gland in the irradiation field and may result in **hypothyroidism**. Younger children are at greater risk of developing hypothyroidism.

Chemotherapy-only preparative regimens have far fewer adverse effects on normal thyroid function. The site of injury by irradiation is at the level of the thyroid gland rather than at the pituitary or hypothalamus. Therapy with thyroxine is very effective for overt hypothyroidism. The cumulative incidence of hypothyroidism increases over time, underscoring the importance of annual thyroid function studies.

Gonadal hormones are essential for normal pubertal growth, as well as for development of secondary sexual characteristics. A significant proportion of patients receiving TBI-containing preparative regimens as well as high doses of alkylating agents show delayed development of secondary sexual characteristics, resulting from primary ovarian or testicular failure. Laboratory evaluation of these patients reveals elevated follicle-stimulating hormone and luteinizing hormone levels with depressed estradiol and testosterone serum levels. These patients benefit from careful follow-up with evaluation of annual sexual maturity rating (Tanner) scores and endocrine function. Supplementation of gonadal hormones is useful for primary gonadal failure and is administered with GH to promote pubertal growth. **Infertility** during adulthood remains a significant risk for these patients, especially those undergoing traditional myeloablative conditioning for HSCT. The use of reduced-intensity regimens may result in sparing fertility in a large proportion of patients, although conditioning regimens vary and studies are limited.

**Bone health** of HSCT survivors can also be impacted by hormonal changes as well as lifestyle practices, such as inadequate exercise and/or dietary intake of vitamin D. Prior exposures, including corticosteroid use, can result in changes to bone density as well as predispose to the development of avascular necrosis. Dual-energy x-ray absorptiometry (DXA) scans are routinely incorporated into the care of those patients at risk for low bone mineral density.

## CARDIOVASCULAR EFFECTS

Survivors of childhood HSCT are at risk for the future development of cardiovascular complications. This population can be prone to developing **metabolic syndrome** (dyslipidemia, hypertension, diabetes mellitus, obesity), especially those with a history of TBI exposure and subsequent hormonal derangements. Prior exposures such as anthracycline chemotherapy and chest radiation further increase the risk for **cardiomyopathy** as well as **atherosclerosis**. As a result, routine anthropometric, imaging, and laboratory screening should be performed in survivors of childhood HSCT to assess and monitor their cardiovascular health.

## SECONDARY MALIGNANCY

The overall risk of developing a secondary form of cancer is significantly higher after HSCT than in the general population. Although few studies have specifically analyzed pediatric patients, available evidence indicates that the cumulative incidence of second malignancies shows a slight, but continuous, tendency to increase over time. The development of myelodysplastic syndrome as well as secondary leukemias must be considered in survivors of HSCT. Several other types of secondary tumors have been identified in patients given HSCT. The most frequently diagnosed neoplasms are thyroid carcinoma, brain tumors, and epithelial cancers. Young age, male gender, use of TBI during the preparative regimen, chronic GVHD, and an intrinsic genetic predisposition to develop cancer (Fanconi anemia) have been reported to be risk factors for development of secondary malignancies after HSCT. Routine physical exams, including yearly skin exams, in those that received TBI are important in the care of these patients.

## GRAFT-VERSUS-HOST DISEASE

In the posttransplant period, multiple studies have shown that quality of life is severely impacted by the presence of GVHD, which is an issue that is also unique to HSCT (see Chapter 179).

## OTHER EFFECTS

HSCT patients can also experience complications related to their pulmonary function, renal function, dental health, and gastrointestinal system, often related to prior exposures as well as their conditioning regimen. It is also important to note that long-term survivors must be monitored for psychologic issues because of their prior and current underlying health conditions. They may need extra assistance

**Table 181.1** Summary of Late Effects After Hematopoietic Stem Cell Transplantation in Childhood

EXPOSURE	LATE EFFECT*	EXPOSURE	LATE EFFECT*
HSCT experience in general	Dental abnormalities Renal toxicity Hepatic toxicity Low BMD Avascular necrosis Increased risk of second cancers Adverse psychosocial/quality-of-life effects Mental health disorders, risk behaviors Psychosocial disability caused by pain or fatigue	Bleomycin	Pulmonary toxicity
		Cytarabine	Neurocognitive deficits Leukoencephalopathy
		Methotrexate	Neurocognitive deficits Leukoencephalopathy Renal toxicity Low BMD
		Corticosteroid	Cataract Low BMD Avascular necrosis
<b>TRANSPLANTATION CONDITIONING</b>		Cranial radiation <sup>§</sup>	Neurocognitive deficits Leukoencephalopathy Cerebrovascular disease Cataract Craniofacial abnormalities Dental abnormalities, xerostomia GH deficiency Hypothyroidism thyroid nodule Increased obesity Precocious puberty Brain tumor
Alkylating agent	Cataract (busulfan) Pulmonary fibrosis (busulfan) Renal toxicity Urinary tract toxicity Gonadal dysfunction Therapy-related AML/MDS Bladder cancer	Spinal radiation (in addition to cranial dose)	Cardiac toxicity Scoliosis/kyphosis, musculoskeletal problems
Epipodophyllotoxin <sup>†</sup> DNA intersecting and cross linking agents (i.e., platinum, heavy metal)	Therapy-related AML/MDS Ototoxicity Renal toxicity Gonadal toxicity	<b>AFTER TRANSPLANTATION (NOT LISTED ABOVE)</b>	
TBI <sup>‡</sup>	Neurocognitive deficits Leukoencephalopathy Cataract Dental abnormalities GH deficiency Hypothyroidism, thyroid nodule Pulmonary toxicity Breast tissue hypoplasia Cardiac toxicity Renal toxicity Gonadal dysfunction Uterine vascular insufficiency Diabetes Dyslipidemia Musculoskeletal growth problems Second cancers	Chronic GVHD	Xerophthalmia Xerostomia, dental abnormalities Pulmonary toxicity Gastrointestinal strictures Genitourinary strictures Skin and joint changes Immunodeficiency Second cancers, especially skin, oral, cervical, lymphoma
<b>PRETRANSPLANTATION EXPOSURES (NOT LISTED ABOVE)</b>		Tyrosine kinase inhibitor	Acute cardiac toxicity reported, but not known to cause late cardiotoxicity
Anthracycline/anthraquinone	Cardiac toxicity Therapy-related AML/MDS	<b>OTHER EXPOSURES</b>	
		Blood transfusions	Hepatitis C, HIV

\*Focused on those late effects that can develop or persist even after cessation of therapy.

<sup>†</sup>Includes etoposide, teniposide.

<sup>‡</sup>At given total dose, risks greater for single-fraction vs fractionated total body irradiation (TBI); single-fraction myeloablative TBI (>500 cGy) now rarely used.

<sup>§</sup>Effects listed are those more likely to be associated with doses used in HSCT survivors (e.g., those given for leukemia treatment, <25 Gy); late effects are more likely if TBI also given. AML/MDS, Acute myeloid leukemia/myelodysplastic syndrome; BMD, bone mineral density; GH, growth hormone; GVHD, graft-versus-host disease; HSCT, hematopoietic stem cell transplantation.

From Chow EJ, Anderson L, Baker KS, et al. Late Effects Surveillance Recommendations among Survivors of Childhood Hematopoietic Cell Transplantation: A Children's Oncology Group Report. *Biol Blood Marrow Transplant*. 2016;22(5):782–795.

with school and vocational attainment. These patients are also often at higher risk for depression and anxiety; yearly psychosocial assessments can identify survivors who need additional therapy or psychotropic medication. Parents may also have posttraumatic stress from the experience.

### SPECIAL CONSIDERATIONS

Certain patient populations who undergo HSCT are at increased risk for late effects. Young children appear to be at a heightened risk for

late complications related to TBI, especially those related to growth, thyroid function, and neurocognition. Patients with an *underlying genetic condition* must also be monitored more closely for specific consequences of therapy, such as specific secondary malignancies in the Fanconi anemia population caused by an underlying DNA repair defect and patients with sickle cell anemia and thalassemia who are predisposed to iron overload.

Visit Elsevier eBooks+ at [eBooks.Health.Elsevier.com](http://eBooks.Health.Elsevier.com) for Bibliography.

## Chapter 182

# Allergy and the Immunologic Basis of Atopic Disease

Cezmi A. Akdis and Scott H. Sicherer

Allergic or atopic patients have an altered state of reactivity to common environmental and food antigens that do not cause clinical reactions in unaffected people. Patients with clinical allergy usually produce immunoglobulin E (IgE) antibodies to the antigens that trigger their illness. The term *allergy* represents the clinical expression of IgE-mediated allergic diseases that have a familial predisposition and that manifest as hyperresponsiveness in target organs such as the lung, skin, gastrointestinal (GI) tract, and nose. The significant increase in the prevalence of allergic diseases in the last few decades is attributed to changes in environmental factors such as exposure to tobacco smoke, air pollution, indoor and outdoor allergens, respiratory viruses, obesity, and perhaps a decline in certain infectious diseases (hygiene hypothesis).

The incidence of allergic asthma and atopic dermatitis started to grow to epidemic proportions after the 1960s. Since 2000, the prevalence of food allergy, eosinophilic esophagitis, and drug-induced anaphylaxis has also risen to epidemic proportions. Currently more than 1 billion patients worldwide are expected to have at least one kind of allergic disease. The hygiene hypothesis, biodiversity hypothesis and epithelial barrier hypothesis are the three main hypotheses that propose mechanisms for the development of allergic diseases.

### HYGIENE HYPOTHESIS

The relatively recent onset of the epidemics of allergic, autoimmune, and metabolic conditions leads to the question of what might underlie their development. A prominent hypothesis is the hygiene hypothesis, which proposes that certain microorganisms or infections protect against inflammatory diseases, and that their loss, due to hygiene measures, results in an increase in allergy, asthma, and autoimmunity. Growing up on a traditional farm has a protective effect from asthma and allergies, which provides a prominent example of the hygiene hypothesis. Children in Amish communities in the United States, where traditional dairy farming is practiced, are highly protected from asthma and allergies. In contrast, Hutterite communities have a significantly higher prevalence of asthma and allergies in children. Interestingly, they practice industrialized farming with extensive cleaning measures. Early development of a **T-helper type 1 (Th1)** response together with **T-regulatory cell (Treg)** response were proposed to play a role in prevention of allergic diseases.

### BIODIVERSITY HYPOTHESIS

Allergic diseases are associated with a microbiome with increased colonization of opportunistic pathogens. The biodiversity hypothesis states that the observed increase in allergies is due to a loss of symbiotic relationships with bacteria and dysbiosis caused by changes in the microbiome of the gut, skin, and respiratory system. Healthy microbiota on the surface of the mucosal barrier regulates many aspects of epithelial barrier homeostasis, such as the modulation of barrier permeability and expression of epithelial barrier molecules, angiogenesis, vascular permeability, local microinflammation, and mucosal tolerance. Young children at risk of developing

allergies have been shown to suffer from gut microbiome dysbiosis with an overall reduced microbiome diversity. The dysbiotic microbiota has been characterized by an underrepresentation of certain bacterial taxa that may produce immune regulatory and epithelial barrier healing or protective factors, such as short-chain fatty acids, retinoic acid, and vitamin D.

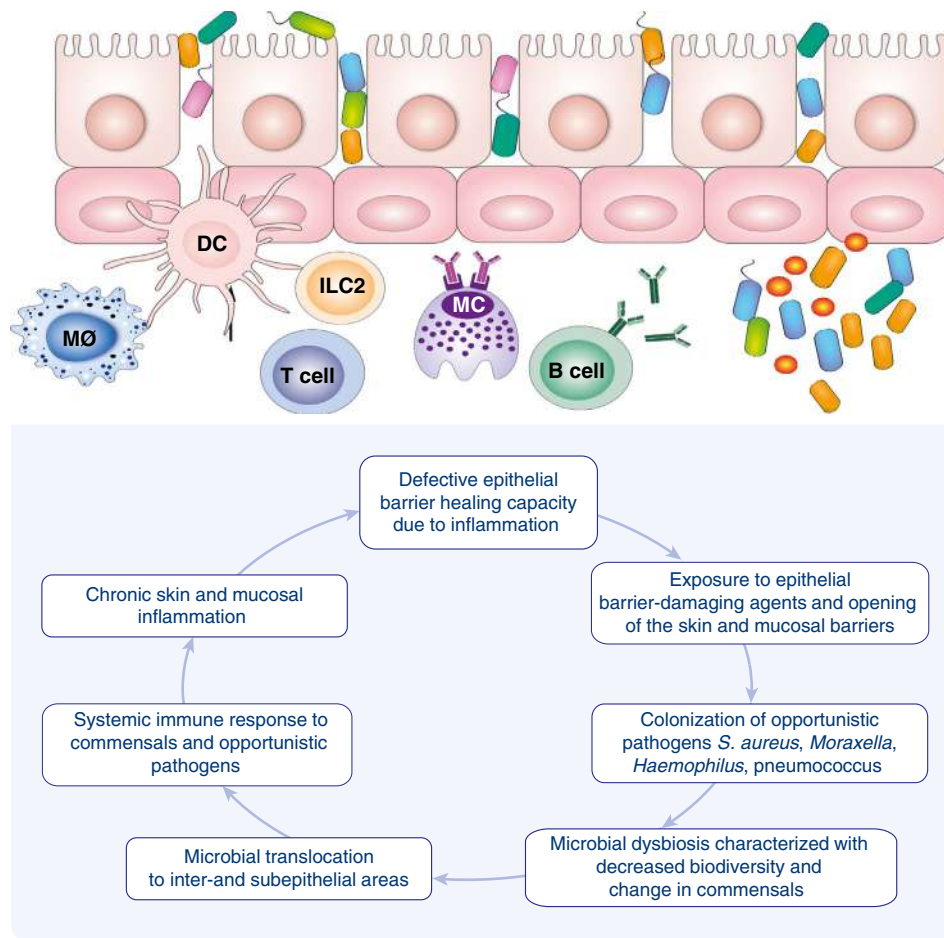
Several shortcomings of the hygiene and biodiversity hypotheses include the fact that water sanitation was established in many western cities in the 1920s, but allergy and asthma epidemics only started in the 1960s. The protective role of parasitic infections that increase biodiversity has been questioned for the same reason. Many parasitic infections started to decrease in 1910 in New York, whereas allergies started to increase after the 1960s. Allergic asthma is still on the rise in some cities in Asia and Africa, which have low standards of hygiene. Another limitation of the hygiene hypothesis and biodiversity hypothesis is that probiotics are not viable alternatives for the prevention or treatment of allergies. Moreover, studies of migrants who move from developing countries to affluent regions demonstrate a rapid increase in asthma and allergic diseases. It appears that domestic living conditions, increased birth by cesarean section, antibiotic usage, dietary practices, urbanization, and indoor air pollution are more prominent factors compared with general public hygiene.

### EPITHELIAL BARRIER HYPOTHESIS

The epithelial barrier hypothesis is a broader hypothesis that covers hygiene and biodiversity hypotheses and adds further insights in the pathogenesis and recent development of allergic diseases. The defective epithelial barrier concept also applies to many autoimmune and metabolic diseases showing increased prevalence during the last few decades, such as diabetes, rheumatoid arthritis, multiple sclerosis, liver steatosis, and obesity. There is epidemiologic evidence from humans and disease models in laboratory animals that demonstrate that even trace amounts of certain toxic substances can damage epithelial barriers, initiate inflammation of the epithelium, and increase microbial dysbiosis and bacterial translocation toward the inside and beneath the epithelium. The epithelial barrier consists of four main components: the epithelial microbiota; the epithelial cell; structural proteins, such as filaggrin, loricrin, and involucrin and tight junctions and adherence junctions; and secreted epithelial products, such as mucus, antimicrobial peptides and fatty acids. Humans are exposed daily to a variety of toxins and chemicals, and substantial data demonstrate disruption of the epithelial barrier by allergens, certain bacteria and their toxins, fungi, viruses, laundry and dishwasher detergents, household cleaners, surfactants, enzymes and emulsifiers used in the food industry, cigarette smoke, particulate matter, diesel exhaust, ozone, nanoparticles, and microplastics.

Epithelial cell activation and release of epithelial cell cytokines, such as interleukin (IL)-25, IL-33, and thymic stromal lymphopoietin (TSLP) play a major role in the development and exacerbation of allergic diseases. Local tissue inflammation opens epithelial barriers. Open epithelial barriers in the mucosa allow the entrance of foreign substances, including allergens, into deeper tissues. Both **Th1** and **T-helper type 2 (Th2)** inflammation affect the skin and mucosal epithelial barriers. Th2 cells and group 2 innate lymphoid cells (ILCs-2) play major roles utilizing IL-13 as major cytokines in the opening of the tight junction barrier.

Microbial dysbiosis caused by transepithelial translocation of commensal microbes, colonization by opportunistic pathogens, and decreased biodiversity are hallmarks of barrier damaged tissues. Colonization by opportunistic pathogens in the microbiota takes place in tissues with a defective epithelial barrier. A dysregulated subepithelial immune response, local inflammation, and incorrect regeneration and remodeling take place as the continuum and chronicity of the local inflammation. Migration of inflamed cells to other affected tissues and systemic low-level immune activation and microinflammation are additional players in the development and exacerbation of many chronic inflammatory diseases (Fig. 182.1).



**Fig. 182.1** The physiopathology of the epithelial barrier hypothesis. Genetic defects in barrier-related molecules or exposure to epithelial barrier-damaging agents cause an opening of the skin and mucosal tight junction barriers. This is followed by translocation of microbiota to inter- and subepithelial areas and colonization of opportunistic pathogens, such as *Staphylococcus aureus*, *Moraxella*, *Haemophilus* and pneumococcus. An immune response develops toward commensals and opportunistic pathogens in the gut and respiratory system and systemic inflammation takes place. In most cases of allergic diseases, a systemic type 2 inflammation predominates, and is directed against allergens, but also commensals and opportunistic pathogens. Anti-*S. aureus* antibodies show a very high prevalence in asthma, chronic sinusitis, and atopic dermatitis. This is associated with microbial dysbiosis and decreased biodiversity of commensals. Chronic inflammation in the subepithelial area develops as the main pathogenetic feature of these diseases. Defective epithelial barrier healing capacity due to inflammation and epigenetic changes take place, developing a vicious circle of leaky barriers, microbial dysbiosis, and chronic inflammation. DC, Dendritic cell; IL, interleukin; ILC, innate lymphoid cells; MC, mast cell; MØ, macrophage.

## KEY ELEMENTS OF ALLERGIC DISEASES

### Allergens

Allergens are almost always *proteins*, but not all proteins are allergens. For a protein antigen to display allergenic activity, it must induce IgE production, which must lead to a type 1 hypersensitivity response on subsequent exposure to the same protein. Biochemical properties of the allergen; stimulating factors of the innate immune response around the allergen substances at the time of exposure; stability of the allergen in the tissues, digestive system, skin, or mucosa; and the dose and time of stay in lymphatic organs during the interaction with the immune system are factors that may cause an antigen to become an allergen. This is distinguished from general antigen responses, which induce a state of immune responsiveness without associated IgE production.

Most allergens are proteins with a molecular weight of 10-70 kDa. Molecules <10 kDa do not bridge adjacent IgE antibody molecules on the surfaces of mast cells or basophils. Most molecules >70 kDa do not pass through mucosal surfaces, a feature needed to reach **antigen-presenting cells (APCs)** for stimulation of the immune system. Allergens frequently contain **proteases**, which promote skin and mucosal epithelial barrier dysfunction and increase allergen penetration into host tissues. A relatively high dose of exposure and stability of the allergenic protein in body fluids to reach the immune cells are important determinants of an allergen. Low molecular weight moieties, such as drugs, can become allergens by reacting with serum proteins or cell membrane proteins to be recognized by the immune system. Carbohydrate structures can also

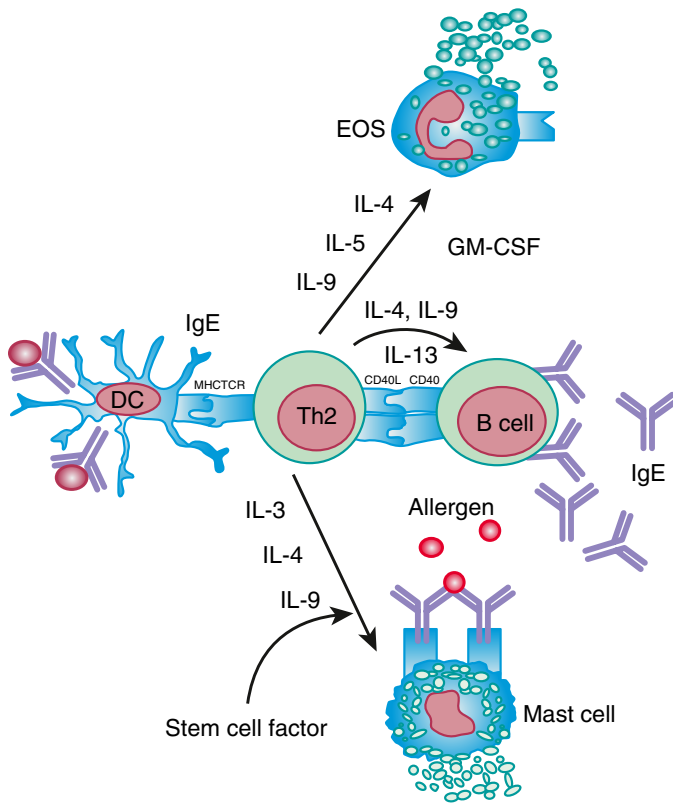
be allergens and are most relevant with the increasing use of *biologics* in clinical practice; patients with cetuximab-induced anaphylaxis have IgE antibodies specific for galactose- $\alpha$ -1,3-galactose.

### T Cells

Everyone is exposed to potential allergens. Atopic individuals respond to allergen exposure with rapid expansion of **Th2** cells that secrete cytokines, such as IL-4, IL-5, and IL-13, favoring IgE synthesis and eosinophilia. Allergen-specific IgE antibodies associated with atopic response are detectable by serum testing or positive immediate reactions to allergen extracts on skin-prick testing. The Th2 cytokines IL-4 and IL-13 play a key role in immunoglobulin isotype switching to IgE (Fig. 182.2). IL-5 and IL-9 are important in the differentiation and development of eosinophils. The combination of IL-3, IL-4, and IL-9 contributes to mast cell activation. T-cell and eosinophil migration to allergic inflammation areas are controlled by IL-4 and IL-13 upregulating their adhesion to endothelial cell walls. IL-9 is responsible for mucus production. Th2 cytokines are important effector molecules in the pathogenesis of asthma and allergic diseases; acute allergic reactions are characterized by infiltration of Th2 cells into affected tissues. In addition, IL-25, IL-33, and **TSLP** secreted from epithelial cells on exposure to allergens and respiratory viruses contribute to Th2 response and eosinophilia.

A fraction of the immune response to allergens results in activation and proliferation of **Th1** cells. Th1 cells are typically involved in the eradication of intracellular organisms, such as mycobacteria, because



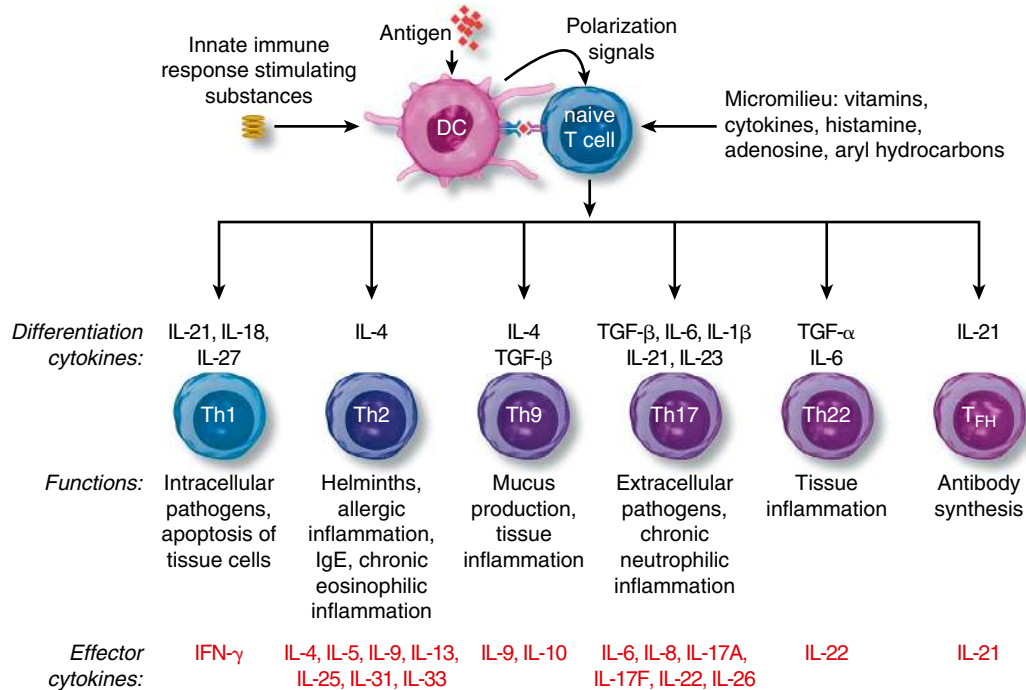


**Fig. 182.2** Role of Th2 cytokines in allergic cascade. DC, Dendritic cell; EOS, eosinophil; GM-CSF, granulocyte-macrophage colony-stimulating factor; IL, interleukin.

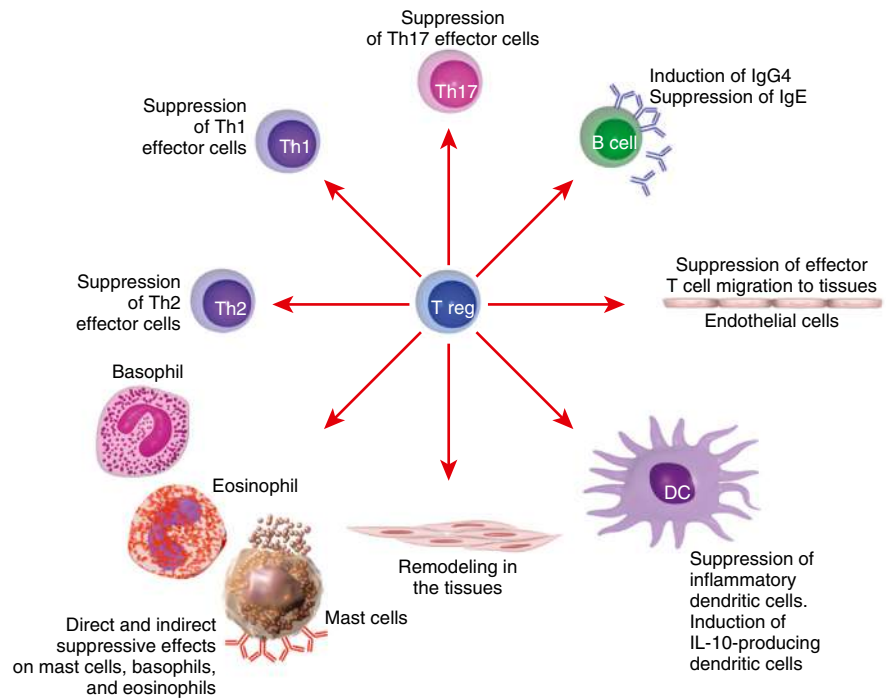
of the ability of Th1 cytokines to activate phagocytes and promote the production of opsonizing and complement-fixing antibodies. The Th1 component of allergen-specific immune response contributes to chronicity and the effector phase in allergic disease. Activation and apoptosis of epithelial cells induced by Th1 cell-secreted interferon- $\gamma$  (IFN- $\gamma$ ), tumor necrosis factor (TNF)- $\alpha$ , and Fas-ligand constitute an essential pathogenetic event for the formation of eczematous lesions in atopic dermatitis and bronchial epithelial cell shedding in asthma.

Chronic lesions of allergic reactions are characterized by infiltration of Th1 and Th17 cells. This is important because Th1 cytokines such as IFN- $\gamma$  can potentiate the function of allergic inflammatory effector cells such as eosinophils, thereby contributing to disease severity. Th17 and Th22 cells link the immune response to tissue inflammation; IL-17A and IL-17F and IL-22 are their respective prototype cytokines. Although both T-helper cell subsets play roles in immune defense to extracellular bacteria, IL-17 augments inflammation, whereas IL-22 plays a tissue-protective role. Cytokines in the IL-17 family act on multiple cell types, including epithelial cells and APCs, to cause the release of chemokines, antimicrobial peptides, and proinflammatory cytokines to enhance inflammation and antimicrobial responses. In addition, Th9 cells produce IL-9, but not other typical Th1, Th2, and Th17 cytokines, and constitute a distinct population of effector T cells that promotes tissue inflammation. Figure 182.3 depicts the complex cytokine cascades involving Th1, Th2, Th9, Th17, and Th22 cells.

Tregs are a subset of T cells thought to play a critical role in expression of allergic and autoimmune diseases. These cells have the ability to suppress effector T cells of Th1, Th2, Th9, Th17, and Th22 phenotypes (Fig. 182.4). Tregs express CD4<sup>+</sup>CD25<sup>+</sup> surface molecules and immunosuppressive cytokines such as IL-10, IL-35, and transforming growth factor- $\beta$  (TGF- $\beta$ <sub>1</sub>). The forkhead box/winged-helix transcription factor gene *FOXP3* is expressed specifically by CD4<sup>+</sup>CD25<sup>+</sup> Tregs and programs their development and function. Adoptive transfer of Tregs inhibits the development of airway eosinophilia and protects against airway hyperreactivity in animal models of asthma. T-cell response to allergens in healthy individuals shows a wide range, from no detectable response to involvement of active peripheral tolerance mechanisms mediated by different subsets of Tregs. Individuals who are not allergic even though they are exposed to high doses of allergens, such as beekeepers and cat



**Fig. 182.3** Effector T-cell subsets. Following antigen presentation by dendritic cells (DCs), naive T cells differentiate into Th1, Th2, Th9, Th17, Th22, and follicular helper (TFH) effector subsets. Their differentiation requires cytokines and other cofactors that are released from DCs and also expressed in the micromilieu. T-cell activation in the presence of interleukin-4 (IL-4) enhances differentiation and clonal expansion of Th2 cells, perpetuating the allergic response. IFN- $\gamma$ , Interferon- $\gamma$ ; TGF- $\beta$ , transforming growth factor- $\beta$ . (From Akdis M, Palomares O, van de Veen W, et al. TH17 and TH22 cells: A confusion of antimicrobial response with tissue inflammation versus protection. *J Allergy Clin Immunol*. 2012;129:1438–1449.)



**Fig. 182.4** Control of allergen-specific immune responses. FoxP3<sup>+</sup>, CD4<sup>+</sup>, CD25<sup>+</sup>, and Tr1 cells contribute to the control of allergen-specific immune responses in several major ways: suppression of dendritic cells (DCs) that support the generation of effector T cells; suppression of Th1, Th2, and Th17 cells; suppression of allergen-specific IgE, and induction of IgG<sub>4</sub> and/or IgA; suppression of mast cells, basophils, and eosinophils; interaction with resident tissue cells and remodeling; and suppression of effector T-cell migration to tissues. IL, Interleukin. (From Akdis CA, Akdis M. *Mechanisms and treatment of allergic disease in the big picture of regulatory T cells.* *J Allergy Clin Immunol.* 2009;123:735–746.)

owners, show a detectable allergen-specific IgG<sub>4</sub> response accompanied by IL-10–producing Tregs. It is thought that CD4<sup>+</sup>CD25<sup>+</sup> Tregs play an important role in mitigating the allergic immune response, and that the lack of such cells may predispose to the development of allergic diseases. Patients with pathogenic variants in the human *FOXP3* gene lack CD4<sup>+</sup>CD25<sup>+</sup> Tregs and develop severe immune dysregulation, with polyendocrinopathy, food allergy, and high serum IgE levels (XLAAD/IPEX disease) (see [Chapter 165.4](#)). In addition to Treg cells, IL-10–secreting and allergen-specific Breg cells increase during allergen-specific immunotherapy and may play a role in allergen tolerance.

### Innate Lymphoid Cells

Immune responses in populations of lymphoid cells that lack rearranged T- and B-cell antigen receptors and surface markers for myeloid and lymphoid lineages, such as T, B, and natural killer (NK) cells, show similarities to Th1, Th2, and Th17/Th22 types of immune responses. These latter cells are defined as **ILC1s**, **ILC2s**, and **ILC3s**, respectively, based on their transcription factors and cytokine production patterns. ILC1s mainly produce IFN- $\gamma$ ; ILC2s produce IL-5, IL-9, and IL-13; and ILC3s produce IL-17 and IL-22 without any need of antigen/allergen exposure. Strong evidence indicates that ILCs play substantial roles in protection against infection and the pathogenesis of inflammatory diseases, such as asthma, allergic diseases, and autoimmune diseases. ILCs control the mucosal environment through close interaction with epithelial cells and other tissue cells, cytokine production, and induction of chemokines that recruit suitable cell populations to initiate and promote distinct types of immune response development and tissue inflammation. ILC2s are likely involved in the induction of asthma, allergic rhinitis, eosinophilic esophagitis, and atopic dermatitis through activation by epithelium-derived cytokines (e.g., IL-33, IL-25, TSLP) and interaction with other immune cells. IL-10–secreting ILCs with an immune regulatory function have been reported. These cells develop from ILC2s and play suppressive roles in allergic inflammation, particularly through IL-10.

### Antigen-Presenting Cells

Dendritic cells (DCs), Langerhans cells, monocytes, and macrophages have the ability to present allergens to T cells, thereby modulating allergic inflammation by controlling the type of T-cell development. APCs are a heterogeneous group of cells that share the property of antigen presentation in the context of the major histocompatibility complex (MHC) and are found primarily in lymphoid organs and the skin. DCs and Langerhans cells are unique in their ability to prime naïve T cells

and are responsible for the primary immune response, or the **sensitization phase** of allergy. Monocytes and macrophages are thought to contribute to activating memory T-cell responses on reexposure to allergen, which characterizes the **elicitation phase** of allergy.

Peripheral DCs residing in sites such as the skin, intestinal lamina propria, and lung are relatively immature. These immature DCs take up antigens in tissues and then migrate to the T-cell areas in locally draining lymph nodes. The DCs undergo phenotypic and functional changes during migration, characterized by increased expression of MHC class I, MHC class II, and co-stimulatory molecules that react with CD28 expressed on T cells. In the lymph nodes, they directly present processed antigens to resting T cells to induce their proliferation and differentiation.

Mature DCs have been designated as **myeloid** or **plasmacytoid** on the basis of their ability to favor Th1 or Th2 differentiation, respectively. The critical factor for polarization to Th1 cells is the level of IL-12 produced by myeloid DC. In contrast, plasmacytoid DCs have low levels of IL-12. Plasmacytoid DCs particularly play a role in antiviral immunity by rapid production of high amounts of IFN- $\alpha$  and help B cells for antibody production. There is considerable interest in the role of TSLP, which is overexpressed in the mucosal surfaces and skin of atopic individuals. TSLP enhances Th2 differentiation by inducing expression of OX40L on immature myeloid DCs in the absence of IL-12 production.

Tissue macrophages are also acting as APCs. They show two main effector subsets in tissues, namely the M1 and M2 macrophages. M1 macrophages are classically activated, typically by IFN- $\gamma$  or lipopolysaccharide (LPS) like innate immune response stimulating substances, and produce proinflammatory cytokines, phagocytize microbes, and initiate an immune response. M1 macrophages produce nitric oxide (NO) or reactive oxygen intermediates (ROIs) to protect against bacteria and viruses. M2 macrophages are alternatively activated by allergen exposure and certain cytokines such as IL-4, IL-10, or IL-13. M2 macrophages will produce either polyamines to induce proliferation or proline to induce collagen production. These macrophages are associated with wound healing and tissue repair remodeling and activation of Th2 cells and ILC2s.

Presence of allergen-specific IgE on the cell surfaces of APCs is a unique feature of atopy. Importantly, the formation of high-affinity IgE receptor I (**Fc $\epsilon$ RI**)/IgE/allergen complexes on APC surfaces greatly facilitates allergen uptake and presentation. The clinical importance of this phenomenon is supported by the observation that Fc $\epsilon$ RI-positive Langerhans cells bearing IgE molecules are a prerequisite for skin-applied, aeroallergen provocation of eczematous lesions in patients with atopic dermatitis. The role of the low-affinity IgE receptor II (**Fc $\epsilon$ RII**, **CD23**)

on monocytes/macrophages is less clear, although under certain conditions it apparently can also facilitate antigen capture. Cross linking of FcεRII, as well as FcεRI, on monocytes/macrophages leads to the release of inflammatory mediators. There is a critical role for DCs in induction of oral tolerance; tolerogenic DCs are compartmentalized within the mucosa and present antigen through a mechanism designed to produce a Th1/Treg-suppressive response that ablates allergen-specific T cells.

### Immunoglobulin E and Its Receptors

The acute allergic response depends on IgE and its ability to bind selectively to the α chain of the high-affinity FcεRI or the low-affinity FcεRII (CD23). Cross linking of receptor-bound IgE molecules by allergen initiates a complex intracellular signaling cascade, followed by the release of various mediators of allergic inflammation from mast cells and basophils. The FcεRI molecule is also found on the surface of antigen-presenting DCs (e.g., Langerhans cells), but differs from the structure found on mast cells/basophils in that the FcεRI molecule found on DCs lacks the β chain. CD23 is found on B cells, eosinophils, platelets, and DCs. Cross linking and FcεRI aggregation on mast cells and basophils can also lead to anaphylaxis (see Chapter 174). Differential expression of tyrosine kinases responsible for positive and negative regulation of mast cell/basophil degranulation are thought to be responsible for this aberrant allergic response.

The induction of IgE synthesis requires two major signals. The first signal (signal 1) initiates IL-4 or IL-13 activation of germline transcription at the ε Ig locus, which dictates isotype specificity. The second signal (signal 2) involves the engagement of CD40 on B cells by CD40 ligand expressed on T cells. This engagement results in activation of the recombination machinery, resulting in DNA switch recombination. Interactions between several co-stimulatory molecule pairs (CD28 and B7; lymphocyte function-associated antigen-1 and intercellular adhesion molecule-1; CD2 and CD58) can further amplify signal 1 and signal 2 to enhance IgE synthesis. Factors that inhibit IgE synthesis include Th1-type cytokines (IL-12, IFN-α, IFN-γ), IL-10 from Tregs, Breg cells, and regulatory DCs and microbial DNA containing CpG (cytosine-phosphate-guanine) repeats.

### Eosinophils

Allergic diseases are characterized by peripheral blood and tissue eosinophilia. Eosinophils participate in both innate and adaptive immune responses and, like mast cells, contain dense intracellular granules that are sources of inflammatory proteins (see Fig. 169.1). These granule proteins include major basic protein, eosinophil-derived neurotoxin, peroxidase, and cationic protein. Eosinophil granule proteins damage epithelial cells, induce airway hyperresponsiveness, and cause degranulation of basophils and mast cells. Major basic protein released from eosinophils can bind to an acidic moiety on the M2 muscarinic receptor and block its function, thereby leading to increased acetylcholine levels and the development of increased airway hyperreactivity. Eosinophils are also a rich source of prostaglandins and **leukotrienes (LTs)**; in particular, cysteinyl LT C4 contracts airway smooth muscle and increases vascular permeability. Other secretory products of eosinophils include cytokines (IL-4, IL-5, TNF-α), proteolytic enzymes, and ROIs, all of which significantly enhance allergic tissue inflammation.

Several cytokines regulate the function of eosinophils in allergic disease. Eosinophils develop and mature in the bone marrow from myeloid precursor cells activated by IL-3, IL-5, and granulocyte-macrophage colony-stimulating factor (GM-CSF). Allergen exposure of allergic patients causes resident hematopoietic CD34 cells to express the IL-5 receptor. The IL-5 receptor activation induces eosinophil maturation, causing eosinophils to synthesize granule proteins, prolonging their survival, potentiating degranulation of eosinophils, and stimulating release of eosinophils from the bone marrow. GM-CSF also enhances proliferation, cell survival, cytokine production, and degranulation of eosinophils. Certain chemokines, such as RANTES (regulated on activation, normal T-cell expressed and secreted), macrophage inflammatory protein-1α (MIP-1α), and eotaxins are important for recruiting eosinophils into local allergic tissue inflammatory reactions. Eotaxins mobilize IL-5-dependent eosinophil colony-forming progenitor cells from the bone marrow. These progenitors are rapidly cleared from the blood and either return to the bone marrow or are recruited to inflamed tissue sites.

### Mast Cells

Mast cells are derived from CD34 hematopoietic progenitor cells that arise in bone marrow. On entering the circulation, they travel to peripheral tissue, where they undergo tissue-specific maturation. Mast cell development and survival relies on interactions between the tyrosine kinase receptor c-kit expressed on the surface of mast cells and the fibroblast-derived c-kit ligand, the stem cell factor. Unlike mature basophils, mature mast cells do not typically circulate in the blood. They are instead widely distributed throughout connective tissues, where they often lie adjacent to blood vessels and beneath epithelial surfaces that are exposed to the external environment, such as the respiratory tract, GI tract, and skin. So placed, mast cells are positioned anatomically to participate in allergic reactions. At least two subpopulations of human mast cells are recognized: mast cells with tryptase and mast cells with both tryptase and chymase. Mast cells with tryptase are the predominant type found in the lung and small intestinal mucosa, whereas mast cells with both tryptase and chymase are the predominant type found in skin, the GI submucosa, and blood vessels.

Mast cells contain, or produce on appropriate stimulation, a diverse array of mediators that have different effects on allergic inflammation and organ function. They include preformed granule-associated mediators (histamine, serine proteases, proteoglycans) and membrane-derived lipid, cytokine, and chemokine mediators arising from de novo synthesis and release. The most important mast cell-derived lipid mediators are the **cyclooxygenase** and **lipoxygenase** metabolites of arachidonic acid, which have potent inflammatory activities. The major cyclooxygenase product of mast cells is **prostaglandin D<sub>2</sub>**, and the major lipoxygenase products are the sulfidopeptide **LTs**: LTC<sub>4</sub> and its peptidolytic derivatives LTD<sub>4</sub> and LTE<sub>4</sub>. Mast cells also can produce cytokines that promote Th2-type responses (IL-4, IL-13, GM-CSF) and inflammation (TNF-α, IL-6) and regulate tissue remodeling (TGF, vascular endothelial cell growth factor). Immunologic activation of mast cells and basophils typically begins with cross-linkage of IgE bound to the FcεRI with multivalent allergen. Mast cell surface FcεRI is increased by IL-4 and IgE. Surface levels of FcεRI decrease in patients receiving treatment with anti-IgE antibody that lowers serum IgE, which is of potential therapeutic interest.

### MECHANISMS OF ALLERGIC TISSUE INFLAMMATION

IgE-mediated immune responses can be classified chronologically according to three reaction patterns. The **early-phase response** is the immediate response after allergen is introduced into target organs. This response is characterized by mast cell degranulation and release of preformed mediators, occurring within an immediate time frame of 1-30 minutes after allergen exposure and resolving within 1-3 hours. Acute reactions are associated with increased local vascular permeability, which leads to leakage of plasma proteins, tissue swelling, and increased blood flow, as well as itching, sneezing, wheezing, and acute abdominal cramps in the skin, nose, lung, and GI tract, respectively, depending on the targeted organ.

A second, **late-phase response** can occur within hours of allergen exposure, reaching a maximum at 6-12 hours and resolving by 24 hours. Late-phase responses are characterized in the skin by edema, redness, and induration; in the nose by sustained nasal blockage; and in the lung by airway obstruction and persistent wheezing. In general, late-phase responses are associated with early infiltration of neutrophils and eosinophils, followed by basophils, monocytes, macrophages, and Th2-type cells. Recruitment of inflammatory cells from the circulation requires increased expression of adhesion molecules on their cell surfaces and expression of their ligand on endothelial cells, which are under the control of cytokines. Several hours after allergen exposure, TNF-α released by activated mast cells induces the vascular endothelial expression of cell adhesion molecules, and this change leads to transendothelial migration of various inflammatory cells. Preferential accumulation of eosinophils occurs through interactions between selective adhesion molecules on the eosinophil cell surface (e.g., α<sub>4</sub>β<sub>1</sub>-integrin or very late antigen-4); vascular cell adhesion molecule-1 surface expression can be enhanced by IL-4 and IL-13 on endothelial cells. ILC2s receive signals from the epithelial cells, such as IL-33, TSLP, and IL-25, and are activated and start to release their cytokines IL-5 and IL-13 to initiate a type 2 immune response.



**Chemokines** are chemotactic cytokines that play a central role in tissue-directed migration of inflammatory cells. RANTES, MIP-1 $\alpha$ , monocyte chemoattractant protein (MCP)-3, and MCP-4 are chemoattractants for eosinophils and mononuclear cells, whereas eotaxins are relatively selective for eosinophils. These chemoattractants have been detected in epithelium, macrophages, lymphocytes, and eosinophils at sites of late-phase responses and allergic tissue inflammation. Blockade of these chemokines leads to significant reduction in tissue-directed migration of allergic effector cells.

In the third reaction pattern, **chronic allergic disease**, tissue inflammation can persist for days to years. Several factors contribute to persistent tissue inflammation, including recurrent exposure to allergens and microbial agents. The repeated stimulation of allergic effector cells such as mast cells, basophils, eosinophils, and Th2 cells contributes to unresolved inflammatory conditions. Additionally, Th2-type cytokines (IL-3, IL-5, GM-CSF) secreted during allergic reactions can prolong survival of allergic effector cells by delaying apoptosis. Local differentiation of tissue-infiltrating eosinophil precursors induced by IL-5 results in self-generation of eosinophils, further sustaining damage of local tissue. Tissue remodeling leading to irreversible changes in target organs is also a feature of chronic allergic disease. In asthma, **remodeling** involves thickening of the airway walls and submucosal tissue, as well as smooth muscle hypertrophy and hyperplasia, which are associated with a decline in lung function. This is an unexpected role for eosinophils in airway remodeling as well as chronic inflammation. In atopic dermatitis, lichenification is an obvious manifestation of skin remodeling.

Generally, it is considered that a type 2 immune response underlines a majority of asthma cases, atopic dermatitis, chronic rhinosinusitis, and allergic rhinitis as a general characteristic of an immune/inflammatory response. Type 2 immune response involves Th2 cells, type 2 B cells, ILC2, IL-4-secreting NK T cells, basophils, eosinophils, and mast cells and their major cytokines. From a complex network of cytokines, IL-4, IL-5, IL-9, and IL-13 are mainly secreted from the immune system cells, and IL-25, IL-31, IL-33, and TSLP from tissue cells, particularly epithelial cells. Many asthma-related antigens, such as protease allergens, fungal extracts, and viral infection, trigger IL-33, TSLP, and IL-25 production from epithelial cells and various immune cells and induce eosinophilic asthma-like airway inflammation through activation of lung ILC2s.

IL-31 plays a role in pruritus in atopic dermatitis. Th2 cytokines do not only maintain allergic inflammation but also influence tissue remodeling by activating resident cells in target organs; IL-4, IL-9, and IL-13 induce mucus hypersecretion and metaplasia of mucus cells; IL-4 and IL-13 stimulate fibroblast growth and synthesis of extracellular matrix proteins; and IL-5 and IL-9 increase subepithelial fibrosis. TGF- $\beta$  produced by eosinophils and fibroblasts can also enhance subepithelial fibrosis. IL-11 expressed by eosinophils and epithelial cells contributes to subepithelial fibrosis, in addition to enhancing deposition of collagen and the accumulation of fibroblasts. The resulting tissue injury amplifies further epithelial injury through proinflammatory cytokine release, extracellular matrix deposition in target organs, and angiogenesis. Genetic predisposition to aberrant injury-repair responses may contribute to chronicity of illness. Once the allergic immune response is established, it can be self-perpetuating due to a general type 2 immune response and can lead to chronic disease in genetically predisposed individuals. The subsequent infiltration of Th1 cells and Th17 cells enhances the inflammatory potential of allergic effector cells and contributes to chronic tissue inflammatory responses through the release of proinflammatory cytokines and chemokines. In addition, an autoimmune response might be playing a causative role in allergic inflammation resulting from possible mechanisms through IgE autoantibodies, IgG autoantibodies, and Th1-cell and Th17-cell autoreactivity.

## GENETIC BASIS OF ATOPY

Allergic diseases are complex genetic conditions susceptible to environmental triggers. Several major groups of genes are associated with allergic diseases: genes that regulate systemic expression of atopy

(increased IgE synthesis, eosinophilia, mast cell responses) and that are usually expressed among various allergic diseases, genes that control barrier function in specific target organs (e.g., skin in atopic dermatitis, lung in asthma, GI tract in food allergy), and genes encoding pattern-recognition receptors of the innate immune system that engage microbial pathogens and influence adaptive immune responses (Fig. 182.5). Once allergic responses have been initiated, a genetic predisposition to chronic allergic inflammation and aberrant injury-repair responses contribute to tissue remodeling and persistent disease.

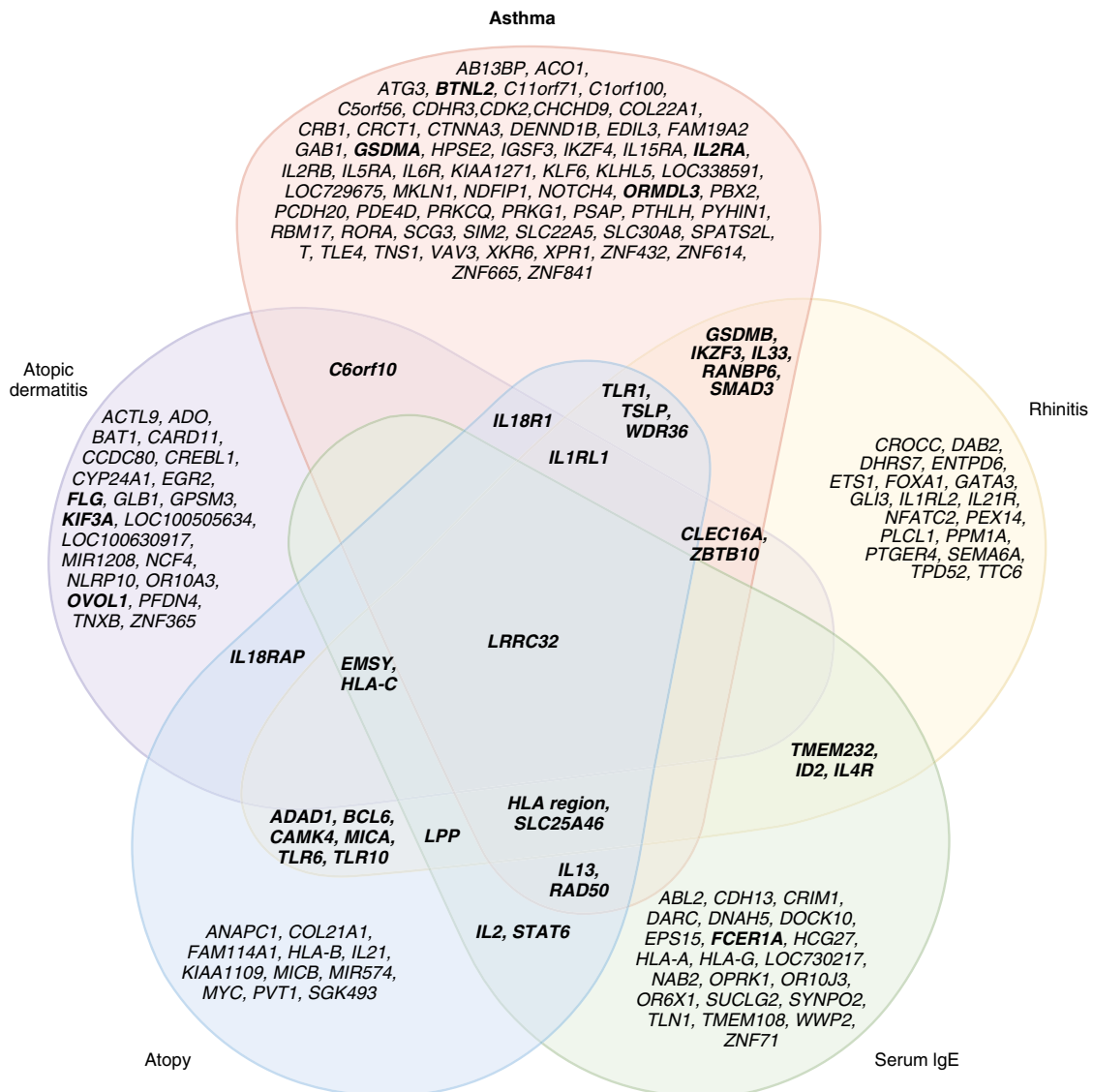
Atopic diseases have a strong familial predisposition, with approximately 60% heritability found in twin studies of asthma and atopic dermatitis. The 5q23-35 region comprises several genes implicated in allergic disease pathogenesis, including genes coding for Th2 cytokines (IL-3, IL-4, IL-5, IL-9, IL-13, GM-CSF). Among these, *IL4* is a well-studied potential candidate gene. A nucleotide change at position 589 of the *IL4* promoter region is associated with the formation of a unique binding site for nuclear factor for activated T cells (NF-AT) transcription factor, increased IL-4 gene transcription, higher NF-AT binding affinity, and increased IgE production. Similarly, *IL13* coding region variants have been associated with asthma and atopic dermatitis. An association has been found between atopy and a gain-of-function polymorphism on chromosome 16, which codes for the  $\alpha$  subunit of the IL-4R. This finding is consistent with the important role of IL-4, IL-13, and their receptors in the immunopathogenesis of allergic diseases.

Genome-wide searches have also linked atopy to chromosome region 11q13. The gene encoding the  $\beta$  subunit of Fc $\epsilon$ RI- $\beta$  has been proposed to be the candidate gene in this region. The  $\beta$  subunit gene modifies the Fc $\epsilon$ RI activity on mast cells, and several variants of Fc $\epsilon$ RI- $\beta$  are associated with asthma and atopic dermatitis. Chromosome 6 contains genes coding for human leukocyte antigen class I and class II molecules, which regulate the specificity and intensity of the immune responses to specific allergens. IgE responses to specific allergens, such as ragweed antigen Amb a V and mite allergen *Der p* I, have been linked to specific MHC class II loci. TNF- $\alpha$ , a key cytokine that contributes to the influx of inflammatory cells, is also located on chromosome 6. TNF- $\alpha$  polymorphisms are associated with asthma. A recent genome-wide association study showed that genetic polymorphisms in the gene encoding IL-33, which is a major activator of ILC2s, and its receptor IL-1RL1 (ST2) are strongly linked to asthma development.

Barrier dysfunction has a key role in the pathogenesis of allergic diseases. Genetic linkage studies of atopic dermatitis have demonstrated the importance of chromosome 1q21, which contains a cluster of genes involved in epidermal differentiation. **Filaggrin** is a protein that is essential in the formation of the stratum corneum. Null pathogenic variants of the filaggrin gene are strongly associated with early-onset and severe atopic dermatitis. Pathogenic variants in the gene encoding the serine protease inhibitor SPINK5 has been shown to cause **Netherton disease**, a single-gene disorder associated with erythroderma, food allergy, and high serum IgE levels. A common polymorphism in SPINK5 (in particular, Glu420Lys) increases the risk of developing atopic dermatitis and asthma. SPINK5 is expressed in the outer epidermis and is thought to be critical to neutralizing the proteolytic activity of *Staphylococcus aureus* and common allergens such as *Der p* I, which use these proteases to penetrate the skin to induce allergic responses. Barrier dysfunction is involved in other allergic diseases, such as asthma and rhinosinusitis, but likely involves other barrier genes, such as those encoding tight junctions. Epithelial tight junctions form a strong barrier on the apical side of mucosal epithelial cells and stratum granulosum of the skin. Epithelial tight junction defects shown in asthma and atopic dermatitis have been linked to two mechanisms, such as polymorphisms in certain claudin molecules or epigenetic regulation of the tight junction molecules. Epithelial cells obtained from asthmatic tissues cannot form a strong barrier in cultures. Chemical inhibition of histone deacetylases strengthens the barrier development capacity of these epithelial cells.

Candidate genes associated with asthma susceptibility have been identified by positional cloning: *GPR4* (G-protein-coupled receptor for asthma susceptibility on chromosome 7p14), *ADAM-33* (a disintegrin and metalloproteinase 33 on chromosome 20p), and





**Fig. 182.5** Overlapping sets of genes have been reported in genome-wide association studies (GWASs) for asthma, rhinitis, serum immunoglobulin E (IgE) levels, atopy, and atopic dermatitis, supporting a common genetic element within the mechanisms predisposing individuals toward different allergic disease phenotypes. GWASs have also identified many genes in association with only one allergic disease phenotype; these most likely represent the tissue-specific component of each allergic disease (e.g., *FLG* in the epidermal barrier in atopic dermatitis). More GWASs have been conducted analyzing genetic variants associated with asthma than with other allergic diseases. In the future it is likely that more risk variants for other allergic diseases will be identified. Genes reported in more than one GWAS are shown in bold font. The genes reported for SNPs detected to be significantly associated ( $P \leq 1 \times 10^{-5}$ ) with each allergic disease phenotype were obtained by searching the National Human Genome Research Institute GWAS catalog. (From Holloway JW. *The genetics of allergic disease and asthma*. In: Leung DYM, Akdis CA, Bacharier LB, et al., eds. *Pediatric Allergy Principles and Practice*. 4th ed. Philadelphia: Elsevier; 2021. Fig. 3.3, p 22.)

*DPP10* (dipeptidyl peptidase 10 on chromosome 2q14). The functions of these genes do not fit into classical pathways of atopy and therefore provide new insights into asthma pathogenesis. *GPR4* encodes a G-protein-coupled receptor, with isoforms expressed in bronchial epithelial cells and smooth muscle in asthmatic persons, suggesting an important role for these tissues in asthma. *ADAM-33* is expressed in bronchial smooth muscle and has been linked to bronchial hyperresponsiveness. *DPP10* encodes a dipeptidyl dipeptidase that can remove the terminal 2 peptides from certain proinflammatory chemokines, a change that may modulate allergic inflammation.

**Pattern-recognition receptors** of the innate immune system, which are expressed by epithelial cells and DCs, are associated with disease susceptibility. These receptors recognize specific microbial components. Polymorphisms in CD14 (engages endotoxin), Toll-like receptor 2 (which engages *S. aureus*), and T-cell immunoglobulin domain and mucin domain (which engage hepatitis A virus) correlate with asthma and/or atopic dermatitis susceptibility. Dysregulation of these frontline immune defense systems would permit abnormal response to common environmental allergens.

Visit Elsevier eBooks+ at [eBooks.Health.Elsevier.com](https://eBooks.Health.Elsevier.com) for Bibliography.

## Bibliography

- Akdis CA. Does the epithelial barrier hypothesis explain the increase in allergy, autoimmunity and other chronic conditions? *Nat Rev Immunol*. 2021;32(22):749–751.
- Akdis CA, Arkwright PD, Brügger MC, et al. Type 2 immunity in the skin and lungs. *Allergy*. 2020;75(7):1582–1605.
- Bachert C, Akdis CA. Phenotypes and emerging endotypes of chronic rhinosinusitis. *J Allergy Clin Immunol Pract*. 2016;4(4):621–628.
- Celebi Sözüner Z, Cevhertas L, Nadeau K, Akdis M, Akdis CA. Environmental factors in epithelial barrier dysfunction. *J Allergy Clin Immunol*. 2020;145(6):1517–1528.
- Cevhertas L, Ogulur I, Maurer DJ, et al. Advances and recent developments in asthma in 2020. *Allergy*. 2020;75(12):3124–3146.
- Kortekaas Krohn I, Shikhagaie MM, Golebski K, et al. Emerging roles of innate lymphoid cells in inflammatory diseases: Clinical implications. *Allergy*. 2018;73(4):837–850.
- Kuo IH, Yoshida T, De Benedetto A, et al. The cutaneous innate immune response in patients with atopic dermatitis. *J Allergy Clin Immunol*. 2013;131:266–278.
- Liu AH, Anderson 3rd WC, Dutmer CM, et al. Advances in asthma 2015: across the lifespan. *J Allergy Clin Immunol*. 2016;138(2):397–404.
- Mjösberg J, Spits H. Human innate lymphoid cells. *J Allergy Clin Immunol*. 2016;138(5):1265–1276.
- Morita H, Kubo T, Rückert B, Ravindran A, et al. Induction of human regulatory innate lymphoid cells from group 2 innate lymphoid cells by retinoic acid. *J Allergy Clin Immunol*. 2019;143(6):2190–2201.e9.
- Palomares O, Akdis M, Martín-Fontecha M, Akdis CA. Mechanisms of immune regulation in allergic diseases: the role of regulatory T and B cells. *Immunol Rev*. 2017;278(1):219–236.
- Tang TS, Bieber T, Williams HC. Does “autoreactivity” play a role in atopic dermatitis? *J Allergy Clin Immunol*. 2012;129:1209–1215.
- Van de Veen W, Stanic B, Yaman G, et al. IgG4 production is confined to human IL-10-producing regulatory B cells that suppress antigen-specific immune responses. *J Allergy Clin Immunol*. 2013;131:1204–1212.
- Vercelli D. Remembrance of things past: HLA genes come back on the allergy stage. *J Allergy Clin Immunol*. 2012;129:846–847.
- Wang M, Tan G, Eljaszewicz A, et al. Laundry detergents and detergent residue after rinsing directly disrupt tight junction barrier integrity in human bronchial epithelial cells. *J Allergy Clin Immunol*. 2019;143(5):1892–1903.
- Zabielinski M, McLeod MP, Aber C, et al. Trends and antibiotic susceptibility patterns of methicillin-resistant and methicillin-sensitive *Staphylococcus aureus* in an outpatient dermatology facility. *JAMA Dermatol*. 2013;149(4):427–432.

## Chapter 183

# Diagnosis of Allergic Disease

Supinda Bunyavanich, Jacob Kattan, and Scott H. Sicherer

## ALLERGY HISTORY

Obtaining a complete history from the allergic patient involves eliciting a description of all symptoms along with their timing and duration, exposure to common allergens, and responses to previous therapies. Because patients often suffer from more than one allergic disease, the presence or absence of other allergic diseases, including allergic rhinoconjunctivitis, asthma, food allergy, eosinophilic esophagitis, atopic dermatitis, and drug allergy, should be determined. A family history of allergic disease is common and is one of the most important factors predisposing a child to the development of allergies. The risk of allergic disease in a child approaches 50% when one parent is allergic and 66% when both parents are allergic, with maternal history of atopy having a greater effect than paternal history.

Several characteristic behaviors are often seen in allergic children. Because of nasal **pruritus** and **rhinorrhea**, children with allergic rhinitis often perform the **allergic salute** by rubbing their nose upward with the palm of their hand. This repeated maneuver may give rise to the **nasal crease**, a horizontal wrinkle over the bridge of the nose. Characteristic vigorous **rubbing** of the eyes with the thumb and side of the fist is frequently observed in children with allergic conjunctivitis. The **allergic cluck** is produced when the tongue is placed against the roof of the mouth to form a seal and withdrawn rapidly in an effort to scratch the palate. The presence of other symptoms, such as fever, unilateral nasal obstruction, and purulent nasal discharge, suggests other diagnoses.

The timing of onset and the progression of symptoms are relevant. The onset of recurrent or persistent nasal symptoms coinciding with placement in a daycare center might suggest recurrent infection rather than allergy. When patients present with a history of episodic acute symptoms, it is important to review the setting in which symptoms occur as well as the activities and exposures that immediately precede their onset. Symptoms associated with lawn mowing suggest allergy to grass pollen or fungi, whereas if symptoms occur in homes with pets, animal dander sensitivity is an obvious consideration. Reproducible reactions after ingestion of a specific food raise the possibility of food allergy. When symptoms wax and wane but evolve gradually and are more chronic in duration, a closer look at whether the timing and progression of symptoms correlate with exposure to a seasonal aeroallergen is warranted.

**Aeroallergens**, such as **pollens** and fungal spores, are prominent causes of allergic disease. The concentrations of these allergens in outdoor air fluctuate seasonally. Correlating symptoms with **seasonal** pollination patterns of geographically relevant plants and trees along with information provided by local pollen counts can aid in identifying the allergen. Throughout most of the United States, trees pollinate in the early spring, grasses pollinate in the late spring and early summer, and weeds pollinate in late summer through the fall. The presence of fungal spores in the atmosphere follows a seasonal pattern in the northern United States, with spore counts rising with the onset of warmer weather and peaking in late summer months, only to recede again with the first frost through the winter. In warmer regions of the southern United States, fungal spores and grass pollens may cause symptoms on a perennial basis.

Rather than experiencing seasonal symptoms, some patients suffer allergic symptoms year-round. In these patients, sensitization to **perennial allergens** usually found indoors, such as dust mites, animal

dander, cockroaches, and fungi, warrants consideration. Species of certain fungi, such as *Aspergillus* and *Penicillium*, are found indoors, whereas *Alternaria* is found in both indoor and outdoor environments. Cockroach and rodent allergens are often problematic in urban environments. Patients sensitive to perennial allergens often also become sensitized to seasonal allergens and experience baseline symptoms year-round with worsening during the pollen seasons.

The age of the patient is an important consideration in identifying potential allergens. Infants and young children are often first sensitized to allergens that are in their environment on a continuous basis, such as dust mites, animal dander, and fungi. Sensitization to seasonal allergens usually takes several seasons of exposure to develop and is thus unlikely to be a significant trigger of symptoms in infants and toddlers.

**Food allergies** are more common in infants and young children, resulting primarily in cutaneous, gastrointestinal, and, less frequently, respiratory and cardiovascular symptoms. Symptoms of immediate or IgE-mediated hypersensitivity food reactions typically develop within minutes to 2 hours after ingestion of the offending food. Symptoms of non-IgE-mediated food allergies are often delayed or chronic (see Chapter 192).

Complete information from previous evaluations and prior treatments for allergic disease should be reviewed, including impact of changes in local environment (e.g., home vs school), response to medications, elimination diets, and duration and impact of allergen immunotherapy (if applicable). Improvement in symptoms with medications or avoidance strategies used to treat allergic disease provides additional evidence for an allergic process.

A thorough **environmental** survey should be performed, focusing on potential sources of allergen and/or irritant exposure, particularly when respiratory symptoms (upper/lower) are reported. The age and type of the dwelling, how it is heated and cooled, the use of humidifiers or air filtration units, and any history of water damage should be noted. Forced air heating may stir up dust mite, fungi, and animal allergens. The irritant effects of wood-burning stoves, fireplaces, and kerosene heaters may provoke respiratory symptoms. Increased humidity or water damage in the home is often associated with greater exposure to dust mites and fungi. Carpeting serves as a reservoir for dust mites, fungi, and animal dander. The number of domestic pets and their movements about the house should be ascertained. Special attention should be focused on the bedroom, where a child spends a significant proportion of time. The age and type of bedding, the use of dust mite covers on pillows and mattresses, the number of stuffed animals, type of window treatments, and the accessibility of pets to the room should be reviewed. The number of smokers living in the home, and what and where they smoke is useful information. Activities that might result in exposure to allergens or respiratory irritants such as paint fumes, cleansers, sawdust, or glues should be identified. Similar information should be obtained in other environments where the child spends long periods, such as a relative's home or school setting.

## PHYSICAL EXAMINATION

In patients with **asthma**, **spirometry** should be performed. If respiratory distress is observed, **pulse oximetry** should be performed.

The child presenting with a chief complaint of **rhinitis** or **rhinoconjunctivitis** should be observed for mouth breathing, paroxysms of sneezing, sniffing/snorting, throat clearing, and rubbing of the nose and eyes (representing **pruritus**; see Chapter 184). Infants should be observed during feeding for nasal obstruction severe enough to interfere with feeding or for more obvious signs of aspiration or gastroesophageal reflux. The frequency and nature of coughing that occurs during the interview and any positional change in coughing or wheezing should be noted. Children with asthma should be observed for congested or wet cough, tachypnea at rest, retractions, and audible wheezes, which may worsen with crying. Patients with atopic dermatitis should be monitored for repetitive scratching and the extent of skin involvement.

Because children with severe asthma as well as those receiving chronic or frequent oral corticosteroids may experience growth suppression, an accurate height should be plotted at regular intervals. The

use of inhaled glucocorticoids in prepubertal children is associated with a small initial decrease in attained height (1 cm) that may persist as a reduction in adult height. Poor weight gain in a child with chronic chest symptoms should prompt consideration of cystic fibrosis. Anthropometric measures are also important to monitor in those on restricted diets because of multiple food allergies or eosinophilic esophagitis. Blood pressure should be measured to evaluate for steroid-induced hypertension. The patient with acute asthma may present with **pulsus paradoxus**, defined as a drop in systolic blood pressure during inspiration  $>10$  mm Hg. Moderate to severe airway obstruction is indicated by a decrease of  $>20$  mm Hg. An increased heart rate may be the result of an asthma flare or the use of a  $\beta$ -agonist or decongestant. Fever is not caused by allergy alone and should prompt consideration of an infectious process, which may exacerbate asthma.

Parents are often concerned about blue-gray to purple discolorations beneath their child's lower eyelids, which can be attributed to venous stasis and are referred to as **allergic shiners** (Fig. 183.1). They are found in up to 60% of allergic patients and almost 40% of patients *without* allergic disease. Thus "shiners" may suggest, but are not diagnostic of, allergic disease. In contrast, the **Dennie-Morgan folds** (Dennie lines) are a feature of atopy (see Fig. 183.1). These are prominent infraorbital skin folds that extend in an arc from the inner canthus beneath and parallel to the lower lid margin.

In patients with **allergic conjunctivitis**, involvement of the eyes is typically bilateral (see Chapter 188). Examination of the conjunctiva reveals varying degrees of lachrymation, conjunctival injection, and edema. In severe cases, periorbital edema involving primarily the lower eyelids or **chemosis** (conjunctival edema that is gelatinous in appearance) may be observed. The classic discharge associated with allergic conjunctivitis is usually described as "stringy" or "ropy." In children with vernal conjunctivitis, a more severe, chronic phenotype, examination of the tarsal conjunctiva may reveal cobblestoning. **Keratoconus**, or protrusion of the cornea, may occur in patients with vernal conjunctivitis or periorbital atopic dermatitis as a result of repeated trauma produced by persistent rubbing of the eyes. Children treated with high-dose or chronic corticosteroids are at risk for development of posterior subcapsular cataracts.



**Fig. 183.1** Bilateral Dennie-Morgan folds. Several linear wrinkles beneath the lower eyelashes (arrow) associated with bilateral allergic shiners: dark circles beneath the lower eyelid (arrowheads). (From Blanc S, Bourrier T, Albertini M, et al. Dennie-Morgan fold plus dark circles: suspect atopy at first sight. *J Pediatr.* 2015;166:1541.)

The external ear should be examined for eczematous changes in patients with atopic dermatitis, including the postauricular area and base of the earlobe. Because otitis media with effusion is common in children with allergic rhinitis, pneumatic otoscopy should be performed to evaluate for the presence of fluid in the middle ear and to exclude infection.

Examination of the nose in allergic patients may reveal the presence of a nasal crease. Nasal patency should be assessed, and the nose examined for structural abnormalities affecting nasal airflow, such as septal deviation, turbinate hypertrophy, and nasal polyps. Decrease or absence of the sense of smell should raise concern about chronic sinusitis or nasal polyps. Nasal polyps in children should raise concerns of cystic fibrosis. The nasal mucosa in allergic rhinitis is classically described as pale to purple compared with the beefy-red mucosa of patients with nonallergic rhinitis. Allergic nasal secretions are typically thin and clear. Purulent secretions suggest another cause of rhinitis. The frontal and maxillary sinuses should be palpated to identify tenderness to pressure that might be associated with acute sinusitis.

Examination of the lips may reveal cheilitis caused by drying of the lips from continuous mouth breathing or repeated licking of the lips in an attempt to replenish moisture and relieve discomfort (**lip licker's dermatitis**). Tonsillar and adenoidal hypertrophy along with a history of impressive snoring raises the possibility of obstructive sleep apnea. The posterior pharynx should be examined for the presence of postnasal drip and posterior pharyngeal lymphoid hyperplasia ("cobblestoning").

Chest findings in asthmatic children vary significantly and may depend on disease duration, severity, and activity. In a child with well-controlled asthma, the chest should appear entirely normal on examination between asthma exacerbations. Examination of the same child during an acute episode of asthma may reveal hyperinflation, tachypnea, use of accessory muscles (retractions), wheezing, and decreased air exchange with a prolonged expiratory time. Tachycardia may be caused by the asthma exacerbation or accompanied by jitteriness after treatment with  $\beta$ -agonists. Decreased airflow or rhonchi and wheezes over the right chest may be noted in children with mucus plugging and right middle lobe atelectasis. The presence of cyanosis indicates severe respiratory compromise. Unilateral wheezing after an episode of coughing and choking in a small child without a history of previous respiratory illness suggests **foreign body aspiration**. Wheezing limited to the larynx in association with inspiratory stridor may be seen in older children and adolescents with **vocal cord dysfunction**. Digital clubbing is rarely seen in patients with uncomplicated asthma and should prompt further evaluation to rule out other potential chronic diagnoses, such as cystic fibrosis.

The skin of the allergic patient should be examined for evidence of **urticaria/angioedema** or **atopic dermatitis** (see Chapters 189 and 186). **Xerosis**, or dry skin, is the most common skin abnormality of allergic children. **Keratosis pilaris**, often found on facial cheeks and extensor surfaces of the upper arms and thighs, is a benign condition characterized by skin-colored or slightly pink papules caused by keratin plugs lodged in the openings of hair follicles. Examination of the skin of the palms and soles may reveal thickened skin and exaggerated palmar and plantar creases (**hyperlinearity**) in children with moderate to severe atopic dermatitis.

## DIAGNOSTIC TESTING

### In Vitro Tests

Allergic diseases are often associated with increased numbers of eosinophils circulating in the peripheral blood and invading the tissues and secretions of target organs. **Eosinophilia**, defined as the presence of  $>500$  eosinophils/ $\mu\text{L}$  in peripheral blood, is the most common hematologic abnormality of allergic patients. Seasonal increases in the number of circulating eosinophils may be observed in sensitized patients after exposure to allergens such as tree, grass, and weed pollens. The number of circulating eosinophils can be suppressed by certain infections and systemic corticosteroids. In certain pathologic conditions, such as drug reactions, eosinophilic pneumonias, and eosinophilic esophagitis, significantly increased numbers of eosinophils may be present in the target organ in the absence



**Table 183.1** Differential Diagnosis of Childhood Eosinophilia

<p><b>PHYSIOLOGIC</b> Prematurity Infants receiving hyperalimentation Hereditary</p> <p><b>INFECTIOUS</b> Parasitic (with tissue-invasive helminths, e.g., trichinosis, strongyloidiasis, pneumocystosis, filariasis, cysticercosis, cutaneous and visceral larva migrans, echinococcosis) Bacterial (brucellosis, tularemia, cat-scratch disease, <i>Chlamydia</i>) Fungal (histoplasmosis, blastomycosis, coccidioidomycosis, allergic bronchopulmonary aspergillosis) Mycobacterial (tuberculosis, leprosy) Viral (HIV-1, HTLV-1, hepatitis A, hepatitis B, hepatitis C, Epstein-Barr virus)</p> <p><b>PULMONARY</b> Allergic (rhinitis, asthma) Eosinophilic granulomatosis with polyangiitis (Churg-Strauss syndrome) Loeffler syndrome Hypersensitivity pneumonitis Eosinophilic pneumonia (chronic, acute) Pulmonary interstitial eosinophilia</p> <p><b>DERMATOLOGIC</b> Atopic dermatitis Pemphigus Dermatitis herpetiformis Infantile eosinophilic pustular folliculitis Eosinophilic fasciitis (Schulman syndrome) Eosinophilic cellulitis (Wells syndrome) Kimura disease (angiolymphoid hyperplasia with eosinophilia)</p>	<p><b>HEMATOLOGIC/ONCOLOGIC</b> Neoplasm (lung, gastrointestinal, uterine) Leukemia/lymphoma Myelofibrosis Myeloproliferative (FIP1L1-PDGFR<math>\alpha</math> positive) hypereosinophilic syndrome Lymphatic hypereosinophilic syndrome Systemic mastocytosis</p> <p><b>IMMUNOLOGIC</b> T-cell immunodeficiencies Hyper-IgE (Job) syndromes Wiskott-Aldrich syndrome Autoimmune lymphoproliferative syndrome (ALPS) Sarcoidosis Graft-versus-host disease Drug hypersensitivity including drug reaction with eosinophilia and systemic symptoms (DRESS) Postirradiation Postsplenectomy</p> <p><b>ENDOCRINE</b> Addison disease Hypopituitarism</p> <p><b>CARDIOVASCULAR</b> Loeffler disease (fibroplastic endocarditis) Congenital heart disease Hypersensitivity vasculitis Eosinophilic myocarditis</p> <p><b>GASTROINTESTINAL</b> Benign proctocolitis Inflammatory bowel disease Eosinophilic gastrointestinal diseases (EGID)</p>
---	---

FIP1L1-PDGFR $\alpha$ , FIP1-like 1-platelet-derived growth factor receptor  $\alpha$ ; HTLV, human T-lymphotropic virus 1.

of peripheral blood eosinophilia. Increased numbers of eosinophils are observed in a wide variety of disorders in addition to allergy; eosinophil counts  $>1,500$  without an identifiable etiology should suggest one of the two hypereosinophilic syndromes (Table 183.1; see Chapter 169).

Nasal and bronchial secretions may be examined for the presence of eosinophils and neutrophils. The presence of eosinophils in the sputum of patients with atopic asthma is frequently seen. An increased number of eosinophils in a smear of nasal mucus with Hansel stain is a more sensitive indicator of nasal allergies than peripheral blood eosinophilia and can aid in distinguishing allergic rhinitis from other causes of rhinitis.

An elevated **IgE** value is often found in the serum of allergic patients, because IgE is the primary antibody associated with immediate hypersensitivity reactions. IgE values are measured in international units (IU), with 1 IU equal to 2.4 ng of IgE. Serum IgE levels gradually rise over the first years of life to peak in the teen years and decrease steadily thereafter. Additional factors, such as genetic influences, gender, certain diseases, and exposure to cigarette smoke and allergens, also affect serum IgE levels. Total serum IgE levels may increase 2- to 4-fold during and immediately after the pollen season and then gradually decline until the next pollen season. Comparison of total IgE levels among patients with allergic diseases reveals that those with atopic dermatitis tend to have the highest levels, whereas patients with allergic asthma generally have higher levels than those with allergic rhinitis. Although average total IgE levels are higher in populations of allergic patients than in comparable populations without allergic disease, the overlap in levels is such that the diagnostic value of a total IgE level is poor. Approximately half of patients with allergic disease have total IgE levels in the normal range. However, measurement of total IgE is indicated when the diagnosis of **allergic bronchopulmonary aspergillosis** is

suspected because total serum IgE concentration  $>1,000$  ng/mL is a criterion for diagnosis of this disorder (see Chapter 283.1). Total serum IgE may also be elevated in several nonallergic diseases (Table 183.2).

The presence of IgE specific for a particular allergen can be documented *in vivo* by skin testing or *in vitro* by the measurement of **allergen-specific IgE (sIgE)** levels in the serum (Table 183.3). The first test for documenting the presence of sIgE was called the radio-allergosorbent test (RAST) because it used a radiolabeled anti-IgE antibody. RAST has been replaced by an improved generation of automated enzymatic sIgE immunoassays. These immunoassays typically use solid-phase supports to which allergens of an individual allergen extract are bound. A small amount of the patient's serum is incubated with the allergen-coated support. The allergen-coated support bound to the patient's sIgE is then incubated with enzyme-conjugated antihuman IgE. Incubation of this sIgE-antihuman IgE complex with a fluorescent substrate of the conjugated enzyme results in the generation of fluorescence that is proportional to the amount of sIgE in the serum sample. The amount of sIgE is calculated by interpolation from a standard calibration curve and reported in arbitrary mass units (kilo-IU of allergen-specific antibody per unit volume of sample,  $kU_A/L$ ). Laboratory reports may specify classes, counts, or units, but quantification of results in  $kU_A/L$  is most useful. sIgE immunoassays are available for foods, environmental allergens, insect venoms, natural rubber latex, and a small number of  $\beta$ -lactam drugs. The sensitivity and specificity of immunoassays for particular allergens vary widely from 30–95%. These immunoassays are not diagnostic for allergy and should not be used for allergy screening. Only targeted sIgE levels for specific antigens should be measured when there is a clinical indication to suspect a specific allergy.

**Table 183.2** Nonallergic Diseases Associated with Increased Serum IgE Concentrations

<b>PARASITIC INFESTATIONS</b>	<b>NEOPLASTIC DISEASES</b>
Ascariasis	Hodgkin disease
Capillariasis	IgE myeloma
Echinococcosis	Bronchial carcinoma
Fascioliasis	<b>OTHER DISEASES AND DISORDERS</b>
Filariasis	Alopecia areata
Hookworm	Bone marrow transplantation
Onchocerciasis	Burns
Malaria	Cystic fibrosis
Paragonimiasis	Dermatitis, chronic acral
Schistosomiasis	Erythema nodosum, streptococcal infection
Strongyloidiasis	Guillain-Barré syndrome
Trichinosis	Kawasaki disease
Visceral larva migrans	Liver disease
<b>INFECTIONS</b>	Medication related
Allergic bronchopulmonary aspergillosis	Nephritis, drug-induced interstitial
Candidiasis, systemic	Nephrotic syndrome
Coccidioidomycosis	Pemphigus, bullous
Cytomegalovirus mononucleosis	Polyarteritis nodosa, infantile
HIV type 1 infections	Primary pulmonary hemosiderosis
Infectious mononucleosis (Epstein-Barr virus)	Juvenile idiopathic arthritis
Leprosy	
Pertussis	
Viral respiratory infections	
<b>IMMUNODEFICIENCY</b>	
Autosomal dominant hyper-IgE syndrome ( <i>STAT3</i> variants)	
Autosomal recessive hyper-IgE syndrome ( <i>DOCK8</i> , <i>TYK2</i> variants)	
IgA deficiency, selective	
Nezelof syndrome (cellular immunodeficiency with immunoglobulins)	
Thymic hypoplasia (DiGeorge anomaly)	
Wiskott-Aldrich syndrome	

**Table 183.3** Determination of Allergen-Specific IgE by Skin Testing vs In Vitro Testing

VARIABLE	SKIN TEST*	sIgE ASSAY
Risk of allergic reaction	Yes (especially ID)	No
Relative sensitivity	High	High
Affected by antihistamines	Yes	No
Affected by corticosteroids	Usually not	No
Affected by extensive dermatitis or dermatographism	Yes	No
Broad selection of antigens	Fewer	Yes
Immediate results	Yes	No
Expensive	No	Yes
Lability of allergens	Yes	No
Results evident to patient	Yes	No

\*Skin testing may be the prick test or intradermal (ID) injection.

**Component testing** refers to diagnostic tests where sIgE is measured to specific proteins that comprise allergens (e.g., Ara h 2 from peanut, Bet v 1 from birch pollen), rather than to a mixture of the allergens extracted from the source. Testing sIgE to component allergens may add additional diagnostic value by differentiating immune responses that are directed toward clinically relevant allergenic proteins.

### In Vivo Tests

**Allergen skin testing** is the primary in vivo procedure for the diagnosis of allergic disease. Mast cells with sIgE antibodies attached to high-affinity receptors on their surface reside in the skin of allergic patients. The introduction of minute amounts of an allergen into the skin of the sensitized patient results in cross linking of IgE antibodies on the mast cell surface, thereby triggering local mast cell activation. Once activated, these mast cells release a variety of preformed and newly generated mediators that act on surrounding tissues. **Histamine** is the mediator most responsible for the immediate **wheal and flare reactions** observed in skin testing. Examination of the site of a positive skin test result reveals a pruritic wheal surrounded by erythema. The time course of these reactions is rapid in onset, reaching a peak within 10–20 minutes and usually resolving over the next 30 minutes.

Skin testing is performed using the **prick/puncture technique**. With this technique, a small drop of allergen is applied to the skin surface, and a tiny amount is introduced into the epidermis by lightly pricking or puncturing the outer layer of skin through the drop of extract with a small needle or other device. When the **skin-prick test (SPT)** result is negative but the history suggestive, selective skin testing (for vaccines, venom, drugs, and aeroallergens) using the **intradermal technique** may be performed. This technique involves using a 26-gauge needle to inject 0.01–0.02 mL of an allergen extract diluted 1,000- to 10-fold into the dermis of the arm. Intradermal skin tests are *not recommended for use with food allergens* because of the risk of triggering anaphylaxis. Irritant rather than allergic reactions can occur with intradermal skin testing if higher concentrations of extracts are used. Although skin-prick testing is less sensitive than intradermal skin testing, positive SPT results tend to correlate better with clinical symptoms.

The number of skin tests performed should be individualized, with the allergens suggested by the history. A positive and negative control SPT, using histamine and saline, respectively, is performed with each set of skin tests. A negative control is necessary to assess for **dermatographism**, in which reactions are caused merely by applying pressure to overly sensitive skin. A positive control is necessary to establish the presence of a cutaneous response to histamine. Medications with antihistaminic properties, in addition to adrenergic agents such as ephedrine and epinephrine, suppress skin test responses and should be avoided for appropriate intervals (approximately five half-lives) before skin testing. Prolonged courses of systemic corticosteroids may suppress cutaneous reactivity by decreasing the number of tissue mast cells as well as their ability to release mediators.

Whether identified via serologic or skin testing, detection of sIgE denotes a sensitized state (i.e., atopy or a tendency toward development of allergic disease) but is not equivalent to a clinically relevant allergic diagnosis. **Many children with positive tests have no clinical symptoms on exposure to the allergen.** Increasingly strong test

results (higher serum sIgE results or larger SPT wheal sizes) generally correlate with increasing likelihood of clinical reactivity (but not severity). Neither serologic testing nor skin testing for allergy is predictive of reaction severity or threshold of reactivity, and these tests will be negative when the allergy is not IgE mediated, such as in food protein-induced enterocolitis syndrome. The limitations of these test modalities underscore the need for a detailed medical history that can guide the selection and interpretation of test results. **Large panels of indiscriminately performed screening tests may provide misleading information and are not recommended.**

Both serum sIgE tests and SPT are sensitive and have similar diagnostic properties. The benefits of the serologic immunoassays are that performance is not limited by the presence of skin disease (i.e., active atopic dermatitis) or medication use (i.e., antihistamines). Advantages of skin testing are that they provide rapid results to the patient/family during the clinic visit, do not require venipuncture, and are less costly.

Under certain circumstances, **provocation testing** is performed to examine the association between allergen exposure and the development of symptoms. The bronchial provocation test most frequently performed clinically is the **methacholine challenge**, which causes potent bronchoconstriction of asthmatic but not of normal airways; it is performed to document the presence and degree of bronchial hyper-reactivity in a patient with suspected asthma. After baseline spirometry values are obtained, increasing concentrations of nebulized methacholine are inhaled until a drop occurs in lung function, specifically a 20% decrease in FEV<sub>1</sub> (forced expiratory volume in the first second of expiration), or the patient is able to tolerate the inhalation of a set concentration of methacholine, typically 25 mg/mL.

Oral **food challenges** are performed to determine whether a specific food causes symptoms or whether a suspected food can be added to the diet. Food challenges are performed when the history and results of skin tests and immunoassays for sIgE are insufficient to clarify the diagnosis of an allergy. These challenges may be performed in an open single-blind, double-blind, or double-blind placebo-controlled manner and involve the ingestion of gradually increasing amounts of the suspected food at set intervals until the patient either experiences a reaction or tolerates a normal portion (i.e., one serving size) of the food openly. Although the double-blind placebo-controlled food challenge is currently the gold standard test for diagnosing food allergy, it is typically only performed in research studies due to the time and labor-intensive nature of this method. Because of the potential for significant allergic reactions, oral food challenges should be performed only in an appropriately equipped facility with personnel experienced in the performance of food challenges and the treatment of anaphylaxis, including cardiopulmonary resuscitation.

Upper gastrointestinal **endoscopy** is required to confirm the diagnosis of **eosinophilic esophagitis**. One or more biopsy specimens from the proximal and distal esophagus must show eosinophil-predominant inflammation. With few exceptions, 15 eosinophils per high-power field (peak value) is considered a minimum threshold for the diagnosis.

Visit Elsevier eBooks+ at [eBooks.Health.Elsevier.com](http://eBooks.Health.Elsevier.com) for Bibliography.

## Bibliography

- Adkinson Jr NF, Bochner BS, Burks AW, et al., eds. *Middleton's allergy: principles & practice*. 9th ed. Philadelphia: Elsevier/Saunders; 2019.
- Cevhertas L, Ogulur I, Maurer DJ, et al. Advances and recent developments in asthma in 2020. *Allergy*. 2020;75(12):3124–3146.
- Dykewicz MS, Wallace DV, Amrol DJ, et al. Rhinitis 2020. A practice parameter update. *J Allergy Clin Immunol*. 2020;146(4):721–767.
- Gonsalves NP, Aceves SS. Diagnosis and treatment of eosinophilic esophagitis. *J Allergy Clin Immunol*. 2020;145(1):1–7.
- Hew M, Menzies-Gow A, Hull JH, et al. Systematic Assessment of Difficult-to-Treat Asthma: Principles and Perspectives. *J Allergy Clin Immunol Pract*. 2020;8(7):2222–2233.
- Khan DA, Banerji A, Blumenthal K et al. Drug allergy: A 2022 practice parameter Update. *J Allergy Clin Immunol* 2022;150(6):1333–1393.
- Nowak-Wegrzyn A, Berin MC, Mehr S. Food Protein-Induced Enterocolitis Syndrome. *J Allergy Clin Immunol Pract*. 2020;8(1):24–35.
- Rodrigues J, Kuruvilla ME, Vanijcharoenkarn K, Patel N, Hom MM, Wallace DV. The spectrum of allergic ocular diseases. *Ann Allergy Asthma Immunol*. 2021;126(3):240–254.
- Sicherer SH, Warren CM, Dant C, Gupta RS, Nadeau KC. Food Allergy from Infancy Through Adulthood. *J Allergy Clin Immunol Pract*. 2020;8(6):1854–1864.
- Worm M, Vieths S, Mahler V. An update on anaphylaxis and urticaria. *J Allergy Clin Immunol*. 2022;150(6):1265–1278.



## Chapter 184

## Allergic Rhinitis

Tamara T. Perry and Scott H. Sicherer

**Allergic rhinitis (AR)** is a common chronic disease affecting 20–30% of children. AR is an inflammatory disorder of the nasal mucosa marked by nasal congestion, rhinorrhea, and itching, often accompanied by sneezing and conjunctival inflammation. Its recognition as a major chronic respiratory disease of children derives from its high prevalence, detrimental effects on quality of life and school performance, and comorbidities. Children with AR often have related conjunctivitis, sinusitis, otitis media, serous otitis, hypertrophic tonsils and adenoids, and eczema. Childhood AR is associated with a threefold increase in risk for asthma at an older age. Over the past 50 years an upsurge in AR has been observed throughout the world, with some symptom surveys reporting incidence rates approaching 40%. Heritability of allergic conditions attests to genetic factors, but the increase stems from changes in the environment, diet, and the microbiome. The symptoms may appear in infancy, with the diagnosis generally established by the time the child reaches age 6 years. The prevalence peaks late in childhood.

Risk factors include family history of atopy and serum IgE higher than 100 IU/mL before age 6 years. Early life exposures and/or their absence have a profound influence on the development of the allergic phenotype. The risk increases in children who are exposed to tobacco smoke prenatally, and above all before the infants reach 1 year, and those with heavy exposure to indoor allergens. A critical period exists early in infancy when the genetically susceptible child is at greatest risk of sensitization. Delivery by cesarean section is associated with AR and atopy in children with a parental history of asthma or allergies. This association may be explained by the lack of exposure to the maternal microbiota through fecal/vaginal flora during delivery.

Children between 2 and 3 years old who have elevated antickroach and antimouse IgE are at increased risk of wheezing, AR, and atopic dermatitis. The occurrence of three or more episodes of rhinorrhea in the first year of life is associated with AR at age 7 years. Favorably, the exposure to dogs, cats, and endotoxin early in childhood protects against the development of atopy. Prolonged breastfeeding, not necessarily exclusive, is beneficial. There is also a decreased risk of asthma, AR, and atopic sensitization with early introduction to wheat, rye, oats, barley, fish, and eggs. However, reduced diversity of the intestinal microbiota during infancy is associated with increased risk of allergic disease at school age.

### ETIOLOGY AND CLASSIFICATION

Two factors necessary for expression of AR are sensitivity to an allergen and the presence of the allergen in the environment. AR classification as **seasonal** or **perennial** is giving way to the designations **intermittent** and **persistent**. The two sets of terms are based on different suppositions, but inhalant allergens are the main cause of all forms of AR irrespective of terminology. AR may also be categorized as **mild-intermittent**, **moderate-severe intermittent**, **mild-persistent**, and **moderate-severe persistent** (Fig. 184.1). The symptoms of intermittent AR occur on <4 days per week or for <4 consecutive weeks. In persistent AR, symptoms occur on >4 days per week and/or for >4 consecutive weeks. The symptoms are considered mild when they are not troublesome, the sleep is normal, there is no impairment in daily activities, and there is no incapacity at work or school. Severe symptoms result in sleep disturbance and impairment in daily activities and school performance.

In temperate climates, airborne pollen responsible for exacerbation of intermittent AR appear in distinct phases: trees pollinate in the spring, grasses in the early summer, and weeds in the late summer. In temperate climates, mold spores persist outdoors only in the summer, but in warm climates they persist throughout the year. Symptoms of

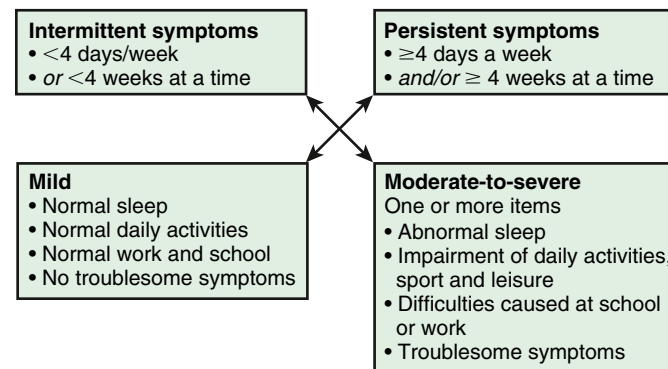
intermittent AR typically cease with the appearance of frost. Knowledge of the time of symptom occurrence, the regional patterns of pollination and mold sporulation, and the patient's allergen-specific IgE (sIgE) is necessary to recognize the cause of intermittent AR. Persistent AR is most often associated with the indoor allergens: house dust mites, animal danders, mice, and cockroaches. Cat and dog allergies are of major importance in the United States. The allergens from saliva and sebaceous secretions may remain airborne for a prolonged time. The ubiquitous major cat allergen, Fel d 1, may be carried on cat owners' clothing into such "cat-free" settings as schools and hospitals.

### PATHOGENESIS

The exposure of an atopic host to an allergen leads to the production of sIgE, which is strongly associated with eczema throughout childhood and with asthma and rhinitis after age 4 years. The clinical reactions on reexposure to the allergen have been designated as *early-phase* and *late-phase* allergic responses. Bridging of the IgE molecules on the surface of mast cells by allergen initiates the early-phase allergic response, characterized by degranulation of mast cells and release of preformed and newly generated inflammatory mediators, including histamine, prostaglandin 2, and the cysteinyl leukotrienes. The late-phase allergic response appears 4–8 hour following allergen exposure. Inflammatory cells, including basophils, eosinophils, neutrophils, mast cells, and mononuclear cells, infiltrate the nasal mucosa. Eosinophils release proinflammatory mediators, including cysteinyl leukotrienes, cationic proteins, eosinophil peroxidase, and major basic protein, and serve as a source of interleukin (IL)-3, IL-5, granulocyte-macrophage colony-stimulating factor, and IL-13. Repeated intranasal introduction of allergens causes "priming," which is a more brisk response even with a lesser provocation. Over the course of an allergy season, a multifold increase in submucosal mast cells takes place. These cells, once thought to have a role exclusively in the early-phase allergic response, have an important function in sustaining chronic allergic disease.

### CLINICAL MANIFESTATIONS

Symptoms of AR may be ignored or mistakenly attributed to a respiratory infection. Older children blow their noses, but younger children tend to sniff and snort. Nasal itching brings on grimacing, twitching, and picking of the nose that may result in epistaxis. Children with AR often perform the **allergic salute**, an upward rubbing of the nose with an open palm or extended index finger. This maneuver relieves itching and briefly unblocks the nasal airway. It also gives rise to the **nasal crease**, a horizontal skin fold over the bridge of the nose. The diagnosis of AR is based on symptoms in the absence of an upper respiratory tract infection and structural abnormalities. Typical complaints include



**Fig. 184.1** Global Allergic Rhinitis and Its Impact on Asthma (ARIA) classification of allergic rhinitis. Every box can be subclassified further into seasonal or perennial on the basis of timing of symptoms or when causative and allergen therapeutic factors are considered. For example, a UK patient with grass pollen allergy might have moderate-severe persistent seasonal rhinitis in June and July and may be suitable for specific allergen immunotherapy. (From Scadding GK, Durham SR, Mirakian R, et al. *BASCI guidelines for the management of allergic and non-allergic rhinitis*. *Clin Exp Allergy*. 2008;38:19–42.)

intermittent nasal congestion, itching, sneezing, clear rhinorrhea, and conjunctival irritation. Symptoms increase with greater exposure to the responsible allergen. The patients may lose their sense of smell and taste, though this has also been noted as a symptom of mild COVID-19 or other viral upper respiratory infections. Some experience headaches, wheezing, and coughing. Preschoolers with chronic wheezing and rhinitis experience more severe wheezing than children without rhinitis. Nasal congestion is often more severe at night, inducing mouth breathing and snoring, interfering with sleep, and rousing irritability.

Signs on physical examination include abnormalities of facial development, dental malocclusion, the **allergic gape** (continuous open-mouth breathing), chapped lips, **allergic shiners** (dark circles under the eyes; see Fig. 183.1), and the transverse nasal crease. Conjunctival edema, itching, tearing, and hyperemia are frequent findings. A nasal exam performed with a source of light and a speculum may reveal clear nasal secretions; edematous, boggy, and bluish mucus membranes with little or no erythema; and swollen turbinates that may block the nasal airway. It may be necessary to use a topical decongestant to perform an adequate examination. Thick, purulent nasal secretions indicate the presence of infection.

### DIFFERENTIAL DIAGNOSIS

Evaluation of AR entails a thorough history, including details of the patient's environment and diet and a family history of allergic conditions (e.g., eczema, asthma, AR), physical examination, and laboratory evaluation. The history and laboratory findings provide clues to the provoking factors. Symptoms such as sneezing, rhinorrhea, nasal itching, and congestion and lab findings of elevated IgE, sIgE antibodies, and positive allergy skin test results typify AR. Intermittent AR differs from persistent AR by history and skin test results. **Nonallergic rhinitides** give rise to sporadic symptoms; their causes are often unknown. Nonallergic inflammatory rhinitis with eosinophils imitates AR in presentation and response to treatment, but without elevated IgE antibodies. **Vasomotor rhinitis** is characterized by excessive responsiveness of the nasal mucosa to physical stimuli. Other nonallergic conditions, such as infectious rhinitis, structural problems (e.g., nasal polyps, septal deviation), **rhinitis medicamentosa** (caused by overuse of topical vasoconstrictors), hormonal rhinitis associated with pregnancy or hypothyroidism, neoplasms, vasculitides, and granulomatous disorders may mimic AR (Table 184.1 and Fig. 184.2). Occupational risks for rhinitis include exposure to allergens (grain dust, insects, latex, enzymes) and irritants (wood dust, paint, solvents, smoke, cold air).

### COMPLICATIONS

AR is associated with complications and comorbid conditions. Undertreated AR detracts from the quality of life, aggravates asthma, and enhances its progression. Children with AR experience frustration over their appearance. Allergic conjunctivitis, characterized by itching, redness, and swelling of the conjunctivae, has been reported in at least 20% of the population and >70% of patients with AR, most frequently in older children and young adults. The two conditions share pathophysiologic mechanisms and epidemiologic characteristics (see Chapter 188). Chronic sinusitis is a common complication of AR, sometimes associated with purulent infection, but most patients have negative bacterial cultures despite marked mucosal thickening, and sinus opacification. The inflammatory process is characterized by marked eosinophilia.

**Aspirin-exacerbated respiratory disease (AERD)** is characterized by the presence of chronic rhinosinusitis with nasal polyposis, asthma, and aspirin sensitivity. The pathophysiology of AERD is not fully understood and symptoms often respond poorly to therapy such as leukotriene modifiers, intranasal or systemic steroids, and aspirin desensitization. Surgical removal of nasal polyps is also a common intervention; however, the rate of recurrence is high with frequent regrowth of polyps. New biologic therapies are available for patients with chronic rhinosinusitis with nasal polyposis and patients with AERD may benefit from the addition of these new therapies.

**Table 184.1** Causes of Rhinitis

#### ALLERGIC RHINITIS

- Seasonal
- Perennial
- Perennial with seasonal exacerbations

#### NONALLERGIC RHINITIS

##### Structural/Mechanical Factors

- Deviated septum/septal wall anomalies
- Hypertrophic turbinates
- Adenoidal hypertrophy
- Foreign bodies
- Nasal tumors
  - Benign
  - Malignant
- Choanal atresia
- CSF leakage

##### Infectious

- Acute infections
- Chronic infections
- Congenital syphilis

##### Inflammatory/Immunologic

- Granulomatosis with polyangiitis
- Sarcoidosis
- Midline granuloma
- Systemic lupus erythematosus
- Sjögren syndrome
- Nasal polyposis

##### Physiologic

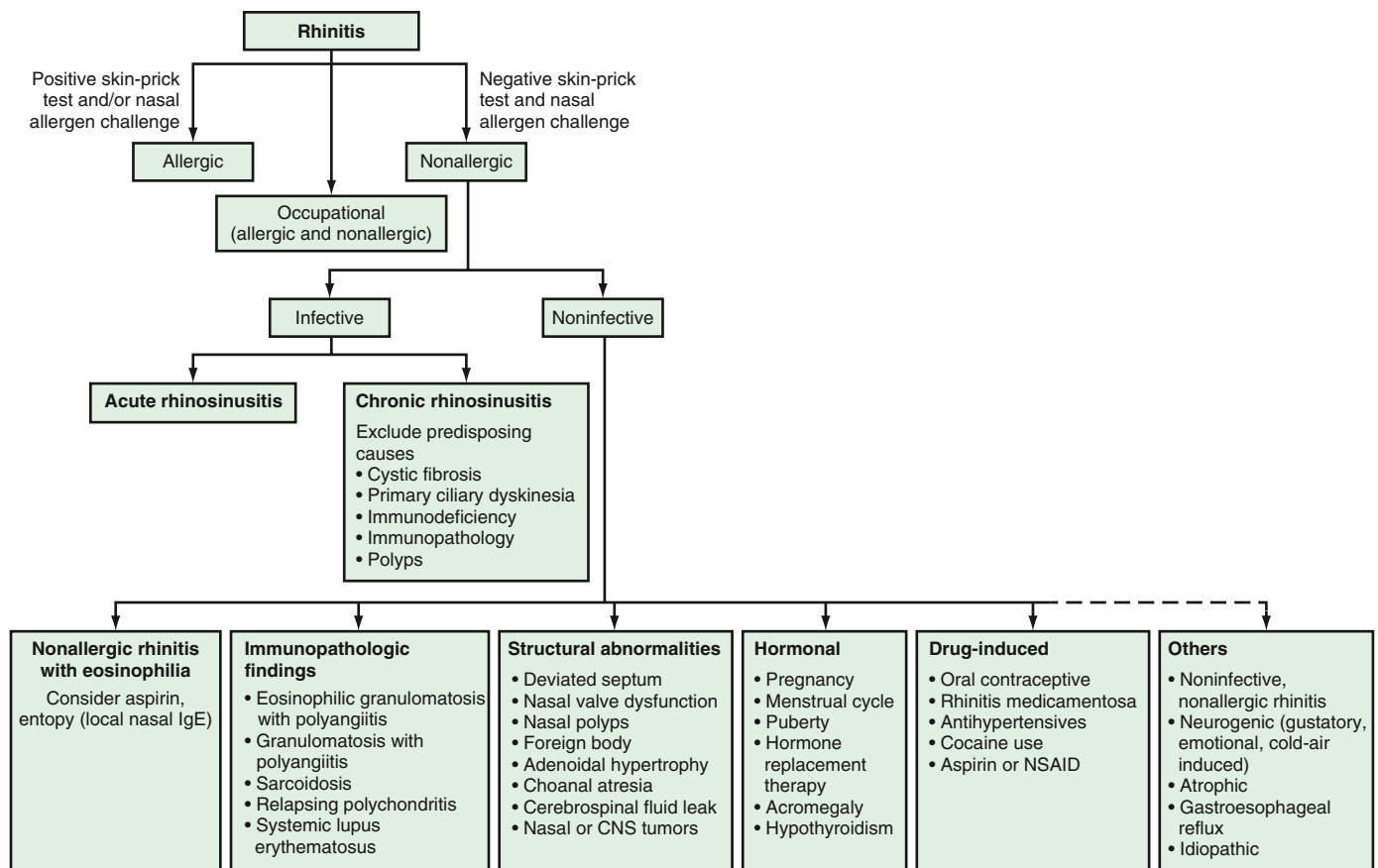
- Primary ciliary dyskinesia
- Atrophic rhinitis
- Hormonally induced
  - Hypothyroidism
  - Pregnancy
  - Oral contraceptives
  - Menstrual cycle
- Exercise
- Atrophic
- Drug induced
  - Rhinitis medicamentosa
  - Oral contraceptives
  - Antihypertensive therapy
  - Aspirin
  - Nonsteroidal antiinflammatory drugs
  - Cocaine
- Reflex induced
  - Gustatory rhinitis
  - Chemical or irritant induced
  - Posture reflexes
  - Nasal cycle
- Environmental factors
  - Odors
  - Temperature (cold air)
  - Weather/barometric pressure
  - Occupational (irritants)

#### OTHER

- Nonallergic rhinitis with eosinophilia syndrome
- Perennial nonallergic rhinitis (vasomotor rhinitis)
- Emotional factors

From Skoner DP. Allergic rhinitis: definition, epidemiology, pathophysiology, detection, and diagnosis. *J Allergy Clin Immunol*. 2001;108(1 Suppl):108:S2–S8.

Rhinitis that coexists with asthma may be taken too lightly or completely overlooked. Up to 78% of patients with asthma have AR, and 38% of patients with AR have asthma. Aggravation of AR coincides with exacerbation of asthma, and treatment of nasal inflammation reduces bronchospasm, asthma-related emergency department visits, and hospitalizations. Postnasal drip associated with AR commonly causes persistent or recurrent cough. Eustachian tube obstruction



**Fig. 184.2** Diagnostic algorithm for rhinitis. Nasal allergen challenge is a research procedure and is not undertaken routinely. CNS, Central nervous system; NSAID, nonsteroidal antiinflammatory drug. (From Greiner AN, Hellings PW, Rotiroti G, Scadding GK. Allergic rhinitis. *Lancet*. 2011;378:2112–2120.)

and middle ear effusion are frequent complications. Chronic allergic inflammation causes hypertrophy of adenoids and tonsils that may be associated with eustachian tube obstruction, serous effusion, otitis media, and obstructive sleep apnea. AR is linked to snoring in children. The association between rhinitis and sleep abnormalities and subsequent daytime fatigue is well documented and may require multidisciplinary intervention.

The Pediatric Rhinoconjunctivitis Quality of Life Questionnaire (PRQLQ) is suitable for children 6–12 years old, and the Adolescent Rhinoconjunctivitis Quality of Life Questionnaire (ARQLQ) is appropriate for patients 12–17 years old. Children with rhinitis have anxiety and physical, social, and emotional issues that affect learning and the ability to integrate with peers. The disorder contributes to headaches and fatigue, limits daily activities, and interferes with sleep. There is evidence of impaired cognitive functioning and learning that may be exacerbated by the adverse effects of sedating medications. AR causes an estimated 824,000 missed school days and 4,230,000 days of decline in quality-of-life activities. Patients with AR report an impairment in the activities of daily living similar to patients with moderate to severe asthma. Some (but not many) patients improve during their teenage years, only to develop symptoms again as young adults. Symptoms often abate in the fifth decade of life.

### LABORATORY FINDINGS

Epicutaneous skin tests provide the best method for detection of sIgE, with a positive predictive value (PPV) of 48.7% for epidemiologic diagnosis of AR. Skin tests are inexpensive and sensitive, and the risks and discomfort are minimal. Responses to seasonal respiratory allergens are rare before two seasons of exposure, and children <1 year old seldom display positive skin test responses to these allergens. To avoid false-negative results, montelukast should be withheld for 1 day, most

sedating antihistamine preparations for 3–4 days, and nonsedating antihistamines for 5–7 days. Serum immunoassays for sIgE provide a suitable alternative (PPV of 43.5%) for patients with dermatographism or extensive dermatitis, those taking medications that interfere with mast cell degranulation, others at high risk for anaphylaxis, and some who cannot cooperate with the procedure. Presence of eosinophils in the nasal smear supports the diagnosis of AR, and neutrophils suggest infectious rhinitis. Eosinophilia and measurements of total serum IgE concentrations have relatively low sensitivity.

### TREATMENT

Guideline-directed management has been shown to improve disease control. **Global Allergic Rhinitis and its Impact on Asthma (ARIA)** provides an evidence-based approach to treatment and includes quality-of-life measures useful for the evaluation of symptoms and the assessment of the response to therapy. Safe effective prevention and relief of symptoms are the current goals of treatment. **Specific measures to limit indoor allergen exposure may reduce the risk of sensitization and symptoms of allergic respiratory disease.** Sealing the patient's mattress, pillow, and covers in allergen-proof encasings reduces the exposure to mite allergen. Bed linen and blankets should be washed every week in hot water (>54.4°C [130°F]). The only effective measure for avoiding animal allergens in the home is the removal of the pet. Avoidance of pollen and outdoor molds can be accomplished by staying in a controlled environment. Air conditioning allows for keeping windows and doors closed, reducing the pollen exposure. High-efficiency particulate air (HEPA) filters lower the counts of airborne mold spores.

**Oral antihistamines help reduce sneezing, rhinorrhea, and ocular symptoms.** Administered as needed, antihistamines provide acceptable treatment for mild-intermittent disease. Antihistamines have been

**Table 184.2** Oral Allergic Rhinitis Treatments (Prescription, Examples)

GENERIC/BRAND	STRENGTH	FORMULATIONS	DOSING
<b>SECOND-GENERATION ANTIHISTAMINES</b>			
<i>Desloratadine</i>			
Clarinet Reditabs*	2.5 mg, 5 mg	Orally disintegrating tablet	Children 6-11 mo of age: 1 mg once daily
Clarinet Tablets	5 mg	Tabs	Children 12 mo to 5yr: 1.25 mg once daily
Clarinet Syrup	0.5 mg/mL	Syrup	Children 6-11 yr: 2.5 mg once daily Adults and adolescents ≥12yr: 5 mg once daily
<b>LEUKOTRIENE ANTAGONIST<sup>†</sup></b>			
<i>Montelukast</i>			
Singulair	10 mg	Tablets	6 mo to 5yr: 4 mg daily
Singulair Chewables*	4 mg, 5 mg	Chewable tablets	6-14yr: 5 mg daily
Singulair Oral Granules	4 mg/packet	Oral granules	>14yr: 10 mg daily

\*Contains phenylalanine

<sup>†</sup>As advised by the FDA, montelukast should be used to treat allergic rhinitis only in patients who are not treated effectively with or cannot tolerate other alternative therapies.Dosing recommendations taken in part from Kleinman K, McDaniel L, Mollay M for the Johns Hopkins Hospital. *The Harriet Lane Handbook*. 22nd ed. Philadelphia: Elsevier; 2021.

classified as **first generation** (relatively sedating) or **second generation** (relatively nonsedating). Antihistamines usually are administered by mouth but are also available for topical ophthalmic and intranasal use. Both first- and second-generation antihistamines are available as nonprescription drugs. **Second-generation antihistamines are preferred because they cause less sedation.** Preparations containing **pseudoephedrine**, typically in combination with other agents, are used for relief of nasal and sinus congestion and pressure and other symptoms such as rhinorrhea, sneezing, lacrimation, itching eyes, oronasopharyngeal itching, and cough. These are not considered first-line agents and should be used with caution. Pseudoephedrine is available without prescription generally in fixed combination with other agents such as first-generation antihistamines (brompheniramine, chlorpheniramine, triprolidine), second-generation antihistamines (desloratadine, fexofenadine, loratadine), antipyretics (acetaminophen, ibuprofen), antitussives (guaifenesin, dextromethorphan), and an anticholinergic (methscopolamine). Pseudoephedrine is an oral vasoconstrictor distrusted for causing irritability and insomnia and for its association with infant mortality. Because younger children (2-3 years) are at increased risk of overdosage and toxicity, some manufacturers of oral nonprescription cough and cold preparations have voluntarily revised their product labeling to warn against the use of preparations containing pseudoephedrine for children <4 years old. Pseudoephedrine is misused as a starting material for the synthesis of methamphetamine and methcathinone. [Tables 184.2, 184.3, and 184.4](#) provide examples of prescription, nonprescription, and combined oral agents, respectively, for treatment of AR. Oral leukotriene receptor antagonists are not recommended for initial treatment of AR because of reduced efficacy compared to other agents and serious neuropsychiatric events that have been reported with montelukast.

The anticholinergic **nasal spray** ipratropium bromide is effective for the treatment of *serous* rhinorrhea ([Table 184.5](#)). **Intranasal decongestants** (oxymetazoline and phenylephrine) should be used for <5 days and should not be repeated more than once a month to avoid rebound nasal congestion. Sodium cromoglycate (available as nonprescription drug) is effective but requires frequent administration, every 4 hours. Leukotriene-modifying agents have a modest effect on rhinorrhea and nasal blockage (see [Chapter 185](#) for additional indications and side effects). Nasal saline irrigation is a good adjunctive option with all other treatments of AR. Patients with more persistent, severe symptoms require **intranasal corticosteroids**, the

most effective therapy for AR, which may also be beneficial for concomitant allergic conjunctivitis ([Table 184.6](#)). These agents reduce the symptoms of AR with eosinophilic inflammation, but not those of rhinitis associated with neutrophils or free of inflammation. Beclomethasone, triamcinolone, and flunisolide are absorbed from the gastrointestinal tract, as well as from the respiratory tract; budesonide, fluticasone, mometasone, and ciclesonide offer greater topical activity with lower systemic exposure. More severely affected patients may benefit from simultaneous treatment with oral antihistamines and intranasal corticosteroids.

**Allergen-specific immunotherapy is a well-defined treatment for IgE-mediated allergic disease.** It may be administered by subcutaneous or sublingual routes. **Sublingual immunotherapy** (SLIT) has been used successfully in Europe and South America and is now approved by the U.S. Food and Drug Administration. **Allergy immunotherapy** (AIT) is an effective treatment for AR and allergic conjunctivitis. In addition to reducing symptoms, it may change the course of allergic disease and induce allergen-specific immune tolerance. Immunotherapy should be considered for children in whom IgE-mediated allergic symptoms cannot be adequately controlled by avoidance and medication, especially in the presence of comorbid conditions. Immunotherapy for AR prevents the onset of asthma. Moreover, progress in molecular characterization of allergens raises the possibility of defined vaccines for allergen immunotherapy. Omalizumab (anti-IgE antibody) is effective for difficult-to-control asthma and is likely to have a beneficial effect on coexisting AR. Dupilumab (IL-4 antagonist) is approved *in adults* for the treatment of chronic rhinosinusitis with nasal polyposis and has shown improvement in nasal symptoms scores as well as improvements in lung function among patients with AERD.

Typically, treatment of AR with oral antihistamines and nasal corticosteroids provides sufficient relief for most patients with coexisting **allergic conjunctivitis**. If it fails, additional therapies directed primarily at allergic conjunctivitis may be added (see [Chapter 188](#)). Intranasal corticosteroids are of some value for the treatment of ocular symptoms, but ophthalmic corticosteroids remain the most potent pharmacologic agents for ocular allergy, although they carry the risk of adverse effects such as delayed wound healing, secondary infection, elevated intraocular pressure, and formation of cataracts. Ophthalmic corticosteroids are only suited for the treatment of allergic conjunctivitis that does not respond to the medications previously discussed. Sound practice calls for the assistance of an ophthalmologist.



**Table 184.3** Oral Allergic Rhinitis Treatments (Nonprescription, Examples)

GENERIC/BRAND	STRENGTH	FORMULATIONS	DOSING
<b>FIRST-GENERATION H<sub>1</sub> ANTAGONISTS</b>			
<i>Chlorpheniramine maleate</i>			
Chlor-Trimeton OTC	4 mg	Tablets	2-5yr: 1 mg every 4-6 hr (max 6 mg/day) 6-11 yr: 2 mg every 4-6 hr (max 12 mg/day)
Chlor-Trimeton Syrup OTC	2 mg/5mL	Syrup	>12yr: 4 mg every 4-6 hr (max 24 mg/day)
<b>SECOND-GENERATION H<sub>1</sub> ANTAGONISTS</b>			
<i>Cetirizine</i>			
Children's Zyrtec Allergy Syrup OTC	1 mg/mL	Syrup	6-11 mo: 2.5 mg daily
Children's Zyrtec Chewable OTC	5 mg, 10 mg	Chewable tablets	12-23 mo: initial 2.5 mg once daily; dosage may be increased to 2.5 mg twice daily
Zyrtec Tablets OTC	5 mg, 10 mg	Tablets	2-5yr: 2.5 mg/day; may be increased to max of 5 mg/day given either as a single dose or divided into two doses
Zyrtec Liquid Gels OTC	10 mg	Liquid-filled gels	≥6yr: 5-10 mg/day as a single dose or divided into two doses
<i>Levocetirizine</i> Xyzal	5 mg 0.5 mg/mL	Tablet Oral solution	6 mo-5yr: 1.25 mg daily in the evening 6-11 yr: 2.5 mg daily in the evening ≥12 yr: 5 mg daily in the evening
<i>Desloratadine</i>			
Clarinx	0.5 mg/mL	Oral solution	6-11 mo: 1 mg daily 1-5 yr: 1.25 mg daily 6-11 yr: 2.5 mg daily
Clarinx	5 mg	Tablet	≥12 yr 5 mg daily
Fexofenadine HCl OTC	30 mg, 60 mg, 180 mg	Tablet	6-11 yr: 30 mg twice daily 12-adult: 60 mg twice daily; 180 mg daily
Children's Allegra OTC ODT*	30 mg	ODTs	6-11 yr: 30 mg twice daily
Children's Allegra Oral Suspension OTC	30 mg/5 mL	Suspension	>2-11 yr: 30 mg every 12 hr
Allegra OTC	Tabs 30, 60, 180 mg	Tablet	>12 yr-adult: 60 mg every 12 hr; 180 mg daily
<i>Loratadine</i>			
Children's Claritin OTC	5 mg/5 mL	Syrup	2-5yr: 5 mg daily 6-adult: 10 mg daily
Alavert OTC ODT*	10 mg 10 mg 10 mg 5 mg 1 mg/mL	ODTs Tablets Liquid-filled caps Chewable tablets Syrup	2-5yr: 5 mg daily >6 yr: 10 mg once daily or 5 mg twice daily

\*Contains phenylalanine.

ODT, Orally disintegrating tablet; OTC, over the counter.

Dosing recommendations taken in part from Kleinman K, McDaniel L, Molloy M for the Johns Hopkins Hospital. *The Harriet Lane Handbook*. 22nd ed. Philadelphia: Elsevier; 2021.**Table 184.4** Combined Antihistamine + Sympathomimetic (Examples)

GENERIC	STRENGTH	FORMULATIONS	DOSING
Chlorpheniramine maleate Phenylephrine HCl Sudafed Sinus & Allergy	4 mg 10 mg	Tablets	>12 yr: 1 tablet every 4 hr, not to exceed 6 tablets per day
Cetirizine + pseudoephedrine Zyrtec-D 12 hour	5 mg cetirizine + 120 mg pseudoephedrine	Extended-release tablet	>12 yr: 1 tablet every 12 hr

Dosing recommendations taken in part from Kleinman K, McDaniel L, Molloy M for the Johns Hopkins Hospital. *The Harriet Lane Handbook*. 22nd ed. Philadelphia: Elsevier; 2021.

Table 184.5 Miscellaneous Intranasal Sprays		
DRUG	INDICATIONS (I), MECHANISM(S) OF ACTION (M), AND DOSING	COMMENTS, CAUTIONS, ADVERSE EVENTS, AND MONITORING
Ipratropium bromide	<i>I</i> : Symptomatic relief of rhinorrhea <i>M</i> : Anticholinergic	Atrovent inhalation aerosol is contraindicated in patients with hypersensitivity to soy lecithin Safety and efficacy of use beyond 4 days in patients with the common cold have not been established <i>Adverse effects</i> : Epistaxis, nasal dryness, nausea
Atrovent nasal spray (0.06%)	Colds (symptomatic relief of rhinorrhea): 5-12 yr: 2 sprays in each nostril tid ≥12 yr and adults: 2 sprays in each nostril tid-qid	
Azelastine	<i>I</i> : Treatment of rhinorrhea, sneezing, and nasal pruritus <i>M</i> : Antagonism of histamine H <sub>1</sub> receptor	May cause drowsiness <i>Adverse effects</i> : Headache, somnolence, bitter taste
Astelin	6-12 yr: 1 spray bid >12 yr: 1-2 sprays bid	
Cromolyn sodium	<i>I</i> : AR <i>M</i> : Inhibition of mast cell degranulation	Not effective immediately; requires frequent administration
NasalCrom	>2 yr: 1 spray tid-qid; max 6 times daily	
Oxymetazoline Afrin Nostrilla	<i>I</i> : Symptomatic relief of nasal mucosal congestion <i>M</i> : Adrenergic agonist, vasoconstricting agent 0.05% solution: instill 2-3 sprays into each nostril bid; therapy should not exceed 3 days	Excessive dosage may cause profound CNS depression Use in excess of 3 days may result in severe rebound nasal congestion Do not repeat more than once a month Use with caution in patients with hyperthyroidism, heart disease, hypertension, or diabetes <i>Adverse effects</i> : Hypertension, palpitations, reflex bradycardia, nervousness, dizziness, insomnia, headache, CNS depression, convulsions, hallucinations, nausea, vomiting, mydriasis, elevated intraocular pressure, blurred vision
Phenylephrine	<i>I</i> : Symptomatic relief of nasal mucosal congestion <i>M</i> : Adrenergic, vasoconstricting agent	Use in excess of 3 days may result in severe rebound nasal congestion Do not repeat more than once a month
Neo-Synephrine	2-6 yr: 1 drop every 2-4 hr of 0.125% solution as needed <i>Note</i> : Therapy should not exceed 3 continuous days 6-12 yr: 1-2 sprays or 1-2 drops every 4 hr of 0.25% solution as needed <i>Note</i> : Therapy should not exceed 3 continuous days >12 yr: 1-2 sprays or 1-2 drops every 4 hr of 0.25% to 0.5% solution as needed; 1% solution may be used in adults with extreme nasal congestion <i>Note</i> : Therapy should not exceed 3 continuous days	0.16% and 0.125% solutions are not commercially available <i>Adverse effects</i> : Reflex bradycardia, excitability, headache, anxiety, dizziness

bid, 2 times daily; CNS, central nervous system; tid, 3 times daily; qid, 4 times daily.

Table 184.6 Intranasal Inhaled Corticosteroids		
DRUG	INDICATIONS (I), MECHANISM(S) OF ACTION (M), AND DOSING	COMMENTS, CAUTIONS, ADVERSE EVENTS, AND MONITORING
Beclomethasone OTC	<i>I</i> : AR <i>M</i> : Antiinflammatory, immune modulator	Shake container before use; blow nose; occlude one nostril, administer dose to the other nostril <i>Adverse effects</i> : Burning and irritation of nasal mucosa, epistaxis Monitor growth
Beconase AQ (42 µg/spray) Qnasl (80 µg/spray) OTC	6-12 yr: 1 spray in each nostril bid; may increase if needed to 2 sprays in each nostril bid >12 yr: 1 or 2 sprays in each nostril bid	
Flunisolide OTC	6-14 yr: 1 spray in each nostril tid or 2 sprays in each nostril bid; not to exceed 4 sprays/day in each nostril ≥15 yr: 2 sprays in each nostril bid (morning and evening); may increase to 2 sprays tid; maximum dose: 8 sprays/day in each nostril (400 µg/day)	Shake container before use; blow nose; occlude one nostril, administer dose to the other nostril <i>Adverse effects</i> : Burning and irritation of nasal mucosa, epistaxis Monitor growth

**Table 184.6** Intranasal Inhaled Corticosteroids—cont'd

DRUG	INDICATIONS (I), MECHANISM(S) OF ACTION (M), AND DOSING	COMMENTS, CAUTIONS, ADVERSE EVENTS, AND MONITORING
Triamcinolone Nasacort AQ (55 µg/spray) OTC	I: AR M: Antiinflammatory, immune modulator	Shake container before use; blow nose; occlude one nostril, administer dose to the other nostril <i>Adverse effects:</i> Burning and irritation of nasal mucosa, epistaxis Monitor growth
Fluticasone propionate (available as generic preparation) OTC	2-6yr: 1 spray in each nostril qd 6-12 yr: 1-2 sprays in each nostril qd ≥12 yr: 2 sprays in each nostril qd  I: AR M: Antiinflammatory, immune modulator	Shake container before use; blow nose; occlude one nostril, administer dose to the other nostril Ritonavir significantly increases fluticasone serum concentrations and may result in systemic corticosteroid effects Use fluticasone with caution in patients receiving ketoconazole or other potent cytochrome P450 3A4 isoenzyme inhibitor <i>Adverse effects:</i> Burning and irritation of nasal mucosa, epistaxis Monitor growth
Flonase (50 µg/spray) OTC	≥4yr: 1-2 sprays in each nostril qd	
Fluticasone furoate Veramyst (27.5 µg/spray)	2-12yr: Initial dose: 1 spray (27.5 µg/spray) per nostril qd (55 µg/day) Patients who do not show adequate response may use 2 sprays per nostril qd (110 µg/day) Once symptoms are controlled, dosage may be reduced to 55 µg qd Total daily dosage should not exceed 2 sprays in each nostril (110 µg)/day ≥12 yr and adolescents: Initial dose: 2 sprays (27.5 µg/spray) per nostril qd (110 µg/day) Once symptoms are controlled, dosage may be reduced to 1 spray per nostril qd (55 µg/day) Total daily dosage should not exceed 2 sprays in each nostril (110 µg)/day	
Mometasone	I: AR M: Antiinflammatory, immune modulator	Mometasone and its major metabolites are undetectable in plasma after nasal administration of recommended doses Preventive treatment of seasonal AR should begin 2-4 wk before pollen season Shake container before use; blow nose; occlude one nostril, administer dose to the other nostril <i>Adverse effects:</i> Burning and irritation of nasal mucosa, epistaxis Monitor growth
Nasonex (50 µg/spray)	2-12yr: 1 spray in each nostril qd >12 yr: 2 sprays in each nostril qd	
Budesonide OTC	I: AR M: Antiinflammatory, immune modulator	Shake container before use; blow nose; occlude one nostril, administer dose to the other nostril <i>Adverse effects:</i> Burning and irritation of nasal mucosa, epistaxis Monitor growth
Rhinocort Aqua (32 µg/spray) OTC	6-12yr: 2 sprays in each nostril qd >12 yr: up to 4 sprays in each nostril qd (max dose)	
Ciclesonide	I: AR M: Antiinflammatory, immune modulator	Before initial use, gently shake, then prime the pump by actuating 8 times If the product is not used for 4 consecutive days, gently shake and reprime with 1 spray or until a fine mist appears
Omna- ris Zetonna (50 µg/spray)	2-12yr: 1-2 sprays in each nostril qd >12 yr: 2 sprays in each nostril qd	
Azelastine/fluticasone (137 µg azelastine/50 µg fluticasone) Dymista	≥6yr: 1 spray in each nostril bid	Shake bottle gently before using Blow nose to clear nostrils Keep head tilted downward when spraying Insert applicator tip 1/4 to 1/2 inch into nostril, keeping bottle upright, and close off the other nostril Breathe in through nose While inhaling, press pump to release spray

OTC, Over the counter; AR, allergic rhinitis; qd, once daily; bid, 2 times daily; tid, 3 times daily.

## PROGNOSIS

Therapy with nonsedating antihistamines and topical corticosteroids, when taken appropriately, improves health-related quality-of-life measures in patients with AR. The reported rates of remission among children are 10–23%. Pharmacotherapy that will target cells and cytokines

involved in inflammation and treat allergy as a systemic process is on the horizon, and more selective targeting of drugs based on the development of specific biomarkers and genetic profiling may soon be realized.

Visit Elsevier eBooks+ at [eBooks.Health.Elsevier.com](http://eBooks.Health.Elsevier.com) for Bibliography.

## Bibliography

- Burks AW, Calderon MA, Casale T, et al. Update on allergy immunotherapy: American Academy of Allergy, Asthma & Immunology/European Academy of Allergy and Clinical Immunology/PRACTALL consensus report. *J Allergy Clin Immunol*. 2013;131:1288–1296.
- Codispoti CD, Bernstein DI, Levin L, et al. Early-life mold and tree sensitivity is associated with allergic eosinophilic rhinitis at 4 yr of age. *Ann Allergy Asthma Immunol*. 2015;114:193–198.e4.
- Cox LS. Sublingual immunotherapy for allergic rhinitis—is 2-year treatment sufficient for long-term benefit? *JAMA*. 2017;317(6):591–593.
- Dykewicz MS, Wallace DV, Amrol DJ, et al. Rhinitis 2020: A practice parameter update. *J Allergy Clin Immunol*. 2020;146(4):721–767.
- Federal Drug Administration. *Singulair (montelukast) and all montelukast generics: strengthened boxed warning – due to restricting use for allergic rhinitis*. <https://www.fda.gov/safety/medical-product-safety-information/singulair-montelukast-and-all-montelukast-generics-strengthened-boxed-warning-due-restricting-use>.
- Garcia-Aymerich J, Benet M, Saeys Y, et al. Phenotyping asthma, rhinitis and eczema in MeDALL population-based birth cohorts: an allergic comorbidity cluster. *Allergy*. 2015;70:973–984.
- Kim JM, Lin SY, Suarez-Cuervo C, et al. Allergen-specific immunotherapy for pediatric asthma and rhinoconjunctivitis: a systematic review. *Pediatrics*. 2013;131(6):1155–1167.
- Laidlaw TM, Mullol J, Fan C, et al. Dupilumab improves nasal polyp burden and asthma control in patients with CRSwNP and AERD. *J Allergy Clin Immunol Pract*. 2019;7:2462.
- Lin SY, Erekosima N, Kim JM, et al. Sublingual immunotherapy for the treatment of allergic rhinoconjunctivitis and asthma: a systematic review. *JAMA*. 2013;309:1278–1288.
- Patil VK, Kurukulaaratchy RJ, Venter C, et al. Changing prevalence of wheeze, rhinitis and allergic sensitisation in late childhood: Findings from 2 Isle of Wight birth cohorts 12 yr apart. *Clin Exp Allergy*. 2015;45:1430–1438.
- Roberts G, Xatzipsalti M, Borrego LM, et al. Paediatric rhinitis: position paper of the European Academy of Allergy and Clinical Immunology. *Allergy*. 2013;68:1102–1116.
- Scadding GK. Optimal management of allergic rhinitis. *Arch Dis Child*. 2015;100:576–582.
- Schmitt J, Schwarz K, Stadler E, et al. Allergy immunotherapy for allergic rhinitis effectively prevents asthma: results from a large retrospective cohort study. *J Allergy Clin Immunol*. 2015;136:1511–1516.
- The Medical Letter. Allergic rhinitis. *Med Lett Drugs Ther*. 2017;59:71–80.
- Valenta R, Campana R, Focke-Tejkl M, et al. Vaccine development for allergen-specific immunotherapy based on recombinant allergens and synthetic allergen peptides: lessons from the past and novel mechanisms of action for the future. *J Allergy Clin Immunol*. 2016;137:351–357.
- Wallace DV, Dykewicz MS, Oppenheimer J, et al. Pharmacologic treatment of seasonal allergic rhinitis: synopsis of guidance from the 2017 joint task force on practice parameter. *Ann Intern Med*. 2017;167:876–881.
- Westman M, Lupinek C, Bousquet J, et al. Early childhood IgE reactivity to pathogenesis-related class 10 proteins predicts allergic rhinitis in adolescence. *J Allergy Clin Immunol*. 2015;135. 1199-1206.e1–1199-1206.e11.
- Wheatly LM, Togias A. Allergic rhinitis. *N Engl J Med*. 2015;372(15):456–462.



bronchiolitis in the first year of life is a significant predisposing factor for asthma at age 5 years. This association implies that host features affecting immunologic host defense, inflammation, and the extent of airways injury from ubiquitous viral pathogens underlie susceptibility to recurrent wheezing in early childhood. Other airways exposures can also exacerbate ongoing airways inflammation, increase disease severity, and drive asthma persistence. Home allergen exposures in sensitized individuals can initiate airways inflammation and hypersensitivity to other irritant exposures and are causally linked to disease severity, exacerbations, and persistence. Consequently, eliminating the offending allergen(s) can lead to resolution of asthma symptoms. Environmental tobacco smoke and common air pollutants can aggravate airways inflammation and increase asthma severity. Cold, dry air; hyperventilation from physical play or exercise; and strong odors can trigger bronchoconstriction. Although many exposures that trigger and aggravate asthma are well recognized, the causal environmental features underlying the development of host susceptibilities to the various common airway exposures are not as well defined. Living in rural or farming communities may be a protective environmental factor.

## EPIDEMIOLOGY

Asthma is a common chronic disease, causing considerable morbidity. In 2020 >7 million children (~11% of U.S. children) had been diagnosed with asthma, with 70% of this group reporting current asthma. Male gender and living in poverty are demographic risk factors for having childhood asthma in the United States. About 13% of males vs 9% of females have had asthma, and ~15% of all children living in poor families (family income less than poverty threshold) have asthma. Childhood asthma is among the most common causes of childhood emergency department (ED) visits, hospitalizations, and missed school days. In the United States in 2019, childhood asthma accounted for >750,000 ED visits, nearly 75,000 hospitalizations, and 178 deaths. However, there are ethnic disparities in asthma outcomes, with nearly three times more deaths as a result of asthma in Black non-Hispanic vs White non-Hispanic children.

Worldwide, childhood asthma appears to be increasing in prevalence, despite considerable improvements in our management and pharmacopeia to treat asthma. Although childhood asthma may have plateaued in the United States after 2008, numerous studies conducted in other countries have reported an increase in asthma prevalence of approximately 50% per decade. Globally, childhood asthma prevalence varies widely in different locales. A study of childhood asthma prevalence in 233 centers in 97 countries (International Study of Asthma and Allergies in Childhood, Phase 3) found a wide range in the prevalence of current wheeze in 6–7-year-old children (2.4–37.6%) and 13–14-year-old children (0.8–32.6%). Asthma prevalence correlated well with reported allergic rhinoconjunctivitis and atopic eczema prevalence. Childhood asthma seems more prevalent in modern metropolitan locales and more affluent nations, and is strongly linked with other allergic conditions. In contrast, children living in rural areas of developing countries and farming communities with domestic animals are less likely to experience asthma and allergy.

Approximately 80% of all asthmatic patients report disease onset before 6 years of age. However, of all young children who experience recurrent wheezing, only a minority go on to have persistent asthma in later childhood. Early childhood risk factors for persistent asthma have been identified (Table 185.1) and have been described as major (parent asthma, eczema, inhalant allergen sensitization) and minor (allergic rhinitis, wheezing apart from colds,  $\geq 4\%$  peripheral blood eosinophils, food allergen sensitization) risk factors. *Allergen sensitization (allergy) in young children with recurrent cough and/or wheeze* is the strongest identifiable factor for the persistence of childhood asthma.

## Types of Childhood Asthma

There are two common types of childhood asthma based on different natural courses: (1) **recurrent wheezing** in early childhood, primarily triggered by common respiratory viral infections, that usually resolves during the preschool/lower school years and (2) **chronic asthma** associated with *allergy* that persists into later childhood and often adulthood

**Table 185.1** Early Childhood Risk Factors for Persistent Asthma

Parental asthma*
Allergy
• Atopic dermatitis (eczema)*
• Allergic rhinitis
• Food allergy
• Inhalant allergen sensitization*
• Food allergen sensitization
Severe lower respiratory tract infection
• Pneumonia
• Bronchiolitis requiring hospitalization
Wheezing apart from colds
Male sex
Low birthweight
Environmental tobacco smoke exposure
Reduced lung function at birth
Formula feeding rather than breastfeeding

\*Major risk factors.

(Table 185.2). School-age children with mild to moderate persistent asthma generally improve as teenagers. About 40% of these children, most of whom have milder disease, will develop intermittent disease. Inhaled corticosteroid (ICS) controller therapy for children with persistent asthma does not alter the likelihood of outgrowing asthma in later childhood; however, reduced lung growth and progressive decline in lung function can be features of persistent, problematic disease.

Asthma is also classified by **disease severity** (e.g., intermittent or persistent [mild, moderate, or severe]) or **control** (e.g., well, not well, or very poorly controlled), especially for asthma management purposes. Because most children with asthma can be well controlled with conventional management guidelines, children with asthma can also be characterized according to treatment response and medication requirements as (1) **easy to control** (well controlled with low levels of controller therapy); (2) **difficult to control** (not as well controlled with multiple and/or high levels of controller therapies); (3) **exacerbators** (despite being controlled, continue to have severe exacerbations); and (4) **refractory asthma** (continue to have poorly controlled asthma despite multiple and high levels of controller therapies; see Table 185.2). Different airways pathologic processes, causing airways inflammation, AHR, and airways congestion and blockage, are believed to underlie these different types of asthma.

## PATHOGENESIS

Airflow obstruction in asthma is the result of numerous pathologic processes. In the small airways, airflow is regulated by smooth muscle encircling the airway lumen; bronchoconstriction of these bronchiolar muscular bands restricts or blocks airflow. A cellular inflammatory infiltrate and exudates distinguished by eosinophils, but also including other inflammatory cell types (neutrophils, monocytes, lymphocytes, mast cells, basophils), can fill and obstruct the airways and induce epithelial damage and desquamation into the airway's lumen. T lymphocytes and other immune cells that produce proallergic, proinflammatory cytokines (interleukin [IL]-4, IL-5, IL-13), and chemokines (eotaxins) mediate this inflammatory process. Hypersensitivity or susceptibility to a variety of provocative exposures or triggers (Table 185.3) can lead to airways inflammation, AHR, edema, basement membrane thickening, subepithelial collagen deposition, smooth muscle and mucous gland hypertrophy, and mucus hypersecretion, which are all processes that contribute to the clinical manifestations of asthma. Although most children with asthma manifest this proallergic “type 2” immunity and inflammation, other pathologic pathways can underlie asthma.

## CLINICAL MANIFESTATIONS AND DIAGNOSIS

Asthma is characterized by repeated episodes of intermittent dry coughing and expiratory wheezing. Older children and adults report

**Table 185.2** Asthma Patterns in Childhood, Based on Natural History and Asthma Management**TRANSIENT NONATOPIC WHEEZING**

Common in early preschool years

Recurrent cough/wheeze, primarily triggered by common respiratory viral infections

Usually resolves during the preschool and lower school years, without increased risk for asthma in later life

Reduced airflow at birth, suggestive of relatively narrow airways; AHR near birth; improves by school age

**PERSISTENT ATOPY-ASSOCIATED ASTHMA**

Begins in early preschool years

Associated with atopy in early preschool years

- Clinical (e.g., atopic dermatitis in infancy, allergic rhinitis, food allergy)
- Biologic (e.g., early inhalant allergen sensitization, increased serum IgE, increased blood eosinophils)

- Highest risk for persistence into later childhood and adulthood

Lung function abnormalities

- Those with onset before 3 yr of age acquire reduced airflow by school age
- Those with later onset of symptoms, or with later onset of allergen sensitization, are less likely to experience airflow limitation in childhood

**ASTHMA WITH DECLINING LUNG FUNCTION**

Children with asthma with progressive increase in airflow limitation

Associated with hyperinflation in childhood, male gender

**ASTHMA MANAGEMENT TYPES**

(From national and international asthma management guidelines)

**Severity Classification\***

- Intrinsic disease severity while not taking asthma medications

Intermittent

Persistent

- Mild
- Moderate
- Severe

**Control Classification\***

- Clinical assessment while asthma being managed and treated

Well controlled

Not well controlled

Very poorly controlled

**Management Patterns**

- *Easy-to-control*: well controlled with low levels of daily controller therapy
- *Difficult-to-control*: inadequately controlled with multiple and/or high levels of controller therapies
- *Frequent exacerbators*: have severe exacerbations
- *Refractory*: continue to have poorly controlled asthma despite multiple and high levels of controller therapies

\*From National Asthma Education and Prevention Program Expert Panel Report 3 (EPR3): *Guideline for the Diagnosis and Management of Asthma*, NIH Pub No 07-4051, Bethesda, MD, 2007, US Department of Health and Human Services; National Institutes of Health; National Heart, Lung, and Blood Institute Health; National Heart, Lung, and Blood Institute; National Asthma Education and Prevention Program.

<https://www.nhlbi.nih.gov/health-pro/guidelines/current/asthma-guidelines/full-report>. AHR, Airways hyperresponsiveness.

associated shortness of breath and chest congestion and tightness; younger children may report intermittent, nonfocal chest pain. Respiratory symptoms can be worse at night, associated with sleep, especially during prolonged exacerbations triggered by respiratory infections or inhalant allergens. Daytime symptoms, often linked with physical activities (exercise-induced) or play, are reported with greatest frequency in children. Other asthma symptoms in children can be subtle and nonspecific, including self-imposed limitation of physical activities, general fatigue (possibly resulting from sleep disturbance),

**Table 185.3** Asthma Triggers**COMMON VIRAL INFECTIONS OF THE RESPIRATORY TRACT AEROALLERGENS IN SENSITIZED ASTHMATIC PATIENTS****Indoor Allergens**

- Animal dander
- Dust mites
- Cockroaches
- Molds

**Seasonal Aeroallergens**

- Pollens (trees, grasses, weeds)
- Seasonal molds

**AIR POLLUTANTS**

- Environmental tobacco smoke
- Ozone
- Nitrogen dioxide
- Sulfur dioxide
- Particulate matter
- Wood- or coal-burning smoke
- Mycotoxins
- Endotoxin
- Dust

**STRONG OR NOXIOUS ODORS OR FUMES**

- Perfumes, hairsprays
- Cleaning agents

**OCCUPATIONAL EXPOSURES**

- Farm and barn exposures
- Formaldehydes, cedar, paint fumes
- Rhinitis
- Sinusitis
- Gastroesophageal reflux

**DRUGS**

- Aspirin and other nonsteroidal antiinflammatory drugs
- $\beta$ -Blocking agents

**OTHER**

- Cold dry air
- Exercise
- Crying, laughter, hyperventilation
- Comorbid conditions

and difficulty keeping up with peers in physical activities. Asking about previous experience with asthma medications (bronchodilators and/or corticosteroids) may provide a history of symptomatic improvement with treatment that supports the diagnosis of asthma. Lack of improvement with bronchodilator and corticosteroid therapy is inconsistent with underlying asthma and should prompt more vigorous consideration of asthma-masquerading conditions.

Asthma symptoms can be triggered by numerous common events or exposures: physical exertion and hyperventilation (laughing), cold or dry air, and airways irritants (see Table 185.3). Exposures that induce airways inflammation, such as infections with common respiratory pathogens (rhinovirus, RSV, enterovirus, coronavirus, metapneumovirus, parainfluenza virus, influenza virus, adenovirus, *Mycoplasma pneumoniae*, *Chlamydia pneumoniae*), and inhaled allergens in sensitized children, also increase AHR to dry, cold air and irritant exposures. An environmental history is essential for optimal asthma management.

The presence of risk factors, such as a history of other allergic conditions (allergic rhinitis, allergic conjunctivitis, atopic dermatitis, food allergies), parental asthma, and/or symptoms apart from colds, supports the diagnosis of asthma. During routine clinic visits, children with asthma typically present without abnormal signs, emphasizing the importance of the medical history in diagnosing asthma. Some may exhibit a dry, persistent cough. The chest findings are often normal.

Deeper breaths with forced exhalation can sometimes elicit otherwise undetectable wheezing. In clinic, quick resolution (within 10 minutes) or convincing improvement in symptoms and signs of asthma with administration of an **inhaled short-acting  $\beta$ -agonist (SABA)** (e.g., albuterol) is supportive of the diagnosis of asthma.

Asthma exacerbations can be classified by their severity based on symptoms, signs, and functional impairment (Table 185.4). Coughing and shortness of breath are common. Expiratory wheezing and a prolonged exhalation phase can usually be appreciated by auscultation. Decreased breath sounds in some of the lung fields, commonly the right lower posterior lung field, are consistent with regional hypoventilation caused by airways obstruction. **Rhonchi** and **crackles** (or **rales**) can sometimes be heard, resulting from excess mucus production and inflammatory exudate in the airways. The combination of segmental crackles and poor breath sounds can indicate lung segmental atelectasis that is difficult to distinguish from bronchial pneumonia and can complicate acute asthma management. In severe exacerbations the greater extent of airways obstruction causes labored breathing and respiratory distress, which manifests as inspiratory and expiratory wheezing, increased prolongation of exhalation, poor air entry, suprasternal and intercostal retractions, nasal flaring, and accessory respiratory muscle use. In extremis, airflow may be so limited that wheezing cannot be heard (**silent chest**).

## DIFFERENTIAL DIAGNOSIS

Many childhood respiratory conditions can present with symptoms and signs like those of asthma (Table 185.5). Along with asthma, other common

causes of chronic, intermittent coughing include gastroesophageal reflux (GER) and rhinosinusitis. Both GER and chronic sinusitis can be challenging to diagnose in children. Often, GER is clinically silent in children, and children with chronic sinusitis do not report sinusitis-specific symptoms, such as localized sinus pressure and tenderness. In addition, both GER and rhinosinusitis are often comorbid with childhood asthma and, if not specifically treated, may make asthma difficult to manage.

In early life, consideration of congenital and anatomic conditions is essential. Chronic coughing and wheezing can indicate recurrent aspiration, **tracheobronchomalacia** (congenital anatomic abnormality of airways), vascular ring/sling, foreign body aspiration, cystic fibrosis, or bronchopulmonary dysplasia.

In older children and adolescents, **vocal cord dysfunction (VCD)** can manifest as intermittent daytime wheezing, most often in the setting of exercise (Table 185.6). The vocal cords involuntarily close inappropriately during inspiration and sometimes exhalation, producing shortness of breath, coughing, throat tightness, and often audible laryngeal wheezing and/or stridor. In most cases of VCD, spirometric lung function testing reveals truncated and inconsistent inspiratory and expiratory flow-volume loops, a pattern that differs from the reproducible pattern of airflow limitation in asthma that improves with bronchodilators. VCD can coexist with asthma. Hypercarbia and severe hypoxia are uncommon in uncomplicated VCD. Flexible rhinolaryngoscopy in the patient with symptomatic VCD can reveal paradoxical vocal cord movements with anatomically normal vocal cords. Before the diagnosis, patients with VCD are often treated unsuccessfully

**Table 185.4** Formal Evaluation of Asthma Exacerbation Severity in the Urgent or Emergency Care Setting\*

	MILD	MODERATE	SEVERE	SUBSET: RESPIRATORY ARREST IMMINENT
<b>SYMPTOMS</b>				
Breathlessness	While walking	While at rest (infant: softer, shorter cry, difficulty feeding)	While at rest (infant: stops feeding)	Extreme dyspnea Anxiety
Talks in...	Can lie down	Prefers sitting	Sits upright	Upright, leaning forward
Alertness	Sentences	Phrases	Words	Unable to talk
	May be agitated	Usually agitated	Usually agitated	Drowsy or confused
<b>SIGNS</b>				
Respiratory rate <sup>†</sup>	Increased	Increased	Often >30 breaths/min	
Use of accessory muscles; suprasternal retractions	Usually not	Commonly	Usually	Paradoxical thoracoabdominal movement
Wheeze	Moderate; often only end-expiratory	Loud; throughout exhalation	Usually loud; throughout inhalation and exhalation	Absence of wheeze
Pulse rate (beats/min) <sup>‡</sup>	<100	100-120	>120	Bradycardia
Pulsus paradoxus	Absent <10 mm Hg	May be present 10-25 mm Hg	Often present >25 mm Hg (adult) 20-40 mm Hg (child)	Absence suggests respiratory muscle fatigue
<b>FUNCTIONAL ASSESSMENT</b>				
Peak expiratory flow (value predicted or personal best)	≥70%	Approx. 40–69% or response lasts <2 hr	<40%	<25% <sup>§</sup>
Pao <sub>2</sub> (breathing air)	Normal (test not usually necessary)	≥60 mm Hg (test not usually necessary)	<60 mm Hg; possible cyanosis	
and/or				
Pco <sub>2</sub>	<42 mm Hg (test not usually necessary)	<42 mm Hg (test not usually necessary)	≥42 mm Hg; possible respiratory failure	
Sao <sub>2</sub> (breathing air) at sea level	>95% (test not usually necessary)	90–95% (test not usually necessary)	<90%	Hypoxia despite oxygen therapy
<b>Hypercapnia (hypoventilation) develops more readily in young children than in adults and adolescents.</b>				

\*Notes:

- The presence of several parameters, but not necessarily all, indicates the general classification of the exacerbation.
- Many of these parameters have not been systematically studied, especially as they correlate with each other; thus they serve only as general guides.
- The emotional impact of asthma symptoms on the patient and family is variable but must be recognized and addressed and can affect approaches to treatment and follow-up.

<sup>†</sup>Normal breathing rates in awake children by age: <2 mo, <60 breaths/min; 2-12 mo, <50 breaths/min; 1-5 yr, <40 breaths/min; 6-8 yr, <30 breaths/min.

<sup>‡</sup>Normal pulse rates in children by age: 2-12 mo, <160 beats/min; 1-2 yr, <120 beats/min; 2-8 yr, <110 beats/min.

<sup>§</sup>Peak expiratory flow testing may not be needed in very severe attacks.

Adapted from National Asthma Education and Prevention Program Expert Panel Report 3 (EPR3). *Guideline for the Diagnosis and Management of Asthma*, NIH Pub No 07-4051, Bethesda, MD: U.S. Department of Health and Human Services; National Institutes of Health; National Heart, Lung, and Blood Institute; National Asthma Education and Prevention Program; 2007. <https://www.nhlbi.nih.gov/health-pro/guidelines/current/asthma-guidelines/full-report>.

**Table 185.5** Differential Diagnosis of Childhood Asthma

UPPER RESPIRATORY TRACT CONDITIONS	PERIPHERAL AIRWAYS CONDITIONS
Allergic rhinitis*	Bronchopulmonary dysplasia (chronic lung disease of preterm infants)
Chronic rhinitis*	Viral bronchiolitis*
Sinusitis*	Gastroesophageal reflux*
Adenoidal or tonsillar hypertrophy	Causes of bronchiectasis
Nasal foreign body	<ul style="list-style-type: none"> <li>• Cystic fibrosis</li> <li>• Immunodeficiency</li> <li>• Allergic bronchopulmonary mycoses (e.g., aspergillosis)</li> <li>• Chronic aspiration</li> </ul>
<b>LARGE/CENTRAL AIRWAYS CONDITIONS</b>	Primary ciliary dyskinesia
Laryngotracheobronchomalacia*	Bronchiolitis obliterans
Laryngotracheobronchitis (e.g., pertussis)*	Interstitial lung diseases
Laryngeal web, cyst, or stenosis	Hypersensitivity pneumonitis (acute or chronic)
Exercise-induced laryngeal obstruction	Loeffler syndrome
Vocal cord dysfunction*	Eosinophilic granulomatosis with angiitis
Vocal cord paralysis	Eosinophilic pneumonia
Tracheoesophageal fistula	Tropical pulmonary eosinophilia
Vascular ring, sling, or external mass compressing on the airway (e.g., tumor)	Pulmonary hemosiderosis
Endobronchial or mediastinal tumor	Tuberculosis
Foreign body aspiration*	Pneumonia
Chronic bronchitis from environmental tobacco smoke exposure*	Pulmonary edema (e.g., congestive heart failure)
Repaired tracheoesophageal fistula	Pulmonary vascular congestions (congenital or acquired heart disease)
Toxic inhalations	Vasculitis
	Sarcoidosis
	Visceral larva migrans
	Medications associated with chronic cough
	<ul style="list-style-type: none"> <li>• Acetylcholinesterase inhibitors</li> <li>• <math>\beta</math>-Adrenergic antagonists</li> <li>• Angiotensin-converting enzyme inhibitors</li> <li>• Daptomycin</li> </ul>

\*More common asthma masqueraders.

**Table 185.6** Features Distinguishing Paradoxical Vocal Cord Motion Disorder from Asthma

FEATURE	PVCM	ASTHMA
Incidence	Less common	More common
Age and sex	Young, female	Any
Triggers	Usually exercise or emotional stress	Many triggers
History of allergy	Usually absent	May be present
Family history	Usually absent	May be present
Sensation of tightness	Throat	Chest
Inspiratory stridor	More common, heard loudly over larynx	Rare
Sputum production	Rare	Common
Nocturnal awakening with symptoms	Rare	Common
Response to bronchodilators and steroids	No response	Good response
Hypoxemia	Rare	Common
Eosinophilia	Rare	Common in allergic asthma
Chest radiograph	Usually normal	May show hyperinflation and peribronchial thickening
Residual volume and total lung capacity	Normal	May be increased
Flow volume loop	Flattening of inspiratory loop	Obstructive pattern
Bronchial provocation test	May be positive	Usually positive
Laryngoscopy	Inspiratory adduction of the anterior two thirds of vocal folds with posterior chink	Usually normal

PVCM, Paradoxical vocal cord motion.

Modified from Ibrahim WH, Gheriani HA, Almohamed AA, Raza T. Paradoxical vocal cord motion disorder: Past present and future. *Post Grad Med J.* 2007;83:164–172. Table 2, p 168.

with multiple different classes of asthma medications. This condition can be well managed with specialized speech therapy training in the relaxation and control of vocal cord movement. Furthermore, treatment of underlying causes of vocal cord irritability (e.g., high GER/aspiration, allergic rhinitis, rhinosinusitis, asthma) can improve VCD. During acute VCD exacerbations, relaxation breathing techniques in

conjunction with inhalation of heliox (a mixture of 70% helium and 30% oxygen) can relieve vocal cord spasm and VCD symptoms.

In some locales, hypersensitivity pneumonitis (farming communities, homes of bird owners), pulmonary parasitic infestations (rural areas of developing countries), or tuberculosis may be causes of chronic coughing and/or wheezing. Rare mimics of asthma in childhood are noted in [Table 185.5](#).



Chronic pulmonary diseases often produce clubbing (e.g., in cystic fibrosis), but clubbing is a very unusual finding in childhood asthma.

### LABORATORY FINDINGS

Laboratory tests such as blood eosinophil counts and allergen-specific IgE testing may be useful for ascertaining allergy, but are not diagnostic for asthma itself. Lung function tests can help to confirm the diagnosis of asthma and to determine disease severity.

### Pulmonary Function Testing

**Forced expiratory airflow** measures are helpful in diagnosing and monitoring asthma and in assessing efficacy of therapy. Lung function testing is particularly helpful in children with asthma who are poor perceivers of airflow obstruction, or when physical signs of asthma do not occur until airflow obstruction is severe.

Many asthma guidelines promote spirometric measures of airflow and lung volumes during forced expiratory maneuvers as standard for asthma assessment. **Spirometry** is a helpful objective measure of airflow limitation (Fig. 185.2). It is an essential assessment tool in children who are at risk for severe asthma exacerbations and those who have poor perception of asthma symptoms. Valid spirometric measures depend on a patient's ability to properly perform a full, forceful, and prolonged expiratory maneuver, usually feasible in children >4-5 years old (with some younger exceptions).

In asthma, airways blockage results in reduced airflow with forced exhalation (see Fig. 185.2). Because asthmatic patients typically have hyperinflated lungs, forced expiratory volume in 1 second ( $FEV_1$ ) can be simply adjusted for full expiratory lung volume (the forced vital capacity [FVC]) with an  $FEV_1/FVC$  ratio, which is generally an  $FEV_1/FVC$  ratio below the lower limit of normal (Table 185.7). Normative values for these measures of lung function have been determined for children by height, gender, and age. Abnormally low  $FEV_1$  as a percentage of predicted norms is one of six

criteria used to determine asthma severity and control in asthma management guidelines sponsored by the U.S. National Institutes of Health (NIH) and the **Global Initiative for Asthma (GINA)**.

Such measures of airflow alone are not diagnostic of asthma, because numerous other conditions can cause airflow limitation. In addition, approximately 50% of children with mild to moderate persistent asthma will have normal spirometric values when well. **Bronchodilator**

**Table 185.7** Lung Function Abnormalities in Asthma

#### Spirometry (in clinic)\*†:

##### Airflow limitation

- Low  $FEV_1$  (relative to percentage of predicted norms), although many children with asthma have normal  $FEV_1$
- $FEV_1/FVC$  ratio below the lower limit of normal for age

##### Bronchodilator response (to inhaled $\beta$ -agonist) assesses reversibility of airflow limitation

Reversibility is determined by an increase in either  $FEV_1 >9-12\%$  or predicted  $FEV_1 >10\%$  after inhalation of a short-acting  $\beta$ -agonist (SABA)‡

##### Exercise challenge

- Worsening in  $FEV_1 \geq 15\%$ ‡

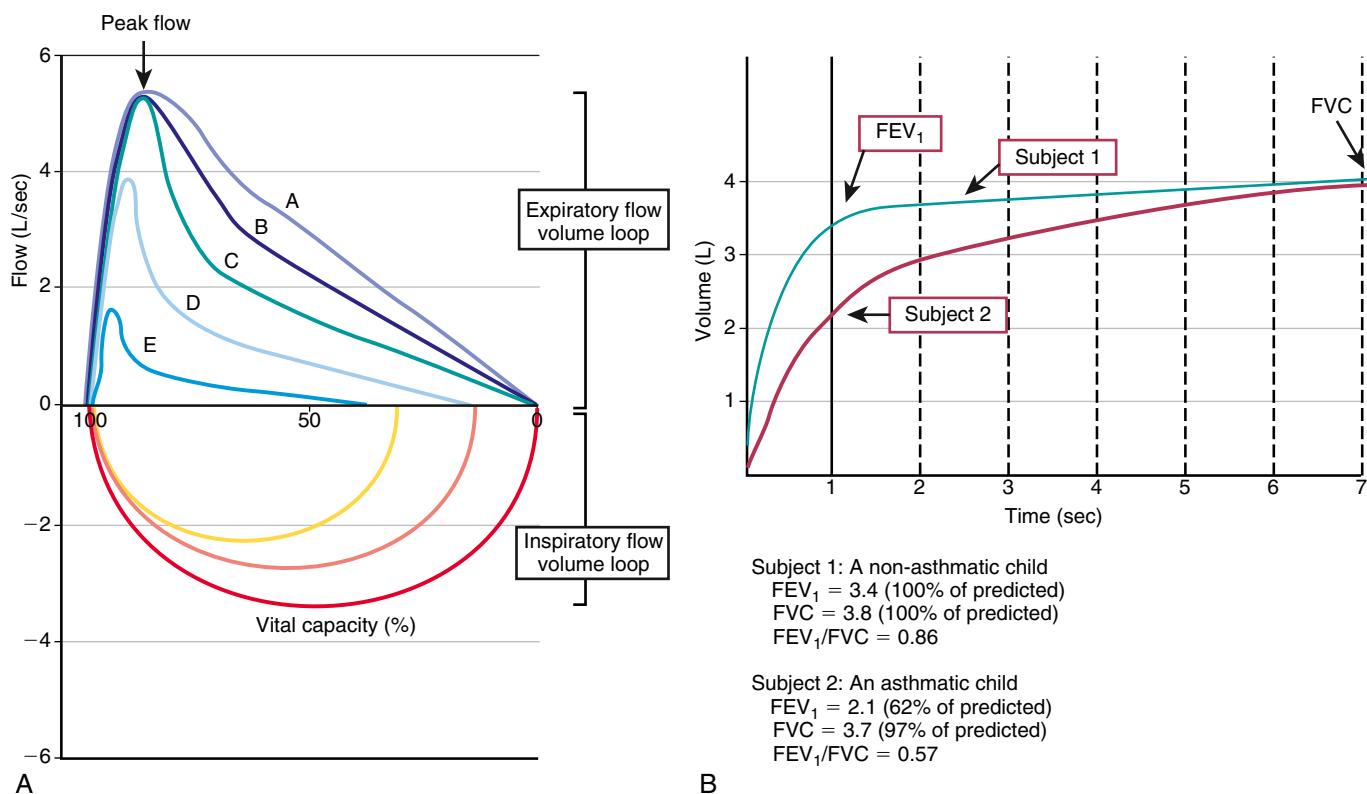
##### Daily peak expiratory flow (PEF)\* or $FEV_1$ monitoring: day-to-day and/or am-to-pm variation $\geq 20\%$ ‡

\*PEF variability is insensitive, while being highly specific for asthma.

†Of note, >50% of children with mild to moderate asthma will have a normal  $FEV_1$  and will not have a significant bronchodilator response.

‡Main criteria consistent with asthma.

$FEV_1$ , Forced expiratory volume in 1 sec; FVC, forced vital capacity; ICS, inhaled corticosteroid; ppb, parts per billion.



**Fig. 185.2** Spirometry. A, Spirometric flow-volume loops. Loop A is an expiratory flow-volume loop of a nonasthmatic person without airflow limitation. Loops B through E are expiratory flow-volume loops in asthmatic patients with increasing degrees of airflow limitation (B is mild; E is severe). Note the "scooped" or concave appearance of the asthmatic expiratory flow-volume loops; with increasing obstruction, there is greater "scooping." B, Spirometric volume-time curves. Subject 1 is a nonasthmatic person; subject 2 is an asthmatic patient. Note how the  $FEV_1$  and FVC lung volumes are obtained. The  $FEV_1$  is the volume of air exhaled in the first second of a forced expiratory effort. The FVC is the total volume of air exhaled during a forced expiratory effort, or forced vital capacity. Note that subject 2's  $FEV_1$  and  $FEV_1/FVC$  ratio are smaller than subject 1's ratio, demonstrating airflow limitation. Also, subject 2's FVC is very close to what is expected.

**Table 185.8** Interpretations of FeNO Test Results for Asthma Diagnosis in Nonsmoking Individuals Not Taking Corticosteroids

FeNO LEVEL		
<25 PPB (<20 IN CHILDREN AGE 5-12 YR)	25-50 PPB (20-35 IN CHILDREN AGE 5-12 YR)	>50 PPB (>35 IN CHILDREN AGE 5-12 YR)
<ul style="list-style-type: none"> <li>Recent or current corticosteroid use</li> <li>Alternative diagnoses</li> <li>Phenotype less likely to benefit from ICS</li> <li>Noneosinophilic asthma</li> <li>COPD</li> <li>Bronchiectasis</li> <li>CF</li> <li>Vocal cord dysfunction</li> <li>Rhinosinusitis</li> <li>Smoking</li> <li>Obesity</li> </ul>	<ul style="list-style-type: none"> <li>Evaluate in clinical context</li> <li>Consider other diagnoses</li> <li>Consider other factors influencing result</li> <li>Eosinophilic asthma less likely</li> </ul>	<ul style="list-style-type: none"> <li>Eosinophilic airways inflammation likely</li> <li>Phenotype more likely to respond to ICS</li> <li>Allergic asthma</li> <li>Eosinophilic bronchitis</li> </ul>

CF, Cystic fibrosis; COPD, chronic obstructive pulmonary disease; FeNO, fractional exhaled nitric oxide; ICS, inhaled corticosteroid; ppb, parts per billion.

From NAEPPCC Expert Panel Working Group: 2020 Focused Updates to the Asthma Management Guidelines: A Report from the National Asthma Education and Prevention Program Coordinating Committee Expert Panel Working Group. *J Allergy Clin Immunol.* 2020;146(6):1217–1269. Table II.

response to an inhaled  $\beta$ -agonist (e.g., albuterol) is greater in asthmatic patients than nonasthmatic persons; an improvement in FEV<sub>1</sub>  $\geq$ 12% is consistent with asthma. However, many children will not demonstrate an improvement with bronchodilator when well. **Bronchoprovocation challenges** can be helpful in diagnosing asthma. Asthmatic airways are hyperresponsive and therefore more sensitive to inhaled methacholine, mannitol, and cold or dry air. The degree of AHR to these exposures correlates to some extent with asthma severity and airways inflammation. Although bronchoprovocation challenges are carefully dosed and monitored in an investigational setting, their use is rarely practical in general practice. **Exercise challenges** (aerobic exertion or “running” for 6–8 minutes) can help to identify children with exercise-induced bronchospasm (EIB). Although the airflow response of nonasthmatic persons to exercise is to increase functional lung volumes and improve FEV<sub>1</sub> slightly (5–10%), exercise often provokes airflow obstruction in persons with inadequately treated asthma. Accordingly, in asthmatic patients, FEV<sub>1</sub> typically decreases during or after exercise by >15% (see Table 185.7). The onset of EIB usually begins within 5 minutes, reaching a peak at 15 minutes after vigorous exercise, and often spontaneously resolves within 30–60 minutes. Studies of exercise challenges in school-age children typically identify an additional 5–10% with EIB and previously unrecognized asthma. There are two caveats regarding exercise challenges: (1) treadmill challenges in the clinic are not completely reliable and can miss exertional asthma that can be demonstrated on the playing field and (2) exercise challenges can induce severe exacerbations in at-risk patients. Careful patient selection for both bronchoprovocation and exercise challenges and preparedness for severe asthma exacerbations are required.

**Peak expiratory flow (PEF)** monitoring devices provide simple and inexpensive home-use tools to measure airflow and can be helpful in some circumstances. Like spirometry in clinics, poor perceivers of asthma may benefit by monitoring PEFs at home to assess their airflow as an indicator of asthma control or problems. PEF devices vary in the ability to detect airflow obstruction; they are less sensitive and reliable than spirometry to detect airflow obstruction, such that, in some patients, PEF values decline only when airflow obstruction is severe. Therefore PEF monitoring should be started by measuring morning and evening PEFs (best of three attempts) for several weeks for patients to practice the technique, to determine diurnal variation and a “personal best,” and to correlate PEF values with symptoms (and ideally spirometry). Diurnal variation in PEF >20% is consistent with asthma (see Table 185.7). If PEF monitoring is employed, morning measurements are preferable when peak flows are typically lower.

### Exhaled Nitric Oxide

Fractional exhaled nitric oxide (FeNO) is a noninvasive measure of allergic/eosinophilic airways inflammation measured in exhaled breath (Table 185.8). FeNO can be used in children as young as 5 years to help distinguish asthma from other airways diseases that are mediated by

nonallergic/noneosinophilic inflammation, such as GER, VCD, and cystic fibrosis. FeNO can substantiate the diagnosis of asthma in untreated patients, complement the assessment of asthma control, predict response to ICS and biologic therapy, assess adherence with ICS therapy, predict loss of control with ICS tapering, and predict future asthma exacerbations. However, an elevated FeNO level alone is not diagnostic of asthma and can be seen in children with allergic rhinitis without asthma.

### Additional Tests to Consider

Other tests, such as allergy testing to assess sensitization to inhalant allergens (skin testing or allergen specific IgE levels) and peripheral blood total eosinophil counts, are markers of allergic “type 2” immunity and inflammation and can help with the management and prognosis of asthma. In a comprehensive U.S. study of 5–12-year-old asthmatic children, the Childhood Asthma Management Program (CAMP), 88% of patients had inhalant allergen sensitization according to results of allergy skin-prick testing.

### Radiology

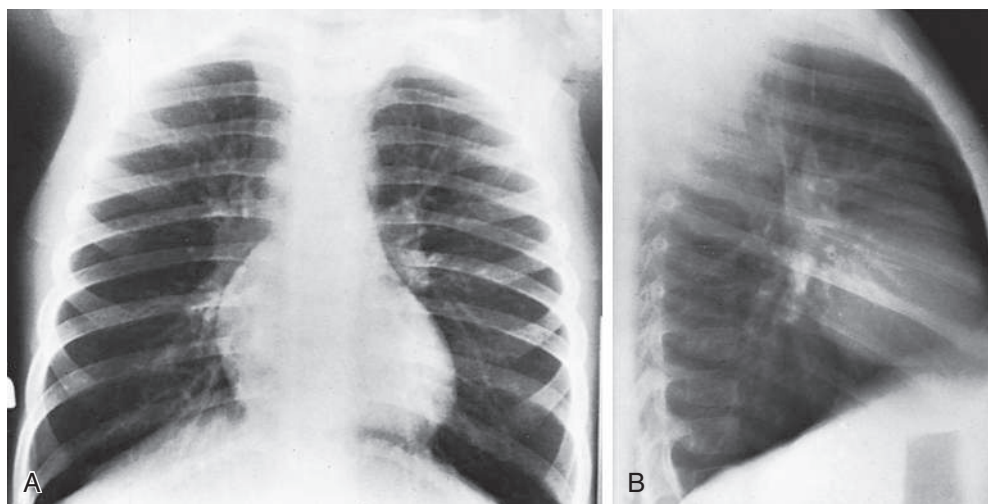
The findings of chest radiographs (posteroanterior and lateral views) in children with asthma often appear to be normal, aside from subtle and nonspecific findings of hyperinflation (e.g., flattening of the diaphragms) and peribronchial thickening (Fig. 185.3). Chest radiographs can help identify abnormalities that are hallmarks of asthma mimics (retained foreign body, vascular rings, aspiration pneumonitis, hyperlucent lung fields in bronchiolitis obliterans) and complications during asthma exacerbations (atelectasis, pneumomediastinum, pneumothorax). Some lung abnormalities can be better appreciated with high-resolution, thin-section chest CT scans. **Bronchiectasis**, which is sometimes difficult to appreciate on chest radiograph but is clearly seen on CT scan, implicates an asthma mimic such as cystic fibrosis, allergic bronchopulmonary mycoses (aspergillosis), ciliary dyskinesias, or immune deficiencies.

### TREATMENT

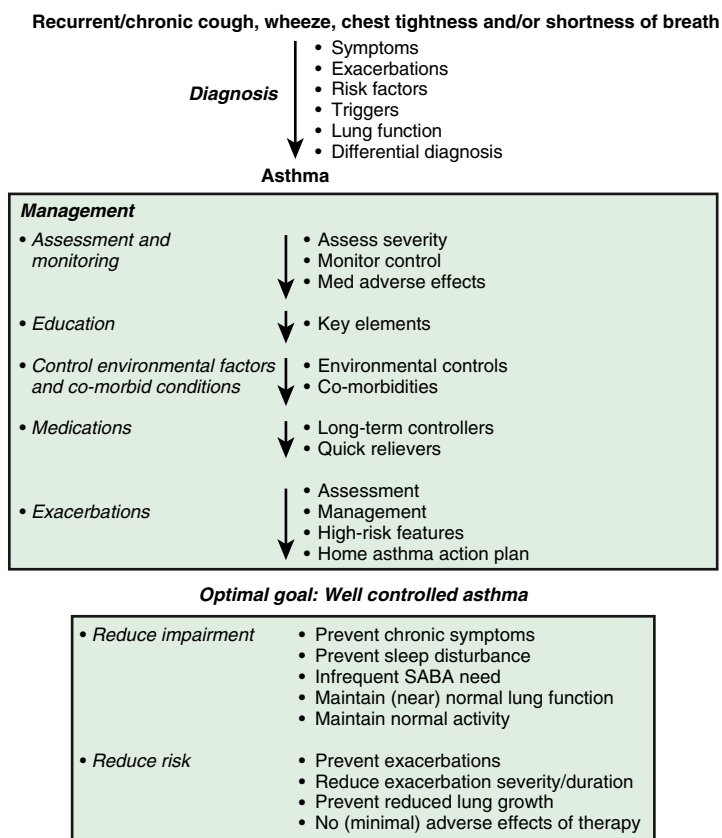
National and international guidelines have been published to help promote evidence-based asthma management. These include the NIH-sponsored National Asthma Education and Prevention Program (NAEPP) Expert Panel Report 4 (EPR4), *Guidelines for the Diagnosis and Management of Asthma*,\* and *The Global Strategy for Asthma Management and Prevention (GINA)*, 2022.† NAEPP and GINA guidelines are generally consistent in their management recommendations for children with asthma, with some key differences that are noted in this chapter.

The key components to optimal asthma management are specified (Fig. 185.4). Management of asthma should have the following

\* <https://www.nhlbi.nih.gov/health-topics/asthma-management-guidelines-2020-updates>  
† <https://ginasthma.org/gina-reports/>



**Fig. 185.3** Frontal (A) and lateral (B) radiographs of a 4-year-old with asthma show pulmonary hyperinflation, flattening of the diaphragms, and minimal peribronchial thickening. No asthmatic complication is apparent.



**Fig. 185.4** The key elements to optimal asthma management. SABA, Short-acting  $\beta$ -agonist.

components: (1) assessment and monitoring of disease activity, (2) education to enhance patient and family knowledge and skills for self-management, (3) identification and management of precipitating factors and comorbid conditions that worsen asthma, and (4) appropriate selection of medications to address the patient's needs. The long-term goals of asthma management are to attain and maintain asthma control, to reduce risk of severe exacerbations, and to minimize impairment of daily activities.

### Component 1: Regular Assessment and Monitoring

Regular assessment and monitoring are based on the concepts of asthma severity, asthma control, and responsiveness to therapy.

**Asthma severity** is the intrinsic intensity of disease, and assessment is generally most accurate in patients not receiving controller therapy. Therefore assessing asthma severity directs the initial level of therapy. The two general categories are **intermittent** asthma and **persistent** asthma, the latter being further subdivided into **mild**, **moderate**, and **severe**. In contrast, **asthma control** is dynamic and refers to the day-to-day variability of an asthmatic patient. In children receiving controller therapy, assessment of asthma control is important in adjusting therapy and is categorized into three levels: well controlled, not well controlled, and very poorly controlled. **Responsiveness to therapy** is the ease or difficulty with which asthma control is attained by treatment.

Classification of asthma severity and control is based on the domains of **impairment** and **risk**. These domains do not necessarily correlate with each other and may respond differently to treatment. Childhood asthma is often characterized by minimal day-to-day impairment, with the potential for frequent, severe exacerbations most often triggered by viral infections. The NIH and GINA guidelines have distinct criteria for three childhood age-groups, 0-4 years (GINA 0-5 years), 5-11 years (GINA 6-11 years), and  $\geq 12$  years, for the evaluation of both severity (Table 185.9) and control (Table 185.10). The level of asthma severity or control is based on the most severe impairment or risk category. In assessing asthma severity, **impairment** consists of an assessment of the patient's recent symptom frequency (daytime and nighttime), with subtle differences in numeric cutoffs between the three age-groups), SABA use for quick relief, ability to engage in normal or desired activities, and airflow compromise evaluated by spirometry in children  $\geq 5$  years. **Risk** refers to the likelihood of developing severe asthma exacerbations. Of note, even in the absence of frequent symptoms, persistent asthma can be diagnosed and long-term controller therapy initiated. For children  $\geq 5$  years, two exacerbations requiring oral corticosteroids (OCSs) in 1 year, and for infants and preschool-age children who have risk factors for asthma (see earlier) and four or more episodes of wheezing over the past year that lasted longer than 1 day and affected sleep, or two or more exacerbations in 6 months requiring systemic corticosteroids, qualifies them as having persistent asthma.

Asthma management can be optimized through regular clinic visits every 2-6 weeks until good asthma control is achieved. For children on controller medication therapy, management is tailored to the child's level of control. The NIH guidelines provide tables for evaluating asthma control for the three age-groups (see Table 185.10). In evaluation of asthma control, as in severity assessment, impairment includes an assessment of the patient's symptom frequency (daytime and nighttime), SABA use for quick relief, ability to engage in normal or desired activities, and for older children, airflow measurements. Validated asthma control questionnaires such as the **Asthma Control Test** (ACT, for adults and children  $\geq 12$  years), the **Childhood ACT** (C-ACT, for children 4-11 years), and the **Test for Respiratory and Asthma Control in Kids** (TRACK, for children  $< 4$  years) can also be used to assess level of control. An ACT score of  $\geq 20$  indicates a child with **well-controlled** asthma, a value of 16-19 indicates **not well-controlled** asthma, and  $\leq 15$  indicates **very poorly controlled** asthma. For the C-ACT, a score  $\geq 20$  indicates *well controlled*, 13-19 indicates *not well controlled*, and  $\leq 12$  indicates *very poorly controlled*. For the TRACK, a score of less than 80 points suggests that a child's breathing problems might not be controlled.

Assessment of risk, in addition to considering severity and frequency of exacerbations requiring systemic corticosteroids, includes tracking the lung growth of older children to identify those with reduced and/or progressive loss of lung function, and monitoring adverse effects of

Table 185.9 Assessing Asthma Severity\*

	CLASSIFICATION OF ASTHMA SEVERITY			
	INTERMITTENT	MILD	MODERATE	SEVERE
<b>COMPONENTS OF SEVERITY</b>				
<i>Impairment</i>				
Daytime symptoms	$\leq 2$ days/wk	$> 2$ days/wk but not daily	Daily	Throughout the day
Nighttime awakenings				
Age 0-4 yr	0	1-2 $\times$ /mo	3-4 $\times$ /mo	$> 1$ $\times$ /wk
Age $\geq 5$ yr	$\leq 2$ $\times$ /mo	3-4 $\times$ /mo	$> 1$ $\times$ /wk but not nightly	Often 7 $\times$ /wk
Short-acting $\beta_2$ -agonist use for symptoms (not for EIB prevention)	$\leq 2$ days/wk	$> 2$ days/wk but not daily, and not more than 1 $\times$ on any day	Daily	Several times per day
Interference with normal activity	None	Minor limitation	Some limitation	Extreme limitation
Lung function				
FEV <sub>1</sub> % predicted, age $\geq 5$ yr	Normal FEV <sub>1</sub> between exacerbations $> 80\%$ predicted	$\geq 80\%$ predicted	60-80% predicted	$< 60\%$ predicted
FEV <sub>1</sub> /FVC ratio <sup>†</sup> :				
Age 5-11 yr	$> 85\%$	$> 80\%$	75-80%	$< 75\%$
Age $\geq 12$ yr	Normal	Normal	Reduced 5%	Reduced $> 5\%$
<i>Risk</i>				
Exacerbations requiring systemic corticosteroids				
Age 0-4 yr	0-1/yr (see notes)	$\geq 2$ exacerbations in 6 mo requiring systemic CS or $\geq 4$ wheezing episodes/yr lasting $> 1$ day and risk factors for persistent asthma		
Age $\geq 5$ yr	0-1/yr (see notes)	$\geq 2$ /yr (see notes)	$\geq 2$ /yr (see notes)	$\geq 2$ /yr (see notes)
Consider severity and interval since last exacerbation. Frequency and severity may fluctuate over time for patients in any severity category. Relative annual risk of exacerbations may be related to FEV <sub>1</sub> .				

\*Notes:

• Level of severity is determined by both impairment and risk. Assess impairment domain by patient's/caregiver's recall of previous 2-4 wk. Symptom assessment for longer periods should reflect a global assessment, such as inquiring whether a patient's asthma is better or worse since the last visit. Assign severity to the most severe category in which any feature occurs.

• At present, there are inadequate data to correspond frequencies of exacerbations with different levels of asthma severity. For treatment purposes, patients who had  $\geq 2$  exacerbations requiring oral systemic corticosteroids in the past 6 mo, or  $\geq 4$  wheezing episodes in the past year, and who have risk factors for persistent asthma, may be considered the same as patients who have persistent asthma, even in the absence of impairment levels consistent with persistent asthma.

<sup>†</sup>Normal FEV<sub>1</sub>/FVC: 8-19 yr, 85%; 20-39 yr, 80%.

FEV<sub>1</sub>, Forced expiratory volume in 1 sec; FVC, forced vital capacity; CS, corticosteroid; EIB, exercise-induced bronchospasm.

Adapted from the National Asthma Education and Prevention Program Expert Panel Report 3 (EPR3). Guidelines for the Diagnosis and Management of Asthma—Summary Report 2007. *J Allergy Clin Immunol*. 2007;120(Suppl):S94-S138.



**Table 185.10** Assessing Asthma Control and Adjusting Therapy in Children\*

	CLASSIFICATION OF ASTHMA CONTROL		
	WELL CONTROLLED	NOT WELL CONTROLLED	VERY POORLY CONTROLLED
<b>COMPONENTS OF CONTROL</b>			
<i>Impairment</i>			
Symptoms	≤2 days/wk but not more than once on each day	>2 days/wk or multiple times on ≤2 days/wk	Throughout the day
Nighttime awakenings:			
Age 0-4 yr	≤1×/mo	>1×/mo	>1×/wk
Age 5-11 yr	≤1×/mo	≥2×/mo	≥2×/wk
Age ≥12 yr	≤2×/mo	1-3×/wk	≥4×/wk
Short-acting β <sub>2</sub> -agonist use for symptoms (not for EIB pretreatment)	≤2 days/wk	>2 days/wk	Several times per day
Interference with normal activity	None	Some limitation	Extremely limited
Lung function:			
Age 5-11 yr:			
FEV <sub>1</sub> (% predicted or personal best)	>80% predicted or personal best	60–80% predicted or personal best	<60% predicted or personal best
FEV <sub>1</sub> /FVC:	>80%	75–80%	<75%
Age ≥12 yr:			
FEV <sub>1</sub> (% predicted or personal best)	>80% predicted or personal best	60–80% predicted or personal best	<60% predicted or personal best
Validated questionnaires†:			
Age ≥12 yr:			
ATAQ	0	1-2	3-4
ACQ	≤0.75	≤1.5	N/A
ACT	≥20	16-19	≤15
<b>Risk</b>			
Exacerbations requiring systemic corticosteroids:			
Age 0-4 yr	0-1/yr	2-3/yr	>3/yr
Age ≥5 yr	0-1/yr	≥2/yr (see notes)	
Consider severity and interval since last exacerbation.			
Treatment-related adverse effects	Medication side effects can vary in intensity from none to very troublesome and worrisome; the level of intensity does not correlate to specific levels of control but should be considered in the overall assessment of risk		
Reduction in lung growth or progressive loss of lung function	Evaluation requires long-term follow-up care		
<b>RECOMMENDED ACTION FOR TREATMENT</b>			
	Maintain current step Regular follow-up every 1-6 mo to maintain control Consider step down if well controlled for at least 3 mo	Step up <sup>‡</sup> (1 step) and reevaluate in 2-6 wk If no clear benefit in 4-6 wk, consider alternative diagnoses or adjusting therapy For side effects, consider alternative options	Consider short course of oral corticosteroids Step up <sup>§</sup> (1-2 steps) and reevaluate in 2 wk If no clear benefit in 4-6 wk, consider alternative diagnoses or adjusting therapy For side effects, consider alternative options

## \*Notes:

- The stepwise approach is meant to assist, not replace, the clinical decision-making required to meet individual patient needs.
- The level of control is based on the most severe impairment or risk category. Assess impairment domain by caregiver's recall of previous 2-4 wk. Symptom assessment for longer periods should reflect a global assessment, such as inquiring whether the patient's asthma is better or worse since the last visit.
- At present, there are inadequate data to correspond frequencies of exacerbations with different levels of asthma control. In general, more frequent and intense exacerbations (e.g., requiring urgent, unscheduled care, hospitalization, or intensive care unit admission) indicate poorer disease control. For treatment purposes, patients who had ≥2 exacerbations requiring oral systemic corticosteroids in the past year may be considered the same as patients who have not well-controlled asthma, even in the absence of impairment levels consistent with not well-controlled asthma.

†Validated questionnaires for the impairment domain (the questionnaires do not assess lung function or the risk domain) and definition of minimal important difference (MID) for each:

- ATAQ, Asthma Therapy Assessment Questionnaire; MID = 1.0.
- ACQ, Asthma Control Questionnaire; MID = 0.5.
- ACT, Asthma Control Test; MID not determined.

‡ACQ values of 0.76-1.40 are indeterminate regarding well-controlled asthma.

§Before step-up therapy: (1) review adherence to medications, inhaler technique, and environmental control and (2) if alternative treatment option was used in a step, discontinue it and use preferred treatment for that step.

FEV<sub>1</sub>, Forced expiratory volume in 1 sec; FVC, forced vital capacity; EIB, exercise-induced bronchospasm; N/A, not available.

Adapted from the National Asthma Education and Prevention Program Expert Panel Report 3 (EPR 3). Guidelines for the Diagnosis and Management of Asthma—Summary Report 2007. *J Allergy Clin Immunol.* 2007;120(Suppl):S94-S138.

medications. The degree of impairment and presence of risk are used to determine the patient's level of asthma control as well controlled, not well controlled, or very poorly controlled. Children with *well-controlled asthma* have daytime symptoms  $\leq 2$  days/week and need a rescue bronchodilator  $\leq 2$  days/week, an FEV<sub>1</sub> of  $>80\%$  of predicted (and FEV<sub>1</sub>/FVC ratio  $>80\%$  for children 5-11 years), no interference with normal activity, and  $<2$  exacerbations in the past year and an ACT score of  $\geq 20$ . The impairment criteria vary slightly depending on age-group. Children whose status does not meet all the criteria of well-controlled asthma are determined to have either *not well-controlled* or *very poorly controlled* asthma, which is determined by the single criterion with the poorest rating.

Two to four asthma checkups per year are recommended for reassessing and maintaining good asthma control. Lung function testing (spirometry) is recommended at least annually and more often if asthma is poorly perceived, is inadequately controlled, and/or lung function is abnormally low.

### Component 2: Patient Education

Asthma education that focuses on home management and medication adherence is critical for optimal clinical care of children with asthma (Table 185.11). Asthma education should consider socio-cultural and ethnic factors and provide an open forum for concerns about asthma and its treatment. Families should be active participants in the development of treatment goals and selection of medications. Self-management skills should be reevaluated regularly (e.g., inhaler medication technique).

During initial patient visits, a basic understanding of the pathogenesis of asthma (chronic inflammation and AHR underlying a clinically intermittent presentation) can help children with asthma and their parents understand the importance of recommendations aimed at reducing airways inflammation to achieve and maintain good asthma control. It is helpful to specify the expectations of good asthma control resulting from optimal asthma management (see Fig. 184.4). Addressing concerns about potential adverse effects of asthma pharmacotherapeutic agents, especially their risks relative to their benefits, is essential in achieving long-term adherence with asthma pharmacotherapy and environmental control measures.

All children with asthma should benefit from a written Asthma Action Plan (Fig. 185.5). This plan has two main components: (1) a daily "routine" management plan describing regular asthma medication use and other measures to keep asthma under good control and (2) an action plan to manage worsening asthma, describing indicators of impending exacerbations, identifying what medications to take, and specifying

when and how to contact the regular physician and/or obtain urgent/emergency medical care.

Regular follow-up visits are recommended to help to maintain optimal asthma control. Follow-up visits provide the opportunity to reassess asthma medication perceptions and delivery techniques. The Asthma Action Plan can be revised as needed.

### Adherence

Asthma is a chronic condition that is usually best managed with daily controller medication. However, symptoms wax and wane and exacerbations may be infrequent. A natural tendency is to reduce or discontinue daily controller therapies once asthma symptoms improve. As such, adherence to a daily controller regimen is frequently suboptimal; ICSs are underused 60% of the time. In one study, children with asthma who required an OCS course for an asthma exacerbation had used their daily controller ICS 15% of the time. Misconceptions about controller medication time to onset, efficacy, and safety often underlie poor adherence and can be addressed by asking about such concerns at each visit.

### Component 3: Control of Factors Contributing to Poor Asthma Control

Controllable factors that can worsen asthma can be generally grouped as (1) environmental exposures and (2) comorbid conditions (Table 185.12).

### Eliminating and Reducing Problematic Environmental Exposures

Steps should be taken to investigate and minimize exposures in asthmatic patients. These exposures include allergens as well as irritants (e.g., smoke, pollutants, and other chemicals such as perfumes), in the patient's home or school. However, patients often cannot identify potential triggers. Allergy testing should be considered for all patients with persistent asthma to identify allergens that may contribute to airway inflammation, asthma symptoms, and exacerbations. For asthmatic patients who are allergic to allergens in their homes and/or schools or daycare centers, reducing or eliminating these indoor allergen exposures can reduce asthma symptoms, medication requirements, AHR, severe exacerbations, and disease persistence. Common home, school, and daycare allergen exposures include furred or feathered animals as pets (cats, dogs, rodents, birds) or as pests (mice, rats, cockroaches), and occult indoor allergens such as dust mites and molds.

Allergen mitigation strategies can be used in patients with allergy of all ages and asthma severities, but these strategies should be tailored to the individual. Multicomponent interventions are recommended to control indoor allergens, because single component interventions are often not effective. Examples of single component interventions for dust mite allergy include (1) encasing bedding and pillows in allergen-impermeable covers, (2) washing bedding weekly in hot water ( $>130^\circ\text{F}$ ), (3) removing wall-to-wall carpeting and upholstered furniture, or (4) reducing and maintaining indoor humidity  $<50\%$ . In contrast, a multicomponent strategy for dust mite allergy might include all of these measures. Integrated pest management strategies are also recommended for patients exposed to cockroaches, mice, or rats in the home who have sensitization to these allergens. Integrated pest management can also be used with other interventions to reduce exposures to pest-related allergens. Families should be educated that it can take  $\geq 6$  months for the levels of these indoor allergens to drop significantly and for asthma control to improve after intervention. Allergen mitigation strategies are not recommended for patients with no allergy to indoor allergens.

Tobacco, wood and coal smoke, dusts, strong odors, and noxious air pollutants (e.g., nitrogen dioxide from inadequately vented gas stoves and furnaces) can also aggravate asthma. These airway irritants should be eliminated from or reduced in the homes, schools/daycare centers, and automobiles/school transportation used by children with asthma. Care providers can be strong influencers of smoking cessation by parents, caregivers, and adolescent patients (see also Chapters 157.2 and 759.1). Secondhand marijuana smoke contains many of the same chemicals and

**Table 185.11** Key Elements of Productive Clinic Visits for Asthma

Standardize assessment of asthma control (e.g., Asthma Control Test, exacerbations in past 12 mo)
Specify goals of asthma management
Explain basic facts about asthma
<ul style="list-style-type: none"> <li>• Contrast normal vs asthmatic airways</li> <li>• Link airways inflammation, "twitchiness," and bronchoconstriction</li> <li>• Long-term-control and quick-relief medications</li> <li>• Address concerns about potential adverse effects of asthma pharmacotherapy</li> </ul>
Teach, demonstrate, and have patient show proper technique
<ul style="list-style-type: none"> <li>• Inhaled medication use (spacer use with metered-dose inhaler)</li> </ul>
Investigate and manage factors that contribute to asthma severity
<ul style="list-style-type: none"> <li>• Environmental exposures</li> <li>• Comorbid conditions</li> </ul>
Create written two-part Asthma Action Plan (see Fig. 185.5)
<ul style="list-style-type: none"> <li>• Daily management</li> <li>• Action plan for asthma exacerbations</li> </ul>
Regular follow-up visits
<ul style="list-style-type: none"> <li>• Twice yearly (more often if asthma not well controlled)</li> <li>• Monitor lung function at least annually</li> </ul>

**Asthma Action Plan**

For: \_\_\_\_\_ Doctor: \_\_\_\_\_ Date: \_\_\_\_\_  
 Doctor's Phone Number \_\_\_\_\_ Hospital/Emergency Department Phone Number \_\_\_\_\_

**GREEN ZONE**

**Doing Well**

- No cough, wheeze, chest tightness, or shortness of breath during the day or night
- Can do usual activities

**And, if a peak flow meter is used,**

**Peak flow:** more than \_\_\_\_\_  
 (80 percent or more of my best peak flow)

My best peak flow is: \_\_\_\_\_

Before exercise  \_\_\_\_\_  2 or  4 puffs \_\_\_\_\_ 5 minutes before exercise

**Take these long-term control medicines each day (include an anti-inflammatory).**

Medicine	How much to take	When to take it
_____	_____	_____
_____	_____	_____

**YELLOW ZONE**

**Asthma Is Getting Worse**

- Cough, wheeze, chest tightness, or shortness of breath, or
- Waking at night due to asthma, or
- Can do some, but not all, usual activities

**Peak flow:** \_\_\_\_\_ to \_\_\_\_\_  
 (50 to 79 percent of my best peak flow)

**First** Add: quick-relief medicine—and keep taking your GREEN ZONE medicine.

\_\_\_\_\_ (short-acting beta<sub>2</sub>-agonist)  2 or  4 puffs, every 20 minutes for up to 1 hour  
 Nebulizer, once

**Second** If your symptoms (and peak flow, if used) return to GREEN ZONE after 1 hour of above treatment:  
 Continue monitoring to be sure you stay in the green zone.

**-Or-** If your symptoms (and peak flow, if used) do not return to GREEN ZONE after 1 hour of above treatment:  
 Take: \_\_\_\_\_ (short-acting beta<sub>2</sub>-agonist)  2 or  4 puffs or  Nebulizer  
 Add: \_\_\_\_\_ (oral steroid) \_\_\_\_\_ mg per day For \_\_\_\_\_ (3–10) days  
 Call the doctor  before/  within \_\_\_\_\_ hours after taking the oral steroid.

**RED ZONE**

**Medical Alert!**

- Very short of breath, or
- Quick-relief medicines have not helped, or
- Cannot do usual activities, or
- Symptoms are same or get worse after 24 hours in Yellow Zone

**Peak flow:** less than \_\_\_\_\_  
 (50 percent of my best peak flow)

**Take this medicine:**

\_\_\_\_\_ (short-acting beta<sub>2</sub>-agonist)  4 or  6 puffs or  Nebulizer  
 \_\_\_\_\_ (oral steroid) \_\_\_\_\_ mg

**Then call your doctor NOW.** Go to the hospital or call an ambulance if:  
 ■ You are still in the red zone after 15 minutes AND  
 ■ You have not reached your doctor.

**DANGER SIGNS** ■ Trouble walking and talking due to shortness of breath ■ Take  4 or  6 puffs of your quick-relief medicine AND  
 ■ Lips or fingernails are blue ■ Go to the hospital or call for an ambulance \_\_\_\_\_ NOW!  
 (phone)

See the reverse side for things you can do to avoid your asthma triggers.

**How To Control Things That Make Your Asthma Worse**

This guide suggests things you can do to avoid your asthma triggers. Put a check next to the triggers that you know make your asthma worse and ask your doctor to help you find out if you have other triggers as well. Then decide with your doctor what steps you will take.

**Allergens**

**Animal Dander**  
 Some people are allergic to the flakes of skin or dried saliva from animals with fur or feathers.  
**The best thing to do:**

- Keep furred or feathered pets out of your home.
- If you can't keep the pet outdoors, then:
  - Keep the pet out of your bedroom and other sleeping areas at all times, and keep the door closed.
  - Remove carpets and furniture covered with cloth from your home. If that is not possible, keep the pet away from fabric-covered furniture and carpets.

**Dust Mites**  
 Many people with asthma are allergic to dust mites. Dust mites are tiny bugs that are found in every home—in mattresses, pillows, carpets, upholstered furniture, bedcovers, clothes, stuffed toys, and fabric or other fabric-covered items.  
**Things that can help:**

- Encase your mattress in a special dust-proof cover.
- Encase your pillow in a special dust-proof cover or wash the pillow each week in hot water. Water must be hotter than 130° F to kill the mites. Cold or warm water used with detergent and bleach can also be effective.
- Wash the sheets and blankets on your bed each week in hot water.
- Reduce indoor humidity to below 60 percent (ideally between 30–50 percent). Dehumidifiers or central air conditioners can do this.
- Try not to sleep or lie on cloth-covered cushions.
- Remove carpets from your bedroom and those laid on concrete, if you can.
- Keep stuffed toys out of the bed or wash the toys weekly in hot water or cooler water with detergent and bleach.

**Cockroaches**  
 Many people with asthma are allergic to the dried droppings and remains of cockroaches.  
**The best thing to do:**

- Keep food and garbage in closed containers. Never leave food out.
- Use poison baits, powders, gels, or paste (for example, boric acid). You can also use traps.
- If a spray is used to kill roaches, stay out of the room until the odor goes away.

**Indoor Mold**

- Fix leaky faucets, pipes, or other sources of water that have mold around them.
- Clean moldy surfaces with a cleaner that has bleach in it.

**Pollen and Outdoor Mold**  
 What to do during your allergy season (when pollen or mold spore counts are high):

- Try to keep your windows closed.
- Stay indoors with windows closed from late morning to afternoon, if you can. Pollen and some mold spore counts are highest at that time.
- Ask your doctor whether you need to take or increase anti-inflammatory medicine before your allergy season starts.

**Irritants**

**Tobacco Smoke**

- If you smoke, ask your doctor for ways to help you quit. Ask family members to quit smoking, too.
- Do not allow smoking in your home or car.

**Smoke, Strong Odors, and Sprays**

- If possible, do not use a wood-burning stove, kerosene heater, or fireplace.
- Try to stay away from strong odors and sprays, such as perfume, talcum powder, hair spray, and paints.

**Other things that bring on asthma symptoms in some people include:**

**Vacuum Cleaning**

- Try to get someone else to vacuum for you once or twice a week, if you can. Stay out of rooms while they are being vacuumed and for a short while afterward.
- If you vacuum, use a dust mask (from a hardware store), a double-layered or microfilter vacuum cleaner bag, or a vacuum cleaner with a HEPA filter.

**Other Things That Can Make Asthma Worse**

- Sulfites in foods and beverages: Do not drink beer or wine or eat dried fruit, processed potatoes, or shrimp if they cause asthma symptoms.
- Cold air: Cover your nose and mouth with a scarf on cold or windy days.
- Other medicines: Tell your doctor about all the medicines you take. Include cold medicines, aspirin, vitamins and other supplements, and nonselective beta-blockers (including those in eye drops).



For More Information, go to: [www.nhlbi.nih.gov](http://www.nhlbi.nih.gov)  
 NIH Publication No. 07-5251  
 April 2007

**Fig. 185.5** Asthma action plan for home use. This plan has two main components: (1) a daily management plan to keep asthma in good control and (2) an action plan to recognize and manage worsening asthma. (From U.S. Department of Health and Human Services, National Institutes of Health, National Heart, Lung, and Blood Institute, NIH Pub No 07-5251, April 2007. <https://www.nhlbi.nih.gov/health/asthma/treatment-action-plan>.)

**Table 185.12** Control of Factors Contributing to Asthma Severity**ELIMINATE OR REDUCE PROBLEMATIC ENVIRONMENTAL EXPOSURES**

Environmental tobacco smoke elimination or reduction in home and automobiles

Allergen exposure elimination or reduction in sensitized asthmatic patients

- Pets (cats, dogs, rodents, birds)
- Pests (mice, rats)
- Dust mites
- Cockroaches
- Molds

Other airway irritants

- Wood- or coal-burning smoke
- Strong chemical odors and perfumes (e.g., household cleaners)
- Dusts

**TREAT COMORBID CONDITIONS**

Rhinitis

Sinusitis

Gastroesophageal reflux

particulates as tobacco smoke, and should also be avoided (see Chapter 759.2). Exposure to electronic cigarette aerosol may also aggravate asthma.

Annual influenza vaccination (both inactivated and live attenuated) is safe in children with asthma and continues to be recommended for all children with asthma to reduce the risk of severe complications, although influenza is not responsible for the large majority of virus-induced asthma exacerbations experienced by children.

**Identifying and Treating Comorbid Conditions**

Rhinitis, sinusitis, GER, and obesity often accompany asthma and may make the asthma difficult to treat. These conditions can also mimic asthma symptoms and lead to misclassification of asthma severity and control. Indeed, these conditions, along with asthma, are the most common causes of chronic cough. Poor conditioning from obesity may also be confused with asthma-related dyspnea. Effective management of these comorbid conditions may improve asthma symptoms, such that less asthma medication is needed to achieve good asthma control.

**Component 4: Principles of Asthma Pharmacotherapy**

The current version of NIH asthma guidelines (2020) provides treatment recommendations that vary by level of asthma severity and age-groups (Table 185.13). There are six treatment steps. Patients at **Treatment Step 1** have intermittent asthma. Children with mild persistent asthma are at **Treatment Step 2**. Children with moderate persistent asthma can be at **Treatment Step 3 or 4**. Children with severe persistent asthma are at **Treatment Steps 5 and 6**. The goals of therapy are to achieve a well-controlled state by reducing the components of both impairment (e.g., preventing or minimizing symptoms, infrequently needing quick-reliever medications, maintaining “normal” lung function and normal activity levels) and risk (e.g., preventing recurrent exacerbations, reduced lung growth, and medication adverse effects). The recommendations for initial therapy are based on assessment of asthma severity, whereas level of control determines any modifications of treatment in children who are already using controller therapy. **A major objective of this approach is to identify and treat all “persistent” and inadequately controlled asthma with anti-inflammatory controller medication.** *Treatment Step 1 (intermittent asthma)* management is simply the use of a SABA as needed for symptoms and for pretreatment in those with EIB. For children <5 years with recurrent episodic wheeze in the setting of viral illness, a short course of daily high-dose ICS may also be considered.

The preferred treatment for all patients with persistent asthma includes an ICS-containing therapy, as monotherapy or in combination

with adjunctive therapy. The type(s) and amount(s) of daily controller medications to be used are determined by the asthma severity and control rating.

At *Treatment Step 2 (mild persistent asthma)*, low-dose daily ICS therapy is the treatment of choice for all children. Common alternative medications include a leukotriene receptor antagonist (LTRA) such as montelukast.

At *Treatment Step 3 (moderate persistent asthma)*, for school-age children, the preferred treatment has recently been modified to the daily and as-needed use of a low-dose ICS/formoterol (a rapid onset, long-acting  $\beta_2$ -agonist [LABA]) combination inhaler, used twice daily as both maintenance therapy and as-needed reliever therapy (in place of a separate SABA inhaler).

*Single maintenance and reliever therapy (SMART)* is a fundamental change from the conventional distinct daily controllers vs quick reliever medications. Although SMART has been determined to be effective in reducing asthma exacerbations relative to use of SABA as a reliever (i.e., favorable benefit-harm ratio), some current challenges to implementation for providers and patients include ICS/formoterol availability/affordability, FDA approval for use as a reliever therapy, and asthma management and action plan reeducation for home and school, including the appropriate use of SABA in asthma care (e.g., exercise pretreatment). A SABA/ICS combination inhaler (albuterol/budesonide 90 mcg/80 mcg per actuation) is FDA approved for as-needed use as a quick reliever in adults ages 18 years and older (not in children).

Common alternate choices for the treatment of school-age children at Treatment Step 3 include (1) medium-dose ICS or (2) low-dose ICS used in combination with an inhaled LABA. In a study of children with uncontrolled asthma receiving low-dose ICS, the addition of LABA was more likely to provide improvement than either adding an LTRA or increasing ICS dosage. However, some children had a good response to medium-dose ICS or the addition of an LTRA, justifying them as step-up controller therapy options. Thus if a child is not well controlled with a given step 3 treatment, trials of the alternate treatment approaches should be considered before stepping up to step 4. In patients 12 years and older with uncontrolled persistent asthma for whom a LABA is not used, current guidelines recommend addition of a LABA or a long-acting muscarinic antagonist (LAMA) to the ICS as a step-up approach. Adding a LAMA is not more efficacious than adding a LABA, so LAMAs should not be selected over a LABA unless necessary. LAMAs also have a less favorable benefit-harm profile and should not be used in patients with a risk of urinary retention or glaucoma. LAMAs can also be added to ICS/LABA combination therapy if the patient remains symptomatic.

For young children ( $\leq 4$  years) at Treatment Step 3, NAEPP guidelines recommend daily medium dose ICS, whereas GINA recommends three co-equal preferred options: (1) daily low-dose ICS/LABA, (2) daily low-dose ICS + LTRA, or (3) daily medium-dose ICS.

At *Treatment Step 4 (moderate persistent asthma)*, the preferred therapy for school-age children is daily and as-needed use of a medium-dose ICS/formoterol combination inhaler, used twice daily for maintenance and as needed for reliever therapy. Alternatives include daily medium-dose ICS with either a LABA, LTRA, or other controller (such as a LAMA in patients 12 years and older). For preschool-age children at Treatment Step 4, daily medium-dose ICS/LABA is recommended.

For children age  $\geq 5$  years with allergic asthma requiring Treatment Steps 2-4 care, *subcutaneous allergen immunotherapy (SCIT)* can be considered. Current guidelines recommend SCIT as an adjunct treatment to standard pharmacotherapy in patients whose asthma can be adequately controlled and managed at the initiation, buildup, and maintenance phases of SCIT. Some requirements for effective and safe SCIT include (1) allergen sensitization evaluation using either immediate hypersensitivity skin testing or in vitro antigen-specific IgE antibody testing, and by a trained healthcare professional skilled in proper testing and result interpretation; (2) before each SCIT injection, evaluation to ensure that asthma is well controlled because poorly controlled asthma is a major risk factor for life-threatening and fatal



**Table 185.13** Stepwise Approach for Managing Asthma in Children\*

Age	Treatment	Intermittent Asthma			Persistent Asthma		
		Step 1	Step 2	Step 3	Step 4	Step 5	Step 6
0–4 years	<b>Preferred</b>	PRN SABA And At the start of RTI: Add short course daily ICS	Daily low-dose ICS and PRN SABA	Daily low-dose ICS-LABA and PRN SABA Or Daily low-dose ICS + montelukast or daily medium-dose ICS and PRN SABA	Daily medium-dose ICS-LABA and PRN SABA	Daily high-dose ICS-LABA and PRN SABA	Daily high-dose ICS-LABA + oral systemic corticosteroids and PRN SABA
	<b>Alternative</b>		Daily montelukast or Cromolyn and PRN SABA		Daily medium-dose ICS + montelukast and PRN SABA	Daily high-dose ICS + montelukast and PRN SABA	Daily high-dose ICS-LABA + montelukast + oral systemic corticosteroids and PRN SABA
				For children age 4 years only, see Step 3 and Step 4 for ages 5–11 years			
5–11 years	<b>Preferred</b>	PRN SABA	Daily low-dose ICS and PRN SABA	Daily and PRN combination low-dose ICS-formoterol	Daily and PRN combination medium-dose ICS-formoterol	Daily high-dose ICS-LABA and PRN SABA	Daily high-dose ICS-LABA + oral systemic corticosteroids and PRN SABA
	<b>Alternative</b>		Daily LTRA, or Cromolyn, or Nedocromil, or Theophylline, and PRN SABA	Daily medium-dose ICS and PRN SABA Or Daily low-dose ICS-LABA, or daily low-dose ICS + LTRA, or daily low-dose ICS + theophylline, and PRN SABA	Daily medium-dose ICS-LABA and PRN SABA Or Daily medium-dose ICS + LTRA, or daily medium-dose ICS + theophylline, and PRN SABA	Daily high-dose ICS + LTRA or daily high-dose ICS + Theophylline, and PRN SABA	Daily high-dose ICS + LTRA + oral systemic corticosteroid or daily high-dose ICS + Theophylline + oral systemic corticosteroid, and PRN SABA
		Steps 2–4: Conditionally recommend use of subcutaneous immunotherapy as an adjunct treatment to standard pharmacotherapy in individuals ≥5 years of age whose asthma is controlled at the initiation, build up, and maintenance phases of immunotherapy				Consider omalizumab	
12+ years	<b>Preferred</b>	PRN SABA	Daily low-dose ICS and PRN SABA Or PRN concomitant ICS and SABA	Daily and PRN combination low-dose ICS-formoterol	Daily and PRN combination medium-dose ICS-formoterol	Daily medium-high dose ICS-LABA + LAMA and PRN SABA	Daily high-dose ICS-LABA + oral systemic corticosteroids and PRN SABA
	<b>Alternative</b>		Daily LTRA and PRN SABA Or Cromolyn, or Nedocromil, or Theophylline, and PRN SABA	Daily medium-dose ICS and PRN SABA Or Daily low-dose ICS-LABA, or Daily low-dose ICS + LAMA, or daily low-dose ICS + LTRA, or daily low-dose ICS + theophylline, and PRN SABA	Daily medium-dose ICS or daily medium-dose ICS + LAMA, and PRN SABA Or Daily medium-dose ICS + LTRA, or daily medium-dose ICS + theophylline, and PRN SABA	Daily medium-high dose ICS-LABA or daily high-dose ICS + LTRA, and PRN SABA	
		Steps 2–4: Conditionally recommend use of subcutaneous allergen immunotherapy as an adjunct treatment to standard pharmacotherapy in individuals ≥5 years of age whose asthma is controlled at the initiation, build up, and maintenance phases of immunotherapy				Consider adding asthma biologics (e.g., anti-IgE, anti-IL5, anti-IL5R, anti-IL4/IL13R, anti-TSLP)	

**Assess control**

- First check adherence, inhaler technique, environmental factors, and comorbid conditions.
- **Step up** if needed, reassess in 4–6 weeks
- **Step down** if possible (if asthma is well controlled for at least 3 consecutive months)

Consult with asthma specialist if Step 3 or higher is required for those 0–4 years of age (and consider consultation at Step 2) or if Step 4 is required for those 5+ years of age (and consider consultation at Step 3).

Control assessment is a key element of asthma care. This involves both impairment and risk. Use of objective measures, self-reported control, and health care utilization are complementary and should be employed on an ongoing basis, depending on the individual's clinical situation.

**Table 185.13** Stepwise Approach for Managing Asthma in Children\*—cont'd

## \*Notes:

- The stepwise approach is meant to assist, not replace, the clinical decision-making required to meet individual patient needs.
- If alternative treatment is used and response is inadequate, discontinue it and use the preferred treatment before stepping up.
- If clear benefit is not observed within 4–6 wk and patient/family medication technique and adherence are satisfactory, consider adjusting therapy or alternative diagnosis.
- Studies on children age 0–4 yr are limited.
- Clinicians who administer allergen immunotherapy or biologic therapy should be prepared and equipped to identify and treat anaphylaxis that may occur.
- Theophylline is a less desirable alternative because of the need to monitor serum concentration levels. The 2016 GINA guidelines do not recommend the use of theophylline as a controller medication and in IV forms to treat status asthmaticus due to its severe adverse effects profile.

†Alphabetical order is used when more than 1 treatment option is listed within either preferred or alternative therapy.

ICS, inhaled corticosteroid; LABA, inhaled long-acting  $\beta_2$ -agonist; LTRA, leukotriene receptor antagonist; OCS, oral corticosteroid; prn, as needed; SABA, inhaled short-acting  $\beta_2$ -agonist. Adapted from the National Asthma Education and Prevention Program Expert Panel Report 3 (EPR3): Guidelines for the diagnosis and management of asthma—summary report 2007, *J Allergy Clin Immunol* 120(Suppl):S94–S138, 2007 and 2020 Focused Updates to Asthma Management Guidelines: A Report from the National Asthma Education and Prevention Program Coordinating Committee Expert Panel Working Group.

allergic reactions from SCIT; and (3) being well prepared to respond to systemic allergic/anaphylactic reactions to SCIT injections. Patients with allergic asthma may also benefit from improvements in comorbid allergic rhinitis and conjunctivitis, which could additionally improve quality of life. SCIT efficacy with regard to asthma medication use and exacerbations is not clear. SCIT is not recommended in patients with severe asthma given the potential for systemic reactions of potentially great severity. Sublingual immunotherapy is not currently recommended based on available data.

At *Treatment Steps 5 and 6 (severe persistent asthma)*, all children should receive daily high-dose ICS plus LABA as the preferred approach; alternative secondary controllers to LABA include LTRA or LAMA. Long-term administration of OCSs as controller therapy may be effective but is rarely required and should be avoided whenever possible due to potential for significant corticosteroid side effects. In addition, biologics should be considered in children with specific asthma phenotypes: (1) omalizumab can be used in children  $\geq 6$  years old with severe allergic asthma; (2) mepolizumab ( $\geq 6$  years), dupilumab ( $\geq 6$  years), and benralizumab ( $\geq 12$  years) can be used in children with severe eosinophilic asthma; and (3) tezepelumab ( $\geq 12$  years) can be used in children with severe asthma. A rescue course of systemic corticosteroids may be necessary at any step for very poorly controlled asthma.

### Adjusting Asthma Pharmacotherapy

By determining the lowest number or dose of daily controller medications that can maintain good control, the potential for medication adverse effects is reduced. ***Asthma controller therapy can be stepped down after good asthma control has been achieved and maintained for at least 3 months.*** Stopping ICS controller therapy should be given careful consideration in children with a history of exacerbations. For example, in children with a history of fall seasonal asthma exacerbations and whose asthma becomes well controlled in the summer, ICS may be reduced but not completely discontinued. Regular follow-up is still emphasized because the variability of asthma's course is well recognized. When asthma is not well controlled, adherence, inhaler technique, and comorbidities should be considered first before increasing controller treatment. If increased treatment is required, the recommendation is to step up by one level and closely monitor for clinical improvement. For a child with very poorly controlled asthma, the recommendations are to consider a short course of prednisone and/or to increase therapy by two step levels, with reevaluation in 2 weeks.

### Referral to Asthma Specialist

Referral to an asthma specialist for consultation or co-management is recommended if there are difficulties in achieving or maintaining good asthma control. For children  $\leq 4$  years, referral is recommended if the patient requires at least Treatment Step 3 care, and should be considered if the patient requires Treatment Step 2 care. For children  $\geq 5$  years, consultation with a specialist is recommended if the patient requires Treatment Step 4 care or higher, and should be considered if Treatment Step 3 is required. Referral is also recommended if allergen immunotherapy (AIT) or biologic therapy is being considered.

### Long-Term Controller Medications

All levels of persistent asthma should be treated with an ICS-containing therapy to reduce airway inflammation, improve long-term control, and reduce exacerbation risk (see [Table 185.13](#)). Other long-term controller medications include LABAs, leukotriene modifiers, LAMAs, SCIT, cromolyn, sustained-release theophylline, and tiotropium in adolescents. Omalizumab and mepolizumab are approved by the FDA for use as an add-on therapy in children  $\geq 6$  years who have severe allergic asthma or eosinophilic asthma, respectively, that remains difficult to control. For adolescents 12 years and older, benralizumab is approved by the FDA for severe asthma with an eosinophilic phenotype. Dupilumab is approved by the FDA for moderate to severe asthma with an eosinophilic phenotype for children 6 years and older. Tezepelumab is approved by the FDA for severe asthma in adolescents 12 years and older (see [Tables 185.13 and 185.14](#)).

### Inhaled Corticosteroids

ICS therapy serves as the cornerstone of therapy in persistent asthma, as it improves lung function; reduces asthma symptoms, AHR, and use of “rescue” medications; improves quality of life; and most importantly reduces exacerbations, the need for systemic corticosteroids, urgent care visits, and hospitalizations. Epidemiologic studies have also shown that ICS therapy in adults substantially lowers the risk of death attributable to asthma if used regularly. Because ICS therapy frequently achieves all the goals of asthma management, it is viewed as first-line treatment for persistent asthma. The selection of the initial ICS dose is based on the determination of disease severity.

Seven ICSs are approved by the FDA for use in children. The NIH and GINA guidelines provide equivalence classifications ([Table 185.15](#)), although direct comparisons of efficacy and safety outcomes are lacking. ICSs are available in metered-dose inhalers (MDIs) using hydrofluoroalkane (HFA) as their propellant, in dry powder inhalers (DPIs), or in suspension for nebulization. Fluticasone propionate, fluticasone furoate, mometasone furoate, ciclesonide, and to a lesser extent budesonide are considered “second-generation” ICSs, in that they have greater antiinflammatory potency and less systemic bioavailability.

Even though ICSs are very effective in most patients, there has been some reluctance to treat children with ICSs due to parental and occasionally physician concerns regarding their potential for adverse effects with chronic use. The most serious adverse effects that occur with long-term systemic corticosteroid therapy have not been seen or have only rarely been reported in children receiving ICSs in recommended doses. The risk of adverse effects from ICS therapy is related to the dose and frequency of administration ([Table 185.16](#)). High doses ( $\geq 1,000$   $\mu\text{g}/\text{day}$  in children) and frequent administration (4 times per day) are more likely to have both local and systemic adverse effects. Children who receive maintenance therapy with higher ICS doses are also likely to require frequent systemic corticosteroid courses for asthma exacerbations, further increasing their risk of corticosteroid adverse effects.

The most common ICS adverse effects are local: oral **candidiasis** (thrush) and **dysphonia** (hoarse voice). Thrush results from propellant-induced mucosal irritation and local immunosuppression, and dysphonia

**Table 185.14** Usual Dosages for Long-Term Control Medications

MEDICATION	AGE		
	0-4YR	5-11YR	≥12YR
<b>INHALED CORTICOSTEROID MONOTHERAPIES (SEE TABLE 185.13)</b>			
<i>Inhaled Corticosteroid/Long-Acting <math>\beta</math>-Agonist (ICS/LABA) Combination Therapies:</i>			
Fluticasone/salmeterol (Advair): DPI: 100, 250, or 500 $\mu$ g/50 $\mu$ g  HFA: 45 $\mu$ g/21 $\mu$ g, 115 $\mu$ g/21 $\mu$ g, 230 $\mu$ g/21 $\mu$ g	N/A	1 inhalation bid; dose depends on level of severity or control (the 100/50 dosage is indicated in children $\geq$ 4yr)	1 inhalation bid; dose depends on level of severity or control
Budesonide/formoterol (Symbicort): HFA: 80 $\mu$ g/4.5 $\mu$ g, 160 $\mu$ g/4.5 $\mu$ g	N/A		2 inhalations bid; dose depends on level of severity or control
Mometasone/formoterol (Dulera): HFA: 100 $\mu$ g/5 $\mu$ g, 200 $\mu$ g/5 $\mu$ g			2 inhalations bid; dose depends on level of severity or control
<i>Leukotriene Receptor Antagonists:</i>			
Montelukast (Singulair): 4 or 5 mg chewable tablet 4 mg granule packets 10 mg tablet <b>Black box warning</b> (see text)	4 mg qhs (1-5yr)	5 mg qhs (6-14yr)	10mg qhs (indicated in children $\geq$ 15yr)
Zafirlukast (Accolate): 10 mg or 20 mg tablet	N/A	10mg bid (7-11yr)	40mg daily (20mg tablet bid)
<i>Biologic Therapies:</i>			
Omalizumab (anti-IgE; Xolair): SC injection, 150 mg	N/A	75-375mg SC q 2-4wk (6-11 yr), depending on body weight and pretreatment serum IgE level	75-375mg SC q 2-4wk, depending on body weight and pretreatment serum IgE level
Mepolizumab (anti-IL-5; Nucala): SC injection, 100 mg	N/A	40mg SC q 4wk (6-11 yr)	100mg SC q 4wk
Benralizumab (anti-IL-5 R $\alpha$ ; Fasenra) SC injection, 30 mg	N/A	N/A	30 mg SC q 4wk $\times$ 3 doses, then 30 mg SC q 8 wk
Dupilumab (anti-IL-4 R $\alpha$ ; Dupixent) SC injection, 200 mg, 300 mg	N/A	15 to <30 kg: 100 mg q 2 wk or 300 mg q 4 wk $\geq$ 30 kg: 200 mg q2 wk	400 mg or 600 mg SC starting dose, then 200 or 300 mg SC q 2wk
Tezepelumab (anti-TSLP; Tezspire) SC injection, 210 mg	N/A	N/A	210 mg SC q 4 wk

bid, Two times daily; DPI, dry powder inhaler; HFA, hydrofluoroalkane; IL, interleukin; q, every; qhs, every night; SC, subcutaneous(ly).

is the result of vocal cord myopathy. These effects are dose dependent and are most common in individuals receiving high-dose ICS or OCS therapy. The incidence of these local effects can be greatly minimized by using a spacer with an MDI with the ICS, because spacers reduce oropharyngeal deposition of the drug and propellant. Mouth rinsing using a “swish and spit” technique after ICS use is also recommended.

The potential for growth suppression and osteoporosis with long-term ICS use had been an unanswered concern. A long-term, prospective NIH-sponsored study (CAMP) followed the growth and bone mineral density (BMD) of >1,000 children (age 6-12 years at entry) with mild to moderate asthma until they reached adulthood and found slight growth suppression and osteopenia in some children who received long-term ICS therapy. A small (1.1 cm), limited (1 year) growth suppressive effect was noted in children receiving budesonide, 200  $\mu$ g twice daily, after 5 years of therapy. Height was then followed until all children had reached adulthood (mean age 25 years). Those who received ICS therapy remained approximately 1 cm shorter than those who received placebo. Thus children treated with long-term low-dose ICS therapy may be about 1 cm shorter than expected as an adult, which is of little clinical significance. BMD was no different in those receiving budesonide vs placebo during the duration of the study, whereas a follow-up study after a mean of 7 years found a slight dose-dependent effect of ICS therapy on bone mineral accretion only among males. A much greater effect on BMD was observed with increasing

numbers of OCS bursts for acute asthma, as well as an increase in risk for osteopenia, which was again limited to males. These findings were with use of low-dose budesonide; higher ICS doses, especially of agents with increased potency, are likely to have a greater potential for adverse effects. Thus osteoporosis screening and prevention measures are recommended for patients receiving higher ICS doses, because these patients are also likely to require systemic courses for exacerbations (see Table 185.16).

### Systemic Corticosteroids

The development of second-generation ICSs, especially when used in combination with a LABA in a single device, along with the addition of biologics, have allowed almost all children with asthma to achieve and maintain good control without need for maintenance OCS therapy. Thus short courses of OCSs are used primarily to treat asthma exacerbations and, very rarely, as maintenance therapy in children with very severe disease. In these patients, every attempt should be made to exclude comorbid conditions and to keep the OCS dose at  $\leq$ 20 mg every other day. Doses exceeding this amount are associated with numerous adverse effects (see Chapter 615). To determine the need for continued OCS therapy, tapering of the OCS dose over several weeks should be attempted, with close monitoring of the patient's symptoms and lung function.

Prednisone, prednisolone, methylprednisolone, and dexamethasone are rapidly and completely absorbed, with peak plasma

**Table 185.15** Estimated Comparative Inhaled Corticosteroid Doses

GLUCOCORTICOID	LOW DAILY DOSE	MEDIUM DAILY DOSE	HIGH DAILY DOSE
Beclomethasone (Qvar) MDI: 40 or 80 µg (Approved for children ≥5 yr)	80-160 µg	160-320 µg	>320 µg
Budesonide (Pulmicort Flexhaler) DPI: 90, 180 µg (Approved for children ≥6 yr)	200 µg	200-400 µg	>400 µg
Budesonide suspension for nebulization (Generic and Pulmicort Respules) 0.25 mg, 0.5 mg, 1 mg (Approved for children 1-8 yr)	0.5 mg	1.0 mg	2.0 mg
Ciclesonide (Alvesco) MDI: 80, 160 µg (Approved for children ≥12 yr)	80 µg	80-160 µg	160 µg
Flunisolide (Aerospan) MDI: 80 µg/puff (Approved for children ≥6 yr)	80 µg	80-160 µg	160 µg
Fluticasone propionate (Flovent, Flovent Diskus) MDI: 44, 110, 220 µg DPI: 50, 100, 250 µg (44 and 50 µg approved for children ≥4 yr)	88-176 µg 100-200 µg	176-440 µg 200-500 µg	>440 µg >500 µg
Fluticasone furoate (Arnuity Ellipta) DPI: 100, 200 µg (Approved for children ≥12 yr)	100 µg	100-200 µg	200 µg
Mometasone Furoate (Asmanex, Asmanex Twisthaler) MDI: 100, 200 µg DPI: 110, 220 µg (Approved for children ≥4 yr)	110 µg 100 µg	110 µg 100 µg	110 µg 100 µg

DPI, Dry powder inhaler; MDI, metered-dose inhaler.

Adapted from National Asthma Education and Prevention Program Expert Panel Report 3 (EPR3). Guidelines for the Diagnosis and Management of Asthma—Summary Report 2007. *J Allergy Clin Immunol.* 2007;120(Suppl):S94–S138.

concentrations occurring within 1-2 hours. Prednisone is an inactive prodrug that requires biotransformation via first-pass hepatic metabolism to prednisolone, its active form. For asthma exacerbations in children, oral dexamethasone is also commonly used given its long half-life of 36-54 hours and association with less vomiting when compared with oral prednisone. These corticosteroids are metabolized in the liver into inactive compounds, with the rate of metabolism influenced by drug interactions and disease states. Anti-convulsants (phenytoin, phenobarbital, carbamazepine) increase the metabolism of prednisolone, methylprednisolone, and dexamethasone, with methylprednisolone most significantly affected. Rifampin also enhances the clearance of corticosteroids and can result in diminished therapeutic effect. Other medications (ketoconazole, oral contraceptives) can significantly delay corticosteroid metabolism. Some macrolide antibiotics, such as erythromycin and clarithromycin, delay the clearance of only methylprednisolone.

Long-term OCS therapy can cause numerous adverse effects over time (see Chapter 617). Some occur immediately (metabolic effects), whereas others can develop insidiously over several months to years (growth suppression, osteoporosis, cataracts). Most adverse effects occur in a cumulative dose- and duration-dependent manner. Children who require routine or frequent short courses of OCSs, especially with concurrent high-dose ICSs and often intranasal corticosteroids, should receive corticosteroid adverse effects screening (see Table 185.16) and osteoporosis preventive measures (see Chapter 749).

### Long-Acting Inhaled β-Agonists

*Although considered daily controller medications, LABAs (salmeterol, formoterol) are not intended for use as monotherapy for persistent asthma because they can increase the risk for serious asthma exacerbations (ICU admission, endotracheal intubation) and asthma-related deaths when*

*used without an ICS.* The likely mechanism involves the ability of LABAs to “mask” worsening asthma inflammation and asthma severity, leading to a delay in seeking urgent care and increased risk of a life-threatening exacerbation. Although both salmeterol and formoterol have a prolonged duration of effect (≥12 hours), salmeterol has a prolonged onset of effect (60 minutes), whereas formoterol’s onset of effect is rapid (5-10 minutes) after administration. Given their long duration of action, LABAs are well suited for patients with nocturnal asthma and for individuals who require frequent use of SABA inhalations during the day to prevent EIB, but only in combination with ICSs. The FDA recommends that once a patient is well controlled on combination ICS/LABA therapy, the LABA component should be discontinued while continuing treatment with the ICS, although many patients experience disease worsening on LABA discontinuation.

### Combination ICS/LABA Therapy

**Combination ICS/LABA therapy is recommended for patients who are suboptimally controlled with ICS therapy alone and those with moderate or severe persistent asthma.** In most patients who are inadequately controlled with ICS alone, combination ICS/LABA therapy is superior to add-on therapy with either an LTRA or LAMA or doubling the ICS dose. Benefits include improvement in baseline lung function, less need for rescue SABA therapy, improved quality of life, and fewer asthma exacerbations. A large study found that in children inadequately controlled with low-dose ICS therapy, combination low-dose fluticasone/salmeterol (100 µg/21 µg) twice daily was almost twice as likely to be effective as other step-up regimens, including fluticasone (250 µg) twice daily or low-dose fluticasone (100 µg twice daily) plus montelukast once daily, with the greatest improvement in reducing exacerbations requiring prednisone and study withdrawals due to poorly controlled asthma. In addition, combination fluticasone/salmeterol was as likely to be effective as medium-dose fluticasone and



**Table 185.16** Risk Assessment for Corticosteroid Adverse Effects

CONDITIONS		RECOMMENDATIONS
Low risk	( $\leq 1$ risk factor*) Low- to medium-dose ICS (see Table 185.13)	Monitor blood pressure and weight with each physician visit Measure height annually (stadiometry); monitor periodically for declining growth rate and pubertal developmental delay Encourage regular physical exercise Ensure adequate dietary calcium and vitamin D with additional supplements for daily calcium if needed. Avoid smoking and alcohol Ensure TSH status if patient has history of thyroid abnormality
Medium risk	(If $> 1$ risk factor,* consider evaluating as high risk) High-dose ICS (see Table 185.13) At least four courses of OCS per year	As above, <i>plus</i> : Yearly ophthalmologic evaluations to monitor for cataracts or glaucoma Baseline bone densitometry (DEXA scan) Consider patient at increased risk for adrenal insufficiency, especially with physiologic stressors (e.g., surgery, accident, significant illness)
High risk	Chronic systemic corticosteroids ( $> 7.5$ mg daily or equivalent for $> 1$ mo) $\geq 7$ OCS burst treatments per year Very-high-dose ICS (e.g., fluticasone propionate $\geq 800$ $\mu\text{g}/\text{day}$ )	As above, <i>plus</i> : DEXA scan: if DEXA z score $\leq 1.0$ , recommend close monitoring (every 12 mo) Consider referral to a bone or endocrine specialist Bone age assessment Complete blood count Serum calcium, phosphorus, and alkaline phosphatase determinations Urine calcium and creatinine measurements Measurements of testosterone in males, estradiol in amenorrheic premenopausal women, vitamin D (25-OH and 1,25-OH vitamin D), parathyroid hormone, and osteocalcin Urine telopeptides for those receiving long-term systemic or frequent OCS treatment Assume adrenal insufficiency for physiologic stressors (e.g., surgery, accident, significant illness)

\*Risk factors for osteoporosis: presence of other chronic illness(es), medications (corticosteroids, anticonvulsants, heparin, diuretics), low body weight, family history of osteoporosis, significant fracture history disproportionate to trauma, recurrent falls, impaired vision, low dietary calcium and vitamin D intake, and lifestyle factors (decreased physical activity, smoking, alcohol intake).

DEXA, Dual-energy x-ray absorptiometry; ICS, inhaled corticosteroid; OCS, oral corticosteroid; TSH, thyroid-stimulating hormone.

was superior to combination fluticasone/montelukast therapy in Black children, arguing against the notion that Black children are more prone to serious asthma exacerbations than White children when treated with combination ICS/LABA therapy.

Despite their efficacy and widespread use, the long-term safety of LABAs, even when used in combination with ICS in a single inhaler, has been questioned. To address this concern of rare, severe asthma-related events with LABA/ICS use, large randomized controlled trials (RCTs) compared the safety of combination ICS/LABA vs ICS monotherapy. Two studies of  $> 23,000$  adults and adolescents  $\geq 12$  years old with various levels of asthma severity were randomized to receive ICS (low or medium dose) monotherapy vs equivalent ICS/LABA (fluticasone vs fluticasone/salmeterol; budesonide vs budesonide/formoterol) over 26 weeks to determine whether small but significant differences might occur in asthma hospitalization, intubation, or death attributable to ICS/LABA. No intubations or asthma deaths occurred during the study, and no differences in asthma hospitalizations between treatment groups were observed. The similar pediatric study enrolled  $> 6,000$  children age 4–11 years with various levels of asthma severity to receive either fluticasone (low or medium dose) or equivalent fluticasone/salmeterol dose over 26 weeks, with similar findings of no significant differences in severe asthma-related events between treatment groups. *These results strongly suggest that the use of combination ICS/LABA products in children and adults with moderate to severe persistent asthma is both effective and safe.*

### Leukotriene-Modifying Agents

Leukotrienes are potent proinflammatory mediators that can induce bronchospasm, mucus secretion, and airways edema. LTRAs have bronchodilator and targeted antiinflammatory properties and reduce exercise-, aspirin-, and allergen-induced bronchoconstriction. LTRAs may be an alternative treatment for mild persistent asthma and as an add-on medication with ICS for moderate persistent asthma. Two LTRAs with FDA-approved use in children are montelukast and

zafirlukast. Both medications improve asthma symptoms, decrease the need for rescue  $\beta$ -agonist use, and modestly improve lung function. **Montelukast** is approved for use in children  $\geq 1$  year of age and is administered once daily, whereas **zafirlukast** is approved in children  $\geq 5$  years and is given twice daily. LTRAs are less effective than ICSs in patients with mild persistent asthma (e.g., ICSs improve baseline lung function 5–15%, whereas LTRAs improve lung function 2.5–7.5%). *The FDA has identified serious behavior and mood-related changes in some patients treated with montelukast and suggests that the benefits of montelukast may not outweigh the risks in some patients, particularly when the symptoms of disease may be mild and adequately treated with other medicines.* When initially prescribing montelukast, a precaution is to inform the child and family that, if mood changes are noted after starting montelukast, they should discontinue its use and contact their physician.

### Long-Acting Inhaled Anticholinergics

**Tiotropium** is a LAMA (24-hour duration of action) that is approved by the FDA for use in children with asthma  $\geq 6$  years old. In studies in children and adolescents with moderate persistent asthma, tiotropium improved lung function as an add-on therapy to ICS. Adding a LAMA is not more efficacious than adding a LABA, so LAMAs should not be selected over a LABA unless necessary. LAMAs can also be added to ICS/LABA combination therapy if the patient remains symptomatic.

### Allergen Immunotherapy

AIT involves administering gradually increasing doses of allergens to a person with allergic disease to reduce or eliminate the patient's allergic response to those allergens, including allergic rhinoconjunctivitis and asthma. Conventional AIT is given subcutaneously (**SCIT**) under the direction of an experienced allergist. The goal of SCIT is to increase the dose of allergen extract administered to reach a therapeutic maintenance dose of each major allergen, in a manner that minimizes the likelihood of systemic allergic reactions. Allergen extracts are formulated for each patient based on documented allergen sensitizations

and problematic exposures. Maintenance doses are generally given monthly, to complete a 3–5-year course. A meta-analysis of 20 trials examining the effects of SCIT on allergic asthma revealed significant improvement with fewer symptoms, improved lung function, less need for medication, and AHR reduction.

Although AIT is regarded as safe, the potential for **anaphylaxis** always exists when patients receive extracts containing allergens to which they are sensitized. Local transient allergic reactions at the injection site are common. Systemic allergic reactions can also occur with SCIT, with fatal anaphylaxis occurring in approximately 1 per 2 million injections. Because of the risks of systemic allergic reactions to SCIT, standard precautions include administering SCIT in medical settings where a physician with access to emergency equipment and medications required for the treatment of anaphylaxis is available (see [Chapter 190](#)). Patients should be observed in the office for 30 minutes after each injection because most systemic reactions to SCIT begin within this time frame. *SCIT should never be given at home or by untrained personnel.* Because of the complexities and risks of administration, SCIT should only be administered by an experienced allergist. SCIT is not recommended for patients with severe and uncontrolled asthma.

AIT should be discontinued in patients who have not shown improvement after 1 year of receiving maintenance doses of an appropriate allergen extract(s), or who have a serious systemic allergic or adverse reaction.

### Biologic Therapies

Biologic therapies are genetically engineered proteins derived from human genes and designed to inhibit specific immune mediators of disease. Several are approved by the FDA as add-on controller therapies (i.e., in addition to conventional controller therapies) for severe asthma in adults and children.

**Omalizumab (Anti-IgE Antibody).** Omalizumab is a humanized monoclonal antibody (mAb) that binds IgE and prevents its binding to the high-affinity IgE receptor on mast cells and basophils, thereby blocking IgE-mediated allergic responses and inflammation. It is approved by the FDA for patients >6 years old with severe allergic asthma who continue to have inadequate disease control despite treatment with high-dose ICS and/or OCS. Omalizumab is given every 2–4 weeks subcutaneously, with the dosage based on body weight and serum IgE levels. Omalizumab can improve asthma control while allowing ICS and/or OCS dose reduction. Omalizumab has been studied in inner-city children with exacerbation-prone asthma. When added to guideline-based controller management, omalizumab reduced exacerbations (50%), particularly those that peak in the spring and fall seasons. A follow-up prospective preseasonal treatment study confirmed the effect on fall seasonal exacerbations and demonstrated how omalizumab restores antiviral (interferon [IFN]- $\alpha$ ) immune responses to rhinovirus (the most common infectious trigger of exacerbations) that are impaired by IgE-mediated mechanisms. Omalizumab is generally well tolerated, although local injection site reactions can occur. Hypersensitivity reactions (including anaphylaxis) have been reported following approximately 0.1% of injections. As a result, omalizumab has an FDA black box warning of potentially serious and life-threatening anaphylactic adverse reactions, and an epinephrine autoinjector should be available to all patients receiving omalizumab.

**Mepolizumab and Reslizumab (Anti-IL-5 Antibodies).** **Mepolizumab**, an anti-IL-5 mAb that blocks IL-5-mediated eosinophilopoiesis, reduces severe asthma exacerbations and lowers sputum and blood eosinophils while allowing for a significant reduction in OCS dose in adults and adolescents with severe exacerbation-prone eosinophilic asthma. It is administered subcutaneously every 4 weeks and is approved by the FDA for severe eosinophilic asthmatic children  $\geq 6$  years old. **Reslizumab**, another anti-IL-5 mAb therapeutic, is administered intravenously and is approved by the FDA for severe asthmatics  $\geq 18$  years old (i.e., not currently approved for use in children).

**Benralizumab (Anti-IL-5 $\alpha$  Antibody).** Benralizumab is also an mAb that binds to the IL-5 receptor  $\alpha$  subunit, resulting in apoptosis of eosinophils and basophils. Benralizumab is approved for patients  $\geq 12$  years old with severe eosinophilic asthma with a suggested absolute blood eosinophil count of at least 300 cells/ $\mu$ L. Benralizumab is administered subcutaneously every 4 weeks for three doses followed by every 8-week dosing.

**Dupilumab (Anti-IL-4 Receptor  $\alpha$  Antibody).** Dupilumab, an anti-IL-4 receptor  $\alpha$  human mAb that inhibits both IL-4 and IL-13 production (both cytokines share the same IL-4 receptor  $\alpha$  chain) and atopic immune responses, reduces exacerbations and symptoms and improves lung function in moderate to severe asthmatic patients with an eosinophilic phenotype. Dupilumab is administered subcutaneously every 2 weeks and is approved by the FDA for patients  $\geq 6$  years old with moderate to severe eosinophilic asthma. It is suggested that patients have an absolute eosinophil count of at least 150 cells/ $\mu$ L or an exhaled nitric oxide level of at least 25 parts per billion (ppb). In meta-analysis, dupilumab was associated with significant reductions of the annualized rate of severe asthma exacerbations and OCS use and a statistical improvement in lung function.

**Tezepelumab (Anti-Thymic Stromal Lymphopoietin [TSLP] Antibody).** Tezepelumab, an anti-TSLP human mAb, binds and blocks TSLP's inflammatory actions, reduces asthma exacerbations and symptoms, and improves lung function. Tezepelumab is administered subcutaneously every 4 weeks and is approved by the FDA for patients  $\geq 12$  years old with severe asthma.

### Quick-Reliever Medications

Quick-reliever or “rescue” medications (SABAs, inhaled anticholinergics, and short-course systemic corticosteroids) are used in the management of acute asthma symptoms ([Table 185.17](#)).

### Short-Acting Inhaled $\beta$ -Agonists

Given their rapid onset of action, effectiveness, and 4–6-hour duration of action, SABAs (albuterol, levalbuterol, terbutaline, pirbuterol) are the drugs of choice for acute asthma symptoms (“rescue” medication) and for preventing EIB.  $\beta$ -Adrenergic agonists cause bronchodilation by inducing airway smooth muscle relaxation, reducing vascular permeability and airways edema, and improving mucociliary clearance. Levalbuterol, the R-isomer of albuterol, is associated with less tachycardia and tremor, which can be bothersome to some asthmatic patients. Overuse of  $\beta$ -agonists is associated with an increased risk of death or near-death episodes from asthma. This is a major concern for some patients with asthma who rely on the frequent use of SABAs as a “quick fix” for their asthma, rather than using controller medications in a preventive manner. It is helpful to monitor the frequency of SABA use, in that use of one or more MDIs per month or three or more MDIs per year (200 inhalations per MDI) indicates inadequate asthma control and necessitates improving other aspects of asthma therapy and management. Of note, a SABA/ICS combination inhaler (albuterol/budesonide 90 mcg/80 mcg per actuation) has recently been FDA approved for as-needed use as a quick reliever in adults ages 18 years and older (not in children).

### Anticholinergic Agents

As bronchodilators, the anticholinergic agents (e.g., ipratropium bromide) are less potent than the  $\beta$ -agonists. Inhaled ipratropium is used primarily in the treatment of acute severe asthma. When used in combination with albuterol, ipratropium can improve lung function and reduce the rate of hospitalization in children who present to the ED with acute asthma. Ipratropium has few central nervous system adverse effects and is available in both MDI and nebulizer formulations. Although widely used in all children with asthma exacerbations, it is approved by the FDA for use in children >12 years old. A combination ipratropium/albuterol product is also available in both nebulized and mist formulations.

**Table 185.17** Management of Asthma Exacerbation (Status Asthmaticus)

**RISK ASSESSMENT ON ADMISSION**

<p>Focused history</p> <p>Clinical assessment</p> <p>Risk factors for asthma morbidity and death</p>	<p>Onset of current exacerbation</p> <p>Frequency and severity of daytime and nighttime symptoms and activity limitation</p> <p>Frequency of rescue bronchodilator use</p> <p>Current medications and allergies</p> <p>Potential triggers</p> <p>History of systemic steroid courses, emergency department visits, hospitalization, intubation, or life-threatening episodes</p> <p>Physical examination findings: vital signs, breathlessness, air movement, use of accessory muscles, retractions, anxiety level, alteration in mental status</p> <p>Pulse oximetry</p> <p>Lung function (defer in patients with moderate to severe distress or history of labile disease)</p> <p>See <a href="#">Table 185.18</a></p>
--	--

**TREATMENT**

DRUG AND TRADE NAME	MECHANISMS OF ACTION AND DOSING	CAUTIONS AND ADVERSE EFFECTS
Oxygen (mask or nasal cannula)	Treats hypoxia	Monitor pulse oximetry to maintain O <sub>2</sub> saturation >92% Cardiorespiratory monitoring
<b>Inhaled short-acting β-agonists</b>	Bronchodilator	During exacerbations, frequent or continuous doses can cause pulmonary vasodilation, V/Q mismatch, and hypoxemia Adverse effects: palpitations, tachycardia, arrhythmias, tremor, hypoxemia
Albuterol nebulizer solution (5 mg/mL concentrate; 2.5 mg/3 mL, 1.25 mg/3 mL, 0.63 mg/3 mL)	Nebulizer: 0.15 mg/kg (minimum 2.5 mg) as often as every 20 min for 3 doses as needed, then 0.15-0.3 mg/kg up to 10 mg every 1-4 hr as needed, or up to 0.5 mg/kg/hr by continuous nebulization	Nebulizer: when giving concentrated forms, dilute with saline to 3 mL total nebulized volume.
Albuterol MDI (90 μg/puff)	2-8 puffs up to every 20 min for 3 doses as needed, then every 1-4 hr as needed	For MDI: use spacer/holding chamber
Levalbuterol (Xopenex) nebulizer solution (1.25 mg/0.5 mL concentrate; 0.31 mg/3 mL, 0.63 mg/3 mL, 1.25 mg/3 mL)	0.075 mg/kg (minimum 1.25 mg) every 20 min for 3 doses, then 0.075-0.15 mg/kg up to 5 mg every 1-4 hr as needed, or 0.25 mg/kg/hr by continuous nebulization	Levalbuterol 0.63 mg is equivalent to 1.25 mg of standard albuterol for both efficacy and side effects
<b>Systemic corticosteroids</b>	Antiinflammatory	If patient has been exposed to chickenpox or measles, consider passive immunoglobulin prophylaxis; also, risk of complications with herpes simplex and tuberculosis For daily dosing, 8 AM administration minimizes adrenal suppression Children may benefit from dosage tapering if course exceeds 7 days Adverse effects monitoring: frequent therapy bursts risk numerous corticosteroid adverse effects (see Chapter 615); see <a href="#">Table 185.14</a> for adverse effects screening recommendations
Prednisone: 1, 2.5, 5, 10, 20, 50 mg tablets Methylprednisolone (Medrol): 2, 4, 8, 16, 24, 32 mg tablets Prednisolone: 5 mg tablets; 5 mg/5 mL and 15 mg/5 mL solution Depo-Medrol (IM); Solu-Medrol (IV)	Short course oral "burst" for exacerbation: 1-2 mg/kg/day divided qd or bid for 3-7 days (maximum 40 mg/day)	
Dexamethasone: 0.5, 0.75, 1, 1.5, 2, 4, 6 mg tablets; 0.5 mg/5 mL, 1 mg/mL Intensol solution	0.5-1 mg/kg every 6-12 hr for 48 hr, then 1-2 mg/kg/day qd or bid Short course oral "burst" for exacerbation: 0.6 mg/kg, maximum 16 mg; can be repeated next day	
<b>Anticholinergics</b>	Mucolytic/bronchodilator	Should not be used as first-line therapy; added to β <sub>2</sub> -agonist therapy
Ipratropium Atrovent (nebulizer solution 0.5 mg/2.5 mL; MDI 18 μg/inhalation)	Nebulizer: 0.5 mg q6-8h (tid-qid) as needed MDI: 2 puffs qid	
Ipratropium with albuterol DuoNeb nebulizer solution (0.5 mg ipratropium + 2.5 mg albuterol/3 mL vial)	1 vial by nebulizer qid	Nebulizer: may mix ipratropium with albuterol
<b>Injectable sympathomimetic epinephrine</b>	Bronchodilator	For extreme circumstances (e.g., impending respiratory failure despite high-dose inhaled SABA, respiratory failure)

Continued

**Table 185.17** Management of Asthma Exacerbation (Status Asthmaticus)—cont'd

Adrenalin 1 mg/mL (1:1000) EpiPen autoinjection device (0.3 mg); EpiPen Jr 0.15 mg)	IM: 0.01 mg/kg (max dose 0.5 mg); may repeat after 15-30 min	
Terbutaline		Terbutaline is $\beta$ -agonist-selective relative to epinephrine Monitoring with continuous infusion: cardiorespiratory monitor, pulse oximetry, blood pressure, serum potassium Adverse effects: tremor, tachycardia, palpitations, arrhythmia, hypertension, headaches, nervousness, nausea, vomiting, hypoxemia
Brethine 1 mg/mL	Continuous IV infusion (terbutaline only): 2-10 $\mu$ g/kg loading dose, followed by 0.1-0.4 $\mu$ g/kg/min Titrate in 0.1-0.2 $\mu$ g/kg/min increments every 30 min, depending on clinical response.	
<b>Other medications</b>		
Magnesium sulfate	25-75 mg/kg over 20 min Max 2 gm	Flushing, headache, hypotension (rare)
<b>RISK ASSESSMENT FOR DISCHARGE</b>		
Medical stability	Discharge home if there has been sustained improvement in symptoms and bronchodilator treatments are at least 3 hr apart, physical findings are normal, PEF >70% of predicted or personal best, and oxygen saturation >92% when breathing room air	
Home supervision	Capability to administer intervention and to observe and respond appropriately to clinical deterioration	
Asthma education	See <a href="#">Table 185.10</a>	

IM, Intramuscular; IV, intravenous; MDI, metered-dose inhaler; PEF, peak expiratory flow; SABA, short-acting  $\beta$ -agonist;  $\dot{V}/\dot{Q}$ , ventilation/perfusion; bid, 2 times daily; tid, 3 times daily; qid, 4 times daily; qd, every day.

### Delivery Devices and Inhalation Technique

Inhaled medications are delivered in aerosolized form in an MDI, as a DPI formulation, or in a suspension form delivered via a nebulizer. **Spacer devices, recommended for the administration of all MDI medications, are simple and inexpensive tools that (1) decrease the coordination required to use MDIs, especially in young children; (2) improve the delivery of inhaled drug to the lower airways; and (3) minimize the risk of drug and propellant-mediated oropharyngeal adverse effects (dysphonia and thrush).** Optimal inhalation technique for each puff of MDI-delivered medication is a slow (5-second) inhalation, then a 5–10-second breath hold. No waiting time is required between puffs of medication. Preschool-age children cannot perform this inhalation technique. As a result, MDI medications in this age-group are delivered with a spacer and mask, using a different technique: Each puff is administered with regular breathing for about 30 seconds or 5-10 breaths; a tight seal must be maintained; and talking, coughing, or crying will blow the medication out of the spacer. This technique will not deliver as much medication per puff as the optimal MDI technique used by older children and adults.

**DPI devices** (e.g., Diskus, Flexhaler, Autohaler, Twisthaler, Aerolizer, Ellipta) are popular because of their simplicity of use, although adequate inspiratory flow is needed. DPIs are breath-actuated devices (the drug comes out only as it is breathed in), and spacers are not needed. Mouth rinsing is recommended after ICS use to remove ICS deposited on the oral mucosa and reduce the swallowed ICS and the risk of thrush.

**Nebulizers** are the mainstay of aerosol treatment for infants and young children. An advantage of using nebulizers is the simple technique required of relaxed breathing. The preferential nasal breathing, small airways, low tidal volume, and high respiratory rate of infants greatly increase the difficulty of inhaled drug therapy targeting the lung airways. Disadvantages of nebulizers include the need for a power source, inconvenience in that treatments take a significantly longer time, are more expensive, and have the potential for bacterial contamination.

### Asthma Exacerbations and Their Management

Asthma exacerbations are acute or subacute episodes of progressively worsening symptoms and airflow obstruction. Airflow obstruction during exacerbations can become extensive, resulting in life-threatening respiratory insufficiency. Often, asthma exacerbations worsen during sleep (between midnight and 8 AM), when airways inflammation and hyperresponsiveness are at their peak. Importantly, SABAs, which are first-line therapy for asthma symptoms and exacerbations, increase pulmonary blood flow through obstructed, unoxygenated areas of the lungs with increasing dosage and frequency. When airways obstruction is not resolved with SABA use, ventilation/perfusion mismatching can cause hypoxemia, which can perpetuate bronchoconstriction and further worsen the condition. Severe, progressive asthma exacerbations need to be managed in a medical setting, with administration of supplemental oxygen as first-line therapy and close monitoring for potential worsening. Complications that can occur during severe exacerbations include atelectasis (common) and air leaks in the chest (pneumomediastinum, pneumothorax; rare).

A severe exacerbation of asthma that does not improve with standard therapy is termed **status asthmaticus**. Immediate management of an asthma exacerbation involves a rapid evaluation of the severity of obstruction and assessment of risk for further clinical deterioration ([Fig. 185.6](#); see [Tables 185.4 and 185.17](#)). For most patients, exacerbations improve with frequent bronchodilator treatments and a course of systemic (oral or intravenous) corticosteroid. However, the optimal management of a child with an asthma exacerbation should include a more comprehensive assessment of the events leading up to the exacerbation and the underlying disease severity. Indeed, the frequency and severity of asthma exacerbations help define the severity of a patient's asthma. Whereas most children who experience life-threatening asthma episodes have moderate to severe asthma by other criteria, some children with asthma appear to have mild disease except when they have severe, even near-fatal exacerbations. The biologic, environmental, economic, and psychosocial risk factors associated with asthma morbidity and death can further guide this assessment ([Table 185.18](#)).

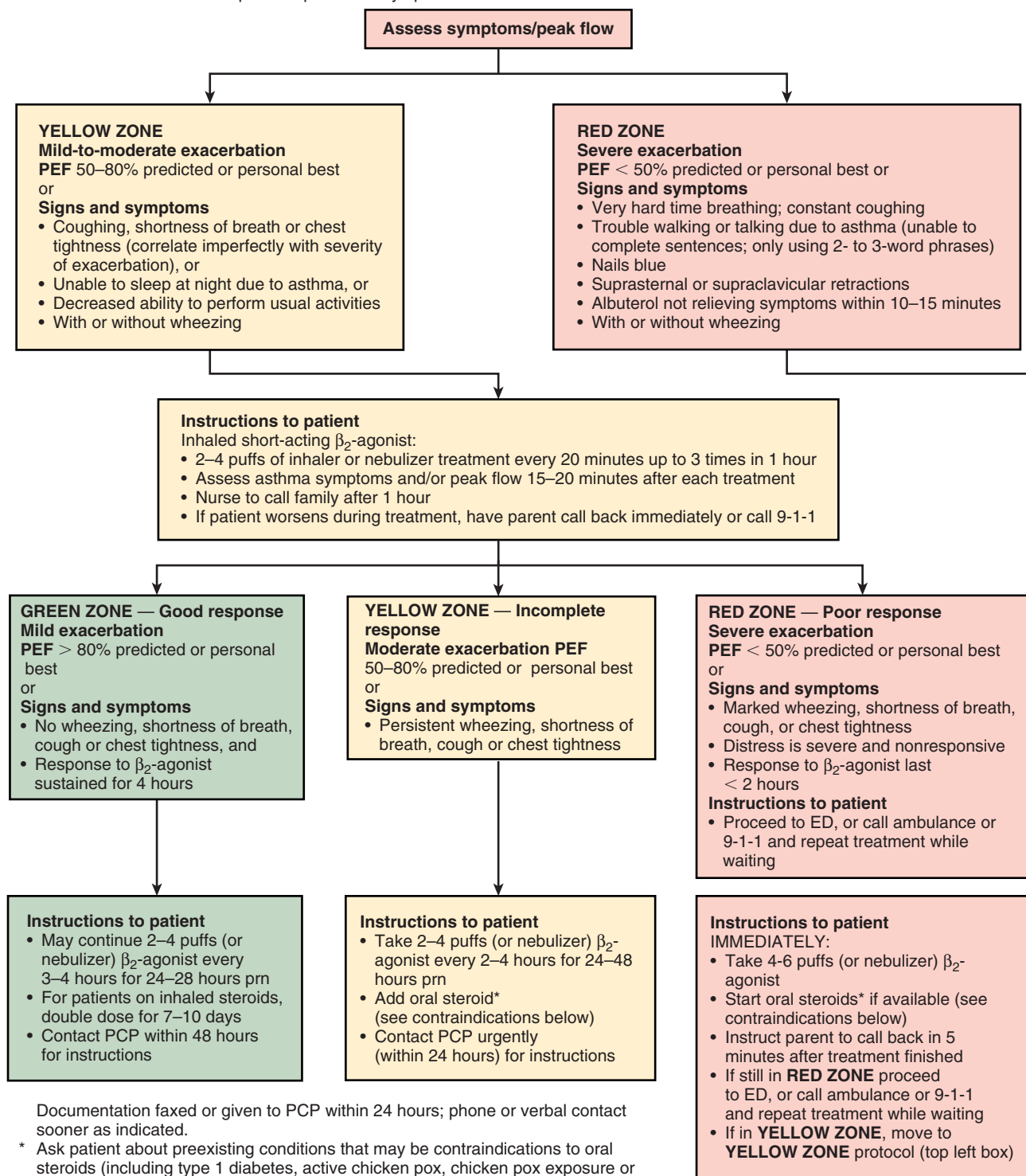


Follow this plan for After Hours patients only. Nurse may decide not to follow this home management plan if:

- Parent does not seem comfortable with or capable of following plan
- Nurse is not comfortable with this plan, based on situation and judgment
- Nurse's time does not allow for callbacks

In all cases, tell parent to call 9-1-1 if signs of respiratory distress occur during the episode

NOTE: If action plan has already been attempted without success, go to "RED ZONE — poor response" or "YELLOW ZONE — incomplete response" as symptoms indicate.



Date: \_\_\_\_\_  
Signature \_\_\_\_\_

**Fig. 185.6** Algorithm for treatment of acute asthma symptoms. ED, Emergency department; PCP, primary care physician; PEF, peak expiratory flow. (Courtesy BJC Healthcare/Washington University School of Medicine, Community Asthma Program, January 2000.)

Asthma exacerbations characteristically vary among individuals but tend to be similar in the same patient. Severe asthma exacerbations, resulting in respiratory distress, hypoxia, hospitalization, and respiratory failure, are the best predictors of future life-threatening exacerbations or a fatal asthma episode. In addition to distinguishing such high-risk children, some experience exacerbations that develop over days, with airflow obstruction resulting from progressive inflammation, epithelial sloughing, and cast impaction of small airways. When such a process is extreme, respiratory failure because of fatigue can ensue, necessitating mechanical ventilation for numerous days. In contrast, some children experience abrupt-onset exacerbations that may result from extreme AHR and physiologic susceptibility to airways closure. Such exacerbations, when extreme, are asphyxial in nature, often occur outside medical settings, are initially associated with very high arterial partial pressure of carbon dioxide (P<sub>CO</sub><sub>2</sub>) levels, and tend to require only brief periods of supportive ventilation. Recognizing the characteristic differences in asthma exacerbations is important for optimizing their early management.

### Home Management of Asthma Exacerbations

Families of all children with asthma should have a **written Asthma Action Plan** (see Fig. 185.5) to guide their recognition and management of exacerbations, along with the necessary education, medications, and tools to manage them. Early recognition of asthma exacerbations to intensify treatment early can often prevent further worsening and keep exacerbations from becoming severe. The NIH guidelines recommend immediate treatment with “rescue” medication (inhaled SABA, 2-4 puffs, up to 3 times every 20 minutes in 1 hour). A good response is

characterized by resolution of symptoms within 1 hour and no further symptoms over the next 4 hours. The child’s physician should be contacted for follow-up, especially if bronchodilators are required repeatedly over the next 24-48 hours. If the child has an incomplete response to initial treatment with rescue medication, a short course of OCS therapy (for example, prednisone, 1-2 mg/kg/day [not to exceed 40 mg/day] for 4 days) should be instituted, in addition to inhaled β-agonist therapy. The physician should also be contacted for further instructions. Immediate medical attention should be sought for severe exacerbations, persistent signs of respiratory distress, lack of expected response or sustained improvement after initial treatment, further deterioration, or high-risk factors for asthma morbidity or mortality (e.g., previous history of severe exacerbations). For patients with severe asthma and/or a history of life-threatening episodes, especially if abrupt in onset, an epinephrine auto-injector and perhaps portable oxygen at home can be considered. Use of either of these extreme measures for home management of asthma exacerbations would be an indication to call 911 for emergency support services.

### Emergency Department Management of Asthma Exacerbations

In the ED, the primary goals of asthma management include correction of hypoxemia, rapid improvement of airflow obstruction, and prevention of progression or recurrence of symptoms. Interventions are based on clinical severity on arrival, response to initial therapy, and presence of risk factors associated with asthma morbidity and mortality (see Table 185.18). Indicators of a severe exacerbation include breathlessness, dyspnea, retractions, accessory muscle use, tachypnea or labored breathing, cyanosis, mental status changes, a silent chest with poor air exchange, and severe airflow limitation (PEF or FEV<sub>1</sub> value <50% of personal best or predicted values). Initial treatment includes supplemental oxygen, inhaled β-agonist therapy every 20 minutes for 1 hour, and, if necessary, oral, injectable or IV systemic corticosteroids (see Tables 185.4 and 185.17, and Fig. 185.6). Inhaled ipratropium may be added to the β-agonist treatment, especially if no significant response is seen with the first inhaled β-agonist treatment. In the ED, single oral, IV, or intramuscular (IM) dose dexamethasone (0.6 mg/kg, maximum 16 mg) is an effective alternative to prednisone and with a lower incidence of emesis. A second dose of dexamethasone can be given the next day whether discharged or admitted to the hospital. An IM injection of epinephrine or other β-agonist may be administered in severe cases. Oxygen should be administered and continued for at least 20 minutes after SABA administration to compensate for possible ventilation/perfusion abnormalities caused by SABAs.

Close monitoring of clinical status, hydration, and oxygenation are essential elements of immediate management. A poor response to intensified treatment in the first hour suggests that the exacerbation will not remit quickly. The patient may be discharged home if there is sustained improvement in symptoms, normal physical findings, PEF >70% of predicted or personal best, and oxygen saturation >92% while the patient is breathing room air for 4 hours. Discharge medications include administration of an inhaled β-agonist up to every 3-4 hours plus a short course of an OCS. Optimizing controller therapy before discharge is also recommended. The addition of ICS to a course of OCS in the ED setting reduces the risk of exacerbation recurrence over the subsequent month.

### Hospital Management of Asthma Exacerbations

For patients with severe exacerbations that do not adequately improve within 1-2 hours of intensive treatment, observation and/or admission to the hospital, at least overnight, is likely to be needed. Other indications for hospital admission include high-risk features for asthma morbidity or death (see Table 185.18). Admission to an ICU is indicated for patients with severe respiratory distress, poor response to therapy, and concern for potential respiratory failure and arrest.

Supplemental oxygen, frequent or continuous administration of an inhaled bronchodilator, and systemic corticosteroid therapy are the conventional interventions for children admitted to the hospital for status asthmaticus (see Table 185.17). Supplemental oxygen is administered because many children hospitalized with acute asthma have or will eventually have hypoxemia, especially at night and with increasing

**Table 185.18** Risk Factors for Asthma Morbidity and Mortality

#### BIOLOGIC

Previous severe asthma exacerbation (intensive care unit admission, intubation for asthma)  
Sudden asphyxia episodes (respiratory failure, arrest)  
Two or more hospitalizations for asthma in past year  
Three or more emergency department visits for asthma in past year  
Increasing and large diurnal variation in peak flows  
Use of >2 canisters of short-acting β-agonists per month  
Poor response to systemic corticosteroid therapy  
Male sex  
Low birthweight  
Non-White  
Sensitivity to *Alternaria*

#### ENVIRONMENTAL

Allergen exposure  
Environmental tobacco smoke exposure  
Air pollution exposure  
Urban environment

#### ECONOMIC AND PSYCHOSOCIAL

Poverty  
Crowding  
Mother <20 yr old  
Mother with less than high school education  
Inadequate medical care  
Inaccessible  
Unaffordable  
No regular medical care (only emergency)  
Lack of written Asthma Action Plan  
No care sought for chronic asthma symptoms  
Delay in care of asthma exacerbations  
Inadequate hospital care for asthma exacerbation  
Psychopathology in the parent or child  
Poor perception of asthma symptoms or severity  
Alcohol or substance abuse

SABA administration. SABAs can be delivered frequently (every 20 minutes to 1 hour) or continuously (at 5-15 mg/hr). When administered continuously, significant systemic absorption of  $\beta$ -agonist occurs, and thus continuous nebulization can obviate the need for IV  $\beta$ -agonist therapy. Adverse effects of frequently administered  $\beta$ -agonist therapy include tremor, irritability, tachycardia, and hypokalemia; lactic acidosis is an uncommon complication. Patients requiring frequent or continuous nebulized  $\beta$ -agonist therapy should have ongoing cardiac monitoring. Because frequent  $\beta$ -agonist therapy can cause ventilation/perfusion mismatch and hypoxemia, oximetry is also indicated. Inhaled ipratropium is often added to albuterol every 6 hours if patients do not show a remarkable improvement, although there is little evidence to support its use in hospitalized children receiving aggressive inhaled  $\beta$ -agonist therapy and systemic corticosteroids. In addition to its potential to provide a synergistic effect with a  $\beta$ -agonist agent in relieving severe bronchospasm, ipratropium may be beneficial in patients who have mucus hypersecretion or who are receiving  $\beta$  blockers.

Short-course systemic corticosteroid therapy is recommended for use in moderate to severe asthma exacerbations to hasten recovery and prevent recurrence of symptoms. Studies in children hospitalized with acute asthma have found corticosteroids administered orally to be as effective as IV corticosteroids. Accordingly, OCS therapy can often be used, although children with sustained respiratory distress and those unable to tolerate oral preparations or liquids are obvious candidates for IV corticosteroid therapy.

Patients with persistent severe dyspnea and high-flow oxygen requirements require additional evaluation, such as complete blood count, arterial blood gases, serum electrolytes, and chest radiograph, to monitor for respiratory insufficiency, comorbidities, infection, and dehydration. Hydration status monitoring is especially important in infants and young children, whose increased respiratory rate (insensible losses) and decreased oral intake put them at higher risk for dehydration. Further complicating this situation is the association of increased antidiuretic hormone secretion with status asthmaticus. Administration of fluids at or slightly below maintenance fluid requirements is recommended. Chest physical therapy, incentive spirometry, and mucolytics are not recommended during asthma exacerbations because they can trigger severe bronchoconstriction.

Despite intensive therapy, some asthmatic children remain critically ill and at risk for respiratory failure, intubation, and mechanical ventilation. Complications (e.g., air leaks) related to asthma exacerbations increase with intubation and assisted ventilation, so every effort should be made to relieve bronchospasm and prevent respiratory failure. Several therapies, including parenteral  $\beta$ -agonists, magnesium sulfate (25-75 mg/kg, maximum dose 2.5 g, given intravenously over 20 minutes), and inhaled heliox (helium and oxygen mixture) have demonstrated some benefit as adjunctive therapies in patients with severe status asthmaticus. Administration of magnesium sulfate requires monitoring of serum levels and cardiovascular status. Noninvasive positive pressure ventilation (e.g., continuous positive airway pressure [CPAP] or biphasic positive airway pressure [BiPAP]) might improve severe asthma exacerbations through a variety of mechanisms. Their use in the care of children with severe persistent asthma exacerbations has increased in efforts to avert mechanical ventilation, even though evidence supporting the intervention has been considered weak, and current NAEP and GINA guidelines do not recommend the intervention. Parenteral (SC, IM, or IV) epinephrine or terbutaline sulfate may be effective in patients with life-threatening obstruction that is not responding to high doses of inhaled  $\beta$ -agonists, because inhaled medication may not reach the lower airway in such patients.

Rarely, a severe asthma exacerbation in a child results in respiratory failure, and intubation and mechanical ventilation become necessary. **Mechanical ventilation** in severe asthma exacerbations requires the careful balance of enough pressure to overcome airways obstruction while reducing hyperinflation, air trapping, and the likelihood of barotrauma (pneumothorax, pneumomediastinum; see Chapter 461). To minimize the likelihood of such complications, mechanical ventilation should be anticipated, and asthmatic children at risk for the development of respiratory failure should be managed in a pediatric ICU. Elective tracheal intubation with rapid-induction sedatives and paralytic agents is

safer than emergency intubation. Mechanical ventilation aims to achieve adequate oxygenation while tolerating mild to moderate hypercapnia ( $\text{Pco}_2$  50-70 mm Hg) to minimize barotrauma. As measures to relieve mucus plugs, chest percussion and airways lavage are not recommended because they can induce further bronchospasm. One must consider the nature of asthma exacerbations leading to respiratory failure; those of rapid or abrupt onset tend to resolve quickly (hours to 2 days), whereas those that progress gradually to respiratory failure can require days to weeks of mechanical ventilation. Such prolonged cases are further complicated by corticosteroid-induced myopathy, which can lead to severe muscle weakness requiring prolonged rehabilitation.

In children, management of severe exacerbations in medical centers is usually successful, even when extreme measures are required. Consequently, asthma deaths in children rarely occur in medical centers; most occur at home or in community settings before lifesaving medical care can be administered. This point highlights the importance of home and community management of asthma exacerbations, early intervention measures to keep exacerbations from becoming severe, and steps to reduce asthma severity. A follow-up appointment within 1-2 weeks of a child's discharge from the hospital after resolution of an asthma exacerbation should be used to monitor clinical improvement and to reinforce key educational elements, including action plans and controller medications.

### Special Management Circumstances

#### Management of Infants and Young Children

Recurrent wheezing episodes in preschool-age children are common, occurring in as much as one-third of this population. Of these, most improve and even become asymptomatic during the prepubescent school-age years, whereas others have lifelong persistent asthma. All require management of their recurrent wheezing problems. The NIH guidelines recommend risk assessment to identify preschool-age children who are likely to have persistent asthma. One implication of this recommendation is that these at-risk children may be candidates for conventional asthma management, including daily controller therapy and early intervention with exacerbations (see [Tables 185.9, 185.10, 185.13, and 185.14](#)). **For young children with recurrent episodic wheeze in the setting of viral illness, a short course of daily high-dose ICS may also be considered.** For young children with a history of moderate to severe exacerbations, nebulized budesonide is approved by the FDA, and its use as a controller medication could prevent subsequent exacerbations.

Using aerosol therapy in infants and young children with asthma presents unique challenges. There are two delivery systems for inhaled medications for this age-group: the nebulizer and the MDI with spacer/holding chamber and face mask. Multiple studies demonstrate the effectiveness of both nebulized albuterol in acute episodes and nebulized budesonide in the treatment of recurrent wheezing in infants and young children. In such young children, inhaled medications administered via MDI with spacer and face mask may be acceptable, although perhaps not preferred because of limited published information and lack of FDA approval for children <4 years of age.

#### Asthma Management During Surgery

Patients with asthma are at risk from disease-related complications from surgery, such as bronchoconstriction and asthma exacerbation, atelectasis, impaired coughing, respiratory infection, and latex exposure, which may induce asthma complications in patients with latex allergy. All patients with asthma should be evaluated before surgery, and those who are inadequately controlled should allow time for intensified treatment to improve asthma stability before surgery, if possible. A systemic corticosteroid course may be indicated for the patient who is having symptoms and/or  $\text{FEV}_1$  or PEF values <80% of the patient's personal best. In addition, patients who have received >2 weeks of systemic corticosteroid and/or moderate- to high-dose ICS therapy may be at risk for intraoperative adrenal insufficiency. For these patients, anesthesia services should be alerted to provide "stress" replacement doses of systemic corticosteroid for the surgical procedure and possibly the postoperative period.



## PROGNOSIS

Recurrent coughing and wheezing occur in 35% of preschool-age children. Of these, approximately one third continue to have persistent asthma into later childhood, and approximately two thirds improve on their own through their teen years. Concomitant atopic disorders (such as allergen sensitization or atopic dermatitis) are associated with greater likelihood of disease persistence. Asthma severity by ages 7-10 years is predictive of asthma persistence in adulthood. Children with moderate to severe asthma and with lower lung function measures are likely to have persistent asthma as adults. Children with milder asthma and normal lung function are likely to improve over time, with some becoming periodically asthmatic (disease-free for months to years).

## PREVENTION

Although chronic airways inflammation may result in pathologic remodeling of lung airways, conventional antiinflammatory interventions—the cornerstone of asthma control—do not help children outgrow their asthma. Although controller medications reduce asthma morbidities, most children with moderate to severe asthma continue to have symptoms into young adulthood. Investigations into the environmental and lifestyle factors responsible for the lower prevalence of childhood asthma in rural areas and farming communities suggest that early immunomodulatory intervention might prevent asthma development. A *hygiene hypothesis* purports that naturally occurring microbial exposures in early life might drive early immune development away from allergic sensitization, persistent airways inflammation, and remodeling through early microbiome and innate immune development. If these natural microbial exposures truly have an asthma-protective effect, without significant adverse health consequences, these findings may foster new strategies for asthma prevention.

Several nonpharmacologic measures with numerous positive health attributes—avoidance of environmental tobacco smoke (beginning prenatally), prolonged breastfeeding (>4 months), an active lifestyle, and a healthy diet—might reduce the likelihood of asthma development. Care providers can be strong influencers of smoking cessation by parents, caregivers, and adolescent patients (see [Chapters 157.2 and 759.1](#)). Immunizations are not considered to increase the likelihood of development of asthma; therefore all standard childhood immunizations are recommended for children with asthma, including varicella, SARS-CoV-2, and annual influenza vaccines.

Visit Elsevier eBooks+ at [eBooks.Health.Elsevier.com](http://eBooks.Health.Elsevier.com) for Bibliography.

## Chapter 186

# Atopic Dermatitis (Atopic Eczema)

Donald Y.M. Leung and Scott H. Sicherer

**Atopic dermatitis (AD)**, or eczema, is the most common chronic relapsing skin disease seen in infancy and childhood. It affects 10–30% of children worldwide and frequently occurs in families with other atopic diseases. Infants with AD are predisposed to the development of food allergy, allergic rhinitis, and asthma later in childhood, a process called *the atopic march*.

## ETIOLOGY

AD is a complex genetic disorder that results in a defective skin barrier, reduced skin innate immune responses, and primarily type 2 adaptive immune responses to environmental allergens and microbes that lead to chronic skin inflammation.

## PATHOLOGY

Acute AD skin lesions are characterized by **spongiosis**, or marked intercellular edema, of the epidermis. In AD, dendritic antigen-presenting cells (APCs) in the epidermis, such as Langerhans cells, exhibit surface-bound IgE molecules with cell processes that reach into the upper epidermis to sense allergens and pathogens. These APCs play an important role in cutaneous responses to type 2 immune responses (see [Chapter 182](#)). There is marked perivascular T-cell and inflammatory monocyte-macrophage infiltration in acute AD lesions. Chronic, lichenified AD is characterized by a hyperplastic epidermis with hyperkeratosis and minimal spongiosis. There are predominantly IgE-bearing Langerhans cells in the epidermis, and macrophages in the dermal mononuclear cell infiltrate. Mast cell and eosinophil numbers are increased, contributing to skin inflammation.

## PATHOGENESIS

AD is associated with multiple phenotypes and endotypes that have overlapping clinical presentations. **Atopic eczema** is associated with IgE-mediated sensitization (at onset or during the course of eczema) and occurs in 70–80% of patients with AD. **Nonatopic eczema** is not associated with IgE-mediated sensitization and is seen in 20–30% of patients with AD. Both forms of AD are associated with eosinophilia. In atopic eczema, circulating T cells expressing the skin homing receptor **cutaneous lymphocyte-associated antigen** produce increased levels of T-helper type 2 (Th2) cytokines, including interleukin (IL)-4 and IL-13, which induce isotype switching to IgE synthesis. Another type 2 cytokine, IL-5, plays an important role in eosinophil development and IL-31 is a key itch cytokine ([Fig. 186.1](#)). Nonatopic eczema is associated with lower IL-4 and IL-13 but increased IL-17 and IL-23 production than in atopic eczema. Age has also been found to affect the immune profile in AD.

Compared with the skin of healthy individuals, both unaffected skin and acute skin lesions of patients with AD have an increased number of cells expressing IL-4, IL-13, and IL-31. Chronic AD skin lesions, by contrast, have fewer cells that express IL-4 and IL-13, but they have more cells that express IL-5, granulocyte-macrophage colony-stimulating factor, IL-12, and interferon (IFN)- $\gamma$  than acute AD lesions. Despite increased type 1 and type 17 immune responses in chronic AD, IL-4 and IL-13 as well as other type 2 cytokines (e.g., thymic stromal lymphopoietin [TSLP], IL-31, IL-33) predominate and reflect increased numbers of type 2 innate lymphoid cells and Th2 cells. The infiltration of IL-22-expressing T cells correlates with severity of AD, blocks keratinocyte differentiation, and induces epidermal hyperplasia. The importance of IL-4 and IL-13 in driving severe persistent AD has been validated by multiple clinical trials now demonstrating that biologics blocking IL-4 and IL-13 action lead to clinical improvement in moderate to severe AD.

In healthy people, the skin acts as a protective barrier against external irritants, moisture loss, and infection. Proper function of the skin depends on adequate moisture and lipid content, functional immune responses, and structural integrity. *Severely dry skin is a hallmark of AD.* This results from compromise of the epidermal barrier, which leads to excess transepidermal water loss, allergen penetration, and microbial colonization. **Filaggrin**, a structural protein in the epidermis, and its breakdown products are critical to skin barrier function, including moisturization of the skin. Genetic pathogenic variants in the filaggrin gene (*FLG*) family have been identified in patients with ichthyosis vulgaris (dry skin, palmar hyperlinearity) and in up to 50% of patients with severe AD. *FLG* pathogenic variant is strongly associated with the development of food allergy and eczema herpeticum. Nonetheless, up to 60% of carriers of an *FLG* pathogenic variant do not develop atopic diseases. Cytokines found in allergic inflammation, such as IL-4, IL-13, IL-22, and IL-25, and tumor necrosis factor, can also reduce filaggrin



## PROGNOSIS

Recurrent coughing and wheezing occur in 35% of preschool-age children. Of these, approximately one third continue to have persistent asthma into later childhood, and approximately two thirds improve on their own through their teen years. Concomitant atopic disorders (such as allergen sensitization or atopic dermatitis) are associated with greater likelihood of disease persistence. Asthma severity by ages 7-10 years is predictive of asthma persistence in adulthood. Children with moderate to severe asthma and with lower lung function measures are likely to have persistent asthma as adults. Children with milder asthma and normal lung function are likely to improve over time, with some becoming periodically asthmatic (disease-free for months to years).

## PREVENTION

Although chronic airways inflammation may result in pathologic remodeling of lung airways, conventional antiinflammatory interventions—the cornerstone of asthma control—do not help children outgrow their asthma. Although controller medications reduce asthma morbidities, most children with moderate to severe asthma continue to have symptoms into young adulthood. Investigations into the environmental and lifestyle factors responsible for the lower prevalence of childhood asthma in rural areas and farming communities suggest that early immunomodulatory intervention might prevent asthma development. A *hygiene hypothesis* purports that naturally occurring microbial exposures in early life might drive early immune development away from allergic sensitization, persistent airways inflammation, and remodeling through early microbiome and innate immune development. If these natural microbial exposures truly have an asthma-protective effect, without significant adverse health consequences, these findings may foster new strategies for asthma prevention.

Several nonpharmacologic measures with numerous positive health attributes—avoidance of environmental tobacco smoke (beginning prenatally), prolonged breastfeeding (>4 months), an active lifestyle, and a healthy diet—might reduce the likelihood of asthma development. Care providers can be strong influencers of smoking cessation by parents, caregivers, and adolescent patients (see [Chapters 157.2 and 759.1](#)). Immunizations are not considered to increase the likelihood of development of asthma; therefore all standard childhood immunizations are recommended for children with asthma, including varicella, SARS-CoV-2, and annual influenza vaccines.

Visit Elsevier eBooks+ at [eBooks.Health.Elsevier.com](http://eBooks.Health.Elsevier.com) for Bibliography.

## Chapter 186

# Atopic Dermatitis (Atopic Eczema)

Donald Y.M. Leung and Scott H. Sicherer

**Atopic dermatitis (AD)**, or eczema, is the most common chronic relapsing skin disease seen in infancy and childhood. It affects 10–30% of children worldwide and frequently occurs in families with other atopic diseases. Infants with AD are predisposed to the development of food allergy, allergic rhinitis, and asthma later in childhood, a process called *the atopic march*.

## ETIOLOGY

AD is a complex genetic disorder that results in a defective skin barrier, reduced skin innate immune responses, and primarily type 2 adaptive immune responses to environmental allergens and microbes that lead to chronic skin inflammation.

## PATHOLOGY

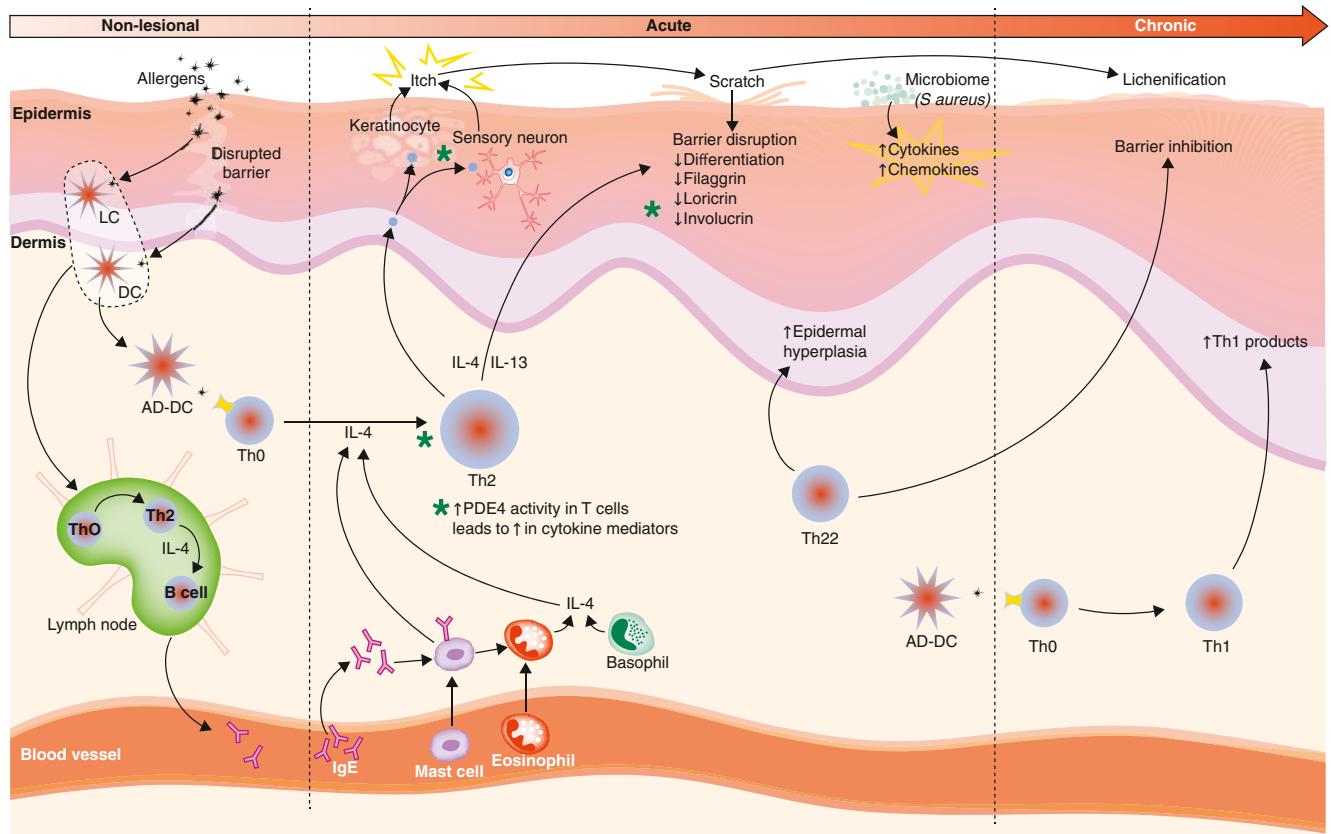
Acute AD skin lesions are characterized by **spongiosis**, or marked intercellular edema, of the epidermis. In AD, dendritic antigen-presenting cells (APCs) in the epidermis, such as Langerhans cells, exhibit surface-bound IgE molecules with cell processes that reach into the upper epidermis to sense allergens and pathogens. These APCs play an important role in cutaneous responses to type 2 immune responses (see [Chapter 182](#)). There is marked perivascular T-cell and inflammatory monocyte-macrophage infiltration in acute AD lesions. Chronic, lichenified AD is characterized by a hyperplastic epidermis with hyperkeratosis and minimal spongiosis. There are predominantly IgE-bearing Langerhans cells in the epidermis, and macrophages in the dermal mononuclear cell infiltrate. Mast cell and eosinophil numbers are increased, contributing to skin inflammation.

## PATHOGENESIS

AD is associated with multiple phenotypes and endotypes that have overlapping clinical presentations. **Atopic eczema** is associated with IgE-mediated sensitization (at onset or during the course of eczema) and occurs in 70–80% of patients with AD. **Nonatopic eczema** is not associated with IgE-mediated sensitization and is seen in 20–30% of patients with AD. Both forms of AD are associated with eosinophilia. In atopic eczema, circulating T cells expressing the skin homing receptor **cutaneous lymphocyte-associated antigen** produce increased levels of T-helper type 2 (Th2) cytokines, including interleukin (IL)-4 and IL-13, which induce isotype switching to IgE synthesis. Another type 2 cytokine, IL-5, plays an important role in eosinophil development and IL-31 is a key itch cytokine ([Fig. 186.1](#)). Nonatopic eczema is associated with lower IL-4 and IL-13 but increased IL-17 and IL-23 production than in atopic eczema. Age has also been found to affect the immune profile in AD.

Compared with the skin of healthy individuals, both unaffected skin and acute skin lesions of patients with AD have an increased number of cells expressing IL-4, IL-13, and IL-31. Chronic AD skin lesions, by contrast, have fewer cells that express IL-4 and IL-13, but they have more cells that express IL-5, granulocyte-macrophage colony-stimulating factor, IL-12, and interferon (IFN)- $\gamma$  than acute AD lesions. Despite increased type 1 and type 17 immune responses in chronic AD, IL-4 and IL-13 as well as other type 2 cytokines (e.g., thymic stromal lymphopoietin [TSLP], IL-31, IL-33) predominate and reflect increased numbers of type 2 innate lymphoid cells and Th2 cells. The infiltration of IL-22-expressing T cells correlates with severity of AD, blocks keratinocyte differentiation, and induces epidermal hyperplasia. The importance of IL-4 and IL-13 in driving severe persistent AD has been validated by multiple clinical trials now demonstrating that biologics blocking IL-4 and IL-13 action lead to clinical improvement in moderate to severe AD.

In healthy people, the skin acts as a protective barrier against external irritants, moisture loss, and infection. Proper function of the skin depends on adequate moisture and lipid content, functional immune responses, and structural integrity. *Severely dry skin is a hallmark of AD.* This results from compromise of the epidermal barrier, which leads to excess transepidermal water loss, allergen penetration, and microbial colonization. **Filaggrin**, a structural protein in the epidermis, and its breakdown products are critical to skin barrier function, including moisturization of the skin. Genetic pathogenic variants in the filaggrin gene (*FLG*) family have been identified in patients with ichthyosis vulgaris (dry skin, palmar hyperlinearity) and in up to 50% of patients with severe AD. *FLG* pathogenic variant is strongly associated with the development of food allergy and eczema herpeticum. Nonetheless, up to 60% of carriers of an *FLG* pathogenic variant do not develop atopic diseases. Cytokines found in allergic inflammation, such as IL-4, IL-13, IL-22, and IL-25, and tumor necrosis factor, can also reduce filaggrin



**Fig. 186.1** Pathogenic pathways and immunologic targets in atopic dermatitis (AD). Skin barrier defects in nonlesional atopic dermatitis leads to penetration by allergens, which encounter antigen-presenting Langerhans cells (LCs) in the epidermis and dendritic cells (DCs) in the dermis, resulting in immune activation and inflammatory cell recruitment. Elevated T-helper type 2 (Th2) cell counts in the acute state leads to increased secretion of cytokines, especially interleukin (IL)-4 and IL-13, which disrupt the skin barrier by decreasing expression of barrier proteins (i.e., filaggrin, loricrin, and involucrin). In addition, Th2 cytokines recruit eosinophils and basophils to lesional sites, and increase B-cell IgE production. Eosinophils, basophils, and activated IgE-bound mast cells release proinflammatory mediators, further potentiating pathogenesis. Th2 cytokines also impair antimicrobial peptide responses to pathogens which, in combination with barrier disruption, increases the risk of colonization and barrier penetration by allergens and pathogens (i.e., *Staphylococcus aureus*). Chronic atopic dermatitis results in a skewed Th1 response, leading to further inflammation and immune activation. Processes mediated by Janus kinase (JAK) receptors are marked with a green asterisk. PDE4, phosphodiesterase-4. (From Vaharia PP, Silverberg JI. New and emerging therapies for paediatric atopic dermatitis. *Lancet Child Adolesc.* 2019;3:343–352.)

and other epidermal proteins and lipids. AD patients are at increased risk of bacterial, viral, and fungal infection related to impairment of innate immunity, disturbances in the microbiome, skin epithelial dysfunction, and overexpression of polarized immune pathways, which dampen host antimicrobial responses. Patients with the combination of AD and food allergy have significantly lower levels of filaggrin and increased type 2 immune activation than patients with AD only.

### CLINICAL MANIFESTATIONS

AD typically begins in infancy. Approximately 50% of patients experience symptoms in the first year of life, and an additional 30% are diagnosed between 1 and 5 years of age. Intense **pruritus**, especially at night, and **cutaneous reactivity** are the cardinal features of AD. Scratching and excoriation cause increased skin inflammation that contributes to the development of more pronounced eczematous skin lesions. Foods (cow's milk, egg, peanut, tree nuts, soy, wheat, fish, shellfish), aeroallergens (pollen, grass, animal dander, dust mites), infection (*Staphylococcus aureus*, herpes simplex, coxsackievirus, molluscum), reduced humidity, excessive sweating, and irritants (wool, acrylic, soaps, toiletries, fragrances, detergents) can trigger pruritus and scratching.

Acute AD skin lesions are intensely pruritic with erythematous papules (Figs. 186.2 and 186.3). Subacute dermatitis manifests as erythematous, excoriated, scaling papules. In contrast, chronic AD is characterized by **lichenification** (Fig. 186.4), or thickening of the skin with accentuated surface markings, and **fibrotic papules**. In chronic AD, all

three types of skin reactions may coexist in the same individual. Most patients with AD have dry, lackluster skin regardless of their stage of illness. Skin reaction pattern and distribution vary with the patient's age and disease activity. AD is generally more acute in infancy and involves the face, scalp, and extensor surfaces of the extremities. The diaper area is usually spared. Older children and children with chronic AD have lichenification and localization of the rash to the flexural folds of the extremities. AD can go into remission as the patient grows older; however, many children with AD have persistent eczema as an adult (see Fig. 186.2C).

### LABORATORY FINDINGS

There are no specific laboratory tests to diagnose AD. Many patients have peripheral blood eosinophilia, increased serum IgE levels, and T cells expressing type 2 cytokines. Serum IgE measurement or skin-prick testing can identify the allergens (foods, inhalant/microbial allergens) to which patients are sensitized. The diagnosis of clinical allergy to these allergens requires confirmation by history and environmental challenges.

### DIAGNOSIS AND DIFFERENTIAL DIAGNOSIS

AD is diagnosed on the basis of three major features: pruritus, an eczematous dermatitis that fits into a typical pattern of skin inflammation, and a chronic or chronically relapsing course (Table 186.1). Associated features, such as a family history of asthma, hay fever, food



**Fig. 186.2** Typical clinical appearance and locations of atopic dermatitis at different ages. **A**, In infants, atopic dermatitis is generally acute, with lesions mainly on the face and the extensor surfaces of the limbs. The trunk might be affected, but the napkin area is typically spared. **B**, From age 1-2 years onward, polymorphous manifestations with different types of skin lesions are seen, particularly in flexural folds. **C**, Adolescents and adults often present lichenified and excoriated plaques at flexures, wrists, ankles, and eyelids; in the head and neck type, the upper trunk, shoulders, and scalp are involved. Adults might have only chronic hand eczema or present with prurigo-like lesions. (From Weidinger S, Novak N. *Atopic dermatitis*. *Lancet*. 2016;387:1111.)

allergy, elevated IgE, and immediate skin test reactivity, reinforce the diagnosis of AD.

Many inflammatory skin diseases, immunodeficiencies, skin malignancies, genetic disorders, infectious diseases, and infestations share symptoms with AD and should be considered and excluded before a diagnosis of AD is established (Tables 186.2 and 186.3). Severe combined immunodeficiency (see Chapter 165.1) should be considered for infants presenting in the first year of life with diarrhea, failure to thrive, generalized scaling rash, and recurrent cutaneous and/or systemic infection. Histiocytosis should be excluded in any infant with AD and failure to thrive (see Chapter 556). Wiskott-Aldrich syndrome, an X-linked recessive disorder associated with thrombocytopenia, immune defects, and recurrent severe bacterial infections, is characterized by a rash almost indistinguishable from that in AD (see Chapter 165.4). One of the hyper-IgE syndromes is characterized by markedly elevated serum IgE values, recurrent deep-seated bacterial infections, chronic dermatitis, and refractory dermatophytosis. Many of these patients have disease as a result of autosomal dominant *STAT3* pathogenic variants. In contrast, some patients with hyper-IgE syndrome present with increased susceptibility to viral infections and an autosomal recessive pattern of disease inheritance. These patients may have a dedicator of cytokinesis 8 gene (*DOCK8*) pathogenic variants. This diagnosis should be considered in young children with severe eczema, food allergy, and disseminated skin viral infections.

Adolescents who present with an eczematous dermatitis but no history of childhood eczema, respiratory allergy, or atopic family history may have allergic **contact dermatitis**. A contact allergen may be the problem in any patient whose AD does not respond to appropriate therapy. Sensitizing chemicals, such as parabens and lanolin, can be irritants for patients with AD and are commonly found as vehicles in therapeutic topical agents. Topical glucocorticoid contact allergy has been reported in patients with chronic dermatitis receiving topical corticosteroid therapy. Eczematous dermatitis has also been reported with HIV infection as well as with a variety of infestations such as scabies. Other conditions that can be confused with AD include psoriasis, ichthyosis, and seborrheic dermatitis.

## TREATMENT

The treatment of AD requires a systematic, multifaceted approach that incorporates skin moisturization, topical antiinflammatory therapy, identification and elimination of flare factors (Table 186.4), and, if necessary, systemic therapy (Fig. 186.5). Assessment of the severity also helps direct therapy (Table 186.5; see Fig. 186.5).

### Cutaneous Hydration

Because patients with AD have impaired skin barrier function from reduced filaggrin and skin lipid levels, they present with diffuse, abnormally dry skin, or **xerosis**. **Moisturizers are first-line therapy**. Lukewarm soaking baths or showers for 15-20 minutes followed by the





**Fig. 186.3** Crusted lesions of atopic dermatitis on the face. (From Eichenfield LF, Friedan IJ, Esterly NB. *Textbook of Neonatal Dermatology*. Philadelphia: Saunders; 2001. p 242.)



**Fig. 186.4** Lichenification of the popliteal fossa from chronic rubbing of the skin in atopic dermatitis. (From Weston WL, Lane AT, Morelli JG. *Color Textbook of Pediatric Dermatology*. 2nd ed. St Louis: Mosby; 1996. p 33.)

application of an occlusive emollient to retain moisture provide symptomatic relief. Hydrophilic ointments of varying degrees of viscosity can be used according to the patient's preference. Occlusive ointments are sometimes not well tolerated because of interference with the function of the eccrine sweat ducts and may induce the development of folliculitis. In these patients, less occlusive agents should be used. Several prescription (classified as a medical device) "therapeutic moisturizers" or "barrier creams" are available, containing components such as ceramides and filaggrin acid metabolites intended to improve skin barrier function. There are minimal data demonstrating their efficacy over standard emollients.

Hydration by baths or wet dressings promotes transepidermal penetration of topical glucocorticoids. Dressings may also serve as effective barriers against persistent scratching, in turn promoting healing of excoriated lesions. Wet dressings are recommended for use on severely affected or chronically involved areas of dermatitis refractory to skin care. It is critical that wet dressing therapy be followed by topical emollient application to avoid potential drying and fissuring from the

**Table 186.1** Clinical Features of Atopic Dermatitis

#### MAJOR FEATURES

Pruritus  
 Facial and extensor eczema in infants and children  
 Flexural eczema in adolescents  
 Chronic or relapsing dermatitis  
 Personal or family history of atopic disease

#### ASSOCIATED FEATURES

Xerosis  
 Cutaneous infections (*Staphylococcus aureus*, group A streptococcus, herpes simplex, coxsackievirus, vaccinia, molluscum, warts)  
 Nonspecific dermatitis of the hands or feet  
 Ichthyosis, palmar hyperlinearity, keratosis pilaris  
 Nipple eczema  
 White dermatographism and delayed blanch response  
 Anterior subcapsular cataracts, keratoconus  
 Elevated serum IgE levels  
 Positive results of immediate-type allergy skin tests  
 Early age at onset  
 Dennie lines (Dennie-Morgan infraorbital folds)  
 Facial erythema or pallor  
 Course influenced by environmental and/or emotional factors  
 Lichenification  
 Perioral, periauricular sites  
 Prurigo

therapy. Wet dressing therapy can be complicated by maceration and secondary infection and should be closely monitored by a physician.

#### Topical Corticosteroids

Topical corticosteroids are the cornerstone of antiinflammatory treatment for acute exacerbations of AD. Patients should be carefully instructed on their use of topical glucocorticoids to avoid potential adverse effects. There are seven classes of topical glucocorticoids, ranked according to their potency, as determined by vasoconstrictor assays (Table 186.6). Because of their potential adverse effects, the ultra-high-potency glucocorticoids should not be used on the face or intertriginous areas and should be used only for very short periods on the trunk and extremities. Mid-potency glucocorticoids can be used for longer periods to treat chronic AD involving the trunk and extremities. Long-term control can be maintained with twice-weekly applications of topical fluticasone or mometasone to areas that have healed but are prone to relapse, once control of AD is achieved after a daily regimen of topical corticosteroids. Compared with creams, ointments have a greater potential to occlude the epidermis, resulting in enhanced systemic absorption.

Adverse effects of topical glucocorticoids can be divided into local adverse effects and systemic adverse effects, the latter resulting from suppression of the hypothalamic-pituitary-adrenal axis. *Local* adverse effects include the development of striae and skin atrophy. *Systemic* adverse effects are related to the potency of the topical corticosteroid, site of application, occlusiveness of the preparation, percentage of the body surface area covered, and length of use. The potential for adrenal suppression from potent topical corticosteroids is greatest in infants and young children with severe AD requiring intensive therapy.

#### Topical Calcineurin Inhibitors

The nonsteroidal topical calcineurin inhibitors are effective in reducing AD skin inflammation. Pimecrolimus cream 1% (Elidel) is indicated for mild to moderate AD. Tacrolimus ointment 0.1% and 0.03% (Protopic) is indicated for moderate to severe AD. Both are approved for short-term or intermittent long-term treatment of AD in patients  $\geq 2$  years whose disease is unresponsive to or who are intolerant of other conventional therapies or for whom these therapies are inadvisable



**Table 186.2** Differential Diagnosis of Atopic Dermatitis

	MAIN AGE GROUP AFFECTED	FREQUENCY*	CHARACTERISTICS AND CLINICAL FEATURES
<b>OTHER TYPES OF DERMATITIS</b>			
Seborrheic dermatitis	Infants	Common	Salmon-red greasy scaly lesions, often on the scalp (cradle cap) and napkin area; generally presents in the first 6 wk of life; typically clears within weeks
Seborrheic dermatitis	Adults	Common	Erythematous patches with yellow, white, or grayish scales in seborrheic areas, particularly the scalp, central face, and anterior chest
Nummular dermatitis	Children and adults	Common	Coin-shaped scaly patches, mostly on legs and buttocks; usually no itch
Irritant contact dermatitis	Children and adults	Common	Acute to chronic eczematous lesions, mostly confined to the site of exposure; history of locally applied irritants is a risk factor; might coexist with AD
Allergic contact dermatitis	Children and adults	Common	Eczematous rash with maximum expression at sites of direct exposure but might spread; history of locally applied irritants is a risk factor; might coexist with AD
Lichen simplex chronicus	Adults	Uncommon	One or more localized, circumscribed, lichenified plaques that result from repetitive scratching or rubbing because of intense itch
Asteatotic eczema	Adults	Common	Scaly, fissured patches of dermatitis overlying dry skin, most often on lower legs
<b>INFECTIOUS SKIN DISEASES</b>			
Dermatophyte infection	Children and adults	Common	One or more demarcated scaly plaques with central clearing and slightly raised reddened edge; variable itch
Impetigo	Children	Common	Demarcated erythematous patches with blisters or honey-yellow crusting
Scabies	Children	Common†	Itchy superficial burrows and pustules on palms and soles, between fingers, and on genitalia; might produce secondary eczematous changes
HIV	Children and adults	Uncommon	Seborrhea-like rash
<b>CONGENITAL IMMUNODEFICIENCIES (SEE TABLE 186.3)</b>			
<b>KERATINIZATION DISORDERS</b>			
Ichthyosis vulgaris	Infants and adults	Uncommon	Dry skin with fine scaling, particularly on the lower abdomen and extensor areas; perifollicular skin roughening; palmar hyperlinearity; full form (i.e., 2 FLG pathogenic variants) is uncommon; often coexists with AD
<b>NUTRITIONAL DEFICIENCY–METABOLIC DISORDERS</b>			
Zinc deficiency (acrodermatitis enteropathica)	Children	Uncommon	Erythematous scaly patches and plaques, most often around the mouth and anus; rare congenital form accompanied by diarrhea and alopecia
Biotin deficiency (nutritional or biotinidase deficiency)	Infants	Uncommon	Scaly periorofacial dermatitis, alopecia, conjunctivitis, lethargy, hypotonia
Pellagra (niacin deficiency)	All ages	Uncommon	Scaly crusted epidermis, desquamation, sun-exposed areas, diarrhea
Kwashiorkor	Infants and children	Geographic dependent	Flaky scaly dermatitis, swollen limbs with cracked peeling patches
Phenylketonuria	Infants	Uncommon	Eczematous rash, hypopigmentation, blonde hair, developmental delay
<b>NEOPLASTIC DISEASE</b>			
Cutaneous T-cell lymphoma	Adults	Uncommon	Erythematous pink-brown macules and plaques with a fine scale; poorly responsive to topical corticosteroids; variable itch (in early stages)
Langerhans cell histiocytosis	Infants	Uncommon	Scaly and purpuric dermatosis, hepatosplenomegaly, cytopenias

\*Common = approximately 1 in 10 to 1 in 100; uncommon = 1 in 100 to 1 in 1,000; rare = 1 in 1,000 to 1 in 10,000; very rare = <1 in 10,000.

†Especially in developing countries.

AD, Atopic dermatitis; FLG, filaggrin gene.

because of potential risks. Topical calcineurin inhibitors may be better than topical corticosteroids in the treatment of patients whose AD is poorly responsive to topical steroids, patients with steroid phobia, and those with face and neck dermatitis, in whom ineffective, low-potency topical corticosteroids are typically used because of fears of steroid-induced skin atrophy.

### Phosphodiesterase Inhibitor

Crisaborole (Eucrisa) is an approved nonsteroidal topical antiinflammatory phosphodiesterase-4 (PDE-4) inhibitor indicated for the treatment of mild to moderate AD of children 3 months or older. It may be used as an alternative to topical corticosteroids or calcineurin inhibitors.

**Table 186.3** Features of Primary Immunodeficiencies Associated with Eczematous Dermatitis

DISEASE	GENE	INHERITANCE	CLINICAL FEATURES	LAB ABNORMALITIES
AD-HIES	STAT3	AD, less commonly sporadic	Cold abscesses Recurrent sinopulmonary infections Mucocutaneous candidiasis Coarse facies Minimal trauma fractures Scoliosis Joint hyperextensibility Retained primary teeth Coronary artery tortuosity or dilation Lymphoma	High IgE (>2,000 IU/μL) Eosinophilia
DOCK8 deficiency	DOCK8	AR	Severe mucocutaneous viral infections Mucocutaneous candidiasis Atopic features (asthma, allergies) Squamous cell carcinoma Lymphoma	High IgE Eosinophilia With or without decreased IgM
PGM3 deficiency	PGM3	AR	Neurologic abnormalities Leukocytoclastic vasculitis Atopic features (asthma, allergies) Sinopulmonary infections Mucocutaneous viral infections	High IgE Eosinophilia
WAS	WASP	XLR	Hepatosplenomegaly Lymphadenopathy Atopic diathesis Autoimmune conditions (especially hemolytic anemia) Lymphoreticular malignancies	Thrombocytopenia (<80,000/μL) Low mean platelet volume Eosinophilia is common Lymphopenia Low IgM, variable IgG
SCID	Variable, depends on type	XLR and AR most common	Recurrent, severe infections Failure to thrive Persistent diarrhea Recalcitrant oral candidiasis Omenn syndrome: lymphadenopathy, hepatosplenomegaly, erythroderma	Lymphopenia common Variable patterns of reduced lymphocyte subsets (T, B, natural killer cells) Omenn syndrome: high lymphocytes, eosinophilia, high IgE
IPEX	FOXP3	XLR	Severe diarrhea (autoimmune enteropathy) Various autoimmune endocrinopathies (especially diabetes mellitus, thyroiditis) Food allergies	High IgE Eosinophilia Various autoantibodies
Netherton syndrome	SPINK5	AR	Hair shaft abnormalities Erythroderma Ichthyosis linearis circumflexa Food allergies Recurrent gastroenteritis Neonatal hypernatremic dehydration Upper and lower respiratory infections	High IgE Eosinophilia

AD, Autosomal dominant; AD-HIES, autosomal-dominant hyper-IgE syndrome; AR, autosomal recessive; DOCK8, dedicator of cytokinesis 8 gene; IPEX, immune dysregulation, polyendocrinopathy, enteropathy, X-linked syndrome; PGM3, phosphoglucomutase 3; SCID, severe combined immunodeficiency; WAS, Wiskott-Aldrich syndrome; XLR, X-linked recessive. From Kliegman RM, Bordini BJ, eds. Undiagnosed and rare diseases in children. *Pediatr Clin N Amer*. 2017;64(1):41-42.

### Tar Preparations

Coal tar preparations have antipruritic and antiinflammatory effects on the skin; however, their antiinflammatory effects are usually not as pronounced as those of topical glucocorticoids or calcineurin inhibitors. Therefore topical tar preparations are not a preferred approach for management of AD. Tar shampoos can be particularly beneficial for scalp dermatitis. Adverse effects associated with tar preparations include skin irritation, folliculitis, and photosensitivity.

### Antihistamines

Systemic antihistamines act primarily by blocking the histamine H<sub>1</sub> receptors in the dermis, thereby reducing histamine-induced pruritus. Histamine is only one of many mediators that induce pruritus of the skin, so patients may derive minimal benefit from antihistaminic therapy. Because pruritus is usually worse at night, sedating antihistamines (hydroxyzine, diphenhydramine) may offer an advantage with their soporific side effects when used at bedtime. Doxepin hydrochloride has both tricyclic antidepressant and H<sub>1</sub>- and H<sub>2</sub>-receptor blocking effects.

Short-term use of a sedative to allow adequate rest may be appropriate in cases of severe nocturnal pruritus. Studies of nonsedating antihistamines have shown variable effectiveness in controlling pruritus in AD, although they may be useful in the small subset of patients with AD and concomitant urticaria. For children, melatonin may be effective in promoting sleep because production is deficient in AD.

### Systemic Corticosteroids

Systemic corticosteroids are rarely indicated in the treatment of chronic AD. The dramatic clinical improvement that may occur with systemic corticosteroids is frequently associated with a severe rebound flare of AD after therapy discontinuation. Short courses of oral corticosteroids may be appropriate for an acute exacerbation of AD while other treatment measures are being instituted in parallel. If a short course of oral corticosteroids is given, as during an asthma exacerbation, it is important to taper the dosage and begin intensified skin care, particularly with topical corticosteroids, and frequent bathing, followed by application of emollients or proactive topical corticosteroids, to prevent rebound flaring of AD.

**Table 186.4** Counseling and Aggravating Factors for Patients with Atopic Dermatitis

Maintain cool temperature in bedroom, and avoid too many bed covers.  
 Increase emollient use with cold weather.  
 Avoid exposure to herpes sores; urgent visit if flare of unusual aspect.  
*Clothing:* Avoid skin contact with irritating fibers (wool, large-fiber textiles).  
 Do not use tight and too-warm clothing to avoid excessive sweating.  
 New, nonirritating clothing designed for AD children is being evaluated.  
*Tobacco:* Avoid exposure.  
*Vaccines:* Normal schedule in noninvolved skin, including egg-allergic patients (see text).  
*Sun exposure:* No specific restriction.  
 Usually helpful because of improvement of epidermal barrier.  
 Encourage summer holidays in altitude or at beach resorts.  
*Physical exercise, sports:* No restriction.  
 If sweating induces flares of AD, progressive adaptation to exercise.  
 Shower and emollients after swimming pool.  
*Food allergens:*  
 Maintain breastfeeding exclusively to 4-6 mo if possible.  
 Consider evaluation for early introduction of allergens (see Chapter 192).  
 Otherwise normal diet, unless an allergy workup has proved the need to exclude a specific food.  
*Indoor aeroallergens:* House dust mites.  
 Use adequate ventilation of housing; keep the rooms well aerated even in winter.  
 Avoid wall-to-wall carpeting.  
 Remove dust with a wet sponge.  
 Vacuum floors and upholstery with an adequately filtered cleaner once a week.  
 Avoid soft toys in bed (cradle), except washable ones.  
 Wash bedsheets at a temperature higher than 55°C (131°F) every 10 days.  
 Use bed and pillow encasings made of Gore-Tex or similar material.  
*Furred pets:* Advise to avoid. If allergy is demonstrated, be firm on avoidance measures, such as pet removal.  
*Pollen:* Close windows during peak pollen season on warm and dry weather days and restrict, if possible, time outdoors.  
 Windows may be open at night and early in the morning or during rainy weather.  
 Avoid exposure to risk situations (lawn mowing).  
 Use pollen filters in motor vehicles.  
 Clothes and pets can vectorize aeroallergens, including pollen.

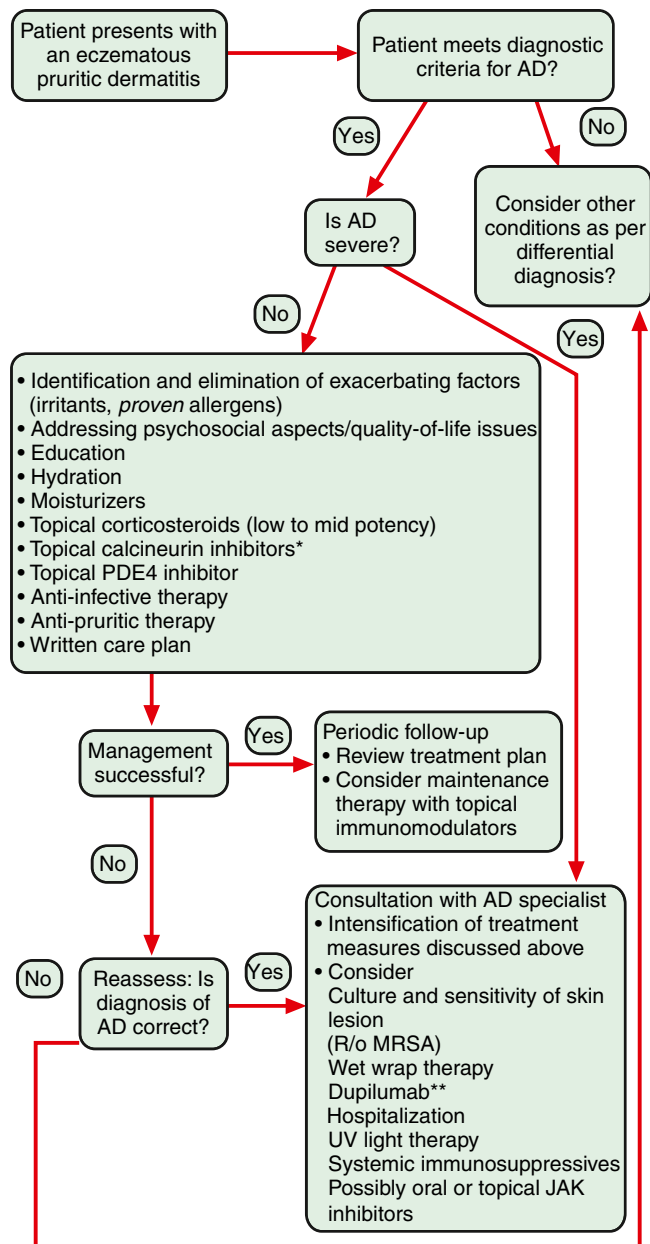
Adapted from Darsow U, Wollenberg A, Simon D, et al. ETFAD/EADV Eczema Task Force 2009 position paper on diagnosis and treatment of atopic dermatitis. *J Eur Acad Dermatol Venereol.* 2010;24:321.

### Dupilumab

A monoclonal antibody that binds to the IL-4 receptor  $\alpha$  subunit, dupilumab (Dupixent) inhibits the signaling of IL-4 and IL-13, cytokines associated with AD. In children with moderate to severe AD not controlled by standard topical therapy, dupilumab reduces pruritus and improves skin clearing. Dupilumab is approved for children 6 years or older. Lebrikizumab, an IgG4 monoclonal antibody that targets IL-13, has shown efficacy in adolescents and adults with moderate to severe atopic dermatitis.

### Phototherapy

Natural sunlight is often beneficial to patients with AD as long as sunburn and excessive sweating are avoided. Many phototherapy modalities are effective for AD, including ultraviolet A-1, ultraviolet B, narrow-band ultraviolet B, and psoralen plus ultraviolet A.



**Fig. 186.5** Approach to the patient with atopic dermatitis (AD). \*Per boxed warning: second-line, intermittent therapy for patients  $\geq 2$  years of age. \*\*Approved for patients  $\geq 12$  years of age with moderate to severe AD. JAK, Janus kinase; MRSA, methicillin-resistant *Staphylococcus aureus*; PDE, phosphodiesterase; UV, ultraviolet. (Modified from Boguniewicz M, Fonacier L, Leung DYM. *Atopic dermatitis and allergic contact dermatitis*. In Hershey GKK, Sheikh A, O'Hehir RE, Holgate ST, eds. *Allergy Essentials*. 2nd ed. Philadelphia: Elsevier; 2022. Fig 11.5.)

Phototherapy is generally reserved for patients in whom standard treatments fail. Maintenance treatments are usually required for phototherapy to be effective. Short-term adverse effects with phototherapy include erythema, skin pain, pruritus, and pigmentation. Long-term adverse effects include predisposition to cutaneous malignancies.

### Cyclosporine

Cyclosporine is a potent immunosuppressive drug that acts primarily on T cells by suppressing cytokine gene transcription and has been shown to be effective in the control of severe AD. Cyclosporine forms a complex with an intracellular protein, cyclophilin, and this complex in turn inhibits calcineurin, a phosphatase required for activation of nuclear factor of activated T cells (NFAT), a transcription factor necessary for cytokine

**Table 186.5** Categorization of Physical Severity of Atopic Eczema

<i>Clear:</i> Normal skin, with no evidence of atopic eczema
<i>Mild:</i> Areas of dry skin, infrequent itching (with or without small areas of redness)
<i>Moderate:</i> Areas of dry skin, frequent itching, redness (with or without excoriation and localized skin thickening)
<i>Severe:</i> Widespread areas of dry skin, incessant itching, redness (with or without excoriation, extensive skin thickening, bleeding, oozing, cracking, and alteration of pigmentation)

From Lewis-Jones S, Muggleston MA, Guideline Development Group. Management of atopic eczema in children aged up to 12 years: summary of NICE guidance. *BMJ*. 2007;335:1263–1264.

gene transcription. Cyclosporine (5 mg/kg/day) for short-term and long-term (1 year) use has been beneficial for children with severe, refractory AD. Possible adverse effects include renal impairment and hypertension.

### Janus Kinase Inhibitors

Oral and topical Janus kinase (JAK) inhibitors have demonstrated rapid improvement in adults and older children with severe AD. These inhibitors also have potential side effects including infections (tuberculosis), malignancy (cutaneous lymphoma), and headaches. Topical therapy is effective and has fewer side effects. Clinical trials are in progress to address the efficacy and safety of JAK inhibitors.

### Antimetabolites

**Mycophenolate mofetil** is a purine biosynthesis inhibitor used as an immunosuppressant in organ transplantation that has been used for treatment of refractory AD. Aside from immunosuppression, herpes simplex retinitis and dose-related bone marrow suppression have been reported with its use. Of note, not all patients benefit from treatment. Therefore mycophenolate mofetil should be discontinued if the disease does not respond within 4–8 weeks.

**Methotrexate** is an antimetabolite with potent inhibitory effects on inflammatory cytokine synthesis and cell chemotaxis. Methotrexate has been used for patients with recalcitrant AD. In AD, dosing is more frequent than the weekly dosing used for psoriasis.

**Azathioprine** is a purine analog with antiinflammatory and antiproliferative effects that has been used for severe AD. Myelosuppression is a significant adverse effect, and thiopurine methyltransferase levels may identify individuals at risk.

Before any of these drugs are used, patients should be referred to an AD specialist who is familiar with treatment of severe AD to weigh relative benefits of alternative therapies.

### Unproven Therapies

Other therapies may be considered in patients with refractory AD.

### Interferon- $\gamma$

IFN- $\gamma$  is known to suppress Th2-cell function. Several studies, including a multicenter, double-blind, placebo-controlled trial and several open trials, have demonstrated that treatment with recombinant human IFN- $\gamma$  results in clinical improvement of AD. Reduction in clinical severity of AD correlated with the ability of IFN- $\gamma$  to decrease total circulating eosinophil counts. Influenza-like symptoms are common side effects during the treatment course.

### Omalizumab

Treatment of patients who have severe AD and elevated serum IgE values with monoclonal anti-IgE may be considered in those with allergen-induced flares of AD. However, there have been no published double-blind, placebo-controlled trials supporting omalizumab as a preferred therapy for moderate to severe AD. Most reports show inconsistent responses to anti-IgE.

**Table 186.6** Selected Topical Corticosteroid Preparations\*

#### GROUP 1

Clobetasol propionate (Temovate) 0.05% ointment/cream  
Betamethasone dipropionate (Diprolene) 0.05% ointment/lotion/gel  
Fluocinonide (Vanos) 0.1% cream

#### GROUP 2

Mometasone furoate (Elocon) 0.1% ointment  
Halcinonide (Halog) 0.1% cream  
Fluocinonide (Lidex) 0.05% ointment/cream  
Desoximetasone (Topicort) 0.25% ointment/cream  
Betamethasone dipropionate (Diprolene) 0.05% cream

#### GROUP 3

Fluticasone propionate (Cutivate) 0.005% ointment  
Halcinonide (Halog) 0.1% ointment  
Betamethasone valerate (Valisone) 0.1% ointment

#### GROUP 4

Mometasone furoate (Elocon) 0.1% cream  
Triamcinolone acetonide (Kenalog) 0.1% ointment/cream  
Fluocinolone acetonide (Synalar) 0.025% ointment

#### GROUP 5

Fluocinolone acetonide (Synalar) 0.025% cream  
Hydrocortisone valerate (Westcort) 0.2% ointment

#### GROUP 6

Desonide (DesOwen) 0.5% ointment/cream/lotion  
Alclometasone dipropionate (Aclovate) 0.05% ointment/cream

#### GROUP 7

Hydrocortisone (Hytone) 2.5%, 1%, 0.5% ointment/cream/lotion

\*Representative corticosteroids are listed by group from 1 (superpotent) through 7 (least potent).

Adapted from Stoughton RB. Vasoconstrictor assay-specific applications. In: Malbach HI, Surber C, eds. *Topical Corticosteroids*. Basel, Switzerland: Karger; 1992. p 42–53.

### Allergen Immunotherapy

In contrast to its acceptance for treatment of allergic rhinitis and extrinsic asthma, immunotherapy with aeroallergens in the treatment of AD is controversial. There are reports of both disease exacerbation and improvement. Studies suggest that specific immunotherapy in patients with AD sensitized to dust mite allergen showed improvement in severity of skin disease, as well as reduction in topical corticosteroid use.

### Probiotics

Perinatal administration of the probiotic *Lactobacillus rhamnosus* strain GG has been shown to reduce the incidence of AD in at-risk children during the first 2 years of life. The treatment response has been found to be more pronounced in patients with positive skin-prick test results and elevated IgE values. Other studies have not demonstrated a benefit.

### Chinese Herbal Medications

Several placebo-controlled clinical trials have suggested that patients with severe AD may benefit from treatment with traditional Chinese herbal therapy. The patients had significantly reduced skin disease and decreased pruritus. The beneficial response of Chinese herbal therapy is often temporary, and effectiveness may wear off despite continued treatment. The possibility of hepatic toxicity, cardiac side effects, or idiosyncratic reactions remains a concern. The specific ingredients of the herbs also remain to be elucidated, and some preparations have been found to be contaminated with corticosteroids. At present, Chinese herbal therapy for AD is considered investigational.



## Vitamin D

Vitamin D deficiency often accompanies severe AD. Vitamin D enhances skin barrier function, reduces corticosteroid requirements to control inflammation, and augments skin antimicrobial function. Several small clinical studies suggest vitamin D can enhance antimicrobial peptide expression in the skin and reduce severity of skin disease, especially in patients with low baseline vitamin D, as during winter, when exacerbation of AD often occurs. Patients with AD might benefit from supplementation with vitamin D, particularly if they have a documented low level or low vitamin D intake.

## AVOIDING TRIGGERS

It is essential to identify and eliminate triggering factors for AD, both during the period of acute symptoms and on a long-term basis to prevent recurrences (see Table 186.4).

## Irritants

Patients with AD have a low threshold response to irritants that trigger their itch-scratch cycle. Soaps or detergents, chemicals, smoke, abrasive clothing, and exposure to extremes of temperature and humidity are common triggers. *Patients with AD should use soaps with minimal defatting properties and a neutral pH.* New clothing should be laundered before wearing to decrease levels of formaldehyde and other chemicals. Residual laundry detergent in clothing may trigger the itch-scratch cycle; using a liquid rather than powder detergent and adding a second rinse cycle facilitates removal of the detergent.

Every attempt should be made to allow children with AD to be as normally active as possible. A sport such as swimming may be better tolerated than others that involve intense perspiration, physical contact, or heavy clothing and equipment. Rinsing off chlorine immediately and lubricating the skin after swimming are important. Although ultraviolet light may be beneficial to some patients with AD, high sun protection factor (SPF) sunscreens should be used to avoid sunburn.

## Foods

Food allergy is comorbid in approximately 40% of infants and young children with moderate to severe AD (see Chapter 192). Undiagnosed food allergies in patients with AD may induce eczematous dermatitis in some patients and urticarial reactions, wheezing, or nasal congestion in others. Increased severity of AD symptoms and younger age correlate directly with the presence of food allergy. Removal of food allergens from the diet may lead to clinical improvement but also carries a risk of the patient developing immediate type allergic reactions to the food allergen removed.

Potential allergens can be identified by a careful history and performing selective skin-prick tests or in vitro blood testing for

allergen-specific IgE. Negative skin and blood test results for allergen-specific IgE have a high predictive value for excluding suspected allergens. Positive results of skin or blood tests using foods often do not correlate with clinical symptoms and should be confirmed with controlled food challenges and elimination diets. Extensive elimination diets, which can be nutritionally deficient, are rarely required. Even with multiple positive skin test results, the majority of patients react to fewer than three foods under controlled challenge conditions.

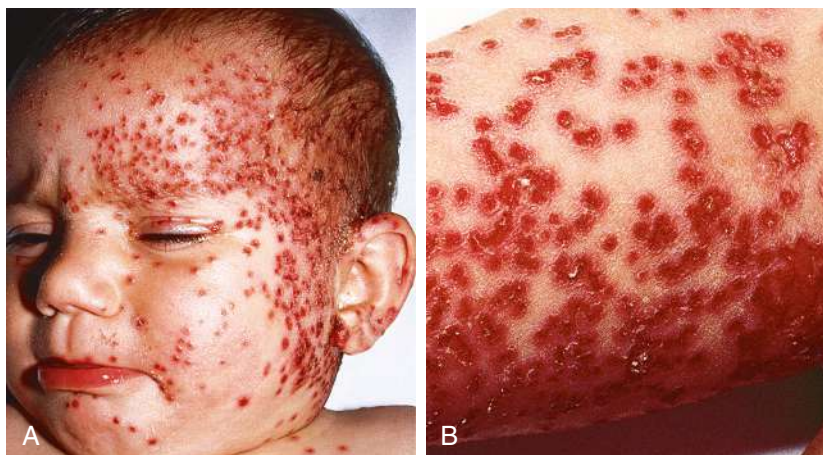
## Aeroallergens

In older children, AD flares can occur after intranasal or epicutaneous exposure to aeroallergens such as fungi, animal dander, grass, and ragweed pollen. Avoiding aeroallergens, particularly dust mites, can result in clinical improvement of AD. Avoidance measures for dust mite-allergic patients include using dust mite-proof encasings on pillows, mattresses, and box springs; washing bedding in hot water weekly; removing bedroom carpeting; and decreasing indoor humidity levels with air conditioning.

## Infections

Patients with AD have increased susceptibility to bacterial, viral, and fungal skin infections. Antistaphylococcal antibiotics are very helpful for treating patients who are heavily colonized or infected with *S. aureus*. Erythromycin and azithromycin are usually beneficial for patients who are not colonized with a resistant *S. aureus* strain; a first-generation cephalosporin (cephalexin) is recommended for macrolide-resistant *S. aureus*. Topical mupirocin is useful in the treatment of localized impetiginous lesions, with systemic clindamycin or trimethoprim/sulfamethoxazole needed for methicillin-resistant *S. aureus* (MRSA). Cytokine-mediated skin inflammation contributes to skin colonization with *S. aureus*. This finding supports the importance of combining effective antiinflammatory therapy with antibiotics for treating moderate to severe AD to avoid the need for repeated courses of antibiotics, which can lead to the emergence of antibiotic-resistant strains of *S. aureus*. Dilute bleach baths (½ cup of bleach in 40 gallons of water) twice weekly may be also considered to reduce *S. aureus* colonization. In one randomized trial, the group who received the bleach baths plus intranasal mupirocin (5 days/month) had significantly decreased severity of AD at 1 and 3 months compared with placebo. Patients rinse off after the soaking. Bleach baths may not only reduce *S. aureus* abundance on the skin but also have antiinflammatory effects.

Herpes simplex virus (HSV) can provoke recurrent dermatitis and may be misdiagnosed as *S. aureus* infection (Fig. 186.6). The presence of punched-out erosions, vesicles, and infected skin lesions that fail to respond to oral antibiotics suggests HSV infection, which can be diagnosed by a Giemsa-stained Tzanck smear of cells scraped from the vesicle base or by viral polymerase chain reaction or culture. Topical



**Fig. 186.6** Eczema herpeticum infection in a patient with atopic dermatitis. Numerous punched-out vesicles and erosions involving the face (A) and extremities (B). (From *Papulosquamous eruptions*. In Cohen BA, ed. *Pediatric Dermatology*. Philadelphia: Saunders; 2013. pp 68–103.)

corticosteroids should be temporarily discontinued if HSV infection is suspected. Reports of life-threatening dissemination of HSV infections in patients with AD who have widespread disease mandate antiviral treatment. Persons with AD are also susceptible to **eczema vaccinatum**, which is similar in appearance to eczema herpeticum and historically follows smallpox (vaccinia virus) vaccination.

Cutaneous warts, coxsackievirus, and molluscum contagiosum are additional viral infections affecting children with AD.

Dermatophyte infections can also contribute to exacerbation of AD. Patients with AD have been found to have a greater susceptibility to *Trichophyton rubrum* fungal infections than nonatopic controls. There has been particular interest in the role of *Malassezia furfur* (formerly known as *Pityrosporum ovale*) in AD because it is a lipophilic yeast commonly present in the seborrheic areas of the skin. IgE antibodies against *M. furfur* have been found in patients with head and neck dermatitis. A reduction of AD severity has been observed in these patients after treatment with antifungal agents.

## COMPLICATIONS

**Exfoliative dermatitis** may develop in patients with extensive skin involvement. It is associated with generalized redness, scaling, weeping, crusting, systemic toxicity, lymphadenopathy, and fever and is usually caused by superinfection (e.g., with toxin-producing *S. aureus* or HSV infection) or inappropriate therapy. In some cases the withdrawal of systemic glucocorticoids used to control severe AD precipitates exfoliative erythroderma.

Eyelid dermatitis and chronic blepharitis may result in visual impairment from corneal scarring. **Atopic keratoconjunctivitis** is usually bilateral and can have disabling symptoms that include itching, burning, tearing, and copious mucoid discharge. Vernal conjunctivitis is associated with papillary hypertrophy or cobblestoning of the upper eyelid conjunctiva. It typically occurs in younger patients and has a marked seasonal incidence with spring exacerbations. **Keratoconus** is a conical deformity of the cornea believed to result from chronic rubbing of the eyes in patients with AD. Cataracts may be a primary manifestation of AD or from extensive use of systemic and topical glucocorticoids, particularly around the eyes.

## PROGNOSIS

AD generally tends to be more severe and persistent in young children, particularly if they have homozygous null pathogenic variants in their filaggrin genes. Periods of remission occur more frequently as patients grow older. Spontaneous resolution of AD has been reported to occur after age 5 years in 40–60% of patients affected during infancy, particularly for mild disease. Earlier studies suggested that approximately 84% of children outgrow their AD by adolescence; however, later studies reported that AD resolves in approximately 20% of children monitored from infancy until adolescence and becomes less severe in 65%. Of those adolescents treated for mild dermatitis, >50% may experience a relapse of disease as adults, which frequently manifests as *hand dermatitis*, especially if daily activities require repeated hand wetting. Predictive factors of a poor prognosis for AD include widespread AD in childhood, *FLG* null pathogenic variants, concomitant allergic rhinitis and asthma, family history of AD in parents or siblings, early age at onset of AD, being an only child, and very high serum IgE levels.

## PREVENTION

Breastfeeding may be beneficial. Probiotics and prebiotics may also reduce the incidence or severity of AD, but this approach is unproven. If an infant with AD is diagnosed with food allergy, the breastfeeding mother may need to eliminate the implicated food allergen from her diet. For infants with severe eczema, introduction of infant-safe forms of peanut as early as 4–6 months, after other solids are tolerated, is recommended after consultation with the child's pediatrician and/or allergist for allergy testing. This approach may prevent peanut allergy (see Chapter 192). Identification and elimination of triggering factors are the mainstay for prevention of flares as well as for the long-term treatment of AD.

Emollient therapy applied to the whole body for the first few months of life may enhance the cutaneous barrier and reduce the risk of eczema.

Visit Elsevier eBooks+ at [eBooks.Health.Elsevier.com](https://eBooks.Health.Elsevier.com) for Bibliography.

## Chapter 187

# Insect Allergy

Julie Wang and Scott H. Sicherer

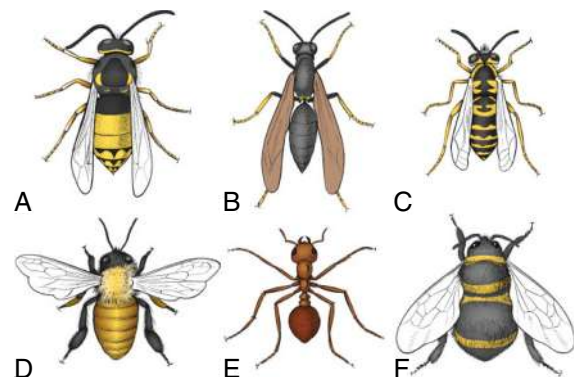
Allergic responses to stinging or, more rarely, biting insects vary from localized cutaneous reactions to systemic anaphylaxis. **Allergic reactions** caused by inhalation of airborne particles of insect origin result in acute and chronic respiratory symptoms of seasonal or perennial rhinitis, conjunctivitis, and asthma.

## ETIOLOGY

Most reactions to stinging and biting insects, such as those induced by wasps, mosquitoes, flies, and fleas, are limited to a primary lesion isolated to the area of the sting or bite and do not represent an allergic response. Occasionally, insect stings or bites induce pronounced localized reactions or systemic reactions that may be based on immediate or delayed hypersensitivity reactions. Systemic allergic responses to insects are usually attributed to IgE antibody-mediated responses, which are caused primarily by stings from venomous insects of the order **Hymenoptera** and more rarely from ticks, spiders, scorpions, and *Triatoma* (kissing bug). Members of the order Hymenoptera include *apids* (honeybee, bumblebee), *vespids* (yellow jacket, wasp, hornet), and *formicids* (fire and harvester ants) (Fig. 187.1). Among winged stinging insects, yellow jackets are the most notorious for stinging because they are aggressive and ground dwelling, and they linger near activities involving food. Hornets nest in trees, whereas wasps build honeycomb nests in dark areas such as under porches; both are aggressive if disturbed. Honeybees are less aggressive and nest in tree hollows; unlike the stings of other flying Hymenoptera, honeybee stings almost always leave a barbed stinger with venom sac.

In the United States, fire ants are found in the Southeast, living in large mounds of soil. When disturbed, the ants attack in large numbers, anchor themselves to the skin by their mandibles, and sting multiple times in a circular pattern. Sterile pseudopustules form at the sting sites. Systemic reactions to stinging insects occur in 0.4–0.8% of children and 3% of adults and account for approximately 40 deaths each year in the United States.

Although reactions to insect bites are common, IgE-mediated reactions are infrequently reported and anaphylaxis is rare. The *Triatoma* (kissing bug) bite causes an erythematous plaque that is painless. Mosquito bites generally result in local reactions that are pruritic. Large,



**Fig. 187.1** Representative venomous Hymenoptera. A, Hornet (*Vespa maculata*). B, Wasp (*Chlorion ichneumerea*). C, Yellowjacket (*Vespa maculiforma*). D, Honeybee (*Apis mellifera*). E, Fire ant (*Solenopsis invicta*). F, Bumblebee (*Bombus* species). (From Erickson TB, Marquez A. Arthropod envenomation and parasitism. In: Auerbach PS, Cushing TA, Harris NS, eds. *Auerbach's Wilderness Medicine*. 7th ed. Philadelphia: Elsevier; 2017: Fig 41-1, p 937.)

local reactions to mosquito bites can occur in some young children; this is known as **skeeter syndrome** and is often misdiagnosed as cellulitis. The *tabanid* species (horsefly, deerfly), typically found in rural and suburban areas, are large flies that induce painful bites.

IgE antibody-mediated allergic responses to airborne particulate matter carrying insect emanations contribute to seasonal and perennial symptoms affecting the upper and lower airways. Seasonal allergy is attributed to exposures to a variety of insects, particularly aquatic insects such as the caddis fly and midge, or lake fly, at a time when larvae pupate and adult flies are airborne. **Perennial allergy** is attributed to sensitization to insects such as cockroaches and ladybugs, as well as house dust mite, which is phylogenetically related to spiders rather than insects and has eight rather than six legs.

## PATHOGENESIS

Hymenoptera venoms contain numerous components with toxic and pharmacologic activity and with allergenic potential. These constituents include vasoactive substances such as histamine, acetylcholine, and kinins; enzymes such as phospholipase and hyaluronidase; apamin; melittin; and formic acid. The majority of patients who experience systemic reactions after Hymenoptera stings have IgE-mediated sensitivity to antigenic substances in the venom. Some venom allergens are homologous among members of the Hymenoptera order; others are family specific. There is substantial cross reactivity among vespid venoms, but these venom allergies are distinct from honeybee venom allergies.

Localized skin responses to biting insects are caused primarily by vasoactive or irritant materials derived from insect saliva; they rarely occur from IgE-associated responses. Systemic IgE-mediated allergic reactions to salivary proteins of biting insects such as mosquitoes are reported but uncommon.

A variety of proteins derived from insects can become airborne and induce IgE-mediated respiratory responses, causing inhalant allergies. The primary allergen from the caddis fly is a hemocyanin-like protein, and that from the midge fly is derived from hemoglobin. Allergens from the cockroach are the best studied and are derived from cockroach saliva, secretions, fecal material, and debris from skin casts.

## CLINICAL MANIFESTATIONS

Clinical reactions to stinging venomous insects are categorized as local, large local, generalized cutaneous, systemic, toxic, and delayed/late. Simple **local reactions** involve limited swelling and pain and generally last <24 hours. **Large local reactions** develop over hours and days, involve swelling of extensive areas (>10 cm) that are contiguous with the sting site, and may last for days. **Generalized cutaneous reactions** typically progress within minutes and include cutaneous symptoms of urticaria, angioedema, and pruritus beyond the site of the sting. **Systemic reactions** are identical to anaphylaxis from other triggers and may include symptoms of generalized urticaria, laryngeal edema, bronchospasm, and hypotension. A subset of patients with hypotension and persistently elevated (once recovered) tryptase levels may have mast cell activation syndrome (see [Chapter 190](#)). Stings from numerous insects at once may result in **toxic reactions** of fever, malaise, emesis, and nausea because of the chemical properties of the venom in large doses. Serum sickness, nephrotic syndrome, vasculitis, neuritis, or encephalopathy may occur as **delayed/late reactions** to stinging insects.

Insect bites are usually urticarial but may be papular or vesicular. **Papular urticaria** affecting the lower extremities in children is usually caused by multiple bites. Occasionally, individuals have large, local reactions. IgE antibody-associated immediate- and late-phase allergic responses to mosquito bites sometimes mimic cellulitis.

Inhalant allergy caused by insects results in clinical disease similar to that induced by other inhalant allergens such as pollens. Depending on individual sensitivity and exposure, reactions may result in seasonal or perennial rhinitis, conjunctivitis, or asthma.

## DIAGNOSIS

The diagnosis of allergy from stinging and biting insects is generally evident from the history of exposure, typical symptoms, and physical findings. The diagnosis of Hymenoptera allergy rests in part on the identification of venom-specific IgE by skin-prick testing or in vitro testing. The primary reasons to pursue testing are to confirm reactivity when **venom immunotherapy (VIT)** is being considered or when it is clinically necessary to confirm venom hypersensitivity as a cause of a reaction. Venoms of five Hymenoptera (honeybee, yellow jacket, yellow hornet, white-faced hornet, and wasp), as well as the jack jumper ant in Australia and whole body extract of fire ant, are available for skin testing. Although skin tests are considered to be the most sensitive modality for detection of venom-specific IgE, additional evaluation with an in vitro serum assay for venom-specific IgE is recommended if skin test results are negative in the presence of a convincing history of a severe systemic reaction. In vitro tests have a 20% incidence of both false-positive and false-negative results, so it is not appropriate to exclude venom hypersensitivity based on this test alone. If initial skin-prick and in vitro test results are negative in the context of a convincing history of a severe reaction, repeat testing is recommended before concluding that allergy is unlikely. Skin tests are usually accurate within 1 week of a sting reaction, but occasionally a refractory period is observed that warrants retesting after 4-6 weeks if the initial results are negative.

An elevated **basal tryptase** level is associated with more severe reactions to venom stings. Therefore basal tryptase should be measured if there is a history of severe reaction to a sting, hypotensive reaction, lack of urticaria in a systemic sting reaction, or negative venom IgE in a patient who has a history of systemic reaction to a sting. As many as 40% of skin test-positive patients may not experience anaphylaxis on sting challenge, so testing without an appropriate clinical history is potentially misleading.

The diagnosis of inhalant insect allergy may be evident from a history of typical symptoms. A chronic respiratory symptom during long-term exposure, as may occur with cockroach allergy, is less amenable to identification by history alone. Skin-prick or in vitro immunoassay tests for specific IgE to the insect are used to confirm inhalant insect allergy. Allergy tests may be particularly warranted for potential cockroach allergy in patients with persistent asthma and known cockroach exposure.

## TREATMENT

For local cutaneous reactions caused by insect stings and bites, treatment with cold compresses, topical medications to relieve itching, and occasionally a systemic antihistamine and oral analgesic are appropriate. Stingers should be removed promptly by scraping, with caution not to squeeze the venom sac because doing so could inject more venom. Sting sites rarely become infected, possibly because of the antibacterial actions of venom constituents. Vesicles left by fire ant stings that are scratched open should be cleansed to prevent secondary infection.

Anaphylactic reactions after a Hymenoptera sting are treated the same as anaphylaxis from any cause; *epinephrine is the drug of choice*. Adjunctive treatment includes antihistamines, corticosteroids, intravenous fluids, oxygen, and transport to the emergency department (see [Chapter 190](#)). Referral to an allergist-immunologist should be considered for patients who have experienced a generalized cutaneous or systemic reaction to an insect sting, who need education about avoidance and emergency treatment, who may be candidates for VIT, or who have a condition that may complicate management of anaphylaxis (e.g., use of  $\beta$  blockers).

## Venom Immunotherapy

Hymenoptera VIT is highly effective (95-97%) in decreasing the risk for **severe anaphylaxis**. The selection of patients for VIT depends on several factors ([Table 187.1](#)). Individuals with local reactions,



**Table 187.1** Risk of Systemic Reaction in Untreated Patients with History of Sting Anaphylaxis and/or Positive Venom Skin Test Results

ORIGINAL STING REACTION		RISK OF SYSTEMIC REACTION	
SEVERITY	AGE	ANY SYSTEMIC (%)	ANAPHYLAXIS (%)
No reaction	Adult	5-15	<3
Large local	All	4-10	<
Cutaneous systemic	All	10	<3
Anaphylaxis	Child	40	30
	Adult	60	40

From Golden DBK: Insect allergy. In Burks AW, Holgate ST, O'Hehir RE, et al., eds. *Middleton's Allergy Principles and Practice*, ed 9, vol 2, Philadelphia: Elsevier, 2020, Table 76.2, p. 1253.

regardless of age, are not at increased risk for severe systemic reactions on a subsequent sting and are not candidates for VIT. The risk of a systemic reaction for those who experienced a large, local reaction is approximately 7%; testing or VIT is usually not recommended, and prescription of self-injectable epinephrine is considered optional but usually not necessary. There is growing evidence that VIT can reduce the size and duration of large, local reactions, and therefore VIT may be considered for those with frequent or unavoidable large, local reactions. **Those who experience severe systemic reactions, such as airway involvement or hypotension, and who have specific IgE to venom allergens, should receive immunotherapy.** Immunotherapy against winged Hymenoptera is generally not required when stings have caused only generalized urticaria or angioedema, because the risk for a systemic reaction after a subsequent sting is approximately 10% and the chance of a more severe reaction is <3%. VIT may be considered if there are potential high-risk cofactors such as comorbid cardiovascular disease or use of specific cardiovascular medications (e.g., angiotensin-converting enzyme [ACE] inhibitors,  $\beta$  blockers), elevated basal tryptase level, or high likelihood of future stings. VIT is usually not indicated if there is no evidence of IgE to venom.

The incidence of adverse effects in the course of *treatment* is not trivial in adults; 50% experience large, local reactions, and about 10% experience systemic reactions. The incidence of both local and systemic reactions is much lower in children. Patients treated with honeybee venom are at higher risk for systemic reactions to VIT than those receiving treatment with vespid venom. Individuals with mast cell disorders are at increased risk for severe anaphylaxis and more frequent systemic reactions with VIT; thus some experts recommend basal tryptase level for risk assessment purposes.

It is uncertain how long immunotherapy with Hymenoptera venom should continue. In general, treatment duration of 3-5 years is recommended because >80% of adults who have received 5 years of therapy tolerate challenge stings without systemic reactions for 5-10 years after completion of treatment. Long-term responses to treatment are even better for children. Follow-up over a mean of 18 years of children with moderate to severe insect sting reactions who received VIT for a mean of 3-5 years and were stung again showed a reaction rate of only 5%; untreated children experienced a reaction rate of 32%. Whereas duration of therapy with VIT may be individualized, it is clear that a significant number of untreated children retain their allergy. Extended or lifelong treatment may be considered for those who have had life-threatening anaphylaxis with insect stings or severe reaction during VIT, those with honeybee allergy, and those with occupational exposures to Hymenoptera. Lifelong VIT should also be considered for

patients with mast cell disorders because they have a higher rate of failure of VIT and relapse when VIT is discontinued.

Less is known about the natural history of fire ant hypersensitivity and efficacy of immunotherapy for this allergy. The criteria for starting immunotherapy are similar to those for hypersensitivities to other Hymenoptera, but there is stronger consideration to treat patients who have only cutaneous systemic reactions with VIT. Only whole body fire ant extract is commercially available for diagnostic skin testing and immunotherapy.

### Inhalant Allergy

The symptoms of inhalant allergy caused by insects are managed as for other causes of seasonal or perennial rhinitis (see Chapter 184), conjunctivitis (see Chapter 188), and asthma (see Chapter 185).

### PREVENTION

*Avoidance of stings and bites is essential.* To reduce the risk of stings, sensitized individuals should have known or suspected nests near the home removed by trained professionals, should wear gloves when gardening, should wear long pants and shoes with socks when walking in the grass or through fields, and should avoid or be cautious about eating or drinking outdoors. Typical insect repellents do not guard against Hymenoptera.

Individuals who are at high risk for future severe reactions to Hymenoptera stings should have immediate access to self-injectable epinephrine. High-risk individuals include those who have a history of severe reactions or have elevated basal tryptase level. Adults responsible for allergic children and older patients who can self-treat must be carefully taught the indications and technique of administration for this medication. Particular attention is necessary for children in out-of-home daycare centers, at school, or attending camps, to ensure that an emergency action plan is in place. The individual at risk for anaphylaxis from an insect sting should also wear medical identification jewelry indicating the allergy.

Avoidance of the insect is the preferred management of inhalant allergy. This can prove difficult, particularly for those living in apartments, where eradication of cockroaches may be problematic. Immunotherapy for dust mites is effective and should be considered in conjunction with avoidance measures. In contrast, there is limited data regarding the efficacy of cockroach immunotherapy.

Visit Elsevier eBooks+ at [eBooks.Health.Elsevier.com](http://eBooks.Health.Elsevier.com) for Bibliography.



## Chapter 188

## Ocular Allergies

Leonard Bielory, Brett P. Bielory, and Scott H. Sicherer

The ocular surface of the eye, the conjunctiva, is the most immunologically active tissue of the external eye. The conjunctiva is a common target of allergic disorders because of its marked vascularity and direct contact with allergens in the environment. Ocular allergies can occur as isolated target organ disease or more often in conjunction with nasal allergies. Ocular symptoms can significantly affect quality of life.

## CLINICAL MANIFESTATIONS

Allergic eye diseases represent a spectrum of conditions that require allergic sensitization and range from acute (seasonal) progressing to the perennial and then to the more chronic forms and potentially sight-threatening forms, vernal and atopic keratoconjunctivitis (Table 188.1).

## Allergic Conjunctivitis

Allergic conjunctivitis is the most common hypersensitivity response of the eye, affecting approximately 25% of the general population and 30% of children with atopy. It is caused by direct exposure of the mucosal surfaces of the eye to environmental allergens. Patients complain of

variable ocular itching, rather than pain, with increased tearing. Clinical signs include bilateral injected conjunctivae with vascular congestion that may progress to *chemosis*, or conjunctival swelling, and a watery discharge (Fig. 188.1).

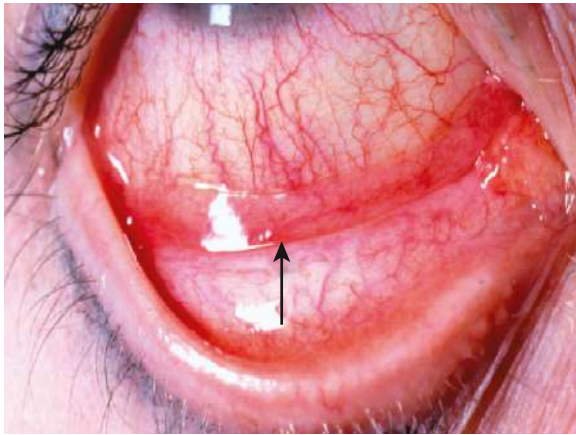
Allergic conjunctivitis occurs in a seasonal or, less frequently, perennial form. **Seasonal allergic conjunctivitis** is typically associated with allergic rhinitis (see Chapter 184) and is most commonly triggered by pollens. Major pollen groups in the temperate zones include trees (late winter to early spring), grasses (late spring to early summer), and weeds (late summer to early fall), but seasons vary significantly in different parts of the United States. Mold spores can also cause seasonal allergy symptoms, principally in the summer and fall. Seasonal allergy symptoms may be aggravated by coincident exposure to perennial allergens. **Perennial allergic conjunctivitis** is triggered by allergens such as animal danders or dust mites that are present throughout the year. Symptoms are usually less severe than with seasonal allergic conjunctivitis. Because pollens and soil molds may be present intermittently by season, and exposure to allergens such as furred animals may be perennial, classification as intermittent (symptoms present <4 days/week or for <4 weeks) and persistent (symptoms present >4 days/week and for >4 weeks) has been proposed.

## Vernal Keratoconjunctivitis

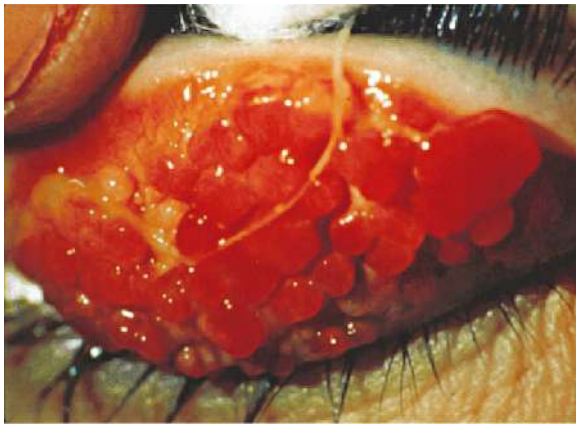
Vernal keratoconjunctivitis is a severe bilateral chronic inflammatory process of the upper tarsal conjunctival surface that occurs in two forms, limbal or palpebral. It may threaten eyesight if there is corneal involvement. Vernal keratoconjunctivitis is only associated with positive cutaneous allergic reactivities in 50% of cases, although it occurs most frequently in children with seasonal allergies, asthma, or atopic dermatitis. Vernal keratoconjunctivitis affects males twice as often as females

Table 188.1 Allergic Diseases of the Eye

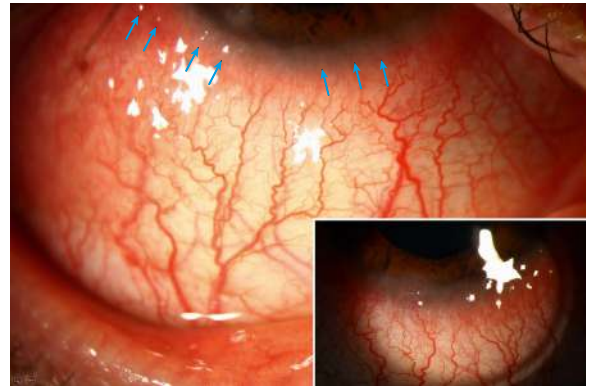
DISEASE	CLINICAL PARAMETERS	SIGNS/SYMPTOMS	DIFFERENTIAL DIAGNOSIS
Seasonal allergic conjunctivitis (SAC)	<ul style="list-style-type: none"> <li>Sensitized individuals</li> <li>Both females and males</li> <li>Bilateral involvement</li> <li>Seasonal allergens</li> <li>Self-limiting</li> </ul>	<ul style="list-style-type: none"> <li>Ocular itching</li> <li>Tearing (watery discharge)</li> <li>Chemosis, redness</li> <li>Often associated with rhinitis</li> <li>Not sight threatening</li> </ul>	<ul style="list-style-type: none"> <li>Infective conjunctivitis</li> <li>Preservative toxicity</li> <li>Medicamentosa</li> <li>Dry eye</li> <li>PAC/AKC/VKC</li> </ul>
Perennial allergic conjunctivitis (PAC)	<ul style="list-style-type: none"> <li>Sensitized individuals</li> <li>Both females and males</li> <li>Bilateral involvement</li> <li>Year-round allergens</li> <li>Self-limiting</li> </ul>	<ul style="list-style-type: none"> <li>Ocular itching</li> <li>Tearing (watery discharge)</li> <li>Chemosis, redness</li> <li>Often associated with rhinitis</li> <li>Not sight threatening</li> </ul>	<ul style="list-style-type: none"> <li>Infective conjunctivitis</li> <li>Preservative toxicity</li> <li>Medicamentosa</li> <li>Dry eye</li> <li>SAC/AKC/VKC</li> </ul>
Atopic keratoconjunctivitis (AKC)	<ul style="list-style-type: none"> <li>Sensitized individuals</li> <li>Peak incidence 20-50 years of age</li> <li>Both females and males</li> <li>Bilateral involvement</li> <li>Seasonal/perennial allergens</li> <li>Atopic dermatitis</li> <li>Chronic symptoms</li> </ul>	<ul style="list-style-type: none"> <li>Severe ocular itching</li> <li>Red flaking periocular skin</li> <li>Mucoid discharge, photophobia</li> <li>Corneal erosions</li> <li>Scarring of conjunctiva</li> <li>Cataract (anterior subcapsular)</li> <li>Sight threatening</li> </ul>	<ul style="list-style-type: none"> <li>Contact dermatitis</li> <li>Infective conjunctivitis</li> <li>Blepharitis</li> <li>Pemphigoid</li> <li>VKC/SAC/PAC/GPC</li> </ul>
Vernal keratoconjunctivitis (VKC)	<ul style="list-style-type: none"> <li>Some sensitized individuals</li> <li>Peak incidence 3-20 years of age</li> <li>Males predominate 3:1</li> <li>Bilateral involvement</li> <li>Warm, dry climate</li> <li>Seasonal/perennial allergens</li> <li>Chronic symptoms</li> </ul>	<ul style="list-style-type: none"> <li>Severe ocular itching</li> <li>Severe photophobia</li> <li>Thick, ropy discharge</li> <li>Cobblestone papillae</li> <li>Corneal ulceration and scarring</li> <li>Sight threatening</li> </ul>	<ul style="list-style-type: none"> <li>Infective conjunctivitis</li> <li>Blepharitis</li> <li>AKC/SAC/PAC/GPC</li> </ul>
Giant papillary conjunctivitis (GPC)	<ul style="list-style-type: none"> <li>Sensitization not necessary</li> <li>Both females and males</li> <li>Bilateral involvement</li> <li>Prosthetic exposure</li> <li>Occurs anytime</li> <li>Chronic symptoms</li> </ul>	<ul style="list-style-type: none"> <li>Mild ocular itching</li> <li>Mild mucoid discharge</li> <li>Giant papillae</li> <li>Contact lens intolerance</li> <li>Foreign body sensation</li> <li>Protein buildup on contact lens</li> <li>Not sight threatening</li> </ul>	<ul style="list-style-type: none"> <li>Infective conjunctivitis</li> <li>Preservative toxicity</li> <li>SAC/PAC/AKC/VKC</li> </ul>



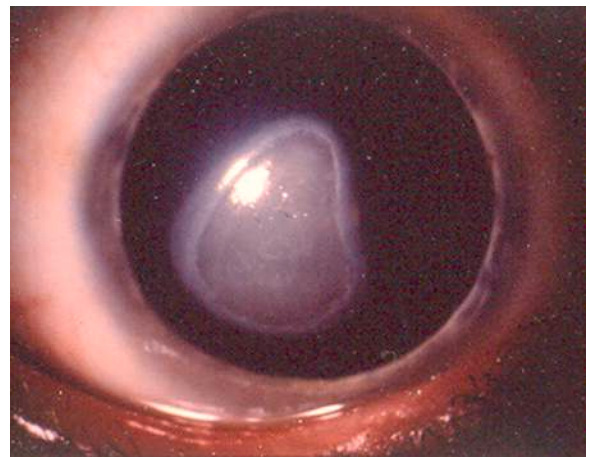
**Fig. 188.1** Allergic conjunctivitis. Arrow indicates area of chemosis in the conjunctivitis. (From Adkinson NF Jr, Bochner BS, Burks AW, et al., eds. *Middleton's Allergy: Principles & Practice*. 8th ed. St Louis: Elsevier, 2014: p. 619.)



**Fig. 188.2** Vernal keratoconjunctivitis. Cobblestone papillae and ropey discharge are seen on the underside (tarsal conjunctiva) of the upper eyelid. (From Adkinson NF Jr, Bochner BS, Burks AW, et al., eds. *Middleton's Allergy: Principles & Practice*. 8th ed. St Louis: Elsevier, 2014: p. 627.)



**Fig. 188.3** Horner-Trantas dots. Classic appearance of small white-yellow chalky concretions with collections of degenerated epithelial cells and eosinophils around the corneal limbus (arrows). (From Cheng J, Jiang L, Morrow NC, et al. *Recognition of atopic keratoconjunctivitis during treatment with dupilumab for atopic dermatitis*. *J Am Acad Dermatol*. 2021;85(1):265–267. Fig 1.)



**Fig. 188.4** Corneal shield ulcer classic depiction of sterile plaques containing fibrin and mucous that accumulate into macro-erosions forming a shield ulcer. (From LaMattina K, Thompson L. *Pediatric conjunctivitis*. *Dis Mon*. 2014;60(6):231–238. Fig 6.)

and is more common in the Mediterranean basin and in persons of Asian and African descent. It affects primarily children in temperate areas, with exacerbations in the spring and summer, but can occur throughout the year. Symptoms include intense ocular itching exacerbated by exposure to irritants, light, or perspiration. In addition, patients may complain of severe photophobia due to corneal involvement, foreign body sensation, and lacrimation. Giant papillae occur predominantly on the upper tarsal plate and are typically described as *cobblestoning* (Fig. 188.2). Other signs include a stringy or thick, ropey discharge, cobblestone papillae, transient yellow-white points at the corneal limbus (*Trantas dots*) (Fig. 188.3) and conjunctiva (*Horner points*), corneal “shield” ulcers (Fig. 188.4), and Dennie lines (Dennie-Morgan folds), which are prominent symmetric skin folds that extend in an arc from the inner canthus beneath and parallel to the lower lid margin. Children with vernal keratoconjunctivitis have measurably longer eyelashes, which may represent a reaction to ocular inflammation.

### Atopic Keratoconjunctivitis

Atopic keratoconjunctivitis is a chronic inflammatory ocular disorder most often involving the lower tarsal conjunctiva. It may

threaten eyesight if there is corneal involvement. Almost all patients have atopic dermatitis, and a significant number have asthma. Atopic keratoconjunctivitis rarely presents before late adolescence. Symptoms include severe bilateral ocular itching, burning, photophobia, and tearing with a mucoid discharge that are much more severe than in allergic conjunctivitis and persist throughout the year. The bulbar conjunctiva is injected and chemotic; cataracts may occur. Trantas dots at the corneal limbus or giant papillae typically found in inferior palpebral conjunctiva may also be present. Eyelid eczema can extend to the periorbital skin and cheeks with erythema and thick, dry scaling. Secondary staphylococcal blepharitis is common because of eyelid induration and maceration. Chronic eye rubbing associated with vernal and atopic keratoconjunctivitis can lead to **keratoconus**, a noninflammatory cone-shaped corneal ectasia. This may lead to corneal thinning and perforation.

### Giant Papillary Conjunctivitis

Giant papillary conjunctivitis is not associated with IgE sensitization, but has been linked to chronic exposure to foreign bodies, such

as contact lenses (both hard and soft), ocular prostheses, and sutures. Symptoms and signs include mild bilateral ocular itching, tearing, a foreign body sensation, and excessive ocular discomfort with mild mucoid discharge with white or clear exudate on awakening, which may become thick and stringy. Trantas dots, limbal infiltration, bulbar conjunctival hyperemia, and edema may develop.

### Contact Allergy

Contact allergy typically involves the eyelids but can also involve the conjunctivae. It is frequently associated with increased exposure to topical medications, contact lens solutions, and preservatives.

### DIAGNOSIS

Nonallergic conjunctivitis can be viral, bacterial, or chlamydial in origin. It is typically unilateral, but can be bilateral with symptoms initially developing in one eye (see Chapter 666). Symptoms include stinging or burning rather than itching and often a foreign body sensation. Ocular discharge can be watery, mucoid, or purulent. Masqueraders of ocular allergy also include nasolacrimal duct obstruction, foreign body, blepharoconjunctivitis, dry eye, uveitis, and trauma.

### Dry Eye

Dry eye conditions are being increasingly recognized as a concomitant and comorbid condition in children directly correlated with increased use of computers and gaming and mobile devices that are associated

with decreased blinking time and increased evaporative tear film dysfunction.

### TREATMENT

Primary treatment of ocular allergies includes avoidance of allergens, cold compresses, and lubrication. Secondary treatment regimens include the use of oral or topical antihistamines and, if necessary, topical decongestants, mast cell stabilizers, and antiinflammatory agents (Table 188.2). Drugs with dual antihistamine and mast cell–blocking activities provide the most advantageous approach in treating allergic conjunctivitis, with both fast-acting symptomatic relief and disease-modifying action. Children often complain of stinging or burning with use of topical ophthalmic preparations and usually prefer oral antihistamines for allergic conjunctivitis. It is important not to contaminate topical ocular medications by allowing the applicator tip to contact the eye or eyelid. Using refrigerated medications may decrease some of the discomfort associated with their use. Topical decongestants act as vasoconstrictors, reducing erythema, vascular congestion, and eyelid edema, but do not diminish the allergic response. Adverse effects of topical vasoconstrictors include burning or stinging and rebound hyperemia or conjunctivitis medicamentosa with chronic use. Combined use of an antihistamine and a vasoconstrictor is more effective than use of either agent alone. Use of topical nasal corticosteroids for allergic rhinoconjunctivitis decreases ocular symptoms, presumably through a nasooocular reflex.

**Table 188.2** Topical Ophthalmic Medications for Allergic Conjunctivitis

DRUG AND TRADE NAMES	MECHANISM OF ACTION AND DOSING	COMMENTS, CAUTIONS AND ADVERSE EVENTS
Azelastine hydrochloride, 0.05% Optivar	Antihistamine <i>Children</i> ≥3 yr: 1 gtt bid	Not for treatment of contact lens–related irritation; the preservative may be absorbed by soft contact lenses Wait at least 10 min after administration before inserting soft contact lenses
Emedastine difumarate, 0.05% Emadine	Antihistamine <i>Children</i> ≥3 yr: 1 gtt qid	Soft contact lenses should not be worn if the eye is red Wait at least 10 min after administration before inserting soft contact lenses
Levocabastine hydrochloride, 0.05% Livostin	Antihistamine <i>Children</i> ≥12 yr: 1 gtt bid-qid up to 2 wk	Not for use in patients wearing soft contact lenses during treatment
Pheniramine maleate	Antihistamine/vasoconstrictor	Avoid prolonged use (>3-4 days) to avoid rebound symptoms Not for use with contact lenses
Naphazoline hydrochloride, 0.3% 0.025% Naphcon-A, Opcon-A	<i>Children</i> >6 yr: 1-2 gtt qid	Avoid prolonged use (>3-4 days) to avoid rebound symptoms Not for use with contact lenses
Cromolyn sodium, 4% Crolom, Opticrom	Mast cell stabilizer <i>Children</i> >4 yr: 1-2 gtt q4-6h	Can be used to treat giant papillary conjunctivitis and vernal keratitis Not for use with contact lenses
Lodoxamide tromethamine, 0.1% Alomide	Mast cell stabilizer <i>Children</i> ≥2 yr: 1-2 gtt qid up to 3 mo	Can be used to treat vernal keratoconjunctivitis Not for use in patients wearing soft contact lenses during treatment
Nedocromil sodium, 2% Alocril	Mast cell stabilizer <i>Children</i> ≥3 yr: 1-2 gtt bid	Avoid wearing contact lenses while exhibiting the signs and symptoms of allergic conjunctivitis
Pemirolast potassium, 0.1% Alamast	Mast cell stabilizer <i>Children</i> >3 yr: 1-2 gtt qid	Not for treatment of contact lens–related irritation; the preservative may be absorbed by soft contact lenses Wait at least 10 min after administration before inserting soft contact lenses
Epinastine hydrochloride, 0.05% Elestat	Antihistamine/mast cell stabilizer <i>Children</i> ≥3 yr: 1 gtt bid	Contact lenses should be removed before use Wait at least 15 min after administration before inserting soft contact lenses Not for the treatment of contact lens irritation

**Table 188.2** Topical Ophthalmic Medications for Allergic Conjunctivitis—cont'd

DRUG AND TRADE NAMES	MECHANISM OF ACTION AND DOSING	COMMENTS, CAUTIONS AND ADVERSE EVENTS
Ketotifen fumarate, 0.025% Zaditor	Antihistamine/mast cell stabilizer <i>Children</i> ≥3 yr: 1 gtt bid q8-12h	Not for treatment of contact lens–related irritation; the preservative may be absorbed by soft contact lenses Wait at least 10 min after administration before inserting soft contact lenses
Olopatadine hydrochloride, 0.1%, 0.2%, 0.7% Patanol, Pataday, Pazeo	Antihistamine/mast cell stabilizer <i>Children</i> ≥3 yr: 1 gtt bid (8 hr apart) <i>Children</i> ≥2 yr: 1 gtt qd	Not for treatment of contact lens–related irritation; the preservative may be absorbed by soft contact lenses Wait at least 10 min after administration before inserting soft contact lenses
Alcaftadine, 0.25% Lastacaft	Antihistamine/mast cell stabilizer <i>Children</i> >2 yr: 1 gtt bid q8-12h	Contact lenses should be removed before application; may be inserted after 10min Not for the treatment of contact lens irritation
Bepotastine besilate, 1.5% Bepreve	Antihistamine/mast cell stabilizer <i>Children</i> >2 yr: 1 gtt bid q8-12h	Contact lenses should be removed before application; may be inserted after 10min Not for the treatment of contact lens irritation
Cetirizine, 0.24% Zerviate	Antihistamine <i>Children</i> >2 yr: 1 gtt bid	Contains lubricant hydrocellulose, preservative free unit doses
Ketorolac tromethamine, 0.5% Acular	NSAID <i>Children</i> ≥3 yr: 1 gtt qid	Avoid with aspirin or NSAID sensitivity Use ocular product with caution in patients with complicated ocular surgeries, corneal denervation or epithelial defects, ocular surface diseases (e.g., dry eye syndrome), repeated ocular surgeries within a short period, diabetes mellitus, or rheumatoid arthritis; these patients may be at risk for corneal adverse events that may be sight threatening <i>Do not use while wearing contact lenses</i>
Fluorometholone, 0.1%, 0.25% suspension and 0.1% ointment FML, FML Forte, Flarex	Fluorinated corticosteroid <i>Children</i> ≥2 yr: 1 gtt into conjunctival sac of affected eye(s) bid-qid During initial 24-48 hr, dosage may be increased to 1 gtt q4h Ointment (~1.3 cm in length) into conjunctival sac of affected eye(s) 1-3 times daily May be applied q4h during initial 24-48 hr of therapy.	If improvement does not occur after 2 days, patient should be reevaluated Patient should remove soft contact lenses before administering (contains benzalkonium chloride) and delay reinsertion of lenses for ≥15 min after administration Close monitoring for development of glaucoma and cataracts
Cyclosporine ophthalmic solution, 0.1% Verkazia	Immunomodulation <i>Children</i> >3 yr: 1 gtt qid	Unpreserved single dose units Approved for treatment of vernal keratoconjunctivitis
loteprednol, 0.5% Lotemax, Alrex	Steroid, antiinflammatory <i>Children</i> >2 yr: 1-2 gtt qid	Lowest steroid associated with cataract formation or increase in intraocular pressure Comes in suspension and gel formulations

NSAID, Nonsteroidal antiinflammatory drug; bid, 2 times daily; gtt, drops; qid, 4 times daily; q4-6h, every 4-6 hr; qd, every day.

Tertiary treatment of ocular allergy includes topical (or rarely oral) corticosteroids and should be conducted in conjunction with an ophthalmologist. Local administration of topical corticosteroids may be associated with increased intraocular pressure, viral infections, and cataract formation. Other immunomodulatory medications, such as topical tacrolimus or topical cyclosporine, are used as steroid-sparing agents. Allergen immunotherapy is very effective in seasonal and perennial allergic conjunctivitis, especially when associated with rhinitis, and can decrease the need for oral or topical medications to control allergy symptoms.

Because vernal and atopic keratoconjunctivitis can be associated with visual morbidity, if these diagnoses are suspected, the patient should be referred to an ophthalmologist. *Symptoms that should prompt referral to an ophthalmologist include unilateral red eye with pain, photophobia, change in vision, refractory dry eyes, or corneal abnormality.*

Visit Elsevier eBooks+ at [eBooks.Health.Elsevier.com](http://eBooks.Health.Elsevier.com) for Bibliography.



## Chapter 189

# Urticaria (Hives) and Angioedema

David A. Khan, Aleena Banerji, and Scott H. Sicherer

Urticaria affects 20% of individuals at some point in their life. Episodes of hives that last for <6 weeks are considered *acute*, whereas those that occur on most days of the week for >6 weeks are designated *chronic*. The distinction is important, because the causes and mechanisms of urticaria formation and the therapeutic approaches are different in each instance.

## ETIOLOGY AND PATHOGENESIS

Urticaria is defined as the presence of wheals (hives), angioedema, or both. **Acute urticaria** is often caused by an allergic IgE-mediated reaction (Table 189.1). This form of urticaria is a self-limited process that occurs when an allergen activates mast cells in the skin. Common causes of acute generalized urticaria include foods, drugs (particularly antibiotics), and stinging-insect venoms. If an allergen (latex, animal dander) penetrates the skin locally, hives often can develop at the site of exposure. Acute urticaria can also result from non-IgE-mediated stimulation of mast cells, caused by viral infections, nonsteroidal anti-inflammatory drugs (NSAIDs), and opiates. The diagnosis of **chronic urticaria** is established when lesions occur on most days of the week for >6 weeks (Tables 189.2 and 189.3). In about half the cases, chronic urticaria is accompanied by angioedema. In 20% of chronic urticaria patients, angioedema occurs without wheals. Acute angioedema without wheals is often a result of allergy, but recurrent isolated angioedema raises the possibility of other diagnoses.

A typical **hive** is an erythematous, pruritic, raised wheal that blanches with pressure, is transient, and resolves without residual lesions, unless the area was intensely scratched. In contrast, urticaria associated with

systemic lupus erythematosus (SLE), or other vasculitides in which a skin biopsy reveals a small-vessel vasculitis, often have distinguishing clinical features. Lesions that burn more than itch, last >24 hours, do not blanch, blister, heal with scarring, or that are associated with bleeding into the skin (purpura) suggest urticarial vasculitis, which is a rare condition in children. Atypical aspects of the gross appearance of the hives or associated systemic symptoms should heighten concern that the urticaria or angioedema may be the manifestation of a systemic disease process (Table 189.4).

## INDUCIBLE URTICARIA

Inducible urticaria and angioedema (previously referred to as physical urticaria) share the common property of being induced by an environmental stimulus, such as a change in temperature or direct stimulation of the skin with pressure, stroking, vibration, or light (Table 189.5; see also Table 189.2). In contrast to chronic spontaneous urticaria (CSU), the wheals of inducible urticaria are more short-lived, often lasting <1 hour.

## Cold-Dependent Disorders

Cold urticaria is characterized by the development of localized pruritus, erythema, and urticaria/angioedema after exposure to a cold stimulus. Total body exposure, as seen with swimming in cold water, can cause anaphylaxis, resulting in hypotension, loss of consciousness, and even death if not promptly treated. The diagnosis is most easily confirmed by challenge testing by holding an ice cube in place on the patient's skin for 5 minutes. In patients with cold urticaria, a urticarial lesion develops about 10 minutes after removal of the ice cube and on rewarming of the chilled skin. Most cases of acquired cold urticaria are idiopathic. Cold urticaria is rarely associated with the presence of **cryoproteins** such as cold agglutinins, cryoglobulins, cryofibrinogen, and the Donath-Landsteiner antibody seen in secondary syphilis (paroxysmal cold hemoglobinuria). Multiple subtypes of atypical cold urticaria with a negative ice cube test have also been reported. Cold

**Table 189.1** Etiology of Acute Urticaria

Foods	Egg, milk, wheat, peanuts, tree nuts, soy, shellfish, fish, direct mast cell degranulation
Medications	Suspect all medications, even nonprescription or homeopathic
Insect stings	Hymenoptera (honeybee, yellow jacket, hornets, wasp, fire ants), biting insects (papular urticaria)
Infections	<b>Bacterial</b> (streptococcal pharyngitis, <i>Mycoplasma</i> , sinusitis); <b>Viral</b> (hepatitis, mononucleosis [Epstein-Barr virus], coxsackieviruses A and B); <b>Parasitic</b> ( <i>Ascaris</i> , <i>Ancylostoma</i> , <i>Echinococcus</i> , <i>Fasciola</i> , <i>Filaria</i> , <i>Schistosoma</i> , <i>Strongyloides</i> , <i>Toxocara</i> , <i>Trichinella</i> ); <b>Fungal</b> (dermatophytes, <i>Candida</i> )
Contact allergy	Latex, pollen, animal saliva, nettle plants, caterpillars
Transfusion reactions	Blood, blood products, or intravenous immune globulin administration

From Lasley MV, Kennedy MS, Altman LC. Urticaria and angioedema. In: Altman LC, Becker JW, Williams PV, eds. *Allergy in Primary Care*. Philadelphia: Saunders; 2000: p. 232.

**Table 189.2** Etiology of Chronic Urticaria

Spontaneous/autoimmune	Approximately 30% of chronic urticaria cases are inducible urticaria, and 60–70% are spontaneous; of the spontaneous cases approximately 20–60% have autoantibodies (see text)
Inducible	Dermographism Cholinergic urticaria Cold urticaria (see Table 189.6) Delayed pressure urticaria Solar urticaria Vibratory urticaria Aquagenic urticaria
Autoimmune diseases	Systemic lupus erythematosus Juvenile idiopathic arthritis Thyroid disease (Graves, Hashimoto) Celiac disease Inflammatory bowel disease Urticarial vasculitis
Autoinflammatory/periodic fever syndromes	See Tables 189.3 and 189.6.
Neoplastic	Lymphoma Mastocytosis Leukemia
Angioedema	Hereditary angioedema Acquired angioedema Angiotensin-converting enzyme inhibitors

Modified from Lasley MV, Kennedy MS, Altman LC. Urticaria and angioedema. In: Altman LC, Becker JW, Williams PV, eds. *Allergy in Primary Care*. Philadelphia: Saunders; 2000: p. 234.

**Table 189.3** Febrile Autoinflammatory Diseases Causing Urticaria in Children

DISEASE	GENE (PROTEIN)	INHERITANCE	ATTACK LENGTH	TIMING OF ONSET	CUTANEOUS FEATURES	EXTRACUTANEOUS CLINICAL FEATURES
FCAS	<i>NLRP3</i> (cryopyrin)	AD	Brief; minutes to 3 days	Neonatal or infantile	Cold-induced pseudourticaria	Arthralgia Conjunctivitis Headache
Muckle-Wells syndrome	<i>NLRP3</i> (cryopyrin)	AD	1-3 days	Neonatal, infantile, childhood (can be later)	Widespread pseudourticaria	Arthralgia/arthritis Sensorineural hearing loss Conjunctivitis/episcleritis Headache Amyloidosis
Neonatal-onset multisystem inflammatory disease (aka chronic infantile neurologic cutaneous articular syndrome)	<i>NLRP3</i> (cryopyrin)	AD	Continuous flares	Neonatal or infantile	Widespread pseudo-urticaria	Deforming osteoarthropathy, epiphyseal overgrowth Sensorineural hearing loss Dysmorphic facies Chronic aseptic meningitis, headaches, papilledema, seizures Conjunctivitis/uveitis, optic atrophy Growth retardation Developmental delay Amyloidosis
HIDS	<i>MVK</i> (mevalonate kinase)	AR	3-7 days	Infancy (<2yr)	Intermittent morbilliform or urticarial rash Aphthous mucosal ulcers Erythema nodosum	Arthralgia/arthritis Cervical lymphadenopathy Severe abdominal pain Diarrhea/vomiting Headache Elevated IgD and IgA antibody levels Elevated urine mevalonic acid during attacks
Tumor necrosis factor receptor-associated periodic syndrome	<i>TNFRSF1A</i> (TNFR1)	AD	>7 days	Childhood	Intermittent migratory erythematous macules and edematous plaques overlying areas of myalgia, often on limbs Periorbital edema	Migratory myalgia Conjunctivitis Serositis Amyloidosis
Systemic-onset juvenile idiopathic arthritis (SoJIA)	Polygenic	Varies	Daily (quotidian)	Peak onset at 1-6yr	Nonfixed erythematous rash; may be urticarial With or without dermatographism With or without periorbital edema	Polyarthritis Myalgia Hepatosplenomegaly Lymphadenopathy Serositis
PLAID	<i>PLCG2</i>	AD	N/A	Infancy	Urticaria induced by evaporative cooling Ulcers in cold-exposed areas	Allergies Autoimmune disease Recurrent sinopulmonary infections Elevated IgE antibody levels Decreased IgA and IgM antibody levels Often elevated antinuclear antibody titers

AD, Autosomal dominant; AR, autosomal recessive; HIDS, hyperimmunoglobulinemia D syndrome; FCAS, familial cold-induced autoinflammatory syndrome; N/A, not available; PLAID, *PLCG2*-associated antibody deficiency and immune dysregulation.

From Youseff MJ, Chiu YE. Eczema and urticaria as manifestations of undiagnosed and rare diseases. *Pediatr Clin North Am.* 2017;64:39-56. Table 2, pp. 49-50.

urticaria must be distinguished from the **familial cold autoinflammatory syndrome** (see later, Diagnosis) (Table 189.6; see also Table 189.3 and Chapter 204). Because 20% of pediatric patients with cold urticaria may experience anaphylaxis, counseling on risks of anaphylaxis and prescribing epinephrine autoinjectors should be considered.

### Cholinergic Urticaria

Cholinergic urticaria is characterized by the onset of small, punctate pruritic wheals surrounded by a prominent erythematous flare and

associated with exercise, hot showers, emotional stress, and sweating. Once the patient cools down, the rash usually subsides in 30-60 minutes. Occasionally, symptoms of more generalized cholinergic stimulation, such as lacrimation, wheezing, salivation, and syncope, are observed. These symptoms are mediated by cholinergic nerve fibers that innervate the musculature via parasympathetic neurons and innervate the sweat glands by cholinergic fibers that travel with the sympathetic nerves. Elevated plasma histamine values parallel the onset of urticaria triggered by changes in body temperature.

**Table 189.4** Distinguishing Features Between Urticaria and Systemic Urticarial Syndromes

COMMON URTICARIA	URTICARIAL SYNDROMES (≥1 OF FOLLOWING)
Only typical wheals:	Atypical “wheals”:
Erythematous edematous lesions	Infiltrated plaques
Transient (<24–36 hr)	Persistent (>24–36 hr)
Asymmetric distribution	Symmetric distribution
Resolution without signs	Resolution with signs (hypo/hyperpigmentation, bruising, or scarring)
No associated different elementary lesions (papules, vesicles, purpura, crustae)	Associated different elementary lesions (papules, vesicles, purpura, scaling, crustae)
Pruritic (rarely stinging/burning)	Not pruritic; rather painful or burning
Possibly associated with angioedema	Usually no associated angioedema
No associated systemic symptoms	Often associated with systemic symptoms (fever, malaise, arthralgia, abdominal pain, weight loss, acral circulatory abnormalities, neurologic signs)

From Peroni A, Colato C, Zanoni G, Girolomoni G. Urticarial lesions: if not urticaria, what else? The differential diagnosis of urticaria. *J Am Acad Dermatol.* 2009;62(4):559.

### Symptomatic Dermographism

Symptomatic dermographism (also called *dermatographism* or *urticaria factitia*) may occur as an isolated disorder or may accompany chronic urticaria or other inducible urticarias. It can be diagnosed by observing the skin after stroking it with a tongue depressor. In patients with dermographism, a linear response occurs secondary to reflex vasoconstriction, followed by pruritus, erythema, and a linear wheal caused by secondary dilation of the vessel and extravasation of plasma. Symptomatic dermographism is distinct from the more common “simple dermographism,” affecting 4% of the population, whereas whealing but no itch occurs with stroking the skin.

### Delayed Pressure Urticaria

Delayed pressure urticaria differs from other inducible urticaria in that symptoms typically occur 4–6 hours after pressure has been applied. Some patients may complain of swelling, with or without pruritus, secondary to pressure, without hives. Other lesions are predominantly wheals and may or may not be associated with significant swelling. When wheals are present, an infiltrative skin lesion is seen, characterized by a perivascular mononuclear cell infiltrate and dermal edema similar to that seen in CSU. Symptoms occur at sites of tight clothing; foot swelling is common after walking; and buttock swelling may be prominent after sitting for a few hours. This condition can coexist with CSU or can occur separately. The diagnosis is confirmed by challenge testing, most commonly via the “sand bag test.” This test can be performed by using 15 lb of weights attached to a strap applied to the shoulder, thigh, or forearm for 15 minutes and observing the site over the next 24 hours for evidence of hives or edema.

### Solar Urticaria

Solar urticaria is a rare disorder in which urticaria develops within minutes of direct sun exposure. Typically, pruritus occurs first, in approximately 30 seconds, followed by edema confined to the light-exposed area and surrounded by a prominent erythematous zone. The lesions usually disappear within 1–3 hours after cessation of sun exposure. When large areas of the body are exposed, systemic symptoms may occur, including hypotension and wheezing. Solar urticaria has

been classified into six types, depending on the wavelength of light that induces skin lesions and the ability or inability to transfer the disorder passively with serum IgE.

### Aquagenic Urticaria

Patients with aquagenic urticaria demonstrate small wheals after contact with water, regardless of its temperature, and are thereby distinguishable from patients with cold urticaria or cholinergic urticaria. Direct application of a compress of water to the skin is used to test for the presence of aquagenic urticaria. Rarely, chlorine or other trace contaminants may be responsible for the reaction.

### CHRONIC SPONTANEOUS URTICARIA

CSU is the most common form of chronic urticaria and is associated with normal routine laboratory values and no evidence of systemic disease. CSU differs from allergen-induced skin reactions and from physically induced urticaria in that histologic studies reveal cellular infiltrate predominantly around small venules. Skin examination reveals infiltrative hives with palpably elevated borders, sometimes varying greatly in size and shape but generally rounded.

Biopsy of a typical lesion reveals nonnecrotizing, perivascular, mononuclear cellular infiltration. Varying histopathologic processes can occur in the skin and manifest as urticaria. Patients with urticarial **vasculitis** can have urticaria and/or angioedema. Biopsy of these lesions in patients who may present with urticaria, arthralgias, myalgias, an elevated erythrocyte sedimentation rate (ESR), and in some cases **hypocomplementemia** as manifestations of urticarial vasculitis can reveal fibrinoid necrosis with a predominantly neutrophilic infiltrate. Although urticarial vasculitis lesions are typically less blanchable, the lesions may be clinically indistinguishable from those seen in the more typical, nonvasculitic cases.

The immunopathogenesis of CSU is not entirely clear; however, mast cell activation is thought to have a key role. A key activating receptor in mast cells is the high-affinity IgE receptor (FcεRI). Two theories suggest that autoimmune factors may lead to FcεRI activation. In **type I autoimmunity (aka autoallergy)**, patients have IgE autoantibodies to self-antigens such as thyroperoxidase or interleukin (IL)-24, which can cross link the IgE autoantibodies leading to mast cell activation and urticaria. In **type II autoimmunity**, patients have autoantibodies (IgG, IgM, IGA) directed against FcεRI or IgE itself, which can similarly lead to mast cell activation. Direct measurement of these autoantibodies is limited to research studies with no clear clinical utility at present. However, the autoallergy theory is an attractive explanation for the effectiveness of anti-IgE therapies like omalizumab.

### Diagnosis

The diagnosis of both acute and chronic urticaria is primarily clinical and requires that the clinician be aware of the various forms of urticaria (wheals and angioedema).

**Hives** are transient, pruritic, erythematous, raised wheals that may become tense and painful. The lesions may coalesce and form polymorphous, serpiginous, or annular lesions (Figs. 189.1 and 189.2). Individual lesions usually last minutes to several hours and rarely more than 24 hours. The lesions often disappear, only to reappear at another site. **Angioedema** involves the deeper subcutaneous tissues in locations such as the eyelids, lips, tongue, genitals, dorsum of the hands or feet, and in the case of hereditary angioedema (HAE), the wall of the gastrointestinal (GI) tract (see Chapter 189.1).

Viral infections, drugs, and foods are the most common identifiable causes of acute urticaria in children. Allergy skin testing for foods can be helpful in identifying a cause of acute urticaria, but only when supported by historical evidence. The role of an offending food can then be proved by elimination and food challenge, when needed. In the absence of information implicating an ingestant cause, skin testing for foods and implementation of elimination diets are generally not useful for either acute or chronic urticaria. Patients with delayed urticaria 3–6 hours after a meal consisting of mammalian meat should be evaluated for IgE to galactose-α-1,3-galactose (“**alpha-gal**”), a carbohydrate allergen. Alpha-gal has been identified as a trigger in this circumstance,

**Table 189.5** Comparison of the Physical Urticarias

URTICARIA	RELATIVE FREQUENCY	PRECIPITANT	TIME OF ONSET	DURATION	LOCAL SYMPTOMS	SYSTEMIC SYMPTOMS	TESTS	MECHANISM	TREATMENT
Symptomatic dermatographism	Most frequent	Stroking skin	Minutes	2-3 hr	Irregular pruritic attacks	None	Stroke skin	Passive transfer, IgE, histamine, possible role of adenosine triphosphate, substance P, possible direct pharmacologic mechanism	Continual antihistamines
Delayed dermatographism	Rare	Stroking skin	30 min to 8 hr	<48 hr	Burning, deep swelling	None	Stroke skin, observe early and late	Unknown	Avoidance of precipitants
Pressure urticaria	Frequent	Pressure	3-12 hr	8-24 hr	Diffuse, tender swelling	Flulike symptoms	Apply weight	Unknown	Avoidance of precipitants; if severe, omalizumab
Solar urticaria	Frequent	Various wavelengths of light	2-5 min	15 min to 3 hr	Pruritic wheals	Wheezing, dizziness, syncope	Phototest	Passive transfer, reverse passive transfer, IgE, possible histamine	Avoidance of precipitants; antihistamines, sunscreens, antimalarials
Familial cold urticaria	Rare	Change in skin temperature	30 min to 3 hr	<48 hr	Burning wheals	Tremor; headache; arthralgia; fever	Expose skin to cold air	Unknown	Avoidance of precipitants
Essential acquired cold urticaria	Frequent	Cold contact	2-5 min	1-2 hr	Pruritic wheals	Wheezing, syncope, drowning	Apply ice-filled copper beaker to arm, immerse	Passive transfer, reverse passive transfer, IgE (IgM), histamine; vasculitis can be induced	Cyproheptadine hydrochloride, other antihistamines; desensitization; avoidance of precipitants
Heat urticaria	Rare	Heat contact	2-5 min (rarely delayed)	1 hr	Pruritic wheals	None	Apply hot water-filled cylinder to arm	Possibly histamine; possibly complement	Antihistamines, desensitization; avoidance of precipitants
Cholinergic urticaria	Very frequent	General overheating of body	2-20 min	30 min to 1 hr	Papular, pruritic wheals	Syncope; diarrhea; vomiting, salivation; headaches	Bathe in hot water; exercise until perspiring, inject methacholine chloride	Passive transfer; possible immunoglobulin; product of sweat gland stimulation; histamine, reduced protease	Application of cold water or ice to skin; antihistamines; omalizumab
Aquagenic urticaria	Rare	Water contact	Several minutes	30-45 min	Papular, pruritic wheals	None reported	Apply water compresses to skin	Unknown	Avoidance of precipitants; antihistamine; application of inert oil
Vibratory angioedema	Very rare	Vibrating against skin	2-5 min	1 hr	Angioedema	None reported	Apply vibration to forearm	Unknown	Avoidance of precipitants

Ig, Immunoglobulin.

From Lee AD, Jorizzo JL. Urticaria. In: Callen JP, Jorizzo JL, Bologna JL, et al., eds. *Dermatological Signs of Internal Disease*. 4th ed. Philadelphia: Elsevier; 2009: p. 59, Table 6.4.



**Table 189.6** Hereditary Diseases with Cold-Induced Urticaria

		EPISODIC SYMPTOMS	SUSTAINED/PROGRESSIVE SYMPTOMS
CAPS	FCAS	Urticarial rash, arthralgia, myalgia, chills, fever, swelling of extremities	Renal amyloidosis
	MWS CINCA	Urticarial rash, arthralgia, chills, fever Fever	Sensorineural deafness, renal amyloidosis Rash, arthritis, chronic meningitis, visual defect, deafness, growth retardation, renal amyloidosis
NAPS12 (FCAS2)		Fever, arthralgia, myalgia, urticaria, abdominal pain, aphthous ulcers, lymphadenopathy	Sensorineural deafness
PLAID (FCAS3)		Urticaria induced by evaporative cooling, sinopulmonary infections	Serum low IgM and IgA levels; high IgE levels; decreased B and NK cells; granulomata; antinuclear antibodies

CAPS, Cryopyrin-associated periodic syndromes; FCAS, familial cold-induced autoinflammatory syndrome; MWS, Muckle-Wells syndrome; CINCA, chronic infantile neurologic cutaneous articular syndrome; NAPS, NLRP-12-associated periodic syndrome; PLAID, PLCG2-associated antibody deficiency and immune dysregulation; NK, natural killer; Ig, immunoglobulin.

From Kanazawa N. Hereditary disorders presenting with urticaria. *Immunol Allergy Clin N Amer.* 2014;34:169–179. Table 4, p. 176.



**Fig. 189.1** Polycyclic lesions of urticaria associated with prostaglandin  $E_2$  infusion. (From Eichenfield LF, Friedan IJ, Esterly NB. *Textbook of Neonatal Dermatology*. Philadelphia: Saunders; 2001: p. 300.)



**Fig. 189.2** Annular urticaria of unknown etiology. (From Eichenfield LF, Friedan IJ, Esterly NB. *Textbook of Neonatal Dermatology*. Philadelphia: Saunders; 2001: p. 301.)

with sensitization linked to tick bites in specific geographic regions, such as the mid-Atlantic area of the United States. Skin testing for aeroallergens is not indicated unless there is a concern about contact urticaria (animal dander or grass pollen).

Autoimmune diseases are very rare causes of chronic urticaria or angioedema. Clinically available tests marketed for chronic urticaria such as basophil activation tests (used as surrogates for detecting type 2 autoantibodies) are generally not recommended. The **differential diagnosis** of chronic urticaria includes atopic or contact dermatitis, cutaneous or systemic mastocytosis, complement-mediated mast cell degranulation as may occur with circulating immune complexes,

malignancies, mixed connective tissue diseases, and cutaneous blistering disorders (e.g., bullous pemphigoid; see [Table 189.2](#)). Routine laboratory testing in chronic urticaria in the absence of other history has not been found to be cost-effective as it rarely changes management. Urticaria guidelines recommend either no testing or limited laboratory testing such as a complete blood cell count with differential and ESR or CRP. Further studies are warranted if the patient has fever, arthralgias, or elevated ESR ([Table 189.7](#); see also [Table 189.4](#)). **HAE** is potentially life-threatening, usually associated with deficient C1 inhibitor (C1-INH) activity, and the most important familial form of angioedema (see Chapter 189.1), but it is not associated with typical urticaria. In patients with eosinophilia, stools should be obtained for ova and parasite testing, because infection with helminthic parasites has been associated with urticaria. A rare syndrome of episodic (approximately 3- to 4-week intervals) angioedema less often with urticaria, weight gain, and occasionally fever with associated **hypereosinophilia** has been described in both adults and children.

Skin biopsy for diagnosis of possible **urticarial vasculitis** is recommended for urticarial lesions that persist at the *same location* for >24 hours, those with pigmented or purpuric components, and those that burn more than itch. Collagen vascular diseases such as SLE may manifest urticarial vasculitis as a presenting feature. The skin biopsy in urticarial vasculitis typically shows endothelial cell swelling of postcapillary venules with necrosis of the vessel wall, perivascular neutrophil infiltrate, diapedesis of red blood cells, and fibrin deposition associated with deposition of immune complexes.

**Mastocytosis** is characterized by mast cell hyperplasia in the bone marrow, liver, spleen, lymph nodes, and skin. Clinical effects of mast cell activation are common, including pruritus, flushing, urtication, abdominal pain, nausea, and vomiting. The diagnosis is confirmed by a bone marrow biopsy showing increased numbers of spindle-shaped mast cells that express CD2 and CD25. Maculopapular cutaneous mastocytosis (aka **urticaria pigmentosa**) is the most common skin manifestation of mastocytosis and may occur as an isolated skin finding. It appears as small, yellow-tan to reddish brown macules or raised papules that urticate on scratching (**Darier sign**). This sign can be masked by antihistamines. The diagnosis is confirmed by a skin biopsy that shows increased numbers of dermal mast cells.

Inducible urticaria should be considered in any patient with chronic urticaria and a suggestive history (see [Tables 189.2 and 189.5](#)). Papular “urticaria” often occurs in small children, generally on the extremities, but the lesions are more persistent than true urticaria. It manifests as grouped or linear, highly pruritic wheals or papules mainly on exposed skin at the sites of insect bites.

**Exercise-induced anaphylaxis** manifests as varying combinations of pruritus, urticaria, angioedema, wheezing, or hypotension after exercise (see [Chapter 190](#)). Cholinergic urticaria is differentiated by positive results of heat challenge tests and the rare occurrence

Table 189.7 Diagnostic Testing for Urticaria and Angioedema	
DIAGNOSIS	DIAGNOSTIC TESTING
Chronic spontaneous urticaria	No testing required for diagnosis
Food and drug reactions	Elimination of offending agent, skin testing, and challenge with suspected foods
Autoimmune urticaria	Autologous serum skin test; antithyroid antibodies
Thyroiditis	Thyroid-stimulating hormone; antithyroid antibodies
Infections	Appropriate cultures or serology
Collagen vascular diseases and cutaneous vasculitis	Skin biopsy, CH <sub>50</sub> , C1q, C4, immunofluorescence of tissues, antinuclear antibodies, cryoglobulins
Cold urticaria	Ice cube test usually positive but may be negative in familial autoinflammatory disorders
Solar urticaria	Exposure to defined wavelengths of light, red blood cell protoporphyrin, fecal protoporphyrin, and coproporphyrin
Dermographism	Stroking with narrow object (e.g., tongue blade)
Pressure urticaria	Application of pressure for defined time and intensity
Vibratory urticaria	Vibration for 4 min
Aquagenic urticaria	Challenge with tap water at various temperatures
Urticaria pigmentosa	Skin biopsy, test for dermographism
Hereditary angioedema	C4, C1-INH testing by protein and function
Familial cold autoinflammatory syndrome	Genetic testing for NALP3 pathogenic variants

of anaphylactic shock. The combination of ingestion of various food allergens and postprandial exercise has been associated with urticaria/angioedema and anaphylaxis. In patients with this combination disorder, the offending food or exercise alone does not produce the reaction.

Muckle-Wells syndrome and familial cold autoinflammatory syndrome are rare, autosomal dominantly inherited conditions associated with recurrent urticaria-like lesions. **Muckle-Wells syndrome** is characterized by arthritis and joint pain that usually appears in adolescence. It is associated with progressive nerve deafness, recurrent fever, elevated ESR (see Tables 189.3 and 189.6), hypergammaglobulinemia, renal amyloidosis, and a poor prognosis. **Familial cold autoinflammatory syndrome** is characterized by a cold-induced rash that has urticarial features but is rarely pruritic. Cold exposure leads to additional symptoms such as conjunctivitis, sweating, headache, and nausea.

### Treatment

Acute urticaria is a self-limited illness requiring little treatment other than antihistamines and avoidance of any identified trigger. Hydroxyzine and diphenhydramine are sedating but are effective and frequently used for treatment of urticaria. Loratadine, fexofenadine, and cetirizine are also effective and are preferable because of reduced sedation (Table 189.8). Epinephrine 1:1,000, 0.01 mg/kg (maximum 0.5 mg) intramuscularly, usually provides rapid relief of acute, severe urticaria/angioedema but is seldom required. A short course of oral corticosteroids may be given for more severe episodes of urticaria and angioedema that are unresponsive to antihistamines.

Table 189.8 Treatment of Urticaria and Angioedema		
CLASS/DRUG	DOSE	FREQUENCY
<b>ANTIHISTAMINES, TYPE H<sub>1</sub> (SECOND GENERATION)</b>		
Fexofenadine	6-11 yr: 30 mg >12 yr: 60 mg	Twice daily
Loratadine	Adult: 10 mg 2-5 yr: 5 mg >6 yr: 10 mg	Once daily Once daily
Desloratadine	6-11 mo: 1 mg 12 mo-5 yr: 1.25 mg	Once daily
Cetirizine	6-11 yr: 2.5 mg >12 yr: 5 mg 6-23 mo: 2.5 mg 2-6 yr: 2.5-5 mg >6 yr: 5-10 mg >12 yr: 10 mg	Once daily
Levocetirizine	6 mo-5 yr: 1.25 mg 6-11 yr: 2.5 mg >12 yr: 5 mg	Once daily Once daily Once daily
<b>ANTIHISTAMINES, TYPE H<sub>2</sub></b>		
Cimetidine	Infants: 10-20 mg/kg/day Children: 20-40 mg/kg/day	Divided q6-12h
Ranitidine	1 mo-16 yr: 5-10 mg/kg/day	Divided q12h
Famotidine	3-12 mo: 1 mg/kg/day 1-16 yr: 1-2 mg/kg/day	Divided q12h
<b>LEUKOTRIENE PATHWAY MODIFIERS</b>		
Montelukast	12 mo-5 yr: 4 mg 6-14 yr: 5 mg >14 yr: 10 mg	Once daily
Zafirlukast	5-11 yr: 10 mg	Twice daily
<b>IMMUNOMODULATORY DRUGS</b>		
Omalizumab (anti IgE)	>11 yr: 300 mg	Every 28 days
Cyclosporine	1-4 mg/kg/day	Divided q12h*

\*Monitor blood pressure and serum creatinine, potassium, and magnesium levels monthly.

The best treatment of inducible urticaria is avoidance of the stimulus; however, for some conditions like cholinergic urticaria, this can be very difficult. Antihistamines with appropriate up dosing, should be tried in all inducible urticarias but may not be effective in many patients.

Management of chronic urticaria through dietary manipulation is not recommended by U.S. guidelines. The mainstay of therapy for chronic urticaria is the use of nonsedating or low-sedating H<sub>1</sub> antihistamines. In those patients not showing response to standard doses, increasing the dose up to fourfold the recommended dose is recommended; however, studies on the safety and efficacy of this approach in children are lacking. The addition of H<sub>2</sub> antihistamines and/or leukotriene receptor antagonists (e.g., montelukast) is controversial. These medications are generally benign but evidence supporting their efficacy is weak. For chronic urticaria patients that are not well controlled, brief courses of oral corticosteroids may be considered, but long-term corticosteroid use is not recommended. The monoclonal antibody omalizumab (anti-IgE) is approved by the US Food and Drug Administration (FDA) for the treatment of chronic urticaria in children 12 years and older. Other agents that have been used for chronic urticaria but are not approved by the FDA include cyclosporine, tacrolimus, mycophenolate, dapsone, hydroxychloroquine, sulfasalazine, and azathioprine. Ultraviolet light therapy may also be beneficial in refractory cases. Bruton tyrosine kinase (BTK) inhibitors have demonstrated efficacy in treating chronic spontaneous urticaria and have a rapid onset of action with few side effects.

Visit Elsevier eBooks+ at eBooks.Health.Elsevier.com for Bibliography.

## 189.1 Hereditary Angioedema

Aleena Banerji, David A. Khan, and Scott H. Sicherer

### ETIOLOGY, PATHOGENESIS, CLINICAL MANIFESTATIONS, AND DIAGNOSTIC APPROACH

HAE (types 1 and 2) is an inherited autosomal dominant genetic disease caused by low functional levels of the plasma protein C1-INH. Patients typically report unpredictable episodic attacks of angioedema or deep localized swelling, most often on a hand or foot, that begin during childhood or adolescence. Cutaneous nonpitting and nonpruritic edema not associated with urticaria is the most common symptom. The swelling usually becomes more severe over about several hours and then resolves over 2-5 days when left untreated. However, the duration of attacks can be quite variable. In some patients, attacks are preceded by the development of a rash, **erythema marginatum**, that is erythematous, not raised, and not pruritic. A second major symptom complex noted by patients is attacks of severe abdominal pain caused by edema of the mucosa of any portion of the GI tract. The intensity of the pain can approximate that of an acute abdomen, often resulting in unnecessary surgery, including appendectomy. Either constipation or diarrhea during these attacks can be noted. The GI edema generally follows the same time course to resolution as the cutaneous attacks. Patients may have a *prodrome*, a tightness or tingling in the area that will swell, usually lasting several hours, followed by the development of angioedema.

**Laryngeal edema**, the most worrisome complication of HAE, can cause complete respiratory obstruction with a high risk of mortality when untreated. Although life-threatening attacks are infrequent, more than half of patients with HAE experience laryngeal involvement at some time during their lives. Laryngeal edema can be triggered by local trauma but can also occur spontaneously without any identifiable trigger. The clinical condition may deteriorate rapidly, progressing through mild discomfort to complete airway obstruction over hours. Soft tissue edema can be readily seen when the disease involves the throat and uvula. If this edema progresses to difficulty swallowing secretions or a change in the tone of the voice, the patient may require emergency intubation or even tracheostomy to ensure an adequate airway. As symptoms are bradykinin mediated, patients with HAE typically do not respond well to treatment with epinephrine, antihistamines, or glucocorticoids.

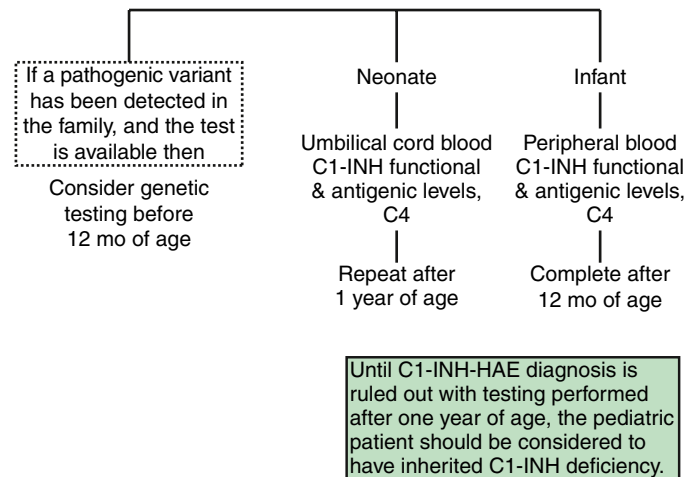
In most cases the cause of the attack is unknown, but in some patients, trauma, infections or emotional stress clearly precipitates attacks. Drugs such as estrogen or angiotensin-converting enzyme (ACE) inhibitors that inhibit the degradation of bradykinin make the disease strikingly worse. In some females, menstruation can be associated with an increase in attacks. The frequency of attacks varies greatly among affected individuals and at different times in the same individual. Some individuals experience weekly episodes, whereas others may go years between attacks. Episodes can start at any age.

C1-INH is a member of the serpin family of proteases, similar to  $\alpha$ -antitrypsin, antithrombin III, and angiotensinogen. These proteins stoichiometrically inactivate their target proteases by forming stable, 1:1 complexes with the protein to be inhibited. Synthesized primarily by hepatocytes, C1-INH is also synthesized by monocytes. The regulation of the protein production is not completely understood, but it is believed that androgens may stimulate C1-INH synthesis, because patients with the disorder respond clinically to androgen therapy with elevated serum C1-INH levels. C1-INH deficiency is an autosomal dominant disease, with as many as 25% of patients giving no family history. Because all C1-INH-deficient patients are heterozygous for this gene variation, it is believed that half the normal level of C1-INH is not sufficient to prevent attacks. [Figure 189.3](#) shows the diagnostic approach.

Although named for its action on the first component of complement (C1 esterase), C1-INH also inhibits components of the fibrinolytic, clotting, and kinin pathways. Specifically, C1-INH inactivates plasmin-activated Hageman factor (factor XII), activated factor XI,

### THE DIAGNOSIS OF C1-INH DEFICIENCY

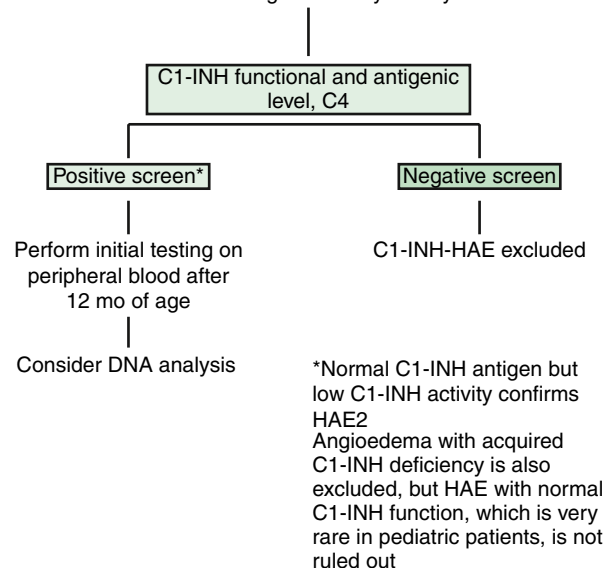
Asymptomatic pediatric patient with positive family history of C1-INH-HAE



A

### THE DIAGNOSIS OF PEDIATRIC C1-INH-HAE

Pediatric patient with angioedema of unknown etiology  
Positive/negative family history



B

**Fig. 189.3** A, Diagnosis of C1-INH deficiency in families with known C1-INH hereditary angioedema (HAE). B, Diagnosis of C1-INH HAE in pediatric patients with angioedema of unknown etiology. (From Farkas H, Martinez-Saguer I, Bork K, et al. *International consensus on the diagnosis and management of pediatric patients with hereditary angioedema with C1 inhibitor deficiency*. *Eur J Allergy Clin Immunol*. 2017;72:300–313. Fig. 1, p. 304.)

plasma thromboplastin antecedent, and kallikrein. Within the complement system, C1-INH blocks the activation of C1 and the rest of the classical complement pathway by binding to C1r and C1s. Without adequate C1-INH, unchecked activation of C1 causes cleavage of C4 and C2, the proteins following in the complement cascade. Levels of C3 are normal. C1-INH also inhibits serine proteases associated with activation of the lectin activation pathway. The major factor responsible for the edema formation is bradykinin, an important nonapeptide mediator that can induce leakage of postcapillary venules. Bradykinin is derived from cleavage of the circulating protein high molecular weight kininogen by the plasma enzyme kallikrein.



Two major genetic types of C1-INH deficiency are described that result in essentially the same phenotypic expression. The *C1-INH* gene is located on chromosome 11 in the p11-q13 region. The inheritance is autosomal dominant with incomplete penetrance. Persons inheriting the variant gene can have a clinical spectrum ranging from asymptomatic to severely affected. **Type 1** HAE is the most common form, accounting for approximately 80–85% of cases. Synthesis of C1-INH is blocked at the site of the faulty allele, or the protein is not secreted normally because of faulty protein processing, but secretion occurs at the normal allele. The result is secretion of the normal protein, yielding quantitative serum concentrations of C1-INH approximately 20–40% of normal. **Type 2** HAE accounts for approximately 15–20% of cases. Pathogenic variants of one of the amino acids near the active site of the inhibitor lead to synthesis of nonfunctional C1-INH protein and again less than half of the normal functioning protein. Patients with type 2 HAE have either normal or increased concentrations of the protein but low values in assays of C1-INH function.

A clinical syndrome resembling HAE termed **HAE with normal C1-INH** has been described that more commonly affects females, with a tendency to cause fewer abdominal attacks and more upper airway attacks. In this condition, no abnormalities of complement or of C1-INH have been described. A small number of affected patients have been found to have a gain-of-function abnormality of clotting factor XII, but the fundamental cause of this syndrome is still unknown. Additional pathogenic variants including ANGPT1 (angiopoietin-1), PLG (plasminogen), KNG1 (kininogen), MYOF (myoferlin), and HS3ST6 (heparan sulfate-glucosamine 3-O-sulfotransferase 6) have been identified. Acquired C1-INH is associated with low levels of C4, C1-INH, and C1q (Table 189.9).

## TREATMENT

Treatment of HAE is aimed at use of on-demand treatment when an attack starts along with long-term prophylaxis to prevent attacks. Short-term prophylaxis is used prior to a known trigger such as a surgical or dental procedure. The medical management of HAE has improved significantly in recent years with the availability of several new safe and effective therapies approved by the FDA in the United States. To provide optimal care and restore a normal quality of life, treatment of patients with HAE needs to be individualized based on patient-specific factors including patient preference and access to emergency care.

Options for **long-term prophylaxis** in patients with HAE include an intravenous formulation of plasma-derived C1-INH concentrate (Cinryze) given twice a week. Cinryze was FDA approved in 2008 for adolescents and adults. The half-life of this plasma protein is relatively short, about 40 hours, and the approved regimen is 1,000 units twice a week. In 2017, a **subcutaneous C1-INH** concentrate formulation given twice a week was approved for long-term prophylaxis in adolescents and adults. **Lanadelumab**, a monoclonal antibody that inhibits plasma kallikrein, given subcutaneously once every 2–4 weeks, along with **berotralstat**, an oral once a day pill, which inhibits plasma kallikrein, are the newest treatment options available for long-term prophylaxis in patients with HAE (see Table 189.10). Garadacimab, a fully human recombinant monoclonal antibody targeting activated factor XII, has shown efficacy as a prophylactic agent.

**Androgens**, like the gonadotropin inhibitor danazol, were previously used more frequently for long-term prophylaxis to prevent attacks. Weak androgens have many side effects that preclude their use in some patients. Their use in children is problematic because of the possibility of premature closure of the epiphyses, and these agents are

**Table 189.9** Complement Evaluation of Patients with Recurrent Angioedema

	C4	C1-INH LEVEL	C1-INH FUNCTION	C1q
Idiopathic angioedema	Normal	Normal	Normal	Normal
Type 1 HAE	Low	Low	Low	Normal
Type 2 HAE	Low	Normal	Low	Normal
HAE-nlC1-INH	Normal	Normal	Normal	Normal
Acquired C1-INH deficiency	Low	Low	Low	Low
Urticarial vasculitis	Low or normal	Normal	Normal	Low or normal

C1-INH, C1 inhibitor; HAE-nlC1-INH, hereditary angioedema with normal C1-INH; nl, normal.

From Joshi SR, Khan DA. Urticaria and angioedema. In: Leung DYM, Akdis CA, Bacharier LB, et al., eds. *Pediatric Allergy Principles and Practice*. 4th ed. Philadelphia: Elsevier; 2021: Table 39.3, p. 338.

**Table 189.10** Long-Term Prophylactic Treatment Options for Patients with Hereditary Angioedema in the United States

DRUG	DATE OF FDA APPROVAL IN US	MECHANISM OF ACTION	ROUTE OF ADMINISTRATION	OTHER CONSIDERATIONS
Intravenous plasma-derived C1-INH	2008	Replacing missing protein	Intravenous	Dependent on plasma supply Extensive clinical experience
Subcutaneous plasma-derived C1-INH	2017	Replacing missing protein	Subcutaneous	Dependent on plasma supply Improved steady-state C1-INH levels
Lanadelumab	2018	Plasma kallikrein inhibitor	Subcutaneous	Unknown safety in pregnancy Infrequent dosing every 2–4 wk
Berotralstat	2020	Plasma kallikrein inhibitor	Oral	Unknown safety in pregnancy Once a day pill
Attenuated androgens	1976	Increases circulating levels of C1-INH protein	Oral	Significant adverse effects Contraindicated in pregnancy, lactation and children
Antifibrinolytics	1986	Reduces complement activation and C1-INH protein consumption	Oral	Significant adverse effects Inferior efficacy compared with other agents



**Table 189.11** On-Demand Treatment Options for Patients with Hereditary Angioedema in the United States

DRUG	DATE OF FDA APPROVAL IN US	MECHANISM OF ACTION	ROUTE OF ADMINISTRATION	OTHER CONSIDERATIONS
Intravenous plasma-derived C1-INH	2009	Replacing missing protein	Intravenous	Dependent on plasma supply Extensive clinical experience
Recombinant C1-INH	2014	Replacing missing protein	Intravenous	No human virus risk Scalable supply
Ecallantide	2009	Plasma kallikrein inhibitor	Subcutaneous	No infectious risk 3–4% risk of anaphylaxis Requires administration by a healthcare provider
Icatibant	2011	B2 bradykinin receptor antagonist	Subcutaneous	No infectious risk Stable at room temperature Local injection reactions

not used in pregnant women. The fibrinolysis inhibitor  $\epsilon$ -aminocaproic acid (EACA) is also effective in preventing attacks and has been used in children, but its use is attenuated by the development of severe fatigue and muscle weakness over time. A cyclized analog of EACA, **tranexamic acid**, has been used extensively in Europe; because of side effects and increased availability of other novel treatment options, it has been used less extensively in the United States. Tranexamic acid is believed to be more effective than EACA and has lower toxicity, but there have been few direct studies. Its mechanism of action is not clearly defined, and not all patients respond to this agent.

There are four **on-demand treatment** options FDA approved in the United States for patients with HAE. The first, approved in 2009, is a purified C1-inhibitor product (**Berinert**) that is administered as 20 U/kg intravenously. It was approved for the *treatment* of attacks. In 2009 the FDA approved a kallikrein inhibitor, **ecallantide**, given subcutaneously, for *acute treatment* in patients age 16 years and older. This 60–amino acid peptide causes anaphylaxis rarely and is approved only for administration by medical personnel. In 2010 a bradykinin type 2 receptor antagonist, **icatibant**, was approved for *acute treatment* in patients age 18 years and older. An intravenous **recombinant C1-INH** product has been FDA approved in 2014 for *treatment* of acute attacks (and in Europe) in adolescents and adults (see [Table 189.11](#)). All treatments are most effective when given early in an attack and begin to have a noticeable effect about 1–4 hours after treatment.

Visit Elsevier eBooks+ at [eBooks.Health.Elsevier.com](http://eBooks.Health.Elsevier.com) for Bibliography.

## Chapter 190

# Anaphylaxis

Hugh A. Sampson, Julie Wang, and Scott H. Sicherer

**Anaphylaxis** is a serious allergic reaction that is rapid in onset and may cause death. Anaphylaxis in children, particularly infants, may be underdiagnosed. Anaphylaxis occurs when there is a sudden release of potent, biologically active mediators from mast cells and basophils, leading to cutaneous (urticaria, angioedema, flushing), respiratory (bronchospasm, laryngeal edema), cardiovascular (hypotension, dysrhythmias, myocardial ischemia), and gastrointestinal (GI; nausea, colicky abdominal pain, vomiting, diarrhea) symptoms ([Table 190.1](#) and [Fig. 190.1](#)).

**Table 190.1** Clinical Criteria for Diagnosing Anaphylaxis

Anaphylaxis is highly likely when any one of the following three criteria is fulfilled:

1. Acute onset of an illness (minutes to several hours) with involvement of the skin, mucosal tissue, or both (e.g., generalized urticaria, itching or flushing, swollen lips-tongue-uvula)

And at least one of the following:

- A. Respiratory compromise (e.g., dyspnea, wheeze-bronchospasm, stridor, hypoxemia)
- B. Reduced blood pressure or associated symptoms of end-organ dysfunction (e.g., hypotonia [collapse], syncope, incontinence)

OR

2. Two or more of the following that occur rapidly after exposure to a **likely allergen** (or other trigger) for that patient (minutes to several hours)
  - A. Involvement of the skin/mucosal tissue (e.g., generalized urticaria, itch-flush, swollen lips-tongue-uvula)
  - B. Respiratory compromise (e.g., dyspnea, wheeze or bronchospasm, stridor, reduced peak expiratory flow, hypoxemia)
  - C. Reduced blood pressure or associated symptoms (e.g., hypotonia [collapse], syncope, incontinence)
  - D. Persistent gastrointestinal symptoms (e.g., crampy abdominal pain, vomiting)

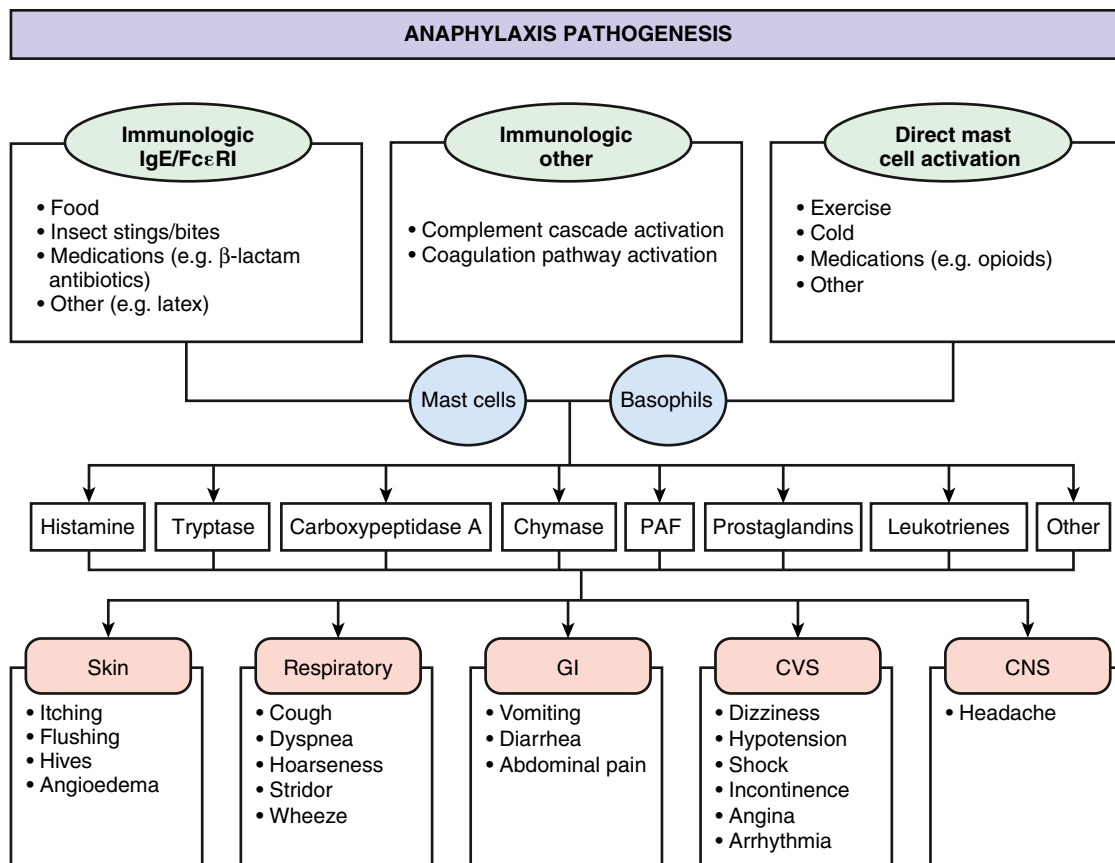
OR

3. Reduced blood pressure after exposure to a **known allergen** or other trigger for that patient (minutes to hours).
  - A. Infants and children: low systolic blood pressure (age-specific) or greater than 30% decrease in systolic blood pressure
  - B. Adults: systolic blood pressure of less than 90 mm Hg or greater than 30% decrease from that person's baseline

From Sampson HA, Muñoz-Furlong A, Campbell RL, et al. Second symposium on the definition and management of anaphylaxis: summary report—Second National Institute of Allergy and Infectious Disease/Food Allergy and Anaphylaxis Network symposium. *J Allergy Clin Immunol.* 2006;117(2):391-7.

## ETIOLOGY

The most common causes of anaphylaxis in children are different for hospital and community settings. Anaphylaxis occurring in the hospital results primarily from allergic reactions to medications and latex. **Food allergy** is the most common cause of anaphylaxis occurring outside the hospital, accounting for about half the anaphylactic reactions reported in pediatric surveys from the United States, Italy, and South Australia ([Table 190.2](#)). **Peanut allergy** is an important cause of food-induced anaphylaxis, accounting for the majority of fatal and near-fatal reactions. In the hospital, latex is a particular problem for children undergoing multiple operations, such as patients with spina bifida and urologic disorders, and has prompted many hospitals to switch to latex-free products.



**Fig. 190.1** Summary of the pathogenesis of anaphylaxis. See text for details about mechanisms, triggers, key cells, and mediators. Two or more target organ systems are typically involved in anaphylaxis. CNS, Central nervous system; CVS, cardiovascular system; GI, gastrointestinal; PAF, platelet-activating factor. (From Leung DYM, Szeffler SJ, Bonilla FA Akdis CA, Sampson HA, eds. *Pediatric Allergy Principles and Practice*. 3rd ed. Philadelphia: Elsevier; 2016: p. 525.)

**Table 190.2** Anaphylaxis Triggers in the Community\*

**ALLERGEN TRIGGERS (IgE-DEPENDENT IMMUNOLOGIC MECHANISM)\***

Foods (e.g., peanut, tree nuts, shellfish, fish, milk, egg, wheat, soy, sesame, meat [galactose- $\alpha$ -1,3-galactose])  
 Food additives (e.g., spices, colorants, vegetable gums, contaminants)  
 Stinging insects: Hymenoptera species (e.g., bees, yellow jackets, wasps, hornets, fire ants)  
 Medications (e.g.,  $\beta$ -lactam antibiotics, ibuprofen)  
 Biologic agents (e.g., monoclonal antibodies [infiximab, omalizumab] and allergens [challenge tests, specific immunotherapy])  
 Natural rubber latex  
 Vaccines  
 Inhalants (rare) (e.g., horse or hamster dander, grass pollen)

**OTHER IMMUNE MECHANISMS (IgE INDEPENDENT)**

IgG mediated (infiximab, high molecular weight dextrans)  
 Immune aggregates (IVIg)  
 Drugs (aspirin, NSAID, opiates, contrast material, ethylene oxide/dialysis tubing)  
 Complement activation  
 Physical factors (e.g., exercise,<sup>†</sup> cold, heat, sunlight/ultraviolet radiation)  
 Ethanol  
 Idiopathic\*

\*In the pediatric population, some anaphylaxis triggers, such as hormones (progesterone), seminal fluid, and occupational allergens, are uncommon, as is idiopathic anaphylaxis.

<sup>†</sup>Exercise with or without a co-trigger, such as a food or medication, cold air, or cold water.

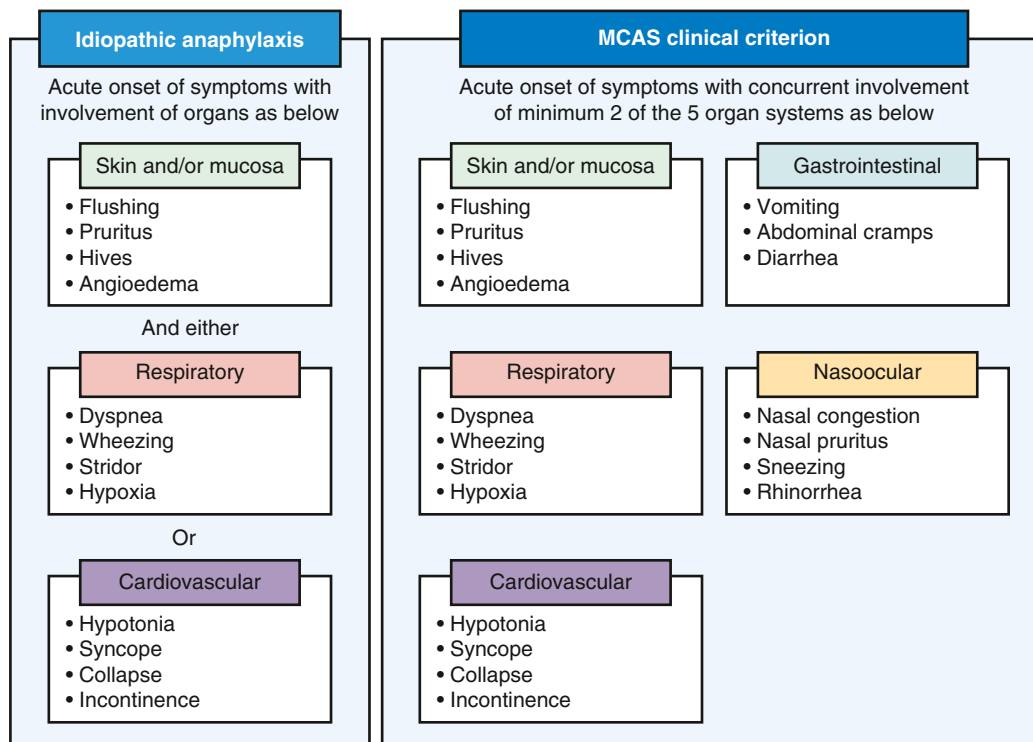
IVIg, Intravenous immunoglobulin; NSAID, nonsteroidal antiinflammatory drug.

Adapted from Leung DYM, Sampson HA, Geha RS, et al. *Pediatric Allergy Principles and Practice*. Philadelphia: Elsevier; 2010. p. 652.

Patients with **latex allergy** may also experience food-allergic reactions from homologous proteins in foods such as bananas, kiwi, avocado, chestnut, and passion fruit. Anaphylaxis to galactose- $\alpha$ -1,3-galactose has been reported 3-6 hours after eating red meat (see [Chapter 189](#)). Anaphylaxis may be **idiopathic** and in some of these patients related to mast cell activation syndrome ([Fig. 190.2](#); see [Chapter 700.1](#)) or familial hypertryptasemia. **Exercise-induced anaphylaxis** has been associated with the combination of certain foods *and* exercise. Ingestion of the food without exercise does not produce allergic symptoms or anaphylaxis.

**EPIDEMIOLOGY**

The overall annual incidence of anaphylaxis in the United States is estimated at 42 cases per 100,000 person-years, totaling >150,000 cases per year. Food allergens are the most common trigger in children, with an incidence rate of approximately 20 per 100,000 person-years. An Australian parental survey found that 0.59% of children 3-17 years of age had experienced at least one anaphylactic event. Having asthma and the severity of asthma are important anaphylaxis risk factors ([Table 190.3](#)). In addition, patients with systemic



**Fig. 190.2** The criteria of idiopathic anaphylaxis versus mast cell activation syndrome. Note that when there is no likely cause of the reactions, if the onset of illness is acute, a diagnosis of idiopathic anaphylaxis can only be made when either reduced blood pressure (or its symptoms such as syncope) and/or respiratory compromise are present accompanied by the involvement of the skin mucosal tissue symptoms. (From Gulen T, Akin C. *Idiopathic anaphylaxis: A perplexing diagnostic challenge for allergists. Curr Allergy Asthma Rep. 2021;21[2]:11. Fig. 1.*)

mastocytosis or monoclonal mast cell-activating syndrome are at increased risk for anaphylaxis, as are patients with an elevated baseline serum tryptase level.

## PATHOGENESIS

Principal pathologic features in fatal anaphylaxis include acute bronchial obstruction with pulmonary hyperinflation, pulmonary edema, intraalveolar hemorrhaging, visceral congestion, laryngeal edema, and urticaria and angioedema. Acute hypotension is attributed to vasomotor dilation and cardiac dysrhythmias.

Most cases of anaphylaxis are believed to be the result of activation of mast cells and basophils via cell-bound allergen-specific IgE molecules (see Fig. 190.1). Patients initially must be exposed to the responsible allergen to generate allergen-specific IgE antibodies. In many cases the child and the parent are unaware of the initial exposure, which may be from passage of food proteins in maternal breast milk or exposure to inflamed skin (e.g., eczematous lesions). When the child is reexposed to the sensitizing allergen, mast cells and basophils, and possibly other cells such as macrophages, release a variety of mediators (histamine, tryptase) and cytokines that can produce allergic symptoms in any or all target organs. Anaphylaxis may also be caused by mechanisms other than IgE-mediated reactions, including direct release of mediators from mast cells by medications and physical factors (opiates, exercise, cold), disturbances of leukotriene metabolism (aspirin and nonsteroidal antiinflammatory drugs), immune aggregates and complement activation (blood products), probable complement activation (radiocontrast dyes, dialysis membranes), and IgG-mediated reactions (high molecular weight dextran, chimeric or humanized monoclonal antibodies) (see Table 190.2).

**Idiopathic anaphylaxis (IA)** is a diagnosis of exclusion when no inciting agent is identified, and other disorders have been excluded (see Chapter 700.1). Symptoms are similar to IgE-mediated causes of anaphylaxis; episodes often recur (see Fig. 190.2). IA may be secondary to mast cell activation syndrome with bone marrow

expansion of mast cells exhibiting a D816V *KIT* pathologic variant or aberrant mast cell clonality on flow cytometry expressing CD117, CD2, or CD25 markers. Associated features of IA-associated mast cell activation syndrome include insect (venom) sting anaphylaxis with hypotension and persistent (once recovered) elevations of tryptase at times associated with autosomal dominant familial hypertryptasemia.

## CLINICAL MANIFESTATIONS

The onset of symptoms may vary depending on the cause of the reaction. Reactions from ingested allergens (foods, medications) are delayed in onset (minutes to 2 hours) compared with those from injected allergens (insect sting, medications) and tend to have more GI symptoms. Initial symptoms may include any of the following constellation of symptoms: pruritus about the mouth and face; flushing, urticaria and angioedema, and oral or cutaneous pruritus; a sensation of warmth, weakness, and apprehension (sense of doom); tightness in the throat, dry staccato cough and hoarseness, periorcular pruritus, nasal congestion, sneezing, dyspnea, deep cough and wheezing; nausea, abdominal cramping, and vomiting, especially with ingested allergens; uterine contractions (manifesting as lower back pain); and faintness and loss of consciousness in severe cases. Some degree of obstructive laryngeal edema is typically encountered with severe reactions. Cutaneous symptoms may be absent in up to 10% of cases, and the acute onset of severe bronchospasm in a previously well person with asthma should suggest the diagnosis of anaphylaxis. Sudden collapse in the absence of cutaneous symptoms should also raise suspicion of vasovagal collapse, myocardial infarction, aspiration, pulmonary embolism, or seizure disorder. Laryngeal edema, especially with abdominal pain, may also be a result of hereditary angioedema (see Chapter 189.1). Symptoms in infants may not be easy to identify. Infants may manifest nonspecific symptoms such as sudden crying, fussiness, flushing, dysphonia, drooling, vomiting, and becoming quiet or drowsy.

**Table 190.3** Patient Risk Factors for Anaphylaxis**AGE-RELATED FACTORS**

Infants: anaphylaxis can be difficult to recognize, especially if the first episode; patients cannot describe symptoms  
 Adolescents and young adults: increased risk-taking behaviors, such as failure to avoid known triggers and to carry an epinephrine autoinjector consistently  
 Pregnancy: risk of iatrogenic anaphylaxis, as from  $\beta$ -lactam antibiotics to prevent neonatal group B streptococcal infection, agents used perioperatively during caesarean sections, and natural rubber latex  
 Older people: increased risk of death because of concomitant disease and drugs

**CONCOMITANT DISEASES**

Asthma and other chronic respiratory diseases  
 Cardiovascular diseases  
 Systemic mastocytosis or monoclonal mast cell-activating syndrome  
 Allergic rhinitis and eczema\*  
 Depression, cognitive dysfunction, substance misuse

**DRUGS**

NSAIDs  
 $\beta$ -Adrenergic blockers<sup>†</sup>  
 Mast cell destabilizers  
 ACE inhibitors<sup>†</sup>  
 Sedatives, antidepressants, narcotics, recreational drugs, and alcohol may decrease the patient's ability to recognize triggers and symptoms.  
 Caffeine

**FACTORS THAT MAY INCREASE RISK FOR ANAPHYLAXIS OR MAKE IT MORE DIFFICULT TO TREAT**

Age  
 Asthma  
 Eczema  
 Drugs  
 Alcohol  
 Other cofactors such as exercise, infection, menses

\*Atopic diseases are a risk factor for anaphylaxis triggered by food, latex, and exercise, but not for anaphylaxis triggered by most drugs or by insect stings.

<sup>†</sup>Those taking  $\beta$ -blockers may not respond optimally to epinephrine treatment and may need glucagon, a polypeptide with non-catecholamine-dependent inotropic and chronotropic cardiac effects, atropine for persistent bradycardia, or ipratropium for persistent bronchospasm.

ACE, Angiotensin-converting enzyme; NSAID, nonsteroidal antiinflammatory drugs. Adapted from Lieberman P, Nicklas RA, Randolph C, et al. Anaphylaxis—a practice parameter update 2015. *Ann Allergy Asthma Immunol.* 2015;115(5):341–384. Table 1-9.

**LABORATORY FINDINGS**

Laboratory studies may indicate the presence of IgE antibodies to a suspected causative agent, but this result is not definitive. Plasma histamine is elevated for a brief period but is unstable and difficult to measure in a clinical setting. **Plasma tryptase** is more stable and remains elevated for several hours but often is not elevated, especially in food-induced anaphylactic reactions. Plasma tryptase may also be elevated with chronic renal disease, eosinophilic GI disorders, parasitic infections, Gaucher disease, and mast cell activation syndrome or as a familial trait.

**DIAGNOSIS**

A National Institutes of Health (NIH)-sponsored expert panel has recommended an approach to the diagnosis of anaphylaxis (see [Table 190.1](#)). The differential diagnosis includes other forms of shock (hemorrhagic, cardiogenic, septic), vasopressor reactions, including flushing syndromes (e.g., carcinoid syndrome), ingestion of monosodium glutamate, scombroidosis, and hereditary angioedema ([Table 190.4](#)).

**Table 190.4** Differential Diagnosis of Anaphylaxis

Anaphylaxis to exogenously administered agents

Physical factors  
 Exercise  
 Cold, heat, sunlight  
 Idiopathic

**VASODEPRESSOR (VASOVAGAL) RESPONSES**

Flushing syndromes  
 Carcinoid, pheochromocytoma, medullary carcinoma of the thyroid  
 Menopause  
 Side effects of chlorpropamide, alcohol, calcium channel blockers  
 Autonomic epilepsy

**FOOD-ASSOCIATED SYNDROMES**

Scombroidosis  
 Sulfites  
 Monosodium glutamate (MSG)

**OTHER FORMS OF SHOCK**

Cardiogenic  
 Septic  
 Vascular

**EXCESS ENDOGENOUS PRODUCTION OF HISTAMINE SYNDROMES**

Mast cell activation syndrome  
 Systemic mastocytosis  
 Cutaneous mastocytosis  
 Mast cell leukemia  
 Acute promyelocytic leukemia

**NONORGANIC DISEASE**

Panic attacks  
 Munchausen stridor  
 Vocal cord dysfunction  
 Undifferentiated somatoform anaphylaxis

**MISCELLANEOUS**

Acute urticaria with or without angioedema  
 Hereditary angioedema  
 Idiopathic angioedema  
 Neurologic (seizure, stroke)  
 Red man syndrome (vancomycin)  
 Capillary leak syndrome

From Dreskin SC, Stitt JM. Anaphylaxis. In: Burks AW, Holgate ST, O'Hehir RE, et al., eds. *Middleton's Allergy: Principles and Practice*. 9th ed. Philadelphia: Elsevier; 2020: Box 75.6, p. 1237.

In addition, panic attack, vocal cord dysfunction, pheochromocytoma, and vancomycin-induced flushing should be considered.

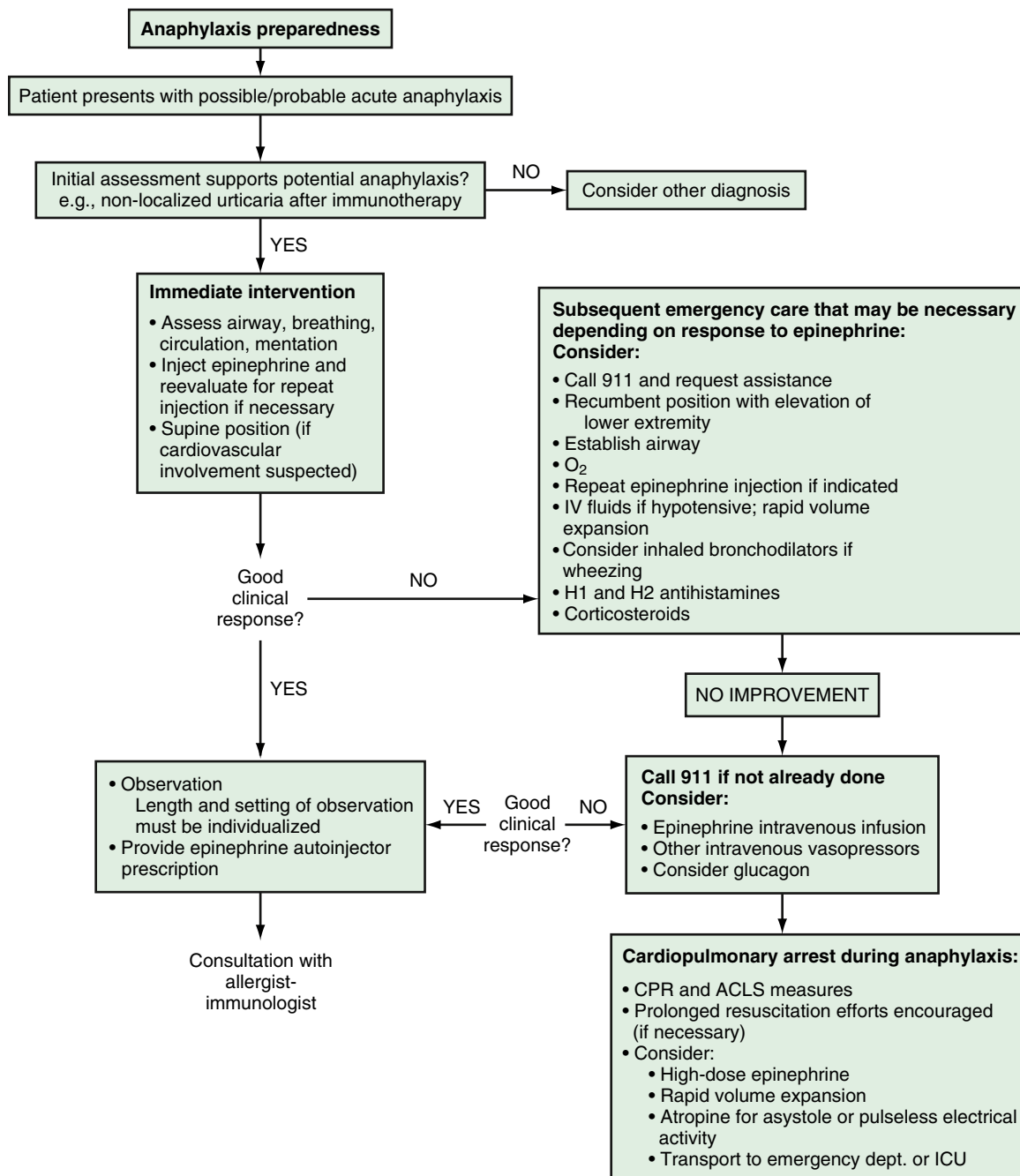
**TREATMENT**

Anaphylaxis is a medical emergency requiring aggressive management with intramuscular (IM, first line) or intravenous (IV) epinephrine. Oral (PO), IM, or IV  $H_1$  and  $H_2$  antihistamine antagonists, oxygen, IV fluids, inhaled  $\beta$ -agonists, and corticosteroids are adjunctive medications that may be used ([Table 190.5](#) and [Fig. 190.3](#)). The initial assessment should ensure an adequate airway with effective respiration, circulation, and perfusion. **Epinephrine** is the most important medication, and there should be no delay in its administration. Epinephrine should be given by the IM route to the lateral thigh (1:1000 dilution, 0.01 mg/kg; maximum 0.5 mg). Children weighing 25 kg or more should receive 0.3 mg IM, with many recommending 0.5 mg IM for older adolescents. The IM dose can be repeated at intervals of 5–15 minutes if symptoms persist or worsen. If there is no response to multiple doses of epinephrine, IV epinephrine using the 1:10,000 dilution



**Table 190.5** Management of a Patient with Anaphylaxis

TREATMENT	MECHANISM(S) OF EFFECT	DOSAGE(S)	COMMENTS; ADVERSE REACTIONS
<b>PATIENT EMERGENCY MANAGEMENT (DEPENDENT ON SEVERITY OF SYMPTOMS)</b>			
Epinephrine (adrenaline)	$\alpha_1$ -, $\beta_1$ -, $\beta_2$ -Adrenergic effects	0.01 mg/kg, up to 0.3 mg IM in lateral thigh (0.5 mg autoinjectors are not available in the United States) Epinephrine autoinjector: 0.1 mg for 7.5-13 kg 0.15 mg for <25 kg 0.3 mg for 25 kg or more A second dose may be given in 5 min if symptoms worsen or do not improve	Tachycardia, hypertension, nervousness, headache, nausea, irritability, tremor
Cetirizine (liquid)	Antihistamine (competitive of $H_1$ receptor)	Cetirizine liquid: 5 mg/5 mL 0.25 mg/kg, up to 10 mg PO	Hypotension, tachycardia, somnolence
<i>Alternative:</i> Diphenhydramine	Antihistamine (competitive of $H_1$ receptor)	1.25 mg/kg up to 50 mg PO or IM	Hypotension, tachycardia, somnolence, paradoxical excitement
Transport to an emergency facility			
<b>EMERGENCY PERSONNEL MANAGEMENT (DEPENDENT ON SEVERITY OF SYMPTOMS)</b>			
Epinephrine (adrenaline)	$\alpha_1$ -, $\beta_1$ -, $\beta_2$ -Adrenergic effects	0.01 mg/kg, up to 0.5 mg IM in lateral thigh Epinephrine autoinjector: 0.1 mg for 7.5-13 kg 0.15 mg for <25 kg 0.3 mg for 25 kg or more 0.01 mL/kg/dose of 1:1,000 (vial) solution, up to 0.5 mL IM May repeat every 10-15 min For severe hypotension: 0.01 mL/kg/dose of 1:10,000 slow IV push	Tachycardia, hypertension, nervousness, headache, nausea, irritability, tremor
<b>Supplemental oxygen and airway management</b>			
<b>Volume Expanders</b>			
Crystalloids (normal saline or Ringer lactate)		30 mL/kg in first hour	Rate titrated against BP response If tolerated, place patient supine with legs raised
Colloids (hydroxyethyl starch)		10 mL/kg rapidly followed by slow infusion	Rate titrated against BP response If tolerated, place patient supine with legs raised
<b>Antihistamines</b>			
Cetirizine (liquid)	Antihistamine (competitive of $H_1$ receptor)	Cetirizine liquid: 5 mg/5 mL 0.25 mg/kg, up to 10 mg PO	Hypotension, tachycardia, somnolence
<i>Alternative:</i> Diphenhydramine	Antihistamine (competitive of $H_1$ receptor)	1.25 mg/kg, up to 50 mg PO, IM, or IV	Hypotension, tachycardia, somnolence, paradoxical excitement
Ranitidine	Antihistamine (competitive of $H_2$ receptor)	1 mg/kg, up to 50 mg IV Should be administered slowly	Headache, mental confusion
<i>Alternative:</i> Cimetidine	Antihistamine (competitive of $H_2$ receptor)	4 mg/kg, up to 200 mg IV Should be administered slowly	Headache, mental confusion
<b>Corticosteroids</b>			
Methylprednisolone	Antiinflammatory	Solu-Medrol (IV): 1-2 mg/kg, up to 125 mg IV Depo-Medrol (IM): 1 mg/kg, up to 80 mg IM	Hypertension, edema, nervousness, agitation
Prednisone	Antiinflammatory	1 mg/kg up, to 75 mg PO	Hypertension, edema, nervousness, agitation
Nebulized albuterol	$\beta$ -Agonist	0.83 mg/mL (3 mL) via mask with $O_2$	Palpitations, nervousness, CNS stimulation, tachycardia; use to supplement epinephrine when bronchospasm appears unresponsive; may repeat
<b>Preventive Treatment</b>			
Prescription for epinephrine autoinjector and antihistamine Provide written plan outlining patient emergency management (may download form from <a href="http://www.aap.org">http://www.aap.org</a> or <a href="http://www.foodallergy.org">http://www.foodallergy.org</a> ; English and Spanish versions available) Follow-up evaluation to determine/confirm etiology Immunotherapy for insect sting allergy			
<b>Patient Education</b>			
Instruction on avoidance of causative agent Information on recognizing early signs of anaphylaxis Stress early treatment of allergic symptoms to avoid systemic anaphylaxis Encourage wearing medical identification jewelry			



**Fig. 190.3** Algorithm for treatment of anaphylactic event in outpatient setting. ACLS, Advance cardiac life support; CPR, cardiopulmonary resuscitation; ICU, intensive care unit; IV, intravenous. (From Lieberman P, Nicklas RA, Oppenheimer J, et al. *The diagnosis and management of anaphylaxis practice parameter: 2010 update. J Allergy Clin Immunol.* 2010;126:477–480 e471-442.)

may be needed. If IV access is not readily available, epinephrine can be administered via the endotracheal or intraosseous routes.

For refractory hypotension, other vasopressors may be needed. Anaphylaxis refractory to repeated doses of epinephrine in a patient receiving  $\beta$ -adrenergic blockers has anecdotally been treated with glucagon. The patient should be placed in a supine position when there is concern for hemodynamic compromise. Fluids are also important in patients with shock. Other drugs (antihistamines, glucocorticosteroids) have a secondary role in the management of anaphylaxis.

Patients may experience **biphasic anaphylaxis**, which occurs when anaphylactic symptoms recur after apparent resolution. The mechanism of this phenomenon is unknown, but more severe initial presentation and the need for more than one dose of epinephrine to treat initial symptoms are risk factors for biphasic anaphylaxis. Treatment with antihistamines or corticosteroids do not provide clear benefit for prevention of biphasic reactions. Extended observation after resolution of initial anaphylaxis symptoms should be considered for patients with risk factors for biphasic anaphylaxis. At discharge,

**Table 190.6** Considerations with Epinephrine Injection for Anaphylaxis**WHY HEALTHCARE PROFESSIONALS FAIL TO INJECT EPINEPHRINE PROMPTLY**

- Lack of recognition of anaphylaxis symptoms; failure to diagnose anaphylaxis
- Episode appears mild, or there is a history of previous mild episode(s)\*
- Inappropriate concern about transient mild pharmacologic effects of epinephrine (e.g., tremor)
- Lack of awareness that serious adverse effects are almost always attributable to epinephrine overdose or IV administration, especially IV bolus, rapid IV infusion, or IV infusion of a 1:1,000 epinephrine solution instead of an appropriately diluted solution (1:10,000 concentration)

**WHY PATIENTS AND CAREGIVERS FAIL TO INJECT EPINEPHRINE PROMPTLY**

- Lack of recognition of anaphylaxis symptoms; failure to diagnose anaphylaxis
- Episode appears mild, or there is a history of previous mild episode(s)\*
- H<sub>1</sub> antihistamine or asthma puffer is used initially instead, relieving early warning signs such as itch or cough, respectively
- Prescription for epinephrine autoinjectors (EAI) is not provided by physician
- Prescription for EAI is provided but not filled at pharmacy (e.g., not affordable)
- Patients do not carry EAI consistently (due to size and bulk, or "don't think they'll need it")
- Patients and caregivers are afraid to use EAI (concern about making an error when giving the injection or about a bad outcome)

- Patients and caregivers are concerned about injury from EAI
- Competence in using EAI is associated with regular allergy clinic visits; it decreases as time elapses from first EAI instruction; regular retraining is needed
- Difficulty in understanding how to use EAI (15% of mothers with no EAI experience could not fire an EAI immediately after a one-on-one demonstration)
- Errors in EAI use can occur despite education, possibly related to the design of some EAI

**WHY PATIENTS OCCASIONALLY FAIL TO RESPOND TO EPINEPHRINE INJECTION**

- Delayed recognition of anaphylaxis symptoms; delayed diagnosis
- Error in diagnosis: problem being treated (e.g., foreign body inhalation) is not anaphylaxis
- Rapid progression of anaphylaxis<sup>†</sup>

**Epinephrine<sup>†</sup>:**

- Injected too late; dose too low on mg/kg basis; dose too low because epinephrine solution has degraded (e.g., past the expiration date, stored in a hot place)
- Injection route or site not optimal; dose took too long to be absorbed
- Patient suddenly sits up or walks or runs, leading to the empty ventricle syndrome
- Concurrent use of certain medications (e.g.,  $\beta$ -adrenergic blockers)

\*Subsequent anaphylaxis episodes can be more severe, less severe, or similar in severity.

<sup>†</sup>Median times to respiratory or cardiac arrest are 5 min in iatrogenic anaphylaxis, 15 min in stinging-insect venom anaphylaxis, and 30 min in food anaphylaxis; however, regardless of the trigger, respiratory or cardiac arrest can occur within 1 min in anaphylaxis.

Adapted from Leung DYM, Szeffer SJ, Bonilla FA, Akdis CA, Sampson HA, eds. *Pediatric Allergy Principles and Practice*. Philadelphia: Elsevier; 2016: p. 531.

referrals should be made to appropriate specialists for further evaluation and follow-up.

**PREVENTION**

For patients experiencing anaphylactic reactions, the triggering agent should be avoided, and education regarding early recognition of anaphylactic symptoms and administration of emergency medications should be provided. Patients with food allergies must be educated in allergen avoidance, including active reading of food ingredient labels and knowledge of potential contamination and high-risk situations. Any child with food allergy and a history of asthma and a peanut, tree nut, fish, or shellfish allergy or a previous systemic reaction should be given an epinephrine autoinjector. The expert panel also indicates that epinephrine autoinjectors should be considered for any patient with IgE-mediated food allergy. In addition, liquid cetirizine (or alternatively, diphenhydramine) and a written emergency plan should also be provided in case of accidental ingestion or allergic reaction. A form can be downloaded from the American Academy of Pediatrics ([www.aap.org](http://www.aap.org)) or Food Allergy Research & Education ([www.foodallergy.org](http://www.foodallergy.org)).

In cases of food-associated exercise-induced anaphylaxis, children must not exercise within 2-4 hours of ingesting the triggering food; children with exercise-induced anaphylaxis should exercise with a

friend, learn to recognize the early signs of anaphylaxis (sensation of warmth, facial pruritus), and stop exercising and seek help immediately if symptoms develop. Foods associated with exercise-induced anaphylaxis include wheat, vegeas, nuts, fruits, and shellfish.

Children experiencing a systemic anaphylactic reaction, including respiratory symptoms, to an insect sting should be evaluated and treated with immunotherapy, which is >90% protective. Reactions to medications can be reduced and minimized by using oral medications instead of injected forms and avoiding cross-reacting medications. Low-osmolarity radiocontrast dyes and pretreatment can be used in patients with suspected reactions to previous radiocontrast dye. Non-latex gloves and materials should be used in children undergoing multiple operations.

Any child at risk for anaphylaxis should receive emergency medications (including epinephrine autoinjector), education on identification of signs and symptoms of anaphylaxis and proper administration of medications (Table 190.6), and a written emergency plan in case of accidental exposure. They should be encouraged to wear medical identification jewelry.

Visit Elsevier eBooks+ at [eBooks.Health.Elsevier.com](http://eBooks.Health.Elsevier.com) for Bibliography.

## Chapter 191

## Serum Sickness

Anna H. Nowak-Wegrzyn and  
Scott H. Sicherer

**Serum sickness** is a systemic, immune complex–mediated hypersensitivity vasculitis classically attributed to the therapeutic administration of foreign serum proteins or other medications (Table 191.1).

## ETIOLOGY

Immune complexes involving heterologous (animal) serum proteins and complement activation are important pathogenic mechanisms in serum sickness. Antibody therapies derived from the horse, sheep, or rabbit are available for treatment of envenomation by the black widow spider and a variety of snakes, for treatment of botulism, and for immunosuppression (antithymocyte globulin [ATG]). The availability of alternative medical therapies, modified or bioengineered antibodies, and biologics of human origin have supplanted the use of nonhuman antisera, reducing the risk of serum sickness. However, rabbit-generated ATGs, which target human T cells, continue to be widely used as immunosuppressive agents during treatment of kidney allograft recipients; serum sickness is associated with a late graft loss in kidney transplant recipients. A **serum sickness–like reaction** may be attributed to drug allergy, triggered by antibiotics (particularly cefaclor, trimethoprim-sulfamethoxazole, anticonvulsants, prolonged high-dose intravenous penicillin G), infections (streptococcal infections, hepatitis B), or rabies vaccine. In contrast to a true serum sickness, serum

sickness–like reactions do not exhibit the immune complexes, hypocomplementemia, vasculitis, and renal lesions that are seen in serum sickness reactions.

## PATHOGENESIS

Serum sickness is a classic example of a type III hypersensitivity reaction caused by antigen-antibody complexes. In the rabbit model using bovine serum albumin as the antigen, symptoms develop with the appearance of antibody against the injected antigen. As free antigen concentration falls and antibody production increases over days, antigen-antibody complexes of various sizes develop in a manner analogous to a precipitin curve. Whereas small complexes usually circulate harmlessly and large complexes are cleared by the reticuloendothelial system, intermediate-sized complexes that develop at the point of slight antigen excess may deposit in blood vessel walls and tissues. There the immune microprecipitates induce vascular (leukocytoclastic vasculitis with immune complex deposition) and tissue damage through activation of complement and granulocytes.

Complement activation (C3a, C5a) promotes chemotaxis and adherence of neutrophils to the site of immune complex deposition. The processes of immune complex deposition and of neutrophil accumulation may be facilitated by increased vascular permeability, because of the release of vasoactive amines from tissue mast cells. Mast cells may be activated by binding of antigen to IgE or through contact with anaphylatoxins (C3a). Tissue injury results from the liberation of proteolytic enzymes and oxygen radicals from the neutrophils.

## CLINICAL MANIFESTATIONS

The symptoms of serum sickness generally begin 7–12 days after injection of the foreign material, but may appear as late as 3 weeks afterward. The onset of symptoms may be accelerated if there has been earlier exposure or previous allergic reaction to the same antigen. A few days before the onset of generalized symptoms, the site of injection may become edematous and erythematous. Symptoms usually include fever, malaise, and rashes. Urticaria and morbilliform rashes are the predominant types of skin eruptions (Fig. 191.1). In a prospective study of serum sickness induced by administration of equine ATG, an initial rash was noted in most patients. It began as a thin, serpiginous band of erythema along the sides of the hands, fingers, feet, and toes at the junction of the palmar or plantar skin with the skin of the dorsolateral surface. In most patients the band of erythema was replaced by petechiae or purpura, presumably because of low platelet counts or local damage to small blood vessels. Additional symptoms include edema, myalgia, lymphadenopathy, symmetric arthralgia or arthritis involving multiple joints, and gastrointestinal complaints, including pain, nausea, diarrhea, and melena. Symptoms typically resolve within 2 weeks of removal of the offending agent, although in unusual cases, symptoms can persist for as long as 2–3 months. Carditis, glomerulonephritis, Guillain-Barré syndrome, and peripheral neuritis are rare complications. **Serum sickness–like reactions** from drugs are characterized by fever, pruritus, urticaria, and arthralgias that usually begin 1–3 weeks after drug exposure. The urticarial skin eruption becomes increasingly

**Table 191.1** Proteins and Medications That Cause Serum Sickness\*

## PROTEINS FROM OTHER SPECIES

Antibotulinum globulin  
Antithymocyte globulin  
Antitetanus toxoid  
Antivenin (Crotalidae) polyvalent (horse serum based)  
Crotalidae polyvalent immune Fab (ovine serum based)  
Antirabies globulin  
Infliximab  
Rituximab  
Etanercept  
Omalizumab  
Adalimumab  
Natalizumab  
Anti-HIV antibodies ([PE]HRG214)  
Hymenoptera stings  
Streptokinase  
H1N1 influenza vaccine  
Rabies vaccine

## DRUGS

**Antibiotics**

Cefaclor  
Penicillins  
Trimethoprim sulfamethoxazole  
Minocycline  
Meropenem

**Neurologic**

Bupropion  
Carbamazepine  
Phenytoin  
Sulfonamides  
Barbiturates

\*Based on review of the most current literature. Other medications that are not listed might also cause serum sickness.

Adapted from Aceves SS. Serum sickness. In: Burg FD, Ingelfinger JR, Polin RA, Gershon AA, eds. *Current Pediatric Therapy*. 18th ed. Philadelphia: Elsevier; 2006: p. 1138.



**Fig. 191.1** Serum sickness–like reaction (SSLR). Note the swollen hand and large urticarial wheals in this girl with SSLR and arthralgias. (From Paller AS, Mancini AJ, eds. *Hurwitz Clinical Pediatric Dermatology*. 5th ed. Philadelphia: Elsevier; 2016: p. 476.)



erythematous as the reaction progresses and can evolve into dusky centers with round plaques. Serum sickness and serum sickness–like reactions are more likely to occur with higher doses and intermittent exposures of culprit antigens.

### DIFFERENTIAL DIAGNOSIS

The differential diagnosis of serum sickness and serum sickness–like reactions includes viral illnesses with exanthems, hypersensitivity vasculitis, Kawasaki disease, acute rheumatic fever, acute meningococcal or gonococcal infection, endocarditis, systemic-onset juvenile idiopathic arthritis (Still disease), Lyme disease, hepatitis, autoinflammatory syndromes, acute annular urticaria (urticaria multiforme), Stevens-Johnson syndrome, drug reaction with eosinophilia and systemic symptoms (DRESS), and erythema multiforme (see Chapters 193 and 686.2).

### DIAGNOSIS

In most patients the diagnosis of serum sickness is made clinically based on the characteristic pattern of acute or subacute onset of a rash, fever, and severe arthralgia and myalgia disproportionate to the degree of swelling, occurring after exposure to a potential culprit. Patients who appear moderately or severely ill, or who are not taking a medication that can be readily identified as the culprit, should be evaluated with the following laboratory tests:

- Complete blood count and differential: Thrombocytopenia is often present.
- Erythrocyte sedimentation rate (ESR) and C-reactive protein: ESR is usually elevated.
- Urinalysis: Mild proteinuria, hemoglobinuria, and microscopic hematuria may be seen.
- Serum chemistries: Including blood urea nitrogen, creatinine, and liver function tests.
- Complement studies, including CH<sub>50</sub>, C3, and C4: Serum complement levels (C3 and C4) are generally decreased and reach a nadir at about day 10. C3a anaphylatoxin may be increased.
- Testing for specific infectious diseases: If indicated by the history or physical examination.
- Appropriate viral or bacterial cultures: If an infection is suspected.

Skin biopsies are not usually necessary for confirming the diagnosis, because the findings are variable and not specific for serum sickness. Direct immunofluorescence studies of skin lesions often reveal immune deposits of IgM, IgA, IgE, or C3.

### TREATMENT

There are no evidence-based guidelines or controlled trials on which to base therapy recommendations. Treatment is primarily supportive, consisting of discontinuation of the offending agent, antihistamines for pruritus, and nonsteroidal antiinflammatory drugs and analgesics for low-grade fever and mild arthralgia. When the symptoms are especially severe, for example, fever >38.5°C (101.3°F), severe arthralgia or myalgia, or renal dysfunction, systemic corticosteroids can be used. Prednisone (1–2 mg/kg/day; maximum 60 mg/day) for 1–2 weeks is usually sufficient. Once the offending agent is discontinued and depending on its half-life, symptoms resolve spontaneously in 1–4 weeks. Symptoms lasting longer suggest another diagnosis.

### PREVENTION

The primary mode of prevention of serum sickness is to seek alternative therapies. In some cases, non-animal-derived formulations may be available (human-derived botulinum immune globulin). Other alternatives are partially digested antibodies of animal origin and engineered (humanized) antibodies. The potential of these therapies to elicit serum sickness–like disease appears low. When only animal-derived antitoxin/antivenom is available, skin tests should be performed before administration of serum, but this procedure indicates the risk only of anaphylaxis, not of serum sickness. For patients who have evidence of anaphylactic sensitivity to horse serum, a risk/benefit assessment must be made to determine the need to proceed with treatment. If needed, the serum can usually be successfully administered by a process of rapid desensitization using protocols of gradual administration outlined by the manufacturers. Serum sickness is not prevented by desensitization or by pretreatment with corticosteroids.

Visit Elsevier eBooks+ at [eBooks.Elsevier.com](http://eBooks.Elsevier.com) for Bibliography.

## Chapter 192

# Food Allergy and Adverse Reactions to Foods

Anna H. Nowak-Wegrzyn, Hugh A. Sampson, Amanda L. Cox, and Scott H. Sicherer

Adverse reactions to foods consist of any untoward reaction following the ingestion of a food or food additive and are classically divided into **food intolerances** and **food allergies**. Food intolerances are non-immunologic physiologic responses and can include metabolic, toxic, pharmacologic, or other mechanisms. **Food allergies** are adverse immunologic responses and can be IgE mediated, non-IgE mediated, or mixed (Tables 192.1 and 192.2). Food allergies appear to have increased over the past 3 decades, primarily in westernized/industrialized countries. Worldwide, estimates of food allergy prevalence range from 1–11% with regional variations. The vast majority of food allergies are due to peanut, tree nuts, seeds, milk, egg, soy, wheat, fish, and

**Table 192.1** Adverse Food Reactions

### FOOD INTOLERANCE (NON-IMMUNE SYSTEM MEDIATED, NONTOXIC, NONINFECTIOUS)

#### Host Factors

Enzyme deficiencies—lactase (primary or secondary), sucrase/isomaltase, hereditary fructose intolerance, galactosemia, alcohol dehydrogenase deficiency  
 Gastrointestinal disorders—inflammatory bowel disease, irritable bowel syndrome, pseudoobstruction, colic  
 Idiosyncratic reactions—caffeine in soft drinks (“hyperactivity”)  
 Psychologic—food phobias, obsessive/compulsive disorder  
 Migraines (rare)

#### Food Factors (Toxic or Infectious or Pharmacologic)

Infectious organisms—*Escherichia coli*, *Staphylococcus aureus*, *Clostridium perfringens*, *Shigella*, botulism, *Salmonella*, *Yersinia*, *Campylobacter*  
 Toxins—histamine (scombroid poisoning), saxitoxin (shellfish)  
 Pharmacologic agents—caffeine, theobromine (chocolate, tea), tryptamine (tomatoes), tyramine (cheese), benzoic acid in citrus fruits (perioral flare)  
 Contaminants—heavy metals, pesticides, antibiotics

### FOOD ALLERGY

#### IgE Mediated

Cutaneous—urticaria, angioedema, morbilliform rashes, flushing, contact urticarial  
 Gastrointestinal—oral allergy syndrome, gastrointestinal anaphylaxis  
 Respiratory—acute rhinoconjunctivitis, bronchospasm  
 Generalized—anaphylactic shock, exercise-induced anaphylaxis

#### Mixed IgE Mediated and Non-IgE Mediated

Cutaneous—atopic dermatitis, contact dermatitis  
 Gastrointestinal—allergic eosinophilic esophagitis and gastroenteritis  
 Respiratory—asthma

#### Non-IgE Mediated

Cutaneous—contact dermatitis, dermatitis herpetiformis (celiac disease)  
 Gastrointestinal—food protein–induced enterocolitis, proctocolitis, and enteropathy syndromes, celiac disease  
 Respiratory—food-induced pulmonary hemosiderosis (Heiner syndrome)  
 Unclassified

IgE, Immunoglobulin E.

shellfish, with regional variations in prevalence. It has been estimated that 8–11% of children have food allergy, with 2.4% having multiple food allergies. Up to 6% of children experience food allergic reactions in the first 3 years of life, including approximately 2.5% with cow's milk allergy, 2% with egg allergy, and 2–3% with peanut allergy. Most children “outgrow” milk and egg allergies, with approximately 50% doing so by school-age. In contrast, 80–90% of children with peanut, tree nut, or seafood allergy retain their allergy for life (Table 192.3).

**Table 192.2** Differential Diagnosis of Adverse Food Reactions

<b>GASTROINTESTINAL DISORDERS (WITH VOMITING AND/OR DIARRHEA)</b>	
Structural abnormalities (pyloric stenosis, Hirschsprung disease, reflux)	
Enzyme deficiencies (primary or secondary)	
Disaccharidase deficiency—lactase, fructase, sucrase-isomaltase	
Galactosemia	
Malignancy with obstruction	
Other: pancreatic insufficiency (cystic fibrosis), peptic disease	
<b>CONTAMINANTS AND ADDITIVES</b>	
Flavorings and preservatives—rarely cause symptoms	
Sodium metabisulfite, monosodium glutamate, nitrites	
Dyes and colorings—very rarely cause symptoms (urticaria, eczema)	
Tartrazine	
Toxins	
Bacterial, fungal (aflatoxin), fish related (scombroid, ciguatera)	
Infectious organisms	
Bacteria ( <i>Salmonella</i> , <i>Escherichia coli</i> , <i>Shigella</i> )	
Virus (rotavirus, enterovirus)	
Parasites ( <i>Giardia</i> , <i>Akis simplex</i> [in fish])	
Accidental contaminants	
Heavy metals, pesticides	
Pharmacologic agents	
Caffeine, glycosidal alkaloid solanine (potato spuds), histamine (fish), serotonin (banana, tomato), tryptamine (tomato), tyramine (cheese)	
<b>PSYCHOLOGIC REACTIONS</b>	
Food phobias	

## GENETIC AND ENVIRONMENTAL RISK FACTORS

Allergic sensitization and food allergy development is influenced by genetics, environment, and genome-environment interactions (possible epigenetic effects). Family and twin studies show that family history confers a 2- to 10-fold increased risk, depending on the study setting, population, specific food, and diagnostic test. Candidate gene studies suggest that genetic variants in the HLA-DQ locus (HLA-DQB1\*02 and DQB1\*06:03P), filaggrin, interleukin (IL)-10, *STAT6*, and *FOXP3* genes are associated with food allergy, although the results are inconsistent across different populations. In a genome-wide association study, differential methylation at the HLA-DR and -DQ regions was associated with food allergy. Epigenetic studies implicate DNA methylation effects on IL-4, -5 and -10, and interferon (IFN)- $\gamma$  genes and in the mitogen-activated protein kinase (MAPK) pathway.

Many environmental factors have been observed to influence the development of food allergy. Skin exposure to foods in the setting of infantile eczema, characterized by impaired skin barrier and inflammation, can lead to sensitization and allergy. Decreased microbial exposure (“hygiene hypothesis”), decreased microbiome diversity, and the specific makeup of microbial communities in the gastrointestinal (GI) tract, airway, and skin, influence allergic conditions, including food allergy (see Chapter 182). Additional environmental factors that may be associated with increased risk of food allergy include reduced diversity of the diet, delayed introduction of allergenic foods, vitamin D deficiency, and other factors.

## PATHOGENESIS

Food intolerances are the result of a variety of nonimmunologic mechanisms, whereas food allergy is predominantly caused by IgE-mediated and cell-mediated immune mechanisms. In food allergy, normal physiologic oral tolerance of food, which is induced largely by regulatory T cells (Tregs) and the microbiome of the gut mucosa, breaks down. Susceptible individuals exposed to certain allergens generate food-specific IgE antibodies that bind to Fc $\epsilon$  receptors on mast cells, basophils, macrophages, and dendritic cells, resulting in allergic sensitization. When food allergens penetrate mucosal barriers and reach cell-bound IgE antibodies, mediators are released that induce vasodilation, smooth muscle contraction, and mucus secretion, which result in symptoms of immediate hypersensitivity (allergy). Activated mast cells, basophils, and macrophages may release several cytokines that attract and activate other cells, such as eosinophils and lymphocytes, leading to prolonged inflammation. During acute IgE-mediated reactions, mast cell and basophil

**Table 192.3** Natural History of Food Allergy

FOOD	USUAL AGE AT ONSET OF ALLERGY	USUAL AGE AT RESOLUTION
Hen's egg white	0-1 yr	7 yr (75% of cases resolve)*
Cow's milk	0-1 yr	5 yr (76% of cases resolve)*
Peanut	1-2 yr	Persistent (20% of cases resolve)
Tree nuts	1-2 yr; in adults, onset occurs after cross reactivity to birch pollen	Persistent (9% of cases resolve)
Fish	Late childhood and adulthood	Persistent†
Shellfish (crustacean)	Adulthood (in 60% of patients with this allergy)	Persistent
Wheat*	6-24 mo	5 yr (80% of cases resolve)
Soybean*	6-24 mo	2 yr (67% of cases resolve)
Kiwi	Any age	Unknown
Apple, carrot, and peach‡	Late childhood and adulthood	Unknown

\*Studies suggest that resolution may occur at a later age, especially in children with multiple food allergies and lifetime peak food-specific IgE >50 kU<sub>A</sub>/L.

†Fish allergy that is acquired in childhood can resolve.

‡Allergy to fresh apples, carrots, and peaches (**oral allergy syndrome**) is typically caused by heat-labile proteins. Fresh fruit causes oral pruritus, but cooked fruit is tolerated. There is generally no risk of anaphylaxis, although in rare cases, allergies to cross-reactive lipid transfer protein can cause anaphylaxis after ingestion of fruits (e.g., peach) and vegetables.

Adapted from Lack G. Food allergy. *N Engl J Med*. 2008;359:1252–1260.

degranulation elicits symptoms that can affect the skin (urticaria, angioedema, flushing, pruritus), GI tract (oral pruritus, angioedema, nausea, abdominal pain, vomiting, diarrhea), respiratory tract (nasal congestion, rhinorrhea, nasal pruritus, sneezing, laryngeal edema, dyspnea, wheezing), and cardiovascular system (dysrhythmias, hypotension, loss of consciousness). In non-IgE food allergies, lymphocytes, primarily food allergen-specific T cells, secrete excessive amounts of various cytokines that lead to a “delayed,” more chronic inflammatory process affecting the skin (pruritus, erythematous rash), GI tract (failure to thrive, early satiety, abdominal pain, vomiting, diarrhea), and respiratory tract (food-induced pulmonary hemosiderosis). Mixed IgE and cellular responses to food allergens can also lead to chronic disorders, such as atopic dermatitis, asthma, eosinophilic esophagitis (EoE), and eosinophilic gastroenteritis.

Children who develop IgE-mediated food allergies may be sensitized by food allergens penetrating the inflamed skin barrier, e.g., eczema, or GI barrier (referred to as **class 1 food allergens**), or by food allergens that are partially homologous to plant pollens penetrating the respiratory tract (referred to as **class 2 food allergens**). Any food may serve as a class 1 food allergen, but *egg, milk, peanuts, tree nuts, seeds, fish, soy, and wheat* account for 90% of food allergies during childhood. Many of the major allergenic proteins of these foods have been characterized. There is variable but significant cross reactivity with other proteins within an individual food group. Exposure and sensitization to these proteins often occur very early in life. Class 2 food allergens are typically vegetable, fruit, or nut proteins that are partially homologous to pollen proteins. With the development of seasonal allergic rhinitis from birch/oak, grass, ragweed, or mugwort weed pollens, subsequent ingestion of certain nuts, uncooked fruits, or vegetables provokes the **pollen-food allergy syndrome (also called oral allergy syndrome)**. *Intermittent ingestion* of allergenic foods may lead to acute symptoms such as urticaria or anaphylaxis, whereas *prolonged exposure* may lead to poor control of chronic disorders such as atopic dermatitis and asthma. Cell-mediated sensitivity typically develops to class 1 allergens.

The **galactose- $\alpha$ -1,3-galactose (alpha-gal) syndrome** is an IgE-mediated allergy to a carbohydrate allergen, and manifests as delayed allergic reactions 2-6 hours after ingestion of mammalian meats (pork, beef, lamb, venison) and rarely gelatin or milk. Sensitization occurs after multiple tick bites, in particular by the lone star tick (*Amblyomma americanum*). This unique form of food allergy is seen more often in teenagers and adults.

## CLINICAL MANIFESTATIONS

From a clinical and diagnostic standpoint, it is most useful to subdivide food hypersensitivity disorders according to the predominant target organ (Table 192.4) and immune mechanism (see Table 192.1).

### Gastrointestinal Manifestations

GI food allergies are often the first form of allergy to affect infants and young children and typically manifest as irritability, vomiting or “spitting-up,” diarrhea, and poor weight gain. Cell-mediated hypersensitivities without IgE involvement predominate, making standard allergy tests such as skin-prick tests and in vitro tests for food-specific IgE antibodies of little diagnostic value. The non-IgE-mediated GI food-allergic disorders food protein-induced enterocolitis syndrome (FPIES), food protein-induced allergic proctocolitis (FPIAP), and eosinophilic GI disorders are discussed in Chapter 192.1.

**Pollen-food allergy syndrome (oral allergy syndrome)** is an IgE-mediated hypersensitivity to certain uncooked or unprocessed plant-based foods that occurs in many older children who have pollen-induced allergic rhinitis. Symptoms are usually confined to

TARGET ORGAN	IMMEDIATE SYMPTOMS	DELAYED SYMPTOMS
Cutaneous	Erythema Pruritus Urticaria Morbilliform eruption Angioedema	Erythema Flushing Pruritus Morbilliform eruption Angioedema Eczematous rash
Ocular	Pruritus Conjunctival erythema Tearing Periorbital edema	Pruritus Conjunctival erythema Tearing Periorbital edema
Upper respiratory	Nasal congestion Pruritus Rhinorrhea Sneezing Laryngeal edema Hoarseness Dry staccato cough	
Lower respiratory	Cough Chest tightness Dyspnea Wheezing Intercostal retractions Accessory muscle use	Cough Dyspnea Wheezing
Gastrointestinal (oral)	Angioedema of the lips, tongue, or palate Oral pruritus Tongue swelling	
Gastrointestinal (lower)	Nausea Colicky abdominal pain Reflux Vomiting Diarrhea	Nausea Abdominal pain Reflux Vomiting Diarrhea Hematochezia Irritability and food refusal with weight loss (young children)
Cardiovascular	Tachycardia (occasionally bradycardia in anaphylaxis) Hypotension Dizziness Fainting Loss of consciousness	
Other	Uterine contractions Sense of “impending doom”	

From Boyce JA, Assa'ad A, Burks AW, et al. Guideline for the diagnosis and management of food allergy in the United States: report of the NIAID-sponsored expert panel. *J Allergy Clin Immunol*. 2010;126(6):S1–S58. Table IV, p. S19.

the oropharynx and consist of the rapid onset of oral pruritus; tingling and angioedema of the lips, tongue, palate, and throat; and occasionally a sensation of pruritus in the ears and tightness in the throat. Symptoms are generally short-lived and are caused by local mast cell activation following contact with fresh raw fruit and vegetable proteins that cross react with birch tree pollen (including but not limited to apple, carrot, potato, celery, hazelnuts, peanuts, kiwi, cherry, pear), grass pollen (potato, tomato, watermelon, kiwi),

mugwort weed pollen (celery, fennel, mustard, peach), and ragweed pollen (banana, melons such as watermelon and cantaloupe).

**Acute GI allergy** generally manifests as acute abdominal pain, vomiting, or diarrhea that accompanies IgE-mediated allergic symptoms in other target organs.

### Skin Manifestations

Cutaneous food allergies are also common in infants and young children.

**Atopic dermatitis** is a form of eczema that generally begins in early infancy and is characterized by pruritus, a chronic relapsing course, and association with asthma and allergic rhinitis (see Chapter 186). Although not often apparent from history, at least 30% of children with moderate to severe atopic dermatitis have IgE-mediated food allergies. The younger the child and the more severe the eczema, the more likely food allergy is playing a pathogenic role in the disorder. Atopic dermatitis is a risk factor for the development of food allergy rather than a result of food allergy.

**Acute urticaria and angioedema** are among the most common symptoms of food allergic reactions (see Chapter 189). The onset of symptoms may be very rapid, within minutes after ingestion of the responsible allergen. Symptoms result from activation of IgE-bearing mast cells by food allergens that are absorbed and circulated rapidly throughout the body. Foods most commonly implicated in children include egg, milk, peanuts, and tree nuts, although reactions to various seeds (sesame, sunflower, poppy) and fruits (kiwi) are becoming more common. Chronic urticaria and angioedema are very rarely caused by food allergies. **Contact urticaria** may occur in the perioral region of infants and young children, especially in those with eczema, when otherwise tolerated food causes small, self-resolving hives on direct skin contact while eating. In the absence of any other symptoms, food exclusion is not generally needed and the rash could be avoided by wiping the face during feeding or using a barrier ointment (such as petroleum jelly) in the perioral area before feeding.

**Perioral dermatitis** is a contact dermatitis often caused by substances in toothpaste, gums, lipstick, or medications. **Perioral flushing** is often noted in infants fed citrus fruits and may be caused by benzoic acid in the food. It may also occur in nursing infants. In both situations the effect is benign. Flushing may also be caused by **auriculotemporal nerve (Frey) syndrome** (familial, forceps delivery), which resolves spontaneously.

### Respiratory Manifestations

Respiratory food allergies are uncommon as isolated symptoms. Although many parents believe nasal congestion in infants to be caused by milk allergy, studies show this not to be the case. **Food-induced rhinoconjunctivitis** symptoms typically accompany allergic symptoms in other target organs, such as skin, and consist of typical allergic rhinitis symptoms (periocular pruritus and tearing, nasal congestion and pruritus, sneezing, rhinorrhea). Wheezing occurs in approximately 25% of IgE-mediated food allergic reactions, but only 10% of asthmatic patients have food-induced respiratory symptoms.

### Anaphylaxis

Anaphylaxis (see Chapter 190) is defined as a serious, multisystem allergic reaction that is rapid in onset and potentially fatal. Food allergic reactions are the most common cause of anaphylaxis seen in U.S. hospital emergency departments. Fatal food-induced anaphylaxis is rare, with death affecting 0.03-0.3 per million per year. In addition to the rapid onset of cutaneous, respiratory, and GI symptoms, patients with anaphylaxis may demonstrate cardiovascular symptoms, including hypotension, vascular collapse, and cardiac dysrhythmias, which are presumably caused by massive

mast cell-mediator release. **Food-dependent exercise-induced anaphylaxis** is a special form of acute IgE-mediated food allergy in which moderate intensity exercise performed within a few hours of ingestion of a particular food, most commonly wheat or shellfish, results in anaphylaxis but when ingested without exercise, there is no allergic reaction.

### DIAGNOSIS

A thorough medical history is necessary to determine whether a patient's symptomatology represents an adverse food reaction (see Table 192.2), whether it is an intolerance or food allergic reaction, and, if the latter, whether it is likely to be an IgE-mediated or a cell-mediated response (Fig. 192.1). An understanding of the basic pathophysiology and clinical presentations of different adverse food reactions is essential and if allergy is suspected, referral to an allergist-immunologist is recommended. The following facts should be established: (1) the food suspected of provoking the reaction and the quantity ingested, (2) the interval between ingestion and the development of symptoms, because most reactions occur within minutes to 2 hours of ingestion, (3) the types of symptoms elicited by the ingestion, which may suggest the pathophysiology of the adverse reaction, (4) whether ingesting the suspected food produced similar symptoms on other occasions because reproducibility is expected, (5) whether other inciting factors, such as exercise, are necessary, and (6) time interval since last reaction to the food because evaluation for potential resolution of the allergy may be warranted.

Skin-prick tests and in vitro laboratory tests are useful for demonstrating *IgE sensitization*, defined as presence of food-specific IgE antibodies. **Sensitization alone is not diagnostic of a food allergy.** In general, increasingly higher serum food-specific IgE levels or increasingly large skin-test wheal size (especially >8 mm diameter) indicate a higher chance of clinical allergy. A negative serum food-specific IgE test or skin test result virtually excludes an IgE-mediated form of food allergy. In limited studies, serum food-specific IgE levels  $\geq 15$  kU<sub>A</sub>/L for milk ( $\geq 5$  kU<sub>A</sub>/L for children  $\leq 1$  year),  $\geq 7$  kU<sub>A</sub>/L for egg ( $\geq 2$  kU<sub>A</sub>/L for children <2 years), and  $\geq 14$  kU<sub>A</sub>/L for peanut are associated with a >95% likelihood of clinical reactivity to these foods in children with suspected allergy. Evaluation of IgE-binding to specific digestion-resistant allergens that trigger reactions or labile proteins unlikely to cause significant reactions in a food, termed molecular or **component-resolved diagnostic (CRD) testing**, can provide additional clinically relevant information. Identification of sensitization to digestion-resistant proteins (components) in the foods correlates with a greater chance of systemic allergic reactions. Examples of tests for digestion-resistant proteins include Ara h 1, 2, 3, and 6 for peanut; Jug r 1 and Jug r 3 for walnut; Ana o 3 for cashew; Ber e 1 for Brazil nut; and Cor a 9 and Cor a 14 for hazelnut. Ara h 8 in peanut is a labile, birch pollen-related protein generally not associated with significant allergic reactions, and isolated sensitization to this component is typically associated with no or only mild oral reactions.

*Importantly, most children with positive serum food-specific IgE or skin test responses do not react when the food is ingested. It is therefore crucial to avoid indiscriminate testing (i.e., sending panels of food tests).* In the absence of a clear history of reactivity to a food and evidence of food-specific IgE antibodies, definitive studies must be performed before recommendations are made for avoidance or the use of highly restrictive diets that may be nutritionally deficient, logistically impractical, disruptive to the family, expensive, and/or a potential source of future feeding disorders. IgE-mediated food allergic reactions are generally very food specific, so the use of broad exclusionary diets, such as avoidance of all legumes, cereal grains, or animal products, is not warranted (Table 192.5). When the earlier diagnostic modalities are not definitive,



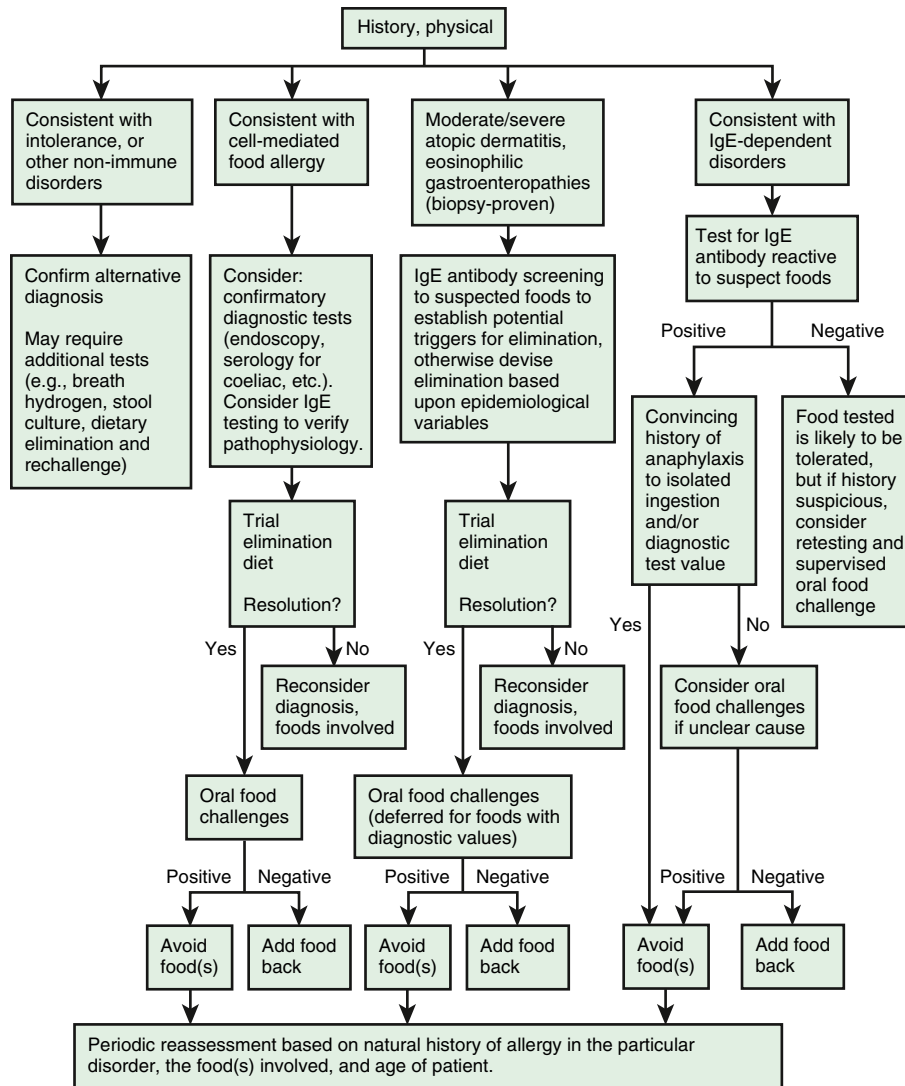


Fig. 192.1 Algorithm for diagnosis of food allergy. (From Sicherer SH. Food allergy. Lancet. 2002;360:701–710.)

Table 192.5 Clinical Implications of Cross-Reactive Proteins in IgE-Mediated Allergy		
FOOD FAMILY	RISK OF ALLERGY TO ≥1 MEMBER (%; APPROXIMATE)	FEATURE(S)
Legumes	5–50	If allergic to peanut, 5–20% likelihood of allergy to other legumes (lupine, green bean, green pea, soy)  If allergic to chickpea (garbanzo bean), >50% likelihood of allergy to lentil and/or pea.
Tree nuts (e.g., almond, cashew, hazelnut, walnut, Brazil)	15–33	Reactions are often severe
Fish	50	Reactions can be severe
Shellfish (crustaceans)	75 (other crustaceans) 50 (mollusks)	Reactions can be severe
Grains	20	Wheat shows cross-reactivity with barley and rye
Mammalian milks	90	Cow's milk is highly cross reactive to goat's or sheep's milk (92%) but not with mare's milk (4%)
Rosaceae (pitted fruits)	55	Risk of reactions to >3 related foods is very low (<10%); symptoms are usually mild (pollen food allergy syndrome)

Modified from Sicherer SH. Food allergy. Lancet. 2002;360:701–710.

which is a common scenario, oral food challenges (OFCs), observed incremental feedings of a food performed under physician supervision, are useful in ruling out or confirming the presence or resolution of a food allergy. *Allergists experienced in dealing with food allergic reactions and able to treat anaphylaxis should perform food challenges.*

There are no laboratory studies to help identify foods that are already in the diet but may be responsible for non-IgE and cell-mediated food reactions. Consequently, elimination diets followed by OFCs are the only way to establish the diagnosis. This approach may be recommended for atopic dermatitis, eosinophilic GI diseases, and some forms of contact dermatitis. Before a food challenge is initiated, the suspected food should be eliminated from the diet for 10-14 days for IgE-mediated food allergy and up to 8 weeks for some cell-mediated disorders, such as EoE (see Chapter 192.1). Some children with cell-mediated reactions to cow's milk do not tolerate hydrolysate formulas and must receive amino acid-derived formulas. If symptoms remain unchanged despite appropriate elimination diets, it is unlikely that food allergy is responsible for the child's disorder.

## TREATMENT

Appropriate identification and elimination of foods responsible for food hypersensitivity reactions are the most established and validated management strategies for food allergies. Complete elimination of common foods (milk, egg, soy, wheat, rice, chicken, fish, peanut, nuts) is very difficult because of their widespread use in a variety of processed foods. The lay organizations Food Allergy Research and Education (FARE; [www.foodallergy.org](http://www.foodallergy.org)) and the Asthma & Allergy Foundation of America (Kids with Food Allergies Division; [www.kidswithfoodallergies.org/recipes-diet.aspx](http://www.kidswithfoodallergies.org/recipes-diet.aspx)) provide excellent information to help parents deal with both the practical and emotional issues surrounding these diets. Egg allergy is not a contraindication for vaccination with measles, mumps, rubella, or influenza vaccines, but remains a concern for the yellow fever vaccine where referral to an allergist is recommended.

Children at risk of food-induced anaphylaxis should be given self-injectable epinephrine and a written emergency plan in case of accidental ingestion (see Chapter 190). Because many food allergies resolve, children should be reevaluated periodically by an allergist to determine whether they have lost their clinical reactivity. A number of clinical trials are evaluating the efficacy of oral, sublingual, and epicutaneous (patch) immunotherapy for the treatment of IgE-mediated food allergies. Immunotherapy is not typically curative but aims to provide temporary "desensitization," or an increase in the threshold of a food that can be consumed without triggering an allergic reaction. Success depends on continuous treatment exposure. An FDA-approved peanut oral immunotherapy (OIT) agent is commercially available for use in children. Combining OIT with anti-IgE treatment (omalizumab) or other biologic agents is under study and may improve safety or efficacy compared to OIT alone. Furthermore, extensively heated milk or egg in baked products are tolerated by the majority of milk and egg-allergic children. Regular ingestion of baked products with milk and egg may accelerate resolution of milk and egg allergy.

## PREVENTION

It was once thought that avoidance of allergenic foods and delayed introduction to the diet would prevent allergy, but the opposite is probably true; delayed introduction of these foods may increase the risk of allergy, especially in children with atopic dermatitis. A trial of early introduction of dietary peanut randomized 640 infants age 4-11 months with severe eczema, egg allergy, or both to consume or avoid peanut until the age 60 months. The early introduction of peanut dramatically decreased the development of peanut allergy among children at high risk for this allergy. A theory behind this approach is that early oral introduction of peanut induces oral tolerance that precedes the potential sensitization to peanut that can

occur with environmental exposure to peanut via the inflamed, disrupted skin barrier seen in infants with eczema. Infants with severe eczema or egg allergy in the first 4-6 months of life might benefit from evaluation by an allergist or physician trained in management of allergic diseases to diagnose any food allergy and assist in promptly implementing appropriate early peanut introduction. For this high-risk group, the clinician can perform an observed peanut challenge for those with evidence of a positive peanut skin test response or serum peanut-specific IgE >0.35 kU<sub>A</sub>/L to determine whether they are clinically reactive before initiating at-home introduction of infant-safe forms of peanut. Additional details for the early introduction of peanut are available from the National Institute of Allergy and Infectious Diseases (NIAID).<sup>\*</sup> Analyses of several early introduction studies have shown that early egg introduction may be associated with reduced egg allergy, while review of data for other allergenic foods is not conclusive. There is however no evidence that delaying the introduction of typically allergenic foods prevents food allergy or other allergic diseases.

There is no compelling evidence to support the practice of restricting the maternal diet during pregnancy or while breastfeeding, or for delaying introduction of various allergenic foods to infants from atopic families. Exclusive breastfeeding for the first 4-6 months of life is strongly encouraged but has not been shown to reduce the development of food allergies. Potentially allergenic foods (eggs, milk, wheat, soy, peanut/tree nut products, fish) should be introduced and maintained in the diet in infant-appropriate forms after this period of exclusive breastfeeding and may prevent the development of allergies later in life. Recent meta-analyses have not supported the use of hydrolyzed infant formulas in cases where breastfeeding cannot be continued for 4-6 months or after weaning to prevent eczema or food allergies in high-risk families. Modulation of the microbiome with probiotics has been an area of interest, where it may affect oral tolerance induction; however, specific interventions have not been proven effective. Probiotic supplements in the third trimester and to the newborn infant may reduce the incidence and severity of eczema, but have not demonstrated effects on food allergy prevention. Other potential influences on the infant/child microbiome are currently being studied, including mode of delivery (vaginal vs C-section), diet diversity, vitamin D supplementation, and household pet exposure. With the recognition that infantile eczema increases the risk of allergic sensitization and food allergy, attention has also focused on early skin care and aggressive treatment of infantile eczema as potential preventive measures. Because some **skin preparations** contain peanut or nut oils, which may sensitize young infants, especially those with cutaneous inflammation, such preparations should be avoided. **Table 192.6** summarizes approaches to food allergy prevention.

Visit Elsevier eBooks+ at [eBooks.Health.Elsevier.com](http://eBooks.Health.Elsevier.com) for Bibliography.

**Table 192.6** Approaches to Prevention of Food Allergy

### RECOMMENDED

Infant-safe forms of peanut, egg introduced around age 6 mo, not before 4 mo  
 Other allergens may be introduced around this time as well  
 Allergy testing before introduction not usually needed (see text)  
 Infants with severe eczema or egg allergy may benefit from evaluation for early peanut introduction at 4-6 mo  
 Diverse infant diet

### UNPROVEN/NOT RECOMMENDED

Hydrolyzed formulas  
 Maternal allergen avoidance during pregnancy or lactation  
 Purposeful delay in introducing allergens to infants

<sup>\*</sup> <https://www.niaid.nih.gov/diseases-conditions/guidelines-clinicians-and-patients-food-allergy>.

## 192.1 Non-IgE Gastrointestinal Food Allergy Disorders

Anna H. Nowak-Węgrzyn, Hugh A. Sampson,  
Amanda L. Cox, and Scott H. Sicherer

### CLINICAL MANIFESTATIONS

GI food allergies are often the first form of allergy to affect infants and young children, and typically manifest as chronic irritability, vomiting or “spitting-up,” diarrhea, and poor weight gain. Cell-mediated hypersensitivities without IgE involvement (non-IgE) predominate, making standard allergy tests such as skin-prick tests and *in vitro* tests for food-specific IgE antibodies of little diagnostic value (Table 192.7).

FPIES is a non-IgE, cell-mediated food allergy that can have dramatic GI symptoms and in its severe form is considered an allergic emergency. FPIES can present as acute or chronic phenotypes (Fig. 192.2).

### EPIDEMIOLOGY

**Prevalence:** The prevalence of FPIES ranges between 0.34% and 0.7% of infants in Israel and Spain; in a population-based survey, physician-diagnosed FPIES was reported in 0.51% (95% confidence interval [CI]; 0.420.62) of U.S. children.

**Food triggers:** Globally, cow’s milk is the most common trigger of FPIES, although in countries with higher rates of breastfeeding rather than formula feeding, complementary foods introduced into infants’ diets early are also reported. Commonly reported triggers include soy, oat, rice, vegetables (avocado, sweet potato), fruits (banana), egg, fish, chicken, turkey, peanut, tree nuts, and fish. Most infants (50–75%) react to one food; however, about 10–15% report more than three food triggers.

**Pathophysiology:** FPIES is characterized by a strong inflammatory response with significant elevation of CRP, neutrophils, and platelets. There is evidence of innate immune compartment activation (monocytes, neutrophils) along with the pan-activation of T lymphocytes and significant elevation in levels of various cytokines and chemokines in the peripheral blood, including IL-17A, IL-22, IL-17C, and tumor necrosis factor (TNF)- $\alpha$ , and a preferential activation of nonconventional T-cell populations, including  $\gamma\delta$ T cells.

**Clinical manifestations:** FPIES typically manifests in the first year of life in an acute form as projectile, repetitive vomiting within 1-4 hours of food ingestion, frequently accompanied by lethargy, pallor (or dusky appearance), and low muscle tone; in a smaller subset, vomiting is followed by watery diarrhea in 5-10 hours (see Fig. 192.2). Prolonged ingestion of the causal allergen may result in abdominal distention, bloody diarrhea, anemia, and failure to thrive, referred to as **chronic FPIES**. Acute FPIES is considered to be an allergic emergency because hypotension occurs in approximately 5–10% of patients after allergen ingestion, which initially may be attributed to sepsis.

**Diagnosis:** Acute FPIES is diagnosed based on the recognition of a constellation of symptoms, (Table 192.8; see Fig. 192.2) and allergy tests detecting food-specific IgE are typically negative. OFCs are rarely required for the confirmation of the initial diagnosis, but are utilized for evaluating resolution of FPIES. Chronic FPIES is diagnosed based on the chronic GI symptoms that resolve within days to weeks following elimination of the allergen and recur acutely within 1-2 hours following a subsequent feeding.

**Differential diagnosis:** The differential diagnosis includes GI infections (viral, bacterial), sepsis, necrotizing enterocolitis, metabolic disorders that induce emesis and lethargy (hyperammonemias, organic acidemias, congenital adrenal hyperplasia), very early-onset inflammatory bowel disease and other immune enteropathies

(IPEX), gastroesophageal reflux (GER) disease, ileus, anatomical small bowel obstruction, celiac disease, anaphylaxis, cyclic vomiting syndrome, poisoning, pyloric stenosis, seizures, and primary immunodeficiencies.

**Emergency management:** Severe FPIES reactions are considered allergic emergencies due to the risk of hypotension (in extreme cases, hypovolemic shock), dehydration, and metabolic derangements including acidemia and methemoglobinemia (Fig. 192.3). Acute management entails vigorous intravenous hydration. Additional therapies include intravenous or intramuscular ondansetron as an antiemetic, and a single dose of steroid (e.g., methylprednisolone) may be administered due to a strong inflammatory response. Mild to moderate reactions can be managed with oral rehydration and oral ondansetron. Epinephrine autoinjectors and oral antihistamines are not prescribed for home management; however, vasopressors may be used for treatment of shock in the medical setting.

**Dietary management:** Breastfeeding mothers rarely need to restrict the foods that trigger symptoms in an infant following direct feeding, unless the infant exhibits symptoms of acute or chronic FPIES during breast milk feeding or has impaired growth. Hypoallergenic infant formulas (extensively hydrolyzed or amino acid) are recommended in non-breastfed infants to avoid cow’s milk and soy. Timely introduction of solids is important for nutrition and for the development of oromotor skills. Following acute FPIES reactions to a solid food, foods from an unrelated food group can be chosen for introduction. Tolerance to one food from a food group usually indicates a favorable likelihood of tolerance to the related foods. Table 192.9 discusses practical guidelines for dietary management of FPIES.

**Monitoring for resolution:** The natural history of infantile FPIES is favorable, with the majority becoming tolerant by 3-5 years of age; persistent FPIES is rare. FPIES to fish and shellfish may start in older children and in adults; the natural history of adult FPIES is unknown. Reintroduction of foods that have caused FPIES is usually done during a physician-supervised OFC. Timing of reintroduction varies based on the nutritional and social importance of the foods; usually attempts are done 6-24 months following the most recent FPIES reaction to the offending food. FPIES induced by cow’s milk may (~10%) evolve into IgE-mediated food allergy.

**Comorbidities:** FPIES is associated with an increased risk of IgE-mediated food allergy to other foods, atopic dermatitis, allergic rhinitis, asthma, and EoE.

FPIAP presents in the first few months of life as blood-streaked stools in otherwise healthy infants that are breastfed and/or formula-fed (see Table 192.7). Blood loss is typically mild, but can occasionally result in anemia. The most commonly implicated dietary triggers are cow’s milk and soy proteins, followed by egg; their elimination, either by maternal dietary restriction if breastfeeding or by use of hypoallergenic formulas, leads to symptom and gross blood resolution within 48-72 hours in most infants. FPIAP is diagnosed clinically based on the presence of blood in the stool; sigmoidoscopy with biopsy, confirming an eosinophilic inflammatory response, is no longer done in routine practice for diagnosis of FPIAP. Blood in the infant’s stool can be attributed to multiple causes other than food allergy (see Table 192.7). Therefore diagnosis based on clinical observation carries the risk of overdiagnosis (especially when FPIAP is diagnosed based on detection of microscopic blood in stool) and unnecessary dietary restrictions resulting in delayed introduction of foods and an associated increased risk of developing IgE sensitization. Therefore, considering benign, nonspecific nature of the symptoms and favorable natural history, in cases of mild to moderate FPIAP, many authorities recommend a trial of the culprit food 2-3 months following symptom resolution to determine whether the infant has “outgrown” the sensitivity.

**Table 192.7** Food Protein–Induced Gastrointestinal Syndromes

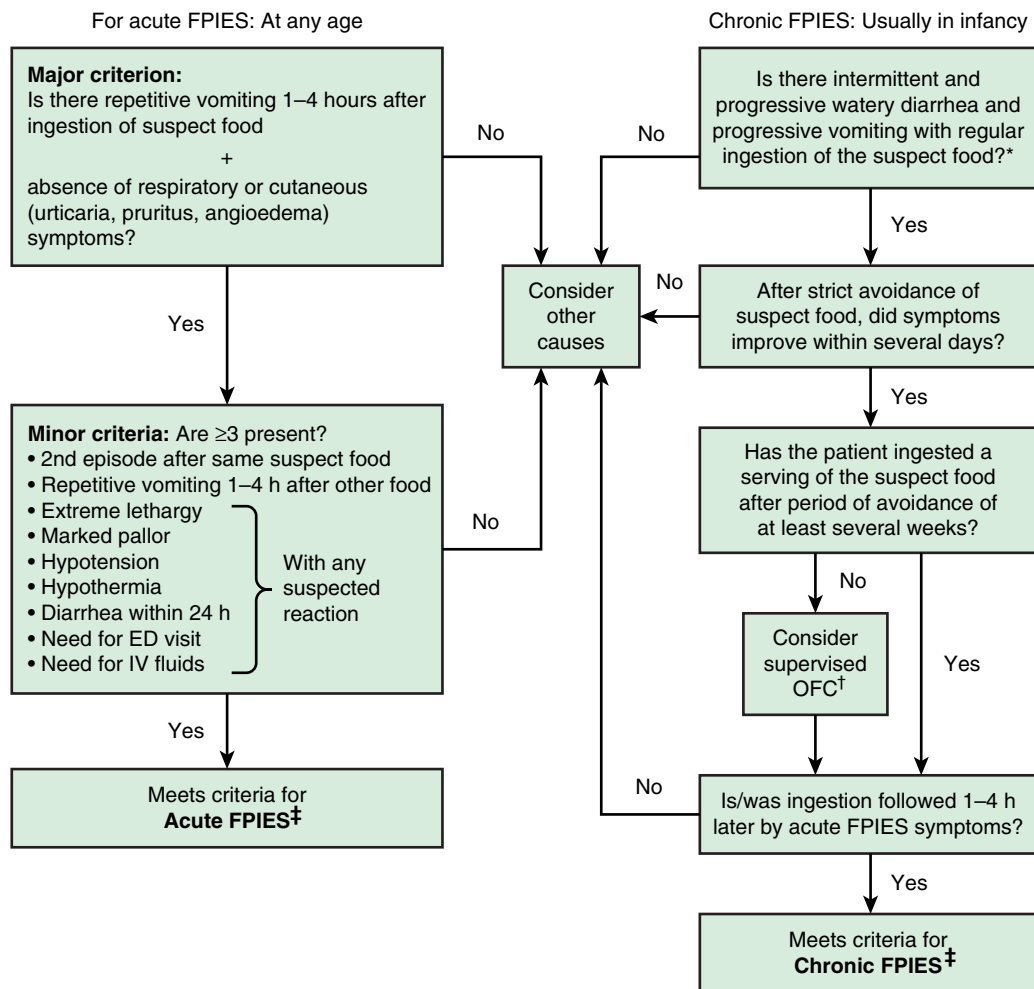
	<b>FPIES</b>	<b>FPIAP</b>	<b>FPE</b>	<b>EOSINOPHILIC GASTROENTEROPATHIES*</b>
Age at onset	1 day to 1 year, later for fish and shellfish	1 day to 6 months	Dependent on age of exposure to antigen, cow's milk and soy up to 2yr	Infant to adolescent
<b>FOOD PROTEINS IMPLICATED</b>				
Most common	Cow's milk, egg, oat, rice	Cow's milk, soy	Cow's milk, soy	Cow's milk, wheat, egg white, soy, peanut, seafood
Less common	Soy, chicken, turkey, fish, pea, peanut, avocado, sweet potato	Egg	Wheat, egg	Meats, corn, rice, fruits, vegetables, legumes
Multiple food hypersensitivities	>50% both cow's milk and soy if younger than 6 mo; 40–50% react to more than one grain, 30% react to more than one fish	40% both cow's milk and soy	Rare	Common
Feeding at the time of onset	Formula	>50% exclusive breastfeeding	Formula	Formula
<b>ATOPIC BACKGROUND</b>				
Family history of atopy	40–70%	25%	Unknown	~50% (often history of EoE)
Personal history of atopy	30%	22%	22%	~50%
<b>SYMPTOMS</b>				
Emesis	Projectile, repetitive, severe	No	Intermittent	Intermittent
Diarrhea	Severe in chronic FPIES	No	Moderate	Moderate
Bloody stools	Occasionally severe	Moderate	Rare	Moderate
Edema	Acute, severe	No	Moderate	Moderate
Shock	15%	No	No	No
Failure to thrive	Moderate	No	Moderate	Moderate
Differential diagnosis	Infection: viral, bacterial Necrotizing enterocolitis, GI obstruction (ileus, pyloric stenosis, Meckel diverticulum); gastroesophageal reflux disease; very early onset inflammatory bowel disease, seizure disorder, metabolic disorder, cardiac disease, anaphylaxis	Rectal fissure, bleeding disorder, vit K deficiency, GI infection e.g., <i>Shigella</i> , inflammatory bowel disease	Celiac disease, primary immunodeficiency, inflammatory bowel disease	Gastroesophageal reflux disease, recurrent vomiting due to other causes, parasitic and fungal infections, congenital rings, Crohn disease, periarteritis, allergic vasculitis, connective tissue diseases, bullous pemphigoid, pemphigoid vegetans, graft-versus-host disease, achalasia, drug hypersensitivity, celiac disease, vasculitis, carcinoma, hypereosinophilic syndrome
<b>LABORATORY FINDINGS</b>				
Anemia	Moderate	Mild	Moderate	Mild-moderate
Hypoalbuminemia	Acute	Rare	Moderate	Mild-severe
Methemoglobinemia	May be present	No	No	No
<b>ALLERGY EVALUATION</b>				
Food skin-prick test	Majority negative <sup>†</sup>	Negative	Negative	Positive in ~50%
Serum food allergen IgE	Majority negative <sup>†</sup>	Negative	Negative	Positive in ~50%
Total IgE	Normal	Negative	Normal	Normal to elevated
Peripheral blood eosinophilia	No	Occasional	No	Present in <50%
<b>BIOPSY FINDINGS</b>				
Colitis	Prominent	Focal	No	May be present
Lymph nodular hyperplasia	No	Common	No	Yes
Eosinophils	Prominent	Prominent	Few	Prominent; also neutrophilic infiltrates, papillary elongation, and basal zone hyperplasia
Food challenge	Emesis in 1-4 hr; diarrhea in 5-8 hr (in a subset)	Rectal bleeding in 6-72 hr	Vomiting, diarrhea, or both in 40-72 hr	Vomiting and diarrhea in hours to days
Treatment	Protein elimination, 80% respond to casein hydrolysate and symptoms clear in 3-10 days; rechallenge under supervision in 0.5-2yr	Protein elimination, symptoms clear in 3 days with casein hydrolysate; resume/continue breastfeeding on maternal antigen-restricted diet; reintroduce at home after 9-12mo of age	Protein elimination, symptoms clear in 1-3wk; rechallenge and biopsy in 1-2yr	Protein elimination, good response to casein hydrolysate, excellent (>90%) response to elemental diet; symptoms clear in 2-3wk, excellent acute response to oral steroids but with high rate of relapse following discontinuation; in EoE 30–50% response to proton pump inhibitors, 70% to swallowed corticosteroids; rechallenge by introducing food at home and biopsy in 1-2yr

Continued



Table 192.7 Food Protein–Induced Gastrointestinal Syndromes—cont’d		FPIES	FPIAP	FPE	EOSINOPHILIC GASTROENTEROPATHIES*
Natural history		Cow’s milk: 60% resolved by 2yr Soy: 25% resolved by 2yr	Resolved by 9-12 mo	Most cases resolve in 2-3yr	Typically a prolonged, relapsing course
Reintroduction of the food		Supervised food challenge	At home, gradually advancing from 1 oz to full feedings over 2wk	Home, gradually advancing	Home, gradually advancing

\*Eosinophilic gastroenteropathies encompass esophagitis, gastritis, and gastroenterocolitis.  
 †If positive, may be a risk factor for persistent disease, referred to as “atypical” FPIES.  
 FPIES, Food protein–induced enterocolitis syndrome; FPIAP, food protein–induced allergic proctocolitis; FPE, food protein–induced enteropathy; GI, gastrointestinal; EoE, eosinophilic esophagitis.



**Fig. 192.2** Diagnostic algorithm for food protein–induced enterocolitis syndrome (FPIES). ED, Emergency department; IV, intravenous; OFC, oral food challenge. \*Chronic FPIES is described almost exclusively with cow’s milk or soy in young infants. †Without a confirmatory OFC or other ingestion with emesis onset in 1-4 hours, diagnosis of chronic FPIES is presumptive. ‡Based on Nowak-Węgrzyn A, Chehade M, Groetch ME, et al. International consensus guidelines for the diagnosis and management of food protein–induced enterocolitis syndrome: Executive summary—Workgroup Report of the Adverse Reactions to Foods Committee, American Academy of Allergy, Asthma & Immunology. *J Allergy Clin Immunol.* 2017;139:1111–1126. (From Sicherer SH, Nowak-Węgrzyn A. *Enterocolitis, proctocolitis, and enteropathies.* In: Leung DYM, Akdis CA, Bacharier LB, et al., eds. *Pediatric Allergy Principles and Practice.* 4th ed. Philadelphia: Elsevier; 2021: Fig. 33.2.)

**Table 192.8** FPIES Diagnostic Criteria

ACUTE FPIES*	
MAJOR CRITERIA (BOTH MUST BE MET), PLUS	MINOR CRITERIA (≥3 OCCURRING WITH EPISODE)
<ul style="list-style-type: none"> <li>• Vomiting 1-4 hr after suspect food ingestion</li> <li>• Absence of immediate, IgE-mediated allergic symptoms (hives, itching, swelling, wheezing, cough)</li> </ul>	<ul style="list-style-type: none"> <li>• ≥2 episodes with same food</li> <li>• One episode with a different food</li> <li>• Lethargy</li> <li>• Pallor</li> <li>• Need for ER visit</li> <li>• Need for IV fluid support</li> <li>• Diarrhea within 24 hr (usually 5-10 hr)</li> <li>• Hypotension</li> <li>• Hypothermia</li> </ul>
CHRONIC FPIES†	
SYMPTOMS AND SEVERITY	CRITERIA
<p><b>Milder</b> (lower doses with intermittent ingestion):</p> <ul style="list-style-type: none"> <li>• Intermittent vomiting and/or diarrhea</li> <li>• Growth faltering</li> <li>• No dehydration or metabolic acidosis</li> </ul> <p><b>Severe</b> (higher doses with chronic ingestion):</p> <ul style="list-style-type: none"> <li>• Intermittent but progressive vomiting and watery diarrhea (occasionally with blood)</li> <li>• Poor weight gain or failure to thrive</li> <li>• Possible dehydration and metabolic acidosis, anemia, hypoproteinemia, neutrophilia, thrombocytosis</li> </ul>	<ul style="list-style-type: none"> <li>• Resolution of symptoms within days to weeks after elimination of offending food(s)</li> <li>• Acute recurrence of symptoms (vomiting in 1-4 hr, diarrhea in &lt;24 hr, usually 5-10 hr) when the food is reintroduced, following a period of elimination</li> <li>• Confirmatory OFC required for conclusive diagnosis; if OFC not performed diagnosis remains presumptive</li> </ul>

\*Major criterion must be met (both) plus at least three minor criteria.

†General criteria because of paucity of available data.

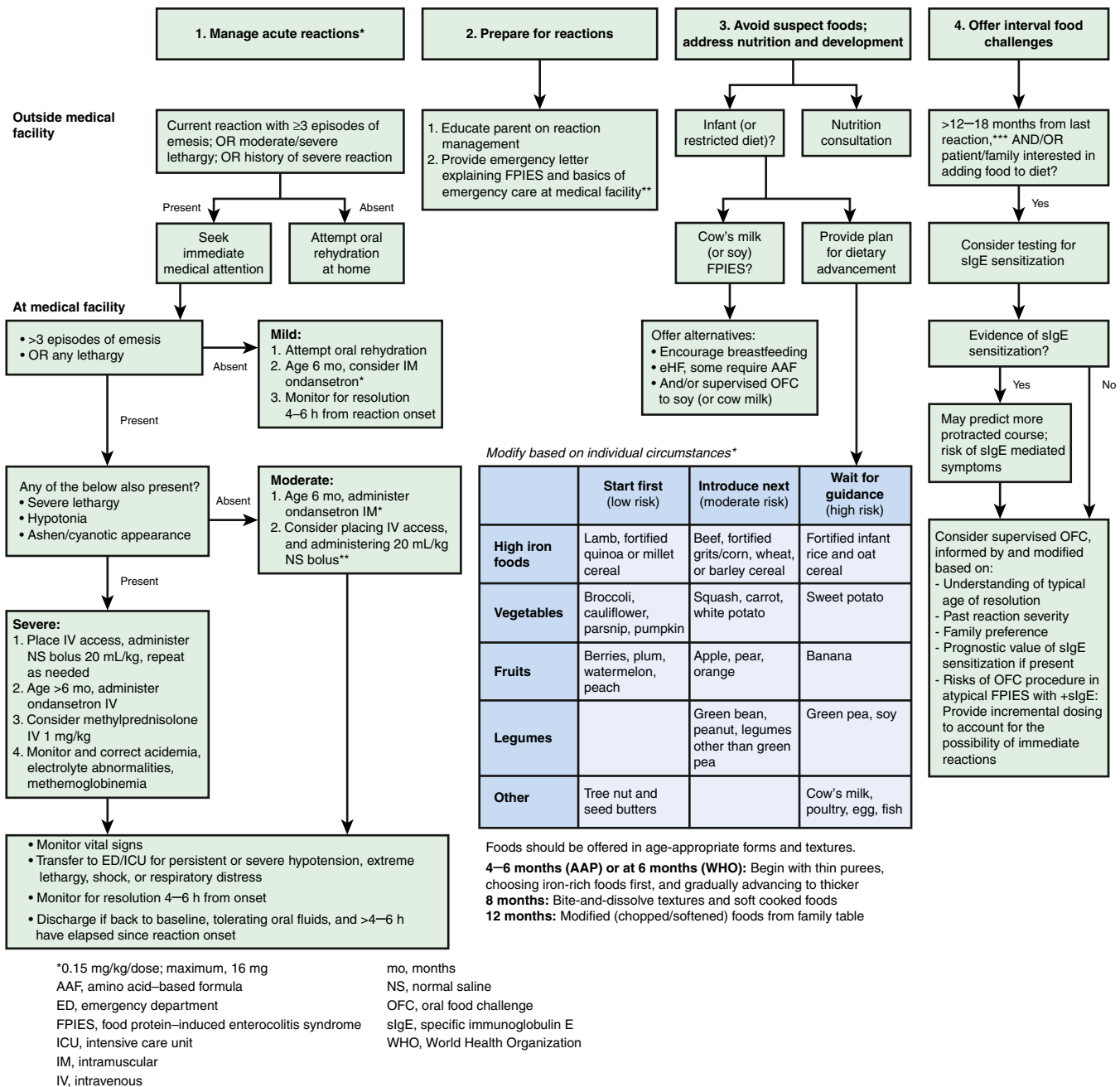
FPIES, Food protein-induced enterocolitis syndrome; ER, emergency room; IV, intravenous; OFC, oral food challenge.

Adapted from Nowak-Węgrzyn A, Chehade M, Groetch ME, et al. International consensus guidelines for the diagnosis and management of food protein-induced enterocolitis syndrome: Executive summary-Workgroup Report of the Adverse Reactions to Foods Committee, American Academy of Allergy, Asthma & Immunology. *J Allergy Clin Immunol.* 2017;139(4):1111-1126.e4.

**Food protein-induced enteropathy (FPE)** often manifests in the first several months of life as diarrhea, often with steatorrhea and poor weight gain (see Table 192.7). Symptoms include protracted diarrhea, vomiting in up to 65% of cases, failure to thrive, abdominal distention, early satiety, and malabsorption. Anemia, edema, and hypoproteinemia occur occasionally. **Cow's milk sensitivity** is the most common cause of FPE in young infants, but it has also been associated with sensitivity to soy, egg, wheat, rice, chicken, and fish in older children. **Celiac disease**, the most severe form of FPE, occurs in about 1 per 100 of the U.S. population, although it may be "silent" in many patients (see Chapter 384). The classic form is characterized by extensive loss of absorptive villi and hyperplasia of the crypts, leading to malabsorption, chronic diarrhea, steatorrhea, abdominal distention, flatulence, and weight loss or failure to thrive. Oral ulcers and other extraintestinal symptoms secondary to malabsorption may occur. Genetically susceptible individuals (HLA-DQ2 or HLA-DQ8) demonstrate a cell-mediated response to tissue transglutaminase deamidated gliadin (a fraction of gluten), which is found in wheat, rye, and barley.

**EoE** may present from infancy through adolescence, more frequently in boys (see Chapter 370). EoE is a cell-mediated disorder, which is often associated with IgE-mediated food allergies in infants and young children, and manifests as chronic GER, intermittent emesis, food refusal, abdominal pain, dysphagia, food impaction, irritability, sleep disturbance, and failure to respond to conventional GER medications. EoE is a clinicopathologic diagnosis. The diagnosis is confirmed when 15 eosinophils per high-power field are seen on esophageal biopsies. Treatment is possible with elimination of dietary allergens but management with medications is typically included (see Chapter 370). **Eosinophilic gastritis and gastroenteritis** are additional **eosinophilic GI disorders** that are far less common and can occur at any age. **Eosinophilic gastritis** often presents with nausea and abdominal pain or bloating, while **eosinophilic enteritis** may also present with nausea, abdominal pain or bloating with additional diarrhea, anemia, or protein loss. **Eosinophilic colitis** may present with loose stool or blood in stool associated with abdominal cramping/pain. More than 50% of patients with these disorders are atopic; however, food-induced IgE-mediated reactions have been implicated only in a minority of patients. Generalized edema secondary to hypoalbuminemia may occur in some infants with marked **protein-losing enteropathy**.

Visit Elsevier eBooks+ at [eBooks.Health.Elsevier.com](http://eBooks.Health.Elsevier.com) for Bibliography.



**Fig. 192.3** Treatment algorithm for food protein–induced enterocolitis syndrome (FPIES). \*Modified from Nowak-Węgrzyn A, Chehade M, Groetch ME, et al. International consensus guidelines for the diagnosis and management of food protein–induced enterocolitis syndrome: Executive summary—Workgroup Report of the Adverse Reactions to Foods Committee, American Academy of Allergy, Asthma & Immunology. *J Allergy Clin Immunol.* 2017;139:1111–1126. \*\*Template may be downloaded at <https://www.fpies.org/wp-content/uploads/2018/08/IFPIES-ER-Letter-2018.pdf>. \*\*\*Interval can be modified at the discretion of the treating physician. (From Sicherer SH, Nowak-Węgrzyn A. Enterocolitis, proctocolitis, and enteropathies. In: Leung DYM, Akdis CA, Bacharier LB, et al., eds. *Pediatric Allergy Principles and Practice*. 4th ed. Philadelphia: Elsevier; 2021: Fig. 33.3.)

**Table 192.9** Empiric Guidelines for Selecting Weaning Foods in Infants with FPIES

AGES AND STAGES <sup>a,b</sup>	LOWER RISK FOODS*	MODERATE RISK FOODS*	HIGHER RISK FOODS <sup>†</sup>
<b>4-6 MO (AS PER AAP, CON)</b> If developmentally appropriate and safe and nutritious foods are available <ul style="list-style-type: none"> <li>• Begin with smooth, thin, purees and progress to thicker purees</li> <li>• Choose foods that are high in iron</li> <li>• Add vegetables and fruits</li> </ul>	Broccoli, cauliflower, parsnip, turnip, pumpkin, kale	<b>VEGETABLES</b>	
		Squash, carrot, white potato, green bean (legume)	Sweet potato, green pea (legume)
<b>6 MO (AS PER WHO)</b> Complementary feeding should begin no later than 6 mo of age <ul style="list-style-type: none"> <li>• In the breastfed infant, high-iron foods or supplemental iron (1 mg/kg/day) is suggested by 6 mo of age</li> <li>• Continue to expand variety of fruits, vegetables, legumes, grains, meats and other foods as tolerated</li> </ul>	Blueberries, strawberries, plum, watermelon, peach	<b>FRUITS</b>	
		Apple, pear, orange	Avocado, banana
<b>8 MO OF AGE OR WHEN DEVELOPMENTALLY APPROPRIATE</b> <ul style="list-style-type: none"> <li>• Offer soft-cooked and bite-and-dissolve textures from around 8 mo of age or as tolerated by infant</li> </ul>	Lamb, beef, pork, fortified quinoa cereal, millet, amaranth	<b>HIGH-IRON FOODS</b>	
		Fortified grits and corn cereal, wheat (whole wheat and fortified), fortified barley cereal	Fortified, infant rice and oat cereals.
<b>12 MO OF AGE OR WHEN DEVELOPMENTALLY APPROPRIATE</b> <ul style="list-style-type: none"> <li>• Offer modified tolerated foods from the family table, chopped meats, soft cooked vegetables, grains, and fruits</li> </ul>	Tree nuts and seed butters* (sesame, sunflower, etc.) *Thinned with water or infant puree for appropriate infant texture and to prevent choking	<b>OTHER</b>	
		Peanut, other legumes (other than green pea)	Milk, soy, poultry, egg, fish, shellfish

\*Risk assessment is based on the clinical experience and the published reports of FPIES triggers.

<sup>†</sup>This is not an exhaustive list and feeding should not be limited to this list of lower and moderate risk foods. Many other foods are appropriate for infant feeding. One may consider delaying the introduction of higher risk foods until there is a nutritional need for the food, the infant already has a diverse diet, or other lower and moderate risk foods are tolerated.

<sup>a</sup>Exclusive breastfeeding until 4-6 mo of age and continuing breastfeeding through the first year of life or longer as long as mutually desired by both mother and child.

<sup>b</sup>If an infant tolerates a variety of early foods, subsequent introduction may be more liberal. Additionally, tolerance to one food in a food group (green pea) is considered as a favorable prognostic indicator for tolerance of other foods from the same group (legumes).

AAP, CON, American Academy of Pediatrics, Committee on Nutrition; WHO, World Health Organization.

Adapted from Nowak-Wegryzn A, Chehade M, Groetch ME, et al. International consensus guidelines for the diagnosis and management of food protein-induced enterocolitis syndrome: Executive Summary—Workgroup Report of the Adverse Reactions to Foods Committee, American Academy of Allergy, Asthma & Immunology. *J Allergy Clin Immunol.* 2017;139(4):1111–1126.e4

## Chapter 193

# Adverse and Allergic Reactions to Drugs

Roland Solensky and Scott H. Sicherer

Adverse drug reactions (ADRs) can be divided into predictable (type A) and unpredictable (type B) reactions. **Predictable drug reactions**, including drug toxicity, drug interactions, and adverse effects, are dose dependent, are related to known pharmacologic actions of the drug, and occur in patients without any unique susceptibility. **Unpredictable drug reactions** are generally dose independent, often are not related to the pharmacologic actions of the drug, and occur in patients who are genetically or otherwise predisposed. These include idiosyncratic reactions, allergic (hypersensitivity) reactions, and pseudoallergic reactions. **Allergic reactions** are immune-mediated and require prior sensitization. They manifest as signs and symptoms characteristic of an underlying allergic mechanism (Table 193.1). Anaphylaxis is due to production of drug-specific IgE antibodies, and delayed cutaneous reactions are due to drug-specific T cells. **Pseudoallergic reactions** resemble allergic

reactions but are caused by non-IgE-mediated release of mediators from mast cells and basophils, such as vancomycin-induced flushing. Drug-independent cross-reactive antigens can induce sensitization manifesting as drug allergy. Patients with cetuximab-induced anaphylaxis have IgE antibodies in pretreatment samples specific for galactose- $\alpha$ -1,3-galactose. This antigen is present on the antigen-binding portion of the cetuximab heavy chain and is similar to structures in the ABO blood group. Sensitization to galactose- $\alpha$ -1,3-galactose may occur from tick bites caused by cross-reactive tick salivary antigens.

## EPIDEMIOLOGY

The incidence of ADRs in the general as well as pediatric populations remains unknown, although data from hospitalized patients show it to be 6.7%, with a 0.32% incidence of fatal ADRs. Databases such as the U.S. Food and Drug Administration (FDA) MedWatch program (<https://www.fda.gov/safety/medwatch-fda-safety-information-and-adverse-event-reporting-program>) likely suffer from underreporting. Cutaneous reactions are the most common form of ADRs, with ampicillin, amoxicillin, penicillin, and trimethoprim/sulfamethoxazole (TMP/SMX) being the most frequently implicated drugs (Tables 193.2 and 193.3). Although the majority of ADRs do not appear to be allergic in nature, 6–10% can be attributed to an allergic or immunologic mechanism. Importantly, given the high probability of recurrence of allergic reactions, these reactions should be preventable, and information technology-based interventions may be especially useful to reduce risk of re-exposure.



**Table 193.1** Classification of Drug Allergies

TYPE	TYPE OF IMMUNE RESPONSE	PATHOPHYSIOLOGY	CLINICAL SYMPTOMS	TYPICAL CHRONOLOGY OF THE REACTION
1	IgE	Mast cell and basophil degranulation	Anaphylactic shock Angioedema Urticaria Bronchospasm	Within 1-6 hr after the last intake of the drug
2	IgG and complement	IgG and complement-dependent cytotoxicity	Cytopenia	5-15 days after the start of the eliciting drug
3	IgM or IgG and complement or FcR	Deposition of immune complexes	Serum sickness Urticaria Vasculitis	7-8 days for serum sickness/urticaria 7-21 days after the start of the eliciting drug for vasculitis
4a	Th1 (IFN- $\gamma$ )	Monocytic inflammation	Eczema	1-21 days after the start of the eliciting drug
4b	Th2 (IL-4 and IL-5)	Eosinophilic inflammation	Maculopapular exanthem, DRESS	1 to several days after the start of the eliciting drug for MPE 2-6 wk after the start of the eliciting drug for DRESS
4c	Cytotoxic T cells (perforin, granzyme B, FASL)	Keratinocyte death mediated by CD4 or CD8	Maculopapular exanthem, SJS/TEN, pustular exanthem	1-2 days after the start of the eliciting drug for fixed drug eruption 4-28 days after the start of the eliciting drug for SJS/TEN
4d	T cells (IL-8/CXCL8)	Neutrophilic inflammation	Acute generalized exanthematous pustulosis	Typically 1-2 days after the start of the eliciting drug ( <i>but could be longer</i> )

CXCL8, C-X-C motif chemokine ligand 8; DRESS, drug reaction with eosinophilia and systemic symptoms; FASL, FAS ligand; FcR, Fc receptor; IFN- $\gamma$ , interferon gamma; IgE, immunoglobulin E; IL, interleukin; MPE, malignant pleural effusion; SJS, Stevens-Johnson syndrome; TEN, toxic epidermal necrolysis; Th1, Th2, T-helper cell type 1 and type 2. From Demoly P, Adkinson NF, Brockow K, et al. International Consensus on drug allergy. *Allergy*. 2014;69(4):420-437.

**Table 193.2** Heterogeneity of Drug-Induced Allergic Reactions

ORGAN-SPECIFIC REACTIONS	CLINICAL FEATURES	EXAMPLES OF CAUSATIVE AGENTS
<b>CUTANEOUS</b>		
Exanthems	Diffuse fine macules and papules evolve over days after drug initiation Delayed-type hypersensitivity	Allopurinol, aminopenicillins, cephalosporins, antiepileptic agents, antibacterial sulfonamides
Urticaria, angioedema	Onset within minutes of drug initiation Potential for anaphylaxis Usually IgE mediated	$\beta$ -Lactam antibiotics Platinum agents
Fixed drug eruption	Hyperpigmented plaques Recur at same skin or mucosal site	Tetracycline, sulfonamides, NSAIDs, carbamazepine
Pustules	Acneiform Acute generalized exanthematous pustulosis (AGEP)	Acneiform: corticosteroids, sirolimus AGEP: antibiotics, calcium-channel blockers
Bullous	Tense blisters Flaccid blisters	Furosemide, vancomycin Captopril, penicillamine
SJS	Fever, erosive stomatitis, ocular involvement, purpuric macules on face and trunk with <10% epidermal detachment	Antibacterial sulfonamides, anticonvulsants, oxycam NSAIDs, allopurinol
TEN	Similar features as SJS but >30% epidermal detachment Mortality as high as 50%	Same as SJS
Cutaneous lupus	Erythematous/scaly plaques in photodistribution	Hydrochlorothiazide, calcium channel blockers, ACEIs
Hematologic	Hemolytic anemia, thrombocytopenia, granulocytopenia	Penicillins, quinine, sulfonamides
Hepatic	Hepatitis, cholestatic jaundice	Para-aminosalicylic acid, sulfonamides, phenothiazines
Pulmonary	Pneumonitis, fibrosis	Nitrofurantoin, bleomycin, methotrexate
Renal	Interstitial nephritis, membranous glomerulonephritis	Penicillin, sulfonamides, gold, penicillamine, allopurinol
<b>MULTIORGAN REACTIONS</b>		
Anaphylaxis	Urticaria/angioedema, bronchospasm, gastrointestinal symptoms, hypotension IgE- and non-IgE-dependent reactions	$\beta$ -Lactam antibiotics, platins
DRESS	Cutaneous eruption, fever, eosinophilia, hepatic dysfunction, lymphadenopathy	Anticonvulsants, sulfonamides, minocycline, allopurinol
Serum sickness	Urticaria, arthralgias, fever	Heterologous antibodies, infliximab
Systemic lupus erythematosus	Arthralgias, myalgias, fever, malaise	Hydralazine, procainamide, isoniazid
Vasculitis	Cutaneous or visceral vasculitis	Hydralazine, penicillamine, propylthiouracil

ACEI, Angiotensin-converting enzyme inhibitor; DRESS, drug reaction with eosinophilia and systemic symptoms; NSAID, nonsteroidal antiinflammatory drug; SJS, Stevens-Johnson syndrome; TEN, toxic epidermal necrolysis.

Adapted from Khan DA, Solensky R. Drug allergy. *J Allergy Clin Immunol*. 2010;125:S126-S137. Table 1, p. S127.

**Table 193.3** Delayed Hypersensitivity Drug Rashes by Category**MACULOPAPULAR EXANTHEMS: ANY DRUG CAN PRODUCE A RASH SEVERAL DAYS INTO THE COURSE**

Allopurinol  
 Antibiotics: penicillins, ampicillin, sulfonamides  
 Antiepileptics: phenytoin, phenobarbital  
 Antihypertensives: thiazide diuretics, calcium channel blockers  
 Radiocontrast material  
 Gold salts  
 Hypoglycemic drugs  
 Meprobamate  
 Phenothiazines  
 Quinine

**DRUG REACTION WITH EOSINOPHILIA AND SYSTEMIC SYMPTOMS (DRESS)**

Anticonvulsants: phenytoin, phenobarbital, valproate, lamotrigine, carbamazepine  
 Antibiotics: sulfonamides, minocycline, dapsone, ampicillin, ethambutol, isoniazid, linezolid, metronidazole, rifampin, streptomycin, vancomycin  
 Allopurinol  
 NSAIDs: celecoxib, ibuprofen, diclofenac  
 Phenothiazines

**STEVENS-JOHNSON SYNDROME/TOXIC EPIDERMAL NECROLYSIS**

Sulfonamides, phenytoin, barbiturates, carbamazepine, allopurinol, amikacin, phenothiazines, acetazolamide, gold, nitrofurantoin, pentazocine, tetracycline, quinidine

**ACUTE GENERALIZED EXANTHEMATOUS PUSTULOSIS**

Antibiotics: penicillins, macrolides, cephalosporins, clindamycin, imipenem, fluoroquinolones, isoniazid, vancomycin, minocycline, doxycycline, linezolid, gentamicin, sulfonamides  
 Antimalarials: chloroquine, hydroxychloroquine  
 Antifungals: terbinafine, nystatin, amphotericin B, fluconazole, itraconazole  
 Anticonvulsants: carbamazepine  
 Calcium-channel blockers  
 Furosemide, thiazides  
 Systemic corticosteroids  
 Protease inhibitors

**COLLAGEN VASCULAR OR LUPUS-LIKE REACTIONS**

Procainamide, hydralazine, phenytoin, penicillamine, trimethadione, methyl dopa, carbamazepine, griseofulvin, nalidixic acid, oral contraceptives, propranolol

**ERYTHEMA NODOSUM**

Oral contraceptives, penicillins, sulfonamides, diuretics, gold, clonidine, propranolol, opiates

**FIXED DRUG REACTIONS**

Phenolphthalein, barbiturates, gold, sulfonamides, penicillins, tetracycline, quinolones, carbamazepine, NSAIDs

Note: See Chapter 686 and Table 686.5.

NSAID, Nonsteroidal antiinflammatory drug.

Adapted from Duvic M. Urticaria, drug hypersensitivity rashes, nodules and tumors, and atrophic diseases. In: Goldman L, Schafer AJ, eds. *Goldman-Cecil Medicine*. 25th ed. Philadelphia: Elsevier; 2016: Table 440.3.

**PATHOGENESIS AND CLINICAL MANIFESTATIONS**

Immunologically mediated ADRs have been classified according to the Gell and Coombs classification: immediate hypersensitivity reactions (**type I**), cytotoxic antibody reactions (**type II**), immune complex reactions (**type III**), and delayed-type hypersensitivity reactions (**type IV**) (see Table 193.1). **Immediate hypersensitivity reactions** occur when a drug or drug metabolite interacts with preformed drug-specific IgE antibodies that are bound to the surfaces of tissue mast cells and/or circulating basophils. The cross linking of adjacent receptor-bound IgE by antigen causes the release

of preformed and newly synthesized mediators, such as histamine and leukotrienes, that contribute to the clinical development of urticaria, bronchospasm, or anaphylaxis. **Cytotoxic antibody reactions** involve IgG or IgM antibodies that recognize drug antigen on the cell membrane. In the presence of serum complement, the antibody-coated cell is either cleared by the monocyte-macrophage system or is destroyed. Examples are drug-induced hemolytic anemia and thrombocytopenia. **Immune complex reactions** are caused by soluble complexes of drug or metabolite in slight antigen excess with IgG or IgM antibodies. The immune complex is deposited in blood vessel walls and causes injury by activating the complement cascade, as seen in serum sickness. Clinical manifestations include fever, urticaria, rash, lymphadenopathy, and arthralgias. Symptoms typically appear 1-3 weeks into the course of the offending drug and persist for days to weeks after the drug is discontinued. **Delayed-type hypersensitivity reactions** are mediated by cellular immune mechanisms. They are subdivided into four categories involving activation and recruitment of monocytes (type IVa), eosinophils (type IVb), CD4<sup>+</sup> or CD8<sup>+</sup> T cells (type IVc), and neutrophils (type IVd). Examples include drug reaction with eosinophilia and systemic symptoms (DRESS), acute generalized exanthematous pustulosis (AGEP) and Stevens-Johnson syndrome (SJS) (see Chapter 686.2). Not all allergic drug reactions can be easily classified using the Gell and Coombs system.

Non-IgE-mediated immediate-type reactions mimic Gell and Coombs type I reactions, with indistinguishable symptoms and signs. The most common drugs associated with these reactions are vancomycin, fluoroquinolones, and opiates, which cause non-specific mast cell degranulation via interaction with the surface receptor MrgprX2. Because these reactions do not require prior sensitization (unlike IgE-mediated reactions), they may occur with first exposure.

The pharmacologic interaction with immune receptors concept (**p-i concept**) is another type of drug hypersensitivity classification. In this scheme, a drug binds noncovalently to a T-cell receptor, which leads to an immune response through interaction with a major histocompatibility complex (MHC) receptor. In this scenario, no sensitization (i.e., previous exposure) is required because there is direct stimulation of memory and effector T cells analogous to the concept of superantigens. Although the various mechanistic schemes of drug-induced allergic reactions are useful, not all drug allergic reactions can be categorized using these various classification systems.

**Stevens-Johnson Syndrome and Toxic Epidermal Necrolysis**

Blistering mucocutaneous disorders induced by drugs encompass a spectrum of reactions, including SJS and toxic epidermal necrolysis (TEN; see Chapters 686.2, 695.2 and 695.3). Although their pathophysiology remains incompletely understood, HLA associations including HLA-B\*1502 with carbamazepine-induced TEN have been recognized, and the pathogenic roles of drug-specific cytotoxic T cells and granulysin have been reported. SJS is defined as the epidermal detachment of <10%, TEN is >30% detachment, and overlap syndrome is 10–30% detachment. The features of SJS include confluent purpuric macules on face and trunk and severe, explosive mucosal erosions, usually at more than one mucosal surface, accompanied by fever and constitutional symptoms. Ocular involvement may be particularly severe, and the liver, kidneys, and lungs may also be involved. TEN, which appears to be related to keratinocyte apoptosis, manifests as widespread areas of confluent erythema followed by epidermal necrosis and detachment with severe mucosal involvement. Skin biopsy differentiates subepidermal cleavage characteristic of TEN from intraepidermal cleavage characteristic of the scalded-skin syndrome induced by staphylococcal toxins. The risks of infection and mortality remain high, but improved outcomes have been demonstrated by immediate withdrawal of the implicated drug, early transfer to a burn unit, and aggressive supportive care. Additional management is reviewed in Chapter 695.3.

### Drug Reaction with Eosinophilia and Systemic Symptoms

DRESS (i.e., drug-induced hypersensitivity syndrome) is a potentially life-threatening reaction that has been described primarily with anti-convulsants, although many other medications have been implicated (see Tables 193.2 and 193.3; see Chapter 686.2). It is likely less common in children compared with adults. DRESS is characterized by fever, maculopapular rash, facial edema, eosinophilia, generalized lymphadenopathy, and potentially life-threatening damage of one or more organs, usually hepatic or renal. Onset is delayed, usually 2-8 weeks after initiation of the medication. It has been associated with reactivation of human herpesvirus 6. Treatment is withdrawal of the medication, systemic steroids, and supportive care, but symptoms can worsen or persist for weeks to months after the drug has been discontinued.

### Drug Metabolism and Adverse Reactions

Most drugs and their metabolites are not immunologically detectable until they have become covalently attached to a macromolecule. This multivalent hapten-protein complex forms a new immunogenic epitope that can elicit T- and B-lymphocyte responses. Penicillins are highly reactive with proteins and can directly haptenate protein carriers, without prior metabolism, possibly accounting for the higher frequency of immune-mediated hypersensitivity reactions with this class of antibiotics.

Incomplete or delayed metabolism of some drugs can give rise to toxic metabolites. Hydroxylamine, a reactive metabolite produced by cytochrome P450 oxidative metabolism, may mediate adverse reactions to sulfonamides. Patients who are *slow acetylators* appear to be at increased risk. In addition, cutaneous reactions in patients with AIDS treated with TMP/SMX, rifampin, and other drugs may be caused by glutathione deficiency resulting in toxic metabolites. Serum sickness-like reactions due to cefaclor may result from an inherited propensity for hepatic biotransformation of drugs into toxic or immunogenic metabolites.

### Risk Factors for Hypersensitivity Reactions

Risk factors for ADRs include prior exposure, previous reactions, age (20-49 years), route of administration (parenteral or topical), dose (high), and dosing schedule (intermittent), and genetic predisposition. Atopy does not appear to predispose patients to allergic reactions to low molecular weight compounds, but asthmatics who experience allergic reactions are likely at increased risk of more serious reactions, analogous to food-allergic patients. Atopic patients also appear to be at greater risk for pseudoallergic reactions induced by radiocontrast media (RCM). Pharmacogenomics has an important role in identifying individuals at risk for certain drug reactions.

### DIAGNOSIS

Skin testing is the most rapid and sensitive method of demonstrating the presence of IgE antibodies to a specific allergen. It can be performed with high molecular weight compounds, such as foreign antisera, hormones, enzymes, and toxoids. Reliable skin testing can also be performed with penicillin, but not with most other antibiotics. Most immunologically mediated ADRs are caused by metabolites rather than by parent compounds, and the metabolites for most drugs other than penicillin have not been defined. In addition, many metabolites are unstable or must combine with larger proteins to be useful for diagnosis. Testing with nonstandardized reagents requires caution in interpretation of both positive and negative results, because some drugs can induce nonspecific irritant reactions. Whereas a wheal and flare reaction is suggestive of drug-specific IgE antibodies, a negative skin test result does not exclude the presence of such antibodies because the relevant immunogen may not have been used as the testing reagent.

In vitro tests (radioallergosorbent test or enzyme-linked immunoassay) for IgE-mediated penicillin allergy have lower sensitivity and comparable specificity compared with skin testing. The positive and negative predictive values (NPVs) of skin testing for antibiotics other than penicillin are not well established. Nevertheless, positive

immediate hypersensitivity skin test responses using nonirritant concentrations of nonpenicillin antibiotics may be interpreted as a presumptive risk of an immediate reaction to such agents.

Results of direct and indirect Coombs tests are often positive in drug-induced hemolytic anemia. Assays for specific IgG and IgM have been shown to correlate with a drug reaction in immune cytopenia, but in most other reactions, such assays are not diagnostic. In general, many more patients express humoral or T-cell immune responses to drug determinants than express clinical disease. Serum **tryptase** is elevated with systemic mast cell degranulation and can be seen with drug-associated reactions such as anaphylaxis; however, not all patients with well-defined anaphylaxis show increased serum tryptase levels. **Patch testing** is the most reliable technique for diagnosis of contact dermatitis caused by topically applied drugs. **Graded drug challenge** is an incremental (usually two-step) administration of a drug under medical supervision and is used in patients who are deemed unlikely to be allergic to the drug. Unlike desensitization, there is no attempt to modify the underlying immune response. Patients who pass a graded challenge are proven to not be allergic to the drug.

### TREATMENT

Drug desensitization alters the immune response to a medication and allows allergic patients to receive it safely. However, the induced tolerance is temporary and if treatment is interrupted, hypersensitivity returns, and patients are again at risk of reacting to the drug. Drug desensitization has classically been used for IgE-mediated allergy, such as penicillin, but the procedure has been successfully applied to immediate non-IgE-mediated reactions, such as taxanes. Rapid desensitization is indicated in patients who are either proven or are strongly suspected to have an immediate-type drug allergy and for whom an alternate drug is not available or appropriate. The procedure warrants close monitoring and preparedness to treat possible anaphylaxis. Depending on the clinical stability of the patient and the severity of the previous reaction (or symptoms during a previous desensitization), it may be performed in outpatient or inpatient settings. Premedications are used for non-IgE-mediated hypersensitivity (such as taxanes and biologic agents), but not for IgE-mediated allergy (such as antibiotics). Desensitization can be performed via parenteral or oral routes. The starting dose is typically 1/10,000 of the full dose, and the dose is doubled every 15 minutes until the full dose is reached. Desensitization has a very high success rate and breakthrough allergic reactions occur about 20-30% of the time, but they are usually mild and do not necessitate aborting the procedure.

### Penicillin Allergy

Penicillin allergy is self-reported by approximately 10% of patients, but following evaluation, about 95% of these individuals are shown to not be allergic and able to tolerate penicillins. This incongruity is due to the reaction being the result of the underlying infection (or interaction between the infectious agent and the antibiotic), mislabeling a predictable reaction as allergic, and the waning of penicillin-specific IgE. Being labeled as penicillin allergic is not benign, because patients are more likely to be treated with less effective, more toxic, or more expensive antibiotics such as fluoroquinolones, vancomycin, later generation cephalosporins, and clindamycin. This prescribing practice compromises optimal medical care and increases costs. Penicillin "allergy" has been associated with increased antimicrobial resistance (such as vancomycin-resistant *Enterococcus* and methicillin-resistant *Staphylococcus aureus*), increased *Clostridium difficile* colitis, increased surgical site infections, prolonged length of hospital stays, increased intensive care admissions, increased hospital readmissions, and increased mortality. Removal of the penicillin allergy label leads to improved antibiotic selection with decreased use of broad-spectrum antibiotics and decreased healthcare utilization (fewer outpatient visits, fewer emergency department [ED] visits, and fewer hospital days). Therefore a proactive effort should be made to de-label penicillin allergy whenever possible. Ideally, this is done electively such as when patients are well and not in immediate need of antibiotic treatment. De-labeling of penicillin allergy is endorsed by the CDC, allergy/immunology, and infectious disease societies.

The penicillin  $\beta$ -lactam ring opens to form various reactive intermediates, which then interact with self-proteins to stimulate immune reactions. Penicillin skin test reagents are based on the immunochemistry, and they are broadly grouped into major and minor allergenic determinants. (Table 193.4) The positive predictive value of penicillin skin testing is ~80% for immediate type reactions. Alternatively, 95% or more of penicillin skin test–negative patients tolerate these antibiotics. The major determinant (penicilloyl-polylysine [PPL]) should always be used for skin testing, but there is controversy regarding the relative importance of various minor determinants (penicillin G, penicilloate, penilloate and ampicillin/amoxicillin) and what effect this has on the NPV. Although PPL is commercially available in the United States as Pre-Pen, the minor determinants are not. Penicillin G and IV ampicillin can be diluted and used off-label for skin testing, but penicilloate and penilloate require synthesis; therefore they are more difficult to obtain.

Patients who are positive on penicillin skin testing should avoid penicillins but consider being reevaluated at a later time, because penicillin allergy wanes and resolves in most (but not all) individuals. If administration of penicillin is deemed necessary, desensitization can be performed. Skin test–negative patients should ideally undergo an amoxicillin challenge, to unequivocally prove lack of allergy. This alleviates the fear and reluctance on the part of the patient, patient's family, or future prescribing clinicians to treat with penicillins. Additionally, effort should be made to remove the penicillin allergy label in all electronic medical systems (hospitals, clinics, private offices, pharmacies, etc.).

The traditional approach to de-label penicillin allergy has been to first perform penicillin skin testing in all patients with suggestive penicillin allergy histories and then challenge with amoxicillin (if skin testing is negative). However, in recent years several publications have challenged this standard, particularly in the pediatric population, by instead directly challenging “low-risk” patients with amoxicillin (without preceding skin testing). Patients deemed appropriate for direct

amoxicillin challenge are those with maculopapular and urticaria eruptions, without other respiratory, cardiovascular, oropharyngeal symptoms, angioedema, and vesicular or exfoliative eruptions. Using this strategy, the rate of observed reactions ranged from 5% to 10% and were no more severe than the historical reactions. For comparison, up to 7% of children (without a previous history of allergy) treated with aminopenicillins develop cutaneous eruptions. The cause of these rashes is presumed to be the underlying infection (typically viral) or an interaction between the infectious agent and the antibiotic. The best characterized example is patients with Epstein-Barr infection, almost 100% of whom develop a nonpruritic morbilliform rash when treated with ampicillin. Pediatric patients who undergo direct amoxicillin challenge should be observed in a clinical setting for at least 1 hour, with preparedness to treat potential allergic reactions including anaphylaxis.

Resensitization is the redevelopment of penicillin allergy after initial resolution. Resensitization after oral treatment with penicillins is rare in both pediatric and adult patients, including after repeated courses, and comparable to the rate of sensitization. Therefore repeat penicillin skin testing is not indicated in patients with a history of penicillin allergy who have tolerated one or more courses of oral penicillin. Data on resensitization after parenteral treatment with penicillins is more limited, but routine repeat penicillin skin testing is likely not necessary in patients with a history of penicillin allergy who have tolerated one or more courses of parenteral penicillin. Consideration may be given to retesting individuals with recent or particularly severe previous reactions.

### $\beta$ -Lactam Cross Reactivity

Penicillins, cephalosporins, carbapenems, and aztreonam share a common  $\beta$ -lactam ring and hence the potential for allergic cross reactivity. Additionally, some penicillins and cephalosporins share identical R group side chains, and these are another source of potential allergic cross reactivity (Table 193.5). Combining published reports of patients proven to be allergic via positive penicillin skin testing and then challenged with cephalosporins, only about 2% experienced allergic reactions. This is similar to the incident rate of new drug reactions to structurally dissimilar medications in patients with prior drug allergies (because patients with a history of drug allergy are more likely to react to structurally unrelated drugs). If cephalosporin skin testing (using nonirritating concentrations) is performed in penicillin skin test–positive subjects before challenging with cephalosporins, the reaction rate decreased to 0%.

In general, the preferred approach to patients with a history of penicillin allergy is to electively de-label the allergy because this greatly simplifies all future  $\beta$ -lactam administration recommendations by allowing treatment with any  $\beta$ -lactam antibiotics. Given that less than 5% of patients with an unverified penicillin allergy are truly allergic and 2% of those who are allergic cross react with cephalosporins, the chance

**Table 193.4** Penicillin Skin Test Reagents

REAGENT*	CONCENTRATION USED FOR SKIN TESTING
Penicilloyl-polylysine (PPL)	$6 \times 10^{-5}$ M
Penicillin G	10,000 units/mL
Penicilloate	0.01 M
Penilloate	0.01 M
Ampicillin/amoxicillin	3-25 mg/mL

\*PPL is the major allergenic determinant; all the other reagents are minor determinants.

**Table 193.5** Groups of  $\beta$ -Lactam Antibiotics That Share Identical Side Chains\*

IDENTICAL R1-GROUP SIDE CHAINS					
Amoxicillin	Ampicillin	Ceftriaxone	Cefoxitin	Cefamandole	Ceftazidime
Cefadroxil	Cefaclor	Cefotaxime	Cephaloridine	Cefonicid	Aztreonam
Cefprozil	Cephalexin	Cefpodoxime	Cephalothin		
Cefatrizine	Cephradine	Cefditoren			
	Cephaloglycin	Ceftizoxime			
	Loracarbef	Cefmenoxime			
IDENTICAL R2-GROUP SIDE CHAINS					
Cephalexin	Cefotaxime	Cefuroxime	Cefotetan	Cefaclor	Ceftibuten
Cefadroxil	Cephalothin	Cefoxitin	Cefamandole	Loracarbef	Ceftizoxime
Cephadrine	Cephaloglycin		Cefmetazole		
	Cephapirin		Cefpiramide		

\*Each column represents a group with identical side chains.

From Solensky R, Khan DA. Drug allergy: an updated practice parameter. *Ann Allergy Asthma Immunol*. 2010;105:273e1–273e78. Tables 16, 17, p. 273e49.



of a cephalosporin reaction is extremely low at approximately 0.1% (5% × 2% = 0.1%). Therefore most experts and guidelines recommend that for patients with a history of nonanaphylactic penicillin allergy, cephalosporins may be administered without prior testing or additional precautions. In patients with a history of penicillin anaphylaxis (or those positive on penicillin skin testing), cephalosporin graded challenge is preferred because the chance of reaction is still very low.

There are rare patients who have selective IgE-mediated allergy to aminopenicillins but tolerate penicillin VK and penicillin G. The allergic determinant is an R-group side chain, rather than the core β-lactam portion of the molecule. In these patients, the positive challenge rate to cephalosporins sharing identical side group chains (such as ampicillin/cephalexin or amoxicillin/cefadroxil; see Table 193.5) is higher, or about 16%. Therefore, in such patients, administration of cephalosporins with identical side group chains should be avoided, given via two-step graded challenge or desensitization, whereas treatment with other cephalosporins does not require a more cautious approach.

The data on allergic cross reactivity between penicillins and carbapenems mirror the discussion on penicillin/cephalosporin cross reactivity. Patients with unconfirmed penicillin allergy treated with carbapenems showed a higher reaction rate compared to patients without a history of penicillin allergy. In studies of penicillin skin test–positive patients challenged with carbapenems, none of 680 reacted; four carbapenem skin test–positive patients were not challenged. Therefore it is recommended that patients with a history of penicillin allergy may receive carbapenems in usual fashion or via two-step graded challenge.

Aztreonam is the only monobactam and the only β-lactam antibiotic that contains a monocyclic ring structure, in contrast to the bicyclic core of other β-lactams. In vitro, skin testing and challenge studies have demonstrated no evidence of allergic cross reactivity between penicillins and aztreonam, including no positive aztreonam challenges in penicillin skin test–positive patients. Therefore patients with a history of penicillin allergy may receive aztreonam in the usual fashion. The only β-lactam that shows cross reactivity with aztreonam is ceftazidime, because these two antibiotics share an identical R-group side chain. Hence, patients allergic to aztreonam or ceftazidime should avoid the other antibiotic.

### Sulfonamides

The most common type of reaction to sulfonamide antibiotics is a maculopapular eruption that occurs about a week into treatment. The incidence of immediate reactions, such as urticaria/angioedema or anaphylaxis, is rare and less frequent than with β-lactam antibiotics. On the other hand, sulfonamides are the most common antibiotic to cause severe cutaneous delayed reactions (SCARs), such as SJS, TEN, and DRESS. Hypersensitivity reactions to sulfonamides occur with greater frequency in HIV-infected individuals. For patients with history of typical delayed maculopapular rashes, both graded one- or two-step challenge and desensitization protocols have been shown to be effective in HIV-positive and non-HIV-positive patients. Because the success rate of graded challenge and desensitization appears comparable, it is not clear that the various desensitization protocols truly modify the immune response. These regimens are not intended for individuals with a history of SJS or TEN. There is no evidence of allergic cross reactivity between sulfonamide antibiotics and nonantibiotic sulfonamides (such as celecoxib, thiazides, furosemide, acetazolamide, sumatriptan, and others).

### Macrolides

Macrolides cause allergic reactions less frequently than penicillins, cephalosporins, or sulfonamides. The most common reactions are delayed onset maculopapular eruptions and urticaria, and they occur in about 1% of patients. IgE-mediated reactions are uncommon, limited to case series, and anaphylactic reactions are extremely rare. When pediatric patients with convincing histories of allergic reactions undergo formal evaluation, less than 10% are confirmed to be allergic. Skin testing with a nonirritating concentration of macrolides may

provide useful information in those patients with immediate reaction histories. However, in patients with an anticipated clinical need for macrolides, graded challenge without preceding testing is used most commonly, given the high likelihood of success and rare nature of anaphylaxis.

### Antiretroviral Agents

There are several categories of antiretroviral drugs to treat HIV (reverse transcriptase inhibitors, protease inhibitors, entry inhibitors, and integrase inhibitors) and all have been implicated in hypersensitivity reactions, which usually present as delayed onset and range from mild self-limited maculopapular eruptions to life-threatening SJS/TEN or DRESS. Hypersensitivity to abacavir is a well-recognized, multiorgan, potentially life-threatening reaction that occurs in HIV-infected children and adults. Rechallenge is strictly contraindicated, because subsequent reactions may be more rapid and severe than the initial reaction. Importantly, these reactions have been associated with the presence of the MHC class I allele HLA-B\*5701, and HLA testing has shown very high sensitivity and NPV. Therefore genetic screening for HLA-B\*5701

is part of guideline-based therapy when abacavir is initially prescribed.

### Chemotherapeutic Agents

Hypersensitivity reactions to chemotherapeutic drugs have been described, most notably to platinum agents and taxanes. The clinical pattern of immediate reactivity to platinum agents, along with skin test findings, is consistent with an IgE-mediated mechanism. Hence reactions occur after patients tolerated several previous treatments. In contrast, immediate reactions to paclitaxel and docetaxel usually occur with first exposure and the risk lessens with repeated exposure. They are believed to be due to emulsifying agents such as Cremophor-EL, which result in complement activation and generation of anaphylatoxins. Rapid desensitization (most typically a 12-step protocol) is effective for both IgE and non-IgE-mediated type reactions.

### Biologics

An increasing number of biologic agents have become available for the treatment of autoimmune, allergic, cardiovascular, infectious, and neoplastic diseases. Their use may be associated with a variety of ADRs, including hypersensitivity reactions. Given the occurrence of anaphylaxis, including cases with delayed onset and protracted progression in spontaneous postmarketing adverse event reports, the FDA issued a black box warning regarding risk of anaphylaxis and need for patient monitoring with use of omalizumab (see Chapter 185).

### Vaccines

Anaphylactic reactions to vaccines are very rare, occurring at a rate of approximately one event per million administrations, and they may be due to various vaccine components such as antibiotics, preservatives, stabilizers, virus-inactivating compounds, residual animal proteins, and latex. Measles mumps rubella (MMR) vaccine has been shown to be safe in egg-allergic patients (although rare reactions to gelatin or neomycin can occur). Egg-allergic patients are not at higher risk of reacting to both inactivated and live influenza vaccine than those without egg allergy. Skin testing with the influenza vaccine is no longer recommended for egg-allergic patients but may be helpful if allergy to the vaccine itself is suspected. The American Academy of Allergy, Asthma, and Immunology (AAAAI)/American College of Allergy, Asthma, and Immunology (ACAAI) Joint Task Force on Practice Parameters recommend that “Influenza vaccines should be administered to individuals with egg allergy of any severity, just as they would be to individuals without egg allergy.” The incidence of anaphylactic reactions following mRNA COVID-19 vaccines may be higher (2.5–4.7 events per million). However, following evaluation by allergists/immunologists, most patients reporting immediate-type reactions to the first vaccine dose are able to tolerate the second dose, arguing against an IgE-mediated mechanism. Therefore the true rate of anaphylaxis is likely lower.

It is uncertain whether patients with underlying atopic conditions or other allergies are at increased risk of reacting to these vaccines. Although polyethylene glycol (PEG) (a component of mRNA COVID vaccines) has been proposed to be a possible culprit, there is limited evidence for the relationship.

### Perioperative Agents

In North America, perioperative anaphylaxis is most frequently due to antibiotics, whereas in European series, neuromuscular blockers are the most common culprit. Other potential causes include induction agents, opioids, colloids and plasma expanders, chlorhexidine, sugammadex, and latex. The mechanism responsible may be IgE-mediated or non-IgE-mediated. Previous surgeries are a risk factor for IgE-mediated reactions because they require prior sensitization. Patients who have experienced perioperative anaphylaxis should be screened for possible mast cell disease. Skin testing with agents known to cause IgE-mediated reactions is useful and can help prevent recurrent reactions during subsequent surgeries. Sometimes, despite a thorough evaluation, an underlying cause for perioperative anaphylaxis is not detected.

### Local Anesthetics

ADRs associated with local anesthetic agents are primarily nonallergic and include vasovagal, psychomotor, sympathetic stimulation, and toxic reactions. IgE-mediated reactions are exceedingly rare. Patients with suspected local anesthetic allergy should be referred to an allergist/immunologist for skin testing followed by a graded challenge. This procedure invariably finds a local anesthetic the patient is able to tolerate, in the rare individuals who are allergic to one of these agents. Although local anesthetics can be broadly grouped into esters (group I) and amides (group II), allergic cross reactivity within these groups is only relevant for delayed Gell and Coombs type IV reactions, not type I reactions.

### Insulin

Insulin use has been associated with a spectrum of ADRs, including local and systemic IgE-mediated reactions, hemolytic anemia, serum sickness reactions, and delayed-type hypersensitivity. In general, human insulin is less allergenic than porcine insulin, which is less allergenic than bovine insulin, but for individual patients, porcine or bovine insulin may be the least allergenic. Patients treated with nonhuman insulin have had systemic reactions to recombinant human insulin even on the first exposure. More than 50% of patients who receive insulin develop antibodies against the insulin preparation, although there may not be any clinical manifestations. Local cutaneous reactions usually do not require treatment and resolve with continued insulin administration, possibly because of IgG-blocking antibodies. More severe local reactions can be treated with antihistamines or by splitting the insulin dose between separate administration sites. Local reactions to the protamine component of neutral protamine Hagedorn insulin may be avoided by switching to lente insulin. Immediate-type reactions to insulin, including urticaria and anaphylactic shock, are unusual and almost always occur after reinstatement of insulin therapy in sensitized patients.

Insulin therapy should not be interrupted if a systemic reaction to insulin occurs, and continued insulin therapy is essential. Skin testing may identify a less antigenic insulin preparation. The dose following a systemic reaction is usually reduced to one-third, and successive doses are increased in 2- to 5-unit increments until the dose resulting

in glucose control is attained. Insulin skin testing and desensitization are required if insulin treatment is subsequently interrupted for >24-48 hours.

### Radiocontrast Media

Immediate type allergic reactions to RCM may occur after intravascular administration, and during myelograms or retrograde pyelograms. The pathogenic mechanism has classically been thought to be non-IgE-mediated mast cell activation (anaphylactoid). However, there is growing evidence that some immediate reactions are IgE mediated. This may be because use of older high-osmolar RCM agents has been replaced by low- and iso-osmolar agents. One approach to patients with previous RCM reactions who require another diagnostic study is to choose an alternate agent and premedicate with prednisone and diphenhydramine. Another approach is to perform skin testing with the culprit and alternate RCM agents, with the results guiding the choice of treatment. The latter method appears to be more useful when the historical reactions are severe (i.e., anaphylactic). There is no evidence that seafood or iodine allergy is associated with or predisposes to RCM reactions.

### Aspirin and Nonsteroidal Antiinflammatory Drugs

Acetylsalicylic acid (ASA) and other NSAIDs have been associated with several types of allergic reactions. Reactions that are caused by modifying effects on arachidonic acid metabolism, namely respiratory reactions (in patients with underlying aspirin-exacerbated respiratory disease [AERD]) and urticarial reactions (in patients with underlying chronic idiopathic urticaria), show cross reactivity with other NSAIDs, as one would expect. Patients with AERD and aspirin-sensitive patients with chronic idiopathic urticaria tolerate drugs that selectively block the cyclooxygenase-2 (COX-2) enzyme, such as celecoxib. On the other hand, acute urticarial or anaphylactic reactions in otherwise normal individuals are medication specific. There are no skin or in vitro tests to identify patients allergic to ASA or other NSAIDs.

Except for respiratory reactions in asthmatics, there are no data on the incidences of reactions to ASA/NSAIDs in children; however, clinical experience suggests that it is much lower than in adults. Furthermore, only 20% of children reporting NSAID allergy are confirmed to be allergic when challenged. The incidence of AERD in children with asthma has been investigated in six prospective studies, the rate varied from 0% to 28%, and there was a trend for more respiratory reactions in adolescents compared with younger children. Overall, the data indicate that ASA sensitivity in asthmatic children under the age of 10 is rare and increases thereafter.

Patients with AERD whose nasal disease or asthma is poorly controlled with use of medications are candidates for ASA desensitization. This procedure, unlike antibiotic or chemotherapy desensitization, involves administration of the drug to cautiously induce a respiratory reaction (rather than prevent it), following which patients enter a refractory phase that can be maintained with continued administration of ASA. Long-term studies of adults maintained on chronic ASA desensitization demonstrated improved clinical outcomes for both upper and lower respiratory diseases. ASA desensitization is rarely performed in children because severe, poorly controlled AERD is encountered very infrequently in the pediatric population, and aspirin is not routinely recommended for children because of the risk of Reyes syndrome.

Visit Elsevier eBooks+ at [eBooks.Health.Elsevier.com](https://eBooks.Health.Elsevier.com) for Bibliography.

# Rheumatic Diseases of Childhood (Connective Tissue Disease, Collagen Vascular Diseases)

PART  
XIV

Chapter 194

## Evaluation of Suspected Rheumatic Disease

C. Eglia Rabinovich

Rheumatic diseases are defined by the constellation of results of the physical examination, autoimmune markers and other serologic tests, tissue pathology, and imaging. Defined diagnostic criteria exist for most rheumatic diseases. Recognition of *clinical patterns* remains essential for diagnosis because there is no single diagnostic test, and tests may be positive in the absence of disease. Further complicating diagnosis, children sometimes present with partial criteria that evolve over time or with features of more than one rheumatic disease (overlap syndromes). The primary mimics of rheumatic diseases are infection and malignancy but also include metabolic, orthopedic, immune deficiencies, autoinflammatory diseases, and chronic pain conditions. Exclusion of possible mimicking disorders is essential before initiation of treatment for a presumptive diagnosis, especially corticosteroids. After careful evaluation has excluded nonrheumatic causes, referral to a pediatric rheumatologist for confirmation of the diagnosis and treatment should be considered.

### SYMPTOMS SUGGESTIVE OF RHEUMATIC DISEASE

There are no classic symptoms of rheumatic diseases, but common symptoms include joint pain, fever, fatigue, and rash. Presenting signs and symptoms help direct the evaluation and limit unnecessary testing. Once a differential diagnosis is developed based on history and physical findings, a directed assessment assists in determining the diagnosis.

**Arthralgias** are common in childhood and are a frequent reason for referral to pediatric rheumatologists. Arthralgias without physical findings for arthritis suggest infection, malignancy, orthopedic conditions, benign syndromes, or pain syndromes such as fibromyalgia (Table 194.1). Although rheumatic diseases may manifest as arthralgias, **arthritis** is a stronger predictor of the presence of rheumatic disease and a reason for referral to a pediatric rheumatologist. The timing of joint pain along with associated symptoms, including poor sleep and interference with normal activities, provides important clues. Poor sleep, debilitating generalized joint pain that worsens with activity, school absences, and normal physical and laboratory findings in an adolescent suggest an amplified **pain syndrome** (see Chapter 212). If arthralgia is accompanied by a history of dry skin, hair loss, fatigue, growth disturbance, or cold intolerance, testing for **thyroid disease** is merited. Nighttime awakenings because of severe pain along with decreased platelet or white blood cell (WBC) count or, alternatively, a very high WBC count, may lead to the diagnosis of malignancy, especially marrow-occupying lesions such as **acute lymphocytic leukemia**

and **neuroblastoma**. Pain with physical activity suggests a mechanical problem such as an overuse syndrome or orthopedic condition. An adolescent presenting with knee pain aggravated by walking up stairs and on patellar distraction likely has **patellofemoral syndrome**. Children age 3-10 years with a history of episodic pain occurring at night, especially after increased daytime physical activity, that is relieved by rubbing but who have no limp or complaints in the morning likely have **growing pains**. There is often a positive family history for growing pains, which may aid in this diagnosis. Intermittent pain in a child, especially a girl 3-10 years old, that is increased with activity and is associated with hyperextensible joints on examination likely has **benign hypermobility syndrome**. Many febrile illnesses cause arthralgias that improve when the temperature normalizes, and arthralgias are part of the diagnostic criteria for **acute rheumatic fever (ARF)**; see Chapter 229.1).

Arthralgia may also be a presenting symptom of pediatric **systemic lupus erythematosus (SLE)** and chronic childhood arthritis such as **juvenile idiopathic arthritis (JIA)**. Interestingly, many children with JIA do not complain of joint symptoms at presentation. Other symptoms more suggestive of arthritis include morning stiffness, joint swelling, limited range of motion, pain with joint motion, gait disturbance, fever, and fatigue or stiffness after physical inactivity (*gelling phenomenon*). A diagnosis of JIA cannot be made without the finding of arthritis on physical examination (see Chapters 196 and 197). No laboratory test is diagnostic of JIA.

**Fatigue** is a nonspecific symptom that may point to the presence of a rheumatic disease but is also common in nonrheumatic causes, such as viral infections, pain syndromes, depression, and malignancy. Fatigue, rather than the specific complaints of muscle weakness, is a common presenting complaint in **juvenile dermatomyositis (JDM)**. It is also frequently present in SLE, vasculitis, and chronic childhood arthritis. Overwhelming fatigue with inability to attend school is more suggestive of chronic fatigue syndrome, pediatric fibromyalgia, or other amplified pain syndrome.

### SIGNS SUGGESTIVE OF RHEUMATIC DISEASE

A complete physical examination is essential in any child with suspected rheumatic disease, because subtle physical findings may further refine the differential diagnosis. In addition, many rheumatic diseases have multisystem effects, and a stepped assessment should focus on delineating the extent of organ system involvement (e.g., skin, joints, muscle, hepatic, renal, cardiopulmonary).

Presence of a **photosensitive malar rash** that spares the nasolabial folds is suggestive of SLE (Table 194.2; see Fig. 199.1A). Diffuse facial rash is more indicative of JDM. A hyperkeratotic rash on the face or around the ears may represent discoid lupus (see Fig. 199.1D). A palpable purpuric rash on the extensor surfaces of the lower extremities points to **IgA vasculitis (Henoch-Schönlein purpura)** (see Fig. 210.2A). Less localized purpuric rashes and petechiae are present in systemic vasculitis or blood dyscrasias, including coagulopathies. Nonblanching erythematous papules on the palms are seen in vasculitis, SLE, and endocarditis. Gottron papules (see Fig. 200.3) and heliotrope rashes (see Fig. 200.2) along with erythematous rashes on the elbows and knees are pathognomonic

**Table 194.1** Symptoms Suggestive of Rheumatic Disease

SYMPTOM	RHEUMATIC DISEASE(S)	POSSIBLE NONRHEUMATIC DISEASES CAUSING SIMILAR SYMPTOMS
Fevers	Systemic JIA, SLE, vasculitis, acute rheumatic fever, sarcoidosis, MCTD	Malignancies, infections and postinfectious syndromes, inflammatory bowel disease, periodic fever (autoinflammatory) syndromes, Kawasaki disease, HSP*
Arthralgias	JIA, SLE, rheumatic fever, JDM, vasculitis, scleroderma, sarcoidosis	Hypothyroidism, trauma, endocarditis, other infections, pain syndromes, growing pains, malignancies, overuse syndromes
Weakness	JDM, myositis secondary to SLE, MCTD, and deep localized scleroderma	Muscular dystrophies, metabolic and other myopathies, hypothyroidism
Chest pain	Juvenile idiopathic arthritis, SLE (with associated pericarditis or costochondritis)	Costochondritis (isolated), rib fracture, viral pericarditis, panic attack, hyperventilation
Back pain	Enthesitis-related arthritis, juvenile ankylosing spondylitis	Vertebral compression fracture, diskitis, intraspinal tumor, spondylolysis, spondylolisthesis, bone marrow-occupying malignancy, pain syndromes, osteomyelitis, muscle spasm, injury
Fatigue	SLE, JDM, MCTD, vasculitis, JIA	Pain syndromes, chronic infections, chronic fatigue syndrome, depression

HSP, Henoch-Schönlein purpura; JDM, juvenile dermatomyositis; JIA, juvenile idiopathic arthritis; MCTD, mixed connective tissue disease; SLE, systemic lupus erythematosus. \*Also known as IgA vasculitis.

**Table 194.2** Signs Suggestive of Rheumatic Disease

SIGN	RHEUMATIC DISEASES	COMMENTS	NONRHEUMATIC CAUSES
Malar rash	SLE, JDM	SLE classically spares nasolabial folds	Sunburn, parvovirus B19 (fifth disease), Kawasaki disease
Oral ulcers	SLE, Behçet disease	Behçet disease also associated with genital ulcers	HSV infection, PFAPA syndrome
Purpuric rash	Vasculitis (e.g., ANCA-associated vasculitis), HSP*	HSP* typically starts as small lesions on lower extremities and buttocks that coalesce	Meningococemia, thrombocytopenia, clotting disorders
Gottron papules	JDM	Look for associated heliotrope rash, periungual telangiectasias	Psoriasis, eczema
Arthritis	Juvenile idiopathic arthritis, SLE, vasculitis, HSP*, MCTD, scleroderma, acute rheumatic fever, reactive arthritis	Chronic joint swelling (>6 wk) required for diagnosis of JIA; MCTD associated with diffuse puffiness of hands	Postviral arthritis, reactive arthritis, trauma, infection, Lyme disease, Kawasaki disease, malignancy, overuse syndromes

ANCA, Antineutrophil cytoplasmic antibody; HSP, Henoch-Schönlein purpura; HSV, herpes simplex virus; JIA, juvenile idiopathic arthritis; JDM, juvenile dermatomyositis; MCTD, mixed connective tissue disease; PFAPA, periodic fever, aphthous stomatitis, pharyngitis, and adenitis; SLE, systemic lupus erythematosus.

\*Also known as IgA vasculitis.

of JDM. Dilated capillary loops in the nail beds (periungual telangiectasias; see Fig. 200.4) are common in JDM, scleroderma, and secondary Raynaud phenomenon. An evanescent macular rash associated with fever is part of the diagnostic criteria for systemic-onset arthritis (see Fig. 196.12). Sun sensitivity or photosensitive rashes are indicative of SLE or JDM but can also be caused by antibiotics.

Mouth ulcers are part of the diagnostic criteria for SLE and Behçet disease (see Fig. 199.1C); painless nasal ulcers and erythematous macules on the hard palate are also common in SLE. Cartilage loss in the nose, causing a saddle nose deformity, is classically present in granulomatosis with polyangiitis (formerly Wegener granulomatosis; see Fig. 210.8) but is also seen in relapsing polychondritis and syphilis. Alopecia can be associated with SLE but is also found in localized scleroderma (see Fig. 201.4) and JDM. **Raynaud phenomenon** may be a primary benign idiopathic disorder or can be a presenting complaint in the child with scleroderma, lupus, mixed connective tissue disease (MCTD), or an overlap syndrome. Diffuse lymphadenopathy is present in many rheumatic diseases, including SLE, polyarticular JIA, and systemic JIA. Irregular pupils may represent the insidious and unrecognized onset of **uveitis** associated with JIA. Erythematous conjunctivae may be a result of uveitis or episcleritis associated with JIA, SLE, sarcoidosis, spondyloarthropathies, or vasculitis.

A pericardial rub and orthopnea are suggestive of **pericarditis**, often seen in systemic JIA, SLE, and sarcoid. Coronary artery dilation is strongly suggestive of Kawasaki disease and multisystem inflammatory syndrome in children (MIS-C) but may also be a finding in systemic arthritis and other forms of systemic vasculitis. Interstitial lung disease,

suggested by dyspnea on exertion or the finding of basilar rales with decreased carbon monoxide diffusion capacity, occurs in SLE, MCTD, and systemic sclerosis. Signs consistent with pulmonary hemorrhage point to granulomatosis with polyangiitis, microscopic angiitis, or SLE. Pulmonary vascular aneurysms are indicative of Behçet disease.

**Arthritis** is defined by the presence of intraarticular swelling or two or more of the following findings on joint examination: pain on motion, loss of motion, erythema, and heat. Arthritis is present in all the chronic childhood arthritis syndromes, along with SLE, JDM, vasculitis, Behçet disease, sarcoidosis, Kawasaki disease, and Henoch-Schönlein purpura. Nonrheumatic causes of arthritis include malignancy, septic arthritis, Lyme disease, osteomyelitis, viral infections (e.g., rubella, hepatitis B, parvovirus B19, chikungunya), and postinfectious etiologies such as Epstein-Barr virus (EBV), ARF, and reactive arthritis. ARF typically involves a migratory (lasting hours to days), painful arthritis. Pain on palpation of long bones is suggestive of malignancy. Specific muscle testing for weakness should be performed in a child presenting with fatigue or difficulty with daily tasks, because both these symptoms may be manifestations of muscle inflammation.

### LABORATORY TESTING

There are no specific screening tests for rheumatologic disease. Once a differential diagnosis is determined, appropriate testing can be performed (Tables 194.3 and 194.4). Initial studies are generally performed in standard local laboratories. Screening for specific autoantibodies can be performed in commercial laboratories, but confirmation of results in a tertiary care center immunology laboratory is often necessary.



**Table 194.3** Autoantibody Specificity and Disease Associations

ANTIBODY	DISEASE	PREVALENCE (%)	SPECIFICITY
Antinuclear antibody (ANA)	SLE, juvenile rheumatoid arthritis, dermatomyositis, scleroderma, psoriatic arthritis, MCTD	—	Associated with increased risk of uveitis in JIA and psoriatic arthritis Up to 30% of children testing positive for ANAs have no underlying rheumatic disease
Double-stranded DNA (dsDNA)	SLE	60-70	High specificity for SLE; associated with lupus nephritis
Smith (Sm)	SLE	20-30	Highly specific for SLE; associated with lupus nephritis
Smooth muscle (Sm)	Autoimmune hepatitis	—	—
Pm-Scl (polymyositis-scleroderma)	Sclerodermatomyositis	—	—
SSA (Ro)	SLE, Sjögren syndrome	25-30	Associated with neonatal lupus syndrome, subacute cutaneous lupus, thrombocytopenia
SSB (La)	SLE, Sjögren syndrome	25-30	Usually coexists with anti-SSA antibody
Ribonuclease protein (RNP)	MCTD, SLE	30-40	Suggestive of MCTD unless meets criteria for SLE
Histone	Drug-induced lupus, SLE	—	—
Centromere	Limited cutaneous systemic sclerosis	70	Nonspecific for systemic sclerosis
Topoisomerase I (Scl-70)	Systemic sclerosis	—	Rare in childhood
Antineutrophil cytoplasmic antibodies (ANCA)	Vasculitis	—	—
Cytoplasmic (cANCA)/PR3-ANCA		—	cANCA associated with granulomatosis with polyangiitis (Wegener), cystic fibrosis
Perinuclear (pANCA)/MPO-ANCA		—	pANCA associated with microscopic polyangiitis, polyarteritis nodosa, SLE, inflammatory bowel disease, cystic fibrosis, primary sclerosing cholangitis, Henoch-Schönlein purpura, Kawasaki disease, Churg-Strauss syndrome
Anticitrullinated protein (ACPA); also called anti-cyclic citrullinated protein (anti-CCP)	RF-positive JIA	50-90	Specific for JIA (RF+), may be positive before RF

MCTD, Mixed connective tissue disease; MPO-ANCA, antimyeloperoxidase; PR3-ANCA, antiproteinase 3; RF, rheumatoid factor; SLE, systemic lupus erythematosus. Adapted from Aggerwal A. Clinical application of tests used in rheumatology. *Indian J Pediatr* 2002;69:889-892.

For initial workup of rheumatic disease, a CBC with differential, alanine transaminase/aspartate transaminase (ALT/AST), albumin, BUN/creatinine, urinalysis, creatine phosphokinase/lactate dehydrogenase (CPK/LDH), and inflammatory markers (sedimentation rate and CRP) are recommended. Further appropriate testing depends on clinical concern (see Table 194.4).

One essential laboratory test for rheumatic disease assessment is the *complete blood count* (CBC), because it yields many diagnostic clues. Elevated WBC count is compatible with malignancy, infection, systemic JIA, and vasculitis. Leukopenia can be postinfectious, especially viral, or caused by SLE or malignancy. Lymphopenia is more specific for SLE than is leukopenia. Platelets are acute-phase reactants and are therefore elevated with inflammatory markers. Exceptions are a bone marrow-occupying malignancy, such as leukemia or neuroblastoma, SLE, and early Kawasaki disease. **Anemia** is nonspecific and may be caused by any chronic illness, but hemolytic anemia (positive Coombs test result) may point to SLE or MCTD. Rheumatoid factor (RF) is present in <10% of children with JIA and thus has poor sensitivity as a diagnostic tool; RF may be elevated by infections such as endocarditis, tuberculosis, syphilis, and viruses (parvovirus B19, hepatitis B and C, mycoplasma), as well as primary biliary cirrhosis and malignancies. In a child with chronic arthritis, RF serves as a prognostic indicator.

Inflammatory markers (erythrocyte sedimentation rate, CRP, ferritin, procalcitonin) are nonspecific and are elevated in infections,

malignancies, and rheumatic diseases (Table 194.5). Their levels may also be normal in rheumatic diseases such as arthritis, scleroderma, and dermatomyositis. The advantages of a CRP include rapid response to inflammatory stimuli, wide range of clinically relevant values, the fact that it is unaffected by age or gender, it is precise and reproducible, and it can be measured on stored sera. Sedimentation rates have classically been used as markers of inflammation, but they can be affected by anemia, red cell morphology, and drugs such as intravenous immunoglobulin (IVIG); they require a fresh blood sample; and they are slow to respond to clinical changes. Inflammatory marker measurements in general are more useful in rheumatic diseases for following response to treatment than as diagnostic tests.

Muscle enzymes include AST, ALT, CPK, aldolase, and LDH, any of which may be elevated in JDM and in other diseases causing muscle breakdown. Muscle-building supplements, medications, and extreme physical activity may also cause muscle breakdown and enzyme elevations. AST, ALT, and aldolase may also be elevated in liver disease, and a  $\gamma$ -glutamyltransferase (GGT) measurement may help differentiate muscle or liver source.

The use of an antinuclear antibody (ANA) measurement as a screening test is *not* recommended because it has low specificity. A positive ANA test result may be induced by infection, especially EBV infection, endocarditis, and parvovirus B19 infection. The ANA test result is also positive in up to 30% of normal children, and ANA level is

**Table 194.4** Evaluation Based on Suspected Diagnosis of Rheumatic Disease

SUSPECTED RHEUMATIC DISEASE(S)	INITIAL EVALUATION	FURTHER EVALUATION	SUBSPECIALTY EVALUATION
Systemic lupus erythematosus (SLE) Mixed connective tissue disease (MCTD)	CBC, ESR, ANA, ALT, AST, CPK, creatinine, albumin, total protein, urinalysis, BP, thyroid profile	If ANA test result is positive: anti-SSA (Ro), anti-SSB (La), anti-Smith, and anti-RNP Abs; anti-dsDNA Ab, C3, C4, Coombs, spot urine protein/creatinine ratio, CXR	Antiphospholipid Abs, lupus anticoagulant, anti- $\beta_2$ -glycoprotein, echocardiogram; consider renal biopsy, PFTs, bronchoscopy with lavage, HRCT of chest; consider lung biopsy
Juvenile dermatomyositis (JDM)	CBC, CPK, ALT, AST, LDH, aldolase, ANA; check gag reflex	Consider MRI of muscle	Consider electromyography and possible muscle biopsy, PFTs, swallowing study, serum neopterin
Juvenile idiopathic arthritis (JIA)	CBC, ESR, creatinine, ALT, AST, consider anti-streptolysin O/anti-DNAase B for streptococcus-induced arthritis, Epstein-Barr virus titers, Lyme titer, parvovirus B19 titer, plain radiograph of joints	Consider Ab titers to unusual infectious agents, purified protein derivative, RF, ANA, HLA-B27, anti-CCP	MRI
Granulomatosis with polyangiitis (Wegener granulomatosis)	CBC, ANCA, AST, ALT, albumin, creatinine, ESR, urinalysis, CXR, BP	Spot urine protein/creatinine ratio, anti-myeloperoxidase and anti-proteinase-3 Abs, PFTs	Bronchoscopy with lavage, HRCT chest; consider lung and kidney biopsies
Sarcoidosis	CBC, electrolytes, AST, ALT, albumin, creatinine, calcium, phosphorous, ACE, BP	CXR, PFTs	Consider testing for Blau syndrome in infants (see <a href="#">Chapter 200</a> ); HRCT of chest; consider renal and lung biopsy
Localized scleroderma	Skin biopsy, CBC, ESR		Serum IgG, ANA, RF, single-stranded DNA Ab, antihistone Ab, CPK
Systemic scleroderma	ANA, CBC, ESR, BP, AST, ALT, CPK, creatinine, CXR	Anti-Scl70, PFTs	HRCT of chest, echocardiogram, upper GI radiography series

Ab, Antibody; ACE, angiotensin-converting enzyme (normally elevated in childhood; interpret with caution); ALT, alanine transaminase; ANA, antinuclear antibody; anti-dsDNA Ab, anti-double-stranded DNA antibody; AST, aspartate transaminase; BP, blood pressure; CBC, complete blood count; CCP, cyclic citrullinated protein; CPK, creatine phosphokinase; CXR, chest x-ray; ESR, erythrocyte sedimentation rate; GI, gastrointestinal; HRCT, high-resolution CT; LDH, lactate dehydrogenase; PFTs, pulmonary function tests; RF, rheumatoid factor; RNP, ribonucleoprotein.

**Table 194.5** Conditions Associated with Elevated C-Reactive Protein Levels**NORMAL OR MINOR ELEVATION (<1 mg/dL)**

Vigorous exercise  
Common cold  
Pregnancy  
Gingivitis  
Seizures  
Depression  
Insulin resistance and diabetes  
Several genetic polymorphisms  
Obesity

**MODERATE ELEVATION (1-10 mg/dL)**

Myocardial infarction  
Malignancies  
Pancreatitis  
Mucosal infection (bronchitis, cystitis)  
Most systemic autoimmune diseases  
Rheumatoid arthritis  
Influenza and adenovirus infections

**MARKED ELEVATION (>10 mg/dL)**

Acute bacterial infection (80–85%)  
Major trauma, surgery  
Systemic vasculitis  
MIS-C

MIS-C, Multisystem inflammatory syndrome in children.

From Firestein GS, Budd RC, Gabriel SE, et al., eds. *Kelley & Firestein's Textbook of Rheumatology*, 10th ed. Philadelphia: Elsevier; 2017, Table 57-4, p. 849.

increased in those with a first-degree relative with a known rheumatic disease. In the majority of children with a positive ANA without signs of a rheumatic disease on initial evaluation, autoimmune disease does not develop over time, so this finding does not necessitate referral to a pediatric rheumatologist. A positive ANA test result is found in many rheumatic diseases, including JIA, in which it serves as a predictor of the risk for inflammatory eye disease (see [Chapter 196](#)). Once a positive ANA test result is discovered in a child, the need for specific autoantibody testing is directed by the presence of clinical signs and symptoms (see [Table 194.3](#)).

**IMAGING STUDIES**

Plain radiographs are useful in evaluation of arthralgias and arthritis, as they offer reassurance in benign pain syndromes and their findings may be abnormal in malignancies, osteomyelitis, and long-standing chronic juvenile arthritis. Musculoskeletal ultrasound can be useful in evaluation of synovitis and joint effusion. MRI findings are abnormal in inflammatory myositis and suggest the optimal site for biopsy. *MRI is more sensitive than plain radiographs in detecting the presence of early erosive arthritis and demonstrates increased joint fluid, synovial enhancement, and sequela of trauma with internal joint derangement.* MRI is also helpful in ruling out infection or malignancy. Cardiopulmonary evaluation is suggested for diseases commonly affecting the heart and lung, including SLE, systemic scleroderma, MCTD, JDM, and sarcoid, as clinical manifestations may be subtle. This evaluation, which may include echocardiogram, pulmonary function tests, and high-resolution CT of the lungs along with consideration of bronchoalveolar lavage, is generally performed by a pediatric rheumatologist to whom the patient is referred (see [Table 194.4](#)).

Visit Elsevier eBooks+ at [eBooks.Health.Elsevier.com](http://eBooks.Health.Elsevier.com) for Bibliography.

**Table 195.1** Multidisciplinary Treatment of Rheumatic Diseases in Childhood

Accurate diagnosis and education of family	Pediatric rheumatologist Pediatrician Nurse <ul style="list-style-type: none"> <li>• Disease-related education</li> <li>• Medication administration (injection teaching)</li> <li>• Safety monitoring</li> </ul> Social worker <ul style="list-style-type: none"> <li>• Facilitation of school services</li> <li>• Resource identification (community, government, financial, advocacy groups, vocational rehabilitation)</li> </ul>
Physical medicine and rehabilitation	Physical therapy <ul style="list-style-type: none"> <li>• Addressing deficits in joint or muscle mobility, limb-length discrepancies, gait abnormalities, and weakness</li> </ul> Occupational therapy <ul style="list-style-type: none"> <li>• Splinting to reduce joint contractures/deformities and lessen stress on joints; adaptive devices for activities of daily living</li> </ul>
Consultant team	Ophthalmology <ul style="list-style-type: none"> <li>• Eye screening for uveitis</li> <li>• Screening for medication-related ocular toxicity (hydroxychloroquine, glucocorticoids)</li> </ul> Nephrology Orthopedics Dermatology Gastroenterology
Physical and psychosocial growth and development	Nutrition <ul style="list-style-type: none"> <li>• Addressing undernourishment from systemic illness and obesity/overnourishment from glucocorticoids</li> </ul> School integration <ul style="list-style-type: none"> <li>• Individualized educational plan (IEP) or 504 plan</li> </ul> Peer-group relationships Individual and family counseling
Coordination of care	Involvement of patient and family as active team members Communication among healthcare providers Involvement of school (school nurse) and community (social worker) resources

qualitatively different from that observed with treatment of neoplasms. Adverse effects include elevated liver enzyme values (15%); GI toxicity (13%); stomatitis (3%); headache (1–2%); and leukopenia, interstitial pneumonitis, rash, and alopecia (<1%). Hepatotoxicity observed among adults with rheumatoid arthritis (RA) treated with MTX has raised concern about similar problems in children. Analysis of liver biopsy specimens in children with JIA undergoing long-term MTX treatment has revealed occasional mild fibrosis but no evidence of even moderate liver damage. Patients receiving MTX should be counseled to avoid alcohol, smoking, and pregnancy. *Folic acid* (1 mg daily) is given as an adjunct to minimize adverse effects. Lymphoproliferative disorders have been reported in adults treated with MTX, primarily in association with Epstein-Barr virus (EBV) infection. Regression of lymphoma may follow withdrawal of MTX.

Monitoring laboratory tests for MTX toxicity include CBC and LFTs at regular intervals, initially every 8–12 weeks for the first 3–6 months of treatment, then every 12 weeks, with more frequent intervals after dosing adjustments or in response to abnormal values.

## Hydroxychloroquine

Hydroxychloroquine sulfate is an antimalarial drug important in the treatment of SLE and dermatomyositis, particularly cutaneous manifestations of disease and to reduce lupus flares. It is not indicated to treat JIA because of lack of efficacy. The most significant potential adverse effect is *retinal toxicity*, which occurs rarely but results in irreversible color blindness or loss of central vision. Complete ophthalmologic examinations, including assessment of peripheral vision and color fields, are conducted at baseline and every 6–12 months to screen for retinal toxicity. Retinal toxicity is rare (1/5,000 patients) and is associated with weight-based dosing exceeding 6.5 mg/kg/day; therefore recommended dosing is 5 mg/kg/day, not to exceed 400 mg/day. Other potential adverse effects include rash, skin discoloration, gastric irritation, bone marrow suppression, central nervous system (CNS) stimulation, and myositis.

## Leflunomide

Leflunomide is a DMARD approved for treatment of RA and also offers an alternative to MTX for treatment of JIA. MTX outperformed leflunomide for treatment of JIA in a randomized trial (at 16 weeks, 89% of patients receiving MTX achieved a 30% response rate vs 68% of those receiving leflunomide), although both drugs were effective. Dosing is oral, once daily, and weight based: 10 mg for children 10 to <20 kg, 15 mg for children 20–40 kg, and 20 mg for children >40 kg. Adverse reactions include paresthesias and peripheral neuropathy, GI intolerance, elevated liver transaminases and hepatic failure, cytopenias, alopecia, and teratogenesis. Leflunomide has a long half-life, and in cases in which discontinuation of the agent is required, a drug elimination protocol with cholestyramine may be indicated. Avoidance of pregnancy is essential. Laboratory tests (e.g., CBC, LFTs) are monitored every 4 weeks for the first 6 months of treatment, then every 8–12 weeks.

## Sulfasalazine

Sulfasalazine is used to treat children with polyarticular JIA, oligoarticular JIA, and the peripheral arthritis and enthesitis associated with juvenile ankylosing spondylitis. In JIA, sulfasalazine 50 mg/kg/day (adult maximum: 3,000 mg/day, divided bid) achieves greater improvement in joint inflammation, global assessment parameters, and laboratory parameters than placebo. More than 30% of sulfasalazine-treated patients withdraw from the treatment because of adverse effects, primarily GI irritation and skin rashes. Sulfasalazine is associated with severe systemic hypersensitivity reactions, including Stevens-Johnson syndrome. Sulfasalazine is generally considered contraindicated in children with active systemic JIA because of increased hypersensitivity reactions. Sulfasalazine should not be used in patients with sulfa or salicylate hypersensitivity or porphyria.

Monitoring laboratory tests for sulfasalazine toxicity include CBC, LFTs, serum creatinine/blood urea nitrogen (BUN), and urinalysis, every other week for the first 3 months of treatment, monthly for 3 months, then every 3 months.

## Mycophenolate Mofetil

Mycophenolate mofetil (MMF) is an immunosuppressive drug approved by the FDA for organ transplant rejection. MMF is used primarily for treatment of lupus, uveitis, and autoimmune skin manifestations. In adult clinical trials, MMF was noninferior to cyclophosphamide for induction therapy of lupus nephritis, with a potential for fewer adverse effects (infection, gonadal toxicity). Dosing is based on body surface area (BSA): 600 mg/m<sup>2</sup> orally twice daily, with maximum dosage limits varying by formulation and BSA. The most common adverse reaction is GI intolerance; infections, cytopenias, and secondary malignancies are also reported.

## Glucocorticoids

Glucocorticoids are given through oral, intravenous (IV), ocular, topical, and intraarticular administration as part of treatment of rheumatic disease. Oral corticosteroids are foundational treatment for moderate to severe lupus, dermatomyositis, and most forms of vasculitis; their long-term use is associated with many well-described, dose-dependent complications, including linear growth suppression, cushingoid features, osteoporosis, avascular necrosis, hypertension, impaired glucose tolerance, mood disturbance, and increased infection risk. Glucocorticoids should be tapered to the lowest effective dose over time and DMARDs introduced as steroid-sparing agents.

**Table 195.2** Therapeutics for Childhood Rheumatic Diseases\*

CLASSIFICATION	THERAPEUTIC <sup>†</sup>	DOSE	INDICATION <sup>†</sup>	ADVERSE REACTIONS	MONITORING
Nonsteroidal antiinflammatory drugs (NSAIDs) <sup>‡</sup>	Etodolac <sup>a</sup>	PO once-daily dose: 20-30 kg: 400 mg 31-45 kg: 600 mg 46-60 kg: 800 mg >60 kg: 1,000 mg	JIA Spondyloarthropathy Pain Serositis Cutaneous vasculitis Uveitis	GI intolerance (abdominal pain, nausea), gastritis, hepatitis, tinnitus, anemia, pseudoporphyria, aseptic meningitis, headache, renal disease	CBC, LFTs, BUN/creatinine, urinalysis at baseline, then every 6-12 mo
	Ibuprofen <sup>a</sup>	40 mg/kg/day PO in 3 divided doses Max 2,400 mg/day			
	Naproxen <sup>a</sup>	15 mg/kg/day PO in 2 divided doses Max 1,000 mg/day			
	Celecoxib <sup>a</sup>	10-25 kg: 50 mg PO bid >25 kg: 100 mg PO bid			
	Meloxicam <sup>a</sup>	0.125 mg/kg PO daily Max 7.5 mg			
Disease-modifying antirheumatic drugs (DMARDs)	Methotrexate <sup>a</sup>	10-20 mg/m <sup>2</sup> /wk (0.35-0.65 mg/kg/wk) PO 20-30 mg/m <sup>2</sup> /wk (0.65-1 mg/kg/wk) SC; higher doses better absorbed by SC injection	JIA Uveitis	GI intolerance (nausea, vomiting), hepatitis, myelosuppression, mucositis, teratogenesis, lymphoma, interstitial pneumonitis	CBC, LFTs at baseline, monthly ×3, then every 8-12 wk
	Leflunomide	PO once daily: 10 to <20 kg: 10 mg 20-40 kg: 15 mg >40 kg: 20 mg	JIA	Hepatitis, hepatic necrosis, cytopenias, mucositis, teratogenesis, peripheral neuropathy	CBC, LFTs, at baseline, monthly ×6, then every 8-12 wk
	Hydroxychloroquine	5 mg/kg PO daily; do not exceed 5 mg/kg/daily Max 400 mg daily	SLE JDMS Antiphospholipid antibody syndrome	Retinal toxicity, GI intolerance, rash, skin discoloration, anemia, cytopenias, myopathy, CNS stimulation, death (overdose)	Ophthalmologic screening every 6-12 mo
	Sulfasalazine <sup>a</sup>	30-50 mg/kg/day in 2 divided doses Adult max 3 g/day	Spondyloarthropathy, JIA	GI intolerance, rash, hypersensitivity reactions, Stevens-Johnson syndrome, cytopenias, hepatitis, headache	CBC, LFTs, BUN/creatinine, urinalysis at baseline, every other wk ×3 mo, monthly ×3, then every 3 mo
Janus kinase inhibitor	Tofacitinib <sup>a</sup>	Oral solution (1 mg/mL) Use for ≥2 yr and ≥10 kg; 10 to <20 kg: 3.2 mg twice daily 20 to <40 kg: 4 mg twice daily ≥40 kg: 5 mg twice daily <b>or</b> Immediate-release tablet (5 mg), 5 mg twice daily	Polyarticular JIA	Infection, headache, increased HDL, cytopenias, potential increased malignancy risk, potential increased thrombosis risk	CBC, LFTs at baseline, then every 3 mo; lipids 4-8 wk after initiation, then periodically



Table 195.2 Therapeutics for Childhood Rheumatic Diseases —cont'd					
CLASSIFICATION	THERAPEUTIC <sup>†</sup>	DOSE	INDICATION <sup>†</sup>	ADVERSE REACTIONS	MONITORING
Tumor necrosis factor (TNF)- $\alpha$ antagonists	Adalimumab <sup>a</sup>	SC once every other wk: 10 to <15 kg: 10 mg 15 to <30 kg: 20 mg $\geq$ 30 kg: 40 mg	JIA Spondyloarthritis Psoriatic arthritis Uveitis	Injection site reaction, infection, rash, cytopenias, lupus-like syndrome, potential increased malignancy risk	TB test; anti-dsDNA, CBC
	Etanercept <sup>a</sup>	0.8 mg/kg SC once weekly (max 50 mg/dose) or 0.4 mg/kg SC twice weekly (max 25 mg/dose)	JIA	Injection site reactions, infections, rash, demyelinating disorders, cytopenias, potential increased malignancy risk	TB test; CBC
	Golimumab <sup>a</sup>	80 mg/m <sup>2</sup> IV at 0 and 4 wk, then every 8 wk	Polyarticular JIA Spondyloarthritis Psoriatic arthritis	Infusion reactions, hepatitis, potential increased malignancy risk	TB test; anti-dsDNA, LFTs
	Infliximab	5-10 mg/kg IV every 4-8 wk	JIA Spondyloarthritis Uveitis Sarcoidosis	Infusion reactions, hepatitis, potential increased malignancy risk	TB test; anti-dsDNA, LFTs
Modulate T-cell activation	Abatacept <sup>a</sup>	IV every 2 wk $\times$ 3 doses, then monthly for $\geq$ 6 yr of age: <75 kg: 10 mg/kg 75-100 kg: 750 mg >100 kg: 1,000 mg  SC once weekly: 10 to <25 kg: 50 mg $\geq$ 25 to <50 kg: 87.5 mg $\geq$ 50 kg: 125 mg	JIA	Infection, headache, potential increased malignancy risk	
Anti-CD20 (B-cell) antibody	Rituximab	575 mg/m <sup>2</sup> , max 1,000 mg, IV on days 1 and 15	SLE	Infusion reactions, lymphopenia, reactivation hepatitis B, rash, serum sickness, arthritis, PML	CBC, BMP; consider monitoring quantitative IgG
Anti-BLyS antibody	Belimumab <sup>e</sup>	10 mg/kg IV every 2 wk $\times$ 3 doses, then every 4 wk	SLE	Infusion reactions, infection, depression	
Interleukin (IL)-1 antagonist	Anakinra	1-2 mg/kg/daily Adult max 100 mg	Systemic JIA CAPS	Injection site reactions, infection	CBC
	Canakinumab <sup>b</sup>	Given SC every 8 wk (CAPS) every 4 wk (systemic JIA): 15-40 kg: 2 mg/kg (up to 3 mg/kg if needed) >40 kg: 150 mg  IV: <30 kg: 10 mg/kg/dose every 4 wk $\geq$ 30 kg: 8 mg/kg/dose every 4 wk; maximum dose: 800 mg/dose  SC: <30 kg: 162 mg/dose once every 3 wk $\geq$ 30 kg: 162 mg/dose once every 2 wk	CAPS Systemic JIA  Polyarticular JIA	Injection site reaction, infection, diarrhea, nausea, vertigo, headache	

Continued

**Table 195.2** Therapeutics for Childhood Rheumatic Diseases —cont'd

CLASSIFICATION	THERAPEUTIC <sup>†</sup>	DOSE	INDICATION <sup>†</sup>	ADVERSE REACTIONS	MONITORING
IL-6 antagonist	Tocilizumab <sup>a</sup>	≥2 yr and ≥30 kg: 8 mg/kg/dose every 2 wk ≥2 yr and ≤30 kg: 12 mg/kg/dose every 2 wk	Systemic JIA	Infusion reactions, elevated LFTs, elevated lipids, thrombocytopenia, infections	CBC, LFTs, platelet count, serum lipid profile
Intravenous immune globulin	IVIg <sup>c</sup>	1,000-2,000 mg/kg IV infusion For JDMS, give monthly	Kawasaki disease JDMS SLE	Infusion reaction, aseptic meningitis, renal failure	Serum creatinine, BUN, IgG level
Cytotoxic	Cyclophosphamide	0.5-1 g/m <sup>2</sup> IV (max 1.5 g) monthly for 6 mo induction, then every 2-3 mo Oral regimen: 1-2 mg/kg/daily; max 150 mg/daily	SLE Vasculitis JDMS Pulmonary hemorrhage	Nausea, vomiting, myelosuppression, mucositis, hyponatremia, alopecia, hemorrhagic cystitis, gonadal failure, teratogenesis, secondary malignancy	CBC
Immunosuppressive	Mycophenolate mofetil	Oral suspension: max 1,200 mg/m <sup>2</sup> /day PO (up to 2 g/day) divided bid Capsules: max 1,500 mg/day PO for BSA 1.25-1.5 m <sup>2</sup> , 2 g/day PO for BSA >1.5 m <sup>2</sup> divided bid	SLE Uveitis	GI intolerance (diarrhea, nausea, vomiting), renal impairment, neutropenia, teratogenesis, secondary malignancy, PML	CBC, BMP
Glucocorticoids	Prednisone <sup>a,d-f</sup>	0.05-2 mg/kg/day PO given in 1-4 divided doses; max varies by individual (80 mg/daily) Adverse effects are dose dependent; lowest effective dose should be used	SLE JDMS Vasculitis JIA Uveitis Sarcoidosis	Cushing syndrome, osteoporosis, increased appetite, weight gain, striae, hypertension, adrenal suppression, hyperglycemia, infection, avascular necrosis	Blood glucose, potassium Blood pressure
	Methylprednisolone <sup>a,d-g</sup>	0.5-1.7 mg/kg/day or 5-25 mg/m <sup>2</sup> /day IM/IV in divided doses every 6-12 hr For severe manifestations: 30 mg/kg/dose (max 1 g) daily for 1-5 days	SLE JDMS Vasculitis Sarcoidosis Localized scleroderma		
	Intraarticular	Dose varies by joint and formulation	JIA	Subcutaneous atrophy, skin hypopigmentation, calcification, infection	
	Prednisolone ophthalmic suspension	1-2 drops into eye up to every hr while awake Needs monitoring by ophthalmologist	Uveitis	Ocular hypertension, glaucoma, nerve damage, cataract, infection	Ophthalmologic exam

\*Consult a clinical pharmacology reference for current dosing and monitoring guidelines and complete list of known adverse effects.

<sup>†</sup>Therapeutics used in practice may not have an FDA-approved indication. Individual therapeutics annotated with FDA-approved indication as follows: a, JIA; b, CAPS; c, Kawasaki disease; d, sarcoidosis; e, SLE; f, uveitis; g, dermatomyositis.

<sup>‡</sup>Many more products are available in this class.

bid, Twice daily; BLys, B-lymphocyte stimulator; BMP, basic metabolic panel; BSA, body surface area; BUN, blood urea nitrogen; CAPS, cryopyrin-associated periodic syndrome; CBC, complete blood count; CNS, central nervous system; dsDNA, double-stranded DNA; GI, gastrointestinal; IM, intramuscular(ly); IV, intravenous(ly); IVIG, intravenous immune globulin; JDMS, juvenile dermatomyositis; JIA, juvenile idiopathic arthritis; LFTs, liver function tests; PML, progressive multifocal leukoencephalopathy; PO, by mouth; SC, subcutaneous(ly); SLE, systemic lupus erythematosus; TB, tuberculosis

**Intravenous corticosteroids** have been used to treat severe, acute manifestations of systemic rheumatic diseases such as SLE, dermatomyositis, and vasculitis. The IV route allows for higher doses to obtain an immediate, profound antiinflammatory effect. Methylprednisolone 10-30 mg/kg/dose up to a maximum of 1 g, given over 1 hour daily for 1-5 days is the IV preparation of choice. Although generally associated with fewer adverse effects than oral corticosteroids, IV steroids are associated with significant and occasionally life-threatening toxicities, such as cardiac arrhythmia, acute hypertension, hypotension, hyperglycemia, shock, pancreatitis, and avascular necrosis.

**Ocular corticosteroids** are prescribed by ophthalmologists as ophthalmologic drops or injections into the soft tissue surrounding the globe (sub-Tenon capsule injection) for active uveitis. Long-term ocular corticosteroid use leads to cataract formation and glaucoma. Current ophthalmologic management with methotrexate and biologic therapy, especially TNF inhibitors, have significantly decreased the frequency of eye complications of JIA-associated uveitis.

**Intraarticular corticosteroids** are frequently used as initial therapy for children with oligoarticular JIA or as bridge therapy while awaiting efficacy of a DMARD in polyarticular disease. Most patients have significant clinical improvement within 3 days. Duration of response depends on steroid preparation used, joint affected, and arthritis subtype; the anticipated response rate to knee injection is 60–80% at 6 months. Intraarticular administration may result in subcutaneous atrophy and hypopigmentation of the skin at the injection site, as well as subcutaneous calcifications along the needle track.

## JANUS KINASE INHIBITORS

Another effective class of DMARDs is the Janus kinase inhibitors, collectively known as **JAKinibs**. In immune cells, these drugs inhibit intracellular signaling through the JAK-STAT pathway in immune cells by binding to various Janus kinases (in humans, JAK 1, JAK 2, JAK 3, and TYK2), thereby negating the response to extracellular cytokine ligation of immune cell receptors. Inhibition affects lymphocyte activation, function, and survival. Many JAKinibs are currently available, including tofacitinib, baricitinib, ruxolitinib, and upadacitinib. Currently, only tofacitinib has FDA approval in pediatric rheumatic disease.

*Tofacitinib* is a small-molecule, oral JAKinib of the JAK1, JAK3, and, to a lesser extent, JAK2 enzymes. Tofacitinib has FDA approval for treatment of polyarticular JIA (age  $\geq$  2 years and weight  $\geq$  10 kg) with twice-daily dosing: 3.2 mg bid for 10–20 kg, 4 mg bid for 20–40 kg, and 5 mg bid for  $>$ 40 kg. It is available as an oral solution (1 mg/mL) and as oral tablets (5 mg). Adverse reactions include increased risk of serious infections, thrombosis including pulmonary and deep venous/arterial, and gastrointestinal perforations; the most common adverse reactions are upper respiratory infections, diarrhea, and headache.

## Biologic Agents

Biologic agents are proteins that have been engineered to target and modulate specific components of the immune system, with the goal of decreasing the inflammatory response. Antibodies have been developed to target specific cytokines such as IL-1 and IL-6 or to interfere with specific immune cell function through depletion of  $\beta$  cells or suppression of T-cell activation (Table 195.3). Biologic agents have increased the therapeutic options for treating rheumatic disease recalcitrant to nonbiologic therapies, and in some cases biologics are first-line interventions. A primary concern is the increased risk of malignancy when biologics are combined with other immunosuppressants.

## Tumor Necrosis Factor- $\alpha$ Antagonists

Three TNF antagonists have an FDA indication for treatment of children with moderate to severe polyarticular JIA (etanercept, adalimumab, and golimumab). *Etanercept* is a genetically engineered fusion protein consisting of two identical chains of the recombinant extracellular TNF receptor monomer fused with the Fc domain of human immunoglobulin G<sub>1</sub>. Etanercept binds both TNF- $\alpha$  and lymphotoxin- $\alpha$  (formerly called TNF- $\beta$ ) and inhibits their activity. Three fourths of children with active polyarticular JIA that fails to respond to MTX demonstrate response to etanercept after 3 months of therapy. Dosing is 0.8 mg/kg subcutaneously weekly (max 50 mg/dose) or 0.4 mg/kg SC twice weekly (max 25 mg/dose). *Adalimumab*

**Table 195.3** Method of Action of Biologic Therapies Studied in Juvenile Idiopathic Arthritis

DRUG	METHOD OF ACTION
Etanercept	Soluble TNF p75 receptor fusion protein that binds to and inactivates TNF- $\alpha$
Infliximab	Chimeric human/mouse monoclonal antibody that binds to soluble TNF- $\alpha$ and its membrane-bound precursor, neutralizing its action
Adalimumab	A humanized IgG <sub>1</sub> monoclonal antibody that binds to TNF- $\alpha$
Abatacept	Soluble, fully human fusion protein of the extracellular domain of CTLA-4, linked to a modified Fc portion of the human IgG <sub>1</sub> . It acts as a costimulatory signal inhibitor by binding competitively to CD80 or CD86, where it selectively inhibits T-cell activation
Tocilizumab	A humanized anti-human IL-6 receptor monoclonal antibody
Anakinra	An IL-1 receptor antagonist (IL-1RA)

CTLA, Cytotoxic T lymphocyte-associated antigen; IL, interleukin; TNF, tumor necrosis factor.

From Beresford MW, Baildam EM. New advances in the management of juvenile idiopathic arthritis. Part 2. The era of biologicals. *Arch Dis Child Educ Pract Ed*. 2009;94:151–156.

is a fully human anti-TNF monoclonal antibody (mAb) used alone or in combination with MTX. In a placebo-controlled withdrawal-design study, children continuing to receive adalimumab were less likely to experience disease flares (43% vs 71%) even if they were also taking MTX (37% vs 65%). Adalimumab is administered subcutaneously every other week at a dose of 10 mg for children weighing 10 to  $<$ 15 kg, 20 mg for children weighing 15 to  $<$ 30 kg, and 40 mg for those weighing  $\geq$ 30 kg. *Golimumab* is a human mAb that binds to both soluble and transmembrane bioactive forms of TNF. It has FDA approval for use in polyarticular JIA at dosing of 80 mg/m<sup>2</sup> IV with initial doses at 0 and 4 weeks and then every 8 weeks thereafter. Non-FDA approved uses include psoriatic arthritis.

*Infliximab*, a chimeric mouse-human mAb, was tested in a randomized controlled trial (RCT) for use in JIA but did not achieve study end-points. However, it is FDA approved for pediatric inflammatory bowel disease and has been used “off label” for treatment of polyarticular JIA, uveitis, Behçet syndrome, and sarcoidosis. *Certolizumab pegol*, a pegylated humanized antibody against TNF, is approved by the FDA for RA, psoriatic arthritis, and ankylosing spondylitis in adults and is currently in pediatric trials for treatment of polyarticular JIA.

The most common adverse effects are injection site reactions that diminish over time. TNF blockade is associated with an increased frequency of serious systemic infections, including sepsis, dissemination of latent tuberculosis (TB), and invasive fungal infections in endemic areas. TNF blockade should not be initiated in patients with a history of chronic or frequent recurrent infections. TB testing should be done before initiation of therapy with TNF antagonists. If test results are positive, antitubercular treatment must be administered before anti-TNF treatment can be started. Theoretically, the risk of malignancy increases with TNF- $\alpha$  antagonists. Case reports describe the development of lupus-like syndromes, leukocytoclastic vasculitis, interstitial lung disease, demyelinating syndromes, antibody formation to the drug, rashes, cytopenias, anaphylaxis, serum sickness, and other reactions. The benefit/risk profile appears favorable after a decade of experience with this therapeutic class; the safety of longer-term suppression of TNF function is unknown.

## Modulator of T-Cell Activation

*Abatacept* is a selective inhibitor of T-cell costimulation resulting in T-cell anergy. It is FDA approved for treatment of moderate to severe polyarticular JIA. In a double-blind withdrawal RCT in children whose disease had not responded to DMARDs, 53% of placebo-treated patients vs 20% of abatacept-treated patients experienced disease flares during the withdrawal period. The frequency of adverse events did not differ between the

groups. Abatacept is administered IV every other week for three doses (<75 kg: 10 mg/kg/dose; 75–100 kg: 750 mg/dose; >100 kg: 1,000 mg/dose; maximum 1,000 mg/dose at 0, 2, and 4 weeks) and then monthly thereafter. Abatacept administered by SC injection was given FDA approval in March 2017 for children ≥4 years old for treatment of polyarticular JIA at doses given weekly: 50 mg for 10–25 kg, 87.5 mg for ≥25 to <50 kg, and 125 mg for ≥50 kg.

### B-Cell Depletion

*Rituximab* is a chimeric mAb to the antigen CD20, a transmembrane protein on the surface of B-cell precursors and mature B lymphocytes. This antibody induces B-cell apoptosis and causes depletion of circulating and tissue-based B cells. Antibody production is not completely abrogated because plasma cells are not removed. Rituximab has FDA approval for treatment of granulomatosis with polyangiitis (GPA) and microscopic polyangiitis (MPA) in children greater than 2 years of age. It is approved for treatment of adult RA and may also have a role in treatment of SLE, particularly its hematologic manifestations. Adverse events include serious infusion reactions, cytopenias, hepatitis B virus reactivation, hypogammaglobulinemia, infections, serum sickness, vasculitis, and a rare but fatal side effect, *progressive multifocal leukoencephalopathy*. Resistance to rituximab may develop over time in patients being treated for lymphoma.

*Belimumab* is a human mAb to B-lymphocyte stimulator (BLys) that negatively affects B-cell proliferation, differentiation, and long-term survival by inhibiting binding of BLys to its receptors on B cells. It is FDA approved for treatment of pediatric SLE in children age 5 years and older. For this indication, it is given as an IV infusion (10 mg/kg) every 2 weeks for the first three doses, then every 4 weeks thereafter. Side effects associated with belimumab include increased risk of serious infections, allergic (hypersensitivity) reactions, and changes in mood.

### Interleukin-1 Antagonists

*Anakinra*, a recombinant form of the human IL-1 receptor antagonist, competitively inhibits binding of IL-1 $\alpha$  and IL-1 $\beta$  to the natural receptor, interrupting the cytokine proinflammatory cascade. Anakinra has been approved for RA in adults. In meta-analyses of treatments for RA, anakinra was outperformed by TNF- $\alpha$  antagonists but has a special niche in pediatric rheumatology for treatment of systemic JIA (sJIA) and other autoinflammatory syndromes, such as cryopyrin-associated periodic syndrome (CAPS). The medication is dosed SC, 1–2 mg/kg, once daily. An IL-1 $\beta$  mAb, *canakinumab*, is FDA approved for use in CAPS, dosed SC every 8 weeks, and sJIA, dosed SC every 4 weeks. Adverse reactions include significant injection site reactions and increased bacterial infections.

### Interleukin-6 Receptor Antagonist

*Tocilizumab* is an anti-IL-6 receptor antibody binding to both soluble and membrane-associated receptors. Tocilizumab has FDA approval for treatment of sJIA and polyarticular JIA. Adverse reactions include transaminase and lipid elevations. Tocilizumab is given as an IV infusion every 2 weeks (sJIA) to 4 weeks (polyarticular JIA), and SC for polyarticular JIA 162 mg every 3 weeks for those <30 kg and every 2 wk for ≥30 kg.

### Intravenous Immune Globulin

Intravenous immunoglobulin (IVIG) is thought to be beneficial in various clinical conditions. IVIG significantly improves the short- and long-term natural history of Kawasaki disease. Open studies have supported benefit for juvenile dermatomyositis, lupus-associated thrombocytopenia, and polyarticular JIA. IVIG is given as 1–2 g/kg/dose, administered once monthly. It has been occasionally associated with severe, systemic allergy-like reactions and postinfusion aseptic meningitis (headache, stiff neck) (Table 195.4).

### Cytotoxics

#### Cyclophosphamide

Cyclophosphamide requires metabolic conversion in the liver to its active metabolites, which alkylate the guanine in DNA, leading to immunosuppression by inhibition of the S2 phase of mitosis. The subsequent decrease in numbers of T and B lymphocytes results in diminished humoral and cellular immune responses. Cyclophosphamide infusions (500–1,000 mg/m<sup>2</sup>) given monthly for 6 months, then every 3 months for 12–18 months,

**Table 195.4** Predisposing Factors for Immunoglobulin-Induced Adverse Effects

ADVERSE EFFECT	PREDISPOSING FACTORS
Flulike symptoms	High dose, rapid infusion rate, accompanying infection, previous adverse effects
Dermatologic adverse effects	High dose, rapid infusion rate, accompanying infection, male patients with chronic inflammatory demyelinating polyneuropathy
Arrhythmia and hypotension	History of heart disease
Transfusion-related acute lung injury	Rapid infusion rate
Thrombotic events	High dose, rapid infusion rate, advanced age, being bedridden, diabetes mellitus, hypertension, dyslipidemia, prior/current thrombosis, preexisting atherosclerotic disease, elevated serum viscosity, oral contraceptive use, hereditary hypercoagulable state, idiopathic thrombocytopenic purpura
Aseptic meningitis	High dose
Renal impairment	Rapid infusion rate, advanced age, renal insufficiency, nephrotic syndrome, diabetes mellitus, dehydration, sepsis paraproteinemia, nephrotoxic drugs, hemolysis, sucrose-containing preparations
Hemolysis	High dose, rapid infusion rate, non-O blood group, underlying inflammatory state

From Guo Y, Tian X, Wang X, Xiao Z. Adverse effects of immunoglobulin therapy. *Frontiers Immunol.* 2018;9:1299, Table 2.

have been shown to reduce the frequency of renal failure in patients with lupus and diffuse proliferative glomerulonephritis. Open trials suggest efficacy in severe CNS lupus. Oral cyclophosphamide (1–2 mg/kg/day) is effective as induction treatment of severe antineutrophilic cytoplasmic antibody (ANCA)-associated vasculitis and other forms of systemic vasculitis, as well as interstitial lung disease or pulmonary hemorrhage associated with rheumatic disease.

Cyclophosphamide is a potent cytotoxic drug associated with significant toxicities. Potential short-term adverse effects include nausea, vomiting, anorexia, alopecia, mucositis, hemorrhagic cystitis, and bone marrow suppression. Long-term complications include an increased risk for sterility and cancer, especially leukemia, lymphoma, and bladder cancer. In adult women with lupus treated with IV cyclophosphamide, 30–40% become infertile; the risk of ovarian failure appears to be significantly lower in adolescent and premenarchal girls. Ovarian suppression with an inhibitor of gonadotropin-releasing hormone to preserve fertility is currently being studied.

### Other Drugs

*Azathioprine* is sometimes used to treat ANCA-associated vasculitis after induction therapy or to treat SLE. *Cyclosporine* has been used occasionally in the treatment of dermatomyositis on the basis of uncontrolled studies and is helpful in the treatment of macrophage activation syndrome complicating sJIA (see Chapter 207). Case reports describe the successful use of *thalidomide*, or its analog *lenalidomide*, as treatment for sJIA, inflammatory skin disorders, and Behçet disease.

Several drugs commonly used in the past to treat arthritis are no longer part of standard treatment, including salicylates, gold compounds, and D-penicillamine.

Visit Elsevier eBooks+ at [eBooks.Health.Elsevier.com](https://www.elsevier.com/ebooks) for Bibliography.



## Chapter 196

## Juvenile Idiopathic Arthritis

Eveline Y. Wu and C. Egla Rabinovich

Juvenile idiopathic arthritis (JIA) is the most common rheumatic disease in children and one of the more common chronic illnesses of childhood. JIA represents a heterogeneous group of disorders sharing the clinical manifestation of arthritis. The etiology and pathogenesis of JIA are largely unknown, and the genetic component is complex, making clear distinction among various subtypes difficult. As a result, several classification schemes exist, each with its own limitations. The former classification of the **American College of Rheumatology (ACR)** uses the term *juvenile rheumatoid arthritis* and categorizes the disease into three onset types (Table 196.1). Attempting to standardize nomenclature, the **International League of Associations for Rheumatology (ILAR)** proposed a different classification using the term *juvenile idiopathic arthritis* (Table 196.2), inclusive of all subtypes of chronic juvenile arthritis. We refer to the ILAR classification criteria; see Chapter 197 for enthesitis-related arthritis (ERA) and psoriatic JIA (Tables 196.3 and 196.4).

### EPIDEMIOLOGY

The worldwide incidence of JIA ranges from 0.8 to 22.6 per 100,000 children per year, with prevalence ranges from 7 to 401 per 100,000. These wide-ranging numbers reflect population differences, particularly environmental exposure and immunogenetic susceptibility, along with variations in diagnostic criteria, difficulty in case ascertainment, and lack of population-based data. An estimated 300,000 U.S. children have arthritis, including 100,000 with a form of JIA. **Oligoarthritis** is the most common subtype (40–50%), followed by **polyarthritis** (25–30%) and **systemic JIA** (5–15%) (see Table 196.4). More females than males are affected in both oligoarticular (3:1) and polyarticular (5:1) JIA but are equally affected in systemic JIA (sJIA). The peak age at onset is 2–4 years for oligoarticular disease. Age of onset has a bimodal distribution in polyarthritis, with peaks at 2–4 years and 10–14 years. sJIA occurs throughout childhood, with a peak at 1–5 years.

### ETIOLOGY

The etiology and pathogenesis of JIA are not completely understood, although both immunogenetic susceptibility and an external trigger are considered necessary. Twin and family studies suggest a substantial

role for genetic factors. JIA is a complex genetic trait in which multiple genes may affect disease susceptibility. Variants in major histocompatibility complex (MHC) class I and class II regions have indisputably been associated with different JIA subtypes. Non-HLA candidate loci are also associated with JIA, including polymorphisms in the genes encoding protein tyrosine phosphatase nonreceptor 22 (PTPN22), tumor necrosis factor (TNF)- $\alpha$ , macrophage inhibitory factor, interleukin (IL)-6 and its receptor, and IL-1 $\alpha$ . Possible nongenetic triggers include bacterial and viral infections, enhanced immune responses to bacterial or mycobacterial heat shock proteins, abnormal reproductive hormone levels, and joint trauma.

### PATHOGENESIS

JIA is an autoimmune disease associated with alterations in both humoral and cell-mediated immunity. T lymphocytes have a central role, releasing proinflammatory cytokines favoring a type 1 helper T-lymphocyte response. Studies of T-cell receptor expression confirm recruitment of T lymphocytes specific for synovial non-self-antigens. B-cell activation, immune complex formation, and complement activation also promote inflammation. Inheritance of specific cytokine alleles may predispose to upregulation of inflammatory networks, resulting in systemic disease or more severe articular disease.

sJIA is characterized by dysregulation of the innate immune system with a lack of autoreactive T cells and autoantibodies. It therefore may be more accurately classified as an **autoinflammatory disorder**, which may transition to an autoimmune process once actual arthritis develops (Fig. 196.1). The IL-1 family of cytokines is key to disease pathogenesis, which is strongly supported by the marked responsiveness to IL-1 inhibitors. IL-18 in particular is a central driver, and serum IL-18 levels are markedly elevated in children with sJIA.

All these immunologic abnormalities cause inflammatory synovitis, characterized pathologically by villous hypertrophy and hyperplasia with hyperemia and edema of the synovial tissue. Vascular endothelial hyperplasia is prominent and is characterized by infiltration of mononuclear and plasma cells with a predominance of T lymphocytes (Fig. 196.2). Advanced and uncontrolled disease leads to pannus formation and progressive erosion of articular cartilage and contiguous bone (Figs. 196.3 and 196.4).

### CLINICAL MANIFESTATIONS

Arthritis must be present  $\geq 6$  weeks to make a diagnosis of any JIA subtype. Arthritis is defined by intraarticular swelling or the presence of two or more of the following signs: limitation in range of motion (ROM), tenderness or pain on motion, and warmth. Initial symptoms may be subtle or acute and often include morning stiffness with a limp or gelling after inactivity. Easy fatigability and poor sleep quality may be present. Involved joints are often swollen, warm to the touch, and uncomfortable on movement or palpation with reduced ROM, but usually are not erythematous. Arthritis in large joints, especially knees, initially accelerates linear growth and causes the affected limb to be longer, resulting in a discrepancy in limb lengths. Continued inflammation stimulates rapid and premature closure of the growth plate, resulting in shortened bones.

**Oligoarthritis** is defined as involving four or fewer joints within the first 6 months of disease onset, and often only a single joint is involved (see Table 196.4). It predominantly affects the large joints of the lower extremities, such as the knees and ankles (Fig. 196.5). Isolated involvement of upper-extremity large joints is less common. Those in whom disease never develops in four or more joints are regarded as having **persistent oligoarticular JIA**, whereas evolution of disease in five or more joints after 6 months changes the classification to **extended oligoarticular JIA** and is associated with a worse prognosis. Isolated involvement of the hip is *almost never* a presenting sign and suggests ERA (see Chapter 197) or a nonrheumatic cause. The presence of a positive antinuclear antibody (ANA) test confers increased risk for asymptomatic anterior uveitis, requiring periodic slit-lamp examination (Table 196.5). ANA positivity may also be correlated with younger age at disease onset, females, asymmetric arthritis, and fewer involved joints over time.

**Table 196.1** Criteria for the Classification of Juvenile Rheumatoid Arthritis

Age at onset: <16 yr
Arthritis (swelling or effusion, or the presence of two or more of the following signs: limitation of range of motion, tenderness or pain on motion, increased heat) in one or more joints
Duration of disease: $\geq 6$ wk
Onset type defined by type of articular involvement in the first 6 mo after onset:
Polyarthritis: five or more inflamed joints
Oligoarthritis: four or fewer inflamed joints
Systemic-onset disease: arthritis with rash and a characteristic quotidian fever
Exclusion of other forms of juvenile arthritis

Adapted from Cassidy JT, Levison JE, Bass JC, et al. A study of classification criteria for a diagnosis of juvenile rheumatoid arthritis. *Arthritis Rheum.* 1986;29:274–281.

**Table 196.2** International League of Associations for Rheumatology Classification of Juvenile Idiopathic Arthritis (JIA)

CATEGORY	DEFINITION	EXCLUSIONS
Systemic JIA	Arthritis in one or more joints with, or preceded by, fever of $\geq 2$ wk in duration that is documented to be daily (quotidian*) for at least 3 days and accompanied by one or more of the following: 1. Evanescent (nonfixed) erythematous rash 2. Generalized lymph node enlargement 3. Hepatomegaly or splenomegaly or both 4. Serositis†	a. Psoriasis or a history of psoriasis in patient or first-degree relative b. Arthritis in an HLA-B27–positive male beginning after the sixth birthday c. Ankylosing spondylitis, enthesitis-related arthritis, sacroiliitis with IBD, Reiter syndrome, or acute anterior uveitis, or history of one of these disorders in a first-degree relative d. Presence of IgM RF on at least two occasions at least 3 mo apart
Oligoarthritis	Arthritis affecting one to four joints during the first 6 mo of disease; two subcategories are recognized: 1. Persistent oligoarthritis—affecting four or fewer joints throughout the disease course 2. Extended oligoarthritis—affecting five or more joints after the first 6 mo of disease	a, b, c, d (above) plus e. Presence of systemic JIA in the patient
Polyarthritis (RF negative)	Arthritis affecting five or more joints during the first 6 mo of disease; a test for RF is negative	a, b, c, d, e
Polyarthritis (RF positive)	Arthritis affecting five or more joints during the first 6 mo of disease; two or more tests for RF at least 3 mo apart during the first 6 mo of disease are positive	a, b, c, e
Psoriatic arthritis	Arthritis and psoriasis or arthritis and at least two of the following: 1. Dactylitis‡ 2. Nail pitting§ and onycholysis 3. Psoriasis in first-degree relative	b, c, d, e
Enthesitis-related arthritis	Arthritis and enthesitis¶ or arthritis or enthesitis with at least two of the following: 1. Presence of or history of sacroiliac joint tenderness or inflammatory lumbosacral pain, or both** 2. Presence of HLA-B27 antigen 3. Onset of arthritis in a male $> 6$ yr old 4. Acute (symptomatic) anterior uveitis 5. History of ankylosing spondylitis, enthesitis-related arthritis, sacroiliitis with IBD, Reiter syndrome, or acute anterior uveitis in first-degree relative	a, d, e
Undifferentiated arthritis	Arthritis that fulfills criteria in no category or two or more of the above categories	

\*Quotidian fever is defined as a fever that rises to  $39^{\circ}\text{C}$  ( $102.2^{\circ}\text{F}$ ) once daily and returns to  $37^{\circ}\text{C}$  ( $98.6^{\circ}\text{F}$ ) between fever peaks.

†Serositis refers to pericarditis, pleuritis, or peritonitis or some combination of the three.

‡Dactylitis is swelling of one or more digit(s), usually in an asymmetric distribution, that extends beyond the joint margin.

§A minimum of two pits on any one or more nails at any time.

¶Enthesitis is defined as tenderness at the insertion of a tendon, ligament, joint capsule, or fascia to bone.

\*\*Inflammatory lumbosacral pain refers to lumbosacral pain at rest with morning stiffness that improves on movement.

IBD, Inflammatory bowel disease; RF, rheumatoid factor.

From Firestein GS, Budd RC, Harris ED Jr, et al., eds. *Kelley's Textbook of Rheumatology*, 8th ed. Philadelphia: Saunders; 2009.

**Table 196.3** Characteristics of ACR and ILAR Classifications of Childhood Chronic Arthritis

PARAMETER	ACR (1977)	ILAR (1997)
Term	Juvenile rheumatoid arthritis (JRA)	Juvenile idiopathic arthritis (JIA)
Minimum duration	$\geq 6$ wk	$\geq 6$ wk
Age at onset	$< 16$ yr	$< 16$ yr
Four or fewer joints in first 6 mo after presentation	Pauciarticular	Oligoarthritis: Persistent: four or fewer joints for course of disease Extended: four or more joints after 6 mo
Four or more joints in first 6 mo after presentation	Polyarticular	Polyarthritis, RF negative Polyarthritis, RF positive
Fever, rash, arthritis	Systemic onset	Systemic
Other categories included	Exclusion of other forms	Psoriatic arthritis Enthesitis-related arthritis Undifferentiated: Fits no other category Fits more than one category
Inclusion of psoriatic arthritis, inflammatory bowel disease, ankylosing spondylitis	No (see Chapter 197)	Yes

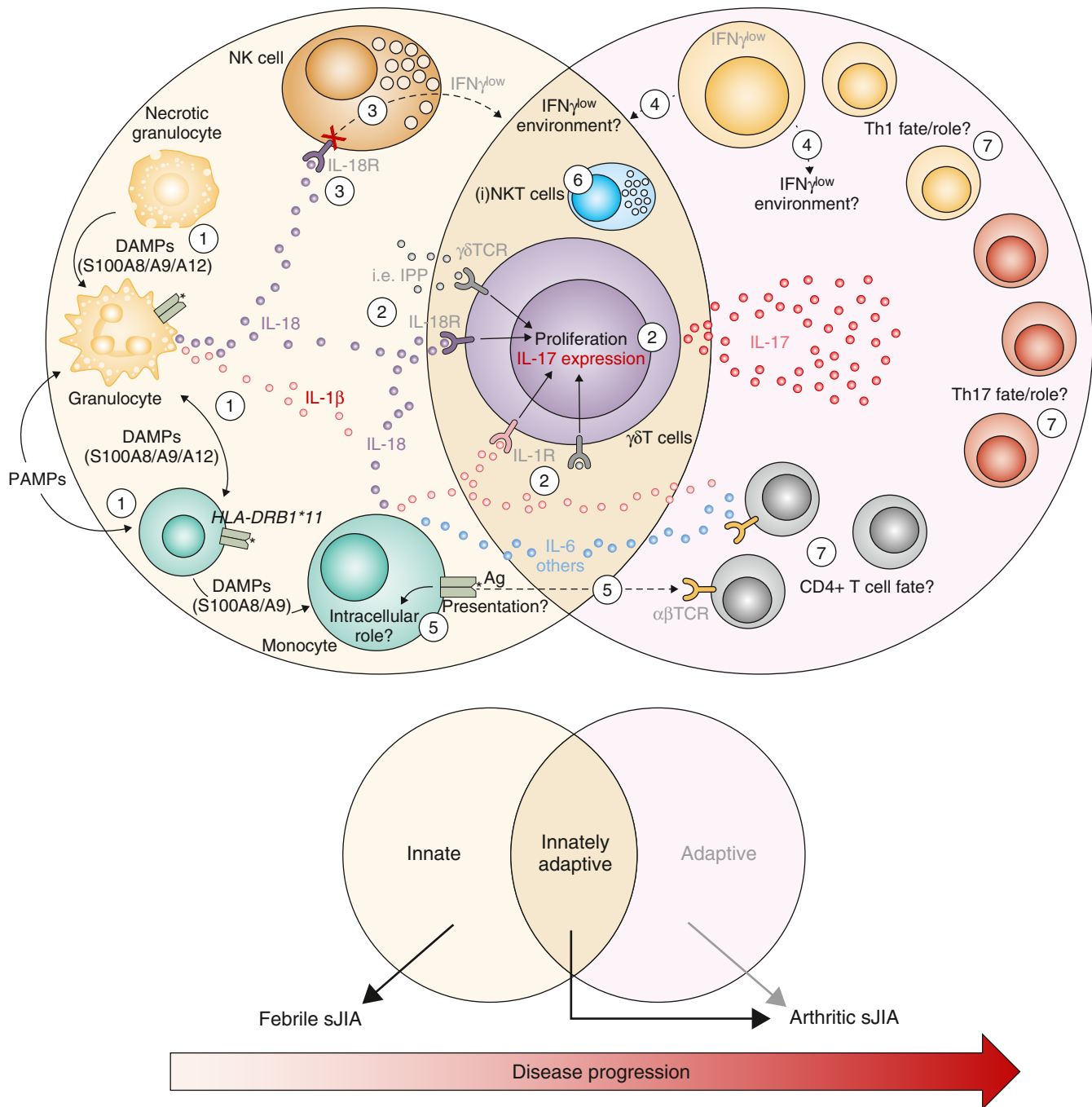
ACR, American College of Rheumatology; ILAR, International League of Associations for Rheumatology; RF, rheumatoid factor.

**Table 196.4** Overview of Main Features of Subtypes of Juvenile Idiopathic Arthritis (JIA)

ILAR SUBTYPE	PEAK AGE AT ONSET (yr)	FEMALE:MALE RATIO	% OF ALL JIA CASES	ARTHRITIS PATTERN	EXTRAARTICULAR FEATURES	LABORATORY INVESTIGATIONS	NOTES ON THERAPY
Systemic arthritis	1-5	1:1	5-15	Polyarticular, often affecting knees, wrists, and ankles; also fingers, neck, and hips	Daily fever; evanescent rash; pericarditis; pleuritis	Anemia; WBC ↑; ESR ↑; CRP ↑; ferritin ↑; platelets ↑ (normal or ↓ in MAS)	Less responsive to standard treatment with MTX and anti-TNF agents; consider IL-1 or IL-6 inhibitors in resistant cases or as first-line therapy
Oligoarthritis	2-4	3:1	40-50 (but ethnic variation)	Knees ++; ankles, fingers +	Uveitis in 30% of cases	ANA positive in 60%; other test results usually normal; may have mildly ↑ ESR/CRP	NSAIDs and intraarticular corticosteroids; MTX occasionally required
Polyarthritis:							
RF negative	2-4 and 10-14	3:1 and 10:1	20-35	Symmetric or asymmetric; small and large joints; cervical spine; temporomandibular joint	Uveitis in 10%	ANA positive in 40%; RF negative; ESR ↑ or ↑↑; CRP ↑ or normal; mild anemia	Standard therapy with MTX and NSAIDs; then, if nonresponsive, anti-TNF agents or other biologics, including abatacept, indicated as first-line therapy
RF positive	9-12	9:1	<10	Aggressive symmetric polyarthritis	Rheumatoid nodules in 10%; low-grade fever	RF positive; ESR ↑; CRP ↑/normal; mild anemia	Long-term remission unlikely; early aggressive therapy is warranted
Psoriatic arthritis	2-4 and 9-11	2:1	5-10	Asymmetric arthritis of small or medium-sized joints	Uveitis in 10%; psoriasis in 50%	ANA positive in 50%; ESR ↑; CRP ↑ or normal; mild anemia	NSAIDs and intraarticular corticosteroids; MTX, anti-TNF agents
Enthesitis-related arthritis	9-12	1:7	5-10	Predominantly lower limb joints affected; sometimes axial skeleton (but less than in adult, ankylosing spondylitis)	Acute anterior uveitis; association with reactive arthritis and inflammatory bowel disease	80% of patients positive for HLA-B27	NSAIDs and intraarticular corticosteroids; consider sulfasalazine as alternative to MTX; anti-TNF agents

ILAR, International League of Associations for Rheumatology; ANA, antinuclear antibody; CRP, C-reactive protein; ESR, erythrocyte sedimentation rate; MAS, macrophage activation syndrome; MTX, methotrexate; NSAIDs, nonsteroidal antiinflammatory drugs; RF, rheumatoid factor; TNF, tumor necrosis factor; WBC, white blood cell count.

From Firestein GS, Budd RC, Harris ED Jr, et al., eds. *Kelley's Textbook of Rheumatology*, 8th ed. Philadelphia: Saunders; 2009.

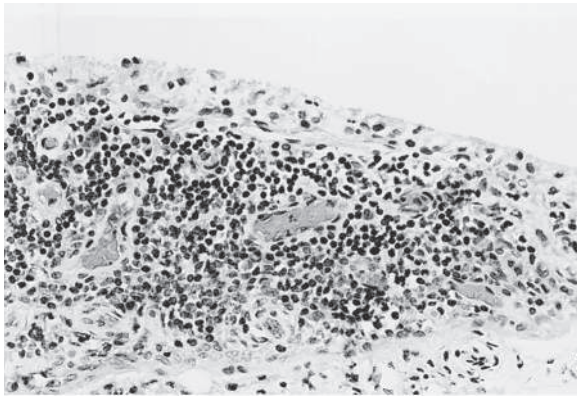


**Fig. 196.1** Innately adaptive or truly autoimmune: a pathophysiological model for disease progression in systemic juvenile idiopathic arthritis (sJIA). Innate immune cells, such as myeloid cells (granulocytes, monocytes) and natural killer (NK) cells, are relevant during the acute febrile phase of systemic JIA. (1) Myeloid cells release interleukin-1 (IL-1) family cytokines (IL-1 $\beta$ , IL-18) and other proinflammatory cytokines, which can either be triggered by infection (pathogen-associated molecular patterns [PAMPs]) or result from pattern-recognition receptor activation by damage-associated molecular patterns (DAMPs) released from stressed or necrotic cells. (2) Together with  $\gamma\delta$  T-cell receptor ( $\gamma\delta$  TCR) activation by endogenous ligands (i.e., isopentenyl pyrophosphate [IPP]) or bacterial ligands, IL-1 and IL-18 can trigger IL-17 expression from  $\gamma\delta$  T cells, while (3) IL-18 fails to trigger interferon- $\gamma$  (IFN $\gamma$ ) expression from NK cells because of a defective IL-18 receptor (IL-18R). (4) Similarly, systemic JIA Th1 cells express only low levels of IFN $\gamma$ . Both cell types may contribute to hypophysiologic IFN $\gamma$  levels, potentially promoting IL-17 expression in disease. Although a genetic association or alterations in frequencies have been reported, the pathomechanistic roles of (5) HLA-DRB1\*11 (whether antigen [Ag] presentation or intracellular function) or (6) invariant NKT (iNKT) and (7) CD4+ T cells in disease progression are yet largely unclear. Thus current data imply that innately adaptive immune cells bridging innate and adaptive immunity, rather than classic B or T lymphocytes, play a central role in promoting disease progression in systemic JIA. (From Kessel C, Hedrich CM, Foeil D. Innately adaptive or truly autoimmune: is there something unique about systemic juvenile idiopathic arthritis? *Arth Rheumatol.* 2020;72:210–219, Fig. 2, p. 214)

**Polyarthritis** is characterized by inflammation of five or more joints in both upper and lower extremities (Figs. 196.6 and 196.7). Rheumatoid factor (RF)-positive polyarthritis resembles the characteristic symmetric presentation of adult rheumatoid arthritis. **Rheumatoid**

**nodules** on the extensor surfaces of the elbows, spine, and over the Achilles tendons, although unusual, are associated with a more severe course and almost exclusively occur in RF-positive individuals (Fig. 196.8). **Micrognathia** reflects chronic temporomandibular joint





**Fig. 196.2** Synovial biopsy specimen from a 10-yr-old child with oligoarticular juvenile idiopathic arthritis. There is a dense infiltration of lymphocytes and plasma cells in the synovium.



**Fig. 196.3** Arthroscopy in the shoulder of a child with juvenile idiopathic arthritis showing pannus formation and cartilage erosions. (Courtesy Dr. Alison Toth.)

disease (Fig. 196.9). Cervical spine involvement (Fig. 196.10), manifesting as decreased neck extension, occurs with a risk of atlantoaxial subluxation and neurologic sequelae. Hip disease may be subtle, with findings of decreased or painful ROM on examination (Fig. 196.11).

**Systemic JIA** is characterized by arthritis (may not be evident on initial presentation), fever, rash, and prominent visceral involvement, including hepatosplenomegaly, lymphadenopathy, and serositis (pericarditis). The characteristic fever, defined as spiking temperatures to  $\geq 39^{\circ}\text{C}$  ( $102.2^{\circ}\text{F}$ ), occurs on a daily or twice-daily basis for at least 2 weeks, with a rapid return to normal or subnormal temperatures (Fig. 196.12). The fever is often present in the evening and is frequently accompanied by a characteristic faint, erythematous, macular rash. The evanescent **salmon-colored lesions**, classic for sJIA, are linear or circular and are usually distributed over the trunk and proximal extremities (Fig. 196.13). The classic rash is nonpruritic and migratory with lesions lasting  $<1$  hour. **Koebner phenomenon**, a cutaneous hypersensitivity in which classic lesions are brought on by superficial trauma, is often present. Heat can also evoke rash. Fever, rash, hepatosplenomegaly, and lymphadenopathy are present in  $>70\%$  of affected children. Without arthritis, the **differential diagnosis** includes the episodic fever (auto-inflammatory) syndromes (see Chapter 204), infection (endocarditis, rheumatic fever, brucellosis, multisystem inflammatory syndrome in children [MIS-C]), other rheumatic disorders (systemic lupus erythematosus [SLE], vasculitis syndromes, serum sickness, Kawasaki



**Fig. 196.4** MRI with gadolinium of a 10-yr-old child with juvenile idiopathic arthritis (same patient as in Fig. 196.2). The dense white signal in the synovium near the distal femur, proximal tibia, and patella reflects inflammation. MRI of the knee is useful to exclude ligamentous injury, chondromalacia of the patella, and tumor.



**Fig. 196.5** Oligoarticular juvenile idiopathic arthritis with swelling and flexion contracture of the right knee.

disease, sarcoidosis, Castleman disease), inflammatory bowel disease, hemophagocytic lymphohistiocytosis syndromes, and malignancy (leukemia, neuroblastoma, lymphoma). Some children initially present with only systemic features and evolve over time, but definitive

**Table 196.5** Frequency of Ophthalmologic Examination in Patients with Juvenile Idiopathic Arthritis**REFERRAL**

- Patients should be referred at the time of diagnosis, or suspicion, of JIA

**INITIAL SCREENING EXAMINATION**

- Should occur as soon as possible and no later than 6 wk from referral
- Symptomatic ocular patients should be seen within a week of referral

**ONGOING SCREENING**

- Screening at 2-monthly intervals from onset of arthritis for 6 mo
- Followed by 3-4 monthly screening for time outlined below

**OLIGOARTICULAR JIA, PSORIATIC ARTHRITIS, AND ENTHESITIS-RELATED ARTHRITIS IRRESPECTIVE OF ANA STATUS, ONSET UNDER 11 YR**

AGE AT ONSET (YR)	LENGTH OF SCREENING (YR)
<3	8
3-4	6
5-8	3
9-10	1

**POLYARTICULAR, ANA-POSITIVE JIA, ONSET <10 YR**

AGE AT ONSET (YR)	LENGTH OF SCREENING (YR)
<6	5
6-9	2

Polyarticular, ANA-negative JIA, onset <7 yr  
5-yr screening for all children

Systemic JIA and rheumatoid factor–positive polyarticular JIA

- Uveitis risk very low; however, diagnostic uncertainty in the early stages and overlap of symptoms may mean initial screening is indicated

All categories, onset >11 yr

- 1-yr screening for all children

After stopping immunosuppression (e.g., methotrexate)

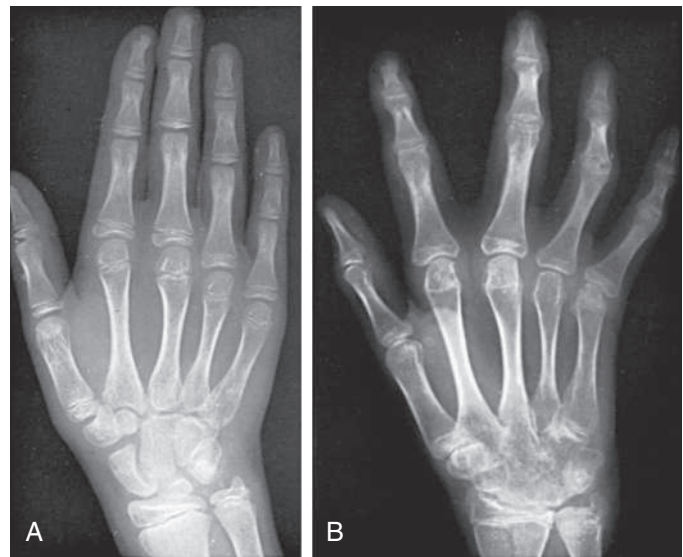
- Two-monthly screening for 6 mo, then revert to previous screening frequency as above

After discharge from screening

- Patients should receive advice about regular self-monitoring by checking vision unilaterally once weekly and when to seek medical advice
- Screening may need to continue indefinitely in situations where a young person may be unable to detect a change in vision or be unwilling to seek re-referral
- Annual check by optometrist as a useful adjunct



**Fig. 196.6** Hands and wrists of a child with polyarticular juvenile idiopathic arthritis, rheumatoid factor negative. Notice the symmetric involvement of the wrists, metacarpophalangeal joints, and proximal and distal interphalangeal joints. In this photograph, there is cream with occlusive dressing on the patient's right hand in preparation for placement of an intravenous line for administration of a biologic agent.



**Fig. 196.7** Progression of joint destruction in a child with polyarticular juvenile idiopathic arthritis, rheumatoid factor positive, despite doses of corticosteroids sufficient to suppress symptoms in the interval between radiographs. **A**, Radiograph of the hand at onset. **B**, Radiograph taken 4 years later, showing a loss of articular cartilage and destructive changes in the distal and proximal interphalangeal and metacarpophalangeal joints as well as destruction and fusion of wrist bones.

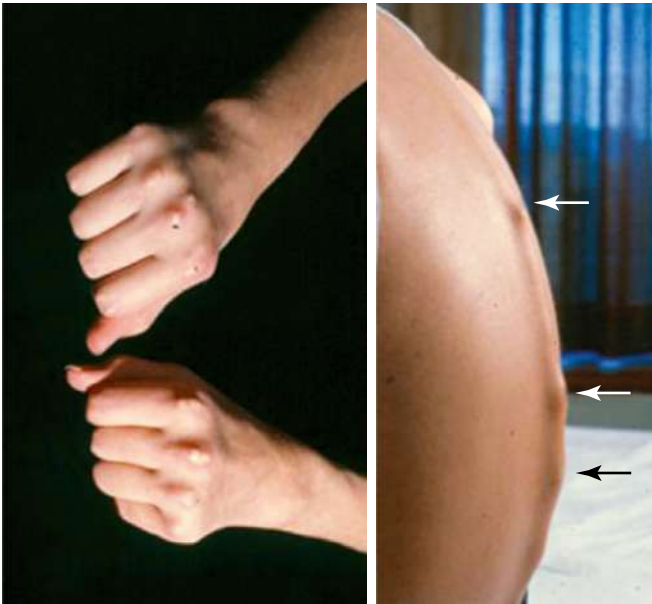
Data from Clarke SLN, Sen ES, Ramanan AV. Juvenile idiopathic arthritis-associated uveitis. *Pediatr Rheumatol*. 2016;14:27.

diagnosis requires the presence of arthritis. Arthritis may affect any number of joints, but the course is classically polyarticular; may be very destructive; and can include hip, cervical spine, and temporomandibular joint involvement.

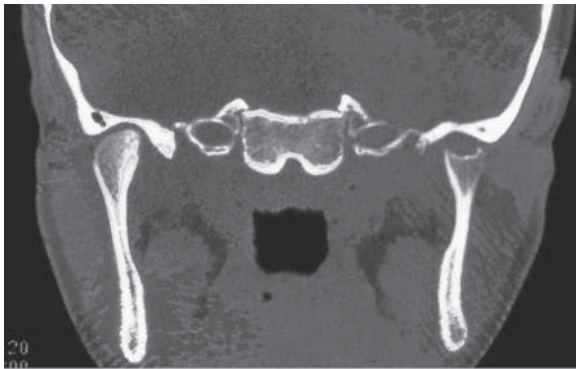
**Macrophage activation syndrome (MAS;** see Chapter 207) is a rare but potentially fatal complication of sJIA that can occur at any time (onset, medication change, active or remission) during the disease course. It is also referred to as *secondary hemophagocytic syndrome* or *hemophagocytic lymphohistiocytosis (HLH)* (see Chapter 556.2). There is increasing evidence that sJIA/MAS and HLH share similar functional defects in granule-dependent cytotoxic lymphocyte activity. In addition, sJIA-associated MAS and HLH share genetic variants in approximately 35% of patients with sJIA/MAS. MAS classically manifests as acute onset of high-spiking fevers, lymphadenopathy, hepatosplenomegaly, and encephalopathy. Laboratory evaluation shows

thrombocytopenia and leukopenia with elevated liver enzymes, lactate dehydrogenase, ferritin, and triglycerides. Patients may have purpura and mucosal bleeding, as well as elevated fibrin split product values and prolonged prothrombin and partial thromboplastin times. The ESR falls because of hypofibrinogenemia and hepatic dysfunction, a feature useful in distinguishing MAS from a flare of systemic disease (Table 196.6). An international consensus panel developed a set of classification criteria for sJIA-associated MAS, including hyperferritinemia (>684 ng/mL) and any two of the following: thrombocytopenia ( $\leq 181 \times 10^9/L$ ), elevated liver enzymes (aspartate transaminase >48 U/L), hypertriglyceridemia (>156 mg/dL), and hypofibrinogenemia ( $\leq 360$  mg/dL) (see Table 196.6). These criteria apply to a febrile patient suspected of sJIA and in the absence of disorders such as immune-mediated thrombocytopenia, infectious hepatitis, familial hypertriglyceridemia, or visceral leishmaniasis. A relative change in laboratory values is likely more relevant in making an early diagnosis than are absolute normal values. A bone marrow aspiration and biopsy may be helpful in diagnosis, but





**Fig. 196.8** Rheumatoid nodules overlying bony prominences in an adolescent with rheumatoid factor–positive polyarthritis. (From Rosenberg AM, Oen KG. Polyarthritis. In: Cassidy JT, Petty RE, Laxer RM, et al., eds. Textbook of Pediatric Rheumatology, 6th ed. Philadelphia: Saunders; 2011: Fig 15-5, p. 257.)



**Fig. 196.9** CT scan of the temporomandibular joint of a child with juvenile idiopathic arthritis exhibiting destruction on the right.

evidence of hemophagocytosis is not always evident. Emergency treatment with high-dose intravenous methylprednisolone, cyclosporine, or anakinra may be effective. Severe cases may require therapy similar to that for primary HLH (see Chapter 556.2).

An inflammatory lung disease has also recently been recognized as a rare but life-threatening complication in children with sJIA. Children can present with little to no respiratory symptoms; acute clubbing can be an early indicator. The predominant pathology is pulmonary alveolar proteinosis and/or endogenous lipoid pneumonia. Compared with children without lung disease, children with sJIA and lung disease are younger at diagnosis, have a history of MAS, have higher serum IL-18 levels, and have higher exposure and adverse reaction rates to cytokine inhibitors. Given the more severe disease course, lung disease in children with sJIA requires a high index of suspicion and prompt evaluation.

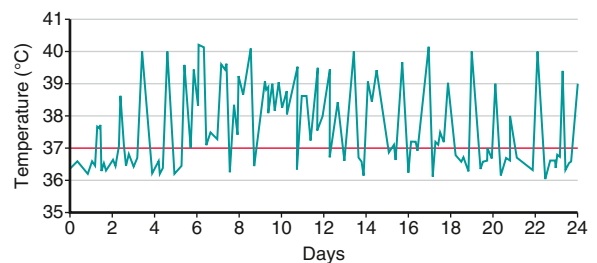
Bone mineral metabolism and skeletal maturation are adversely affected in children with JIA, regardless of subtype. Children with JIA have decreased bone mass (osteopenia), which appears to be associated with increased disease activity. Increased levels of cytokines such as TNF- $\alpha$  and IL-6, both key regulators in bone metabolism, have deleterious effects on bone both within the joint and systemically in the axial



**Fig. 196.10** Radiograph of the cervical spine of a child with active juvenile idiopathic arthritis showing fusion of the neural arch between joints C2 and C3, narrowing and erosion of the remaining neural arch joints, obliteration of the apophyseal space, and loss of the normal lordosis.



**Fig. 196.11** Severe hip disease in 13-yr-old male with active systemic juvenile idiopathic arthritis. Radiograph shows destruction of the femoral head and acetabula, joint space narrowing, and subluxation of left hip. The child had received corticosteroids systemically for 9 years.

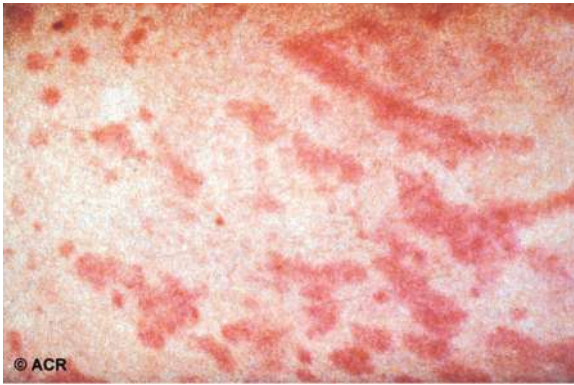


**Fig. 196.12** High-spiking intermittent fever in a 3-yr-old child with systemic juvenile idiopathic arthritis. (From Ravelli A, Martini A. Juvenile idiopathic arthritis. Lancet 2007;369:767–778.)

and appendicular bones. Abnormalities of skeletal maturation become most prominent during the pubertal growth spurt.

## DIAGNOSIS

JIA is a clinical diagnosis without any diagnostic laboratory tests. The meticulous clinical exclusion of other diseases and many mimics is therefore essential. Laboratory studies, including tests for ANA and RF,



**Fig. 196.13** The rash of systemic juvenile idiopathic arthritis is salmon-colored, macular, and nonpruritic. Individual lesions are transient and occur in crops over the trunk and extremities. (From American College of Rheumatology. Clinical Slide Collection on the Rheumatic Diseases. Atlanta, GA: ACR. Copyright 1991, 1995, 1997.)

**Table 196.6** Macrophage Activation Syndrome (MAS)

#### LABORATORY FEATURES\*

1. Cytopenias
2. Abnormal liver function tests
3. Coagulopathy (hypofibrinogenemia)
4. Decreased erythrocyte sedimentation rate
5. Hypertriglyceridemia
6. Hyponatremia
7. Hypoalbuminemia
8. Hyperferritinemia
9. Elevated sCD25 and sCD163

#### CLINICAL FEATURES\*

1. Nonremitting fever
2. Hepatomegaly
3. Splenomegaly
4. Lymphadenopathy
5. Hemorrhages
6. Central nervous system dysfunction (headache, seizures, lethargy, coma, disorientation)

#### HISTOPATHOLOGIC FEATURES\*

1. Macrophage hemophagocytosis in the bone marrow aspirate
2. Increased CD163 staining of the bone marrow

#### PROPOSED CRITERIA FOR MAS IN SJIA†

1. Serum ferritin  $>684$  ng/mL and
2. Any two of the following:
  - Thrombocytopenia ( $\leq 181 \times 10^9/L$ )
  - Elevated liver enzymes (aspartate transaminase  $>48$  U/L)
  - Hypertriglyceridemia ( $>156$  mg/dL)
  - Hypofibrinogenemia ( $\leq 360$  mg/dL)

\*From Ravelli A, Grom A, Behrens E, Cron R. Macrophage activation syndrome as part of systemic juvenile idiopathic arthritis: Diagnosis, genetics, pathophysiology and treatment. *Genes Immun.* 2012;13:289–298.

†From Ravelli A, Minoia F, Davi S, et al. 2016 Classification criteria for macrophage activation syndrome complicating systemic juvenile idiopathic arthritis: a European League Against Rheumatism/American College of Rheumatology/Paediatric Rheumatology International Trials Organisation collaborative initiative. *Arthritis Rheumatol.* 2016;68:566–576.

are only supportive or prognostic, and their results may be normal in patients with JIA (see Tables 196.1, 196.3, and 196.4).

## DIFFERENTIAL DIAGNOSIS

The differential diagnosis for arthritis is broad, and a careful, thorough investigation for other underlying etiology is imperative (Table 196.7). History, physical examination, laboratory tests, and

radiography may help exclude other possible causes. Arthritis can be a presenting manifestation for any of the multisystem rheumatic diseases of childhood, including SLE (see Chapter 199), juvenile dermatomyositis (see Chapter 200), sarcoidosis (see Chapter 209), and the vasculitic syndromes (see Chapter 210). In scleroderma (see Chapter 201), limited ROM caused by sclerotic skin overlying a joint may be confused with sequelae from chronic inflammatory arthritis. **Acute rheumatic fever** is characterized by exquisite joint pain and tenderness, remittent fever, and migratory polyarthritis. **Autoimmune hepatitis** can also be associated with an acute arthritis.

Many infections are associated with arthritis, and a recent history of infectious symptoms may help make a distinction. Viruses, including parvovirus B19, rubella, Epstein-Barr virus, hepatitis B virus, and HIV, can induce a transient arthritis. Arthritis may follow enteric infections (see Chapter 198). **Lyme disease** should be considered in children with oligoarthritis living in or visiting endemic areas (see Chapter 268). Although a history of tick exposure, preceding flulike illness, and subsequent rash should be sought, these are not always present. Monoarticular arthritis unresponsive to antiinflammatory treatment may be the result of chronic mycobacterial or other infection, such as *Kingella kingae*, and the diagnosis is established by synovial fluid analysis (polymerase chain reaction [PCR]) or biopsy. Acute onset of fever and a painful, erythematous, hot joint suggests septic arthritis (see Chapter 726). Isolated hip pain with limited ROM suggests suppurative arthritis, osteomyelitis (see Chapter 725), toxic synovitis, Legg-Calvé-Perthes disease, slipped capital femoral epiphysis, and chondrolysis of the hip (see Chapter 719).

Lower-extremity arthritis and tenderness over insertion of ligaments and tendons, especially in a male child, suggest ERA (see Chapter 197). **Psoriatic arthritis** can manifest as limited joint involvement in an unusual distribution (e.g., small joints of the hand and ankle) years before the onset of cutaneous disease. **Inflammatory bowel disease** may manifest as oligoarthritis, usually affecting joints in the lower extremities, as well as gastrointestinal symptoms, elevations in ESR, and microcytic anemia.

Many conditions present solely with arthralgia (i.e., joint pain). Hypermobility may cause joint pain, especially in the lower extremities. Growing pains should be suspected in a child age 4–12 years complaining of leg pain in the evening with normal investigative studies and no morning symptoms. Nocturnal pain that awakens the child also alerts to the possibility of a malignancy. An adolescent with missed school days may suggest a diagnosis of fibromyalgia (see Chapter 211.3).

Children with **leukemia** or **neuroblastoma** may have joint or bone pain resulting from malignant infiltration of the bone, synovium, or more often the bone marrow, sometimes months before demonstrating lymphoblasts on peripheral blood smear. Physical examination may reveal no tenderness, a deeper pain with palpation of the bone, or pain out of proportion to exam findings. Malignant pain often awakens the child from sleep and may cause cytopenias. Because platelets are an acute-phase reactant, a high ESR with leukopenia and a low-normal platelet count may also be a clue to underlying leukemia. In addition, the characteristic quotidian fever of sJIA is absent in malignancy. Bone marrow examination is necessary for diagnosis. Some diseases, such as cystic fibrosis, diabetes mellitus, and the glycogen storage diseases, have associated arthropathies. Swelling that extends beyond the joint can be a sign of lymphedema or IgA vasculitis (formerly Henoch-Schönlein purpura; see Chapter 210.1). A peripheral arthritis indistinguishable from JIA occurs in the humoral immunodeficiencies (see Chapter 165), such as common variable immunodeficiency and X-linked agammaglobulinemia. Skeletal dysplasias associated with a degenerative arthropathy are diagnosed from their characteristic radiologic abnormalities.

Systemic onset of JIA often presents as a fever of unknown origin (see Chapter 222). Important considerations in the differential diagnosis include infections (endocarditis, brucellosis, cat-scratch disease, Q fever, mononucleosis), autoinflammatory disease (see Chapter 204), malignancy (leukemia, lymphoma, neuroblastoma), and HLH.



**Table 196.7** Conditions Causing Arthritis or Extremity Pain**RHEUMATIC AND INFLAMMATORY DISEASES**

Juvenile idiopathic arthritis  
 Systemic lupus erythematosus  
 Juvenile dermatomyositis  
 Polyarteritis nodosa  
 Scleroderma  
 Sjögren syndrome  
 Behçet disease  
 Overlap syndromes  
 Antineutrophilic cytoplasmic antibody (ANCA)-associated vasculitis  
 Sarcoidosis  
 Kawasaki syndrome  
 IgA vasculitis (formerly Henoch-Schönlein purpura)  
 Chronic recurrent multifocal osteomyelitis

**SERONEGATIVE SPONDYLOARTHROPATHIES**

Juvenile ankylosing spondylitis  
 Inflammatory bowel disease  
 Psoriatic arthritis  
 Reactive arthritis associated with urethritis, iridocyclitis, and mucocutaneous lesions

**INFECTIOUS ILLNESSES**

Bacterial arthritis (septic arthritis, *Staphylococcus aureus*, *Kingella kingae*, pneumococcal, gonococcal, *Haemophilus influenzae*)  
 Lyme disease  
 Viral illness (parvovirus, rubella, mumps, Epstein-Barr, hepatitis B, chikungunya)  
 Fungal arthritis  
 Mycobacterial infection  
 Spirochetal infection  
 Endocarditis

**REACTIVE ARTHRITIS**

Acute rheumatic fever  
 Reactive arthritis (postinfectious caused by *Shigella*, *Salmonella*, *Yersinia*, *Chlamydia*, post-streptococcal, or meningococcus)  
 Serum sickness  
 Toxic synovitis of the hip  
 Postimmunization

**IMMUNODEFICIENCIES**

Hypogammaglobulinemia  
 Immunoglobulin A deficiency  
 Common variable immunodeficiency disease (CVID)  
 Human immunodeficiency virus (HIV)

**CONGENITAL AND METABOLIC DISORDERS**

Gout  
 Pseudogout  
 Mucopolysaccharidoses  
 Thyroid disease (hypothyroidism, hyperthyroidism)  
 Hyperparathyroidism  
 Vitamin C deficiency (scurvy)  
 Hereditary connective tissue disease (Marfan syndrome, Ehlers-Danlos syndrome)  
 Fabry disease  
 Farber disease  
 Fucosidosis  
 Amyloidosis (familial Mediterranean fever)

**BONE AND CARTILAGE DISORDERS**

Trauma  
 Patellofemoral syndrome  
 Hypermobility syndromes  
 Osteochondritis dissecans  
 Avascular necrosis (including Legg-Calvé-Perthes disease)  
 Hypertrophic osteoarthropathy  
 Slipped capital femoral epiphysis  
 Osteolysis  
 Benign bone tumors (including osteoid osteoma)  
 Langerhans cell histiocytosis  
 Rickets  
 Idiopathic multicentric osteolysis  
 Camptodactyly-arthropathy-coxa vara-pericarditis syndrome  
 Progressive pseudorheumatoid dysplasia  
 Pachydermodactyly

**NEUROPATHIC DISORDERS**

Peripheral neuropathies  
 Carpal tunnel syndrome  
 Charcot joints

**NEOPLASTIC DISORDERS**

Leukemia  
 Neuroblastoma  
 Lymphoma  
 Bone tumors (osteosarcoma, Ewing sarcoma)  
 Histiocytic syndromes  
 Synovial tumors

**HEMATOLOGIC DISORDERS**

Hemophilia  
 Hemoglobinopathies (including sickle cell disease)

**MISCELLANEOUS DISORDERS**

Autoinflammatory diseases  
 Recurrent multifocal osteomyelitis  
 Pigmented villonodular synovitis  
 Plant-thorn synovitis (foreign body arthritis)  
 Myositis ossificans  
 Eosinophilic fasciitis  
 Tendinitis (overuse injury)  
 Raynaud phenomenon  
 Hemophagocytic syndromes

**PAIN SYNDROMES**

Fibromyalgia  
 Growing pains  
 Depression (with somatization)  
 Complex regional pain syndrome

**LABORATORY FINDINGS**

Hematologic abnormalities often reflect the degree of systemic or articular inflammation, with elevated white blood cell (WBC) and platelet counts and a microcytic anemia. Inflammation may also cause elevations in ESR and CRP, although it is not unusual for both to be normal in children with JIA.

Elevated ANA titers are present in 40–85% of children with oligoarticular or polyarticular JIA but are rare with sJIA. ANA seropositivity is associated with increased risk of **chronic uveitis** in JIA. Approximately 5–15% of patients with polyarticular JIA are seropositive for RF. Anti-cyclic citrullinated peptide antibody, as with RF, is a marker of more aggressive disease. Both ANA and RF seropositivity can occur in association with transient events, such as viral infection.

Children with sJIA usually have striking elevations in inflammatory markers and WBC and platelet counts. Hemoglobin levels are low, typically 7-10 g/dL, with indices consistent with anemia of chronic disease. The ESR is usually high, except in MAS. Although immunoglobulin levels tend to be high, ANA and RF are uncommon. Ferritin values are typically elevated and can be markedly increased in MAS (>10,000 ng/mL). In the setting of MAS, all cell lines have the potential to decline precipitously because of the consumptive process. A low or normal WBC count and/or platelet count in a child with active sJIA should raise concerns for MAS.



**Fig. 196.14** Early (6 month duration) radiographic changes of juvenile idiopathic arthritis. Soft tissue swelling and periosteal new bone formation appear adjacent to the second and fourth proximal interphalangeal joints.

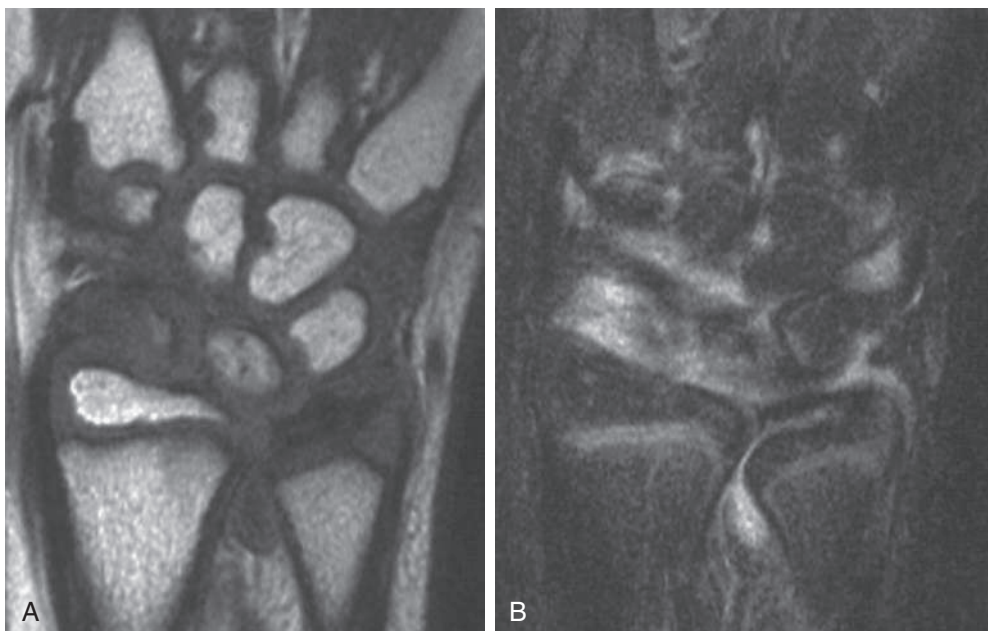
Early radiographic changes of arthritis include soft tissue swelling, periarticular osteopenia, and periosteal new-bone apposition around affected joints (Fig. 196.14). Continued active disease may lead to subchondral erosions, loss of cartilage with varying degrees of bony destruction, and fusion. Characteristic radiographic changes in the cervical spine, most frequently in the neural arch joints at C2-C3 (see Fig. 196.10), may progress to atlantoaxial subluxation. MRI is more sensitive than radiography to detect early changes (Fig. 196.15).

## TREATMENT

The goals of treatment are to achieve disease remission, prevent or halt joint damage, and foster normal growth and development. All children with JIA need individualized treatment plans, and management is tailored according to disease subtype and severity, presence of poor prognostic indicators, and response to medications. Disease management also requires monitoring for potential medication toxicities (see Chapter 195).

Children with oligoarthritis often show partial response to non-steroidal antiinflammatory drugs (NSAIDs), with improvement in inflammation and pain (Table 196.8). Those who have no or partial response after 4-6 weeks of treatment with NSAIDs or who have functional limitations such as joint contracture or leg-length discrepancy benefit from injection of intraarticular corticosteroids. *Triamcinolone hexacetonide* is a long-lasting preparation that provides a prolonged response. A substantial fraction of patients with oligoarthritis show no response to NSAIDs and injections and therefore require treatment with *disease-modifying antirheumatic drugs (DMARDs)*, including conventional synthetic DMARDs (csDMARDs) like methotrexate, and, if no response, biologic DMARDs (bDMARDs) like TNF inhibitors.

NSAIDs alone rarely induce remission in children with polyarthritis or sJIA. *Methotrexate* is the oldest and least toxic of the csDMARDs available for adjunctive therapy. It may take 6-12 weeks to see the effects of methotrexate. Failure of methotrexate monotherapy warrants the addition of a bDMARD. bDMARDs that inhibit proinflammatory cytokines, such as TNF- $\alpha$ , IL-1, and IL-6, demonstrate excellent disease control. TNF- $\alpha$  antagonists (e.g., *etanercept*, *adalimumab*, *golimumab*) are used to treat children with an inadequate response to methotrexate, poor prognostic factors, or severe disease onset. Early aggressive therapy with a combination of methotrexate and a TNF- $\alpha$  antagonist may result in earlier achievement of clinically inactive disease. *Abatacept*, a selective inhibitor of T-cell activation, and *tocilizumab*, an IL-6



**Fig. 196.15** MRI of the wrist in a child with wrist arthritis. A, Multiple erosions of carpal bones. B, After administration of gadolinium contrast agent, uptake is consistent with active synovitis.

**Table 196.8** Pharmacologic Treatment of Juvenile Idiopathic Arthritis (JIA)

TYPICAL MEDICATIONS	TYPICAL DOSES	JIA SUBTYPE	SIDE EFFECT(S)
<b>NONSTEROIDAL ANTIINFLAMMATORY DRUGS</b>			
Naproxen	15 mg/kg/day PO divided bid (maximum dose 500 mg bid)	Polyarthritis Systemic Oligoarthritis	Gastritis, renal and hepatic toxicity, pseudoporphyria
Ibuprofen	40 mg/kg/day PO divided tid (maximum dose 800 mg tid)	Same as above	Same as above
Meloxicam	0.125 mg/kg PO once daily (maximum dose 15 mg daily)	Same as above	Same as above
<b>DISEASE-MODIFYING ANTIRHEUMATIC DRUGS</b>			
Methotrexate	0.5-1 mg/kg PO or SC weekly (maximum dose 25 mg/wk)	Polyarthritis Systemic Persistent or extended oligoarthritis	Nausea, vomiting, oral ulcerations, hepatic toxicity, blood count dyscrasias, immunosuppression, teratogenicity
Sulfasalazine	Initial 12.5 mg/kg PO daily; increase by 10 mg/kg/day Maintenance: 40-50 mg/kg divided bid (maximum dose 2 g/day)	Polyarthritis	GI upset, allergic reaction, pancytopenia, renal and hepatic toxicity, Stevens-Johnson syndrome
Leflunomide*	10-20 mg PO daily	Polyarthritis	GI upset, hepatic toxicity, allergic rash, alopecia (reversible), teratogenicity (needs washout with cholestyramine)
<b>BIOLOGIC AGENTS</b>			
<b>Anti-Tumor Necrosis Factor-<math>\alpha</math></b>			
Etanercept	0.8 mg/kg SC weekly or 0.4 mg/kg SC twice weekly (maximum dose 50 mg/wk)	Polyarthritis Systemic Persistent or extended oligoarthritis	Immunosuppressant, concern for malignancy, demyelinating disease, lupus-like reaction, injection site reaction
Infliximab*	3-10 mg/kg IV q4-8wk	Same as above	Same as above, infusion reaction
Adalimumab	10 to <15 kg: 10 mg SC every other week 15 to <30 kg: 20 mg SC every other week >30 kg: 40 mg SC every other week	Same as above	Same as above
Golimumab	80 mg/m <sup>2</sup> IV wk 0 and 4 and then q8 wk	Same as above	Same as above
<b>Anticytotoxic T-Lymphocyte-Associated Antigen-4 Immunoglobulin</b>			
Abatacept	<75 kg: 10 mg/kg/dose IV q4wk 75-100 kg: 750 mg/dose IV q4wk >100 kg: 1,000 mg/dose IV q4wk SC once weekly: 10 to <25 kg: 50 mg $\geq$ 25 to <50 kg: 87.5 mg $\geq$ 50 kg: 125 mg	Polyarthritis	Immunosuppressant, concern for malignancy, infusion reaction
<b>Anti-CD20</b>			
Rituximab*	750 mg/m <sup>2</sup> IV 2 wk $\times$ 2 (maximum dose 1,000 mg)	Polyarthritis	Immunosuppressant, infusion reaction, progressive multifocal encephalopathy
<b>Interleukin-1 Inhibitors</b>			
Anakinra*	1-2 mg/kg SC daily	Systemic	Immunosuppressant, GI upset, injection site reaction
Canakinumab	4 mg/kg/dose SC q4wk (maximum dose 300 mg)	Systemic	Immunosuppressant, headache, GI upset, injection site reaction
Rilonacept*	2.2 mg/kg/dose SC weekly (maximum dose 160 mg)	Systemic	Immunosuppressant, allergic reaction, dyslipidemia, injection site reaction
<b>Interleukin-6 Receptor Antagonist</b>			
Tocilizumab	<30 kg: 12 mg/kg/dose IV q2wk (maximum dose 800 mg) 162 mg SC q2wk $\geq$ 30 kg: 8 mg/kg/dose IV q2wk (maximum dose 800 mg) 162 mg SC weekly	Systemic	Immunosuppressant, hepatic toxicity, dyslipidemia, cytopenias, GI upset, infusion reaction
	<30 kg: 10 mg/kg/dose IV q4wk (maximum dose 800 mg) 162 mg SC q3wk $\geq$ 30 kg: 8 mg/kg/dose IV q4wk 162 mg SC q2wk	Polyarthritis	
<b>Janus Kinase Inhibitors</b>			
Tofacitinib	10 to <20 kg: 3.2 mg PO bid 20 to <40 kg: 4 mg PO bid $\geq$ 40 kg = 5 mg PO bid	Polyarthritis	Immunosuppressant, GI perforation, thrombosis

\*Not indicated by the U.S. Food and Drug Administration for use in JIA as of 2021.



receptor antagonist, have demonstrated efficacy in and are approved for treatment of polyarticular JIA (see Table 196.8).

TNF inhibition is not as effective for the systemic symptoms found in sJIA. When systemic symptoms dominate, systemic corticosteroids are started, followed by the initiation of IL-1 or IL-6 antagonist therapy, which often induces a dramatic and rapid response. Patients with severe disease activity may go directly to anakinra. *Canakinumab*, an IL-1 $\beta$  inhibitor, and *tocilizumab* are Food and Drug Administration (FDA)-approved treatments for sJIA in children older than 2 years (see Table 196.8). Standardized consensus guiding therapy for sJIA provide four treatment plans based on glucocorticoids, methotrexate, anakinra, or tocilizumab, with optional glucocorticoid use in the latter three plans as clinically indicated.

With the use of DMARDs, the use of systemic corticosteroids can often be avoided or minimized. Systemic corticosteroids are recommended only for management of severe systemic illness, for *bridge therapy* during the wait for therapeutic response to a DMARD, and for control of uveitis. Steroids impose risks of severe toxicities, including Cushing syndrome, growth retardation, and osteopenia, and they do not prevent joint destruction.

Small molecule drugs, including Janus kinase (JAK) inhibitors, are an alternative to csDMARDs and bDMARDs. Oral JAK inhibitors (*tofacitinib*, *ruxolitinib*) inhibit JAK signaling pathways involved in immune activation and inflammation. *Tofacitinib* is FDA approved for children older than 2 years with polyarticular JIA.

Management of JIA must include periodic slit-lamp ophthalmologic examinations to monitor for asymptomatic uveitis (Figs. 196.16 and 196.17; see Table 196.4). Optimal treatment of uveitis requires collaboration between the ophthalmologist and rheumatologist; initial management may include mydriatics and corticosteroids used topically, systemically, or through periocular injection. DMARDs allow for a decrease in exposure to steroids, and methotrexate and TNF- $\alpha$  inhibitors (*adalimumab* and *infliximab*) are effective in treating severe uveitis.

Dietary evaluation and counseling to ensure appropriate calcium, vitamin D, protein, and caloric intake are important for children with JIA. Physical therapy and occupational therapy are invaluable adjuncts to any treatment program. A social worker and nurse clinician can be important resources for families to recognize stresses imposed by a chronic illness, to identify appropriate community resources, and to aid compliance with the treatment protocol.

## PROGNOSIS

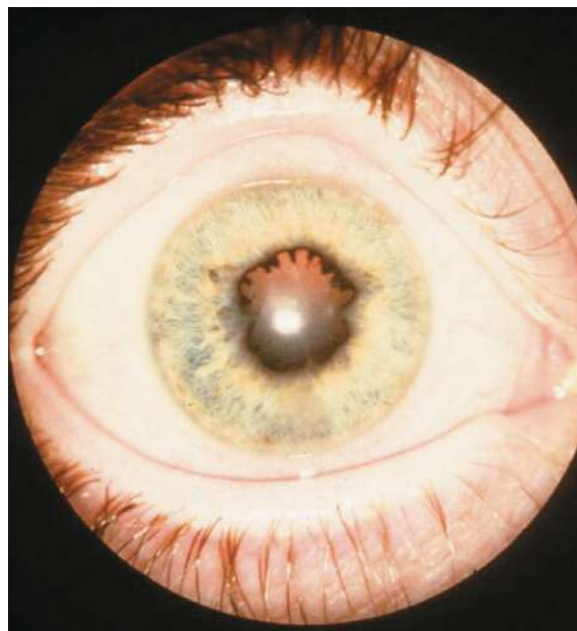
Although the course of JIA in an individual child is unpredictable, some prognostic generalizations can be made on the basis of disease type and course. Studies analyzing management of JIA in the pre-TNF- $\alpha$  era indicate that up to 50% of JIA patients had active disease persisting into early adulthood, often with severe limitations of physical function.

Children with persistent oligoarticular disease fare well, with a majority achieving disease remission. Those with extended oligoarticular disease have a poorer prognosis. Children with oligoarthritis, particularly females who are ANA positive and with onset of arthritis before 6 years of age, are at greatest risk for development of chronic uveitis. There is no association between the activity or severity of arthritis and uveitis. Persistent, uncontrolled anterior uveitis (see Fig. 196.16) can cause posterior synechiae, cataracts, glaucoma, and band keratopathy, with resultant blindness. Morbidity can be averted with early diagnosis and implementation of systemic therapy.

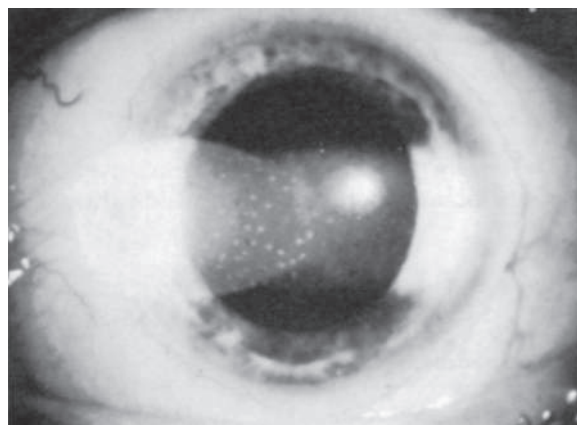
The child with polyarticular JIA often has a more prolonged course of active joint inflammation and requires early and aggressive therapy. Predictors of severe and persistent disease include young age at onset, RF seropositivity or rheumatoid nodules, presence of anti-cyclic citrullinated peptide antibodies, and many affected joints. Disease involving the hip and hand/wrist is also associated with a poorer prognosis and may lead to significant functional impairment.

sJIA is often the most difficult to control in terms of both articular inflammation and systemic manifestations. Poorer prognosis is related to polyarticular distribution of arthritis, fever lasting >3 months, and increased inflammatory markers, such as platelet count and ESR, for >6 months. IL-1 and IL-6 inhibitors have changed the management and improved the outcomes for children with severe and prolonged systemic disease.

Orthopedic complications include leg-length discrepancy and flexion contractures, particularly of the knees, hips, and wrists. Discrepancies



**Fig. 196.16** Chronic anterior uveitis demonstrating posterior synechiae and absence of significant scleral inflammation. (From Firestein GS, Budd RC, Gabriel SE, et al., eds. *Kelley & Firestein's Textbook of Rheumatology*, 10th ed. Philadelphia: Elsevier; 2017: Fig. 107-5, p. 1838.)



**Fig. 196.17** Slit-lamp examination shows "flare" in the fluid of the anterior chamber (caused by increased protein content) and keratic precipitates on the posterior surface of the cornea, representing small collections of inflammatory cells. (Courtesy Dr. H.J. Kaplan. From Petty RE, Rosenbaum JT. *Uveitis in juvenile idiopathic arthritis*. In Cassidy JT, Petty RE, Laxer RM, et al., eds. *Textbook of Pediatric Rheumatology*, 6th ed. Philadelphia: Saunders; 2011: Fig. 20-3, p. 309.)

in leg length can be managed with a shoe lift on the shorter side to prevent secondary scoliosis. Joint contractures require aggressive medical control of arthritis, often in conjunction with intraarticular corticosteroid injections, appropriate splinting, and stretching of the affected tendons. Popliteal cysts may require no treatment if they are small or respond to intraarticular corticosteroids in the anterior knee.

Psychosocial adaptation may be affected by JIA. Studies indicate that, compared with controls, a significant number of children with JIA have problems with lifetime adjustment and employment. Disability not directly associated with arthritis may continue into young adulthood in as many as 20% of patients, together with continuing chronic pain syndromes at a similar frequency. Psychological complications, including problems with school attendance and socialization, may respond to counseling by mental health professionals.

Visit Elsevier eBooks+ at [eBooks.Health.Elsevier.com](http://eBooks.Health.Elsevier.com) for Bibliography.



## Chapter 197

## Ankylosing Spondylitis and Other Spondyloarthritides

Pamela F. Weiss

The diseases collectively referred to as *spondyloarthritides* include ankylosing spondylitis (AS), arthritis associated with inflammatory bowel disease (IBD) or psoriasis, and reactive arthritis after gastrointestinal (GI) or genitourinary (GU) infections (Table 197.1 and Table 197.2). **Spondyloarthritis** is more common in adults, but all forms can present during childhood with varying symptoms and signs. Many children with spondyloarthritis are classified in the **juvenile idiopathic arthritis (JIA)** categories of **enthesitis-related arthritis (ERA)** or psoriatic arthritis. Children and adolescents with spondyloarthritis who may not meet JIA criteria include arthritis associated with IBD, juvenile ankylosing spondylitis (JAS), and reactive arthritis.

## EPIDEMIOLOGY

JIA is diagnosed in 90 per 100,000 U.S. children every year (see Chapter 196). ERA accounts for 10–20% of JIA and has a mean age at onset of 12 years. In India, ERA is the most common category of JIA, accounting for 35% of cases. Unlike other JIA categories, males are affected more often than females, accounting for 60% of ERA cases. AS occurs in 0.2–0.5% of adults, with approximately 15% of cases beginning in childhood. These disorders can be familial, largely as a result of the influence of human leukocyte antigen (HLA)-B27, which is found in 90% of JAS and 50% of ERA patients compared to 7% of healthy individuals. Approximately 20% of children with ERA have a family history of HLA-B27-associated disease, such as reactive arthritis, AS, or IBD with sacroiliitis.

## ETIOLOGY AND PATHOGENESIS

Spondyloarthritides are complex diseases in which susceptibility is largely genetically determined. Only 30% of heritability has been defined, with HLA-B27 responsible for two thirds of the total, and >100 additional genetic loci accounting for only one third. Genes that influence interleukin (IL)-23 responses (e.g., *CARD9*, *IL23R*, *JAK2*, *TYK2*, *STAT3*) and the function of HLA-B27 (*ERAP1*) are particularly important. Unusual properties of HLA-B27, such as its tendency to misfold and form abnormal cell surface structures, may have a role. Infection with certain GI or GU pathogens can trigger reactive arthritis (see Table 197.2 and Chapter 198). Altered gut microbiota and an abnormal immune response to normal microbiota may also play a role in pathogenesis. Inflamed joints and entheses in spondyloarthritis contain T and B cells, macrophages, osteoclasts, proliferating fibroblasts, and osteoblasts, with activation of the IL-23/IL-17 pathway. Bone loss and osteoproliferation in and around vertebral bodies and facet joints in long-standing AS contribute to significant morbidity.

## CLINICAL MANIFESTATIONS AND DIAGNOSIS

Clinical manifestations that help distinguish spondyloarthritis from other forms of juvenile arthritis include arthritis of the axial skeleton (sacroiliac joints or spine) and hips, enthesitis (inflammation at the site of a tendon, ligament, or joint capsule attachment to bone), symptomatic eye inflammation (acute anterior uveitis), and GI inflammation (even in the absence of IBD) (Table 197.3, but see also Table 197.1).

## Enthesitis-Related Arthritis

Children fulfill classification criteria for ERA if they have *either* arthritis and enthesitis *or* arthritis or enthesitis with at least two of the following characteristics: (1) sacroiliac joint tenderness or inflammatory lumbosacral pain, (2) presence of HLA-B27, (3) onset of arthritis in a male older than 6 years, (4) acute anterior uveitis, and (5) a family history of an HLA-B27-associated disease (ERA, sacroiliitis with IBD, reactive arthritis, or acute anterior uveitis) in a first-degree relative. Patients with psoriasis (or a family history of psoriasis in a first-degree relative), a positive–rheumatoid factor (RF) test result, or systemic arthritis are excluded from this group. During the first 6 months of disease the arthritis is typically

Table 197.1 Overlapping Characteristics of the Spondyloarthritides\*

CHARACTERISTIC	JUVENILE ANKYLOSING SPONDYLITIS	JUVENILE PSORIATIC ARTHRITIS	INFLAMMATORY BOWEL DISEASE	REACTIVE ARTHRITIS
Enthesitis	+++	+	+	++
Axial arthritis	+++	++	++	+
Peripheral arthritis	+++	+++	+++	+++
HLA-B27 positive	+++	+	++	+++
Antinuclear antibody positive	–	++	–	–
Rheumatoid factor positive	–	–	–	–
<b>SYSTEMIC DISEASE</b>				
Eyes	+	+	+	+
Skin	–	+++	+	+
Mucous membranes	–	–	+	+
Gastrointestinal tract	–	–	++++	+++

\*Frequency of characteristics: –, absent; +, &lt;25%; ++, 25–50%; +++, 50–75%; +++++, ≥75%.

From Petty RE, Laxer RM, Lindsley CB, et al., eds. *Textbook of Pediatric Rheumatology*, 8th ed. Philadelphia: Elsevier; 2021.

**Table 197.2** Etiologic Microorganisms of Reactive Arthritis

PROBABLE	POSSIBLE
<i>Chlamydia trachomatis</i>	<i>Neisseria gonorrhoeae</i>
<i>Shigella</i> species	<i>Mycoplasma fermentans</i>
<i>Salmonella enteritidis</i>	<i>Mycoplasma genitalium</i>
<i>Salmonella typhimurium</i>	<i>Ureaplasma urealyticum</i>
<i>Yersinia enterocolitica</i>	<i>Escherichia coli</i>
<i>Yersinia pseudotuberculosis</i>	<i>Cryptosporidium</i>
<i>Campylobacter jejuni</i> and <i>coli</i>	<i>Entamoeba histolytica</i>
	<i>Giardia lamblia</i>
	<i>Brucella abortus</i>
	<i>Clostridium difficile</i>
	<i>Streptococcus pyogenes</i>
	<i>Chlamydia pneumoniae</i>
	<i>Chlamydia psittaci</i>

From Kim PS, Klausmeier TL, Orr DP. Reactive arthritis: a review. *J Adolesc Health*. 2009;44:309–315, Table 2, p. 311.

**Table 197.3** Assessment in SpondyloArthritis International Society (ASAS) Classification Criteria for Spondyloarthritis (SpA)

AXIAL SpA	PERIPHERAL SpA
In patients with $\geq 3$ months back pain and age at onset $< 45$ years	In patients with peripheral symptoms ONLY
Sacroiliitis on imaging* plus one or more SpA feature(s)	Arthritis or enthesitis or dactylitis plus
or HLA-B27 plus two or more other SpA features	
SpA features	One or more SpA feature(s):
<ul style="list-style-type: none"> <li>Inflammatory back pain (IBP)</li> <li>Arthritis</li> <li>Enthesitis (heel)</li> <li>Uveitis</li> <li>Dactylitis</li> <li>Psoriasis</li> <li>Crohn disease/ulcerative colitis</li> <li>Good response to NSAIDs</li> <li>Family history for SpA</li> <li>HLA-B27</li> <li>Elevated CRP</li> </ul>	<ul style="list-style-type: none"> <li>Uveitis</li> <li>Psoriasis</li> <li>Crohn disease/ulcerative colitis</li> <li>Preceding infection</li> <li>HLA-B27</li> <li>Sacroiliitis on imaging*</li> </ul>
	or
	Two or more other SpA features:
	<ul style="list-style-type: none"> <li>Arthritis</li> <li>Enthesitis</li> <li>Dactylitis</li> <li>IBP ever</li> <li>Family history for SpA</li> </ul>

\*Active (acute) inflammation on MRI highly suggestive of sacroiliitis associated with SpA. Definite radiographic sacroiliitis according to modified NY criteria.

CRP, C-reactive protein; NSAIDs, nonsteroidal antiinflammatory drugs.

Adapted from Rudwaleit M, van der Heijde D, Landewé R, et al. The development of Assessment of Spondyloarthritis International Society classification criteria for axial spondyloarthritis. Part II. Validation and final selection. *Ann Rheum Dis*. 2009;68(6):777–783; and The Assessment of Spondyloarthritis International Society classification criteria for peripheral spondyloarthritis and for spondyloarthritis in general. *Ann Rheum Dis*. 2011;70(1):25–31.

**Table 197.4** Symptoms Characteristic of Inflammatory Back Pain

Pain at night with morning stiffness (and improvement on arising)
No improvement with rest
Improvement with exercise
Insidious onset
Good response to nonsteroidal antiinflammatory drugs

asymmetric and involves fewer than four joints, most frequently the knees, ankles, and hips. Inflammation of the small joints of the foot, or *tarsitis*, is highly suggestive of ERA. Enthesitis is typically symmetric and affects the lower limbs. Up to 40% of children develop clinical or radiographic evidence of sacroiliac joint arthritis as part of their disease; approximately 20% have evidence of sacroiliac joint arthritis at diagnosis. When the sacroiliac or other axial joints are involved, children may experience **inflammatory back pain** (Table 197.4), hip pain, and alternating buttock pain. Patients may also

experience pain with palpation of the lower back or with pelvic compression. The risk of sacroiliac joint arthritis is highest in children who are HLA-B27 positive and have an elevated C-reactive protein (CRP). Untreated sacroiliitis may, but does not always, evolve into AS; additional risk factors for progression are unclear.

### Psoriatic Arthritis

Psoriatic arthritis accounts for approximately 5% of JIA. Common clinical features of psoriatic arthritis are nail pitting (Fig. 197.1), onycholysis, and dactylitis (sausage-like swelling of fingers or toes).

Children fulfill classification criteria for psoriatic arthritis if they have arthritis and psoriasis or arthritis and at least two of the following: (1) dactylitis, (2) nail pitting or onycholysis, and (3) psoriasis in a first-degree relative. The presence of psoriasis aids in diagnosis but is not required. Disease onset peaks during the preschool and early adolescent years. Children with onset during the preschool years are more often female, antinuclear antibody (ANA) positive, and at risk for asymptomatic ocular inflammation. Disease onset during adolescence is equally common among males and females. In the majority



**Fig. 197.1** Nail pitting in a 9-year-old with JPsA. (From Srinivasalu H, Sikora KA, Colbert RA. Recent updates in juvenile spondyloarthritis. *Rheum Dis Clin N Am.* 2021;47:565–583, Fig. 2, p. 569.)

of children, the arthritis is asymmetric and affects four or fewer joints at presentation. Large (knees and ankles) and small (fingers and toes) joints may be involved. Although distal interphalangeal joint involvement is uncommon, it is highly suggestive of the diagnosis. Enthesitis is detectable in ~20–75% of patients and seems to be more frequent in those who present at an older age (Table 197.5, Fig. 197.2). Axial (sacroiliac) and root (hip) joints may be affected in up to 30% of children; the risk of axial arthritis is highest in those who are HLA-B27 positive.

### Juvenile Ankylosing Spondylitis

JAS frequently begins with oligoarthritis and enthesitis. The arthritis occurs predominantly in the lower extremities and often involves the hips. In comparison to adult-onset AS, axial disease and inflammatory back pain are less frequent at disease onset, whereas enthesitis and peripheral arthritis are more common. AS is diagnosed according to the modified New York (NY) criteria if there is sufficient radiographic evidence of sacroiliitis (sacroiliitis of grade 2 or greater bilaterally or at least grade 3 unilaterally) and if the patient meets at least one clinical criterion involving inflammatory back pain, limitation of motion in the lumbar spine (Fig. 197.3), or limitation of chest expansion. JAS is present if the patient is <16 years old. Juvenile-onset AS is frequently used to describe adult AS when the symptoms began before 16 years of age but full criteria were not met until later.

To fulfill the modified NY criteria for AS, patients must have radiographic changes in the sacroiliac joints and clinical sequelae of axial disease. Because radiographic sacroiliitis can take many years to develop in adults and even longer in children, and clinical sequelae may lag further behind, criteria to identify preradiographic axial spondyloarthritis were developed by the **Assessment of SpondyloArthritis International Society**. To meet criteria for axial spondyloarthritis (SpA), patients must have at least 3 months of back pain and sacroiliitis on imaging (acute inflammation on MRI or definite radiographic sacroiliitis by NY criteria) plus one feature of SpA (inflammatory back pain, arthritis, enthesitis [heel], uveitis, dactylitis, psoriasis, Crohn disease/ulcerative colitis, good response to nonsteroidal antiinflammatory drugs [NSAIDs], family history for SpA, HLA-B27, or elevated CRP). Alternatively, patients can fulfill axial SpA criteria if they are HLA-B27 positive and have at least two SpA features. These criteria have low sensitivity and specificity in the pediatric population but, in the absence of alternative pediatric criteria, may be useful as a guide to evaluating preradiographic axial SpA.

### Arthritis with Inflammatory Bowel Disease

The presence of erythema nodosum, pyoderma gangrenosum, oral ulcers, abdominal pain, diarrhea, fever, weight loss, or anorexia in a

**Table 197.5** Enteseal Sites Studied in Historical JSpA Cohorts

ENTHESEAL SITES	PERCENTAGE
Insertion of infrapatellar tendon on patella	27-44
Achilles tendon	21-74
Interosseous ligaments of the sacroiliac joint	30.3
Plantar fascia insertion to calcaneus	12-39
Tibial tuberosity	23-30
Quadriceps insertion to upper poles of patella	22-46
Second MTP	21
Third MTP	16
First MTP	14
Greater trochanter	14
Iliac crest	14

JSpA, Juvenile spondyloarthritis; MTP, metatarsophalangeal.

From Srinivasalu H, Sikora KA, Colbert RA. Recent updates in juvenile spondyloarthritis. *Rheum Dis Clin N Am.* 2021;47:565–583, Table 1, p. 567.

child with chronic arthritis should raise suspicion of IBD. Two patterns of arthritis complicate IBD. **Polyarthritis** affecting large and small joints is most common and often reflects the activity of the intestinal inflammation. Less frequently, **arthritis of the axial skeleton**, including the sacroiliac joints, occurs. As with psoriatic arthritis, the presence of HLA-B27 is a risk factor for the development of axial disease. The severity of axial involvement is independent of the activity of the GI inflammation.

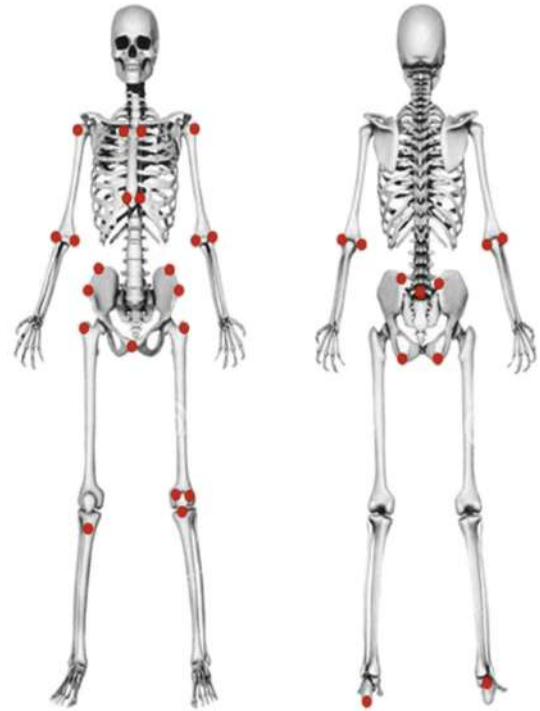
### LABORATORY FINDINGS

Laboratory evidence of systemic inflammation with elevation of the erythrocyte sedimentation rate (ESR) and/or CRP value is variable in most spondyloarthritides and may or may not be present at the onset of disease. RF and ANAs are absent, except in children with psoriatic arthritis, as many as 50% of whom are ANA positive. HLA-B27 is present in approximately 90% of children with JAS, compared with 7% of healthy individuals, but is less frequent in ERA and other SpA types.

### Imaging

Conventional radiographs detect chronic bony changes and damage but not active inflammation and are unreliable in the assessment of pediatric disease. Early radiographic changes in the sacroiliac joints include indistinct margins and erosions. **Sclerosis** typically starts on the iliac side of the joint (Fig. 197.4). Peripheral joints may exhibit periarticular **osteoporosis**, with loss of sharp cortical margins in areas of enthesitis, which may eventually show erosions or bony spurs (enthesophytes). Squaring of the corners of the vertebral bodies and syndesmophyte formation resulting in the classic “bamboo spine” characteristic of advanced AS are rare in early disease, particularly in childhood. CT, like radiographs, can detect chronic bony changes but not active inflammation and has the disadvantage of more radiation exposure. The gold standard for early visualization of sacroiliitis is evidence of bone marrow edema adjacent to the joint on MRI with fluid-sensitive sequences such as short-T1 inversion recovery (STIR) (Figs. 197.5 and 197.6). Gadolinium does not add value to the study of the sacroiliac joints if STIR is used. MRI will reveal abnormalities before the plain radiograph. Whole

Anatomic region	Enthesitis exam
Foot and ankle	Achilles tendon insertion to calcaneus Plantar fascia insertion to calcaneus Plantar fascia insertion to metatarsal heads Plantar fascia insertion to base of fifth metatarsal
Knee	Quadriceps tendon insertion to patella (2 and 10 o'clock) Infrapatellar ligament insertion to patella (6 o'clock) and tibial tuberosity
Pelvis	Hip extensor insertion at greater trochanter of femur Sartorius insertion at anterior superior iliac spine Posterior superior iliac spine Abdominal muscle insertions to iliac crest Gracilis and adduction insertion to pubis symphysis Hamstrings insertion to ischial tuberosity
Spine	5th lumbar spinous process
Upper extremity	Common flexor insertion at medial epicondyle of humerus Common extensor insertion at lateral epicondyle of humerus Supraspinatus insertion into greater tuberosity of humerus
Chest	Costosternal junctions (1st and 7th)



**Fig. 197.2** Anatomic sites for assessment of enthesitis in ERA and JAS. (From Petty RE, Laxer RM, Lindsley CB, et al., eds. *Textbook of Pediatric Rheumatology*, 8th ed. Philadelphia: Elsevier; 2021: Fig. 20.1, p. 254.)



**Fig. 197.3** Loss of lumbodorsal spine mobility in a boy with ankylosing spondylitis. The lower spine remains straight when the patient bends forward.



**Fig. 197.4** Well-developed sacroiliitis in a boy with ankylosing spondylitis. Both sacroiliac joints show extensive sclerosis, erosion of joint margins, and apparent widening of the joint space.

body MRI may also be used to evaluate the axial skeleton in adults with early disease because it can detect vertebral lesions in addition to sacroiliac changes.

### DIFFERENTIAL DIAGNOSIS

The onset of arthritis after a recent history of diarrhea or symptoms of urethritis or conjunctivitis may suggest **reactive arthritis** (see [Chapter 198](#)). Lower back pain can be caused by strain, infectious

arthritis of the sacroiliac joint, osteomyelitis of the pelvis or spine, chronic nonbacterial osteomyelitis (CNO) of the pelvis or spine, osteoid osteoma of the posterior elements of the spine, pelvic muscle pyomyositis, or malignancies. In addition, mechanical conditions such as spondylolysis, spondylolisthesis, and Scheuermann disease should be considered. Back pain secondary to **fibromyalgia** usually affects the soft tissues of the upper back in a symmetric pattern and is associated with well-localized tender points and sleep disturbance (see [Chapter 211.3](#)). Legg-Calvé-Perthes disease (avascular necrosis of the femoral head), slipped capital femoral epiphysis, and chondrolysis may also manifest as pain over the inguinal ligament and loss of internal rotation of the hip joint, but without other SpA features, such as involvement of other entheses and/or joints. Radiography and MRI are critical for distinguishing these conditions.





**Fig. 197.5** Coronal MRI (STIR) of the pelvis in a 14-year-old boy with ERA (HLA-B27 positive). Fluid and pathology appear bright, spinal fluid also appears bright. Increased signal abnormality is observed around bilateral triradiate cartilages and greater trochanteric apophyses (arrowheads), common areas of involvement for ERA. Also, signal abnormality appears on the iliac side of the sacroiliac joints bilaterally around more curvilinear, dark, sclerotic subchondral areas representing erosions and sacroiliitis (arrows). (From Tse SM, Laxer RM. *New advances in juvenile spondyloarthritis*. *Nat Rev Rheumatol*. 2012;10;8:269–279.)

## TREATMENT

The goals of therapy are to control inflammation, minimize pain, preserve function, and prevent ankylosis (fusion of adjacent bones) using a combination of antiinflammatory medications, physical therapy, and education. Treatment regimens for SpA include monotherapy or combination therapy with NSAIDs, disease-modifying antirheumatic drugs (DMARDs), or biologic agents. NSAIDs, such as naproxen (15–20 mg/kg/day), are frequently used to help relieve symptoms and may slow the progression of structural damage (syndesmophyte formation and growth) if used continually. With relatively mild monoarticular disease, intraarticular corticosteroids (e.g., triamcinolone acetone/hexacetonide) may also help to control peripheral joint inflammation. DMARDs such as sulfasalazine (up to 50 mg/kg/day; maximum 3 g/day) or methotrexate (10 mg/m<sup>2</sup>) may be beneficial for peripheral arthritis, but these medications have not been shown to improve axial disease in adults. For axial arthritis, it is typically necessary to add a biologic therapy. Tumor necrosis factor (TNF) inhibitors (e.g., etanercept, infliximab, adalimumab) have been efficacious in reducing symptoms and improving function in adults with AS. It remains unclear whether TNF inhibitors have an impact on structural damage in established AS, underscoring the need for earlier recognition and better therapies. Drugs that target IL-17 (secukinumab/ixekizumab), IL-23/IL-12



**Fig. 197.6** Short T1 inversion recovery image from whole body MRI of a 15-yr-old boy with HLA-B27–negative JSpA. The MRI shows active corner inflammatory lesions of vertebral end plates at multiple levels (straight arrows) and more chronic-appearing discovertebral unit changes (curved arrow). (From Srinivasalu H, Sikora KA, Colbert RA. *Recent updates in juvenile spondyloarthritis*. *Rheum Dis Clin N Am*. 2021;47:565–583, Fig. 7, p. 574.)

(ustekinumab), and the JAK/STAT pathway (tofacitinib/upadacitinib) reduce clinical disease activity in adults with AS.

*Physical therapy and low-impact exercise should be included in the treatment program for all children with spondyloarthritis.* Exercise to maintain range of motion in the back, thorax, and affected joints should be instituted early in the disease course. Custom-fitted insoles and heel cups are particularly useful in the management of painful entheses around the feet, and the use of pillows to position the lower extremities while the child is in bed can be helpful.

## PROGNOSIS

Observational studies suggest that ongoing disease activity for >5 years in juvenile spondyloarthritis predicts disability. Disease remission occurs in <20% of children with spondyloarthritis 5 years after diagnosis. Factors associated with disease progression include tarsitis, HLA-B27 positivity, hip arthritis within the first 6 months, and disease onset after age 8. Important questions, such as which patients with ERA will go on to have JAS/AS, have yet to be addressed. Outcomes for JAS compared with adult-onset AS suggest that hip disease requiring replacement is more common in children but axial disease is more severe in adults.

Visit Elsevier eBooks+ at [eBooks.Health.Elsevier.com](https://eBooks.Health.Elsevier.com) for Bibliography.

## Chapter 198

## Reactive and Postinfectious Arthritis

Pamela F. Weiss

In addition to causing arthritis by means of direct microbial infection (i.e., septic arthritis; see Chapter 726), microbes activate innate and adaptive immune responses, which can lead to the generation and deposition of immune complexes and antibody or T-cell-mediated cross-reactivity with self. Furthermore, microbes may influence the immune system in ways that promote immune-mediated inflammatory diseases such as systemic lupus erythematosus (SLE), inflammatory bowel disease (IBD), juvenile idiopathic arthritis (JIA), and spondyloarthritis. **Reactive arthritis** and **postinfectious arthritis** are defined as joint inflammation caused by a sterile inflammatory reaction after a recent infection. The term *reactive arthritis* is used to refer to arthritis that occurs after enteropathic or urogenital infections and *postinfectious arthritis* to describe arthritis that occurs after infectious illnesses not classically considered in the reactive arthritis group, such as infection with group A streptococcus or viruses. In some patients, nonviable components of the initiating organism have been demonstrated in affected joints, and the presence of viable, yet nonculturable, bacteria within the joint remains an area of investigation.

The course of reactive arthritis is variable and may remit or progress to a chronic spondyloarthritis, including ankylosing spondylitis (see Chapter 197). In postinfectious arthritis, the pain or joint swelling is usually transient, lasting <6 weeks, and does not necessarily share the typical spondyloarthritis pattern of joint involvement. The distinction between postinfectious arthritis and reactive arthritis is not always clear, either clinically or pathophysiologically.

## PATHOGENESIS

Reactive arthritis typically follows enteric infection with *Salmonella* species, *Shigella flexneri*, *Yersinia enterocolitica*, *Campylobacter jejuni*, or genitourinary (GU) tract infection with *Chlamydia trachomatis*. *Escherichia coli* and *Clostridium difficile* are also causative enteric agents, although less common (see Table 197.2). Acute **rheumatic fever** caused by group A streptococcus (see Chapters 229 and 229.1), arthritis associated with infective endocarditis (see Chapter 486), and the tenosynovitis associated with *Neisseria gonorrhoeae* are similar in some respects to reactive arthritis.

Approximately 75% of patients with reactive arthritis are HLA-B27 positive. Incomplete elimination of bacteria and bacterial products, such as DNA, has been proposed as a factor in reactive arthritis. A relationship with clinical characteristics of specific infectious disorders is not present. In postinfectious arthritis, several viruses (rubella, varicella-zoster, herpes simplex, cytomegalovirus) have been isolated from the joints of patients. Antigens from other viruses (e.g., hepatitis B, adenovirus) have been identified in immune complexes from joint tissue.

Patients with reactive arthritis who are HLA-B27 positive have an increased frequency of acute and symptomatic uveitis and other extraarticular features. In addition, HLA-B27 is a risk factor for persistent gastrointestinal (GI) inflammation after enteric infections, even after resolution of the initial infection, and significantly increases the risk that the individual will develop chronic spondyloarthritis. Nevertheless, reactive arthritis also occurs in HLA-B27-negative patients, emphasizing the importance of other genes in disease susceptibility.

## CLINICAL MANIFESTATIONS AND DIFFERENTIAL DIAGNOSIS

Symptoms of reactive arthritis begin approximately 3 days to 6 weeks after infection. The classic triad of arthritis, urethritis, and conjunctivitis

is relatively uncommon in children. The arthritis is typically asymmetric and oligoarticular, with a predilection for the lower extremities. Dactylitis may occur, and enthesitis is common, affecting as many as 90% of patients (Fig. 198.1). Cutaneous manifestations can occur and may include circinate balanitis, ulcerative vulvitis, erythematous oral macules or plaques or erosions, erythema nodosum, paronychia, painful erosions or pustules on fingertips, and keratoderma blennorrhagica, which is similar in appearance to pustular psoriasis (Fig. 198.2). Systemic symptoms may include fever, malaise, and fatigue. Less common features may include conjunctivitis, optic neuritis, aortic valve involvement, sterile pyuria, and polyneuropathy. Early in the disease course, markers of inflammation—erythrocyte sedimentation rate (ESR), C-reactive protein, and platelets—may be greatly elevated. The clinical manifestations may last for weeks to months.

Familiarity with other causes of postinfectious arthritis is vital when a diagnosis of reactive arthritis is being considered. Numerous viruses are associated with postinfectious arthritis and may result in particular patterns of joint involvement (Table 198.1). Rubella and hepatitis B virus typically affect the small joints, whereas mumps and varicella often involve large joints, especially the knees. **Hepatitis B arthritis-dermatitis syndrome** is characterized by urticarial rash and a symmetric migratory polyarthritis resembling that of serum sickness. Rubella-associated arthropathy may follow natural rubella infection and, infrequently, rubella immunization. It typically occurs in young women, with an increased frequency with advancing age, and is uncommon in preadolescent children and in males. Arthralgia of the knees and hands usually begins within 7 days of onset of the rash or 10–28 days after immunization. Parvovirus B19, which is responsible for erythema infectiosum (fifth disease), can cause arthralgia, symmetric



Fig. 198.1 Enthesitis—swelling of the posterior aspect of the left heel and lateral aspect of the ankle. (Courtesy Dr. Nora Singer, Case Western Reserve University and Rainbow Babies' Hospital.)



Fig. 198.2 Keratoderma blennorrhagica. (Courtesy Dr. MF Rein and the Centers for Disease Control and Prevention Public Health Image Library, 1976. Image #6950.)

**Table 198.1** Viruses Associated with Arthritis

<b>TOGAVIRUSES</b>	<b>HERPESVIRUSES</b>
<b>RUBIVIRUS</b>	Epstein-Barr
Rubella	Cytomegalovirus
<b>ALPHAVIRUSES</b>	Varicella-zoster
Ross River	Herpes simplex
Chikungunya	<b>PARAMYXOVIRUSES</b>
O'nyong-nyong	Mumps
Mayaro	<b>FLAVIVIRUS</b>
Sindbis	Zika virus
Ockelbo	<b>HEPADNAVIRUS</b>
Pogosta	Hepatitis B
<b>ORTHOPOXVIRUSES</b>	<b>ENTEROVIRUSES</b>
Variola virus (smallpox)	Echovirus
Vaccinia virus	Coxsackievirus B
Parvoviruses	<b>CORONAVIRUSES</b>
<b>ADENOVIRUSES</b>	SARS-CoV-2
Adenovirus 7	

Adapted from Infectious arthritis and osteomyelitis. In: Petty RE, Laxer RM, Lindsley CB, et al., eds. *Textbook of Pediatric Rheumatology*, 8th ed. Philadelphia: Elsevier; 2021.

joint swelling, and morning stiffness, particularly in adult women and less frequently in children. Arthritis occurs occasionally during cytomegalovirus infection and may occur during varicella infections but is rare after Epstein-Barr virus infection. Varicella may also be complicated by suppurative arthritis, usually secondary to group A streptococcus infection. HIV is associated with an arthritis that resembles psoriatic arthritis more than JIA (see [Chapter 196](#)).

**Poststreptococcal arthritis** may follow infection with either group A or group G streptococcus. It is typically oligoarticular, affecting lower-extremity joints, and mild symptoms can persist for months. Poststreptococcal arthritis differs from rheumatic fever, which typically manifests with painful migratory polyarthritis of brief duration. Because valvular lesions have occasionally been documented by echocardiography after the acute illness, some clinicians consider poststreptococcal arthritis to be an incomplete form of acute rheumatic fever (see [Chapter 229.1](#)). Certain HLA-DRB1 types may predispose children to development of either poststreptococcal arthritis (HLA-DRB1\*01) or acute rheumatic fever (HLA-DRB1\*16).

**Transient synovitis (toxic synovitis)**, another form of postinfectious arthritis, typically affects the hip, often after an upper respiratory tract infection (see [Chapter 719.2](#)). Males 3-10 years of age are most often affected and have acute onset of severe pain in the hip (groin), with referred pain to the thigh or knee, lasting approximately 1 week. ESR and white blood cell count are usually normal. Radiologic or ultrasound examination may confirm widening of the joint space secondary to an effusion. Aspiration of joint fluid is often necessary to exclude septic arthritis and typically results in dramatic clinical improvement. The trigger is presumed to be viral, although responsible microbes have not been identified.

**Nonsuppurative arthritis** has been reported in children, usually adolescent males, in association with severe truncal acne. Patients often have fever and persistent infection of the pustular lesions. **Pyogenic (sterile) arthritis, pyoderma gangrenosum, and acne (cystic) syndrome**, an autosomal dominant disorder caused by a pathogenic variant in the *PSTPIP1* gene, is a difficult-to-treat but rare autoimmune inflammatory disorder that has responded to anakinra or anti-tumor necrosis factor antibody therapy in a few patients (see [Chapter 710](#)). Recurrent episodes of erosive arthritis begin in childhood; cystic acne and the painful ulcerating lesions of pyoderma gangrenosum begin during adolescence. Recurrent episodes may also be associated with a sterile myopathy and may last for several months.

**Infective endocarditis** can be associated with arthralgia, arthritis, or signs suggestive of vasculitis, such as Osler nodes, Janeway lesions,

and Roth spots. Postinfectious arthritis, perhaps because of immune complexes, also occurs in children with *N. gonorrhoeae*, *Neisseria meningitidis*, *Haemophilus influenzae* type b, and *Mycoplasma pneumoniae* infections.

## DIAGNOSIS

A recent GU or GI infection may suggest the diagnosis of reactive arthritis, but there is no diagnostic test. A complete blood count, acute-phase reactants, complete metabolic panel, and urinalysis may be helpful to exclude other etiologies. Although stool or urogenital tract cultures can be performed in an attempt to isolate it, the triggering organism is not typically found at the time arthritis presents. Imaging findings are nonspecific or normal. Documenting previous streptococcal infection with antibody testing (anti-streptolysin O and anti-DNAse B) may help to diagnose postinfectious arthritis. Serum sickness associated with the antibiotic treatment of preceding infection must be excluded.

Because the preceding infection can be remote or mild and often not recalled by the patient, it is also important to rule out other causes of arthritis. Acute and painful arthritis affecting a single joint suggests septic arthritis, mandating joint aspiration. Osteomyelitis may cause pain and an effusion in an adjacent joint but is more often associated with focal bone pain and tenderness at the site of infection. Arthritis affecting a single joint, particularly the knee, may also be secondary to Lyme disease in endemic areas. The diagnosis of postinfectious arthritis is often established by exclusion and after the arthritis has resolved. Arthritis associated with GI symptoms or abnormal liver function test results may be triggered by infectious or autoimmune hepatitis. Arthritis or spondyloarthritis may occur in children with IBD, such as Crohn disease or ulcerative colitis (see [Chapters 382.1](#) and [382.2](#)). Parvovirus infection, macrophage activation (hemophagocytic) syndrome, and leukemia should be strongly considered when two or more blood cell lines are low or progressively decrease in a child with arthritis. Persistent arthritis (>6 weeks) suggests the possibility of a chronic rheumatic disease, including JIA (see [Chapter 196](#)) and SLE (see [Chapter 199](#)).

## TREATMENT

Specific treatment is unnecessary for most cases of reactive or postinfectious arthritis. Nonsteroidal antiinflammatory drugs (NSAIDs) are often needed for management of pain and functional limitation. Unless ongoing *Chlamydia* infection is suspected, attempts to treat the offending organism are not warranted. If swelling or arthralgia recurs, further evaluation may be necessary to exclude active infection or evolving rheumatic disease. Intraarticular corticosteroid injections may be given for refractory or severely involved joints once acute infection has been ruled out. Systemic corticosteroids or disease-modifying antirheumatic drugs (DMARDs) are rarely indicated but may be considered for chronic disease. Participation in physical activity should be encouraged, and physical therapy may be needed to maintain normal function and prevent muscle atrophy. For postinfectious arthritis caused by streptococcal disease, current recommendations include penicillin prophylaxis for at least 1 year. Long-term prophylaxis is often recommended, but the duration is controversial and may need to be individualized.

## COMPLICATIONS AND PROGNOSIS

Postinfectious arthritis after viral infections usually resolves without complications unless it is associated with involvement of other organs, such as **encephalomyelitis**. Children with reactive arthritis after enteric infections occasionally experience IBD months to years after onset. Both **uveitis** and **carditis** have been reported in children diagnosed with reactive arthritis. Reactive arthritis, especially after bacterial enteric infection or GU tract infection with *C. trachomatis*, has the potential for evolving to chronic arthritis, particularly spondyloarthritis (see [Chapter 197](#)). The presence of HLA-B27 or significant systemic features increases the risk of chronic disease.

Visit Elsevier eBooks+ at [eBooks.Health.Elsevier.com](http://eBooks.Health.Elsevier.com) for Bibliography.



## Chapter 199

## Systemic Lupus Erythematosus

Rebecca E. Sadun and Stacy P. Ardoin

Systemic lupus erythematosus (SLE) is a chronic autoimmune disease characterized by multisystem inflammation and the presence of circulating autoantibodies directed against self-antigens. SLE occurs in both children and adults, disproportionately affecting females of reproductive age. Although nearly every organ may be affected, most commonly involved are the skin, joints, kidneys, blood-forming cells, blood vessels, and the central nervous system. Systemic signs of inflammation such as fever and lymphadenopathy can also be seen. Compared with adults, children and adolescents with SLE have more severe disease and more widespread organ involvement.

## ETIOLOGY

The pathogenesis of SLE remains largely unknown, but several factors likely influence risk and severity of disease, including genetics, hormonal milieu, and environmental exposures.

A genetic predisposition to SLE is suggested by the association with specific genetic variants, including congenital deficiencies of C1q, C2, and C4, as well as several polymorphisms (e.g., interferon regulatory factor 5 and protein tyrosine phosphatase N22) and familial clustering of SLE or other autoimmune disease (Table 199.1). In addition, certain human leukocyte antigen (HLA) types (including HLA-B8, HLA-DR2, and HLA-DR3) occur with increased frequency in patients with SLE. Although SLE clearly has a genetic component, its occurrence is sporadic in families and its concordance is incomplete (estimated at 2–5% among dizygotic twins and 25–60% among monozygotic twins), suggesting nonmendelian genetics and involvement of epigenetic and environmental factors. Patients with SLE often have family members—especially mothers and sisters—with SLE or various other autoimmune diseases.

Because SLE preferentially affects females, especially during their reproductive years, it is suspected that hormonal factors are important in pathogenesis. Of individuals with SLE, 90% are female, making female sex the strongest risk factor for SLE. Estrogens are likely to play a role in SLE, and both in vitro and animal model studies suggest that estrogen exposure promotes B-cell autoreactivity. Estrogen-containing oral contraceptives do not appear to induce flares in quiescent SLE, though the risk of flares may be increased in postmenopausal women receiving hormone replacement.

**Environmental exposures** that may trigger the development of SLE remain largely unknown; certain viral infections (including Epstein-Barr virus) may play a role in susceptible individuals, and ultraviolet light exposure is known to trigger SLE disease activity. Environmental influences also may induce epigenetic modifications to DNA, increasing the risk of SLE and drug-induced lupus; in mouse models, drugs such as procainamide and hydralazine can promote lymphocyte hypomethylation, causing a lupus-like syndrome.

## EPIDEMIOLOGY

The reported prevalence of SLE in children and adolescents (1-6/100,000) is lower than that in adults (20-70/100,000). Prevalence of SLE is highest among patients of African, Asian, Hispanic, Native American, and Pacific Island ancestry for both adult and pediatric populations. SLE predominantly affects females, with a reported 2-5:1 ratio before puberty, 9:1 ratio during reproductive years, and

return to near-prepubertal ratios in the postmenopausal period. Childhood SLE is rare before 5 years of age and is usually diagnosed in adolescence, with a median age at diagnosis of 11-12 years. Up to 20% of all individuals with SLE are diagnosed before age 16 years. Pediatric-onset SLE (pSLE) is defined as onset of symptoms before age 16 or 18 years.

## PATHOLOGY

Histologic features most suggestive of SLE include findings in the kidney and skin. Renal manifestations of SLE are classified histologically according to the criteria of the International Society of Nephrology (see Chapter 560.2). The finding of diffuse proliferative glomerulonephritis (class IV) significantly increases the risk for renal morbidity. Renal biopsies are helpful to establish the diagnosis of SLE and to stage disease. Immune complexes are commonly found with “full house” deposition of immunoglobulin and complement. The characteristic **discoid rash** depicted in Figure 199.1D is characterized on biopsy by hyperkeratosis, follicular plugging, and infiltration of mononuclear cells into the dermal-epidermal junction. The histopathology of photosensitive rashes can be nonspecific, but immunofluorescence examination of both affected and nonaffected skin may reveal deposition of immune complexes within the dermal-epidermal junction. This finding is called the *lupus band test*, which is specific for SLE.

## PATHOGENESIS

A hallmark of SLE is the generation of *autoantibodies* directed against self-antigens, particularly nucleic acids. These intracellular antigens are ubiquitously expressed but are usually inaccessible and cloistered within the cell. During cell necrosis or *apoptosis*, the antigens are released. SLE skin cells are highly susceptible to damage from ultraviolet light, and the resulting cell death leads to release of cell contents, including nucleic antigens. Individuals with SLE may have impaired apoptosis or impaired ability to clear cell debris, causing prolonged exposure to nucleic antigens in the bloodstream and increased opportunity for recognition by immune cells, leading to B-cell stimulation and autoantibody production. Circulating autoantibodies form *immune complexes* and deposit in tissues, leading to local complement activation, initiation of a proinflammatory cascade, and, ultimately, tissue damage. Antibodies to **double-stranded DNA** (dsDNA) can form immune complexes, deposit in glomeruli, and initiate inflammation leading to glomerulonephritis. However, many individuals with SLE have circulating antibodies to dsDNA yet do not have nephritis, suggesting that autoantibodies are not the only pathway leading to end-organ damage in SLE.

Both the innate and adaptive arms of the immune system have been implicated in the dysregulation of the immune system seen in SLE. High levels of interferon- $\alpha$  production by plasmacytoid dendritic cells promote expression of other proinflammatory cytokines and chemokines, maturation of monocytes into myeloid dendritic cells, promotion of autoreactive B and T cells, and loss of self-tolerance. Nearly 85% of patients with SLE exhibit this cytokine profile, known as the *type I interferon signature*. Other cytokines with increased expression in SLE include interleukin (IL)-1, IL-2, IL-6, IL-10, IL-12, IL-17, and IL-21; anti-tumor necrosis factor- $\alpha$ ; interferon- $\gamma$ ; and *B-lymphocyte stimulator* (BLyS), also known as *B-cell-activating factor* (BAFF). Both B and T cells demonstrate functional impairments in SLE. In active SLE, B-cell populations have impaired tolerance and increased autoreactivity, enhancing B cells' ability to produce autoantibodies after exposure to self-antigen. In addition, cytokines such as BLyS/BAFF may promote abnormal B-cell number and function. T-cell abnormalities in SLE include increased numbers of memory T cells and decreased number and function of T-regulatory cells. SLE T cells display aberrant signaling and increased autoreactivity. As a result, they are resistant to attrition by normal apoptosis pathways. In addition, a neutrophil signature can be identified in 65% of adult SLE patients and has recently been recognized as a potential biomarker for active lupus nephritis.

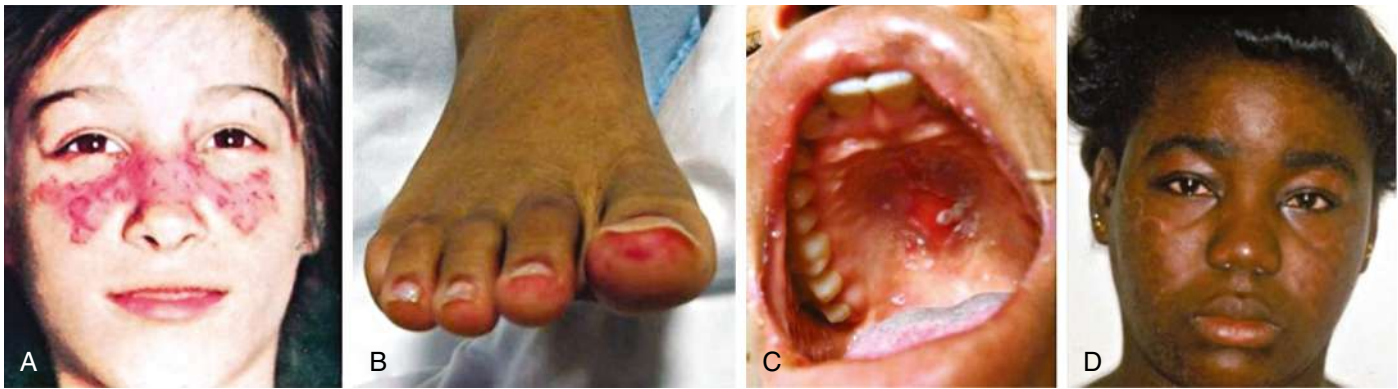


**Table 199.1** Reviewed Proteins and Genes Associated with Monogenic Forms of Systemic Lupus Erythematosus and Lupus-Like Phenotypes

PROTEIN	GENE	INHERITANCE	MECHANISM	FEMALE-TO-MALE PATIENT RATIO	ASSOCIATED SYMPTOMS
C1q	<i>C1QA, C1QB, C1QC</i>	Autosomal recessive	Complement deficiency	1:1	SLE (cutaneous, renal, CNS, arthritis, ANA), young age onset, recurrent bacterial infections
C1r/s	<i>C1R, C1S</i>	Autosomal recessive	Complement deficiency	1:1	SLE (fever, cutaneous, arthritis, renal, ANA, ENA), recurrent infections, encapsulated bacteria, Hashimoto thyroiditis
C2	<i>C2</i>	Autosomal recessive	Complement deficiency	7:1	SLE (cutaneous, arthritis), young age onset, type 1 diabetes
C3	<i>C3</i>	Autosomal recessive	Complement deficiency	1:1	Recurrent sinopulmonary infections, lupus-like syndrome, glomerulonephritis
C4	<i>C4A, C4B</i>	Autosomal recessive	Complement deficiency	1:1	SLE (severe photosensitive rash, renal, ANA, Ro), young age onset
TREX1/DNASE III	<i>TREX1</i>	Autosomal dominant (FCL), autosomal recessive and dominant (AGS)	Abnormal DNA clearance leading to IFN activation	Likely 1:1	FCL, AGS, SLE
MDA5	<i>IFIH1</i>	Autosomal dominant	Activation of IFN production	Likely 1:1	AGS, SLE, FCL, IgA deficiency
SAMHD1	<i>SAMHD1</i>	Autosomal recessive and dominant	Abnormal DNA or RNA clearance leading to IFN production	Likely 1:1	AGS, SLE, FCL, photosensitivity
RNaseH2	<i>RNASH2</i>	Autosomal dominant and recessive	Abnormal RNA clearance leading to IFN production	Likely 1:1	AGS, SLE
ADAR1	<i>ADAR1</i>	Mainly autosomal dominant	Abnormal RNA clearance leading to IFN production	Likely 1:1	AGS, SLE
STING	<i>TMEM173</i>	Autosomal dominant	Activation of IFN production	1:1	SAVI, FCL, SLE
DNase I	<i>DNASE1</i>	Autosomal dominant	Abnormal DNA clearance-break intolerance	Likely 1:1	SLE (dsDNA), adolescent onset, Sjögren syndrome
DNase 1-like-3	<i>DNASE1L3</i>	Autosomal recessive	Abnormal DNA clearance-break intolerance	1:2	SLE (hypocomplementemia, dsDNA, cANCA, renal), HUVS
DNASE2	<i>DNASE2</i>	Possible autosomal recessive	Abnormal DNA clearance	1:1	Neonatal-onset cytopenias, hepatosplenomegaly, arthritis, nephritis
Protein kinase C-delta	<i>PRKCD</i>	Autosomal recessive; dominant	Disrupts B-cell proliferation and apoptosis, NK-cell activity	1:1	Early onset SLE nephritis, lymphoproliferation autoimmunity
Ras/MAPK Pathway	<i>KRAS</i> GoF	Somatic mutation	Altered cell proliferation, differentiation, apoptosis	Likely 1:1	Pancytopenia, autoantibodies, arthritis, hepatosplenomegaly, pericarditis
Noonan syndrome	<i>NRAS</i> GoF	Somatic mutation	Altered cell proliferation, differentiation apoptosis	Likely 1:1	Chilblain lupus, pancytopenia, autoantibodies

AGS, Aicardi-Goutières syndrome; ANA, antinuclear antibody; ANCA, antineutrophil cytoplasmic antibody; CNS, central nervous system; dsDNA, double-stranded DNA; ENA, extractable nuclear antigen antibody; FCL, familial chilblain lupus; GOF, gain of function; HUVS, hypocomplementemic urticarial vasculitis syndrome; IFN, interferon; IgA, immunoglobulin A; SAVI, STING-associated vasculopathy with onset in infancy; SLE, systemic lupus erythematosus.

Modified from Hiraki LT, Silverman ED. Genomics of systemic lupus erythematosus: insights gained by studying monogenic young-onset systemic lupus erythematosus. *Rheum Dis Clin N Am*. 2017;43:415–434, Table 1, p. 417.

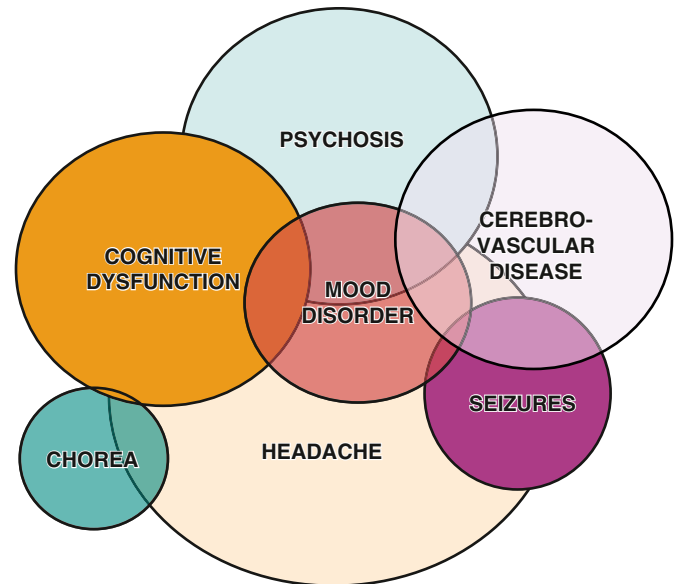


**Fig. 199.1** Mucocutaneous manifestations of SLE. A, Malar rash. B, Vasculitic rash on toes. C, Oral mucosal ulcers. D, Discoid rash in malar distribution.

<b>Table 199.2</b> Potential Clinical Manifestations of Systemic Lupus Erythematosus	
<b>TARGET ORGAN</b>	<b>POTENTIAL CLINICAL MANIFESTATIONS</b>
Constitutional	Fatigue, anorexia, weight loss, fever, lymphadenopathy
Musculoskeletal	Arthritis, myositis, tendonitis, arthralgias, myalgias, avascular necrosis, osteoporosis
Skin	Malar rash, discoid (annular) rash, photosensitive rash, cutaneous vasculitis (petechiae, palpable purpura, digit ulcers, gangrene, urticaria), livedo reticularis, periungual capillary abnormalities, Raynaud phenomenon, alopecia, oral and nasal ulcers, panniculitis, chilblains, alopecia
Renal	Hypertension, proteinuria, hematuria, edema, nephrotic syndrome, renal failure
Cardiovascular	Pericarditis, myocarditis, conduction system abnormalities, Libman-Sacks endocarditis
Neurologic	Seizures, psychosis, cerebritis, stroke, transverse myelitis, depression, cognitive impairment, headaches, migraines, pseudotumor, peripheral neuropathy (mononeuritis multiplex), chorea, optic neuritis, cranial nerve palsies, acute confusional states, dural and cerebral venous sinus thrombosis
Pulmonary	Pleuritis, interstitial lung disease, pulmonary hemorrhage, pulmonary hypertension, pulmonary embolism
Hematologic	Immune-mediated cytopenias (hemolytic anemia, thrombocytopenia or leukopenia), anemia of chronic inflammation, hypercoagulability, thrombocytopenic thrombotic microangiopathy, macrophage activation syndrome
Gastroenterology	Hepatosplenomegaly, pancreatitis, vasculitis affecting bowel, protein-losing enteropathy, peritonitis
Ocular	Retinal vasculitis, scleritis, episcleritis, papilledema, dry eyes, optic neuritis

**CLINICAL MANIFESTATIONS**

Any organ system can be involved in SLE, so the potential clinical manifestations are myriad (Table 199.2). The presentation of SLE in childhood or adolescence differs somewhat from that seen in adults. The most common presenting complaints of children with SLE include fever, fatigue,



**Fig. 199.2** Overlapping neuropsychiatric symptoms in pediatric SLE. Patients with pediatric SLE most commonly have more than one neuropsychiatric symptom—in particular for seizures. (From Silverman E, Eddy A. Systemic lupus erythematosus. In Cassidy JT, Petty RE, Laxer RM, et al., eds. *Textbook of Pediatric Rheumatology*, 6th ed. Philadelphia: Saunders; 2011: Fig. 21-17, p. 329.)

hematologic abnormalities, arthralgia, and arthritis. Arthritis is usually present in the first year of diagnosis; arthritis may be painful or painless swelling, often with stiffness in the morning, and is usually a **symmetric polyarthritis** affecting large and small joints. Tenosynovitis is often present, but joint erosions or other radiographic changes are rare.

Renal disease in SLE is often asymptomatic, underscoring the need for careful monitoring of blood pressure and urinalyses; in adolescents, SLE can present with **nephrotic syndrome** and/or **renal failure**, with the predominant symptoms being edema, fatigue, changes in urine color, and nausea/vomiting. Because SLE symptoms and findings may develop serially over several years and not all be present simultaneously, the diagnosis may require longitudinal follow-up. SLE is often characterized by periods of flare and disease quiescence but may follow a more smoldering disease course. The **neuropsychiatric complications** of SLE may occur with or without apparently active SLE, posing a particularly difficult diagnostic challenge in adolescents, who are already at high risk for mood disorders (Fig. 199.2). Long-term complications of SLE and its therapy, including accelerated atherosclerosis and osteoporosis, become clinically evident in early to middle adulthood. SLE is a disease that evolves over time in each affected individual, and new manifestations arise even many years after diagnosis.

**Table 199.3** Comparison of 1997 American College of Rheumatology and 2012 Systemic Lupus International Collaborating Clinics (SLICC) Classification Criteria for Systemic Lupus Erythematosus\*

	1997 ACR CRITERIA*	2012 SLICC CRITERIA*
<b>CLINICAL CRITERIA</b>		
Acute cutaneous lupus	<ul style="list-style-type: none"> <li>• Malar rash<sup>†</sup></li> </ul>	<ul style="list-style-type: none"> <li>• Malar rash, bullous lupus, toxic epidermal necrolysis variant of SLE, maculopapular lupus rash, photosensitive lupus rash, or subacute cutaneous lupus<sup>†</sup></li> </ul>
Chronic cutaneous lupus	<ul style="list-style-type: none"> <li>• Discoid rash</li> </ul>	<ul style="list-style-type: none"> <li>• Classic discoid rash, hypertrophic (verrucous) lupus, lupus panniculitis (profundus), mucosal lupus, lupus erythematosus tumidus, chilblains lupus, or discoid lupus/lichen planus overlap</li> </ul>
Mucosal ulcers	<ul style="list-style-type: none"> <li>• Oral or nasal ulcers</li> </ul>	<ul style="list-style-type: none"> <li>• Oral (palate, buccal, tongue) or nasal ulcers</li> </ul>
Other cutaneous	<ul style="list-style-type: none"> <li>• Photosensitivity</li> </ul>	<ul style="list-style-type: none"> <li>• Nonscarring alopecia</li> </ul>
Arthritis	<ul style="list-style-type: none"> <li>• Nonerosive arthritis in ≥ two peripheral joints</li> </ul>	<ul style="list-style-type: none"> <li>• Synovitis in ≥ two peripheral joints</li> </ul>
Serositis	<ul style="list-style-type: none"> <li>• Pleuritis or pericarditis</li> </ul>	<ul style="list-style-type: none"> <li>• Pleurisy or pericardial pain ≥1 day, pleural effusion or rub, pericardial effusion or rub, or ECG evidence of pericarditis</li> </ul>
Renal	<ul style="list-style-type: none"> <li>• Persistent proteinuria representing &gt; 500 mg/24 hr or cellular casts</li> </ul>	<ul style="list-style-type: none"> <li>• Urine protein/creatinine ratio representing &gt;500 mg protein/24 hr or red blood cell casts</li> </ul>
Neurologic	<ul style="list-style-type: none"> <li>• Seizure or psychosis</li> </ul>	<ul style="list-style-type: none"> <li>• Seizures, psychosis, mononeuritis multiplex, myelitis, peripheral or cranial neuropathy, or acute confusional state</li> </ul>
Hematologic	<ul style="list-style-type: none"> <li>• Hemolytic anemia, leukopenia (&lt;4,000/mm<sup>3</sup>, lymphopenia (&lt;1,500/mm<sup>3</sup>), or thrombocytopenia (&lt;100,000/mm<sup>3</sup>)</li> </ul>	<ul style="list-style-type: none"> <li>• Hemolytic anemia</li> <li>• Leukopenia (&lt;4,000/mm<sup>3</sup>) or lymphopenia (&lt;1,000/mm<sup>3</sup>)</li> <li>• Thrombocytopenia (&lt;100,000/mm<sup>3</sup>)</li> </ul>
<b>IMMUNOLOGIC</b>	<ul style="list-style-type: none"> <li>• Positive anti-double-stranded antibody or positive anti-Smith antibody</li> <li>• Positive antiphospholipid antibody (false-positive rapid plasma reagin test, positive lupus anticoagulant test result, or elevated anticardiolipin antibody level [IgG or IgM])</li> <li>• Positive ANA</li> </ul>	<ul style="list-style-type: none"> <li>• Positive anti-double-stranded DNA antibody</li> <li>• Positive anti-Smith antibody</li> <li>• Positive antiphospholipid antibody (false-positive rapid plasma regain test, positive lupus anticoagulant test, medium to high titer anticardiolipin antibody level [IgA, IgG, IgM], or positive anti-B2-glycoprotein I antibody [IgA, IgG, IgM])</li> <li>• Low C3, C4, or Ch50 level</li> <li>• Positive direct Coombs test (in the absence of hemolytic anemia)</li> <li>• Positive ANA</li> </ul>

\*For the 1997 ACR Criteria, the presence of 4 of 11 cumulative criteria establishes the classification of SLE. For the 2012 SLICC criteria, the presence of 4 cumulative criteria also establishes the classification of SLE; however, at least 1 clinical criterion and at least 1 immunologic criterion are required. In addition, the presence of biopsy-proven lupus nephritis with positive ANA or anti-double-stranded DNA satisfies the 2012 SLICC criteria. For both sets of classification criteria, all items must be attributable to lupus and not an alternate cause (e.g., medication side effect).

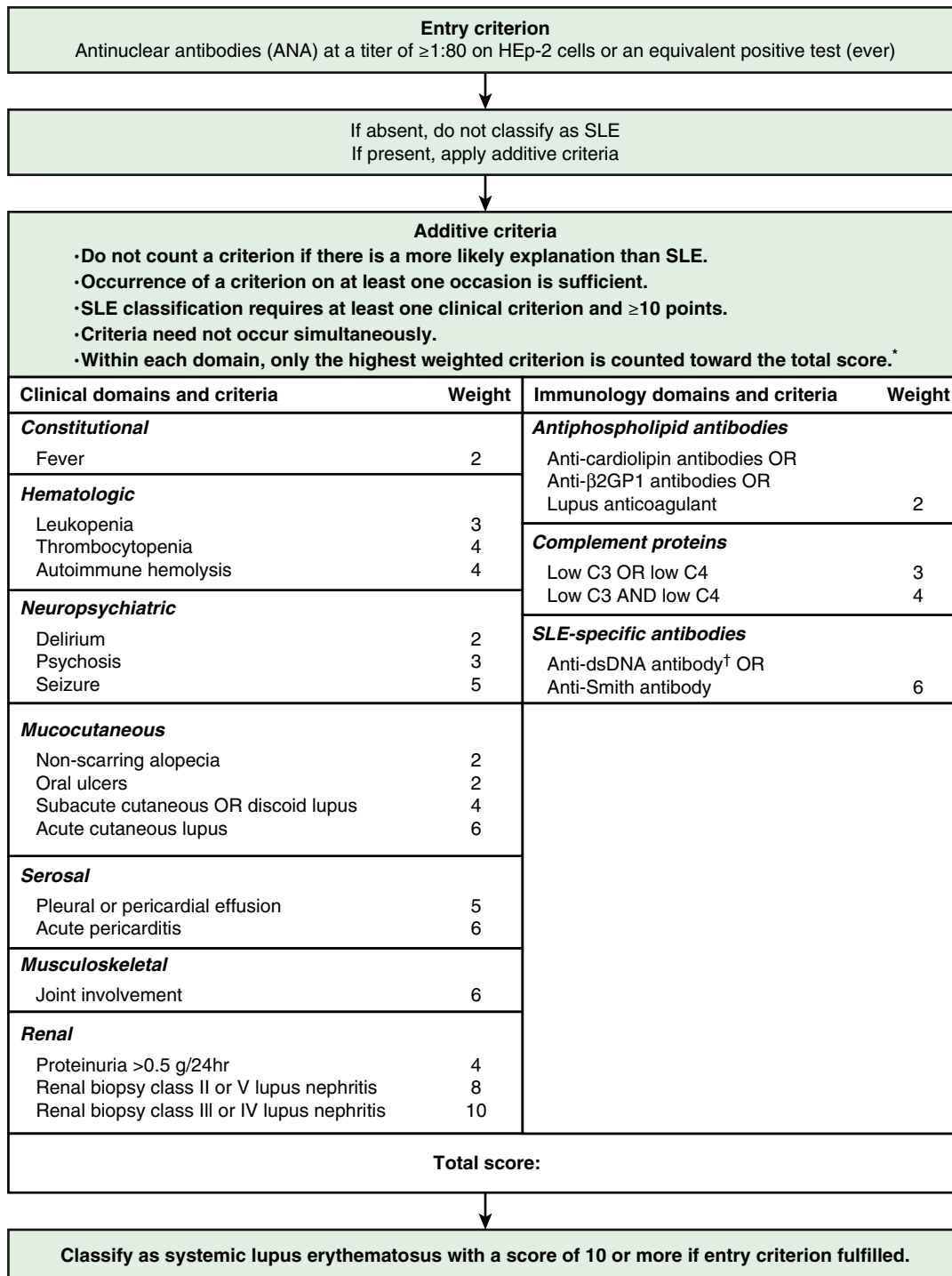
<sup>†</sup>Each bullet point counts as a single criterion whether 1 or more definitions are satisfied.

Adapted from Hochberg MC: Updating the American College of Rheumatology revised criteria for the classification of systemic lupus erythematosus, *Arthritis Rheum* 1997;40:1725; and from Petri M, et al: Derivation and validation of the Systemic Lupus International Collaborating Clinics classification criteria for systemic lupus erythematosus, *Arthritis Rheum* 2012;64:2677-2686.

## DIAGNOSIS

The diagnosis of SLE requires a comprehensive clinical and laboratory assessment revealing characteristic multisystem disease and excluding other etiologies, including infection and malignancy. Classification criteria

for SLE were developed to identify appropriate subjects for clinical trials but are often used as guideposts for SLE diagnosis. Over the past several decades, SLE classification criteria have undergone serial updates. Both the **American College of Rheumatology (ACR) 1997 Revised Classification**



**Fig. 199.3** Classification criteria for systemic lupus erythematosus (SLE). \*Additional criteria items within the same domain will not be counted. <sup>†</sup>In an assay with  $\geq 90\%$  specificity against relevant disease controls. (From Aringer M, Costenbader K, Daikh D, et al. 2019 European League Against Rheumatism/American College of Rheumatology classification criteria for systemic lupus erythematosus. *Arthritis Rheum.* 2019;71[9]:1400–1412.)

Criteria for SLE and the 2012 Systemic Lupus International Collaborating Clinics (SLICC) Classification Criteria (Table 199.3) are validated in childhood onset SLE populations, with the SLICC Criteria achieving higher sensitivity and the 1997 ACR Criteria achieving better specificity. In both the 1997 ACR and 2012 SLICC Criteria, a positive antinuclear antibody (ANA) test result is not required for the diagnosis of SLE; however, ANA-negative lupus is extremely rare. The ANA test is very sensitive for SLE (95–99%) but is not very specific (~50%). The ANA may become positive many years before a diagnosis of SLE is established; however, most asymptomatic ANA-positive patients will never develop SLE. More recently, the 2019 European League Against Rheumatism/American College of

Rheumatology (EULAR/ACR) SLE Classification Criteria (Fig. 199.3) provided a different approach by requiring a positive antinuclear antibody (ANA) test result at a titer  $\geq 1:80$ . Although the 2019 EULAR/ACR criteria have excellent sensitivity and specificity in the adult SLE population, they are still being validated in pediatric populations.

Anti-dsDNA and anti-Smith antibodies are specific for SLE (~98%) but not as sensitive (40–65%) as the ANA. **Hypocomplementemia** was not included in earlier classification criteria, but has been added to the two most recent classification criteria. The 2012 SLICC Criteria also added as criteria nonscarring alopecia, additional cutaneous and neurologic manifestations, and a positive direct Coombs test in the absence of hemolytic anemia.



**Table 199.4** Main Differential Diagnoses of SLE (SLE Mimickers)

<b>OTHER CONNECTIVE TISSUE DISEASES</b>
Sjögren (SSA+), dermatomyositis (rash), mixed connective tissue disease
<b>INFECTIOUS DISEASES</b>
Endocarditis; hepatitis A, B, C, E; parvovirus B19; HIV; EBV; CMV; Lyme; disseminated gonococcal arthritis; toxoplasmosis; histoplasmosis; mycobacterial diseases; tinea faciei; visceral leishmaniasis; Whipple disease
<b>HEMATOLOGIC MALIGNANCIES</b>
Hodgkin lymphoma, myelodysplastic syndromes, angioimmunoblastic T-cell lymphoma
<b>SOLID TUMORS AND PARANEOPLASTIC SYNDROMES</b>
Thymoma, carcinoma of the lung, breast, and ovary with paraneoplastic syndromes
<b>OTHER DISEASES</b>
Meigs and Pseudo-Meigs syndrome
Multiple sclerosis
Castleman disease
Interferonopathies (monogenic SLE)
Still disease (and other autoinflammatory diseases)
Evans syndrome (with primary immune deficiency)
Complement deficiency
Hypocomplementemic urticarial vasculitis
Schizophrenia and other psychoses
Kikuchi disease
IgG4-related disease
Chilblains (cold-induced)
Ackerman syndrome and erythema elevatum diutinum with polyarthritis
Drug-induced lupus and drug-induced polyarthritis
Graft-versus-host disease
Systemic manifestations of atrial myxoma
Prolidase deficiency

From Chasset F, Richez C, Martin T, et al. Rare diseases that mimic systemic lupus erythematosus (lupus mimickers). *Joint Bone Spine*. 2019;86:165–171, Table 1, p. 166 Copyright Elsevier Masson SAS.

## DIFFERENTIAL DIAGNOSIS

Multiorgan disease is the hallmark of SLE, and given its wide array of potential clinical manifestations, SLE is in the differential diagnosis of many clinical scenarios, including unexplained fevers, joint pain or arthritis, rash, cytopenias, nephritis, nephrotic syndrome, pleural or pericardial effusions or other cardiopulmonary abnormalities, and new-onset psychosis or seizures. For patients ultimately diagnosed with pediatric SLE, the initial differential diagnosis often includes infections (sepsis, Epstein-Barr virus, parvovirus B19, endocarditis), malignancies (leukemia and lymphoma), poststreptococcal glomerulonephritis, other rheumatologic conditions (juvenile idiopathic arthritis, vasculitides), and drug-induced lupus (Table 199.4).

**Drug-induced lupus** refers to the presence of SLE manifestations triggered by exposure to specific medications, including hydralazine, minocycline, many anticonvulsants, sulfonamides, antiarrhythmic agents, and other drugs (Table 199.5). In individuals prone to SLE, these agents may act as a trigger for true SLE, but more commonly these agents provoke a reversible lupus-like syndrome. Unlike SLE, drug-induced lupus affects males and females equally. A genetic predisposition toward slow drug acetylation may increase the risk of drug-induced lupus. Circulating **antihistone antibodies** are often present in drug-induced SLE; these antibodies are only detected in up to 20% of individuals with SLE. Hepatitis, which is rare in SLE, is more common in drug-induced lupus. Individuals with drug-induced lupus are less likely to demonstrate antibodies to dsDNA, hypocomplementemia, and significant renal or neurologic disease. In contrast to SLE, manifestations of drug-induced

**Table 199.5** Medications Associated with Drug-Induced Lupus

<b>DEFINITE ASSOCIATION</b>
Minocycline, procainamide, hydralazine, isoniazid, penicillamine, diltiazem, interferon- $\alpha$ , methyldopa, chlorpromazine, etanercept, infliximab, adalimumab
<b>PROBABLE ASSOCIATION</b>
Phenytoin, ethosuximide, carbamazepine, sulfasalazine, amiodarone, quinidine, rifampin, nitrofurantoin, $\beta$ blockers, lithium, captopril, interferon- $\gamma$ , hydrochlorothiazide, glyburide, docetaxel, penicillin, tetracycline, statins, gold, valproate, griseofulvin, gemfibrozil, propylthiouracil

**Table 199.6** Autoantibodies Commonly Associated with Systemic Lupus Erythematosus (SLE)

ANTIBODY	CLINICAL ASSOCIATION
Anti-double-stranded DNA (anti-dsDNA)	Correlates with disease activity, especially nephritis, in some with SLE
Anti-Smith antibody (anti-Sm)	Specific for the diagnosis of SLE
Anti-ribonucleoprotein antibody (anti-RNP)	Increased risk for Raynaud phenomenon, interstitial lung disease, and pulmonary hypertension
Anti-Ro antibody (anti-SSA) Anti-La antibody (anti-SSB)	Associated with sicca syndrome May suggest diagnosis of Sjögren syndrome Increased risk of neonatal lupus in offspring (congenital heart block) May be associated with cutaneous and pulmonary manifestations of SLE May be associated with isolated discoid lupus
Antiphospholipid antibodies (including lupus anticoagulant and anti-cardiolipin or anti-beta-2 glycoprotein antibodies)	Increased risk for venous and arterial thrombotic events
Antihistone antibodies	Present in a majority of patients with drug-induced lupus May be present in SLE

lupus typically resolve after withdrawal of the offending medication; however, complete recovery may take several months to years, requiring treatment, often with hydroxychloroquine, NSAIDs, and/or corticosteroids.

## LABORATORY FINDINGS

A positive ANA test is present in 95–99% of individuals with SLE. The ANA has poor specificity for SLE, as up to 20% of healthy individuals also have a positive ANA test result, making the ANA a poor screen for SLE when used in isolation. After diagnosis, ANA titers are not reflective of disease activity; therefore repeat ANA testing in SLE patients is not helpful. Antibodies to dsDNA are specific for SLE, and in many individuals, anti-dsDNA levels correlate with disease activity, particularly in those with significant nephritis. Anti-Smith antibody, although found specifically in patients with SLE, does not correlate with disease activity. Serum levels of total hemolytic complement ( $CH_{50}$ ), C3, and C4 are typically decreased in active disease and often improve with treatment. Table 199.6 lists autoantibodies

found in SLE along with their clinical associations. Hypergammaglobulinemia is a common but nonspecific finding. Inflammatory markers, particularly the erythrocyte sedimentation rate, are often elevated in active disease. C-reactive protein (CRP) correlates less well with disease activity; significantly elevated CRP values often reflect infection, whereas chronic mild elevation of CRP may indicate increased cardiovascular risk.

**Antiphospholipid antibodies**, which increase clotting risk, can be found in up to 66% of children and adolescents with SLE. The primary antiphospholipid antibodies are lupus anticoagulant, anticardiolipin, and anti-β<sub>2</sub> glycoprotein antibodies. When an arterial or venous clotting event occurs in the presence of an antiphospholipid antibody, **antiphospholipid antibody syndrome** is diagnosed. Antiphospholipid antibody syndrome can occur in the context of SLE (secondary) or independent of SLE (primary) (see Chapter 528). Rarely, antiphospholipid antibodies can result in catastrophic antiphospholipid syndrome, a condition in which clots affect three or more organs/tissues simultaneously; this condition has a very high mortality rate.

## TREATMENT

Treatment of SLE is tailored to the individual and is based on specific disease manifestations and medication tolerability. For all patients, sunscreen and avoidance of prolonged direct sun exposure and other ultraviolet light may help control disease and should be reinforced at every visit with the patient. **Hydroxychloroquine is recommended for all individuals with SLE when tolerated.** In addition to treating mild SLE manifestations such as rash and mild arthritis, hydroxychloroquine prevents SLE flares, improves lipid profiles, and may have a beneficial impact on mortality and renal outcomes. Potential toxicities include retinal pigmentation that leads to vision impairment; therefore *annual ophthalmology exams are recommended for patients taking hydroxychloroquine, including automated visual field testing and spectral-domain optical coherence tomography (SD-OCT)*. Given that risk factors for ocular toxicity include duration of use and dose, hydroxychloroquine in SLE should not be prescribed at doses greater than 5 mg/kg to a maximum of 400 mg daily.

Corticosteroids are a treatment mainstay for significant manifestations of SLE and work quickly to improve acute deterioration; side effects often limit patient adherence, especially in adolescence, and potential toxicities are worrisome. It is important to limit the dose and length of exposure to corticosteroids whenever possible. Potential consequences of corticosteroid therapy include growth disturbance, weight gain, striae, acne, hyperglycemia, hypertension, cataracts, avascular necrosis, and osteoporosis. The optimal dosing of corticosteroids in children and adolescents with SLE remains unknown; **severe disease is often treated with high doses of intravenous methylprednisolone (e.g., 30 mg/kg/day to a maximum of 1,000 mg for each of 3 days, sometimes followed by a period of weekly pulses) and/or high doses of oral prednisone (often starting at 1 mg/kg/day)**. As disease manifestations improve, corticosteroid dosages are gradually tapered over months. For most patients it is necessary to introduce a steroid-sparing immunosuppressive medication in order to limit cumulative steroid exposure.

**Steroid-sparing immunosuppressive agents** for the treatment of pediatric SLE include methotrexate, leflunomide, azathioprine, mycophenolate mofetil, tacrolimus, cyclophosphamide, rituximab, and belimumab. Methotrexate, leflunomide, and azathioprine are often used to treat persistent moderate disease, including arthritis, significant cutaneous or hematologic involvement, and pleural disease. Cyclophosphamide, mycophenolate mofetil, and azathioprine are appropriate for the treatment of lupus nephritis, whereas mycophenolate mofetil and rituximab are often used for the treatment of significant hematologic manifestations, including severe leukopenia, hemolytic anemia, or thrombocytopenia.

Cyclophosphamide, usually administered intravenously, is reserved for the most severe, potentially life-threatening SLE manifestations, such as renal, neurologic, and cardiopulmonary disease. Although

cyclophosphamide is highly effective in controlling disease, the potential toxicities are significant, including cytopenias, infection, hemorrhagic cystitis, premature gonadal failure, and increased risk of future malignancy. Attention to adequate hydration can attenuate the risk of hemorrhagic cystitis. Fortunately, young females are at much lower risk of gonadal failure than older women, and the use of gonadotropin-releasing hormone agonists, such as leuprolide acetate, may help prevent gonadal failure.

The Childhood Arthritis Rheumatology Research Alliance (CARRA) has developed a consensus treatment plan for induction therapy of newly diagnosed proliferative lupus nephritis (class III and IV) that is specific to the pSLE population; the treatment plan is considered necessary for class III and IV lupus nephritis but also appropriate for certain patients with other classes of lupus nephritis. The CARRA treatment plan advises 6 months of induction therapy with either cyclophosphamide (given per the National Institutes of Health [NIH] protocol as 500-1,000 mg/m<sup>2</sup> IV monthly) or mycophenolate mofetil (dosed as 600 mg/m<sup>2</sup> bid up to 1,500 mg bid), used in combination with one of three standardized glucocorticoid regimens. For patients who fail to achieve a partial response in 6 months, it is appropriate to switch agents. For adult-weight adolescents, the cyclophosphamide dosing regimen used in the Euro-Lupus Nephritis Trial can be considered in lieu of the previous 6-month therapy in an effort to reduce toxicity from cyclophosphamide exposure. Per this protocol, a fixed dose of 500 mg is given every 2 weeks for 3 months; in adults, this regimen is thought to reduce adverse effects while maintaining comparable efficacy for lupus nephritis, though this regimen has not been studied specifically in pediatric lupus. It should be noted that oral medication adherence is very poor in pSLE, and this must be taken into consideration when weighing the benefits of an IV infusion versus a twice daily oral medication such as mycophenolate mofetil. After the 6-month induction therapy, maintenance therapy for lupus nephritis consists of quarterly IV cyclophosphamide (dosed 500-1,000 mg/m<sup>2</sup> once every 3 months), mycophenolate, or azathioprine, with mycophenolate generally being the preferred agent. Maintenance therapy is typically continued for a minimum of 30 months after the completion of induction therapy, but in many circumstances, it is continued longer.

Calcineurin inhibitors such as tacrolimus are often adjunct therapy in the treatment of refractory lupus nephritis. Voclosporin, Food and Drug Administration (FDA)-approved for adults with lupus nephritis, awaits pediatric study. Clinical trial data on the use of rituximab in SLE with treatment-resistant glomerulonephritis has been largely disappointing, but post hoc analysis from the LUNAR study suggests there may be benefit for subpopulations of SLE patients. The FDA has approved the use of belimumab, a monoclonal antibody against BlyS/BAFF, for the treatment of lupus in adults and children; when added to standard SLE therapy, belimumab improves markers of disease activity in renal and nonrenal lupus. Belimumab has been shown to improve renal outcomes in adults, and while it is not used as monotherapy to treat lupus nephritis, it can be used in addition to standard therapy to help achieve renal remission without substantial increase in risk of infectious complications. Anifrolumab (a monoclonal antibody to the interferon-α receptor), achieved 2021 FDA approval for treatment of adult nonrenal SLE, and studies in lupus nephritis and pediatric lupus are forthcoming. Several novel therapies are in the pipeline for the treatment of SLE and lupus nephritis, including Janus kinase inhibitors.

Given the lifelong nature of SLE, optimal care of children and adolescents with this disease also involves preventive practices. Owing to the enhanced risk of atherosclerosis in SLE, attention to cholesterol levels, smoking status, body mass index, blood pressure, and other traditional cardiovascular risk factors is warranted. Even though the Atherosclerosis Prevention in Pediatric Lupus Erythematosus (APPLE) study failed to support placing all children with SLE on a statin, post hoc analyses suggest that statins can be considered for primary prevention of atherosclerotic disease in certain clinical circumstances, particularly pubertal patients with an elevated CRP.

**Table 199.7** Morbidity in Childhood Lupus

Renal	Hypertension, dialysis, transplantation
Central nervous system	Organic brain syndrome, seizures, psychosis, neurocognitive dysfunction
Cardiovascular	Atherosclerosis, myocardial infarction, cardiomyopathy, valvular disease
Immune	Recurrent or severe infection, functional asplenia, malignancy
Musculoskeletal	Osteopenia, compression fractures, avascular necrosis
Ocular	Cataracts, glaucoma, retinal detachment, blindness
Endocrine	Diabetes, obesity, growth failure, infertility, fetal wastage

From Cassidy JT, Petty RE, Laxer RM, et al., eds. *Textbook of Pediatric Rheumatology*, 6th ed. Philadelphia: Saunders; 2011.

SLE patients with antiphospholipid antibody syndrome (antiphospholipid antibodies and a history of arterial or venous clot or pregnancy morbidity) are treated with long-term anticoagulation to prevent thrombotic events; for SLE patients who are antiphospholipid antibody positive without a history of clots, many pediatric rheumatologists prescribe aspirin 81 mg daily.

For all SLE patients, adequate intake of calcium and vitamin D is necessary to prevent future osteoporosis, particularly as vitamin D levels are lower in pSLE patients compared with age-matched healthy controls. It is worth noting recent studies suggest a link between hypovitaminosis D and SLE susceptibility and also offer an emerging role for vitamin D in immunomodulation.

Infections, particularly pneumococcal disease, commonly complicate SLE, so routine immunization is recommended, including the annual influenza vaccination, SARS-CoV-2 vaccination, and vaccination against human papilloma virus (HPV). In addition, pSLE patients age 6 or older should receive a dose of PPSV23 at least 8 weeks after completing all recommended pneumococcal vaccine series with PCV13 or PCV15. Many of the immunosuppressant medications used in SLE contraindicate administration of live vaccines. Prompt attention to febrile episodes should include an evaluation for serious infections. Because pSLE patients are at high risk for developing anxiety and depression, screening for depression is important. Peer support and cognitive-behavioral therapy interventions reduce pain and enhance resilience in pSLE.

Pregnancy can worsen SLE, and obstetric complications are common. In addition, many medications used to treat SLE are teratogenic. As a consequence, it is important to counsel adolescent girls about these risks and facilitate access to appropriate contraceptive options. Hydroxychloroquine is recommended throughout pregnancy for all SLE patients, whereas other medications may need to be adjusted.

## COMPLICATIONS

Within the first several years of diagnosis, the most common causes of death in individuals with SLE include infection and complications of glomerulonephritis and neuropsychiatric disease (Table 199.7). Over the long term, the most common causes of mortality are atherosclerosis and malignancy. The increased risk of premature atherosclerosis in SLE is not explained by traditional risk factors and is partly a result of the chronic immune dysregulation and inflammation associated with SLE. Increased malignancy rates may be caused by immune dysregulation and exposure to

**Table 199.8** A Summary of Signs and Symptoms Indicative of Lupus Emergencies

SIGNS/SYMPTOMS	DIFFERENTIAL CONSIDERATIONS
Fever	Evaluate for infection Consider disease flare Consider macrophage activation syndrome
Thrombosis/hemoptysis	May be arterial or venous Evaluate for antiphospholipid syndrome
Chest pain	Pleurisy, pericarditis, pulmonary infarction/embolus
Dyspnea	Pneumonitis, alveolar hemorrhage, pleural effusions, congestive heart failure
Headache	Vascular headaches, meningitis, thrombus, cerebrovascular accident, hypertensive crisis
Altered mental status	Cerebritis, hypertensive crisis, macrophage activation syndrome, stroke, thrombotic thrombocytopenic purpura, and atypical hemolytic uremic syndrome
Rash	Vasculitis lesions, palpable purpura, infarction
Icterus	Autoimmune hemolysis Autoimmune hepatitis
Petechiae	Thrombotic thrombocytopenia purpura
Seizure	Cerebritis, infection, metabolic causes, hypertensive crisis

From Harry O, Yasin S, Brunner H. Childhood-onset systemic lupus erythematosus: a review and update. *J Pediatr*. 2018;196:22–30, Table IV.

medications with carcinogenic potential. Potential lupus emergencies are noted in Table 199.8.

## PROGNOSIS

SLE disease severity is higher in childhood-onset SLE compared with adult-onset SLE. Fortunately, advances in the diagnosis and treatment of SLE have led to dramatically improved survival over the past 50 years. The 5-year and 10-year survival rates for pSLE are 99% and 97%, respectively, in high-income countries, although these survival rates are 85% and 79%, respectively, in low- and middle-income countries. Infection contributes significantly to mortality in pediatric lupus. In addition, early in the disease course, lupus nephritis, lupus cerebritis, and complications such as macrophage activation syndrome are primary causes of mortality, whereas later in the disease course, atherosclerosis and malignancy become larger contributors to mortality. Given their long burden of disease, children and adolescents with SLE face high risks of future morbidity and mortality from the disease and its complications, as well as medication side effects. Because pSLE is a complex, chronic disease with a high risk for morbidity and mortality, optimal care for children and adolescents with SLE includes treatment by pediatric rheumatologists in a multidisciplinary clinic with access to a full complement of pediatric subspecialists. Furthermore, because SLE is a lifelong disease, it is critically important to ensure an appropriate transition to an adult model of care, which helps avoid interruptions in rheumatology care.

Visit Elsevier eBooks+ at [eBooks.Health.Elsevier.com](http://eBooks.Health.Elsevier.com) for Bibliography.



## 199.1 Neonatal Lupus

Deborah M. Friedman, Jill P. Buyon,  
Rebecca E. Sadun, and Stacy P. Ardoin

Neonatal lupus erythematosus (NLE), an entity distinct from SLE, is one of the few rheumatic disorders manifesting in the neonate. NLE is not an autoimmune disease of the fetus, but instead results from passively acquired autoimmunity, when maternal immunoglobulin G autoantibodies cross the placenta and enter the fetal circulation. In contrast to SLE, neonatal lupus is not characterized by ongoing immune dysregulation, although infants with neonatal lupus may be at some increased risk for development of future autoimmune disease. The vast majority of NLE cases are associated with maternal anti-Ro (also known as SSA), anti-La antibodies (also known as SSB), or anti-RNP autoantibodies.

Despite the clear association with maternal autoantibodies, their presence alone is not sufficient to cause disease, as only ~2% of offspring born to mothers with anti-Ro and anti-La antibodies develop neonatal lupus. Increasing evidence supports the observation that generally high maternal anti-Ro titers are necessary for fetal clinical disease. In the prospective evaluation of fetuses with autoimmune-associated congenital heart block followed in the PR Interval and Dexamethasone Evaluation (PRIDE) study, the median anti-Ro titer for pregnancies resulting in heart block was 5 times as high as the median anti-Ro titer in unaffected pregnancies. Another group identified heart block in 8% of cases with very high anti-Ro antibody titers, with no cases among women with low or moderate titers.

Siblings of infants with NLE have a 15–20% chance of developing NLE. Neonatal lupus seems to be independent of the maternal health because many mothers are asymptomatic and only identified to have anti-Ro/anti-La antibodies subsequent to the diagnosis of NLE. Roughly half of the infants with NLE are born to the mothers with a defined rheumatic disease such as Sjogren syndrome or SLE.

Clinical manifestations of neonatal lupus include a characteristic annular or macular rash typically affecting the face (especially the periorbital area), trunk, and scalp (Fig. 199.4). The rash can be present at birth but more often appears within the first 6–8 weeks of life, after exposure to ultraviolet light, and typically lasts 3–4 months. Infants may also have cytopenias and hepatitis, each occurring in ~25% of cases, but the most concerning complication is congenital heart block.

Conduction system abnormalities range from prolongation of the PR interval to complete heart block, with development of progressive cardiomyopathy in the most severe cases. The noncardiac manifestations of neonatal lupus are usually reversible, whereas third-degree congenital heart block is permanent. Conduction system abnormalities can be detected in utero by fetal echocardiogram beginning at 16 weeks of gestational age. Neonatal lupus cardiac disease has a mortality rate of ~20%. Cardiac NLE can manifest as heart block, cardiomyopathy, valvular dysfunction, and endocardial fibroelastosis. Fetal bradycardia from heart block can lead to hydrops fetalis.

In vitro studies suggest that during cardiac development via apoptosis, Ro and La antigens may be exposed on the surface of cardiac cells in the proximity of the atrioventricular node, making the antigens accessible to maternal autoantibodies. Binding incites a local immune response, resulting in fibrosis within the conduction system and more extensive disease in fatal cases. In the skin, exposure to ultraviolet light results in cell damage and the subsequent exposure of Ro and La antigens, inducing a similar local inflammatory response that produces the characteristic rash.

Although the scant clinical trial data have been mixed, fluorinated corticosteroids (dexamethasone or betamethasone), intravenous immunoglobulin (IVIG) at 1–2 g/kg maternal weight, plasmapheresis, hydroxychloroquine, and terbutaline (combined with steroids) have been used in pregnant women with anti-Ro or anti-La antibodies to prevent occurrence or progression of fetal cardiac abnormalities.



**Fig. 199.4** Neonatal lupus syndrome. Typical rash, often photosensitive with a malar distribution, appearing as annular plaques with erythema and scaling. (From Pain C, Beresford MW. Neonatal lupus syndrome. *Paediatr Child Health*. 2007;17:223–227.)

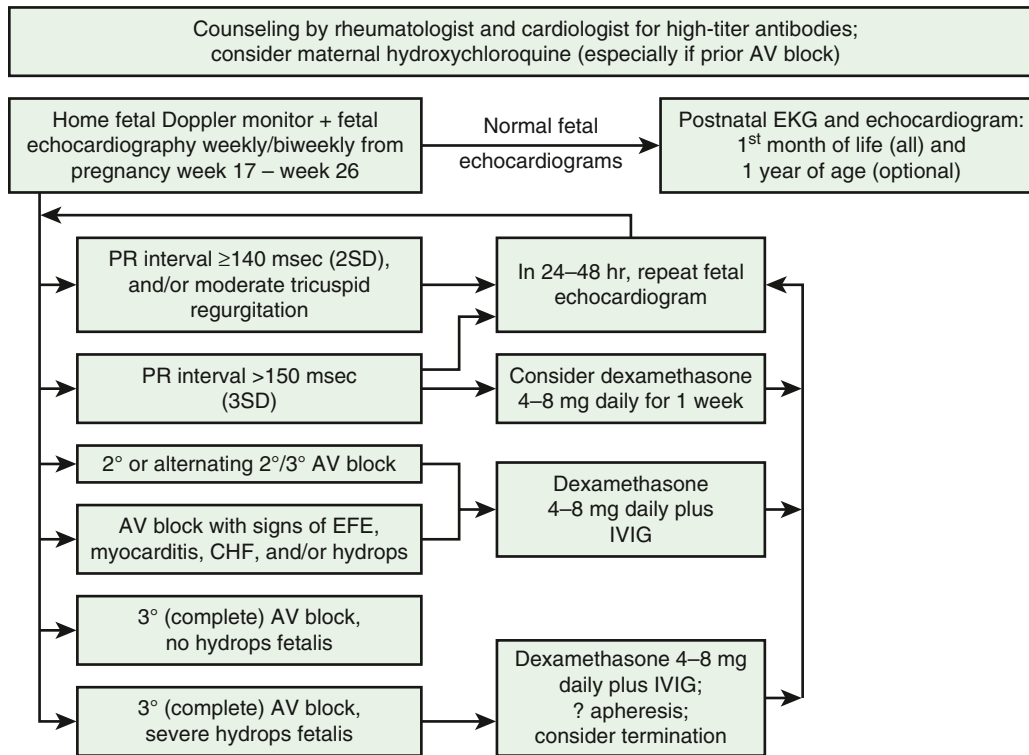
Most encouraging are retrospective cohort studies suggesting maternal treatment with hydroxychloroquine may reduce the frequency and recurrence of congenital heart block. In a multicenter, single-arm, open-label clinical trial assessing the efficacy of hydroxychloroquine to prevent recurrent autoantibody-associated congenital heart block, hydroxychloroquine treatment reduced the risk of recurrent heart block compared to historical controls by over 50%, from 17.5% to less than 8% of pregnancies.

Significant conduction system abnormalities after birth are treated with cardiac pacing and occasionally IVIG and steroids, whereas severe cardiomyopathy may require cardiac transplantation. If the conduction defect is not addressed, affected children are at risk for exercise intolerance, arrhythmias, and death. With cardiac pacing, however, children with conduction system disease in the absence of cardiomyopathy have an excellent prognosis. In a long-term follow-up study of 239 subjects enrolled in the Research Registry for Neonatal Lupus, 22% of subjects had cardiac dysfunction in the first year of life. Cardiac dysfunction often regressed; nevertheless, some dysfunction did appear later in childhood. Risk factors for cardiac dysfunction were being male or of low socioeconomic status and having low fetal heart rates, a longer period of pacing, or extranodal cardiac disease. In a Swedish cohort of 119 children with congenital heart block, 16.8% developed cardiomyopathy ± congestive heart failure. Congenital heart block increased the risk of cerebral infarctions and infections. Pacemaker treatment was associated with decreased risk of developing cerebral infarction but increased risk of infection and cardiomyopathy.

Noncardiac manifestations are typically transient and are conservatively managed, often with supportive care alone. Topical steroids can be used to treat moderate to severe NLE rash. Cytopenias may improve over time but severe cases occasionally require IVIG. Supportive care is usually appropriate for hepatic and neurologic manifestation. When the neonate clears maternal autoantibodies over the first 6 months of life, these inflammatory manifestations gradually resolve.



## One Approach to the Management of Anti-Ro ± Anti-La Pregnancy



**Fig. 199.5** Suggested algorithm for the management of anti-Ro ± anti-La pregnancy. All such pregnancies should include counseling and serial fetal echocardiograms.

Because maternal autoantibodies begin to gain access to the fetus through the placenta via FcRn at about 12 weeks gestation, all pregnant women with circulating anti-Ro and/or anti-La antibodies, or those with a history of offspring with neonatal lupus or congenital heart block, are generally advised to be monitored by a pediatric cardiologist, with screening fetal echocardiography performed weekly or biweekly from 17–26 weeks of gestation. The period of greatest vulnerability is usually 18–24 weeks. If fetal bradycardia is found during routine in utero monitoring in a mother never evaluated for the putative antibodies and if fetal echocardiography confirms a conduction defect, screening for maternal anti-Ro and anti-La antibodies is warranted. In pregnancies at risk for congenital heart block, maternal home monitoring of fetal heart rate using a handheld fetal heart rate monitor 2–3 times daily allows for accurate and early detection of heart rate abnormalities.

A proposed management algorithm is presented in [Figure 199.5](#).

A multicenter retrospective study concluded that *maternal treatment* with dexamethasone and/or intravenous gamma globulin should be initiated in all cases of anti-SSA/Ro antibody cardiac manifestations, including significant first-degree or any higher atrioventricular block, isolated endocardial fibroelastosis, or sinus bradycardia. However, other studies suggest that treatment should be individualized to fetuses at high risk and not universally instituted for isolated complete third-degree block, which is generally considered immutable.

The negative predictive value of antibody titers to identify pregnancies at low risk of fetal atrioventricular block has also been studied.

Excluding women with previously affected children, leveraging samples obtained from anti-SSA/Ro exposed pregnancies with and without fetal atrioventricular block, no case of heart block developed among subjects with anti-Ro52 and anti-Ro60 titers of <110 arbitrary units per milliliter using the multiplex bead assay of the Associated Regional and University Pathologists Laboratories (n=141). Applying these 100% negative predictive value thresholds, approximately 50% of the anti-Ro/SSA antibody pregnancies that ultimately had no fetal atrioventricular block could be excluded from surveillance.

Emerging data suggest that not all mothers with anti-SSA/Ro antibodies require surveillance. Based on review of the literature, the Society for Maternal-Fetal Medicine published guidelines that recommended "...that serial fetal echocardiograms for assessment of the PR interval not be routinely performed in patients with anti-SSA/SSB antibodies outside of a clinical trial setting" but rather that, "Doppler assessment of fetal heart rate during routine prenatal visits can be used to screen for fetal complete heart block. Once complete heart block develops, management is expectant, with weekly ultrasound examinations recommended to assess for hydrops."

Guidelines in this domain continue to evolve as new data advances our approach to risk stratification

Visit Elsevier eBooks+ at [eBooks.Elsevier.com](http://eBooks.Elsevier.com) for Bibliography.

## Chapter 200

## Juvenile Dermatomyositis

Jeffrey A. Dvergsten and Ann M. Reed

Juvenile dermatomyositis (JDM) is the most common of the *juvenile idiopathic inflammatory myopathies (JIIMs)*, representing up to 85% of all patients with these rare vasculopathic diseases. It is characterized by proximal muscle weakness and distinctive rashes of the face and extensor joint surfaces.

### EPIDEMIOLOGY

The incidence of JDM is approximately 3 cases/1 million children/yr, with an incidence similar in White and Black non-Hispanics and an apparent lower incidence in Hispanics. The peak age of onset is 7 years with a second peak of onset in late adulthood (45-64 years); however, adult-onset dermatomyositis appears to be a distinctly separate entity, both in prognosis and etiology. In the United States the ratio of females to males with JDM is 2:1. Multiple cases of myositis in a single family are rare, but familial autoimmune disease may be increased in families with children who have JDM when compared to families of children without autoimmune disease. Reports of seasonal association have not been confirmed, although clusters of cases may occur.

### ETIOLOGY

A precise understanding of the etiology and pathogenesis of JDM remains elusive; many factors that affect elements of innate and adaptive immunity have been identified as contributing to onset and perpetuation of disease. Evidence suggests that the etiology of JDM is multifaceted, with a genetic predisposition influenced by an environmental factor triggering events leading to disease pathogenesis.

Genetic factors that are associated with increased susceptibility to JDM include human leukocyte antigen (HLA) alleles DRB1\*0301, DQA1\*0501, and DQA1\*0301. Additionally, HLA-DQA1\*0501 is found on maternal cells present in blood and tissue samples of children with JDM, an example of maternal microchimerism, which has been proposed to play an etiologic role in JDM by creating an immune response comparable to graft-versus-host disease (GVHD). Other polymorphisms implicated in JDM include those affecting cytokine genes such as the tumor necrosis factor (TNF)- $\alpha$  promoter and the variable-number tandem repeats of the interleukin (IL)-1 receptor antagonist A1 gene. An increase in TNF- $\alpha$  may be associated with persistent immune activation leading to a longer disease course. The IL-1 receptor antagonist A1 allele is associated with the development of JIIM in White but not in Black persons, in whom the A3 allele, instead, is a possible risk factor. Environmental factors may also play a contributing role, with geographic and seasonal clustering reported. Short-term increases in ultraviolet (UV) index before the onset of disease have been reported; however, no clear theory of etiology has emerged. A history of infection in the 3 months before disease onset is usually reported; multiple studies have failed to produce a causative organism. Constitutional signs and upper respiratory symptoms predominate, but one third of patients report preceding gastrointestinal (GI) symptoms. Group A streptococcus, upper respiratory infections, GI infections, coxsackievirus B, toxoplasma, enteroviruses, parvovirus B19, and multiple other organisms have been postulated as possible pathogens in the etiology of JDM. Despite these concerns, results of serum antibody testing and polymerase chain reaction amplification of the blood and muscle tissue for multiple infectious diseases have not been revealing.

### PATHOGENESIS

JDM and related immune myositis syndromes are believed to be an autoimmune vasculopathic inflammatory disease affecting capillaries of multiple organs, but most notably, the skin, muscles, and GI tract

(Table 200.1). Pathogenic mechanisms are both immune and nonimmune with cellular and soluble constituents of the innate and adaptive immune systems and pathways of cellular injury involved. Type I interferons (IFNs), principally  $\alpha$  and  $\beta$ , are cytokines of the innate immune system that play a significant role in the pathogenesis of JDM by modulating several immune mechanisms, including upregulation of major histocompatibility complex (MHC) class I molecules on muscle cells; induction of proinflammatory cytokine, chemokine, and adhesion molecule production; and supporting cytotoxic effects of innate and adaptive immune cells. Plasmacytoid dendritic cells (pDCs) play an important role in JDM and are principal producers of type I IFN upon activation of Toll-like receptor (TLR) 9 on their surface by viruses. Cells involved in the inflammatory cascade include monocytes/macrophages (CD14), T-cell subsets (CD4, CD8, Th17), natural killer (NK) cells (CD56), and dendritic cells (DCs). MHC class I upregulation induces endoplasmic reticulum (ER) stress, which results in the degradation of contractile proteins; additional downstream effects of type I IFN include autoantibody production and B-cell proliferation. Galectin-9 and CXCL10 (IP-10) are two IFN-related proteins that have been validated as sensitive and specific peripheral biomarkers of disease activity in JDM.

### CLINICAL MANIFESTATIONS

Children with JDM present with either rash, insidious onset of weakness, or both. Fevers, dysphagia or dysphonia, arthritis, muscle tenderness, and fatigue are also commonly reported at diagnosis (Tables 200.2 and 200.3). Certain myositis-specific antibodies are associated with different phenotypic patterns of disease (Fig. 200.1).

Rash develops as the first symptom in 50% of patients and appears concomitant with weakness only 25% of the time. Children often exhibit extreme photosensitivity to UV light exposure with generalized erythema in sun-exposed areas. If seen over the chest and neck, this erythema is known as the **shawl sign**. Erythema is also commonly seen over the knees and elbows. The characteristic **heliotrope rash** is a blue-violet discoloration of the eyelids that may be associated with periorbital edema (Fig. 200.2). Facial erythema crossing the nasolabial folds is also common, in contrast to the malar rash without nasolabial involvement typical of systemic lupus erythematosus (SLE). Classic **Gottron papules** are bright-pink or pale, shiny, thickened, or atrophic plaques over the metacarpal phalangeal joints, proximal interphalangeal joints, and distal interphalangeal joints and occasionally on the knees, elbows, small joints of the toes, and ankle malleoli (Fig. 200.3). The rash of JDM is sometimes mistaken for eczema or psoriasis. Rarely, a thickened erythematous and scaly rash develops in children over the palms (known as **mechanic's hands**) and soles along the flexor tendons, which is associated with anti-Jo-1 antibodies.

Evidence of small vessel inflammation is often visible in the nail folds and gums as individual capillaries display changes including loops, thickening, tortuosity, or loss (Fig. 200.4C). Telangiectasias may be visible to the naked eye but are more easily visualized under capillaroscopy or with another magnifier (e.g., ophthalmoscope). Severe vascular inflammation causes cutaneous ulcers on toes, fingers, axillae, or epicanthal folds.

Early in disease, weakness associated with JDM is often insidious and difficult to differentiate from fatigue. It is typically symmetric, affecting proximal muscles such as the neck flexors, shoulder girdle, and hip flexors. Parents may report difficulty climbing stairs, combing hair, and getting out of bed. Examination reveals inability to perform a sit-up, head lag in a child after infancy, and **Gower sign** (use of hands climbing on thighs to help stand from a sitting position). Patients with JDM may roll to the side rather than sit straight up from lying to compensate for truncal weakness. Approximately half of children exhibit muscle tenderness because of muscle inflammation.

Esophageal and respiratory muscles are also affected, resulting in aspiration or respiratory failure. It is essential to assess for dysphonia or nasal speech, palatal elevation with gag, dysphagia, and gastroesophageal reflux by means of history and physical examination. If any of these are abnormal, a swallow study should be pursued. Respiratory muscle weakness can be a medical emergency and lead to respiratory failure.

**Table 200.1** Clinical Associations: Myositis-Specific Antibodies (MSA) and Myositis-Associated Antibodies (MAA) in Juvenile-Onset Myositis (JOM)

AUTOANTIBODY	TARGET AUTOANTIGEN	PREVALENCE (%) IN PATIENTS WITH JOM	CLINICAL ASSOCIATIONS
<b>Common myositis-specific autoantibodies are found in 45–55% of patients with juvenile-onset myositis</b>			
Anti-Mi2	Nucleosome remodeling deacetylase complex (NuRD)	3–4	<ul style="list-style-type: none"> <li>• “Classic” dermatomyositis</li> <li>• Responds well to standard therapies</li> <li>• Favorable prognosis</li> </ul>
Anti-TIF1g (p155/140, TRIM33)	Transcriptional intermediary factor 1 gamma (TIF1-γ)	18–35	<ul style="list-style-type: none"> <li>• Severe cutaneous disease</li> <li>• Rashes in photoexposed pattern</li> <li>• Chronic disease course</li> <li>• Lipodystrophy</li> </ul>
Anti-NXP2 (p140, MJ)	Nuclear matrix protein 2 (NXP2)	15–22	<ul style="list-style-type: none"> <li>• Calcinosis</li> <li>• More severe muscle disease</li> <li>• Gastrointestinal bleeding, ulcers, and dysphagia</li> <li>• Worse disease outcome and functional status</li> </ul>
Anti-MDA5 (CADM-140)	Melanoma differentiation–associated gene 5 (MDA5)	6	<ul style="list-style-type: none"> <li>• More common in East Asia, where associated with clinically amyopathic myositis, rapidly progressive interstitial lung disease, and a high mortality rate</li> <li>• In White populations associated with mild muscle disease, interstitial lung disease, arthritis, and ulceration</li> </ul>
<b>Rare but clinically important myositis-specific autoantibodies are found in 5–8% of patients with juvenile-onset myositis antisynthetases (Jo-1, PL12, PL7, OJ, EJ, KS, Zo, and Ha)</b>			
<b>ANTISYNTHETASES</b>			
- Jo-1	- Histidyl	2–3	<ul style="list-style-type: none"> <li>• Antisynthetase syndrome: myositis, interstitial lung disease, fever, mechanic’s hands, Raynaud phenomenon, and arthritis</li> <li>• Occurs in older children</li> <li>• Increased mortality</li> </ul>
- PL12	- Alanyl	2–3	
- PL7	- Threonyl	2–3	
- OJ	- Isoleucyl	2–3	
- EJ	- Glycyl	2–3	
- KS	- Asparaginylyl	2–3	
- Zo	- Phenylalanyl	2–3	
- Ha	- Tyrosyl	2–3	
Anti-SRP	Signal recognition particle (SRP)	2	<ul style="list-style-type: none"> <li>• Necrotizing autoimmune myositis</li> <li>• Severe weakness, muscle necrosis, high CK</li> <li>• Cardiac involvement</li> <li>• Occurs in older children</li> <li>• No rash</li> <li>• May be refractory to standard treatment</li> </ul>
Anti-HMGCR	HMGCR	1	<ul style="list-style-type: none"> <li>• Necrotizing autoimmune myositis, muscle necrosis, high CK, dysphagia, no statin exposure</li> </ul>
Anti-SAE	Small ubiquitin-like modifier–activating enzyme (SAE)	1	<ul style="list-style-type: none"> <li>• Initially amyopathic disease with muscle involvement occurring later</li> </ul>
<b>Myositis-associated autoantibodies are found in 16–20% of patients with juvenile-onset myositis. Some may occur in conjunction with a myositis-specific autoantibody.</b>			
Anti-PmScl	Exosome-associated PM- Scl-75; PM-Scl-100; C1D	5	<ul style="list-style-type: none"> <li>• Overlap syndromes</li> </ul>
Anti-U1RNP	U1RNP	2	<ul style="list-style-type: none"> <li>• Overlap syndromes</li> </ul>
Anti-Ro52	Ro52	5	<ul style="list-style-type: none"> <li>• Overlap syndromes</li> <li>• May be found in conjunction with other MSA, particularly antisynthetases</li> </ul>

Common MSAs are present in 45–55% of the U.S. pediatric population with juvenile-onset myositis. Rare MSAs are present in 5–8%. Myositis-associated autoantibodies (MAAs) are found in 16–20% of juvenile-onset myositis, with or without an accompanying MSA.

CK, Creatine kinase; HMGCR, 3-hydroxy-3-methylglutaryl-coenzyme reductase; MDA, melanoma differentiation-associated; NuRD, nucleosome remodeling deacetylase; SAE, small ubiquitin-like modifier–activating enzyme; SRP, signal recognition particle; TIF, transcriptional intermediary factor.

Modified from Pachman LM, Khojah AM. Advances in juvenile dermatomyositis: myositis specific antibodies aid in understanding disease heterogeneity. *J Pediatr*. 2018;195:16–27.

Table 200.2 Diagnostic Criteria for Juvenile Dermatomyositis	
Classic rash	Heliotrope rash of the eyelids Gottron papules
Plus three of the following:	
Weakness	Symmetric Proximal
Muscle enzyme elevation ( $\geq 1$ )	Creatine kinase Aspartate transaminase Lactate dehydrogenase Aldolase
Electromyographic changes	Short, small polyphasic motor unit potentials Fibrillations Positive sharp waves Insertional irritability Bizarre, high-frequency repetitive discharges
Muscle biopsy	Necrosis Inflammation

Data from Bohan A, Peter JB. Polymyositis and dermatomyositis (second of two parts). *N Engl J Med*. 1975;292:403–407.

Table 200.3 Clinical Features of Juvenile Dermatomyositis During Disease Course	
FEATURE	%
Muscle weakness	90-100
Dysphagia or dysphonia	13-40
Muscle atrophy	10
Muscle pain and tenderness	30-75
Skin lesions	85-100
Heliotrope rash of eyelids	66-95
Gottron papules	57-95
Erythematous rash of malar/facial area	42-100
Periungual (nail fold) capillary changes	80-90
Photosensitive rash	5-42
Ulcerations	22-30
Calcinosis	12-30
Lipodystrophy	11-14
Raynaud phenomenon	2-15
Arthritis and arthralgia	22-58
Joint contractures	26-27
Fever	16-65
Gastrointestinal signs and symptoms	8-37
Restrictive pulmonary disease	4-32
Interstitial lung disease	1-7
Cardiac involvement	0-3

From Rider LG, Lindsley CB, Cassidy JT. Juvenile dermatomyositis. In: Cassidy JT, Petty RE, Laxer RM, et al., eds. *Textbook of Pediatric Rheumatology*, 6th ed. Philadelphia: Saunders; 2011: Table 24.20, p. 410.

Children with respiratory muscle weakness do *not* manifest typical symptoms of impending respiratory failure with increased work of breathing, instead demonstrating hypercarbia rather than hypoxemia. Evaluation of respiratory muscle function by negative inspiratory force (NIF) measurement can be performed in the clinic or at the bedside.

## DIAGNOSIS

Diagnosis of dermatomyositis requires the presence of a characteristic rash and at least three signs of muscle inflammation and weakness (see Table 200.2). Diagnostic criteria developed in 1975 predate the use of MRI and have not been validated in children. Diagnosis is often delayed because of the insidious nature of disease onset.

Electromyography (EMG) shows signs of myopathy (increased insertional activity, fibrillations, sharp waves) and muscle fiber necrosis (decreased action potential amplitude and duration). Nerve conduction studies are typically normal unless severe muscle necrosis and atrophy are present. It is important that EMG be performed in a center with experience in pediatric EMG and its interpretation. **Muscle biopsy** is typically indicated when the diagnosis is in doubt or for grading disease severity (see Fig. 200.4A). Biopsy of involved muscle reveals focal necrosis and phagocytosis of muscle fibers, fiber regeneration, endomysial proliferation, inflammatory cell infiltrates and vasculitis, and tubuloreticular inclusion bodies within endothelial cells. Findings of lymphoid structures and vasculopathy may portend more severe disease.

Some children present with classic rash but no apparent muscle weakness or inflammation; this variation is called **amyopathic JDM** or **dermatomyositis sine myositis**. It is unclear whether these children have isolated skin disease or mild undetected muscle inflammation, risking progression to more severe muscle involvement with long-term sequelae such as calcinosis and lipodystrophy if untreated.

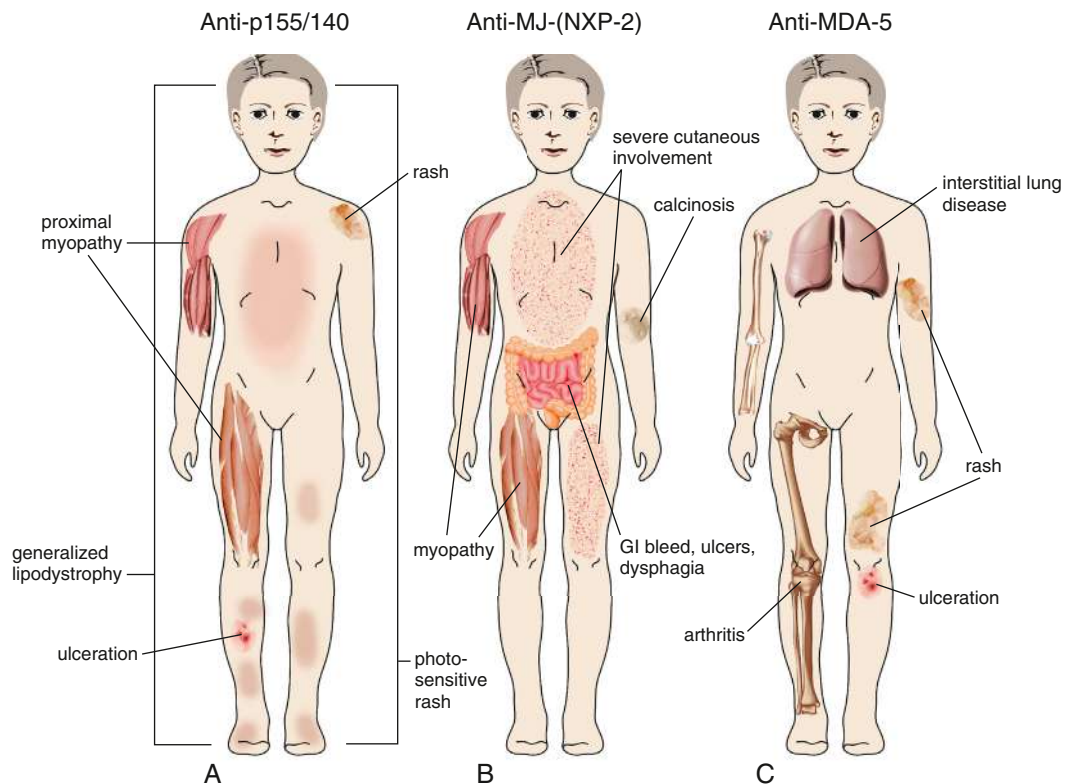
## DIFFERENTIAL DIAGNOSIS

The differential diagnosis depends on the presenting symptoms. If the presenting complaint is solely weakness without rash or atypical disease, other causes of myositis or myopathy should be considered, including polymyositis, infection-related myositis (influenza A and B, coxsackievirus B, and other viral illnesses), muscular dystrophies (e.g., Duchenne, Becker), myasthenia gravis, Guillain-Barré syndrome, endocrinopathies (hyperthyroidism, hypothyroidism, Cushing syndrome, Addison disease, parathyroid disorders), mitochondrial myopathies, TNF receptor-associated periodic syndrome (TRAPS), and metabolic disorders (glycogen and lipid storage diseases). Infections associated with prominent muscular symptoms include trichinosis, *Bartonella* infection, toxoplasmosis, staphylococcal pyomyositis, and SARS-CoV-2. Blunt trauma and crush injuries may lead to transient rhabdomyolysis with myoglobinuria. Myositis in children may also be associated with vaccinations, drugs, growth hormone, and GVHD. The rash of JDM may be confused with dyshidrotic eczema, psoriasis, erythema nodosa, malar rash from SLE, capillary telangiectasias from Raynaud phenomenon, and other rheumatic diseases. Muscle inflammation is also seen in children with SLE, juvenile idiopathic arthritis, mixed connective tissue disease, inflammatory bowel disease, and antineutrophil cytoplasmic antibody-positive vasculitides. Necrotizing immune-mediated myopathies are characterized by muscle necrosis without lymphocytic infiltration. Antibodies to signal recognition particle (SRP) or 3-hydroxy-3-methylglutaryl-coenzyme A (HMG-CoA) distinguish the two types from each other and from JDM. Table 200.4 compares other juvenile idiopathic inflammatory myositis disorders: JDM, juvenile polymyositis, and juvenile connective tissue myositis.

## LABORATORY FINDINGS

Elevated serum levels of muscle-derived enzymes (creatinine kinase [CK], aldolase, aspartate transaminase, alanine transaminase [ALT], lactate dehydrogenase) reflect muscle inflammation. Not all enzyme levels rise with inflammation in a specific individual; ALT is usually elevated on initial presentation, whereas CK level may be normal.





**Fig. 200.1** Phenotypes associated with the three most common myositis specific antibodies in children with myositis: anti-p155/140, anti-MJ, and antiMDA-5. **A**, Anti-p155/140, present in 18–30% of idiopathic juvenile inflammatory myopathies, displays an extensive photosensitive rash that ulcerates, a chronic disease course, and generalized lipodystrophy. **B**, Fifteen to twenty-three percent of children positive for anti-MJ (nuclear matrix protein 2 in the United Kingdom) may have disease onset at a younger age and have dysphonia, muscle cramps, atrophy, and contractures, with increased weakness, and they are more likely to develop calcifications and gastrointestinal symptoms; their rash often spares the truncal area. **C**, Anti-MDA-5 is increased in the Japanese population (33%) vs the United Kingdom (6%) and is associated with inflammatory lung disease, oral and cutaneous ulcers, arthritis, and a milder form of muscle involvement. GI, gastrointestinal. (Modified from Rider LG, Nistala K. *The juvenile idiopathic inflammatory myopathies: Pathogenesis, clinical and autoantibody phenotypes, and outcomes.* J Intern Med. 2016;280:24–38, Fig 3.)



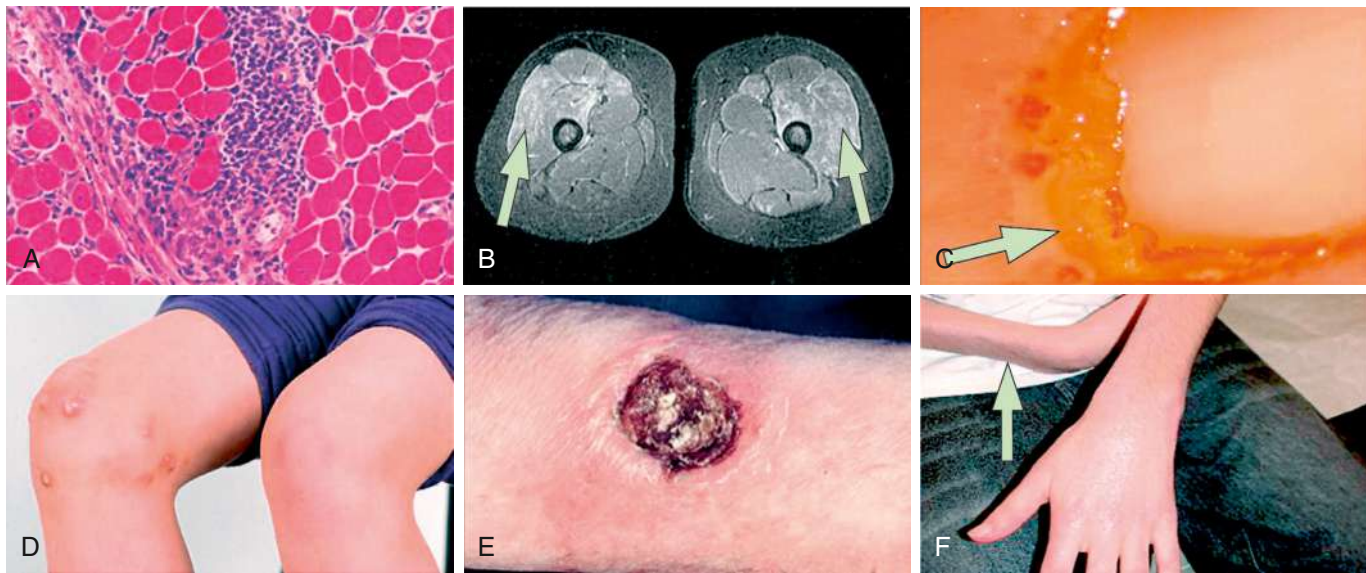
**Fig. 200.2** The facial rash of juvenile dermatomyositis. There is erythema over the bridge of the nose and malar areas with violaceous (heliotropic) discolorations of the upper eyelids.

The erythrocyte sedimentation rate (ESR) is often normal, and the rheumatoid factor (RF) test result is typically negative. There may be anemia consistent with chronic disease. Antinuclear antibody (ANA) is present in >80% of children with JDM. Serologic testing results are divided into two groups: **myositis-associated antibodies**



**Fig. 200.3** The rash of juvenile dermatomyositis. The skin over the metacarpal and proximal interphalangeal joints may be hypertrophic and pale red (Gottron papules).

(MAAs) and **myositis-specific antibodies (MSAs)** (see Table 200.1). MAAs are associated with JDM but are not specific and can be seen in both overlap conditions and other rheumatic diseases. The presence of MAAs such as SSA, SSB, Sm, ribonucleoprotein (RNP), and double-stranded (ds) DNA may increase the likelihood of overlap disease or connective tissue myositis. Antibodies to Pm/Scl identify a small, distinct subgroup of myopathies with a protracted disease course, often complicated by pulmonary interstitial fibrosis and cardiac involvement. MSAs are specific for myositis and are identified in



**Fig. 200.4** Features of juvenile dermatomyositis. A, Perivascular and perifascicular inflammatory infiltrates with necrotic fibers, per fascicular atrophy, and regeneration in a muscle biopsy. B, MRI is a sensitive indicator of myositis. Inflamed areas appear bright on short-tau inversion recovery-weighted images (arrows). C, Capillaries are most often abnormal when viewed at the nail fold. Typical changes of dilation with adjacent dropout (arrow) are seen. D, About 30% of juvenile dermatomyositis (JDM) patients have dystrophic calcinosis. E, Cutaneous ulceration with central necrosis, crust, and surrounding erythema at the elbow of 10-year-old boy with severe JDM. F, Lipoatrophy of the forearm (arrow) in a boy with JDM. (From Feldman BM, Rider LG, Reed AM, Pachman LM. Juvenile dermatomyositis and other idiopathic inflammatory myopathies of childhood. *Lancet*. 2008;371:2201–2212, Fig. 3, p. 2205.)

approximately 40–60% of children with JIM. These antibodies suggest a diagnosis of myositis, and their presence may define distinct clinical subsets and may predict prognosis. Anti-TIF-1- $\gamma$  antibodies are reported in 23–30% of children with JDM and are associated with photosensitive rashes, ulceration, and lipodystrophy. Unlike in adults, this antibody is not associated with malignancy in children with JDM. Anti-NXP2 antibodies are reported in 12–23% of children with JDM and are associated with cramps, muscle atrophy, contractures, and dysphonia. Anti-MDA5 antibodies are found in approximately 7% of children with JDM and may predict the development of interstitial lung disease (ILD). Because certain MSAs have defined clinical phenotypes in JDM and IFN-related biomarkers that may correlate with disease activity, there is interest in assessing IFN signature by MSA type.

Radiographic studies aid both diagnosis and medical management. MRI using T2-weighted images and fat suppression (see Fig. 200.4B) identifies active sites of disease, reducing sampling error and increasing the sensitivity of muscle biopsy and EMG, results of which are nondiagnostic in 20% of cases if the procedures are not directed by MRI. Extensive rash and abnormal MRI findings may be found despite normal serum levels of muscle-derived enzymes. Muscle biopsy often demonstrates evidence of disease activity and chronicity that is not suspected from the levels of the serum enzymes alone.

A contrast swallow study may document palatal dysfunction and risk of aspiration. Pulmonary function testing detects a restrictive defect consistent with respiratory weakness and reduced diffusion capacity of carbon monoxide from alveolar fibrosis associated with other connective tissue diseases. Serial measurement of vital capacity or negative inspiratory force can document changes in respiratory weakness, especially in an inpatient setting. **Calcinosis** is seen easily on radiographs, along the fascial planes, and within muscles (see Figs. 200.4D and E and Fig. 200.5).

## TREATMENT

The aid of an experienced pediatric rheumatologist is invaluable in outlining an appropriate course of treatment for a child with JDM. Before the advent of corticosteroids, one third of patients spontaneously improved; a third had a chronic, lingering course; and a third died from the disease. Corticosteroids have altered the course of the

disease, lowering morbidity and mortality. Methotrexate decreases the length of treatment with corticosteroids, thereby reducing morbidity from steroid toxicity. Intravenous (IV) gamma globulin is frequently used as an adjunct for the treatment of severe disease and can be given at 2 g/kg (maximum 70 g) every 2 weeks for three doses, then every 4 weeks as needed. The efficacy and safety have been reported in open-label studies. In the 2010 **Childhood Arthritis and Rheumatology Research Alliance (CARRA)** treatment utilization report, IVIG was used most frequently for initial treatment of severe disease and treatment of refractory disease. It is also a steroid-sparing agent. Consensus treatment plans for guiding treatment of children with JDM are available from CARRA online through PubMed and Figure 200.6.

Corticosteroids remain the mainstay of treatment. In a clinically stable child without debilitating weakness, oral prednisone at 2 mg/kg/day (maximum 60 mg daily) is recommended. Children with GI involvement may have decreased absorption of oral corticosteroids and require IV administration. In more severe cases with respiratory or oropharyngeal weakness, high-dose pulse methylprednisolone is used (30 mg/kg/day for 3 days, maximum dose 1 g/day) with ongoing weekly or monthly IV dosing along with daily oral corticosteroids as needed. Corticosteroid dosage is slowly tapered over 12 months, after indicators of inflammation (muscle enzymes) normalize and strength improves.

Weekly oral, IV, or subcutaneous methotrexate (the lesser of 1 mg/kg or 15 mg/m<sup>2</sup>) is often used as a steroid-sparing agent in JDM. The concomitant use of methotrexate halves the cumulative dosage of steroids needed for disease control. Risks of methotrexate include immunosuppression, blood count dyscrasias, chemical hepatitis, pulmonary toxicity, nausea/vomiting, and teratogenicity. *Folic acid is typically given with methotrexate starting at a dose of 1 mg daily to reduce toxicity and side effects of folate inhibition (oral ulcers, nausea, anemia).* Children who are taking immunosuppressive medications such as methotrexate should avoid live-virus vaccination, although inactivated influenza vaccination is recommended yearly. An international trial found the combination of methotrexate plus corticosteroids to perform better than corticosteroids alone and with fewer side effects than corticosteroids plus cyclosporine A.

**Hydroxychloroquine** has little toxicity risk and is used as a secondary disease-modifying agent to reduce rash and maintain remission.

**Table 200.4** Frequency of Manifestations of Juvenile Dermatomyositis (JDM), Juvenile Polymyositis (JPM), and Overlap Myositis

MANIFESTATION	FREQUENCY AT ONSET (%)		
	JDM	JPM	OVERLAP MYOSITIS
Progressive proximal muscle weakness	82-100	100	100
Easy fatigue	80-100	85	84
Gottron papules	57-91	0	74-80
Heliotrope rash	66-87	0	40-59
Erythematous rash of malar/facial area	42-100	0-6	20-51
Periungual nailfold capillary changes	35-91	33	67-80
Muscle pain or tenderness	25-83	61-66	55
Weight loss	33-36	52	53
Falling episodes	40	59	29
Arthritis	10-65	0-45	69-80
Fever	16-65	0-41	0-49
Lymphadenopathy	8-75	0-12	20-22
Dysphagia or dysphonia	15-44	39	40
Joint contractures	9-55	17-42	57-60
V- or shawl-sign rashes	19-29	3-6	8-14
Dyspnea on exertion	5-43	17-42	40
Gastrointestinal symptoms	5-37	9-33	6-53
Photosensitive rashes	5-51	0-6	22-40
Raynaud phenomenon	9-28	0-24	41-60
Edema	11-34	15	20
Gingivitis	6-30	9	0-37
Cutaneous ulceration	5-30	3	20-22
Calcinosis	3-34	6	24
Cardiac involvement	2-13	36	19
Interstitial lung disease	5	15	26
Lipodystrophy	4-14	3	0-6
Gastrointestinal bleeding or ulceration	3-4	3	4-10

From Rider LG, Lindsley CB, Miller FW. Juvenile Dermatomyositis. In: Petty RE, Laxer RM, Lindsley CB, Wedderburn L, eds. *Textbook of Pediatric Rheumatology*, 7th ed. Philadelphia: Elsevier; 2016: Table 26.4.

Typically, it is administered at doses of 4-6 mg/kg/day orally in either tablet or liquid form. Ophthalmologic follow-up one time per year to monitor for rare retinal toxicity is recommended. Other side effects include hemolysis in patients with glucose-6-phosphate deficiency, GI intolerance, and skin/hair discoloration.

The use of **rituximab** in a trial of steroid-dependent patients with resistant inflammatory myopathies, including JDM, did not meet the primary study end-point showing a difference in time to improvement between individuals given rituximab at baseline or at 8 weeks, but overall, 83% of all patients met the definition of improvement in the trial. Additionally, rituximab was noted to have a significant steroid-sparing effect.

Other medications used to treat severe refractory disease include mycophenolate mofetil, cyclosporine, and cyclophosphamide. Given the strong type I IFN signal in JDM and that these cytokines activate intracellular signaling through the Janus kinase (JAK)/signal transducers and activators of transcription (STAT) pathway, consideration of JAK inhibitors, including *tofacitinib*, *baricitinib*, and *ruxolitinib*, as potential therapeutic candidates has been bolstered by case reports and

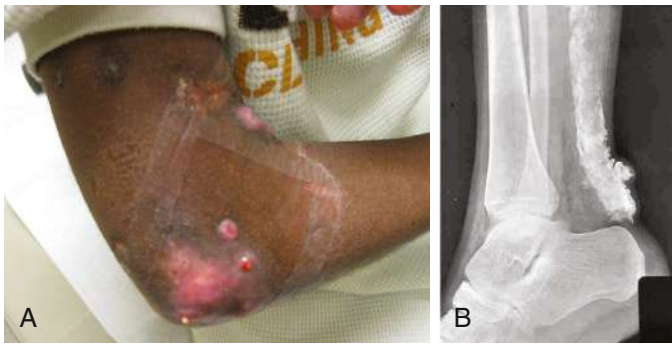
case series that report generally promising results with these drugs in off-label treatment of JDM.

Children with pharyngeal weakness may need nasogastric or gastrostomy feedings to avoid aspiration, whereas those with GI vasculitis require full bowel rest. Rarely, children with severe respiratory weakness require ventilator therapy and even tracheostomy until the respiratory weakness improves.

**Physical therapy and occupational therapy** are integral parts of the treatment program, initially for passive stretching early in the disease course and then for direct reconditioning of muscles to regain strength and range of motion. Therapy may improve muscle strength measures and cardiovascular fitness. Bed rest is not indicated, because weight bearing improves bone density and prevents contractures. Social work and psychology services may facilitate adjustment to the frustration of physical impairment in a previously active child and aid with sleep disturbances associated with rheumatic disease.

All children with JDM should avoid sun exposure and apply high-sun protection factor (SPF) sunscreen daily, even in winter and on cloudy days. Vitamin D and calcium supplements are indicated for all





**Fig. 200.5** Calcifications in dermatomyositis. A, Skin effects of calcification. B, Radiographic evidence of calcification.

MODERATE JDM
<p style="text-align: center;"><b>Plan 1</b></p> <p>Methotrexate<sup>a</sup> 15 mg/m<sup>2</sup> or 1 mg/kg weekly AND Prednisone<sup>b</sup> 2 mg/kg/d for 4 wk then decrease by 20%</p> <p style="text-align: center;"><b>Plan 2</b></p> <p>Plan 1 AND IV methylprednisolone 30 mg/kg for 3 d, then weekly<sup>c</sup></p> <p style="text-align: center;"><b>Plan 3</b></p> <p>Plan 2 AND IVIg 2 g/kg<sup>d</sup> q2wk × 3 doses then monthly</p>
SKIN PREDOMINANT JDM
<p style="text-align: center;"><b>Plan 1</b></p> <p>Hydroxychloroquine 5 mg/kg/d<sup>e</sup></p> <p style="text-align: center;"><b>Plan 2</b></p> <p>Plan 1 AND Methotrexate<sup>a</sup> 15 mg/m<sup>2</sup> or 1 mg/kg weekly</p> <p style="text-align: center;"><b>Plan 3</b></p> <p>Plan 2 AND Prednisone<sup>b</sup> 2 mg/kg/d for 4 wk then decrease by 20%</p>
SKIN RESISTANT JDM
<p style="text-align: center;"><b>Plan 1</b></p> <p>IVIg 2 g/kg<sup>d</sup> q2wks × 3 doses then monthly</p> <p style="text-align: center;"><b>Plan 2</b></p> <p>Plan 1 AND Mycophenolate mofetil<sup>f</sup> BID 10 mg/kg/dose OR 600 mg/m<sup>2</sup></p> <p style="text-align: center;"><b>Plan 3</b></p> <p>Cyclosporine 3 mg/kg<sup>g</sup></p>

**Fig. 200.6** Recommended consensus treatment plans from CARRA for JDM patients with moderate, skin-predominant, and skin-resistant disease. IV, intravenous; IG, immunoglobulin. <sup>a</sup>Lesser of 15 mg/m<sup>2</sup> or 1 mg/kg (max 40 mg), <sup>b</sup>max 60 mg, <sup>c</sup>optional, <sup>d</sup>max 70 g, <sup>e</sup>max 400 mg, <sup>f</sup>max 1,500 mg bid, <sup>g</sup>higher doses based on toxicity, efficacy. (From Kim H, Huber AM, Kim S. Updates on juvenile dermatomyositis from the last decade: classification to outcomes. *Rheum Dis Clin N Am*. 2021;47:669–690, Fig. 1, p. 679.)

children undergoing long-term corticosteroid therapy to reduce drug-induced osteopenia and osteoporosis.

## COMPLICATIONS

Most complications from JDM are related to prolonged and severe weakness from muscle atrophy to cutaneous calcifications and scarring

or atrophy to lipodystrophy. Secondary complications from medical treatments are also common. Children with acute and severe weakness are at risk for aspiration pneumonia and respiratory failure and occasionally require nasogastric feeding and mechanical ventilation until weakness improves. Rarely, **vasculitis** of the GI tract develops in children with severe JDM. Crampy abdominal pain and occult GI bleeding may indicate bowel wall vasculitis and lead to ischemia, GI bleeding, and perforation if not treated with complete bowel rest and aggressive treatment for the underlying inflammation. Surgery should be avoided, if possible, because the GI vasculitis is diffuse and not easily amenable to surgical intervention. Contrast-enhanced CT may show dilation or thickening of the bowel wall, intraluminal air, or evidence of bowel necrosis.

Involvement of the cardiac muscle with pericarditis, myocarditis, and conduction defects with arrhythmias has been reported, as has reduced diastolic and systolic function related to ongoing disease activity.

**Lipodystrophy** and **calcinosis** are thought to be associated with long-standing or undertreated disease (see Fig. 200.4D-F). Dystrophic deposition of calcium phosphate, hydroxyapatite, or fluoroapatite crystals occurs in subcutaneous plaques or nodules, resulting in painful ulceration of the skin with extrusion of crystals or calcific liquid. Calcification is found in up to 40% of large cohorts of children with JDM. Pathologic calcifications may be related to severity of disease and prolonged delay to treatment and potentially to genetic polymorphisms of TNF- $\alpha$ -308. Calcium deposits tend to form in subcutaneous tissue and along muscle. Some ulcerate through the skin and drain a soft calcific liquid, and others manifest as hard nodules along extensor surfaces or embedded along muscle. Draining lesions serve as a nidus for cellulitis or osteomyelitis. Nodules cause skin inflammation that may mimic cellulitis. Spontaneous regression of calcium deposits may occur, but there is no evidence-based recommendation for treatment of calcinosis. Some experts recommend aggressive treatment of underlying myositis. Others have recommended bisphosphonates, TNF inhibitors, and sodium thiosulfate, but no evidence-based trials have been conducted for this condition.

Lipodystrophy manifests in 10–40% of patients with JDM and can be difficult to recognize. Lipodystrophy results in progressive loss of subcutaneous and visceral fat, typically over the face and upper body, and may be associated with a metabolic syndrome similar to polycystic ovarian syndrome with insulin resistance, hirsutism, acanthosis, hypertriglyceridemia, and abnormal glucose tolerance. Lipodystrophy may be generalized or localized.

Children receiving prolonged corticosteroid therapy are prone to complications such as cessation of linear growth, weight gain, hirsutism, adrenal suppression, immunosuppression, striae, cushingoid fat deposition, mood changes, osteoporosis, cataracts, avascular necrosis, and steroid myopathy. Families should be counseled on the effects of corticosteroids and advised to use medical alert identification and to consult a nutritionist regarding a low-salt, low-fat diet with adequate vitamin D and calcium supplementation.

An association with malignancy at disease onset is observed in adults with dermatomyositis but very rarely in children.

## PROGNOSIS

The mortality rate in JDM has decreased since the advent of corticosteroids, from 33% to currently approximately 1%; little is known about the long-term consequences of persistent vascular inflammation. The period of active symptoms has decreased from about 3.5 years to <1.5 years with more aggressive immunosuppressive therapy; the vascular, skin, and muscle symptoms of children with JDM generally respond well to therapy. At 7 years of follow-up, 75% of patients have little to no residual disability, but 25% continue to have chronic weakness and 40% have chronic rash. Up to one-third may need long-term medications to control their disease. Children with JDM appear able to repair inflammatory damage to vasculature and muscle, but there is some emerging concern about long-term effects on cardiovascular risk.

Visit Elsevier eBooks+ at [eBooks.Health.Elsevier.com](https://www.elsevier.com/ebooks) for Bibliography.



## Chapter 201

## Scleroderma and Raynaud Phenomenon

Heather A. Van Mater and  
C. Eglia Rabinovich

Juvenile scleroderma encompasses a range of conditions unified by the presence of fibrosis of the skin. Juvenile scleroderma is divided into two major categories, **juvenile localized scleroderma (JLS)**, also known as **morphea**, which is largely limited to the skin, and **juvenile systemic sclerosis (JSSc)**, with multisystem organ involvement. Localized disease is the predominant type seen in pediatric populations (>95%), but systemic sclerosis is associated with mortality and severe multiorgan morbidity.

**ETIOLOGY AND PATHOGENESIS**

The etiology of scleroderma is unknown, but the mechanism of disease appears to be a combination of a vasculopathy, autoimmunity, immune activation, and fibrosis. Triggers, including trauma, infection, and, possibly, subclinical graft versus host reaction from persistent maternal cells (*microchimerism*), injure vascular endothelial cells, resulting in increased expression of adhesion molecules. These molecules entrap platelets and inflammatory cells, resulting in vascular changes with manifestations such as Raynaud phenomenon and pulmonary hypertension. Inflammatory cells infiltrate the area of initial vascular damage, causing further vascular damage and resulting in thickened artery walls and reduction in capillary numbers. Macrophages and other inflammatory cells then migrate into affected tissues and secrete cytokines that induce fibroblasts to reproduce and

synthesize excessive amounts of collagen, resulting in fibrosis and subsequent lipoatrophy and dermal fibrosis, with loss of sweat glands and hair follicles. In late stages the entire dermis may be replaced by compact collagen fibers.

**Autoimmunity** is believed to be a key process in the pathogenesis of both localized and systemic scleroderma, given the high percentage of affected children with autoantibodies (Table 201.1). Children with localized disease often have a positive antinuclear antibody (ANA) test result (42%), and 47% of this subgroup have antihistone antibodies. Children with JSSc have higher rates of ANA positivity (80.7%) and may have anti-Scl-70 antibody (34%, antitopoisomerase I). The relationship between specific autoantibodies and the various forms of scleroderma is not well understood, and all antibody test results may be negative, especially in JLS.

**CLASSIFICATION**

Localized scleroderma is distinct from systemic scleroderma and rarely progresses to systemic disease. The category of JLS includes several subtypes differentiated by both the distribution of the lesions and the depth of involvement (Tables 201.2 and 201.3). Up to 15% of children have a combination of two or more subtypes.

**EPIDEMIOLOGY**

Juvenile scleroderma is rare, with an estimated prevalence of 1 in 100,000 children. Localized scleroderma (LS) is much more common than systemic sclerosis (SSc) in children, by a 10:1 ratio, with **linear scleroderma** being the most common subtype. LS is predominantly a pediatric condition, with 65% of patients diagnosed before age 18 years. After age 8 years the female/male ratio for both LS and SSc is approximately 3:1, whereas in patients younger than 8 years, the prevalence is equal.

**CLINICAL MANIFESTATIONS****Localized Scleroderma**

The onset of scleroderma is generally insidious, and manifestations vary according to disease subtype. The initial skin manifestations of localized disease usually include erythema or a bluish hue seen around an area of waxy induration; subtle erythema may be the only presenting

**Table 201.1** Clinical Subtypes of Systemic Sclerosis: Associated Organ Manifestations and Autoantibody Association

SUBTYPE	ORGAN SYSTEM	ORGAN SYSTEM FEATURES	ANTIBODY ASSOCIATION
Diffuse cutaneous (dc)	Skin	Thickness proximal to elbows and knees Rapid progressive thickening	Topoisomerase (Scl-70) RNA Polymerase III U3-RNP (fibrillarin)
	Cardiac	Congestive heart failure Conduction abnormalities	
	Renal	Scleroderma renal crisis	
	Pulmonary	Interstitial lung disease	
Limited cutaneous (lc)	Skin	Thickness limited to distal extremities (and face) Restricted and nonprogressive thickening	Centromere Th/To
	Gastrointestinal	Esophageal dysmotility GI strictures Malabsorption	
	Pulmonary	Pulmonary arterial hypertension	
Overlap syndrome	Skin	Either dcSSc or lcSSc pattern Skin manifestations of other CTD, such as Gottron papules (DM) and malar rash (SLE)	PM-Scl U1-RNP Ku
	Musculoskeletal	Arthritis Myositis	
	Cardiac	Can have any of the dcSSc or lcSSc manifestations	
	Renal	Additional organ involvement in association with other CTD feature, such as lupus nephritis	
	Pulmonary		
	Gastrointestinal		

CTD, Connective tissue disease; DM, dermatomyositis; PM-Scl, polymyositis-scleroderma antibody; SLE, systemic lupus erythematosus; U1-RNP, U1 ribonucleoprotein antibody. From Petty RE, Laxer RM, Lindsley CB, et al., eds. *Textbook of Pediatric Rheumatology*, 8th ed. Philadelphia: Elsevier; 2021: Table 27.3, p. 382.

**Table 201.2** Classification of Pediatric Scleroderma (Morphea)**LOCALIZED SCLERODERMA****Plaque morphea**

Confined to dermis, occasionally superficial panniculus

Well-circumscribed circular area of induration, often a central waxy, ivory-colored area surrounded by a violaceous halo; unilateral

**Generalized morphea**

Involves dermis primarily, occasionally panniculus

Defined as confluence of individual morphea plaques or lesions in three or more anatomic sites; more likely to be bilateral

**Bullous morphea**

Bullous lesions that can occur with any of the subtypes of morphea

**Linear scleroderma**

Linear lesions can extend through the dermis, subcutaneous tissue, and muscle to underlying bone; more likely unilateral

Limbs/trunk:

One or more linear streaks of the extremities or trunk

Flexion contracture occurs when lesion extends over a joint; limb-length discrepancies

En coup de sabre:

Involves the scalp and/or face; lesions can extend into the central nervous system, resulting in neurologic sequelae, most commonly seizures and headaches

Parry-Romberg syndrome:

Hemifacial atrophy without a clearly definable en coup de sabre lesion; can also have neurologic involvement

**Deep Morphea**

Involves deeper layers, including panniculus, fascia, and muscle; more likely to be bilateral

Subcutaneous morphea:

Primarily involves the panniculus or subcutaneous tissue

Plaques are hyperpigmented and symmetric

Eosinophilic fasciitis:

Fasciitis with marked blood eosinophilia

Fascia is the primary site of involvement; typically involves extremities

Classic description is “peau d’orange,” or orange peel texture, but early disease manifests as edema (see Fig. 201.2)

Morphea profunda:

Deep lesion extending to fascia and sometimes muscle, but may be limited to a single plaque, often on the trunk

Disabling pansclerotic morphea of childhood:

Generalized full-thickness involvement of skin on the trunk, face, and extremities, sparing fingertips and toes

**SYSTEMIC SCLEROSIS****Diffuse**

Most common type in childhood

Symmetric thickening and hardening of the skin (sclerosis) with fibrous and degenerative changes of viscera

**Limited**

Rare in childhood

Previously known as CREST (calcinosis cutis, Raynaud phenomenon, esophageal dysfunction, sclerodactyly, and telangiectasia) syndrome

**Table 201.3** Provisional Criteria for Classification of Juvenile Systemic Sclerosis (JSSc)**MAJOR CRITERION (REQUIRED)\***

Proximal skin sclerosis/induration of the skin proximal to metacarpophalangeal or metatarsophalangeal joints

**MINOR CRITERIA (AT LEAST TWO REQUIRED)**

*Cutaneous:* Sclerodactyly

*Peripheral vascular:* Raynaud phenomenon, nail fold capillary abnormalities (telangiectasias), digital tip ulcers

*Gastrointestinal:* Dysphagia, gastroesophageal reflux

*Cardiac:* Arrhythmias, heart failure

*Renal:* Renal crisis, new-onset arterial hypertension

*Respiratory:* Pulmonary fibrosis (high-resolution CT/radiography), decreased diffusing capacity for carbon monoxide, pulmonary arterial hypertension

*Neurologic:* Neuropathy, carpal tunnel syndrome

*Musculoskeletal:* Tendon friction rubs, arthritis, myositis

*Serologic:* Antinuclear antibodies—SSc-selective autoantibodies (anticentromere, antitopoisomerase I [Scl-70], antifibrillarin, anti-PM/Scl, antifibrillin, or anti-RNA polymerase I or III)

\*Diagnosis requires at least one major and at least two minor criteria. From Zulian F, Woo P, Athreya BH, et al. The Pediatric Rheumatology European Society/American College of Rheumatology/European League against Rheumatism provisional classification criteria for juvenile systemic sclerosis. *Arthritis Rheum.* 2007;57:203–212.

sign (Fig. 201.1). Edema and erythema are followed by indurated, hypopigmented or hyperpigmented atrophic lesions (Fig. 201.2). LS varies in size from a few centimeters to the entire length of the extremity, with varying depth. Patients may present with arthralgias, synovitis, or flexion contractures (Fig. 201.3). Children also experience limb-length discrepancies as a result of growth impairment caused by involvement of muscle and bone. Children with **en coup de sabre** may have symptoms unique to central nervous system (CNS) involvement, such as seizures, hemifacial atrophy, ipsilateral uveitis, and learning/behavioral changes (Fig. 201.4). Up to 25% of children with LS have extracutaneous manifestations, most frequently arthritis (47%) in linear disease and neurologic symptoms (17%) associated with en coup de sabre.

**Systemic Scleroderma**

SSc is a severe disease in children, starting with an insidious onset followed by a prolonged course characterized by periods of remission and exacerbation, commonly resulting in chronic disability and death, with a 5-year mortality rate of 7.5%.

The **skin manifestations** of SSc include an early phase of edema that spreads proximally from the dorsum of the hands and fingers and includes the face. An eventual decrease in edema is followed by induration and fibrosis of skin, ultimately resulting in loss of subcutaneous fat, sweat glands, and hair follicles. Later, atrophic skin becomes shiny and waxy in appearance. As lesions spread proximally, flexion contractures develop at the elbows, hips, and knees associated with secondary muscle weakness and atrophy. In the face, this process results in a small oral stoma with decreased mouth aperture. Skin ulceration over pressure points, such as the elbows, may be associated with subcutaneous calcifications. Severe **Raynaud phenomenon** (RP; Fig. 201.5) causes ulceration of the fingertips with subsequent loss of tissue pulp and tapered fingers (**sclerodactyly**) (Fig. 201.6). Resorption of the distal tufts of the distal phalanges may occur (**acroosteolysis**). Hyperpigmented postinflammatory changes surrounded by atrophic depigmentation give a salt-and-pepper appearance to skin. Over years, remodeling of lesions sometimes results in focal improvement in skin thickening.

**Pulmonary disease** is the most common visceral manifestation of SSc and includes both arterial and interstitial involvement (alveolitis). Symptoms range from asymptomatic disease to exercise intolerance, dyspnea at



**Fig. 201.1** Child with generalized morphea. Note the active circular lesion (arrowheads) with a surrounding rim of erythema. The largest lesion has areas of postinflammatory hyperpigmentation and depression with an area of erythema on the right. The small lesion (arrow) demonstrates depression caused by lipoatrophy.



**Fig. 201.2** Inactive linear scleroderma demonstrating hyperpigmented lesion with areas of normal skin (skip lesions).



**Fig. 201.3** Child with untreated linear scleroderma resulting in knee contracture, immobility of ankle, chronic skin breakdown of scar on the lateral knee, and areas of hypopigmentation and hyperpigmentation. The affected leg is 1 cm shorter.

rest, and right-sided heart failure. **Pulmonary arterial hypertension** is a poor prognostic sign, developing because of lung disease or independently as part of the vasculopathy. Clinical manifestations of pulmonary arterial hypertension in children appear late in the course, are subtle, and include cough and dyspnea on exertion. Pulmonary evaluation should include pulmonary function tests (PFTs) such as diffusion capacity of carbon monoxide (DLco), bronchoalveolar lavage (BAL), and high-resolution chest computed tomography (HRCT). PFTs reveal decreased vital capacity and decreased DLco, whereas neutrophilia or eosinophilia on BAL suggests active alveolitis. Chest CT is much more sensitive than chest radiographs, which are often normal, showing typical basilar ground-glass abnormalities, reticular linear opacities, nodules, honeycombing, and mediastinal adenopathy.

**Gastrointestinal tract disease** is seen in 25% of children with SSc. Common manifestations include esophageal and intestinal dysmotility resulting in dysphagia, reflux, dyspepsia, gastroparesis, bacterial overgrowth, dilated bowel loops and pseudoobstruction, and dental caries, as well as malabsorption and failure to thrive. **Renal** arterial disease can cause chronic or severe episodic hypertension; unlike adult disease, renal



**Fig. 201.4** Child with en coup de sabre lesion on scalp extending down to forehead. Before treatment, the skin on the scalp was bound down with chronic skin breakdown. Note the area of hypopigmentation extending down the forehead (arrows).



**Fig. 201.5** Active Raynaud phenomenon with well-demarcated pallor at the fingertips in a patient with scleroderma. (From Firestein GS, Budd RC, Gabriels SE, et al., eds. Firestein & Kelley's Textbook of Rheumatology, 11th ed. Philadelphia: Elsevier; 2021: Fig. 89.2, p. 1507.)



**Fig. 201.6** Sclerodactyly and finger ulcerations in a patient with systemic sclerosis who is poorly compliant with treatment.

crisis is rare. **Cardiac** fibrosis is associated with arrhythmias, ventricular hypertrophy, and decreased cardiac function. Mortality from JSSc is usually a result of cardiopulmonary disease. A scoring system helps identify the severity of the multiorgan involvement (Table 201.4).



**Table 201.4** Medsger Systemic Sclerosis Severity Scale\*

ORGAN SYSTEM	0 (NORMAL)	1 (MILD)	2 (MODERATE)	3 (SEVERE)	4 (END STAGE)
General	Wt loss <5% Hct 37%+ Hb 12.3+ g/dL	Wt loss 5–10% Hct 33–37% Hb 11.0–12.2 g/dL	Wt loss 10–15% Hct 29–33% Hb 9.7–10.9 g/dL	Wt loss 15–20% Hct 25–29% Hb 8.3–9.6 g/dL	Wt loss 20%+ Hct 25% Hb <8.3 g/dL
Peripheral vascular	No RP; RP not requiring vasodilators	RP requiring vasodilators	Digital pitting scars	Digital tip ulcerations	Digital gangrene
Skin	TSS 0	TSS 1–14	TSS 15–29	TSS 30–39	TSS 40+
Joint/tendon	FTP 0–0.9 cm	FTP 1.0–1.9 cm	FTP 2.0–3.9 cm	FTP 4.0–4.9 cm	FTP 5.0+ cm
Muscle	Normal proximal muscle strength	Proximal weakness, mild	Proximal weakness, moderate	Proximal weakness, severe	Ambulation aids required
Gastrointestinal tract	Normal esophagogram; normal small bowel series	Distal esophageal hypoperistalsis; small bowel series abnormal	Antibiotics required for bacterial overgrowth	Malabsorption syndrome; episodes of pseudoobstruction	Hyperalimentation required
Lung	DLco 80%+ FVC 80%+ No fibrosis on radiograph sPAP <35 mm Hg	DLco 70–79% FVC 70–79% Basilar rales; fibrosis on radiograph sPAP 35–49 mm Hg	DLco 50–69% FVC 50–69% sPAP 50–64 mm Hg	DLco <50% FVC <50% sPAP 65+ mm Hg	Oxygen required
Heart	ECG normal LVEF 50%+	ECG conduction defect LVEF 45–49%	ECG arrhythmia LVEF 40–44%	ECG arrhythmia requiring therapy LVEF 30–40%	CHF LVEF <30%
Kidney	No history of SRC with serum creatinine <1.3 mg/dL	History of SRC with serum creatinine <1.5 mg/dL	History of SRC with serum creatinine 1.5–2.4 mg/dL	History of SRC with serum creatinine 2.5–5.0 mg/dL	History of SRC with serum creatinine >5.0 mg/dL or dialysis required

\*If two items are included for a severity grade, only one is required for the patient to be scored as having disease of that severity level.

CHF, Congestive heart failure; DLco, diffusing capacity for carbon monoxide, % predicted; ECG, electrocardiogram; FTP, fingertip-to-palm distance in flexion; FVC, forced vital capacity, % predicted; Hb, hemoglobin; Hct, hematocrit; LVEF, left ventricular ejection fraction; RP, Raynaud phenomenon; sPAP, estimated pulmonary artery pressure by Doppler echo; SRC, scleroderma renal crisis; TSS, total skin score; Wt, weight.

Modified from Medsger TA Jr, Bombardieri S, Czirjak L, et al. Assessment of disease severity and prognosis, *Clin Exp Rheumatol*. 2003;21(3 Suppl 29):S51, Table 1, p. S-43.

## Raynaud Phenomenon

Raynaud phenomenon is the most frequent initial symptom in pediatric SSC, present in 70% of affected children months to years before other manifestations and seen in nearly all over the course of the disease. RP refers to the classic triphasic sequence of blanching, cyanosis, and erythema of the digits induced by cold exposure and/or emotional stress (see Fig. 201.5). RP is typically independent of an underlying rheumatic disease (Raynaud disease) but can result from rheumatic diseases such as scleroderma, systemic lupus erythematosus (SLE), and mixed connective tissue disease (Fig. 201.7). The color changes are brought about by (1) initial arterial vasoconstriction, resulting in hypoperfusion and pallor (blanching), (2) venous stasis (cyanosis), and (3) reflex vasodilation caused by the factors released from the ischemic phase (erythema). The color change is classically reproduced by immersing the hands in iced water and reversed by warming. During the blanching phase, there is inadequate tissue perfusion in the affected area, associated with pain and paresthesias and resulting in ischemic damage only when associated with a rheumatic disease. The blanching usually affects the distal fingers but may also involve thumbs, toes, ears, and tip of the nose. The affected area is usually well demarcated and uniformly white. *Digital ulcers* associated with RP are indicative of underlying rheumatic disease.

**Raynaud disease** often begins in adolescence and is characterized by symmetric occurrence, the absence of digital ulcers, tissue necrosis and gangrene, and the lack of manifestations of an underlying rheumatic disease. Children have normal nail fold capillaries (absence of periungual telangiectasias). RP should be distinguished from acrocyanosis and chilblains. **Acrocyanosis** is a vasospastic disorder resulting in cool, painless, bluish discoloration in the hands and feet despite normal tissue perfusion. It may be exacerbated by stimulant medications used to treat attention-deficit disorder. **Chilblains** is a condition with episodic color changes and the development of nodules related to severe cold exposure and spasm-induced

vessel and tissue damage; it has been associated with SLE and is also referred to as *lupus pernio*, but the majority of children with chilblains do not have lupus.

## DIAGNOSIS

The diagnosis of JLS is based on the distribution and depth of characteristic lesions. Biopsy is helpful to confirm the diagnosis. The diagnosis of JSSc requires proximal sclerosis/induration of the skin and the presence of 2 of 20 minor criteria (see Table 201.3).

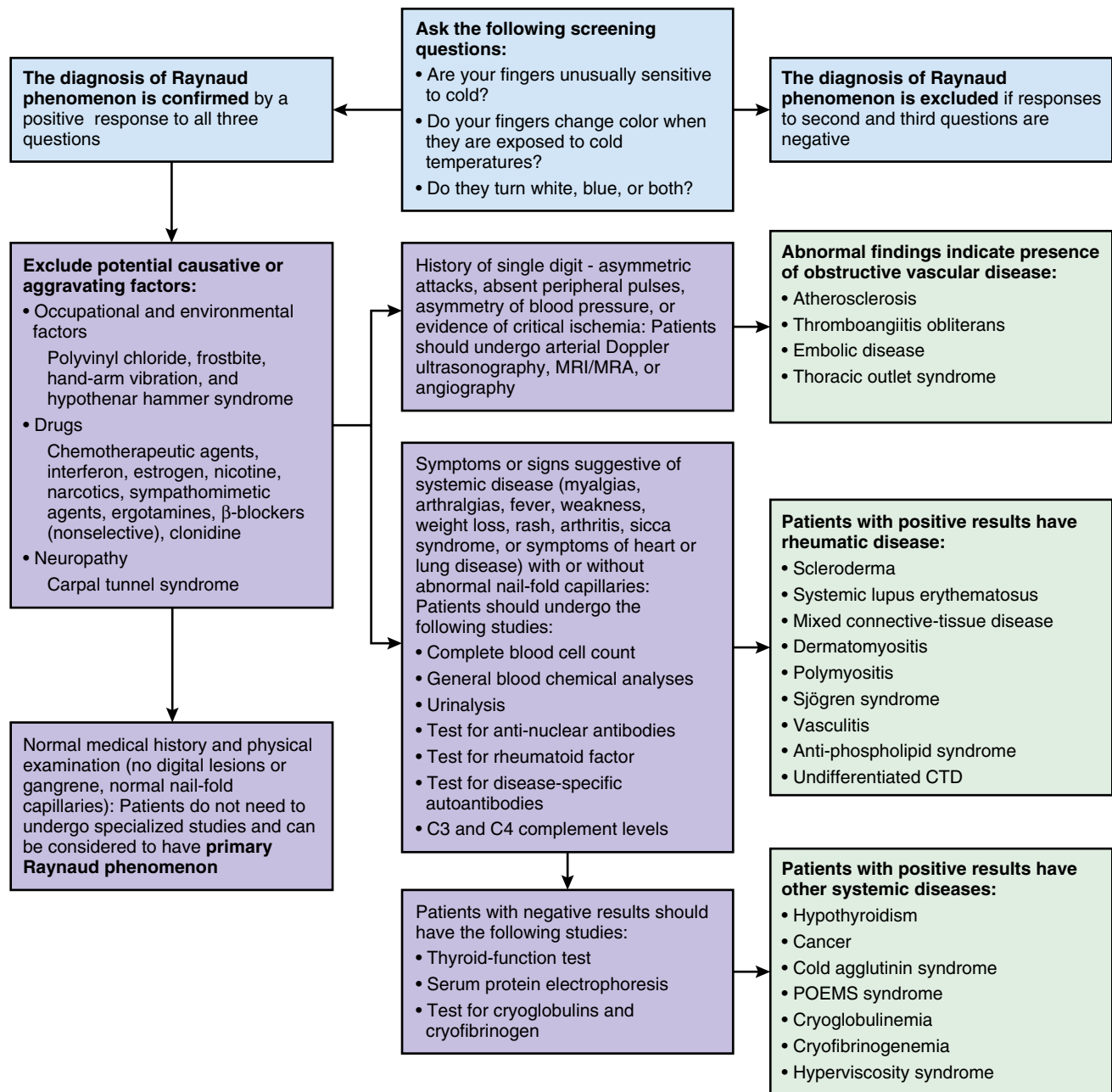
## DIFFERENTIAL DIAGNOSIS

The most important condition to differentiate from JLS is JSSc. Contractures and synovitis from juvenile arthritis can be differentiated from those caused by LS by the absence of skin changes. Other conditions to consider include chemically induced scleroderma-like disease, diabetic cheiroarthropathy, pseudoscleroderma, and scleredema. **Pseudoscleroderma** comprises a group of unrelated diseases characterized by patchy or diffuse cutaneous fibrosis without the other manifestations of scleroderma. These include phenylketonuria, syndromes of premature aging, and localized idiopathic fibrosis. **Scleredema** is a transient, self-limited disease of both children and adults that has sudden onset after a febrile illness (especially streptococcal infections) and is characterized by patchy sclerodermatous lesions on the neck and shoulders and extending to the face, trunk, and arms.

## Laboratory Findings

No laboratory studies are diagnostic of either localized or systemic scleroderma. Although the results of complete blood counts, serum chemistry analyses, and urinalysis are normal, children may have elevated erythrocyte sedimentation rate, eosinophilia, or hypergammaglobulinemia, all of which normalize with treatment. Elevations of muscle enzymes, particularly aldolase, can be seen with muscle





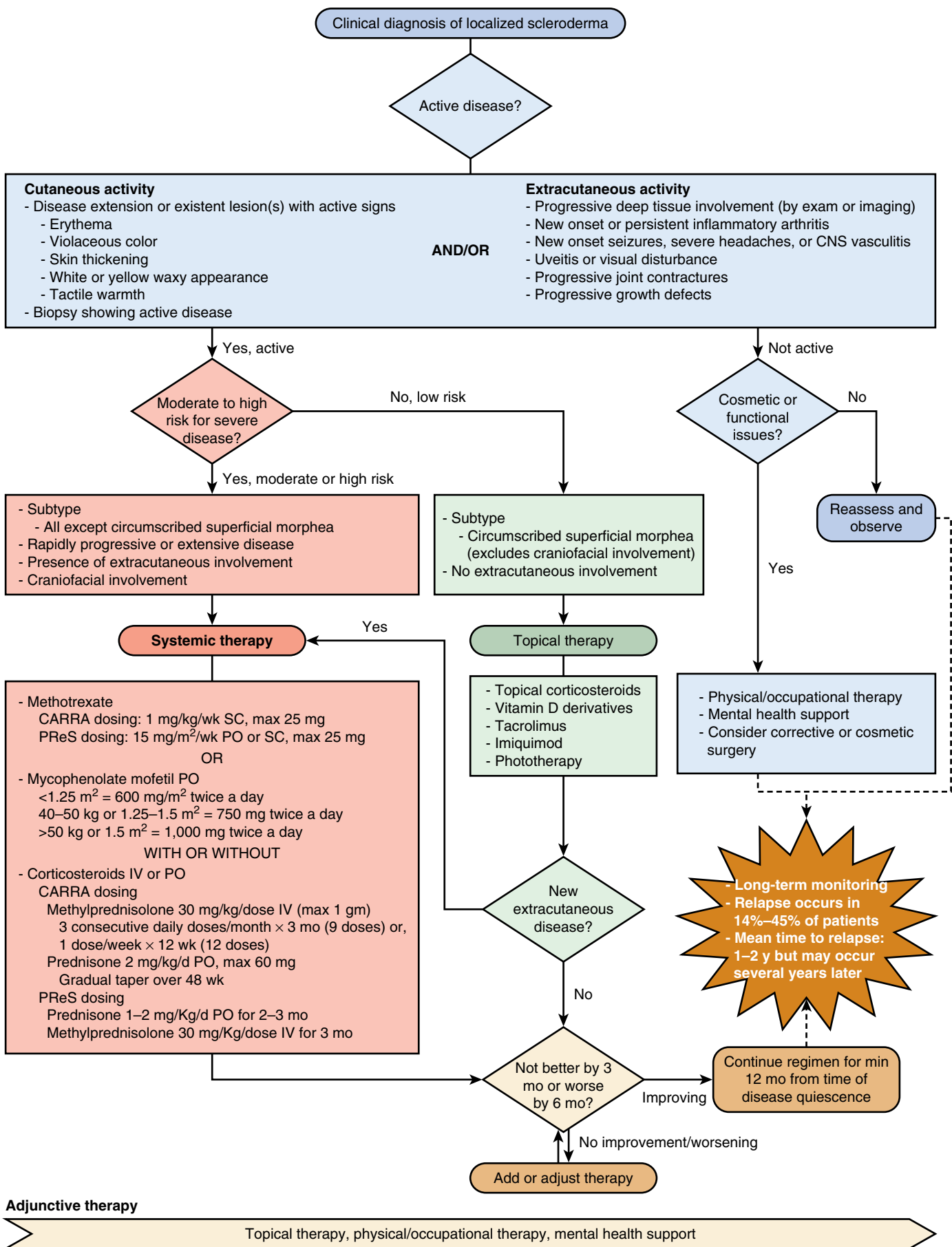
**Fig. 201.7** Diagnostic algorithm for Raynaud phenomenon. CTD, Connective tissue disease; MRA, magnetic resonance angiography; POEMS, polyneuropathy, organomegaly, endocrinopathy, monoclonal gammopathy, and skin changes. (From Firestein GS, Budd RC, Gabriel SE, et al., eds. Kelley & Firestein's Textbook of Rheumatology, 10th ed. Philadelphia: Elsevier; 2017: Fig 84-3.)

involvement. Patients with JSSc may have anemia, leukocytosis, and eosinophilia and autoantibodies (ANA, anti-Scl-70). Imaging studies delineate the affected area and can be used to follow disease progression. MRI is useful in en coup de sabre and Parry-Romberg syndrome (facial hemiatrophy) for determination of CNS or orbital involvement. Infrared thermography uses the temperature variation between areas of active and inactive cutaneous disease to help differentiate active disease from damage. The role of ultrasound to examine lesion activity is evolving. HRCT, PFTs, echocardiography, and manometry are useful tools for diagnosing and monitoring visceral involvement in JSSc.

## TREATMENT

Treatment for scleroderma varies according to the subtype and severity. **Superficial morphea may benefit from topical corticosteroids**

**or ultraviolet therapy.** For lesions involving deeper structures, systemic therapy is recommended. A combination of *methotrexate* and *corticosteroids* is effective in treating JLS by preventing lesion extension and resulting in significant skin softening and improved range of motion of affected joints. The Childhood Arthritis and Rheumatology Research Alliance (CARRA) consensus treatment plans for JLS include (1) weekly subcutaneous (SC) methotrexate at 1 mg/kg (maximum dose 25 mg); (2) weekly SC methotrexate (1 mg/kg; max 25 mg) plus either 3 months of high-dose intravenous (IV) corticosteroids (30 mg/kg; max 1,000 mg) for 3 consecutive days a month or weekly corticosteroids at the same dose for 3 months; or (3) high-dose daily oral corticosteroids (2 mg/kg/day, max 60 mg) with a slow taper over 48 weeks (Fig. 201.8). *Mycophenolate mofetil* (MMF) and abatacept have shown promise as second-line agents for recalcitrant



**Fig. 201.8** LS treatment recommendations. This algorithm outlines factors to consider when deciding upon treatment and CARRA- and PReS-recommended treatments. Careful and long-term monitoring for both cutaneous and extracutaneous activity is important. The algorithm is based upon the authors' experiences and not intended to serve as prescriptive instructions. CARRA, Childhood Arthritis and Rheumatology Research Alliance; IV, intravenous; max, maximum; min, minimum; PO, by mouth; PReS, Pediatric Rheumatology European Society; SC, subcutaneous. (From Vasquez-Canizares N, Li SC. Juvenile localized scleroderma – updates and differences from adult-onset disease. *Rheum Dis Clin N Am*. 2021;47:737–755, Fig. 5, p. 749.)

disease. Physical and occupational therapy are important adjuncts to pharmacologic treatment. Eosinophilic fasciitis often responds well to corticosteroids and methotrexate. Close follow-up is necessary in JLS given high rates of relapse—up to 40%.

Treatments for JSSc target specific disease manifestations (Tables 201.5 and 201.6). RP is treated with cold avoidance, and pharmacologic interventions are reserved for severe disease. Calcium channel blockers (nifedipine 30–60 mg sustained-release form daily; amlodipine 2.5–10 mg daily) are the most common pharmacologic interventions. Additional potential therapies for RP include losartan, prazosin, bosentan, and sildenafil. Angiotensin-converting enzyme (ACE) inhibitors (captopril, enalapril) are recommended for hypertension associated with renal disease. Methotrexate or MMF may be beneficial for skin manifestations. Cyclophosphamide and MMF are used to treat pulmonary alveolitis and prevent fibrosis. Corticosteroids should be used cautiously in SSc because of an association with renal crisis. Adults with SSc have been successfully treated with high-dose cyclophosphamide, antithymocyte globulin, and autologous stem cell transplantation. Systemic sclerosis–associated interstitial lung disease has been managed with nintedanib, a tyrosine kinase inhibitor, which has antiinflammatory and antifibrotic effects. Nintedanib combination therapy with MMF is also effective as an initiation therapy or when escalation of therapy is needed.

The treatment of RP begins with avoiding cold stimuli, using hand and foot warmers, and avoiding carrying bags by their handles (impairs circulation). Nifedipine (10–20 mg three times daily—adult

dose) reduces, but does not eliminate, the number and severity of episodes. Side effects include headache, flushing, and hypotension. Topical nitrates may result in digital vasodilation and may reduce the severity of an episode.

## PROGNOSIS

JLS is ultimately generally self-limited, with the initial inflammatory stage followed by a period of stabilization and then softening, for an average disease duration of 3–5 years, although there are reports of active disease lasting up to 20 years. Prolonged disease activity is associated primarily with linear and deep disease subtypes. JLS, especially linear and deep subtypes, can result in significant morbidity, disfigurement, and disability as a result of joint contractures, muscle atrophy, limb shortening, facial asymmetry, and hyperpigmentation and hypopigmentation. Death from an en coup de sabre lesion with progressive neurologic decline has been reported.

JSSc has a more variable prognosis. Although many children have a slow, insidious course, others demonstrate a rapidly progressive form with early organ failure and death. Skin manifestations reportedly soften years after disease onset. Overall, the prognosis of JSSc is better than that of the adult form, with 5-, 10-, and 15-year survival rates, respectively, in children of 89%, 80–87%, and 74–87%. The most common cause of death is heart failure caused by myocardial and pulmonary fibrosis.

Visit Elsevier eBooks+ at [eBooks.Health.Elsevier.com](http://eBooks.Health.Elsevier.com) for Bibliography.

**Table 201.5** Organ-Specific Treatment of Systemic Sclerosis

MANIFESTATION	FIRST-LINE	SECOND-LINE	VERY SEVERE
Raynaud phenomenon	Calcium channel blockers*	PDE-5 inhibitors† Fluoxetine Angiotensin II receptor antagonists‡ Topical nitrates§	Prostacyclins (iloprost)¶ Sympathectomy Botulism toxin Fat grafting
Digital ulcers	PDE-5 inhibitors†	Endothelin receptor antagonists#	Prostacyclins (iloprost)
Pulmonary hypertension	PDE-5 inhibitors† Endothelin receptor antagonists	Prostacyclins (epoprostenol)¶ Riociguat	
Interstitial lung disease	Cyclophosphamide Mycophenolate mofetil Corticosteroids	Rituximab	Hematopoietic stem cell transplantation
Skin	Methotrexate Mycophenolate mofetil Corticosteroids (low dose)	Abatacept Immune globulin	Cyclophosphamide Rituximab
Renal crisis	ACE inhibitors**		
Musculoskeletal	NSAIDs Hydroxychloroquine Methotrexate Corticosteroids (low dose)	Rituximab Abatacept Tocilizumab	

\*Calcium channel blockers (nifedipine, amlodipine).

†PDE-5 inhibitors (sildenafil, tadalafil).

‡Angiotensin receptor antagonists (losartan).

§Topical nitrates (glyceryl trinitrate).

¶Prostacyclins (iloprost, epoprostenol).

#Endothelin receptor antagonist (bosentan, ambrisentan, macitentan).

\*\*ACE inhibitors (captopril, enalapril).

ACE, Angiotensin converting enzyme; NSAIDs, nonsteroidal antiinflammatory drugs; PDE-5, phosphodiesterase-5.

From Petty RE, Laxer RM, Lindsley CB, et al., eds. *Textbook of Pediatric Rheumatology*, 8th ed. Philadelphia: Elsevier; 2021: Table 27.8, p. 395.

**Table 201.6** Treatment of Gastrointestinal Manifestations of Juvenile SSc

ORGAN	MANIFESTATION	TREATMENT
Oral	Buccal, lingual fibrosis Tooth decay Mandibular resorption Gingival recession Dysphagia	Dental hygiene Fluoride treatments every 3 months Dental sealant Soft foods, small portions, adequate fluids Gingival mucosa grafting Dietary restriction (low sugar, soft foods)
Esophageal	Dysmotility Reflux Constriction	Metoclopramide, erythromycin Weight loss; small, frequent meals; avoid eating 3 hr before bed; raise head of bed 6 inches Avoid tight clothes, heavy lifting, bending Proton pump inhibitors, H <sub>2</sub> blockers Dilatation
Stomach	GAVE (watermelon stomach) Fructose intolerance	Metoclopramide Erythromycin* Octreotide
Small intestines	Bacterial overgrowth Bezoars Malabsorption leading to malnutrition Pseudoobstruction	FODMAP diet Vitamin supplementation Low-residue, elemental diet Metoclopramide Antibiotics Octreotide
Colon	Fibrosis of lymphatics Ischemia	Erythromycin Metamucil High-fiber diet
Anorectal	Internal anal sphincter atrophy	Biofeedback Pelvic floor exercises Sacral nerve stimulation

\*Side effects of erythromycin can be avoided by using low doses (rather than antibiotic-level doses).

FODMAP, Fermentable oligosaccharides, disaccharides, monosaccharides, and polyol; GAVE, gastric antrum vascular ectasia; SSc, systemic sclerosis. From Petty RE, Laxer RM, Lindsley CB, et al., eds. *Textbook of Pediatric Rheumatology*, 8th ed. Philadelphia: Elsevier; 2021: Table 27.9, p. 398.

## Chapter 202

# Behçet Disease

Seza Ozen

Behçet disease (BD) is classified as a primary *multisystem variable vessel vasculitis* because of the involvement of any size and type (arterial, venous) of blood vessel. BD is probably underdiagnosed in children as a result of the heterogeneity in clinical features, the large spectrum of differential diseases, and lack of specific tests. Originally described with recurrent oral ulcerations, uveitis, and skin abnormalities, the BD spectrum is much broader.

### EPIDEMIOLOGY

BD has a high prevalence in countries along the *Silk Road*, extending from Japan to the Eastern Mediterranean. It is increasingly recognized among people of European ancestry as well. BD has a prevalence of 5-7 per 100,000 adults. The increased disease recognition might have had a role in the rising prevalence of BD as well as the migrations of the 20th century. Prevalence in children is probably not more than 10% of the adult counterparts in Eastern

Mediterranean countries; boys and girls are equally affected. A family history of BD is present in approximately 20% of the cases. Onset in children is usually 8-12 years of age. Newborns of affected mothers have demonstrated symptoms of BD.

### ETIOLOGY AND PATHOGENESIS

The etiology of BD is unknown. It is a polygenic disorder with autoinflammatory features. The autoinflammatory nature of BD is suggested by its episodic nature, the prominent innate immune system activation, the absence of identifiable autoantibodies, and the co-association with the *MEFV* gene. However, there is evidence supporting the role of the adaptive immune system as well. BD has also been considered to be an MHC-I-opathy because of the strong association with HLA-B51. Genetic contribution to BD is evident through this well-known association with HLA-B5101, the familial cases, the sibling and twin recurrence rate, the specific frequency of the disease among people along the Silk Road, evidence for genetic anticipation, and genome-wide analysis. Genome-wide analysis studies among Turkish and Japanese BD patients confirm the marked association with HLA-B5101. Other significant associations include interleukin (IL)-10 and IL-23R/IL-12R $\beta_2$  genes. Other possible susceptibility loci demonstrate associations with *STAT4* (a transcription factor in a signaling pathway related to cytokines such as IL-12, type I interferons, and IL-23) and *ERAP1* (an endoplasmic reticulum-expressed



aminopeptidase that functions in the processing of peptides onto major histocompatibility complex class I).

An infectious agent may be responsible for inducing the aberrant innate immune system attacks in the genetically predisposed host. A number of infectious agents have been implicated and include streptococci and herpes simplex virus type 1. A microbiome study in BD proposed a distinct salivary signature.

BD has some genetic and immune similarities to periodic fever, aphthous stomatitis, pharyngitis, cervical adenitis (PFAPA) syndrome and recurrent aphthous stomatitis, suggesting a spectrum of these disorders.

## CLINICAL MANIFESTATIONS AND DIAGNOSIS

The course of BD is characterized by exacerbations and remissions. There is marked heterogeneity in disease manifestations.

The mean age of the first symptom is between 8 and 12 years. The most frequent initial symptom is a *painful oral ulcer* (Fig. 202.1). The oral ulcers are often recurrent, may be single or multiple, range from 2 to 10 mm, and may be in any location in the oral cavity. They are often very painful. The oral ulcers last 3-10 days and heal without scarring. In contrast, the genital ulcers heal with scars. Genital scars are noted in 60–85% of the patient, usually occur after puberty, and are seen on the labia, scrotum, penis, or anal area.

Another key feature of BD that has significant morbidity is the bilateral eye involvement seen in 30–60% of pediatric patients. The main symptoms of **anterior uveitis** are blurred vision, redness, periorbital or global pain, and photophobia. Although it is often in the form of panuveitis, anterior uveitis may be seen in females. Uveitis in general is more common in males. Vitritis and retinal vasculitis are the most prominent features of *posterior* involvement. Complications of uveitis include blindness (unusual with treatment), glaucoma, and cataracts. Retinal vasculitis, retinal detachment, and retrobulbar neuritis (optic neuritis) are less common eye manifestations of BD.

The skin lesions are the third most common symptom of BD. They range from erythema nodosum (seen in approximately 50% of patients) to papulopustular acneiform lesions (85%), folliculitis, purpura, and ulcers. Pathergy (seen in 50%) is another skin feature associated with BD and is a pustular reaction occurring 24-48 hours after a sterile needle puncture or saline injection; it is not pathognomonic of BD.

The vasculitis of BD involves both arteries and veins, thrombosis and aneurysm formation, occlusions, or stenosis in arteries of any size. In children, deep venous thrombosis of the lower limbs is the most frequent vasculitic feature. If the hepatic vein is thrombosed, Budd-Chiari syndrome may occur. Pulmonary artery aneurysms

are the most severe feature of pediatric BD, associated with the highest mortality. Coronary artery aneurysms may confuse BD with Kawasaki or multisystem inflammatory syndrome in children (MIS-C) disease. Microvascular involvement may be noted in the nail bed capillaries.

Central nervous system (CNS) manifestations (approximately 10%) in children include meningoencephalitis (headache, meningismus, cerebrospinal fluid pleocytosis), encephalomyelitis, pseudotumor cerebri, dural sinus thrombosis, and organic psychiatric disorders (psychosis, depression, dementia). Dural sinus thrombosis is the most common CNS manifestation in children.

Gastrointestinal (GI) involvement (seen in 10–30%) manifests with abdominal pain, diarrhea, and intestinal ulcerations, most often in the ileocecal region. Gastrointestinal BD may be difficult to distinguish from inflammatory bowel disease. Oligoarticular arthritis/arthralgia is present in >50% of patients and can be recurrent, but is nondeforming. Other rare manifestations include orchitis, renal vasculitis, glomerulonephritis, or amyloidosis and cardiac involvement.

The International Study Group for Behçet Disease (ISG) criteria used to be the most widely used and require the presence of oral ulcers (at least 3 times per year) along with two other major features, including genital ulcers, a positive pathergy test, uveitis, and the characteristic skin lesions. If only one of the criteria is present along with oral ulcerations, the term *incomplete* or *partial Behçet disease* is applied. The revised International Criteria for Behçet Disease (ICBD) have been reported to have a much better performance than the 1990 ISG criteria.

Additional classification criteria for children have been suggested by the use of an international prospective observational cohort. According to these criteria, BD is diagnosed when three of the following criteria are present: recurrent oral aphthosis, genital ulcers, skin involvement (necrotic folliculitis, acneiform lesions, erythema nodosum), ocular involvement, neurologic involvement, and vascular involvement (venous thrombosis, arterial thrombosis, arterial aneurysm). These criteria performed better than the ISG criteria in the pediatric cohort (Table 202.1).

There are no specific laboratory tests. Acute-phase reactants are often mildly elevated. The diagnosis relies on the constellation of symptoms and excluding other causes.

**Hughes-Stovin syndrome** is characterized by thrombophlebitis and multiple bronchial or pulmonary artery aneurysms. This vasculitic



Fig. 202.1 A deep aphthous ulcer in a patient with Behçet disease.

Table 202.1 Consensus Classification of Pediatric Behçet Disease

ITEM	DESCRIPTION
Recurrent oral aphthosis	At least three attacks/year
Genital ulceration or aphthosis	Typically with scar
Skin involvement	Necrotic folliculitis, acneiform lesions, erythema nodosum
Ocular involvement	Anterior uveitis, posterior uveitis, retinal vasculitis
Neurologic signs	With the exception of isolated headaches
Vascular signs	Venous thrombosis, arterial thrombosis, arterial aneurysm

From Koné-Paut I, Shahram F, Darce-Bello M, et al, for PEDBD group. Consensus classification criteria for paediatric Behçet's disease from a prospective observational cohort: PEDBD. *Ann Rheum Dis*. 2016;75:958–964.

process is regarded as a clinical variant of BD (partial or incomplete) but without ulcerations.

### TREATMENT AND PROGNOSIS

**Azathioprine** is highly recommended to treat inflammatory eye disease. Anti-tumor necrosis factor (TNF) treatment and interferon (IFN)- $\alpha$  should be considered for refractory eye disease. For oral and genital ulcers, topical treatment and colchicine are recommended (sucralfate, corticosteroids). **Apremilast**, an oral phosphodiesterase-4 inhibitor, is effective in treating the oral ulcers of BD. In patients without major organ involvement, colchicine significantly improves oral and genital ulcers, skin features, and disease activity. There is no evidence-based treatment for GI disease, but 5-ASA derivatives, corticosteroids, azathioprine, and anti-TNF agents have been recommended. For CNS disease and venous thrombosis, corticosteroids, azathioprine, and anti-TNF agents are recommended. Patients treated with anti-TNF drugs have had persistent responses in 90%, 89%, 100%, and 91% of patients with resistant mucocutaneous, ocular, GI, and CNS involvement, respectively. There is no consensus about the benefit of anticoagulation in the management of vein thrombosis in BD.

In patients with pulmonary arterial or cardiac involvement, cyclophosphamide is typically used initially.

Mortality in children with BD is low except for the pulmonary aneurysms. However, BD is a chronic disease associated with significant morbidity. Early diagnosis and effective treatment improve the outcome of BD.

Visit Elsevier eBooks+ at [eBooks.Health.Elsevier.com](http://eBooks.Health.Elsevier.com) for Bibliography.

disease, which usually precedes the associated autoimmune disease by years.

### ETIOLOGY AND PATHOGENESIS

The etiology of Sjögren syndrome is complex and includes genetic predisposition and possibly an infectious trigger. Lymphocytes and plasma cells infiltrate salivary glands, forming distinct periductal and periacinar foci that become confluent and may replace epithelial structure. Several genes regulating apoptosis influence the chronicity of lymphocytic infiltration.

### CLINICAL MANIFESTATIONS

International classification criteria have been developed for the diagnosis of Sjögren syndrome in adult patients, but these criteria apply poorly to children. Although diagnostic criteria in children have been proposed, they have not been validated (Table 203.1). Recurrent parotid gland enlargement and parotitis are the most common manifestations in children (>70%), whereas **sicca syndrome** (dry mouth, painful mucosa, halitosis, widespread dental caries) predominates in adults. Children tend to have a higher prevalence of systemic symptoms, including fevers and adenopathy, compared to adults. In a cross-sectional study of children with Sjögren syndrome, manifestations included recurrent parotitis (72%), sicca symptoms (38%), polyarthritis (18%), vulvovaginitis (12%), hepatitis (10%), Raynaud phenomenon (10%), fever (8%), renal tubular acidosis (9%), lymphadenopathy (8%), and central nervous system (CNS) involvement (5%).

**Table 203.1** Proposed Pediatric Criteria for Diagnosis of Sjögren Syndrome (SS)

JUVENILE SS	
<b>CLINICAL SYMPTOMS</b>	
<ol style="list-style-type: none"> <li>1. Recurrent parotitis or parotid enlargement</li> <li>2. Recurrent conjunctivitis (nonallergic and noninfectious)</li> <li>3. Recurrent vaginitis</li> <li>4. Systemic: fever of unknown origin, arthralgias, hypokalemic paralysis, or abdominal pain</li> </ol>	
<b>OBJECTIVE</b>	
<ol style="list-style-type: none"> <li>5. Ocular dryness (ocular staining or a Schirmer test)</li> <li>6. Abnormal sialography</li> <li>7. Elevated serum amylase</li> <li>8. Leukopenia or elevated ESR</li> <li>9. Hyperimmunoglobulinemia (polyclonal)</li> <li>10. Renal tubular acidosis</li> </ol>	
<b>SEROLOGY</b>	
<ol style="list-style-type: none"> <li>11. At least one of anti-SSA, anti-SSB, high titer ANA (speckled pattern), RF</li> </ol>	
<b>HISTOPATHOLOGY</b>	
<ol style="list-style-type: none"> <li>12. Lymphocytic infiltration of salivary glands or other organs</li> </ol>	
<b>DIAGNOSIS OR CLASSIFICATION REQUIREMENTS</b>	
<ol style="list-style-type: none"> <li>13. Diagnosis requires at least 4 of 12 items</li> </ol>	

Modified from Yokogawa N, Lieberman SM, Sherry DD, Vivino FB. Features of childhood Sjögren's syndrome in comparison to adult Sjögren's syndrome: considerations in establishing child-specific diagnostic criteria. *Clin Exper Rheumatol*. 2016;34:343–351, Table 1.

## Chapter 203

# Sjögren Syndrome

C. Egla Rabinovich

Sjögren syndrome is a chronic, inflammatory autoimmune disease characterized by progressive lymphocytic and plasma cell infiltration of the exocrine glands, especially salivary and lacrimal (parotid being prototypical), with potential for systemic manifestations. It is rare in children and has classic symptoms of dry eyes (**keratoconjunctivitis sicca**) and dry mouth (**xerostomia**).

### EPIDEMIOLOGY

Sjögren syndrome typically manifests at 35–45 years of age, with 90% of cases among females, but it is underrecognized in children because symptoms often start in childhood. The mean age at diagnosis in children is 9–10 years; 75% are female. The disease can occur as an isolated disorder, referred to as **primary** Sjögren syndrome (**sicca complex**), or as a **secondary** Sjögren syndrome in association with other rheumatic disorders, such as systemic lupus erythematosus (SLE), scleroderma, or mixed connective tissue

Subjective symptoms of xerostomia complaints are relatively rare in juvenile cases, perhaps indicating that Sjögren syndrome is a slowly progressive disease; however, increased dental caries is seen clinically in children. Serologic markers (antinuclear antibodies [ANAs], antibodies to Ro [SSA] and La [SSB]) and articular manifestations are significantly more common in adults. Reported frequencies of ANAs and SSA and SSB antibodies in children are 78%, 75%, and 65%, respectively, with rheumatoid factor present in 67%. Additional clinical manifestations from a variety of organ involvement patterns include a decreased sense of smell; hoarseness; chronic otitis media; leukocytoclastic vasculitis (purpura); and internal organ exocrine disease involving the lungs (diffuse interstitial lymphocytosis), pancreas, hepatobiliary system, gastrointestinal tract, kidneys (renal tubular acidosis), musculoskeletal (arthritis and arthralgia), hematologic (cytopenias), peripheral nervous system (sensory and autonomic neuropathy), and CNS (optic neuritis, transverse myelitis, meningoencephalitis).

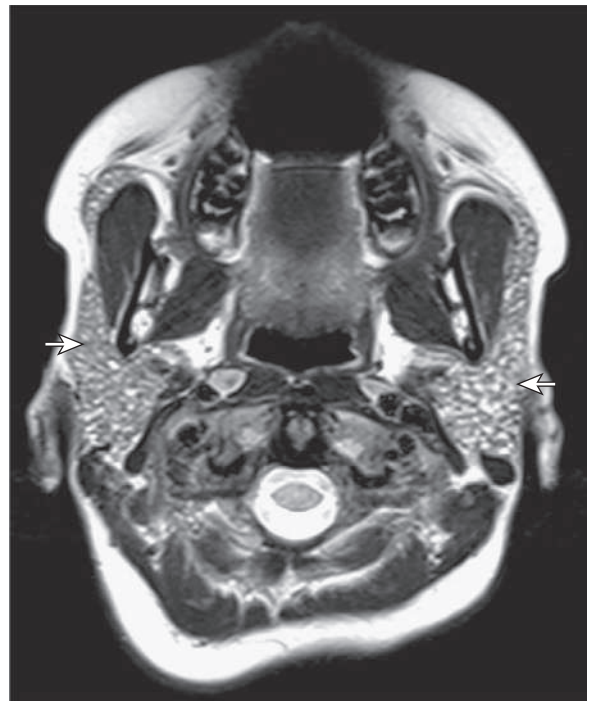
Nonexocrine disease manifestations of Sjögren syndrome may be related to inflammatory vascular disease (skin, muscle and joints, serosal surfaces, CNS, peripheral nervous system), noninflammatory vascular disease (Raynaud phenomenon), mediator-induced disease (hematologic cytopenias, fatigue, fever), and autoimmune endocrinopathy (thyroiditis).

## DIAGNOSIS

Clinical presentation of recurrent **parotitis** and/or recurrent parotid gland swelling in a child or adolescent is characteristic and should raise the suspicion for Sjögren syndrome. The diagnosis is based on clinical features supported by biopsy of salivary or parotid glands demonstrating foci of lymphocytic infiltration, the current gold standard for diagnosis. Children are more likely to have normal minor salivary gland but abnormal parotid gland biopsies. Supporting laboratory abnormalities include cryoglobulinemia, elevated erythrocyte sedimentation rate, hypergammaglobulinemia, positive rheumatoid factor, and presence of SSA and SSB antibodies. The Schirmer test detects abnormal tear production ( $\leq 5$  mm of wetting of a filter paper strip in 5 minutes). Special dyes (e.g., fluorescein, Lissamine green) detects damaged ocular epithelial conjunctival and corneal cells. Imaging studies, including MRI, technetium ( $^{99m}\text{Tc}$ ) scintigraphy, parotid ultrasound, and sialography, are useful in the diagnostic evaluation for Sjögren syndrome (Fig. 203.1).

## DIFFERENTIAL DIAGNOSIS

The differential diagnosis of Sjögren syndrome in children includes **juvenile recurrent parotitis**, characterized by intermittent *unilateral* parotid swelling typically lasting only a few days; it is frequently associated with fever and may undergo remission with puberty. Unlike in Sjögren syndrome, there is a male predominance, juvenile recurrent parotitis is seen in the younger children (3-6 years), and there is a lack of focal lymphocytic infiltrates on biopsy. Other conditions in the differential diagnosis include eating disorders, infectious parotitis (mumps, streptococcal and staphylococcal infections, Epstein-Barr virus, cytomegalovirus, HIV, parainfluenza, influenza enterovirus), and local trauma to the buccal mucosa. Rarely, polycystic parotid disease, tumors, and sarcoidosis may present with recurrent parotid swelling.



**Fig. 203.1** T2-weighted MRI of a child with Sjögren syndrome showing parotitis (arrows).

In these conditions, sicca complex, rash, arthralgia, and ANAs are usually absent.

## TREATMENT

Symptomatic treatment of Sjögren syndrome includes the use of artificial tears, massage of the parotids, oral lozenges, and fluids to limit the damaging effects of decreased secretions. Corticosteroids, nonsteroidal antiinflammatory drugs, and hydroxychloroquine are among the more commonly used agents for treatment, with reports of methotrexate and etanercept used for treatment of arthritis. Stronger immunosuppressive agents, such as cyclosporine and cyclophosphamide, are reserved for severe manifestations (e.g., lung involvement) and life-threatening complications.

## COMPLICATIONS AND PROGNOSIS

The symptoms of Sjögren syndrome develop and progress slowly. Diminished salivary flow typically remains constant for years. Because monoclonal B-lymphocyte disease originates chiefly from lymphocytic foci within salivary glands or from parenchymal internal organs, there is increased risk for mucosa-associated lymphoid tissue lymphoma. Maternal Sjögren syndrome can be an antecedent to neonatal lupus syndrome (see Chapter 199.1).

Visit Elsevier eBooks+ at [eBooks.Health.Elsevier.com](http://eBooks.Health.Elsevier.com) for Bibliography.

## Chapter 205

## Interferonopathies

Sara E. Sabbagh and James W. Verbsky

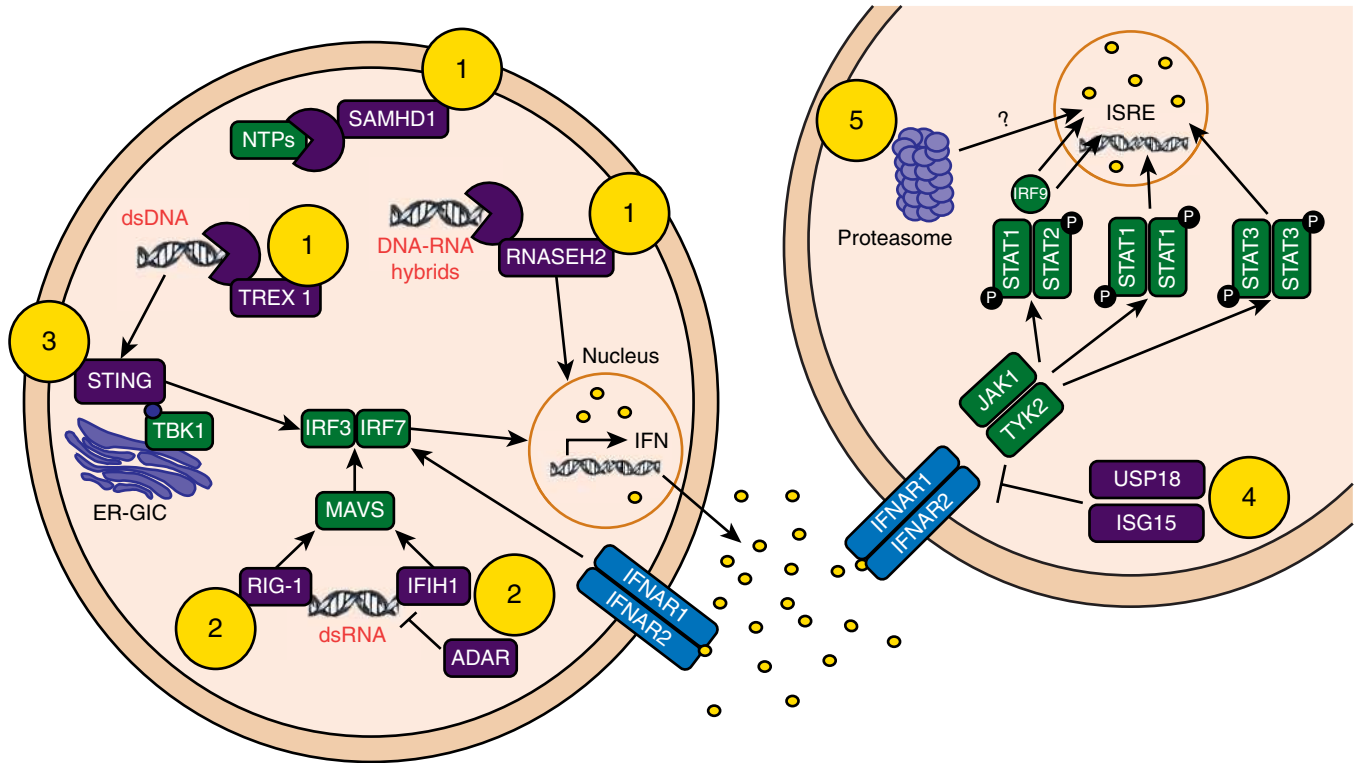
Type I interferonopathies refer to a group of inherited autoinflammatory disorders that are characterized by dysregulation of the type I interferon (IFN) pathway (Table 205.1). Type I interferonopathies were recognized when a report described the phenotypic overlap between Aicardi-Goutières syndrome (AGS) encephalopathy, congenital viral infections, and monogenic systemic lupus erythematosus (SLE). The clinical similarities of these diseases stimulated the theory of a shared pathologic mechanism. Pathogenic variants involved in type I IFN signaling were identified to be causative for AGS and monogenic forms of SLE. Several other novel monogenic disorders with aberrant IFN signaling have been identified.

Type I IFNs are ubiquitously expressed inflammatory polypeptides that are induced by microbial and viral nucleic acids. During viral replication, accumulation of viral nucleic acids is sensed by several different cellular mechanisms, which leads to downstream IFN production (Fig. 205.1). Type I IFNs are released from the cell and bind to IFN receptors (IFNRs) through autocrine and paracrine action. The IFNR then activates signal translation through Janus kinase/signal transducers and activators of transcription (JAK-STAT) pathways, which promotes the expression of IFN-simulated genes (ISGs), which stops cell replication and protein translation of the infected cell. There are several molecular mechanisms that lead to altered regulation of IFN signaling: (1) loss-of-function variants of genes that encode enzymes responsible for DNA or DNA-RNA hybrid molecule degradation; (2) variants that lead to constitutive activation or reduction of the activation threshold of intracytosolic nucleic acid sensors; (3) gain-of-function variants of positive IFN signaling regulators; (4) loss-of-function variants of negative IFN signaling regulators; and (5) proteasomal dysfunction leading to the unfolded protein response and downstream IFN pathway activation. Examples of these altered molecular mechanisms and the associated

**Table 205.1** Mutated Gene, Protein Function, Pattern of Inheritance, and Main Symptoms of Known Type 1 Interferonopathies

DISEASE	GENE	PROTEIN FUNCTION	INHERITANCE	SYMPTOMS
Aicardi-Goutières syndrome (AGS) type 1	<i>TREX-1</i>	3'-5' DNA exonuclease	AR and AD	Classical AGS
AGS2	<i>RNASEH2B</i>	Components of RNase H2 complex. Removes ribonucleotides from RNA-DNA hybrids	AR	Classical AGS
AGS3	<i>RNASEH2C</i>			Classical AGS
AGS4	<i>RNASEH2A</i>			Classical AGS with dysmorphic features
AGS5	<i>SAMHD1</i>	Restricts the availability of cytosolic deoxynucleotides	AR	Mild AGS, mouth ulcer, deforming arthropathy, cerebral vasculopathy with early-onset stroke
AGS6	<i>ADAR</i>	Deaminates adenosine to inosine in endogenous dsRNA, preventing recognition by MDA5 receptor	AR and AD	Classical AGS, bilateral striatal necrosis
AGS7	<i>IFIH1</i>	Cytosolic receptor for dsRNA	AD	Classic or mild AGS, asymptomatic
Retinal vasculopathy with cerebral leukodystrophy (RVCL)	<i>TREX-1</i>	3'-5' DNA exonuclease	AD	Adult-onset loss of vision, stroke, motor impairment, cognitive decline, Raynaud, and liver involvement
Spondyloenchondrodysplasia (SPENCD)	<i>ACP5</i>	Lysosomal phosphatase activity	AR	Spondyloenchondrodysplasia, immune dysregulation, and in some cases combined immunodeficiency
STING-associated vasculopathy with onset in infancy (SAVI)	<i>TMEM173</i>	Transduction of cytoplasmic DNA-induced signal	AD	Systemic inflammation, cutaneous vasculopathy, pulmonary inflammation
Proteasome-associated autoinflammatory syndrome (PRAAS)	<i>PSMB8</i>	Part of the proteasome complex	AR	Autoinflammation, lipodystrophy, dermatosis, hyperimmunoglobulinemia, joint contractures, short stature
ISG15 deficiency	<i>ISG15</i>	Stabilizes USP18, a negative regulator of type 1 interferon	AR	Brain calcifications, seizures, mycobacterial susceptibility
Singleton-Merten syndrome (SMS)	<i>IFIH1</i>	Cytosolic receptor for dsRNA	AD	Dental dysplasia, aortic calcifications, skeletal abnormalities, glaucoma, psoriasis
Atypical SMS	<i>DDX58</i>	Cytosolic receptor for dsRNA	AD	Aortic calcifications, skeletal abnormalities, glaucoma, psoriasis
Trichohepatoenteric syndrome (THES)	<i>SKIV2L</i>	RNA helicase	AR	Severe intractable diarrhea, hair abnormalities (trichorrhexis nodosa), facial dysmorphism, immunodeficiency in most cases





**Fig. 205.1** Schematic representation of various pathways affected in genetic interferonopathies. Purple rectangles indicate variant proteins in type I interferonopathies. Numbered yellow circles indicate the common mechanistic defect. 1. Loss-of-function pathogenic variants of genes that encode enzymes responsible for DNA or DNA-RNA hybrid molecule degradation. 2. Pathogenic variants that lead to constitutive activation or reduction of activation threshold of intracytosolic nucleic acid sensors. 3. Gain-of-function pathogenic variants of positive IFN signaling regulators; 4. Loss-of-function pathogenic variants of negative IFN signaling regulators; and 5. Proteasomal dysfunctional leading to the unfolded protein response and downstream IFN pathway activation. STING: stimulator of interferon genes; SAMHD1: SAM domain and HD domain deoxynucleoside triphosphate triphosphohydrolase 1; NTPs: nucleoside triphosphates; TREX1: DNA 3' repair exonuclease 1; ISG15: interferon-stimulated gene 15; MAVS: mitochondrial antiviral-signaling protein; RIG-I: retinoic acid-inducible gene I; TBK1: TANK-binding kinase 1; USP18: ubiquitin-specific peptidase 18; RNASEH2, ribonuclease H domain 2; IFIH1: IFN-induced helicase C domain-containing protein 1; ADAR: RNA adenosine deaminase; IRF3: interferon regulatory factor 3; IRF7: interferon regulatory factor 7; IRF9: interferon regulatory factor 9; ERGIC: endothelial reticulum–Golgi intermediate compartment; IFNAR: interferon- $\alpha$  receptor; ISGF3: the transcriptional activator induced by interferon- $\alpha$ ; ISRE: interferon-sensitive response element; JAK1: Janus kinase 1; TYK2: tyrosine kinase 2; STAT: signal transducer and activator of transcription. P indicates phosphorylation.

genetic variants are depicted in [Figure 205.1](#). Each genetic variant that leads to dysregulation of IFN signaling is causative of a unique clinical syndrome or subtype of a clinical syndrome that has been classified as a type I interferonopathy. Despite some disease heterogeneity, interferonopathies have a characteristic clinical phenotype, which may include recurrent fevers, early onset of skin vasculopathy with chilblains, livedo reticularis, panniculitis, lipodystrophy, interstitial lung disease with fibrosis, and encephalopathic CNS involvement ([Fig. 205.2](#) and [Table 205.2](#)).

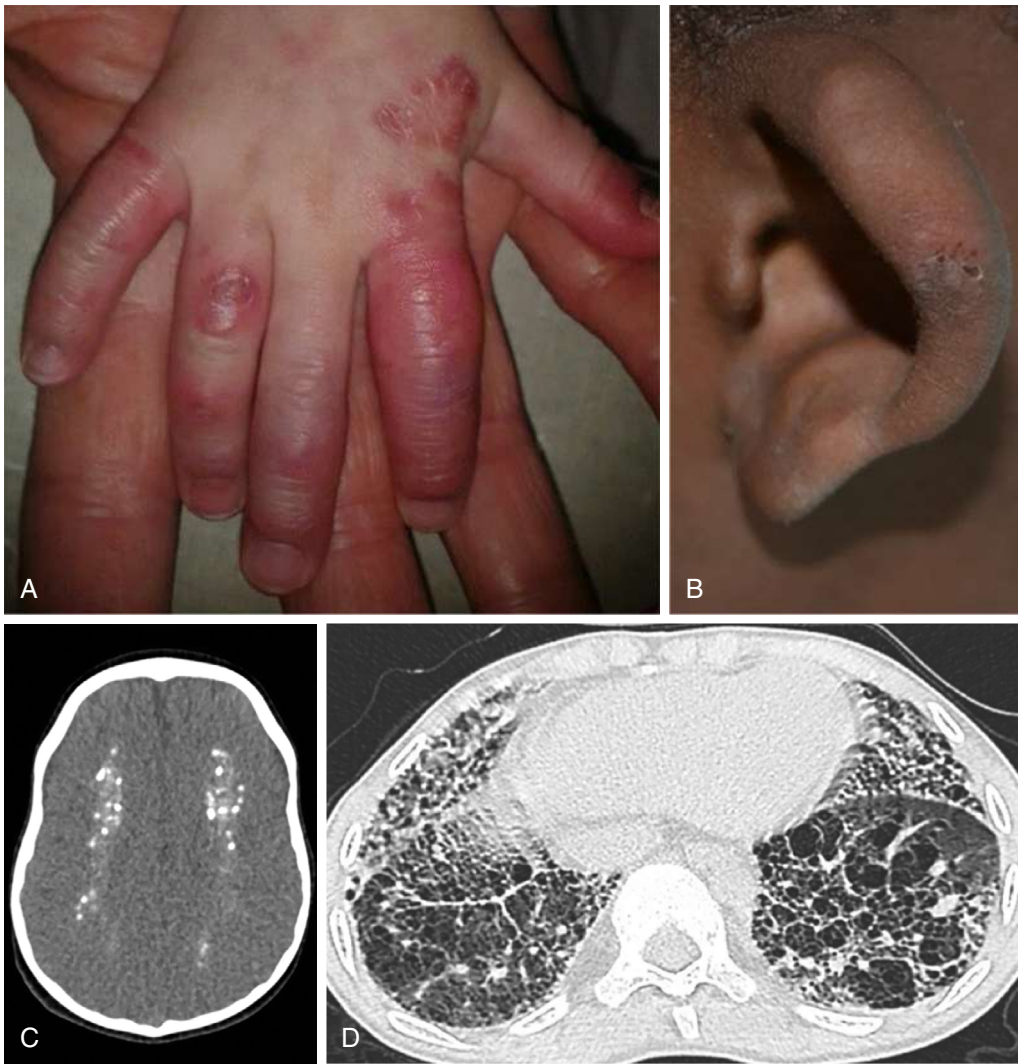
## AUTOINFLAMMATORY INTERFERONOPATHIES

### Aicardi-Goutières Syndrome

AGS is a clinically heterogeneous disease with a spectrum of associated phenotypes. AGS is characterized by an early-onset progressive encephalopathy with basal ganglia calcifications, leukoencephalopathy, and cerebral atrophy with elevated type I IFN cerebrospinal fluid (CSF) levels and CSF pleocytosis. Cutaneous features, seen in about 30% of patients, include chilblains, or cold-induced acral dermatosis of the digits and auricles secondary to peripheral inflammatory vasculopathy. Other common manifestations include thrombocytopenia, hepatosplenomegaly, transaminitis, psoriasis, interstitial lung disease, and intermittent fever. Most frequently, AGS has an infantile onset in which patients develop abrupt irritability, sterile pyrexias, and developmental regression within the

first few months of life. Neurologic symptoms may include limb hypertonia with truncal hypotonia, dystonia, excessive startle, abnormal eye movements, epileptic seizures, and slowing of head growth. *RNASEH2B* variants are commonly seen in this context; however, variants of any associated AGS-related genes may present with this clinical scenario. AGS may also present prenatally with a striking similarity to transplacentally acquired infections (pseudo-TORCH), with onset of disease in utero. At birth, patients may have irritability, feeding difficulties, jitteriness, microcephaly, abnormal movements, epileptic seizures, thrombocytopenia, anemia, and liver dysfunction. This presentation is most frequently associated with *TREX1* pathogenic variants and leads to profound developmental sequelae and increased risk of death in infancy. In both clinical presentations, neuroimaging shows a highly characteristic pattern of diffuse abnormal white matter, intracranial calcifications, swelling of temporal or frontal lobes, and cerebral atrophy, similar to radiologic findings seen in congenital infections. Patients may also develop autoimmunity, including type 1 diabetes mellitus, hypothyroidism, hypergammaglobulinemia, and hemolytic anemia. Rarely, AGS can have a later onset with abrupt profound neurologic regression after an extended period of normal development.

There are seven recognized genetic variants and corresponding disease subtypes of AGS (AGS 1-7), all of which are responsible for RNA/DNA degradation or detection, resulting in type I



**Fig. 205.2** Characteristic clinical phenotypes of interferonopathies. Chilblain lesions typical of monogenic type I interferonopathies, seen most frequently on the toes, fingers (A), ears (B), and nose. The lesions are generally worse in the cold months. C, Representative brain CT scan of intracranial calcifications seen in a patient with Aicardi-Goutières syndrome due to *TREX1* homozygous pathogenic variants. D, Chest CT scan of a SAVI patient (performed at the age of 12.5 years) showing evidence of interstitial lung disease (interlobular septal thickening, intralobular lines, cystic lesions, and some ground-glass lesions) and fibrosis (honeycombing). (Modified from Melki I, Fremont ML. Type I interferonopathies: from a novel concept to targeted therapeutics. *Curr Rheum Reports*. 2020;22:32, Fig. 1.)

IFN production and upregulation of ISGs. These include variants of 3'-5' DNA exonuclease-*TREX1* (AGS1); ribonucleases including *RNASEH2B* (AGS2), *RNASEH2C* (AGS3), and *RNASEH2A* (AGS4); SAM and HD domain-containing deoxynucleoside triphosphate triphosphohydrolase 1-*SAMHD1* (AGS5); adenosine deaminase acting on RNA 1-*ADAR1* (AGS6); and IFN-induced helicase C domain-containing protein-*IFIH1* (AGS7). The majority of AGS subtypes are autosomal recessive; however, heterozygous gain-of-function variants can also occur in AGS1 and AGS6, and variants causing AGS7 are autosomal dominant.

There are several manifestations that are strongly associated with distinct AGS subtypes. Bilateral striatal necrosis with severe dystonia is associated with variants in *ADAR1* (AGS6), and spastic paraparesis has been associated with variants in *ADAR1* (AGS6), *IFIH1* (AGS7), and *RNASEH2B* (AGS2). Variants involving *SAMHD1* (AGS5) have the most variable phenotype with cutaneous involvement, glaucoma, progressive contractures, stroke, and cerebral aneurysms. Beyond the phenotype diversity between different AGS variants, there are descriptions of marked intrafamilial variation in siblings harboring identical homozygous variants, which raises questions regarding how environmental factors influence disease expression and penetrance.

### Spondyloenchondrodysplasia

Spondyloenchondrodysplasia (SPENCD) is a rare autosomal recessive disorder best characterized as a skeletal dysplasia with sclerosis, enchondromas, short stature, platyspondyly, and irregularity of vertebral end plates. Patients may also develop intracranial calcifications, spasticity, and a spectrum of autoimmunity that bears resemblance to SLE, including hemolytic anemia, thrombocytopenia, glomerulonephritis, malar rash, myositis, antiphospholipid syndrome, and autoantibody positivity. Patients have also developed hypothyroidism, Raynaud phenomenon, Sjögren syndrome, and vitiligo. SPENCD is caused by variants of the *ACP5* gene on chromosome 19p13, which encodes tartrate-resistant acid phosphatase (TRAP). Loss of TRAP expression impairs inactivation of osteopontin (Opn), a protein involved in bone metabolism and Th1 differentiation, via signaling through TLR9 in plasmacytoid dendritic cells (pDCs). Increased levels of Opn thus leads to increased IFN- $\alpha$  production.

### STING-Associated Vasculopathy with Onset in Infancy

STING-associated vasculopathy with onset in infancy (SAVI) is a rare disorder that presents with systemic inflammation, fevers, and elevated inflammatory markers in the first months of life.

<b>Table 205.2 Suggestive Features of Type I Interferonopathies</b>	
Familial history	Several affected individuals, even if phenotypic spectrum might be variable within the same family
Age of onset	<ul style="list-style-type: none"> <li>• Young age at onset, in favor of monogenic disease</li> <li>• Later onset also reported</li> </ul>
Neurologic phenotypes	<p><b>Clinical signs:</b></p> <ul style="list-style-type: none"> <li>• Spasticity, spastic paraparesis</li> <li>• Acute or subacute dystonia</li> <li>• Encephalopathy with seizures and progressive microcephaly</li> <li>• Cortical blindness</li> <li>• Variable developmental delay</li> <li>• Ataxia</li> <li>• Psychosis</li> <li>• Vascular neurologic disease (Moyamoya)/strokes</li> <li>• Rare demyelinating or multifocal neuropathies</li> </ul> <p><b>Lumbar puncture:</b></p> <ul style="list-style-type: none"> <li>• Meningitis (inconstant)</li> <li>• Elevated pterins/neopterin in the CSF</li> <li>• Elevated IFN-<math>\alpha</math> activity or protein in the CSF</li> </ul> <p><b>Morphologic imaging features:</b></p> <ul style="list-style-type: none"> <li>• CT scans: ICC, basal ganglia calcifications or progressive cerebral atrophy</li> <li>• Cerebral MRI: leukoencephalopathy, white matter rarefaction, delayed myelination, bilateral striatal necrosis, deep white matter cysts, or intracranial aneurysms</li> </ul>
Cutaneous features	<ul style="list-style-type: none"> <li>• Chilblains/FCL; necrotizing vasculitis of fingers, toes, helix, cheeks, and nose, telangiectasia, cutaneous ulcerations</li> <li>• Livedo reticularis</li> <li>• Panniculitis, violaceous periorbital rash</li> <li>• Lentiginosities</li> <li>• Psoriasis</li> <li>• Nail dystrophy, sparse hair</li> </ul>
Failure to thrive/short stature	<ul style="list-style-type: none"> <li>• Secondary to osseous dysplasia (ACP5)</li> <li>• Secondary to the inflammatory status (TMEM173)</li> </ul>
Systemic inflammation and immune features	<ul style="list-style-type: none"> <li>• Recurrent fevers</li> <li>• Autoimmune features/SLE/autoantibodies (not necessarily specific)</li> <li>• Inconstant immune deficiency</li> <li>• Elevated IFN I pathway in whole blood/serum/plasma</li> </ul>
Hematologic	<ul style="list-style-type: none"> <li>• AI anemia, dyserythropoiesis</li> <li>• Thrombocytopenia or thrombocytosis</li> <li>• Malignancies (chronic lymphocytic leukemia, cutaneous T cell lymphoma, <i>SAMHD1</i>)</li> </ul>
Lung features	<ul style="list-style-type: none"> <li>• Interstitial lung disease (isolated or not)</li> <li>• Lung fibrosis</li> <li>• Intraalveolar hemorrhage</li> <li>• Macrophagic alveolitis</li> </ul>
Vascular features	<ul style="list-style-type: none"> <li>• Calcification of the aorta or blood vessels</li> </ul>
Musculoskeletal features	<ul style="list-style-type: none"> <li>• Joint pain, arthritis</li> <li>• Contractures and joint retractions</li> <li>• Jaccoud arthropathy, tendon rupture</li> <li>• Muscle weakness and pain/myositis</li> <li>• Calcinosis</li> <li>• X-rays: acro-osteolysis, wide medullar cavities phalange, deforming arthropathies/joint subluxation with conserved interarticular space, calcinosis</li> </ul>
Ophthalmologic features	<ul style="list-style-type: none"> <li>• Glaucoma</li> <li>• Papillary edema<sup>a</sup></li> </ul>
Kidney features	<ul style="list-style-type: none"> <li>• Lupus nephritis</li> </ul>
Gastrointestinal features	<ul style="list-style-type: none"> <li>• VEO-IBD (very severe protein-losing enteropathy)</li> </ul>
Dental anomalies	<ul style="list-style-type: none"> <li>• Retained primary teeth<sup>b</sup></li> <li>• Early loss of permanent teeth</li> </ul>

<sup>a</sup>Reported in one SAVI patient treated with JAK1/2 inhibitor.

<sup>b</sup>Data not published.

Ab, Autoantibodies; AI, autoimmune; CSF, cerebrospinal fluid; CT, computerized tomography; FCL, familial chilblain lupus; ICC, intracranial calcifications; IFN, interferon; IFN I, type I interferon; MRI, magnetic resonance imaging; SLE, systemic lupus erythematosus; VEO-IBD, very-early-onset inflammatory bowel disease.

From Melki I, Fremont ML. Type I interferonopathies: From a novel concept to targeted therapeutics. *Curr Rheum Reports*. 2020;22:3, Table 2.





**Fig. 205.3** Clinical manifestations of stimulator of interferon genes (STING)-associated vasculopathy with onset in infancy (SAVI). **A**, Typical facial distribution of telangiectatic lesions on the nose and cheeks with atrophy and scarring of the skin with loss of deep tissue of the nose. **B**, Violaceous, scaling, atrophic plaques on both hands and progressive autoamputations of several fingers. **C**, Hilar lymphadenopathy and bilateral interstitial infiltrates on high-resolution computed tomography (CT) image. **D**, Ulcerated lesions on the pinna of the ear with scales and crusts. (Courtesy Dr. Raphaela Goldbach-Mansky. From Petty RE, Laxer RM, Lindsley CB, et al., eds. *Textbook of Pediatric Rheumatology*, 8th ed. Philadelphia: Elsevier; 2021: Fig. 39.11, p. 541.)

Cutaneous involvement is characterized by vasculopathic rashes in acral areas (Fig. 205.3). These lesions present as violaceous plaques or nodules on the face, ears, or nose or as distal ulceration and may become necrotic. Lesional skin biopsy reveals leukocytoclastic vasculitis, microthrombotic angiopathy, neutrophilia, and occasional immune complex deposition. As STING is expressed in alveolar macrophages, type 2 pneumocytes, and bronchial epithelium, patients with SAVI also develop pulmonary complications. Paratracheal adenopathy, interstitial lung disease, and lung fibrosis have been described to a variable extent. Patients may also develop myositis, arthritis, arthralgia, oral ulcers, aphthosis, and nasal septum perforation. Low-titer autoantibodies (e.g., antinuclear antibody, anticardiolipin antibodies, and antibodies against  $\beta 2$  glycoprotein I) may be seen. Notably, the presence of antineutrophil cytoplasmic antibodies (cANCA) may lead to misdiagnosis of childhood granulomatosis with polyangiitis. SAVI is caused by a dominant gain-of-function variant in *TMEM173*, which encodes the stimulator of interferon genes (STING). Working as both a direct cytosolic DNA sensor and as an adaptor protein in type I IFN signaling, STING mediates the production of IFN- $\alpha/\beta$ .

#### Chronic Atypical Neutrophilic Dermatitis with Lipodystrophy and Elevated Temperature/Proteasome-Associated Autoinflammatory Syndromes

Chronic atypical neutrophilic dermatitis with lipodystrophy and elevated temperature (CANDLE) syndrome is a rare autoinflammatory disease caused by abnormal functioning of the proteasome-immunoproteasome. CANDLE presents in early infancy with fevers, systemic inflammation, and cutaneous involvement including

neutrophilic dermatosis, annular erythema, violaceous eyelid swelling, and erythema nodosum-like panniculitis. Histology reveals a characteristic mononuclear interstitial infiltrate, which includes “immature” neutrophils in the dermis. Lipodystrophy, usually of the face, trunk, and upper limbs, begins in early childhood. Arthralgias, without radiographic evidence of arthritis, are common in children, and severe joint contractures may develop into adulthood. Acute attacks of inflammatory myositis, aseptic meningitis, sterile epididymitis, conjunctivitis, nodular episcleritis, parotitis, pneumonitis, nephritis, carditis, and otitis have been reported. Autoimmunity can occur, including Coombs-positive hemolytic anemia and hypothyroidism. Most commonly, CANDLE is due to loss-of-function variants in the *PSMB8* gene, which encodes the proteasome  $\beta 5i$  subunit. More recently, variants in other genes encoding other proteasome-immunoproteasome subunits or the regulatory protein POMP have been discovered in patients with CANDLE syndrome. The defective proteasome function may lead to an accumulation of damaged proteins, resulting in cellular stress and type 1 IFN upregulation.

#### ISG15 Deficiency/USP18 Deficiency

Ubiquitin-like protein IFN stimulated gene-15 (*ISG15*) deficiency has only been reported in a few individuals and leads to a phenotype similar to AGS, with intracranial calcifications and seizures. ISG15 is an IFN-induced protein that plays a central role in the host antiviral response, although, in humans, ISG15 deficiency does not cause an increased susceptibility to viral infection. Rather, the absence of intracellular ISG15 prevents the accumulation of ubiquitin-specific peptidase 18 (USP18), a potent negative regulator of IFN- $\alpha/\beta$  signaling, which results in an unchecked IFN- $\alpha/\beta$



response. Notably, loss-of-function recessive variants of USP18 have been reported in five patients, all of whom had neonatal demise soon after birth owing to the dysregulation of type I IFN responses.

### Singleton-Merten Syndrome

Singleton-Merten syndrome (SMS) is an autosomal dominant disorder characterized by early-onset severe aortic and valvular calcification, dental anomalies, acro-osteolysis, osteoporosis, and glaucoma. There is a broad spectrum of disease with variable expressivity, and patients have been reported to have an SLE or AGS phenotype. SMS is caused by gain-of-function variants in *IFIH1* and *DDX58*, which encode retinoic acid–inducible gene-I (RIG-I)–like receptor family members melanoma differentiation-associated gene 5 (*MDA5*) and *RIG-I*, respectively. *MDA5* and *RIG-I* are cytosolic pattern recognition receptors that detect viral RNA and promote type I and III IFN expression. The phenotype variability of SMS suggests that other genetic and/or environmental factors may influence the clinical presentation.

### X-Linked Reticulate Pigmentary Disorder

X-linked reticulate pigmentary disorder (XLPDR) is an X-linked dominant disorder that manifests in the first few months of life in affected males with recurrent pneumonia, bronchiectasis, diarrhea, and failure to thrive. Diffuse skin hyperpigmentation occurs in early childhood, and distinct facial features develop. Female carriers typically exhibit only pigmentary changes along the lines of Blaschko. Hypohidrosis, corneal scarring, enterocolitis, and urethral strictures can develop. The defect in XLPDR is in an intron of the *POLA1* gene, which encodes the catalytic subunit of DNA polymerase- $\alpha$ . Although this defect does not affect DNA replication, it does appear to increase IFN production and IFN-induced genes as well as NF- $\kappa$ B–induced genes in response to dsDNA, cytosolic dsRNA, and TNF- $\alpha$ .

### DNase II Deficiency

Deoxyribonucleases (DNases) degrade double-stranded DNA molecules and exist in several forms. DNase II degrades DNA contained in lysosomes, and recently deficiency of DNase II was shown to cause a form of monogenic SLE. This autosomal recessive disease presents with severe anemia, thrombocytopenia, and hepatosplenomegaly at birth that may resolve over time. In childhood patients may then develop membranoproliferative glomerulonephritis, arthropathy, lipodystrophy, chilblain-like vasculitis, and hypogammaglobulinemia. Laboratory testing shows high titer ANA and dsDNA antibodies and high levels of serum IFNs and IFN-stimulated gene expression. In addition to DNase II, there are two extracellular DNases (DNase1 and DNase1L3) that do cause a monogenic form of SLE. Although these are likely to exhibit high IFN signatures, no data are available on these two diseases, and thus they are not classically considered interferonopathies.

## AUTOIMMUNE INTERFERONOPATHIES

### Systemic Lupus Erythematosus

There were descriptions of increased levels of IFN in the serum of patients with SLE. Further rationale for IFN contributing to SLE pathogenesis was supported by observational studies of patients

who developed a lupuslike disease with autoantibody formation after treatment with IFN- $\alpha$ . Several groups showed that the majority of patients with SLE have an increased expression of type I IFN-regulated genes and that active SLE could be distinguished by an IFN-induced gene expression pattern. Many clinical features of SLE are associated with increased production of IFN, and a high IFN signature has been correlated with cytopenia, autoantibody formation, and cutaneous disease activity. There are a large number of possible inducers of IFN production in SLE. Neutrophil extracellular TRAP formation, transposable elements, and immune complexes have all been associated with IFN production in SLE patients. From a genetic standpoint, over 100 risk loci have been associated with SLE, many of which encode proteins with functions linked to type I IFN production or response. There are also several *rare* forms of monogenic SLE that are due to pathogenic variants involving type I IFN signaling. Monogenic forms of SLE, including loss-of-function variants in *DNase II*, *DNASE1L3*, and *DNASE1*, are classically grouped under the umbrella of interferonopathies and are characterized by typical SLE clinical manifestations with autoantibody formation and immune complex deposition (see [Chapter 199](#)). Success of targeting the IFN pathway has been documented in SLE, and multicenter phase 3 randomized placebo-controlled trials are currently underway in extrarenal disease.

### Juvenile Dermatomyositis

Dermatomyositis has become recognized as a disease partly driven by aberrant IFN signaling. An elevated IFN signature was first discovered in muscle tissue and later identified in peripheral blood cells of patients with adult and juvenile-onset dermatomyositis (DM, JDM). Subsequently, multiple studies have shown an association between type I IFN in the circulation and disease activity in myositis. Targeting the IFN pathway has shown success in treatment of DM and JDM, and there are several ongoing clinical trials evaluating small-molecule Janus kinase (JAK) inhibitors for the treatment of dermatomyositis.

### Therapeutics Targeting the Interferon Pathway

Treatments for interferonopathies has been historically empiric. Numerous immunosuppressive medications, including corticosteroids and a variety of biologics, have been tried in case reports with variable results. However, because interferonopathies have a common pathway involving IFN signaling, the use of small-molecule JAK inhibitors (JAKinibs) has gained interest as a targeted therapy for these disorders. Signaling through the IFN pathway involves JAKs that phosphorylate signal transducers and activators of transcription (STAT) proteins that then dimerize and enter the nucleus to drive transcription of IFN-stimulated genes. JAKinibs block activation of JAK proteins and have been used to treat various autoimmune diseases. There is Food and Drug Administration (FDA) approval of several JAKinibs, including tofacitinib, baricitinib, and upadacitinib, for the treatment of rheumatoid arthritis; tofacitinib is also approved for the treatment of psoriatic arthritis, ulcerative colitis, and polyarticular juvenile idiopathic arthritis. Clinical trials are underway to test the utility of JAKinibs in interferonopathies.

Visit Elsevier eBooks+ at [eBooks.Health.Elsevier.com](http://eBooks.Health.Elsevier.com) for Bibliography.

## Chapter 206

## Amyloidosis

Deborah L. Stone and Karyl S. Barron

Amyloidosis is the result of extracellular deposition of insoluble, fibrous amyloid proteins in various body tissues. It may be caused by a hereditary abnormality in an amyloidogenic protein or occur as a result of chronic inflammation associated with some infectious and rheumatologic diseases.

## ETIOLOGY

Amyloidosis is a result of protein misfolding. These misfolded proteins aggregate and form insoluble fibrils that can affect the normal function of several vital organs. In the amyloidosis nomenclature, a distinction is made between amyloidosis that develops from pathogenic gene variants in the amyloid fibril proteins (**hereditary amyloidoses**) and amyloidosis associated with genetic mutation in nonamyloid proteins. The hereditary amyloidoses include diseases caused by pathogenic variants in the genes for transthyretin and apolipoprotein A and usually do not present in childhood. However, children may be affected by **amyloid A (AA) amyloidosis**, which develops in patients with chronic inflammatory states. It is estimated that approximately 45% of all amyloid cases worldwide are AA amyloidosis. In the past, chronic infectious diseases such as tuberculosis, malaria, leprosy, and chronic osteomyelitis accounted for most cases of AA amyloidosis. Since the development of effective treatments for these infections, other causes of AA have become more common.

Individuals with chronic inflammatory rheumatic diseases, such as **rheumatoid arthritis (RA)**, **juvenile idiopathic arthritis (JIA)**, and **ankylosing spondylitis**, as well as **hereditary autoinflammatory diseases**, have an increased risk for the development of AA amyloidosis. AA amyloidosis has also been associated with sarcoidosis, cystic fibrosis, Crohn disease, malignancies (mesothelioma and Hodgkin disease), intravenous drug use disorders, and HIV infection. Approximately 6% of AA amyloidosis cases have no identified disease association.

## EPIDEMIOLOGY

Only AA amyloidosis affects children in appreciable numbers. The factors that determine the risk for amyloidosis as a complication of inflammation are not clear. Many individuals with long-standing inflammatory disease do not demonstrate tissue amyloid deposition, but some children with relatively recent onset of disease may develop amyloid. In developed countries, before therapy with disease-modifying antirheumatic drugs (DMARDs) and biologic agents was available, **rheumatoid arthritis** was the most common inflammatory disease associated with AA amyloidosis. Patients who had a long history of severe and poorly controlled disease with extraarticular manifestations were at the greatest risk of developing amyloidosis, and the median time from first symptoms of their rheumatic condition to the diagnosis of amyloidosis was 212 months. The use of DMARDs and biologic therapy has resulted in a sustained decline in the number of new cases of RA-associated amyloidosis.

JIA may be associated with AA amyloidosis, with the highest prevalence occurring in patients with systemic JIA, followed by those with polyarticular disease. AA amyloidosis has been observed in JIA patients as soon as 1 year after diagnosis. Before the availability of DMARDs and biologics, the prevalence of AA amyloidosis in JIA patients ranged from 1% to 10%. Higher prevalence was seen in Northern European patients, especially Polish patients, who had a prevalence of 10.6%; a lower prevalence was observed in North American patients. The reasons for this discrepancy are not completely understood, although it is speculated that selection bias, genetic background, and tendency toward earlier, more aggressive therapy in North Americans may have played a role. As with RA, the occurrence of new amyloid cases

in patients with JIA has significantly decreased in the past 20 years because of the increased efficacy of treatment with DMARDs and biologics.

The **hereditary autoinflammatory diseases** define a group of illnesses characterized by attacks of seemingly unprovoked recurrent inflammation without significant levels of either autoantibodies or antigen-specific T cells, which are typically found in patients with autoimmune diseases. These attacks often appear to be initiated by stress, immunizations, or trauma. Common findings of autoinflammatory diseases include fevers, cutaneous rashes, arthritis, serositis, and ocular involvement. The inflammatory attacks are accompanied by intense elevations in inflammatory markers (erythrocyte sedimentation rate and C-reactive protein) and high levels of serum amyloid A (SAA). Amyloidosis AA is associated with some, but not all, hereditary autoinflammatory diseases.

**Familial Mediterranean fever (FMF)** is the most common of the Mendelian autoinflammatory diseases and is seen most frequently in the Armenian, Arab, Turkish, and Sephardic Jewish populations. FMF is an autosomal recessive disease that results from pathogenic variants in the *MEFV* gene, which encodes the pyrin protein. *MEFV* pathogenic variants affecting the M680 and M694 amino acid residues are associated with early onset of symptoms, severe disease, and an increased risk of AA amyloidosis. Patients residing in Armenia, Turkey, and Arab countries have an increased risk of developing AA amyloidosis compared with patients with the same *MEFV* mutations living in North America. While one might assume that FMF patients who have frequent, severe attacks would be at the highest risk for the development of AA amyloidosis, this is not always the case. Some patients with a history of frequent attacks never develop amyloidosis, whereas others develop amyloidosis at an early age.

**Tumor necrosis factor receptor-associated periodic syndrome (TRAPS)** is associated with pathogenic variants in the *TNFRSF1A* gene, which encodes the 55-kDa tumor necrosis factor (TNF) receptor protein (TNFR1). It is estimated that 14–25% of untreated patients with TRAPS will develop AA amyloidosis. The risk of amyloidosis appears to be greater among patients with cysteine pathogenic variants or the T50M pathogenic variant. These cysteine residues normally create disulfide bonds within the protein, and disruption of these bonds by amino acid substitutions is thought to interfere with protein folding.

Pathogenic variants in the *NLRP3* (NLR family pyrin domain containing 3) gene encoding the NLRP3 or cryopyrin protein cause three clinically distinct diseases or cryopyrinopathies: **familial cold autoinflammatory syndrome (FCAS, or NLRP3-AID mild)**, **Muckle-Wells syndrome (MWS, or NLRP3-AID moderate)**, and **neonatal-onset multisystem inflammatory disease (NOMID, or NLRP3-AID severe)**, also known as **chronic infantile neurologic cutaneous and articular (CINCA) syndrome**. Pathogenic variants in *NLRP3* are inherited in an autosomal dominant fashion or as de novo variants in patients with the most severe disease. A few patients have been found to carry somatic variants in *NLRP3*.

FCAS is the least severe of the cryopyrinopathies and is rarely associated with AA amyloidosis. MWS presents with fevers, myalgias, arthralgias, articular-like rash, and progressive sensorineural hearing loss. AA amyloidosis is quite common in MWS, affecting up to one third of the patients. NOMID/CINCA is the most severe cryopyrinopathy. NOMID patients have not developed AA amyloidosis as often as MWS patients, but this may be attributable to the fact that before the availability of effective treatments, 20% of NOMID patients died before reaching adulthood.

**Mevalonate kinase deficiency (MKD) – mild (formally known as Hyper-IgD syndrome, or HIDS)** is an autoinflammatory disease that presents in early childhood with high fevers, abdominal pain, lymphadenopathy, and occasional rash. MVK-mild is an autosomal recessive disease that involves loss-of-function variants in the *MVK* gene that encodes the mevalonate kinase enzyme. Patients with MVK-mild retain a low level of enzyme activity, whereas patients with MVK-severe (**mevalonic aciduria**) have severe *MVK* variants that completely abolish enzyme activity, causing recurrent fevers, dysmorphic features, and developmental delays. Inflammatory markers are high during

MVK-mild attacks and may remain elevated between attacks. AA amyloidosis is rare in patients with MVK-mild but has been reported, most often associated with the V377I/I268T genotype.

Although seen less frequently than in the hereditary periodic fever syndromes, AA amyloidosis occurs in an estimated 1% of U.S. patients and up to 3% of Northern European patients with **Crohn disease**. Conversely, AA amyloidosis in patients with ulcerative colitis is extremely rare, with an estimated prevalence of 0.07%. Patients with Crohn disease and AA usually have a long-standing history of aggressive, poorly controlled disease, although there are reports of amyloidosis in patients with well-controlled inflammatory markers.

Thirty-six proteins have been identified as being amyloidogenic in humans, but most of these rarely cause disease during childhood. **Transthyretin-related hereditary amyloidosis** is an autosomal dominant disorder with variable penetrance and onset in the second to third decades of life. Manifestations include familial amyloidotic polyneuropathy, familial amyloid cardiomyopathy, nephropathy, and ocular disease.

## PATHOGENESIS

The deposition of AA amyloid fibrils is a result of a prolonged inflammatory state that leads to misfolding of the AA amyloid protein and deposition into tissues. The precursor protein of the fibrils in AA amyloidosis is an apolipoprotein called **serum amyloid A**. SAA is expressed by three different genes on chromosome 11p15.1. SAA1 and SAA2 are two isoforms that are acute-phase reactants synthesized by the liver. SAA is produced in response to proinflammatory cytokines, such as interleukin (IL)-1, IL-6, and TNF- $\alpha$ , and can increase more than 1,000-fold during inflammation.

It has been speculated that SAA has a role as a chemoattractant and in lipid metabolism. Supporting this theory is the finding that amyloid deposition occurs initially in organs that are major sites of lipid and cholesterol metabolism, such as the kidney, liver, and spleen. Approximately 80% of secreted SAA1 and SAA2 is bound to lipoproteins. Usually SAA secreted by the liver is completely degraded by macrophages. The secreted SAA protein is 104 amino acids in length and is primarily secreted in an  $\alpha$ -helix structure. For reasons not completely understood, patients with AA amyloidosis have incomplete degradation and accumulation of intermediate SAA products. In these patients, SAA is transferred to the lysosome where the c-terminal portion of the 104-amino acid SAA protein is cleaved, allowing the remaining 66-76 amino acid proteins to fold into a  $\beta$ -pleated sheet configuration. These cleaved fragments polymerize, form fibrils that are deposited in the extracellular space, and bind proteoglycans and other proteins such as serum amyloid P. These fibrils are resistant to proteolysis and deposit in organ tissues.

## CLINICAL MANIFESTATIONS

Although organ involvement may vary, AA amyloidosis most frequently affects the kidneys; 90% of patients have some degree of renal involvement. Unexplained proteinuria may be the presenting feature in some patients. Nephrotic syndrome and renal failure may develop if the underlying inflammatory condition is not well-controlled. Patients with higher SAA levels have a significantly higher risk of death than those with lower SAA levels. Gastrointestinal (GI) involvement is seen in approximately 20% of patients and usually manifests as chronic diarrhea, GI bleeding, abdominal pain, and malabsorption. When biopsied, the testes are frequently discovered to be involved (87%). Relatively uncommon findings associated with AA amyloidosis include anemia, amyloid goiter, hepatomegaly, splenomegaly, adrenal involvement, and pulmonary involvement. The heart, tongue, and skin are rarely involved.

## DIAGNOSIS

The diagnosis of amyloidosis is established by a biopsy demonstrating amyloid fibril proteins in affected tissues. The tissues tested may include kidney, rectum, abdominal fat pad, and gingiva. Amyloid deposits are composed of seemingly homogeneous eosinophilic material that stains with Congo red dye and demonstrates the pathognomonic “apple-green

birefringence” in polarized light. Tissue staining and genetic testing are useful for diagnosing transthyretin amyloidosis.

## LABORATORY FINDINGS

In the United States, specific laboratory testing is not commercially available for AA amyloid, but SAA levels are available in some other countries and can be monitored to guide response to treatment.

## TREATMENT

There is no established therapy for AA amyloidosis, and thus the primary approach is aggressive management of the underlying inflammatory or infectious disease. As newer therapies are developed to treat the underlying conditions, emerging evidence shows that the incidence of AA amyloidosis is decreasing. **Colchicine** is effective not only in controlling the attacks of FMF but also in preventing the development of amyloidosis associated with FMF. AA amyloidosis associated with other autoinflammatory diseases and chronic rheumatic diseases does not respond to colchicine. Biologic agents against proinflammatory cytokines used to treat RA, JIA, spondyloarthropathies, and the hereditary autoinflammatory diseases appear to decrease the risk of developing AA amyloidosis and may even reverse the deposition of amyloid.

The class of medications referred to as the **TNF inhibitors** have been paramount in the management of RA and other autoimmune diseases, and there are reports documenting the effectiveness of anti-TNF agents in blunting the progression of amyloidosis. Adverse effects of anti-TNF medications include reactivation of tuberculosis and hepatitis B, and thus screening should be performed before instituting therapy. Caution should be used in prescribing anti-TNF agents to patients with a history of heart failure or demyelinating disease, because their use may cause exacerbations of underlying cardiac and neurologic diseases.

The IL-1 pathway is the target of three biologic medications used in autoimmune and autoinflammatory diseases. The available IL-1 antagonists are **anakinra** (IL-1 receptor antagonist), **rilonacept** (soluble IL-1 receptor decoy), and **canakinumab** (long-acting fully humanized IgG<sub>1</sub> anti-IL-1 $\beta$  monoclonal antibody). **A trial of canakinumab in patients with colchicine-resistant FME, MKD, and TRAPS showed that it was effective in controlling and preventing flares.** The various IL-1 inhibitors have been successful at slowing the progression of AA amyloidosis, and in some cases treatment results in regression of amyloid proteinuria.

**Tocilizumab**, an anti-IL-6 receptor antibody, has been shown to attenuate experimental AA amyloid and to reverse AA amyloidosis complicating JIA and RA. A trial using **eprosidate disodium** in AA amyloid patients failed to meet its primary end-point of reducing progression to end-stage renal disease and was halted in 2016.

Transthyretin amyloidosis has been treated with liver transplantation, which removes the source of mutated transthyretin molecules, and several medications that inhibit the synthesis of the mutated protein, stabilize tetramers of the protein, or disrupt fibrils.

## PROGNOSIS

End-stage renal failure is the underlying cause of death in 40–60% of patients with amyloidosis. According to a large-scale study of 374 patients with AA amyloidosis, the factors associated with a poor prognosis include older age, a lower albumin serum level, end-stage renal disease at baseline, and prolonged serum elevation of SAA. An elevated SAA value was the most powerful risk factor for end-stage renal disease and death from AA amyloidosis.

## PREVENTION

The primary means of preventing AA amyloidosis is treatment of the underlying inflammatory or infectious disease, resulting in decreases in the level of SAA protein and the risk of amyloid deposition. Although the period of latency between the onset of inflammation from the underlying disease and the initial clinical signs of AA amyloidosis may vary and is often prolonged, progression of the amyloid depositions can be rapid.

Visit Elsevier eBooks+ at [eBooks.Health.Elsevier.com](http://eBooks.Health.Elsevier.com) for Bibliography.



## Chapter 207

# Macrophage Activation Syndrome

Rebecca Trachtman and  
Edward M. Behrens

Macrophage activation syndrome (MAS) is a potentially fatal complication of rheumatic diseases thought to be caused by excessive activation and expansion of macrophages and T cells. These events lead to an overwhelming inflammatory reaction, involving fever, hepatosplenomegaly, lymphadenopathy, cytopenias, liver dysfunction, and coagulopathy resembling disseminated intravascular coagulation (DIC). Extreme hyperferritinemia is a characteristic laboratory feature that separates MAS from primary disease flare.

Inflammatory infiltrates composed predominantly of T lymphocytes and hemophagocytic macrophages are commonly seen in the bone marrow; they are also found in the liver, spleen, or lymph nodes. These hemophagocytic macrophages can infiltrate most organs in the body. Both the systemic and local inflammation can cause severe organ damage, which can be life-threatening and progress to multiple organ failure. The abundance of tissue macrophages exhibiting hemophagocytic activity in inflammatory lesions in MAS suggests that MAS is related to a group of histiocytic disorders collectively known as *hemophagocytic lymphohistiocytosis* (HLH).

## EPIDEMIOLOGY

Although MAS can occur in many rheumatic diseases, it is seen most frequently in systemic juvenile idiopathic arthritis (SJIA) and in its adult equivalent, adult-onset Still disease (AOSD). The reasons for this association remain unclear; elevated interleukin (IL)-18 may be a causative factor. Approximately 7–17% of patients with SJIA develop severe disease, whereas more mild subclinical MAS may be seen in as many as 30% of patients with SJIA.

Systemic lupus erythematosus (SLE) and Kawasaki disease are other rheumatologic conditions in which MAS occurs somewhat more frequently than in other rheumatic diseases. In SLE, MAS occurs in approximately 1–9% of patients.

MAS most often occurs subsequent to the onset of rheumatologic disease; MAS has also been known to occur at the initial presentation of a rheumatic illness. Approximately 23% of episodes of MAS have occurred at the onset of SJIA. MAS typically occurs in the setting of active primary rheumatic disease. However, it can occur despite good control of underlying rheumatic disease. Many cases occur in the setting of infections and/or modifications in drug therapy. Both of these triggers are possibly related to subsequent active rheumatic disease.

## PATHOPHYSIOLOGY AND OTHER HYPERINFLAMMATORY SYNDROMES

The exact mechanisms behind MAS remain unclear; however, much has been extrapolated from the pathogenesis of primary HLH (pHLH). Consistent with parallels to pHLH, in MAS there is an abundance of interferon-gamma (IFN- $\gamma$ )-producing CD8<sup>+</sup> T cells in inflammatory lesions. Further suggesting a role for T-cell-mediated inflammation, cyclosporine A, a therapeutic agent that acts predominantly on T cells, is very effective in the treatment of the majority of MAS patients. CXCL9, a biomarker of IFN- $\gamma$  activity, is also elevated in patients during an MAS episode. Cytotoxic function appears to be impaired in certain subsets of SJIA patients, perhaps specifically in those at risk for MAS, although this finding has been inconsistent. Some studies have demonstrated an enrichment of heterozygous pathogenic variants in known pHLH genes in MAS populations, suggesting that *hypomorphic* lesions in cytolytic pathways may result in disease.

Translational studies in SJIA patients suggest that elevated serum IL-18 is a risk factor for the development of SJIA/MAS. A common link to the “IFN- $\gamma$ -centric” models is that IL-18 is perhaps most noted for its ability to stimulate IFN- $\gamma$  production by T cells and natural killer cells. In the case of MAS caused by activating pathogenic variants in the *NLRC4* gene, IL-18 has been shown to be highly elevated, and case reports of IL-18 blockade leading to resolution of both disease and IFN- $\gamma$  activity suggest a causal link.

## Cytokine Storm

A “cytokine storm” is the common pathophysiologic state in many hyperinflammatory diseases. There is increasing interest in the relative roles of cytokines in MAS pathophysiology, and the similarities and differences to HLH, multisystem inflammatory syndrome in children (MIS-C) related to SARS-CoV-2 virus, and sepsis.

## HLH

MAS belongs to a group of hemophagocytic disorders, which includes HLH. The current classification of histiocytic disorders distinguishes primary, or familial, HLH and secondary, or reactive, HLH (see Chapter 556.2). Clinically, they may be difficult to distinguish from each other. pHLH is a constellation of rare autosomal recessive immune disorders linked to genetic defects in various genes all affecting the cytolytic pathway. The clinical symptoms of pHLH usually become evident within the first months of life. Secondary HLH tends to occur in older children or adults. It may be associated with an identifiable infectious episode, most often Epstein-Barr virus (EBV) or cytomegalovirus (CMV) infection. However, when EBV-associated HLH occurs as part of a genetic syndrome, such as the X-linked proliferative disorders, it is more properly considered pHLH. The group of secondary hemophagocytic disorders also includes malignancy-associated HLH. Some consider MAS to be a form of secondary HLH, whereas others make a distinction and prefer the moniker “Rheuma-HLH” to separate MAS from other secondary HLH conditions. The distinction between primary and secondary HLH is becoming less distinct because of other genetic causes, some of which are associated with less severe and more distinct clinical presentations. Some of these may present later in life because heterozygous or compound heterozygous pathogenic variants in cytolytic pathway genes that confer a partial dominant negative effect on the cytolytic function.

The exact relationship between HLH and MAS is an area of extensive investigation, and some rheumatologists believe that MAS should be categorized as secondary HLH occurring in a setting of a rheumatic disease (or MAS-HLH). Although there are multiple attempts to try to standardize the nomenclature for these various syndromes, at this point, best practice would be to use the term *primary HLH* for cases with known molecular diagnoses or a clear genetic component. For secondary cases, there is not yet a prescribed specific terminology, but inclusion of known secondary causes can add clarity to the specific syndromes being described (e.g., SJIA-MAS, EBV-HLH).

## Multisystem Inflammatory Syndrome in Children (MIS-C)

Children may develop a postinfectious hyperinflammatory syndrome after SARS-CoV-2 virus exposure that bears some resemblance to MAS. Approximately 4–8 weeks after infection, children developed multiorgan dysfunction, frequently involving persistent fever, abdominal pain, and rash, and sometimes accompanied by abnormal cardiac function or hypotension. Laboratory evaluation is significant for elevation of markers of inflammation and sometimes hyperferritinemia, coagulopathy, and liver dysfunction. Similar to MAS, this phenomenon occurred after infectious trigger, and cytokine storm has been invoked in multiple studies, especially involving IL-18, IL-10, IL-6, and the IFN- $\gamma$ -induced CXCL9.

## CLINICAL AND LABORATORY MANIFESTATIONS

The clinical findings in overt MAS are dramatic and often evolve rapidly. High persistent fever, hepatosplenomegaly, generalized lymphadenopathy, liver dysfunction, and changes in mental status are common. Coagulopathy resembling DIC can be associated with hemorrhagic



skin rashes ranging from mild petechiae to extensive ecchymotic lesions. These can progress to epistaxis and hematemesis secondary to upper gastrointestinal bleeding. Mental status changes, seizures, and coma are the most common manifestations of CNS disease. Cerebrospinal fluid examination in these patients usually reveals pleocytosis with mildly elevated protein. Deterioration in renal function has been noted in several series and may be associated with particularly high mortality. Pulmonary infiltrates can occur, and hemophagocytic macrophages can be found in bronchoalveolar lavage fluid.

These clinical symptoms are associated with notable laboratory features. A precipitous fall in at least two of three blood cell lines (leukocytes, erythrocytes, or platelets) is one of the early findings, caused in part by increased destruction of cells by phagocytosis and consumption at inflammatory sites. Decreasing erythrocyte sedimentation rate (ESR) despite persistently high CRP is another characteristic laboratory feature. This parallels hypofibrinogenemia, likely secondary to fibrinogen consumption and liver dysfunction. Prolonged prothrombin and partial thromboplastin times, fibrin degradation products, and moderate deficiency of vitamin K-dependent clotting factors are usually present as well. Liver involvement is common in MAS, and most patients develop marked hepatomegaly, and sometimes mild jaundice. Liver function tests frequently reveal high serum transaminase activity and mildly elevated levels of serum bilirubin. Serum ammonia levels are typically normal or only mildly elevated. Additional laboratory findings in MAS include hypertriglyceridemia, hypoalbuminemia, and elevated lactate dehydrogenase (LDH).

Perhaps the most striking laboratory change in MAS is the elevation of serum ferritin. Although diagnostic/classification criteria set levels of 500 ng/mL and 684 ng/mL as cutoffs for HLH and SJIA-MAS respectively, levels are often greater than 10,000 ng/mL. The reasons for this elevated ferritin are not clear and are likely multifactorial. Although extremely high ferritin is often a good serologic marker of HLH and MAS, high levels are not pathognomonic and can be seen in a wide variety of conditions. Thus ferritin needs to be interpreted in the context of the other features of the disease to support a diagnosis. Further, serum ferritin is usually 60–80% glycosylated, whereas intracellular ferritin is not glycosylated. In hemophagocytic syndromes, the percentage of glycosylated ferritin in the serum is low, typically below 20%; assessment of glycosylated ferritin may also be a useful tool for MAS diagnosis.

It has been recognized that as many as one third of patients with active SJIA may have mild subclinical MAS. These patients typically have moderate hyperferritinemia, highly increased CRP, moderately decreased hemoglobin, and relatively low platelet counts. These patients may also have mild hepatosplenomegaly and mildly elevated liver enzymes. Serum fibrinogen tends to remain in the normal range despite highly increased CRP.

## DIAGNOSIS

Recognition of MAS is crucial, but early diagnosis is often difficult. There is no single clinical or laboratory feature that is specific for MAS, including hemophagocytosis, and many clinical features of MAS overlap with those seen in the underlying rheumatic diseases. The MAS clinical presentation also overlaps with sepsis-like syndromes associated with infection. This is further complicated by the fact that MAS may also be triggered by a flare of the underlying rheumatic disease or infection. In a patient with active underlying rheumatologic disease, persistent fevers and decrease in ESR and platelet count in combination with increasing serum ferritin and persistently high CRP should raise suspicion for impending MAS. Increasing liver enzymes, aspartate aminotransferase in particular, is another characteristic laboratory change. The diagnosis of MAS might be confirmed by bone marrow biopsy, with the presence of increased hemophagocytosis. However, demonstration of hemophagocytosis may be limited by sampling error, particularly at the early stages of the syndrome. In such cases, additional staining of the bone marrow with anti-CD163 antibodies may be helpful. Features consistent with MAS include massive expansion of highly activated histiocytes. The diagnosis of MAS is supported by elevated levels of soluble IL2R $\alpha$  and soluble CD163 in serum.

**Table 207.1** The Classification Criteria for Macrophage Activation Syndrome in Systemic Juvenile Idiopathic Arthritis

A febrile patient with known or suspected systemic juvenile idiopathic arthritis is classified as having macrophage activation syndrome if the following criteria are met:

Ferritin >684 ng/mL and any two of the following:

Platelet count  $\leq 181 \times 10^9/L$

Aspartate aminotransferase >48 U/L

Triglycerides >156 mg/dL

Fibrinogen  $\leq 360$  mg/dL

Evidence is mounting that IFN- $\gamma$  is the pivotal cytokine in MAS; however, peripheral measurement of IFN- $\gamma$  can be difficult because of retention in tissues. Therefore the IFN-induced chemokine CXCL9 may be a more reliable serum biomarker of MAS. Although substantial elevation in the serum levels of soluble IL2R $\alpha$  receptors and CXCL9 in an SJIA patient is highly suggestive of MAS, these assessments remain nonspecific, and elevation can be associated with some malignancies and viral infections, such as viral hepatitis.

Striking clinical similarities between MAS and HLH have led some to advocate for the use of the HLH-2004 diagnostic guidelines developed by the HLH Study Group of the International Histiocyte Society (see Chapter 556.2). However, the application of the HLH diagnostic criteria to SJIA patients with suspected MAS is problematic, both because there is significant overlap with common features of active rheumatic disease and because SJIA patients may reach some of the criteria only later in the clinical course. NK function testing as a means to assess cytotoxic activity is problematic, as defects in this pathway are only variably associated with SJIA and MAS.

Criteria for the diagnosis of MAS complicating SJIA are noted in Table 207.1. In cross-validation analyses, the criteria revealed a sensitivity of 0.72–0.76 and a specificity 0.97–0.99. It should be noted that these criteria were developed for classification for studies and trials and were not optimized for clinical diagnostic purposes. One limitation of the MAS classification criteria is that background treatment with biologics might modify the clinical presentation of MAS. Although IL-1 and IL-6 inhibitors effectively control the disease in the majority of SJIA patients, they do not provide full protection against MAS and may impede diagnosis. Furthermore, the MAS classification criteria are less likely to classify tocilizumab-treated patients as having MAS compared with historical controls or canakinumab-treated patients.

## DIFFERENTIAL DIAGNOSIS

It is most important to distinguish MAS from a flare of an underlying rheumatologic disease and from intercurrent infection. Further, one must consider other clinical entities associated with hyperferritinemia, hepatic dysfunction, coagulopathy, cytopenias, or encephalopathy, specifically DIC, thrombotic thrombocytopenic purpura (TTP), and malignancy-associated HLH. Some other important differential diagnoses include sepsis and drug reactions; a thorough infectious workup is necessary for the majority of MAS patients. Hyperferritinemia is not specific for hemophagocytic syndromes and may be observed in various liver and kidney diseases, hematologic malignancies, or conditions requiring chronic blood transfusions.

## TREATMENT

MAS is still associated with high mortality rates; therefore prompt recognition and initiation of immediate therapeutic intervention are critical. To achieve rapid reversal of coagulation abnormalities and cytopenias, most clinicians start with intravenous methylprednisolone pulse therapy (30 mg/kg for three consecutive days) followed by 2 to 3 mg/kg/day in four divided doses.

## Chapter 208

## Kawasaki Disease

Mindy S. Lo, Mary Beth F. Son, and Jane W. Newburger

If response to glucocorticoids is not satisfactory, cyclosporine A (2–7 mg/kg/day) is usually added to the treatment regimen based on several reports describing the rapid resolution of MAS features in response to this medication. Cyclosporine is preferentially used orally, and careful monitoring for toxicity is required, especially if it is administered intravenously. In many patients, administration of cyclosporine A not only provides rapid control of symptoms but also avoids excessive use of steroids. Case reports support the use of tacrolimus as an alternative to cyclosporine A, as it is often effective and has a desirable safety profile.

There is also reported efficacy with the use of anakinra for MAS. Because MAS episodes may be triggered by disease flare, biologics that neutralize IL-1 could extinguish the underlying inflammation driving the cytokine storm. There are several case reports and two case series of anakinra treatment for MAS with promising results, particularly when used in higher doses. However, in established SJIA, continuous treatment with standard doses of anti-IL-1 and anti-IL-6 biologic therapies does not absolutely protect against MAS even if the underlying disease responds well to the treatment. In the phase 3 clinical trial of canakinumab, IL-1 blockade did not confer full protection from MAS even in patients with fully controlled SJIA. These results suggest that IL-1 inhibition effectively treats MAS in many patients, but does not completely prevent the occurrence of MAS, particularly in the setting of viral infection in treated subjects.

Intravenous immune globulin treatment has been successful in virus-associated reactive HLH. Rituximab—a treatment that depletes B lymphocytes, the main type of cells harboring EBV virus—has been successfully used in EBV-induced lymphoproliferative disease and could be considered in EBV-driven MAS.

If MAS remains active despite the use of corticosteroids, anakinra, and cyclosporine A, the HLH-2004 treatment protocol developed by the HLH Study Group of the International Histiocyte Society may be considered. In addition to steroids and cyclosporine A, this protocol includes etoposide (or VP16), a podophyllotoxin derivative that inhibits DNA synthesis by forming a complex with topoisomerase II and DNA. However, this protocol is limited by the toxicity of etoposide and its likelihood of causing kidney and liver damage. In addition, severe bone marrow suppression, overwhelming infection, and death have been reported. The use of lower doses of etoposide (50–100 mg/m<sup>2</sup> range rather than 150 mg/m<sup>2</sup>, as suggested by the HLH-2004 protocol) has been advocated by some groups.

It has also been suggested that antithymocyte globulin (ATG) might be a safer alternative to etoposide, particularly in patients with renal and hepatic impairment. ATG depletes both CD4<sup>+</sup> and CD8<sup>+</sup> T cells through complement-dependent cell lysis. Mild depletion of monocytes is noted in some patients as well. Although this treatment was tolerated well in reported cases, infusion reactions are frequently reported with the use of ATG, and adequate laboratory and supportive medical resources must be readily available if this treatment is used. Occasional reports describe successful use of cyclophosphamide to control MAS, mainly in patients with SLE.

The monoclonal antibody tocilizumab is very effective in treating SJIA. However, in a phase 3 clinical trial of tocilizumab in SJIA, several patients developed MAS. Similar to canakinumab, at the time of MAS presentation, underlying SJIA in most of these patients was well controlled. Furthermore, tocilizumab can cause normalization of some of the laboratory parameters of MAS, without actually altering the course of MAS activity itself, providing false reassurance of disease control.

In a patient with an inflammasomopathy caused by gain-of-function pathogenic variants in *NLRP4*, administration of the recombinant IL-18BP resulted in rapid and sustained improvement, including the resolution of all MAS-like features. It remains unclear whether a similar therapeutic intervention might be effective in MAS as well. Based on their essential roles in transmitting cytokine-induced signals, particularly from IFN- $\gamma$ , the JAK/STAT pathways have become a target for pharmacologic manipulation in inflammatory diseases. Ruxolitinib, a potent inhibitor of JAK1 and JAK2, has been shown to ameliorate the disease-influencing patterns of JAK/STAT-dependent gene expression in animal models of pHLH, but it remains to be determined whether this treatment will be routinely effective in patients with MAS.

Visit Elsevier eBooks+ at [eBooks.Elsevier.com](https://ebooks.elsevier.com) for Bibliography.

Kawasaki disease (KD), formerly known as *mucocutaneous lymph node syndrome* and *infantile polyarteritis nodosa*, is an acute febrile illness of childhood seen worldwide, with the highest incidence occurring in Asian children. KD is a systemic inflammatory disorder manifesting as a vasculitis with a predilection for the coronary arteries. Approximately 20–25% of untreated children develop **coronary artery abnormalities (CAAs)**, including aneurysms, whereas <5% of children treated with intravenous immunoglobulin (IVIG) develop CAA. Nonetheless, KD is the leading cause of acquired heart disease in children in most developed countries, including the United States and Japan.

### ETIOLOGY

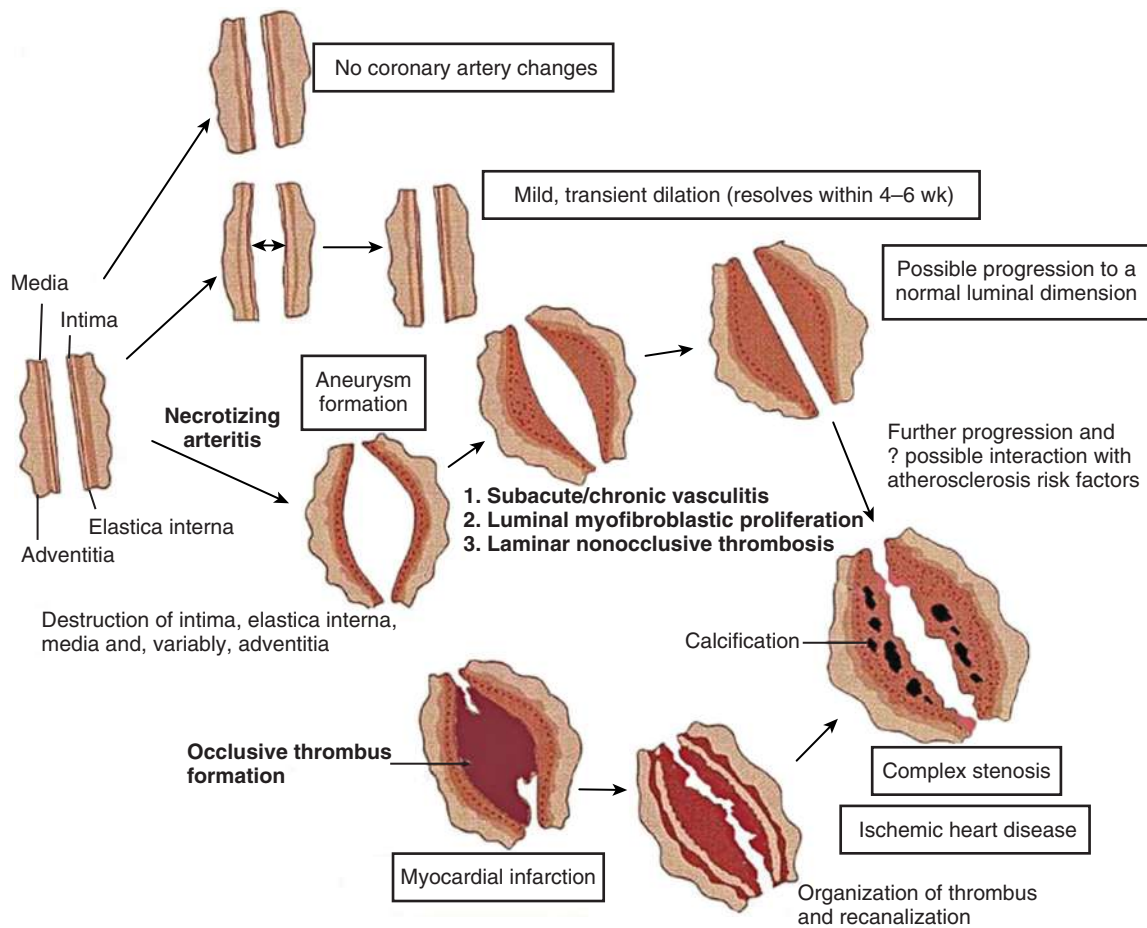
The cause of KD remains unknown. Certain epidemiologic and clinical features support an infectious origin, including the young age-group affected; epidemics with wavelike geographic spread of illness; the self-limited nature of the acute febrile illness; and the clinical features of fever, rash, enanthem, conjunctival injection, and cervical lymphadenopathy. Further evidence of an infectious trigger includes the infrequent occurrence of the illness in infants <3 months old, possibly the result of protective maternal antibodies, and the rarity of cases in adults, possibly the result of prior exposures with subsequent immunity. Furthermore, the number of hospitalizations per year for KD significantly decreased during the COVID-19 pandemic, both in Japan and the United States, possibly due to low circulating causative viruses. However, there are also features that are not consistent with an infectious origin; it is unusual to have multiple cases present at the same time within a family or daycare center. Furthermore, no single infectious etiologic agent has been successfully identified, despite an exhaustive search. Other environmental triggers such as airborne toxins and climate shifts have also been speculated to play a role.

Genetic factors clearly influence the pathogenesis of KD, as evidenced by the higher risk of KD in Asian children regardless of country of residence and in siblings and children of individuals with a history of KD. The concordance rate among identical twins is approximately 13%. Linkage studies and genome-wide association studies (GWAS) have identified significant potential associations between polymorphisms in the *ITPKC* gene, a T-cell regulator, with increased susceptibility to KD and more severe disease. Other candidate genes for KD identified by GWAS include *CASP3*, *BLK*, and *FCGR2A*. Lastly, multiple alleles in different human leukocyte antigen (HLA) regions have been reported to influence risk for KD.

### EPIDEMIOLOGY

For the majority of patients, KD is a disease of early childhood, and nearly all epidemiologic studies show a higher susceptibility to KD in males. Large database studies suggest that the hospitalization rate for KD in the United States has been mostly stable over time, although the proportion of hospitalizations complicated by “KD shock syndrome” has increased over time. In 2017, the Kids’ Inpatient Database estimated 19.3 hospitalizations/100,000 children <4 years of age. Children of Asian/Pacific Islander descent had the highest rates of KD among all racial groups.

In other countries, such as the United Kingdom, South Korea, and Japan, the rate of KD seems to be increasing. In Japan, nationwide surveys have been administered every 2 years to monitor trends in KD incidence. In 2018 the highest recorded rate thus far of 359 per 100,000 children ages 0–4 years was described, with the highest rate in young children ages 9–11 months. Fortunately, the proportion of Japanese



**Fig. 208.1** Natural history of coronary artery abnormalities. (Modified from Kato H. Cardiovascular complications in Kawasaki disease: coronary artery lumen and long-term consequences. *Prog Pediatr Cardiol.* 2004;19:137–145.)

patients with coronary aneurysms and myocardial infarction has decreased over time, at 2.6% for the former in the most recent survey.

Several risk-stratification models have been constructed to determine which patients with KD are at highest risk for CAA. Predictors of poor outcome across several studies include young age; being male; persistent prolonged fever; poor response to IVIG; and laboratory abnormalities, including neutrophilia, thrombocytopenia, transaminitis, hyponatremia, hypoalbuminemia, elevated levels of N-terminal brain natriuretic protein, and elevated C-reactive protein (CRP) levels. Asian, Pacific Islander, and Hispanic ethnicity are also risk factors for CAA. Three risk scores for IVIG resistance, which refers to incomplete response to the first treatment, have been constructed by Japanese researchers; of these, the **Kobayashi score** is the most widely used and has high sensitivity and specificity. Unfortunately, when applied to non-Japanese populations, these scores do not appear to be as accurate in identifying children at risk for IVIG resistance and CAA. Body surface area (BSA)-adjusted coronary artery dimensions on initial echocardiography are good predictors of CAA development. In a North American cohort, coronary artery  $z$  scores  $\geq 2.0$  are predictive of CAA development; similar findings have been reported in Japanese cohorts as well. Accordingly, coronary artery  $z$  scores at initial presentation are useful imaging biomarkers that can be used to guide adjunctive therapy for high-risk patients.

## **PATHOLOGY**

KD is a vasculitis that predominantly affects medium-size arteries. The coronary arteries are most often involved, although other arteries (e.g., axillary, subclavian, femoral, popliteal, brachial) can also develop dilation. A three-phase process to the arteriopathy of KD has been described. The first phase is a neutrophilic necrotizing arteritis

occurring in the first 2 weeks of illness that begins in the endothelium and moves through the coronary wall. Saccular aneurysms may form from this arteritis. The second phase is a subacute/chronic vasculitis driven by lymphocytes, plasma cells, and eosinophils, which may last weeks to years and results in fusiform aneurysms. The vessels affected by the subacute/chronic vasculitis then develop smooth muscle cell myofibroblasts, which may cause diminution of internal lumen dimension and progressive stenosis in the third phase. Thrombi may form in the lumen and obstruct blood flow (Fig. 208.1).

## **CLINICAL MANIFESTATIONS**

Fever is characteristically high ( $\geq 38.3^{\circ}\text{C}$  [ $101^{\circ}\text{F}$ ]), persistent, and unresponsive to antipyretics. The duration of fever without treatment is generally 1–2 weeks but may be as short as 5 days or may persist for 3–4 weeks. In addition to fever, the **five principal clinical criteria** of KD are (1) bilateral *nonexudative* conjunctival injection with limbal sparing; (2) erythema of the oral and pharyngeal mucosa with strawberry tongue and red, cracked lips; (3) edema (induration) and erythema of the hands and feet; (4) rash of various forms (maculopapular, urticarial, erythema multiforme-like, scarlatiniform, and rarely, micropustular or psoriatic-like); and (5) nonsuppurative cervical lymphadenopathy, usually unilateral, with node size  $>1.5$  cm (Table 208.1 and Figs. 208.2–208.5). Superficial perineal desquamation is common in the acute phase. Periungual desquamation of the fingers and toes begins 2–3 weeks after the onset of illness and may progress to involve the entire hand and foot (Fig. 208.6).

Additional symptoms other than the principal clinical criteria are common in the 10 days before diagnosis of KD, which may be explained in part by the finding that up to a third of patients with KD have confirmed, concurrent infections. Gastrointestinal (GI)



**Table 208.1** Clinical and Laboratory Features of Kawasaki Disease

**EPIDEMIOLOGIC CASE DEFINITION (CLASSIC CLINICAL CRITERIA)\***

Fever persisting at least 5 days<sup>†</sup>

Presence of at least four principal features:

- Changes in extremities
  - Acute: erythema of palms, soles; edema of hands, feet
  - Subacute: periungual peeling of fingers, toes in wk 2 and 3
- Polymorphous exanthem
- Bilateral bulbar conjunctival injection without exudate
- Erythema and cracking of lips, strawberry tongue, and/or erythema of oral and pharyngeal mucosa
- Cervical lymphadenopathy (>1.5 cm diameter), usually unilateral

Exclusion of other diseases with similar findings<sup>‡</sup>

*These features do not have to occur concurrently.*

**OTHER CLINICAL AND LABORATORY FINDINGS**

**Cardiovascular System**

Myocarditis, pericarditis, valvular regurgitation, cardiogenic shock

Coronary artery abnormalities

Aneurysms of medium-sized noncoronary arteries

Peripheral gangrene

Aortic root enlargement

**Respiratory System**

Peribronchial and interstitial infiltrates on chest radiograph

Pulmonary nodules

**Musculoskeletal System**

Arthritis, arthralgias (pleocytosis of synovial fluid)

**Gastrointestinal Tract**

Diarrhea, vomiting, abdominal pain

Hepatitis, jaundice

Hydrops of gallbladder

Pancreatitis

Parotitis

**Central Nervous System**

Extreme irritability

Aseptic meningitis (pleocytosis of cerebrospinal fluid)

Facial nerve palsy

Sensorineural hearing loss

**Genitourinary System**

Urethritis/meatitis, hydrocele

**Other Findings**

Desquamating rash in groin

Retropharyngeal phlegmon

Anterior uveitis by slit-lamp examination

Erythema, induration at bacille Calmette-Guérin inoculation site

**LABORATORY FINDINGS IN ACUTE KAWASAKI DISEASE**

Leukocytosis with neutrophilia and immature forms

Elevated erythrocyte sedimentation rate

Elevated C-reactive protein

Elevated nitrogen-terminal pro B-type natriuretic peptide (NT-proBNP)

Anemia

Abnormal plasma lipids

Hypoalbuminemia

Hyponatremia

Thrombocytosis after wk 1<sup>§</sup>

Sterile pyuria

Elevated serum transaminase

Elevated serum  $\gamma$ -glutamyl transpeptidase

Pleocytosis of cerebrospinal fluid

Leukocytosis in synovial fluid

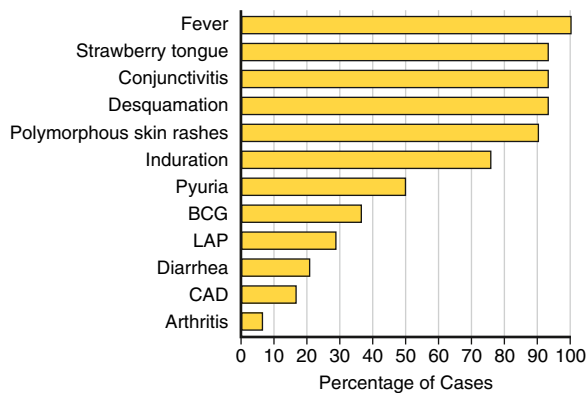
\*Patients with fever at least 5 days and fewer than four principal criteria can be diagnosed with Kawasaki disease when coronary artery abnormalities are detected by two-dimensional echocardiography or angiography.

<sup>†</sup>In the presence of four or more principal criteria, particularly when redness and swelling of the hands and feet are present, Kawasaki disease diagnosis can be made on day 4 of illness. Experienced clinicians who have treated many patients with Kawasaki disease may establish a diagnosis before day 4 in rare cases.

<sup>‡</sup>See the differential diagnosis (Table 208.3).

<sup>§</sup>Rarely infants present with thrombocytopenia and disseminated intravascular coagulation.

From McCrindle BW, Rowley A, Newburger JW, et al. Diagnosis, treatment, and long-term management of Kawasaki disease: a scientific statement for health professionals from the American Heart Association. *Circulation*. 2017;135(17):e927–e999.



**Fig. 208.2** Clinical symptoms and signs of Kawasaki disease. Summary of clinical features from 110 cases of Kawasaki disease seen in Kaohsiung, Taiwan. LAP, Lymphadenopathy in head and neck area; BCG, reactivation of bacille Calmette-Guérin inoculation site; CAD, coronary artery dilation, defined by an internal diameter >3 mm. (From Wang CL, Wu YT, Liu CA, et al. *Kawasaki disease: infection, immunity and genetics. Pediatr Infect Dis J*. 2005;24:998–1004.)



**Fig. 208.3** Kawasaki disease. Strawberry tongue in patient with mucocutaneous lymph node syndrome. (Courtesy Tomisaku Kawasaki, MD. From Hurwitz S. *Clinical Pediatric Dermatology*, 2nd ed. Philadelphia: Saunders; 1993.)





**Fig. 208.4** Kawasaki disease. Congestion of bulbar conjunctiva in a patient with mucocutaneous lymph node syndrome. (Courtesy Tomisaku Kawasaki, MD. From Hurwitz S. *Clinical Pediatric Dermatology*, 2nd ed. Philadelphia: Saunders; 1993.)



**Fig. 208.5** Kawasaki disease. Indurative edema of the hands in a patient with mucocutaneous lymph node syndrome. (Courtesy Tomisaku Kawasaki, MD. From Hurwitz S. *Clinical Pediatric Dermatology*, 2nd ed. Philadelphia: Saunders; 1993.)



**Fig. 208.6** Kawasaki disease. Desquamation of the fingers in a patient with mucocutaneous lymph node syndrome. (Courtesy Tomisaku Kawasaki, MD. From Hurwitz S. *Clinical Pediatric Dermatology*, 2nd ed. Philadelphia: Saunders; 1993.)

symptoms (vomiting, diarrhea, or abdominal pain) occur in >60% of patients, and at least one respiratory symptom (rhinorrhea or cough) occurs in 35%. Other clinical findings can include significant irritability that is especially prominent in infants and likely caused by aseptic meningitis, mild hepatitis, hydrops of the gallbladder, urethritis and meatitis with sterile pyuria, uveitis, and arthritis. Arthritis may occur early in the illness or may develop in the second or third week. Small or

large joints may be affected, and the arthralgias may persist for several weeks. Patients previously vaccinated with bacillus Calmette-Guerin (BCG) may show reactivation at the inoculation site. Clinical features that are *not consistent* with KD include exudative/purulent conjunctivitis; exudative pharyngitis; generalized lymphadenopathy; discrete oral lesions (e.g., ulceration); splenomegaly; and bullous, petechial, or vesicular rashes.

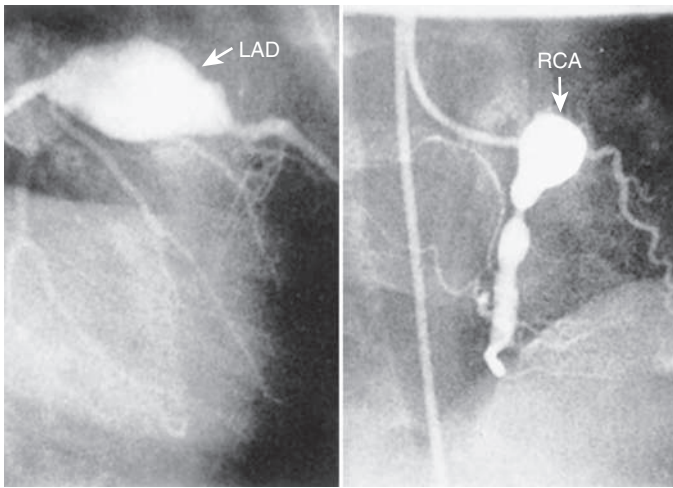
Cardiac involvement is the most important manifestation of KD. Myocarditis may occur in patients with acute KD and may manifest as tachycardia disproportionate to fever, along with diminished left ventricular systolic function. Occasionally, patients with KD present in cardiogenic shock (**KD shock syndrome**), with hypotension and greatly diminished left ventricular function. In addition, KD shock syndrome may manifest with thrombocytopenia, a high band count, and a high CRP. Case series of KD shock syndrome indicate that these patients may be at higher risk for coronary artery dilation. Pericarditis with a small pericardial effusion can also occur during the acute illness. Mitral regurgitation of at least mild severity is evident on echocardiography in 10–25% of patients at presentation but diminishes over time, except among rare patients with coronary aneurysms and ischemic heart disease. Up to 25% of untreated patients develop CAA by Japanese Ministry of Health criteria in the second to third week of illness; initially these are usually asymptomatic and detected by echocardiography. Almost all the morbidity and mortality in KD occur in patients with **large or giant coronary artery aneurysms**, defined by the 2017 American Heart Association (AHA) scientific statement on the diagnosis and treatment of KD as having a z score  $\geq 10$  or an absolute dimension of  $\geq 8$  mm. Specifically, large or giant aneurysms are associated with the greatest risk of later thrombosis or stenosis, angina, and myocardial infarction (Figs. 208.7 and 208.8A). Rupture of a giant aneurysm is a rare complication that generally occurs in the first month after illness onset and may present as hemopericardium with tamponade. Axillary, popliteal, iliac, or other systemic medium-sized muscular arteries may also become aneurysmal, but always in the setting of giant coronary aneurysms (see Fig. 208.8B); these usually regress.

Occasionally KD presents initially with only fever and lymphadenopathy (**node-first KD**). This presentation may be confused with bacterial or viral cervical lymphadenitis and may delay the diagnosis and treatment. Persistence of high fever, lack of response to antibiotics, and subsequent development of other signs of KD suggest the diagnosis. Children with node-first KD tend to be older (4 vs 2 years) and have more days of fever and higher CRP levels. In addition to cervical adenopathy, many node-first patients had retropharyngeal and peritonsillar inflammation on CT scans (Fig. 208.9). Patients with node-first KD have a higher incidence of coronary aneurysms. Patients with infectious adenitis usually respond to antibiotics; they may have abscesses noted on imaging studies (ultrasonography or CT).

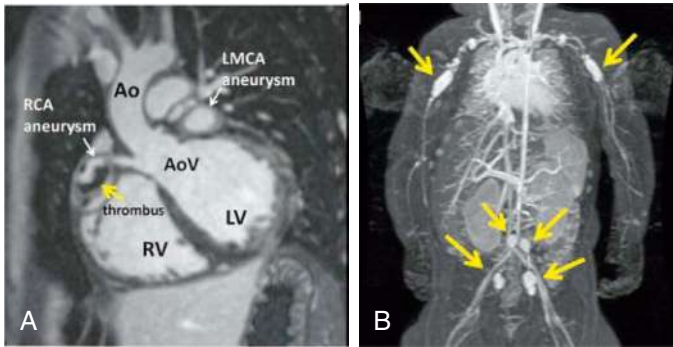
KD can be divided into three clinical phases. The **acute febrile phase** is characterized by fever and the other acute signs of illness and usually lasts 1–2 weeks. The **subacute phase** is associated with desquamation, thrombocytosis, development of CAA, and the highest risk of sudden death in patients who develop aneurysms; it generally lasts 3 weeks. The **convalescent phase** begins when all clinical signs of illness have disappeared and continues until the erythrocyte sedimentation rate (ESR) returns to normal, typically 6–8 weeks after the onset of illness.

### LABORATORY AND RADIOLOGY FINDINGS

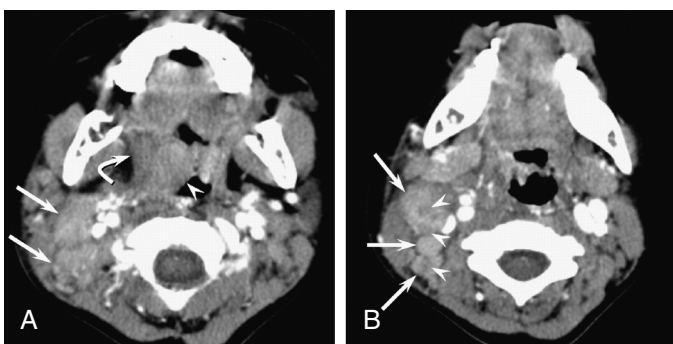
There is no diagnostic test for KD, but patients usually have characteristic laboratory findings. The leukocyte count is often elevated, with a predominance of neutrophils and immature forms. Normocytic, normochromic anemia is common. The platelet count is generally normal in the first week of illness and rapidly increases by the second to third week of illness, sometimes exceeding 1 million/mm<sup>3</sup>. An elevated ESR or CRP value is universally present in the acute phase of illness. The ESR may remain elevated for weeks, in part from the effect of IVIG. Sterile pyuria, mild elevations of the hepatic transaminases, hyperbilirubinemia, and cerebrospinal fluid pleocytosis may also be present. KD is unlikely if the ESR, CRP, and platelet counts are normal after 7 days of fever.



**Fig. 208.7** Coronary angiograms in 6-yr-old boy with Kawasaki disease. *Left*, Giant aneurysm of the left anterior descending coronary artery (LAD) with obstruction. *Right*, Giant aneurysm of the right coronary artery (RCA) with an area of severe narrowing. (From Newburger JW, Takahashi M, Gerber MA, et al. *Diagnosis, treatment, and long-term management of Kawasaki disease*. *Pediatrics*. 2004;114:1708–1733.)



**Fig. 208.8** MRI of coronary and peripheral artery aneurysms in Kawasaki disease. *A*, Image of left ventricular outflow tract showing a giant right coronary artery (RCA) aneurysm with nonocclusive thrombus (yellow arrow) and a giant left main coronary artery (LMCA) aneurysm. Ao, Aorta; AoV, aortic valve; LV, left ventricle; RV, right ventricle. *B*, Aneurysms in the axillary and subclavian arteries and the iliac and femoral arteries (arrows). (From McCrindle BW, Rowley A, Newburger JW, et al. *Diagnosis, treatment, and long-term management of Kawasaki disease: a scientific statement for health professionals from the American Heart Association*. *Circulation* 2017;135[17]:e927–e999, Fig. 2G and H, p. e935.)



**Fig. 208.9** Contrast-enhanced CT in 3-yr-old boy with Kawasaki disease. *A*, Right-sided cervical lymphadenopathy (arrows), peritonsillar hypodense area (curved arrow), and swelling of right palatine tonsil (arrowhead). *B*, Right-sided cervical lymphadenopathy with perinodal infiltration (arrows) and intranodal focal low attenuation (arrowheads). (From Kato H, Kanematsu M, Kato Z, et al. *Computed tomographic findings of Kawasaki disease with cervical lymphadenopathy*. *J Comput Assist Tomogr*. 2012;36[1]:138–142, Fig. 1, p. 139.)

Two-dimensional echocardiography is the most useful test to monitor for development of CAA. Although frank aneurysms are rarely detected in the first week of illness, coronary arteries are commonly dilated. Coronary artery dimensions, adjusted for BSA ( $z$  scores), may increase over the first 6 weeks of illness, and higher  $z$  scores at the time of diagnosis are the strongest risk factor for the presence of coronary aneurysms 2–8 weeks after illness onset. Children with non-KD febrile illnesses also have mildly increased  $z$  scores compared with nonfebrile controls, but to a lesser degree than patients with KD. Aneurysms have been defined with the use of absolute dimensions by the Japanese Ministry of Health and are classified as small ( $\leq 4$  mm internal diameter [ID]), medium ( $>4$  to  $\leq 8$  mm ID), or giant ( $>8$  mm ID). Some experts believe that a  $z$  score-based system for classification of aneurysm size may be more discriminating, because it adjusts the coronary dimension for BSA. The AHA  $z$  score classification system is noted in Table 208.2.

**Echocardiography** should be performed at diagnosis and again after 1–2 weeks of illness. If the results are normal, a repeat study should be performed 6–8 weeks after onset of illness. If results of either of the initial studies are abnormal or the patient has recurrent fever or symptoms, more frequent echocardiography or other studies may be necessary. In patients in whom CAA has not developed in the first 4–6 weeks of illness, the patient may be discharged from cardiology care, although follow-up through 12 months may be considered. Children and families should be counseled regarding healthy diet and the importance of exercise at regular primary care visits. For patients with CAA, the type of testing and the frequency of cardiology follow-up visits are tailored to the patient's coronary artery status (see Table 208.2).

## DIAGNOSIS

The diagnosis of KD is based on the presence of characteristic clinical signs. For **classic KD**, the diagnostic criteria require the presence of fever for at least 5 days and at least four of five of the other principal characteristics of the illness (see Table 208.1). The diagnosis of KD should be made within 10 days, and ideally within 7 days, of fever onset to improve coronary artery outcomes. In **incomplete KD**, patients have persistent fever but fewer than four of the five characteristic clinical signs. In patients with incomplete KD, laboratory and echocardiographic data can assist in the diagnosis (Fig. 208.10). Incomplete cases occur most frequently in infants, who also have the highest likelihood of development of CAA. Ambiguous cases should be referred to a center with experience in the diagnosis of KD. Establishing the diagnosis with prompt initiation of treatment is essential to prevent potentially devastating coronary artery disease. For this reason, it is recommended that *any infant age  $\leq 6$  months with fever for  $\geq 7$  days and signs of systemic inflammation without explanation undergo echocardiography to assess the coronary arteries.*

## DIFFERENTIAL DIAGNOSIS

Adenovirus, measles, and scarlet fever lead the list of common childhood infections that mimic KD (Table 208.3). Children with **adenovirus** typically have exudative pharyngitis and exudative conjunctivitis, allowing differentiation from KD. A common clinical problem is the differentiation of **scarlet fever** from KD in a child who is a group A streptococcal carrier. Patients with scarlet fever typically have a rapid clinical response to appropriate antibiotic therapy. Such treatment for 24–48 hours with clinical reassessment generally clarifies the diagnosis. Furthermore, ocular findings are quite rare in group A streptococcal pharyngitis and may assist in the diagnosis of KD.

Features of **measles** that distinguish it from KD include exudative conjunctivitis, Koplik spots, rash that begins on the face and hairline and behind the ears, and leukopenia. **Cervical lymphadenitis** can be the initial diagnosis in children who are ultimately recognized to have KD. Less common infections such as Rocky Mountain spotted fever and leptospirosis are occasionally confused with KD. **Rocky Mountain spotted fever** is a potentially lethal bacterial infection, and appropriate antibiotics should not be withheld if the diagnosis is under consideration. Its distinguishing features include pronounced myalgias and headache at onset, centripetal rash, and petechiae on the palms and soles. **Leptospirosis** can also be an illness of considerable severity. Risk factors include exposure to water contaminated



**Table 208.2** Classification of Coronary Artery Dilatation or Aneurysms (after AHA Guidance with Modification)

CLASSIFICATION OF RISK LEVEL	DESCRIPTION OF CORONARY ARTERIES	FOLLOW-UP INTERVAL	IMAGING REQUIRED TO ASSESS FOR INDUCIBLE ISCHEMIA (STRESS ECHO OR STRESS MRI)	PSP	REGIONAL SPECIALIST KAWASAKI DISEASE CLINIC
1	No involvement at any time point (z score <2)	2 wk 6 wk 6 mo 12 mo Discharge if normal at 12 mo	None	No	No—annual cardiac and general health review with GP recommended*
2	Dilatation only (2 < z score ≤2.5): resolves within 1 year	2 wk 6 wk 6 mo 12 mo Discharge if normal at 12 mo	None	No	No—annual cardiac and general health review with GP recommended*
3	Small aneurysm (2.5 ≤ z score <5): (a) current or persistent (b) decreased to normal or z score <2.5	2 wk 6 wk 6 mo 12 mo Annual review	Coronary angiography (preferably CT) at 12 mo as baseline Consider stress imaging for inducible myocardial ischemia every 2 years Imaging (echo) for coronary surveillance annually	Yes	Yes
4	Medium aneurysm (5 ≤ z score <10): (a) persistent aneurysm (b) decreased to normal or z score <2.5	2 wk 6 wk 6 mo 12 mo Annual review	Coronary angiography (preferably CT) at 12 mo as baseline Consider stress imaging for inducible myocardial ischemia annually Imaging (echo, CT, <sup>†</sup> or MRI) for coronary thrombus surveillance annually	Yes	Yes
5	Giant aneurysm (z score ≥10 or ≥8 mm): (a) persistent giant aneurysm (b) persistent aneurysm (but regressed to medium or small aneurysms) (c) regressed to normal dimensions	2 wk 6 wk 3 mo 6 mo 9 mo 12 mo Then every 6 mo	Coronary angiography (preferably CT) at 6-12 mo as baseline Consider stress imaging for inducible myocardial ischemia annually Imaging (echo, CT, <sup>†</sup> or MRI) for coronary thrombus surveillance every 6 mo	Yes	Yes

\*GP review should include clinical examination, blood pressure measurement, general health discussion, and advice on avoidance of cardiovascular risk factors and lifestyle choices, including maintaining a healthy weight, reducing the risk of diabetes, avoiding smoking, and taking regular exercise. This provides the opportunity to discuss any parent or patient questions and concerns.

<sup>†</sup>CT should not be used repeatedly if possible. Use MRI or ultrasound where possible to reduce radiation exposure.

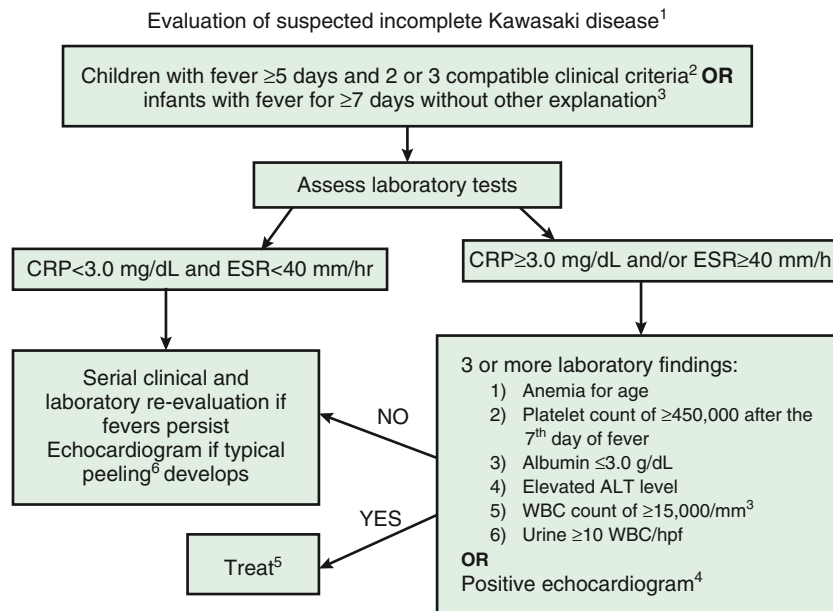
ADP, Adenosine diphosphate; AHA, American Heart Association; FBC, full blood count; GP, general practitioner; PSP, person-specific protocol.

From McCrindle BW, Rowley AH, Newburger JW, et al. Diagnosis, treatment, and long-term management of Kawasaki disease: A scientific statement for health professionals from the American Heart Association [published correction appears in *Circulation*. 2019 Jul 30;140(5):e181-e184]. *Circulation*. 2017;135(17):e927-e999.

with urine from infected animals. The classic description of leptospirosis is of a biphasic illness with a few asymptomatic days between an initial period of fever and headache and a late phase with renal and hepatic failure. In contrast, patients with KD have consecutive days of fever at diagnosis and rarely have renal or hepatic failure.

Drug hypersensitivity reactions, including Stevens-Johnson syndrome, share some characteristics with KD. Drug reaction features such as the presence of oral ulcerations and a normal or minimally elevated ESR are not seen in KD. **Systemic juvenile idiopathic arthritis (sJIA)** is also characterized by fever and rash, but physical findings include diffuse lymphadenopathy and hepatosplenomegaly. Arthritis may or may not be present in the initial illness. Fevers typically show a quotidian or double-quotidian pattern, in contrast to the unremitting fevers seen in KD. Laboratory findings may include coagulopathy, elevated fibrin degradation product values, and hyperferritinemia. Interestingly, there are reports of children with sJIA who have echocardiographic evidence of CAA. Coronary aneurysms have also been reported in Behçet disease, primary cytomegalovirus infection, granulomatosis with polyangiitis, lupus, infantile polyarteritis nodosa, hyper-IgE syndrome, hyper-IgD syndrome (mevalonic aciduria), and meningococemia.

Children with KD may present with **Kawasaki disease shock syndrome**, with a clinical picture similar to that of toxic shock syndrome or of the multisystem inflammatory syndrome in children associated with COVID-19 (MIS-C; see Chapter 311). Features of **toxic shock syndrome** that are not usually seen in KD include renal insufficiency, coagulopathy, pancytopenia, and myositis. With COVID-19 disease, some children developed a KD-like illness presenting in cardiogenic shock. **multisystem inflammatory syndrome in children (MIS-C)**, also known as *pediatric inflammatory multisystem syndrome temporally associated with SARS-CoV-2* (PIMS-TS), occurs 2-6 weeks after infection with SARS-CoV-2. The initial infection may be asymptomatic. Children with MIS-C may show conjunctival injection, oropharyngeal changes, and rashes similar to that seen in KD. CAAs have also been described in MIS-C, but the risk of CAA in MIS-C does not strictly correlate with criteria for incomplete or complete KD. Furthermore, patients are often older and have a greater degree of myocardial dysfunction as compared with KD; distinguishing laboratory features include greater hyperferritinemia, more pronounced cytopenias, and elevated D-dimer in MIS-C (Table 208.4).



**Fig. 208.10** Algorithm for the evaluation of suspected incomplete Kawasaki disease (KD). <sup>1</sup>In the absence of a gold standard for diagnosis of KD, this algorithm cannot be evidence based, but rather represents the informed opinion of the expert committee. Consultation with an expert should be sought any time assistance is needed. <sup>2</sup>Clinical findings of KD are listed in Table 208.1. Characteristics suggesting that another diagnosis should be considered include exudative conjunctivitis, exudative pharyngitis, ulcerative intraoral lesions, bullous or vesicular rash, generalized adenopathy, and splenomegaly. <sup>3</sup>Infants ≤6 months of age are most likely to develop prolonged fever without other clinical criteria for KD; these infants are at particularly high risk of developing coronary artery abnormalities. <sup>4</sup>Echocardiography is considered positive for purposes of this algorithm if any of three conditions are met: z score of left anterior descending coronary artery or right coronary artery ≥2.5; coronary artery aneurysm is observed; or three or more other suggestive features exist, including decreased left ventricular function, mitral regurgitation, pericardial effusion, or z scores in the left anterior descending coronary artery or right coronary artery of 2-2.5. <sup>5</sup>If the echocardiogram is positive, treatment should be given within 10 days of fever onset or after the 10th day of fever in the presence of clinical and laboratory signs (C-reactive protein [CRP], erythrocyte sedimentation rate [ESR]) of ongoing inflammation. <sup>6</sup>Typical peeling begins under the nail beds of fingers and toes. ALT, Alanine transaminase; WBC, white blood cell. (From McCrindle BW, Rowley A, Newburger JW, et al. *Diagnosis, treatment, and long-term management of Kawasaki disease: A scientific statement for health professionals from the American Heart Association. Circulation.* 2017;135:e927–e999, Fig. 2, p. e937.)

Table 208.3	Differential Diagnosis of Kawasaki Disease
<b>VIRAL INFECTIONS*</b>	
Adenovirus	
Enterovirus	
Measles	
Epstein-Barr virus	
Cytomegalovirus	
<b>BACTERIAL INFECTIONS</b>	
Scarlet fever	
Rocky Mountain spotted fever	
Leptospirosis	
Bacterial cervical lymphadenitis ± retropharyngeal phlegmon	
Meningococemia	
Urinary tract infection	
<b>RHEUMATOLOGIC DISEASE</b>	
Systemic-onset juvenile idiopathic arthritis	
Behçet disease	
Rheumatic fever	
Polyarteritis nodosa	
Takayasu arteritis	
<b>OTHER</b>	
Multisystem inflammatory syndrome in children (MIS-C) associated with COVID-19	
Toxic shock syndromes	
Serum sickness	
Staphylococcal scalded skin syndrome	
Macrophage activation syndrome (may also complicate Kawasaki disease)	
Hemophagocytic lymphohistiocytosis	
Drug hypersensitivity reactions	
Stevens-Johnson syndrome	
Aseptic meningitis	
Autoinflammatory diseases	

\*Detection of a virus does not exclude Kawasaki disease in the presence of the principal clinical features (see Table 208.1).

Table 208.4	Comparing and Contrasting Multisystem Inflammatory Syndrome in Children (MIS-C) with Kawasaki Disease
MIS-C	KAWASAKI DISEASE
Mean age 8-12 years	Mean age <5 years
Fever >24 hr	Fever >5 days
GI symptoms common (severe abdominal pain) (50–90%)	GI complaints not common (~20%)
Myocarditis/myocardial dysfunction (left ventricular dysfunction)	Myocardial function normal/mildly reduced*
Coronary artery dilation or aneurysms (25–50%)	Coronary artery abnormalities such as aneurysms common if untreated
Hypotension	Normal BP*
Renal involvement more common	Renal involvement rare
Proinflammatory state common	Proinflammatory state common
Lymphopenia common	Lymphopenia not common
Thrombocytopenia	Thrombocytosis
Elevated ferritin	Ferritin usually normal

\*Except in Kawasaki shock syndrome (~5%).  
GI, Gastrointestinal.  
Modified from Naka F, Melnick L, Gorelik M, et al. A dermatologic perspective on multisystem inflammatory syndrome in children. *Clin Dermatol.* 2021;39(1):163–168, Table 5.

**TREATMENT**  
Patients with acute KD should be treated with 2 g/kg of IVIG as a single infusion, usually administered over 10-12 hours within 10 days of disease onset, and ideally as soon as possible after diagnosis (Table 208.5).



In addition, moderate-dose (30-50 mg/kg/day divided every 6 hours) aspirin should be administered until the patient is afebrile, then lowered to antiplatelet doses (3-5 mg/kg/day). Other NSAIDs should *not* be given during therapy with aspirin because they may block aspirin's antiplatelet effect. The mechanism of action of IVIG in KD is likely multifaceted, but treatment results in defervescence and resolution of clinical signs of illness in approximately 85% of patients. Using Japanese Ministry of Health criteria, the prevalence of coronary disease is 20–25% in children treated with aspirin alone and falls to <5% in those treated with IVIG and aspirin within the first 10 days of illness. In children diagnosed after the 10th day of fever, IVIG should still be offered to patients with persistent fever, abnormal dimensions of the coronary arteries, or signs of systemic inflammation. Low-dose aspirin is continued for its antithrombotic effect until 6-8 weeks after illness onset and is then discontinued in patients who have had normal echocardiography findings throughout the course of their illness. Patients with CAA continue with aspirin therapy longer and may require anticoagulation, depending on the degree of coronary dilation (see later).

Glucocorticoids have been used as primary therapy with the first dose of IVIG in hopes of improving coronary outcomes. A North American trial using a single pulse dose of intravenous methylprednisolone (30 mg/kg) with IVIG as primary therapy did not improve coronary outcomes. However, a trial in Japan using the Kobayashi score to identify high-risk children demonstrated improved coronary outcomes with a regimen of

methylprednisolone/prednisolone (2 mg/kg/day, divided every 12 hours) plus IVIG as primary therapy. Furthermore, a systematic review and meta-analysis of 16 comparative studies demonstrated that early treatment with glucocorticoids improved coronary artery outcomes in children with KD. These data suggest that primary glucocorticoid therapy in addition to standard of care (IVIG plus aspirin) may be helpful in children at *high risk* for CAA. Fewer data are available to support the use of TNF alpha inhibitors for prevention of coronary artery aneurysms.

**IVIG-resistant KD** (nonresponders) occurs in approximately 15% of patients and is defined by persistent or recrudescent fever 36 hours after completion of the initial IVIG infusion. Patients with IVIG resistance are at increased risk for CAA. Therapeutic options for the child with IVIG resistance include a second dose of IVIG (2 g/kg), a tapering course of glucocorticoids, infliximab, or possibly anakinra (Table 208.6). For the most severely affected patients with enlarging coronary aneurysms, additional therapies such as cyclosporine or cyclophosphamide may be administered, with consultation from specialists in pediatric rheumatology and cardiology.

## COMPLICATIONS

Acute KD is complicated in 1–2% of patients by macrophage activation syndrome (MAS; see Chapter 207), a syndrome of life-threatening hyperinflammation on the spectrum of hemophagocytic lymphohistiocytosis. MAS may mimic MIS-C. These patients may present with hyperferritinemia, coagulopathy, thrombocytopenia, and shock, warranting more aggressive immunosuppressive therapy.

In all phases of KD, patients with giant coronary aneurysms may experience myocardial infarction, angina, and sudden death due to thrombosis. For this reason, aspirin is continued indefinitely in children with coronary aneurysms (Table 208.7). When aneurysms are moderate-sized, dual antiplatelet therapy (e.g., aspirin and clopidogrel) is sometimes administered. For those with large or giant aneurysms, anticoagulation with warfarin or low-molecular-weight heparin is added to aspirin. For acute thrombosis that occasionally occurs in an aneurysmal or stenotic coronary artery, thrombolytic therapy may be lifesaving. In very rare circumstances of severe, giant aneurysms, rupture can occur.

Long-term follow-up of patients with CAAs is tailored to the past (i.e., worst-ever) and current coronary status, with a schedule of testing recommended in the 2017 AHA scientific statement on KD (see Table 208.2). Testing may include echocardiography, assessment for inducible ischemia, advanced imaging (CT, MRI, or invasive angiography), physical activity counseling, and cardiovascular risk factor assessment and management. Patients with coronary artery stenosis and inducible ischemia may be managed with coronary artery bypass grafting (CABG) or catheter

**Table 208.5** Treatment of Kawasaki Disease

ACUTE STAGE	
<i>Standard risk:</i> Intravenous immune globulin 2g/kg over 10-12hr <i>and</i> Aspirin 30-50mg/kg/day divided every 6hr orally until patient is afebrile for at least 48hr	
<i>High risk* for coronary artery abnormalities:</i> Intravenous immune globulin and aspirin as above, <i>plus</i> methylprednisolone 2 mg/kg/d IV divided q12hr until afebrile, then prednisolone orally until CRP normalized, then taper over 2-3 wk	
CONVALESCENT STAGE	
Aspirin 3-5mg/kg once daily orally until 6- after illness onset if normal coronary findings throughout course	

\*High risk for coronary artery abnormalities is defined as age <6 months or baseline left anterior descending (LAD) or right circumflex artery (RCA) z-score greater than or equal to 2.5.

**Table 208.6** Treatment Options for IVIG-Resistant Patients with Kawasaki Disease\*

AGENT	DESCRIPTION	DOSE
<b>MOST FREQUENTLY ADMINISTERED</b>		
IVIG: second infusion	Pooled polyclonal IG	2 g/kg IV
IVIG + methylprednisolone/prednisolone	IVIG + glucocorticoid	IVIG: 2 g/kg IV + methylprednisolone 2 mg/kg/d IV divided every 12 hr until afebrile, then oral prednisolone 2 mg/kg/d divided twice daily
Infliximab	Monoclonal antibody against TNF- $\alpha$	Single infusion: 5-10 mg/kg IV
<b>ALTERNATIVE TREATMENTS</b>		
Anakinra	Recombinant IL-1 $\beta$ receptor antagonist	2-8 mg/kg/day given by subcutaneous injection or IV infusion
Cyclosporine	Inhibitor of calcineurin-NFAT pathway	IV: 3 mg/kg/d divided every 12 hr PO: 4-8 mg/kg/d divided every 12 hr Adjust dose to achieve trough 50-150 ng/mL; 2 hr peak level 300-600 ng/mL
Cyclophosphamide	Alkylating agent blocks DNA replication	10-15 mg/kg IV, 1 or 2 doses
Plasma exchange	Replaces plasma with albumin	1-5 cycles

\*IVIG resistance is defined as persistent or recrudescent fever at least 36 hr and <7 days after completion of first IVIG infusion. The top three treatments have been most frequently used, although no comparative effectiveness trial has been performed. Pulsed high-dose corticosteroid treatment is not recommended. The alternative treatments have been used in a limited number of patients with KD.

CRP, C-reactive protein; IG, immunoglobulin; IL, interleukin; IV, intravenous(ly); IVIG, intravenous immune globulin; NFAT, nuclear factor of activated T cells; PO, oral; TNF, tumor necrosis factor.

**Table 208.7** Anticoagulation for Coronary Artery Abnormalities in Kawasaki Disease**LONG TERM THERAPY**

Small aneurysms: Aspirin 3-5 mg/kg/d

Medium aneurysms: Aspirin +/- clopidogrel 1 mg/kg/d (max 75 mg/d)

Giant aneurysms: Aspirin + anticoagulation with warfarin, low molecular weight heparin, or direct oral anticoagulants (e.g. apixaban)

**ACUTE CORONARY THROMBOSIS**

Prompt fibrinolytic therapy with tissue plasminogen activator or other thrombolytic agent under the supervision of a pediatric cardiologist

interventions, including percutaneous transluminal coronary rotational ablation, directional coronary atherectomy, and stent implantation.

Patients undergoing long-term aspirin therapy should receive annual influenza vaccination to reduce the risk of Reye syndrome. A different antiplatelet agent can be substituted for aspirin during the 6 weeks after varicella vaccination. IVIG may interfere with the immune response to live virus vaccines as a result of a specific antiviral antibody, so the measles-mumps-rubella and varicella vaccinations should generally be deferred until 11 months after IVIG administration. Nonlive vaccinations do not need to be delayed.

**PROGNOSIS**

The vast majority of patients with KD return to normal health; timely treatment reduces the risk of coronary aneurysms to <5%. Acute KD recurs in 1–3% of cases. Published fatality rates are very low, generally <1%. The prognosis for patients with CAA depends on the severity of coronary disease; therefore recommendations for follow-up and management are stratified according to coronary artery status. A 6-week echocardiogram may be unnecessary in patients with normal coronary artery measurements at baseline and at 2 weeks of illness, as these children very rarely develop new abnormalities over time. Overall, ~50% of CAAs remodel to normal lumen diameter by 1-2 years after the illness, with smaller aneurysms being more likely to regress. Intravascular ultrasonography has demonstrated that regressed aneurysms are associated with marked myointimal thickening and abnormal vascular function. Giant aneurysms are less likely to regress to normal lumen diameter and are more likely to lead to thrombosis or stenosis. Bypass grafting may be required if there is inducible ischemia; it is best accomplished with the use of arterial grafts, which grow with the child and are more likely than venous grafts to remain patent over the long term. Heart transplantation has been required in rare cases where revascularization is not feasible because of distal coronary stenoses, distal aneurysms, or severe ischemic cardiomyopathy. A study from Japan reported outcomes in adult patients with a history of KD and giant aneurysms. These patients required multiple cardiac and surgical procedures, but the 30-years survival rate approached 90%.

The long-term outcomes of children who have had KD and never had coronary artery abnormalities, based upon reliable echocardiograms performed early in the course of disease, appear to be similar to those in the normative population. Although studies of endothelial dysfunction in children with a history of KD and normal coronary dimensions have produced conflicting results, reassuring data suggest that the standardized mortality ratio among adults in Japan who had KD in childhood without aneurysms is indistinguishable from that of the general population. All children with a history of KD should be counseled regarding a heart-healthy diet, adequate amounts of exercise, tobacco avoidance, and intermittent lipid monitoring. Among children with coronary aneurysms, the AHA recommends treatment thresholds for risk factors for atherosclerotic heart disease that are lower than those for the normal population.

Visit Elsevier eBooks+ at [eBooks.Health.Elsevier.com](http://eBooks.Health.Elsevier.com) for Bibliography.

## Chapter 209

**Sarcoidosis**

Laura Cannon and Eveline Y. Wu

Sarcoidosis is a rare multisystem granulomatous disease of unknown etiology. There appears to be two distinct, age-dependent patterns of disease among children with sarcoidosis. The clinical features in older children are similar to those in adults (pediatric-onset adult sarcoidosis), with frequent systemic features (fever, weight loss, malaise), pulmonary involvement, and lymphadenopathy. In contrast, early-onset sarcoidosis manifesting in children <4 years of age is characterized by the triad of rash, uveitis, and polyarthrits.

**ETIOLOGY**

The etiology of sarcoidosis remains obscure but likely results from exposure of a genetically susceptible individual to one or more unidentified antigens. This exposure initiates an exaggerated immunologic response that ultimately leads to the formation of granulomas. The human major histocompatibility complex is located on chromosome 6, and specific human leukocyte antigen (HLA) class I and class II alleles are associated with disease phenotype. Genetic polymorphisms involving various cytokines and chemokines may also have a role in development of sarcoidosis. Familial clustering supports the contribution of genetic factors to sarcoidosis susceptibility. Environmental and occupational exposures are also associated with disease risk. There are positive associations between sarcoidosis and agricultural employment, occupational exposure to insecticides, and moldy environments typically associated with microbial bioaerosols.

**Blau syndrome** is an autosomal dominant, familial form of sarcoidosis and is typified by the early onset of granulomatous inflammation involving the skin, eyes, and joints. Pathogenic genetic variants in the *CARD15/NOD2* gene have been found in affected family members and appear to be associated with development of sarcoidosis. Similar genetic variants have been found in individuals with a sporadic **early-onset sarcoidosis (EOS)** (rash, uveitis, arthritis), suggesting that this nonfamilial form and Blau syndrome are genetically and phenotypically identical (see [Chapter 204](#)).

**EPIDEMIOLOGY**

A nationwide patient registry of childhood sarcoidosis in Denmark estimated the annual incidence to be 0.22-0.27 per 100,000 children. The incidence increases with age, and peak onset occurs at 20-39 years. The most common age of reported childhood cases is 13-15 years. In comparison, an international registry and Spanish cohort of Blau syndrome and EOS reported the mean age of disease onset as 30 months and 36 months, respectively. There is no clear gender predilection in any form of childhood sarcoidosis. The majority of U.S. childhood sarcoidosis cases are reported in the southeastern and southcentral states.

**PATHOLOGY AND PATHOGENESIS**

*Noncaseating, epithelioid granulomatous lesions* are a cardinal feature of sarcoidosis. Activated macrophages, epithelioid cells, and multinucleated giant cells, as well as CD4<sup>+</sup> T lymphocytes, accumulate and become tightly packed in the center of the granuloma. The causative agent that initiates this inflammatory process is unknown. The periphery of the granuloma contains a loose collection of monocytes, CD4<sup>+</sup> and CD8<sup>+</sup> T lymphocytes, and fibroblasts. The interaction between the macrophages and CD4<sup>+</sup> T lymphocytes is important in the formation and maintenance of the granuloma. The activated macrophages secrete high levels of tumor necrosis factor (TNF)- $\alpha$  and other proinflammatory mediators. The CD4<sup>+</sup> T lymphocytes differentiate into type 1 helper T cells and release interleukin (IL)-2 and interferon (IFN)- $\gamma$ , promoting proliferation of lymphocytes. Granulomas may heal or resolve with complete preservation of the parenchyma. In approximately 20% of the

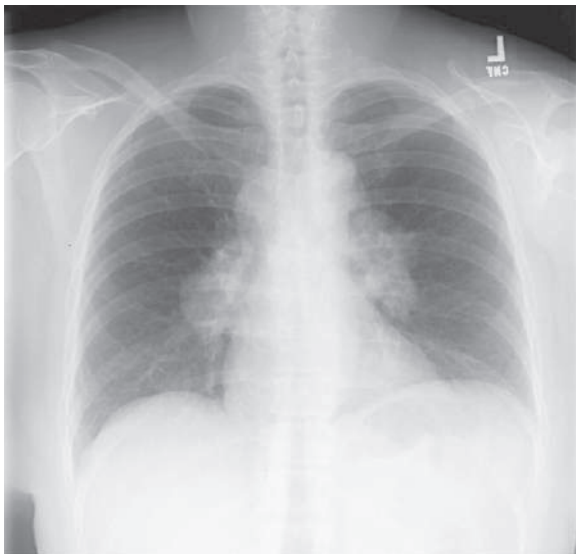
lesions, the fibroblasts in the periphery proliferate and produce fibrotic scar tissue, leading to significant and irreversible organ dysfunction.

The sarcoid macrophage is able to produce and secrete 1,25-(OH)<sub>2</sub>-vitamin D, or *calcitriol*, an active form of vitamin D typically produced in the kidneys. The hormone's natural functions are to increase intestinal absorption of calcium and bone resorption and decrease renal excretion of calcium and phosphate. An excess of calcitriol may result in hypercalcemia and hypercalciuria in patients with sarcoidosis.

### CLINICAL MANIFESTATIONS

Sarcoidosis is a multisystem disease, and granulomatous lesions may occur in any organ of the body. The clinical manifestations depend on the extent and degree of granulomatous inflammation and are extremely variable. Children may present with nonspecific symptoms, such as fever, weight loss, and general malaise. In adults and older children, pulmonary involvement is most frequent, with infiltration of the thoracic lymph nodes and lung parenchyma. Isolated bilateral hilar adenopathy on chest radiograph is the most common finding (Fig. 209.1), but parenchymal infiltrates and miliary nodules may also be seen (Figs. 209.2, 209.3, and 209.4). Patients with lung involvement are usually found to have restrictive changes on pulmonary function testing. Symptoms of pulmonary disease are seldom severe and generally consist of a dry, persistent cough.

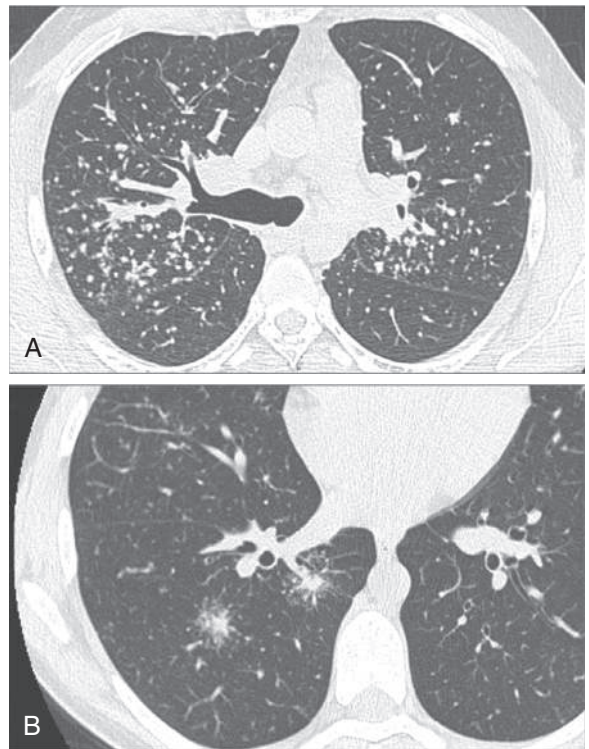
Extrathoracic lymphadenopathy and infiltration of the liver, spleen, and bone marrow also occur often (Table 209.1). Infiltration of the liver and spleen typically leads to isolated hepatomegaly and splenomegaly, respectively, but actual organ dysfunction is rare. Cutaneous disease, such as plaques, nodules, erythema nodosum in acute disease, or lupus pernio in chronic sarcoidosis, appears in one quarter of cases and is usually present at onset. Red-brown to purple maculopapular lesions <1 cm on the face, neck, upper back, and extremities are the most common skin finding (Fig. 209.5). Papulonodular granulomatous lesions have been reported to develop in cosmetic (eyebrows) and decorative tattoos (tattoo sarcoidosis). Ocular involvement is frequent and has variable manifestations, including anterior or posterior uveitis, conjunctival granulomas, eyelid inflammation, and orbital or lacrimal gland infiltration. The arthritis in sarcoidosis can be confused with **juvenile idiopathic arthritis** (JIA). Central nervous system (CNS) involvement is rare in early childhood but may manifest as seizures, cranial nerve involvement, intracranial mass lesions, and hypothalamic dysfunction (Fig. 209.6). Kidney disease occurs infrequently in children but typically



**Fig. 209.1** Sarcoidosis. Chest radiograph demonstrating stage I disease with enlarged mediastinal and hilar lymph nodes. (From Iannuzzi M. *Sarcoidosis*. In Goldman L, Schafer AI, eds. *Goldman's Cecil Medicine*, 24th ed. Philadelphia: Saunders; 2012: Fig. 95-1, p. 582.)



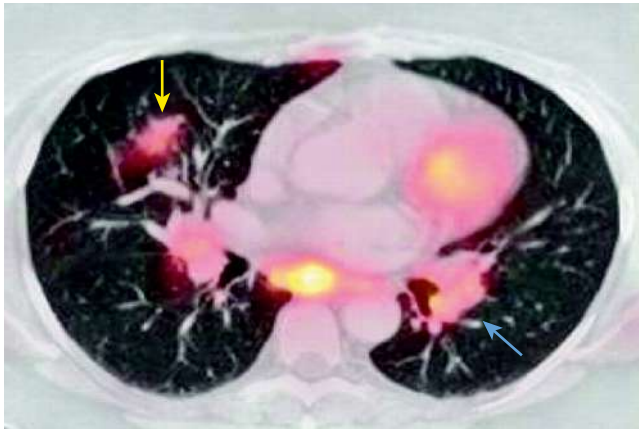
**Fig. 209.2** Sarcoidosis. Chest radiograph of 10-year-old girl showing widely disseminated peribronchial infiltrates, multiple small nodular densities, hyperaeration of the lungs, and hilar lymphadenopathy.



**Fig. 209.3** Typical features of lung sarcoidosis on CT. **A**, Usual perilymphatic distribution of micronodules with fissural spreading. **B**, Typical nodules with irregular margins and satellite micronodules known as the *galaxy sign*. (From Valerye D, Prasse A, Nunes H, et al. *Sarcoidosis*. *Lancet*. 2014;383:1155–1167, Fig. 2, p. 1158.)

manifests as renal insufficiency, proteinuria, transient pyuria, or microscopic hematuria caused by early monocellular infiltration or granuloma formation in kidney tissue. Only a small fraction of children have hypercalcemia or hypercalciuria. Sarcoid granulomas can also infiltrate the heart and lead to cardiac arrhythmias and, rarely, sudden death. Other





**Fig. 209.4** Confluent parenchymal lung nodules and mediastinal and bilateral hilar lymphadenopathy with increased FDG uptake in a female with biopsy-proven sarcoidosis. PET/CT shows confluent parenchymal lung nodules (yellow arrow) and mediastinal and bilateral hilar lymphadenopathy (blue arrow). These abnormalities show increased FDG uptake on fused PET/CT. (Modified from Prabhakar HB, Rabinowitz CB, Gibbons FK, et al. Imaging features of sarcoidosis on MDCT, FDG PET, and PET/CT. *AJR Am J Roentgenol.* 2008;190:S1–S6, Fig. 6, p. S4.)

rare sites of disease involvement include blood vessels of any size, the gastrointestinal tract, parotid gland, muscles, bones, and testes.

In contrast to the variable clinical presentation of sarcoidosis in older children, **Blau syndrome and EOS** (NOD2-associated sarcoidosis) classically manifest as the triad of uveitis, arthritis, and rash (see Chapter 204). **Infantile-onset panniculitis with uveitis and systemic granulomatosis** is an uncommon manifestation of sarcoidosis.

### LABORATORY FINDINGS

There is no single standard laboratory test diagnostic of sarcoidosis. Anemia, leukopenia, and eosinophilia may be seen. Other nonspecific findings include hypergammaglobulinemia and elevations in acute-phase reactants, including ESR and CRP. Hypercalcemia and/or hypercalciuria occur in only a small proportion of children with sarcoidosis. Angiotensin-converting enzyme (ACE) is produced by the epithelioid cells of the granuloma, and *its serum value may be elevated, but this finding lacks diagnostic sensitivity and specificity.* ACE levels are estimated to be elevated in >50% of children with sarcoidosis. In addition, ACE values may be difficult to interpret because reference values for serum ACE are age dependent. Fluorodeoxyglucose-positron emission tomography (FDG-PET) (with either CT or MRI) can help identify nonpulmonary (lymph nodes, bone, cardiac, liver, spleen) sites for a diagnostic evaluation or biopsy (Fig. 209.7).

### DIAGNOSIS

Definitive diagnosis ultimately requires demonstration of the characteristic noncaseating granulomatous lesions in a biopsy specimen (usually taken from the most readily available affected organ) and exclusion of other known causes of granulomatous inflammation. Skin and transbronchial lung biopsies have higher yield, greater specificity, and fewer associated adverse events than biopsy of mediastinal lymph nodes or liver. Additional diagnostic testing includes chest radiography, pulmonary function testing with measurement of diffusion capacity, hepatic enzyme measurements, and renal function assessment. Ophthalmologic slit-lamp examination is essential because ocular inflammation is frequently present and may be asymptomatic in sarcoidosis, and vision loss is a sequela of untreated disease.

Bronchoalveolar lavage may be used to assess for disease activity, and the fluid typically reveals an excess of lymphocytes with an increased CD4<sup>+</sup>/CD8<sup>+</sup> ratio of 2-13:1. In addition to flexible bronchoscopy with transbronchial biopsy, endosonographic-guided intrathoracic node aspiration has been valuable in obtaining tissue to assess for noncaseating granulomas.

**Table 209.1** Sarcoidosis: Extrapulmonary Localizations

SYMPTOMS	
Skin	Papules, nodules, plaques, scar sarcoidosis, lupus pernio, subcutaneous sarcoidosis, granuloma annulare, lip granulomas, vitiligo, erythema nodosum, Lofgren syndrome*
Peripheral lymphadenopathy	Mostly cervical or supraclavicular; inguinal, axillary, epitrochlear, or submandibular lymph node sites also possible; painless and mobile
Eye	Anterior, intermediate, or posterior uveitis; retinal vascular change; conjunctival nodules; lacrimal gland enlargement
Liver	Often symptom free; abnormal liver function tests in 20–30% of patients; hepatomegaly; rarely hepatic insufficiency, chronic intrahepatic cholestasis, or portal hypertension
Spleen	Splenomegaly; rarely, pain or pancytopenia; very rarely, splenic rupture
Heart	Atrioventricular or bundle branch block; ventricular tachycardia or fibrillation; congestive heart failure; pericarditis; impairment of sympathetic nerve activity; sudden death
Nervous system	Facial nerve palsy, optic neuritis, leptomeningitis, diabetes insipidus, hypopituitarism, seizures, cognitive dysfunction, deficits, hydrocephalus, psychiatric manifestations, spinal cord disease, polyneuropathy, small-fiber neuropathy
Kidney	Rare symptoms; increased creatinine sometimes associated with hypercalcemia; nephrocalcinosis; kidney stones
Parotitis	Symmetric parotid swelling; Heerfordt syndrome when associated with uveitis, fever, and facial palsy
Nose	Nasal stuffiness, nasal bleeding, crusting, anosmia
Larynx	Hoarseness, breathlessness, stridor, dysphagia
Bones	Often asymptomatic; hands and feet classically most involved, also large bones and axial skeleton
Skeletal muscles	Proximal muscle weakness, amyotrophy, myalgia, intramuscular nodules
Genitourinary tract	All organs can be involved, including breast, uterus, epididymis, and testicle
Gastrointestinal tract	Most often symptom free, but the esophagus, stomach, small intestine, and colon can be involved

\*Lofgren syndrome: acute arthritis, erythema nodosum, and hilar adenopathy. Adapted from Valerye D, Prasse A, Nunes H, et al. Sarcoidosis. *Lancet.* 2014;383:1155–1167, Table 1.

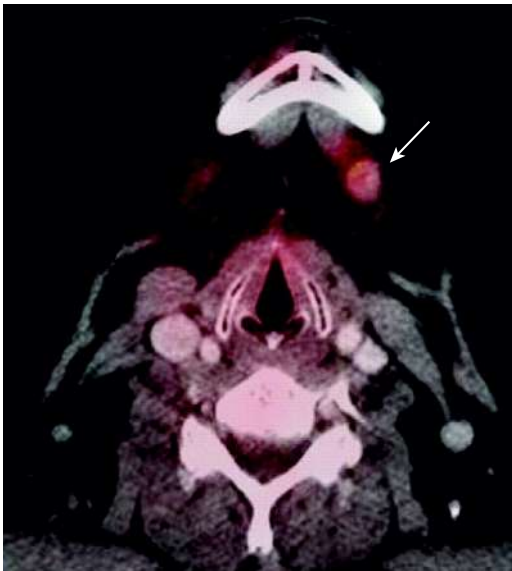


**Fig. 209.5** Sarcoidosis nodules on the face. (From Shah BR, Laude TA. *Atlas of Pediatric Clinical Diagnosis.* Philadelphia: Saunders; 2000.)





**Fig. 209.6** Neurologic involvement in sarcoidosis. Typical involvement of hypothalamus, pituitary gland, and optic chiasm seen on a sagittal gadolinium-enhanced T1-weighted sequence MRI (small arrow). Abnormal nodular enhancement of the fourth ventricle is seen (large arrow). (Modified from Valerye D, Prasse A, Nunes H, et al. *Sarcoidosis*. *Lancet*. 2014;383:1155–1167, Fig. 3D, p. 1160.)



**Fig. 209.7** Palpable submental lymph node with FDG uptake. Axial fused contrast-enhanced PET/CT image shows enlarged left submental lymph node (arrow) with increased FDG uptake. Lesion was biopsied and was consistent with sarcoidosis. (From Prabhakar HB, Rabinowitz CB, Gibbons FK, et al. *Imaging features of sarcoidosis on MDCT, FDG PET, and PET/CT*. *AJR Am J Roentgenol*. 2008;190:S1–S6, Fig. 5, p. S3.)

## DIFFERENTIAL DIAGNOSIS

Because of its protean manifestations, the differential diagnosis of sarcoidosis is extremely broad and depends largely on the initial clinical manifestations. **Granulomatous infections**, including tuberculosis, cryptococcosis, pulmonary mycoses (histoplasmosis, blastomycosis, coccidioidomycosis), brucellosis, tularemia, and toxoplasmosis, must be excluded. Other causes of granulomatous inflammation are granulomatosis with polyangiitis (formerly Wegener granulomatosis), hypersensitivity pneumonia, chronic berylliosis, and other occupational exposures to metals. Localized granulomatous lesions of the head and neck may be due to **orofacial granulomatosis (Melkersson-Rosenthal syndrome)**. Other granulomatous

**Table 209.2** Granulomatous Disorders with Head and Neck Manifestations

### AUTOIMMUNE

GPA (Wegener granulomatosis)  
Churg-Strauss syndrome  
Behçet disease

### INFECTIOUS

Tuberculosis  
Cat-scratch fever  
Syphilis  
Leprosy  
Fungal (blastomycosis, histoplasmosis)  
Actinomycosis

### IDIOPATHIC/INFLAMMATION

Sarcoidosis  
Orofacial granulomatosis (Melkersson-Rosenthal syndrome)

### HEREDITARY

CGD

### OTHER DISEASES WITH SECONDARY GRANULOMATOUS MANIFESTATIONS

Relapsing polychondritis  
LCH  
SLE  
Rheumatoid arthritis  
Chemical exposure (e.g., cocaine, talc, beryllium)

CGD, chronic granulomatous disease; GPA, Granulomatosis with polyangiitis; LCH, Langerhans cell histiocytosis; SLE, systemic lupus erythematosus.

Modified from Nwawka OK, Nadgir R, Fujita A, Sakai O. Granulomatous disease in the head and neck: Developing a differential diagnosis. *RadioGraphics*. 2014;34(5):1240–1256, Table 1.

lesions involving the head, neck, and orofacial regions are noted in [Table 209.2](#). Immunodeficiencies that may manifest with granulomatous lesions include common variable immunodeficiency, selective IgA deficiency, chronic granulomatous disease, ataxia telangiectasia, and severe combined immunodeficiency. Granulomas of the lung, skin, or lymph nodes have been reported in patients treated with anti-TNF agents. Lymphoma should be ruled out in cases of hilar or other lymphadenopathy. Sarcoid arthritis may mimic JIA. Evaluation for endocrine disorders is needed in the setting of hypercalcemia or hypercalciuria.

## TREATMENT

Treatment should be based on disease severity and the number and type of organs involved. *Corticosteroids are the mainstay of treatment for most acute and chronic disease manifestations.* The optimal dose and duration of corticosteroid therapy in children have not been established. Induction treatment typically begins with oral prednisone or prednisolone (1–2 mg/kg/day up to 40 mg daily) for 8–12 weeks until manifestations improve. Corticosteroid dosage is then gradually decreased over 6–12 months to the minimal effective maintenance dose (e.g., 5–10 mg/day) that controls symptoms, or discontinued if symptoms resolve. *Methotrexate* or *leflunomide* may be effective as a corticosteroid-sparing agent. On the basis of the role of TNF- $\alpha$  in the formation of granulomas, there is rationale for the use of TNF- $\alpha$  antagonists. Results of small clinical trials showed modest effects with *infliximab* and *adalimumab* treatment of selected disease manifestations (CNS, lupus pernio, pulmonary, ocular), whereas etanercept does not appear to be particularly effective. Other therapeutics used for sarcoidosis manifestations include topical corticosteroids (eye), inhaled corticosteroids (lung), azathioprine (CNS), cyclophosphamide (cardiac, CNS), hydroxychloroquine (skin), mycophenolate mofetil (CNS, skin), thalidomide or its analogs (skin), and nonsteroidal antiinflammatory drugs (joints).

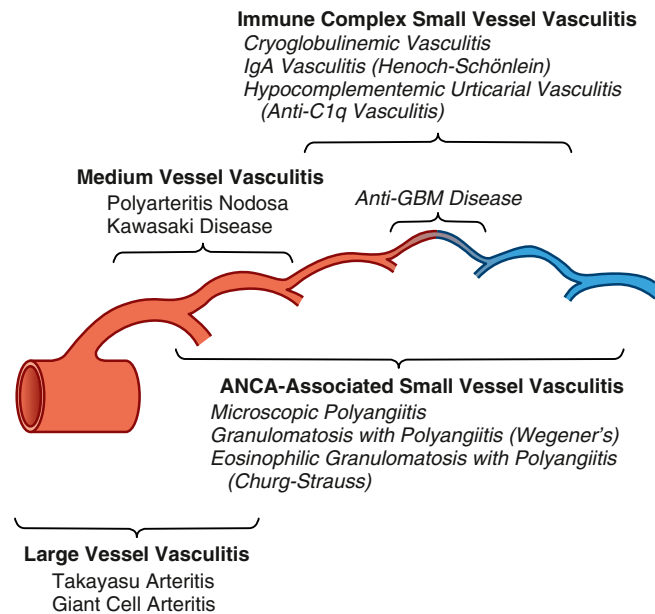
## PROGNOSIS

The prognosis of childhood sarcoidosis is not well defined. The disease may be self-limited with complete recovery or may persist with a progressive or relapsing course. Outcome is worse in the setting of

multiorgan or CNS involvement. Most children requiring treatment experience considerable improvement with corticosteroids, although a significant number have morbid sequelae, mainly involving the lungs and eyes. Children with early-onset sarcoidosis have a poorer prognosis and generally experience a more chronic, progressive disease course. The greatest morbidity is associated with ocular involvement, including cataract formation, development of synechiae, and loss of visual acuity or blindness. Long-term systemic treatment may be required for the eye disease. Progressive polyarthritis may result in joint destruction. The overall mortality rate in older children with sarcoidosis is low.

Serial pulmonary function tests and chest radiographs are useful in following the course of lung involvement. Monitoring for other organ involvement should also include electrocardiogram with consideration of an echocardiogram, urinalysis, renal function tests, and measurements of hepatic enzymes and serum calcium. Other potential indicators of disease activity include inflammatory markers and serum ACE, although changes in ACE level do not always correlate with other indicators of disease status. Given the frequency of asymptomatic eye disease and the ocular morbidity associated with pediatric sarcoidosis, all patients should have an ophthalmologic examination at presentation with monitoring at regular intervals, perhaps every 3-6 months, as recommended in children with JIA.

Visit Elsevier eBooks+ at [eBooks.Health.Elsevier.com](http://eBooks.Health.Elsevier.com) for Bibliography.



**Fig. 210.1** Distribution of vessel involvement in large, medium, and small vessel vasculitis. There is substantial overlap with respect to arterial involvement, and all three major categories of vasculitis can affect any size artery. Large vessel vasculitis affects large arteries more often than other vasculitides. Medium vessel vasculitis predominantly affects medium arteries. Small vessel vasculitis predominantly affects small vessels, but medium arteries and veins may be affected, although immune complex small vessel vasculitis rarely affects arteries. Not shown is *variable vessel vasculitis*, which can affect any type of vessel, from aorta to veins. The diagram depicts (from left to right) aorta, large artery, medium artery, small artery/arteriole, capillary, venule, and vein. ANCA, Antineutrophil cytoplasmic antibody; GBM, glomerular basement membrane. (From Jennette JC, Falk RJ, Bacon PA, et al. 2012 Revised International Chapel Hill Consensus Conference Nomenclature of Vasculitides. *Arthritis Rheum.* 2013;65:1-11, Fig. 2, p. 4.)

## Chapter 210

# Vasculitis Syndromes

Vidya Sivaraman, Edward C. Fels, and Stacy P. Ardoin

## INTRODUCTION

Childhood vasculitis encompasses a broad spectrum of diseases that share inflammation of the blood vessels as the central pathophysiology. The pathogenesis of the vasculitides is generally idiopathic. Some forms of vasculitis are associated with infectious agents and medications, whereas others may occur in the setting of preexisting autoimmune or autoinflammatory diseases. The pattern of vessel injury provides insight into the form of vasculitis and serves as a framework to delineate the different vasculitic syndromes. The distribution of vascular injury includes *small vessels* (capillaries, arterioles, and postcapillary venules), *medium vessels* (renal arteries, mesenteric vasculature, and coronary arteries), and *large vessels* (the aorta and its proximal branches) (Fig. 210.1). Additionally, some forms of small vessel vasculitis are characterized by the presence of **antineutrophil cytoplasmic antibodies (ANCA)**, whereas others are associated with **immune complex** deposition in affected tissues. A combination of clinical features, histologic appearance of involved vessels, and laboratory data is used to classify vasculitis (Tables 210.1-210.4). A nomenclature system from the 2012 International Chapel Hill Consensus Conference (see Table 210.1) has proposed using the pathologic diagnosis rather than eponyms for vasculitis nomenclature. For example, Henoch-Schönlein purpura would be referred to as IgA vasculitis. Additionally, the classification criteria endorsed by the European League Against Rheumatism (EULAR), Pediatric Rheumatology International Trial Organization (PRINTO), and Pediatric Rheumatology European Society (PRES) have been validated in childhood vasculitis (see Table 210.2).

Childhood vasculitis varies from a relatively benign and self-limited disease such as Henoch-Schönlein purpura (IgA vasculitis) to catastrophic disease with end-organ damage, as seen in granulomatosis with polyangiitis (formerly Wegener granulomatosis). Vasculitis generally manifests as a heterogeneous multisystem disease. Although some features, such as purpura, are easily identifiable, others, such as hypertension secondary to renal artery stenosis or glomerulonephritis, can be subtler. Ultimately, the key to recognizing vasculitis relies heavily on *pattern recognition*. Demonstration of vessel injury and inflammation on biopsy or vascular imaging is required to confirm a diagnosis of vasculitis.

Clues to the diagnosis of a vasculitis disorder are noted in Table 210.3, and a broad diagnostic approach is noted in Table 210.5.

Visit Elsevier eBooks+ at [eBooks.Health.Elsevier.com](http://eBooks.Health.Elsevier.com) for Bibliography.

## 210.1 Henoch-Schönlein Purpura (IgA Vasculitis)

Vidya Sivaraman, Edward C. Fels, and Stacy P. Ardoin

Henoch-Schönlein purpura (HSP) is the most common vasculitis of childhood and is characterized by leukocytoclastic vasculitis and immunoglobulin A deposition in the small vessels in the skin, joints, gastrointestinal tract, and kidney. HSP is also referred to as **IgA vasculitis**, based on the presence of vasculitis with predominance of IgA deposits affecting small vessels.

**Table 210.1** 2012 Chapel Hill Consensus Conference on Nomenclature of Systemic Vasculitis

<b>LARGE VESSEL VASCULITIS (LVV)*</b>	
Giant cell (temporal) arteritis (GCA)	Granulomatous arteritis of the aorta and its major branches with a predilection for the extracranial branches of the carotid artery <i>Often involves the temporal artery</i> <i>Usually occurs in patients older than 50 yr of age and often associated with polymyalgia rheumatica<sup>†</sup></i>
Takayasu arteritis (TAK)	Granulomatous inflammation of the aorta and its major branches <i>Usually occurs in patients much younger than 50 yr of age</i>
<b>MEDIUM VESSEL VASCULITIS (MVV)*</b>	
Polyarteritis nodosa (PAN)	Necrotizing inflammation of medium-sized or small arteries without glomerulonephritis or vasculitis in arterioles, capillaries, or venules and not associated with ANCA
Kawasaki disease (KD)	Arteritis involving large, medium-sized, and small arteries associated with mucocutaneous lymph node syndrome <i>Coronary arteries are often involved</i> <i>Aorta and veins may be affected</i> <i>Usually occurs in children</i>
<b>SMALL VESSEL VASCULITIS (SVV)*</b>	
<b>ANCA-associated vasculitis (AAV)</b>	
Granulomatosis with polyangiitis (Wegener) (GPA)	Granulomatous inflammation involving the respiratory tract associated with necrotizing vasculitis affecting small- to medium-sized vessels <i>Necrotizing glomerulonephritis is common</i>
Eosinophilic granulomatosis with polyangiitis (Churg-Strauss) (EGPA)	Eosinophilic and granulomatous inflammation involving the respiratory tract accompanied by necrotizing vasculitis affecting small to medium-sized vessels associated with asthma and eosinophilia
Microscopic polyangiitis (MPA)	Necrotizing vasculitis with few or no immune deposits, affecting small vessels <i>Necrotizing arteritis involving small and medium-sized arteries may be present</i> <i>Necrotizing glomerulonephritis is common</i> <i>Pulmonary capillaritis often occurs</i>
<b>Immune Complex Small Vessel Vasculitis</b>	
IgA vasculitis (Henoch-Schönlein) (IgAV)	Vasculitis characterized by immunoglobulin A–dominant immune deposits affecting small vessels <i>Typically involves skin, gut, and glomeruli. Arthralgias and arthritis are common</i>
Cryoglobulinemic vasculitis (CPV)	Vasculitis with cryoglobulin immune deposits affecting small vessels associated with cryoglobulinemia <i>Skin and glomeruli are often involved</i>
Anti–glomerular basement membrane (anti-GBM) disease	Vasculitis affecting pulmonary and renal capillaries with deposition of anti–glomerular basement membrane antibodies
Hypocomplementemic urticarial vasculitis	Associated with anti-C1q antibodies <i>Affects kidney, joints, lungs, and eyes</i>
<b>VARIABLE VESSEL VASCULITIS (VVV)</b>	
Behçet disease (BD)	Affects arteries and veins with thrombosis, arteritis, and arterial aneurysms <i>Oral and/or genital aphthous ulcers and can involve skin, eyes, joints, and central nervous system</i>
Cogan syndrome (CS)	Affects small, medium, or large arteries; aortitis, aortic, and mitral valvulitis
<b>SINGLE-ORGAN VASCULITIS (SOV)</b>	
Cutaneous leukocytoclastic angiitis	Vasculitis Isolated cutaneous leukocytoclastic angiitis without systemic vasculitis or glomerulonephritis
Cutaneous arteritis	Cutaneous vasculitis not associated with systemic vasculitis
Primary central nervous system vasculitis	CNS vasculitis not associated with systemic vasculitis
Isolated aortitis	Aortitis not associated with systemic vasculitis
Others	
<b>VASCULITIS ASSOCIATED WITH SYSTEMIC DISEASE</b>	
Lupus vasculitis	
Rheumatoid vasculitis	
Sarcoid vasculitis	
Others	
<b>VASCULITIS ASSOCIATED WITH PROBABLE ETIOLOGY</b>	
Hepatitis C–associated cryoglobulinemia vasculitis	
Hepatitis B–associated vasculitis	
Syphilis-associated vasculitis	
Drug-associated immune complex vasculitis	
Drug-associated ANCA associated vasculitis	
Cancer-associated vasculitis	
Others	

\*Large vessels: aorta and its larger branches directed toward major anatomic regions; medium vessels: renal, hepatic, coronary, and mesenteric arteries; small vessels: venules, capillaries, arterioles, and intraparenchymal distal arteries and arterioles.

<sup>†</sup>Essential components are in normal type; *italicized type* represents usual, but not essential, components.  
Adapted from Jennette JC, Falk RJ, Bacon P, et al. *Arthritis Rheum.* 2013;65(1):1–11.

**Table 210.2** EULAR/PRES Classification of Childhood Vasculitis

<p><b>I. PREDOMINANTLY LARGE-SIZED VESSEL VASCULITIS</b></p> <ul style="list-style-type: none"> <li>• Takayasu arteritis</li> </ul> <p><b>II. PREDOMINANTLY MEDIUM-SIZED VESSEL VASCULITIS</b></p> <ul style="list-style-type: none"> <li>• Childhood polyarteritis nodosa</li> <li>• Cutaneous polyarteritis</li> <li>• Kawasaki disease</li> </ul> <p><b>III. PREDOMINANTLY SMALL-SIZED VESSEL VASCULITIS</b></p> <p>A. Granulomatous</p> <ul style="list-style-type: none"> <li>• Wegener granulomatosis*</li> <li>• Churg-Strauss syndrome*</li> </ul> <p>B. Nongranulomatous</p> <ul style="list-style-type: none"> <li>• Microscopic polyangiitis</li> <li>• Henoch-Schönlein purpura</li> <li>• Isolated cutaneous leukocytoclastic vasculitis</li> <li>• Hypocomplementemic urticarial vasculitis</li> </ul> <p><b>IV. OTHER VASCULITIDES</b></p> <ul style="list-style-type: none"> <li>• Behçet disease</li> <li>• Vasculitis secondary to infection (including hepatitis B–associated polyarteritis nodosa), malignancies, and drugs (including hypersensitivity vasculitis)</li> <li>• Vasculitis associated with connective tissue diseases</li> <li>• Isolated vasculitis of the central nervous system</li> <li>• Cogan syndrome</li> <li>• Unclassified</li> </ul>
--

\*This classification predated the removal of eponyms and histopathologic subclassification by the CHCC 2012.

From Ozen S, Ruperto N, Dillon MJ, Bagga A, Barron K, Davin JC, et al. EULAR/PreS endorsed consensus criteria for the classification of childhood vasculitides. *Ann Rheum Dis*. 2006;65:936–941.

## EPIDEMIOLOGY

HSP occurs worldwide and affects all ethnic groups. The incidence is estimated at 14–20 per 100,000 children per year and affects males more than females, with a 1.2–1.8:1 male/female ratio. Approximately 90% of HSP cases occur in children, usually between ages 3 and 10 years. HSP is distinctly less common in adults, who often have severe and chronic complications. HSP is more common in the winter and spring and is unusual in summer months. Many cases of HSP follow a documented upper respiratory infection.

## PATHOLOGY

Skin biopsies demonstrate **leukocytoclastic vasculitis** of the dermal capillaries and postcapillary venules. The inflammatory infiltrate includes neutrophils and monocytes. Renal histopathology typically shows endocapillary proliferative glomerulonephritis, ranging from a focal segmental process to extensive crescentic involvement. In all tissues, immunofluorescence identifies IgA deposition in walls of small vessels (Fig. 210.2), accompanied to a lesser extent by deposition of C3, fibrin, and IgM.

## PATHOGENESIS

The exact pathogenesis of HSP remains unknown. Given the seasonality of HSP and the frequency of preceding upper respiratory infections, infectious triggers such as group A  $\beta$ -hemolytic streptococcus, *Staphylococcus aureus*, *Mycoplasma*, and adenovirus have been suspected. The common finding of deposition of IgA, specifically IgA<sub>1</sub>, suggests that HSP is a disease mediated by IgA and IgA immune complexes. HSP occasionally clusters in families, suggesting a genetic component. HLA-B34 and HLA-DRB1\*01 alleles have been linked to HSP nephritis. Patients with familial Mediterranean fever, hereditary periodic fever syndromes, and complement deficiencies are at increased risk for developing HSP, suggesting that genetically determined immune dysregulation may contribute.

**Table 210.3** Features that Suggest a Vasculitic Syndrome

### CLINICAL FEATURES

Fever, weight loss, fatigue of unknown origin  
 Skin lesions (palpable purpura, fixed urticaria, livedo reticularis, nodules, ulcers)  
 Neurologic lesions (headache, mononeuritis multiplex, focal central nervous system lesions)  
 Arthralgia or arthritis, myalgia, or myositis, serositis  
 Hypertension, hematuria, renal failure  
 Pulmonary infiltrates or hemorrhage  
 Myocardial ischemia, arrhythmias

### LABORATORY FEATURES

Increased erythrocyte sedimentation rate or C-reactive protein level  
 Leukocytosis, anemia, thrombocytosis  
 Eosinophilia  
 Antineutrophil cytoplasmic antibodies  
 Elevated factor VIII–related antigen (von Willebrand factor)  
 Cryoglobulinemia  
 Circulating immune complexes  
 Hematuria

From Petty RE, Laxer RM, Lindsley CB, Wedderburn LR. *Textbook of Pediatric Rheumatology*, 7th ed. Philadelphia: Saunders; 2016.

## CLINICAL MANIFESTATIONS

The hallmark of HSP is its **rash**: palpable purpura starting as pink macules or wheals and developing into petechiae, raised purpura, or larger ecchymoses. Occasionally, bullae and ulcerations develop. The skin lesions are usually symmetric and occur in gravity-dependent areas (lower extremities), the extensor aspect of the upper extremities, or on pressure points (buttocks) (Figs. 210.2 and 210.3). The skin lesions often evolve in groups, typically lasting 3–10 days, and may recur up to 4 months after initial presentation. Subcutaneous edema localized to the dorsa of the hands and feet, periorbital area, lips, scrotum, or scalp is also common.

Musculoskeletal involvement, including arthritis and arthralgias, is common, occurring in up to 75% of children with HSP. The arthritis tends to be self-limited and oligoarticular, with a predilection for large joints such as the knees and ankles, and does not lead to deformities. Periarticular swelling and tenderness without erythema or effusions are common. The arthritis usually resolves within 2 weeks but can recur.

Gastrointestinal (GI) manifestations occur in up to 80% of children with HSP and include abdominal pain, vomiting, diarrhea, paralytic ileus, and melena. Intussusception, mesenteric ischemia, and intestinal perforation are rare but serious complications. Endoscopic evaluation is usually not needed but may identify vasculitis of the intestinal tract.

Renal involvement occurs in up to 30% of children with HSP, manifesting as microscopic hematuria, proteinuria, hypertension, frank nephritis, nephrotic syndrome, and acute or chronic renal failure. However, progression to end-stage renal disease (ESRD) is uncommon in children (1–2%) (see Chapter 560.3). Renal manifestations can be delayed for several months after the initial illness, so close follow-up with serial urinalyses and blood pressure monitoring is necessary.

Neurologic manifestations of HSP, caused by hypertension (posterior reversible encephalopathy syndrome) or central nervous system (CNS) vasculitis, may also occur, including intracerebral hemorrhage, seizures, headaches, depressed level of consciousness, cranial or peripheral neuropathies, and behavior changes. Other, less common potential manifestations of HSP are inflammatory eye disease, carditis, pulmonary hemorrhage, orchitis, and testicular torsion.

## DIAGNOSIS

The diagnosis of HSP is clinical and often straightforward when the typical rash is present. However, in at least 25% of cases, the rash appears after other manifestations, making early diagnosis challenging.



**Table 210.4** Clinicopathologic Characteristics of Vasculitides in Childhood

SYNDROME	FREQUENCY	VESSELS AFFECTED	CHARACTERISTIC PATHOLOGY
<b>POLYARTERITIS</b> Polyarteritis nodosa	Rare	Medium-size and small muscular arteries and sometimes arterioles	Focal segmental (often near bifurcations); fibrinoid necrosis; gastrointestinal, renal microaneurysms; lesions at various stages of evolution
Kawasaki disease	Common	Coronary and other muscular arteries	Thrombosis, fibrosis, aneurysms, especially of coronary vessels
<b>LEUKOCYTOCLASTIC VASCULITIS</b> Henoch-Schönlein purpura (IgA vasculitis) Hypersensitivity angitis	Common Rare	Arterioles and venules, often small arteries and veins Arterioles and venules	Leukocytoclasia; mixed cells, eosinophils, IgA deposits in affected vessels Leukocytoclastic or lymphocytic, varying eosinophils, occasionally granulomatous; widespread lesions at same stage of evolution
<b>GRANULOMATOUS VASCULITIS</b> Granulomatosis with polyangiitis (Wegener granulomatosis) Eosinophilic granulomatosis with polyangiitis (Churg-Strauss syndrome)	Rare Rare	Small arteries and veins, occasionally larger vessels Small arteries and veins, often arterioles and venules	Upper and lower respiratory tract, necrotizing granulomata glomerulonephritis Necrotizing extravascular granulomata; lung involvement; eosinophilia
<b>GIANT CELL ARTERITIS</b> Takayasu arteries Temporal arteritis	Uncommon Rare	Large arteries Medium-size and large arteries	Granulomatous inflammation, giant cells; aneurysms, dissection Granulomatous inflammation, giant cell arteries

Adapted from Cassidy JT, Petty RE. *Textbook of Pediatric Rheumatology*, 6th ed. Philadelphia: Saunders; 2011.

Table 210.6 summarizes the EULAR/PRES classification criteria for HSP. Most patients are afebrile.

The **differential diagnosis** for HSP depends on specific organ involvement, but usually includes other small vessel leukocytoclastic vasculitides (Table 210.7), infections, acute poststreptococcal glomerulonephritis, hemolytic-uremic syndrome, coagulopathies, and other acute intraabdominal processes. Additional disorders in the differential include papular-purpuric glove and sock syndrome, systemic lupus erythematosus (SLE), other vasculitides (urticarial, hypersensitivity), and thrombocytopenia.

**Infantile acute hemorrhagic edema (AHE)**, an isolated cutaneous leukocytoclastic vasculitis that affects infants <2 years of age, resembles HSP clinically. AHE manifests as fever; tender edema of the face, scrotum, hands, and feet; and ecchymosis (usually larger than the purpura of HSP) on the face and extremities (Fig. 210.4). The trunk is spared, but petechiae may be seen in mucous membranes. The patient usually appears well except for the rash. The platelet count is normal or elevated, and the urinalysis results are normal. The younger age, nature of the lesions, absence of other organ involvement, and a biopsy may help distinguish infantile AHE from HSP.

### LABORATORY FINDINGS

No laboratory finding is diagnostic of HSP. Common but nonspecific findings include leukocytosis, thrombocytosis, mild anemia, and elevations of erythrocyte sedimentation rate (ESR) and C-reactive protein (CRP). *The platelet count is normal in HSP.* Occult blood is frequently found in stool specimens. Serum albumin levels may be low because of renal or intestinal protein loss. Autoantibody testing such as anti-nuclear antibody (ANA) is not useful diagnostically except to exclude other diseases. Serum IgA values are often elevated but are not routinely measured. Assessment of renal involvement with blood pressure, urinalysis, and serum creatinine is necessary.

Ultrasound is often used in the setting of GI complaints to look for bowel wall edema or the rare occurrence of an associated intussusception. Barium enema can also be used to both diagnose and treat intussusception. Although often unnecessary in typical HSP, biopsies of skin and kidney can provide important diagnostic information, particularly

in atypical or severe cases, and characteristically show leukocytoclastic vasculitis with IgA deposition in affected tissues.

### TREATMENT

Treatment for mild and self-limited HSP is *supportive*, with an emphasis on ensuring adequate hydration, nutrition, and analgesia. Corticosteroids are most often used to treat significant GI involvement or other life-threatening manifestations. Glucocorticoids such as oral prednisone (1-2 mg/kg/day), or in severe cases, intravenous (IV) methylprednisolone for 1-2 weeks, followed by taper, reduce abdominal and joint pain but do not alter the overall prognosis. Corticosteroids are not routinely recommended for prevention of complications such as nephritis. Rapid tapering of corticosteroids may lead to a flare of HSP symptoms. Although few data are available to demonstrate efficacy, intravenous immunoglobulin (IVIG) and plasma exchange are sometimes used for severe disease. In some patients, chronic HSP renal disease is managed with a variety of immunosuppressants, including azathioprine, cyclophosphamide, cyclosporine, and mycophenolate mofetil. ESRD develops in <5% of children with HSP nephritis.

### COMPLICATIONS

Acutely, serious GI involvement, including intussusception and intestinal perforation, imparts significant morbidity and mortality. Renal disease is the major long-term complication, occurring in 1-2% of children with HSP. Renal disease can develop up to 6 months after diagnosis but rarely does so if the initial urinalysis findings are normal. Therefore, it is recommended that children with HSP undergo serial monitoring of blood pressure and urinalysis for at least 6 months after diagnosis to monitor for development of nephritis.

### PROGNOSIS

Overall, the prognosis for childhood HSP is excellent, and most children experience an acute, self-limited course lasting on average 4 weeks. However, 15-60% of children with HSP experience one or more recurrences, typically within 4-6 months of diagnosis. With each relapse, symptoms are usually milder than at presentation. Children

**Table 210.5** Recommendations on the Diagnosis of Rare Pediatric Systemic Vasculitides

RECOMMENDATION	RECOMMENDATION
<ol style="list-style-type: none"> <li>1. In any pediatric patient with ongoing or a history of unexplained systemic inflammation, the diagnosis of systemic vasculitis should be considered and referral to a pediatric rheumatologist should be made, particularly in the presence of unexplained organ involvement.</li> <li>2. Clinical features combined with laboratory evidence of inflammation that suggest a vasculitic syndrome warranting referral to a pediatric rheumatologist are included in the following nonexhaustive list: <ul style="list-style-type: none"> <li>• Pyrexia of unknown origin</li> <li>• Vasculitic skin rash</li> <li>• PNS or CNS involvement</li> <li>• Unexplained arthritis, myalgia, serositis</li> <li>• Unexplained pulmonary, gastrointestinal, cardiovascular, or renal disease</li> </ul> </li> <li>3. When vasculitis is suspected, the diagnosis is often difficult and differential diagnoses are broad. The general workup for diagnosis of a specific vasculitic syndrome should include tissue histology, imaging, and determination of ANCA.</li> <li>4. In every patient in whom a specific vasculitic syndrome is suspected, basic screening investigations, along with blood pressure measurement, should include: <ul style="list-style-type: none"> <li>• Hematology and acute-phase reactants: <ul style="list-style-type: none"> <li>• Full blood count, ESR, CRP, clotting, prothrombotic screen (if patchy ischemia of digits or skin)</li> <li>• Peripheral blood smear</li> </ul> </li> <li>• Basic biochemistry: <ul style="list-style-type: none"> <li>• Renal function, liver function, CPK, LDH</li> <li>• Urine dipstick test of urine with UA:UC ratio or UP:UC ratio</li> </ul> </li> <li>• Infection: <ul style="list-style-type: none"> <li>• Routine pediatric infection screen</li> <li>• Anti-streptolysin O antibody titer (ASOT) and/or anti-DNase b</li> <li>• VZV antibody status</li> </ul> </li> <li>• Immunologic tests: <ul style="list-style-type: none"> <li>• ANA, ENA antibodies, ANCA, antiphospholipid antibodies</li> <li>• Immunoglobulins IgG/IgA/IgM/IgE</li> <li>• Complement (C3, C4)</li> <li>• RF (if nephritis or interstitial lung disease)</li> <li>• GBM antibody</li> </ul> </li> <li>• Radiologic/other: <ul style="list-style-type: none"> <li>• CXR</li> <li>• Doppler abdominal ultrasound scan</li> <li>• ECG; echocardiography</li> <li>• Digital clinical photography of lesions</li> </ul> </li> </ul> </li> <li>5. When considering a specific vasculitic syndrome, depending on presenting symptoms, tests with specific indications should be considered: <ul style="list-style-type: none"> <li>• The following may be useful if blood pressure abnormalities: <ul style="list-style-type: none"> <li>• Four limb blood pressure measurements</li> <li>• 24-hr ambulatory blood pressure monitor</li> </ul> </li> <li>• The following may be useful if evidence/suspicion of specific organ involvement: <ul style="list-style-type: none"> <li>• CT (e.g., thorax, abdomen, brain)</li> <li>• MRI</li> <li>• MRI/MRA of aorta and major branches</li> </ul> </li> </ul> </li> </ol>	<ul style="list-style-type: none"> <li>• Selective contrast visceral arteriography</li> <li>• Tissue biopsy (e.g., skin, nasal or sinus, kidney, sural nerve, lung, liver, gut, temporal artery, brain)</li> <li>• Nail fold capillaroscopy</li> <li>• Possible bone/joint involvement: radiograph of suspected sites</li> <li>• Eye symptoms: ophthalmology screen</li> <li>• Pulmonary symptoms: V/Q scan</li> <li>• Renal involvement: Tc-99m DMSA scan</li> <li>• Peripheral vascular symptoms: ultrasound scan Doppler of peripheral arteries</li> <li>• Neuropathy: nerve conduction studies</li> <li>• Cerebral involvement: MRI/MRA of brain and cerebral contrast angiography</li> <li>• Organ-specific autoantibodies (e.g., ASCAs, brain/neuronal specific autoantibodies)</li> <li>• Cryoglobulins or cryoprecipitants (technical expertise required), particularly if skin involved predominantly at peripheral sites</li> </ul> <ol style="list-style-type: none"> <li>• The following may be useful when the differential diagnosis includes malignancy: <ul style="list-style-type: none"> <li>• Lymph node excision biopsy</li> <li>• Bone marrow analysis</li> <li>• PET-CT</li> </ul> </li> <li>• The following may be useful when the differential diagnosis includes infection: <ul style="list-style-type: none"> <li>• Tuberculosis screen</li> <li>• PCR for viral infection (e.g., CMV, EBV, enterovirus, adenovirus, VZV, HBV, HCV)</li> <li>• Serology for HIV, rickettsiae, <i>Borrelia burgdorferi</i>, <i>Mycoplasma</i></li> <li>• Viral serology for hepatitis B and C, parvovirus B19</li> <li>• Cryoglobulins or cryoprecipitants (technical expertise required)</li> </ul> </li> <li>• The following may be useful when the differential diagnosis includes autoinflammatory syndromes: <ul style="list-style-type: none"> <li>• DNA analysis for MEFV (familial Mediterranean fever), TNFRSF1A (TNF-<math>\alpha</math> receptor-associated periodic fever syndrome [TRAPS]), MVK (mevalonate kinase deficiency; previously referred to as hyper-IgD syndrome [HIDS]), NLRP3 (cryopyrin-associated periodic syndrome [CAPS]), NOD2 (Crohn/Blau/juvenile sarcoid mutations), ADA2 (deficiency of ADA2), genetic screening for SAVI (TMEM173) and CANDLE (PSMB8, 4, 9, and other proteasome genes if available).</li> </ul> </li> </ol> <ol style="list-style-type: none"> <li>6. In the clinical assessment of suspected systemic vasculitis, a structured multiorgan assessment should take place.</li> <li>7. For suspected systemic vasculitis, the Pediatric Vasculitis Activity Score (PVAS) may facilitate structured multiorgan assessment. The PVAS can be found here: <a href="http://ard.bmj.com/content/72/10/1628.short">http://ard.bmj.com/content/72/10/1628.short</a></li> <li>8. At diagnosis and in ongoing follow-up of systemic vasculitis, a PVAS score should be performed to assess disease activity.</li> <li>9. At diagnosis and in ongoing follow-up of systemic vasculitis, a multiorgan assessment of damage should be undertaken.</li> <li>10. There is no currently validated tool to assess pediatric vasculitis damage. This is an ongoing unmet need. The PVDI, while unvalidated, can be assessed here: <a href="https://ard.bmj.com/content/73/Suppl_2/696.4">https://ard.bmj.com/content/73/Suppl_2/696.4</a></li> </ol>

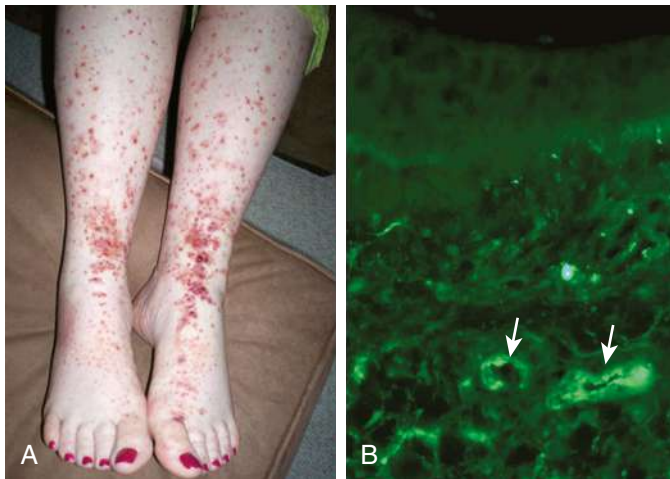
PNS, Peripheral nervous system; PVAS, pediatric vasculitis activity score; PVDI, pediatric vasculitis damage index; CNS, central nervous system; CPK, creatine phosphokinase; LDH, lactate dehydrogenase; UA:UC, urine albumin to urinary creatinine ratio; UP:UC, urine protein to urinary creatinine ratio; VZV, varicella-zoster virus; CXR, chest x-ray; ECG, electrocardiogram; MRA, magnetic resonance angiography; V/Q, ventilation/perfusion; DMSA, dimercaptosuccinic acid; ASCA, anti-*Saccharomyces cerevisiae* antibodies; SAVI, STING-associated vasculitis of infancy; CANDLE, chronic atypical neutrophilic dermatosis lipodystrophy and elevated temperature.

Modified from de Graeff N, Groot N, Brogan P, et al. European consensus-based recommendations for the diagnosis and treatment of rare paediatric vasculitides – the SHARE initiative. *Rheumatology*. 2019;58(4):656–671, Table 1.

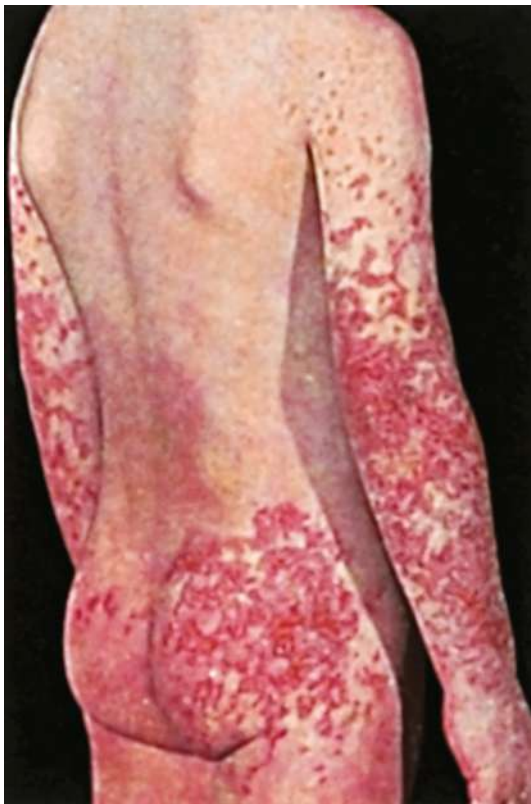
with a more severe initial course are at higher risk for relapse. The long-term prognosis usually depends on the severity and duration of GI or renal involvement. Chronic renal disease develops in 1–2% of children with HSP, and <5% of those with HSP nephritis go on to have ESRD.

The risk of HSP recurrence and graft loss after renal transplantation is estimated at 7.5% after 10 years.

Visit Elsevier eBooks+ at [eBooks.Health.Elsevier.com](http://eBooks.Health.Elsevier.com) for Bibliography.



**Fig. 210.2** Henoch-Schönlein purpura. A, Typical palpable purpura in lower extremities. B, Skin biopsy of lesion shows direct immunofluorescence of IgA (arrows) within the walls of dermal capillaries.



**Fig. 210.3** Henoch-Schönlein purpura. (From Korting GW. *Hautkrankheiten bei Kindern und Jugendlichen*, 3rd ed. Stuttgart: FK Schattaur Verlag; 1982.)

## 210.2 Takayasu Arteritis

Vidya Sivaraman, Edward C. Fels, and Stacy P. Ardoin

Takayasu arteritis (TA), also known as *pulseless disease*, is a chronic large vessel vasculitis of unknown etiology that predominantly involves the aorta and its major branches.

### EPIDEMIOLOGY

Although TA occurs worldwide and can affect all ethnic groups, the disease is most common in those of Asian descent. Age of onset is typically between 10 and 40 years. Most children are diagnosed as

### Table 210.6 Classification Criteria for Henoch-Schönlein Purpura\*

#### EUROPEAN LEAGUE AGAINST RHEUMATISM/PEDIATRIC RHEUMATOLOGY EUROPEAN SOCIETY CRITERIA<sup>†</sup>

Palpable purpura (in absence of coagulopathy or thrombocytopenia) and one or more of the following criteria must be present:

- Abdominal pain (acute, diffuse, colicky pain)
- Arthritis or arthralgia
- Biopsy of affected tissue demonstrating predominant IgA deposition
- Renal involvement (proteinuria >0.3 g/24 hr, hematuria, or red cell casts)

\*Classification criteria are developed for use in research and are not validated for clinical diagnosis.

<sup>†</sup>Developed for use in pediatric populations only.

Adapted from Ozen S, Pistorio A, Lusan SM, et al. EULAR/PRINTO/PRES criteria for Henoch-Schönlein purpura, childhood polyarteritis nodosa, childhood Wegener granulomatosis and childhood Takayasu arteritis: Ankara 2008. Part II. Final classification criteria. *Ann Rheum Dis*. 2010;69:798–806.

### Table 210.7 Conditions Associated with Leukocytoclastic Vasculitis

Immunoglobulin (Ig) A vasculitis (Henoch-Schönlein)  
 Hypersensitivity vasculitis  
 Hypocomplementemic urticarial vasculitis  
 Mixed cryoglobulinemia  
 Cutaneous polyarteritis  
 Antineutrophil cytoplasmic antibody (ANCA)-associated small-vessel vasculitis\*  
 Goodpasture syndrome  
 Rheumatic disorders: systemic lupus erythematosus (SLE), juvenile dermatomyositis, mixed connective tissue disease (MCTD), scleroderma, juvenile idiopathic arthritis (JIA)  
 Mucha-Habermann disease  
 Relapsing polychondritis  
 Köhlmeier-Degos syndrome  
 Antiphospholipid antibody syndrome  
 Chronic atypical neutrophilic dermatosis with lipodystrophy and elevated temperature (CANDLE) syndrome  
 Malignancy-associated disease  
 Sweet syndrome  
 Cronkhite-Canada syndrome  
 Stevens-Johnson syndrome  
 Erythema elevatum diutinum  
 COVID-19/MIS-C

\*Leukocytoclastic vasculitis may occur in cutaneous lesions in some patients with ANCA-associated vasculitis and collagen vascular diseases.

Modified from Petty RE, Laxer RM, Lindsley CB, et al., eds. *Textbook of Pediatric Rheumatology*, 8th ed. Philadelphia: Elsevier; 2021: Box 33.1, p. 457.

adolescents, on average at age 13 years. Up to 20% of individuals with TA are diagnosed before 19 years. Younger children may be affected, but diagnosis in infancy is rare. TA preferentially affects females, with a reported 2-4:1 female/male ratio in children and adolescents and a 9:1 ratio among adults. Occlusive complications are more common in the United States, Western Europe, and Japan, whereas aneurysms predominate in Southeast Asia and Africa.

### PATHOLOGY

TA is characterized by inflammation of the vessel wall, starting in the vasa vasorum. Involved vessels are infiltrated by T cells, natural killer cells, plasma cells, and macrophages. Giant cells and granulomatous inflammation develop in the media. Persistent inflammation damages the elastic lamina and muscular media, leading to blood vessel





**Fig. 210.4** Infantile acute hemorrhagic edema. Typical lesions on the arm of an infant. (From Eichenfield LF, Frieden IJ, Esterly NB. *Textbook of Neonatal Dermatology*. Philadelphia: Saunders; 2001.)

dilation and the formation of aneurysms. Progressive scarring and intimal proliferation can result in stenotic or occluded vessels. The subclavian, renal, and carotid arteries are the most commonly involved aortic branches; pulmonary, coronary, and vertebral arteries may also be affected.

### **PATHOGENESIS**

The etiology of TA remains unknown. The presence of abundant T cells with a restricted repertoire of T-cell receptors in TA vascular lesions points to the importance of cellular immunity and suggests the existence of a specific but unknown aortic tissue antigen. Expression of interleukin (IL)-1, IL-6, and tumor necrosis factor (TNF)- $\alpha$  is reported to be higher in patients with active TA than in patients with inactive TA and in healthy controls. In some patient populations, IL-1 genetic polymorphisms are linked to TA. Some individuals with TA have elevated serum values of antiendothelial antibodies. The increased prevalence of TA in certain ethnic populations and its occasional occurrence in monozygotic twins and families suggest a genetic predisposition to the disease.

### **CLINICAL MANIFESTATIONS**

The diagnosis of TA is challenging because early disease manifestations are often nonspecific. As a result, diagnosis can be delayed for several months, and the time to diagnosis is usually longer in children than in adults. Fever, malaise, weight loss, headache, hypertension, myalgias, arthralgias, dizziness, and abdominal pain are common early complaints in the *prepulseless* phase of the disease. Among children, hypertension and headache are particularly common presenting manifestations and should prompt consideration of TA when present without alternative explanation. Some individuals with TA report no systemic symptoms and instead present with vascular complications. It is only after substantial vascular injury that evidence of hypoperfusion becomes clinically evident. Later manifestations of disease include diminished pulse, asymmetric blood pressure, claudication, Raynaud phenomenon, renal failure, and symptoms of pulmonary or cardiac ischemia. Inflammation can extend to the aortic valve, resulting in

### **Table 210.8** Proposed Classification Criteria for Pediatric-Onset Takayasu Arteritis

Angiographic abnormalities (conventional, CT, or magnetic resonance angiography) of the aorta or its main branches and at least one of the following criteria:

- Decreased peripheral artery pulse(s) and/or claudication of extremities
- Blood pressure difference between arms or legs of  $>10$  mm Hg
- Bruits over the aorta and/or its major branches
- Hypertension (defined by childhood normative data)
- Elevated acute-phase reactant (erythrocyte sedimentation rate or C-reactive protein)

Adapted from Ozen S, Pistorio A, Lusan SM, et al. EULAR/PRINTO/PRES criteria for Henoch-Schönlein purpura, childhood polyarteritis nodosa, childhood Wegener granulomatosis and childhood Takayasu arteritis: Ankara 2008. Part II. Final classification criteria. *Ann Rheum Dis*. 2010;69:798–806.

valvular insufficiency. Other findings may include pericardial effusion, pericarditis, pleuritis, splenomegaly, and arthritis.

**Supradiaphragmatic** (aortic arch) disease often manifests with CNS (stroke, transient ischemic attack) and cardiac (heart failure, palpitations) symptoms. **Infradiaphragmatic** (midaortic syndrome) disease may produce hypertension, abdominal bruits, and pain. Most patients have involvement in both areas.

### **DIAGNOSIS**

Specific pediatric criteria for TA have been proposed (Table 210.8). The 2022 ACR/ EULAR classification criteria for Takayasu arteritis propose a criterion-based scoring system in adults (Table 210.9). *Radiographic demonstration of large vessel vasculitis is necessary*. A thorough physical examination is required to detect an aortic murmur, diminished or asymmetric pulses, and vascular bruits. Four extremity blood pressures should be measured;  $>10$  mm Hg asymmetry in systolic pressure is indicative of disease.

### **DIFFERENTIAL DIAGNOSIS**

In the early phase of TA, when nonspecific symptoms predominate, the differential diagnosis includes a wide array of systemic infections, autoimmune conditions, and malignancies. Although **giant cell arteritis**, also known as *temporal arteritis*, is a common large vessel vasculitis in older adults, this entity is rare in childhood. Noninflammatory conditions that can cause large vessel compromise include fibromuscular dysplasia, Marfan syndrome, and Ehlers-Danlos syndrome.

### **LABORATORY FINDINGS**

The laboratory findings in TA are nonspecific, and there is no specific diagnostic laboratory test. ESR and CRP values are typically elevated, and other nonspecific markers of chronic inflammation may include leukocytosis, thrombocytosis, anemia of chronic inflammation, and hypergammaglobulinemia. Autoantibodies, including ANA and ANCA, are not useful in diagnosing TA except to help exclude other autoimmune diseases.

*Radiographic assessment is essential to establish large vessel arterial involvement*. Conventional arteriography of the aorta and major branches, including carotid, subclavian, pulmonary, renal, and mesenteric branches, can identify luminal defects, including dilation, aneurysms, and stenoses, even in smaller vessels such as the mesenteric arteries. Figure 210.5 shows a conventional arteriogram in a child with TA. Although not yet thoroughly validated in TA, magnetic resonance angiography (MRA) and computed tomographic angiography (CTA) also provide important information about vessel wall thickness and enhancement, although they may not image smaller vessels as well as conventional angiography. Positron emission tomography (PET) may detect vessel wall inflammation but has not been studied extensively. Ultrasound with duplex color flow Doppler imaging may identify vessel wall thickening and assesses arterial flow. Echocardiography is recommended to assess for aortic valvular



**Table 210.9** 2022 American College of Rheumatology/ EULAR Classification Criteria for Takayasu Arteritis**Considerations when applying these criteria:**

- These classification criteria should be applied to classify the patient as having Takayasu arteritis when a diagnosis of medium-vessel or large-vessel vasculitis has been made.
- Alternate diagnoses mimicking vasculitis should be excluded before applying the criteria.

**ABSOLUTE REQUIREMENTS**

Age  $\leq$  60 yr at time of diagnosis  
Evidence of vasculitis on imaging<sup>1</sup>

**ADDITIONAL CLINICAL CRITERIA**

Female sex	+1
Angina or ischemic cardiac pain	+2
Arm or leg claudication	+2
Vascular bruit <sup>2</sup>	+2
Reduced pulse in upper extremity <sup>3</sup>	+2
Carotid artery abnormality <sup>4</sup>	+2
Systolic blood pressure difference in arms $\geq$ 20 mm Hg	+1

**ADDITIONAL IMAGING CRITERIA**

Number of affected arterial territories (select one) <sup>5</sup>	
One arterial territory	+1
Two arterial territories	+2
Three arterial territories	+3
Symmetric involvement of paired arteries <sup>6</sup>	+1
Abdominal aorta involvement with renal or mesenteric involvement <sup>7</sup>	+3

\*TOTAL:

<sup>\*</sup>Sum the scores for 10 items, if present. A score of  $\geq$  5 points is needed for the classification of Takayasu arteritis.

<sup>1</sup>Evidence of vasculitis in the aorta or branch arteries must be confirmed by vascular imaging (e.g., computed tomographic/catheter-based/magnetic resonance angiography, ultrasonography, positron emission tomography).

<sup>2</sup>Bruit detected by auscultation of a large artery, including the aorta, carotid, subclavian, axillary, brachial, renal, or iliofemoral arteries.

<sup>3</sup>Reduction or absence of pulse by physical examination of the axillary, brachial, or radial arteries.

<sup>4</sup>Reduction or absence of pulse of the carotid artery or tenderness of the carotid artery.

<sup>5</sup>Number of arterial territories with luminal damage (e.g., stenosis, occlusion, or aneurysm) detected by angiography or ultrasonography from the following nine territories: thoracic aorta, abdominal aorta, mesenteric, left or right carotid, left or right subclavian, left or right renal arteries.

<sup>6</sup>Bilateral luminal damage (stenosis, occlusion, or aneurysm) detected by angiography or ultrasonography in any of the following paired vascular territories: carotid, subclavian, or renal arteries.

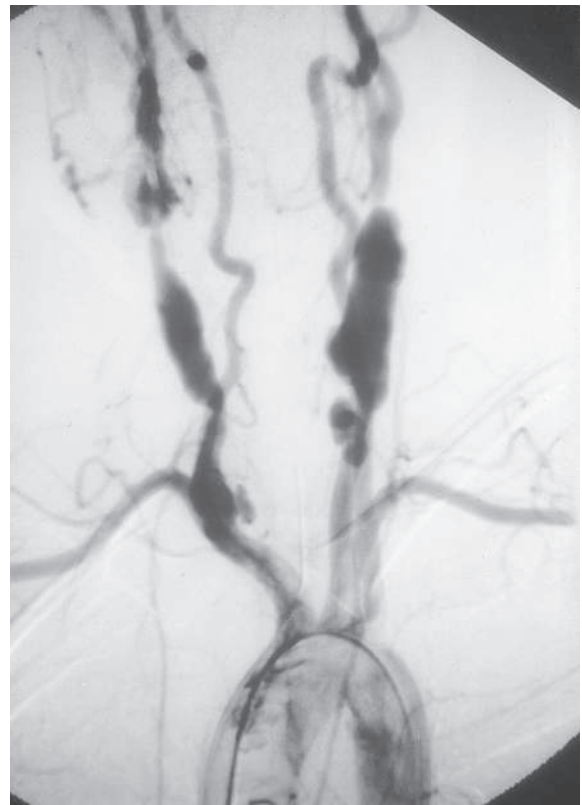
<sup>7</sup>Luminal damage (stenosis, occlusion, aneurysm) detected by angiography or ultrasonography involving the abdominal aorta and either the renal or mesenteric arteries.

From Grayson PC, Ponte C, Suppiah R, et al. 2022 American College of Rheumatology/ EULAR classification criteria for Takayasu arteritis. *Ann Rheum Dis*. 2022;81(12):1654–1660. Fig. 1.

involvement. Serial vascular imaging is usually necessary to assess response to treatment and to detect progressive vascular damage.

**TREATMENT**

Glucocorticoids are the mainstay of therapy, typically starting with high doses (1–2 mg/kg/day of prednisone or methylprednisolone IV) followed by gradual dosage tapering. When TA progresses or recurs, steroid-sparing therapy is often required, usually involving methotrexate or azathioprine. *Cyclophosphamide* is reserved for severe or refractory disease. Results of small case series also suggest that *mycophenolate mofetil* or anti-TNF- $\alpha$  therapy may be beneficial in select patients. Anti-IL-6 therapy with tocilizumab has shown promising results in a small case series



**Fig. 210.5** Child with Takayasu arteritis. Conventional angiogram shows massive bilateral carotid dilation, stenosis, and poststenotic dilation.

of children with TA. Antihypertensive medications are often necessary to control blood pressure caused by renovascular disease.

**COMPLICATIONS**

Progressive vascular damage can result in arterial stenoses, aneurysms, and occlusions, which produce ischemic symptoms and can be organ or life threatening. Potential ischemic complications include stroke, renal impairment or failure, myocardial infarction, mesenteric ischemia, and limb-threatening arterial disease. When these complications occur or are imminent, intervention with *surgical* vascular grafting or catheter-based angioplasty and stent placement may be necessary to restore adequate blood flow. A high rate of recurrent stenosis has been reported after angioplasty and stent placement. Aortic valve replacement may be required if significant aortic insufficiency develops.

**PROGNOSIS**

Although up to 20% of individuals with TA have a monophasic course and achieve sustained remission, most suffer relapses. Survival for individuals with TA has improved considerably over the decades, although higher mortality rates are reported in children and adolescents. The overall estimated survival for individuals with TA is 93% at 5 years and 87% at 10 years. However, morbidity from vascular complications remains high, particularly when there is evidence of ongoing active inflammation as detected by elevated CRP or ESR. Given the chronic endothelial insult and inflammation, children and adolescents with TA are probably at high risk for accelerated atherosclerosis. Early detection and treatment are critical to optimizing outcomes in TA.

Visit Elsevier eBooks+ at [eBooks.Elsevier.com](https://eBooks.Elsevier.com) for Bibliography.

### 210.3 Polyarteritis Nodosa and Cutaneous Polyarteritis Nodosa

Vidya Sivaraman, Edward C. Fels, and Stacy P. Ardoin

Polyarteritis nodosa (PAN) is a systemic necrotizing vasculitis affecting small and medium-size arteries. Aneurysms and stenoses form at irregular intervals throughout affected arteries. Cutaneous PAN is limited to the skin.

#### EPIDEMIOLOGY

PAN is rare in childhood. Males and females are equally affected, and the mean age at presentation is 9 years. The cause is unknown, but the development of PAN after infections, including group A streptococcus and chronic hepatitis B, suggests that PAN may represent a postinfectious autoimmune response. Infections with other organisms, including Epstein-Barr virus, *Mycobacterium tuberculosis*, cytomegalovirus, parvovirus B19, and hepatitis C virus, have also been associated with PAN. There is a possible association between PAN and familial Mediterranean fever.

#### PATHOLOGY

Biopsies show **necrotizing vasculitis** with granulocytes and monocytes infiltrating the walls of small and medium-size arteries. Involvement is usually segmental and tends to occur at vessel bifurcations. Granulomatous inflammation is not present, and deposition of complement and immune complexes is rarely observed. Different stages of inflammation are found, ranging from mild inflammatory changes to panmural fibrinoid necrosis associated with aneurysm formation, thrombosis, and vascular occlusion.

#### PATHOGENESIS

Immune complexes are believed to be pathogenic, but the mechanism is poorly understood. It is not known why PAN has a predilection for small and medium-size blood vessels. The inflamed vessel wall becomes thickened and narrowed, impeding blood flow and contributing to end-organ damage characteristic of this disease. Although there is no clear genetic association with PAN, PAN-like vasculitis is a component of three recently described monogenic autoinflammatory conditions.

Deficiency in **adenosine deaminase 2 (DADA2)**, caused by mutations in the *CECR1* gene, causes a familial form of vasculitis with an autosomal recessive inheritance (see [Chapter 204](#)).

#### CLINICAL MANIFESTATIONS

The clinical presentation of PAN is variable but generally reflects the distribution of inflamed vessels. Constitutional symptoms are present in most children at disease onset. Weight loss and severe abdominal pain suggest mesenteric arterial inflammation and ischemia. Renovascular arteritis can cause hypertension, hematuria, or proteinuria, although glomerulonephritis is not typical. Cutaneous manifestations include purpura, livedo reticularis, ulcerations, digital ischemia, and painful nodules ([Fig. 210.6](#)). Arteritis affecting the nervous system can result in cerebrovascular accidents, transient ischemic attacks, psychosis, and ischemic motor or sensory peripheral neuropathy (**mononeuritis multiplex**). Myocarditis or coronary arteritis can lead to heart failure and myocardial ischemia; pericarditis and arrhythmias have also been reported. Arthralgias, arthritis, or myalgias are frequently present. Less common symptoms include testicular pain that mimics testicular torsion, bone pain, and vision loss as a result of retinal arteritis. The pulmonary vasculature is usually spared in PAN.

#### DIAGNOSIS

The diagnosis of PAN requires demonstration of vessel involvement on biopsy or angiography ([Table 210.10](#)). Biopsy of cutaneous lesions shows small or medium vessel vasculitis. Kidney biopsy in patients with renal manifestations may show necrotizing arteritis. Electromyography in children with peripheral neuropathy identifies affected nerves, and sural nerve biopsy may reveal vasculitis. Conventional arteriography is the gold-standard diagnostic imaging study for PAN and reveals areas of aneurysmal dilation and segmental stenosis, the classic “beads on a string” appearance ([Fig. 210.7](#)). MRA and CTA, less invasive imaging



**Fig. 210.6** Purpuric and necrotic lesions on the legs of a child with polyarteritis nodosa. (From Petty RE, Laxer RM, Lindsley CB, et al., eds. *Textbook of Pediatric Rheumatology*, 8th ed. Philadelphia: Elsevier; 2021: Fig. 34.1, p. 468.)

alternatives, are gaining acceptance but may not be as effective in identifying small vessel disease or in younger children.

#### DIFFERENTIAL DIAGNOSIS

Early skin lesions may resemble those of HSP, although the finding of nodular lesions and the presence of systemic features help distinguish PAN. Because pulmonary vascular involvement is very rare in PAN, pulmonary lesions suggest ANCA-associated vasculitis or Goodpasture disease. Other rheumatic diseases, including SLE, have characteristic target-organ involvement and associated autoantibodies distinguishing them from PAN. Prolonged fever and weight loss should also prompt consideration of inflammatory bowel disease or malignancy.

**Deficiency of DADA2** is a mimic of PAN and should be suspected in the presence of vasculitic rash ([Fig. 210.8](#)), hypogammaglobulinemia, cytopenias, and strokes. In addition, **SAVI** (STING-associated vasculopathy with onset in infancy) presents in infancy with ulcerating skin lesions that form eschars, cytopenias, interstitial lung disease, and failure to thrive (see [Chapter 204](#)).

#### LABORATORY FINDINGS

Nonspecific laboratory findings include elevations of ESR and CRP, anemia, leukocytosis, and hypergammaglobulinemia. Abnormal urine sediment, proteinuria, and hematuria indicate renal disease. Laboratory findings may be normal in cutaneous PAN or similar to those of systemic PAN. Elevated hepatic enzyme values may suggest hepatitis B or C infection. Serologic tests for hepatitis (hepatitis B surface antigen and hepatitis C antibody) should be performed in all patients.

**Table 210.10** Proposed Classification Criteria for Pediatric-Onset Polyarteritis Nodosa\*

CRITERION	FINDINGS
Histopathology	Necrotizing vasculitis in medium or small arteries
Angiographic abnormalities	Angiography showing aneurysm, stenosis, or occlusion of medium or small artery not from noninflammatory cause
Cutaneous findings	Livedo reticularis, tender subcutaneous nodules, superficial skin ulcers, deep skin ulcers, digital necrosis, nail bed infarctions, or splinter hemorrhages
Muscle involvement	Myalgia or muscle tenderness
Hypertension	Systolic or diastolic blood pressure >95th percentile for height
Peripheral neuropathy	Sensory peripheral neuropathy, motor mononeuritis multiplex
Renal involvement	Proteinuria (>300 mg/24 hr equivalent), hematuria or red blood cell casts, impaired renal function (glomerular filtration rate <50% normal)

\*The presence of five criteria provides 89.6% sensitivity and 99.6% specificity for the diagnosis of childhood-onset polyarteritis nodosa. Adapted from Ozen S, Pistorio A, Iusan SM, et al: EULAR/PRINTO/PRES criteria for Henoch-Schönlein purpura, childhood polyarteritis nodosa, childhood Wegener granulomatosis and childhood Takayasu arteritis: Ankara 2008. Part II. Final classification criteria. *Ann Rheum Dis.* 2010;69:798–806.



**Fig. 210.7** Child with polyarteritis nodosa. Abdominal aortogram shows bilateral renal artery aneurysms (arrows), superior mesenteric artery aneurysm (asterisk), and left common iliac artery occlusion (arrowhead). (Courtesy Dr. M. Hogan.)

### TREATMENT

Oral *prednisone* (1–2 mg/kg/day) or IV pulse *methylprednisolone* (30 mg/kg/day) are the mainstay of therapy. Oral or IV cyclophosphamide is often used as adjunctive therapy, and plasma exchange may



**Fig. 201.8** Retiform purpura in a child with deficiency of adenosine deaminase type 2. (From Petty RE, Laxer RM, Lindsley CB, et al., eds. *Textbook of Pediatric Rheumatology*, 8th ed. Philadelphia: Elsevier; 2021, Fig. 34.3, p. 469.)

be warranted for life-threatening disease. If hepatitis B is identified, appropriate antiviral therapy should be initiated (see Chapter 406). Most cases of cutaneous PAN can be treated with less intense therapy such as corticosteroids alone, nonsteroidal antiinflammatory drugs (NSAIDs), and methotrexate. Azathioprine, mycophenolate mofetil, IVIG, thalidomide, cyclosporine, and anti-TNF agents such as infliximab have all been reported as successful in the treatment of refractory cutaneous or systemic PAN. If an infectious trigger for PAN is identified, antibiotic prophylaxis can be considered.

### COMPLICATIONS

Cutaneous nodules may ulcerate and become infected. Hypertension and chronic renal disease may develop from renovascular involvement in PAN. Cardiac involvement may lead to decreased cardiac function or coronary artery disease. Mesenteric vasculitis can predispose to bowel infarction, rupture, and malabsorption. Stroke and rupture of hepatic arterial aneurysm are uncommon complications of this disorder.

### PROGNOSIS

The course of PAN varies from mild disease with few complications to a severe, multiorgan disease with high morbidity and mortality. Poor prognostic factors in PAN include elevated serum creatinine, proteinuria, severe GI involvement, cardiomyopathy, and CNS involvement. Early and aggressive immunosuppressive therapy increases the likelihood of clinical remission. Compared with disease in adults, childhood PAN is associated with less mortality. Cutaneous PAN is unlikely to transition to systemic disease. Early recognition and treatment of the disease are important to minimizing potential long-term vascular complications.

Visit Elsevier eBooks+ at [eBooks.Health.Elsevier.com](http://eBooks.Health.Elsevier.com) for Bibliography.

## 210.4 Antineutrophilic Cytoplasmic Antibody–Associated Vasculitis

Vidya Sivaraman, Edward C. Fels, and Stacy P. Ardoin

The ANCA-associated vasculitides are characterized by small vessel involvement, circulating ANCAs, and a paucity of immune complex deposition in affected tissues, thus the term **pauci-immune vasculitis**. ANCA-associated vasculitis is categorized into three distinct forms: **granulomatosis with polyangiitis (GPA)** (Table 210.11),



**Table 210.11** 2022 American College of Rheumatology/ EULAR Classification Criteria for Granulomatosis with Polyangiitis

**Considerations when applying these criteria:**

- These classification criteria should be applied to classify a patient as having granulomatosis with polyangiitis when a diagnosis of small-vessel or medium-vessel vasculitis has been made.
- Alternate diagnoses mimicking vasculitis should be excluded before applying the criteria.

**CLINICAL CRITERIA**

Nasal involvement: bloody discharge, ulcers, crusting, congestion, blockage, or septal defect / perforation	+3
Cartilaginous involvement (inflammation of ear or nose cartilage, hoarse voice or stridor, endobronchial involvement, or saddle nose deformity)	+2
Conductive or sensorineural hearing loss	+1

**LABORATORY, IMAGING, AND BIOPSY CRITERIA**

Positive test for cytoplasmic antineutrophil cytoplasmic antibodies (cANCA) or antiproteinase 3 (anti-PR3) antibodies	+5
Pulmonary nodules, mass, or cavitation on chest imaging	+2
Granuloma, extravascular granulomatous inflammation, or giant cells on biopsy	+2
Inflammation, consolidation, or effusion of the nasal/ paranasal sinuses, or mastoiditis on imaging	+1
Pauci-immune glomerulonephritis on biopsy	+1
Positive test for perinuclear antineutrophil cytoplasmic antibodies (pANCA) or antimyeloperoxidase (anti-MPO) antibodies	-1
Blood eosinophil count $\geq 1 \times 10^9$ /liter	-4

\*TOTAL:

\*Sum the scores for 10 items, if present. A score of  $\geq 5$  points is needed for the classification of granulomatosis with polyangiitis.

From Robson JC, Grayson PC, Ponte C, et al. 2022 American College of Rheumatology/European Alliance of Associations for Rheumatology classification criteria for granulomatosis with polyangiitis. *Ann Rheum Dis.* 2022;81(3):315–320. Fig. 1.

formerly Wegener granulomatosis; **microscopic polyangiitis (MPA)** (Table 210.12); and **eosinophilic granulomatosis with polyangiitis (Table 210.13)**, formerly Churg-Strauss syndrome (CSS). The 2022 ACR/ EULAR classification criteria for adults with GPA, MPA and EGPA employ a criterion-based scoring system for classification of these vasculitides.

**EPIDEMIOLOGY**

GPA is a necrotizing, granulomatous, small and medium vessel vasculitis that occurs at all ages and targets the upper and lower respiratory tracts and the kidneys. Most cases of GPA occur in adults; the disease also occurs in children with a mean age at diagnosis of 14 years. There is a female predominance of 3-4:1, and pediatric GPA is most prevalent in the White population.

MPA is a small vessel necrotizing vasculitis with clinical features similar to those of GPA, but without granulomas and upper airway involvement. CSS is a small vessel necrotizing granulomatous (allergic granulomatosis) vasculitis associated with a history of refractory asthma and peripheral eosinophilia. MPA and CSS are rare in children, and there does not appear to be a gender predilection in either disease.

**PATHOLOGY**

Necrotizing vasculitis is the cardinal histologic feature in both GPA and MPA. Kidney biopsies typically demonstrate crescentic glomerulonephritis with little or no immune complex deposition

**Table 210.12** Presenting Manifestations (Reported as Percentages) in Children with Granulomatosis with Polyangiitis and Microscopic Polyangiitis from the ARChiVe Cohort (n = 231)

CLINICAL FEATURE	GPA (n = 183)	MPA (n = 48)
<b>CONSTITUTIONAL/GENERAL</b>	88	85
Malaise, fatigue	83	77
Fever	53	52
Weight loss	44	31
<b>RENAL</b>	83	75
Proteinuria	72	69
Hematuria	72	60
Biopsy proven glomerulonephritis	94 (101 of 108)	94 (30 of 32)
Elevated serum creatinine	54	58
<b>PULMONARY</b>	74	44
Hemoptysis/alveolar hemorrhage	42	15
Nodules	54	0
Fixed pulmonary infiltrates	36	0
Oxygen dependency	22	13
Pleurisy	14	8
Requiring ventilation	12	4
<b>EAR, NOSE, THROAT</b>	70	4
Nasal involvement	53	0
Sinusitis	39	0
Otitis/mastoiditis	17	0
Subglottic involvement	10	0
Hearing loss	10	0
Oral ulcers	15	4
<b>MUSCULOSKELETAL</b>	65	52
Arthralgia/arthritis	61*	42
Myalgia, muscle weakness, or myositis	14	19
<b>CUTANEOUS</b>	47	52
Palpable purpura/petechia	27	31
<b>EYES</b>	43	31
Nonspecific red eye	10	2
Conjunctivitis	11	6
Scleritis/episcleritis	8	4
<b>GASTROINTESTINAL</b>	36	58
Nonspecific abdominal pain	22	38
Chronic nausea	12	33
<b>NERVOUS SYSTEM</b>	20	21
Severe headache	11	13
Dizziness	7	4
<b>CARDIOVASCULAR</b>	5	6

\*Arthralgias and arthritis at disease onset were not reported separately. GPA, Granulomatosis with polyangiitis; MPA, microscopic polyangiitis. From Petty RE, Laxer RM, Lindsley CB, et al., eds. *Textbook of Pediatric Rheumatology*, 8th ed. Philadelphia: Elsevier; 2021: Table 36.2, p. 487.

(“pauci-immune”), in contrast to biopsies from patients with SLE. Although granulomatous inflammation is common in GPA and CSS, it is typically not present in MPA. Biopsies showing perivascular eosinophilic infiltrates distinguish CSS from both MPA and GPA.



**Table 210.13** American College of Rheumatology Criteria for Classification of Eosinophilic Granulomatosis with Polyangiitis Syndrome

CRITERION*	DESCRIPTION
Asthma	History of wheezing or diffuse high-pitched rales on expiration
Eosinophilia	Eosinophils >10% of differential white blood cell count
History of allergy	History of seasonal allergy (e.g., allergic rhinitis) or documented allergies, including food, contactants, and others (except for drug allergies)
Mononeuropathy or polyneuropathy	Mononeuropathy, multiple mononeuropathies or polyneuropathy (i.e., glove/stocking distribution) attributable to a systemic vasculitis
Pulmonary infiltrates	Migratory or transitory pulmonary infiltrates on radiographs attributable to a systemic vasculitis
Paranasal sinus abnormality	History of acute or chronic paranasal sinus pain or tenderness or radiographic opacification of the paranasal sinuses
Extravascular eosinophils	Biopsy including artery, arteriole, or venule, showing accumulation of eosinophils in extravascular areas

\*For classification purposes, a patient is said to have EGPA if at least four of these criteria are present. The presence of any four or more criteria has a sensitivity of 85% and a specificity of 99.7%.

From Petty RE, Laxer RM, Lindsley CB, et al., eds. *Textbook of Pediatric Rheumatology*, 8th ed. Philadelphia: Elsevier; 2021, Fig. 36.7, p. 495.

## PATHOGENESIS

The etiology of ANCA-associated vasculitis remains unknown, although neutrophils, monocytes, and endothelial cells are involved in disease pathogenesis. Neutrophils and monocytes are activated by ANCAs, specifically by the ANCA-associated antigens proteinase-3 (PR3) and myeloperoxidase (MPO), and release proinflammatory cytokines such as TNF- $\alpha$  and IL-8. Localization of these inflammatory cells to the endothelium results in vascular damage characteristic of the ANCA vasculitides. Why the respiratory tract and kidneys are preferential targets in GPA and MPA is unknown.

## CLINICAL MANIFESTATIONS

The early disease course is characterized by nonspecific constitutional symptoms, including fever, malaise, weight loss, myalgias, and arthralgias. In GPA, upper airway involvement can manifest as sinusitis, nasal ulceration, epistaxis, otitis media, and hearing loss. Lower respiratory tract symptoms in GPA include cough, wheezing, dyspnea, and hemoptysis. Pulmonary hemorrhage can cause rapid respiratory failure. Compared with adults, childhood GPA is more frequently complicated by subglottic stenosis (Fig. 210.9). Inflammation-induced damage to the nasal cartilage can produce a saddle nose deformity (see Fig. 210.9). Ophthalmic involvement includes conjunctivitis, scleritis, uveitis, optic neuritis, and invasive orbital pseudotumor (causing proptosis). Perineural vasculitis or direct compression on nerves by granulomatous lesions can cause cranial and peripheral neuropathies. Hematuria, proteinuria, and hypertension in GPA signal renal disease. Cutaneous lesions include palpable purpura and ulcers. Venous thromboembolism is a rare but potentially fatal complication of GPA. The frequencies of

organ system involvement throughout the disease course in GPA are as follows: respiratory tract, 74%; kidneys, 83%; joints, 65%; eyes, 43%; skin, 47%; sinuses, 70%; and nervous system, 20%. Table 210.11 lists the classification criteria for pediatric-onset GPA.

The clinical presentation of MPA closely resembles that of GPA, although sinus disease is less common; systemic features of fever, malaise, weight loss, myalgias, and arthralgias may be dominant. MPA predominantly affects the kidney and lungs; other organ systems include skin, CNS, muscle, heart, and eyes (see Table 210.12).

CSS frequently causes inflammation of the upper and lower respiratory tracts, but cartilage destruction is rare. CSS may initially demonstrate chronic or recurrent rhinitis/sinusitis, nasal polyposis, nonfixed pulmonary lesions, and difficult-to-treat asthma. Eosinophilia (>10% of leukocytes) with pulmonary infiltrates may precede a vasculitic phase. Other organ involvement includes skin, cardiac, peripheral neuropathy, GI tract, and muscle. Renal involvement in CSS is uncommon.

## DIAGNOSIS

GPA should be considered in children who have recalcitrant sinusitis, pulmonary infiltrates, and evidence of nephritis. Chest radiography often fails to detect pulmonary lesions, and chest CT may show nodules, ground-glass opacities, mediastinal lymphadenopathy, and cavitary lesions (Fig. 210.10). The diagnosis is confirmed by the presence of c-ANCA with anti-PR3 specificity (PR3-ANCAs) and the finding of necrotizing granulomatous vasculitis on pulmonary, sinus, or renal biopsy. The ANCA test result is positive in approximately 90% of children with GPA, and the presence of anti-PR3 increases the specificity of the test.

In MPA, ANCAs are also frequently present (70% of patients) but are usually p-ANCA with reactivity to MPO (MPO-ANCAs). MPA can be distinguished from PAN by the presence of ANCAs and the tendency for small vessel involvement. The ANCA test result is positive in 50–70% of cases of CSS, and MPO-ANCAs are more common than PR3-ANCAs. In addition, the presence of chronic asthma and peripheral eosinophilia suggests the diagnosis of CSS.

## DIFFERENTIAL DIAGNOSIS

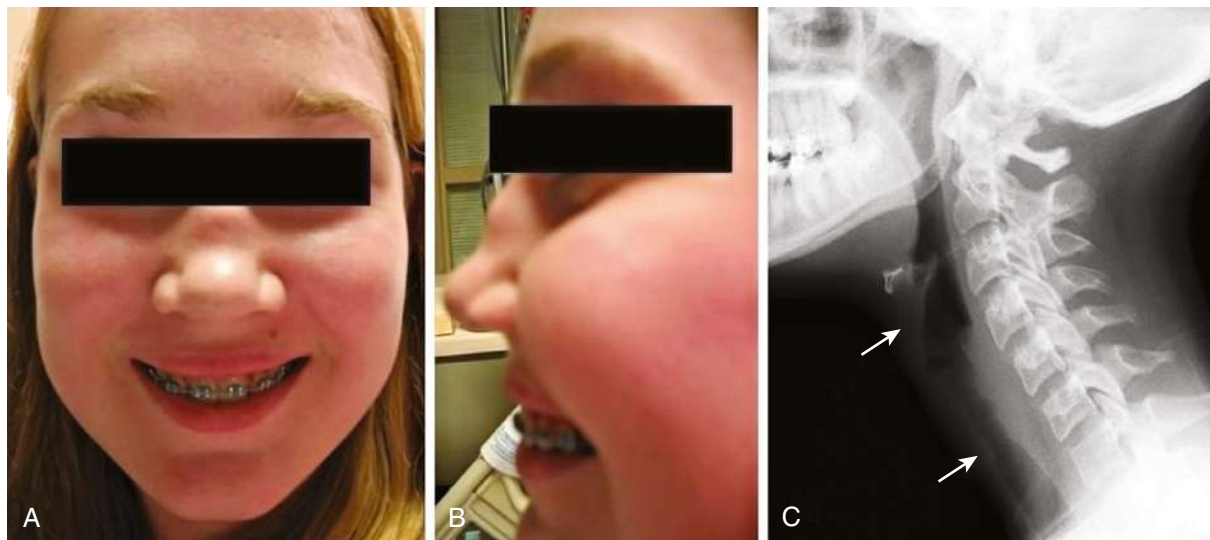
ANCAs are absent in other granulomatous diseases, such as sarcoidosis and tuberculosis. **Goodpasture syndrome** is characterized by antibodies to glomerular basement membrane. Medications such as propylthiouracil, hydralazine, and minocycline are associated with drug-induced ANCA (usually perinuclear ANCA) vasculitis. SLE and HSP can manifest as pulmonary hemorrhage and nephritis.

## LABORATORY FINDINGS

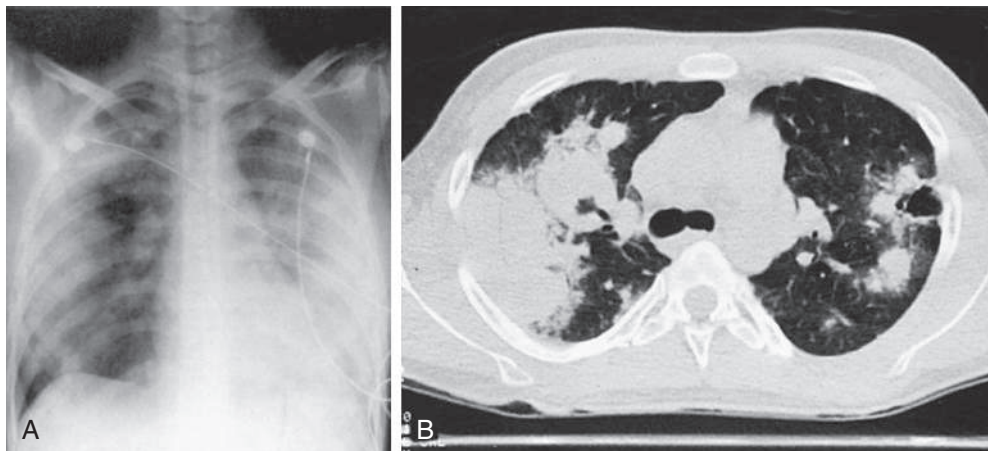
Nonspecific laboratory abnormalities include elevated ESR and CRP values, leukocytosis, and thrombocytosis, which are present in most patients with an ANCA-associated vasculitis but are nonspecific. Anemia may be caused by chronic inflammation or pulmonary hemorrhage. ANCA antibodies show two distinct immunofluorescence patterns: *perinuclear* (p-ANCA) and *cytoplasmic* (c-ANCA). In addition, ANCAs can be defined by their specificity for PR3 or MPO antigen. GPA is strongly associated with c-ANCAs/anti-PR3 antibodies, whereas 75% of patients with MPA have a positive p-ANCA. There is no clear correlation between ANCA titers and disease activity or relapse.

## TREATMENT

When the lower respiratory tract or kidneys are significantly involved, initial induction therapy usually consists of prednisone (oral 2 mg/kg/day or IV methylprednisolone 30 mg/kg/day  $\times$  3 days) in conjunction with daily oral or monthly IV cyclophosphamide. *Rituximab*, a monoclonal antibody to CD20 on activated B cells, is an option for induction therapy in ANCA-positive vasculitides, although it has been studied primarily in adults. *Plasmapheresis* in conjunction with methylprednisolone has a role in the therapy of patients with severe disease manifestations such as pulmonary hemorrhage or ESRD, with the potential for reducing dialysis dependency. Patients are transitioned to a less toxic maintenance medication (usually methotrexate, azathioprine, or



**Fig. 210.9** Adolescent with granulomatosis with polyangiitis. A and B, Anterior and lateral views of saddle nose deformity. C, Segment of subglottic posterior tracheal irregularity (between arrows) on lateral neck radiograph.



**Fig. 210.10** Radiographs of lower respiratory tract disease in granulomatosis with polyangiitis (GPA). A, Chest radiograph of 14-yr-old girl with GPA and pulmonary hemorrhage. Extensive bilateral, fluffy infiltrates are visualized. B, Chest CT scan in 17-yr-old boy with GPA. Air space consolidation, septal thickening, and a single cavitory lesion are present. (A from Cassidy JT, Petty RE. *Granulomatous vasculitis, giant cell arteritis and sarcoidosis*. In *Textbook of Pediatric Rheumatology*, 3rd ed. Philadelphia: Saunders; 1995; B from Kuhn JP, Slovis TL, Haller JO. *Caffey's Pediatric Diagnostic Imaging*, 10th ed. Philadelphia: Mosby; 2004.)

mycophenolate mofetil) within 3-6 months once remission is achieved. The Childhood Arthritis and Rheumatology Research Alliance has published treatment guidelines for the induction and maintenance therapy of children with severe ANCA-associated vasculitides consisting of induction therapy with cyclophosphamide or rituximab and maintenance therapy with rituximab, methotrexate, or azathioprine. Trimethoprim-sulfamethoxazole (one 160 mg/800 mg tablet 3 days/week) is often prescribed both for prophylaxis against *Pneumocystis jirovecii* infection and to reduce upper respiratory bacterial colonization with *S. aureus*, which may trigger disease activity. If disease is limited to the upper respiratory tract, corticosteroids (1-2 mg/kg/day) and methotrexate (0.5-1.0 mg/kg/week) may be first-line treatment. *Avacopan*, a C5a receptor inhibitor, has been shown to be effective in reducing the need for corticosteroids in addition to standard therapy in adults with ANCA-associated vasculitis but has not been studied in children.

*Mepolizumab*, an anti-IL-5 monoclonal antibody, may have a role in the treatment of eosinophilic granulomatosis with polyangiitis (CSS).

## COMPLICATIONS

Upper respiratory tract lesions can invade the orbit and threaten the optic nerve, and lesions in the ear can cause permanent hearing loss. Respiratory complications include potentially life-threatening pulmonary hemorrhage and upper airway obstruction caused by subglottic stenosis. Chronic lung disease secondary to granulomatous inflammation, cavitory lesions, and scarring can predispose to infectious complications. Chronic glomerulonephritis may progress to ESRD in a subset of patients with advanced or undertreated disease.

## PROGNOSIS

The course is variable, but disease relapse occurs in up to 60% of patients. Mortality has been reduced with the introduction of cyclophosphamide and other immunosuppressive agents. Compared with adults, children are more likely to develop multiorgan involvement, renal involvement, and subglottic stenosis.

Visit Elsevier eBooks+ at [eBooks.Health.Elsevier.com](http://eBooks.Health.Elsevier.com) for Bibliography.

## 210.5 Other Vasculitis Syndromes: Hypersensitivity, CNS, and COVID-19 Related

Vidya Sivaraman, Edward C. Fels, and Stacy P. Ardoin

Other vasculitic conditions can occur in childhood; the most common is **Kawasaki disease** (see Chapter 208). **Behçet disease** is a rare form of vasculitis seen in children of Turkish and Mediterranean descent, characterized by the triad of recurrent aphthous stomatitis, genital ulcers, and uveitis (see Chapter 202).

**Hypersensitivity vasculitis** is a cutaneous vasculitis triggered by medication or toxin exposure. The rash consists of palpable purpura or other nonspecific rash. Skin biopsies reveal characteristic changes of **leukocytoclastic vasculitis** (small vessels with neutrophilic perivascular or extravascular neutrophilic infiltration) (Table 210.14). **Hypocomplementemic urticarial vasculitis** involves small vessels and manifests as recurrent urticaria that resolves over several days but leaves residual hyperpigmentation. This condition is associated with low levels of complement component C1q and systemic findings that include fever, GI symptoms, arthritis, and glomerulonephritis. Some patients with urticarial vasculitis have normal complement levels. **Cryoglobulinemic vasculitis** can complicate mixed essential cryoglobulinemia and is a small vessel vasculitis affecting skin, joints, kidneys, and lungs.

**Primary angiitis of the central nervous system** represents vasculitis confined to the CNS and requires exclusion of other systemic vasculitides. **Large vessel disease** (angiography positive) may be progressive or nonprogressive and may manifest with focal deficits similar to an occlusive stroke, with hemiparesis, focal gross or fine motor deficits, language disorders, or cranial nerve deficits. Diffuse cognitive, memory, and concentration deficits and behavioral disorders are seen in 30–40% of patients. **Small vessel disease** (angiography negative, biopsy positive) more often results in language problems and diffuse deficits, such as cognitive, memory, behavior, and concentration problems, as well as focal seizures. In both types

of cerebral angiitis, patients may have an elevated ESR or CRP and abnormal CSF findings (increased protein, pleocytosis), although these are not consistent findings in all patients. Diagnosis remains a challenge, and brain biopsy is often indicated to confirm the diagnosis and exclude vasculitis mimics such as infections that could worsen with immunosuppressive therapy (Table 210.15).

**Table 210.15** Differential Diagnosis of Small Vessel Primary Central Nervous System (CNS) Vasculitis in Children

### CNS VASCULITIS COMPLICATING OTHER DISEASES

#### Infections

- Bacterial: *Mycobacterium tuberculosis*, *Mycoplasma pneumoniae*, *Streptococcus pneumoniae*
- Viral: Epstein-Barr virus, cytomegalovirus, enterovirus, varicella-zoster virus, hepatitis C virus, parvovirus B19, West Nile virus
- Fungal: *Candida albicans*, *Actinomyces*, *Aspergillus*
- Spirochetal: *Borrelia burgdorferi*, *Treponema pallidum*

#### Rheumatic and Inflammatory Diseases

- Systemic vasculitis such as granulomatosis with polyangiitis, microscopic polyangiitis, Henoch-Schönlein purpura, Kawasaki disease, polyarteritis nodosa, Behçet disease
- Systemic lupus erythematosus, juvenile dermatomyositis, morphea
- Inflammatory bowel disease
- Autoinflammatory syndromes
- Hemophagocytic lymphohistiocytosis
- Neurosarcoidosis
- Adenosine deaminase-2 deficiency

#### Other

- Drug-induced vasculitis
- Malignancy-associated vasculitis

### NONVASCULITIS INFLAMMATORY BRAIN DISEASES

#### Demyelinating Diseases

- Multiple sclerosis, acute demyelinating encephalomyelitis (ADEM), optic neuritis, transverse myelitis

#### Antibody-Mediated Inflammatory Brain Disease

- Anti-NMDA receptor encephalitis, neuromyelitis optica (NMO), antibody-associated limbic encephalitis (antibodies against LGI, AMP, AMP-binding protein), Hashimoto encephalopathy, celiac disease, pediatric autoimmune neuropsychiatric disorders associated with streptococcal infections (PANDAS)

#### T-Cell-Associated Inflammatory Brain Disease

- Rasmussen encephalitis

#### Other

- Febrile infection-related epilepsy syndrome (FIRES)

### NONINFLAMMATORY VASCULOPATHIES

- Hemoglobinopathies (sickle cell disease), thromboembolic disease
- Radiation vasculopathy, graft versus host disease
- Metabolic and genetic diseases such as cerebral autosomal dominant arteriopathy with subcortical infarcts and leukoencephalopathy (CADASIL), mitochondrial encephalopathy lactic acidosis and strokelike episodes (MELAS), cerebral autosomal recessive arteriopathy with subcortical infarcts and leukoencephalopathy (CARASIL), Moyamoya disease, Fabry disease
- Malignancy (lymphoma)

Modified from Gowdie P, Twilt M, Benseler SM. Primary and secondary central nervous system vasculitis. *J Child Neurol*. 2012;27:1448–1459.

**Table 210.14** Criteria for Diagnosis of Hypersensitivity Vasculitis\*

CRITERION	DEFINITION
Age at onset >16yr	Development of symptoms after 16yr of age
Medication at disease onset	Medication that may have been a precipitating factor was taken at the onset of symptoms
Palpable purpura	Slightly elevated purpuric rash over one or more areas; does not blanch with pressure and is not related to thrombocytopenia
Maculopapular rash	Flat and raised lesions of various sizes over one or more areas of the skin
Biopsy, including arteriole and venule	Histologic changes showing granulocytes in a perivascular or extravascular location

\*For purposes of classification, a patient is said to have hypersensitivity vasculitis if at least three of these criteria are present. The presence of three or more criteria has a diagnostic sensitivity of 71.0% and specificity of 83.9%. The age criterion is not applicable for children.

Adapted from Calabrese LH, Michel BA, Bloch DA, et al. The American College of Rheumatology 1990 criteria for the classification of hypersensitivity vasculitis. *Arthritis Rheum*. 1990;33:1108–1113, Table 2, p. 1110; and Petty RE, Laxer RM, Lindsley CB, Wedderburn LR. *Textbook of Pediatric Rheumatology*, 7th ed. Philadelphia: Saunders; 2016: Table 38.2, p. 511.



Table 210.16 Diagnostic Considerations for Other Vasculitis Syndromes	
VASCULITIS SYNDROME	APPROACH TO DIAGNOSIS
Hypersensitivity vasculitis	Skin biopsy demonstrating leukocytoclastic vasculitis
Hypocomplementemic urticarial vasculitis	Biopsy of affected tissue demonstrating small vessel vasculitis Low levels of circulating C1q
Cryoglobulinemic vasculitis	Biopsy of affected tissue demonstrating small vessel vasculitis Measurement of serum cryoglobulins Exclusion of hepatitides B and C infections
Primary angiitis of CNS	Conventional, CT, or MRA evidence of CNS vasculitis Consideration of dura or brain biopsy
Nonprogressive angiography-positive CNS vasculitis	Conventional, CT, or MRA evidence of CNS vasculitis
Cogan syndrome	Ophthalmology and audiology evaluations Conventional, CT, or MRA evidence of CNS or aortic vasculitis

Table 210.17 Acral and Nonacral Potential Cutaneous Manifestations of Pediatric COVID-19	
ACRAL	NONACRAL
Pernio-like lesions	Urticaria
EM-like lesions	Erythematous patches
Plantar papules	EM-like lesions
Retiform purpura	Vesicles/papulovesicles
Ecchymotic-like lesions	Herpetiform oral eruption
Livedo reticularis	Roseola-like rash
	Maculopapular rash
	Macular eruption
	Lingual papillitis
	Eccrine hidradenitis
	Erythema nodosum
	Petechiae
	Purpura

Modified from Neale H, Hawryluk EB. COVID-19 pediatric dermatology. *Dermatol Clin.* 2021;39:505–519, Table 4, p. 513.

**Nonprogressive angiography-positive CNS vasculitis**, also known as *transient CNS angiopathy*, represents a more benign variant and can be seen after varicella infection. **Cogan syndrome** is rare in children; its potential clinical manifestations include constitutional symptoms; inflammatory eye disease such as uveitis, episcleritis, or interstitial keratitis; vestibuloauditory dysfunction (vertigo, hearing loss, tinnitus); arthritis; and large vessel vasculitis or aortitis. Cerebral autosomal dominant arteriopathy with subcortical infarcts and leukoencephalopathy (**CADASIL**) is caused by pathogenic variants in the *NOTCH3* gene and manifests with stroke, mood changes, cognitive decline, and migraines; it is a vasculitis mimic and demonstrates osmophilic granules in cerebral arteries. Cerebral autosomal recessive arteriopathy with subcortical infarcts and leukoencephalopathy (**CARASIL**) is another mimic of angiitis caused by pathogenic variants in the *HTRA1* gene. It manifests with early-onset hair loss, spasticity, stroke, memory loss, and personality changes.

Identification of these vasculitis syndromes requires a comprehensive history and physical examination. **Table 210.16** outlines other diagnostic considerations. Although tailored to disease severity, treatment generally includes prednisone (up to 2 mg/kg/day). Potent immunosuppressive medications, such as cyclophosphamide, are often indicated, particularly in primary angiitis of the CNS to prevent rapid neurologic decline. For hypersensitivity vasculitis, withdrawal of the triggering medication or toxin is indicated if possible.

**COVID-19**, including multisystem inflammatory syndrome in children (**MIS-C**), has been associated with a variety of cutaneous lesions that resemble vasculitis, vasculopathy, and vasoocclusive etiologies (see Chapter 311) (**Table 210.17**, **Fig. 210.11**). Lesions include pernio (chilblain: COVID toes)—like lesions suggestive of a vasculitis. Other cutaneous manifestations include urticarial vasculitis and livedo reticularis-like or livedo racemosa—both resemble a pauci-inflammatory occlusive vasculitis. Sweet syndrome and erythema multiforme-like lesions have also been described. Most cutaneous lesions associated with known COVID-19 or MIS-C do not require a biopsy, but some of those that were biopsied have demonstrated a leukocytoclastic vasculitis.

Visit Elsevier eBooks+ at [eBooks.Health.Elsevier.com](https://eBooks.Health.Elsevier.com) for Bibliography.



**Fig. 210.11** Pernio-like lesions in children. **A**, A child with purpuric papules on the first, second, fourth, and fifth right digits and second proximal left digit. **B**, Digits on the same child appearing with increased erythema. **C**, Right toes of a child appearing with pink and dusky papules and plaques, also involving the child’s left digits (**D**). (From Neale H, Hawryluk EB. COVID-19 pediatric dermatology. *Dermatol Clin.* 2021;39:505–519, Fig. 3, p. 511.)



## Chapter 211

# Musculoskeletal Pain Syndromes

James J. Nocton

Musculoskeletal pain is a frequent reason for children to visit a health-care provider and is the most common problem referred to pediatric rheumatology clinics. Prevalence estimates of persistent musculoskeletal pain in community samples range from 10% to 40%. Although inflammatory diseases such as juvenile idiopathic arthritis (JIA) and systemic lupus erythematosus (SLE) are associated with musculoskeletal pain, noninflammatory conditions such as trauma, hypermobility, overuse, and **idiopathic pain syndromes** are much more common causes of musculoskeletal pain in children.

## CLINICAL MANIFESTATIONS

Acute and subacute musculoskeletal pain in children is most commonly the result of trauma, overuse, hypermobility, or some combination of these. The history and physical findings of trauma are most often readily apparent, and the pain associated with overuse or hypermobility is most often described as related to activities and improving with rest. The physical examination of children with pain related to overuse, hypermobility, and other mechanical causes of pain does not reveal signs of inflammation such as warmth, swelling, or limited range of motion and most often reveals hypermobility with perhaps mild tenderness over tendons and their insertion points.

**Chronic idiopathic musculoskeletal pain syndromes** are defined by pain of at least 3 months duration in the absence of objective abnormalities on physical examination or laboratory screening (see [Chapter 212](#)). The prevalence of chronic idiopathic musculoskeletal pain syndromes increases with age and is higher in females. These syndromes often persist despite treatment with nonsteroidal antiinflammatory drugs (NSAIDs) and other analgesics. Chronic pain may occur anywhere and is most often diffuse and poorly localized, but may sometimes involve only a single extremity or part of an extremity. Pain may start in one location before potentially developing in other areas over time.

Psychologic and emotional distress, including anxiety, depression, stress, or a combination of these, is quite common in those with chronic idiopathic musculoskeletal pain syndromes. Frequent crying, school and social stress, poor concentration, and excessive worry are often described. Sleep disturbance in children with chronic pain syndromes may include difficulty falling asleep, multiple night awakenings, disrupted sleep-wake cycles with increased daytime sleeping, nonrestorative sleep, and fatigue.

Children who are high achievers, excellent students, mature, and responsible, with high expectations of themselves have a predisposition to the development of pain syndromes in general, including chronic musculoskeletal pain. As a result, headaches and abdominal pain or other gastrointestinal symptoms are also frequently present in those with chronic idiopathic musculoskeletal pain syndromes.

The constellation of chronic pain, psychologic distress, and sleep disturbance often leads to a high degree of functional impairment. Poor school attendance is common, and children may struggle to complete other daily activities relating to self-care and participation in household chores. Decreased physical fitness can also occur, along with changes in gait and posture, as children avoid the use of the area affected by pain. Peer relationships may also be disrupted by decreased opportunities for social interaction because of pain. Loneliness and social isolation characterized by few friends and lack of participation in extracurricular activities are common.

## DIAGNOSIS AND DIFFERENTIAL DIAGNOSIS

The diagnosis of a musculoskeletal pain syndrome is based primarily on history and physical examination. Children with pain require a thorough clinical history, including a complete social history and review of systems, and a careful, comprehensive physical examination. The specific characteristics of the pain should be defined, evidence of potential systemic disease should be sought, and any additional associated symptoms and signs should be elicited.

The need for laboratory testing and imaging studies should be individualized, depending on the information elicited in the history and discovered with the physical examination. Possible indicators of an inflammatory cause for musculoskeletal pain include objective joint warmth, swelling, limited range of joint motion on physical examination, localized bone tenderness, and muscle weakness; potential indicators of a systemic disease include poor linear growth, weight loss, and constitutional symptoms. The lack of these symptoms and objective abnormalities on physical examination is more suggestive of a non-inflammatory cause for pain ([Table 211.1](#)). The complete blood count (CBC) and erythrocyte sedimentation rate (ESR) are often abnormal in children whose pain is secondary to a bone or joint infection, rheumatic disease, or a malignancy. Bone tumors, fractures, and other focal pathology resulting from infection, malignancy, or trauma can often be identified through imaging studies, including plain radiographs or MRI.

The presence of chronic, persistent pain, accompanied by psychologic distress, sleep disturbance, and/or functional impairment, in the absence of objective laboratory or physical examination abnormalities, suggests the diagnosis of an **idiopathic musculoskeletal pain syndrome**. [Table 211.2](#) outlines common causes of pediatric musculoskeletal pain according to anatomic location, including **growing pains** (see [Chapter 211.1](#)), diffuse **amplified pain syndromes** and chronic widespread pain (see [Chapter 211.3](#)), **complex regional pain syndrome** (see [Chapter 211.4](#)), localized pain syndromes, low back pain, and chronic overuse-related pain (e.g., Osgood-Schlatter disease). A differential diagnosis of more serious conditions is noted in [Table 211.3](#).

## TREATMENT

The primary goal of treatment for acute and subacute musculoskeletal pain related to trauma, hypermobility, overuse, or other mechanical factors is to minimize the discomfort as much as possible and to promote normal activities. Rest, topical analgesics, mechanical joint support to be worn with activities, ice, oral analgesics, and physical therapy may all be used. Education of children and families regarding pain related to these mechanical factors is critical in helping them to understand what to expect. Although it is common for the discomfort related to hypermobility and overuse to be recurrent, the prognosis for these mechanical pains is excellent, and most children learn to manage their discomfort with few, if any, restrictions on activities.

The primary goal of treatment of chronic idiopathic musculoskeletal pain syndromes is to improve function and relieve pain; these outcomes may not occur simultaneously or quickly. Pain may persist even as children resume normal function (e.g., increased school attendance and participation in extracurricular activities). For all children and adolescents with pediatric musculoskeletal pain syndromes whose school attendance has been affected by their symptoms, regular school attendance is a primary initial goal. The dual nature of treatment, targeting both *function* and *pain*, needs to be clearly explained. Children and families need to be supported in disengaging from the sole pursuit of pain relief and embracing the equally imperative goal of improved functioning.

Recommended treatment modalities include physical and/or occupational therapy, pharmacologic interventions, and cognitive-behavioral and/or other psychotherapeutic interventions. The overarching goal of **physical therapy** is to improve children's physical function and should emphasize participation in aggressive but graduated aerobic exercise. **Pharmacologic** interventions should be used judiciously. Low-dose

**Table 211.1** Potential Indicators of Inflammatory vs Noninflammatory Causes of Musculoskeletal Pain

CLINICAL FINDING	NONINFLAMMATORY	INFLAMMATORY
Effects of rest vs activity on pain	Relieved by rest and worsened by activity	Present at rest and may be relieved by activity
Time of day pain and/or stiffness occurs	End of the day and nights	Morning*
Objective joint swelling	No	Yes
Joint characteristics	Hypermobility/normal	Stiffness, limited range of motion
Bone tenderness	No	Possible
Muscle strength	Normal	Possible weakness
Gait	Normal	Limp
Growth	Normal growth pattern or weight gain	Poor growth and/or weight loss
Constitutional symptoms	Fatigue without other constitutional symptoms	Possible
Laboratory findings	Normal CBC, ESR, CRP	Abnormal CBC, raised ESR and CRP
Imaging findings	Normal	Effusion, osteopenia, radiolucent metaphyseal lines, joint space loss, bone destruction

\*Cancer pain is often severe and worst at night.

CBC, Complete blood count; CRP, C-reactive protein level; ESR, erythrocyte sedimentation rate.

Data from Malleson PN, Beauchamp RD. Diagnosing musculoskeletal pain in children. *CMAJ* 2001;165:183–188.

**Table 211.2** Common Musculoskeletal Pain Syndromes in Children by Anatomic Region

ANATOMIC REGION	PAIN SYNDROMES
Shoulder	Impingement syndrome
Elbow	“Little League elbow” Avulsion fractures Osteochondritis dissecans Tennis elbow Panner disease
Arm	Localized hypermobility syndrome Complex regional pain syndrome
Pelvis and hip	Avulsion injuries Legg-Calvé-Perthes syndrome Slipped capital femoral epiphysis Congenital hip dysplasia
Knee	Osteochondritis dissecans Osgood-Schlatter disease Sinding-Larsen syndrome Patellofemoral syndrome Malalignment syndromes
Leg	Growing pains Complex regional pain syndrome Localized hypermobility syndrome Shin splints Stress fractures Compartment syndromes
Foot	Plantar fasciitis Tarsal coalition Stress fractures Achilles tendonitis Juvenile bunions
Spine	Musculoskeletal strain Spondylolysis Spondylolysis Scoliosis Scheuermann disease (kyphosis) Low back pain
Generalized	Hypermobility syndrome Diffuse amplified pain syndrome Chronic widespread pain

Adapted from Anthony KK, Schanberg LE. Assessment and management of pain syndromes and arthritis pain in children and adolescents. *Rheum Dis Clin North Am*. 2007;33:625–660, Box 1.

tricyclic antidepressants (amitriptyline 0.1 mg/kg at bedtime; can increase to 0.5 to 2 mg/kg as tolerated) may improve sleep; selective serotonin reuptake inhibitors (sertraline 25–100 mg daily) may help to alleviate symptoms of depression and anxiety if present. **Cognitive-behavioral therapy (CBT)** and/or other psychotherapeutic interventions are designed to teach children and adolescents coping skills for controlling the behavioral, cognitive, and physiologic responses to pain. Specific components often include cognitive restructuring, relaxation, distraction, and problem-solving skills. Parent education and involvement in the psychological intervention are important to ensure maintenance of progress. More intensive family-based approaches are warranted if barriers to treatment success are identified at the family level. These could include parenting strategies or family dynamics that serve to maintain children's pain complaints, such as overly solicitous responses to the child's pain and maladaptive models for coping with pain.

### COMPLICATIONS AND PROGNOSIS

Musculoskeletal pain related to hypermobility and/or overuse may be recurrent and related to specific activities, but is typically mild, does not usually significantly limit activities, and is most often managed symptomatically. Conversely, chronic idiopathic musculoskeletal pain syndromes have a much greater potential to negatively affect development and future role functioning. Worsening pain and the symptoms of depression and anxiety associated with chronic pain can lead to substantial school absences, peer isolation, and developmental delays later in adolescence and early adulthood. Specifically, adolescents with chronic idiopathic musculoskeletal pain syndromes may fail to achieve the level of autonomy and independence necessary for age-appropriate activities, such as attending college, living away from home, and maintaining a job. Fortunately, not all children and adolescents with these syndromes experience this degree of impairment. Factors that contribute to the persistence of pain are increasingly understood and include female gender, pubertal stage at pain onset, older age of pain onset, increased psychological distress associated with the pain, and greater functional impairment. The likelihood of positive health outcomes is increased with multidisciplinary treatment addressing the pain, the functional disabilities, and the psychological comorbidities associated with pain.

Visit Elsevier eBooks+ at [eBooks.Elsevier.com](http://eBooks.Elsevier.com) for Bibliography.

**Table 211.3** Differential Diagnosis of Idiopathic Musculoskeletal Pain Syndrome**CHANNELOPATHIES**

Erythromelalgia: primary (associated with the *SCN9A* gene) or secondary  
 Paroxysmal extreme pain disorder (*SCN9A* gene)  
 Small fiber neuropathy (*SCN9A*, *SCN10A* genes)  
 Familial episodic pain syndrome (*SCN11A*, *TRPA1* genes)

**CONNECTIVE TISSUE DISORDERS**

Ehlers-Danlos syndrome  
 Marfan syndrome

**IMMUNE/AUTOIMMUNE**

Systemic lupus erythematosus  
 Sarcoidosis  
 Juvenile idiopathic arthritis  
 Sjögren syndrome  
 Familial Mediterranean fever and other autoinflammatory recurrent fever syndromes  
 Hereditary angioedema  
 Chronic nonbacterial osteomyelitis  
 Mononeuritis multiplex associated with vasculitis

**METABOLIC/NUTRITION**

Fabry disease  
 Gaucher disease  
 Porphyria  
 Mitochondrial neuropathies  
 Vitamin deficiency (thiamine, B<sub>12</sub>, C, D)  
 X-linked adrenoleukodystrophy

**OTHER**

Guillain-Barré syndrome  
 Multiple sclerosis  
 Toxic: lead, arsenic, chemotherapy  
 HIV  
 Familial amyloid neuropathy  
 Complex regional pain syndrome types 1 and 2  
 Sickle cell anemia  
 Thalamic stroke  
 Primary, metastatic, or recurrent malignancy (acute lymphocytic leukemia, neuroblastoma)  
 Neurofibromatosis  
 Radiculopathy  
 Nerve entrapment syndromes
 

1. Peroneal
2. Suprascapular
3. Anterior, posterior hip
4. Anterior cutaneous nerve (abdominal)

From Kliegman RM, Toth H, Bordini BJ, Basel D, eds. *Nelson Pediatric Symptom-Based Diagnosis*, 2nd ed. Philadelphia: Elsevier; 2023: Table 33.2, p. 547.

## 211.1 Growing Pains (Benign Limb Pain of Childhood)

James J. Nocton

The cause of benign limb pain of childhood, historically referred to as **growing pains**, is unknown. Low pain threshold, overuse, and behavioral causes have been postulated, and it is possible that there are multiple causes for these pains. This pain affects 10–20% of children, with peak incidence between age 4 and 12 years. Benign limb pains of childhood are intermittent and usually bilateral, poorly localized, and predominantly affecting the anterior thigh, shin, and calf. Occasionally, bilateral upper extremity pain may be associated with leg pain. Children typically describe cramping or aching that occurs most often in the late afternoon or evening. Pain may wake the child from sleep, may be severe, and may last a few minutes to hours, but typically resolves quickly with massage or analgesics; pain is nearly always resolved by the following morning (Table 211.4). Pain may often follow a day with increased or excessive physical activity. Physical examination is normal, and gait is not impaired.

**Treatment** should focus on reassurance, education, and healthy sleep hygiene while preparing parents and children for the possibility that the pain may occur intermittently for years, with eventual resolution. Massage, acetaminophen, or NSAIDs during the episode are nearly always effective.

**Restless legs syndrome (RLS)**, seen more frequently among adolescents and adults, is a sensorimotor disturbance that may be confused with growing pains (see Chapter 31). Often familial, RLS is a difficult-to-control *urge* to move the leg that is exacerbated during rest and at night and is relieved by movement (see Table 211.4). There is significant overlap in the diagnostic features of growing pains and RLS. Moreover, these conditions can be comorbid, and there is a high incidence of RLS in the parents of children with growing pains. RLS appears to be best distinguished from growing pains by the *urge* to move the legs, associated uncomfortable leg sensations that may not be described as painful; worsening with periods of rest; and relief through movement. Iron supplementation may benefit pediatric patients with RLS.

Visit Elsevier eBooks+ at [eBooks.Health.Elsevier.com](https://eBooks.Health.Elsevier.com) for Bibliography.

## 211.2 Small Fiber Polyneuropathy

James J. Nocton

Some patients with juvenile-onset widespread pain syndromes have evidence of a small fiber polyneuropathy causing dysfunctional or degeneration of small-diameter unmyelinated C fibers and thinly myelinated A delta fibers that mediate nociception and the autonomic nervous system. In addition to pain, these children may have dizziness, postural orthostatic tachycardia syndrome (POTS), constipation and/or gastrointestinal dysmotility, and other symptoms suggestive of dysautonomia (Fig. 211.1).

The diagnosis of small fiber polyneuropathy requires distal leg immunolabeled skin biopsy to identify epidermal nociceptive fibers and autonomic function testing to examine cardiovagal, adrenergic, and sudomotor small fiber function. Genetic testing for pathogenic variants in genes coding for sodium channels may reveal *SCN9A*, *SCN10A*, or *SCN11A* variants. Some small studies have reported the presence of autoantibodies to trisulfated disaccharide and fibroblast growth factor receptor 3, suggestive of immune-mediated pathogenesis. Other potential etiologies for small fiber neuropathy are noted in Table 211.5; most cases are idiopathic. In addition, other genetic painful neuropathies should be considered (Table 211.6).

**Optimal treatment** of patients with small fiber polyneuropathy is unknown. Corticosteroids and intravenous immune globulin have been effective in very small numbers of patients.

Visit Elsevier eBooks+ at [eBooks.Health.Elsevier.com](https://eBooks.Health.Elsevier.com) for Bibliography.

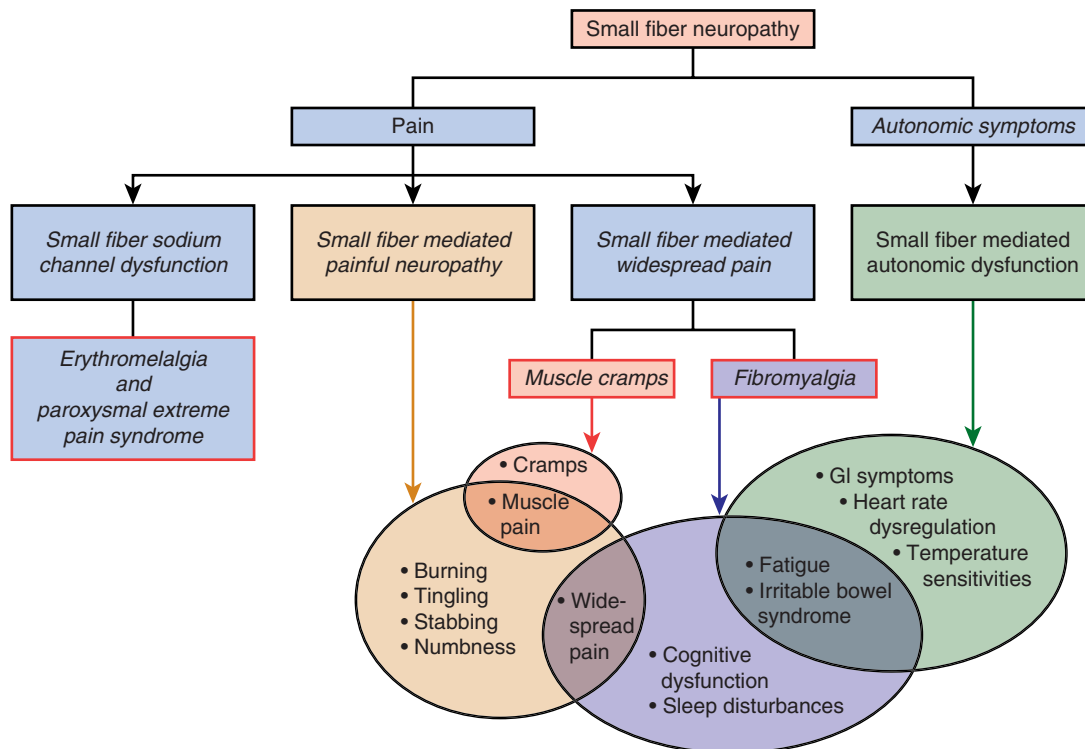
## 211.3 Diffuse Amplified Pain Syndromes

James J. Nocton

Diffuse amplified pain syndrome is more common in children than localized amplified pain. In addition to widespread pain, children frequently have associated chronic fatigue, sleep disturbance, headaches, chronic abdominal pain and gastrointestinal symptoms, stress, anxiety, and/or symptoms of depression (see also Chapter 212). The terms *diffuse amplified pain syndrome*, *chronic widespread pain syndrome*, *chronic myofascial pain syndrome*, and *juvenile primary fibromyalgia syndrome* are often used to describe the same constellation of symptoms. Some of these children have findings that fulfill the criteria that have been developed for adult patients with fibromyalgia by either the American College of Rheumatology (Table 211.7) or the Analgesic, Anesthetic, and Addiction Clinical Trial Translations Innovations Opportunities and Networks-American Pain Society (Table 211.8 and

Table 211.4 Inclusion and Exclusion Criteria for Growing Pains Including Features of Restless Legs Syndromes (RLS)			
	INCLUSIONS	EXCLUSIONS	RLS FEATURES
Nature of pain	Intermittent; some pain-free days and nights, deep aching, cramping	Persistent; increasing intensity, pain during the day	Urge to move legs often accompanied by unpleasant sensations in legs, but may not be painful
Unilateral or bilateral	Bilateral	Unilateral	
Location of pain	Anterior thigh, calf, posterior knee—in muscles not the joints	Articular, back, or groin pain	Urge to move and discomfort throughout leg
Onset of pain	Late afternoon or evening	Pain still present next morning	Worse later in day or night but also present at periods of rest or inactivity throughout the day
Physical findings	Normal	Swelling, erythema, tenderness; local trauma or infection; reduced joint range of motion; limping, fever, weight loss, mass	
Laboratory findings	Normal	Objective evidence of abnormalities; increased erythrocyte sedimentation rate or C-reactive protein; abnormal complete blood count, radiography, bone scan, or MRI	

Adapted from Evans AM, Scutter SD. Prevalence of “growing pains” in young children. *J Pediatr.* 2004;145:255–258; and Walters AS, Gabelia D, Frauscher B. Restless legs syndrome (Willis-Ekbom disease) and growing pains: are they the same thing? A side-by-side comparison of the diagnostic criteria for both and recommendations for future research. *Sleep Med.* 2013;14:1247–1252.



**Fig. 211.1** Small fiber neuropathy symptom clusters and neuropathy classifications. (From Levine TD. *Small fiber neuropathy: disease classification beyond pain and burning.* *J Central Nervous Sys Dis.* 2018;10:1–6, Fig. 1, p. 3).

**Fig. 211.2).** Separate criteria for the diagnosis of juvenile primary fibromyalgia syndrome in children have been proposed, but these have not been validated (Table 211.9). The evaluation of fibromyalgia tender points has not been useful or diagnostic.

Although the precise cause of diffuse amplified pain is unknown, there is an emerging understanding that the development and maintenance of chronic pain are related both to biologic and psychologic factors. Diffuse amplified pain likely has multifactorial causes and is hypothesized to be an abnormality of central pain processing associated

with disordered sleep physiology, enhanced pain perception, disordered mood, and dysregulation of hypothalamic-pituitary-adrenal and other neuroendocrine axes, resulting in lower pain thresholds and increased pain sensitivity. Children and adolescents with diffuse amplified pain often find themselves in a vicious cycle of pain, where symptoms build on one another and contribute to the onset and maintenance of new symptoms.

Diffuse amplified pain has a chronic course that can detrimentally affect child health and development. Adolescents who do not



**Table 211.5** Causes of Small Fiber Neuropathy

PRIMARY	SECONDARY
<b>IDIOPATHIC</b> Idiopathic small fiber neuropathy Burning mouth syndrome	<b>METABOLIC</b> Impaired glucose tolerance Diabetes mellitus Rapid glycemic control Vitamin B <sub>12</sub> deficiency Dyslipidemia Hypothyroidism Chronic kidney disease
<b>HEREDITARY/GENETIC</b> Familial amyloid polyneuropathy Fabry disease Tangier disease Sodium channelopathies (see text)	<b>INFECTIONS</b> HIV Hepatitis C Influenza  <b>TOXINS AND DRUGS</b> Antiretrovirals Antibiotics—metronidazole, nitrofurantoin, linezolid Chemotherapy—bortezomib Flecainide Statin Alcohol Vitamin B <sub>6</sub> toxicity  <b>IMMUNE MEDIATED</b> Celiac disease Sarcoidosis Sjögren syndrome Rheumatoid arthritis Systemic lupus erythematosus Vasculitis Inflammatory bowel disease Paraneoplastic Monoclonal gammopathy/amyloid

Note that a number of these conditions may present as a small fiber neuropathy and then evolve to include large fibers.

Modified from Themistocleous AC, Ramirez JD, Serra J, Bennett DLH. The clinical approach to small fibre neuropathy and painful channelopathy. *Pract Neurol*. 2014;14:368–379, Table 1.

receive treatment or who are inadequately treated may withdraw from school and the social milieu, complicating their transition to adulthood. **Treatment** of diffuse amplified pain is ideally multidisciplinary. The major goals are to restore function and alleviate pain and to improve comorbid mood and sleep disorders. Treatment strategies include parent/child education, pharmacologic interventions, exercise-based interventions, and psychologic interventions. Graduated **aerobic exercise** is the recommended exercise-based intervention, whereas psychologic interventions should include training in pain coping skills, stress management skills, emotional support, and sleep hygiene. CBT is particularly effective in reducing symptoms of depression in children and adolescents with chronic pain and helps to reduce functional disability.

Drug therapies, although largely unsuccessful in isolation, may include tricyclic antidepressants (amitriptyline 0.1 mg/kg at bedtime; can increase to 0.5 to 2 mg/kg as tolerated), selective serotonin reuptake inhibitors (sertraline 25–100 mg daily), and anticonvulsants. Pregabalin and duloxetine hydrochloride are approved by the U.S. Food and Drug Administration (FDA) for treatment of fibromyalgia in adults ( $\geq 18$  years of age); however, data regarding the efficacy of these medications in children are limited.

Visit Elsevier eBooks+ at [eBooks.Health.Elsevier.com](http://eBooks.Health.Elsevier.com) for Bibliography.

## 211.4 Complex Regional Pain Syndrome

James J. Nocton

Complex regional pain syndrome (CRPS) is characterized by chronic, persistent limb pain, often burning in character. **CRPS type 1**, also termed *reflex sympathetic dystrophy*, has no evidence of nerve injury, whereas the less common **CRPS type 2** is associated with a known mechanism of nerve injury. The pain of CRPS is typically extreme and disproportionate to the inciting event. Associated features include **allodynia** (a heightened pain response to normally non-noxious stimuli), **hyperalgesia** (exaggerated pain reactivity to noxious stimuli), swelling of the affected extremity, and indicators of **autonomic dysfunction** (cyanosis, mottling, hyperhidrosis).

There are no diagnostic criteria specifically for pediatric CRPS; in adults, several sets of criteria have been developed (Table 211.10); the clinical utility of these criteria is controversial. The diagnosis of CRPS is clinical and can be made when continuous pain is present that is disproportionate to any potential inciting event with associated allodynia, or hyperalgesia, evidence of edema, skin blood flow abnormalities, or excessive sweating activity, and exclusion of other disorders. Other features that may be present include atrophy of hair or nails, loss of joint mobility, weakness, tremor, and dystonia.

Although many pediatric patients with CRPS present with a history of minor trauma or repeated stress injury (e.g., caused by competitive sports), a significant proportion are unable to identify a precipitating event. Usual age of onset is between 8 and 16 years, and females outnumber males with the disease by as much as 6:1. Childhood CRPS differs from the adult form in that lower extremities, rather than upper extremities, are most often affected. The incidence of CRPS in children is unknown, largely because it is often undiagnosed or diagnosed late. Left untreated, CRPS can have severe consequences for children, including bone demineralization, muscle wasting, and joint contractures.

The **treatment** of CRPS, like that of more diffuse pain syndromes, is ideally multidisciplinary. Aggressive physical therapy (PT) should be initiated as soon as the diagnosis is made, and CBT added as needed. PT is recommended three to four times a week, and children may need analgesic premedication at the onset, particularly before PT sessions. PT is initially limited to desensitization and then moves to weight bearing, range of motion, and other functional activities. CBT used as an adjunctive therapy targets psychosocial obstacles to fully participating in PT and provides pain-coping skills training. The goal of both pharmacologic and adjunctive treatments for CRPS is to provide sufficient pain relief to allow the child to participate in aggressive physical rehabilitation. Multiple studies have shown that noninvasive treatments, particularly PT and CBT, are at least as efficacious as nerve blocks in helping children with CRPS achieve resolution of their symptoms.

Visit Elsevier eBooks+ at [eBooks.Health.Elsevier.com](http://eBooks.Health.Elsevier.com) for Bibliography.

## 211.5 Erythromelalgia

James J. Nocton

Children with erythromelalgia experience episodes of intense burning pain, erythema, edema, and heat, most often in the hands and feet (Fig. 211.3) and less frequently in other locations. Symptoms are most often triggered by exposure to heat or exercise and typically last for hours to days. Erythromelalgia is more common in females during adolescence, and the diagnosis is often delayed for many years. Although many cases are sporadic, an autosomal dominant hereditary form results most often from gain-of-function pathogenic variants of the *SCN9A* gene, which encodes the alpha subunit of the sodium channel Na<sub>v</sub>1.7 found in nociceptive neurons that transmit pain signals. Age of onset for the

**Table 211.6** Clinical Features of Human Disorders Caused by Pathogenic Gene Variants in Ion-Channel Genes that Lead to Altered Pain Perception and Are Inherited in a Mendelian Manner

	GENE (PROTEIN)	TYPE AND EFFECT OF GENE VARIANT	MAIN PHENOTYPE	ADDITIONAL FEATURES
Inherited erythromelalgia	SCN9A(Na <sub>v</sub> 1.7)	Heterozygous, activating	Onset by age 20 yr; episodic pain triggered by warmth; feet affected more frequently than hands	Erythema of feet
Paroxysmal extreme pain disorder	SCN9A(Na <sub>v</sub> 1.7)	Heterozygous, activating	Onset at birth; episodic pain; sacral region is affected most frequently; face is affected more often than the limbs; physical triggers include defecation	Erythema of the sacrum; tonic attacks
Small-fiber neuropathy	SCN9A(Na <sub>v</sub> 1.7)	Heterozygous, activating	Onset at any age but more common in early adulthood; persistent burning pain; feet affected more frequently than hands	Could be autonomic features
Small-fiber neuropathy	SCN10A(Na <sub>v</sub> 1.8)	Heterozygous, activating	Persistent burning pain	Could be autonomic features
Familial episodic pain syndrome type I	TRPA1(TRPA1)	Heterozygous, activating	Onset at birth or in infancy; episodic chest or arm pain; triggers are hunger and cold	
Familial episodic pain syndrome type III	SCN11A(Na <sub>v</sub> 1.9)	Heterozygous, activating	Onset in first decade; episodic hand and foot pain; triggers are intercurrent illness or exercise	

Na<sub>v</sub>, Sodium ion channel.

Modified from Bennett DLH, Woods CG. Painful and painless channelopathies. *Lancet Neurol.* 2014;13:587–599, Table 1.

**Table 211.7** American College of Rheumatology Fibromyalgia Diagnostic Criteria (2016 Revision)

The following three conditions must be met:

1. Widespread Pain Index (WPI)  $\geq 7$  and Symptom Severity Scale (SSS) score  $\geq 5$  or WPI 4–6 and SSS score  $\geq 9$ .
2. Generalized pain, defined as pain in at least four of five regions, must be present. Jaw, chest, and abdominal pain are not included in generalized pain definition.
3. Symptoms have been generally present for at least 3 mo.

#### ASCERTAINMENT OF WPI

The WPI is the number of areas in which a patient has had pain over the last week. The score will be between 0 and 19: Left Upper Region: left jaw, left shoulder girdle, left upper arm, left lower arm; Right Upper Region: right jaw, right shoulder girdle, right upper arm, right lower arm; Left Lower Region: left hip (buttock, trochanter), left upper leg, left lower leg; Right Lower Region: right hip (buttock, trochanter), right upper leg, right lower leg; Axial Region: chest, abdomen, upper back, lower back, and neck.

#### ASCERTAINMENT OF SSS SCORE

The SSS score is the sum of the severity of three symptoms (fatigue, waking unrefreshed, and cognitive symptoms) over the past week (each given a score from 0 to 3) plus the sum of the number of the following symptoms the patient has been bothered by that occurred during the previous 6 mo: headaches, pain or cramps in the lower abdomen, and depression (each given a score from 0 to 1). The final score will be between 0 and 12. For fatigue, waking unrefreshed, and cognitive symptoms, the level of severity over the past week is rated using the following scale:

- 0 = No problem
- 1 = Slight or mild problems, generally mild or intermittent
- 2 = Moderate, considerable problems, often present and/or at a moderate level
- 3 = Severe: pervasive, continuous, life-disturbing problems
- For headaches, pain or cramps in the lower abdomen, and depression, the severity for each is scored as 0 or 1.

Adapted from Wolfe F, Clauw DJ, Fitzcharles MA, et al. 2016 Revisions to the 2010/2011 fibromyalgia diagnostic criteria. *Semin Arthritis Rheum.* 2016;46(3):319–329.

**Table 211.8** Analgesic, Anesthetic, and Addiction Clinical Trial Translations Innovations Opportunities and Networks-American Pain Society Pain Taxonomy (AAPT) Fibromyalgia Diagnostic Criteria

Core diagnostic criteria:

1. Musculoskeletal pain defined as 6 or more pain sites from a total of 19 possible sites (see Fig. 211.2)
2. Moderate to severe sleep problems OR fatigue
3. Musculoskeletal pain plus fatigue or sleep problems must have been present for at least 3 mo

NOTE: The presence of another pain disorder or related symptoms does not rule out a diagnosis of fibromyalgia. However, a clinical assessment is recommended to evaluate for any condition that could fully account for the patient's symptoms or contribute to the severity of the symptoms.

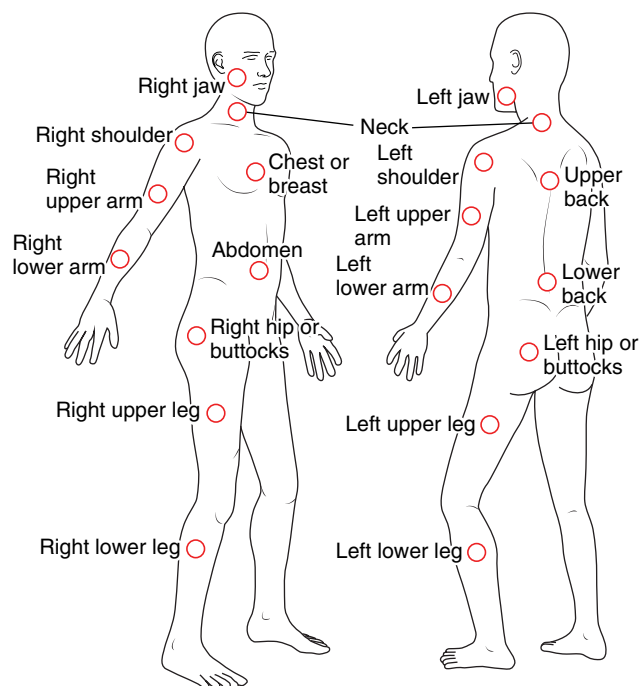
Adapted from Arnold LM, Bennett RM, Crofford LJ, et al. AAPT Diagnostic Criteria for Fibromyalgia. *J Pain.* 2019;20:611–628.

familial form ranges from 1 to 16 years. **Secondary** erythromelalgia is associated with many disorders, including myeloproliferative diseases, peripheral neuropathies, frostbite, and rheumatic diseases. The differential diagnosis includes Fabry disease, Raynaud phenomenon or disease, reflex sympathetic dystrophy, and peripheral neuropathies. In contrast to Raynaud phenomenon, the pain in erythromelalgia is relieved by cooling the affected area. Treatment includes avoidance of heat exposure and other precipitating situations and the use of cooling techniques that do not cause tissue damage during attacks. There is no proven reliably efficacious treatment, and NSAIDs, narcotics, anesthetic agents (lidocaine patch), anticonvulsants (oxcarbazepine, carbamazepine, gabapentin), antidepressants, sodium nitroprusside, magnesium, mexiletine, and misoprostol, as well as biofeedback, medical and surgical nerve blocks, and hypnosis have had variable efficacy.

Visit Elsevier eBooks+ at [eBooks.Elsevier.com](https://www.elsevier.com/ebooks) for Bibliography.

### Widespread Pain Index (1 point per circle; score range: 0–19 points)

Please indicate if you have had pain or tenderness **during the past 7 days** in the areas shown below. Fill in the circles on the diagram for each area in which you have had pain or tenderness.



**Fig. 211.2** Widespread pain index. (Modified from Fraix M. *Fibromyalgia*. In Tallia AF, Scherger JE, Dickey NW (eds). *Swanson's Family Medicine Review*, 9th ed. Philadelphia: Elsevier, 2022. Fig 47.1.)

### Table 211.10 Budapest Clinical Diagnostic Criteria for Complex Regional Pain Syndrome

All of the following criteria must be met:

- Continuing pain, which is disproportionate to any inciting event
- Must report at least one symptom in each of the following four categories:
  - Sensory*: Hyperesthesia and/or allodynia
  - Vasomotor*: Temperature asymmetry, skin color changes, and/or skin color asymmetry
  - Sudomotor/edema*: Edema, sweating changes, and/or sweating asymmetry
  - Motor/trophic*: Decreased range of motion, motor dysfunction (tremor, weakness, dystonia) and/or trophic changes (hair, nail, skin)
- Must display at least one sign at time of evaluation in two or more of the following four categories:
  - Sensory*: Evidence of hyperesthesia (to pin prick) and/or allodynia (to light touch, temperature sensation, deep somatic pressure, and/or joint movement)
  - Vasomotor*: Evidence of temperature asymmetry ( $>1^{\circ}\text{C}$ ), skin color changes, and/or skin color asymmetry
  - Sudomotor/edema*: Edema, sweating changes, and/or sweating asymmetry
  - Motor/trophic*: Decreased range of motion, motor dysfunction (tremor, weakness, dystonia) and/or trophic changes (hair, nail, skin)
- There is no other diagnosis that better explains the signs and symptoms.

Adapted from Harden RN, Bruel S, Stanton-Hicks, et al. Proposed new diagnostic criteria for complex regional pain syndrome. *Pain Med*. 2007;8:326–331.

### Table 211.9 Suggested Diagnostic Criteria for Juvenile Primary Fibromyalgia Syndrome (JPFS)

#### MAJOR CRITERIA

- Generalized musculoskeletal aching at three or more sites for  $\geq 3$  mo
- Absence of an underlying condition/cause
- Normal laboratory tests
- Five or more typical tender points\*

#### MINOR CRITERIA

- Chronic anxiety or tension
- Fatigue
- Poor sleep
- Chronic headaches
- Irritable bowel syndrome
- Subjective soft tissue swelling
- Numbness
- Pain modulated by physical activities
- Pain modulated by changes in weather
- Pain modulated by anxiety/stress

\*Thirty-one potential tender points were listed for these criteria when proposed in 1985. JPFS is diagnosed when all major criteria are met, plus three of the minor criteria or when there are four tender points and five minor criteria.

Adapted from Coles M, Weissmann R, Uziel Y. Juvenile primary fibromyalgia syndrome: Epidemiology, etiology, pathogenesis, clinical manifestations and diagnosis. *Pediatr Rheumatol Online J*. 2021;19(1):22.



**Fig. 211.3** Characteristic redness and edema of the foot associated with erythromelalgia. (From Pfund Z, Stankovics J, Decsi T, Illes Z. Childhood steroid-responsive acute erythromelalgia with axonal neuropathy of large myelinated fibers: a dysimmune neuropathy? *Neuromuscul Disord*. 2009;19:49–52, Fig. 1A, p. 50.)

## Chapter 212

## Chronic Overlapping Pain Conditions

Thomas C. Chelimsky and  
Gisela G. Chelimsky

In chronic overlapping pain conditions (COPCs), several painful symptoms affecting different body systems coexist without clear underlying pathophysiology. Other terms for COPCs include **medically unexplained symptoms**, **functional somatic syndromes (FSS)**, and **central sensitivity syndromes**. These disorders are probably highly prevalent; for example, two COPCs, irritable bowel syndrome (IBS) and migraine, each affect 10–20% of the population. Pediatric COPC studies usually focus on populations with one painful condition (headaches) and their psychiatric comorbidities, rather than somatic comorbidities. The overlap of these disorders with psychiatric conditions has led both the public and the medical specialists to dichotomize these disorders artificially into “physical,” by implication, “real” disorders and “psychologic,” by implication, “not real” disorders. This classification ignores the unity of brain and body and hinders progress in understanding these disorders. COPC connotes a nonassumptive neutral position, appropriately attributing no assumed pathophysiology to the disorder, in contrast to other terms, such as “medically unexplained syndrome,” subtly suggesting a psychologic process, more strongly implied in the term “functional.”

## PREVALENCE

The prevalence of COPCs is unknown depending on which symptom is being assessed and how much overlap exists across disorders. A large study from 28 countries (about 400,000 participants) found a prevalence of headache of 54%, stomachache 50%, and backache 37%, occurring at least once a month for at least 6 months. Females had a higher prevalence of having all three complaints when compared with males; the prevalence increased with age. These three pain syndromes, headache, stomachache, and backache, frequently coexist.

IBS and chronic abdominal pain affect 6–20% of children and adolescents. Idiopathic musculoskeletal pain affects about 16% of schoolchildren age 5–16 years and is often associated with sleep disturbances, headache, abdominal pain, daytime tiredness, and feeling sad. Migraines present >6 months occur in about 8% of the population (children and adolescents <20 years). Fibromyalgia is present in 1.2–6%. The prevalence of chronic disabling fatigue increases during adolescence from about 1.9% at age 13 to 3% at 18 years. As with most COPCs, fibromyalgia has many comorbid disorders, such as sleep disturbance, fatigue, headache, sore throat, joint pain, and abdominal pain. The American College of Rheumatology definition of fibromyalgia incorporates some of these comorbid conditions.

## SYMPTOM/DISORDER OVERLAP

Diagnostic criteria of many of these disorders overlap with one another, making differentiation between two disorders more of a semantic issue rather than a clinical differentiation. **Chronic fatigue syndrome (CFS)**, clinically the most concerning symptom, shares many of the diagnostic criteria with fibromyalgia. Patients with a single pain condition, such as fibromyalgia, CFS, IBS, multiple chemical sensitivity (MCS), headaches, or temporomandibular joint disorder (TMJD), will typically have another disorder. This overlap of symptoms may reflect a shared pathophysiology, possibly a central nervous system (CNS) dysfunction, as was implied in the prior term “central sensitization syndrome.” A CNS pathophysiology would also explain the “invisibility” of these disorders to usual screening tools that most often target an end organ.

COPCs also harbor many symptoms that are not strictly “pain,” although they may be equally or more disabling. Adolescents seen in a tertiary referral center with a **functional gastrointestinal disorder (FGID)** also manifest dizziness, chronic nausea, chronic fatigue, and sleep disturbance, as well as migraines. Up to 50% of adolescents complain of weekly fatigue, and 15%, daily fatigue. COPCs are studied in their discipline-specific silos rather than collectively as a group.

Migraine headaches are frequently associated with anxiety and depression. **Anxiety** also predicts the persistence of migraine headaches. Sleep disturbance and migraine also interact closely. Poor sleep can trigger a migraine or a migraine cluster; migraine headache itself disturbs sleep. Juvenile fibromyalgia is associated with sleep disturbances such as prolonged sleep latency, frequent awakening, less total sleep time, and periodic limb movements. Adult patients with IBS also have sleep disturbances, correlating with anxiety, depression, and stress.

The **comorbidities** of **hypermobility Ehlers-Danlos (hEDS)** and **postural orthostatic tachycardia syndrome (POTS)** with COPC have been significant. Patients with hEDS may complain of widespread and sometimes debilitating pain with or after activity, severe fatigue, handwriting difficulties, “cracking” of joints, joint swelling, joint dislocation, subluxation, or back pain. The chronic pain reduces exercise tolerance, with poorer quality of life and an ever-worsening cycle because exercise is a key piece of management. Patients with FGID may also have hEDS, fibromyalgia, chronic pain, and higher somatizations scores than those with organic gastrointestinal (GI) disorders.

The diagnosis of pediatric POTS requires an increase in heart rate >40 beats/min in the first 10 minutes of upright tilt test associated with orthostatic symptoms. POTS is also associated with multiple comorbidities, including sleep disruption, chronic pain, Raynaud-like symptoms, GI abnormalities, and less frequently, headaches, syncope, and urinary complaints. Patients with both POTS and hEDS usually have more migraines and syncope than those with POTS alone. The prevalence of comorbid disorders in children with COPC is identical whether they have POTS or hEDS.

## PSYCHIATRIC COMORBIDITIES

Many of these disorders have significant psychiatric comorbidities. Juvenile fibromyalgia is associated with anxiety disorders and major mood disorders. Children with medically unexplained symptoms generally have more anxiety and depression than children with other chronic disorders. Other associations include disruptive behaviors, symptom internalization, fearfulness, greater dependency, hyperactivity, and concern about sickness.

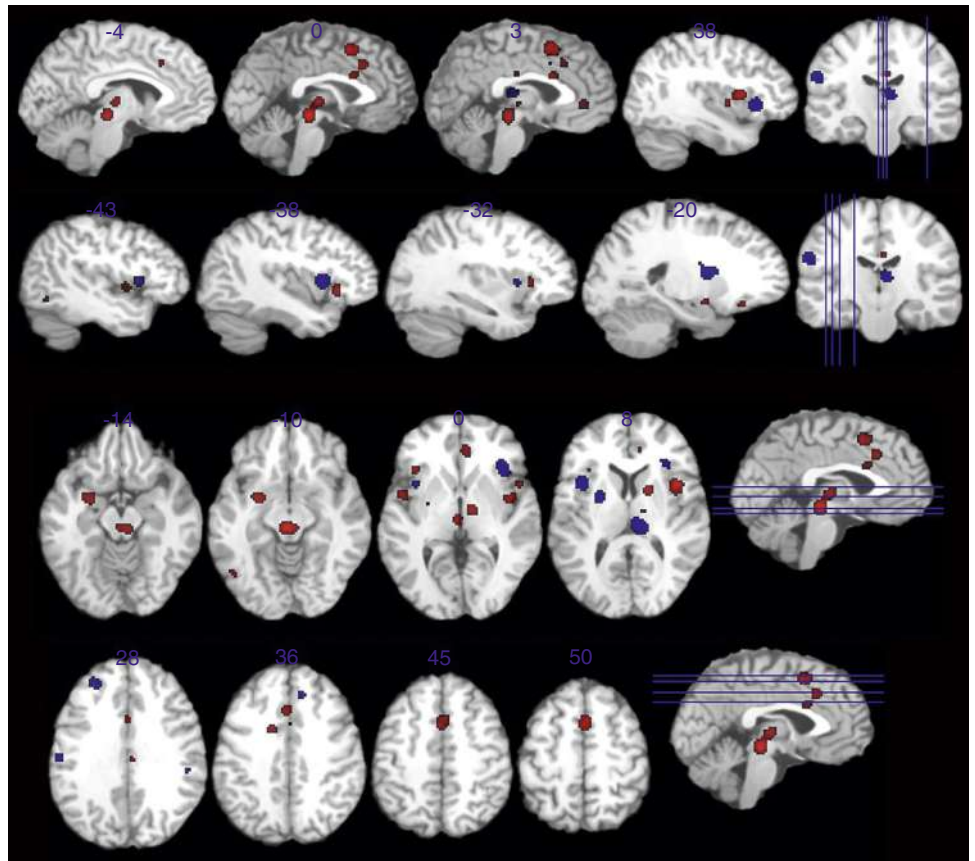
## PREDISPOSING FACTORS

Female gender and older age (adolescence) increase the risk of COPCs. Certain conditions (e.g., headache) are more common in males or have similar prevalence across genders during childhood, but the prevalence in females increases after puberty. Trauma or posttraumatic stress disorder increases psychologic comorbidities in juvenile fibromyalgia. Some studies suggest that anxiety predisposes to chronic pain. A population-based study following children from 18 months to 14 years of age suggested that maternal psychologic distress in early childhood and depressive and pain complaints in preadolescence increase the risk of recurrent abdominal pain at age 14. Postinfectious IBS is an identifiable risk factor for new-onset anxiety, depression, and sleep disruption in adults. Children with recurrent abdominal pain often have parents with abdominal pain. It is unclear if this association is caused by a common environmental/genetic factor or a learned behavior of the child imitating the parent.

## NATURAL HISTORY

The natural history of COPC is not well known. Chronic disabling fatigue in the general adolescent population persists 2–3 years in about 25% of patients, but only 8% of youth affected at age 13 still had the complaints at ages 16 and 18. A meta-analysis suggests that the prognosis of CFS in children is usually good, with a small minority having persistent disabling symptoms. The patient’s belief in an underlying





**Fig. 212.1** Brain areas demonstrating more (red) or less (blue) activation in irritable bowel syndrome compared with healthy control in a meta-analysis of rectal distension. (From Tillisch K, Mayer EA, Labus JS. Quantitative meta-analysis identifies brain regions activated during rectal distension in irritable bowel syndrome. *Gastroenterology*. 2011;140:91–100, Fig. 3.).

physical disorder and the presence of psychiatric comorbidities predict a poorer outcome.

In a study of children with FGID, the outcome depended on specific variables. Those who perceived their abdominal pain as more threatening, with high levels of pain catastrophization and little capacity to cope with pain because of reduced activity levels, had a poorer outcome. This “high pain dysfunctional profile” subgroup was predominantly female (70%) with a mean age of 12.2 years. Two thirds of this subgroup still complained of FGID at follow-up vs about one third of those in the other groups. These groups included a “high pain adaptive profile” group with similar pain levels but better adaptive skills and less catastrophization, predominantly slightly younger (11.8 years) females, and a “low pain adaptive profile” group, slightly younger (11.1 years), with equal males and females but less abdominal pain, better coping mechanisms, and less impairment of daily activities. In the high pain dysfunctional profile group, 41% had both FGID and nonabdominal chronic pain at follow-up vs 11% in the high pain adaptive and 17% in the low pain adaptive group. Another study following children ages 4–16.6 years with IBS demonstrated resolution of symptoms in 58%, usually without medication. The differences between these studies may result from the age of the groups, with better outcome in the younger patients, as well as the number of comorbidities and psychologic profile. Similarly, in juvenile fibromyalgia, symptoms are still present 2–6 years later in about 60% of affected children. The psychiatric comorbidities, mainly depression, and controlling family environments are associated with a poor prognosis.

### PROPOSED PATHOPHYSIOLOGY

There may be dysfunction in the hypothalamic-hypophyseal-adrenal axis, circadian patterns, autonomic responses, some aspects of CNS processing, the inflammatory immune response, and the musculoskeletal system. Vagal tone measured by heart rate variability is decreased in some children with FGID symptoms and in children with COPCs. Alterations in the autonomic nervous system may affect the immune system and circadian patterns. The stress response may increase muscle tone, which in turn leads to body aches and tension headaches. In fibromyalgia the cortisol response is altered, with lower cortisol levels

on awakening and throughout the day. **Orthostatic intolerance** from autonomic abnormalities may also contribute to poor concentration from brain hypoperfusion and blood pooling in the lower extremities.

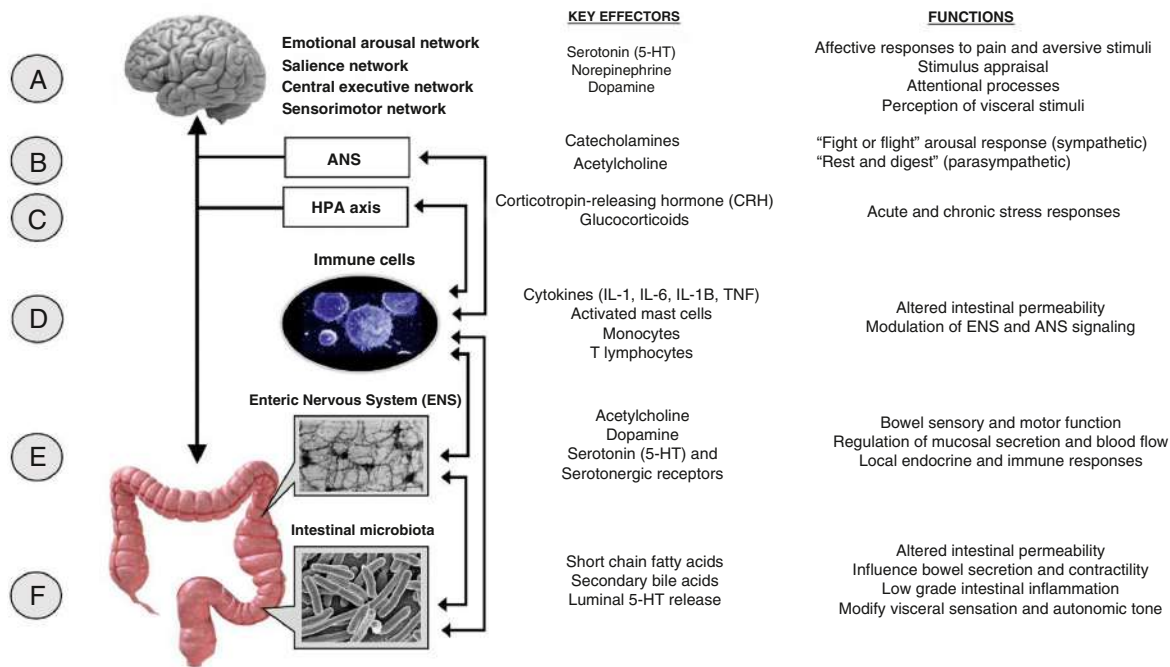
The pathophysiology has been better studied in myalgic encephalomyelitis (ME)/CFS. ME/CFS has been associated with joint hypermobility, orthostatic intolerance, decreased range of motion, and reduced activity. These patients demonstrate excessive glial activation resulting in neuroexcitation, neuroinflammation, and possibly neurodegeneration. These features may contribute to the cognitive issues and fatigue present in this disorder.

Neuroinflammation and other changes in processing may lead to abnormal descending inhibitory pain pathways, resulting in distal pain and “central sensitization.” The malfunction of descending antinociceptive pathways allows pain to spread in the body, associated with increased activity of the nociceptive facilitator pathways. These facilitator pathways are further activated by psychologic factors, such as catastrophization, depression, lack of acceptance, and hypervigilance. Other signals such as pressure, sound, heat, and cold are also aberrantly processed, with activation of areas of the brain that are typically activated only by acute pain stimuli, such as the insula, prefrontal cortex, and anterior cingulate cortex, as well as some regions usually not involved in pain processing.

The neuromechanisms involved in dysregulated brain-gut interactions in patients with FGID include changes in functional connectivity between brain regions associated with nociceptive processing and the somatosensory cortex. Enhanced sensory processing of the gut homeostasis (homeostatic afferent) and attentive responses to salience stimuli (salience network) as well as changes in certain brain regions are noted in patients with FGID (Fig. 212.1). These alterations affect the perception of pain and may affect the endocrine and autonomic nervous systems. What was once called FGIDs is currently considered disorders of gut-brain interactions. Proposed mechanisms are noted in Figure 212.2. Research investigating the role of the microbiome in regulating microglia, astrocytes, and immune cells may lead to central sensitization and chronic pain.

### TREATMENT

In general, *chronic pain should never be treated with opioids; cognitive-behavioral therapy (CBT) and a gradually progressive exercise program*



**Fig. 212.2** Key effectors and functions of the brain-gut-microbiota axis. ANS, autonomic nervous system; HPA, hypothalamic pituitary axis. (From Tait C, Sayuk GS. *The brain-gut-microbial axis: A framework for understanding functional GI illness and their therapeutic interventions. Eur J Int Med.* 2021;84:1–9, Fig. 2.)

**constitute the cornerstones of treatment.** The complex comorbid nature of COPCs typically requires a multidisciplinary approach. Because neither CBT nor exercise will have any effect in the absence of full patient engagement and understanding, the team must include the family and the patient, a pain psychologist with experience in CBT, a physical therapist, and the primary care physician. Depending on comorbid conditions, rheumatology, neurology, or gastroenterology may have important roles for symptom management and a possible alternative diagnosis. Depending on the initial symptomatology, the differential diagnosis should include inflammatory bowel disease, celiac disease, juvenile idiopathic arthritis, systemic lupus erythematosus, dermatomyositis, autoinflammatory disorders, Fabry disease, porphyrias, hereditary sensory-autonomic neuropathies, and Ehlers-Danlos syndrome. Red flags suggesting a medical/organic etiology for abdominal pain (Table 212.1), headache (Tables 212.2 and 212.3), and musculoskeletal pain (Table 212.4) must be assessed.

When a thorough evaluation for a structural cause of symptoms is unrevealing, an important next step is patient and family education. This should include the common presentation, the expectation that “markers” for these types of disorders would typically be absent, and the presence of solid management tools with high probability of improvement. Families and patients need to receive encouragement to stop seeking a “magic diagnosis and cure” and to begin the path to full recovery. Without this step, critical patient engagement in the treatment will not occur. In our practice, we sometimes call *functional* disorders a problem of “software,” in contrast to *structural* issues that would involve “hardware.” We explain that successful management must change the software, not just mask symptoms. Approaches that accomplish such a goal include CBT and a rehabilitative program that may require physical therapy, a vigorous exercise program with interval training, meditation, and/or yoga. Patients are often deconditioned and may need to start with a very low level of physical activity. In addition, their exercise tolerance may be significantly hampered by an orthostatic intolerance syndrome (e.g., POTS). For these reasons, we frequently recommend starting with a *water aerobics* program, which provides several benefits: (1) very low gravitational force, so the patient can be set up for success, working only on conditioning and not simultaneously fighting an orthostatic challenge; (2) builds both limb and core strength; and (3) gentle on joints for those with arthralgias or a hypermobility syndrome. When water is unavailable, we recommend starting with a recumbent exercise program

such as a recumbent stationary bike. In both circumstances, we then slowly introduce upright aerobic activities on land over 2-3 months. Strength exercises are also useful. A Cochrane review in adults with painful disorders showed exercise to have minimal side effects and to improve functionality, reduce pain, and improve quality of life. Patients with fibromyalgia who undergo a 3-month multidisciplinary program with twice-weekly physical therapy and CBT benefited in function and physical activity level, and most importantly continued to exercise regularly at 1 year follow-up. Pharmacologic interventions have less impact than nonmedical treatments.

When children are missing school or are homebound, it is important to work closely with the school to encourage reentry. This may require modifying the school schedule initially, starting with fewer hours at school, and providing extra time for homework on days that the children are not feeling well.

Although medications such as tricyclic antidepressants are often added to the treatment, the improvement with these medications for chronic pain is minimal, and the side effects need to be considered. Nonetheless, amitriptyline and anticonvulsants like gabapentin are often used because they help in treating headaches and abdominal pain and improve sleep quality, a critical element to manage any chronic pain condition.

Visit Elsevier eBooks+ at [eBooks.Elsevier.com](https://eBooks.Elsevier.com) for Bibliography.

## 212.1 Chronic Fatigue Syndrome

Mark R. Magnusson

Chronic fatigue syndrome (CFS), also known as **myalgic encephalomyelitis (ME)**, is a complex, diverse, and debilitating illness characterized by chronic or intermittent fatigue accompanied by select symptoms and occurring in children, adolescents, and adults. The combination of fatigue and other symptoms interferes significantly with daily activities and has no identified medical explanation (Fig. 212.3). The fatigue does not require exertion by the patient, nor does rest relieve it. Some consider **postexertion malaise**, or worsening of

**Table 212.1** Red Flags and Clues to an Organic Cause of Abdominal Pain

Age <4 yr old
Localized pain in nonperiumbilical site
Referred pain
Sudden onset of excruciating pain
Crescendo nature of pain
Sudden worsening of pain
Fever (high fever >39.4°C suggests pneumonia, pyelonephritis, dysentery, cholangitis, more than perforation or abscess)
Jaundice
Distention*
Dysphagia
Dysuria
Emesis (especially bilious)
Anorexia
Weight loss, failure to thrive
Positive family history (metabolic disorders, peptic ulcer disease) <sup>†</sup>
Change in urine or stool color (blood, acholic) or frequency
Vaginal discharge
Menstrual abnormalities (amenorrhea)
Sexual activity
Delayed sexual development (chronic pain)
Anemia
Elevated erythrocyte sedimentation rate
Elevated stool calprotectin
Specific physical findings (hepatomegaly, splenomegaly, absent bowel sounds, adnexal tenderness, palpable mass, involuntary guarding, focal or diffuse tenderness, positive rectal examination results, perianal disease, joint swelling, rashes)

\*Consider the five Fs: fat, feces, flatus (aerophagia, obstruction), fluid (ascites, hydronephrosis, cysts), fetus (pregnancy or fetal-like abnormal growth [e.g., tumors]).  
<sup>†</sup>Family history is also positive for chronic pain syndromes (constipation, irritable bowel, dysmenorrhea, and lactase or sucrase deficiency).  
 Modified from Kliegman RM, Toth H, Bordini BJ, Basel D, eds. *Nelson Pediatric Symptom-Based Diagnosis*, 2nd ed. Philadelphia: Elsevier; 2023: Table 13.8, p. 229.

**Table 212.3** Physical Examination Red Flags for Secondary Headaches

<b>Abnormal vital signs:</b>
Hypertension
Growth failure
Increased head circumference or bulging fontanel
Fever
Meningeal signs with or without fever
Evidence of cranial trauma
Cranial bruit
Frontal bony tenderness
Macrocephaly
<b>Abnormal ophthalmologic findings:</b>
Papilledema
Abnormal ocular movements
Squinting
Pathologic pupillary response
Visual field defects
<b>Abnormal neurologic findings:</b>
Impaired mental status
Cranial nerve palsy
Ataxia
Abnormal gait
Abnormal coordination
Abnormal reflexes
Asymmetric motor or sensory examination
Hemiparesis
Developmental regression
Precocious, delayed, or arrested puberty
<b>Skin findings:</b>
Café-au-lait or ash leaf macules
Petechiae or purpura
Facial hemangioma
Malar rash

From Kliegman RM, Toth H, Bordini BJ, Basel D, eds. *Nelson Pediatric Symptom-Based Diagnosis*, 2nd ed. Philadelphia: Elsevier; 2023: Table 34.6, p. 553.

**Table 212.2** History-Related Red Flags for Secondary Headaches

<b>Quality:</b>
“Thunderclap” rapid-onset headache or the “worst headache of my life”
Recent worsening in severity or frequency
Change in quality
New-onset symptoms consistent with cluster headache
<b>Location:</b>
Unilateral without alteration of sides
Chronic or recurrent occipital headache
<b>Timing:</b>
Awakens from sleep
Occurs in morning or causes morning vomiting
Acute or chronic progressive pattern
Positional or activity-related variations:
Worsened in the recumbent position or when bending over
Headache experienced or worsened with cough or the Valsalva maneuver
<b>Associated neurologic history:</b>
Neurologic dysfunction other than typical aura
Altered sensorium during headache
Sensory deficits or changes in vision, gait, or coordination
Other focal neurologic deficits
Seizures or syncope
Decreased visual acuity
Mental status changes (e.g., confusion or disorientation)
Regression in fine or gross motor developmental skills
Decline in cognition or school performance
Change in mood, behavior, or personality
<b>Associated general history:</b>
Vomiting without nausea and morning/fasting nausea or vomiting
Polyuria or polydipsia
Preschool or younger age
History of head trauma
<b>Neck pain:</b>
Medical comorbidities
History of ventriculoperitoneal shunt
Certain medications
Signs of systemic or localized head/neck infection
Negative family history of primary headache disorders

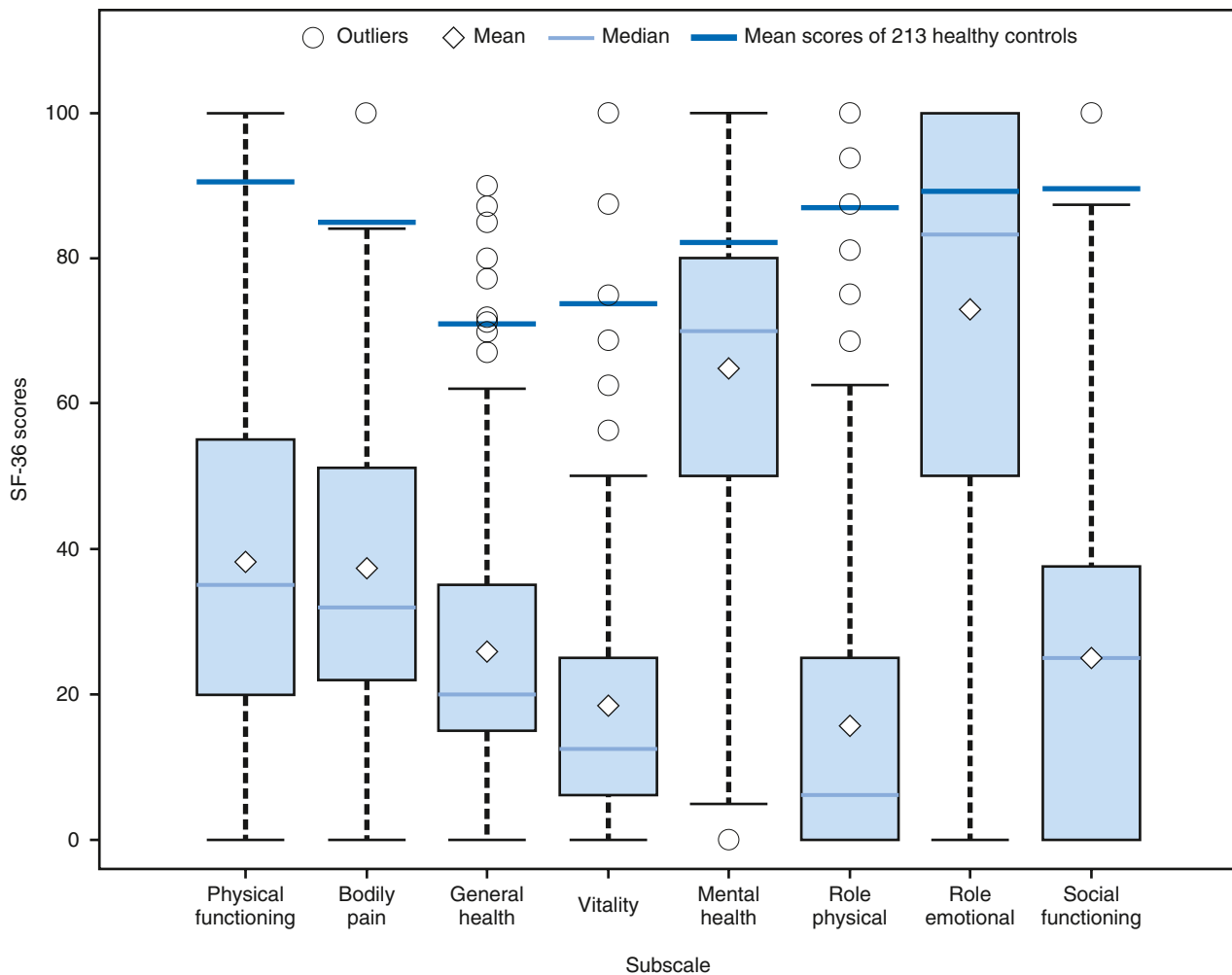
From Kliegman RM, Toth H, Bordini BJ, Basel D, eds. *Nelson Pediatric Symptom-Based Diagnosis*, 2nd ed. Philadelphia: Elsevier; 2023: Table 34.5, p. 553.

**Table 212.4** Musculoskeletal/Joint Pain Warning Signals Requiring Further Workup

<ul style="list-style-type: none"> <li>• Arthritis: Erythema, warmth, swelling, pain on palpation</li> <li>• Pain/stiffness in the morning</li> <li>• Abnormal radiographic findings</li> <li>• Pain at rest, relieved by activity</li> <li>• Pain at night: Worsened by massage, analgesics ineffective</li> <li>• Refusal to walk</li> <li>• Extremity atrophy</li> <li>• Bony tenderness</li> <li>• Poor growth</li> <li>• Weight loss</li> <li>• Fever</li> <li>• Rash</li> <li>• Abnormal blood results: Including complete blood count (CBC), C-reactive protein (CRP), erythrocyte sedimentation rate</li> </ul>
---

Modified from Friedrichsdorf SJ, Giordano J, Dakoji KD, et al. Chronic pain in children and adolescents: Diagnosis and treatment of primary pain disorders in head, abdomen, muscles and joints. *Children*. 2016;3:42, Table 3.

the fatigue with additional symptoms after mental or physical exertion and lasting >24 hours, to be characteristic of CFS. A definitive causal agent or process has not been identified, although the differential diagnosis includes infectious, inflammatory, metabolic, genetic, and autoimmune diseases. Our understanding of this condition is largely from studies of adults and adolescents, with limited descriptions of chronic fatiguing illnesses in younger children.



**Fig. 212.3** Functional status\* of 471 patients enrolled in the CDC Multisite Clinical Assessment† of ME/CFS§—United States, September 2015. \*Measured by box plots of scores in the eight subscales of Short-Form Health Survey (SF-36) scores (25th and 75th percentile at bottom and top of box). SF-36 scores range from 0 to 100, with higher scores indicating better functioning. †<https://www.cdc.gov/cfs/programs/clinical-assessment/index.html>. §ME/CFS (myalgic encephalomyelitis/chronic fatigue syndrome) patients show significant impairment, particularly in vitality and physical functioning subscale scores, but with preservation of mental health and emotional role functioning. (From Unger ER, Lin JMS, Brimmer DJ, et al. CDC Grand Rounds: Chronic fatigue syndrome—advancing research and clinical education. *MMWR*. 2016;65[50–51]:1434–1438.)

The illness was formally defined in 1988 as *chronic fatigue syndrome* because persistent unexplained fatigue was considered the principal and invariable physical symptom. A variety of other names have been used to describe the illness, including *chronic mononucleosis*, *chronic Epstein-Barr virus (EBV) infection*, *postinfection syndrome*, and *immune dysfunction syndrome*. Several case definitions have been developed and are in use in both clinical care and research (Table 212.5).

The Institute of Medicine (IOM) 2015 recommendations apply to all ages and include a special focus on pediatrics. The IOM suggested new diagnostic criteria and a new name, **systemic exertion intolerance disease (SEID)**, to emphasize the postexertion malaise criterion and better understand the illness (Table 212.6).

### EPIDEMIOLOGY

Based on worldwide studies, 0.2–2.3% of adolescents or children have CFS. Most epidemiology studies use the 1994 definition. CFS is more prevalent in adolescents than in younger children. The variation in CFS prevalence estimates may result from variations in case definition, study methodology and application, study population composition (specialty vs general practice or general population), and data collection (parent, self-reporting vs clinician evaluation). Gender distribution in children differs from that in adults, with a

more equal distribution in children <15 years old, while remaining two-fold to three-fold higher in females 15–18 years old. Few studies have reported the incidence of CFS among children <10 years old. In adolescents in the Netherlands, the pediatrician-diagnosed incidence of CFS/ME was 0.01%, and in the United Kingdom, 0.5%.

### PATHOGENESIS

Although the etiology and pathophysiology of CFS are unknown, some patients and clinicians correlate the onset with a recent episode of a viral illness such as infectious mononucleosis (10–12%) (EBV; see Chapter 301). A pathophysiologic relationship of CFS to infection is suggested because the symptoms and biologic markers elicited by the nonspecific innate host responses to infections in general are present in CFS. CFS-like illness after infectious mononucleosis is not predicted by viremia or altered host response to EBV infection, but is associated with the severity of the primary infection. A wide variety of other candidate viral infections have been associated with postinfectious fatigue syndromes, particularly in adolescents and adults. SARS CoV-2/COVID-19 infection has also been implicated, as patients with a history of COVID-19 infection have presented with symptoms similar to patients with ME/CFS, labeled long COVID, post-acute sequelae of SARS CoV-2 infection (PASC), or post-COVID-19 conditions (Table 212.7) (see



**Table 212.5** Overview of Current Case Definitions for Systemic Exertion Intolerance Disease (SEID) and Past Definitions of Chronic Fatigue Syndrome or Myalgic Encephalomyelitis

SYMPTOM	SEID	CFS	ME
Fatigue and impairment of daily function	≥6 mo	≥6 mo	≥6 mo
Sudden onset	Yes	Yes	
Muscle weakness			Yes
Muscle pain		Yes	
Postexertional symptoms	Yes	Yes	Yes
Sleep disturbance	Yes		Yes
Memory or cognitive disturbances	Yes		Yes
Autonomic symptoms			Yes
Sore throat		Yes	
Lymph node involvement		Yes	
Cardiovascular symptoms	Yes		
Headaches		Yes	
Arthralgias		Yes	Yes

CFS, Chronic fatigue syndrome; ME, myalgic encephalomyelitis.

Data from Institute of Medicine. *Beyond Myalgic Encephalomyelitis/Chronic Fatigue Syndrome Redefining an Illness*. Washington, DC: National Academies Press; 2015; Jason L, Evans M, Porter N, et al. The development of a revised Canadian myalgic encephalomyelitis chronic fatigue syndrome case definition. *Am J Biochem Biotechnol*. 2010;6:120–135; Reeves WC, Wagner D, Nisenbaum R, et al. Chronic fatigue syndrome—a clinically empirical approach to its definition and study. *BMC Med*. 2005;3:19.

**Table 212.6** Criteria for Diagnosis of Myalgic Encephalomyelitis/Chronic Fatigue Syndrome (ME/CFS)

Patient has each of the following three symptoms at least half the time to at least a moderately severe degree:

- A substantial reduction or impairment in the ability to engage in preillness levels of occupational, educational, social, or personal activities that persists for >6 mo and is accompanied by fatigue, which is often profound, is of new or definite onset (not lifelong), is not the result of ongoing excessive exertion, and is not substantially alleviated by rest.
- Postexertional malaise\*
- Unrefreshing sleep\*

Plus at least one of the two following manifestations (chronic, severe):

- Cognitive impairment\*
- Orthostatic intolerance

\*Frequency and severity of symptoms should be assessed. The diagnosis of ME/CFS should be questioned if patients do not have these symptoms at least half of the time with moderate, substantial, or severe intensity.

From Institute of Medicine. *Beyond Myalgic Encephalomyelitis/Chronic Fatigue Syndrome*. Washington, DC: National Academies Press; 2015.

Chapter 449.1). Similar features have been described in **post-intensive care syndrome**.

Similarities between CFS symptoms and those experienced by patients with autoimmune and other inflammatory disorders suggests primary perturbation of immune function in the pathogenesis of CFS. Hypogammaglobulinemia and hypergammaglobulinemia, immunoglobulin subclass deficiencies, elevated levels of circulating immune complexes, altered helper/suppressor lymphocyte ratios, natural killer cell dysfunction, elevated cytokines, and monocyte dysfunction have been inconsistently reported in adult patients with CFS. These findings have not been consistent among studies. CFS patients as a group differ from healthy controls, but most laboratory values of the immune parameters are not outside the normal range.

**Table 212.7** WHO Definition of Long (Post)–COVID-19 Condition

- Post–COVID-19 condition occurs in individuals with a history of probable or confirmed SARS-CoV-2 infection, usually 3 mo from the onset of COVID-19, with symptoms that last for at least 2 mo and cannot be explained by an alternative diagnosis.
- Common symptoms include fatigue, shortness of breath, and cognitive dysfunction and generally have an impact on everyday functioning.
- Symptoms might be new onset after initial recovery from an acute COVID-19 episode or persist from the initial illness.
- Symptoms might also fluctuate or relapse over time; a separate definition might be applicable for children.

Modified from Munblit D, O'Hara ME, Akrami A, et al. Long COVID: Aiming for a consensus. *Lancet Respir Med*. 2022;10(7):632–634.

Autonomic nervous system (ANS) changes are suggested by the **orthostatic intolerance** (OI) experienced by some patients with CFS. OI syndromes with circulatory dysfunction include **neutrally mediated hypotension** and **POTS** and have been observed in some patients with CFS and could contribute to the syndrome. The pathophysiology of these manifestations among adolescents with CFS is unclear, but in postinfectious states could be associated with unreplenished fluid and electrolyte losses associated with acute infection or immune-mediated injury (autoantibodies directed against ANS).

Because the widespread musculoskeletal pain in CFS is similar to **fibromyalgia**, and because some consider these to be overlapping syndromes, fibromyalgia and CFS may share similarities in pathogenesis. Other hypotheses under investigation for the biologic basis of CFS involve alterations in energy metabolism (e.g., mitochondrion, particularly as related to exercise intolerance and postexertion malaise), alterations in sleep, the stress response, and the hypothalamic-pituitary axis. Understanding CFS has proved so challenging because it likely represents more than one underlying pathophysiology. Current studies and guidelines are attempting to stratify or subgroup patients to address this possibility.

## CLINICAL MANIFESTATIONS

The dominant symptom expressed by adolescents and adults is a substantial reduction or impairment in the ability to engage in pre-illness levels of activity, accompanied by fatigue (see Fig. 212.2). In younger children, who often do not spontaneously report symptoms, exertion induces behavioral changes, manifested by a lack of their usual energy and reduced participation in activities. In adolescents, fatigue and postexertion malaise may lead to decreased participation in school, family activities, and social exchange.

**Cognitive impairment** includes reported difficulties in concentrating, which are common and indicated by reduced participation in school, difficulty keeping up with homework, and a drop in grades. Sleep may be impaired, and nonrestorative sleep is common. Other sleep complaints include difficulty falling asleep and staying asleep, whereas diagnosed sleep disorders, including restless legs syndrome, parasomnias, and sleep apnea, are less common. Myalgia and arthralgia may accompany fatigue and altered sleep. Sore throat and cervical lymph node tenderness can occur but may be part of an inciting illness. Adolescents also have increased reports of headache, abdominal pain, nausea, and sensitivity to light and sound with amplified pain.

Patients diagnosed with CFS in primary care practices are more likely to report abrupt onset of their symptoms, often as part of an initial virus-like illness, whereas gradual onset is more common in those identified in population-based studies. School absenteeism is a major social issue. In one study, two thirds of adolescents missed >2 weeks over a 6-week observation period, and one third required home tutoring. Unlike school phobia, inactivity due to CFS persists on the weekends and during holidays the same as it does during the school week.

Although fatigue and accompanying symptoms are subjective, the magnitude of impairment of each component can be measured by questionnaires addressing pain and function or, in the case of suspected orthostatic instability, by recording routine supine and standing heart rate and blood pressure measurements. Fatigue cannot be dismissed as a minor ailment. It generally manifests as lassitude, profound tiredness, intolerance of exertion with easy fatigability, and general malaise.

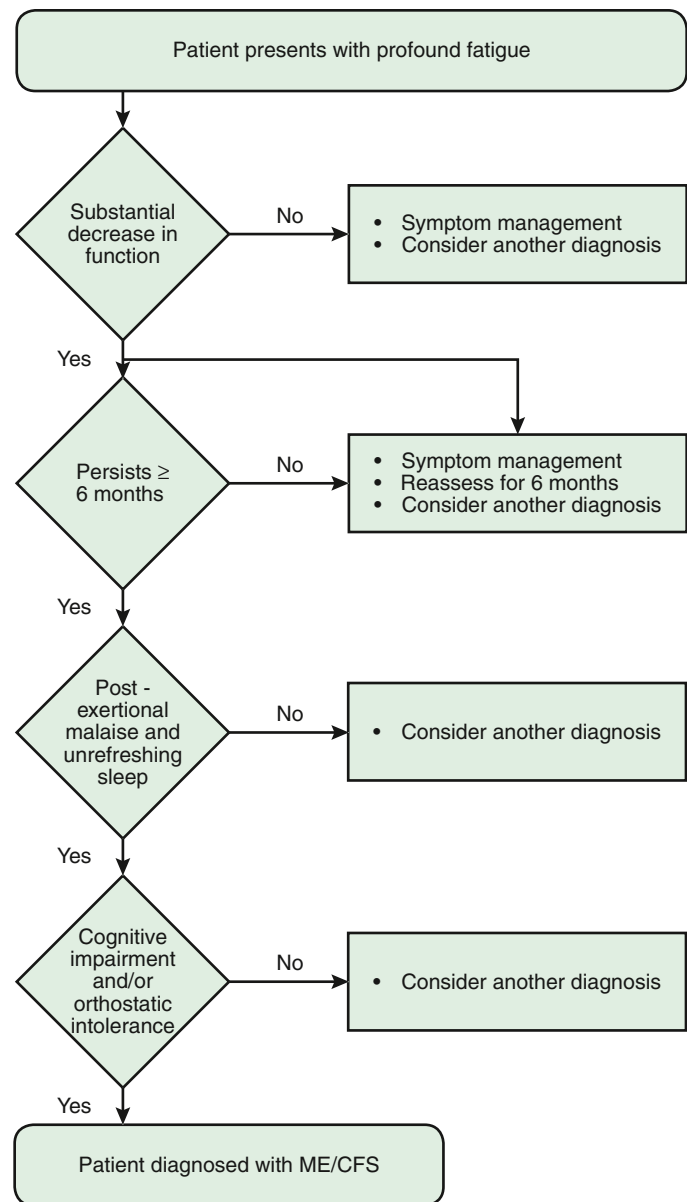
Abnormal physical examination findings are conspicuously absent, providing both reassurance and consternation for the patient, family, and physician. The presence of “alarm symptoms” such as weight loss, chest pain with exertion, paresthesia, dry mouth and eyes, fevers, diarrhea, cough, night sweats, and rash is uncommon and warrants consideration of a diagnosis other than CFS.

## DIAGNOSIS

There are no pathognomonic signs or diagnostic tests for CFS. The diagnosis is clinically defined based on inclusion and exclusion criteria (Fig. 212.4). The diagnostic criteria are applicable to adults and adolescents >11 years old because of the current requirement for a self-generated history. Whereas duration of symptoms is 3-6 months depending on age, symptom management should not wait until this criterion is met.

CFS is difficult to diagnose in children, who may have difficulty describing their symptoms and articulating their concerns. Sole reliance on parental history can be fraught with confusion because parents may also struggle to interpret their children's symptoms and feelings in providing accurate historical information. A combination of child and parent reporting is most effective. It is important to document the child's activity levels and worsening of symptoms after physical or mental endeavors. Changes in participation in hobbies and family or other social activities can help identify the impact of CFS on function.

The diagnosis of CFS can be established only after other medical and psychiatric causes of fatigue and other symptoms, many of which are treatable, have been excluded. These include medical conditions presenting with chronic symptoms, such as hypothyroidism,



**Fig. 212.4** Diagnostic algorithm for myalgic encephalomyelitis/chronic fatigue syndrome (ME/CFS). ANS, autonomic nervous system; HPA, hypothalamic-pituitary axis. (From Institute of Medicine. *Beyond Myalgic Encephalomyelitis/Chronic Fatigue Syndrome: Redefining an Illness*. Washington, DC: National Academies Press; 2015.)

adrenal insufficiency, respiratory and food allergies, sleep apnea, narcolepsy, substance abuse, posttraumatic stress disorder, adverse drug reactions, and obesity. A previously diagnosed medical condition with incomplete or uncertain resolution that may explain fatigue needs to be considered.

Certain illnesses (e.g., fibromyalgia), amplified pain syndrome, post-COVID-19 condition, post-intensive care syndrome, and depression share similar symptoms with CFS but are not exclusionary diagnoses. These should be considered in the differential diagnosis in select cases. There is concern that CFS might be mistaken for readily identifiable psychiatric disorders such as anxiety and mood disorders, but evidence supports differences in their clinical presentation from CFS. CFS should not be diagnosed in persons with a prior diagnosis of major depressive disorder with psychotic or melancholic features, bipolar affective disorders, schizophrenia

of any subtype, delusional disorders of any subtype, dementia of any subtype, eating disorder of any type, or alcohol or other substance abuse within 2 years before the onset of the chronic fatigue or any time thereafter.

Although evaluation of each patient should be individualized, initial laboratory evaluation should be limited to screening laboratory testing sufficient to provide reassurance of the lack of significant medical illness. Further evaluation should be directed primarily toward excluding treatable illnesses that may be suggested by the history, symptoms, signs, or physical exam findings present in specific patients.

## MANAGEMENT

Management of CFS is based on relief of the core and most disruptive symptoms in the individual patient. The diagnostic criterion of 6 months duration of illness should not delay evaluation and symptom management, because these may be initiated as soon as the child or adolescent presents with a CFS-like picture. Problems with sleep can be addressed by encouraging patients to adopt good sleep habits using standard sleep hygiene techniques. It may be beneficial to refer the patient to a sleep medicine specialist for the identification and treatment of sleep disorders and disturbances. Once pain is found not to be related to other specific disease or illness, nonpharmacologic treatment is indicated.

One of the nonpharmacologic approaches to pain management, CBT, may also assist the patient in managing and coping with CFS. Through explanation and changes in perception of the illness, CBT may help patients and their families develop coping skills and provide emotional support. Improved methods of coping may allow some improved function while living with the illness. Comorbid psychiatric conditions such as anxiety require appropriate evaluation and intervention. Guided graded-exercise therapy may be beneficial and added to CBT.

Although the overall goal is to help patients with CFS tolerate activity, children and adolescents with CFS should limit physical or mental efforts that result in aggravated symptoms. Return to school should be initiated gradually and systematically with the goal to return to full-time attendance. Home tutoring, cyber-school, and partial attendance can be interim steps. Parents and clinicians can work with teachers and school administrators to define appropriate expectations for attendance and performance for children with CFS. Because of the crucial importance of learning socialization skills, even brief attendance in school or participation in school activities should be encouraged, remembering that too rapid remobilization usually exacerbates symptoms and should be avoided.

Continued empathy and support by the treating physician are crucial in maintaining a physician-parent-patient relationship that is conducive to managing this illness. Careful attention must be directed to family dynamics to identify and resolve family problems or psychopathology that may be contributing to children's perception of their symptoms.

## PROGNOSIS

The natural history of CFS is highly variable, and patients and families understand that the symptoms will wax and wane. Children and adolescents with CFS appear to have a more optimistic outcome than adults, typically with an undulating course of gradual improvement over several years. Overall, a good functional outcome has been reported in up to 80% of patients. Poor prognostic factors include gradual onset, increased school absenteeism, lower socioeconomic status, chronic maternal health problems, and untreated comorbid individual and family psychiatric disorders. Favorable prognostic factors include patient control of the rehabilitation program, with continuing support from health professionals and family members, and improvement in orthostatic intolerance.

Visit Elsevier eBooks+ at [eBooks.Health.Elsevier.com](http://eBooks.Health.Elsevier.com) for Bibliography.

## Chapter 213

# Miscellaneous Conditions Associated with Arthritis

Angela Byun Robinson and  
C. Eglia Rabinovich

## RELAPSING POLYCHONDRITIS

Relapsing polychondritis (RP) is a rare condition characterized by episodic chondritis causing cartilage destruction and deformation of the ears (sparing the earlobes), nose, larynx, and tracheobronchial tree. Antibodies to matrilin-1 and collagen (types II, IX, and XI) are present in approximately 60% of patients with RP, suggesting an autoimmune pathogenesis. Patients may experience arthritis, uveitis, and hearing loss resulting from inflammation near the auditory and vestibular nerves. Children may initially relate episodes of intense erythema over the outer ears. Other dermatologic manifestations may include erythema nodosum, maculopapular rash, and purpura. Cardiac involvement, including conduction defects and coronary vasculitis, has been reported. Severe, progressive, and potentially fatal disease resulting from destruction of the tracheobronchial tree and airway obstruction is unusual in childhood. **Diagnostic criteria** established for adults are useful guidelines for evaluating children with suggestive symptoms (Table 213.1). The clinical course of RP is variable; flares of disease are often associated with elevations of acute-phase reactants and may remit spontaneously. Although seen more often in the adult population, RP may coexist with other rheumatic disease (e.g., systemic lupus erythematosus, Sjögren syndrome, Henoch-Schönlein purpura) in up to 30% of patients. The differential diagnosis includes **ANCA-associated vasculitis** (granulomatosis with polyangiitis) (see Chapter 210.4) and **Cogan syndrome**, which is characterized by auditory nerve inflammation and keratitis but not chondritis. **MAGIC** (mouth and genital ulcers with inflamed cartilage) syndrome has many similarities to Behçet disease (see Chapter 202). A genetic syndrome named vacuoles, E1 enzyme, X-linked, autoinflammatory, somatic (VEXAS) syndrome is caused by somatic pathogenic variants affecting the *UBA1* gene. Adolescent and adult patients (most are male) with this syndrome may have fevers, myalgia, arthralgia, auricular chondritis, and erythema nodosum. Approximately 50% of patients with VEXAS meet criteria for relapsing polychondritis. Between 5% and 10% of patients originally thought to have RP have pathogenic variants in *UBA1*. Affected patients have a high CRP and ESR in addition to lower platelet counts when compared with patients with only RP.

Many children respond to nonsteroidal antiinflammatory drugs, but some require corticosteroids or other immunosuppressive agents

**Table 213.1** Suggested Criteria for Relapsing Polychondritis\*

### MAJOR

Typical inflammatory episodes of ear cartilage  
Typical inflammatory episodes of nose cartilage  
Typical inflammatory episodes of laryngotracheal cartilage

### MINOR

Eye inflammation (conjunctivitis, keratitis, episcleritis, uveitis)  
Hearing loss  
Vestibular dysfunction  
Seronegative inflammatory arthritis

\*The diagnosis is established by the presence of two major or one major and two minor criteria. Histologic examination of affected cartilage is required when the presentation is atypical.

Data from Michet CJ Jr, McKenna CH, Luthra HS, et al. Relapsing polychondritis: Survival and predictive role of early disease manifestations. *Ann Intern Med.* 1986;104:74-78.



**Fig. 213.1** Pityriasis lichenoides et varioliformis acuta (PLEVA). Symmetric, oval and round, reddish brown macular, papular, necrotic, and crusted lesions on the chest of 9-yr-old boy. (From Paller AS, Mancini AJ, eds. *Hurwitz Clinical Pediatric Dermatology, 5th ed.* Philadelphia: Elsevier; 2016: Fig. 4-33, p. 87.)

(azathioprine, methotrexate, hydroxychloroquine, colchicine, cyclophosphamide, cyclosporine, and anti-tumor necrosis factor [TNF] agents), as reported in small series and case reports.

### MUCHA-HABERMANN DISEASE/PITYRIASIS LICHENOIDES ET VARIOLIFORMIS ACUTA

Pityriasis lichenoides et varioliformis acuta (PLEVA) is a benign, self-limited cutaneous vasculitis characterized by episodes of macules, papules, and papulovesicular lesions that can develop central ulceration, necrosis, and crusting (Fig. 213.1). Different stages of development are usually seen at once. PLEVA fulminans or febrile ulceronecrotic Mucha-Habermann disease (FUMHD) is the severe, life-threatening form of PLEVA. Large, coalescing, ulceronecrotic lesions are seen, accompanied by high fever and elevated ESR. Systemic manifestations can include interstitial pneumonitis, abdominal pain, malabsorption, arthritis, and neurologic manifestations. PLEVA has a male predominance and occurs more frequently in childhood. The diagnosis is confirmed by biopsy of skin lesions, which reveals perivascular and intramural lymphocytic inflammation affecting capillaries and venules in the upper dermis that may lead to keratinocyte necrosis. Phototherapy has been used in some cases of PLEVA. When disease is severe, corticosteroids have been used with questionable effect, and methotrexate has been reported to induce rapid remission in resistant cases. Cyclosporine and anti-TNF agents have also been efficacious in case reports.

### SWEET SYNDROME

Sweet syndrome, or **acute febrile neutrophilic dermatosis**, is a rare entity in children. It is characterized by fever, elevated neutrophil count, and raised, tender erythematous plaques and nodules over the face, extremities, and trunk. Skin biopsy reveals neutrophilic perivascular infiltration in the upper dermis. Female predominance is seen in the adult population, whereas gender distribution is equal in children. Established criteria are useful for diagnosis (Table 213.2). Children can also have arthritis, multifocal nonbacterial osteomyelitis, myositis, and other extracutaneous manifestations. Sweet syndrome may be idiopathic or secondary to malignancy (particularly acute myelogenous leukemia), drugs (granulocyte colony-stimulating factor, tretinoin, azathioprine, or trimethoprim-sulfamethoxazole), or rheumatic diseases (Behçet disease, antiphospholipid antibody syndrome, systemic lupus erythematosus). It has also been reported in association with COVID-19, VEXAS, CANDL (chronic atypical neutrophilic dermatosis with lipodystrophy and elevated temperature), Majeed syndrome, and deficiency of interleukin-1 receptor antagonist (DIRA) and pyrin associated autoinflammation with neutrophilic dermatosis (PAAND) syndromes (see Chapter 204). **The condition usually responds to treatment with corticosteroids, treatment of underlying disease, or removal of the associated medication.**

### HYPERTROPHIC OSTEOARTHROPATHY

Children with chronic disease, especially pulmonary or cardiac disease, can demonstrate clubbing of the terminal phalanges and have associated

**Table 213.2** Diagnostic Criteria for Classic Sweet Syndrome\*

#### MAJOR CRITERIA

Abrupt onset of painful erythematous plaques or nodules

Histopathologic evidence of dense neutrophilic infiltrate without evidence of leukocytoclastic vasculitis

#### MINOR CRITERIA

Pyrexia >38°C

Association with underlying hematologic or visceral malignancy, inflammatory disease, or pregnancy or preceded by an upper respiratory or gastrointestinal infection or vaccination

Excellent response to systemic corticosteroids or potassium iodide

Abnormal laboratory values at presentation (three of four):

Erythrocyte sedimentation rate >20 mm/hr

Positive C-reactive protein test result

>8,000 leukocytes/mm<sup>3</sup>

>70% neutrophils/mm<sup>3</sup>

\*The diagnosis is established by the presence of two major criteria plus two of the four minor criteria.

Adapted from Walker DC, Cohen PR. Trimethoprim-sulfamethoxazole-associated acute febrile neutrophilic dermatosis: Case report and review of drug induced Sweet's syndrome. *J Am Acad Dermatol.* 1996;34:918–923.

periosteal reaction and arthritis. These findings characterize the classic presentation of hypertrophic osteoarthropathy (HOA). HOA can be **primary** (idiopathic) or **secondary**. Although rare, **secondary** HOA is more common in children and is seen in those with chronic pulmonary disease (cystic fibrosis), congenital heart disease, gastrointestinal disease (malabsorption syndromes, biliary atresia, inflammatory bowel disease), and malignancy (nasopharyngeal sarcoma, osteosarcoma, Hodgkin disease). It may precede a diagnosis of cardiopulmonary disease or malignancy. The pathogenesis of secondary HOA is unknown; symptoms often improve if the underlying condition is treated successfully. HOA-related pain can be disabling; in adults, management with bisphosphonates has been reported. Evaluation of children presenting with HOA should include a chest radiograph to evaluate for pulmonary disease or intrathoracic mass. Autosomal recessive pathogenic variants in prostaglandin pathway genes have been described in primary HOA, also described as **pachydermoperiostosis**.

### PLANT THORN SYNOVITIS

A diagnosis of plant thorn synovitis should be considered in children with monoarticular arthritis nonresponsive to antiinflammatory therapy. Acute or chronic arthritis can occur after a plant thorn or other foreign object penetrates a joint. Unlike septic arthritis, children with plant thorn synovitis are usually afebrile. The most common organism seen with plant thorn synovitis is *Pantoea agglomerans*, although cultures are often negative. The initial injury may be unknown or forgotten, making the diagnosis difficult. Ultrasound or MRI can be useful in identifying the foreign body. **Removal of the foreign body using arthroscopy, followed by an antibiotic course, is the accepted therapy.**

### PIGMENTED VILLONODULAR SYNOVITIS

Proliferation of synovial tissue is seen in pigmented villonodular synovitis (PVNS). This proliferation is localized or diffuse and can affect the joint, tendon sheath, or bursa. Macrophages and multinucleated giant cells with brownish hemosiderin are present histologically. It is unclear if the etiology of PVNS is inflammatory or neoplastic in nature. Although findings are not pathognomonic, MRI with contrast is a useful diagnostic tool by which PVNS can be seen as a mass or bone erosion. Brown or bloody synovial fluid is seen with arthrocentesis, but the diagnosis is made by tissue biopsy. **Surgical removal of the affected tissue is the therapeutic modality, and with diffuse disease, a total synovectomy is recommended.**

Visit Elsevier eBooks+ at eBooks.Health.Elsevier.com for Bibliography.



## Section 1

# General Considerations

## Chapter 214

# Public Health Approach to Pandemics

Kevin P. O'Callaghan

### INTRODUCTION

Public health as a field aims to promote healthy lifestyles and communities and to protect the public at large from health threats from known and emerging diseases, chronic noncommunicable diseases, and environmental risks and vulnerabilities. In this context, public health authorities have a core role in prevention, preparedness, and response to epidemic and pandemic infectious diseases. The field of public health has a long and storied history in investigating and ending outbreaks of infectious diseases, extending back to one of the founders of modern epidemiology, John Snow, and the Broad Street pump cholera outbreak. Modern epidemiology and public health practices have an integral role in the management of outbreaks, epidemics, and pandemics, using both traditional methodologies that look like the “shoe leather epidemiology” of John Snow’s time, meshed with modern best practices that leverage genomic sequencing, data analytics, and medical innovations in therapeutics and vaccination.

### DEFINITIONS

Infectious disease outbreak response hinges on an understanding of current and ongoing incidence and prevalence of the disease in the affected community. The transmission dynamics of a disease will look different in a population that is entirely **susceptible** (e.g., a novel or emerging disease) than in a population in which some members are **recovered/immune** (e.g., a disease has been present for some time).

**Sporadic** diseases occur infrequently and irregularly in a population. **Endemic** diseases are continually circulating, often at low levels, maintaining a constant presence among members of the community. **Epidemic** disease occurs when there is a substantial increase above the baseline amount of a disease. This may occur as an increase in a disease that is already endemic at low levels or by the introduction of a novel disease that has not been seen in the affected population. A **pandemic** refers to an epidemic that has spread over several countries and continents, affecting large numbers of people. This is frequently defined and declared by international public health authorities, for example, the World Health Organization.

### Public Health Authorities and Partners

Although describing “public health” as a specialty may sound somewhat monolithic, the majority of public health work is done collaboratively across a variety of partners, including local, city, state, and national public health authorities, city and state governments, health-care systems, individual clinical providers, and members of the affected communities. The most important aspect of public health work is often community involvement, whether as part of outbreak investigations, public-facing communications, or education around prevention and response measures.

At an international level, the World Health Organization operates as an international collaborative agency set up in 1948 under the auspices of the United Nations. One of its core responsibilities is to direct and coordinate the world’s response to health emergencies, working with national governments, international organizations, researchers, and health systems. At a national level, responsibility for public health management typically devolves to national and federal government departments (e.g., the Department of Health and Human Services in the United States) and their constituent agencies, such as the Centers for Disease Control and Prevention (CDC). The CDC coordinates national surveillance systems for a variety of health conditions, including endemic and newly emergent diseases.

The bulk of regional and local public health surveillance, preparedness, and response work falls under the purview of city, county, and state public health departments. These agencies liaise closely with healthcare systems, specialty and primary care practices, and individual clinicians within their region to help facilitate their public health goals, as well as with nonmedical partners, including school districts, other government agencies, and community groups.

### Aims of Public Health Response to Infectious Diseases

Broadly, the aims of a public health response are to prevent the emergence of novel diseases in human hosts, prevent the spread of new diseases or the increase in prevalence of a known endemic disease, and mitigate the health effects of any spread that may occur. Based on these goals, the arms of public health response for epidemic and pandemic infectious diseases fall into four groupings: mitigation/prevention, preparedness, response, and recovery. These areas stem from a common approach to emergency management in general but have specific meanings and impact in the context of pandemic response. Some active public health measures, such as education and public-facing communication, occur across all four arms.

### Arms of Intervention Mitigation/Prevention

A primary approach to pandemic management includes proactive activities to prevent new human infections with target diseases, both to prevent endemic diseases from becoming epidemic and to arrest emergence of novel diseases. Some recent epidemics and pandemics likely represent “spillover” events from animal populations, with these zoonoses then becoming prevalent in human populations through human-to-human transmission (e.g., Zika, SARS-CoV-2). There is a complex interplay between human and animal populations related to farming, deforestation, changes in land use, water management, and climate change that makes the emergence of new zoonotic diseases intermittently more likely and unfortunately somewhat unpredictable. Prevention of emergence of these diseases is best approached through a One Health approach, which is an international project using a “collaborative, multisectoral, and transdisciplinary approach” at local, national, and international levels to optimize health outcomes, recognizing the interconnectedness of people, animals, plants, and their environment. Individual approaches to prevent disease outbreaks of this type may require the involvement of agricultural regulators and inspectors, veterinarians, and environmental health specialists, among others.

A more concrete example of a salient mitigation effort involving human healthcare providers is antimicrobial stewardship. The emergence of multidrug-resistant (MDR) and extensively drug-resistant (XDR) organisms in response to the selection pressure of antimicrobial usage is a critical vulnerability in epidemic and pandemic preparedness. Stewardship efforts at a grassroots, individual patient level provide a necessary bulwark against the proliferation of further MDR and XDR strains of currently endemic diseases.

## Preparedness

Separate from mitigation and prevention, a preparedness stance plans for the potentially inevitable outcome of the emergence of a novel epidemic or pandemic disease. Preparedness efforts can be targeted against specific disease threats (e.g., seasonal and pandemic influenza, which has predictable seasonality) or against previously unknown or less predictable threats (e.g., SARS-CoV-2, Ebola virus disease). Given the broad range of potential pathogens that may pose a threat over time, much preparedness planning takes place in an “all hazards” stance, where the preparation is necessarily agnostic as to the specific pathogen, with surveillance and resources that can be quickly pivoted to cover a broad variety of potential risks.

A core element of preparedness involves case-based surveillance or the active observation and documentation of incidence and prevalence of a specific disease or syndrome at local, regional, and national levels. Robust surveillance infrastructure requires both regulatory and material support, including both voluntary and mandatory reporting requirements, as well as a reporting infrastructure that includes clear and consistent case definitions that are reproducible across venues of care. In the United States, the National Notifiable Diseases Surveillance System (NNDSS) coordinates case definitions and reporting requirements for approximately 120 nationally notifiable diseases. A coherent and centralized reporting infrastructure such as that provided by NNDSS allows for a more global understanding of burden of disease and disease trends over time. However, case surveillance as described here remains dependent on close partnership with healthcare systems, clinical laboratories, and individual providers at a local level to ensure that these systems are both sensitive and specific. Case-based surveillance is also predicated on a good understanding of both the pathophysiology and available diagnostics for a specific disease. For newly emergent diseases, where a coherent case definition is less readily available, early warning systems seek to detect syndromic clusters that elude identification on routine diagnostics. Expansion of such programs in the wake of the 2019 SARS-CoV-2 pandemic have received governmental support and may use novel approaches such as wastewater screening and genomic sequencing within syndromic clusters.

In terms of tangible supplies that may be required for an acute response, personal protective equipment (PPE) and medical countermeasures (MCMs, e.g., vaccines, therapeutics) may be needed in high volume on short notice, at which point a “just in time” supply chain approach may prove lacking. Stockpiling of critical supply needs is a necessary part of pandemic preparedness, particularly with regard to high-risk, low-frequency, unpredictable events such as international travel of a patient with undiagnosed Ebola virus disease. For a longer-term outbreak or epidemic, such as that seen with the 2020 response to COVID-19, even the most aggressive stockpiling cannot support a protracted pandemic response, and close collaboration with manufacturers of durable medical supplies, therapeutics, and vaccines may be necessary to ensure sustained availability and a flexible supply chain.

Lastly, healthcare capacity is a separate but critically important resource with concrete limits (e.g., total bed spaces, provider person-days, and critical care and ventilator availability). In responding to the exponential growth of a rapidly reproducing pathogen, hospital capacity may be rapidly overwhelmed, as seen in some early surges of COVID-19 in 2020. Infrastructure planning for healthcare systems can help alleviate some of these pressures through rapidly accessible, flexible patient care space normally kept in reserve and through thoughtful capacity management, such as plans that allow for restriction of elective or nonemergent care for short periods. Ultimately, such efforts need to be matched with public-facing interventions described later, which can “flatten the curve” of epidemic transmission.

## Response

Pandemic response begins with identification of the emergence of a specific risk (through surveillance systems described previously), followed by activation of applicable plans developed during the preparedness phase. Early pandemic response may be, by necessity, non-specific to a known disease, particularly if the identification of risk is predicated on a syndromic cluster or a novel, not-yet-identified pathogen.

For novel pathogens, short-term goals will include rapid identification of the pathogen at a genus and species level, sequencing of its genome, development of accurate and readily available diagnostic tests, and development of targeted therapeutics and vaccines. As these individual targets may take weeks to months to come to fruition, early response will focus on mitigation of disease transmission through the application of standard public health measures, including social distancing, transmission-based precautions, isolation of cases, contact tracing, and quarantine of known contacts. All of these approaches occur simultaneously and require extensive public communication and education to ensure their effectiveness. **Social distancing** involves the temporary application of new social norms and social constructs designed to keep individuals, particularly those from separate households, physically distanced so that the likelihood of disease transmission between individuals is substantially reduced or eliminated. This may include infrastructural changes that promote contactless payment options at stores, physical barriers in offices and at public-facing service desks, and others. This distancing is assisted by application of **transmission-based precautions**, which are PPE recommendations based on the transmission modality of a specific pathogen. In non-healthcare settings, the most common application of PPE is facial masking designed to protect oral and nasal mucosa from diseases spread by droplets (e.g., influenza). **Isolation of cases** is a public health measure that strongly encourages or, depending on regulatory support, legally requires diagnosed cases of a specific disease to isolate for the duration of their period of infectivity, usually at home, in a healthcare setting, or at a designated isolation facility. After identification of a case, **contact tracing** should occur, during which identification of potential contacts of the known case (during the period of infectivity) is made. Completion of contact tracing involves notification of the affected contacts and a recommendation that they quarantine, typically for the duration of the upper bound of the incubation period for the disease. All of these responses require a large commitment in terms of time, personnel, and resources, and in a rapidly accelerating epidemic, these resources may ultimately be overwhelmed.

While these core public health responses are ongoing, rapid development of diagnostics, therapeutics, and vaccine candidates will continue. Of these, the earliest steps involve genomic sequencing and targeted diagnostics, the latter of which ultimately will greatly assist with consistent case definitions and subsequent contact tracing, isolation, and quarantine. The timeline for development of suitable vaccine candidates has greatly decreased in recent decades, with development of messenger RNA (mRNA) vaccine candidates during the COVID-19 pandemic being a hallmark example. Regulatory changes in timelines for vaccine assessment and approval for emergency use have assisted in these efforts, while not altering safety and efficacy oversight.

## Recovery

Termination of pandemic response is rarely clear-cut, as elimination or eradication of specific pathogens from human population is rare. Most epidemic or pandemic responses end with a slow decrease in case counts and ultimate quiescence for a period (e.g., Ebola virus disease outbreaks) or the attainment of endemicity—the low-level constant circulation of a pathogen within remaining susceptible human hosts. Ultimately, transition from response to recovery is predicated on ongoing case counts, pressure on healthcare infrastructure, and an amalgamation of other metrics that may include test positivity, case severity, vaccine uptake, and hospitalization rates.

A core aspect of the recovery phase is an analysis of pandemic response measures as a whole, including their relative success, their tolerability, and their tangible and intangible costs. Future pandemic response, for the same and other pathogens, can be informed and improved by this analysis, typically developed in an after-action report or similar post hoc analytic framework.

## Communication and Education

A core element of public health response to epidemic and pandemic disease, which spans across all four stances, is public communication and education. At each stage of pandemic preparedness and response, public engagement is key. This is particularly true in a response phase, where data become available rapidly and contradictory findings in early reports can cause confusion and mistrust. Clear, concise messaging

that focuses on core concepts of preparedness and response is key. A large portion of public health response may be spent in developing and promulgating this messaging, but it can be extremely worthwhile insofar as it can lead to dramatic increases in tolerability and uptake of other public health interventions, including social distancing, isolation and quarantine, and vaccines.

Viruses, bacteria, fungi, and other microbes are a fact of life on this earth and are an integral part of the biodiversity upon which we as humans depend. Although infectious diseases may also be a dependable fact of life, their broader societal impact can be shifted, reduced, and controlled in the ways described here. Pandemic preparedness and response can be difficult and time-consuming, but done well, with engaged partners at all levels, can be lifesaving on a societal level.

Visit Elsevier eBooks+ at [eBooks.Health.Elsevier.com](https://eBooks.Health.Elsevier.com) for Bibliography.

## Section 2

# Preventive Measures

### Chapter 215

## Immunization Practices

Alexandra Kilinsky, Henry H. Bernstein, and Walter A. Orenstein

Immunization is one of the most beneficial and cost-effective disease prevention measures available. As a result of effective and safe vaccines, smallpox has been eradicated, polio is close to worldwide eradication, and measles and rubella are no longer endemic in the United States. However, cases of vaccine-preventable diseases, including measles, mumps, and pertussis, continue to occur in the United States. Incidence of most vaccine-preventable diseases of childhood has been reduced by  $\geq 99\%$  from representative 20th-century annual morbidity, usually before development of the corresponding vaccines (Table 215.1), with most of the newer vaccines not achieving quite the same percentage decrease (Table 215.2). An analysis of effective prevention measures recommended for widespread use by the U.S. Preventive Services Task Force (USPSTF) reported that childhood immunization received a perfect score based on clinically preventable disease burden and cost-effectiveness.

**Immunization** is the process of inducing immunity against a specific disease. Immunity can be induced either passively or actively. **Passive immunity** is generated through administration of an antibody-containing preparation. **Active immunity** is achieved by administering a vaccine or toxoid to stimulate the immune system to produce a prolonged humoral and/or cellular immune response. As of 2023, infants, children, and adolescents in the United States are recommended to be routinely immunized against **19 pathogens**: *Corynebacterium diphtheriae*, *Clostridium tetani*, *Bordetella pertussis*, polio virus, *Haemophilus influenzae* type b (**Hib**), hepatitis A, hepatitis B, measles virus, mumps virus, rubella virus, rotavirus, varicella-zoster virus, SARS-CoV-2, pneumococcus, meningococcus, influenza virus, human papillomavirus (**HPV**), and respiratory syncytial virus (**RSV**).

### PASSIVE IMMUNITY

Rather than producing antibodies through the body's own immune system, passive immunity is achieved by administration of preformed antibodies. Protection is immediate, yet transient, lasting weeks to months. Products used include:

- Immunoglobulin administered intramuscularly (**IMIG**), intravenously (**IVIG**), or subcutaneously (**SCIG**)
- Specific or hyperimmune immunoglobulin preparations administered IM or IV

**Table 215.1** Comparison of 20th-Century Annual Morbidity and Current Morbidity: Vaccine-Preventable Diseases

DISEASE	20TH-CENTURY ANNUAL MORBIDITY*	2019 REPORTED CASES†	PERCENT DECREASE
Smallpox	29,005	0	100
Diphtheria	21,053	2	>99
Measles	530,217	1275	>99
Mumps	162,344	3780	98
Pertussis	200,752	18,617	91
Polio (paralytic)	16,316	0	100
Rubella	47,745	6	>99
Congenital rubella syndrome	152	1	>99
Tetanus	580	26	95
Haemophilus influenzae type b (Hib)	20,000	18‡	>99

\*Data from Roush SW, Murphy TV; Vaccine-Preventable Disease Table Working Group. Historical comparisons of morbidity and mortality for vaccine-preventable diseases in the United States. *JAMA*. 2007;298(18):2155–2163.

†Data from Centers for Disease Control and Prevention. *National Notifiable Diseases Surveillance System, Weekly Tables of Infectious Disease Data*. Atlanta, GA: CDC Division of Health Informatics and Surveillance Available at <https://wonder.cdc.gov/nndss/static/2019/annual/2019-table1.html>.

‡Hib <5 yr of age. An additional 667 cases of *Haemophilus influenzae* invasive disease (<5 yr of age)—non-b serotype (213 cases), nontypeable (200 cases), and unknown serotype (254 cases)—are estimated to have occurred.

**Table 215.2** Comparison of Pre-Vaccine Era Estimated Annual Morbidity with Current Estimate: Vaccine-Preventable Diseases

DISEASE	PRE-VACCINE ERA ANNUAL ESTIMATE*	2019 ESTIMATE (UNLESS OTHERWISE SPECIFIED)†	PERCENT DECREASE
Hepatitis A	117,333*	18,846‡	86
Hepatitis B (acute)	66,232*	3544‡	95
Pneumococcus (invasive)			
All ages	63,067*	19,689‡	69
<5 yr of age	16,069*	1091‡	93
Rotavirus (hospitalizations, <3 yr of age)	62,500‡	30,625‡	51
Varicella	4,085,120*	8297‡	>99

\*Data from Roush SW, Murphy TV; Vaccine-Preventable Disease Table Working Group. Historical comparisons of morbidity and mortality for vaccine-preventable diseases in the United States. *JAMA*. 2007;298(18):2155–2163.

†Data from Centers for Disease Control and Prevention. *National Notifiable Diseases Surveillance System, Weekly Tables of Infectious Disease Data*. Atlanta, GA: CDC Division of Health Informatics and Surveillance Available at: <https://wonder.cdc.gov/nndss/static/2019/annual/2019-table1.html>

‡Data from Centers for Disease Control and Prevention. Prevention of rotavirus gastroenteritis among infants and children: recommendations of the Advisory Committee on Immunization Practices. *MMWR Recomm Rep*. 2009;58(RR-2):1–25.

§Data from New Vaccine Surveillance Network 2017 data: U.S. rotavirus disease now has biennial pattern (unpublished).



that focuses on core concepts of preparedness and response is key. A large portion of public health response may be spent in developing and promulgating this messaging, but it can be extremely worthwhile insofar as it can lead to dramatic increases in tolerability and uptake of other public health interventions, including social distancing, isolation and quarantine, and vaccines.

Viruses, bacteria, fungi, and other microbes are a fact of life on this earth and are an integral part of the biodiversity upon which we as humans depend. Although infectious diseases may also be a dependable fact of life, their broader societal impact can be shifted, reduced, and controlled in the ways described here. Pandemic preparedness and response can be difficult and time-consuming, but done well, with engaged partners at all levels, can be lifesaving on a societal level.

Visit Elsevier eBooks+ at [eBooks.Health.Elsevier.com](https://eBooks.Health.Elsevier.com) for Bibliography.

## Section 2

# Preventive Measures

### Chapter 215

## Immunization Practices

Alexandra Kilinsky, Henry H. Bernstein, and Walter A. Orenstein

Immunization is one of the most beneficial and cost-effective disease prevention measures available. As a result of effective and safe vaccines, smallpox has been eradicated, polio is close to worldwide eradication, and measles and rubella are no longer endemic in the United States. However, cases of vaccine-preventable diseases, including measles, mumps, and pertussis, continue to occur in the United States. Incidence of most vaccine-preventable diseases of childhood has been reduced by  $\geq 99\%$  from representative 20th-century annual morbidity, usually before development of the corresponding vaccines (Table 215.1), with most of the newer vaccines not achieving quite the same percentage decrease (Table 215.2). An analysis of effective prevention measures recommended for widespread use by the U.S. Preventive Services Task Force (USPSTF) reported that childhood immunization received a perfect score based on clinically preventable disease burden and cost-effectiveness.

**Immunization** is the process of inducing immunity against a specific disease. Immunity can be induced either passively or actively. **Passive immunity** is generated through administration of an antibody-containing preparation. **Active immunity** is achieved by administering a vaccine or toxoid to stimulate the immune system to produce a prolonged humoral and/or cellular immune response. As of 2023, infants, children, and adolescents in the United States are recommended to be routinely immunized against **19 pathogens**: *Corynebacterium diphtheriae*, *Clostridium tetani*, *Bordetella pertussis*, polio virus, *Haemophilus influenzae* type b (**Hib**), hepatitis A, hepatitis B, measles virus, mumps virus, rubella virus, rotavirus, varicella-zoster virus, SARS-CoV-2, pneumococcus, meningococcus, influenza virus, human papillomavirus (**HPV**), and respiratory syncytial virus (**RSV**).

### PASSIVE IMMUNITY

Rather than producing antibodies through the body's own immune system, passive immunity is achieved by administration of preformed antibodies. Protection is immediate, yet transient, lasting weeks to months. Products used include:

- Immunoglobulin administered intramuscularly (**IMIG**), intravenously (**IVIG**), or subcutaneously (**SCIG**)
- Specific or hyperimmune immunoglobulin preparations administered IM or IV

**Table 215.1** Comparison of 20th-Century Annual Morbidity and Current Morbidity: Vaccine-Preventable Diseases

DISEASE	20TH-CENTURY ANNUAL MORBIDITY*	2019 REPORTED CASES†	PERCENT DECREASE
Smallpox	29,005	0	100
Diphtheria	21,053	2	>99
Measles	530,217	1275	>99
Mumps	162,344	3780	98
Pertussis	200,752	18,617	91
Polio (paralytic)	16,316	0	100
Rubella	47,745	6	>99
Congenital rubella syndrome	152	1	>99
Tetanus	580	26	95
Haemophilus influenzae type b (Hib)	20,000	18‡	>99

\*Data from Roush SW, Murphy TV; Vaccine-Preventable Disease Table Working Group. Historical comparisons of morbidity and mortality for vaccine-preventable diseases in the United States. *JAMA*. 2007;298(18):2155–2163.

†Data from Centers for Disease Control and Prevention. *National Notifiable Diseases Surveillance System, Weekly Tables of Infectious Disease Data*. Atlanta, GA: CDC Division of Health Informatics and Surveillance Available at <https://wonder.cdc.gov/nndss/static/2019/annual/2019-table1.html>.

‡Hib <5 yr of age. An additional 667 cases of *Haemophilus influenzae* invasive disease (<5 yr of age)—non-b serotype (213 cases), nontypeable (200 cases), and unknown serotype (254 cases)—are estimated to have occurred.

**Table 215.2** Comparison of Pre-Vaccine Era Estimated Annual Morbidity with Current Estimate: Vaccine-Preventable Diseases

DISEASE	PRE-VACCINE ERA ANNUAL ESTIMATE*	2019 ESTIMATE (UNLESS OTHERWISE SPECIFIED)†	PERCENT DECREASE
Hepatitis A	117,333*	18,846‡	86
Hepatitis B (acute)	66,232*	3544‡	95
Pneumococcus (invasive)			
All ages	63,067*	19,689‡	69
<5 yr of age	16,069*	1091‡	93
Rotavirus (hospitalizations, <3 yr of age)	62,500‡	30,625‡	51
Varicella	4,085,120*	8297‡	>99

\*Data from Roush SW, Murphy TV; Vaccine-Preventable Disease Table Working Group. Historical comparisons of morbidity and mortality for vaccine-preventable diseases in the United States. *JAMA*. 2007;298(18):2155–2163.

†Data from Centers for Disease Control and Prevention. *National Notifiable Diseases Surveillance System, Weekly Tables of Infectious Disease Data*. Atlanta, GA: CDC Division of Health Informatics and Surveillance Available at: <https://wonder.cdc.gov/nndss/static/2019/annual/2019-table1.html>

‡Data from Centers for Disease Control and Prevention. Prevention of rotavirus gastroenteritis among infants and children: recommendations of the Advisory Committee on Immunization Practices. *MMWR Recomm Rep*. 2009;58(RR-2):1–25.

§Data from New Vaccine Surveillance Network 2017 data: U.S. rotavirus disease now has biennial pattern (unpublished).



- Antibodies of animal origin
- Monoclonal antibodies

Passive immunity also can be induced naturally through transplacental transfer of maternal antibodies (IgG) during gestation. This transfer can provide protection during an infant's first few months of life; other antibodies (IgA) are transferred to the infant during breastfeeding. Protection for some diseases can persist for as long as 1 year after birth, depending on the quantity of antibody transferred and the time until levels fall below those considered protective.

The major indications for inducing passive immunity are immunodeficiencies in children with B-lymphocyte defects who have difficulty making antibodies (e.g., hypogammaglobulinemia, secondary immunodeficiencies), who have exposure to infectious diseases or to imminent risk of exposure when there is inadequate time for them to develop an active immune response to a vaccine (e.g., newborn exposed to maternal hepatitis B), and who have infectious diseases that require antibody administration as part of the specific therapy (Table 215.3).

### Intramuscular Immunoglobulin

Immunoglobulin is a sterile antibody-containing solution, usually derived through cold ethanol fractionation of large pools of human plasma from adults. Antibody concentrations reflect the infectious disease exposure and immunization experience of plasma donors. IMIG contains 15–18% protein and is predominantly IgG. Intravenous use of human IMIG is contraindicated. Immunoglobulin is not known to transmit infectious agents, including viral hepatitis and HIV. The major indications for immunoglobulin are:

- Replacement therapy for children with antibody deficiency disorders
- Measles prophylaxis
- Hepatitis A prophylaxis

For **replacement therapy**, the usual dose of IMIG is 100 mg/kg (equivalent to 0.66 mL/kg) monthly. The usual interval between doses is 2–4 weeks depending on trough IgG serum concentrations and clinical response. In practice, IVIG has replaced IMIG for replacement therapy.

IMIG can be used to prevent or modify **measles** if administered to susceptible children within 6 days of exposure (usual dose: 0.5 mL/kg body weight; maximum dose: 15 mL). The recommended dose of IVIG is 400 mL/kg. Data suggest that measles vaccine, if given within 72 hours of measles exposure, will provide protection in some cases to infants ≥6 months of age. Measles vaccine and immunoglobulin should not be administered at the same time.

Two methods are available for **postexposure prophylaxis** against **hepatitis A** depending on the patient's age: Children 6–11 months old should receive a dose of hepatitis A vaccine before international travel. However, the dose of hepatitis A vaccine received before 12 months should not be counted in determining compliance with the recommended two-dose schedule. In those 12 months to 40 years of age, hepatitis A immunization is preferred over immunoglobulin for postexposure prophylaxis and for protection of people traveling to areas where hepatitis A is endemic. Persons age >40 years, persons with immunocompromising conditions, and persons with chronic liver disease planning on traveling to an area with high or intermediate hepatitis A virus (HAV) endemicity should receive a single dose of hepatitis A vaccine as soon as travel is considered. Persons traveling in <2 weeks should receive the initial dose of hepatitis A vaccine and simultaneously may be administered immunoglobulin in a different anatomic injection site (e.g., separate limbs). A second dose of hepatitis A vaccine is not required for postexposure prophylaxis; however, for long-term immunity, the vaccination series should be completed with a second dose at least 6 months after the first dose.

The most common adverse reactions to immunoglobulin are pain and discomfort at the injection site and, less commonly, flushing, headache, chills, and nausea. Serious adverse events are rare and include chest pain, dyspnea, anaphylaxis, and systemic collapse. Immunoglobulin should *not* be administered to people with selective IgA deficiency who can produce antibodies against the trace amounts of IgA in immunoglobulin preparations and can develop reactions after repeat doses. These reactions can include fever, chills, and a shocklike syndrome. Because these reactions are rare, testing for selective IgA deficiencies is not recommended.

### Intravenous Immunoglobulin

IVIG is a highly purified preparation of immunoglobulin antibodies prepared from adult plasma donors using alcohol fractionation and is

**Table 215.3** Immunoglobulin and Animal Antisera Preparations

PRODUCT	MAJOR INDICATIONS
Intramuscular immunoglobulin (IMIG)	Replacement therapy in antibody-deficiency disorders Hepatitis A prophylaxis Measles prophylaxis Rubella prophylaxis (pregnant women)
Intravenous immunoglobulin (IVIG)	Replacement therapy in antibody-deficiency disorders Kawasaki disease Pediatric HIV infection Hypogammaglobulinemia in chronic B-lymphocyte lymphocytic leukemia Varicella postexposure prophylaxis Guillain-Barré syndrome and chronic inflammatory demyelinating polyneuropathy and multifocal motor neuropathy Toxic shock syndrome Postexposure measles prophylaxis for immunocompromised contacts May be useful in a variety of other conditions
Subcutaneous immunoglobulin (SCIG)	Treatment of patients with primary immunodeficiencies
Hepatitis B immunoglobulin (IM)	Postexposure prophylaxis Prevention of perinatal infection in infants born to hepatitis B surface antigen-positive mothers
Rabies immunoglobulin (IM)	Postexposure prophylaxis
Tetanus immunoglobulin (IM)	Wound prophylaxis Treatment of tetanus
Varicella-zoster immunoglobulin (VariZIG, IM)	Postexposure prophylaxis of susceptible people at high risk for complications from varicella
Cytomegalovirus (IV)	Prophylaxis of disease in seronegative transplant recipients
Vaccinia immunoglobulin (IV)	Reserved for certain complications of smallpox immunization and has no role in treatment of smallpox
Human botulism (IV), BabyBIG	Treatment of infant botulism
Diphtheria antitoxin, equine	Treatment of diphtheria
Heptavalent botulinum antitoxin against all seven (A–G) botulinum toxin types (BAT)	Treatment of noninfant food and wound botulism
Palivizumab (monoclonal antibody), humanized mouse (IM)	Prophylaxis for infants against respiratory syncytial virus (see Chapter 307)
Nirsevimab (monoclonal antibody) produced in Chinese hamster ovary (CHO) cells by recombinant DNA technology. (IM)	Passive immunization to prevent RSV-associated lower respiratory tract infection among infants and younger children (see Chapter 307)
Crotalidae immune F(ab) <sup>2</sup> (equine)	Effective for viper and pit viper bites, including rattlesnakes, copperheads, moccasins

Data from Passive Immunization. In Kimberlin DW, Barnett ED, Lynfield R, Sawyer MH, eds. Red Book: 2021–2024 Report of the Committee on Infectious Diseases, 32nd ed. Itasca, IL: American Academy of Pediatrics; 2021. (Recommendations for use of specific immunoglobulins are located in the sections for specific diseases in Section 3 of Red Book.)

modified to allow IV use. IVIG is more than 95% IgG and is tested to ensure minimum antibody titers to *C. diphtheriae*, hepatitis B virus, measles virus, and poliovirus. Antibody concentrations against other pathogens vary widely among products and even among lots from the same manufacturer. Liquid and lyophilized powder preparations are available. IVIG does not contain thimerosal.

Not all IVIG products are approved by the U.S. Food and Drug Administration (FDA) for all indications. The major recommended FDA-approved indications for IVIG are:

- Replacement therapy for primary immunodeficiency disorders
- Kawasaki disease to prevent coronary artery abnormalities and shorten the clinical course
- Replacement therapy for prevention of serious bacterial infections in children infected with HIV
- Prevention of serious bacterial infections in people with hypogammaglobulinemia in chronic B-lymphocyte leukemia
- Immune-mediated thrombocytopenia to increase platelet count

IVIG may be helpful for patients with severe toxic shock syndrome, Guillain-Barré syndrome, and anemia caused by parvovirus B19. IVIG is also used for many other conditions based on clinical experience, such as multisystem inflammatory syndrome in children (MIS-C) associated with COVID-19. IVIG may be used for varicella after exposure when varicella-zoster immunoglobulin is not available.

Reactions to IVIG may occur in up to 25% of patients. Some of these reactions appear to be related to the rate of infusion and can be mitigated by decreasing the rate. Such reactions include fever, headache, myalgia, chills, nausea, and vomiting. More serious reactions, including anaphylactoid events, thromboembolic disorders, aseptic meningitis, hemolytic anemia, and renal insufficiency, have rarely been reported. Renal failure occurs mainly in patients with preexisting renal dysfunction.

Specific or hyperimmune immunoglobulin preparations are derived from donors with high titers of antibodies to specific agents and are designed to provide protection against those agents (see Table 215.3).

### Subcutaneous Immunoglobulin

(SCIG) is safe and effective in children and adults with primary immune deficiency disorders. Smaller doses administered weekly result in less fluctuation of serum IgG concentrations over time. Systemic reactions are less frequent than with IVIG, and the most common adverse effects of SCIG are injection site reactions. There are no data on administration of IMIG by the subcutaneous route.

### Hyperimmune Animal Antisera Preparations

Animal antisera preparations are derived from horses. The immunoglobulin fraction is concentrated using ammonium sulfate, and some products are further treated with enzymes to decrease reactions to foreign proteins. The following two equine antisera preparations are available for humans (as of 2018):

- **Diphtheria antitoxin**, which can be obtained from the U.S. Centers for Disease Control and Prevention (CDC) (<http://www.cdc.gov/diphtheria/dat.html>) and is used to treat diphtheria.
- **Heptavalent botulinum antitoxin**, available from the CDC for use in adults with botulism. To request it, one can call the CDC's 24-hour line at 770-488-7100. This product contains antitoxin against all seven (A-G) botulinum toxin types.

Great care must be exercised before administering animal-derived antisera because of the potential for severe allergic reactions. Due caution includes testing for sensitivity before administration, desensitization if necessary, and treating potential reactions, including febrile events, serum sickness, and anaphylaxis. For infant botulism, IVIG (BabyBIG), a human-derived antitoxin, is licensed and should be used.

### Monoclonal Antibodies

Monoclonal antibodies (mAbs) are antibody preparations produced against a single antigen. They are mass-produced from a hybridoma, a hybrid cell used as the basis for production of large amounts of antibodies. A hybridoma is created by fusing an antibody-producing B lymphocyte with a fast-growing immortal cell such as a cancer cell. There are two injectable monoclonal antibody products that help protect infants and young children from lower respiratory tract infection caused by RSV: nirsevimab and palivizumab. **Palivizumab** is used for prevention of severe disease

from respiratory syncytial virus (RSV) among children  $\leq 24$  months old with bronchopulmonary dysplasia (BPD, a form of chronic lung disease), a history of premature birth, or congenital heart lesions or neuromuscular diseases. The American Academy of Pediatrics (AAP) has developed specific recommendations for the use of palivizumab. **Nirsevimab** is recommended for infants younger than 8 months of age who were born shortly before or are entering their first RSV season if the mother did not receive RSV vaccine (Abrysvo) during pregnancy, if the mother's RSV vaccination status is unknown, or the infant was born within 14 days of maternal RSV vaccination. Additionally, a dose of nirsevimab is recommended for some children 8 to 19 months of age who are at increased risk for severe RSV disease and entering their second RSV season. Given the atypical interseasonal change in RSV epidemiology in 2021-2023, the AAP strongly supports the use of palivizumab and nirsevimab in patients who would be candidates per the current eligibility recommendations. See <https://publications.aap.org/redbook/resources/25379/> for details (see Chapter 307).

mAbs also are used to prevent transplant rejection and to treat some types of cancer, autoimmune diseases, and asthma. Use of mAbs against interleukin (IL)-2 and tumor necrosis factor (TNF)- $\alpha$  are being used as part of the therapeutic approach to patients with a variety of malignant and autoimmune diseases.

Serious adverse events associated with palivizumab are rare, primarily including cases of anaphylaxis and hypersensitivity reactions. Adverse reactions to nirsevimab are rare and mild to moderate in severity, including rash and injection site reactions. Adverse reactions to mAbs directed at modifying the immune response, such as antibodies against IL-2 or TNF- $\alpha$ , can be more serious and include cytokine release syndrome, fever, chills, tremors, chest pain, immunosuppression, and infection with various organisms, including mycobacteria.

## ACTIVE IMMUNIZATION

**Vaccines** are defined as whole or parts of microorganisms administered to prevent an infectious disease. Vaccines can consist of whole inactivated microorganisms (e.g., polio, hepatitis A), parts of the organism (e.g., acellular pertussis, HPV, hepatitis B), polysaccharide capsules (e.g., pneumococcal and meningococcal polysaccharide vaccines), polysaccharide capsules conjugated to protein carriers (e.g., Hib, pneumococcal, and meningococcal conjugate vaccines), live-attenuated microorganisms (e.g., measles, mumps, rubella, varicella, rotavirus, and live-attenuated influenza vaccines), and toxoids (e.g., tetanus, diphtheria) (Table 215.4). In addition, vaccines against SARS-CoV-2 are messenger RNA (mRNA) vaccines, viral vector vaccines, or protein subunit vaccines. A **toxoid** is a bacterial toxin modified to be nontoxic but still capable of inducing an active immune response against the toxin.

Vaccines can contain a variety of other constituents besides the immunizing antigen. *Suspending* fluids may be sterile water or saline but can be a complex fluid containing small amounts of proteins or other constituents used to grow the immunobiologic culture. Preservatives, stabilizers, and antimicrobial agents are used to inhibit bacterial growth and prevent degradation of the antigen. Such components can include gelatin, 2-phenoxyethanol, and specific antimicrobial agents. Preservatives are added to multidose vials of vaccines, primarily to prevent bacterial contamination on repeated entry of the vial. In the past, many vaccines for children contained thimerosal, a preservative containing ethyl mercury. Removal of thimerosal as a preservative from vaccines for children began as a precautionary measure in 1999 in the absence of any data on harm from the preservative. This objective was accomplished by switching to single-dose packaging. Of the vaccines recommended for young children, only some preparations of influenza vaccine contain thimerosal as a preservative.\*

*Adjuvants* are used in some vaccines to enhance the immune response. In the United States, the only adjuvants currently licensed by the FDA to be part of vaccines are **aluminum salts**: AsO<sub>4</sub>, composed of 3-O-desacyl-4'-monophosphoryl 301 lipid A (MPL) adsorbed on to aluminum (as hydroxide salt) and MF59 and 1018 adjuvant. AsO<sub>4</sub> is

\* The thimerosal content in U.S.-licensed vaccines currently being manufactured is listed at <http://www.fda.gov/BiologicsBloodVaccines/SafetyAvailability/VaccineSafety/ucm096228.htm#pres>.

**Table 215.4** Currently Available\* Vaccines and Immunizing Agents in the United States by Type

PRODUCT	TYPE	PRODUCT	TYPE
Adenovirus	Live, oral vaccine indicated for active immunization for the prevention of febrile acute respiratory disease caused by adenovirus types 4 and 7 for use in military populations 17-50 yr of age	Influenza virus vaccine inactivated (IIV <sup>1</sup> )	Available as quadrivalent inactivated formulations that contain hemagglutinin-derived influenza A(H1N1)pdm09 and influenza A(H3N2) components, along with two influenza B viruses (one from each Victoria and Yamagata lineage) Flucelvax is a cell-based inactivated quadrivalent vaccine
Anthrax vaccine adsorbed	Cell-free filtrate of components including protective antigen	Influenza virus vaccine live-attenuated, intranasal (LAIV4)	Live-attenuated, temperature-sensitive, cold-adapted quadrivalent intranasal vaccine containing the hemagglutinin and neuraminidase genes from the wild strains reassorted to have the six other genes from the cold-adapted parent; recommended for 2-49 yr of age
Bacille Calmette-Guérin (BCG) vaccine	Live-attenuated mycobacterial strain used to prevent tuberculosis in very limited circumstances	Recombinant influenza vaccine (RIV4)	A quadrivalent formulation of influenza vaccine approved for persons 18 yr old and older
Cholera vaccine	Oral vaccine containing live-attenuated <i>Vibrio cholerae</i> CVD 103-HgR strain for protection against serogroup O1 in adults age 18-64 traveling to cholera-affected areas	Japanese encephalitis vaccine	Purified, inactivated whole virus
COVID-19 vaccines	Two messenger mRNA-based: Comirnaty (Pfizer-BioNTech) and Spikevax (Moderna). A single adjuvanted, protein subunit-based vaccine, is a Novavax product.	Measles, mumps, rubella (MMR) vaccine	Live-attenuated viruses
Dengue vaccine	Tetravalent live-attenuated dengue virus (DENV) manufactured by Sanofi Pasteur Use in children age 9-16 yr, with laboratory-confirmed previous dengue virus infection and living in an area where dengue is endemic	Measles, mumps, rubella, varicella (MMRV) vaccine	Live-attenuated viruses
Diphtheria and tetanus toxoids and acellular pertussis (DTaP) vaccine	Toxoids of diphtheria and tetanus and purified and detoxified components from <i>Bordetella pertussis</i>	Meningococcal conjugate vaccine against serogroups A, C, W135, and Y (MenACWY)	Polysaccharide from each serogroup conjugated to diphtheria toxoid CRM <sub>197</sub> protein
DTaP-hepatitis B-inactivated polio vaccine (DTaP-HepB-IPV)	DTaP with hepatitis B surface antigen (HBsAg) produced through recombinant techniques in yeast with inactivated whole polioviruses	Meningococcal polysaccharide vaccine against serogroups A, C, W135, and Y (MPSV4)	Polysaccharides from each of the serogroups conjugated to diphtheria toxoid protein. No longer available in the United States.
DTaP with IPV and <i>Haemophilus influenzae</i> type b (Hib) (DTaP-IPV/Hib)	DTaP with inactivated whole polioviruses and Hib polysaccharide conjugated to tetanus toxoid	Meningococcal B (MenB)	Recombinant proteins from serogroup B developed in <i>Escherichia coli</i>
DTaP with inactivated polio vaccine, <i>Haemophilus influenzae</i> type b, and hepatitis B (DTaP-IPV-Hib-HepB)	DTaP with inactivated whole polioviruses, Hib conjugate, and hepatitis B vaccine	Mpox vaccine	Live replication-deficient modified vaccinia Ankara vaccine
DTaP and inactivated polio vaccine (DTaP-IPV)	DTaP with inactivated whole polioviruses	Pneumococcal conjugate vaccine (15, 20 valent PCV15, PCV20)	Pneumococcal polysaccharides conjugated to diphtheria toxin CRM <sub>197</sub> , containing 15 and 20 pneumococcal serotypes, respectively. These serotypes accounted for >80% of invasive disease in young children before vaccine licensure
Ebola	Live, recombinant viral vector vaccine: backbone: vesicular stomatitis virus (VSV), with gene encoding for envelope glycoprotein of <i>Zaire ebolavirus</i> . Approved for individuals 18 yr of age and older as a single-dose administration.	Pneumococcal polysaccharide vaccine (23 valent) (PPSV23)	Pneumococcal polysaccharides of 23 serotypes responsible for 85-90% of bacteremic disease in the United States
Hib conjugate vaccine (Hib)	Polysaccharide conjugated to either tetanus toxoid or meningococcal group B outer membrane protein	Poliomyelitis (inactivated, enhanced potency) (IPV)	Inactivated whole virus highly purified from monkey kidney cells, trivalent types 1, 2, and 3
Hepatitis A vaccine (HepA)	Inactivated whole virus	Rabies vaccines (human diploid and purified chicken fibroblasts)	Inactivated whole virus
Hepatitis A-hepatitis B vaccine (HepA-HepB)	Combined hepatitis A and B vaccine	Respiratory syncytial virus vaccines	RSVPreF3 (Arexvy) and RSVpreF (Abrysvo). Both vaccines are recombinant protein vaccines and are currently approved as a single dose in adults ages 60 and older. Arexvy is adjuvanted. For pregnant women during RSV season, one dose of Abrysvo is recommended
Hepatitis B vaccine (HepB)	HBsAg produced through recombinant techniques in yeast	RSV immunization	Human immunoglobulin G1 kappa (IgG1κ) monoclonal antibody produced in Chinese hamster ovary (CHO) cells by recombinant DNA technology.
Human papillomavirus vaccine 9-valent (9vHPV)	The L1 capsid proteins of HPV types 6 and 11 to prevent genital warts and types 16, 18, 31, 33, 45, 52, and 58 to prevent cervical cancer (9vHPV)		



**Table 215.4** Currently Available\* Vaccines and Immunizing Agents in the United States by Type—cont'd

PRODUCT	TYPE	PRODUCT	TYPE
Rotavirus vaccines (RV5 and RV1)	Bovine rotavirus pentavalent vaccine (RV5), live reassortment attenuated virus, and human live-attenuated virus (RV1)	Typhoid vaccine (polysaccharide)	Vi capsular polysaccharide of <i>Salmonella</i> Typhi Ty2 strain
Smallpox vaccine	Vaccinia virus, an attenuated poxvirus that provides cross-protection against smallpox (variola)	Typhoid vaccine (oral)	Live-attenuated Ty21a strain of <i>S. typhi</i>
Tetanus and diphtheria toxoids, adsorbed (Td, adult use)	Tetanus toxoid plus a reduced quantity of diphtheria toxoid compared with diphtheria toxoid used for children <7 yr of age	Varicella vaccine	Live-attenuated Oka/Merck strain
Tetanus and diphtheria toxoids adsorbed plus acellular pertussis (Tdap) vaccine	Tetanus toxoid plus a reduced quantity of diphtheria toxoid plus acellular pertussis vaccine to be used in adolescents and adults and in children 7-10 yr of age who have not been appropriately immunized with DTaP	Yellow fever vaccine	Live-attenuated 17D-204 strain
Tickborne encephalitis vaccine	Whole tickborne-encephalitis virus (TBE) inactivated vaccine. Currently no ACIP/CDC recommendations available for this vaccine	Herpes zoster (shingles) vaccine	Zoster vaccine recombinant, adjuvanted (Shingrix) for use in adults ≥50 yr and in adults age 18 yr and older who are or will be at increased risk of herpes zoster because of immunodeficiency or immunosuppression caused by known disease or therapy

\*As of November 2023.

†There are various types of inactivated flu vaccines—IV4, cclIV4, and allV4.

Data from U.S. Food and Drug Administration. Vaccines licensed for use in the United States. <http://www.fda.gov/BiologicsBloodVaccines/Vaccines/ApprovedProducts/ucm093833.tm>.

found in one type of HPV vaccine, no longer available in the United States but still used in Europe. **MF59** is an oil-in-water emulsion found in one type of influenza vaccine approved for people ≥65 years old; it is also being studied in children. 1018 is an immunostimulatory sequence adjuvant used in HepB-CpG, a hepatitis B vaccine approved for persons >18 years. HepB-CpG contains yeast-derived recombinant hepatitis B surface antigen (HBsAg) and is prepared by combining purified HBsAg with small synthetic immunostimulatory cytidine-phosphate-guanosine oligodeoxynucleotide motifs. The 1018 adjuvant binds to toll-like receptor 9 to simulate a directed immune response to HBsAg. Vaccines with adjuvants should be injected deeply into muscle masses to avoid local irritation, granuloma formation, and necrosis associated with SC or intracutaneous administration.

Vaccines can induce immunity by stimulating antibody formation, cellular immunity, or both. Protection induced by most vaccines is thought to be mediated primarily by B lymphocytes, which produce antibodies. Such antibodies can inactivate toxins, neutralize viruses, and prevent their attachment to cellular receptors, facilitate phagocytosis and killing of bacteria, interact with complement to lyse bacteria, and prevent adhesion to mucosal surfaces by interacting with the bacterial cell surface.

Most B-lymphocyte responses require the assistance of CD4 helper T lymphocytes. These T-lymphocyte-dependent responses tend to induce high levels of functional antibody with high avidity. The T-dependent responses mature over time from primarily an IgM response to a persistent, long-term IgG response and induce immunologic memory that leads to enhanced responses on boosting. **T-lymphocyte-dependent vaccines**, which include protein moieties, induce good immune responses even in young infants. In contrast, polysaccharide antigens induce B-lymphocyte responses in the absence of T-lymphocyte help. These **T-lymphocyte-independent vaccines** are associated with poor immune responses in children <2 years old and with short-term immunity and absence of an enhanced or booster response on repeat exposure to the antigen. With some polysaccharide vaccines, repeat doses actually are associated with reduced responses, as measured by antibody concentrations, compared with first doses (i.e., *hyporesponsive*). To overcome problems with plain polysaccharide vaccines, polysaccharides have been **conjugated**, or covalently linked, to protein carriers, converting the vaccine to a T-lymphocyte-dependent vaccine. In contrast to plain polysaccharide vaccines, conjugate vaccines induce higher-avidity antibody, immunologic memory leading to booster responses on repeat exposure to the antigen, long-term immunity, and community protection by decreasing carriage of the organism (Table 215.5). As of 2023 in the United States, licensed conjugate vaccines are available to prevent Hib, pneumococcal, and meningococcal diseases.

**Table 215.5** Characteristics of Polysaccharide and Conjugate Vaccines

CHARACTERISTIC	CONJUGATE	POLYSACCHARIDE
T-lymphocyte-dependent immune response	Yes	No
Immune memory	Yes	No
Persistence of protection	Yes	No
Booster effect	Yes	No
Reduction of carriage	Yes	No
Community protection	Yes	No
Lack of hyporesponsiveness	Yes	No

Serum antibodies may be detected as soon as 7-10 days after initial injection of antigen. Early antibodies are usually of the IgM class that can fix complement. IgM antibodies tend to decline as IgG antibodies increase. The IgG antibodies tend to peak approximately 1 month after vaccination and with most vaccines persist for some time after a primary vaccine course. Secondary or booster responses occur more rapidly and result from rapid proliferation of memory B and T lymphocytes.

Assessment of the immune response to most vaccines is performed by measuring serum antibodies. Although detection of serum antibody at levels considered protective after vaccination can indicate immunity, loss of detectable antibody over time does not necessarily mean susceptibility to disease. Some vaccines induce immunologic memory, leading to a booster or anamnestic response on exposure to the microorganism, with resultant protection from disease. In some cases, cellular immune response is used to evaluate the status of the immune system. Certain vaccines (e.g., acellular pertussis) do not have an accepted serologic correlate of protection.

Live-attenuated vaccines routinely recommended for children and adolescents include measles, mumps, and rubella (MMR); MMR and varicella (MMRV); rotavirus; and varicella. In addition, a cold-adapted, live-attenuated quadrivalent influenza vaccine (LAIV4) is available for influenza.

**Live-attenuated vaccines** tend to induce long-term immune responses. They replicate, often similarly to natural infections, until an immune response inhibits reproduction. Most live vaccines are administered in one-dose or two-dose schedules. The purpose of



repeat doses, such as a second dose of the MMR or MMRV vaccine, is to induce an initial immune response in those who failed to respond to the first dose. Because influenza viruses tend to mutate to evade preexisting immunity to prior strains, at least one of the strains in influenza vaccines each year is often different than in the previous year. Thus influenza vaccines are recommended to be administered yearly.

The remaining vaccines in the recommended schedule for children and adolescents are inactivated vaccines. **Inactivated vaccines** tend to require multiple doses to induce an adequate immune response and are more likely than live-attenuated vaccines to need booster doses to maintain that immunity. However, some inactivated vaccines appear to induce long-term or perhaps lifelong immunity after a primary series, including hepatitis B vaccine and inactivated polio vaccine.

## VACCINATION SYSTEM IN THE UNITED STATES

### Vaccine Production

Vaccine production is primarily a responsibility of private industry. Many of the vaccines recommended routinely for children are produced by only one vaccine manufacturer. Vaccines with multiple manufacturers include Hib, hepatitis B, rotavirus, MCV4 (meningococcal conjugate vaccine against serogroups A, C, W135, and Y), COVID-19 vaccine, diphtheria and tetanus toxoids and acellular pertussis (DTaP), and tetanus and diphtheria toxoids and acellular pertussis (Tdap) vaccines for adolescents and adults. Inactivated polio vaccine (IPV) as an IPV-only vaccine has only one manufacturer, but IPV is also available in combination products (DTaP–hepatitis B–IPV, DTaP–IPV/Hib, and DTaP–IPV) from different manufacturers. Influenza vaccine for children 6–35 months of age is produced by fewer manufacturers. MMR, MMRV, varicella, pneumococcal conjugate vaccines, and tetanus and diphtheria (Td) vaccines also are produced by single manufacturers. The FDA has authorized for emergency use the Pfizer-BioNTech and Moderna COVID-19 vaccines for the prevention of COVID-19 disease in individuals 6 months of age and older. The FDA has also authorized the Novavax COVID-19 vaccine for individuals 12 years of age and older.

### Vaccine Policy

Two major committees make vaccine policy recommendations for children: the Committee on Infectious Diseases (COID) of the AAP (the *Red Book* Committee) and the Advisory Committee on Immunization Practices (ACIP) of the CDC. Annually, the AAP, ACIP, American Academy of Family Physicians (AAFP), American College of Obstetricians and Gynecologists (ACOG), American College of Nurse-Midwives ([www.midwife.org](http://www.midwife.org)), American Academy of Physician Assistants ([www.aapa.org](http://www.aapa.org)), and National Association of Pediatric Nurse Practitioners ([www.napnap.org](http://www.napnap.org)) issue a harmonized childhood and adolescent immunization schedule. (<http://www.cdc.gov/vaccine/s/schedules/index.html>). The ACIP recommendations (<http://www.cdc.gov/vaccines/acip/recs/index.html>) are official only after adoption by the CDC director, which leads to publication in the *Morbidity and Mortality Weekly Report* (*MMWR Morb Mortal Wkly Rep*). The AAP recommendations are published in *Pediatrics* and the *Red Book*, which includes its continuously updated online version ([aapredbook.org](http://aapredbook.org)).

### Vaccine Financing

Approximately 50% of vaccines routinely administered to children and adolescents <19 years of age are purchased through a contract negotiated by the federal government with licensed vaccine manufacturers. Three major sources of funds are available to purchase vaccines through this contract. The greatest portion comes from the **Vaccines for Children (VFC)** program (<http://www.cdc.gov/vaccines/programs/vfc/index.html>), a federal entitlement program established in 1993. The VFC program covers children receiving Medicaid, children without insurance (uninsured), and Native Americans and Alaska Natives. In addition, underinsured children whose insurance does not cover immunization can be covered through VFC, but only if they go to a federally qualified health center (<http://www.cms.gov/center/fqhc.asp>). In contrast to other public funding sources that require approval of discretionary funding by legislative bodies, VFC funds are immediately available for new recommendations. These funds are only available if the ACIP votes the vaccine and the recommendation for its use into the VFC program, the federal government negotiates a contract, and the Office of Management and Budget (OMB)

apportions funds. The VFC program can provide free vaccines to participating private providers for administration to children eligible for coverage under the program. The second major federal funding source is the Section 317 **Discretionary Federal Grant Program** to states and selected localities. These funds must be appropriated annually by Congress, and in contrast to VFC, they do not have eligibility requirements for use. The third major public source of funds is **state appropriations**.

The VFC program itself does not cover vaccine administration costs. Medicaid covers the administration fees for children enrolled in the program. Parents of other children eligible for VFC must pay administration fees out of pocket, although the law stipulates that no one eligible for the program can be denied vaccines because of inability to pay the administration fee. The Affordable Care Act (ACA) states that all vaccines recommended by ACIP and those included in the harmonized annual immunization schedules must be provided by qualified insurance programs with no copay and no deductible. For eligible children and adults, the COVID-19 vaccine is free of charge. (<https://www.cdc.gov/vaccines/programs-/bridge/index.html>).

### Vaccine Safety Monitoring

Monitoring vaccine safety is the responsibility of the FDA, CDC, and vaccine manufacturers. A critical part of that monitoring depends on reports provided to the **Vaccine Adverse Event Reporting System (VAERS)**, the country's early warning system for vaccine safety managed by the CDC and the FDA. Adverse events after immunization can be reported by completing a VAERS form, which can be obtained from <http://www.vaers.hhs.gov>, or by calling 800-822-7967. VAERS can rapidly detect safety signals and rare adverse events but is not designed to assess causality. Individual VAERS case reports may be helpful in identifying potential vaccine safety concerns that can generate hypotheses about whether vaccines are causing certain clinical syndromes. In general, however, the reports are not helpful in evaluating the causal role of vaccines in the adverse event, because most clinical syndromes that follow vaccination are similar to syndromes that occur in the absence of vaccination, which constitute background rates. For causality assessment, epidemiologic studies are often necessary, comparing the incidence rate of the adverse event after vaccination with the rate in unvaccinated individuals. A statistically significant higher rate in vaccinated individuals would be consistent with causation. **V-safe** is a smartphone-based tool that uses text messaging and web surveys to provide personalized health check-ins for up to a year after someone receives a COVID-19 vaccine. Through v-safe, COVID-19 vaccine recipients are able to communicate with the CDC regarding possible side effects (<https://www.cdc.gov/coronavirus/2019-ncov/vaccines/safety/pdfs/v-safe-information-sheet-508c.pdf>).

The **Vaccine Safety Datalink** gathers data from nine participating integrated healthcare organizations on over 12 million people per year. It consists of inpatient and outpatient records of some of the largest managed-care organizations in the United States and facilitates causality evaluation. In addition, the **Clinical Immunization Safety Assessment (CISA)** network has been established to advise primary care physicians on evaluation and management of adverse events (<http://www.cdc.gov/vaccinesafety/Activities/CISA.html>). CISA facilitates the CDC's collaboration with a network of vaccine safety experts at seven leading academic medical centers and strengthens national capacity for vaccine safety monitoring and clinical research.

The Health and Medicine Division (HMD) of the National Academies of Sciences, Engineering and Medicine, previously the Institute of Medicine (IOM), has independently reviewed a variety of vaccine safety concerns and published reports summarizing its findings.\* From 2001 through 2004, the IOM released eight reports, concluding that the body of epidemiologic evidence did not show an association between vaccines and autism. In 2012 the IOM (HMD) report *Adverse Effects of Vaccines: Evidence and Causality*\*\* reviewed a list of reported adverse effects associated with eight vaccines to evaluate the scientific evidence, if any, of an event-vaccine relationship. The IOM committee had developed 158 causality conclusions and assigned each relationship between a vaccine and

\* <http://nationalacademies.org/hmd/Reports.aspx?filters=inmeta:activity=Immunization+Safety+Review>.

\*\* <https://www.nap.edu/catalog/13164/adverse-effects-of-vaccines-evidence-and-causality>

an adverse health problem to one of four causation categories. The committee concluded that available evidence convincingly supported a causal relationship between **anaphylaxis** and MMR, varicella-zoster, influenza, hepatitis B, meningococcal, and tetanus-containing vaccines. Additionally, the evidence *avored rejection* of five vaccine–adverse event relationships, including MMR vaccine and autism, inactivated influenza vaccines and asthma episodes and Bell palsy, and MMR and DTaP and type 1 diabetes mellitus. For the majority of cases (135 vaccine–adverse event pairs), the evidence was inadequate to accept or reject a causal relationship because of the rarity of the events. Overall, the committee concluded that few health problems are caused by or clearly associated with vaccines.

In 2013, the HMD released the report *Childhood Immunization Schedule and Safety: Stakeholder Concerns, Scientific Evidence, and Future Studies*.<sup>†</sup> The HMD uncovered no evidence of major safety concerns associated with adherence to the recommended childhood immunization schedule. The HMD specifically found no links between the immunization schedule and autoimmune diseases, asthma, hypersensitivity, seizures, child developmental disorders, learning or developmental disorders, or attention-deficit or disruptive disorders. Additionally, use of nonstandard schedules is harmful, because it increases the period of risk of acquiring vaccine-preventable diseases and increases the risk of incomplete immunization.<sup>‡</sup> In addition, the Agency for Healthcare Research and Quality (AHRQ) contracted with the Rand Corporation for an independent systematic review of the immunization schedule. That review concluded that although some vaccines are associated with serious adverse events, these events are extremely rare and must be weighed against the protective benefits that vaccines provide. The AAP has summarized the information on a variety of safety issues and different vaccines.<sup>§</sup>

The **National Vaccine Injury Compensation Program (VICP)** is designed to compensate people injured by vaccines in the childhood and adolescent immunization schedule. The program is funded through an excise tax of \$0.75 on vaccines recommended by the CDC per disease prevented per dose (e.g., the quadrivalent influenza vaccine is taxed \$0.75 because it prevents one disease; the MMR vaccine is taxed \$2.25 because it prevents three diseases). As of 2023, this program covers all the routinely recommended vaccines that protect children against 16 diseases. The VICP was established to provide a no-fault system, with a table of related injuries and time frames. In April 2018 the table was modified to reflect changes in the 21st Century Cures Act, requiring that the VICP cover vaccines recommended for routine administration in pregnant women. All people alleging injury from covered vaccines must first file with the program. If the injury meets the requirements of the table, compensation is automatic. If not, the claimant has the responsibility to prove causality. If compensation is accepted, the claimant cannot sue the manufacturer or physician administering the vaccine. If the claimant rejects the judgment of the compensation system, the claimant can enter the tort system, which is uncommon. Information on the VICP is available at <http://www.hrsa.gov/vaccinecompensation> or by calling 800-338-2382. All vaccines included in the child and adolescent vaccine schedule are covered by VICP except dengue, PPSV23, and COVID-19 vaccines. COVID-19 vaccines that are authorized or approved by the FDA are covered by the Countermeasures Injury Compensation Program (CICP). For more information, see [www.hrsa.gov/vaccinecompensation](http://www.hrsa.gov/vaccinecompensation) or [www.hrsa.gov/cicp](http://www.hrsa.gov/cicp). All physicians administering a vaccine covered by the program are required by law to give the approved **Vaccine Information Statement (VIS)** to the child's parent or guardian at each visit before administering vaccines. Information on the VIS can be obtained from <http://www.cdc.gov/vaccines/hcp/vis/index.html>. There is no VIS for COVID-19 vaccines authorized under an emergency use authorization (EUA). For each COVID-19 vaccine approved by the FDA, a Vaccine Information Fact Sheet for recipients and caregivers is available. The FDA also requires that recipients or their caregivers be provided with certain vaccine-specific information for any COVID vaccine authorized under an EUA to help make an informed decision about vaccination.

This is accomplished by providing an EUA Fact Sheet for Recipients and Caregivers. The fact sheet is similar in purpose and content to VISs for licensed vaccines but differs in that the EUA fact sheet is specific to each authorized COVID-19 vaccine, is developed by the manufacturer of the vaccine, and is authorized by the FDA. EUA fact sheets are available at <https://www.cdc.gov/vaccines/covid-19/eua/index.html>.

### Vaccine Delivery

To ensure potency, vaccines should be stored at recommended temperatures before and after reconstitution. A comprehensive resource for providers on vaccine storage and handling recommendations and best practice strategies is available (<https://www.cdc.gov/vaccines/hcp/admin/storage/index.html>). Expiration dates should be noted and expired vaccines discarded. Lyophilized vaccines often have long shelf lives. However, the shelf life of reconstituted vaccines generally is short, ranging from 30 minutes for varicella vaccine to 8 hours for MMR vaccine.

All vaccines have a preferred route of administration, which is specified in package inserts and in AAP and ACIP recommendations. Most inactivated vaccines, including DTaP, hepatitis A, hepatitis B, Hib, inactivated influenza vaccine (IIV), HPV, PCV, COVID-19 vaccines, MCV4, and Tdap, are administered IM. In contrast, the more commonly used live-attenuated vaccines (MMR, MMRV, and varicella) should be dispensed by the SC route. Rotavirus vaccine is administered orally. IPV and PPS23 (pneumococcal polysaccharide vaccine) can be given IM or SC. One influenza vaccine, LAIV4, when recommended, is administered intranasally. For IM injections, the anterolateral thigh muscle is the preferred site for infants and young children. The recommended needle length varies depending on age and size:  $\frac{5}{8}$  inch for newborn infants, 1 inch for infants 2-12 months old, and  $\frac{3}{8}$  to 1 inch for children 3-10 years of age. For adolescents and adults, the deltoid muscle of the arm is the preferred site for IM administration with needle lengths of 1-1 $\frac{1}{4}$  inches depending on patient size. Most IM injections can be made with 23- to 25-gauge needles. For SC injections, needle lengths generally range from  $\frac{3}{8}$  to  $\frac{3}{4}$  inch with 23- to 25-gauge needles.

Additional aspects of immunization important for pediatricians and other healthcare providers are detailed on the websites listed in [Table 215.6](#).

### RECOMMENDED IMMUNIZATION SCHEDULE

All children in the United States should be immunized against 19 diseases ([Fig. 215.1](#) and [Table 215.7](#)) (annually updated schedule available at <http://www.cdc.gov/vaccines/schedules/index.html>).

Hepatitis B vaccine (HepB) is recommended in a three-dose schedule starting at birth. The birth dose, as well as hepatitis B immunoglobulin, is critical for infants born to mothers who are HBsAg-positive or whose hepatitis B immune status is unknown. The recommendation is to administer the first hepatitis B vaccine to all newborns within 24 hours of birth, the second dose at 1-2 months, with a minimal interval between the first and second dose of 4 weeks, and the third dose from 6 to 18 months of age, ensuring that 8 weeks has passed between the second and third dose. If either the DTaP-HepB-IPV combination vaccine or the DTaP-IPV-Hib-HepB combination vaccine is used, a four-dose schedule is permissible, which includes the stand-alone hepatitis B vaccine at birth and the combination vaccine for the next three doses. There are multiple alternatives for catch-up vaccination with HepB vaccine depending on the child's age. See the immunization schedule notes for clarification.

The **DTaP** series consists of five doses administered at 2, 4, 6, and 15 through 18 months of age and 4 through 6 years of age. The fourth dose of DTaP may be administered as early as 12 months of age, provided at least 6 months have elapsed since the third dose. The fifth (booster) dose of DTaP vaccine is not necessary if the fourth dose was administered at 4 years or older. One dose of an adult preparation of Tdap is recommended for all adolescents 11 through 12 years of age, even if a dose of Tdap or DTaP was administered inadvertently or as part of the catch-up series at 7-9 years of age. If Tdap is administered at 10 years of age, an additional booster at 11-12 years of age is not recommended. Adolescents 13 through 18 years who missed the 11 through 12 year Tdap booster dose should receive a single dose of Tdap if they have completed the diphtheria, tetanus, and pertussis (DTP)/DTaP series. Tdap may be given at any interval after the last Td. [Table 215.8](#) lists preparations in which DTaP is

<sup>†</sup> <https://www.nap.edu/catalog/13563/the-childhood-immunization-schedule-and-safety-stakeholder-concerns-scientific-evidence>.

<sup>‡</sup> For more information on the reports, see <http://nationalacademies.org/hmd/Reports.aspx>.

<sup>§</sup> <https://www.healthychildren.org/English/safety-prevention/immunizations/Pages/Vaccine-Studies-Examine-the-Evidence.aspx>.

**Table 215.6** Vaccine Websites and Resources

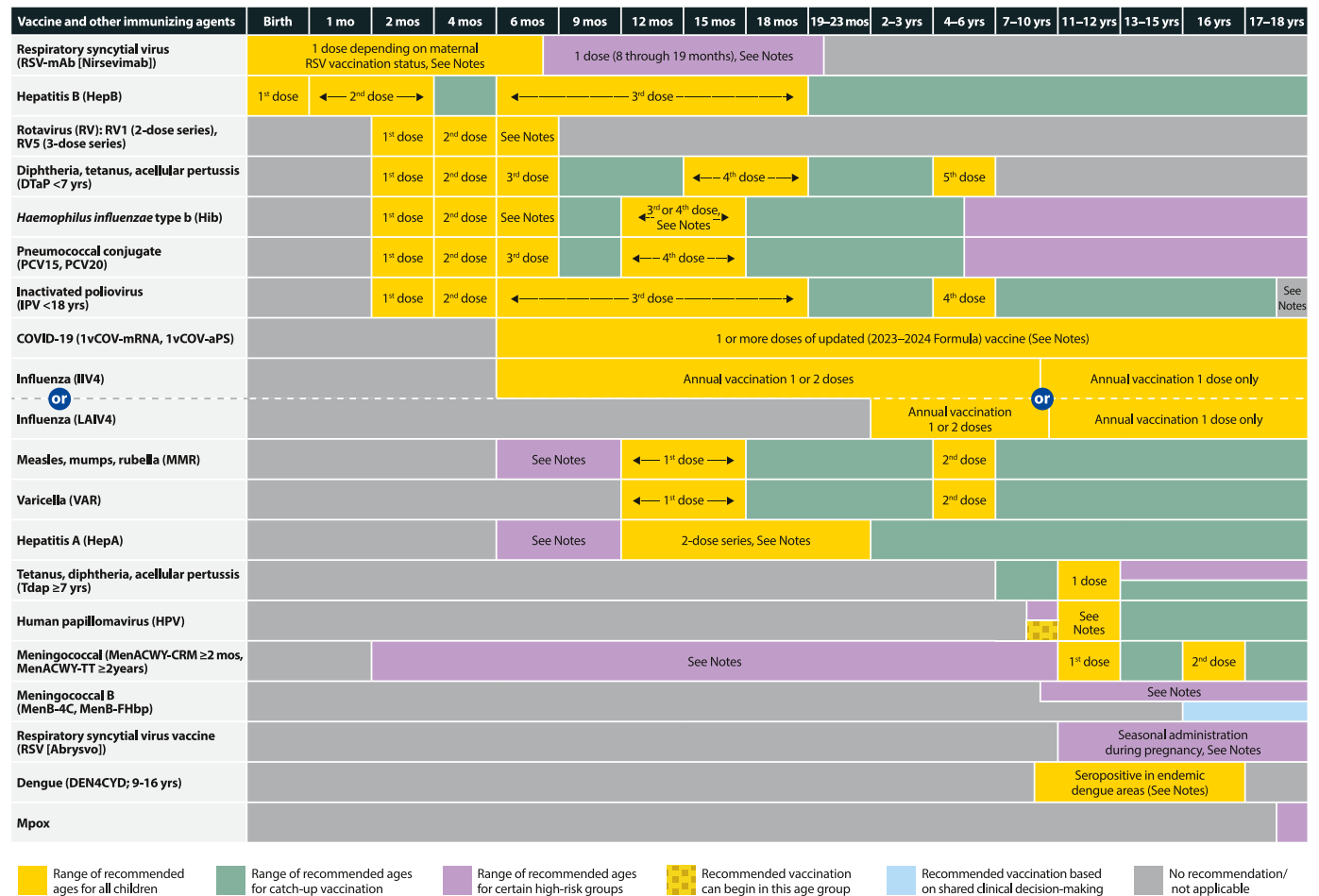
ORGANIZATION	WEBSITE
<b>HEALTH PROFESSIONAL ASSOCIATIONS</b>	
American Academy of Family Physicians (AAFP)	<a href="http://www.familydoctor.org/online/famdocen/home.html">http://www.familydoctor.org/online/famdocen/home.html</a>
American Academy of Pediatrics (AAP)	<a href="http://www.aap.org/">http://www.aap.org/</a>
American Academy of Physician Assistants (AAPA)	<a href="https://www.aapa.org">https://www.aapa.org</a>
AAP Childhood Immunization Support Program	<a href="http://www.aap.org/immunization/">http://www.aap.org/immunization/</a>
American Association of Occupational Health Nurses (AAOHN)	<a href="http://www.aohn.org/">http://www.aohn.org/</a>
American Association of Nurse Practitioners (AANP)	<a href="https://www.aanp.org">https://www.aanp.org</a>
American College Health Association (ACHA)	<a href="http://www.acha.org/">http://www.acha.org/</a>
American College of Nurse-Midwives (ACNM)	<a href="https://www.midwife.org">https://www.midwife.org</a>
American College of Obstetricians and Gynecologists (ACOG)— Immunization for Women	<a href="http://www.immunizationforwomen.org/">http://www.immunizationforwomen.org/</a>
American Medical Association (AMA)	<a href="http://www.ama-assn.org/">http://www.ama-assn.org/</a>
American Nurses Association (ANA)	<a href="http://www.nursingworld.org/">http://www.nursingworld.org/</a>
American Pharmacists Association (APhA)	<a href="http://www.pharmacist.com/">http://www.pharmacist.com/</a>
American School Health Association (ASHA)	<a href="http://www.ashaweb.org/">http://www.ashaweb.org/</a>
American Travel Health Nurses Association (ATHNA)	<a href="http://www.athna.org/">http://www.athna.org/</a>
Association for Professionals in Infection Control and Epidemiology (APIC)	<a href="http://www.apic.org/">http://www.apic.org/</a>
Association of State and Territorial Health Officials (ASTHO)	<a href="http://www.astho.org/">http://www.astho.org/</a>
Association of Teachers of Preventive Medicine (ATPM)	<a href="http://www.atpm.org/">http://www.atpm.org/</a>
National Medical Association (NMA)	<a href="http://www.nmanet.org/">http://www.nmanet.org/</a>
Society of Teachers of Family Medicine—Group on Immunization Education	<a href="http://www.immunizationed.org/">http://www.immunizationed.org/</a>
<b>NONPROFIT GROUPS AND UNIVERSITIES</b>	
Albert B. Sabin Vaccine Institute	<a href="http://www.sabin.org/">http://www.sabin.org/</a>
Brighton Collaboration	<a href="https://brightoncollaboration.org/public">https://brightoncollaboration.org/public</a>
Center for Vaccine Awareness and Research—Texas Children’s Center	<a href="http://www.texaschildrens.org/departments/immunization-project">http://www.texaschildrens.org/departments/immunization-project</a>
Children’s Vaccine Program	<a href="http://www.path.org/vaccineresources/">http://www.path.org/vaccineresources/</a>
Every Child by Two (ECBT)	<a href="http://www.ecbt.org/">http://www.ecbt.org/</a>
Families Fighting Flu	<a href="http://www.familiesfightingflu.org/">http://www.familiesfightingflu.org/</a>
GAVI, the Vaccine Alliance	<a href="http://www.gavialliance.org/">http://www.gavialliance.org/</a>
Health on the Net Foundation (HON)	<a href="http://www.hon.ch/">http://www.hon.ch/</a>
Immunization Action Coalition (IAC)	<a href="http://www.immunize.org/">http://www.immunize.org/</a>
Infectious Diseases Society of America (IDSA)	<a href="http://www.idsociety.org/Index.aspx">http://www.idsociety.org/Index.aspx</a>
Institute for Vaccine Safety (IVS), Johns Hopkins Bloomberg School of Public Health	<a href="http://www.vaccinesafety.edu/">http://www.vaccinesafety.edu/</a>
National Academies: Health and Medicine Division	<a href="http://www.nationalacademies.org/hmd/">http://www.nationalacademies.org/hmd/</a>
National Alliance for Hispanic Health	<a href="http://www.hispanichealth.org/">http://www.hispanichealth.org/</a>
National Association of Certified Professional Midwives	<a href="https://nacpm.org">https://nacpm.org</a>
National Foundation for Infectious Diseases (NFID)	<a href="http://www.nfid.org">http://www.nfid.org</a>
National Foundation for Infectious Diseases (NFID)—Childhood Influenza Immunization Coalition (CIIC)	<a href="http://www.preventchildhoodinfluenza.com/">http://www.preventchildhoodinfluenza.com/</a>
National Network for Immunization Information (NNii)	<a href="http://www.immunizationinfo.net/">http://www.immunizationinfo.net/</a>
Parents of Kids with Infectious Diseases (PKIDS)	<a href="http://www.pkids.org/">http://www.pkids.org/</a>
PATH Vaccine Resource Library	<a href="http://www.path.org/resources/vaccine-resource-library-website">http://www.path.org/resources/vaccine-resource-library-website</a>
Vaccine Education Center at the Children’s Hospital of Philadelphia	<a href="http://www.chop.edu/service/vaccine-education-center/home.html">http://www.chop.edu/service/vaccine-education-center/home.html</a>
Vaccinate Your Baby	<a href="http://www.vaccinateyourbaby.org/">http://www.vaccinateyourbaby.org/</a>
<b>GOVERNMENT ORGANIZATIONS</b>	
<b>Centers for Disease Control and Prevention (CDC)</b>	
Advisory Committee on Immunization Practices (ACIP)	<a href="http://www.cdc.gov/vaccines/acip/index.html">http://www.cdc.gov/vaccines/acip/index.html</a>
ACIP Vaccine Recommendations	<a href="http://www.cdc.gov/vaccines/hcp/acip-recs/index.html">http://www.cdc.gov/vaccines/hcp/acip-recs/index.html</a>
Current Vaccine Delays and Shortages	<a href="http://www.cdc.gov/vaccines/vac-gen/shortages/">http://www.cdc.gov/vaccines/vac-gen/shortages/</a>
Epidemiology and Prevention of Vaccine-Preventable Diseases (also known as the Pink Book)	<a href="https://www.cdc.gov/vaccines/pubs/pinkbook/index.html">https://www.cdc.gov/vaccines/pubs/pinkbook/index.html</a>
Manual for the Surveillance of Vaccine-Preventable Diseases	<a href="http://www.cdc.gov/vaccines/pubs/surv-manual/index.html">www.cdc.gov/vaccines/pubs/surv-manual/index.html</a>
Public Health Image Library	<a href="https://phil.cdc.gov/phil/home.asp">https://phil.cdc.gov/phil/home.asp</a>
Travelers’ Health	<a href="http://www.cdc.gov/travel/">http://www.cdc.gov/travel/</a>
CDC Health Information for International Travel (also known as the Yellow Book)	<a href="https://wwwnc.cdc.gov/travel/yellowbook/2016/table-of-contents">https://wwwnc.cdc.gov/travel/yellowbook/2016/table-of-contents</a>
Vaccine Adverse Events Reporting System (VAERS)	<a href="http://www.cdc.gov/vaccinesafety/Activities/vaers.html">http://www.cdc.gov/vaccinesafety/Activities/vaers.html</a>
Vaccine Administration: Recommendations and Guidelines	<a href="http://www.cdc.gov/vaccines/recs/vac-admin/default.htm">http://www.cdc.gov/vaccines/recs/vac-admin/default.htm</a>
Vaccines and Immunizations	<a href="http://www.cdc.gov/vaccines/">http://www.cdc.gov/vaccines/</a>
Vaccines for Children Program	<a href="http://www.cdc.gov/vaccines/programs/vfc/index.html">http://www.cdc.gov/vaccines/programs/vfc/index.html</a>
Vaccines for Children—Vaccine Price List	<a href="http://www.cdc.gov/vaccines/programs/vfc/awardees/vaccine-management/price-list/index.html">http://www.cdc.gov/vaccines/programs/vfc/awardees/vaccine-management/price-list/index.html</a>
Vaccine Information Statements	<a href="http://www.cdc.gov/vaccines/hcp/vis/index.html">www.cdc.gov/vaccines/hcp/vis/index.html</a>

**Table 215.6** Vaccine Websites and Resources—cont'd

ORGANIZATION	WEBSITE
Vaccine Safety	<a href="http://www.cdc.gov/vaccinesafety/index.html">http://www.cdc.gov/vaccinesafety/index.html</a>
Vaccine Storage and Handling	<a href="http://www.cdc.gov/vaccines/recs/storage/default.htm">http://www.cdc.gov/vaccines/recs/storage/default.htm</a>
Department of Health and Human Services (HHS) National Vaccine Program Office (NVPO)	<a href="http://www.hhs.gov/nvpo/">http://www.hhs.gov/nvpo/</a>
Health Resources and Services Administration National Vaccine Injury Compensation Program	<a href="http://www.hrsa.gov/vaccinecompensation/">http://www.hrsa.gov/vaccinecompensation/</a>
National Institute of Allergy and Infectious Diseases (NIAID) Vaccines	<a href="https://www.niaid.nih.gov/about/vrc">https://www.niaid.nih.gov/about/vrc</a>
World Health Organization (WHO) Immunization, Vaccines, and Biologicals	<a href="http://www.who.int/immunization/en/">http://www.who.int/immunization/en/</a>

**Recommended Child and Adolescent Immunization Schedule for Ages 18 Years or Younger, United States, 2024**

These recommendations must be read with the notes that follow. For those who fall behind or start late, provide catch-up vaccination at the earliest opportunity as indicated by the green bars. To determine minimum intervals between doses, see the catch-up schedule (Table 215.7).



**Fig. 215.1** Recommended immunization schedule for children and adolescents age 18 yr or younger—United States, 2024, including an appendix detailing contraindications and precautions for commonly used vaccines. *These recommendations must be read with the notes that follow.* For those who fall behind or start late, provide catch-up vaccination at the earliest opportunity as indicated by the green bars. A new addendum section has been added to list any ACIP recommendations that occur by majority vote and are approved by CDC Director after the 2024 immunization schedules are approved and published. To determine minimum intervals between doses, see the Catch-Up Schedule (see Table 215.7). (Courtesy U.S. Centers for Disease Control and Prevention, Atlanta, 2023. <https://www.cdc.gov/vaccines/schedules/downloads/child/0-18yrs-child-combined-schedule.pdf>; Appendix is adapted from the Advisory Committee on Immunization Practices [ACIP] General Best Practice Guidelines for Immunization: Contraindication and Precautions, Table 4-1, available at [www.cdc.gov/vaccines/hcp/acip-recs/general-recs/contraindications.html](http://www.cdc.gov/vaccines/hcp/acip-recs/general-recs/contraindications.html) and from the ACIP's Recommendations for the Prevention and Control of 2023-24 seasonal influenza with vaccines available at [www.cdc.gov/mmwr/volumes/71/rr/rr7101a1.htm](http://www.cdc.gov/mmwr/volumes/71/rr/rr7101a1.htm).)



## Notes

For vaccination recommendations for persons ages 19 years or older, see the Recommended Adult Immunization Schedule, 2024.

## Additional information

- For calculating intervals between doses, 4 weeks = 28 days. Intervals of  $\geq 4$  months are determined by calendar months.
- Within a number range (e.g., 12–18), a dash (–) should be read as “through.”
- Vaccine doses administered  $\leq 4$  days before the minimum age or interval are considered valid. Doses of any vaccine administered  $\geq 5$  days earlier than the minimum age or minimum interval should not be counted as valid and should be repeated as age appropriate. **The repeat dose should be spaced after the invalid dose by the recommended minimum interval.** For further details, see Table 3-2, Recommended and minimum ages and intervals between vaccine doses, in *General Best Practice Guidelines for Immunization* at [www.cdc.gov/vaccines/hcp/acip-recs/general-recs/timing.html](http://www.cdc.gov/vaccines/hcp/acip-recs/general-recs/timing.html).
- Information on travel vaccination requirements and recommendations is available at [www.cdc.gov/travel/](http://www.cdc.gov/travel/).
- For vaccination of persons with immunodeficiencies, see Table 8-1, Vaccination of persons with primary and secondary immunodeficiencies, in *General Best Practice Guidelines for Immunization* at [www.cdc.gov/vaccines/hcp/acip-recs/general-recs/immunocompetence.html](http://www.cdc.gov/vaccines/hcp/acip-recs/general-recs/immunocompetence.html), and Immunization in Special Clinical Circumstances (In: Kimberlin DW, Barnett ED, Lynfield Ruth, Sawyer MH, eds. *Red Book: 2021–2024 Report of the Committee on Infectious Diseases*. 32<sup>nd</sup> ed. Itasca, IL: American Academy of Pediatrics; 2021:72–86).
- For information about vaccination in the setting of a vaccine-preventable disease outbreak, contact your state or local health department.
- The National Vaccine Injury Compensation Program (VICP) is a no-fault alternative to the traditional legal system for resolving vaccine injury claims. All vaccines included in the child and adolescent vaccine schedule are covered by VICP except dengue, PPSV23, RSV, Mpox and COVID-19 vaccines. Mpox and COVID-19 vaccines are covered by the Countermeasures Injury Compensation Program (CICP). For more information, see [www.hrsa.gov/vaccinecompensation](http://www.hrsa.gov/vaccinecompensation) or [www.hrsa.gov/cicp](http://www.hrsa.gov/cicp).

- Previously vaccinated\* with 3 or more doses of any Moderna or Pfizer-BioNTech:** 1 dose of updated (2023–2024 Formula) Moderna or Pfizer-BioNTech at least 8 weeks after the most recent dose.

## Age 12–18 years

- Unvaccinated:**
  - 3-dose series of updated (2023–2024 Formula) Moderna at 0, 4, 8 weeks
  - 3-dose series of updated (2023–2024 Formula) Pfizer-BioNTech at 0, 3, 7 weeks
  - 2-dose series of updated (2023–2024 Formula) Novavax at 0, 3 weeks
- Previously vaccinated\* with 1 dose of any Moderna:** 2-dose series of updated (2023–2024 Formula) Moderna at 0, 4 weeks (minimum interval between previous Moderna dose and dose 1: 4 weeks).
- Previously vaccinated\* with 2 doses of any Moderna:** 1 dose of updated (2023–2024 Formula) Moderna at least 4 weeks after the most recent dose.
- Previously vaccinated\* with 1 dose of any Pfizer-BioNTech:** 2-dose series of updated (2023–2024 Formula) Pfizer-BioNTech at 0, 4 weeks (minimum interval between previous Pfizer-BioNTech dose and dose 1: 3 weeks).
- Previously vaccinated\* with 2 doses of any Pfizer-BioNTech:** 1 dose of updated (2023–2024 Formula) Pfizer-BioNTech at least 4 weeks after the most recent dose.
- Previously vaccinated\* with 3 or more doses of any Moderna or Pfizer-BioNTech:** 1 dose of any updated (2023–2024 Formula) COVID-19 vaccine at least 8 weeks after the most recent dose.
- Previously vaccinated\* with 1 or more doses of Janssen or Novavax or with or without dose(s) of any Original monovalent or bivalent COVID-19 vaccine:** 1 dose of any updated (2023–2024 Formula) COVID-19 vaccine at least 8 weeks after the most recent dose.

There is no preferential recommendation for the use of one COVID-19 vaccine over another when more than one recommended age-appropriate vaccine is available.

Administer an age-appropriate COVID-19 vaccine product for each dose. For information about transition from age 4 years to age 5 years or age 11 years to age 12 years during COVID-19 vaccination series, see Tables 1 and 2 at [www.cdc.gov/vaccines/covid-19/clinical-considerations/interim-considerations-us.html#%3Acovid-vaccines](http://www.cdc.gov/vaccines/covid-19/clinical-considerations/interim-considerations-us.html#%3Acovid-vaccines).

## COVID-19 vaccination

(minimum age: 6 months [Moderna and Pfizer-BioNTech COVID-19 vaccines], 12 years [Novavax COVID-19 Vaccine])

## Routine vaccination

## Age 6 months–4 years

- Unvaccinated:**
  - 2-dose series of updated (2023–2024 Formula) Moderna at 0, 4–8 weeks
  - 3-dose series of updated (2023–2024 Formula) Pfizer-BioNTech at 0, 3–8, 11–16 weeks
- Previously vaccinated\* with 1 dose of any Moderna:** 1 dose of updated (2023–2024 Formula) Moderna 4–8 weeks after the most recent dose.
- Previously vaccinated\* with 2 or more doses of any Moderna:** 1 dose of updated (2023–2024 Formula) Moderna at least 8 weeks after the most recent dose.
- Previously vaccinated\* with 1 dose of any Pfizer-BioNTech:** 2-dose series of updated (2023–2024 Formula) Pfizer-BioNTech at 0, 8 weeks (minimum interval between previous Pfizer-BioNTech and dose 1: 3–8 weeks).
- Previously vaccinated\* with 2 or more doses of any Pfizer-BioNTech:** 1 dose of updated (2023–2024 Formula) Pfizer-BioNTech at least 8 weeks after the most recent dose.

## Age 5–11 years

- Unvaccinated:** 1 dose of updated (2023–2024 Formula) Moderna or Pfizer-BioNTech vaccine.
- Previously vaccinated\* with 1 or more doses of Moderna or Pfizer-BioNTech:** 1 dose of updated (2023–2024 Formula) Moderna or Pfizer-BioNTech at least 8 weeks after the most recent dose.

## Age 12–18 years

- Unvaccinated:**
  - 1 dose of updated (2023–2024 Formula) Moderna or Pfizer-BioNTech vaccine
  - 2-dose series of updated (2023–2024 Formula) Novavax at 0, 3–8 weeks
- Previously vaccinated\* with any COVID-19 vaccine(s):** 1 dose of any updated (2023–2024 Formula) COVID-19 vaccine at least 8 weeks after the most recent dose.

Current COVID-19 schedule and dosage formulation available at [www.cdc.gov/covidschedule](http://www.cdc.gov/covidschedule). For more information on Emergency Use Authorization (EUA) indications for COVID-19 vaccines, see [www.fda.gov/emergency-preparedness-and-response/coronavirus-disease-2019-covid-19/covid-19-vaccines](http://www.fda.gov/emergency-preparedness-and-response/coronavirus-disease-2019-covid-19/covid-19-vaccines)

**\*Note:** Previously vaccinated is defined as having received any Original monovalent or bivalent COVID-19 vaccine (Janssen, Moderna, Novavax, Pfizer-BioNTech) prior to the updated 2023–2024 formulation.

**\*\*Note:** Persons who are moderately or severely immunocompromised have the option to receive one additional dose of updated (2023–2024 Formula) COVID-19 vaccine at least 2 months following the last recommended updated (2023–2024 Formula) COVID-19 vaccine dose. Further additional updated (2023–2024 Formula) COVID-19 vaccine dose(s) may be administered, informed by the clinical judgement of a healthcare provider and personal preference and circumstances. Any further additional doses should be administered at least 2 months after the last updated (2023–2024 Formula) COVID-19 vaccine dose. Moderately or severely immunocompromised children 6 months–4 years of age should receive homologous updated (2023–2024 Formula) mRNA vaccine dose(s) if they receive additional doses.

## Dengue vaccination

(minimum age: 9 years)

## Routine vaccination

- Age 9–16 years living in areas with endemic dengue AND have laboratory confirmation of previous dengue infection
  - 3-dose series administered at 0, 6, and 12 months
- Endemic areas include Puerto Rico, American Samoa, US Virgin Islands, Federated States of Micronesia, Republic of Marshall Islands, and the Republic of Palau. For updated guidance on dengue endemic areas and pre-vaccination laboratory testing see [www.cdc.gov/mmwr/volumes/70/rr/r7006a1.htm?5\\_cid=rr7006a1\\_w](http://www.cdc.gov/mmwr/volumes/70/rr/r7006a1.htm?5_cid=rr7006a1_w) and [www.cdc.gov/dengue/vaccine/hcp/index.html](http://www.cdc.gov/dengue/vaccine/hcp/index.html)
- Dengue vaccine should not be administered to children traveling to or visiting endemic dengue areas.

## Diphtheria, tetanus, and pertussis (DTaP) vaccination

(minimum age: 6 weeks [4 years for Kinrix® or Quadtracel®])

## Routine vaccination

- 5-dose series (3-dose primary series at age 2, 4, and 6 months, followed by a booster doses at ages 15–18 months and 4–6 years)

## Special situations

Persons who are moderately or severely immunocompromised\*\*

## Age 6 months–4 years

- Unvaccinated:**
  - 3-dose series of updated (2023–2024 Formula) Moderna at 0, 4, 8 weeks
  - 3-dose series of updated (2023–2024 Formula) Pfizer-BioNTech at 0, 3, 11 weeks.
- Previously vaccinated\* with 1 dose of any Moderna:** 2-dose series of updated (2023–2024 Formula) Moderna at 0, 4 weeks (minimum interval between previous Moderna and dose 1: 4 weeks).
- Previously vaccinated\* with 2 doses of any Moderna:** 1 dose of updated (2023–2024 Formula) Moderna at least 4 weeks after the most recent dose.
- Previously vaccinated\* with 3 or more doses of any Moderna:** 1 dose of updated (2023–2024 Formula) Moderna at least 8 weeks after the most recent dose.
- Previously vaccinated\* with 1 dose of any Pfizer-BioNTech:** 2-dose series of updated (2023–2024 Formula) Pfizer-BioNTech at 0, 8 weeks (minimum interval between previous Pfizer-BioNTech and dose 1: 3 weeks).
- Previously vaccinated\* with 2 or more doses of any Pfizer-BioNTech:** 1 dose of updated (2023–2024 Formula) Pfizer-BioNTech at least 8 weeks after the most recent dose.

## Age 5–11 years

- Unvaccinated:**
  - 3-dose series of updated (2023–2024 Formula) Moderna at 0, 4, 8 weeks
  - 3-dose series updated (2023–2024 Formula) Pfizer-BioNTech at 0, 3, 7 weeks.
- Previously vaccinated\* with 1 dose of any Moderna:** 2-dose series of updated (2023–2024 Formula) Moderna at 0, 4 weeks (minimum interval between previous Moderna and dose 1: 4 weeks).
- Previously vaccinated\* with 2 doses of any Moderna:** 1 dose of updated (2023–2024 Formula) Moderna at least 4 weeks after the most recent dose.
- Previously vaccinated\* with 1 dose of any Pfizer-BioNTech:** 2-dose series of updated (2023–2024 Formula) Pfizer-BioNTech at 0, 4 weeks (minimum interval between previous Pfizer-BioNTech and dose 1: 3 weeks)
- Previously vaccinated\* with 2 doses of any Pfizer-BioNTech:** 1 dose of 2023–2024 Pfizer-BioNTech at least 4 weeks after the most recent dose.

- Prospectively:** Dose 4 may be administered as early as age 12 months if at least 6 months have elapsed since dose 3.
- Retrospectively:** A 4<sup>th</sup> dose that was inadvertently administered as early as age 12 months may be counted if at least 4 months have elapsed since dose 3.

## Catch-up vaccination

- Dose 5 is not necessary if dose 4 was administered at age 4 years or older and at least 6 months after dose 3.
- For other catch-up guidance, see Table 2.

## Special situations

- Wound management** in children less than age 7 years with history of 3 or more doses of tetanus-toxoid-containing vaccine: For all wounds except clean and minor wounds, administer DTaP if more than 5 years since last dose of tetanus-toxoid-containing vaccine. For detailed information, see [www.cdc.gov/mmwr/volumes/67/rr/rr6702a1.htm](http://www.cdc.gov/mmwr/volumes/67/rr/rr6702a1.htm).

## Haemophilus influenzae type b vaccination

(minimum age: 6 weeks)

## Routine vaccination

- ActHIB®, Hiberix®, Pentacel®, or Vaxelis®:** 4-dose series (3-dose primary series at age 2, 4, and 6 months, followed by a booster dose\* at age 12–15 months)
  - \*Vaxelis® is not recommended for use as a booster dose. A different Hib-containing vaccine should be used for the booster dose.
- PedvaxHIB®:** 3-dose series (2-dose primary series at age 2 and 4 months, followed by a booster dose at age 12–15 months)

## Catch-up vaccination

- Dose 1 at age 7–11 months:** Administer dose 2 at least 4 weeks later and dose 3 (final dose) at age 12–15 months or 8 weeks after dose 2 (whichever is later).
- Dose 1 at age 12–14 months:** Administer dose 2 (final dose) at least 8 weeks after dose 1.
- Dose 1 before age 12 months and dose 2 before age 15 months:** Administer dose 3 (final dose) at least 8 weeks after dose 2.
- 2 doses of PedvaxHIB® before age 12 months:** Administer dose 3 (final dose) at age 12–59 months and at least 8 weeks after dose 2.
- 1 dose administered at age 15 months or older:** No further doses needed
- Unvaccinated at age 15–59 months:** Administer 1 dose.

Fig. 215.1, cont'd

- **Previously unvaccinated children age 60 months or older who are not considered high risk:** Do not require catch-up vaccination

For other catch-up guidance, see Table 2. Vaxelis® can be used for catch-up vaccination in children less than age 5 years. Follow the catch-up schedule even if Vaxelis® is used for one or more doses. For detailed information on use of Vaxelis® see [www.cdc.gov/mmwr/volumes/69/wr/mm6905a5.htm](http://www.cdc.gov/mmwr/volumes/69/wr/mm6905a5.htm).

#### Special situations

- **Chemotherapy or radiation treatment:**  
**Age 12–59 months**

- Unvaccinated or only 1 dose before age 12 months: 2 doses, 8 weeks apart
- 2 or more doses before age 12 months: 1 dose at least 8 weeks after previous dose

Doses administered within 14 days of starting therapy or during therapy should be repeated at least 3 months after therapy completion.

- **Hematopoietic stem cell transplant (HSCT):**  
- 3-dose series 4 weeks apart starting 6 to 12 months after successful transplant, regardless of Hib vaccination history

- **Anatomic or functional asplenia (including sickle cell disease):**  
**Age 12–59 months**

- Unvaccinated or only 1 dose before age 12 months: 2 doses, 8 weeks apart
- 2 or more doses before age 12 months: 1 dose at least 8 weeks after previous dose

**Unvaccinated\* persons age 5 years or older**  
- 1 dose

- **Elective splenectomy:**  
**Unvaccinated\* persons age 15 months or older**

- 1 dose (preferably at least 14 days before procedure)

- **HIV infection:**  
**Age 12–59 months**

- Unvaccinated or only 1 dose before age 12 months: 2 doses, 8 weeks apart
- 2 or more doses before age 12 months: 1 dose at least 8 weeks after previous dose

**Unvaccinated\* persons age 5–18 years**  
- 1 dose

- **Immunoglobulin deficiency, early component complement deficiency:**  
**Age 12–59 months**

- Unvaccinated or only 1 dose before age 12 months: 2 doses, 8 weeks apart

#### Special situations

- Revaccination is not generally recommended for persons with a normal immune status who were vaccinated as infants, children, adolescents, or adults.

- **Post-vaccination serology testing and revaccination** (if anti-HBs <10mIU/mL) is recommended for certain populations, including:

- Infants born to HBsAg-positive mothers
- Persons who are predialysis or on maintenance dialysis
- Other immunocompromised persons
- For detailed revaccination recommendations, see [www.cdc.gov/vaccines/hcp/acip-recs/vacc-specific/hepb.html](http://www.cdc.gov/vaccines/hcp/acip-recs/vacc-specific/hepb.html).

**Note:** HepB-B and PreHevBrio are not recommended in pregnancy due to lack of safety data in pregnant persons

**Human papillomavirus vaccination**  
(minimum age: 9 years)

#### Routine and catch-up vaccination

- HPV vaccination routinely recommended at **age 11–12 years (can start at age 9 years)** and catch-up HPV vaccination recommended for all persons through age 18 years if not adequately vaccinated

- 2- or 3-dose series depending on age at initial vaccination:
  - **Age 9–14 years at initial vaccination:** 2-dose series at 0, 6–12 months (minimum interval: 5 months; repeat dose if administered too soon)
  - **Age 15 years or older at initial vaccination:** 3-dose series at 0, 1–2 months, 6 months (minimum intervals: dose 1 to dose 2: 4 weeks / dose 2 to dose 3: 12 weeks / dose 1 to dose 3: 5 months; repeat dose if administered too soon)

- No additional dose recommended when any HPV vaccine series of any valency has been completed using recommended dosing intervals.

#### Special situations

- **Immunocompromising conditions, including HIV infection:** 3-dose series, even for those who initiate vaccination at age 9 through 14 years.

- **History of sexual abuse or assault:** Start at age 9 years

- **Pregnancy:** Pregnancy testing not needed before vaccination; HPV vaccination not recommended until after pregnancy; no intervention needed if vaccinated while pregnant

- 2 or more doses before age 12 months: 1 dose at least 8 weeks after previous dose

\***Unvaccinated** = Less than routine series (through age 14 months) **OR** no doses (age 15 months or older)

**Hepatitis A vaccination**  
(minimum age: 12 months for routine vaccination)

#### Routine vaccination

- 2-dose series (minimum interval: 6 months) at age 12–23 months

#### Catch-up vaccination

- Unvaccinated persons through age 18 years should complete a 2-dose series (minimum interval: 6 months).

- Persons who previously received 1 dose at age 12 months or older should receive dose 2 at least 6 months after dose 1.
- Adolescents age 18 years or older may receive the combined HepA and HepB vaccine, **Twinnix**®, as a 3-dose series (0, 1, and 6 months) or 4-dose series (3 doses at 0, 7, and 21–30 days, followed by a booster dose at 12 months).

#### International travel

- Persons traveling to or working in countries with high or intermediate endemic hepatitis A ([www.cdc.gov/travel/](http://www.cdc.gov/travel/)):

- **Infants age 6–11 months:** 1 dose before departure; revaccinate with 2 doses (separated by at least 6 months) between age 12–23 months.

- **Unvaccinated age 12 months or older:** Administer dose 1 as soon as travel is considered.

**Hepatitis B vaccination**  
(minimum age: birth)

#### Routine vaccination

- 3-dose series at age 0, 1–2, 6–18 months (use **monovalent HepB vaccine for doses administered before age 6 weeks**)

- Birth weight ≥2,000 grams: 1 dose within 24 hours of birth if medically stable

- Birth weight <2,000 grams: 1 dose at chronological age 1 month or hospital discharge (whichever is earlier and even if weight is still <2,000 grams).

- Infants who did not receive a birth dose should begin the series as soon as possible (see Table 2 for minimum intervals).

- Administration of 4 doses is permitted when a combination vaccine containing HepB is used after the birth dose.

- **Minimum intervals (see Table 2):** when 4 doses are administered, substitute “dose 4” for “dose 3” in these calculations

#### Influenza vaccination

(minimum age: 6 months [IIV], 2 years [LAIV4], 18 years [recombinant influenza vaccine, RIV4])

#### Routine vaccination

- Use any influenza vaccine appropriate for age and health status annually:

- **Age 6 months–8 years** who have received **fewer** than 2 influenza vaccine doses before July 1, 2023, or whose influenza vaccination history is unknown: 2 doses, separated by at least 4 weeks. Administer dose 2 even if the child turns 9 years between receipt of dose 1 and dose 2.

- **Age 6 months–8 years** who have received at least 2 influenza vaccine doses before July 1, 2023: 1 dose

- **Age 9 years or older:** 1 dose

- For the 2023–2024 season, see [www.cdc.gov/mmwr/volumes/72/tr/rr7202a1.htm](http://www.cdc.gov/mmwr/volumes/72/tr/rr7202a1.htm).

- For the 2024–25 season, see the 2024–25 ACIP influenza vaccine recommendations.

#### Special situations

- **Close contacts (e.g., household contacts) of severely immunosuppressed persons who require a protected environment:** should not receive LAIV4. If LAIV4 is given, they should avoid contact with for such immunosuppressed persons for 7 days after vaccination.

- Note:** Persons with an egg allergy can receive any influenza vaccine (egg-based and non-egg-based) appropriate for age and health status.

**Measles, mumps, and rubella vaccination**  
(minimum age: 12 months for routine vaccination)

#### Routine vaccination

- 2-dose series at age 12–15 months, age 4–6 years

- MMR or MMRV\* may be administered

- Note:** For dose 1 in children age 12–47 months, it is recommended to administer MMR and varicella vaccines separately. MMRV\* may be used if parents or caregivers express a preference.

#### Catch-up vaccination

- Unvaccinated children and adolescents: 2-dose series at least 4 weeks apart\*

- The maximum age for use of MMRV\* is 12 years.

- **Final (3rd or 4th) dose:** age 6–18 months (minimum age 24 weeks)

- **Mother is HBsAg-positive**

- **Birth dose (monovalent HepB vaccine only):** administer **HepB vaccine** and **hepatitis B immune globulin (HBIG)** (in separate limbs) within 12 hours of birth, regardless of birth weight.

- **Birth weight <2000 grams:** administer 3 additional doses of HepB vaccine beginning at age 1 month (total of 4 doses)

- **Final (3rd or 4th) dose:** administer at age 6 months (minimum age 24 weeks)

- Test for HBsAg and anti-HBs at age 9–12 months. If HepB series is delayed, test 1–2 months after final dose. Do not test before age 9 months.

- **Mother is HBsAg-unknown**

If other evidence suggestive of maternal hepatitis B infection exists (e.g., presence of HBV DNA, HBsAg-positive, or mother known to have chronic hepatitis B infection), manage infant as if mother is HBsAg-positive

- **Birth dose (monovalent HepB vaccine only):**

- Birth weight ≥2,000 grams: administer **HepB vaccine** within 12 hours of birth. Determine mother’s HBsAg status as soon as possible. If mother is determined to be HBsAg-positive, administer **HBIG** as soon as possible (in separate limb), but no later than 7 days of age.

- Birth weight <2,000 grams: administer **HepB vaccine** and **HBIG** (in separate limbs) within 12 hours of birth.

- Administer 3 additional doses of **HepB vaccine** beginning at age 1 month (total of 4 doses)

- **Final (3rd or 4th) dose:** administer at age 6 months (minimum age 24 weeks)

- If mother is determined to be HBsAg-positive or if status remains unknown, test for HBsAg and anti-HBs at age 9–12 months. If HepB series is delayed, test 1–2 months after final dose. Do not test before age 9 months.

#### Catch-up vaccination

- Unvaccinated persons should complete a 3-dose series at 0, 1–2, 6 months. See Table 2 for minimum intervals

- Adolescents age 11–15 years may use an alternative 2-dose schedule with at least 4 months between doses (adult formulation **Recombivax HB**® only).

- Adolescents age 18 years may receive:

- **HepB-B**®: 2-dose series at least 4 weeks apart

- **PreHevBrio**®: 3-dose series at 0, 1, and 6 months

- Combined HepA and HepB vaccine, **Twinnix**®: 3-dose series (0, 1, and 6 months) or 4-dose series (3 doses at 0, 7, and 21–30 days, followed by a booster dose at 12 months).

#### Special situations

- **International travel**

- **Infants age 6–11 months:** 1 dose before departure; revaccinate with 2-dose series at age 12–15 months (12 months for children in high-risk areas) and dose 2 as early as 4 weeks later.\*

- **Unvaccinated children age 12 months or older:** 2-dose series at least 4 weeks apart before departure\*

- In mumps outbreak settings, for information about additional doses of MMR (including 3rd dose of MMR), see [www.cdc.gov/mmwr/volumes/67/wr/mm6701a7.htm](http://www.cdc.gov/mmwr/volumes/67/wr/mm6701a7.htm)

\***Note:** If MMRV is used, the minimum interval between MMRV doses is 3 months

**Meningococcal serogroup A, C, W, Y vaccination**  
(minimum age: 2 months [MenACWY-CRM, Menveo], 2 years [MenACWY-TT, MenQuadfi]), 10 years [MenACWY-TT/MenB-FHb, Penbraya])

#### Routine vaccination

- 2-dose series at age 11–12 years; 16 years

#### Catch-up vaccination

- Age 13–15 years: 1 dose now and booster at age 16–18 years (minimum interval: 8 weeks)

- Age 16–18 years: 1 dose

#### Special situations

**Anatomic or functional asplenia (including sickle cell disease), HIV infection, persistent complement component deficiency, complement inhibitor (e.g., eculizumab, ravulizumab) use:**

- **Menveo**®\*

- Dose 1 at age 2 months: 4-dose series (additional 3 doses at age 4, 6, and 12 months)

- Dose 1 at age 3–6 months: 3- or 4-dose series (dose 2 [and dose 3 if applicable] at least 8 weeks after previous dose until a dose is received at age 7 months or older, followed by an additional dose at least 12 weeks later and after age 12 months)

- Dose 1 at age 7–23 months: 2-dose series (dose 2 at least 12 weeks after dose 1 and after age 12 months)

- Dose 1 at age 24 months or older: 2-dose series at least 8 weeks apart

- **MenQuadfi**®

- Dose 1 at age 24 months or older: 2-dose series at least 8 weeks apart

Fig. 215.1, cont'd

**Travel to countries with hyperendemic or epidemic meningococcal disease, including countries in the African meningitis belt or during the Hajj** ([www.cdc.gov/travel/](http://www.cdc.gov/travel/)):

- Children less than age 24 months:
  - **Menveo\*\* (age 2–23 months)**
  - Dose 1 at age 2 months; 4-dose series (additional 3 doses at age 4, 6, and 12 months)
  - Dose 1 at age 3–6 months; 3- or 4-dose series (dose 2 [and dose 3 if applicable] at least 8 weeks after previous dose until a dose is received at age 7 months or older, followed by an additional dose at least 12 weeks later and after age 12 months)
  - Dose 1 at age 7–23 months; 2-dose series (dose 2 at least 12 weeks after dose 1 and after age 12 months)
- Children age 2 years or older: 1 dose Menveo\*\* or MenQuadfi\*

**First-year college students who live in residential housing (if not previously vaccinated at age 16 years or older) or military recruits:**

- 1 dose **Menveo\*\*** or **MenQuadfi\***

**Adolescent vaccination of children who received MenACWY prior to age 10 years:**

- **Children for whom boosters are recommended** because of an ongoing increased risk of meningococcal disease (e.g., those with complement component deficiency, HIV, or asplenia): Follow the booster schedule for persons at increased risk.

- **Children for whom boosters are not recommended** (e.g., a healthy child who received a single dose for travel to a country where meningococcal disease is endemic): Administer MenACWY according to the recommended adolescent schedule with dose 1 at age 11–12 years and dose 2 at age 16 years.

\*Menveo has two formulations: lyophilized and liquid. The liquid formulation should not be used before age 10 years. See [www.cdc.gov/vaccines/vpd/mening/downloads/menveo-single-vial-presentation.pdf](http://www.cdc.gov/vaccines/vpd/mening/downloads/menveo-single-vial-presentation.pdf).

**Note:** For MenACWY **booster dose recommendations** for groups listed under “Special situations” and in an outbreak setting and additional meningococcal vaccination information, see [www.cdc.gov/mmwr/volumes/69/rr/r6909a1.htm](http://www.cdc.gov/mmwr/volumes/69/rr/r6909a1.htm).

Children age 10 years or older may receive a single dose of Penbraya™ as an alternative to separate administration of MenACWY and MenB when both vaccines would be given on the same clinic day (see “Meningococcal serogroup B vaccination” section below for more information).

### Special situations

**Children and adolescents with cerebrospinal fluid leak; chronic heart disease; chronic kidney disease (excluding maintenance dialysis and nephrotic syndrome); chronic liver disease; chronic lung disease (including moderate persistent or severe persistent asthma); cochlear implants; or diabetes mellitus:**

#### Age 2–5 years

- Any incomplete\* PCV series with:
  - 3 PCV doses: 1 dose PCV (at least 8 weeks after the most recent PCV dose)
  - Less than 3 PCV doses: 2 doses PCV (at least 8 weeks after the most recent dose and administered at least 8 weeks apart)
- Completed recommended PCV series but have not received PPSV23
  - Previously received at least 1 dose of PCV20: no further PCV or PPSV23 doses needed
  - Not previously received PCV20: administer 1 dose PCV20 OR 1 dose PPSV23 administer at least 8 weeks after the most recent PCV dose.

#### Age 6–18 years

- Not previously received any dose of PCV13, PCV15, or PCV20: administer 1 dose of PCV15 or PCV20. If PCV15 is used and no previous receipt of PPSV23, administer 1 dose of PPSV23 at least 8 weeks after the PCV15 dose.\*\*
- Received PCV before age 6 years but have not received PPSV23
  - Previously received at least 1 dose of PCV20: no further PCV or PPSV23 doses needed
  - Not previously received PCV20: 1 dose PCV20 OR 1 dose PPSV23 administer at least 8 weeks after the most recent PCV dose.
- Received PCV13 only at or after age 6 years: administer 1 dose PCV20 OR 1 dose PPSV23 at least 8 weeks after the most recent PCV13 dose.
- Received 1 dose PCV13 and 1 dose PPSV23 at or after age 6 years: no further doses of any PCV or PPSV23 indicated.

**Children and adolescents on maintenance dialysis, or with immunocompromising conditions such as nephrotic syndrome; congenital or acquired asplenia or splenic dysfunction; congenital or acquired immunodeficiencies; diseases and conditions treated with immunosuppressive drugs or radiation therapy, including malignant neoplasms, leukemias, lymphomas, Hodgkin disease, and solid organ transplant; HIV infection; or sickle cell disease or other hemoglobinopathies:**

### Meningococcal serogroup B vaccination

(minimum age: 10 years [MenB-4C, Bexsero®; MenB-FHbp, Trumenba®; MenACWY-TT/MenB-FHbp, Penbraya™])

### Shared clinical decision-making

- **Adolescents not at increased risk** age 16–23 years (preferred age 16–18 years) based on shared clinical decision-making:
  - **Bexsero®:** 2-dose series at least 1 month apart
  - **Trumenba®:** 2-dose series at least 6 months apart (if dose 2 is administered earlier than 6 months, administer a 3<sup>rd</sup> dose at least 4 months after dose 2)

For additional information on shared clinical decision-making for MenB, see [www.cdc.gov/vaccines/hcp/admin/downloads/isd-job-aid-scdm-mening-b-shared-clinical-decision-making.pdf](http://www.cdc.gov/vaccines/hcp/admin/downloads/isd-job-aid-scdm-mening-b-shared-clinical-decision-making.pdf)

### Special situations

**Anatomic or functional asplenia (including sickle cell disease), persistent complement component deficiency, complement inhibitor (e.g., eculizumab, ravulizumab) use:**

- **Bexsero®:** 2-dose series at least 1 month apart
- **Trumenba®:** 3-dose series at 0, 1–2, 6 months (if dose 2 was administered at least 6 months after dose 1, dose 3 not needed; if dose 3 is administered earlier than 4 months after dose 2, a 4<sup>th</sup> dose should be administered at least 4 months after dose 3)

**Note:** Bexsero® and Trumenba® are not interchangeable; the same product should be used for all doses in a series.

For MenB **booster dose recommendations** for groups listed under “Special situations” and in an outbreak setting and additional meningococcal vaccination information, see [www.cdc.gov/mmwr/volumes/69/rr/r6909a1.htm](http://www.cdc.gov/mmwr/volumes/69/rr/r6909a1.htm).

Children age 10 years or older may receive a dose of Penbraya™ as an alternative to separate administration of MenACWY and MenB when both vaccines would be given on the same clinic day. For age-eligible children not at increased risk, if Penbraya™ is used for dose 1 MenB, MenB-FHbp (Trumenba) should be administered for dose 2 MenB. For age-eligible children at increased risk of meningococcal disease, Penbraya™ may be used for additional MenACWY and MenB doses (including booster doses) if both would be given on the same clinic day and at least 6 months have elapsed since most recent Penbraya™ dose.

### Age 2–5 years

- Any incomplete\* PCV series:
  - 3 PCV doses: 1 dose PCV (at least 8 weeks after the most recent PCV dose)
  - Less than 3 PCV doses: 2 doses PCV (at least 8 weeks after the most recent dose and administered at least 8 weeks apart)
- Completed recommended PCV series but have not received PPSV23
  - Previously received at least 1 dose of PCV20: no further PCV or PPSV23 doses needed
  - Not previously received PCV20: administer 1 dose PCV20 OR 1 dose PPSV23 at least 8 weeks after the most recent PCV dose. If PPSV23 is used, administer 1 dose of PCV20 or dose 2 PPSV23 at least 5 years after dose 1 PPSV23.

### Age 6–18 years

- Not previously received any dose of PCV13, PCV15, or PCV20: administer 1 dose of PCV15 or 1 dose of PCV20. If PCV15 is used and no previous receipt of PPSV23, administer 1 dose of PPSV23 at least 8 weeks after the PCV15 dose.\*\*
- Received PCV before age 6 years but have not received PPSV23
  - Previously received at least 1 dose of PCV20: no additional dose of PCV or PPSV23
  - Not previously received PCV20: administer 1 dose PCV20 OR 1 dose PPSV23 at least 8 weeks after the most recent PCV dose. If PPSV23 is used, administer either PCV20 or dose 2 PPSV23 at least 5 years after dose 1 PPSV23.
- Received PCV13 only at or after age 6 years: administer 1 dose PCV20 OR 1 dose PPSV23 at least 8 weeks after the most recent PCV13 dose. If PPSV23 is used, administer 1 dose of PCV20 or dose 2 PPSV23 at least 5 years after dose 1 PPSV23.
- Received 1 dose PCV13 and 1 dose PPSV23 at or after age 6 years: administer 1 dose PCV20 OR 1 dose PPSV23 at least 8 weeks after the most recent PCV13 dose and at least 5 years after dose 1 PPSV23.

\*Incomplete series = Not having received all doses in either the recommended series or an age-appropriate catch-up series. See Table 2 in ACIP pneumococcal recommendations at [stacks.cdc.gov/view/cdc/133252](http://stacks.cdc.gov/view/cdc/133252)

\*\*When both PCV15 and PPSV23 are indicated, administer all doses of PCV15 first. PCV15 and PPSV23 should not be administered during the same visit.

For guidance on determining which pneumococcal vaccines a patient needs and when, please refer to the mobile app, which can be downloaded here: [www.cdc.gov/vaccines/vpd/pneumo/hcp/pneumoapp.html](http://www.cdc.gov/vaccines/vpd/pneumo/hcp/pneumoapp.html)

### Mpox vaccination

(minimum age: 18 years [Jynneos®])

### Special situations

- **Age 18 years and at risk for Mpox infection:** 2-dose series, 28 days apart.

**Risk factors for Mpox infection include:**

- Persons who are gay, bisexual, and other MSM, transgender or nonbinary people who in the past 6 months have had:
  - A new diagnosis of at least 1 sexually transmitted disease
  - More than 1 sex partner
  - Sex at a commercial sex venue
  - Sex in association with a large public event in a geographic area where Mpox transmission is occurring
- Persons who are sexual partners of the persons described above
- Persons who anticipate experiencing any of the situations described above

- **Pregnancy:** There is currently no ACIP recommendation for Jynneos use in pregnancy due to lack of safety data in pregnant persons. Pregnant persons with any risk factor described above may receive Jynneos.

For detailed information, see: [www.cdc.gov/vaccines/acip/meetings/downloads/slides-2023-10-25-26/04-MPOX-Rao-508.pdf](http://www.cdc.gov/vaccines/acip/meetings/downloads/slides-2023-10-25-26/04-MPOX-Rao-508.pdf)

### Pneumococcal vaccination

(minimum age: 6 weeks [PCV15], [PCV20]; 2 years [PPSV23])

### Routine vaccination with PCV

- 4-dose series at 2, 4, 6, 12–15 months

### Catch-up vaccination with PCV

- Healthy children ages 2–4 years with any incomplete\* PCV series: 1 dose PCV
- For other catch-up guidance, see Table 2.

**Note:** For children without risk conditions, PCV20 is not indicated if they have received 4 doses of PCV13 or PCV15 or another age appropriate complete PCV series.

### Poliovirus vaccination

(minimum age: 6 weeks)

### Routine vaccination

- 4-dose series at ages 2, 4, 6–18 months, 4–6 years; administer the final dose on or after age 4 years and at least 6 months after the previous dose.
- 4 or more doses of IPV can be administered before age 4 years when a combination vaccine containing IPV is used. However, a dose is still recommended on or after age 4 years and at least 6 months after the previous dose.

### Catch-up vaccination

- In the first 6 months of life, use minimum ages and intervals only for travel to a polio-endemic region or during an outbreak.
- **Adolescents age 18 years known or suspected to be unvaccinated or incompletely vaccinated:** administer remaining doses (1, 2, or 3 IPV doses) to complete a 3-dose primary series.\* Unless there are specific reasons to believe they were not vaccinated, most persons aged 18 years or older born and raised in the United States can assume they were vaccinated against polio as children.

**Series containing oral poliovirus vaccine (OPV),** either mixed OPV-IPV or OPV-only series:

- Total number of doses needed to complete the series is the same as that recommended for the U.S. IPV schedule. See [www.cdc.gov/mmwr/volumes/66/wr/mm6601a6.htm?\\_id=mm6601a6\\_w](http://www.cdc.gov/mmwr/volumes/66/wr/mm6601a6.htm?_id=mm6601a6_w).
- Only trivalent OPV (tOPV) counts toward the U.S. vaccination requirements.
  - Doses of OPV administered before April 1, 2016, should be counted (unless specifically noted as administered during a campaign).
  - Doses of OPV administered on or after April 1, 2016, should not be counted.
  - For guidance to assess doses documented as “OPV,” see [www.cdc.gov/mmwr/volumes/66/wr/mm6606a7.htm?\\_id=mm6606a7\\_w](http://www.cdc.gov/mmwr/volumes/66/wr/mm6606a7.htm?_id=mm6606a7_w).
- For other catch-up guidance, see Table 2.

Fig. 215.1, cont’d



**Special situations**

- **Adolescents aged 18 years at increased risk of exposure to poliovirus and completed primary series\***: may administer one lifetime IPV booster

\***Note**: Complete primary series consist of at least 3 doses of IPV or trivalent oral poliovirus vaccine (tOPV) in any combination.

For detailed information, see: [www.cdc.gov/vaccines/vpd/polio/hcp/recommendations.html](http://www.cdc.gov/vaccines/vpd/polio/hcp/recommendations.html)

**Respiratory syncytial virus immunization**  
 (minimum age: birth [Nirsevimab, RSV-mAb (Beyfortus<sup>™</sup>)])
**Routine immunization**

- **Infants born October – March in most of the continental United States\***

- Mother did not receive RSV vaccine OR mother's RSV vaccination status is unknown: administer 1 dose nirsevimab within 1 week of birth in hospital or outpatient setting

- Mother received RSV vaccine **less than 14 days** prior to delivery: administer 1 dose nirsevimab within 1 week of birth in hospital or outpatient setting

- Mother received RSV vaccine **at least 14 days** prior to delivery: nirsevimab not needed but can be considered in rare circumstances at the discretion of healthcare providers (see special populations and situations at [www.cdc.gov/vaccines/vpd/rsv/hcp/child-faqs.html](http://www.cdc.gov/vaccines/vpd/rsv/hcp/child-faqs.html))

- **Infants born April–September in most of the continental United States\***

- Mother did not receive RSV vaccine OR mother's RSV vaccination status is unknown: administer 1 dose nirsevimab shortly before start of RSV season\*

- Mother received RSV vaccine **less than 14 days** prior to delivery: administer 1 dose nirsevimab shortly before start of RSV season\*

- Mother received RSV vaccine **at least 14 days** prior to delivery: nirsevimab not needed but can be considered in rare circumstances at the discretion of healthcare providers (see special populations and situations at [www.cdc.gov/vaccines/vpd/rsv/hcp/child-faqs.html](http://www.cdc.gov/vaccines/vpd/rsv/hcp/child-faqs.html))

Infants with prolonged birth hospitalization\*\* (e.g., for prematurity) discharged October through March should be immunized shortly before or promptly after discharge.

**Tetanus, diphtheria, and pertussis (Tdap) vaccination**  
 (minimum age: 11 years for routine vaccination, 7 years for catch-up vaccination)
**Routine vaccination**

- **Age 11–12 years**: 1 dose Tdap (adolescent booster)
- **Pregnancy**: 1 dose Tdap during each pregnancy, preferably in early part of gestational weeks 27–36.

**Note**: Tdap may be administered regardless of the interval since the last tetanus- and diphtheria-toxoid-containing vaccine.

**Catch-up vaccination**

- **Age 13–18 years who have not received Tdap**: 1 dose Tdap (adolescent booster)
  - **Age 7–18 years not fully vaccinated\* with DTaP**: 1 dose Tdap as part of the catch-up series (preferably the first dose); if additional doses are needed, use Td or Tdap.
  - **Tdap administered at age 7–10 years**:
    - **Age 7–9 years** who receive Tdap should receive the adolescent Tdap booster dose at age 11–12 years.
    - **Age 10 years** who receive Tdap do not need the adolescent Tdap booster dose at age 11–12 years.
  - **DTaP inadvertently administered on or after age 7 years**:
    - **Age 7–9 years**: DTaP may count as part of catch-up series. Administer adolescent Tdap booster dose at age 11–12 years.
    - **Age 10–18 years**: Count dose of DTaP as the adolescent Tdap booster dose.
- For other catch-up guidance, see Table 2.

**Special situations**

- **Wound management** in persons age 7 years or older with history of 3 or more doses of tetanus-toxoid-containing vaccine: For clean and minor wounds, administer Tdap or Td if more than 10 years since last dose of tetanus-toxoid-containing vaccine; for all other wounds, administer Tdap or Td if more than 5 years since last dose of tetanus-toxoid-containing vaccine. Tdap is preferred for persons age 11 years or older who have not previously received Tdap or whose Tdap history is unknown. If a tetanus-toxoid-containing vaccine is indicated for a pregnant adolescent, use Tdap.

For detailed information, see [www.cdc.gov/mmwr/volumes/69/wr/mm6903a5.htm](http://www.cdc.gov/mmwr/volumes/69/wr/mm6903a5.htm).

\*Fully vaccinated = 5 valid doses of DTaP OR 4 valid doses of DTaP if dose 4 was administered at age 4 years or older

**Special situations**

- **Ages 8–19 months with chronic lung disease of prematurity requiring medical support (e.g., chronic corticosteroid therapy, diuretic therapy, or supplemental oxygen) any time during the 6-month period before the start of the second RSV season; severe immunocompromise; cystic fibrosis with either weight for length <10th percentile or manifestation of severe lung disease (e.g., previous hospitalization for pulmonary exacerbation in the first year of life or abnormalities on chest imaging that persist when stable)\*\***:
  - 1 dose nirsevimab shortly before start of second RSV season\*

- **Ages 8–19 months who are American Indian or Alaska Native**:
  - 1 dose nirsevimab shortly before start of second RSV season\*

- **Age-eligible and undergoing cardiac surgery with cardiopulmonary bypass\*\***: 1 additional dose of nirsevimab after surgery. For additional details see special populations and situations at [www.cdc.gov/vaccines/vpd/rsv/hcp/child-faqs.html](http://www.cdc.gov/vaccines/vpd/rsv/hcp/child-faqs.html)

\***Note**: While the timing of the onset and duration of RSV season may vary, nirsevimab may be administered October through March in most of the continental United States. Providers in jurisdictions with RSV seasonality that differs from most of the continental United States (e.g., Alaska, jurisdiction with tropical climate) should follow guidance from public health authorities (e.g., CDC, health departments) or regional medical centers on timing of administration based on local RSV seasonality. Although optimal timing of administration is just before the start of the RSV season, nirsevimab may also be administered during the RSV season to infants and children who are age-eligible.

\*\***Note**: Nirsevimab can be administered to children who are eligible to receive palivizumab. Children who have received nirsevimab should not receive palivizumab for the same RSV season.

For further guidance, see [www.cdc.gov/mmwr/volumes/72/wr/mm7234a4.htm](http://www.cdc.gov/mmwr/volumes/72/wr/mm7234a4.htm) and [www.cdc.gov/vaccines/vpd/rsv/hcp/child-faqs.html](http://www.cdc.gov/vaccines/vpd/rsv/hcp/child-faqs.html)

**Varicella vaccination**

(minimum age: 12 months)

**Routine vaccination**

- 2-dose series at age 12–15 months, 4–6 years
  - VAR or MMRV may be administered\*
  - Dose 2 may be administered as early as 3 months after dose 1 (a dose inadvertently administered after at least 4 weeks may be counted as valid)
- \***Note**: For dose 1 in children age 12–47 months, it is recommended to administer MMR and varicella vaccines separately. MMRV may be used if parents or caregivers express a preference.

**Catch-up vaccination**

- Ensure persons age 7–18 years without evidence of immunity (see *MMWR* at [www.cdc.gov/mmwr/pdf/rr/rr5604.pdf](http://www.cdc.gov/mmwr/pdf/rr/rr5604.pdf)) have a 2-dose series:
  - **Age 7–12 years**: Routine interval: 3 months (a dose inadvertently administered after at least 4 weeks may be counted as valid)
  - **Age 13 years and older**: Routine interval: 4–8 weeks (minimum interval: 4 weeks)
- The maximum age for use of *MMRV* is 12 years.

**Respiratory syncytial virus vaccination**  
 (RSV [Abrysvo<sup>™</sup>])
**Routine vaccination**

- **Pregnant at 32 weeks 0 days through 36 weeks and 6 days gestation from September through January in most of the continental United States\***: 1 dose RSV vaccine (Abrysvo<sup>™</sup>). Administer RSV vaccine regardless of previous RSV infection.
  - Either maternal RSV vaccination or infant immunization with nirsevimab (RSV monoclonal antibody) is recommended to prevent respiratory syncytial virus lower respiratory tract infection in infants.

- **All other pregnant persons**: RSV vaccine not recommended.

There is currently no ACIP recommendation for RSV vaccination in subsequent pregnancies. No data are available to inform whether additional doses are needed in later pregnancies.

\***Note**: Providers in jurisdictions with RSV seasonality that differs from most of the continental United States (e.g., Alaska, jurisdiction with tropical climate) should follow guidance from public health authorities (e.g., CDC, health departments) or regional medical centers on timing of administration based on local RSV seasonality.

**Rotavirus vaccination**  
 (minimum age: 6 weeks)
**Routine vaccination**

- **Rotarix<sup>™</sup>**: 2-dose series at age 2 and 4 months
- **RotaTeq<sup>™</sup>**: 3-dose series at age 2, 4, and 6 months
- If any dose in the series is either **RotaTeq<sup>™</sup>** or unknown, default to 3-dose series.

**Catch-up vaccination**

- Do not start the series on or after age 15 weeks, 0 days.
- The maximum age for the final dose is 8 months, 0 days.
- For other catch-up guidance, see Table 2.



## Appendix

## Recommended Child and Adolescent Immunization Schedule for Ages 18 Years or Younger, United States, 2024

## Guide to Contraindications and Precautions to Commonly Used Vaccines

Vaccines and other Immunizing Agents	Contraindicated or Not Recommended <sup>1</sup>	Precautions <sup>2</sup>
COVID-19 mRNA vaccines [Pfizer-BioNTech, Moderna]	<ul style="list-style-type: none"> <li>Severe allergic reaction (e.g., anaphylaxis) after a previous dose or to a component of an mRNA COVID-19 vaccine<sup>4</sup></li> </ul>	<ul style="list-style-type: none"> <li>Diagnosed non-severe allergy (e.g., urticaria beyond the injection site) to a component of an mRNA COVID-19 vaccine<sup>4</sup>; or non-severe, immediate (onset less than 4 hours) allergic reaction after administration of a previous dose of an mRNA COVID-19 vaccine</li> <li>Myocarditis or pericarditis within 3 weeks after a dose of any COVID-19 vaccine</li> <li>Multisystem inflammatory syndrome in children (MIS-C) or multisystem inflammatory syndrome in adults (MIS-A)</li> <li>Moderate or severe acute illness, with or without fever</li> </ul>
COVID-19 protein subunit vaccine [Novavax]	<ul style="list-style-type: none"> <li>Severe allergic reaction (e.g., anaphylaxis) after a previous dose or to a component of a Novavax COVID-19 vaccine<sup>4</sup></li> </ul>	<ul style="list-style-type: none"> <li>Diagnosed non-severe allergy (e.g., urticaria beyond the injection site) to a component of Novavax COVID-19 vaccine<sup>4</sup>; or non-severe, immediate (onset less than 4 hours) allergic reaction after administration of a previous dose of a Novavax COVID-19 vaccine</li> <li>Myocarditis or pericarditis within 3 weeks after a dose of any COVID-19 vaccine</li> <li>Multisystem inflammatory syndrome in children (MIS-C) or multisystem inflammatory syndrome in adults (MIS-A)</li> <li>Moderate or severe acute illness, with or without fever</li> </ul>
Influenza, egg-based, inactivated injectable (IIV4)	<ul style="list-style-type: none"> <li>Severe allergic reaction (e.g., anaphylaxis) after previous dose of any influenza vaccine (i.e., any egg-based IIV, cclIV, RIV, or LAIV of any valency)</li> <li>Severe allergic reaction (e.g., anaphylaxis) to any vaccine component<sup>3</sup> (excluding egg)</li> </ul>	<ul style="list-style-type: none"> <li>Guillain-Barré syndrome (GBS) within 6 weeks after a previous dose of any type of influenza vaccine</li> <li>Moderate or severe acute illness with or without fever</li> </ul>
Influenza, cell culture-based inactivated injectable (ccIV4) [Flucelvax Quadrivalent]	<ul style="list-style-type: none"> <li>Severe allergic reaction (e.g., anaphylaxis) to any ccIV of any valency, or to any component<sup>3</sup> of ccIV4</li> </ul>	<ul style="list-style-type: none"> <li>Guillain-Barré syndrome (GBS) within 6 weeks after a previous dose of any type of influenza vaccine</li> <li>Persons with a history of severe allergic reaction (e.g., anaphylaxis) after a previous dose of any egg-based IIV, RIV, or LAIV of any valency. If using ccIV4, administer in medical setting under supervision of health care provider who can recognize and manage severe allergic reactions. May consult an allergist.</li> <li>Moderate or severe acute illness with or without fever</li> </ul>
Influenza, recombinant injectable (RIV4) [Flublok Quadrivalent]	<ul style="list-style-type: none"> <li>Severe allergic reaction (e.g., anaphylaxis) to any RIV of any valency, or to any component<sup>3</sup> of RIV4</li> </ul>	<ul style="list-style-type: none"> <li>Guillain-Barré syndrome (GBS) within 6 weeks after a previous dose of any type of influenza vaccine</li> <li>Persons with a history of severe allergic reaction (e.g., anaphylaxis) after a previous dose of any egg-based IIV, ccIV, or LAIV of any valency. If using RIV4, administer in medical setting under supervision of health care provider who can recognize and manage severe allergic reactions. May consult an allergist.</li> <li>Moderate or severe acute illness with or without fever</li> </ul>
Influenza, live attenuated (LAIV4) [Flumist Quadrivalent]	<ul style="list-style-type: none"> <li>Severe allergic reaction (e.g., anaphylaxis) after previous dose of any influenza vaccine (i.e., any egg-based IIV, ccIV, RIV, or LAIV of any valency)</li> <li>Severe allergic reaction (e.g., anaphylaxis) to any vaccine component<sup>3</sup> (excluding egg)</li> <li>Children age 2–4 years with a history of asthma or wheezing</li> <li>Anatomic or functional asplenia</li> <li>Immunocompromised due to any cause including, but not limited to, medications and HIV infection</li> <li>Close contacts or caregivers of severely immunosuppressed persons who require a protected environment</li> <li>Pregnancy</li> <li>Cochlear implant</li> <li>Active communication between the cerebrospinal fluid (CSF) and the oropharynx, nasopharynx, nose, ear or any other cranial CSF leak</li> <li>Children and adolescents receiving aspirin or salicylate-containing medications</li> <li>Received influenza antiviral medications oseltamivir or zanamivir within the previous 48 hours, peramivir within the previous 5 days, or baloxavir within the previous 17 days</li> </ul>	<ul style="list-style-type: none"> <li>Guillain-Barré syndrome (GBS) within 6 weeks after a previous dose of any type of influenza vaccine</li> <li>Asthma in persons age 5 years old or older</li> <li>Persons with underlying medical conditions other than those listed under contraindications that might predispose to complications after wild-type influenza virus infection, e.g., chronic pulmonary, cardiovascular (except isolated hypertension), renal, hepatic, neurologic, hematologic, or metabolic disorders (including diabetes mellitus)</li> <li>Moderate or severe acute illness with or without fever</li> </ul>

- When a contraindication is present, a vaccine should **NOT** be administered. Kroger A, Bahta L, Hunter P. *ACIP General Best Practice Guidelines for Immunization*.
- When a precaution is present, vaccination should generally be deferred but might be indicated if the benefit of protection from the vaccine outweighs the risk for an adverse reaction. Kroger A, Bahta L, Hunter P. *ACIP General Best Practice Guidelines for Immunization*.
- Vaccination providers should check FDA-approved prescribing information for the most complete and updated information, including contraindications, warnings, and precautions. See [Package inserts for U.S.-licensed vaccines](#).
- See [package inserts](#) and [FDA EUA fact sheets](#) for a full list of vaccine ingredients. mRNA COVID-19 vaccines contain polyethylene glycol (PEG).

Fig. 215.1, cont'd

Vaccines and other Immunizing Agents	Contraindicated or Not Recommended <sup>1</sup>	Precautions <sup>2</sup>
Dengue (DEN4CYD)	<ul style="list-style-type: none"> <li>Severe allergic reaction (e.g., anaphylaxis) after a previous dose or to a vaccine component<sup>3</sup></li> <li>Severe immunodeficiency (e.g., hematologic and solid tumors, receipt of chemotherapy, congenital immunodeficiency, long-term immunosuppressive therapy or patients with HIV infection who are severely immunocompromised)</li> <li>Lack of laboratory confirmation of a previous Dengue infection</li> </ul>	<ul style="list-style-type: none"> <li>Pregnancy</li> <li>HIV infection without evidence of severe immunosuppression</li> <li>Moderate or severe acute illness with or without fever</li> </ul>
Diphtheria, tetanus, pertussis (DTaP)	<ul style="list-style-type: none"> <li>Severe allergic reaction (e.g., anaphylaxis) after a previous dose or to a vaccine component<sup>3</sup></li> <li>For DTaP only: Encephalopathy (e.g., coma, decreased level of consciousness, prolonged seizures) not attributable to another identifiable cause within 7 days of administration of previous dose of DTP or DTaP</li> </ul>	<ul style="list-style-type: none"> <li>Guillain-Barré syndrome (GBS) within 6 weeks after previous dose of tetanus-toxoid-containing vaccine</li> <li>History of Arthus-type hypersensitivity reactions after a previous dose of diphtheria-toxoid-containing or tetanus-toxoid-containing vaccine; defer vaccination until at least 10 years have elapsed since the last tetanus-toxoid-containing vaccine</li> <li>For DTaP only: Progressive neurologic disorder, including infantile spasms, uncontrolled epilepsy, progressive encephalopathy; defer DTaP until neurologic status clarified and stabilized</li> <li>Moderate or severe acute illness with or without fever</li> </ul>
<i>Haemophilus influenzae</i> type b (Hib)	<ul style="list-style-type: none"> <li>Severe allergic reaction (e.g., anaphylaxis) after a previous dose or to a vaccine component<sup>3</sup></li> <li>Less than age 6 weeks</li> </ul>	<ul style="list-style-type: none"> <li>Moderate or severe acute illness with or without fever</li> </ul>
Hepatitis A (HepA)	<ul style="list-style-type: none"> <li>Severe allergic reaction (e.g., anaphylaxis) after a previous dose or to a vaccine component<sup>3</sup> including neomycin</li> </ul>	<ul style="list-style-type: none"> <li>Moderate or severe acute illness with or without fever</li> </ul>
Hepatitis B (HepB)	<ul style="list-style-type: none"> <li>Severe allergic reaction (e.g., anaphylaxis) after a previous dose or to a vaccine component<sup>3</sup> including yeast</li> <li>Pregnancy: <i>HepB</i> and <i>PreHevBrio</i> are not recommended due to lack of safety data in pregnant persons. Use other hepatitis B vaccines if HepB is indicated<sup>4</sup>.</li> </ul>	<ul style="list-style-type: none"> <li>Moderate or severe acute illness with or without fever</li> </ul>
Hepatitis A-Hepatitis B vaccine (HepA-HepB) [Twinrix]	<ul style="list-style-type: none"> <li>Severe allergic reaction (e.g., anaphylaxis) after a previous dose or to a vaccine component<sup>3</sup> including neomycin and yeast</li> </ul>	<ul style="list-style-type: none"> <li>Moderate or severe acute illness with or without fever</li> </ul>
Human papillomavirus (HPV)	<ul style="list-style-type: none"> <li>Severe allergic reaction (e.g., anaphylaxis) after a previous dose or to a vaccine component<sup>3</sup></li> <li>Pregnancy: <i>HPV</i> vaccination not recommended.</li> </ul>	<ul style="list-style-type: none"> <li>Moderate or severe acute illness with or without fever</li> </ul>
Measles, mumps, rubella (MMR) Measles, mumps, rubella, and varicella (MMRV)	<ul style="list-style-type: none"> <li>Severe allergic reaction (e.g., anaphylaxis) after a previous dose or to a vaccine component<sup>3</sup></li> <li>Severe immunodeficiency (e.g., hematologic and solid tumors, receipt of chemotherapy, congenital immunodeficiency, long-term immunosuppressive therapy or patients with HIV infection who are severely immunocompromised)</li> <li>Pregnancy</li> <li>Family history of altered immunocompetence, unless verified clinically or by laboratory testing as immunocompetent</li> </ul>	<ul style="list-style-type: none"> <li>Recent (<math>\leq 11</math> months) receipt of antibody-containing blood product (specific interval depends on product)</li> <li>History of thrombocytopenia or thrombocytopenic purpura</li> <li>Need for tuberculin skin testing or interferon-gamma release assay (IGRA) testing</li> <li>Moderate or severe acute illness with or without fever</li> <li>For MMRV only: Personal or family (i.e., sibling or parent) history of seizures of any etiology</li> </ul>
Meningococcal ACWY (MenACWY) MenACWY-CRM [Menveo] MenACWY-TT [MenQuadfi]	<ul style="list-style-type: none"> <li>Severe allergic reaction (e.g., anaphylaxis) after a previous dose or to a vaccine component<sup>3</sup></li> <li>For Men ACWY-CRM only: severe allergic reaction to any diphtheria toxoid—or CRM197—containing vaccine</li> <li>For MenACWY-TT only: severe allergic reaction to a tetanus toxoid-containing vaccine</li> </ul>	<ul style="list-style-type: none"> <li>For MenACWY-CRM only: Preterm birth if less than age 9 months</li> <li>Moderate or severe acute illness with or without fever</li> </ul>
Meningococcal B (MenB) MenB-4C [Bexsero] MenB-FHbp [Trumenba]	<ul style="list-style-type: none"> <li>Severe allergic reaction (e.g., anaphylaxis) after a previous dose or to a vaccine component<sup>3</sup></li> </ul>	<ul style="list-style-type: none"> <li>Pregnancy</li> <li>For MenB-4C only: Latex sensitivity</li> <li>Moderate or severe acute illness with or without fever</li> </ul>
Meningococcal ABCWY (MenACWY-TT/MenB-FHbp) [Penbraya]	<ul style="list-style-type: none"> <li>Severe allergic reaction (e.g., anaphylaxis) after a previous dose or to a vaccine component<sup>3</sup></li> <li>Severe allergic reaction to a tetanus toxoid-containing vaccine</li> </ul>	<ul style="list-style-type: none"> <li>Moderate or severe acute illness, with or without fever</li> </ul>
Mpox [Jynneos]	<ul style="list-style-type: none"> <li>Severe allergic reaction (e.g., anaphylaxis) after a previous dose or to a vaccine component<sup>3</sup></li> </ul>	<ul style="list-style-type: none"> <li>Moderate or severe acute illness, with or without fever</li> </ul>
Pneumococcal conjugate (PCV)	<ul style="list-style-type: none"> <li>Severe allergic reaction (e.g., anaphylaxis) after a previous dose or to a vaccine component<sup>3</sup></li> <li>Severe allergic reaction (e.g., anaphylaxis) to any diphtheria-toxoid-containing vaccine or its component<sup>3</sup></li> </ul>	<ul style="list-style-type: none"> <li>Moderate or severe acute illness with or without fever</li> </ul>
Pneumococcal polysaccharide (PPSV23)	<ul style="list-style-type: none"> <li>Severe allergic reaction (e.g., anaphylaxis) after a previous dose or to a vaccine component<sup>3</sup></li> </ul>	<ul style="list-style-type: none"> <li>Moderate or severe acute illness with or without fever</li> </ul>
Poliovirus vaccine, inactivated (IPV)	<ul style="list-style-type: none"> <li>Severe allergic reaction (e.g., anaphylaxis) after a previous dose or to a vaccine component<sup>3</sup></li> </ul>	<ul style="list-style-type: none"> <li>Pregnancy</li> <li>Moderate or severe acute illness with or without fever</li> </ul>
RSV monodonal antibody (RSV-mAb)	<ul style="list-style-type: none"> <li>Severe allergic reaction (e.g., anaphylaxis) after a previous dose or to a vaccine component<sup>3</sup></li> </ul>	<ul style="list-style-type: none"> <li>Moderate or severe acute illness with or without fever</li> </ul>
Respiratory syncytial virus vaccine (RSV)	<ul style="list-style-type: none"> <li>Severe allergic reaction (e.g., anaphylaxis) after a previous dose or to a vaccine component<sup>3</sup></li> </ul>	<ul style="list-style-type: none"> <li>Moderate or severe acute illness with or without fever</li> </ul>
Rotavirus (RV) RV1 [Rotarix] RV5 [RotaTeq]	<ul style="list-style-type: none"> <li>Severe allergic reaction (e.g., anaphylaxis) after a previous dose or to a vaccine component<sup>3</sup></li> <li>Severe combined immunodeficiency (SCID)</li> <li>History of intussusception</li> </ul>	<ul style="list-style-type: none"> <li>Altered immunocompetence other than SCID</li> <li>Chronic gastrointestinal disease</li> <li>RV1 only: Spina bifida or bladder exstrophy</li> <li>Moderate or severe acute illness with or without fever</li> </ul>
Tetanus, diphtheria, and acellular pertussis (Tdap) Tetanus, diphtheria (Td)	<ul style="list-style-type: none"> <li>Severe allergic reaction (e.g., anaphylaxis) after a previous dose or to a vaccine component<sup>3</sup></li> <li>For Tdap only: Encephalopathy (e.g., coma, decreased level of consciousness, prolonged seizures) not attributable to another identifiable cause within 7 days of administration of previous dose of DTP, DTaP, or Tdap</li> </ul>	<ul style="list-style-type: none"> <li>Guillain-Barré syndrome (GBS) within 6 weeks after a previous dose of tetanus-toxoid-containing vaccine</li> <li>History of Arthus-type hypersensitivity reactions after a previous dose of diphtheria-toxoid-containing or tetanus-toxoid-containing vaccine; defer vaccination until at least 10 years have elapsed since the last tetanus-toxoid-containing vaccine</li> <li>For Tdap only: Progressive or unstable neurological disorder, uncontrolled seizures, or progressive encephalopathy until a treatment regimen has been established and the condition has stabilized</li> <li>Moderate or severe acute illness with or without fever</li> </ul>
Varicella (VAR)	<ul style="list-style-type: none"> <li>Severe allergic reaction (e.g., anaphylaxis) after a previous dose or to a vaccine component<sup>3</sup></li> <li>Severe immunodeficiency (e.g., hematologic and solid tumors, receipt of chemotherapy, congenital immunodeficiency, long-term immunosuppressive therapy or patients with HIV infection who are severely immunocompromised)</li> <li>Pregnancy</li> <li>Family history of altered immunocompetence, unless verified clinically or by laboratory testing as immunocompetent</li> </ul>	<ul style="list-style-type: none"> <li>Recent (<math>\leq 11</math> months) receipt of antibody-containing blood product (specific interval depends on product)</li> <li>Receipt of specific antiviral drugs (acyclovir, famciclovir, or valacyclovir) 24 hours before vaccination (avoid use of these antiviral drugs for 14 days after vaccination)</li> <li>Use of aspirin or aspirin-containing products</li> <li>Moderate or severe acute illness with or without fever</li> <li>If using MMRV, see MMR/MMRV for additional precautions</li> </ul>

1. When a contraindication is present, a vaccine should NOT be administered. Kroger A, Bahta L, Hunter P. ACIP General Best Practice Guidelines for Immunization. [www.cdc.gov/vaccines/hcp/acip-recs/general-recs/contraindications.html](http://www.cdc.gov/vaccines/hcp/acip-recs/general-recs/contraindications.html)  
2. When a precaution is present, vaccination should generally be deferred but might be indicated if the benefit of protection from the vaccine outweighs the risk for an adverse reaction. Kroger A, Bahta L, Hunter P. ACIP General Best Practice Guidelines for Immunization. [www.cdc.gov/vaccines/hcp/acip-recs/general-recs/contraindications.html](http://www.cdc.gov/vaccines/hcp/acip-recs/general-recs/contraindications.html)  
3. Vaccination providers should check FDA-approved prescribing information for the most complete and updated information, including contraindications, warnings, and precautions. Package inserts for U.S.-licensed vaccines are available at [www.fda.gov/vaccines-blood-biologics/approved-products/vaccines-licensed-use-united-states](http://www.fda.gov/vaccines-blood-biologics/approved-products/vaccines-licensed-use-united-states).  
4. For information on the pregnancy exposure registries for persons who were inadvertently vaccinated with HepB or PreHevBrio while pregnant, please visit [heplisavbpregnancyregistry.com](http://heplisavbpregnancyregistry.com) or [www.prehevbrio.com/#safety](http://www.prehevbrio.com/#safety).  
5. Full prescribing information for BEYFORTUS (nirsevimab-alip) [www.accessdata.fda.gov/drugsatfda\\_docs/label/2023/761328s000lbl.pdf](http://www.accessdata.fda.gov/drugsatfda_docs/label/2023/761328s000lbl.pdf)

Fig. 215.1, cont'd

**Table 215.7** Recommended Catch-Up Immunization Schedule for Children and Adolescents Who Start Late or Who Are More than 1 Month Behind United States, 2024.\*

VACCINE	MINIMUM AGE FOR DOSE 1	MINIMUM INTERVAL BETWEEN DOSES			
		DOSE 1 TO DOSE 2	DOSE 2 TO DOSE 3	DOSE 3 TO DOSE 4	DOSE 4 TO DOSE 5
<b>CHILDREN AGE 4 MONTHS THROUGH 6 YEARS</b>					
Hepatitis B	Birth	4 weeks	8 weeks <i>and</i> at least 16 weeks after first dose minimum age for the final dose is 24 weeks		
Rotavirus	6 weeks Maximum age for first dose is 14 weeks, 6 days.	4 weeks	4 weeks maximum age for final dose is 8 months, 0 days		
Diphtheria, tetanus, and acellular pertussis	6 weeks	4 weeks	4 weeks	6 months	6 months A fifth dose is not necessary if the fourth dose was administered at age 4 years or older <i>and</i> at least 6 months after dose 3
<i>Haemophilus influenzae</i> type b	6 weeks	No further doses needed if first dose was administered at age 15 months or older. 4 weeks if first dose was administered before the 1st birthday. 8 weeks (as final dose) if first dose was administered at age 12 through 14 months.	No further doses needed if previous dose was administered at age 15 months or older 4 weeks if current age is younger than 12 months <i>and</i> first dose was administered at younger than age 7 months <i>and</i> at least 1 previous dose was PRP-T (ActHib®, Pentacel®, Hiberix®), Vaxelis® or unknown 8 weeks <i>and</i> age 12 through 59 months (as final dose) if current age is younger than 12 months <i>and</i> first dose was administered at age 7 through 11 months; <b>OR</b> if current age is 12 through 59 months <i>and</i> first dose was administered before the 1st birthday <i>and</i> second dose was administered at younger than 15 months; <b>OR</b> if both doses were PedvaxHIB® and were administered before the 1st birthday	8 weeks (as final dose) This dose only necessary for children age 12 through 59 months who received 3 doses before the 1st birthday.	
Pneumococcal conjugate	6 weeks	No further doses needed for healthy children if first dose was administered at age 24 months or older 4 weeks if first dose was administered before the 1st birthday 8 weeks (as final dose for healthy children) if first dose was administered at the 1st birthday or after	No further doses needed for healthy children if previous dose was administered at age 24 months or older 4 weeks if current age is younger than 12 months <i>and</i> previous dose was administered at <7 months old 8 weeks (as final dose for healthy children) if previous dose was administered between 7–11 months (wait until at least 12 months old); <b>OR</b> if current age is 12 months or older <i>and</i> at least 1 dose was administered before age 12 months	8 weeks (as final dose) This dose is only necessary for children age 12 through 59 months regardless of risk, or age 60 through 71 months with any risk, who received 3 doses before age 12 months.	
Inactivated poliovirus	6 weeks	4 weeks	4 weeks if current age is <4 years 6 months (as final dose) if current age is 4 years or older	6 months (minimum age 4 years for final dose)	

**Table 215.7** Recommended Catch-Up Immunization Schedule for Children and Adolescents Who Start Late or Who Are More than 1 Month Behind United States, 2024.\*—cont'd

VACCINE	MINIMUM AGE FOR DOSE 1	MINIMUM INTERVAL BETWEEN DOSES			
		DOSE 1 TO DOSE 2	DOSE 2 TO DOSE 3	DOSE 3 TO DOSE 4	DOSE 4 TO DOSE 5
<b>CHILDREN AGE 4 MONTHS THROUGH 6 YEARS</b>					
Measles, mumps, rubella	12 months	4 weeks			
Varicella	12 months	3 months			
Hepatitis A	12 months	6 months			
Meningococcal ACWY	2 months MenACWY-CRM 2 years MenACWY-TT	8 weeks	See Notes	See Notes	
<b>CHILDREN AND ADOLESCENTS AGE 7 THROUGH 18 YEARS</b>					
Meningococcal ACWY	Not applicable (N/A)	8 weeks			
Tetanus, diphtheria; tetanus, diphtheria, and acellular pertussis	7 years	4 weeks	4 weeks if first dose of DTaP/DT was administered before the 1st birthday 6 months (as final dose) if first dose of DTaP/DT or Tdap/Td was administered at or after the 1st birthday	6 months if first dose of DTaP/DT was administered before the 1st birthday	
Human papillomavirus	9 years	Routine dosing intervals are recommended.			
Hepatitis A	N/A	6 months			
Hepatitis B	N/A	4 weeks	8 weeks and at least 16 weeks after first dose		
Inactivated poliovirus	N/A	4 weeks	6 months A fourth dose is not necessary if the third dose was administered at age 4 years or older and at least 6 months after the previous dose.	A fourth dose of IPV is indicated if all previous doses were administered at <4 years OR if the third dose was administered <6 months after the second dose.	
Measles, mumps, rubella	N/A	4 weeks			
Varicella	N/A	3 months if younger than age 13 years. 4 weeks if age 13 years or older			
Dengue	9 years	6 months	6 months		

\*Always use this table in conjunction with Figure 215.1 and the notes that follow it.

This table provides catch-up schedules and minimum intervals between doses for children whose vaccinations have been delayed. A vaccine series does not need to be restarted, regardless of the time that has elapsed between doses. Use the section appropriate for the child's age.

For vaccination recommendations for persons ages 19 yr or older, see the Recommended Adult Immunization Schedule, 2024 <https://www.cdc.gov/vaccines/schedules/hcp/imz/adult.html>.

Courtesy U.S. Centers for Disease Control and Prevention, Atlanta, Georgia. 2024. <https://www.cdc.gov/vaccines/schedules/hcp/imz/catchup.html#table-catchup>.



combined with other vaccines. Either Td vaccine or Tdap can be used for the decennial Td booster, for tetanus prophylaxis in wound management, or for additional required doses in the catch-up immunization schedule if a person has received at least one Tdap dose. One dose of Tdap vaccine is recommended for pregnant adolescents with each pregnancy, preferably between 27 and 36 weeks of gestation, regardless of the time since the last Tdap or Td. Current available data suggest that vaccinating earlier in the 27- through 36-week period will maximize passive antibody transfer to the infant. This recommendation was made in response to data predicting lack of infant protection when maternal Tdap had been received before pregnancy.

There are three licensed preparations of single-antigen **Hib** vaccines. The two monovalent vaccines conjugated to tetanus toxoid (PRP-T) are each given in a four-dose series at 2, 4, 6, and 12 through 15 months of age. The third Hib vaccine is conjugated to meningococcal outer membrane protein (PRP-OMP) and is recommended in a three-dose series at 2, 4, and 12 through 15 months of age. There also are several vaccines in which Hib is a component, in addition to single-antigen Hib conjugate vaccines (see [Tables 215.8 and 215.9](#)).

**Influenza** vaccine is recommended for all children beginning at 6 months of age, with a minimum age of 6 months for IIVs and 24 months for LAIV4. Various influenza vaccine preparations are FDA-licensed for different age-groups.\* Children 6 months through 8 years of age being vaccinated for the first time should receive two doses at least 4 weeks apart. If such children only received a single dose of IIV before July 1 of the current season, they need two doses. Children who have received two doses in a prior season only need one dose annually thereafter. For additional guidelines, follow dosing instructions in the influenza policy statements, which are updated annually by both the CDC (<https://www.cdc.gov/flu/professionals/acip/index.htm>) and AAP ([aapredbook.org](http://aapredbook.org)). Influenza vaccine usually is given in October or November, although there are benefits even when administered as late as February or March because influenza seasons most frequently peak in February. People  $\geq 9$  years old should receive one dose of influenza vaccine annually. LAIV4 is recommended for the 2023-2024 season. Because of limited use of LAIV4, there have been no effectiveness estimates in the United States. Data from other countries have demonstrated similar protection from LAIV4 to that of standard-dose, egg-based IIV in children. Although there are no reports of additional safety risks for LAIV4 in children with immunodeficiencies, anatomic or functional asplenia, cochlear implants, or active cerebrospinal fluid leaks, it is not recommended in these populations because the vaccine is a live attenuated product (see [Table 215.7](#)). For more information see <https://pediatrics.aappublications.org/content/146/4/e2020024588>

**IPV** should be administered at 2, 4, and 6 through 18 months of age with a booster dose at 4 through 6 years. The final dose in the series should be administered on or after 4 years of age and at least 6 months after the previous dose. Four or more doses of IPV can be administered before age 4 years when a combination vaccine containing IPV is used. The final dose in the IPV series should still be administered at 4 years or older regardless of the number of previous doses, and the minimal interval from dose 3 to dose 4 is 6 months. For series that contain oral polio vaccine (OPV), the total number of doses needed to complete the series is the same as that recommended for the U.S. IPV schedule. Only documentation specifying receipt of trivalent OPV constitutes proof of vaccination according to the U.S. polio vaccination recommendations. This is important because since April 2016, trivalent OPV (tOPV) is no longer available with the type 2 serotype removed. Thus children vaccinated since that time only received the type 1 and 3 components and are not immune to type 2. In contrast, IPV contains all three polio serotypes. Only IPV is available in the United States. One lifetime IPV booster should be considered for adolescents 18 years old who are at increased risk of exposure to poliovirus and completed IPV primary series. For catch-up vaccine recommendations, see the recommended childhood immunization schedule at <http://www.cdc.gov/vaccines/schedules/hcp/imz/catchup.html> (see [Table 215.7](#)).

**MMR** should be administered at 12 through 15 months of age followed by a second dose at 4 through 6 years. Before all international travel, infants 6 through 11 months of age should receive one dose of MMR vaccine. These children should be revaccinated with the routinely recommended two doses of MMR vaccine beginning at 12 months of age. For children 12 months or older, administer two doses before international travel; the second dose should be administered at least 4 weeks after the first dose.

Two doses of **varicella** vaccine should be given, the first at 12 through 15 months of age and the second at 4 through 6 years. The second dose may be administered before 4 years of age provided at least 3 months have elapsed since the first dose. MMR and MMRV preparations are available. Ensure persons age 7-18 years without evidence of immunity have a two-dose series. The **quadrivalent MMRV** vaccine is preferred in place of separate MMR and varicella vaccines at the 4- to 6-year-old visit. For dose 1 in children age 12-47 months, it is recommended to administer MMR and varicella vaccines separately because of the slight increase in febrile seizures associated with the combined MMRV vaccine compared with simultaneous administration of the separate products. MMRV may be used if parents or caregivers express a preference.

Protection against pneumococcal disease can be provided by either conjugated or polysaccharide vaccines. Conjugated vaccines offer several benefits over polysaccharide vaccines (see [Table 215.5](#)). A four-dose series of either PCV15 or 20 is recommended at 2, 4, 6, and 12 to 15 months of age. In the latest immunization schedule, PCV15 and 20 are referenced. Use of either pneumococcal conjugate vaccines is recommended for all children age 2-23 months according to currently recommended PCV dosing and schedules. References to the previously available thirteen-valent (PCV13) have been removed. For children without high risk conditions, PCV20 is not indicated if they have received four doses of PCV13 or PCV15 or another age-appropriate complete PCV series. For guidance on determining which pneumococcal vaccines a patient needs and when, a mobile app has been created. ([www.cdc.gov/vaccines/vpd/pneumo/hcp/pneumoapp.html](http://www.cdc.gov/vaccines/vpd/pneumo/hcp/pneumoapp.html)). PPSV23 is recommended for select children with conditions that place them at risk for pneumococcal disease. When both PCV and PPSV23 are indicated, administer PCV first. PCV and PPSV23 should be administered during the same visit.

A two-dose series of MCV4 includes a recommended dose for all adolescents at 11 through 12 years of age followed by a second dose at 16 years. If the first dose is administered at 13 through 15 years of age, a booster dose should be administered at 16-18 years. No booster dose is needed if the first dose is administered at 16 years. In addition, MCV4 should be administered to people 2 months through 55 years of age with underlying conditions that place them at high risk of meningococcal disease. There are two licensed quadrivalent meningococcal vaccines and one pentavalent vaccine that additionally provides coverage against serogroup B disease. Each vaccine has a different minimum age for beginning vaccination with that product. In addition to the quadrivalent meningococcal vaccine, two other vaccines provide coverage against serogroup B meningococcal disease. Two to three doses of the meningococcal B (MenB) vaccines are recommended for persons  $>10$  years old at increased risk of meningococcal disease. Further, consideration should be given to adolescents not at increased risk (16-23 years, preferred age 16-18 years) based on shared clinical decision making, which involves patients and families coming together to discuss the potential benefits of vaccination (<https://www.cdc.gov/vaccines/hcp/admin/downloads/isd-job-aid-scdm-mening-b-shared-clinical-decision-making.pdf>).

Children 10 years of age or older may receive a single dose of the quadrivalent vaccine as an alternative to separate administration of MenACWY and MenB when both vaccines would be given on the same clinic day. The two licensed MenB vaccine products are not interchangeable. MCV4 vaccines may be administered simultaneously with MenB vaccines if indicated, but at a different anatomic site if feasible.

**Hepatitis A** vaccine, licensed for administration to children  $\geq 12$  months old, is recommended for universal administration to all children at 12 through 23 months of age and for certain high-risk groups. The two doses in the series should be separated by at least 6 months.

\* See <http://www.cdc.gov/flu/protect/vaccine/vaccines.htm> and <http://aapredbook.aappublications.org/site/news/vaccstatus.xhtml#flu>.

**Table 215.8** Combination Vaccines Licensed and Available in the United States

VACCINE PRODUCT (MANUFACTURER)*	TRADE NAME (YR LICENSED)	COMPONENTS	RECOMMENDED AGES	
			PRIMARY SERIES	BOOSTER DOSE
DTaP-IPV/Hib (Sanofi Pasteur)	Pentacel (2008)	DTaP-IPV + PRP-T	2, 4, and 6 mo	15-18 mo
DTaP-HepB-IPV (GlaxoSmithKline)	Pediarix (2002)	DTaP + HepB + IPV	2, 4, and 6 mo	
DTaP-HepB-IPV-Hib (MSP Vaccine Company)	Vaxelis (2020)	DTaP + HepB+ IPV + Hib	2, 4, and 6 mo	
DTaP-IPV	Kinrix (2008), Quadracel (2015)	DTaP + IPV		Kinrix: For use as the fifth dose of DTaP and the fourth dose of IPV in children age 4-6 yr Quadracel: For use as the fifth dose in the DTaP series and as the fourth or fifth dose in the IPV series in children 4-6 yr of age
HepA-HepB (GlaxoSmithKline)	Twinrix (2001)	HepA + HepB	>18yr of age; 0, 1, and 6 mo schedule	
MMRV (Merck & Co)	ProQuad (2005)	MMR + varicella	†	4-6yr

\*Dash (-) indicates that products are supplied in their final form by the manufacturer and do not require mixing or reconstitution by user; slash (/) indicates that products are mixed or reconstituted by user.

†Although ProQuad is available for the first dose (at 12-15 mo of age), the CDC recommends that MMR vaccine and varicella vaccine be administered separately for the first dose in this age-group unless the parent or caregiver expresses a preference for MMRV vaccine.

DTaP, Diphtheria and tetanus toxoids and acellular pertussis vaccine; HepA, hepatitis A vaccine; HepB, hepatitis B vaccine; IPV/Hib, trivalent inactivated polio vaccine and *Haemophilus influenzae* type b vaccine; MMRV, measles-mumps-rubella and varicella vaccine, PRP-T, *H. influenzae* type b capsular polysaccharide (polyribosyl-ribitol279 phosphate [PRP]) covalently bound to tetanus toxoid (PRP-T).

Adapted from Cohn AC, MacNeil JR, Clark TA, et al. Prevention and control of meningococcal disease: recommendations of the Advisory Committee on Immunization Practices. *MMWR*. 2013;62(2):1-28.

**Table 215.9** Vaccines Recommended for Children and Adolescents with Underlying Conditions or at High Risk

VACCINES	SPECIAL SITUATIONS
Pneumococcal conjugate (and PPSV23 in certain conditions)	Cerebrospinal fluid leak Chronic heart disease Chronic kidney disease (excluding maintenance dialysis and nephrotic syndrome, which are included in immunocompromising conditions) Chronic liver disease Chronic lung disease (including moderate persistent or severe persistent asthma) Cochlear implant Diabetes mellitus Immunocompromising conditions (on maintenance dialysis or with nephrotic syndrome; congenital or acquired asplenia or splenic dysfunction; congenital or acquired immunodeficiencies; diseases and conditions treated with immunosuppressive drugs or radiation therapy, including malignant neoplasms, leukemias, lymphomas, Hodgkin disease, and solid organ transplant; HIV infection; and sickle cell disease and other hemoglobinopathies)
MCV4	Anatomic or functional asplenia (including sickle cell disease) Persistent complement component deficiency Complement inhibitor use Residents of or travelers to countries in African meningitis belt or pilgrims on the Hajj During outbreaks caused by a vaccine serogroup First-year college students who live in residential housing (if not previously vaccinated at age 16 yr or older) or military recruits HIV infection
MenB	Anatomic or functional asplenia (including sickle cell disease) Children with persistent complement component deficiency Complement inhibitor use During outbreaks caused by a vaccine serogroup
Hib	In addition to routine Hib vaccine recommendations. Persons at increased risk for Hib disease, including chemotherapy recipients and those with anatomic or functional asplenia (including sickle cell disease), HIV infection, immunoglobulin deficiency, or early component complement deficiency Recipients of hematopoietic stem cell transplant (HSCT) Elective splenectomy
Hep B	In addition to routine Hep B vaccine recommendations; infants born to HBsAg-positive mothers or mothers whose HBsAg status is unknown (administer vaccine within 12 hr of birth)
HPV	In addition to routine HPV vaccine recommendations; immunocompromising conditions, including HIV infection History of sexual abuse or assault
Tetanus	Wound management recommendations exist based on age, number of prior doses of tetanus-toxoid-containing vaccine, and type of wound.

From Centers for Disease Control and Prevention. Child and adolescent schedule. <https://www.cdc.gov/vaccines/schedules/hcp/imz/child-adolescent.html>

Persons who previously received one dose at age 12 months or older should receive dose 2 at least 6 months after dose 1. Unvaccinated persons through age 18 years should complete a two-dose series with a minimum interval of 6 months. Adolescents age 18 years or older may receive the combined HepA and HepB vaccine. Immunity against hepatitis A infection is particularly important in people with chronic liver disease and clotting factor disorders, in men who have sex with men, in those who use injection or noninjection drugs, in people who are homeless, exposed to hepatitis A virus at work or travel, and those in close contact with international adoptees. Before all international travel, infants 6 through 11 months of age should receive one dose of hepatitis A vaccine. These children should be revaccinated with the routinely recommended two doses of hepatitis A vaccine beginning at 12 months of age. For unvaccinated children 12 months or older, administer dose 1 as soon as travel is considered. Preferably two doses should be administered before international travel to countries with high or intermediate endemic hepatitis A; the second dose should be administered at least 6 months after the first dose.

The **9vHPV** vaccine is recommended at age 11 or 12 years, although some advocate for routinely administering it as early as 9 years of age. Catch-up HPV vaccination is recommended for all persons through age 18 years if not adequately vaccinated. For those who initiate the series before their 15th birthday, the recommended schedule is two doses of 9vHPV vaccine. The minimum interval is 5 months between the first and second dose. If the second dose is given at a shorter interval, a third dose should be administered a minimum of 12 weeks after the second dose and a minimum of 5 months after the first dose. For those initiating the series on or after their 15th birthday, the recommended schedule is three doses of 9vHPV vaccine. The minimum intervals are 4 weeks between the first and second dose, 12 weeks between the second and third dose, and 5 months between the first and third dose. For children with a history of sexual abuse or assault, the ACIP recommends routine HPV vaccination beginning at age 9 years. In males and females with primary or secondary immunocompromising conditions such as B-lymphocyte deficiencies, T-lymphocyte complete or partial defects, HIV, malignancy, transplantation, autoimmune disease, or immunosuppressive therapy, the ACIP recommends vaccination with three doses of 9vHPV (0, 1-2, and 6 months) because immune response to vaccination might be attenuated. 9vHPV may be used to continue or complete a vaccination series in patients who started with 4vHPV or 2vHPV, though no additional doses are recommended after completing the series with recommended dosing intervals using any HPV vaccine. If the vaccination schedule is interrupted, the series does not need to be restarted. HPV vaccination is not recommended until after pregnancy, but no intervention is needed if vaccinated while pregnant. Pregnancy testing is not needed before vaccination.

Two **rotavirus** vaccines are available: RotaTeq (RV5) and Rotarix (RV1). With both vaccines, the first dose can be administered as early as 6 weeks of age. Do not start the series on or after age 15 weeks, 0 days. The RV5 vaccine is administered in three doses at least 4 weeks apart. The RV1 vaccine is administered in two doses at least 4 weeks apart. If any dose in the series is either RotaTeq or unknown, default to a three-dose series. The maximum age for the final dose is 8 months, 0 days as stated in the immunization schedule.

A dengue vaccine (Dengvaxia) was approved by the FDA in May 2019 for use in children age 9-16 years living in dengue-endemic territories AND having laboratory confirmation of *previous* dengue infection. It is a three-dose series administered at 0, 6, and 12 months. Endemic areas include Puerto Rico, American Samoa, U.S. Virgin Islands, Federated States of Micronesia, Republic of Marshall Islands, and the Republic of Palau. For updated guidance on dengue-endemic areas and pre-vaccination laboratory testing see <https://apps.who.int/mediacentre/factsheets/fs117/en/index.html>. Dengvaxia is not approved for use in U.S. travelers who are visiting but not living in an area where dengue is endemic. See <https://www.aappublications.org/news/2020/05/01/mmwr050120> for more information.

For those that are 18 years of age or older and at risk for Mpox infection, 2 doses of the Mpox vaccine are recommended. See [https://www.cdc.gov/poxvirus/mpox/interim-considerations/jynneos-vaccine.html#:~:text=JYNNEOS%20is%20approved%20for%20the,22\)%3A734%2D742](https://www.cdc.gov/poxvirus/mpox/interim-considerations/jynneos-vaccine.html#:~:text=JYNNEOS%20is%20approved%20for%20the,22)%3A734%2D742) for more information.

To prevent RSV in infants, one dose of nirsevimab is recommended for infants younger than 8 months of age who were born shortly before or are entering their first RSV season (typically fall through spring) if: (1) the mother did not receive RSV vaccine during pregnancy, (2) the mother's RSV vaccination status is unknown, or (3) the infant was born within 14 days of maternal RSV vaccination. Additionally, a dose of nirsevimab is recommended for some children 8 to 19 months of age who are at increased risk for severe RSV disease and entering their second RSV season (<https://www.cdc.gov/mmwr/volumes/72/wr/mm7234a4.htm#suggestedcitation>).

The present schedule, excluding influenza vaccine, can require as many as 41 doses. Of the doses, more than half are recommended before 2 years of age. Influenza vaccination, starting at age 6 months, can add an additional 20 injections through 18 years. To reduce the injection burdens, several combination vaccines are available (see [Table 215.8](#)).

The recommended childhood and adolescent immunization schedule establishes a routine adolescent visit at 11 through 12 years of age. MCV4, a Tdap booster, and 9vHPV vaccine should be administered during this visit in addition to the COVID-19 vaccine if the child is 12 years of age or older. Influenza vaccine should be administered annually. In addition, the 11- to 12-year-old visit is an opportune time to review all the immunizations the adolescent has received previously, to provide any doses that were missed, and to review other age-appropriate preventive services. The 11- to 12-year visit establishes an important platform for incorporating other vaccines. Information on the current status of new vaccine licensure and recommendations for use is available.\*

For children who are at least 1 month behind in their immunizations, catch-up immunization schedules are available for children 4 months through 18 years of age (<http://www.cdc.gov/vaccines/schedules/hcp/imz/catchup.html>) (see [Table 215.7](#)). Interactive immunization schedules are available for children from birth through 18 years of age at <https://www2a.cdc.gov/vaccines/childquiz/>. Only written/electronic, dated, authentic records should be accepted as evidence of immunization. In general, when in doubt, a person with unknown or uncertain immunization status should be considered “disease susceptible,” and recommended immunizations should be initiated without delay on a schedule commensurate with the person's current age. No evidence suggests that administration of vaccines to already-immune recipients is harmful. A new addendum section has been added to list any ACIP recommendations that occur by majority vote and are approved by CDC Director after the 2024 immunization schedules are approved and published.

## VACCINES RECOMMENDED IN SPECIAL SITUATIONS

Eight vaccines—PCV, PPSV23, MCV4, MenB, Flu, Hib, HepA, and HepB—are recommended for children and adolescents at increased risk for complications from vaccine-preventable diseases or children who have an increased risk for exposure to these diseases who are outside the age-groups for which these vaccines are normally recommended (PPSV23 and MenB are not routinely recommended for any age-group of children and are only used for children with high-risk conditions; [Fig. 215.2](#) and [Table 215.9](#)). Specific recommendations for use of these vaccines in children with underlying conditions can be found in the recommended immunization schedule.

**PCV15** or **PCV20** is recommended for children 24-71 months of age with specialized risk conditions that place them at high risk for pneumococcal disease. This recommendation includes children with sickle cell disease and other hemoglobinopathies, including hemoglobin SS, hemoglobin S-C, or hemoglobin S-β-thalassemia,

\* <http://aapredbook.aappublications.org/site/news/vaccstatus.xhtml> and <http://www.fda.gov/BiologicsBloodVaccines/Vaccines/ApprovedProducts/UCM093833>

Vaccine and other immunizing agents	Pregnancy	Immunocompromised (excluding HIV infection)	HIV infection CD4 percentage and count <sup>a</sup>		CSF leak or cochlear implant	Asplenia or persistent complement component deficiencies	Heart disease or chronic lung disease	Kidney failure, End-stage renal disease or on Dialysis	Chronic liver disease	Diabetes
			<15% or <200mm	≥15% and ≥200mm						
RSV-mAb (nirsevimab)		2nd RSV season	1 dose depending on maternal RSV vaccination status, See Notes				2nd RSV season for chronic lung disease (See Notes)	1 dose depending on maternal RSV vaccination status, See Notes		
Hepatitis B										
Rotavirus		SCID <sup>b</sup>								
DTaP/Tdap	DTaP									
	Tdap: 1 dose each pregnancy									
Hib		HSCT: 3 doses	See Notes			See Notes				
Pneumococcal										
IPV										
COVID-19			See Notes							
IIV4										
LAIV4							Asthma, wheezing: 2–4 years <sup>c</sup>			
MMR	*									
VAR	*									
Hepatitis A										
HPV	*	3 dose series, See Notes								
MenACWY										
MenB										
RSV (Abrysvo)	Seasonal administration, See Notes									
Dengue										
Mpox	See Notes									

a. For additional information regarding HIV laboratory parameters and use of live vaccines, see the General Best Practice Guidelines for Immunization, "Altered Immunocompetence," at [www.cdc.gov/vaccines/hcp/acip-recs/general-recs/immunocompetence.html](http://www.cdc.gov/vaccines/hcp/acip-recs/general-recs/immunocompetence.html) and Table 4-1 (footnote J) at [www.cdc.gov/vaccines/hcp/acip-recs/general-recs/contraindications.html](http://www.cdc.gov/vaccines/hcp/acip-recs/general-recs/contraindications.html)

b. Severe Combined Immunodeficiency

c. LAIV4 contraindicated for children 2–4 years of age with asthma or wheezing during the preceding 12 months

**Fig. 215.2** Recommended child and adolescent immunization schedule by medical indication—United States, 2024. Always use this figure in conjunction with Figure 215.1 and the notes that follow it. (Courtesy U.S. Centers for Disease Control and Prevention, Atlanta, Georgia. 2024. <https://www.cdc.gov/vaccines/schedules/downloads/child/0-18yrs-child-combined-schedule.pdf>.)

or children who are functionally or anatomically asplenic; children with HIV infection; and children who have chronic disease (see Table 215.9 and Fig. 215.2). (For further recommendations on pneumococcal vaccine recommendations, see <https://www.cdc.gov/vaccines/vpd/pneumo/hcp/who-when-to-vaccinate.html>.)

Children at high risk for pneumococcal disease also should receive PPSV23 to provide immunity to serotypes not contained in the 13- or 15-valent conjugate vaccine. PPSV23 should be administered on or after the second birthday and should follow completion of the PCV series by at least 8 weeks. Two doses of PPSV23 are recommended, with an interval of 5 years between doses. Immunization of children >5 years old with high-risk conditions can be performed with PCV15 or PCV20 and/or PPSV23, depending on the condition and vaccination history. When both PCV and PPSV23 are indicated, PCV should be administered first.

MCV4 is recommended for HIV-infected persons ≥2 months old, children with anatomic or functional asplenia (including sickle cell disease), children with persistent complement component deficiency (includes persons with inherited or chronic deficiencies in C3, C5-9, properdin, factor D, or factor H), or children taking a complement inhibitor (e.g., eculizumab or ravulizumab).

Meningococcal B (MenB) vaccine is recommended for persons ≥10 years old at increased risk of meningococcal disease. This includes people with complement deficiencies or anatomic or functional asplenia, people at increased risk because of serogroup B meningococcal disease outbreaks, and microbiologists who routinely are exposed to isolates of *Neisseria meningitidis*. Young adults age 16-23 (preferred range: 16-18 years) who are not at increased risk for meningococcal disease may be

vaccinated with either of the two MenB vaccines, which are not interchangeable, to provide short-term protection against most strains of serogroup B meningococcal disease.

Hib vaccine and HepA vaccine are recommended for children with certain high-risk conditions. HepB is recommended for infants born to HBsAg-positive mothers or mothers whose HBsAg status is unknown (administer the vaccine within 12 hours of birth) (see Table 215.9).

In addition to vaccines in the recommended childhood and adolescent schedule, a variety of vaccines are available for children who will be traveling to areas of the world where certain infectious diseases are common (Table 215.10). Vaccines for travelers include typhoid fever, hepatitis A, hepatitis B, Japanese encephalitis, MCV4, cholera, rabies, and yellow fever, depending on the location and circumstances of travel. Measles is endemic in many parts of the world. Children 6-11 months old should receive a dose of MMR and hepatitis A vaccines before international travel outside of the United States. However, doses of MMR and hepatitis A vaccines received before 12 months should not be counted in determining compliance with the recommended two-dose MMR schedule. For unvaccinated children ≥12 months old, administer two doses before international travel following the recommended schedule. (Additional information on vaccines for international travel can be found at <http://wwwnc.cdc.gov/travel/>.)

Vaccine recommendations for children with immunocompromising conditions, either primary (inherited) or secondary (acquired), vary according to the underlying condition, the degree of immune deficit, the risk for exposure to disease, and the vaccine (Table 215.11 and see Fig. 215.2). Immunization of children who are



**Table 215.10** Recommended Immunizations for International Travel\*

IMMUNIZATIONS	LENGTH OF STAY	
	Brief, <1 mo	Long-Term / Residential, >1 mo
Review and complete age-appropriate childhood and adolescent schedule (see text for details) <ul style="list-style-type: none"> <li>• DTaP, poliovirus, pneumococcal, and <i>Haemophilus influenzae</i> type b (Hib) vaccines may be given at 4-wk intervals if necessary to complete recommended schedule before departure.</li> <li>• Influenza</li> <li>• MMR: two additional doses given if &lt;12 mo old at first dose</li> <li>• Meningococcal disease (MenACWY)<sup>†</sup></li> <li>• Rotavirus</li> <li>• Varicella</li> <li>• Human papillomavirus (HPV)</li> <li>• Hepatitis A: two additional doses given if &lt;12 mo old at 1st dose<sup>‡,§</sup></li> <li>• Hepatitis B<sup>§</sup></li> <li>• Tdap</li> </ul>	+	+
Yellow fever <sup>#</sup>	+	+
Typhoid fever <sup>¶</sup>	+	+
Rabies <sup>**</sup>	±	±
Japanese encephalitis <sup>‡</sup>	±	+
Cholera <sup>††</sup>	±	±

\*See disease-specific chapters in the Centers for Disease Control and Prevention's *Yellow Book* for details. For further sources of information, see text.

<sup>†</sup>Recommended for regions of Africa with endemic infection and during local epidemics and required for travel to Saudi Arabia for the Hajj.

<sup>‡</sup>For infants age 6-11 mo, first dose is recommended before departure for all international travel. For unvaccinated children 12 mo and older, this vaccine is indicated for travelers to areas with intermediate or high endemic rates of hepatitis A virus infection.

<sup>§</sup>If there is insufficient time to complete 6-mo primary series, accelerated series can be given.

<sup>#</sup>For regions with endemic infection, see Health Information for International Travel (<http://www.cdc.gov/travel>). Because of the risk of serious adverse events after yellow fever vaccination, clinicians should only vaccinate people who (1) are at risk of exposure to yellow fever virus (YFV) or (2) require proof of vaccination to enter a country.

<sup>¶</sup>Indicated for travelers who will consume food and liquids in areas of poor sanitation.

<sup>\*\*</sup>Indicated for people with high risk for animal exposure (especially to dogs) and for travelers to countries with endemic infection.

<sup>‡</sup>For regions with endemic infection (see Health Information for International Travel). For high-risk activities in areas experiencing outbreaks, vaccine is recommended, even for brief travel.

<sup>††</sup>Cholera vaccine (CVD 103-HgR, Vaxchora) is recommended for adult (18-64 yr old) travelers to an area of active toxigenic *V. cholerae* O1 transmission.

+, Recommended; ±, consider; DTaP, diphtheria and tetanus toxoids and acellular pertussis.

Data from Centers for Disease Control and Prevention. Travelers' health. <https://wwwnc.cdc.gov/travel>.

**Table 215.11** Vaccination of Persons with Primary and Secondary Immune Deficiencies

PRIMARY				
CATEGORY	SPECIFIC IMMUNODEFICIENCY	CONTRAINDICATED VACCINES*	RISK-SPECIFIC RECOMMENDED VACCINES*	EFFECTIVENESS AND COMMENTS
B lymphocyte (humoral)	Severe antibody deficiencies (e.g., X-linked agammaglobulinemia and common variable immunodeficiency)	OPV <sup>a</sup> Smallpox <sup>b</sup> LAIV4 BCG Ty21a Yellow fever virus (YFV) and live-bacteria vaccines <sup>c</sup> No data for rotavirus vaccines	Annual IIV is the only vaccine given to patients receiving IG therapy; routine inactivated vaccines can be given if not receiving IVIG. Pneumococcal Hib (children 12-59 mo of age)	The effectiveness of any vaccine will be uncertain if it depends only on the humoral response (e.g., PPSV23). IG therapy interferes with the immune response to live vaccines MMR and VAR.
	Less severe antibody deficiencies (e.g., selective IgA deficiency and IgG subclass deficiency)	OPV <sup>a</sup> BCG YFV vaccine Other live vaccines <sup>d</sup> appear to be safe.	Vaccines should be given as on the annual immunization schedule for immunocompetent people. <sup>e</sup> PPSV23 should be given beginning at 2yr of age. <sup>f</sup> Pneumococcal Hib (children 12-59 mo of age)	All vaccines are probably effective. Immune response may be attenuated.
T lymphocyte (cell-mediated and humoral)	Complete defects (e.g., SCID, complete DiGeorge syndrome)	All live vaccines <sup>c,d,g</sup>	Pneumococcal Hib (children 12-59 mo of age) and annual IIV	All inactivated vaccines are probably ineffective.
	Partial defects (e.g., most patients with DiGeorge syndrome, hyper-IgM syndrome, Wiskott-Aldrich syndrome, ataxia-telangiectasia)	All live vaccines <sup>c,d,g</sup>	Routine inactivated vaccines should be given. <sup>e</sup> PPSV23 should be given beginning at 2yr of age. <sup>f</sup> Pneumococcal Hib (children 12-59 mo of age)	Effectiveness of any vaccine depends on degree of immune suppression.
	Interferon (IFN)-γ-interleukin (IL)-12 axis deficiencies	All live vaccines for IL-12/IL-12R deficiencies, IFN-γ, IFN-α, or STAT1 deficiencies	None	None

**Table 215.11** Vaccination of Persons with Primary and Secondary Immune Deficiencies—cont'd

PRIMARY				
CATEGORY	SPECIFIC IMMUNODEFICIENCY	CONTRAINDICATED VACCINES*	RISK-SPECIFIC RECOMMENDED VACCINES*	EFFECTIVENESS AND COMMENTS
Complement	Persistent complement, properdin, MBL, or factor B deficiency; secondary deficiency because taking eculizumab (Solaris)	None	PPSV23 should be given beginning at 2yr of age. <sup>f</sup> MCV series beginning in infancy. <sup>h</sup> MenB series beginning at 10 yr of age and Hib vaccine (children 12-59 mo of age)	All routine vaccines are probably effective.
Phagocytic function	Chronic granulomatous disease	Live-bacteria vaccines <sup>c</sup>	None	All inactivated vaccines are safe and probably effective. Live-virus vaccines are probably safe and effective.
	Phagocytic deficiencies that are undefined or accompanied by defect in T-cell and NK-cell dysfunction (e.g., Chédiak-Higashi syndrome, leukocyte adhesion defects, myeloperoxidase deficiency)	MMR, MMRV, OPV, <sup>a</sup> smallpox, LAIV4, Ty21a, YF, all bacteria vaccines	PPSV23 should be given beginning at 2yr of age. <sup>f</sup> MCV series beginning in infancy. <sup>h</sup>	All inactivated vaccines are safe and probably effective.
SECONDARY				
SPECIFIC IMMUNODEFICIENCY	CONTRAINDICATED VACCINES*	RISK-SPECIFIC RECOMMENDED VACCINES*	EFFECTIVENESS AND COMMENTS	
HIV/AIDS	OPV <sup>a</sup> Smallpox BCG Combined MMRV LAIV4 Withhold MMR, varicella, and zoster in severely immunocompromised persons. YF vaccine may have a contraindication or precaution depending on the indicators of immune function. <sup>l</sup>	PPSV23 should be given beginning at 2yr of age. <sup>f</sup> MCV series beginning in infancy. <sup>h</sup> HepB vaccine Consider Hib (if not administered in infancy). <sup>l</sup>	Rotavirus vaccine is recommended on standard schedule. MMR and VAR are recommended for HIV-infected children who are asymptomatic or only low-level immunocompromised. <sup>k</sup> All inactivated vaccines may be effective.	
Generalized malignant neoplasm, transplantation, autoimmune disease, immunosuppressive or radiation therapy	Live-virus and live-bacteria vaccines, depending on immune status. <sup>c,d,m</sup>	PPSV23 should be given beginning at 2yr of age. <sup>f</sup> Annual IIV (unless receiving intensive chemotherapy or anti-B-cell antibodies). Hib vaccine may be indicated. <sup>n</sup>	Effectiveness of any vaccine depends on degree of immune suppression; inactivated standard vaccines are indicated if not highly immunosuppressed, but doses should be repeated after chemotherapy ends.	
Asplenia (functional, congenital anatomic, surgical)	LAIV4	PPSV23 should be given beginning at 2yr of age. <sup>f</sup> MCV series beginning in infancy. <sup>h</sup> MenB series beginning at 10 yr of age. Hib (if not administered in infancy) <sup>o</sup>	All routine vaccines are probably effective.	
Chronic renal disease	None	PPSV23 should be given beginning at 2yr of age. <sup>f</sup> HepB is indicated if not previously immunized.	All routine vaccines are probably effective.	
CNS anatomic barrier defect (cochlear implant, congenital dysplasia of the inner ear, persistent CSF communication with naso-/oropharynx)	None	PPSV23 should be given beginning at 2yr of age. <sup>f</sup>	All standard vaccines are indicated.	

\*Other vaccines that are universally or routinely recommended should be given if not contraindicated.

<sup>a</sup>OPV is no longer available in the United States.

<sup>b</sup>This table refers to contraindications for nonemergency vaccination (i.e., ACIP recommendations).

<sup>c</sup>Live-bacteria vaccines: BCG and oral Ty21a *Salmonella* Typhi vaccine.

<sup>d</sup>Live-virus vaccines: MMR, MMRV, VAR, OPV, LAIV, YF, zoster, rotavirus, and vaccinia (smallpox). Smallpox vaccine is not recommended for children or the general public.

<sup>e</sup>Children who are delayed or underimmunized should be immunized with routinely recommended vaccines, according to age and catch-up schedule.

<sup>f</sup>PPSV23 is begun at 2 yr or older. If PCV13 is required, PCV13 doses should be administered first, followed by PPSV23 at least 8 wk later; a second dose of PPSV23 is given 5 yr after the first.

<sup>g</sup>Regarding T-lymphocyte immunodeficiency as a contraindication for rotavirus vaccine, data exist only for SCID.

**Table 215.11** Vaccination of Persons with Primary and Secondary Immune Deficiencies—cont'd

<sup>a</sup>Age and schedule of doses depend on the product; repeated doses are required.

<sup>b</sup>Pneumococcal vaccine is not indicated for children with chronic granulomatous disease beyond age-based universal recommendations for PCV13. Children with chronic granulomatous disease are not at increased risk for pneumococcal disease.

<sup>c</sup>YF vaccine is contraindicated in HIV-infected children <6 yr old who are highly immunosuppressed. There is a precaution for the use of YF vaccine in asymptomatic HIV-infected children <6 yr old with total lymphocyte percentage of 15–24%, and >6 yr old with CD4<sup>+</sup> T-lymphocyte counts of 200–499 cells/mm<sup>3</sup>. Data from Centers for Disease Control and Prevention. Yellow fever vaccine: recommendations of the Advisory Committee on Immunization Practices, *MMWR Recomm Rep*. 2010;59(RR-07); 1–27.

<sup>d</sup>HIV-infected children should receive immunoglobulin after exposure to measles and may receive varicella vaccine if CD4<sup>+</sup> T-lymphocyte percentage is ≥15% for those <6 yr old or CD4<sup>+</sup> T-lymphocyte count ≥200 cells/mm<sup>3</sup> for those ≥6 yr old. People with perinatal HIV infection who were vaccinated with measles-, rubella-, or mumps-containing vaccine before the establishment of combination antiretroviral therapy (cART) should be considered unvaccinated and should receive two appropriately spaced doses of MMR vaccine once effective cART has been established (at least 6 mo with CD4<sup>+</sup> T lymphocytes ≥15% for children <6 yr old, or CD4<sup>+</sup> T-lymphocyte count ≥200 cells/mm<sup>3</sup> for children ≥6 yr old).

<sup>e</sup>For patients 5–18 yr old who have not received a Hib primary series and a booster dose or at least one Hib dose after age 14 mo.

<sup>f</sup>Withholding inactivated vaccines also is recommended with some forms of immunosuppressive therapy, such as anti-CD20 antibodies, induction or consolidation chemotherapy, or patients with major antibody deficiencies receiving immunoglobulins. Inactivated influenza vaccine is an exception, but consideration should be given to repeating doses of any inactivated vaccine administered during these therapies.

<sup>g</sup>For persons <60 mo old undergoing chemotherapy or radiation therapy who have not received a Hib primary series plus a booster dose or at least one Hib dose after age 14 mo.

<sup>h</sup>For persons >59 mo old who are asplenic and persons ≥15 mo who are undergoing elective splenectomy and who have not received a Hib primary series and a booster dose or at least one Hib dose after age 14 mo.

BCG, Bacille Calmette-Guérin vaccine; CNS, central nervous system; Hib, *Haemophilus influenzae* type b vaccine; HIV/AIDS, human immunodeficiency virus/acquired immunodeficiency syndrome; IG, immunoglobulin; IIV, inactivated influenza vaccine; LAIV4, live-attenuated influenza vaccine; MMR, measles, mumps, rubella vaccine; MMRV, measles-mumps-rubella-varicella; MCV, quadrivalent meningococcal polysaccharide vaccine; MenB, serogroup B meningococcal vaccine; OPV, oral poliovirus vaccine (live); PPSV23, pneumococcal polysaccharide vaccine; SCID, severe combined immunodeficiency disease; VAR, varicella; YF, yellow fever.

Adapted from Immunization in Special Circumstances. In: Kimberlin DW, Barnett ED, Lynfield R, Sawyer MH, eds. *Red Book: 2021–2024 Report of the Committee on Infectious Diseases*, 32nd ed. Itasca, IL: American Academy of Pediatrics; 2021.

immunocompromised poses the following potential concerns: the incidence or severity of some vaccine-preventable diseases is higher, and therefore certain vaccines are recommended specifically for certain conditions; vaccines may be less effective during the period of altered immunocompetence and may need to be repeated when immune competence is restored; and because of altered immunocompetence, some children and adolescents may be at increased risk for an adverse event after receipt of a live-virus vaccine. Live-attenuated vaccines generally are contraindicated in immunocompromised persons. The exceptions include **MMR**, which may be given to a child with HIV infection provided the child is asymptomatic or symptomatic without evidence of severe immunosuppression, and **varicella** vaccine, which may be given to HIV-infected children if the CD4<sup>+</sup> lymphocyte count is at least 15% and the total CD4<sup>+</sup> cell count is >200/mm<sup>3</sup>. MMRV is not recommended in these situations.

Altered immunocompetence is considered a precaution for rotavirus; however, the vaccine is contraindicated in children with severe combined immunodeficiency disease. Inactivated vaccines may be administered to immunocompromised children, although their effectiveness might not be optimal depending on the immune deficit. Children with complement deficiency disorders may receive all vaccines, including live-attenuated vaccines. In contrast, children with phagocytic disorders may receive both inactivated and live-attenuated viral vaccines but not live-attenuated bacterial vaccines.\*

**Corticosteroids can suppress the immune system.** Children receiving corticosteroids (≥2 mg/kg/day or ≥20 mg/day of prednisone or equivalent) for ≥14 days should not receive live vaccines until therapy has been discontinued for at least 1 month. Children on the same dose levels but for <2 weeks may receive live-virus vaccines as soon as therapy is discontinued, although some experts recommend waiting 2 weeks after therapy has been discontinued. Children receiving lower doses of corticosteroids may be vaccinated while receiving therapy.

Children and adolescents with malignancy and those who have undergone solid organ or hematopoietic stem cell transplantation and immunosuppressive or radiation therapy should not receive live-virus and live-bacteria vaccines depending on their immune status. Children who have undergone chemotherapy for leukemia may need to be reimmunized with age-appropriate single doses of previously administered vaccines. Preterm infants generally can be vaccinated at the same chronological age as full-term infants according to the recommended childhood immunization schedule. An exception is the birth dose of HepB. When mother is HBsAg-negative, infants weighing ≥2 kg and who are medically stable should receive a birth dose within the first 24

hours of life. However, HepB should be deferred in infants weighing <2 kg at birth until chronological age 1 month or hospital discharge (whichever is earlier and even if weight is still <2 kg). All preterm, low-birthweight infants born to HBsAg-positive mothers should receive hepatitis B immunoglobulin (HBIG) and HepB vaccine (at separate anatomic sites) within 12 hours of birth. However, such infants should receive an additional three doses of vaccine starting at 30 days of age (see Fig. 215.1). Infants born to HBsAg-positive mothers should be tested for HBsAg and antibody at 9–12 months, or 1–2 months after completion of the HepB series if the series was delayed. If the test is negative for antibody against the surface antigen (anti-HBs), an additional dose of HepB is recommended with testing 1–2 months after the dose. If the child is still antibody negative, an additional two doses of vaccine should be administered.

If the mother's HBsAg status is unknown within 12 hours of birth, administer HepB vaccine regardless of birthweight. For infants weighing <2,000 g, administer HBIG in addition to HepB within 12 hours of birth. Determine the mother's HBsAg status as soon as possible and, if the mother is HBsAg-positive, also administer HBIG to infants weighing ≥2,000 g as soon as possible, but no later than 7 days of age.

**Varicella-zoster immunoglobulin (VarizIG)** is recommended for patients without evidence of immunity to varicella who are at high risk for severe varicella and complications, who have been exposed to varicella or herpes zoster, and for whom varicella vaccine is contraindicated. This includes immunocompromised patients without evidence of immunity, newborn infants whose mothers have signs and symptoms of varicella around the time of delivery (i.e., 5 days before to 2 days after), hospitalized premature infants born at ≥28 weeks of gestation whose mothers do not have evidence of immunity to varicella, hospitalized premature infants born at <28 weeks of gestation or who weigh ≤1,000 g at birth (regardless of their mother's evidence of immunity to varicella), and pregnant women without evidence of immunity.

The ACIP recommends the use of COVID-19 vaccines within the scope of the EUA or fully approved by the FDA based on a Biological License Application for the particular vaccine. Interim ACIP recommendations for the use of COVID-19 vaccines can be found at <https://www.cdc.gov/vaccines/hcp/acip-recs/vacc-specific/covid-19.html>. COVID-19 vaccine and other routine vaccines may be administered on the same day. For more information about COVID-19 vaccines authorized for use in the United States, see <https://www.cdc.gov/vaccines/covid-19/info-by-product/index.html>. Rare serious adverse events have been reported after COVID-19 vaccination, including myocarditis in children older than 5 years of age. The ACIP continues to conclude that the benefits outweigh the risks for rare serious adverse events after COVID-19 vaccination.

\*<https://www.cdc.gov/vaccines/pubs/pinkbook/downloads/appendices/a/immuno-table.pdf>

Some children have situations that are not addressed directly in current immunization schedules. Physicians can use general rules to guide immunization decisions in some of these instances. General Best Practice Guidelines for Immunization (including contraindications and precautions) can be found at <https://www.cdc.gov/vaccines/hcp/acip-recs/general-recs/index.html>. In general, vaccines may be given simultaneously on the same day, whether inactivated or live. Different inactivated vaccines can be administered at any interval between doses. However, because of theoretical concerns about viral interference, different live-attenuated vaccines (MMR, varicella), if not administered on the same day, should be given at least 1 month apart. An inactivated and a live vaccine may be spaced at any interval from each other.

Immunoglobulin does not interfere with inactivated vaccines. However, immunoglobulin can interfere with the immune response to measles vaccine and, by inference, to varicella vaccine. In general, immunoglobulin, if needed, should be administered at least 2 weeks after the measles vaccine. Depending on the dose of immunoglobulin received, MMR should be deferred for as long as 3-11 months. Immunoglobulin is not expected to interfere with the immune response to LAIV4 or rotavirus vaccines.

Certain adult (including pregnancy) immunizations are recommended to decrease the risk of infection in their children; these include influenza virus and pertussis (Tdap).

### PRECAUTIONS AND CONTRAINDICATIONS

Observation of valid precautions and contraindications is critical to ensure that vaccines are used in the safest manner possible and to obtain optimal immunogenicity. When a child presents for immunization with a clinical condition considered a **precaution**, the physician must weigh benefits and risks to that individual child. If benefits are judged to outweigh risks, the vaccine or vaccines in question may be administered. A **contraindication** means the vaccine should not be administered under any circumstances.

A general contraindication for all vaccines is **anaphylactic reaction** to a prior dose. Anaphylactic hypersensitivity to vaccine constituents is also a contraindication. However, if a vaccine is essential, there are desensitizing protocols for some vaccines. The major constituents of concern are *egg proteins* for vaccines grown in eggs; *gelatin*, a stabilizer in many vaccines; and antimicrobial agents. The recommendations for persons with egg allergy were modified as follows: A previous severe allergic reaction to influenza vaccine is a contraindication to future receipt of any influenza vaccine. Persons with a history of egg allergy who have experienced only hives after exposure to egg should receive any flu vaccine appropriate for age and health status. Persons who had symptoms other than hives (e.g., angioedema, respiratory distress, need for emergency medical services or epinephrine) should receive any influenza vaccine appropriate for age and health status annually. If using an influenza vaccine other than Flublok or Flucelvax, administer in a medical setting under supervision of a healthcare provider who is able to recognize and manage severe allergic conditions. LAIV4 should not be used for persons with a history of severe allergic reaction to any component of the vaccine (excluding egg) or to a previous dose of any influenza vaccine. The measles and mumps components of MMR are grown in chick embryo fibroblast tissue culture. However, the amount of egg protein in MMR is so small that there are no special procedures for administering the vaccine to someone with a history of anaphylaxis after egg ingestion.

Vaccines should usually be deferred in children with moderate to severe acute illnesses, regardless of the presence of fever, until the child recovers. *However, children with mild illnesses may be vaccinated.* Studies of undervaccinated children have documented opportunities that were missed because mild illness was used as an invalid contraindication.

Complete tables of contraindications and precautions by vaccine can be found at <https://www.cdc.gov/vaccines/hcp/acip-recs/general-recs/contraindications.html> and as an appendix to the 2024 immunization schedule (<https://www.cdc.gov/vaccines/schedules/hcp/imz/child-adolescent.html#appendix>).

### MEDICAL EXEMPTIONS

All 50 states, the District of Columbia, and Puerto Rico have regulations requiring verification of immunization for childcare and school attendance. This provides direct protection to the immunized population and indirect protection to those unable to be immunized. It also functions to improve timely immunization of children. Regulations also allow for medical exemption from immunization requirements in all 50 states, and the majority of states also have varied regulations that allow for nonmedical exemptions. Rare, medically recognized contraindications are important to observe. Nonmedical exemptions to immunization requirements include exemptions because of religious or philosophical beliefs. Persons with exemptions are at greater risk of vaccine-preventable diseases than the general population. When children with exemptions cluster, as can happen with nonmedical exemptions, the community may be at risk for outbreaks, leading to exposure of children who cannot be protected by vaccination to vaccine-preventable diseases, such as children too young for vaccination and those with medical contraindications. (For more information, see <http://pediatrics.aappublications.org/content/early/2016/08/25/peds.2016-2145>.)

### IMPROVING IMMUNIZATION COVERAGE

Standards for child and adolescent immunization practices have been developed to support achievement of high levels of immunization coverage while providing vaccines in a safe and effective manner and educating parents about risks and benefits of vaccines (Table 215.12).

Pediatric vaccine uptake has decreased since the start of the COVID-19 pandemic resulting in decreased vaccination coverage. This identified decline may indicate that U.S. children and their communities face increased risks for outbreaks of vaccine-preventable diseases (Fig. 215.3).

Despite benefits that vaccines have to offer, many children are underimmunized as a result of not receiving recommended vaccines or not receiving them at the recommended ages. Much of the underimmunization problem can be solved through physician actions. Most children have a regular source of healthcare. However, missed opportunities to provide immunizations at healthcare visits include but are not limited to failure to provide all recommended vaccines that could be administered at a single visit during that visit, failure to provide immunizations to children outside of well child care encounters when contraindications are not present, and referral of children to public health clinics because of inability to pay for vaccines. Simultaneous administration of multiple vaccines is generally safe and effective. When the benefits of simultaneous vaccination are explained, many parents prefer such immunization to making an extra visit. Providing all needed vaccines simultaneously should be the standard of practice.

Only valid contraindications and precautions to vaccine administration should be observed. Ideally, immunizations should be provided during well child visits; however, if no contraindications exist, it is important to administer vaccines at other visits, particularly if the child is behind in the schedule. There is no good evidence that providing immunizations outside of well child care ultimately decreases the number of well child visits.

Financial barriers to immunization should be minimized. Participation in the VFC program allows physicians to receive vaccines at no cost for their eligible patients, which helps such patients get immunized in their medical home.

Several interventions have been shown to help physicians increase immunization coverage in their practices. Reminder systems for children before an appointment or recall systems for children who fail to keep appointments have repeatedly been demonstrated to improve coverage. Assessment and feedback are also important interventions. Many physicians overestimate the immunization coverage among patients they serve and thus are not motivated to make any changes in their practices to improve performance. Assessing the immunization coverage of patients served by an individual physician with feedback of results can be a major motivator for improvement. Often, public health departments can be contacted to provide the assessments and feedback. Alternatively, physicians can perform self-assessment. Review of approximately 60 consecutive charts of 2-year-old children may provide



**Table 215.12** Standards for Child and Adolescent Immunization Practices**AVAILABILITY OF VACCINES**

Vaccination services are readily available.  
 Vaccinations are coordinated with other healthcare services and provided in a medical home when possible.  
 Barriers to vaccination are identified and minimized.  
 Patient costs are minimized.

**ASSESSMENT OF VACCINATION STATUS**

Healthcare professionals review the vaccination and health status of patients at every encounter to determine which vaccines are indicated.  
 Healthcare professionals assess for and follow only medically accepted contraindications.

**EFFECTIVE COMMUNICATION ABOUT VACCINE BENEFITS AND RISKS**

Parents or guardians and patients are educated about the benefits and risks of vaccination in a culturally appropriate manner and in easy-to-understand language.\*  
 Healthcare professionals offer strong and consistent recommendations for all universally recommended vaccines according to the current immunization schedule. They use presumptive language (e.g., these vaccines are routine) and deliver this recommendation in the same manner for all vaccines.  
 Healthcare professionals answer parents' or guardians' and patients' questions thoroughly and emphasize an unwavering commitment to the recommendation. If parents or guardians and patients are hesitant or refuse, healthcare professionals persevere and offer the vaccine again at the next most appropriate time.

**PROPER STORAGE AND ADMINISTRATION OF VACCINES AND DOCUMENTATION OF VACCINATIONS**

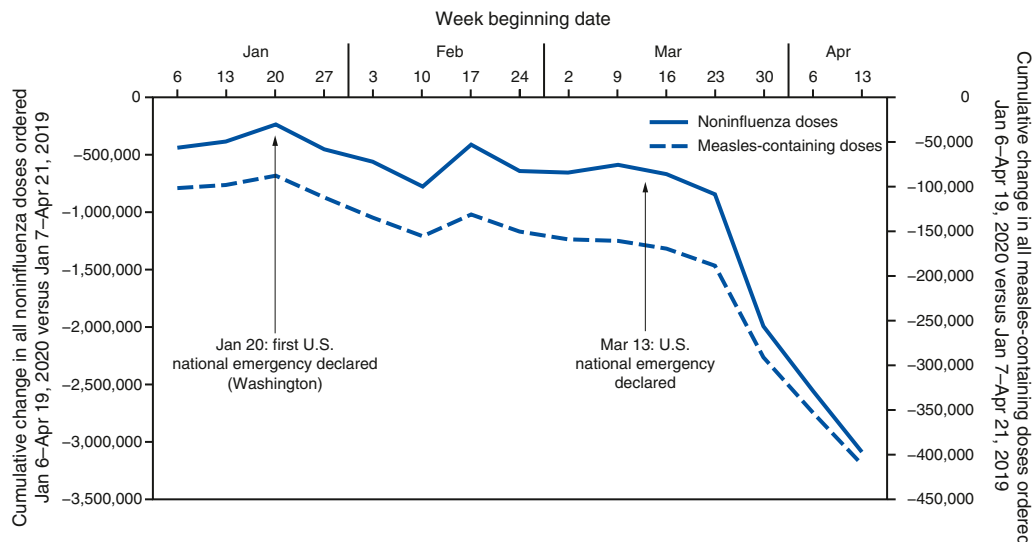
Healthcare professionals follow appropriate procedures for vaccine storage and handling.  
 Up-to-date, written vaccination protocols are accessible at all locations where vaccines are administered.  
 Persons who administer vaccines and staff who manage or support vaccine administration are knowledgeable and receive ongoing education.  
 Healthcare professionals simultaneously administer as many indicated vaccine doses as possible.  
 Vaccination records for patients are accurate, complete, and easily accessible.  
 Healthcare professionals report adverse events after vaccination promptly and accurately to the Vaccine Adverse Event Reporting System (VAERS) and are aware of a separate program, the National Vaccine Injury Compensation Program (VICP).  
 Healthcare professionals and personnel review the immunization timeline with parents or guardians and patients and schedule follow-up immunization visits before the family leaves the care setting.  
 All personnel who have contact with patients are appropriately vaccinated and communicate consistent messages about vaccines.

**IMPLEMENTATION OF STRATEGIES TO IMPROVE VACCINATION COVERAGE**

Systems are used to remind parents or guardians, patients, and healthcare professionals when vaccinations are due and to recall those who are overdue.  
 Office- or clinic-based patient record reviews and vaccination coverage assessments are performed annually.  
 Healthcare professionals practice community-based approaches.  
 Healthcare professionals understand cultural needs and disparities of different populations and use the most effective strategies for these populations.  
 Most healthcare visits (including acute care or sick visits) are viewed as opportunities to review immunization records, provide vaccines that are due, and catch up on missed vaccinations.

\*Additional resources to help improve immunization rates include the following:

- Provider Resources for Vaccine Conversations with Parents from CDC, AAP, and American Academy of Family Physicians ([www.cdc.gov/vaccines/hcp/conversations/index.html](http://www.cdc.gov/vaccines/hcp/conversations/index.html))
  - American Academy of Pediatrics (AAP) Training Guide (<https://shar.es/1JRNmJ>)
  - Centers for Disease Control and Prevention (CDC): *Pink Book*, Chapter 6: Vaccine administration (<https://www.cdc.gov/vaccines/pubs/pinkbook/vac-admin.html>) and quality improvement projects and educational materials (<https://www.cdc.gov/vaccines/ed/index.html>)
  - Immunization Action Coalition: Suggestions to improve your immunization services (<http://www.immunize.org/catg.d/p2045.pdf>)
- Adapted from National Vaccine Advisory Committee. Standards for child and adolescent immunization practices. *Pediatrics*. 2003;112:958–963; and Bernstein HH, Bocchini JA; AAP Committee on Infectious Diseases. The need to optimize adolescent immunization. *Pediatrics*. 2017;139(3):e20164186, and Practical approaches to optimize adolescent immunization. *Pediatrics*. 2017;139(3):e20164187.



**Fig. 215.3** Weekly changes in Vaccines for Children Program (VFC) provider orders\* and Vaccine Safety Datalink (VSD) doses administered† for routine pediatric vaccines — United States, January 6–April 19, 2020. \*VFC data represent the difference in cumulative doses of VFC-funded non-influenza and measles-containing vaccines ordered by healthcare providers at weekly intervals between Jan. 7–Apr. 21, 2019, and Jan. 6–Apr. 19, 2020; †VSD data depict weekly measles-containing vaccine doses administered by age-group (age  $\leq 24$  mo and  $>24$  mo to 18 yr). (From Santoli JM, Lindley MC, DeSilva MB, et al. Effects of the COVID-19 pandemic on routine pediatric vaccine ordering and administration — United States, 2020. *MMWR Morb Mortal Wkly Rep*. 2020;69:591–593.)

a reasonable estimate of practice coverage. Another approach is to have a staff member review the chart of every patient coming in for a visit and placing immunization needs reminders on the chart for the physician. Electronic medical records can be designed to accomplish this goal.

## VACCINE HESITANCY

The World Health Organization (WHO) characterized *vaccine hesitancy* as a delay in acceptance or refusal of vaccines despite availability of vaccination services. The COVID-19 pandemic has also changed the way outpatient care is being delivered across the United States. Because of COVID-19, providers face the additional challenges of maintaining and strengthening routine vaccinations. As communities are reopening, it is vitally important for providers to work with parents to ensure their children stay up to date on routine, universally recommended vaccines. The pandemic is a reminder of the threat of infectious diseases. Providers are well positioned to counsel parents about the value of vaccination. Uptake is highest when parents are aware that their child is due for specific vaccines and when they feel safe about their children receiving those vaccines. Factors implicated in vaccine hesitancy include complacency, convenience, and confidence. The percentage of children having a parent reporting they were “hesitant about childhood shots” was 25.8% in 2018 and 19.5% in 2019 (<https://pediatrics.aappublications.org/content/146/6/e2020007609>). Concerns about vaccine safety and questions about the necessity of vaccines are often cited as reasons for refusal. Vaccine-hesitant individuals are a heterogeneous group, and their individual concerns should be respected and addressed. Multiple studies have shown that the most important factor in persuading parents to accept vaccines remains the *one-on-one contact* with an informed, caring, and concerned pediatrician. Parents should be reassured that vaccines are tested thoroughly before licensure, that ongoing mechanisms of monitoring safety exist after licensure, and that the current vaccine schedule is the only recommended schedule. It is important to stress that serious disease can occur if a child and family are not immunized, because unvaccinated children put medically exempt children who live in that same area at risk, as well as some children who have been vaccinated (although most vaccines are highly effective, no vaccine is 100% effective). Parental education can be provided through reputable sources for vaccine information (see Table 215.8). (For more information, see <http://pediatrics.aappublications.org/content/early/2016/08/25/peds.2016-2146>.) Provider resources for vaccine conversations with parents are available at <https://www.cdc.gov/vaccines/hcp/conversations/index.html>.

Physician concerns about liability should be addressed by appropriate documentation of discussions in the chart. The Committee on Bioethics of the AAP has published guidelines for dealing with parents' refusal of immunization. Physicians also might want to consider having parents sign a **refusal waiver**. A sample refusal-to-vaccinate waiver can be found at <http://www2.aap.org/immunization/pediatricians/pdf/refusaltovaccinate.pdf>.

Visit Elsevier eBooks+ at [eBooks.Health.Elsevier.com](http://eBooks.Health.Elsevier.com) for Bibliography.

## 215.1 International Immunization Practices

W. William Schluter, Kari Johansen, and Tracey Goodman

Given that the epidemiology of infectious diseases varies across countries and continents, it is necessary for vaccination programs to be adapted accordingly. The WHO's Strategic Advisory Group of Experts (SAGE) on immunization evaluates the scientific evidence available for the various vaccines and products and develops advice on global policies and strategies ranging from vaccine type, recommendations for vaccine delivery, links with other health interventions, and suggested vaccine research. Its remit includes all vaccine-preventable infectious diseases for all age-groups. The WHO SAGE recommendations are summarized in the WHO Vaccine Position papers that are updated regularly. The latest information for recommended routine

immunizations for children up to 18 years of age, including recommended ages for the initiation of the primary series and dose intervals, as well as recommendations for subsequent booster doses are listed in Table 215.13.

The WHO policy recommendations are adapted by the Regional and National Immunization Technical Advisory Groups making recommendations to respective country governments. As a consequence, the immunization schedules and the types of vaccines, including the specific vaccine products used, vary substantially. Country-specific immunization schedules have been compiled and are available online (<https://immunizationdata.who.int/listing.html?topic=vaccine-schedule>). Availability and cost play a major role in the choice of vaccine products and schedules in many countries.

According to the WHO recommended schedule, all children should be protected against 12 vaccine-preventable infectious pathogens: *Bordetella pertussis*, *Clostridium tetani*, *Corynebacterium diphtheriae*, *Haemophilus influenzae* type b, hepatitis B virus, human papillomavirus (HPV), measles virus, *Mycobacterium tuberculosis*, poliovirus, rotavirus, rubella virus, and *Streptococcus pneumoniae* (see Table 215.13).

## BIRTH DOSE VACCINES

At birth, hepatitis B vaccine is recommended for all children within 24 hours of birth to prevent perinatal transmission. Additionally, Bacille Calmette-Guérin (BCG) vaccine is recommended at birth in countries or settings with a high incidence of tuberculosis (TB) and/or high leprosy burden, and the first dose of bivalent oral polio vaccine containing poliovirus type 1 and 3 (bOPV) is recommended to be given at birth in polio-endemic countries and in countries at high risk for importation and subsequent spread of poliovirus.

## Primary Infant Series

Infant immunization visits are recommended to begin from the age of 6-8 weeks, with an interval of 4-8 weeks between doses to complete the primary series for protection against hepatitis B, polio, diphtheria, pertussis, tetanus, rotavirus, and invasive bacterial infections caused by *H. influenzae* type b and *S. pneumoniae*. To reduce the number of injections, some of these vaccines are provided in combination vaccines. Rotavirus vaccines are provided orally and can be administered concomitantly with the injectable vaccines and OPV. It should be noted that for all countries using OPV, two doses of injectable IPV are recommended from 14 weeks of age with an interval of at least 4 months between doses.

Two doses of measles vaccines are recommended, with the first dose given at 9-12 months of age and the second dose in the second year of life. Only one dose of rubella given at 9 months of age is sufficient to provide >95% protection. However, when using a rubella-containing vaccine that is combined with measles, it is often easier to provide a second dose using the same MR or MMR vaccine product for both doses, dependent on availability. HPV vaccine is recommended for girls from 9-14 years of age.

## Booster Doses

In addition to the three doses provided in infancy, three booster doses of combination diphtheria toxoid- and tetanus toxoid-containing vaccine should be provided during childhood and adolescence, at 12-23 months (using DTP-containing vaccine), 4-7 years (with DT or Td), and 9-15 years of age (with Td). Ideally, there should be at least 4 years between booster doses. Depending on disease epidemiology, booster doses may also be recommended for Hib and pneumococcal conjugate vaccines. For countries where DTP/DT/Td booster doses are not provided, maternal vaccination with tetanus-containing vaccine (TT or Td) is provided to protect against neonatal and maternal tetanus.

## Vaccination Against Outbreak-Prone Diseases for Endemic Areas

Cholera, Japanese encephalitis, meningococcal conjugate, typhoid, and yellow fever vaccines may be recommended for infants, children, and adolescents living in endemic areas, as shown in Table 215.14.

**Table 215.13** Summary of Recommended Routine Immunization for All Children Up to 18 Years Based on WHO Vaccine Position Papers (updated as of September 2020)

For the most recent version of the respective position papers, the summary tables and further details per vaccine, consult the reference provided here\*:

VACCINE		AGE OF FIRST DOSE	NUMBER OF DOSES IN PRIMARY SERIES	INTERVAL BETWEEN DOSES			BOOSTER DOSE(S) AFTER PRIMARY SERIES	CONSIDERATIONS TO BE MADE
				FIRST TO SECOND	SECOND TO THIRD	THIRD TO FOURTH		
BCG		As soon as possible after birth	1	NA	NA	NA	NA	<ul style="list-style-type: none"> <li>• Universal vs selective vaccination of high-risk groups</li> <li>• Co-administration with hepatitis B and OPV</li> <li>• Birth dose and HIV</li> <li>• Vaccination of older age-groups</li> </ul>
Hepatitis B	Option 1	As soon as possible after birth (<24 hr)	3	4 wk (min) with DTPCV1	4 wk (min) with DTPCV2	NA	NA	<ul style="list-style-type: none"> <li>• Premature and low birthweight infants</li> <li>• Co-administration with other vaccines</li> <li>• High-risk infants</li> </ul>
	Option 2	As soon as possible after birth (<24 hr)	4	4 wk (min) with DTPCV1	4 wk (min) with DTPCV2	4 wk with DTPCV3	NA	
Rotavirus		6 wk (min)	2 or 3 (dependent on product used)	4 wk (min) with DTPCV2	For the three-dose schedule: 4 wk with DTPCV3	NA	NA	<ul style="list-style-type: none"> <li>• Not recommended if child &gt;24 mo old</li> </ul>
DTP-containing vaccine (DTPCV)		6 wk (min)	3	4 wk (min) to 8 wk	4 wk (min) to 8 wk	NA	3 boosters with DTPCV at 12-23 mo, 4-7 yr (Td/DT), and 9-15 yr (Td)	<ul style="list-style-type: none"> <li>• Co-administration with other vaccines/combination vaccines</li> <li>• Maternal immunization if needed</li> </ul>
Hemophilus influenzae type b	Option 1	6 wk (min) to 59 mo (max)	3	4 wk (min) with DTPCV2	4 wk (min) with DTPCV3	NA	At least 6 mo after last dose	<ul style="list-style-type: none"> <li>• Single dose if &gt;12 mo of age</li> <li>• Not recommended for children &gt;5 yr</li> <li>• Co-administration with other vaccines/combination vaccines</li> </ul>
	Option 2	6 wk (min) to 59 mo (max)	2-3	8 wk (min) if only 2 doses 4 wk (min) if 3 doses	4 wk (min) if 3 doses	NA	At least 6 mo (min) after last dose	
Pneumococcal conjugate	Option 1 3p + 0	6 wk (min)	3	4 wk (min)	4 wk	NA		<ul style="list-style-type: none"> <li>• Schedule options</li> <li>• HIV+</li> <li>• Preterm neonate booster</li> </ul>
	Option 2 2p + 1	6 wk (min)	2	8 wk (min)		NA	9-18 mo	
Poliovirus	Option 1 bOPV + IPV	bOPV 6 wk IPV 14 wk	5 (3 bOPV + 2 IPV)	bOPV 4 wk (min) with DTPCV2 IPV 4 mo (min)	bOPV 4 wk (min) with DTPCV3			<ul style="list-style-type: none"> <li>• bOPV birth dose</li> <li>• Fractional dose</li> <li>• Transmission and importation criteria</li> </ul>
	Option 2 IPV/bOPV sequential	8 wk (IPV first)	1-2 IPV 2 bOPV	4-8 wk	4-8 wk	4-8 wk		
	Option 3 IPV-only	8 wk	3	4-8 wk	4-8 wk		Under evaluation	<ul style="list-style-type: none"> <li>• IPV booster needed for early schedule (i.e., first dose given &lt;8 wk)</li> </ul>

**Table 215.13** Summary of Recommended Routine Immunization for All Children Up to 18 Years Based on WHO Vaccine Position Papers (updated as of September 2020)—cont'd

VACCINE	AGE OF FIRST DOSE	NUMBER OF DOSES IN PRIMARY SERIES	INTERVAL BETWEEN DOSES			BOOSTER DOSE(S) AFTER PRIMARY SERIES	CONSIDERATIONS TO BE MADE
			FIRST TO SECOND	SECOND TO THIRD	THIRD TO FOURTH		
Measles	9 or 12 mo	2	4 wk (min)			NA	<ul style="list-style-type: none"> <li>• Combination vaccines</li> <li>• HIV early vaccination</li> <li>• Pregnancy</li> </ul>
Rubella	9 or 12 mo with measles-containing vaccine	1				NA	<ul style="list-style-type: none"> <li>• Achieve and sustain 80% vaccination coverage</li> <li>• Combination vaccine</li> <li>• Pregnancy</li> </ul>
HPV	As soon as possible from 9 yr of age (females only)	2	6 mo (min 5 mo)			NA	<ul style="list-style-type: none"> <li>• Target 9- to 14-yr-old girls</li> <li>• Vaccination during pregnancy to be avoided</li> <li>• Older age &gt;15 yr, HIV, and immunocompromised irrespective of age need three doses</li> </ul>

DTPCV1, DTP-containing vaccine dose 1; NA, not applicable.

\*<https://who.int/teams/immunization-vaccines-and-biologicals/policies/who-recommendations-for-routine-immunization—summary-tables>

Courtesy of the World Health Organization, Department of Immunization, Vaccines and Biologicals. [https://cdn.who.int/media/docs/default-source/immunization/immunization\\_schedules/table\\_2\\_feb\\_2023\\_english.pdf?sfvrsn=3e27ab48\\_11](https://cdn.who.int/media/docs/default-source/immunization/immunization_schedules/table_2_feb_2023_english.pdf?sfvrsn=3e27ab48_11)



**Table 215.14** Summary of Recommended Routine Immunization for Children Residing in Endemic Areas, Belonging to Identified High-Risk Populations or in Countries with More Extensive Vaccination Programs Based on WHO Vaccine Position Papers (updated as of 2020)\*

VACCINE	AGE OF FIRST DOSE	NUMBER OF DOSES IN PRIMARY SERIES	INTERVAL BETWEEN DOSES			BOOSTER DOSE(S) AFTER PRIMARY SERIES	CONSIDERATIONS (SEE FOOTNOTES FOR DETAILS)
			FIRST TO SECOND	SECOND TO THIRD	THIRD TO FOURTH		
<b>RECOMMENDATIONS FOR CHILDREN RESIDING IN CERTAIN REGIONS</b>							
Japanese encephalitis	Option 1. Inactivated Vero cell derived	6 mo	2	4 wk (generally)			Vaccine options Pregnancy Immunocompromised
	Option 2. Live attenuated	8 mo	1				
	Option 3. Live recombinant	9 mo	1				
Yellow fever	9-12 mo with measles-containing vaccine	1					
Tickborne encephalitis	>1 yr FSME-Immun and Encepur >3 yr TBE-Moscow and EnceVir	3	1-3 mo FSME-Immun and Encepur 1-7 mo TBE-Moscow and EnceVir	5-12 mo FSME-Immun and Encepur 12 mo TBE-Moscow and EnceVir			At least 1 every 3 yr Definition of high-risk Vaccine options Timing of booster doses
<b>RECOMMENDATIONS FOR CHILDREN IN SOME HIGH-RISK POPULATIONS</b>							
Typhoid	Option 1. TCV (Typbar)	>6 mo	1				Definition of high risk
	Option 2. Vi PS	2 yr (min)	1				Definition of high risk
	Option 3. Ty21a	Capsules 5 yr	3 or 4	1 day	1 day	1 day	Every 3-7 yr Definition of high risk
Cholera	Dukoral (WC-rBS)	2 yr	3 for 2-5 yr 2 >6 yr	>7 days to 6 wk	>7 days to 6 wk	Every 6 mo Every 2 yr Minimum age Definition of high risk	
	Shancol, Euvichol and mORCVAX	1 yr	2	14 days			After 2 yr
Meningococcal	MenA conjugate	9-18 mo	1				Definition of high risk Vaccine options 2 doses if <9 mo with 8-wk interval
	MenC conjugate	>2-11 mo	2	8 wk			After 1 yr Definition of high-risk Vaccine options
		>12 mo	1				
	Quadrivalent (ACWY)	9-23 mo >2 yr	2 1				Definition of high risk Vaccine options

**Table 215.14** Summary of Recommended Routine Immunization for Children Residing in Endemic Areas, Belonging to Identified High-Risk Populations or in Countries with More Extensive Vaccination Programs Based on WHO Vaccine Position Papers (updated as of 2020)\*—cont'd

VACCINE	AGE OF FIRST DOSE	NUMBER OF DOSES IN PRIMARY SERIES	INTERVAL BETWEEN DOSES			BOOSTER DOSE(S) AFTER PRIMARY SERIES	CONSIDERATIONS (SEE FOOTNOTES FOR DETAILS)
			FIRST TO SECOND	SECOND TO THIRD	THIRD TO FOURTH		
Hepatitis A	1 yr	At least 1					Level of endemicity Vaccine options Definition of high-risk groups
Rabies	As required	2	7 days				Preexposure vs postexposure prophylaxis Definition of high-risk groups
Dengue (CYD-TDV)	9 yr	3	6 mo	6 mo			Prevaccination screening
<b>RECOMMENDATIONS FOR CHILDREN RECEIVING VACCINATIONS IN IMMUNIZATION PROGRAMS WITH CERTAIN CHARACTERISTICS</b>							
Seasonal influenza	Inactivated	6 mo	2 (<9 yr) 1 (≥9 yr)	4 wk		Revaccinate annually, 1 dose	Priority risk groups, especially pregnant women Lower dosage for children 6-35 mo
Mumps	12-18 mo with measles-containing vaccine	2		1 mo min to school entry			Coverage criteria >80% Combination vaccines
Varicella	12-18 mo	1-2		4 wk to 3 mo per manufacturer recommendations			Achieve and sustain >80% coverage necessary Pregnancy Co-administration with other live vaccines

\*<https://www.who.int/teams/immunization-vaccines-and-biologicals/policies/who-recommendations-for-routine-immunization—summary-tables>  
 Courtesy the World Health Organization, Department of Immunization, Vaccines and Biologicals. [https://cdn.who.int/media/docs/default-source/immunization/immunization\\_schedules/table\\_2\\_feb\\_2023\\_english.pdf?sfvrsn=3e27ab48\\_11&download=true](https://cdn.who.int/media/docs/default-source/immunization/immunization_schedules/table_2_feb_2023_english.pdf?sfvrsn=3e27ab48_11&download=true)

Downloaded for mohamed ahmed (dr.mmas2020@gmail.com) at University of Southern California from ClinicalKey.com by Elsevier on April 21, 2024. For personal use only. No other uses without permission. Copyright © 2024. Elsevier Inc. All rights reserved.

**Table 215.15** International Vaccine Websites and Resources

ORGANIZATION	WEBSITE
<b>PUBLIC HEALTH ORGANIZATIONS</b>	
WHO recommendations for routine immunization	<a href="https://www.who.int/teams/immunization-vaccines-and-biologicals/policies/who-recommendations-for-routine-immunization—summary-tables">https://www.who.int/teams/immunization-vaccines-and-biologicals/policies/who-recommendations-for-routine-immunization—summary-tables</a>
WHO Vaccine Position Papers	<a href="https://www.who.int/teams/immunization-vaccines-and-biologicals/policies/position-papers">https://www.who.int/teams/immunization-vaccines-and-biologicals/policies/position-papers</a>
WHO SAGE	<a href="https://www.who.int/groups/strategic-advisory-group-of-experts-on-immunization/about">https://www.who.int/groups/strategic-advisory-group-of-experts-on-immunization/about</a>
Global NITAG network systematic reviews	<a href="https://www.nitag-resource.org">https://www.nitag-resource.org</a>
WHO Regional Office for Africa	<a href="https://www.afro.who.int/">https://www.afro.who.int/</a>
WHO Regional Office for the Americas or Pan American Health Organization	<a href="https://www.paho.org/en">https://www.paho.org/en</a>
WHO Regional Office for the Eastern Mediterranean	<a href="http://www.emro.who.int/index.html">http://www.emro.who.int/index.html</a>
WHO Regional Office for Europe	<a href="https://www.euro.who.int/en">https://www.euro.who.int/en</a>
WHO Regional Office for Southeast Asia	<a href="https://www.who.int/southeastasia">https://www.who.int/southeastasia</a>
WHO Regional Office for the Western Pacific	<a href="https://www.who.int/westernpacific">https://www.who.int/westernpacific</a>
Country-specific vaccination schedules	<a href="https://apps.who.int/immunization_monitoring/globalsummary">https://apps.who.int/immunization_monitoring/globalsummary</a>
Canada provincial and territorial immunization schedule	<a href="https://www.canada.ca/en/public-health/services/provincial-territorial-immunization-information/provincial-territorial-routine-vaccination-programs-infants-children.html">https://www.canada.ca/en/public-health/services/provincial-territorial-immunization-information/provincial-territorial-routine-vaccination-programs-infants-children.html</a>
European Center for Disease Prevention and Control (ECDC)	<a href="https://www.ecdc.europa.eu/en">https://www.ecdc.europa.eu/en</a>
ECDC Vaccine Scheduler	<a href="https://vaccine-schedule.ecdc.europa.eu">https://vaccine-schedule.ecdc.europa.eu</a>
Japan	<a href="https://www.jpeds.or.jp/uploads/files/2020%20English%20JPS%20Imm%20Schedule.pdf">https://www.jpeds.or.jp/uploads/files/2020%20English%20JPS%20Imm%20Schedule.pdf</a>
Mexico National Vaccination Schedule	<a href="https://www.gob.mx/salud/articulos/esquema-de-vacunacion">https://www.gob.mx/salud/articulos/esquema-de-vacunacion</a>
UK immunization schedule	<a href="https://www.gov.uk/government/groups/joint-committee-on-vaccination-and-immunisation">https://www.gov.uk/government/groups/joint-committee-on-vaccination-and-immunisation</a>
UK Immunisation against infectious disease – the Green Book	<a href="https://www.gov.uk/government/collections/immunisation-against-infectious-disease-the-green-book">https://www.gov.uk/government/collections/immunisation-against-infectious-disease-the-green-book</a>
Pan American Health Organization/WHO revolving fund for access to vaccines	<a href="https://www.paho.org/en/revolvingfund">https://www.paho.org/en/revolvingfund</a>
UNICEF Supply Division	<a href="https://www.unicef.org/supply/vaccines">https://www.unicef.org/supply/vaccines</a>
<b>NONPROFIT GROUPS</b>	
GAVI, the Alliance	<a href="http://www.gavialliance.org/">http://www.gavialliance.org/</a>
COVAX facility	<a href="https://www.gavi.org/covax-facility">https://www.gavi.org/covax-facility</a>
Coalition for Epidemic Preparedness Innovations (CEPI)	<a href="https://cepi.net">https://cepi.net</a>

### Vaccine Supply and Production

Since 2000, the Global Alliance for Vaccines and Immunizations (GAVI, now known as *GAVI, The Vaccine Alliance*) has helped expand access to vaccines for infants, children, and adolescents in low-income countries by cost-sharing vaccine introduction and through market-sharing activities to expand vaccine production to drive down vaccine costs. There are other initiatives by the WHO and United Nations Children's Fund (UNICEF) that support pooled vaccine procurement to help expand access to vaccines in low- and middle-income countries. In many low- and middle-income countries, the private vaccine market is increasing. For relevant international vaccine websites and resources, see [Table 215.15](#).

Vaccines are currently produced in many countries around the world, with India hosting the largest vaccine producers that serve many low- and middle-income countries. The number of countries with vaccine production capacity are expected to increase in the coming years as a result of the COVID-19 pandemic. Occasionally counterfeit vaccines have been identified, and therefore vigilant surveillance is needed to ensure safe and effective products reach the end consumer.

### Vaccine Hesitancy and Demand

In addition to access, population willingness to accept vaccination is an important consideration influencing control of vaccine-preventable diseases. In 2019, the WHO declared vaccine hesitancy, which is the reluctance or refusal to accept vaccinations despite availability, as one of the top 10 threats to global health. Vaccination coverage for recommended vaccines varies between countries, and it is estimated that in

2022, 20.5 million children worldwide at the age of 1 year were considered unvaccinated or undervaccinated using DTP3 coverage data collected by UNICEF/WHO. Significant attempts to reach the unvaccinated and undervaccinated are underway, irrespective of the reasons.

### Eradication and Elimination

After the success of the global eradication of smallpox, global eradication or regional disease elimination goals have been adopted for polio, measles, and rubella. In 1988 the World Health Assembly endorsed the goal of eradicating polio from the world by the end of 2000. Although that goal has not yet been reached, endemic wild poliovirus (WPV) transmission in 2023 is limited to two countries worldwide (Afghanistan and Pakistan). The principal eradication strategy has been the use of OPV both for routine immunization and mass supplemental immunization campaigns in endemic or high-risk areas, targeting all children <5 years of age for immunization, regardless of prior immunization status. In areas with low polio population immunity, the OPV virus can mutate over time to develop neurovirulence, similar to WPV. These mutated vaccine viruses are known as *vaccine-derived poliovirus* (VDPV). Since 2018, more paralytic cases have been caused by VDPVs than WPV. Once interruption of WPV transmission is achieved, the goal is to stop the use of OPV.

All six WHO regions have resolved to achieve measles elimination, and five (all but the Eastern Mediterranean region) have rubella elimination goals. In 2015, the Region of the Americas was the first region to achieve rubella elimination and has maintained that status since that time. Regional measles elimination in the Americas was verified in 2016 but was lost in 2018 when measles virus was reintroduced

and continued circulating for more than 12 months in Venezuela and Brazil. Though no other WHO region has achieved certification of regional measles or rubella elimination, national-level certification of elimination is continuing in all regions, with the European Region nearing regional elimination for both measles and rubella.

Goals to eliminate epidemics or to eliminate diseases as a public health problem have not been adopted for other vaccine-preventable diseases that are not eradicable such as bacterial meningitis (*S. pneumoniae*, *N. meningitidis*), cervical cancer (HPV), cholera, hepatitis B, rabies, and tetanus (maternal and neonatal tetanus).

### Vaccine Schedules in High-Income Countries

Immunization schedules in high-income countries are more variable than in low- and low-middle-income countries. In general, in high-income countries where disease incidence may be lower, doses of many vaccines are recommended to be given later than with the WHO recommended schedule. The infant primary series doses are usually given at 2, 3, and 4 months or at 2, 4, and 6 months (as in the United States) instead of starting early at 6 weeks of age. The first dose of measles-containing vaccines are often not administered until 12 months of age or later, with the second dose provided before school entry. Most middle- and high-income countries have moved to sequential IPV/OPV schedules or an IPV-only program with five or six recommended doses using combination vaccines.

Immunization recommendations for Canada are developed by the Canadian National Advisory Committee on Immunization (NACI) but vary by province. The Canadian schedule is similar to the U.S. immunization schedule, with a few exceptions. A birth dose of hepatitis B vaccine is not specifically recommended as it is in the United States, although some Canadian provinces do provide a birth dose. Conjugate meningococcal C vaccine is recommended in a one- or two-dose series, depending on the age at the time of administration (one dose if  $\geq 12$  months). In contrast to the United States, hepatitis A vaccine is not recommended in Canada as a routine pediatric immunization.

In Europe, there is significant variation in vaccines used and the immunization schedules recommended. The number of infectious diseases for which vaccines are offered vary between 12 and 17. As an example, an extensive immunization schedule is offered in the United Kingdom as recommended by the UK Joint Committee on Vaccine and Immunisation (JCVI). In 2023, it includes visits at 2, 3, and 4 months of age, when a combination DTaP-Hib-IPV-HepB vaccine is administered. Infants at high risk of developing hepatitis B infection from infected mothers are given doses of hepatitis B vaccine at birth, 4 weeks, and 1 year of age. MMR is recommended in a two-dose schedule at 12 and 40 months of age. During the second MMR visit, a booster of dTaP-IPV is provided. A Td/IPV booster is recommended at age 14 years. PCV13 is recommended at 3 and 12 months of age. Conjugate meningococcal C vaccine (MenC) is given in combination with a booster dose of Hib at 12 months, whereas MenB is offered at 2, 4, and 12 months of age, and conjugated MenACWY-135 is offered to adolescents at 14 years, with catch-up available up to 25 years of age. HPV vaccine is recommended for females and males at 12-13 years of age, with catch-up vaccination available up to 25 years of age. Rotavirus vaccination is offered at 2 and 3 months of age. Live attenuated influenza vaccine is provided to children 2-10 years of age. BCG is offered at birth in areas of the country with a TB incidence  $>40/100,000$  or in families with a parent or grandparent born in a high-incidence country. As of June 2021, the UK schedule does not include the varicella and hepatitis A vaccines for universal childhood immunization.

Varicella vaccination has been initiated in 12 of the European Union countries, whereas hepatitis A vaccine is only offered routinely in a handful of these countries. However, hepatitis A is often provided to European children ahead of traveling to other regions of the world.

The 2020 Japanese immunization schedule differs from the U.S. schedule, in that a birth dose of hepatitis B vaccine is recommended only for infants born to mothers who test positive for HbsAg. The Japanese do not use MMR, instead recommending MR with mumps vaccine available on a voluntary basis. The recommendation for routine HPV vaccination was suspended in 2013 because of concerns about adverse events but was included for adolescent females in the 2020 schedule.

### VACCINATION OF CHILDREN STARTING IMMUNIZATION OUTSIDE THE UNITED STATES

Some children come to the United States having started or completed international immunization schedules with vaccines produced outside the United States. In general, doses administered in other countries should be considered valid if administered at the same ages as recommended in the United States. For missing doses, age-inappropriate doses, lost immunization records, or other concerns, pediatricians have two options: administer or repeat missing or inappropriate doses, or perform serologic tests and, if they are negative, administer vaccines.

The childhood immunization schedule for China is unique because it recommends a sequential series for polio with IPV at 2 and 3 months of age, followed by OPV at 3 and 4 months of age. The infant primary series with diphtheria-tetanus-pertussis-containing vaccines is recommended at 3, 4, and 5 months of age. Similarly, China's schedule recommends one dose of MR vaccine at 8 months of age followed by one dose of MMR at 18 months.

India's childhood immunization schedule follows the WHO recommendations but includes two fractional doses (one fifth) of a full dose of IPV administered intradermally at 6 and 14 weeks.

Mexico recommends a schedule for pediatric immunization that is largely similar to the schedule in the United States. Some differences include that Mexico recommends the use of BCG and recommends HPV for females, but not males.

### Vaccination Against Outbreak-Prone Diseases

Outbreaks spanning large geographical areas have affected several countries or continents caused by Ebola virus, influenza virus, circulating VDPV, and coronaviruses, including SARS-CoV-2 virus, have highlighted the need for preparedness to develop and assess in formal clinical trials and, if successful, rapidly produce vaccines to be used in outbreak response measures. For the Ebola virus outbreaks first identified in 2014 in West Africa and later in Democratic Republic of Congo, two new vaccines based on the recombinant vector-technology platform were developed, tested, and then used successfully in ring-vaccination outbreak vaccination campaigns.

The 2009 influenza A H1N1 pandemic triggered production of pandemic influenza vaccines (following the strain selection by WHO) by seasonal influenza vaccine producers worldwide, and adjuvants were used by several producers with the aim to be dose-sparing.

The eradication goal for polio and the chosen global strategy using a combination of OPV and IPV and the associated rare adverse event vaccine-induced paralytic polio have triggered development of a new oral poliovirus (nOPV) vaccine. This virus is more genetically stable and maintains an attenuation phenotype that will support the Global Polio Eradication Initiative during the final push to eliminate poliovirus globally, with the most immediate need in ongoing outbreak settings to control and eliminate circulating VDPVs.

The COVID-19 outbreak that started in late 2019 triggered unprecedented vaccine development, with clinical trials being conducted during the ongoing outbreak. Favorable short-term efficacy and safety data have resulted in the emergency use listing of eleven COVID-19 vaccines that were recommended by the WHO. The WHO vaccination recommendations had not been vaccine-product specific until the COVID-19 vaccines were made available. Since January 2021, each of the COVID-19 vaccine products has been recommended individually, because they are based on different technology production platforms and have been assessed in clinical trials including different age-groups and using different endpoints. Vaccination of children and adolescents 6 months of age and older is authorized for two mRNA vaccines. In June 2021, China was the first country globally that approved inactivated COVID-19 vaccines for children age 3-17 years. COVID-19 vaccines are made available globally either through direct contracts between vaccine producers and each country or through the COVAX facility, a global risk-sharing mechanism for pooled procurement and equitable distribution of COVID-19 vaccines.

Visit Elsevier eBooks+ at [eBooks.Elsevier.com](https://eBooks.Elsevier.com) for Bibliography.



## Chapter 216

## Infection Prevention and Control

Kevin P. O'Callaghan and Julia S. Sammons

Infection prevention and control (IPC) programs are a critical and core component of ensuring patient and employee safety in pediatric healthcare systems. The scope of IPC programs is often large and requires a coordinated, well-resourced, multidisciplinary approach. At their heart, IPC programs are designed to prevent the **acquisition** and **transmission** of potentially pathogenic organisms within a healthcare setting. A robust regulatory and policy focus on the prevention of healthcare-associated infections (HAIs) is critical given their frequency. Data from the Centers for Disease Control and Prevention (CDC) National Healthcare Safety Network (NHSN) provides evidence that on any given day approximately 1 in 31 hospitalized patients experiences at least one HAI. Federal and state-level infrastructures that support HAI improvement efforts include the CDC NHSN, which operates a national surveillance system for HAIs, and the Joint Commission's 2022 National Patient Safety Goals. With improved surveillance and detection and focused improvement efforts, preventable events of harm (including HAIs) are now linked by many payors to reduced levels of reimbursement to offset costs associated with these events.

As our understanding of HAIs has developed over time with better surveillance metrics, reporting has expanded beyond the walls of hospitals to include HAIs occurring throughout healthcare systems. This scope includes infections in ambulatory surgical and medical settings, nursing homes, long-term acute care facilities, and even in patients' homes, especially with regard to medical device-associated infections. We have also expanded our understanding of epidemiologic risk factors, environmental pressures, and specific at-risk patient populations. Through a variety of avenues, IPC programs seek to eliminate transmission events and keep patients and employees safe.

### TRANSMISSION IN THE HEALTHCARE SETTING

Fundamentally, transmission in the healthcare setting is multifaceted and multimodal. Patients, their family and caregivers, healthcare personnel, and others interact in a complex environment that is fraught with opportunity for transmission events to occur. Modern understanding of human microbiota informs us that all humans carry a plethora of microorganisms that could potentially be pathogenic in the right circumstances and in the right host. These colonizing microbiotas can be transmitted from one person to another in the healthcare setting through contaminated hands or medical equipment. The majority of infections that arise in healthcare settings occur from endogenous flora representing colonizing organisms. New HAIs require the presence of a number of independent but linked concepts, including a susceptible host, an infectious agent, a portal of entry, and modes of transmission.

Modes of transmission are a critical element of HAI prevention work and include **contact**, **droplet**, and **airborne**. Contact transmission occurs by direct contact with the patient or indirect contact with environmental surfaces or patient care items in the patient's environment that are contaminated with the offending microorganism (e.g., rotavirus). Droplet transmission occurs through large respiratory droplets, which are generated by coughing, sneezing, or talking and typically travel approximately 3 feet from an infectious person (e.g., influenza). These droplets are heavy and do not remain suspended in air for long periods. Airborne transmission occurs through small particles, which can remain suspended in air and can be widely dispersed by air currents (e.g., measles, tuberculosis). Although many infections can occur through transmission directly from an infectious host to a susceptible

host, infections can also occur through contact with contaminated environments, whether through contaminated surfaces, fomites, or previously occupied air spaces.

### PREVENTION STRATEGIES

#### Hand Hygiene

One of the most fundamental elements of infection prevention is hand hygiene; thus one of the most critical elements of an IPC program is hand hygiene education and auditing. Ignaz Semmelweis first postulated the effects of hand hygiene in 1847 when he noted epidemiologic differences in maternal mortality rates secondary to puerperal fever between physician- and midwife-delivered pregnancies. The critical difference was hand hygiene, and this proved to be a seminal finding in the field of infection prevention. Growing evidence of the importance of hand hygiene led to the first national hand hygiene guidelines in the 1980s and the development of international guidance on hand hygiene in healthcare. The World Health Organization (WHO) has developed an internationally used framework for hand hygiene education, called the *5 Moments for Hand Hygiene*. This program provides a structure for recognizing critical moments where hand hygiene can influence a transmission event, including before and after touching a patient, before a clean or aseptic procedure, after a body fluid exposure risk, and after touching patient surroundings (Table 216.1). Use of this or similar frameworks provides a structure for staff education around the practice of hand hygiene and serves as an auditing tool to assess rates of compliance with optimal practice.

Hand hygiene itself is the act of either handwashing (placing hands under running water and using friction with or without a soap product) or using a waterless hygiene product (e.g., alcohol-based foams or gels) to remove the burden of surface flora from the skin and nails of the hand. Alcohol-based hand hygiene products are widely available, are quick and easy to use, and allow for repeated in-the-moment use, such that they are the preferred method for hand hygiene for most healthcare situations. However, because they do not remove visible dirt or debris, handwashing with soap and water is recommended over alcohol-based products after dirty tasks when visible soiling is likely, such as after changing a diaper or using the restroom. Alcohol-based products are also not the preferred agents for certain hardy microbes such as norovirus or *Clostridioides difficile* spores, especially in outbreak settings.

#### Personal Protective Equipment

Personal protective equipment (PPE) is equipment worn to prevent or reduce exposure to potential hazards in the workplace, including infectious diseases. In the healthcare setting, PPE is targeted to prevent exposure of healthcare personnel's skin, eyes, respiratory tract, and mucous membranes to potential infectious agents but is also used to protect patients from the colonizing flora and respiratory secretions of healthcare personnel. Various types of PPE may be used in different settings, with the specific type of PPE tied to the **precautions** that are indicated for a specific patient and/or a specific pathogen. The five primary components of PPE include **gowns**, **gloves**, **masks**, **eye protection**, and **respirators** (e.g., **N95 or Powered Air-Purifying Respirator**). Gowns can either be reusable (launderable) or disposable and are designed to prevent contamination of the provider's clothing, particularly from those infectious agents that are spread through a contact mechanism. Depending on the setting, gowns may be required to be resistant to liquid soaking in order to maximize their effectiveness.

Gloves are used most commonly as a component of standard precautions when performing a task where there is a reasonable expectation of soiling of the hands (e.g., changing a diaper or examining a wound). Importantly, glove use is not required for every moment of patient contact (e.g., routine physical exam), and glove use is not a substitute for effective hand hygiene in breaking the chain of transmission. Therefore gloves should never be used as the only element of infection prevention. Hand hygiene before donning of gloves and after removal of gloves is a critical and necessary step in breaking the chain of transmission.

Face masks and eye protection are intended to prevent exposure of a provider's mouth, nose, and eyes from expectorated and aerosolized pathogens. Protection of the eyes can include clear shields attached

**Table 216.1** Recommendations for Application of Standard Precautions for Care of All Patients in All Healthcare Settings

COMPONENT	RECOMMENDATIONS
Hand hygiene	Before and after each patient contact, regardless of whether gloves are used. After contact with blood, body fluids, secretions, excretions, or contaminated items; immediately after removing gloves; before and after entering patient rooms. Alcohol-containing antiseptic hand rubs preferred except when hands are visibly soiled with blood or other proteinaceous material or if exposure to spores (e.g., <i>Clostridium difficile</i> , <i>Bacillus anthracis</i> ) or nonenveloped viruses (norovirus) is likely to have occurred; in these cases, soap and water is required.
<b>PERSONAL PROTECTIVE EQUIPMENT (PPE)</b>	
Gloves	For touching blood, body fluids, secretions, excretions, or contaminated items; for touching mucous membranes and nonintact skin. Employ hand hygiene before and after glove use.
Gown	During procedures and patient-care activities when contact of clothing or exposed skin with blood, body fluids, secretions, or excretions is anticipated.
Mask, eye protection (goggles), face shield	During procedures and patient-care activities likely to generate splashes or sprays of blood, body fluids, or secretions, such as suctioning and endotracheal intubation, to protect healthcare personnel. For patient protection, use of a mask by the person inserting an epidural anesthesia needle or performing myelograms when prolonged exposure of the puncture site is likely to occur.
Soiled patient-care equipment	Handle in a manner that prevents transfer of microorganisms to others and to the environment. Wear gloves if equipment is visibly contaminated. Perform hand hygiene.
<b>ENVIRONMENT</b>	
Environmental control	Develop procedures for routine care, cleaning, and disinfection of environmental surfaces, especially frequently touched surfaces in patient-care areas.
Textiles (linens) and laundry	Handle in a manner that prevents transfer of microorganisms to others and the environment.
<b>PATIENT CARE</b>	
Injection practices (use of needles and other sharps)	Do not recap, bend, break, or manipulate used needles; if recapping is required, use a one-handed scoop technique only. Use needle-free safety devices when available, placing used sharps in puncture-resistant container. Use a sterile, single-use, disposable needle and syringe for each injection. Single-dose medication vials preferred when medications may be administered to more than one patient.
Patient resuscitation	Use mouthpiece, resuscitation bag, or other ventilation devices to prevent contact with mouth and oral secretions.
Patient placement	Prioritize for single-patient room if patient is at increased risk for transmission, is likely to contaminate the environment, is unable to maintain appropriate hygiene, or is at increased risk for acquiring infection or developing adverse outcome after infection.
Respiratory hygiene/cough etiquette (source containment of infectious respiratory secretions in symptomatic patients) beginning at initial point of encounter, such as triage or reception areas in emergency department or physician office	Instruct symptomatic persons to cover nose/mouth when sneezing or coughing; use tissues with disposal in no-touch receptacles. Employ hand hygiene after soiling of hands with respiratory secretions. Wear surgical mask if tolerated or maintain spatial separation (>3 ft if possible).

Adapted from Kimberlin DW, Brady MT, Jackson MA, et al., eds. *Red Book 2018–2021: Report of the Committee on Infectious Diseases*, 31st ed. Elk Grove Village, IL: American Academy of Pediatrics; 2018:148–150.

directly to surgical masks, separate face shields, or goggles, but protection of both forward-facing and lateral aspects of the ocular region is required.

In the setting of a true aerosolized pathogen, respirator use is indicated. Respirator masks include National Institute of Occupational Safety and Health (NIOSH)–approved N95s, so-called because they filter out up to 95% of particles in the air when used appropriately. Other respirator options that meet international standards include KN95 masks, but these may not meet NIOSH standards and should not be used in lieu of an N95. The use of fitted face mask respirators such as the N95 requires a fit-testing program to ensure that healthcare personnel are using a correctly sized and fitted mask at all times. Alternatives to a fitted respiratory mask include the powered air purifying respirator

(PAPR), which uses a motor and fan to provide constant pressurized air flow from under a loosely fitting hood over the entire head.

### Precautions and Isolation

*Precautions* and *isolation* are terms to describe in a specific patient-care setting which equipment, practices, and procedures should be used to best prevent against a transmission event related to a known or suspected pathogen.

**Standard precautions** are used in any setting in which patient care occurs to prevent transmission of a potential pathogen to or from a healthcare worker, regardless of suspected or confirmed infection status of the patient. These include consistent hand hygiene and use of barrier PPE (gown, glove, mask) as required based on risk of exposure

to blood and body fluids, including expectorations and respiratory secretions (e.g., routine use of mask and eye protection during endotracheal intubation).

**Isolation** procedures, or **transmission-based precautions**, are targeted to prevent transmission of known or suspected pathogens or in the setting of specific syndromes (e.g., infectious diarrhea, upper respiratory tract symptoms). **Contact isolation** typically includes gloves and gown in addition to standard precautions and is used to limit the spread of pathogens by direct contact with a patient (e.g., patients with norovirus). **Droplet isolation** includes protection of mucosal surfaces from expectorated large droplets and should include face mask and eye protection. Some pathogens may spread efficiently by both contact and droplet (e.g., rhinovirus), and thus these two isolation types may be combined as **droplet and contact**.

**Airborne isolation** is used for pathogens that are readily aerosolized and requires the use of eye protection and use of an appropriate respirator (either N95 or PAPR depending on the employee). Additionally, patients with airborne infections require placement in specialized airborne infection isolation rooms (AIIRs), which have specialized air handling that can maintain negative pressure compared with the surrounding environment and have increased air turnovers per unit time.

## ENVIRONMENT, DISINFECTION, AND STERILIZATION

A critical component of preventing transmission of infectious pathogens in healthcare settings includes appropriate environmental cleaning, elimination of potential reservoirs, and disinfection and sterilization of medical equipment.

Maintaining cleanliness (and, where appropriate, sterility) of all patient care spaces, equipment, and medical devices requires an institutional focus on the environment of care that highlights accountability and highly reliable policies and procedures. For each individual healthcare worker, cleanliness of personal medical equipment used in patient care is key. This includes personal stethoscopes, which should be cleaned whenever they are visibly soiled and should be disinfected with an appropriate topical agent (e.g., alcohol) between each use. Similarly, shared patient devices such as thermometers, otoscopes, and ophthalmoscopes should either have disposable single-use covers or should have a cleaning protocol that is adhered to after each patient use.

Higher-level cleaning and disinfection, known as high-level disinfection, are required for reusable items that contact mucous membranes or nonintact skin (e.g., endoscopes), and sterilization is required for critical items that enter sterile tissue or the vascular system (e.g., surgical tools).

## VISITATION AND PATIENT AND CAREGIVER MANAGEMENT

In pediatric healthcare settings, unlike adult settings, patients frequently are accompanied by parents, caregivers, and family members throughout their healthcare experience. Visitor and caregiver management is a critical tool in preventing healthcare transmission events in these settings. Limitation of total numbers of visitors at a bedside may be indicated in the setting of local or seasonal outbreaks of disease, such as during influenza season. Similarly, age-based limitations are commonly used to keep siblings of patients away from the healthcare setting, particularly during the winter respiratory viral season. Visitor screening at points of entry can be effective in identifying caregivers and siblings who may not be presenting for care but have evident symptoms of infection and may need to be excluded from the healthcare setting.

## OCCUPATIONAL HEALTH AND CLINICIAN EDUCATION

Typically, infection prevention and control programs work closely with occupational or employee health programs because both departments have a responsibility for keeping healthcare workers safe from workplace hazards, including infection. Occupational health and IPC programs may work together to develop on-boarding requirements for vaccination for common diseases and programs for seasonal vaccination for influenza. Annual and as-needed education for healthcare workers is an important role of IPC programs, including education

on best practices for hand hygiene, use of PPE, and promoting understanding of patient isolation categories.

## SPECIAL POPULATIONS

### Immunocompromised Hosts

Immunocompromised hosts include those patients with inborn disorders of immunity and patients with iatrogenically caused immune deficits (e.g., patients undergoing chemotherapy, solid organ, or bone marrow transplant or those using immune-modulating therapies). Immunocompromised hosts pose a special infection prevention problem, as they are typically more susceptible to infections that may be common and benign in other patients and more susceptible to infections that are highly unusual in hosts with intact immune systems, such as invasive mold.

The environment of care for these patients may have additional considerations over and above the norm. **Positive pressure ventilation** can be used to provide a protective environment for such patients during periods of highest risk (e.g., immediately after bone marrow transplantation). A focus on air handling capability, including high-efficiency particulate absorbing (HEPA) filtration, is critically important, especially in settings where construction or renovation is ongoing, as this increases the risk of aerosolization of fungal and mold spores.

### Patients with Indwelling Medical Devices

Indwelling medical devices such as pacemakers, orthopedic hardware, intracranial shunts, and indwelling venous catheters pose a special infection risk because of disruption of normal immunologic barriers (e.g., skin) that can allow for communication between sterile and nonsterile spaces and because of the presence of foreign material, which can present a nidus for biofilm formation. IPC programs are frequently involved in quality improvement projects around the optimal insertion and maintenance of such devices, both in the healthcare setting and at home.

### Surveillance and Reporting

In addition to the primary prevention work of an IPC program, another core element includes response to transmission events, which critically includes a surveillance and reporting mechanism. IPC programs typically monitor for events of infection within the healthcare setting, such as surgical site infection or new diagnoses of viral respiratory infection so as to generate data about current trends, detect clusters and outbreaks, and guide future policy. Most states require reporting of healthcare-associated events such as infections to a state- and/or federal-level body such as NHSN.

### Preparedness, Bioresponse, and Public Health

An important additional element of IPC work is preparedness and planning for community-based outbreaks or epidemics that can affect healthcare operations. Planning for low-likelihood, high-risk pathogens such as Ebola virus requires a multidisciplinary planning team, including hospital operations, IPC, clinical teams, transport services, and others. Scheduled periodic retraining of a core group of healthcare workers can increase their comfort in managing the care of these patients and in decreasing the risk of PPE and isolation breaches that could lead to an event of transmission.

In addition to internal systemwide planning, interfacing with public health bodies is an important responsibility of IPC teams. This responsibility includes reporting of notifiable diseases (e.g., sexually transmitted infections [STIs], tuberculosis, measles), which may require a broader public health response in the community. In the absence of positive test results, individual clinician suspicion of a disease is frequently the initial trigger for public health notification, and so an understanding of reporting requirements is important for each healthcare worker.

IPC is increasingly a complex and specialized area of expertise within healthcare operations. However, at its heart it requires the active participation and commitment of every member of the healthcare team. As such, the best way to keep patients safe is to approach every moment of patient interaction as an opportunity to create a safe and clean environment of care.

Visit Elsevier eBooks+ at [eBooks.Health.Elsevier.com](http://eBooks.Health.Elsevier.com) for Bibliography.

## Chapter 217

## Childcare and Communicable Diseases

Gail V. Carter-Hamilton and Susan E. Coffin

More than 20 million children <5 years old attend a childcare facility. These facilities can include part-day or full-day programs at nursery schools or preschools and full-day programs based in either a licensed childcare center or another person's home. Regardless of the age at entry, children entering childcare settings are more prone to infections, largely from the exposure to greater numbers of children.

Childcare facilities can be classified based on the number of children enrolled, ages of attendees, health status of the attendees, and type of setting. As defined in the United States, **childcare facilities** consist of childcare centers, small and large family childcare homes, and facilities for ill children or for children with special needs. Centers are licensed and regulated by state governments and care for a larger number of children than are typically cared for in family homes. In contrast, **family childcare homes** are designated as small (1-6 children) or large (7-12 children), may be full-day or part-day, and may be designed for either daily or sporadic attendance. Family childcare homes generally are not licensed or registered, depending on state requirements.

Although many children who attend childcare facilities are cared for in family childcare homes, most studies of infectious diseases in infants and toddlers have been conducted in childcare centers. Almost any organism has the potential to be spread and to cause disease in a childcare setting. Epidemiologic studies have established that children in childcare facilities are 2-18 times more likely to acquire a variety of infectious diseases than children not enrolled in childcare (Table 217.1).

Children who attend childcare facilities are more likely to receive more courses of antimicrobial agents for longer periods and to acquire antibiotic-resistant organisms. Transmission of infectious agents in group care depends on the age and immune status of the children, season, hygiene practices, crowding, and environmental characteristics of the facilities. The pathogen characteristics, including infectivity, survivability in the environment, and virulence, also influence transmission in childcare settings. Rates of infection, duration of illness, and risk for hospitalization tend to decrease among children in childcare facilities after the first 6 months of attendance and decline to levels observed among homebound children after 3 years of age. Adult caregivers are also at increased risk for acquiring and transmitting infectious diseases, particularly in the first year of working in these settings.

### EPIDEMIOLOGY

**Respiratory tract infections** and **gastroenteritis** are the most common diseases associated with childcare. These infections occur in children and their household contacts and in childcare workers and can spread into the community. The severity of illness caused by a given respiratory and enteric pathogen depends on the person's underlying health status, the inoculum, and prior exposures to the pathogen, either by infection or immunization. Some organisms, such as hepatitis A virus (HAV), can cause subclinical disease in young children and produce overt and sometimes serious disease in older children and adults. Other diseases, such as otitis media and varicella, usually affect children rather than adults. Both infections and infestations of the skin and hair may be acquired through contact with contaminated linens or through close personal contact, which is inevitable in childcare settings.

### RESPIRATORY TRACT INFECTIONS

Respiratory tract infections account for the majority of childcare-related illnesses. Children <2 years old who attend childcare centers have more upper and lower respiratory tract infections than do age-matched

children not in childcare. The organisms responsible for these illnesses are similar to those that circulate in the community and include respiratory syncytial virus (RSV), parainfluenza viruses, influenza viruses, human metapneumoviruses, adenoviruses, rhinoviruses, endemic and epidemic coronaviruses, parvovirus B19, and *Streptococcus pneumoniae*.

Upper respiratory tract infections, including **otitis media**, are among the most common manifestations of these infections. The risk for developing otitis media is 2-3 times greater among children who attend childcare centers than among children cared for at home. Most prescriptions for antibiotics for children <3 years old in childcare are to treat otitis media. These children also are at increased risk for recurrent

**Table 217.1** Infectious Diseases in the Childcare Setting

DISEASE	INCREASED INCIDENCE WITH CHILDCARE
<b>RESPIRATORY TRACT INFECTIONS</b>	
Otitis media	Yes
Sinusitis	Probably
Pharyngitis	Probably
Pneumonia	Yes
<b>GASTROINTESTINAL TRACT INFECTIONS</b>	
Diarrhea (rotavirus, norovirus, calicivirus, astrovirus, enteric adenovirus, <i>Giardia lamblia</i> , <i>Cryptosporidium</i> , <i>Shigella</i> , <i>Escherichia coli</i> O157:H7, and <i>Clostridium difficile</i> )	Yes
Hepatitis A	Yes
<b>SKIN DISEASES</b>	
Impetigo	Probably
Scabies	Probably
Pediculosis	Probably
Tinea (ringworm)	Probably
<b>INVASIVE BACTERIA INFECTIONS</b>	
<i>Haemophilus influenzae</i> type b	No*
<i>Neisseria meningitidis</i>	Probably
<i>Streptococcus pneumoniae</i>	Yes
<b>ASEPTIC MENINGITIS</b>	
Enteroviruses	Probably
<b>HERPESVIRUS INFECTIONS</b>	
Cytomegalovirus	Yes
Varicella-zoster virus	Yes
Herpes simplex virus	Probably
<b>BLOOD-BORNE INFECTIONS</b>	
Hepatitis B	Few case reports
HIV	No cases reported
Hepatitis C	No cases reported
<b>VACCINE-PREVENTABLE DISEASES</b>	
Measles, mumps, rubella, diphtheria, pertussis, tetanus	Not established
Polio	No
<i>H. influenzae</i> type b	No*
Varicella	Yes
Rotavirus	Yes
COVID-19	Yes

\*Not in the post-vaccine era; yes in the pre-vaccine era.



otitis media, further increasing the use of antimicrobial agents in this population. Studies have demonstrated reductions in both otitis media and antibiotic use subsequent to pneumococcal vaccination implementation. Pharyngeal carriage of group A *Streptococcus* occurs earlier among children in childcare; systemic illness may occur including pneumonia, empyema, septic arthritis, or osteomyelitis. **Influenza** vaccination of younger infants reduces influenza infection and secondary sequelae in both the children and the adults who care for them in their home and in childcare settings. After adoption of the acellular pertussis vaccine, increases in clusters and outbreaks of infection caused by *Bordetella pertussis* have led to the recognition of less durable immunity, with older children and adults serving as reservoirs of infection.

Transmission of these organisms typically occurs through either direct or indirect contact with the respiratory droplets of an infected child. In childcare settings, contamination of surfaces occurs frequently as children mouth toys, drool, and cough or sneeze. Additionally, some respiratory pathogens are spread through large droplets that typically can travel 3–6 feet. However, intimate contact between children is a routine part of the play and care of young children, thus facilitating transmission. The most common surfaces from which airborne droplets can be spread are the hands, so the most efficient form of infection control in the childcare setting is good hand hygiene.

### GASTROINTESTINAL TRACT INFECTIONS

Acute infectious **diarrhea** is 2–3 times more common among children in childcare than among children cared for in their homes. Outbreaks of diarrhea, which occur frequently in childcare centers, are usually caused by enteric viruses, such as norovirus, caliciviruses, enteric adenoviruses, and astroviruses, or by enteric parasites such as *Giardia lamblia* or *Cryptosporidium*. A dramatic and sustained decline in the burden of rotavirus infection has been demonstrated since introduction of the rotavirus vaccination program in 2006, and this trend is likely reflected in the population of children attending childcare and early childhood education programs. Bacterial **enteropathogens** such as *Shigella* and *Escherichia coli* O157:H7 and, less often *Campylobacter*, *Clostridium difficile*, and *Bacillus cereus* also have caused outbreaks of diarrhea in childcare settings. *Salmonella* rarely is associated with outbreaks of diarrhea in childcare settings because person-to-person spread of this organism is uncommon.

Outbreaks of **HAV infection** in children enrolled in childcare facilities have resulted in community-wide outbreaks. HAV infection is typically mild or asymptomatic in young children and often is identified only after symptomatic illness becomes apparent among either older children or adult contacts of children in childcare. Enteropathogens and HAV are transmitted in childcare facilities by the fecal-oral route and can also be transmitted through contaminated food or water. Children in diapers constitute a high risk for the spread of gastrointestinal infections through the fecal-oral route. As such, enteric illness and HAV infection are more common in centers that care for children who are not toilet-trained and where proper hygienic practices are not followed. The most common enteropathogens, such as norovirus and *G. lamblia*, are characterized by low infective doses and high rates of asymptomatic excretion among children in childcare, characteristics that facilitate transmission and outbreaks.

### SKIN DISEASES

The most recognized skin infections or infestations in children in childcare are impetigo caused by *Staphylococcus aureus* or group A *Streptococcus*, pediculosis, scabies, tinea capitis, tinea corporis, and molluscum contagiosum. Many of these diseases are spread by contact with infected linens, clothing, hairbrushes, and hats and through direct personal contact; they more often affect children >2 years old. The magnitude of these infections and infestations in children in childcare is not known.

**Parvovirus B19**, which causes fifth disease (erythema infectiosum), is spread through the respiratory route and has been associated with outbreaks in childcare centers. The rash of fifth disease is a systemic manifestation of parvovirus B19 infection; the child is no longer contagious once the rash is present (see Chapter 298). The greatest health hazard is for pregnant women and immunocompromised hosts because of their respective risks for fetal loss and aplastic crisis.

### INVASIVE ORGANISMS AND SYSTEMIC INFECTIONS

Before universal immunization, *Haemophilus influenzae* type b invasive disease was more common among children in childcare than children in home care. Although the largest burden of invasive *H. influenzae* infection in the pediatric population still occurs in children <5 years old, infection is now primarily caused by nontypeable *H. influenzae* or non-type b encapsulated strains of *H. influenzae*; there have been no reported outbreaks of nontypeable or type b *H. influenzae* in >5 years in the United States.

Data suggest that the risk for primary disease caused by *Neisseria meningitidis* is higher among children in childcare than among children in home care. Childcare attendance is also associated with nasopharyngeal carriage of penicillin-resistant *S. pneumoniae* and invasive pneumococcal disease, especially among children with a history of recurrent otitis media and use of antibiotics. Secondary spread of *S. pneumoniae* and *N. meningitidis* has been reported, indicating the potential for outbreaks to occur in this setting. Routine use of pneumococcal conjugate vaccine has decreased the incidence of invasive disease and reduced carriage of serotypes of *S. pneumoniae* contained in the vaccine both in the vaccinated child and in younger siblings. A vaccine against serogroup B meningococcus has been introduced for routine use in children <2 years old in the United Kingdom. It is anticipated that infant vaccination against meningococcus will be adopted in the near future. Outbreaks of aseptic meningitis have been reported among children in childcare centers and among their parents and their teachers.

### HERPESVIRUSES

As many as 70% of diapered children who become infected with **cytomegalovirus (CMV)** shed virus in urine and saliva for prolonged periods. CMV-infected children often transmit the virus to other children with whom they have contact and to their care providers and their mothers at a rate of 8–20% per year. Transmission occurs as a result of contact with either saliva or urine. The overwhelming majority of primary infections with and reactivation of CMV in otherwise healthy children results in asymptomatic shedding of CMV; nonetheless, this shedding can pose a health risk for previously uninfected pregnant childcare providers or immunocompromised persons. A licensed CMV vaccine is not yet available, but research is ongoing, with recent trials demonstrating tolerability and immunogenicity of candidate CMV vaccines (see Chapter 302).

**Varicella** often is transmitted in childcare centers, but routine use of varicella vaccine has reduced this risk. Vaccinated children who become infected with varicella often have mild, atypical symptoms and signs of disease that can result in delayed recognition and spread of infection to susceptible contacts. The role of childcare facilities in the spread of **herpes simplex virus**, especially during episodes of gingivostomatitis, requires further clarification.

### BLOOD-BORNE PATHOGENS

Hepatitis B virus (HBV) transmission has been reported rarely in childcare settings, and transmission of hepatitis C virus (HCV), hepatitis D virus (HDV), and HIV has not been reported in a childcare setting. However, it is impossible to identify every child who might have a blood-borne infection such as hepatitis B, C, or D, or HIV, and it is critical that standard precautions be observed routinely to reduce the risk for transmitting these viruses and other pathogens.

Concerns have been raised about the risk of HIV transmission in childcare settings and the acquisition of opportunistic infections by HIV-infected children who attend childcare, but experience has revealed that this risk is minimal. Children with HIV infection enrolled in childcare facilities should be kept up to date on their vaccines and monitored for exposure to infectious diseases.

Transmission of blood-borne pathogens can theoretically occur when there is contact between blood or body fluids and a mucous membrane or an open wound. Blood-borne pathogens are unlikely to spread by toddler **biting** in a group setting. Most bites do not break the skin, and if a bite does break the skin, the mouth of the biter does not stay on the victim long enough for blood to transfer from the biter to the victim. If there are concerns about transmission of HBV, HCV, or HIV infection, it is recommended to check the status of the biter rather than the bite victim as part of the initial evaluation process.

**ANTIBIOTIC USE AND BACTERIAL RESISTANCE**

Antibiotic resistance has become a major global problem and threatens the health of children who attend childcare facilities because the incidence of infection by organisms resistant to frequently used antimicrobial agents has increased dramatically. It is estimated that children in childcare are 2-4 times more likely to receive an antibiotic and that they receive longer courses of antibiotics compared with age-matched children in homecare. This frequency of antibiotic use combined with the propensity for person-to-person transmission of pathogens in a crowded environment has resulted in an increased prevalence of antibiotic-resistant bacteria in the respiratory and intestinal tracts, including *S. pneumoniae*, *H. influenzae*, *Moraxella catarrhalis*, *E. coli* O157:H7, and *Shigella* spp.

Methicillin-resistant *S. aureus* (MRSA) has historically been found primarily in the healthcare setting but is now prevalent in the community setting. Traditional childcare center attendance is cited as a risk factor for colonization with MRSA, and carriage is associated with increased risk of infection and transmission. Population-based surveillance has demonstrated a rise in both invasive and noninvasive MRSA infections in community settings over the past 2 decades. Currently, large-scale studies investigating the epidemiology of *S. aureus* in the childcare setting are limited.

**PREVENTION**

Written policies designed to prevent or to control the spread of infectious agents in a childcare center should be available and should be reviewed regularly. All programs should use a health consultant to help with development and implementation of infection prevention and control (IPC) policies (see Chapter 216). Standards for environmental and personal hygiene should include maintenance of current immunization records for both children and staff, appropriate policies for exclusion of ill children and caretakers, targeting of potentially contaminated areas for frequent cleaning, adherence to appropriate

procedures for changing diapers, appropriate handling of food, management of pets, and surveillance for and reporting of communicable diseases. Staff whose primary function is preparing food should not change diapers. Appropriate and thorough **hand hygiene** is the most important factor for reducing infectious diseases in the childcare setting. Strategies for improving adherence to these standards should be implemented. Children at risk for introducing an infectious disease should not attend childcare until they are no longer contagious (Tables 217.2 and 217.3).

Routine vaccination is proven to improve the health of children in childcare settings. In the United States, there are 17 diseases and organisms against which all children should be immunized unless there are contraindications: diphtheria, pertussis, tetanus, measles, mumps, rubella, polio, hepatitis A and hepatitis B, varicella, *H. influenzae* type b, *S. pneumoniae*, rotavirus, *N. meningitidis*, influenza, COVID-19, and human papillomavirus (see Chapter 215). Rates of immunization among children in licensed childcare facilities are high, in part because of laws in almost all states that require age-appropriate immunizations of children who attend licensed childcare programs. Vaccines against influenza, *H. influenzae* type b, hepatitis B, rotavirus, varicella, *S. pneumoniae*, COVID-19, and hepatitis A are of particular benefit to children in childcare centers.

**Childcare providers** should receive all immunizations that are recommended routinely for adults, including tetanus and diphtheria toxoids and acellular pertussis (Tdap) booster, influenza, and COVID-19 vaccines and should have a preemployment health evaluation, with a tuberculin skin test or interferon-γ release blood assay. Local public health authorities should be notified of cases of reportable communicable disease that occur in children or providers in childcare settings.

**STANDARDS**

Every state has specific standards for licensing and reviewing childcare centers and family childcare homes. The American Academy of Pediatrics, American Public Health Association, and National Resource

**Table 217.2** Disease- or Condition-Specific Recommendations for Exclusion of Children in Out-of-Home Childcare

CONDITION	MANAGEMENT OF CASE	MANAGEMENT OF CONTACTS
COVID-19	Return to class after 10 days from onset and no fever for at least 24 hr without antipyretics.	Varies and evolving but many include being tested ≥5 days from exposure, wearing a mask, checking for symptoms, stay at home if symptoms develop (see latest recommendations at CDC) (see also Chapter 311).
<i>Clostridium difficile</i>	Exclusion until stools are contained in the diaper or child is continent and stool frequency is no more than two stools above that child's normal frequency for the time the child is in the program. Stool consistency does not need to return to normal to be able to return to childcare. Neither test of cure nor repeat testing should be performed for asymptomatic children in whom <i>C. difficile</i> was diagnosed previously.	Symptomatic contacts should be excluded until stools are contained in the diaper or child is continent and stool frequency is no more than two stools above that child's normal frequency for the time the child is in the program. Testing is not required for asymptomatic contacts.
Hepatitis A virus (HAV) infection	Serologic testing to confirm HAV infection in suspected cases. Exclusion until 1 wk after onset of illness.	In facilities with diapered children, if one or more cases confirmed in child or staff attendees or two or more cases in households of staff or attendees, hepatitis A vaccine (HepA) or immune globulin intramuscular (IGIM) should be administered within 14 days of exposure to all unimmunized staff and attendees. In centers without diapered children, HepA or IGIM should be administered to unimmunized classroom contacts of index case. Asymptomatic IGIM recipients may return after receipt of IGIM.
Impetigo	No exclusion if treatment has been initiated and as long as lesions on exposed skin are covered.	No intervention unless additional lesions develop.
Measles	Exclusion until 4 days after beginning of rash and when the child is able to participate.	Immunize exposed children without evidence of immunity within 72hr of exposure. Children who do not receive vaccine within 72hr or who remain unimmunized after exposure should be excluded until at least 2wk after onset of rash in the last case of measles.

Continued

**Table 217.2** Disease- or Condition-Specific Recommendations for Exclusion of Children in Out-of-Home Childcare—cont'd

CONDITION	MANAGEMENT OF CASE	MANAGEMENT OF CONTACTS
Mumps	Exclusion until 5 days after onset of parotid gland swelling.	In outbreak setting, people without documentation of immunity should be immunized or excluded. Immediate readmission may occur after immunization. Unimmunized people should be excluded for 26 or more days after onset of parotitis in last case. A second dose of MMR vaccine (or MMRV, if age appropriate) should be offered to all students (including those in postsecondary school) and to all healthcare personnel born in or after 1957 who have only received one dose of MMR vaccine. A second dose of MMR also may be considered during outbreaks for preschool-age children who have received one MMR dose. People previously vaccinated with two doses of a mumps-containing vaccine who are identified by public health as at increased risk for mumps because of an outbreak should receive a third dose of a mumps-containing vaccine to improve protection against mumps disease and related complications.
Pediculosis capitis (head lice) infestation	Treatment at end of program day and readmission on completion of first treatment. Children should not be excluded or sent home early from school because of head lice, because this infestation has low contagion within classrooms.	Household and close contacts should be examined and treated if infested. No exclusion necessary.
Pertussis	Exclusion until completion of 5 days of the recommended course of antimicrobial therapy if pertussis is suspected. Children and providers who refuse treatment should be excluded until 21 days have elapsed from cough onset.	Immunization and chemoprophylaxis should be administered as recommended for household contacts. Symptomatic children and staff should be excluded until completion of 5 days of antimicrobial therapy. Untreated adults should be excluded until 21 days after onset of cough.
Rubella	Exclusion for 7 days after onset of rash for postnatal infection.	During an outbreak, children without evidence of immunity should be immunized or excluded for 21 days after onset of rash of the last case in the outbreak. Pregnant contacts should be evaluated.
Infection with <i>Salmonella</i> serotypes Typhi or Paratyphi	Exclusion until three consecutive stool cultures obtained at least 48 hr after cessation of antimicrobial therapy are negative, stools are contained in the diaper or child is continent, and stool frequency is no more than two stools above that child's normal frequency for the time the child is in the program.	When <i>Salmonella</i> serotype Typhi infection is identified in a child care staff member, local or state health departments may be consulted regarding regulations for length of exclusion and testing, which may vary by jurisdiction.
Infection with nontyphoidal <i>Salmonella</i> spp., <i>Salmonella</i> of unknown serotype	Exclusion until stools are contained in the diaper or child is continent and stool frequency is no more than two stools above that child's normal frequency for the time the child is in the program. Stool consistency does not need to return to normal to be able to return to childcare. Negative stool culture results <i>not</i> required for nonserotype Typhi or Paratyphi <i>Salmonella</i> spp.	Symptomatic contacts should be excluded until stools are contained in the diaper or child is continent and stool frequency is no more than two stools above that child's normal frequency for the time the child is in the program. Stool cultures are not required for asymptomatic contacts.
Scabies	Exclusion until after treatment given.	Close contacts with prolonged skin-to-skin contact should receive prophylactic therapy. Bedding and clothing in contact with skin of infected people should be laundered.
Infection with Shiga toxin-producing <i>Escherichia coli</i> (STEC), including <i>E. coli</i> O157:H7	Exclusion until two stool cultures (obtained at least 48 hr after any antimicrobial therapy, if administered, has been discontinued) are negative, stools are contained in the diaper or child is continent, and stool frequency is no more than two stools above that child's normal frequency. Some state health departments have less stringent exclusion policies for children who have recovered from less virulent STEC infection.	Meticulous hand hygiene; stool cultures should be performed for any symptomatic contacts. In outbreak situations involving virulent STEC strains, stool cultures of asymptomatic contacts may aid in controlling spread. Center(s) with cases should be closed to new admissions during STEC outbreak.
Shigellosis	Exclusion until treatment complete and one or more posttreatment stool cultures are negative for <i>Shigella</i> spp., stools are contained in the diaper or child is continent, and stool frequency is no more than two stools above that child's normal frequency for the time the child is in the program. Some states may require more than one negative stool culture.	Meticulous hand hygiene; stool cultures should be performed for any symptomatic contacts.

Table 217.2 Disease- or Condition-Specific Recommendations for Exclusion of Children in Out-of-Home Childcare—cont'd		
CONDITION	MANAGEMENT OF CASE	MANAGEMENT OF CONTACTS
<i>Staphylococcus aureus</i> skin infections	Exclusion only if skin lesions are draining and cannot be covered with a watertight dressing.	Meticulous hand hygiene; cultures of contacts are not recommended.
Streptococcal pharyngitis	Exclusion until at least 12 hr after treatment has been initiated.	Symptomatic contacts of documented cases of group A streptococcal infection should be tested and treated if test results are positive.
Tuberculosis	Most children younger than 10yr are not considered contagious. For those with active disease, exclusion until determined to be noninfectious by physician or health department authority. No exclusion for latent tuberculosis infection (LTBI).	Local health department personnel should be informed for contact investigation.
Varicella	Exclusion until all lesions have crusted or, in immunized people without crusts, until no new lesions appear within a 24-hr period.	For people without evidence of immunity, varicella vaccine should be administered, ideally within 3 days, but up to 5 days after exposure, or when indicated, varicella-zoster immune globulin (VariZIG) should be administered up to 10 days after exposure; if VariZIG is not available, intravenous immunoglobulin (IGIV) should be considered as an alternative. If vaccine cannot be administered and VariZIG/IGIV is not indicated, preemptive oral acyclovir or valacyclovir can be considered.

From Kimberlin DW, Barnett ED, Lynfield R, Sawyer MH, eds. *Red Book: 2021–2024 Report of the Committee on Infectious Diseases*, 32nd ed. Itasca, IL: American Academy of Pediatrics; 2021, Table 2.3, pp. 128–132.

Table 217.3 Recommendations for Inclusion or Exclusion of Childcare*	
<p><b>CHILDREN NEED NOT BE EXCLUDED FOR A MINOR ILLNESS UNLESS ANY OF THE FOLLOWING EXISTS:</b></p> <ul style="list-style-type: none"> <li>• The illness prevents the child from participating comfortably in program activities.</li> <li>• The illness results in a greater care need than the childcare staff can provide without compromising the health and safety of the other children.</li> <li>• The child has any of the following conditions: fever, unusual lethargy, irritability, persistent crying, difficulty breathing, or other signs of possible severe illness.</li> <li>• Diarrhea (defined as an increased number of stools compared with the child's normal pattern, with increased stool water and/or decreased form) that is not contained by diapers or toilet use.</li> <li>• Vomiting two or more times in the previous 24 hours, unless the vomiting is determined to be caused by a noncommunicable condition and the child is not in danger of dehydration.</li> <li>• Mouth sores associated with an inability of the child to control his or her saliva, unless the child's physician or local health department authority states that the child is noninfectious.</li> <li>• Rash with fever or behavior change, until a physician has determined the illness to not be a communicable disease.</li> <li>• Purulent conjunctivitis (defined as pink or red conjunctiva with white or yellow eye discharge, often with matted eyelids after sleep and eye pain or redness of the eyelids or skin surrounding the eye), until examined by a physician and approved to readmission, with or without treatment.</li> <li>• Tuberculosis, until the child's physician or local health department authority states that the child is noninfectious.</li> </ul>	<ul style="list-style-type: none"> <li>• Impetigo, until 24 hours after treatment has been initiated.</li> <li>• Streptococcal pharyngitis, until 24 hours after treatment has been initiated and unless the child has been afebrile for 24 hours.</li> <li>• Head lice (pediculosis), until the morning after the first treatment.</li> <li>• Scabies, until after treatment has been completed.</li> <li>• Varicella, until the sixth day after the onset of rash or sooner if all lesions have dried and crusted.</li> <li>• Pertussis (which is confirmed by laboratory or suspected based on symptoms of the illness or because of cough onset within 14 days of having face-to-face contact with a person in a household or classroom who has a laboratory-confirmed case of pertussis), until 5 days of appropriate antibiotic therapy (currently: erythromycin) has been completed (total course of treatment is 14 days).</li> <li>• Mumps, until 9 days after onset of parotid gland swelling.</li> <li>• Hepatitis A virus infection, until 1 week after onset of illness and jaundice, if present, has disappeared or until passive immunoprophylaxis (immune serum globulin) has been administered to appropriate children and staff in the program, as directed by the responsible health department.</li> </ul> <p>Certain conditions do not constitute a prior reason for excluding a child from childcare unless the child would be excluded by the above criteria or the disease is determined by a health authority to contribute to transmission of the illness at the program. These conditions include the following: a symptomatic excretion of an enteropathogen; nonpurulent conjunctivitis (defined as pink conjunctiva with a clear, watery eye discharge and without fever, eye pain, or eyelid redness); rash without fever and without behavior change; cytomegalovirus infection; hepatitis B virus carrier state; and HIV infection.</p>

\*Child and caregiver-specific exclusion policies reflect the present state of knowledge. From Centers for Disease Control and Prevention: <https://dhealth.dc.gov/sites/default/files/dc/sites/doh/publication/attachments/Recommendations%20for%20Inclusion%20or%20Exclusion%20CDC.pdf>

Center jointly publish comprehensive health and safety performance standards that can be used by pediatricians and other healthcare professionals to guide decisions about management of infectious diseases in childcare facilities (available at <http://nrckids.org/CFOC>). Additionally, the **National Association for the Education of Young Children (NAEYC)**, a professional organization supporting early childhood education efforts and volunteer accreditation, is gaining recognition as

a resource for health and safety standards for childcare facilities (<http://www.naeyc.org/>). Specific standards set by all states can be reviewed at the U.S. Department of Health and Human Services' **National Center on Early Childhood Quality Assurance** website (<https://childcareta.cf.hhs.gov/licensing>).

Visit Elsevier eBooks+ at [eBooks.Elsevier.com](http://eBooks.Elsevier.com) for Bibliography.



## Chapter 218

# Health Advice for Children Traveling Internationally

John C. Christenson and James G. Carlucci

Children are traveling internationally with increasing frequency and to more exotic destinations that pose unique injury and disease risks. Compared to adults, children are *less* likely to receive pretravel advice and *more* likely to be seen by a medical provider or be hospitalized on return for a travel-related illness. Primary care providers are confronted with the challenge of trying to ensure safe, healthy travel for their patients, whether travel is occurring for purposes of tourism, study abroad, visiting friends and relatives, or volunteerism. Whenever possible, health professionals are encouraged to consult with **travel medicine specialists**, especially when uncertain about pretravel advice, unique travel medicine vaccines (e.g., yellow fever, Japanese encephalitis, typhoid, rabies), and recommendations for malaria medications.

**Travel medicine** is a unique specialty, and experienced travel medicine practitioners provide specialized guidance on the infectious and noninfectious risks based on age, itinerary, duration, season, purpose of travel, and underlying traveler characteristics (health and vaccination status). A **pretravel consultation** includes the essential elements of (1) safety and preventive counseling against injuries and diseases, (2) routine, recommended, and required vaccinations, based on individual risk assessment, (3) counseling and medications for self-treatment of traveler's diarrhea, and (4) when indicated by itinerary, malaria chemoprophylaxis (Table 218.1).

In the United States, recommendations and vaccine requirements for travel to different countries are provided by the Centers for Disease Control and Prevention (CDC) and are available online at <https://wwwnc.cdc.gov/travel/page/yellowbook-home> (Table 218.2). Some travel vaccines and medications may not be recommended based on specifics of travel itinerary, trip duration, or patient characteristics. Alternatively, some vaccinations are not approved for younger children because of lack of data or limited immunologic response but may still confer potential benefit to the young traveler with off-label vaccine administration. In both scenarios, consultation or referral to a knowledgeable travel medicine practitioner is encouraged, especially if uncertainty exists regarding pretravel recommendations.

## THE PEDIATRIC TRAVEL MEDICINE CONSULTATION

Parents of traveling children should seek medical consultation at least 1 month before departure to review the travel itinerary, obtain safety and preventive counseling, ensure adequate vaccinations (routine, recommended, and required), receive necessary medications for chronic health conditions, and obtain important medications for self-treatment of traveler's diarrhea and, when indicated, malaria chemoprophylaxis with counseling. Advice, vaccinations, and medications should be emphasized as important measures, with the provider goal of keeping the child healthy during travel rather than to discourage traveling.

## Pediatric Travelers Visiting Friends and Relatives

Compared to most children traveling internationally, the **pediatric visiting-friends-and-relatives (VFR) traveler** is the most vulnerable population uniquely at risk for travel-related illnesses. VFR travelers may include immigrants, refugees, migrants, students, or displaced persons who are traveling back to their country of origin for the purposes of visiting friends and relatives. Pediatric VFR travelers are typically children accompanying their parents or family members back to their ancestral country, where relational, social, and cultural connections remain. Compared to tourist travelers, VFR travelers are more likely to travel for longer durations, visit more remote destinations, travel by

higher-risk local transportation modes, experience closer contact with the local population, and use fewer insect, food, and water precautions. Adult and pediatric VFR travelers are also less likely to perceive a risk of travel-related illnesses, seek pretravel advice, receive travel immunizations, or use effective malaria prophylaxis on arrival in the destination country. VFR travel comprises ~60% of imported malaria in U.S. children (i.e., malaria acquired outside the United States), and pediatric VFR travelers are reported to be 25 times more likely than tourist travelers to acquire malaria. Among all travelers, unvaccinated pediatric VFR travelers remain at higher risk for contracting and having symptomatic illness caused by hepatitis A virus. Several studies suggest that VFR travelers are at disproportionate risk of acquiring typhoid fever and possibly tuberculosis as well.

## SAFETY AND PREVENTIVE COUNSELING TOPICS

### Health and Evacuation Insurance, Underlying Health Conditions, and Medications

Parents should be made aware that their medical insurance policy might not provide coverage for hospitalizations or medical emergencies in foreign countries and is unlikely to cover the high cost of an emergency medical evacuation. Supplemental **travel medical insurance** and **evacuation insurance** may be purchased and are especially recommended for prolonged travel itineraries, for remote destinations, and for children with higher-risk preexistent health conditions going to countries where inpatient care at a level comparable to the traveler's home country may not be available. Information regarding medical and evacuation insurance providers can be found at the U.S. Department of State International Travel advisory website (<https://travel.state.gov/content/travel/en/international-travel/before-you-go/your-health-abroad/insurance-providers-overseas.html>) and the CDC Travel Health website (<https://wwwnc.cdc.gov/travel/page/insurance>).

Parents of children with medical conditions should take with them a brief medical summary and a sufficient supply of prescription medications for their children, with bottles that are clearly identified by prescription labels. For children requiring care by specialists, an international directory for that specialty can be consulted. A directory of physicians worldwide who speak English and who have met certain qualifications is available from the International Society of Travel Medicine (<https://www.istm.org>). If medical care is needed urgently when abroad, sources of information include the U.S. embassy or consulate, hotel managers, travel agents catering to foreign tourists, and missionary hospitals.

A travel health kit consisting of prescription medications and non-prescription items, such as acetaminophen, an antihistamine, oral rehydration solution packets, antibiotic ointment, bandages, insect repellent (DEET or picaridin), and sunscreen, is highly recommended for all children. Children with persistent asthma should have bronchodilators and oral corticosteroids prescribed for treatment of any acute asthma exacerbations encountered during overseas travel. Children with a history of angioedema, anaphylaxis, or severe allergies to food or insects should have an epinephrine autoinjector (EpiPen) and antihistamines available for use during travel.

Parents and family members should be aware of the prevalence of *counterfeit medication* and lack of quality control of medications in many areas of the world, particularly in low- and middle-income countries. Critical medications, including insulin and newly prescribed antimalarials, should be purchased before international travel and packed in original prescription containers.

## Safety and Injury Prevention

**Motor vehicle accidents** are a leading cause of traumatic injuries, hospitalizations, and deaths, both in pediatric and adult travelers. Differences in traffic patterns and regulations (e.g., right- vs. left-hand traffic and pedestrian right of way) should be emphasized to children, and the use of safety belts should be reinforced. When possible, child safety seats should be taken on the trip. Parents should also be aware of additional risks for small children that may exist overseas, such as open balconies, windows without screens or bars, exposed wires and electrical outlets, paint chips, pest and rodent poison, and stray animals.

**Table 218.1** Checklist of Items to Address in the Pretravel Consultation

CATEGORY	ISSUES THAT SHOULD BE ADDRESSED
Patient risk assessment	Obtain history: itinerary, type of travel, personal medical history, age, underlying diseases, allergies, current medications, pregnancy status, previous vaccination status
Immunizations	Update routine immunizations Provide routine travel immunizations Provide destination-specific immunizations
Malaria prophylaxis	If indicated: Provide malaria education and advice; discuss bite-avoidance measures Prescribe antimalaria prophylaxis
Traveler's diarrhea	Prescribe oral rehydration therapy and loperamide (Imodium)* Prescribe appropriate antibiotic (see Table 218.4)
Prevention against mosquito bites	Give advice regarding mosquito-borne disease Discuss personal protection measures
Rabies prevention	Give advice regarding behavior near animals Discuss measures to take if bitten or scratched by an animal—seek urgent medical advice Administer vaccine when indicated
Prevention of sexually transmitted diseases	Provide education regarding safe sex
Zika virus	Discuss potential risk of congenital Zika syndrome for pregnant women or women/men planning to conceive after return from an endemic area

Some of the recommendations are indicated only for specific destinations or specific at-risk groups.

\*Contraindicated in bacterial diarrhea, dysentery.

Modified from Matson KB, Siraj DS. Travel medicine. In Kellerman RD, Rakei DP, Heidelbaugh JJ, Lee EM, eds. *Conn's Current Therapy 2023*. Philadelphia: Elsevier; 2023: Table 2, p. 1474.

**Water-related activities** also are associated with significant injuries in pediatric travelers, and pools and oceanfronts are often unsupervised and without lifeguards at overseas destinations. Injuries to children on flights are also well-documented. Children should not sit in aisle seats, as they can be injured by aisle traffic, service carts, and falling objects from overhead storage bins.

### Animal Contact

Among travelers, attacks from domestic or stray animals are much more likely to occur than attacks from wild animals. Wounds from animal bites present a risk for bacterial infections, tetanus, and rabies. **Dogs** are responsible for >95% of all **rabies** transmission in Asia, Africa, and Latin America. Globally, the World Health Organization (WHO) estimates that approximately 59,000 human deaths result from rabies each year, with the vast majority of cases occurring in South Asia, Southeast Asia, and Africa. Rabies transmission is reported less frequently after bites from cats and other carnivores, monkeys, and bats. Macaque monkeys native to Asia and North Africa can be found in urban centers and tourist sites and pose a risk for rabies and herpes B virus infections after bites and scratches.

Young children are more likely to be bitten and experience more severe facial wounds because of their short stature. They are at higher risk for rabies exposure from dogs and other animals during travel and require greater supervision. Parents should always encourage their children to report bite injuries and to avoid petting, feeding, or handling dogs, monkeys, and stray animals. Before travel, tetanus vaccinations need to be current for all travelers. Children, long-term travelers, expatriates, and all individuals likely to come into contact with animals in a rabies-endemic region (primarily Africa and South and Southeast Asia) should consider preexposure vaccination for rabies before international travel (see Rabies later). Bite or scratch wounds should be washed thoroughly and for a prolonged time ( $\geq 15$  minutes) with copious water and soap. Local wound care will substantially reduce the risk of canine and other mammalian rabies transmission. Rabies **post-exposure vaccination** and rabies immunoglobulin is likely indicated in most cases, and medical care should be sought emergently. Antibiotics (e.g., amoxicillin-clavulanate) may need to be administered to a child to prevent secondary infections, especially for animal bites involving the hands and head/neck areas.

### ROUTINE CHILDHOOD VACCINATIONS REQUIRED FOR PEDIATRIC TRAVEL

Parents should allow at least 4 weeks before departure for optimal administration of vaccines to their children. All children who travel should be immunized according to the routine childhood immunization schedule with all vaccines appropriate for their age. The immunization schedule can be accelerated to maximize protection for traveling children, especially for unvaccinated or incompletely vaccinated children (see Fig. 215.1 in Chapter 215). Routine and catch-up childhood vaccine schedules can be found at the CDC website (<https://www.cdc.gov/vaccines/schedules/>).

Live-attenuated viral vaccines should be administered concurrently or  $\geq 4$  weeks apart to minimize immunologic interference. Intramuscular immunoglobulin administration interferes with the immune response to measles immunization and possibly to varicella immunization. If a child requires measles or varicella immunization, the vaccines should be given either 2 weeks before or 3 months after immunoglobulin administration (longer with higher doses of intravenous immunoglobulin). Immunoglobulin does not interfere with the immune response to oral typhoid, poliovirus, or yellow fever vaccines.

Vaccine products produced in eggs (yellow fever, influenza) may be associated with hypersensitivity responses, including anaphylaxis in persons with known severe **egg sensitivity**. Screening by inquiring about adverse effects when eating eggs is a reasonable way to identify those at risk for anaphylaxis from receiving influenza or yellow fever vaccines. Although measles and mumps vaccines are produced in chick embryo cell cultures, children with egg allergy are at very low risk for anaphylaxis with these vaccines.

### Diphtheria-Tetanus-Pertussis

Children traveling internationally should be fully vaccinated with diphtheria and tetanus toxoids and acellular pertussis (DTaP), having completed the fourth or fifth booster dose by 4-6 years of age. A single dose of an adolescent/adult preparation of tetanus and diphtheria toxoids and acellular pertussis (Tdap) vaccine is recommended at 11-12 years of age for those who have completed the recommended primary DTaP (or DTP) series.

Adolescents and adults should receive a single Tdap booster if >5 years have elapsed since the last dose, since a tetanus-containing booster (Td or Tdap) may not be readily available for tetanus-prone wounds during international travel or in remote settings (e.g., adventure travel, wilderness).

### Haemophilus influenzae Type b

*Haemophilus influenzae* type b (Hib) remains a leading cause of meningitis in children 6 months to 3 years of age in many low- and middle-income countries. Before they travel, all unimmunized children <5 years old should be vaccinated against Hib (see Chapter 215). A single dose of Hib vaccine should also be administered to unvaccinated or

partially vaccinated children  $\geq 5$  years old if they have anatomic or functional asplenia, sickle cell disease, HIV infection, leukemia, malignancy, or other immunocompromising condition. Unvaccinated children  $> 5$  years old do not need vaccination unless they have a high-risk condition.

### Hepatitis A

Hepatitis A is a routine childhood vaccine in the United States but requires special considerations in the traveling pediatric patient. Protection from hepatitis A in specific children may also involve the provision of immunoglobulin. For these reasons, hepatitis A vaccination is covered later in Specialized Pediatric Travel Vaccinations.

### Hepatitis B

Hepatitis B can be a travel-associated infection. Hepatitis B is highly prevalent throughout much of the world, including areas of South America, sub-Saharan Africa, Eastern and Southeastern Asia, and most of the Pacific basin. In certain parts of the world, 8–15% of the population may be chronically infected. Disease can be transmitted by blood transfusions not screened for hepatitis B surface antigen, exposure to unsterilized needles, close contact with local children who have open skin lesions, and sexual exposure. Exposure to hepatitis B is more likely for travelers residing for prolonged periods in endemic areas. Partial protection may be provided by one or two doses, but ideally three doses should be given before travel. For unvaccinated adolescents, a three-dose hepatitis B vaccine series should be administered, with a minimum interval of 4 weeks between the first and second doses, 8 weeks between the second and third doses, and at least 16 weeks between the first and third doses.

All unvaccinated children and adolescents should receive the accelerated hepatitis B vaccine series before travel. Because one or two doses provide some protection, hepatitis B vaccination should be initiated even if the full series cannot be completed before travel.

### Respiratory Viruses

Infections by respiratory viruses such as influenza and SARS-CoV-2 are well recognized as a cause of morbidity among adult and pediatric travelers. Disease caused by these viruses can be prevented through vaccination. The risk for exposure to influenza during international travel varies depending on the time of year, destination, and close contact with infected persons. During the peak of the SARS-CoV-2 pandemic, the use of lockdowns and quarantine, masks, and physical distancing used in many countries to control the spread of SARS-CoV-2 greatly altered the epidemiology of influenza and other respiratory viruses, resulting in few reported infections. More recently, influenza appears to have returned to its “traditional” seasonality.

Influenza vaccination is recommended for all children older than 6 months of age and for adults. Vaccines against SARS-CoV-2 are also available (for persons  $\geq 6$  months of age) and are recommended to prevent severe disease, hospitalization, and death. **Oseltamivir** can be used to treat (and prevent) influenza infections. Antivirals are available to treat serious SARS-CoV-2 infections, especially for high-risk individuals.

There are no available vaccines effective against avian influenza strains such as influenza A H5N1 and H7N9, which have become a great concern worldwide. Because these strains of influenza virus are spread through contact with infected birds, precautions include avoiding direct contact with birds or surfaces with bird droppings, avoiding poultry farms or bird markets, eating only well-cooked poultry or products, and washing hands frequently. **Oseltamivir** is the antiviral of choice to treat infections caused by these viruses.

### Measles-Mumps-Rubella

Measles is still endemic in many low- and middle-income countries and in some industrialized nations. It remains a leading cause of vaccine-preventable death in much of the world. Vaccine status for measles is important for all traveling children, particularly if they are traveling to low- and middle-income countries or areas with measles outbreaks. Measles vaccine, preferably in combination with mumps and rubella vaccines (MMR), should be given to all children at 12–15

months and at 4–6 years of age, unless there is a contraindication (see [Chapter 215](#)). In children traveling internationally, the second vaccination can be given as soon as 4 weeks after the first to induce immunity among those children who did not respond to the first MMR vaccine.

Children 6–12 months old traveling to low- and middle-income countries should be vaccinated early. The monovalent measles vaccine is not available in the United States, so MMR can be administered. Early vaccination (i.e., 6–12 months of age) will provide some immunity to measles, but antibody response may not be durable or lasting. Therefore any MMR vaccine administered before 12 months of age should not be counted toward the routine vaccination schedule; children vaccinated early for purposes of international travel must be revaccinated on or after their first birthday with two doses separated by at least 4 weeks. Infants  $< 6$  months old are generally protected by maternal antibodies (assuming the mother has previously been immunized against measles or had natural infection) and would not need early MMR vaccination before travel.

### Pneumococcal Vaccines

*Streptococcus pneumoniae* is the leading cause of childhood bacterial pneumonia and is among the leading causes of bacteremia and bacterial meningitis in children in low- and middle-income and industrialized nations. Preparing a child to travel internationally includes routine or catch-up vaccination with 20-valent pneumococcal conjugate vaccine (PCV20) and, for children with certain high-risk conditions, use of 23-valent pneumococcal polysaccharide vaccine (PPSV23). A single dose of PCV20 should be administered to previously unvaccinated children 6–18 years old with underlying high-risk medical conditions, including anatomic or functional asplenia (including sickle cell disease), HIV infection, a congenital immunodeficiency or immunocompromising condition, chronic heart or lung disease, chronic renal failure or nephrotic syndrome, diabetes mellitus, cerebrospinal fluid leak, or cochlear implant. The Advisory Committee on Immunization Practices (ACIP) also recommends that high-risk children  $\geq 2$  years old receive the PPSV23 vaccine  $\geq 8$  weeks after their last PCV13 dose. ACIP recommendations on prevention of pneumococcal disease among infants and children using PCV13 and PPSV23 can be found at <http://www.cdc.gov/vaccines/hcp/acip-recs/vacc-specific/pneumo.html>.

### Polio Vaccine

Poliomyelitis (wild type) was eradicated from the Western Hemisphere in 1991. Polio remains endemic in two countries—Afghanistan and Pakistan—with additional surrounding countries at risk for importation of polio. Unfortunately, many other countries throughout the world, mainly Africa, are experiencing infections by vaccine-derived poliovirus. The poliovirus vaccination schedule in the United States is a four-dose, all-inactivated poliovirus (IPV) regimen (see [Chapter 215](#)). Traveling infants should begin the IPV series as early as 6 weeks of age (for an accelerated dosing schedule for children, see [Fig. 215.1](#) and [Table 215.1](#)). Length of immunity conferred by IPV immunization is not known; a single booster dose of IPV is therefore recommended for previously vaccinated adolescents and adults traveling to polio-endemic areas if approximately 10 years have elapsed since they completed their primary series. Oral poliovirus vaccine is no longer available in the United States.

### Varicella

All children  $\geq 12$  months old who have no history of varicella vaccination or chickenpox should be vaccinated unless there is a contraindication to vaccination (see [Chapter 215](#)). Unlike measles vaccine (see earlier), varicella vaccine is not approved or recommended for traveling children 6–12 months of age. Infants  $< 6$  months old are generally protected by maternal antibodies. All children now require two doses, the first at 12 months of age and the second at 4–6 years. The second dose can be given as soon as 3 months after the first dose. For unvaccinated children  $\geq 13$  years old, the first and second doses can be separated by 4 weeks.

## SPECIALIZED PEDIATRIC TRAVEL VACCINATIONS

[Table 218.2](#) summarizes the dosages and age restrictions of vaccines specifically given to children traveling internationally.



## Cholera

Cholera is present in many low- and middle-income countries, but the risk for infection among travelers to these countries is extremely low. Travelers entering countries reporting cholera outbreaks are at minimal risk of acquiring cholera if they take adequate safe food and water precautions and practice frequent handwashing. No country or territory currently requires cholera vaccination as a condition for entry. Of note, a live-attenuated, single-dose oral suspension vaccine is licensed in the United States to prevent disease in travelers 2–64 years of age visiting endemic regions.

## Hepatitis A Vaccination and Preexposure Immunoglobulin

Hepatitis A virus (HAV) is endemic in most of the world, and travelers are at risk, even if their travel is restricted to the usual tourist routes. HAV infection can result from eating shellfish harvested from sewage-contaminated waters, eating unwashed vegetables or fruits, or eating food prepared by an asymptomatic HAV carrier. Young children infected with hepatitis A are often asymptomatic but can transmit infection to unvaccinated older children and adults, who are more likely to develop clinical hepatitis. Few areas carry no risk of HAV infection, and therefore immunization is recommended for all travelers. Hepatitis A vaccine (HepA) is recommended in the United States for universal immunization of all children  $\geq 12$  months old, administered as two doses 6 months apart. A single dose of HepA vaccine given to travelers will provide adequate protection. Protective immunity develops within 2 weeks after the initial vaccine dose. A combined three-dose HepA and hepatitis B vaccine (Twinrix, GlaxoSmithKline) is available in the United States but is licensed for use only in individuals  $>18$  years old. Pediatric combination hepatitis A–hepatitis B vaccine (HepA–HepB) (Twinrix–Junior, GlaxoSmithKline) is licensed for use in children 1–18 years old in Canada and Europe. In many countries, a combination hepatitis A–typhoid fever vaccine is available for persons  $>16$  years of age.

Children  $<1$  year old are at lower risk of clinical HAV infection, especially if they are breastfed or residing in areas with safe water for formula reconstitution. Some experts recommend use of preexposure intramuscular immunoglobulin for children  $<6$  months who are traveling internationally to higher-risk destinations, particularly low-income destinations or regions where hygienic or sanitary conditions are limited. However, administration of immunoglobulin diminishes the immunogenicity of live-virus vaccines, in particular measles vaccine, that may be needed for infant travelers. Vaccination against measles should occur  $\geq 2$  weeks before any immunoglobulin administration, and a 3-month interval is suggested between immunoglobulin administration and subsequent measles immunization.

Because measles-endemic countries frequently overlap with higher-risk travel destinations for HAV infection, HepA vaccine is recommended for infant travelers 6–11 months of age. Several studies demonstrate that infants as young as 6 months will develop antibodies after HepA, especially if there are no interfering maternal antibodies from prior maternal vaccination or disease. There is potential for a more durable immune response to the HepA vaccination, especially in later infancy, when potential interfering maternal antibody concentrations are lower. If early HepA vaccination is given rather than immunoglobulin to infant travelers (age 6–11 months), it should not count toward the routine two-dose vaccine series. Similar to MMR vaccination, an informed decision should be made with the parents, balancing the risk of travel-associated disease and vaccine adverse events with the potential protective benefit to the traveling infant.

## Japanese Encephalitis

Japanese encephalitis is a disease transmitted by mosquitoes in many areas of Asia, especially in rural farming areas. Although it is a leading cause of vaccine-preventable encephalitis in children in many Asian countries and parts of western Pacific countries, the risk of disease to nonimmune travelers is low. A map showing where Japanese encephalitis transmission occurs can be found at <https://wwwnc.cdc.gov/travel/yellowbook/2024/infections-diseases/japanese-encephalitis>.

Most human infections with **Japanese encephalitis virus (JEV)** are asymptomatic, and  $<1\%$  of individuals develop clinical disease. With

symptomatic disease, the fatality rate is 20–30%, and the incidence of neurologic or psychiatric sequelae in survivors is 30–50%. The risk of JEV disease for pediatric travelers is unknown, but among all travelers, it is estimated to be less than 1 case per 1 million travelers to Asia. However, if residing in a rural area with active JEV transmission in the rainy season, the risk may increase to 5–50 cases per 100,000 population per year. Risk of Japanese encephalitis neurologic disease after mosquito-bite transmission is thought to be higher in children than in adults. The disease occurs primarily from June to September in temperate zones and throughout the entire year in tropical zones. Vaccination is recommended for travelers planning visits  $>1$  months to rural areas of Asia, where the disease is endemic, especially areas of rice or pig farming. Vaccination is recommended for shorter visits to such areas if the traveler will often be outdoors or where increased disease activity is reported. Risk for infection can be greatly reduced by following the standard precautions to avoid mosquito bites.

The inactivated Vero cell culture–derived Japanese encephalitis vaccine (Ixiaro) has replaced the older inactivated mouse brain–derived vaccine (JE-VAX), which is no longer manufactured. Japanese encephalitis vaccine efficacy is  $>95\%$  in adults who receive two doses administered 7–28 days apart. The licensed range for Japanese encephalitis vaccine has been extended to include children as young as 2 months, with a dose administered on days 0 and 28.

## Meningococcal Vaccines

Meningococcal vaccines currently available in the United States include two quadrivalent conjugate A/C/Y/W-135 vaccines, MenACWY-CRM (Menveo) and MenACWY-TT (MenQuadfi), and two meningococcal B vaccines (Bexsero, Trumenba).

Children traveling to those equatorial countries in sub-Saharan Africa (i.e., the “meningitis belt”) where the incidence of meningococcal disease (especially group A) is highest should receive a *Neisseria meningitidis* quadrivalent vaccine, especially if travel is prolonged or occurs during the dry season of December to June. Risk is greatest in the meningitis belt of sub-Saharan Africa, with rates of meningococcal disease in endemic regions reaching up to 1,000 cases per 100,000 population per year. Vaccination programs for resident populations with a monovalent group A vaccine in highly endemic areas have resulted in a decrease in cases of invasive disease. In recent years, other serogroups have become more prevalent. Conjugate A/C/Y/W-135 vaccines are available to pediatric travelers  $\geq 2$  months of age, but the dosing schedule varies by product and age, as outlined in [Table 218.2](#). Booster doses of conjugate A/C/Y/W-135 should occur every 3–5 years for travelers returning to endemic areas, depending on the age of the pediatric traveler. Providers may also want to consider meningococcal vaccination for other pediatric travelers, especially if there is remote or rural travel within low-income countries with limited healthcare access, because meningococcal outbreaks can occur anywhere in the world. Proof of receipt of quadrivalent meningococcal vaccination is also necessary for individuals traveling to Saudi Arabia for the annual Hajj or Umrah pilgrimage.

Serogroups A and C are most often associated with epidemics of meningitis in sub-Saharan Africa, especially in the meningitis belt of equatorial Africa during the dry season months (December to June). Serogroups Y and W-135 have also been found in meningococcal outbreaks. Serogroup B is associated with more sporadic cases of invasive meningococcal disease in industrialized countries, including the United States. Routine vaccination of travelers with meningococcal B vaccine is currently not recommended. Additional vaccine information on meningococcal vaccination regimens and booster intervals can be found at the CDC website (<https://wwwnc.cdc.gov/travel/yellowbook/2024/infections-diseases/meningococcal-disease>).

## Rabies

Rabies is endemic in many countries in Africa, Asia, and Central and South America. Children are at particular risk because they are less likely to report bites and because facial bites are more common in children. Rabies has the potential for an extended latency period (months) and is uniformly fatal once the clinical symptoms emerge. **Preexposure prophylaxis** is recommended for ambulatory children with extended



**Table 218.2** Travel Vaccine Summary Table

VACCINE	TRADE NAME (MFR)	AGE	DOSE	ROUTE	SCHEDULE	BOOSTER
Cholera CVD 103-HgR vaccine	Vaxchora (PaxVax)	18-64 yr	100 mL (reconstituted)	Oral	1 dose <sup>1</sup>	Undetermined <sup>2</sup>
Hepatitis A vaccine, inactivated	Havrix (GlaxoSmithKline)	1-18 yr	0.5 mL (720 ELISA units)	IM	0 and 6-12 mo	None
		≥19 yr	1.0 mL (1,440 ELISA units)	IM	0 and 6-12 mo	None
Hepatitis A vaccine, inactivated	Vaqta (Merck & Co., Inc.)	1-18 yr	0.5 mL (25 U)	IM	0 and 6-18 mo	None
		≥19 yr	1.0 mL (50 U)	IM	0 and 6-18 mo	None
Hepatitis B vaccine, recombinant with novel adjuvant (1018)	Heplisav-B (Dynavax Technologies Corp.)	>18	0.5 mL (20 µg HBsAg and 3,000 µg of 1018)	IM	0, 1 mo	None
Hepatitis B vaccine, recombinant <sup>2,3</sup>	Engerix-B (GlaxoSmithKline)	0-19 yr	0.5 mL (10 µg HBsAg)	IM	0, 1, 6 mo	None
		0-10 yr (accelerated)	0.5 mL (10 µg HBsAg)	IM	0, 1, 2 mo	12 mo
		11-19 yr (accelerated)	1 mL (20 µg HBsAg)	IM	0, 1, 2 mo	12 mo
		≥20 yr (primary)	1 mL (20 µg HBsAg)	IM	0, 1, 6 mo	None
		≥20 yr (accelerated)	1 mL (20 µg HBsAg)	IM	0, 1, 2 mo	12 mo
Hepatitis B vaccine, recombinant <sup>2,3</sup>	Recombivax HB (Merck & Co., Inc.)	0-19 yr (primary)	0.5 mL (5 µg HBsAg)	IM	0, 1, 6 mo	None
		11-15 yr (adolescent accelerated)	1 mL (10 µg HBsAg)	IM	0, 4-6 mo	None
		≥20 yr (primary)	1 mL (10 µg HBsAg)	IM	0, 1, 6 mo	None
Combined hepatitis A and hepatitis B vaccine	Twinrix (GlaxoSmithKline)	≥18 yr (primary)	1.0 mL (720 ELU HAV + 20 µg HBsAg)	IM	0, 1, 6 mo	None
		≥18 yr (accelerated)	1.0 mL (720 ELU HAV + 20 µg HBsAg)	IM	0, 7, and 21-30 days	12 mo
Japanese encephalitis vaccine, inactivated	Ixiaro (Valneva)	2 mo to 2 yr	0.25 mL	IM	0, 28 days	≥1 year after primary series <sup>4</sup>
		3-17 yr	0.5 mL	IM	0, 28 days	≥1 yr after primary series <sup>4</sup>
		18-65 yr	0.5 mL	IM	0, 7-28 days	≥1 yr after primary series <sup>4</sup>
		>65 yr	0.5 mL	IM	0, 28 days	≥1 yr after primary series <sup>4</sup>
Meningococcal polysaccharide tetanus toxoid conjugate vaccine (MenACWY-TT) <sup>5</sup>	MenQuadfi (Sanofi Pasteur)	≥2 yr	0.5 mL	IM	1 dose <sup>6</sup>	If at continued risk <sup>7</sup>
Meningococcal oligosaccharide diphtheria CRM <sup>197</sup> conjugate vaccine (MenACWY-CRM) <sup>5</sup>	Menveo (GSK)	2-12 mo	0.5 mL	IM	0, 2, 4, 10 mo	If at continued risk <sup>7</sup>
		7-23 yr	0.5 mL	IM	0, 3 mo (second dose administered in second year of life)	
		≥2 yr	0.5 mL	IM	1 dose <sup>6</sup>	

**Table 218.2** Travel Vaccine Summary Table—cont'd

VACCINE	TRADE NAME (MFR)	AGE	DOSE	ROUTE	SCHEDULE	BOOSTER
Polio vaccine, inactivated	IPOL (Sanofi Pasteur)	≥18 yr	0.5 mL	SC or IM	1 dose if patient has completed a pediatric series	Repeat boosters may be needed for long-term travelers to polio-affected countries; see Chapter 296
Rabies vaccine (human diploid cell)	Imovax (Sanofi Pasteur)	Any	1 mL	IM	Preexposure series: days 0, 7, and 21 or 28 days	None; see Chapter 320 for postexposure immunization
Rabies vaccine (purified chick embryo cell)	RabAvert (Novartis)	Any	1 mL	IM	Preexposure series: days 0, 7, and 21 or 28 days	None; see Chapter 320 for postexposure immunization
Typhoid vaccine (oral, live, attenuated)	Vivotif (PaxVax)	≥6 yr	1 capsule <sup>8</sup>	Oral	0, 2, 4, 6 days	Repeat primary series after 5 yr
Typhoid vaccine (Vi capsular polysaccharide)	Typhim Vi (Sanofi Pasteur)	≥2 yr	0.5 mL	IM	1 dose	2 yr
Yellow fever	YF-Vax (Sanofi Pasteur)	≥9 mo <sup>9</sup>	0.5 mL <sup>10</sup>	SC	1 dose	Not recommended for most <sup>11</sup>

<sup>1</sup>Must be administered in a healthcare setting.

<sup>2</sup>In a clinical trial, vaccine efficacy was 90% at 10 days postvaccination and declined to 80% at 3 months postvaccination in prevention of severe diarrhea after oral cholera challenge. Long-term immunogenicity is unknown. Clinicians advising travelers who are at continued or repeated risk over an extended period may consider revaccination, although the appropriate interval and efficacy are unknown.

<sup>3</sup>Consult the prescribing information for differences in dosing for hemodialysis and other immunocompromised patients.

<sup>4</sup>If potential for Japanese encephalitis virus exposure continues.

<sup>5</sup>If an infant is receiving the vaccine before travel, two doses may be administered as early as 8 wk apart.

<sup>6</sup>People with HIV, anatomic or functional asplenia, and persistent complement deficiencies (C3, C5-9, properdin, factor D, and factor H or people taking eculizumab [Soliris]) should receive a two-dose primary series 8-12 wk apart.

<sup>7</sup>Revaccination with meningococcal conjugate vaccine (MenACWY-D or MenACWY-CRM) is recommended after 3 yr for children who received their last dose at <7 yr of age.

Revaccination with meningococcal conjugate vaccine is recommended after 5 yr for people who received their last dose at ≥7 yr of age and every 5 yr thereafter for people who are at continued risk.

<sup>8</sup>Must be kept refrigerated at 35.6°F to 46.4°F (2°C to 8°C); administer with cool liquid no warmer than 98.6°F (37°C).

<sup>9</sup>Ages 6-8 mo and ≥60 yr are precautions and age <6 mo is a contraindication to the use of yellow fever vaccine.

<sup>10</sup>YF Vax is available in single-dose and multiple-dose (five-dose) vials.

<sup>11</sup>For full details regarding revaccination, see <https://wwwnc.cdc.gov/travel/page/yellow-book-resources>.

ACIP, Advisory Committee on Immunization Practices; ELU, ELISA units of inactivated HAV; HAV, hepatitis A virus; HBsAg, hepatitis B surface antigen; IM, intramuscular; U, units HAV antigen; SC, subcutaneous.

From Centers for Disease Control and Prevention (CDC). International travel with infants and children: Yellow Book 2024. Atlanta: CDC, 2024. <https://wwwnc.cdc.gov/travel/yellowbook>

travel to high-risk regions, especially expatriate children and younger children traveling to or living in rural areas where enzootic dog rabies is endemic. Rabies preexposure vaccination should also be considered for adventure travelers (e.g., hikers, bikers), individuals likely to come into contact with rabies vectors (e.g., students working with animal or bat conservation), or travelers with itineraries to rabies-endemic regions where timely, effective **postexposure prophylaxis** might not be available after an animal bite. Most animal bites in a rabies-endemic area should be considered a medical emergency, especially bites from stray dogs, other carnivores, and bats. Immediate and copious wound irrigation should be followed by prompt administration of appropriate postexposure rabies prophylaxis at a medical facility. Postexposure prophylaxis is required even for persons who received preexposure vaccination. Algorithms for preexposure and postexposure vaccination are the same regardless of patient age.

Numerous rabies vaccine formulations exist around the world. In the United States, two rabies vaccines are available: human diploid cell vaccine (HDCV; Imovax, Sanofi Pasteur, SA) and purified chick embryo cell vaccine (PCEC; RabAvert, Novartis). Preexposure prophylaxis is given intramuscularly (HDCV or PCEC) as two doses (1 mL) on days 0 and 7. For previously unvaccinated individuals, postexposure

prophylaxis is given as four doses (1 mL) of HDCV or PCEC vaccine intramuscularly on days 0, 3, 7, and 14. A fifth dose is recommended at day 28 for immunocompromised individuals. For previously vaccinated individuals, only two doses (1 mL) intramuscularly on days 0 and 3 are recommended. Previously unvaccinated persons should also receive rabies immunoglobulin (RIG, 20 IU/kg), with as much of the dose as possible infiltrated around the wound site at the time of initial postexposure prophylaxis. Previously vaccinated persons do not require RIG. Unpurified or purified equine RIG preparations are still used in some low- and middle-income countries and are associated with a higher risk for severe reactions, including serum sickness and anaphylaxis. Purified cell culture-derived vaccines also are not always available abroad; travelers should be aware that any rabies vaccines derived from neural tissue carry an increased risk for adverse reactions, often with neurologic sequelae. If rabies prophylaxis is initiated abroad, neutralizing titers should be checked on return and immunization completed with a cell culture-derived vaccine. If rabies prophylaxis cannot be provided abroad, children with high-risk bites (e.g., stray dog) should be emergently transported to a site where they can receive prophylaxis, because the vaccinations should be started as soon as possible after the bite and ideally within 24 hours. Infants and

young children respond well to rabies vaccine, and both preexposure and postexposure vaccinations can be given at any age, using the same dose and schedule as adults. Individual travelers simultaneously receiving mefloquine or chloroquine may have limited immune reactions to intradermal (ID) rabies vaccine and should be vaccinated intramuscularly. The ID administration route is not currently recommended in the United States.

### Tuberculosis

The risk for tuberculosis in the typical traveler is low. Pretravel and posttravel testing for tuberculosis is controversial and should be done on an individualized basis depending on the itinerary, duration, and activities (e.g., working in a hospital setting). Immunization with bacille Calmette-Guérin (BCG) is even more controversial. BCG vaccine has variable efficacy in reducing severe tuberculosis disease in infants and young children, is not available in the United States, and is generally not recommended for pediatric travelers. However, parents traveling with young children who plan to reside in countries with high endemic rates of tuberculosis may consider vaccination once in country to prevent disseminated disease. Infection with *Mycobacterium bovis* can be prevented through avoiding consumption of unpasteurized dairy products.

### Typhoid

*Salmonella* Typhi infection, or **typhoid fever**, is common in many low- and middle-income countries in Asia, Africa, and Latin America (see Chapter 244). Typhoid vaccination is recommended for most children  $\geq 2$  years old who are traveling to the Indian subcontinent because the incidence of typhoid is 10-100 times higher for travelers to the Indian subcontinent than all other travel destinations. Vaccination should be strongly considered for other travelers to low- and middle-income countries, particularly if they are VFR travelers, lack access to reliable clean water and food, are traveling for a prolonged duration, or are adventurous eaters.

Two typhoid vaccines, the intramuscular (IM) Vi-polysaccharide vaccine and the oral Ty21a strain live-attenuated vaccine, are recommended for use in children in the United States. Both produce a protective response in 50–80% of recipients. The Ty21a vaccine may offer partial protection against *Salmonella* Paratyphi, another cause of enteric fever. Travelers who have had prior diagnoses of typhoid fever should still receive vaccination because past infection does not confer long-term immunity.

The IM Vi-polysaccharide vaccine is licensed for use in children  $\geq 2$  years old. It can be given any time before departure, but it should ideally be administered 2 weeks before travel, with a booster needed 2-3 years later. The oral Ty21a vaccine can only be used in children  $\geq 6$  years old and is given in four doses over 1 week. Enteric-coated capsules are to be swallowed with a cool or room-temperature drink, at least 1 hour before a meal, every other day until the four doses are completed. Oral typhoid capsules must remain refrigerated (not frozen). Capsules should never be broken open, because vaccine efficacy depends on capsules being swallowed whole in order to pass through the acidic stomach contents. The oral vaccine is associated with an immune response lasting 5-7 years (depending on national labeling). Antibiotics inhibit the immune response to the oral Ty21a vaccine; the vaccine should not be given within 72 hours of antibiotic treatment, and antibiotics should be avoided until 7 days after completing the vaccine series. Studies demonstrate that mefloquine, chloroquine, and atovaquone-proguanil can be given concurrently with the oral Ty21a vaccine without affecting the immunogenicity of the vaccine. Oral Ty21a vaccine should not be given to immunocompromised children; these children should receive the IM Vi-polysaccharide vaccine.

### Yellow Fever

Yellow fever (see Chapter 316) is a mosquito-borne viral illness resembling other viral hemorrhagic fevers (see Chapter 317) but with more prominent hepatic involvement. Yellow fever is present in tropical areas of South America and Africa.

Yellow fever vaccination is indicated in children  $>9$  months old traveling to an endemic area. Many countries require yellow fever vaccination by law for travelers arriving from endemic areas, and some African countries require evidence of vaccination from all entering travelers. Current recommendations can be obtained by contacting state or local health departments or the Division of Vector-Borne Infectious Diseases of the CDC (800-232-4636; <https://wwwnc.cdc.gov/travel/yellow-book/2024/infections-diseases/yellow-fever>).

Most countries accept a medical waiver for children who are too young to be vaccinated (i.e.,  $<6$  months of age) and for persons with a contraindication to vaccination. Children with asymptomatic HIV infection may be vaccinated if exposure to yellow fever virus (YFV) cannot be avoided.

Yellow fever vaccine (0.5 mL subcutaneously), a *live-attenuated vaccine* (17D strain) developed in chick embryos, is safe and highly effective in children  $>9$  months old, but in young infants is associated with a greatly increased risk for vaccine-associated encephalitis (0.5-4/1,000) and other severe reactions. Yellow fever vaccine should *never* be given to infants  $<6$  months old; infants 6-8 months old should be vaccinated only in consultation with the CDC or a travel medicine expert to assess the current epidemiology, travel itinerary and duration, and whether the risk of YFV exposure is greater than vaccine risks. In children  $>9$  months old, adverse effects are rare, although vaccine-associated neurotropic and viscerotropic disease associated with the vaccine has been reported. The risk of these reactions is higher in those with thymic disease, altered immune status, multiple sclerosis, or age  $<9$  months (neurotropic disease) or  $>60$  years. Yellow fever vaccination is generally contraindicated in pregnancy and for nursing mothers, unless extended travel to a yellow fever–endemic area is unavoidable.

Children with immunodeficiency or an immunosuppressed state, a thymic disorder or dysfunction (e.g., DiGeorge syndrome), or a history of anaphylactic reactions to eggs *should not receive* yellow fever vaccine. Long-lived immunity develops with this vaccine, perhaps even lasting for a lifetime. Effective July 2016, the WHO and countries following international health regulations no longer require revaccination every 10 years (i.e., a single lifetime dose is now accepted); however, individuals traveling to high-risk areas with active yellow fever transmission and who anticipate frequent or prolonged stays should still consider being reimmunized every 10 years.

### TRAVELER'S DIARRHEA

Ingestion of contaminated food or water makes travel-associated diarrhea the most common health complaint among international travelers. Traveler's diarrhea, characterized by a twofold or greater increase in the frequency of unformed bowel movements, occurs in as many as 40% of all travelers overseas (see Chapter 387.1). Children, especially those  $<3$  years old, have a higher incidence of diarrhea, more severe symptoms, and more prolonged symptoms than adults, with a reported attack rate of 60% for those  $<3$  years old in one study.

An important risk factor for traveler's diarrhea is the country of destination. High-risk areas (attack rates of 25–50%) include low- and middle-income countries of Latin America, Africa, the Middle East, and Asia. Intermediate risk occurs in Mediterranean countries, China, and Israel. Low-risk areas include North America, Northern Europe, Australia, and New Zealand. Fecal-oral diarrheal pathogens that children acquire during travel are similar to those acquired by adults and include enterotoxigenic and enteroaggregative *Escherichia coli*, *Campylobacter*, *Salmonella* (nontyphoidal serotypes predominate), and *Shigella* spp. Enteric protozoa are a much less common cause of traveler's diarrhea than bacterial pathogens; *Giardia lamblia* is the most likely protozoal cause of persistent diarrhea. Less common travel-associated protozoa include *Cryptosporidium* spp., *Entamoeba histolytica*, and *Cyclospora*. Viral infections, particularly rotavirus and norovirus infections, may also cause travel-associated diarrhea in children. Clinicians should be aware that not all diarrheal illness in children is food-borne or water-borne; for example, febrile children with malaria may also present with vomiting and/or nonbloody diarrhea and may be misdiagnosed as having traveler's diarrhea.

### Guidance on Prevention of Traveler's Diarrhea

Food and water hygiene remain important measures to reduce the incidence of traveler's diarrhea in children. However, creating long lists of foods to avoid or offering the popular, simple advice of “Boil it, peel it, cook it, or forget it!” is generally an ineffective method of reducing traveler's diarrhea. Most studies show that these types of dietary directives are difficult to keep and may have little impact on the incidence of traveler's diarrhea. In adult studies, the risk of developing traveler's diarrhea appears to be more associated with *where a person eats rather than what they eat*. Eating in a relative's or friend's home is generally safer than eating in a restaurant, where restaurant kitchen hygiene and proper refrigeration may be lacking and employee handwashing may be sporadic.

In general, travel medicine providers can give some commonsense food and water advice to family travelers. Boiled or bottled water, hot beverages, and canned or bottled beverages are generally safe to consume. Ice should be avoided. In low- and middle-income countries, tap water is generally unsafe for drinking or brushing teeth. Boiling water for  $\geq 1$  minute (or 3 minutes at altitudes  $> 2,000$  meters) remains a reliable method of disinfecting water. Food that is thoroughly cooked and served hot is almost always safe to eat. Dry foods, such as pastry items, breads, and cookies, are generally safe to eat. Unpasteurized milk or other dairy products (cheese) should always be avoided. Breastfeeding should be encouraged for young children, especially infants  $< 6$  months old, to reduce exposure to contaminated water or formula. All children should be reminded to wash their hands before eating and after playing around soil or animals. Chemoprophylactic agents for traveler's diarrhea are not recommended for children.

### Management of Traveler's Diarrhea

**Dehydration** is the greatest threat presented by a diarrheal illness in a small child. Parents should be made aware of the symptoms and signs of dehydration and given instructions on how to prepare and administer rehydration solutions. Prepackaged WHO **oral rehydration solution** packets, which are available at stores or pharmacies in almost all low- and middle-income countries, should be part of a child's travel kit. Oral rehydration solution should be mixed as directed with bottled or boiled water and given slowly, as tolerated, to the child while symptoms persist.

**Antimotility agents** such as diphenoxylate (Lomotil) and loperamide (Imodium) should be avoided in infants and young children. The American Academy of Pediatrics (AAP) does not recommend their routine use in acute gastroenteritis. Use of antimotility agents may be beneficial in older children and adolescents with afebrile, nonbloody traveler's diarrhea. In general, antimotility agents should not distract parents from giving frequent oral rehydration solution, because ongoing intestinal fluid losses likely continue despite a decrease in stooling. Bismuth subsalicylate for acute gastroenteritis should be avoided because of concern for toxicity and Reye syndrome.

### Presumptive Antibiotic Treatment

**Oral rehydration** is the mainstay of treatment for pediatric traveler's diarrhea. However, antibiotics should be prescribed for the pediatric traveler, with parental instructions to start presumptive treatment early in the diarrheal illness (Tables 218.3 and 218.4). Systemic antibiotics can shorten the duration and severity of diarrheal illness, especially if presumptive antibiotics are initiated immediately after the onset of traveler's diarrhea. For children, the drug of choice is **azithromycin** (10 mg/kg once daily for up to 3 days, with a maximum daily dose of 500 mg). **Ciprofloxacin** (10 mg/kg per dose twice daily for up to 3 days, maximum dose of 500 mg twice daily) is an alternative but should not be prescribed for travelers to the Indian subcontinent or Southeast Asia, where fluoroquinolone resistance is common. Shiga toxin-producing *E. coli*, such as *E. coli* O157:H7, is an extremely uncommon cause of pediatric traveler's diarrhea in nonindustrialized countries, and the benefit of presumptive antibiotic therapy in traveling children, even with bloody diarrhea, typically outweighs the low risk of developing hemolytic-uremic syndrome. Parents need to be aware that

**Table 218.3** Traveler's Diarrhea Empiric Treatment Recommendations

**Therapy of mild traveler's diarrhea: diarrhea that is tolerable, is not distressing, and does not interfere with planned activities.**

- Antibiotic treatment is not recommended in patients with mild traveler's diarrhea.
- Loperamide or BSS may be considered in the treatment of mild traveler's diarrhea in older children.

**Therapy of moderate traveler's diarrhea: diarrhea that is distressing or interferes with planned activities.**

- Antibiotics may be used to treat cases of moderate traveler's diarrhea.
- Fluoroquinolones may be used to treat moderate traveler's diarrhea depending on resistance patterns of country or region.
- Azithromycin may be used to treat moderate traveler's diarrhea.
- Rifaximin may be used to treat moderate, noninvasive traveler's diarrhea.
- Loperamide may be used as adjunctive therapy for moderate to severe traveler's diarrhea. Antimotility agents alone are not recommended for patients with bloody diarrhea or those who have diarrhea and fever.
- Loperamide may be considered for use as monotherapy in moderate traveler's diarrhea in older children.

**Therapy of severe traveler's diarrhea: diarrhea that is incapacitating or completely prevents planned activities: all dysentery is considered severe.**

- Antibiotics should be used to treat severe traveler's diarrhea.
- Azithromycin is preferred to treat severe traveler's diarrhea.
- Fluoroquinolones may be used to treat severe, nondysenteric traveler's diarrhea depending on resistance patterns of country or region.
- Rifaximin may be used to treat severe, nondysenteric traveler's diarrhea.\*
- Single-dose antibiotic regimens may be used to treat traveler's diarrhea.

\*These treatment recommendations were developed before the approval of rifaximin SV in the United States. Because it is in the same category of antimicrobial drug as rifaximin and because they have the same mechanism of action, rifaximin SV can be considered as an alternative to rifaximin.

Modified from Centers for Disease Control and Prevention (CDC). International travel with infants and children: Yellow Book 2024. Atlanta: CDC, 2020. Box 2-04 and Table 2-10. <https://wwwnc.cdc.gov/travel/yellowbook/2024/preparing/travelers-diarrhea#treatment>

the use of antibiotics for the treatment of traveler's diarrhea has been associated with colonization with highly resistant organisms such as extended-spectrum  $\beta$ -lactamase-producing Enterobacteriaceae. These organisms could later cause infections once back home.

Azithromycin is highly effective against most bacterial pathogens that cause traveler's diarrhea and is the preferred antibiotic among many travel experts. Azithromycin can be prescribed in powder form that can be reconstituted with safe water into a liquid suspension when needed. Amoxicillin, trimethoprim-sulfamethoxazole (cotrimoxazole), and erythromycin should *not* be prescribed for self-treatment of traveler's diarrhea, because of widespread resistance among diarrheal pathogens. Traveler's diarrhea that results in bloody stools, persistently high fevers, systemic chills and rigors, severe or localizing abdominal pain, or continued fluid losses should prompt additional medical evaluation.

### INSECT-BORNE INFECTIONS

Insect-borne infections for which traveling children are most at risk include malaria, dengue, chikungunya, yellow fever, Zika, and Japanese encephalitis, depending on the area of travel. **Malaria** is transmitted by nighttime biting *Anopheles* mosquitoes, whereas **dengue** occurs from mosquito species (*Culex*, *Aedes*) that are predominantly active during the day. Families should be encouraged to protect children against daytime and nighttime biting mosquitoes, because many regions of the world where malaria is found also have diseases transmitted by daytime



**Table 218.4** Acute Diarrhea Adult Antibiotic Treatment Recommendations\*

ANTIBIOTIC*	DOSE	DURATION
Azithromycin <sup>†,‡</sup>	1,000 mg	Single or divided dose <sup>§</sup>
	500 mg daily	3 days
Levofloxacin	500 mg daily	1-3 days <sup>§</sup>
Ciprofloxacin	750 mg	Single dose <sup>§</sup>
	500 mg bid	3 days
Ofloxacin	400 mg bid	1-3 days <sup>§</sup>
Rifamycin SV <sup>  </sup>	388 mg bid	3 days
Rifaximin <sup>  </sup>	200 mg tid	3 days

\*See also Chapter 387.1. Lower weight-based dosing should be used where appropriate.

†Antibiotic regimens may be combined with loperamide 4 mg initially followed by 2 mg after each loose stool, not to exceed 16 mg in a 24-hr period. This is the adult dose of loperamide, which might be appropriate for older children and adolescents, but antimotility agents are generally not recommended for younger children, and if they are used then lower doses may be more appropriate.

‡Use empirically as first-line in Southeast Asia or other areas if fluoroquinolone-resistant bacteria are suspected.

§Preferred regimen for dysentery or febrile diarrhea.

||If symptoms are not resolved after 24 hr, continue daily dosing for up to 3 days.

¶Do not use if clinical suspicion for *Campylobacter*, *Salmonella*, *Shigella*, or other causes of invasive diarrhea. Use may be reserved for patients unable to receive fluoroquinolones or azithromycin.

From Centers for Disease Control and Prevention (CDC). International travel with infants and children: Yellow Book 2024. Atlanta: CDC, 2024. Table 2-09. <https://wwwnc.cdc.gov/travel/yellowbook/2024/preparing/travelers-diarrhea#table 209>

biting mosquitoes (dengue, Zika, chikungunya). Zika can also be sexually transmitted, so sexually active adolescents and young adults need to be advised on these additional risks when traveling to Zika-endemic regions. In addition to insect bite prevention using insect repellents, methods of contraception should be discussed with the traveler. Ticks, fleas, lice, and other arthropods are also known to transmit rickettsial, borrelial, and parasitic pathogens, but transmission can be prevented by close attention to measures to mitigate exposures that are appropriate when outdoors, close inspection for ticks once returning indoors, and use of insect repellents on skin and clothing with products containing DEET and permethrin, respectively.

Exposure to insect bites can be reduced by wearing appropriate attire and using insect repellents containing *N,N*-diethyl-*m*-toluamide (DEET) or picaridin. The AAP recommends avoiding DEET-containing repellents in children <2 months old. Rare cases of neurologic events have been reported in very young children with exposure to inappropriate, frequent applications of DEET-containing repellents (>10 times/day) or who licked off DEET. Concentrations of 25–30% DEET need be applied every 4–6 hours, as needed, whereas 5–7% DEET provides only 1–2 hours of protection time. DEET concentrations >40–50% do not confer a substantially longer protection time for children and are not recommended.

**Picaridin** is fragrance-free, effective, and generally well tolerated on exposed skin and faces. It has similar efficacy to DEET but with less inhalational or dermal irritation. Picaridin at concentrations of 20% or higher provides adequate protection against *Anopheles* mosquitoes that have potential to transmit malaria. When applying sunscreen and insect repellent, sunscreen should be applied first, followed by DEET or picaridin.

Spraying or treating clothing with **permethrin**, a synthetic pyrethroid, is a safe and effective method of further reducing insect bites in children. Permethrin can be applied directly to clothing, bed nets, shoes, and hats and should be allowed to dry fully before use. As an insecticide, permethrin should never be applied to skin. Permethrin-treated garments retain both repellency and insecticidal activity, even with repeated laundering. Clothing will eventually need to be retreated to maintain repellency, according to the product label. Bed nets, particularly permethrin-impregnated bed nets, also decrease the risk of insect bites, and their use is highly recommended in malarial areas.

## MALARIA CHEMOPROPHYLAXIS

Malaria, a mosquito-borne infection, is the leading parasitic cause of death in children worldwide (see Chapter 334). Of the five *Plasmodium*

species that infect humans, *Plasmodium falciparum* causes the greatest morbidity and mortality. Each year, >8 million U.S. citizens visit parts of the world where malaria is endemic (sub-Saharan Africa, Central and South America, India, Southeast Asia, Oceania). Children accounted for 15–20% of imported malaria cases in a WHO study in Europe. Given travel of young children with their families to endemic countries, physicians in industrialized countries are increasingly required to give advice on prevention, diagnosis, and treatment of malaria. **Risk factors** for severe malaria and death include inadequate adherence to chemoprophylaxis, delay in seeking diagnosis and medical care, and nonimmune status, but the case-fatality rate of imported malaria remains <1% in children from nonendemic countries. The CDC maintains updated information at <https://wwwnc.cdc.gov/travel/yellowbook/2024/infections-diseases/malaria>, as well as a malaria hotline for physicians (770-488-7788). It is important to check this updated information, because recommendations for prophylaxis and treatment are often modified as a result of changes in the risk for developing malaria in different areas of the world, changing *Plasmodium* resistance patterns, and the availability of new antimalarial medications.

Avoidance of mosquitoes and **barrier protection** from mosquitoes are an important part of malaria prevention for travelers to endemic areas. The *Anopheles* mosquito feeds from dusk to dawn. Travelers should remain in well-screened areas, wear clothing that covers most of the body, sleep under a bed net (ideally impregnated with permethrin), and use insect repellents with DEET during these hours. Parents should be discouraged from taking a young child on a trip that will entail evening or nighttime exposure in areas endemic for *P. falciparum*.

Chemoprophylaxis is the cornerstone of malaria prevention for nonimmune children and adults who travel to malaria-endemic areas *but is not a replacement for other protective measures*. Travelers often do not take malaria prophylaxis as prescribed or at all. They are more likely to use prophylactic antimalarial drugs if their physicians provide appropriate recommendations and education before departure. However, in one survey, only 14% of persons who sought medical advice obtained correct information about malaria prevention and prophylaxis. Families with children visiting friends and relatives are particularly less likely to take malaria prophylaxis or seek pretravel medical advice.

Resistance of *P. falciparum* to the traditional chemoprophylactic agent, **chloroquine**, is widespread, and in most areas of the world other agents must be used (Table 218.5). Factors that must be considered

Table 218.5 Antimalarial Chemoprophylaxis for Children														
AREA	DRUG	ADULT DOSE	PEDIATRIC DOSE	ADVANTAGES	DISADVANTAGES	COMMENTS								
Chloroquine-resistant area	Mefloquine*†	250 mg salt (228 mg base) tablets One tablet weekly	Weight <10 kg: 5 mg salt (4.6 mg base)/kg/week	Once-weekly dosing	Bitter taste No pediatric formulation Side effects of sleep disturbance, vivid dreams	Children going to malaria-endemic area for ≥4 wk Children unlikely to take daily medication								
			Weight 10-19 kg: ¼ tablet/week											
			Weight 20-30 kg: ½ tablet/week											
			Weight 31-45 kg: ¾ tablet/week											
			Weight >45 kg: 1 tablet/week											
	Doxycycline‡	100 mg tablet One tablet daily	2.2 mg/kg daily (max: 100 mg)		Known safety profile Readily available in most pharmacies	Prolonged (>21 days) courses should not be given to children <8 yr old Daily dosing Must take with food or causes stomach upset Photosensitivity Yeast superinfections	Children ≥8 yr old going to area for <4 wk who cannot take or cannot obtain atovaquone-proguanil							
								Atovaquone-proguanil§ (Malarone)	250/100 adult tablet One tablet daily	Pediatric tablet: 62.5 mg atovaquone/25 mg proguanil	Pediatric tablet formulation available Generally well tolerated	Daily dosing Expensive Can cause stomach upset	Children going to malaria-endemic area for <4 wk	
														Weight 5-8 kg: ½ pediatric tablet once daily
														Weight >8-10 kg: ¾ pediatric tablet once daily
														Weight >10-20 kg: 1 pediatric tablet once daily
Weight >20-30 kg: 2 pediatric tablets once daily														
Weight >30-40 kg: 3 pediatric tablets once daily														
Weight >40 kg: 1 adult tablet once daily														
Chloroquine-susceptible area	Chloroquine phosphate	500 mg salt (300 mg base) One tablet weekly	8.3 mg/kg salt (5 mg/kg base) weekly, up to maximum adult dose of 500 mg salt	Once-weekly dosing Generally well tolerated Safe in pregnancy	Bitter taste No pediatric formulation	Best medication for children traveling to areas with <i>Plasmodium falciparum</i> or <i>P. vivax</i> that is chloroquine susceptible								
	Hydroxychloroquine	400 mg of salt (310 mg of base)	6.5 mg/kg of salt (5 mg/kg of base) once weekly, up to maximum adult dose of 400 mg of salt	Safe in pregnancy		Alternative when chloroquine is unavailable for travelers to areas with <i>P. falciparum</i> or <i>P. vivax</i> that is chloroquine susceptible								

Continued

**Table 218.5** Antimalarial Chemoprophylaxis for Children—cont'd

AREA	DRUG	ADULT DOSE	PEDIATRIC DOSE	ADVANTAGES	DISADVANTAGES	COMMENTS
Terminal prophylaxis (antirelapse therapy) for regions predominantly with <i>P. vivax</i> and <i>P. ovale</i> .	Primaquine	26.3 mg salt (15 mg base) tablets; 2 tablets once daily for 14 days after departure from malarious area.	0.8 mg/kg of salt form (0.5 mg/kg of base) once daily for 14 days after departure from malarious area	Reduce risk for relapses by <i>P. vivax</i> and <i>P. ovale</i> .	May cause hemolysis in persons with glucose-6-phosphate dehydrogenase (G6PD) deficiency. Contraindicated in pregnancy and breastfeeding mothers.	Must confirm G6PD sufficiency before administration.
Short-term prophylaxis for regions with predominantly <i>Plasmodium vivax</i>	Primaquine	26.3 mg salt (15 mg base) tablets; 2 tablets. Begin 1-2 days before travel to malarious areas, continue for 7 days after leaving area.	0.8 mg/kg of salt form (0.5 mg/kg of base). Begin 1-2 days before travel to malarious areas, continue for 7 days after leaving area.	Reduce risk for relapses by <i>P. vivax</i> .	May cause hemolysis in persons with G6PD deficiency. Contraindicated in pregnancy and breastfeeding mothers.	Must confirm G6PD sufficiency before administration.
Terminal prophylaxis (antirelapse therapy) for regions predominantly with <i>P. vivax</i>	Tafenoquine (Krintafel)	150 mg tablets; ≥16 yr: 2 tablets, single dose	Not recommended	Single dose	May cause hemolysis in persons with G6PD deficiency. Contraindicated in pregnancy and breastfeeding mothers.	Must confirm G6PD sufficiency before administration.
Prophylaxis against all <i>Plasmodium</i> spp.	Tafenoquine (Arakoda)	100 mg tablets; ≥18 yr: 2 tablets, daily for 3 days before travel. Weekly during travel (starting 1 wk after last pretravel dose). Once 1 wk after travel	Not recommended	Effective against all <i>Plasmodium</i> spp.	May cause hemolysis in persons with G6PD deficiency. Contraindicated in pregnancy and breastfeeding mothers.	Must confirm G6PD sufficiency before administration.

\*Chloroquine and mefloquine should be started 1-2 wk before departure and continued for 4 wk after last exposure.

<sup>†</sup>Mefloquine resistance exists in western Cambodia and along the Thailand-Cambodia and Thailand-Myanmar borders. Travelers to these areas should take doxycycline or atovaquone-proguanil. See text for precautions about mefloquine use.

<sup>‡</sup>Doxycycline should be started 1-2 days before departure and continued for 4 wk after last exposure. Do not use in children <8 yr old or in pregnant women.

<sup>§</sup>Atovaquone-proguanil (Malarone) should be started 1-2 days before departure and continued for 7 days after last exposure; should be taken with food or a milky drink. Not recommended in pregnant women, children who weigh <5 kg, and women breastfeeding infants who weigh <5 kg. Contraindicated in individuals with severe renal impairment (creatinine clearance <30 mL/min).

Drugs used for chloroquine-resistant areas can also be used in chloroquine-susceptible areas.

in choosing appropriate chemoprophylaxis medications and dosing schedules include age of the child, travel itinerary (including whether the child will be traveling to areas of risk within a particular country and whether chloroquine-resistant *P. falciparum* is present in the country), vaccinations being given, allergies or other known adverse reactions to antimalarial agents, and the availability of medical care during travel.

Children traveling to areas with chloroquine-resistant *P. falciparum* can be given mefloquine, atovaquone-proguanil, or doxycycline (if >8 years old) as malaria prophylaxis. For trips shorter than 4 weeks, atovaquone-proguanil is the preferred medication, because it is given for only a short period before and after travel. Atovaquone-proguanil or doxycycline is also preferred for travel of any duration to western Cambodia and the Thailand-Cambodia and Thailand-Myanmar borders because of mefloquine resistance

in these areas. For periods of travel >4 weeks to all other areas with chloroquine-resistant *P. falciparum*, mefloquine is the preferred medication because it can be taken weekly.

**Mefloquine** is FDA approved only for children weighing >15 kg, but the CDC recommends mefloquine prophylaxis for all children regardless of weight because the risk for acquiring severe malaria outweighs the risk for potential mefloquine toxicity. Adults taking mefloquine prophylaxis have a 10–25% incidence of sleep disturbance and dysphoria and, less frequently, more serious neuropsychiatric symptoms. These side effects appear to be less common in children. Other potential side effects of mefloquine therapy include nausea and vomiting.

The lack of a liquid or suspension formulation for all antimalarial agents can make administration difficult. For children who cannot take tablets, parents should take a chloroquine or mefloquine prescription

to a compounding pharmacy, which can pulverize the tablets and place exact dosages into gel capsules. Parents can then open the gel capsules and sprinkle the powder into food. Disguising these medications, which have a bitter taste, is important; chocolate syrup has been used successfully as a vehicle for the medication. Persons with depression, neuropsychiatric disorders, seizure disorders, or cardiac conduction defects should not take mefloquine.

**Atovaquone-proguanil** fixed combination (Malarone) is an effective and safe chemoprophylaxis for travelers to chloroquine-resistant malaria-endemic areas. Adverse effects are infrequent and mild (abdominal pain, vomiting, and headache) and infrequently result in discontinuation of the medication. Atovaquone-proguanil prophylaxis must be taken every day with food, so it is better suited for prophylaxis during short periods of exposure. Recent data allow dosing down to 5 kg body weight, although the use of atovaquone-proguanil in children weighing 5-10 kg is considered off-label.

Daily **doxycycline** is an alternative chemoprophylaxis regimen for chloroquine-resistant *P. falciparum* malaria. Doxycycline has been used extensively and is highly effective. Use in children <8 years old should be avoided, as courses >21 days are usually required and safety data are limited in this age-group. Adverse effects (nausea, vomiting, photosensitivity, vaginal candidiasis) are relatively uncommon. Persons given doxycycline prophylaxis should be warned to decrease exposure to direct sunlight, wear protective clothing (long sleeves and brimmed hat), and use sunscreen to minimize the possibility of photosensitivity.

**Primaquine** has also been used successfully as chemoprophylaxis, especially in areas of high prevalence of *Plasmodium vivax* and *Plasmodium ovale*, but there are limited data about its use in nonimmune children. Primaquine prophylaxis for children should only be given in consultation with the CDC or a travel medicine specialist.

Chloroquine, chloroquine-proguanil, and azithromycin do not provide adequate protection for children traveling to a chloroquine-resistant malaria-endemic area.

In areas of the world where *P. falciparum* remains fully chloroquine-sensitive (Haiti, the Dominican Republic, Central America west of the Panama Canal, and some countries in the Middle East), weekly chloroquine is the drug of choice for malaria chemoprophylaxis. Updated information on chloroquine susceptibility and recommended malaria prophylaxis is available at <https://wwwnc.cdc.gov/travel/yellowbook/2024/infections-diseases/malaria>.

On leaving an area endemic for *P. vivax* or *P. ovale* after a prolonged visit (usually >3 months), travelers should consider terminal prophylaxis with primaquine (0.5 mg/kg base) daily, up to a maximum dose of 30 mg base or 52.6 mg salt, for 14 days, to eliminate extraerythrocytic forms of *P. vivax* and *P. ovale* and prevent relapses. Screening for glucose-6-phosphate dehydrogenase (G6PD) deficiency is mandatory before primaquine treatment, because primaquine is contraindicated in G6PD-deficient persons because it can cause severe hemolysis.

Small amounts of antimalarial drugs are secreted into breast milk. The amounts of transferred drug are not considered to be either harmful or sufficient to provide adequate prophylaxis against malaria. Prolonged infant exposure to doxycycline through breast milk is not advisable.

**Self-treatment** of presumptive malaria during travel remains controversial. It should never be substituted for seeking appropriate medical care, but it can be considered in special circumstances such as travel to remote areas, intolerance of prophylaxis, or refusal of chemoprophylaxis by the traveler. Self-treatment medication should be different from the prescribed chemoprophylaxis. The CDC or a travel medicine specialist should be consulted if self-treatment medication is being considered for a traveler.

## THE RETURNING TRAVELER

Posttravel evaluations are part of travel medicine and continuing care. Physicians unfamiliar with diseases that occur in low- and middle-income countries often misdiagnose the cause of illness in a child returning from travel abroad. Among returning patients identified from the GeoSentinel Surveillance Network sites who were ill, the most common disorders (in descending order of frequency) included malaria, giardiasis, dengue fever, campylobacteriosis, cutaneous larva migrans, enteric fever, spotted fever (rickettsiosis), chikungunya fever, hepatitis A, and influenza. Returning pediatric travelers who are severely ill or with continued fevers should be seen in consultation with a pediatric travel medicine or infectious diseases specialist. The cause of fever may be suggested by the geographic area (Table 218.6) and incubation period (Table 218.7).

Among all persons returning from travel (children and adults), three major patterns of illness have been noted (Table 218.8). The etiology of each of these disease presentations in part depends on the country or geographic region visited (see Table 218.6). Table 218.9 provides suggestive clues to a diagnosis.

**Table 218.6** Common Causes of Fever by Geographic Area

GEOGRAPHIC AREA	COMMON TROPICAL DISEASE-CAUSING FEVER	OTHER INFECTIONS CAUSING OUTBREAKS OR CLUSTERS IN TRAVELERS
Caribbean	Chikungunya, dengue, malaria (Haiti), Zika	Acute histoplasmosis, leptospirosis
Central America	Chikungunya, dengue, malaria (primarily <i>Plasmodium vivax</i> ), Zika	Leptospirosis, histoplasmosis, coccidioidomycosis
South America	Chikungunya, dengue, malaria (primarily <i>P. vivax</i> ), Zika	Bartonellosis, leptospirosis, enteric fever, histoplasmosis
Southcentral Asia	Dengue, enteric fever, malaria (primarily non- <i>P. falciparum</i> )	Chikungunya
Southeast Asia	Dengue, malaria (primarily non- <i>P. falciparum</i> )	Chikungunya, leptospirosis
Sub-Saharan Africa	Malaria (primarily <i>P. falciparum</i> ), tick-borne rickettsiae (main cause of fever in southern Africa), acute schistosomiasis, dengue	

<https://wwwnc.cdc.gov/travel/yellowbook/2024/posttravel-evaluation/general-approach-to-the-returned-traveler>

From Centers for Disease Control and Prevention (CDC). International travel with infants and children: Yellow Book 2024. Wilson ME. Post-travel evaluation. Atlanta: CDC, 2024. Table 11-09.



**Table 218.7** Common Infections by Incubation Period

DISEASE	USUAL INCUBATION PERIOD (RANGE)	DISTRIBUTION
<b>INCUBATION &lt;14 DAYS</b>		
Chikungunya	2-4 days (1-14 days)	Tropics, subtropics
Dengue	4-8 days (3-14 days)	Tropics, subtropics
Encephalitis, arboviral (Japanese encephalitis, tick-borne encephalitis, West Nile virus, other)	3-14 days (1-20 days)	Specific agents vary by region
Enteric fever (typhoid/paratyphoid)	7-18 days (3-60 days)	Especially in Indian subcontinent
Acute HIV	10-28 days (10 days to 6 weeks)	Worldwide
Influenza	1-3 days	Worldwide, can also be acquired while traveling
Legionellosis	5-6 days (2-10 days)	Widespread
Leptospirosis	7-12 days (2-26 days)	Widespread, most common in tropical areas
Malaria, <i>Plasmodium falciparum</i>	6-30 days (98% onset within 3 mo of travel)	Tropics, subtropics
Malaria, <i>Plasmodium vivax</i>	8 days to 12 mo (almost half have onset >30 days after completion of travel)	Widespread in tropics and subtropics
Spotted-fever rickettsiae	Few days to 2-3 wk	Causative species vary by region
Zika virus infection	3-14 days	Widespread in Latin America, endemic through much of Africa, Southeast Asia, and Pacific Islands
<b>INCUBATION 14 DAYS TO 6 WEEKS</b>		
Encephalitis, arboviral; enteric fever; acute HIV; leptospirosis; malaria	See above incubation periods for relevant diseases.	See above distribution for relevant diseases
Amebic liver abscess	Weeks to months	Most common in resource-poor countries
Hepatitis A	28-30 days (15-50 days)	Most common in resource-poor countries
Hepatitis E	26-42 days (2-9 wk)	Widespread
Acute schistosomiasis (Katayama syndrome)	4-8 wk	Most common in sub-Saharan Africa
<b>INCUBATION &gt;6 WK</b>		
Amebic liver abscess, hepatitis E, malaria, acute schistosomiasis	See above incubation periods for relevant diseases.	See above distribution for relevant diseases
Hepatitis B	90 days (60-150 days)	Widespread
Leishmaniasis, visceral	2-10 mo (10 days to years)	Asia, Africa, Latin America, Southern Europe, and the Middle East
Tuberculosis	Primary, weeks; reactivation, years	Global distribution, rates, and levels of resistance vary widely

<https://wwwnc.cdc.gov/travel/yellowbook/2024/posttravel-evaluation/general-approach-to-the-returned-traveler>

From Centers for Disease Control and Prevention (CDC). International travel with infants and children: Yellow Book 2024. Fairley JK. General approach to the returned traveler. Atlanta: CDC, 2024. Table 11-02.

**Fever** is a particularly worrisome symptom. Children with a febrile/systemic illness after recent travel to a malarial destination should be promptly evaluated for malaria, especially if having traveled to sub-Saharan Africa and Papua New Guinea. *P. falciparum* malaria will generally present within 1-2 months after return from travel to a malaria-endemic area, but can occur within the first year after return. In contrast, symptoms of *P. vivax* or *P. ovale* malaria are typically later in onset after travel (i.e., several months), are milder in disease severity, and may occur in a relapsing pattern if undiagnosed or improperly treated. Other symptoms of malaria can be nonspecific and include chills, malaise, headache, myalgias, vomiting, diarrhea, cough, and possible seizures. Children are more likely than adults to have higher fevers and also gastrointestinal symptoms, hepatomegaly, splenomegaly, and severe anemia. Thrombocytopenia (without increased bleeding) and fever in a child returning from an endemic area are highly suggestive of malaria.

Thick and thin blood smears need to be performed for diagnosis if malaria is clinically suspected. If results are negative initially, two or more additional smears should be done 12-24 hours after the initial smears. The diagnostic yield of blood smears may be higher if obtained during a febrile episode. Rapid malaria antigen tests (BinaxNOW Malaria) are also available, are FDA-approved, and are sensitive for diagnosing *P. falciparum* malaria. At times, a polymerase chain reaction (PCR) assay is necessary to confirm the malarial parasite species. Treatment should be initiated immediately once the diagnosis is confirmed or empirically if presentation is severe with suspected malaria. Treatment should be determined in consultation with a pediatric infectious disease specialist and/or the CDC for updated information on the drugs of choice, which are similar to those for adults (see Chapter 334). Great caution should be used with young children, nonimmune patients, and pregnant patients with *P. falciparum* malaria, and hospitalization of these

**Table 218.8** Patterns of Illness in Returning International Travelers

SYSTEMIC FEBRILE ILLNESS
Malaria
Dengue
Zika
Enteric fever (typhoid/paratyphoid)
Chikungunya virus
Spotted fever rickettsiae
Hepatitis A
Acute HIV
Leptospirosis
Measles
Infectious mononucleosis
Respiratory causes (pneumonia, influenza)
Undetermined fever source
ACUTE DIARRHEA
<i>Campylobacter</i>
<i>Shigella</i> spp.
<i>Salmonella</i> spp.
Diarrheagenic <i>Escherichia coli</i> (enterotoxigenic <i>E. coli</i> , enteroadherent <i>E. coli</i> —not tested for by routine stool culture methods)
Giardiasis (acute, persistent, or recurrent)
<i>Entamoeba histolytica</i>
<i>Cryptosporidium</i> spp.
<i>Cyclospora cayetanensis</i>
Presumed viral enteritis
DERMATOLOGIC MANIFESTATIONS
Rash with fever (dengue)
Arthropod-related dermatitis (insect bites)
Cutaneous larva migrans ( <i>Ancylostoma braziliense</i> )
Bacterial skin infections—pyoderma, impetigo, ecthyma, erysipelas
Myiasis (tumbu and botfly)
Scabies
Tungiasis
Superficial mycosis
Animal bites
Leishmaniasis
Rickettsial diseases
Marine envenomation/dermatitis
Photoallergic dermatitis and phytophotodermatitis

patients should be strongly considered until reliable improvement is observed.

**Enteric (typhoid) fever** should be considered in children with persistent or recurrent fevers, especially after return from the Indian subcontinent. Multiple blood cultures and a stool culture may both be necessary for diagnosis of enteric fever. **Dengue** is another cause of fever and systemic illness in ill travelers, particularly when returning from Southeast Asia, the Caribbean, Central and South America, or the Indian subcontinent. Many bacterial and protozoal causes of acute traveler's diarrhea may also result in fever and systemic symptoms in children. Additional travel-associated febrile, diarrheal, and dermatologic illnesses exist, of which the most common etiologies can be found in [Tables 218.8 and 218.9](#).

### THE ADOLESCENT TRAVELER

The preparation of an adolescent interested in traveling abroad can pose a challenge for most clinicians. Study abroad, gap year, humanitarian volunteer work, adventure, and tourism are among many reasons for travel to countries with limited resources. Although many travel-related problems discussed in this chapter are relevant to this group, other high-risk activities such as sexual intercourse, alcohol

**Table 218.9** Common Clinical Findings and Associated Infections

COMMON CLINICAL FINDINGS	INFECTIONS TO CONSIDER AFTER TRAVEL
Fever and rash	Dengue, chikungunya, Zika, rickettsial infections, enteric fever (skin lesions may be sparse or absent), acute HIV infection, measles
Fever and abdominal pain	Enteric fever, amebic liver abscess
Undifferentiated fever and normal or low white blood cell count	Dengue, malaria, rickettsial infection, enteric fever, chikungunya, Zika
Fever and hemorrhage	Viral hemorrhagic fevers (dengue and others), meningococemia, leptospirosis, rickettsial infections
Fever and arthralgia or myalgia, sometimes persistent	Chikungunya, dengue, Zika
Fever and eosinophilia	Acute schistosomiasis, drug hypersensitivity reaction, fascioliasis and other parasitic infections (rare)
Fever and pulmonary infiltrates	Common bacterial and viral pathogens, legionellosis, acute schistosomiasis, Q fever, leptospirosis
Fever and altered mental status	Cerebral malaria, viral or bacterial meningoenzephalitis, African trypanosomiasis, scrub typhus
Mononucleosis syndrome	Epstein-Barr virus (EBV) infection, cytomegalovirus (CMV) infection, toxoplasmosis, acute HIV infection
Fever persisting >2 wk	Malaria, enteric fever, EBV infection, CMV infection, toxoplasmosis, acute HIV infection, acute schistosomiasis, brucellosis, tuberculosis, Q fever, visceral leishmaniasis (rare)
Fever with onset >6 wk after travel	<i>Plasmodium vivax</i> or <i>P. ovale</i> malaria, acute hepatitis (B, C, or E), tuberculosis, amebic liver abscess

From Centers for Disease Control and Prevention (CDC). International travel with infants and children: Yellow Book 2024. Wilson ME. Post-travel evaluation. Atlanta: CDC, 2024. Table 11-4. <https://wwwnc.cdc.gov/travel/yellowbook/2024/posttravel-evaluation/general-approach-to-the-returned-traveler>.

consumption, driving, use of illicit drugs, and adventure travel (e.g., mountain climbing, white water rafting, kayaking, biking) require special attention and discussion with the traveler and parents/guardians. Topics such as HIV exposure, sexually transmitted infections, sexual assault, and unplanned pregnancy may require specific preventive strategies such as condom use, contraception, and postexposure HIV prophylaxis.

Visit Elsevier eBooks+ at [eBooks.Elsevier.com](https://eBooks.Elsevier.com) for Bibliography.

## Chapter 219

## Fever

Linda S. Nield and Deepak Kamat

**Fever** is defined as a rectal temperature  $\geq 38^{\circ}\text{C}$  ( $100.4^{\circ}\text{F}$ ), and a fever  $>40^{\circ}\text{C}$  ( $104^{\circ}\text{F}$ ) is called **hyperpyrexia**. Traditionally, body temperature fluctuates in a defined normal range ( $36.6\text{--}37.9^{\circ}\text{C}$  [ $97.9\text{--}100.2^{\circ}\text{F}$ ] rectally), so that the highest point is reached in the early evening and the lowest point is reached in the morning. Any abnormal rise in body temperature should be considered a symptom and sign of an underlying condition.

## PATHOGENESIS

Body temperature is regulated by thermosensitive neurons located in the preoptic or anterior hypothalamus that respond to changes in blood temperature, as well as by cold and warm receptors located in skin and muscles. Thermoregulatory responses include redirecting blood to or from cutaneous vascular beds, increased or decreased sweating, regulation of extracellular fluid (ECF) volume by arginine vasopressin, and behavioral responses, such as seeking a warmer or cooler environmental temperature.

Three different mechanisms can produce fever: pyrogens, heat production exceeding heat loss, and defective heat loss. The first mechanism involves endogenous and exogenous pyrogens that raise the hypothalamic temperature set point. **Endogenous pyrogens** include the cytokines interleukin (IL)-1 and IL-6, tumor necrosis factor (TNF)- $\alpha$ , and interferon (IFN)- $\beta$  and IFN- $\gamma$ . Stimulated leukocytes and other cells produce lipids that also serve as endogenous pyrogens. The best-studied lipid mediator is prostaglandin  $E_2$ , which attaches to the prostaglandin receptors in the hypothalamus to produce the new temperature set point. Along with infectious diseases, drugs, malignancy, and inflammatory diseases can cause fever through the production of endogenous pyrogens. Some substances produced within the body are not pyrogens but are capable of stimulating endogenous pyrogens. Such substances include antigen-antibody complexes in the presence of complement components, lymphocyte products, bile acids, and androgenic steroid metabolites. **Exogenous pyrogens** come from outside the body and consist of mainly infectious pathogens and drugs. Microbes, microbial toxins, or other products of microbes are the most common exogenous pyrogens, which stimulate macrophages and other cells to produce endogenous pyrogens. **Endotoxin** is one of the few substances that can directly affect thermoregulation in the hypothalamus and stimulate endogenous pyrogen release. Many drugs cause fever, and the mechanism for increasing body temperature varies with the class of drug. Drugs that are known to cause fever include vancomycin, amphotericin B, and allopurinol.

**Heat production exceeding heat loss** is the second mechanism that leads to fever; examples include salicylate poisoning and malignant hyperthermia. **Defective heat loss**, the third mechanism, may occur in children with ectodermal dysplasia or victims of severe heat exposure.

## ETIOLOGY

The causes of fever can be organized into four main categories: *infectious*, *inflammatory*, *neoplastic*, and *miscellaneous*. Self-limited viral infections (common cold, influenza, gastroenteritis) and uncomplicated bacterial infections (otitis media, pharyngitis, sinusitis) are the most common causes of acute fever. The body temperature rarely rises above potentially lethal levels ( $42^{\circ}\text{C}$  [ $107.6^{\circ}\text{F}$ ]) in the neurologically intact child unless extreme hyperthermic environmental conditions are present or other extenuating circumstances exist, such as underlying malignant hyperthermia or thyrotoxicosis.

The pattern of the fever can provide clues to the underlying etiology. Viral infections typically are associated with a slow decline of fever over several days, whereas bacterial infections are often associated with

a prompt resolution of fever after effective antimicrobial treatment. Although antimicrobials can result in rapid elimination of bacteria, if tissue injury has been extensive, the inflammatory response and fever can continue for days after all microbes have been eradicated.

**Intermittent fever** is an exaggerated circadian rhythm that includes a period of normal temperatures on most days; extremely wide fluctuations may be termed **septic** or **hectic fever**. **Sustained fever** is persistent and does not vary by  $>0.5^{\circ}\text{C}$  ( $0.9^{\circ}\text{F}$ )/day. **Remittent fever** is persistent and varies by  $>0.5^{\circ}\text{C}$ /day. **Relapsing fever** is characterized by febrile periods separated by intervals of normal temperature; **tertian fever** occurs on the first and third days (malaria caused by *Plasmodium vivax*), and **quartan fever** occurs on the first and fourth days (malaria caused by *Plasmodium malariae*). Diseases characterized by relapsing fevers should be distinguished from infectious diseases that tend to relapse (Table 219.1). **Biphasic fever** indicates a single illness with two distinct periods (**camelback fever** pattern); poliomyelitis is the classic example. A biphasic course is also characteristic of other enteroviral infections, leptospirosis, dengue fever, yellow fever, Colorado tick fever, spirillary rat-bite fever (caused by *Spirillum minus*), and the African hemorrhagic fevers (Marburg, Ebola, and Lassa fevers). The term **periodic fever** is used narrowly to describe fever syndromes with a regular periodicity (cyclic neutropenia and periodic fever, aphthous

Table 219.1 Fevers Prone to Relapse

## INFECTIOUS CAUSES

Acute rheumatic fever  
 Babesiosis  
 Blastomycosis  
 Brucellosis  
 Chronic meningococcemia  
 Coccidioidomycosis  
 Colorado tick fever  
 COVID-19/SARS-CoV-2 and MIS-C  
 Dengue fever  
 Epstein-Barr virus infection  
 Histoplasmosis  
 Leptospirosis  
 Lyme disease (*Borrelia burgdorferi*)  
 Lymphocytic choriomeningitis (LCM) infection  
 Malaria  
 Melioidosis (*Pseudomonas pseudomallei*)  
 Noninfluenza respiratory viral infection  
 Oroya fever (*Bartonella bacilliformis*)  
 Q fever (*Coxiella burnetii*)  
 Rat-bite fever (*Spirillum minus*)  
 Relapsing fever (*Borrelia recurrentis*)  
 Syphilis (*Treponema pallidum*)  
 Tuberculosis  
 Typhoid fever (*Salmonella typhi*)  
 Visceral leishmaniasis  
 Yellow fever

## NONINFECTIOUS CAUSES

Behçet disease  
 Crohn disease  
 Leukocytoclastic vasculitis syndromes  
 Sweet syndrome  
 Systemic lupus erythematosus and other autoimmune disorders  
 Weber-Christian disease (panniculitis)  
 Others

## PERIODIC FEVER SYNDROMES (SEE CHAPTER 204)

Cyclic neutropenia  
 Familial Mediterranean fever  
 Hyper-immunoglobulin D syndrome  
 Muckle-Wells syndrome  
 Periodic fever, aphthous stomatitis, pharyngitis, and adenopathy (PFAPA)  
 Tumor necrosis factor receptor-associated periodic syndrome (TRAPS)  
 Others

MIS-C, multisystem inflammatory syndrome in children.

stomatitis, pharyngitis, adenopathy) or more broadly to include disorders characterized by recurrent episodes of fever that do not follow a strictly periodic pattern (familial Mediterranean fever, TNF receptor-associated periodic syndrome [Hibernian fever], hyper-IgD syndrome, Muckle-Wells syndrome) (see [Chapter 204](#)). **Factitious fever**, or self-induced fever, may be caused by intentional manipulation of the thermometer or injection of pyrogenic material.

The **double quotidian fever** (or fever that peaks twice in 24 hours) is classically associated with juvenile idiopathic arthritis. In general, a single isolated fever spike is not associated with an infectious disease. Such a spike can be attributed to the infusion of blood products and some drugs, as well as some procedures or manipulation of a catheter on a colonized or infected body surface. Similarly, temperatures in excess of 41°C (105.8°F) are most often associated with a noninfectious cause. Causes for very high temperatures (>41°C [105.8°F]) include central fever (resulting from central nervous system dysfunction involving the hypothalamus or spinal cord injury), malignant hyperthermia, malignant neuroleptic syndrome, drug fever, or heat stroke. Temperatures that are lower than normal (<36°C [96.8°F]) can be associated with overwhelming sepsis but are more often related to cold exposure, hypothyroidism, autonomic instability, central nervous system lesions, or overuse of antipyretics.

## CLINICAL FEATURES

The clinical features of fever can range from no symptoms to extreme malaise. Children might complain of feeling hot or cold, display facial flushing, and experience shivering. Fatigue and irritability may be evident. Parents often report that the child looks ill or pale and has a decreased appetite. The underlying etiology also produces accompanying symptoms. Although the underlying etiologies can manifest in varied ways clinically, there are some predictable features. For example, **fever with petechiae** in an ill-appearing patient indicates the high possibility of life-threatening conditions such as meningococemia, Rocky Mountain spotted fever, or acute bacterial endocarditis. The unusual symptom of loss of smell and taste can accompany fever in COVID-19.

Changes in heart rate, most frequently tachycardia, accompany fever. Normally heart rate rises by 10 beats/min per 1°C (1.8°F) rise in temperature for children >2 months old. Relative tachycardia, when the pulse rate is elevated disproportionately to the temperature, is usually caused by noninfectious diseases or infectious diseases in which a toxin is responsible for the clinical manifestations. **Relative bradycardia** (temperature-pulse dissociation), when the pulse rate remains low in the presence of fever, can accompany typhoid fever, brucellosis, leptospirosis, or drug fever. Bradycardia in the presence of fever also may be a result of a conduction defect resulting from cardiac involvement with acute rheumatic fever, Lyme disease, viral myocarditis, or infective endocarditis.

## EVALUATION

Most acute febrile episodes in a normal host can be diagnosed by a careful history and physical examination and require few, if any, laboratory tests. Because infection is the most likely etiology of acute fever, the evaluation should initially be geared to discovering an underlying infectious cause ([Table 219.2](#) and [Chapter 220](#)). The details of the history should include the onset and pattern of fever and any accompanying signs and symptoms. The patient often displays signs or symptoms that provide clues to the cause of the fever. Exposures to other ill persons at home, daycare, and school should be noted, along with any recent travel, animal exposures, or medications. The past medical history should include information about underlying immune deficiencies or other major illnesses and receipt of childhood vaccines.

Physical examination should begin with a complete evaluation of vital signs, which should include pulse oximetry, because hypoxia may indicate lower respiratory infection. In the acutely febrile child, the physical examination should focus on any localized complaints, but a complete head-to-toe screen is recommended, because clues to the underlying diagnosis may be found. For example, palm and sole lesions may be discovered during a thorough skin examination and provide a clue for infection with coxsackievirus.

**Table 219.2** Evaluation of Acute Fever

<p>Thorough history: onset, other symptoms, exposures (daycare, school, family, pets, playmates, other ill individuals), travel, medications, other underlying disorders, immunizations</p> <p>Physical examination: complete, with focus on localizing symptoms</p> <p>Laboratory studies on a case-by-case basis:</p> <ul style="list-style-type: none"> <li>• Blood: complete blood count, culture, C-reactive protein, procalcitonin, sedimentation rate</li> <li>• Cerebrospinal fluid: cell count, culture, glucose, Gram stain, NAAT for herpes simplex virus, protein</li> <li>• Nasopharyngeal: NAAT for respiratory viruses</li> <li>• Pharyngeal: NAAT and culture for group A <i>Streptococcus</i></li> <li>• Stool: calprotectin, culture, NAAT for enteric pathogens</li> <li>• Urine: culture, gross and microscopic analysis, NAAT for genital pathogens</li> <li>• Others (such as chest radiograph or other radiologic imaging)</li> </ul>
--

NAAT, Nucleic acid amplification test.

If a fever has an obvious cause, laboratory evaluation may not be required, and management is tailored to the underlying cause with as-needed reevaluation. If the cause of the fever is not apparent, further diagnostic evaluation should be considered on a case-by-case basis. The history of presentation and abnormal physical examination findings guide the evaluation. The child with respiratory symptoms and hypoxia may require a chest radiograph, rapid antigen testing for respiratory syncytial virus or influenza, or polymerase chain reaction (PCR) testing for SARS-CoV-2. The child with pharyngitis can benefit from PCR testing for group A *Streptococcus* and a throat culture. Dysuria, back pain, or a history of vesicoureteral reflux should prompt a urinalysis and urine culture, and bloody diarrhea should prompt a stool culture. A complete blood count and blood culture should be considered in the ill-appearing child, along with cerebrospinal fluid studies if the child has neck stiffness or if the possibility of meningitis is considered. Well-defined high-risk groups require a more extensive evaluation on the basis of age, associated disease, or immunodeficiency status and might warrant prompt antimicrobial therapy before a pathogen is identified. Fever in neonates and young infants (0-3 months old), fever in older children, and fever of unknown origin are discussed in [Chapters 220, 221, and 222](#), respectively.

## MANAGEMENT

Although fever is a common parental worry, no evidence supports the belief that high fever can result in brain damage or other bodily harm, except in rare instances of febrile status epilepticus and heat stroke. *Treating fever in self-limiting illnesses for the sole reason of bringing the body temperature back to normal is not necessary in the otherwise healthy child.* Most evidence suggests that fever is an adaptive response and should be treated only in select circumstances. In humans, increased temperatures are associated with decreased microbial replication and an increased inflammatory response. Although fever can have beneficial effects, it also increases oxygen consumption, carbon dioxide production, and cardiac output and can exacerbate cardiac insufficiency in patients with heart disease or chronic anemia (e.g., sickle cell disease), pulmonary insufficiency in patients with chronic lung disease, and metabolic instability in patients with diabetes mellitus or inborn errors of metabolism. Children between 6 months and 5 years of age are at increased risk for simple febrile seizures. *The focus of the evaluation and treatment of febrile seizures is aimed at determining the underlying cause of the fever.* Children with idiopathic epilepsy also often have an increased frequency of seizures associated with a fever. High fever during pregnancy may be teratogenic.

*Fever with temperatures <39°C (102.2°F) in healthy children generally does not require treatment.* However, as temperatures become higher, patients tend to become more uncomfortable, and treatment of fever is then reasonable. If a child is included in one of the high-risk groups previously discussed or if the child's caregiver is concerned that the fever is adversely affecting the child's behavior and causing discomfort, treatment may be given to hasten the resolution of the fever.



Other than providing symptomatic relief, antipyretic therapy does not change the course of infectious diseases. Encouraging good hydration is the first step to replacing fluids that are lost related to the increased metabolic demands and insensible losses of fever. Antipyretic therapy is beneficial in high-risk patients and patients with discomfort. **Hyperpyrexia** (>41°C [105.8°F]) indicates high probability of a hypothalamic disorder or central nervous system injury (hemorrhage, other etiology) and should be treated with antipyretics. Some studies show that hyperpyrexia may be associated with a significantly increased risk of serious bacterial infection, but other studies have not substantiated this relationship. The most common antipyretics are **acetaminophen 10-15 mg/kg/dose every 4 hours and ibuprofen in children >6 months old at 5-10 mg/kg/dose every 8 hours**. Antipyretics reduce fever by reducing production of prostaglandins. If used appropriately, antipyretics are safe; potential adverse effects include liver damage (acetaminophen) and gastrointestinal or kidney disturbances (ibuprofen). To reduce fever most safely, the caregiver should choose one type of medication and clearly record the dose and time of administration so that overdosage does not occur, especially if multiple caregivers are involved in the management. Physical measures such as tepid baths and cooling blankets are not considered effective to reduce fever. Evidence is also scarce for the use of complementary and alternative medicine interventions.

Fever caused by specific underlying etiologies resolves when the condition is properly treated. Examples include administration of intravenous immunoglobulin to treat Kawasaki disease or the administration of antibiotics to treat bacterial infections.

Visit Elsevier eBooks+ at [eBooks.Health.Elsevier.com](http://eBooks.Health.Elsevier.com) for Bibliography.

## Chapter 220

# Fever Without a Focus in the Neonate and Young Infant

Laura Brower and Samir S. Shah

Fever is a common reason for neonates and young infants to undergo medical evaluation in the hospital or ambulatory setting. For this age-group (0-3 months), **fever without a focus** refers to a rectal temperature of 38°C (100.4°F) or greater without other presenting signs or symptoms. The evaluation of these patients can be challenging because of the difficulty distinguishing between a serious infection (bacterial or viral) and a self-limited viral illness. The etiology and evaluation of fever without a focus depend on the age of the child. Three age-groups are typically considered: neonates 0-28 days, young infants 29-90 days, and children 3-36 months.

### ETIOLOGY AND EPIDEMIOLOGY

**Serious bacterial infection (SBI)** occurs in 7-13% of neonates and young infants with fever. In this group, the most common SBIs are urinary tract infection (UTI; 5-13%), bacteremia (1-2%), and meningitis (0.2-0.5%). The risk for SBI is highest in those appearing ill (in contrast to well appearing) and those with risk factors and is inversely related to postnatal age. The term **invasive bacterial infection (IBI)**, which refers to bacteremia and meningitis, recognizes that infants with UTIs may be managed differently (e.g., often with oral antibiotics) than those with bacteremia or meningitis. *Escherichia coli* is the most common organism causing SBI, followed by group B *Streptococcus* (GBS). The frequency of GBS infections has decreased as a consequence of

increased screening of pregnant women and use of intrapartum antibiotic prophylaxis. Other, less common organisms include *Klebsiella* spp., *Enterococcus* spp., *Streptococcus pneumoniae*, *Neisseria meningitidis*, and *Staphylococcus aureus* (Table 220.1). *Listeria monocytogenes* is a rare cause of neonatal infections, potentially related to changes in public health education and improvements in food safety. Additional details about specific bacteria are available in the following chapters: *E. coli* (see Chapter 246), GBS (see Chapter 230), *S. pneumoniae* (see Chapter 228), *N. meningitidis* (see Chapter 237), *S. aureus* (see Chapter 227.1), and *L. monocytogenes* (see Chapter 234). Specific bacterial infections that can present with fever in this age-group, although often with symptoms other than isolated fever, include pneumonia (see Chapter 449), gastroenteritis (see Chapter 387), osteomyelitis (see Chapter 725), septic arthritis (see Chapter 726), omphalitis (see Chapter 144), cellulitis, and other skin and soft tissue infections (see Chapter 706).

Herpes simplex virus (HSV) infections (see Chapter 299) should also be considered in febrile neonates, particularly those under 28 days old, given the high rate of mortality and significant morbidity among survivors. Neonatal HSV is rare, with a prevalence of 0.2-0.3% among febrile neonates. Most of these infections are caused by HSV type 2, though HSV type 1 can also cause neonatal infection. Neonates with disseminated disease and skin, eye, and mouth (SEM) disease typically present at 5-12 days of life. Neonates with central nervous system (CNS) disease generally present at 16-19 days. Perinatally acquired HSV occasionally manifests beyond 28 days of age, although most cases beyond 28 days of age represent postnatal acquisition.

In febrile infants who appear well, viral illnesses are much more common than bacterial or serious viral infections. The most common viruses include respiratory syncytial virus (RSV; see Chapter 307), enteroviruses (see Chapter 297), influenza viruses (see Chapter 305), parainfluenza viruses (see Chapter 306), human metapneumovirus (see Chapter 308), adenovirus (see Chapter 309), parechoviruses (see Chapter 297), and rhinovirus (see Chapter 310).

### CLINICAL MANIFESTATIONS

In neonates and young infants, bacterial and viral infections can present with isolated fever or nonspecific symptoms, making diagnosis of serious illnesses challenging. Some neonates and young infants will have signs of systemic illness at presentation, including abnormal temperature (hypothermia <36°C [96.8°F], fever ≥38°C [100.4°F]), abnormal respiratory examination (tachypnea >60 breaths/min, respiratory distress, apnea), abnormal circulatory examination (tachycardia >180 beats/min, delayed capillary refill >3 seconds, weak or bounding pulses), abnormal abdominal examination, abnormal neurologic

**Table 220.1** Bacterial Pathogens in Neonates and Young Infants with Urinary Tract Infection, Bacteremia, or Meningitis

FREQUENCY	URINARY TRACT INFECTION	BACTEREMIA AND MENINGITIS
Common	<i>Escherichia coli</i>	<i>Escherichia coli</i> Group B <i>Streptococcus</i>
Less common	<i>Klebsiella</i> spp. <i>Enterococcus</i> spp.	<i>Listeria monocytogenes</i> <i>Streptococcus pneumoniae</i> <i>Staphylococcus aureus</i> <i>Klebsiella</i> spp.
Rare	Group B <i>Streptococcus</i> <i>Staphylococcus aureus</i> <i>Pseudomonas aeruginosa</i> <i>Enterobacter</i> spp. <i>Citrobacter</i> spp. <i>Proteus mirabilis</i>	<i>Neisseria meningitidis</i> <i>Salmonella</i> spp. <i>Enterobacter</i> spp. <i>Enterococcus</i> spp. <i>Cronobacter sakazakii</i> <i>Haemophilus influenzae</i> <i>Citrobacter</i>

Other than providing symptomatic relief, antipyretic therapy does not change the course of infectious diseases. Encouraging good hydration is the first step to replacing fluids that are lost related to the increased metabolic demands and insensible losses of fever. Antipyretic therapy is beneficial in high-risk patients and patients with discomfort. **Hyperpyrexia** (>41°C [105.8°F]) indicates high probability of a hypothalamic disorder or central nervous system injury (hemorrhage, other etiology) and should be treated with antipyretics. Some studies show that hyperpyrexia may be associated with a significantly increased risk of serious bacterial infection, but other studies have not substantiated this relationship. The most common antipyretics are **acetaminophen 10-15 mg/kg/dose every 4 hours and ibuprofen in children >6 months old at 5-10 mg/kg/dose every 8 hours**. Antipyretics reduce fever by reducing production of prostaglandins. If used appropriately, antipyretics are safe; potential adverse effects include liver damage (acetaminophen) and gastrointestinal or kidney disturbances (ibuprofen). To reduce fever most safely, the caregiver should choose one type of medication and clearly record the dose and time of administration so that overdosage does not occur, especially if multiple caregivers are involved in the management. Physical measures such as tepid baths and cooling blankets are not considered effective to reduce fever. Evidence is also scarce for the use of complementary and alternative medicine interventions.

Fever caused by specific underlying etiologies resolves when the condition is properly treated. Examples include administration of intravenous immunoglobulin to treat Kawasaki disease or the administration of antibiotics to treat bacterial infections.

Visit Elsevier eBooks+ at [eBooks.Health.Elsevier.com](http://eBooks.Health.Elsevier.com) for Bibliography.

## Chapter 220

# Fever Without a Focus in the Neonate and Young Infant

Laura Brower and Samir S. Shah

Fever is a common reason for neonates and young infants to undergo medical evaluation in the hospital or ambulatory setting. For this age-group (0-3 months), **fever without a focus** refers to a rectal temperature of 38°C (100.4°F) or greater without other presenting signs or symptoms. The evaluation of these patients can be challenging because of the difficulty distinguishing between a serious infection (bacterial or viral) and a self-limited viral illness. The etiology and evaluation of fever without a focus depend on the age of the child. Three age-groups are typically considered: neonates 0-28 days, young infants 29-90 days, and children 3-36 months.

### ETIOLOGY AND EPIDEMIOLOGY

**Serious bacterial infection (SBI)** occurs in 7–13% of neonates and young infants with fever. In this group, the most common SBIs are urinary tract infection (UTI; 5–13%), bacteremia (1–2%), and meningitis (0.2–0.5%). The risk for SBI is highest in those appearing ill (in contrast to well appearing) and those with risk factors and is inversely related to postnatal age. The term **invasive bacterial infection (IBI)**, which refers to bacteremia and meningitis, recognizes that infants with UTIs may be managed differently (e.g., often with oral antibiotics) than those with bacteremia or meningitis. *Escherichia coli* is the most common organism causing SBI, followed by group B *Streptococcus* (GBS). The frequency of GBS infections has decreased as a consequence of

increased screening of pregnant women and use of intrapartum antibiotic prophylaxis. Other, less common organisms include *Klebsiella* spp., *Enterococcus* spp., *Streptococcus pneumoniae*, *Neisseria meningitidis*, and *Staphylococcus aureus* (Table 220.1). *Listeria monocytogenes* is a rare cause of neonatal infections, potentially related to changes in public health education and improvements in food safety. Additional details about specific bacteria are available in the following chapters: *E. coli* (see Chapter 246), GBS (see Chapter 230), *S. pneumoniae* (see Chapter 228), *N. meningitidis* (see Chapter 237), *S. aureus* (see Chapter 227.1), and *L. monocytogenes* (see Chapter 234). Specific bacterial infections that can present with fever in this age-group, although often with symptoms other than isolated fever, include pneumonia (see Chapter 449), gastroenteritis (see Chapter 387), osteomyelitis (see Chapter 725), septic arthritis (see Chapter 726), omphalitis (see Chapter 144), cellulitis, and other skin and soft tissue infections (see Chapter 706).

Herpes simplex virus (HSV) infections (see Chapter 299) should also be considered in febrile neonates, particularly those under 28 days old, given the high rate of mortality and significant morbidity among survivors. Neonatal HSV is rare, with a prevalence of 0.2–0.3% among febrile neonates. Most of these infections are caused by HSV type 2, though HSV type 1 can also cause neonatal infection. Neonates with disseminated disease and skin, eye, and mouth (SEM) disease typically present at 5-12 days of life. Neonates with central nervous system (CNS) disease generally present at 16-19 days. Perinatally acquired HSV occasionally manifests beyond 28 days of age, although most cases beyond 28 days of age represent postnatal acquisition.

In febrile infants who *appear well*, viral illnesses are much more common than bacterial or serious viral infections. The most common viruses include respiratory syncytial virus (RSV; see Chapter 307), enteroviruses (see Chapter 297), influenza viruses (see Chapter 305), parainfluenza viruses (see Chapter 306), human metapneumovirus (see Chapter 308), adenovirus (see Chapter 309), parechoviruses (see Chapter 297), and rhinovirus (see Chapter 310).

### CLINICAL MANIFESTATIONS

In neonates and young infants, bacterial and viral infections can present with isolated fever or nonspecific symptoms, making diagnosis of serious illnesses challenging. Some neonates and young infants will have signs of systemic illness at presentation, including abnormal temperature (hypothermia <36°C [96.8°F], fever ≥38°C [100.4°F]), abnormal respiratory examination (tachypnea >60 breaths/min, respiratory distress, apnea), abnormal circulatory examination (tachycardia >180 beats/min, delayed capillary refill >3 seconds, weak or bounding pulses), abnormal abdominal examination, abnormal neurologic

**Table 220.1** Bacterial Pathogens in Neonates and Young Infants with Urinary Tract Infection, Bacteremia, or Meningitis

FREQUENCY	URINARY TRACT INFECTION	BACTEREMIA AND MENINGITIS
Common	<i>Escherichia coli</i>	<i>Escherichia coli</i> Group B <i>Streptococcus</i>
Less common	<i>Klebsiella</i> spp. <i>Enterococcus</i> spp.	<i>Listeria monocytogenes</i> <i>Streptococcus pneumoniae</i> <i>Staphylococcus aureus</i> <i>Klebsiella</i> spp.
Rare	Group B <i>Streptococcus</i> <i>Staphylococcus aureus</i> <i>Pseudomonas aeruginosa</i> <i>Enterobacter</i> spp. <i>Citrobacter</i> spp. <i>Proteus mirabilis</i>	<i>Neisseria meningitidis</i> <i>Salmonella</i> spp. <i>Enterobacter</i> spp. <i>Enterococcus</i> spp. <i>Cronobacter sakazakii</i> <i>Haemophilus influenzae</i> <i>Citrobacter</i>

examination (lethargy, irritability, alterations in tone), or abnormal skin examination (rash, petechiae, cyanosis). Infants with **septic arthritis** or **osteomyelitis** may appear well except for signs around the involved joint or bone or may only manifest with *pseudoparalysis* (disuse) and *paradoxical irritability* (infant experiences pain during attempts to comfort the child).

## DIAGNOSIS

Historically, all neonates <60 or <90 days of age were hospitalized; underwent laboratory evaluation of the blood, urine, and cerebrospinal

fluid (CSF); and received empirical antibiotics. Additionally, some patients had stool cultures, had chest radiographs, had HSV evaluation, and/or received empirical antiviral agents. Under this approach, many infants without SBI or serious viral infection received evaluation, treatment, and hospitalization. Protocols were subsequently developed to identify infants at lower risk of SBI, who may be managed outside the hospital setting. The most current protocol is the American Academy of Pediatrics (AAP) guideline, which considers UTIs separately from bacteremia and meningitis (Table 220.2). Despite protocols, substantial variation continues to exist in the approach to and management

**Table 220.2** Management of Fever Without Source in Infants 0-36 Months Old

GROUP	MANAGEMENT
Any toxic-appearing child 0–36 mo and temperature $\geq 38^{\circ}\text{C}$ (100.4°F)	Hospitalize, cultures (blood, urine, CSF) plus other tests*, parenteral antibiotics
<b>WELL-APPEARING CHILD</b>	
Child <22 days and temperature $\geq 38^{\circ}\text{C}$ (100.4°F)	Hospitalize, cultures (blood, urine, CSF) plus other tests*, parenteral antibiotics
Child 22–60 days and temperature $\geq 38^{\circ}\text{C}$ (100.4°F)	<p><b>Three-Step Process</b></p> <ol style="list-style-type: none"> <li>Determine risk based on history, physical examination, and laboratory studies.               <p>Low risk:</p> <ul style="list-style-type: none"> <li>Uncomplicated medical history</li> <li>Well-appearing physical examination</li> <li>Normal laboratory studies</li> <li>Urine: negative leukocyte esterase and nitrite, <math>\leq 5</math> WBC/hpf centrifuged and <math>&lt; 10</math> WBC/hpf uncentrifuged</li> <li>Inflammatory markers: temperature <math>\leq 38.5^{\circ}\text{C}</math>, procalcitonin <math>\leq 0.5</math> ng/mL, CRP <math>\leq 20</math> mg/L, absolute neutrophil count <math>\leq 4,000</math>-5,200/mm<sup>3</sup></li> <li>Stool studies if diarrhea (no RBC and <math>&lt; 5</math> WBC/hpf)</li> </ul> </li> <li>If child fulfills all low-risk criteria, use age to determine need for LP, parenteral antimicrobials, and hospital observation.               <ul style="list-style-type: none"> <li><b>Age 22-28 days:</b> Obtain UA, blood culture, inflammatory markers. May perform LP. May administer parenteral antimicrobials. Observe in hospital.</li> <li><b>Age 29-60 days old:</b> Obtain UA, blood culture, inflammatory markers. Need not perform LP. Need not administer antimicrobials. Observe closely at home with follow-up within 24-36 hr.</li> </ul> </li> <li>If child does not fulfill all low-risk criteria, use age and lab results to determine need for LP, antimicrobials, and hospital observation.               <ul style="list-style-type: none"> <li><b>Age 22-28 days</b> with abnormal UA and normal inflammatory markers: May perform LP. Administer parenteral antimicrobials. Observe in hospital.</li> <li><b>Age 22-28 days</b> with abnormal inflammatory markers: Perform LP. If CSF pleocytosis, CSF uninterpretable, or abnormal UA, administer parenteral antimicrobials and observe in hospital. If CSF and UA are normal, may observe at home after parenteral antimicrobials or observe in the hospital with or without parenteral antimicrobials.</li> <li><b>Age 29-60 days</b> with abnormal UA and normal inflammatory markers: Administer oral antimicrobials. May observe closely at home with follow-up in 12-24 hr.</li> <li><b>Age 29-60 days</b> with abnormal inflammatory markers: May perform LP. If CSF pleocytosis, administer parenteral antimicrobials and observe in hospital. If CSF is normal, may administer parenteral or oral antimicrobials and may observe closely in hospital or at home. If CSF is not available or uninterpretable, administer parenteral antimicrobials and may observe closely in hospital or at home.</li> </ul> </li> </ol>
Child 2-36 mo and temperature $38$ – $39^{\circ}\text{C}$ (100.4–102.2°F)	Reassurance that diagnosis is likely self-limited viral infection, but advise return with persistence of fever, temperatures $> 39^{\circ}\text{C}$ (102.2°F), and/or new signs and symptoms.
Child 2-36 mo and temperature $> 39^{\circ}\text{C}$ (102.2°F)	<p><b>Two-Step Process</b></p> <ol style="list-style-type: none"> <li>Determine immunization status.</li> <li>If received conjugate pneumococcal and <i>Haemophilus influenzae</i> type b vaccines, obtain urine studies (urine WBC, leukocyte esterase, nitrite, and culture) for all females, all males <math>&lt; 6</math> mo old, all uncircumcised males <math>&lt; 2</math> yr, and all children with recurrent urinary tract infections.</li> </ol> <p>If did not receive conjugate pneumococcal and <i>H. influenzae</i> type b vaccines, manage according to the 1993 Guidelines (see Baraff et al. <i>Ann Emerg Med.</i> 1993;22:1198–1210).</p>

\*Other tests may include chest radiograph, stool studies, herpes simplex and other virus polymerase chain reaction.

CSF, Cerebrospinal fluid; hpf, high-powered field; LP, lumbar puncture; RBC, red blood cell; UA, urinalysis; WBC, white blood cell.

Modified from Huppler A. Fever. In: Kliegman RM, Toth H, Bordini BJ, Basel D, eds. *Nelson Pediatric Symptom-Based Diagnosis*, 2nd ed. Philadelphia: Elsevier, 2023: Table 52.5, p. 971; with data from Pantell RH, Roberts KB, Adams WG, et al. Evaluation and management of well appearing febrile infants 8 to 60 days old. *Pediatrics.* 2021;148(2):e2021052228.



of the febrile infant. *It must be emphasized that these criteria apply to the well-appearing child; those who appear critically ill (septic) require prompt evaluation, resuscitation, and empiric antibiotic therapy (within 1 hour).*

In the past, experts advocated that all neonates  $\leq 28$  days old undergo a complete evaluation for serious infection, receive empirical antimicrobials, and be hospitalized. In prior risk criteria, one allowed neonates  $\leq 28$  days to be designated as “low risk” and managed outside the hospital without antimicrobials. In one study,  $<1\%$  of low-risk infants  $\leq 28$  days old had SBI; however, in another study applying the other criteria to neonates, 3–4% of those classified as low risk had SBI. In the current protocols, neonates 22–28 days who meet certain low-risk criteria can be managed outside the hospital; in one study, the risk of bacteremia in this age-group was lower than in infants  $<22$  days (1.6% vs 3.3–5.3%).

Young febrile infants  $\geq 29$  days old who *appear ill* (with signs of systemic illness) require complete evaluation for serious infection, empiric antimicrobials, and hospitalization; however, well-appearing infants can be managed safely as outpatients using low-risk criteria as indicated in Table 220.2. With each of these approaches, infants must have a normal physical examination, must be able to reliably obtain close follow-up, and must meet certain laboratory and/or radiographic criteria. Based on these protocols, all infants meeting the previous criteria would undergo lumbar puncture (LP), whereas low-risk infants meeting other criteria and following the current protocols would not. There is substantial variation in clinical practice in the performance of LPs in well-appearing infants  $>28$  days. When deciding whether to perform an LP in this age-group, clinicians should consider multiple factors, including the home situation and the ability to contact the family.

The protocols discussed in Table 220.2 were initially developed for use in the emergency department (ED). Infants evaluated in the office setting may warrant a different approach when a relationship between the physician and family already exists to facilitate clear communication and timely follow-up. In one large study of febrile infants  $<3$  months old who were initially evaluated for fever in the office setting, clinicians hospitalized only 36% of infants but initiated antibiotics in 61 of the 63 infants with bacteremia or bacterial meningitis. These findings suggest that, with very close follow-up (including multiple in-person visits or frequent contacts by telephone), some febrile infants perceived to be at low risk for **invasive bacterial infection** (bacteremia and meningitis) on the basis of history, physical examination, and normal but limited laboratory testing can be managed in an office-based setting. It is important to note that 3% of infants with SBI did not initially receive empiric antibiotics, necessitating careful consideration of risks and benefits of selective rather than universal testing and empiric antibiotic treatment of febrile infants evaluated in the office setting.

### Viral Respiratory Illness

Several studies have demonstrated a decreased risk of SBI in infants with positive testing for influenza, RSV, and other respiratory viral illnesses, although the risk of UTI remains significant. In one prospective study, the risk of SBI in neonates  $<28$  days old was not altered by RSV status. Given these data, young febrile infants with bronchiolitis may not require LP, particularly if they can be closely observed or have close follow-up.

### Urinary Tract Infection and Bacterial Meningitis

In the past, infants with abnormal findings on urinalysis (UA) would undergo complete evaluation for infection, including LP. In well-appearing infants  $>28$  days old with an abnormal UA, some evidence suggests that the risk of bacterial meningitis is extremely low:  $<0.5\%$ . For neonates 0–28 days, the risk of concomitant bacterial meningitis with UTI is 1–2%.

CSF pleocytosis in the absence of bacterial meningitis (i.e., **sterile pleocytosis**) has been reported in  $\sim 23\%$  infants with UTI. The cause is uncertain, with some studies attributing this phenomenon to traumatic

LPs or undetected viral infection rather than inflammation in the context of systemic illness.

## LABORATORY DIAGNOSIS

### Complete Blood Count

The peripheral complete blood cell count (CBC) and differential are frequently obtained by providers when evaluating febrile neonates and infants. The white blood cell (WBC) count alone cannot accurately predict SBI risk. In one series, isolated use of the WBC cutoffs of outside 5,000–15,000 WBCs/mm<sup>3</sup> would miss at least 33% of infants with bacteremia and 40% of those with meningitis. A prospective study found no increased risk of SBI in febrile, well-appearing infants with leukopenia (WBC count  $<5,000$ /mm<sup>3</sup>). The WBC count combined with other factors may help determine an infant’s risk of SBI, but it should not be used in isolation to predict infection risk. The absolute neutrophil count (ANC) has also been used in evaluating the risk of serious infection. Two recent large studies derived ANC cutoffs of greater than 4,000 and 5,200 per mm<sup>3</sup> for use in specific protocols; however, these protocols used ANC in conjunction with other markers.

### Blood Culture

The ability to identify pathogens in the blood depends on the volume of blood, the timing of the blood culture in relation to antimicrobial administration, and, to a lesser degree, the number of blood cultures obtained. A negative blood culture does not exclude the possibility of bacterial meningitis; in one study, 38% of infants with culture-proven bacterial meningitis had negative blood cultures. For additional information on the time to positivity of blood cultures in neonates and young infants, see “Discharge from the Hospital.”

### Urinalysis

Different methods can assist in making a presumptive diagnosis of UTI while awaiting results of a urine culture. *Traditional* UA consists of dipstick biochemical analysis of urine for nitrites or leukocyte esterase (LE) and microscopic examination of the urine for WBCs and bacteria. One study found that the traditional UA had a higher negative predictive value (NPV) than dipstick alone (99.2% vs 98.7%), but that dipstick alone had a higher positive predictive value (PPV, 66.8% for dipstick alone vs 51.2% for traditional UA). *Enhanced* UA includes hemocytometer cell count (to decrease variability of urine cell counts) and Gram stain on uncentrifuged urine. The enhanced UA has a higher sensitivity but comparable specificity to traditional UA. However, the enhanced UA has not been studied in the most common protocols for evaluation of the febrile infant, and many institutions/office practices do not perform this test.

### Cerebrospinal Fluid

CSF evaluation consists of culture and Gram stain, cell count, glucose, and protein. Polymerase chain reaction (PCR) testing may also be sent based on the clinical scenario, usually for enterovirus or HSV (some include bacterial pathogens). Normal CSF parameters vary by age of the infant and should be interpreted in combination with other clinical and historical risk factors, given that some infants with normal CSF parameters may rarely have CNS infections (Table 220.3). The CSF Gram stain can be a useful adjunct to other CSF parameters given the high specificity of the test (99.3–99.9%; i.e., relatively few false-positive results), although the range of reported sensitivity is much broader (67–94.1%).

The interpretation of CSF can be challenging in the setting of a traumatic LP, where the CSF is contaminated with peripheral blood. Some clinicians assume a ratio of WBCs to red blood cells (RBCs) of 1:500 in the CSF. Others advocate calculating the expected CSF WBCs based on the peripheral blood WBCs and RBCs and then using the observed-to-predicted ratio of CSF WBCs to aid in the identification of bacterial meningitis. This calculation assumes that the ratio of WBCs to RBCs in the peripheral blood remains constant after introduction into the CSF. Next-generation molecular testing is helpful in identifying the most



**Table 220.3** Values of Cerebrospinal Fluid (CSF) Studies in Neonates and Infants by Age

CSF WHITE BLOOD CELL COUNTS	CELLS/MM <sup>3</sup>	CSF PROTEIN	MG/DL
Upper limit of normal by age*		90th percentile by age <sup>†</sup>	
1-28 days	18	0-7 days	153
29-60 days	8.5	8-28 days	84-106
61-90 days	8.5	29-56 days	84-105
Upper limit of normal by age <sup>#</sup>		95th percentile by age <sup>§</sup>	
0-28 days	15	0-14 days	132
29-60 days	9	15-28 days	100
90th percentile by age <sup>†</sup>		29-42 days	89
0-7 days	26	43-56 days	83
8-28 days	8-9	95th percentile by age <sup>#</sup>	
29-56 days	6-8	0-28 days	118
95th percentile by age <sup>‡</sup>		29-60 days	91
0-28 days	19	<b>CSF GLUCOSE</b>	<b>MG/DL</b>
29-56 days	9	Lower limit of normal by age*	
95th percentile by age <sup>#</sup>		1-28 days	30
0-28 days	16	29-60 days	30.5
29-60 days	11	61-90 days	33.5
<b>CSF PROTEIN</b>	<b>MG/DL</b>	Lower limit of normal by age <sup>#</sup>	
Upper limit of normal by age*		0-28 days	25
1-28 days	131	29-60 days	27
29-60 days	105.5	10th percentile for infants 0-56 days <sup>†</sup>	38-43
61-90 days	71	10th percentile by age <sup>#</sup>	
Upper limit of normal by age <sup>#</sup>		0-28 days	37
0-28 days	127	29-60 days	39
29-60 days	99		

\*Data from Byington CL, Kendrick J, Sheng X. Normative cerebrospinal fluid profiles in febrile infants. *J Pediatr.* 2011;158(1):130–134. All infants had nontraumatic lumbar puncture (LP) and no evidence of bacterial or viral infection.

<sup>†</sup>Data from Chadwick SL, Wilson JW, Levin JE, Martin JM. Cerebrospinal fluid characteristics of infants who present to the emergency department with fever: establishing normal values by week of age. *Pediatr Infect Dis J.* 2011;30(4):e63–e67. All infants were excluded if they had identified viral or bacterial meningitis, positive blood or urine cultures, a ventriculoperitoneal shunt, recent neurosurgery/antibiotics/seizure, or a traumatic LP.

<sup>‡</sup>Data from Kestenbaum LA, Ebberson J, Zorc JJ, et al. Defining cerebrospinal fluid white blood cell count reference values in neonates and young infants. *Pediatrics.* 2010;125(2):257–264. Infants were excluded for traumatic LP, serious bacterial infection, congenital infection, seizure, presence of ventricular shunt, or positive CSF testing for enterovirus.

<sup>§</sup>Data from Shah SS, Ebberson J, Kestenbaum LA, et al. Age-specific reference values for cerebrospinal fluid protein concentration in neonates and young infants. *J Hosp Med.* 2011;6(1):22–27. Infants were excluded for traumatic LP, serious bacterial infection, congenital infection, seizure, presence of a ventricular shunt, positive CSF testing for enterovirus, or elevated serum bilirubin.

<sup>#</sup>Data from Thomson J, Sucharew H, Cruz AT, et al. Cerebrospinal fluid reference values for young infants undergoing lumbar puncture. *Pediatrics.* 2018;141(3):e20173405. Infants were excluded for missing any component of the CSF profile, traumatic LP, serious bacterial infection, viral CNS infection, non-CNS HSV disease, or prolonged hospital length of stay.

common bacterial and viral pathogens despite a traumatic LP; results are often available within a few hours.

One retrospective cohort study concluded that an observed/predicted CSF WBC ratio of  $\leq 0.01$  was helpful in predicting the absence of bacterial meningitis; however, another retrospective cohort study and one case series of traumatic LPs concluded that adjustment of CSF WBC count does not improve the accuracy of diagnosis of meningitis in patients with traumatic LPs. Clinicians may consider hospitalization and empirical antimicrobials in patients with traumatic LPs given the challenge of interpreting the CSF WBC count when there is blood contamination of the specimen.

Treatment with antibiotics before LP can complicate the interpretation of CSF cultures. CSF cultures are negative relatively rapidly after antibiotic administration, within 2 hours for *N. meningitidis* and

4-24 hours for *S. pneumoniae*. Next-generation molecular testing is not affected by prior antibiotic treatment, thus enhancing a diagnosis despite prior antibiotic therapy. In patients with bacterial meningitis, CSF glucose increases to normal range, often within 4-24 hours of antibiotic administration, whereas CSF protein concentrations, despite decreasing, remain abnormal for >24 hours after antibiotic administration. Changes in CSF WBC count and ANC are minimal in the first 24 hours of antibiotic therapy. Therefore CSF findings can provide relevant management information even in the setting of antibiotic administration before LP.

### Herpes Simplex Virus Testing

No consensus exists on which neonates should be tested and empirically treated for HSV infection. Historical and clinical features that

should raise concern for HSV include exposure to individuals infected with HSV, particularly mothers with primary HSV infections or first-time genital infections, seizure or abnormal neurologic examination, vesicular rash, ill appearance, apnea, hypothermia, petechial rash/excessive bleeding, hepatic failure, or a history of a scalp electrode. However, neonates with HSV can present *without any high-risk* clinical or historical features, particularly with early isolated CNS disease. Published approaches to neonatal HSV include (1) testing and empirical treatment of all neonates <21 days old who are evaluated for infection; (2) testing and empirical treatment of neonates with the presence of high-risk clinical features for HSV; and (3) testing and empirical treatment for all neonates with high-risk features plus testing the CSF of all neonates <21 days old while deferring empirical acyclovir in those without high-risk features, unless the CSF HSV PCR test is positive.

The AAP Committee on Infectious Diseases recommends that neonates undergoing evaluation for HSV have the following laboratory studies performed: surface cultures or PCR of the conjunctiva, mouth or nasopharynx, rectum, and any vesicles; CSF PCR (sensitivity: 75–100%); whole blood PCR; and serum levels of alanine transaminase (ALT). HSV PCR testing of the mouth, conjunctiva, nasopharynx, rectum, and vesicles has been shown to be more sensitive than culture, with comparable specificity, although no direct comparisons have been performed in neonates.

### Enterovirus Testing

Enterovirus is a common and typically benign cause of fever in febrile infants, although it can be difficult to distinguish from SBI on initial presentation. Enterovirus PCR testing of the CSF is a sensitive and rapid means to diagnose infection. One retrospective study of patients with CSF enterovirus testing found no cases of bacterial meningitis in patients with positive enterovirus PCR; this study did not include neonates ≤28 days old. Several studies have demonstrated shorter length of stay, fewer antibiotics, and lower cost among infants with positive CSF enterovirus test results. These results suggest that during local enterovirus seasons, and if PCR testing is available, testing for enterovirus may be of benefit in the evaluation of febrile infants and neonates. Some centers have implemented multiplex PCR panels, which permit testing for multiple viruses, including enterovirus and HSV (and bacteria) simultaneously.

### Other Inflammatory Markers

Investigations have examined the utility of inflammatory markers such as C-reactive protein (CRP) and serum procalcitonin (PCT) in the diagnosis of SBI and, more specifically, IBI (bacteremia and meningitis) (see [Table 220.2](#)). One meta-analysis reported that PCT is superior to WBC count and CRP for the detection of IBI in children <3 years old, whereas another found that PCT was inferior to prediction rules in identifying SBI in young infants. A prospective multicenter cohort study of febrile infants 7–91 days old determined that the PCT was better at identifying patients with IBI than CRP, WBC count, or ANC. Building on these results, clinical prediction rules for febrile infants, such as the **Step-by-Step** approach, incorporate PCT and CRP, along with age ≤21 days, ill appearance, ANC >10,000/mm<sup>3</sup>, and pyuria in a stepwise approach to determine which patients are at high risk for IBI; only 0.7% of infants who met none of those criteria had IBI. In the approach from the AAP, inflammatory markers are recommended for all infants 22 days and older as part of risk stratification. If available, this approach recommends PCT along with either CRP or ANC. If PCT is unavailable, then CRP, ANC, and elevation in temperature should be considered as markers of inflammation (see [Table 220.2](#)).

### Other Diagnostic Studies

Older infants with positive RSV and influenza testing have a very low risk of SBI beyond UTI. One large case-based survey demonstrated decreased admission rates and antibiotic use for infants with positive

respiratory viral tests, and another study demonstrated that implementation of a care algorithm incorporating viral testing led to a shorter length of stay and antibiotic course.

Chest radiographs are unlikely to be clinically useful in the evaluation of the febrile infant without respiratory symptoms. Studies that have examined routine use of radiographs have found limited utility because in infants without respiratory symptoms, most results will be normal and abnormal results can be difficult to interpret.

## TREATMENT

### Antimicrobials

Ill-appearing and high-risk infants and those <22 days old hospitalized for evaluation for SBI should receive antimicrobial therapy. Commonly used regimens include (1) a third-generation cephalosporin (typically cefepime or ceftazidime), (2) a third-generation cephalosporin and ampicillin, or (3) an aminoglycoside and ampicillin.

**Ampicillin** is the preferred treatment of GBS and covers *L. monocytogenes* and many *Enterococcus* spp. and some *E. coli*. For neonates 0–28 days, options 2 or 3 have been recommended, given the risk of *L. monocytogenes*. For young infants >28 days, option 1 (third-generation cephalosporin: ceftriaxone) is a reasonable choice. For ill-appearing infants or those with positive CSF Gram stains, additional antibiotics may include vancomycin or broad-spectrum antibiotics such as carbapenems. Local epidemiology and resistance patterns may assist in these choices. Neonates with concern for HSV should be empirically treated with high-dose acyclovir (60 mg/kg/day).

Treatment duration and route of antimicrobial administration depend on the infection. Additional details based on specific infections and organisms are available in the following chapters: meningitis (see [Chapter 148](#)), UTI (see [Chapter 575](#)), *E. coli* (see [Chapter 246](#)), GBS (see [Chapter 230](#)), and HSV (see [Chapter 299](#)).

### Discharge from the Hospital

Traditionally, infants remained in the hospital receiving antimicrobial therapy until bacterial cultures were negative for 48 hours or even longer. Multiple studies have suggested that shorter culture observation periods (i.e., 24 or 36 hours) may be reasonable because most pathogens in the blood grow within this time frame when automated blood culture monitoring systems are used. In one multicenter retrospective cross-sectional study, 91% of blood cultures were positive by 24 hours and 96% by 36 hours. Fewer studies have evaluated the *time to positivity* of CSF and urine cultures, but in one large study of febrile infants 28–90 days old, all positive CSF cultures grew within 24 hours (median time to positivity, 18 hours). For blood cultures, 1.3% grew after 24 hours (median time to positivity, 16 hours), and for urine cultures, 0.9% grew after 24 hours (median time to positivity, 16 hours). In one multicenter study including infants <60 days old, 82% of CSF cultures were positive by 24 hours and 86% by 36 hours. For neonates undergoing evaluation for HSV, it is reasonable to await results of HSV testing before discharge to home. For patients with identified bacterial infections or HSV infections, the duration of the hospital stay will be determined by the specific pathogen and site of infection.

## PROGNOSIS

Most well-appearing neonates and young infants with fever recover completely and relatively quickly, depending on the etiology of the fever. Most infection-related mortality and long-term morbidity result from HSV infection and bacterial meningitis. For HSV, reported mortality rates range from 27% to 31% for disseminated disease and from 4% to 6% for CNS disease. Of those who survive, 83% of patients with disseminated disease and 31% of those with CNS disease will have normal development at 12 months old. The mortality of bacterial meningitis varies by pathogen but ranges from 4% to 15%. In one study of children who had meningitis as infants, 84% had normal development at age 5 years.

Visit Elsevier eBooks+ at [eBooks.Health.Elsevier.com](http://eBooks.Health.Elsevier.com) for Bibliography.

## Chapter 221

## Fever in the Older Child

Laura Brower and Samir S. Shah

Fever is the most common reason for a child to seek medical care. While most infants and children have benign viral causes of fever, a small proportion will have more serious infections. Unlike fever in young infants, pediatricians can rely more readily on symptoms and physical examination findings to establish a diagnosis in older children. Laboratory testing and radiographic studies are not routinely indicated but may be helpful when diagnostic uncertainty exists or the patient appears critically ill. Occult infections, such as urinary tract infection (UTI), may be present, and testing for such infections should be guided by demographic and contextual factors such as patient age, patient gender, and environmental exposures.

**DIAGNOSIS**

The many potential causes of fever in older infants and children can be broadly categorized into viral and bacterial infections, further organized by body region, as well as the less common inflammatory, oncologic, endocrine, and medication-induced causes (Table 221.1).

**Viral Infections**

Viral infections are the most common cause of fever, and the prevalence of specific viral infections varies by season. Typically, in the summer and early fall, enteroviruses (e.g., coxsackieviruses) predominate, usually presenting as hand-foot-and-mouth disease, herpangina, aseptic meningitis, or a variety of other manifestations. In the late fall and winter, viral upper and lower respiratory tract infections caused by respiratory viruses such as respiratory syncytial virus (RSV) and influenza and gastroenteritis caused by gastrointestinal (GI) viruses such as norovirus and rotavirus are common. Parainfluenza viruses are a common cause of **laryngotracheobronchitis (croup)** and occur primarily in the fall and spring, affecting mostly infants and toddlers. Varicella is a less common cause of fever than in the past because of childhood vaccination but still occurs, with the highest incidence in winter and early spring. Coronavirus disease 2019 (COVID-19) caused by SARS-CoV-2 can cause fever alone or with either upper or lower respiratory tract symptoms in young children, though asymptomatic infections also occur.

**Bacterial Infections**

Common bacterial infections include acute **otitis media** and **streptococcal pharyngitis (strep throat)**. Acute otitis media is diagnosed by the presence of a bulging, erythematous, and nonmobile tympanic membrane upon insufflation. Streptococcal pharyngitis occurs most frequently in the late fall and winter and is uncommon before age 3 years. The presence of focal auscultatory findings, including crackles, suggests a lower respiratory tract infection, such as bacterial pneumonia, but may also be present among children with **bronchiolitis** and viral pneumonia. **Atypical pneumonia** caused by mycoplasma typically occurs in school-age children and is often associated with headache, sore throat, malaise, and low-grade fever. The presence of neck pain (especially with neck extension for those with retropharyngeal abscess), drooling, or muffled voice may indicate a deep neck infection such as a **retropharyngeal abscess**, which occurs in infants and young children, or a **peritonsillar abscess**, which typically affects older children. Skin and soft tissue infections such as cellulitis and abscess may also present with fever, with the buttocks a common area for abscesses in young children. Bone and joint infections such as **osteomyelitis** and **septic arthritis** may present with fever and refusal to bear weight or limp in the young child. Invasive bacterial infections, including **sepsis** and **bacterial meningitis**, must be considered in young children presenting with fever. Although uncommon, these infections are potentially life-threatening and require prompt recognition and treatment. Ill appearance, lethargy, and tachycardia are typically present among children with severe

sepsis, and petechiae may be an early finding among children with meningococemia or other invasive bacterial diseases. Figures 221.1 and 221.2 show age-related diagnoses and organisms producing bacterial sepsis in infants and children. Children with fever who are immunosuppressed, such as children receiving chemotherapy or those with sickle cell disease, are at higher risk for invasive bacterial infection.

**Infants and children age 2-24 months** merit special consideration because they have limited verbal skills, are at risk for occult bacterial infections, and may be otherwise asymptomatic except for fever (see Chapter 220).

**Occult Urinary Tract Infection**

Among children 2-24 months old without symptoms or physical examination findings that identify another focal source of infection, the prevalence of UTI may be as high as 5-10%. The highest risk of UTI occurs in females and uncircumcised males, with a very low rate of infection (<0.5%) in circumcised males. Table 221.2 lists clinical risk factors for UTI.

**Occult Bacteremia**

Occult bacteremia is defined as a positive blood culture for a pathogen in a well-appearing child without an obvious source of infection. In the 1990s, before vaccination programs against *Haemophilus influenzae* type b (Hib) and *Streptococcus pneumoniae*, up to 5% of young children age 2 to 24 (up to 36) months with fever  $\geq 39^{\circ}\text{C}$  ( $102.2^{\circ}\text{F}$ ) had occult bacteremia, most often caused by *S. pneumoniae*. Currently, the prevalence of occult bacteremia is far less than 1% in febrile, well-appearing young children. Most cases of pneumococcal occult bacteremia are transient, with a minority of these children developing new focal infections, sepsis, or other sequelae. Unimmunized and incompletely immunized young children remain at higher risk for occult bacteremia because of pneumococcus (see Chapter 228). Bacteremia caused by Hib or meningococcus should not be considered benign because subsequent serious invasive infection may rapidly follow the bacteremia.

**GENERAL APPROACH**

The general approach to fever in the older child begins with an assessment of the child's overall appearance and vital signs. A detailed history of the present illness and a thorough physical examination should be performed to identify the cause of the fever.

**Overall Appearance and Vital Signs**

Children who are ill or appear toxic or who have abnormal vital signs (e.g., tachycardia, tachypnea, hypotension) require rapid assessment, including a focused physical examination to evaluate for the possibility of an invasive bacterial infection. A more detailed history and physical exam can be performed in the well-appearing child.

**Symptoms**

A thorough history should be obtained from the caregiver (and patient, when appropriate), including a characterization of the fever and any other associated symptoms. The degree and duration of the fever should be assessed, and the method of taking the temperature should be ascertained (e.g., forehead, axillary, oral, rectal). For children with prolonged fever, it is important to determine whether the fever has been episodic or persistent. Patients with prolonged fever may harbor occult infections, UTI, or bone or soft tissue infections or may have an inflammatory or oncologic condition. Additionally, Kawasaki disease and multisystem inflammatory syndrome in children (MIS-C) should be considered among children with prolonged fever, and a careful evaluation for other stigmata associated with these conditions is warranted (see Chapter 208).

After characterizing the fever, it is important to ask systematically about the presence of symptoms that may identify an etiology for the fever, including symptoms of common viral infections such as rhinorrhea, cough, vomiting, and diarrhea. Additionally, symptoms should be elicited for each body system: headache, ear pain, sore throat, neck pain or swelling, difficulty breathing, chest pain, abdominal pain, rash or changes in skin color, extremity pain or difficulty with ambulation (including refusal to bear weight in a

**Table 221.1** Etiologies of Fever in Children >2 Mo of Age

<p><b>INFECTIOUS</b></p> <p><b>Central Nervous System</b></p> <p>Bacterial meningitis Viral meningitis Viral encephalitis Epidural abscess Brain abscess</p> <p><b>Ear, Nose, and Throat</b></p> <p>Acute otitis media Mastoiditis Viral upper respiratory infection (i.e., common cold) Acute bacterial sinusitis Acute streptococcal pharyngitis Acute viral pharyngitis Retropharyngeal abscess Ludwig angina Peritonsillar abscess Herpangina Herpes simplex virus gingivostomatitis Acute bacterial lymphadenitis Viral laryngotracheobronchitis (i.e., croup) Bacterial tracheitis Epiglottitis Lemierre syndrome</p> <p><b>Face and Ocular</b></p> <p>Parotitis (viral and bacterial) Erysipelas Preseptal cellulitis Orbital cellulitis</p> <p><b>Lower Respiratory Tract</b></p> <p>Acute viral bronchiolitis Pneumonia (viral and bacterial) Complicated pneumonia (e.g., empyema, pleural effusion) Tuberculosis</p> <p><b>Cardiac</b></p> <p>Pericarditis Myocarditis Endocarditis</p> <p><b>Gastrointestinal</b></p> <p>Gastroenteritis (viral and bacterial) Mesenteric adenitis Acute appendicitis Hepatitis Pancreatitis Gallbladder disease (e.g., cholecystitis, cholangitis) Intraabdominal abscess</p> <p><b>Genitourinary</b></p> <p>Urinary tract infection/pyelonephritis Renal abscess Epididymitis Pelvic inflammatory disease Tubo-ovarian abscess</p> <p><b>Skin, Soft Tissue, and Muscle</b></p> <p>Viral exanthemas (e.g., varicella, coxsackievirus, roseola, measles) Scarlet fever Syphilis Cellulitis Abscess Necrotizing fasciitis Myositis (viral and bacterial and immune)</p>	<p><b>Bone and Joint</b></p> <p>Osteomyelitis Septic arthritis Transient synovitis Spondylodiscitis</p> <p><b>Toxin Mediated</b></p> <p>Toxic shock syndrome Staphylococcal scalded skin syndrome</p> <p><b>Invasive Bacterial Infections</b></p> <p>Occult bacteremia Bacterial sepsis Bacterial meningitis Disseminated gonococcal infection</p> <p><b>Systemic Infection</b></p> <p>EBV CMV HIV Cat scratch disease Brucellosis Influenza Others (see Chapter 222)</p> <p><b>Vector-Borne (Tick, Mosquito)</b></p> <p>Lyme disease Rickettsiae (e.g., Rocky Mountain spotted fever) Ehrlichiosis Arboviruses (e.g., West Nile virus) Dengue fever</p> <p><b>INFLAMMATORY</b></p> <p>Kawasaki disease Acute rheumatic fever Systemic lupus erythematosus Inflammatory bowel disease Juvenile idiopathic arthritis IgA vasculitis (Henoch-Schönlein purpura) Other rheumatologic diseases (e.g., dermatomyositis) Periodic fever syndromes Serum-like sickness syndrome Multisystem inflammatory syndrome in children (MIS-C)</p> <p><b>ONCOLOGIC</b></p> <p>Leukemia Lymphoma Solid tumors (e.g., neuroblastoma)</p> <p><b>ENDOCRINE</b></p> <p>Thyrotoxicosis/thyroid storm</p> <p><b>MEDICATION INDUCED</b></p> <p>Serotonin syndrome Anticholinergic toxidrome (e.g., antihistamines) Sympathomimetic toxidrome (e.g., cocaine) Salicylate toxicity</p> <p><b>OTHER</b></p> <p>Hemophagocytic lymphohistiocytosis Macrophage activation syndrome Ectodermal dysplasia Dysautonomia Factitious</p>
--	--

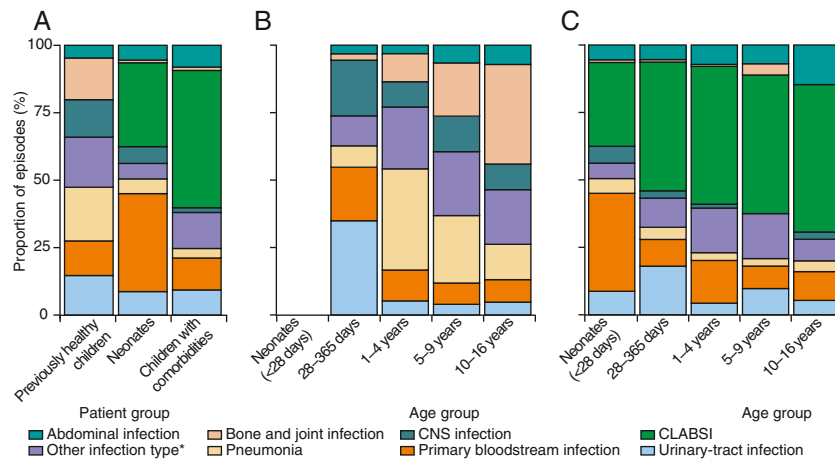
young child), and overall activity level. In older children, the presence of dysuria, urinary frequency, or back pain may indicate UTI. Assessment of oral intake and urine output is also critical because dehydration may accompany common childhood infections and is associated with higher rates of morbidity. The presence of weight loss or night sweats may indicate leukemia, lymphoma, or tuberculosis. Additionally, a thorough social history should be performed,

inquiring about attendance at daycare, any travel, and any sick contacts at daycare, school, or in the household.

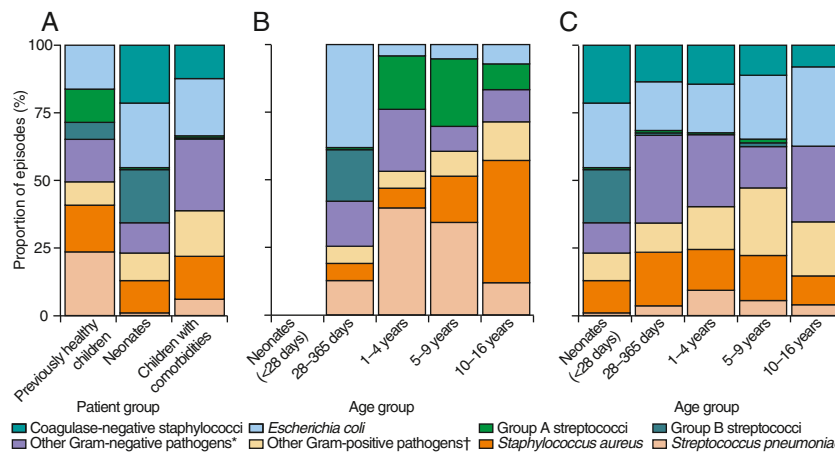
### Physical Examination

A complete physical examination includes particular attention to body systems with associated symptoms (e.g., thorough exam of oropharynx for child with sore throat). A complete physical





**Fig. 221.1** Age distribution of sites of infection causing blood culture–proven bacterial sepsis in children. Sites of infection are shown for (A) the three patient groups together and separately for (B) previously healthy children  $\geq 28$  days old and (C) neonates and children with comorbidities  $\geq 28$  days old. CLABSI, Central line–associated bloodstream infection; CNS, central nervous system. \*Skin infection, wound infection, endocarditis, toxic shock syndrome; ear, nose, and throat infection; other, nonspecified focal infection. (From Agyeman PKA, Schlapbach LJ, Giannoni E, et al. *Epidemiology of blood culture-proven bacterial sepsis in children in Switzerland: a population-based cohort study*. *Lancet Child Adolesc*. 2017;1:124–133, Fig. 3.)



**Fig. 221.2** Age distribution of pathogens causing blood culture–proven bacterial sepsis in children. Pathogens isolated in blood culture are shown for (A) the three patient groups together and separately for (B) previously healthy children  $\geq 28$  days old and (C) neonates and children with comorbidities  $\geq 28$  days old. †*Pseudomonas aeruginosa*, *Klebsiella* spp., *Neisseria meningitidis*, *Haemophilus influenzae*, other gram-negative pathogens. †*Enterococcus* spp., viridans group streptococci, other gram-positive pathogens. (From Agyeman PKA, Schlapbach LJ, Giannoni E, et al. *Epidemiology of blood culture-proven bacterial sepsis in children in Switzerland: a population-based cohort study*. *Lancet Child Adolesc*. 2017;1:124–133, Fig. 4.)

examination is particularly important in young children  $< 24$  months old who have limited verbal skills to communicate localized pain. In older children the physical exam may proceed systematically from head to toe, but in younger children, who may be fearful of the exam, it is important to auscultate the heart and lungs first before proceeding to potentially painful or distressing aspects of the examination (e.g., inspection of ears or oropharynx). In addition to a careful evaluation of each body system, a complete examination should include an assessment of neck pain and mobility, which may be limited in children with meningitis. Additionally, the examiner should palpate carefully for the presence of lymphadenopathy, which may be present with infectious and oncologic causes of fever. Erythema and exudate of the tonsils with palatal petechiae suggest streptococcal pharyngitis. Erythema, bulging, and decreased mobility of the tympanic membrane are the cardinal signs of acute otitis media. Diffuse crackles and wheezes on auscultation of the lungs occur with acute viral bronchiolitis, whereas focal crackles or decreased breath sounds are more consistent with bacterial pneumonia. Focal tenderness in the right lower quadrant of the abdomen suggests appendicitis, and suprapubic tenderness may indicate UTI (cystitis). Any focal bony tenderness may reflect a diagnosis of osteomyelitis, whereas erythema, swelling, and limitation of range of motion suggest a diagnosis of septic arthritis. Abnormal gait or pain with ambulation without focal findings may also reflect a bone or joint infection. A careful skin examination should also be performed. The

presence of petechiae may suggest meningococcal or other invasive bacterial infection, whereas viral exanthems are typically associated with a blanching macular or maculopapular rash.

## EVALUATION

### Laboratory Testing

Laboratory testing is not routinely indicated in the well-appearing child without a focus of infection on examination. Urine testing should be considered based on the child's age, duration of fever, and risk factors for UTI (see Table 221.2). In general, the decision to perform laboratory testing should be guided by the overall appearance and vital signs of the child, the presence of specific symptoms or physical examination findings, and the child's age.

For children who are ill or appear toxic or who have vital sign abnormalities indicative of an invasive bacterial infection (tachycardia, hypotension), rapid laboratory evaluation should be performed. Testing may include a blood culture and possibly urine and cerebrospinal fluid (CSF) cultures, depending on the age of the child and the presence or absence of physical exam findings indicative of UTI or bacterial meningitis. Markers of inflammation, such as procalcitonin or C-reactive protein may also be considered. Complete blood counts (CBCs) identify leukocytosis or leukopenia, anemia, and thrombocytosis or thrombocytopenia. Children with infectious mononucleosis may have lymphocyte predominance and the presence of atypical lymphocytes. Children

who are immunosuppressed or who have a central venous catheter should also undergo diagnostic testing and receive prompt antimicrobial therapy, given their higher risk of invasive bacterial infection.

For well-appearing children with symptoms or signs indicative of a viral upper respiratory or GI infection, routine viral testing is not generally indicated. **Influenza** testing may be indicated within 48 hours of symptom onset in certain higher-risk populations, with immunosuppression, chronic respiratory or cardiac disease, sickle cell disease, hospitalization, and age <2 years influencing the decision to treat with an antiviral agent. Testing for **SARS-CoV-2** may be indicated based on local prevalence and symptoms (fever, cough, congestion, loss of taste or smell, shortness of breath, body aches, fatigue, headache, sore throat, nausea, vomiting, or diarrhea). Viral testing may also be useful with prolonged fever to identify a source of the fever and avoid extensive evaluation for inflammatory conditions such as Kawasaki disease or MIS-C.

**Rapid strep testing** of the oropharynx is indicated for children  $\geq 3$  years old with signs of streptococcal pharyngitis on examination. Although strep throat is uncommon in children <3 years old, this group should undergo rapid strep testing if they have signs of strep throat on exam and a household contact with streptococcal pharyngitis (see Chapter 229).

Febrile children 2 months to 2 years old with several of the risk factors for UTI listed in Table 221.2, particularly females and uncircumcised males, should undergo evaluation with urine dipstick, urine microscopy, and urine culture. Females and uncircumcised males 2-6 months old with high fever or fever that lasts  $\geq 2$  days may undergo urine testing even in the presence of respiratory tract infection, given the higher risk of UTI in this younger group (see Chapter 575).

Given the very low risk of occult bacteremia, routine performance of blood testing (e.g., CBC, blood culture) is not indicated in the vast majority of immunized children with fever. Unimmunized and underimmunized children <2 years old remain at higher risk of occult pneumococcal bacteremia, and CBC, blood culture, and/or inflammatory markers may be considered in this population in the absence of another source of infection.

## Imaging

The presence of focal crackles or decreased breath sounds on auscultation in the febrile child is suggestive of **pneumonia**. Current guidelines

**Table 221.2** Risk Factors for Urinary Tract Infection in Children

AMERICAN ACADEMY OF PEDIATRICS CLINICAL PRACTICE GUIDELINE\*

CHILDREN 2-24 MO OF AGE

**Female**

Age <1 yr

Temperature  $\geq 39^\circ\text{C}$  (102.2°F)

Fever duration  $\geq 2$  days

No obvious source of infection

**Male**

Uncircumcised males at higher risk

Temperature  $\geq 39^\circ\text{C}$  (102.2°F)

Fever duration >1 day

No obvious source of infection

UNIVERSITY OF PITTSBURGH UTICALC<sup>†</sup>  
CHILDREN 2-23 MO OF AGE

Age <12 mo

Maximum temperature  $\geq 39^\circ\text{C}$

History of UTI

Female or uncircumcised male

Duration of fever  $\geq 48$  hr

No other source of fever

\*Adapted from Subcommittee on Urinary Tract Infection, et al. Urinary tract infection clinical practice guideline for the diagnosis and management of the initial UTI in febrile infants and children 2 to 24 months. *Pediatrics*. 2011;128(3):595-610.

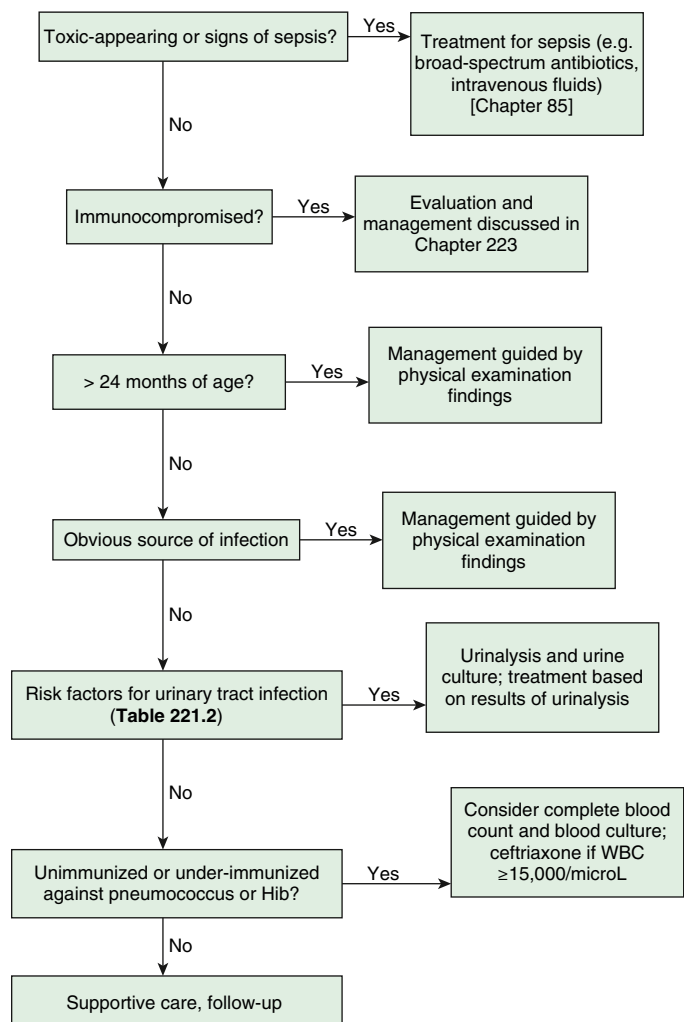
<sup>†</sup>Adapted from Shaikh N, Hoberman A, Hum SW, et al. Development and validation of a calculator for estimating the probability of urinary tract infection in young febrile children. *JAMA Pediatr*. 2018;172(6):550-556 and UTICalc Version 3.0, University of Pittsburgh 2021, <https://uticalc.pitt.edu/>

recommend presumptive antibiotic treatment for pneumonia based on clinical grounds and reserve the use of chest radiography for children with hypoxemia or significant respiratory distress and for those who fail outpatient therapy. Chest radiography is indicated for hospitalized children to assess for complicated pneumonia, including **empyema**. The performance of other imaging should be dictated by physical exam findings. The presence of drooling and neck or throat pain in an infant or toddler may be suggestive of a retropharyngeal abscess, which is usually confirmed by imaging that may include a lateral radiograph of the soft tissue of the neck or computed tomography (CT) if clinical suspicion is high. Ultrasonography (US) may be performed to assess for **appendicitis** in children with fever and focal right lower quadrant pain or abdominal pain that is severe. However, definitive imaging, including CT or MRI, may be required if US is nondiagnostic or if clinical suspicion is high.

## MANAGEMENT

### General Management Principles

Management should be guided by the presence of specific symptoms by history or signs on physical examination. Based on the child's age and duration of fever, management may also be guided by focused diagnostic testing, such as a urinalysis and selective urine culture testing among young febrile children (Fig. 221.3 and see Table 221.2). Supportive care, including the use of antipyretics and adequate hydration, should be reviewed with the patient and caregiver for all children with fever. Children with viral infections generally require supportive care only, except for children at higher risk of severe or complicated disease with **influenza virus** (see Chapter 305) or SARS-CoV-2 (see Chapter 311). Antibiotics should



**Fig. 221.3** Algorithm for evaluation and management of fever in infants and children >2 mo of age. Hib, *Haemophilus influenzae* type b; WBC, white blood cell count.

be reserved for children with evidence of bacterial infection on physical examination. A wait-and-see approach can be considered for children with acute **otitis media**, in whom a prescription for antibiotics can be provided to the family but instructions given to not fill the prescription unless severe or worsening symptoms develop (see [Chapter 680](#)). Oral antibiotics can be prescribed to young children with UTI, although children who cannot tolerate oral intake, are vomiting or dehydrated, or appear toxic require parenteral antibiotics and hospitalization.

Blood tests, including CBC and blood culture, should be considered to evaluate for occult **bacteremia** in the unimmunized child. One management strategy for these children is to administer a parenteral antibiotic (e.g., ceftriaxone) if leukocytosis (white blood cell count  $\geq 15,000/\mu\text{L}$ ), elevated absolute neutrophil count ( $\geq 10,000/\mu\text{L}$ ), or elevated inflammatory markers (procalcitonin  $>0.5$  ng/mL) are present while awaiting results of blood culture. Children who appear toxic or who have signs of either sepsis or bacterial meningitis require emergent treatment with parenteral antibiotics as well as adjunct therapies to support the child's hemodynamics (see [Chapter 85](#)).

Importantly, anticipatory guidance should be provided to all families of children with fever, including the criteria to return to care and the importance of fever control and adequate hydration.

### Other Considerations

Children who are unimmunized or underimmunized are at higher risk of invasive bacterial infection, as are children who are immunocompromised. Management of fever in these children is described further in [Chapter 223](#). Additionally, the approach to fever in the returning traveler should be focused on identifying commonly encountered infections based on the region of travel (see [Chapter 218](#)).

Visit Elsevier eBooks+ at [eBooks.Health.Elsevier.com](http://eBooks.Health.Elsevier.com) for Bibliography.

## Chapter 222

# Fever of Unknown Origin

Andrew P. Steenhoff

Fever of unknown origin (FUO) is a diagnostic dilemma for pediatricians because it is often difficult to distinguish clinically between benign and potentially life-threatening causes. Pediatricians face the important challenge of not missing the diagnosis of a serious illness or an easily treatable condition that can result in increased morbidity. Fortunately, FUO is usually an uncommon presentation of a common disease, with most of these common diseases being easily treatable.

The classification of FUO is best reserved for children with a temperature  $>38^\circ\text{C}$  ( $100.4^\circ\text{F}$ ) documented by a healthcare provider and for which the cause could not be identified after at least 8 days of evaluation ([Table 222.1](#)). It is important to differentiate FUO from **fever without a source (FWS)**. FWS is fever where the source has not yet been identified and is differentiated from FUO by the duration of the fever. FWS can progress to FUO if no cause is elicited after 7 days of evaluation.

### ETIOLOGY

The many causes of FUO in children are infectious, rheumatologic (connective tissue or autoimmune), autoinflammatory, oncologic, neurologic, genetic, factitious, and iatrogenic processes ([Table 222.2](#)). Although oncologic disorders should be seriously considered, most children with malignancies do not have fever alone. The possibility of **drug fever** should be considered if the patient is receiving any drug. Drug fever is usually sustained and not associated with other symptoms. Discontinuation of the drug is associated with resolution of the fever, generally within 72 hours, although certain drugs, such as iodides, are excreted for a prolonged period, with fever that can persist for as long as 1 month after drug withdrawal.

Most fevers of unknown origin result from atypical presentations of common diseases. In some cases, the presentation as an FUO is characteristic of the disease (e.g., juvenile idiopathic arthritis), but the definitive diagnosis can be established only after prolonged observation, because initially there are no associated or specific findings on physical examination, and all laboratory results are negative or normal.

In the United States the systemic infectious diseases most commonly implicated in children with FUO are bacterial enterocolitis, including salmonellosis, as well as tuberculosis, rickettsial diseases, syphilis, Lyme disease, cat-scratch disease, atypical prolonged presentations of common viral diseases such as adenovirus infection, Epstein-Barr virus (EBV) infection, cytomegalovirus (CMV) infection, viral hepatitis, coccidioidomycosis, histoplasmosis, malaria, *Angiostrongylus cantonensis* infection, and toxoplasmosis. Less common infectious causes of FUO include tularemia, brucellosis, leptospirosis, and rat-bite fever. Acquired immunodeficiency syndrome (AIDS) alone is not usually responsible for FUO, although febrile illnesses often occur in patients with AIDS as a result of opportunistic infections (see [Table 222.1](#)).

**Juvenile idiopathic arthritis (JIA)** and **systemic lupus erythematosus (SLE)** are the connective tissue diseases most often associated with FUO. **Inflammatory bowel disease (IBD)** and **Kawasaki disease** are also frequently reported as causes of FUO. If **factitious fever** (inoculation of pyogenic material or manipulation of the thermometer by the patient or parent) is suspected, the presence and pattern of fever should be documented in the hospital. Prolonged and continuous observation of the patient, which can include electronic or video surveillance, is imperative. FUO lasting  $>6$  months is uncommon in children and suggests granulomatous, autoinflammatory, or autoimmune disease. Repeat interval evaluation is required, including history, physical examination, laboratory evaluation, and imaging studies.

Historically, 90% of pediatric FUO cases in the United States had an identifiable cause: approximately 50% infectious, 10–20% collagen vascular, and 10% oncologic. Other studies had variable results: 20–44% infectious, 0–7% collagen vascular, 2–3% oncologic, and up to 67% undiagnosed. The reason for the paradoxical increase in undiagnosed cases of FUO ironically is likely caused by improved infectious and autoimmune diagnostic techniques. The advent of polymerase chain reaction (PCR), improved culture techniques, and better understanding of atypical viral and bacterial pathogenesis and autoimmune processes likely contribute to *earlier* diagnosis of these conditions and fewer children with these conditions *advancing* to the category of FUO. By contrast, causes of FUO remain primarily infectious in low and middle income settings where there is a higher infectious disease burden and advanced diagnostic techniques are more limited.

### DIAGNOSIS

The evaluation of FUO requires a thorough history and physical examination supplemented by a few screening laboratory tests and additional laboratory and imaging evaluation informed by the history or abnormalities on examination or initial screening tests (see [Table 222.2](#)). Occasionally the **fever pattern** helps make a diagnosis ([Fig. 222.1](#)). Nonetheless, most diseases causing an FUO do not have a typical fever pattern.

### History

A detailed fever history should be obtained, including onset, frequency, duration, response or nonresponse to therapy, recurrence, and associated symptoms. Repetitive chills and temperature spikes are common in children with **septicemia** (regardless of cause), particularly when associated with kidney disease, liver or biliary disease, infective endocarditis, malaria, brucellosis, rat-bite fever, or a localized collection of pus.

The age of the patient is helpful in evaluating FUO. Children  $>6$  years old often have a respiratory or genitourinary tract infection, localized infection (abscess, osteomyelitis), JIA, or rarely, leukemia. Adolescent patients are more likely to have IBD, autoimmune processes, lymphoma, or tuberculosis in addition to the causes of FUO found in younger children.

A history of exposure to wild or domestic **animals** should be solicited. The incidence of **zoonotic infections** in the United States is



be reserved for children with evidence of bacterial infection on physical examination. A wait-and-see approach can be considered for children with acute **otitis media**, in whom a prescription for antibiotics can be provided to the family but instructions given to not fill the prescription unless severe or worsening symptoms develop (see [Chapter 680](#)). Oral antibiotics can be prescribed to young children with UTI, although children who cannot tolerate oral intake, are vomiting or dehydrated, or appear toxic require parenteral antibiotics and hospitalization.

Blood tests, including CBC and blood culture, should be considered to evaluate for occult **bacteremia** in the unimmunized child. One management strategy for these children is to administer a parenteral antibiotic (e.g., ceftriaxone) if leukocytosis (white blood cell count  $\geq 15,000/\mu\text{L}$ ), elevated absolute neutrophil count ( $\geq 10,000/\mu\text{L}$ ), or elevated inflammatory markers (procalcitonin  $>0.5 \text{ ng/mL}$ ) are present while awaiting results of blood culture. Children who appear toxic or who have signs of either sepsis or bacterial meningitis require emergent treatment with parenteral antibiotics as well as adjunct therapies to support the child's hemodynamics (see [Chapter 85](#)).

Importantly, anticipatory guidance should be provided to all families of children with fever, including the criteria to return to care and the importance of fever control and adequate hydration.

### Other Considerations

Children who are unimmunized or underimmunized are at higher risk of invasive bacterial infection, as are children who are immunocompromised. Management of fever in these children is described further in [Chapter 223](#). Additionally, the approach to fever in the returning traveler should be focused on identifying commonly encountered infections based on the region of travel (see [Chapter 218](#)).

Visit Elsevier eBooks+ at [eBooks.Health.Elsevier.com](http://eBooks.Health.Elsevier.com) for Bibliography.

## Chapter 222

# Fever of Unknown Origin

Andrew P. Steenhoff

Fever of unknown origin (FUO) is a diagnostic dilemma for pediatricians because it is often difficult to distinguish clinically between benign and potentially life-threatening causes. Pediatricians face the important challenge of not missing the diagnosis of a serious illness or an easily treatable condition that can result in increased morbidity. Fortunately, FUO is usually an uncommon presentation of a common disease, with most of these common diseases being easily treatable.

The classification of FUO is best reserved for children with a temperature  $>38^\circ\text{C}$  ( $100.4^\circ\text{F}$ ) documented by a healthcare provider and for which the cause could not be identified after at least 8 days of evaluation ([Table 222.1](#)). It is important to differentiate FUO from **fever without a source (FWS)**. FWS is fever where the source has not yet been identified and is differentiated from FUO by the duration of the fever. FWS can progress to FUO if no cause is elicited after 7 days of evaluation.

### ETIOLOGY

The many causes of FUO in children are infectious, rheumatologic (connective tissue or autoimmune), autoinflammatory, oncologic, neurologic, genetic, factitious, and iatrogenic processes ([Table 222.2](#)). Although oncologic disorders should be seriously considered, most children with malignancies do not have fever alone. The possibility of **drug fever** should be considered if the patient is receiving any drug. Drug fever is usually sustained and not associated with other symptoms. Discontinuation of the drug is associated with resolution of the fever, generally within 72 hours, although certain drugs, such as iodides, are excreted for a prolonged period, with fever that can persist for as long as 1 month after drug withdrawal.

Most fevers of unknown origin result from atypical presentations of common diseases. In some cases, the presentation as an FUO is characteristic of the disease (e.g., juvenile idiopathic arthritis), but the definitive diagnosis can be established only after prolonged observation, because initially there are no associated or specific findings on physical examination, and all laboratory results are negative or normal.

In the United States the systemic infectious diseases most commonly implicated in children with FUO are bacterial enterocolitis, including salmonellosis, as well as tuberculosis, rickettsial diseases, syphilis, Lyme disease, cat-scratch disease, atypical prolonged presentations of common viral diseases such as adenovirus infection, Epstein-Barr virus (EBV) infection, cytomegalovirus (CMV) infection, viral hepatitis, coccidioidomycosis, histoplasmosis, malaria, *Angiostrongylus cantonensis* infection, and toxoplasmosis. Less common infectious causes of FUO include tularemia, brucellosis, leptospirosis, and rat-bite fever. Acquired immunodeficiency syndrome (AIDS) alone is not usually responsible for FUO, although febrile illnesses often occur in patients with AIDS as a result of opportunistic infections (see [Table 222.1](#)).

**Juvenile idiopathic arthritis (JIA)** and **systemic lupus erythematosus (SLE)** are the connective tissue diseases most often associated with FUO. **Inflammatory bowel disease (IBD)** and **Kawasaki disease** are also frequently reported as causes of FUO. If **factitious fever** (inoculation of pyogenic material or manipulation of the thermometer by the patient or parent) is suspected, the presence and pattern of fever should be documented in the hospital. Prolonged and continuous observation of the patient, which can include electronic or video surveillance, is imperative. FUO lasting  $>6$  months is uncommon in children and suggests granulomatous, autoinflammatory, or autoimmune disease. Repeat interval evaluation is required, including history, physical examination, laboratory evaluation, and imaging studies.

Historically, 90% of pediatric FUO cases in the United States had an identifiable cause: approximately 50% infectious, 10–20% collagen vascular, and 10% oncologic. Other studies had variable results: 20–44% infectious, 0–7% collagen vascular, 2–3% oncologic, and up to 67% undiagnosed. The reason for the paradoxical increase in undiagnosed cases of FUO ironically is likely caused by improved infectious and autoimmune diagnostic techniques. The advent of polymerase chain reaction (PCR), improved culture techniques, and better understanding of atypical viral and bacterial pathogenesis and autoimmune processes likely contribute to *earlier* diagnosis of these conditions and fewer children with these conditions *advancing* to the category of FUO. By contrast, causes of FUO remain primarily infectious in low and middle income settings where there is a higher infectious disease burden and advanced diagnostic techniques are more limited.

### DIAGNOSIS

The evaluation of FUO requires a thorough history and physical examination supplemented by a few screening laboratory tests and additional laboratory and imaging evaluation informed by the history or abnormalities on examination or initial screening tests (see [Table 222.2](#)). Occasionally the **fever pattern** helps make a diagnosis ([Fig. 222.1](#)). Nonetheless, most diseases causing an FUO do not have a typical fever pattern.

### History

A detailed fever history should be obtained, including onset, frequency, duration, response or nonresponse to therapy, recurrence, and associated symptoms. Repetitive chills and temperature spikes are common in children with **septicemia** (regardless of cause), particularly when associated with kidney disease, liver or biliary disease, infective endocarditis, malaria, brucellosis, rat-bite fever, or a localized collection of pus.

The age of the patient is helpful in evaluating FUO. Children  $>6$  years old often have a respiratory or genitourinary tract infection, localized infection (abscess, osteomyelitis), JIA, or rarely, leukemia. Adolescent patients are more likely to have IBD, autoimmune processes, lymphoma, or tuberculosis in addition to the causes of FUO found in younger children.

A history of exposure to wild or domestic **animals** should be solicited. The incidence of **zoonotic infections** in the United States is



**Table 222.1** Summary of Definitions and Major Features of Four Subtypes of Fever of Unknown Origin (FUO)

FEATURE	CLASSIC FUO	HEALTHCARE-ASSOCIATED FUO	IMMUNE-DEFICIENT FUO	HIV-RELATED FUO
Definition	>38°C (100.4°F), >3 wk, >2 visits, or 1 wk in hospital	≥38°C (100.4°F), >1 wk, not present or incubating on admission	≥38°C (100.4°F), >1 wk, negative cultures after 48 hr	≥38°C (100.4°F), >3 wk for outpatients, >1 wk for inpatients, HIV infection confirmed
Patient location	Community, clinic, or hospital	Acute care hospital	Hospital or clinic	Community, clinic, or hospital
Leading causes	Cancer, infections, inflammatory conditions, undiagnosed, habitual hyperthermia	Healthcare-associated infections, postoperative complications, drug fever	Majority caused by infections, but cause documented in only 40–60%	HIV itself, typical and atypical mycobacteria, CMV, lymphomas, toxoplasmosis, cryptococcosis, immune reconstitution inflammatory syndrome (IRIS)
History emphasis	Travel, contacts, animal and insect exposure, medications, immunizations, family history, cardiac valve disorder	Operations and procedures, devices, anatomic considerations, drug treatment	Stage of chemotherapy, drugs administered, underlying immunosuppressive disorder	Drugs, exposures, risk factors, travel, contacts, stage of HIV infection
Examination emphasis	Fundi, oropharynx, temporal artery, abdomen, lymph nodes, spleen, joints, skin, nails, genitalia, rectum or prostate, lower-limb deep veins	Wounds, drains, devices, sinuses, urine	Skinfolds, IV sites, lungs, perianal area	Mouth, sinuses, skin, lymph nodes, eyes, lungs, perianal area
Investigation emphasis	Imaging, biopsies, sedimentation rate, skin tests	Imaging, bacterial cultures	CXR, bacterial cultures	Blood and lymphocyte count; serologic tests; CXR; stool examination; biopsies of lung, bone marrow, and liver for cultures and cytologic tests; brain imaging
Management	Observation, outpatient temperature chart, investigations, avoidance of empirical drug treatments	Depends on situation	Antimicrobial treatment protocols	Antiviral and antimicrobial protocols, vaccines, revision of treatment regimens, good nutrition
Time course of disease	Months	Weeks	Days	Weeks to months
Tempo of investigation	Weeks	Days	Hours	Days to weeks

CMV, Cytomegalovirus; CXR, chest radiograph; HIV, human immunodeficiency virus; IV, intravenous line.

Adapted from Mackowak PA, Durack DT. Fever of unknown origin. In: Mandell GL, Bennett, JE, Dolin R, eds. *Mandell, Douglas, and Bennett's Principles and Practice of Infectious Diseases*, 7th ed. Philadelphia: Elsevier, 2010: Table 51-1.

increasing, and these infections are often acquired from pets that are not overtly ill. Immunization of dogs against specific disorders such as **leptospirosis** can prevent canine disease but does not always prevent the animal from carrying and shedding leptospire, which may be transmitted to household contacts. A history of ingestion of rabbit or squirrel meat might provide a clue to the diagnosis of oropharyngeal, glandular, or typhoidal **tularemia**. A history of tick bite or travel to tick- or parasite-infested areas should be obtained.

Any history of **pica** should be elicited. Ingestion of dirt is a particularly important clue to infection with *Toxocara canis* (visceral larva migrans) or *Toxoplasma gondii* (toxoplasmosis).

A history of unusual dietary habits or travel as early as the birth of the child should be sought. Tuberculosis, malaria, histoplasmosis, and coccidioidomycosis can reemerge years after visiting or living in an endemic area. It is important to identify prophylactic immunizations and precautions taken by the patient against ingestion of contaminated water or food during foreign travel. Rocks, dirt, and artifacts from geographically distant regions that have been collected and brought into the home as souvenirs can serve as vectors of disease.

A **medication** history should be pursued rigorously. This history should elicit information about nonprescription preparations

and topical agents, including eyedrops, that may be associated with atropine-induced fever.

The genetic background of a patient also is important. Descendants of the Ulster Scots may have FUO because they are afflicted with nephrogenic diabetes insipidus. **Familial dysautonomia** (Riley-Day syndrome), a disorder in which hyperthermia is recurrent, is more common among Jews than among other population groups. Ancestry from the Mediterranean region should suggest **familial Mediterranean fever**. Both familial Mediterranean fever and hyper-IgD syndrome are inherited as autosomal recessive disorders. Tumor necrosis factor receptor-associated periodic syndrome and Muckle-Wells syndrome are inherited as autosomal dominant traits.

**Pseudo-FUO** is defined as successive episodes of benign, self-limited infections with fever that the parents perceive as one prolonged fever episode. This needs to be carefully ruled out before undertaking an unnecessary evaluation. Usually, pseudo-FUO starts with a well-defined infection (frequently viral) that resolves but is followed by other febrile viral illnesses that may be less well defined. Diagnosis of pseudo-FUO usually requires a careful history, focusing on identifying afebrile periods between febrile episodes. If pseudo-FUO is suspected and the patient does not appear ill, keeping a *fever diary* can be helpful.

**Table 222.2** Etiology of Fever of Unknown Origin (FUO) in Children

<b>ABSCESSSES</b>	Malaria
Brain	Naegleria
Hepatic	Toxoplasmosis
Intraabdominal*	Trichinosis
Odontogenic (dental)	Trypanosomiasis
Pelvic*	Visceral larva migrans ( <i>Toxocara</i> )
Perinephric and renal	
Psoas	<b>RHEUMATOLOGIC DISEASES</b>
Rectal	Autoimmune hepatitis
Subphrenic	Behçet syndrome
	Chronic noninfectious osteomyelitis (CNO)
<b>BACTERIAL DISEASES</b>	Juvenile dermatomyositis
Actinomycosis	Juvenile idiopathic arthritis* ± macrophage activation syndrome
<i>Bartonella henselae</i> (cat-scratch disease)*	Rheumatic fever
Brucellosis	Systemic lupus erythematosus*
<i>Campylobacter</i>	Vasculitis syndromes (granulomatous, nongranulomatous)
<i>Chlamydia</i>	
<i>Francisella tularensis</i> (tularemia)	<b>HYPERSENSITIVITY DISEASES</b>
<i>Fusobacterium</i> (Lemierre syndrome)	Drug fever, including DRESS
Leptospirosis	Hypersensitivity pneumonitis
<i>Listeria monocytogenes</i> (listeriosis)	Hypersensitivity vasculitis/reactive arthritis*
Lymphogranuloma venereum	Serum sickness
Meningococemia (chronic)	Weber-Christian disease
<i>Mycoplasma pneumoniae</i>	
Psittacosis	<b>NEOPLASMS</b>
Rat-bite fever ( <i>Streptobacillus moniliformis</i> ; streptobacillary form of rat-bite fever)	Atrial myxoma
<i>Salmonella</i>	Cholesterol granuloma
Tuberculosis*	Hodgkin lymphoma
Whipple disease	Inflammatory pseudotumor
Yersiniosis	Langerhans cell histiocytosis
	Leukemia
<b>LOCALIZED INFECTIONS</b>	Lymphoma*
Bacterial endocarditis*	Pheochromocytoma
Cholangitis	Neuroblastoma
Ludwig angina	Wilms tumor
Mastoiditis	
Osteomyelitis*	<b>GRANULOMATOUS DISEASES</b>
Pericarditis	Crohn disease
Pneumonia	Granulomatous hepatitis
Pyelonephritis*	Polyangiitis with granulomatosis
Sinusitis	Sarcoidosis
Spondylodiskitis	
	<b>FAMILIAL AND HEREDITARY DISEASES</b>
<b>SPIROCHETES</b>	Anhidrotic ectodermal dysplasia
<i>Borrelia burgdorferi</i> (Lyme disease)	Autoimmune lymphoproliferative syndrome (ALPS)
Leptospirosis	Autonomic neuropathies
Rat-bite fever ( <i>Spirillum minus</i> ; spirillary form of rat-bite fever)	Fabry disease
Relapsing fever ( <i>Borrelia recurrentis</i> , <i>Borrelia miyamotoi</i> )	Familial dysautonomia
Syphilis	Familial Hibernian fever
	Familial Mediterranean fever and the many other autoinflammatory (periodic fever) diseases (see <a href="#">Chapter 204</a> )
<b>FUNGAL DISEASES</b>	Hypertriglyceridemia
Blastomycosis (extrapulmonary)	Ichthyosis
Coccidioidomycosis (disseminated)	Sickle cell crisis
Cryptococcosis	Spinal cord/brain injury
Histoplasmosis (disseminated)	
	<b>MISCELLANEOUS</b>
<b>RICKETTSIAE-LIKE ORGANISMS</b>	Addison disease
Anaplasmosis	Allergic alveolitis
Ehrlichiosis	Castleman disease
Q fever	Cyclic neutropenia
Rocky Mountain spotted fever	Diabetes insipidus (non-nephrogenic and nephrogenic)
Tick-borne typhus	Erythema multiforme
	Factitious fever
<b>VIRUSES</b>	Hemophagocytic lymphohistiocytosis (HLH)
Arboviruses	Hypereosinophilia syndromes
Chikungunya	Hypothalamic-central fever
Cytomegalovirus*	Infantile cortical hyperostosis
Epstein-Barr virus*	Inflammatory bowel disease*
Hantavirus	Kawasaki disease*
Hepatitis viruses	Kikuchi-Fujimoto disease
HIV	Metal fume fever
Human herpesviruses (HHV-6 and HHV-7)	Multisystem inflammatory syndrome in children (MIS-C)
Lymphocytic choriomeningitis	Pancreatitis
Respiratory viruses (especially, adenovirus and enteroviruses)*	Poisoning
Zika virus	Pulmonary embolism
	Rosai-Dorfman disease
<b>PARASITIC DISEASES</b>	Thrombotic thrombocytopenia purpura
Amebiasis	Thrombophlebitis
Babesiosis	Thyrototoxicosis, thyroiditis
Baylisascaris	

\*Most common identified causes of FUO in children.

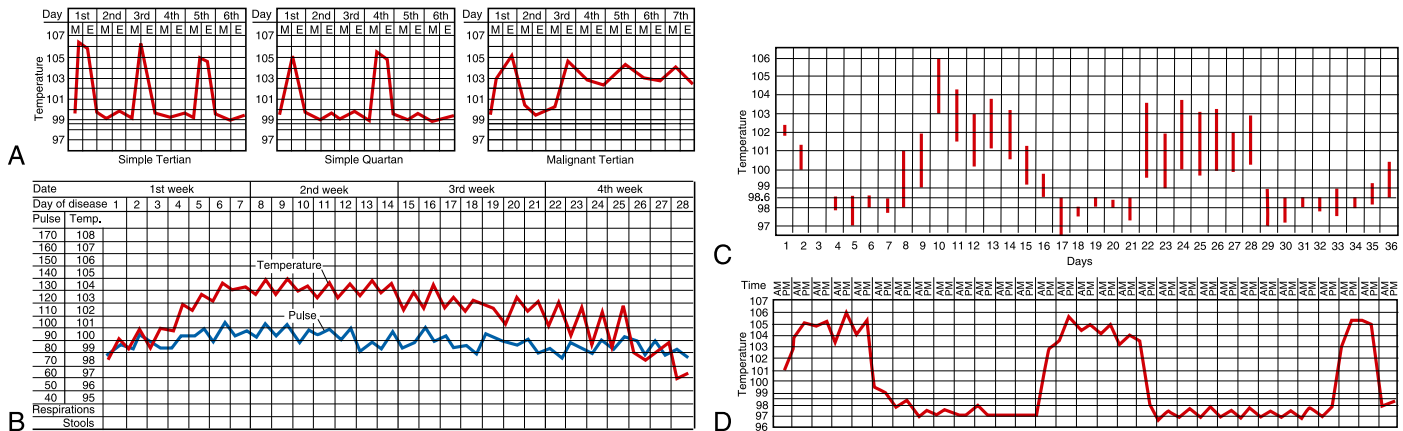
DRESS, Drug reaction with eosinophilia and systemic symptoms.

Modified from Huppler AR. Fever. In: Kliegman RM, Toth H, Bordini BJ, Basel D, eds. *Nelson Pediatric Symptom-Based Diagnosis*, 2nd ed. Philadelphia: Elsevier; 2023: [Table 52.9](#), pp. 980–981.

**Physical Examination**

A complete physical examination is essential to search for any clues to the underlying diagnosis, and often it is worthwhile to repeat a detailed examination on different days to detect signs that may have changed or been missed (Tables 222.3-222.5). The child's general appearance,

including sweating during fever, should be noted. The continuing absence of sweat in the presence of an elevated or changing body temperature suggests dehydration caused by vomiting, diarrhea, or central or nephrogenic diabetes insipidus. It also should suggest anhidrotic ectodermal dysplasia, familial dysautonomia, or exposure to atropine.



**Fig. 222.1** Distinctive fever patterns. A, Malaria. B, Typhoid fever (demonstrating relative bradycardia). C, Hodgkin disease (Pel-Ebstein fever pattern). D, Borreliosis (relapsing fever pattern). (From Woodward TE. The fever pattern as a clinical diagnostic aid. In Mackowiak PA, ed. *Fever: Basic Mechanisms and Management*, 2nd ed. Philadelphia: Lippincott-Raven; 1997:215–236.)

Table 222.3 Subtle Physical Findings with Special Significance in Patients with Fever of Unknown Origin		
BODY SITE	PHYSICAL FINDING	DIAGNOSIS
Head	Sinus tenderness	Sinusitis
Temporal artery	Nodules, reduced pulsations	Temporal arteritis
Oropharynx	Ulceration	Disseminated histoplasmosis, SLE, IBD, Behçet syndrome, periodic fever syndromes
	Tender tooth	Periapical abscess, sinus referred pain
	Loose teeth	Langerhans cell histiocytosis, leukemia
Fundi or conjunctivae	Choroid tubercle	Disseminated granulomatosis*
	Petechiae, Roth spots	Endocarditis
Thyroid	Enlargement, tenderness	Thyroiditis
Heart	Murmur	Infective or marantic endocarditis
	Relative bradycardia	Typhoid fever, malaria, leptospirosis, psittacosis, central fever, drug fever
Abdomen	Enlarged iliac crest lymph nodes, splenomegaly	Lymphoma, endocarditis, disseminated granulomatosis*
	Audible abdominal aortic or renal artery bruit	Large vessel vasculitis such as Takayasu arteritis
	Costovertebral tenderness	Chronic pyelonephritis, perinephric abscess
Rectum	Perirectal fluctuance, tenderness	Abscess
	Prostatic tenderness, fluctuance	Abscess
Genitalia	Testicular nodule	Periarteritis nodosa, cancer
	Epididymal nodule	Disseminated granulomatosis
Spine	Spinal tenderness	Vertebral osteomyelitis
	Paraspinal tenderness	Paraspinal collection
Lower extremities	Deep venous tenderness	Thrombosis or thrombophlebitis
Upper or lower extremities	Pseudoparesis	Syphilitic bone disease
Skin and nails	Petechiae, splinter hemorrhages, subcutaneous nodules, clubbing	Vasculitis, endocarditis

\*Includes tuberculosis, histoplasmosis, coccidioidomycosis, sarcoidosis, granulomatosis with polyangiitis, and syphilis.

Adapted from Mackowiak PA, Durack DT. Fever of unknown origin. In: Mandell GL, Bennett, JE, Dolin R, eds. *Mandell, Douglas, and Bennett's Principles and Practice of Infectious Diseases*, 7th ed. Philadelphia: Elsevier; 2010: Table 51-8.

**Table 222.4** Examples of Potential Diagnostic Clues to Infections Presenting as Fever of Unknown Origin

ETIOLOGY	HISTORICAL CLUES	PHYSICAL CLUES
Anaplasmosis	Transmitted by bite of <i>Ixodes</i> tick in association with outdoor activity in northern-central and eastern United States	Fever, headache, arthralgia, myalgia, pneumonitis, thrombocytopenia, lymphopenia, elevated liver enzymes
Babesiosis	Transmitted by bite of <i>Ixodes</i> tick in association with outdoor activity in northeastern United States	Arthralgias, myalgias, relative bradycardia, hepatosplenomegaly, anemia, thrombocytopenia, elevated liver enzymes
Bartonellosis	Recent travel to Andes Mountains (Oroya fever; <i>Bartonella bacilliformis</i> ), association with homelessness in urban settings ( <i>Bartonella quintana</i> ) or scratch of infected kitten or feral cat ( <i>Bartonella henselae</i> )	Conjunctivitis, retroorbital pain, anterior tibial bone pain, macular rash, nodular plaque lesions, regional lymphadenopathy
Blastomycosis	Contact with soil adjacent to Mississippi and Ohio River valleys, Saint Lawrence River in New York and Canada, and North American Great Lakes or exposure to infected dogs	Arthritis, atypical pneumonia, pulmonary nodules, and/or fulminant adult respiratory distress syndrome; verrucous, nodular, or ulcerative skin lesions; prostatitis
Brucellosis	Associated with contact or consumption of products from infected goats, pigs, camels, yaks, buffalo, or cows and with abattoir work	Arthralgias, hepatosplenomegaly, suppurative musculoskeletal lesions, sacroiliitis, spondylitis, uveitis, hepatitis, pancytopenia
Coccidioidomycosis	Exposure to soil or dust in southwestern United States	Arthralgias, pneumonia, pulmonary cavities, pulmonary nodules, erythema multiforme, erythema nodosum
Ehrlichiosis	Transmitted by bite of <i>Amblyomma</i> , <i>Dermacentor</i> , or <i>Ixodes</i> tick in association with outdoor activity in midwestern and southeastern United States	Pneumonitis, hepatitis, thrombocytopenia, lymphopenia
Enteric fever ( <i>Salmonella enterica</i> serovar Typhi)	Recent travel to a low- or middle-income country (LMIC) with consumption of potentially contaminated food or water	Headache, arthritis, abdominal pain, relative bradycardia, hepatosplenomegaly, leukopenia
Histoplasmosis	Exposure to bat or blackbird excreta in roosts, chicken houses, or caves in region surrounding Ohio and Mississippi River valleys	Headache, pneumonia, pulmonary cavities, mucosal ulcers, adenopathy, erythema nodosum, erythema multiforme, hepatitis, anemia, leukopenia, thrombocytopenia
Leptospirosis	Occupational exposure among workers in sewers, rice and sugarcane fields, and abattoirs; recreational water sports and exposure to contaminated waters or infected dogs	Bitemporal and frontal headache, calf and lumbar muscle tenderness, conjunctival suffusion, hepatic and renal failure, hemorrhagic pneumonitis
Leishmaniasis (visceral disease)	Associated with recent travel to areas endemic for sand flies	Hepatosplenomegaly, lymphadenopathy, and hyperpigmentation of face, hand, foot, and abdominal skin (kala-azar)
Malaria	Recent travel to endemic areas in Asia, Africa, and Central/South America	Fever, headaches, nausea, emesis, diarrhea, hepatomegaly, splenomegaly, anemia
Psittacosis ( <i>Chlamydia psittaci</i> )	Associated with contact with birds, especially psittacine birds	Fever, pharyngitis, hepatosplenomegaly, pneumonia, blanching maculopapular eruptions; erythema multiforme, marginatum, and nodosum
Q fever ( <i>Coxiella burnetii</i> )	Associated with farm, veterinary, or abattoir work; consumption of unpasteurized milk; contact with infected sheep, goats, or cattle	Atypical pneumonia, hepatitis, hepatomegaly, relative bradycardia, splenomegaly
Rat-bite fever ( <i>Streptobacillus moniliformis</i> )	Recent bite or scratch by rat, mouse, or squirrel; ingestion of food or water contaminated by rat excrement	Headaches, myalgias, polyarthritis, and maculopapular, morbilliform, petechial, vesicular, or pustular rash over the palms, soles, and extremities
Relapsing fever ( <i>Borrelia recurrentis</i> )	Associated with poverty, crowding, and poor sanitation (louse-borne) or with camping (tick-borne), particularly in the Grand Canyon	High fever with rigors, headache, delirium, arthralgias, myalgias, and hepatosplenomegaly
Rocky Mountain spotted fever	Associated with outdoor activity in the South Atlantic or southeastern United States and exposure to <i>Dermacentor</i> tick bites	Headache, petechial rash involving the extremities, palms, and soles
Tuberculosis	Recent contact with tuberculosis; recent immigration from endemic country; work or residence in homeless shelters, correctional facilities, or healthcare facilities	Night sweats, weight loss, atypical pneumonia; on chest x-ray, hilar adenopathy is most common in younger children, with cavitary pulmonary lesions seen in youth.
Tularemia	Associated with bites by <i>Amblyomma</i> or <i>Dermacentor</i> ticks, deer flies, and mosquitoes or direct contact with tissues of infected animals such as rabbits, squirrels, deer, raccoons, cattle, sheep, and swine	Ulcerated skin lesions at a bite site, pneumonia, relative bradycardia, lymphadenopathy, conjunctivitis

Continued



**Table 222.4** Examples of Potential Diagnostic Clues to Infections Presenting as Fever of Unknown Origin—cont'd

ETIOLOGY	HISTORICAL CLUES	PHYSICAL CLUES
Whipple disease ( <i>Tropheryma whipplei</i> )	Potential association with exposure to sewage	Chronic diarrhea, arthralgia, weight loss, malabsorption, malnutrition

Adapted from Wright WF, Mackowiak PA. Fever of unknown origin. In: Bennett JE, Blaser MJ, Dolin R, et al., eds. *Mandell, Douglas, and Bennett's Principles and Practice of Infectious Diseases*, 8th ed. Philadelphia: Saunders; 2015: Table 56-9.

**Table 222.5** Discriminating Features of Noninfectious Causes of Fever of Unknown Origin

CAUSES OF FEVER	EXPOSURE OR CONDITION	FEATURES	DIAGNOSTIC METHOD
Kikuchi-Fujimoto disease		Regional or generalized lymphadenopathy; elevated inflammatory markers	Biopsy or histology
Inflammatory pseudotumor	History of nonspecific illness (presumed host-controlled infection)	Insidious; malaise, weight loss, vague abdominal pain or tenderness; anemia; elevated inflammatory markers	Abdominal CT; biopsy or histology
Kawasaki disease (incomplete)		Asynchronous or incomplete features of Kawasaki disease; elevated inflammatory markers; thrombocytosis	Clinical constellation; echocardiogram
Juvenile idiopathic arthritis	Familial, sporadic	Hepatosplenomegaly, lymphadenopathy, exanthem; anemia, elevated inflammatory markers	Clinical constellation
Systemic lupus erythematosus	Familial, sporadic	Malaise, weight loss; then multisystem involvement (kidneys, joints, skin)	Serum antinuclear antibody, anti-double-stranded DNA, anti-smooth muscle antibody
Hemophagocytic lymphohistiocytosis	Familial, virus, or rheumatologic (macrophage activation syndrome) induced	Severe, rapidly progressive illness; hepatomegaly, lymphadenopathy, exanthem; cytopenias; extreme elevations of inflammatory markers	Ferritin, triglyceride levels, gene panel, other diagnostic criteria; erythrophagocytosis by macrophages; natural killer cell, CD8 <sup>+</sup> T-lymphocyte dysfunction
Vasculitis syndromes	Familial, sporadic	Specific hallmarks (renal, neurologic, stomatitis or perianal ulcers, uveitis, pulmonary)	Clinical constellation; specific autoantibodies; biopsy or histology
Sarcoidosis	Geography; race	Fatigue, weight loss, leg pain; anemia; elevated inflammatory markers; mediastinal lymphadenopathy; uveitis	Clinical constellation; biopsy or histology; soluble interleukin-2 receptor level
Inflammatory bowel disease	Familial; sporadic	Linear growth failure, subtle gastrointestinal symptoms or abdominal tenderness; perirectal skin tag; iron-deficiency anemia; elevated inflammatory markers	Abdominal CT; barium study
Lymphoreticular malignancy		Weight loss, fatigue; nonarticular bone pain; lymphadenopathy; cytopenias	Bone marrow or tissue biopsy
Drug hypersensitivity	Prescription or nonprescription drug exposure	Preserved sense of well-being; exanthems; eosinophilia; organ dysfunction (renal, cardiac, pulmonary)	Clinical constellation; withdrawal of drug
Factitious fever or Munchausen syndrome by proxy	Predisposing parent-patient dynamic	Discordant temperature and vital signs; discordant parent-measured temperature and urine temperature; normal inflammatory markers	Clinical constellation; verification of temperature in medical setting
Hypothalamic dysfunction, diabetes insipidus, dysautonomia, or absent corpus callosum	Underlying condition; genetic syndrome; anatomic abnormality	Normal inflammatory markers; hypernatremia; no response to nonsteroidal antiinflammatory drugs	Clinical constellation; laboratory tests and imaging

Modified from Long SS, Prober CG, Fischer M, eds. *Principles and Practice of Pediatric Infectious Diseases*, 5th ed. Philadelphia: Elsevier; 2018: Table 15.2, p. 121.

The general activity of the patient and the presence or absence of rashes should also be noted.

A careful ophthalmic examination is important. Red, weeping eyes may be a sign of connective tissue disease, particularly polyarteritis nodosa. Palpebral **conjunctivitis** in a febrile patient may be a clue to

measles, coxsackievirus infection, tuberculosis, infectious mononucleosis, lymphogranuloma venereum, or cat-scratch disease. In contrast, bulbar conjunctivitis in a child with FUO suggests Kawasaki disease or leptospirosis. Petechial conjunctival **hemorrhages** suggest infective endocarditis. Uveitis suggests sarcoidosis, JIA, SLE, Kawasaki disease,

Behçet disease, and vasculitis. **Chorioretinitis** suggests CMV, toxoplasmosis, and syphilis. **Proptosis** suggests an orbital tumor, thyrotoxicosis, metastasis (neuroblastoma), orbital infection, granulomatosis with polyangiitis, or orbital pseudotumor.

The ophthalmoscope should also be used to examine nail-fold capillary abnormalities that are associated with connective tissue diseases such as juvenile dermatomyositis and systemic scleroderma. Immersion oil or lubricating jelly is placed on the skin adjacent to the nailbed, and the capillary pattern is observed with the ophthalmoscope set on +40.

FUO is sometimes caused by **hypothalamic dysfunction**. A clue to this disorder is failure of pupillary constriction because of absence of the sphincter constrictor muscle of the eye. This muscle develops embryologically when hypothalamic structure and function also are undergoing differentiation.

Fever resulting from familial dysautonomia may be suggested by lack of tears, an absent corneal reflex, or a smooth tongue with absence of fungiform papillae. Tenderness to tapping over the sinuses or the upper teeth suggests sinusitis. Recurrent oral candidiasis may be a clue to various disorders of the immune system, especially involving the T lymphocytes. Hyperactive deep tendon reflexes can suggest thyrotoxicosis as the cause of FUO.

**Hyperemia** of the pharynx, with or without exudate, suggests streptococcal infection, EBV infection, CMV infection, toxoplasmosis, salmonellosis, tularemia, Kawasaki disease, gonococcal infection, or leptospirosis.

The muscles and bones should be palpated carefully. Point tenderness over a bone can suggest occult osteomyelitis or bone marrow invasion from neoplastic disease. Tenderness over the trapezius muscle may be a clue to subdiaphragmatic abscess. Generalized muscle tenderness suggests dermatomyositis, trichinosis, polyarteritis, Kawasaki disease, or *Mycoplasma* or arboviral infection.

Rectal examination can reveal perirectal lymphadenopathy or tenderness, which suggests a deep pelvic abscess, iliac adenitis, or pelvic osteomyelitis. A guaiac test should be obtained; occult blood loss can suggest granulomatous colitis or ulcerative colitis as the cause of FUO.

### Laboratory Evaluation

The laboratory evaluation of the child with FUO and whether inpatient or outpatient are determined on a case-by-case basis. Hospitalization may be required for laboratory or imaging studies that are unavailable or impractical in an ambulatory setting, for more careful observation, or for temporary relief of parental anxiety. The **tempo** of diagnostic evaluation should be adjusted to the tempo of the illness; haste may be imperative in a critically ill patient, but if the illness is more chronic, the evaluation can proceed in a systematic manner and can be carried out in an outpatient setting. If there are no clues in the patient's history or on physical examination that suggest a specific infection or area of suspicion, it is unlikely that diagnostic studies will be helpful. In this common scenario, continued surveillance and repeated reevaluations of the child should be employed to detect any new clinical findings.

Although ordering a large number of diagnostic tests in every child with FUO according to a predetermined list is discouraged, certain studies should be considered in the evaluation. A complete blood cell count (CBC) with a white blood cell (WBC) differential and a urinalysis should be part of the initial laboratory evaluation. An absolute neutrophil count (ANC) of  $<5,000/\mu\text{L}$  is evidence against indolent bacterial infection other than typhoid fever. Conversely, in patients with a polymorphonuclear leukocyte (PMN) count of  $>10,000/\mu\text{L}$  or a nonsegmented PMN count of  $>500/\mu\text{L}$ , a severe bacterial infection is highly likely. Direct examination of the blood smear with Giemsa or Wright stain can reveal organisms of malaria, trypanosomiasis, babesiosis, or relapsing fever.

An erythrocyte sedimentation rate (ESR)  $>30$  mm/hr indicates inflammation and the need for further evaluation for infectious, autoimmune, autoinflammatory, or malignant diseases, tuberculosis, Kawasaki disease, or autoimmune disease. A low ESR does not eliminate the possibility of infection or JIA. C-reactive protein (CRP) is another acute-phase reactant that becomes elevated and returns to normal more rapidly than the ESR. Experts recommend checking either ESR or CRP, because there is no evidence that measuring both in the same patient with FUO is clinically useful.

**Blood cultures** should be obtained aerobically. Anaerobic blood cultures have an extremely low yield and should be obtained only if there are specific reasons to suspect anaerobic infection. Multiple or repeated blood cultures may be required to detect bacteremia associated with infective endocarditis, osteomyelitis, or deep-seated abscesses. Polymicrobial bacteremia suggests factitious or self-induced infection or gastrointestinal (GI) pathology. The isolation of leptospires, *Francisella*, or *Yersinia* requires selective media or specific conditions not routinely used. Therefore it is important to inform the laboratory what organisms are suspected in a particular case. Urine culture should be obtained in all cases. Next-generation sequencing of tissue or whole blood or plasma may identify undetected or unculturable bacteria, fungi, or viruses.

Tuberculin skin testing (TST) should be performed with intradermal placement of 5 units of purified protein derivative that has been kept appropriately refrigerated. In children  $>2$  years old, it is reasonable to test for tuberculosis using an interferon- $\gamma$  release assay (IGRA).

**Imaging studies** of the chest, sinuses, mastoids, or GI tract may be indicated by specific historical or physical findings. Radiographic evaluation of the GI tract for IBD may be helpful in evaluating selected children with FUO and no other localizing signs or symptoms.

Examination of the bone marrow can reveal leukemia; metastatic neoplasm; mycobacterial, fungal, or parasitic infection; histiocytosis; hemophagocytosis; or storage diseases. If a bone marrow aspirate is performed, cultures for bacteria, mycobacteria, and fungi should be obtained.

**Serologic tests** can aid in the diagnosis of EBV infection, CMV infection, toxoplasmosis, salmonellosis, tularemia, brucellosis, leptospirosis, cat-scratch disease, Lyme disease, rickettsial disease, and on some occasions JIA. The clinician should be aware that the reliability and the sensitivity and specificity of these tests vary; for example, serologic tests for Lyme disease outside of reference laboratories have been generally unreliable.

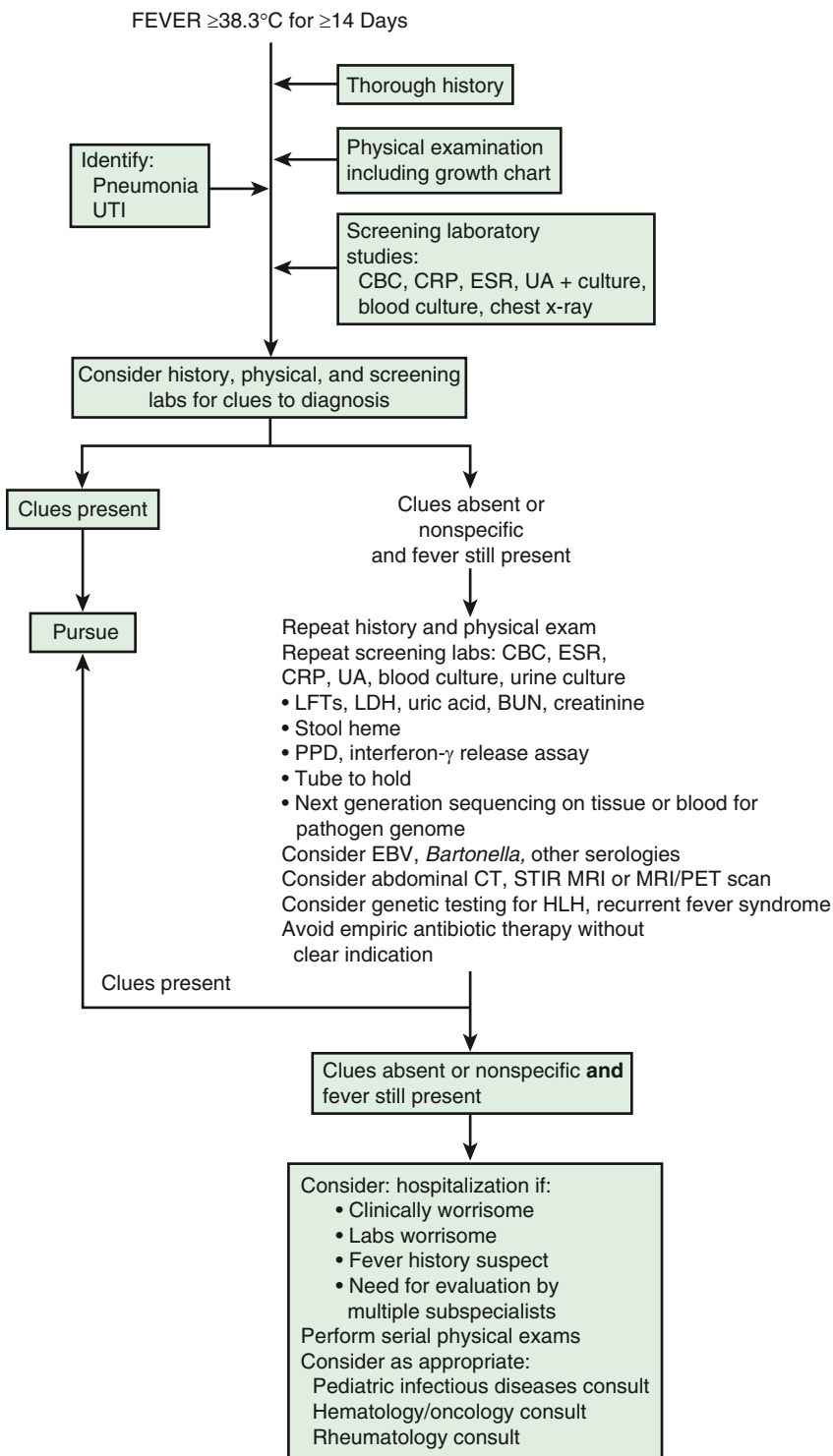
**MRI scans** may be helpful in detecting abdominal abscesses and osteomyelitis, especially if the focus cannot be localized to a specific limb or multifocal disease is suspected.  $^{18}\text{F}$ -fluorodeoxyglucose positron emission tomography (PET) combined with MRI or CT is a helpful imaging modality and contributed to an ultimate diagnosis in 48% of children in a Dutch study. Echocardiograms can demonstrate vegetation on the leaflets of heart valves, suggesting infective endocarditis. Ultrasonography (US) can identify intraabdominal abscesses of the liver, subphrenic space, pelvis, or spleen.

*Total-body CT or MRI (both with contrast) is usually the first imaging study of choice; both permit detection of neoplasms and collections of purulent material without the use of surgical exploration or radioisotopes.* CT and MRI are helpful in identifying lesions of the head, neck, chest, retroperitoneal spaces, liver, spleen, intraabdominal and intrathoracic lymph nodes, kidneys, pelvis, and mediastinum. CT- or US-guided aspiration or biopsy of suspicious lesions has reduced the need for exploratory laparotomy or thoracotomy. MRI is particularly useful for detecting osteomyelitis or myositis if there is concern about a specific limb. Diagnostic imaging can be helpful in confirming or evaluating a suspected diagnosis. With CT scans, however, the child is exposed to large amounts of radiation. PET-CT or MRI may help localize an occult tumor.

Biopsy is occasionally helpful in establishing a diagnosis of FUO. Bronchoscopy, laparoscopy, mediastinoscopy, and GI endoscopy can provide direct visualization and biopsy material when organ-specific manifestations are present. When employing any of the more invasive testing procedures, the risk/benefit ratio for the patient must always be considered before proceeding further. A diagnostic approach to an FUO is noted in [Figure 222.2](#).

### MANAGEMENT

The ultimate treatment of FUO is tailored to the underlying diagnosis. Fever and infection in children are not synonymous, and **antimicrobial agents** should only be used when there is evidence of infection, with avoidance of empirical trials of medication. An exception may be the use of antituberculous treatment in critically ill children with



**Fig. 222.2** Algorithmic approach to the evaluation of fever of unknown origin (FUO). EBV, Epstein-Barr virus; HLH, hemophagocytic lymphohistiocytosis; LDH, lactate dehydrogenase; LFT, liver function test; PPD, purified protein derivative; STIR, short tau inversion recovery rapid MRI; UTI, urinary tract infection. (Modified from Huppler AR. Fever. In Kliegman RM, Toth H, Bordini BJ, Basel D, eds. *Nelson Pediatric Symptom-Based Diagnosis*, 2nd ed. Philadelphia: Elsevier; 2023, Fig. 52.2, p. 982.)

suspected disseminated tuberculosis. Empirical trials of other antimicrobial agents may be dangerous and can obscure the diagnosis of infective endocarditis, meningitis, parameningeal infection, or osteomyelitis. After a complete evaluation, **antipyretics** may be indicated to control fever associated with adverse symptoms.

## PROGNOSIS

Children with FUO have a better prognosis than adults. The outcome in a child depends on the primary disease process. In many cases, no diagnosis can be established, and fever abates spontaneously. In as many as 25% of children in whom fever persists, the cause of the fever remains unclear even after thorough evaluation.

In a series of 69 patients referred for “prolonged” unexplained fever, 10 were not actually having fever, and 11 had diagnoses that were readily apparent at the initial visit. The remaining 48 were classified as having FUO. The median duration of reported fever for these patients was 30 days. Fifteen received a diagnosis, and 10 (67%) had confirmed infections: acute EBV or CMV infection ( $n = 5$ ; with 1 patient developing hemophagocytic lymphohistiocytosis), cat-scratch disease (3), and histoplasmosis (2). The other 5 patients had inflammatory conditions (systemic JIA, 2; IBD, 1), central fever (1), or malignancy (acute lymphoblastic leukemia, 1).

Visit Elsevier eBooks+ at [eBooks.Health.Elsevier.com](https://eBooks.Health.Elsevier.com) for Bibliography.

## Chapter 223

Infections in  
Immunocompromised  
PersonsMarian G. Michaels, Hey Jin Chong, and  
Michael Green

Infection develops when the host immune system fails to protect adequately against potential pathogens (see also Chapters 165, 166, and 180). For individuals with an intact immune system, infection occurs in the setting of naïveté to the microbe and absence of or inadequate preexisting microbe-specific immunity, or when protective barriers of the body such as the skin have been breached. Healthy children are able to meet the challenge of most infectious agents with an immunologic armamentarium capable of preventing significant disease. Once an infection begins to develop, an array of immune responses is set into action to control the disease and prevent it from reappearing. In contrast, immunocompromised children might not have this same capability. Depending on the level and type of immune defect, the affected child might not be able to contain the pathogen or develop an appropriate immune response to prevent recurrence.

**Primary immunodeficiencies** are compromised states that result from genetic defects affecting one or more arms of the immune system. **Acquired, or secondary, immunodeficiencies** may result from infection (e.g., infection with HIV), from malignancy, or as a consequence of immunomodulating or immunosuppressing medications. The latter include medications that affect T cells (corticosteroids, calcineurin inhibitors, tumor necrosis factor [TNF] inhibitors, chemotherapy), neutrophils (myelosuppressive agents, idiosyncratic or immune-mediated neutropenia), specific immunoregulatory cells (TNF blockers, interleukin-2 inhibitors), or all immune cells (chemotherapy). Perturbations of the mucosal and skin barriers or the normal microbial flora can also be characterized as secondary immunodeficiencies, predisposing the host to infections, if only temporarily.

The pathogens causing infections among *immunocompetent* hosts are also responsible for infections among children with *immunodeficiencies*. In addition, less virulent or opportunistic organisms, including normal skin flora, commensal bacteria of the oropharynx or gastrointestinal (GI) tract, environmental fungi, and common community viruses of low-level pathogenicity, can cause severe, life-threatening illnesses in immunocompromised patients (Table 223.1). Close communication with the diagnostic laboratory is critical to ensure that the laboratory does not disregard normal flora and organisms normally considered contaminants as being unimportant.

223.1 Infections Occurring with Primary  
ImmunodeficienciesMarian G. Michaels, Hey Jin Chong, and  
Michael Green

Currently, more than 450 genes involving inborn errors of immunity have been identified, accounting for a wide array of diseases presenting with susceptibility to infection, allergy, autoimmunity, and autoinflammation, as well as malignancy (see Chapters 165 and 166).

## ABNORMALITIES OF THE PHAGOCYtic SYSTEM

Children with abnormalities of the phagocytic and neutrophil system have problems with bacteria and environmental fungi. Disease manifests as recurrent infections of the skin, mucous membranes, lungs,

Table 223.1 Most Common Causes of Infections in  
Immunocompromised Children

## BACTERIA, AEROBIC

*Acinetobacter*  
*Bacillus*  
*Burkholderia cepacia*  
*Citrobacter*  
*Corynebacterium*  
*Enterobacter* spp.  
*Enterococcus faecalis*  
*Enterococcus faecium*  
*Escherichia coli*  
*Klebsiella* spp.  
*Listeria monocytogenes*  
*Mycobacterium* spp.  
*Neisseria meningitidis*  
*Nocardia* spp.  
*Pseudomonas aeruginosa*  
*Staphylococcus aureus*  
*Staphylococcus, coagulase-negative*  
*Streptococcus pneumoniae*  
*Streptococcus, viridans* group

## BACTERIA, ANAEROBIC

*Bacillus*  
*Clostridium*  
*Fusobacterium*  
*Peptococcus*  
*Peptostreptococcus*  
*Propionibacterium*  
*Veillonella*

## FUNGI

*Aspergillus*  
*Candida albicans*  
Other *Candida* spp.  
*Cryptococcus neoformans*  
*Fusarium* spp.  
*Pneumocystis jirovecii*  
Zygomycoses (*Mucor*, *Rhizopus*, *Rhizomucor*)

## VIRUSES

Adenoviruses  
Cytomegalovirus  
Epstein-Barr virus  
Herpes simplex virus  
Human herpesvirus 6  
Polyomavirus (BK)  
Respiratory and enteric community-acquired viruses  
Varicella-zoster virus

## PROTOZOA

*Cryptosporidium parvum*  
*Giardia lamblia*  
*Toxoplasma gondii*

liver, and bones. Dysfunction of this arm of the immune system can be a result of inadequate numbers, abnormal movement properties, or aberrant function of neutrophils (see Chapter 168).

**Neutropenia** is defined as an absolute neutrophil count (ANC) of <1,000 cells/mm<sup>3</sup> and can be associated with significant risk for developing severe bacterial and fungal disease, particularly when prolonged or when the ANC is <500 cells/mm<sup>3</sup>. Although acquired neutropenia secondary to bone marrow suppression from a virus or medication is common, practitioners should be cognizant of genetic causes of neutropenia. **Primary congenital neutropenia** most often manifests during the first year of life with cellulitis, perirectal abscesses, or stomatitis from *Staphylococcus aureus* or *Pseudomonas aeruginosa*. Episodes of severe disease, including bacteremia and meningitis, are also possible. Bone marrow evaluation shows a failure of maturation of myeloid precursors. Many of the neutropenic syndromes respond to colony-stimulating factor. Cyclic neutropenia can be associated with autosomal dominant inheritance or de novo sporadic gene variations



and manifests as fixed cycles of severe neutropenia between periods of normal granulocyte numbers. Often the ANC has normalized by the time the patient presents with symptoms, thus hampering the diagnosis. The cycles classically occur every 21 days (range: 14–36 days), with neutropenia lasting 3–6 days. Most often the disease is characterized by recurrent aphthous ulcers and stomatitis during the periods of neutropenia. However, life-threatening necrotizing myositis or cellulitis and systemic disease can occur, especially with *Clostridium perfringens*.

**Leukocyte adhesion deficiencies (LADs)** are caused by defects of neutrophil aggregation and attachment to endothelial surfaces, rendering them unable to enter sites of infection (see Chapter 168). In the most severe form, there is a total absence of CD18, seen in LAD type 1, but genetic defects in fucose metabolism (LAD type 2) and FERMT3 (LAD type 3) have also been described. Generally, children with LAD have a history of delayed cord separation and recurrent infections of the skin, oral mucosa, and genital tract beginning early in life. Ecthyma gangrenosum also occurs. Because the defect involves leukocyte migration and adherence, the ANC in the peripheral blood is usually *extremely elevated*, but a key hallmark of LAD is that pus is not found at the site of infection. The mainstay of treatment is aggressive antibiotic use, with curative therapy being hematopoietic stem cell transplantation (HSCT).

**Chronic granulomatous disease (CGD)** is an inherited neutrophil dysfunction syndrome, which can be either X-linked or autosomal recessive, although spontaneous genetic changes can also occur (see Chapter 170). Neutrophils and other myeloid cells have defects in their nicotinamide-adenine dinucleotide phosphate oxidase function, decreasing superoxide production and thereby impairing intracellular killing. Accordingly, microbes that destroy their own hydrogen peroxide (*S. aureus*, *Serratia marcescens*, *Burkholderia cepacia*, *Nocardia* spp., *Aspergillus*) cause recurrent infections in these children. Less common but considered pathognomonic are *Granulibacter bethesdensis*, *Francisella philomiragia*, *Chromobacterium violaceum*, and *Paecilomyces* infections. Infections have a predilection to involve the lungs, liver, and bone. **Mulch pneumonitis** can be seen in patients with known CGD but also can be a unique presenting feature in adults with autosomal recessive CGD. Mulch pneumonitis can resemble hypersensitivity pneumonitis, and bronchoscopy may yield *Aspergillus* but often may not identify a clear organism. Treatment with antifungals and corticosteroids for the inflammation is recommended. *S. aureus* abscesses can occur in the liver despite prophylaxis. In addition, these children can present with recurrent abscesses affecting the skin, perirectal region, or lymph nodes. Sepsis can occur but is more common with certain gram-negative organisms such as *C. violaceum* and *F. philomiragia*.

Prophylaxis with trimethoprim-sulfamethoxazole (TMP-SMX), recombinant human interferon- $\gamma$ , and oral antifungal agents with activity against *Aspergillus* spp., such as itraconazole or newer azoles, substantially reduces the incidence of severe infections. Patients with life-threatening infections are also reported to benefit from aggressive treatment with white blood cell transfusions along with antimicrobial agents directed against the specific pathogen. In addition, HSCT can be curative, and gene therapy trials are also a consideration. It is important to remember that patients with CGD do not make pus, and thus drainage alone for liver abscesses is not effective. Instead, patients should be treated with intravenous (IV) antibiotics as well as IV corticosteroids, with surgical resection considered if these measures fail.

### DEFECTIVE SPLENIC FUNCTION, OPSONIZATION, OR COMPLEMENT ACTIVITY

Children who have congenital asplenia or splenic dysfunction associated with polysplenia or hemoglobinopathies, such as sickle cell disease, as well as those who have undergone splenectomy are at risk for serious infections from encapsulated bacteria and blood-borne protozoa such as *Plasmodium* and *Babesia*. Prophylaxis against bacterial infection with penicillin or amoxicillin should be considered for these patients, particularly children <5 years of age. The most common causative bacterial organisms include *Staphylococcus pneumoniae*, *Haemophilus influenzae* type b (Hib), and *Salmonella*, which can cause sepsis, pneumonia, meningitis, and osteomyelitis. Defects in the early complement components, particularly C2 and C3, may also be associated with severe infection

from these bacteria. **Terminal complement defects** (C5, C6, C7, C8, and C9) are associated with recurrent infections with *Neisseria*. Patients with complement deficiency also have an increased incidence of autoimmune disorders. Vaccines for *S. pneumoniae*, Hib, and *N. meningitidis* should be administered to all children with abnormalities in opsonization or complement pathways (see Chapters 173 and 174).

### B-CELL DEFECTS (HUMORAL IMMUNODEFICIENCIES)

**Antibody deficiencies** account for the majority of primary immunodeficiencies among humans (see Chapters 165 and 166). Patients with defects in the B-cell arm of the immune system fail to develop appropriate antibody responses, with abnormalities that range from complete **agammaglobulinemia** to isolated failure to produce antibody against a specific antigen or organism. Complete antibody deficiencies found in children with **X-linked agammaglobulinemia (XLA)** or other rarer autosomal recessive **agammaglobulinemia** predispose to infections with encapsulated organisms such as *S. pneumoniae* and Hib. Other bacteria can also be problematic in these children (see Table 223.1). Patients with XLA can also have neutropenia, with one case series showing 12 of 13 patients with XLA having neutropenia as part of the initial presentation. Because of the neutropenia, patients with XLA can present with *Pseudomonas* septicemia. Viral infections can also occur, with rotavirus leading to chronic diarrhea. Enteroviruses can disseminate and cause a chronic meningoencephalitis syndrome in these patients. Paralytic polio can develop after immunization with live polio vaccine. Protozoan infections such as giardiasis can be severe and persistent.

Children with agammaglobulinemia are usually asymptomatic until 5–6 months of age, when maternally derived antibody levels begin to wane. Around 6 months of age these children begin to develop recurrent episodes of otitis media, bronchitis, pneumonia, bacteremia, and meningitis. Many of these infections respond quickly to antibiotics, delaying the recognition of antibody deficiency, with studies showing some patients diagnosed in their teens. Children with B-cell defects can develop bronchiectasis over time after chronic or recurrent pulmonary infections and require lifelong IgG replacement therapy. Careful physical examination identifies lack of tonsils in these children, and lymphocyte subsets should confirm the lack of circulating B cells.

**Selective IgA deficiency** is the most common antibody deficiency and leads to a lack of production of secretory antibody at the mucosal membranes (see Chapter 166). Even though most patients have no increased risk for infections, some have mild to moderate disease at sites of mucosal barriers. Accordingly, recurrent sinopulmonary infection and GI disease are the major clinical manifestations. These patients also have an increased incidence of allergies and autoimmune disorders compared with the normal population.

**Common variable immunodeficiency (CVID)** is considered an antibody deficiency, with ~30% of cases found to have a monogenic cause. Diagnosis can be made in children over the age of 4, with low IgG as well as low IgM or IgA and lack of protective vaccine titers. These patients develop sinopulmonary and GI infections with common organisms, although they can have more severe presentations than their immunocompetent counterparts. They also have increased risk of autoimmunity and malignancy and often require IgG replacement.

**Hyper-IgM syndrome** encompasses a group of genetic defects associated with immunoglobulin class-switch recombination. The most common type is caused by a defect in the CD40 ligand on the T cell, leading to inability of the B cell to class-switch (see Chapter 166). Similar to other patients with humoral defects, these patients are at risk for bacterial sinopulmonary infections. However, unlike a true pure antibody defect, besides being important in T-cell–B-cell interactions, CD40 ligand is also important in the interaction between T cells and macrophages/monocytes, predisposing to opportunistic infections such as *Pneumocystis jirovecii* pneumonia (PJP) and *Cryptosporidium* intestinal infection.

### T-CELL DEFECTS (CELL-MEDIATED IMMUNODEFICIENCIES)

Children with primary T-cell–mediated immunodeficiencies can present early in life and are susceptible to viral, fungal, and protozoan infections. Clinical manifestations include chronic diarrhea,

mucocutaneous candidiasis, and recurrent pneumonia, rhinitis, and otitis media. In thymic hypoplasia (**DiGeorge syndrome**), hypoplasia or aplasia of the thymus and parathyroid glands occurs during fetal development in association with the presence of other congenital abnormalities. Hypocalcemia and cardiac anomalies can be the presenting features of DiGeorge syndrome, which should prompt evaluation of the T-cell system.

**Chronic mucocutaneous candidiasis (CMC)** is a group of immunodeficiencies leading to susceptibility to fungal infections of the skin, nails, oral cavity, and genitals. Most frequently caused by *Candida* spp., dermatophyte infections with *Microsporium*, *Epidermophyton*, and *Trichophyton* have also been described. Interestingly, patients with CMC do not have an increased risk for histoplasmosis, blastomycosis, or coccidioidomycosis. Despite chronic cutaneous and mucosal infection with *Candida* spp., these patients often lack a delayed hypersensitivity to skin tests for *Candida* antigen. Several gene defects have been identified in people with CMC, including *STAT1* gain-of-function pathologic gene variations, *IL17R* defects, *CARD9* deficiency, and *ACT1* deficiency. Although patients with CMC generally do not develop invasive candidiasis, patients with CMC as a feature of an inborn error or immunity certainly do develop invasive *Candida* infection. Endocrinopathies, autoimmunity, and life-threatening vascular abnormalities can be seen as well, making genetic testing important in the prognosis and management of patients with CMC.

### COMBINED B-CELL AND T-CELL DEFECTS

Patients with defects in both the B-cell and T-cell components of the immune system have variable manifestations depending on the extent of the defect (see Chapter 165). Complete or almost complete immunodeficiency is found with **severe combined immunodeficiency disorder (SCID)**, whereas partial defects can be present in such states as **ataxia-telangiectasia**, **Wiskott-Aldrich syndrome**, **hyper-IgE syndrome**, and **X-linked lymphoproliferative disorder**. Rather than one disorder, SCID represents a heterogeneous group of genetic defects that present in the first year of life with recurrent and typically severe infections caused by a variety of bacteria, fungi, and viruses. Failure to thrive, chronic diarrhea, mucocutaneous or systemic candidiasis, PJP, or cytomegalovirus (CMV) infections are common early in life. Passive maternal antibody is relatively protective against the bacterial pathogens during the first few months of life, but thereafter patients are susceptible to both gram-positive and gram-negative organisms. Exposure to live-virus vaccines can also lead to disseminated disease; accordingly, the use of live vaccines (including rotavirus vaccine) is contraindicated in patients with suspected or proven SCID. Without stem cell transplantation or gene therapy, most affected children succumb to infections within the first year of life.

Children with **ataxia-telangiectasia** develop recurrent sinopulmonary infections from both bacteria and respiratory viruses and are particularly susceptible to chronic lung infections because of their immunodeficiency and their muscular weakness leading to poor airway clearance. In addition, these children experience an increased incidence of malignancies and neurologic complications, with most patients being wheelchair bound by the second decade of life. **Wiskott-Aldrich syndrome** is an X-linked recessive disease associated with eczema, thrombocytopenia, reduced number of CD3 lymphocytes, moderately suppressed mitogen responses, and impaired antibody response to polysaccharide antigens. Accordingly, infections with *S. pneumoniae* or Hib can be seen.

**Hyper-IgE syndrome (HIES)** is characterized by elevated levels of IgE, infections, and eczema, with the most common cause being the result of dominant negative gene variation in *STAT3*. Pathogenic gene variants in *TYK2*, *PGM3*, *ZNF341*, *CARD11*, and *IL6ST* have also been reported to cause this phenotype. Patients can present with recurrent episodes of *S. aureus* abscesses of the skin, lungs, and musculoskeletal system. These abscesses were initially described as “cold” in that they did not have the characteristic warmth and rubor typically seen in immunocompetent patients and thereby are easily missed, delaying therapy. Patients can also develop infections caused by *Candida* and, depending on the gene defect, severe viral infections. Patients with

*STAT3* HIES should receive prophylaxis against *S. aureus* with aggressive management of eczema as well.

Visit Elsevier eBooks+ at [eBooks.Health.Elsevier.com](http://eBooks.Health.Elsevier.com) for Bibliography.

## 223.2 Infections Occurring with Acquired Immunodeficiencies

Marian G. Michaels, Hey Jin Chong, and Michael Green

Immunodeficiencies can be secondarily acquired from infections or other underlying disorders, such as malignancy, cystic fibrosis, diabetes mellitus, sickle cell disease, or malnutrition. Immunosuppressive medications used to prevent rejection after organ transplantation, to prevent graft-versus-host disease (GVHD) after stem cell transplantation, or to treat malignancies may also leave the host vulnerable to infections. Similarly, medications used to control rheumatologic or other autoimmune diseases may be associated with an increased risk for developing infection. Surgical removal of the spleen likewise puts a person at increased risk for infections. Further, any process that disrupts the normal mucosal and skin barriers (e.g., burns, surgery, indwelling catheters) may lead to an increased risk for infection.

### ACQUIRED IMMUNODEFICIENCY FROM INFECTIOUS AGENTS

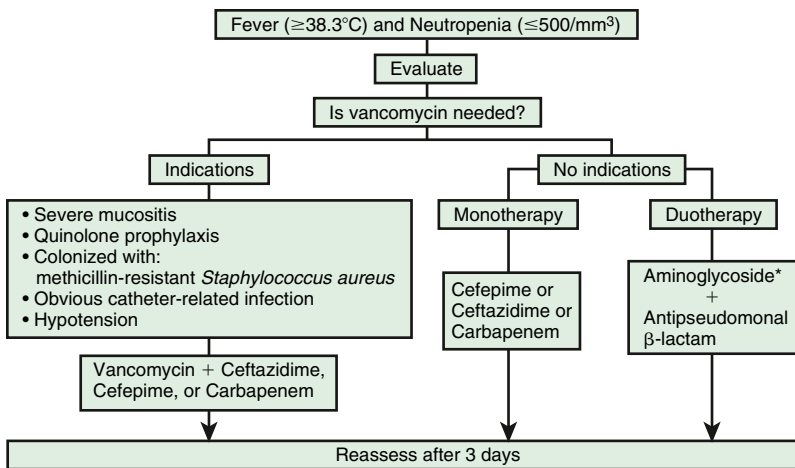
Infection with HIV, the causative agent of **AIDS**, remains globally an important infectious cause of acquired immunodeficiency (see Chapter 322). Left untreated, HIV infection has profound effects on many parts of the immune system but in particular T-cell-mediated immunity that leads to susceptibility to the same types of infections as with primary T-cell immunodeficiencies.

Other organisms can also lead to temporary alterations of the immune system. Very rarely, transient neutropenia associated with community-acquired viruses can lead to significant disease with bacterial infections. Secondary infections can occur because of impaired immunity or disruption of normal mucosal immunity, as exemplified by the increased risk for pneumonia from *S. pneumoniae* or *S. aureus* after influenza infection and group A streptococcal cellulitis and fasciitis after varicella.

### MALIGNANCIES

The immune systems of children with malignancies are compromised by the therapies used to treat the cancer and, at times, by direct effects of the cancer itself. The type, duration, and intensity of anticancer therapy remain the major risk factors for infections in these children and often affect multiple arms of the immune system. The presence of mucous membrane abnormalities, indwelling catheters, malnutrition, prolonged exposure to antibiotics, and frequent hospitalizations adds to the risk for infection in these children.

Even though several arms of the immune system can be affected, the major abnormality predisposing to infection in children with cancer is **neutropenia**. The depth and duration of neutropenia are the primary predictors of the risk of infection in children being treated for cancer. Patients are at particular risk for bacterial and fungal infections if the ANC decreases to  $<500$  cells/mm<sup>3</sup>, and the risk is highest in those with counts  $<100$  cells/mm<sup>3</sup>. Counts of  $>500$  cells/mm<sup>3</sup> but  $<1,000$  cells/mm<sup>3</sup> incur some increased risk for infection, but not nearly as great. The lack of neutrophils can lead to a diminution of inflammatory response, limiting the ability to localize sites of infection and potentially leaving fever as the only manifestation of infection. Accordingly, the absence of physical signs and symptoms does not reliably exclude the presence of infection, resulting in the need for empirical antibiotics (Fig. 223.1). Because patients with **fever and neutropenia** might only have subtle signs and symptoms of infection, the presence of fever warrants an intensive investigation, including a thorough physical examination with careful attention to the oropharynx, lungs, perineum and anus, skin, nailbeds, and intravascular catheter insertion sites (Table 223.2).



**Fig. 223.1** Algorithm for the initial management of the febrile neutropenic patient. Monotherapy can be considered with cefepime, imipenem/cilastatin, meropenem, piperacillin-tazobactam, or ticarcillin-clavulanic acid. \*Aminoglycoside antibiotics should be avoided if the patient is also receiving nephrotoxic, ototoxic, or neuromuscular blocking agents; has renal or severe electrolyte dysfunction; or is suspected of having meningitis (because of poor blood-brain perfusion). (Adapted from Freifeld AG, Bow EJ, Sepkowitz KA, et al. *Clinical practice guideline for the use of antimicrobial agents in neutropenic patients with cancer: 2010 update by the Infectious Diseases Society of America. Clin Infect Dis.* 2011;52:e56–e93.)

A comprehensive laboratory evaluation, including a complete blood cell count, serum creatinine, blood urea nitrogen, and serum transaminases, should be obtained. Blood cultures should be taken from each port of any **central venous catheter** (CVC) and from a peripheral vein and repeated if the original culture is negative. Although peripheral vein sampling is often omitted with continued fevers and neutropenia, it should be obtained before the initial antibiotic administration and reconsidered in children with one or more positive cultures from a CVC, facilitating localization (line vs systemic) of the source of the infection. Other microbiologic studies should be done if there are associated clinical symptoms, including a nasal aspirate for viruses in patients with upper respiratory findings; stool for viruses such as rotavirus or norovirus and for *Clostridium difficile* toxin in patients with diarrhea; urinalysis and culture in young children or in older patients with symptoms of urgency, frequency, dysuria, or hematuria; and biopsy and culture of cutaneous lesions. Chest radiographs should be obtained in any patient with lower respiratory tract symptoms, although pulmonary infiltrates may be absent in children with severe neutropenia. Sinus films should be obtained for children >2 years of age if rhinorrhea is prolonged. Abdominal CT scans should also be considered in children with profound neutropenia and abdominal pain to evaluate for the presence of typhlitis. Chest CT scan should be considered for children not responding to broad-spectrum antibiotics who have continued fever and neutropenia for >96 hours. Although some have considered the use of fungal biomarkers (e.g., galactomannan,  $\beta$ -D-glucan, fungal polymerase chain reaction [PCR]), these assays have poor positive predictive values, and their use is not routinely recommended. Biopsies for cytology, Gram stain, and culture should be considered if abnormalities are found during endoscopic procedures or if lung nodules are identified radiographically.

Past studies demonstrated that before the routine institution of empirical antimicrobial therapy for fever and neutropenia, 75% of children with fever and neutropenia were ultimately found to have a documented site of infection, suggesting that most children with fever and neutropenia will have an underlying infection (see Table 223.2). Current data suggest that bacteremia is present in ~20% of febrile neutropenic pediatric patients with leukemia; ~90% have bacterial disease (Fig. 223.2). Currently, gram-positive cocci are the most common pathogens identified in these patients; however, gram-negative organisms such as *P. aeruginosa*, *Escherichia coli*, and *Klebsiella* can cause life-threatening infection and must be considered in the empirical treatment regimen. Other multidrug-resistant Enterobacterales are increasingly recovered in these children. Although coagulase-negative staphylococci often cause infections in these children in association with CVCs, these infections are typically indolent, and a short delay in treatment usually does not lead to a detrimental outcome. Other gram-positive bacteria, such as *S. aureus* and *S. pneumoniae*, can cause more fulminant disease and require prompt institution of therapy. Viridans streptococci are particularly important potential pathogens in patients with the oral mucositis that is often associated with use of cytarabine and in patients who experience selective pressure from treatment with certain antibiotics such as quinolones. Infection caused by this group

of organisms can present with an acute septic shock syndrome. Also, patients with prolonged neutropenia are at increased risk for opportunistic fungal infections (fungemia or tissue invasion), with *Candida* spp. and *Aspergillus* spp. being the most commonly identified fungi. Other fungi that can cause serious disease in these children include zygomycetes, *Fusarium* spp., and dematiaceous molds. In patients with repeatedly negative blood cultures but persistent fevers, next-generation sequencing in blood or plasma may help identify bacterial, viral, fungal, or protozoan pathogens.

## FEVER AND NEUTROPENIA

The use of empirical antimicrobial treatment as part of the management of fever and neutropenia decreases the risk of progression to sepsis, septic shock, acute respiratory distress syndrome, organ dysfunction, and death. In 2017 the International Pediatric Fever and Neutropenia Guideline Panel updated a comprehensive guideline for the management of neutropenic children with cancer or after HSCT (see Fig. 223.1).

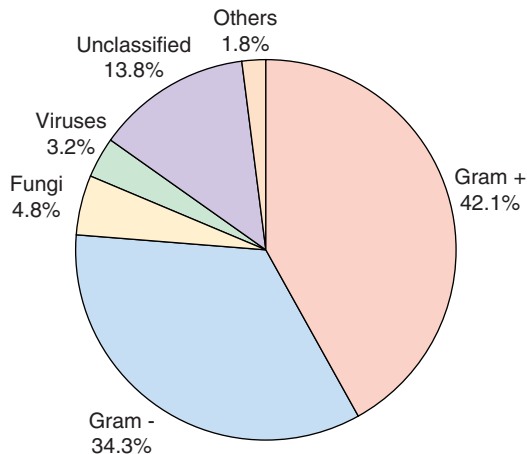
First-line antimicrobial therapy should take into consideration the types of microbes anticipated and the local resistance patterns encountered at each institution as well as the level of risk for severe infection associated with a given patient. In addition, antibiotic choices may be limited by specific circumstances, such as the presence of drug allergy and renal or hepatic dysfunction. Guidelines for the management of fever and neutropenia in children with cancer and/or undergoing HSCT conclude that the use of oral antimicrobial therapy as either initial or stepdown therapy can be considered in low-risk children who can tolerate oral antibiotics and in whom careful monitoring can be ensured. However, the guideline emphasizes that oral medication use may present major challenges in children, including the availability of liquid formulations of appropriate antibiotics, cooperation of young children, and the presence of mucositis potentially interfering with absorption. Accordingly, decisions to implement this approach should be reserved for a select subset of these children presenting with fever and neutropenia and institutions with an appropriate infrastructure to follow them as outpatients.

The decision to initially use IV monotherapy versus an expanded regimen of antibiotics depends on the severity of illness of the patient, history of previous colonization with resistant organisms, and obvious presence of catheter-related infection. Glycopeptide addition (such as vancomycin) to the initial empirical regimen should be implemented if the patient has hypotension or other evidence of septic shock, an obvious catheter-related infection, a history of colonization with methicillin-resistant *S. aureus*, or the patient is at high risk for infection with viridans streptococci (severe mucositis, acute myelogenous leukemia, or prior use of quinolone prophylaxis). Otherwise, use of monotherapy with an antipseudomonal  $\beta$ -lactam, such as piperacillin-tazobactam, a fourth-generation cephalosporin, or a carbapenem can be considered. Cefazidime should not be used as monotherapy if concern exists for gram-positive organisms or resistant gram-negative bacteria. The addition of a second anti-gram-negative bacterial agent (e.g., aminoglycoside) for empirical therapy can be considered in patients who are clinically unstable when multidrug-resistant organisms are suspected.



**Table 223.2** Host Defense Defects and Common Pathogens by Time After Bone Marrow or Hematopoietic Stem Cell Transplantation

TIME PERIOD	HOST DEFENSE DEFECTS	CAUSES	COMMON PATHOGENS
Pretransplant	Neutropenia Abnormal anatomic barriers	Underlying disease Prior chemotherapy	Aerobic gram-negative bacilli
Preengraftment	Neutropenia Abnormal anatomic barriers	Chemotherapy Radiation Indwelling catheters	Aerobic gram-positive cocci Aerobic gram-negative bacilli <i>Candida</i> <i>Aspergillus</i> Herpes simplex virus (in previously infected patients) Community-acquired viral pathogens
Postengraftment	Abnormal cell-mediated immunity Abnormal anatomic barriers	Chemotherapy Immunosuppressive medications Radiation Indwelling catheters Unrelated cord blood donor	Gram-positive cocci Aerobic gram-negative bacilli Cytomegalovirus Adenoviruses Community-acquired viral pathogens <i>Pneumocystis jirovecii</i>
Late posttransplant	Delayed recovery of immune function (cell-mediated, humoral, and abnormal anatomic barriers)	Time required to develop donor-related immune function Graft-versus-host disease	Varicella-zoster virus <i>Streptococcus pneumoniae</i>



**Fig. 223.2** Pathogens involved in the microbiologically documented infections in pediatric oncology patients with febrile neutropenia. (From Boeriu E, Borda A, Dumitru D, et al. *Diagnosis and management of febrile neutropenia in pediatric oncology patients – a systematic review. Diagnostics.* 2022;12:1800.)

Regardless of the regimen chosen initially, it is critical to evaluate the patient carefully and continually for response to therapy, development of secondary infections, and adverse effects. Management recommendations for these children are evolving. Patients who have negative blood cultures at 48 hours, who have been afebrile for at least 24 hours, and who have evidence of bone marrow recovery can have all antibiotics discontinued. However, if symptoms persist or evolve, IV antibiotics should be continued. Continuation of antibiotics in children whose fever has abated and who are clinically well but continue to have depression of neutrophils is more controversial. Pediatric guidelines advocate for discontinuing antibiotics in low-risk patients at 72 hours for children who have negative blood cultures and who have been afebrile for at least 24 hours regardless of bone marrow recovery, as long as careful follow-up is ensured.

Next-generation sequencing (NGS) during episodes of fever and neutropenia may enhance pathogen detection when blood cultures and other tests are negative. NGS has the advantage of detecting bacteria, fungi, viruses and polymicrobial infections. When fever persists despite empiric antibiotics, NGS results may help modify antimicrobial therapy based on the pathogens identified.

Patients without an identified etiology but with **persistent fever** should be reassessed daily. At day 3-5 of persistent fever and

neutropenia, those remaining clinically well may continue on the same regimen, although consideration should be given to discontinuing vancomycin or double gram-negative bacterial coverage if they were included initially. Patients who remain febrile with clinical instability warrant escalation of therapy with the addition of a glycopeptide, if it was not included initially and risk factors exist, and modification of the empirical antibacterial regimen to cover potential antimicrobial resistance and anaerobic infections in these children. If fever persists for >96 hours, the addition of an **antifungal agent** with antimold activity should be considered, particularly for those at high risk for invasive fungal infection (those with acute myelogenous leukemia or relapsed acute lymphocytic leukemia or who are receiving highly myelosuppressive chemotherapies for other cancers or with allogeneic HSCT). Liposomal amphotericin products and echinocandins have been studied in children; voriconazole, itraconazole, and posaconazole have been successfully used in adults, with increasing experience in children. Azoles may have substantial drug-drug interactions; however, their use has not been thoroughly evaluated. Studies comparing caspofungin with liposomal amphotericin for children with malignancies and fever and neutropenia have shown that caspofungin is noninferior.

The use of **antiviral agents** in children with fever and neutropenia is not warranted without specific evidence of viral disease. Active herpes simplex or varicella-zoster lesions merit treatment to decrease the time of healing; even if these lesions are not the source of fever, they are potential portals of entry for bacteria and fungi. CMV is a rare cause of fever in children with cancer and neutropenia. If CMV infection is suspected, assays to evaluate viral load in the blood and organ-specific infection should be obtained. Ganciclovir, foscarnet, or cidofovir may be considered while evaluation is pending, although ganciclovir can cause bone marrow suppression and foscarnet and cidofovir can be nephrotoxic. If influenza is identified, specific treatment with an antiviral agent (oseltamivir, zanamivir) should be administered. The possibility of severe acute respiratory syndrome–coronavirus type 2 (SARS-CoV-2) infection should be evaluated by PCR, and treatment should be considered based on current recommendations and local availability of antiviral therapies.

The use of **hematopoietic growth factors** shortens the duration of neutropenia but has not been proved to reduce morbidity or mortality. Accordingly, guidelines do not endorse the routine use of hematopoietic growth factors in patients with established fever and neutropenia, although the recommendations do note that hematopoietic growth factors can be considered as prophylaxis in those with neutropenia at high risk for fever.

**Prophylaxis with levofloxacin** has been shown to decrease bacteremia for children with acute leukemia receiving intensive chemotherapy and may also be effective in those undergoing allogeneic HSCT. However, monitoring for breakthrough bacteremia and for quinolone resistance is important.



## FEVER WITHOUT NEUTROPENIA

Infections occur in children with cancer in the absence of neutropenia. Most often, these infections are viral in etiology. However, *P. jirovecii* can cause pneumonia regardless of the neutrophil count. Administration of prophylaxis against *Pneumocystis* is an effective preventive strategy and should be provided to all children undergoing active treatment for malignancy. First-line therapy remains TMP-SMX, with second-line alternatives including pentamidine, atovaquone, dapsone, or dapsone-pyrimethamine. Environmental fungi such as *Cryptococcus*, *Histoplasma*, and *Coccidioides* can also cause disease. *Toxoplasma gondii* is an uncommon but occasional pathogen in children with cancer. Infections caused by pathogens encountered in healthy children (*S. pneumoniae*, group A streptococcus) can also occur in children with cancer regardless of the granulocyte count.

## TRANSPLANTATION

Transplantation of hematopoietic stem cells and solid organs (including heart, liver, kidney, lungs, pancreas, and intestines) is increasingly used as therapy for a variety of disorders. Children undergoing transplantation are at risk for infections caused by many of the same microbial agents that cause disease in children with primary immunodeficiencies. Although the types of infections after transplantation generally are similar among all recipients of these procedures, some differences exist between patients depending on the type of transplantation performed, the type and amount of immunosuppression given, and the child's preexisting immunity to specific pathogens.

### Stem Cell Transplantation

Infections after HSCT can be classified as occurring during the **pretransplantation period**, **preengraftment period** (0–30 days after transplantation), **postengraftment period** (30–100 days), or **late posttransplantation period** (>100 days). Specific defects in host defenses predisposing to infection vary within each of these periods (see [Table 223.2](#)). In addition, risk is affected by type of transplant (autologous, allogeneic, T-cell depleted, cord blood) along with the quality of the donor-recipient match. Neutropenia and abnormalities in cell-mediated and humoral immune function occur predictably during specific periods after transplantation. In contrast, breaches of anatomic barriers caused by indwelling catheters and mucositis secondary to radiation or chemotherapy create defects in host defenses that may be present any time after transplantation.

### Pretransplantation Period

Children come to HSCT with a heterogeneous history of underlying diseases, chemotherapy exposure, degree of immunosuppression, and previous infections. Approximately 12% of all infections among adult HSCT recipients occur during the pretransplantation period. These infections are often caused by aerobic gram-negative bacilli and manifest as localized infections of the skin, soft tissue, and urinary tract. Importantly, the development of infection during this period does not delay or adversely affect the success of engraftment.

### Preengraftment Period

**Bacterial infections** predominate in the preengraftment period (0–30 days). **Bacteremia** is the most common documented infection and occurs in as many as 50% of all HSCT recipients during the first 30 days after transplantation. Bacteremia is typically associated with the presence of either mucositis or an indwelling catheter but may also be seen with pneumonia. Similarly, >40% of children undergoing HSCT experience one or more infections in the preengraftment period. Gram-positive cocci, gram-negative bacilli, yeast, and, less frequently, other fungi cause infection during this period. *Aspergillus* has been identified in 4–20% of HSCT recipients, most often after 3 weeks of neutropenia. Infections caused by the emerging fungal pathogens *Fusarium* and *Pseudallescheria boydii* are associated with the prolonged neutropenia during the preengraftment period.

**Viral infections** also occur during the preengraftment period. Among adults, reactivation of herpes simplex virus (HSV) is the most common viral disease observed, but this is less common among children. A history of HSV infection or seropositivity indicates the

need for prophylaxis. Nosocomial exposure to community-acquired viral pathogens, including SARS-CoV-2, respiratory syncytial virus (RSV), influenza virus, adenovirus, rotavirus, and norovirus, represents another important source of infection during this period. There is growing evidence that community-acquired viruses cause increased morbidity and mortality for HSCT recipients during this period. Adenovirus is a particularly important viral pathogen that can occur early, although it typically presents after engraftment.

### Postengraftment Period

The predominant defect in host defenses in the postengraftment period is altered cell-mediated immunity. Accordingly, organisms historically categorized as *opportunistic pathogens* predominate during this period. The risk is especially accentuated 50–100 days after transplantation, when host immunity is lost and donor immunity is not yet established. *P. jirovecii* presents during this period if patients are not maintained on appropriate prophylaxis. Reactivation of *T. gondii*, a rare cause of disease among HSCT recipients, can also occur after engraftment. Hepatosplenic candidiasis often presents during the postengraftment period, although seeding likely occurs during the neutropenic phase.

**Cytomegalovirus (CMV)** is an important cause of morbidity and mortality among HSCT recipients. Unlike patients undergoing solid organ transplantation (SOT), where primary infection from the donor causes the greatest harm, CMV reactivation in an HSCT recipient whose donor is naïve to the virus can also cause severe disease. Disease risk from CMV after HSCT is also increased in recipients of cord blood transplants or matched unrelated T-cell-depleted transplants and those with GVHD. **Adenovirus**, another important viral pathogen, has been recovered from up to 5% of adult and pediatric HSCT recipients and causes invasive disease in approximately 20% of cases. Children receiving matched unrelated donor organs or unrelated cord blood cell transplants have an incidence of adenovirus infection as high as 14% during this early postengraftment period. **Polyomaviruses** such as BK virus have been increasingly recognized as a cause of renal dysfunction and hemorrhagic cystitis after bone marrow transplantation. Infections with other herpesviruses (Epstein-Barr virus [EBV] and human herpesvirus 6) as well as community-acquired pathogens are associated with excess morbidity and mortality during this period, similar to the preengraftment period.

### Late Posttransplantation Period

Infection is unusual after 100 days in the absence of chronic GVHD. However, the presence of chronic GVHD significantly affects anatomic barriers and is associated with defects in humoral, splenic, and cell-mediated immune function. Viral infections, including primary infection with or reactivation of varicella-zoster virus (VZV), are responsible for >40% of infections during this period. This may decrease over time, as the Oka varicella vaccine strain has a lower rate of reactivation than wild-type varicella. Pandemic SARS-CoV-2 has also been noted to have more severe outcomes in children after HSCT. Bacterial infections, particularly of the upper and lower respiratory tract, account for approximately 30% of infections. These infections may be associated with deficiencies in immunoglobulin production, especially IgG2. Fungal infections account for <20% of confirmed infections during the late posttransplantation period.

### Solid Organ Transplantation

Factors predisposing to infection after organ transplantation include those that either existed before transplantation or are secondary to intraoperative events or posttransplantation therapies ([Table 223.3](#)). Some of these additional risks cannot be prevented, and some risks acquired during or after the operation depend on decisions or actions of members of the transplant team. Organ recipients are at risk for infection from potential exposure to pathogens in the donor organ. Although some donor-derived infections can be anticipated through donor screening, many pathogens are not routinely screened for, and strategies defining when and how to screen for all but a small subset of potential pathogens have not been identified or implemented. Similar to other children who have undergone surgical procedures, surgical site infections are a frequent cause of infection early after transplantation. Beyond this, the need for immunosuppressive agents to prevent rejection is the major factor predisposing to infection after transplantation. Despite efforts to

**Table 223.3** Risk Factors for Infections After Solid Organ Transplantation in Children**PRETRANSPLANTATION FACTORS**

Age of patient  
 Underlying disease, malnutrition  
 Specific organ transplanted  
 Previous exposures to infectious agents  
 Previous immunizations  
 Presence of infection in the donor

**INTRAOPERATIVE FACTORS**

Duration of transplant surgery  
 Exposure to blood products  
 Technical problems  
 Organisms transmitted with donor organ

**POSTTRANSPLANTATION FACTORS**

Immunosuppression  
 Induction immunosuppression type  
 Maintenance immunosuppression  
 Augmented treatment for rejection  
 Indwelling catheters  
 Nosocomial exposures  
 Community exposures

optimize immunosuppressive regimens to prevent or treat rejection with minimal impairment of immunity, all current regimens interfere with the ability of the immune system to prevent infection. The primary target of the majority of these immunosuppressive agents in organ recipients is the cell-mediated immune system, but regimens can and do impair many other aspects of the transplant recipient's immune system as well.

**Timing**

The timing of specific types of infections is generally predictable, regardless of which organ is transplanted. Infectious complications typically develop in one of three intervals: early (0-30 days after transplantation), intermediate (30-180 days), or late (>180 days); most infections present in the first 180 days after transplantation. Table 223.4 should be used as a general guideline to the types of infections encountered, but the timing of the presentation may be modified with the introduction of newer immunosuppressive therapies and by the use of prophylaxis.

Early infections are usually the result of a complication of the transplant surgery itself, the unexpected acquisition of a bacterial or fungal pathogen from the donor, or the presence of an indwelling catheter. In contrast, infections during the intermediate period typically result from a complication of the immunosuppression, which tends to be at its greatest intensity during the first 6 months after transplantation. This is the period of greatest risk for infections caused by opportunistic pathogens such as CMV, EBV, and *P. jirovecii*. Anatomic abnormalities, such as bronchial stenosis and biliary stenosis, that develop as a result of the transplant surgery can also predispose to recurrent infection in this period.

Infections developing late after transplantation typically result from uncorrected anatomic abnormalities, chronic rejection, or exposure to community-acquired pathogens. Augmented immunosuppression as treatment for late acute cellular rejection or chronic rejection can increase the risk for late presentations with CMV, EBV, and other potential opportunistic infections. Acquisition of infection from community-acquired pathogens such as RSV can result in severe infection secondary to the immunocompromised state of the transplant recipient during the early and intermediate periods. Compared with the earlier periods, community-acquired infections in the late period are usually benign because immunosuppression is typically maintained at significantly lower levels. However, certain pathogens such as VZV and EBV may be associated with severe disease even at this late period.

**Bacterial and Fungal Infections**

Although there are important graft-specific considerations for bacterial and fungal infections after transplantation, some principles are generally applicable to all transplant recipients. Bacterial and fungal infections after organ transplantation are usually a direct consequence of the surgery, a breach in an anatomic barrier, a foreign body, or an

**Table 223.4** Timing of Infectious Complications After Solid Organ Transplantation**EARLY PERIOD (0-30 DAYS)****Bacterial Infections**

Gram-negative enteric bacilli
 

- Small bowel, liver, neonatal heart

*Pseudomonas*, *Burkholderia*, *Stenotrophomonas*, *Alcaligenes*

- Cystic fibrosis lung

 Gram-positive organisms
 

- All transplant types

**Fungal Infections**

- All transplant types

**Viral Infections**

Herpes simplex virus
 

- All transplant types

 Nosocomial respiratory viruses
 

- All transplant types

**MIDDLE PERIOD (1-6 MO)****Viral Infections**

Cytomegalovirus
 

- All transplant types
- Seronegative recipient of seropositive donor

 Epstein-Barr virus
 

- All transplant types (small bowel the highest-risk group)
- Seronegative recipient

 Varicella-zoster virus
 

- All transplant types
- Opportunistic infections

*Pneumocystis jirovecii*

- All transplant types

*Toxoplasma gondii*

- Seronegative recipient of cardiac transplant from a seropositive donor are highest risk group

**Bacterial Infections**

*Pseudomonas*, *Burkholderia*, *Stenotrophomonas*, *Alcaligenes*

- Cystic fibrosis lung

 Gram-negative enteric bacilli
 

- Small bowel

**LATE PERIOD (>6 MO)****Viral Infections**

Epstein-Barr virus
 

- All transplant types, but less risk than middle period

 Varicella-zoster virus
 

- All transplant types

 Community-acquired viral infections
 

- All transplant types

**Bacterial Infections**

*Pseudomonas*, *Burkholderia*, *Stenotrophomonas*, *Alcaligenes*

- Cystic fibrosis lung
- Lung transplants with chronic rejection

 Gram-negative bacillary bacteremia
 

- Small bowel

**Fungal Infections**

*Aspergillus*

- Lung transplants with chronic rejection

Adapted from Green M, Michaels MG. Infections in solid organ transplant recipients. In: Long SS, Prober CG, Fischer M, eds. *Principles and Practice of Pediatric Infectious Diseases*, 5th ed. Philadelphia: Elsevier; 2018: Table 95-1.

abnormal anatomic narrowing or obstruction. With the exception of infections related to the use of indwelling catheters, sites of bacterial infection tend to occur at or near the transplanted organ. Infections after abdominal transplantation (liver, intestine, or renal) usually occur in the abdomen or at the surgical wound. The pathogens are typically enteric gram-negative bacteria, *Enterococcus*, and occasionally *Candida*. Infections after thoracic transplantation (heart, lung) usually occur in the lower respiratory tract or at the surgical wound. Pathogens associated with these infections include *S. aureus* and gram-negative bacteria. Patients undergoing lung transplantation for cystic fibrosis

experience a particularly high rate of infectious complications because they are often colonized with *P. aeruginosa* or *Aspergillus* before transplantation. Even though the infected lungs are removed, the sinuses and upper airways remain colonized with these pathogens, and subsequent reinfection of the transplanted lungs can occur. Children receiving organ transplants are often hospitalized for long periods and receive many antibiotics; thus recovery of multidrug-resistant bacteria is common after all types of organ transplantation. Infections caused by *Aspergillus* are less common but occur after all types of organ transplantation and are associated with high rates of morbidity and mortality.

### Viral Infections

Viral pathogens, especially herpesviruses, are a major source of morbidity and mortality after SOT. In addition, BK virus is a major cause of renal disease after kidney transplantation. Although SARS-CoV-2 has affected pediatric SOT recipients less than adult recipients, disease severity is increased compared with nonimmunosuppressed children. The patterns of disease associated with individual viral pathogens are generally similar among all organ transplant recipients. However, the incidence, mode of presentation, and severity differ according to the type of organ transplanted and, for many viral pathogens, pretransplant serologic status of the recipient.

Viral pathogens can be generally categorized as latent pathogens, which cause infection through reactivation in the host or acquisition from the donor (e.g., CMV, EBV) or as community-acquired viruses (e.g., SARS-CoV-2, RSV, influenza). For CMV and EBV, primary infection occurring after transplantation is associated with the greatest degree of morbidity and mortality. The highest risk is seen in a naïve host who receives an organ from a donor who previously was infected with one of these viruses. This mismatched state is frequently associated with severe disease. However, even if the donor is negative for CMV and EBV, primary infection can be acquired from a close contact or through blood products. Secondary infections (reactivation of a latent strain within the host or superinfection with a new strain) tend to result in milder illness unless the patient is highly immunosuppressed, which can occur in the setting of treatment of significant rejection.

CMV is one of the most commonly recognized transplant viral pathogens. Disease from CMV has decreased significantly with the use of preventive strategies, including antiviral prophylaxis, most commonly using ganciclovir or oral valganciclovir, as well as viral load monitoring to inform preemptive antiviral therapy. Some centers have implemented a sequential approach where surveillance viral load monitoring follows a relatively short period of chemoprophylaxis. Clinical manifestations of CMV disease can range from a syndrome of fatigue and fever to tissue-invasive disease that most often affects the liver, lungs, and GI tract.

Infection caused by EBV is another important complication of SOT. Clinical symptoms range from a mild mononucleosis syndrome to disseminated **posttransplant lymphoproliferative disorder (PTLD)**. EBV-associated PTLD is more common among children than adults, because primary EBV infection in the immunosuppressed host is more likely to lead to uncontrolled proliferative disorders, including post-transplant lymphoma.

Other viruses, such as adenovirus, also have the capacity to be donor associated, but appear to be less common. The unexpected development of donor-associated viral pathogens, including hepatitis B virus, hepatitis C virus, and HIV, is rare today because of intensive donor screening. However, the changing epidemiology of some viruses (e.g., dengue, chikungunya, Zika) raises concerns for the *donor-derived transmission* of these emerging viral pathogens.

Community-acquired viruses, including those associated with respiratory tract infection (SARS-CoV-2, RSV, influenza virus, adenovirus, parainfluenza virus) and GI infection (enteroviruses, norovirus, and rotavirus), can cause important disease in children after organ transplantation. In general, risk factors for more severe infection include young age, acquisition of infection early after transplantation, and augmented immune suppression. Infection in the absence of these risk factors frequently results in a clinical illness that is comparable to that seen in immunocompetent children. However, some community-acquired viruses, such as adenovirus, can be associated with graft dysfunction even when acquired late after transplantation.

Although children with SARS-CoV-2 infection after transplantation fare better than adult counterparts, they are at risk for more severe symptoms early after transplant and if they have comorbidities. Immunization remains one of the best preventive strategies against severe disease even though efficacy is less compared to nonimmunosuppressed children.

### Opportunistic Pathogens

Children undergoing SOT are also at risk for symptomatic infections from pathogens that do not usually cause clinical disease in immunocompetent hosts. Although these typically present in the intermediate period, these infections can also occur late in patients, requiring prolonged and high levels of immunosuppression. *P. jirovecii* is a well-recognized cause of pneumonia after SOT, although routine prophylaxis has essentially eliminated this problem. *T. gondii* can complicate cardiac transplantations because of tropism of the organism for cardiac muscle and risk for donor transmission; less often, it complicates other types of organ transplantation.

Visit Elsevier eBooks+ at [eBooks.Health.Elsevier.com](https://eBooks.Health.Elsevier.com) for Bibliography.

## 223.3 Prevention of Infection in Immunocompromised Persons

Marian G. Michaels, Hey Jin Chong, and Michael Green

Although infections cannot be completely prevented in children who have defects in one or more arms of their immune system, measures can be taken to decrease the risks for infection. Replacement immunoglobulin is a benefit to children with primary B-cell deficiencies. Interferon (IFN)- $\gamma$ , TMP-SMX, and oral antifungal agents have long been used to reduce the number of infections occurring in children with CGD, although the relative benefit of IFN- $\gamma$  has been questioned. Children who have depressed cellular immunity resulting from primary diseases, advanced HIV infection, or immunosuppressive medications benefit from prophylaxis against *P. jirovecii*. Strategies for safe living for all children with immunocompromising conditions should be emphasized, including hand hygiene, avoidance of community members with communicable infections, and attention to local environmental risk factors. These strategies were stressed and employed during the era of pandemic SARS-CoV-2 circulation. Immunizations prevent many infections and are particularly important for children with compromised immune systems who do not have a contraindication or inability to respond. For children rendered immunocompromised because of medication or splenectomy, immunizations should be administered before treatment whenever possible. This timing allows for superior response to vaccine antigens, avoids the risk of live vaccines, which may be contraindicated depending on the immunosuppression, and importantly, provides protection before the immune system is compromised.

Although immunodeficient children are a heterogeneous group, some principles of prevention are generally applicable. The use of inactivated vaccines does not lead to an increased risk for adverse effects, although their efficacy may be reduced because of an impaired immune response. In most cases, children with immunodeficiencies should receive all the recommended inactivated vaccines. Live-attenuated vaccinations can cause disease in some children with immunologic defects, and therefore alternative immunizations should be used whenever possible, such as inactivated influenza vaccine rather than live-attenuated influenza vaccine or inactivated typhoid vaccine rather than the oral live typhoid vaccine for travelers. In general, live-virus vaccines should not be used in children with primary T-cell abnormalities; efforts should be made to ensure that close contacts are all immunized to decrease the risk of exposure. In some patients in whom wild-type viral infection can be severe, immunizations, even with live-virus vaccine, are warranted in the immunosuppressed child. For example, children with HIV infection and a CD4 level of  $>15\%$  should receive vaccinations against measles and varicella. In addition, growing evidence suggests that select transplant recipients can safely receive live vaccines as well. Some vaccines should be given to children with immunodeficiencies in addition to routine



vaccinations. As an example, children with asplenia or splenic dysfunction should receive meningococcal vaccine and both the conjugate and the polysaccharide pneumococcal vaccines. Influenza and SARS-CoV-2 vaccination is recommended for all eligible individuals (>6 months old for influenza) and should be emphasized for immunocompromised children and all household contacts to minimize risk for transmission to the immunocompromised child.

Visit Elsevier eBooks+ at [eBooks.Health.Elsevier.com](https://ebooks.health.elsevier.com) for Bibliography.

## Chapter 224

# Infection Associated with Medical Devices

Hana Hakim and Joshua Wolf

Use of implanted synthetic and prosthetic devices has revolutionized pediatric practice by providing long-term venous access, limb-salvage surgery, and successful treatment of hydrocephalus, urinary retention, and renal failure. However, infectious complications of these devices remain a major concern and account for a significant number of healthcare-acquired infections (HAIs) and attributable morbidity and mortality among hospitalized patients. Several federal and hospital programs in the United States and elsewhere focus on prevention initiatives to reduce device-related HAI rates, most frequently central line-associated bloodstream infection (CLABSI), catheter-associated urinary tract infection (CAUTI), and ventilator-associated pneumonia (VAP). HAIs are typically defined as infections that occur at least 2 days after admission to the hospital and that were not incubating at the time of admission. Device-associated infections are related to the development of **biofilms**, organized communities of microorganisms on the device surface protected from the immune system and from antimicrobial therapy. A number of factors are important to the development of infection, including host susceptibility, device composition, duration of implantation, and exposure to colonizing or contaminating organisms.

## INTRAVASCULAR ACCESS DEVICES

Intravascular access devices range from short, stainless steel needles or plastic cannulae inserted for brief periods to multilumen, implantable, synthetic plastic catheters that are expected to remain in use for years. Infectious complications include local skin and soft tissue infections, such as exit site, tunnel tract, and device pocket infections, and **catheter-related bloodstream infections (CRBSIs)**. The use of central venous devices has improved the quality of life of high-risk patients but has also increased the risk of infection.

### Catheter Types

Short-term peripheral cannulae are most often used in pediatric patients, and infectious complications occur infrequently. The rate of peripheral CRBSIs in children is <0.15%. Patient age <1 year, duration of use >144 hours (6 days), and some infusates are associated with increased risk for catheter-related infection. Catheter-associated phlebitis is more common (1–6%) but is rarely infective and can be treated conservatively by cannula removal.

**Central venous catheters (CVCs)**, which terminate in a central vein such as the superior or inferior vena cava, are widely used in both adult and pediatric patients and are responsible for the majority of catheter-related infections. These catheters are frequently used in patients with chronic illnesses such as oncologic, gastrointestinal, and cardiovascular diseases and in critically ill patients, including neonates, who have many other risk factors for nosocomial infection. Patients in an intensive care unit (ICU) with a CVC in place

have a fivefold greater risk for developing a nosocomial bloodstream infection than those without. Other risk factors that have been associated with increased incidence of CLABSIs include prolonged hospital stay, total parenteral nutrition, use of multiple concurrent CVCs or a CVC with multiple lumens, and use of short-term nontunneled CVC.

The use of peripherally inserted central catheters, which are inserted into a peripheral vein and terminate in a central vein, has increased in pediatric patients. Infection rates seem to be similar to long-term tunneled CVCs, ranging between 2.0 and 3.51 per 1,000 catheter-days, but other complications such as fracture, dislodgment, and occlusion are more common.

When prolonged intravenous (IV) access is required, a cuffed silicone rubber (Silastic) or polyurethane catheter may be inserted into the superior vena cava through the subclavian, cephalic, or jugular vein. The extravascular segment of the catheter passes through a subcutaneous (SC) tunnel before exiting the skin, usually on the superior aspect of the chest (e.g., Broviac or Hickman catheter). A cuff around the catheter near the exit site induces a fibrotic reaction to seal the tunnel. Totally implanted devices comprise a tunneled central catheter attached to an SC reservoir or port with a self-sealing silicone septum immediately under the skin that permits repeated percutaneous needle access.

The incidence of local (exit site, tunnel, and pocket) infection with long-term catheters is 0.2–2.8/1,000 catheter-days. The incidence of external tunneled CRBSI is 0.5–11.0/1,000 catheter-days. The incidence of CRBSI in implantable devices is much lower at 0.3–1.8/1,000 catheter-days; however, treatment with total parenteral nutrition (TPN) eliminates this risk reduction because of a much greater relative increase in infection rate in ports. The risk for CRBSI is increased among premature infants, young children, and TPN patients.

### Catheter-Associated Skin and Soft Tissue Infection

A number of local infections can occur in the presence of a CVC. The clinical manifestations of local infection include erythema, tenderness, and purulent discharge at the exit site or along the SC tunnel tract of the catheter. **Exit site infection** denotes infection localized to the exit site, without significant tracking along the tunnel, often with purulent discharge. **Tunnel tract infection** indicates infection in the SC tissues tracking along a tunneled catheter, which may also include serous or serosanguineous discharge from a draining sinus along the path. **Pocket infection** indicates suppurative infection of an SC pocket containing a totally implanted device. Bloodstream infection may coexist with local infection.

The diagnosis of local infection is established clinically, but a Gram-stained smear and culture of any exit site drainage should be performed to identify the microbiologic cause. The source is usually contamination by skin or gastrointestinal flora, and the most common organisms are *Staphylococcus aureus*, coagulase-negative staphylococci, *Pseudomonas aeruginosa*, *Candida* spp., and mycobacteria. Green discharge is strongly suggestive of mycobacterial infection, and appropriate stains and culture should be performed.

Treatment of local infection related to a short-term CVC should include device removal. Exit site infection may resolve with device removal alone, but systemic symptoms should initially be managed with antimicrobial therapy. In the case of long-term CVCs, exit site infections usually respond to local care with topical or systemic antibiotics alone. However, tunnel or pocket infections require removal of the catheter and systemic antibiotic therapy in almost all cases. When a tunneled CVC is removed as a result of tunnel infection, the cuff should also be removed and sent for culture if possible. In cases of mycobacterial infection, wide surgical debridement of the tissues is usually required for cure.

### Catheter-Related Bloodstream Infection

CRBSI occurs when microorganisms attached to the CVC are shed into the bloodstream, leading to bacteremia. The term **catheter-related bloodstream infection** is reserved for a bloodstream infection that is demonstrated by CVC tip culture or other techniques to have been caused by colonization of the device. In contrast, the more general term **central line-associated bloodstream infection (CLABSI)** is typically



used for surveillance and can refer to any bloodstream infection that occurs in a patient with a CVC, unless there is an identified alternative source. On the device, the organisms are embedded in biofilms as organized communities. Colonization may be present even in the absence of symptoms or positive cultures.

Organisms may contaminate the external surface of the CVC during insertion or the intraluminal surface through handling of the catheter hub or contaminated infusate. Most cases of CRBSI appear to be caused by intraluminal colonization, but external colonization may play a greater role in infections related to recently inserted (<30 days) catheters or in immunocompromised patients. In most populations, gram-positive cocci predominate, with about half of infections caused by coagulase-negative staphylococci. Gram-negative enteric bacteria are isolated in approximately 20–30% of episodes, and fungi account for 5–10% of episodes.

Fever without an identifiable focus is the most common clinical presentation of CRBSI; local soft tissue symptoms and signs are usually absent. Onset of fever or rigors during or soon after flushing of a catheter is highly suggestive of CRBSI. Symptoms and signs of complicated infection, such as septic thrombophlebitis, endocarditis, and ecthyma gangrenosum, may also be present.

Blood cultures collected before beginning antibiotic therapy are generally positive from both the CVC and the peripheral blood. It is important not to collect cultures unless infection is suspected, as blood culture contamination may occur and can lead to inappropriate therapy. To help interpret positive cultures with common skin contaminants, blood cultures should be collected from at least two sites, preferably including all lumens of a CVC, before initiation of antibiotic therapy.

Tests to differentiate CRBSI from other sources of bacteremia in the presence of a CVC include culture of the catheter tip, quantitative blood cultures, and **differential time to positivity** of blood cultures drawn from different sites. Definitive diagnosis of CRBSI can be important to identify those patients who might benefit from catheter removal. Although CVC tip culture can identify CRBSI, it precludes salvage of the catheter. The most readily available technique to confirm CRBSI without catheter removal is calculation of differential time to positivity between blood cultures drawn through a catheter and from a peripheral vein or separate lumen. During CRBSI, blood obtained through the responsible lumen will usually indicate growth at least 2–3 hours before peripheral blood or uncolonized lumens because of a higher intraluminal microorganism burden. Identical volumes of blood must be collected simultaneously from each site, and a continuously monitored blood culture system is required. Specificity of this test is good (94–100%), and sensitivity is good when a peripheral blood culture is available (approximately 90%) but poorer when comparing two lumens of a CVC (64%). Where available, quantitative blood culture showing at least a threefold higher number of organisms from central compared with peripheral blood is similarly diagnostic.

Treatment of CRBSI related to **long-term vascular access devices** (e.g., Hickman, Broviac, totally implantable devices) with systemic antibiotics is successful for many bacterial infections without removal of the device. Antibiotic therapy should be directed to the isolated pathogen and given for a total of 10–14 days from the date of blood culture clearance. Until pathogen identification and susceptibility testing are available, empirical therapy, based on local antimicrobial susceptibility data and usually including **vancomycin** plus an antipseudomonal aminoglycoside (e.g., gentamicin), penicillin (e.g., piperacillin-tazobactam), or cephalosporin (e.g., ceftazidime or cefepime), is generally indicated. An echinocandin or azole antifungal should be initiated if fungemia is suspected. Patients who have a recent history of CRBSI with a resistant organism treated without CVC removal who subsequently develop severe sepsis should generally receive initial empirical therapy directed against that organism, because relapse is common.

**Antibiotic lock or dwell therapy**, with administration of solutions of high concentrations of antibiotics or ethanol that remain in the catheter for up to 24 hours, has been proposed to improve outcomes when used as an adjuvant to systemic therapy. Antibiotic locks are recommended in patients receiving dialysis who may not have antibiotics frequently delivered through the CVC, but evidence does not suggest

that routine use of lock therapy is beneficial in other patient populations, and it may cause harm. Ethanol lock therapy increases the risk of CVC occlusion, and lock therapy can result in delays to necessary CVC removal.

If blood cultures remain positive after 72 hours of appropriate therapy, or if a patient deteriorates clinically, the device should be removed. Failure of CRBSI salvage therapy is common and can be serious in infections caused by *S. aureus* (approximately 50%), *Candida* spp. (>70%), and *Mycobacterium* spp. (>70%). Other indications for removing a long-term catheter include severe sepsis, suppurative thrombophlebitis, and endocarditis. Prolonged therapy (4–6 weeks) is indicated for persistent bacteremia or fungemia after catheter removal, because this may represent unrecognized infective endocarditis or thrombophlebitis. The decision to attempt catheter salvage should weigh the risk and clinical impact of persistent or relapsed infection against the risk of surgical intervention.

CRBSI may be complicated by other intravascular infections such as septic thrombophlebitis or endocarditis. The presence of these conditions may be suggested by preexisting risk factors (e.g., congenital heart disease), signs and symptoms, or persistent bacteremia or fungemia 72 hours after device removal and appropriate therapy. Screening for these complications in otherwise low-risk children, even those with *S. aureus* infection, is not recommended, because the overall frequency is low, and the tests can be difficult to interpret and may lead to inappropriate therapy.

### Prevention of Infection

Consistent implementation of evidence-based prevention bundles has been essential to reduce HAI CLABSI rates. Prevention of CLABSI starts with preinsertion planning for the type and number of CVC lumens and selection of the venous site for CVC insertion. Insertion bundle elements include meticulous hand hygiene, aseptic skin preparation using 2% chlorhexidine gluconate, and use of maximal sterile barrier precautions in an operating room–like environment. Maintenance bundles guide the daily safe care of CVCs to prevent infections, including protecting the CVC from gross contamination with excretions or body fluids, evidence-based techniques to access and scrub the CVC hub and connectors, and assessing and changing the CVC site dressing. Regular assessment of the need for the catheter should be part of the daily medical and nursing care team discussions. In general, children with external CVCs are discouraged from swimming because of concern of subsequent CRBSI. However, existing evidence regarding risk of CRBSI related to swimming is limited. It is important to educate patient caregivers about the potential risk and the importance of maintaining a secured CVC with water-resistant dressing if patients choose to swim. Catheters should routinely be removed as soon as they are no longer needed. Although prevalence of infection increases with prolonged duration of catheter use, routine replacement of a required CVC, either at a new site or over a guide wire, results in significant morbidity and is not recommended. Other practices that have been associated with reduction in CLABSI rates include use of a chlorhexidine-impregnated sponge at the exit site and daily bathing of ICU patients with 2% chlorhexidine gluconate. Use of antibiotic, taurolidine, or ethanol lock solutions; heparin with preservatives; and alcohol-impregnated caps, as well as antimicrobial-impregnated/coated catheters may be appropriate in high-risk populations. There is no evidence that routine replacement of short-term peripheral catheters prevents phlebitis or other complications in children, so they should only be replaced when clinically indicated (e.g., phlebitis, dysfunction, dislodgment).

### URINARY CATHETERS

Urinary catheters are a frequent cause of HAIs, with approximately 14 infections per 1,000 admissions, resulting in increasing duration of hospitalization, cost of patient care, morbidity, and mortality. Rates of CAUTI are highest among ICU patients. As with other devices, microorganisms adhere to the urinary catheter surface and establish a biofilm that allows proliferation. The physical presence of the catheter reduces the normal host defenses by preventing complete emptying of the bladder, thus providing a medium for growth, distending the urethra, and blocking periurethral glands. Almost all patients catheterized

for >30 days develop bacteriuria. The mechanism of the infection can be either from organisms colonizing the patient's perineal or rectal area or from organisms contaminating the hands of healthcare providers or contaminating equipment such as a collection bag. The organism burden in CAUTI is typically  $\geq 100,000$  colony-forming units/mL. Lower thresholds may be used where there is a high index of suspicion, but these episodes usually represent colonization rather than infection. Urine culture should only be performed in catheterized patients when infection is suspected, because asymptomatic colonization is ubiquitous and may lead to over-treatment and subsequent development of bacterial resistance. Gram-negative bacilli and *Enterococcus* spp. are the predominant organisms isolated in CAUTI; coagulase-negative staphylococci are implicated in approximately 15% of cases. Symptomatic UTIs should be treated with antibiotics and catheter removal. Catheter colonization with *Candida* spp. is common but rarely leads to invasive infection, and treatment does not have a long-term impact on colonization. Treatment for asymptomatic candiduria or bacteriuria is not recommended, except in neonates, immunocompromised patients, and those with urinary tract obstruction.

All urinary catheters introduce a risk for infection and thus should be used only when necessary and for the minimum required duration. Existing evidence supports the benefit of using alternatives to indwelling urethral catheters to prevent CAUTI, including external catheters in male patients, intermittent catheterization, or suprapubic catheters in selected patients. Hand hygiene and aseptic technique are part of the insertion bundles of interventions aimed at preventing CAUTI. Evidence-based urinary catheter maintenance practices are essential to prevent hospital-acquired CAUTI, including perineal hygiene, a closed drainage system, maintenance of unobstructed urine flow, and keeping the collection bag below the level of the bladder. Technologic advances have led to the development of silver- or antibiotic-impregnated urinary catheters that are associated with lower rates of infection. Prophylactic antibiotics do not significantly reduce the infection rates for long-term catheters but clearly increase the risk for infection with antibiotic-resistant organisms.

### MECHANICAL VENTILATORS

Endotracheal intubation and mechanical ventilation are lifesaving technologies to support patients with respiratory failure and patients undergoing surgical procedures. However, VAP has contributed to prolonged hospital stay and increased costs in patients in medical and surgical ICUs. VAP is more frequently reported in adult than in pediatric patients. The mechanism of VAP is through microaspiration of colonizing oropharyngeal organisms to the lower respiratory tract and its associated host inflammatory response. Common pathogens causing VAP include gram-negative bacilli (e.g., *Escherichia coli*, *Klebsiella pneumoniae*, *Enterobacter* spp., and *P. aeruginosa*) and gram-positive cocci (e.g., *S. aureus* and *Streptococcus* spp.). Risk factors for VAP include medications that increase gastric pH (e.g.,  $H_2$  blockers, antacids, proton pump inhibitors), decreased level of consciousness, use of paralytics or muscle relaxant agents, and prolonged intubation. Progressive or acute-onset respiratory deterioration requiring increased mechanical setting support in a patient who has been intubated for more than 2 days should raise the suspicion of VAP. Chest diagnostic imaging and cultures of lower respiratory specimens (e.g., endotracheal aspiration or bronchoalveolar lavage) should be considered.

Evidence-based practices to prevent VAP include use of noninvasive ventilation (e.g., continuous positive airway pressure [CPAP], bilevel positive airway pressure [BiPAP]) when possible to avoid endotracheal intubation and prevention of microaspiration by elevating the head of the bed, controlling cuff pressure, minimizing and early weaning of sedation, and maintaining closed ventilator circuits. Oral care with chlorhexidine gluconate for oropharyngeal decontamination has been included as an element in several VAP prevention bundles. Evidence regarding the efficacy and safety of other interventions such as use of probiotics or silver-coated endotracheal tubes has been inconclusive.

### CEREBROSPINAL FLUID SHUNTS

Cerebrospinal fluid (CSF) shunting is required for the treatment of many children with **hydrocephalus**. The usual procedure uses a

silicone rubber device with a proximal portion inserted into the ventricle, a unidirectional valve, and a distal segment that diverts the CSF from the ventricles to either the peritoneal cavity (**ventriculoperitoneal** [VP] shunt) or right atrium (**ventriculoatrial** [VA] shunt). The incidence of shunt infection ranges from 1% to 20% (average, 10%). The highest rates are reported in young infants, patients with prior shunt infections, and certain etiologies of hydrocephalus. Most infections result from intraoperative contamination of the surgical wound by skin flora. Accordingly, coagulase-negative staphylococci are isolated in more than half the cases. *S. aureus* is isolated in approximately 20% and gram-negative bacilli in 15% of cases.

Four distinct clinical syndromes have been described: colonization of the shunt, infection associated with wound infection, distal infection with peritonitis, and infection associated with meningitis. The most common type of infection is **colonization of the shunt**, with non-specific symptoms that reflect shunt malfunction as opposed to frank infection. Symptoms associated with colonized VP shunts include lethargy, headache, vomiting, a full fontanel, and abdominal pain. Fever is often absent or may be low-grade ( $<39^\circ\text{C}$  or  $102.2^\circ\text{F}$ ). Symptoms usually occur within months of the surgical procedure. Colonization of a VA shunt results in more severe systemic symptoms, and specific symptoms of shunt malfunction are often absent. Septic pulmonary emboli, pulmonary hypertension, and infective endocarditis are frequently reported complications of VA shunt colonization. Chronic VA shunt colonization may cause hypocomplementemic glomerulonephritis from antigen-antibody complex deposition in the glomeruli, commonly called *shunt nephritis*; clinical findings include hypertension, microscopic hematuria, elevated blood urea nitrogen and serum creatinine levels, and anemia.

Diagnosis is by Gram stain, microscopy, biochemistry, and culture of CSF. CSF should be obtained by direct aspiration of the shunt before administration of antibiotics, because CSF obtained from either lumbar or ventricular puncture is often sterile. It is unusual to observe signs of ventriculitis, and CSF findings can be only minimally abnormal. Blood culture results are usually positive in VA shunt colonization but negative in cases of VP colonization.

**Wound infection** presents with obvious erythema, swelling, discharge, or dehiscence along the shunt tract and most often occurs within days to weeks of the surgical procedure. *S. aureus* is the most common isolate. In addition to the physical findings, fever is common, and signs of shunt malfunction eventually ensue in most cases.

Distal infection of VP shunts with **peritonitis** presents with abdominal symptoms, usually without evidence of shunt malfunction. The pathogenesis is likely related to perforation of the bowel at VP shunt placement or translocation of bacteria across the bowel wall. Thus gram-negative isolates predominate, and mixed infection is common. The infecting organisms are often isolated from only the distal portion of the shunt.

Common pathogens responsible for community-acquired **meningitis**, including *Streptococcus pneumoniae*, *Neisseria meningitidis*, and *Haemophilus influenzae* type b, cause bacterial meningitis in patients with shunts only rarely, and the clinical presentation is similar to that for acute bacterial meningitis in other children (see [Chapter 643.1](#)).

**Treatment** of shunt colonization includes removal of the shunt and systemic antibiotic therapy directed against the isolated organisms. Treatment without removal of the shunt is rarely successful and should not be routinely attempted. After collection of appropriate samples for culture, empirical therapy is usually with vancomycin plus an antipseudomonal agent with relatively good CSF penetration, such as ceftazidime or meropenem. Definitive therapy should be directed toward the isolate and should account for poor penetration of most antibiotics into the CSF across noninflamed meninges. Accordingly, intraventricular antibiotics may be indicated but are usually reserved unless there is evidence of treatment failure. If the isolate is susceptible, a parenteral antistaphylococcal penicillin with or without intraventricular vancomycin is the treatment of choice. If the organism is resistant to penicillins, systemic vancomycin and possibly intraventricular vancomycin are recommended. In gram-negative infections, a third-generation cephalosporin with or without an intraventricular aminoglycoside is

optimal. When using intraventricular antibiotics, monitoring CSF levels is necessary to avoid toxicity.

**Removal** of the colonized device is required for cure, and final replacement should be delayed until clearance of CSF cultures is documented. Many neurosurgeons immediately remove the shunt and place an external ventricular drain to relieve intracranial pressure (ICP), with a second-stage shunt replacement once CSF sterilization has been confirmed. Others opt initially to exteriorize the distal end of the shunt and replace the shunt in a single-stage procedure once CSF cultures remain sterile for 48–72 hours. Daily CSF cultures should be collected until clearance has been documented on two to three consecutive specimens, and antibiotics should be continued for at least 10 days after documented sterilization of the CSF. Gram-negative organisms may require a longer duration of therapy (up to 21 days). The CSF white cell count generally increases for the first 3–5 days of appropriate therapy, and that alone should not prompt concern for treatment failure. Distal shunt infection with peritonitis and wound infection are managed in a similar fashion.

Treatment of **bacterial meningitis** with typical community-acquired pathogens such as meningococcus or pneumococcus usually requires only systemic antibiotic therapy. Shunt replacement is not required in the absence of device malfunction, poor clinical response, persistent CSF culture positivity, or relapse of infection after antibiotic therapy.

### Prevention of Infection

Prevention of shunt infection includes meticulous cutaneous preparation and surgical technique. Systemic and intraventricular antibiotics, antibiotic-impregnated shunts, and soaking the shunt tubing in antibiotics are used to reduce the incidence of infection, with varying success. Systemic prophylactic antibiotics given before and during shunt insertion can reduce the risk for infection and should be used routinely but should not be continued for more than 24 hours postoperatively. Antibiotic-impregnated catheters also appear to reduce the risk of infection and may be used in high-risk patients where the devices are available.

### PERITONEAL DIALYSIS CATHETERS

During the first year of peritoneal dialysis for end-stage renal disease, 65% of children will have one or more episodes of peritonitis. Bacterial entry comes from luminal or periluminal contamination of the catheter or by translocation across the intestinal wall. Hematogenous infection is rare. Infants and young children who are in diapers are at highest risk for peritoneal dialysis catheter-associated infections. Infections can be localized at the exit site or associated with peritonitis, or both. Organisms responsible for peritonitis include coagulase-negative staphylococci (30–40%), *S. aureus* (10–20%), streptococci (10–15%), *E. coli* (5–10%), *Pseudomonas* spp. (5–10%), other gram-negative bacteria (5–15%), *Enterococcus* spp. (3–6%), and fungi (2–10%). *S. aureus* is more common in localized exit site or tunnel tract infections (42%). Most infectious episodes are caused by a patient's own flora, and carriers of *S. aureus* have increased rates of infection compared with noncarriers.

The clinical manifestations of peritonitis may be subtle and include low-grade fever with mild abdominal pain or tenderness. Cloudy peritoneal dialysis fluid may be the first and predominant sign. With peritonitis, the peritoneal fluid cell count is usually >100 white blood cells/ $\mu$ L. When peritonitis is suspected, the effluent dialysate should be submitted for a cell count, Gram stain, and culture. The Gram stain is positive in up to 40% of cases of peritonitis.

Patients with cloudy fluid and clinical symptoms should receive empirical therapy, preferably guided by results of a Gram stain. If no organisms are visualized, vancomycin and either an aminoglycoside or a third- or fourth-generation cephalosporin with antipseudomonal activity should be given by the intraperitoneal route. Blood levels should be measured for glycopeptides and aminoglycosides. Patients without cloudy fluid and with minimal symptoms may have therapy withheld pending culture results. Once the cause is identified by culture, changes in the therapeutic regimen may be needed. Oral **rifampin** may be added as adjunctive therapy for susceptible *S. aureus* isolates but should not be used as a standalone agent and must prompt consideration of drug interactions. Candidal peritonitis should be treated with catheter removal and intraperitoneal or oral **fluconazole** or an IV

**echinocandin** such as caspofungin or micafungin, depending on the *Candida* spp.; catheter retention has been associated with almost inevitable relapse and higher risk of mortality in adult studies. The duration of therapy for peritonitis is a minimum of 14 days, with longer treatment of 21–28 days for episodes of *S. aureus*, *Pseudomonas* spp., and resistant gram-negative bacteria and 28–42 days for fungi. Repeat episodes of peritonitis with the same organism within 4 weeks of previous therapy should lead to consideration of catheter removal or attempt at salvage with administration of a fibrinolytic agent and a longer course of up to 6 weeks of antibiotic therapy.

In all cases, if the infection fails to clear after appropriate therapy or if a patient's condition is deteriorating, the catheter should be removed. Exit site and tunnel tract infections may occur independently of peritonitis or may precede it. Appropriate antibiotics should be administered on the basis of Gram stain and culture findings and are typically given systemically only, unless peritonitis is also present. Some experts recommend that the peritoneal catheter be removed if *Pseudomonas* spp. or fungal organisms are isolated.

### Prevention of Infection

In addition to usual hygienic practices such as hand hygiene and aseptic care of the catheter exit site, regular application of **mupirocin** or **gentamicin** cream to the catheter exit site reduces exit site infections and peritonitis. Some practitioners recommend against the use of gentamicin cream because of the risk of infection with gentamicin-resistant bacteria. Systemic antibiotic prophylaxis should be considered at catheter insertion, if there is accidental contamination, and at dental procedures. Antifungal prophylaxis with oral nystatin or fluconazole should be considered during antibiotic therapy to prevent fungal infection.

### IMPLANTABLE ORTHOPEDIC DEVICES

Implantable orthopedic devices are used infrequently in children. Orthopedic device infection most often follows introduction of microorganisms at surgery through airborne contamination or direct inoculation, hematogenous spread, breakdown of overlying skin, or contiguous spread from an adjacent infection. Early postoperative infection occurs within 2–4 weeks of surgery, with manifestations typically including fever, pain, and local symptoms of wound infection. Chronic infection presents >1 month after surgery and is often caused by organisms of low virulence that contaminated the implant at surgery or by failure of wound healing. Typical manifestations include pain and deterioration in function. Local symptoms such as erythema, swelling, or drainage may also occur. Acute hematogenous infections are most often observed  $\geq 2$  years after surgery and may be more common in children with immunocompromise. Options for treatment include conservative management with operative debridement and irrigation and retention of the prosthesis, followed by a 3- to 6-month course of antimicrobial therapy, or more radical intervention with removal and replacement of all hardware—as either a one- or two-stage exchange with a shorter course of antibiotic therapy (2–6 weeks). If the prosthesis is retained, suppressive oral antibiotic therapy may be considered after an initial treatment course, especially in patients who are undergoing intensive time-limited treatment such as chemotherapy. As with other long-term implanted devices, the most common organisms are coagulase-negative staphylococci and *S. aureus*. With prior antibiotic therapy, the prosthesis culture may be negative; in these situations, molecular techniques to identify the organism are available, but sensitivity and specificity are poorly understood.

Orthopedic hardware such as screws and plates are more commonly encountered in children than true implantable orthopedic devices. The management of infections associated with these kinds of hardware is similar to other orthopedic device infections, but because the hardware is typically temporary, it should generally be removed as soon as feasible.

Systemic antibiotic prophylaxis, antibiotic-containing bone cement, and operating rooms fitted with laminar airflow have been proposed to reduce infection. To date, results from clinical studies are conflicting.



## Section 3

## Antibiotic Therapy

## Chapter 225

## Principles of Antibacterial Therapy

Mark R. Schleiss

Antibacterial therapy in infants and children presents many challenges. A daunting problem is the paucity of pediatric data regarding pharmacokinetics and optimal dosages; as a consequence, pediatric recommendations are frequently extrapolated from adult studies. A second challenge is the need for the clinician to consider important differences among pediatric age-groups with respect to the pathogenic species most often responsible for bacterial infections. Age-appropriate antibiotic dosing and toxicities must be considered, taking into account the developmental status and physiology of infants and children. Finally, the style of how a pediatrician uses antibiotics in children, particularly young infants, has some important differences compared with how antibiotics are used in adult patients.

Specific antibiotic therapy is optimally driven by a **microbiologic diagnosis**, predicated on isolation of the pathogenic organism from a sterile body site and supported by antimicrobial susceptibility testing. However, given the inherent difficulties that can arise in collecting specimens from pediatric patients and given the high risk of mortality and disability associated with serious bacterial infections in very young infants, much of pediatric infectious diseases practice is based on clinical diagnoses and **empirical** use of antibacterial agents, often administered before and/or without identification of the specific pathogen. Although there is an ever-increasing emphasis on **antimicrobial stewardship**, driven by the importance of using empirical therapy sparingly (to avoid selecting for resistant organisms), there are some settings in which antimicrobials must be administered before the presence of a specific bacterial pathogen is proven. This is particularly relevant to the care of the febrile or ill-appearing neonate or young infant under 30 days of age.

Several key considerations influence decision-making regarding the appropriate empirical use of antibacterial agents in infants and children. It is important to know the age-specific differential diagnosis with respect to likely pathogens. This information affects the choice of antimicrobial agent and also the dose, dosing interval, and route of administration (oral vs parenteral). A complete history and physical examination, combined with appropriate laboratory and radiographic studies, are necessary to identify specific diagnoses, information that in turn affects the choice, dosing, and degree of urgency of administration of antimicrobial agents. The vaccination history may confer reduced risk for some invasive infections (i.e., *Haemophilus influenzae* type b, *Streptococcus pneumoniae*, *Neisseria meningitidis*), but a history of vaccination does not necessarily eliminate risk. The threat of serious bacterial infection in pediatric practice is also affected by the child's immunologic status, which may be compromised by immaturity (neonates), underlying disease, and immunosuppressive medications used to treat other disorders (see Chapter 223). Infections in immunocompromised children may result from bacteria that are not considered pathogenic in immunocompetent children. The presence of foreign bodies (medical devices) also increases the risk of bacterial infections (see Chapter 224). The likelihood of central nervous system (CNS) involvement must be considered in all pediatric patients with serious

bacterial infections, because many bacteremic pathogens in childhood carry a significant risk of hematogenous spread to the CNS.

The patterns of **antimicrobial resistance** in the community and for the potential causative pathogen being empirically covered must also be considered. Resistance to penicillin and cephalosporins is frequent among strains of *S. pneumoniae*, often necessitating the use of other classes of antibiotics. Similarly, the striking emergence of community-acquired methicillin-resistant *Staphylococcus aureus* (MRSA) infections has complicated antibiotic choices, both when this pathogen is isolated in culture and for empirical coverage of skin and soft tissue infections. Extended-spectrum  $\beta$ -lactamase (ESBL)-producing gram-negative bacteria (Enterobacteriaceae) have reduced the effectiveness of penicillins and cephalosporins. Furthermore, carbapenem-resistant Enterobacteriaceae (CRE) are an increasing problem among hospitalized patients, particularly in children with an epidemiologic connection to regions of the world, such as India, where such strains are frequently encountered.

Antimicrobial resistance occurs through many modifications of the bacterial genome (Tables 225.1 and 225.2). Mechanisms include enzyme inactivation of the antibiotic, decreased cell membrane permeability to intracellularly active antibiotics, efflux of antibiotics out of the bacteria, protection or alteration of the antibiotic target site, excessive production of the target site, and bypassing the antimicrobial site of action. CRISPR (clustered regularly interspaced short palindromic repeats) elements in bacteria have also been shown to be related to emergence of antimicrobial resistance. CRISPRs are detectable in many bacterial genomes, protecting their genomes from attack by foreign DNA during transformation, phage invasion, or plasmid insertion. The mechanism of protection is mediated by insertion of small sequences of the invading DNA between palindromic repeats within the CRISPR element. Upon re-exposure to similar DNA sequences from phage or invading bacteria, the existing sequence within the CRISPR is transcribed into a small RNA that associates with CRISPR-associated nucleases, blocking integration of the targeted foreign DNA. Deletion of CRISPR elements in *Enterococcus* is inversely related to antibiotic resistance, and CRISPR-deficient strains are selected for in the context of healthcare-associated infections. CRISPR deficiency allows for evolution of significantly larger genomes, and the attendant insertion of large sequences of DNA in turn enables expression of multiple antibiotic-resistance genes.

Antimicrobial resistance has reached *crisis proportions*, driven by the emergence of new resistance mechanisms (e.g., carbapenemases, including *Klebsiella pneumoniae*-associated carbapenemases, or KPCs) and by overuse of antibiotics, both in healthcare and in other venues, such as agribusiness and animal husbandry. This increase in antibiotic resistance has rendered some bacterial infections encountered in clinical practice virtually untreatable. Accordingly, there is an urgent need to develop new antimicrobials and to rediscover some older antibiotics that have been out of use in recent decades but still retain activity against resistant organisms. It is vital that practitioners use antibiotics only when truly indicated, with the narrowest feasible antimicrobial spectrum, to help thwart emergence of resistance. In addition, advocacy for **vaccines**, particularly conjugate pneumococcal vaccine, can also decrease the selective pressure that excessive antimicrobial use exerts on resistance.

Effective antibiotic action requires achieving therapeutic levels of the drug at the site of infection. Other factors to consider include the impact of pH on antibiotic activity; for example, an antibiotic may penetrate an abscess with adequate levels but may be inactive in the acidic milieu of the abscess cavity. Although measuring the level of antibiotic at the site of infection is not always possible, one may measure the serum level and use this level as a surrogate marker to achieve the desired effect at the tissue level. Various target serum levels are appropriate for different antibiotic agents and are assessed by the peak and trough serum levels and the area under the therapeutic drug level curve (Fig. 225.1). These levels in turn are a reflection of the route of administration, drug absorption (IM, PO), volume of distribution, and drug elimination half-life, as well as drug-drug interactions that might



enhance or impede enzymatic inactivation of an antibiotic or result in antimicrobial synergism or antagonism (Fig. 225.2).

## AGE- AND RISK-SPECIFIC USE OF ANTIBIOTICS IN CHILDREN

### Neonates

The causative pathogens associated with neonatal infections are typically acquired around the time of delivery. Thus empirical antibiotic selection must take into account the importance of these organisms (see Chapter 148). Among the causes of neonatal sepsis in infants, **group B Streptococcus** (GBS) is the most common. Although intrapartum antibiotic prophylaxis administered to women at increased risk for transmission of GBS to the infant has greatly decreased the incidence of this infection in neonates, particularly with respect to so-called *early-onset disease*, GBS infections are still frequently encountered in clinical practice (see Chapter 230). Gram-negative enteric organisms acquired from the maternal birth canal, in particular *Escherichia coli*, are also common causes of neonatal sepsis. Although less common, *Listeria monocytogenes* is an important pathogen to consider, in particular because this organism is intrinsically resistant to cephalosporin antibiotics, which are often used as empirical therapy for serious bacterial infections in young children. *Salmonella* bacteremia and **meningitis** on a global basis is a well-recognized infection in infants. All these organisms can be associated with meningitis in the neonate; therefore lumbar puncture should always be considered in the setting of bacteremic infections in this age-group, and antibiotic management should include agents capable of crossing the blood-brain barrier if meningitis cannot be excluded.

### Older Children

Antibiotic choices in toddlers and young children were once driven by the high risk of this age-group to invasive disease caused by *H. influenzae* type b (**Hib**; see Chapter 240). With the advent of conjugate vaccines against Hib, invasive disease has declined dramatically. However, outbreaks still occur and have been observed in the context of parental refusal of vaccines. Therefore the use of antimicrobials that are active

against Hib remains important in many clinical settings, particularly if meningitis is a consideration. Other important pathogens to consider in this age-group include *E. coli*, *S. pneumoniae*, *N. meningitidis*, and *S. aureus*. Strains of *S. pneumoniae* that are resistant to penicillin and cephalosporin antibiotics are frequently encountered in clinical practice. Similarly, MRSA is highly prevalent in children in the outpatient setting. Antibiotic resistance in *S. pneumoniae* and MRSA is a result of mutations that confer alterations in penicillin-binding proteins, the molecular targets of penicillin and cephalosporin activity (see Table 225.1).

Depending on the specific clinical diagnosis, other pathogens encountered among older children include *Moraxella catarrhalis*, nontypeable (nonencapsulated) strains of *H. influenzae*, and *Mycoplasma pneumoniae*, which cause upper respiratory tract infections and pneumonia; group A *Streptococcus*, which causes pharyngitis, skin and soft tissue infections, osteomyelitis, septic arthritis, and rarely, bacteremia with toxic shock syndrome; *Kingella kingae*, which causes bone and joint infections and bacteremia; viridians group streptococci and Enterococcus, which cause endocarditis; and *Salmonella* spp., which cause enteritis, bacteremia, osteomyelitis, and septic arthritis. Vector-borne bacterial infections, including infections with *Borrelia burgdorferi*, *Rickettsia rickettsii*, and *Anaplasma phagocytophilum*, are increasingly recognized in certain regions, with an emerging increase in prevalence related to global climate change. Zoonotic exposures, pet ownership, and uncommon dietary intake may suggest less common pathogens such as *Coxiella burnetii*, *Brucella abortus*, *Bartonella henselae*, *Yersinia pestis*, *L. monocytogenes*, and *Francisella tularensis*, all of which have unique antibiotic susceptibility profiles. These complexities

**Table 225.1** Mechanisms of Resistance to  $\beta$ -Lactam Antibiotics

- I. Alter target site (PBP)
  - A. Decrease affinity of PBP for  $\beta$ -lactam antibiotic
    1. Modify existing PBP
      - a. Create mosaic PBP
        - (1) Insert nucleotides obtained from neighboring bacteria (e.g., penicillin-resistant *Streptococcus pneumoniae*)
        - (2) Mutate structural gene of PBP(s) (e.g., ampicillin-resistant  $\beta$ -lactamase-negative *Haemophilus influenzae*)
      - b. Import new PBP (e.g., *mecA* in methicillin-resistant *Staphylococcus aureus*)
    2. Destroy  $\beta$ -lactam antibiotic
      - A. Increase production of  $\beta$ -lactamases, carbapenemases
        1. Acquire more efficient promoter
          - a. Mutate existing promoter
          - b. Import new promoter
        2. Deregulate control of  $\beta$ -lactamase production
          - a. Mutate regulator genes (e.g., *ampD* in "stably derepressed" *Enterobacter cloacae*)
      - B. Modify structure of resident  $\beta$ -lactamase
        1. Mutate structural gene (e.g., ESBLs in *Klebsiella pneumoniae*)
      - C. Import new  $\beta$ -lactamase(s) with different spectrum of activity
  - II. Decrease concentration of  $\beta$ -lactam antibiotic inside cell
    - A. Restrict its entry (loss of porins)
    - B. Pump it out (efflux mechanisms)

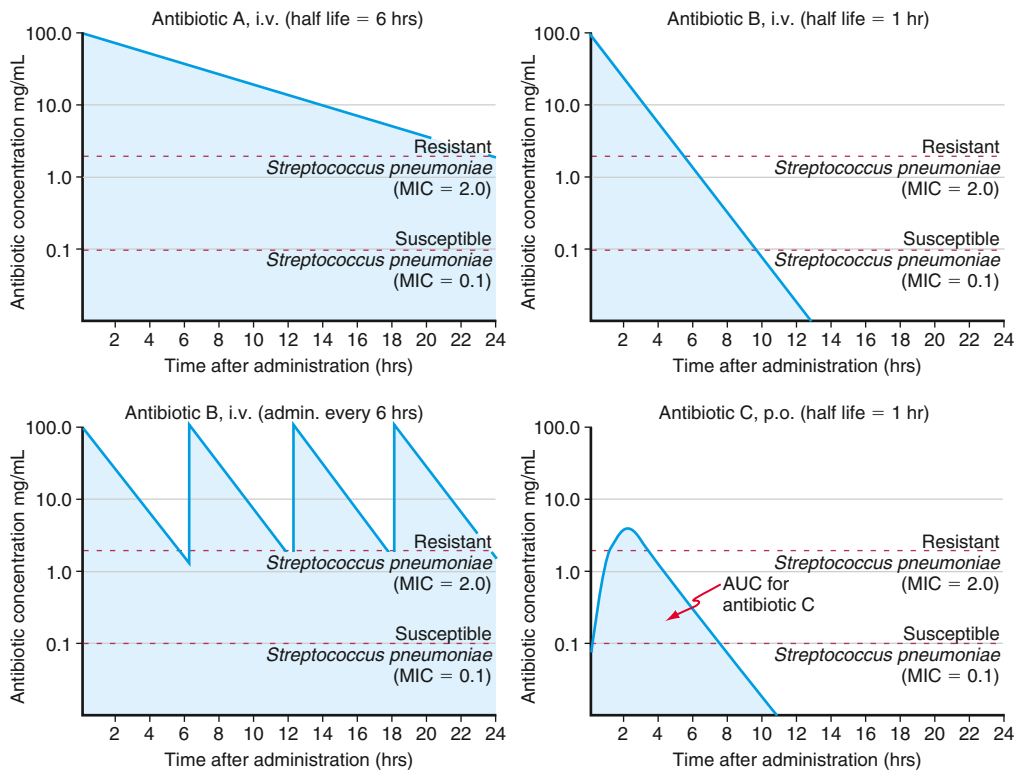
ESBLs, Extended-spectrum  $\beta$ -lactamases; PBP, penicillin-binding protein. Adapted from Opal SM, Pop-Vicas A. Molecular mechanisms of antibiotic resistance in bacteria. In: Bennett JE, Dolin R, Blaser MJ, eds. *Mandell, Douglas, and Bennett's Principles and Practice of Infectious Diseases*, 9th ed. Philadelphia: Elsevier; 2020: Table 18-4.

**Table 225.2** Aminoglycoside-Modifying Enzymes\*

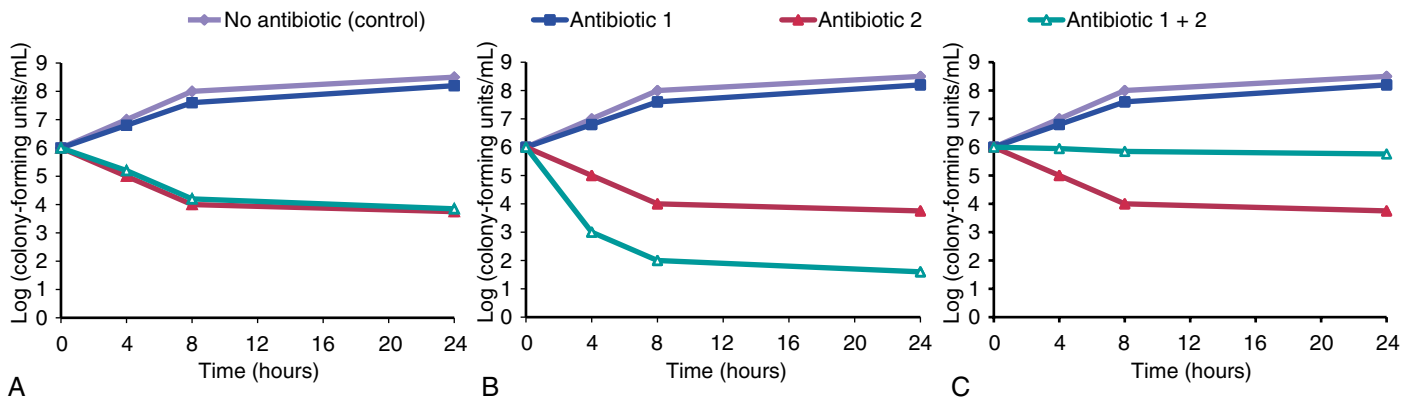
ENZYMES	USUAL ANTIBIOTICS MODIFIED	COMMON GENERA
<b>PHOSPHORYLATION</b>		
APH(2 <sup>*</sup> )	K, T, G	SA, SR
APH(3 <sup>'</sup> )-I	K	E, PS, SA, SR
APH(3 <sup>'</sup> )-III	K $\pm$ A	E, PS, SA, SR
<b>ACETYLATION</b>		
AAC(2 <sup>*</sup> )	G	PR
AAC(3 <sup>'</sup> )-I	$\pm$ T, G	E, PS
AAC(3 <sup>'</sup> )-III, -IV, or -V	K, T, G	E, PS
AAC(6 <sup>'</sup> )	K, T, A	E, PS, SA
<b>ADENYLATION</b>		
ANT(2 <sup>*</sup> )	K, T, G	E, PS
ANT(4 <sup>'</sup> )	K, T, A	SA
<b>BIFUNCTIONAL ENZYMES</b>		
AAC(6 <sup>'</sup> )-APH(2 <sup>*</sup> )	G, Ar	SA, Ent
AAC(6 <sup>'</sup> )-Ibcr	G, K, T, FQ*	E

\*Aminoglycoside-modifying enzymes confer antibiotic resistance through three general reactions: N-acetylation, O-nucleotidylation, and O-phosphorylation. For each of these general reactions, there are several different enzymes that attack a specific amino or hydroxyl group. The nomenclature for these enzymes lists the molecular site where the modification occurs after the type of enzymatic activity. An aminoglycoside acetyltransferase (AAC) that acts at the 3' site is designated AAC(3'). There may be more than one enzyme that catalyzes the same reaction, however, and Roman numerals may be necessary (e.g., AAC[3']-IV).

A, Amikacin; AAC, aminoglycoside acetyltransferase; ANT, aminoglycoside nucleotidytransferase; APH, aminoglycoside phosphotransferase; Ar, arbekacin, E, Enterobacteriaceae; Ent, enterococci, FQ, fluoroquinolone (acetylates the piperazine ring in some fluoroquinolones), G, gentamicin; K, kanamycin; PR, *Providencia-Proteus*; PS, pseudomonads; SA, staphylococci; SR, streptococci; T, tobramycin. Adapted from Opal SM, Pop-Vicas A. Molecular mechanisms of antibiotic resistance in bacteria. In: Bennett JE, Dolin R, Blaser MJ, eds. *Mandell, Douglas, and Bennett's Principles and Practice of Infectious Diseases*, 9th ed. Philadelphia: Elsevier; 2020: Table 18-5.



**Fig. 225.1** Area under the curve (AUC; shaded area) for different antibiotics. The AUC provides a measure of antibiotic exposure to bacterial pathogens. The greatest exposure comes with antibiotics that have a long serum half-life and are administered parenterally (upper left panel, antibiotic A). The lowest exposure occurs with oral administration (lower right panel, antibiotic C). Dosing of antibiotic B once a day (upper right panel) provides far less exposure than dosing the same antibiotic every 6 hr (lower left panel). MIC, Minimal inhibitory concentration. (From Pong AL, Bradley JS. Guidelines for the selection of antibacterial therapy in children. *Pediatr Clin North Am.* 2005;52:869–894.)



**Fig. 225.2** Antibacterial effects of antibiotic combinations. A, Combination of antibiotics 1 and 2 is *indifferent*; killing by antibiotic 2 is unchanged when antibiotic 1 is added. B, Combination of antibiotics 1 and 2 results in *synergy*; killing by antibiotic 2 is significantly enhanced when antibiotic 1 is added at a subinhibitory concentration. C, Combination of antibiotics 1 and 2 is *antagonistic*; killing by antibiotic 2 is diminished in the presence of antibiotic 1. (From Eliopoulos GM, Moellering RC Jr. *Principles of anti-infective therapy*. In: Bennett JF, Dolin R, Blaser MJ, eds. *Mandell, Douglas, and Bennett's Principles and Practice of Infectious Diseases*, 8th ed. Philadelphia: Elsevier; 2015: Fig 17-1.)

underscore the importance of formulation of a complete differential diagnosis in children with suspected severe bacterial infections, including an assessment of the severity of the infection in parallel with consideration of local epidemiologic disease trends. Knowledge of the antimicrobial susceptibility patterns in the community is also critically important in devising an antibiotic treatment strategy.

### Immunocompromised and Hospitalized Patients

It is important to consider the risks associated with immunocompromising conditions (malignancy, solid organ or hematopoietic stem cell transplantation, immunodeficiencies) and the risks conferred by conditions leading to prolonged hospitalization (intensive care, trauma, burns). Influenza infection can also predispose to invasive bacterial infections, especially those caused by *S. aureus*. Measles infection is well-known to predispose to serious bacterial infection, particularly with *Mycobacteria*. Infection with SARS-CoV-2 can also be associated

with bacterial and fungal opportunistic infections. Immunocompromised children are predisposed to develop a wide range of bacterial, viral, fungal, or parasitic infections. Prolonged hospitalization can lead to nosocomial infections, often associated with indwelling catheters and caused by highly antibiotic-resistant gram-negative enteric organisms. In addition to bacterial pathogens already discussed, *Pseudomonas aeruginosa* and enteric organisms, including *E. coli*, *K. pneumoniae*, *Enterobacter*, and *Serratia*, are important opportunistic pathogens in these settings.

The so-called *ESKAPE pathogens* are a group of six highly virulent and antibiotic-resistant organisms that are being increasingly recognized in hospitalized patients, including *Enterococcus faecium*, *Staphylococcus aureus*, *Klebsiella pneumoniae*, *Acinetobacter baumannii*, *Pseudomonas aeruginosa*, and *Enterobacter* species. Selection of appropriate antimicrobials is challenging because of the diverse causes and scope of antimicrobial resistance exhibited by these organisms. Many strains of enteric

organisms have resistance because of ESBLs (see Table 225.1). Class B metallo- $\beta$ -lactamases (also known as *New Delhi metallo- $\beta$ -lactamases*) that hydrolyze all  $\beta$ -lactam antibiotics except aztreonam and KPCs that confer resistance to carbapenems are increasingly being described. CRE are different from other multidrug-resistant microorganisms in that they are susceptible to few (if any) antibacterial agents.

Other modes of antimicrobial resistance exist that complicate management of common hospital-acquired infections. *P. aeruginosa* encodes proteins that function as efflux pumps to eliminate multiple classes of antimicrobials from the cytoplasm or periplasmic space. In addition to these gram-negative pathogens, infections caused by *Enterococcus faecalis* and *E. faecium* are inherently difficult to treat. Isolates of *E. faecalis* are typically susceptible to ampicillin, whereas most *E. faecium* are resistant to ampicillin, with resistance mediated by alterations in either the stoichiometry or sequence of a specific penicillin binding protein (PBP). These organisms may cause urinary tract infection (UTI) or infective endocarditis in immunocompetent children and may be responsible for a variety of syndromes in immunocompromised patients, especially in the setting of prolonged intensive care. The emergence of infections caused by **vancomycin-resistant enterococcus (VRE)** has further complicated antimicrobial selection in high-risk patients and has necessitated the development of newer antimicrobials that target these highly resistant gram-positive bacteria.

### Infections Associated with Medical Devices

A special situation affecting antibiotic use is the presence of an indwelling medical device, such as a venous catheter, ventriculoperitoneal shunt, stent, or other catheter (see Chapter 224). In addition to *S. aureus*, coagulase-negative staphylococci are a major consideration. Coagulase-negative staphylococci seldom cause serious disease in the absence of risk factors such as indwelling catheters. Empirical antibiotic regimens must take this risk into consideration. In addition to appropriate antibiotic therapy, removal or replacement of the colonized prosthetic material is usually required for cure.

## ANTIBIOTICS, INCLUDING NEWER AGENTS AND THERAPIES COMMONLY USED IN PEDIATRIC PRACTICE

Table 225.3 lists selected antibiotic medications, including recently licensed agents. Not all agents have formal pediatric indications, but dosage considerations for infants and children are provided, as available.

### Penicillins

Although there has been ever-increasing emergence of resistance to penicillins, these agents remain valuable and are commonly used for management of many pediatric infectious diseases.

Penicillins remain the drugs of choice for pediatric infections caused by group A and group B streptococci, *Treponema pallidum* (syphilis), *L. monocytogenes*, and *N. meningitidis*. The **semisynthetic penicillins** (nafcillin, cloxacillin, dicloxacillin) are useful for management of susceptible (non-MRSA) staphylococcal infections. The **aminopenicillins** (ampicillin, amoxicillin) were developed to provide broad-spectrum activity against gram-negative organisms, including *E. coli* and *H. influenzae*, but the emergence of resistance (typically mediated by a  $\beta$ -lactamase) has limited their utility in many clinical settings. The **carboxypenicillins** (ticarcillin) and **ureidopenicillins** (piperacillin, mezlocillin, azlocillin) also have bactericidal activity against most strains of *P. aeruginosa*.

Resistance to penicillin is mediated by a variety of mechanisms (see Table 225.1). The production of  $\beta$ -lactamase is a common mechanism exhibited by many organisms that may be overcome, with variable success, by including a  $\beta$ -lactamase inhibitor in the therapeutic formulation with the penicillin. Such combination products (ampicillin-sulbactam, amoxicillin-clavulanate, ticarcillin-clavulanic acid [no longer available in the United States], piperacillin-tazobactam) are potentially very useful for management of resistant isolates, but only if the resistance is  $\beta$ -lactamase mediated. Notably, MRSA and *S.*

*pneumoniae* mediate resistance to penicillins through mechanisms other than  $\beta$ -lactamase production, rendering these combination agents of little value for the management of these infections. Cephalosporin (ceftazidime/avibactam, ceftolozane/tazobactam) and carbapenem (meropenem/vaborbactam, and imipenem/relebactam) antibiotics combined with  $\beta$ -lactamase inhibitors have also been recently licensed by the FDA (described later). In addition, the FDA has recently approved a novel  $\beta$ -lactam- $\beta$ -lactamase inhibitor combination, sulbactam-durlobactam (SUL-DUR), designed specifically for the treatment of carbapenem-resistant *Acinetobacter baumannii* infections, in particular, those associated with hospital-acquired and ventilator-associated pneumonias.

Table 225.4 lists adverse reactions to penicillins.

### Cephalosporins

Cephalosporins differ structurally from penicillins insofar as the  $\beta$ -lactam ring exists as a six-member ring, compared with the five-member ring structure of the penicillins. These agents are widely used in pediatric practice, both in oral and parenteral formulations (Table 225.5). The **first-generation cephalosporins** (e.g., cefazolin, a parenteral formulation, and cephalixin, an oral equivalent) are commonly used for management of skin and soft tissue infections caused by susceptible strains of *S. aureus* and group A streptococcus. The **second-generation cephalosporins** (e.g., cefuroxime, cefoxitin) have better activity against gram-negative bacterial infections than first-generation cephalosporins and are used to treat respiratory tract infections, UTIs, and skin and soft tissue infections. A variety of orally administered second-generation agents (cefaclor, cefprozil, loracarbef, cefpodoxime) are commonly used in the outpatient management of sinopulmonary infections and otitis media. The agents cefoxitin and cefotetan are also referred to as **cephamycins**, because they were originally isolated from actinomycetes (although synthetic versions also have been developed). The **third-generation cephalosporins** (cefotaxime [no longer available], ceftriaxone, and ceftazidime) are typically used for serious pediatric infections, including meningitis and sepsis. Oral third-generation cephalosporins have been developed, including cefixime, ceftibuten, cefdinir, cefpodoxime, and cefditoren. Ceftazidime is highly active against most strains of *P. aeruginosa*, making this a useful agent for febrile, neutropenic oncology patients. The FDA approved the combination of ceftazidime and the novel  $\beta$ -lactamase inhibitor avibactam in 2015. Current indications include complicated intraabdominal infections and UTIs. The combination may also be useful for the treatment of infection caused by KPCs. Pediatric experience is limited. Ceftriaxone should not be mixed or reconstituted with a calcium-containing product, such as Ringer or Hartmann solution or parenteral nutrition containing calcium, because particulate formation can result. Cases of fatal reactions with ceftriaxone-calcium precipitates in the lungs and kidneys in neonates have been reported.

Cefepime is a **fourth-generation cephalosporin** and has activity against *P. aeruginosa* along with good activity against methicillin-susceptible *S. aureus*. Phase 3 studies of two new formulations of cefepime (one combined with a  $\beta$ -lactamase inhibitor, taniborbactam, and the other with a penicillanic acid sulfone  $\beta$ -lactamase inhibitor, enmetazobactam) are ongoing. *Cefpirome* is a fourth-generation cephalosporin with activity against *P. aeruginosa* and methicillin-sensitive *S. aureus* (MSSA) and is licensed for complicated UTIs and ventilator-associated pneumonia in adults, but no data on pediatric use are available. *Ceftizoxime* is a fourth-generation cephalosporin that is no longer in use in the United States. *Cefiderocol* is a novel cephalosporin that is classified as a *siderophore* antibiotic and is used for treatment of resistant gram-negative organisms, particularly *P. aeruginosa*, associated with complicated UTIs. It also recently received FDA approval for the treatment of hospital-acquired bacterial pneumonia caused by resistant gram-negative organisms. Its mechanism of action involves binding to iron, followed by active transport into bacterial cells. It was the first siderophore antibiotic to be approved by the FDA. It is approved for ages 18 and older, so pediatric experience is limited. Some classification schemes have classified it as a fourth-generation cephalosporin.

**Table 225.3** Selected Antibacterial Medications (Antibiotics)\*

DRUG (TRADE NAMES, FORMULATIONS)	INDICATIONS (MECHANISM OF ACTION) AND DOSING	COMMENTS
<b>Amikacin sulfate</b> Amikin Injection: 50 mg/mL, 250 mg/mL	<b>Aminoglycoside antibiotic active against gram-negative bacilli, especially <i>Escherichia coli</i>, <i>Klebsiella</i>, <i>Proteus</i>, <i>Enterobacter</i>, <i>Serratia</i>, and <i>Pseudomonas</i></b> Neonates: Postnatal age ≤7 days, weight 1,200-2,000 g: 7.5 mg/kg q12-18h IV or IM; weight >2,000 g: 10 mg/kg q12h IV or IM; postnatal age >7 days, weight 1,200-2,000 g: 7.5 mg/kg q8-12h IV or IM; weight >2,000 g: 10 mg/kg q8h IV or IM Children: 15-25 mg/kg/24 hr divided q8-12h IV or IM Adults: 15 mg/kg/24 hr divided q8-12h IV or IM	<b>Cautions:</b> Anaerobes, <i>Streptococcus</i> (including <i>S. pneumoniae</i> ) are resistant. May cause ototoxicity and nephrotoxicity. Monitor renal function. Drug eliminated renally. Administered IV over 30-60 min. <b>Drug interactions:</b> May potentiate other ototoxic and nephrotoxic drugs. <b>Target serum concentrations:</b> Peak 25-40 mg/L; trough <10 mg/L.
<b>Amoxicillin</b> Amoxil, Polymox Capsule: 250, 500 mg Tablet: chewable: 125, 250 mg Suspension: 125 mg/5 mL, 250 mg/5 mL Drops: 50 mg/mL	<b>Penicillinase-susceptible β-lactam: gram-positive pathogens except <i>Staphylococcus</i>; susceptible gram-negatives, including <i>Salmonella</i>, <i>Shigella</i>, <i>Neisseria</i> species, <i>E. coli</i>, and <i>Proteus mirabilis</i></b> Children: 20-50 mg/kg/24 hr divided q8-12h PO; higher dose of 80-90 mg/kg 24 hr PO for otitis media Adults: 250-500 mg q8-12h PO	<b>Cautions:</b> Rash, diarrhea, abdominal cramping. Drug eliminated renally. <b>Drug interaction:</b> Probenecid.
<b>Amoxicillin-clavulanate</b> Augmentin Oral Tablet: 250, 500, 875 mg Tablet, chewable: 125, 200, 250, 400 mg Suspension: 125 mg/5 mL, 200 mg/5 mL, 250 mg/5 mL, 400 mg/5 mL	<b>β-Lactam (amoxicillin) combined with β-lactamase inhibitor (clavulanate) enhances amoxicillin activity against penicillinase-producing bacteria. <i>S. aureus</i> (not methicillin-resistant organism), <i>Streptococcus</i>, <i>Haemophilus influenzae</i>, <i>Moraxella catarrhalis</i>, <i>E. coli</i>, <i>Klebsiella</i>, <i>Bacteroides fragilis</i></b> Neonates: 30 mg/kg/24 hr divided q12h PO Children: 20-45 mg/kg 24 hr divided q8-12h PO; higher dose 80-90 mg/kg/24 hr PO for otitis media	<b>Cautions:</b> Drug dosed on amoxicillin component. May cause diarrhea, rash. Drug eliminated renally. <b>Drug interaction:</b> Probenecid. <b>Comment:</b> Higher dose may be active against penicillin-tolerant/resistant <i>S. pneumoniae</i> .
<b>Ampicillin</b> Polycillin, Omnipen Capsule: 250, 500 mg Suspension: 125 mg/5 mL, 250 mg/5 mL, 500 mg/5 mL Injection Oral	<b>β-Lactam with same spectrum of antibacterial activity as amoxicillin</b> Neonates: Postnatal age ≤7 days weight ≤2,000 g: 50 mg/kg/24 hr IV or IM q12h (meningitis: 100 mg/kg/24 hr divided q12h IV or IM); weight >2,000 g: 75 mg/kg/24 hr divided q8h IV or IM (meningitis: 150 mg/kg/24 hr divided q8h IV or IM). Postnatal age >7 days weight <1,200 g: 50 mg/kg/24 hr IV or IM q12h (meningitis: 100 mg/kg/24 hr divided q12h IV or IM); weight 1,200-2,000 g: 75 mg/kg/24 hr divided q8h IV or IM (meningitis: 150 mg/kg/24 hr divided q8h IV or IM); weight >2,000 g: 100 mg/kg/24 hr divided q6h IV or IM (meningitis: 200 mg/kg/24 hr divided q6h IV or IM) Children: 100-200 mg/kg/24 hr divided q6h IV or IM (meningitis: 200-400 mg/kg/24 hr divided q4-6h IV or IM) Adults: 250-500 mg q4-8h IV or IM	<b>Cautions:</b> Less bioavailable than amoxicillin, causing greater diarrhea. <b>Drug interaction:</b> Probenecid.
<b>Ampicillin-sulbactam</b> Unasyn Injection	<b>β-Lactam (ampicillin) and β-lactamase inhibitor (sulbactam) enhances ampicillin activity against penicillinase-producing bacteria: <i>S. aureus</i>, <i>H. influenzae</i>, <i>M. catarrhalis</i>, <i>E. coli</i>, <i>Klebsiella</i>, <i>B. fragilis</i></b> Children: 100-200 mg/kg/24 hr divided q4-8h IV or IM Adults: 1-2 g q6-8h IV or IM (max daily dose: 8 g)	<b>Cautions:</b> Drug dosed on ampicillin component. May cause diarrhea, rash. Drug eliminated renally. <b>Note:</b> Higher dose may be active against penicillin-tolerant/resistant <i>S. pneumoniae</i> . <b>Drug interaction:</b> Probenecid.
<b>Azithromycin</b> Zithromax Tablet: 250 mg Suspension: 100 mg/5 mL, 200 mg/5 mL	<b>Azalide antibiotic with activity against <i>S. aureus</i>, <i>Streptococcus</i>, <i>H. influenzae</i>, <i>Mycoplasma</i>, <i>Legionella</i>, <i>Chlamydia trachomatis</i>, <i>Babesia microti</i></b> Children: 10 mg/kg PO on day 1 (max dose: 500 mg) followed by 5 mg/kg PO q24h for 4 days Group A streptococcus pharyngitis: 12 mg/kg/24 hr PO (max dose: 500 mg) for 5 days Adults: 500 mg PO on day 1, followed by 250 mg for 4 days Uncomplicated <i>C. trachomatis</i> infection: single 1 g dose PO	<b>Note:</b> Very long half-life permitting once-daily dosing. No metabolic-based drug interactions (unlike erythromycin and clarithromycin), limited GI distress. Shorter-course regimens (e.g., 1-3 days) under investigation. For a 3-day course of therapy, use dose of (10 mg/kg/24 hr × 3 days); single-dose therapy, 30 mg/kg (not for streptococcal pharyngitis).
<b>Aztreonam</b> Azactam Injection	<b>β-Lactam (monobactam) antibiotic with activity against gram-negative aerobic bacteria, Enterobacteriaceae, and <i>Pseudomonas aeruginosa</i></b> Neonates: Postnatal age ≤7 days weight ≤2,000 g: 60 mg/kg/24 hr divided q12h IV or IM; weight >2,000 g: 90 mg/kg/24 hr divided q8h IV or IM; postnatal age >7 days weight <1,200 g: 60 mg/kg/24 hr divided q12h IV or IM; weight 1,200-2,000 g: 90 mg/kg/24 hr divided q8h IV or IM; weight >2,000 g: 120 mg/kg/24 hr divided q6-8h IV or IM Children: 90-120 mg/kg/24 hr divided q6-8h IV or IM. For cystic fibrosis, up to 200 mg/kg/24 hr IV Adults: 1-2 g IV or IM q8-12h (max dose: 8 g/24 hr)	<b>Cautions:</b> Rash, thrombophlebitis, eosinophilia. Renally eliminated. <b>Drug interaction:</b> Probenecid.

Continued



Table 225.3 Selected Antibacterial Medications (Antibiotics)\*—cont'd

DRUG (TRADE NAMES, FORMULATIONS)	INDICATIONS (MECHANISM OF ACTION) AND DOSING	COMMENTS
Cefadroxil Generic Capsule: 500 mg Tablet: 1,000 mg Suspension: 125 mg/5 mL, 250 mg/5 mL, 500 mg/5 mL	First-generation cephalosporin active against <i>S. aureus</i> , <i>Streptococcus</i> , <i>E. coli</i> , <i>Klebsiella</i> , and <i>Proteus</i> Children: 30 mg/kg/24 hr divided q12h PO (max dose: 2 g) Adults: 250-500 mg q8-12h PO	Cautions: $\beta$ -Lactam safety profile (rash, eosinophilia). Renally eliminated. Long half-life permits q12-24h dosing. Drug interaction: Probenecid.
Cefazolin Ancef, Kefzol Injection	First-generation cephalosporin active against <i>S. aureus</i> , <i>Streptococcus</i> , <i>E. coli</i> , <i>Klebsiella</i> , and <i>Proteus</i> Neonates: Postnatal age $\leq 7$ days 40 mg/kg/24 hr divided q12h IV or IM; $> 7$ days 40-60 mg/kg/24 hr divided q8h IV or IM Children: 50-100 mg/kg/24 hr divided q8h IV or IM Adults: 0.5-2g q8h IV or IM (max dose: 12 g/24 hr)	Caution: $\beta$ -Lactam safety profile (rash, eosinophilia). Renally eliminated. Does not adequately penetrate CNS. Drug interaction: Probenecid.
Cefdinir Omnicef Capsule: 300 mg Oral suspension: 125 mg/5 mL	Extended-spectrum, semisynthetic cephalosporin Children 6 mo-12 yr: 14 mg/kg/24 hr in 1 or 2 doses PO (max dose: 600 mg/24 hr) Adults: 600 mg q24h PO	Cautions: Reduce dosage in renal insufficiency (creatinine clearance $< 60$ mL/min). Avoid taking concurrently with iron-containing products and antacids because absorption is markedly decreased; take at least 2 hr apart. Drug interaction: Probenecid.
Cefepime Maxipime Injection	Expanded-spectrum, fourth-generation cephalosporin active against many gram-positive and gram-negative pathogens, including <i>P. aeruginosa</i> and many multidrug-resistant pathogens Children: 100-150 mg/kg/24 hr q8-12h IV or IM Adults: 2-4 g/24 hr q12h IV or IM	Adverse events: Diarrhea, nausea, vaginal candidiasis. Cautions: $\beta$ -lactam safety profile (rash, eosinophilia). Renally eliminated. Drug interaction: Probenecid.
Cefiderocol Fetroja Injection 1 g vials	Expanded-spectrum, classified in some classifications as a fourth-generation cephalosporin; novel siderophore antibiotic; mechanism of action is mediated by binding to iron, followed by active transport into bacterial cells Indicated for treatment of complicated urinary tract infections, including pyelonephritis, caused by susceptible gram-negative microorganisms and for hospital-acquired and ventilator-associated pneumonia Adults: 2 g IV q8hr for 7-14 days Children: dose not established	Cautions: $\beta$ -Lactam safety profile (rash, eosinophilia). Renally eliminated. Not indicated for meningitis (in contrast with cefepime).
Cefixime Suprax Oral Tablet: 200, 400 mg Suspension: 100 mg/5 mL	Third-generation cephalosporin active against streptococci, <i>H. influenzae</i> , <i>M. catarrhalis</i> , <i>Neisseria gonorrhoeae</i> , <i>Serratia marcescens</i> , and <i>Proteus vulgaris</i> No antistaphylococcal or antipseudomonal activity Children: 8 mg/kg/24 hr divided q12-24h PO Adults: 400 mg/24 hr divided q12-24h PO	Cautions: $\beta$ -Lactam safety profile (rash, eosinophilia). Renally eliminated. Does not adequately penetrate CNS. Drug interaction: Probenecid.
Cefoperazone sodium Cefobid Injection	Third-generation cephalosporin active against many gram-positive and gram-negative pathogens Neonates: 100 mg/kg/24 hr divided q12h IV or IM Children: 100-150 mg/kg/24 hr divided q8-12h IV or IM Adults: 2-4 g/24 hr divided q8-12h IV or IM (max dose: 12 g/24 hr)	Cautions: Highly protein-bound cephalosporin with limited potency reflected by weak antipseudomonal activity. Variable gram-positive activity. Primarily hepatically eliminated in bile. Drug interaction: Disulfiram-like reaction with alcohol.
Cefotaxime sodium Claforan Injection	Third-generation cephalosporin active against gram-positive and gram-negative pathogens. No antipseudomonal activity Neonates: $\leq 7$ days: 100 mg/kg/24 hr divided q12h IV or IM; $> 7$ days: weight $< 1,200$ g 100 mg/kg/24 hr divided q12h IV or IM; weight $> 1,200$ g: 150 mg/kg/24 hr divided q8h IV or IM Children: 150 mg/kg/24 hr divided q6-8h IV or IM (meningitis: 200 mg/kg/24 hr divided q6-8h IV) Adults: 1-2 g q8-12h IV or IM (max dose: 12 g/24 hr)	
Cefotetan disodium Cefotan Injection	Second-generation cephalosporin active against <i>S. aureus</i> , <i>Streptococcus</i> , <i>H. influenzae</i> , <i>E. coli</i> , <i>Klebsiella</i> , <i>Proteus</i> , and <i>Bacteroides</i> . Inactive against <i>Enterobacter</i> Children: 40-80 mg/kg/24 hr divided q12h IV or IM Adults: 2-4 g/24 hr divided q12h IV or IM (max dose: 6 g/24 hr)	Cautions: Highly protein-bound cephalosporin, poor CNS penetration; $\beta$ -lactam safety profile (rash, eosinophilia), disulfiram-like reaction with alcohol. Renally eliminated ( $\sim 20\%$ in bile).

**Table 225.3** Selected Antibacterial Medications (Antibiotics)\*—cont'd

DRUG (TRADE NAMES, FORMULATIONS)	INDICATIONS (MECHANISM OF ACTION) AND DOSING	COMMENTS
Cefoxitin sodium Mefoxin Injection	Second-generation cephalosporin active against <i>S. aureus</i> , <i>Streptococcus</i> , <i>H. influenzae</i> , <i>E. coli</i> , <i>Klebsiella</i> , <i>Proteus</i> , and <i>Bacteroides</i> . Inactive against <i>Enterobacter</i> Neonates: 70-100 mg/kg/24 hr divided q8-12h IV or IM Children: 80-160 mg/kg/24 hr divided q6-8h IV or IM Adults: 1-2 g q6-8h IV or IM (max dose: 12 g/24 hr)	<i>Cautions:</i> Poor CNS penetration; $\beta$ -lactam safety profile (rash, eosinophilia). Renally eliminated. Painful given intramuscularly. <i>Drug interaction:</i> Probenecid.
Cefpirome Cefrom Keiten Broact Cefir	Fourth-generation cephalosporin; indicated for complicated urinary tract infections, including pyelonephritis, caused by susceptible gram-negative microorganisms; indicated for hospital-acquired and ventilator-associated pneumonia Adults: 2 g IV q 8hr for 7-14 days Children: Dose not established	<i>Cautions:</i> $\beta$ -Lactam safety profile (rash, eosinophilia). Renally eliminated. Not indicated for meningitis (in contrast with cefepime).
Cefpodoxime proxetil Vantin Tablet: 100 mg, 200 mg Suspension: 50 mg/5 mL, 100 mg/5 mL	Third-generation cephalosporin active against <i>S. aureus</i> , <i>Streptococcus</i> , <i>H. influenzae</i> , <i>M. catarrhalis</i> , <i>N. gonorrhoeae</i> , <i>E. coli</i> , <i>Klebsiella</i> , and <i>Proteus</i> No antipseudomonal activity Children: 10 mg/kg/24 hr divided q12h PO Adults: 200-800 mg/24 hr divided q12h PO (max dose: 800 mg/24 hr) Uncomplicated gonorrhea: 200 mg PO as single-dose therapy	<i>Cautions:</i> $\beta$ -Lactam safety profile (rash, eosinophilia). Renally eliminated. Does not adequately penetrate CNS. Increased bioavailability when taken with food. <i>Drug interaction:</i> Probenecid; antacids and H <sub>2</sub> receptor antagonists may decrease absorption.
Cefprozil Cefzil Tablet: 250, 500 mg Suspension: 125 mg/5 mL, 250 mg/5 mL	Second-generation cephalosporin active against <i>S. aureus</i> , <i>Streptococcus</i> , <i>H. influenzae</i> , <i>E. coli</i> , <i>M. catarrhalis</i> , <i>Klebsiella</i> , and <i>Proteus spp.</i> Children: 30 mg/kg/24 hr divided q8-12h PO Adults: 500-1,000 mg/24 hr divided q12h PO (max dose: 1.5 g/24 hr)	<i>Cautions:</i> $\beta$ -Lactam safety profile (rash, eosinophilia). Renally eliminated. Good bioavailability; food does not affect bioavailability. <i>Drug interaction:</i> Probenecid.
Ceftaroline fosamil Teflaro Injection 400 mg/vial (20 mg/mL reconstituted) 600 mg/vial (30 mg/mL reconstituted)	Fifth-generation cephalosporin active against <i>S. aureus</i> (including MRSA when used for skin and soft tissue infection), <i>S. pyogenes</i> , <i>S. agalactiae</i> , <i>E. coli</i> , <i>K. pneumoniae</i> , <i>H. influenzae</i> , and <i>K. oxytoca</i> Children: skin/skin structure infections or community-acquired pneumonia, 24 mg/kg/24 hr divided q8h IV (2-23 mo old) $\times$ 5-14 days; 36 mg/kg/24 hr divided q8h IV (weight $\leq$ 33 kg) $\times$ 5-14 days; 400 mg q8h IV (weight >33 kg) Adults: 600 mg q12h IV	<i>Caution:</i> $\beta$ -Lactam safety profile (rash, eosinophilia). <i>Drug interaction:</i> Probenecid.
Ceftazidime Fortaz, Ceptaz, Tazicef, Tazidime Injection	Third-generation cephalosporin active against gram-positive and gram-negative pathogens, including <i>P. aeruginosa</i> Neonates: Postnatal age $\leq$ 7 days: 100 mg/kg/24 hr divided q12h IV or IM; >7 days weight $\leq$ 1,200 g: 100 mg/kg/24 hr divided q12h IV or IM; weight >1,200 g: 150 mg/kg/24 hr divided q8h IV or IM Children: 150 mg/kg/24 hr divided q8h IV or IM (meningitis: 150 mg/kg/24 hr IV divided q8h) Adults: 1-2 g q8-12h IV or IM (max dose: 8-12 g/24 hr)	<i>Cautions:</i> $\beta$ -Lactam safety profile (rash, eosinophilia). Renally eliminated. Increasing pathogen resistance developing with long-term, widespread use. <i>Drug interaction:</i> Probenecid.
Ceftazidime/avibactam Avycaz Injection (2 g/0.5 g)/vial: 2.5 g Equivalent to 2.635 g of ceftazidime and 0.551 g of avibactam sodium	Third-generation cephalosporin active against gram-positive and gram-negative pathogens, including <i>P. aeruginosa</i> ; addition of $\beta$ -lactamase; inhibits <i>K. pneumoniae</i> carbapenemases and AmpC-type $\beta$ -lactamases that are resistant to $\beta$ -lactamases, tazobactam, and clavulanic acid Useful for complicated intraabdominal infections, urinary tract infections, and pneumonia Adults: 2.5 g (2 g/0.5 g) IV q8h infused over 2 hr for 7-14 days Children: 3 mo to <2 yr: 62.5 mg/kg (ceftazidime 50 mg/kg and avibactam 12.5 mg/kg) IV q8h for 5-14 days 2 yr to <18 yr: 62.5 mg/kg (ceftazidime 50 mg/kg and avibactam 12.5 mg/kg) IV q8h for 5-14 days; not to exceed 2.5 g (ceftazidime 2 g and avibactam 0.5 g)	<i>Cautions:</i> $\beta$ -Lactam safety profile (rash, eosinophilia). Renally eliminated. Increasing pathogen resistance developing with long-term, widespread use. <i>Drug interaction:</i> Probenecid.

Continued

Table 225.3 Selected Antibacterial Medications (Antibiotics)\*—cont'd

DRUG (TRADE NAMES, FORMULATIONS)	INDICATIONS (MECHANISM OF ACTION) AND DOSING	COMMENTS
Ceftolozane/tazobactam Zerbaxa Injection	Fifth-generation cephalosporin (with $\beta$ -lactamase inhibitor) indicated for complicated intraabdominal infections; acute pyelonephritis; complicated urinary tract infections; hospital-acquired and ventilator-associated bacterial pneumonia Adults: Community-acquired pneumonia, skin and soft tissue infections 600 mg IV q12 h $\times$ 5-7 days Children: Birth to <2 mo: 6 mg/kg IV q8h $\times$ 5-14 days 2 mo to <2 yr: 8 mg/kg IV q8h $\times$ 5-14 days 2 yr to <18 yr ( $\leq$ 33 kg): 12 mg/kg IV q8h $\times$ 5-14 days 2 yr to <18 yr (>33 kg): 400 mg q8h OR 600 mg q12h IV $\times$ 5-14 days	<i>Cautions:</i> $\beta$ -Lactam safety profile (rash, eosinophilia). Renally eliminated. <i>Drug interaction:</i> Probenecid.
Ceftriaxone sodium Rocephin Injection	Third-generation cephalosporin widely active against gram-positive and gram-negative pathogens <b>No antipseudomonal activity</b> Neonates: 50-75 mg/kg q24h IV or IM Children: 50-75 mg/kg q24h IV or IM (meningitis: 75 mg/kg dose once then 80-100 mg/kg/24 hr divided q12-24h IV or IM) Adults: 1-2 g q24h IV or IM (max dose: 4 g/24 hr) Gonorrhea: 500 mg IM, single dose	<i>Cautions:</i> $\beta$ -Lactam safety profile (rash, eosinophilia). Eliminated via kidney (33–65%) and bile; can cause sludging. Long half-life and dose-dependent protein binding favors q24h rather than q12h dosing. Can add 1% lidocaine for IM injection. <i>Drug interaction:</i> Probenecid. In neonates, co-administration with calcium-containing products can result in severe precipitation and attendant embolic complications.
Cefuroxime (cefuroxime axetil for oral administration) Ceftin, Kefurox, Zinacef Injection Suspension: 125 mg/5 mL Tablet: 125, 250, 500 mg	Second-generation cephalosporin active against <i>S. aureus</i> , <i>Streptococcus</i> , <i>H. influenzae</i> , <i>E. coli</i> , <i>M. catarrhalis</i> , <i>Klebsiella</i> , and <i>Proteus</i> Neonates: 40-100 mg/kg/24 hr divided q12h IV or IM Children: 200-240 mg/kg/24 hr divided q8h IV or IM; PO administration: 20-30 mg/kg/24 hr divided q8-12h PO Adults: 750-1,500 mg q8h IV or IM (max dose: 6 g/24 hr)	<i>Cautions:</i> $\beta$ -Lactam safety profile (rash, eosinophilia). Renally eliminated. Food increases PO bioavailability. <i>Drug interaction:</i> Probenecid.
Cephalexin Keflex, Kefstab Capsule: 250, 500 mg Tablet: 500 mg, 1 g Suspension: 125 mg/5 mL, 250 mg/5 mL, 100 mg/mL drops	First-generation cephalosporin active against <i>S. aureus</i> , <i>Streptococcus</i> , <i>E. coli</i> , <i>Klebsiella</i> , and <i>Proteus</i> Children: 25-100 mg/kg/24 hr divided q6-8h PO Adults: 250-500 mg q6h PO (max dose: 4 g/24 hr)	<i>Cautions:</i> $\beta$ -Lactam safety profile (rash, eosinophilia). Renally eliminated. <i>Drug interaction:</i> Probenecid.
Cephradine Velocef Capsule: 250, 500 mg Suspension: 125 mg/5 mL, 250 mg/5 mL	First-generation cephalosporin active against <i>S. aureus</i> , <i>Streptococcus</i> , <i>E. coli</i> , <i>Klebsiella</i> , and <i>Proteus</i> Children: 50-100 mg/kg/24 hr divided q6-12h PO Adults: 250-500 mg q6-12h PO (max dose: 4 g/24 hr)	<i>Cautions:</i> $\beta$ -Lactam safety profile (rash, eosinophilia). Renally eliminated. <i>Drug interaction:</i> Probenecid.
Ciprofloxacin Cipro Tablet: 100, 250, 500, 750 mg Injection Ophthalmic solution and ointment Otic suspension Oral suspension: 250 and 500 mg/5 mL	Quinolone antibiotic active against <i>P. aeruginosa</i> , <i>Serratia</i> , <i>Enterobacter</i> , <i>Shigella</i> , <i>Salmonella</i> , <i>Campylobacter</i> , <i>N. gonorrhoeae</i> , <i>H. influenzae</i> , <i>M. catarrhalis</i> , some <i>S. aureus</i> , and some <i>Streptococcus</i> Neonates: 10 mg/kg q12h PO or IV Children: 15-30 mg/kg/24 hr divided q12h PO or IV; cystic fibrosis: 20-40 mg/kg/24 hr divided q8-12h PO or IV Adults: 250-750 mg q12h; 200-400 mg IV q12h PO (max dose: 1.5 g/24 hr)	<i>Cautions:</i> Concerns of joint destruction in juvenile animals but not seen in humans; tendonitis, superinfection, dizziness, confusion, crystalluria, some photosensitivity. <i>Drug interactions:</i> Theophylline; magnesium-, aluminum-, or calcium-containing antacids; sucralfate; probenecid; warfarin; cyclosporine.
Clarithromycin Biaxin Tablet: 250, 500 mg Suspension: 125 mg/5 mL, 250 mg/5 mL	Macrolide antibiotic with activity against <i>S. aureus</i> , <i>Streptococcus</i> , <i>H. influenzae</i> , <i>Legionella</i> , <i>Mycoplasma</i> , and <i>C. trachomatis</i> Children: 15 mg/kg/24 hr divided q12h PO Adults: 250-500 mg q12h PO (max dose: 1 g/24 hr)	<i>Cautions:</i> Adverse events less than erythromycin; GI upset, dyspepsia, nausea, cramping. <i>Drug interactions:</i> Same as erythromycin: astemizole, carbamazepine, terfenadine, cyclosporine, theophylline, digoxin, tacrolimus.
Clindamycin Cleocin Capsule: 75, 150, 300 mg Suspension: 75 mg/5 mL Injection Topical solution, lotion, and gel Vaginal cream	Protein synthesis inhibitor active against most gram-positive aerobic and anaerobic cocci except <i>Enterococcus</i> Neonates: Postnatal age $\leq$ 7 days weight <2,000 g: 10 mg/kg/24 hr divided q12h IV or IM; weight >2,000 g: 15 mg/kg/24 hr divided q8h IV or IM; >7 days weight <1,200 g: 10 mg/kg/24 hr IV or IM divided q12h; weight 1,200-2,000 g: 15 mg/kg/24 hr divided q8h IV or IM; weight >2,000 g: 20 mg/kg/24 hr divided q8h IV or IM Children: 10-40 mg/kg/24 hr divided q6-8h IV, IM, or PO Adults: 150-600 mg q6-8h IV, IM, or PO (max dose: 5 g/24 hr IV or IM or 2 g/24 hr PO)	<i>Cautions:</i> Diarrhea, nausea, <i>Clostridium difficile</i> -associated colitis, rash. Administer slow IV over 30-60 min. Topically active as an acne treatment.

**Table 225.3** Selected Antibacterial Medications (Antibiotics)\*—cont'd

DRUG (TRADE NAMES, FORMULATIONS)	INDICATIONS (MECHANISM OF ACTION) AND DOSING	COMMENTS
Cloxacillin sodium Tegopen Capsule: 250, 500 mg Suspension: 125 mg/5 mL	Penicillinase-resistant penicillin active against <i>S. aureus</i> and other gram-positive cocci except <i>Enterococcus</i> and coagulase-negative staphylococci Children: 50-100 mg/kg/24 hr divided q6h PO Adults: 250-500 mg q6h PO (max dose: 4 g/24 hr)	<i>Cautions:</i> β-Lactam safety profile (rash, eosinophilia). Primarily hepatically eliminated; requires dose reduction in renal disease. Food decreases bioavailability. <i>Drug interaction:</i> Probenecid.
Colistin (colistimethate sodium; polymyxin E) Injection Inhalation	Treatment of multidrug-resistant gram-negative organisms ( <i>Enterobacteriaceae</i> including extended-spectrum β-lactamase- and carbapenemase-producing strains) Children: 2.5-5 mg/kg/day divided in 2-4 divided doses IV Adults: 300 mg/day in 2-4 divided doses IV	<i>Cautions:</i> Nephrotoxicity (~3% in young children; higher rates in adolescents and adults); adjust dose for renal insufficiency; neurotoxicity (headaches, paresthesia, ataxia). <i>Drug interactions:</i> Should not be administered concomitantly with polymyxins or aminoglycosides.
Co-trimoxazole (trimethoprim-sulfamethoxazole; TMP-SMX) Bactrim, Cotrim, Septra, Sulfatrim Tablet: SMX 400 mg and TMP 80 mg Tablet DS: SMX 800 mg and TMP 160 mg Suspension: SMX 200 mg and TMP 40 mg/5 mL Injection	Antibiotic combination with sequential antagonism of bacterial folate synthesis with broad antibacterial activity: <i>Shigella</i> , <i>Legionella</i> , <i>Nocardia</i> , <i>Chlamydia</i> , <i>Pneumocystis jiroveci</i> <b>Dosage based on TMP component</b> Children: 6-20 mg TMP/kg/24 hr or IV divided q12h PO <i>Pneumocystis carinii</i> pneumonia: 15-20 mg TMP/kg/24 hr divided q12h PO or IV <i>P. carinii</i> prophylaxis: 5 mg TMP/kg/24 hr or 3 times/wk PO Adults: 160 mg TMP q12h PO	<i>Cautions:</i> Drug dosed on TMP (trimethoprim) component. Sulfonamide skin reactions: rash, erythema multiforme, Stevens-Johnson syndrome, nausea, leukopenia. Renal and hepatic elimination; reduce dose in renal failure. <i>Drug interactions:</i> Protein displacement with warfarin, possibly phenytoin, cyclosporine.
Dalbavancin Dalvance 500 mg/vial (20 mg/mL after reconstitution) Injection	<b>Glycopeptide antibiotic; bacteriocidal; disrupts cell wall synthesis</b> Indicated for acute bacterial skin and skin structure infections caused by susceptible gram-positive bacteria; active against MRSA Adult dose: 1-dose regimen of 1,500 mg IV or 2-dose regimen of 1000 mg IV followed 1 wk later by 500 mg IV; infuse IV over 30 min Pediatric dose: Not approved for use in children	Rapid IV infusion, as with other glycopeptide antibacterial agents, can cause reactions, including upper body flushing, urticaria, pruritus, back pain, and rash; stopping or slowing infusion may result in cessation of these reactions.
Daptomycin Cubicin Injection	<b>Disrupts bacterial cell membrane function, causing depolarization leading to inhibition of protein, DNA, and RNA synthesis, which results in bacterial cell death</b> <b>Active against enterococci (including glycopeptide-resistant strains), staphylococci (including MRSA), streptococci, and corynebacteria. Approved for skin and soft tissue infections</b> <b>Acceptable for bacteremia and right-sided endocarditis with susceptible strains</b> Adults: In skin and soft tissue infections, 4 mg/kg daptomycin IV once daily. For <i>S. aureus</i> bacteremia or right-sided endocarditis, 6 mg/kg IV once daily Children: For skin/skin structure infections, 12-23 mo, 10 mg/kg IV q24h; 2-6 yr, 9 mg/kg IV q24h; 7-11 yr, 7 mg/kg q24h; 12-17 yr, 5 mg/kg q24h, all for up to 14 days. For staphylococcal bacteremia, 1-6 yr, 12 mg/kg q24h; 7-11 yr, 9 mg/kg q24h; 12-17 yr, 7 mg/kg q24h; all for up to 42 days. For staphylococcal endocarditis, 1-5 yr, 10 mg/kg IV q24h for at least 6 wk; ≥6 yr, 6 mg/kg IV q24h for at least 6 wk	<i>Cautions:</i> Should not be used for pneumonia because drug inactivated by surfactants. Associated with rash, renal failure, anemia, and headache. Is reported to cause myopathy, rhabdomyolysis, and eosinophilic pneumonia. <i>Drug interactions:</i> Should not be administered with statins.
Delafloxacin Baxdela Injection Oral Injection, lyophilized powder for reconstitution 300 mg/vial (equivalent to 433 mg delafloxacin meglumine) Tablet, 450 mg (equivalent to 649 mg delafloxacin meglumine)	<b>Fluoroquinolone class of drugs; active against MSSA, MRSA, CoNS, and streptococci; retains activity against fluoroquinolone-resistant <i>S. aureus</i> strains.</b> <b>Approved for skin and soft tissue infections and community-acquired pneumonia.</b> Adults: 300 mg IV q12h for 5-14 days OR 300 mg IV q12h, then switch to a 450-mg tablet PO q12h for 5-14 days OR 450 mg PO q12h for 5-14 days Children: No dosage established	Similar to ciprofloxacin.

Continued



Table 225.3 Selected Antibacterial Medications (Antibiotics)\*—cont'd

DRUG (TRADE NAMES, FORMULATIONS)	INDICATIONS (MECHANISM OF ACTION) AND DOSING	COMMENTS
Demeclocycline Declomycin Tablet: 150, 300 mg Capsule: 150 mg	Tetracycline active against most gram-positive cocci except <i>Enterococcus</i> , many gram-negative bacilli, anaerobes, <i>Borrelia burgdorferi</i> (Lyme disease), <i>Mycoplasma</i> , and <i>Chlamydia</i> Children: 8-12 mg/kg/24 hr divided q6-12h PO Adults: 150 mg PO q6-8h Syndrome of inappropriate antidiuretic hormone secretion: 900-1,200 mg/24 hr or 13-15 mg/kg/24 hr divided q6-8h PO with dose reduction based on response to 600-900 mg/24 hr	<b>Cautions:</b> Teeth staining, possibly permanent (if administered <8yr old) with prolonged use; photosensitivity, diabetes insipidus, nausea, vomiting, diarrhea, superinfections. <b>Drug interactions:</b> Aluminum-, calcium-, magnesium-, zinc- and iron-containing food, milk, dairy products may decrease absorption.
Dicloxacillin Dynapen, Pathocil Capsule: 125, 250, 500 mg Suspension: 62.5 mg/5 mL	Penicillinase-resistant penicillin active against <i>S. aureus</i> and other gram-positive cocci except <i>Enterococcus</i> and coagulase-negative staphylococci Children: 12.5-100 mg/kg/24 hr divided q6h PO Adults: 125-500 mg q6h PO	<b>Cautions:</b> $\beta$ -Lactam safety profile (rash, eosinophilia). Primarily renal (65%) and biliary (30%) elimination. Food may decrease bioavailability. <b>Drug interaction:</b> Probenecid.
Doripenem Doribax Injection	Carbapenem antibiotic with broad-spectrum activity against gram-positive cocci and gram-negative bacilli, including <i>P. aeruginosa</i> and anaerobes Children: dose unknown Adults: 500 mg q8h IV	<b>Cautions:</b> $\beta$ -Lactam safety profile; does not undergo hepatic metabolism. Renal elimination (70-75%); dose adjustment for renal failure. <b>Drug interactions:</b> Valproic acid, probenecid.
Doxycycline Vibramycin, Doxy Injection Capsule: 50, 100 mg Tablet: 50, 100 mg Suspension: 25 mg/5 mL Syrup: 50 mg/5 mL	Tetracycline antibiotic active against most gram-positive cocci except <i>Enterococcus</i> , many gram-negative bacilli, anaerobes, <i>B. burgdorferi</i> (Lyme disease), <i>Mycoplasma</i> , and <i>Chlamydia</i> Children: 2-5 mg/kg/24 hr divided q12-24h PO or IV (max dose: 200 mg/24 hr) Adults: 100-200 mg/24 hr divided q12-24h PO or IV	<b>Cautions:</b> Teeth staining, possibly permanent (<8yr old) with prolonged use; photosensitivity, nausea, vomiting, diarrhea, superinfections. <b>Drug interactions:</b> Aluminum-, calcium-, magnesium-, zinc-, iron-, kaolin-, and pectin-containing products, food, milk, dairy products may decrease absorption. Carbamazepine, rifampin, and barbiturates may decrease half-life.
Eravacycline Xerava 50 mg single-dose vials	Tetracycline-class antibiotic (glycylcycline) active against Enterobacteriaceae, including extended spectrum $\beta$ -lactamase producers; streptococci (including VRE); staphylococci (including MRSA); and CRE Indicated for treatment of complicated intraabdominal infections in adults Dose: 1 mg/kg IV q12h $\times$ 4-14 days; infuse IV over ~60 min	Contraindications similar to other tetracyclines, including photosensitivity; pseudotumor cerebri; concerns for discoloration of tooth enamel in children under 8 yr of age.
Erythromycin E-Mycin, Ery-Tab, Eryc, Ilosone Estolate 125, 500 mg Tablet EES: 200 mg Tablet base: 250, 333, 500 mg Suspension: estolate 125 mg/5 mL, 250 mg/5 mL, EES 200 mg/5 mL, 400 mg/5 mL Estolate drops: 100 mg/mL; EES drops: 100 mg/2.5 mL Available in combination with sulfisoxazole (Pediazole), dosed on erythromycin content	Bacteriostatic macrolide antibiotic most active against gram-positive organisms, <i>Corynebacterium diphtheriae</i> , and <i>Mycoplasma pneumoniae</i> Neonates: Postnatal age $\leq$ 7 days: 20 mg/kg/24 hr divided q12h PO; >7 days weight <1,200 g: 20 mg/kg/24 hr divided q12h PO; weight >1,200 g: 30 mg/kg/24 hr divided q8h PO (give as 5 mg/kg/dose q6h to improve feeding intolerance) Children: Usual max dose: 2 g/24 hr Base: 30-50 mg/kg/24 hr divided q6-8h PO Estolate: 30-50 mg/kg/24 hr divided q8-12h PO Stearate: 20-40 mg/kg/24 hr divided q6h PO Lactobionate: 20-40 mg/kg/24 hr divided q6-8h IV Glucetate: 20-50 mg/kg/24 hr divided q6h IV; usual max dose: 4 g/24 hr IV Adults: Base: 333 mg PO q8h; estolate/stearate/base: 250-500 mg q6h PO	<b>Cautions:</b> Motilin agonist leading to marked abdominal cramping, nausea, vomiting, and diarrhea. Associated with hypertrophic pyloric stenosis in young infants. Many different salts with questionable tempering of GI adverse events. Rare cardiac toxicity with IV use. Dose of salts differs. Topical formulation for treatment of acne. <b>Drug interactions:</b> Antagonizes hepatic CYP 3A4 activity: astemizole, carbamazepine, terfenadine, cyclosporine, theophylline, digoxin, tacrolimus.
Gentamicin Garamycin Injection Ophthalmic solution, ointment, topical cream	Aminoglycoside antibiotic active against gram-negative bacilli, especially <i>E. coli</i> , <i>Klebsiella</i> , <i>Proteus</i> , <i>Enterobacter</i> , <i>Serratia</i> , and <i>Pseudomonas</i> Neonates: Postnatal age $\leq$ 7 days weight 1,200-2,000 g: 2.5 mg/kg q12-18h IV or IM; weight <2,000 g: 2.5 mg/kg q12h IV or IM; postnatal age >7 days weight 1,200-2,000 g: 2.5 mg/kg q8-12h IV or IM; weight >2,000 g: 2.5 mg/kg q8h IV or IM Children: 2.5 mg/kg/24 hr divided q8-12h IV or IM; alternatively, may administer 5-7.5 mg/kg/24 hr IV once daily Intrathecal: Preservative-free preparation for intraventricular or intrathecal use: neonate: 1 mg/24 hr; children: 1-2 mg/24 hr intrathecal; adults: 4-8 mg/24 hr Adults: 3-6 mg/kg/24 hr divided q8h IV or IM	<b>Cautions:</b> Anaerobes, <i>S. pneumoniae</i> , and other <i>Streptococcus</i> are resistant. May cause ototoxicity and nephrotoxicity. Monitor renal function. Drug eliminated renally. Administered IV over 30-60 min. <b>Drug interactions:</b> May potentiate other ototoxic and nephrotoxic drugs. <b>Target serum concentrations:</b> Peak 6-12 mg/L; trough >2 mg/L with intermittent daily dose regimens only.

**Table 225.3** Selected Antibacterial Medications (Antibiotics)\*—cont'd

DRUG (TRADE NAMES, FORMULATIONS)	INDICATIONS (MECHANISM OF ACTION) AND DOSING	COMMENTS
<b>Imipenem-cilastatin</b> Primaxin Injection	Carbapenem antibiotic with broad-spectrum activity against gram-positive cocci and gram-negative bacilli, including <i>P. aeruginosa</i> and anaerobes. No activity against <i>Stenotrophomonas maltophilia</i> Neonates: Postnatal age ≤7 days weight <1,200 g: 20 mg/kg q18-24h IV or IM; weight >1,200 g: 40 mg/kg divided q12h IV or IM; postnatal age >7 days weight 1,200-2,000 g: 40 mg/kg q12h IV or IM; weight >2,000 g: 60 mg/kg q8h IV or IM Children: 60-100 mg/kg/24 hr divided q6-8h IV or IM Adults: 2-4 g/24 hr divided q6-8h IV or IM (max dose: 4 g/24 hr)	Cautions: β-Lactam safety profile (rash, eosinophilia), nausea, seizures. Cilastatin possesses no antibacterial activity; reduces renal imipenem metabolism. Primarily renally eliminated. Drug interaction: Possibly ganciclovir.
<b>Imipenem/relebactam</b> (imipenem/cilastatin/relebactam) Recarbrio 500 mg/500 mg/250 mg per vial (i.e., 1.25 g/vial)	Carbapenem antibiotic similar to imipenem/cilastatin; addition of relebactam restores activity against <i>K. pneumoniae</i> isolates that encode KPCs; is indicated for treatment of complicated urinary tract infections and complicated intraabdominal infections and hospital-acquired/ventilator-associated bacterial pneumonia in adults 18 yr of age and older Adults: 1.25 g IV q6h ×4-14 days Children: No dosing information available	Cautions: β-Lactam safety profile (rash, eosinophilia), nausea, seizures. Cilastatin possesses no antibacterial activity; reduces renal imipenem metabolism. Primarily renally eliminated.
<b>Linezolid</b> Zyvox Tablet: 400, 600 mg Oral suspension: 100 mg/5 mL Injection: 100 mg/5 mL	Oxazolidinone antibiotic active against gram-positive cocci (especially drug-resistant organisms), including <i>Staphylococcus</i> , <i>Streptococcus</i> , <i>E. faecium</i> , and <i>Enterococcus faecalis</i> . Interferes with protein synthesis by binding to 50S ribosome subunit Children: 10 mg/kg q12h IV or PO Adults: Pneumonia: 600 mg q12h IV or PO; skin infections: 400 mg q12h IV or PO	Adverse events: Myelosuppression, pseudomembranous colitis, nausea, diarrhea, headache, peripheral and optic neuropathy. Drug interaction: Probenecid.
<b>Loracarbef</b> Lorabid Generic Capsule: 200 mg Suspension: 100 mg/5 mL, 200 mg/5 mL	Carbacephem very closely related to cefaclor (second-generation cephalosporin) active against <i>S. aureus</i> , <i>Streptococcus</i> , <i>H. influenzae</i> , <i>M. catarrhalis</i> , <i>E. coli</i> , <i>Klebsiella</i> , and <i>Proteus</i> Children: 30 mg/kg/24 hr divided q12h PO (max dose: 2 g) Adults: 200-400 mg q12h PO (max dose: 800 mg/24 hr)	Cautions: β-Lactam safety profile (rash, eosinophilia). Renally eliminated. Drug interaction: Probenecid.
<b>Meropenem</b> Merrem Injection	Carbapenem antibiotic with broad-spectrum activity against gram-positive cocci and gram-negative bacilli, including <i>P. aeruginosa</i> and anaerobes No activity against <i>S. maltophilia</i> Children: 60 mg/kg/24 hr divided q8h IV; meningitis: 120 mg/kg/24 hr (max dose: 6 g/24 hr) q8h IV Adults: 1.5-3 g q8h IV	Cautions: β-Lactam safety profile; appears to possess less CNS excitation than imipenem; 80% renal elimination. Drug interaction: Probenecid.
<b>Meropenem/vaborbactam</b> Vabomere 1 g/1 g vials	Carbapenem antibiotic with broad-spectrum activity against gram-positive cocci and gram-negative bacilli, including <i>P. aeruginosa</i> and anaerobes Vaborbactam protects meropenem from degradation by certain serine β-lactamases including <i>K. pneumoniae</i> carbapenemases (KPCs); added to enhance activity for complicated urinary tract infections, including pyelonephritis caused by <i>E. coli</i> , <i>K. pneumoniae</i> , and <i>E. cloacae</i> species complex in adults ≥18 yr Adults: 4 g (meropenem [2 g]/vaborbactam [2 g]) IV q8h for up to 14 days; infuse over 3 hr.	Cautions: β-Lactam safety profile; appears to possess less CNS excitation than imipenem; 80% renal elimination. Drug interaction: Probenecid.
<b>Metronidazole</b> Flagyl, Metro I.V., Topical gel, vaginal gel Injection Tablet: 250, 500 mg	Highly effective in the treatment of infections caused by anaerobes. Oral therapy of <i>C. difficile</i> colitis Neonates: weight <1,200 g: 7.5 mg/kg/48 hr PO or IV; postnatal age ≤7 days weight 1,200-2,000 g: 7.5 mg/kg/24 hr q24h PO or IV; weight 2,000 g: 15 mg/kg/24 hr divided q12h PO or IV; postnatal age <7 days weight 1,200-2,000 g: 15 mg/kg/24 hr divided q12h PO or IV; weight >2,000 g: 30 mg/kg/24 hr divided q12h PO or IV Children: 30 mg/kg/24 hr divided q6-8h PO or IV Adults: 30 mg/kg/24 hr divided q6h PO or IV (max dose: 4 g/24 hr)	Cautions: Dizziness, seizures, metallic taste, nausea, disulfiram-like reaction with alcohol. Administer IV slow over 30-60 min. Adjust dose with hepatic impairment. Drug interactions: Carbamazepine, rifampin, phenobarbital may enhance metabolism; may increase levels of warfarin, phenytoin, lithium.
<b>Mezlocillin sodium</b> Mezlin Infection	Extended-spectrum penicillin active against <i>E. coli</i> , <i>Enterobacter</i> , <i>Serratia</i> , and <i>Bacteroides</i> ; limited antipseudomonal activity Neonates: Postnatal age ≤7 days: 150 mg/kg/24 hr divided q12h IV; >7 days: 225 mg/kg divided q8h IV Children: 200-300 mg/kg/24 hr divided q4-6h IV; cystic fibrosis 300-450 mg/kg/24 hr IV Adults: 2-4 g/dose q4-6h IV (max dose: 12 g/24 hr)	Cautions: β-Lactam safety profile (rash, eosinophilia); painful given intramuscularly; each gram contains 1.8mEq sodium. Interferes with platelet aggregation with high doses; increases noted in liver function test results. Renally eliminated. Inactivated by β-lactamase enzyme. Drug interaction: Probenecid.

Continued

**Table 225.3** Selected Antibacterial Medications (Antibiotics)\*—cont'd

DRUG (TRADE NAMES, FORMULATIONS)	INDICATIONS (MECHANISM OF ACTION) AND DOSING	COMMENTS
Mupirocin Bactroban Ointment	Topical antibiotic active against <i>Staphylococcus</i> and <i>Streptococcus</i> Topical application: Nasal (eliminate nasal carriage) and to the skin 2-4 times daily	<i>Caution:</i> Minimal systemic absorption because drug metabolized within the skin.
Nafcillin sodium Nafcil, Unipen Injection Capsule: 250 mg Tablet: 500 mg	Penicillinase-resistant penicillin active against <i>S. aureus</i> and other gram-positive cocci, except <i>Enterococcus</i> and coagulase-negative staphylococci Neonates: Postnatal age ≤7 days weight 1,200-2,000 g: 50 mg/kg/24 hr divided q12h IV or IM; weight >2,000 g: 75 mg/kg/24 hr divided q8h IV or IM; postnatal age >7 days weight 1,200-2,000 g: 75 mg/kg/24 hr divided q8h; weight >2,000 g: 100 mg/kg/24 hr divided q6-8h IV (meningitis: 200 mg/kg/24 hr divided q6h IV) Children: 100-200 mg/kg/24 hr divided q4-6h IV Adults: 4-12 g/24 hr divided q4-6h IV (max dose: 12 g/24 hr)	<i>Cautions:</i> β-Lactam safety profile (rash, eosinophilia), phlebitis; painful given intramuscularly; oral absorption highly variable and erratic (not recommended). <i>Adverse effect:</i> Neutropenia.
Nalidixic acid NegGram Tablet: 250, 500, 1,000 mg Suspension: 250 mg/5 mL	First-generation quinolone effective for short-term treatment of lower UTIs caused by <i>E. coli</i> , <i>Enterobacter</i> , <i>Klebsiella</i> , and <i>Proteus</i> Children: 50-55 mg/kg/24 hr divided q6h PO; suppressive therapy: 25-33 mg/kg/24 hr divided q6-8h PO Adults: 1 g q6h PO; suppressive therapy: 500 mg q6h PO	<i>Cautions:</i> Vertigo, dizziness, rash. Not for use in systemic infections. <i>Drug interactions:</i> Liquid antacids.
Neomycin sulfate Mycifradin Tablet: 500 mg Topical cream, ointment Solution: 125 mg/5 mL	Aminoglycoside antibiotic used for topical application or orally before surgery to decrease GI flora (nonabsorbable) and hyperammonemia Infants: 50 mg/kg/24 hr divided q6h PO Children: 50-100 mg/kg/24 hr divided q6-8h PO Adults: 500-2,000 mg/dose q6-8h PO	<i>Cautions:</i> In patients with renal dysfunction because small amount absorbed may accumulate. <i>Adverse events:</i> Primarily related to topical application, abdominal cramps, diarrhea, rash. Like any aminoglycoside, ototoxicity and nephrotoxicity occur if absorbed.
Nitrofurantoin Furadantin, Furan, Macrochantin Capsule: 50, 100 mg Extended-release capsule: 100 mg Macrocrystal: 50, 100 mg Suspension: 25 mg/5 mL	Effective in treatment of lower UTIs caused by gram-positive and gram-negative pathogens Children: 5-7 mg/kg/24 hr divided q6h PO (max dose: 400 mg/24 hr); suppressive therapy 1-2.5 mg/kg/24 hr divided q12-24h PO (max dose: 100 mg/24 hr) Adults: 50-100 mg/24 hr divided q6h PO	<i>Cautions:</i> Vertigo, dizziness, rash, jaundice, interstitial pneumonitis. Do not use with moderate to severe renal dysfunction. <i>Drug interactions:</i> Liquid antacids.
Ofloxacin Ocuflox 0.3% ophthalmic solution: 1, 5, 10 mL Floxin 0.3% otic solution: 5, 10 mL	Quinolone antibiotic for treatment of conjunctivitis or corneal ulcers (ophthalmic solution) and otitis externa or chronic suppurative otitis media (otic solution) caused by susceptible gram-positive, gram-negative, anaerobic bacteria, or <i>C. trachomatis</i> <i>Child &gt;1-12 yr:</i> Conjunctivitis: 1-2 drops in affected eye(s) q2-4h for 2 days, then 1-2 drops qid for 5 days Corneal ulcers: 1-2 drops q30min while awake and at 4-hr intervals at night for 2 days, then 1-2 drops hourly for 5 days while awake, then 1-2 drops q6h for 2 days Otitis externa (otic solution): 5 drops into affected ear bid for 10 days Chronic suppurative otitis media: treat for 14 days <i>Child &gt;12 yr and adults:</i> Ophthalmic solution doses same as for younger children. Otitis externa (otic solution): Use 10 drops bid for 10 or 14 days as for younger children	<i>Adverse events:</i> Burning, stinging, eye redness (ophthalmic solution), dizziness with otic solution if not warmed.
Omadacycline Nuzyra Injection 100 mg/single-dose vial Oral 150 mg tablet	New subclass of tetracyclines; active against MSSA, MRSA CoNS, streptococci, including pneumococcus, and enterococci, including VRE Adults: 200 mg IV once OR 100 mg IV × 2 doses OR 300 mg PO × 2 doses Follow with maintenance dosing starting on day 2: Maintenance dose 100 mg IV qday OR 300 mg PO qday Treatment duration: 7-14 days Children: No dosing information available	Omadacycline has comparable adverse events to other tetracyclines such as tooth discoloration, enamel hypoplasia, and inhibition of bone growth. However, no cases of photosensitivity were observed in phase 3 studies.

**Table 225.3** Selected Antibacterial Medications (Antibiotics)\*—cont'd

DRUG (TRADE NAMES, FORMULATIONS)	INDICATIONS (MECHANISM OF ACTION) AND DOSING	COMMENTS
Oxacillin sodium Prostaphlin Injection Capsule: 250, 500 mg Suspension: 250 mg/5 mL	Penicillinase-resistant penicillin active against <i>S. aureus</i> and other gram-positive cocci, except <i>Enterococcus</i> and coagulase-negative staphylococci Neonates: Postnatal age $\leq 7$ days weight 1,200-2,000 g: 50 mg/kg/24 hr divided q12h IV; weight $> 2,000$ g: 75 mg/kg/24 hr IV divided q8h IV; postnatal age $> 7$ days weight $< 1,200$ g: 50 mg/kg/24 hr IV divided q12h IV; weight 1,200-2,000 g: 75 mg/kg/24 hr divided q8h IV; weight $> 2,000$ g: 100 mg/kg/24 hr IV divided q6h IV Infants: 100-200 mg/kg/24 hr divided q4-6h IV Children: PO 50-100 mg/kg/24 hr divided q4-6h IV Adults: 2-12 g/24 hr divided q4-6h IV (max dose: 12 g/24 hr)	Cautions: $\beta$ -Lactam safety profile (rash, eosinophilia) Moderate oral bioavailability (35–65%). Primarily renally eliminated Drug interaction: Probenecid Adverse effect: Neutropenia
Penicillin G Injection Tablets	Penicillin active against most gram-positive cocci; <i>S. pneumoniae</i> (resistance is increasing), group A <i>Streptococcus</i> , and some gram-negative bacteria (e.g., <i>N. gonorrhoeae</i> , <i>N. meningitidis</i> ) Neonates: Postnatal age $\leq 7$ days weight 1,200-2,000 g: 50,000 units/kg/24 hr divided q12h IV or IM (meningitis: 100,000 U/kg/24 hr divided q12h IV or IM); weight $> 2,000$ g: 75,000 U/kg/24 hr divided q8h IV or IM (meningitis: 150,000 U/kg/24 hr divided q8h IV or IM); postnatal age $> 7$ days weight $\leq 1,200$ g: 50,000 U/kg/24 hr divided q12h IV (meningitis: 100,000 U/kg/24 hr divided q12h IV); weight 1,200-2,000 g: 75,000 U/kg/24 hr q8h IV (meningitis: 225,000 U/kg/24 hr divided q8h IV); weight $> 2,000$ g: 100,000 U/kg/24 hr divided q6h IV (meningitis: 200,000 U/kg/24 hr divided q6h IV) Children: 100,000-250,000 units/kg/24 hr divided q4-6h IV or IM (max dose: 400,000 U/kg/24 hr) Adults: 2-24 million units/24 hr divided q4-6h IV or IM	Cautions: $\beta$ -Lactam safety profile (rash, eosinophilia), allergy, seizures with excessive doses particularly in patients with marked renal disease. Substantial pathogen resistance. Primarily renally eliminated Drug interaction: Probenecid
Penicillin G, benzathine Bicillin Injection	Long-acting repository form of penicillin effective in treatment of infections responsive to persistent, low penicillin concentrations (1-4wk) (e.g., group A <i>Streptococcus</i> pharyngitis, rheumatic fever prophylaxis) Neonates weighing $> 1,200$ g: 50,000 units/kg IM once Children: 300,000-1.2 million units/kg q3-4wk IM (max dose: 1.2-2.4 million units/dose) Adults: 1.2 million units IM q3-4wk	Cautions: $\beta$ -Lactam safety profile (rash, eosinophilia), allergy. Administer by IM injection only. Substantial pathogen resistance. Primarily renally eliminated. Drug interaction: Probenecid.
Penicillin G, procaine Crysticillin Injection	Repository form of penicillin providing low penicillin concentrations for 12 hr Neonates with weight $> 1,200$ g: 50,000 units/kg/24 hr IM Children: 25,000-50,000 units/kg/24 hr IM for 10 days (max dose: 4.8 million units/dose) Gonorrhea: 100,000 units/kg (max dose: 4.8 million units/24 hr) IM once with probenecid 25 mg/kg (max dose: 1 g) Adults: 0.6-4.8 million units q12-24h IM	Cautions: $\beta$ -Lactam safety profile (rash, eosinophilia) allergy. Administer by IM injection only. Substantial pathogen resistance. Primarily renally eliminated. Drug interaction: Probenecid.
Penicillin V Pen VK, V-Cillin K Tablet: 125, 250, 500 mg Suspension: 125 mg/5 mL, 250 mg/5 mL	Preferred oral dosing form of penicillin, active against most gram-positive cocci; <i>S. pneumoniae</i> (resistance is increasing), other streptococci, and some gram-negative bacteria (e.g., <i>N. gonorrhoeae</i> , <i>N. meningitidis</i> ) Children: 25-50 mg/kg/24 hr divided q4-8h PO Adults: 125-500 mg q6-8h PO (max dose: 3 g/24 hr)	Cautions: $\beta$ -Lactam safety profile (rash, eosinophilia), allergy, seizures with excessive doses particularly in patients with renal disease. Substantial pathogen resistance. Primarily renally eliminated. Inactivated by penicillinase. Drug interaction: Probenecid.
Piperacillin Pipracil Injection	Extended-spectrum penicillin active against <i>E. coli</i> , <i>Enterobacter</i> , <i>Serratia</i> , <i>P. aeruginosa</i> , and <i>Bacteroides</i> Neonates: Postnatal age $\leq 7$ days 150 mg/kg/24 hr divided q8-12h IV; $> 7$ days: 200 mg/kg divided q6-8h IV Children: 200-300 mg/kg/24 hr divided q4-6h IV; cystic fibrosis: 350-500 mg/kg/24 hr IV Adults: 2-4 g/dose q4-6h (max dose: 24 g/24 hr) IV	Cautions: $\beta$ -Lactam safety profile (rash, eosinophilia); painful given intramuscularly; each gram contains 1.9 mEq sodium. Interferes with platelet aggregation/serum sickness-like reaction with high doses; increases in liver function test results. Renally eliminated. Inactivated by penicillinase. Drug interaction: Probenecid.
Piperacillin-tazobactam Zosyn Injection	Extended-spectrum penicillin (piperacillin) combined with a $\beta$ -lactamase inhibitor (tazobactam) active against <i>S. aureus</i> , <i>H. influenzae</i> , <i>E. coli</i> , <i>Enterobacter</i> , <i>Serratia</i> , <i>Acinetobacter</i> , <i>P. aeruginosa</i> , and <i>Bacteroides</i> Children: 300-400 mg/kg/24 hr divided q6-8h IV or IM Adults: 3.375 g q6-8h IV or IM	Cautions: $\beta$ -Lactam safety profile (rash, eosinophilia); painful given intramuscularly; each gram contains 1.9 mEq sodium. Interferes with platelet aggregation, serum sickness-like reaction with high doses, increases in liver function test results. Renally eliminated. Drug interaction: Probenecid.

Continued



**Table 225.3** Selected Antibacterial Medications (Antibiotics)\*—cont'd

DRUG (TRADE NAMES, FORMULATIONS)	INDICATIONS (MECHANISM OF ACTION) AND DOSING	COMMENTS
Plazomicin Zemdri 500 mg/10 mL (50 mg/mL) vials Each vial contains plazomicin sulfate equivalent to 500 mg plazomicin free base	Aminoglycoside active against resistant Enterobacteriaceae, including CRE Adults: 15 mg/kg IV q24hr infused over 30 min Duration of therapy should be guided by the severity of infection and the patient's clinical status for up to 7 days; usual duration 4-7 days Children: no pediatric dose established	May cause ototoxicity and nephrotoxicity. Monitor renal function. Drug eliminated renally. <i>Drug interactions:</i> May potentiate other ototoxic and nephrotoxic drugs.
Quinupristin/dalfopristin Synercid IV injection: powder for reconstitution, 10 mL contains 150 mg quinupristin, 350 mg dalfopristin	Streptogramin antibiotic (quinupristin) active against vancomycin-resistant <i>E. faecium</i> (VRE) and methicillin-resistant <i>S. aureus</i> (MRSA). Not active against <i>E. faecalis</i> Children and adults: VRE: 7.5 mg/kg q8h IV for VRE; skin infections: 7.5 mg/kg q12h IV	<i>Adverse events:</i> Pain, edema, or phlebitis at injection site; nausea; diarrhea. <i>Drug interactions:</i> Synercid is a potent inhibitor of CYP 3A4.
Sulfadiazine Tablet: 500 mg	Sulfonamide antibiotic primarily indicated for treatment of lower UTIs caused by <i>E. coli</i> , <i>P. mirabilis</i> , and <i>Klebsiella</i> Toxoplasmosis: Neonates: 100 mg/kg/24 hr divided q12h PO with pyrimethamine 1 mg/kg/24 hr PO (with folinic acid) Children: 120-200 mg/kg/24 hr divided q6h PO with pyrimethamine 2 mg/kg/24 hr divided q12h PO ≥3 days, then 1 mg/kg/24 hr (max dose: 25 mg/24 hr) with folinic acid Rheumatic fever prophylaxis: weight ≤30 kg: 500 mg/24 hr q24h PO; weight >30 kg: 1 g/24 hr q24h PO	<i>Cautions:</i> Rash, Stevens-Johnson syndrome, nausea, leukopenia, crystalluria. Renal and hepatic elimination; avoid use with renal disease. Half-life: ~10 hr. <i>Drug interactions:</i> Protein displacement with warfarin, phenytoin, methotrexate.
Sulfamethoxazole Gantanol Tablet: 500 mg Suspension: 500 mg/5 mL	Sulfonamide antibiotic used for treatment of otitis media, chronic bronchitis, and lower UTIs caused by susceptible bacteria Children: 50-60 mg/kg/24 hr divided q12h PO Adults: 1 g/dose q12h PO (max dose: 3 g/24 hr)	<i>Cautions:</i> Rash, Stevens-Johnson syndrome, nausea, leukopenia, crystalluria. Renal and hepatic elimination; avoid use with renal disease. Half-life: ~12 hr. Initial dose often a loading dose (doubled). <i>Drug interactions:</i> Protein displacement with warfarin, phenytoin, methotrexate.
Sulfisoxazole Gantrisin Tablet: 500 mg Suspension: 500 mg/5 mL Ophthalmic solution, ointment	Sulfonamide antibiotic used for treatment of otitis media, chronic bronchitis, and lower UTIs caused by susceptible bacteria. Also used for <i>Nocardia</i> <i>Plasmodium falciparum</i> resistant to chloroquine, toxoplasmosis in combination with pyrimethamine (sulfadiazine preferred). Children: 120-150 mg/kg/24 hr divided q4-6h PO (max dose: 6 g/24 hr) Adults: 4-8 g/24 hr divided q4-6h PO	<i>Cautions:</i> Rash, Stevens-Johnson syndrome, nausea, leukopenia, crystalluria. Renal and hepatic elimination; avoid use with renal disease. Half-life: ~7-12 hr. Initial dose often a loading dose (doubled). <i>Drug interactions:</i> Protein displacement with warfarin, phenytoin, methotrexate.
Tedizolid Sivextro 200 mg vial 200 mg tablet	Oxazolidinone agent; indicated for skin and soft tissue/skin structure infections caused by susceptible gram-positive organisms; active against MSSA, MRSA, streptococci, enterococci Adults: 200 mg PO/IV qday for 6 days Children: Indicated for acute bacterial skin and skin structure infections in patients age ≥12 yr <12 yr: Safety and efficacy not established 12-18 yr: 200 mg PO/IV qday for 6 days	Similar to linezolid. <i>Adverse events</i> may include myelosuppression, pseudomembranous colitis, nausea, diarrhea, headache, peripheral and optic neuropathy.
Tigecycline Tygacil Injection	Tetracycline-class antibiotic (glycylcycline) active against Enterobacteriaceae, including extended spectrum β-lactamase producers; streptococci (including VRE); staphylococci (including MRSA); and anaerobes Children: unknown Adults: 100 mg loading dose followed by 50 mg q12h IV	<i>Cautions:</i> Pregnancy; children <8 yr old; photosensitivity; hypersensitivity to tetracyclines; hepatic impairment (~60% hepatic clearance). <i>Drug interaction:</i> Warfarin; mycophenolate mofetil.
Tobramycin Nebcin, Tobrex Injection Ophthalmic solution, ointment Inhalation capsule (28 mg); inhalation solution (60 mg/mL; 75 mg/mL)	Aminoglycoside antibiotic active against gram-negative bacilli, especially <i>E. coli</i> , <i>Klebsiella</i> , <i>Enterobacter</i> , <i>Serratia</i> , <i>Proteus</i> , and <i>Pseudomonas</i> Can be administered by inhalational route Neonates: Postnatal age ≤7 days, weight 1,200-2,000 g: 2.5 mg/kg q12-18h IV or IM; weight >2,000 g: 2.5 mg/kg q12h IV or IM; postnatal age >7 days, weight 1,200-2,000 g: 2.5 mg/kg q8-12h IV or IM; weight >2,000 g: 2.5 mg/kg q8h IV or IM Children: 2.5 mg/kg/24 hr divided q8-12h IV or IM. Alternatively, may administer 5-7.5 mg/kg/24 hr IV. Preservative-free preparation for intraventricular or intrathecal use: neonate, 1 mg/24 hr; children, 1-2 mg/24 hr; adults, 4-8 mg/24 hr Adults: 3-6 mg/kg/24 hr divided q8h IV or IM	<i>Cautions:</i> <i>S. pneumoniae</i> , other streptococcus, and anaerobes are resistant. May cause ototoxicity and nephrotoxicity. Monitor renal function. Drug eliminated renally. Administered IV over 30-60 min. <i>Drug interactions:</i> May potentiate other ototoxic and nephrotoxic drugs. <i>Target serum concentrations:</i> Peak 6-12 mg/L; trough <2 mg/L.

**Table 225.3** Selected Antibacterial Medications (Antibiotics)\*—cont'd

DRUG (TRADE NAMES, FORMULATIONS)	INDICATIONS (MECHANISM OF ACTION) AND DOSING	COMMENTS
Trimethoprim Proloprim, Trimplex Tablet: 100, 200 mg	Folic acid antagonist effective in prophylaxis and treatment of <i>E. coli</i> , <i>Klebsiella</i> , <i>P. mirabilis</i> , and <i>Enterobacter</i> UTIs; <i>P. carinii</i> pneumonia Children: For UTI: 4-6 mg/kg/24 hr divided q12h PO Children >12 yr and adults: 100-200 mg q12h PO. <i>P. carinii</i> pneumonia (with dapson): 15-20 mg/kg/24 hr divided q6h for 21 days PO	<i>Cautions:</i> Megaloblastic anemia, bone marrow suppression, nausea, epigastric distress, rash. <i>Drug interactions:</i> Possible interactions with phenytoin, cyclosporine, rifampin, warfarin.
Vancomycin Vancocin, Lyphocin Injection Capsule: 125 mg, 250 mg Suspension	Glycopeptide antibiotic active against most gram-positive pathogens including staphylococci (including MRSA and coagulase-negative staphylococci), <i>S. pneumoniae</i> including penicillin-resistant strains, <i>Enterococcus</i> (resistance is increasing), and <i>C. difficile</i> -associated colitis Neonates: Postnatal age ≤7 days, weight <1,200 g: 15 mg/kg/24 hr divided q24h IV; weight 1,200-2,000 g: 15 mg/kg/24 hr divided q12-18h IV; weight >2,000 g: 30 mg/kg/24 hr divided q12h IV; postnatal age >7 days, weight <1,200 g: 15 mg/kg/24 hr divided q24h IV; weight 1,200-2,000 g: 15 mg/kg/24 hr divided q8-12h IV; weight >2,000 g: 45 mg/kg/24 hr divided q8h IV Children: 45-60 mg/kg/24 hr divided q8-12h IV; <i>C. difficile</i> -associated colitis; 40-50 mg/kg/24 hr divided q6-8h PO	<i>Cautions:</i> Ototoxicity and nephrotoxicity, particularly when co-administered with other ototoxic and nephrotoxic drugs. Infuse IV over 45-60 min. Cutaneous and systemic side effects can be observed with rapid IV infusions, fever, chills, phlebitis (central line is preferred for infusions). Renally eliminated. <i>Target serum concentrations:</i> Peak (1 hr after 1 hr infusion) 30-40 mg/L; trough 5-10 mg/L.

\*In the Drug column, the generic drug name is in bold. In the Indications column, bold indicates major organisms targeted and mechanisms of action. CNS, Central nervous system; GI, gastrointestinal; IM, intramuscular/ly; IV, intravenous/ly; PO, oral/ly; UTIs, urinary tract infections.

**Table 225.4** Adverse Reactions to Penicillins

TYPE OF REACTION	FREQUENCY (%)	OCCURS MOST FREQUENTLY WITH
<b>ALLERGIC</b>		
Immunoglobulin E antibody	0.04-0.015	Penicillin G
Anaphylaxis*		
Early urticaria* (<72 hr)		
Cytotoxic antibody	Rare	Penicillin G
Hemolytic anemia*		
Antigen-antibody complex disease	Rare	Penicillin G
Serum sickness*		
Delayed hypersensitivity	2-5	Ampicillin, amoxicillin
Contact dermatitis*		
<b>IDIOPATHIC</b>	2-5	Ampicillin
Skin rash		
Fever		
Late-onset urticaria		
<b>GASTROINTESTINAL</b>		
Diarrhea	3-11	Ampicillin
<i>Clostridioides difficile</i> (formerly <i>Clostridium difficile</i> )-associated colitis	Rare	Ampicillin
<b>HEMATOLOGIC</b>		
Hemolytic anemia	Rare	Penicillin G
Neutropenia	10-17	Penicillin G, nafcillin, oxacillin†
Platelet dysfunction	43-73	Piperacillin
<b>HEPATIC</b>		
Elevated serum aspartate transaminase	0.01-22	Flucloxacillin, oxacillin

Continued

**Table 225.4** Adverse Reactions to Penicillins—cont'd

TYPE OF REACTION	FREQUENCY (%)	OCCURS MOST FREQUENTLY WITH
<b>ELECTROLYTE DISTURBANCE</b>		
Hypokalemia	Rare	Nafcillin, oxacillin
Hyperkalemia, acute	Rare	Penicillin G
<b>NEUROLOGIC</b>		
Seizures	Rare	Penicillin G
Bizarre sensations (Hoigné syndrome)	Rare	Procaine penicillin
<b>RENAL</b>		
Interstitial nephritis*	Variable	Any penicillin

\*Reaction can occur with any of the penicillins.

†With prolonged therapy.

Adapted from Doi Y. Penicillins and  $\beta$ -lactamase inhibitors. In Bennett JE, Dolin R, Blaser MJ, eds. *Mandell, Douglas, and Bennett's Principles and Practice of Infectious Diseases*, 9th ed. Philadelphia: Elsevier; 2020: Table 20-7.

**Table 225.5** Classification of Parenteral and Oral Cephalosporins

CEPHALOSPORINS	FIRST GENERATION	SECOND GENERATION	CEPHAMYCINS	THIRD GENERATION	FOURTH GENERATION	FIFTH GENERATION (MRSA ACTIVE)
Parenteral	Cefazolin (Ancef, Kefzol)	Cefamandole (Mandol)*	Cefmetazole (Zefazone)*	Cefoperazone (Cefobid)*	Cefepime (Maxipime)	Ceftaroline (Teflaro)
	Cephalothin (Keflin, Seffin)*	Cefonicid (Monocid)*	Cefotetan (Cefotan)	Cefotaxime (Claforan)	Cefpirome (Cefrom)	Ceftobiprole (Zeftera)*
	Cephapirin (Cefadyl)*	Cefuroxime (Kefurox, Zinacef)	Cefoxitin (Mefoxin)	Ceftazidime (Fortaz)	Cefiderocol (Fetroja; Siderophore antibiotic)	Ceftolozane (combined with tazobactam; Zerbaxa)
	Cephradine (Velosef)*			Ceftizoxime (Cefizox)*		
				Ceftriaxone (Rocephin)		
				Moxalactam*		
				Ceftazidime-avibactam (Avycaz)		
Oral	Cefadroxil (Duricef, Ultracef)	Cefaclor (Ceclor)*	Cefprozil (Cefzil)	Cefdinir (Omnicef)	Cefditoren (Spectracef)	
	Cephalexin (Keflex, Biocef, Keftab)	Cefuroxime axetil (Ceftin)	Loracarbef (Lorabid)*	Cefixime (Suprax)	Cefpodoxime (Vantin)	
	Cephadrine (Velosef)*			Ceftibuten (Cedax)		

\*Not currently available in the United States.

Adapted from Lepak AJ, Andes DR. Cephalosporins. In: Bennett JE, Dolin R, Blaser MJ, eds. *Mandell, Douglas, and Bennett's Principles and Practice of Infectious Diseases*, 9th ed. Philadelphia: Elsevier; 2020: Table 21-1.

A **fifth-generation cephalosporin** called *ceftaroline* has been licensed. Ceftaroline is the active metabolite of the prodrug ceftaroline fosamil (which is the agent administered to the patient). Ceftaroline is a broad-spectrum cephalosporin with bactericidal activity against resistant gram-positive organisms, including MRSA, and common gram-negative pathogens. It has FDA approval and is licensed for use in children. Ceftaroline is indicated for MRSA in the treatment of skin and soft tissue infections. It is also licensed for treatment of community-acquired pneumonia but is not indicated for MRSA pneumonia. Ceftaroline's activity is attributed to its ability to bind to PBP 2a with higher affinity than other  $\beta$ -lactams. Another fifth-generation cephalosporin with a similar spectrum of activity, *ceftobiprole*, has been approved for use in Canada and the European Union. A third

fifth-generation cephalosporin, *ceftolozane*, has been licensed. It is a derivative of ceftazidime with improved activity against *Pseudomonas* spp. It is not stable against most ESBLs or carbapenemases. It is marketed in combination with the  $\beta$ -lactam inhibitor tazobactam to improve its activity against  $\beta$ -lactamase-producing Enterobacteriaceae. Experience with children is limited.

[Table 225.6](#) lists adverse reactions to cephalosporins.

### Carbapenems

The carbapenem group of antibiotics includes imipenem (formulated in combination with cilastatin), meropenem, ertapenem, and doripenem. The basic structure of these agents is similar to that of  $\beta$ -lactam antibiotics, and these drugs have a similar mechanism of

**Table 225.6** Potential Adverse Effects of Cephalosporins

TYPE	SPECIFIC	FREQUENCY
Hypersensitivity	Rash	1–3%
	Urticaria	<1%
	Serum sickness	<1%
	Anaphylaxis	0.01%
Gastrointestinal	Diarrhea	1–19%
	Nausea, vomiting	1–6%
	Transient transaminase elevation	1–7%
	Biliary sludge	20–46%*
Hematologic	Eosinophilia	1–10%
	Neutropenia	<1%
	Thrombocytopenia	<1–3%
	Hypoprothrombinemia	<1%
	Impaired platelet aggregation	<1%
	Hemolytic anemia	<1%
Renal	Interstitial nephritis	<1–5%
Central nervous system	Seizures	<1%
	Encephalopathy	<1%
False-positive laboratory	Coombs positive	3%
	Glucosuria	Rare
	Serum creatinine	Rare
Other	Drug fever	Rare
	Disulfiram-like reaction <sup>†</sup>	Rare
	Superinfection	Rare
	Phlebitis	Rare
	Calcium-antibiotic precipitation*	Unknown; can be associated with embolic events

\*Ceftriaxone.

<sup>†</sup>Cephalosporins with thiomethyl tetrazole ring (MTT) side chain.Adapted from Craig WA, Andes DR. Cephalosporins. In: Bennett JE, Dolin R, Blaser MJ, eds. *Mandell, Douglas, and Bennett's Principles and Practice of Infectious Diseases*, 9th ed. Philadelphia: Elsevier; 2020: Table 21-6.

action. The carbapenems provide the broadest spectrum of antibacterial activity of any licensed class of antibiotics and are active against gram-positive, gram-negative, and anaerobic organisms. Among the carbapenems, **meropenem** is the only agent licensed for treatment of pediatric meningitis. Importantly, MRSA and *E. faecium* are *not* susceptible to carbapenems. Carbapenems also tend to be poorly active against *Stenotrophomonas maltophilia*, rendering their use for cystic fibrosis patients who are infected with this organism problematic. Ertapenem is poorly active against *P. aeruginosa* and *Acinetobacter* species and should be avoided when these pathogens are encountered. Although imipenem-cilastatin is the first carbapenem approved for clinical use and the carbapenem with the greatest clinical experience, this antibiotic unfortunately has a propensity to cause seizures in children, particularly in the setting of intercurrent meningitis. Accordingly, meropenem is typically more suitable for pediatric use, where meningitis is commonly a consideration. Carbapenems have also been combined with  $\beta$ -lactamase inhibitors. One example is **meropenem/vaborbactam**, where the  $\beta$ -lactamase inhibitor vaborbactam extends the spectrum of activity to include some ESBL- and

carbapenemase-producing bacteria. No dosage recommendations exist as yet for pediatric use. Another example is **imipenem/relebactam** (imipenem/cilastatin/relebactam), which is approved for complicated urinary tract and intraabdominal infections and for ventilator-associated pneumonia.

Other carbapenems in various stages of clinical trials include benipenem, panipenem, biapenem, razupenem, and tomopenem. Tebipenem pivoxil is an orally available prodrug of tebipenem, a carbapenem with activity against multidrug-resistant gram-negative pathogens, including quinolone-resistant and ESBL-producing Enterobacteriaceae. Sulopenem/sulopenem etzadroxil/probenecid is an oral carbapenem combination. Sulopenem etzadroxil is an oral prodrug form of sulopenem, a thiopenem with broad-spectrum antibacterial activity against most gram-positive and gram-negative bacteria, not including *P. aeruginosa*. Probenecid is included to prolong half-life. Panipenem is a combination agent coformulated with betamipron, which inhibits renal uptake of panipenem (analogous to imipenem/cilastatin). Panipenem, biapenem, and tebipenem/pivoxil are licensed in Japan. There is minimal experience with pediatric dosing for all of these newer carbapenems.



## Glycopeptides

Glycopeptide antibiotics include **vancomycin** and **teicoplanin**, the less commonly available analog. These agents are bactericidal and act by inhibiting cell wall biosynthesis. The antimicrobial activity of the glycopeptides is limited to gram-positive organisms, including *S. aureus*, coagulase-negative staphylococci, pneumococcus, enterococci, *Bacillus*, and *Corynebacterium*. Vancomycin is frequently employed in pediatric practice and is of particular value for serious infections, including meningitis, caused by MRSA and penicillin- and cephalosporin-resistant *S. pneumoniae*. Vancomycin is also commonly used for infections in the setting of fever and neutropenia in oncology patients, in combination with other antibiotics (see [Chapter 223](#)), and for infections associated with indwelling medical devices (see [Chapter 224](#)). Oral formulations of vancomycin are occasionally used to treat pseudomembranous colitis caused by *Clostridium difficile* infections; intrathecal therapy may also be used for selected CNS infections. Vancomycin must be administered with care because of its propensity to produce **vancomycin infusion syndrome**, which is a reversible adverse effect that is rare in young children and can typically be readily managed by slowing the rate of drug infusion.

Newer FDA-approved glycopeptide antibiotics include telavancin, dalbavancin, and oritavancin; pediatric experience is limited. **Telavancin** is indicated for skin and skin structure infections caused by *S. aureus* (including MRSA), group A streptococcus, and *E. faecalis* (vancomycin-susceptible isolates only). It is also approved for hospital-acquired (including ventilator-associated) pneumonia caused by *S. aureus*. The recommended adult dose for skin and soft tissue infections, and for nosocomial pneumonia, is 10 mg/kg intravenously (IV) every 24 hours for 7-21 days. Telavancin appears to be more nephrotoxic than vancomycin and has been associated with prolongation of the QT interval. **Dalbavancin's** unique characteristic is its long half-life, 150-250 hours. In adults with normal renal function, the dose is 1000 mg IV, followed 1 week later by 500 mg IV. This agent can be considered when MRSA is confirmed or strongly suggested. Dalbavancin is not active against vancomycin-resistant *S. aureus*. It is FDA-approved for bacterial skin and soft tissue infections. **Oritavancin** is a vancomycin derivative with indications similar to those of dalbavancin. It has a half-life of approximately 250 hours. The dosage for adults is a single 1200-mg dose administered IV over 3 hours. The FDA has approved dalbavancin and oritavancin for the treatment of acute bacterial skin and skin structure infections caused by gram-positive bacteria, including MRSA. **Cefilavancin** is a unique agent spanning two antimicrobial classes in a single agent. It is a covalently linked glycopeptide-cephalosporin heterodimer antibiotic that is highly active against gram-positive bacteria and is in a phase 3 study.

## Aminoglycosides

Aminoglycoside antibiotics include streptomycin, kanamycin, gentamicin, tobramycin, netilmicin, and amikacin. The most commonly used aminoglycosides in pediatric practice are **gentamicin** and **tobramycin**. They exert their action by inhibiting bacterial protein synthesis. Although they are most often used to treat gram-negative infections, the aminoglycosides are broad-spectrum agents, with activity against *S. aureus* and synergistic activity against GBS, *L. monocytogenes*, viridans streptococci, *Corynebacteria jeikeium*, *P. aeruginosa*, coagulase-negative staphylococci, and enterococci when co-administered with a  $\beta$ -lactam agent. Aminoglycoside use has decreased with the development of alternatives, but they still play a key role in pediatric practice in the management of neonatal sepsis, UTIs, gram-negative bacterial sepsis, and complicated intraabdominal infections; infections in cystic fibrosis patients (including both parenteral and aerosolized forms of therapy); and oncology patients with fever and neutropenia. Aminoglycosides, in particular streptomycin, are also important in the management of *Francisella tularensis*, *Mycobacterium tuberculosis*, and nontuberculous mycobacterial infections.

Toxicities of aminoglycoside therapy include nephrotoxicity and ototoxicity (cochlear and/or vestibular), and serum levels as well as renal function and hearing should be monitored in patients on long-term therapy. Toxicities of aminoglycosides may be reduced by the use of once-daily dosing regimens with appropriate monitoring of serum levels. Hypokalemia, volume depletion, hypomagnesemia, and other nephrotoxic drugs may increase the renal toxicity of aminoglycosides. A rare complication of aminoglycosides is **neuromuscular blockade**, which may occur in the presence of other neuromuscular blocking agents and in the setting of infant botulism.

A novel aminoglycoside, **plazomicin**, has recently been approved by the FDA for adult use. It was designed to evade all of the clinically relevant aminoglycoside-modifying enzymes ([Table 225.2](#)) responsible for aminoglycoside resistance. It is approved for complicated UTIs, including pyelonephritis caused by *E. coli*, *K. pneumoniae*, *Proteus mirabilis*, and *Enterobacter cloacae*. FDA approval is pending for bloodstream infections caused by multidrug-resistant *Enterobacteriaceae*, including CRE.

## Tetracyclines

The tetracyclines (tetracycline hydrochloride, doxycycline, minocycline, demeclocycline, eravacycline, omadacycline, and minocycline) are bacteriostatic antibiotics that exhibit their antimicrobial effect by binding to the bacterial 30S ribosomal subunit, inhibiting protein translation. These agents have a broad spectrum of antimicrobial activity against gram-positive and gram-negative bacteria, rickettsia, and some parasites. The oral bioavailability of these agents facilitates oral dosing for many infections, including Rocky Mountain spotted fever, anaplasmosis, ehrlichiosis, Lyme disease, and malaria. Tetracyclines must be prescribed judiciously to children <9 years old, because they can cause staining of teeth, hypoplasia of dental enamel, and abnormal bone growth in this age-group.

**Tigecycline**, a semisynthetic derivative of minocycline, is a parenteral agent of a new antibiotic class (**glycylcyclines**) and is licensed in the United States. It has a broader spectrum of activity (bacteriostatic) than traditional tetracyclines but retains the side effect profile of tetracyclines. Tigecycline is active against tetracycline-resistant gram-positive and gram-negative pathogens, including MRSA and possibly VRE, but not *Pseudomonas*. **Demeclocycline** is an orally administered tetracycline with a similar antimicrobial spectrum as other agents in this class. A novel tetracycline derivative, **eravacycline** (a fluorocycline), has recently been approved for treatment of complicated intraabdominal infections in adults and has the broadest spectrum of any tetracycline, including MRSA and CRE. **Omadacycline** is another new tetracycline that is similar to that of other tetracyclines, functioning as an inhibitor of bacterial protein synthesis, but has activity against bacterial strains expressing the two main forms of tetracycline resistance, specifically, antibiotic efflux and ribosomal protection.

Complications of tetracyclines include eosinophilia, leukopenia and thrombocytopenia (tetracycline), pseudotumor cerebri, anorexia, emesis and nausea, hepatitis, photosensitivity, and a hypersensitivity reaction (urticaria, asthma exacerbation, facial edema, dermatitis) as well as a systemic lupus erythematosus-like syndrome (most common with minocycline). The FDA has issued a "black box" warning regarding tigecycline based on a meta-analysis of 10 studies that showed increased mortality among patients receiving this drug.

A salutary side effect of **demeclocycline** has been identified; it is occasionally used as an off-label treatment of hyponatremia resulting from the syndrome of inappropriate antidiuretic hormone (ADH). The mechanism of action appears to be inhibition of adenylyl cyclase activation after ADH binds to renal vasopressin receptors.

## Sulfonamides

Trimethoprim and the sulfonamides are bacteriostatic agents that inhibit the bacterial folate synthesis pathway, in the process impairing both nucleic acid and protein synthesis. Sulfonamides interfere

with the synthesis of dihydropteroic acid from paraaminobenzoic acid, whereas trimethoprim acts at a site further downstream, interfering with synthesis of tetrahydrofolic acid from dihydrofolic acid. The sulfonamides are available in both parenteral and oral formulations. Although there have historically been a large number of sulfonamide antibiotics developed for clinical use, relatively few remain available for pediatric practice. The most important agent is the combination of **trimethoprim-sulfamethoxazole** (TMP-SMX), used for treatment of UTIs. TMP-SMX has also emerged as a commonly prescribed agent for staphylococcal skin and soft tissue infections, because this antibiotic generally retains activity against MRSA. TMP-SMX also plays a unique role in immunocompromised patients, as a prophylactic and therapeutic agent for *Pneumocystis jiroveci* infection. Other common sulfonamides include **sulfisoxazole**, which is useful in the management of UTIs, and **sulfadiazine**, which is a drug of choice in the treatment of toxoplasmosis.

Recently, a novel sulfonamide, **iclaprim**, demonstrated noninferiority to vancomycin in the treatment of complicated skin and soft tissue infections. Iclaprim is a diaminopyrimidine with a 20-fold higher affinity for the target molecule for sulfonamides, dihydrofolate reductase, than trimethoprim. It was granted orphan drug status by the FDA for treatment of *S. aureus* infection in patients with cystic fibrosis but has not been formally approved for general use.

### Macrolides

The macrolide antibiotics most often used in pediatric practice include **erythromycin**, **clarithromycin**, and **azithromycin**. This class of antimicrobials exerts its antibiotic effect through binding to the 50S subunit of the bacterial ribosome, producing a block in elongation of bacterial polypeptides. Clarithromycin is metabolized to 14-hydroxy clarithromycin, and this active metabolite also has potent antimicrobial activity. The spectrum of antibiotic activity includes many gram-positive bacteria. Unfortunately, resistance to these agents among *S. aureus* and group A streptococcus is fairly widespread, limiting the usefulness of macrolides for many skin and soft tissue infections and for streptococcal pharyngitis. Azithromycin and clarithromycin have demonstrated efficacy for otitis media. All macrolide members have an important role in the management of pediatric respiratory infections, including atypical pneumonia caused by *M. pneumoniae*, *Chlamydia pneumoniae*, and *Legionella pneumophila*, as well as infections caused by *Bordetella pertussis*.

**Telithromycin**, a ketolide antibiotic derived from erythromycin, was initially FDA-approved for the treatment in adults of mild to moderate community-acquired pneumonia, acute exacerbations of chronic bronchitis, and acute sinusitis, having good activity against the agents causing these infections (*S. pneumoniae*, *M. pneumoniae*, *C. pneumoniae*, and *L. pneumophila* for community-acquired pneumonia; *M. catarrhalis* and *H. influenzae* for sinusitis). Reports of liver failure and myasthenia gravis from telithromycin prompted the withdrawal of the drug from the market. **Solithromycin** is a related next-generation oral and IV fluoroketolide in phase 3 clinical development for the treatment of community-acquired pneumonia.

Drug interactions are common with erythromycin and to a lesser extent with clarithromycin. These agents can inhibit the CYP 3A4 enzyme system, resulting in increased levels of certain drugs, such as astemizole, cisapride, statins, pimozide, and theophylline. Itraconazole may increase macrolide levels, whereas rifampin, carbamazepine, and phenytoin may decrease macrolide levels. There are few reported adverse drug interactions with azithromycin. Cross-resistance may develop between a macrolide and the subsequent use of clindamycin.

### Lincosamides

The prototype of the lincosamide class of antibiotics is **clindamycin**, which acts at the ribosomal level to exert its antimicrobial effect. The 50S subunit of the bacterial ribosome is the molecular target of this agent. Its spectrum of activity includes gram-positive aerobes and anaerobes. Clindamycin has no significant activity against

gram-negative organisms. An important role for clindamycin has emerged in the management of MRSA infections. Because of its outstanding penetration into body fluids (excluding the CNS) and tissues and bone, clindamycin can be used for therapy of serious infections caused by MRSA. Clindamycin is also useful in the management of invasive group A streptococcus infections and in the management of many anaerobic infections, often in combination with a  $\beta$ -lactam. A form of **inducible clindamycin resistance** is exhibited by some strains of MRSA; therefore consultation with the clinical microbiology laboratory is necessary before treating a serious MRSA infection with clindamycin. Pseudomembranous colitis, a common complication of clindamycin therapy in adults, is seldom observed in pediatric patients. Clindamycin also plays an important role in the treatment of malaria and babesiosis (when co-administered with quinine), *P. jiroveci* pneumonia (when co-administered with primaquine), and toxoplasmosis.

### Quinolones

The **fluoroquinolones** (ciprofloxacin, levofloxacin, moxifloxacin, gemifloxacin, besifloxacin [ophthalmic suspension], ofloxacin, and delafloxacin) are antimicrobials that inhibit bacterial DNA replication by binding to the topoisomerases of the target pathogen, inhibiting the bacterial enzyme DNA gyrase. This class has broad-spectrum activity against both gram-positive and gram-negative organisms. Some fluoroquinolones exhibit activity against penicillin-resistant *S. pneumoniae* as well as MRSA. These agents uniformly show excellent activity against gram-negative pathogens, including the Enterobacteriaceae and respiratory tract pathogens such as *M. catarrhalis* and *H. influenzae*. Quinolones are also highly active against pathogens associated with atypical pneumonia, particularly *M. pneumoniae* and *L. pneumophila*.

Although these agents are not approved for use in children, there is a reasonable body of evidence that the fluoroquinolones are generally safe, well tolerated, and effective against a variety of bacterial infections frequently encountered in pediatric practice. Parenteral quinolones are appropriate for critically ill patients with gram-negative infections. The use of oral quinolones in stable outpatients may also be reasonable for treatment of infections that would otherwise require parenteral antibiotics (e.g., *P. aeruginosa* soft tissue infections such as osteochondritis) or selected genitourinary tract infections. However, these agents should be reserved for situations when no other oral antibiotic alternative is feasible. In 2013 the FDA changed the warning labels for the fluoroquinolones to better describe the associated risk of permanent peripheral neuropathy. Additional risks include tendonitis, arrhythmias, and retinal detachment. Moreover, in situations of overuse (e.g., typhoid fever, gonococcal infection), organisms have been demonstrated to rapidly develop resistance. The FDA has advised against the use of quinolones for uncomplicated infections such as sinusitis and bronchitis. Thus use of fluoroquinolones in pediatric practice should still be approached with continued caution, and consultation with an expert is recommended.

### Streptogramins and Oxazolidinones

The emergence of highly resistant gram-positive organisms, in particular VRE, has necessitated development of new classes of antibiotics. One such class especially useful for resistant gram-positive infections is the streptogramins. The currently licensed agent in this category is **dalfopristin-quinupristin**, which is available in a parenteral formulation. It is appropriate for treatment of MRSA, coagulase-negative staphylococci, penicillin-susceptible and penicillin-resistant *S. pneumoniae*, and vancomycin-resistant *E. faecium* but not *E. faecalis*.

Another licensed class of antibiotics for highly resistant gram-positive infections is the oxazolidinone class. The prototype in this group is **linezolid**, available in both oral and parenteral formulations and approved for use in pediatric patients. Its mechanism of action involves inhibition of ribosomal protein synthesis. It is indicated for MRSA, VRE, coagulase-negative staphylococci, and penicillin-resistant

*S. pneumoniae*. A related drug, **tedizolid phosphate**, is also FDA-approved for acute bacterial skin and skin structure infections. It is more potent in vitro than linezolid against MRSA and may be associated with less myelosuppression. It is available in both IV and oral formulations.

There is little information on streptogramins and oxazolidinones in the treatment of CNS infections, and neither class is approved for pediatric meningitis. Linezolid can cause significant anemia and thrombocytopenia and is a monoamine oxidase inhibitor.

A novel oxazolidinone, **contezolid acefosamil** (MRX-4), was recently approved for use in China. It is an orally active prodrug of the active antimicrobial metabolite, **contezolid** (MRX-1), an oxazolidinone that shows potent in vitro activity against various multidrug-resistant gram-positive bacteria, including MRSA. It also has activity against *M. tuberculosis*.

### Daptomycin

**Daptomycin** is a novel member of the cyclic lipopeptide class of antibiotics. Its spectrum of activity includes virtually all gram-positive organisms, including *E. faecalis* and *E. faecium* (including VRE) and *S. aureus* (including MRSA). The structure of daptomycin is a 13-member amino acid peptide linked to a 10-carbon lipophilic tail, which results in a novel mechanism of action of disruption of the bacterial membrane through the formation of transmembrane channels. These channels cause leakage of intracellular ions, leading to depolarization of the cellular membrane and inhibition of macromolecular synthesis. A theoretical advantage of daptomycin for serious infections is its bactericidal activity against MRSA and enterococci. It is administered intravenously; experience in children is limited. Myopathy and elevations in creatine phosphokinase have been described. An FDA warning has been issued linking some cases of eosinophilic pneumonitis to the use of daptomycin. Daptomycin is inactivated by surfactant and should not be used to treat pneumonia.

### Miscellaneous Agents

**Metronidazole**, which functions by disruption of DNA synthesis, has a unique role as an antianaerobic agent and also possesses antiparasitic and anthelmintic activity. In 2017 a related drug, **benznidazole**, was approved through the FDA's orphan drug Accelerated Approval Pathway. This antiprotozoal agent inhibits the synthesis of DNA, RNA, and proteins within *Trypanosoma cruzi* and is approved for adult and pediatric use for Chagas disease. **Rifampin** is a rifamycin antibiotic that inhibits bacterial RNA polymerase and has a major role in the management of tuberculosis. It is also of value in the management of other bacterial infections in pediatric patients, usually used as a second (synergistic) agent in the treatment of *S. aureus* infections or to eliminate nasopharyngeal colonization of Hib or *N. meningitidis*. **Rifabutin** is a related drug that has an off-label indication for treatment of tuberculosis, an orphan drug indication for Crohn disease, and an indication for prevention or treatment of disseminated *Mycobacterium avium* complex disease in patients with HIV or immune deficiency. **Rifaximin** is a *nonabsorbed rifamycin* that has been used as an adjunct agent to treat patients with multiple recurrences of *C. difficile* infection. **Fidaxomicin** is a first-in-class member of a new category of narrow-spectrum macrocyclic antibiotic drugs. It is an RNA polymerase inhibitor with activity against *C. difficile* infection.

The emerging crisis in antimicrobial resistance has also necessitated the rediscovery of antimicrobial agents seldom used in clinical practice in recent decades, such as **colistin** (colistimethate sodium), a member of the polymyxin family of antibiotics (polymyxin E). The general structure of polymyxins consists of a cyclic peptide with hydrophobic tails. After binding to lipopolysaccharide in the outer membrane of gram-negative bacteria, polymyxins disrupt both outer and inner membranes, leading to cell death. Colistin is broadly active against the Enterobacteriaceae family, including *P. aeruginosa*. It is also active against ESBL- and carbapenemase-producing strains. Toxicities are chiefly renal and neurologic.

Visit Elsevier eBooks+ at [eBooks.Elsevier.com](http://eBooks.Elsevier.com) for Bibliography.

## Chapter 226

# Antimicrobial Stewardship

Kathleen Chiotos and Jeffrey S. Gerber

Antibiotics are the most common class of medications prescribed to pediatric outpatients, and over 50% of pediatric inpatients receive antibiotics during their hospitalization. It is estimated that between 25% and 50% of antibiotic prescriptions are inappropriate in drug choice, dose, or duration or are unnecessary altogether.

### THE NEED FOR ANTIMICROBIAL STEWARDSHIP: HARMS FROM OVERUSE

There are many negative consequences of antibiotic overuse, including contributing to the dramatic rise in **antibiotic resistance** observed over the past 30 years, which has led to antibiotic resistance being named by the World Health Organization (WHO) as one of the top 10 threats to human health. Antibiotics also carry with them a risk of individual patient-level harm, including development of ***Clostridioides difficile* infection** and **antibiotic adverse events**. For example, 21% of antibiotic courses among pediatric inpatients are complicated by an adverse event, and each additional day of antibiotic therapy is associated with 7% greater odds of experiencing an adverse event. Among pediatric outpatients receiving broad- versus narrow-spectrum antibiotics for acute respiratory tract infections, adverse events are significantly more common in patients treated with broad-spectrum therapy. Finally, an emerging area of research is the **deleterious impact of antibiotics on the developing microbiome** and its potential influence on future disease states, including childhood obesity, asthma, and other allergic diseases. Collectively, these data highlight the importance of judicious antibiotic prescribing, both on a societal and individual patient level.

### DEFINING ANTIMICROBIAL STEWARDSHIP AND AN ANTIMICROBIAL STEWARDSHIP PROGRAM

**Antimicrobial stewardship** is defined as coordinated interventions designed to improve the use of antimicrobial agents, such that dose, duration of therapy, and route of administration are optimized. The goal of these actions is to achieve the best clinical outcome for the patient, while minimizing the development of antimicrobial resistance and risk of adverse events. **It is paramount to recognize that simply reducing antimicrobial use is not a primary goal of antimicrobial stewardship.** However, because inappropriate antibiotic use is so common, optimization often results in de-escalation from a broader to a narrower spectrum of therapy or discontinuing antibiotics altogether.

**Antimicrobial stewardship programs (ASPs)** are multidisciplinary teams designed to improve the safety and quality of patient care by deploying these coordinated interventions. ASPs are often led or coled by infectious diseases trained physicians and clinical pharmacists and work in collaboration with the infection prevention and control department, the clinical microbiology laboratory, and numerous stakeholder groups, including hospital leadership, clinicians, nurses, and pharmacy. Multiple studies have demonstrated reductions in antibiotic use, decreasing rates of *C. difficile* infections, and cost avoidance after the implementation of ASPs, with variable impact on local antibiotic resistance rates. With this growing evidence base and the crisis of antimicrobial resistance, ASPs are now a Standard from The Joint Commission and a Centers for Medicare and Medicaid Services (CMS) Condition of Participation. **Several guidelines provide evidence-based recommendations for implementation of an ASP, including the joint Infectious Diseases Society of America (IDSA) and**



Society for Healthcare Epidemiology of America (SHEA) guideline, the Centers for Disease Control and Prevention (CDC) Core Elements of Hospital Antibiotic Stewardship Programs, the CDC Core Elements of Outpatient Antibiotic Stewardship, and the WHO Practical Toolkit for Antimicrobial Stewardship Programmes in Healthcare Facilities in Low- and Middle-Income Countries.

## INPATIENT ANTIMICROBIAL STEWARDSHIP STRATEGIES

Core elements of inpatient antimicrobial stewardship include hospital leadership commitment; accountability through appointment of a leader or coleaders; pharmacy expertise; implementation of actions or interventions to improve antibiotic use (Table 226.1); tracking

**Table 226.1** Summary of Inpatient Antimicrobial Stewardship Interventions

ACTION	DESCRIPTION
<b>PRIORITY ACTIONS</b>	
Preauthorization	Clinician must contact the stewardship program to obtain approval for use of the antimicrobial before prescribing (see also text and Table 226.2).
Prospective audit and feedback	Antimicrobials are reviewed by the stewardship program after 48-72 hr and recommendations for optimization are provided at that point (see also text and Table 226.2).
Facility-specific treatment guidelines	These local guidelines should establish clear recommendations for commonly encountered infections based on published data or national guidelines, local susceptibility data, formulary options, and patient mix. These guidelines should address diagnostic testing, empiric treatment, and definitive treatment and should be developed in collaboration with clinician stakeholders.
<b>ADDITIONAL ACTIONS</b>	
Antibiotic “time-outs”	A “time-out” occurs after a set duration of antimicrobial therapy (e.g., 48-72 hr) and involves a clinician-led reassessment of the need for and choice of antibiotics. This differs from prospective audit and feedback in that the review is led by the frontline clinician, not the stewardship program. Time-outs may augment prospective audit and feedback led by the ASP but should not be considered an equivalent substitute.
Assessing penicillin allergy	Although penicillin allergies are reported in 10–15% of hospitalized patients, less than 1% are true serious allergies. Patients with penicillin allergy labels receive broader-spectrum antibiotics than would otherwise be recommended, and penicillin allergy labels may be associated with worse clinical outcomes. Clinicians or stewardship personnel may be able to “delabel” patients through performing a history and/or administering a challenge dose of penicillin or amoxicillin.
Documentation of antibiotic indications in orders or prescriptions	Requiring documentation of an indication for antibiotics can improve antibiotic prescribing practices. In addition, this facilitates other interventions, such as audit with feedback, where knowledge of the intended indication is needed.
Intravenous to oral antibiotic therapy	Transitioning from intravenous to oral therapy when an oral antibiotic is available can reduce the duration of hospitalization, need for long-term intravenous access, and improve patient satisfaction.
Pharmacist-based interventions	Pharmacists are uniquely positioned to optimize antibiotic use through making recommendations for optimal antibiotic dosing and administration (e.g., extended infusions of $\beta$ -lactam antibiotics, therapeutic drug monitoring for vancomycin and aminoglycosides, identifying duplicative therapy such as overlapping anaerobic coverage, and detection/prevention of antibiotic-related drug-drug interactions).
Time-sensitive automatic stop orders	Including a stop date in antibiotic orders, after which the antimicrobial order is removed from the patient’s active medication orders, can promote timely discontinuation of antibiotics. This may be particularly valuable for antibiotics where durations are short and well-defined (e.g., surgical prophylaxis).
Selective reporting of susceptibility testing results	Microbiology labs can partner with stewardship programs to report select antibiotics that are consistent with hospital guidelines or use “cascade” reporting in which susceptibilities to broader-spectrum agents are reported only if resistance to narrower-spectrum drugs is demonstrated.
Comments in microbiology reports	Comments in microbiology reports may guide prescribers to making appropriate antibiotic decisions, for example, by indicating bacterial growth may reflect contamination or guiding providers to using specific preferred antibiotics.
Rapid diagnostic tests for bacterial diagnostics	Molecular diagnostic tests (for example, tests using PCR, microarrays, or mass spectroscopy) may allow more rapid identification of organisms or resistance determinants than traditional culture-based techniques. When implemented together with real-time stewardship program guidance, assays performed on positive blood cultures may reduce time to optimal antibiotic therapy and improve patient outcomes.
Nursing-based interventions	Key opportunities to engage bedside nurses in stewardship activities include optimizing the appropriate collection of microbiology cultures, encouraging intravenous to oral transitions, and prompting antibiotic timeouts.

PCR, Polymerase chain reaction.

Adapted from Centers for Disease Control and Prevention. Core Elements of Hospital Antibiotic Stewardship Programs. Atlanta, GA: US Department of Health and Human Services, CDC; 2019. Available at <https://www.cdc.gov/antibiotic-use/core-elements/hospital.html>



**Table 226.2** Comparing Preauthorization and Prospective Audit and Feedback

PREAUTHORIZATION	PROSPECTIVE AUDIT AND FEEDBACK
Allows stewardship oversight from the point of antimicrobial initiation.	Stewardship oversight focuses on antimicrobial duration, de-escalation, or discontinuation.
Requires dedicated and expert personnel for “real-time” phone calls or electronic communication through at least the majority of the day.	Resource intensive, particularly if done hospital-wide, but can be scaled to available resource (e.g., focused on a single unit).
Opportunity to counsel provider on optimal diagnostic testing before starting antimicrobials.	Culture and susceptibility testing may be available at the time the intervention is made, such that recommendations for definitive therapy can be made.
Requires a coordinated process including providers, pharmacy, and the stewardship program to ensure approved antimicrobials are dispensed promptly and that antimicrobial requests that are declined are not dispensed.	Prescribers may or may not follow the recommendations made by the stewardship program.
May be seen as a threat to autonomy and/or having the potential to delay therapy.	Generally well-received by providers, with high adherence to recommendations reported.
Only the antimicrobials that are restricted are affected and only at the point of initiation.	More flexibility for the stewardship team regarding the timing of interventions, as well as the potential to act on all antimicrobials prescribed to an individual patient during a single discussion.

antibiotic use, resistance, and *C. difficile* rates; reporting antibiotic use and resistance metrics to prescribers and hospital leaders; and education.

### Prospective Audit and Feedback Versus Preauthorization

Two broad approaches to antimicrobial stewardship are supported by the IDSA/SHEA guideline and the CDC Core Elements: preauthorization and prospective audit and feedback. Preauthorization is a strategy in which the clinician must contact the ASP and secure approval for use of the antimicrobial before prescribing the drug. In contrast, prospective audit and feedback is performed by the ASP 48-72 hours after the start of antimicrobial therapy, and recommendations for antimicrobial de-escalation, discontinuation, transition from intravenous to oral therapy, change in dose, or changes in duration are made. Each of these approaches has pros and cons (Table 226.2), and ASPs generally adapt these broad strategies to the local context and availability of resources, often using a hybrid approach. “Handshake stewardship” is a specific type of audit and feedback where recommendations from the ASP are delivered face-to-face to prescribers; this approach has the advantage of developing collaborative relationships but is resource intensive and therefore may not be feasible in all settings. Regardless of which strategy is used, it is critical that ASPs view the interaction with the prescriber as an opportunity to collaboratively optimize antimicrobial therapy and that the guidance provided is evidence-based and, whenever available, aligned with local clinical practice guidelines.

### Development and Implementation of Local Guidelines

Creation of evidence-based **local guidelines** containing recommendations for empiric and definitive therapy for common infectious

diseases diagnoses and syndromes is a key activity of ASPs. In pediatrics, key target conditions include community-acquired pneumonia, urinary tract infections, intraabdominal infections, skin and soft tissue infections, and neonatal and pediatric sepsis. Coproduction of these guidelines with relevant stakeholders, including prescribing clinicians, offers a unique opportunity to broadly improve antimicrobial prescribing through standardization of evidence-based practices. Because the approach is agreed upon a priori, adhering to these recommendations may also be more appealing to prescribers relative to more “top-down” approaches, where the ASP is either unilaterally authorizing antimicrobial use or providing directive feedback.

### Education

While educational interventions alone are insufficient to improve antimicrobial use, education is critical to the success of ASPs and should be integrated along with other strategies. Education can take place in many forms, including at the point of an individual prescriber-steward interaction during preauthorization or prospective audit and feedback; as part of the implementation of a new local treatment guideline or other specific improvement intervention; or as a stand-alone or recurring lecture focused on a topic of relevance, preferably one deemed important to the learners.

### OUTPATIENT ANTIMICROBIAL STEWARDSHIP STRATEGIES

The majority of antibiotic use in children occurs in the outpatient setting. Effective outpatient antimicrobial stewardship is therefore critical and requires approaches distinct from the individual-level preauthorization and prospective audit with feedback that form the foundation of inpatient antimicrobial stewardship. Relative to hospital-based stewardship, fewer studies have been conducted in outpatient settings to inform best practices. However, the CDC provides four elements to guide outpatient stewardship efforts, which include commitment to optimizing antibiotic prescribing, including appointment of an accountable leader; actions for policy and practice; tracking and reporting antibiotic use; and education and expertise.

### Commitment

In addition to commitment on the part of practice or system leadership, a **written and publicly displayed commitment poster** stating that the individual clinician will only prescribe antibiotics when they are indicated is a powerful tool to reduce unnecessary antibiotic prescribing in the ambulatory setting. This strategy is particularly appealing, as it requires minimal resources to implement and may not only influence provider behavior but also stimulate a discussion between provider and patient around the importance of judicious antibiotic use. In addition, clear communication across clinic providers and staff to ensure this message is consistent and practices are aligned is paramount.

### Actions to Improve Antibiotic Prescribing

As with hospital-based stewardship programs, development and implementation of **local guidelines** to inform antibiotic prescribing for relevant conditions is a key strategy for ambulatory stewardship programs. Target conditions in this setting include acute respiratory tract infections, such as pharyngitis, sinusitis, otitis media, and community-acquired pneumonia, given that these conditions account for the vast majority of ambulatory antibiotic use and are associated with significant variation in antibiotic prescribing practices across clinics. A number of strategies have been used to optimize adherence to such guidelines, including audit with feedback at the practice or provider level, clinician education, and computerized decision support. An additional evidence-based practice that may improve antibiotic use in the outpatient setting for specific conditions is use of **delayed prescriptions**, namely, prescriptions provided to patients with mild infections likely to improve without antibiotics at the time of the clinic visit, with instructions to fill the prescription only if symptoms worsen or fail to improve. Delayed prescribing is endorsed by the American Academy of Pediatrics for acute otitis media and acute sinusitis. This type of

“contingency plan” may contribute to patient and parent acceptance of an initial recommendation against antibiotics.

### Education

Education is also a fundamental element of outpatient stewardship. In contrast to education in the inpatient setting, which focuses on clinicians, education in the ambulatory setting additionally requires a focus on the patient and family, as well as teaching providers to promote optimal communication. For example, a commonly cited challenge to judicious antibiotic prescribing in the pediatric outpatient setting is a perception on the part of providers that antibiotic prescriptions are strongly desired by parents, even in situations where bacterial infections are unlikely. **However, several studies have refuted this notion and instead suggest that communication of both “positive” treatment recommendations (e.g., specific measures to take to improve symptoms) and “negative” treatment recommendations (e.g., recommendations against using antibiotics when they are not indicated, antibiotic adverse events) is a driver of parent satisfaction and desired by parents.**

### TRACKING AND REPORTING ANTIMICROBIAL USE MEASURES

Quantifying antimicrobial use and reporting it to key stakeholders, including clinicians and hospital leadership, are key elements for both inpatient and outpatient stewardship efforts.

### Antimicrobial Use Measures

Most antimicrobial stewardship measures are process measures. **The preferred metric for inpatient antimicrobial use is antimicrobial days of therapy (DOTs) per 1,000 patient days.** Each antimicrobial prescribed on each hospital day counts as one DOT, independent of the number of doses the patient receives in the day. For example, if a patient with an intraabdominal infection receives ceftriaxone and metronidazole on the same day, each drug contributes 1 DOT and the total DOT is 2. If instead, this patient received meropenem alone, just 1 DOT would be recorded. DOT/1,000 patient days is a metric particularly useful to track antimicrobial use over time or in response to a specific stewardship intervention and can be measured for an individual drug, a specific unit, or throughout the hospital. Limitations of the measure are that it does not measure the appropriateness of therapy or spectrum of activity, and as demonstrated in the previous example, multidrug regimens will contribute a greater number of DOTs even if the spectrum of the combination of drugs is narrower than the single drug. Finally, DOT/1,000 patient days does not account for differences in patient complexity, illness severity, or comorbid conditions, a limitation that should be considered when making comparisons across units or hospitals.

Antibiotic use measures in the outpatient setting can include individual- or facility-level tracking of antibiotic prescriptions in all visits, or in visits with a certain diagnosis or collection of diagnoses. Metrics could include the proportion of visits in which antibiotics were prescribed, the appropriateness of the antibiotic choice (e.g., broad- versus narrow-spectrum, compliance with local guidelines), and/or the correct duration of antibiotics for a given condition. **Individual-level measures are preferred**, as they facilitate audit and feedback based on individual performance, as well as peer comparisons, strategies that have been used successfully to improve adherence to evidence-based guidelines for antibiotic use in the outpatient setting.

### Outcome Measures

The impact of reductions in antimicrobial use through implementation of ASPs or specific interventions should ideally be linked to clinical outcomes. In practice, however, specific outcomes can be difficult to identify, particularly in children where adverse outcomes attributable to antibiotics are uncommon (e.g., *C. difficile* infection) or resource intensive to measure (e.g., drug adverse events, patient-reported outcomes). Improvement in antibiotic resistance rates over time is an appealing hospital-level measure, but improvement occurs slowly and is influenced by multiple factors other than inpatient antibiotic use, including infection prevention and control practices and outpatient prescribing

patterns. Other outcome measures that may be considered include revisits, readmissions, or hospital length of stay, though few studies have evaluated these outcomes, which may be confounded by multifactorial influences. Importantly, because antibiotic exposure has been clearly linked to development of antibiotic resistance, *C. difficile* infection, and other adverse drug events, decreases in antibiotic use process measures without a worsening of clinical outcomes are relevant and should be considered sufficient for defining success, even if the reduction in antibiotic use does not result in improved clinical outcomes.

### SUMMARY

Antimicrobial stewardship is an important element of patient safety and quality that is the responsibility of all clinicians prescribing antimicrobials. Formal ASPs can guide these local efforts, and abundant evidence demonstrates the positive impact of these programs on improving antibiotic use in both the inpatient and ambulatory settings. Key needs in the field of pediatric antimicrobial stewardship include development of risk-adjusted antibiotic use measures for benchmarking across centers; development of measures to quantify antibiotic-associated harm; incorporating perspectives from nursing and patients/families; and adapting stewardship strategies and organizational structures successful in acute care hospitals to other settings.

Visit Elsevier eBooks+ at [eBooks.Health.Elsevier.com](http://eBooks.Health.Elsevier.com) for Bibliography.

## Section 4 Gram-Positive Bacterial Infections

### Chapter 227

## Staphylococcus

Carol M. Kao, Patrick J. Reich, and  
Stephanie A. Fritz

Staphylococci are hardy, aerobic, gram-positive bacteria that grow in pairs and clusters and are ubiquitous as normal flora of humans and present on fomites and in dust. They are resistant to heat and drying and may be recovered from nonbiologic environments weeks to months after contamination. Strains are classified as *Staphylococcus aureus* if they are coagulase positive or as one of the many species of **coagulase-negative staphylococci** (e.g., *S. epidermidis*, *S. lugdunensis*, *S. saprophyticus*, *S. haemolyticus*). *S. aureus* has many virulence factors that mediate various serious diseases, whereas coagulase-negative staphylococci tend to be less pathogenic unless an indwelling foreign body (e.g., intravascular catheter) is present. *S. aureus* strains resistant to  $\beta$ -lactam antibiotics, typically referred to as **methicillin-resistant *Staphylococcus aureus* (MRSA)**, are a significant problem in both community and hospital settings.

### 227.1 *Staphylococcus aureus*

Carol M. Kao, Patrick J. Reich, and Stephanie A. Fritz

*S. aureus* is the most common cause of skin and soft tissue infections (SSTIs). **Bacteremia** (primary or secondary) is common and can be associated with, or can result in, musculoskeletal infection (osteomyelitis, pyomyositis, septic arthritis), pneumonia, endocarditis, and rarely meningitis. **Toxin-mediated diseases**, including food poisoning,

staphylococcal scarlet fever, scalded skin syndrome, and toxic shock syndrome (TSS), are caused by certain *S. aureus* strains.

## ETIOLOGY

*S. aureus* strains produce a wide spectrum of virulence factors. These factors contribute to pathogenesis in human disease by protecting the organism from host defenses, causing local tissue damage, and affecting noninfected sites through toxin elaboration.

Most strains of *S. aureus* possess factors that protect the organism from host defenses. The microbial surface components recognizing adhesive matrix molecules (MSCRAMMs) are a family of cell wall-anchored proteins with a broad spectrum of virulence properties, including host tissue and cell adhesion and invasion, biofilm formation, and evasion of the host immune response. Many staphylococci produce a loose extracellular polysaccharide that promotes formation of **biofilms**, which may interfere with opsonophagocytosis. Production of clumping factor and coagulase differentiates *S. aureus* from coagulase-negative staphylococci. **Clumping factor** interacts with fibrinogen to create large clumps of organisms, interfering with effective phagocytosis. **Coagulase** causes plasma to clot by interacting with fibrinogen and may have an important role in abscess formation. **Protein A** is located on the outermost coat of the cell wall and can absorb serum immunoglobulins, preventing opsonization and thus inhibiting phagocytosis. The **chemotaxis inhibiting protein of *S. aureus* (ChIPS)** and **extracellular adherence protein (Eap)** interfere with the native host immune response by inhibiting leukocyte chemotaxis. The staphylococcal enzyme **catalase** inactivates hydrogen peroxide, promoting intracellular survival.

Many strains of *S. aureus* produce substances that cause local tissue destruction. A number of immunologically distinct **hemolysins** that act on cell membranes and cause tissue necrosis have been identified ( $\alpha$ -toxin,  $\beta$ -hemolysin,  $\delta$ -hemolysin). The leukocidins (LukAB, LukDE, Panton-Valentine leukocidin) are pore-forming cytotoxins resulting in increased cell membrane permeability and eventual cell death. Strains of *S. aureus* that produce **Panton-Valentine leukocidin** are associated with more severe and invasive skin disease, necrotizing pneumonia, and osteomyelitis. Many strains of *S. aureus* release one or more exotoxins. **Exfoliatins A and B** are serologically distinct proteins that produce localized (bullous impetigo) or generalized (scalded skin syndrome, staphylococcal scarlet fever) dermatologic manifestations (see [Chapter 706](#)).

*S. aureus* can produce >20 distinct **enterotoxins** (types A-V). Ingestion of preformed enterotoxin, particularly types A or B, can result in **food poisoning**, resulting in vomiting and diarrhea and, in some cases, profound hypotension.

**Toxic shock syndrome toxin-1 (TSST-1)** is associated with **toxic shock syndrome (TSS)**, related to menstruation and focal staphylococcal infection (see [Chapter 227.2](#)). TSST-1 is a superantigen that induces production of interleukin (IL)-1 and tumor necrosis factor (TNF), resulting in hypotension, fever, and multisystem involvement. Focal infections associated with enterotoxins A or B also may be associated with nonmenstrual TSS.

*S. aureus* also possesses intrinsic factors that can contribute to pathogenesis, including proteins that promote adhesion to fibrinogen, fibronectin, collagen, and other human proteins. Expression of proteins that mediate antibiotic resistance is also of critical importance. Although historically sensitive to penicillin, *S. aureus* isolates now almost universally produce **penicillinase** or  **$\beta$ -lactamase**, which inactivates many  $\beta$ -lactams at the molecular level and represents the major resistance mechanism against many penicillin and some cephalosporin antibiotics. Thus treatment of *S. aureus* with  $\beta$ -lactam antibiotics requires either a penicillinase-resistant  $\beta$ -lactam ring (e.g., antistaphylococcal penicillins such as oxacillin or nafcillin) or combination with a  $\beta$ -lactamase inhibitor (e.g., ampicillin-sulbactam). Production of altered **penicillin-binding proteins (PBPs)** in the bacterial cell wall mediates resistance to penicillinase-resistant antibiotics; an **altered PBP-2A**, encoded by the gene *mecA*, is responsible for the methicillin, cephalosporin, and carbapenem resistance of MRSA isolates.

## EPIDEMIOLOGY

*S. aureus* is a significant cause of morbidity and mortality, particularly in pediatric healthcare-associated infections including infections of the

bloodstream, surgical sites, and respiratory tract. Genetically distinct strains of MRSA are termed *community-associated MRSA (CA-MRSA)*; USA300 is the predominant pulsotype circulating in the United States. These strains led to an epidemic of SSTIs, and occasionally necrotizing invasive infections, in healthy individuals without the traditional healthcare-associated risk factors for MRSA. Ambulatory visits for purulent SSTIs rose from 5 million to 11 million annually between 2000 and 2013 but have since plateaued and even declined in some populations. Additionally, the incidence of invasive nosocomial MRSA infections (e.g., bacteremia) has also declined; however, the incidence of SSTIs and bloodstream infections caused by MSSA has increased.

Approximately 20–40% of healthy individuals carry at least one strain of *S. aureus* in the anterior nares at any given time, with intermittent carriage occurring in up to 70% of individuals. In children, the oropharynx, umbilicus, inguinal folds, and rectum are also important reservoirs of *S. aureus* carriage. Many neonates are colonized within the first 2 months of life, usually by a maternal strain. The prevalence of colonization with MRSA in the general pediatric population ranges from 2% to 10%, with higher prevalence in some locales and in children with significant healthcare exposure and chronic medical conditions.

*S. aureus* is acquired and transmitted through close person-to-person contact and contact with contaminated objects or environmental surfaces. *S. aureus* colonization poses a risk for subsequent *S. aureus* infection. In community settings, populations traditionally at high risk for *S. aureus* infection have included athletes, military personnel, young children, veterinarians, injection drug users, and inmates in correctional facilities. However, given the high colonization prevalence in the community, *S. aureus* infections commonly occur in individuals with no identifiable risk factors. In the outpatient setting, SSTI is the most common entity caused by *S. aureus*, accounting for 8 million annual ambulatory visits.

Households are an important reservoir for *S. aureus* transmission because of close personal contact among colonized family members. Increased disease frequency occurs among household contacts of *S. aureus*-colonized or -infected individuals. Additionally, *S. aureus* can persist on environmental surfaces over time. Contamination of environmental surfaces such as hand towels, television remote controls, and bed linens can further perpetuate transmission among household members and is a risk factor for recurrent infection. Thus preventive strategies are aimed at decreasing the burden of *S. aureus* carriage in affected individuals and household members, as well as targeted household environmental surfaces.

## PATHOGENESIS

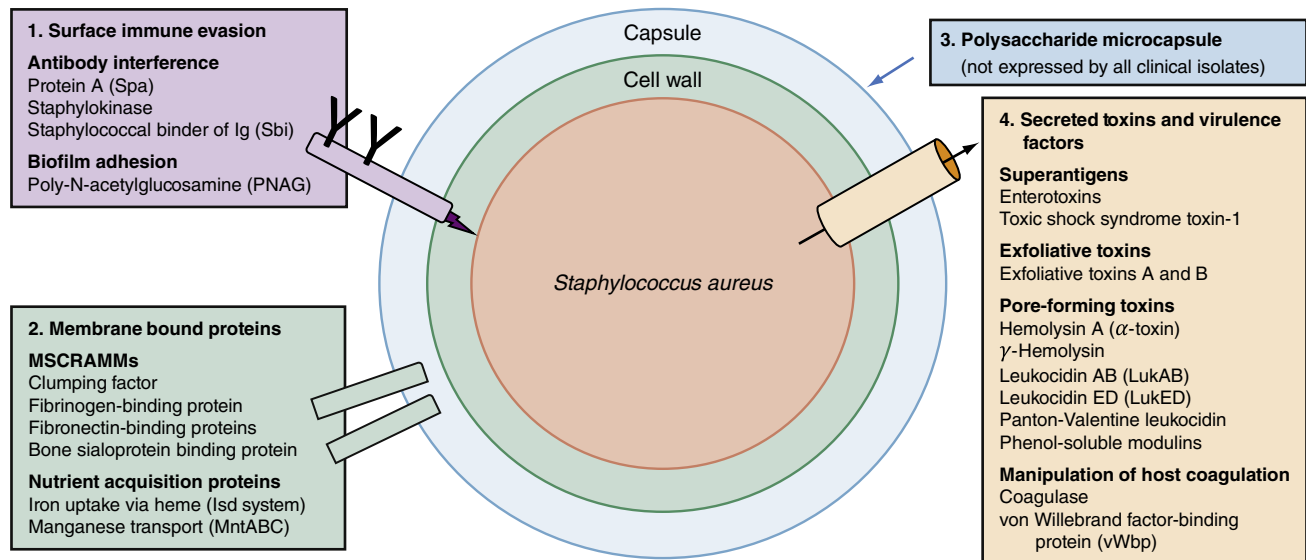
Except in the case of food poisoning resulting from ingestion of preformed enterotoxins, disease associated with *S. aureus* typically begins with colonization. Subsequent disease manifestations in susceptible individuals results either directly from tissue invasion or from injury caused by various toxins and enzymes produced by the organism ([Fig. 227.1](#)).

The most significant risk factor for the development of infection is **disruption of intact skin**, including breaches from wounds, skin diseases such as eczema, epidermolysis bullosa, insect bites, burns, ventriculoperitoneal shunts, and central venous catheter placement. Additional risk factors include immunodeficiency and malnutrition, although infection can also occur in otherwise healthy children. Viral infections of the respiratory tract, especially influenza virus infection, may predispose to secondary bacterial infection with staphylococci.

Congenital defects in chemotaxis (hyper-IgE syndromes, Chédiak-Higashi, and Wiskott-Aldrich syndromes) and defective phagocytosis and killing (neutropenia, chronic granulomatous disease) increase the risk for staphylococcal infections. Patients with HIV infection have neutrophils that are defective in their ability to kill *S. aureus* in vitro. Young infants with invasive infection or individuals with *recurrent pyogenic infection* should be evaluated for immune defects, especially those involving neutrophil dysfunction. Poor mucus clearance in children with cystic fibrosis frequently leads to chronic pulmonary staphylococcal colonization and persistent inflammation in these patients.

Infants may acquire type-specific humoral immunity to staphylococci transplacentally. Older children and adults develop antibodies to staphylococci as a result of colonization or minor infections. Antibody





**Fig. 227.1** Schematic of virulence factors and relevant surface adhesins of *Staphylococcus aureus*. YY, Immunoglobulin-binding site; MSCRAMMs, microbial surface components that recognize adhesive matrix molecules. (From Thomsen I, Creech CB. *Staphylococcus aureus*. In Long SS, Prober CG, Fischer M, Kimberlin DW, eds. *Principles and Practice of Pediatric Infectious Diseases*, 6th ed. Philadelphia: Elsevier; 2023, Fig. 115.1, p. 711.)

to the various *S. aureus* toxins appears to protect against those specific toxin-mediated diseases, but humoral immunity does not necessarily protect against focal or disseminated *S. aureus* infection with the same organisms.

## CLINICAL MANIFESTATIONS

*S. aureus* has the potential to invade any tissue. Disease severity is influenced by local suppuration, systemic dissemination with metastatic infection, or systemic effects of toxin production.

### Newborn

*S. aureus* is an important cause of neonatal infections (see Chapter 148).

### Skin

*S. aureus* is an important cause of **pyogenic** skin infections, including impetigo contagiosa, ecthyma, bullous impetigo, folliculitis, furuncles (boils), carbuncles (multiple coalesced boils), and paronychia. **Toxicogenic** infection with skin manifestations include staphylococcal scalded skin syndrome and staphylococcal scarlet fever. *S. aureus* is a frequent cause of superinfection of underlying dermatologic conditions, such as eczema, hidradenitis suppurativa, or insect bites. Skin abscesses caused by CA-MRSA commonly affect the lower extremities and buttocks. Up to 70% of individuals with SSTI will experience a recurrent infection. *S. aureus* is also an important cause of traumatic and surgical wound infections and can cause deep soft tissue involvement, including cellulitis and, rarely, necrotizing fasciitis.

### Respiratory Tract

Infections of the upper respiratory tract (otitis media, sinusitis) caused by *S. aureus* are rare, in particular considering the frequency with which the anterior nares are colonized. *S. aureus* sinusitis is relatively common in children with cystic fibrosis or defects in leukocyte function and may be the only focus of infection in some children with TSS. Suppurative **parotitis** is a rare infection, but *S. aureus* is a common cause. A membranous **tracheitis** that complicates viral croup may result from infection with *S. aureus*, although other organisms may also be responsible.

**Pneumonia** caused by *S. aureus* is uncommon but can present with rapidly progressive respiratory failure. Children may present with recent flulike illness (see Chapter 449). Hematogenous pneumonia may be secondary to septic emboli from right-sided endocarditis or septic thrombophlebitis, with or without intravascular devices. Inhalation pneumonia is caused by alteration of mucociliary clearance, leukocyte dysfunction, or bacterial adherence initiated by a viral infection. Common symptoms and signs include high fever, abdominal

pain, tachypnea, dyspnea, and localized or diffuse bronchopneumonia or lobar disease. In particular, USA300 strains of *S. aureus* often cause a **necrotizing pneumonia** that may be associated with early development of empyema, pneumatoceles, pyopneumothorax, and bronchopleural fistulas (Fig. 227.2). Chronic pulmonary infection with *S. aureus* contributes to progressive pulmonary dysfunction in children with cystic fibrosis (see Chapter 454).

### Bacteremia and Sepsis

*S. aureus* bacteremia and sepsis may be primary or secondary because of a localized infection such as an infected central venous catheter or thrombus, bone, or skin and soft tissue. Risk factors for *S. aureus* bacteremia include presence of a central venous catheter, immunodeficiency, malnutrition, recent MRSA STTI, and recent surgery. The onset may be acute and marked by nausea, vomiting, myalgia, fever, and chills.

Prolonged *S. aureus* bacteremia is associated with an increased risk of developing complications such as septic emboli, thrombi, and metastatic foci of infection. Methicillin resistance, musculoskeletal infection, endovascular infection, and delayed intervention for source control are risk factors for prolonged bacteremia. In general, removal of an infected central venous catheter is recommended because of the difficulty clearing *S. aureus* bacteremia in these patients.

A positive blood culture for MRSA or methicillin-sensitive *S. aureus* (MSSA) should always be considered pathogenic, and antistaphylococcus treatment should be initiated with vancomycin or daptomycin with a  $\beta$ -lactam until antimicrobial susceptibility is available. In the absence of an obvious source (isolated bacteremia), endocarditis must be considered. MSSA bacteremia should be treated with a  $\beta$ -lactam such as cefazolin or oxacillin, given poorer outcomes in children treated with vancomycin. Although vancomycin has been traditionally used as first-line treatment of MRSA bacteremia in children, daptomycin and ceftaroline, a  $\beta$ -lactam and fifth-generation cephalosporin, can also be considered. The duration of antibiotic therapy depends on the age and presence of associated infections. In general, 7-14 days of intravenous therapy is appropriate for uncomplicated bacteremia; however, additional studies are needed to determine the optimal duration in children. Repeat blood cultures should be obtained until negative for 2 days to document clearance of bacteremia. Prolonged positive blood cultures while on therapy suggest endocarditis, an infected thrombus, abscess formation, foreign body (central lines, bone prosthesis, or internal fixation of fractures), or other factors leading to poor source control. Whole body MRI or PET-MRI scanning may detect unrecognized metastatic foci. Infectious disease consultation has been shown to improve cure rates and outcomes in children with *S. aureus* bacteremia, including decreased mortality and decreased recurrence of bacteremia.



### Muscle

Localized staphylococcal abscesses in muscle, sometimes without septicemia, have been called **pyomyositis**. This disorder is reported most frequently from tropical areas and is termed *tropical pyomyositis*, but also occurs in the United States in otherwise healthy children. Multiple abscesses occur in 30–40% of cases, most commonly affecting the pelvic and lower extremity muscles. History may include prior trauma at the site of the abscess. More commonly, pyomyositis results from seeding secondary to bacteremia, often near the site of osteomyelitis. Surgical drainage and appropriate antibiotic therapy are essential.

### Bones and Joints

*S. aureus* is the most common cause of osteomyelitis and suppurative arthritis in children, most commonly the result of hematogenous seeding and, less often, from a contiguous focus of infection or through inoculation from trauma or a surgical procedure (see [Chapters 725 and 726](#)).

### Central Nervous System

Meningitis caused by *S. aureus* is uncommon; it is associated with penetrating cranial trauma and neurosurgical procedures (craniotomy, cerebrospinal fluid [CSF] shunt placement) and, less frequently, with endocarditis, parameningeal foci (epidural or brain abscess), prematurity, complicated sinusitis, diabetes mellitus, or malignancy. The CSF profile of *S. aureus* meningitis is indistinguishable from that in other forms of bacterial meningitis (see [Chapter 643.1](#)).

### Heart

*S. aureus* is a common cause of acute endocarditis on native valves and results in high rates of morbidity and mortality. Left-sided endocarditis is most common. The clinical presentation can be indolent with symptoms such as malaise, weight loss, or myalgias, and the typical signs of endocarditis are often not present in children (see [Chapter 486](#)).

### Kidney

*S. aureus* is a common cause of renal and perinephric abscess, usually of hematogenous origin. Pyelonephritis and cystitis caused by *S. aureus* are unusual (see [Chapter 575](#)).

### Toxic Shock Syndrome

*S. aureus*, more commonly MSSA than MRSA, is the principal cause of TSS, which should be suspected in anyone with fever, shock, and/or a diffuse erythroderma (see [Chapter 227.2](#)).

### Intestinal Tract

Staphylococcal enterocolitis may rarely follow overgrowth of normal bowel flora by *S. aureus*, which can result from broad-spectrum oral antibiotic therapy. Diarrhea is associated with blood and mucus. Peritonitis associated with *S. aureus* in patients receiving long-term ambulatory peritoneal dialysis usually involves the catheter tunnel.

**Food poisoning** may be caused by ingestion of *preformed* enterotoxins produced by staphylococci in contaminated foods (see [Chapter 387](#)). The source of contamination is often colonized or infected food workers. Approximately 2–7 hours after ingestion of the toxin, sudden, severe vomiting begins. Watery diarrhea may develop, but fever is absent or low grade. Symptoms rarely persist >12–24 hours. Rarely, shock and death may occur.

### DIAGNOSIS

The diagnosis of *S. aureus* infection depends on isolation of the organism in culture from the site of infection, such as cellulitis aspirates, abscess cavities, blood, bone, or joint aspirates, or other sites of infection. In patients with musculoskeletal infection, ~50% of children will have blood cultures that yield *S. aureus*. Thus surgical debridement or an aspirate or biopsy obtained by interventional radiology can maximize recovery of the organism, which is important for targeted antibiotic selection. Tissue samples or fluid aspirates in a syringe provide the best culture material. Because of the high prevalence of MRSA and the severity of *S. aureus* infections, it is important to obtain cultures before starting antibiotic treatment. The organism can be grown readily in liquid and on solid media. After isolation, identification is made on the

basis of Gram stain and coagulase, clumping factor, and catalase activity. Molecular techniques and mass spectrometry are used to supplement traditional identification and antibiotic susceptibility methods. These technologies may allow for rapid species identification from positive blood cultures and simultaneously identify genetic patterns associated with methicillin resistance, such as presence of the *mecA* gene produced by MRSA. Diagnosis of *S. aureus* food poisoning is usually made on the basis of epidemiologic and clinical findings.

### Differential Diagnosis

Many of the clinical entities caused by *S. aureus* can also be caused by other bacterial pathogens, and consideration of the differential diagnosis is particularly important when making empirical antibiotic choices before definitive identification of the offending pathogen. Skin lesions caused by *S. aureus* may be indistinguishable from those caused by group A streptococci, although *S. aureus* usually expands slowly and is more likely to be suppurative, whereas group A streptococci are prone to spread more rapidly and can be very aggressive. Fluctuant skin and soft tissue lesions also can be caused by other organisms, including *Mycobacterium tuberculosis*, atypical mycobacteria, *Nocardia*, *Bartonella henselae* (cat-scratch disease), *Francisella tularensis*, and various fungi. *S. aureus* pneumonia is often suspected in very ill-appearing children or after failure to improve with standard treatment that does not cover *Staphylococcus*, or on the basis of chest radiographs that reveal pneumatoceles, pyopneumothorax, or lung abscess (see [Fig. 227.2](#)). Other etiologies of cavitory pneumonias include group A streptococci, *Klebsiella pneumoniae*, and *M. tuberculosis*. In bone and joint infections, culture is the only reliable way to differentiate *S. aureus* from other etiologies, including group A streptococci and, in young children, *Kingella kingae*.

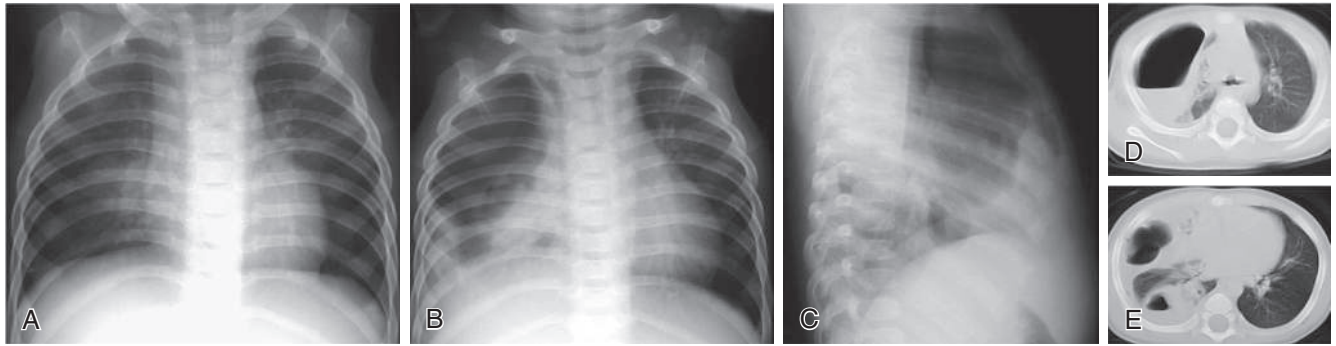
### TREATMENT

Antibiotic therapy alone is rarely effective in individuals without source control of the focus of infection. Loculated collections of purulent material should be relieved by incision and drainage. Foreign bodies (e.g., orthopedic instrumentation, ventricular shunts, central venous catheters) should be removed, if possible. Therapy always should be initiated with an antibiotic consistent with the local staphylococcal susceptibility patterns, severity, and anatomic site of infection. For most patients with serious *S. aureus* infection, initial intravenous (IV) treatment is usually recommended, and transition to oral therapy can be considered based on clinical response and source of infection.

Treatment of *S. aureus* osteomyelitis ([Chapter 725](#)), meningitis ([Chapter 643.1](#)), and endocarditis ([Chapter 486](#)) is discussed in the respective chapters on these diagnoses.

Initial treatment for serious infections thought to be caused by **methicillin-susceptible *S. aureus* (MSSA)** should include a semisynthetic penicillin (e.g., nafcillin, oxacillin) or a first-generation cephalosporin (e.g., cefazolin). Penicillin and ampicillin are not appropriate, because >90% of all staphylococci isolated, regardless of source, are resistant to these agents. Addition of a  $\beta$ -lactamase inhibitor (clavulanic acid, sulbactam, tazobactam) to a penicillin-based drug also confers antistaphylococcal activity but has no effect on MRSA. The spectrum of these  $\beta$ -lactam/ $\beta$ -lactamase inhibitor agents (which includes gram-negative bacteria and anaerobes) can be an advantage when broad empirical coverage is needed, but narrower coverage should be selected once *S. aureus* is identified. *Antistaphylococcal penicillins and most cephalosporins do not provide activity against MRSA.*

Vancomycin is typically selected for initial treatment for penicillin-allergic individuals and those with suspected serious infections caused by MRSA. Although serum level monitoring has traditionally been used for patients receiving vancomycin, this method is no longer recommended for severe MRSA infections. Instead, calculating the ratio of area under the curve (AUC) over 24 hours to the minimum inhibitory concentration (MIC) as the primary predictor of vancomycin activity is currently recommended. Monitoring for nephrotoxicity is also important while on vancomycin therapy. Vancomycin intermediate *S. aureus* strains (VISAs), defined as having an MIC of vancomycin greater than 2  $\mu\text{g/mL}$ , and, rarely, vancomycin-resistant strains of *S. aureus* (VRSA, MIC of vancomycin >16  $\mu\text{g/mL}$ ) have also been reported, mostly in patients being treated with vancomycin. For critically ill patients with



**Fig. 227.2** Progressive methicillin-resistant *Staphylococcus aureus* (MRSA) pneumonia with pneumatoceles in a previously healthy 9-mo-old male. Chest radiographic findings spanning 4 days showed a perihilar right lower lobe infiltrate (A) progressing to a worsening infiltrate and large hydropneumothorax with mediastinal shift (B and C) despite appropriate therapy. Axial CT of the chest without contrast (lung windows) showed partial loculation of hydropneumothorax, multilobar consolidation, pneumatoceles, and atelectasis (D and E). Video-assisted thoracoscopic surgery (VATS) was performed, and a chest tube was placed for 3 days. MRSA was isolated from pleural fluid. After 2 weeks of clindamycin therapy, the chest radiograph had only minor abnormalities. (Courtesy Dr. Sarah S. Long.)

suspected *S. aureus* infection, empirical therapy with both vancomycin and a  $\beta$ -lactam (cefazolin or nafcillin) should be considered until culture results are available. Initial treatment with IV **clindamycin** followed by a transition to oral clindamycin can be considered in bone, joint, and soft tissue infection; however, not all strains of MSSA or MRSA are susceptible to clindamycin. Inducible clindamycin resistance in isolates initially reported as susceptible must be ruled out by D-test or molecular methods. Clindamycin is bacteriostatic and should not be used to treat endocarditis, persistent bacteremia, or CNS infections caused by *S. aureus*. Given that the mechanism of action of clindamycin involves inhibition of protein synthesis, many experts use clindamycin as an adjunctive agent to treat *S. aureus* toxin-mediated illnesses (e.g., TSS) to inhibit toxin production.

Although the broad-spectrum carbapenems (meropenem, ertapenem, and imipenem) have activity against MSSA, they have no activity against MRSA. As a result, carbapenems are rarely used for empirical therapy of possible staphylococcal infection and are too broad in most cases for use in identified MSSA infections. **Linezolid**, **daptomycin**, and **ceftaroline** are useful for serious *S. aureus* infections, providing excellent coverage of MRSA and MSSA (Table 227.1). A number of novel antistaphylococcal antibiotics have emerged for use in resistant or refractory MSSA and MRSA infection in adults that may be required for pediatric therapy in select patients under the guidance of a pediatric infectious disease specialist. These include the lipoglycopeptides, including **telavancin**, **oritavancin**, and **dalbavancin**, which are structurally related to vancomycin but have very long half-lives and broad activity against gram-positive organisms. **Rifampin** or **gentamicin** in addition to a  $\beta$ -lactam or vancomycin are recommended for prosthetic-valve endocarditis, although patients need to be monitored closely for adverse side effects; their use as combined therapy for other infections is not recommended.

In many infections, after an initial period of parenteral therapy, patients may be transitioned to oral antimicrobials to complete the course of treatment after determination of antimicrobial susceptibilities. Oral antimicrobials can be used as initial treatment in less severe infections (e.g., skin abscess). **Cephalexin** (25–100 mg/kg/24 hr divided 3–4 times daily PO) and cefadroxil (30 mg/kg/24 hr divided 2 times daily PO for noninvasive infections, 50–60 mg/kg/24 hr divided 2 times daily PO for osteoarticular infections) are absorbed well orally (PO) and are effective against MSSA. (Variable cefadroxil dosing regimens have been described, ranging from 30–150 mg/kg/day divided 2–4 times daily PO.) **Amoxicillin-clavulanate** (40–80 mg amoxicillin/kg/24 hr divided 3 times daily PO) is also effective when a broader spectrum of coverage is required. Clindamycin (30–40 mg/kg/24 hr divided 3–4 times daily PO) is highly absorbed from the intestinal tract and is frequently used for empirical coverage when both MRSA and MSSA are possible and for susceptible MRSA infections or for MSSA in penicillin/cephalosporin-allergic patients. Compliance with oral clindamycin may be limited in small children because of poor palatability of liquid formulations. **Trimethoprim-sulfamethoxazole** (TMP-SMX) may be an effective oral antibiotic for many strains of both MSSA and MRSA for

SSTI. Oral linezolid is an option for severe MRSA infections that have improved but require ongoing therapy when more common options are not tolerated or are ineffective because of resistance patterns. The duration of linezolid therapy is typically limited to 2–3 weeks given toxicities such as myelosuppression and peripheral and optic neuropathy with prolonged courses. Despite in vitro susceptibility of *S. aureus* to ciprofloxacin and other quinolone antibiotics, these agents should *not* routinely be used in serious staphylococcal infections, because their use is associated with rapid development of resistance.

The **duration** of antibiotic therapy depends on the anatomic site and severity of infection and response, as determined by the clinical response and, in some cases, radiologic and laboratory findings.

## PROGNOSIS

Untreated *S. aureus* septicemia is associated with a high fatality rate, which has been reduced significantly by appropriate antibiotic treatment. *S. aureus* pneumonia can be fatal at any age but is more likely to be associated with high morbidity and mortality in young infants or in patients whose therapy has been delayed. Prognosis also may be influenced by numerous host factors, including nutrition, immunologic competence, and the presence or absence of other debilitating diseases.

## PREVENTION

*S. aureus* is transmitted primarily by direct contact. Strict attention to **hand hygiene** is the most effective measure for preventing the spread of staphylococci between individuals (see Chapter 216). Hospital surveillance programs to identify nosocomial acquisition of *S. aureus* colonization and/or infection are common, particularly in neonatal intensive care units. Clusters of nosocomial cases may be defined by molecular typing, and if associated with a singular molecular strain, investigation to identify any potential point sources (e.g., a colonized healthcare worker or contaminated environmental reservoir) should occur.

As *S. aureus* colonization often predisposes to infection, a number of protocols are aimed at **decolonization**, which is the application of topical antimicrobials to the skin and/or nares to eradicate *S. aureus* colonization. In healthcare settings, decolonization is often performed among vulnerable populations to prevent nosocomial infections. In community settings, decolonization is often recommended for patients with recurrent *S. aureus* skin infections. Decolonization regimens often involve combinations of decontaminating baths (hypochlorite, 1 tsp common bleach solution per gallon of water, or chlorhexidine 4% soap), nasal mupirocin twice daily for at least 5 days, and enhanced hygiene measures, including frequent laundering of household linens and targeted decontamination of frequently touched household surfaces. Although success is not universal, recurrent infections may be reduced, particularly when eradication is done in both the patient and household contacts, especially those with history of SSTI. Most cases of mild, recurrent disease will resolve in time without these measures.

Because of the potential severity of infections with *S. aureus* and concerns about emerging resistance, much work has focused on

**Table 227.1** Parenteral Antimicrobial Agent(s) for Treatment of Serious *Staphylococcus aureus* Infections

SUSCEPTIBILITY	ANTIMICROBIALS	COMMENTS
<b>I. INITIAL EMPIRICAL THERAPY (ORGANISM OF UNKNOWN SUSCEPTIBILITY)</b>		
Drugs of choice	Vancomycin + nafcillin/oxacillin or cefazolin	For <b>life-threatening infections</b> (e.g., septicemia, endocarditis, CNS infection); linezolid, daptomycin, or ceftaroline could be substituted depending on the clinical scenario and site of infection
	Vancomycin	For <b>non-life-threatening infection</b> without signs of severe sepsis (e.g., skin infection, cellulitis, osteomyelitis, pyarthrosis) when prevalence of MRSA infection in the community is >20% of all <i>S. aureus</i> infections
	Cefazolin or nafcillin/oxacillin	For <b>non-life-threatening infection</b> when low likelihood of MRSA is suspected
	Clindamycin	For non-life-threatening infection without signs of severe sepsis when rates of MRSA infection in the community is substantial (>20% of all <i>S. aureus</i> infections) and prevalence of clindamycin resistance is low
<b>II. METHICILLIN-SUSCEPTIBLE, PENICILLIN-RESISTANT <i>S. AUREUS</i></b>		
Drugs of choice	Cefazolin or oxacillin/nafcillin	May change to oral therapy after infection is controlled in low-risk situations
Alternatives (depending on susceptibility results)	Clindamycin	Only for patients with a serious penicillin allergy and clindamycin-susceptible strain
	Vancomycin	Only for penicillin- and cephalosporin-allergic patients
	Ampicillin + sulbactam	When broader coverage, including gram-negative organisms and/or anaerobes is required
<b>III. METHICILLIN-RESISTANT <i>S. AUREUS</i> (MRSA)</b>		
Drugs of choice	Vancomycin (some combine with a $\beta$ -lactam) (some may begin with ceftaroline)	Linezolid, daptomycin, or ceftaroline* could be substituted or added depending on the clinical scenario, site of infection, or persistent bacteremia
Alternatives: susceptibility testing results available before alternative drugs are used	Clindamycin (if susceptible)	
	Trimethoprim-sulfamethoxazole	
	Doxycycline	

\*Linezolid, daptomycin, and ceftaroline are agents with activity and efficacy against multidrug-resistant, gram-positive organisms, including *S. aureus*. Because experience with these agents in children is limited, consultation with an infectious diseases specialist should be considered before use. Daptomycin is ineffective for treatment of pneumonia, as it is inactivated by pulmonary surfactant.

developing a staphylococcal vaccine for use in high-risk patients, but to date, clinical trials have been disappointing. Because *S. aureus* is frequently a co-infection in severe influenza infections, an indirect preventive impact against staphylococcal pneumonia and tracheitis may be achieved through annual influenza vaccination.

To prevent *S. aureus* food poisoning, cooked foods should be eaten immediately or refrigerated within 2 hours of preparation to prevent multiplication of *S. aureus* that may have contaminated the food (see Chapter 387). Treatment is supportive.

Visit Elsevier eBooks+ at [eBooks.Health.Elsevier.com](http://eBooks.Health.Elsevier.com) for Bibliography.

## 227.2 Toxic Shock Syndrome

Carol M. Kao, Patrick J. Reich, and Stephanie A. Fritz

Toxic shock syndrome (TSS) is an acute and potentially severe illness characterized by fever, hypotension, diffuse erythroderma with subsequent desquamation on the hands and feet, and multisystem involvement.

### ETIOLOGY

TSS is caused by TSST-1-producing and some enterotoxin-producing strains of *S. aureus*, which may colonize the skin or mucous membranes or cause focal sites of staphylococcal infection.

### EPIDEMIOLOGY

TSS continues to occur in the United States in men, women, and children, with the highest rates in menstruating women 15-25 years of age.

**Nonmenstrual TSS** is associated with *S. aureus*-infected nasal packing and wounds, sinusitis, tracheitis, pneumonia, empyema, abscesses, burns, osteomyelitis, and primary bacteremia. The majority of strains of *S. aureus* associated with TSS are methicillin susceptible. Most strains of USA300, the predominant clone of community-associated MRSA in the United States, do not possess the genes expressing the most common TSS superantigens; however, MRSA-associated TSS can occur.

### PATHOGENESIS

The primary toxin associated with TSS is TSST-1, although a significant proportion of nonmenstrual TSS is caused by one or more staphylococcal enterotoxins. These toxins act as **superantigens**, which trigger cytokine release, causing massive loss of fluid from the intravascular space and end-organ cellular injury. Epidemiologic and in vitro studies suggest that these toxins are selectively produced in a clinical environment consisting of a neutral pH, a high Pco<sub>2</sub>, and an aerobic Po<sub>2</sub>, which are the conditions found in abscesses and the vagina with tampon use during menstruation. The risk factors for symptomatic disease include a non-immune host who is colonized with a toxin-producing organism that is exposed to focal growth conditions (menstruation plus tampon use or abscess) that in turn induce toxin production. Some hosts may have a varied cytokine response to TSST-1 exposure, helping to explain a spectrum of severity of TSS that may include staphylococcal scarlet fever. The overall mortality rate of treated patients is 3–5% when treated early.

Approximately 90% of adults have antibody to TSST-1 without a history of clinical TSS, suggesting that most individuals are colonized at some point with a toxin-producing organism at a site (e.g., anterior nares) where low-grade or inactive toxin exposure results in an immune response without disease.



## CLINICAL MANIFESTATIONS

The diagnosis of TSS is based on clinical manifestations (Table 227.2). Milder cases and those with incomplete clinical characteristics may be common, particularly if the nidus of infection is addressed quickly (e.g., removal of a tampon or nasal packing). The onset of classic TSS is abrupt, with high fever, vomiting, and diarrhea, and is accompanied by sore throat, headache, and myalgias. A diffuse erythematous rash (sunburn-like or scarlatiniform) appears within 24 hours and may be associated with hyperemia of pharyngeal, conjunctival, and vaginal mucous membranes. A strawberry tongue is common. Symptoms may include alterations in the level of consciousness, oliguria, and hypotension, which in severe cases may progress to shock and disseminated intravascular coagulation. Complications, including acute respiratory distress syndrome (ARDS), myocardial dysfunction, and renal failure, are commensurate with the degree of shock. Recovery occurs within 7–10 days and is associated with desquamation, particularly of the palms and soles; hair and nail loss have also been observed after 1–2 months. Immunity to the toxins is slow to develop, so recurrences can occur, especially if there is inadequate antibiotic treatment and/or recurrent tampon use. Many cases of apparent scarlet fever without shock may be caused by TSST-1–producing *S. aureus* strains.

## DIAGNOSIS

There is no specific laboratory test, and diagnosis depends on meeting certain clinical and laboratory criteria in the absence of an alternative diagnosis (see Fig. 227.2). Appropriate tests reveal involvement of multiple organ systems, including the hepatic, renal, muscular, gastrointestinal,

cardiopulmonary, and central nervous systems. Bacterial cultures of the associated focus (vagina, abscess) before administration of antibiotics usually yield *S. aureus*, although this is not a required element of the definition.

## Differential Diagnosis

Group A streptococci can cause a similar TSS-like illness, termed **streptococcal TSS** (see Chapter 229), which is often associated with severe streptococcal sepsis or a focal streptococcal infection such as cellulitis, necrotizing fasciitis, or pneumonia.

**Kawasaki disease** closely resembles TSS clinically but is usually not as severe or rapidly progressive. Both conditions are associated with fever unresponsive to antibiotics, hyperemia of mucous membranes, and an erythematous rash with subsequent desquamation. However, many of the clinical features of TSS are rare in Kawasaki disease, including diffuse myalgia, vomiting, abdominal pain, diarrhea, azotemia, hypotension, ARDS, and shock (see Chapter 208). Kawasaki disease typically occurs in children <5 years old. Measles, scarlet fever, Rocky Mountain spotted fever, leptospirosis, toxic epidermal necrolysis, and bacterial sepsis must also be considered in the differential diagnosis.

## TREATMENT

Identification and drainage/removal of any focal source of infection (e.g., abscess, tampon, nasal packing), when present, is essential. Recommended antibiotic therapy for TSS should include the combination of a  $\beta$ -lactamase-resistant antistaphylococcal antibiotic (nafcillin, oxacillin, or cefazolin) plus clindamycin to reduce toxin production. Although TSS is most often caused by MSSA, clinicians should consider use of vancomycin in addition to the  $\beta$ -lactam in areas where MRSA rates are very high, when hospital-acquired MRSA is suspected, and when the clinical picture overlaps with staphylococcal sepsis.

TSS often requires intensive supportive care, including aggressive fluid replacement to prevent or treat hypotension, renal failure, and cardiovascular collapse. Inotropic agents may be needed to treat shock; intravenous immunoglobulin may be helpful in severe cases.

## PREVENTION

The risk for acquiring menstrual TSS is low (1–2 cases/100,000 menstruating women). Changing tampons at least every 8 hours is recommended. If a fever, rash, or dizziness develops during menstruation, any tampon should be removed immediately and medical attention sought. Avoidance of tampon use with subsequent menstrual cycles may also reduce the risk for recurrent menstrual TSS.

Visit Elsevier eBooks+ at eBooks.Health.Elsevier.com for Bibliography.

## 227.3 Coagulase-Negative Staphylococci

Carol M. Kao, Patrick J. Reich, and Stephanie A. Fritz

At present, there are approximately 50 identified species of coagulase-negative staphylococci (CoNS) affecting or colonizing humans. *Staphylococcus epidermidis* and, less often, *Staphylococcus hominis*, *S. haemolyticus*, and others are widely distributed on the skin and are significant causes of nosocomial infection, particularly in the bloodstream of neonatal and immunocompromised hosts, in surgical patients, and in those with indwelling catheters and other medical devices. *Staphylococcus saprophyticus* is a common cause of urinary tract infection (UTI). *Staphylococcus lugdunensis* and *Staphylococcus schleiferi* can cause severe infection similar to *S. aureus* and have been increasingly recognized as important pathogens since improved species identification with matrix-assisted laser desorption/ionization time of flight (MALDI-TOF) mass spectrometry in clinical microbiology laboratories.

## EPIDEMIOLOGY

In the United States, CoNS may be the most common cause of hospital-acquired infection, particularly in neonatal intensive care units (NICUs). In many instances, growth of CoNS from clinical specimens represents contamination from skin rather than a cause of true disease, posing significant challenges for clinicians and infection prevention specialists. CoNS are normal inhabitants of the human skin, throat,

**Table 227.2** Toxic Shock Syndrome (Other Than Streptococcal) (TSS) 2011 Case Definition

### CLINICAL CRITERIA

1. Fever: temperature  $\geq 102.0^{\circ}\text{F}$  ( $\geq 38.9^{\circ}\text{C}$ )
2. Rash: diffuse macular erythroderma
3. Desquamation: 1–2 weeks after onset of rash
4. Hypotension: systolic blood pressure  $\leq 90$  mm Hg for adults or less than fifth percentile by age for children age less than 16 years
5. Multisystem involvement (three or more of the following organ systems):
  - Gastrointestinal: vomiting or diarrhea at onset of illness
  - Muscular: severe myalgia or creatine phosphokinase level at least twice the upper limit of normal
  - Mucous membrane: vaginal, oropharyngeal, or conjunctival hyperemia
  - Renal: blood urea nitrogen or creatinine at least twice the upper limit of normal for laboratory or urinary sediment with pyuria ( $\geq 5$  leukocytes per high-power field) in the absence of urinary tract infection
  - Hepatic: total bilirubin, alanine aminotransferase enzyme, or aspartate aminotransferase enzyme levels at least twice the upper limit of normal for laboratory
  - Hematologic: platelets less than  $100,000/\text{mm}^3$
  - Central nervous system: disorientation or alterations in consciousness without focal neurologic signs when fever and hypotension are absent

### LABORATORY CRITERIA FOR DIAGNOSIS

- Negative results on the following tests, if obtained:
- Blood or cerebrospinal fluid cultures (blood culture may be positive for *Staphylococcus aureus*)
  - Negative serologies for Rocky Mountain spotted fever, leptospirosis, or measles

### CASE CLASSIFICATION

#### Probable

A case that meets the laboratory criteria and in which four of the five clinical criteria described above are present

#### Confirmed

A case that meets the laboratory criteria and in which all five of the clinical criteria described above are present, including desquamation, unless the patient dies before desquamation occurs



mouth, vagina, and urethra. *S. epidermidis* is the most common and persistent species, representing 65–90% of staphylococci present on the skin and mucous membranes. Colonization, sometimes with strains acquired during hospitalization, precedes infection. Alternatively, direct inoculation during surgery may initiate infection of CSF shunts, prosthetic valves, or indwelling vascular lines.

### **PATHOGENESIS**

CoNS produce an exopolysaccharide protective biofilm, particularly on indwelling medical devices, that surrounds the organism and may enhance adhesion to foreign surfaces, resist phagocytosis, and impair penetration of antibiotics. However, the low virulence of CoNS usually requires the presence of another factor for development of clinical disease. Of these, the most significant is the presence of an indwelling catheter or other medical device, including central venous catheters (CVCs), hemodialysis shunts and grafts, CSF shunts (meningitis), peritoneal dialysis catheters (peritonitis), pacemaker wires and electrodes (local infection), prosthetic cardiac valves (endocarditis), and prosthetic joints (septic arthritis). Other risk factors for the development of infection include immature or compromised immunity and significant exposure to antibiotics.

### **CLINICAL MANIFESTATIONS**

#### **Bacteremia**

CoNS, specifically *S. epidermidis*, are the most common cause of nosocomial bacteremia, usually in association with central vascular catheters. In neonates, CoNS bacteremia, with or without a CVC, can manifest as localized disease in the CNS, lungs, skin, heart, bones, and joints, or even as sepsis or necrotizing enterocolitis. Persistent positive blood cultures despite adequate antimicrobial therapy is common, particularly when catheters are not removed. In older children with intact immune systems, CoNS bacteremia is indolent and is not usually associated with overwhelming septic shock.

#### **Endocarditis**

Infection of native heart valves or the right atrial wall may occur secondary to an infected thrombosis at the end of a central line. *S. epidermidis* and other CoNS may rarely produce native valve subacute endocarditis in previously healthy hosts without a CVC. CoNS is a common cause of prosthetic valve endocarditis, presumably a result of inoculation at surgery. Infection of the valve sewing ring, with abscess formation and dissection, produces valve dysfunction or obstruction, dehiscence, or arrhythmias (see [Chapter 486](#)). *S. lugdunensis* has been increasingly associated with severe endocardial infection in adults but remains an uncommon cause in children.

#### **Central Venous Catheter Infection**

CVCs become infected through the exit site and subcutaneous tunnel, which provide a direct path to the bloodstream. *S. epidermidis* is the most frequent pathogen, in part because of its high rate of cutaneous colonization. Line sepsis is usually manifested as fever and leukocytosis; tenderness and erythema may be present at the exit site or along the subcutaneous tunnel. Catheter thrombosis may complicate line sepsis. Disease severity with CoNS is often less severe than other etiologies of line infection.

#### **Cerebrospinal Fluid Shunts**

CoNS, introduced at surgery, is the most common pathogen associated with CSF shunt meningitis. Most infections (70–80%) occur within 2 months of the operation and manifest as signs of meningeal irritation, fever, increased intracranial pressure (headache, vomiting), or peritonitis from the intraabdominal position of the distal end of the shunt tubing.

#### **Urinary Tract Infection**

*S. saprophyticus* is a common cause of primary UTIs in sexually active females. Manifestations are similar to those characteristics of UTI caused by *Escherichia coli* (see [Chapter 575](#)). CoNS also cause asymptomatic UTI in hospitalized patients with urinary catheters and after urinary tract surgery or transplantation.

### **DIAGNOSIS**

Because *S. epidermidis* is a common skin inhabitant and may contaminate poorly collected blood cultures, differentiating bacteremia from contamination is often difficult. True bacteremia should be suspected if blood cultures grow rapidly (within 15 hours of incubation in a continuously monitored blood culture system), more than one blood culture is positive with the same CoNS strain, cultures from both the blood and another sterile site are positive, and clinical and laboratory signs and symptoms compatible with CoNS sepsis are present and subsequently resolve with appropriate therapy. Growth of CoNS from a blood culture in a neonate or patient with an intravascular catheter should be considered evidence of true bacteremia until careful review of the foregoing criteria and evaluation of the patient. Before initiating presumptive antimicrobial therapy in such patients, it is always prudent to draw two separate blood cultures to facilitate subsequent interpretation if CoNS is grown. Molecular and mass spectrometry assays similar to those used for identification of *S. aureus* allow for rapid identification of CoNS in positive blood cultures.

### **TREATMENT**

Because most CoNS strains are resistant to methicillin (with the exception of *S. lugdunensis* and *S. saprophyticus*, which are generally methicillin susceptible), **vancomycin** is the initial drug of choice. Resistance to vancomycin has rarely been reported with *S. haemolyticus*. For patients with indwelling medical devices, the addition of rifampin to vancomycin may increase antimicrobial efficacy because of good penetration of this antibiotic into biofilms. Other antibiotics with good in vitro activity against CoNS may be considered in certain circumstances. These include linezolid, ceftaroline, and daptomycin. Removal of an infected catheter is ideal. However, this is not always possible because of the therapeutic requirements of the underlying disease (e.g., nutrition for short bowel syndrome, chemotherapy for malignancy). A trial of IV vancomycin (potentially with the addition of rifampin) with the retained catheter can be attempted to preserve the use of the central line, as long as systemic manifestations of infection are not severe. Antibiotic therapy given through an infected CVC and the use of antibiotic locks in conjunction with systemic therapy may increase the likelihood of curing CoNS line sepsis without line removal. Prosthetic heart valves and CSF shunts usually need to be removed to adequately treat the infection.

**Peritonitis** caused by *S. epidermidis* in patients on continuous ambulatory peritoneal dialysis is an infection that may be treated with IV or intraperitoneal antibiotics without removing the dialysis catheter. If the organism is resistant to methicillin, vancomycin adjusted for renal function is appropriate therapy. Unlike most CoNS, *S. saprophyticus* is usually methicillin susceptible, and UTIs can typically be treated with a first-generation cephalosporin (cephalexin), amoxicillin-clavulanic acid, or TMP-SMX.

### **PROGNOSIS**

Most episodes of CoNS bacteremia respond successfully to antibiotics and removal of any foreign material that is present. Poor prognosis is associated with malignancy, neutropenia, and infected prosthetic or native heart valves. CoNS infections increase the morbidity, duration of hospitalization, and mortality among patients with underlying complicated illnesses.

### **PREVENTION**

Iatrogenic morbidity and resource use caused by contaminated blood cultures can be reduced by following recommended strategies to prevent CVC-associated bloodstream infections during catheter insertion and maintenance. These strategies include basic techniques such as central line care “bundles,” which incorporate good hand hygiene, decontamination of hubs and ports before access, minimizing frequency of access, and frequent replacement of external connections and infusion materials. Antibiotic-impregnated catheters can be considered when other preventive measures have failed.

Visit Elsevier eBooks+ at [eBooks.Health.Elsevier.com](http://eBooks.Health.Elsevier.com) for Bibliography.

## Chapter 228

***Streptococcus pneumoniae***  
**(Pneumococcus)**

Kacy A. Ramirez and Timothy R. Peters

*Streptococcus pneumoniae* (pneumococcus) is an important pathogen that results in more than 1 million children deaths each year. Childhood invasive pneumococcal disease is prevalent and typically severe, causes numerous clinical syndromes, and is a major cause of life-threatening pneumonia, bacteremia, endocarditis, and meningitis; it may also cause sinusitis, otitis media, and bone and joint infections. Antimicrobial resistance in pneumococcus is a major public health problem, with 15–30% of isolates worldwide classified as **multidrug resistant (MDR)**; resistant to at least three classes of antibiotics). Pneumococcal polysaccharide-protein conjugate vaccines (PCVs) developed for infants have been highly successful in the control of disease caused by virulent vaccine-specific serotypes. Epidemiologic surveillance reveals a dynamic pneumococcal ecology with emergence of highly virulent MDR serotypes. Ongoing vaccine development and distribution efforts remain the best approach to control this threat to childhood health.

**ETIOLOGY**

*S. pneumoniae* is a gram-positive, lancet-shaped, polysaccharide encapsulated diplococcus, occurring occasionally as individual cocci or in chains; >90 serotypes have been identified by type-specific capsular polysaccharides. Antisera to some pneumococcal polysaccharides cross-react with other pneumococcal types, defining serogroups (e.g., 6A and 6B). Encapsulated strains cause most serious disease in humans. Capsular polysaccharides impede phagocytosis. Virulence is related in part to capsule size, but pneumococcal types with capsules of the same size can vary widely in virulence.

On solid media, *S. pneumoniae* forms unpigmented, umbilicated colonies surrounded by a zone of incomplete ( $\alpha$ ) hemolysis. *S. pneumoniae* is bile soluble (i.e., 10% deoxycholate) and optochin sensitive. *S. pneumoniae* is closely related to the viridans groups of *Streptococcus mitis*, which typically overlap phenotypically with pneumococci. The conventional laboratory definition of pneumococci continues to rely on bile and optochin sensitivity, although considerable confusion occurs in distinguishing pneumococci and other  $\alpha$ -hemolytic streptococci. Pneumococcal capsules can be microscopically visualized and typed by exposing organisms to type-specific antisera that combine with their unique capsular polysaccharide, rendering the capsule refractile (Quellung reaction). Specific antibodies to capsular polysaccharides confer protection on the host, promoting opsonization and phagocytosis. Additionally, CD4<sup>+</sup> T cells have a direct role in antibody-independent immunity to pneumococcal nasopharyngeal colonization. Conjugated PCVs promote T-cell immunity and protect against pneumococcal colonization, in contrast to the pneumococcal polysaccharide vaccine (PPSV23) that is used in adults and certain high-risk pediatric populations and that does not affect nasopharyngeal colonization.

**EPIDEMIOLOGY**

Most healthy individuals carry (colonized) various *S. pneumoniae* serotypes in their upper respiratory tract; >90% of children between 6 months and 5 years of age harbor *S. pneumoniae* in the nasopharynx at some time. A single serotype usually is carried by a given individual for an extended period (45 days to 6 months). Carriage does not consistently induce local or systemic immunity sufficient to prevent

later reacquisition of the same serotype. Rates of pneumococcal carriage peak during the first and second year of life and decline gradually thereafter. Carriage rates are highest in institutional settings and during the winter and are lowest in summer. Nasopharyngeal carriage of pneumococci is common among young children attending out-of-home care, with rates of 21–59% in point prevalence studies.

Before the introduction of heptavalent pneumococcal conjugate vaccine (PCV7) in 2000, serotypes 4, 6B, 9V, 14, 18C, 19F, and 23F caused most invasive childhood pneumococcal infections in the United States. The introduction of PCVs resulted in a marked decrease in **invasive pneumococcal infections (IPIs)** in children. By 2005, however, IPIs began to increase slightly because of an increase in non-PCV7 serotypes, particularly serotype 19A. **Serotype replacement** can result from expansion of existing nonvaccine serotypes and from vaccine-type pneumococci acquiring the polysaccharide capsule of a nonvaccine serotype (**serotype switching**). Since the introduction of PCV13 in 2010 in the United States, there has been a decline in IPIs caused by new vaccine serotypes, including 19A. Nonetheless, 19A remains an important cause of meningitis. Indirect protection of unvaccinated persons has occurred since PCV introduction, and this *herd protection* is likely a result of decreases in nasopharyngeal carriage of virulent pneumococcal vaccine serotypes.

*S. pneumoniae* is the most frequent cause of bacteremia, bacterial pneumonia, and bacterial meningitis and among the most common causes of otitis media and sinusitis in children. The decreased ability in children <2 years old to produce antibody against the T-cell-independent polysaccharide antigens and the high prevalence of colonization may explain an increased susceptibility to pneumococcal infection and the decreased effectiveness of polysaccharide vaccines. Children at increased risk of pneumococcal infections include those with sickle cell disease, asplenia, deficiencies in humoral (B-cell) immunity, deficiencies in complement-mediated immunity, toll like receptor deficiencies, HIV infection, certain malignancies (e.g., leukemia, lymphoma), chronic heart, lung, or renal disease (particularly nephrotic syndrome), cerebrospinal fluid (CSF) leak, and cochlear implants. [Table 228.1](#) lists other high-risk groups. Some American Indian, Alaska Native, and African American children may also be at increased risk. Children <5 years old in out-of-home daycare are at increased risk (approximately twofold higher) of experiencing IPIs than other children. Males are more frequently affected than females. Because immunocompetent vaccinated children have had fewer episodes of IPI, the proportion of infected children with immunologic risk factors has increased (estimated at 20%).

Pneumococcal disease usually occurs sporadically but can be spread from person to person by respiratory droplet transmission. *S. pneumoniae* is an important cause of secondary bacterial pneumonia in patients with influenza. During influenza epidemics and pandemics, most deaths result from bacterial pneumonia, and pneumococcus is the predominant bacterial pathogen isolated in this setting. Pneumococcal co-pathogenicity may be important in disease caused by other respiratory viruses as well.

**PATHOGENESIS**

Invasion of the host is affected by a number of factors. Nonspecific defense mechanisms, including the presence of other bacteria in the nasopharynx, may limit multiplication of pneumococci. Aspiration of secretions containing pneumococci is hindered by the epiglottic reflex and by respiratory epithelial cell cilia, which move infected mucus toward the pharynx. Similarly, normal ciliary flow of fluid from the middle ear through the eustachian tube and sinuses to the nasopharynx usually prevents infection with nasopharyngeal flora, including pneumococci. Interference with these normal clearance mechanisms by allergy, viral infection, or irritants (e.g., smoke) may allow colonization and subsequent infection with these organisms in otherwise normally sterile sites.

Virulent pneumococci are intrinsically resistant to phagocytosis by alveolar macrophages. Pneumococcal disease frequently is facilitated by viral respiratory tract infection, which may produce mucosal injury, diminish epithelial cell ciliary activity, and depress the function of

**Table 228.1** Children at Increased Risk of Invasive Pneumococcal Infection

RISK GROUP	CONDITION
Immunocompetent children	Chronic heart disease* Chronic lung disease† Chronic kidney disease (excluding dialysis and nephrotic syndrome) Chronic liver disease Diabetes mellitus Cerebrospinal fluid leaks Cochlear implant
Children with immunocompromising conditions	HIV infection Maintenance dialysis or nephrotic syndrome Congenital or acquired asplenia or splenic dysfunction Congenital or acquired immunodeficiencies Sickle cell disease and other hemoglobinopathies Congenital immunodeficiency‡ Diseases and conditions treated with immunosuppressive drugs or radiation therapy, including malignant neoplasm, leukemia, lymphoma, and Hodgkin disease, or solid organ transplantation

\*Particularly cyanotic congenital heart disease and cardiac failure.

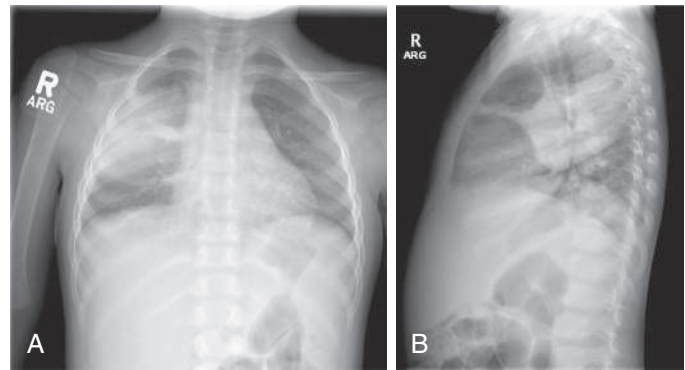
†Including moderate persistent or severe persistent asthma.

‡Includes humoral or T lymphocyte deficiency; complement deficiencies, particularly C1, C2, C3 and C4 deficiency; and phagocytic disorders (excluding chronic granulomatous disease).

Adapted from Kobayashi M, Farrar JI, Gierke R, et al. Use of 15-valent pneumococcal conjugate vaccine among U.S. children: updated recommendations of the Advisory Committee on Immunization Practices – United States, 2022. *MMWR Morb Mortal Wkly Rep.* 2022;71(4):1174-1181; and Centers for Disease Control and Prevention. ACIP updates: Recommendations for use of 20-valent pneumococcal conjugate vaccine in children—United States, 2023. *MMWR Morb Mortal Wkly Rep.* 2023;72(39):1072.

alveolar macrophages and neutrophils. Phagocytosis may be impeded by respiratory secretions and alveolar exudate. In the lungs and other tissues, the spread of infection is facilitated by the antiphagocytic properties of the pneumococcal capsule. Surface fluids of the respiratory tract contain only small amounts of immunoglobulin G (IgG) and are deficient in complement. During inflammation, there is limited influx of IgG, complement, and neutrophils. Phagocytosis of bacteria by neutrophils may occur, but normal human serum may not opsonize pneumococci and facilitate phagocytosis by alveolar macrophages. In tissues, pneumococci multiply and spread through the lymphatics or bloodstream or, less often, by direct extension from a local site of infection (e.g., sinuses). In bacteremia the severity of disease is related to the number of organisms in the bloodstream and to the integrity of specific host defenses. A poor prognosis correlates with very large numbers of pneumococci and high concentrations of capsular polysaccharide in the blood and CSF.

Invasive pneumococcal disease is 30- to 100-fold more prevalent in children with sickle cell disease and other hemoglobinopathies and in children with congenital or surgical asplenia than in the general population. This risk is greatest in infants <2 years old, the age when antibody production to most serotypes is poor. The increased frequency of pneumococcal disease in asplenic persons is related to both deficient opsonization of pneumococci and absence of clearance by the spleen of circulating bacteria. Children with sickle cell disease also have deficits in the antibody-independent properdin (alternative) pathway of complement activation in addition to functional asplenia. Both complement pathways contribute to antibody-independent and antibody-dependent **opsonophagocytosis** of pneumococci. With advancing age (e.g., >5 years), children with sickle cell disease produce anticapsular



**Fig. 228.1** Bacterial “round” pneumonia caused by *Streptococcus pneumoniae* in 2-yr-old child with a 2-day history of cough, high fever, leukocytosis, and back pain.

antibody, augmenting antibody-dependent opsonophagocytosis and greatly reducing, but not eliminating, the risk of severe pneumococcal disease. Deficiency of many of the complement components (e.g., C2 and C3) is associated with recurrent pyogenic infection, including *S. pneumoniae* infection. The efficacy of phagocytosis also is diminished in patients with B- and T-cell immunodeficiency syndromes (e.g., agammaglobulinemia, severe combined immunodeficiency) or loss of immunoglobulin (e.g., nephrotic syndrome) and is largely caused by a deficiency of opsonic anticapsular antibody. These observations suggest that opsonization of pneumococci depends on the alternative complement pathway in antibody-deficient persons and that recovery from pneumococcal disease depends on the development of anticapsular antibodies that act as opsonins, enhancing phagocytosis and killing of pneumococci. Children with HIV infection also have high rates of IPI similar to or greater than rates in children with sickle cell disease, although rates of invasive pneumococcal disease decreased after the introduction of highly active antiretroviral therapy (HAART).

## CLINICAL MANIFESTATIONS

The signs and symptoms of pneumococcal infection are related to the anatomic site of disease. Common clinical syndromes include otitis media (see Chapter 680), sinusitis (see Chapter 429), pneumonia (Fig. 228.1) (see Chapter 449), and sepsis (see Chapter 85). Before routine use of PCVs, pneumococci caused >80% of bacteremia episodes in infants 3-36 months old with fever without an identifiable source (i.e., occult bacteremia). Bacteremia may be followed by meningitis (see Chapter 643), osteomyelitis (see Chapter 725), suppurative (septic) arthritis (see Chapter 726), endocarditis (see Chapter 486), and, rarely, brain abscess (see Chapter 644). Primary peritonitis (see Chapter 419.1) may occur in children with peritoneal effusions caused by nephrotic syndrome and other ascites-producing conditions. Local complications of infection may occur, causing empyema, pericarditis, mastoiditis, epidural abscess, periorbital cellulitis, or meningitis. Hemolytic-uremic syndrome (see Chapter 533.4) and disseminated intravascular coagulation also occur as rare complications of pneumococcal infections. Epidemic conjunctivitis caused by nonencapsulated or encapsulated pneumococci occurs as well.

## DIAGNOSIS

The diagnosis of pneumococcal infection is established by recovery of *S. pneumoniae* from the site of infection or the blood/sterile body fluid. Although pneumococci may be found in the nose or throat of patients with otitis media, pneumonia, septicemia, or meningitis, cultures of these locations are generally not helpful for diagnosis, because they are not indicative of causation. Blood cultures should be obtained in children with pneumonia, meningitis, endocarditis, arthritis, osteomyelitis, peritonitis, pericarditis, or gangrenous skin lesions. Because of the implementation of universal vaccination with PCVs, there has been a substantial decrease in the incidence of occult bacteremia, but blood



cultures should still be considered in febrile patients with clinical toxicity or significant leukocytosis. Leukocytosis often is pronounced, with total white blood cell (WBC) counts frequently  $>15,000/\mu\text{L}$ . In severe cases of pneumococcal disease, WBC count may be low.

Pneumococci can be identified in body fluids as gram-positive, lancet-shaped diplococci. Early in the course of pneumococcal meningitis, many bacteria may be seen in relatively acellular CSF. With methods of continuously monitored blood culture systems, the average time to isolation of pneumococcal organisms is 14–15 hours. Multiplex real-time polymerase chain reaction (PCR) assays are specific and more sensitive than culture of CSF and blood, particularly in patients who have recently received antimicrobial therapy. Antigen detection of C-polysaccharide in urine may be useful in adults with pneumococcal pneumonia but lacks specificity in children who may have positive results with asymptomatic colonization. Antigen immunochromatographic or PCR assays on pleural fluid are not routinely used but could be considered.

## TREATMENT

Antimicrobial resistance among *S. pneumoniae* continues to be a serious healthcare concern, especially for the widely used  $\beta$ -lactams, macrolides, and fluoroquinolones. Serotypes 6A, 6B, 9V, 14, 19A, 19F, and 23F are the most common serotypes associated with resistance to penicillin. Consequently, the introduction of the 7- and 13-valent pneumococcal conjugate vaccines (PCV7 and PCV13) has altered antimicrobial resistance patterns. By 2014, only ~5% of pneumococcal strains were penicillin nonsusceptible. However, pneumococcal serotypes 11A, 35F, and 35B have contributed to steady erosion of pneumococcal antibiotic susceptibility to penicillin, third-generation cephalosporins, fluoroquinolones, and carbapenems.

Resistance in pneumococci to penicillin and cephalosporins is defined by the minimum inhibitory concentration (MIC) and clinical syndrome. Pneumococci are considered *susceptible*, *intermediate*, or *resistant* to various antibacterial agents based on specific MIC breakpoints. For patients with pneumococcal meningitis, penicillin-susceptible strains have MICs  $\leq 0.06 \mu\text{g/mL}$ , and penicillin-resistant strains have MICs  $\geq 0.12 \mu\text{g/mL}$ . For patients with nonmeningeal pneumococcal infections, breakpoints are higher; in particular, penicillin-susceptible strains have MICs  $\leq 2 \mu\text{g/mL}$ , and penicillin-resistant strains have MICs  $\geq 8 \mu\text{g/mL}$ . For patients with meningitis, ceftriaxone-susceptible strains have MICs  $\leq 0.5 \mu\text{g/mL}$ , and resistant strains have MICs  $\geq 2.0 \mu\text{g/mL}$ . For patients with nonmeningeal pneumococcal disease, breakpoints are higher, and ceftriaxone-susceptible strains have MICs  $\leq 1 \mu\text{g/mL}$ , and resistant strains have MICs  $\geq 4 \mu\text{g/mL}$ . In cases when pneumococcus is resistant to erythromycin but sensitive to clindamycin, a *D*-test should be performed to determine whether clindamycin resistance can be induced; if the *D*-test is positive, clindamycin should not be used to complete treatment of the patient. More than 30% of pneumococcal isolates are resistant to trimethoprim-sulfamethoxazole (TMP-SMX); levofloxacin resistance is low but has also been reported. All isolates from children with severe infections should be tested for antibiotic susceptibility, given widespread pneumococcal MDR strains. Resistance to vancomycin has not been seen at this time, but vancomycin-tolerant pneumococci that are killed at a slower rate have been reported, and these tolerant pneumococci may be associated with a worse clinical outcome. Linezolid is an oxazolidinone antibacterial with activity against MDR gram-positive organisms, including pneumococcus, and has been used in the treatment of MDR pneumococcal pneumonia, meningitis, and severe otitis media. Despite early favorable studies, use of this drug is limited by myelosuppression and high cost, and linezolid resistance in pneumococcus is reported.

Children  $\geq 1$  month old with suspected pneumococcal meningitis should be treated with combination therapy using **vancomycin** (60 mg/kg/24 hr divided every 6–8 hr IV) and high-dose **ceftriaxone** (100 mg/kg/24 hr divided every 12 hr IV). Proven pneumococcal meningitis can be treated with penicillin alone or ceftriaxone alone if the isolate is penicillin susceptible. If the organism is nonsusceptible (i.e., intermediate or full resistance) to penicillin but susceptible to ceftriaxone, pneumococcal meningitis can be treated with ceftriaxone alone. However, if

the organism is nonsusceptible to penicillin and to ceftriaxone, pneumococcal meningitis should be treated with combination vancomycin plus ceftriaxone, not with vancomycin alone, and consideration should be given to the addition of **rifampin**. Some experts recommend use of corticosteroids in pneumococcal meningitis early in the course of disease, but data demonstrating clear benefit in children are lacking.

The 2011 Infectious Diseases Society of America guidelines recommend **amoxicillin** as first-line therapy for previously healthy, appropriately immunized infants and preschool children with mild to moderate, uncomplicated community-acquired pneumonia. **Ampicillin** or **penicillin G** may be administered to the fully immunized infant or school-age child admitted to a hospital with uncomplicated community-acquired pneumonia when local epidemiologic data document lack of substantial high-level penicillin resistance for invasive *S. pneumoniae*. Empirical therapy with parenteral ceftriaxone should be prescribed for hospitalized infants and children who are not fully immunized, in regions where local epidemiology of invasive pneumococcal strains documents widespread penicillin resistance, or for infants and children with life-threatening infection, including those with empyema. Non- $\beta$ -lactam agents, such as vancomycin, have not been shown to be more effective than ceftriaxone in the treatment of pneumococcal pneumonia, given the degree of drug resistance currently seen in the United States.

Higher doses of amoxicillin (80–90 mg/kg/24 hr) have been successful in the treatment of otitis media caused by relatively penicillin-resistant pneumococcal strains. If the patient has failed initial antibiotic therapy, alternative agents should be active against penicillin-nonsusceptible pneumococcus as well as  $\beta$ -lactamase-producing *Haemophilus influenzae* and *Moraxella catarrhalis*. These include high-dose oral amoxicillin-clavulanate (in the 14:1 formulation to reduce the risk of diarrhea), oral cefdinir, cefpodoxime, or cefuroxime or a 3-day course of daily intramuscular (IM) ceftriaxone if patients fail oral therapy. Empirical treatment of pneumococcal disease should be based on knowledge of susceptibility patterns in specific communities.

For individuals with a non-type I allergic reaction to penicillin, cephalosporins (standard dosing) can be used. For type I allergic reactions (immediate, anaphylactic) to  $\beta$ -lactam antibiotics, clindamycin and levofloxacin are preferred alternatives depending on the site of infection (e.g., clindamycin may be effective for pneumococcal infections other than meningitis). TMP-SMX may also be considered for susceptible strains but should be avoided in the absence of susceptibility results. Erythromycin and related macrolides (e.g., azithromycin, clarithromycin) should be avoided given high rates of resistance.

## PROGNOSIS

Prognosis depends on the integrity of host defenses, virulence and numbers of the infecting organism, age of the host, site and extent of the infection, and adequacy of treatment. The mortality rate for pneumococcal meningitis is approximately 10% in most studies. Pneumococcal meningitis results in sensorineural hearing loss in 20–30% of patients and can cause other serious neurologic sequelae, including paralysis, epilepsy, blindness, and intellectual deficits.

Invasive pneumococcal disease is associated with various primary immunodeficiency states, leading some to suggest screening for immune defects in all or some patients with invasive diseases. In the absence of other risk factors (see Table 228.1), screening for immune defects (complement, B-cell, toll-like receptor, asplenia) may be indicated for patients with recurrent invasive disease, infection by a serotype covered by vaccination in a fully vaccinated child, children  $\geq 2$  years of age, or in some centers all patients with invasive disease.

## PREVENTION

The highly successful PCVs have resulted in a marked decrease in IPIs in children. PCVs provoke protective antibody responses in 90% of infants given these vaccines at 2, 4, and 6 months of age, and greatly enhanced responses (e.g., immunologic memory) are apparent after vaccine doses given at 12–15 months of age (Table 228.2). In a large



Table 228.2 Comparison of Pneumococcal Vaccines Licensed in United States\*

CARRIER PROTEIN	PNEUMOCOCCAL CAPSULAR POLYSACCHARIDES	MANUFACTURER
Diphtheria CRM <sub>197</sub> protein	<b>4, 6B, 9V, 14, 18C, 19F, 23F</b>	Wyeth Lederle (PCV7, Prevnar)
Diphtheria CRM <sub>197</sub> protein	<b>1, 3, 4, 5, 6A, 6B, 7F, 9V, 14, 18C, 19A, 19F, 23F</b>	Wyeth Lederle (PCV13, Prevnar 13)
Diphtheria CRM <sub>197</sub> protein	<b>1, 3, 4, 5, 6A, 6B, 7F, 9V, 14, 18C, 19A, 19F, 22F, 23F, 32F</b>	Merck Sharp and Dohme (PCV15, Prevnar 15)
Diphtheria CRM <sub>197</sub> protein	<b>1, 3, 4, 5, 6A, 6B, 7F, 8, 9V, 10A, 11A, 12F, 14, 15B, 18C, 19A, 19F, 22F, 23F, 32F</b>	Merck Sharp and Dohme (PCV20, Prevnar 20)
None	<b>1, 2, 3, 4, 5, 6B, 7F, 8, 9N, 9V, 10A, 11A, 12F, 14, 15B, 17F, 18C, 19A, 19F, 20, 22F, 23F, 33F</b>	Sanofi Pasteur MSD (PPSV23, Pneumovax II)

\*PCV7 serotypes in bold.

Table 228.3 Recommended Routine Vaccination Schedule for 15- or 20-Valent Pneumococcal Conjugate Vaccine (PCV15 or 20) Among Infants and Children Who Have Not Received Previous Doses of Conjugate Vaccines, by Age at First Dose—United States, 2010

AGE AT FIRST DOSE (MO)	PRIMARY PCV15 OR PCV20 SERIES*	PCV15 OR PCV20 BOOSTER DOSE†
2-6	3 doses	1 dose at age 12-15 mo
7-11	2 doses	1 dose at age 12-15 mo
12-23	2 doses	—
24-59 (healthy children)	1 dose	—
24-71 (children with certain chronic diseases or immunocompromising conditions‡)	2 doses	—

\*The minimum interval between doses is 8 wk except for children vaccinated at age &lt;12 mo, for whom the minimum interval between doses is 4 wk. The minimum age for administration of the first dose is 6 wk.

†Given at least 8 wk after the previous dose.

‡See Table 228.1. If two doses of PCV15 are used, then 1 dose of PPSV23 vaccine is given ≥8 weeks later.

Adapted from Kobayashi M, Farrar JI, Gierke R, et al. Use of 15-valent pneumococcal conjugate vaccine among U.S. children: updated recommendations of the Advisory Committee on Immunization Practices – United States, 2022. *MMWR Morb Mortal Wkly Rep.* 2022;71(4):1174-1181; and Centers for Disease Control and Prevention. ACIP updates: Recommendations for use of 20-valent pneumococcal conjugate vaccine in children—United States, 2023. *MMWR Morb Mortal Wkly Rep.* 2023;72(39):1072.

clinical trial, PCV7 was shown to reduce invasive disease caused by vaccine serotypes by up to 97% and to reduce invasive disease caused by all serotypes, including serotypes not in the vaccine, by 89%. Children who received PCV7 had 7% fewer episodes of acute otitis media and underwent 20% fewer tympanostomy tube placements than unvaccinated children. After PCV13, a 98% reduction in IPIs caused by vaccine serotypes has been seen, particularly in children <5 years old. The number of pneumococcal isolates and percentage of isolates with high-level penicillin resistance from cultures taken from children with otitis media or mastoiditis for clinical indications decreased, largely related to decreases in serotype 19A. Rates of hospitalization for pneumococcal pneumonia among U.S. children decreased after PCV13 introduction. The number of cases of pneumococcal meningitis in children remain unchanged, but the proportion of PCV13 serotypes has decreased significantly. In addition, pneumococcal conjugate vaccines significantly reduce nasopharyngeal carriage of vaccine serotypes. PCVs have significantly decreased rates of invasive pneumococcal disease in children with sickle cell disease, and studies suggest substantial protection for HIV-infected children and splenectomized adults. Adverse events after the administration of PCV have included local swelling and redness and slightly increased rates of fever when used in conjunction with other childhood vaccines.

Currently, the predominant non-PCV13 serotypes are 22F, 12F, 33F, 24F, 15C, 15B, 23B, 10A, 11A, 35B, 35F, and 38. Serotypes 12F and 24F have high invasive disease potential, with the latter responsible for a rebound in incidence of pneumococcal meningitis since 2015. Serotypes 11A, 35F, and 35B in nasopharyngeal and middle ear samples

are increasingly resistant to antibiotics. PCV15 or PCV20, which have replaced PCV13, do not contain serotypes 24 or 35, but PCV20 includes 11A and 12F.

Immunologic responsiveness and efficacy after administration of pneumococcal polysaccharide vaccines (PPSV23) is unpredictable in children <2 years old. PPSV23 contains purified polysaccharide of 23 pneumococcal serotypes responsible for >95% of invasive disease. The clinical efficacy of PPSV23 is controversial, and studies have yielded conflicting results.

Immunization with PCV15 or PCV20 is recommended for all infants on a schedule for primary immunization, in previously unvaccinated infants, and for transition for those partially vaccinated (Table 228.3). High-risk children ≥2 years old, such as those with asplenia, sickle cell disease, some types of immune deficiency (e.g., antibody deficiencies), HIV infection, cochlear implant, CSF leak, diabetes mellitus, and chronic lung (including moderate persistent or severe persistent asthma), heart, liver, or kidney disease (including nephrotic syndrome) or immunocompromising conditions, such as asplenia, sickle cell disease, some types of immune deficiency (e.g., antibody deficiencies), HIV infection, etc., may also benefit from PPSV23 administered after 2 years of age after priming with the scheduled doses of PCV15 or 20. Thus it is recommended that children 2 years of age and older with these conditions receive supplemental vaccination with PPSV23. A second dose of PPSV23 is recommended 5 years after the first dose of PPSV23 for persons ≥2 years old who have immunocompromising conditions including sickle cell disease and functional or anatomic asplenia. Additional doses of PPSV23 are not required, however, if the patient has ever received PCV20. Additional

TABLE 228.4 CDC Advisory Committee on Immunization Practices Recommendations for Use of PCV in Children, June 2023

AGE AND RISK GROUP	RECOMMENDATIONS
Children age <24 mo	<ul style="list-style-type: none"> <li>Use of either PCV15 or PCV20 is recommended for all children age 2–23 mo according to previously recommended PCV dosing and schedules.</li> <li>If only PCV13 is available when the child is scheduled to receive a PCV, PCV13 may be given as previously recommended.</li> <li>If a child started the PCV series with PCV13, the child may complete the series with PCV15 or PCV20 without giving additional doses; the PCV series does not need to be restarted.</li> <li>For children who have received all recommended dosing and schedules with PCV13 or PCV15, a supplemental dose of PCV20 is not indicated.</li> </ul>
Healthy children age 24–59 mo with an incomplete PCV vaccination status*	<ul style="list-style-type: none"> <li>A single dose of either PCV15 or PCV20 is recommended.</li> <li>A supplemental dose of PCV15 or PCV20 is not indicated for healthy children who have received 4 doses of PCV13 or who completed another age-appropriate PCV13 schedule.</li> </ul>
Children age 24–71 mo with any risk condition†	<ul style="list-style-type: none"> <li>Use either PCV15 or PCV20 according to previously recommended PCV dosing and schedules.</li> <li>If only PCV13 is available when the child is scheduled to receive a PCV, PCV13 may be given as previously recommended.</li> </ul>
Children age 2–18 yr with any risk condition who completed a recommended PCV series before age 6 yr	<ul style="list-style-type: none"> <li>Completed series includes <math>\geq 1</math> dose of PCV20: <ul style="list-style-type: none"> <li>No additional doses of any pneumococcal vaccine are indicated.</li> <li>This recommendation may be updated as additional data become available.</li> </ul> </li> <li>Completed series using PCV13 or PCV15 (no PCV20): <ul style="list-style-type: none"> <li>Either a single dose of PCV20 or PPSV23 using previously recommended dosing and schedules is recommended to complete the recommended vaccine series.</li> </ul> </li> </ul>
Children age 6–18 yr with any risk condition with no previous PCV13, PCV15, or PCV20 vaccination	<ul style="list-style-type: none"> <li>For children age 6–18 yr with any risk condition who have not received any dose of PCV (PCV13, PCV15, or PCV20) a single dose of either PCV15 or PCV20 is recommended.</li> <li>If the child has previously received PCV7 and/or PPSV23, a single dose of either PCV15 or PCV20 is recommended <math>\geq 8</math> wk after the most recent dose of pneumococcal vaccination. <ul style="list-style-type: none"> <li>PCV15 should be followed by a dose of PPSV23 if not previously given.</li> <li>PCV20 does not need to be followed by a dose of PPSV23.</li> </ul> </li> </ul>
Children who have received HSCT	<ul style="list-style-type: none"> <li>Children who received HSCT are recommended to receive three doses of PCV20, 4 wk apart starting 3–6 mo after HSCT.</li> <li>A fourth PCV20 dose is recommended <math>\geq 6</math> mo after the third PCV20 dose, or <math>\geq 12</math> mo after HSCT, whichever is later.</li> <li>HSCT recipients who have started their pneumococcal vaccine series with PCV13 or PCV15 may complete their 4-dose pneumococcal vaccine series with PCV20 without giving extra doses.</li> <li>If PCV20 is not available, three doses of PCV15, 4 wk apart starting 3–6 mo after HSCT, followed by a dose of PPSV23 <math>\geq 12</math> mo after HSCT may be given.</li> <li>For patients with chronic graft-versus-host disease who are receiving PCV15, a fourth dose of PCV15 can be given in place of PPSV23 since these children are less likely to respond to PPSV23. A patient's clinical team is best positioned to determine the appropriate timing of vaccination.</li> </ul>

\*Routine use of PCV is not recommended for healthy children age  $\geq 5$  yr.

†Risk conditions include: cerebrospinal fluid leak; chronic heart disease; chronic kidney disease (excluding maintenance dialysis and nephrotic syndrome, which are included in immunocompromising conditions); chronic liver disease; chronic lung disease (including moderate persistent or severe persistent asthma); cochlear implant; diabetes mellitus; immunocompromising conditions (on maintenance dialysis or with nephrotic syndrome; congenital or acquired asplenia or splenic dysfunction; congenital or acquired immunodeficiencies; diseases and conditions treated with immunosuppressive drugs or radiation therapy, including malignant neoplasms, leukemias, lymphomas, Hodgkin disease, and solid organ transplant; HIV infection; and sickle cell disease or other with these conditions who received PCV13 or PCV15 are also recommended to receive 23-valent pneumococcal polysaccharide vaccine.

PCV, pneumococcal conjugate vaccine; PCV13, 13-valent PCV; PCV15, 15-valent PCV; PCV20, 20-valent PCV; PPSV23, 23-valent pneumococcal polysaccharide vaccine; HSCT, hematopoietic stem cell transplant.

From Centers for Disease Control and Prevention. ACIP updates: Recommendations for use of 20-valent pneumococcal conjugate vaccine in children—United States, 2023. *MMWR Morb Mortal Wkly Rep.* 2023;72(39):1072. (Table 1).

recommendations have been made for at-risk children 6–18 years old (Table 228.4).

Immunization with pneumococcal vaccines also may prevent pneumococcal disease caused by nonvaccine serotypes that are serotypically related to a vaccine strain. However, because current vaccines do not eliminate all pneumococcal invasive infections, penicillin prophylaxis is recommended for children at high risk of invasive pneumococcal disease, including children with asplenia or sickle cell disease. Oral penicillin V potassium (125 mg twice daily for children <3 years old; 250 mg twice daily for children  $\geq 3$  years old) decreases the incidence of pneumococcal sepsis in children with sickle cell disease. Once-monthly IM benzathine penicillin G (600,000 units every 3–4 weeks for children weighing <60 lb; 1,200,000 units every 3–4 weeks for children weighing  $\geq 60$  lb) may also provide prophylaxis. Erythromycin may be used in children with penicillin allergy, but

its efficacy is unproven. Prophylaxis in sickle cell disease has been safely discontinued after the fifth birthday in children who have received all recommended pneumococcal vaccine doses and who had not experienced invasive pneumococcal disease. Prophylaxis is often administered for at least 2 years after splenectomy or up to 5 years of age. Efficacy in children >5 years old and adolescents is unproven. If oral antibiotic prophylaxis is used, strict compliance must be encouraged.

Given the rapid emergence of penicillin-resistant pneumococci, especially in children receiving long-term, low-dose therapy, prophylaxis cannot be relied on to prevent disease. High-risk children with fever should be promptly evaluated and treated regardless of vaccination or penicillin prophylaxis history.

Visit Elsevier eBooks+ at [eBooks.Elsevier.com](https://eBooks.Elsevier.com) for Bibliography.

## Chapter 229

Group A *Streptococcus*

Stanford T. Shulman and Ami B. Patel

Group A *Streptococcus* (GAS), also known as *Streptococcus pyogenes*, is a common cause of infections of the upper respiratory tract (**pharyngitis**) and the skin (**impetigo**, **pyoderma**) in children. Less frequently, GAS causes perianal cellulitis, vaginitis, septicemia, pneumonia, empyema, endocarditis, pericarditis, osteomyelitis, suppurative arthritis, myositis, cellulitis, omphalitis, and other infections. This organism also causes distinct clinical entities (**scarlet fever** and **erysipelas**), as well as streptococcal **toxic shock syndrome** and monomicrobial **necrotizing fasciitis**. GAS is also the cause of at least two potentially serious non-suppurative complications: **rheumatic fever** (see [Chapters 229.1 and 487](#)) and **acute glomerulonephritis** (see [Chapter 559.4](#)).

**ETIOLOGY**

Group A streptococci are gram-positive, coccoid-shaped bacteria that tend to grow in chains. Streptococci are broadly classified by their hemolytic activity on mammalian (typically sheep) red blood cells. The zone of complete hemolysis that surrounds colonies grown on blood agar distinguishes  $\beta$ -hemolytic (complete hemolysis) from  $\alpha$ -hemolytic (green or partial hemolysis) and  $\gamma$  (nonhemolytic) species. The  $\beta$ -hemolytic streptococci can be divided into groups by a group-specific polysaccharide (**Lancefield C carbohydrate**) located in the bacterial cell wall. More than 20 serologic groups are identified, designated by the letters A through V, although only A through D are medically important. Serologic grouping by the Lancefield method is precise, but group A organisms can be identified more readily by any of a number of latex agglutination, coagglutination, molecular assays or enzyme immunoassays. Group A strains can also be distinguished from other groups by differences in sensitivity to bacitracin, as other groups are generally resistant to this antibiotic.

GAS can be subdivided into at least 220 serotypes on the basis of the **M protein** antigen, which is located on the cell surface and in fimbriae that project from the outer surface of the cell. Currently, a molecular approach to M-typing GAS isolates using the polymerase chain reaction (PCR) is based on sequencing the terminal portion of the *emm* gene of GAS that encodes the M protein. This *emm* typing system correlates with known serotypes and *emm* types. The *emm* types can be grouped into *emm* clusters that share structural and binding properties. It is important to note that immunity is largely based on type-specific opsonic anti-M antibody.

M/*emm* typing is valuable for epidemiologic studies; specific GAS diseases tend to be associated with certain M types. Types 1, 12, 28, 4, 3, and 2 (in that order) are the most common causes of uncomplicated streptococcal pharyngitis in the United States. M types usually associated with pharyngitis rarely cause skin infections, and the M types associated with skin infections rarely cause pharyngitis. A few **pharyngeal** GAS strains (e.g., M type 12) are associated with glomerulonephritis, but many more **skin** GAS strains (e.g., M types 49, 55, 57, and 60) are considered nephritogenic. Several pharyngeal serotypes (e.g., M types 1, 3, 5, 6, 18, and 29), but no proven skin strains, are associated with **acute rheumatic fever** in North America.

**EPIDEMIOLOGY**

Humans are the natural reservoir for GAS. These bacteria are highly communicable and can cause disease in normal individuals of all ages who do not have type-specific immunity against the particular serotype involved. Disease in neonates is uncommon in developed countries, probably because of maternally acquired antibody. The incidence of **pharyngitis** is highest in children 5-15 years of age, especially in young school-age children. Acute streptococcal pharyngitis is uncommon in children younger than 3 years, and testing

is generally not recommended. These infections are most common in the northern regions of the United States, especially during winter and early spring. Children with untreated acute pharyngitis spread GAS by salivary droplets and nasal discharge. Transmission is favored by close proximity; therefore schools, military barracks, and homes are important environments for spread. GAS has the potential to be an important upper respiratory tract pathogen and to produce outbreaks of disease in the daycare setting. Foods contaminated by GAS occasionally cause explosive outbreaks of pharyngotonsillitis. The incubation period for pharyngitis is usually 2-5 days. Children are usually no longer infectious within 24 hours of starting appropriate antibiotic therapy. Chronic pharyngeal carriers of GAS rarely transmit this organism to others.

**Streptococcal pyoderma (impetigo, pyoderma)** occurs most frequently during the summer in temperate climates, or year-round in warmer climates, when the skin is exposed and abrasions and insect bites are more likely to occur (see [Chapter 727](#)). Colonization of healthy skin by GAS usually precedes the development of impetigo. Because GAS cannot penetrate intact skin, impetigo and other skin infections usually occur at the site of open lesions (insect bites, traumatic wounds, burns). Although impetigo serotypes may colonize the throat, spread is usually from skin to skin, not via the respiratory tract. Fingernails and the perianal region can harbor GAS and play a role in disseminating impetigo. Multiple cases of impetigo in the same family are common. Both impetigo and pharyngitis are more likely to occur among children living in crowded homes and in poor hygienic circumstances.

The incidence of **severe invasive** GAS infections, including bacteremia, pneumonia and empyema, osteomyelitis, septic arthritis, retropharyngeal abscess, lymphadenitis, streptococcal **toxic shock syndrome**, **scarlet fever**, and **necrotizing fasciitis**, has increased in recent decades. The incidence appears to be highest in very young and elderly persons. Before the routine use of varicella vaccine, varicella was the most commonly identified risk factor for invasive GAS infection in children. Other risk factors include diabetes mellitus, HIV infection, intravenous drug use, and chronic pulmonary or chronic cardiac disease. The portal of entry is unknown in almost 50% of cases of severe invasive GAS infection; in most cases, it is believed to be skin or, less often, mucous membranes. Severe invasive disease rarely follows clinically apparent GAS pharyngitis. Invasive GAS disease was reported in many children's hospitals in multiple countries during the COVID-19 pandemic. It is unclear why this has happened, but masking, social distancing, and school closures may have reduced exposure to common viral pathogens or colonization with GAS, resulting in more severe infection when mask and social distancing have stopped and schools have reopened. Co-infection with respiratory viruses (respiratory syncytial virus [RSV], other) may predispose to more severe infection.

**PATHOGENESIS**

The virulence of GAS depends primarily on the **M protein**, and strains rich in M protein resist phagocytosis in fresh human blood, whereas M-negative strains do not. M protein stimulates the production of protective opsonophagocytic antibodies that are type specific, protecting against infection with a homologous M type but much less so against other M types. Therefore multiple GAS infections attributable to various M types are common during childhood and adolescence. By adult life, individuals are probably immune to many of the common M types in the environment.

GAS produces a large variety of extracellular enzymes and toxins, including erythrogenic toxins, known as **streptococcal pyrogenic exotoxins**. Streptococcal pyrogenic exotoxins A, C, and SSA, alone or in combination, are responsible for the **rash of scarlet fever** and are elaborated by streptococci that contain a particular bacteriophage. These exotoxins stimulate the formation of specific antitoxin antibodies that provide immunity against the scarlatiniform rash but not against other streptococcal infections. Pathogenic variants in genes that are promoters of several virulence genes, including pyrogenic exotoxins, as well as several newly discovered exotoxins, appear to be involved in the



pathogenesis of invasive GAS disease, including streptococcal toxic shock syndrome.

The importance of other streptococcal toxins and enzymes in human disease is not yet established. Many of these extracellular substances are antigenic and stimulate antibody production after an infection. However, these antibodies do not confer immunity. The measurement of select toxins and antibodies is useful for establishing evidence of a recent streptococcal infection to aid in the diagnosis of postinfectious illnesses. Tests for antibodies against streptolysin O (anti-streptolysin O) and DNase B (anti-DNase B) are the most frequently used antibody determinations.

### CLINICAL MANIFESTATIONS

The most common infections caused by GAS involve the respiratory tract and the skin and soft tissues.

#### Respiratory Tract Infections

GAS is an important cause of acute **pharyngitis** (see Chapter 430) and pneumonia, often with empyema (see Chapter 449).

#### Scarlet Fever

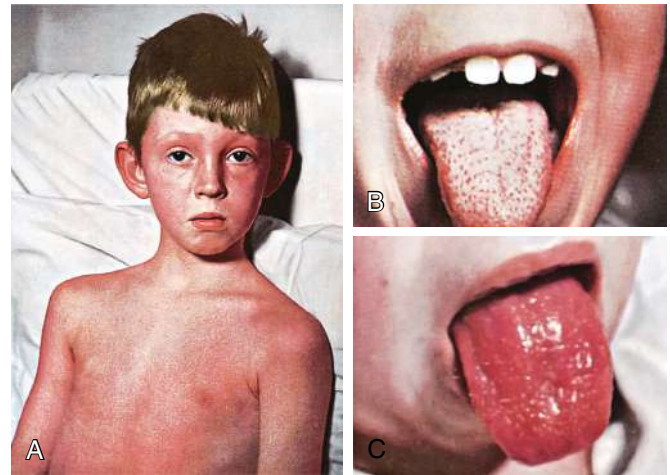
**Scarlet fever** is GAS pharyngitis associated with a characteristic rash, which is caused by an infection with **pyrogenic exotoxin** (erythrogenic toxin)-producing GAS in individuals who do not have antitoxin antibodies. It is now encountered less often and is less virulent than in the past, but the incidence is cyclic, depending on the prevalence of toxin-producing strains and the immune status of the population. The modes of transmission, age distribution, and other epidemiologic features are otherwise similar to those for GAS pharyngitis.

The scarlet fever rash appears within 24-48 hours after the onset of symptoms, although it may appear with the first signs of illness (Fig. 229.1A). It often begins around the neck and spreads over the trunk and extremities. The rash is a diffuse, finely papular, erythematous eruption producing bright-red discoloration of the skin, which blanches on pressure. It is often accentuated in the creases of the elbows, axillae, and groin (Pastia lines). The skin has a goose-pimple appearance and feels rough. The cheeks are often erythematous with perioral pallor. After 3-4 days, the rash begins to fade and is followed by **desquamation**, initially on the face, progressing caudally, and often resembling a mild sunburn. Occasionally, sheetlike desquamation may occur around the free margins of the fingernails, the palms, and the soles. Examination of the pharynx of a patient with scarlet fever reveals essentially the same findings as with GAS pharyngitis. In addition, the tongue is usually coated and the papillae are swollen (see Fig. 229.1B). After desquamation, the reddened papillae are prominent, giving the tongue a strawberry appearance (see Fig. 229.1C).

Typical scarlet fever is not difficult to diagnose; the milder form with equivocal pharyngeal findings can be confused with viral exanthems, Kawasaki disease, and drug eruptions. Staphylococcal infections are occasionally associated with a scarlatiniform rash. A history of recent exposure to a GAS infection is helpful. Identification of GAS in the pharynx confirms the diagnosis.

#### Impetigo

Impetigo (or pyoderma) has traditionally been classified into two clinical forms: bullous and nonbullous (see Chapter 706.1). **Nonbullous impetigo** is the more common form and is a superficial infection of the skin that appears first as a discrete papulovesicular lesion surrounded by a localized area of redness. The vesicles rapidly become purulent and covered with a thick, confluent, amber-colored crust that gives the appearance of having been stuck onto the skin. The lesions may occur anywhere but are most common on the face and extremities. If untreated, nonbullous impetigo is a mild but chronic illness, often spreading to other parts of the body, but occasionally self-limited. Regional **lymphadenitis** is common. Nonbullous impetigo is generally not accompanied by fever or other systemic signs or symptoms. Impetiginized excoriations around the nares are seen with active GAS



**Fig. 229.1** Scarlet fever. A, Punctate, erythematous rash (second day). B, White strawberry tongue (first day). C, Red strawberry tongue (third day). (Courtesy Dr. Franklin H. Top, Professor and Head of the Department of Hygiene and Preventive Medicine, State University of Iowa, College of Medicine, Iowa City, IA; and Parke, Davis & Company's Therapeutic Notes. From Gershon AA, Hotez PJ, Katz SL. *Krugman's Infectious Diseases of Children*, 11th ed. Philadelphia: Mosby; 2004, Plate 53.)

infections of the nasopharynx, particularly in young children. However, impetigo is rarely associated with overt streptococcal infection of the upper respiratory tract.

**Bullous impetigo** is less common and occurs most often in neonates and young infants. It is characterized by flaccid, transparent bullae usually <3 cm in diameter on previously untraumatized skin. The usual distribution involves the face, buttocks, trunk, and perineum.

Although *Staphylococcus aureus* has traditionally been accepted as the sole pathogen responsible for bullous impetigo, there has been confusion about the organisms responsible for nonbullous impetigo. In most episodes of nonbullous impetigo, either GAS or *S. aureus* (or both) is isolated. Earlier investigations suggested that GAS was the causative agent in most cases of nonbullous impetigo and that *S. aureus* was only a secondary invader. However, *S. aureus* has emerged as the causative agent in most cases of nonbullous impetigo. Culture of the lesions is the only way to distinguish nonbullous impetigo caused by *S. aureus* from that caused by GAS.

#### Erysipelas

Erysipelas is a relatively rare acute GAS infection involving the deeper layers of the skin and the underlying connective tissue. The skin in the affected area is edematous, highly erythematous, and very tender. The erythema associated with erysipelas is very bright, which differentiates it from the dusky appearance of necrotizing fasciitis. Superficial blebs may be present. The most characteristic finding is a sharply defined, slightly elevated border. At times, reddish streaks of lymphangitis project out from the margins of the lesion. The onset is abrupt, and signs and symptoms of a systemic infection, such as high fever and sepsis, are often present. Cultures obtained by needle aspirate of the advancing margin of the inflamed area often reveal the causative agent.

#### Perianal Dermatitis

Perianal dermatitis, also called *perianal cellulitis* or **perianal streptococcal disease**, is a distinct clinical entity characterized by well-demarcated, perianal erythema associated with anal pruritus, painful defecation, and occasionally blood-streaked stools. Most children are 2-7 years old (range: 18 days-12 years). Physical examination reveals flat, pink to beefy-red perianal erythema with sharp margins extending



as far as 2 cm from the anus. Erythema may involve the vulva and vagina. Lesions may be very tender and, particularly when chronic, may fissure and bleed. Systemic symptoms and fever are unusual. Culture or a rapid streptococcal test of a perianal swab will yield GAS or detect antigen.

### Vaginitis

GAS is a common cause of vaginitis in prepubertal girls (see [Chapter 586](#)). Patients usually have a serous discharge with marked erythema and irritation of the vulvar area, accompanied by discomfort in walking and in urination.

### Severe Invasive Disease

Invasive GAS infection is defined by isolation of GAS from a normally sterile body site and includes three overlapping clinical syndromes. **GAS toxic shock syndrome (TSS)** is differentiated from other types of invasive GAS infections by the presence of shock and multiorgan system dysfunction early in the course of the infection ([Table 229.1](#)). The second syndrome is **GAS necrotizing fasciitis**, characterized by extensive local necrosis of subcutaneous soft tissues and skin. The third syndrome is the group of **focal and systemic infections** that do not meet the criteria for TSS or necrotizing fasciitis and includes bacteremia with sepsis with no identified focus, meningitis, pneumonia and empyema, peritonitis, puerperal sepsis, osteomyelitis, suppurative arthritis, myositis, and surgical wound and other infections. GAS TSS, necrotizing fasciitis, and focal and systemic infections can be present in any combination.

The pathogenic mechanisms responsible for severe, invasive GAS infections, including streptococcal TSS and necrotizing fasciitis, have yet to be defined completely, but an association with **streptococcal pyrogenic exotoxins** is strongly suspected. At least two of the three original streptococcal pyrogenic exotoxins (A and C) and potentially other as yet unidentified toxins produced by GAS act as **superantigens**, which stimulate intense activation and proliferation of T lymphocytes and macrophages, resulting in the production of large quantities of proinflammatory cytokines. These cytokines are capable of inducing shock and tissue injury and appear to mediate many of the clinical manifestations of severe, invasive GAS infections.

### DIAGNOSIS OF GAS PHARYNGITIS

When deciding whether to perform a diagnostic test on a patient presenting with acute pharyngitis, the clinical and epidemiologic findings should be considered. A history of close contact with a well-documented case of GAS pharyngitis is helpful, as is an awareness of a high prevalence of GAS infections in the community. The signs and symptoms of streptococcal and nonstreptococcal pharyngitis overlap too broadly to allow the requisite diagnostic precision on clinical grounds alone. The clinical diagnosis of GAS pharyngitis cannot be made with reasonable accuracy even by the most experienced physicians, and laboratory confirmation is required, except for patients with

overt viral signs and symptoms (e.g., rhinorrhea, cough, mouth ulcers, hoarseness), who generally do not need a GAS diagnostic test performed, as GAS is highly unlikely.

Culture of a throat swab on a sheep blood agar plate is effective for documenting the presence of GAS and for confirming the clinical diagnosis of acute GAS pharyngitis. When performed correctly, a single throat swab has a sensitivity of 90–95% for detecting the presence of GAS in the pharynx.

The significant disadvantage of culturing a throat swab on a blood agar plate is the delay (overnight or longer) in obtaining the culture result. **Streptococcal rapid antigen detection** tests are available for the identification of GAS directly from throat swabs. Their advantage over culture is the speed in providing results, often <10–15 minutes. Rapid identification and treatment of patients with streptococcal pharyngitis can reduce the risk for spread of GAS, allowing the patient to return to school or work sooner, and can reduce the acute morbidity of this illness.

Almost all currently available rapid antigen detection tests have excellent specificity of >95% compared with blood agar plate cultures. False-positive test results are quite unusual, and therefore therapeutic decisions can be made with confidence on the basis of a positive test result. Unfortunately, the sensitivity of most of these tests is 70–90% when compared with blood agar plate culture. Therefore a negative rapid test does not completely exclude the presence of GAS, and a confirmatory throat culture should be performed in children and adolescents, but not necessarily in adults, who are at exceptionally low risk for developing acute rheumatic fever. Definitive studies are not available to determine whether some rapid antigen detection tests are significantly more sensitive than others or whether any of these tests is sensitive enough to be used routinely in children and adolescents without throat culture confirmation of negative test results. Some experts believe that physicians who use a rapid antigen detection test without culture backup should compare the results with that specific test to those of throat cultures to confirm adequate sensitivity in their practice.

In point-of-care settings and laboratories testing for GAS pharyngitis, culture methods are being replaced by rapid antigen and molecular assays. These molecular assays include PCR methods and **nucleic acid amplification tests** using isothermal loop amplification. Some of these methods have been reported to have a sensitivity of up to 100% and specificity of >96% compared to culture or PCR. This very high sensitivity may lead to higher numbers of positive results, which in turn may contribute to identification of more patients with asymptomatic GAS colonization and unnecessary antibiotic therapy. Therefore it is important that the appropriate clinical context to perform these highly sensitive tests be considered. However, the benefit of faster results, sometimes <10 minutes, which ensures more expedited initiation of appropriate antibiotic therapy for patients with GAS pharyngitis, may be of value.

GAS infection can also be diagnosed retrospectively on the basis of an elevated or increasing streptococcal antibody titer. The **anti-streptolysin O** assay is the streptococcal antibody test most often used. The test is not specific for group A infection because streptolysin O also is produced by groups C and G streptococci. The anti-streptolysin O response can be feeble after streptococcal skin infection. In contrast, the anti-DNase B responses are generally present after either skin or throat infections. A significant antibody increase is usually defined as an increase in titer of two or more dilution increments ( $\geq$  fourfold rise) between the acute-phase and convalescent-phase specimens, regardless of the actual height of the antibody titer. Physicians frequently misinterpret streptococcal antibody titers because of a failure to appreciate that the normal levels of these antibodies are substantially higher among school-age children than adults. Both the traditional anti-streptolysin O and the anti-DNase B tests are neutralization assays. Newer tests use **latex agglutination** or nephelometric assays. Unfortunately, these newer tests often have not been well standardized against the traditional neutralization assays. Physicians should be aware of these potential problems when interpreting the results of streptococcal serologic testing.

**Table 229.1** Definition of Streptococcal Toxic Shock Syndrome

#### CLINICAL CRITERIA

Hypotension *plus* two or more of the following:

- Renal impairment
- Coagulopathy
- Hepatic involvement
- Adult respiratory distress syndrome
- Generalized erythematous macular rash
- Soft tissue necrosis

#### DEFINITE CASE

Clinical criteria *plus* group A *Streptococcus* from a normally sterile site

#### PROBABLE CASE

Clinical criteria *plus* group A *Streptococcus* from a nonsterile site

## Differential Diagnosis

Viruses are the most common cause of acute pharyngitis in children. Respiratory viruses such as influenza virus, parainfluenza virus, rhinovirus, coronavirus, adenovirus, and RSV are frequent causes of acute pharyngitis. Other viral causes of acute pharyngitis include enteroviruses and herpes simplex virus. Epstein-Barr virus is a frequent cause of acute pharyngitis that is often accompanied by other clinical findings of infectious mononucleosis (e.g., splenomegaly, generalized lymphadenopathy). Systemic infections with other viral agents, including cytomegalovirus, rubella virus, measles virus, and HIV, may be associated with acute pharyngitis.

GAS is by far the most common cause of bacterial pharyngitis, accounting for 15–30% of cases of acute pharyngitis in children and a lower proportion in adults. Groups C and G  $\beta$ -hemolytic streptococcus also cause acute pharyngitis, typically in teens and young adults (see Chapter 231). *Arcanobacterium haemolyticum* and *Fusobacterium necrophorum* are additional, less common causes. *Neisseria gonorrhoeae* can occasionally cause acute pharyngitis in sexually active adolescents and adults. Other bacteria, such as *Francisella tularensis* and *Yersinia enterocolitica*, as well as mixed infections with anaerobic bacteria (Vincent angina), are very rare causes of acute pharyngitis. *Chlamydia pneumoniae* and *Mycoplasma pneumoniae* have been implicated as causes of acute pharyngitis, particularly in adults. *Corynebacterium diphtheriae* is a serious cause of pharyngitis but is very rare in areas with universal immunization (see Chapter 233). Although other bacteria (e.g., *S. aureus*, *Haemophilus influenzae*, *Streptococcus pneumoniae*) are frequently cultured from the throats of children with acute pharyngitis, their etiologic role in pharyngitis has not been established, because they are often isolated from healthy children.

*GAS pharyngitis is the only common cause of acute pharyngitis for which antibiotic therapy is definitely indicated.* Therefore when confronted with a patient with acute pharyngitis, the clinical decision that usually needs to be made is whether or not the pharyngitis is attributable to GAS.

## TREATMENT OF GAS PHARYNGITIS

Timely antibiotic therapy for patients with GAS pharyngitis can prevent acute rheumatic fever (RF), shorten the clinical course of the illness, reduce transmission of the infection to others, and prevent suppurative complications. *For the patient with classic scarlet fever, antibiotic therapy should be started immediately, but for the majority of patients, who present with much less distinctive findings, treatment should be withheld until there is laboratory confirmation by throat culture, molecular assay, or rapid antigen detection test.* Rapid antigen detection tests, because of their high degree of specificity, allow initiation of antibiotic therapy immediately for the patient with a positive test result.

GAS is exquisitely sensitive to penicillin and cephalosporins, and resistant strains have never been encountered. Penicillin or amoxicillin is therefore the drug of choice (except in patients who are allergic to penicillins) for pharyngeal infections and for suppurative complications. Oral penicillin V (250 mg/dose 2 or 3 times daily [bid-tid] for children weighing  $\leq 60$  lb and 500 mg/dose bid-tid for children  $>60$  lb) is recommended but must be taken for a full 10 days, even though symptomatic improvement may occur within 2–3 days. Penicillin V (phenoxymethylpenicillin) is preferred over penicillin G, because it may be given without regard to mealtime. The major concern with all forms of oral therapy is the risk that the drug will be discontinued before the 10-day course has been completed. Therefore when oral treatment is prescribed, the necessity of completing a full course of therapy must be emphasized. If the parents seem unlikely to comply with oral therapy because of family disorganization, difficulties in comprehension, or other reasons, parenteral therapy with a single intramuscular (IM) injection of benzathine penicillin G (600,000 IU for children weighing  $\leq 60$  lb and 1.2 million IU for children  $>60$  lb) is the most efficacious and often the most practical method of treatment. Disadvantages include soreness around the site of injection, which may last for several days, and potential for injection into nerves or blood

vessels if not administered correctly. The local reaction is diminished when the refrigerated drug is warmed to room temperature and when benzathine penicillin G is combined in a single injection with procaine penicillin G, although it is necessary to ensure that an adequate dose of benzathine penicillin G is administered.

In several comparative clinical trials, once-daily amoxicillin (50 mg/kg, maximum: 1,000 mg) for 10 days has been demonstrated to be as effective in treating GAS pharyngitis as amoxicillin administered orally multiple times per day. This somewhat broader-spectrum agent has the advantage of once-daily dosing, which may enhance adherence. In addition, amoxicillin is relatively inexpensive and is considerably more palatable than penicillin V suspension.

A 10-day course of a narrow-spectrum oral cephalosporin is recommended for most penicillin-allergic individuals. It has been suggested that a 10-day course with an oral cephalosporin is superior to 10 days of oral penicillin in eradicating GAS from the pharynx. Analysis of these data suggests that the difference in eradication is mainly the result of a higher rate of eradication of GAS carriage included unintentionally in these clinical trials. Some penicillin-allergic persons (up to 10%) are also allergic to cephalosporins, and these agents should be avoided in patients with immediate (anaphylactic-type) hypersensitivity to penicillin. Most oral broad-spectrum cephalosporins are considerably more expensive than penicillin or amoxicillin and are more likely to select for antibiotic-resistant flora.

Oral clindamycin is an appropriate agent for treating penicillin-allergic patients, and resistance to clindamycin among GAS isolates in the United States is currently  $<6\%$ . An oral macrolide (erythromycin or clarithromycin) or azalide (azithromycin) is also an appropriate agent for patients allergic to penicillins. Ten days of therapy is indicated except for azithromycin, which is given at 12 mg/kg on day 1 and then 6 mg/kg on days 2–5. Erythromycin is associated with substantially higher rates of gastrointestinal side effects than the other agents. In recent years, macrolide resistance rates among pharyngeal isolates of GAS in most areas of the United States have been approximately 5–10%. Sulfonamides and the tetracyclines are not recommended for treatment of GAS pharyngitis. However, studies showed that trimethoprim-sulfamethoxazole (TMP-SMX) is highly active in vitro against GAS and was comparable to IM penicillin for GAS impetigo in clinical trials.

Most oral antibiotics must be administered for the conventional 10 days to achieve maximal pharyngeal eradication rates of GAS and prevention of RF, but certain newer agents are reported to achieve comparable bacteriologic and clinical cure rates when given for  $\leq 5$  days. However, definitive results from comprehensive studies are not available to allow full evaluation of these proposed shorter courses of oral antibiotic therapy, which therefore cannot be recommended at this time. In addition, these antibiotics have a much broader spectrum than penicillin and are generally more expensive, even when administered for short courses.

The majority of patients with GAS pharyngitis respond clinically to antimicrobial therapy, and GAS is eradicated from the pharynx. Posttreatment throat cultures are indicated only in the relatively few patients who remain symptomatic, whose symptoms recur, or who have had RF or rheumatic heart disease and are therefore at unusually high risk for recurrence.

## Treatment of GAS Skin Infections

Antibiotic therapy for a patient with nonbullous impetigo can prevent local extension of the lesions, spread to distant infectious foci, and transmission of the infection to others. However, the ability of antibiotic therapy to prevent poststreptococcal glomerulonephritis has not been definitively demonstrated. Patients with a few superficial, isolated lesions and no systemic signs can be treated with topical antibiotics. **Mupirocin** is a safe and effective agent that has become the topical treatment of choice. If there are widespread lesions or systemic signs, oral therapy with coverage for both GAS and *S. aureus* is needed. With the rapid emergence of methicillin-resistant *S. aureus* in many communities, one should consider using clindamycin alone or a combination

of TMP-SMX and amoxicillin as first-line therapy. Oral cefuroxime is an effective treatment of perianal streptococcal disease.

### Treatment of Invasive GAS Infection

Theoretical considerations and experimental data suggest that intravenous clindamycin is a more effective agent for the treatment of severe, invasive GAS infections than IV penicillin. However, because approximately 4–6% of GAS isolates in the United States are resistant to clindamycin, clindamycin initially should be used in combination with penicillin for these infections until susceptibility to clindamycin has been established. If **necrotizing fasciitis** is suspected, immediate surgical exploration may be required to identify a deep soft tissue infection that should be debrided immediately. Patients with **streptococcal TSS** require rapid and aggressive fluid replacement, management of respiratory or cardiac failure, if present, and anticipatory management of multiorgan system failure. Limited data suggest that intravenous immune globulin (IVIG) is effective as adjunctive therapy in the management of streptococcal TSS.

### COMPLICATIONS

Suppurative complications from the spread of GAS to adjacent structures were extremely common in the preantibiotic era. Cervical lymphadenitis, peritonsillar abscess, retropharyngeal abscess, otitis media, mastoiditis, and sinusitis still occur in children in whom the primary illness has gone unnoticed or in whom treatment of the pharyngitis has been inadequate. GAS pneumonia can also occur.

**Acute rheumatic fever** (see Chapter 229.1) and acute poststreptococcal **glomerulonephritis** (see Chapter 559.4) are both nonsuppurative sequelae of infections with GAS that occur after an asymptomatic latent period. These complications occur after the initial GAS infection resolves and involves sites distal to the initial GAS infection site. These sequelae are thought to be the result of the immune response and not of direct GAS infection. Acute RF and acute glomerulonephritis differ in their clinical manifestations, epidemiology, and potential morbidity. In addition, acute glomerulonephritis follows a GAS infection of either the upper respiratory tract or the skin, but acute RF is only proven to follow an infection of the upper respiratory tract. Some investigators have suggested that in some highly endemic areas, particularly in New Zealand and Australia, GAS skin infection may trigger acute RF, but this remains controversial.

### PROGNOSIS

The prognosis for appropriately treated GAS pharyngitis is excellent, and complete recovery is the rule. When therapy is instituted within 9 days of the onset of symptoms and continued for the full course, acute RF is almost always prevented. There is no comparable evidence that acute poststreptococcal glomerulonephritis can be prevented once pharyngitis or pyoderma with a nephritogenic strain of GAS has occurred. In rare instances, particularly in neonates or in children whose response to infection is compromised, fulminant pneumonia, septicemia, and death may occur despite usually adequate therapy.

### PREVENTION

The only specific indication for long-term use of an antibiotic to prevent GAS infections is for patients with a history of acute RF and/or rheumatic heart disease. Mass prophylaxis is generally not feasible except possibly to reduce the number of infections during epidemics of impetigo and to control epidemics of pharyngitis in military populations and in schools. Because the ability of antimicrobial agents to prevent GAS infections is limited, a group A streptococcal vaccine would offer the possibility of a more effective approach.

Several candidate vaccines are in development, including a 30-valent M protein–based recombinant vaccine, another recombinant vaccine that includes several conserved non–M protein epitopes that induce protective antibody, and an M-protein vaccine that includes an epitope

in a highly conserved region of M protein to provide broad immunity. All these vaccines are in relatively early stages of development.

### Poststreptococcal Reactive Arthritis

Poststreptococcal reactive arthritis (PSRA) describes a syndrome characterized by the onset of acute arthritis after an episode of GAS pharyngitis in a patient whose illness does not fulfill the Jones Criteria for diagnosis of acute RF. It is still unclear whether this entity represents a distinct syndrome or is a variant of acute RF. Although PSRA usually involves the large joints, similar to the arthritis of acute RF, it may also involve small peripheral joints and the axial skeleton and is typically nonmigratory, a characteristic distinct from the arthritis of acute RF. The latent period between the antecedent episode of GAS pharyngitis and PSRA may be considerably *shorter* (usually <10 days) than that typically seen with acute RF (usually 14–21 days). In contrast to the arthritis of acute RF, PSRA *does not* respond dramatically to therapy with aspirin or other nonsteroidal antiinflammatory drugs (NSAIDs). In addition, fewer patients with PSRA than with acute RF have a temperature >38°C (100.4°F). Even though no more than half of PSRA patients with throat culture have GAS isolated, all have serologic evidence of a recent GAS infection. Because a very small proportion of patients with PSRA have been reported to develop valvular heart disease subsequently, these patients should be carefully observed for several months for clinical evidence of carditis. Some recommend that these patients receive secondary antistreptococcal prophylaxis for up to 1 year. If clinical evidence of carditis is not observed at that point, the prophylaxis can be discontinued. If valvular disease is detected, the patient should be classified as having had acute RF and should continue to receive secondary prophylaxis appropriate for RF patients.

### Pediatric Autoimmune Neuropsychiatric Disorders Associated with *Streptococcus pyogenes*

Pediatric autoimmune neuropsychiatric disorders associated with *S. pyogenes* (**PANDAS**) is a term proposed for a group of neuropsychiatric disorders (originally obsessive-compulsive disorder [OCD], tic disorder, and Tourette syndrome, or only OCD or feeding abnormality) for which a possible relationship with GAS infections has been hypothesized (see Chapter 37). *This relationship has not been proved.* It has been proposed that this subset of patients with OCDs may produce autoimmune antibodies in response to a GAS infection that cross-react with brain tissue, similar to the autoimmune response believed to be responsible for the manifestations of **Sydenham chorea**. It has also been suggested that secondary prophylaxis that prevents recurrences of rheumatic fever, including Sydenham chorea, might also be effective in preventing exacerbations of OCDs in these patients, but clinical trials have not confirmed this. It has also been proposed that these patients may benefit from immunoregulatory therapy such as plasma exchange or IVIG, but these unproven modalities should only be used in a clinical research trial. That PANDAS may represent an extension of the spectrum of acute RF is intriguing, but it should be considered only as a yet-unproven hypothesis. Until carefully designed and well-controlled studies have established a causal relationship between neurobehavioral abnormalities and GAS infections, routine diagnostic laboratory testing for GAS and antistreptococcal antibodies, long-term antistreptococcal prophylaxis, or immunoregulatory therapy (e.g., IVIG, plasma exchange) to treat exacerbations of this disorder clearly are not recommended (see Chapter 37). It has also been suggested that a broad spectrum of infectious agents may have the ability to trigger exacerbations in children with these neurobehavioral disorders, which have been termed *pediatric acute-onset neuropsychiatric syndrome* (PANS), but this remains highly controversial.

Visit Elsevier eBooks+ at [eBooks.Health.Elsevier.com](http://eBooks.Health.Elsevier.com) for Bibliography.



## 229.1 Rheumatic Fever

Stanford T. Shulman and Ami B. Patel

See also [Chapter 487](#).

Overwhelming evidence supports the link between antecedent GAS pharyngitis and **acute rheumatic fever (RF)** and **rheumatic heart disease**. As many as two thirds of patients with an acute episode of RF have a history of an upper respiratory tract infection several weeks before; the peak age and seasonal incidence of acute RF closely parallel that of GAS pharyngitis. Patients with acute RF almost always have serologic evidence of a recent GAS infection. Their antibody titers are usually *considerably higher* than those seen in patients with uncomplicated GAS infections. Outbreaks of GAS pharyngitis in closed communities, such as boarding schools or military bases, may be followed by community outbreaks of acute RF. Antimicrobial therapy that eliminates GAS from the pharynx also prevents initial episodes of acute RF, and long-term, continuous antibiotic prophylaxis that prevents GAS pharyngitis also prevents recurrences of acute RF.

Not all serotypes of GAS can cause RF. When some GAS strains (e.g., M type 4) caused acute pharyngitis in a very susceptible rheumatic population, there were no recurrences of RF. In contrast, episodes of pharyngitis caused by other serotypes in the same population led to frequent recurrences of acute RF, suggesting that the latter organisms were rheumatogenic. The concept of *rheumatogenicity* is further supported by the observation that although serotypes of GAS frequently associated with skin infection can be isolated also from the upper respiratory tract, they rarely cause recurrences of RF in individuals with a previous history of RF or first episodes of RF. In addition, certain serotypes of GAS (M types 1, 3, 5, 6, 18, and 29) are more frequently isolated from patients with acute RF than are other serotypes.

### EPIDEMIOLOGY

The annual incidence of acute RF in some developing countries exceeds 50 per 100,000 children, and very high rates are also seen in ethnic minority populations within Australia and New Zealand. Worldwide, **rheumatic heart disease** remains the most common form of acquired heart disease in all age-groups, accounting for up to 50% of all cardiovascular disease and 50% of all cardiac admissions in many developing countries. Striking differences in the incidence of acute RF and rheumatic heart disease among different ethnic groups are often evident within the same country; these differences are partially related to differences in socioeconomic status, and there is a genetic basis for increased susceptibility.

In the United States at the beginning of the 20th century, acute RF was a leading cause of death among children and adolescents, with annual incidence rates of 100-200 per 100,000 population. In addition, rheumatic heart disease was a leading cause of heart disease among adults <40 years old. At that time, as many as 25% of pediatric hospital beds in the United States were occupied by patients with acute RF or its complications. By the 1940s, the annual incidence of acute RF had decreased to 50 per 100,000 population, and over the next 4 decades, the decline in incidence accelerated rapidly. By the early 1980s, the annual incidence in some areas of the United States was as low as 0.5 per 100,000 population, and rates of acute RF since the 1980s have declined substantially. This sharp decline in the incidence of acute RF has been observed in other industrialized countries as well.

The explanation for this dramatic decline in the incidence of acute RF and rheumatic heart disease in the United States and other industrialized countries is not clear but is likely related in large part to a *decline in circulating rheumatogenic strains causing acute pharyngitis*. Historically, acute RF was associated with poverty and overcrowding, particularly in urban areas. Much of the decline in the incidence of acute RF in industrialized countries during the preantibiotic era was probably the result of improved living conditions. Of the various manifestations of poverty, crowding, which facilitates the spread of GAS infections,

is most closely associated with the incidence of acute RF. The decline in incidence of acute RF in industrialized countries over the past 4 decades is also attributable to the greater availability of medical care and to the widespread use of antibiotics. Antibiotic therapy of GAS pharyngitis is important in preventing initial attacks and, particularly, recurrences of the disease. In addition, the decline in the United States is attributed to a shift in the prevalent strains of GAS causing pharyngitis from mostly rheumatogenic to nonrheumatogenic.

Certain rheumatogenic serotypes (types 1, 3, 5, 6, and 18) that were isolated less often during the 1970s and early 1980s dramatically reappeared during rheumatic fever outbreaks, and their appearance in selected communities was probably a major factor. GAS that are associated with rheumatogenicity often form highly mucoid colonies on throat culture plates.

In addition to the specific characteristics of the infecting strain of GAS, the risk of developing acute RF also depends on various host factors. The incidence of both initial attacks and recurrences of acute RF peaks in children 5-15 years old, the age of greatest risk for GAS pharyngitis. Patients who have had an attack of acute RF tend to have recurrences, and the clinical features of the recurrences tend to mimic those of the initial attack. In addition, there appears to be a genetic predisposition to acute RF. Studies in twins show a higher concordance rate of acute RF in monozygotic than in dizygotic twin pairs. Preliminary studies from Oceania in a population with high rates of rheumatic heart disease have identified an allele of interest that increases one's risk of rheumatic heart disease.

### PATHOGENESIS

The **cytotoxicity theory** suggests that a GAS toxin is involved in the pathogenesis of acute RF and rheumatic heart disease. GAS produces a number of enzymes that are cytotoxic for mammalian cardiac cells, such as streptolysin O, which has a direct cytotoxic effect on mammalian cells in tissue culture. A major problem with the cytotoxicity hypothesis is its inability to explain the substantial latent period (usually 10-21 days) between GAS pharyngitis and onset of acute RF.

An **immune-mediated pathogenesis** for acute RF and rheumatic heart disease has been suggested by its clinical similarity to other illnesses with an immunopathogenesis and by the latent period between the GAS infection and acute RF. The immunologic cross-reactivity of several GAS cellular and extracellular epitopes with cardiac antigenic epitopes also lends support to the hypothesis of molecular mimicry. Common epitopes are shared between certain GAS components (e.g., M protein, cell membrane, group A cell wall carbohydrate, capsular hyaluronate) and specific mammalian tissues (e.g., heart valve, sarcolemma, brain, joint).

### CLINICAL MANIFESTATIONS AND DIAGNOSIS

The current **Jones Criteria**, as revised in 2015 by the American Heart Association (AHA), are intended for diagnosis of the *initial* attack of acute RF and *recurrent* attacks ([Table 229.2](#)). There are **five major and four minor criteria** and a requirement for evidence of recent GAS infection. The 2015 revision includes separate criteria for **low-risk populations** (defined as those with incidence  $\leq 2$  per 100,000 school-age children per year or all-age rheumatic heart disease prevalence of  $\leq 1$  per 1,000 population) and **moderate/high-risk populations** (defined as those with higher incidence or prevalence rates). Virtually all of the United States, Canada, and Western Europe are low-risk, whereas moderate/high-risk populations include Maoris in New Zealand, aborigines in Australia, Pacific Islanders, and most developing countries. Diagnosis of a first attack or recurrent attack of acute RF can be established when a patient fulfills **two major or one major and two minor criteria and has evidence of preceding GAS infection**. Diagnosis of recurrent acute RF can also be made only in the moderate/high-risk population by the presence of three minor criteria with evidence of preceding GAS infection. In the 2015 Jones Criteria, a major change from previous versions expands the definition of the major criterion **carditis** to include *subclinical evidence* (e.g., in the absence of a murmur, echocardiographic evidence of mitral regurgitation [MR] meeting specific criteria to distinguish physiologic from



**Table 229.2** Guidelines for the Diagnosis of an Initial or Recurrent Attack of Rheumatic Fever (Jones Criteria, Updated 2015)<sup>1-5</sup>

MAJOR MANIFESTATIONS	MINOR MANIFESTATIONS	SUPPORTING EVIDENCE OF ANTECEDENT GROUP A STREPTOCOCCAL INFECTION
Carditis Polyarthritides Erythema marginatum Subcutaneous nodules Chorea	<b>Clinical features:</b> Arthralgia Fever  <b>Laboratory features:</b> Elevated acute-phase reactants: Erythrocyte sedimentation rate C-reactive protein Prolonged P-R interval	Positive throat culture or rapid streptococcal antigen test Elevated or increasing streptococcal antibody titer

<sup>1</sup>**Initial attack:** Two major manifestations or one major and two minor manifestations plus evidence of recent GAS infection. **Recurrent attack:** Two major, or one major and two minor, or three minor manifestations (the latter only in the moderate/high-risk population), plus evidence of recent GAS infection (see text).

<sup>2</sup>**Low-risk population** is defined as acute rheumatic fever (ARF) incidence <2 per 100,000 school-age children per year or all-age rheumatic heart disease (RHD) prevalence of <1 per 1,000 population. **Moderate/high-risk population** is defined as ARF incidence >2 per 100,000 school-age children per year or all-age RHD prevalence of >1 per 1,000 population.

<sup>3</sup>Carditis is now defined as clinical and/or subclinical (echocardiographic valvulitis). See Table 229.3.

<sup>4</sup>Arthritis (major) refers only to polyarthritides in low-risk populations but also to monoarthritis or polyarthralgia in moderate/high-risk populations.

<sup>5</sup>Minor criteria for moderate/high-risk populations only include monoarthralgia (polyarthralgia for low-risk populations), fever of >38°C (>38.5°C in low-risk populations), and ESR >30 mm/hr (>60 mm/hr in low-risk populations).

From Gewitz MH, Baltimore RS, Tani LY, et al. Revision of the Jones Criteria for the diagnosis of acute rheumatic fever in the era of Doppler echocardiography: a scientific statement from the American Heart Association. *Circulation*. 2015;131(20):1806–1818.

pathologic MR) (see Table 487.1). Areas in which the Jones Criteria differ in low-risk from moderate/high-risk populations relate to the major criterion of **arthritis** and the minor criteria of arthralgia, definition of fever, and elevated inflammatory markers (see Table 229.2 and text that follows). These changes are designed to make it easier to fulfill the Jones Criteria in patients from moderate/high-risk populations. Even with strict application of the criteria, overdiagnosis and underdiagnosis of acute RF may occur. The diagnosis of acute RF can be made without strict adherence to the Jones Criteria in three circumstances: (1) when chorea occurs as the only major manifestation of acute RF, (2) when indolent carditis is the only manifestation in patients who first come to medical attention only months after the apparent onset of acute RF, and (3) in a limited number of patients with recurrence of acute RF in particularly high-risk populations.

### The Five Major Criteria Migratory Polyarthritides

**Arthritis** occurs in approximately 75% of patients with acute RF and typically involves larger joints, particularly the knees, ankles, wrists, and elbows. Involvement of the spine, small joints of the hands and feet, or hips is uncommon. Rheumatic joints are classically hot, red, swollen, and exquisitely tender, with even the friction of bedclothes being uncomfortable. The pain can precede and can appear to be disproportionate to the objective findings. The joint involvement is characteristically migratory in nature; that is, a severely inflamed joint can become normal within 1–3 days without treatment, even as one or more other large joints become involved. Severe arthritis can persist for several weeks in untreated patients. Monoarticular arthritis is unusual unless antiinflammatory therapy is initiated prematurely, aborting the progression of the migratory polyarthritides. If a child with fever and arthritis is suspected to have acute RF, it is frequently useful to withhold antiinflammatory medications like salicylates or NSAIDs and observe for migratory progression. A dramatic response to even low doses of salicylates is another characteristic feature of the arthritis, and the absence of such a response should suggest an alternative diagnosis.

Rheumatic arthritis is almost never deforming. Synovial fluid in acute RF usually has 10,000–100,000 white blood cells/μL with a predominance of neutrophils, protein level of approximately 4 g/dL, normal glucose level, and formation of a good mucin clot. Frequently, arthritis is the earliest manifestation of acute RF and may correlate temporally with peak antistreptococcal antibody titers. There is often an inverse relationship between the severity of arthritis and the severity of cardiac involvement. In moderate/high-risk populations only,

monoarthritis in the absence of prior inflammatory therapies, or even polyarthralgia without frank objective signs of arthritis, can fulfill this major criterion. Before **polyarthralgia** should be considered a major criterion in the moderate/high-risk population, other potential causes should be excluded.

### Carditis

A major change in the 2015 revision of the Jones Criteria is the acceptance of **subclinical carditis** (defined as without a murmur of valvulitis but with echocardiographic evidence of valvulitis) or **clinical carditis** (with a valvulitis murmur) as fulfilling the major criterion of carditis in all populations. The echocardiographic features of subclinical carditis must meet those included in Table 487.1 in Chapter 487 to distinguish pathologic from physiologic degrees of valve regurgitation. Silent or latent rheumatic heart disease describes echocardiographic evidence of rheumatic heart disease in individuals with no known history of acute RF and no clinical symptoms. In endemic regions, active surveillance via screening echocardiography has emerged as a potential strategy to detect *asymptomatic subclinical* rheumatic heart disease.

Carditis and resultant chronic rheumatic heart disease are the most serious manifestations of acute RF and account for essentially all the associated morbidity and mortality. Rheumatic carditis is characterized by **pancarditis**, with active inflammation of the myocardium, pericardium, and endocardium (see Chapter 487). Cardiac involvement during acute RF varies in severity from fulminant, potentially fatal exudative pancarditis to mild, transient cardiac involvement. **Endocarditis** (valvulitis) is a universal finding in rheumatic carditis, whereas the presence of pericarditis or myocarditis is variable. Myocarditis and/or pericarditis without clinical evidence of endocarditis almost never is rheumatic carditis; alternative etiologies (especially viral) need to be sought. Most rheumatic heart disease is isolated mitral valvular disease or combined aortic and mitral valvular disease. Isolated aortic or right-sided valvular involvement is quite uncommon. Serious and long-term illness is related entirely to the severity of valvular heart disease as a consequence of a single attack or recurrent attacks of acute RF. Valvular insufficiency is characteristic of both acute and convalescent stages of acute RF, whereas mitral and/or aortic valvular stenosis usually appears years or even decades after the acute illness. However, in developing countries, where acute RF often occurs at a younger age, mitral stenosis and aortic stenosis may develop sooner after acute RF than in developed countries and can occur in young children.

**Acute rheumatic carditis** usually presents as tachycardia and cardiac murmurs, with or without evidence of myocardial or pericardial

involvement. Moderate to severe rheumatic carditis can result in cardiomegaly and heart failure with hepatomegaly and peripheral and pulmonary edema. Echocardiographic findings include pericardial effusion, decreased ventricular contractility, and aortic and/or mitral regurgitation. **Mitral regurgitation** is characterized typically by a high-pitched apical holosystolic murmur radiating to the axilla. In patients with significant MR, this may be associated with an apical mid-diastolic murmur of relative mitral stenosis. Aortic insufficiency is characterized by a high-pitched decrescendo diastolic murmur at the left sternal border.

Carditis occurs in approximately 50–60% of all cases of acute RF. Recurrent attacks of acute RF in patients who had carditis with their initial attack are associated with high rates of carditis with increasing severity of cardiac disease. The major consequence of acute rheumatic carditis is chronic, progressive valvular disease, particularly valvular stenosis, which can require surgical intervention.

## Chorea

**Sydenham chorea** occurs in approximately 10–15% of patients with acute RF and usually presents as an isolated, frequently subtle, movement disorder. Emotional lability, incoordination, poor school performance, uncontrollable movements, and facial grimacing are characteristic, all *exacerbated* by stress and *disappearing* with sleep. Chorea occasionally is unilateral (hemichorea). The latent period from acute GAS infection to chorea is usually substantially longer than for arthritis or carditis and can be months. The onset can be insidious, with symptoms being present for several months before recognition. Clinical maneuvers to elicit features of chorea include (1) demonstration of *milkmaid's grip* (irregular contractions and relaxations of the muscles of the fingers while squeezing the examiner's fingers), (2) spooning and pronation of the hands when the patient's arms are extended, (3) wormian darting movements of the tongue on protrusion, and (4) examination of handwriting to evaluate fine motor movements. Diagnosis is based on clinical findings with supportive evidence of GAS antibodies. However, in the usual patient with a long latent period from the inciting streptococcal infection to onset of chorea, antibody levels have often declined to normal. Although the acute illness is distressing, chorea rarely, if ever, leads to permanent neurologic sequelae.

## Erythema Marginatum

**Erythema marginatum** is a rare (approximately 1% of patients with acute RF) but characteristic rash of acute RF. It consists of erythematous, serpiginous, macular lesions with pale centers that are not pruritic (Fig. 229.2). It occurs primarily on the trunk and extremities, but not on the face, and it can be accentuated by warming the skin.



**Fig. 229.2** Polycyclic red borders of erythema marginatum in a febrile child with acute rheumatic fever. (From Schachner LA, Hansen RC, eds. *Pediatric Dermatology*, 3rd ed. Philadelphia: Mosby; 2003:808.)

## Subcutaneous Nodules

Subcutaneous nodules are a rare ( $\leq 1\%$  of patients with acute RF) finding and consist of firm nodules approximately 0.5–1 cm in diameter along the extensor surfaces of tendons near bony prominences. There is a correlation between the presence of these nodules and significant rheumatic heart disease.

## Minor Criteria

These are more *nonspecific* than major criteria, and the 2015 revised Jones Criteria have included some changes from the previous criteria. The first of the two clinical **minor criteria** involve joint manifestations (only if arthritis is not used as a major criterion) and is defined as *polyarthralgia* in low-risk populations and *monoarthralgia* in moderate/high-risk populations. The second clinical minor manifestation is fever, defined as *at least 38.5°C* in low-risk populations and *at least 38.0°C* in moderate/high-risk populations. The two laboratory minor criteria are (1) elevated acute-phase reactants, defined as erythrocyte sedimentation rate (ESR) at least 60 mm/hr and/or C-reactive protein (CRP) at least 3.0 mg/dL (30 mg/L) in low-risk populations and ESR at least 30 mm/hr and/or CRP at least 3.0 mg/dL (30 mg/L) in moderate/high-risk populations and (2) prolonged P-R interval on ECG (unless carditis is a major criterion). However, a prolonged P-R interval alone does not constitute evidence of carditis or predict long-term cardiac sequelae.

## Recent Group A *Streptococcus* Infection

An absolute requirement for the diagnosis of acute RF is supporting evidence of a recent GAS infection. Acute RF typically develops 10–21 days after an acute episode of GAS pharyngitis at a time when clinical findings of pharyngitis are no longer present and when only 10–20% of patients still harbor GAS in the throat. One third of patients with acute RF have no history of an antecedent clinically symptomatic pharyngitis. Therefore evidence of an antecedent GAS infection is usually based on elevated or rising serum antistreptococcal antibody titers. If only a single antibody is measured (usually anti-streptolysin O), only 80–85% of patients with acute RF have an elevated titer; however, 95–100% have an elevation if three different antibodies (anti-streptolysin O, anti-DNase B, anti-hyaluronidase) are measured. Therefore when acute RF is suspected clinically, multiple antibody tests should be performed. Except for chorea, the clinical findings of acute RF generally coincide with peak antistreptococcal antibody responses. Most patients with chorea have elevation of antibodies to at least one GAS antigen. However, in patients with a long latent period from the inciting GAS infection, antibody levels may have declined to within the normal range. The diagnosis of acute RF should *not* be made in those patients with elevated or increasing streptococcal antibody titers who do not fulfill the Jones Criteria.

## Differential Diagnosis

The differential diagnosis of RF includes many infectious and noninfectious illnesses (Table 229.3). When children present with arthritis, a collagen vascular disease must be considered. **Juvenile idiopathic arthritis** (JIA) must be distinguished from acute RF. Children with JIA tend to be younger and usually have less joint pain relative to their other clinical findings than those with acute RF. Spiking fevers, nonmigratory arthritis, lymphadenopathy, and splenomegaly are more suggestive of JIA than acute RF. The response to salicylate therapy is also much less dramatic with JIA than with acute RF. **Systemic lupus erythematosus** (SLE) can usually be distinguished from acute RF by antinuclear antibodies in SLE. Other causes of arthritis such as pyogenic arthritis, malignancies, serum sickness, Lyme disease, sickle cell disease, and reactive arthritis related to gastrointestinal infections (e.g., *Shigella*, *Salmonella*, *Yersinia*) should also be considered. Poststreptococcal reactive arthritis is discussed earlier (see Chapter 229).

When **carditis** is the sole major manifestation of suspected acute RF, viral myocarditis, viral pericarditis, Kawasaki disease, and infective endocarditis should also be considered. Patients with infective

**Table 229.3** Differential Diagnosis of Acute Rheumatic Fever

ARTHRITIS	CARDITIS	CHOREA
Juvenile idiopathic arthritis	Viral myocarditis	Huntington chorea
Reactive arthritis (e.g., <i>Shigella</i> , <i>Salmonella</i> , <i>Yersinia</i> )	Viral pericarditis	Wilson disease
Serum sickness	Infective endocarditis	Systemic lupus erythematosus
Sickle cell disease	Kawasaki disease	Tic disorder
Malignancy	Congenital heart disease	Hyperactivity
Systemic lupus erythematosus	Mitral valve prolapse	Encephalitis (infectious or autoimmune)
Lyme disease ( <i>Borrelia burgdorferi</i> )	Innocent murmurs	
Pyogenic arthritis	MIS-C	
Poststreptococcal reactive arthritis	Lyme disease	

MIS-C, Multisystem inflammatory syndrome in children (COVID-19).

endocarditis may present with both joint and cardiac manifestations. These patients can usually be distinguished from patients with acute RF by blood cultures and the presence of extracardiac findings (e.g., hematuria, splenomegaly, splinter hemorrhages). When **chorea** is the sole major manifestation of suspected acute RF, Huntington chorea, Wilson disease, SLE, and various encephalitides should also be considered.

## TREATMENT

All patients with acute RF should be placed on bed rest and monitored closely for evidence of **carditis**. They can be allowed to ambulate when the signs of acute inflammation have improved. However, patients with carditis require longer periods of bed rest.

### Antibiotic Therapy

Once the diagnosis of acute RF has been established and regardless of the throat culture results, the patient should receive 10 days of orally administered penicillin or amoxicillin or a single IM injection of benzathine penicillin to ensure eradication of GAS from the upper respiratory tract. If penicillin allergic, 10 days of erythromycin, 5 days of azithromycin, or 10 days of clindamycin is indicated. After this initial course of antibiotic therapy, long-term antibiotic prophylaxis for secondary prevention should be instituted (see later).

### Antiinflammatory Therapy

Antiinflammatory agents (e.g., salicylates, corticosteroids) should be withheld if arthralgia or atypical arthritis is the only clinical manifestation of presumed acute RF. Premature treatment with one of these agents may interfere with the development of the characteristic migratory polyarthritis and thus obscure the diagnosis of acute RF. Acetaminophen can be used to control pain and fever while the patient is being observed for more definite signs of acute RF or for evidence of another disease.

Patients with typical migratory polyarthritis and those with carditis without cardiomegaly or congestive heart failure should be treated with oral salicylates. The usual dose of aspirin is 50-70 mg/kg/day in four divided doses orally (PO) for 3-5 days, followed by 50 mg/kg/day in four divided doses PO for 2-3 weeks and half that dose for another 2-4 weeks. Determination of the serum salicylate level is not necessary unless the arthritis does not respond or signs of salicylate toxicity (tinnitus, hyperventilation) develop. There is no evidence that NSAIDs are more effective than salicylates.

Patients with carditis and more than minimal cardiomegaly and/or congestive heart failure should receive corticosteroids. The usual dose of prednisone is 2 mg/kg/day in four divided doses for 2-3 weeks, followed by half the dose for 2-3 weeks, and then tapering of the dose by 5 mg/24 hr every 2-3 days. When prednisone is being tapered, aspirin should be started at 50 mg/kg/day in four divided doses for 6 weeks to prevent rebound of inflammation. Supportive therapies for patients with moderate to severe carditis include digoxin, fluid and salt restriction, diuretics, and oxygen. The cardiac toxicity of digoxin is enhanced with myocarditis.

Termination of the antiinflammatory therapy may be followed by the reappearance of clinical manifestations or of elevation in ESR and CRP (rebound). It may be prudent to increase salicylates or corticosteroids until near-normalization of inflammatory markers is achieved.

### Sydenham Chorea

Because chorea often occurs as an isolated manifestation after the resolution of the acute phase of the disease, antiinflammatory agents are usually not indicated. Sedatives may be helpful early in the course of chorea; phenobarbital (16-32 mg every 6-8 hours PO) is the drug of choice. If phenobarbital is ineffective, haloperidol (0.01-0.03 mg/kg/24 hr divided twice daily PO) or chlorpromazine (0.5 mg/kg every 4-6 hours PO) should be initiated. Some patients may benefit from a few-week course of corticosteroids.

## COMPLICATIONS

The arthritis and chorea of acute RF resolve completely without sequelae. Therefore the long-term sequelae of RF are essentially limited to the heart (see [Chapter 487](#)).

The AHA has published updated recommendations regarding the use of prophylactic antibiotics to prevent infective endocarditis (see [Chapter 486](#)). The AHA recommendations no longer suggest routine endocarditis prophylaxis for patients with rheumatic heart disease who are undergoing dental or other procedures. However, the maintenance of optimal oral healthcare remains an important component of an overall healthcare program. For the relatively few patients with rheumatic heart disease in whom infective endocarditis prophylaxis remains recommended, such as those with a prosthetic valve or prosthetic material used in valve repair, the current AHA recommendations should be followed (see [Chapter 486](#)). These recommendations advise using an agent other than a penicillin to prevent infective endocarditis in those receiving penicillin prophylaxis for RF because oral  $\alpha$ -hemolytic streptococci are likely to have developed resistance to penicillin.

## PROGNOSIS

The prognosis for patients with acute RF depends on the clinical manifestations present at the initial episode, the severity of the initial episode, and the prevention of recurrences. Approximately 50-70% of patients with carditis during the initial episode of acute RF recover with no residual heart disease; the more severe the initial cardiac involvement, the greater the risk for residual heart disease. Patients without carditis during the initial episode are less likely to have carditis with recurrent attacks, but there is a stepwise increase in cardiac involvement as the number of episodes increases. In contrast, patients with carditis during the initial episode are very likely to have carditis with recurrences, and the risk for permanent heart damage increases with each recurrence. Patients who have had acute RF are susceptible to recurrent attacks after reinfection of the upper respiratory tract with GAS, with approximately 50% risk with each GAS pharyngitis. Therefore these patients require long-term continuous chemoprophylaxis.



**Table 229.4** Chemoprophylaxis for Recurrences of Acute Rheumatic Fever (Secondary Prophylaxis)

DRUG	DOSE	ROUTE
Penicillin G benzathine	600,000 IU for children weighing ≤60 lb and 1.2 million IU for children >60 lb, every 4 wk*	Intramuscular
<i>or</i>		
Penicillin V	250 mg, twice daily	Oral
<i>or</i>		
Sulfadiazine or sulfisoxazole	500 mg once daily for patients weighing ≤60 lb 1000 mg once daily for patients weighing >60 lb	Oral
<b>FOR PEOPLE WHO ARE ALLERGIC TO PENICILLIN AND SULFONAMIDE DRUGS</b>		
Macrolide or azalide	Variable	Oral

\*In high-risk situations, administration every 3 wk is recommended.

Adapted from Gerber MA, Baltimore RS, Eaton CB, et al. Prevention of rheumatic fever and diagnosis and treatment of acute streptococcal pharyngitis: a scientific statement from the American Heart Association Rheumatic Fever, Endocarditis, and Kawasaki Disease Committee of the Council on Cardiovascular Disease in the Young. *Circulation*. 2009;119:1541–1551.

Before antibiotic prophylaxis was available, 75% of patients who had an initial episode of acute RF had one or more recurrences in their lifetime. These recurrences were a major source of morbidity and mortality. The risk of recurrence is highest in the first 5 years after the initial episode and decreases with time.

Approximately 20% of patients who present with isolated chorea who are not given secondary prophylaxis develop rheumatic heart disease within 20 years. Therefore patients with chorea, even in the absence of other manifestations of RF, require long-term antibiotic prophylaxis (Table 229.4).

## PREVENTION

Prevention of both initial and recurrent episodes of acute RF depends on controlling GAS infections of the upper respiratory tract. Prevention of initial attacks (**primary prevention**) depends on identification and eradication of GAS causing acute pharyngitis. A New Zealand study in a population with very high rates of acute RF showed that a school-based GAS pharyngitis screening and management program using oral amoxicillin substantially decreased pharyngeal GAS prevalence and rates of acute RF. Individuals who have already suffered an attack of acute RF are particularly susceptible to recurrences of RF with any subsequent GAS upper respiratory tract infection, whether or not they are symptomatic. Therefore these patients should receive continuous antibiotic prophylaxis to prevent recurrences (**secondary prevention**).

### Primary Prevention

Appropriate antibiotic therapy instituted before the ninth day of symptoms of acute GAS pharyngitis is highly effective in preventing the first attacks of acute RF. However, approximately 30% of patients with acute RF do not recall a preceding episode of pharyngitis and did not seek therapy.

### Secondary Prevention

Secondary prevention is directed at preventing acute GAS pharyngitis in patients at substantial risk of recurrent acute RF. Secondary prevention requires continuous antibiotic prophylaxis, which should begin as soon as the diagnosis of acute RF has been made and immediately after a full course of antibiotic therapy has been completed. Because patients who have had carditis with their initial episode of acute RF are at higher risk for having carditis with recurrences and for sustaining additional cardiac damage, they should receive long-term antibiotic prophylaxis well into adulthood and perhaps for life (see Table 229.4 and Table 229.5).

Patients who did not have carditis with their initial episode of acute RF have a relatively low risk for carditis with recurrences. Antibiotic prophylaxis should continue in these patients until the patient reaches

**Table 229.5** Duration of Prophylaxis for People Who Have Had Acute Rheumatic Fever: AHA Recommendations

CATEGORY	DURATION
Rheumatic fever without carditis	5 yr or until 21 yr of age, whichever is longer
Rheumatic fever with carditis but without residual heart disease (no valvular disease*)	10 yr or until 21 yr of age, whichever is longer
Rheumatic fever with carditis and residual heart disease (persistent valvular disease*)	10 yr or until 40 yr of age, whichever is longer; sometimes lifelong prophylaxis

\*Clinical or echocardiographic evidence.

Adapted from Gerber MA, Baltimore RS, Eaton CB, et al. Prevention of rheumatic fever and diagnosis and treatment of acute streptococcal pharyngitis: a scientific statement from the American Heart Association (AHA) Rheumatic Fever, Endocarditis, and Kawasaki Disease Committee of the Council on Cardiovascular Disease in the Young. *Circulation*. 2009;119:1541–1551.

21 years of age or until 5 years have elapsed since the last RF attack, whichever is longer. The decision to discontinue prophylactic antibiotics should be made only after careful consideration of potential risks and benefits and of epidemiologic factors such as the risk for exposure to GAS infections.

The regimen of choice for secondary prevention is a single IM injection of benzathine penicillin G (600,000 IU for children weighing ≤60 lb and 1.2 million IU for those >60 lb) every 4 weeks (see Table 229.4). In certain high-risk patients and in certain areas of the world where the incidence of RF is particularly high, use of benzathine penicillin G every 3 weeks may be necessary because serum concentrations of penicillin may decrease to marginally effective levels after 3 weeks. In the United States, administration of benzathine penicillin G every 3 weeks is recommended only for those who have recurrent acute RF despite adherence to a 4-week regimen. In compliant patients, continuous oral antimicrobial prophylaxis can be used. Penicillin V (250 mg twice daily) and sulfadiazine or sulfisoxazole (500 mg for those weighing ≤60 lb or 1,000 mg for those >60 lb, once daily) are equally effective when used in such patients. For the exceptional patient who is allergic to both penicillin and sulfonamides, a macrolide (erythromycin or clarithromycin) or azalide (azithromycin) may be used. Table 229.5 notes the duration of secondary prophylaxis.

Visit Elsevier eBooks+ at eBooks.Elsevier.com for Bibliography.



## Chapter 230

Group B *Streptococcus*

Thomas A. Hooven

Group B *Streptococcus* (GBS), or *Streptococcus agalactiae*, is a major cause of **neonatal bacterial sepsis** worldwide. Although advances in prevention strategies have led to a decline in the incidence of neonatal disease, GBS remains a dangerous pathogen for neonates, pregnant women, and nonpregnant adults.

**ETIOLOGY**

Group B streptococci are facultative, anaerobic, gram-positive cocci that form chains or diplococci in broth and small, gray-white or orange-tinged colonies on solid medium. GBS is definitively identified by demonstration of the Lancefield group B carbohydrate antigen, such as with latex agglutination techniques widely used in clinical laboratories. Presumptive identification can be established on the basis of a narrow zone of  $\beta$ -hemolysis on blood agar, resistance to bacitracin and trimethoprim-sulfamethoxazole (TMP-SMX), lack of hydrolysis of bile esculin, and elaboration of CAMP factor (named for the discoverers, Christie, Atkins, and Munch-Petersen), an extracellular protein that, in the presence of the  $\beta$  toxin of *Staphylococcus aureus*, produces a zone of enhanced hemolysis on sheep blood agar. Individual GBS strains are serologically classified according to the presence of one of the structurally distinct capsular polysaccharides, which are important virulence factors and stimulators of antibody-associated immunity. Ten GBS capsular types have been identified: types Ia, Ib, II, III, IV, V, VI, VII, VIII, and IX.

**EPIDEMIOLOGY**

GBS emerged as a prominent neonatal pathogen in the late 1960s. For the next 2 decades, the incidence of neonatal GBS disease remained fairly constant, affecting 1.0–5.4 per 1,000 liveborn infants in the United States. Two patterns of disease were seen: **early-onset disease**, which presents at <7 days of age, and **late-onset disease**, which presents at  $\geq 7$  days of age. Since the early 1990s, widespread implementation of **maternal intrapartum antibiotic prophylaxis** has led to a striking decrease in the incidence of early-onset neonatal GBS disease in the United States, from 1.7 to 0.19 per 1,000 live births in recent years. This strategy has *not* had a significant effect on the incidence of late-onset disease, which has remained stable at approximately 0.3–0.4 per 1,000 live births (Fig. 230.1). The incidence of neonatal GBS disease is higher in premature and low birthweight infants, although most cases occur in full-term infants. Rates of both early- and late-onset disease are higher in Black infants.

Colonization by GBS in healthy adults is common. Vaginal or rectal colonization occurs in up to approximately 30% of pregnant women and is the usual source for GBS transmission to newborn infants. In the absence of maternal antibiotic prophylaxis, approximately 50% of infants born to colonized women acquire GBS colonization, and 1–2% of infants born to colonized mothers develop early-onset disease. Heavy maternal colonization increases the risk for infant colonization and development of early-onset disease. Additional risk factors for early-onset disease include prolonged rupture of membranes, intrapartum fever, prematurity, maternal bacteriuria during pregnancy, and previous delivery of an infant who developed GBS disease. Risk factors for late-onset disease are less well defined. Whereas late-onset disease may follow vertical transmission, horizontal acquisition from nursery or other community sources (such as family, healthcare providers, or environmental exposure) has also been described.

GBS is also an important cause of invasive disease in adults. GBS may cause urinary tract infections, bacteremia, endometritis, chorioamnionitis, and wound infection in pregnant and parturient women. In nonpregnant adults, especially those with underlying medical conditions

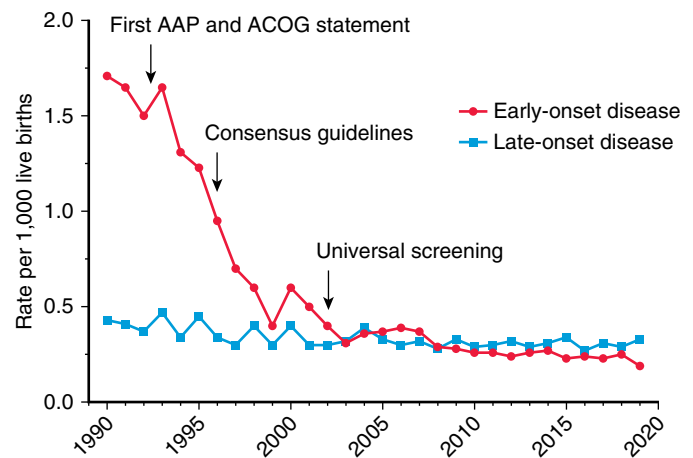
such as diabetes mellitus, cirrhosis, or malignancy, GBS may cause serious infections such as bacteremia, skin and soft tissue infections, bone and joint infections, endocarditis, pneumonia, and meningitis. In the era of maternal chemoprophylaxis, most invasive GBS infections occur in nonpregnant adults. Unlike neonatal disease, the incidence of invasive GBS disease in adults has increased substantially, roughly tripling between 1990 and 2016.

The serotypes most frequently associated with neonatal GBS disease are types Ia, III, and V. Strains of serotype III are the most common subtype isolated from colonized pregnant women and are also the most frequent cause of invasive disease among newborns and adults. Global epidemiologic studies have revealed regional variation in subtype prevalence, some of which may reflect local dietary and healthcare practices.

**PATHOGENESIS**

A major risk factor for the development of early-onset neonatal GBS infection is maternal vaginal or rectal colonization by GBS. Infants acquire GBS by ascending infection or during passage through the birth canal. Fetal aspiration of infected amniotic fluid may occur. The incidence of early-onset GBS infection increases with the duration of rupture of membranes. Infection may also occur through transcellular passage across intact membranes. In cases of late-onset infection, GBS may be vertically transmitted or acquired later from maternal or non-maternal sources.

Several bacterial factors are implicated in the pathogenesis of invasive GBS disease, primarily the type-specific **capsular polysaccharide**. Strains that are associated with invasive disease in humans elaborate more capsular polysaccharide than do colonizing isolates. All GBS capsular polysaccharides are high molecular weight polymers composed of repeating oligosaccharide subunits that include a short side chain terminating in *N*-acetylneuraminic acid (**sialic acid**). Studies of type III GBS show that the sialic acid component of the capsular polysaccharide prevents activation of the alternative complement pathway in the absence of type-specific antibody. Sialylated capsular polysaccharide on the GBS surface also interacts with sialic acid-binding lectins or siglecs on human leukocytes to dampen inflammatory gene activation. Thus the capsular polysaccharide appears to exert a virulence effect by protecting the organism from opsonophagocytosis in the non-immune host and by downregulating leukocyte activation. In addition, type-specific virulence attributes are suggested by the fact that type III strains are implicated in most cases of late-onset neonatal GBS disease and meningitis. Type III strains are taken up by brain endothelial cells



**Fig. 230.1** Incidence of early- and late-onset invasive group B streptococcal (GBS) disease—active bacterial core surveillance areas, 1990–2019, and activities for prevention of GBS disease. AAP, American Academy of Pediatrics; ACOG, American College of Obstetricians and Gynecologists. (Adapted from Jordan HT, Farley MM, Craig A, et al. Revisiting the need for vaccine prevention of late-onset neonatal group B streptococcal disease: a multistate, population-based analysis. *Pediatr Infect Dis J.* 2008;27:1057–1064.)

more efficiently in vitro than are strains of other serotypes, although studies using acapsular mutant strains demonstrate that the capsule by itself does not facilitate cellular invasion. A single clade of type III GBS is highly associated with late-onset disease and meningitis. This clonal group, ST-17, produces a surface-anchored protein called *hypervirulent GBS adhesin (HvgA)* that is not present in other GBS isolates. HvgA contributes to GBS adherence to intestinal and endothelial cells and mediates invasion into the central nervous system (CNS) in an experimental infection model in mice. Other putative GBS virulence factors include GBS surface proteins, which may play a role in adhesion to host cells; C5a peptidase, which is postulated to inhibit the recruitment of polymorphonuclear cells to sites of infection;  $\beta$ -hemolysin/cytolysin, which has been associated with cell injury in vitro; and hyaluronidase, which has been postulated to act as a spreading factor in host tissues.

In a classic study of pregnant women colonized with type III GBS, those who gave birth to healthy infants had higher levels of capsular polysaccharide-specific antibody than those who gave birth to infants who developed invasive disease. In addition, there is a high correlation between antibody titer to GBS type III in the mother and titer in the paired infants. These observations indicate that transplacental transfer of maternal antibody is critically involved in neonatal immunity to GBS. Optimal immunity to GBS also requires an intact complement system. The classical complement pathway is an important component of GBS immunity in the absence of specific antibody; in addition, antibody-mediated opsonophagocytosis may proceed by the alternative complement pathway. These and other results indicate that anticapsular antibody can overcome the prevention of C3 deposition on the bacterial surface by the sialic acid component of the type III capsule.

The precise steps between GBS colonization and invasive disease remain unclear. In vitro studies showing GBS entry into alveolar epithelial cells and pulmonary vasculature endothelial cells suggest that GBS may gain access to the bloodstream by invasion from the alveolar space, perhaps after intrapartum aspiration of infected amniotic fluid.  $\beta$ -hemolysin/cytolysin may facilitate GBS entry into the bloodstream after inoculation into the lungs. Other studies have demonstrated intestinal GBS colonization preceding invasive disease among newborns, suggesting translocation across the intestinal wall as a pathogenic mechanism.

GBS induces the release of proinflammatory cytokines. The group B antigen and the peptidoglycan component of the GBS cell wall are potent inducers of tumor necrosis factor- $\alpha$  release in vitro, whereas purified type III capsular polysaccharide is not. Even though the capsule plays a central role in virulence through avoidance of immune clearance, the capsule does not directly contribute to cytokine release and the resultant inflammatory response.

The complete genome sequences of hundreds of GBS strains have been reported, facilitating a genomic approach to better understanding GBS. Analysis of these sequences shows that GBS is closely related to *Streptococcus pyogenes* and *Streptococcus pneumoniae*. Many known and putative GBS virulence genes are clustered in the genome in pathogenicity islands that also contain mobile genetic elements, suggesting

that interspecies acquisition of genetic material plays an important role in genetic diversity.

## CLINICAL MANIFESTATIONS

Two syndromes of neonatal GBS disease are distinguishable on the basis of age at presentation, epidemiologic characteristics, and clinical features (Table 230.1). **Early-onset neonatal GBS disease** presents within the first 6 days of life and is often associated with maternal obstetric complications, including chorioamnionitis, prolonged rupture of membranes, and premature labor. Infants may appear ill at the time of delivery, and most infants become ill within 24 hours of birth. In utero infection may result in septic abortion or immediate distress after birth. More than 80% of early-onset GBS disease presents as sepsis; pneumonia and meningitis are other common manifestations. Asymptomatic bacteremia is uncommon but can occur. In symptomatic patients, nonspecific signs such as hypothermia or fever, irritability, lethargy, apnea, and bradycardia may be present. Respiratory signs are prominent regardless of the presence of pneumonia and include cyanosis, apnea, tachypnea, grunting, flaring, and retractions. A fulminant course with hemodynamic abnormalities, including tachycardia, acidosis, and shock, may ensue. Persistent fetal circulation may develop. Clinically and radiographically, pneumonia associated with early-onset GBS disease is difficult to distinguish from **respiratory distress syndrome**. Patients with meningitis often present with nonspecific findings as described for sepsis or pneumonia, with more specific signs of CNS involvement initially absent.

**Late-onset neonatal GBS disease** presents at  $\geq 7$  days of life. Most cases occur within the first 3 months of life, but later presentations are also possible. Like early-onset disease, late-onset illness usually manifests as bacteremia (45–65%), often accompanied by meningitis (25–35%). Focal infections involving bone and joints, skin and soft tissue, the urinary tract, or lungs may also be seen. Cellulitis and adenitis are often localized to the submandibular or parotid regions. In contrast to early-onset disease, maternal obstetric complications are not risk factors for the development of late-onset GBS disease. Infants with late-onset disease are often less severely ill on presentation than infants with early-onset disease, and the disease is often less fulminant.

Invasive GBS disease in children beyond early infancy is uncommon. Bacteremia without a focus is the most common syndrome associated with childhood GBS disease beyond early infancy. Focal infections may include meningitis, pneumonia, endocarditis, and bone and joint infections.

## DIAGNOSIS

A major challenge is distinguishing between respiratory distress syndrome and invasive neonatal GBS infection in preterm infants because the two illnesses share clinical and radiographic features. Severe apnea, early onset of shock, abnormalities in the peripheral leukocyte count, and greater lung compliance may be more likely in infants with GBS disease. Other neonatal pathogens, including *Escherichia coli* and *Listeria monocytogenes*, may cause illness that is clinically indistinguishable from that caused by GBS.

**Table 230.1** Characteristics of Early- and Late-Onset Group B *Streptococcus* Disease

	EARLY-ONSET DISEASE	LATE-ONSET DISEASE
Age at onset	0-6 days	7-90 days
Increased risk after obstetric complications	Yes	No
Common clinical manifestations	Sepsis, pneumonia, meningitis	Bacteremia, meningitis, osteomyelitis, other focal infections
Common serotypes	Ia, III, V	Ia, III
Case fatality rate	4.5%	3.3%

Adapted from Seale AC, Bianchi-Jassir F, Russell NJ, et al. Estimates of the burden of Group B streptococcal disease worldwide for pregnant women, stillbirths, and children. *Clin Infect Dis*. 2017;65(Suppl 2):S200–S219.

The diagnosis of invasive GBS disease is established by isolation and identification of the organism from a normally sterile site, such as blood, urine, or cerebrospinal fluid (CSF). Isolation of GBS from gastric or tracheal aspirates or from skin or mucous membranes indicates colonization and is not diagnostic of invasive disease. CSF should be examined in all neonates suspected of having sepsis because specific CNS signs are often absent in the presence of meningitis, especially in early-onset disease. Antigen detection methods that use group B polysaccharide-specific antiserum, such as latex particle agglutination, are available for testing of urine, blood, and CSF, but these tests are less sensitive than culture. Moreover, antigen is often detected in urine samples collected by bag from otherwise healthy neonates who are colonized with GBS on the perineum or in the rectum. Commercially available methods for polymerase chain reaction (PCR) amplification of GBS-specific DNA sequences from blood or CSF samples are increasingly available, allowing earlier presumptive diagnosis than traditional culture. When possible, PCR-based diagnosis should be verified with a sterilely obtained culture; however, in certain cases the PCR result may be more accurate than the culture. A common example is a PCR performed on CSF sampled from an infant who has already received empiric antibiotic therapy, in which case the culture may remain negative despite the persistence of PCR-detectable GBS DNA. Test results must therefore be interpreted in the context of a patient's specific clinical history.

### LABORATORY FINDINGS

Frequently present are abnormalities in the peripheral white blood cell count, including an increased or decreased absolute neutrophil count, elevated band count, increased ratio of bands to total neutrophils, or leukopenia. An elevated C-reactive protein level has been investigated as a potential early marker, but this test is nonspecific and cannot be used in isolation to diagnose GBS disease. Findings on chest radiograph are often indistinguishable from those of respiratory distress syndrome and may include reticulogranular patterns, patchy infiltrates, generalized opacification, pleural effusions, or increased interstitial markings. GBS meningitis is diagnosed based on a positive microbiologic test (culture or PCR), usually in combination with elevated CSF protein levels, leukocytic infiltration, and hypoglycorrhachia (decreased CSF glucose concentration).

### TREATMENT

**Penicillin G is the treatment of choice for confirmed GBS infection.** Empirical therapy of neonatal sepsis that could be caused by GBS generally includes ampicillin and an aminoglycoside, both for the need for broad coverage pending organism identification and for synergistic bactericidal activity. Once GBS has been definitively identified and a good clinical response has occurred, therapy may be completed with penicillin alone. Especially in patients with meningitis, high doses of penicillin (450,000-500,000 units/kg/day) or ampicillin (300 mg/kg/day) are recommended because of the relatively high mean inhibitory concentration (MIC) of penicillin for GBS and the potential for a high initial CSF inoculum. The duration of therapy varies according to the

site of infection and should be guided by clinical circumstances (Table 230.2). Extremely ill near-term patients with respiratory failure have been successfully treated with extracorporeal membrane oxygenation.

Although some experts recommend that, in culture-proven meningitis, additional CSF be sampled at 24-48 hours to determine whether sterility has been achieved, there is no strong evidence to support this practice. A repeat lumbar puncture, preferably paired with intracranial imaging such as MRI or CT, may be considered in patients with persistent neurologic symptoms after initiation of appropriately dosed antibiotics. The purpose in such a case is to rule out the presence of an abscess or other focal nidus of infection that may be escaping effective antibiotic exposure.

For **recurrent neonatal GBS disease**, standard intravenous antibiotic therapy recommendations for the infant should be followed. GBS recurrence can be caused by contaminated breast milk. Therefore breastfed infants with more than one episode of GBS infection should receive formula or pasteurized breast milk until expressed breast milk can be cultured for the presence of GBS. If breast milk contamination is confirmed, the mother should be counseled to consider a 5- to 7-day course of amoxicillin or rifampin to eradicate GBS carriage, followed by retesting of the milk.

### PROGNOSIS

Studies from the 1970s and 1980s showed that up to 30% of infants surviving GBS meningitis had major long-term neurologic sequelae, including developmental delay, spastic quadriplegia, microcephaly, seizure disorder, cortical blindness, or deafness. A study of infants who survived GBS meningitis diagnosed from 1998 through 2006 found that 19% had severe **neurologic impairment** and 25% had mild to moderate impairment at long-term follow-up. Periventricular leukomalacia and severe developmental delay may result from GBS disease and accompanying shock in premature infants, even in the absence of meningitis. The outcome of focal GBS infections outside the CNS is generally favorable.

In 2015, a global survey on the impact of GBS disease found the case fatality rates associated with early- and late-onset neonatal GBS disease in developed countries were 4.5% and 3.3%, respectively. Case fatality rates were higher in developing countries. Mortality is higher in premature infants; one study reported a case fatality rate of 30% in infants at gestational age <33 weeks and 2% in those ≥37 weeks. The case fatality rate in children age 3 months to 14 years was 9% and was 11.5% in nonpregnant adults.

### PREVENTION

Persistent morbidity and mortality from perinatal GBS disease despite advances in neonatal care have spurred intense investigation into modes of prevention. Two basic approaches to GBS prevention have been investigated: elimination of colonization from the mother or infant (chemoprophylaxis) and induction of protective immunity (immunoprophylaxis).

### Chemoprophylaxis

Administration of antibiotics to pregnant women *before* the onset of labor does not reliably eradicate maternal GBS colonization and is not an effective means of preventing neonatal GBS disease. **Interruption of neonatal colonization is achievable through administration of antibiotics to the mother during labor.** Infants born to GBS-colonized women with premature labor or prolonged rupture of membranes who were given **intrapartum chemoprophylaxis** had a substantially lower rate of GBS colonization (9% vs 51%) and early-onset disease (0% vs 6%) than did the infants born to women who were not treated. Maternal postpartum febrile illness was also decreased in the treatment group.

In the mid-1990s, guidelines for chemoprophylaxis were issued that specified administration of intrapartum antibiotics to women identified as *high risk* by either culture-based or risk factor-based criteria. These guidelines were revised in 2002 after epidemiologic data indicated the superior protective effect of the **culture-based** approach in the prevention of neonatal GBS disease, and further revised guidelines

**Table 230.2** Recommended Duration of Therapy for Manifestations of Group B *Streptococcus* Disease

TREATMENT	DURATION
Bacteremia without a focus	10 days
Uncomplicated meningitis	14 days
Ventriculitis	At least 4 wk
Septic arthritis or osteomyelitis	3-4 wk

Data from the American Academy of Pediatrics. Group B streptococcal infections. In Kimberlin DW, Barnett ED, Lynfield R, Sawyer MH, eds. *Red Book: 2021-2024 Report of the Committee on Infectious Diseases*, 32nd ed. Elk Grove Village, IL: American Academy of Pediatrics; 2021:707-713.

were issued in 2010 and 2020. According to current recommendations, **vagino-rectal GBS screening cultures or PCR testing (where available) should be performed for all pregnant women at 36 0/7 to 37 6/7 weeks of gestation, except for those with GBS bacteriuria during the current pregnancy or a previous infant with invasive GBS disease.** Any woman with a positive prenatal screening culture, GBS bacteriuria during pregnancy, or a previous infant with invasive GBS disease should receive intrapartum antibiotics. Women whose culture status is unknown (culture not done, incomplete, or results unknown) and present in labor with a substantial risk of preterm birth, prolonged rupture of membranes ( $\geq 18$  hr), or intrapartum fever ( $\geq 38^\circ\text{C}$  [ $100.4^\circ\text{F}$ ]) should also receive intrapartum chemoprophylaxis (Table 230.3). **Routine intrapartum prophylaxis is**

**not recommended for women with GBS colonization undergoing planned cesarean delivery who have not begun labor or had rupture of membranes.**

Penicillin remains the preferred agent for **maternal chemoprophylaxis** because of its narrow spectrum and the universal penicillin susceptibility of GBS isolates associated with human infection (Fig. 230.2). Ampicillin is an acceptable alternative. If amnionitis is suspected, broad-spectrum antibiotic therapy that includes an agent active against GBS should replace GBS prophylaxis. Occasional GBS isolates have demonstrated increased MICs to penicillin and other  $\beta$ -lactam antibiotics in association with mutations in penicillin-binding proteins. However, the clinical significance of these higher MIC values is unclear.

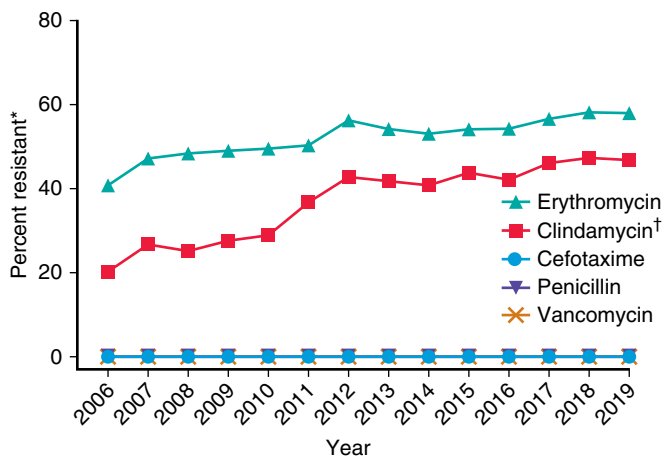
**Table 230.3** Summary and References for GBS Prevention/Treatment Guidelines

AT-RISK POPULATION	KEY PREVENTION/TREATMENT PRACTICES	PRACTICE GUIDELINE GOVERNING BODY
Women with history of a previous neonate with invasive GBS disease	Administer IAP during labor*	ACOG
Women with GBS bacteriuria during current pregnancy	Administer IAP during labor*	ACOG
Women with uncomplicated pregnancy	Perform prospective GBS colonization screening at 36 0/7 to 37 6/7 weeks of gestation	ACOG
	Administer IAP to colonized women during labor*	
	Women who present in term labor with unknown GBS status may qualify for IAP depending on additional clinical details	
Mothers with PROM, preterm labor, preterm intraamniotic infection, and unknown GBS colonization status	Administer IAP	ACOG
Term or late preterm (>34 wk) newborns with risk factors for GBS infection	For persistent clinical symptoms consistent with sepsis, obtain a blood culture and start empiric antibiotics with anti-GBS activity	AAP Redbook AAP Pediatrics
	In the absence of clinical symptoms, three possible approaches are available: <ol style="list-style-type: none"> <li>1. Categorical risk-based management</li> <li>2. Use of an online Bayesian sepsis risk calculator to guide management</li> <li>3. Serial observation of the infant</li> </ol>	
Preterm newborns $\leq 34$ wk with risk factors for GBS	For persistent clinical symptoms consistent with sepsis, obtain a blood culture and start empiric antibiotics with anti-GBS activity	AAP Redbook AAP Pediatrics
	If delivery followed spontaneous preterm labor, PROM, or concern for intraamniotic infection, obtain a blood culture and administer empiric antibiotics	
	If delivery followed induction of labor and there was concern for intraamniotic infection or if IAP was indicated but not provided, obtain a blood culture and administer empiric antibiotics	
Infants with signs of late-onset GBS disease	For empiric therapy of late-onset GBS disease in those who are not critically ill and in whom meningitis is not suspected, initial empiric therapy with ampicillin plus either gentamicin or cefotaxime is appropriate. If meningitis is suspected, ampicillin plus cefotaxime is recommended	AAP Redbook

\*Infants born by cesarean section for maternal indications with no preceding labor or ROM: postnatal management should be guided by the newborn's clinical status and subsequent risk of GBS exposure.

AAP, American Academy of Pediatrics; ACOG, American College of Obstetrics and Gynecology; IAP, Intrapartum antibiotic prophylaxis; PROM, Preterm rupture of membranes





**Fig. 230.2** GBS antibiotic resistance rates measured through Centers for Disease Control and Prevention active bacterial core surveillance, 2006–2019. \*Resistant includes those isolates intermediate or fully resistant to antibiotics tested. †Before 2011, only constitutive resistance to clindamycin was tested. In 2011 and beyond, both constitutive and inducible resistance to clindamycin were tested. (Courtesy Centers for Disease Control and Prevention.)

For women who report a penicillin allergy but who have not undergone formal sensitivity testing, the American College of Obstetrics and Gynecology recommends allergy skin testing, which can be performed safely during pregnancy. Because of frequent resistance of GBS to clindamycin (up to 46%), first-generation cephalosporins (such as cefazolin) should be used for intrapartum chemoprophylaxis for penicillin-intolerant women with a low risk of anaphylaxis. For penicillin-allergic women at high risk for anaphylaxis, clindamycin should be used only if isolates are demonstrated to be susceptible. Vancomycin should be used if isolates are resistant to, or demonstrate inducible resistance to, clindamycin or if clindamycin susceptibility is unknown.

In 2019, the American Academy of Pediatrics (AAP) published updated guidelines with recommendations for prevention of early-onset GBS disease in newborns with risk factors (see Table 230.3). These replaced earlier prevention guidelines released by the AAP and Centers for Disease Control and Prevention. A key point of these revised recommendations is that **newborns with risk factors for GBS disease (such as inadequately treated maternal colonization or preterm delivery) who have persistent signs of infection after birth (beyond those attributable to transitional physiology) should undergo a laboratory evaluation that includes a blood culture and should receive empiric antibiotic therapy until infection has been ruled out.** For asymptomatic or minimally symptomatic infants born after 35 0/7 weeks of gestation, the extent of newborn evaluation and the decision to institute empiric antibiotics may be guided by one of **three systems for risk assessment:** a categorical decision chart based on the presence or absence of specific risk factors, repeated clinical evaluations, or a validated online “sepsis calculator” tool, developed from large datasets, which can estimate a newborn’s risk of early-onset disease based on historical factors and clinical presentation. **For infants born before 35 0/7 weeks of gestation, the AAP recommends a blood culture and empiric antibiotics in all cases where spontaneous preterm labor, preterm rupture of the membranes, or any concern of intraamniotic infection preceded birth. Empiric treatment is also recommended in any case of a vaginal delivery before 35 0/7 weeks in which maternal chemoprophylaxis was indicated but not administered (see Table 230.3).**

Increasingly, there is recognition that decisions about whether to start empiric antibiotics for well-appearing infants with sepsis risk factors must also take into consideration the local resources available

for systematic, serial examination. In medical environments where well-trained staff are available for careful, repeated observations of the newborn for 36–48 hours after birth, the threshold for initiating empiric antibiotics may be higher than sites where serial examinations are not possible. Of note, in the era of maternal chemoprophylaxis, most cases of early-onset disease are seen in infants born to women with negative prenatal screening cultures. Data from a large epidemiologic study indicate that the administration of maternal intrapartum antibiotics does not change the clinical spectrum or delay the onset of clinical signs in infants who developed GBS disease despite maternal prophylaxis.

A significant concern with maternal intrapartum chemoprophylaxis has been that large-scale antibiotic use among parturient women might lead to increased rates of antimicrobial resistance or infection in infants with organisms other than GBS, but this has not been borne out. In a population-based study of early-onset neonatal infection from 2005 to 2014, the incidence of early-onset sepsis both overall and caused by *E. coli* remained stable. At present, the substantial decline in early-onset neonatal GBS disease favors continued broad-scale intrapartum chemoprophylaxis, but continued surveillance is required.

A limitation of the maternal chemoprophylaxis strategy is that intrapartum antibiotic use is unlikely to have an impact on late-onset neonatal disease, miscarriages, or stillbirths attributed to GBS or adult GBS disease. In addition, with wider implementation of maternal chemoprophylaxis, an increasing percentage of early-onset neonatal disease has been detected in patients born to women with negative cultures, that is, false-negative screens.

### Maternal Immunization

Human studies demonstrate that transplacental transfer of naturally acquired maternal antibody to the GBS capsular polysaccharide protects newborns from invasive GBS infection and that efficient transplacental passage of vaccine-induced GBS antibodies occurs. Conjugate vaccines composed of the GBS capsular polysaccharides coupled to carrier proteins have been produced for human use. In early clinical trials, conjugate GBS vaccines were well tolerated and induced levels of functional antibodies well above the range believed to be protective in >90% of recipients. A trivalent vaccine containing three subtypes of GBS capsule polysaccharide coupled to CRM<sub>197</sub> was safely administered to pregnant women in a phase 2 clinical trial, eliciting functionally active type-specific antibodies that were efficiently transported to the fetus remaining detectable in the newborn. A more recent hexavalent vaccine candidate led to protective antibodies against six GBS capsular subtypes in experimental animal pregnancy models and generated robust antibody elaboration in nonpregnant adults in a phase 1/2 trial. Vaccines containing GBS surface proteins have been considered as a means to provide serotype-independent GBS protection, and availability of whole genome sequencing has enabled identification of vaccine protein candidates.

A successful GBS maternal vaccine administered before or during pregnancy should lead to transplacental passage of vaccine-induced antibody that protects the fetus and newborn against infection by several GBS serotypes. Such a vaccine would eliminate the need for cumbersome cultures during pregnancy, circumvent the various risks associated with large-scale antibiotic prophylaxis, likely have an impact on both early- and late-onset disease, and provide a prevention strategy in middle- and low-income countries, where maternal chemoprophylaxis may not be feasible. Intrapartum chemoprophylaxis will likely remain an important aspect of prevention, particularly for women in whom opportunities for GBS immunization are missed and for infants born so early that levels of transplacentally acquired antibodies may not be high enough to be protective.

Visit Elsevier eBooks+ at [eBooks.Health.Elsevier.com](https://eBooks.Health.Elsevier.com) for Bibliography.

## Chapter 231

Non-Group A or B  
Streptococci

David B. Haslam

The genus *Streptococcus* is exceptionally diverse and includes the major human pathogens *Streptococcus pyogenes* (group A *Streptococcus Streptococcus agalactiae* (group B *Streptococcus*), and *Streptococcus pneumoniae* (Table 231.1). Other important pathogens include large-colony species bearing groups C and G Lancefield antigens and numerous small-colony variants that may or may not express Lancefield carbohydrate antigen included among the viridans streptococci (see Table 231.1). This chapter focuses on *Streptococcus dysgalactiae* subspecies *equisimilis* (SDSE), commonly known as “group C and G streptococci,” while Chapter 228 discusses *S. pneumoniae* and Chapter 232 discusses enterococci.

All members of the genus *Streptococcus* are gram-positive, catalase-negative organisms. Lancefield carbohydrate antigen, hemolytic activity, and colony morphology have classically been used to further distinguish and classify streptococci. These features provide a useful framework for the clinician and are still the most commonly used classification schema. However, grouping based on these phenotypic features does not precisely correlate with genetic relatedness, and it is becoming clear that disease propensity is better correlated with sequence homology than Lancefield grouping or hemolytic activity.

In this chapter, groups C and G streptococci refer exclusively to the large colony-forming organisms, often called *S. pyogenes-like*, as their microbiologic and clinical features tend to mimic those of group A *Streptococcus*. Despite their different Lancefield antigens, the large-colony-forming C and G streptococci are grouped together as SDSE. The remaining large-colony group C streptococci, predominantly

animal pathogens, are grouped as *S. dysgalactiae* subspecies *dysgalactiae*. Nonhuman group G isolates are often considered part of a single species designated *Streptococcus canis* and are genetically distinct from the SDSE group G organisms.

The groups C and G streptococci share a number of virulence factors with *S. pyogenes*, including the production of streptolysin O, M protein, streptococcal pyrogenic exotoxin B, and hyaluronidase. The M protein is similar to that of *S. pyogenes* and may account for the postinfectious glomerulonephritis that is occasionally seen after infection with these organisms. A toxic shock–like syndrome associated with groups C and G streptococcal infection has been related to M protein type and production of a pyrogenic exotoxin by SDSE.

SDSE are common inhabitants of the pharynx, being detected in up to 5% of asymptomatic children. Other potential sites of colonization include the skin and gastrointestinal tract. Colonization of the vagina is reported and may be the source of occasional SDSE isolated from the umbilicus of healthy neonates.

Clinical manifestations of disease caused by SDSE overlap those of *S. pyogenes*. In children, these organisms are implicated most commonly in pharyngitis. The true role of these organisms as a cause of pharyngitis is difficult to determine because asymptomatic colonization is common. Nevertheless, several epidemics of SDSE pharyngitis have been reported, including foodborne outbreaks. A large study from Sweden recently demonstrated similar rates of detection of *S. pyogenes* (15%) and SDSE (14%) in children with pharyngitis. *S. pyogenes* was most prevalent in young children, whereas SDSE predominated in older children and adolescents. The clinical presentation of SDSE is indistinguishable from *S. pyogenes*–associated pharyngitis. Isolated case reports have described SDSE pneumonia in children, which is commonly complicated by abscess formation, empyema, and bacteremia. Additional respiratory infections include rare reports of epiglottitis and sinusitis.

SDSE are a significant cause of skin and soft tissue infections. As with *S. pyogenes*, lymphangitis can complicate superficial infections caused by SDSE. Necrotizing fasciitis caused by SDSE is being described with increasing frequency. Musculoskeletal infections, particularly pyogenic arthritis, occasionally are caused by SDSE. Pediatric cases are uncommon but may be increasing in incidence.

**Table 231.1** Relationship of Large-Colony Streptococci Identified by Hemolysis and Lancefield Grouping to Sites of Colonization and Disease

	<b>GROUP A STREPTOCOCCUS (<i>S. pyogenes</i>)</b>	<b>GROUP B STREPTOCOCCUS (<i>S. agalactiae</i>)</b>	<b>OTHER β-HEMOLYTIC STREPTOCOCCI</b>	<b>VIRIDANS STREPTOCOCCI</b>
Hemolysis	β	β	β	α
Lancefield group	A	B	C-H, K-V Especially C and G	
Species or strains	M types (>180)	Serotypes (Ia, Ib, II, III, IV, V, VI, VII, and VIII)	<i>S. dysgalactiae</i> subspecies <i>equisimilis</i> <i>S. dysgalactiae</i> subspecies <i>dysgalactiae</i> <i>S. canis</i>	<i>Streptococcus bovis</i> <i>Streptococcus mitis</i> <i>Streptococcus mutans</i> <i>Streptococcus sanguis</i> Many others
Normal flora	Pharynx, skin, anus	Gastrointestinal and genitourinary tract	Pharynx, skin, gastrointestinal and genitourinary tracts	Pharynx, nose, skin, genitourinary tract
Common human diseases	Pharyngitis, tonsillitis, erysipelas, impetigo, septicemia, wound infections, necrotizing fasciitis, cellulitis, meningitis, pneumonia, scarlet fever, toxic shock–like syndrome, rheumatic fever, acute glomerulonephritis	Puerperal sepsis, chorioamnionitis, endocarditis, neonatal sepsis, meningitis, osteomyelitis, pneumonia	Wound infections, cellulitis, necrotizing fasciitis, pneumonia, endocarditis, brain abscess, sepsis, nosocomial infections, opportunistic infections	Endocarditis, human bite infections

α, Partial hemolysis; β, complete hemolysis; γ, no hemolysis (nonhemolytic).

Reactive arthritis has been described after SDSE infection; however, unlike *S. pyogenes*, the association between SDSE infection and acute rheumatic fever has not clearly been defined, and antibiotic prophylaxis is not recommended after reactive arthritis with this organism.

Endocarditis, bacteremia, brain abscess, and toxic shock syndrome caused by SDSE have all been described but are uncommon in children. These infections generally occur in children with immune deficits or in adolescents after delayed recognition of sinusitis.

These organisms can cause neonatal septicemia similar to early-onset group B streptococcal disease. Risk factors include prematurity and prolonged rupture of membranes. Respiratory distress, hypotension, apnea, bradycardia, and disseminated intravascular coagulation may be seen, and associated maternal infection is common. Neonatal toxic shock syndrome associated with SDSE has also been described.

Treatment of SDSE infections is similar to that of *S. pyogenes*. These organisms retain susceptibility to penicillin and other  $\beta$ -lactams. Other agents with reliable activity include linezolid, daptomycin, and vancomycin, though occasional isolates demonstrate tolerance to vancomycin. Clindamycin and macrolides have poor bactericidal activity against these organisms, and resistance rates are significant. Resistance to quinolones is reported, and up to 70% of SDSE are resistant to tetracycline.

Visit Elsevier eBooks+ at eBooks.Elsevier.com for Bibliography.

## Chapter 232

# Enterococcus

David B. Haslam

*Enterococcus* has long been recognized as a pathogen in select populations and has become a common and particularly troublesome cause of hospital-acquired infection in recent years. Enterococci were formerly classified with *Streptococcus bovis* and *Streptococcus equinus* as Lancefield group D streptococci but are now placed in a separate genus and are notorious for their propensity to cause infection in compromised hosts and frequent resistance to antibiotics.

### ETIOLOGY

Enterococci are gram-positive, catalase-negative facultative anaerobes that grow in pairs or short chains. Most are nonhemolytic (also called  $\gamma$ -hemolytic) on sheep blood agar, although some isolates have  $\alpha$ - or  $\beta$ -hemolytic activity. Enterococci are distinguished from most Lancefield groupable streptococci by their ability to grow in bile and hydrolyze esculin. They are able to grow in 6.5% NaCl and hydrolyze L-pyrrolidonyl- $\beta$ -naphthylamide, features used by clinical laboratories to distinguish enterococci from group D streptococcus. Identification at the species level is enabled by differing patterns of carbohydrate fermentation.

### EPIDEMIOLOGY

Enterococci are normal inhabitants of the gastrointestinal tract of humans and organisms throughout the animal kingdom, suggesting they are highly evolved to occupy this niche. Oral secretions and dental plaque, the upper respiratory tract, skin, and vagina may also be colonized by these organisms. *Enterococcus faecalis* is the predominant enterococcal species, with colonization commonly occurring in the first week of life. By the time of adulthood, *E. faecalis* colonization is nearly ubiquitous. *Enterococcus faecium* colonization is less consistent, although approximately 25% of adults harbor this organism. Disruption of the normal intestinal microbiota by antibiotic exposure or hematopoietic stem cell transplantation markedly enriches for fecal enterococcal abundance and dramatically increases the risk of subsequent bloodstream infection (BSI).

*E. faecalis* accounts for approximately 80% of enterococcal infections, with almost all of the remaining infections caused by *E. faecium*.

Only rarely are other species, such as *Enterococcus gallinarum* and *Enterococcus casseliflavus*, associated with invasive infection, but these organisms are notable for their intrinsic low-level vancomycin resistance. Whole genome sequencing suggests that the patient's indigenous flora is the source of enterococcal infection in most cases. However, direct spread from person to person or from contaminated medical devices may occur, particularly within newborn nurseries and intensive care units, where nosocomial spread has resulted in hospital outbreaks.

### PATHOGENESIS

Enterococci are not aggressively invasive organisms, usually causing disease only in children with damaged mucosal surfaces or an impaired immune system. Their dramatic emergence as a cause of nosocomial infection is predominantly a result of their resistance to antibiotics commonly used in the hospital setting. Hospital-associated enterococci generally lack CRISPR (clustered regularly interspaced short palindromic repeats) elements that defend against phage-mediated horizontal gene transfer, an important source of antimicrobial-resistance genes. Secreted and cell-surface molecules are implicated in pathogenesis. Adhesion-promoting factors such as the surface protein Eps likely account for the propensity of these organisms to cause endocarditis and urinary tract infections (UTIs). The ability to form biofilms likely facilitates the colonization of urinary and vascular catheters. Other proposed virulence factors include cytolysin, aggregation substance, gelatinase, and extracellular superoxide.

### Antimicrobial Resistance

Enterococci are highly resistant to cephalosporins and semisynthetic penicillins such as nafcillin, oxacillin, and methicillin. They are moderately resistant to extended-spectrum penicillins such as ticarcillin and carbenicillin. Ampicillin and penicillin are the most active  $\beta$ -lactams against these organisms. Some strains of *E. faecalis* and *E. faecium* demonstrate decreased resistance to  $\beta$ -lactam antibiotics because of mutations in one of the penicillin-binding proteins. In addition, occasional strains of *E. faecalis* produce a plasmid-encoded  $\beta$ -lactamase similar to that found in *Staphylococcus aureus*. These isolates are completely resistant to penicillins, necessitating the combination of a penicillin plus a  $\beta$ -lactamase inhibitor or the use of imipenem or vancomycin. Any active drug may be insufficient if used alone for serious infections wherein high bactericidal activity is desired (Tables 232.1 and 232.2).

All enterococci have intrinsic low-level resistance to aminoglycosides because these antibiotics are poorly transported across the *Enterococcus* cell wall. Concomitant use of a cell wall-active agent, such as a  $\beta$ -lactam or glycopeptide antibiotic, improves the permeability of the cell wall for the aminoglycosides, resulting in synergistic killing. However, some isolates demonstrate high-level resistance, defined as mean inhibitory concentration (MIC)  $>2,000 \mu\text{g/mL}$  and a result of modification or inactivation of aminoglycoside agents. Strains demonstrating high-level resistance and even some isolates with moderate-level resistance are not affected synergistically by aminoglycosides and cell wall-active antibiotics.

**Table 232.1** Intrinsic Resistance Mechanisms Among Enterococci

ANTIMICROBIAL	MECHANISM
Ampicillin, penicillin	Altered binding protein
Aminoglycoside (low level)	Decreased permeability, altered ribosomal binding
Clindamycin	Altered ribosomal binding
Erythromycin	Altered ribosomal binding
Tetracyclines	Efflux pump
Trimethoprim-sulfamethoxazole	Utilize exogenous folate



**Table 232.2** Acquired Resistance Mechanisms Among Enterococci

ANTIMICROBIAL	MECHANISM
Ampicillin, penicillin (high level)	Mutation of PBP5
Aminoglycoside (high level)	Enzyme modification
Quinolones	DNA gyrase mutation
Chloramphenicol	Efflux pump
Glycopeptide	Altered cell wall binding
Quinupristin/dalfopristin	Ribosomal modification, efflux pump
Linezolid	Point mutation
Daptomycin	Unknown

Resistance to almost all other antibiotic classes, including tetracyclines, macrolides, and glycopeptides, has been described among the enterococci, necessitating individual susceptibility testing for these antibiotics when their use is considered. Despite apparent susceptibility in vitro, trimethoprim-sulfamethoxazole has poor activity in vivo and should not be used as the primary agent against enterococcal infections.

Vancomycin has traditionally been effective against *Enterococcus* isolates, but resistance to vancomycin, defined as MIC >32 µg/mL, and other glycopeptides, including teicoplanin, is increasingly common. The emergence of vancomycin-resistant *Enterococcus* (VRE) has become a major challenge in the care of hospitalized patients. In particular, mortality in patients with VRE BSIs is considerable, and treatment is complicated by frequent resistance of VRE to most other antibiotic classes. High-level vancomycin resistance (MIC ≥64 µg/mL) can be transferred by way of conjugation and usually results from plasmid-mediated transfer of the *vanA* gene. High-level resistance is most common among *E. faecium* but is increasingly seen among *E. faecalis* isolates. Moderate-level resistance (MIC 8–256 µg/mL) results from a chromosomal homolog of *vanA* known as *vanB*. Isolates that harbor the *vanB* gene are only moderately resistant to vancomycin and initially demonstrate susceptibility to teicoplanin, although resistance can emerge during therapy. Resistance to newer agents, including linezolid and daptomycin, is rare thus far. Linezolid resistance is a result of mutations in the 26S ribosomal subunit, whereas daptomycin resistance is associated with pathogenic variants in genes required for membrane synthesis and repair.

## CLINICAL MANIFESTATIONS

*Enterococcus* infections traditionally occurred predominantly in newborn infants; infection in older children is increasingly common. Most enterococcal infections occur in patients with breakdown of normal physical barriers such as the gastrointestinal tract, skin, or urinary tract. Other risk factors for enterococcal infection include prolonged hospitalization, indwelling vascular catheters, prior use of antibiotics, and compromised immunity.

### Neonatal Infections

*Enterococcus* accounts for up to 15% of all neonatal bacteremia and septicemia. Like group B streptococcus infections, enterococcal infections are seen in two distinct settings in neonatal patients. Early-onset infection (<7 days of age) may mimic early-onset group B streptococcus septicemia but tends to be milder. Early-onset enterococcal sepsis most often occurs in full-term infants who are otherwise healthy. Late-onset infection (≥7 days of age) is associated with risk factors such as extreme prematurity, presence of an intravascular catheter, or necrotizing enterocolitis or follows an intraabdominal surgical procedure. Symptoms in late-onset disease are more severe than those in early-onset disease and include apnea, bradycardia, and deteriorating respiratory function. Focal infections such as scalp abscess and catheter infection are commonly associated. Mortality rates range from 6% in early-onset septicemia to 15% in late-onset infections associated with necrotizing enterocolitis.

Enterococci are an occasional cause of meningitis. In neonates in particular, meningitis usually occurs as a complication of septicemia. Alternatively, the organism may gain access to the central nervous system by way of contiguous spread, such as through a neural tube defect or in association with an intraventricular shunt. Enterococcal meningitis can be associated with minimal abnormality of cerebrospinal fluid.

### Infections in Older Children

*Enterococcus* rarely causes UTIs in healthy children but accounts for approximately 15% of cases of nosocomially acquired UTIs in both children and adults. Presence of an indwelling urinary catheter is the major risk factor for nosocomial UTIs. *Enterococcus* is frequently isolated in intraabdominal infections after intestinal perforation or surgery. The significance of enterococci in polymicrobial infections has been questioned, although reported mortality rates are higher when intraabdominal infections include enterococci. *Enterococcus* is increasingly common as a cause of nosocomial bacteremia; these organisms accounted for approximately 10% of nosocomial BSIs in children, ranking second only to coagulase-negative staphylococci. Predisposing factors for enterococcal bacteremia and endocarditis include an indwelling central venous catheter, gastrointestinal surgery, immunodeficiency, and cardiovascular abnormalities. Risk factors for vancomycin-resistant enterococcal bacteremia include prolonged mechanical ventilation, immunosuppression, and recent vancomycin exposure.

## TREATMENT

Treatment of invasive enterococcal infections must recognize that these organisms are resistant to antimicrobial agents frequently used as empirical therapy. In particular, cephalosporins should not be relied upon in situations where *Enterococcus* is known or suspected to be involved. In general, in the immunocompetent host, minor localized infections caused by susceptible *Enterococcus* can be treated with ampicillin alone. Antibiotics containing β-lactamase inhibitors (clavulanate or sulbactam) provide advantage only for the very few organisms whose resistance is caused by the production of β-lactamase. In uncomplicated UTIs, nitrofurantoin is efficacious when the organism is known to be sensitive to this antibiotic.

Invasive infections such as sepsis and meningitis have traditionally been treated with a combination of penicillin or ampicillin and an aminoglycoside when the isolate is susceptible. Recent experience suggests that adjunctive aminoglycosides may increase the risk of nephrotoxicity without improving outcomes in uncomplicated BSIs. Vancomycin can be substituted for the penicillins in allergic patients but should be used with an aminoglycoside because vancomycin alone is not bactericidal. Endocarditis from strains possessing high-level aminoglycoside resistance may relapse even after prolonged therapy. Continuous-infusion penicillin or the combination of ampicillin plus ceftriaxone has been proposed for treatment of these infections in adults, yet ultimately valve replacement may be necessary. In patients with catheter-associated enterococcal bacteremia, the catheter should be removed promptly in most cases, although salvage of infected lines has occurred with the combined use of ampicillin or vancomycin with an aminoglycoside.

### Treatment of Vancomycin-Resistant Enterococci

The treatment of serious infections caused by multiresistant, vancomycin-resistant strains is particularly challenging. The two most commonly used antibiotics are linezolid and daptomycin. Linezolid, an oxazolidinone antibiotic that inhibits protein synthesis, is bacteriostatic against most *E. faecium* and *E. faecalis* isolates, including vancomycin-resistant isolates. Response rates to linezolid are generally over 90%, including cases of bacteremia and sepsis, and this antibiotic is currently the only drug approved by the FDA for treatment of VRE infections. Anecdotal reports reveal the success of linezolid in treating meningitis caused by VRE. Unfortunately, as seen with other antibiotics, linezolid resistance is documented, and nosocomial spread of resistant organisms can occur. Linezolid frequently causes reversible bone marrow suppression after prolonged use and is associated with rare occurrences of lactic acidosis and irreversible peripheral neuropathy.



Serotonin syndrome may be seen in patients taking concomitant selective serotonin uptake inhibitor antidepressants. Newer oxazolidinones include tedizolid, which has better in vitro activity against enterococci and appears to have favorable pharmacokinetic and toxicity profiles when compared to linezolid.

Daptomycin is a cyclic lipopeptide that is rapidly bactericidal against a broad range of gram-positive organisms. The antibiotic inserts into the bacterial cell wall, causing membrane depolarization and cell death. It has been approved for the treatment of adults with serious skin and soft tissue infections, right-sided endocarditis, and bacteremia caused by susceptible organisms. Most strains of VRE (both *E. faecium* and *E. faecalis*) are susceptible to daptomycin in vitro, and daptomycin has become the first-line agent for VRE treatment in many centers. However, treatment failures occur when administered at the standard dose of 6 mg/kg/day, necessitating higher treatment doses in patients with severe invasive infections. Furthermore, daptomycin dosages may need to be higher in children when compared with adults because of more rapid renal clearance. The addition of a  $\beta$ -lactam antibiotic, such as ampicillin or ceftaroline, may enhance activity of daptomycin and provide benefit over daptomycin alone for severe VRE infections, including endocarditis. Daptomycin has unreliable activity in the lung and therefore should not be used as a sole agent to treat pneumonia. Resistance of both *S. aureus* and *Enterococcus* to daptomycin has rarely been described, sometimes arising during therapy.

Several studies and meta-analyses have suggested that clinical outcomes of invasive VRE infection are similar when linezolid and daptomycin are used. However, infection-related mortality remains significant, especially among adults, and alternative or combination therapies continue to be explored.

Ceftaroline, a fifth-generation cephalosporin with activity against methicillin-resistant *S. aureus*, has activity against many *E. faecalis* strains but is inadequate when used alone for the treatment of *E. faecium*.

Newer tetracyclines have been developed with activity against VRE, including tigecycline, omadacycline, and eravacycline. Tigecycline is approved for use in complicated intraabdominal and skin and soft tissue infections but fails to achieve high serum concentrations and may be associated with treatment failure for VRE BSIs. Gastrointestinal side effects are common with tigecycline and may be intolerable. Experience with omadacycline and eravacycline in treatment of pediatric patients with VRE infection is lacking.

Lipoglycopeptides are a newer class of antibiotics that possess a core structure similar to vancomycin with the addition of a lipid substituent. Lipoglycopeptides include telavancin, dalbavancin, and oritavancin. Only oritavancin has reliable activity against VRE, but resistance may develop, and thus far clinical experience in children is limited.

## PREVENTION

Strategies for preventing enterococcal infections include timely removal of urinary and intravenous catheters and debridement of necrotic tissue. Infection control strategies, including surveillance cultures, patient and staff cohorting, and strict gown and glove isolation, are effective at decreasing colonization rates with VRE. Unfortunately, these organisms may persist on inanimate objects such as stethoscopes, complicating efforts to limit their nosocomial spread. In order to prevent the emergence and spread of vancomycin-resistant organisms, the Centers for Disease Control and Prevention has developed a series of guidelines for prudent vancomycin use. Antibiotics with broad activity against anaerobic organisms are also thought to contribute to colonization with VRE, suggesting that prudent use of such antibiotics may also help limit spread of VRE. Decolonization strategies have been attempted but are generally ineffective in eradicating skin or gastrointestinal carriage of VRE. In particular, antimicrobial therapy is not indicated for this purpose. The role of probiotic agents in eliminating VRE colonization is currently unclear but may be a useful adjunct to prudent antimicrobial usage and other infection control interventions in limiting nosocomial spread of VRE.

Visit Elsevier eBooks+ at [eBooks.Health.Elsevier.com](http://eBooks.Health.Elsevier.com) for Bibliography.

## Chapter 233

# Diphtheria (*Corynebacterium diphtheriae*)

Amruta Padhye and Stephanie A. Fritz

Diphtheria is an acute toxic infection caused by toxin-producing strains of *Corynebacterium diphtheriae* and, less often, by toxin-producing strains of *Corynebacterium ulcerans*. Non-toxin-producing *C. diphtheriae* can also cause disease, although less severe. *C. ulcerans* is more often isolated from animal sources and can cause human disease similar to *C. diphtheriae*.

Although respiratory and cutaneous presentations of diphtheria are the most common, mortality is substantially higher with respiratory diphtheria. Classic respiratory diphtheria caused by toxigenic *Corynebacterium* species is the main focus of World Health Organization (WHO) case surveillance. In the United States, the case definition was modified in 2019, and currently toxigenic cases of diphtheria, including respiratory and nonrespiratory (e.g., skin, wound, conjunctiva, ear, genital mucosa) forms, are reportable to the Centers for Disease Control and Prevention (CDC).

## ETIOLOGY

Corynebacteria are aerobic, nonencapsulated, non-spore-forming, mostly nonmotile, pleomorphic, gram-positive bacilli. *C. diphtheriae* is by far the most frequently isolated agent of diphtheria. Toxigenic *C. ulcerans* can cause mastitis in cattle and respiratory infections in animals and can spread to humans through close contact with secretions. It can cause cutaneous and respiratory illnesses that are clinically indistinguishable from diphtheria in humans. Person-to-person transmission of *C. ulcerans* is possible, though not well established. A selective medium (e.g., cystine-tellurite blood agar or Tinsdale agar) that inhibits growth of competing organisms is required for isolation and, when reduced by *C. diphtheriae*, renders colonies gray-black. Differentiation of *C. diphtheriae* from *C. ulcerans* is based on urease activity; *C. ulcerans* is urease-positive. Four *C. diphtheriae* biotypes (*mitis*, *intermedius*, *belfanti*, *gravis*) are capable of causing diphtheria and are differentiated by colony morphology, hemolysis, and fermentation reactions. The ability of either *C. diphtheriae* or *C. ulcerans* to produce diphtheritic toxin results from acquisition of a lysogenic corynebacteriophage, which encodes the diphtheritic toxin gene and confers diphtheria-producing potential in these strains. Demonstration of diphtheritic toxin production by the modified Elek test, an agar immunoprecipitin technique, alone or in conjunction with polymerase chain reaction (PCR) testing for carriage of the toxin gene, is necessary to confirm disease. Toxigenic and nontoxigenic strains are indistinguishable by colony type, microscopic features, or biochemical test results.

## EPIDEMIOLOGY

Unlike other diphtheroids (coryneform bacteria), which are ubiquitous in nature, *C. diphtheriae* is an exclusive inhabitant of human mucous membranes and skin. Spread is primarily by respiratory droplets, direct contact with respiratory secretions of symptomatic individuals, or exudate from infected skin lesions. Asymptomatic respiratory tract carriage is important in transmission. In areas where diphtheria is endemic, 3–5% of healthy individuals can carry toxigenic organisms, but carriage is exceedingly rare in nonendemic areas. Skin infection and skin carriage are silent reservoirs of *C. diphtheriae*, and organisms can remain viable in dust or on fomites for up to 6 months.

In the 1920s, >125,000 diphtheria cases and 10,000 diphtheria-related deaths were reported annually in the United States, with the highest fatality

rates among very young and elderly persons. The incidence then began to decrease and, with widespread use of diphtheria toxoid in the United States after World War II, declined steadily through the late 1970s. From 1996 to 2018, only 14 cases of respiratory diphtheria, including 1 fatal case, were reported in the United States, an average of  $\leq 1$  case annually. During this same period, five cases of culture-confirmed respiratory diphtheria-like illness caused by toxigenic *C. ulcerans* were also identified.

Despite the worldwide decrease in disease incidence, diphtheria remains endemic in many developing countries with poor immunization rates against diphtheria. Since the introduction of toxoid immunization, the disease has shifted from affecting children  $<15$  years old to adults who lack natural exposure to toxigenic *C. diphtheriae* in the vaccine era and have low rates of booster immunization. The largest outbreak of diphtheria in the developed world since the 1960s occurred from 1990 to 1996 in the newly independent countries of the former Soviet Union, involving  $>150,000$  cases in 14 countries. Of these,  $>60\%$  of cases occurred in individuals  $>14$  years old. Case fatality rates ranged from 3% to 23% by country. Factors contributing to the epidemic included a large population of underimmunized adults, decreased childhood immunization rates, population migration, crowding, and failure to respond aggressively during early phases of the epidemic. Cases of diphtheria among travelers from these endemic areas were transported to many countries in Europe.

WHO surveillance reports indicate that most cases of diphtheria worldwide occur in the Southeast Asia and Africa regions, reporting more than 10,000 cases worldwide in 2020. India contributes a substantial proportion to the global burden of diphtheria, with an average of over 4,000 cases annually reported to the WHO in the past decade.

Although diphtheria was reduced from a major cause of childhood death to a medical rarity in the Western Hemisphere in the early 20th century, recurring reminders of the fragility of this success, particularly in conflict areas, emphasize the need to continue vigorous promotion of those same control principles across the global community. The largest diphtheria outbreak in the refugee setting occurred when the Rohingya people were displaced from Myanmar to Bangladesh in 2017, eventually lasting over 2 years and with 7064 cases and 45 deaths reported as of November 2019. Along with outbreaks in Venezuela, Haiti, Yemen, and more recently Nigeria, these are stark reminders of the threat of re-emergence that vaccine-preventable diseases pose. Improving surveillance, vaccination coverage, and public awareness of the disease are key for control of disease during outbreaks.

When diphtheria was common, **cutaneous diphtheria** accounted for more than 50% of reported *C. diphtheriae* isolates in the United States. This indolent local infection, compared with mucosal infection, is associated with more prolonged bacterial shedding, greater contamination of the environment, and increased transmission to the pharynx and skin of close contacts. Outbreaks are associated with homelessness, crowding, poverty, alcoholism, poor hygiene, contaminated fomites, underlying dermatosis, and introduction of new strains from exogenous sources. It is no longer a tropical or subtropical disease; 1,100 *C. diphtheriae* infections were documented in a Seattle neighborhood (the site of the last major U.S. outbreak) from 1971 to 1982; 86% were cutaneous, and 40% involved toxigenic strains. The incidence of *C. diphtheriae* isolates from cutaneous infections has risen dramatically over the past decade. Cutaneous diphtheria is an important source of toxigenic *C. diphtheriae* in the United States, and its importation from endemic areas is frequently the source of subsequent sporadic cases of respiratory tract diphtheria. Between 2015 and 2018, the CDC confirmed four cases of cutaneous diphtheria from toxin-producing *C. diphtheriae* in U.S. residents returning from travel to endemic areas. Cutaneous diphtheria caused by *C. ulcerans* from travel to tropical countries or animal contact has also been increasingly reported.

In Europe, increasing reports of respiratory and systemic infections have been attributed to *C. ulcerans*; animal contact is the predominant risk factor. In the United Kingdom, from 2008 to 2017, of the 33 toxigenic cases of diphtheria, just over half of the cases were caused by *C. diphtheriae*, and the remainder were caused by *C. ulcerans*. Most of the *C. diphtheriae* cases were cutaneous, while the *C. ulcerans* cases were equally respiratory and cutaneous. Travel to an endemic area was the

major risk factor for *C. diphtheriae* acquisition, while contact with a companion animal was the major factor associated with acquisition of *C. ulcerans*. Incomplete vaccination status was strongly associated with the risk of hospitalization and death.

## **PATHOGENESIS**

Both toxigenic and nontoxigenic strains of *C. diphtheriae* cause skin and mucosal infection and can rarely cause invasive disease, including endocarditis and bacteremia. The organism usually remains in the superficial layers of skin lesions or respiratory tract mucosa, inducing a local inflammatory reaction. The major virulence of the organism lies in its ability to produce a potent polypeptide exotoxin, the diphtheritic toxin, which inhibits protein synthesis and causes local tissue necrosis and the resultant local inflammatory response. Within the first few days of respiratory tract infection (usually in the pharynx), a dense necrotic coagulum of organisms, epithelial cells, fibrin, leukocytes, and erythrocytes forms, initially white and advancing to become a gray-brown, leather-like, adherent **pseudomembrane** (*diphtheria* is Greek for leather). Removal is difficult and reveals a bleeding, edematous submucosa. Paralysis of the palate and hypopharynx is an early local effect of diphtheritic toxin. Toxin absorption can lead to systemic manifestations: kidney tubule necrosis, thrombocytopenia, cardiomyopathy, and demyelination of nerves. Because the latter two complications can occur 2-10 weeks after mucocutaneous infection, the pathophysiology in some cases is suspected to be immunologically mediated. Among infected adults in the Seattle outbreak, 3% with cutaneous infections and 21% with symptomatic nasopharyngeal infection demonstrated toxic myocarditis, neuropathy, or obstructive respiratory tract complications. All had received at least 20,000 units of equine antitoxin at the time of hospitalization.

## **CLINICAL MANIFESTATIONS**

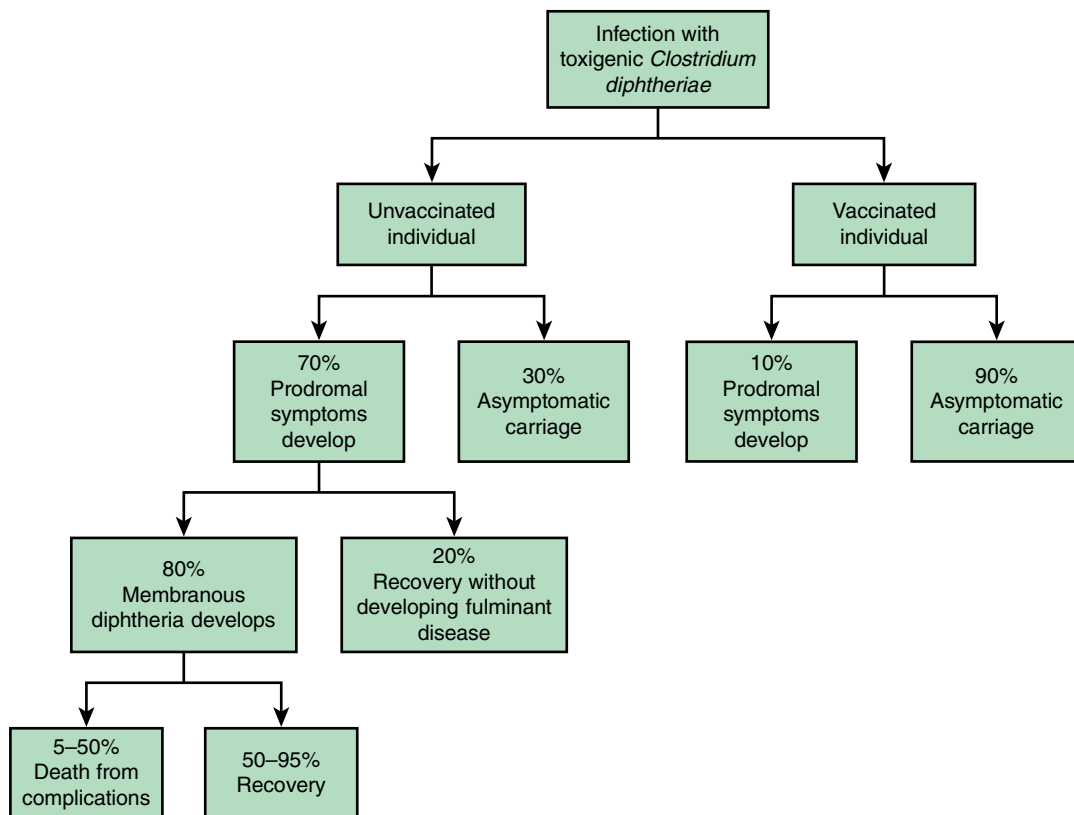
The manifestations of *C. diphtheriae* infection are influenced by the anatomic site of infection, the immune status of the host, and the production and systemic distribution of toxin. Although 98% of infections occur in the respiratory tract, other sites include cutaneous, conjunctival, ear, and vaginal mucosa.

New estimates of epidemiologic and clinical aspects of diphtheria from a comprehensive update by Truelove et al., with systematic reviews including recent literature, are summarized in [Figure 233.1](#).

### **Respiratory Tract Diphtheria**

The pharynx or tonsils is the most common location of infection in the respiratory tract (75–94%), followed by the larynx (25%). Although the incubation period has traditionally been regarded to be 2-5 days (range 1-10 days), emerging data suggest that the median time from infection to onset of prodromal symptoms is only 1.4 days. An estimated 80% of untreated symptomatic cases progress to membranous diphtheria in an average of 2-3 days after symptom onset. In tonsillar and **pharyngeal diphtheria**, sore throat is the universal early symptom. Only half of patients have fever, and fewer have dysphagia, hoarseness, malaise, or headache. Mild pharyngeal infection is followed by unilateral or bilateral tonsillar membrane formation, which can extend to involve the uvula (which may cause toxin-mediated paralysis), soft palate, posterior oropharynx, hypopharynx, or glottic areas ([Fig. 233.2](#)). Underlying soft tissue edema and enlarged lymph nodes can cause a bull-neck appearance. The degree of local extension correlates directly with profound prostration, bull-neck appearance, and fatality caused by airway compromise or toxin-mediated complications ([Fig. 233.3](#)). In infants, infection of the anterior nares is more common and causes serosanguineous, purulent, erosive rhinitis with membrane formation. Shallow ulceration of the external nares and upper lip is characteristic.

The characteristic adherent pseudomembrane, extension beyond the faucial area, dysphagia, and relative lack of fever help differentiate diphtheria from **exudative pharyngitis** caused by *Streptococcus pyogenes* or Epstein-Barr virus. Vincent angina, infective phlebitis with thrombosis of the jugular veins (Lemierre syndrome), and mucositis in patients undergoing cancer chemotherapy are usually differentiated by the clinical setting. Infection of the larynx, trachea, and bronchi



**Fig. 233.1** Clinical manifestations of *Clostridium diphtheriae* infection among unvaccinated and vaccinated individuals. Among unvaccinated individuals infected with toxigenic *C. diphtheriae*, prodromal symptoms develop in ~70%, of whom 80% develop membranous diphtheria. Of those with membranous diphtheria, case fatality can be as high as 5–50%. Among vaccinated individuals infected with toxigenic *C. diphtheriae*, the toxoid vaccine provides protection from symptoms; 10% develop prodromal symptoms, whereas 90% become asymptomatic carriers. These symptomatic vaccinated individuals have a lower risk of severe disease and death and are more likely to recover. (Adapted from Truelove SA, Keegan LT, Moss WJ, et al. *Clinical and epidemiological aspects of diphtheria: a systematic review and pooled analysis*. *Clin Infect Dis*. 2020;71[1]:89–97.)



**Fig. 233.2** Tonsillar diphtheria. (Courtesy Franklin H. Top, MD, Professor and Head of the Department of Hygiene and Preventive Medicine, State University of Iowa, College of Medicine, Iowa City, IA; and Parke, Davis & Company's Therapeutic Notes.)



**Fig. 233.3** Diphtheria. Bull-neck appearance of diphtheritic cervical lymphadenopathy. (From the Centers for Disease Control and Prevention [CDC]. Public health image library [PHIL], image #5325. Available at: <https://phil.cdc.gov/Details.aspx?pid=5325>.)



can be primary or a secondary extension from the pharyngeal infection, presenting with hoarseness, stridor, dyspnea, and croupy cough. Differentiation from bacterial epiglottitis, severe viral laryngotracheobronchitis, and staphylococcal or streptococcal tracheitis hinges partially on the relative paucity of other signs and symptoms in patients with diphtheria and primarily on visualization of the adherent pseudomembrane at laryngoscopy and intubation.

Patients with laryngeal diphtheria are at significant risk for suffocation because of local soft tissue edema and airway obstruction by the diphtheria membrane. This progression of airway obstruction in laryngeal infection within 1–2 weeks after symptom onset is responsible for 60–65% of overall deaths. Establishment of an artificial airway and resection of the pseudomembrane can be lifesaving, but further obstructive complications are common, and systemic toxic complications are inevitable.

### Cutaneous Diphtheria

Classic cutaneous diphtheria is an indolent, nonprogressive infection characterized by a superficial, ecthyma-like, nonhealing ulcer with a gray-brown membrane. Diphtheria skin infections cannot always be differentiated from streptococcal or staphylococcal impetigo, and these conditions frequently coexist. In most cases, a primary process, such as dermatosis, laceration, burn, bite, or impetigo, becomes secondarily infected with *C. diphtheriae*. Extremities are more often affected than the trunk or head. Pain, tenderness, erythema, and exudate are typical. Local hyperesthesia or hypesthesia is unusual. Respiratory tract colonization or symptomatic infection with toxic complications occurs in the minority of patients with cutaneous diphtheria.

### Infection at Other Sites

*C. diphtheriae* occasionally causes mucocutaneous infections at other sites, such as the ear (otitis externa), the eye (purulent and ulcerative conjunctivitis), and the genital tract (purulent and ulcerative vulvovaginitis). The clinical setting, ulceration, membrane formation, and submucosal bleeding help differentiate diphtheria from other bacterial and viral causes. Rare cases of septicemia are described and are universally fatal. Sporadic cases of endocarditis occur, and clusters among intravenous drug users have been reported in several countries; the skin was the probable portal of entry, and almost all strains were nontoxicogenic. Sporadic cases of pyogenic arthritis, mainly from nontoxicogenic strains, have been reported in adults and children. Diphtheroids isolated from sterile body sites should not be routinely dismissed as contaminants without careful consideration of the clinical setting.

### DIAGNOSIS

Specimens for culture should be obtained from the nose and throat and any other mucocutaneous lesion. A portion of membrane should be removed and submitted for culture along with underlying exudate. The laboratory must be notified to use selective medium. *C. diphtheriae* survives drying. If obtained in a remote area, a dry swab specimen can be placed in a silica gel pack and sent to the laboratory. Evaluation of a direct smear using Gram stain or specific fluorescent antibody is unreliable. Culture isolates of coryneform organisms should be identified to the species level, and toxigenicity and antimicrobial susceptibility tests should be performed for *C. diphtheriae* isolates. It is recommended that all isolates be sent to a reference laboratory. In the United States, the CDC's Pertussis and Diphtheria Laboratory provides support to local and state health departments needing assistance with isolation, identification, and subtyping of *C. diphtheriae* and *C. ulcerans*.

### COMPLICATIONS

Respiratory tract obstruction by pseudomembranes may require bronchoscopy or intubation and mechanical ventilation. Two other tissues usually remote from sites of *C. diphtheriae* infection can be significantly affected by **diphtheritic toxin**: the heart and the nervous system.

### Toxic Cardiomyopathy

Toxic cardiomyopathy occurs in 10–25% of patients with respiratory diphtheria, resulting in death in 35–60% of cases with this complication and responsible for 20–25% of deaths overall. Subtle signs of myocarditis

can be detected in most patients, especially the elderly, but the risk for significant complications correlates directly with the extent and severity of exudative local oropharyngeal disease, along with a delay in administration of antitoxin. The first evidence of cardiac toxicity characteristically occurs 7–14 days after the onset of respiratory symptoms but can appear acutely as early as the first week of illness, a poor prognostic sign, or as late as the sixth week. Tachycardia disproportionate to fever is common and may be evidence of cardiac toxicity or autonomic nervous system dysfunction. A prolonged P-R interval and changes in the ST-T wave on an electrocardiographic tracing are relatively frequent findings; dilated and hypertrophic cardiomyopathy detected by echocardiogram has been described. Single or progressive cardiac **dysrhythmias** can occur, including first-, second-, and third-degree heart block. Temporary transvenous pacing may improve outcomes. Atrioventricular dissociation and ventricular tachycardia are also described, the latter having a high associated mortality. Heart failure may appear insidiously or acutely. Elevation of the serum aspartate transaminase concentration closely parallels the severity of myonecrosis. Severe dysrhythmia portends death. Histologic postmortem findings are variable: little or diffuse myonecrosis with acute inflammatory response. Recovery from toxic myocardiopathy is usually complete, although survivors of more severe dysrhythmias can have permanent conduction defects.

### Toxic Neuropathy

Neurologic complications occur in 20–25% of untreated cases, resulting in death in 50% of cases who develop them and responsible for 15% of deaths overall. They parallel the severity of primary infection and are multiphasic in onset. Acutely or 2–3 weeks after onset of oropharyngeal inflammation, hyperesthesia and local **paralysis** of the soft palate typically occur. Weakness of the posterior pharyngeal, laryngeal, and facial nerves may follow, causing a nasal quality in the voice, difficulty in swallowing, and risk for aspiration. **Cranial neuropathies** characteristically occur in the fifth week, leading to oculomotor and ciliary paralysis, which can cause strabismus, blurred vision, or difficulty with accommodation. Symmetric demyelinating **polyneuropathy** has onset 10 days to 3 months after oropharyngeal infection and causes principally motor deficits with diminished deep tendon reflexes. Nerve conduction velocity studies and cerebrospinal fluid findings in diphtheritic polyneuropathy are indistinguishable from those of Guillain-Barré syndrome. Paralysis of the diaphragm may ensue. Complete neurologic recovery is likely, but rarely vasomotor center dysfunction 2–3 weeks after onset of illness can cause hypotension or cardiac failure.

Recovery from myocarditis and neuritis is often slow but usually complete. Corticosteroids do not diminish these complications and are not recommended.

### TREATMENT

Specific diphtheria **antitoxin** is the mainstay of therapy and should be administered as soon as possible, without delay on the basis of clinical diagnosis. Because it neutralizes only free toxin, antitoxin efficacy diminishes with elapsed time after the onset of mucocutaneous symptoms. Equine diphtheria antitoxin is available in the United States only from the CDC. Physicians treating a case of suspected diphtheria should contact the CDC Emergency Operations Center at 1-770-488-7100 after consulting with their state health department. Antitoxin is available from CDC under expanded access investigational new drug application protocol. Antitoxin is administered as a single empirical dose of 20,000–100,000 units based on the degree of severity, site, and duration of illness. Skin testing for hypersensitivity must be performed before administration of antitoxin. Patients with positive sensitivity testing or with a history of hypersensitivity reaction to horse equine protein should be desensitized. Antitoxin is probably of no value for local manifestations of cutaneous diphtheria, but its use is prudent because toxic sequelae can occur. Commercially available intravenous immunoglobulin preparations contain low titers of antibodies to diphtheria toxin; their use for therapy of diphtheria is not proven or approved. Antitoxin is not recommended for asymptomatic carriers.

The role of **antimicrobial therapy** is to halt toxin production, treat localized infection, and prevent transmission of the organism



to contacts. Although *C. diphtheriae* is usually susceptible to various agents in vitro, including penicillins, erythromycin, clindamycin, rifampin, and tetracycline, only erythromycin or penicillin are recommended for treatment. Erythromycin is marginally superior to penicillin for eradication of nasopharyngeal carriage. Resistance to erythromycin is common in populations where the drug has been used broadly, and resistance to penicillin has also been reported. Appropriate therapy is **erythromycin** (40-50 mg/kg/day divided every 6 hours by mouth [PO] or intravenously [IV]; maximum 2 g/day), **aqueous crystalline penicillin G** (150,000 - 250,000 units/kg/day divided every 6 hr IV or intramuscularly [IM], up to 2-3 million units/day), or **procaine penicillin** (300,000 units every 12 hr IM for those  $\leq 10$  kg in weight; 600,000 units every 12 hr IM for those  $>10$  kg in weight) for 14 days. Once oral medications are tolerated, oral erythromycin (see dosing above) or penicillin V (50 mg/kg/day, divided every 6 hr, maximum 2 g per day) may be used for the remaining duration of therapy. *Antibiotic therapy is not a substitute for antitoxin therapy.* Some patients with cutaneous diphtheria have been treated for 7-10 days. Elimination of the organism should be documented by negative results of at least two successive cultures of specimens from the nose and throat (or skin) obtained at least 24 hours apart, collected 24 hours after completion of antimicrobial therapy. Treatment with erythromycin should be repeated if either culture yields *C. diphtheriae*.

Individuals untreated with antibiotics, including those with either symptomatic or asymptomatic infection, remain colonized with *C. diphtheriae* for an average of 18.5 days, with 5% remaining colonized longer than 48 days. With antibiotic treatment, they clear *C. diphtheriae* colonization within an average of 5.2 days, reducing the duration of infectiousness by 2 weeks.

## SUPPORTIVE CARE

**Droplet precautions** are instituted for patients with pharyngeal diphtheria; for patients with cutaneous diphtheria, **contact precautions** are observed until the results of specimen cultures taken after cessation of therapy are negative. Cutaneous wounds are cleaned thoroughly with soap and water. Bed rest is essential during the acute phase of disease, usually for  $\geq 2$  weeks until the risk for symptomatic cardiac damage has passed, with return to physical activity guided by the degree of toxicity and cardiac involvement.

## PROGNOSIS

The prognosis for patients with diphtheria depends on the virulence of the organism (subspecies *gravis* has the highest fatality rate), patient age, immunization status, site of infection, and speed of administration of the antitoxin. Mechanical obstruction from laryngeal diphtheria or bull-neck diphtheria and the complications of myocarditis account for most diphtheria-related deaths. The case fatality ratio for untreated, never-vaccinated cases is 29%, improving to 10% with antitoxin treatment. The risk of fatality increases with every day of delayed antitoxin treatment. Children age  $<5$  years are more likely to die from symptomatic infection than adults  $>20$  years of age, whereas children 5-19 years of age are less likely to die from infection than adults age  $>20$  years. At recovery, administration of diphtheria toxoid is indicated to complete the primary series or booster doses of immunization, because not all patients develop antibodies to diphtheria toxin after infection.

## PREVENTION

Protection against serious disease caused by imported or indigenously acquired *C. diphtheriae* depends on immunization. In the absence of a precisely determined minimum protective level for diphtheria antitoxin, the presumed minimum is 0.01-0.10 IU/mL. In outbreaks, 90% of individuals with clinical disease have had antibody values  $<0.01$  IU/mL, and 92% of asymptomatic carriers have had values  $>0.1$  IU/mL. In serosurveys in the United States and Western Europe, where almost universal immunization during childhood has been achieved, 25% to  $>60\%$  of adults lack protective antitoxin levels, with typically very low levels in elderly persons. A serosurvey in the United States (1988-1994) indicated that 60% of the overall population had protective immunity against diphtheria; however, this level of protection declined from 80% in persons age 12-19 years to about 30% in persons age 60-69 years.

All suspected diphtheria cases should be reported to local and state health departments. Investigation is aimed at preventing secondary cases in exposed individuals and at determining the source and carriers to halt spread. The serial interval, or time between symptom onset of the infector/infectee pair, is a median of 5.9 days, with 5% of intervals  $<0.8$  days and 5% longer than 21 days.

## Asymptomatic Case Contacts

All household contacts and people who have had intimate respiratory or habitual physical contact with a patient are closely monitored for illness for 7 days. Cultures of the nose, throat, and any cutaneous lesions are performed. Antimicrobial prophylaxis is presumed effective and is administered regardless of immunization status, using a single injection of benzathine penicillin G (600,000 units IM for patients weighing  $<30$  kg, or 1,200,000 units IM for patients weighing  $\geq 30$  kg or adults,) or erythromycin (40-50 mg/kg/day divided every 6 hr PO for 7-10 days; max 1 g/day). Diphtheria toxoid vaccine, in age-appropriate form, is given to immunized individuals who have not received a booster dose within 5 years. Children who have not received their fourth dose should be vaccinated. Those who have received fewer than three doses of diphtheria toxoid or who have uncertain immunization status should be immunized with an age-appropriate preparation on a primary schedule.

## Asymptomatic Carriers

When an asymptomatic carrier is identified, antimicrobial prophylaxis is given for 10-14 days, and an age-appropriate preparation of diphtheria toxoid vaccination is administered immediately if a booster has not been given within 1 year. Droplet precautions (respiratory tract colonization) or contact precautions (cutaneous colonization only) are observed until at least two subsequent cultures obtained at least 24 hours apart, collected 24 hours after cessation of therapy, have negative results.

Repeat cultures are performed about 2 weeks after completion of therapy for cases and carriers; if results are positive, an additional 10-day course of oral erythromycin should be given and follow-up cultures performed. Susceptibility testing of isolates should be performed, as erythromycin resistance is reported. Neither penicillin nor erythromycin eradicates carriage in 100% of individuals. In one report, a single course of therapy failed in 21% of carriers. Transmission of diphtheria in modern hospitals is rare. Only those who have an unusual contact with respiratory or oral secretions should be managed as contacts. Investigation of the casual contacts of patients and carriers or persons in the community without known exposure has yielded extremely low carriage rates and is not routinely recommended.

## Vaccine

Universal immunization with diphtheria toxoid throughout life, designed to provide constant protective antitoxin antibody levels and to reduce severity of *C. diphtheriae* disease, is the only effective control measure. Although immunization does not preclude subsequent respiratory or cutaneous carriage of toxigenic *C. diphtheriae*, it decreases local tissue spread, prevents toxic complications, diminishes transmission of the organism, and provides herd immunity when at least 80-85% of a population is immunized.

Full vaccination is highly effective in preventing symptomatic disease (87% with three or more doses, increasing to 99% with five doses), severe disease (defined as local and systemic symptoms plus a major complication; 81%), and death (93%). Even though vaccines do not prevent colonization, they reduce transmission by 60%, likely through reduced symptomatic shedding. Asymptomatic carriers are still able to transmit infection, albeit at only 24% the rate of symptomatic cases. In an outbreak setting, both vaccination and antibiotic treatment to clear colonization are necessary to interrupt transmission. Although full vaccination coverage can interrupt transmission in only 27% of outbreak settings, this figure increases to 70% when rapid antibiotic treatment is initiated in 90% of symptomatic cases.

The COVID-19 pandemic resulted in disruptions in immunization services in 2020, leading to 3.5 million children missing their first dose of diphtheria, tetanus, and pertussis vaccine (DTP) as compared with 2019. Global annual vaccination coverage for first-dose DTP vaccine decreased from 90% in 2019 to 87% in 2020; third-dose DTP vaccine

decreased from 86% in 2019 to 83% in 2020. The impact this will have on the resurgence of vaccine-preventable infections is yet to be determined.

Diphtheria toxoid is prepared by formaldehyde treatment of toxin, standardized for potency and adsorbed to aluminum salts, enhancing immunogenicity. Two preparations of diphtheria toxoids are formulated according to the *limit of flocculation* (Lf) content, a measure of the quantity of toxoid. The pediatric (6 months to 6 years) preparations (i.e., **DTaP** [diphtheria and tetanus toxoids with acellular pertussis vaccine] and **DT** [diphtheria and tetanus toxoids vaccine]) contain 6.7–25.0 Lf units of diphtheria toxoid per 0.5 mL dose; tetanus toxoid with vaccines for  $\geq 7$  years (Td [tetanus and diphtheria toxoid vaccine] and **Tdap** [diphtheria and tetanus toxoids with acellular pertussis vaccine]) contain no more than 2–2.5 Lf units of toxoid per 0.5 mL dose. The *higher-potency* (D) formulation of toxoid is used for primary series and booster doses for children through 6 years of age, given its superior immunogenicity and minimal reactogenicity. For individuals  $\geq 7$  years old, Td or Tdap is recommended for the primary series and booster doses because the lower concentration of diphtheria toxoid is adequately immunogenic and increasing the content of diphtheria toxoid heightens reactogenicity with increasing age.

For children 6 weeks to 6 years of age, five 0.5-mL doses of diphtheria-containing (D) vaccine (DTaP preferred) are given in the primary series, including doses at 2, 4, and 6 months of age, and a fourth dose, an integral part of the primary series, at 15–18 months. Dose 4 may be administered as early as age 12 months if at least 6 months have elapsed since dose 3. A booster dose is given at 4–6 years of age (unless the fourth primary dose was administered at  $\geq 4$  years). For persons  $\geq 7$  years to 18 years not previously immunized for diphtheria, three 0.5-mL doses of *lower-level* diphtheria-containing (d) vaccine are given in a primary series of two doses at least 4 weeks apart and a third dose 6 months after the second dose. The first dose should be Tdap, and subsequent doses can be Td or Tdap.

A booster dose, consisting of Tdap, is recommended at 11–12 years of age. Tdap may be administered regardless of the interval since the last tetanus- and diphtheria-toxoid-containing vaccine. Adolescents 13–18 years old who have not received Tdap at 11–12 years should receive a single dose of Tdap, then a Td or Tdap booster every 10 years. Pregnant women should receive a single dose of Tdap during every pregnancy, preferably during gestational weeks 27–36. Adults who have never received Tdap should receive a single dose of Tdap, regardless of when they last got Td. A Td or Tdap booster should be given every 10 years.

Updated recommendations allow for use of either Td or Tdap vaccine in situations where previously only Td was recommended. This includes the decennial Td booster, tetanus prophylaxis for wound management, and for additional required doses in the catch-up immunization schedule if a person has received at least one Tdap dose.

The only contraindication to tetanus and diphtheria toxoid is a history of neurologic or severe hypersensitivity reaction after a prior dose. For children  $< 7$  years old in whom pertussis immunization is contraindicated, DT is used. Those whose immunization is begun with DTaP or DT before 1 year of age should have a total of five 0.5-mL doses of diphtheria-containing (D) vaccines by 6 years of age. For those whose immunization is begun at around 1 year old, the primary series is three 0.5-mL doses of diphtheria-containing (D) vaccine, with a booster given at 4–6 years, unless the third dose was given after the fourth birthday.

There is no association of DT or Td with seizures. Local adverse effects alone do not preclude continued use. The rare patient who experiences an Arthus-type hypersensitivity reaction or a temperature  $> 39.4^{\circ}\text{C}$  ( $103^{\circ}\text{F}$ ) after a dose of Td usually has high serum tetanus antitoxin levels and should not be given Td more frequently than every 10 years, even if the patient sustains a significant tetanus-prone injury.

The DT or Td preparation can be given concurrently with other vaccines. Meningococcal and pneumococcal conjugate vaccines containing diphtheria toxoid or a variant of diphtheria toxin, CRM197 protein, are not substitutes for diphtheria toxoid immunization and do not affect reactogenicity.

Visit Elsevier eBooks+ at [eBooks.Health.Elsevier.com](https://ebooks.health.elsevier.com) for Bibliography.

## Chapter 234

# *Listeria monocytogenes*

Ashley C. Howard and Thomas S. Murray

**Listeriosis** in humans is caused principally by *Listeria monocytogenes*, 1 of 17 species of the genus *Listeria* that are widely distributed in the environment and throughout the food chain. Human infections can usually be traced to an animal reservoir. Infection usually occurs at the extremes of age. In the pediatric population, perinatal infections predominate and usually occur secondary to maternal infection or colonization. Outside the newborn period, disease is most often encountered in *immunosuppressed* (usually T-cell deficiencies) children and adults and in elderly persons. For most people the major risk for infection with *Listeria* is **food-borne transmission**. In the United States, food-borne outbreaks are caused by improperly processed dairy products and contaminated vegetables and principally affect the same individuals at risk for sporadic disease.

## ETIOLOGY

Members of the genus *Listeria* are facultatively anaerobic, non-spore-forming, motile, gram-positive bacilli that are catalase positive. The 17 *Listeria* species are divided into two genomically distinct groups on the basis of DNA-DNA hybridization studies. One group contains the species *L. grayi*, and 10 others discovered since 2009 are considered nonpathogenic. The second group contains six species: the nonhemolytic species *L. innocua*, *L. welshimeri*, and *L. marthii* and the hemolytic species *L. monocytogenes*, *L. seeligeri*, and *L. ivanovii*. *L. ivanovii* is pathogenic primarily in animals, and the vast majority of both human and animal disease is caused by *L. monocytogenes*.

Subtyping of *L. monocytogenes* isolates for epidemiologic purposes is now performed predominately with whole genome sequencing. This demonstrates the clonal structure of populations of *L. monocytogenes* as well as the sharing of populations between human and animal sources. **Subtyping** is an important component of determining whether cases are connected or sporadic but usually requires collaboration with a specialized laboratory.

Historically, selected biochemical tests, together with the demonstration of *tumbling motility*, an umbrella-type formation below the surface in semisolid medium, hemolysis, and a typical cyclic adenosine monophosphate test, are usually sufficient to establish a presumptive identification of *L. monocytogenes*. Once growth is present, *L. monocytogenes* can now be rapidly identified with matrix-assisted laser desorption/ionization time of flight (MALDI-TOF) mass spectrometry.

## EPIDEMIOLOGY

*L. monocytogenes* is widespread in nature, has been isolated throughout the environment, and is associated with epizootic disease and asymptomatic carriage in  $> 42$  species of wild and domestic animals and 22 avian species. Epizootic disease in large animals (e.g., sheep, cattle) is associated with abortion and “circling disease,” a form of basilar meningitis. *L. monocytogenes* is isolated from sewage, silage, and soil, where it survives for  $> 295$  days. Human-to-human transmission rarely occurs except in maternal-fetal transmission. The annual incidence of listeriosis decreased by 36% between 1996 and 2004 and has remained level since then, estimated between two and five cases per year per million people. However, **food-borne outbreaks** continue to occur. The rate of *Listeria* infections varies among states. Epidemic human listeriosis has been associated with food-borne transmission in several large outbreaks, especially in association with aged soft cheeses; improperly pasteurized milk and milk products; contaminated raw and ready-to-eat beef, pork, and poultry and packaged meats and

salads; and vegetables, both fresh and frozen, harvested from farms where the ground is contaminated with the feces of colonized animals. In 2017-2018, the largest *Listeria* outbreak ever recorded occurred in South Africa with >900 cases and 200 deaths related to a processed contaminated meat product, “polony.” U.S. food-borne outbreaks from 2019 to 2020 included deli meats and cheeses, packaged hard-boiled eggs, and enoki mushrooms. The ability of *L. monocytogenes* to grow at temperatures as low as 4°C (39.2°F) increases the risk for transmission from aged soft cheeses and stored contaminated food. Listeriosis is an uncommon but important recognized etiology of neonatal sepsis and meningitis. Small clusters of nosocomial person-to-person transmission have occurred in hospital nurseries and obstetric suites. Sporadic endemic listeriosis is less well characterized. Likely routes include food-borne infection and zoonotic spread. **Zoonotic transmission** with cutaneous infections occurs in veterinarians and farmers who handle sick animals.

Reported cases of listeriosis are clustered at the extremes of age. Some studies show higher rates in males and a seasonal predominance in the late summer and fall in the Northern Hemisphere. In the United States, there is an increased risk of infection in nonpregnant non-Hispanic Asians, non-Hispanic Blacks, and Hispanics compared with non-Hispanic Whites. Outside the newborn period and during pregnancy, disease is usually reported in patients with underlying immunosuppression, with a 100-300 times increased risk in HIV-infected persons and in the elderly population (Table 234.1). In a prospective cohort study for listeriosis, 82.5% of participants had at least one immunocompromising condition, and those with bacteremia and neuroinvasive disease were found to have a fivefold increased risk of death if there was an underlying malignancy.

The incubation period, which is defined only for common-source food-borne disease, is 21-30 days but in some cases may be longer. Asymptomatic carriage and fecal excretion are reported in 1-5% of healthy persons and 5% of abattoir workers, but duration of excretion, when studied, is short (<1 month).

## **PATHOLOGY**

One of the major concepts of *Listeria* pathology and pathogenesis is its ability to survive as an intracellular pathogen. *Listeria* incites a mononuclear response and elaboration of cytokines, producing multisystem disease, particularly pyogenic meningitis. Granulomatous reactions and microabscess formation develop in many organs, including the liver, lungs, adrenals, kidneys, central nervous system (CNS), and notably the placenta. Animal models demonstrate *translocation*, the transfer of intraluminal organisms across intact intestinal mucosa. Histologic examination of tissues, including the placenta, shows granulomatous inflammation and microabscess formation. Intracellular organisms can often be demonstrated with special stains.

**Table 234.1** Types of *Listeria monocytogenes* Infections

Listeriosis in pregnancy
Neonatal listeriosis
Early onset
Late onset
Food-borne outbreaks/febrile gastroenteritis
Listeriosis in normal children and adults (rare)
Focal <i>Listeria</i> infections (e.g., meningitis, endocarditis, pneumonia, liver abscess, osteomyelitis, septic arthritis)
Listeriosis in immunocompromised persons
Lymphohematogenous malignancies
Collagen vascular diseases
Diabetes mellitus
HIV infection
Transplantation
Renal failure with peritoneal dialysis
Listeriosis in elderly persons

## **PATHOGENESIS**

*Listeria* organisms usually enter the host through the gastrointestinal (GI) tract. Gastric acidity provides some protection, and drugs that raise gastric pH may promote infection. Studies of intracellular and intercellular spread of *L. monocytogenes* have revealed a complex pathogenesis. Four pathogenic steps are described: internalization, escape from the vacuole, nucleation of actin filaments, and cell-to-cell spread. **Listeriolysin O**, a hemolysin, mediates lysis of vacuoles and is responsible for the zone of hemolysis around colonies on blood-containing solid media. In cell-to-cell spread, locomotion proceeds via polymerization of actin filaments, which extrude the bacteria in pseudopods, which in turn are internalized by adjacent cells, necessitating escape from a double-membrane vacuole. This mechanism protects intracellular bacteria from the humoral arm of immunity and is responsible for the well-known requirement of T-cell-mediated activation of monocytes by lymphokines for clearance of infection and establishment of immunity. The significant risk for listeriosis in patients with depressed T-cell immunity speaks for the role of this arm of the immune system. The role of opsonizing antibody in protecting against infection is unclear. In addition, siderophores scavenge iron from the host, enhancing growth of the organism and likely explaining the relatively high risk of listeriosis in iron overload syndromes.

## **CLINICAL MANIFESTATIONS**

The clinical presentation of listeriosis depends greatly on the age of the patient and the circumstances of the infection.

### **Listeriosis in Pregnancy**

Pregnant women have increased susceptibility to *Listeria* infections (approximately 20 times higher than nonpregnant women), probably because of a relative impairment in cell-mediated immunity. *L. monocytogenes* has been grown from placental and fetal cultures of pregnancies ending in spontaneous abortion. The usual presentation in the second and third trimesters is a flulike illness that may result in seeding of the uterine contents by bacteremia. Rarely is maternal listeriosis severe, but meningitis in pregnancy has been reported. Recognition and treatment at this stage are associated with normal pregnancy outcomes, but the fetus may not be infected even if listeriosis in the mother is not treated. In other instances, placental listeriosis develops with infection of the fetus that may be associated with stillbirth or premature delivery. Delivery of an infected premature fetus is associated with very high infant mortality. Disseminated disease is apparent at birth, often with a diffuse pustular rash. Infection in the mother usually resolves without specific therapy after delivery, but postpartum fever and infected lochia may occur.

### **Neonatal Listeriosis**

Two clinical presentations are recognized for neonatal listeriosis: early-onset neonatal disease (<5 days, usually within 1-2 days of birth), which is a predominantly **septicemic** form, and late-onset neonatal disease (>5 days, mean 14 days of life), which is a predominantly **meningitic** form (Table 234.2). The principal characteristics of the two presentations resemble the clinical syndromes described for group B *Streptococcus* (see Chapter 230).

**Early-onset disease** occurs with milder transplacental or ascending infections from the female genital tract. There is a strong association with recovery of *L. monocytogenes* from the maternal genital tract, obstetric complications, prematurity, and neonatal sepsis with multi-organ involvement, including rash, but without CNS localization (Fig. 234.1). The mortality rate is approximately 20-30%.

The epidemiology of **late-onset disease** is poorly understood. Onset is usually after 5 days but before 30 days of age. Affected infants frequently are full-term, and the mothers are culture negative and asymptomatic. The presenting syndrome is usually purulent meningitis with parenchymal brain involvement, which, if adequately treated, has a mortality rate of <20%.



**Table 234.2** Characteristic Features of Early- and Late-Onset Neonatal Listeriosis

EARLY ONSET (<5 DAYS)	LATE ONSET (≥5 DAYS)
Positive result of maternal <i>Listeria</i> culture	Negative results of maternal <i>Listeria</i> culture
Obstetric complications	Uncomplicated pregnancy
Premature delivery	Term delivery
Low birthweight	Normal birthweight
Neonatal sepsis	Neonatal meningitis
Mean age at onset 1.5 days	Mean age at onset 14.2 days
Mortality rate <30%	Mortality rate <20% Nosocomial outbreaks



**Fig. 234.1** *Listeria monocytogenes*. The generalized maculopapular rash present at birth disappeared within a few hours of life. (From Benitez-Segura I, Fiol-Jaume M, Balliu PR, Tejedor M. *Listeria monocytogenes*: generalized maculopapular rash may be the clue. *Arch Dis Child Fetal Neonatal Ed.* 2013;98[1]:F64, Fig. 1.)

### Postneonatal Infections

Listeriosis beyond the newborn period may rarely occur in otherwise healthy children but is most often encountered in association with underlying malignancies (especially lymphomas) or immunosuppression. When associated with food-borne outbreaks, disease may cause GI symptoms or any of the *Listeria* syndromes. The clinical presentation is usually meningitis, less commonly sepsis, and rarely other CNS involvement, such as cerebritis, meningoencephalitis, brain abscess, spinal cord abscess, or a focus outside the CNS, such as suppurative arthritis, osteomyelitis, endocarditis, peritonitis (associated with peritoneal dialysis), or liver abscess. It is not known whether the frequent GI signs and symptoms result from enteric infection because the mode of acquisition is often unknown.

### DIAGNOSIS

Listeriosis should be included in the differential diagnosis of infections in pregnancy, of neonatal sepsis and meningitis, and of sepsis or meningitis in older children who have underlying malignancies (lymphomas), are receiving immunosuppressive therapy, or have undergone transplantation. The diagnosis is established by culture of *L. monocytogenes* from blood or cerebrospinal fluid (CSF). Cultures from the maternal cervix, vagina, lochia, and placenta, if possible, should be obtained when intrauterine infections lead to premature delivery or early-onset neonatal sepsis. Cultures from closed-space

infections may also be useful. It is helpful to alert the laboratory to suspected cases so that *Listeria* isolates are not discarded as contaminating diphtheroids.

Histologic examination of the placenta is also useful. Molecular assays are now commercially available to detect *L. monocytogenes* from CNS samples and directly from positive blood culture bottles. Serodiagnostic tests are not useful.

### Differential Diagnosis

Listeriosis is indistinguishable clinically from neonatal sepsis and meningitis caused by other organisms. The presence of increased peripheral blood monocytes suggests listeriosis. Monocytosis or lymphocytosis may be modest or striking. Beyond the neonatal period, *L. monocytogenes* CNS infection is associated with fever, headache, seizures, and signs of meningeal irritation. The brainstem may be characteristically affected. The white blood cell concentration may vary from normal to slightly elevated, and the CSF laboratory findings are variable and less striking than in the more common causes of bacterial meningitis. Polymorphonuclear leukocytes or mononuclear cells may predominate, with shifts from polymorphonuclear to mononuclear cells in sequential lumbar puncture specimens. The CSF glucose concentration may be normal, but a low level mirrors the severity of disease. The CSF protein concentration is moderately elevated. *L. monocytogenes* is isolated from the blood in 40–75% of cases of meningitis caused by the organism. Deep focal infections from *L. monocytogenes*, such as endocarditis, osteomyelitis, and liver abscess, are also indistinguishable clinically from such infections from more common organisms. Cutaneous infections should be suspected in patients with a history of contact with animals, especially products of conception.

### TREATMENT

The emergence of multiantibiotic resistance mandates routine susceptibility testing of all isolates. The recommended therapy is **ampicillin** (100–200 mg/kg/day divided every 6 hours intravenously [IV]; 300–400 mg/kg/day divided every 6 hours IV if meningitis is present), alone or in combination with an **aminoglycoside** (2.0–3.0 mg/kg/day IV divided every 8–24 hours depending on postnatal age). The aminoglycoside enhances the bactericidal activity and is generally recommended in cases of endocarditis and meningitis. The adult dose is ampicillin 4–6 g/day divided every 6 hours plus an aminoglycoside. The ampicillin dose is doubled if meningitis is present. Special attention to dosing is required for neonates, who require longer dosing intervals because of the longer half-lives of the antibiotics in their bodies. *L. monocytogenes* is not susceptible to the cephalosporins, including third-generation cephalosporins. If these agents are used for empirical therapy for neonatal sepsis or meningitis in a newborn, ampicillin must be added for possible *L. monocytogenes* infection. Vancomycin, vancomycin plus an aminoglycoside, and trimethoprim-sulfamethoxazole are alternatives to ampicillin. The duration of therapy is usually 2–3 weeks, with 3 weeks recommended for immunocompromised persons and patients with meningitis. A longer course is needed for endocarditis, brain abscess, and osteomyelitis. Antibiotic treatment is unnecessary for gastroenteritis without invasive disease.

### PROGNOSIS

Early gestational listeriosis may be associated with abortion or stillbirth, although maternal infection with sparing of the fetus has been reported. There is no convincing evidence that *L. monocytogenes* is associated with repeated spontaneous abortions in humans. The mortality rate is >50% for premature infants infected in utero, 30% for early-onset neonatal sepsis, 15% for late-onset neonatal meningitis, and <10% in older children with prompt institution of appropriate antimicrobial therapy. Mental retardation, hydrocephalus, and other CNS sequelae are reported in survivors of *Listeria* meningitis.



**Table 234.3** Prevention of Food-Borne Listeriosis**GENERAL RECOMMENDATIONS TO PREVENT *LISTERIA* INFECTION****FDA recommendations for washing and handling food:**

- Rinse raw produce, such as fruits and vegetables, thoroughly under running tap water before eating, cutting, or cooking. Even if the produce will be peeled, it should still be washed first.
- Scrub firm produce, such as melons and cucumbers, with a clean produce brush.
- Dry the produce with a clean cloth or paper towel.
- Separate uncooked meats and poultry from vegetables, cooked foods, and ready-to-eat foods.

**Keep your kitchen and environment cleaner and safer:**

- Wash hands, knives, countertops, and cutting boards after handling and preparing uncooked foods.
- Be aware that *Listeria monocytogenes* can grow in foods in the refrigerator. Use an appliance thermometer, such as a refrigerator thermometer, to check the temperature inside your refrigerator. The refrigerator should be 4.5°C (40°F) or lower and the freezer –17.8°C (0°F) or lower.
- Clean up all spills in your refrigerator promptly, especially juices from hot dog and lunch meat packages, raw meat, and raw poultry.
- Clean the inside walls and shelves of your refrigerator with hot water and liquid soap, then rinse.

**Cook meat and poultry thoroughly:**

- Thoroughly cook raw food from animal sources, such as beef, pork, or poultry, to a safe internal temperature. For a list of recommended temperatures for meat and poultry, visit the safe minimum cooking temperatures chart at <http://www.FoodSafety.gov>.

**Store foods safely:**

- Use precooked or ready-to-eat food as soon as you can. Do not store the product in the refrigerator beyond the use-by date; follow USDA refrigerator storage time guidelines:
  - Hot dogs: store opened package no longer than 1 wk and unopened package no longer than 2 wk in the refrigerator.
  - Luncheon and deli meat: store factory-sealed, unopened package no longer than 2 wk. Store opened packages and meat sliced at a local deli no longer than 3-5 days in the refrigerator.
- Divide leftovers into shallow containers to promote rapid, even cooling. Cover with airtight lids or enclose in plastic wrap or aluminum foil. Use leftovers within 3-4 days.

**Choose safer foods:**

- Do not drink raw (unpasteurized) milk, and do not eat foods that have unpasteurized milk in them.

**RECOMMENDATIONS FOR PERSONS AT HIGHER RISK\***

In addition to the recommendations listed above, include:

**Meats**

- Do not eat hot dogs, luncheon meats, cold cuts, other deli meats (e.g., bologna) or fermented or dry sausages unless they are heated to an internal temperature of 73.9°C (165°F) or until steaming hot just before serving.
- Avoid getting fluid from hot dog and lunch meat packages on other foods, utensils, and food preparation surfaces, and wash hands after handling hot dogs, luncheon meats, and deli meats.
- Pay attention to labels. Do not eat refrigerated pâté or meat spreads from a deli or meat counter or from the refrigerated section of a store. Foods that do not need refrigeration, such as canned or shelf-stable pâté and meat spreads, are safe to eat. Refrigerate after opening.

**Cheeses**

- Do not eat soft cheese such as feta, queso blanco, queso fresco, brie, Camembert, blue-veined, or panela (queso panela) unless it is labeled as made with pasteurized milk. Make sure the label says "Made With Pasteurized Milk."

**Seafood**

- Do not eat refrigerated smoked seafood, unless it is contained in a cooked dish, such as a casserole, or unless it is a canned or shelf-stable product.
- Refrigerated smoked seafood, such as salmon, trout, whitefish, cod, tuna, and mackerel, is most often labeled as "nova-style," "lox," "kippered," "smoked," or "jerky."
  - These fish are typically found in the refrigerator section or sold at seafood and deli counters of grocery stores and delicatessens.
- Canned and shelf-stable tuna, salmon, and other fish products are safe to eat.

**Follow this general FDA advice for melon safety:**

- Consumers and food preparers should wash their hands with warm water and soap for at least 20 sec before and after handling any whole melon, such as cantaloupe, watermelon, or honeydew.
- Scrub the surface of melons, such as cantaloupes, with a clean produce brush under running water and dry them with a clean cloth or paper towel before cutting. Be sure that your scrub brush is sanitized after each use to avoid transferring bacteria between melons.
- Promptly consume cut melon or refrigerate promptly. Keep your cut melon refrigerated ≤4.5°C (40°F) (0–1.1°C [32–34°F] is best) for no more than 7 days.
- Discard cut melons left at room temperature for >4 hours.

\*Including pregnant women, persons with a weakened immune system, and older adults. FDA, Food and Drug Administration; USDA, U.S. Department of Agriculture.

Adapted from Centers for Disease Control and Prevention: *Listeria* (listeriosis): prevention. <http://www.cdc.gov/listeria/prevention.html>.

**PREVENTION**

Listeriosis can be prevented by pasteurization and thorough cooking of foods. Irradiation of meat products may also be beneficial. Consumption of unpasteurized or improperly processed dairy products should be avoided, especially aged soft cheeses, uncooked and precooked meat products that have been stored at 4°C (39.2°F) for extended periods, and unwashed vegetables (Table 234.3). This avoidance is particularly important during pregnancy and for immunocompromised persons. Infected domestic animals should be avoided when possible. Education regarding risk reduction is aimed particularly at pregnant women and people being treated for cancer.

Careful handwashing is essential to prevent nosocomial spread within obstetric and neonatal units. Immunocompromised patients

given prophylaxis with trimethoprim-sulfamethoxazole are protected from *Listeria* infections. Cases, and especially outbreaks, should be reported immediately to public health authorities so that timely investigation can be initiated in order to interrupt transmission from the contaminated source.

**ACKNOWLEDGMENTS**

We would like to acknowledge Robert S. Baltimore, MD, for his contribution to this chapter and Michelle R. Rychalsky, PharmD, for reviewing antibiotic dosing regimens.

Visit Elsevier eBooks+ at [eBooks.Health.Elsevier.com](http://eBooks.Health.Elsevier.com) for Bibliography.

## Chapter 235

**Actinomyces**

Hamid Bassiri

**TAXONOMY AND MICROBIOLOGY**

Members of the phylum Actinobacteria are common soil and water gram-positive bacteria with high guanine and cytosine DNA content and play important roles in the decomposition of organic materials. A proportion of Actinobacteria form filamentous and branching structures (similar to *Nocardia* spp.) that resemble fungal mycelia; these are included in the class Actinomycetia. The genus *Actinomyces* (which translates literally to “ray fungus”) belongs to the order Actinomycetales (along with *Mycobacteria* and *Nocardia*) and family Actinomycetaceae and constitutes several microaerophilic to facultatively anaerobic nonmotile species that are fastidious and slow growing.

More than 50 species of *Actinomyces* have been identified using 16S rRNA sequencing, with more than half of these species associated with human infection. *Actinomyces israelii* is the predominant species causing human actinomycosis. Other species associated with infection include but are not limited to *A. odontolyticus*, *A. meyeri*, *A. naeslundii*, *A. graevenitzi*, *A. neuii*, and *A. turicensis*.

**PATHOGENESIS AND EPIDEMIOLOGY**

*Actinomyces* are commensal organisms of the human oropharynx and gastrointestinal and urogenital tracts, and infections by these organisms (termed **actinomycosis**) typically emanate from these anatomic sites. The hallmark of actinomycosis is contiguous spread that fails to respect tissue or fascial planes. As such, these infections can extend to contiguous structures and form abscesses and chronically suppurative granulomatous infections and sinus tracts. Cicatricial healing can then ensue, from which the organism can further spread by burrowing along fascial planes, causing deeply communicating scarred sinus tracts. Sites of infection show dense cellular infiltrates and suppuration that form many interconnecting abscesses and sinus tracts. Bacteremia and infections of more distal sites (such as endocarditis, pericarditis, and central nervous system [CNS] infections) have also been documented. Notably, polymicrobial infections are typical, especially with copathogens such as *Aggregatibacter* (formerly *Actinobacillus*) *actinomycetemcomitans*, as well as *Fusobacterium*, *Clostridia*, *Eikenella*, *Enterococcus*, *Bacteroides*, and *Peptostreptococcus* spp.

Knowledge regarding the epidemiology of actinomycosis is limited to case reports and case series. Based on these reports, actinomycosis appears to affect people of all ages, with no racial or ethnic predilection, seasonality, or occupational associations. Actinomycosis occurs in immunocompetent and immunocompromised hosts. However, pediatric actinomycosis only represents approximately 3% of reported cases. Risk factors in children include trauma, dental caries, debilitation, and poorly controlled diabetes. Although actinomycosis is not a common opportunistic infection, disease has been associated with corticosteroid use, leukemia, renal failure, congenital immunodeficiencies, HIV infection, and solid organ or hematopoietic stem cell transplantation.

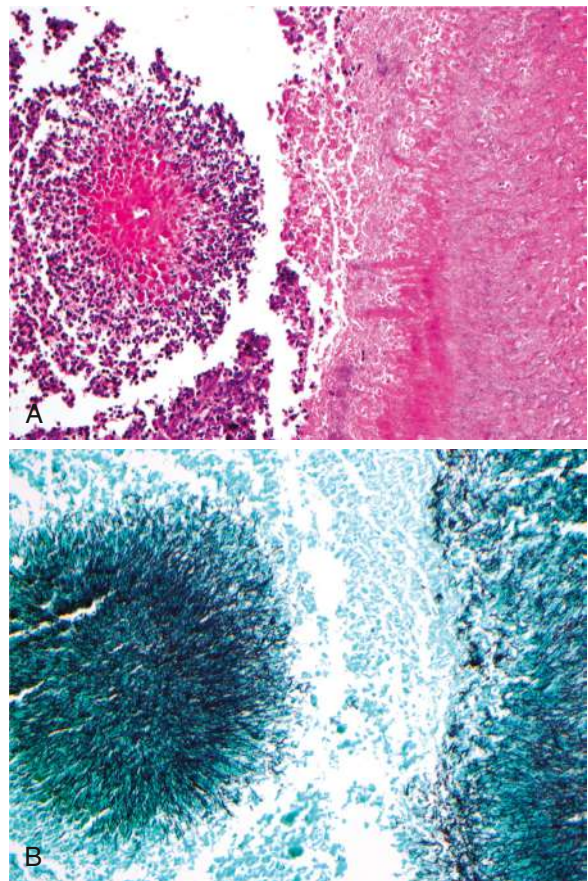
Given the sites of colonization, the most common presentations of *Actinomyces* infections include cervicofacial, abdominal/pelvic, and thoracic regions (in order of frequency). Importantly, certain medical interventions can result in mucosal barrier injuries and infection. For instance, use of intrauterine contraceptive devices can predispose to pelvic actinomycosis, and aspiration events, poor dentition, and recent dental procedures can result in involvement of the thoracic region. However, more than one third of patients do not have an identifiable antecedent event that would explain the onset of actinomycosis. Importantly, actinomyces infections are not contagious.

**DIAGNOSIS**

Diagnosis of actinomycosis relies on identification of the organism in tissues of affected areas via culture, molecular methods, and/or histopathology. However, growth in cultures can take up to 2-3 weeks, and up to 50% of cultures may reveal no growth because of prior antibiotic exposure, failure to maintain anaerobic conditions during sample transport, or inadequate incubation.

The presence of **sulfur granules** on macroscopic or microscopic evaluation (Fig. 235.1) of involved tissue is suggestive of actinomycosis. Despite their name, these granules are not composed of sulfur, instead deriving this designation because of their typical yellow color on macroscopic appearance; they can also be white, gray, or brown. Similar granules can be formed by *Nocardia brasiliensis*, *Streptomyces madurae* (which can cause mycetomas), and *Staphylococcus aureus* (which can cause botryomycosis). Microscopically, these granules appear on hematoxylin-eosin or Gomori methenamine silver stains as masses of gram-positive, branching, filamentous rods surrounded by the host immune cells (e.g., polymorphonuclear neutrophils) and a milieu of eosinophilic staining inert material, often referred to as the **Splendore-Hoeppli phenomenon**. Notably, *A. meyeri* is nonbranching and *A. odontolyticus* does not form sulfur granules.

*Nocardia* are indistinguishable from *Actinomyces* on Gram stain, but *Nocardia* take up the modified acid-fast stain, whereas *Actinomyces* spp. do not. Although suggestive of actinomycosis, sulfur granules are often absent, and thus additional testing such as cultures are necessary for the diagnosis. Affected tissues can be cultured on



**Fig. 235.1** Actinomycosis. A, Small cluster of *Actinomyces* on left, with sulfur granule and surrounding mixed inflammation demonstrating the Splendore-Hoeppli phenomenon ( $\times 200$ ). B, Gomori methenamine silver stain of the same field, highlighting the filamentous forms ( $\times 200$ ). (From Johnson MM. Ear, nose, and throat infections. In: Kradin RL, ed. *Diagnostic Pathology of Infectious Disease*, 2nd ed. Philadelphia: Elsevier; 2018: Fig. 7.6.)

brain-heart infusion agar incubated at 37°C anaerobically and aerobically to reveal organisms within the lines of streak at 24–48 hours. *A. israelii* colonies appear as loose masses of delicate, branching filaments with a characteristic spider-like growth. Unfortunately, even under the right conditions, it is challenging to grow *Actinomyces*, and the yield of different culturing techniques varies by species. Additionally, conventional biochemical testing for speciation is complex and may result in misclassifications. The evolution of diagnostic tools such as 16S rRNA sequence analysis and matrix-assisted laser desorption/ionization time of flight (MALDI-TOF) mass spectrometry has improved the accuracy of speciation of cultured organisms and highlighted the potential for detection of *Actinomyces* directly from the involved tissue without culture.

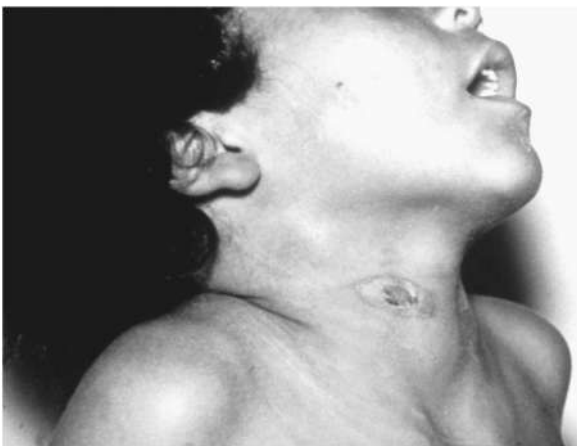
Importantly, actinomycosis is usually, if not always, **polymicrobial** in nature. In a large study of >650 cases, infection with *Actinomyces* was identified in pure culture in only 1 case. Cultures usually also identify other endogenous flora, including members of the **HACEK group**, which includes *Haemophilus* spp. (typically *H. aphrophilus*, *H. parainfluenzae*, or *H. paraphrophilus*), *A. actinomycetemcomitans*, *Cardiobacterium hominis*, *Eikenella corrodens*, and *Kingella kingae*. *A. actinomycetemcomitans* is a fastidious, gram-negative bacillus that is part of the oral flora and has been implicated in periodontal disease. Other bacteria frequently isolated concomitantly in human actinomycosis include *Fusobacterium*, *Bacteroides*, *Capnocytophaga*, and aerobic and anaerobic streptococci.

CT or MRI of involved areas is often employed in the initial patient evaluation. Imaging evidence of an invasive process spreading across tissue planes and ignoring anatomic boundaries is highly suggestive of actinomycosis. Furthermore, imaging can be helpful in establishing the extent of the infection, guiding subsequent diagnostic and therapeutic interventions, and monitoring for disease resolution.

## COMMON CLINICAL PRESENTATIONS

### Cervicofacial Actinomycosis

Cervicofacial disease is the most common form of pediatric actinomycosis and often manifests as a neck or submandibular mass that persists for weeks to months. Less than half of patients will have associated pain, and less than one third of patients will have fever. A minority of patients will report dysphagia or have a draining sinus (Fig. 235.2). Less frequently, cervicofacial actinomycosis manifests clinically as an acute pyogenic infection with a tender, fluctuant mass with trismus, firm swelling, and fistulas with drainage containing sulfur granules. Bone is not involved early in the disease, but periostitis, mandibular osteomyelitis, or perimandibular abscess may subsequently develop. Infection may spread through sinus tracts to cranial bones, possibly leading to meningitis. The ability of *Actinomyces* to burrow through tissue planes, including the periosteum, is a key difference between



**Fig. 235.2** A 2-yr-old male with HIV infection who has cervicofacial actinomycosis and a draining fistula.

actinomycosis and nocardiosis. Whereas predisposing factors for cervicofacial actinomycosis are not well defined for children, adult cases are often preceded by a history of oral trauma, oral surgery, dental procedures, or caries, facilitating entry of organisms into cervicofacial tissues.

### Abdominal and Pelvic Actinomycosis

Of all the forms of actinomycosis, delayed diagnosis is most typical for abdominal and pelvic infection. A disruption of the mucosa of the gastrointestinal (GI) tract (e.g., acute GI perforation, abdominal trauma, prior abdominal surgery) is often postulated as the inciting event for adult-onset abdominopelvic actinomycosis. In pediatric patients, however, medical history sometimes fails to identify prior evidence of mucosal barrier injury. In a contemporary pediatric case series of abdominal and pelvic actinomycosis, prior abdominal surgery (all appendectomies) was reported in only 21% of patients and dental caries in 11%. In two thirds to three fourths of patients, the presenting signs are abdominal pain and a palpable mass on physical exam. Fever accompanies the abdominal pain in more than half of cases, with weight loss in almost one third. As with other forms of actinomycosis, abdominopelvic infection can spread across tissue planes by contiguous extension involving any tissue or organ, including muscle, solid abdominopelvic viscera, and walls of the intestinal tract. Imaging studies may reveal a mass with invasion of tissue planes, leading to misdiagnosis of malignancies, inflammatory bowel disease with fistulae, or abdominal tuberculosis. Genitourinary actinomycosis is often associated with use of intrauterine contraceptive devices (IUDs) in adults and can mimic gynecologic tumors, but these infections are quite rare in adolescents. Because of delays in diagnosis, more than one third of pediatric cases present with draining sinus fistulae.

### Thoracic Actinomycosis

Thoracic actinomycosis may present with cough, chest pain, hemoptysis, and fever. In a retrospective review of reported pediatric cases of thoracic infection, almost half presented with a chest wall mass. Additional symptoms such as cough, fever, chest pain, and weight loss were reported in <40% of patients. Radiographic imaging may reveal hilar lymphadenopathy, endobronchial infection, tumor-like lesions, diffuse pneumonia, pleural effusions, or abscesses with or without cavitation and parenchymal lung destruction. These abscesses can also form sinus tracts to the diaphragm or mediastinum, which are often pathognomonic for actinomycosis. Other complications include bony destruction of adjacent ribs, sternum, and vertebral bodies. Multiple lobe involvement of the lungs is occasionally found. Importantly, evidence of thoracic actinomycosis can be found incidentally on radiographs ordered for noninfectious concerns. The variation in presentation and indolent nature of thoracic actinomycosis often delay the diagnosis.

### Other Forms of Actinomycosis

**CNS actinomycosis** is often the result of hematogenous spread to the brain parenchyma from a distant site but can also ensue from contiguous spread from a cervicofacial lesion. The former often results in multiple brain abscesses. **Laryngeal** actinomycosis rarely has been reported in older teenagers. Oropharyngeal colonization with *Actinomyces* may be involved in the development of obstructive tonsillar hypertrophy. Severe forms of **periodontitis**, particularly localized juvenile periodontitis, are associated with *Actinomyces*, especially in adolescents. *Actinomyces* has a propensity for infecting heart valves, a process that results in subacute endocarditis, with fever present in less than half of cases.

## DIFFERENTIAL DIAGNOSIS

Actinomycosis has been referred to as a “great imitator” with presentations that mimic appendicitis, pseudoappendicitis caused by *Yersinia enterocolitica*, amebiasis, malignancy, and inflammatory bowel disease. Actinomycosis must be differentiated from other chronic infections,



including tuberculosis, nocardiosis, polymicrobial bacterial infections, and fungal infections.

## TREATMENT

Most cases of actinomycosis can be managed with antibiotics, although surgery can be adjunctive and may shorten the duration of antibiotic use. Routine susceptibility testing is not typically performed, as most *Actinomyces* spp. are susceptible to penicillin. Accordingly, penicillin G is the drug of choice for parenteral therapy, and penicillin V or amoxicillin is the preferred enteral antibiotic. Because actinomycosis is often found to be polymicrobial in nature, use of combination  $\beta$ -lactam/ $\beta$ -lactamase inhibitors (e.g., ampicillin-sulbactam or amoxicillin-clavulanate) may be warranted, especially if there is an initial poor response. In particular, *A. actinomycetemcomitans* is a copathogen in at least 30% of cases of actinomycosis. Failure to recognize this organism and treat it adequately has resulted in clinical relapse and deterioration.

Treating actinomycosis in a patient with a penicillin allergy can be challenging, as there is variation in susceptibility by *Actinomyces* spp. to other antibiotic classes; alternatives generally include cephalosporins, carbapenems, macrolides, and tetracyclines. Despite being anaerobic, a large percentage of *Actinomyces* are not susceptible to metronidazole, and isolates are variably susceptible to clindamycin. Fluoroquinolones and aminoglycosides have little to no activity against *Actinomyces* spp. Infectious disease specialists should be consulted to guide antibiotic usage in patients with penicillin allergy or deep-seated infections such as brain abscesses, endocarditis, or osteomyelitis. Commercially available sensitivity testing methods are available and can be employed in patients with severe disease or poor response to initial therapy.

No definitive comparative effectiveness data exist to guide the optimal route and duration of therapy. For severe or extensive infections, most experts recommend initial parenteral administration of antibiotics for 4-6 weeks and then transitioning to enteral therapy upon documentation of clinical improvement. The exceptions include endocarditis and CNS disease, which generally require parenteral administration for the entire course of therapy. In cases of mild or limited disease, enteral antibiotics could be considered even at initiation. Given concern for relapses, antibiotics are often continued for several months, with total durations ranging between 2-6 months for mild/limited disease and 6-12 months for severe/extensive disease. Shorter courses of antibiotic therapy can result in relapses, especially in cases of thoracic actinomycosis without surgical debridement. Longer courses up to 18 months have also been used in invasive disease and in immunocompromised patients. At the same time, courses of antibiotic therapy <3 months have been used successfully in cases of local disease, especially after surgical resection. Close follow-up and monitoring are indicated in patients treated with short courses of antibiotics. The total duration of treatment is often ultimately dictated by the location of the infection and follow-up clinical exams and imaging.

Traditionally, an adjunctive surgical intervention was thought to be necessary for a successful outcome. However, in some case series a subset of patients have responded well to medical management alone. In the setting of significant abscesses and/or sinus tracts, a surgical approach to establish source control and, if possible, completely resect involved tissue can hasten clinical improvement. The morbidity of the surgical procedure needs to be weighed against the potential benefits for each patient.

## PROGNOSIS

The prognosis is excellent with early diagnosis, prompt initiation of antibiotic therapy, adherence to a prolonged course of antibiotics, and adequate surgical debridement, if necessary. Despite a good overall prognosis, permanent scarring can still develop. Although actinomycosis can present in immunocompetent children, disseminated or recalcitrant actinomycosis should raise suspicion for immunodeficiency.

Visit Elsevier eBooks+ at [eBooks.Health.Elsevier.com](https://ebooks.health.elsevier.com) for Bibliography.

## Chapter 236

# *Nocardia*

Coralee Del Valle Mojica

Various *Nocardia* species have been identified causing localized and disseminated disease in children and adults. These organisms are predominantly opportunistic pathogens infecting immunocompromised individuals, but cases in immunocompetent hosts are increasingly reported. Infection caused by these bacteria is termed *nocardiosis*, which consists of acute, subacute, or chronic suppurative manifestations.

## ETIOLOGY

*Nocardia* spp. are a complex group of environmental, gram-positive bacteria that belong to aerobic actinomycetes. They can grow on diverse media (e.g., blood agar, brain-heart infusion agar, Lowenstein-Jensen media, buffered charcoal-yeast extract [BCYE], Sabouraud dextrose agar) and have been referred to as bacteria that masquerade as fungi, sometimes misdirected to the mycology or mycobacteriology section of clinical laboratories for identification. Colonies can appear as early as 48 hours, but typically growth of *Nocardia* is slower than in other bacteria and may take 1-2 weeks. Growth appears as waxy, folded, or heaped colonies at the edges, and yield is best achieved in conditions that include a temperature of 37°C (98.6°F) with 10% carbon dioxide. However, many isolates of *Nocardia* are thermophilic and will grow at temperatures up to 50°C (122°F). Microscopically, *Nocardia* spp. are weakly gram-positive, rod-shaped, filamentous bacteria. For some isolates, there may be alternating areas of gram-positive and gram-negative staining, giving a beaded appearance often described with *Nocardia*. These organisms are also weakly acid-fast, and the modified Kinyoun acid-fast staining technique can be helpful to identify organisms from clinical specimens such as a tissue biopsy or bronchoalveolar lavage (BAL).

To date, more than 80 species of *Nocardia* have been described and 50 species have been identified to be human pathogens. The distribution of *Nocardia* spp. causing disease varies across studies, partly because of revisions in taxonomic classification over time. A retrospective study looking at isolates in the United States from 1995 to 2004 reported *N. nova*, *N. brasiliensis*, and *N. farcinica* as the most common species. In contrast, a more recent study from China reported *N. otitidiscaviarum* as the most common species, and a systematic review from Iran from 1992 to 2021 reported *N. asteroides* and *N. cyriacigeorgica* as the two most common species. Species identification can be critical for optimal clinical outcomes because of variability in virulence strategies and antibiotic-resistance profiles. Traditional approaches to speciation require biochemical processing that can be laborious and inefficient. Techniques such as 16S rDNA polymerase chain reaction (PCR) or matrix-assisted laser desorption/ionization (MALDI) time of flight (TOF) mass spectrometry are now considered the gold standard.

## EPIDEMIOLOGY

Once thought to be a rare human disease, nocardiosis is being recognized more frequently and has been diagnosed in people of all ages. Pediatric patients with compromised cellular immunity are at particular risk, including children receiving immune suppression after solid organ or stem cell transplantation, chemotherapy for malignancy, prolonged corticosteroid therapy, children with poorly controlled HIV infection, or those with a primary immunodeficiency, especially chronic granulomatous disease. Notably, nocardiosis has been described in patients without an identified immune defect, although in these clinical scenarios, other predisposing factors such as bronchiectasis are often present.



Due to the lack of a national reporting system for *Nocardia* infections and the molecular advances impacting the classification of this organism, measuring the incidence of the disease remains a challenge. Current knowledge of nocardiosis incidence in the United States is based on a historical survey of 171 infectious diseases physicians from 1974 and isolates received at the CDC reference laboratory, estimating 500–1000 cases annually. Prevalence estimates in high-risk populations have been reported to be less than 1%, with conflicting reports about the trends of infections in different geographic locations around the world.

## PATHOGENESIS

*Nocardia* organisms are environmental saprophytes that are ubiquitous in soil and decaying vegetable matter and have been isolated from soil worldwide. Infection can be acquired via inhalation or direct cutaneous inoculation, including after arthropod and cat bites. From 70% to 80% of *Nocardia* infections originate in the pulmonary parenchyma, with 10–25% being primary cutaneous disease.

*Nocardia* can disseminate from the primary site of infection to any organ or any musculoskeletal location. Dissemination after primary lung infection is common, occurring in 15–50% of patients; those with an underlying immunocompromised condition are more likely to have disseminated disease. The central nervous system (CNS) is the most concerning and most common secondary site of infection, complicating as much as 25% of pulmonary disease. Although rare, isolated CNS disease has been described. Whereas most cases are the result of environmental exposure, *Nocardia* species diversity in the hospital environment has been reported as a reservoir for the development of nosocomial infections.

## CLINICAL AND RADIOGRAPHIC MANIFESTATIONS

The clinical presentation can be nonspecific, with fever reported in approximately 60% of patients, cough in 30%, and dyspnea in 25%. Extrapulmonary signs and symptoms can correspond to the site of infection. In particular, neurologic deficit has been reported in up to 25% of all cases and in more than 50% of patients with CNS involvement. Neurologic complaints can include headache, confusion or altered mental status, weakness, and speech impairment. Renal nocardiosis can cause dysuria, hematuria, or pyuria, and gastrointestinal (GI) involvement may be associated with nausea, vomiting, diarrhea, abdominal distention, or melena. Skin infection can manifest with nodular lymphangitis (Fig. 236.1). Mycetoma is a chronic, progressive infection developing days to months after inoculation, usually on a distal location on the limbs. Musculoskeletal, endovascular, and ocular infections have also been reported.

Given the nonspecific symptoms and signs of nocardiosis (with the exception of cutaneous lesions), radiographic imaging is often necessary to define the location and extent of disease. Pulmonary infection can appear as a consolidation consistent with typical bacterial pneumonia or even as a necrotizing pneumonia with or without a pleural effusion. Single or multiple nodules and cavitory lesions have also been described. Cavitory lesions are more common in patients with an underlying immunocompromising condition. CNS disease can take the form of meningitis or focal lesions. Meningitis presents as neutrophil- or lymphocyte-predominant pleocytosis, elevated cerebrospinal fluid protein, and hypoglycorrhachia. For focal lesions, CT or MRI of the brain often reveals single- or multiple-ring enhancing lesions. Similar to the brain, when other organs or soft tissues are involved, CT or MRI also typically reveals single- or multiple-ring enhancing lesions, suggestive of an abscess or abscesses.

## DIAGNOSIS

Microbiologic evidence is necessary to confirm the diagnosis of nocardiosis. In one systematic review, blood cultures were the only positive microbiologic specimen in 38% of cases, thus serving as an important noninvasive diagnostic test for nocardiosis. In the remaining patients,

an invasive procedure such as bronchoscopy, tissue biopsy, or abscess aspiration is necessary to procure specimens for diagnostic testing. Histopathologic staining of such material can reveal beaded, weakly gram-positive or modified acid-fast filamentous bacteria. Histopathology can also show delicately branching bacteria with a proclivity to fragment.

Molecular methodologies, specifically gene sequencing, have become the most accurate for definitively identifying *Nocardia* to the species level. Speciation of *Nocardia* is becoming increasingly reliant on 16S rDNA PCR or MALDI-TOF technologies, with a specificity of 74% and a sensitivity of 88% in a multicenter study assessing the performance of 16S sequencing in 68 patients with proven or probable nocardiosis. Given that *Nocardia* spp. can colonize the respiratory airway, a sputum or BAL culture that yields a *Nocardia* species is not itself confirmatory of nocardiosis. However, a positive microbiologic test for a *Nocardia* species from one of these specimens in conjunction with the clinical and radiographic findings is strongly supportive of nocardiosis.

When a diagnosis of nocardiosis is made, strong consideration should be given to evaluation for disseminated disease, even in the absence of signs or symptoms, especially in the immunocompromised host. Although data are limited, most experts agree that, at a minimum, MRI of the brain should be performed in the immunocompromised host with nocardiosis.

## TREATMENT

The choice, dose, and duration of antimicrobial treatment depend on the site and extent of infection, immune status of the patient, initial clinical response, and species and susceptibility testing of the *Nocardia* isolate. Several therapeutic options exist for the treatment of nocardiosis; however, there are no comparative effectiveness studies to inform the optimal therapeutic regimen. **Trimethoprim-sulfamethoxazole (TMP-SMX)** is the sulfonamide formulation that is recommended, although sulfadiazine and sulfisoxazole have been used. Increasing recognition of resistance to TMP-SMX across and within *Nocardia* spp. highlights the importance of speciation of *Nocardia* isolates and of performing sensitivity testing in a certified microbiology laboratory. TMP-SMX resistance rates as high as 42% have been reported. Administration of TMP-SMX as prophylaxis against *Pneumocystis jirovecii* pneumonia is not always protective against nocardiosis, and thus clinicians should not exclude this diagnosis from the differential in patients receiving TMP-SMX prophylaxis.



**Fig. 236.1** A 9-yr-old healthy child with infected knee laceration (A) 10 days after falling onto concrete in his school playground, complicated by nodular lymphangitis (B). (From Williams PCM, Bartlett AW, Palasanthiran P, McMullan B. A not so innocuous playground fall: lymphocutaneous nocardiosis in an immunocompetent boy. *Arch Dis Child.* 2022;107[3]:257–258, Figs. 1 and 2.)

Other antibacterial agents with in vitro activity against *Nocardia* spp. include but are not limited to **amikacin, amoxicillin-clavulanate, ceftriaxone, ciprofloxacin, clarithromycin, imipenem, linezolid, and minocycline**. A recent study profiling the antimicrobial susceptibility pattern of a diverse range of *Nocardia* revealed that among 146 isolates, the susceptibilities were 100% to linezolid, 96% to amikacin, 94% to TMP-SMX, and 76% to imipenem. A similar retrospective study conducted in the United States from 1995 to 2004 revealed that 42% of the isolates were resistant to TMP-SMX. Therefore while awaiting sensitivity testing in patients with *Nocardia* isolated from a clinical specimen, it may be reasonable to administer linezolid empirically, taking into account local susceptibility data. Subsequent therapeutic decisions should be guided by final sensitivity results and consideration of the site of infection and pharmacokinetics of the available agents. It is not clear whether parenteral administration is superior to enteral formulations. However, most experts support the use of parenteral therapy for more severe disease, including endocarditis and CNS disease.

In vitro and in vivo animal models have suggested the benefit of combination regimens for the treatment of nocardiosis. There are no clinical data to confirm the need for combination therapy; however, based on the preclinical data, there is expert support for using combination therapy in CNS nocardiosis, in disseminated disease, and in children with an underlying immunocompromising condition. A variety of combination therapies have been suggested, with many experts favoring TMP-SMX, amikacin, and a carbapenem or third-generation cephalosporin. Since data on combination therapy are limited, antibiotic choices should primarily be guided by sensitivity testing of the clinical *Nocardia* isolate.

Surgical drainage of abscesses can be helpful in hastening resolution of nocardiosis. However, no comparative data have documented improvement in overall outcomes with adjunctive surgical intervention, and success has been reported with medical management alone in resolving deep-seated abscesses, even in the CNS. A literature review showed that among patients with CNS nocardiosis, 1-year overall mortality was approximately 20%, limited by cases lost to follow-up. Among patients who were treated with a combination of antibiotics and neurosurgical procedures, mortality was lower (7%). Therefore the decision to intervene surgically needs to be balanced with the potential consequences of a surgical procedure to drain an abscess. Intraventricular antibiotics have been reported.

The necessary duration of therapy for nocardiosis varies depending on the clinical presentation and the status of the patient. The optimal duration is uncertain, but long-term therapy is common because of the propensity for relapse. Historically, superficial cutaneous infection has been treated for 3 months, pulmonary or systemic nocardiosis has been treated for 6–12 months, and CNS infection has been treated for at least 12 months. These intervals should only be considered as a guide for expected therapeutic durations. The ultimate duration should be dictated by clinical and radiographic resolution of disease.

## PROGNOSIS

Historically, nocardiosis has been associated with significant mortality. Fortunately, more recent reports have documented an improved rate of complete cure to approximately 80%. Predictably, attributable case fatality rates vary by disease entity. There is no attributable case fatality associated with cutaneous disease, but 10–20% attributable case fatality has been assigned to disseminated and visceral disease. CNS disease has the highest attributable case fatality rates, reaching 25%. Importantly, much of the data on case fatality rates are informed by predominantly adult cohorts, and thus there may be fewer fatal outcomes in children. Nonetheless, early diagnosis and intervention are important to reduce the morbidity and mortality of nocardiosis, especially in immunocompromised patients at increased risk for disseminated disease.

Visit Elsevier eBooks+ at [eBooks.Health.Elsevier.com](http://eBooks.Health.Elsevier.com) for Bibliography.

## Section 5

# Gram-Negative Bacterial Infections

## Chapter 237

# *Neisseria meningitidis* (Meningococcus)

Manish Sadarangani

*Neisseria meningitidis* (the meningococcus) is a commensal of the human nasopharynx in approximately 10% of the population and, on rare occasions, enters the bloodstream to cause devastating invasive disease such as meningitis and meningococcal septicemia (meningococemia). Although a rare endemic disease in most countries, the epidemiology of meningococcal disease varies widely over time and in different geographic regions, with both hyperendemic and epidemic disease patterns occurring. Onset of disease in susceptible individuals may be very rapid, within hours, and the case fatality rate is high, especially among those presenting with septic shock, despite access to modern critical care. Individual susceptibility is known to involve a complex relationship among environmental, host, and bacterial factors, and prevention of meningococcal disease through behavior modification (e.g., avoiding tobacco smoke) and vaccination offers the best prospect for control.

## ETIOLOGY

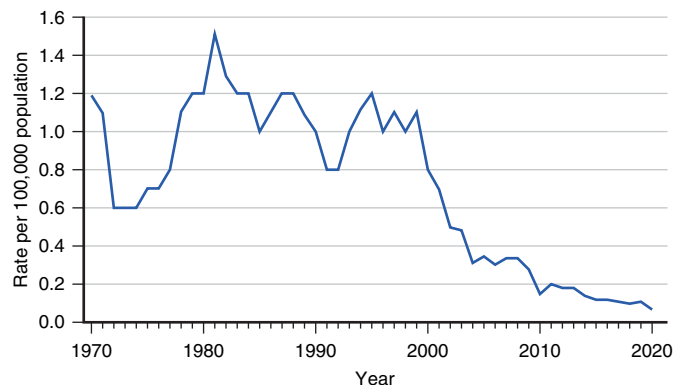
*N. meningitidis* is a gram-negative, fastidious, encapsulated, oxidase-positive, aerobic diplococcus. Differences in the chemistry of the polysaccharide capsule allow definition of 12 (previously thought to be 13) serologically distinct meningococcal capsular groups, of which 6, designated A, B, C, W (previously designated W135), X, and Y, are responsible for almost all cases of disease. Meningococcal strains may be subclassified on the basis of antigenic variation in two porin proteins found in the outer membrane, **PorB** (serotype) and **PorA** (serosubtype), and **lipopolysaccharide** (immunotype), using serology. Serologic typing is being replaced by molecular typing methods, which target genes under immune selection to provide **antigen sequence typing** (based on amino acid variation in various surface proteins, including PorA and FetA). Sequencing of antigen genes (e.g., *porA*, *fHbp*, *nadA*, *nhba*) is an important means of monitoring pressure on meningococcal populations by protein-based vaccines containing these antigens. Because meningococci readily exchange genetic material, typing based on a few antigens cannot provide an accurate picture of relatedness of strains, an important goal in monitoring epidemiology. **Multilocus sequence typing**, which types meningococci using variation in seven housekeeping genes, has been widely used to map the distribution of genetic lineages of meningococci (<http://pubmlst.org/neisseria/>) and provides a clearer picture of the genetic and epidemiologic relatedness of strains. To provide still better definition of genetic variation, in some countries, including the United Kingdom, **whole genome sequencing** is used to type meningococci and appears set to replace both antigen and multilocus sequence typing as costs continue to fall. The application of molecular approaches to epidemiology has established that (1) endemic meningococcal disease is caused by genetically heterogeneous strains, although only a small number of genetic lineages are associated with the majority of cases of invasive disease, and (2) outbreaks are usually clonal, caused by single strains.

## EPIDEMIOLOGY

Meningococci are transmitted during close contact through aerosol droplets or exposure to respiratory secretions, as by kissing. The organism does not survive for long periods in the environment. Enhanced rates of mucosal colonization and increased disease risk are associated with activities that increase the likelihood of exposure to a new strain or increase proximity to a carrier, thus facilitating transmission, including kissing, bar patronage, binge drinking, attendance at nightclubs, men having sex with men, and living in freshman college dormitories. Factors that damage the nasopharyngeal mucosa, such as smoking and respiratory viral infection (notably influenza), are also associated with increased rates of carriage and disease, perhaps by driving upregulation of host adhesion molecules that are receptors for meningococci. Carriage is unusual in early childhood and peaks during adolescence and young adulthood.

Meningococcal disease is a global problem, but disease rates vary by a factor of 10- to 100-fold in different geographic locations at one point in time and in the same location at different times. Most cases of meningococcal disease are sporadic, but small outbreaks (usually in schools or colleges, representing <3% of U.S. cases), **hyperendemic** disease (increased rates of disease persisting for a decade or more as a result of a single clone), and epidemic disease are all recognized patterns. However, over the past decade, rates of meningococcal disease have declined in most industrialized countries, partly through introduction of immunization programs and possibly aided by widespread legislation against smoking in public places. The arrival of hyperinvasive lineages and their eventual decline through development of natural immunity is recognized as a major driver of changes in disease rates over time. The U.S. disease rate was 1.1 cases per 100,000 population in 1999 but had fallen to 0.11 per 100,000 by 2019 (Fig. 237.1). By contrast, the rate of disease in Ireland in 1999 was >12 per 100,000, and rates of 1,000 per 100,000 have been described during epidemic disease in sub-Saharan Africa. Disease caused by dominant hyperendemic clones has been recognized in the past 2 decades in Oregon, United States; Quebec, Canada; Normandy, France; and across New Zealand. Laboratory data underreport meningococcal disease incidence rates because up to 50% of cases are not culture confirmed, particularly where prehospital antibiotics are recommended for suspected cases. In the United Kingdom, polymerase chain reaction (PCR) methods are used routinely for diagnosis of suspected cases, doubling the number of confirmed cases.

The highest rate of meningococcal disease occurs in infants <1 year old, probably as a result of *immunologic inexperience* (antibody that recognizes meningococcal antigens is naturally acquired during later childhood), immaturity of the alternative and lectin complement pathways, and perhaps the poor responses made by infants to bacterial polysaccharides. In the absence of immunization, incidence rates decline through childhood, except for a peak of disease among adolescents and



**Fig. 237.1** Rate of meningococcal disease, by year—United States, 1970–2020. (Modified from Cohn AC, MacNeil JR, Clark TA, et al; Centers for Disease Control and Prevention. *Prevention and control of meningococcal disease: recommendations of the Advisory Committee on Immunization Practices. MMWR Recomm Rep* 2013;62[RR-2]:1–28, updated with data from the CDC meningococcal surveillance data tables: <https://www.cdc.gov/meningococcal/surveillance/surveillance-data.html#figure01>.)

young adults, which may be related to increased opportunity for exposure from social activities. The incidence of meningococcal disease is increased among persons with HIV infection.

In the United States, most cases of disease in the first 5 years of life are caused by capsular **group B** strains. After age 5 years, disease cases are mostly distributed among capsular groups C, W, and Y. In most other industrialized countries, capsular group B strains predominate at all ages, in part because of introduction of routine capsular **group C** meningococcal conjugate vaccine among infants and/or toddlers. For unclear reasons, disease in children caused by group Y strains was uncommon in the United States before the 1990s and then began to increase. Rates of disease caused by this capsular group have also increased in several other countries but are declining in the United States. Disease caused by capsular **group W** strains has increased in the United Kingdom and in other countries in Europe and Australia as a result of a hyperinvasive clone, which appears to have originated in Latin America.

Large outbreaks of capsular **group A** meningococcal disease occurred during and immediately after the First World War and Second World War in both Europe and the United States, but since the 1990s, almost all cases caused by capsular group A strains have occurred in Eastern Europe, Russia, and developing countries. The highest incidence of capsular group A disease has occurred in a band across sub-Saharan Africa, the *meningitis belt*, with annual endemic rates of 10–25 per 100,000 population. For more than a century, this region has experienced large capsular group A epidemics every 7–10 years, with annual rates as high as 1,000 per 100,000 population. The onset of cases in the sub-Saharan region typically begins during the dry season, possibly related to drying and damage to the nasopharyngeal mucosa; subsides with the rainy season; and may reemerge the following dry season. Rates of capsular group A meningococcal disease are currently falling across this region as a result of a mass vaccine implementation targeting strains bearing the A polysaccharide. However, both endemic and epidemic meningococcal disease in this region is also caused by capsular groups C, W, and X strains. Capsular group A and **group X** are infrequent causes of disease in other areas of the world, although both A and W strains have been associated with outbreaks among pilgrims returning from the Hajj.

## PATHOGENESIS AND PATHOPHYSIOLOGY

Colonization of the nasopharynx by *N. meningitidis* is the first step in either carriage or invasive disease. Disease usually occurs 1–14 days after acquisition of the pathogen. Initial contact of meningococci with host epithelial cells is mediated by pili, which may interact with the host CD46 molecule or an integrin. Close adhesion is then mediated by Opa and Opc binding to carcinoembryonic antigen (CEA) cell adhesion molecule receptors and integrins, respectively. Subsequent internalization of meningococci by epithelial cells is followed by transcytosis through to the basolateral tissues and dissemination into the bloodstream. Immunoglobulin A<sub>1</sub> protease secreted by invasive bacteria degrades secretory IgA on the mucosal surface, circumventing this first-line host defense mechanism.

Once in the bloodstream, meningococci multiply rapidly to high levels to cause septicemia (**meningococcemia**). Patients with a higher bacterial load have a more rapid clinical deterioration and longer period of hospitalization, as well as a higher risk of death and permanent sequelae. Resistance to complement-mediated lysis and phagocytosis is largely mediated by the polysaccharide capsule and **lipopolysaccharide (LPS)**. Outer membrane vesicles released from the surface of the organism contain LPS, outer membrane proteins, periplasmic proteins, and phospholipid and play a major role in the inflammatory cascade that leads to severe disease.

Much of the tissue damage is caused by host immune mechanisms activated by meningococcal components, in particular LPS. During invasive disease LPS is bound to a circulating plasma protein known as *LPS-binding protein*. The host receptor complex for LPS consists of toll-like receptor (TLR)-4, CD14, and myeloid differentiation protein 2. Binding of LPS to TLR-4, which is upregulated on circulating leukocytes during septicemia, results in activation of a number of different cell types. An intense inflammatory reaction results from secretion of proinflammatory cytokines such as tumor necrosis factor (TNF)- $\alpha$ , interleukin



(IL)-1 $\beta$ , IL-6, IL-8, and granulocyte-macrophage colony-stimulating factor, levels of which are closely associated with plasma levels of LPS. The major antiinflammatory cytokines IL-1R $\alpha$ , IL-2, IL-4, and IL-12 and transforming growth factor- $\beta$  are present at very low levels. Both high and low levels have been observed for IL-10 and interferon- $\gamma$ .

The pathophysiologic events that occur during meningococcal septicemia are largely related to microvascular injury. This injury leads to increased vascular permeability and capillary leak syndrome, pathologic vasoconstriction and vasodilation, disseminated intravascular coagulation (DIC), and profound myocardial dysfunction. Increased vascular permeability can lead to dramatic fluid loss and severe hypovolemia. **Capillary leak syndrome** with or without aggressive fluid resuscitation (which is essential in severe cases) leads to pulmonary edema and respiratory failure. Initial vasoconstriction is a compensatory mechanism in response to hypovolemia and results in the clinical features of pallor and cold extremities. After resuscitation, some patients experience **warm shock**, that is, intense vasodilation with bounding pulses and warm extremities, despite persistent hypotension and metabolic acidosis. Virtually all antithrombotic mechanisms appear to be dysfunctional during meningococcal sepsis, leading to a procoagulant state and DIC. All these factors contribute to depressed myocardial function, but there is also a direct negative cytokine effect on myocardial contractility, thought to be largely mediated by IL-6. Hypoxia, acidosis, hypoglycemia, hypokalemia, hypocalcemia, and hypophosphatemia are all common features in severe septicemia and further depress cardiac function. Some patients become unresponsive to the positive inotropic effects of catecholamines and require high levels of inotropic support during intensive care management. These processes result in impairment of microvascular blood flow throughout the body and ultimately lead to **multiorgan failure**, which is responsible for much of the mortality.

After invasion of the circulation, meningococci may also penetrate the blood-brain barrier and enter the cerebrospinal fluid (CSF), facilitated by pili and possibly Opc. Once there, bacteria continue to proliferate, and LPS and other outer membrane products can stimulate a proinflammatory cascade similar to that observed in the blood. This leads to upregulation of specific adhesion molecules and recruitment of leukocytes into the CSF. Central nervous system damage occurs directly by meningeal inflammation and indirectly by circulatory collapse and causes a high rate of neurologic sequelae in affected patients. Death can occur from cerebral edema, which leads to **increased intracranial pressure (ICP)** and cerebral or cerebellar herniation.

### Immunity

There is an inverse correlation between the incidence of disease and the prevalence of complement-dependent **serum bactericidal antibody (SBA)**. The level of SBA is highest at birth and among adults and lowest in children between 6 months and 2 years of age, when the highest incidence of disease occurs. Such antibodies are naturally elicited by asymptomatic carriage of pathogenic and nonpathogenic *Neisseria*, such as *Neisseria lactamica*, and other antigenically related gram-negative bacteria. A similar relationship was described for capsular groups A, B, and C. Vaccine trials support these earlier findings. For the meningococcal capsular group C conjugate vaccine, an SBA titer  $\geq 1:8$  correlated strongly with postlicensure vaccine effectiveness. For capsular group B disease, the data are less certain, but the proportions of capsular group B vaccine recipients with more than fourfold rises in SBA after vaccination or SBA titers  $\geq 1:4$  have been correlated with clinical effectiveness in studies of outer membrane vesicle vaccines. These cutoffs are therefore currently used for regulatory approval of new meningococcal vaccines. The strong association between disease risk and genetic variation in human complement factor H further supports the importance of complement-mediated protection against disease.

There is evidence that mechanisms other than complement-dependent bactericidal antibodies may be important in determining protection against meningococcal disease. Disease in individuals with complement deficiency has a different age distribution, has less severe clinical features, and often involves unusual capsular groups. In particular, complement deficiency does not appear strongly related to an increased risk of capsular group B disease. Alternative surrogate markers of protection include the opsonophagocytic assay and antibody avidity, but no studies

have attempted to link these laboratory tests with vaccine efficacy or even population protection, as has been found with SBA.

### Host Factors

Host susceptibility is strongly related to age, as previously described, indicating that immunologic responsiveness and/or naïveté in infancy and early childhood are key determinants of risk. **Complement** is a key factor in protection against meningococcal disease. Individuals with inherited deficiencies of properdin, factor D, or terminal complement components have up to a 1,000-fold higher risk for development of meningococcal disease than complement-sufficient people. The risk of meningococcal disease is also increased in patients with acquired complement deficiencies associated with diseases such as nephrotic syndrome, systemic lupus erythematosus (SLE), and hepatic failure and in patients treated with eculizumab, a monoclonal antibody against complement protein C5.

Among those with complement deficiencies, meningococcal disease is more prevalent during late childhood and adolescence, when carriage rates are higher than in children <10 years old; meningococcal infections in these patients may be recurrent. Although meningococcal disease can occasionally be overwhelming in patients with late complement component deficiency, cases are more typically described as being less severe than in complement-sufficient persons (with properdin deficiency being the exception), perhaps reflecting that these cases are often caused by unusual capsular groups. In one study, one third of individuals with meningococcal disease caused by capsular groups X, Y, and W had a complement deficiency. Although protective against early infection, extensive complement activation and bacteriolysis may contribute to the pathogenesis of severe disease once bacterial invasion has occurred.

The sibling risk ratio for meningococcal disease is similar to that for other diseases where susceptibility shows polygenic inheritance, and a number of host genetic factors have now been identified to affect either susceptibility to meningococcal disease or severity of disease. The molecules implicated include proteins on epithelial surfaces, the complement cascade, pattern recognition receptors, clotting factors, and inflammatory mediators. Deficiencies in the complement pathways are consistently associated with an increased risk of meningococcal disease, with specific polymorphisms in mannose-binding lectin and factor H found to be associated with disease susceptibility. A genome-wide association study of 7,522 individuals in Europe identified single nucleotide polymorphisms (SNPs) within the *CFH* and *CFHR3* genes that were associated with host susceptibility to meningococcal disease. Complement-mediated bacteriolysis is known to be extremely important in protection against meningococcal disease, giving these associations biologic plausibility. In particular, factor H attaches to various binding proteins expressed on the bacterial surface, downregulating complement activation and allowing the organism to evade host responses.

In terms of disease severity, a meta-analysis of data from smaller studies found that SNPs in genes encoding plasminogen activator inhibitor 1 (*SERPINE1*), IL-1 receptor antagonist (*IL1RN*), and IL-1 $\beta$  (*IL1B*) are associated with increased mortality from meningococcal disease, as reflected in pathophysiologic changes that occur during invasive disease.

### CLINICAL MANIFESTATIONS

The most common form of meningococcal infection is asymptomatic carriage of the organism in the nasopharynx. In the rare cases where invasive disease occurs, the clinical spectrum of meningococcal disease varies widely, but the highest proportion of cases present with meningococcal meningitis (30–50%). Other recognized presentations include bacteremia without sepsis, meningococcal septicemia with or without meningitis, pneumonia, chronic meningococcemia, and occult bacteremia. Focal infections in various sites (e.g., myocardium, joints, pericardium, bone, eye, peritoneum, sinuses, middle ear) are well recognized, and all may progress to disseminated disease. Urethritis, cervicitis, vulvovaginitis, orchitis, and proctitis may also occur.

**Acute meningococcal septicemia** cannot be distinguished from other viral or bacterial infections early after onset of symptoms (Table 237.1). Typical nonspecific early symptoms include fever, irritability, lethargy, respiratory symptoms, refusal to drink, and vomiting. Less



**Table 237.1** Prevalence of Symptoms and Signs in Children and Young People with Meningococcal Septicemia, Meningococcal Disease, and Meningococcal Meningitis

SYMPTOM OR SIGN	PREVALENCE RANGE (NUMBER OF STUDIES)		
	BACTERIAL MENINGITIS	MENINGOCOCCAL DISEASE	MENINGOCOCCAL SEPTICEMIA
Fever	66–97% (10)	58–97% (7)	98% (1)
Vomiting or nausea	18–70% (10)	44–76% (6)	
Rash	9–62% (6)	59–100% (9)	70% (1)
Headache	3–59% (7)	16–49% (5)	40% (1)
Lethargy	13–87% (6)	36–65% (3)	59% (1)
Coughing	N/A (0)	15–27% (2)	33% (1)
Irritable or unsettled	21–79% (8)	36–67% (3)	32% (1)
Runny nose	N/A (0)	24% (1)	31% (1)
Muscle ache or joint pain	23% (1)	7–65% (3)	30% (1)
Refusing food or drink	26–76% (4)	13–60% (3)	27% (1)
Altered mental state*	26–93% (6)	45–81% (3)	N/A (0)
Stiff neck	13–74% (13)	5–71% (6)	N/A (0)
Impaired consciousness	60–87% (4)	10–72% (2)	N/A (0)
Unconsciousness	4–18% (4)	N/A (0)	N/A (0)
Chills or shivering	N/A (0)	39% (1)	N/A (0)
Photophobia	5–16% (2)	2–31% (5)	N/A (0)
Respiratory symptoms	25–49% (4)	16–23% (2)	N/A (0)
Breathing difficulty	13–34% (4)	11% (1)	N/A (0)
Cold hands or feet	N/A (0)	43% (1)	N/A (0)
Shock	8–16% (2)	27–29% (2)	N/A (0)
Seizures	14–38% (12)	7–17% (3)	N/A (0)
Diarrhea	21–29% (2)	7–9% (2)	N/A (0)
Abdominal pain or distention	17% (1)	4% (1)	N/A (0)
Leg pain	N/A (0)	11–37% (2)	N/A (0)
Thirst	N/A (0)	8% (1)	N/A (0)
Sore throat, coryza, or throat infection	18% (1)	24% (1)	N/A (0)
Ill appearance	N/A (0)	79% (1)	N/A (0)
Capillary refill time >2sec	N/A (0)	83% (1)	N/A (0)
Hypotension	N/A (0)	28% (1)	N/A (0)
Abnormal skin color	N/A (0)	19% (1)	N/A (0)
Bulging fontanel <sup>†</sup>	13–45% (4)	N/A (0)	N/A (0)
Ear infection or ear, nose, and throat infections <sup>‡</sup>	18–49% (5)	N/A (0)	N/A (0)
Chest infection	14% (1)	N/A (0)	N/A (0)
Brudzinski sign	11–66% (2)	N/A (0)	N/A (0)
Kernig sign	10–53% (3)	N/A (0)	N/A (0)
Abnormal pupils	10% (1)	N/A (0)	N/A (0)
Cranial nerve pair involvement	4% (1)	N/A (0)	N/A (0)

**Table 237.1** Prevalence of Symptoms and Signs in Children and Young People with Meningococcal Septicemia, Meningococcal Disease, and Meningococcal Meningitis—cont'd

SYMPTOM OR SIGN	PREVALENCE RANGE (NUMBER OF STUDIES)		
	BACTERIAL MENINGITIS	MENINGOCOCCAL DISEASE	MENINGOCOCCAL SEPTICEMIA
Toxic or moribund state	3–49% (2)	N/A (0)	N/A (0)
Back rigidity	46% (1)	N/A (0)	N/A (0)
Paresis	6% (1)	N/A (0)	N/A (0)
Focal neurologic deficit	6–47% (3)	N/A (0)	N/A (0)

\*This includes confusion, delirium, and drowsiness.

†The age ranges in the four studies are 0–14 yr, 0–2 yr, 0–12 mo, and 0–13 wk.

‡One study reported the number of children and young people with ear, nose, and throat infections; the four other studies reported the number of ear infections only.

Classification of conditions presented in the table reflects the terminology used in the evidence.

N/A, Not applicable.

Data from National Collaborating Center for Women's and Children's Health (UK). Bacterial meningitis and meningococcal septicaemia: management of bacterial meningitis and meningococcal septicaemia in children and young people younger than 16 years in primary and secondary care. *NICE Clinical Guidelines, No 102*. London: RCOG Press; 2010.



**Fig. 237.2** Meningococemia. A maculopapular, nonhemorrhagic rash that subsequently became petechial. (From *Habif TP, ed. Clinical Dermatology, 6th ed. Philadelphia: Mosby; 2016: Fig 9-59.*)



**Fig. 237.4** Rash of chronic meningococemia. (From *Persa OD, Jazmati N, Robinson N, et al. A pregnant woman with chronic meningococcaemia from *Neisseria meningitidis* with *lpxL1*-mutations. *Lancet*. 2014;384:1900.*)



**Fig. 237.3** A, Purpuric rash in 3-yr-old child with meningococemia. B, Purpura fulminans in 11-mo-old child with meningococemia. (From *Thompson ED, Herzog KD. Fever and rash. In: Zaoutis L, Chiang V, eds. Comprehensive Pediatric Hospital Medicine. Philadelphia: Mosby; 2007: Figs. 62-6 and 62-7.*)

frequently, diarrhea, sore throat, and chills/shivering are reported. A maculopapular rash, which is indistinguishable from rashes seen after viral infections, is evident in approximately 10% of cases early in the course of infection (Fig. 237.2). Limb pain, myalgia, or refusal to

walk may occur as the primary complaint in 7% of otherwise clinically unsuspected cases. As the disease progresses, cold hands or feet and abnormal skin color may be important signs, capillary refill time becomes prolonged, and a nonblanching or petechial rash will develop in >80% of cases. In fulminant meningococcal septicemia, the disease progresses rapidly over several hours from fever with nonspecific signs to septic shock characterized by prominent petechiae and purpura (**purpura fulminans**) with poor peripheral perfusion, tachycardia (to compensate for reduced blood volume resulting from capillary leak), increased respiratory rate (to compensate for pulmonary edema), hypotension (a late sign of shock in young children), confusion, and coma (resulting from decreased cerebral perfusion). Coagulopathy, electrolyte disturbance (especially hypokalemia), acidosis, adrenal hemorrhage, renal failure, and myocardial failure may all develop (Fig. 237.3). Meningitis may be present.

**Meningococcal meningitis** is indistinguishable from meningitis caused by other bacteria. Nonspecific symptoms and signs (see Table 237.1), including fever and headache, predominate, especially in the young and early in the illness. Children <5 years old rarely report headache. More specific symptoms of photophobia, nuchal rigidity, bulging of the fontanel, and clinical signs of meningeal irritation may develop but are unusual in infants. Seizures and focal neurologic signs occur less frequently than in patients with meningitis caused by *Streptococcus pneumoniae* or *Haemophilus influenzae*. A meningoencephalitis-like picture can occur, associated with rapidly progressive cerebral edema and death from increased ICP, which may be more common with capsular group A infection.

**Occult meningococcal bacteremia** manifests as fever with or without associated symptoms that suggest a minor viral infection. Resolution of bacteremia may occur without antibiotics, but sustained bacteremia leads to meningitis in approximately 60% of cases and to distant infection of other tissues.

**Chronic meningococemia**, which occurs rarely, is characterized by fever, nontoxic appearance, arthralgia, headache, splenomegaly, and a maculopapular or petechial rash (Fig. 237.4). Symptoms are intermittent, with a mean duration of illness of 6–8 weeks. Blood culture results are usually positive, but cultures may initially be sterile. Chronic meningococemia may spontaneously resolve, but meningitis may develop in untreated cases. Some cases have been associated with complement deficiency and others with sulfonamide therapy. One report indicates that up to 47% of isolates from patients with chronic meningococemia (vs <10% in acute cases) have a pathogenic variant in the *lpxI* gene, leading to a reduced inflammatory response and a milder course of infection.

## DIAGNOSIS

The initial diagnosis of meningococcal disease should be made on clinical assessment to avoid delay in implementation of appropriate therapy. Laboratory findings are variable but may include leukocytopenia or leukocytosis, often with increased percentages of neutrophils and band forms, and anemia, thrombocytopenia, proteinuria, and hematuria. Elevations of erythrocyte sedimentation rate (ESR) and C-reactive protein (CRP) may occur, but in patients with rapid onset of disease, these values may be within normal limits at presentation. Increased CRP in the presence of fever and petechiae makes the diagnosis likely. Hypoalbuminemia, hypocalcemia, hypokalemia, hypomagnesemia, hypophosphatemia, hypoglycemia, and metabolic acidosis, often with increased lactate levels, are common in patients with meningococcal septicemia. Patients with coagulopathy have decreased serum concentrations of prothrombin and fibrinogen and prolonged coagulation times.

A confirmed diagnosis of meningococcal disease is established by isolation of *N. meningitidis* from a normally sterile body fluid such as blood, CSF, or synovial fluid. Meningococci may be identified in a Gram stain preparation and/or culture of petechial or purpuric skin lesions, although this procedure is rarely undertaken, and occasionally are seen on Gram stain of the buffy coat layer of a centrifuged blood sample. Although blood culture may be positive in more than two thirds of cases before antibiotic use, culture results often are negative if the patient has been treated with antibiotics before collection of the culture specimen; data suggest that <50% are culture positive. Isolation of the organism from the nasopharynx is not diagnostic of invasive disease because the organism is a common commensal.

PCR using primers specific for meningococcal genes (e.g., *ctrA*) has high sensitivity and specificity for detection of meningococci using whole blood samples and has increased confirmation of suspected cases by >40% in the United Kingdom.

Lumbar puncture should be undertaken to establish a diagnosis of meningococcal meningitis in patients without contraindications, including presence of septic shock, coagulopathy, thrombocytopenia, respiratory distress, seizures, increased ICP, or local infection. In patients with meningococcal meningitis, the cellular and chemical characteristics of the CSF are those of acute bacterial meningitis, showing gram-negative diplococci in up to 75% of cases. CSF culture results may be positive in patients with meningococemia in the absence of CSF pleocytosis or clinical evidence of meningitis; conversely, positive CSF specimens that are gram positive are sometimes culture negative. Overdecolorized pneumococci in Gram stain preparations can be mistaken for meningococci, and therefore empirical therapy should not be narrowed to *N. meningitidis* infection on the basis of Gram stain findings alone.

Detection of capsular polysaccharide antigens using rapid latex agglutination tests on CSF can support the diagnosis in cases clinically consistent with meningococcal disease, but the tests have not performed adequately in clinical practice (poor sensitivity and cross-reactivity of capsular group B test with *Escherichia coli* K1 antigen) and have been replaced by molecular diagnostic methods. Urine antigen testing is insensitive and should not be used. PCR-based assays for detection of meningococci in blood and CSF have been developed, and multiplex PCR assays that detect several bacterial species associated with meningitis, including the meningococcus, are used in some laboratories.

## Differential Diagnosis

Meningococcal disease can appear similar to sepsis or meningitis caused by many other gram-negative bacteria, *S. pneumoniae*,

*Staphylococcus aureus*, or group A streptococcus; to Rocky Mountain spotted fever, ehrlichiosis, or epidemic typhus; and to bacterial endocarditis. Viral and other infectious etiologies of meningoencephalitis should be considered in some cases.

Petechial rashes are common in viral infections (enteroviruses, influenza and other respiratory viruses, measles virus, Epstein-Barr virus, cytomegalovirus, parvovirus) and may be confused with meningococcal disease. Petechial or purpuric rashes are also associated with protein C or protein S deficiency, platelet disorders (including idiopathic thrombocytopenic purpura), Henoch-Schönlein purpura, connective tissue disorders, drug eruptions, and trauma, including nonaccidental injury. The nonpetechial, blanching maculopapular rash observed in some cases of meningococcal disease, especially early in the course, may initially be confused with a viral exanthem.

## TREATMENT

### Antibiotics

Empirical antimicrobial therapy should be initiated immediately after the diagnosis of invasive meningococcal infection is suspected and cultures are obtained, using a **third-generation cephalosporin** to cover the most likely bacterial pathogens until the diagnosis is confirmed. In regions with a high rate of  $\beta$ -lactam-resistant *S. pneumoniae*, empirical addition of intravenous (IV) **vancomycin** is recommended (see Chapter 643.1) while awaiting the outcome of bacterial identification and sensitivity, but this is unnecessary in other settings where cephalosporin resistance of pneumococci is very rare (in these settings a risk assessment of each case should be made). Once the diagnosis of  $\beta$ -lactam-sensitive meningococcal disease is confirmed in the laboratory, some authorities recommend a switch to penicillin. Even with no evidence that survival outcomes are different, however, limited evidence from one study indicates that in meningococcal purpura, necrotic skin lesions are less common among children treated with ceftriaxone than with penicillin. Furthermore, it may be cost-effective to use a once-daily dose of ceftriaxone for therapy in younger children, and this is the recommended practice in the United Kingdom (Table 237.2). No adequate studies have investigated the optimal duration of therapy for children, but the course is generally continued for 5–7 days.

Early treatment of meningococcal infections may prevent serious sequelae, but timely early diagnosis is often difficult in the absence of petechial or purpuric skin findings. Among children presenting with petechial rashes, 1–10% may have underlying meningococcal disease, and protocols have been established to ensure that these patients are identified without exposing the >90% of cases without meningococcal disease to unnecessary parenteral antibiotic therapy (Fig. 237.5).

Isolates of *N. meningitidis* with decreased susceptibility to penicillin (minimal inhibitory concentration of penicillin of 0.1–1.0 mg/mL) have been reported from Europe, Africa, Canada, and the United States (4% of isolates in 2006). Decreased susceptibility is caused at least in part by altered penicillin-binding protein 2 and does not appear to adversely affect the response to therapy. Isolates with reduced susceptibility to third-generation cephalosporins have been described in France, but the level of reduced susceptibility is not likely to affect therapeutic outcomes where these agents are used for treatment.

### Supportive Care

Most children with meningococcal disease can be managed with antibiotics and simple supportive care and will improve rapidly. However, with an overall 5–10% case fatality rate, the priority in initiating management of children presenting with meningococcal disease is identification of the life-threatening features of the disease: shock and increased ICP. Delayed initiation of supportive therapy is associated with poor outcome, and protocols have therefore been established to aid clinicians in a step-by-step approach (<http://www.meningitis.org>). In all children presenting with meningococcal disease, assessment of the airway should be performed, because the airway could be compromised as a result of a depressed level of consciousness (elevated ICP in meningitis or poor cerebral perfusion in shock). In patients with meningococcal septicemia, supplementary oxygen should be used to treat hypoxia, which is caused by pulmonary edema (from capillary leak), and some patients will require endotracheal intubation. Hypovolemia requires both volume



**Table 237.2** Treatment of *Neisseria meningitidis* Invasive Infections Beyond the Newborn Period

DRUG	ROUTE	DOSE	DOSING INTERVAL (hr)	MAXIMUM DAILY DOSE	NOTES
Penicillin G	IM or IV	300,000-400,000 units/kg/day	4-6 (4-hourly for meningitis)	12-24 million units	Does not clear carriage, and "prophylaxis" is required at the end of treatment
Ampicillin	IM or IV	200-400 mg/kg/day	4-6 (4-hourly for meningitis)	8 g	Does not clear carriage, and "prophylaxis" is required at the end of treatment
Cefotaxime <sup>‡</sup>	IM or IV	180-225 mg/kg/day	6-8 (6-hourly for meningitis)	8-12 g	Recommended in the neonate
Ceftriaxone	IM or IV	75-100 mg/kg/day	12-24	2-4 g	Preferred treatment as only once or twice daily, and may reduce skin complications
<b>ALTERNATIVE THERAPY IN THE FACE OF LIFE-THREATENING β-LACTAM ALLERGY</b>					
Chloramphenicol <sup>*</sup>	IV	50-100 mg/kg/day	6	2-4 g	Adjust based on target serum concentrations (15-25 mg/L)
Meropenem <sup>†</sup>	IV	60-120 mg/kg/day	8	3-6 g	

\*Monitor blood levels to avoid toxicity.

<sup>†</sup>Rate of cross-reactivity in penicillin-allergic adults is 2-3%.

<sup>‡</sup>May not be available due to manufacturing issues.

IM, Intramuscular; IV, intravenous.

replacement and inotropic support to maintain cardiac output. Because ongoing fluid resuscitation may lead to pulmonary edema, endotracheal intubation and ventilation should be initiated in a patient who remains in compensated shock after 40 mL/kg of fluid resuscitation to improve oxygenation and reduce work of breathing. Aggressive fluid resuscitation with unbuffered electrolyte solutions in febrile African children led to increased mortality; similar studies in industrialized settings are required. Metabolic and hematologic abnormalities are common in meningococcal septicemia, and protocols recommend anticipation, assessment, and correction of glucose, potassium, calcium, magnesium, phosphate, clotting factors, and anemia.

Children with meningococcal meningitis should be cautiously managed with maintenance fluids (fluid restriction is not recommended and may be harmful), and those with increased ICP should be managed with close attention to maneuvers to maintain normal cerebral perfusion. If there is shock in the presence of elevated ICP, the shock should be carefully corrected to ensure that cerebral perfusion pressure is maintained.

Many adjunctive therapies have been attempted in patients with severe meningococcal septicemia, but few have been subjected to randomized controlled trials (RCTs). Data are insufficient to recommend the use of anticoagulant or fibrinolytic agents, extracorporeal membrane oxygenation, plasmapheresis, or hyperbaric oxygen. In well-designed clinical trials, an antibody directed against endotoxin (HA1A) did not confer any benefit in children with meningococcal disease, and although initially promising in adult sepsis, activated protein C was not useful in pediatric sepsis and was associated with an increased risk of bleeding. Recombinant bactericidal permeability increasing protein was studied in an underpowered (survival end-point) trial and showed some potentially beneficial effects against secondary end-points (amputations, transfusions, functional outcome) and requires further investigation.

Although the benefits of **corticosteroids** for adjunctive therapy in pediatric bacterial meningitis caused by *H. influenzae* type b (Hib) are accepted, no pediatric data specifically demonstrate benefit in meningococcal meningitis. However, some authorities extrapolate from animal data, from experience with Hib, and from compelling data from adult meningitis and recommend corticosteroids as adjunctive therapy in pediatric meningococcal meningitis, given with or soon after the first dose of antibiotics. Therapeutic doses of corticosteroids should not be used routinely in meningococcal septicemia. Some intensivists recommend replacement doses of corticosteroids in patients with treatment-refractory septic shock, because severe sepsis caused by meningococcus is associated with adrenal insufficiency resulting from adrenal necrosis or hemorrhage (Waterhouse-Friderichsen syndrome).

## COMPLICATIONS

Adrenal hemorrhage, endophthalmitis, arthritis, endocarditis, pericarditis, myocarditis, pneumonia, lung abscess, peritonitis, and renal infarcts can occur during acute infection. Renal insufficiency requiring dialysis may result from prerenal failure. Reactivation of latent herpes simplex virus infections is common during meningococcal infection.

A self-limiting immune complex vasculitis may occur, usually in the first 10 days after onset of the disease, resulting in various manifestations, including fever, rash, arthritis, and rarely, iritis, pericarditis, or carditis. The arthritis is monoarticular or oligoarticular, involves large joints, and is associated with sterile effusions that respond to nonsteroidal antiinflammatory drugs. Because most patients with meningococcal meningitis become afebrile by the seventh hospital day, persistence or recrudescence of fever after 5 days of antibiotics warrants evaluation for immune complex-mediated complications.

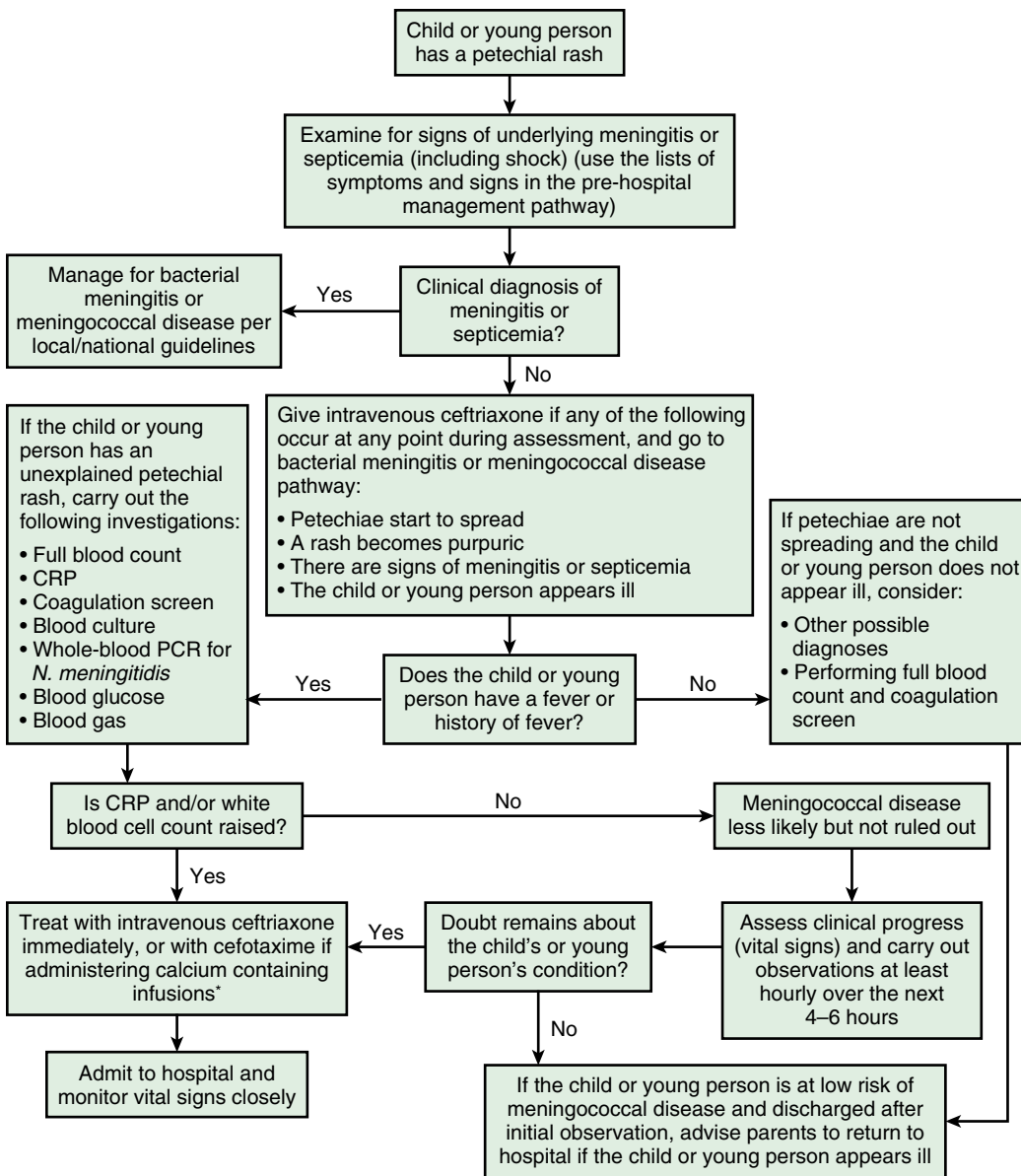
The most common complication of acute severe meningococcal septicemia is focal skin infarction, which typically affects the lower limbs and can lead to substantial scarring and require skin grafting. Distal tissue necrosis in purpura fulminans may require amputation (which should be delayed to allow demarcation) in approximately 2% of survivors. Avascular necrosis of epiphyses and epiphyseal-metaphyseal defects can result from the generalized DIC and may lead to growth disturbance and late skeletal deformities.

Deafness is the most frequent neurologic sequela of meningitis, occurring in 5-10% of children. Cerebral arterial or venous thrombosis with resultant cerebral infarction can occur in severe cases. Meningococcal meningitis is rarely complicated by subdural effusion or empyema or by brain abscess. Other rare neurologic sequelae include ataxia, seizures, blindness, cranial nerve palsies, hemiparesis or quadriplegia, and obstructive hydrocephalus (manifests 3-4 weeks after the onset of illness). Behavioral and psychosocial complications of the disease are frequently reported.

## PROGNOSIS

The case fatality rate for invasive meningococcal disease is 5-10%, with clear differences related to age of the patient and meningococcal genotype. Most deaths occur within 48 hours of hospitalization in children with meningococcemia. Poor prognostic factors on presentation include hypothermia or extreme hyperpyrexia, hypotension or shock, purpura fulminans, seizures, leukopenia, thrombocytopenia (including DIC), acidosis, and high circulating levels of endotoxin and TNF- $\alpha$ . The presence of petechiae for <12 hours before admission, absence of meningitis, and low or normal ESR indicate rapid, fulminant progression and a poorer prognosis.





**Fig. 237.5** Treatment algorithm for petechial rash. \*See Medicines and Healthcare Products Regulatory Agency Drug Safety Update, 2009;3(3). Available from [www.mhra.gov.uk](http://www.mhra.gov.uk). CRP, C-reactive protein; PCR, polymerase chain reaction. (Data from National Collaborating Center for Women's and Children's Health (UK). *Bacterial meningitis and meningococcal septicaemia: management of bacterial meningitis and meningococcal septicaemia in children and young people younger than 16 years in primary and secondary care*. NICE Clinical Guidelines, No 102. London: RCOG Press; 2010.)

Because complement deficiency is rare in patients with capsular group B infection, screening is unlikely to be useful in detecting cases caused by this group, but some authorities recommend routine screening in these cases. However, with one third or more of cases of disease caused by groups X, Y, and W apparently associated with complement deficiency, it is clearly appropriate to screen after infection with non-B capsular groups.

## PREVENTION

### Secondary Prevention

Close contacts of patients with meningococcal disease are at increased risk of infection because such individuals are likely to be colonized with the index case's (hyperinvasive) strain. Antibiotic prophylaxis should be offered as soon as possible to individuals who have been exposed directly to a patient's oral secretions, for whom the risk may be 1,000 times the background rate in the population. This includes household, kissing, and close family contacts of cases, as well as child-care and recent preschool contacts in the United States. Up to 30% of cases occur in the first week, but the risk persists for up to 1 year after presentation of the index case. Although prophylaxis is effective in preventing secondary cases, coprimary cases may occur in the days after presentation of the index case, and contacts should be carefully evaluated if they develop symptoms. Advice on management of nonclose contacts, such as those in daycare, nursery settings, or school and other

institutions, varies in different countries because the risk of a secondary case in this situation is low and opinion on risk assessment varies. **Ceftriaxone**, **ciprofloxacin**, and **rifampin** are 90–95% effective in reducing nasopharyngeal carriage of *N. meningitidis* and are acceptable agents for prophylaxis, with ciprofloxacin the drug of choice in some countries (Table 237.3). **Azithromycin** should not be used as the first-line choice for prophylaxis but is recommended in the rare instance of ciprofloxacin resistance. Prophylaxis is not routinely recommended for medical personnel except those with exposure to aerosols of respiratory secretions, such as through mouth-to-mouth resuscitation, intubation, or suctioning before or in the 24 hours after antibiotic therapy is initiated in the index case.

Neither penicillin nor ampicillin treatment eradicates nasopharyngeal carriage and should not be routinely used for prophylaxis. Patients with meningococcal infection treated solely with penicillin or ampicillin are therefore at risk of relapse or transmission to a close contact and should receive antimicrobial prophylaxis with one of the agents listed in Table 237.3 before hospital discharge. The preference is to use ceftriaxone for treatment of the index case, in which case further prophylaxis is not required. Droplet infection control precautions should be observed for hospitalized patients for 24 hours after initiation of effective therapy. All confirmed or probable cases of meningococcal infection must be reported to the local public health department according to national or regional regulations.

**Table 237.3** Antibiotic Prophylaxis to Prevent *Neisseria meningitidis* Infection\*

AGE-GROUP	DOSE	DURATION	EFFICACY
<b>RIFAMPIN<sup>†</sup></b>			
Infants <1 mo <sup>‡</sup>	5 mg/kg PO every 12 hr	2 days (4 doses)	
Children ≥1 mo and adults	15-20 mg/kg PO every 12 hr (max 600 mg)	2 days (4 doses)	90-95%
<b>CEFTRIAOXONE</b>			
Children <15 yr	125 mg IM	1 dose	90-95%
Children ≥15 yr and adults	250 mg IM	1 dose	90-95%
<b>CIPROFLOXACIN</b>			
Children ≥1 mo and adults <sup>†,‡</sup>	20 mg/kg (max 500 mg) PO	1 dose	90-95%
<b>AZITHROMYCIN (NOT RECOMMENDED ROUTINELY)</b>			
All ages	10 mg/kg (max 500 g) PO	1 dose	90%

\*Recommended for household and kissing contacts. In the United States, chemoprophylaxis is recommended for:

- Household contact, especially children <2 yr old
- Childcare or preschool contact at any time during 7 days before onset of illness
- Direct exposure to index patient's secretions through kissing, sharing toothbrushes, or eating utensils at any time during 7 days before onset of illness
- Mouth-to-mouth resuscitation, unprotected contact during endotracheal intubation during 7 days before onset of illness
- Frequently slept in same dwelling as index patient during 7 days before onset of illness
- Passengers seated directly next to the index case during airline flights lasting more than 8 hours (gate to gate), or passengers seated within one seat in any direction from an index case on a flight of any duration if the index case was coughing or vomiting during the flight
- Always check with current local public health guidance for full recommendations

<sup>†</sup>Not recommended for pregnant women (ceftriaxone is agent of choice in this setting).

<sup>‡</sup>Use only if fluoroquinolone-resistant strains of *N. meningitidis* have not been identified in the community.

<sup>§</sup>Discussion with an expert is recommended for treatment in infants age <1 mo. IM, Intramuscularly; PO, orally (by mouth).

Close contacts of cases could also be immunized to further reduce the risk of secondary infection, as described later.

### Vaccination

Meningococcal plain *polysaccharide vaccines* containing capsular polysaccharides from capsular groups A + C or capsular groups A, C, W, and Y have been available since the 1960s and used in the control of outbreaks and epidemics and for high-risk groups. However, polysaccharide vaccines are poorly immunogenic in infants, do not induce immunologic memory, and are associated with *immunologic hyporesponsiveness* (reduced response to future doses of polysaccharide). Plain polysaccharide vaccines have been superseded by meningococcal protein-polysaccharide *conjugate vaccines*, which are generally more immunogenic than plain polysaccharides, are immunogenic from early infancy, induce immunologic memory, and are not associated with hyporesponsiveness. The conjugate vaccines contain meningococcal polysaccharides that are chemically conjugated to a carrier protein. Three carrier proteins are used in various meningococcal conjugate vaccines: tetanus toxoid, diphtheria toxoid, and the mutant diphtheria toxin CRM197. However, although plain polysaccharide vaccines should be considered redundant in most industrialized countries where the new-generation conjugates are available, they may still have a role in some regions where conjugates are not yet available.

The first meningococcal conjugate vaccine used was a monovalent capsular group C meningococcal conjugate vaccine (**MenC**), introduced in the United Kingdom in 1999 and administered to all children and young people <19 years old in a mass catch-up campaign before establishment in the routine infant immunization schedule. The MenC vaccine has proved highly effective (>95%) in controlling disease through both direct protection of the vaccinated population and induction of herd immunity, protecting the wider population. *Herd immunity* is induced through the impact of conjugate vaccines on colonization, reducing carriage and blocking transmission of meningococci among adolescents and young adults. Monovalent MenC vaccines are used widely in the industrialized countries of Western Europe, Canada, and Australia, where disease caused by capsular group C meningococci has virtually disappeared. However, serologic surveys show that antibody levels wane, especially after infant immunization, and booster doses are now recommended during adolescence to sustain individual and population immunity.

Quadrivalent meningococcal A, C, Y, and W conjugate vaccines (**MenACWY**) have been available since 2005 and are routinely used for U.S. adolescents and as a single adolescent booster dose in some countries that had established MenC infant programs more than a decade ago.

MenACWY was initially introduced as a single dose at 11 years of age in the United States, but concerns about waning immunity led to the adoption of a second dose. The initial reports on the effectiveness (>80%) of MenACWY in the U.S. program indicates that these vaccines are likely to provide control of disease caused by capsular groups C, W, and Y (capsular group A being unimportant currently), although the program has taken some time to become fully established. As the population of immunized adolescents and young adults in the United States grows, the effects of these vaccines on carriage of meningococci likely will reduce disease among other segments of the population through herd immunity, assuming the transmission dynamics of Y and W meningococci are the same as for capsular group C. Although MenACWY vaccines are not currently recommended in the United States for routine use in younger age-groups in view of the low rate of disease caused by these capsular groups in infancy, they may provide broader protection in countries that are already using MenC vaccines in infant programs. Other combination vaccines containing various conjugates, including Hib-MenC (used in the United Kingdom as a 12-month booster) and Hib-MenCY, may have a role in broadening protection beyond MenC in early life. [Table 237.4](#) outlines the current U.S. programmatic recommendations.

Individuals of any age at high risk of meningococcal disease, such as those with complement deficiency, and travelers to regions where there is a risk of epidemic meningococcal disease caused by A or W should receive MenACWY (see [Table 237.4](#)). The risk of disease among close contacts of cases of disease caused by vaccine capsular groups may be further reduced if they are offered MenACWY in addition to antimicrobial prophylaxis. A possible association between MenACWY-diphtheria toxoid and Guillain-Barré syndrome, which caused concern early after the vaccine was first used in the United States, has not been substantiated.

A capsular group A meningococcal conjugate vaccine (**MenA**) has been developed for use in the sub-Saharan African meningitis belt, and implementation in 2010 through mass vaccination appears to have interrupted disease caused by this capsular group.

The majority of disease in infants and in most industrialized countries is caused by capsular group *B polysaccharide-bearing meningococci*. This polysaccharide capsule has chemical identity with glycosylated protein antigens in the human fetus and, as a “self” antigen, is therefore not immunogenic in humans and leads to the theoretical risk of induction of autoimmunity. Vaccine development has therefore focused on subcapsular protein antigens. Several countries (e.g., Cuba, Norway, New Zealand) successfully controlled capsular group B epidemics by immunizing with tailor-made outer membrane vesicle vaccines

**Table 237.4** Recommendations for Meningococcal Vaccination (United States, 2021)

GENERAL POPULATION			
2-23 MO	2-10 YR	11-23 YR	≥24 YR
Not routinely recommended	Not routinely recommended	A single dose of MenACWY conjugate vaccine at age 11-12 yr with a booster dose at age 16 yr  MenB series may be offered at age 16-23 yr on basis of shared clinical decision-making (2 doses of MenB-FHbp or 4CMenB)	Not routinely recommended
SPECIAL POPULATIONS AT INCREASED RISK OF MENINGOCOCCAL DISEASE			
RISK FACTOR	2-23 MO	2-9 YR	≥10 YR
Persistent complement deficiencies (including patients using a complement inhibitor), functional or anatomic asplenia	4 doses of MenACWY conjugate vaccine at 2, 4, 6, and 12 mo*; if commencing at age 7-23 mo, 2 doses of MenACWY conjugate vaccine, with second dose administered at age ≥12 mo and ≥12 wk after first dose	2 doses of MenACWY conjugate vaccine at least 8 wk apart*	2 doses of MenACWY conjugate vaccine at least 8 wk apart* and MenB vaccine (2 doses of 4CMenB or 3 doses of MenB-FHbp) †
At risk during a community outbreak with a vaccine capsular group covered by the relevant vaccine	4 doses of MenACWY conjugate vaccine at 2, 4, 6, and 12 mo*; if commencing at age 7-23 mo, 2 doses of MenACWY conjugate vaccine, with second dose administered at age ≥12 mo and ≥12 weeks after first dose	2 doses of MenACWY conjugate vaccine at least 8 wk apart*	2 doses of MenACWY conjugate vaccine at least 8 wk apart* or MenB vaccine (2 doses of 4CMenB or 3 doses of MenB-FHbp) † depending on the capsular group of the outbreak
Travel to or resident of countries where meningococcal disease is hyperendemic or epidemic <sup>‡</sup>	4 doses of MenACWY conjugate vaccine at 2, 4, 6, and 12 mo*; if commencing at age 7-23 mo, 2 doses of MenACWY conjugate vaccine, with second dose administered at age ≥12 mo and ≥12 weeks after first dose	2 doses of MenACWY conjugate vaccine at least 8 wk apart*	2 doses of MenACWY conjugate vaccine at least 8 wk apart*
Persons with HIV infection	4 doses of MenACWY conjugate vaccine at 2, 4, 6, and 12 mo*; if commencing at age 7-23 mo, 2 doses of MenACWY conjugate vaccine, with second dose administered at age ≥12 mo and ≥12 weeks after first dose	2 doses of MenACWY conjugate vaccine at least 8 wk apart*	2 doses of MenACWY conjugate vaccine at least 8 wk apart*

\*Booster every 5 yr if ongoing risk (after 3 yr if <7 yr old).

†Boosters 1 yr after primary series and every 2-3 yr thereafter if remains at increased risk.

‡For example, visitors to the "meningitis belt" of sub-Saharan Africa. Vaccination also is required by the government of Saudi Arabia for all travelers to Mecca during the annual Hajj. Note that different MenACWY conjugate vaccines are interchangeable, but different MenB vaccines (4CMenB and MenB-FHbp) are not interchangeable.

Adapted from <https://www.cdc.gov/vaccines/hcp/acip-recs/vacc-specific/mening.html>

prepared from blebs of outer membrane harvested from the respective epidemic strains. The principal limitation of outer membrane vesicle vaccines is that the bactericidal antibody responses induced by immunization are limited to the vaccine strain, because the response is largely directed against the homologous PorA (serosubtype) protein, and they are therefore not considered for use in endemic settings, including the United States or most other industrialized countries.

Promising approaches for prevention of capsular group B disease have been developed over the past decade. One vaccine that was developed for adolescent immunization was licensed in the United States in 2014 and contains two variants of factor H-binding protein (2FHbp; Pfizer vaccines); it appears highly immunogenic in the target population, inducing bactericidal antibodies directed against a panel of strains bearing variants of fHbp. It is currently recommended for use in high-risk groups and during outbreaks (see Table 237.4). Factor H-binding protein appears to be an important virulence determinant, aiding survival of meningococci in blood, and is expressed by virtually all strains.

A four-component meningococcal vaccine, 4CMenB (Bexsero, GSK Vaccines), is licensed in Europe and North America and available in various other regions. This vaccine contains outer membrane vesicles (derived from the New Zealand outbreak strain) and three

recombinant proteins: a single variant of factor H-binding protein (FHbp), neisserial adhesin A (NadA), and neisserial heparin-binding antigen (NHBA). 4CMenB vaccine induced bactericidal antibodies against strains containing the vaccine antigens in infants, toddlers, and adolescents in clinical trials. The vaccine appears to have a generally favorable safety profile, although induction of fever in infants and pain at the injection site in other age-groups are common. This vaccine has been used to control university outbreaks of capsular group B meningococcal disease in the United States and Canada and hyperendemic disease in Quebec, Canada. Current recommendations for use in the United States are outlined in Table 237.4. It was recommended for routine use in the infant immunization program in the United Kingdom in 2014 and deployed from September 2015. Early data reported a 75% reduction in age-groups that were fully eligible for vaccination, with a high coverage rate of 95% (a nonsignificant vaccine effectiveness of 53% after two doses and 59% after a booster dose at 1 year of age). A large cluster randomized trial in Australia found no effect of 4CMenB on carriage of disease-causing meningococci, highlighting that the benefit of this vaccine is likely to be via direct protection.

Visit Elsevier eBooks+ at [eBooks.Elsevier.com](https://www.elsevier.com/ebooks) for Bibliography.

## Chapter 238

***Neisseria gonorrhoeae***  
**(Gonococcus)**Katherine Hsu, Sanjay Ram, and  
Toni Darville

*Neisseria gonorrhoeae* is the causative agent of **gonorrhea**, an infection of the genitourinary tract mucous membranes and of the mucosa of the rectum, oropharynx, and conjunctiva. Among sexually transmissible infections, gonorrhea transmitted by sexual contact or perinatally is second only to chlamydial infections in the number of cases reported to the U.S. Centers for Disease Control and Prevention (CDC). This high prevalence and the development of antibiotic-resistant strains have led to significant morbidity.

**ETIOLOGY**

*N. gonorrhoeae* is a nonmotile, aerobic, non-spore-forming, gram-negative diplococcus with flattened adjacent surfaces. Optimal growth occurs at 35–37°C (95–98.6°F) and at pH 7.2–7.6 in an atmosphere of 3–5% carbon dioxide. The specimen should be inoculated quickly onto fresh, moist, modified Thayer-Martin or specialized transport media, because gonococci do not tolerate drying. Thayer-Martin selective medium contains antimicrobial agents that inhibit the normal flora present in clinical specimens from mucosal sites that may otherwise overgrow gonococci. Presumptive identification may be based on colony appearance, Gram stain, and production of cytochrome oxidase. Gonococci are differentiated from other *Neisseria* spp. by the fermentation of glucose but not maltose, sucrose, or lactose. Gram-negative diplococci are seen in infected material, often within polymorphonuclear leukocytes (PMNs).

As with all gram-negative bacteria, *N. gonorrhoeae* possesses a cell envelope composed of an inner cytoplasmic membrane, a middle layer of peptidoglycan, and an outer membrane. The outer membrane contains **lipooligosaccharide (LOS)**; also called **endotoxin**, phospholipid, and a variety of proteins that contribute to cell adherence, tissue invasion, and resistance to host defenses. Systems previously used to characterize gonococcal strains included auxotyping and serotyping. **Auxotyping** is based on genetically stable requirements of strains for specific nutrients or cofactors as defined by an isolate's ability to grow on chemically defined media. **Serotyping** systems were based on specific monoclonal antibodies directed against a porin protein called **PorB** (formerly *Protein I* or *PorI*), a trimeric outer membrane protein that makes up a substantial part of the gonococcal envelope structure. Changes in the PorB protein present in a community are believed to result, at least in part, from selective immune pressure. DNA-based typing methods have now supplanted auxotyping and serotyping. Older gel-based DNA-based typing methods that included restriction fragment length polymorphism (RFLP) analysis of genomic DNA or rRNA (ribotyping) or typing of genes encoding opacity protein (*opa*) were labor intensive and sometimes lacked the ability to accurately discriminate among strains. Methods currently used include the *N. gonorrhoeae* multiantigen sequence typing (NG-MAST), which examines the sequences of the variable internal fragments of two highly polymorphic *N. gonorrhoeae* genes (*porB* encoding PorB and *tbpB* encoding subunit B of transferrin-binding protein), multilocus sequence typing (MLST), which analyzes the sequences of seven chromosomal housekeeping genes, and whole genome sequencing.

**EPIDEMIOLOGY**

Since gonorrhea became a nationally notifiable disease in 1944, U.S. rates have ranged between a historic high of 467.7 cases per 100,000 population in 1975 and a historic low of 98.1 per 100,000 in 2009.

However, rates of gonorrhea have increased almost every year since 2009 (with an overall increase of 118% between 2009 and 2021), with a total of 710,151 cases and a rate of 214.0/100,000 reported in 2021. Rates of reported gonorrhea are also highest in the South (242.9/100,000); among young adults age 20–24 (860.5 cases per 100,000); among males (249.7/100,000 vs 177.9/100,000 among females); and among Blacks (652.9/100,000 vs 78.9/100,000 among Whites). The higher case rate among men and the magnitude of recent increases suggest either increased transmission, increased case ascertainment (e.g., through increased extragenital screening among men who have sex with men [MSM]), or both. The concurrent increase in cases reported among women suggests parallel increases in heterosexual transmission, increased screening among women, or both.

Molecular typing methods (e.g., NG-MAST, MLST) are used to analyze the spread of individual strains of *N. gonorrhoeae* within a community. Maintenance and subsequent spread of gonococcal infections in a community are sustained through continued transmission by asymptotically infected people and also by a **hyperendemic, high-risk** core group such as commercial sex workers, MSM, or adolescents with multiple sexual partners. This latter observation reflects that most persons who have symptomatic gonorrhea cease sexual activity and seek care, unless economic need or other factors (e.g., drug addiction) drive persistent sexual activity. Thus many core transmitters belong to a subset of infected persons who lack or ignore symptoms and continue to be sexually active, underscoring the importance of seeking out and treating the sexual contacts of infected persons who present for treatment. **Oral sex** has a role in sustaining gonorrhea in MSM by providing a pool of untreated asymptomatic pharyngeal infections and may account for as much as one third of symptomatic gonococcal urethritis in MSM.

Gonococcal infection of neonates usually results from peripartum exposure to infected exudate from the cervix of the mother. An acute infection begins 2–5 days after birth. The incidence of neonatal infection depends on the prevalence of gonococcal infection among pregnant women, prenatal screening for gonorrhea, and neonatal ophthalmic prophylaxis.

**PATHOGENESIS AND PATHOLOGY**

*N. gonorrhoeae* infects primarily columnar epithelium because stratified squamous epithelium is relatively resistant to invasion. Mucosal invasion by gonococci results in a local inflammatory response that produces a purulent exudate consisting of PMNs, serum, and desquamated epithelium. The gonococcal LOS (endotoxin) exhibits direct cytotoxicity, causing ciliostasis and sloughing of ciliated epithelial cells. Tumor necrosis factor (TNF) and other cytokines are thought to mediate the cytotoxicity of gonococcal infections. Complement activation also contributes to the acute inflammatory response.

Gonococci may ascend the urogenital tract, causing urethritis or epididymitis in postpubertal males and acute endometritis, salpingitis, and peritonitis (collectively termed **acute pelvic inflammatory disease** or **PID**) in postpubertal females. Dissemination from the fallopian tubes through the peritoneum to the liver capsule results in **perihepatitis** (Fitz-Hugh–Curtis syndrome). Gonococci that invade the lymphatics and blood vessels may cause inguinal lymphadenopathy; perineal, perianal, ischiorectal, and periprostatic abscesses; and **disseminated gonococcal infection (DGI)**.

A number of gonococcal virulence and host immune factors are involved in the penetration of the mucosal barrier and subsequent manifestations of local and systemic infection. Selective pressure from different mucosal environments probably leads to changes in the outer membrane of the organism, including expression of variants of pili, opacity (*Opa*) proteins (formerly called *protein II*), and LOS. These changes may enhance gonococcal attachment, invasion, replication, and evasion of the host's immune response.

For infection to occur, the gonococcus must first attach to host cells. Gonococci adhere to the microvilli of nonciliated epithelial cells by hairlike protein structures (pili) that extend from the cell wall. Pili undergo high-frequency antigenic variation that may aid in



the organism's escape from the host immune response and may provide specific ligands for different cell receptors. Opa proteins, most of which confer an opaque appearance to colonies, function as ligands for members of the carcinoembryonic antigen-related cell adhesion molecule (CEACAM) family of proteins or heparin sulfate proteoglycans (HSPGs) to facilitate binding to human cells. Interactions between complement receptor 3 (CR3) on cervical epithelial cells and complement iC3b (deposited on bacteria), pili, and PorB on the gonococcal surface facilitate cellular entry of gonococci in women. In contrast, the interaction between LOS and asialoglycoprotein receptor (ASGP-R) permits gonococcal entry into male urethral epithelial cells. Gonococci that express certain Opa proteins adhere to CEACAM3 and are phagocytosed by human neutrophils in the absence of serum. The interaction of Opa with CEACAM1 on CD4<sup>+</sup> T lymphocytes may suppress their activation and proliferation and contribute to the immunosuppression associated with gonorrhea. A gonococcal IgA protease inactivates IgA1 by cleaving the molecule in the hinge region and could contribute to colonization or invasion of host mucosal surfaces.

Other phenotypic changes that occur in response to environmental stresses allow gonococci to establish infection. Examples include iron-repressible proteins such as transferrin-binding proteins (TbpA and TbpB) and lactoferrin-binding proteins (LbpA and LbpB) for binding to and extracting iron from transferrin or lactoferrin, respectively, anaerobically expressed proteins, and proteins that are synthesized in response to contact with epithelial cells. Gonococci may grow in vivo under anaerobic conditions or in an environment with a relative lack of iron.

Approximately 24 hours after attachment, the epithelial cell surface invaginates and surrounds the gonococcus in a phagocytic vacuole. This phenomenon is thought to be mediated by the insertion of the gonococcal PorB protein into the host cell, causing alterations in membrane permeability. Subsequently, phagocytic vacuoles begin releasing gonococci into the subepithelial space by means of exocytosis. Viable organisms may then cause local disease (i.e., salpingitis) or disseminate through the bloodstream or lymphatics.

Serum IgG and IgM directed against gonococcal proteins and LOS activate complement on gonococci. Gonococci have evolved several mechanisms to dampen complement activation. Scavenging cytidine monophospho-*N*-acetyl neuraminic acid (CMP-Neu5Ac, the donor molecule for sialic acid) to sialylate its LOS is one such example, which reduces binding of bactericidal antibodies and simultaneously enhances binding of a complement inhibitor called **factor H** (FH). This property is often lost on subculturing gonococci on medium that lacks CMP-Neu5Ac and is thus termed *unstable serum resistance*. In contrast, *stable serum resistance* (complement resistance independent of LOS sialylation) is often seen in gonococci that express particular porin proteins (most PorB.1As and select PorB.1Bs), which enables them to bind to complement inhibitors such as FH and C4b-binding protein (C4BP). Such strains are often associated with disseminated disease. *N. gonorrhoeae* differentially subverts the effectiveness of complement and alters the inflammatory responses elicited in human infection. Stably serum-resistant DGI isolates show less C3b deposition on their surface, inactivate C3b more rapidly, generate less C5a, and result in less inflammation at local sites. PID isolates (grown in the absence of the donor molecule for sialic acid) are serum sensitive, deposit more C3b on their surface, generate more C5a, and result in more inflammation at local sites. IgG antibody directed against gonococcal reduction-modifiable protein (**Rmp**) blocks complement-mediated killing of *N. gonorrhoeae*. Anti-Rmp blocking antibodies may harbor specificity for outer membrane protein (e.g., OmpA) sequences shared with other *Neisseria* spp. or Enterobacteriaceae, may be directed against a unique Rmp sequence upstream of the OmpA-shared region that includes a cysteine loop, or both. Preexisting antibodies directed against Rmp facilitate transmission of gonococcal infection to exposed women; Rmp is highly conserved in *N. gonorrhoeae*, and the blocking of mucosal defenses may be one of its functions. Gonococcal adaptation also appears to be important in the evasion of killing by neutrophils. Examples include sialylation of LOS, increases in catalase production, and changes in the expression of surface proteins. Neutrophil phagosomes

bearing gonococci show delayed fusion with primary granules, promoting gonococcal survival within neutrophils. Other strategies gonococci employ to evade killing by neutrophils include blocking lysozyme activity (mediated by the proteins SliC and adhesin complex protein [ACP]) and degrading neutrophil extracellular traps.

Host factors may influence the incidence and manifestations of gonococcal infection. Prepubertal girls are susceptible to vulvovaginitis and rarely experience salpingitis. *N. gonorrhoeae* infects noncornified epithelium, and the thin noncornified vaginal epithelium and alkaline pH of the vaginal mucin predispose this age-group to infection of the lower genital tract. Estrogen-induced cornification of the vaginal epithelium in neonates and mature females resists infection. Postpubertal females are more susceptible to salpingitis, especially during menses, when diminished bactericidal activity of the cervical mucus and reflux of blood from the uterine cavity into the fallopian tubes facilitate passage of gonococci into the upper reproductive tract.

Populations at risk for DGI include asymptomatic carriers; neonates; menstruating, pregnant, and postpartum women; MSM; and individuals with congenital or acquired (for example, via pharmacologic inhibition) defects in complement. The asymptomatic carrier state implies failure of the host immune system to recognize the gonococcus as a pathogen, the capacity of the gonococcus to avoid being killed, or both. **Pharyngeal colonization** has been proposed as a risk factor for DGI. The high rate of asymptomatic infection in pharyngeal gonorrhea may account for this phenomenon. Women are at greater risk for development of DGI during menstruation, pregnancy, and the postpartum period, presumably because of the maximal endocervical shedding and decreased peroxidase bactericidal activity of the cervical mucus during these periods. A lack of neonatal bactericidal IgM antibody is thought to account for the increased susceptibility of neonates to DGI. Persons with terminal complement component deficiencies (C5–C9) are at considerable risk for development of recurrent episodes of DGI.

## CLINICAL MANIFESTATIONS

Gonorrhea is manifested by a spectrum of clinical presentations from asymptomatic carriage, to the characteristic localized mucosal infections, to disseminated systemic infection (see [Chapter 163](#)).

### Asymptomatic Gonorrhea

The incidence of asymptomatic gonorrhea in children has not been ascertained. Gonococci have been isolated from the oropharynx of young children who have been abused sexually by male contacts; oropharyngeal symptoms are usually absent. Most genital tract infections produce symptoms in children. However, as many as 80% of sexually mature females with urogenital gonorrhea infections are asymptomatic in settings in which most infections are detected through screening or other case-finding efforts. This situation is in contrast to that in men, who are asymptomatic only 10% of the time. Asymptomatic rectal carriage of *N. gonorrhoeae* has been documented in 26–68% of females with urogenital infection. Most persons with positive rectal culture results are asymptomatic. Most pharyngeal gonococcal infections are asymptomatic, although rarely **acute tonsillopharyngitis** or **cervical lymphadenopathy** can occur. Pharyngeal gonorrhea is easily acquired through fellatio and may account for a significant proportion of urethral gonorrhea in MSM. Pharyngeal gonorrhea is increasingly prevalent, particularly among adolescents and young adults, associated with overall increasing prevalence of oral sex behaviors.

### Uncomplicated, Localized Gonorrhea

Genital gonorrhea has an incubation period of 2–5 days in men and 5–10 days in women. Primary infection develops in the urethra of males, the vulva and vagina of prepubertal females, and the cervix of postpubertal females. Neonatal ophthalmitis (ophthalmia neonatorum) occurs in both genders.

**Urethritis** is usually characterized by a purulent discharge and by dysuria without urgency or frequency. Untreated urethritis in males resolves spontaneously in several weeks or may be complicated by epididymitis, penile edema, lymphangitis, prostatitis, or seminal vesiculitis. Gram-negative intracellular diplococci are found in the discharge.

In MSM, the rectal mucosa can become infected after receptive anal intercourse. Symptoms range from painless mucopurulent discharge and scant rectal bleeding to overt proctitis with associated rectal pain and tenesmus.

In prepubertal females, **vulvovaginitis** is usually characterized by a purulent vaginal discharge with a swollen, erythematous, tender, and excoriated vulva. Dysuria may occur. Gonococcal infection should be considered in any girl with vaginal discharge, even when sexual abuse is not suspected; sexual abuse must be considered strongly when gonococcal infection is diagnosed in prepubertal children beyond the neonatal period. In postpubertal females, symptomatic gonococcal **cervicitis** and urethritis are characterized by purulent discharge, suprapubic pain, dysuria, intermenstrual bleeding, and dyspareunia. The cervix may be inflamed and tender. In urogenital gonorrhoea limited to the lower genital tract, pain is not enhanced by moving the cervix and the adnexa are not tender to palpation. Purulent material may be expressed from the urethra or ducts of the Bartholin gland. Rectal gonorrhoea is often asymptomatic but may cause proctitis with symptoms of anal discharge, pruritus, bleeding, pain, tenesmus, and constipation. Asymptomatic rectal gonorrhoea may not be from anal intercourse but may represent translocation of infected secretions from cervicovaginal infection.

Gonococcal **ophthalmitis** may be unilateral or bilateral and may occur in any age-group after inoculation of the eye with infected secretions. **Ophthalmia neonatorum** caused by *N. gonorrhoeae* usually appears from 2-5 days after birth (see Chapter 674). Ocular infection in older patients results from inoculation or autoinoculation from a genital site. The infection begins with mild inflammation and a sero-sanguineous discharge. Within 24 hours, the discharge becomes thick and purulent and tense edema of the eyelids with marked chemosis occurs. If the disease is not treated promptly, corneal ulceration, rupture, and blindness may follow.

### Disseminated Gonococcal Infection

Hematogenous dissemination occurs in 1-3% of all gonococcal infections, more frequently after asymptomatic primary infections than symptomatic infections. Women previously accounted for the majority of cases, with symptoms beginning 7-30 days after infection and within 7 days of menstruation in about one half of cases, but more recent case series describe more male than female cases. The most common manifestations are asymmetric arthralgia, petechial or pustular acral skin lesions, tenosynovitis, suppurative arthritis, and rarely, carditis, meningitis, and osteomyelitis. The most common initial symptom is acute onset of **polyarthralgia with fever**. Only 25% of patients complain of skin lesions. Most deny genitourinary symptoms; however, primary mucosal infection is documented by genitourinary cultures. Results of approximately 80-90% of cervical cultures are positive in women with DGI. In males, urethral culture results are positive in 50-60%, pharyngeal culture results are positive in 10-20%, and rectal culture results are positive in 15% of cases.

DGI is classified into two clinical syndromes that have some overlapping features. The more common **tenosynovitis-dermatitis syndrome** is characterized by fever, chills, skin lesions, and polyarthralgia predominantly involving the wrists, hands, and fingers. Blood culture results are positive in approximately 30-40% of cases, and results of synovial fluid cultures are almost uniformly negative. In **suppurative arthritis syndrome**, systemic symptoms and signs are less prominent and monoarticular arthritis is more common, often involving the knee. A polyarthralgia phase may precede the monoarticular infection. In cases of monoarticular involvement, synovial fluid culture results are positive in approximately 45-55%, and synovial fluid findings are consistent with septic arthritis. Blood culture results are usually negative. DGI in neonates usually occurs as a polyarticular suppurative arthritis.

Dermatologic lesions usually begin as painful, discrete, 1- to 20-mm, pink or red macules that progress to maculopapular, vesicular, bullous, pustular, or petechial lesions. The typical necrotic pustule on an erythematous base is distributed unevenly over the extremities, including the palmar and plantar surfaces, usually sparing the face and scalp. The

lesions number between 5 and 40, and 20-30% may contain gonococci. Although immune complexes may be present in DGI, complement levels are normal, and the role of the immune complexes in pathogenesis is uncertain.

**Acute endocarditis** is an uncommon (1-3%) but often fatal manifestation of DGI that usually leads to rapid destruction of the aortic valve. **Acute pericarditis** is a rarely described entity in patients with disseminated gonorrhoea. **Meningitis** with *N. gonorrhoeae* has been documented, and signs and symptoms are similar to those of any acute bacterial meningitis.

### DIAGNOSIS

Laboratory confirmation of gonococcal infection is essential, given the legal implications of potential sexual abuse in children and the need to refer sex partners of adolescents and adults for treatment. Given the advent of highly sensitive and specific nucleic acid amplification tests (NAATs), the use of less sensitive, nonamplified test technologies (nucleic acid hybridization/probe tests, nucleic acid genetic transformation tests, or enzyme immunoassays) is no longer justified. Culture and susceptibility testing capability still need to be maintained, because culture is necessary to evaluate suspected cases of gonorrhoea treatment failure and to monitor developing resistance to current treatment regimens.

### Gram Stain and Culture

Gram stains can be useful in the initial evaluation of patients with suspected gonococcal infection. In males with symptomatic urethritis, a presumptive diagnosis of gonorrhoea can be made by identification of gram-negative intracellular diplococci (within PMNs) in the urethral discharge. A similar finding in females is not sufficient because *Mima polymorpha* and *Moraxella*, which are normal vaginal flora, have a similar appearance. The sensitivity of the Gram stain for diagnosing gonococcal cervicitis and asymptomatic infections is also low. The presence of commensal *Neisseria* spp. in the oropharynx prevents the use of the Gram stain for diagnosis of pharyngeal gonorrhoea.

Culture can be performed of any site, including nongenital sites. Advantages of culture include the availability of an isolate for further studies, including antibiotic susceptibility testing. Disadvantages of culture include more stringent transport and growth requirements, lower sensitivity than NAATs, and a delay in availability of results. Material for cervical cultures is obtained as follows. After the exocervix is wiped, a swab is placed in the cervical os and rotated gently for several seconds. Male urethral specimens are obtained by placement of a small swab 2-3 cm into the urethra. Rectal swabs are best obtained by passing a swab 2-4 cm into the anal canal; specimens that are heavily contaminated by feces should be discarded. For optimal culture results, specimens should be obtained with noncotton swabs, inoculated directly onto culture plates containing selective media (see later), and incubated immediately. The choice of anatomic sites to culture depends on the sites exposed and the clinical manifestations. If symptoms are present, samples from the urethra and rectum can be cultured for men, and samples from the endocervix and rectum can be cultured for all females, regardless of a history of anal intercourse. A pharyngeal culture specimen should be obtained from both men and women if symptoms of pharyngitis are present with a history of recent oral exposure or oral exposure to a person known to have genital gonorrhoea. In a suspected case of **child sexual abuse**, culture or FDA approved NAAT are recommended methods of detection for *N. gonorrhoeae* in genital and extragenital specimens. Culture of the endocervix should not be attempted until after puberty.

Specimens from sites that are normally colonized by other organisms (e.g., cervix, rectum, pharynx) should be inoculated on a selective culture medium, such as modified Thayer-Martin medium (fortified with vancomycin, colistin, nystatin, and trimethoprim to inhibit growth of indigenous flora). Specimens from sites that are normally sterile or minimally contaminated (i.e., synovial fluid, blood, cerebrospinal fluid) should be inoculated on a nonselective chocolate agar medium. If DGI is suspected, blood, pharynx, rectum, urethra, cervix, and synovial fluid (if involved) should be cultured. Cultured specimens should

be incubated promptly at 35–37°C (95–98.6°F) in 3–5% carbon dioxide. When specimens must be transported to a central laboratory for culture plating, a reduced, nonnutrient holding medium (i.e., Amies [modified Stuart] transport medium) preserves specimens with minimal loss of viability for up to 6 hours. When transport may delay culture plating by >6 hours, it is preferable to inoculate the sample directly onto a culture medium and transport it at an ambient temperature in a CO<sub>2</sub>-enriched atmosphere. The Transgrow and John E. Martin Biological Environmental Chamber (JEMBEC) systems of modified Thayer-Martin medium are alternative transport systems.

### Nucleic Acid Amplification Tests

The U.S. FDA has approved NAATs for use with genital (endocervical, vaginal, male urethral, and female and male first-catch urine) and extragenital (pharyngeal and rectal) specimens. Advantages of using NAATs include less stringent transport conditions, more rapid turnaround time, flexibility in sampling source (providing additional feasibility of testing in settings where a physical exam is not done), and patient preference for less invasive sampling. However, NAATs cannot provide antimicrobial susceptibility results, so in cases of persistent gonococcal infection after treatment, clinicians should perform both culture and antimicrobial susceptibility testing. Although urine specimens are acceptable for women, the sensitivity for screening appears to be lower than with vaginal or endocervical swab samples. In contrast, the sensitivity and specificity of urine and urethral swab specimens from men are similar, so first-catch urine is the recommended sample type for urethral screening in men. Product inserts for each NAAT vendor must be carefully examined to assess current indications and allowable specimens. Some NAAT platforms are now FDA cleared for use with specimens from the rectum and pharynx, facilitating their use for clinical management of extragenital infections (gonorrhea screening of rectal and pharyngeal sites with NAATs is recommended quarterly for some sexually active MSM, e.g., those taking HIV prophylaxis). NAATs have not yet been FDA cleared for specimens from the conjunctiva, joint fluid, blood, or cerebrospinal fluid. Rapid NAATs with shortened turnaround times of 30 minutes and waivers allowing use in point-of-care settings such as physician offices, community clinics, and other outpatient settings have now also been FDA cleared.

Although data regarding NAAT for children are more limited and performance is test-dependent, there is no evidence that performance of FDA-approved NAAT for detection of *N. gonorrhoeae* among children differs from that among adults. In a multicenter study of NAATs using strand displacement amplification or transcription-mediated amplification in children being evaluated for sexual abuse, urine from prepubertal girls was a reliable alternative to vaginal culture for detection for *N. gonorrhoeae*. Consultation with an expert is necessary before using NAAT in this context, both to minimize the possibility of cross-reaction with nongonococcal *Neisseria* species and other commensals (e.g., *N. meningitidis*, *N. sicca*, *N. lactamica*, *N. cinerea*, or *Moraxella catarrhalis*) and to ensure correct interpretation of results. Because of the implications of a diagnosis of *N. gonorrhoeae* infection in a child, only CLIA-validated, FDA-cleared NAATs should be used, and all positive specimens should be retained for additional confirmatory testing.

### TREATMENT

All patients who are presumed or proven to have gonorrhea should be evaluated for concurrent syphilis, HIV, and *Chlamydia trachomatis* infection. The incidence of *Chlamydia* co-infection is 15–25% among males and 35–50% among females. Patients beyond the neonatal period should be treated presumptively for *C. trachomatis* infection unless a negative chlamydial NAAT result is documented at the time treatment is initiated for gonorrhea. However, if chlamydial test results are not available or if a non-NAAT result is negative for *Chlamydia*, patients should be treated for both gonorrhea and *Chlamydia* infection (see Chapter 272.2). Persons who receive a diagnosis of gonorrhea should be instructed to abstain from sexual activity for 7 days after treatment and until all sex partners are adequately treated (7 days after receiving treatment and resolution of symptoms, if present). Sexual

partners exposed in the preceding 60 days should be examined, specimens collected, and presumptive treatment started.

*N. gonorrhoeae* has progressively developed resistance to the antibiotics used to treat it. Antimicrobial resistance in *N. gonorrhoeae* occurs as plasmid-mediated resistance to penicillin and tetracycline and chromosomally mediated resistance to penicillins, tetracyclines, spectinomycin, fluoroquinolones, cephalosporins, and azithromycin. Emergence of cephalosporin resistance worldwide has prompted designation of *N. gonorrhoeae* as antibiotic-resistance threat level “Urgent” by the CDC. Surveillance data from the CDC Gonococcal Isolate Surveillance Project reveal concerning fluctuations in minimum inhibitory concentration (MIC) for the oral cephalosporin **cefixime** and the injectable third-generation cephalosporin **ceftriaxone**, leading the CDC to revise its U.S. gonorrhea treatment guidelines in 2012 to dual therapy (usually a combination of ceftriaxone and azithromycin) in an attempt to preserve the last commercially available effective treatment. However, the CDC revised its recommendations in 2020; ceftriaxone is now the only first-line recommended treatment for gonorrhea at all sites. The change from dual therapy to monotherapy was based on (1) increasing concern for antimicrobial stewardship and the potential impact of dual therapy on commensal organisms and concurrent pathogens, (2) new pharmacokinetic and pharmacodynamic data regarding optimal dosing for gonorrhea, and (3) increasing azithromycin resistance (and therefore no optimal second drug to pair with a cephalosporin if dual therapy were the goal).

**Table 238.1** summarizes first-line treatment regimens for neonate, child (weight ≤45 kg), adolescent, and adult gonococcal regimens. Mucosal, localized infections are treatable with single doses; disseminated infections are treated for a minimum of 1 week.

Alternative regimens exist for adolescents and adults but are extremely limited. For patients with cephalosporin allergy, the combination of gentamicin (240 mg intramuscularly [IM]) plus azithromycin (2 g orally [PO]) cured 100% of uncomplicated urogenital cases in a trial of U.S. patients age 15–60 years; the combination of gemifloxacin (320 mg PO) (not licensed for use in those <18 years old) plus azithromycin (2 g PO) cured >99% of uncomplicated urogenital cases in the same trial but was limited by 8% of patients vomiting within 1 hour of dual oral drug administration. For patients with azithromycin allergy, doxycycline (100 mg PO twice daily for 7 days) can be used in place of azithromycin as an alternative second antimicrobial. If ceftriaxone is not available, alternative cephalosporins include oral cefixime (800 mg PO), which has limited efficacy for pharyngeal gonorrhea, and other single-dose injectable cephalosporin regimens, such as ceftizoxime (500 mg IM) or cefoxitin (2 g IM) with probenecid (1 g PO), neither of which offers any advantage over ceftriaxone for urogenital infection, and their efficacy against pharyngeal infection is less certain.

Pregnant women with gonococcal infection should be treated with standard adult therapy. If allergy precludes standard treatment, consultation with an infectious disease specialist is recommended. HIV-co-infected patients with gonococcal infection are treated the same as HIV-negative patients.

Follow-up test of cure is not recommended for persons diagnosed with uncomplicated urogenital or rectal gonorrhea receiving recommended or alternative regimens. However, any person with pharyngeal gonorrhea should return 7–14 days after treatment for a test of cure using culture, NAAT, or both, because pharyngeal gonorrhea is more difficult to eradicate. Symptoms persisting after treatment should be evaluated by culture for *N. gonorrhoeae* (with or without simultaneous NAAT), and any gonococci isolated should be tested for antimicrobial susceptibility. **Treatment failure** should be considered in (1) persons whose symptoms do not resolve within 3–5 days after appropriate treatment and who report no sexual contact during posttreatment follow-up and (2) persons with a positive test of cure (i.e., positive culture >72 hours or positive NAAT ≥7 days after receiving recommended treatment) who report no sexual contact during posttreatment follow-up.

### COMPLICATIONS

Prompt diagnosis and correct therapy ensure complete recovery from uncomplicated gonococcal disease. Complications of gonorrhea result



**Table 238.1** Recommended Treatment of Gonococcal Infections

AGE GROUP	INFECTION	TREATMENT REGIMEN	LENGTH OF THERAPY
Neonates	Ophthalmia neonatorum	Ceftriaxone* 25-50 mg/kg IV or IM OR cefotaxime 100 mg/kg IV or IM	Once
	Disseminated infection Scalp abscess Septic arthritis	Ceftriaxone 25-50 mg/kg IV or IM every day OR cefotaxime 25-50 mg/kg IV or IM q8-12h <sup>†</sup>	7 days
	Meningitis	Ceftriaxone 25-50 mg/kg IV or IM every day OR cefotaxime 25-50 mg/kg IV or IM q8-12h	10-14 days
	Endocarditis	Ceftriaxone 25-50 mg/kg IV or IM every day OR cefotaxime 25-50 mg/kg IV or IM q8-12h	Minimum 28 days
Children ≤45 kg	Pharyngeal infection Anorectal infection Urogenital infection	Ceftriaxone 25-50 mg/kg IV or IM (max 500 mg)	Once
	Conjunctivitis	Ceftriaxone 50 mg/kg IM (max 1 g) plus consider lavage of infected eye with saline solution	Once
	Disseminated infection Septic arthritis	Ceftriaxone 50 mg/kg IV or IM every day (max 1 g daily)	7 days
	Meningitis	Ceftriaxone 50 mg/kg IV or IM q12-24h (max 4 g daily)	10-14 days
	Endocarditis	Ceftriaxone 50 mg/kg IV or IM q12-24h (max 4 g daily)	Minimum 28 days
Adults, adolescents, and children >45 kg	Pharyngeal infection Anorectal infection Urogenital infection	Ceftriaxone 500 mg IM (or 1 g IM for persons ≥150 kg)	Once
	Conjunctivitis	Ceftriaxone 1 g IM plus consider lavage of infected eye with saline solution	Once
	Disseminated infection Septic arthritis	Ceftriaxone 1 g IV or IM every day	7 days
	Meningitis	Ceftriaxone 1-2 g IV q12-24h	10-14 days
	Endocarditis	Ceftriaxone 1-2 g IV q12-24h	Minimum 28 days

\*Ceftriaxone should be administered cautiously to neonates with hyperbilirubinemia, especially those born prematurely. Cefotaxime can be administered for those neonates unable to receive ceftriaxone because of simultaneous administration of IV calcium. Consult neonatal dosing references.

<sup>†</sup>Dose or dosing frequency changes after postnatal age >7 days of life: consult neonatal dosing references.

IM, Intramuscularly; IV, intravenously; max, maximum; PO, orally.

From Wangu Z, Hsu KK. *Neisseria gonorrhoeae*. In Long SS, Prober CG, Fischer M, Kimberlin D, eds. *Principles and Practice of Pediatric Infectious Diseases*, 6th ed. Philadelphia: Elsevier; 2023: Table 126.1.

from the spread of gonococci from a local site of invasion. Complications and permanent sequelae may be associated with delayed treatment, recurrent infection, metastatic sites of infection (meninges, aortic valve), and delayed or topical therapy of gonococcal ophthalmia.

The interval between primary infection and development of a complication is usually days to weeks. In postpubertal females, endometritis may occur, especially during menses, and may progress to salpingitis, tuboovarian abscess, and peritonitis (PID). Manifestations of PID include signs of lower genital tract infection (e.g., vaginal discharge, suprapubic pain, cervical tenderness) and upper genital tract infection (e.g., fever, leukocytosis, elevated erythrocyte sedimentation rate, and adnexal tenderness or mass). The differential diagnosis includes gynecologic diseases (ovarian cyst, ovarian tumor, ectopic pregnancy) and intraabdominal disorders (appendicitis, urinary tract infection, inflammatory bowel disease). Although *N. gonorrhoeae* and *C. trachomatis* are implicated in many cases of PID, this syndrome encompasses a spectrum of infectious diseases of the upper genital tract caused by *N. gonorrhoeae*, *C. trachomatis*, and endogenous flora (streptococci, anaerobes, gram-negative bacilli). Treatment must therefore be broad. For women with more severe symptoms (inability to exclude surgical emergency, presence of tuboovarian abscess, severe illness, nausea, vomiting, or high fever), pregnancy, or lack of response to outpatient therapy within 72 hours, parenteral therapy should be initiated in the hospital. The decision to hospitalize adolescents with acute PID should

be based on the same criteria used for older women, because the clinical response to outpatient treatment is similar among younger and older women.

Recommended parenteral regimens are ceftriaxone (1 g intravenously [IV] every 24 hours [q24h]) and metronidazole (500 mg PO or IV q12h); or cefotetan (2 g IV q12h); or cefoxitin (2 g IV q6h). Each of these regimens (ceftriaxone and metronidazole; cefotetan; or cefoxitin) should be combined with doxycycline (100 mg PO or IV q12h). An alternative parenteral regimen is ampicillin-sulbactam (3 g IV q6h) plus doxycycline (100 mg PO or IV q12h) or clindamycin (900 mg IV q8h) plus a loading dose of gentamicin (2 mg/kg IV or IM) followed by maintenance gentamicin (1.5 mg/kg q8h). Clinical experience should guide the transition to oral therapy, which usually can be initiated within 24 hours of improvement. Thereafter doxycycline (100 mg PO twice daily [bid]) to complete 14 days of total therapy, with oral clindamycin (450 mg PO 4 times daily [qid]) or metronidazole (500 mg PO bid) added for more effective anaerobic coverage, is provided. Parenteral therapy and IM/PO therapy appear to be similar in terms of clinical efficacy for younger and older women with PID of mild to moderate severity. Recommended IM/PO therapy regimens are as follows: a single dose of ceftriaxone (500 mg IM); single doses of cefoxitin (2 g IM) and probenecid (1 g PO) plus doxycycline (100 mg PO bid); or another parenteral third-generation cephalosporin (e.g., ceftizoxime). Each of these regimens (ceftriaxone; cefoxitin and probenecid; other



parenteral third-generation cephalosporin) should be combined with doxycycline (100 mg PO bid) and metronidazole (500 mg PO bid) for 14 days.

Once inside the peritoneum, gonococci may seed the liver capsule, causing a perihepatitis with right upper quadrant pain (**Fitz-Hugh-Curtis syndrome**), with or without signs of salpingitis. Perihepatitis may also be caused by *C. trachomatis*. Progression to PID occurs in approximately 20% of cases of gonococcal cervicitis, and *N. gonorrhoeae* is isolated in approximately 40% of cases of PID in the United States. Untreated cases may lead to hydrosalpinx, pyosalpinx, tubo-ovarian abscess, and eventual sterility. Even with adequate treatment of PID, the risk for sterility from bilateral tubal occlusion approaches 20% after one episode of salpingitis and exceeds 60% after three or more episodes. The risk for ectopic pregnancy is increased approximately sevenfold after one or more episodes of salpingitis. Additional sequelae of PID include chronic pain, dyspareunia, and increased risk for recurrent PID.

Urogenital gonococcal infection acquired during the first trimester of pregnancy carries a high risk for septic abortion. After 16 weeks of pregnancy, infection leads to **chorioamnionitis**, a major cause of premature rupture of the membranes and premature delivery.

In males, without treatment, gonococcal urethritis usually resolves spontaneously over several weeks to months. Epididymitis and acute or chronic prostatitis are uncommon complications; most men with gonococcal epididymitis also have overt urethritis. Even more unusual complications include penile edema associated with penile dorsal lymphangitis or thrombophlebitis, periurethral abscess or fistulas, seminal vesiculitis, and balanitis in uncircumcised men.

## PREVENTION

Efforts to develop gonococcal vaccines that confer broad cross-protection have been unsuccessful thus far. A pilus vaccine elicited an antibody response and conferred protection against challenge with the homologous strain but did not protect against disease in a trial involving 3,250 volunteers. The high degree of interstrain and intrastrain antigenic variability of pili poses a formidable barrier to the development of a single effective pilus vaccine. An outer membrane vaccine that was enriched in PorB also elicited an antibody response but failed to protect male volunteers against challenge with the homologous strain, likely because small amounts of Rmp present in the vaccine preparation elicited subversive antibodies. A formalin-killed whole cell vaccine trial in 62 volunteers in an Inuvik population in Canada also failed to provide any protection. Gonococcal surface structures, such as the porin protein (isolated without contaminating Rmp), proteins expressed under various stress conditions that may be encountered in vivo and have been identified by proteomic and transcriptomic approaches, and lipooligosaccharides, may prove more promising as vaccine candidates.

A retrospective epidemiologic analysis showed that a meningococcal outer membrane vesicle vaccine (MeNZB) that was used to curb an epidemic of group B meningococcal disease in New Zealand was associated with a clinical efficacy of 31% against gonorrhea, which lends optimism for development of a gonococcal vaccine. However, efficacy was only 14% in persons co-infected with gonorrhea and chlamydia. Cross-reactive antigens shared by *N. gonorrhoeae* and *N. meningitidis* may have contributed to the efficacy of the group B outer membrane vesicle vaccine against gonorrhea.

In the absence of a vaccine, prevention of gonorrhea in adolescents and adults can be achieved through **education**, use of **barrier protection** (especially condoms), **frequent screening** of high-risk populations as recommended by the U.S. Preventive Services Task Force (PSTF) and CDC (e.g., sexually active women  $\leq 24$  years old, MSM, individuals previously infected with gonorrhea), and **early identification and treatment** of contacts—all sex partners within the 60 days preceding symptom onset or gonorrhea diagnosis or, if none, the most recent sex partner should be examined and treated presumptively. For heterosexual patients, expedited partner therapy (EPT) with cefixime (800 mg) can be delivered to partners by the patient, a public health worker, or a collaborating pharmacy, as permitted by law (<https://www.cdc.gov/std/ept/legal/>).

EPT has been shown to be safe and effective in the prevention of reinfection with gonorrhea and is endorsed by the American Academy of Pediatrics, American Academy of Family Physicians, and Society of Adolescent Health and Medicine, along with other clinical organizations, for use when in-person evaluation and treatment of the partner is impractical or unsuccessful. (Because of limited data regarding the effectiveness of EPT in reducing persistent or recurrent gonorrhea among MSM and the high risk for coexisting undiagnosed sexually transmitted infections such as HIV, shared clinical decision-making regarding EPT for MSM is recommended.)

An infant born to a woman with cervical gonococcal infection has an approximately 30% risk of acquiring ophthalmic infection compared with a <5% risk if ocular prophylaxis is given. **Gonococcal ophthalmia neonatorum** can be prevented by instilling erythromycin (0.5%) ophthalmic ointment into each eye in a single application at birth (see [Chapter 674](#)). If erythromycin ointment is unavailable, infants at risk for *N. gonorrhoeae* (especially those born to a mother with untreated gonococcal infection or with no prenatal care) can be administered ceftriaxone 25–50 mg/kg IV or IM, not to exceed 500 mg, in a single dose.

Visit Elsevier eBooks+ at [eBooks.Health.Elsevier.com](https://www.elsevier.com/ebookshealth) for Bibliography.

## Chapter 239

# Kingella kingae

Pablo Yagupsky

*Kingella kingae* is being increasingly recognized as the most common etiology of skeletal system infections in young children.

## ETIOLOGY

*K. kingae* is a fastidious, facultative anaerobic,  $\beta$ -hemolytic member of the Neisseriaceae family that appears as pairs or short chains of gram-negative coccobacilli with tapered ends ([Fig. 239.1](#)).

## EPIDEMIOLOGY

*K. kingae* is asymptotically carried in the posterior pharynx, and the colonized mucosa is the source of bloodstream invasion of the bacterium and its dissemination to the skeletal system or the endocardium, sites for which the organism has a particular tropism. **Colonization** usually starts after 6 months of age, suggesting that maternally derived immunity, coupled with limited socialization, prevents the early acquisition of the bacterium. Colonization reaches a prevalence of 10% between 12 and 24 months and decreases in older children. Carried strains are replaced after weeks or months, suggesting that carriage induces a strain-specific immune response that eradicates the colonizing strain but does not prevent the acquisition of an antigenically different organism. The vast majority of colonized children remain healthy, and the annual risk of a carrier to develop an invasive infection is <1%.

Pharyngeal colonization plays a crucial role in the **transmission** of the organism through intimate contact between siblings and playmates. Daycare attendance increases the risk for colonization and transmission, and clusters of invasive infection have been reported in childcare facilities.

The species elaborates four different polysaccharide capsules (a–d), which appear to represent important virulence factors. Whereas capsules a and b characterize 95% of all invasive strains, capsules c and d are especially found in mere pharyngeal colonizers. Colonizing *K. kingae* strains differ in their invasive potential. Whereas certain clones are commonly found as respiratory colonizers but are seldom isolated from disease sites, other clones are responsible for most of the morbidly burden worldwide.

Invasive *K. kingae* disease is most frequently diagnosed in otherwise healthy children between the ages 6 months and 4 years, coinciding

with the peak prevalence of **pharyngeal carriage** (Fig. 239.2). In contrast, older children and adults with *K. kingae* infections often have underlying chronic diseases, immunosuppressing conditions, malignancy, or cardiac valve pathology. Because of the highly fastidious nature of the organism, *K. kingae* is rarely recovered using traditional culture methods. An annual incidence of 9.4 per 100,000 culture-proven invasive infections among Israeli children <5 years old has been calculated, but this figure can be considered only a minimal estimate because of the suboptimal culture detection of the organism. When sensitive species-specific nucleic acid amplification test (NAAT) methods are consistently used, *K. kingae* appears as the most frequent etiology of skeletal system infections in children 6 months to 4 years old. In a Swiss study in which sensitive NAATs were routinely employed, the organisms caused 88% of all joint and bone infections in this age-group.

## PATHOGENESIS

The pathogenesis of *K. kingae* disease begins with adherence of the organism to the pharyngeal epithelium, mediated by pili and a non-pilus adhesin. *K. kingae* secretes a potent repeats-in-toxin (RTX) toxin that is cytotoxic to respiratory epithelial cells, macrophages, and synovocytes, suggesting that it may play a role in disrupting the respiratory mucosa, promoting survival of the bacterium in the bloodstream, and facilitating invasion of skeletal system tissues. Children with *K. kingae* disease frequently present with symptoms of an upper respiratory infection, hand-foot-and-mouth disease, herpangina, herpetic stomatitis, or buccal aphthous ulcers, suggesting that viral-induced damage to the colonized mucosal surface facilitates invasion of the bloodstream.

## CLINICAL DISEASE

Septic arthritis is the most common invasive *K. kingae* infection in children, followed by bacteremia, osteomyelitis, and endocarditis (Table 239.1). Except for patients with endocarditis, the presentation of invasive *K. kingae* infections is frequently mild, and a normal body temperature <38°C (100.4°F), a normal C-reactive protein (CRP) level, and a normal white blood cell (WBC) count are common, requiring a high index of clinical suspicion. Mild to moderate thrombocytosis has been described in more than one third of patients.

### Septic Arthritis

*K. kingae* septic arthritis primarily affects the large, weight-bearing joints and the upper extremity joints. However, *K. kingae* infections of the small metacarpophalangeal, sternoclavicular, sacroiliac, and tarsal joints and the vertebral facets are also relatively common, in contrast to traditional bacterial pathogens associated with septic arthritis (see Chapter 726). The disease has an acute presentation, and

children are brought to medical attention after a median of 3 days. The leukocyte count in the synovial fluid shows <50,000 WBCs/μL in almost 25% of the patients, and the Gram stain of synovial fluid is positive in only a small percentage of cases. Involvement of the hip joint resembles toxic synovitis, and the possibility of a *K. kingae* infection should always be suspected in children <4 years old presenting with hip pain or a limp.

### Osteomyelitis

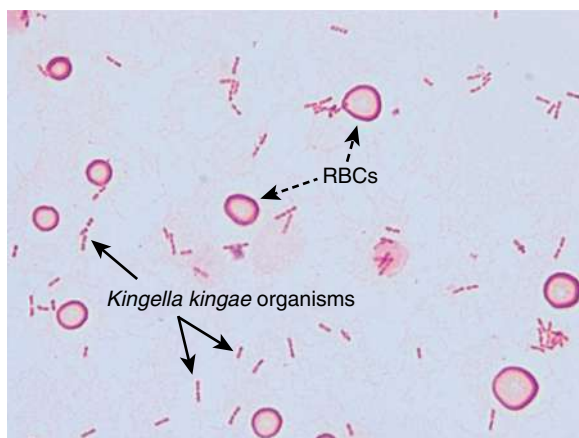
*K. kingae* osteomyelitis usually involves the long bones of the extremities (see Chapter 725). The calcaneus, talus, sternum, and clavicle are also frequently affected (and are rarely infected by other bacterial pathogens). In contrast to *K. kingae* arthritis, the onset of *K. kingae* bone infections is insidious, and the disease follows a subacute and indolent clinical course (Fig. 239.3). In >70% of patients *K. kingae* osteomyelitis is diagnosed after ≥1 week. MRI may show a distinct involvement of cartilages that are not yet ossified, which is only accompanied by a minor soft tissue reaction. Dissemination to the apophysis or epiphysis and contiguous joints is frequent. Despite the frequent diagnostic delay, chronic osteomyelitis and functional orthopedic disabilities are unusual.

### SPONDYLODISCITIS

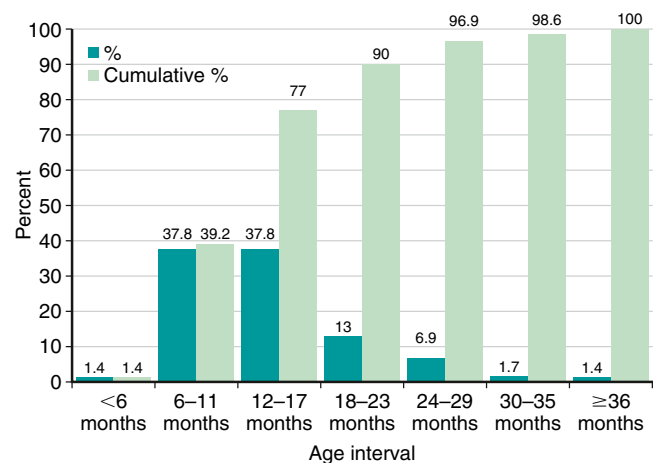
In industrialized countries, *K. kingae* is the most common bacterium detected in children <4 years old with spondylodiscitis. The organism presumably penetrates the rich network of blood vessels that traverse the cartilaginous vertebral end plates and enters the annulus in young children during a bacteremic episode. *K. kingae* spondylodiscitis usually involves the lumbar intervertebral spaces and, with decreasing frequency, thoracolumbar, thoracic, lumbosacral, and cervical disks. Involvement of multiple disks is uncommon. Patients present with limping, lumbar pain, back stiffness, refusal to sit or walk, neurologic symptoms, or abdominal complaints. Radiography or MRI studies demonstrate narrowing of the intervertebral space. Patients respond well to appropriate antibiotic treatment and recover without complications, although residual thinning of the intervertebral space may occur. Drainage of paraspinal abscesses is necessary when signs of cord compression appear.

### Tenosynovitis

*K. kingae* is the etiology of most cases of hematogenous invasion of the tendon sheaths in children <4 years of age. The disease usually affects the extensor tendons of the hands and wrists and, more rarely, the ankles and the feet.



**Fig. 239.1** Typical Gram stain of a positive blood culture vial from a child with *K. kingae* bacteremia showing pairs and short chains of plump gram-negative coccobacilli. RBCs, Red blood cells.



**Fig. 239.2** Age distribution of 291 previously healthy children with invasive *K. kingae* infection. (Data from Dubnov-Raz G, Ephros M, Garty BZ, et al. Invasive pediatric *Kingella kingae* infections: a nationwide collaborative study. *Pediatr Infect Dis J.* 2010;29:639–643.)

**Table 239.1** Clinical Spectrum and Relative Frequency of *K. kingae* Infections

CLINICAL DISEASE	FREQUENCY
Septic arthritis	+++
Osteomyelitis	++
Spondylodiscitis	+
Tenosynovitis	±
Bursitis	±
Bacteremia with no focus	+++
Endocarditis	+
Pericarditis	+
Laryngotracheobronchitis	±
Pneumonia	±
Pleural empyema	±
Keratitis	±
Corneal abscess	±
Endophthalmitis	±
Eyelid abscess	±

+++ , Very common; ++ , common; + , infrequent; ± , exceptional.

### Occult Bacteremia

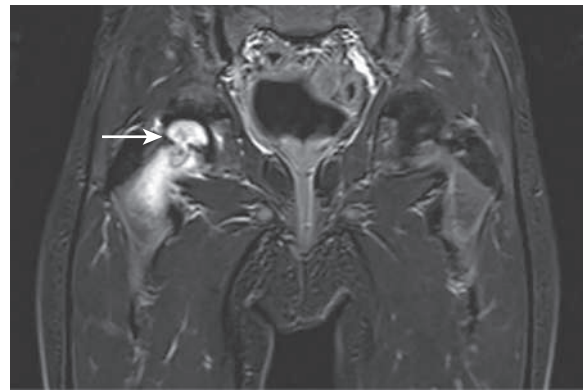
Patients with *K. kingae* bacteremia and no focal infection (occult bacteremia) usually present with mild to moderate fever, symptoms suggestive of a viral upper respiratory infection, a mean CRP level of 2.2 mg/dL, and a mean WBC count of 12,700/ $\mu$ L. Children with *K. kingae* bacteremia respond favorably to a short course of antibiotics.

### Endocarditis

In contrast to other *K. kingae* infections, *K. kingae* endocarditis is also diagnosed in school-age children, adolescents, and adult patients. The disease may affect native and prosthetic valves. Predisposing factors include congenital cardiac malformations or rheumatic valvular disease, but some patients have previously normal hearts. Typically, the left side of the heart is involved, usually the mitral valve. Fever and acute-phase reactants are elevated more in patients with endocarditis than in those with uncomplicated bacteremia; no particular cutoff value accurately distinguishes between the two conditions. Despite the exquisite susceptibility of *K. kingae* to antibiotics, cardiac failure, septic shock, cerebrovascular accident (stroke), and other life-threatening complications are common; the mortality rate is high (>10%); and many surviving patients later require valvular repair or replacement. Because of the potential severity of *K. kingae* endocarditis, routine echocardiographic evaluation of bacteremic children is recommended by some experts.

### DIAGNOSIS

The diagnosis of *K. kingae* disease can be established by isolation of the bacterium from a normally sterile site such as blood, synovial fluid, or bone tissue. Although *K. kingae* grows on routine bacteriologic media, its recovery from exudates is frequently unsuccessful. Detection is enhanced by inoculating synovial fluid specimens into blood culture vials, suggesting that diluting samples in a large volume of nutrient broth reduces the concentration of detrimental factors. The bacteriologic diagnosis is significantly improved by the use of NAATs (polymerase chain reaction). The initial approach consisted of amplifying the 16S ribosomal RNA (rRNA) gene, which is present in all bacteria followed by sequencing the species-specific amplicon to identify the pathogen. The original molecular assays are being replaced by



**Fig. 239.3** *K. kingae* transphyseal osteomyelitis of the femur (arrow). This 3-yr-old child limped for 3 weeks and was diagnosed with toxic synovitis. He was afebrile and had a leukocyte count of  $9.8 \times 10^9$  cells/L, a C-reactive protein level of 12 mg/L, and an erythrocyte sedimentation rate of 42 mm/hr. (Courtesy Prof. Dimitri Ceroni, Hôpitaux Universitaires de Genève.)

real-time polymerase chain reaction tests that target *K. kingae*-specific genes that can be completed in a few hours. Routine use of these assays results in a fourfold improvement in the detection of the organism compared with the blood culture vial method and reduces the fraction of culture-negative septic arthritis in young children. The three *K. kingae*-specific genes that are targeted by the current tests are the *rtxA* operon that encodes the RtxA toxin; the *cpn60* (chaperonin 60 gene), also known as *groEL*; and the malate dehydrogenase (*mdh*) gene that combines excellent sensitivity and specificity and should be the preferred method.

Because the bacterium frequently invades joints and bones that are small or difficult to reach or intervertebral disks, exudate samples or tissues are often unavailable for analysis. An alternative noninvasive diagnostic approach has been proposed consisting of obtaining an oropharyngeal specimen and subjecting it to a sensitive *K. kingae*-specific NAAT. A compatible clinical picture, coupled with a positive test result, supports *K. kingae* as the probable cause of the disease. This strategy has the obvious limitation that the background carriage rate of the organism is around 10% in children of the relevant age and twice as high in those attending daycare centers, reducing the predictive value of a positive result. On the other hand, because the colonized oropharynx is the source of the bloodborne dissemination of the bacterium, the negative predictive value of the assay is high. For practical purposes, failure to detect *K. kingae* DNA sequences when using a sensitive molecular test virtually rules out the organism as the etiology of the infection.

Novel commercially available plasma metagenomic next-generation sequencing assays appear to be a promising tool for detecting the organism, especially in patients with endocarditis receiving antibiotics.

### TREATMENT

*K. kingae* is usually highly susceptible to penicillin and cephalosporins but exhibits decreased susceptibility to oxacillin, precluding the use of isoxazolyl penicillins for confirmed *K. kingae* infections. Although  $\beta$ -lactamase production is frequently detected in colonizing *K. kingae* strains, its prevalence among invasive organisms is low and shows wide geographic variation. Testing for  $\beta$ -lactamase production should be routinely performed in all isolates derived from normally sterile body sites.

Because of the lack of specific guidelines for treating *K. kingae* disease, patients have been administered a variety of antibiotic regimens according to protocols developed for infections caused by traditional bacterial pathogens. The first-line therapy for skeletal infections in young children usually consists of intravenous (IV) administration of a second- or third-generation **cephalosporin**, pending culture or NAAT results. *K. kingae* is always *resistant* to glycopeptide antibiotics and clindamycin, a serious concern in areas where skeletal infections caused by community-associated methicillin-resistant *Staphylococcus aureus* are common, and **vancomycin** or **clindamycin** are initially



administered to children with presumptive septic arthritis or osteomyelitis. The initial antibiotic regimen is frequently changed to a cephalosporin (e.g., ceftriaxone) once *K. kingae* is identified or to ampicillin after  $\beta$ -lactamase production is excluded. A favorable clinical response and decreasing CRP levels to  $\leq 20$   $\mu\text{g}/\text{mL}$  are used to guide switching to oral antibiotics and defining the duration of therapy. Antibiotic treatment has ranged from 2 to 3 weeks for *K. kingae* arthritis, from 3 to 6 weeks for *K. kingae* osteomyelitis, and from 3 to 12 weeks for *K. kingae* spondylodiscitis. Although some children with septic arthritis have been managed with repeat joint aspirations and lavage, most patients respond promptly to conservative treatment with appropriate antibiotics and do not require invasive surgical procedures.

Children with *K. kingae* bacteremia without focal infection are initially treated with an IV  $\beta$ -lactam antibiotic and are subsequently switched to an oral drug once the clinical condition has improved. In most cases, therapy is administered for 1-2 weeks.

Patients with *K. kingae* endocarditis are usually treated with an IV  $\beta$ -lactam antibiotic alone or in combination with an aminoglycoside for 4-7 weeks. Early surgical intervention is necessary for life-threatening complications unresponsive to medical therapy.

## PREVENTION

Because the risk of asymptomatic pharyngeal carriers for developing an invasive *K. kingae* infection is low, in the absence of clinical disease, there is no indication to eradicate the organism from the colonized mucosal surfaces. Nonetheless, in 25 reported outbreaks of *K. kingae* infections in child daycare centers, 68 of 402 (17%) classmates developed a proven or presumptive infection, including fatal endocarditis, within 1 month, indicating that the causative strains combined unusual transmissibility and virulence. Under these circumstances, prophylactic antibiotic therapy to eradicate colonization in contacts and prevent further cases of the disease has been employed, consisting of either rifampin alone 10 mg/kg or 20 mg/kg twice daily for 2 days or rifampin in combination with amoxicillin (80 mg/kg/day) for 2 days or 4 days. The effectiveness of these regimens has ranged between 47% and 80%, indicating that eradication of *K. kingae* from colonized mucosae is difficult to achieve. However, after antibiotic prophylaxis administration, no further cases of the disease have been detected, suggesting that reduction of the bacterial density by antibiotics, extinction of the precipitating viral infection, and/or induction of an effective immune response by prolonged carriage is enough to decrease transmissibility and prevent additional cases.

Visit Elsevier eBooks+ at [eBooks.Health.Elsevier.com](http://eBooks.Health.Elsevier.com) for Bibliography.

## Chapter 240

# *Haemophilus influenzae*

Nadia A. Kadry and Joseph W. St. Geme III

Effective vaccines to prevent *Haemophilus influenzae* type b (Hib) disease, introduced in the United States and most other countries, have resulted in a dramatic decrease in the incidence of infections caused by this organism. However, mortality and morbidity from Hib infection remain a problem worldwide, primarily in resource poor countries. Occasional cases of invasive disease caused by non-type b strains continue to occur but are infrequent. Nontypeable isolates of *H. influenzae* are an important cause of otitis media, sinusitis, and chronic bronchitis.

## ETIOLOGY

*H. influenzae* is a fastidious, gram-negative, pleomorphic coccobacillus that requires factor X (hematin) and factor V (phosphopyridine nucleotide) for growth. Some *H. influenzae* isolates are surrounded by a polysaccharide capsule and can be segregated into one of six antigenically and biochemically distinct serotypes designated types a, b, c, d, e, and f. Isolates without a polysaccharide capsule are considered

nontypeable. Isolates can also be categorized based on the production of indole and the presence of ornithine decarboxylase and urease and are sorted into biotypes I-VIII.

## EPIDEMIOLOGY

Before the advent of an effective Hib conjugate vaccine in 1988, Hib was a major cause of serious disease among children. There was a striking age distribution of cases, with >90% in children <5 years old and the majority in children <2 years old. The annual attack rate of invasive disease was 64-129 cases per 100,000 children <5 years old. Invasive disease caused by strains producing a non-type b capsule has been much less frequent but continues to occur. The incidence of invasive disease caused by type b and non-type b serotypes has been estimated at approximately 0.08 and 1.02 cases, respectively, per 100,000 children <5 years old per year in the United States. Nontypeable (nonencapsulated) *H. influenzae* strains also occasionally cause invasive disease, especially in neonates, immunocompromised children, and children in resource poor countries. The estimated rate of invasive disease caused by nontypeable *H. influenzae* in the United States is 1.88 per 100,000 children <5 years old per year. Nontypeable isolates are common etiologic agents in otitis media, sinusitis, and chronic bronchitis. More recent evidence also implicates nasopharyngeal colonization with nontypeable *H. influenzae* in the development of asthma and allergic airway disease.

Humans are the only natural hosts for *H. influenzae*, which is part of the normal respiratory flora in 60-90% of healthy children. Most isolates are nontypeable. Before the advent of Hib conjugate vaccines, *H. influenzae* type b could be isolated from the pharynx of 2-5% of healthy preschool and school-age children, with lower rates among infants and adults. Asymptomatic colonization with Hib occurs at a much lower rate in immunized populations.

The continued circulation of type b strains despite current vaccine coverage levels suggests that elimination of Hib disease may be a formidable task. The few cases of Hib invasive disease in the United States now occur in both unvaccinated and fully vaccinated children. Approximately 50% of cases occur in infants who are too young to have received a complete primary vaccine series. Among the cases in patients who are old enough to have received a complete vaccine series, the majority are underimmunized. To highlight this point, during a shortage of Hib vaccine, invasive disease developed in five children in Minnesota, all of whom were incompletely immunized. Continued efforts are necessary to provide currently available Hib conjugate vaccines to children in resource poor countries, where affordability remains an important issue.

In the prevaccine era, certain groups and individuals had an increased incidence of invasive Hib disease, including Alaskan Natives, American Indians (Apache, Navajo), and African Americans. Persons with certain chronic medical conditions were also known to be at increased risk for invasive disease, including individuals with sickle cell disease, asplenia, congenital and acquired immunodeficiencies, and malignancies. Unvaccinated infants with invasive Hib infection are also at increased risk for recurrence, reflecting that they typically do not develop a protective immune response to *H. influenzae*.

Socioeconomic risk factors for invasive Hib disease include childcare outside the home, the presence of siblings of elementary school age or younger, short duration of breastfeeding, and parental smoking. A history of otitis media is associated with an increased risk for invasive disease. Much less is known about the epidemiology of invasive disease caused by non-type b strains, and it is not clear whether the epidemiologic features of Hib disease apply to disease caused by non-Hib strains.

Among age-susceptible household contacts who have been exposed to a case of invasive Hib disease, there is increased risk for secondary cases of invasive disease in the first 30 days after exposure, especially in susceptible children <24 months old. Whether a similar increased risk exists for contacts of individuals with non-Hib disease is unknown.

The mode of transmission is usually direct contact or inhalation of respiratory tract droplets containing *H. influenzae*. The incubation period for invasive disease is variable, and the exact period of communicability is unknown. Most children with invasive Hib disease are colonized in the nasopharynx before initiation of antimicrobial therapy; 25-40% may remain colonized during the first 24 hours of therapy.



With the decline of disease caused by type b organisms, disease caused by other serotypes (a, c-f) and by nontypeable strains has been recognized more clearly. There is no evidence that non-type b infections have increased in frequency. However, clusters of type a and, less often, type e and type f infections have occurred. Data from Israel suggest that nontypeable *H. influenzae* is the most common cause of invasive *H. influenzae* disease in that country.

### PATHOGENESIS

The pathogenesis of Hib disease begins with adherence to respiratory epithelium and colonization of the nasopharynx, which is mediated by pilus and nonpilus adherence factors. The mechanism of entry into the intravascular compartment is unclear but appears to be influenced by cytotoxic factors. Once in the bloodstream, Hib, and perhaps other encapsulated strains, resist intravascular clearance mechanisms at least in part because of the polysaccharide capsule. In the case of Hib, the magnitude and duration of bacteremia influence the likelihood of dissemination of bacteria to sites such as the meninges and joints.

Noninvasive *H. influenzae* infections such as otitis media, sinusitis, and bronchitis are usually caused by nontypeable strains. These organisms gain access to sites such as the middle ear and sinus cavities by direct extension from the nasopharynx. Factors facilitating spread from the nasopharynx include eustachian tube dysfunction and antecedent viral infections of the upper respiratory tract.

### Antibiotic Resistance

Ampicillin resistance is increasingly common among *H. influenzae* isolates. Resistance is typically driven by plasmid-mediated production of a  $\beta$ -lactamase.  $\beta$ -lactamase-negative ampicillin-resistant isolates have been identified and manifest resistance by production of a  $\beta$ -lactam-insensitive cell wall synthesis enzyme called *penicillin binding protein 3* (PBP 3).

**Amoxicillin-clavulanate** is uniformly active against *H. influenzae* clinical isolates except for the rare  $\beta$ -lactamase-negative ampicillin-resistant isolates. Among macrolides, azithromycin has in vitro activity against a high percentage of *H. influenzae* isolates; in contrast, the activity of erythromycin and clarithromycin against *H. influenzae* clinical isolates is poor. *H. influenzae* resistance to third-generation cephalosporins has not been documented. Resistance to quinolones is rare, and resistance to trimethoprim-sulfamethoxazole (TMP-SMX) is present in approximately 10% of isolates.

### Immunity

In the prevaccine era, the most important known element of host defense was antibody directed against the type b capsular polysaccharide polyribosylribitol phosphate (PRP). Anti-PRP antibody is acquired in an age-related fashion and facilitates clearance of Hib from blood, in part related to opsonic activity. Antibodies directed against antigens such as outer membrane proteins or lipopolysaccharide (LPS) may also have a role in opsonization. Both the classical and alternative complement pathways are important in defense against Hib.

Before the introduction of vaccination, protection from Hib infection was presumed to correlate with the concentration of circulating anti-PRP antibody at the time of exposure. A serum antibody concentration of  $>0.15 \mu\text{g/mL}$  was considered protective against invasive

infection. Unimmunized infants  $>6$  months old and young children usually lacked an anti-PRP antibody concentration of this magnitude and were susceptible to disease after encountering Hib. This lack of antibody in infants and young children may have reflected a maturational delay in the immunologic response to thymus-independent type 2 antigens such as unconjugated PRP, presumably explaining the high incidence of type b infections in infants and young children in the prevaccine era.

The conjugate vaccines act as thymus-dependent antigens and elicit serum antibody responses in infants and young children (Table 240.1). These vaccines are believed to prime memory antibody responses on subsequent encounters with PRP. The concentration of circulating anti-PRP antibody in a child primed by a conjugate vaccine may not correlate precisely with protection, presumably because a memory response may occur rapidly on exposure to PRP and provide protection. Conjugate vaccines have been shown to be highly effective against Hib disease and have been shown to reduce nasopharyngeal carriage rates.

Much less is known about immunity to other *H. influenzae* serotypes or to nontypeable isolates. For nontypeable isolates, evidence suggests that antibodies directed against one or more outer membrane proteins are bactericidal and protect against experimental challenge. A variety of antigens have been evaluated in an attempt to identify vaccine candidates for nontypeable *H. influenzae*, including outer membrane proteins (P1, P2, P4, P5, P6, D15, and Tbp A/B), LPS, various adhesins (e.g., Hap, HMW1, and HMW2), and lipoprotein D.

### DIAGNOSIS

Presumptive identification of *H. influenzae* is established by direct examination of a clinical specimen after staining with Gram reagents. Because of its small size, pleomorphism, and occasional poor uptake of stain, as well as the tendency for proteinaceous fluids to have a red background, *H. influenzae* is sometimes difficult to visualize. Furthermore, given that identification of *H. influenzae* by microscopy requires at least  $10^5$  bacteria/mL in a clinical specimen (e.g., cerebrospinal fluid [CSF]), failure to visualize organisms does not preclude their presence.

Culture of *H. influenzae* requires prompt transport and processing of specimens because the organism is fastidious. Specimens should not be exposed to drying or temperature extremes. Primary isolation of *H. influenzae* can be accomplished on chocolate agar.

Serotyping of *H. influenzae* is accomplished by slide agglutination with type-specific antisera or through polymerase chain reaction (PCR) amplification of the capsule locus (*cap*). Importantly, antigen-based detection methods are prone to false positives because of antigen cross-reactivity with other encapsulated organisms and are therefore not recommended as the primary diagnostic approach. Real-time PCR and nucleic acid amplification tests (NAATs) can be used to specifically detect *H. influenzae*. Accurate serotyping is essential to monitor progress toward elimination of type b invasive disease. Timely reporting of cases to public health authorities should be ensured.

### CLINICAL MANIFESTATIONS AND TREATMENT

The initial antibiotic therapy for invasive infections possibly caused by *H. influenzae* should be a parenterally administered antibiotic effective

**Table 240.1** *Haemophilus influenzae* Type b (Hib) Conjugate Vaccines Available in the United States

VACCINE	TRADE NAME	COMPONENTS	MANUFACTURER
PRP-T	ActHib	PRP conjugated to tetanus toxoid	Sanofi
PRP-T	Hibrix	PRP conjugated to tetanus toxoid	GlaxoSmithKline Biologicals
PRP-OMP	PedvaxHIB	PRP conjugated to OMP	Merck
PRP-T/DTaP-IPV	Pentacel	PRP-T + DTaP-IPV vaccines	Sanofi Pasteur
PRP-OMP/DTaP-IPV-HepB	Vaxelis	PRP-OMP + DTaP-IPV + HepB vaccines	Merck

DTaP, Diphtheria and tetanus toxoids and acellular pertussis vaccine; HepB, hepatitis B vaccine; IPV, trivalent inactivated polio vaccine; OMP, outer membrane protein complex from *Neisseria meningitidis*; PRP, polyribosylribitol phosphate.

in sterilizing all foci of infection and effective against ampicillin-resistant strains, usually an **extended-spectrum cephalosporin** such as ceftriaxone. After the antimicrobial susceptibility of the isolate has been determined, an appropriate agent can be selected to complete the therapy. **Ampicillin** remains the drug of choice for the therapy of infections caused by susceptible isolates. If the isolate is resistant to ampicillin, in selected circumstances **ceftriaxone** can be administered once daily for outpatient therapy.

Oral antimicrobial agents are sometimes used to complete a course of therapy initiated by the parenteral route and are typically initial therapy for noninvasive infections such as otitis media and sinusitis. If the organism is susceptible, **amoxicillin** is the drug of choice. An oral second- or third-generation cephalosporin or amoxicillin-clavulanate may be used when the isolate is resistant to ampicillin.

### Meningitis

In the prevaccine era, meningitis accounted for more than half of all cases of invasive *H. influenzae* disease. Clinically, meningitis caused by Hib cannot be differentiated from meningitis caused by *Neisseria meningitidis* or *Streptococcus pneumoniae* (see Chapter 643.1). It may be complicated by other foci of infection such as the lungs, joints, bones, and pericardium.

**Antimicrobial therapy should be administered intravenously for 7-14 days for uncomplicated cases.** Ceftriaxone and ampicillin cross the blood-brain barrier during acute inflammation in concentrations adequate to treat *H. influenzae* meningitis. Intramuscular therapy with ceftriaxone may be an alternative in patients with normal organ perfusion.

The prognosis of Hib meningitis depends on the age at presentation, duration of illness before appropriate antimicrobial therapy, CSF capsular polysaccharide concentration, and rapidity with which organisms are cleared from CSF, blood, and urine. Clinically manifested inappropriate secretion of antidiuretic hormone and evidence of focal neurologic deficits at presentation are poor prognostic features. Approximately 6% of patients with Hib meningitis are left with some hearing impairment, probably because of inflammation of the cochlea and the labyrinth. **Dexamethasone** (0.6 mg/kg/day divided every 6 hours for 2 days), particularly when given shortly before or concurrent with the initiation of antimicrobial therapy, decreases the incidence of hearing loss. Major neurologic sequelae of Hib meningitis include behavior problems, language disorders, impaired vision, mental retardation, motor abnormalities, ataxia, seizures, and hydrocephalus.

### Cellulitis

Children with Hib cellulitis often have an antecedent upper respiratory tract infection. They usually have no prior history of trauma, and the infection is thought to represent seeding of the organism to the involved soft tissues during bacteremia. The head and neck, particularly the cheek and preseptal region of the eye, are the most common sites of involvement. The involved region generally has indistinct margins and is tender and indurated. **Buccal cellulitis** is classically erythematous with a violaceous hue, although this sign may be absent. *H. influenzae* may often be recovered directly from an aspirate of the leading edge, although this procedure is seldom performed. A blood culture may also reveal the causative organism. Other foci of infection may be present concomitantly, particularly in children <18 months old. A diagnostic lumbar puncture should be considered at diagnosis in these children.

**Parenteral antimicrobial therapy is indicated until patients become afebrile**, after which an appropriate oral antimicrobial agent may be substituted. A 7- to 10-day course is customary.

### Preseptal Cellulitis

Infection involving the superficial tissue layers anterior to the orbital septum is termed *preseptal cellulitis*, which may be caused by *H. influenzae*. Uncomplicated preseptal cellulitis does not imply a risk for visual impairment or direct central nervous system (CNS) extension. However, concurrent bacteremia may be associated with the development of meningitis. *H. influenzae* preseptal cellulitis is characterized by fever, edema, tenderness, warmth of the lid, and, occasionally, purple discoloration. Evidence of interruption of the integument is usually absent.

Conjunctival drainage may be associated. *S. pneumoniae*, *Staphylococcus aureus*, and group A *Streptococcus* cause clinically indistinguishable preseptal cellulitis. The latter two pathogens are more likely when fever is absent and the integument is interrupted (e.g., because of an insect bite or trauma).

Children with preseptal cellulitis in whom *H. influenzae* and *S. pneumoniae* are etiologic considerations (young age, high fever, intact integument) should have a blood culture obtained. In addition, a diagnostic lumbar puncture should be considered.

Parenteral antibiotics are indicated for preseptal cellulitis. Because methicillin-susceptible and methicillin-resistant *S. aureus*, *S. pneumoniae*, and group A  $\beta$ -hemolytic streptococci are other causes, empirical therapy should include agents active against these pathogens. Patients with preseptal cellulitis without concurrent meningitis should receive **parenteral therapy for about 5 days, until fever and erythema have abated**. In uncomplicated cases, antimicrobial therapy should be given for 10 days.

### Orbital Cellulitis

Infections of the orbit are infrequent and usually develop as complications of acute ethmoid or sphenoid sinusitis. Orbital cellulitis may manifest as lid edema but is distinguished by the presence of proptosis, chemosis, impaired vision, limitation of the extraocular movements, decreased mobility of the globe, or pain on movement of the globe. The distinction between preseptal and orbital cellulitis may be difficult and is best determined by CT scan.

Orbital infections are treated with **parenteral therapy for at least 14 days**. Underlying sinusitis or orbital abscess may require surgical drainage and more prolonged antimicrobial therapy.

### Supraglottitis or Acute Epiglottitis

Supraglottitis is a cellulitis of the tissues of the laryngeal inlet (see Chapter 433). It has become exceedingly rare since the introduction of conjugate Hib vaccines. Direct bacterial invasion of the involved tissues is probably the initiating pathophysiologic event. This dramatic, potentially lethal condition can occur at any age. Because of the risk of sudden, unpredictable airway obstruction, supraglottitis is a medical emergency. Other foci of infection, such as meningitis, are rare. Antimicrobial therapy directed against *H. influenzae* and other etiologic agents should be administered parenterally, but only after the airway is secured, and therapy should be continued until patients are able to take fluids by mouth. The duration of antimicrobial therapy is typically 7 days.

### Pneumonia

The true incidence of *H. influenzae* pneumonia in children is unknown because invasive procedures required to obtain culture specimens are seldom performed (see Chapter 449). In the prevaccine era, type b strains were believed to be the usual cause. The signs and symptoms of pneumonia caused by *H. influenzae* cannot be differentiated from those of pneumonia caused by many other microorganisms. Other foci of infection may be present concomitantly.

Children <12 months old in whom *H. influenzae* pneumonia is suspected should receive parenteral antimicrobial therapy initially because of their increased risk for bacteremia and its complications. Older children who do not appear severely ill may be managed with an oral antimicrobial. Therapy is continued for 7-10 days. Uncomplicated pleural effusion associated with *H. influenzae* pneumonia requires no special intervention. However, if empyema develops, chest tube or **surgical drainage** is generally indicated.

### Suppurative Arthritis

Large joints, such as the knee, hip, ankle, and elbow, are affected most often (see Chapter 726). Other foci of infection may be present concomitantly. Although single-joint involvement is the rule, multijoint involvement occurs in approximately 6% of cases. The signs and symptoms of septic arthritis caused by *H. influenzae* are indistinguishable from those in arthritis caused by other bacteria.

Uncomplicated septic arthritis should generally be treated with an appropriate **parenteral antimicrobial for at least a few days**. If the clinical response is satisfactory, the remainder of the course of

antimicrobial treatment may be given orally. Therapy is typically given for 3 weeks for uncomplicated septic arthritis, but may be continued beyond 3 weeks, until the C-reactive protein concentration is normal and clinical symptoms are resolved.

### Pericarditis

*H. influenzae* is a rare cause of pericarditis (see Chapter 489). Affected children often have had an antecedent upper respiratory tract infection. Fever, respiratory distress, and tachycardia are consistent findings. Other foci of infection may be present concomitantly.

The diagnosis may be established by recovery of the organism from blood or pericardial fluid. Gram stain or detection of PRP in pericardial fluid, blood, or urine (when type b organisms are the cause) may aid the diagnosis. Antimicrobials should be provided parenterally in a regimen similar to that used for meningitis (see Chapter 643.1). Pericardiectomy is useful for draining the purulent material effectively and preventing tamponade and constrictive pericarditis.

### Bacteremia Without an Associated Focus

Bacteremia caused by *H. influenzae* may be associated with fever without any apparent focus of infection (see Chapter 220). In this situation, risk factors for occult bacteremia include the magnitude of fever ( $\geq 39^{\circ}\text{C}$  [ $102.2^{\circ}\text{F}$ ]) and the presence of leukocytosis ( $\geq 15,000$  cells/ $\mu\text{L}$ ). In the prevaccine era, meningitis developed in approximately 25% of children with occult Hib bacteremia if left untreated. In the vaccine era, this *H. influenzae* infection has become exceedingly rare. When it does occur, the child should be reevaluated for a focus of infection and a second blood culture should be performed. The child should be hospitalized and given parenteral antimicrobial therapy after a diagnostic lumbar puncture and chest radiograph are obtained.

### Miscellaneous Infections

Rarely, *H. influenzae* causes urinary tract infection, epididymo-orchitis, cervical adenitis, acute glossitis, infected thyroglossal duct cysts, uvulitis, endocarditis, endophthalmitis, primary peritonitis, osteomyelitis, and periapical abscess.

### Invasive Disease in Neonates

Neonates occasionally have invasive *H. influenzae* infection. In the infant with illness within the first 24 hours of life, especially in association with maternal chorioamnionitis or prolonged rupture of membranes, transmission of the organism to the infant is likely to have occurred through the maternal genital tract (which is colonized with nontypeable *H. influenzae* in <1% of pregnant women). Manifestations of neonatal invasive infection include bacteremia with sepsis, pneumonia, respiratory distress syndrome with shock, conjunctivitis, scalp abscess or cellulitis, and meningitis. Less frequently, mastoiditis, septic arthritis, and congenital vesicular eruption may occur.

### Otitis Media

Acute otitis media is one of the most common infectious diseases of childhood (see Chapter 680). It results from the spread of bacteria from the nasopharynx through the eustachian tube into the middle ear cavity. Usually, because of a preceding viral upper respiratory tract infection, the mucosa in the area becomes hyperemic and swollen, resulting in obstruction and an opportunity for bacterial multiplication in the middle ear.

The most common bacterial pathogens are *H. influenzae*, *S. pneumoniae*, and *Moraxella catarrhalis*. Most *H. influenzae* isolates causing otitis media are nontypeable. Ipsilateral conjunctivitis may also be present. **Amoxicillin (80-90 mg/kg/day)** is a suitable first-line oral antimicrobial agent, because the probability that the causative isolate is resistant to amoxicillin and the risk for invasive potential are sufficiently low to justify this approach. Alternatively, in certain cases, a single dose of ceftriaxone constitutes adequate therapy.

In the case of treatment failure or if a  $\beta$ -lactamase-producing isolate is obtained by tympanocentesis or from drainage fluid, amoxicillin-clavulanate (Augmentin) is a suitable alternative.

### Conjunctivitis

Acute infection of the conjunctivae is common in childhood (see Chapter 666). In neonates, *H. influenzae* is an infrequent cause. However, it is an important pathogen in older children. Most *H. influenzae* isolates associated with conjunctivitis are nontypeable, although type b isolates and other serotypes are occasionally found. Empirical treatment of conjunctivitis beyond the neonatal period usually consists of topical antimicrobial therapy with **sulfacetamide**. Topical fluoroquinolone therapy is to be avoided because of its broad spectrum, high cost, and high rate of emerging resistance among many bacterial species. Ipsilateral otitis media caused by the same organism may be present and requires oral antibiotic therapy.

### Sinusitis

*H. influenzae* is an important cause of acute sinusitis in children, likely the most common etiology since implementation of routine vaccination against *S. pneumoniae* (see Chapter 429). Chronic sinusitis lasting >1 year or severe sinusitis requiring hospitalization is often caused by *S. aureus* or anaerobes such as *Peptococcus*, *Peptostreptococcus*, and *Bacteroides*. Nontypeable *H. influenzae* and viridans group streptococci are also frequently recovered.

For uncomplicated sinusitis, **amoxicillin** is acceptable initial therapy. However, if clinical improvement does not occur, a broader-spectrum agent, such as amoxicillin-clavulanate, may be appropriate. A 10-day course is sufficient for uncomplicated sinusitis. Hospitalization for parenteral therapy is rarely required; the usual reason is suspicion of progression to orbital cellulitis.

### PREVENTION

**Immunization with a Hib conjugate vaccine is recommended for all infants.** Prophylaxis is indicated if close contacts of an index patient with type b disease are unvaccinated. The contagiousness of non-Hib infections is not known, and prophylaxis is not recommended.

### Vaccine

Several Hib conjugate vaccines are currently marketed in the United States, containing either PRP–outer membrane protein (**PRP-OMP**) or PRP–tetanus toxoid (**PRP-T**), which differ in the carrier protein used and the method of conjugating the polysaccharide to the protein (see Table 240.1 and Chapter 215). Available combination vaccines include Pentacel (Sanofi Pasteur), which consists of PRP-T combined with DTaP vaccine (diphtheria and tetanus toxoids and acellular pertussis) and IPV vaccine (trivalent, inactivated polio vaccine), and Vaxelis (Merck), which consists of PRP-OMP combined with DTaP, IPV, and hepatitis B vaccine.

The Hib conjugate vaccines stimulate circulating antipolysaccharide antibody and provide long-term immunity through B-cell memory.

### Prophylaxis

Unvaccinated children <48 months old who are in close contact with an index case of invasive Hib infection are at increased risk for invasive infection. The risk for secondary disease for children >3 months old is inversely related to age. About half the secondary cases among susceptible household contacts occur in the first week after hospitalization of the index case. Because many children are now protected against Hib by prior immunization, the need for prophylaxis has greatly decreased. When prophylaxis is used, **rifampin** is indicated for all members of the household or close-contact group, including the index patient, if the group includes one or more children <48 months old who are not fully immunized.

Parents of children hospitalized for invasive Hib disease should be informed of the increased risk for secondary infection in other young children in the same household if they are not fully immunized. Parents of children exposed to a single case of invasive Hib disease in a childcare center or nursery school should be similarly informed, although there is disagreement about the need for rifampin prophylaxis for these children.

For prophylaxis, children should be given rifampin orally (0-1 months old, 10 mg/kg/dose; >1 month old, 20 mg/kg/dose, not to exceed 600 mg/dose) once daily for 4 consecutive days. The adult dose is 600 mg once daily. Rifampin prophylaxis is not recommended for pregnant women.

Visit Elsevier eBooks+ at [eBooks.Health.Elsevier.com](http://eBooks.Health.Elsevier.com) for Bibliography.



## Chapter 241

Chancroid (*Haemophilus ducreyi*)

H. Dele Davies and Shirley Delair

Chancroid is a sexually transmitted disease characterized by painful genital ulceration and inguinal lymphadenopathy.

**ETIOLOGY AND EPIDEMIOLOGY**

Chancroid is caused by *Haemophilus ducreyi*, a fastidious gram-negative bacillus. It is most common in many low- and middle-income countries but also occurs sporadically in high-income countries. Most cases in high-income countries occur in returning travelers (90% are male) from endemic areas or occasionally in localized urban outbreaks associated with commercial sex workers. Chancroid is a risk factor for transmission of HIV. Diagnosis of chancroid in infants and children is strong evidence of sexual abuse. Male circumcision lowers the risk for chancroid. The incidence of chancroid has declined significantly since 1981 and remains low in the United States.

**CLINICAL MANIFESTATIONS**

The incubation period is 4-7 days, with a small, inflammatory papule on the preputial orifice or frenulum in men and on the labia, fourchette, or perineal region in women. The lesion becomes pustular, eroded, and ulcerative within 2-3 days. The ulcer edge is classically ragged and undermined. Without treatment, the ulcers may persist for weeks to months. Painful, tender inguinal lymphadenitis occurs in >50% of cases, more often among men. The lymphadenopathy can become fluctuant to form **booes**, which can spontaneously rupture.

**DIAGNOSIS**

Diagnosis is usually established by the clinical presentation and the exclusion of both syphilis (*Treponema pallidum*) and herpes simplex virus infections. The ulcer of chancroid is accompanied by concurrent **lymphadenopathy** that is usually unilateral, unlike lymphogranuloma venereum (see Chapter 272.4). Genital herpes is characterized by vesicular lesions with a history of recurrence (see Chapter 299). Gram stain of ulcer secretions may show gram-negative coccobacilli in parallel clusters ("school of fish"). Culture requires expensive, special media and has a sensitivity of only 80%. There are currently no U.S. Food and Drug Administration (FDA)-approved polymerase chain reaction (PCR) tests for *H. ducreyi*. PCR and indirect immunofluorescence using monoclonal antibodies are available as research tools and are performed by some clinical laboratories using their own in-house Clinical Laboratory Improvement Amendments (CLIA)-verified kits.

**TREATMENT**

Most *H. ducreyi* organisms are resistant to penicillin and ampicillin because of plasmid-mediated  $\beta$ -lactamase production. Spread of plasmid-mediated resistance among *H. ducreyi* has resulted in lack of efficacy of previously useful drugs such as sulfonamides and tetracyclines. Chancroid is easy to treat if recognized early. The current treatment recommendation is for **azithromycin** (1 g as a single dose orally [PO]) or **ceftriaxone** (250 mg as a single dose intramuscularly) or **ciprofloxacin** (500 mg twice daily PO for 3 days) or **erythromycin** (500 mg 3 times daily PO for 7 days), the latter most often used in low- and middle-income countries. Fluctuant nodes may require drainage. Symptoms usually resolve within 3-7 days. Relapses can usually be treated successfully with the original treatment regimen. Patients with HIV infection may require a longer duration of treatment. Persistence of the ulcer and the organism after therapy should raise suspicion of resistance to the prescribed antibiotic.

Patients with chancroid should be evaluated for other sexually transmitted infections, including syphilis, genital herpes, hepatitis B virus, HIV, chlamydia, and gonorrhea; an estimated 10% have concomitant syphilis or genital herpes. If initial HIV or syphilis testing is negative, patients should be tested again in 3 months because of the high rates of co-infections. In low- and middle-income countries, patients with a compatible genital ulcer are treated for both chancroid and syphilis. All sexual contacts of patients with chancroid should be evaluated and treated.

**COMPLICATIONS**

Complications include **phimosis** in men and secondary bacterial infection. **Bubo** formation may occur in untreated cases. Genital ulceration as a syndrome increases the risk for transmission of HIV.

Visit Elsevier eBooks+ at [eBooks.Health.Elsevier.com](http://eBooks.Health.Elsevier.com) for Bibliography.

## Chapter 242

*Moraxella catarrhalis*Timothy F. Murphy and  
Oscar G. Gómez-Duarte

*Moraxella catarrhalis* is an unencapsulated, gram-negative diplococcus and is a **human-specific pathogen** that colonizes the respiratory tract beginning in infancy. Patterns of colonization and infection with *M. catarrhalis* are changing in countries where pneumococcal conjugate vaccines are used widely. The most important clinical manifestation of *M. catarrhalis* infection in children is **otitis media**.

**ETIOLOGY**

*M. catarrhalis* has long been considered to be an upper respiratory tract commensal. Substantial genetic heterogeneity exists among strains of *M. catarrhalis*. Several outer membrane proteins demonstrate sequence differences among strains, particularly in regions of the proteins that are exposed on the bacterial surface. *M. catarrhalis* endotoxin lacks repeating polysaccharide side chains and is thus a lipooligosaccharide (LOS). In contrast to other gram-negative respiratory pathogens, such as *Haemophilus influenzae* and *Neisseria meningitidis*, the LOS of *M. catarrhalis* is relatively conserved among strains; only three serotypes (A, B, and C), based on oligosaccharide structure, have been identified. Genetic and antigenic differences among strains account for the observation that resolving an infection by one strain does not induce protective immunity to other strains. *M. catarrhalis* causes recurrent infections, which generally represent reinfection by new strains.

**EPIDEMIOLOGY**

The ecologic niche of *M. catarrhalis* is the human respiratory tract. The bacterium has not been recovered from animals or environmental sources. **Age** is the most important determinant of the prevalence of upper respiratory tract colonization. Common throughout infancy, nasopharyngeal colonization is a dynamic process with active turnover as a result of acquisition and clearance of strains of *M. catarrhalis*. Some geographic variation in rates of colonization is observed. On the basis of monthly or bimonthly cultures, colonization during the first year of life may range from 33% to 100%. Several factors likely account for this variability among studies, including living conditions, daycare attendance, hygiene, environmental factors (e.g., household smoking), and genetics of the population. The prevalence of colonization steadily decreases with age. Understanding nasopharyngeal colonization patterns is important, because the pathogenesis of otitis media involves migration of the bacterium from the nasopharynx to the middle ear via the eustachian tube.



The widespread use of pneumococcal polysaccharide vaccines in many countries has resulted in alteration of patterns of nasopharyngeal colonization in the population. A relative decrease in colonization by vaccine pneumococcal serotypes and *M. catarrhalis* has resulted in a decreased number of new upper respiratory infection episodes associated with *Streptococcus pneumoniae* and *M. catarrhalis*.

### PATHOGENESIS OF INFECTION

Strains of *M. catarrhalis* differ in their virulence properties. The species is composed of complement-resistant and complement-sensitive genetic lineages, with the **complement-resistant** strains being more strongly associated with virulence. Strains that cause infection in children differ in several phenotypic characteristics from strains that cause infection in adults, in whom the most common clinical manifestation is lower respiratory tract infection in the setting of chronic obstructive pulmonary disease.

The presence of several **adhesin** molecules with differing specificities for various host cell receptors reflects the importance of adherence to the human respiratory epithelial surface in the pathogenesis of infection. *M. catarrhalis* has long been viewed as an exclusively extracellular pathogen. However, the bacterium is now known to invade multiple cell types, including bronchial epithelial cells, small airway cells, and type 2 alveolar cells. In addition, *M. catarrhalis* resides intracellularly in lymphoid tissue, providing a reservoir for persistence in the human respiratory tract. As with many gram-negative bacteria, *M. catarrhalis* sheds vesicles from its surface during growth. These vesicles are internalized by respiratory epithelial cells and mediate several virulence mechanisms, including B-cell activation, induction of inflammation, and delivery of  $\beta$ -lactamases. Analysis of genomes reveals modest genetic heterogeneity among strains.

*M. catarrhalis* forms biofilms *in vitro* and in the middle ears of children with chronic and recurrent otitis media. It also promotes stable polymicrobial biofilms by enhancing the survival of other bacterial colonizing otopathogens. **Biofilms** are communities of bacteria encased in a matrix attached to a surface. Bacteria in biofilms are more resistant to antibiotics and to host immune responses than bacteria growing individually in planktonic form.

### CLINICAL MANIFESTATIONS

*M. catarrhalis* causes predominantly mucosal infections in children. The mechanism of infection is **migration** of the infecting strains from the nasopharynx to the middle ear in the case of otitis media or to the sinuses in the case of sinusitis. The inciting event for both otitis media and sinusitis is often a preceding viral infection.

#### Acute Otitis Media

Approximately 80% of children have one or more episodes of otitis media by age 3 years. Otitis media is the most common reason that children receive antibiotics. On the basis of culture of middle ear fluid obtained by tympanocentesis, the predominant causes of acute otitis media are *S. pneumoniae*, *H. influenzae*, and *M. catarrhalis*. *M. catarrhalis* is cultured from the middle ear fluid in 15–20% of patients with acute otitis media. When more sensitive methods (e.g., polymerase chain reaction [PCR]) are used, the number of middle ear fluid samples from children with otitis media in which *M. catarrhalis* is detected is substantially greater than by culture alone. The distribution of the causative agents of otitis media is changing as a result of widespread administration of pneumococcal conjugate vaccines, with *M. catarrhalis* and *H. influenzae* proportionally more common than *S. pneumoniae*.

Acute otitis media caused by *M. catarrhalis* is clinically milder than otitis media caused by *H. influenzae* or *S. pneumoniae*, with less fever and lower prevalence of a red, bulging tympanic membrane. However, substantial overlap in symptoms is seen, making it impossible to predict etiology in an individual child on the basis of clinical features. Tympanocentesis is required to make an etiologic diagnosis but is not performed routinely, and thus treatment of otitis media is generally empirical.

#### Recurrent Otitis Media and Otitis Media with Effusion

*Otitis media with effusion* refers to the presence of fluid in the middle ear in the absence of signs and symptoms of acute infection. Children who experience four or more episodes of acute otitis media in a year or who have at least 8 months of middle ear effusion in a year are defined as **otitis prone**. These children have conductive hearing loss, which places them at risk for speech delays and altered language development. Analysis of middle ear fluid from children with otitis media with effusion using sensitive molecular techniques (e.g., PCR) indicates that bacterial DNA is present in up to 80% of samples from such children. Indeed, *M. catarrhalis* DNA is present, both alone and as a copathogen, in a larger proportion of cases of otitis media with effusion than of acute otitis media. Biofilms may account for these observations, although definitive evidence is lacking.

#### Sinusitis

A small proportion of viral upper respiratory tract infections are complicated by bacterial sinusitis. According to findings of studies that use sinus puncture, *M. catarrhalis* accounts for approximately 20% of cases of acute bacterial sinusitis in children and a smaller proportion in adults. Sinusitis caused by *M. catarrhalis* is clinically indistinguishable from that caused by *S. pneumoniae* or *H. influenzae*.

#### Bacteremia

*M. catarrhalis* rarely causes bacteremia or invasive infections in children. When bacteremia occurs, the usual source is the respiratory tract. Some children have underlying immunocompromising conditions, but no particular immunodeficiency is associated with invasive *M. catarrhalis* infections.

#### Pneumonia

*M. catarrhalis* is an uncommon cause of community-acquired pneumonia in children. Among older patients with chronic obstructive pulmonary disease, *M. catarrhalis* is associated with acute exacerbations.

### DIAGNOSIS

The clinical diagnosis of otitis media is made by demonstration of erythema and bulging of the tympanic membrane and/or fluid in the middle ear by pneumatic otoscopy. A tympanocentesis is required to establish an etiologic diagnosis, but this procedure is not performed routinely. Thus the choice of antibiotic for otitis media is empirical and generally based on guidelines. Management of bacterial sinusitis is also empirical, because determining the etiology of sinusitis requires a **sinus puncture**, also a procedure that is not performed routinely.

The key to making a microbiologic diagnosis is distinguishing *M. catarrhalis* from commensal *Neisseria* organisms that are part of the normal upper respiratory tract flora. Indeed, the difficulty in distinguishing colonies of *M. catarrhalis* from *Neisseria* spp. explains in part why *M. catarrhalis* has been overlooked in the past as a respiratory tract pathogen. *M. catarrhalis* produces round, opaque colonies that can be slid across the agar surface without disruption—the “hockey puck sign.” In addition, after 48 hours, *M. catarrhalis* colonies tend to be larger than *Neisseria* and take on a pink color. A variety of biochemical tests distinguish *M. catarrhalis* from *Neisseria* spp., and commercially available kits based on these tests are available.

Sensitive tests that employ PCR to detect respiratory tract bacterial pathogens in human respiratory tract secretions are in development. In addition, metagenomics next-generation sequencing is a noninvasive option to make a diagnosis of upper or lower respiratory infections associated with *M. catarrhalis* through evaluation of bacterial-derived DNA in blood samples. Their application will likely contribute new information about the epidemiology and disease patterns of *M. catarrhalis*.

### TREATMENT

A high proportion of cases of *M. catarrhalis* otitis media resolve spontaneously. Treatment of otitis media is empirical, and clinicians are advised to follow guidelines of the American Academy of Pediatrics (see Chapter 680).

Strains of *M. catarrhalis* rapidly acquired  $\beta$ -lactamase worldwide in the 1970s and 1980s, rendering essentially all strains resistant to amoxicillin. When *M. catarrhalis* is present as a copathogen in otitis media, its  $\beta$ -lactamase reduces the susceptibility of nontypeable *H. influenzae* and *S. pneumoniae* to amoxicillin. Antimicrobial susceptibility patterns have remained relatively stable for decades. However, strains of *M. catarrhalis* that are resistant to macrolides and fluoroquinolones have been isolated in several centers in Asia. Careful surveillance will be important to track the potential emergence of resistant strains more widely. Most strains of *M. catarrhalis* are susceptible to amoxicillin/clavulanic acid, extended-spectrum cephalosporins, macrolides (azithromycin, clarithromycin), trimethoprim-sulfamethoxazole, and fluoroquinolones.

## PREVENTION

**Vaccines** to prevent otitis media and other infections caused by *M. catarrhalis* are under development, but none is yet available.

Visit Elsevier eBooks+ at [eBooks.Health.Elsevier.com](http://eBooks.Health.Elsevier.com) for Bibliography.

## Chapter 243

# Pertussis (*Bordetella pertussis* and *Bordetella parapertussis*)

Emily E. Souder and Sarah S. Long

Pertussis is an acute respiratory tract infection; the term *pertussis* means “intense cough” and is preferable to *whooping cough*, because most infected individuals do not “whoop.”

## ETIOLOGY

*Bordetella pertussis* is the cause of epidemic pertussis and the usual cause of sporadic pertussis. *Bordetella parapertussis* is an occasional cause of sporadic pertussis that contributes significantly to total cases of pertussis in Eastern and Western Europe and has been detected during occasional regional pertussis outbreaks in the United States. *B. pertussis* and *B. parapertussis* are exclusive pathogens of humans and some primates. *Bordetella holmesii*, first identified as a cause of bacteremia in immunocompromised hosts without cough illness, is increasingly reported to cause pertussis-like cough illness in small outbreaks in healthy persons. *Bordetella bronchiseptica* is a common animal pathogen. Occasional reports in humans describe a variety of body sites involved, and cases typically occur in immunocompromised persons or young children with intense exposure to animals. *Bordetella petrii*, frequently found in soil, has been reported in cases of osteomyelitis, mastoiditis, and chronic respiratory infection in patients with cystic fibrosis. *Bordetella hinzii* has been isolated from the respiratory tract of poultry and rodents and has rarely been associated with human disease, including endocarditis, bacteremia, and urinary tract infection. Protracted coughing (which in some cases can be paroxysmal) is attributable sporadically to *Mycoplasma*, parainfluenza viruses, influenza viruses, enteroviruses, respiratory syncytial virus (RSV), or adenoviruses.

## EPIDEMIOLOGY

A recent modeling study estimated that in 2014, 24.1 million cases of pertussis and 160,700 deaths caused by pertussis occurred worldwide in children <5 years, reflecting significantly higher numbers than actual case counts. Before vaccination was available, pertussis was the leading cause of death from communicable disease among U.S. children <14 years, with 10,000 deaths annually. Widespread use of whole cell pertussis vaccine (DTP) led to a >99% decline in cases. After the

low U.S. number of 1,010 cases reported in 1976, there was an increase in annual pertussis incidence to 1.2 cases per 100,000 population from 1980 through 1989, with epidemic pertussis in many states in 1989–1990, 1993, and 1996. Since then, pertussis has become increasingly endemic, with shifting burden of disease to young infants, adolescents, and adults. By 2004, the incidence of reported pertussis in the United States was 8.9 cases per 100,000 in the general population and approximately 150 per 100,000 in infants <2 months, with 25,827 total cases reported, the highest since 1959. A total of 40 pertussis-related deaths were reported in 2005, and 16 pertussis-related deaths were reported in 2006; >90% of these cases occurred in infants.

Prospective and serologic studies show that pertussis is underrecognized, especially among adolescents and adults, in whom the actual number of U.S. cases is estimated to be 600,000 annually. A number of studies have documented pertussis in 13–32% of adolescents and adults with cough illness for >7 days. Responding to these changes in epidemiology, vaccination containing tetanus toxoid, reduced-content diphtheria toxoid, and acellular pertussis antigens (**Tdap**) was recommended in 2006 for 11- to 12-year-olds and was aimed to enhance control. With >70% uptake of Tdap in adolescents, the burden of disease in young adolescents fell commensurately, but without evidence of protection of the community (herd) of young infants, older adolescents, and adults. An epidemiologic shift has occurred as a result of substantial and rapid waning of protection after both DTaP and Tdap in the aging cohort of children and adolescents who were not primed with DTP (whole cell) vaccine, which was no longer used in the United States after 1997. The >42,000 cases of pertussis and 20 deaths reported in 2012 were the highest numbers in >50 years. A shift in disease burden was observed among 7- to 10-year-olds in 2010, 13- to 14-year-olds in 2012, and 14- to 16-year-olds in 2014 as the cohort of solely DTaP-vaccinated persons aged.

Neither natural disease nor vaccination provides complete or lifelong immunity against pertussis reinfection or disease. Subclinical reinfection undoubtedly contributed significantly to immunity against disease ascribed previously to both vaccine and prior infection. The resurgence of pertussis can be attributed to a variety of factors, including partial control of pertussis leading to less continuous exposure and increased awareness and improved diagnostics. Rapidly waning vaccine-induced immunity and pathogen adaptation are the most important factors currently. Although the DTaP series is protective short-term, vaccine effectiveness wanes rapidly, with estimates of only 10% protection 8.5 years after the fifth dose. Tdap protection also is short-lived, with efficacy falling from >70% initially to 34% within 2–4 years. A retrospective cohort study of children born between 1999 and 2016 found that the risk of pertussis among immunized children was 5 times higher  $\geq 3$  years after vaccination compared with <1 year after vaccination. Divergence of circulating strains from vaccine strains began with the introduction of DTP, but with the exclusive use of acellular pertussis vaccines, **pertactin-deficient strains** emerged and have become dominant in countries where these vaccines are used. Pertactin-deficient *B. pertussis* was first reported in the United States from a Philadelphia infant case collection from 2008 to 2011. The Centers for Disease Control and Prevention (CDC) subsequently reported the earliest U.S. isolate from 1994 and rapid dominance of pertactin-deficient strains in the United States since 2010. Despite the role of pertactin as a bacterial virulence factor, illness severity in infants with pertactin-deficient *B. pertussis* is similar to that of pertactin-producing strains. Pending introduction of novel pertussis vaccine(s) that reduce colonization and transmission, pertussis will continue to be endemic, with cycling epidemics.

## PATHOGENESIS

*Bordetella* organisms are small, fastidious, gram-negative coccobacilli that colonize only ciliated epithelium. The exact mechanism of disease symptomatology remains unknown. *Bordetella* species share a high degree of DNA homology among virulence genes. Only *B. pertussis* expresses **pertussis toxin (PT)**, the major virulence protein. PT has numerous proven biologic activities (e.g., histamine sensitivity, insulin secretion, leukocyte dysfunction). Although injection of PT in experimental animals causes lymphocytosis immediately by rerouting lymphocytes to remain in the circulating blood pool, PT

does not cause cough. PT appears to have a central, but not a singular, role in pathogenesis. *B. pertussis* produces an array of other biologically active substances, many of which are postulated to have a role in disease and immunity. After aerosol acquisition, **filamentous hemagglutinin (FHA)**, some **agglutinogens** (especially fimbriae [Fim] types 2 and 3), and the 69-kDa **pertactin (Prn)** protein are important for attachment to ciliated respiratory epithelial cells. **Tracheal cytotoxin, adenylate cyclase**, and PT appear to inhibit clearance of organisms. Tracheal cytotoxin, **dermonecrotic factor**, and adenylate cyclase are postulated to be predominantly responsible for the local epithelial damage that produces respiratory symptoms and facilitates absorption of PT. Both antibody and cellular immune responses follow infection and immunization. Antibody to PT neutralizes toxin, and antibody to Prn enhances opsonophagocytosis. Both disease and DTP appear to drive a mixed cellular and antibody (Th1) immunologic response, whereas both DTaP and Tdap drive a narrow, antibody-dominant (Th2) response.

Pertussis is extremely contagious, with attack rates as high as 100% in susceptible individuals exposed to aerosol droplets at close range. High airborne transmission rates were shown in a baboon model of pertussis despite vaccination with the acellular vaccine. *B. pertussis* does not survive for prolonged periods in the environment. Chronic carriage by humans is not documented. After intense exposure, as in households, the rate of subclinical infection is as high as 80% in fully immunized or previously infected individuals. When carefully sought, a symptomatic source case can be found for most patients—usually a sibling or related adult.

## CLINICAL MANIFESTATIONS

Classically, pertussis is a prolonged disease, divided into catarrhal, paroxysmal, and convalescent stages. The **catarrhal stage** (1-2 weeks) begins insidiously after an incubation period ranging from 3 to 12 days with nondistinctive symptoms of congestion and rhinorrhea variably accompanied by low-grade fever, sneezing, lacrimation, and conjunctival suffusion. As initial symptoms wane, coughing marks the onset of the **paroxysmal stage** (2-6 weeks). The cough begins as a dry, intermittent, irritative hack and evolves into the inexorable paroxysms that are the hallmark of pertussis. A well-appearing, playful toddler with insignificant provocation suddenly expresses an anxious aura and may clutch a parent or comforting adult before beginning a machine-gun burst of uninterrupted cough on a single exhalation, chin and chest held forward, tongue protruding maximally, eyes bulging and watering, face purple, until coughing ceases and a loud whoop follows as inspired air traverses the still partially closed airway. **Posttussive emesis** is common, and exhaustion is universal. The number and severity of paroxysms escalate over days to a week and remain at that plateau for days to weeks. At the peak of the paroxysmal stage, patients may have one or more episodes hourly. As the paroxysmal stage fades into the **convalescent stage** ( $\geq 2$  weeks), the number, severity, and duration of episodes diminish.

**Infants <3 months old** do not display the classic stages. The catarrhal phase lasts only a few days or is unnoticed, and then, after the most insignificant startle from a draft, light, sound, sucking, or stretching, a well-appearing young infant begins to choke, gasp, gag, and flail the extremities, with face reddened. Cough may not be prominent, especially in the early phase, and whoop is infrequent. Apnea and cyanosis can follow a coughing paroxysm, or apnea can occur as the only symptom (without cough). Both are more common with pertussis than with neonatal viral infections. The paroxysmal and convalescent stages in young infants are lengthy. Paradoxically, in infants, cough and whooping may become louder and more classic in convalescence. “Exacerbations” of paroxysmal coughing can occur throughout the first year of life with subsequent respiratory illnesses; these are not a result of recurrent infection or reactivation of *B. pertussis*.

**Adolescents** and previously immunized children have foreshortening of all stages of pertussis. **Adults** have no distinct stages. Classically, adolescents and adults describe a sudden feeling of strangulation followed by uninterrupted coughs, feeling of suffocation, bursting headache, diminished awareness, and then a gasping breath, usually without

a whoop. Posttussive emesis and intermittency of paroxysms separated by hours of well-being are specific clues to the diagnosis. At least 30% of adolescents and adults with pertussis have nonspecific cough illness, distinguished only by duration, which usually is  $>21$  days.

Findings on physical examination generally are uninformative. Signs of lower respiratory tract disease are not expected unless complicating secondary bacterial pneumonia is present. Conjunctival hemorrhages and petechiae on the upper body are common.

## DIAGNOSIS

Pertussis should be suspected in any individual who has a pure or predominant complaint of cough, especially if the following features are *absent*: fever, malaise or myalgia, exanthem or enanthem, sore throat, hoarseness, tachypnea, wheezes, and rales. For sporadic cases, a clinical case definition of cough of  $\geq 14$  days' duration with at least one associated symptom of paroxysms, whoop, or posttussive vomiting has a sensitivity of 81% and specificity of 58% for confirmation of pertussis. Pertussis should be suspected in older children whose cough illness is *escalating* at 7-10 days and whose coughing is *not* continuous, but rather comes in bursts. Pertussis should be suspected in infants  $<3$  months old with gagging, gasping, apnea, cyanosis, or a brief resolved unexplained event (BRUE). Sudden infant death occasionally is caused by *B. pertussis*.

Adenoviral infections usually are distinguishable by associated features, such as fever, sore throat, and conjunctivitis. *Mycoplasma* causes protracted episodic coughing, but patients usually have a history of fever, headache, and systemic symptoms at the onset of disease as well as more continuous cough and the frequent finding of rales on auscultation of the chest. Epidemics of *Mycoplasma* and *B. pertussis* in young adults can be difficult to distinguish on clinical grounds. Although pertussis often is included in the differential diagnosis of young infants with afebrile pneumonia, *B. pertussis* is not associated with staccato cough (breath with every cough), purulent conjunctivitis, tachypnea, rales, or wheezes that typify infection by *Chlamydia trachomatis* or predominant lower respiratory tract signs that typify infection by RSV. Unless an infant with pertussis has secondary pneumonia and then appears ill, the findings on examination between paroxysms, including respiratory rate, are entirely normal. Foreign body aspiration should be considered in the differential diagnosis.

Leukocytosis (15,000-100,000 cells/ $\mu$ L) caused by *absolute lymphocytosis* is characteristic in the catarrhal stage. Lymphocytes are normal small cells, rather than the large, atypical lymphocytes seen with viral infections. Adults, partially immune children, and occasionally infants may have less impressive lymphocytosis. Absolute increase in neutrophils suggests a different diagnosis or secondary bacterial infection. Eosinophilia is not a manifestation of pertussis. A severe course and death are correlated with rapid-rise and extreme leukocytosis (median peak white blood cell count in fatal vs nonfatal cases: 94,000 vs 18,000/ $\mu$ L, respectively) and thrombocytosis (median peak platelet count in fatal vs nonfatal cases: 782,000 vs 556,000/ $\mu$ L, respectively). Chest radiographic findings are only mildly abnormal in the majority of hospitalized infants, showing perihilar infiltrate or edema (sometimes with a butterfly appearance) and variable atelectasis. Parenchymal consolidation suggests secondary bacterial infection. Pneumothorax, pneumomediastinum, and subcutaneous emphysema can be seen occasionally.

Methods for confirmation of infection by *B. pertussis* (culture, polymerase chain reaction [PCR], serology) have limitations in sensitivity, specificity, or practicality, and the relative value of tests depends on the setting, phase of disease, and purpose of use (e.g., as clinical diagnostic vs epidemiologic tools). **PCR** testing on nasopharyngeal wash specimens is the laboratory test of choice for *B. pertussis* identification. Both stand-alone and multiplex assays are U.S. Food and Drug Administration (FDA) cleared and available commercially. PCR assays using only single primers (IS481) cannot differentiate between some *Bordetella* spp. and do not detect *B. parapertussis*. Multiplex assays using multiple targets can distinguish species. All assays detect pertactin-deficient strains. For **culture**, a specimen is obtained by deep nasopharyngeal aspiration or with the use of a flexible swab



(Dacron or calcium alginate–tipped) held in the posterior nasopharynx for 15–30 seconds (or until the cough occurs). A 1% casamino acid liquid is acceptable for holding a specimen up to 2 hours; Stainer-Scholte broth or Regan-Lowe semisolid transport medium is used for longer transport periods, up to 4 days. The preferred isolation media are Regan-Lowe charcoal agar with 10% horse blood and 5–40 µg/mL cephalixin and Stainer-Scholte media with cyclodextrin resins. Cultures are incubated at 35–37°C in a humid environment and examined daily for 7 days for slow-growing, tiny, glistening colonies. Results of culture and PCR are expected to be positive in unimmunized, untreated children during the catarrhal and early paroxysmal stages of disease. *However, less than 20% of culture or PCR tests have positive results in partially or remotely immunized individuals tested in the paroxysmal stage.*

Serologic tests for detection of change in antibodies to *B. pertussis* antigens between acute and convalescent samples are the most sensitive diagnostic tests in immunized individuals and are useful epidemiologically. A single serum sample showing IgG antibody to PT >90 IU/mL (>2 standard deviations [SD] above the mean of the immunized population) indicates recent symptomatic infection and usually is positive in the mid-paroxysmal phase. Tests for IgA and IgM pertussis antibody, or antibody to antigens other than PT, are not reliable methods for serologic diagnosis of pertussis.

## TREATMENT

Infants <3 months old with suspected pertussis usually are hospitalized, as are many 3- to 6-month-old patients (i.e., unless witnessed paroxysms are not severe) and patients of any age if significant complications occur. Prematurely born young infants have a high risk for severe, potentially fatal disease, and children with underlying cardiac, pulmonary, muscular, or neurologic disorders have increased risk of poor outcome beyond infancy. Table 243.1 lists caveats in the assessment and care of infants with pertussis. The specific, limited goals of hospitalization are to (1) assess progression of disease and likelihood of life-threatening events at peak of disease, (2) maximize nutrition, (3) prevent or treat complications, and (4) educate parents in the natural history of the disease and in care that will be given at home. Heart rate, respiratory rate, and pulse oximetry are monitored continuously with alarm settings so that paroxysms can be witnessed and recorded by healthcare personnel. Detailed cough records and documentation of feeding, vomiting, and weight change provide data to assess severity. Features of typical paroxysms that are not life threatening are duration <45 seconds; red, but not blue, color change; tachycardia or bradycardia (but not <60 beats/min in infants); oxygen desaturation that spontaneously resolves rapidly at the end of the paroxysm; whooping or strength for brisk self-rescue at the end of the paroxysm; self-expectorated mucus plug; and posttussive exhaustion but not unresponsiveness. Assessing the need to provide oxygen, stimulation, or suctioning requires skilled personnel who can watchfully observe an infant's ability for self-rescue but who will intervene rapidly and expertly when necessary. The benefit

**Table 243.1** Considerations in the Assessment and Care of Infants with Pertussis

- Infants with potentially fatal pertussis may appear well between episodes.
- A paroxysm must be witnessed before a decision is made between hospital and home care.
- Only analysis of carefully compiled cough record permits assessment of severity and progression of illness.
- Suctioning of the nose, oropharynx, or trachea should not be performed on a “preventive” schedule.
- Feeding in the period after a paroxysm may be more successful than after napping.
- Family support begins at the time of hospitalization with empathy for the child's and family's experience to date, transfer of the burden of responsibility for the child's safety to the healthcare team, and delineation of assessments and treatments to be performed.
- Family education, recruitment as part of the team, and continued support after discharge are essential.

of a quiet, dimly lighted, undisturbed, comforting environment cannot be overestimated or forfeited in a desire to monitor and intervene. Feeding children with pertussis is challenging. The risk of precipitating cough by nipple feeding does not warrant nasogastric, nasojejunal, or parenteral alimentation in most infants. The composition or thickness of formula does not affect the quality of secretions, cough, or retention. Large-volume feedings are avoided.

Within 48–72 hours, the direction and severity of disease are obvious from an analysis of the recorded information. Hospital discharge is appropriate if, over 48 hours, disease severity is unchanged or diminished, intervention is not required during paroxysms, nutrition is adequate, no complication has occurred, and parents are adequately prepared for care at home. Apnea and seizures occur in the incremental phase of illness and in patients with complicated disease. Portable oxygen, monitoring, or a suction apparatus should not be needed at home.

Infants who have apnea, paroxysms that lead to life-threatening events, or respiratory failure require escalating respiratory support and frequently require intubation and pharmaceutically induced paralysis.

## Antibiotics

An antimicrobial agent always is given when pertussis is suspected or confirmed to decrease contagiousness and to afford possible clinical benefit. *Azithromycin* is the drug of choice in all age-groups, either for treatment or postexposure prophylaxis (Table 243.2). Macrolide resistance has been reported rarely in the United States, and recent isolates have retained susceptibility despite genetic strain adaptations. *Infantile hypertrophic pyloric stenosis* (IHPS) is associated with macrolide use in young infants, especially in those <14 days old, with higher risk in those receiving erythromycin vs azithromycin. The benefits of postexposure prophylaxis or treatment of infants far outweigh the risk of IHPS. Young infants should be managed expectantly if projectile vomiting occurs. The FDA also warns of the risk of fatal heart rhythms with the use of azithromycin in patients already at risk for cardiovascular events, especially those with prolongation of the QT interval. Trimethoprim-sulfamethoxazole (TMP-SMX) is an alternative to azithromycin for infants >2 months old and children unable to receive azithromycin. Because of its limited effectiveness, treatment of *B. parapertussis* is based on clinical judgment and is considered in high-risk populations. Agents are the same as for *B. pertussis*. Treatment of infections caused by other *Bordetella* spp. should be undertaken with consultation of a subspecialist.

## Adjunct Therapies

No rigorous clinical trial has demonstrated a beneficial effect of  $\beta_2$ -adrenergic stimulants such as salbutamol and albuterol. Fussing associated with aerosol treatment triggers paroxysms. No randomized, blinded clinical trial of sufficient size has been performed to evaluate the usefulness of corticosteroids in the management of pertussis; their clinical use is not warranted. A randomized, double-blind, placebo-controlled trial of pertussis immunoglobulin (IGIV) was halted prematurely because of expiration/lack of additional supply of the study product; there was no indication of clinical benefit. Standard immunoglobulin has not been studied and should not be used for treatment or prophylaxis.

## Isolation

Patients with suspected pertussis are placed in isolation with **droplet precautions** to reduce close respiratory or mucous membrane contact with respiratory secretions. All healthcare personnel should wear a mask on entering the room. Screening for cough should be performed on entrance of patients to emergency departments, offices, and clinics to begin isolation immediately and until 5 days after initiation of azithromycin therapy. Children and staff with pertussis in childcare facilities or schools should be excluded until therapy has been taken for 5 days.

## Care of Household and Other Close Contacts

Azithromycin should be given promptly to all household contacts and other close contacts, such as those in daycare, regardless of age, history



**Table 243.2** Recommended Antimicrobial Treatment and Postexposure Prophylaxis for Pertussis

AGE GROUP	PRIMARY AGENTS		ALTERNATIVE AGENT*	
	AZITHROMYCIN	ERYTHROMYCIN	CLARITHROMYCIN	TMP-SMX
<1 mo	Recommended agent 10 mg/kg/day in a single dose for 5 days	Not preferred Erythromycin is substantially associated with infantile hypertrophic pyloric stenosis Use if azithromycin is unavailable; 40-50 mg/kg/day in 4 divided doses for 14 days	Not recommended (safety data unavailable)	Contraindicated for infants <2 mo of age (risk for kernicterus)
1-5 mo	10 mg/kg/day in a single dose for 5 days	40-50 mg/kg/day in 4 divided doses for 14 days	15 mg/kg/day in 2 divided doses for 7 days	Contraindicated at age <2 mo For infants age ≥2 mo: TMP 8 mg/kg/day plus SMX 40 mg/kg/day in 2 divided doses for 14 days
Infants age ≥6 mo and children	10 mg/kg in a single dose on day 1 (max 500 mg), then 5 mg/kg/day (max 250 mg) on days 2-5	40-50 mg/kg/day (max 2 g/day) in 4 divided doses for 14 days	15 mg/kg/day in 2 divided doses (max 1 g/day) for 7 days	TMP 8 mg/kg/day plus SMX 40 mg/kg/day in 2 divided doses (max TMP: 320 mg/day) for 14 days
Adults	500 mg in a single dose on day 1, then 250 mg/day on days 2-5	2 g/day in 4 divided doses for 14 days	1 g/day in 2 divided doses for 7 days	TMP 320 mg/day to SMX 1600 mg/day in 2 divided doses for 14 days

\*Trimethoprim-sulfamethoxazole (TMP-SMX) can be used as an alternative agent to macrolides in patients ≥2 mo old who are allergic to macrolides, who cannot tolerate macrolides, or who are infected with a rare macrolide-resistant strain of *Bordetella pertussis*.

Adapted from Centers for Disease Control and Prevention (CDC). Recommended antimicrobial agents for treatment and postexposure prophylaxis of pertussis: 2005 CDC guidelines. *MMWR*. 2005;54:1-16.

of immunization, or symptoms (see Table 243.2). The same drugs and age-related doses used for treatment are used for prophylaxis. Visitation and movement of coughing family members in the hospital must be assiduously controlled until therapy has been taken for 5 days. In close contacts <7 years old who have received fewer than four doses of DTaP, DTaP should be given to complete the recommended series. Children <7 years old who received a third DTaP dose >6 months before exposure, or a fourth dose ≥3 years before exposure, should be given a booster dose. Individuals ≥9 years old should be given Tdap. Unmasked healthcare personnel exposed to untreated cases should be evaluated for postexposure prophylaxis and follow-up. Coughing healthcare personnel with or without known exposure to pertussis should be evaluated promptly for pertussis.

## COMPLICATIONS

Infants <2 months old have the highest reported rates of pertussis-associated hospitalization (82%), pneumonia (25%), seizures (4%), encephalopathy (1%), and death (1%). Infants <4 months old account for 90% of cases of fatal pertussis. Preterm birth and young maternal age are significantly associated with fatal pertussis. Neonates with pertussis have substantially longer hospitalizations, greater need for oxygen, and greater need for mechanical ventilation than neonates with viral respiratory tract infection. The strategy of preventing pertussis in newborns through the vaccination of women with Tdap during pregnancy from 27 through 36 weeks of gestation is 80-91% effective. One study found that among infants with pertussis, disease severity was reduced in those whose mothers were vaccinated during pregnancy, with maternal vaccination being 58% effective in preventing hospitalization.

The principal complications of pertussis are **apnea**, **secondary infections** (e.g., otitis media, pneumonia), and **physical sequelae** of forceful coughing. Fever, tachypnea or respiratory distress between paroxysms, and absolute neutrophilia are clues to pneumonia. Expected pathogens include *Staphylococcus aureus*, *Streptococcus pneumoniae*, and bacteria of oropharyngeal flora. Increased intrathoracic and intraabdominal pressure during coughing can result in conjunctival and scleral hemorrhage, petechiae on the upper body, epistaxis, pneumothorax and subcutaneous emphysema, umbilical or inguinal hernia, and rarely, hemorrhage in the central nervous system or retina. Laceration of the lingual frenulum occurs occasionally.

The need for intensive care and mechanical ventilation usually is limited to infants <3 months old and children with underlying conditions. Respiratory failure from apnea may mandate intubation and ventilation through the days when disease peaks; the prognosis is good. Progressive **pulmonary hypertension** in very young infants and secondary **bacterial pneumonia** are severe complications of pertussis and are the usual causes of death. Pulmonary hypertension and cardiogenic shock with fatal outcome are associated with extreme elevation of lymphocyte and platelet counts. Autopsies in fatal cases show luminal aggregates of leukocytes in the pulmonary vasculature. Extracorporeal membrane oxygenation of infants with pertussis in whom mechanical ventilation failed has been associated with >80% fatality (questioning the advisability of this procedure). Exchange transfusion or leukapheresis is associated with marked reduction in lymphocyte and platelet counts. Although recovery has been reported in several cases, the benefit is unproven. Echocardiography should be performed in critically ill infants with pertussis to detect the presence of pulmonary hypertension and to intervene expeditiously.

Acute neurologic events during pertussis almost always are the result of **hypoxemia** or **hemorrhage** associated with coughing or apnea in young infants. Apnea or bradycardia or both may result from apparent laryngospasm or vagal stimulation just before a coughing episode, from obstruction during an episode, or from hypoxemia after an episode. Seizures usually are a result of hypoxemia, but hyponatremia from excessive secretion of antidiuretic hormone during pneumonia can occur. The only neuropathology documented in pertussis is parenchymal hemorrhage and ischemic necrosis.

Bronchiectasis has been reported rarely after pertussis. Children who have pertussis before age 2 years may have abnormal pulmonary function into adulthood.

## PREVENTION

Universal immunization of children with pertussis vaccine, beginning in infancy with reinforcing dose(s) through adolescence and adulthood, is central to the *control* of pertussis. *Prevention* of pertussis mortality in young infants depends on universal maternal immunization during each pregnancy and focused full immunization of contacts, both children and adults of all ages.

### DTaP Vaccines

Several diphtheria and tetanus toxoids combined with acellular pertussis vaccines (DTaP) or combination products currently are licensed in the United States for children <7 years old. Acellular pertussis vaccines all contain inactivated PT and two or more additional antigens (FHA, Prn, and Fim 2 and 3). Clinical effectiveness immediately at completion of the five-dose series is approximately 80% for illness defined as “paroxysmal cough” for >21 days. Mild local and systemic adverse events are not uncommon, but more serious events (i.e., persistent crying for ≥3 hours or a hypotonic hyporesponsive episode) are rare after DTaP, are not specific to pertussis vaccine or associated with serious sequelae, and are not contraindications to subsequent doses.

Four doses of DTaP should be administered during the first 2 years of life, generally at ages 2, 4, 6, and 15-18 months. In high-risk settings, infants may be given DTaP as early as 6 weeks of age, with monthly doses through the third dose. The fourth dose may be administered as early as 12 months of age, provided that 6 months have elapsed since the third dose. When feasible, the same DTaP product is recommended for all doses of the primary vaccination series. The fifth dose of DTaP is recommended for children at 4-6 years of age; a fifth dose is not necessary if the fourth dose in the series is administered on or after the fourth birthday.

Local reactions increase modestly in rate and severity with successive doses of DTaP. Swelling of the entire thigh or upper arm, sometimes accompanied by pain, erythema, and fever, has been reported in 2-3% of vaccinees after the fourth or fifth dose of a variety of DTaP products. Limitation of activity is less than might be expected. Swelling subsides spontaneously without sequelae. The pathogenesis is unknown. Extensive limb swelling after the fourth dose of DTaP usually is not associated with a similar reaction to the fifth dose and is not a contraindication to subsequent dose(s) of pertussis vaccines.

Exempting children from pertussis immunization should be considered only within the narrow limits as recommended. Exemptors have significantly increased the risk for pertussis and play a role in outbreaks of pertussis among immunized populations. Although well-documented pertussis confers short-term protection, the duration of protection is unknown; immunization should be completed on schedule in children diagnosed with pertussis. Pertussis vaccine (DTaP or Tdap) can be administered concurrently with any vaccine on the immunization schedule.

### Tdap Vaccines

Two tetanus toxoid, reduced-diphtheria toxoid, and acellular pertussis antigen vaccine (Tdap) products were licensed in 2005 and recommended universally in 2006 for adolescents. The preferred age for Tdap vaccination is 11-12 years. All adolescents and adults of any age (including ≥65 years) who have not received Tdap should receive a single dose of Tdap promptly, regardless of interval since Td, or at least in place of one Td booster at the 10-year interval, or when indicated during wound management.

Pregnant women should be given Tdap during every pregnancy to provide passive antibody protection to the infant until administration of DTaP. Although Tdap can be given at any time during pregnancy, optimal administration is early in the period between 27 through 36 weeks of gestation to maximize antibody concentration at birth. The safety of Tdap during pregnancy and effectiveness in reducing fatal pertussis in infants are proven. Special effort should be made to ensure that contacts of infants have received DTaP or Tdap as recommended.

Clinical trials support the safety and immunogenicity of a second dose of Tdap; however, antipertussis antibodies decline rapidly after the first year. The CDC performed a decision analysis model of repeating Tdap at either a 5- or 10-year interval for the general population and concluded that “booster(s)” would have limited impact on pertussis disease burden. There is not a recommendation for a routine second dose of Tdap in the general population. A single dose of Tdap should be given to children 7-10 years of age who lack DTaP dose(s). Since 2019, the updated CDC recommendations allow use of either Tdap or Td when Td alone is indicated for catch-up dose(s), or for decennial immunization, or for wound management in individuals who have received Tdap.

### Vaccines Under Development

Several strategies are being tested to create pertussis vaccines that elicit a Th1 response, dampen the density of mucosal infection and transmission, provide sustained protection against disease, and have tolerable reactogenicity. These include use of live attenuated *B. pertussis*, a genetically (rather than a chemically) inactivated PT component, novel antigens, and adjuvants.

Visit Elsevier eBooks+ at [eBooks.Health.Elsevier.com](http://eBooks.Health.Elsevier.com) for Bibliography.

## Chapter 244

# Salmonella

Jeffrey S. McKinney

**Salmonellosis** is one of the most widely distributed and common food-borne and fecal-oral diseases in humans, and *Salmonellae* live in the intestinal tracts of multiple species. *Salmonella* infections are a major public health problem, with disproportionate morbidity and mortality among infants and children and in certain immunocompromised individuals.

Clinically, *Salmonellae* have been most broadly classified as being either nontyphoidal or typhoidal, with the latter causing typhoid (also known as *enteric*) fever. The differences in the disease manifestations from these two groups of pathogens, one predominantly causing intestinal inflammation and the other leading to systemic disease, are increasingly understood to be related to specific genes and pathogenicity islands in the genomes of the respective organisms.

Most nontyphoidal serovars of *Salmonella* (widely distributed across multiple host species) are rarely able to overcome defense mechanisms in humans that limit bacterial dissemination from the intestine. Thus in immunocompetent humans, nontyphoidal serovars usually produce a self-limiting gastroenteritis. By contrast, *S. Typhi* and *S. Paratyphi* (i.e., the typhoidal strains of *Salmonella*, notably host-restricted to only humans) possess virulence traits that more readily allow them to overcome mucosal barrier functions and then cause severe systemic illness, even in immunocompetent patients.

However, a purely binary classification of *Salmonellae* as nontyphoidal vs typhoidal can be a problematic oversimplification. For example, reports from Africa have identified strains of nontyphoidal *Salmonellae* that are highly invasive and increasingly common. Like many gram-negative bacteria, mobile or differentially expressed genetic elements can radically alter phenotypes in *Salmonellae*, sometimes in direct response to selective pressures like antimicrobial exposures given to individual patients and/or in broader settings like agricultural antimicrobial use.

Although DNA hybridization studies result in enough similarities for all *Salmonellae* to currently be classified in the single species *Salmonella enterica*, serologic studies can resolve more than 2,000 serotypes. Serotype and DNA sequencing identification has helped clinical laboratories better trace disease outbreaks, and the Centers for Disease Control and Prevention (CDC) has published recent guidelines for a more consistent terminology to help both laboratory and clinical teams confront complex classification nomenclature.

Host differences are also profoundly relevant to the outcomes of *Salmonella* exposures, infections, and disease. Infants and children, patients with certain immunologic vulnerabilities, and the extent to which a given *Salmonella* infection can evade host defenses and/or antibacterial drugs can help predict, or at least better understand, the ultimate impact of *Salmonella* on both individual and public health.

## 244.1 Nontyphoidal Salmonellosis

Jeffrey S. McKinney

### ETIOLOGY

*Salmonellae* are motile, nonsporulating, gram-negative rods that grow in aerobic and facultative anaerobic conditions. They remain viable at ambient or reduced temperatures for days and may survive for weeks in sewage, foods, pharmaceutical agents, and fecal material. They are resistant to many physical agents but can be killed by heat to 54.4°C (130°F) for 1 hour or 60°C (140°F) for 15 minutes.

Most serotypes of nontyphoidal *Salmonella* have a broad host spectrum, including both warm-blooded and cold-blooded vertebrates, and even insects like flies and cockroaches. Some serotypes have more limited host ranges, such as *S. dublin* in cattle (recovered in human infections associated with unpasteurized milk) and *S. choleraesuis* in pigs. In human infections, these two serotypes also have a notable propensity to cause more bacteremia and fewer gastrointestinal symptoms as compared with many other nontyphoidal *Salmonellae*. In sub-Saharan Africa, nontyphoidal *Salmonella* has become a leading cause of bacteremia. Up to 95% of the serovars associated with invasive *Salmonella* disease among children in this geographic region are *Salmonella* serovar Typhimurium (mostly of an unusual variant designated **multilocus sequence type 313**), a variant of sequence type 313 that does not express phase 2 flagella, or *Salmonella* serovar Enteritidis. This information represents a deviation from the historical assumption that nontyphoidal *Salmonella* is, by definition, relatively noninvasive.

In the United States, nontyphoidal *Salmonella* infections still generally cause **gastroenteritis** that is localized and self-limiting. In these uncomplicated cases, nontyphoidal *Salmonella* infection does not justify treatment with antibiotics. However, nontyphoidal infections can be severe in the young, the elderly, and patients with vulnerabilities in their immunity.

### EPIDEMIOLOGY

Salmonellosis has a significant cost to society. Globally, estimates suggest there are more than 90 million cases of *Salmonella* gastroenteritis annually, causing more than 150,000 deaths. In the United States, CDC estimates suggest an annual burden of more than 1.3 million *Salmonella* infections, causing more than 26,000 hospitalizations, 420 deaths, and \$400 million in direct medical costs, with approximately 30 people with unreported *Salmonella* illness for every one case confirmed by a laboratory test. Nearly half of culture-proven nontyphoidal *Salmonella* infections occur in children, with the highest incidence among infants. With the burden of HIV infections and malnutrition in Africa, nontyphoidal *Salmonella* bacteremia has emerged as a major cause of morbidity and mortality among both children and adults in Africa.

Nontyphoidal *Salmonella* has a worldwide distribution, with the incidence influenced by local standards of hygiene, sanitation, and availability of safe water and food. Modern practices of mass food production and distribution increase the potential for epidemics, which may be scattered so broadly as to only be fully appreciated via **robust national monitoring systems**, such as the CDC's **FoodNet** (<https://www.cdc.gov/foodnet/foodnet-fast.html>). FoodNet also helps build capacity for food-borne disease surveillance through close collaborations with PulseNet, EHS-Net, Global SalmSurv, and other partners.

Poultry meat and eggs are traditionally known to be a common source of salmonellosis, and even riding in a shopping cart next to poultry meat is a risk factor for infection of infants. However, consumption of a wide variety of foods has now been associated with outbreaks, including fruits, vegetables, and multiple factory-processed foods such as peanut butter, cookies, and infant formula.

*Salmonella* infections in many parts of the world may be related to **animal husbandry practices**, including drug-resistant strains that emerge in response to the widespread use of agricultural antimicrobials. Subtherapeutic antimicrobials are often added to animal feeds to promote animal growth. There is now strong evidence linking resistance to quinolones to the use of this group of antimicrobials in animal

feeds. Resistance to ciprofloxacin approached 10% of all nontyphoidal *Salmonella* isolates assessed by the CDC in 2017.

In addition to the effect of antibiotic use in animal feeds, the relationship of *Salmonella* infections to prior antibiotic use in children in the month before the infection is well recognized. This association may be related to alterations in gut microbial ecology, which predisposes to colonization and infection with antibiotic-resistant *Salmonella* isolates. The CDC reports that nontyphoidal *Salmonella* isolates during the period 2015–2017 continue to manifest increasing rates of resistance, with 16% of isolates being resistant to at least one essential antibiotic (including ciprofloxacin, azithromycin, ceftriaxone, ampicillin, and trimethoprim-sulfamethoxazole). *Variation in resistance among different strains makes Salmonella culture and antibiotic susceptibility testing very important.*

It appears that some **multidrug-resistant (MDR)** strains of *Salmonella* are also more virulent than susceptible strains. Poor clinical outcomes with these infections do not relate solely to the initial empiric choice of ineffective antibiotics. Over the past 3 decades, **S. Typhimurium phage type DT104** has emerged as a globally disseminated MDR strain. Typically resistant to ampicillin, chloramphenicol, streptomycin, sulfonamides, and tetracycline, DT104 also has the capacity to acquire resistance to other antibiotics. Many of the resistance genes in DT104 are harbored on genomic islands. Integrons can also encode and disseminate virulence genes.

Several risk factors are associated with outbreaks of *Salmonella* infection. Animals constitute the principal source of human disease from nontyphoidal *Salmonella*. **High-risk pets** include reptiles, amphibians, poultry and other birds, rodents, and other small mammals. The risk of *Salmonella* from turtles was so high that the U.S. Food and Drug Administration (FDA) banned the interstate sale and distribution of turtles with shell length of less than 4 inches. Exposures can also occur from contact with cages or tanks with pets, from touching some pet foods and treats, and even at zoos *without* direct contact with an infected animal.

Animals that carry *Salmonella* still appear healthy and clean and can readily transmit nontyphoidal *Salmonella*, including in **childcare centers and schools**. When nontyphoidal serovars are identified in a childcare attendee or staff member, adherence to hygiene practices is used to control infection. Return to school is allowed as long as stools are contained in a young child's diaper, toilet-trained children do not have accidents using the toilet, and stool frequency becomes no more than two stools above the child's normal stooling frequency per day. In notable contrast to infections with typhoidal strains, demonstration of clearance of nontyphoidal *Salmonella* from stool cultures is neither sought nor required.

Given the ubiquitous nature of the organism, **nosocomial infections** with nontyphoidal *Salmonella* strains can also occur via contaminated equipment and diagnostic or pharmacologic preparations. Patient-to-patient spread can also occur in hospital settings, particularly among vulnerable hosts like neonates. Nursery nosocomial infections from *Salmonella* can be very difficult to control, sometimes taking months to stop and/or serving as a source for further spread through a hospital.

### PATHOGENESIS

The estimated number of bacteria that must be ingested to cause symptomatic disease in healthy adults is  $10^6$ – $10^8$  *Salmonella* organisms. Normal gastric acidity inhibits *Salmonella* multiplication, with most organisms rapidly killed at gastric pH <2.0. Achlorhydria, buffering medications, and rapid gastric emptying after gastroenterostomy allow more viable organisms to reach the small intestine and thus lower the infectious dose. Neonates and infants have hypochlorhydria and rapid gastric emptying, which contribute to their increased vulnerability to infection, even at lower inoculum exposures.

The typical intestinal response to nontyphoidal *Salmonella* infection is **enterocolitis**, with diffuse mucosal inflammation and edema, sometimes with erosions and microabscesses. Intestinal inflammation with neutrophils and macrophages usually involves the lamina propria. Underlying intestinal lymphoid tissue and mesenteric lymph



nodes enlarge and may demonstrate small areas of necrosis. Lymphoid hypertrophy may interfere with blood supply to the gut mucosa and/or serve as a leading edge for intussusception. Hyperplasia of the reticuloendothelial system can also be found in the liver and spleen. If bacteremia develops, it may lead to localized infection and suppuration in almost any organ.

Central to *S. Typhimurium* pathogenesis are two **type III secretion systems**. These systems secrete and translocate bacterial proteins termed **effectors** into host cells. These effectors manipulate the host cell to allow bacterial invasion and assembly of an intracellular niche conducive to bacterial survival and replication. Two **genomic pathogenicity islands** encode these type III systems.

The *Salmonella* pathogenicity island 1 (SPI-1) is involved with epithelial cell adherence and invasion (Fig. 244.1), which involves host cell membrane ruffling caused by organized actin rearrangement (Fig. 244.2). This adherent and invasive phenotype of *Salmonella* is activated under conditions like those found in the human small intestine (high osmolarity, low oxygen).

The *Salmonella* pathogenicity island 2 (SPI-2) is involved with formation of the *Salmonella*-containing vacuole (Fig. 244.3), creating a replication-permissive intracellular space (Fig. 244.4). Intracellular *S. Typhimurium* is found within special vacuoles that have diverged from the normal endocytic pathway. An ability to survive within monocytes/macrophages is a key process for *S. Typhimurium* to establish a systemic infection. Survival within host cells also shields *Salmonella* from antimicrobials. For example, gentamicin is not considered effective *in vivo* against *Salmonella*, even for strains found susceptible to this drug *in vitro*, because gentamicin does not effectively reach intracellular bacteria.

Bacteremia and systemic disease are possible with any *Salmonella* serotype, especially in individuals with reduced host defenses. Inflammatory bowel disease or gut ischemia can cause intestinal mucosal barrier defects. Malnutrition, corticosteroid therapy, interleukin (IL)-12/interferon gamma axis defects, and posttransplant immunosuppressant agents can significantly compromise cell-mediated immunity. The reticuloendothelial system can be overloaded with hemoglobin or iron or have impaired function from lymphoma or leukemia. In addition, other underlying systemic conditions can predispose to serious *Salmonella* infections, including sickle cell disease, collagen vascular diseases, HIV/AIDS, defects in T<sub>H</sub>1 or T<sub>H</sub>17 immunity, and chronic granulomatous disease.

As stated earlier, neonates and infants less than 3 months of age are also at higher risk of bacteremia from nontyphoidal *Salmonella*. This risk influences empiric treatment with appropriate antibiotics, even in otherwise healthy patients in this young age-group.

Patients with sickle cell disease are at very high risk for *Salmonella* septicemia and osteomyelitis. This risk may be related to the presence of numerous infarcted areas in the gastrointestinal tract, bones, and reticuloendothelial organs, along with reduced phagocytic and opsonizing capacity of patients with sickle cell disease.

## CLINICAL MANIFESTATIONS

### Acute Enteritis

The most common clinical presentation of salmonellosis is acute enteritis. After an incubation period of 6-72 hours (mean 24 hours), there is often abrupt-onset nausea, vomiting, and crampy abdominal pain, located predominantly in the periumbilical area and the lower abdominal quadrants. These symptoms are usually followed by mild to severe watery diarrhea, sometimes containing blood, neutrophils, and mucus. Although fever is a classic feature, younger infants may exhibit a normal or subnormal temperature. Symptoms usually subside within 2-7 days in otherwise healthy children. However, some children experience a septicemia-like picture, with symptoms including high fever, drowsiness, confusion, abdominal distention, meningismus, and/or seizures.

### Bacteremia

After *Salmonella* gastroenteritis, it is estimated that 1-5% of otherwise healthy children are thought to experience transient

bacteremia after nontyphoidal *Salmonella* in U.S. settings. Bacteremia is usually accompanied by fever in older children but is often not associated with fever in infants. As described earlier, specific vulnerable hosts are far more likely to have systemic infection. Children with HIV can have recurrent nontyphoidal *Salmonella* septicemia, despite antibiotic therapy, even without positive stool cultures or any clear nidus of infection. Some nontyphoidal strains are more likely to result in bacteremia, even without obvious gastrointestinal symptoms, including *S. dublin* and *S. choleraesuis*. In Africa, nontyphoidal *Salmonella* is a much more common cause of pediatric bacteremia (see next).

## Nontyphoidal *Salmonella* Bacteremia as Emerging Disease in Africa

In Africa, particularly sub-Saharan Africa, nontyphoidal *Salmonella* has been increasingly recognized among the most common causes of *all* bacteremia in febrile children. Children age 6-36 months are at greatest risk, and case fatality rates can reach 25%.

Clinical features among children with invasive nontyphoidal *Salmonella* infections can be confusing, as diarrhea is often *not* a prominent feature. Furthermore, 60% of these children have an apparent lower respiratory tract infection (perhaps from co-infection or comorbidity). Fever is present in 95% but may have no apparent focus. Figure 244.5 summarizes other clinical features. The lack of specificity of these features severely compromises the ability of current clinical algorithms to identify invasive nontyphoidal *Salmonella* infections. Accordingly, blood culture and clinical microbiology systems for bacterial growth, isolation, speciation, and antibiotic susceptibility testing are required for diagnosis and well-informed treatment decision-making.

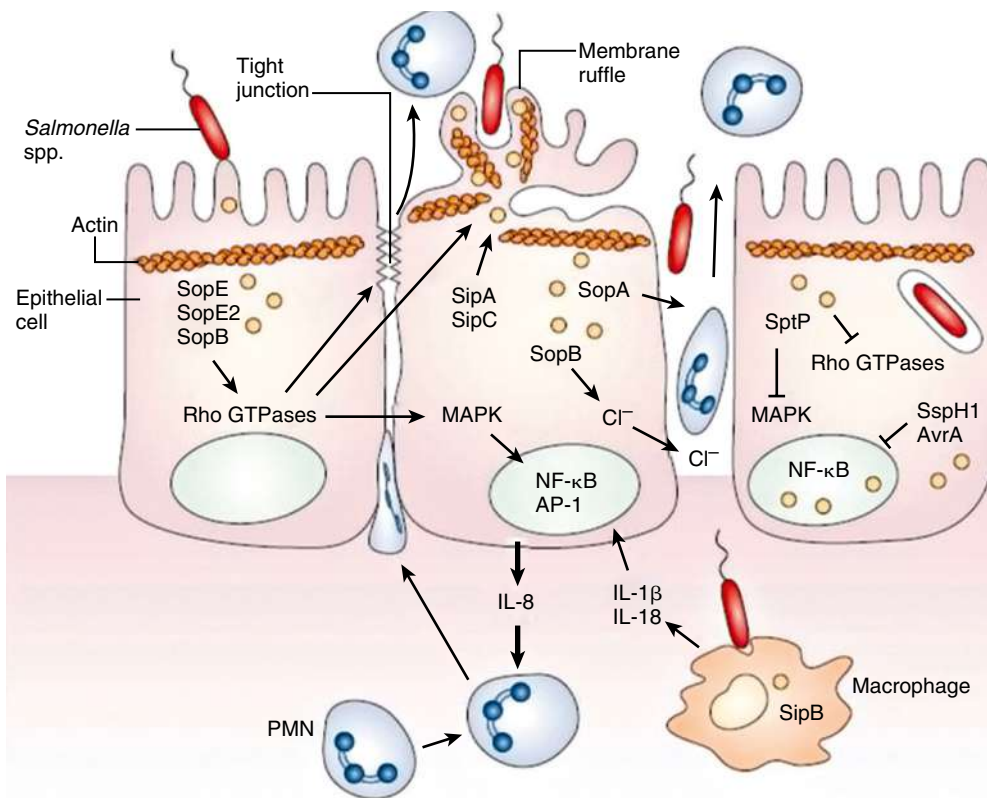
It remains unclear exactly why invasive infections by nontyphoidal *Salmonella* seem so much more frequent in Africa compared with the dominance of typhoid *Salmonellae* in Asia. HIV is one identified host risk factor for nontyphoidal *Salmonella* infection. Indeed, recurrent nontyphoidal *Salmonella* infection was part of early CDC case definitions for AIDS. However, only 20% of African children with invasive nontyphoidal *Salmonella* disease are HIV positive. Other risks for invasive nontyphoidal *Salmonella* may include recent or severe malaria infections, anemia, and malnutrition.

The epidemic patterns thus far appreciated for invasive infections by nontyphoidal *Salmonella* in Africa suggest that epidemics may occur over several years, peaking in the rainy season. However, it remains unclear how relevant human diarrheal disease or gastrointestinal carriage, or even food or zoonotic sources are, for invasive nontyphoidal *Salmonella* infection in this setting. Thus optimal strategies for interrupting transmission are also not known. This is particularly problematic, given the emergence of extensive antibiotic resistance among nontyphoidal *Salmonella* isolates, including the lineage referred to as *sequence type 313* (ST313).

Recent studies have attempted to better understand the geographic spread and genetic features of ST313 lineage variants isolated internationally over time. Intriguingly, the antibiotic-resistance patterns of these lineages seem to correlate with some large-scale or sequential changes in empiric (e.g., chloramphenicol, third-generation cephalosporins, ciprofloxacin, and azithromycin) antibiotic use. ST313 lineage genomic analysis also reveals the accumulation of **pseudogenes**, in what may be crucial **loss-of-function genetic events** involved in ST313 stepwise evolution, perhaps as part of adaptation to a more restricted (human) host range and from an intestinal to a systemic lifestyle.

For invasive nontyphoidal *Salmonella* infections in Africa, evolving resistance patterns seem likely to force increasing reliance on more expensive treatment options. Local resistance patterns may help empirically, but given the rapid spread of various ST313 lineages, susceptibility testing of individual patient isolates will be needed to ensure appropriate antibiotic choices. Targeted resistance gene sequencing, especially for gyrase mutations related to quinolone resistance, may also be warranted as that drug class becomes more widely used.





**Fig. 244.1** On contact with the epithelial cell, *Salmonellae* assemble the *Salmonella* pathogenicity island 1–encoded type III secretion system (TTSS-1) and translocate effectors (yellow spheres) into the eukaryotic cytoplasm. Effectors such as SopE, SopE2, and SopB then activate host Rho guanine triphosphatase (GTPase), resulting in the rearrangement of the actin cytoskeleton into membrane ruffles, induction of mitogen-activated protein kinase (MAPK) pathways, and destabilization of tight junctions. Changes in the actin cytoskeleton, which are further modulated by the actin-binding proteins SipA and SipC, lead to bacterial uptake. MAPK signaling activates the transcription factors activator protein-1 (AP-1) and nuclear factor- $\kappa$ B (NF- $\kappa$ B), which turn on production of the proinflammatory polymorphonuclear leukocyte (PMN) chemokine interleukin (IL)-8. SipB induces caspase-1 activation in macrophages, with the release of IL-1 $\beta$  and IL-18, augmenting the inflammatory response. In addition, SopB stimulates Cl<sup>-</sup> secretion by its inositol phosphatase activity. The destabilization of tight junctions allows the transmigration of PMNs from the basolateral to the apical surface, paracellular fluid leakage, and access of bacteria to the basolateral surface. However, the transmigration of PMNs also occurs in the absence of tight-junction disruption and is further promoted by SopA. The actin cytoskeleton is restored, and MAPK signaling is turned off by the enzymatic activities of SptP. This also results in the downmodulation of inflammatory responses, to which SspH1 and AvrA also contribute by inhibiting activation of NF- $\kappa$ B. (From Haraga A, Ohlson MB, Miller SI. *Salmonellae* interplay with host cells. *Nat Rev Microbiol.* 2008;6:53–66.)

### Nontyphoidal *Salmonella* Bacteremia in Other Geographic Regions

The emergence of invasive, high-mortality nontyphoidal *Salmonella* infections in Africa underscores that the traditional binary division of *Salmonella* infections into typhoidal vs nontyphoidal may be a problematic oversimplification. However, in settings outside of Africa, nontyphoidal *Salmonella* infections still tend to be self-limiting and noninvasive and are low-mortality events for most children who are immunocompetent.

Risk factors for systemic spread of nontyphoidal *Salmonella* include underlying sickle cell disease, HIV/AIDS, intestinal mucosal barrier defects, malnutrition, IL-12/interferon gamma axis defects, defects in T<sub>H</sub>1 or T<sub>H</sub>17 immunity, corticosteroid therapy or posttransplant immunosuppressants, reticuloendothelial system dysfunction (e.g., from overload with hemoglobin or iron), lymphoma or leukemia, collagen vascular diseases, and chronic granulomatous disease. Neonates and infants less than 3 months of age are also at higher risk of bacteremia from nontyphoidal *Salmonella*.

### Extraintestinal Focal Infection

After bacteremia, *Salmonellae* have the propensity to cause focal suppurative infection of many organs. The most common focal infections involve the skeletal system, meninges, and intravascular sites. The peak incidence of *Salmonella* meningitis is in infancy, and the infection may

be associated with a florid clinical course, high mortality, and neurologic sequelae in survivors.

### Chronic *Salmonella* Carriage

Although traditionally considered a complication among adults with *Salmonella* infection, chronic *Salmonella* carriage has important medical and epidemiologic implications and may occasionally occur in children. Colonization of the gallbladder by *S. Typhi* and persistent shedding from the gallbladder have long been appreciated. Reports suggest some nontyphoidal *Salmonellae* (e.g., invasive nontyphoidal *Salmonella* currently in Africa) can also establish long-term carriage states.

Antibiotic treatments of *Salmonella* infections are paradoxical in that the prospect of becoming a chronic carrier is believed to be increased by exposure to antibiotics. Yet clearance of established chronic carrier status requires prolonged medical treatment using antibiotics to which the *Salmonella* is susceptible and sometimes requires gallstone or gallbladder removal.

### DIAGNOSIS

Few clinical features are specific enough to *Salmonella* to allow differentiation from other infectious causes of gastroenteritis or diarrhea. Serologic tests also do not have diagnostic value. Definitive diagnosis requires identification of *Salmonella* via stool **nucleic acid amplification test (NAAT)** or **bacterial cultures**. Stool cultures have higher yields

than rectal swabs. Blood cultures are suggested for patients at higher risk of bacteremia or endovascular focus and when enteric fever is a concern. Additionally, cultures of bone marrow (particularly valuable

if antimicrobial agents have been administered or if stringent criteria are met for **fever of unknown origin**), duodenal fluid, and urine may be beneficial to detect enteric fever. In patients with sites of local suppuration, aspirated specimens should be Gram-stained and cultured.

*Salmonella* organisms grow well on nonselective or enriched media, such as blood agar, chocolate agar, and nutrient broth, but stool specimens containing mixed bacterial flora require a selective medium, such as McConkey, xylose-lysine-deoxycholate, bismuth sulfate, or Salmonella-Shigella (SS) agar for isolation of *Salmonella*. Given *Salmonella* variation and evolution, it is important to pursue bacterial isolation, species identification, and **antibiotic susceptibility testing to best inform the choice of effective therapeutic agents**. State public health laboratories require *Salmonella* isolates as part of outbreak detection and investigation, increasingly via genomic characterization of strains.

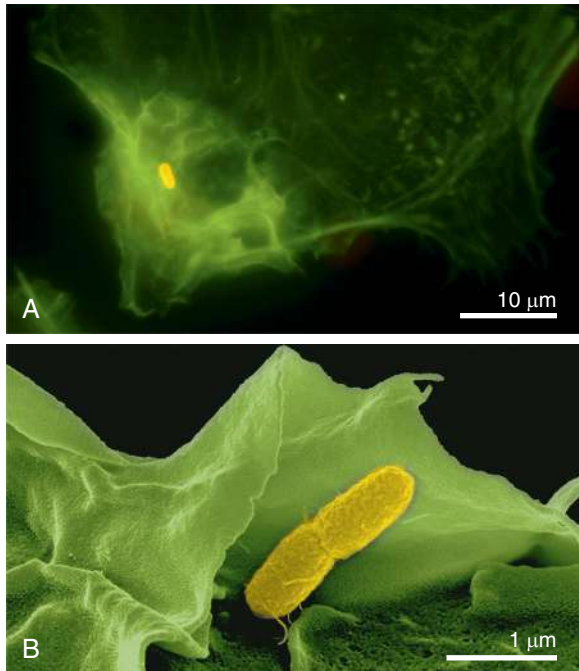
## TREATMENT

Appropriate therapy depends on the specific clinical presentation of *Salmonella* infection. In children with gastroenteritis, rapid clinical assessment, correction of dehydration and electrolyte disturbances, and supportive care are key. Antimotility drugs (e.g., loperamide) should not be given to children less than 18 years of age with acute diarrhea, but antiemetic drugs (e.g., ondansetron) can be given to facilitate oral rehydration in children older than 4 years.

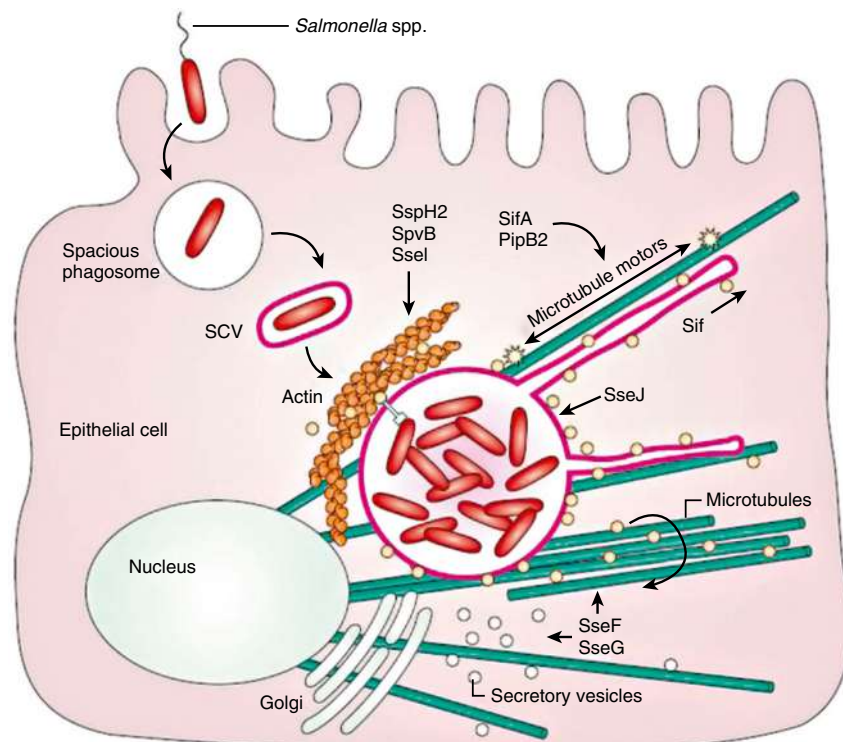
Antibiotics are generally *not* recommended for the treatment of isolated uncomplicated *Salmonella* gastroenteritis because they can disrupt normal intestinal flora and potentially prolong the fecal excretion of *Salmonella*.

However, empiric antibiotics are started for young infants (<3 months old) and for children with increased possibility of disseminated infection (e.g., children with HIV, malignancies, sickle cell disease, immunodeficiencies, or immunosuppression, as detailed earlier). In the United States, this empiric therapy includes a third-generation cephalosporin, with a blood culture obtained just before the initial dose. If a patient does not appear ill and does not have any evidence of disseminated infection, oral azithromycin can be started, pending blood culture results. Ampicillin, trimethoprim-sulfamethoxazole, or a fluoroquinolone may be considered as treatment options for susceptible strains.

In cases of bacteremia, blood cultures need to be repeated to confirm clearance of infection. Transition from parenteral third-generation

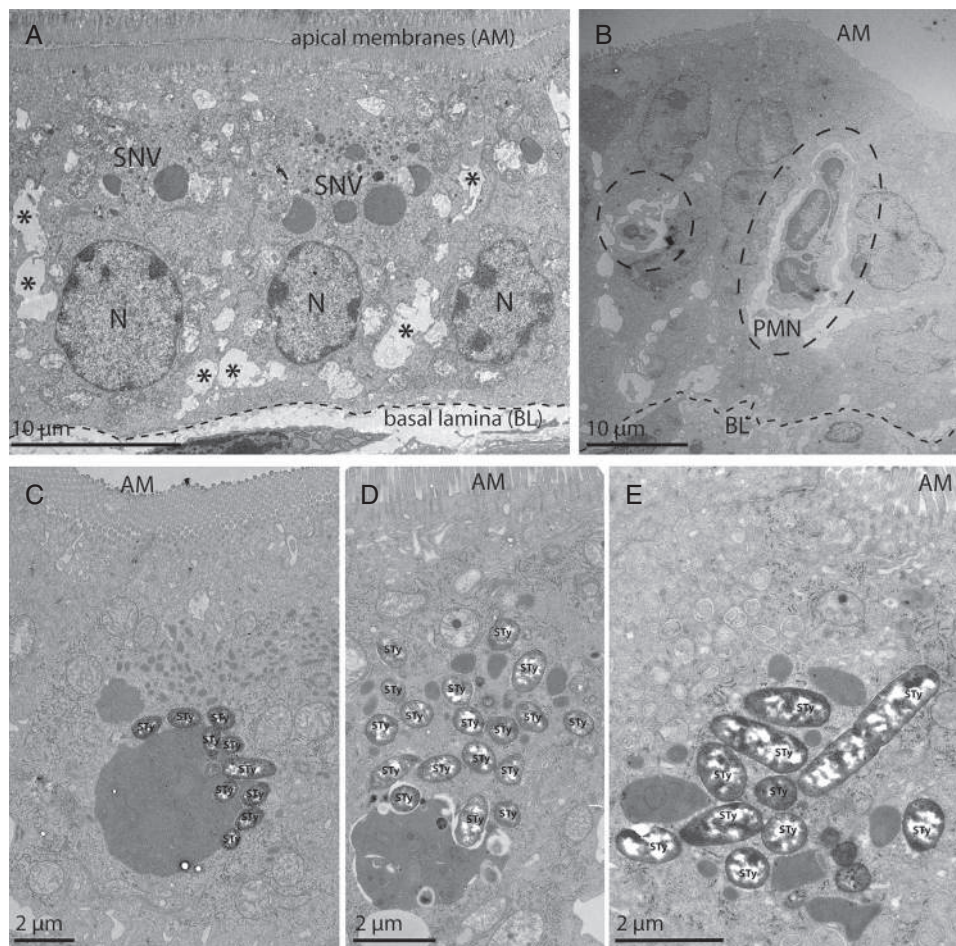


**Fig. 244.2** *Salmonella* SPI-1-mediated effects include host cell actin cytoskeletal rearrangements and host cell membrane ruffling as part of *Salmonella* invasion. **A**, HeLa cell infected with *Salmonella* fixed and stained for the actin cytoskeleton with phalloidin (green) and for *Salmonella* (yellow). **B**, Cos cell infected with *Salmonella* and prepared for scanning electron microscopy. Cell surface extensions in the process of enveloping the bacterium are pseudocolored green, and the microbe is in yellow. (From Rottner K, Stradal TEB, Wehland J. Bacteria-host-cell interactions at the plasma membrane: stories on actin cytoskeleton subversion. *Dev Cell*. 2005;9:3–17.)

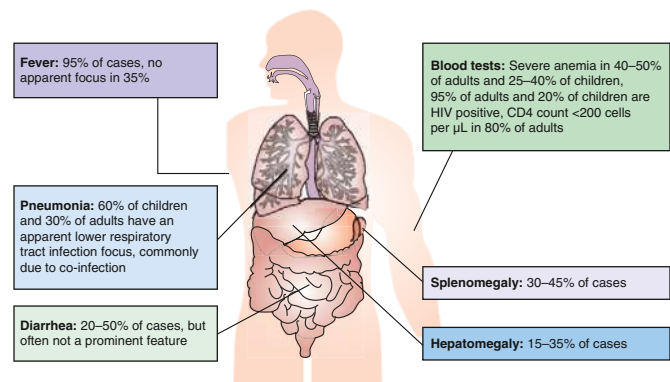


**Fig. 244.3** Formation of the *Salmonella*-containing vacuole (SCV) and induction of the *Salmonella* pathogenicity island 2 (SPI-2) type III secretion system (TTSS) within the host cell. Shortly after internalization by macropinocytosis, *Salmonellae* are enclosed in a spacious phagosome that is formed by membrane ruffles. Later, the phagosome fuses with lysosomes, acidifies, and shrinks to become adherent around the bacterium and is called the SCV. It contains the endocytic marker lysosomal-associated membrane protein 1 (LAMP-1; purple). The *Salmonella* SPI-2 is induced within the SCV and translocates effector proteins (yellow spheres) across the phagosomal membrane several hours after phagocytosis. The SPI-2 effectors SifA and PipB2 contribute to formation of *Salmonella*-induced filament along microtubules (green) and regulate microtubule motor (yellow star shape) accumulation on the Sif and the SCV. SseJ is a deacylase that is active on the phagosomal membrane. SseF and SseG cause microtubule bundling adjacent to the SCV and direct Golgi-derived vesicle traffic toward the SCV. Actin accumulates around the SCV in an SPI-2-dependent manner, in which SspH2, SpvB, and SseI are thought to have a role. (From Haraga A, Ohlson MB, Miller SI. *Salmonellae* interplay with host cells. *Nat Rev Microbiol*. 2008;6:53–66.)





**Fig. 244.4** Ultrastructural analysis of the distal small intestine with transmission electron microscopy. Distal small intestinal tissue was fixed with 1% glutaraldehyde. Short segments were cut open, post fixed with osmium tetroxide, contrasted with uranyl acetate, and dehydrated with a graded ethanol series before being embedded in epoxy resin. Thin sections were contrasted with lead citrate and analyzed in a JEM-1400 transmission electron microscope (JEOL). Images were taken with TemCam-F216 camera using EM MENU software (both TVIPS). **A**, Enterocytes in the distal intestine of healthy 5-day old neonates exhibit large supranuclear vacuoles (SNV) in their apical cytoplasm; the nuclei are situated at the basolateral site (N). SNV contain internalized milk proteins. Asterisks indicate intercellular spaces between enterocytes. **B**, 4 days after infection of 1-day-old mice with *S. Typhimurium*, the epithelium is infiltrated by polymorphonuclear cells (PMN). **C-E**, Intraepithelial *Salmonella* microcolonies are observed. Some bacteria reside in spherical vacuoles, which contain electron-dense material resembling the content of SNVs. Other bacteria appear to be localized in tight membrane-bound vesicles with few visible connections between them, or with vesicles filled with electron dense material. (From Zhang K, Griffiths G, Repnik U, Hornef M. Seeing is understanding: *Salmonella's* way to penetrate the intestinal epithelium. *Int J Med Microbiol*. 2018 Jan;308:97-106. Fig. 2.)



**Fig. 244.5** Clinical features of invasive nontyphoidal *Salmonella* (NTS) disease in adults and children in Africa. (From Feasey NA, Dougan G, Kingsley RA, et al. Invasive non-typhoidal *Salmonella* disease: an emerging and neglected tropical disease in Africa. *Lancet*. 2012;379:2489–2499.)

secondary sites, for a total 7- to 10-day course. Disseminated disease needs to be rigorously excluded, as therapy is more prolonged for meningitis (4 weeks) and osteomyelitis or other focal metastatic infections (4–6 weeks).

Given the heterogeneity, evolution, and rapid geographic spread of *Salmonella*, it is important to maintain awareness of resistance trends as related to local and national community isolate patterns, any relevant interstate outbreaks, and global patterns of emerging *Salmonella* resistance. Serially updated resources with this information include local microbiology laboratory data and open-access reporting systems like the U.S. National Antimicrobial Resistance Monitoring System for Enteric Bacteria (NARMS). In NARMS reports from 2018, the majority (81%) of nontyphoidal *Salmonella* from humans were still *not* resistant to any of the antimicrobials tested. However, approximately 3%, 10%, and 0.3% of nontyphoidal *Salmonella* isolated from humans were intrinsically resistant to ceftriaxone, ciprofloxacin, and azithromycin, respectively.

Some contemporary nontyphoidal *Salmonellae* are of particular interest, given their resistance to antimicrobials. *S. Typhimurium* DT104 spread globally in the 1990s, when it was resistant to ampicillin, chloramphenicol, streptomycin, sulfonamides, and tetracycline. DT104 now sometimes also has reduced susceptibility to fluoroquinolones. Nontyphoidal *Salmonella* ST313 lineages (described earlier) continue

cephalosporin to oral azithromycin or a fluoroquinolone can be considered after documented clearance of blood cultures and exclusion of

to show resistance pattern evolution in Africa. In the United States, *S. Infantis* has now supplanted other leading serotypes in poultry and not only exhibits decreased susceptibility to fluoroquinolones because of a *gyrA* pathogenic variant but also contains an MDR plasmid that carries up to 10 resistance genes, conferring resistance to cephalosporins, tetracycline, chloramphenicol, and sulfonamides. This MDR strain of serovar *Infantis* has been reported to account for up to 35% of the nontyphoidal *Salmonella* infections in Israel.

### PROGNOSIS

Most otherwise healthy children with *Salmonella* gastroenteritis recover fully without antimicrobial treatment. Malnourished children and those who do not receive adequate supportive care can be at risk for prolonged diarrhea and complications. Young infants and immunocompromised patients often have systemic involvement, and children with HIV can have a florid and recurring course.

After infection, nontyphoidal *Salmonella* are excreted in feces for a median of 5 weeks, during which time the recovering patient can infect others via fecal-oral routes or by contaminating foods. A prolonged carrier state is rare in children but is more common among those with biliary tract disease and/or cholelithiasis.

### PREVENTION

Control of transmission of *Salmonella* infections to humans requires control of the infection in animal reservoirs, judicious use of agricultural antimicrobials, prevention of contamination of foodstuffs, and appropriate standards of food processing and inspection. Parents should be advised about the risk of various pets (especially reptiles, amphibians, and rodents).

Large outbreaks are often related to mass food production, presenting among widely geographically distributed patients. In the United States, CDC outbreak investigations are reported, via this site: <https://www.cdc.gov/Salmonella/outbreaks.html>, which includes maps and epidemiologic, traceback, and laboratory data, including outbreaks linked to specific foods, animals, and other sources. Awareness of these events can potentially blunt the extent of a given outbreak and/or alert caregivers of vulnerable hosts.

Visit Elsevier eBooks+ at [eBooks.Health.Elsevier.com](https://www.elsevier.com/ebooks) for Bibliography.

## 244.2 Enteric Fever (Typhoid and Paratyphoid Fever)

Jeffrey S. McKinney

Enteric fever (*typhoid or paratyphoid fever*) remains endemic in many developing countries. Given the ease of modern travel, cases regularly occur in developed countries as well, usually among returning travelers or from secondary transmission from an asymptomatic carrier.

### ETIOLOGY

Typhoid fever is caused by *S. enterica* serovar Typhi (*S. Typhi*). A similar but often less severe disease is caused by *Salmonella* Paratyphi A, B, and C. All are classically referred to as typhoidal *Salmonellae*. Typhoidal *Salmonellae* share more than 90% of their genes with the classic nontyphoidal strain, *S. Typhimurium*, but several genetic clusters known as *pathogenicity islands* and other genes have been acquired during evolution. The inactivation of single genes and the acquisition or loss of genes may have contributed to host adaptation and restriction of typhoidal strains. Importantly, whereas nontyphoidal *Salmonella* are found in many hosts and can be transmitted among them, typhoidal *Salmonella* only infects humans.

In contrast to the diarrheal symptoms classically encountered in gastroenteritis caused by nontyphoidal *Salmonellae*, enteric fever caused by typhoid or paratyphoid *Salmonellae* may present as abdominal pain without diarrhea, a fever without focus, and/or with extraintestinal foci of infection. Indeed, although enteric fever clearly starts in the gastrointestinal tract, the systemic nature of its presentation and

symptomatology (and even its initial hard-to-detect primary bacteremia) can delay diagnosis, in particular among patients returning from or living in endemic areas, where the differential diagnosis for fevers is broad.

### EPIDEMIOLOGY

Recent large-scale data and modeling efforts estimate that 14.3 million cases of typhoid and paratyphoid fevers occurred globally in 2017, a decline from 25.9 million cases in 1990. Incidence rates peak in the 5- to 9-year-old age-group, with roughly 13% of cases occurring in children younger than 5 years and roughly 56% of cases among children younger than 15 years of age. South and Southeast Asia have notably high incidence rates, whereas moderate incidence rates are reported from Central and South America, Africa, Central and East Asia, and Oceania (Fig. 244.6).

*Typhoid fever is notable for the ongoing emergence of heterogeneous new patterns of drug resistance.* After early outbreaks of chloramphenicol-resistant *S. Typhi* infections, *S. Typhi* strains emerged that were **multidrug resistant (MDR)**, fully resistant to all three of the traditional primary treatment antimicrobials: ampicillin, trimethoprim-sulfamethoxazole, and chloramphenicol. There is also a considerable increase in fluoroquinolone-resistant and even ceftriaxone-resistant isolates of *S. Typhi*. In the United States, most travel-associated cases of typhoid fever are now fluoroquinolone resistant.

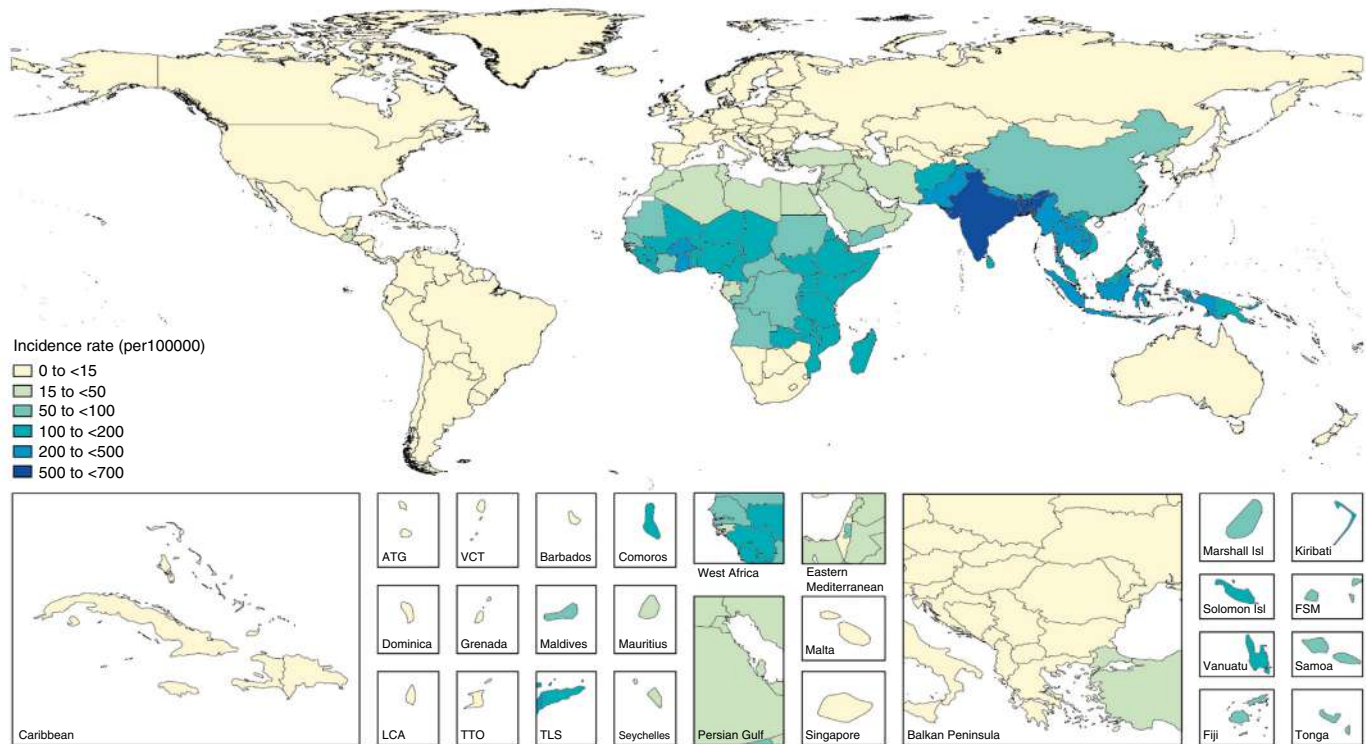
There are now *S. Typhi* strains that are **extensively drug resistant (XDR)** not only to ampicillin, trimethoprim-sulfamethoxazole, and chloramphenicol but also to ceftriaxone and with full or intermediate resistance to ciprofloxacin. It appears that the new XDR *S. Typhi* strains came from a large outbreak in 2016 linked to contaminated water in Pakistan's Sindh province. XDR Typhi infections were then reported globally among travelers to or from Pakistan. In 2019 U.S. residents with no history of international travel were also diagnosed with XDR typhoid fever. The optimal therapy for these XDR isolates is still being determined, with preliminary recommendations suggesting the empiric use of a carbapenem (e.g., meropenem), azithromycin, or both.

*S. Typhi* is highly adapted to infections of humans, and the discovery of a large number of **pseudogenes** in *S. Typhi* suggests that its genome may have undergone degeneration as part of a specialized association with the human host. *S. Typhi* has no apparent ability to cause transmissible disease in other animals. Thus direct or indirect contact with an infected human (either sick or a chronic carrier) is a prerequisite for infection. Ingestion of foods or water contaminated with human feces is the most common mode of transmission. So-called street vendor foods outside the home are one risk factor noted in one case control study from Pakistan; such risks are included in practical guidance for travelers about food and water precautions from the CDC Yellow Book (Health Information for International Travel). However, more general water-borne outbreaks related to poor sanitation or water system contamination have also been described. Other causes of infection include consuming oysters and other shellfish cultivated in water contaminated by human sewage and the use of night soil as fertilizer.

### PATHOGENESIS

Human volunteer experiments have established an infecting dose of about  $10^5$ – $10^9$  organisms, with an incubation period ranging from 4 to 14 days. After ingestion, *S. Typhi* invades the gut mucosa of the terminal ileum via specialized antigen sampling cells known as *M cells* that overlie gut-associated lymphatic tissues, through enterocytes, or via a paracellular route. In contrast to nontyphoidal *Salmonella*, *S. Typhi* expresses factors that notably downregulate the pathogen receptor-mediated host inflammatory response. It assembles type III secretion systems to inject bacterial effectors that modulate host cell biology in elegant ways, including but not limited to rearrangements of host cell actin, facilitating invasion across the outer cell membrane and a host cell membrane ruffling process that forms a phagosome containing the bacteria. This phagosome fuses with lysosomes, acidifies, and shrinks to become adherent around the bacterium, forming the *Salmonella*-containing vacuole (SCV). This intracellular niche offers *Salmonella* a physical barrier to some





**Fig. 244.6** Incidence rates (per 100,000) of typhoid and paratyphoid fevers, by country, in 2017. Inset maps detail smaller locations. ATG, Antigua and Barbuda; FSM, Federated States of Micronesia; Isl, Islands; LCA, Saint Lucia; TLS, Timor-Leste; TTO, Trinidad and Tobago; VCT, Saint Vincent and the Grenadines. (From GBD 2017 Typhoid and Paratyphoid Collaborators. *The global burden of typhoid and paratyphoid fevers: a systematic analysis for the Global Burden of Disease Study 2017*. *Lancet Infect Dis*. 2019;19(4):369–381.)

drugs (e.g., gentamicin, which has very poor intracellular penetration) and an intracellular replication site and means of host cell-mediated systemic spread.

After passing through the intestinal mucosa, *S. Typhi* organisms enter the mesenteric lymphoid system and then pass into the bloodstream via the lymphatics. This primary bacteremia is usually asymptomatic, and blood culture results are frequently negative at this early stage. The blood-borne bacteria are disseminated through the body and are thought to colonize the organs of the reticuloendothelial system, where they replicate within macrophages. After a period of bacterial replication, *S. Typhi* organisms are shed back into the blood, causing a secondary bacteremia that coincides with the onset of clinical symptoms and marks the end of the incubation period (Fig. 244.7). During this secondary bacteremia, classically with fever, blood cultures are far more frequently positive, although culture of bone marrow can be even more sensitive.

Both typhoidal and nontyphoidal *Salmonellae* are members of the same species and share substantive commonalities, including more than 90% of their DNA sequences. Yet a deeper appreciation of how and why typhoidal and nontyphoidal species differ offers insights at multiple levels, ranging from genetics and ecology, to pathobiology, to more nuanced clinical recognition and care.

Despite typhoidal (and paratyphoidal, used interchangeably in this section, unless specified otherwise) fevers being synonymous with the clinical diagnosis of **enteric fever**, the initial enteric inflammation from *S. Typhi* is notably less than that caused from most nontyphoidal *Salmonellae*. Clinically, presenting symptoms of typhoid tend to include less diarrhea and far less gut mucosal inflammation. In host cell cultures, *S. Typhi* induces lower levels of IL-8 neutrophil chemoattractant and less of a toll-like receptor 5 (TLR5)–driven pro-inflammatory response than seen with nontyphoidal *Salmonella*. One potential implication of this is that nontyphoidal *Salmonella* may use inflammation-derived luminal substances such as electron acceptors

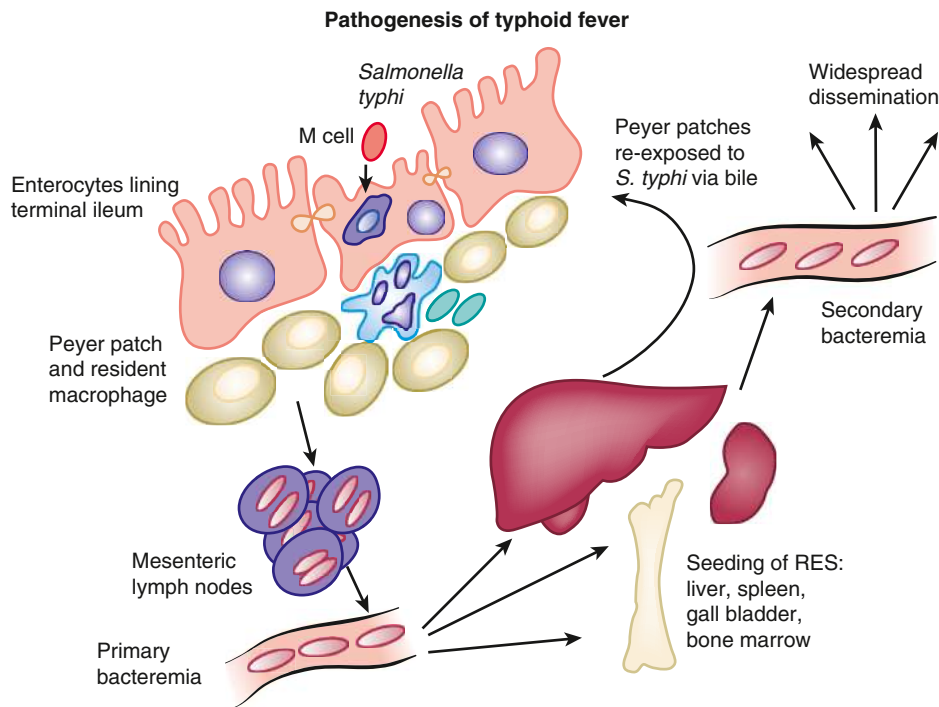
like nitrate and tetrathionate, perhaps in competition with other fermenting gut microbes. Intriguingly, *S. Typhi* has genomic *decay* in a network of nontyphoidal *Salmonella* genes that are involved in anaerobic metabolic pathways.

This is not to say that *S. Typhi* never results in intestinal lesions. In advanced stages of typhoid fever, life-threatening intestinal perforation can occur. However, the histopathology of typhoid perforation is distinct from the inflammation seen with nontyphoidal *Salmonella* gastroenteritis. With *S. Typhi*, inflammation that can finally penetrate the intestinal muscularis and serosa to cause perforation seems to originate from *deeper* sites, including underlying lymphoid tissue. In other tissues, including liver, spleen, lymph nodes, and bone marrow, **typhoid nodules** composed of macrophage aggregates can also form.

**Gallbladder colonization** is also a notable feature of *S. Typhi* and can result in years-long *Salmonella* carriage and shedding, with profound public health implications. The primary bacteremia of *S. Typhi* can seed the gallbladder, where exposure to bile upregulates *S. Typhi* (but seemingly *not* nontyphoidal *Salmonella*) type 3 secretion system genes that result in increased epithelial cell invasion.

*S. Typhi* expresses a surface **Vi (virulence) capsular polysaccharide** that is *not* present in nontyphoidal *Salmonella* or in *S. Paratyphi* A or B (which is relevant to the community-level impact of current Vi-based vaccines). Encoded as part of the *S. Typhi* pathogenicity island 7 (SPI-7), the Vi capsular polysaccharide interferes with the surface exposure of *S. Typhi* lipopolysaccharide and flagellin in ways that dampen host TLR-4 and -5 mediated **innate immune responses**. Vi also blocks complement C3 binding to the *S. Typhi* surface, interfering with **phagocytosis**.

Characterization of the **typhoid toxin** represents a major advance in understanding typhoid fever. Furthermore, in contrast to the Vi capsular polysaccharide, the typhoid toxin is expressed in both typhoidal *and* paratyphoidal *Salmonellae*. This toxin may prove important for new therapeutic or diagnostic innovations based on antitoxin



**Fig. 244.7** Pathogenesis of typhoid fever, involving invasion of ileal enterocyte and Peyer patches and mesenteric lymph nodes, seeding the reticuloendothelial system (RES). Both primary and secondary bacteremia events can occur and relate to clinical stages of disease. (Adapted from Richens J. *Typhoid fever*. In: Cohen J, Powderly WG, Opal SM, eds. *Infectious Diseases*, 2nd ed. London: Mosby; 2004:1561–1566.)

approaches. Typhoid toxin has three subunits. Subunit CdtB has DNase I-like nuclease activity that causes double-stranded breaks in host cell DNA, leading to host G2/M cell cycle arrest and/or cell death. Subunit PltA is a pertussis-like toxin with mono-adenosine diphosphate (ADP)-ribotransferase activity. Subunit PltB is a pertussis-like toxin with receptor binding activity to glycans, especially sialoglycans, terminated in Neu5Ac. The functional typhoid toxin is composed of one CdtB and one PltA subunit, plus five PltB subunits. Typhoid toxin genes are expressed by intracellular *S. Typhi* in the SCV of host cells. The trafficking of the toxin uses an elegant mechanism, in which PltB binding to Neu5Ac is involved in both toxin export and toxin endocytosis into target cells. The fact that Neu5Ac is the target for binding by PltB may help explain the cell tropism of typhoid toxin and also some of the human restriction of typhoidal infections and pathobiology at a molecular level.

The presence/gain/site-specific expression of certain virulence factors by typhoidal *Salmonellae* may help explain disease nuances involved in typhoid fever. Acquisition and spread of resistance genes are also a clear and present danger.

The overall quantity of **pseudogenes** in *S. Typhi* versus nontyphoidal *Salmonella* genomes is also noteworthy. Whereas *S. Typhi*'s 200 pseudogenes account for roughly 4% of all its genes, the classic nontyphoidal *Salmonella* exemplar *S. Typhimurium* genome includes less than 1% pseudogenes. One broad conceptual model for this is that *S. Typhimurium* remains more of a “generalist,” with a broad host range and more genes to facilitate survival in different hosts. By contrast, *S. Typhi* may have become a “specialist,” evolving to infect only humans. Furthermore, *S. Typhi* may infect humans in specific ways that better evade/suppress early mucosal inflammatory events and cause more systemic spread, as well as sustained colonization and long-term shedding. This conceptual model may offer insights to understand the ongoing evolution or emergence of some new nontyphoidal *Salmonella* strains that (akin to typhoidal strains) tend to cause more systemic infections, as highlighted by the evolution of the nontyphoidal *Salmonella* ST313 strain in Africa.

In addition to the virulence of infecting organisms, host factors also influence predisposition to infection. Patients with HIV are at significantly higher risk for infection with *S. Typhi* and *S. Paratyphi*. Patients with *Helicobacter pylori* infection also have an increased risk of acquiring typhoid fever. Compared to most nontyphoidal

*Salmonella* infections that are often more severe and systemic in hosts with immune abnormalities, outbreaks of typhoid fever with systemic spread often affect many hosts who do *not* have significant underlying immunocompromise.

## CLINICAL MANIFESTATIONS

The incubation period of typhoid fever is usually 7–14 days but depends on the infecting dose and ranges between 3 and 30 days. The presentation varies, from mild illness with low-grade fever and malaise, to a severe clinical picture with profound abdominal discomfort and multiple complications.

Severity and clinical outcome are influenced by many factors. These include duration of illness, age, previous exposure or vaccination history, virulence of the infecting strain, and quantity of the inoculum ingested. Given the profound changes in antimicrobial susceptibility patterns, choice of appropriate antimicrobial therapy is increasingly challenging, both empirically (given multiple various patterns of resistance) and after antimicrobial susceptibility results are secured (given the increasing inadequacy of many previously effective drugs).

The presentation of typhoid fever may vary by patient age. Some reports from South Asia suggest typhoid fever may be more severe in children less than 5 years old in terms of rates of complications and hospitalization. In infancy, complications such as disseminated intravascular coagulation seem more common, with higher case fatality rates. By contrast, neurologic complications and intestinal bleeding or perforation seem less common among children.

Typhoid fever can start as a seemingly mild illness and then progress to a clinical picture that manifests as high-grade fever. It can include a wide variety of associated features, such as anorexia, vomiting, hepatomegaly or splenomegaly, abdominal pain, and/or headache (Table 244.1). In children, diarrhea may occur in earlier stages of the illness but may be followed by constipation, potentially interfering with ready access to stool for important microbial culture and susceptibility testing. In the absence of localizing signs, the early stages of the disease may be very difficult to differentiate from other endemic diseases, such as malaria and dengue fever. In some cases, a macular or maculopapular rash (“rose spots”) may be visible around the seventh to tenth day of the illness. These lesions may be difficult to see in dark-skinned children and may occur in crops on the lower

chest and abdomen, typically lasting 2-3 days (Fig. 244.8). Although so-called pulse fever dissociation (relative bradycardia during fevers) has historically been invoked as a feature of typhoid fever, it has low positive predictive value, is nonspecific, and seems much less common in children than in adults.

It is recognized that MDR *S. Typhi* infection is a more severe clinical illness with higher rates of toxicity, complications, and case fatality rates. Depending on the specific infecting strain, this may be related to greater virulence and higher numbers of circulating bacteria.

If no complications occur, symptoms and physical findings gradually resolve within 2-4 weeks. However, illness may contribute to malnutrition. Although enteric fever caused by *S. Paratyphi* has traditionally been considered a more mild illness than that from *S. Typhi*, paratyphoid fever can also be severe, with significant drug resistance, morbidity, and complications.

## COMPLICATIONS

Although altered liver function is found in many patients with enteric fever, clinically significant hepatitis, jaundice, and cholecystitis are relatively rare and may be associated with worse outcomes. Intestinal hemorrhage and perforation are infrequent among children. Intestinal perforation may be preceded by marked increase in abdominal pain (often in the right lower quadrant), tenderness, vomiting, and features of peritonitis. Peritoneal signs may be masked in patients receiving steroids.

Rare complications include toxic myocarditis, which may manifest as arrhythmias, sinoatrial block, or cardiogenic shock (Table 244.2). Neurologic complications are relatively uncommon among children; they include delirium, psychosis, increased intracranial pressure, acute cerebellar ataxia, chorea, deafness, and Guillain-Barré syndrome. Although case fatality rates can be higher among patients with neurologic complications, recovery usually occurs without sequelae. Other reported complications include fatal bone marrow necrosis, disseminated intravascular coagulation, hemolytic-uremic syndrome, pyelonephritis, nephrotic syndrome, meningitis, endocarditis, parotitis, orchitis, and suppurative lymphadenitis.

The propensity to become a carrier follows the epidemiology of gallbladder disease and cholelithiasis, generally increasing with patient age and antimicrobial resistance.

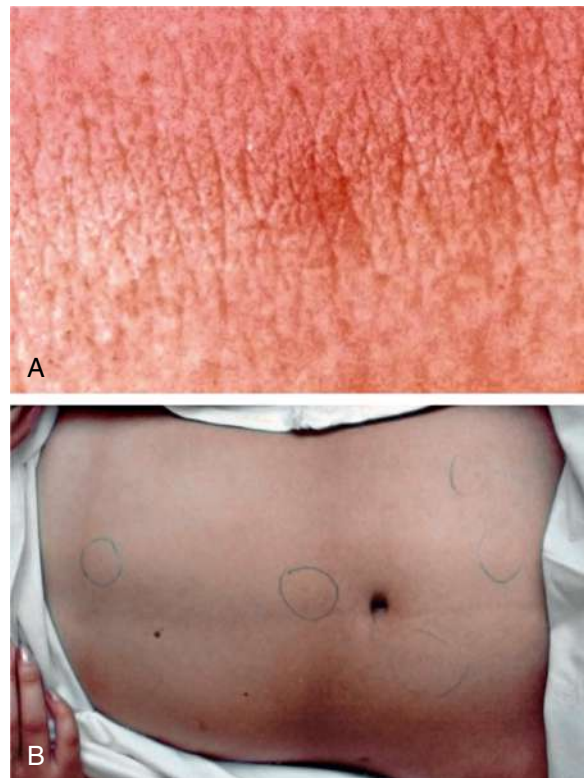
## DIAGNOSIS

The mainstay of the diagnosis of typhoid fever is a positive culture of *S. Typhi* or *S. Paratyphi* from the blood or other anatomic site. Results of blood cultures are positive in 40-60% of patients seen early in the course of disease, but serial high-volume blood cultures may be required to identify *Salmonella* bacteremia. Stool and urine culture results may also become positive after the first week, and the stool culture may occasionally be positive even during the incubation period. NAATs for *Salmonella* can be part of diagnostic screening, but rectal swab samples are less sensitive than stool samples. In this era of increasing antibiotic resistance (not only common but also heterogeneous patterns), species identification without culture to check antibiotic susceptibilities is suboptimal. *Indeed, antibiotic susceptibility testing is now essential for determining optimal therapy.* Bone marrow culture is highly sensitive (around 90%) and remains positive in more than 50% of cases despite several days of antibiotic therapy. Bone marrow collection is relatively invasive, however, and tends to be employed as part of an extensive workup for patients meeting stringent criteria for a true fever of unknown origin. Punch biopsies from characteristic rose spots may be culture positive in up to 63% of cases, even with prior antibiotic treatment.

Results of other laboratory investigations are largely nonspecific for the diagnosis of typhoid fever. The Widal test has common false-negative and false-positive results, and as a serologic test is highly dependent on geographic area and endemicity. Tests such as coagulation studies, liver function studies, and abdominal imaging are examples of studies that may be of use in assessing for complications of typhoid fever.

Table 244.1	Common Clinical Features of Typhoid Fever in Children*
FEATURE	RATE (%)
High-grade fever	95
Coated tongue	76
Anorexia	70
Vomiting	39
Hepatomegaly	37
Diarrhea	36
Toxicity	29
Abdominal pain	21
Pallor	20
Splenomegaly	17
Constipation	7
Headache	4
Jaundice	2
Obtundation	2
Ileus	1
Intestinal perforation	0.5

\*Data collected in Karachi, Pakistan, from 2,000 children.



**Fig. 244.8** A, "Rose spot" in volunteer with experimental typhoid fever. B, Small cluster of rose spots, usually located on lower abdomen. Lesions may be more difficult to identify in darker-skinned people. (From Huang DB, DuPont HL. Problem pathogens: extra-intestinal complications of *Salmonella enterica* serotype *Typhi* infection. *Lancet Infect Dis.* 2005;5:341-348.)



**Table 244.2** Extraintestinal Infectious Complications of Typhoid Fever Caused by *Salmonella enterica* Serotype Typhi

ORGAN SYSTEM	PREVALENCE (%)	RISK FACTORS	COMPLICATIONS
Central nervous system	3–35	Residence in endemic region, malignancy, endocarditis, congenital heart disease, paranasal sinus infections, pulmonary infections, meningitis, trauma, surgery, osteomyelitis of skull	Encephalopathy, cerebral edema, subdural empyema, cerebral abscess, meningitis, ventriculitis, transient Parkinsonism, motor neuron disorders, ataxia, seizures, Guillain-Barré syndrome, psychosis
Cardiovascular system	1–5	Cardiac abnormalities (e.g., existing valvular abnormalities, rheumatic heart disease, congenital heart defects)	Endocarditis, myocarditis, pericarditis, arteritis, congestive heart failure
Pulmonary system	1–6	Residence in endemic region, past pulmonary infection, sickle cell anemia, alcohol abuse, diabetes, HIV infection	Pneumonia, empyema, bronchopleural fistula
Bone and joint	<1	Sickle cell anemia, diabetes, systemic lupus erythematosus, lymphoma, liver disease, previous surgery or trauma, extremes of age, corticosteroid use	Osteomyelitis, septic arthritis
Hepatobiliary system	1–26	Residence in endemic region, pyogenic infections, intravenous drug use, splenic trauma, HIV, hemoglobinopathy	Cholecystitis, hepatitis, hepatic abscesses, splenic abscess, peritonitis, paralytic ileus
Genitourinary system	<1	Urinary tract abnormalities, pelvic pathology, systemic abnormalities	Urinary tract infection, renal abscess, pelvic infections, testicular abscess, prostatitis, epididymitis
Soft tissue infections	At least 17 cases reported in English-language literature	Diabetes	Psoas abscess, gluteal abscess, cutaneous vasculitis
Hematologic	At least 5 cases reported in English-language literature		Hemophagocytosis syndrome

From Huang DB, DuPont HL. Problem pathogens: extra-intestinal complications of *Salmonella enterica* serotype Typhi infection. *Lancet Infect Dis.* 2005;5:341–348.

## DIFFERENTIAL DIAGNOSIS

Typhoid fever may mimic many febrile illnesses without localizing signs. In early stages, it can be confused with alternative conditions, such as gastroenteritis, bronchitis, and bronchopneumonia. As the disease progresses, the differential diagnosis may include bacterial sepsis, malaria, dengue fever, infectious mononucleosis, acute hepatitis, tuberculosis, brucellosis, tularemia, leptospirosis, amebiasis, Q fever, toxoplasmosis, and rickettsial diseases. A classic cause of fevers among travelers returning from endemic areas, typhoid fever can also occur in those with direct, or even unappreciated, contact with other infected people.

## TREATMENT

Antibiotic resistance among *S. Typhi* strains is now so heterogeneous and dynamic that the importance of obtaining **antibiotic susceptibility tests** on clinical isolates cannot be overemphasized. Although empiric antibiotics still may be started, final decision-making about optimal treatment should be based on antibiotic susceptibility results. Molecular testing of specific resistance genes can also help assess mechanisms and evolution of resistance.

For years, third-generation cephalosporins (e.g., ceftriaxone or cefotaxime) were a mainstay of empiric therapy. They were considered effective even for **MDR S. Typhi** and/or for the increasing number of *S. Typhi* that were quinolone resistant. Yet now, with the recent emergence of **XDR S. Typhi**, third-generation cephalosporins may no longer be sufficient.

In *S. Typhi*, **MDR** isolates are defined as resistant to all the first line of antibiotics previously suggested by the World Health Organization (WHO): ampicillin, trimethoprim-sulfamethoxazole, and chloramphenicol. **XDR S. Typhi** is not only resistant to ampicillin, trimethoprim-sulfamethoxazole, and chloramphenicol but also resistant to third-generation cephalosporins and quinolones. Gene sequencing, including one innovative study using clinical isolates from children with *S. Typhi* septicemia, found the phenotype of the **XDR S.**

*Typhi* isolates matches with their genotypes, featured by the acquisitions of the genes *bla*<sub>TEM1</sub>, *dhfr7*, *sul1*, *catA1*, *qnrS*, and *bla*<sub>CTX-M-15</sub> and a point mutation on *gyrA*.

**XDR S. Typhi** cases were first noted by Pakistani health authorities in 2016, originating in Hyderabad, Sindh. By 2018, international transmission of **XDR S. Typhi** cases had been noted. In 2019 and 2020, **XDR S. Typhi** was recovered from patients in the United States, both with and *without* a travel history. Patients without a travel history lived in six widely distributed states and did not appear to be linked or have a common source of infection. An unrelated cluster of ceftriaxone-resistant *Typhi* infections linked to Iraq has also been reported in the United States and the United Kingdom.

Taken together, this information led to an official CDC Health Advisory in 2021 suggesting the need for empiric carbapenem, azithromycin, or both for patients in the United States with suspected typhoid fever who traveled to Pakistan or Iraq, as well as those who had *not* traveled from the United States. Patients with severe or complicated illness should receive a carbapenem, such as meropenem. Case reports have suggested that patients who do not improve on a carbapenem alone may benefit from the addition of a second antibiotic such as azithromycin. Patients with uncomplicated illness may be treated with oral azithromycin alone. By contrast, for patients in the United States who traveled to countries other than Pakistan or Iraq, ceftriaxone *may* still be effective.

In the United States, resistance to meropenem (a carbapenem) or azithromycin was not reported during 2017–2021. By contrast, roughly 80% of *Typhi* strains isolated in the United States now are resistant or have decreased susceptibility to quinolones, including ciprofloxacin.

New **MDR** and **XDR** strains illustrate the profound importance of recognizing what antimicrobials will likely *not* work. Meanwhile, an encouraging relative reduction in the proportion of **MDR** strains in some areas of Asia means some patients with susceptible *S. Typhi* infections can be treated with agents recently considered ineffective. Namely, in some highly endemic regions of South and Southeast Asia,



strains susceptible to amoxicillin or trimethoprim-sulfamethoxazole are increasingly common.

The optimal duration of antimicrobial therapy is unclear, but most agents are suggested for at least 10–14 days, with longer courses for amoxicillin or trimethoprim-sulfamethoxazole, 21 days for chloramphenicol, and as little as 7 days for azithromycin. Relapse rates can occur in almost 20% of patients within 4 weeks, especially in immunocompromised patients.

In addition to antimicrobials, supportive treatment and maintenance of appropriate fluid and electrolyte balance are important. Although additional treatment with dexamethasone (3 mg/kg initial dose, followed by 1 mg/kg every 6 hours for 48 hours) is recommended by some for severely ill patients with shock, obtundation, stupor, or coma, corticosteroids should be administered only under strict supervision, because their use may mask signs of abdominal complications.

## PROGNOSIS

The prognosis for a patient with enteric fever depends on the rapidity of diagnosis and institution of appropriate antibacterial therapy. Other factors are patient age, underlying health and nutrition, the causative *Salmonella* serotype, and the appearance of complications. Infants and children with underlying malnutrition and infections with resistant isolates are at higher risk of adverse outcomes.

Despite appropriate therapy, 2–4% of infected children may experience relapse. Individuals who excrete *S. Typhi* more than 3 months after infection are regarded as chronic carriers. A chronic urinary carrier state can develop in children with schistosomiasis.

## PREVENTION

Of the major risk factors for outbreaks of typhoid fever, contamination of water supplies with sewage is most important. Other risk factors are contact with another acutely infected individual or a chronic carrier and lack of water or sanitation services. During outbreaks, central chlorination and domestic water purification are important. In endemic situations, consumption of street foods, especially ice cream and cut fruit, is recognized as an important risk factor. Human-to-human spread by chronic carriers is also important, and attempts should be made to target food handlers and high-risk groups for *S. Typhi* carriage screening. Chronic carriers can be counseled as to the risk for disease transmission and the importance of handwashing.

In the United States, two vaccines have been licensed by the FDA. Systematic review and meta-analysis of randomized controlled clinical trials estimate the cumulative efficacy of these two vaccines as only roughly 50%. The Ty21a **live attenuated vaccine** can be used in people 6 years and older. It is administered orally, every other day, for a total of four doses to be completed at least 1 week before potential exposure; booster frequency is every 5 years. The Ty21a vaccine induces both cell-mediated and humoral immune responses against *S. Typhi*. It also may provide some protection against *S. Paratyphi B*. The **unconjugated Vi capsular polysaccharide vaccine** can be used in people 2 years and older. It is administered intramuscularly in a single dose to be administered at least 2 weeks before potential exposure; booster frequency is every 2 years. This unconjugated vaccine induces a **T-cell-independent humoral immune response** with lack of prolonged protection.

**Conjugated vaccines** have been recommended, developed, and now deployed by the WHO. By covalently conjugating the Vi capsular polysaccharide to carrier proteins, conjugate vaccines can induce a **T-cell-dependent humoral immune response**, even in young children. Conjugated typhoid vaccines are under development, using a variety of carrier proteins, including tetanus toxoid, Exoprotein A from *Pseudomonas*, and diphtheria toxoid. The WHO has recommended the introduction of a single-dose typhoid conjugate vaccine for infants and children age 6 months and older. A large study of the Typbar-TCV conjugate vaccine in Hyderabad, Pakistan, found vaccine effectiveness was 55% against suspected typhoid fever and 95% against blood culture-confirmed *S. Typhi*. The vaccine was also 97% effective against XDR *S. Typhi*. In 2019, a historic milestone was successfully achieved in Pakistan with the vaccination in Sindh province of more than 9.4

million children age from 9 months to 15 years against typhoid fever, with a coverage rate of 95%. Pakistan is the first country in the world to introduce the WHO-recommended typhoid conjugate vaccine (TCV) into its routine immunization program.

Visit Elsevier eBooks+ at [eBooks.Health.Elsevier.com](https://eBooks.Health.Elsevier.com) for Bibliography.

## Chapter 245

# Shigella

Patrick C. Seed

**Shigellosis**, infection by *Shigella* species, is acute invasive enteric infection clinically manifested by diarrhea that is often bloody. The term **dysentery** describes a syndrome of bloody diarrhea with fever, abdominal cramps, rectal pain, and mucoid stools. **Bacillary dysentery** is a term often used to distinguish dysentery caused by *Shigella* from amebic dysentery caused by *Entamoeba histolytica*.

## ETIOLOGY

Four species of *Shigella* cause the disease shigellosis: *Shigella dysenteriae* (group A), *Shigella flexneri* (group B), *Shigella boydii* (group C), and *Shigella sonnei* (group D). Serotypes 15, 19, 19, and 1 in groups A–D, respectively, further distinguish the species. Species and group distributions vary geographically and by antimicrobial susceptibility.

## EPIDEMIOLOGY

The World Health Organization (WHO) estimates that 80–165 million cases of shigellosis occur each year worldwide, resulting in 600,000 deaths annually. *Shigella* spp. are endemic to temperate and tropical climates and are most common in countries and regions with inadequate public health sanitation and hygiene. In the U.S. Foodborne Disease Active Surveillance Network (**FoodNet**), *Shigella* remains the third most important pathogen. In 2020, the top three diarrheagenic pathogens, *Campylobacter*, *Salmonella*, and *Shigella*, had laboratory-confirmed incidence rates (cases per 100,000 population) of 14.35, 13.33, and 3.05, respectively. Although infection can occur at any age, children younger than 10 years, identified as Black and of Hispanic ethnicity, have the highest incidence rates. Males have an approximately 2.7-fold higher incidence than females. Upwards of 30% of children with shigellosis are hospitalized. Death resulting from shigellosis is rare among children (<0.1%). Infection in the first 6 months of life is rare. Breast milk from women living in endemic areas contains antibodies to both virulence plasmid-encoded antigens and lipopolysaccharides, and breastfeeding might partially explain the age-related incidence.

Asymptomatic infection of children and adults occurs frequently in endemic areas. In cases of *Shigella* dysentery, up to 75% of family member contacts may have asymptomatic infection. Infection with *Shigella* occurs most often during the warm months in temperate climates and during the rainy season in tropical climates. In industrialized societies, up to 50% of locally diagnosed cases are associated with international travel; the highest-risk travel designation is Africa, followed by Central America, South America, and parts of Asia. In recent years in the United States, travel to Haiti, the Dominican Republic, or India has been associated with acquisition of antibiotic-resistant (fluoroquinolone) *S. sonnei* infections. Additional risk factors include men who have sex with men (MSM), including recent U.S. outbreaks of azithromycin-resistant *S. sonnei* infections among affected individuals in the Midwest.

In developed countries, *S. sonnei* is the most common cause and *S. flexneri* is the second most common cause of bacillary dysentery; in preindustrial societies, *S. flexneri* is most common and *S. sonnei* second

in frequency. *S. boydii* is found primarily in India. *S. dysenteriae* serotype 1 tends to occur in massive epidemics but is also endemic in Asia and Africa, where it is associated with high mortality rates (5–15%). The epidemiologic transition has favored the emergence of *S. sonnei* as the dominant serogroup in some countries, although the reason for this epidemiologic shift is not clear.

Contaminated food (often a salad or other item requiring extensive handling of the ingredients) and water are important vectors. Exposure to both contaminated freshwater and contaminated salt water is a risk factor for infection. Rapid spread within families, custodial institutions, and childcare centers demonstrates the ability of *Shigella* to be transmitted from one individual to the next and the requirement for ingestion of very few organisms to cause illness. Human challenge studies have demonstrated the high infectivity and low infectious dose for *Shigella* spp. Ten bacteria of the species *S. sonnei* and *S. dysenteriae* can cause dysentery. In contrast, ingestion of  $10^8$ – $10^{10}$  *Vibrio cholerae* is necessary to cause cholera.

## PATHOGENESIS

*Shigella* has specialized mechanisms to survive the low gastric pH. *Shigella* survives the acid environment in the stomach and moves through the gut to the colon, its target organ. *Shigella* spp. use a coordinated, temperature-controlled program to hijack and invade colonic epithelial cells. A large (220 kb) plasmid encodes a group of polypeptides involved in cell invasion and killing, and loss of the plasmid attenuates virulence. **Enteroinvasive *Escherichia coli* (EIEC)** that harbor a closely related plasmid containing these invasion genes behave clinically similar to *Shigellae* (see Chapter 246). The virulence plasmid encodes a type III secretion system required to trigger entry into epithelial cells and apoptosis in macrophages. This secretion system translocates effector molecules from the bacterial cytoplasm to the membrane and cytoplasm of target host cells through a needle-like appendage. The **type III secretion system** is composed of approximately 50 proteins, including the Mxi and Spa proteins involved in assembly and regulation of the type III secretion system, chaperones (IpgA, IpgC, IpgE, and Spa15), transcription activators (VirF, VirB, and MxiE), translocators (IpaB, IpaC, and IpaD), and approximately 30 effector proteins. In addition to the major plasmid-encoded virulence traits, chromosomally encoded factors are required for full virulence.

Shigellosis mostly affects the distal colon, although pancolitis can occur. *Shigella* spp. traverse the colonic epithelium through M cells in the follicle-associated epithelium overlying the Peyer patches. Localized or diffuse mucosal edema, ulcerations, friable mucosa, bleeding, and exudate may occur. Microscopically, ulcerations, pseudomembranes, epithelial cell death, infiltration extending from the mucosa to the muscularis mucosae by polymorphonuclear leukocytes (PMNs) and mononuclear cells, and submucosal edema occur.

After *Shigella* transcytosis through M cells, it encounters resident macrophages and subverts macrophage killing by activating the inflammasome and inducing pyroptosis, apoptosis, and proinflammatory signaling. Free bacteria invade the epithelial cells from the basolateral side, move into the cytoplasm by actin polymerization, and spread to adjacent cells. Proinflammatory signaling by macrophages and epithelial cells further activates the innate immune response involving natural killer cells and attracts PMNs. The influx of PMNs disintegrates the epithelial cell lining, which initially exacerbates the infection and tissue destruction by facilitating the invasion of more bacteria. Ultimately, PMNs phagocytose and kill *Shigella*, thus contributing to the resolution of the infection.

Some *Shigella* spp. produce toxins, including Shiga toxin and enterotoxins. **Shiga toxin** is a potent exotoxin that inhibits protein synthesis. It is produced in significant amounts by *S. dysenteriae* serotype 1, by a subset of *E. coli* known as **enterohemorrhagic *E. coli* (EHEC)** or Shiga toxin-producing *E. coli*, and occasionally by other *Shigella* spp. Shiga toxin inhibits protein synthesis to injure vascular endothelial cells and trigger the severe complication of hemolytic-uremic syndrome (see Chapter 246). Targeted deletion of the genes for other enterotoxins (*ShET1* and *ShET2*) decreases the incidence of fever and dysentery in human challenge studies. Lipopolysaccharides are virulence factors for

all *Shigellae*; other traits are important for only a few serotypes (e.g., Shiga toxin synthesis by *S. dysenteriae* serotype 1 and *ShET1* by *S. flexneri* 2a).

## IMMUNITY

In symptomatic infection, *Shigella* activates an intense innate immune response through triggering extracellular and intracellular pathogen recognition systems. The induction of acute inflammation with a massive recruitment of PMNs produces intensive local tissue destruction. In rectal biopsies of infected patients, acute-phase proinflammatory cytokines are induced, including interleukin (IL)-1 $\beta$ , IL-6, IL-8, tumor necrosis factor (TNF)- $\alpha$ , and TNF- $\beta$ . Concurrently, antiinflammatory genes encoding IL-10 and transforming growth factor- $\beta$  are also upregulated to mitigate uncontrolled inflammation. Furthermore, interferon- $\gamma$  expression is induced during human infection and is required to limit *Shigella* invasion in intestinal epithelial cells and macrophages. *Shigella*-specific immunity elicited upon natural infection is characterized by the induction of a humoral response. Local secretory immunoglobulin A (IgA) and serum IgG are produced against lipopolysaccharide and some protein effectors (Ipas). Protection is thought to be serotype specific. Natural protective immunity arises only after several episodes of infection, is of short duration, and seems to be effective in limiting reinfection, particularly in young children. However, children have delayed and reduced antigen-specific antibody-secreting cells with late and reduced mucosa IgA production against *Shigella*. Less effective adaptive immunity may put children at more risk for increased disease severity, mortality, and recurrences.

## CLINICAL MANIFESTATIONS AND COMPLICATIONS

*Shigella* spp. produce intractable and extraintestinal symptoms. *Bacillary dysentery* is clinically similar regardless of infecting serotype or species, but different species produce illnesses with different severity and risk for mortality, with *S. dysenteriae* type 1 most likely to produce any single manifestation and with greater severity. Ingestion of *Shigellae* is followed by an incubation period of 12 hours to several days before symptoms ensue. Severe abdominal pain, emesis, anorexia, generalized toxicity, urgency, and painful defecation characteristically occur (Table 245.1). *The typically high fever with shigellosis distinguishes it from EHEC.* The **diarrhea** may be watery and large volume initially, evolving into frequent, small-volume, bloody, mucoid stools. Most children never progress to the stage of bloody diarrhea, but some have bloody stools from the outset. Significant dehydration is related to the fluid and electrolyte losses in stool and emesis. Untreated diarrhea can last 7–10 days; only approximately 10% of patients have diarrhea persisting for >10 days. Persistent diarrhea occurs in malnourished infants, children with AIDS, and occasionally previously normal children. Even nondysenteric disease can be complicated by persistent illness. Physical examination initially shows abdominal distention and tenderness, hyperactive bowel sounds, and a tender rectum on digital examination. **Rectal prolapse** may be present, particularly in malnourished children.

Neurologic findings are among the most common extraintestinal manifestations of bacillary dysentery, occurring in as many as 40% of hospitalized children. EIEC can cause similar neurologic toxicity. Convulsions, headache, lethargy, confusion, nuchal rigidity, or hallucinations may be present before or after the onset of diarrhea. Animal models suggest Shiga toxins activate brain endothelial cells and microglia and increase neurotransmitter levels. However, infections with Shiga toxin-positive and -negative strains can lead to neurologic features. **Seizures** sometimes occur when little fever is present, suggesting that simple febrile convulsions do not explain their appearance. Hypocalcemia or hyponatremia may be associated with seizures in a small number of patients. Although symptoms often suggest central nervous system infection, and cerebrospinal fluid pleocytosis with minimally elevated protein levels can occur, meningitis caused by *Shigellae* is rare. Based on animal studies, it has been suggested that proinflammatory mediators, including TNF- $\alpha$  and IL-1 $\beta$ , nitric oxide, and corticotropin-releasing hormone, play a role in the enhanced susceptibility to *Shigella*-mediated seizures and encephalopathy.

The most common complication of shigellosis is **dehydration** (Table 245.2). Inappropriate secretion of antidiuretic hormone with profound hyponatremia can complicate dysentery, particularly when *S. dysenteriae* is the etiologic agent. Hypoglycemia and protein-losing enteropathy are common and are decreased by early appropriate antibiotic therapy. Severe protein-losing enteropathy is associated with prolonged illness and linear growth shortfalls. **Bacteremia** is uncommon except in girls or women infected with HIV, malnourished children, young infants, and children with *S. dysenteriae* serotype 1 infection. When bacteremia occurs with dysentery (<5%), it is as likely to be caused by other enteric bacteria as by *Shigella* itself. The presence of *E. coli*, *Klebsiella*, and other enteric bacteria in blood cultures of children with shigellosis may reflect the loss of the barrier function during severe colitis. The mortality rate is high (approximately 20%) when sepsis occurs, with a greater likelihood of occurrence in HIV-infected persons. Other major complications include **disseminated intravascular coagulation** (DIC), particularly in very young, malnourished children. Despite the extent to which the intestinal epithelial barrier is lost, bacteremia and DIC are uncommon.

Neonatal shigellosis is rare, particularly among exclusively breastfed infants. Neonates may have only low-grade fever with mild, nonbloody diarrhea. However, complications occur more often in neonates than in older children and include septicemia, meningitis, dehydration, colonic perforation, and toxic megacolon.

Hemolysis, anemia, and **hemolytic-uremic syndrome** (HUS) frequently complicate *S. dysenteriae* serotype 1 infection. HUS is caused by Shiga toxin-mediated vascular endothelial injury. Shiga toxin-producing non-dysenteriae *Shigella* and *E. coli* that produce Shiga toxins (e.g., *E. coli* O157:H7, *E. coli* O111:NM, *E. coli* O26:H11, and less often, many other serotypes) also cause HUS (see Chapter 560.5).

Rectal prolapse, toxic megacolon or pseudomembranous colitis (usually associated with *S. dysenteriae*), cholestatic hepatitis, conjunctivitis, iritis, corneal ulcers, pneumonia, arthritis (usually 2-5 weeks after enteritis), reactive arthritis, cystitis, myocarditis, and vaginitis (typically with blood-tinged discharge associated with *S. flexneri*) are uncommon events. Although rare, surgical complications of shigellosis can be severe; the most common are intestinal obstruction and appendicitis with and without perforation.

On average, the severity of illness and risk of death are least with disease caused by *S. sonnei* and greatest with infection by *S. dysenteriae* type 1. Risk groups for severe illness and poor outcomes include infants; children who are not breastfed; children with HIV; children recovering from measles; malnourished children and adults; adults >50 years old; and patients with dehydration, unconsciousness, hypothermia or hyperthermia, hyponatremia, or lesser stool frequency who have a history of convulsions when first seen. Death is a rare outcome in well-nourished older children. Multiple factors contribute to death in malnourished children with shigellosis, including illness in the first year of life, altered consciousness, dehydration, hypothermia, thrombocytopenia, anemia, hyponatremia, renal failure, hyperkalemia, hypoglycemia, bronchopneumonia, and bacteremia.

The rare shigellosis-associated Ekiri syndrome, or “lethal toxic encephalopathy,” constitutes severe toxicity, convulsions, extreme hyperpyrexia, and headache, followed by brain edema and a rapidly fatal outcome without sepsis or significant dehydration.

## DIFFERENTIAL DIAGNOSIS

Although clinical features suggest shigellosis, they usually are insufficiently specific to allow confident diagnosis. Infection by *Campylobacter jejuni*, *Salmonella* spp., EIEC, Shiga toxin-producing *E. coli* (EHEC, e.g., *E. coli* O157:H7), *Yersinia enterocolitica*, *Clostridioides difficile*, and *Entamoeba histolytica*, as well as inflammatory bowel disease, produce overlapping features and may challenge the clinician.

## DIAGNOSIS

Presumptive data supporting a diagnosis of bacillary dysentery include the finding of fecal leukocytes (usually >50 or 100 PMNs per high-power field, confirming the presence of colitis), fecal blood, and

**Table 245.2** Clinical Complications of Shigellosis

### INTESTINAL COMPLICATIONS

Rectal prolapse\*  
Toxic megacolon  
Intestinal perforation  
Intestinal obstruction  
Appendicitis  
Persistent diarrhea

### EXTRAIESTINAL COMPLICATIONS

Dehydration  
Severe hyponatremia (serum sodium <126 mmol/L)\*  
Hypoglycemia  
Focal infections (e.g., meningitis, osteomyelitis, arthritis, splenic abscesses, vaginitis)  
Sepsis, usually in malnourished or immunocompromised persons  
Seizure or encephalopathy  
Leukemoid reaction (peripheral leukocytes >40 000/μL)\*

### POSTINFECTIOUS MANIFESTATIONS

Hemolytic-uremic syndrome (HUS)\*  
Reactive arthritis†  
Irritable bowel syndrome (IBS)‡  
Malnutrition

\*Significantly more common in episodes with *Shigella dysenteriae* type 1 than with all other *Shigella* spp. among Bangladeshi children younger than 15yr during the 1990s (rectal prolapse [52% vs 15%], severe hyponatremia [58% vs 26%], leukemoid reaction [22% vs 2%], and HUS [8% vs 1%]).

†Typical acute symptoms include asymmetric oligoarthritis (usually lower limb), enthesitis, dactylitis, and back pain. Extraarticular manifestations include conjunctivitis and uveitis; urethritis and other genitourinary tract manifestations; oral, skin, and nail lesions; and rarely, cardiac abnormalities.

‡IBS follows approximately 4% of *Shigella* episodes in studies from high-resource settings.

Adapted from Kotloff KL, Riddle MS, Platts-Mills JA, et al. Shigellosis. *Lancet*. 2018;391:801–810.

**Table 245.1** Acute Clinical Manifestations of Shigellosis in Children <5 Years Old

MANIFESTATION	DYSENTERY (n = 757)	WATERY DIARRHEA (n = 288)
Fever	607 (80%)	207 (72%)
Abdominal cramps	616 (81%)	137 (48%)
Vomiting	136 (18%)	89 (31%)
WHO-defined dehydration	95 (13%)	134 (47%)
Tenesmus	511 (68%)	32 (11%)
Rectal prolapse	19 (3%)	4 (1%)



demonstration in peripheral blood of leukocytosis with a dramatic left shift (often with more bands than mature segmented neutrophils). The total peripheral white blood cell count is usually 5,000-15,000 cells/ $\mu$ L, although leukopenia and leukemoid reactions occur.

Culture of both stool and rectal swab specimens optimizes the chance of diagnosing *Shigella* infection. Culture media should include MacConkey agar and selective media such as xylose-lysine-deoxycholate and *Salmonella-Shigella* agar. Transport media should be used if specimens cannot be cultured promptly. Appropriate media should be used to exclude *Campylobacter* and *Salmonella* spp. and other agents. Studies of outbreaks and illness in volunteers show that the laboratory is often not able to confirm the clinical suspicion of shigellosis even when the pathogen is present. Multiple fecal cultures improve the yield of *Shigella*.

Culture-based diagnosis of *Shigella* infection, as with other enteric infections, is being displaced by molecular methods, often multiplexed, allowing testing for a panel of potential agents in a single rapid assay. Studies using molecular methods such as polymerase chain reaction (PCR) suggest that culture significantly underestimates the true frequency of infection. Quantitative PCR improves the ascertainment of *Shigella* burden in children with moderate to severe diarrhea in low-income countries. The generally **high negative predictive value** (NPV) of many molecular tests for *Shigella* (generally >95-97%) make the tests useful for decisions regarding antibiotic use and discontinuation and the necessity to test for additional etiologies of diarrhea. Molecular testing provides no information about antibiotic susceptibility. Stool cultures should be considered where antibiotic-resistant organisms are prevalent. In children who appear toxic, blood cultures should be obtained, especially in very young or malnourished infants, because of their increased risk of bacteremia.

## TREATMENT

As with gastroenteritis from other causes, the first concern in a child with suspected shigellosis should be for fluid and electrolyte correction and maintenance (see Chapter 387). Drugs that impair intestinal motility (e.g., diphenoxylate hydrochloride with atropine [Lomotil] or loperamide [Imodium]) should not be used because of the risk of more severe and prolonged illness.

**Nutrition** is a key concern in areas where malnutrition is common. A high-protein and high-caloric diet during convalescence enhances growth in 6 months after infection. Controlled studies show that cooked green bananas, a food rich in amylase-resistant starches, significantly improves outcome in severe disease. A single large dose of **vitamin A** (200,000 IU) lessens the severity of shigellosis in settings where vitamin A deficiency is common. **Zinc** supplementation (20 mg elemental zinc for 14 days) significantly decreases the duration of diarrhea, improves weight gain during recovery, enhances adaptive immunity to *Shigellae*, and decreases diarrheal disease in malnourished children.

The decision to use **antibiotics** remains challenging (Fig. 245.1). Many experts recommend withholding antibacterial therapy because of the self-limited nature of the infection, the cost of drugs, the risk of emergence of resistant organisms, the risk of prolonging carriage (if *Salmonella* is present), or increasing the risk for HUS (EHEC). When a rapid multiplexed molecular stool pathogen detection test is available, waiting for a definitive diagnosis before administering antibiotics should be considered. However, a counter-argument of empirical treatment for all children with suspected shigellosis has validity. Untreated illness can cause a child to have prolonged illness; chronic or recurrent diarrhea can ensue. Malnutrition can develop or worsen during prolonged illness, particularly in children in developing countries. The risk of continued excretion and subsequent infection of family contacts further argues against the strategy of withholding antibiotics.

*Shigella* antimicrobial susceptibility varies by species and geography. In the United States, strains are frequently resistant to ampicillin (74%) and trimethoprim-sulfamethoxazole (TMP-SMX) (36%). In general,

the proportion of antibiotic-resistant isolates is lower in North America and Europe than in Asia or Africa. Previously, *Shigella* was widely regarded as susceptible in vitro to azithromycin, ceftriaxone, cefotaxime, cefixime, nalidixic acid, and quinolones. However, the Centers for Disease Control and Prevention (CDC) reports that 87% of *S. sonnei*-related U.S. cases are ciprofloxacin nonsusceptible, of which only approximately half followed international travel. Among MSM, clusters of shigellosis caused by *S. sonnei* and, to a lesser extent, *S. flexneri* were reported with up to 87% azithromycin resistance. International travel increases the risk for antibiotic-resistant infection. For example, Chinese isolates of *S. sonnei* are often resistant to TMP-SMX (94.5%), ampicillin (40.3%), piperacillin (36.5%), and ceftriaxone (12.8%).

Currently, in most developed and resource-poor countries, *Shigella* strains are often resistant to ampicillin and TMP-SMX. Therefore these drugs should not be used for empirical treatment of suspected shigellosis; they should be instituted only if the strain is known to be susceptible (e.g., in an outbreak caused by a defined strain). Empirical therapy in children with dysentery should be given based on considerations of regional infection cluster data and international travel history. **Ceftriaxone** (50-100 mg/kg/24 hr as a single daily dose intravenously or intramuscularly) can be used for empirical therapy, especially for small infants. The oral third-generation cephalosporin **cefixime** (8 mg/kg/24 hr divided every 12-24 hours) may be considered, although treatment failures for *S. sonnei* infections have been reported in adults; oral first- and second-generation cephalosporins are inadequate as alternative drugs despite in vitro susceptibility. **Azithromycin** (12 mg/kg/24 hr orally for the first day, followed by 6 mg/kg/24 hr for the next 4 days) has proved to be an effective alternative drug for shigellosis. **Ciprofloxacin** (20-30 mg/kg/24 hr divided into two doses) is the drug of choice recommended by the WHO for all patients with bloody diarrhea, regardless of age. Note that since 2015, the CDC has tracked increasing resistance and reduced susceptibility to ciprofloxacin and azithromycin in the United States. Concurrent zinc supplementation is recommended with antibiotic therapy.

Although **quinolones** are reported to cause arthropathy in immature animals and are associated with neuropathy, these risks are low in children and are outweighed by the value of these drugs for the treatment of this potentially life-threatening disease. However, some experts recommend that the quinolones be reserved for seriously ill children with bacillary dysentery caused by an organism suspected or known to be resistant to other agents, because overuse of quinolones promotes the development of resistance to these drugs.

Treatment of patients in whom *Shigella* infection is suspected on clinical grounds should be initiated when these patients are first evaluated. Molecular stool testing or culture is obtained to exclude other pathogens and, in the case of culture, to assist in antibiotic changes should a child fail to respond to empirical therapy. A child who has typical dysentery and who responds to initial empirical antibiotic treatment should be continued on that drug for a full 5-day course even if the stool culture is negative, because of the method's low NPV. The logic of this recommendation is based on the proven difficulty of culturing *Shigella* from stools of ill patients during adult volunteer infection studies. In a child who fails to respond to therapy of a dysenteric syndrome in the presence of initially negative stool culture results, additional cultures should be obtained, or molecular testing, where available and cost-permissive, should be performed, and the child should be reevaluated for other possible diagnoses. In the child with negative molecular stool testing for *Shigellae*, the high NPV makes the diagnosis less likely, and alternative diagnoses should be considered.

## PREVENTION

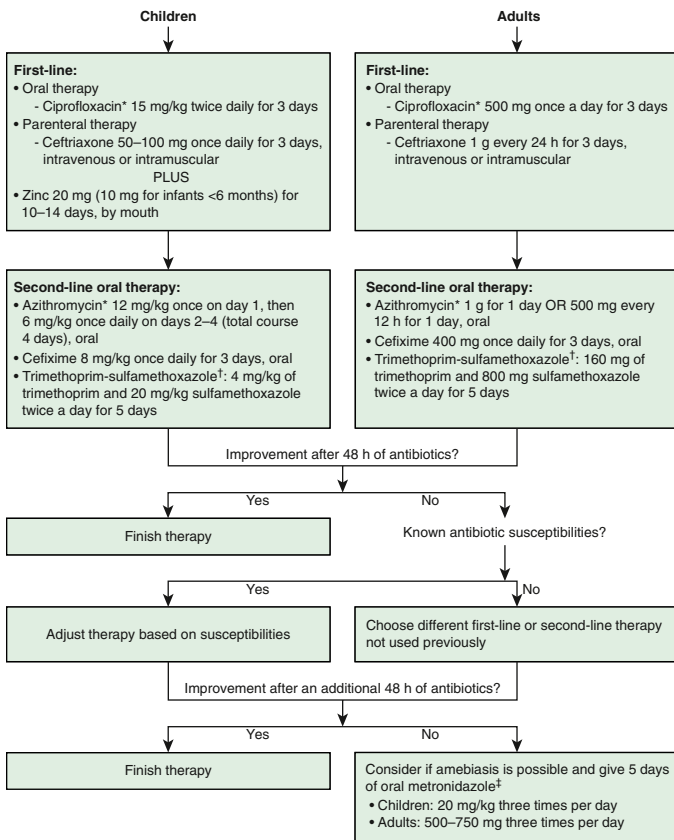
Numerous measures have been recommended to decrease the risk of *Shigella* transmission to children. Mothers should be encouraged to *prolong breastfeeding* of infants. Families and daycare personnel



## Chapter 246

**Escherichia coli**

Patrick C. Seed



**Fig. 245.1** Management algorithm: guidelines for treatment of shigellosis. Empirical therapy should be directed by hospital, clinical laboratory, or public health antibiograms whenever possible. Minimal inhibitory concentrations of 0.12–1.0 µg/mL for ciprofloxacin might be considered susceptible by laboratory standards but could harbor resistance genes known to confer decreased susceptibility. \*Fluoroquinolones and azithromycin should be used with caution in patients taking the antimalarial artemether, because these drugs can prolong the QT interval on the electrocardiogram and trigger arrhythmias. †Trimethoprim-sulfamethoxazole should be used if susceptibility is known or expected based on local data. ‡Per WHO recommendations. Another acceptable regimen is a 7- to 10-day course of metronidazole followed by a luminal agent such as paromomycin or diiodohydroxyquinoline. (Data from *The selection and use of essential medicines: report of the WHO Expert Committee, 2017*. Geneva: World Health Organization; 2017. WHO technical report series; no. 1006.)

should be educated in *proper handwashing* techniques and encouraged to wash hands after using the toilet, changing diapers, or engaging in preparation of foods. They should be taught how to manage potentially contaminated materials such as raw vegetables, soiled diapers, and diaper-changing areas. Children with diarrhea should be excluded from childcare facilities. Children should be supervised when handwashing after they use the toilet. Caretakers should be informed of the risk of transmission if they prepare food when they are ill with diarrhea. Families should be educated regarding the danger of swallowing contaminated water from ponds, lakes, or untreated pools. In developing countries, a safe water supply and appropriate sanitation systems are important measures for reducing the risk for shigellosis. There is not yet a vaccine that is effective for preventing infection by *Shigella*. **Measles immunization** can substantially reduce the incidence and severity of diarrheal diseases, including shigellosis. Every infant should be immunized against measles at the recommended age.

Visit Elsevier eBooks+ at [eBooks.Elsevier.com](http://eBooks.Elsevier.com) for Bibliography.

*Escherichia coli* is an important cause of intractable and extraintestinal infections. **Intractable infections** present as diarrheal illnesses. **Extraintestinal infections** include disease of the urinary tract (see Chapter 575), bloodstream (Chapters 148, 220, and 221), and central nervous system (Chapter 643). *E. coli* causing extraintestinal and intractable infections carry unique genetic attributes that encode different sets of virulence factors and genetic programs. Extraintestinal pathogenic *E. coli* increasingly harbor multidrug resistances, including transferrable plasmids resulting in extended-spectrum β-lactamase (ESBL) production and resistance to penicillins, cephalosporins, and aztreonam. Carbapenemase-bearing *E. coli* have also emerged, often in combination with multi-antibiotic class resistance, resulting in highly drug-resistant strains.

*E. coli* are members of the Enterobacteriaceae family and are facultative anaerobic, gram-negative bacilli that usually ferment lactose. Most fecal *E. coli* organisms are commensal, are ubiquitous among the human gut microbiota starting in the first month of life, and do not cause diarrhea. Six major groups of **diarrheogenic** *E. coli* pathotypes have been characterized based on clinical, biochemical, and molecular-genetic features: enterotoxigenic *E. coli* (ETEC); enteroinvasive *E. coli* (EIEC); enteropathogenic *E. coli* (EPEC); Shiga toxin-producing *E. coli* (STEC), also known as enterohemorrhagic *E. coli* (EHEC) or verotoxin-producing *E. coli* (VTEC); enteroaggregative *E. coli* (EAEC) or EggEC; and diffusely adherent *E. coli* (DAEC).

*E. coli* strains can also be categorized by their serogroup, where O refers to the lipopolysaccharide (LPS) O-antigen or serotype and H refers to the flagellar antigen, for example, *E. coli* O157:H7. However, because each pathotype contains many serotypes (e.g., 117 ETEC serotypes have been identified) and some serotypes can belong to more than one pathotype (e.g., O26:H11 can be either EPEC or EHEC depending on which specific virulence genes are present), serotyping usually does not provide definitive identification of pathotypes.

Virulence characteristics and the association of those traits with illness define **enteric** *E. coli* pathogenicity (Table 246.1). The mechanism by which *E. coli* produces **diarrhea** typically involves specific adherence to a glycoprotein or glycolipid receptor on a target intestinal cell, followed by production of a factor that injures or disturbs the function of intestinal cells. The genes for virulence properties and antibiotic resistance are often carried on transferable plasmids, pathogenicity islands, or bacteriophages.

In the developing world, diarrheogenic *E. coli* cause frequent infections in the first years of life and are responsible for 30–40% of all diarrhea cases in children worldwide. Cases peak during the warm months in temperate climates and during rainy season months in tropical climates. Most diarrheogenic *E. coli* strains (except STEC) require a large inoculum of organisms to induce disease, thus necessitating exposure to grossly contaminated ingestible materials. Infection is most likely when food-handling or sewage-disposal practices are suboptimal. The diarrheogenic *E. coli* pathotypes are also important in North America and Europe, although their epidemiology is less well defined in these areas than in the developing world. In North America, the various diarrheogenic *E. coli* strains may cause as much as 30% of infectious diarrhea in children <5 years old.

A significant proportion of asymptomatic healthy children living in developing countries carry diarrheogenic *E. coli* pathotypes. **Fecal contamination** (human and animal), which is common in the low-resource environments, facilitates the transmission of pathogens. Modern, highly sensitive microbiologic methods enhance the sensitivity

**Table 246.1** Clinical Characteristics, Pathogenesis, and Diagnosis of Diarrheagenic *E. coli*

PATHOGEN	POPULATIONS AT RISK	CHARACTERISTICS OF DIARRHEA			MAIN VIRULENCE FACTORS		
		WATERY	BLOODY	DURATION	ADHERENCE FACTORS	TOXINS	DIAGNOSIS
ETEC	>1 yr old and travelers	+++	–	Acute	Colonization factor antigens (CFs or CFAs); ECP	Heat-labile enterotoxin (LT) Heat-stable enterotoxin (ST)	Detection of enterotoxins (LT and ST) by enzyme immunoassays or PCR ( <i>lt</i> , <i>st</i> )
EIEC	>1 yr old	+	++	Acute	Invasion plasmid antigen ( <i>ipaA-D</i> )		Detection of invasion plasmid antigen of <i>Shigella</i> ( <i>ipaH</i> ) by PCR
EPEC	<2 yr old	+++	+	Acute, prolonged or persistent	A/E lesion, intimin/Tir, EspABD, Bfp	EspF, Map, EAST1, SPATEs (EspC)	Detection of intimin gene ( <i>eae</i> ) ± bundle-forming pili ( <i>bfpA</i> ) by PCR and absence of <i>Shiga</i> toxins; HEp-2 cells adherence assay (LA, LLA)
STEC (EHEC/VTEC)	6 mo to 10 yr and elderly persons	+	+++	Acute	A/E lesion, intimin/Tir, EspABD	<i>Shiga</i> toxins ( <i>Stx1</i> , <i>Stx2</i> , and variants of <i>Stx2</i> )	Detection of <i>Shiga</i> toxins by enzyme immunoassays or PCR ( <i>Stx1</i> , <i>Stx2</i> ); stool culture on MacConkey-sorbitol media to detect <i>E. coli</i> O157. Simultaneous culture for O157 and nonculture assays to detect <i>Shiga</i> toxins
EAEC	<2 yr old, HIV-infected patients, and travelers	+++	+	Acute, prolonged, or persistent	Aggregative adherence fimbriae (AAF)	SPATEs (Pic, Pet), ShET1, EAST1	Detection of <i>AggR</i> , AA plasmid, and other virulence genes: <i>aap</i> , <i>aatA</i> , <i>astA</i> , <i>set1A</i> by PCR; HEp-2 cells adherence assay (AA)
DAEC	>1 yr old and travelers	++	–	Acute	Afa/Dr, AIDA-I	SPATEs (Sat)	Detection of Dr adhesins ( <i>daaC</i> or <i>daaD</i> ) and Dr-associated genes by PCR; HEp-2 cells adherence assay (DA)

–, Not present; +, present; ++, common; +++, very common; A/E lesion, attaching and effacing lesion; AA, aggregative adherence; Bfp, bundle-forming pili; DA, diffuse adherence; DAEC, diffusely adherent *E. coli*; EAEC, enteroaggregative *E. coli*; EAST1, enteroaggregative heat-stable toxin; ECP, *E. coli* common pilus; EHEC, enterohemorrhagic *E. coli*; EIEC, enteroinvasive *E. coli*; EPEC, enteropathogenic *E. coli*; EspABD, *E. coli*-secreted proteins A, B, and D; ETEC, enterotoxigenic *E. coli*; LA, localized adherence; LLA, localized-like adherence; PCR, polymerase chain reaction; ShET1, *Shigella* enterotoxin 1; SPATEs, serine-protease autotransporter of Enterobacteriaceae; STEC, *Shiga* toxin-producing *E. coli*; Tir, translocated intimin receptor; VTEC, verotoxin-producing *E. coli*.

of detection in stool samples, and small numbers of bacteria can be detected in stool samples. Therefore the prevalence of various enteropathogens in children with and without diarrhea must be considered. Excretion of enteropathogens by children without diarrhea may be explained by characteristics of the pathogens (virulence heterogeneity), the host (host susceptibility, age, nutritional status, breastfeeding, immunity), and environmental factors (inoculum size).

### ENTEROTOXIGENIC *ESCHERICHIA COLI*

ETEC accounts for a sizable fraction of dehydrating infantile diarrhea in the developing world (10–30%) and of **traveler's diarrhea** (20–60% of cases); ETEC is the most common cause of traveler's diarrhea. The

Global Enteric Multicenter Study (GEMS) found heat-stable enterotoxin (ST)-expressing ETEC (with or without coexpression of heat-labile enterotoxin [LT]) to be a leading cause of diarrhea and increased risk for death in young children in developing countries of Asia and Africa. The typical signs and symptoms include explosive watery, non-mucoid, nonbloody diarrhea; abdominal pain; nausea; vomiting; and little or no fever. The illness is usually self-limited and resolves in 3–5 days but occasionally lasts >1 week.

Diarrhea follows ETEC colonization of the small intestine and elaboration of enterotoxin; however, ETEC causes few to no structural alterations in the gut mucosa. ETEC strains secrete one or two enterotoxins. LT, a large molecule consisting of five receptor-binding subunits

and one enzymatically active subunit, is structurally, functionally, and neutralizing antibody cross-reactive with cholera toxin produced by *Vibrio cholerae*. LT stimulates adenylate cyclase, resulting in increased cyclic adenosine monophosphate. ST is not related to cholera toxin and stimulates guanylate cyclase, resulting in increased cyclic guanosine monophosphate. Each toxin induces ion and water secretion into the intestinal lumen, resulting in profuse watery diarrhea. The toxin genes are carried on plasmids.

Colonization of the intestine requires fimbria **colonization factor antigens (CFAs)**, which promote adhesion to the intestinal epithelium. Over 25 CFA types exist and can be expressed alone or in combination. Roughly 30–50% of ETEC isolates lack a characterized CFA. However, novel CFAs continue to be identified.

CFAs are highly immunogenic, but their multiplicity and allelic variation elude vaccine development. Many strains produce a type IV pilus involved in colonization and shared among other gram-negative bacterial pathogens. ETEC express type 1 pili (the “common pilus”), produced by commensal and pathogenic *E. coli* strains. TibA, a non-fimbrial adherence factor, mediates potent bacterial attachment and invasion of cells. For many years, the O serogroup was used to distinguish pathogenic from commensal *E. coli*. Molecular classification of pathogenic *E. coli* based on specific virulence genes and whole genome phylogeny has largely replaced classic O serogroup typing.

### ENTEROINVASIVE ESCHERICHIA COLI

EIEC infections produce watery diarrhea or dysentery with blood, mucus, and leukocytes in the stools, as well as fever, systemic toxicity, crampy abdominal pain, tenesmus, and urgency. The illness resembles **bacillary dysentery** because EIEC shares virulence genes with *Shigella* spp. Sequencing of multiple housekeeping genes indicates that EIEC is more related to *Shigella* than to noninvasive *E. coli*. EIEC diarrhea occurs mostly in outbreaks; however, endemic disease occurs in developing countries. In some areas of the developing world, as many as 5% of sporadic diarrhea episodes and 20% of bloody diarrhea cases are caused by EIEC (see Chapter 245).

EIEC behave like *Shigella* in their capacity to invade gut epithelium and cause colonic lesions with ulcerations, hemorrhage, mucosal and submucosal edema, and infiltration by polymorphonuclear leukocytes (PMNs). The invasive process involves initial entry into cells, intracellular multiplication, intracellular and intercellular spread, and host cell death. All bacterial genes necessary for entry into the host cell are clustered within a 30-kb region of a large virulence plasmid; these genes are closely related to those found on the invasion plasmid of *Shigella* spp. This region carries genes encoding the entry-mediating proteins, including proteins that form a needle-like injection apparatus called *type III secretion*, required for secreting the invasins (IpaA-D and IpgD). The Ipas are the primary effector proteins of epithelial cell invasion. EIEC contact with host cells triggers the syringe-like type III secretion apparatus and injection of Ipas into the host cell cytoplasm.

Like *Shigella* spp., EIEC are nonmotile (they lack H or flagellar antigens) and are usually non-lactose fermenting. The serogroups of EIEC share LPS antigens related to *Shigella* LPS.

### ENTEROPATHOGENIC ESCHERICHIA COLI

EPEC causes acute, prolonged, and persistent diarrhea, primarily in children <2 years old in resource-poor countries, where the organism may account for 20% of infant diarrhea. In developed countries, EPEC causes occasional daycare center and pediatric ward outbreaks. Profuse watery, nonbloody diarrhea with mucus, vomiting, and low-grade fever are common symptoms. Prolonged diarrhea (>7 days) and persistent diarrhea (>14 days) can lead to **malnutrition**, a potentially mortality-associated outcome of EPEC infection in infants in the developing world. Studies show that breastfeeding is protective against diarrhea caused by EPEC.

EPEC colonization causes blunting of intestinal villi, local inflammatory changes, and sloughing of superficial mucosal cells; EPEC-induced lesions extend from the duodenum through the colon. EPEC induces a characteristic attaching and effacing histopathologic lesion, which is defined by the intimate attachment of bacteria to the epithelial

surface and effacement of host cell microvilli. Factors responsible for the attaching and effacing lesion formation are encoded by the *locus of enterocyte effacement (LEE)*, a pathogenicity island with genes for a type III secretion system, the translocated intimin receptor (Tir) and intimin, and multiple effector proteins such as the *E. coli*-secreted proteins (EspA-B-D). Some strains adhere to the host intestinal epithelium in a pattern known as *localized adherence*, a trait that is mediated in part by the type IV bundle-forming pilus (Bfp) encoded by a plasmid (the EAF plasmid). After initial contact, proteins are translocated through filamentous appendages, forming a physical bridge between the bacteria and the host cell; bacterial effectors (EspB, EspD, Tir) are translocated through these conduits. Tir moves to the surface of host cells, where it is bound by a bacterial outer membrane protein intimin (encoded by the *eae* gene). Intimin-Tir binding triggers polymerization of actin and other cytoskeletal components at the site of attachment. These cytoskeletal changes result in intimate bacterial attachment to the host cell, enterocyte effacement, and pedestal formation.

Other LEE-encoded effectors include Map, EspF, EspG, EspH, and SepZ. Various other effector proteins are encoded outside the LEE and secreted by the type III secretion system (the non-LEE-encoded proteins, or Nle). The contribution of these putative effectors (e.g., NleA/EspI, NleB, NleC, NleD) to virulence is still under investigation. The presence and expression of virulence genes vary among EPEC strains.

The *eae* (intimin) and *bfpA* genes serve as molecular markers of EPEC and genetically subdivide EPEC into typical and atypical strains. *E. coli* strains that are *eae*<sup>+</sup>/*bfpA*<sup>+</sup> are classified as “typical” EPEC; most of these strains belong to common O:H serotypes. *E. coli* strains that are *eae*<sup>+</sup>/*bfpA*<sup>-</sup> are classified as “atypical” EPEC. Current data suggest that atypical EPEC are more prevalent than typical EPEC in both developed and developing countries, even in persistent diarrhea cases. In the GEMS study, typical EPEC was most associated with increased risk of mortality, particularly in infants in Africa.

### ENTEROAGGREGATIVE ESCHERICHIA COLI

EAEC infection produces (1) acute, prolonged, and persistent pediatric diarrhea in developing countries, most prominently in children <2 years old and in malnourished children; (2) acute and persistent diarrhea in HIV-infected adults and children; and (3) acute traveler's diarrhea; EAEC is the second most common cause of traveler's diarrhea after ETEC. Typical EAEC illness is manifested by watery, mucoid, secretory diarrhea with low-grade fever and little or no vomiting. The watery diarrhea can persist for ≥14 days. Patients with EAEC may have grossly bloody stools, and EAEC cannot be excluded on stool characteristics. EAEC colonization and infection lead to growth retardation and malnutrition in infants in the developing world.

EAEC organisms form a characteristic biofilm on the intestinal mucosa and induce shortening of the villi, hemorrhagic necrosis, and inflammatory responses. The proposed model of pathogenesis of EAEC infection involves three phases: adherence to the intestinal mucosa by way of the aggregative adherence fimbriae or related adhesins, stimulation of enhanced mucus production, and toxin-mediated inflammation that results in damage to the mucosa and intestinal secretion. Diarrhea caused by EAEC is predominantly secretory. The intestinal inflammatory response (elevated fecal lactoferrin, interleukin [IL]-8 and IL-1β) may be related to growth impairment and malnutrition.

EAEC strains adhere in an aggregative, stacked-brick pattern, called *aggregative adherence (AA)*, mediated by the AA fimbriae (AAF-I, -II, and -III). Some strains produce toxins, including the plasmid-encoded enterotoxin EAST1 (encoded by *astA*), a homolog of the ETEC ST; an autotransporter toxin called Pet; other STATE toxins; and the chromosomally encoded enterotoxin ShET1 (encoded by *setA* and *setB*). Other virulence factors include outer membrane and secreted proteins, such as dispersin (*aap*), and the dispersin transport complex (aatPABCD). EAEC is a heterogeneous group of *E. coli*. A transcriptional activator called **AggR** controls the expression of plasmid-borne and chromosomal virulence factors. Identification of AggR appears to reliably identify illness-associated pathogenic EAEC strains (“typical” EAEC). EAEC *aggR*-positive strains carrying one to three of the genes *aap*, *astA*, and *set1A* are significantly associated with diarrhea compared



with EAEC isolates lacking these genes. Other than the AAF and AggR factors, EAEC strains are genetically diverse, display variable virulence, and belong to multiple serogroups.

### SHIGA TOXIN-PRODUCING *ESCHERICHIA COLI*

The STEC, which include EHEC, produce a range of clinical syndromes from asymptomatic colonization, to mild diarrhea, to severe hemorrhagic colitis. Watery diarrhea that becomes bloody over several days characterizes STEC illness. STEC infrequently causes fever, a distinguishing difference with shigellosis or EIEC disease. Most people with STEC recover from the infection without further complication. However, 5–10% of children with STEC hemorrhagic colitis go on within a few days to develop systemic complications such as **hemolytic-uremic syndrome** (HUS), characterized by acute kidney failure, thrombocytopenia, and microangiopathic hemolytic anemia (see Chapter 560). Severe illnesses occur most often among children 6 months to 10 years old. Young children with STEC-associated bloody diarrhea and neutrophilic leukocytosis in the early course of their diarrhea are at risk for HUS progression. Older individuals can also develop HUS or thrombotic thrombocytopenic purpura.

STEC transmits person to person (e.g., in families and daycare centers) and in contaminated food and water; a small inoculum can lead to infection. STEC food-borne outbreaks have arisen from undercooked hamburger, apple cider, lettuce, spinach, mayonnaise, salami, dry fermented sausage, and unpasteurized dairy products.

STEC primarily affects the colon, where organisms adhere to intestinal cells and produce attaching-effacing lesions such as those seen with EPEC and contain related genes (e.g., *intimin*, *Tir*, *EspA-D*). Unlike EPEC, STEC produces two major **Shiga toxins** (Stx1 and Stx2; previously called *verotoxins* and *Shiga-like*). STEC may produce one or both toxins and their closely related variants. **Stx1** is essentially identical to Shiga toxin, the protein synthesis-inhibiting exotoxin of *Shigella dysenteriae* serotype 1. **Stx2** and variants of Stx2 are more distantly related to Shiga toxin, although they share conserved sequences.

STEC Shiga toxins are composed of a single A subunit noncovalently associated with a pentamer composed of identical B subunits. The B subunits bind to globotriaosylceramide (Gb<sub>3</sub>), a glycosphingolipid receptor on host cells. The A subunit is taken up by endocytosis. The toxin target is the 28S ribosomal RNA (rRNA), which is depurated by the toxin at a specific adenine residue, causing protein synthesis to cease and affected cells to die. These toxins are carried on bacteriophages that are normally inactive (lysogenic) in the bacterial chromosome; when the phages are induced to replicate (e.g., by the stress induced by many antibiotics), they cause lysis of the bacteria and release of large amounts of toxin. Toxin translocation across the intestinal epithelium into the systemic circulation can lead to damage of vascular endothelial cells, resulting in activation of the coagulation cascade, formation of microthrombi, intravascular hemolysis, and ischemia.

The clinical outcome of an STEC infection depends on a strain-specific combination of epithelial attachment and the toxin factors. The Stx2 toxins are associated with a higher risk of causing HUS. Strains producing only Stx1 often cause only watery diarrhea and, infrequently, HUS.

The most common STEC serotypes are *E. coli* O157:H7, *E. coli* O111:NM, and *E. coli* O26:H11, although several hundred other STEC serotypes have also been described. *E. coli* O157:H7 is the most virulent serotype and the serotype most frequently associated with HUS; however, other non-O157 serotypes also cause this illness.

### ENTEROAGGREGATIVE HEMORRHAGIC *ESCHERICHIA COLI*

In 2011, a massive outbreak of an unusual O104:H4 strain of diarrheagenic *E. coli* began in Germany. Eventually, >4,000 individuals were sickened with hemorrhagic colitis; the outbreak involved primarily adults (<100 children were reported affected). More than 800 people developed HUS, and >50 of these individuals died. Genomic analysis suggested the outbreak strain was most closely related to EAEC and had acquired a lambdoid bacteriophage with genes for Shiga toxin Stx2a. It was thus a **hybrid** pathogen with colonization mechanisms

similar to a typical EAEC strain and toxin production typical of an STEC strain. This outbreak strain carries Pic on the chromosome and a pAA-like plasmid encoding AAF, AggR, Pet, SHET1, and dispersin. A second virulence plasmid encodes multiple antibiotic resistances. The high morbidity and mortality associated with this strain may reflect the stronger adherence of EAEC compared with STEC, delivering more Stx to target cells. Alternative terminology for this strain includes **enteroaggregative hemorrhagic *E. coli*** and **Shiga toxin-producing EAEC**. Whether Shiga toxin production in an EAEC background merits separate classification is unclear. Organisms with Shiga toxin genes in an atypical EPEC background were designated as a separate group (referred to as STEC, EHEC, or **verotoxin-producing *E. coli***) before the relative importance of the various genes was clear. EPEC strains are a heterogeneous group themselves. The important issue is not the nomenclature, but rather the concept that virulence genes can move between *E. coli*, resulting in new variants.

### DIFFUSELY ADHERENT *ESCHERICHIA COLI*

Multiple studies in both developed and developing countries find DAEC associated with diarrhea, particularly in children after the first 1–2 years of life. DAEC strains isolated from children and adults seem to represent two different bacterial populations. **Age-dependent susceptibility** or the use of inappropriate detection methods may explain discrepancies among epidemiologic studies. Data suggest that these organisms also cause traveler's diarrhea in adults. DAEC produces prolonged watery diarrhea that is usually not dysenteric.

DAEC strains produce **diffuse adherence** on intestinal epithelial cells using the Afa/Dr-like surface fimbriae (designated F1845). The outer membrane protein AIDA-I also associates with **diffuse adherence**. DAEC secrete the serine-protease autotransporters of Enterobacteriaceae (SPATE) cytotoxin Sat. Bacteria expressing Afa/Dr adhesins interact with membrane-bound receptors, including decay-accelerating factor (DAF). The structural and functional lesions induced by DAEC include loss of microvilli and a decrease in the expression and enzyme activities of functional brush border-associated proteins. Afa/Dr DAEC isolates produce a secreted autotransporter toxin that induces marked fluid accumulation in the intestine. DAEC strains typically induce IL-8 production in vitro.

### DIAGNOSIS

The features of suspected *E. coli* diarrheal illness are seldom distinctive enough to allow confident diagnosis strictly on clinical observations and routine laboratory studies such as blood counts. Practical, non-DNA-dependent methods for routine diagnosis of diarrheagenic *E. coli* have been developed primarily for STEC. Serotype O157:H7 is suggested by isolation of an *E. coli* that fails to ferment sorbitol on MacConkey sorbitol medium; latex agglutination confirms that the organism contains O157 LPS. Commercially available enzyme immunoassay or latex agglutination assays detect Shiga toxins in the routine hospital laboratory, although their variable sensitivity may limit their value.

Commercial assays such as the FilmArray Gastrointestinal Panel and Eurofins Diatherix Panel rapidly detect genetic markers for EPEC, EAEC, ETEC, STEC, and EIEC, among other pathogen genes, directly from a fecal sample in several hours and have been shown to reduce hospitalizations and treatment costs. Although some STEC (O157:H7 strains) can be detected in routine microbiology laboratories using selective media and appropriate antisera, the diagnosis of other diarrheagenic *E. coli* infection is traditionally made based on tissue culture assays (e.g., HEp-2-cells assay for EPEC, EAEC, and DAEC) or identification of specific virulence factors of the bacteria by phenotype (e.g., toxins) or genotype. Multiplex, real-time, or conventional polymerase chain reaction (PCR) can be used for presumptive diagnosis of isolated *E. coli* colonies. The genes commonly used for diagnostic PCR are *lt* and *st* for ETEC; *lpaH* or *ial* for EIEC; *eae* and *bfpA* for EPEC; *eae*, *Stx1*, and *Stx2* for STEC; *AggR* or the AA plasmid for EAEC; and *daaC* or *daaD* for DAEC.

Serotyping does not provide definitive identification of pathotypes (except for selected cases such as O157:H7) because each pathotype



contains many serotypes and some serotypes can belong to more than one pathotype. Consequently, serotyping should not be used routinely for diarrheagenic *E. coli* identification in clinical laboratories (e.g., to diagnose EPEC in infantile diarrhea), except during an outbreak investigation.

Other laboratory data are, at best, *nonspecific* indicators of etiology. Fecal leukocyte examination of the stool is often positive with EIEC or occasionally positive with other diarrheagenic *E. coli*. With EIEC and STEC there may be an elevated peripheral blood PMN count with a left shift. Determination of *Stx2* blood levels in the early, post-bloody diarrhea period may be useful to identify children at risk of HUS; however, a validated clinical test is not readily available. Fecal lactoferrin, IL-8, and IL-1β can be used as inflammatory markers. Electrolyte changes are nonspecific, reflecting only fluid loss.

**TREATMENT**

The cornerstone of management is appropriate fluid and electrolyte therapy (Fig. 246.1). In general, this therapy should include oral replacement and maintenance with rehydration solutions such as those specified by the World Health Organization (WHO). Early volume expansion during STEC infection may reduce renal injury and improve patient outcomes. Upon refeeding, continued supplementation with oral rehydration fluids is appropriate to prevent recurrence of dehydration. Early refeeding (within 6-8 hours of initiating rehydration) with breast milk or infant formula or solid foods should be encouraged. Prolonged withholding of feeding can lead to chronic diarrhea and malnutrition. If the child is malnourished, oral zinc should be given to speed recovery and decrease the risk of future diarrheal episodes.

In children, validated criteria for antimicrobial therapy of diarrheal disease do not exist. The routine use of antimicrobials to treat childhood diarrhea is not recommended by the WHO except in severe cases. Nonbloody diarrhea rarely requires antimicrobial therapy. Antimicrobials should be reserved for dysenteric presentations, when host immunity is compromised by specific disorders, malnutrition, and chronic disease (Table 246.2). Antimicrobials should also be considered for severe traveler’s diarrhea and diarrhea accompanied by fever and bloody stools. In settings of good healthcare resources, rapid molecular testing for STEC should be performed before initiating antibiotics, which can increase the risk for HUS.

Emerging antimicrobial resistance among diarrheal *E. coli* and other bacterial pathogens complicates treatment. Multiple studies in developing countries have found that diarrheagenic *E. coli* strains typically are resistant to antibiotics such as trimethoprim-sulfamethoxazole (TMP-SMX) and ampicillin (60–70%). Most data come from case series or clinical trials in adults with traveler’s diarrhea. ETEC responds to antimicrobial agents such as TMP-SMX when the *E. coli* strains are susceptible. ETEC cases from traveler’s diarrhea trials respond to ciprofloxacin, azithromycin, and rifaximin. However, other than for a child recently returning from travel in the developing world, empirical treatment of severe *watery diarrhea* with antibiotics is seldom appropriate.

In resource-poor settings where rapid molecular panel tests are not available, EIEC infections may be treated before culture results are finalized because the clinician suspects shigellosis and has begun empirical therapy. If the organisms prove to be susceptible, TMP-SMX is an appropriate choice. Although treatment of EPEC infection with TMP-SMX intravenously or orally for 5 days may be effective in speeding resolution, the lack of a rapid diagnostic test in the resource-poor setting makes treatment decisions difficult. Ciprofloxacin or rifaximin is useful for EAEC traveler’s diarrhea, but pediatric data are sparse. Specific therapy for DAEC has not been defined.

The STEC strains represent a particularly difficult therapeutic dilemma; many antibiotics can induce bacterial stress, toxin production, and phage-mediated bacterial lysis with toxin release. Antibiotics should not be given for STEC infection because they can increase the risk of HUS (see Chapter 560). In settings with rapid molecular diagnostics, a delay in providing antibiotics is rarely consequential and can allow the clinician to more confidently recommend or exclude antibiotics from the therapeutic plan.

**PREVENTION OF ILLNESS**

In the developing world, prevention of disease caused by pediatric diarrheagenic *E. coli* is probably best done by maintaining prolonged breastfeeding, paying careful attention to personal hygiene, and following proper food- and water-handling procedures. People traveling

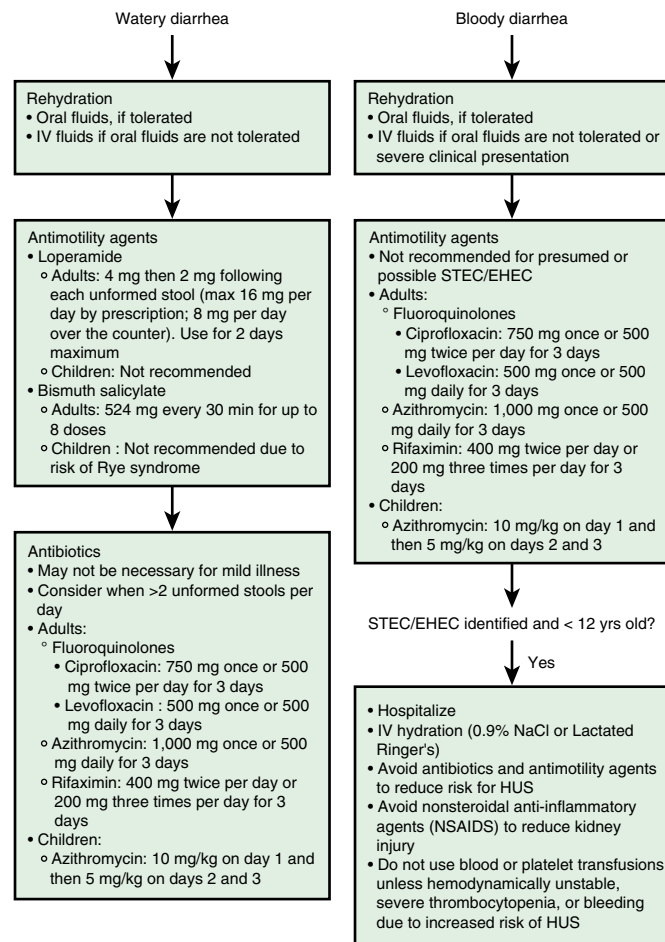


Fig. 246.1 Algorithmic treatment summary for presumed and possible *E. coli* diarrheal illness.

**Table 246.2** Risk Factors Favoring Antibiotic Therapy in Children with Acute Diarrhea

RISK FACTOR	EVIDENCE
<b>CHILD FACTORS</b>	
Age <3 mo	Poor evidence in general; strong indication for neonates
Severe clinical presentation	Poor evidence but strong indications
Malnutrition	Strong evidence
Chronic disease and immune deficiency	Strong evidence (IBD and HIV); otherwise poor evidence; strong indications
<b>SETTING FACTORS</b>	
Daycare centers, closed institutions, hospitals	Strong evidence if bacteria spread is a potential
Traveler’s diarrhea	Evidence for adult is strong; poor evidence in children

to these places can be best protected by handwashing and consuming only processed water, bottled beverages, breads, fruit juices, fruits that can be peeled, or foods that are served steaming hot.

Prophylactic antibiotic therapy is effective in adult travelers but has not been studied in children and is not recommended. Public health measures, including sewage disposal and food-handling practices, have made pathogens that require a large inoculum to produce illness relatively uncommon in industrialized countries where food screening and public health measures are robust. Food-borne outbreaks of STEC are a problem for which no adequate solution has been found. During the occasional hospital outbreak of EPEC disease, attention to enteric isolation precautions and cohorting may be critical.

Protective immunity against diarrheagenic *E. coli* remains an active area of research, and no vaccines are available for clinical use in children. Multiple vaccine candidates based on bacterial toxins and colonization factors have shown promise for prevention of ETEC in adult travelers, but long-term protection with these vaccines has not been optimal, particularly in children.

Visit Elsevier eBooks+ at [eBooks.Health.Elsevier.com](http://eBooks.Health.Elsevier.com) for Bibliography.

## Chapter 247

# Cholera

James P. Nataro

Cholera is a dehydrating diarrheal disease that rapidly leads to death in the absence of immediate initiation of appropriate treatment. Worldwide, 1.3 billion people are at risk for cholera, resulting in an estimated 1–4 million cases and 95,000 deaths annually. Cholera is highly prone to producing outbreaks, and the ongoing outbreaks in Yemen and Haiti emphasize how cholera and potentially other infectious diseases can easily reemerge in areas that have long been considered free of the disease after a natural disaster or war-related conflicts.

### ETIOLOGY

Cholera is caused by *Vibrio cholerae*, a gram-negative, comma-shaped bacillus, subdivided into serogroups by its somatic O antigen. Of the >200 serogroups, only serogroups O1 and O139 have been associated with epidemics, although some non-O1, non-O139 *V. cholerae* strains (e.g., O75, O141) are pathogenic and can cause small outbreaks. A flagellar H antigen is present but is not used for species identification. The O1 serogroup is further divided into classical and El Tor biotypes based on its biochemical characteristics. Since the turn of the 21st century, only **O1 El Tor** has been reported; hybrids and variants of *V. cholerae* O1 El Tor possessing classical genes have been reported worldwide. These hybrid and variant strains have been associated with more severe disease.

Each biotype of *V. cholerae* can be further subdivided into Inaba, Ogawa, and Hikojima serotypes based on the antigenic determinants on the O antigen. **Inaba** strains have A and C antigenic determinants, whereas **Ogawa** strains have A and B antigenic determinants. **Hikojima** strains produce all three antigenic determinants but are unstable and rare. Recent studies reveal that serotype switching results from a selection process as yet unidentified.

### EPIDEMIOLOGY

The first six cholera pandemics originated in the Indian subcontinent and were caused by classical O1 *V. cholerae*. The seventh pandemic is the most extensive of all and is caused by *V. cholerae* O1 El Tor. This pandemic began in 1961 in Sulawesi, Indonesia, and has spread to the Indian subcontinent, Southeast Asia, Africa, Oceania, Southern Europe, and the Americas. In 1991, *V. cholerae* O1 El Tor first

appeared in Peru before rapidly spreading in the Americas. Cholera becomes **endemic** in areas after outbreaks when a large segment of the population develops immunity to the disease after recurrent exposure. Although the Ganges River valley is the historical home of cholera, it is estimated that >90% of global cases now occur in Africa, where the disease remains highly endemic.

In 1992 the first non-O1 *V. cholerae* that resulted in epidemics was identified in India and Bangladesh and was designated *V. cholerae* **O139**. From 1992 to 1994, this organism replaced O1 as the predominant cause of cholera in South Asia but has since been an uncommon etiologic agent.

The hybrid El Tor strains were first identified sporadically in Bangladesh. In 2004, during routine surveillance in Mozambique, isolates of *V. cholerae* O1 El Tor carrying classical genes were identified. Since then, hybrid and variant El Tor strains have been reported in other parts of Asia and Africa and have caused outbreaks in India and Vietnam. Although the classical biotype has virtually disappeared, its genes remain within the El Tor biotype. The current circulating strain in Haiti is closely related to the South Asian strain.

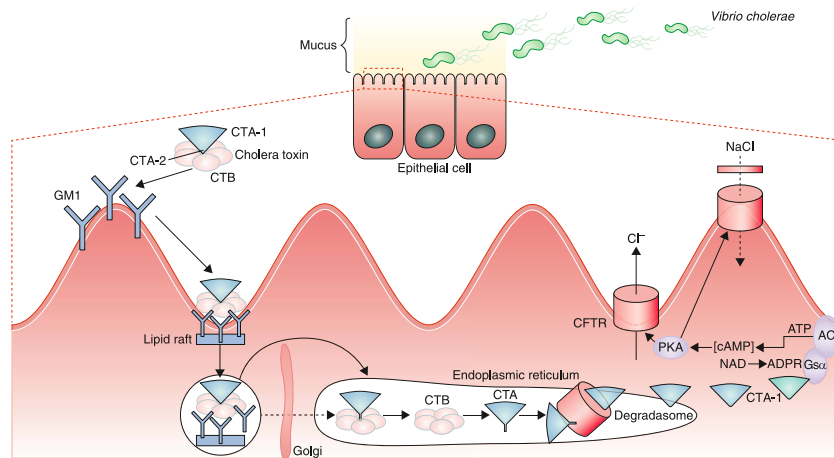
Humans are the only known hosts for *V. cholerae*, but free-living and plankton-associated *V. cholerae* exist in the marine environment. The organism thrives best in moderately salty water but can survive in rivers and freshwater if nutrient levels are high, as occurs when there is organic pollution such as human feces. The formation of a biofilm on abiotic surfaces and the ability to enter a viable but nonculturable state have been hypothesized as factors that allow *V. cholerae* to persist in the environment during interepidemic periods. Surface sea temperature, pH, chlorophyll content, the presence of iron compounds and chitin, and climatic conditions such as amount of rainfall and sea level rise are all important environmental factors that influence the survival of *V. cholerae* in the environment.

Consumption of **contaminated water** and ingestion of **undercooked shellfish** are the main modes of transmission, but additional food sources are becoming increasingly common. In cholera-endemic areas, the incidence is highest among children <2 years old, probably driven by the lack of previous exposure in young children. However, during cholera epidemics, all age-groups are usually affected, particularly in areas with no previous *V. cholerae* transmission. Persons with blood group O, decreased gastric acidity, malnutrition, immunocompromised states, and absence of local intestinal immunity (i.e., prior exposure) are at increased risk for developing severe disease. Household contacts of cholera-infected patients are at high risk of infection, because the stools of infected patients contain high concentrations of the pathogen. Moreover, upon repeated cycles of passage through humans, the organism becomes more virulent, demonstrating an increased number of copies of the cholera toxin-encoding genes.

### PATHOGENESIS

Large inocula of bacteria (>10<sup>8</sup> colony-forming units [CFUs]) are required for severe cholera to occur; however, for persons whose gastric barrier is disrupted, a much lower dose (10<sup>5</sup> CFUs) is required, and the infectious dose may be lower after serial propagation of the pathogen through humans. After ingestion of *V. cholerae* from the environment, several changes occur in the microorganisms as they traverse the human intestine: increased expression of genes required for nutrient acquisition, downregulation of chemotactic responses, and expression of motility factors. Freshly excreted organisms (5–24 hours after shedding) are maximally infectious and may represent the predominant pathway for person-to-person transmission during epidemics.

The principal virulence factors of *V. cholerae* O1 are the cholera toxin and the toxin-coregulated pilus, a colonization factor that confers adherence to the epithelium of the small intestine (Fig. 247.1). The cholera toxin consists of five binding B subunits and one active A subunit. The B subunits are responsible for binding to the GM<sub>1</sub> ganglioside receptors located in the small intestinal epithelial cells. After binding, the A subunit is translocated into the cell, where it catalyzes adenosine diphosphate (ADP) ribosylation of the *alpha* subunit of the G<sub>s</sub> signaling protein, which becomes constitutively active. G<sub>s</sub> stimulates adenylate cyclase, leading to accumulation of cyclic adenosine



**Fig. 247.1** Cholera pathogenesis and cholera toxin action. After ingestion, *Vibrio cholerae* colonize the small intestine and secrete cholera toxin, which has a doughnut-like structure with a central enzymatic toxic-active A (CTA-1 + CTA-2) subunit associated with a pentameric B subunit (CTB). After binding to GM<sub>1</sub> ganglioside receptors on small intestinal epithelial cells, which are mainly localized in lipid rafts on the cell surface, the cholera toxin is endocytosed and transported to the degradosome via the endoplasmic reticulum (ER) by a retrograde pathway, which, dependent on cell type, may or may not involve passage through the Golgi apparatus. In the ER, CTA dissociates from CTB, allowing CTA-1 to reach the cytosol by being translocated through the degradosome pathway. In the cytosol, CTA-1 subunits rapidly re-fold and bind to the G $\alpha$  subunit of adenylate cyclase (AC) in the cell membrane; on binding, CTA-1 adenosine diphosphate (ADP)-ribosylates the G $\alpha$  subunit, which stimulates AC activity, leading to an increase in intracellular concentration of cyclic adenosine monophosphate (cAMP), activation of protein kinase A (PKA), phosphorylation of the cystic fibrosis transmembrane conductance regulator (CFTR), a major chloride channel, and extracellular secretion of chloride ions (Cl<sup>-</sup>) and water. Cholera toxin-induced Cl<sup>-</sup> (and bicarbonate ion) secretion is particularly pronounced in intestinal crypt cells, whereas the increased intracellular cAMP concentrations in villus cells mainly inhibit the uptake of sodium chloride (NaCl) and water. (Adapted from Clemens J, Shin S, Sur D, et al. New-generation vaccines against cholera. *Nat Rev Gastroenterol Hepatol*. 2011;8:701–710; by permission of Nature Publishing Group.)

monophosphate and subsequent hyperactivation of the cystic fibrosis transmembrane conductance regulator (CFTR) chloride channel. Increased chloride and bicarbonate secretion by CFTR is accompanied by sodium and water loss into the small bowel, greatly exceeding the ability of the colon to reabsorb the fluid. These events eventually lead to massive purging of electrolyte-rich stool, potentially resulting in rapid dehydration and depletion of electrolytes, including sodium, chloride, bicarbonate, and potassium. Metabolic acidosis and hypokalemia then ensue.

### CLINICAL MANIFESTATIONS

Most cases of cholera are mild or inapparent. Among symptomatic individuals, approximately 20% develop severe **dehydration** that can rapidly lead to death. After a typical incubation period of 1–2 days (range: several hours to 5 days), acute watery **diarrhea** and **vomiting** ensue. The onset may be sudden, with profuse watery diarrhea, but some patients have a prodrome of anorexia and abdominal discomfort and the stool may initially be brown. Diarrhea can progress to painless purging of profuse *rice-water stools* (suspended flecks of mucus) with a fishy smell, which is the hallmark of the disease (Figs. 247.2 and 247.3). Fever is infrequent and suggests a different diagnosis. Vomiting with clear watery fluid is usually present at the onset of the disease. Stool from cholera patients typically contains more sodium (along with potassium and bicarbonate) compared with stool from diarrhea caused by other pathogens; the high stool volume, coupled with the presence of electrolytes, challenges clinicians to avoid dehydration and electrolyte imbalance. Muscle cramping and weakness commonly occur as a result of potassium and calcium imbalance.

The term **cholera gravis** refers to the most severe form of the disease, characterized by rice water stools and fecal purging at rates of up to 500–1,000 mL/hr. This condition inevitably leads to dehydration, manifested by decreased urine output, a sunken fontanel (in infants), sunken eyes, absence of tears, dry oral mucosa, shriveled hands and feet (“washerwoman’s hands”), poor skin turgor, thready pulse, and tachycardia. If left untreated, hypotension and vascular collapse are inevitable (see Fig. 247.3). Patients with metabolic acidosis can present with typical Kussmaul breathing. Although patients may be initially thirsty and awake, they rapidly progress to obtundation and coma. If fluid losses are not rapidly corrected, death can occur within hours.

Cholera sicca is an unusual manifestation of severe cholera in which very rapid fluid loss is confined to the intestinal lumen; such patients may succumb to dehydration without frank diarrhea.

### LABORATORY FINDINGS

Findings associated with dehydration such as elevated urine specific gravity and hemoconcentration are evident. **Hypoglycemia** is a common finding that is caused by decreased food intake during the acute illness. Serum potassium may be initially normal or even high in the presence of metabolic acidosis; however, as the acidosis is corrected, hypokalemia may become evident. **Metabolic acidosis** caused by bicarbonate loss and tissue hypoperfusion is a prominent finding in severe cholera. Serum sodium and chloride levels may be normal or decreased, depending on the severity of the disease. Serum calcium may be elevated because of hemoconcentration.

### DIAGNOSIS AND DIFFERENTIAL DIAGNOSIS

In children who have acute watery diarrhea with severe dehydration residing in a cholera-endemic area or who have recently traveled to an area known to have cholera, the disease may be suspected pending laboratory confirmation. Cholera differs from other diarrheal diseases in that it often occurs in large outbreaks affecting both adults and children. Treatment of dehydration should begin as soon as possible. Diarrhea caused by other etiologies (e.g., enterotoxigenic *Escherichia coli* or rotavirus) may be difficult to distinguish from cholera clinically. Microbiologic isolation of *V. cholerae* remains the gold standard for diagnosis. Although definitive diagnosis is not required for treatment to be initiated, laboratory confirmation is necessary for epidemiologic surveillance. *V. cholerae* may be isolated from stools, vomitus, or rectal swabs. Specimens may be transported on Cary-Blair media if they cannot be processed immediately. Selective media, such as thiosulfate–citrate–bile salts sucrose (TCBS) agar, should be used; *V. cholerae* exhibits a distinctive morphology on this medium, with confirmation made by serotyping. Because most laboratories in industrialized countries do not routinely culture for *V. cholerae*, clinicians should request appropriate cultures for clinically suspected cases.

Rapid diagnostic tests are currently available and show high sensitivity and specificity. These tests may be especially useful in areas with limited laboratory capacity, allowing early identification of cases at the





**Fig. 247.2** Rice-water stool in a patient with cholera. (Modified from Harris JB, LaRocque RC, Qadri F. Cholera. *Lancet*. 2012;379:2466–2474.)



**Fig. 247.3** A child lying on a cholera cot showing typical signs of severe dehydration from cholera. The patient has sunken eyes, lethargic appearance, and poor skin turgor, but within 2 hours was sitting up, alert, and eating normally. (From Sack DA, Sack RB, Nair GB, et al. Cholera. *Lancet*. 2004;363:223–233.)

onset of an outbreak and facilitating a timely response. Molecular identification with the use of polymerase chain reaction and DNA probes is available but often not feasible in areas where cholera exists. Stool examination reveals few fecal leukocytes and erythrocytes because cholera does not cause inflammation. Dark-field microscopy may be used for rapid identification of typical *darting motility* in wet mounts of rice-water stools, a finding that disappears once specific antibodies against *V. cholerae* O1 or O139 are added.

### COMPLICATIONS

When optimally treated, patients with cholera typically recover fully without complications. Most adverse outcomes occur as a result of

delayed or inadequate rehydration therapy. **Renal failure** from prolonged hypotension can occur. Unless potassium supplementation is provided, **hypokalemia** can lead to nephropathy and focal myocardial necrosis. Hypoglycemia is common among children and can lead to seizures unless it is appropriately corrected. Pneumonia is a frequent complication in young children and may be the result of aspiration during vomiting.

### TREATMENT

**Rehydration** is the mainstay of therapy (see Chapter 74). Appropriate case management substantially decreases case fatalities to <1%. Application of World Health Organization (WHO) recommendations for diarrheal rehydration is recommended for all patients with diarrhea, but particularly when cholera is in the differential diagnosis. Children with mild or moderate dehydration may be treated with oral rehydration solution (ORS) unless the patient is in shock, is obtunded, or has intestinal ileus. Careful monitoring should occur during ORS, with attention to progression to more severe dehydration. Vomiting is not a contraindication to ORS. Severely dehydrated patients (>10% body weight) require intravenous fluid, ideally with lactated Ringer solution. When available, rice-based ORS should be used when oral rehydration is attempted, because this fluid has been shown to be superior to standard ORS in children and adults with cholera. The aim of rehydration should be replacement of the entire fluid deficit within 4 hours, if possible. Careful monitoring of ongoing losses is essential. If stool volumes cannot be measured, losses may be roughly estimated at 10–20 mL/kg of body weight for each episode of diarrhea or vomiting. After initial rehydration, patients should be reassessed every 1–2 hours, or more frequently if profuse diarrhea is ongoing; diarrhea typically begins to remit after 24 hours. Feeding should not be withheld during diarrhea. Frequent, small feedings are better tolerated than less frequent, large feedings.

**Antibiotics** should only be given in patients with moderately severe to severe dehydration. As soon as vomiting stops (usually within 4–6 hours after initiation of rehydration therapy), an antibiotic to which local *V. cholerae* strains are sensitive must be administered. Antibiotics shorten the duration of illness, decrease fecal excretion of *Vibrio*, decrease the volume of diarrhea, and reduce the fluid requirement during rehydration. Single-dose antibiotics increase compliance and are generally recommended; **doxycycline**, **ciprofloxacin**, and **azithromycin** are effective against cholera. The most clinical evidence for efficacy exists for tetracycline antibiotics (especially a single 300-mg dose of doxycycline). However, there are increasing reports of resistance to tetracyclines and to trimethoprim-sulfamethoxazole and other drugs. Because of these multidrug-resistant strains, antibiotic treatment must be tailored based on available susceptibility results from the area. **Recommendations for single-dose therapy for children include** doxycycline 2–4 mg/kg PO as a single dose up to 300 mg; 300 mg PO should be given to children 12 years of age and older. Alternative single dose regimens include azithromycin 20 mg/kg (max 1 g) PO, or ciprofloxacin 20 mg/kg (max 1 g) PO. Children >12 years of age should receive the adult doses. Cephalosporins and aminoglycosides are not clinically effective against cholera and therefore should not be used, even if in vitro tests show strains to be sensitive.

*Zinc should be given as soon as vomiting stops.* Zinc deficiency is common among children in many developing countries. Zinc supplementation in children <5 years old shortens the duration of diarrhea and reduces subsequent diarrhea episodes when given daily for 14 days at the time of the illness. Children <6 months old should receive 10 mg of oral zinc daily for 2 weeks, and children >6 months should receive 20 mg of oral zinc daily for 2 weeks.

### PREVENTION

Improved personal hygiene, access to clean water, and sanitation are the mainstays of cholera control. Travelers from developed countries often have no prior exposure to cholera and are therefore at risk of developing the disease. Children traveling to cholera-affected areas should avoid drinking potentially contaminated water and eating high-risk



**Table 247.1** Available Oral Cholera Vaccines\*

VACCINE TRADE NAME	CONTENTS	DOSING SCHEDULE
Dukoral (Crucell)	1 mg of recombinant B subunit of cholera toxin plus $2.5 \times 10^{10}$ colony-forming units of the following strains of <i>V. cholerae</i> : Formalin-killed El Tor Inaba (Phil 6973) Heat-killed classical Inaba (Cairo 48) Heat-killed classical Ogawa (Cairo 50) Formalin-killed classical Ogawa (Cairo 50)	Children 2-6yr old: 3 doses, 1-6wk apart Adults and children >6 yr old: 2 doses, 1-6 wk apart
Shanchol (Shantha Biotech) Euvichol (Eubiologics)	<i>V. cholerae</i> O1: 600 EU Formalin-killed El Tor Inaba (Phil 6973) 300 EU Heat-killed classical Inaba (Cairo 48) 300 EU Heat-killed classical Ogawa (Cairo 50) 300 EU Formalin-killed classical Ogawa (Cairo 50) <i>V. cholerae</i> O139-600 EU of formalin-killed strain 4260B	Adults and children $\geq 1$ yr old: 2 doses, 2 wk apart

\*WHO-prequalified vaccines.

foods such as raw or undercooked fish and shellfish. No country or territory requires vaccination against cholera as a condition for entry.

Alarmed by the increasing prevalence of cholera, in 2011 the World Health Assembly recommended the use of oral cholera vaccines to complement existing water, sanitation, and hygiene initiatives for cholera control. In 2016, a live oral cholera vaccine, CVD 103-Hg-R (Vaxchora, PaxVax), was licensed in the United States for use in adults age 18-64 years traveling to cholera-affected areas.

Older-generation parenteral cholera vaccines have not been recommended by the WHO because of the limited protection they confer and their high reactogenicity. Oral cholera vaccines are safe, are protective for approximately 2-5 years and confer moderate herd protection. Three oral cholera vaccines are currently available internationally and recognized by the WHO (Table 247.1). An internationally licensed killed whole cell oral cholera vaccine with recombinant B subunit (Dukoral, Crucell) has been available in >60 countries, including the European Union, and provides protection against cholera in endemic areas as well as cross-protection against certain strains of enterotoxigenic *E. coli*. The two other vaccines (Shanchol, Shantha Biotech; and Euvichol, Eubiologics) are variants of the first vaccine and contain the *V. cholerae* O1 and O139 antigens but do not contain the B subunit. Without the B subunit, these vaccines do not require buffer for administration, thereby reducing administration costs and resources, making them easier to deploy.

Several countries are now using oral cholera vaccines in mass vaccination campaigns where cholera remains a substantial problem. A cholera vaccine stockpile, established by the WHO, is now available and can be accessed by countries at risk for cholera, supplementing efforts to lessen the impact of this ongoing cholera scourge.

Visit Elsevier eBooks+ at [eBooks.Elsevier.com](https://www.elsevier.com/ebooks) for Bibliography.

## Chapter 248

# Campylobacter

Ericka V. Hayes

*Campylobacter*, typically *Campylobacter jejuni* and *Campylobacter coli*, are found globally and are among the most common causes of human intestinal infections. Clinical presentation varies by age and underlying conditions.

### ETIOLOGY

More than 20 species of *Campylobacter* are recognized. Most of these have been isolated from humans, and many are considered pathogenic.

The most significant of these are *C. jejuni* and *C. coli*, which are believed to cause the majority of human enteritis. More than 100 serotypes of *C. jejuni* have been identified. *C. jejuni* has been subspecialized into *C. jejuni* subsp. *jejuni* and *C. jejuni* subsp. *doylei*. Although *C. jejuni* subsp. *doylei* has been isolated from humans, it is much less common, less hardy, and more difficult to isolate. Other species, including *Campylobacter fetus*, *Campylobacter lari*, and *Campylobacter upsaliensis*, have been isolated from patients with diarrhea, although much less frequently (Table 248.1). Emerging *Campylobacter* spp. have been implicated in acute gastroenteritis, inflammatory bowel disease, and peritonitis, including *C. concisus* and *C. ureolyticus*. Additional *Campylobacter* spp. have been isolated from clinical specimens, but their roles as pathogens have not been established.

*Campylobacter* organisms are gram-negative, curved, thin (0.2-0.8  $\mu\text{m}$  wide), non-spore-forming rods (0.5-5  $\mu\text{m}$  long) that usually have tapered ends. They are smaller than most other enteric bacterial pathogens and have variable morphology, including short, comma-shaped or S-shaped organisms and long, multispiraled, filamentous, seagull-shaped organisms. Individual organisms are usually motile with a flagellum at one or both poles depending on the species. Such morphology enables these bacteria to colonize the mucosal surfaces of both the gastrointestinal (GI) and respiratory tracts and move through them in a spiraling motion. Most *Campylobacter* organisms are micro-aerophilic, occasionally partially anaerobic, and oxidase positive. Most can transform into coccoid forms under adverse conditions, especially oxidation.

### EPIDEMIOLOGY

Worldwide, *Campylobacter* enteritis is a leading cause of acute diarrhea. Efforts to reduce *Campylobacter* contamination and use of safe handling practices have led to decreased incidence. *Campylobacter* infections can be both food-borne and water-borne and most frequently result from ingestion of contaminated **poultry** (chicken, turkey) or **raw milk**. Less often, the bacteria come from drinking water, household pets (cats, dogs, hamsters), and farm animals. Infections are more common in resource-limited settings, are prevalent year-round in tropical areas, and can exhibit seasonal peaks in temperate regions (late spring with a peak midsummer in most of the United States, with a smaller secondary peak in late fall). In industrialized countries, *Campylobacter* infections peak in early childhood and again in young adulthood (15-44 years). This second peak is not seen with *Salmonella* and *Shigella* infections. In resource-limited countries, repeated infections are common in childhood, leading to increased immunity and rare disease in adulthood. Each year in the United States, there are an estimated 1.5 million cases of *Campylobacter* infection; in 2022 the incidence of infections with *Campylobacter* was 19.2 infections per 100,000 population. Of these, death is rare, with 50-150 reports annually. In The Netherlands, medical record review shows that, on average, each resident acquires asymptomatic *Campylobacter* colonization every 2 years, progressing to symptomatic infection in approximately 1% of colonized people.

**Table 248.1** *Campylobacter* Species Associated with Human Disease

SPECIES	DISEASES IN HUMANS	COMMON SOURCES
<i>C. jejuni</i>	Gastroenteritis, bacteremia, Guillain-Barré syndrome	Poultry, raw milk, cats, dogs, cattle, swine, monkeys, water
<i>C. coli</i>	Gastroenteritis, bacteremia	Poultry, raw milk, cats, dogs, cattle, swine, monkeys, oysters, water
<i>C. fetus</i>	Bacteremia, meningitis, endocarditis, mycotic aneurysm, diarrhea	Sheep, cattle, birds, dogs
<i>C. hyointestinalis</i>	Diarrhea, bacteremia, proctitis	Swine, cattle, deer, hamsters, raw milk, oysters
<i>C. lari</i>	Diarrhea, colitis, appendicitis, bacteremia, UTI	Seagulls, water, poultry, cattle, dogs, cats, monkeys, oysters, mussels
<i>C. upsaliensis</i>	Diarrhea, bacteremia, abscesses, enteritis, colitis, hemolytic-uremic syndrome	Cats, dogs, other domestic pets
<i>C. concisus</i>	Diarrhea, gastritis, enteritis, periodontitis	Human oral cavity, dogs
<i>C. sputorum</i>	Diarrhea, bedsores, abscesses, periodontitis	Human oral cavity, cattle, swine, dogs
<i>C. rectus</i>	Periodontitis	
<i>C. mucosalis</i>	Enteritis	Swine, dogs
<i>C. jejuni</i> subsp. <i>doylei</i>	Diarrhea, colitis, appendicitis, bacteremia, UTI	Swine
<i>C. curvus</i>	Gingivitis, alveolar abscess	Poultry, raw milk, cats, dogs, cattle, swine, monkeys, water, human oral cavity
<i>C. gracilis</i>	Head and neck abscesses, abdominal abscesses, empyema	Dogs
<i>C. cryaerophila</i>	Diarrhea	Swine

**Food-borne infection** is most common and can be seen with the consumption of raw or undercooked meat and by cross-contamination of other foods. Although **chickens** are the classic source of *Campylobacter*, many animal sources of human food can also harbor *Campylobacter*, including seafood. *C. coli* has been linked to swine. Poultry is more likely to be heavily contaminated, whereas red meats often have fewer organisms. Unpasteurized milk products are also a documented source. Additionally, many pets can carry *Campylobacter*, and flies inhabiting contaminated environments can acquire the organism. Shedding from animals can contaminate water sources. Humans can acquire infection from water, although much less frequently than from contaminated food. **Airborne (droplet) transmission** of *Campylobacter* has occurred in poultry workers. Use of antimicrobials in animal foods may increase the prevalence of antibiotic-resistant *Campylobacter* isolated from humans.

Human infection can result from exposure to as few as 500 bacteria, although a higher dose (>9,000 bacteria) is often needed to cause illness reproducibly. Inoculum effectiveness is dependent on host factors, including immune status and stomach acidification. *C. jejuni* and *C. coli* spread person to person, perinatally, and at childcare centers where diapered toddlers are present. People infected with *C. jejuni* usually shed the organism for weeks, but some can shed for months, with children tending toward longer shedding. **Handwashing** is critical to preventing spread in these environments.

## PATHOGENESIS

Most *Campylobacter* isolates are acid sensitive and should, in theory, be eradicated in the stomach. Therefore models for the pathogenesis of *C. jejuni* enteritis include mechanisms to transit the stomach, adhere to intestinal mucosal cells, and initiate intestinal lumen fluid accumulation. Host conditions associated with reduced gastric acidity, such as proton pump inhibitor use, and foods capable of shielding organisms in transit through the stomach may help allow *Campylobacter* to reach the intestine. Once there, *Campylobacter* is able to adhere to and invade intestinal mucosal cells through motility, including use of flagellae, and by the use of surface proteins (e.g., PEB1, CadF), large plasmids (e.g., pVir), surface

adhesins (e.g., JlpA), and chemotactic factors. Lumen fluid accumulation is associated with direct damage to mucosal cells resulting from bacterial invasion and potentially from an enterotoxin and other cytotoxins. Additionally, *C. jejuni* has mechanisms that enable transit away from the mucosal surface. The factors used depend on the species involved.

*Campylobacter* spp. differ from other enteric bacterial pathogens in that they have both *N*- and *O*-linked glycosylation capacities. *N*-linked glycosylation is associated with molecules expressed on the bacterial surface, and *O*-linked glycosylation appears limited to flagellae. Slipped-strand mispairing in glycosylation loci results in modified, antigenically distinct surface structures. It is hypothesized that antigenic variation provides a mechanism for immune evasion.

*C. fetus* possesses a high molecular weight S-layer protein that mediates high-level resistance to serum-mediated killing and phagocytosis and is therefore thought to be responsible for the propensity to produce bacteremia. *C. jejuni* and *C. coli* are generally sensitive to serum-mediated killing, but serum-resistant variants exist. Some suggest these serum-resistant variants may be more capable of systemic dissemination.

*Campylobacter* infections can be followed by **Guillain-Barré syndrome** (GBS), **reactive arthritis**, and **erythema nodosum**. Such complications are thought to be from molecular mimicry between nerve, joint, and dermal tissue and *Campylobacter* surface antigens. Most *Campylobacter* infections are not followed by immunoreactive complications, indicating that host conditions along with other factors, in addition to molecular mimicry, are required for these complications. It is proposed that low-grade inflammation caused by *Campylobacter*, below the threshold that can be detected by endoscopy, results in cross-talk with gut nerves, leading to symptoms.

## CLINICAL MANIFESTATIONS

There are a variety of clinical presentations of *Campylobacter* infections, depending on host factors such as age, immune competence, and underlying conditions. Infection presents most often as gastroenteritis, but also as bacteremia, neonatal infections, and, less often, extraintestinal infections.

### Acute Gastroenteritis

Acute gastroenteritis with diarrhea is usually caused by *C. jejuni* (90–95%) or *C. coli* and, rarely, by *C. lari*, *C. hyointestinalis*, or *C. upsaliensis*. Infections with *C. jejuni* and *C. coli* are indistinguishable by clinical presentation. The average incubation period is 3 days (range: 1–7 days). One third of symptomatic patients can have a prodrome with fever, headache, dizziness, and myalgias; 1–3 days later, they develop cramping abdominal pain and loose, watery stools or, less frequently, mucus-containing bloody stools. In severe cases (approximately 15%), blood appears in the stools 2–4 days after the onset of symptoms. In younger children, >50% may develop blood in their stools. Some patients do not develop diarrhea at all, most often children who are 6–15 years old. Fever may be the only manifestation initially and is most pronounced in patients >1 year old. A reported 60–90% of older children also complain of abdominal pain. The abdominal pain is most frequently periumbilical and sometimes persists after the stools return to normal. The abdominal pain can mimic appendicitis, colitis, or intussusception. Nausea is common, with up to 25% of adults developing vomiting. Vomiting tends to be more common the younger the patient and is most frequent in infants. Infection with species other than *C. jejuni* and *C. coli* may have milder symptoms.

Diarrhea lasts approximately 7 days and will resolve spontaneously. More mild disease can last 1–2 days; 20–30% of patients will have symptoms for 2 weeks, and 5–10% are symptomatic for >2 weeks. Relapse can occur in 5–10% of patients. Persistent or recurrent *Campylobacter* gastroenteritis has been reported in immunocompetent patients, in patients with hypogammaglobulinemia (both congenital and acquired), and in patients with AIDS. Persistent infection can mimic chronic **inflammatory bowel disease** (IBD); therefore *Campylobacter* infection should also be considered when evaluating for IBD. Some evidence supports that *Campylobacter* infection may also be the trigger for development of IBD. Fecal shedding of the organisms in untreated patients usually lasts for 2–3 weeks, with a range from a few days to several months. Shedding tends to occur longer in young children. Acute appendicitis, mesenteric lymphadenitis, and ileocolitis have been reported in patients who have had appendectomy during *C. jejuni* infection.

### Bacteremia

Transient bacteremia has been shown in early acute infection in 0.1–1% of patients. With the exception of bacteremia caused by *C. fetus*, bacteremia with *Campylobacter* occurs most often among patients with chronic illnesses or immunodeficiency (e.g., HIV), severe malnutrition, and in extremes of age. However, bacteremia is also well described in patients without underlying disease. The majority of cases of bacteremia are asymptomatic. *C. fetus* causes bacteremia in adults with or without identifiable focal infection, usually in the setting of underlying conditions such as malignancy, immunodeficiency, or diabetes mellitus. When symptomatic, *C. jejuni* bacteremia is associated with fever, headache, malaise, and abdominal pain. Relapsing or intermittent fever is associated with night sweats, chills, and weight loss when the illness is prolonged. Lethargy and confusion can occur, but focal neurologic signs are unusual without cerebrovascular disease or meningitis. Moderate leukocytosis with left shift may be found. Variable presentations have been described, including transient asymptomatic bacteremia, rapidly fatal septicemia, and prolonged bacteremia of 8–13 weeks.

### Focal Extraintestinal Infections

Focal infections caused by *C. jejuni* are rare and occur mainly among neonates and immunocompromised patients. Multiple sites have been reported, including meningitis, pneumonia, thrombophlebitis, pancreatitis, cholecystitis, ileocectitis, urinary tract infection, arthritis, peritonitis, pericarditis, and endocarditis. *C. fetus* shows a predilection for vascular endothelium, leading to endocarditis, pericarditis, thrombophlebitis, and mycotic aneurysms. *C. hyointestinalis* has been

associated with proctitis, *C. upsaliensis* with breast abscesses, and *C. rectus* with periodontitis.

### Perinatal Infections

Perinatal infections are most often acquired at birth from a mother infected with or shedding *Campylobacter*. Maternal *C. fetus* and *C. jejuni* infections may be asymptomatic and can result in abortion, stillbirth, premature delivery, or neonatal infection with sepsis and meningitis. Severe perinatal infections are uncommon and are caused most often by *C. fetus* and, rarely, by *C. jejuni*. Neonatal infection with *C. jejuni* is associated with diarrhea that may be bloody. Nosocomial infections in nurseries have also been described.

### DIAGNOSIS

The clinical presentation of *Campylobacter* enteritis can be similar to that of enteritis caused by other bacterial pathogens. The differential diagnosis includes *Shigella*, *Salmonella*, *Escherichia coli*, *Yersinia enterocolitica*, *Aeromonas*, *Vibrio parahaemolyticus*, and amebiasis. Fecal leukocytes are found in as many as 75% of cases, and fecal blood is present in 50% of cases (higher in pediatric patients). *Campylobacter* should be considered in patients with bloody stools, fever, and abdominal pain.

The diagnosis of *Campylobacter* enteritis is usually confirmed by identification of the organism in cultures of stool or rectal swabs. Isolation is most likely from selective media such as CAMPY-agar grown in microaerophilic conditions (5–10% oxygen), 1–10% carbon dioxide, with some hydrogen. Some *C. jejuni* grow best at 42°C (107.6°F). Growth on solid media results in small (0.5–1.0 mm), slightly raised, smooth colonies. Organisms can be identified from stool microscopically in approximately 50% of known *Campylobacter* cases. Gram stain is even less sensitive. Stool culture is >90% sensitive and is the standard method of diagnosis. Visible growth on stool culture is most often present in 1–2 days. Visible growth in blood cultures is often not apparent until 5–14 days after inoculation.

Routine culture may be adequate for isolation of *C. jejuni* because of the large numbers of bacteria that are often present. However, because *Campylobacter* organisms grow more slowly under routine conditions than do other enteric bacteria, routine culture can result in failure because of overgrowth of other enteric bacteria. *Campylobacter* culture can be enhanced, when necessary, with selective media. However, selective culture media developed to enhance isolation of *C. jejuni* may inhibit the growth of other *Campylobacter* spp. Filtration methods are available and can preferentially enrich for *Campylobacter* by selecting for their small size. These methods allow subsequent culture of the enriched sample on antibiotic-free media, enhancing rates of isolation of *Campylobacter* organisms inhibited by the antibiotics included in standard selective media. Isolation of *Campylobacter* from normally sterile sites does not require enhancement procedures. Clinically, it is not necessary to speciate *Campylobacter* because the disease is the same. Speciation can be done, when needed, and specialized laboratories can perform strain typing when required for epidemiologic purposes.

For rapid diagnosis of *Campylobacter* enteritis, direct carbolfuchsin stain of fecal smear, indirect fluorescence antibody test, dark-field microscopy, or latex agglutination were used historically. Polymerase chain reaction testing is more specific and sensitive and has become more widely available for rapid testing, often grouped with testing for other bacterial, viral, and parasitic stool pathogens in a multiplex assay. At this time, the recommendation remains to confirm all positive rapid tests with culture, which also allows for susceptibility testing and epidemiologic investigations. Antigen tests are also available, although false-positive results have been reported. Serologic diagnosis is also possible and is most helpful in patients with late-onset reactive arthritis or GBS, because these patients may have negative stool cultures by the time of presentation with these late complications.



## COMPLICATIONS

Severe, prolonged *C. jejuni* infection can occur in patients with immunodeficiencies, including hypogammaglobulinemia, malnutrition, and AIDS. In patients with AIDS, increased frequency and severity of *C. jejuni* infection occurs; severity correlates inversely with CD4 count. Complications can include acute complications, as described earlier, and late-onset complications that may present after the acute infection has resolved. The most common late-onset complications include reactive arthritis and GBS.

### Reactive Arthritis

Reactive arthritis can accompany *Campylobacter* enteritis in adolescents and adults, especially in patients who are positive for HLA-B27 (see Chapter 198). Reactive arthritis occurs in up to 3% of patients, although up to 13% may have joint symptoms. This manifestation usually appears 1-2 weeks after the onset of diarrhea (range 5-40 days). It involves mainly large joints and resolves without sequelae. The arthritis is typically migratory and occurs without fever. Synovial fluid lacks bacteria. The arthritis responds well to nonsteroidal antiinflammatory drugs and typically resolves after 1 week, though cases are reported with symptoms lasting for several months. Reactive arthritis with conjunctivitis, urethritis, and rash (including erythema nodosum) also occurs but is less common.

### Guillain-Barré Syndrome

GBS is an acute demyelinating disease of the peripheral nervous system characterized clinically by acute flaccid paralysis and is the most common cause of neuromuscular paralysis worldwide (see Chapter 656). GBS carries a mortality rate of approximately 2%, and approximately 20% of patients develop major neurologic sequelae. *C. jejuni* has been identified as the trigger in up to 40% of patients with GBS and is most closely linked to the serotypes Penner O19 and O41. It has been reported 1-12 weeks after *C. jejuni* gastroenteritis in 1 of every 1,000 *C. jejuni* infections. Stool cultures obtained from patients with GBS at the onset of neurologic symptoms have yielded *C. jejuni* in >25% of the cases. Serologic studies suggest that 20-45% of patients with GBS have evidence of recent *C. jejuni* infection. Molecular mimicry between nerve tissue GM<sub>1</sub> ganglioside and *Campylobacter* surface antigens may be the triggering factor in *Campylobacter*-associated GBS. The Miller Fisher variant, which more often affects cranial nerves, is characterized by ataxia, areflexia, and ophthalmoplegia and is linked to cross-reacting antibodies to the GQ1b ganglioside found in cranial nerve myelin; the most common serotype for this variant is Penner O2. When associated with *Campylobacter*, GBS is more likely to be the axonal form and has a worse prognosis with slower recovery and more neurologic disability. The management of GBS includes supportive care, intravenous immunoglobulin, and plasma exchange.

### Other Complications

Immunoglobulin A nephropathy and immune complex glomerulonephritis with *C. jejuni* antigens in the kidneys have been reported. *Campylobacter* infection has also been associated with hemolytic anemia and hemolytic-uremic syndrome.

### Treatment

Fluid replacement, correction of electrolyte imbalance, and supportive care are the mainstays of treatment of children with *Campylobacter* gastroenteritis. Antimotility agents are contraindicated because they can cause prolonged or fatal disease. The need for antibiotic therapy in healthy patients with uncomplicated gastroenteritis is controversial. Most healthy children do not require antibiotic therapy. Data suggest a shortened duration of symptoms (by an average of 1.3 days) and intestinal shedding of organisms if antibiotics are initiated early in the disease. Antibiotics are recommended for patients with bloody stools, high fever, or a severe course and for

children who are immunosuppressed or have underlying diseases and individuals at high risk of developing severe disease (e.g., pregnancy). Extraintestinal infections (e.g., bacteremia) should also be treated with antibiotics.

Most *Campylobacter* isolates are susceptible to macrolides, fluoroquinolones, aminoglycosides, chloramphenicol, tetracyclines, and clindamycin (though there is no clinical efficacy data for these last three agents, only *in vitro* data) and are resistant to cephalosporins, penicillins, and trimethoprim. Resistance to tetracyclines, macrolides, and more often, fluoroquinolones has been increasingly reported. **Antibiotic resistance** among *C. jejuni* has become a serious worldwide problem. Macrolide resistance is increased in areas such as Thailand and Ireland, whereas fluoroquinolone resistance has been reported in Spain, Hungary, and multiple low and middle income countries in >50% of cultured *Campylobacter*. Fluoroquinolone resistance continues to increase in the United States and is related to the use of quinolones in veterinary medicine and food products along with acquisition from travelers and antibiotic overuse. Erythromycin-resistant *Campylobacter* isolates are less common in the United States; therefore **azithromycin** is the drug of choice if therapy is required, particularly in pediatric patients. For treatment of gastroenteritis, the duration is 3-5 days. Drug sensitivities should be determined for patients who do not respond to therapy or any patient with invasive or extraintestinal infection. Sepsis is treated with parenteral antibiotics such as meropenem or imipenem, with or without an aminoglycoside. For extraintestinal infection caused by *C. fetus*, prolonged therapy is advised. *C. fetus* isolates resistant to erythromycin and fluoroquinolones have been reported; therefore empirical therapy for serious *C. fetus* infection should avoid these agents pending susceptibilities.

### PROGNOSIS

Although *Campylobacter* gastroenteritis is usually self-limited, immunosuppressed children (including children with AIDS) can experience a protracted or severe course. Septicemia in newborns and immunocompromised hosts has a poor prognosis, with an estimated mortality rate of 30-40%. Additional prognosis is based on the secondary sequelae that may develop.

### PREVENTION

Most human *Campylobacter* infections are sporadic and are acquired from infected animals or contaminated foods or water. Interventions to minimize transmission include good hand hygiene; cooking meats thoroughly; preventing recontamination after cooking by not using the same surfaces, utensils, or containers for both uncooked and cooked food; and avoiding unpasteurized dairy products. Also, it is important to ensure that water sources are not contaminated and that water is kept in clean containers. Persons infected with *Campylobacter* should avoid recreational water for at least 1 week after resolution of symptoms or as guided by local public health authorities. Contact with infected animals should be avoided. No specific isolation is required; **standard precautions** are sufficient, although in a hospital or clinic setting with an incontinent child, **contact precautions** are indicated. Outbreaks can occur in childcare settings. Infants and children should be excluded from childcare centers until stools are able to be contained in the diaper or for continent children when they no longer have fecal accidents and stool frequency is no more than two stools above that child's baseline (stools may remain loose). Breastfeeding appears to decrease symptomatic *Campylobacter* disease but does not reduce colonization. All cases of *Campylobacter* should be reported to local health departments, as it is a nationally notifiable condition.

Several approaches at immunization have been studied, including the use of live-attenuated organisms, subunit vaccines, and killed-whole cell vaccines. No vaccine is currently available.

Visit Elsevier eBooks+ at [eBooks.Elsevier.com](http://eBooks.Elsevier.com) for Bibliography.



## Chapter 249

## Yersinia

Ericka V. Hayes

The genus *Yersinia* is a member of the order Enterobacterales, family Yersiniaceae and comprises more than 14 named species, 3 of which are established as human pathogens. *Yersinia enterocolitica* is by far the most common *Yersinia* species causing human disease and produces fever, abdominal pain that can mimic appendicitis, and diarrhea. *Y. pseudotuberculosis* is most often associated with mesenteric lymphadenitis. *Y. pestis* is the agent of **plague** and typically causes an acute febrile lymphadenitis (bubonic plague) and less often occurs as septicemic, pneumonic, pharyngeal, or meningeal plague. Other *Yersinia* species are uncommon causes of infections in humans, and their identification is often an indicator of immunodeficiency.

*Yersinia* is enzootic and can colonize pets. Infections in humans are incidental and most often result from contact with infected animals or their tissues; ingestion of contaminated water, milk, or meat; or for *Y. pestis*, the bite of infected fleas or inhalation of respiratory droplets (human, dog, cat). Association with human disease is less clear for *Y. frederiksenii*, *Y. intermedia*, *Y. kristensenii*, *Y. aldovae*, *Y. bercovieri*, *Y. mollaretii*, *Y. rohdei*, and *Y. ruckeri*. Some *Yersinia* isolates replicate at low temperatures (1–4°C [33.8–39.2°F]) or survive at high temperatures (50–60°C [122–140°F]). Thus common food preparation and storage and common pasteurization methods might not limit the number of bacteria. Most are sensitive to oxidizing agents.

249.1 *Yersinia enterocolitica*

Ericka V. Hayes

## ETIOLOGY

*Yersinia enterocolitica* is a large, gram-negative coccobacillus that exhibits little or no bipolarity when stained with methylene blue and carbol-fuchsin. It ferments glucose and sucrose but not lactose, is oxidase negative, and reduces nitrate to nitrite. These facultative anaerobes grow well on common culture media and are motile at 22°C (71.6°F) but not 37°C (98.6°F). Optimal growth temperature is 25–28°C (77–82.4°F); however, the organism can grow at refrigerator temperature. *Y. enterocolitica* includes pathogenic and nonpathogenic members. It has six different biotypes (1A, 1B, and 2-5). *Y. enterocolitica* relies on other bacteria for iron uptake, and conditions associated with **iron overload** increase the risk of infection.

## EPIDEMIOLOGY

*Y. enterocolitica* is transmitted to humans through food, water, animal contact, and contaminated blood products. Transmission can occur from mother to newborn. *Y. enterocolitica* appears to have a global distribution but is seldom a cause of tropical diarrhea. In 2022, the Centers for Disease Control and Prevention (CDC) Foodborne Diseases Active Surveillance Network (FoodNet) reported an incidence of culture-confirmed *Y. enterocolitica* infection in the United States of 1.97 per 100,000 population (635% increase compared to 2015, and an increase of 216% since 2020). Infection may be more common in Northern Europe. Most infections occur among children <5 years old (incidence: 1.6–1.9 per 100,000 population), with the majority among children <1 year old. It is estimated that *Y. enterocolitica* accounts for 5% of illnesses secondary to major bacterial enteric pathogens in children <5 years old in the United States. Cases are more common in colder months and among males.

Natural reservoirs of *Y. enterocolitica* include pigs, rodents, rabbits, sheep, cattle, horses, dogs, and cats, with **pigs** being the major animal

reservoir. Direct or indirect contact with animals, including pets, other domesticated animals, and wild animals, may be responsible for <1% of cases of enteric illnesses caused by *Y. enterocolitica*. Culture and molecular techniques have found the organism in a variety of foods and beverages, including vegetable juice, pasteurized milk, carrots, and water. Consumption of contaminated water or food, particularly undercooked pork, is the most common form of transmission to humans. A source of sporadic *Y. enterocolitica* infections is **chitterlings** (pig intestines, “chitlins”), a traditional dish in the southeastern United States and in Latin America, often in celebration of winter holidays. The infection is often seen in young infants in the household because of contamination of bottle and food preparation when chitterlings are prepared. In one study, 71% of human isolates were indistinguishable from the strains isolated from pigs. *Y. enterocolitica* is an occupational threat to butchers.

In part because of its capacity to multiply at refrigerator temperatures, *Y. enterocolitica* can be transmitted by intravenous injection of contaminated fluids, including blood products.

Patients with conditions leading to iron overload are at higher risk of developing *Yersinia* infections.

## PATHOGENESIS

The *Yersinia* organisms most often enter by the gastrointestinal tract and cause mucosal ulcerations in the ileum. Necrotic lesions of Peyer patches and **mesenteric lymphadenitis** occur. If septicemia develops, suppurative lesions can be found in infected organs. Infection can trigger **reactive arthritis** and **erythema nodosum**, particularly in HLA-B27–positive individuals.

Virulence traits of pathogenic biotypes (1B and 2-5) are encoded by chromosomal genes and a highly conserved 70-kb virulence plasmid (pYV/pCD). The chromosomal genes control the production of heat-stable enterotoxins, and the plasmid allows penetration through the intestinal wall. Adherence, invasion, and toxin production are the essential mechanisms of pathogenesis. The bacteria mainly invade the intestinal epithelium in the Peyer patches of the ileum. After invasion, plasmid-encoded type III secretion of three antiphagocytic proteins protects *Yersinia* against the immunologic response of local macrophages. From Peyer patches, bacteria can disseminate to cause local or systemic disease. Motility appears to be required for *Y. enterocolitica* pathogenesis. Bioserotypes most associated with clinical illness in humans are 1B/O:8, 2/O:5,27, 2/O:9, 3/O:3, and 4/O:3, with bioserotype 4/O:3 being the most common type in the United States. *Yersinia* does not produce siderophores and uses analogous siderophores from other bacteria or host-chelated iron stores to thrive, placing patients with iron overload, as in hemochromatosis, thalassemia, and sickle cell disease, at higher risk for infection.

## CLINICAL MANIFESTATIONS

Disease occurs most often as enterocolitis with diarrhea, fever, and abdominal pain. Acute enteritis is more common among younger children, and mesenteric lymphadenitis that can mimic appendicitis may be found in older children and adolescents. The incubation period is usually 4–6 days after exposure (range: 1–14 days). Stools may be watery and contain leukocytes and, less often, frank blood and mucus. Duration of diarrhea is often longer for *Y. enterocolitica* than for other causes of acute gastroenteritis, ranging from 12 to 22 days in several studies. Fever is common. Notably, prominent **pharyngitis** may be seen in 20% of patients at presentation, which may help distinguish it from other causes of gastroenteritis. *Y. enterocolitica* is excreted in stool for 1–4 weeks. Family contacts of a patient are often found to be asymptotically colonized with *Y. enterocolitica*. *Y. enterocolitica* septicemia is less common and is most often found in very young children (<3 months old) and immunocompromised persons. Systemic infection can be associated with splenic and hepatic abscesses, osteomyelitis, septic arthritis, meningitis, endocarditis, and mycotic aneurysms. Exudative pharyngitis, pneumonia, empyema, lung abscess, and acute respiratory distress syndrome occur infrequently.

Reactive complications include **erythema nodosum**, **reactive arthritis**, and rarely uveitis. These manifestations may be more

common in select populations (Northern Europeans), in association with HLA-B27, and in females.

## DIAGNOSIS

Diagnosis is made typically through isolation of the organism, usually from the stool. *Y. enterocolitica* is easily cultured from normally sterile sites but requires special procedures for isolation from stool, where other bacteria can outgrow it. *Yersinia* should be cultured on selective agar (cefsulodin-irgasan-novobiocin [CIN]) at 25–28°C (77–82.4°F) to increase yield. If O:3 serogroup is suspected, MacConkey agar should be used at 25–28°C (77–82.4°F). Multiplex polymerase chain reaction (PCR) testing for *Y. enterocolitica* is also available, including on commercially available multiplex stool panels. Many laboratories do not routinely perform the tests required to detect *Y. enterocolitica*; procedures targeted to this organism must be specifically requested. A history indicating contact with environmental sources of *Yersinia* and detection of fecal leukocytes are helpful indicators of a need to test for *Y. enterocolitica*. The isolation of *Yersinia* from stool should be followed by tests to confirm that the isolate is a pathogen. Serodiagnosis is not readily available, and utility is limited by cross-reactivity.

## Differential Diagnosis

The clinical presentation is similar to other forms of bacterial enterocolitis. The most common considerations include *Shigella*, *Salmonella*, *Campylobacter*, *Clostridioides difficile*, enteroinvasive *Escherichia coli*, *Y. pseudotuberculosis*, and occasionally *Vibrio*-related diarrheal disease. Amebiasis, appendicitis, Crohn disease, ulcerative colitis, diverticulitis, and pseudomembranous colitis should also be considered.

## TREATMENT

Enterocolitis in an immunocompetent patient is a self-limited disease, and no benefit from antibiotic therapy is established. Patients with systemic infection and very young children (in whom septicemia is common) should be treated. *Y. enterocolitica* organisms are typically susceptible to trimethoprim-sulfamethoxazole (TMP-SMX), aminoglycosides, third-generation cephalosporins, and quinolones, although strains resistant to quinolones have been reported. *Y. enterocolitica* produces β-lactamases, which are responsible for resistance to penicillins and first-generation cephalosporins. **TMP-SMX is the recommended empirical treatment for enterocolitis in children (generally a 5-day course) because it has activity against most strains and is well tolerated. In severe infections such as bacteremia, third-generation cephalosporins, with or without aminoglycosides, are effective, and usually a 3-week course of therapy is administered, with possible transition to oral therapy.** Patients on deferoxamine should discontinue iron chelation therapy during treatment for *Y. enterocolitica*, especially if they have complicated gastrointestinal (GI) infection or extraintestinal infection.

## COMPLICATIONS

Reactive arthritis, erythema nodosum, erythema multiforme, hemolytic anemia, thrombocytopenia, and systemic dissemination of bacteria have been reported in association with *Y. enterocolitica* infection. Septicemia is more common in younger children, and reactive arthritis is more common in older patients. Arthritis appears to be mediated by immune complexes, which form as a result of antigenic mimicry, and viable organisms are not present in involved joints.

## PREVENTION

Prevention centers on reducing contact with environmental sources of *Yersinia*. Families should be warned of the high risk of chitterling preparation, especially with young infants and children in the household. The CDC has developed guidance for the public regarding safe practices for chitterling preparation found here: <https://www.cdc.gov/yersinia/chitlins.html>. Breaking the chain of transmission from animal reservoirs to humans holds the greatest potential to reduce infections, and the techniques applied must be tailored to the reservoirs in each geographic area. There is no licensed vaccine.

Visit Elsevier eBooks+ at [eBooks.Health.Elsevier.com](http://eBooks.Health.Elsevier.com) for Bibliography.

## 249.2 *Yersinia pseudotuberculosis*

Erica V. Hayes

*Yersinia pseudotuberculosis* has a worldwide distribution; *Y. pseudotuberculosis* disease is less common than *Y. enterocolitica* disease. The most common form of disease is a **mesenteric lymphadenitis** that produces an appendicitis-like syndrome. *Y. pseudotuberculosis* is associated with a Kawasaki syndrome-like illness in approximately 8% of cases.

## ETIOLOGY

*Y. pseudotuberculosis* is a small, gram-negative, aerobic, and facultative anaerobic coccobacillus. As with *Y. enterocolitica*, it ferments glucose and does not ferment lactose, is oxidase negative, catalase producing, urea splitting, and shares a number of morphologic and culture characteristics. It is differentiated biochemically from *Y. enterocolitica* on the basis of ornithine decarboxylase activity; fermentation of sucrose, sorbitol, and cellobiose; and other tests, although some overlap between species occurs. Antisera to somatic O antigens and sensitivity to *Yersinia* phages can also be used to differentiate the two species. Subspecies-specific DNA sequences that allow direct probe- and primer-specific differentiation of *Y. pestis*, *Y. pseudotuberculosis*, and *Y. enterocolitica* have been described. *Y. pseudotuberculosis* is more closely related phylogenetically to *Y. pestis* than to *Y. enterocolitica*.

## EPIDEMIOLOGY

*Y. pseudotuberculosis* is zoonotic, with reservoirs in wild rodents, rabbits, deer, farm animals, various birds, and domestic animals, including cats and canaries. Transmission to humans is by consumption of or contact with contaminated animals or contact with an environmental source contaminated by animals, often water. Direct evidence of transmission of *Y. pseudotuberculosis* to humans by consumption of lettuce and raw carrots has been reported. The organism has a worldwide distribution; however, infections are more commonly reported in Europe, in boys, and in the winter. During 1996–2014, FoodNet reported 224 cases of infections secondary to *Y. pseudotuberculosis* in the United States, with an annual average incidence of 0.03 per 100,000 persons. Compared with *Y. enterocolitica* infections, those caused by *Y. pseudotuberculosis* are more likely to be invasive and occur in adolescents and adults. Iron-overloading conditions, AIDS, other immunodeficiencies, and other debilitating diseases (including liver cirrhosis) may predispose to invasive *Y. pseudotuberculosis* infection.

## PATHOGENESIS

Ileal and colonic mucosal ulceration and mesenteric lymphadenitis are hallmarks of the infection. Necrotizing epithelioid granulomas may be seen in the mesenteric lymph nodes, but the appendix is often grossly and microscopically normal. The mesenteric nodes are often the only source of isolation of the organism. *Y. pseudotuberculosis* antigens bind directly to human leukocyte antigen (HLA) class II molecules and can function as **superantigens**, which might account for the clinical illness resembling **Kawasaki syndrome**.

## CLINICAL MANIFESTATIONS

**Pseudoappendicitis** and **mesenteric lymphadenitis** with **abdominal pain** (often right lower quadrant tenderness), fever, and leukocytosis constitute the most common clinical presentation. Enterocolitis and extraintestinal spread are uncommon. Iron overload, diabetes mellitus, and chronic liver disease are often found concomitantly with extraintestinal *Y. pseudotuberculosis* infection. Renal involvement with tubulointerstitial nephritis, azotemia, pyuria, and glucosuria can occur. *Y. pseudotuberculosis* can present as a Kawasaki syndrome-like illness with fever of 1–6 days' duration, strawberry tongue, pharyngeal erythema, scarlatiniform rash, cracked, red, and swollen lips, conjunctivitis, sterile pyuria, periungual desquamation, and thrombocytosis.

Some of these children have had coronary changes. Other uncommon manifestations include septic arthritis, massive lower GI bleeding, postaneurysmal prosthetic vascular infection, and acute encephalopathy.

## DIAGNOSIS

PCR of involved tissue can be used to identify *Y. pseudotuberculosis*; isolation by culture can require an extended interval. Involved mesenteric lymph nodes removed at appendectomy can yield the organism by culture. Abdominal CT scan or ultrasound examination of children with unexplained fever and abdominal pain can reveal a characteristic picture of enlarged mesenteric lymph nodes and thickening of the terminal ileum with or without peritoneal findings, including appendiceal inflammation and periappendiceal fluid. *Y. pseudotuberculosis* is rarely recovered from stool. Serologic testing is available in specialized labs.

## Differential Diagnosis

Appendicitis (most common), inflammatory bowel disease, and other intraabdominal infections should be considered. Kawasaki syndrome, staphylococcal or streptococcal disease, leptospirosis, Stevens-Johnson syndrome, and collagen vascular diseases, including acute-onset juvenile idiopathic arthritis, can mimic the syndrome with prolonged fever and rash. *C. difficile* colitis, meningitis, encephalitis, enteropathic arthropathies, acute pancreatitis, sarcoidosis, toxic shock syndrome, typhoid fever, and ulcerative colitis may also be considered.

## TREATMENT

Uncomplicated mesenteric lymphadenitis caused by *Y. pseudotuberculosis* is a self-limited disease, and antimicrobial therapy is not required. Few data exist on optimal treatment and duration of therapy. Infections with *Y. pseudotuberculosis* can generally be managed the same as those caused by *Y. enterocolitica*. Culture-confirmed bacteremia should be treated with a third-generation cephalosporin with or without an aminoglycoside, TMP-SMX, fluoroquinolones, or chloramphenicol.

## COMPLICATIONS

**Erythema nodosum** and reactive arthritis can follow infection. Coronary aneurysm formation has been described with disease presenting as Kawasaki syndrome-like illness. Rare local complications of GI disease include perforation, obstruction, and intussusception.

## PREVENTION

Avoiding exposure to potentially infected animals and good food-handling practices can prevent infection. The sporadic nature of the disease makes application of targeted prevention measures difficult.

Visit Elsevier eBooks+ at [eBooks.Health.Elsevier.com](http://eBooks.Health.Elsevier.com) for Bibliography.

## 249.3 Plague (*Yersinia pestis*)

Ericka V. Hayes

## ETIOLOGY

*Y. pestis* is a gram-negative, facultative anaerobe that is a pleomorphic, nonmotile, non-spore-forming coccobacillus and a potential agent of bioterrorism. It evolved from *Y. pseudotuberculosis* through acquisition of chromosomal changes and plasmid-associated factors that are essential to its virulence and survival in mammalian hosts and fleas. *Y. pestis* shares bipolar staining appearance with *Y. pseudotuberculosis* and can be differentiated by biochemical reactions, serology, phage sensitivity, and molecular techniques. *Y. pestis* exists in four biovars: Antigua (Africa), Medievalis (Central Asia), Orientalis (widespread), and Microtus (Asia). Of note, Microtus, while highly virulent in mice, does not cause disease in humans.

## EPIDEMIOLOGY

Plague is endemic in at least 24 countries, with Democratic Republic of the Congo, Madagascar, and Peru accounting for the highest numbers of cases. Approximately 3,000 cases are reported worldwide per year, with 100-200 deaths. Plague is uncommon in the United States (0-40 reported cases/yr); most of these cases occur west of a line from east Texas to east Montana, with 80% of cases in California, New Mexico, Arizona, and Colorado. In 2015, there was a cluster of 11 cases (with 3 deaths) in 4 months related to exposure at Yosemite National Park in California's Sierra Nevada Mountains. The epidemic form of disease killed approximately 25% of the population of Europe in the Middle Ages in a series of several epidemics and pandemics. The epidemiology of **epidemic** plague involves extension of infection from the zoonotic reservoirs to urban rats, *Rattus rattus* and *Rattus norvegicus*, and from fleas of urban rats to humans. Epidemics are no longer seen. Selective pressure exerted by plague pandemics in medieval Europe is hypothesized for enrichment of a pathogenic deletion variant in the gene encoding CCR5 (CCR5-Δ32). The enhanced frequency of this mutation in European populations endows approximately 10% of European descendants with relative resistance to acquiring HIV-1.

The most common mode of transmission of *Y. pestis* to humans is through **flea bites**. Historically, most human infections are thought to have resulted from bites of fleas that acquired infection from feeding on infected urban rats. Less frequently, infection is caused by contact with infectious body fluids or tissues or inhalation of respiratory secretions of infected animals. Currently, most cases of plague secondary to direct animal contact or inhalation of animal secretions are related to domestic **cats** or **dogs**. Direct transmission from human to human through droplet inhalation is possible but extremely rare. Laboratory transmission of *Y. pestis* has been described as well. Sylvatic plague can exist as a stable enzootic infection or as an epizootic disease with high host mortality. Ground squirrels, rock squirrels, prairie dogs, rats, mice, bobcats, cats, rabbits, and chipmunks may be infected. Transmission among animals is usually by flea bite or by ingestion of contaminated tissue. *Xenopsylla cheopis* is the flea usually associated with transmission to humans, but >30 species of fleas have been demonstrated as vector competent, and *Pulex irritans*, the human flea, can transmit plague and might have been an important vector in some historical epidemics. Both sexes are similarly affected by plague, and transmission is more common in colder regions and seasons, possibly because of temperature effects on *Y. pestis* infections in vector fleas.

## PATHOGENESIS

In the most common form of plague, infected fleas regurgitate organisms into a patient's skin during feeding. The bacteria translocate via lymphatics to regional lymph nodes, where *Y. pestis* replicates, resulting in **bubonic plague**. In the absence of rapidly implemented specific therapy, **bacteremia** can occur, resulting in purulent, necrotic, and hemorrhagic lesions in many organs. Both plasmid and chromosomal genes are required for full virulence. Pneumonic plague can be secondary to bacteremia or primary when infected material is inhaled. The organism is highly transmissible from persons with pneumonic plague and from domestic cats with pneumonic infection. This high transmissibility and high morbidity and mortality have provided an impetus for attempts to use *Y. pestis* as a biologic weapon.

## CLINICAL MANIFESTATIONS

*Y. pestis* infection can manifest as several clinical syndromes; infection can also be subclinical. The three principal clinical presentations of plague are bubonic plague, septicemic plague, and pneumonic plague. **Bubonic plague** is the most common form and accounts for 80-90% of cases in the United States. From 2 to 8 days after a flea bite, lymphadenitis develops in lymph nodes closest to the inoculation site, including the inguinal (most common), axillary, or cervical regions. These buboes are very tender. Fever, chills, weakness, prostration, headache, and the development of septicemia are common. The skin might show insect bites or scratch marks. Purpura and gangrene of the extremities can



develop as a result of disseminated intravascular coagulation (DIC). These lesions may be the origin of the name Black Death. Untreated plague results in death in >50% of symptomatic patients. Death can occur within 2-4 days after onset of symptoms.

Occasionally, *Y. pestis* establishes systemic infection and induces the systemic symptoms seen with bubonic plague without causing a bubo (**primary septicemic plague**). Because of the delay in diagnosis linked to the lack of the bubo, septicemic plague carries an even higher case fatality rate than bubonic plague. In some regions, bubo-free septicemic plague accounts for 25% of cases.

**Pneumonic plague** is the least common but most dangerous and lethal form of the disease. Incubation for primary pneumonic plague is 1-6 days. Pneumonic plague can result from hematogenous dissemination or, rarely, as primary pneumonic plague after inhalation of the organism from a human or animal with plague pneumonia or potentially from a biologic attack. Signs of pneumonic plague include severe pneumonia with high fever, dyspnea, and hemoptysis.

Meningitis, tonsillitis, and gastroenteritis can occur. Meningitis tends to be a late complication after inadequate treatment. Tonsillitis and gastroenteritis can occur with or without apparent bubo formation or lymphadenopathy.

## DIAGNOSIS

Plague should be suspected in patients with fever and history of exposure to small animals in endemic areas. Bubonic plague should be suspected in a patient with a painful swollen lymph node, fever, and prostration who has been potentially exposed to fleas or rodents in the western United States. A history of camping or the presence of flea bites increases the index of suspicion.

*Y. pestis* is readily transmitted to humans by some routine laboratory manipulations. **Thus it is imperative to clearly notify a laboratory when submitting a sample suspected of containing *Y. pestis*.** Laboratory diagnosis is based on bacteriologic culture or direct visualization using Gram, Giemsa, or Wayson stain of lymph node aspirates, blood, sputum, or exudates. *Y. pestis* grows slowly under routine culture conditions and best at temperatures that differ from those used for routine cultures in many clinical laboratories. Colonies are described as having a classic “fried egg appearance” and grow on sheep blood and chocolate agars, typically growing after 48-72 hours of incubation. Note some automated biochemical bacteria identification systems may misidentify *Y. pestis*. Suspected isolates of *Y. pestis* should be forwarded to a reference laboratory for confirmation. Special containment shipping precautions are required. A rapid antigen test detecting *Y. pestis* F1 antigen in sputum and serum samples exists. PCR testing and immunohistochemical staining for rapid identification are available in some reference and public health laboratories. Cases of plague should be reported to local and state health departments and the CDC. Serologic testing is also available. A single positive serologic test confirms the diagnosis, but in early illness seroconversion may not yet have occurred; negative tests should be interpreted with caution, particularly if there is high clinical suspicion for the diagnosis, and patients should continue to be treated.

## Differential Diagnosis

The Gram stain of *Y. pestis* may be confused with *Enterobacter agglomerans*. Mild and subacute forms of bubonic plague may be confused with other disorders causing localized lymphadenitis and lymphadenopathy, including bacterial lymphadenitis, tularemia, and *Bartonella henselae* (cat scratch) lymphadenitis. Septicemic plague may be indistinguishable from other forms of overwhelming bacterial sepsis.

Pulmonary manifestations of plague are similar to those of anthrax, Q fever, and tularemia, all agents with **bioterrorism** and **biologic**

**warfare** potential. Thus the presentation of a suspected case, and especially any cluster of cases, requires immediate reporting. Additional information on this aspect of plague and procedures can be found at <https://emergency.cdc.gov/agent/plague/index.asp>.

## TREATMENT

Patients with suspected plague should be placed on **droplet isolation** until pneumonia is ruled out, sputum cultures are negative, and antibiotic treatment has been administered for 48 hours. The treatment of choice for bubonic plague historically has been **streptomycin** (30 mg/kg/day, maximum 2 g/day, divided every 12 hours intramuscularly [IM] for 10 days). Intramuscular streptomycin is inappropriate for septicemia because absorption may be erratic when perfusion is poor. The poor central nervous system penetration of streptomycin also makes this an inappropriate drug for meningitis. Furthermore, streptomycin might not be widely and immediately available. **Gentamicin (children, 7.5 mg/kg IM or intravenously [IV] every 24 hours; adults, 5 mg/kg IM or IV every 24 hours) has been shown to be as efficacious as streptomycin; in patients with abscesses, an additional agent may be needed in addition to an aminoglycoside because of poor abscess penetration (typically a fluoroquinolone). Dual therapy is recommended for moderate to severe septicemic or pneumonic plague as well as bubonic plague with large buboes or any suspected case of bioterrorism-related plague. Ciprofloxacin 10 mg/kg every 8 or 12 hr IV or 15 mg/kg every 8 or 12 hr PO (maximum 400 mg/dose IV, 500 mg/dose every 8 hr PO or 750 mg/dose every 12 hr PO) and levofloxacin are also effective. Meningitis is usually treated with chloramphenicol or a fluoroquinolone. Resistance to these agents and relapses are rare. *Y. pestis* is susceptible in vitro to fluoroquinolones, which are effective in treating experimental plague in animals. *Y. pestis* is susceptible in vitro to penicillin, but penicillin is ineffective in treatment of human disease. Mild bubonic disease may be treated with oral chloramphenicol or doxycycline in children >8 years old. Clinical improvement is usually noted within 48 hours of initiating treatment. Recommended duration of therapy is 10-14 days, with a switch to oral therapy 2 days after defervescence and clinical improvement. Drainage of suppurative buboes may be needed; material is infectious, and appropriate precautions should be taken intraoperatively.**

**Postexposure prophylaxis** should be given to close contacts of patients with pneumonic plague. Antimicrobial prophylaxis is recommended within 7 days of exposure for persons with direct, close contact with a patient with pneumonic plague or those exposed to an accidental or bioterrorist aerosol. Recommended regimens for postexposure prophylaxis for children regardless of age include doxycycline, ciprofloxacin, or levofloxacin for a 7-day course at the treatment doses. Contacts of cases of uncomplicated bubonic plague do not require prophylaxis. *Y. pestis* is a potential agent of bioterrorism that can require mass casualty prophylaxis.

## PREVENTION

Avoidance of exposure to infected animals and fleas is the best method of prevention of infection. In the United States, special care is required in environments inhabited by rodent reservoirs of *Y. pestis* and their ectoparasites. Patients with plague should be isolated if they have pulmonary symptoms, and infected materials should be handled with extreme care. There is currently no available licensed vaccine for *Y. pestis* in the United States. Several vaccine development trials are underway, and recombinant subunit vaccines based on rF1 and rV antigens seem to be the most promising. Using baits containing live vaccines for oral immunization of wild animals may be a helpful alternative for control of epidemics.

Visit Elsevier eBooks+ at [eBooks.Elsevier.com](https://eBooks.Elsevier.com) for Bibliography.



## Chapter 250

**Aeromonas and Plesiomonas**

Ameneh Khatami and Adam J. Ratner

*Aeromonas* and *Plesiomonas* are gram-negative bacilli that include species capable of causing enteritis and, less frequently, skin and soft tissue infections and invasive disease. They are common in freshwater and brackish water and colonize animals and plants in these environments.

**250.1 Aeromonas**

Ameneh Khatami and Adam J. Ratner

**ETIOLOGY**

*Aeromonas* is a member of the Aeromonadaceae family and includes two major groups of isolates: the nonmotile *psychrophilic* organisms that infect cold-blooded animals, most often fish, and the motile *mesophilic* organisms that infect humans and other warm-blooded animals. *Aeromonas* species are oxidase- and catalase-positive, facultatively anaerobic, gram-negative bacilli that ferment glucose. *Aeromonas* is a diverse genus with difficult taxonomy and species differentiation because of high nucleotide variability and has undergone multiple reclassifications of species and taxa in recent years. Sixteen species are recognized as clinically significant human pathogens, with *Aeromonas hydrophila*, *Aeromonas veronii* biotype *sobria*, and *Aeromonas caviae* most frequently associated with human infection. *Aeromonas dhakensis*, which was first isolated from children with diarrhea in Dhaka, Bangladesh, and was initially classified as a subspecies of *A. hydrophila*, has been recognized as a distinct species and an important cause of human infection.

**EPIDEMIOLOGY**

*Aeromonas* organisms are found in fresh and brackish aquatic environments, including rivers and streams, well water, both treated and bottled drinking water, and sewage. These organisms are most often detected in aquatic environments during warm-weather months, when they reach greater population densities. Rates of human infection may also exhibit seasonality depending on local conditions. For example, *Aeromonas* is isolated with increased frequency from May to October in the Northern Hemisphere. Some species resist chlorination of water and exhibit tolerance to high salt concentrations. *Aeromonas* has been isolated from meats, milk, seafood, seaweed, and vegetables consumed by humans. Asymptomatic colonization occurs in humans and is more common in inhabitants of tropical regions. Most human infections with *Aeromonas* are associated with exposure to contaminated water but may also be contracted via other routes, including ingestion of contaminated food. A systematic review of cases of traveler's diarrhea worldwide implicated *Aeromonas* in 0.8–3.3% of infections, with highest frequencies in travelers to Southeast Asia and Africa. A study in Bangladesh of >56,000 stool samples from patients with diarrhea found that approximately 25% had a bacterial etiology detected, 13% of which were *Aeromonas*. *Aeromonas* infections have also been acquired at various sites of natural disasters. For example, after the 2004 Thailand tsunami, *Aeromonas* was the leading cause of skin and soft tissue infection among survivors.

**PATHOGENESIS**

Clinical and epidemiologic data seem to support that *Aeromonas* organisms are **enteric** pathogens, although this point is not universally

accepted. Reasons for uncertainty include a lack of outbreaks with clonally distinct isolates, infrequent person-to-person transmission, absence of a robust animal model, and overlapping prevalence in symptomatic and asymptomatic individuals. In addition, there are conflicting data when comparing the human challenge model with characteristics of suspected outbreaks of *Aeromonas* enteritis, further complicating interpretation.

*Aeromonas* isolates possess a variety of potential virulence factors, including constitutive *polar* and inducible *lateral* flagella, fimbriae, outer membrane proteins, endotoxin (lipopolysaccharide), and capsule. The mechanistic role of many of these factors in human pathogenicity remains unclear. Polar flagella provide motility in liquid media, and lateral flagella may act as adhesins. There are numerous hemolysins, proteases, and heat-labile and heat-stable enterotoxins. *Aeromonas* cytotoxic enterotoxin (**Act/aerolysin**) is secreted by a type II secretion system and is able to lyse erythrocytes, inhibit phagocytosis, and induce cytotoxicity in eukaryotic cells. *Aeromonas* also has a type III secretion system with an effector protein that causes actin reorganization and eventual apoptosis in vitro. A type VI secretion system has been described and functions analogously to a phage tail, with antimicrobial activity.

*Aeromonas sobria* is the most enterotoxic among clinical isolates, and cytotoxic activity with cytopathic and intracellular effects is found in 89% of isolates. A few strains produce Shiga toxin. Some clinically important species have also been shown to harbor a cholera-like toxin (**Asao toxin**). *Aeromonas* has serine proteases that can cause a cascade of inflammatory mediators, leading to vascular leakage, and in vitro studies show induction of apoptosis in murine macrophages by human isolates of *Aeromonas*. There are limited data on *quorum-sensing* molecules, which coordinate gene expression according to local density and may be involved in biofilm production or population control.

**CLINICAL MANIFESTATIONS**

*Aeromonas* may colonize humans asymptotically or cause illness, including enteritis, focal invasive infections, and septicemia. Although apparently immunologically normal individuals may present with any of these manifestations, invasive disease is more common among immunocompromised persons.

**Enteritis**

The most common clinical manifestation of infection with *Aeromonas* is enteritis, which occurs primarily among children <3 years old. *Aeromonas* is the third or fourth most common cause of childhood **bacterial diarrhea** and has been isolated from 2% to 10% of patients with diarrhea and 1–5% of asymptomatic controls. One study demonstrated isolation from hospitalized neonates with diarrhea at rates of 0–19% depending on the season. Isolation from human feces also varies geographically based on food habits, level of sanitation, population demographics, aquaculture and farming practices, and laboratory isolation methods used. *Aeromonas* diarrhea is often watery and self-limited, although a dysentery-like syndrome with blood and mucus in the stool has also been described. Fever, abdominal pain, and vomiting are common in children. Choleric diarrhea with “rice-water” stools can also occur. Enteritis caused by *A. hydrophila* and *A. sobria* tends to be acute and self-limited, whereas 30% of patients with *A. caviae* enteritis have chronic or intermittent diarrhea that may last 4–6 weeks. *A. sobria* and *A. caviae* are most frequently associated with **traveler's diarrhea**. Complications of *Aeromonas* enteritis include intussusception, failure to thrive, hemolytic-uremic syndrome, bacteremia, and postinfectious chronic colitis. *Aeromonas* infection may also present as acute segmental colitis, mimicking inflammatory bowel disease or ischemic colitis.

**Skin and Soft Tissue Infections**

Skin and soft tissue infections are the second most common presentation of *Aeromonas*, most commonly associated with *A. hydrophila*, *A. veronii*, and *A. schubertii*. Predisposing factors include local trauma and exposure to contaminated fresh water. *Aeromonas* soft tissue infections have been reported after bites from a number of animal species, including alligators, tigers, bears, and snakes, and from tick

bites. These infections have also been reported after sports injuries and medicinal leech therapy. Antibiotic prophylaxis is generally used in conjunction with leech therapy because of the presence of *A. hydrophila* in the gastrointestinal (GI) tract of leeches, where they aid in the breakdown of ingested red blood cells. However, emerging reports of ciprofloxacin-resistant strains of *Aeromonas* isolated from leeches may affect this practice. The spectrum of skin and soft tissue infections is broad, ranging from a localized skin nodule to life-threatening necrotizing fasciitis, myonecrosis, and gas gangrene. Soft tissue infections are most frequently found on the extremities, are often polymicrobial, and are 3 times more likely in men than in women. *Aeromonas cellulitis*, the most common skin manifestation, clinically presents similar to other forms of bacterial cellulitis but should be suspected in wounds after contact with a water source, especially during the summer.

### Septicemia

*Aeromonas* septicemia, strongly associated with *A. veronii* biovar *sobria* and *A. dhakensis* infection, is the third most common presentation of infection and is associated with a mortality rate of 27–73%. Higher incidence occurs during summer months or during the wet season in the tropics. Patients present with the classic signs and symptoms of gram-negative sepsis and may have GI symptoms, including abdominal pain, nausea, vomiting, and diarrhea. From 2% to 4% of patients may present with ecthyma gangrenosum-like lesions. *Aeromonas* may be the only organism isolated or may be part of a polymicrobial bacteremic illness. Most cases (approximately 80%) occur in immunocompromised adults or those with hepatobiliary disease and in young children in whom the source of infection is probably *Aeromonas* in the GI tract. Less frequently, bacteremia can be secondary to trauma-related myonecrosis or infected burns. In such patients, mortality is often higher than in those with primary bacteremia because of the underlying trauma. Rarely, *Aeromonas* bacteremia occurs in otherwise healthy adults exposed to fresh water.

### Other Infections

*Aeromonas* is a rare cause of GI infections such as necrotizing gastroenteritis, peritonitis, cholecystitis, appendicitis, and liver and pancreas abscess formation; cardiovascular infections, including endocarditis and septic embolism; and pulmonary infections, including tracheobronchitis, pneumonia, empyema, and lung abscess formation. *Aeromonas* is also associated with musculoskeletal infections, including osteomyelitis, pyogenic arthritis, pyomyositis, and necrotizing fasciitis, as well as ocular and ear, nose, and throat infections, including endophthalmitis, keratitis, orbital cellulitis, otitis media, and epiglottitis. Other rare infections include meningitis, urinary tract infection, pelvic inflammatory disease, lymphadenitis, hot tub folliculitis, and surgical wound infections. *Aeromonas* is associated with tracheobronchitis and aspiration pneumonia after near-drowning.

### DIAGNOSIS

Diagnosis is established by isolation of *Aeromonas* in culture. The organism is generally grown on standard media when the source material is normally sterile. Often, *Aeromonas* is not identified by typical laboratory protocols for examining stool specimens. If *Aeromonas* is suspected, the yield may increase if the laboratory is notified before testing, because overnight enrichment in alkaline peptone water and culture on selective agars may be useful. Most strains (approximately 90%) produce  $\beta$ -hemolysis on blood agar. Lactose-fermenting strains of *Aeromonas* like *A. caviae* may not be identified if the clinical laboratory does not routinely perform oxidase tests on lactose fermenters isolated on MacConkey agar. *Aeromonads* are resistant to vibriostatic agent O129; however, differentiation of *Aeromonas* from *Vibrio* spp. and identification of *Aeromonas* spp. and subspp. is not reliable using biochemical testing. Similarly, classification of *Aeromonas* strains at the species and subspecies level is difficult to achieve by sequencing regions of the

16S rRNA gene. Sequencing of housekeeping genes, such as *gyrB* and *rpoD*, and multilocus sequence typing are accurate for species identification but are time-, cost- and labor-intensive. Increasingly, laboratories use matrix-assisted laser desorption/ionization time of flight (MALDI-TOF) mass spectrometry to rapidly identify organisms because this method is accurate for *Aeromonas* as a genus and for many of the clinically important species. Because stool culture-based diagnosis is time-consuming, labor-intensive, and costly on per positive culture basis, molecular tests for various enteric bacterial pathogens, including multiplex polymerase chain reaction (PCR) assays that include targets for detection of *Aeromonas*, have been developed and are commercially available in some areas.

### TREATMENT

*Aeromonas enteritis* is usually self-limited, and antimicrobial therapy may not be indicated, although some studies suggest that **antimicrobial therapy** may shorten the course of the illness. Antimicrobial therapy is reasonable to consider in patients with protracted diarrhea, dysentery-like illness, or underlying conditions such as hepatobiliary disease or an immunocompromised state. Antibiotic sensitivity varies among species and also by geography; therefore it is important to perform **susceptibility testing**. Chromosomally mediated class B, C, and D  $\beta$ -lactamases are found in most species and can be difficult to identify because many are inducible. These include metallo- and AmpC  $\beta$ -lactamases, which can lead to clinical failure if carbapenems or third-generation cephalosporins are used as monotherapy in high-organism-load infections. There is near-uniform resistance to penicillins. Surgical intervention is the primary therapeutic modality in cases of **necrotizing fasciitis**, with most patients requiring more than one **debridement** in the first 48 hours. **Septicemia** can be treated with a **fourth-generation cephalosporin** (e.g., cefepime) or **ciprofloxacin**, with or without an aminoglycoside, although specific therapy should be guided by susceptibility data. Another option for less severe infections includes trimethoprim-sulfamethoxazole (TMP-SMX). Evidence-based recommendations for duration of treatment are lacking, and thus treatment is typically guided by clinical response. In general, diarrhea is treated for 3 days, wound infections for 7–10 days, and bacteremia for 14–21 days, depending on clinical response and host characteristics.

### PREVENTION

Reducing contact with contaminated environmental fresh and brackish water and contaminated foods should reduce the risk for *Aeromonas* infections. Some *Aeromonas* outer membrane proteins are immunogenic and are candidate antigens for preclinical vaccine development.

Visit Elsevier eBooks+ at [eBooks.Health.Elsevier.com](http://eBooks.Health.Elsevier.com) for Bibliography.

## 250.2 *Plesiomonas shigelloides*

Ameneh Khatami and Adam J. Ratner

### ETIOLOGY

*Plesiomonas shigelloides* is a facultatively anaerobic, gram-negative, non-spore-forming bacillus that ferments glucose. It is a catalase-, oxidase-, and indole-positive motile organism with polar flagella. A high level of genetic diversity has been recognized among *P. shigelloides* strains, reflecting frequent homologous recombination.

### EPIDEMIOLOGY

*P. shigelloides* is ubiquitous in freshwater and, because it can tolerate salinity of up to 4%, can be found in estuarine or brackish water, as well as animal inhabitants of these ecosystems, including fish, shellfish, crustaceans, water mammals, amphibians, reptiles, and other vertebrates. *P. shigelloides* has been recovered from healthy (colonized)

and diseased animals, including cats. It can cause both sporadic infections and outbreaks in a range of animals. As a mesophile with optimal growth temperature of 35–39°C (95–102.2°F), *P. shigelloides* has been found most often in tropical waters or during warmer months, although there are increasing reports of isolation from surface water in colder climates. Similarly, most cases of infection occur during the warmer months of the year. *P. shigelloides* is not a usual commensal organism in the human GI tract, and infection of humans is thought to be the result of consumption of contaminated water or raw seafood or possibly through contact with colonized animals. The frequency of isolation of *P. shigelloides* from diarrheal stools in these circumstances has been reported to range from 2% to >10%. Mixed infection with *Salmonella*, *Aeromonas*, rotavirus, or other enteric pathogens may occur in almost one third of patients. The majority of symptomatic patients in North America have a known exposure to potentially contaminated water or seafood (notably oysters) or have traveled abroad. *Plesiomonas* has been reported to be associated with 1.3–5.4% of episodes of **traveler's diarrhea**, with the highest rates associated with travel to South and Southeast Asia. Other risk factors include immune compromise (in particular HIV infection), blood dyscrasias (including sickle cell disease), and young age. The highest rates of *Plesiomonas* **enteritis** occur in children <2 years old. Although *P. shigelloides* has a worldwide distribution, there is unexplained geographic variability in the incidence of enteritis that may be related to water temperatures and a lack of hygiene and sanitation.

### **PATHOGENESIS**

Epidemiologic and microbiologic evidence in the form of a series of food-borne outbreaks attributable to *P. shigelloides* indicates that this organism is an **enteropathogen**. However, the pathogenic capacity of *P. shigelloides* has not been confirmed through oral challenge studies, and these organisms have been isolated from the stools of healthy individuals at a low rate. The mechanism of enteritis is not known, but putative virulence factors have been described, including cholera-like toxin, heat-labile and heat-stable enterotoxins, and lipopolysaccharide. Most strains of *P. shigelloides* also secrete a  $\beta$ -hemolysin, which is thought to be a major virulence factor. In vitro studies show that isolates of *P. shigelloides* can invade and induce apoptosis in cells of enteric origin, as well as exhibiting evidence of modulation of host defenses through inhibition of cathepsins involved in antigen processing and presentation.

### **CLINICAL MANIFESTATIONS**

Clinical disease in humans generally begins 24–48 hours after exposure to the organism, although incubation periods in excess of 4 days have been reported. Diarrhea can occur in all age-groups, including neonates, is typically secretory, and less often presents as invasive dysentery. Secretory **enteritis** usually presents as a mild self-limiting disease with watery diarrhea and abdominal pain, but in 13% of cases diarrhea can persist for >2 weeks. Dehydration, hypokalemia, and peritonitis are uncommon complications; however, there have been several reports of a cholera-like presentation with severe secretory diarrhea. The frequency of secretory vs dysenteric presentation seems to cluster by individual outbreak, suggesting that either the human populations or the bacterial populations involved are associated with each particular presentation. **Dysentery** presents with macroscopic blood and/or mucus in the stool, significant abdominal pain, and vomiting, with more severe cases also associated with fever. Fatal outcomes have been reported with severe cases of *Plesiomonas* dysentery, although in most of these cases the exact role of *P. shigelloides* is unclear.

Extraintestinal infections, usually bacteremia, are rare and usually occur in patients with underlying immunodeficiency. About 90% of these cases are monomicrobial, and in almost half, *P. shigelloides* is also

isolated from a site other than blood. Rarely, bacteremia accompanying enteritis has been documented in apparently otherwise normal children. Septicemia also appears to result from ingestion of contaminated water or seafood and has a high mortality rate in adults. Other extraintestinal diseases include pneumonia, meningitis, osteomyelitis, septic arthritis, reactive arthritis, abscesses, and focal infections of the GI or reproductive tracts. Almost one third of all bacteremias occur in neonates who present with early-onset sepsis and meningitis, and although rare, these make up most of the reported cases of *P. shigelloides* meningitis and have a very high mortality rate (80%). In several cases of neonatal disease, *Plesiomonas* has also been isolated from maternal feces, suggesting intrapartum vertical transmission. Compared with *Aeromonas* and *Vibrio* spp., traumatic wounds sustained in aquatic environments less often contain *P. shigelloides*.

### **DIAGNOSIS**

*P. shigelloides* is a non-lactose-fermenting organism and grows well on traditional enteric media with optimal growth at 30°C (86°F), although selective techniques may be required to isolate the organism from mixed cultures and to differentiate *P. shigelloides* from *Shigella* spp. If enrichment is necessary, alkaline peptone water or bile peptone broth may be used. Colonies are nonhemolytic on 5% blood agar. Many strains cross-react with *Shigella* on serologic testing but can be differentiated easily as oxidase-positive organisms. *P. shigelloides* has a unique biochemical profile and can generally be identified using commercial kits. Rapid identification systems, including MALDI-TOF, can also be used to identify *P. shigelloides*. *P. shigelloides* is included in at least one U.S. Food and Drug Administration (FDA)-approved commercial panel that detects a range of enteropathogens directly from diarrheal stools (culture independent) by PCR.

### **TREATMENT**

Enteritis caused by *P. shigelloides* is usually mild and self-limited. In cases associated with dehydration or with a cholera-like disease, patients usually respond favorably to **oral rehydration solution**. Consideration of **antimicrobial therapy** is reserved for patients with prolonged or bloody diarrhea, those who are immunocompromised, the elderly, and the very young. Data from uncontrolled studies suggest that antimicrobial therapy may decrease the duration of symptoms, although no difference was found in an exclusively pediatric study.

*P. shigelloides* produces a chromosomally encoded, noninducible  $\beta$ -lactamase, which generally renders strains resistant to the penicillins, including broad-spectrum penicillins. *P. shigelloides* is also usually resistant to aminoglycosides and tetracyclines. Most strains of *P. shigelloides* are susceptible to  $\beta$ -lactam/ $\beta$ -lactamase inhibitor combinations and to TMP-SMX, some cephalosporins, carbapenems, and fluoroquinolones; however, therapy should be guided by **antimicrobial susceptibility testing** because resistance to TMP-SMX, fluoroquinolones, and other agents has been reported.

Severe cases of *P. shigelloides* dysentery should be treated similarly to shigellosis (with empirical **azithromycin** or a **third-generation cephalosporin** for children and ciprofloxacin or azithromycin for adults). Antibiotics are essential for therapy of extraintestinal disease. Empirical therapy with a third-generation cephalosporin is often first-line management, because most isolates are susceptible in vitro. Alternatives include carbapenems, aztreonam,  $\beta$ -lactam/ $\beta$ -lactamase inhibitor combinations, and quinolones. Definitive therapy should be guided by the susceptibility of the individual isolate. Duration of therapy ranges from 1 to 2 weeks but may be extended depending on underlying chronic conditions and clinical response.

Visit Elsevier eBooks+ at [eBooks.Health.Elsevier.com](http://eBooks.Health.Elsevier.com) for Bibliography.



## Chapter 251

***Pseudomonas*,  
*Burkholderia*, and  
*Stenotrophomonas*****251.1 *Pseudomonas aeruginosa***

Thomas S. Murray and Ashley C. Howard

**ETIOLOGY**

*Pseudomonas aeruginosa* is an aerobic, gram-negative rod. It can multiply in a great variety of environments that contain minimal amounts of organic compounds. Strains from clinical specimens do not ferment lactose, are oxidase positive, and may produce  $\beta$ -hemolysis on blood agar. Many strains produce pigments, including pyocyanin, pyoverdine, and pyorubrin, that diffuse into and color the surrounding medium. Strains of *P. aeruginosa* are differentiated for epidemiologic purposes by a variety of genotyping methods, including restriction fragment length polymorphisms using pulsed-field gel electrophoresis, multilocus sequence typing, and more recently, whole genome sequencing.

**EPIDEMIOLOGY**

*P. aeruginosa* is a classic “opportunistic.” It rarely causes disease in people who do not have a predisposing risk factor. Compromised host defense mechanisms resulting from trauma, neutropenia, mucositis, immunosuppression, or impaired mucociliary transport explain the predominant role of this organism in producing opportunistic infections. In pediatric settings, it is frequently seen in the respiratory secretions of children with **cystic fibrosis** (CF). In a pediatric review of 2,545 facilities from 2015 to 2017 by the National Healthcare Safety Network (NHSN), *P. aeruginosa* ranked among the top 10 organisms to cause **central line–associated bloodstream infections** in all units: 2.8% neonatal intensive care unit (NICU), 5% pediatric intensive care unit (PICU), 5% pediatric oncology units, and 3.1% pediatric wards. *P. aeruginosa* was also the second most common cause of **catheter-associated urinary tract infections** (UTIs) (18.4%) and **ventilator-associated pneumonia** (16.1%) and the third most common cause of postoperative surgical site infections (8.3%). In a multicenter U.S. prospective study of 33 sites from 2014 to 2018, *P. aeruginosa* was isolated in 2.7% of bacteremic episodes in children  $\leq 1$  year old and 3.7% in children  $\leq 17$  years of age.

*P. aeruginosa* and other pseudomonads frequently enter the hospital environment on the clothes, skin, or shoes of patients or hospital personnel, with plants or vegetables brought into the hospital, and in the gastrointestinal (GI) tract of patients. Colonization of any moist or liquid substance may ensue; the organisms may be found growing in any water reservoir, including distilled water, and in hospital kitchen sinks and laundries, some antiseptic solutions, and equipment used for respiratory therapy and urinary procedures. Colonization of skin, throat, stool, and nasal mucosa of patients is low at admission to the hospital but increases to as high as 50–70% with prolonged hospitalization and with the use of broad-spectrum antibiotics, chemotherapy, mechanical ventilation, and urinary catheters. Patients’ intestinal microbial flora may be altered by the broad-spectrum antibiotics, reducing resistance to colonization and permitting *P. aeruginosa* in the environment to populate the GI tract. Intestinal mucosal breakdown associated with medications, especially cytotoxic agents, and nosocomial enteritis may provide a pathway by which *P. aeruginosa* spreads to the lymphatics or bloodstream.

**PATHOLOGY**

The pathologic manifestations of *P. aeruginosa* infections depend on the site and type of infection. Because of its elaboration of toxins and invasive factors, the organism can often be seen invading blood vessels and causing vascular necrosis. In some infections there is spread through tissues with necrosis and microabscess formation. In patients with CF, focal and diffuse bronchitis/bronchiolitis leading to bronchiolitis obliterans has been reported.

**Pathogenesis**

Invasiveness of *P. aeruginosa* is mediated by a host of virulence factors. Bacterial attachment is facilitated by pili that adhere to epithelium damaged by prior injury or infection. Extracellular proteins, proteases, elastases, and cytotoxins disrupt cell membranes, and in response, host-produced cytokines cause capillary vascular permeability and induce an inflammatory response. Dissemination and bloodstream invasion follow extension of local tissue damage and are facilitated by the antiphagocytic properties of endotoxin, the exopolysaccharide, and protease cleavage of immunoglobulin G. *P. aeruginosa* also produces numerous exotoxins, including exotoxin A, which causes local necrosis and facilitates systemic bacterial invasion. *P. aeruginosa* possesses a type III secretion system composed of a needle structure that inserts into host cell membranes and allows secretion of exotoxins directly into host cells. The host responds to infection with a robust inflammatory response, recruiting neutrophils to the infection site and producing antibodies to *P. aeruginosa* proteins. There is a lack of convincing data that these antibodies are protective against the establishment of infection.

In addition to acute infection, *P. aeruginosa* is also capable of chronic persistence because of the formation of **biofilms**, organized communities of bacteria encased in an extracellular matrix. Biofilm formation requires attachment to a surface, proliferation of the organism, and production of exopolysaccharide as the main bacterial component of the extracellular matrix. A mature biofilm can persist despite an intense host immune response and is resistant to many antimicrobials.

**CLINICAL MANIFESTATIONS**

Most clinical patterns are related to opportunistic infections in immunocompromised hosts (see Chapter 223) or are associated with shunts and indwelling catheters (see Chapter 224). *P. aeruginosa* may be introduced into a minor wound of a healthy person as a secondary invader, and cellulitis and a localized abscess that exudes green or blue pus may follow. The characteristic skin lesions of *P. aeruginosa*, **ecthyma gangrenosum**, whether caused by direct inoculation or a metastatic focus secondary to septicemia, begin as pink macules and progress to hemorrhagic nodules and eventually to ulcers with ecchymotic and gangrenous centers with eschar formation, surrounded by an intense red areola (Table 251.1 and Fig. 251.1).

Outbreaks of dermatitis and UTIs caused by *P. aeruginosa* have been reported in healthy persons after use of pools or hot tubs. Skin lesions of folliculitis develop several hours to 2 days after contact with these water sources. Skin lesions may be erythematous, macular, papular, or pustular. Illness may vary from a few scattered lesions to extensive truncal involvement. In some children, malaise, fever, vomiting, sore throat, conjunctivitis, rhinitis, and swollen breasts may be associated with dermal lesions. UTIs caused by *P. aeruginosa* are most often nosocomial and are often associated with the presence of an indwelling urinary catheter, urinary tract malformations, and previous antibiotic use. UTIs may be minimized or prevented by prompt removal of the catheter and by early identification and corrective surgery of obstructive lesions when present.

**Burns and Wound Infection**

The surfaces of burns or wounds are frequently populated by *P. aeruginosa* and other gram-negative organisms; this initial colonization with a low number of adherent organisms is a prerequisite to invasive disease. *P. aeruginosa* colonization of a burn site may develop into **burn wound sepsis**, which has a high mortality rate when the density of organisms reaches a critical concentration. Administration of antibiotics may



**Table 251.1** *Pseudomonas aeruginosa* Infections

INFECTION	COMMON CLINICAL CHARACTERISTICS
Endocarditis	Native right-sided (tricuspid) valve disease with intravenous drug abuse
Pneumonia	Compromised local (lung) or systemic host defense mechanisms; nosocomial (respiratory), bacteremic (malignancy), or abnormal mucociliary clearance (cystic fibrosis) may be pathogenetic; cystic fibrosis is associated with mucoid <i>P. aeruginosa</i> organisms producing capsular slime
Central nervous system infection	Meningitis, brain abscess; contiguous spread (mastoiditis, dermal sinus tracts, sinusitis); bacteremia or direct inoculation (trauma, surgery)
External otitis	Swimmer's ear; humid warm climates, swimming pool contamination
Malignant otitis externa	Invasive, indolent, febrile, toxic, destructive, necrotizing lesion in young infants, immunosuppressed neutropenic patients, or diabetic patients; associated with seventh nerve palsy and mastoiditis
Chronic mastoiditis	Ear drainage, swelling, erythema; perforated tympanic membrane
Keratitis	Corneal ulceration; contact lens keratitis
Endophthalmitis	Penetrating trauma, surgery, penetrating corneal ulceration; fulminant progression
Osteomyelitis/septic arthritis	Puncture wounds of foot and osteochondritis; intravenous drug abuse; fibrocartilaginous joints, sternum, vertebrae, pelvis; open fracture osteomyelitis; indolent pyelonephritis and vertebral osteomyelitis
Urinary tract infection	Iatrogenic, nosocomial; recurrent UTIs in children, instrumented patients, and those with obstruction or stones
Intestinal tract infection	Immunocompromised, neutropenia, typhlitis, rectal abscess, ulceration, rarely diarrhea; peritonitis in peritoneal dialysis
Ecthyma gangrenosum	Metastatic dissemination; hemorrhage, necrosis, erythema, eschar, discrete lesions with bacterial invasion of blood vessels; also subcutaneous nodules, cellulitis, pustules, deep abscesses
Primary and secondary skin infections	Local infection; burns, trauma, decubitus ulcers, toe web infection, green nail (paronychia); whirlpool dermatitis; diffuse, pruritic folliculitis; vesiculopustular or maculopapular, erythematous lesions



**Fig. 251.1** Round, nontender skin lesion on 2-yr-old female's buttock. Note the black ulcerated center of the lesion and its red margin. (From Ghanaie H, Engelhard D. A healthy 2-year-old child with a round black skin lesion. *J Pediatr.* 2013;163:1225.)

diminish the susceptible microbiologic flora, permitting strains of relatively resistant *P. aeruginosa* to flourish. Multiplication of organisms in devitalized tissues or associated with prolonged use of intravenous or urinary catheters increases the risk for septicemia with *P. aeruginosa*, a major problem in burned patients (see [Chapter 89](#)).

### Cystic Fibrosis

*P. aeruginosa* is common in patients with CF, with increasing prevalence as children get older (see [Chapter 454](#)). Initial infection is caused by **nonmucoid environmental strains** of *P. aeruginosa*, but after a variable period, **mucoid strains** of *P. aeruginosa* that produce the antiphagocytic exopolysaccharide alginate, which are rarely encountered in other conditions, predominate. Repeated isolation of mucoid

*P. aeruginosa* from the sputum is associated with increased morbidity and mortality. The infection begins insidiously or even asymptotically, and the progression has a highly variable pace. In children with CF, antibody does not eradicate the organism, and antibiotics are only partially effective; thus after infection becomes chronic, it cannot be completely eradicated. Repeated courses of antibiotics select for *P. aeruginosa* strains that are resistant to multiple antibiotics.

### Immunocompromised Persons

Children with leukemia or other malignancies, particularly those who are receiving immunosuppressive therapy and who are neutropenic, typically with intravascular catheters, are extremely susceptible to septicemia caused by invasion of the bloodstream by *P. aeruginosa* that is colonizing the respiratory or GI tract. Signs of sepsis are often accompanied by a generalized vasculitis, and hemorrhagic necrotic lesions may be found in all organs, including the skin (ecthyma gangrenosum) (see [Fig. 251.1](#)). Hemorrhagic or gangrenous perirectal cellulitis or abscesses may occur, associated with ileus and profound hypotension.

### Nosocomial Pneumonia

Although not a frequent cause of community-acquired pneumonia in children, *P. aeruginosa* does cause nosocomial pneumonia, especially ventilator-associated pneumonia, in patients of all ages. *P. aeruginosa* has historically been found to contaminate ventilators, tubing, and humidifiers. Such contamination is uncommon now because of disinfection practices and routine changing of equipment. Nevertheless, colonization of the upper respiratory tract and the GI tract may be followed by aspiration of *P. aeruginosa*-contaminated secretions, resulting in severe pneumonia. Prior use of broad-spectrum antibiotics is a risk factor for colonization with antibiotic-resistant strains of *P. aeruginosa*. One of the most challenging situations is distinguishing between colonization and pneumonia in intubated patients. This distinction can

often only be definitively resolved by using invasive culture techniques such as quantitative bronchoalveolar lavage.

### Infants

*P. aeruginosa* is an occasional cause of **nosocomial bacteremia** in newborns and accounts for 2–5% of positive blood culture results in NICUs. A frequent focus preceding bacteremia is **conjunctivitis**. Older infants rarely present with community-acquired sepsis caused by *P. aeruginosa*. In the few reports describing community-acquired sepsis, preceding conditions included ecthyma-like skin lesions, virus-associated transient neutropenia, and prolonged contact with contaminated bath water or a hot tub.

### DIAGNOSIS

*P. aeruginosa* infection is rarely clinically distinctive. Diagnosis depends on recovery of the organism from the blood, cerebrospinal fluid (CSF), urine, or needle aspirate of the lung or from purulent material obtained by aspiration of subcutaneous abscesses or areas of cellulitis. In the appropriate clinical setting, recovery of *P. aeruginosa* from a coughed or suctioned sputum may represent infection; but it also may only represent colonization, and clinical judgment is required. Rarely, skin lesions that resemble *P. aeruginosa* infection may follow septicemia caused by *Aeromonas hydrophila*, other gram-negative bacilli, and *Aspergillus*. When *P. aeruginosa* is recovered from nonsterile sites such as skin, mucous membranes, or voided urine, quantitative cultures may be useful to differentiate colonization from invasive infection. In general,  $\geq 100,000$  colony-forming units/mL of fluid or gram of tissue is evidence suggestive of invasive infection. Quantitative cultures of tissue and skin are not routine and require consultation with the clinical microbiology laboratory.

### TREATMENT

Systemic infections with *P. aeruginosa* should be treated promptly with an antibiotic to which the organism is susceptible in vitro. Response to treatment may be limited, and prolonged treatment may be necessary for systemic infection in immunocompromised hosts.

Septicemia and other aggressive infections should be treated with either one or two bactericidal agents. Although the number of agents required is controversial, the evidence continues to suggest that the benefit of adding a second agent is questionable, even when studies have included immunosuppressed patients. *Appropriate antibiotics for single-agent therapy include ceftazidime, cefepime, ticarcillin-clavulanate, and piperacillin-tazobactam. Gentamicin or another aminoglycoside may be used concomitantly for synergistic effect.*

**Ceftazidime** has proved to be extremely effective in patients with CF, at 150–400 mg/kg/day divided every 6–8 hours intravenously (IV) to a maximum of 6 g/day. Piperacillin or piperacillin-tazobactam 240–400 mg/kg/day divided every 6–8 hours IV to a maximum of 12 g/day also has proved to be effective therapy for susceptible strains of *P. aeruginosa*. Continuous infusions of  $\beta$ -lactam antibiotics are more effective than the same daily dose given as pulse infusions.

Additional effective antibiotics include imipenem-cilastatin, meropenem, and aztreonam. Ciprofloxacin (20–30 mg/kg/day orally every 8–12 hours up to 500 mg/dose) is the only available effective oral *P. aeruginosa* therapy, and although commonly used in children with CF, it is not approved in the United States for persons <18 years old, except for oral treatment of UTIs or when treating multidrug-resistant (MDR) *P. aeruginosa*. Inhaled therapy with either tobramycin or aztreonam is also used for chronic pulmonary infection, with inhaled colistin reserved for the treatment of resistant pseudomonads. Macrolide therapy decreases pulmonary exacerbations in patients with chronic lung disease and *P. aeruginosa* infection. The mechanism relates to altering the virulence properties of *P. aeruginosa* rather than direct bactericidal killing.

It is important to base continued treatment on antimicrobial susceptibility tests because **antibiotic resistance** of *P. aeruginosa* is increasing. *P. aeruginosa* has many mechanisms for resistance to multiple classes of antibiotics, including but not limited to pathogenic variants, production of  $\beta$ -lactamases, and drug efflux pumps. Throughout the United

States there has been an alarming increase in MDR *P. aeruginosa* isolates resistant to at least three antibiotic classes recovered from children. NHSN data from 2015 to 2017 show 2.8% NICU, 12% PICU, 6% pediatric oncology, and 5.5% pediatric ward *P. aeruginosa* isolates were MDR, with increasing rates of carbapenem and piperacillin/tazobactam resistance as well.

Several newer agents demonstrate efficacy against MDR *P. aeruginosa*. Ceftazidime-avibactam and ceftolozane-tazobactam combine cephalosporins with a  $\beta$ -lactamase inhibitor. Ceftolozane-tazobactam inhibits AmpC and other extended-spectrum  $\beta$ -lactamases but lacks activity against carbapenemases. Ceftazidime-avibactam inhibits class A carbapenemases but not metallo- $\beta$ -lactamases. Cefiderocol, a siderophore cephalosporin, has enhanced stability to  $\beta$ -lactamases, including metallo- $\beta$ -lactamases, Amp C, and carbapenemases.

**Meningitis** can occur by spread from a contiguous focus, as a secondary focus when there is bacteremia, or after invasive procedures. *P. aeruginosa* meningitis is best treated with ceftazidime or meropenem in combination with an aminoglycoside such as gentamicin, both given IV. Concomitant intraventricular or intrathecal treatment with gentamicin may be required when IV therapy fails but is not recommended for routine use.

### SUPPORTIVE CARE

*P. aeruginosa* infections vary in severity from *superficial* to *intense* septic presentations. With severe infections there is often multisystem involvement and a systemic inflammatory response. Supportive care is similar to care for severe sepsis caused by other gram-negative bacilli and requires support of blood pressure, oxygenation, and appropriate fluid management.

### PROGNOSIS

The prognosis is dependent primarily on the nature of the underlying factors that predisposed the patient to *P. aeruginosa* infection. In severely immunocompromised patients, the prognosis for patients with *P. aeruginosa* sepsis is poor unless susceptibility factors such as neutropenia or hypogammaglobulinemia can be reversed. The overall mortality rate was 12.3% in one series of 232 children with *P. aeruginosa* bacteremia, with 3% dying within 48 hours of admission. Resistance of the organism to first-line antibiotics also decreases the chance of survival. The outcome may be improved when there is a urinary tract portal of entry, absence of neutropenia or recovery from neutropenia, and drainage of local sites of infection.

*P. aeruginosa* is recovered from the lungs of most children who die of CF and adds to the slow deterioration of these patients. The prognosis for normal development is poor in the few infants who survive *P. aeruginosa* meningitis.

### PREVENTION

Prevention of infections is dependent on limiting contamination of the healthcare environment and preventing transmission to patients. Effective hospital infection control programs are necessary to identify and eradicate sources of the organism as quickly as possible. In hospitals, infection can be transmitted to children by the hands of personnel, from washbasin surfaces, from catheters and other hospital equipment, and from solutions used to rinse suction catheters.

Strict attention to hand hygiene before and between contacts with patients may prevent or interdict epidemic disease. Meticulous care and sterile procedures in the suctioning of endotracheal tubes, insertion and maintenance of indwelling catheters, and removal of catheters as soon as medically reasonable greatly reduce the hazard of extrinsic contamination by *P. aeruginosa* and other gram-negative organisms. Prevention of follicular dermatitis caused by *P. aeruginosa* contamination of whirlpools or hot tubs is possible by maintaining pool water at a pH of 7.2–7.8. Antimicrobial stewardship programs that promote the appropriate use of antibiotics in the hospital setting are critical for reducing the rates of MDR *P. aeruginosa*.

Infections in burned patients may be minimized by protective isolation, debridement of devitalized tissue, and topical applications of bactericidal cream. Administration of intravenous immunoglobulin

may be used. Approaches under investigation to prevent infection include development of a *P. aeruginosa* vaccine. No vaccine is currently licensed in the United States.

Visit Elsevier eBooks+ at [eBooks.Health.Elsevier.com](https://eBooks.Health.Elsevier.com) for Bibliography.

## 251.2 *Burkholderia cepacia* Complex

Ashley C. Howard and Thomas S. Murray

*Burkholderia cepacia* is a filamentous gram-negative rod now recognized to be a group of related species or **genomovars** (*B. cepacia*, *B. cenocepacia*, *B. multivorans*). It is ubiquitous in the environment but may be difficult to isolate from respiratory specimens in the laboratory, requiring an enriched, selective media oxidation-fermentation base supplemented with polymyxin B–bacitracin–lactose agar (OFPBL) and as long as 3 days of incubation.

*B. cepacia* is a classic opportunist that rarely infects normal tissue but can be a pathogen for individuals with preexisting damage to respiratory epithelium, especially persons with CF or with immune dysfunction such as chronic granulomatous disease. *B. cepacia* has multiple virulence factors, including lipopolysaccharide, flagella, and a type III secretion system that promotes invasion of respiratory epithelial cells. Resistance to many antibiotics and disinfectants appears to be a factor in the emergence of *B. cepacia* as a nosocomial pathogen. In critical care units it may colonize the tubing used to ventilate patients with respiratory failure. In some patients this colonization may lead to invasive pneumonia and septic shock. Although *B. cepacia* is found throughout the environment, human-to-human spread among CF patients occurs either directly by inhalation of aerosols or indirectly from contaminated equipment or surfaces, accounting for the strict infection control measures for children with CF who are colonized with *B. cepacia*. For example, CF patients colonized with *B. cepacia* are asked not to attend events where other persons with CF will be present. *B. cepacia* infections in persons with CF may represent chronic infection in some patients, but others, especially those with *Burkholderia cenocepacia*, genomovar III, can develop an acute respiratory syndrome of fever, leukocytosis, and progressive respiratory failure, with more rapid decline in pulmonary function and lower survival rate. In 2016–2017, two healthcare-associated *B. cepacia* outbreaks among non-CF patients occurred as a result of contaminated liquid docusate that infected 63 persons from 12 states and prefilled saline flushes that infected 163 persons with 7 deaths. In August 2021, a healthcare-associated outbreak of *B. stabilis* was linked to ultrasound gel used in 59 persons in six states, with 48 cases of bloodstream infection.

Treatment in hospitals should include standard precautions and avoidance of placing colonized and uncolonized patients in the same room. The use of antibiotics is guided by susceptibility studies of a patient's isolates, because the susceptibility pattern of this species is quite variable and resistant strains are common. *Trimethoprim-sulfamethoxazole* (TMP-SMX) and *doxycycline* or *minocycline* are potential oral therapies for *B. cepacia* complex. For IV therapy without meningitis, *meropenem* (20–40 mg/kg/dose every 8 hours with a maximum dose of 6 g/day) with a second agent such as TMP-SMX, *doxycycline*, *minocycline*, *ceftazidime*, or *amikacin* is recommended. Extended infusions should be considered for difficult-to-treat infections. Even though there is primary resistance to aminoglycosides, these agents may be useful in combination with other antibiotics. Treatment with two or more agents may be necessary to control the infection and avoid the development of resistance. Cefiderocol, because of its increased stability against  $\beta$ -lactamases, has activity against some MDR *B. cepacia* complex.

### BURKHOLDERIA MALLEI (GLANDERS)

**Glanders** is a severe infectious disease of horses and other domestic and farm animals that is caused by *Burkholderia mallei*, a nonmotile, gram-negative bacillus that is occasionally transmitted to humans. It is acquired by inoculation into the skin, usually at the site of a previous



**Fig. 251.2** Thigh abscesses at the sites of mosquito bites in a 15-yr-old Pennsylvania resident who had recently returned from Thailand, July 2016. Photo was taken 7 wk after onset. (From Mitchell PK, Campbell C, Montgomery MP, et al. Notes from the field: travel-associated melioidosis and resulting laboratory exposures—United States, 2016. *MMWR*. 2017;66[37]:1001–1002.)

abrasion, or by inhalation of aerosols. Laboratory workers may acquire it from clinical specimens. The disease is relatively common in Asia, Africa, and the Middle East. The clinical manifestations include septicemia, acute or chronic pneumonitis, and hemorrhagic necrotic lesions of the skin, nasal mucous membranes, and lymph nodes. The diagnosis is usually made by recovery of the organism in cultures of affected tissue. Glanders is treated with sulfadiazine, tetracyclines, or chloramphenicol and streptomycin over many months. The disease has been eliminated from the United States, but interest in this organism has increased because of the possibility of its use as a bioterrorism agent (see Chapter 763). Although standard precautions are appropriate when caring for hospitalized infected patients, biosafety level 3 precautions are required for laboratory staff working with *B. mallei*. No vaccine is available.

### BURKHOLDERIA PSEUDOMALLEI (MELIOIDOSIS)

**Melioidosis** is an important disease of Southeast Asia and northern Australia and occurs in the United States mainly in persons returning from endemic areas. The causative agent is *Burkholderia pseudomallei*, an inhabitant of soil and water in the tropics. It is ubiquitous in endemic areas, and infection follows inhalation of dust, ingestion, or direct contamination of abrasions or wounds. Human-to-human transmission has only rarely been reported. Serologic surveys demonstrate that asymptomatic infection occurs in endemic areas. The disease may remain latent and appear when host resistance is reduced, sometimes years after the initial exposure. Diabetes mellitus is a risk factor for severe melioidosis. In 2021, four cases of melioidosis with two deaths occurred in Kansas, Minnesota, Texas, and Georgia in persons, including children, with no known travel. The exposure is unknown but thought to be from a single source, such as a contaminated imported product or animal.

Melioidosis may present as a **primary skin lesion** (vesicle, bulla, or urticaria) (Fig. 251.2). Pulmonary infection may be subacute and mimic tuberculosis or may present as an acute necrotizing pneumonia. Occasionally, septicemia occurs and numerous abscesses are noted in various organs of the body. Myocarditis, pericarditis, endocarditis, intestinal abscess, cholecystitis, acute gastroenteritis, UTIs, septic arthritis, paraspinal abscess, osteomyelitis, mycotic aneurysm, and generalized lymphadenopathy all have been observed. Melioidosis may also present as an encephalitic illness with fever and seizures. It is also an agent of severe wound infections after contact with contaminated water after a tsunami. Diagnosis is based on visualization of characteristic small, gram-negative rods in exudates or growth on laboratory media such as eosin–methylene blue or MacConkey agar. Serologic



tests are available, and diagnosis can be established by a fourfold or greater increase in antibody titer in an individual with an appropriate syndrome. It is recognized as a possible agent of bioterrorism, and if suspected, the clinical microbiology laboratory should be notified immediately (see Chapter 763).

*B. pseudomallei* is susceptible to many antimicrobial agents, and the U.S. Centers for Disease Control and Prevention (CDC) recommends meropenem or ceftazidime as IV therapies and TMP-SMX or doxycycline as oral therapy. Other choices include aminoglycosides, tetracycline, chloramphenicol, and amoxicillin-clavulanate. Therapy should be guided by antimicrobial susceptibility tests; two or three agents such as ceftazidime or meropenem plus TMP-SMX, sulfisoxazole, or an aminoglycoside are usually chosen for severe or septicemic disease. For severe disease, prolonged treatment for 2-6 months is recommended to prevent relapses. Appropriate antibiotic therapy generally results in recovery.

Visit Elsevier eBooks+ at [eBooks.Health.Elsevier.com](https://eBooks.Health.Elsevier.com) for Bibliography.

### 251.3 *Stenotrophomonas*

Ashley C. Howard and Thomas S. Murray

*Stenotrophomonas maltophilia* (formerly *Xanthomonas maltophilia* or *Pseudomonas maltophilia*) is a short to medium-sized, straight, gram-negative bacillus. It is ubiquitous in nature and can be found in the hospital environment, especially in tap water or standing water, and may contaminate sinks and hospital equipment such as nebulizers. Strains isolated in the laboratory may be contaminants, may be a commensal from the colonized surface of a patient, or may represent an invasive pathogen. The species is an opportunist and is often recovered from immunosuppressed patients and patients with CF after multiple courses of antimicrobial therapy. Serious infections usually occur among those requiring intensive care, including neonatal intensive care, typically patients with ventilator-associated pneumonia or catheter-associated infections. Prolonged antibiotic exposure appears to be a frequent factor in nosocomial *S. maltophilia* infections, probably because of its endogenous antibiotic-resistance pattern. Common types of infection include pneumonia after airway colonization and aspiration, bacteremia, soft tissue infections, endocarditis, and osteomyelitis. *S. maltophilia* bacteremia is a **nosocomial infection** associated with the presence of a central venous catheter.

Strains vary as to antibiotic susceptibility, and the treatment of *S. maltophilia* can be difficult because of inherent antimicrobial resistance. Data are lacking on whether there is clinical benefit to treat *S. maltophilia* recovered from the respiratory tract of a patient with CF. For invasive infections, **TMP-SMX** (20 mg/kg/day TMP component every 6-8 hours) is the treatment of choice and is the only antimicrobial for which susceptibility is routinely reported. **Minocycline** monotherapy has recently been shown to be a viable alternative to TMP-SMX and is reported for TMP-SMX resistance strains with fewer adverse effects and similar clinical outcomes. Mean inhibitory concentration testing is available for other antibiotics, such as ticarcillin-clavulanate, and also reserved for TMP-SMX-resistant isolates. For resistant organisms or for patients who cannot tolerate sulfa drugs, other options based on clinical outcome include ciprofloxacin and ceftazidime alone or in combination with other agents such as aminoglycosides.

#### ACKNOWLEDGMENTS

We would like to acknowledge Dr. Robert S. Baltimore for his contribution to this chapter and Dr. Michelle R. Rychalsky for antibiotic dosing regimens.

Visit Elsevier eBooks+ at [eBooks.Health.Elsevier.com](https://eBooks.Health.Elsevier.com) for Bibliography.

## Chapter 252

# Tularemia (*Francisella tularensis*)

Kevin J. Downes

Tularemia is a **zoonosis** caused by the gram-negative bacterium *Francisella tularensis*. Tularemia is primarily a disease of wild animals; human disease is incidental and usually results from **tick** or **deer fly** bites or from contact with infected live or dead wild animals. The illness caused by *F. tularensis* is manifest by multiple clinical syndromes, the most common consisting of an ulcerative lesion at the site of inoculation with regional **lymphadenopathy** or **lymphadenitis**. *F. tularensis* is also a potential agent of **bioterrorism** (see Chapter 763).

#### ETIOLOGY

*Francisella tularensis* is a small, nonmotile, pleomorphic, catalase-positive, gram-negative coccobacillus. It can be classified into four main subspecies: *F. tularensis* subsp. *tularensis* (type A), *F. tularensis* subsp. *holartica* (type B), *F. tularensis* subsp. *mediasiatica*, and *F. tularensis* subsp. *novicida*. Type A can be further subdivided into four distinct genotypes designated A1a, A1b, A2a, and A2b, with A1b appearing to produce more serious disease in humans. Although all subspecies of *F. tularensis* can cause human infections, types A and B are most common, and type A is the most virulent. *F. tularensis* is an intracellular organism than can infect various host cell types, including macrophages, hepatocytes, and epithelial cells. It is one of the most virulent bacterial pathogens known, with as few as 10 microorganisms causing infections in humans and animals.

#### EPIDEMIOLOGY

Tularemia is primarily found in the Northern Hemisphere. Type A is found predominantly in North America, whereas type B is found throughout North America, Europe, and Asia. Human infections with type B are usually milder and have lower mortality rates compared to infections with type A. *F. tularensis* subsp. *mediasiatica* appears to be restricted to Central Asia, whereas *F. tularensis* subsp. *novicida* has been isolated in North America, Australia, and Southeast Asia.

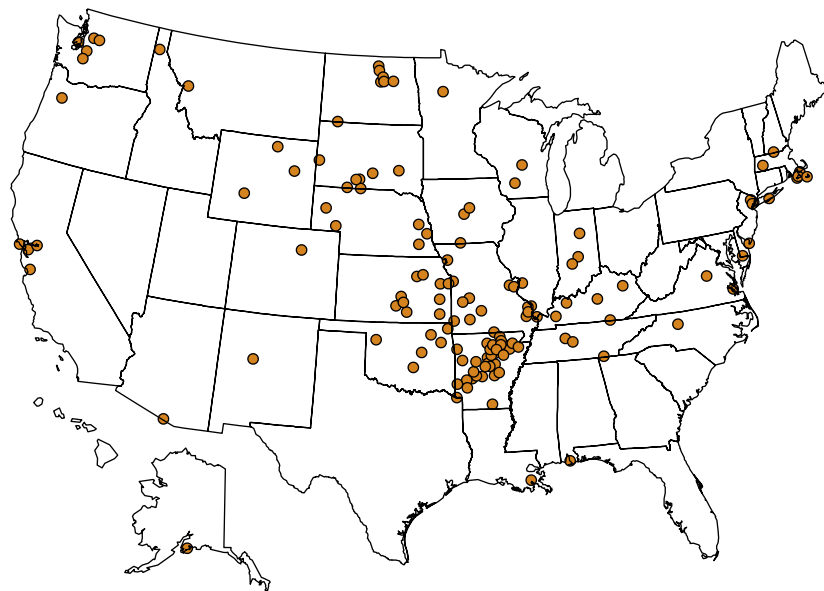
According to the Centers for Disease Control and Prevention (CDC), the number of annual reported cases of tularemia in the United States from 2010 to 2019 ranged from 124 to 314 per year. In 2015 the number of cases reported in the United States was the highest it had been over the previous 50 years. Tularemia occurs all over the United States, with the majority of cases reported from central states (Fig. 252.1). The U.S. incidence of tularemia from 2010 to 2019 was 0.10 per 100,000 residents; Arkansas (3.1/100,000), South Dakota (1.9/100,000), and Nebraska (0.9/100,000) were the states with the highest incidence.

Although cases of tularemia occur all year, most cases and outbreaks occur in warm summer months (May-September). Tularemia is more common in males, although this is less true in children compared with adults. There is a bimodal distribution based on age with peaks in childhood (5-9 years) and later adulthood (50-69 years), potentially because of greater opportunities for environmental and animal exposures at these ages (Fig. 252.2).

#### PATHOGENESIS

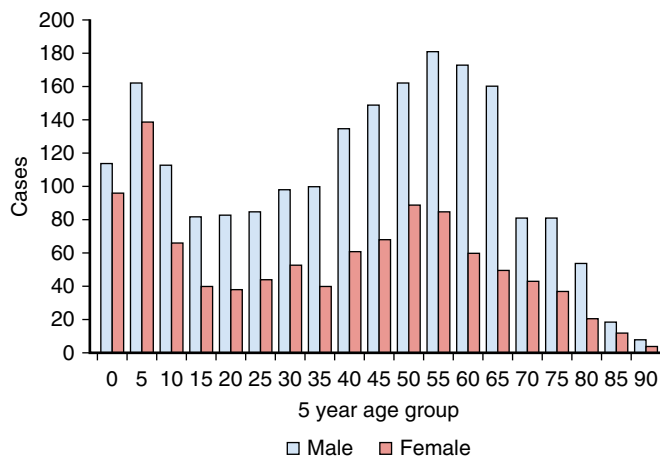
Of all the zoonotic diseases, tularemia is unusual because of the different modes of transmission of disease. A large number of animals serve as a reservoir for this organism. In the United States, rabbits and ticks are the principal reservoirs. Dogs may be an intermediate vector. In the United States, *Amblyomma americanum* (lone star tick), *Dermacentor variabilis* (dog tick), and *Dermacentor andersoni* (wood tick) are the most common tick vectors. These ticks usually feed on infected small





\* One dot is placed randomly within county of residence for each reported case.

**Fig. 252.1** Map of reported cases of tularemia—United States, 2020. (From Centers for Disease Control and Prevention: *Tularemia—Statistics*, <https://www.cdc.gov/tularemia/statistics/index.html>, Accessed: August 25, 2021.)



**Fig. 252.2** Incidence of reported cases of tularemia by age and sex—United States, 2001–2020. (From Centers for Disease Control and Prevention: *Tularemia—Statistics*, <https://www.cdc.gov/tularemia/statistics/index.html>, Accessed: August 25, 2021.)

rodents and later feed on humans. Deer flies (*Chrysops* spp.) can also transmit tularemia and are present in the western United States. *F. tularensis* subsp. *tularensis* is carried by rabbits, ticks, and tabanid flies (e.g., deer flies), whereas subsp. *holarctica* is associated with aquatic habitats and transmitted primarily by mosquitoes, but also aquatic rodents (beavers, muskrats), hares, voles, ticks, tabanid flies, and ingestion of contaminated water (e.g., ponds, rivers).

The organism can penetrate both intact skin and mucous membranes (eyes, mouth, gastrointestinal [GI] tract, or lungs), which are the most common portals of entry. Transmission can occur through the bite of infected ticks or other biting insects, by contact with infected animals or their carcasses, by consumption of contaminated foods or water, or through inhalation, as might occur in a laboratory setting or if a machine (e.g., lawn mower) runs over an infected animal carcass. Hunting or skinning infected wild rodents, such as rabbits or prairie dogs, has been the source of infection in numerous reports. Domesticated animals such as cats and hamsters can also

transmit tularemia. Importantly, this organism is not transmitted from person to person.

Usually  $>10^8$  organisms are required to produce infection if *F. tularensis* bacteria are ingested, but as few as 10 organisms may cause disease if they are inhaled or injected into the skin (i.e., via an insect bite). Infection with *F. tularensis* stimulates the host to produce antibodies, which have been recognized as important in the immune response to this organism. The *F. tularensis* envelope is largely responsible for virulence and plays major roles in the ability of the organism to evade the immune system, attach to and invade cells, and cause severe disease. The body is most dependent on cell-mediated immunity to contain and eradicate *F. tularensis*. Tularemia is usually followed by specific protection; chronic infection or reinfection is therefore unlikely.

### CLINICAL MANIFESTATIONS

Symptoms of tularemia vary based on the mode of transmission. The average incubation period from infection until clinical symptoms is 3 days (range: 1–21 days). Early symptoms of infection are generally nonspecific: fever, chills, myalgias, arthralgias, headache, and fatigue. Bacteremia may be common in the early stages of infection. Acute infections often present with sudden onset of fever, and a pulse-temperature dissociation may be present. Findings on physical examination may include lymphadenopathy, hepatosplenomegaly, or skin lesions. [Table 252.1](#) shows the frequency of various symptoms and examination findings.

The clinical manifestations of tularemia have been divided into six major clinical syndromes ([Table 252.2](#)). **Ulceroglandular** and **glandular** disease are the two most common forms of tularemia in children. Infections after the bites of ticks or deer flies take these forms. Within 48–72 hours after inoculation of the skin, an erythematous, tender, or pruritic papule may appear at the portal of entry. This papule may enlarge and form an ulcer with a black base. Ulcers are generally erythematous and painful with raised borders and may last several weeks, especially if untreated. Various other skin lesions have been described, including erythema multiforme and erythema nodosum. Approximately 20% of patients may develop a generalized maculopapular rash that occasionally becomes pustular. The unifying manifestation of glandular and ulceroglandular forms of tularemia is **painful regional lymphadenopathy**. Adenopathy may develop before, concurrent with, or

**Table 252.1** Common Clinical Manifestations of Tularemia in Children

SIGN OR SYMPTOM	APPROXIMATE FREQUENCY (%)
Lymphadenopathy	90
Fever (>38.3°C [100.9°F])	85
Ulcer/eschar/papule	45
Pharyngitis	40
Myalgias/arthralgias	40
Nausea/vomiting	35
Hepatosplenomegaly	35

**Table 252.2** Clinical Syndromes of Tularemia in Children

CLINICAL SYNDROME	CHARACTERISTICS OF SYNDROME
Ulceroglandular	Skin ulcer/eschar at site of inoculation; painful regional adenopathy
Glandular	Painful regional adenopathy without detectable skin ulceration
Pneumonia	Nonproductive cough, dyspnea, pleuritic chest pain; multilobar/diffuse infiltrates > lobar infiltrates on chest radiography
Oropharyngeal	Pharyngitis, mucosal ulcers, cervical adenopathy
Oculoglandular	Unilateral, painful, and often purulent conjunctivitis; chemosis; conjunctival ulcers; preauricular adenopathy
Typhoidal	Severe systemic disease (sepsis-like syndrome): high fever, headaches, myalgias, arthralgias, neurologic symptoms

after skin ulceration in ulceroglandular disease. Cervical or posterior auricular nodes are involved after bites on the head or neck, whereas enlarged axillary or epitrochlear nodes signal exposure on the arms. Nodes may vary in size from 0.5 to 10 cm and appear singly or in clusters. These affected nodes may become fluctuant and drain spontaneously and are often associated with overlying skin changes. Late suppuration of the involved nodes has been described in 25–30% of patients despite effective therapy. Examination of this material from such lymph nodes usually reveals sterile necrotic material. Mortality with these forms of tularemia is rare, especially with implementation of effective treatment.

**Oropharyngeal** tularemia results from consumption of poorly cooked meats or contaminated water. This syndrome is characterized by acute pharyngitis, with or without tonsillitis, and cervical lymphadenitis. Infected tonsils may become large and develop a yellowish-white membrane that may resemble the membranes associated with diphtheria. GI disease may also occur and usually presents with mild, unexplained diarrhea or emesis but may progress to rapidly fulminant and fatal disease. GI bleeding can develop in more severe forms associated with intestinal ulcers.

**Oculoglandular** disease is uncommon, but when it does occur, the portal of entry is the conjunctiva. Contact with contaminated fingers or debris is the most common mechanism of this form of tularemia. Disease is generally unilateral. The conjunctiva is painful and inflamed with yellowish nodules and pinpoint ulcerations. Purulent conjunctivitis with ipsilateral preauricular or submandibular lymphadenopathy can develop and is referred to as **Parinaud oculoglandular syndrome**, although this term is not specific to tularemia. Corneal ulceration and perforation are uncommon but serious complications of this form of disease.

The **typhoidal** form is usually associated with a large inoculum of organisms and is a term used to describe nonlocalizing disease, regardless of the mode of transmission or portal of entry. Patients are often critically ill and bacteremic, and symptoms mimic those with other forms of sepsis: high fevers, confusion, rigors, myalgias, vomiting, and diarrhea. Clinicians practicing in tularemia-endemic regions must always consider this diagnosis in critically ill children. Complications of bacteremia with *F. tularensis* can include the development of meningitis, pericarditis, hepatitis, peritonitis, endocarditis, skin/soft tissue abscesses, and osteomyelitis. Because of its increased virulence, *F. tularensis* subsp. *tularensis* (type A disease) is more often associated with typhoidal tularemia. Patients with tularemia meningitis usually develop a marked cerebrospinal fluid (CSF) pleocytosis with a monocytic predominance. As with other causes of bacterial meningitis, CSF glucose is low and protein is high.

Pneumonia caused by *F. tularensis* (**pneumonic form**) can develop after inhalation (primary pulmonary infection) or secondary to hematogenous spread. Inhalation-related infection has been described in laboratory workers who are working with the organism and results in a relatively high mortality rate. Aerosols from farming activities involving rodent contamination (haying, threshing) or animal carcass destruction with lawn mowers have been reported to cause pneumonia as well. Patients generally complain of a nonproductive cough, dyspnea, or pleuritic chest pain. Chest radiographs of patients with pneumonic tularemia most often reveal diffuse, patchy infiltrates rather than focal areas of consolidation. Pleural effusions can also be present. In pulmonary infections, hilar or mediastinal adenopathy can develop, and in severe forms, necrotizing or hemorrhagic pneumonitis can occur. Mortality with pneumonic tularemia is high if untreated.

## DIAGNOSIS

The diagnosis can be delayed because symptoms are often similar to other, more common infections. The history and physical examination of the patient may suggest the diagnosis, especially if the patient has a history of animal or tick exposure. Routine hematologic blood tests are nondiagnostic. **Definitive diagnosis is made by growth of *F. tularensis* in culture.** *F. tularensis* can be isolated in culture of lymph node biopsies or aspirates, blood, wounds, pharyngeal swabs, pleural fluid, or sputum specimens, although cultures are positive in only approximately 10% of cases. The organism can be identified on culture from skin lesions and lymph nodes for as long as a month after onset of disease. Polymerase chain reaction of tissue specimens may be more sensitive than culture but is currently used to make a presumptive diagnosis only.

*F. tularensis* can be cultured in the microbiology laboratory on cysteine–glucose–blood agar, but care should be taken to alert the personnel in the laboratory if this is attempted so that they can take the proper precautions to protect themselves from acquiring infection; biosafety level 3 containment is necessary to avoid occupational exposure. Histopathologic findings of involved lymph nodes demonstrate granulomas with central necrosis (early) and caseation (late). Unfortunately, these findings cannot distinguish tularemia from other causes of granulomatous lymphadenitis, such as tuberculosis, cat-scratch disease (*Bartonella henselae* infection), or sarcoidosis.

The diagnosis of tularemia is most often established via serology. In the standard tube agglutination (TA) test, a single titer of  $\geq 1:160$  in a patient with a compatible history and physical findings can establish the diagnosis. A microagglutination (MA) test is also available, and  $\geq 1:128$  is considered positive. Patients often do not produce detectable antibodies until the second week of illness, so negative testing in the acute phase does not rule out infection. A fourfold increase in titer from paired serum samples collected  $>2$  weeks apart (i.e., acute and convalescent titers) can also be considered diagnostic. False-negative serologic responses can be obtained early in the infection or if paired sera are collected too close together. False-positive serologic tests can also result from cross-reactivity with other gram-negative organisms, such as *Brucella* or *Legionella* species, particularly at low titers. Once infected, patients may have a positive agglutination test result (1:20-1:80) that persists for life. Other testing techniques available include enzyme-linked immunosorbent assay (ELISA), analysis of urine for tularemia antigen, indirect immunofluorescent assay, and immunohistochemical staining; these studies have less well-established roles in the diagnosis of tularemia.

### Differential Diagnosis

The differential diagnosis of **ulceroglandular** or **glandular** tularemia is broad and includes infection with pathogens that cause acute or subacute lymphadenitis: cat-scratch disease (*B. henselae*), infectious mononucleosis, typical bacterial pathogens (*Staphylococcus aureus*, group A streptococcus), *Mycobacterium tuberculosis*, nontuberculous mycobacteria, *Toxoplasma gondii*, *Sporothrix schenckii*, plague (*Yersinia pestis*), anthrax (*Bacillus anthracis*), melioidosis (*Burkholderia pseudomallei*), and rat-bite fever (*Streptobacillus moniliformis*, *Spirillum minus*). Noninfectious processes such as sarcoidosis and Kawasaki disease can also present similarly. **Oculoglandular** disease may also occur with other infectious agents, such as *B. henselae*, *Treponema pallidum*, *Coccidioides immitis*, herpes simplex virus (HSV), adenoviruses, and the bacterial agents responsible for purulent conjunctivitis. **Oropharyngeal** tularemia must be differentiated from the same diseases that cause ulceroglandular/glandular disease and from cytomegalovirus, HSV, adenovirus, and other viral or bacterial etiologies. **Pneumonic** tularemia must be differentiated from the other atypical pathogens that cause community-acquired pneumonia, such as *Mycoplasma* and *Chlamydia*, as well as mycobacteria, fungi, and rickettsiae. Inhalation plague, anthrax, and Q fever could also present similarly. **Typhoidal** tularemia must be differentiated from other forms of sepsis and from enteric fever (typhoid and paratyphoid fever) and brucellosis.

### TREATMENT

Aminoglycosides are the mainstay of treatment of tularemia: **gentamicin is the drug of choice for the treatment of tularemia in children**, and streptomycin is the drug of choice in adults. Table 252.3 displays therapeutic options for treatment of tularemia and for postexposure prophylaxis. **Ciprofloxacin is often used for mild (localized) cases**, especially those caused by subsp. *holarctica*, but is less commonly prescribed in children. Doxycycline has been used successfully, but the relapse rate is higher than with aminoglycosides, and so it is not generally recommended. Ciprofloxacin and doxycycline are often used as adjunctive therapy for treatment of tularemia meningitis because of the poor penetration of aminoglycosides in the CSF. Ciprofloxacin can also be considered in cases of moderate/severe disease after initial treatment with an aminoglycoside, if an IV-to-PO switch is warranted based on clinical improvement.  $\beta$ -lactam agents demonstrate poor activity against *F. tularensis* and should not be used.

**Therapy with aminoglycosides is typically continued for 7-10 days, but a longer course is needed in more severe disease;** 5-7 days may be sufficient for mild cases. Ciprofloxacin treatment is typically 10-14 days, although there is no FDA-approved regimen for tularemia specifically. Treatment with doxycycline should be continued for 14-21 days because of an increased risk of relapse, likely because of its bacteriostatic nature.

### PROGNOSIS

Poor outcomes are associated with a delay in appropriate treatment, but with rapid recognition and treatment, fatalities are exceedingly rare. The mortality rate for severe untreated disease (e.g., pneumonia, typhoidal disease) can be as high as 30%. Otherwise, the overall mortality rate is  $<1\%$ . Subspecies *tularensis* is associated with more aggressive disease and worse outcomes than subsp. *holarctica*.

Relapses are uncommon if aminoglycoside therapy is used. Patients typically defervesce within 24-48 hours after starting therapy, although lymphadenopathy can take several weeks to resolve fully. Late suppuration of involved lymph nodes may occur despite adequate therapy. Patients who have not started on appropriate therapy early may respond more slowly to antimicrobial therapy.

### PREVENTION

Prevention of tularemia is based on avoiding exposure. Children living in tick-endemic regions should be taught to avoid tick-infested areas. Families should have a tick control plan for their immediate environment and for their pets. Protective clothing should be worn when entering a tick-infested area. Insect repellents can be used safely

**Table 252.3** Recommended Treatment for Children with Tularemia

INDICATION	DRUG AND DOSAGE	DURATION
Moderate-severe disease	Gentamicin 5-7.5 mg/kg/day IV or IM divided every 8-12 hr* or Streptomycin 30-40 mg/kg/day IM divided every 12 hr (max 1 g/dose)	$\geq 10$ days
Mild disease	Gentamicin 5-7.5 mg/kg/day IV or IM divided every 8-12 hr* or Ciprofloxacin 20-40 mg/kg/day PO divided every 12 hr (max 500 mg/dose)	5-7 days 10-14 days
Meningitis	Streptomycin or gentamicin (in doses given for moderate-severe disease) PLUS Ciprofloxacin (20-40 mg/kg/day IV divided every 12 hr) or Doxycycline 4.4 mg/kg/day IV divided every 12 hr (max 100 mg/dose)	$\geq 10$ days
Postexposure prophylaxis	Doxycycline 4.4 mg/kg/day PO divided twice daily (max 100 mg/dose) or Ciprofloxacin 20-40 mg/kg/day PO divided twice daily (max 500 mg/dose)	14 days

\*Once-daily dosing of gentamicin could be considered, although it has not specifically been studied for this indication. IM, Intramuscularly; IV, intravenously; PO, per os (i.e., by mouth).

in infants and children. Children should undergo frequent tick checks during and after their time in tick-infested areas. If ticks are found on the child, forceps should be used to pull the tick straight out. The skin should be cleansed before and after this procedure. Children should also be taught to avoid sick and dead animals. Children should be encouraged to wear gloves, masks, and eye protection while cleaning wild game. Further, families should cook wild game thoroughly before eating.

Prophylactic antimicrobial agents are generally not effective in preventing tularemia and should not be used after exposure, with the exception of laboratory or bioterrorism exposures. No tularemia vaccine is currently available to the general public (one is available for high-risk laboratory workers through the Department of Defense). Standard precautions are adequate for hospitalized children with tularemia because no cases of person-to-person transmission have been identified.

Visit Elsevier eBooks+ at [eBooks.Health.Elsevier.com](http://eBooks.Health.Elsevier.com) for Bibliography.

## Chapter 253

# *Brucella*

Kevin J. Downes

Human **brucellosis** is caused by organisms of the genus *Brucella* and continues to be a major public health problem worldwide. Humans are accidental hosts and acquire this **zoonosis** from direct contact with an infected animal (cattle, sheep, camels, goats, and swine) or consumption of products of an infected animal. Although brucellosis is widely recognized as an occupational risk among adults working with livestock, much of the brucellosis in children is food-borne and is associated with consumption of unpasteurized dairy products. *Brucella* spp. are also potential agents of bioterrorism (see [Chapter 763](#)).

### ETIOLOGY

*Brucella abortus* (cattle), *Brucella melitensis* (goats and sheep), *Brucella suis* (swine), and *Brucella canis* (dogs) are the most common organisms responsible for human disease. These organisms are small, aerobic, non-spore-forming, nonmotile, gram-negative coccobacillary bacteria. *Brucella* spp. are fastidious in their growth but can be grown on various laboratory media, including blood and chocolate agars.

### EPIDEMIOLOGY

Brucellosis is endemic in many parts of the world and is especially prevalent in the Mediterranean basin, Persian Gulf, Indian subcontinent, and parts of Mexico and Central and South America. There are approximately 500,000 new cases annually worldwide, although accurate estimates of the prevalence of disease are lacking because of underreporting and underdiagnosis. Childhood brucellosis accounts for 10–30% of cases.

*B. melitensis* is the most prevalent species causing human brucellosis and is most often carried by sheep, goats, camels, and buffalo. Elk, caribou, bison, deer, moose, and swine can also be infected. Because of improved sanitation and animal vaccination, brucellosis has become rarer in countries with effective public health and domestic animal health programs, although recreational or occupational exposures continue to occur. **Consumption of raw or unpasteurized dairy products** in a child who has lived in or traveled to an endemic area is the key risk factor for pediatric brucellosis because most childhood

cases are acquired via ingestion. In the United States in 2010, >50% of cases occurred in California, Arizona, Florida, and Texas. All age-groups can be infected by *Brucella*, and infections are more common in males, likely because of more frequent occupational and recreational exposures.

*B. abortus* cattle vaccine strain RB51 is a live, attenuated vaccine that has been used to vaccinate cattle in the United States since 1996. Very rare cases of human infection with this vaccine strain have been reported secondary to consumption of unpasteurized milk from vaccinated cows. These strains are resistant to rifampin, a primary agent used in the treatment of brucellosis, so clinicians should consider RB51 in a patient with the correct exposure history.

### PATHOGENESIS

Modes of transmission for these organisms include inoculation through cuts or abrasions in the skin, inoculation of the conjunctiva, inhalation of infectious aerosols, or ingestion of contaminated meat or dairy products. **Infected livestock are the most common source of human infection.** In children the primary means of infection is through eating or drinking unpasteurized or raw dairy products. Individuals in endemic areas with occupational exposures to animals, such as farmers, veterinarians, and slaughterhouse workers, are at highest risk; exposure to an infected animal's abortion products or feces are notable risk factors in such occupations. Laboratory workers are more often exposed to infected aerosols. The risk for infection depends on the nutritional and immune status of the host, the route of inoculation, and the species of *Brucella*. For reasons that remain unclear, it has been suggested that *B. melitensis* and *B. suis* are more virulent than *B. abortus* or *B. canis*.

The major virulence factor for *Brucella* spp. appears to be its cell wall lipopolysaccharide (LPS). Strains containing smooth LPS have been demonstrated to have greater virulence and are more resistant to killing by polymorphonuclear leukocytes. These organisms are facultative intracellular pathogens that can survive and replicate within the mononuclear phagocytic cells (monocytes, macrophages) of the reticuloendothelial system. Even though *Brucella* spp. are chemotactic for entry of leukocytes into the body, the leukocytes are less efficient at killing these organisms than other bacteria despite the assistance of serum factors such as complement. *Brucella* spp. possess multiple strategies to evade immune responses and establish and maintain chronic infection. Specifically, during chronic stages of infection, organisms persist within the liver, spleen, lymph nodes, and bone marrow and result in granuloma formation.

Antibodies are produced against the LPS and other cell wall antigens, providing a means of diagnosis and likely playing a role in long-term immunity. The major factor in recovery from infection appears to be development of a cell-mediated immune response, resulting in macrophage activation and enhanced intracellular killing. Specifically, sensitized T lymphocytes release cytokines (e.g., interferon- $\gamma$ , tumor necrosis factor- $\alpha$ ), which activate the macrophages and enhance their intracellular killing capacity.

### CLINICAL MANIFESTATIONS

Brucellosis is a systemic illness that can be quite difficult to diagnose in children. Symptoms can be acute or insidious in nature and are usually nonspecific. The incubation period is generally 2–4 weeks but may be shorter with *B. melitensis*. Fever is present in >75% of cases, and the fever pattern can vary widely. The most common physical complaints are arthralgia, myalgia, and back pain. Systemic symptoms, such as fatigue, sweats, chills, anorexia, headache, weight loss, and malaise, are reported in the majority of adult cases but are less frequent in children. Other associated symptoms include abdominal pain, diarrhea, rash, vomiting, cough, and pharyngitis.

The most common physical manifestation of brucellosis is hepatic and splenic enlargement, which is present in approximately half of cases. Whereas arthralgia is common, arthritis occurs in a minority of cases. Arthritis is typically monoarticular and most



often involves the knee or hip in children and the sacroiliac joint in adolescents and adults. Several types of skin lesions have been described with brucellosis, but there is no typical rash for this infection. Epididymo-orchitis also can occur and is more common in adolescents and adults.

In endemic countries, *Brucella* spp. are an important cause of occult bacteremia in young children. Because of the organism's ability to establish chronic infection, hepatic and splenic abscesses may develop. High-grade fever and elevations in liver enzymes are common among children with primary bacteremia. Children with positive blood cultures typically have more acute presentations with increased markers of inflammation (leukocyte count, CRP, ferritin) compared with culture-negative cases. Recurrent episodes of bacteremia can also occur (<10% of cases), especially with inadequate primary treatment. These recurrent episodes are less often associated with fever (40% of cases), potentially indicating the indolent nature of chronic *Brucella* infections in children.

Serious manifestations of brucellosis include endocarditis, meningitis, osteomyelitis, and **spondylitis**. Although headache and malaise may be demonstrated in patients with uncomplicated brucellosis, invasion of the nervous system occurs in only 1–4% of cases. Death from brucellosis is rare, occurring in less than 1% of cases. Neonatal and congenital infections with these organisms have also been described, resulting from transplacental transmission, breast milk, and blood transfusions. The signs and symptoms associated with congenital/neonatal brucellosis are nonspecific.

Hematologic abnormalities are common with brucellosis but occur in less than half of cases; leukopenia is the most common cytopenia to develop. Hemolytic complications can include microangiopathic hemolytic anemia, thrombotic microangiopathy, and autoimmune hemolytic anemia. Secondary cases of hemophagocytic lymphohistiocytosis have also been described after brucellosis in children. Elevations of liver enzymes occur in approximately half of all cases of brucellosis and are more common when bacteremia is present.

## DIAGNOSIS

A definitive diagnosis of brucellosis is established by isolating and identifying the organisms from cultures of the blood (most common), bone marrow, or other fluids and tissues. Unfortunately, cultures are insensitive and positive in only a minority of pediatric cases. In a study of 436 children with brucellosis in Israel from 2005 to 2014, 76% had positive blood cultures. However, the prevalence of bacteremia in this cohort, 64% of whom were hospitalized, was much higher than most prior reports, in which less than half of cases have had positive blood cultures. Isolation of the organism from a blood culture sample may require as long as 4 weeks unless the laboratory is using an automated culture system such as the lysis-centrifugation method, where the organism can be recovered in 5–7 days. Therefore it is prudent to alert the clinical microbiology laboratory that brucellosis is suspected, so that cultures can be held longer. Bone marrow cultures may be superior to blood cultures when evaluating patients who have received previous antimicrobial therapy.

In addition to bacterial isolation, various serologic tests have been applied to the diagnosis of brucellosis. Microagglutination or serum (tube) agglutination tests are the most widely used and detect antibodies against *B. abortus*, *B. melitensis*, and *B. suis*. These methods do not detect antibodies against *B. canis* or *B. abortus* vaccine strain RB51, which lack the smooth LPS; *B. canis*-specific antigen is required to diagnose this species. Antibodies can also be detected by other tests such as enzyme-linked immunosorbent assay (ELISA). The Rose Bengal plate test (RBT) is a rapid agglutination test that is used as a screening test in many endemic regions. It has good sensitivity (>95%) and low cost, but confirmation of RBT results with microbiologic or other serologic tests is advised.

For a diagnosis to be made via serology alone, acute and convalescent samples taken 2–4 weeks apart are recommended; a four-fold or greater rise in titers is diagnostic of an acute infection. No single titer is ever diagnostic, but most patients with acute infections have titers of  $\geq 1:160$ ; lower titers may be present early in the disease course. Immunoglobulin M (IgM) antibodies can generally be detected within a week of illness onset, whereas IgG is detectable 2–4 weeks after infection.

Because patients with active infection have both an IgM and an IgG response and the serum agglutination test measures the total quantity of agglutinating antibodies, the total quantity of IgG is measured by treatment of the serum with 2-mercaptoethanol. This fractionation is important in determining the significance of the antibody titer because low levels of IgM can remain in the serum for weeks to months after the infection has been treated. IgG titers decrease with effective therapy, and a negative 2-mercaptoethanol test after treatment indicates a favorable response.

It is important to remember that all serologic results must be interpreted in light of a patient's history and physical examination. False-positive results from cross-reacting antibodies to other gram-negative organisms, such as *Yersinia enterocolitica*, *Francisella tularensis*, and *Vibrio cholerae*, can occur. In addition, the prozone effect can give false-negative results in the presence of high titers of antibody. To avoid this issue, serum that is being tested should be diluted to  $\geq 1:320$ .

The enzyme immunoassay should only be used for suspected cases with negative serum agglutination tests or for the evaluation of patients in the following situations: (1) complicated cases, (2) suspected chronic brucellosis, or (3) reinfection. Polymerase chain reaction assays have been developed but are not available in most clinical laboratories.

## Differential Diagnosis

Brucellosis should be considered in the differential diagnosis of fever of unknown origin in endemic areas. It may present similar to other infections such as tularemia, cat scratch disease, malaria, typhoid fever, histoplasmosis, blastomycosis, and coccidioidomycosis. Infections caused by *Mycobacterium tuberculosis*, atypical mycobacteria, rickettsiae, and *Yersinia* can also present similar to brucellosis.

## TREATMENT

Many antimicrobial agents are active in vitro against *Brucella* spp., but clinical effectiveness does not always correlate with these results. Agents that provide good intracellular killing are required for elimination of *Brucella* infections. Because of the risk of relapse with monotherapy, combination therapy is generally recommended. Additionally, prolonged therapy (6 weeks or longer) is necessary to ensure an adequate and sustained response.

For uncomplicated infections in children 8 years of age or older,  $\geq 6$  weeks of doxycycline in combination with rifampin is recommended (Table 253.1). For children younger than age 8 years, trimethoprim-sulfamethoxazole (TMP-SMX) plus rifampin is advised because of concerns about prolonged tetracycline use in young children. Although data support that the combination of doxycycline plus an aminoglycoside (streptomycin, gentamicin) is superior to the other oral combination therapies, with fewer treatment failures and relapses, the inconvenience of parenteral therapy may limit this approach in uncomplicated cases, particularly in resource-limited settings. Fluoroquinolones may be a viable alternative to doxycycline or TMP-SMX but have not been studied in children.

In more serious infections (e.g., endocarditis, meningitis, osteoarticular infections), three-drug therapy is advised. An aminoglycoside (streptomycin, gentamicin) should be administered for the first 7–14

**Table 253.1** Recommended Therapy for Treatment of Brucellosis

AGE/CONDITION	TREATMENT REGIMEN	DURATION
≥8 yr, uncomplicated infection	Doxycycline (PO; 4.4 mg/kg/day, max 200 mg/day) in 2 divided doses	≥6 wk
	<b>plus</b> Rifampin (PO; 15-20 mg/kg/day, max 600-900 mg/day) in 1-2 divided doses	≥6 wk
	<b>Alternative:</b> Doxycycline (PO; 4.4 mg/kg/day, max 200 mg/day) in 2 divided doses	≥6 wk
	<b>plus</b> Streptomycin (IM/IV; 20-40 mg/kg/day, max 1 g/day) in 2-4 divided doses	2-3 wk
	<b>or</b> Gentamicin (IM/IV; 5-7.5 mg/kg/day) once daily*	1-2 wk
<8 yr, uncomplicated infection	Trimethoprim-sulfamethoxazole (PO; trimethoprim: 10 mg/kg/day, max 480 mg/day; sulfamethoxazole: 50 mg/kg/day, max 2.4 g/day) in 2 divided doses	≥6 wk
	<b>plus</b> Rifampin (PO; 15-20 mg/kg/day, max 600-900 mg/day) in 1-2 divided doses	≥6 wk
Complicated infection (meningitis, endocarditis, osteomyelitis, spondylitis)	Streptomycin (IM/IV; 20-40 mg/kg/day, max 1 g/day) in 2-4 divided doses	1-2 wk
	<b>or</b> Gentamicin (IM/IV; 5-7.5 mg/kg/day) once daily*	1-2 wk
	<b>plus</b> Doxycycline (IV/PO; 4.4 mg/kg/day, max 200 mg/day) in 2 divided doses (Trimethoprim-sulfamethoxazole should be used for children <8 yr of age)	≥6 wk <sup>†</sup>
	<b>plus</b> Rifampin (IV/PO; 15-20 mg/kg/day, max 600-900 mg/day) in 1-2 divided doses	≥6 wk <sup>†</sup>

\*Gentamicin can be given in divided doses if indicated based on age.

<sup>†</sup>4-6 mo for meningitis or endocarditis.

Note: Because of resistance of *B. abortus* strain RB51 to rifampin, treatment with doxycycline plus trimethoprim-sulfamethoxazole should be used if this isolate is identified.

days of therapy, along with doxycycline (or TMP-SMX) plus rifampin, which are continued for at least 6 weeks. For meningitis and endocarditis, therapy is often continued for 4-6 months. Surgical intervention should be pursued when appropriate, such as when deep tissue abscesses have developed.

If *B. abortus* RB51 (cattle vaccine strain) is identified (or suspected) as the cause of infection, the use of rifampin should be avoided. This is because the strain was derived by selection in rifampin-enriched media and is thus inherently resistant to rifampin. As a result, a combination of doxycycline and TMP-SMX should be used as treatment.

Although relapse occurs in approximately 5-15% of cases, antimicrobial resistance is rare. Relapse is confirmed by isolation of *Brucella* within weeks to months after therapy has ended. Prolonged treatment is the key to preventing disease relapse, and steps should be taken to assure compliance with the long courses of therapy needed to achieve eradication.

## PROGNOSIS

The primary indication of clinical response is resolution of symptoms, which may be slow; the average time to defervescence is 4-5

days. The prognosis after therapy is excellent if patients are compliant with the prolonged therapy. Patients should be followed clinically and serologically for 1-2 years. Before the use of antimicrobial agents, the course of brucellosis was often prolonged and associated with death. Since the institution of specific therapy, most deaths are a result of specific organ system involvement (e.g., endocarditis) in complicated cases. Initiation of antimicrobial therapy may precipitate a Jarisch-Herxheimer-like reaction, presumably because of a large antigen load, but these reactions are rarely associated with serious complications.

## PREVENTION

Prevention of brucellosis depends on effective eradication of the organism from livestock. Pasteurization of milk and dairy products for human consumption remains an important aspect of prevention. It should be noted that certification of raw milk does not eliminate the risk of brucellosis acquisition. No vaccine currently exists for use in children, and therefore education of the public continues to have a prominent role in the prevention of brucellosis.

Visit Elsevier eBooks+ at [eBooks.Health.Elsevier.com](http://eBooks.Health.Elsevier.com) for Bibliography.

## Chapter 254

**Legionella**

Jeffrey S. Gerber

**Legionellosis** comprises **Legionnaires' disease** (*Legionella pneumophila*), other invasive extrapulmonary *Legionella* infections, and an acute flulike illness known as **Pontiac fever**. In contrast to the syndromes associated with invasive disease, Pontiac fever is a self-limited illness that develops after aerosol exposure and may represent a toxic or hypersensitivity response to *Legionella*.

**ETIOLOGY**

Legionellaceae are aerobic, non-spore-forming, nonencapsulated, gram-negative bacilli that stain poorly with Gram stain when performed on smears from clinical specimens. Stained smears of *Legionella pneumophila* taken from colonial growth resemble *Pseudomonas*. Unlike other *Legionella* species, *Legionella micdadei* stains acid fast. Although more than 60 species of the genus have now been identified, the majority (90%) of clinical infections are caused by *L. pneumophila*, and most of the remainder are caused by *L. micdadei*, *L. bozemanii*, *L. dumoffii*, and *L. longbeachae*.

The organisms are fastidious and require L-cysteine, ferric ion, and  $\alpha$ -keto acids for growth. Colonies develop within 3-5 days on buffered charcoal yeast extract agar, which may contain selected antibiotics to inhibit overgrowth by other microorganisms; *Legionella* rarely grows on routine laboratory media.

**EPIDEMIOLOGY**

The environmental reservoir of *Legionella* in nature is freshwater (lakes, streams, thermally polluted waters, potable water), and invasive pneumonia (Legionnaires' disease) is related to exposure to human-made water systems (plumbing, showerheads, cooling towers, certain medical devices, decorative fountains, hot tubs) via aerosols containing the bacteria. Growth of *Legionella* occurs more readily in warm water, and exposure to warm-water sources is an important risk factor for disease. Epidemic and sporadic cases (most common) of community-acquired Legionnaires' disease can be attributed to potable water in the local environment of the patient. Risk factors for acquisition of sporadic community-acquired pneumonia include exposure to cooling towers, nonmunicipal water supply, residential plumbing repairs, and lower water heater temperatures, which facilitate growth of bacteria or lead to release of a bolus of biofilm containing *Legionella* into potable water. The mode of transmission may be by inhalation of aerosols or by microaspiration. Outbreaks of Legionnaires' disease have been associated with protozoa in the implicated water source; replication within these eukaryotic cells presumably amplifies and maintains *Legionella* within the potable-water distribution system or in cooling towers. Outbreaks of community-acquired pneumonia and some nosocomial outbreaks have been linked to common sources, including hot water heaters, evaporative condensers, cooling towers, whirlpool baths, water births, humidifiers, and nebulizers. Travel-associated Legionnaires' disease and Pontiac fever are increasingly recognized in major outbreaks. Although person-to-person transmission has been reported, if it does occur, it is extremely rare.

Hospital-acquired infections are most often linked to potable water. Exposure may occur through three general mechanisms: (1) inhalation of contaminated water vapor through artificial ventilation; (2) aspiration of ingested microorganisms, including those in gastric feedings that are mixed with contaminated tap water; and (3) inhalation of aerosols from showers, sinks, and fountains. Extrapulmonary legionellosis may occur through topical application of contaminated tap water into surgical or traumatic wounds. In contrast to Legionnaires' disease, Pontiac fever outbreaks have occurred through exposure to aerosols from whirlpool baths and ventilation systems.

The incidence of legionellosis in the United States continues to rise, and nearly 10,000 cases were reported to the Centers for Disease Control and Prevention (CDC) through the National Notifiable Disease Surveillance System in 2018. Because this is a passive reporting system, these are likely underestimates of the incidence of disease, which is estimated to occur at least twice as often as reported. An active laboratory-based and population-based surveillance system for tracking *Legionella* infections was recently launched by CDC, which will help to better assess its true incidence and epidemiology. (For up-to-date information, see <https://www.cdc.gov/legionella/>.)

Legionellosis demonstrates geographic differences, and the vast majority of cases are classified as Legionnaires' disease (99.5%), with a small fraction as Pontiac fever (0.5%). *Legionella* infections are reported most frequently in fall and summer, and recent studies show an association with total monthly rainfall and humidity. Approximately 0.5–5.0% of those exposed to a common source develop pneumonia, whereas the attack rate in Pontiac fever outbreaks is very high (85–100%). Although *Legionella* is associated with 0.5–10% of pneumonia cases in adults, it is a rare cause of pneumonia in children, accounting for <1% of cases; however, infrequent testing for *Legionella* might underestimate its prevalence. Acquisition of antibodies to *L. pneumophila* in healthy children occurs progressively over time, although these antibodies presumably reflect subclinical infection, mild respiratory disease, or antibodies that cross-react with other bacterial species. Community-acquired Legionnaires' disease in children is increasingly reported (1.7% of reported cases), and most cases occur in children 15–19 years old, followed by infants. The incidence in infants is reported to be 0.11 per 100,000. Legionnaires' disease is particularly severe in neonates. The epidemiology of hospital-acquired Legionnaires' disease in children is derived almost exclusively from case reports, so the true incidence of this entity is unknown.

**PATHOGENESIS**

Although *Legionella* can be grown on artificial media, the intracellular environment of eukaryotic cells provides the definitive site of growth. *Legionella* organisms are facultative intracellular parasites of eukaryotic cells. In nature, *Legionella* replicate within protozoa found in freshwater. In humans, the main target cell for *Legionella* is the alveolar macrophage, although other cell types may also be invaded. After entry, virulent strains of *L. pneumophila* stimulate the formation of a special phagosome that permits bacterial replication to proceed. The phagosome consists of components of the endoplasmic reticulum and escapes the degradative lysosomal pathway. Growth in macrophages occurs to the point of cell death, followed by reinfection of new cells, until these cells are activated and can subsequently kill intracellular microorganisms. Acute, severe infection of the lung provokes an acute inflammatory response and necrosis. Early on, more bacteria are found in extracellular spaces as a result of intracellular replication, lysis, and release of bacteria. Subsequently, macrophage activation and other immune responses produce intense infiltration of tissue by macrophages that contain intracellular bacteria, ultimately leading to control of bacterial replication and killing.

**Corticosteroid therapy** poses a high risk for infection by interfering with T-cell and macrophage function. Although community-acquired Legionnaires' disease may occur in healthy, immunocompetent patients without other comorbid conditions, those who have defects in cellular-mediated immunity are at higher risk for infection. As in other diseases caused by facultative intracellular microorganisms, the outcome is critically dependent on the specific and nonspecific immune responses of the host, particularly macrophage and T-cell responses.

Risk factors for Legionnaires' disease in adults include chronic diseases of the lung (smoking, bronchitis), older age, diabetes, renal failure, immunosuppression associated with organ transplantation, corticosteroid therapy, and episodes of aspiration. In surveys of community-acquired infection, a significant number of adults have no identified risk factors. The number of reported cases of community-acquired Legionnaires' disease in children is small. Among these cases, immunocompromised status, especially corticosteroid treatment, coupled with exposure to contaminated potable water, is the major risk factor.

Infection in a few children with chronic pulmonary disease without immune deficiency has also been reported, but infection in children lacking any risk factors is uncommon. The modes of transmission of community-acquired disease in children include exposure to mists, freshwater, water coolers, and other aerosol-generating apparatuses. Nosocomial *Legionella* infection has been reported more frequently than community-acquired disease in children and usually occurs in those who are immunocompromised (e.g., stem cell transplants, solid organ transplants), those with structural lung disease, or neonates receiving mechanical ventilation. The modes of acquisition include **microaspiration**, frequently associated with nasogastric tubes, and **aerosol inhalation**. Bronchopulmonary *Legionella* infections are reported in patients with cystic fibrosis and have been associated with aerosol therapy or mist tents. Legionnaire's disease is also reported in children with asthma and tracheal stenosis. Chronic corticosteroid therapy for asthma is a reported risk factor for *Legionella* infections in children.

## CLINICAL MANIFESTATIONS

Legionnaires' disease was originally believed to cause atypical pneumonia associated with extrapulmonary symptoms and laboratory abnormalities, including diarrhea, confusion, hyponatremia, hypophosphatemia, abnormal liver function studies, and evidence of renal dysfunction. Although a subset of patients may exhibit these classic manifestations, *Legionella* infection typically causes pneumonia that is indistinguishable from pneumonia produced by other infectious agents. The incubation period for Legionnaires' disease is typically between 2 and 10 days, though it occasionally can be 3–4 weeks. Fever, cough, and chest pain are common presenting symptoms; the cough may be productive of purulent sputum or may be nonproductive. Although the classic chest radiographic appearance demonstrates rapidly progressive alveolar filling infiltrates, the chest radiographic appearance is widely variable, with tumor-like shadows, evidence of nodular infiltrates, unilateral or bilateral infiltrates, or cavitation, although cavitation is rarely seen in immunocompetent patients. This picture overlaps substantially with disease caused by *Streptococcus pneumoniae*. Although pleural effusion is less often associated with Legionnaires' disease, its frequency varies so widely that neither the presence nor absence of effusion is helpful in the differential diagnosis.

Most reports of nosocomial *Legionella* pneumonia in children demonstrate the following clinical features: rapid onset, temperature >38.5°C (101.3°F), cough, pleuritic chest pain, tachypnea, and dyspnea. Abdominal pain, headache, and diarrhea are also common. Chest radiographs reveal lobar consolidations or diffuse bilateral infiltrates, and pleural effusions may be noted. Usually there is no clinical response to broad-spectrum  $\beta$ -lactam (penicillins and cephalosporins) or aminoglycoside antibiotics. Concomitant infection with other pathogens, including *Mycoplasma pneumoniae* and *Chlamydia pneumoniae*, occurs in 5–10% of cases of Legionnaires' disease; therefore, detection of another potential pulmonary pathogen does not preclude the diagnosis of legionellosis.

## Pontiac Fever

Pontiac fever in adults and children is characterized by a shorter incubation period (1–3 days) followed by high fever, myalgia, headache, and extreme debilitation, lasting for 3–5 days. Cough, breathlessness, diarrhea, confusion, and chest pain may occur, but there is no evidence for invasive infection. The disease is self-limited without sequelae. Virtually all exposed individuals seroconvert to *Legionella* antigens. A very large outbreak in Scotland that affected 35 children was attributed to *L. micdadei*, which was isolated from a whirlpool spa. The onset of illness was 1–7 days (median: 3 days), and all exposed children developed significant titers of specific antibodies to *L. micdadei*. The pathogenesis of Pontiac fever is not known. In the absence of evidence of true infection, the most likely hypothesis is that this syndrome is caused by a toxic or hypersensitivity reaction to microbial antigens.

## DIAGNOSIS

Culture of *Legionella* from sputum, other respiratory tract specimens, blood, or tissue is the gold standard against which indirect methods of detection should be compared. If present, pleural fluid should be obtained for culture. Specimens obtained from the respiratory tract

that are contaminated with oral flora must be treated and processed to reduce contaminants and plated onto selective media. Because these are costly and time-consuming methods, many laboratories do not process specimens for culture.

The urinary antigen assay that detects *L. pneumophila* serogroup I has revolutionized the diagnosis of *Legionella* infection and has 80% sensitivity and 99% specificity. The assay is a useful method in the prompt diagnosis of Legionnaires' disease caused by this serogroup, which accounts for the majority of symptomatic infections. In the United States, this test is frequently used because it is widely available in reference laboratories. Where available, polymerase chain reaction (PCR) is used to identify *L. pneumophila* from bronchoscopic lavage and other clinical specimens to the exclusion of other respiratory pathogens. Other methods, including direct immunofluorescence, have low sensitivity and are generally not employed. Serological testing is of little clinical utility, as seroconversion may not occur for several weeks after the onset of infection, the available serologic assays do not detect all strains of *L. pneumophila* or all species, and cross reactivity occurs with several other gram-negative organisms.

In view of the low sensitivity of direct detection and the slow growth of the microorganism in culture, multiple diagnostics (culture, urine antigen, PCR if available) should be sent simultaneously and empiric antibiotic therapy considered when there is suggestive clinical evidence, including the lack of response to usual antibiotics.

## TREATMENT

In community-acquired pneumonia in adults who are hospitalized, guidelines recommend empiric treatment with a  $\beta$ -lactam plus a macrolide or quinolone for treatment of atypical microorganisms (*Legionella*, *C. pneumoniae*, *M. pneumoniae*). Evidence-based guidelines for management of community-acquired pneumonia in children typically do not include *Legionella* in the differential diagnosis or empiric treatment recommendations. Effective treatment of Legionnaires' disease is based in part on the intracellular concentration of antibiotics. **Azithromycin** or the **quinolones** (ciprofloxacin and levofloxacin) have generally replaced erythromycin as therapy for patients with diagnosed *Legionella* infection. **Doxycycline** is an acceptable alternative. In serious infections or in high-risk patients, parenteral therapy is recommended initially, although oral conversion is favored when tolerated, particularly because of the generally high bioavailability of oral macrolides, quinolones, and tetracyclines. The duration of antibiotic therapy for Legionnaires' disease in adults is typically for a minimum of 5 days, although therapy may be continued for 10–14 days in more seriously ill or immunocompromised patients. Treatment of extrapulmonary infections, including prosthetic valve endocarditis and sternal wound infections, may require prolonged therapy. In vitro data and case reports suggest that trimethoprim-sulfamethoxazole may also be effective. A large, retrospective study of hospitalized adults with *Legionella* pneumonia found no difference in mortality between those treated with azithromycin and with quinolones. The role of combination therapy is unknown. Antibiotic treatment for Pontiac fever is not recommended.

## PROGNOSIS

The mortality rate for community-acquired Legionnaires' disease in adults who are hospitalized is approximately 15% but may exceed 50% in immunocompromised patients, although reporting bias might inflate these estimates. Precise estimates for children are unknown. The prognosis depends on underlying host factors and possibly on the duration of illness before initiation of appropriate therapy. Despite appropriate antibiotic therapy, patients may succumb to respiratory complications, such as acute respiratory distress syndrome. A high mortality rate is noted in case reports of premature infants and children, virtually all of whom have been immunocompromised. Delay in diagnosis is also associated with increased mortality. Consequently, *Legionella* should be considered in the differential diagnosis of both community-acquired and nosocomial pneumonia in children, especially in cases refractory to empirical therapy or with epidemiologic risk factors for legionellosis.

Visit Elsevier eBooks+ at [eBooks.Health.Elsevier.com](http://eBooks.Health.Elsevier.com) for Bibliography.



## Chapter 255

**Bartonella**

Rachel C. Orscheln

The spectrum of disease resulting from human infection with *Bartonella* species includes the association of **bacillary angiomatosis** and **cat scratch disease** with *Bartonella henselae*. There are more than 30 validated species of *Bartonella*, but six major species are responsible for most human disease: *B. henselae*, *B. quintana*, *B. bacilliformis*, *B. elizabethae*, *B. vinsonii*, and *B. clarridgeiae* (Table 255.1). The remaining *Bartonella* spp. have been found primarily in animals, particularly rodents and moles. However, zoonotic infections from animal-associated strains of *Bartonella* spp. have been reported. In 2013 a novel *Bartonella* agent with the proposed name *Candidatus Bartonella ancashi* (*Bartonella ancashensis*) was described as a cause of **verruca peruana**.

Members of the genus *Bartonella* are gram-negative, oxidase-negative, fastidious, aerobic rods that ferment no carbohydrates. *B. bacilliformis* is the only species that is motile, achieving motility by means of polar flagella. Optimal growth is obtained on fresh media containing ≥5% sheep or horse blood in the presence of 5% carbon dioxide. The use of lysis centrifugation for specimens from blood followed by cultivation on chocolate agar for extended periods (2-6 weeks) enhances recovery.

Visit Elsevier eBooks+ at [eBooks.Health.Elsevier.com](http://eBooks.Health.Elsevier.com) for Bibliography.

### 255.1 Cat Scratch Disease (*Bartonella henselae*)

Rachel C. Orscheln

The most common presentation of *Bartonella* infection is cat scratch disease (CSD), which is a subacute, regional lymphadenitis caused most frequently by *B. henselae*. CSD is the most common cause of chronic lymphadenitis that persists for >3 weeks.

#### ETIOLOGY

*B. henselae* can be cultured from the blood of healthy cats. *B. henselae* organisms are the small, pleomorphic, gram-negative bacilli visualized with Warthin-Starry stain in affected lymph nodes from patients

with CSD. Development of serologic tests that showed prevalence of antibodies in 84–100% of cases of CSD, culturing of *B. henselae* from CSD nodes, and detection of *B. henselae* by polymerase chain reaction (PCR) in the majority of lymph node samples and pus from patients with CSD confirmed the organism as the cause. Occasional cases of CSD may be caused by other organisms, including *B. clarridgeiae*, *B. grahamii*, *B. alsatica*, and *B. quintana*.

#### EPIDEMIOLOGY

CSD is common, with >24,000 estimated cases per year in the United States. *B. henselae* is transmitted most frequently by cutaneous inoculation through the bite or scratch of a cat. However, transmission may occur through other routes, such as flea bites. Most patients (87–99%) with CSD have had contact with cats, many of which are kittens <6 months old, and >50% of patients have a definite history of a cat scratch or bite. Cats have high-level bacteremia with *Bartonella* spp. for months without any clinical symptoms; kittens are more frequently bacteremic than adult cats. Transmission between cats occurs through the cat flea, *Ctenocephalides felis*. In temperate zones, most cases occur between September and March, perhaps in relation to the seasonal breeding of domestic cats or to the close proximity of family pets in the fall and winter. In tropical zones, there is no seasonal prevalence. Distribution is worldwide, and infection occurs in all races.

Cat scratches appear to be more common among children, and males are affected more often than females. CSD is a sporadic illness; usually only one family member is affected, even though many siblings play with the same kitten. However, clusters do occur, with family cases within weeks of one another. Anecdotal reports have implicated other sources, such as dog scratches, wood splinters, fishhooks, cactus spines, and porcupine quills.

#### PATHOGENESIS

The pathologic findings in the primary inoculation **papule** and affected lymph nodes are similar. Both show a central avascular, necrotic area with surrounding lymphocytes, giant cells, and histiocytes. Three stages of involvement occur in affected nodes, sometimes simultaneously in the same node. The first stage consists of generalized enlargement with thickening of the cortex and hypertrophy of the germinal center and with a predominance of lymphocytes. Epithelioid granulomas with Langerhans giant cells are scattered throughout the node. The second stage is characterized by granulomas that increase in density, fuse, and become infiltrated with polymorphonuclear leukocytes, with beginning central necrosis. In the third stage, necrosis progresses with formation of large, pus-filled sinuses. This purulent material may rupture into surrounding tissue. Similar granulomas have been found in the liver, spleen, and osteolytic lesions of bone when those organs are involved.

**Table 255.1** *Bartonella* Species Causing the Majority of Human Disease

DISEASE	ORGANISM	VECTOR	PRIMARY RISK FACTOR
Bartonellosis (Carrión disease)	<i>B. bacilliformis</i>	Sandfly ( <i>Lutzomyia verrucarum</i> )	Living in endemic areas (Andes Mountains)
Cat scratch disease	<i>B. henselae</i> <i>B. clarridgeiae</i>	Cat	Cat scratch or bite
Trench fever	<i>B. quintana</i>	Human body louse	Body louse infestation during outbreak
Bacteremia, endocarditis	<i>B. henselae</i> <i>B. elizabethae</i> <i>B. vinsonii</i> <i>B. quintana</i>	Cat for <i>B. henselae</i> Rat for <i>B. elizabethae</i> Vole for <i>B. vinsonii</i> Human body louse for <i>B. quintana</i>	Severe immunosuppression
Bacillary angiomatosis	<i>B. henselae</i> <i>B. quintana</i>	Cat for <i>B. henselae</i> Human body louse for <i>B. quintana</i>	Severe immunosuppression
Peliosis hepatis	<i>B. henselae</i> <i>B. quintana</i>	Cat for <i>B. henselae</i> Human body louse for <i>B. quintana</i>	Severe immunosuppression

## CLINICAL MANIFESTATIONS

After an incubation period of 7-12 days (range: 3-30 days), one or more 3- to 5-mm red papules develop at the site of cutaneous inoculation, often reflecting a linear cat scratch. These lesions are often overlooked because of their small size but are found in at least 65% of patients when careful examination is performed (Fig. 255.1). Lymphadenopathy is generally evident within 1-4 weeks (Fig. 255.2). **Chronic regional lymphadenitis** is the hallmark, affecting the first or second set of nodes draining the entry site. Affected lymph nodes in order of frequency include the axillary, cervical, submandibular, preauricular, epitrochlear, femoral, and inguinal nodes. Involvement of one or more groups of nodes occurs in 10-20% of patients, although at a given site, half the cases involve several nodes.

Nodes involved are usually tender and have overlying erythema but without cellulitis. They usually range between 1 and 5 cm in size, although they can become much larger. From 10% to 40% eventually suppurate. The duration of enlargement is usually 1-2 months, with persistence up to 1 year in rare cases. Fever occurs in approximately 30% of patients, usually 38-39°C (100.4-102.2°F). Other nonspecific symptoms, including malaise, anorexia, fatigue, and headache, affect less than one third of patients. Transient rashes, which may occur in approximately 5% of patients, are mainly truncal maculopapular rashes. Erythema nodosum, erythema multiforme, and erythema annulare have also been reported.



**Fig. 255.1** A child with typical cat scratch disease demonstrating the original scratch injuries and the primary papule that soon thereafter developed proximal to the middle finger. (Courtesy Dr. V.H. San Joaquin, University of Oklahoma Health Sciences Center, Oklahoma City.)



**Fig. 255.2** Right axillary lymphadenopathy followed the scratches and development of a primary papule in this child with typical cat scratch disease. (From Mandell GL, Bennett JE, Dolin R, eds. *Principles and Practice of Infectious Diseases*, 6th ed. Philadelphia: Elsevier; 2006:2737.)

CSD is usually a self-limited infection that spontaneously resolves within a few weeks to months. The most common ocular presentation of CSD is **Parinaud oculoglandular syndrome**, which is unilateral conjunctivitis followed by preauricular lymphadenopathy and occurs in 5% of patients with CSD (Fig. 255.3). Direct eye inoculation as a result of rubbing with the hands after cat contact is the presumed mode of spread. A conjunctival granuloma may be found at the inoculation site. The involved eye is usually not painful and has little or no discharge but may be quite red and swollen. Submandibular or cervical lymphadenopathy may also occur.

More severe, disseminated illness occurs up to 14% of patients and is characterized by presentation with high fever, often persisting for several weeks. Other prominent symptoms include significant abdominal pain and weight loss. **Hepatosplenomegaly** may occur, although hepatic dysfunction is rare (Fig. 255.4). Granulomatous changes may be seen in the liver and spleen. Another common site of dissemination is bone, with the development of multifocal **granulomatous osteolytic lesions** associated with localized pain but without erythema,



**Fig. 255.3** The granulomatous conjunctivitis of Parinaud oculoglandular syndrome is associated with ipsilateral local lymphadenopathy, usually preauricular and, less often, submandibular. (From Mandell GL, Bennett JE, Dolin R, eds. *Principles and Practice of Infectious Diseases*, 6th ed. Philadelphia: Elsevier; 2006:2739.)



**Fig. 255.4** In this CT scan of a patient with hepatic involvement of cat scratch disease, the absence of enhancement of the multiple lesions after contrast infusion is consistent with the granulomatous inflammation of this entity. Treated empirically with various antibiotics without improvement before establishment of this diagnosis, the patient subsequently recovered fully with no further antimicrobial therapy. (Courtesy Dr. V.H. San Joaquin, University of Oklahoma Health Sciences Center, Oklahoma City.)

tenderness, or swelling. Other uncommon manifestations are neuroretinitis with papilledema and stellate macular exudates, encephalitis, endocarditis, and atypical pneumonia.

## DIAGNOSIS

In most cases the diagnosis can be strongly suspected on clinical grounds in a patient with history of exposure to a cat. Serologic testing can be used to confirm the diagnosis. Most patients have elevated IgG antibody titers at presentation. However, the IgM response to *B. henselae* has frequently resolved by the time testing is considered. There is cross reactivity among *Bartonella* spp., particularly *B. henselae* and *B. quintana*.

If tissue specimens are obtained, bacilli may be visualized with Warthin-Starry and Brown-Hopps tissue stains. *Bartonella* DNA can be identified through PCR analysis of tissue specimens. Culturing of the organism is not generally practical for clinical diagnosis. Next-generation sequencing and 16S rRNA sequencing have been used to identify *Bartonella* species on tissue that is fresh or formalin-fixed, as well as on body fluids other than blood.

## Differential Diagnosis

The differential diagnosis of CSD includes virtually all causes of lymphadenopathy (see Chapter 539). The more common entities include pyogenic (suppurative) lymphadenitis, primarily from staphylococcal or streptococcal infections, atypical mycobacterial infections, and malignancy. Less common entities are tularemia, brucellosis, and sporotrichosis. Epstein-Barr virus, cytomegalovirus, and *Toxoplasma gondii* infections usually cause more generalized lymphadenopathy.

## LABORATORY FINDINGS

Routine laboratory tests are not helpful. The erythrocyte sedimentation rate is often elevated. The white blood cell count may be normal or mildly elevated. Hepatic transaminases are often normal but may be elevated in systemic disease. Ultrasonography or CT may reveal many granulomatous nodules in the liver and spleen; the nodules appear as hypodense, round, irregular lesions and are usually multiple. However, CSD presenting as a solitary splenic lesion has been reported.

## TREATMENT

Antibiotic treatment of CSD is not always needed and is not clearly beneficial. For most patients, treatment consists of conservative symptomatic care and observation. Studies show a significant discordance between in vitro activity of antibiotics and clinical effectiveness. For many patients, diagnosis is considered in the context of failure to respond to  $\beta$ -lactam antibiotic treatment of presumed staphylococcal lymphadenitis.

A small prospective study of oral azithromycin (500 mg on day 1, then 250 mg on days 2-5; for smaller children, 10 mg/kg/24 hr on day 1 and 5 mg/kg/24 hr on days 2-5) showed a decrease in initial lymph node volume in 50% of patients during the first 30 days, but after 30 days there was no difference in lymph node volume. No other clinical benefit was found. For the majority of patients, CSD is self-limited, and resolution occurs over weeks to months without antibiotic treatment. Azithromycin, clarithromycin, trimethoprim-sulfamethoxazole (TMP-SMX), rifampin, ciprofloxacin, and gentamicin appear to be the best agents if treatment is considered.

Suppurative lymph nodes that become tense and extremely painful may require surgical drainage for both therapeutic and diagnostic purposes.

Children with hepatosplenic CSD appear to respond well to treatment with azithromycin with or without the addition of rifampin.

## COMPLICATIONS

**Encephalopathy** can occur in as many as 5% of patients with CSD and typically manifests 1-3 week after the onset of lymphadenitis as

the sudden onset of neurologic symptoms, which often include seizures, combative or bizarre behavior, and altered level of consciousness. Imaging studies are generally normal. The cerebrospinal fluid is normal or shows minimal pleocytosis and protein elevation. Recovery occurs without sequelae in almost all patients but may take place slowly over many months.

Other neurologic manifestations include peripheral facial nerve paralysis, myelitis, radiculitis, compression neuropathy, and cerebellar ataxia. One patient has been reported to have encephalopathy with persistent cognitive impairment and memory loss.

**Stellate macular retinopathy** is associated with several infections, including CSD. Children and young adults present with unilateral or, rarely, bilateral loss of vision with central scotoma, optic disc swelling, and macular star formation from exudates radiating out from the macula. The findings usually resolve completely, with recovery of vision, generally within 2-3 months. The optimal treatment for the neuroretinitis is unknown, although treatment of adults with doxycycline and rifampin for 4-6 weeks has had good results.

**Hematologic manifestations** include hemolytic anemia, thrombocytopenic purpura, nonthrombocytopenic purpura, and eosinophilia. **Leukocytoclastic vasculitis**, similar to Henoch-Schönlein purpura, has been reported in association with CSD in one child. A systemic presentation of CSD with pleurisy, arthralgia or arthritis, mediastinal masses, enlarged nodes at the head of the pancreas, and atypical pneumonia also has been reported.

## PROGNOSIS

The prognosis for CSD in a normal host is generally excellent, with resolution of clinical findings over weeks to months. Recovery is occasionally slower and may take as long as 1 year.

## PREVENTION

Person-to-person spread of *Bartonella* infections is not known. Isolation of the affected patient is not necessary. Prevention would require elimination of cats from households, which is not practical or necessarily desirable. Awareness of the risk of cat (and particularly kitten) scratches should be emphasized to parents. Cat scratches or bites should be washed immediately. Cat flea control is helpful.

Visit Elsevier eBooks+ at eBooks.Health.Elsevier.com for Bibliography.

## 255.2 Bartonellosis (*Bartonella bacilliformis*)

Rachel C. Orscheln

The first human *Bartonella* infection described was **bartonellosis**, a geographically distinct disease caused by *B. bacilliformis*. There are two predominant forms of illness caused by *B. bacilliformis*: **Oroya fever**, a severe, febrile hemolytic anemia, and **verruca peruana** (verruca peruana), an eruption of hemangioma-like lesions. *B. bacilliformis* also causes asymptomatic infection. Bartonellosis is also called **Carrión disease**.

## ETIOLOGY

*B. bacilliformis* is a small, motile, gram-negative organism with a brush of  $\geq 10$  unipolar flagella, which appear to be important components for invasiveness. An obligate aerobe, it grows best at 28°C (82.4°F) in semisolid nutrient agar containing rabbit serum and hemoglobin.

## EPIDEMIOLOGY

Bartonellosis is a zoonosis found only in mountain valleys of the Andes Mountains in Peru, Ecuador, Colombia, Chile, and Bolivia at altitudes and environmental conditions favorable for the vector, which is the **sandfly**, *Lutzomyia verrucarum*.



## PATHOGENESIS

After the sandfly bite, *Bartonella* organisms enter the endothelial cells of blood vessels, where they proliferate. Found throughout the reticuloendothelial system, they then reenter the bloodstream and parasitize erythrocytes. They bind on the cells, deform the membranes, and then enter intracellular vacuoles. The resultant hemolytic anemia may involve as many as 90% of circulating erythrocytes. Patients who survive this acute phase may or may not experience the cutaneous manifestations, which are nodular hemangiomatous lesions or verrucae ranging in size from a few millimeters to several centimeters.

## CLINICAL MANIFESTATIONS

The incubation period is 2-14 weeks. Patients may be totally asymptomatic or may have nonspecific symptoms such as headache and malaise without anemia.

**Oroya fever** is characterized by fever with rapid development of anemia. Clouding of the sensorium and delirium are common symptoms and may progress to overt psychosis. Physical examination demonstrates signs of severe hemolytic anemia, including icterus and pallor, sometimes in association with generalized lymphadenopathy.

In the preruleptive stage of **verruca peruana** (Fig. 255.5), patients may complain of arthralgias, myalgias, and paresthesias. Inflammatory reactions such as phlebitis, pleuritis, erythema nodosum, and encephalitis may develop. The appearance of verrucae is pathognomonic of the eruptive phase. Lesions vary greatly in size and number.

## DIAGNOSIS

The diagnosis of bartonellosis is established on clinical grounds in conjunction with a blood smear demonstrating organisms or with blood culture. The anemia is macrocytic and hypochromic, with reticulocyte counts as high as 50%. *B. bacilliformis* may be seen on Giemsa stain preparation as red-violet rods in the erythrocytes. In the recovery phase, organisms change to a more coccoid form and disappear from the blood. In the absence of anemia, the diagnosis depends on blood cultures. In the eruptive phase, the typical verruca confirms the diagnosis. Antibody testing has been used to document infection.



**Fig. 255.5** A single large lesion of verruca peruana on the leg of an inhabitant of the Peruvian Andes. Such lesions are prone to superficial ulceration, and their vascular nature may lead to copious bleeding. Erythema of the skin surrounding the lesion is also evident. (Courtesy Dr. J.M. Crutcher, Oklahoma State Department of Health, Oklahoma City.)

## TREATMENT

*B. bacilliformis* is sensitive to many antibiotics, including rifampin, tetracycline, and chloramphenicol. Treatment is highly effective in rapidly diminishing fever and eradicating the organism from the blood. **Chloramphenicol** (50-75 mg/kg/day) is considered the drug of choice because it is also useful in the treatment of concomitant infections such as *Salmonella*. Fluoroquinolones are used successfully as well. Blood transfusions and supportive care are critical in patients with severe anemia. Antimicrobial treatment for verruca peruana is considered when there are >10 cutaneous lesions, if the lesions are erythematous or violaceous, or if the onset of the lesions was <1 month before presentation. Oral rifampin is effective in the healing of lesions. Surgical excision may be needed for lesions that are large and disfiguring or that interfere with function.

## PREVENTION

Prevention depends on avoidance of the vector, particularly at night, by the use of protective clothing and insect repellents (see Chapter 218).

Visit Elsevier eBooks+ at eBooks.Health.Elsevier.com for Bibliography.

## 255.3 Trench Fever (*Bartonella quintana*)

Rachel C. Orscheln

### ETIOLOGY

The causative agent of trench fever was first designated *Rickettsia quintana*, was then assigned to the genus *Rochalimaea*, and now has been reassigned as *Bartonella quintana*.

### EPIDEMIOLOGY

Trench fever was first recognized as a distinct clinical entity during World War I, when more than a million troops in the trenches were infected. Infection with *B. quintana* is currently rare in the United States and primarily occurs in the setting of conditions favorable to body lice infestations, such as homelessness, crowding, and poor sanitation. When pooled samples of head and body lice have been collected from homeless populations, up to 33% of individuals have lice pools that test positive for *B. quintana*.

Humans are the only known reservoir. No other animal is naturally infected, and usual laboratory animals are not susceptible. The **human body louse**, *Pediculus humanus* var. *corporis*, is the vector and is capable of transmission to a new host 5-6 days after feeding on an infected person. Lice excrete the organism for life; transovarian passage does not occur. Humans may have prolonged asymptomatic bacteremia for years.

### CLINICAL MANIFESTATIONS

The incubation period for trench fever averages about 22 days (range: 4-35 days). The clinical presentation is highly variable. Symptoms can be very mild and brief. About half of infected persons have a single febrile illness with abrupt onset lasting 3-6 days. In other patients, prolonged, sustained fever may occur. More commonly, patients have periodic febrile illness with three to eight episodes lasting 4-5 days each, sometimes occurring over 1 year or more. This form is reminiscent of malaria or **relapsing fever** (*Borrelia recurrentis*). Afebrile bacteremia can occur.

Clinical findings usually consist of fever (typically with a temperature of 38.5-40°C [101.3-104°F]), malaise, chills, sweats, anorexia, and severe headache. Common findings include marked conjunctival injection, tachycardia, myalgias, arthralgias, and severe pain in the neck, back, and legs. Crops of erythematous macules or papules may occur on the trunk on as many as 80% of patients. Splenomegaly and mild liver enlargement may be noted.



**DIAGNOSIS**

In nonepidemic situations, it is impossible to establish a diagnosis of trench fever on clinical grounds because the findings are not distinctive. A history of body louse infection or having been in an area of epidemic disease should heighten suspicions. *B. quintana* can be cultured from the blood with modification to include culture on epithelial cells. Serologic tests for *B. quintana* are available, but there is cross-reaction with *B. henselae*.

**TREATMENT**

There are no controlled trials of treatment, but bacteremia with *Bartonella* treated with a combination of gentamicin and doxycycline increases the rate of cure compared with other regimens, such as doxycycline or  $\beta$ -lactam antibiotics alone.

Visit Elsevier eBooks+ at [eBooks.Health.Elsevier.com](http://eBooks.Health.Elsevier.com) for Bibliography.

## 255.4 Bacillary Angiomatosis and Bacillary Peliosis Hepatis (*Bartonella henselae* and *Bartonella quintana*)

Rachel C. Orscheln

Both *B. henselae* and *B. quintana* cause vascular proliferative disease in severely immunocompromised persons, primarily adult patients with acquired immune deficiency syndrome (AIDS), persons receiving cancer chemotherapy, and organ transplant recipients. The subcutaneous and lytic bone lesions of bacillary angiomatosis can be caused by infection with either *B. henselae* or *B. quintana*. The lesions of peliosis hepatis are almost exclusively associated with *B. henselae*.

**BACILLARY ANGIOMATOSIS**

Lesions of cutaneous bacillary angiomatosis, also known as **epithelioid angiomatosis**, are the most easily identified and recognized form of *Bartonella* infection in immunocompromised hosts. They are found primarily in patients with AIDS who have very low CD4 counts. The clinical appearance can be quite diverse. The vasoproliferative lesions of bacillary angiomatosis may be cutaneous or subcutaneous and may resemble the vascular lesions (verruca peruana) of *B. bacilliformis* in immunocompetent persons, characterized by erythematous papules on an erythematous base with a collarette of scale. They may enlarge to form large, pedunculated lesions and may ulcerate. Trauma may result in profuse bleeding.

Bacillary angiomatosis may be clinically indistinguishable from Kaposi sarcoma. Other considerations in the differential diagnosis are pyogenic granuloma and verruca peruana (*B. bacilliformis*). Deep soft tissue masses caused by bacillary angiomatosis may mimic a malignancy.

**Osseous bacillary angiomatosis** lesions typically involve the long bones. These lytic lesions are very painful and highly vascular and are occasionally associated with an overlying erythematous plaque. The high degree of vascularity produces a positive result on a technetium-99m methylene diphosphonate bone scan, resembling that of a malignant lesion.

Lesions can be found in virtually any organ, producing similar vascular proliferative lesions. They may appear raised, nodular, or ulcerative when seen on endoscopy or bronchoscopy. They may be associated with enlarged lymph nodes with or without an obvious local cutaneous lesion. Brain parenchymal lesions have been described.

**BACILLARY PELIOSIS**

Bacillary peliosis affects the reticuloendothelial system, primarily the liver (**peliosis hepatis**) and, less frequently, the spleen and lymph nodes. It is a vasoproliferative disorder characterized by random proliferation of venous lakes surrounded by fibromyxoid stroma harboring numerous bacillary organisms. Clinical findings include fever and abdominal pain in association with abnormal liver function test results, particularly a greatly increased alkaline phosphatase level. Cutaneous bacillary angiomatosis with splenomegaly may be associated with thrombocytopenia or pancytopenia. The vascular proliferative lesions in the liver and spleen appear on CT scan as hypodense lesions scattered throughout the parenchyma. The differential diagnosis includes hepatic Kaposi sarcoma, lymphoma, and disseminated infection with *Pneumocystis jirovecii* or *Mycobacterium avium* complex.

**BACTEREMIA AND ENDOCARDITIS**

*B. henselae*, *B. quintana*, *B. vinsonii*, and *B. elizabethae* all are reported to cause bacteremia or endocarditis. They are associated with symptoms such as prolonged fevers, night sweats, and profound weight loss. A cluster of cases in Seattle in 1993 occurred in a homeless population with chronic alcoholism. These patients with high fever or hypothermia were thought to represent *urban trench fever*, but no body louse infestation was associated. Some cases of culture-negative endocarditis may represent *Bartonella* endocarditis. One report described central nervous system involvement with *B. quintana* infection in two children.

**DIAGNOSIS**

The diagnosis of bacillary angiomatosis is made initially by biopsy. The characteristic small-vessel proliferation with mixed inflammatory response and the staining of bacilli by Warthin-Starry silver distinguish bacillary angiomatosis from pyogenic granuloma or Kaposi sarcoma (see Chapter 304). Travel history can usually preclude verruca peruana.

Culture is impractical for CSD but is the diagnostic procedure for suspected bacteremia or endocarditis. Lysis centrifugation technique or fresh chocolate or heart infusion agar with 5% rabbit blood and prolonged incubation may increase the yield of culture. PCR on tissue can also be a useful tool, and positive serologic testing can provide support for the diagnosis.

**TREATMENT**

*Bartonella* infections in immunocompromised hosts caused by both *B. henselae* and *B. quintana* have been treated successfully with antimicrobial agents. Bacillary angiomatosis responds rapidly to erythromycin, azithromycin, and clarithromycin, which are the drugs of choice. Alternative choices are doxycycline or tetracycline. Severely ill patients with peliosis hepatis or patients with osteomyelitis may be treated initially with a macrolide or doxycycline and the addition of rifampin or gentamicin. The use of doxycycline for 6 weeks with the addition of an aminoglycoside for a minimum of 2 weeks is associated with improved prognosis in endocarditis. A Jarisch-Herxheimer reaction may occur. Relapses may follow, and prolonged treatment for several months may be necessary.

**PREVENTION**

Immunocompromised persons should consider the potential risks of cat ownership because of the risks for *Bartonella* infections as well as toxoplasmosis and enteric infections. Those who elect to obtain a cat should adopt or purchase a cat >1 year old and in good health. Prompt washing of any wounds from cat bites or scratches is essential.

Visit Elsevier eBooks+ at [eBooks.Health.Elsevier.com](http://eBooks.Health.Elsevier.com) for Bibliography.

## Section 6

# Anaerobic Bacterial Infections

## Chapter 256

## Botulism (*Clostridium botulinum*)

Mark R. Schleiss

There are three naturally occurring forms of human botulism, characterized by mode of acquisition: **infant botulism** (intestinal toxemia), **food-borne botulism**, and **wound botulism**. Infant botulism is the most common form in the United States. Under rare circumstances of altered intestinal anatomy, physiology, and microflora, older children and adults may contract infant-type botulism (**adult intestinal toxemia**). Two other forms, both human-made, also occur: **inhalational botulism**, from inhaling accidentally aerosolized toxin, and **iatrogenic botulism**, from overdosage of botulinum toxin used for therapeutic or cosmetic purposes.

### ETIOLOGY

Botulism is the acute, flaccid paralysis caused by the neurotoxin produced by *Clostridium botulinum* or, infrequently, an equivalent neurotoxin produced by the related species *Clostridium butyricum* and *Clostridium baratii*. *C. botulinum* is a gram-positive, spore-forming, obligate anaerobe whose natural habitat worldwide is soil, dust, and marine sediments. The organism is found in a wide variety of fresh and cooked agricultural products. Remarkably, the spores of some *C. botulinum* strains endure boiling for several hours, enabling the organism to survive efforts at food preservation. In contrast, botulinum toxin is heat labile and easily destroyed by heating at  $\geq 85^{\circ}\text{C}$  ( $185^{\circ}\text{F}$ ) for 5 minutes. Neurotoxicogenic *C. butyricum* has been isolated from soils near Lake Weishan in China, the site of food-borne botulism outbreaks associated with this organism, and from vegetables, soured milk, and cheeses. Although first recognized in China, cases of infant botulism caused by *C. butyricum* have now been identified in Japan, Europe, and the United States. Little is known about the ecology of neurotoxicogenic *C. baratii*.

**Botulinum toxin** is synthesized as a 150-kDa precursor protein that enters the circulation and is transported to the neuromuscular junction. The toxin is only released by actively replicating (vegetative) bacteria and not the spore form. At the neuromuscular junction, toxin binds to the neuronal membrane on the presynaptic side of the neural synapse. It undergoes proteolysis to a 100-kDa heavy chain and a 50-kDa light chain. These chains are joined via disulfide bond formation. The heavy chain contains the neuronal attachment sites that mediate binding to presynaptic nerve terminals. It also mediates translocation of the light chain into the cell cytoplasm after binding. The light chain, a key component of the toxin, is a member of the zinc metalloprotease family and mediates cleavage of the fusogenic SNARE (Soluble NSF Attachment REceptor) protein family member, SNAP-25. Cleavage of this protein precludes release of acetylcholine from axons at the presynaptic terminal, abrogating nerve signaling and producing paralysis. Botulinum toxin is among the most potent poisons known to humankind; indeed, the parental human lethal dose is estimated to be on the order of  $10^{-6}$  mg/kg. The toxin blocks neuromuscular transmission and causes death through airway and respiratory muscle paralysis. At least nine antigenic toxin types, designated by letters A-H and X, are distinguished

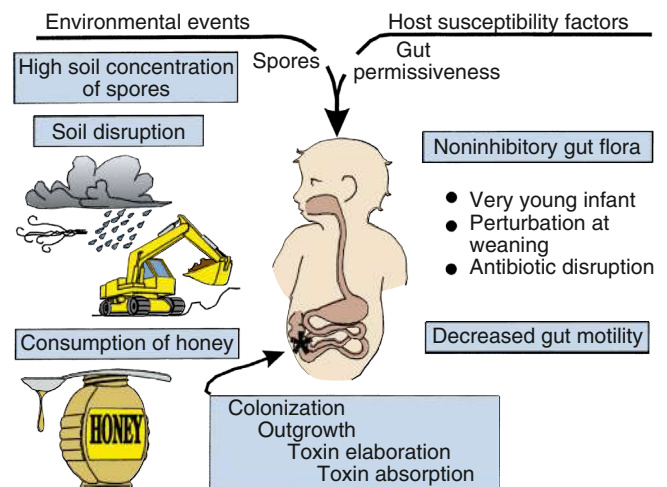
serologically by demonstration of the inability of neutralizing antibody against one toxin type to protect against a different type. Toxin types are further differentiated into subtypes by differences in the nucleotide sequences of their toxin genes. The gene for botulinum toxin for some toxin types and subtypes resides on a plasmid. Some toxins are fully activated by the bacteria that produce them (proteolytic strains of types A, B, and F), and some require exogenous proteolytic activation (types E and nonproteolytic types B and F).

The toxin types serve as convenient clinical and epidemiologic markers. Toxin types A, B, E, and F are well-established causes of human botulism, whereas types C and D cause illness in other animals. Toxin types A and B cause the majority of cases of infant botulism in the United States. Neurotoxicogenic *C. butyricum* strains produce a type E toxin, whereas neurotoxicogenic *C. baratii* strains produce a type F toxin. Type G toxin has not been established as a cause of either human or animal disease. Some strains produce two toxins such as B and A or B and F; rare strains may produce three toxins. Dual (bivalent) toxin mediated disease tends to be more severe than single toxin production.

### EPIDEMIOLOGY

**Infant botulism** has been reported from all inhabited continents except Africa. Notably, in a typical case the infant is the only family member who is ill. The most striking epidemiologic feature of infant botulism is its age distribution: approximately 90% of cases involving infants 3 weeks to 6 months of age, with a broad peak spanning 2-4 months of age. Cases have been recognized in infants as young as 1.5 days or as old as 382 days at onset. Identified risk factors for the illness include breastfeeding, the ingestion of honey, a slow intestinal transit time ( $<1$  stool/day), and ingestion of untreated well water (Fig. 256.1). Although breastfeeding appears to provide protection against fulminant sudden death from infant botulism, cases can occur in breastfed infants at the time of introduction of nonhuman milk for feeding.

Although infant botulism is an uncommon and often unrecognized illness, it is the most common form of human botulism in the United States, with approximately 80-140 hospitalized cases diagnosed annually. The Council of State and Territorial Epidemiologists (CSTE) maintains a **National Botulism Surveillance System** for intensive surveillance for cases of botulism in the United States (<https://www.cdc.gov/botulism/surveillance.html>). In 2017, 182 laboratory-confirmed botulism cases were reported to Centers for Disease Control and Prevention (CDC). Botulism was predominately observed in infants, with 141 such cases reported. A total of 19 (10%) food-borne cases and 19 (10%) wound cases were reported. Infant botulism cases were reported from 26 states and the District of Columbia, with California reporting the



**Fig. 256.1** Environmental, host, and pathophysiological events in infant botulism. (From Arnon SS, Long SS. *Clostridium botulinum* [Botulism]. In Long SS, Prober CG, Fischer M, Kimberlin DW, eds. *Principles and Practice of Pediatric Infectious Diseases*, 6th ed. Philadelphia: Elsevier; 2023: Fig. 189.3, p. 1019.)

most (n = 48, 34%). Toxin type B (n = 88) predominated. The median age of infants was 4 months (range: 0-12 months), and no deaths were reported.

**Food-borne botulism** results from the ingestion of a food in which *C. botulinum* has multiplied and produced toxin. Although the traditional view of food-borne botulism has been thought of as resulting chiefly from ingestion of home-canned foods, in fact, outbreaks in North America have been more often associated with restaurant-prepared foods, including nacho cheese in convenience stores, sautéed onions, chopped garlic, and seal blubber (in Alaska). Other outbreaks in the United States have occurred from commercial foods sealed in plastic pouches that relied solely on refrigeration to prevent outgrowth of *C. botulinum* spores. Uncanned foods responsible for food-borne botulism cases include peyote tea, hazelnut flavoring added to yogurt, sweet cream cheese, sautéed onions in patty melt sandwiches, potato salad, and fresh and dried fish, including botulism type E that has been acquired by eating an Egyptian salt-cured fish dish called fesikh. For food-borne botulism cases reported to the 2017 National Botulism Surveillance System, the median age of patients was 42 years (range: 14-85 years), and three deaths were reported. Most of the continental U.S. outbreaks resulted from proteolytic type A or type B strains, whereas in Alaska and Canada, most food-borne outbreaks have resulted from nonproteolytic type E strains. A further hazard of type E strains is their ability to grow at the temperatures maintained by household refrigerators (5°C [41°F]).

**Wound botulism** is an exceptionally rare disease, with <400 cases reported worldwide, but it is important to pediatrics because adolescents and children may be affected. Although many cases have occurred in young, physically active males who are at the greatest risk for traumatic injury, wound botulism also occurs with crush injuries in which no break in the skin is evident. In recent years, wound botulism from injection has become increasingly common in adult heroin abusers in the western United States and in Europe, not always with concomitant evidence of abscess formation or cellulitis.

A single outbreak of **inhalational botulism** was reported in 1962 in which three laboratory workers in Germany were exposed unintentionally to aerosolized botulinum toxin. Some patients in the United States have been hospitalized by accidental overdose of therapeutic or cosmetic botulinum toxin.

## PATHOGENESIS

All forms of botulism produce disease through a final common pathway. Botulinum toxin is carried by the bloodstream to peripheral cholinergic synapses, where it binds irreversibly, blocking acetylcholine release and causing impaired neuromuscular and autonomic transmission. **Infant botulism** results from ingesting the spores of botulinum toxin-producing strains, with subsequent spore germination, multiplication, and production of botulinum toxin in the large intestine. This sequence is distinct from **food-borne botulism**, which is an intoxication that results when preformed botulinum toxin contained in an improperly preserved or inadequately cooked food is swallowed. **Wound botulism** results from spore germination and colonization of traumatized tissue by *C. botulinum*; the pathogenesis of this form of botulism is similar in this respect to that of tetanus. **Inhalational botulism** occurs when aerosolized botulinum toxin is inhaled and could conceivably be a route of exposure generated by a bioterrorist attack.

Because botulinum toxin is not a *cytotoxin*, it does not cause overt macroscopic or microscopic pathology. Pathologic changes (pneumonia, petechiae on intrathoracic organs) may be found at autopsy, but these are secondary changes and not primarily attributable to botulinum toxin. No diagnostic technique is available to identify botulinum toxin binding at the neuromuscular junction. Nerve conduction velocity studies are typically normal. Electromyography (EMG) findings are often nonspecific and nondiagnostic (see later). The healing process in botulism consists of sprouting new terminal unmyelinated motor neurons. Movement resumes when these new nerve terminals locate noncontracting muscle fibers and reinnervate them by inducing formation of a new motor end plate. In experimental animals, this process takes about 4 weeks.



**Fig. 256.2** A 3-mo-old infant with botulism just before intubation. Note bilateral ptosis and facial palsy and the absence of tears. (From Arnon SS, Long SS. *Clostridium botulinum* [Botulism]. In: Long SS, Prober CG, Fischer M, Kimberlin DW, eds. *Principles and Practice of Pediatric Infectious Diseases*, 6th ed. Philadelphia: Elsevier; 2023: Fig. 189.4, p. 1020.)

## CLINICAL MANIFESTATIONS

The full clinical spectrum of **infant botulism** ranges from mild to fulminant sudden death. Botulinum toxin is distributed hematogenously. Because relative blood flow and density of innervation are greatest in the bulbar musculature, all forms of botulism manifest neurologically as a symmetric, *descending*, flaccid paralysis beginning with the cranial nerve musculature and progressing over hours to days. **Bulbar palsies** may manifest with such symptoms as poor feeding, weak suck, feeble cry, drooling, and even obstructive apnea. These clinical clues unfortunately may not be recognized as bulbar in origin (Fig. 256.2). Patients with evolving illness may already have generalized weakness and hypotonia in addition to bulbar palsies when first examined. The brain itself is spared in infant botulism, because botulinum toxin does not cross the blood-brain barrier.

In contrast to botulism caused by *C. botulinum*, a majority of the rare cases caused by intestinal colonization with *C. butyricum* are associated with a Meckel diverticulum accompanying abdominal distention, often leading to misdiagnosis as an acute abdomen. The also rare *C. baratii* type F infant botulism cases have been characterized by very young age at onset, rapidity of onset, and greater severity but shorter duration of paralysis.

In older children with **food-borne** or **wound botulism**, the onset of neurologic symptoms follows a characteristic pattern of diplopia, ptosis, dry mouth, dysphagia, dysphonia, and dysarthria, with decreased gag and corneal reflexes. Importantly, because the toxin acts only on motor nerves, paresthesias are not seen in botulism, except when a patient hyperventilates from anxiety. The sensorium remains clear, but this fact may be difficult to ascertain because of the slurred speech.

**Food-borne botulism** begins with gastrointestinal (GI) symptoms of nausea, vomiting, or diarrhea in approximately 30% of cases. These symptoms are thought to result from metabolic by-products of growth of *C. botulinum* or from the presence of other toxic contaminants in the food, because GI distress is rarely observed in wound botulism. Constipation may occur in food-borne botulism once flaccid paralysis becomes evident. Illness usually begins 12-36 hours after ingestion of



the contaminated food but can range from as short as 2 hours to as long as 8 days. The incubation period in **wound botulism** is 4-14 days. Fever may be present in wound botulism but is absent in food-borne botulism unless a secondary infection (often pneumonia) is present. All forms of botulism display a wide spectrum of clinical severity, from the very mild, with minimal ptosis, flattened facial expression, minor dysphagia, and dysphonia, to the fulminant, with rapid onset of extensive paralysis, frank apnea, and fixed, dilated pupils. *Fatigability with repetitive muscle activity* is the clinical hallmark of botulism.

**Infant botulism** differs in apparent initial symptoms of illness only because the infant cannot verbalize them. Clinical progression can be more rapid and more severe in very young infants. The incubation period in infant botulism is estimated to be 3-30 days. Usually, the first indication of illness is a decreased frequency or even absence of defecation, and indeed, constipation may be the chief complaint (although this sign is also frequently overlooked). Parents typically notice inability to feed, lethargy, weak cry, and diminished spontaneous movement. Dysphagia may be evident, and an increase in secretions drooling from the mouth may be noted. Gag, suck, and corneal reflexes all diminish as the paralysis advances. Oculomotor palsies may be evident. Paradoxically, the pupillary light reflex may be unaffected until the child is severely paralyzed, or it may be initially sluggish. Loss of head control is typically a prominent sign. Opisthotonos may be observed. Respiratory arrest may occur suddenly from airway occlusion by unswallowed secretions or from obstructive flaccid pharyngeal musculature. Death from botulism results either from airway obstruction or paralysis of the respiratory muscles. Occasionally, the diagnosis of infant botulism is suggested by a respiratory arrest that occurs after the infant is curled into position for lumbar puncture or after the administration of an aminoglycoside antibiotic administered for suspected sepsis (see later).

In mild cases or in the early stages of illness, the physical signs of infant botulism may be subtle and easily missed. Eliciting cranial nerve palsies and fatigability of muscular function requires careful examination. Ptosis may not be seen unless the head of the child is kept erect.

## DIAGNOSIS

Definitive diagnosis of botulism is made by specialized laboratory testing that requires hours to days to complete. Therefore clinical diagnosis is the foundation for early recognition of and response to all forms of botulism. Routine laboratory studies, including those of the cerebrospinal fluid (CSF), are normal in botulism unless dehydration, undernourishment (metabolic acidosis and ketosis), or secondary infection is present.

The **classic triad** of botulism is the acute onset of a symmetric, flaccid descending paralysis with clear sensorium, no fever, and no paresthesias. Suspected botulism represents a medical and public health emergency that is immediately reportable by telephone in most U.S. health jurisdictions. State health departments (first call) and the CDC (770-488-7100 at any time) can arrange for diagnostic testing, epidemiologic investigation, and provision of equine antitoxin.

The diagnosis of botulism is unequivocally established by demonstration of the presence of botulinum toxin in serum or of *C. botulinum* toxin or organisms in wound material, enema fluid, or feces. *C. botulinum* is not part of the normal resident intestinal flora of humans, and its presence in the setting of acute flaccid paralysis is diagnostic. An epidemiologic diagnosis of food-borne botulism can be established when *C. botulinum* organisms and toxin are found in food eaten by patients.

**Electromyography** can sometimes distinguish between causes of acute flaccid paralysis, although results may be variable, including normal, in patients with botulism. The distinctive EMG finding in botulism is facilitation (potentiation) of the evoked muscle action potential at high-frequency (50 Hz) stimulation. In infant botulism, a characteristic pattern known as **BSAP** (Brief, Small, Abundant motor unit action Potentials) is present only in clinically weak muscles. Nerve conduction velocity and sensory nerve function are normal in botulism.

Infant botulism requires a high index of suspicion for early diagnosis (Table 256.1). "Rule-out sepsis" remains the most common admission

**Table 256.1** Mimics of Initial Diagnosis of Infant Botulism

### NEUROMUSCULAR

Spinal muscular atrophy (type 1)  
Congenital myasthenia gravis  
Guillain-Barré syndrome and its variants  
Poliomyelitis  
Acute flaccid paralysis  
Transverse myelitis  
ADEM  
Congenital myopathy  
Encephalitis (viral, autoimmune)  
Global developmental delay  
Leukodystrophy

### METABOLIC

Medium chain acetyl-coenzyme A deficiency  
Carnitine deficiency  
Congenital disorders of glycosylation  
Urea cycle defects  
Mitochondrial disorders  
Glutaric aciduria type 1  
Maple syrup urine disease

### INFECTIOUS

Enteroviral and parechovirus encephalitis  
Sepsis

### OTHERS

Hypothyroidism  
Drug ingestion  
Organophosphate poisoning  
Heavy metal poisoning (lead, arsenic)

diagnosis. If a previously healthy infant (usually 2-4 months of age) demonstrates weakness with difficulty in sucking, swallowing, crying, or breathing, infant botulism should be considered a likely diagnosis. A careful cranial nerve examination is then quite helpful. Rare instances of co-infection with *Clostridioides difficile*, respiratory syncytial virus, or influenza virus have occurred.

## Differential Diagnosis

Botulism is frequently misdiagnosed, most often as a **polyradiculoneuropathy** (Guillain-Barré or Miller Fisher syndrome), myasthenia gravis, or a central nervous system (CNS) disease (Table 256.2). In the United States, botulism is more likely than **Guillain-Barré syndrome**, intoxication, or poliomyelitis to cause a *cluster of cases* of acute flaccid paralysis. Botulism differs from other flaccid paralyses in its initial and prominent cranial nerve palsies that are disproportionate to milder weakness and hypotonia below the neck, in its symmetry, and in its absence of sensory nerve damage. Spinal muscular atrophy may closely mimic infant botulism at presentation.

Additional diagnostic procedures may be useful in rapidly excluding botulism as the cause of paralysis. The CSF is unchanged in botulism but is abnormal in many CNS diseases. Although the CSF protein concentration is eventually elevated in Guillain-Barré syndrome, it may be normal early in the illness. Imaging of the brain, spine, and chest may reveal hemorrhage, inflammation, or neoplasm. A test dose of edrophonium chloride briefly reverses paralytic symptoms in many patients with myasthenia gravis and, reportedly, in some with botulism, although this is rarely performed in infants. A close inspection of the skin, especially the scalp, may reveal an attached tick that is causing paralysis. Possible organophosphate intoxication should be pursued aggressively, because specific antidotes (oximes) are available and because the patient may be part of a commonly exposed group, some of whom have yet to demonstrate illness. Other tests that require days for results include stool culture for *Campylobacter jejuni* as a precipitant of Guillain-Barré syndrome, spinal muscular atrophy and other genetic (including mitochondrial) disorders, and assays for the autoantibodies that cause myasthenia gravis, Lambert-Eaton syndrome, and Guillain-Barré syndrome.



**Table 256.2** Conditions Considered in the Differential Diagnosis of Food-Borne Botulism and Wound Botulism

Acute gastroenteritis
Myasthenia gravis
Guillain-Barré syndrome
Organophosphate poisoning
Meningitis
Encephalitis
Transverse myelitis
Psychiatric illness
Cerebrovascular accident
Poliomyelitis
Hypothyroidism
Genetic disorder
Aminoglycoside-associated paralysis
Tick paralysis
Hypocalcemia
Hypermagnesemia
Carbon monoxide poisoning
Hyperemesis gravidarum
Laryngeal trauma
Diabetic complications
Inflammatory myopathy
Overexertion

## TREATMENT

Human botulism immune globulin, given intravenously (BIG-IV, also referred to as *BabyBIG*), is licensed for the treatment of infant botulism caused by type A or B botulinum toxin. The purified immunoglobulin is derived from pooled adult plasma from individuals immunized with pentavalent botulinum toxoid who were selected for their high titers of neutralizing antibody against botulinum neurotoxins type A and B. Treatment with BIG-IV consists of a single intravenous infusion of 50 mg/kg (see package insert) that should be given as soon as possible after infant botulism is suspected so as to immediately end the toxemia that is the cause of the illness and arrest progression of paralysis. *When the diagnosis of infant botulism is suspected, treatment should not be delayed for laboratory confirmation.* In the United States, for clinical consultation for a patient with suspected infant botulism, the patient's physician should contact the Infant Botulism Treatment and Prevention Program (IBTPP) on-call physician at (510) 231-7600 (24/7/365). To obtain BabyBIG for a patient with suspect infant botulism, the physician must contact the IBTPP on-call physicians (<https://www.infantbotulism.org/physician/obtain.php>). The use of BIG-IV shortens mean hospital stay from approximately 6 weeks to 2 weeks. Most of the decrease in hospital stay results from shorter duration of mechanical ventilation and reduced days in intensive care.

Older patients with suspected food, wound, or inhalational botulism may be treated with one vial of licensed equine heptavalent (A-G) botulinum antitoxin (HBAT). (<https://www.cdc.gov/mmwr/preview/mmwrhtml/mm5910a4.htm>), which is available in the United States through the CDC by way of state and local health departments.

*Antibiotic therapy is not part of the treatment of uncomplicated infant or food-borne botulism*, because the toxin is primarily an intracellular molecule that is released into the intestinal lumen with vegetative bacterial cell death and lysis. Indeed, there is a theoretical concern that antibiotics with clostridiocidal activity may increase the amount of free toxin in the large bowel and actually worsen an infant's clinical status. Antibiotic use in infant botulism patients is indicated only for the treatment of secondary infections. In these patients, aminoglycosides in particular should be avoided, because this class of antibiotics can potentiate the action of botulinum toxin at the neuromuscular junction. Wound botulism requires aggressive treatment with antibiotics and antitoxin in a manner analogous to that for tetanus (see [Chapter 257](#)) and may require wound debridement to remove the source of the toxin.

## SUPPORTIVE CARE

Management of botulism rests on the following three principles: (1) fatigability with repetitive muscle activity is the clinical hallmark of the disease, (2) complications are best avoided by anticipating them, and (3) meticulous supportive care is a necessity. The first principle applies mainly to feeding and breathing. Correct positioning is imperative to protect the airway and improve respiratory mechanics. The patient should be positioned face-up on a rigid-bottomed crib (or bed), the head of which is tilted at 30 degrees. A small cloth roll is placed under the cervical vertebrae to tilt the head back so that secretions drain to the posterior pharynx and away from the airway. In this tilted position, the abdominal viscera pull the diaphragm down, thereby improving respiratory mechanics. The patient's head and torso should not be elevated by bending the middle of the bed; in such a position, the hypotonic thorax would slump into the abdomen, and breathing would be compromised.

About half of patients with infant botulism require endotracheal intubation, which is best done prophylactically. The indications include diminished gag and cough reflexes and progressive airway obstruction by secretions. Enteral nutrition should be undertaken using a nasogastric or nasojejunal tube until sufficient oropharyngeal strength and coordination enable oral feeding by breast or bottle. Expressed breast milk is the most desirable food for infants, in part because of its immunologic components (e.g., secretory IgA, lactoferrin, leukocytes). Tube feeding also assists in the restoration of peristalsis, a nonspecific but probably essential part of eliminating *C. botulinum* from the intestinal flora. Intravenous feeding (hyperalimentation) is discouraged because of the potential for infection and the advantages of tube feeding.

Because sensation and cognitive function remain fully intact, providing auditory, tactile, and visual stimuli is beneficial. Maintaining strong central respiratory drive is essential, so sedatives and CNS depressants should be avoided. Full hydration and stool softeners such as lactulose may mitigate the protracted constipation. Cathartics are not recommended. Patients with food-borne and infant botulism excrete *C. botulinum* toxin and organisms in their feces, often for many weeks, and care should be taken in handling their excreta, with full engagement of hospital infection control staff. When bladder palsy occurs in severe cases, gentle suprapubic pressure with the patient in the sitting position with the head supported may help attain complete voiding and reduce the risk for urinary tract infection (UTI). Families of affected patients may require emotional and financial support, especially when the paralysis of botulism is prolonged.

## COMPLICATIONS

Almost all the complications of botulism are *nosocomial*, and a few are iatrogenic ([Table 256.3](#)). Some critically ill, toxin-paralyzed patients who must spend weeks or months on ventilators in intensive care units inevitably experience some of these complications. Suspected "relapses" of infant botulism usually reflect premature hospital discharge or an inapparent underlying complication such as pneumonia, UTI, or otitis media.

## PROGNOSIS

When the regenerating nerve endings have induced formation of a new motor end plate, neuromuscular transmission is restored. In the absence of complications, particularly those related to hypoxia, the prognosis in infant botulism is for full and complete recovery. Hospital stay in untreated infant botulism averages 5.7 weeks but differs significantly by toxin type, with patients with untreated type B disease being hospitalized a mean of 4.2 weeks and those with untreated type A disease being hospitalized a mean of 6.7 weeks.

In the United States, the case fatality ratio for hospitalized cases of infant botulism is <1%. After recovery, patients with untreated infant botulism appear to have an increased incidence of strabismus that requires timely screening and treatment. The case fatality ratio in food-borne and wound botulism varies by age, with younger patients having the best prognosis. Some adults with botulism have reported chronic weakness and fatigue for >1 year as sequelae of the illness.

**Table 256.3** Complications of Infant Botulism

Acute respiratory distress syndrome
Aspiration
<i>Clostridioides difficile</i> enterocolitis
Hypotension
Inappropriate antidiuretic hormone secretion
Long bone fractures
Misplaced or plugged endotracheal tube
Nosocomial anemia
Otitis media
Pneumonia
Pneumothorax
Recurrent atelectasis
Seizures secondary to hyponatremia
Sepsis
Subglottic stenosis
Tracheal granuloma
Tracheitis
Transfusion reaction
Urinary tract infection

## PREVENTION

Food-borne botulism is best prevented by adherence to safe methods of home canning (pressure cooker and acidification), by avoiding suspicious foods, and by heating all home-canned foods to 85°C (185°F) for ≥5 minutes. Wound botulism is best prevented by not using illicit drugs and by treating contaminated wounds with thorough cleansing, surgical debridement, and provision of appropriate antibiotics.

Many patients with infant botulism are presumed to have inhaled and then swallowed airborne clostridial spores; these cases cannot be prevented. However, a clearly identified and avoidable source of botulinum spores for infants is honey. *Honey is an unsafe food for any child <1 year old.* Corn syrups were once thought to be a possible source of botulinum spores, but evidence indicates otherwise. Breastfeeding appears to slow the onset of infant botulism and to diminish the risk for sudden death in infants in whom the disease develops.

Visit Elsevier eBooks+ at [eBooks.Health.Elsevier.com](http://eBooks.Health.Elsevier.com) for Bibliography.

## Chapter 257

# Tetanus (*Clostridium tetani*)

Mark R. Schleiss

## ETIOLOGY

The clinical syndrome of **tetanus** involves an acute, spastic paralytic illness caused by a neurotoxin produced by *Clostridium tetani*. Thus tetanus can be considered a toxin-mediated process more than an acute infectious process per se, because there are few, if any, symptoms elicited either by the presence of replicating microorganisms or through elicitation of the host inflammatory response. Unlike other pathogenic clostridia species, *C. tetani* is not a tissue-invasive organism. Instead, it causes illness through the toxin, **tetanospasmin**, more commonly referred to as *tetanus toxin*. Tetanospasmin is the second most poisonous substance known, surpassed in potency only by botulinum toxin. The human lethal dose of tetanus toxin is estimated to be 10<sup>-5</sup> mg/kg. *C. tetani* is a motile, gram-positive, spore-forming obligate anaerobe. The organism's natural habitat worldwide is soil, dust, and the alimentary tracts of various animals.

*C. tetani* forms spores terminally, with a classic morphologic appearance resembling a drumstick or tennis racket when viewed microscopically. The formation of spores is a critical aspect of the organism's persistence in the environment. Spores can survive boiling but not autoclaving, whereas the vegetative cells are killed by antibiotics, heat, and standard disinfectants.

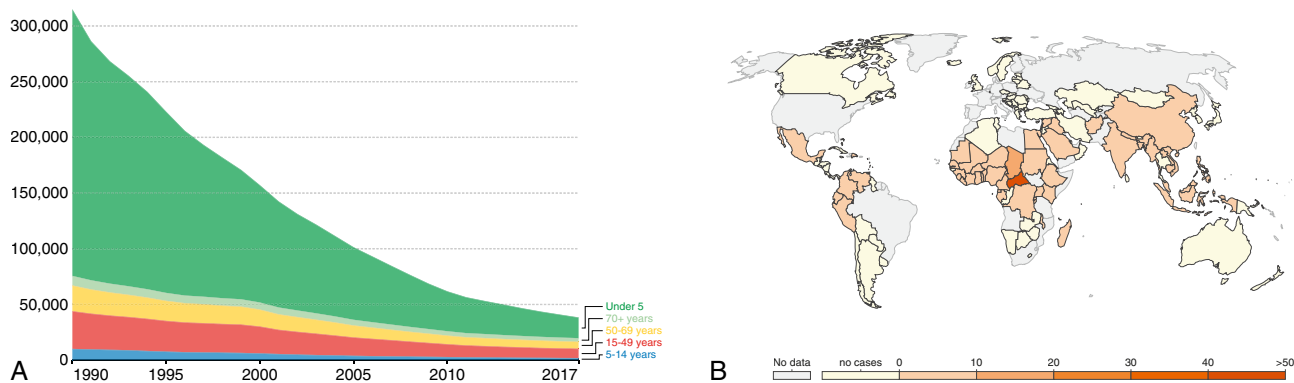
## EPIDEMIOLOGY

Tetanus occurs worldwide and is endemic in many developing countries, although its incidence varies considerably. Public health efforts in recent years have had an impressive impact on tetanus-associated mortality, but many challenges remain. In 1990, 314,000 people died because of tetanus, whereas in 2017 there were just slightly over 38,000 deaths. Over half of these deaths (approximately 18,000) were in children under 5 years of age (Fig. 257.1A). Individuals age 15-49 years represent the second most common group to suffer tetanus-related mortality. Global mortality in adults is largely driven by **maternal tetanus**, which results from postpartum, postabortal, or postsurgical wound infection with *C. tetani*. Most mortality related to **neonatal tetanus** (also referred to as **umbilical tetanus**) occurs in South Asia and sub-Saharan Africa. The mortality of neonatal tetanus has been substantially reduced globally, driven by increased rates of maternal tetanus vaccination, although the disease remains endemic in a number of countries (see Fig. 257.1B). Reported tetanus cases in the United States have declined more than 95% since 1947, and deaths caused by tetanus have declined by more than 99% in that same period. From 2009 to 2017, a total of 264 cases and 19 deaths from tetanus were reported in the United States. Sixty (23%) cases were in persons 65 years of age or older, 168 (64%) were in persons 20 through 64 years of age, and 36 (13%) were in persons younger than 20 years, including 3 cases of neonatal tetanus. The majority of childhood cases of tetanus in the United States have occurred in unimmunized children whose parents objected to vaccination.

Most nonneonatal cases of tetanus are associated with a traumatic injury, often a penetrating wound inflicted by a dirty object such as a nail, splinter, fragment of glass, or unsterile injection. Tetanus may also occur in the setting of illicit drug injection. The disease has been associated with the use of contaminated suture material and after intramuscular injection of medicines, most notably quinine for chloroquine-resistant falciparum malaria. The disease may also occur in association with animal bites, abscesses (including dental abscesses), ear and other body piercing, chronic skin ulceration, burns, compound fractures, frostbite, gangrene, intestinal surgery, ritual scarification, infected insect bites, and female circumcision. Rarely, cases may present to clinical attention without an antecedent history of trauma. Tetanus is not transmitted person to person.

## PATHOGENESIS

Tetanus typically occurs after spores (introduced by traumatic injury) germinate, multiply, and produce tetanus toxin. A plasmid carries the toxin gene. Toxin is produced only by the vegetative cell, not the spore. It is released after the vegetative phase of replication, with replication occurring under anaerobic conditions. The low oxidation-reduction potential of an infected injury site therefore provides an ideal environment for transition from the spore to the vegetative stage of growth. After bacterial cell death and lysis, **tetanospasmin** is produced. The toxin has no known function for clostridia in the soil environment where they normally reside. Tetanus toxin is a 150-kDa simple protein consisting of a heavy chain (100 kDa) and a light (50 kDa) chain joined by a single disulfide bond. Tetanus toxin binds at the neuromuscular junction and enters the motor nerve by endocytosis, after which it undergoes retrograde axonal transport, facilitated by dyneins, to the cytoplasm of the  $\alpha$ -motoneuron. In the sciatic nerve, the transport rate was found to be 3.4 mm/hr. The toxin exits the motoneuron in the spinal cord and next enters adjacent spinal inhibitory interneurons, where it prevents release of the neurotransmitters glycine and  $\gamma$ -aminobutyric acid (GABA). Tetanus toxin thus blocks the normal inhibition of antagonistic muscles on which voluntary coordinated movement depends; as a consequence, affected muscles sustain maximal contraction and cannot relax. This aspect of pathogenesis lead to



**Fig. 257.1** Evolving epidemiology of tetanus. **A**, Deaths from tetanus, by age, globally from 1990 to 2017. Most cases of tetanus occur in children under the age of 5, and this group accounts for ~50% of the global mortality attributable to this infection. (Source: Institute for Health Metrics and Evaluation, Global Burden of Disease). **B**, Global distribution of neonatal tetanus. Number of new cases of neonatal tetanus per million, 2016. Sources: World Health Organization and UN Population Prospects, 2017. (From Behrens H, Ochmann S, Dadonaite B, Roser M. Tetanus. Published online at OurWorldInData.org, 2019. Retrieved from <https://ourworldindata.org/tetanus>.)

the term *lockjaw*, classically applied to the clinical manifestations of tetanus in the affected individual. Neurotransmission at neuromuscular junctions in the autonomic nervous system are also rendered unstable in tetanus, producing “autonomic storm” (described later).

The phenomenal potency of tetanus toxin is enzymatic. The 50-kDa light chain (A-chain) of tetanus toxin is a zinc-containing endoprotease whose substrate is synaptobrevin, a constituent protein of the docking complex that enables the synaptic vesicle to fuse with the terminal neuronal cell membrane. The cleavage of synaptobrevin is the final target of tetanus toxin, and even in low doses the neurotoxin will inhibit neurotransmitter exocytosis in the inhibitory interneurons. The blockage of GABA and glycine causes the physiologic effects of tetanus toxin. The 100-kDa heavy chain (B-chain) of the toxin contains its binding and internalization domains. It binds to disialogangliosides (GD2 and GD1b) on the neuronal membrane. The translocation domain aids the movement of the protein across that membrane and into the neuron.

Because *C. tetani* is not an invasive organism, its toxin-producing vegetative cells remain where introduced into the wound, which may display local inflammatory changes and a mixed bacterial flora.

## CLINICAL MANIFESTATIONS

Tetanus is most often generalized but may also be localized. The incubation period typically is 2–14 days but may be as long as months after the injury. In **generalized tetanus**, the presenting symptom in about half of cases is **trismus** (masseter muscle spasm, or lockjaw). Headache, restlessness, and irritability are early symptoms, often followed by stiffness, difficulty chewing, dysphagia, and neck muscle spasm. The so-called **sardonic smile of tetanus** (*risus sardonicus*) results from intractable spasms of facial and buccal muscles. When the paralysis extends to abdominal, lumbar, hip, and thigh muscles, the patient may assume an arched posture of extreme hyperextension of the body, or **opisthotonos**, with the head and the heels bent backward and the body bowed forward. In severe cases, only the back of the head and the heels of the patient are noted to be touching the supporting surface. Opisthotonos is an equilibrium position that results from unrelenting total contraction of opposing muscles, all of which display the typical boardlike rigidity of tetanus. Laryngeal and respiratory muscle spasm can lead to airway obstruction and asphyxiation. Because tetanus toxin does not affect sensory nerves or cortical function, the patient unfortunately remains conscious, in extreme pain, and in fearful anticipation of the next tetanic seizure. The seizures are characterized by sudden, severe tonic contractions of the muscles, with fist clenching, flexion, and adduction of the arms and hyperextension of the legs. Without treatment, the duration of these seizures may range from a few seconds to a few minutes in length with intervening respite periods. As the illness progresses, the spasms become sustained and exhausting. The smallest disturbance by sight, sound, or touch may trigger a tetanic

spasm. Dysuria and urinary retention result from bladder sphincter spasm; forced defecation may occur. Fever, occasionally as high as 40°C (104°F), is common and is caused by the substantial metabolic energy consumed by spastic muscles. Notable autonomic effects include tachycardia, dysrhythmias, labile hypertension, diaphoresis, and cutaneous vasoconstriction. The tetanic paralysis usually becomes more severe in the first week after onset, stabilizes in the second week, and ameliorates gradually over the ensuing 1–4 weeks.

**Neonatal tetanus**, the infantile form of generalized tetanus, typically manifests within 3–12 days of birth. It presents as progressive difficulty in feeding (sucking and swallowing), associated hunger, and crying. Paralysis or diminished movement, stiffness and rigidity to the touch, and spasms, with or without opisthotonos, are characteristic. The umbilical stump, which is typically the portal of entry for the microorganism, may retain remnants of dirt, dung, clotted blood, or serum, or it may appear relatively benign.

**Localized tetanus** results in painful spasms of the muscles adjacent to the wound site and may precede generalized tetanus. **Cephalic tetanus** is a rare form of localized tetanus involving the bulbar musculature and cranial nerves (particularly cranial nerve VII) that occurs with wounds or foreign bodies in the head, nostrils, or face. It also occurs in association with chronic otitis media. Cephalic tetanus is characterized by retracted eyelids, deviated gaze, trismus, *risus sardonicus*, and spastic paralysis of the tongue and pharyngeal musculature and may mimic a cerebrovascular accident.

## DIAGNOSIS

The picture of tetanus is one of the most dramatic in medicine, and the diagnosis may be established clinically. The typical setting is an unimmunized patient (and/or mother) who was injured or born within the preceding 2 weeks, who presents with trismus, dysphagia, generalized muscle rigidity and spasm, and a clear sensorium.

Results of routine laboratory studies are usually normal. A peripheral leukocytosis may result from a secondary bacterial infection of the wound or may be stress-induced from the sustained tetanic spasms. The cerebrospinal fluid analysis is normal, although the intense muscle contractions may raise intracranial pressure. Serum muscle enzymes (creatine kinase, aldolase) may be elevated. Neither the electroencephalogram nor the electromyogram (EMG) shows a characteristic pattern, although EMG may show a continuous discharge of motor subunits and shortening or absence of the silent interval normally observed after an action potential. An assay for antitoxin levels is not readily available, although a serum antitoxin level of 0.01 IU/mL or higher is generally considered protective and makes the diagnosis of tetanus less likely. *C. tetani* is not always visible on Gram stain of wound material and is isolated by culture in only approximately 30% of cases. The **spatula test** is a simple diagnostic



bedside test that involves touching the oropharynx with a spatula or tongue blade. Normally this maneuver will elicit a gag reflex, as the patient tries to expel the spatula (negative test). If tetanus is present, patients develop a reflex spasm of the masseters and bite the spatula (positive test). This bedside diagnostic maneuver is said to have a high sensitivity and specificity.

### Differential Diagnosis

Florid and generalized tetanus is typically not mistaken for any other disease. However, trismus may result from parapharyngeal, retropharyngeal, or dental abscesses or, rarely, from acute encephalitis involving the brainstem. Either rabies or tetanus may follow an animal bite, and rabies may manifest as trismus with seizures. Rabies may be distinguished from tetanus by hydrophobia, marked dysphagia, predominantly clonic seizures, and pleocytosis (see Chapter 320). Although strychnine poisoning may result in tonic muscle spasms and generalized seizure activity, it seldom produces trismus, and unlike in tetanus, general relaxation usually occurs between spasms. Hypocalcemia may produce tetany that is characterized by laryngeal and carpopedal spasms, but trismus is absent. Occasionally, epileptic seizures, narcotic withdrawal, or other drug reactions may suggest tetanus.

### TREATMENT

Management of tetanus requires eradication of *C. tetani*, correction of wound environment conditions conducive to its anaerobic replication, neutralization of all accessible tetanus toxin, control of seizures and respiration, palliation, provision of meticulous supportive care, and, finally, prevention of recurrences.

Surgical wound excision and debridement are often needed to remove the foreign body or devitalized tissue that created the anaerobic growth conditions necessary for vegetative replication. Surgery should be performed promptly after administration of **human tetanus immunoglobulin (TIG)** and antibiotics. Excision of the umbilical stump in the neonate with tetanus is no longer recommended.

Tetanus toxin cannot be neutralized by TIG after it has begun its axonal ascent to the spinal cord. However, TIG should be given as soon as possible, with the goal of neutralizing toxin that diffuses from the wound into the circulation before the toxin can bind at distant muscle groups. The optimal dose of TIG has not been determined. Most experts recommend that a **single intramuscular (IM) injection of 500 units of TIG** is sufficient to neutralize systemic tetanus toxin; although doses as high as 3,000–6,000 have been recommended by some experts, they do not seem to confer better outcomes. Infiltration of part of the dose of TIG into the wound is no longer recommended by the Red Book Committee of the American Academy of Pediatrics, and the entire dose can be administered IM. If TIG is unavailable, use of human intravenous immunoglobulin (at a dose of 200–400 mg/kg) can be considered. Intravenous immunoglobulin contains 4–90 units/mL of TIG; the optimal dosage of intravenous immunoglobulin for treating tetanus is not known, and its use is not approved for this indication. In parts of the world where it is available, another alternative may be equine-derived tetanus antitoxin (TAT). This product is no longer available in the United States. A dose of 1,500–3,000 U is recommended and should be administered after appropriate testing for sensitivity and desensitization, because up to 15% of patients given the usual dose of TAT will experience serum sickness. The human-derived immunoglobulins are much preferred because of their longer half-lives (30 days) and the virtual absence of allergic and serum sickness adverse effects. Results of studies examining the potential benefit of intrathecal administration of TIG are conflicting. The TIG preparation available for use in the United States is neither licensed nor formulated for intrathecal or intravenous use.

Oral (or intravenous) **metronidazole** (30 mg/kg per day, given at 6-hour intervals; maximum dose, 4 g/day) decreases the number of vegetative forms of *C. tetani* and is currently considered the antibiotic of choice. **Parenteral penicillin G** (100,000 U/kg per day, administered at 4- to 6-hour intervals, with a daily maximum of 12 million U) is an alternative treatment. Antimicrobial therapy for a total duration of 7–10 days is recommended (<https://publications.aap.org/redbook/book/347/chapter-abstract/5757094/Tetanus-Lockjaw>).

Supportive care and pharmacologic interventions targeted at control of tetanic spasms are of critical importance in the management of tetanus. In light of this goal, all patients with generalized tetanus should receive muscle relaxants. **Diazepam** provides both relaxation and seizure control. For neonatal tetanus, an initial dose of 0.1–0.2 mg/kg every 3–6 hours given intravenously is subsequently titrated to control the tetanic spasms (continuous IV infusion doses of 15–40 mg/kg/day have been recommended, titrated to control the spasm). After 5–7 days, the dosage can be decreased by 5–10 mg/day, with the drug given orally or by the nasogastric route, after which the effective dose is sustained for 2–6 weeks before a tapered withdrawal. **Magnesium sulfate** may be useful in controlling autonomic dysfunction: a loading dose of 40 mg/kg IV over 30 minutes has been recommended in a study in tetanus patients >15 years of age, in which the loading dose was followed by 2 g/hr continuously for patients weighing >45 kg, or 1.5 g/hr continuously for patients weighing <45 kg. For neonatal tetanus, a loading dose of 50 mg/kg of magnesium sulfate, followed by a maintenance infusion of 30–50 mg/kg/hr (titrated against clinical effect) has been recommended. Monitoring of serum magnesium levels at least every 6 hours is recommended. In addition to diazepam, other benzodiazepines (**midazolam**), **chlorpromazine**, **dantrolene**, and **baclofen** are also used. Intrathecal baclofen produces such complete muscle relaxation that apnea often ensues; like most other agents listed, baclofen should be used only in an intensive care unit setting. Favorable survival rates in generalized tetanus have been described with the use of neuromuscular blocking agents such as vecuronium and pancuronium, which produce a general flaccid paralysis that is then managed by mechanical ventilation. Autonomic instability is regulated with standard  $\alpha$ - or  $\beta$ - (or both) blocking agents; morphine has also proved useful.

### SUPPORTIVE CARE

Meticulous supportive care in a quiet, dark, secluded setting is most desirable. Because tetanic spasms may be triggered by minor stimuli, the patient should be sedated and protected from all unnecessary sounds, sights, and touch, and all therapeutic and other manipulations must be carefully scheduled and coordinated. Endotracheal intubation may not be required, but it should be done to prevent aspiration of secretions before laryngospasm develops. A tracheostomy kit should be immediately at hand for unintubated patients. Endotracheal intubation and suctioning easily provoke reflex tetanic seizures and spasms, so early tracheostomy should be considered in severe cases not managed by pharmacologically induced flaccid paralysis. Therapeutic botulinum toxin has been used for this purpose (i.e., to overcome trismus). Cardiorespiratory monitoring, frequent suctioning, and maintenance of the patient's substantial fluid, electrolyte, and caloric needs are fundamental. Careful nursing attention to mouth, skin, bladder, and bowel function is needed to avoid ulceration, infection, and obstipation. Prophylactic subcutaneous heparin has been suggested to be of value, but it must be balanced with the risk for hemorrhage. Enoxaparin would be an alternative for the patient for whom deep venous thrombosis (DVT) prophylaxis is warranted.

### COMPLICATIONS

The seizures and the severe, sustained rigid paralysis of tetanus predispose the patient to many complications. Aspiration of secretions with attendant pneumonia is an important complication to consider and may be present at the time of the initial diagnosis. Maintaining airway patency often mandates endotracheal intubation and mechanical ventilation with their attendant hazards, including pneumothorax and mediastinal emphysema. The seizures may result in lacerations of the mouth or tongue, in intramuscular hematomas or **rhabdomyolysis** with myoglobinuria and renal failure, or in long bone or spinal fractures. Venous thrombosis, pulmonary embolism, gastric ulceration with or without hemorrhage, paralytic ileus, and decubitus ulceration are described as complications. Excessive use of muscle relaxants, which are an integral part of care, may produce iatrogenic apnea. Cardiac arrhythmias, including asystole, unstable blood pressure, and labile temperature regulation, reflect disordered autonomic nervous system control that may be aggravated by inattention to maintenance of intravascular volume needs.



**Table 257.1** Tetanus Vaccination and Immune Globulin Use in Wound Management

HISTORY OF ABSORBED TETANUS TOXOID	CLEAN, MINOR WOUNDS		ALL OTHER WOUNDS*	
	DTaP, Tdap, OR Td†	TIG‡	DTaP, Tdap, Or TD†	TIG‡
Uncertain or <3 doses	Yes	No	Yes	Yes
3 or more doses	No, if <10 yr since last dose of tetanus-containing vaccine	No	No, if <5 yr since last tetanus-containing vaccine <sup>1</sup>	No
	Yes, if ≥10 yr since last dose of tetanus-containing vaccine	No	Yes, if ≥5 yr since last tetanus-containing vaccine dose	No

\*Including but not limited to wounds contaminated with dirt, feces, and saliva; puncture wounds; avulsions; wounds resulting from missiles, crushing, burns, and frostbite.

<sup>1</sup>DTaP is used for children younger than 7 yr. Tdap is preferred over Td for underimmunized children 7 yr and older who have not received Tdap previously.

‡Intravenous immune globulin should be used when TIG is unavailable.

†More frequent boosters are not needed and can accentuate adverse events.

DT, Diphtheria and tetanus toxoid vaccine; DTaP, combined diphtheria toxoid–tetanus toxoid–acellular pertussis vaccine; Td, tetanus toxoid and reduced diphtheria toxoid vaccine; Tdap, tetanus toxoid, reduced diphtheria toxoid, and acellular pertussis vaccine; TIG, tetanus immune globulin.

Data from American Academy of Pediatrics. Tetanus (lockjaw). In Kiberlin DW, Barnett ED, Lynfield R, Sawyer MH, eds. *Red Book: 2021–2024 Report of the Committee on Infectious Diseases*, 32nd ed. Itasca, IL: American Academy of Pediatrics, 2021;750–755.

## PROGNOSIS

Recovery in tetanus occurs through regeneration of synapses within the spinal cord that results in restoration of muscle relaxation. Interestingly, an episode of tetanus does not result in the production of toxin-neutralizing antibodies, presumably because the infinitesimally small amounts of toxin required to cause disease are not sufficient to elicit an immune response. Therefore active immunization with tetanus toxoid during convalescence and/or at discharge, with provision for completion of the primary vaccine series, is mandatory.

The most important factor that influences outcome is the quality of supportive care. Mortality is highest in the very young and the very old. A favorable prognosis is associated with a long incubation period, absence of fever, and localized disease. An unfavorable prognosis is associated with onset of trismus <7 days after injury and with onset of generalized tetanic spasms <3 days after onset of trismus. Sequelae of hypoxic brain injury, especially in infants, include cerebral palsy, diminished mental abilities, and behavioral difficulties. Most fatalities occur within the first week of illness. Reported case fatality rates for generalized tetanus are 5–35%, and for neonatal tetanus they extend from <10% with intensive care treatment to >75% without it. Cephalic tetanus has an especially poor prognosis because of breathing and feeding difficulties.

## PREVENTION

Tetanus is an entirely and easily preventable disease. A serum antibody titer of ≥0.01 units/mL is considered protective. Active immunization should begin in early infancy with combined diphtheria toxoid–tetanus toxoid–acellular pertussis (DTaP) vaccine at 2, 4, 6, and 15–18 months of age, with boosters at 4–6 years (DTaP) and 11–12 years (Tdap) of age, and at 10-year intervals thereafter throughout adult life with tetanus and reduced diphtheria toxoid (Td). Recovery from tetanus does not confer permanent protective immunity, so immunization is recommended in those who have survived documented infection. Immunization of women with tetanus toxoid prevents neonatal tetanus, and pregnant women should receive one dose of reduced diphtheria and pertussis toxoids (Tdap) during each pregnancy, preferably at 27–36 weeks of gestation. Recommended immunization schedules are regularly updated; the most current versions may be found at <http://www.cdc.gov/vaccines/schedules>.

Arthus reactions (type III hypersensitivity reactions), a localized vasculitis associated with deposition of immune complexes and activation of complement, are reported rarely after tetanus vaccination. Mass immunization campaigns in developing countries have occasionally provoked a widespread hysterical reaction.

## Wound Management

Tetanus prevention measures after trauma consist of inducing active immunity to tetanus toxin and of passively providing antitoxic antibody (Table 257.1). Tetanus prophylaxis is an essential part of all wound management, but specific measures depend on the nature of the injury and the immunization status of the patient. Prevention of tetanus must be included in planning for the consequences of bombings, natural disasters, and other possible civilian mass-casualty events.

**Tetanus toxoid** should always be given after a dog or other animal bite, even though *C. tetani* is infrequently found in canine mouth flora. **Nonminor wounds require human TIG** except those in a fully immunized patient (i.e., ≥3 doses of adsorbed tetanus toxoid). In any other circumstance (e.g., patients with an unknown or incomplete immunization history; crush, puncture, or projectile wounds; wounds contaminated with saliva, soil, or feces; avulsion injuries; compound fractures; or frostbite), TIG 250 units should be administered intramuscularly, regardless of the patient's age or weight. If TIG is unavailable, use of human intravenous immunoglobulin may be considered. If neither of these products is available, then 3,000–5,000 units of equine-derived TAT (in regions of the world where it is available) may be given intramuscularly after testing for hypersensitivity. Serum sickness may occur with this agent. Human monoclonal antibodies against the tetanus neurotoxin have recently been generated and characterized, but these are not yet available for clinical use.

The wound should undergo immediate, thorough surgical cleansing and debridement to remove foreign bodies and any necrotic tissue in which anaerobic conditions might develop. Tetanus toxoid should be given to stimulate active immunity and may be administered concurrently with TIG (or TAT); if a tetanus toxoid-containing vaccine and TIG are administered at the same time, then separate syringes and sites should be used. A tetanus toxoid booster (preferably Tdap) is administered to all persons with any wound if the tetanus immunization status is unknown or incomplete. A booster is administered to injured persons who have completed the primary immunization series if (1) the wound is clean and minor, but 10 or more years have passed since the last booster, or (2) the wound is more serious, and 5 or more years have passed since the last booster (see Table 257.1). Persons who experienced an Arthus reaction after a dose of tetanus toxoid-containing vaccine should not receive Td more frequently than every 10 years, even for tetanus prophylaxis as part of wound management. In a situation of delayed wound care, active immunization should be started at once.

Visit Elsevier eBooks+ at [eBooks.Health.Elsevier.com](http://eBooks.Health.Elsevier.com) for Bibliography.

## Chapter 258

***Clostridioides difficile* Infection**

David P. Galloway and Mitchell B. Cohen

*Clostridioides difficile* (formerly *Clostridium difficile*) infection (CDI), also known as **pseudomembranous colitis** or *C. difficile*-associated diarrhea, refers to gastrointestinal (GI) colonization with *C. difficile* resulting in a diarrheal illness. It is a common cause of **antibiotic-associated diarrhea** and the most common cause of healthcare-associated infections in the United States, accounting for 12% of these infections. An increase in inpatient and outpatient (community) acquisition of CDI has been observed, and additional risk factors have been identified.

**ETIOLOGY**

*C. difficile* is a gram-positive, spore-forming, anaerobic bacillus that is resistant to killing by alcohol. It is acquired from the environment or by the fecal-oral route. Organisms causing symptomatic intestinal disease produce **toxin A** and/or **toxin B**. These toxins affect intracellular signaling pathways, resulting in inflammation and cell death. The cytotoxic **binary toxin**, which belongs to the AB toxin family, is not present in the majority of strains but has been detected in epidemic strains.

**EPIDEMIOLOGY**

The incidence of CDI is increasing in pediatric patients, and the setting of acquisition is changing. There is both high incidence in hospitalized children and an emergence of community-onset infection. National data from the Centers for Disease Control and Prevention (CDC) estimate three cases of community-acquired CDI in children for every healthcare-acquired case. In addition to an overall increase in all strains, a **hypervirulent strain**, denoted **NAP1/BI/027** (also called **BI**), has emerged and is estimated to cause 10–20% of pediatric infections. This strain produces **binary toxin** and exhibits 16- and 23-fold increases in the production of toxins A and B, respectively.

Asymptomatic carriage occurs with potentially pathogenic strains and is common in neonates and infants  $\leq 1$  year old. A carrier frequency rate of 50% may occur in children  $< 1$  year old. Colonization rates decrease to less than 5% in healthy children  $> 5$  years old. Asymptomatic colonization with *C. difficile* is common in recently hospitalized patients, with rates of 20%. Carriers can infect other susceptible individuals.

Risk factors for CDI include the use of broad-spectrum antibiotics, hospitalization, exposure to a household member with diarrhea or an asymptomatic carrier, GI surgery, inflammatory bowel disease (IBD), Hirschsprung disease, chemotherapy, enteral tube feeding, proton pump inhibitor (PPI) or  $H_2$ -receptor antagonist use, malnutrition, and chronic illness.

**PATHOGENESIS**

Disease is caused by GI infection with a toxin-producing strain. Any process that disrupts normal flora, impairs the acid barrier defense, alters the normal GI immune response (e.g., IBD), or inhibits intestinal motility may lead to infection. Normal bowel flora appears to be protective, conferring **colonization resistance**.

By affecting intracellular signaling pathways and cytoskeletal organization, toxins induce an inflammatory response and cell death, leading to diarrhea and pseudomembrane formation. Antibodies against **toxin A** have been shown to confer protection against symptomatic disease, and failure of antibody production occurs in patients with recurrent disease.

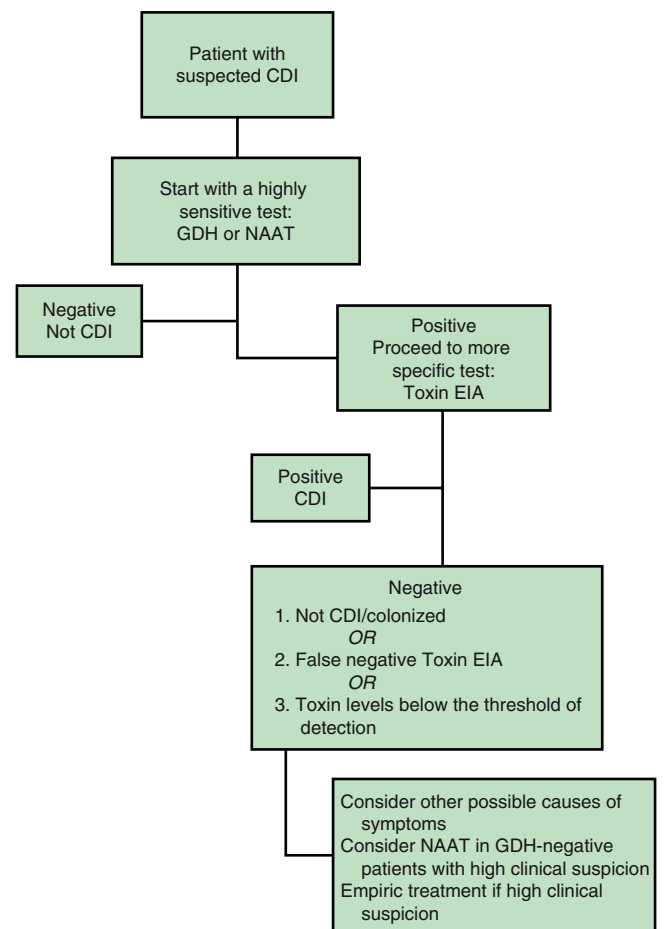
**CLINICAL MANIFESTATIONS**

Infection with toxin-producing strains of *C. difficile* leads to a spectrum of disease ranging from mild, self-limited diarrhea, to explosive, watery diarrhea with occult blood or mucus, to **pseudomembranous colitis**, and even death. **Pseudomembranous colitis** is characterized by bloody diarrhea with accompanying fever, abdominal pain/cramps, nausea, and vomiting. Rarely, small-gut involvement, **toxic megacolon**, bacteremia, abscess formation, intestinal perforation, and death can occur.

Symptoms of CDI generally begin less than a week after colonization and may develop during or weeks after antibiotic exposure. Symptoms are generally more severe in certain populations, including patients receiving chemotherapy, patients with chronic GI disease (e.g., IBD), and some patients with cystic fibrosis (CF). CDI-associated **reactive arthritis** is an occasional complication, occurring in approximately 1.4% of children with CDI. Reactive arthritis begins a median of 10 days after initial GI symptoms, often accompanied by fever or rash. Joint involvement may be migratory or polyarticular and may resemble septic arthritis.

**DIAGNOSIS**

Evaluation for CDI should be reserved for children with **diarrhea**, defined as the passage of at least three loose stools within a 24-hour period or bloody diarrhea (Fig. 258.1 and Table 258.1). CDI is diagnosed by the detection of a *C. difficile* toxin in the stool of a symptomatic patient. Most patients present with a history of recent antibiotic



**Fig. 258.1** Proposed algorithm for testing of *Clostridioides difficile* infection (CDI). EIA, Enzyme immunoassay; GDH, glutamate dehydrogenase; NAAT, nucleic acid amplification testing. (From Kelly CR, Fischer M, Allegretti JR, et al. ACG clinical guidelines: prevention, diagnosis, and treatment of *Clostridioides difficile* in infections. *Am J Gastroenterol.* 2021;116:1124–1147, Fig. 1.)

**Table 258.1** Diagnosis of *C. difficile* Disease

- *Clostridium difficile* (renamed *Clostridioides difficile*) infection is diagnosed by a combination of clinical and laboratory findings.
- Diagnosis requires a positive test for the presence of *C. difficile* toxins.
- Glutamate dehydrogenase (GDH), produced by *C. difficile*, can be detected in stool. However, it is not specific and can be produced by nontoxigenic *C. difficile*.
- Enzyme immunoassay testing for toxin A and/or B has a variable sensitivity and specificity, a turnaround time of about 24 hours and correlates well with disease activity.
- Polymerase chain reaction testing has a high sensitivity and specificity, a turnaround time of less than 4 hours, and correlates less with disease activity, thus identifying patients with colonization and active infection. Increasingly, combination testing is being employed to improve diagnostic accuracy.
- Laboratory testing for *C. difficile* toxins should only be performed on patients with at least three unformed stools per 24 hours, who are not on laxatives, and is not useful as a test of cure.
- Pathologic findings can help to confirm the diagnosis.

From Semel JD. *Clostridioides difficile* colitis. In: Kellerman RD, Rakel DP, Heidelbaugh JJ, Lee EM, eds. *Conn's Current Therapy 2023*. Philadelphia: Elsevier; 2023:561.

use, but the absence of antibiotic exposure should not dissuade the clinician from considering this diagnosis and ordering the appropriate test. Conversely, high carriage rates without illness among infants should prompt careful consideration when testing and treating children <3 years old.

The standard test for toxin is the **enzyme immunoassay (EIA)**, a same-day test for **toxin A** and/or **toxin B** with sufficient specificity (94–100%) but less-than-ideal sensitivity (88–93%). Many laboratories use **nucleic acid amplification tests (NAATs)** to supplement or supplant EIA with the goal of improving sensitivity. The sensitivities of the real-time polymerase chain reaction (PCR) assay for **toxin A/B** are superior compared with EIA for **toxin A/B** (95% vs 35%, respectively), and the specificity is equal (100%). However, some have questioned the clinical significance of low copy number–positive tests. For example, positive *C. difficile* PCR results occur with similar frequency in patients with IBD with and without an IBD exacerbation. A positive result in a highly sensitive PCR assay that detects low copy numbers of a toxin gene in *C. difficile* may reflect colonization in a subset of patients (e.g., with IBD), confounding clinical decision-making in managing disease exacerbations. To address this, NAAT-positive tests may be “confirmed” by toxin assays. In addition, eliminating certain high carrier populations from testing (e.g., children under 1 year of age) will increase the positive predictive value of laboratory testing. Because sensitivity is so high with molecular tests, if the first test is negative, repeat testing during the same episode of diarrhea is discouraged, as repeat testing in this setting is more likely to result in another negative or a false-positive test than a true positive test. Because shedding of *C. difficile* in stool can persist for several months after symptom resolution, tests of cure are impractical and are not performed.

Culture for organism isolation is a sensitive test but is labor intensive, taking several days. Culture alone is not specific because it does not differentiate between toxin-producing and non-toxin-producing strains.

Pseudomembranous nodules and characteristic plaques may be seen in colonoscopy or sigmoidoscopy, but endoscopy is usually not performed to make the diagnosis.

## TREATMENT

Initial treatment of CDI involves discontinuation of any nonvital antibiotic therapy and administration of fluid and electrolyte replacement. For mild cases, this treatment may be curative. Drugs that decrease intestinal motility should be avoided. Asymptomatic patients should not be treated. Persistent symptoms or moderate to severe disease warrant antimicrobial therapy directed against *C. difficile*.

Oral metronidazole or vancomycin is the first-line therapy for mild to moderate CDI in children (Table 258.2). In adults, vancomycin or fidaxomicin are the preferred first-line therapies. For more severe

**Table 258.2** Treatment Recommendations for *Clostridioides difficile* Infection in Children

CDI CLASSIFICATION	ANTIBIOTIC REGIMEN
First episode or first recurrence,* nonsevere	Metronidazole 7.5 mg/kg/dose (max 500 mg/dose) PO tid × 10 days; OR Vancomycin 10 mg/kg/dose (max 125 mg/dose) PO qid × 10 days
Second or subsequent† recurrence, nonsevere	Vancomycin in a tapered and pulsed regimen‡; OR Vancomycin (dosing and duration as above) followed by rifaximin 10 mg/kg/dose (max 400 mg/dose) PO tid × 20 days§; OR Fidaxomicin 16 mg/kg/dose (max 200 mg/dose) PO bid × 10 days; OR Fecal microbiota transplantation
Severe/fulminant¶ (first or recurrent   episode)	Vancomycin 10 mg/kg/dose (max 500 mg/dose) PO qid × 10 days If critically ill, consider adding metronidazole 7.5 mg/kg/dose (max 500 mg/dose) IV tid × 10 days

\*For first recurrence, consider vancomycin if metronidazole was used to treat initial episode.

†Recommend tapered and pulsed regimen if vancomycin was used for the initial infection.

‡Tapered and pulsed regimen: vancomycin 10 mg/kg/dose (max 125 mg/dose) qid × 10–14 days, then 10 mg/kg/dose (max 125 mg/dose) bid × 1 wk, then 10 mg/kg/dose (max 125 mg/dose) qd × 1 wk, and then 10 mg/kg/dose (max 125 mg/dose) every 2–3 days for 2–8 wk.

§Pediatric rifaximin dosing is not available and not FDA-approved for children younger than 12 yr.

¶Definitions for severe and fulminant CDI are based on expert consensus for adult patients and have not been validated. Severe: leukocytosis with a white blood cell count of ≥15,000 cells/μL or a serum creatinine level >1.5 mg/dL. Fulminant: hypotension or shock, ileus, megacolon.

||If treating a recurrent episode that is severe/fulminant, consider extending vancomycin in a pulsed, tapering fashion as indicated above§ or fecal microbiota transplantation when clinically improved.

Data from McDonald LC, Gerding DN, Johnson S, et al. Clinical practice guidelines for *Clostridium difficile* infection in adults and children: 2017 update by the Infectious Diseases Society of America (IDSA) and Society for Healthcare Epidemiology of America (SHEA). *Clin Infect Dis*. 2018; 66(7):e1–e48.

infection, oral vancomycin is approved by the U.S. Food and Drug Administration (FDA) for CDI. Vancomycin exhibits ideal pharmacologic properties for treatment of this enteric pathogen because it is not absorbed in the gut. Vancomycin is suggested as a first-line agent for severe disease, as manifested by hypotension, peripheral leukocytosis, or severe pseudomembranous colitis. Fidaxomicin is approved for use in children at least 6 months of age and is a narrow-spectrum macrolide antibiotic with noninferior efficacy to vancomycin but superior recurrence prevention. Because treatment of CDI continues to evolve, adult-based protocols (Table 258.3) may be relevant to older children and adolescents.

## PROGNOSIS AND RECURRENCE

The response rate to initial treatment of CDI can reach >95%. Studies have demonstrated a variation in response rates based on the severity of CDI and the treatment agent. Treatment failure and recurrence have been increasing; the risk of subsequent reappearance increases with each recurrence.

**Recurrences** occur in 5–20% of patients, are diagnosed clinically, and generally occur within 4 weeks of treatment. Some recurrences result from incomplete eradication of the original strain, and others are caused by reinfection with a different strain. Treatment for the initial recurrence involves retreatment with the original antibiotic course.

**Table 258.3** Recommendations for the Treatment of *C. difficile* Infection in Adults

CLINICAL DEFINITION		SUPPORTIVE CLINICAL DATA	RECOMMENDED TREATMENT*	STRENGTH OF RECOMMENDATION/QUALITY OF EVIDENCE	
Initial infection		Leukocytosis with white blood cell count of $\leq 15,000$ cells/mL and serum creatinine level $< 1.5$ mg/dL	Fidaxomicin 200 mg bid $\times$ 10 days	Strong/high	
			Vancomycin 125 mg qid $\times$ 10 days	Strong/high	
			Alternate if previous agents are unavailable: metronidazole 500 mg tid PO $\times$ 10-14 days	Weak/high	
	Fulminant	Hypotension or shock, ileus, megacolon	Vancomycin 500 mg qid PO or by nasogastric tube  If ileus, consider adding rectal instillation of vancomycin; intravenous metronidazole (500 mg every 8 hr) should be administered with oral or rectal vancomycin, particularly if ileus is present	Strong/moderate (oral vancomycin), weak/low (rectal vancomycin), strong/moderate (intravenous metronidazole)	
Recurrence	First recurrence, nonsevere		Fidaxomicin 200 mg bid $\times$ 10 days, or bid $\times$ 5 days, then qod for 20 days or	Weak/low	
			Use prolonged tapered and pulsed vancomycin regimen (if standard regimen was used for initial episode) 125 mg qid for 10-14 days, bid for 1 wk, qd for 1 wk, and then every 2 or 3 days for 2-8 wk, or	Weak/low	
			Vancomycin 125 mg qid $\times$ 10 days (if metronidazole was used for the initial episode)	Weak/moderate	
	Second or subsequent recurrence			Fidaxomicin 200 mg bid $\times$ 10 days, or bid $\times$ 5 days, then qod for 20 days	Weak/low
				Vancomycin in a tapered or pulsed regimen or	Weak/low
				Vancomycin 125 mg qid $\times$ 10 days, followed by rifaximin 400 mg tid $\times$ 20 days, or	Weak/low
				Fecal microbiota transplantation†	Strong/moderate

\*All randomized trials have compared 10-day treatment courses, but some patients (particularly those treated with metronidazole) may have delayed response to treatment, and clinicians should consider extending treatment duration to 14 days in those circumstances.

†The opinion of the panel is that appropriate antibiotic treatments for at least two recurrences (i.e., three CDI episodes) should be tried before offering fecal microbiota transplantation. For adult patients with a recurrent CDI episode within the last 6 months, current guidelines suggest using bezlotoxumab in addition to appropriate antibiotics as the first approach.

PO, Orally (by mouth); qd, once daily; bid, twice daily; tid, 3 times daily; qid, 4 times daily; qod, every other day.

Adapted from McDonald LC, Gerding DN, Johnson S, et al. Clinical practice guidelines for *Clostridium difficile* infection in adults and children: 2017 update by the Infectious Diseases Society of America (IDSA) and Society for Healthcare Epidemiology of America (SHEA). *Clin Infect Dis*. 2018;66(7):e1–e48, Table 1; and Johnson S, Laverigne V, Skinner AM, et al. Clinical practice guideline by the Infectious Diseases Society of America (IDSA) and Society for Healthcare Epidemiology of America (SHEA): 2021 focused update guidelines on management of *Clostridioides difficile* infection in adults. *Clin Infect Dis*. 2021;73(5):e1029–e1044, Table 1.

Recurrences of CDI may be caused by a suboptimal immune response, failure to kill organisms that have sporulated, or failure of delivery of antibiotic to the site of infection in the case of ileus or toxic megacolon. Subsequent treatment with pulsed or tapered vancomycin decreases recurrence rates. In addition to this approach, other antibiotics (rifaximin or nitazoxanide), toxin-binding polymers (Tolevamer), and probiotics (*Saccharomyces boulardii* or *Lactobacillus* GG) have been used as adjunctive therapy. For adult patients with a recurrent CDI episode within the last 6 months, guidelines suggest using bezlotoxumab, a humanized monoclonal antibody against *C. difficile* toxin

B, as a co-intervention. Because treatment of CDI continues to evolve, adult-based protocols (see Table 258.3) may be applicable for treatment of older children and adolescents.

Because failure to manifest an adequate antitoxin immune response is associated with a higher frequency of recurrent CDI, intravenous immune globulin has been used to treat recurrent disease. In the case of ileus or toxic megacolon, an enema of vancomycin may be used to place the antibiotic directly at the site of infection, although most often intravenous therapy is first attempted in this circumstance.



**Fecal microbiota transplantation (FMT)** has been used to address the disruption in normal gut flora thought to allow colonization with *C. difficile* (see Table 258.3). FMT involves the instillation of fecal material from a healthy donor into the patient's GI tract by nasogastric tube, enema, capsules, or colonoscopy. Published FMT results in children with recurrent CDI are limited to case reports and small case series. There are few data to guide clinicians on the indications, route, efficacy, and safety of FMT in children. Initial reports indicate an overall success rate of approximately 90% in patients with recurrent CDI. Current approaches to FMT are not specific and involve complete reconstitution of the gut microbiome. The gut microbiota has been shown to influence susceptibility to genetic and environmentally acquired conditions. Transplantation of healthy donor fecal material to patients with CDI may reestablish the "normal" composition of the gut microbiota but has the theoretical concern of adding new, microbiome-based susceptibilities derived from the donor microbiome.

The FDA has approved an orally administered commercially available fecal microbiotic product for patients ≥18 years old, following antibiotic therapy for recurrent CDI. The goal is to prevent recurrence of CDI. Fecal-derived live bacteria from screened donors is administered once daily for 3 days.

It is important to recognize that postinfectious diarrhea may result from other causes, such as postinfectious irritable bowel syndrome, microscopic colitis, and IBD.

## PREVENTION

The strategies for prevention of CDI include recognition of common sites of acquisition (hospitals, childcare settings, extended-care facilities); effective environmental cleaning (i.e., use of chlorinated cleaning solutions); appropriate antibiotic (antibiotic stewardship) and PPI prescription practices; cohorting of infected patients; contact precautions; and proper handwashing with soap and water. Probiotics may possibly reduce the incidence of *C. difficile*-associated diarrhea.

Visit Elsevier eBooks+ at eBooks.Health.Elsevier.com for Bibliography.

## Chapter 259

# Other Anaerobic Infections

Michael E. Russo

Anaerobic bacteria are among the most numerous organisms colonizing humans and are also present widely in the soil. **Obligate anaerobes** are markedly or entirely intolerant of exposure to oxygen. **Facultative anaerobes** can survive in the presence of environmental oxygen but grow better in settings of reduced oxygen tension. This chapter concentrates on obligate anaerobes and associated infections.

Infections with endogenous anaerobes usually occur adjacent to mucosal surfaces, often as polymicrobial infections with aerobes. In many of these polymicrobial infections, it is unclear how direct a role anaerobes are playing in illness versus just being present by virtue of breached mucosal barriers. Traumatized areas that have been devascularized with resultant low oxygen tension provide ideal sites for anaerobic infection. Abscess formation can evolve over days to weeks and generally involves both aerobes and anaerobes. An example of such an infection is ruptured appendicitis leading to secondary peritonitis and intrabdominal abscesses. Pure anaerobic infections from endogenous bacteria are much less common

(although certain relevant clinical syndromes such as Lemierre syndrome are discussed later).

The most common and clinically relevant anaerobic bacteria in pediatrics are listed in Table 259.1 and discussed further later in the chapter. The taxonomy has undergone significant changes over the years, and many species that would not have been easily identifiable may now be identified in clinical specimens with the widespread use of matrix-assisted laser desorption/ionization time-of-flight mass spectrometry (MALDI-TOF MS). Our understanding of anaerobic bacteria in infections is largely limited to easily culturable species. As many anaerobes of the human microbiota remain unculturable, our understanding of anaerobic infections will continue to evolve with culture-independent methods such as metagenomic sequencing.

*Bacteroides fragilis* and related species are the predominant anaerobes of the large intestine and thus are involved in complicated intraabdominal infections. *Prevotella* spp., *Porphyromonas* spp., and *Fusobacterium* spp. reside in the upper respiratory tract and intestine and are most frequently involved in complications of pharyngitis and sinusitis or in aspiration pneumonia. The gram-positive anaerobic cocci (GPAC) have undergone significant taxonomic changes in recent years, with most prior *Peptostreptococcus* spp. being reclassified into the genera of *Finnegoldia*, *Parvimonas*, *Anaerococcus*, and *Peptoniphilus*. It is not clear yet how clinically relevant this reclassification is. Collectively, the GPAC are normal flora of the skin and upper respiratory, intestinal, and genital mucosa. They may be involved in complications of infections of any of these areas, but they are relatively less virulent than other anaerobic bacteria, and their recovery in culture may or may not be clinically relevant. The gram-positive anaerobic bacilli can be divided into spore forming (*Clostridium* spp.) and non-spore-forming (*Cutibacterium acnes* [formerly *Propionibacterium acnes*] and *Actinomyces* spp.). *C. acnes* lives within hair follicles and sebaceous glands and is an important cause of prosthetic infections, particularly related to ventricular shunts. Some *Actinomyces* spp. are obligate or facultative anaerobes and are discussed in Chapter 235. *Clostridium* spp. cause disease by proliferation and often by production of toxins. Of the >60 species that have been identified, only a few cause infections in humans. The most frequently implicated *Clostridium* spp. are *C. difficile* (see Chapter 258), *C. perfringens* (discussed further later), *C. botulinum* (see Chapter 256), and *C. tetani* (see Chapter 257).

## CLINICAL MANIFESTATIONS

Anaerobic infections occur in a variety of sites throughout the body, with examples including complications of pharyngitis such as peritonsillar abscess and Lemierre syndrome (see Chapter 432), dental abscesses (see Chapter 358), complications of sinusitis such as orbital cellulitis (see Chapter 674) and brain abscess (see Chapter 644), aspiration pneumonia (see Chapter 447) and lung abscess (see Chapter 453), secondary peritonitis (see Chapter 419), appendicitis (see Chapter 391), necrotizing enterocolitis (see Chapter 136), and pelvic inflammatory disease and tubo-ovarian abscesses (see Chapter 163).

**Table 259.1**

Clinically Relevant Anaerobic Bacteria in Common Pediatric Infections

Gram-positive cocci	<i>Peptostreptococcus</i> , <i>Finnegoldia</i> , <i>Parvimonas</i> , <i>Anaerococcus</i> , and <i>Peptoniphilus</i> spp.
Gram-positive, spore-forming rods	<i>Clostridium</i> spp.
Gram-positive, non-spore-forming rods	<i>Cutibacterium acnes</i> Some <i>Actinomyces</i> spp.
Gram-negative bacilli	<i>Bacteroides fragilis</i> <i>Prevotella</i> , <i>Porphyromonas</i> , and <i>Fusobacterium</i> spp.

### Anaerobic Bacteremia

Anaerobic bacteremia is relatively rare in children, and the yield of routine anaerobic blood cultures in various settings and patient populations continues to be debated. There is wide practice variation on the routine collection of anaerobic blood culture bottles, and multiple studies have failed to consistently identify predictive risk factors for anaerobic bacteremia in children. *B. fragilis* bacteremia has been seen most frequently (albeit uncommonly) in two settings: early-onset sepsis in premature infants and sepsis in those with compromised lower gastrointestinal tract mucosa (perforation, surgery, or chemotherapy-induced mucositis). *Fusobacterium* spp. bacteremia is typically seen in the setting of Lemierre syndrome: **septic thrombophlebitis** of the internal jugular vein as a complication of pharyngitis.

### Myonecrosis (Gas Gangrene)

*C. perfringens* is the major etiologic cause of myonecrosis, a rapidly progressive anaerobic soft tissue infection. Gas gangrene usually affects muscles compromised by surgical or trauma sites that become contaminated with *C. perfringens* spores from soil or other foreign material. Infection progresses rapidly (within 24 hours) with swelling, edema, crepitus, and myonecrosis. Severe shock and multiorgan dysfunction are common. A clue to the diagnosis of gas gangrene is pain out of proportion to the clinical appearance of the wound. Exudate from surgical specimens reveals gram-positive bacilli but few leukocytes. Early and complete debridement with excision of necrotic tissue is key to controlling the infection. Repeated, frequent assessment of tissue viability in the operating room is required; however, the prognosis is poor, and morbidity and mortality are high. The role of adjunctive hyperbaric oxygen therapy is uncertain.

### Food Poisoning

*C. perfringens* can also produce an enterotoxin that causes **food poisoning**. This intoxication results in the acute onset of watery diarrhea and crampy abdominal pain. Therapy is mainly supportive and consists of rehydration and electrolyte replacement if necessary. The illness resolves spontaneously within 24 hours of onset, and thus specific etiologic diagnosis is rarely made unless a large outbreak is investigated by public health authorities. Frequent sources of infection include meat and other animal products served in group settings during which food is allowed to sit for hours at temperatures warm enough to promote growth of *C. perfringens*.

### DIAGNOSIS

The diagnosis of anaerobic infection requires a high index of suspicion and the collection of appropriate and adequate specimens for anaerobic culture (Table 259.2). Culture specimens should be obtained in a manner that protects them from contamination with mucosal bacteria. Aspirates of infected sites, abscess material, and

**Table 259.2** Clues to the Presumptive Diagnosis of Anaerobic Infections\*

<p>Infection contiguous to or near a mucosal surface colonized with anaerobic bacteria (oropharynx, intestinal-genitourinary tract)</p> <p>Severe tissue necrosis, abscesses, gangrene, or fasciitis</p> <p>Gas formation in tissues (crepitus on exam or gas visible on imaging)</p> <p>Failure to culture organisms using conventional aerobic microbiologic methods, despite the presence of visible organisms on Gram stain</p> <p>Toxin-mediated syndromes: botulism, tetanus, gas gangrene, food poisoning, pseudomembranous colitis</p>
--

\*Suspicion of anaerobic infection is critical before specimens are sampled for culture to ensure optimal microbiologic techniques.

biopsy specimens are appropriate for anaerobic culturing. Specimens should be protected from atmospheric oxygen and transported to the laboratory immediately. Anaerobic transport medium increases the likelihood of recovery of obligate anaerobes. Gram staining is useful, because even if the organisms do not grow in culture, they can be seen on the smear. Once growth has occurred, many clinically relevant anaerobes may now be identified by MALDI-TOF MS. 16S ribosomal RNA (rRNA) gene sequencing at a reference laboratory can identify less common bacteria.

**Antimicrobial resistance** among anaerobes has increased over time, and the susceptibility of anaerobes to certain antibiotics has become less predictable. A rapid and simple screening test for  $\beta$ -lactamase production and presumptive penicillin resistance can be performed on some anaerobic gram-negative bacilli. More detailed susceptibility testing is usually only available at reference laboratories and may be recommended for isolates recovered from sterile body sites that are deemed clinically important and are known to have variable or unique susceptibilities. Because anaerobic bacteria are less routinely submitted for susceptibility testing, local antibiogram data are frequently limited and extrapolated from larger national case series.

### TREATMENT

Treatment of anaerobic infections usually requires adequate drainage and appropriate antimicrobial therapy. Anaerobes can be generally lumped into groups of predicted susceptibility, but because most anaerobic infections are polymicrobial, the choice of agents is frequently driven by the aerobic bacteria suspected or proven to be involved. The specific dose, frequency, and duration vary widely by the specific clinical syndrome.

### ANAEROBIC GRAM-NEGATIVE BACILLI

Most *B. fragilis* produces a  $\beta$ -lactamase that hydrolyzes penicillins but is inhibited by most  $\beta$ -lactamase inhibitors (clavulanate, sulbactam, and tazobactam but not avibactam). They also produce a cephalosporinase that hydrolyzes most cephalosporins but not cephamycins. Neither of the enzymes hydrolyzes carbapenems. Hence, most isolates are susceptible to ampicillin-sulbactam, amoxicillin-clavulanate, piperacillin-tazobactam, cefoxitin, and carbapenems (imipenem, meropenem, doripenem, and ertapenem). Notably, ceftazidime-avibactam is the exception to the reliability of  $\beta$ -lactamase inhibitors and does not have reliable *B. fragilis* activity. *Prevotella*, *Porphyromonas*, and *Fusobacterium* spp. are all generally less resistant than *Bacteroides*. They less frequently produce a  $\beta$ -lactamase, and many remain susceptible to penicillin. *Fusobacterium* spp. are usually susceptible to cephalosporins such as ceftriaxone, but *Prevotella* and *Porphyromonas* have more variable susceptibility.

Metronidazole is reliably active against nearly all anaerobic gram-negative bacilli. Clindamycin resistance in *B. fragilis* has increased over the years, and thus clindamycin is no longer recommended for empiric treatment, leading to the admonition against using clindamycin for infections “below the diaphragm.” The other anaerobic gram-negative bacilli are usually still susceptible to clindamycin. Because of increasing resistance, moxifloxacin is no longer recommended as first-line therapy for infections involving anaerobic gram-negative bacilli.

### ANAEROBIC GRAM-POSITIVE ORGANISMS

Most non-spore-forming, positive bacilli and some GPAC are resistant to metronidazole. Most are highly susceptible to penicillin but variably susceptible to clindamycin. Treatment of clostridial infections varies widely by the specific clinical syndrome and may or may not involve antibiotics and/or specific antitoxins.

Visit Elsevier eBooks+ at [eBooks.Health.Elsevier.com](http://eBooks.Health.Elsevier.com) for Bibliography.

## Section 7

# Mycobacterial Infections

## Chapter 260

## Principles of Antimycobacterial Therapy

Stacene R. Maroushek

The treatment of mycobacterial infection and disease can be challenging. Patients require therapy with multiple agents, the offending pathogens commonly exhibit complex drug resistance patterns, and patients often have underlying conditions that affect drug choice and monitoring. Several of the drugs have not been well studied in children, and current recommendations are extrapolated from the experience in adults.

Single-drug therapy of *Mycobacterium tuberculosis* and nontuberculous mycobacteria is not recommended because of the high likelihood of developing antimicrobial resistance. Susceptibility testing of mycobacterial isolates often can aid in therapeutic decision-making.

### AGENTS USED AGAINST MYCOBACTERIUM TUBERCULOSIS

#### Commonly Used Agents

##### Isoniazid

Isoniazid (INH) is a hydrazide form of isonicotinic acid and is bactericidal for rapidly growing *M. tuberculosis*. The primary target of INH involves the *INH A* gene, which encodes the enoyl acyl carrier protein (ACP) reductase needed for the last step of the mycolic acid biosynthesis pathway of cell wall production. Resistance to INH occurs after pathogenic variants in the *INH A* gene or in other genes encoding enzymes that activate INH, such as *katG*.

INH is indicated for the treatment of *M. tuberculosis*, *M. kansasii*, and *M. bovis*. The pediatric dosage is 10-15 mg/kg/day orally (PO) in a single dose, not to exceed 300 mg/day. The adult dosage is 5 mg/kg/day PO in a single dose, not to exceed 300 mg/day. Alternative pediatric dosing is 20-30 mg/kg PO in a single dose, not to exceed 900 mg/dose, given twice weekly under **directly observed therapy (DOT)**, in which patients are observed to ingest each dose of antituberculosis medication to maximize the likelihood of completing therapy. The duration of treatment depends on the disease being treated (Table 260.1). INH needs to be taken 1 hour before or 2 hours after meals because food decreases absorption. It is available in liquid, tablet, intravenous (IV; not approved by the U.S. Food and Drug Administration [FDA]), and intramuscular (IM) preparations.

Major **adverse effects** include hepatotoxicity in 1% of children and approximately 3% of adults (increasing with age) and dose-related peripheral neuropathy. Pyridoxine can prevent the peripheral neuropathy and is indicated for breastfeeding infants and their mothers, children and youth on milk- or meat-deficient diets, pregnant adolescents, and symptomatic HIV-infected children. Minor adverse events include rash, worsening of acne, epigastric pain with occasional nausea and vomiting, decreased vitamin D levels, and dizziness. The liquid formulation of INH contains sorbitol, which often causes diarrhea and stomach upset.

INH is accompanied by significant drug-drug interactions (Table 260.2). The metabolism of INH is by acetylation. Acetylation rates have minimal effect on efficacy, but **slow acetylators** have an increased risk for hepatotoxicity, especially when INH is used in combination with rifampin. Routine baseline liver function testing or monthly monitoring is only indicated for persons with underlying hepatic disease or those receiving concomitant hepatotoxic drugs, including other antimycobacterial agents, acetaminophen, or alcohol. Monthly clinic visits while taking INH alone are encouraged to monitor adherence, adverse effects, and worsening of infection.

##### Rifamycins

The rifamycins (rifampin, rifabutin, rifapentine) are a class of macro-lide antibiotics developed from *Streptomyces mediterranei*. Rifampin is a synthetic derivative of rifamycin B, and rifabutin is a derivative of rifamycin S. Rifapentine is a cyclopentyl derivative. The rifamycins inhibit the DNA-dependent RNA polymerase of mycobacteria, resulting in decreased RNA synthesis. These agents are generally bactericidal at treatment doses, but they may be bacteriostatic at lower doses. Resistance is from a pathogenic variant in the DNA-dependent RNA polymerase gene (*rpoB*) that is often induced by previous incomplete therapy. Cross-resistance between rifampin and rifabutin has been demonstrated.

**Rifampin** is active against *M. tuberculosis*, *M. leprae*, *M. kansasii*, and *M. avium* complex. Rifampin is an integral drug in standard combination treatment of active *M. tuberculosis* disease and can be used as an alternative to INH in the treatment of latent tuberculosis infection in children who cannot tolerate INH. **Rifabutin** has a similar spectrum, with increased activity against *M. avium* complex. **Rifapentine** is undergoing pediatric clinical trials and appears to have activity similar to the activity of rifampin. The pediatric dosage of rifampin is 10-15 mg/kg/day PO in a single dose, not to exceed 600 mg/day. The adult dosage of rifampin is 5-10 mg/kg/day PO in a single dose, not to exceed 600 mg/day. Commonly used rifampin preparations include 150- and 300-mg capsules and a suspension that is usually formulated at a concentration of 10 mg/mL. The shelf life of rifampin suspension is short (approximately 4 weeks), so it should not be compounded with other antimycobacterial agents. An IV form of rifampin is also available for initial treatment of patients who cannot take oral preparations. Dosage adjustment is needed for patients with liver failure. Other rifamycins (rifabutin and rifapentine) have been poorly studied in children and are not recommended for pediatric use.

Rifampin can be associated with **adverse effects** such as transient elevations of liver enzymes; gastrointestinal (GI) upset with cramps, nausea, vomiting, and anorexia; headache; dizziness; and immunologically mediated fever and flulike symptoms. Thrombocytopenia and hemolytic anemias can also occur. Rifabutin has a similar spectrum of toxicities, except for an increased incidence of rash (4%) and neutropenia (2%). Rifapentine has fewer adverse effects but is associated with hyperuricemia and cytopenias, especially lymphopenia and neutropenia. All rifamycins can turn urine and other secretions (tears, saliva, stool, sputum) *orange*, which can stain contact lenses. Patients and families should be warned about this common but otherwise innocuous adverse effect.

Rifamycins induce the hepatic cytochrome P450 (CYP) isoenzyme system and are associated with the increased metabolism and decreased level of several drugs when administered concomitantly. These drugs include digoxin, corticosteroids such as prednisone and dexamethasone, dapson, fluconazole, phenytoin, oral contraceptives, warfarin, and many antiretroviral agents, especially protease inhibitors and nonnucleoside reverse transcriptase inhibitors. Rifabutin has less of an effect on lowering protease inhibitor levels.

The use of pyrazinamide in combination with rifampin for short-course latent tuberculosis therapy has been associated with serious liver dysfunction and death. This combination has never been well studied or recommended for pediatric patients and should not be used.

**Table 260.1** Recommended Usual Treatment Regimens for Drug-Susceptible Tuberculosis in Infants, Children, and Adolescents

INFECTION/DISEASE CATEGORY	REGIMEN	COMMENTS
<b>LATENT MYCOBACTERIUM TUBERCULOSIS INFECTION*</b>		
Isoniazid susceptible	12 wk of isoniazid plus rifapentine once a wk or 4 mo of rifampin once a day or 9 mo of isoniazid once a day	Continuous daily therapy is required. Intermittent therapy even by DOT is not recommended. If daily therapy is not possible, DOT twice a week can be used for 9 mo.
Isoniazid resistant	4 mo of rifampin once a day	Continuous daily therapy is required. Intermittent therapy even by DOT is not recommended.
Isoniazid-rifampin resistant	Consult a tuberculosis specialist.	Moxifloxacin or levofloxacin with or without ethambutol or pyrazinamide.
<b>PULMONARY AND EXTRAPULMONARY INFECTION</b>		
Except meningitis <sup>†</sup>	2 mo of isoniazid, rifampin, pyrazinamide, and ethambutol daily or twice weekly, followed by 4 mo of isoniazid and rifampin <sup>‡</sup> by DOT <sup>§</sup> for drug-susceptible <i>M. tuberculosis</i>	Some experts recommend a three-drug initial regimen (isoniazid, rifampin, and pyrazinamide) if the risk of drug resistance is low. DOT is highly desirable. If hilar adenopathy only and the risk of drug resistance is low, 6-mo course of isoniazid and rifampin is sufficient. Drugs can be given 2 or 3 times/wk under DOT.
	9-12 mo of isoniazid and rifampin for drug-susceptible <i>Mycobacterium bovis</i>	
Meningitis	2 mo of isoniazid, rifampin, pyrazinamide and an aminoglycoside <sup>  </sup> or ethionamide once daily, followed by 7-10 mo of isoniazid and rifampin once daily or twice weekly (9-12 mo total) for drug-susceptible <i>M. tuberculosis</i> At least 12 mo of therapy without pyrazinamide for drug-susceptible <i>M. bovis</i>	For patients who may have acquired tuberculosis in geographic areas where resistance to streptomycin is common, kanamycin, amikacin, or capreomycin can be used instead of streptomycin.

\*Positive TST or IGRA result, no disease. See text for comments and additional acceptable/alternative regimens.

<sup>†</sup>Duration of therapy may be longer for human immunodeficiency virus (HIV)-infected people, and additional drugs and dosing intervals may be indicated

<sup>‡</sup>Medications should be administered daily for the first 2 wk to 2 mo of treatment and then can be administered 2-3 times/wk by DOT. (Twice-weekly therapy is not recommended for HIV-infected people.)

<sup>§</sup>If initial chest radiograph shows pulmonary cavities and sputum culture after 2 mo of therapy remains positive, the continuation phase is extended to 7 mo, for a total treatment duration of 9 mo.

<sup>||</sup>Streptomycin, kanamycin, amikacin, or capreomycin.

DOT, Directly observed therapy; IGRA, interferon- $\gamma$  release assay; TST, tuberculin skin test.

Adapted from American Academy of Pediatrics: *Red Book: 2018–2021 report of the Committee on Infectious Diseases*, 31st ed. Elk Grove Village, IL: AAP, 2018: Table 3.85.

**Table 260.2** Isoniazid Drug-Drug Interactions

DRUG USED WITH ISONIAZID	EFFECTS
Acetaminophen, alcohol, rifampin	Increased hepatotoxicity of isoniazid or listed drugs
Aluminum salts (antacids)	Decreased absorption of isoniazid
Carbamazepine, phenytoin, theophylline, diazepam, warfarin	Increased level, effect, or toxicity of listed drugs due to decreased metabolism
Itraconazole, ketoconazole, oral hypoglycemic agents	Decreased level or effect of listed drugs due to increased metabolism
Cycloserine, ethionamide	Increased central nervous system adverse effects of cycloserine and ethionamide
Prednisolone	Increased isoniazid metabolism

No routine laboratory monitoring for rifamycins is indicated unless the patient is symptomatic. In patients with signs of toxicity, complete blood count (CBC) and kidney and liver function tests are indicated.

### Pyrazinamide

Pyrazinamide (PZA) is a synthetic pyrazine analog of nicotinamide that is bactericidal against intracellular *M. tuberculosis* organisms in acidic environments, such as within macrophages or inflammatory lesions. A bacteria-specific enzyme (pyrazinamidase) converts PZA to pyrazinoic acid, which leads to low pH levels not tolerated by *M. tuberculosis*. Resistance is poorly understood but can arise from bacterial pyrazinamidase alterations.

PZA is indicated for the initial treatment phase of active tuberculosis in combination with other antimycobacterial agents. The pediatric dosage is 30-40 mg/kg/day PO in a single dose, not to exceed 2,000 mg/day. Twice-weekly dosing with DOT only is with 50 mg/kg/day PO in a single dose, not to exceed 4,000 mg/day. It is available in a 500-mg tablet and can be made into a suspension of 100 mg/mL.

**Adverse effects** include GI upset (e.g., nausea, vomiting, poor appetite) in approximately 4% of children, dosage-dependent hepatotoxicity, and elevated serum uric acid levels that can precipitate gout in susceptible adults. Approximately 10% of pediatric patients have elevated uric acid levels but with no associated clinical sequelae. Minor reactions include arthralgias, fatigue, and, rarely, fever.

Use of PZA in combination with rifampin for short-course treatment of latent tuberculosis is associated with serious liver dysfunction and death, and this combination should be avoided.



No routine laboratory monitoring for PZA is required, but monthly visits to reinforce the importance of therapy are desirable.

### Ethambutol

Ethambutol is a synthetic form of ethylenedi-imino-di-1-butanol dihydrochloride that inhibits RNA synthesis needed for cell wall formation. At standard dosages, ethambutol is bacteriostatic, but at dosages >25 mg/kg, it has bactericidal activity. The mechanism of resistance to ethambutol is unknown, but resistance develops rapidly when ethambutol is used as a single agent against *M. tuberculosis*.

Ethambutol is indicated for the treatment of infections caused by *M. tuberculosis*, *M. kansasii*, *M. bovis*, and *M. avium* complex. Ethambutol should only be used as part of a combination treatment regimen for *M. tuberculosis*. Daily dosing is 15-25 mg/kg PO in a single dose, not to exceed 2,500 mg/day. Twice-weekly dosing is with 50 mg/kg PO in a single dose, not to exceed 2,500 mg/day. Dosage adjustment is needed in renal insufficiency. Ethambutol is available in 100- and 400-mg tablets.

The major adverse effect with ethambutol is **optic neuritis**, and thus ethambutol should generally be reserved for children old enough to have visual acuity and color discrimination reliably monitored. Visual changes are usually dosage dependent and reversible. Other adverse events include headache, dizziness, confusion, hyperuricemia, GI upset, peripheral neuropathy, hepatotoxicity, and cytopenias, especially neutropenia and thrombocytopenia.

Routine laboratory monitoring includes baseline and periodic visual acuity and color discrimination testing, CBC, serum uric acid levels, and kidney and liver function tests.

### Less Commonly Used Agents Aminoglycosides

The aminoglycosides used for mycobacterial infections include streptomycin, amikacin, kanamycin, and capreomycin. **Streptomycin** is isolated from *Streptomyces griseus* and was the first drug used to treat *M. tuberculosis*. **Capreomycin**, a cyclic polypeptide from *Streptomyces capreolus*, and **amikacin**, a semisynthetic derivative of kanamycin, are newer agents that are recommended when streptomycin is unavailable. Aminoglycosides act by binding irreversibly to the 30S subunit of ribosomes and inhibiting subsequent protein synthesis. Streptomycin exhibits concentration-dependent bactericidal activity, and capreomycin is bacteriostatic. Resistance results from a pathogenic variant in the binding site of the 30S ribosome, by decreased transport into cells, or by inactivation by bacterial enzymes. Cross-resistance between aminoglycosides has been demonstrated.

The aminoglycosides are indicated for the treatment of *M. tuberculosis* and *M. avium* complex. All are considered second-line drugs in the treatment of *M. tuberculosis* and should be used only when resistance patterns are known. Aminoglycosides are poorly absorbed orally and are administered by IM injection. Pediatric dosing ranges for streptomycin are 20 mg/kg/day if given daily and 20-40 mg/kg/day if given twice weekly; dosing is IM in a single daily dose. Capreomycin, amikacin, and kanamycin dosages are 15-30 mg/kg/day IM in a single dose, not to exceed 1 g/day. Dosage adjustment is necessary in renal insufficiency.

Aminoglycosides have **adverse effects** on proximal renal tubules, the cochlea, and the vestibular apparatus of the ear. Nephrotoxicity and ototoxicity account for most of the significant adverse events. Rarely, patients exhibit fever or rash with administration of aminoglycosides. Concomitant use of other nephrotoxic or ototoxic agents should be avoided, because adverse effects may be additive. An infrequent but serious synergistic, dosage-dependent aminoglycoside effect with non-depolarizing neuromuscular blockade agents can result in respiratory depression or paralysis.

Hearing and kidney function should be monitored at baseline and periodically. Early signs of ototoxicity include tinnitus, vertigo, and hearing loss. Ototoxicity appears to be irreversible, but early kidney damage may be reversible. As with other aminoglycosides, peak and trough drug levels are helpful in dosing and managing early toxicities.

### Cycloserine

Cycloserine, derived from *Streptomyces orchidaceus* or *Streptomyces garyphalus*, is a synthetic analog of the amino acid D-alanine that interferes with bacterial cell wall synthesis through competitive inhibition of D-alanine components to be incorporated into the cell wall. It is bacteriostatic, and the mechanism of resistance is unknown.

Cycloserine is used to treat *M. tuberculosis* and *M. bovis*. The dosage is 10-20 mg/kg/day PO divided into two doses, not to exceed 1 g/day. It is available in a 250-mg capsule.

The major adverse effect is **neurotoxicity** with significant psychological disturbance, including seizures, acute psychosis, headache, confusion, depression, and personality changes. The neurotoxic effects are additive with ethionamide and INH. Cycloserine has also been associated with megaloblastic anemia. It must be dosage-adjusted in patients with kidney impairment and should be used with caution in patients with underlying psychiatric illness.

Routine laboratory monitoring includes kidney and hepatic function, CBC, and cycloserine levels. Psychiatric symptoms are less common at blood levels <30 µg/mL.

### Ethionamide

Ethionamide is structurally related to INH and is an ethyl derivative of thioisonicotinamide that inhibits peptide synthesis by an unclear mechanism thought to involve nicotinamide adenine dinucleotide (NAD) and NAD phosphate dehydrogenase disruptions. Ethionamide is bacteriostatic at most therapeutic levels. Resistance develops quickly if ethionamide is used as a single-agent therapy, although the mechanism is unknown.

Ethionamide is used as an alternative to streptomycin or ethambutol in the treatment of *M. tuberculosis* and has some activity against *M. kansasii* and *M. avium* complex. A metabolite, ethionamide sulfoxide, is bactericidal against *M. leprae*. Ethionamide has been shown to have good central nervous system (CNS) penetration and has been used as a fourth drug in combination with rifampin, INH, and PZA. The pediatric dosing is 15-20 mg/kg/day PO in two divided doses, not to exceed 1 g/day. It is available as a 250-mg tablet.

GI upset is common, and other **adverse effects** include neurologic disturbances (anxiety, dizziness, peripheral neuropathy, seizures, acute psychosis), hepatic enzyme elevations, hypothyroidism, hypoglycemia, and hypersensitivity reaction with rash and fever. Ethionamide should be used with caution in patients with underlying psychiatric or thyroid disease. The psychiatric adverse effects can be potentiated with concomitant use of cycloserine.

In addition to close assessment of mood, routine monitoring includes thyroid and liver function tests. In diabetic patients taking ethionamide, blood glucose levels should be monitored.

### Fluoroquinolones

The fluoroquinolones are fluorinated derivatives of the quinolone class of antibiotics. Ciprofloxacin is a first-generation fluoroquinolone, and levofloxacin is the more active l-isomer of ofloxacin. **Moxifloxacin** and **gatifloxacin** are agents with emerging use in pediatric mycobacterial disease. Fluoroquinolones are not indicated for use in children <18 years old, but studies of their use in pediatric patients continue to indicate that they may be used in special circumstances. Fluoroquinolones are bactericidal and exert their effect by inhibition of DNA gyrase. The alterations in DNA gyrase result in relaxation of supercoiled DNA and breaks in double-stranded DNA. The mechanism of resistance is not well defined but likely involves pathogenic variants in the DNA gyrase.

**Levofloxacin** is an important second-line drug in the treatment of multidrug-resistant (MDR) *M. tuberculosis*. **Ciprofloxacin** has activity against *M. fortuitum* complex and against *M. tuberculosis*. The pediatric dosage of ciprofloxacin is 20-30 mg/kg/day PO or IV, not to exceed 1.5 mg/day PO or 800 mg/day IV. The adult dosage of ciprofloxacin is 500-750 mg/dose PO in two divided doses or 200-400 mg/dose IV every 12 hours. Ciprofloxacin is available in 100-, 250-, 500-, and 750-mg tablets and can be made in 5% (50 mg/mL) or 10% (100 mg/mL) suspensions. The dosage of levofloxacin for children is 5-10 mg/kg/day

given once daily either PO or IV, not to exceed 1,000 mg/day, and for adults, 500-1,000 mg/day PO or IV, not to exceed 1,000 mg/day. Levofloxacin is available in 250-, 500-, and 750-mg tablets, and a 50 mg/mL suspension can be extemporaneously compounded. The suspension has a shelf life of only 8 weeks.

The most common adverse effect of fluoroquinolones is **GI upset**, with nausea, vomiting, abdominal pain, and diarrhea, including pseudomembranous colitis. Other less common adverse effects include bone marrow depression, CNS effects (e.g., lowered seizure threshold, confusion, tremor, dizziness, headache), elevated liver transaminases, photosensitivity, and arthropathies. The potential for arthropathies (e.g., tendon ruptures, arthralgias, tendinitis) is the predominant reason that fluoroquinolones are not recommended for pediatric use. The mechanism of injury appears to involve the disruption of extracellular matrix of cartilage and depletion of collagen, a particular concern related to the bone and joint development of children.

Fluoroquinolones induce the CYP isoenzymes that can increase the concentrations of dually administered theophylline and warfarin. Non-steroidal antiinflammatory drugs (NSAIDs) can potentiate the CNS effects of fluoroquinolones and should be avoided while taking a fluoroquinolone. Both ciprofloxacin and levofloxacin should be dosage-adjusted in patients with significant renal dysfunction.

While taking fluoroquinolones, patients should be monitored for hepatic and renal dysfunction, arthropathies, and hematologic abnormalities.

### Linezolid

Linezolid is a synthetic oxazolidinone derivative. This drug is not currently approved for use against mycobacterial infection in pediatric or adult patients but has activity against some mycobacterial species. Studies on efficacy of treatment of mycobacterial infections are under way. Linezolid inhibits translation by binding to the 23S ribosomal component of the 50S ribosome subunit, preventing coupling with the 70S subunit. Resistance is thought to be from a point a pathogenic variant at the binding site but is poorly studied because only a few cases of resistance have been reported.

The approved indications for linezolid are for bacterial infections other than mycobacteria, but studies reveal in vitro activity against rapidly growing mycobacteria (*M. fortuitum* complex, *M. chelonae*, *M. abscessus*), *M. tuberculosis*, and *M. avium* complex. The dosage for 0- to 11-year-old children is 10 mg/kg/day PO or IV in divided doses every 8-12 hours. For persons >12 years old, the dosage is 600 mg PO or IV every 12 hours. Linezolid is available in 400- and 600-mg tablets and as a 20-mg/mL suspension.

**Adverse effects** of linezolid include GI upset (e.g., nausea, vomiting, diarrhea), CNS disturbances (e.g., dizziness, headache, insomnia, peripheral neuropathy), lactic acidosis, fever, myelosuppression, and pseudomembranous colitis. Linezolid is a weak inhibitor of monoamine oxidase A, and patients are advised to avoid foods with high tyramine content. Linezolid should be used cautiously in patients with preexisting myelosuppression.

In addition to monitoring for GI upset and CNS perturbations, routine laboratory monitoring includes CBC at least weekly.

### Paraaminosalicylic Acid

Paraaminosalicylic acid (**PAS**) is a structural analog of paraaminobenzoic acid (PABA). It is bacteriostatic and acts by competitively inhibiting the synthesis of folic acid, similar to the action of sulfonamides. Resistance mechanisms are poorly understood.

PAS acts against *M. tuberculosis*. The dosage is 150 mg/kg/day PO in two or three divided doses. PAS is dispensed in 4-g packets, and the granules should be mixed with liquid and swallowed whole.

Common **adverse effects** include GI upset, and less common events include hypokalemia, hematuria, albuminuria, crystalluria, and elevations of hepatic transaminases. PAS can decrease the absorption of rifampin, and co-administration with ethionamide potentiates the adverse effects of PAS.

In addition to monitoring for weight loss, routine laboratory monitoring includes liver and kidney function tests.

### Bedaquiline Fumarate

This oral diarylquinoline has been recommended for the treatment of MDR tuberculosis. Bedaquiline fumarate should be used as part of combination therapy and administered by direct observation. Although approved for patients  $\geq 18$  years old, bedaquiline may be considered for children on a case-by-case basis.

Serious **adverse effects** include hepatotoxicity and a prolonged QT interval.

### Delamanid

Delamanid is a dihydro-nitroimidazooxazole derivative recently approved for use in the treatment of MDR tuberculosis. It acts by inhibiting the synthesis of mycobacterial cell wall compounds such as methoxymycolic acid and ketomycolic acid. Limited studies are available in the pediatric population, and delamanid should be used only in conjunction with a tuberculosis specialist.

**Adverse effects** include nausea, vomiting, dizziness, anxiety, shaking, and QT prolongation.

## AGENTS USED AGAINST MYCOBACTERIUM LEPRAE

### Dapsone

Dapsone is a sulfone antibiotic with characteristics similar to sulfonamides. Similar to other sulfonamides, dapsone acts as a competitive antagonist of PABA, which is needed for the bacterial synthesis of folic acid. Dapsone is bacteriostatic against *M. leprae*. Resistance is not well understood but is thought to occur after alterations at the PABA-binding site.

Dapsone is used in the treatment of *M. leprae* in combination with other antileprosy agents (rifampin, clofazimine, ethionamide). The pediatric dosage is 1-2 mg/kg/day PO as a single dose, not to exceed 100 mg/day, for a duration of 3-10 years. The adult dosage is 100 mg/day PO as a single dose. Dapsone is available in 25- and 100-mg scored tablets and as an oral suspension of 2 mg/mL. The dosage should be adjusted in renal insufficiency.

Dapsone has many reported **adverse effects**, including dosage-related hemolytic anemia, especially in patients with glucose-6-phosphate dehydrogenase (G6PD) deficiency, pancreatitis, renal complications (acute tubular necrosis, acute renal failure, albuminuria), increased liver enzymes, psychosis, tinnitus, peripheral neuropathy, photosensitivity, and a hypersensitivity syndrome with fever, rash, hepatic damage, and malaise. Treatment may produce a *lepra reaction*, which is a nontoxic, paradoxical worsening of lepromatous leprosy with the initiation of therapy. This hypersensitivity reaction is not an indication to discontinue therapy. Dapsone should be used with caution in patients with G6PD deficiency or taking other folic acid antagonists. Dapsone levels can decrease with concomitant rifampin use and can increase with concomitant clotrimazole use.

Routine laboratory monitoring includes CBC weekly during the first month of therapy, weekly through 6 months of therapy, and then every 6 months thereafter. Other periodic assessments include kidney function with creatine levels, urinalysis, and liver function tests.

### Clofazimine

Clofazimine is a synthetic phendimetrazine tartrate derivative that acts by binding to the mycobacterial DNA at guanine sites. It has slow bactericidal activity against *M. leprae*. Mechanisms of resistance are not well studied. No cross-resistance between clofazimine and dapsone or rifampin has been shown.

Clofazimine is indicated as part of a combination therapy for the treatment of *M. leprae*. It appears there may be some activity against other mycobacteria such as *M. avium* complex, although treatment failures are common. The safety and efficacy of clofazimine are poorly studied in children. The pediatric dosage is 1 mg/kg/day PO as a single dose, not to exceed 100 mg/day, in combination with dapsone and rifampin for 2 years and then additionally as a single agent for >1 year. The adult dosage is 100 mg/day PO. Clofazimine should be taken with food to increase absorption.

The most common adverse effect is a dosage-related, reversible, pink to tan-brown discoloration of the skin and conjunctiva. Other **adverse**

effects include a dry, itchy skin rash, headache, dizziness, abdominal pain, diarrhea, vomiting, peripheral neuropathy, and elevated hepatic transaminases.

Routine laboratory monitoring includes periodic liver function tests.

## AGENTS USED AGAINST NONTUBERCULOUS MYCOBACTERIA

### Cefoxitin

Cefoxitin, a cephamycin derivative, is a second-generation cephalosporin that, like other cephalosporins, inhibits cell wall synthesis by linking

with penicillin-binding proteins to create an unstable bacterial cell wall. Resistance develops by alterations in penicillin-binding proteins.

Cefoxitin is often used in combination therapy for mycobacterial disease (Table 260.3). Pediatric dosing is based on disease severity, with a range of 80-160 mg/kg/day divided every 4-8 hours, not to exceed 12 g/day. Adult dosages are 1-2 g/dose, not to exceed 12 g/day. Cefoxitin is available in IV and IM formulations. Increased dosing intervals are needed with renal insufficiency.

**Adverse effects** are primarily hematologic (eosinophilia, granulocytopenia, thrombocytopenia, hemolytic anemia), GI (nausea, vomiting,

**Table 260.3** Treatment of Nontuberculous Mycobacteria Infections in Children

ORGANISM	DISEASE	INITIAL TREATMENT
<b>SLOWLY GROWING SPECIES</b>		
<i>Mycobacterium avium</i> complex (MAC); <i>Mycobacterium haemophilum</i> ; <i>Mycobacterium lentiflavum</i>	Lymphadenitis	Complete excision of lymph nodes; if excision incomplete or disease recurs, clarithromycin or azithromycin plus ethambutol and/or rifampin (or rifabutin).
	Pulmonary infection	Clarithromycin or azithromycin plus ethambutol with rifampin or rifabutin (pulmonary resection in some patients who fail to respond to drug therapy). For severe disease, an initial course of amikacin or streptomycin often is included. Clinical data in adults with mild to moderate disease support that 3-times-weekly therapy is as effective as daily therapy, with less toxicity. For patients with advanced or cavitary disease, drugs should be given daily.
<i>Mycobacterium chimaera</i>	Prosthetic valve endocarditis	Valve removal, prolonged antimicrobial therapy based on susceptibility testing.
	Disseminated	See text.
<i>Mycobacterium kansasii</i>	Pulmonary infection	Rifampin plus ethambutol with isoniazid daily. If rifampin resistance is detected, a three-drug regimen based on drug susceptibility testing should be used.
	Osteomyelitis	Surgical debridement and prolonged antimicrobial therapy using rifampin plus ethambutol with isoniazid.
<i>Mycobacterium marinum</i>	Cutaneous infection	None, if minor; rifampin, TMP-SMX, clarithromycin, or doxycycline* for moderate disease; extensive lesions may require surgical debridement. Susceptibility testing not routinely required.
<i>Mycobacterium ulcerans</i>	Cutaneous and bone infections	Daily intramuscular streptomycin and oral rifampin for 8wk; excision to remove necrotic tissue, if present; potential response to thermotherapy.
<b>RAPIDLY GROWING SPECIES</b>		
<i>Mycobacterium fortuitum</i> group	Cutaneous infection	Initial therapy for serious disease is amikacin plus meropenem IV, followed by clarithromycin, doxycycline,* TMP-SMX, or ciprofloxacin PO on the basis of in vitro susceptibility testing; may require surgical excision. Up to 50% of isolates are resistant to cefoxitin.
	Catheter infection	Catheter removal and amikacin plus meropenem IV; clarithromycin, TMP-SMX, or ciprofloxacin orally on the basis of in vitro susceptibility testing.
<i>Mycobacterium abscessus</i>	Otitis media; cutaneous infection	There is no reliable antimicrobial regimen because of variability in drug susceptibility. Clarithromycin plus an initial course of amikacin plus cefoxitin or imipenem/meropenem; may require surgical debridement on the basis of in vitro susceptibility testing (50% are amikacin resistant).
	Pulmonary infection (in cystic fibrosis)	Serious disease; clarithromycin, amikacin, and cefoxitin or imipenem/meropenem on the basis of susceptibility testing; most isolates have very low MIC to tigecycline; may require surgical resection.
<i>Mycobacterium chelonae</i>	Catheter infection, prosthetic valve endocarditis	Catheter removal; debridement, removal of foreign material; valve replacement; and tobramycin (initially) plus clarithromycin, meropenem, and linezolid.
	Disseminated cutaneous infection	Tobramycin and meropenem or linezolid (initially) plus clarithromycin.

\*Doxycycline can be used for short durations (i.e., ≤21 days) without regard to patient age but is not recommended for longer treatment durations in children <8yr old. Only 50% of isolates of *M. marinum* are susceptible to doxycycline.

IV, Intravenously; MIC, minimum inhibitory concentration; PO, orally (by mouth); TMP-SMX, trimethoprim-sulfamethoxazole.

From Kimberlin DW, Barnett ED, Lynfield R, Sawyer MH, eds. *Red Book: 2021–2024 Report of the Committee on Infectious Diseases*, 32nd ed. Itasca, IL: American Academy of Pediatrics; 2021.



diarrhea with possible pseudomembranous colitis), and CNS related (dizziness, vertigo). Potential additive adverse effects can occur when cefoxitin is used with aminoglycosides.

Routine laboratory monitoring with long-term use includes CBC and liver and renal function tests.

### Doxycycline

Doxycycline is in the tetracycline family of antibiotics and has limited use in pediatrics. As with other tetracyclines, doxycycline acts to decrease protein synthesis by binding to the 30S ribosome and to transfer RNA. It can also cause alterations to the cytoplasmic membrane of susceptible bacteria.

Doxycycline is used to treat *M. fortuitum* (see Table 260.3). Although it can be used to treat *M. marinum*, adult treatment failures have occurred. Pediatric dosing is based on age and weight. For children >8 years old who weigh <45 kg, the dosage is 4.4 mg/kg/day divided twice daily. Dosing for larger children and adults is 100 mg twice daily. Doxycycline is available as 50- and 100-mg capsules or tablets and in 25-mg/5 mL and 50-mg/5 mL suspensions.

Doxycycline use in children is limited by a **permanent tooth discoloration**, which becomes worse with long-term use. Other **adverse effects** include photosensitivity, liver and kidney dysfunction, and esophagitis, which can be minimized by dosing with large volumes of liquid. Doxycycline can decrease the effectiveness of oral contraceptives. Rifampin, carbamazepine, and phenytoin can decrease the concentration of doxycycline.

Routine laboratory monitoring with long-term use includes kidney and liver function tests as well as CBC.

### Macrolides

Clarithromycin and azithromycin belong to the macrolide family of antibiotics. Clarithromycin is a methoxy derivative of erythromycin. Macrolides act by binding to the 50S subunit of ribosomes, subsequently inhibiting protein synthesis. Resistance mechanisms for mycobacteria are not well understood but might involve binding site alterations. Clarithromycin appears to have synergistic antimycobacterial activity when combined with rifamycins, ethambutol, or clofazimine.

**Clarithromycin** is widely used for the prophylaxis and treatment of *M. avium* complex disease and also has activity against *M. abscessus*, *M. fortuitum*, and *M. marinum*. Azithromycin has significantly different pharmacokinetics compared with other macrolide agents and has not been studied and is not indicated for mycobacterial infections. The pediatric dosage of clarithromycin for primary prophylaxis of *M. avium* complex infections is 7.5 mg/kg/dose PO given twice daily, not to exceed 500 mg/day. This dosage is used for recurrent *M. avium* complex disease in combination with ethambutol and rifampin. The adult dosage is 500 mg PO twice daily to be used as a single agent for primary prophylaxis or as part of combination therapy with ethambutol and rifampin. Dosage adjustment is needed for renal insufficiency but not liver failure. Clarithromycin is available in 250- and 500-mg tablets and suspensions of 125 mg/5 mL and 250 mg/5 mL.

The primary adverse effect of clarithromycin is **GI upset**, including vomiting (6%), diarrhea (6%), and abdominal pain (3%). Other **adverse effects** include taste disturbances, headache, and QT prolongation if used with inhaled anesthetics, clotrimazole, antiarrhythmic agents, or azoles. Clarithromycin should be used cautiously in patients with renal insufficiency or liver failure.

Routine laboratory monitoring with prolonged use of clarithromycin includes periodic liver enzyme tests. Diarrhea is an early sign of pseudomembranous colitis.

### Trimethoprim-Sulfamethoxazole

Trimethoprim-sulfamethoxazole (TMP-SMX) is formulated in a fixed ratio of one part TMP to five parts SMX. SMX is a sulfonamide that inhibits synthesis of dihydrofolic acid by competitively inhibiting PABA, similar to dapsone. TMP blocks production of tetrahydrofolic

acid and downstream biosynthesis of nucleic acids and protein by reversibly binding to dihydrofolate reductase. The combination of the two agents is synergistic and often bactericidal.

TMP-SMX is often used in combination therapy for mycobacterial disease (see Table 260.3). Oral or IV pediatric dosage for serious infections is TMP 15-20 mg/kg/day divided every 6-8 hours, and for mild infections, TMP 6-12 mg/kg/day divided every 12 hours. The adult dosage is 160 mg TMP and 800 mg SMX every 12 hours. Dosage reduction may be needed in renal insufficiency. TMP-SMX is available in single-strength tablets (80/400 mg TMP-SMX) and double-strength tablets (160/800 mg TMP-SMX) and in a suspension of 40 mg TMP and 200 mg SMX per 5 mL.

The most common adverse effect with TMP-SMX is **myelosuppression**. It must be used with caution in patients with G6PD deficiency. Other **adverse effects** include renal abnormalities, rash, aseptic meningitis, GI disturbances (e.g., pancreatitis, diarrhea), and prolonged QT interval if co-administered with inhaled anesthetics, azoles, or macrolides.

Routine laboratory monitoring includes monthly CBC and periodic electrolytes and creatinine to monitor renal function.

Visit Elsevier eBooks+ at [eBooks.Health.Elsevier.com](http://eBooks.Health.Elsevier.com) for Bibliography.

## Chapter 261

# Tuberculosis (*Mycobacterium tuberculosis*)

Lindsay H. Cameron and Jeffrey R. Starke

*Mycobacterium tuberculosis* has caused human disease for more than 4,000 years and is one of the most important infectious diseases worldwide. There are five closely related mycobacteria in the *Mycobacterium tuberculosis* complex: *M. tuberculosis*, *M. bovis*, *M. africanum*, *M. microti*, and *M. canetti*. *M. tuberculosis* is the most important cause of tuberculosis (TB) disease in humans. The tubercle bacilli are non-spore-forming, nonmotile, pleomorphic, weakly gram-positive curved rods 1-5  $\mu\text{m}$  long, typically slender, and slightly bent. They can appear beaded or clumped under microscopy. They are obligate aerobes that grow in synthetic media containing glycerol as the carbon source and ammonium salts as the nitrogen source (Löwenstein-Jensen culture media). These mycobacteria grow best at 37–41°C (98.6–105.8°F), produce niacin, and lack pigmentation. A lipid-rich cell wall accounts for resistance to the bactericidal actions of antibody and complement. A hallmark of all mycobacteria is **acid fastness**—the capacity to form stable mycolate complexes with arylmethane dyes (crystal violet, carbolfuchsin, auramine, and rhodamine). They resist decoloration with ethanol and hydrochloric or other acids.

*M. tuberculosis* grows slowly, with a generation time of 12-24 hours. Isolation from clinical specimens on solid synthetic media usually takes 3-6 weeks, and drug susceptibility testing requires an additional 2-4 weeks. Growth can be detected in 1-3 weeks in selective liquid medium using radiolabeled nutrients (e.g., BACTEC radiometric system), and drug susceptibilities can be determined in an additional 3-5 days. Once mycobacterial growth is detected, the species of mycobacteria present can be determined within hours using high-pressure liquid chromatography analysis (identifying the mycolic acid fingerprint of each species) or DNA probes/nucleic amplification tests (NAATs).



NAATs are used to identify genes associated with *M. tuberculosis* drug resistance and complement phenotypic drug susceptibility testing. Results are available in hours, which expedites management decisions. Phenotypic drug susceptibility testing is necessary to confirm susceptibility to each drug. Restriction fragment length polymorphism genetic profiling of mycobacteria is a helpful tool to study the epidemiology of TB strain relatedness in both outbreaks and routine epidemiology of TB in a community.

### CLINICAL STAGES

There are three major clinical stages of TB: exposure, infection, and disease. **Exposure** means a child has had recent significant contact (shared the air) with an adult or adolescent with infectious TB but lacks proof of infection. In this stage, the tuberculin skin test (TST) or interferon- $\gamma$  release assay (IGRA) result is negative, the chest radiograph is normal, the physical examination is normal, and the child lacks signs or symptoms of disease. However, the child may be infected and develop TB disease rapidly, because there may not have been enough time for the TST or IGRA to turn positive. **Tuberculosis infection (TBI)** occurs when the individual inhales droplet nuclei containing *M. tuberculosis*, which survive intracellularly within the lung and associated lymphoid tissue. The hallmark of TBI is a positive TST or IGRA result. In this stage the child has no signs or symptoms and has a normal physical examination, and the chest radiograph is either normal or reveals only granuloma or calcifications in the lung parenchyma. **Disease** occurs when signs or symptoms or radiographic manifestations caused by *M. tuberculosis* become apparent. Not all infected individuals have the same risk of developing disease. An immunocompetent adult with untreated TBI has approximately a 5–10% lifetime risk of developing disease. In contrast, an infected child <1 year old has a 40% chance of developing TB disease within 9 months.

### EPIDEMIOLOGY

TB remains a leading cause of death from an infectious disease worldwide. The global burden of TB is influenced by several factors, including the HIV pandemic; the development of **multidrug-resistant (MDR) tuberculosis**; the disproportionately low access of populations in low-resource settings worldwide to both diagnostic tests and effective medical therapy; and the COVID-19 pandemic.

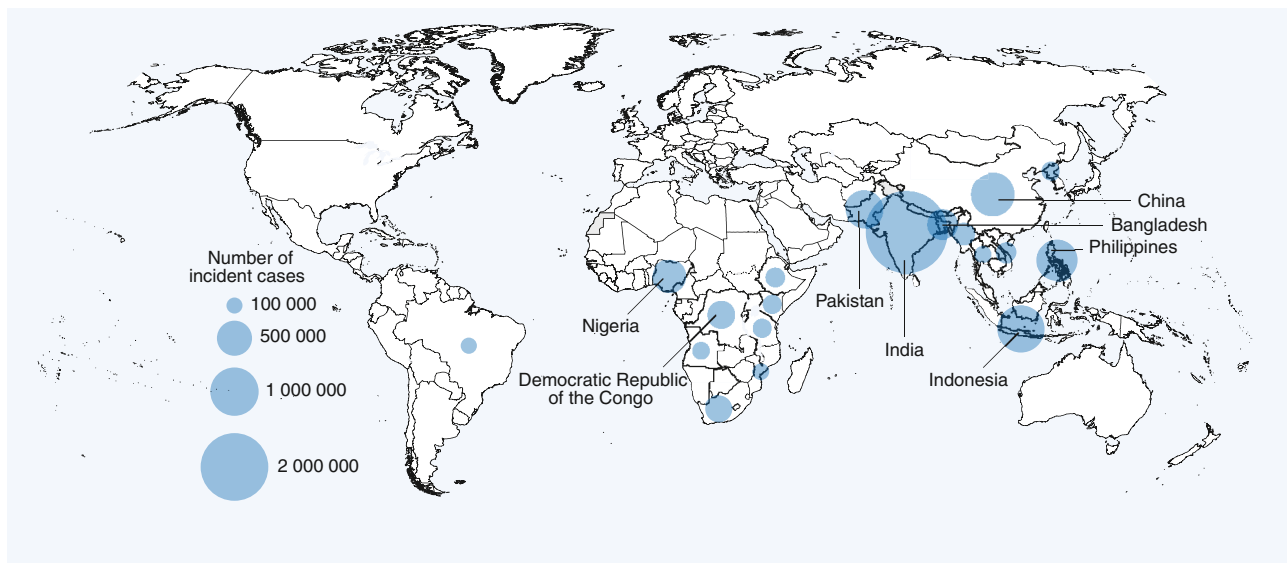
The World Health Organization (WHO) 2020 Global Tuberculosis Report estimates that the COVID-19 pandemic could have a significant

impact on access to essential TB services (human capital, financial), which may increase the rates of TB-associated morbidity and mortality. Many countries have had to allocate public health resources from TB prevention efforts toward COVID-19 prevention, including contact tracing and using GeneXpert machines for COVID-19 testing. The WHO predicts that this resource diversion from TB case-finding, testing, treatment, and prevention may result in an increase of global TB-associated deaths by 0.2–0.4 million per year.

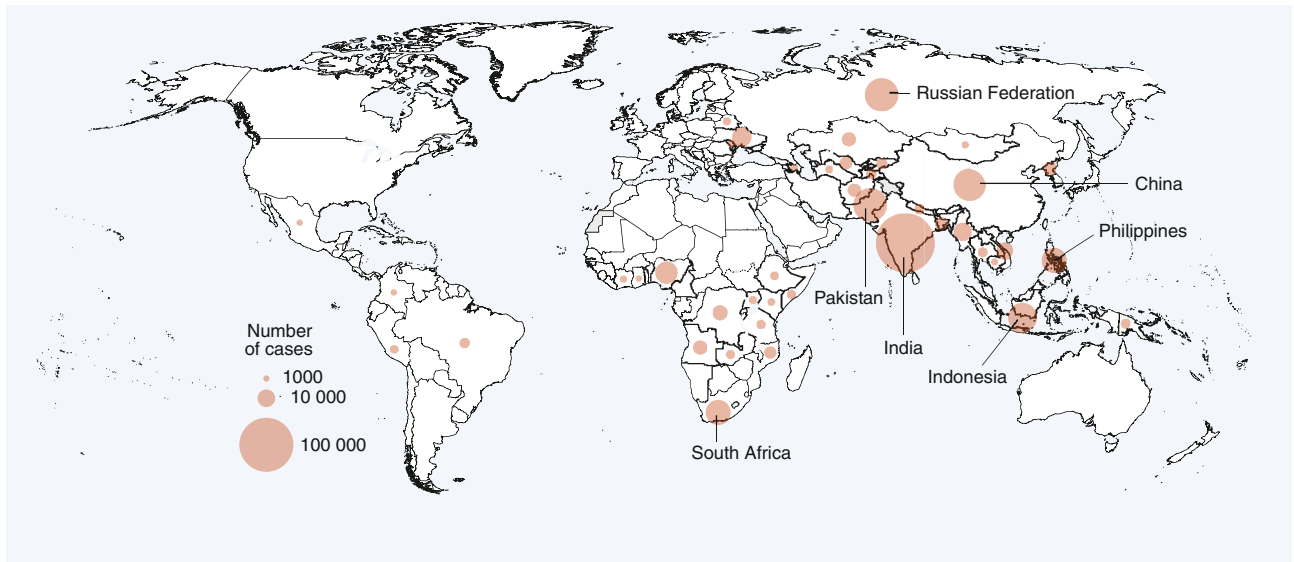
Approximately 95% of TB cases occur in the developing world. In 2019, the 30 high-TB-burden countries accounted for 87% of incident cases (Fig. 261.1). Two thirds of cases occurred in eight countries, including India, Indonesia, China, the Philippines, Pakistan, Nigeria, Bangladesh, and South Africa. An estimated 10 million incident cases and 1.4 million TB-associated deaths occurred worldwide in 2019. The WHO 2020 Global Tuberculosis Report estimates that in 2019 there were 1.2 million childhood incident cases and 230,000 TB-associated deaths among children, including 32,000 TB-associated deaths among children living with HIV.

The incidence of drug-resistant TB has increased in some areas of the world in both adults and children. In 2019, the WHO reported a global total of 206,030 cases of multidrug- or rifampicin-resistant TB, a 10% increase from 2018 (Fig. 261.2). Isoniazid (INH)-mono-resistant TB is resistance to INH alone, rifampicin-resistant TB (RR-TB) is resistance to at least rifampin, MDR-TB is defined as resistance to at least isoniazid and rifampin, and extensively drug-resistant tuberculosis TB (XDR-TB) includes MDR-TB plus resistance to any fluoroquinolone and at least one of three injectable drugs (kanamycin, capreomycin, or amikacin). In 2014, the worldwide estimate for MDR-TB in children was 2.9% of all cases and 0.1% for XDR-TB. The highest incidence of MDR-TB in children occurs in the Southeast Asian, African, and Western Pacific regions; however, the proportion of drug-resistant cases is highest in countries belonging to the Russian Federation, where over 30% of children with TB have a drug-resistant organism.

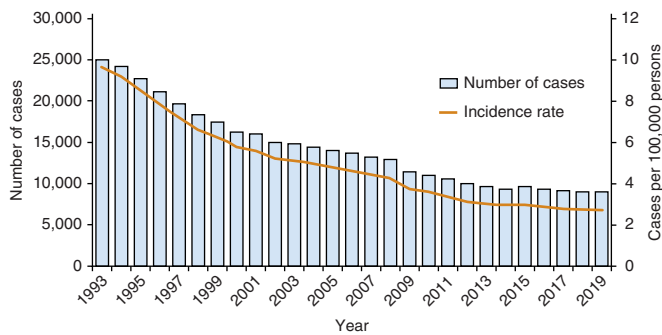
In the United States, TB case rates decreased steadily during the first half of the 20th century, long before the advent of antituberculosis drugs, as a result of improved living conditions and likely genetic selection favoring persons resistant to developing disease. A resurgence of TB in the late 1980s was associated primarily with the HIV epidemic, transmission of the organism in congregate settings including health-care institutions, disease occurring in recent immigrants, and poor conduct of community TB control. Since 1992, the TB incidence in the



**Fig. 261.1** Countries that had at least 100,000 incident cases of TB in 2021. The countries that rank first to eighth in terms of numbers of cases and that accounted for about two thirds of global cases in 2021 are labeled. (From the World Health Organization: *Global Tuberculosis Report 2022*. Geneva: World Health Organization; 2022, Fig 12. License: CC BY-NC-SA 3.0 IGO.)



**Fig. 261.2** Percentage of new TB cases with MDR/RR-TB. The seven countries with the highest burden in terms of numbers of MDR/RR-TB cases and that accounted for two thirds of global MDR/RR-TB cases in 2021 are labeled. (From the World Health Organization: *Global Tuberculosis Report 2022*. Geneva: World Health Organization; 2022, Fig 17. License: CC BY-NC-SA 3.0 IGO.)



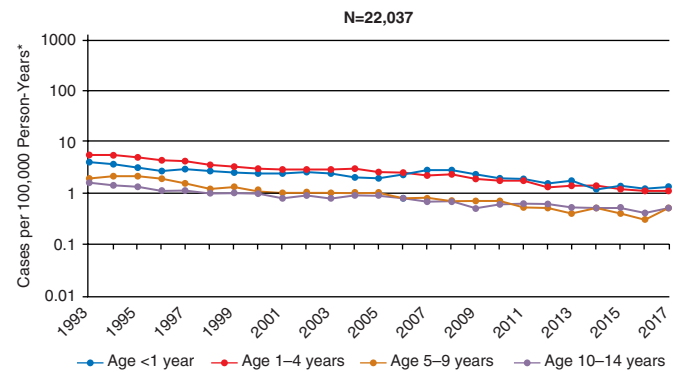
**Fig. 261.3** Reported tuberculosis cases in the United States for 1993–2019 (as of October 29, 2020). (From Centers for Disease Control and Prevention. *Trends in Tuberculosis*, 2019. Atlanta: U.S. Department of Health and Human Services; 2020.)

United States has decreased over time. In 2020, the case rate was at the all-time low of 2.2 per 100,000 persons (Fig. 261.3).

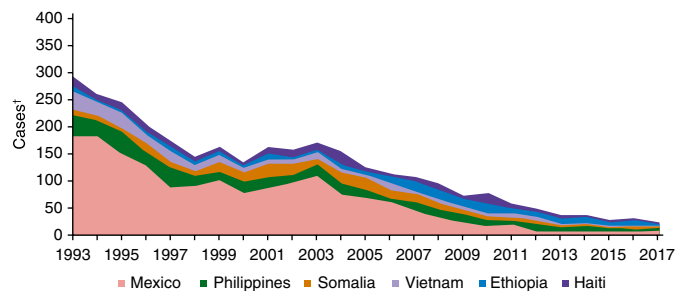
In 2017, the incidence rate of TB among children <15 years was 0.7 cases per 100,000 person-years, a decline of 41% from 1993. The TB incidence rates were highest in children less than 12 months of age (1.3 per 100,000 person-years), followed by children age 1-4 years (1.1 per 100,000 person-years), and were lowest among children age 5-14 years (0.5 per 100,000 person-years) (Fig. 261.4).

From 1993 to 2017, non-United States–born children, children born to non-United States–born parents, and children of racial or ethnic minority status were disproportionately affected by TB. Non-United States–born children accounted for approximately 25% of the total number of childhood TB cases, the majority being from Mexico, followed by the Philippines, Somalia, Vietnam, Ethiopia, and Haiti (Fig. 261.5).

According to data reported to the National TB Surveillance System from 2007 to 2017, among United States–born children, the incidence rates of TB if both parents were non-United States–born and if one parent was non-United States–born were eight and three times higher, respectively, compared to United States–born children with both parents being United States–born. This is supported by prior research that found that 75% of United States–born children with TB had some international connection through a family member or previous travel or residence in a TB-endemic country. Similar to adults in the United



**Fig. 261.4** Reported pediatric tuberculosis (TB) cases in the United States by age-group for the years 1993-2017. \*Rates are presented on a logarithmic scale. (From Centers for Disease Control and Prevention, National Center for HIV/AIDS, Viral Hepatitis, STD and TB Prevention. *Pediatric Tuberculosis in United States, 1993–2017*. Atlanta: U.S. Department of Health and Human Services; 2018.)



**Fig. 261.5** Top six countries of birth for non-United States–born\* pediatric TB cases for the years 1993-2017. \*Non-United States–born refers to persons born outside the United States or its territories or not born to a US citizen. †Cases in United States–born children of non-United States–born parents are included in United States–born counts and thus not displayed in this figure. (From Centers for Disease Control and Prevention, National Center for HIV/AIDS, Viral Hepatitis, STD and TB Prevention. *Pediatric Tuberculosis in United States, 1993–2017*. Atlanta: U.S. Department of Health and Human Services; 2018.)

States, TB among children of racial-ethnic minority status occurs disproportionately. The incidence rates of TB among children of Native Hawaiian or Pacific Islander, Asian, Native American or Native Alaskan, Black, and Hispanic children were 144, 44, 22, 19, and 18 times higher, respectively, than among non-Hispanic White children.

The rates of drug-resistant TB in children in the United States remain low. A total of 89 childhood cases of MDR-TB were reported in the United States in 2015; of those, 70.8% were non-United States-born. Among children with culture-confirmed TB in the United States in 2015, 15.2% had organisms with resistance to at least one first-line drug and 0.9% had MDR organisms.

Most children are infected with *M. tuberculosis* in their home by someone close to them, but outbreaks of childhood TB also have occurred in elementary and high schools, nursery schools, daycare centers and homes, churches, school buses, and sports teams. Adults living with HIV who have pulmonary TB can transmit *M. tuberculosis* to children, and children living with HIV are at increased risk for developing TB after infection. Other specific groups are at high risk for acquiring TBI and progressing to tuberculosis disease (Table 261.1).

**Table 261.1** Groups at High Risk for Acquiring Tuberculosis Infection and Developing Disease in Countries with Low Incidence

#### RISK FACTORS FOR TUBERCULOSIS INFECTION

Children exposed to high-risk adults  
Foreign-born persons from high-prevalence countries  
Homeless persons  
Persons who inject drugs  
Present and former residents or employees of correctional institutions, homeless shelters, and nursing homes  
Healthcare workers caring for high-risk patients (if infection control is not adequate)

#### RISK FACTORS FOR PROGRESSION OF TUBERCULOSIS INFECTION TO TUBERCULOSIS DISEASE

Infants and children  $\leq 4$  yr old, especially those  $< 2$  yr old  
Adolescents and young adults  
Persons co-infected with human immunodeficiency virus  
Persons with skin test conversion in the past 1-2 yr  
Persons who are immunocompromised, especially in cases of malignancy and solid organ transplantation, immunosuppressive medical treatments including anti-tumor necrosis factor therapies, diabetes mellitus, chronic renal failure, silicosis, and malnutrition

#### RISK FACTORS FOR DRUG-RESISTANT TUBERCULOSIS

Personal or contact history of treatment for tuberculosis  
Contacts of patients with drug-resistant tuberculosis  
Birth or residence in a country with a high rate of drug resistance  
Poor response to standard therapy  
Positive sputum smears (acid-fast bacilli) or culture  $\geq 2$  mo after initiating appropriate therapy

## TRANSMISSION

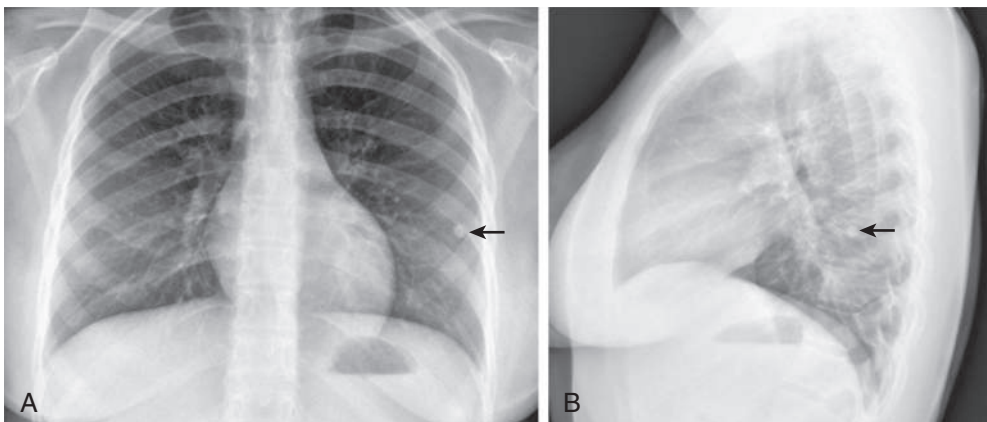
Transmission of *M. tuberculosis* is usually by inhalation of airborne mucus droplet nuclei, particles 1-5  $\mu\text{m}$  in diameter that contain *M. tuberculosis*. Transmission rarely occurs by direct contact with an infected discharge or a contaminated fomite. The chance of transmission increases when the patient has a positive acid-fast smear of sputum, an extensive upper lobe infiltrate or cavity, copious production of thin sputum, and severe and forceful cough (although the absence of cough does not eliminate the risk of TBI). Environmental factors such as poor air circulation enhance transmission. Within several days to 2 weeks after beginning adequate chemotherapy, most adults no longer transmit the organism, but some patients remain infectious for many weeks. Young children with TB rarely infect other children or adults; tubercle bacilli are sparse in their endobronchial secretions, and cough is often absent or lacks the tussive force required to suspend infectious particles of the correct size. However, adolescents often present with adult-type cavity or endobronchial TB and can easily transmit the organism.

Airborne transmission of *M. bovis* and *M. africanum* also occurs rarely. *M. bovis* can penetrate the gastrointestinal (GI) mucosa or invade the lymphatic tissue of the oropharynx when large numbers of the organism are ingested. Human infection with *M. bovis* is rare in developed countries as a result of the pasteurization of milk and effective TB control programs for cattle. Approximately 46% of culture-proven childhood TB cases from the San Diego, California, region since 1994 were caused by *M. bovis*, likely acquired by children when visiting Mexico or another country or consuming dairy products from countries with suboptimal veterinary TB control programs.

Zoonotic transmission is an uncommon source of *M. tuberculosis* that has been reported in adults exposed to elephants and potentially cattle.

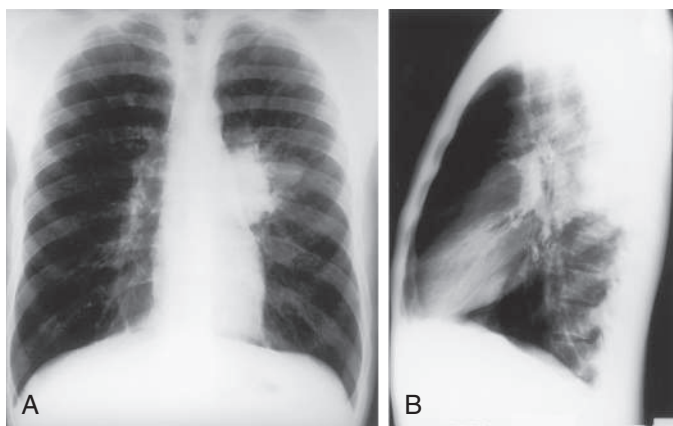
## PATHOGENESIS

The **primary complex** (or **Ghon complex**) of TB includes local infection at the portal of entry and the regional lymph nodes that drain the area. The lung is the portal of entry in  $>98\%$  of cases. The tubercle bacilli multiply initially within alveoli and alveolar ducts. Most of the bacilli are killed, but some survive within nonactivated macrophages, which carry them through lymphatic vessels to the regional lymph nodes. When the primary infection is in the lung, the hilar lymph nodes usually are involved, although an upper lobe focus can drain into paratracheal nodes. The tissue reaction in the lung parenchyma and lymph nodes intensifies over the next 2-12 weeks as the organisms grow in number and **tissue hypersensitivity** develops. The parenchymal portion of the primary complex often heals completely by fibrosis or calcification after undergoing caseous necrosis and encapsulation (Fig. 261.6). Occasionally, this portion continues to enlarge, resulting in focal pneumonitis and pleuritis. If caseation is intense, the center of the lesion liquefies and empties into the associated bronchus, leaving a residual cavity.



**Fig. 261.6** Posteroanterior (A) and lateral (B) chest radiographs of an adolescent showing a 7-mm calcified granuloma in the left lower lobe (arrows). (From Lighter J, Rigaud M. Diagnosing childhood tuberculosis: traditional and innovative modalities. *Curr Probl Pediatr Adolesc Health Care*. 2009;39:55-88.)





**Fig. 261.7** A 14-yr-old child with proven primary tuberculosis. Frontal (A) and lateral (B) views of the chest show hyperinflation, prominent left hilar lymphadenopathy, and alveolar consolidation involving the posterior segment of the left upper lobe and the superior segment of the left lower lobe. (From Hilton SVW, Edwards DK, eds. *Practical Pediatric Radiology*, 3rd ed. Philadelphia: Saunders; 2003:334.)



**Fig. 261.8** An 8-yr-old child with a history of cough. A single frontal view of the chest shows marked right hilar and paratracheal lymphadenopathy with alveolar disease involving the right middle and lower lung fields. This was also a case of primary tuberculosis. (From Hilton SVW, Edwards DK, eds. *Practical Pediatric Radiology*, 3rd ed. Philadelphia: Saunders; 2003:335.)

The foci of infection in the regional lymph nodes develop some fibrosis and encapsulation, but healing is usually less complete than in the parenchymal lesion. Viable *M. tuberculosis* can persist for decades within these foci. In most cases of initial TBI, the lymph nodes remain normal in size. However, hilar and paratracheal lymph nodes that enlarge significantly as part of the host inflammatory reaction can encroach on a regional bronchus (Figs. 261.7 and 261.8). Partial obstruction of the bronchus caused by external compression can cause hyperinflation in the distal lung segment. Complete obstruction results in atelectasis. Inflamed caseous nodes can attach to the bronchial wall and erode through it, causing endobronchial TB or a fistula tract. The caseum causes complete obstruction of the bronchus. The resulting lesion is a combination of pneumonitis and atelectasis and has been called a **collapse-consolidation lesion** or **segmental lesion** (Fig. 261.9).

During the development of the primary complex, tubercle bacilli are carried to most tissues of the body through the blood and lymphatic vessels. Although seeding of the organs of the reticuloendothelial system is common, bacterial replication is more likely to occur in organs with conditions that favor their growth, such as the lung apices, brain, kidneys, and bones. **Disseminated tuberculosis** occurs if the number of circulating bacilli is large and the host's cellular immune response is inadequate. More often, the number of bacilli is small, leading to



**Fig. 261.9** Right-sided hilar lymphadenopathy and collapse-consolidation lesions of primary tuberculosis in a 4-yr-old child. (From Kimberlin DW, Barnett ED, Lynfield R, Sawyer MH (eds). *Red Book: 2021-2024 Report of the Committee on Infectious Diseases*, 32nd ed. Itasca, IL: American Academy of Pediatrics, 2021. p 805-806; with data from Furin J, Seddon J, Becerra M, et al. *Management of Multi-drug-Resistant Tuberculosis Children: A Field Guide*, 4th ed. Boston: The Sentinel Project for Pediatric Drug-Resistant Tuberculosis, 2019. Available at: [http://sentinel-project.org/wp-content/uploads/2019/02/Updated\\_DRTB-Field-Guide-2019-V3.pdf](http://sentinel-project.org/wp-content/uploads/2019/02/Updated_DRTB-Field-Guide-2019-V3.pdf))

clinically inapparent metastatic foci in many organs. These remote foci usually become encapsulated, but they may be the origin of both **extrapulmonary tuberculosis** and **reactivation pulmonary tuberculosis**.

The time between initial infection and clinically apparent TB disease is variable. Disseminated and meningeal TB are early manifestations, often occurring within 2-6 months of acquisition. Significant lymph node or endobronchial TB usually appears within 3-9 months. Lesions of the bones and joints take several years to develop, whereas renal lesions become evident decades after infection. Extrapulmonary manifestations are more common in children than in adults and develop in 25-35% of children with TB vs approximately 10% of immunocompetent adults.

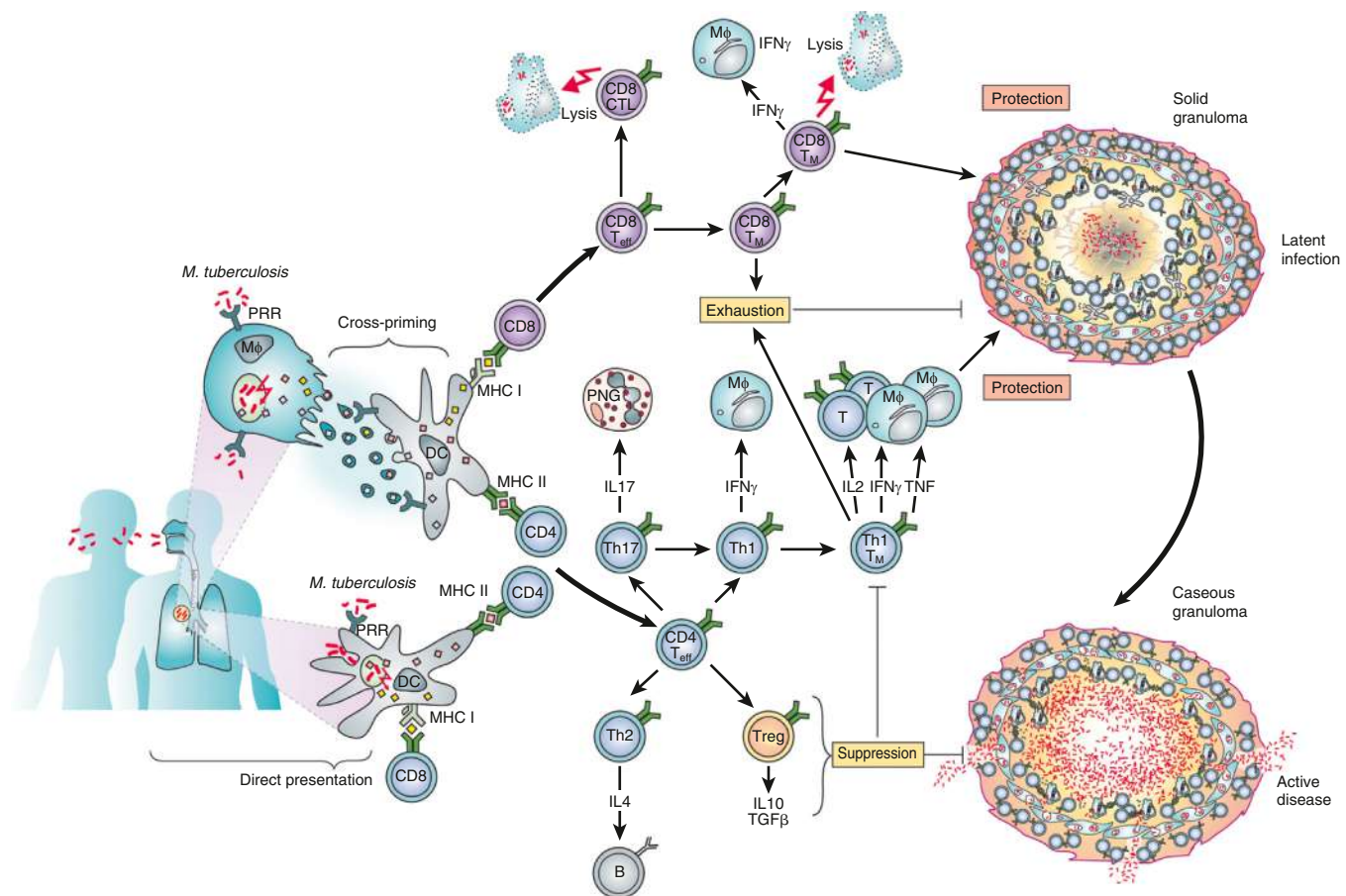
Pulmonary TB that occurs >1 year after the primary infection is usually caused by endogenous regrowth of bacilli persisting in partially encapsulated lesions. This **reactivation TB** is rare in young children but is common among adolescents and young adults. The most common form is an infiltrate or cavity in the apex of the upper lobes, where oxygen tension and blood flow are highest.

The risk for dissemination of *M. tuberculosis* is very high in persons living with HIV. Reinfection also can occur in persons with advanced HIV or AIDS. In immunocompetent persons, the response to the initial infection with *M. tuberculosis* usually provides protection against reinfection when a new exposure occurs. However, exogenous reinfection has been reported to occur in adults and children without immune compromise in highly endemic areas.

### Immunity

Conditions that adversely affect cell-mediated immunity predispose to progression from TBI to disease. Rare specific genetic defects (Mendelian susceptibility to mycobacterial disease [MSMD]) associated with deficient cell-mediated immunity in response to mycobacteria include interleukin (IL)-12 receptor B1 deficiency *TYK2* pathogenic gene variants; ~15 other genes associated with primary immunodeficiencies such as *NEMO*, *STAT1*, *JAK1*, and *RORC*; and complete and partial interferon (IFN)- $\gamma$  receptor 1 chain deficiencies. TBI is associated with a humoral antibody response, which plays a little known role in host defense. Shortly after infection, tubercle bacilli replicate in both free alveolar spaces and inactivated alveolar macrophages. Sulfatides in the





**Fig. 261.10** Overview of the immune response in tuberculosis. Control of *Mycobacterium tuberculosis* is mainly the result of productive teamwork between T-cell populations and macrophages (M $\phi$ ). *M. tuberculosis* survives within macrophages and dendritic cells (DCs) inside the phagosomal compartment. Gene products of major histocompatibility complex (MHC) class II are loaded with mycobacterial peptides that are presented to CD4 T cells. CD8 T-cell stimulation requires loading of MHC I molecules by mycobacterial peptides in the cytosol, either by egression of mycobacterial antigens into the cytosol or cross-priming, by which macrophages release apoptotic bodies carrying mycobacterial peptides. These vesicles are taken up by DCs and peptides presented. The CD4 T-helper (Th) cells polarize into different subsets. DCs and macrophages express pattern recognition receptors (PRRs), which sense molecular patterns on pathogens. Th1 cells produce interleukin (IL)-2 for T-cell activation, interferon- $\gamma$  (IFN- $\gamma$ ), or tumor necrosis factor (TNF) for macrophage activation. Th17 cells, which activate polymorphonuclear granulocytes (PNGs), contribute to the early formation of protective immunity in the lung after vaccination. Th2 cells and regulatory T cells (Treg) counterregulate Th1-mediated protection via IL-4, transforming growth factor- $\beta$  (TGF- $\beta$ ), or IL-10. CD8 T cells produce IFN- $\gamma$  and TNF, which activate macrophages. They also act as cytolytic T lymphocytes (CTLs) by secreting perforin and granzysin, which lyse host cells and directly attack *M. tuberculosis*. These effector T cells (Teff) are succeeded by memory T cells (T<sub>M</sub>). T<sub>M</sub> cells produce multiple cytokines, notably IL2, IFN- $\gamma$ , and TNF. During active containment in solid granuloma, *M. tuberculosis* recesses into a dormant stage and is immune to attack. Exhaustion of T cells is mediated by interactions between T cells and DCs through members of the programmed death 1 system. Treg cells secrete IL-10 and TGF- $\beta$ , which suppress Th1. This process allows resuscitation of *M. tuberculosis*, which leads to granuloma caseation and active disease. B, B cell. (From Kaufman SHE, Hussey G, Lambert PH. New vaccines for tuberculosis. *Lancet*. 2010;375:2110–2118.)

mycobacterial cell wall inhibit fusion of the macrophage phagosome and lysosomes, allowing the organisms to escape destruction by intracellular enzymes. **Cell-mediated immunity** develops 2–12 weeks after infection, along with tissue hypersensitivity (Fig. 261.10). After bacilli enter macrophages, lymphocytes that recognize mycobacterial antigens proliferate and secrete lymphokines and other mediators that attract other lymphocytes and macrophages to the area. Certain lymphokines activate macrophages, causing them to develop high concentrations of lytic enzymes that enhance their mycobactericidal capacity. A discrete subset of regulator helper and suppressor lymphocytes modulates the immune response. Development of specific cellular immunity prevents progression of the initial infection in most persons.

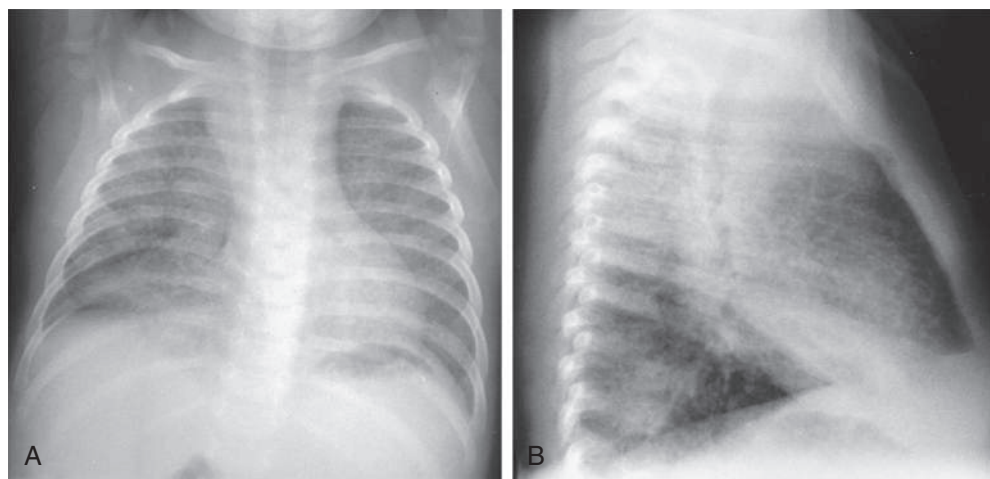
The pathologic events in the initial TBI seem to depend on the balance among the mycobacterial antigen load; cell-mediated immunity (which enhances intracellular killing); and tissue hypersensitivity, which promotes extracellular killing. When the antigen load is small and the degree of tissue sensitivity is high, granuloma formation results from the organization of lymphocytes, macrophages, and fibroblasts. When both antigen load and degree of sensitivity are high, granuloma

formation is less organized. Tissue necrosis is incomplete, resulting in formation of caseous material. When the degree of tissue sensitivity is low, as often occurs in infants or immunocompromised persons, the reaction is diffuse and the infection is not well contained, leading to dissemination and local tissue destruction. Tumor necrosis factor (TNF) and other cytokines released by specific lymphocytes promote cellular destruction and tissue damage in susceptible persons.

## CLINICAL MANIFESTATIONS

### Primary Pulmonary Disease

The **primary complex** includes the parenchymal pulmonary focus and the regional lymph nodes. Approximately 70% of lung foci are subpleural, and localized pleurisy is common. The initial parenchymal inflammation usually is not visible on chest radiograph, but a localized, nonspecific infiltrate may be seen before the development of tissue hypersensitivity. All lobar segments of the lung are at equal risk for initial infection. Two or more primary foci are present in 25% of cases. The hallmark of primary TB in the lung is the relatively large size of the regional lymphadenitis compared with the relatively small size



**Fig. 261.11** Posteroanterior (A) and lateral (B) chest radiographs of an infant with miliary tuberculosis. The child's mother had failed to complete treatment for pulmonary tuberculosis twice within 3 years of this child's birth.

of the initial lung focus (see Figs. 261.7 and 261.8). As delayed-type hypersensitivity develops, the hilar lymph nodes continue to enlarge in some children, especially infants, compressing the regional bronchus and causing obstruction. The usual sequence is *hilar lymphadenopathy*, *focal hyperinflation*, and then *atelectasis*. The resulting radiographic shadows have been called **collapse-consolidation** or *segmental TB* (see Fig. 261.9). Rarely, inflamed caseous nodes attach to the endobronchial wall and erode through it, causing endobronchial TB or a fistula tract. The caseum causes complete obstruction of the bronchus, resulting in extensive infiltrate and collapse. Enlargement of the subcarinal lymph nodes can cause compression of the esophagus and, rarely, a bronchoesophageal fistula.

Most cases of tuberculous bronchial obstruction in children resolve fully with appropriate treatment. Occasionally, there is residual calcification of the primary focus or regional lymph nodes. The appearance of calcification implies that the lesion has been present for at least 6-12 months. Healing of the segment can be complicated by scarring or contraction associated with cylindrical bronchiectasis, but this is rare.

Children can have lobar TB pneumonia without impressive hilar lymphadenopathy. If the primary infection is progressively destructive, liquefaction of the lung parenchyma can lead to formation of a thin-walled primary TB cavity. Rarely, bullous tuberculous lesions occur in the lungs and lead to pneumothorax if they rupture. Erosion of a parenchymal focus of TB into a blood or lymphatic vessel can result in dissemination of the bacilli and a **miliary** pattern, with small nodules evenly distributed on the chest radiograph (Fig. 261.11).

The symptoms and physical signs of primary pulmonary TB in children are surprisingly meager considering the degree of radiographic changes often present. When active case finding is performed, up to 50% of infants and children with radiographically moderate to severe pulmonary TB have no physical findings. Infants are more likely to experience signs and symptoms. Nonproductive cough and mild dyspnea are the most common symptoms. Systemic complaints such as fever, night sweats, anorexia, and decreased activity occur less often. Some infants have difficulty gaining weight or develop a true failure-to-thrive syndrome that often does not improve significantly until several months of effective treatment have been taken. Pulmonary signs are even less common. Some infants and young children with bronchial obstruction have localized wheezing or decreased breath sounds that may be accompanied by tachypnea or, rarely, respiratory distress. These pulmonary symptoms and signs are occasionally alleviated by antibiotics, suggesting bacterial superinfection.

### Progressive Primary Pulmonary Disease

A rare but serious complication of TB in a child occurs when the primary focus enlarges steadily and develops a large caseous center. Liquefaction can cause formation of a primary cavity associated with large numbers of tubercle bacilli. The enlarging focus can slough necrotic debris into the adjacent bronchus, leading to further intrapulmonary dissemination.

Significant signs or symptoms are common in locally progressive disease in children. High fever, severe cough with sputum production, weight loss, and night sweats are common. Physical signs include diminished breath sounds, rales, and dullness or egophony over the cavity. The prognosis for full recovery is excellent with appropriate therapy.

### Reactivation Tuberculosis

Pulmonary TB in adults usually represents endogenous reactivation of a site of TBI established previously in the body. This form of TB is rare in childhood but can occur in adolescence. Children with a healed TBI acquired when they were <2 years old rarely develop chronic reactivation pulmonary disease, which is more common in those who acquire the initial infection when they are >7 years old. The most common pulmonary sites are the original parenchymal focus, lymph nodes, and the apical seedings (**Simon foci**) established during the hematogenous phase of the early infection. This form of TB disease usually remains localized in the lungs, because the established immune response prevents further extrapulmonary spread. The most common radiographic findings are extensive infiltrates and thick-walled cavities in the upper lobes.

Older children and adolescents with reactivation TB are more likely to experience fever, anorexia, malaise, weight loss, night sweats, productive cough, hemoptysis, and chest pain than children with primary pulmonary TB. However, physical examination findings usually are minor or absent, even when cavities or large infiltrates are present. Most signs and symptoms improve within several weeks of starting effective treatment, although the cough can last for several months. This form of TB may be highly contagious if there is significant sputum production and cough. The prognosis for full recovery is excellent with appropriate therapy.

### Pleural Effusion

Tuberculous pleural effusions, which can be local or general, originate in the discharge of bacilli into the pleural space from a subpleural pulmonary focus or caseated lymph node. Asymptomatic local pleural effusion is so common in primary TB that it is considered part of the primary complex. Larger and clinically significant effusions occur months to years after the primary infection. Tuberculous pleural effusion is uncommon in children <6 years old and rare in children <2 years old. Effusions are usually unilateral but can be bilateral. They are rarely associated with a segmental pulmonary lesion and are uncommon in disseminated TB. Often the radiographic abnormality is more extensive than would be suggested by physical findings or symptoms (Fig. 261.12).

Clinical onset of tuberculous pleurisy is often sudden and characterized by low to high fever, shortness of breath, chest pain on deep inspiration, and diminished breath sounds. The fever and other symptoms can last for several weeks after the start of antituberculosis chemotherapy. The TST is positive in 70-80% of cases. The prognosis is



Fig. 261.12 Pleural tuberculosis in 16-yr-old female.

excellent, but radiographic resolution often takes months. Scoliosis is a rare complication from a long-standing effusion.

Examination of pleural fluid and the pleural membrane is important to establish the diagnosis of tuberculous **pleurisy**. The pleural fluid is usually yellow and only occasionally tinged with blood. The specific gravity is usually 1.012–1.025, the protein level is usually 2–4 g/dL, and the glucose concentration may be low, although it is usually in the low-normal range (20–40 mg/dL). Typically, there are several hundred to several thousand white blood cells per microliter (WBCs/ $\mu$ L), with an early predominance of polymorphonuclear leukocytes (PMNs) followed by a high percentage of lymphocytes. Acid-fast smears of the pleural fluid are rarely positive. Cultures of the fluid are positive in <30% of cases. Measurement of adenosine deaminase (ADA) levels may enhance the diagnosis of pleural TB. Biopsy of the pleural membrane is more likely to yield a positive acid-fast stain or culture, and granuloma formation can be demonstrated.

### Pericardial Disease

The most common form of cardiac TB is pericarditis. It is rare, occurring in 0.5–4% of TB cases in children. Pericarditis usually arises from direct invasion or lymphatic drainage from subcarinal lymph nodes. The presenting symptoms are nonspecific, including low-grade fever, malaise, and weight loss. Chest pain is unusual in children. A pericardial friction rub or distant heart sounds with pulsus paradoxus may be present. The pericardial fluid is typically serofibrinous or hemorrhagic. Acid-fast smear of the fluid rarely reveals the organism, but cultures are positive in 30–70% of cases. ADA levels are elevated in TB pericarditis. The culture yield from pericardial biopsy may be higher, and the presence of granulomas often suggests the diagnosis. Partial or complete pericardiectomy may be required when constrictive pericarditis develops.

### Lymphohematogenous (Disseminated) Disease

Tubercle bacilli are disseminated to distant sites, including the liver, spleen, skin, and lung apices, in all cases of TBI. Lymphohematogenous spread is usually asymptomatic. Rare patients experience protracted hematogenous TB caused by the intermittent release of tubercle bacilli as a caseous focus erodes through the wall of a blood vessel in the lung. The clinical picture subsequent to lymphohematogenous dissemination depends on the burden of organisms released from the primary focus to distant sites and the adequacy of the host's immune response. Although the clinical picture may be acute, more often it is indolent and prolonged, with spiking fever accompanying the release of organisms

into the bloodstream. Multiple organ involvement is common, leading to hepatomegaly, splenomegaly, lymphadenitis in superficial or deep nodes, and papulonecrotic tuberculids appearing on the skin. Bones and joints or kidneys also can become involved. Meningitis occurs only late in the course of the disease. Early pulmonary involvement is surprisingly mild, but diffuse involvement becomes apparent with prolonged infection.

The most clinically significant form of disseminated TB is miliary disease, which occurs when massive numbers of tubercle bacilli are released into the bloodstream, causing disease in two or more organs. **Miliary tuberculosis** usually complicates the primary infection, occurring within 2–6 months of the initial infection. Although this form of disease is most common in infants and young children, it is also found in adolescents and older adults, resulting from the breakdown of a previously healed primary pulmonary lesion. The clinical manifestations of miliary TB are protean, depending on the number of organisms that disseminate and where they lodge. Lesions are often larger and more numerous in the lungs, spleen, liver, and bone marrow than in other tissues. Because this form of TB is most common in infants and malnourished or immunosuppressed patients, the host's immune incompetence likely plays a role in pathogenesis.

Rarely, the onset of miliary TB is explosive, and the patient can become gravely ill in several days. More often, the onset is insidious, with early systemic signs, including anorexia, weight loss, and low-grade fever. At this time, abnormal physical signs are usually absent. Generalized lymphadenopathy and hepatosplenomegaly develop within several weeks in approximately 50% of cases. The fever can then become higher and more sustained, although the chest radiograph usually is normal and respiratory symptoms are minor or absent. Within several more weeks, the lungs can become filled with tubercles, and dyspnea, cough, rales, or wheezing occur. The lesions of miliary TB are usually <2–3 mm in diameter when first visible on chest radiograph (see Fig. 261.11). The smaller lesions coalesce to form larger lesions and sometimes extensive infiltrates. As the pulmonary disease progresses, an alveolar air block syndrome can result in frank respiratory distress, hypoxia, and pneumothorax or pneumomediastinum. Signs or symptoms of meningitis or peritonitis are found in 20–40% of patients with advanced disease. Chronic or recurrent headache in a patient with miliary TB usually indicates the presence of meningitis, whereas the onset of abdominal pain or tenderness is a sign of tuberculous peritonitis. **Cutaneous lesions** include papulonecrotic tuberculids, nodules, or purpura. Choroid tubercles occur in 13–87% of patients and are highly specific for the diagnosis of miliary TB. Unfortunately, the TST is non-reactive in up to 40% of patients with disseminated TB.

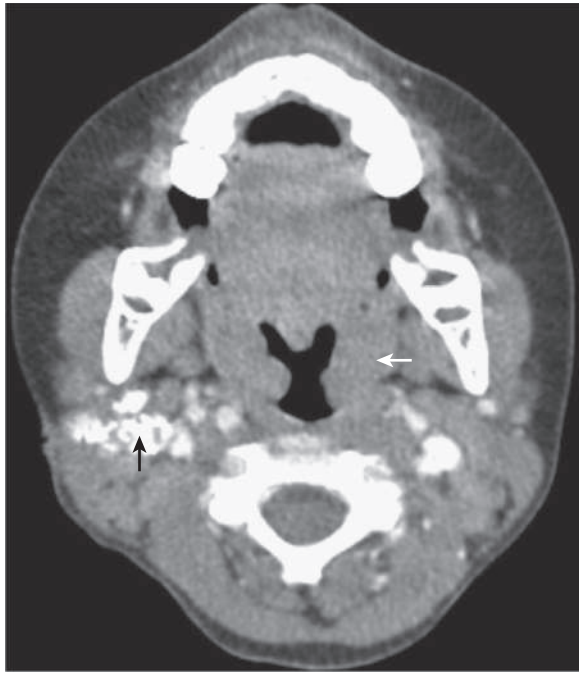
Diagnosis of disseminated TB can be difficult, and a high index of suspicion by the clinician is required. Often the patient presents with fever of unknown origin (FUO). Early sputum or gastric aspirate cultures have a low sensitivity. Biopsy of the liver or bone marrow with appropriate bacteriologic and histologic examinations more often yields an early diagnosis. The most important clue is usually a history of recent exposure to an adult with infectious TB.

The resolution of miliary TB is slow, even with proper therapy. Fever usually declines within 2–3 weeks of starting chemotherapy, but the chest radiographic abnormalities might not resolve for many months. Occasionally, corticosteroids hasten symptomatic relief, especially when air block, peritonitis, or meningitis is present. The prognosis is excellent with early diagnosis and adequate chemotherapy.

### Upper Respiratory Tract Disease

TB of the upper respiratory tract is rare in developed countries but is still observed in developing countries. Children with laryngeal TB have a croup-like cough, sore throat, hoarseness, and dysphagia. Most children with laryngeal TB have extensive upper lobe pulmonary disease, but occasional patients have primary laryngeal disease with a normal chest radiograph. TB of the middle ear results from aspiration of infected pulmonary secretions into the middle ear or from hematogenous dissemination in older children. The most common signs and symptoms are painless unilateral otorrhea, tinnitus, decreased hearing, facial paralysis, and a perforated tympanic membrane. Enlargement of

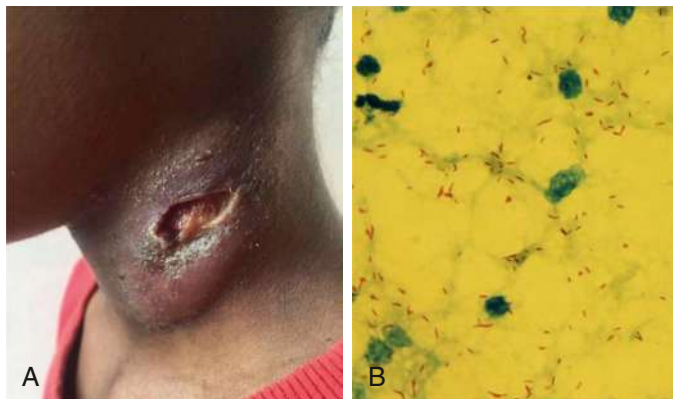




**Fig. 261.13** Scrofula. Axial CT image of the neck in 8-yr-old male shows calcified right cervical lymphadenopathy (black arrow) and tonsillar swelling (white arrow). (From Lighter J, Rigaud M. Diagnosing childhood tuberculosis: traditional and innovative modalities. *Curr Probl Pediatr Adolesc Health Care*. 2009;39:55–88.)



**Fig. 261.15** Scrofula. Tuberculous lymphadenitis with fistula in 4-yr-old male associated with scrofuloderma (arrows). (From Pereira C, Cascais M, Felix M, Salgado M. Scrofula in a child. *J Pediatr*. 2017;189:235.)



**Fig. 261.14** Scrofula. A, Ulcerative lesion 3.2 × 2.1 cm with undermined edges and necrotic base with surrounding induration. B, Acid-fast bacilli. (From Sharawat IK. Scrofula. *J Pediatr*. 2017;189:236.)

lymph nodes in the preauricular or anterior cervical chains can accompany this infection. Diagnosis is difficult, because stains and cultures of ear fluid are often negative, and histology of the affected tissue often shows a nonspecific acute and chronic inflammation without granuloma formation.

### Lymph Node Disease

TB of the superficial lymph nodes, often referred to as **scrofula**, is the most common form of extrapulmonary TB in children (Figs. 261.13–261.15). Historically, scrofula was usually caused by drinking unpasteurized cow's milk laden with *M. bovis*. Most current cases occur within 6–9 months of initial infection by *M. tuberculosis*, although some cases appear years later. The tonsillar, anterior cervical, submandibular, and supraclavicular nodes become involved secondary to extension of a primary lesion of the upper lung fields or abdomen. Infected nodes in the inguinal, epitrochlear, or axillary regions result from regional

lymphadenitis associated with TB of the skin or skeletal system. The nodes usually enlarge gradually in the early stages of lymph node disease. They are discrete, nontender, and firm but not hard. The nodes often feel fixed to underlying or overlying tissue. Disease is most often **unilateral**, but bilateral involvement can occur because of the cross-over drainage patterns of lymphatic vessels in the chest and lower neck. As infection progresses, multiple nodes are infected, resulting in a mass of matted nodes. Systemic signs and symptoms other than a low-grade fever are usually absent. The TST is usually reactive. The chest radiograph is often normal (in 70% of cases). The onset of illness is occasionally more acute, with rapid enlargement, tenderness, and fluctuance of lymph nodes and with high fever. The initial presentation is rarely a fluctuant mass with overlying cellulitis or skin discoloration.

Lymph node TB can resolve if left untreated but more often progresses to caseation and necrosis. The capsule of the node breaks down, resulting in the spread of infection to adjacent nodes. Rupture of the node usually results in a draining sinus tract that can require surgical removal. **Tuberculous lymphadenitis** can usually be diagnosed by fine-needle aspiration (FNA) of the node and responds well to antituberculosis therapy, although the lymph nodes do not return to normal size for months or even years. Surgical removal is not usually necessary and must be combined with antituberculosis medication, because the lymph node disease is only one part of a systemic infection.

A definitive diagnosis of tuberculous adenitis usually requires histologic, bacteriologic, or molecular confirmation, which is best accomplished by FNA for culture, molecular testing, stain, and histology. If FNA is not successful in establishing a diagnosis, excisional biopsy of the involved node is indicated. Culture of lymph node tissue yields the organism in only approximately 50% of cases. Many other conditions can be confused with tuberculous adenitis, including infection caused by **nontuberculous mycobacteria (NTM)**, cat scratch disease (*Bartonella henselae*), tularemia, brucellosis, toxoplasmosis, pyogenic infection, or noninfectious causes, including tumor, branchial cleft cyst, and cystic hygroma. The most common problem is distinguishing infection caused by *M. tuberculosis* from lymphadenitis caused by NTM in geographic areas where NTM are common. Both conditions are usually associated with a normal chest radiograph and a reactive TST. An important clue to the diagnosis of tuberculous adenitis is an epidemiologic link to an adult with infectious TB. In areas where both diseases are common, culture or PCR testing of the involved tissue may be necessary to establish the exact cause of the disease.

### Central Nervous System Disease

TB of the central nervous system (CNS) is the most serious complication in children and is fatal without prompt and appropriate treatment. **Tuberculous meningitis** usually arises from the formation of a metastatic caseous lesion in the cerebral cortex or meninges that develops



during the lymphohematogenous dissemination of the primary infection. This initial lesion increases in size and discharges small numbers of tubercle bacilli into the subarachnoid space. The resulting gelatinous exudate infiltrates the corticomeningeal blood vessels, producing inflammation, obstruction, and subsequent infarction of the cerebral cortex. The brainstem is often the site of greatest involvement, which accounts for the commonly associated dysfunction of cranial nerves III, VI, and VII. The exudate also interferes with the normal flow of cerebrospinal fluid (CSF) in and out of the ventricular system at the level of the basilar cisterns, leading to a communicating hydrocephalus. The combination of vasculitis, infarction, cerebral edema, and hydrocephalus results in the severe damage that can occur gradually or rapidly. Profound abnormalities in electrolyte metabolism from salt wasting or the syndrome of inappropriate antidiuretic hormone secretion (SIADH) also contribute to the pathophysiology of tuberculous meningitis.

Tuberculous meningitis complicates approximately 0.3% of untreated TBIs in children. It is most common in children 6 months to 4 years old. Occasionally, tuberculous meningitis occurs many years after the infection, when rupture of one or more of the subependymal tubercles discharges tubercle bacilli into the subarachnoid space. The clinical progression of tuberculous meningitis may be rapid or gradual. Rapid progression tends to occur more often in infants and young children, who can experience symptoms for only several days before the onset of acute hydrocephalus, seizures, and cerebral edema. More often, the signs and symptoms progress slowly over weeks and are divided into three stages.

The **first stage** typically lasts 1-2 weeks and is characterized by nonspecific symptoms such as fever, headache, irritability, drowsiness, and malaise. Focal neurologic signs are absent, but infants can experience a stagnation or loss of developmental milestones. The **second stage** usually begins more abruptly. The most common features are lethargy, nuchal rigidity, seizures, positive Kernig and Brudzinski signs, hyperreflexia, vomiting, cranial nerve palsies, and other focal neurologic signs. The accelerating clinical illness usually correlates with the development of hydrocephalus, increased intracranial pressure, and vasculitis. Some children have no evidence of meningeal irritation but can have signs of encephalitis, such as disorientation, movement disorders, or speech impairment. The **third stage** is marked by coma, hemiplegia or paraplegia, hypertension, decerebrate posturing, deterioration of vital signs, and eventually death.

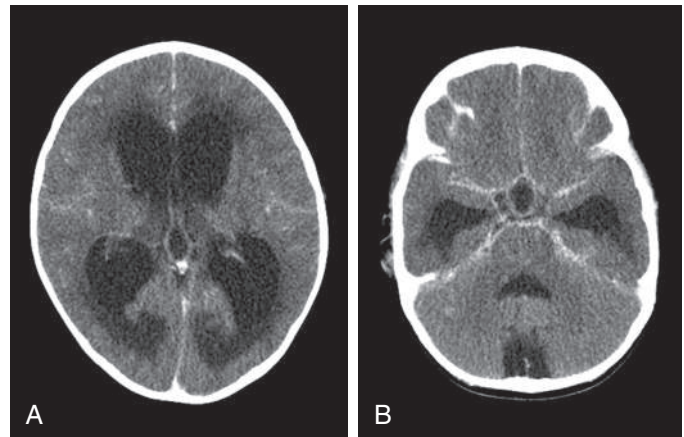
The prognosis of tuberculous meningitis correlates most closely with the clinical stage of illness at the time treatment is initiated. The majority of patients in the first stage have an excellent outcome, whereas most patients in the third stage who survive have permanent disabilities, including blindness, deafness, paraplegia, diabetes insipidus, or mental retardation. The prognosis for young infants is generally worse than for older children. It is imperative that antituberculosis treatment be considered for any child who develops basilar meningitis and hydrocephalus, cranial nerve palsy, or stroke with no other apparent etiology. Often the key to the correct diagnosis is identifying an adult who has infectious TB and is in contact with the child. Because of the short incubation period of tuberculous meningitis, the illness has not yet been diagnosed in the adult in many cases.

The diagnosis of tuberculous meningitis can be difficult early in its course, requiring a high degree of suspicion on the part of the clinician. The TST is nonreactive in up to 50% of cases, and 20–50% of children have a normal chest radiograph. The most important laboratory test for the diagnosis of tuberculous meningitis is examination and culture of the lumbar CSF. The CSF leukocyte count usually ranges from 10 to 500 cells/ $\mu$ L. PMNs may be present initially, but lymphocytes predominate in the majority of cases. The CSF glucose is typically <40 mg/dL but rarely <20 mg/dL. The protein level is elevated and may be extremely high (400–5,000 mg/dL) secondary to hydrocephalus and spinal block. Although the lumbar CSF is grossly abnormal, ventricular CSF can have normal chemistries and cell counts because this fluid is obtained from a site proximal to the inflammation and obstruction. During early stage one, the CSF can resemble that of viral aseptic meningitis, only to progress to the more severe CSF profile over several weeks. The success

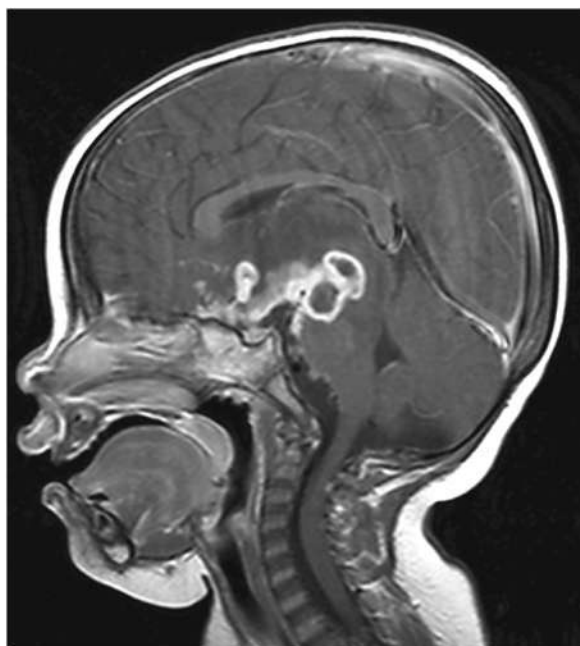
of the microscopic examination of acid-fast-stained CSF and mycobacterial culture is related directly to the volume of the CSF sample. Examinations or culture of small amounts of CSF are unlikely to demonstrate *M. tuberculosis*. It is recommended that serial collections of large-volume lumbar CSF (up to 15 mL) be obtained for acid-fast stain and culture. When 5–10 mL of lumbar CSF can be obtained, the acid-fast stain of the CSF sediment is positive in up to 30% of cases and the culture is positive in 50–70% of cases. Polymerase chain reaction (PCR) testing of the CSF and ADA levels can improve the diagnosis. Cultures of other body fluids can help confirm the diagnosis.

Radiographic studies can aid in the diagnosis of tuberculous meningitis. CT or MRI of the brain of patients with tuberculous meningitis may be normal during early stages of the disease. As the disease progresses, basilar enhancement and communicating hydrocephalus with signs of cerebral edema or early focal ischemia are the most common findings (Fig. 261.16). Some young children with tuberculous meningitis have one or several clinically silent tuberculomas, occurring most often in the cerebral cortex or thalamic regions.

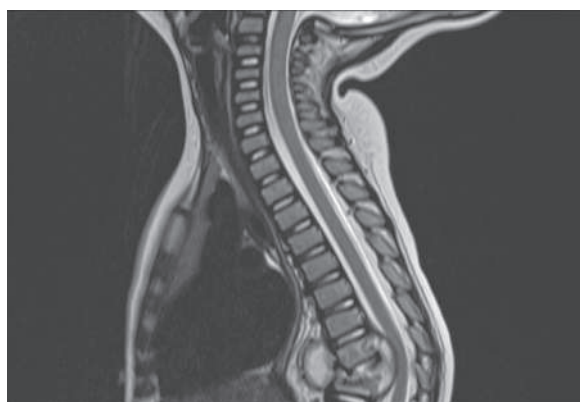
Another manifestation of CNS TB is the **tuberculoma**, a tumor-like mass resulting from aggregation of caseous tubercles that usually manifests clinically as a brain tumor. Tuberculomas account for up to 30% of brain tumors in some areas of the world but are rare in North America. In adults, tuberculomas are most often supratentorial, but in children, they are often infratentorial, located at the base of the brain near the cerebellum (Fig. 261.17). Lesions are most often singular but may be multiple. The most common symptoms are headache, fever, focal neurologic findings, and convulsions. The TST is usually reactive, but the chest radiograph is usually normal. Surgical excision is sometimes necessary to distinguish tuberculoma from other causes of brain tumor. However, surgical removal is not necessary because most tuberculomas resolve with medical management. Corticosteroids are administered during the first few weeks of treatment or in the immediate postoperative period to decrease cerebral edema. On CT or MRI of the brain, tuberculomas usually appear as discrete lesions with a significant amount of surrounding edema. Contrast medium enhancement is often impressive and can result in a ringlike lesion. Since the advent of CT, the paradoxical development of tuberculomas in patients with tuberculous meningitis who are receiving ultimately effective chemotherapy has been recognized. The cause and nature of these tuberculomas are poorly understood, but they do not represent failure of antimicrobial treatment. This phenomenon should be considered whenever a child with tuberculous meningitis deteriorates or develops focal neurologic findings during treatment. Corticosteroids



**Fig. 261.16** Tuberculous meningitis in a child. A and B, Postcontrast CT images demonstrate intense enhancement in the suprasellar cistern, sylvian cistern, and prepontine cistern. Dilation of the ventricular system is seen, consistent with associated hydrocephalus. (From Lerner A, Rajamohan A, Shiroishi MS, et al. *Cerebral infections and inflammation*. In Haaga JR, Boll DT, eds. *CT and MRI of the Whole Body*, 6th ed. Philadelphia: Elsevier; 2017: Fig 10-20.)



**Fig. 261.17** MRI of brain of 3-yr-old child showing multiple pontine tuberculomas.



**Fig. 261.18** Tuberculosis of the spine in a toddler. (From Feder HM Jr, Rigos L, Teti K. Pott's disease in a Connecticut toddler. *Lancet*. 2016;388:504–505.)

can alleviate the occasionally severe clinical signs and symptoms that occur. These lesions can persist for months or years.

### Cutaneous Disease

Cutaneous TB is rare in the United States but occurs worldwide and accounts for 1–2% of tuberculosis (see [Chapter 706](#)).

### Bone and Joint Disease

TB involving bone or joints is most likely to involve the vertebrae. The classic manifestation of **tuberculous spondylitis** is progression to **Pott disease**, in which destruction of the vertebral bodies leads to gibbus deformity and kyphosis ([Fig. 261.18](#)) (see [Chapter 720.4](#)). **Skeletal tuberculosis** is a late complication of TB and has become a rare entity since the availability of antituberculosis therapy but is more likely to occur in children than in adults. Tuberculous bone lesions can resemble pyogenic and fungal infections or bone tumors. *Multifocal bone involvement can occur*. A bone biopsy is essential to confirm the diagnosis. Surgical intervention is generally not necessary for cure, and the prognosis is excellent with adequate medical treatment. A sterile polyarticular (large joint) arthritis may also be noted in patients with active TB at another site.

### Abdominal and Gastrointestinal Disease

TB of the oral cavity or pharynx is quite unusual. The most common lesion is a painless ulcer on the mucosa, palate, or tonsil with enlargement of the regional lymph nodes. TB of the parotid gland has been reported rarely in endemic countries. TB of the esophagus is rare in children but may be associated with a tracheoesophageal fistula in infants. These forms of TB are usually associated with extensive pulmonary disease and swallowing of infectious respiratory secretions. They can occur in the absence of pulmonary disease, by spread from mediastinal or peritoneal lymph nodes.

**Tuberculous peritonitis** occurs most often in young males and is uncommon in adolescents and rare in children. Generalized peritonitis can arise from subclinical or miliary hematogenous dissemination. Localized peritonitis is caused by direct extension from an abdominal lymph node, intestinal focus, or genitourinary TB. Rarely, the lymph nodes, omentum, and peritoneum become matted and can be palpated as a doughy, irregular, nontender mass. Abdominal pain or tenderness, ascites, anorexia, and low-grade fever are typical manifestations. The TST is usually reactive. The diagnosis can be confirmed by paracentesis with appropriate stains and cultures, but this procedure must be performed carefully to avoid entering a bowel that is adherent to the omentum.

**Tuberculous enteritis** is caused by hematogenous dissemination or by swallowing tubercle bacilli discharged from the patient's own lungs. The jejunum and ileum near Peyer patches and the appendix are the most common sites of involvement. The typical findings are shallow ulcers that cause pain, diarrhea or constipation, weight loss, and low-grade fever. Mesenteric adenitis usually complicates the infection. The enlarged nodes can cause intestinal obstruction or erode through the omentum to cause generalized peritonitis. The clinical presentation of tuberculous enteritis is nonspecific, mimicking other infections and conditions that cause diarrhea. The disease should be suspected in any child with chronic GI complaints and a reactive TST or positive IGRA. Biopsy, acid-fast stain, and culture of the lesions are usually necessary to confirm the diagnosis.

### Genitourinary Disease

**Renal TB** is rare in children because the incubation period is several years or longer. Tubercle bacilli usually reach the kidney during lymphohematogenous dissemination. The organisms often can be recovered from the urine in cases of miliary TB and in some patients with pulmonary TB in the absence of renal parenchymal disease. In true renal TB, small caseous foci develop in the renal parenchyma and release *M. tuberculosis* into the tubules. A large mass develops near the renal cortex that discharges bacteria through a fistula into the renal pelvis. Infection then spreads locally to the ureters, prostate, or epididymis. Renal TB is often clinically silent in its early stages, marked only by sterile pyuria and microscopic hematuria. Dysuria, flank or abdominal pain, and gross hematuria develop as the disease progresses. Superinfection by other bacteria is common and can delay recognition of the underlying TB. Hydronephrosis or ureteral strictures can complicate the disease. Urine cultures for *M. tuberculosis* are positive in 80–90% of cases, and acid-fast stains of large volumes of urine sediment are positive in 50–70% of cases. The TST is nonreactive in up to 20% of patients. A pyelogram or CT scan often reveals mass lesions, dilation of the proximal ureters, multiple small filling defects, and hydronephrosis if ureteral stricture is present. Disease is most often unilateral.

**Genital tract TB** is uncommon in prepubescent males and females. This condition usually originates from lymphohematogenous spread, although it can be caused by direct spread from the intestinal tract or bone. Adolescent females can develop genital tract TB during the primary infection. The fallopian tubes are most often involved (90–100% of cases), followed by the endometrium (50%), ovaries (25%), and cervix (5%). The most common symptoms are lower abdominal pain and dysmenorrhea or amenorrhea. Systemic manifestations are usually absent, and the chest radiograph is normal in the majority of cases. The TST is usually reactive. Genital TB in adolescent males causes epididymitis or orchitis. The condition usually manifests as a painless, unilateral nodular swelling of the scrotum. Involvement of the glans

penis is extremely rare. Genital abnormalities and a positive TST in an adolescent male or female suggest genital tract TB.

### Pregnancy and the Newborn

Pulmonary and particularly extrapulmonary TB other than lymphadenitis in a pregnant woman is associated with increased risk for prematurity, fetal growth retardation, low birthweight, and perinatal mortality. **Congenital TB** is rare because the most common result of female genital tract TB is infertility. Primary infection in the mother just before or during pregnancy is more likely to cause congenital infection than is reactivation of a previous infection. Congenital transmission usually occurs from a lesion in the placenta through the umbilical vein, when tubercle bacilli infect the fetal liver, where a primary focus with periportal lymph node involvement can occur. Organisms pass through the liver into the main fetal circulation and infect many organs. The bacilli in the lung usually remain dormant until after birth, when oxygenation and pulmonary circulation increase significantly. Congenital TB can also be caused by aspiration or ingestion of infected amniotic fluid. However, the most common route of infection for the neonate is postnatal airborne transmission from an adult with infectious pulmonary TB.

### Perinatal Disease

Symptoms of congenital TB may be present at birth but usually begin by the second or third week of life. The most common signs and symptoms are respiratory distress, fever, hepatic or splenic enlargement, poor feeding, lethargy or irritability, lymphadenopathy, abdominal distention, failure to thrive, ear drainage, and skin lesions. The clinical manifestations vary in relation to the site and size of the caseous lesions. Many infants have an abnormal chest radiograph, most often with a miliary pattern. Some infants with no pulmonary findings early in the course of the disease later develop profound radiographic and clinical abnormalities. Hilar and mediastinal lymphadenopathy and lung infiltrates are common. Generalized lymphadenopathy and meningitis occur in 30–50% of infants.

The clinical presentation of TB in newborns is similar to that caused by bacterial sepsis and other congenital infections, such as syphilis, toxoplasmosis, and cytomegalovirus. The diagnosis should be suspected in an infant with signs and symptoms of bacterial or congenital infection whose response to antibiotic and supportive therapy is poor and in whom evaluation for other infections is unrevealing. The most important clue for rapid diagnosis of congenital TB is a maternal or family history of TB. Often, the mother's disease is discovered only after the neonate's diagnosis is suspected. The infant's TST is negative initially but can become positive in 1–3 months. A positive acid-fast stain of an early morning gastric aspirate from a newborn usually indicates TB. Direct acid-fast stains on middle ear discharge, bone marrow, tracheal aspirate, or tissue biopsy (especially liver) can be useful. The CSF should be examined, cultured, and sent for PCR testing. The mortality rate of congenital TB remains very high because of delayed diagnosis. Many children have a complete recovery if the diagnosis is made promptly and adequate chemotherapy is started.

### Tuberculosis Disease in Children Living with HIV

In the United States, the rate of TB disease in children living with untreated HIV is 30 times higher than in children without HIV. Establishing the diagnosis of TB in a child living with HIV may be difficult because TST reactivity can be absent (also with a negative IGRA), culture confirmation is difficult, and the clinical features of TB are similar to many other HIV-related opportunistic infections and conditions. TB in children living with HIV is often more severe, progressive, and likely to occur in extrapulmonary sites. Radiographic findings are similar to those in children with normal immune systems, but lobar disease and lung cavitation are more common. Nonspecific respiratory symptoms, fever, and weight loss are the most common complaints. Rates of drug-resistant TB tend to be higher in adults living with HIV and probably are also higher in children living with HIV. Recurrent TB disease and relapsed TB occur more frequently in children living with HIV. The

prognosis generally is good if TB disease is not far advanced at diagnosis and appropriate antituberculosis drugs are available.

The mortality rate of children living with HIV with TB is high, especially as the CD4 lymphocyte numbers decrease. In adults, the host immune response to TBI appears to enhance HIV replication and accelerate the immune suppression caused by HIV. Increased mortality rates are attributed to progressive HIV infection rather than TB. Therefore children living with HIV with potential TB exposures and/or recent TBI should be promptly evaluated and treated for TB. Conversely, all children with TB disease should be tested for HIV infection.

Children living with HIV who are given highly active antiretroviral therapy (HAART) are at high risk of developing **immune reconstitution inflammatory syndrome (IRIS)**. IRIS should be suspected in patients who experience a worsening of TB symptoms while receiving antituberculosis therapy (*paradoxical* IRIS) or who develop new-onset TB symptoms and radiographic findings after initiation of HAART (*unmasking* IRIS). Factors suggesting IRIS are temporal association (within 3 months of starting HAART), unusual clinical manifestations, unexpected clinical course, exclusion of alternative explanations, evidence of preceding immune restoration (rise in CD4 lymphocyte count), and decrease in HIV viral load. The most common clinical manifestations of IRIS in children are fever, cough, new skin lesions, enlarging lymph nodes in the thorax or neck, and appearance or enlargement of tuberculomas in the brain, with or without accompanying meningitis. The treatment of TB-associated IRIS in children living with HIV often included steroids but should be undertaken by a clinician with specific expertise in TB treatment.

## IMMUNE-BASED TESTING (“TESTS OF TUBERCULOSIS INFECTION”)

### Tuberculin Skin Testing

The development of delayed-type hypersensitivity in most persons infected with the *M. tuberculosis* complex organisms makes the TST a useful diagnostic tool. The **Mantoux TST** is the intradermal injection of 0.1 mL purified protein derivative stabilized with Tween 80. T cells sensitized by prior infection are recruited to the skin, where they release lymphokines that induce induration through local vasodilation, edema, fibrin deposition, and recruitment of other inflammatory cells to the area. The amount of induration in response to the test should be measured by a trained person 48–72 hours after administration. In some patients, the onset of induration is >72 hours after placement; this is also a positive result. Immediate hypersensitivity reactions to tuberculin or other constituents of the preparation are short-lived (<24 hours) and not considered a positive result. Tuberculin sensitivity develops 3 weeks to 3 months (most often in 4–8 weeks) after inhalation of organisms.

Host-related factors, including very young age, malnutrition, immunosuppression by disease or drugs, viral infections (measles, mumps, varicella, influenza), vaccination with live-virus vaccines, and overwhelming TB, can depress the skin test reaction in a child infected with *M. tuberculosis*. Corticosteroid therapy can decrease the reaction to tuberculin, but the effect is variable; TST done at the time of initiating corticosteroid therapy is usually reliable. Approximately 10% of immunocompetent children with TB disease (up to 50% of those with meningitis or disseminated disease) do not react initially to purified protein derivative; most become reactive after several months of antituberculosis therapy. False-positive reactions to tuberculin can be caused by cross-sensitization to antigens of NTM, which generally are more prevalent in the geographic environment as one approaches the equator. These cross-reactions are usually transient over months to years and produce <10–12 mm of induration, but larger areas of induration can occur. Previous vaccination with bacille Calmette-Guérin (BCG) also can cause a reaction to a TST, especially if a person has received two or more BCG vaccinations. Approximately 50% of the infants who receive a BCG vaccine never develop a reactive TST, and the reactivity usually wanes in 2–3 years in those with initially positive skin test results. Older children and adults who receive a BCG vaccine are more likely to develop tuberculin reactivity, but most lose the reactivity by 5–10 years after vaccination. However,



**Table 261.2** Tuberculin Skin Test (TST) or Interferon- $\gamma$  Release Assay (IGRA): Recommendations for Infants, Children, and Adolescents\*

**CHILDREN FOR WHOM IMMEDIATE TST OR IGRA IS INDICATED<sup>†</sup>**  
 Contacts of people with confirmed or suspected contagious tuberculosis (contact investigation)  
 Children with radiographic or clinical findings suggesting tuberculosis disease  
 Children immigrating from countries with endemic infection (e.g., Asia, Middle East, Africa, Latin America, countries from former Soviet Union), including international adoptees  
 Children with travel histories to countries with endemic infection and substantial contact with indigenous people from such countries<sup>‡</sup>  
 Children who should have annual TST or IGRA: Children infected with human immunodeficiency virus

**CHILDREN AT INCREASED RISK FOR PROGRESSION OF TUBERCULOSIS INFECTION TO TUBERCULOSIS DISEASE**

Children with other medical conditions, including diabetes mellitus, chronic renal failure, malnutrition, and congenital or acquired immunodeficiencies, and children receiving tumor necrosis factor (TNF) antagonists deserve special consideration. Without recent exposure, these children are not at increased risk of acquiring tuberculosis infection. Underlying immune deficiencies associated with these conditions theoretically would enhance the possibility for progression to severe disease.

Initial histories of potential exposure to tuberculosis should be included for all of these patients. If these histories or local epidemiologic factors suggest a possibility of exposure, immediate and periodic TST or IGRA should be considered.

**An initial TST or IGRA should be performed before initiation of immunosuppressive therapy, including prolonged corticosteroid administration, organ transplantation, or use of TNF- $\alpha$  antagonists or blockers, or immunosuppressive therapy in any child requiring these treatments.**

\*Bacille Calmette-Guérin immunization is not a contraindication to a TST.

<sup>†</sup>Beginning as early as 3 mo of age.

<sup>‡</sup>If the child is well and has no history of exposure, the TST or IGRA should be delayed up to 10 wk after return.

From Kimberlin DW, Barnett ED, Lynfield R, Sawyer MH, eds. *Red Book: 2021–2024 Report of the Committee on Infectious Diseases*, 32nd ed. Itasca, IL: American Academy of Pediatrics; 2021:789.

some individuals maintain tuberculin reactivity from BCG vaccine for many years. When present, skin test reactivity usually causes <10 mm of induration, although larger reactions occur in some persons.

The appropriate size of induration indicating a positive Mantoux TST result varies with related epidemiologic and risk factors. In children with no TB risk factors, skin test reactions are usually false-positive results. The American Academy of Pediatrics (AAP) and Centers for Disease Control and Prevention (CDC) discourage routine testing of all children and recommend targeted tuberculin testing of children at risk identified through periodic screening questionnaires (Table 261.2). Possible exposure to an adult with or at high risk for infectious pulmonary TB is the most crucial risk factor for children. Reaction size limits for determining a positive TST result vary with the person's risk for infection (Table 261.3). In those at highest risk of progression to TB disease, TST sensitivity is most important, whereas specificity is more important for persons at low risk of progression.

### Interferon- $\gamma$ Release Assay

Two blood tests—T-SPOT.TB (Oxford Immunotec; Marlborough, MA) and QuantiFERON-TB Gold/Gold Plus (QFT, Qiagen; Germantown, MD) detect IFN- $\gamma$  generation by the patient's T cells in response to specific *M. tuberculosis* antigens (ESAT-6, CFP-10, and TB7.7). The QFT test measures whole blood concentrations of IFN- $\gamma$ , and the T-SPOT.TB test measures the number of lymphocytes/monocytes producing IFN- $\gamma$ . The test antigens are not present on *M. bovis*-BCG (vaccine) and *M. avium* complex, the major group of environmental mycobacteria, so one would expect higher specificity

**Table 261.3** Definitions of Positive Tuberculin Skin Test (TST) Results in Infants, Children, and Adolescents\*

**INDURATION  $\geq$ 5 MM**

Children in close contact with known or suspected contagious people with tuberculosis disease

Children suspected to have tuberculosis disease:

- Findings on chest radiograph consistent with active or previously tuberculosis disease
- Clinical evidence of tuberculosis disease<sup>†</sup>

Children receiving immunosuppressive therapy<sup>‡</sup> or with immunosuppressive conditions, including HIV infection

**INDURATION  $\geq$ 10 MM**

Children at increased risk of disseminated tuberculosis disease:

- Children <4 yr old
- Children with other medical conditions, including Hodgkin disease, lymphoma, diabetes mellitus, chronic renal failure, or malnutrition (see Table 261.2)

Children with increased exposure to tuberculosis disease:

- Children born in high-prevalence regions of the world
- Children often exposed to adults with HIV infection, homeless, users of illicit drugs, residents of nursing homes, incarcerated or institutionalized, or migrant farm workers
- Children who travel to high-prevalence regions of the world

**INDURATION  $\geq$ 15 MM**

Children  $\geq$ 4 yr old without any risk factors

\*These definitions apply regardless of previous BCG immunization; erythema at TST site does not indicate a positive test result. Tests should be read at 48–72 hr after placement.

<sup>†</sup>Evidence by physical examination or laboratory assessment that would include tuberculosis in the working differential diagnosis (e.g., meningitis).

<sup>‡</sup>Including immunosuppressive doses of corticosteroids or tumor necrosis factor- $\alpha$  antagonists.

BCG, Bacille Calmette-Guérin; HIV, human immunodeficiency virus.

From Kimberlin DW, Barnett ED, Lynfield R, Sawyer MH, eds. *Red Book: 2021–2024 Report of the Committee on Infectious Diseases*, 32nd ed. Itasca, IL: American Academy of Pediatrics; 2021:788.

compared with the TST and fewer false-positive results. Both IGRAs have internal positive and negative controls. Internal positive controls allow for detection of an anergic test response, which is useful in children who are young and immunocompromised. Indeterminate (QFT)/invalid (T-SPOT.TB) responses occur when the test sample is negative but the positive control has insufficient activity or if the negative control has high background activity. Indeterminate/invalid results are also caused by technical factors (e.g., insufficient shaking of QFT tubes, delayed processing time). Most studies report indeterminate or invalid rates in children of 0–10%, which is influenced by a child's age and immune status. In children <2 years old, indeterminate rates can be as high as 8.1% vs 2.7% in older children, although more recent studies generally report much lower rates. *An indeterminate or invalid IGRA result is neither negative nor positive and cannot be used to guide treatment decisions.*

Some IGRAs cannot differentiate between TBI and TB disease. If available, certain IGRA tests will test CD4 and CD8 T-cell reactivity, which may help differentiate latent from active disease. Two clear advantages of the IGRAs are the need for only one patient encounter (vs two with TST) and the lack of cross-reaction with BCG vaccination and most other mycobacteria, thereby increasing test specificity for TBI. Studies comparing IGRA and TST performance in children have shown comparable sensitivity (85% in culture-confirmed children) between the two tests and superior IGRA specificity (95% vs 49%) in BCG-immunized, low-risk children.

Neither the TST nor the IGRAs perform well in infants and young children who are malnourished, severely immunocompromised, or have disseminated TB disease. It is now standard to use an IGRA in the evaluation of healthy young children  $\geq$ 2 years of age, and most experts use IGRAs in younger children who are at low risk of TB infection, especially in those who have received a BCG vaccine. Both TST and



**Table 261.4** Recommendations for Use of Tuberculin Skin Test (TST) and Interferon- $\gamma$  Release Assay (IGRA) in Children

<p>TST preferred, IGRA acceptable:</p> <ul style="list-style-type: none"> <li>• Children &lt;2 yr of age*</li> </ul> <p>IGRA preferred, TST acceptable:</p> <ul style="list-style-type: none"> <li>• Children <math>\geq 2</math> yr of age who have received BCG vaccine</li> <li>• Children <math>\geq 2</math> yr of age who are unlikely to return for TST reading</li> </ul> <p>TST and IGRA should be considered when:</p> <ul style="list-style-type: none"> <li>• The initial and repeat IGRAs are indeterminate or invalid</li> <li>• The initial test (TST or IGRA) is negative and: <ul style="list-style-type: none"> <li>• Clinical suspicion for TB disease is moderate to high<sup>†</sup></li> <li>• The child has a TB risk factor and is at high risk of progression and poor outcome (especially therapy with an immunomodulating biologic agent, e.g., TNF-<math>\alpha</math> antagonist)<sup>†</sup></li> </ul> </li> <li>• The initial TST is positive and: <ul style="list-style-type: none"> <li>• <math>\geq 2</math> yr old and history of BCG vaccination</li> <li>• Additional evidence needed to increase adherence with therapy</li> </ul> </li> </ul>
---

\*Some experts do not use an IGRA for children younger than 2yr because of a relative lack of data for this age-group and the high risk of progression to disease.

<sup>†</sup>Positive result of either test is considered significant in these groups.

BCG, Bacille Calmette-Guérin; TB, tuberculosis, TNF, tumor necrosis factor.

Adapted from Starke JR, AAP Committee of Infectious Diseases. Interferon- $\gamma$  release assays for diagnosis of tuberculosis infection and disease in children. *Pediatrics*. 2014;134(6):e1763–1773.

IGRA testing should be considered in children whose initial TST or IGRA result is negative for whom the risk of TB is high (to enhance the sensitivity of the combination of the two tests).

Technical advantages of the IGRAs over the TST include the need for a single patient encounter (vs two spaced in time with the TST), the lack of cross-reaction with BCG vaccination and most environmental mycobacteria, and eliminating the need for experience in correctly interpreting the TST. IGRAs are also useful for those who are unlikely to return for TST interpretation, those whose family is reluctant to treat a child with TBI based on a TST result alone, and those with a positive TST result in whom NTM disease is suspected (Table 261.4).

Most studies have shown no consistent, significant difference between the two commercially available IGRAs, and the CDC recommends no preference. Because of cost constraints, the WHO does not endorse IGRA use in low- and middle-income countries, even in those with a high prevalence of tuberculosis.

## MYCOBACTERIAL SAMPLING, SUSCEPTIBILITY, AND CULTURE

The most specific confirmation of pulmonary TB is isolation of *M. tuberculosis* from a clinical sample. Sputum specimens for culture should be collected from adolescents and older children who are able to expectorate. Induced sputum with a jet nebulizer, inhaled saline, and chest percussion followed by nasopharyngeal suctioning is effective in children as young as 1 year. Sputum induction provides samples for both culture and acid-fast bacilli (AFB) staining. The traditional culture specimen in young children is the early morning gastric acid obtained before the child has arisen and peristalsis has emptied the stomach of the pooled respiratory secretions that have been swallowed overnight. However, even under optimal conditions, three consecutive morning gastric aspirates yield the organisms in <50% of cases. The culture yield from bronchoscopy is even lower, but this procedure can demonstrate the presence of endobronchial disease or a fistula. To improve the sensitivity of a diagnosis of TB in children, in high-burden TB settings, there is an increasing trend to collect nontraditional specimens, including stool, nasopharyngeal, and urine specimens. These specimens are easier to obtain than respiratory specimens but less sensitive in diagnosing TB in children compared to sputum or serial gastric aspirate specimens. Their diagnostic utility is increased when multiple specimens are collected in conjunction with traditional respiratory specimens. *Negative cultures never exclude the diagnosis of TB*

*in a child.* The presence of a positive TST or IGRA, an abnormal chest radiograph consistent with TB, and history of recent exposure to an adult with infectious TB is highly suggestive of the clinical diagnosis of TB disease. If a likely adult source case has been identified, drug susceptibility test results of the isolate from the adult source usually can be used to determine the best therapeutic regimen for the child, except in very high-incidence areas, where the apparent source case might not be the actual one. Cultures should be always obtained from the child whenever the source case is unknown, there are multiple possible source cases, or the source case has possible or confirmed drug-resistant TB.

Confirmation of extrapulmonary TB is best achieved with a positive culture or PCR testing. However, for many forms of TB, the culture yield is only 25–50%, and probable diagnosis is by a combination of clinical signs and symptoms, analysis of body fluids when possible, radiographic or histopathologic evidence of TB, PCR testing, and elimination of other possible diagnoses.

## Nucleic Acid Amplification Tests

The main NAAT studied in children with TB is PCR, which uses specific DNA sequences as markers for microorganisms. Compared with a clinical diagnosis of pulmonary TB in children, the sensitivity of PCR has varied from 25% to 83%, and specificity has varied from 80% to 100%. A negative PCR result never eliminates the diagnosis of TB, and the diagnosis is not confirmed by a positive PCR result.

NAAT identifies genes associated with drug resistance and is used to supplement culture-based (phenotypic) methods for drug susceptibility testing. It also decreases the time to identification of drug resistance from weeks to hours, which expedites the initiation of optimal therapy. Culture-based, phenotypic, drug susceptibility testing is necessary to confirm susceptibility to each drug; the absence of resistance genes is not always predictive of drug susceptibility. The interpretation of molecular-based drug susceptibility testing is constantly evolving, and an expert in the management of pediatric TB should be involved when drug resistance is suspected.

**Gene Xpert MTB/RIF** cartridge and Xpert MTB Ultra cartridge (Xpert; Cepheid, Sunnyvale, CA) are real-time PCR assays for *M. tuberculosis* that simultaneously detect **rifampin resistance**, which is often used as a proxy for MDR-TB. These assays use a self-contained cartridge system, which yields results from direct specimens in 2 hours and is less operator dependent than traditional PCR detection methods. Sensitivity and specificity of Xpert MTB/RIF have averaged 72–77% and 99% in AFB sputum smear–negative adults and 98–99% and 99–100% in AFB sputum smear–positive adults, respectively. Pediatric studies reveal that, compared to culture, the sensitivity and specificity of Xpert MTB/RIF is 62% and 98% on induced or expectorated sputa and 66% and 98% on gastric aspirates, respectively. For other specimen types (nasopharyngeal aspirate and stool), Xpert MTB/RIF pooled sensitivity for pulmonary TB ranges between 46% and 73% with a pooled specificity of 98% and 100%. Compared with smear microscopy, Xpert improved the sensitivity of detecting pediatric TB cases by 36–44%. For lymph node aspirates or biopsies, Xpert MTB/RIF compared with culture had a sensitivity and specificity of 90%. Compared to culture, Xpert MTB/RIF's sensitivity and specificity to detect rifampin resistance in respiratory specimens collected from children with suspected pulmonary TB are 86% and 98%, respectively.

**Xpert Ultra** is a next-generation assay that has enhanced performance in children who often have paucibacillary or smear-negative TB. The pooled sensitivity of Ultra for detection of *M. tuberculosis* was 73% in sputum samples, 64% in gastric aspirate samples, 53% in stool specimens, and 46% in nasopharyngeal samples. The pooled specificity was 98% in sputum samples, 98% in nasopharyngeal aspirate specimens, 98% in stool samples, and 95% in gastric aspirate samples. The WHO recommends use of Xpert Ultra in sputum and nasopharyngeal specimens collected from children for the diagnosis of TB and rifampin resistance, in addition to the use of Xpert MTB/RIF in sputum, gastric aspirate, nasopharyngeal aspirate, and stool specimens. Although cartridges for the Xpert systems are expensive, they offer advantages in rapid detection of MDR-TB and are especially useful in settings lacking

laboratory infrastructure. In many low-resource settings, Xpert has replaced smear microscopy; however, it has not replaced mycobacterial cultures and drug susceptibility studies.

## TREATMENT

The basic principles of management of TB disease in children and adolescents are the same as in adults. Several drugs are used to effect a relatively rapid cure and prevent the emergence of secondary drug resistance during therapy (Tables 261.5 to 261.8). The choice of regimen depends on the extent of TB disease, the host, and the likelihood of drug resistance (see Chapter 260, Table 260.1). As recommended by the WHO and AAP, the standard therapy of intrathoracic, presumed or confirmed drug-susceptible TB (pulmonary disease and/or hilar lymphadenopathy) in children is a 4- to 6-month regimen of multidrug therapy. The initial treatment regimen includes isoniazid, rifampin, pyrazinamide, and ethambutol. The ethambutol can be discontinued once the organism is known to be susceptible to the other first-line drugs. Pyrazinamide is

discontinued after 2 months, and isoniazid and rifampin are continued for an additional 2-4 months. Several clinical trials have shown that a 6-month regimen yields a success rate approaching 100%, with an incidence of clinically significant adverse reactions of <2%. Data from the SHINE trial (Shorter Treatment for Minimal Tuberculosis in Children) found that a 4-month treatment regimen in children age 0-16 years ( $\geq 3$  kg) with nonsevere, smear negative, presumed drug-susceptible TB was noninferior to a 6-month course. Based on the results of this trial, the WHO supports the use of a 4-month treatment regimen in eligible children. Most experts recommend that all drug administration be either directly observed or electronically observed, meaning that a healthcare worker watches when the medications are administered to/or taken by the patients. When in-person **directly observed therapy (DOT)** or video directly observed therapy (VDOT) is used, intermittent (twice or thrice weekly) administration of drugs after an initial period as short as 2 weeks of daily therapy is as effective for drug-susceptible TB in children as daily therapy for the entire course.

Table 261.5		Dosage Recommendations for the Treatment of TB in Adults and Children <sup>1</sup>				
DOSE IN MG/KG (MAXIMUM DOSAGE IN PARENTHESES)						
DRUG	ADULTS/CHILDREN <sup>2</sup>		DAILY	1 TIME/WK <sup>3</sup>	2 TIMES/WK <sup>3</sup>	3 TIMES/WK <sup>3</sup>
Isoniazid	Adults		5 mg/kg (300 mg)	15 mg/kg (900 mg)	15 mg/kg (900 mg)	15 mg/kg (900 mg)
	Children		10–15 mg/kg (300 mg)	—	20–30 mg/kg (900 mg)	—
Rifampin	Adults		10 mg/kg (600 mg)	—	10 mg/kg (600 mg)	10 mg/kg (600 mg)
	Children		10–20 mg/kg (600 mg)	—	—	10–20 mg/kg (600 mg)
Rifabutin	Adults		5 mg/kg (300 mg)	—	5 mg/kg (300 mg)	5 mg/kg (300 mg)
	Children $\geq 12$ yr		Appropriate dosing for children unknown			
Rifapentine	Adults		—	10 mg/kg (600 mg; continuation phase)	—	—
	Children		—			
Pyrazinamide	Adults (weight)	40–55 kg	18.2–25 mg/kg (1000 mg)	—	36.4–50 mg/kg (2000 mg)	27.3–37.5 mg/kg (1500 mg)
		56–75 kg	20–26.8 mg/kg (1500 mg)	—	40–53.6 mg/kg (3000 mg)	33.3–44.6 (2500 mg)
		76–90 kg	22.2–26.3 mg/kg (2000 mg)	—	44.4–52.6 mg/kg (4000 mg)	33.3–39.5 mg/kg (3000 mg)
	Children <40 kg		30–40 mg/kg (2000 mg)	—	—	50 mg/kg (2000 mg)
Ethambutol <sup>4</sup>	Adults (weight)	40–55 kg	14.5–20 mg/kg (800 mg)	—	36.4–50 mg/kg (2000 mg)	21.8–30 mg/kg (1200 mg)
		56–75 kg	16–21.4 mg/kg (1200 mg)	—	37.3–50 mg/kg (2800 mg)	26.7–35.7 mg/kg (2000 mg)
		76–90 kg	17.8–21.1 mg/kg (1600 mg)	—	44.4–52.6 mg/kg (4000 mg)	26.7–31.6 mg/kg (2400 mg)
	Children		15–20 mg/kg (1000 mg)	—	50 mg/kg (2500 mg)	—

<sup>1</sup>Although these regimens are broadly applicable, modifications may be needed for certain circumstances (patients on antiretroviral therapy [ART]). For more information, refer to treatment of tuberculosis guidelines. *MMWR* 2003; 52 (No. RR-11).

<sup>2</sup>For purposes of this document, adult dosing begins at age 15 years. Children weighing more than 40 kg should be dosed as adults. Adjust doses as the patient's weight changes.

<sup>3</sup>All patients prescribed an intermittent regimen should be given DOT.

<sup>4</sup>Ethambutol should be used with caution in young children since it is difficult to monitor their vision. However, if they have TB that is resistant to INH or RIF, a dose of 15 mg/kg per day can be used.

From Centers for Disease Control and Prevention. *Core Curriculum on Tuberculosis: What the Clinician Should Know*, 7<sup>th</sup> ed. Atlanta: CDC, 2021. Table 6.4. <https://www.cdc.gov/tb/education/corecurr/pdf/chapter6.pdf>

CAUSED BY	ADVERSE REACTION	SIGNS AND SYMPTOMS	SIGNIFICANCE OF REACTION*
Any drug	Allergic	<ul style="list-style-type: none"> <li>• Skin rash</li> </ul>	May be serious or minor
Ethambutol	Eye damage	<ul style="list-style-type: none"> <li>• Blurred or changed vision</li> <li>• Changed color vision</li> </ul>	Serious
Isoniazid Pyrazinamide Rifampin	Hepatic toxicity	<ul style="list-style-type: none"> <li>• Abdominal pain</li> <li>• Abnormal liver function test results</li> <li>• Dark urine</li> <li>• Fatigue</li> <li>• Fever for 3 or more days</li> <li>• Flulike symptoms</li> <li>• Lack of appetite</li> <li>• Nausea</li> <li>• Vomiting</li> <li>• Yellowish skin or eyes</li> </ul>	Serious
Isoniazid	Nervous system damage	<ul style="list-style-type: none"> <li>• Dizziness; tingling or numbness around the mouth</li> </ul>	Serious
	Peripheral neuropathy	<ul style="list-style-type: none"> <li>• Tingling sensation in hands and feet</li> </ul>	Serious
Pyrazinamide	Stomach upset	<ul style="list-style-type: none"> <li>• Stomach upset</li> <li>• Vomiting</li> <li>• Lack of appetite</li> </ul>	May be serious or minor
	Gout	<ul style="list-style-type: none"> <li>• Abnormal uric acid level**</li> <li>• Joint aches</li> </ul>	Serious
Rifampin	Bleeding problems	<ul style="list-style-type: none"> <li>• Easy bruising</li> <li>• Slow blood clotting</li> </ul>	Serious
	Discoloration of body fluids	<ul style="list-style-type: none"> <li>• Orange urine, sweat, or tears</li> <li>• Permanently stained soft contact lenses</li> </ul>	Minor
	Drug interactions	<ul style="list-style-type: none"> <li>• Interferes with certain medications such as birth control pills, birth control implants, and methadone treatment</li> </ul>	May be serious or minor
	Sensitivity to the sun	<ul style="list-style-type: none"> <li>• Frequent sunburn</li> </ul>	Minor

\*Patients should stop medication for serious adverse reactions and consult a clinician immediately. Patients can continue taking medication if they have minor adverse reactions.

\*\*Asymptomatic elevated uric acid levels are expected with PZA treatment. Acute gouty arthritis, which is rare without preexisting gout, is a contraindication to PZA use.

EMB, ethambutol; INH, isoniazid; PZA, pyrazinamide; RIF, rifampin.

From Centers for Disease Control and Prevention. *Core Curriculum on Tuberculosis: What the Clinician Should Know*, 7<sup>th</sup> ed. Atlanta: CDC, 2021. Table 6.11. <https://www.cdc.gov/tb/education/corecurr/pdf/chapter6.pdf>

DRUGS	DOSAGE FORMS AND AGE GROUP	ADMINISTRATION	DURATION (MO)	AGE RESTRICTION	COMMENTS
Isoniazid + Rifapentine (3HP)	Age ≥12 yr INH: 15 mg/kg rounded up to the nearest 50 or 100 mg (max 900 mg) Rifapentine (by weight): 10-14 kg: 300 mg 14.1-25 kg: 450 mg 25.1-32 kg: 600 mg 32.1-49.9 kg: 750 mg ≥50 kg: 900 mg Age 2-11 yr INH: 25 mg/kg, rounded up to the nearest 50 or 100 mg (max 900 mg) Rifapentine (see above)	Weekly (DOT)	3	Not for children <2 yr	Take with food, containing fat if possible, pyridoxine for selected patients RFP has drug-drug interactions
Rifampin (4R)	Adult: 10 mg/kg (max 600 mg) Child: 15-20 mg/kg (max 600 mg)	Daily (SAT)	4	None	Drug-drug interactions
INH + Rifampin	Same daily doses as when the drugs are used individually	Daily (SAT)	3	None	RIF has drug-drug interactions
INH	Adult: 5 mg/kg (max 300 mg) Child 10-15 mg/kg (max 300 mg) Adult: 15 mg/kg (max 900 mg) Child: 20-30 mg/kg (max 900 mg)	Daily (SAT) Twice weekly (DOT)	6 or 9	None	Seizures with overdose; pyridoxine for selected patients*

\*Exclusively breastfed infants and for children and adolescents on meat- and milk-deficient diets; children with nutritional deficiencies, including all asymptomatic children living with HIV infection; and pregnant adolescents and women.

From Kimberlin DW, Barnett ED, Lynfield R, Sawyer MH, eds. *Red Book: 2021–2024 Report of the Committee on Infectious Diseases*, 32nd ed. Itasca, IL: American Academy of Pediatrics; 2021:805–806; and Nolt D, Starke JR. Tuberculosis infection in children and adolescents: testing and treatment. *Pediatrics*. 2021;148(6):e2021054663.

**Table 261.8** Drug Grouping for the Treatment of MDR-TB

GROUP	INSTRUCTIONS	DRUG
Group A	Include all three drugs (unless they cannot be used), add delamanid if age >3 yr	Levofloxacin OR moxifloxacin Bedaquiline Linezolid
Group B	Add both drugs (unless they cannot be used)	Clofazimine Cycloserine or terizidone
Group C	Add to complete regimen (of four to five agents) Add when drugs from groups A or B cannot be used	Ethambutol Delamanid Pyrazinamide Imipenem-cilastatin Meropenem Amikacin OR streptomycin Ethionamide OR prothionamide p-Aminosalicylic acid

**Extrapulmonary tuberculosis** is usually caused by small numbers of mycobacteria. In general, the treatment for most forms of extrapulmonary TB in children, including cervical lymphadenopathy, is the same as for pulmonary TB. *Exceptions are bone and joint, disseminated, and CNS TB, for which there are inadequate data to recommend 6 months of therapy; these conditions are usually treated for 9-12 months.* Surgical debridement in bone and joint disease and ventriculoperitoneal shunting in CNS disease may be necessary adjuncts to medical therapy.

The optimal treatment of TB in children living with HIV has not been established. Adults living with HIV with TB disease can be treated successfully with standard regimens that include isoniazid, rifampin, pyrazinamide, and ethambutol. The total duration of therapy should be 6-9 months or 6 months after culture of sputum becomes sterile, whichever is longer. Data for children are limited to relatively small series. *Most experts believe that children living with inadequately controlled HIV who have drug-susceptible TB should receive the standard four-drug regimen for the first 2 months followed by isoniazid and rifampin for a total duration of at least 9 months. However, all treatment should be daily, not intermittent.* Children living with HIV appear to have more frequent adverse reactions to antituberculosis drugs and must be monitored closely during therapy. Co-administration of rifampin and some antiretroviral agents results in subtherapeutic blood levels of protease inhibitors and nonnucleoside reverse transcriptase inhibitors and toxic levels of rifampin. Concomitant administration of these drugs is not recommended. Treatment of children living with HIV with TB is often empirically based on epidemiologic and radiographic information because the radiographic appearance of other pulmonary complications of HIV in children, such as lymphoid interstitial pneumonitis and bacterial pneumonia, may be similar to that of TB. Therapy should be considered when TB cannot be excluded.

### Drug-Resistant Tuberculosis

The incidence of drug-resistant TB is increasing in many areas of the world, including North America. There are two major types of drug resistance. **Primary resistance** occurs when a person is infected with *M. tuberculosis* that is already resistant to a particular drug. **Secondary resistance** occurs when drug-resistant organisms emerge as the dominant population during treatment. The major causes of secondary drug resistance are poor adherence to the medication by the patient or inadequate treatment regimens prescribed by the physician. Nonadherence to one drug is more likely to lead to secondary resistance than is failure to take all drugs. Secondary resistance is rare in children because of the small size of their mycobacterial population. Consequently, most drug resistance in children is primary, and patterns of drug resistance among children tend to mirror those found among adults in the same population. The main predictors of drug-resistant TB among adults are history of previous antituberculosis treatment, co-infection with HIV, and exposure to another adult with infectious drug-resistant TB.

*Treatment of drug-resistant TB is successful only when at least two bactericidal drugs are given to which the infecting strain of *M. tuberculosis* is susceptible.* When a child has possible drug-resistant TB, usually at least four or five drugs should be administered initially until the susceptibility pattern is determined and a more specific regimen can be designed. The specific treatment plan must be individualized for each patient according to the results of susceptibility testing on the isolates from the child or the adult source case. Treatment duration of 9 months with rifampin, pyrazinamide, and ethambutol is usually adequate for isoniazid-resistant TB in children. High-dose isoniazid is often added in those with low-level isoniazid-resistant TB. The recommendations for the treatment of MDR-TB have rapidly evolved in recent years. In 2019, the WHO advocated for the use of all-oral (injectable-free) regimens and reprioritized the order of the available oral drugs (Tables 261.8 and 261.9). Treatment regimens should prioritize administering group A and B drugs in addition to delamanid for children older than 3 years of age. Bedaquiline can be used in those older than 6 years of age. First-line treatment includes an all-oral regimen using three group A drugs and at least one group B drug. If only one or two group A medications are used, then group B drugs should be added to make a regimen of four drugs. Group C drugs are only used if the isolate is susceptible and when drugs from groups A and B cannot be used. The WHO recommends treatment of those with severe MDR-TB disease for 12-18 months; however, in children younger than 15 years with less severe MDR-TB disease, the treatment duration can be shortened to 9-12 months. The WHO defines severe MDR-TB disease as children with cavities or bilateral parenchymal disease on chest radiography or extrapulmonary forms of disease other than lymphadenopathy. Those with severe malnutrition; advanced immunosuppression; or positive smear, NAAT, or culture are also often treated with a longer course of therapy.

The second-line drugs require close monitoring for adverse effects and toxicity (see Table 261.9). The prognosis of single-drug-resistant or MDR-TB in children with nonsevere disease is good if the drug resistance is identified early in the treatment, if appropriate drugs are administered under DOT, if adverse reactions from the drugs are minor, and if the child and family are in a supportive environment. The treatment of drug-resistant TB in children always should be undertaken by a clinician with specific expertise in TB treatment.

### Corticosteroids

Corticosteroids are useful in treating some children with TB disease. They are most beneficial when the host inflammatory reaction contributes significantly to tissue damage or impairment of organ function. There is convincing evidence that corticosteroids decrease mortality rates and long-term neurologic sequelae in some patients with **tuberculous meningitis** by reducing vasculitis, inflammation, and ultimately intracranial pressure. Lowering the intracranial pressure limits tissue damage and favors circulation of antituberculosis drugs through



**Table 261.9** Drugs Used for Treating Drug-Resistant Tuberculosis in Infants, Children, and Adolescents\*

DRUGS	DOSAGE, FORMS	DAILY DOSAGE (mg/kg)	MAXIMUM DOSE	ADVERSE REACTIONS
Amikacin <sup>†</sup>	Vials: 500 mg, 1 g	15-20 (IV or IM administration)	1 g	Auditory and vestibular toxic effects, nephrotoxic effects
Amoxicillin-clavulanate	(Strength expressed in terms of amoxicillin component) Syrup: 50 mg/mL 80 mg/mL 120 mg/mL (ES 600) Tablets: 500 mg 875 mg 1000 mg (XR tablet)	40 (amoxicillin component), twice daily	4 g (amoxicillin) 500 mg (clavulanate)	Abdominal pain, diarrhea, rash
Bedaquiline	Tablets: 20 mg, 100 mg	Adults and children ≥5 yr, 15 to <30 kg weeks 1-2: 200 mg/day; weeks 3-24: 100 mg 3x/week > 30 kg weeks 1-2: 400 mg/day; weeks 3-24: 200 mg 3x/week	600 mg/week	QTc prolongation, reduced levels with efavirenz co-administration
Clofazimine	Gelcaps: 50 mg 100 mg	2-5 per day	100 mg	QTc prolongation, reversible skin pigmentation
Cycloserine or terizidone	Capsules: 250 mg	10-20, given in 2 divided doses	1 g	Psychosis, personality changes, seizures, rash
Delamanid	Tablets: 50 mg 100 mg	6-11 years: 50 mg 2x/day 12-17 years: 100 mg 2x/day	100 mg/dose	QTc prolongation, adverse events with hypoalbuminemia, avoid if metronidazole allergic
Ethambutol	Tablets: 100 mg 400 mg	Children <40 kg: 15-25 Children ≥40 kg: 40-55 kg: 800 mg/day PO 56-75 kg: 1200 mg/day PO 76-90 kg: 1600 mg/day PO	2.5 g	Optic neuritis (usually reversible), decreased red-green color discrimination, gastrointestinal tract disturbances, hypersensitivity
Ethionamide	Tablets: 125 mg 250 mg	15-20, given in 1-2 divided doses	1 g	GI tract disturbances, hepatotoxic effects, hypersensitivity reactions, hypothyroidism
Imipenem-cilastatin		60-100 per day, divided in 4 doses	4 g	Anemia, thrombocytopenia, eosinophilia, elevated liver enzymes
Levofloxacin	Tablets: 250 mg 500 mg 750 mg Oral solution: 25/mL Vials: 25 mg/mL	Adults: 750-1000 mg (daily) Children: 15-20 mg/kg daily	1 g	Theoretic effect on growing cartilage, joint pain, GI tract disturbances, rash, headache, restlessness, confusion
Linezolid	Tablets: 400 mg 600 mg Syrup: 20 mg/mL	Children <16 kg: 15 mg/kg once daily Children >16 kg: 10-12 mg/kg/day once daily	600 mg if ≥12 yr 300 mg if <12 yr	Bone marrow suppression, peripheral neuropathy, lactic acidosis, potential overlapping toxicity with nucleoside reverse transcriptase inhibitors
Moxifloxacin	Tablets: 400 mg IV solution: 400 mg/250 mL in 0.8% saline	Adults/adolescents: 400 mg Children: 10-15 mg/kg daily	400 mg; maximum doses of 600-800 mg per day are used for higher MIC or in malabsorption	Arthropathy, arthritis
p-Aminosalicylic acid (PAS)	Packets: 3 g	200-300 (2-4 times a day)	10 g	GI tract disturbances, hypersensitivity, hepatotoxic effects
Prothionamide	Tablets: 250 mg 500 mg	15-20 (divided twice daily)	1 g	GI tract disturbances, hepatotoxic effects, hypersensitivity reactions, hypothyroidism

**Table 261.9** Drugs Used for Treating Drug-Resistant Tuberculosis in Infants, Children, and Adolescents\*—cont'd

DRUGS	DOSAGE, FORMS	DAILY DOSAGE (mg/kg)	MAXIMUM DOSE	ADVERSE REACTIONS
Pyrazinamide	Scored tablets: 500 mg	30-40	2 g	Hepatotoxic effects, hyperuricemia, arthralgias, gastrointestinal tract upset
Streptomycin <sup>†</sup>	Vials: 1 g 4 g	20-40 (IM administration)	1 g	Auditory and vestibular toxic effects, nephrotoxic effects, rash

\*These drugs should be used in consultation with a specialist in tuberculosis.

<sup>†</sup>Dose adjustment in renal insufficiency.

GI, Gastrointestinal; IM, intramuscular; IV, intravenous.

From Kimberlin DW, Barnett ED, Lynfield R, Sawyer MH, eds. *Red Book: 2021–2024 Report of the Committee on Infectious Diseases*, 32nd ed. Itasca, IL: American Academy of Pediatrics; 2021:805–806; and Furin J, Seddon J, Becerra M, et al. *Management of Multi-drug-Resistant Tuberculosis Children: A Field Guide*, 4th ed. Boston: The Sentinel Project for Pediatric Drug-Resistant Tuberculosis; 2019. Available at: [http://sentinel-project.org/wp-content/uploads/2019/02/Updated\\_DRTB-Field-Guide-2019-V3.pdf](http://sentinel-project.org/wp-content/uploads/2019/02/Updated_DRTB-Field-Guide-2019-V3.pdf)

the brain and meninges. Short courses of corticosteroids also may be effective for children with **endobronchial tuberculosis** that causes respiratory distress, localized emphysema, or segmental pulmonary lesions. Several randomized clinical trials have shown that corticosteroids can help relieve symptoms and constriction associated with acute tuberculous **pericardial effusion**. Corticosteroids can cause dramatic improvement in symptoms in some patients with tuberculous pleural effusion and shift of the mediastinum. However, the long-term course of the disease is probably unaffected. Some children with severe **miliary tuberculosis** have dramatic improvement with corticosteroid therapy if the inflammatory reaction is so severe that alveolocapillary block is present. There is no convincing evidence to support a specific corticosteroid preparation. The most common regimen is **prednisone** 1-2 mg/kg/day in one to two divided doses orally for 4-6 weeks followed by a taper.

### Supportive Care

Children receiving TB treatment should be followed carefully to promote **adherence** to therapy, to monitor for toxic reactions to medications, and to ensure that the TB is being adequately treated. Adequate **nutrition** is important. Patients should be seen at monthly intervals and should be given just enough medication to last until the next visit. **Anticipatory guidance** with regard to the administration of medications to children is crucial. The physician should foresee difficulties that the family might have in introducing several new medications in inconvenient dosage forms to a young child. The clinician must report all cases of suspected TB in a child to the local health department to be sure that the child and family receive appropriate care and evaluation.

**Nonadherence** to TB treatment is the major problem. The patient and family must know what is expected of them through verbal and written instructions in their primary language. Approximately 30–50% of patients taking long-term treatment are significantly nonadherent with self-administered medications, and clinicians are usually not able to determine in advance which patients will be nonadherent. Preferably, DOT should be instituted by the local health department.

### *Mycobacterium tuberculosis* Infection

The following aspects of the natural history and treatment of TBI, often referred to as *latent TB infection*, in children must be considered in the formulation of recommendations about therapy:

1. Infants and children <5 years old with TBI who have been infected recently.
2. The risk for progression to disease is high.
3. Untreated infants with TBI have up to a 40% chance of development of TB disease.
4. The risk for progression decreases gradually through childhood until adolescence, when the risk increases.
5. Infants and young children are more likely to have life-threatening forms of TB, including meningitis and disseminated disease.
6. Children with TBI have more years at risk for development of disease than adults.

Because of these factors and the excellent safety profile of isoniazid, rifampin, and rifapentine in children, there is a tendency to err on the side of overtreatment in infants, young children, and adolescents.

The main TBI treatment regimens used in children are summarized in **Table 261.7**. The regimens include 6-9 months of **isoniazid** (daily or twice weekly by DOT), 3 months of daily **rifampin** and isoniazid, 4 months of daily rifampin, and once-weekly isoniazid and **rifapentine** (3HP) for 12 total doses. Because of improved treatment completion rates and noninferiority, the rifamycin-based, shorter treatment regimens are often favored over isoniazid monotherapy. The main indication for the use of isoniazid is if the child is at risk of drug-drug interactions with rifamycins.

Isoniazid therapy for TBI appears to be more effective for children than for adults, with several large clinical trials demonstrating a risk reduction of 70–90%. The risk of isoniazid-related hepatitis is minimal in infants, children, and adolescents, who tolerate the drug better than adults. Analysis of data from several studies demonstrates that the efficacy decreased significantly if isoniazid was taken for <9 months. However, the international standard is 6 months of treatment with isoniazid because of resource considerations. Isoniazid given twice weekly has been used extensively to treat TBI in children, especially schoolchildren and close contacts of case patients. DOT or VDOT should be considered when it is unlikely that the child and family will adhere to daily self-administration or if the child is at increased risk for rapid development of disease (newborns and infants, recent contacts, immunocompromised children). For healthy children taking isoniazid but no other potentially hepatotoxic drugs, routine biochemical monitoring and supplementation with pyridoxine are not necessary. Rifampin alone for 4 months is now frequently used for the treatment of TBI in infants, children, and adolescents. This regimen is most often used when a shorter, self-administered treatment regimen is preferred, when isoniazid cannot be tolerated, or the child has had contact with a source case infected with an isoniazid-resistant but rifamycin-susceptible organism. If a child is identified with TBI during a contact investigation or if the cost of rifampin is prohibitive for families, administration of the medication through VDOT programs offered by health departments should be considered. Rifapentine is a rifamycin with a very long half-life, allowing for weekly administration in conjunction with high-dose isoniazid. Studies have demonstrated that 12 doses of once-weekly isoniazid and rifapentine (3HP) are as effective for treating TBI and as safe as 9 months of daily isoniazid in children as young as 2 years. This is becoming the preferred regimen for the treatment of TBI in age-eligible children who are exposed to a contact with presumed pan-susceptible TB. Given the risk of selecting for drug-resistant isolates by missing intermittent doses of rifamycins, this treatment regimen currently is recommended only with DOT under the supervision of local health departments. The main reason children or adolescents are unable to complete this regimen is the inability to crush the tablets and the high pill burden. In these situations, the children are often transitioned to an alternative treatment regimen. A 3-month daily regimen of rifampin and isoniazid has been used throughout

Europe. Although this regimen has not been used regularly in the United States, experts believe it is favorable in children less than 5 years of age in whom the pill burden of 3HP is difficult. Studies have revealed that the shorter treatment regimens for TBI in children are equally efficacious as 9 months of isoniazid and are associated with superior treatment completion rates.

For children with MDR-TB, the regimen will depend on the drug-susceptibility profile of the contract case's organism; an expert in TB should be consulted. There are data that support the use of levofloxacin or moxifloxacin for treatment of MDR-TBI.

Few controlled studies have been published regarding the efficacy of any form of treatment for TBI in children living with HIV. A 9-month course of daily isoniazid is recommended. Most experts recommend that routine monitoring of serum hepatic enzyme concentrations be performed and pyridoxine be given when children living with HIV are treated with isoniazid. The optimal duration of rifampin therapy in children living with HIV with TBI is not known, but many experts recommend at least a 6-month course.

*Isoniazid or rifampin should be given to children <5 years old who have a negative TST or IGRA result but who have a known recent exposure to an adult with potentially contagious TB disease.* This practice is often referred to as **window prophylaxis**. By the time delayed hypersensitivity develops (2-3 months), an untreated child already may have developed severe TB. For these children, TST or IGRA is repeated 8-10 weeks after contact with the source case for TB has been broken (*broken contact* is defined as physical separation or adequate initial treatment of the source case). If the second test result is positive, the child should complete a treatment course for TBI (either 9 months of isoniazid or 4 months of rifampin). There is a benefit to using rifampin over isoniazid for window prophylaxis (unless contraindicated because of drug-drug interactions or prohibitive because of cost). By the time of the second test result (8-10 weeks later), if positive, the child receiving rifampin has approximately 2 months of therapy to complete compared to 7 months of isoniazid. Alternatively, if a new, shorter TBI treatment course is started after the second test result becomes positive (either 4 months of rifampin [if isoniazid was given as window prophylaxis], 12 weekly doses of isoniazid and rifampin, or 3 months of isoniazid and rifampin), the treatment start date is day 1 of the new regimen. If the second test result is negative, TBI treatment can be stopped.

## PREVENTION

The highest priority of any TB control program should be case finding and treatment, which interrupt transmission of infection between close contacts. All children and adults with symptoms suggestive of TB disease and those in close contact with an adult with suspected infectious pulmonary TB should be tested for TBI (by TST or IGRA) and examined as soon as possible. On average, 30–50% of household contacts to infectious cases are also infected, and 1% of contacts already have overt disease. This scheme relies on effective and adequate public health response and resources. Children, particularly young infants, should receive high priority during contact investigations because their risk for infection is high and they are more likely to rapidly develop severe forms of TB.

Mass testing of large groups of children for TBI is an inefficient process. When large groups of children at low risk for TB are tested, the vast majority of TST reactions are actually false-positive reactions because of biologic variability or cross-sensitization with NTM. However, testing of high-risk groups of adults or children should be encouraged because most of these persons with positive TST or IGRA results have TBI. Testing should take place only if effective mechanisms are in place to ensure adequate evaluation, follow-up, and treatment of the persons who test positive.

## Bacille Calmette-Guérin Vaccination

The only available vaccine against TB is the BCG vaccine. The original vaccine organism was a strain of *M. bovis* attenuated by subculture every 3 weeks for 13 years. This strain was distributed to dozens

of laboratories that continued to subculture the organism on different media under various conditions. The result has been production of many BCG vaccines that differ widely in morphology, growth characteristics, sensitizing potency, and animal virulence.

The administration route and dosing schedule for the BCG vaccines are important variables for efficacy. The preferred route of administration is intradermal injection with a syringe and needle because it is the only method that permits accurate measurement of an individual dose.

The BCG vaccines are extremely safe in immunocompetent hosts. Local ulceration and regional suppurative adenitis occur in 0.1–1% of vaccine recipients. Local lesions do not suggest underlying host immune defects and do not affect the level of protection afforded by the vaccine. Most reactions are mild and usually resolve spontaneously, but chemotherapy is needed occasionally. Surgical excision of a suppurative draining node is rarely necessary and should be avoided if possible. **Osteitis** is a rare complication of BCG vaccination that appears to be related to certain strains of the vaccine that are no longer in wide use. Systemic complaints such as fever, convulsions, loss of appetite, and irritability are extraordinarily rare after BCG vaccination. Profoundly immunocompromised patients can develop disseminated BCG infection after vaccination. Children living with HIV appear to have rates of local adverse reactions to BCG vaccines that are comparable with rates in immunocompetent children. However, the incidence in these children of disseminated infection months to years after vaccination is currently unknown.

Recommended vaccine schedules vary widely among countries. The official WHO recommendation is a single dose administered during infancy in populations where the risk for TB is high. However, *infants with known or suspected HIV infection should not receive a BCG vaccination*. In some countries, repeat vaccination is universal, although no clinical trials support this practice. In others, it is based on either TST or the absence of a typical scar. The optimal age for BCG administration and dosing schedule are unknown because adequate comparative trials have not been performed.

Although dozens of BCG trials have been reported in various human populations, the most useful data have come from several controlled trials. The results of these studies have been disparate. Some demonstrated substantial protection from BCG vaccines, but others showed no efficacy at all. A meta-analysis of published BCG vaccination trials suggested that BCG is 50% effective in preventing pulmonary TB in adults and children. The protective effect for disseminated and meningeal TB appears to be slightly higher, with BCG preventing 50–80% of cases. A variety of explanations for the varied responses to BCG vaccines have been proposed, including methodologic and statistical variations within the trials, interaction with NTM that either enhances or decreases the protection afforded by BCG, different potencies among the various BCG vaccines, and genetic factors for BCG response within the study populations. BCG vaccination administered during infancy has little effect on the ultimate incidence of TB in adults, suggesting waning protection with time.

BCG vaccination has worked well in some situations but poorly in others. Clearly, BCG vaccination has had little effect on the ultimate control of TB throughout the world, because >5 billion doses have been administered, but TB remains epidemic in most regions. BCG vaccination does not substantially influence the chain of transmission, because cases of contagious pulmonary TB in adults that can be prevented by BCG vaccination constitute a small fraction of the sources of infection in a population. The best use of BCG vaccination is to prevent life-threatening forms of TB in infants and young children.

BCG vaccination has never been adopted as part of the strategy for TB control in the United States. Widespread use of the vaccine would render subsequent TSTs less useful. However, BCG vaccination can contribute to TB control in select population groups. BCG is recommended for TST-negative, HIV-negative infants and children who are at high risk for intimate and prolonged exposure to persistently untreated or ineffectively treated adults with infectious

pulmonary TB and who cannot be removed from the source of infection or placed on long-term preventive therapy. It also is recommended for those who are continuously exposed to persons with TB who have bacilli that are resistant to isoniazid and rifampin. Any child receiving BCG vaccination should have a documented negative TST before receiving the vaccine. After receiving the vaccine, the child should be separated from the possible sources of infection until it can be demonstrated that the child has had a vaccine response, as evidenced by tuberculin reactivity, which usually develops within 1-3 months.

### Prevention of Perinatal Tuberculosis

The most effective way of preventing TB infection and disease in the neonate or young infant is through appropriate testing and treatment of the mother and other family members. High-risk pregnant women should be tested with TST or IGRA, and those with a positive test result should receive a chest radiograph with appropriate abdominal shielding. If the mother has a negative chest radiograph and is clinically well, no separation of the infant and mother is needed after delivery. The child needs no special evaluation or treatment if the child remains asymptomatic. Other household members should undergo testing for TBI and further evaluation as indicated.

If the mother has suspected TB at the time of delivery, the newborn should be separated from the mother until the chest radiograph is obtained. If the mother's chest radiograph is abnormal, separation should be maintained until the mother has been evaluated thoroughly, including examination of the sputum. If the mother's chest radiograph is abnormal but the history, physical examination, sputum examination, and evaluation of the radiograph show no evidence of current active TB, it is reasonable to assume that the infant is at low risk for infection. The mother should receive appropriate TB treatment, and she and her infant should receive careful follow-up care.

If the mother's chest radiograph or AFB sputum smear shows evidence of current TB disease, additional steps are necessary to protect the infant. Isoniazid therapy for newborns has been so effective that separation of the mother and infant is no longer considered mandatory. Separation should occur only if the mother is ill enough to require hospitalization, has been or is expected to become nonadherent to treatment, or has suspected drug-resistant TB. Isoniazid treatment for the infant should be continued until the mother is sputum culture negative for  $\geq 3$  months. At that time, a TST should be placed on the child. If the test is positive, isoniazid is continued for a total duration of 9-12 months; if the TST is negative, isoniazid can be discontinued. Once the mother and child are taking adequate therapy, it is usually safe for the mother to breastfeed, because the medications, although found in milk, are present in low concentrations. If isoniazid resistance is suspected or the mother's adherence to medication is in question, continued separation of the infant from the mother should be considered. The duration of separation must be at least as long as is necessary to render the mother noninfectious. A TB expert should be consulted if the young infant has potential exposure to the mother or another adult with TB disease caused by an isoniazid-resistant strain of *M. tuberculosis*.

Although isoniazid is not thought to be teratogenic, the treatment of pregnant women who have asymptomatic TBI is often deferred until after delivery. However, symptomatic pregnant women or those with radiographic evidence of TB disease should be appropriately evaluated. Because pulmonary TB is harmful to both the mother and the fetus and represents a great danger to the infant after delivery, TB in pregnant women always should be treated. The most common regimen for drug-susceptible TB is isoniazid, rifampin, and ethambutol. The aminoglycosides and ethionamide should be avoided because of their teratogenic effect. The safety of pyrazinamide in pregnancy has not been established.

Visit Elsevier eBooks+ at [eBooks.Elsevier.com](https://www.elsevier.com/ebooks) for Bibliography.

## Chapter 262

# Hansen Disease (*Mycobacterium leprae*)

Cristina Tomatis Souverbielle and  
Asuncion Mejias

**Leprosy** (Hansen disease [HD]) is a heterogeneous, curable infection caused by *Mycobacterium leprae* that primarily affects the upper airway, skin, and peripheral nerves. Disease manifestations are mainly determined by the host's immunologic response to infection, resulting in a wide clinical spectrum. The majority of exposed individuals never develop clinical disease. HD is currently the accepted designation of leprosy, and contrary to popular folklore, HD is *not* highly transmissible and *is* treatable. In addition, the associated morbidity and disability can be prevented with early diagnosis and appropriate treatment.

### MICROBIOLOGY

*M. leprae* is an obligate, intracellular, acid-fast, gram-positive bacillus of the family Mycobacteriaceae measuring 1-8  $\mu\text{m}$  in length. It grows optimally at 27-33°C (80.6-91.4°F) yet cannot be cultured in vitro. The bacillus multiplies slowly, with a doubling time of 11-13 days. It is the only bacterium known to infect **Schwann cells** of peripheral nerves. Identification of acid-fast bacilli (AFB) in peripheral nerves is pathognomonic of leprosy.

### EPIDEMIOLOGY

The prevalence of leprosy is variable, with most cases being identified in tropical and subtropical areas. The World Health Organization (WHO) goal to eliminate leprosy as a public health problem, defined as a reduction in its prevalence to less than 1 case per 10,000 population, was achieved at the global level in 2000. Despite an overall decline in reported prevalence, HD continues to afflict more than 2 million people worldwide. In 2022, 174,059 new cases were reported globally, with most cases occurring in Southeast Asia (mostly India), Africa, and South America (mostly Brazil). Of those, 5.92% occurred in children <15 years. In 2018, the WHO reviewed the available evidence on key issues related to the elimination of leprosy and developed a guidance WHO Guidelines for the Diagnosis, Treatment and Prevention of Leprosy. More recently, the WHO released Towards Zero Leprosy – Global Leprosy (Hansen's Disease) Strategy 2021-2030, which was aligned with the 2021-2030 road map for neglected tropical diseases during the same period.

Since 1984, HD has been a *notifiable disease* in the United States, with about 14,000 cases recorded since then. Since the 1990s, an average of 175 new cases are reported annually. Of the 159 new U.S. cases reported in 2020, 69% were identified in Texas, Louisiana, Hawaii, California, Florida, and New York. Most new cases (~75%) in the United States were identified among immigrants from HD-endemic countries or in citizens who have worked abroad in endemic areas. However, over one third of U.S. cases are **autochthonous** and do not report contact with foreign countries or people with leprosy.

The likelihood of developing HD is determined by several variables: age (with two incidence peaks: 10-14 years and 30 years), gender (male/female ratio 2:1, with no differences observed in children), genetics, immune status, type of leprosy (with higher risk in those exposed to patients with multibacillary disease), and possibly through exposure to **armadillos**. Whole genome sequencing has allowed identification of genes and polymorphisms associated with increased susceptibility to leprosy and found that approximately 5% of people are genetically susceptible to *M. leprae* infection. HD in immunocompromised



hosts has been reported in solid organ and bone marrow transplant recipients and patients receiving tumor necrosis factor (TNF)-blocking monoclonal antibodies. Patients with HIV infection do not appear to be at increased risk of acquiring leprosy, increased disease severity, or poor response to treatment. However, clinicians should be aware that concomitant HIV infection and leprosy can result in worsening of symptoms of leprosy during HIV treatment as a result of an immune reconstitution inflammatory syndrome.

The exact mechanism of transmission is not fully understood but is thought to occur primarily by the respiratory route. Natural infection occurs in humans and armadillos, which are the only recognized nonhuman reservoir. The risk of transmission from armadillos to humans seems low, and again, the mechanism is not fully understood. The incubation period between natural infection and overt clinical disease in humans ranges from 3 months to 20 years, with a mean of 4 years for **tuberculoid** leprosy and 10 years for **lepromatous** leprosy. Up to  $10^7$  viable bacilli per day can be shed in respiratory secretions of patients with **multibacillary** leprosy. The relative risk for developing disease in household contacts is 8- to 10-fold for lepromatous disease and 2- to 4-fold for the tuberculoid form. Transmissions by breast milk, the transplacental route, and through broken skin have been reported. Environmental factors and subclinically infected humans may also play a role in disease transmission. The infectivity of patients with HD becomes negligible within 24 hours of the first administration of effective therapy.

## PATHOGENESIS

In the skin, *M. leprae* shows affinity for keratinocytes, macrophages, and histiocytes, and in peripheral nerves, the organism can be found in the Schwann cells. The mechanism of mycobacterial dissemination from the respiratory tract to the skin and nerves is thought to occur hematogenously but has not been completely elucidated. *M. leprae* induces demyelination and binds to the laminin-2 glycoprotein present in the basal lamina of Schwann cells in peripheral nerves, where it replicates slowly over several years. Infection stimulates the dedifferentiation of Schwann cells to immature cells through the activation of the Erk1/2 pathway. This reprogramming of Schwann cells seems to be linked to disease dissemination. In addition to the direct nerve invasion, the immune response to infection also contributes to nerve damage. Schwann cells express human leukocyte antigen (HLA) class II molecules and present mycobacterial peptides to the HLA class II restricted CD4<sup>+</sup> T cells, which initiate an inflammatory response. These events explain the nerve damage seen in paucibacillary disease and in reversal reactions. Swelling within the perineurium leads to ischemia, further nerve damage, and eventually fibrosis and axonal death.

## DISEASE CLASSIFICATION

Disease classification is important to determine potentially infectious cases and prognosis. Based on the cellular immune response and disease dissemination, two classification schemes for leprosy are frequently used: the Ridley-Jopling scale and the WHO classification:

- A. The **Ridley-Jopling scale** is used in the United States and describes the five types of leprosy, according to clinical spectrum of disease, bacillary load, and findings on histopathology.
1. **Tuberculoid form:** Patients usually have a vigorous and specific cellular immune response to *M. leprae* antigens and have a small number of skin lesions, generally one to three well-demarcated macules or plaques with elevated borders (Fig. 262.1) and reduced or absent sensation. The lesions are infiltrated by T-helper 1 (Th1) cells producing abundant interferon (IFN)- $\gamma$  and TNF- $\alpha$ , forming well-demarcated granulomas, with few, if any, bacilli found within the lesions.
  2. **Borderline tuberculoid form**
  3. **Borderline form**
  4. **Borderline lepromatous**
  5. **Lepromatous form:** Patients have an absence of specific cellular immunity to *M. leprae* (but intact immunity to *Mycobacterium*



Fig. 262.1 Tuberculous leprosy in a patient who has a single skin lesion with a raised border and flattened center.

*tuberculosis*) and present the most severe form of disease. They manifest clinically apparent infiltration of peripheral nerves and skin lesions (usually many lesions and not all hypoesthetic or anesthetic), with a high load of bacilli in the absence of an effective cell-mediated immune response. Skin biopsies reveal extensive infiltration of the skin and nerves, containing messenger RNA for Th2 cytokines such as interleukin (IL)-4 and IL-10, poorly formed granulomas, and uncontrolled proliferation of bacilli within foamy macrophages. A large amount of circulating antibody to *M. leprae* is present but does not confer protective immunity. Over time, patients with the lepromatous form develop a systemic disease with symmetric peripheral nerve involvement and a diffuse infiltrative dermatopathy that includes thickening of the facial skin and hair loss of the eyelashes and eyebrows (madarosis), leading to the classic presentation of the *leonine facies*. They also have involvement of the nasal mucosa causing nasal congestion and epistaxis.

6. The majority of patients will present with a borderline form. From borderline tuberculoid to borderline lepromatous forms, there is a progressive reduction in cellular immune responses, an increase in bacillary load, more frequent hypopigmented skin lesions and nerve involvement, and higher antibody titers (Fig. 262.2). Patients with the extreme forms of the disease (tuberculoid and lepromatous) are considered to have stable cell-mediated immunity, because their disease manifestations do not change much over time. In contrast, patients with borderline disease have unstable cell-mediated immunity and demonstrate changes in their clinical manifestations over time toward the polar forms (downgrade) or present sudden reversal reactions (upgrade). *Indeterminate leprosy* is the earliest form of the disease and is seen most frequently in young children. Patients usually have a single hypopigmented macule with poorly defined borders, without erythema or induration. Anesthesia is minimal or absent, especially if the lesion is on the face. The diagnosis is



**Fig. 262.2** Borderline leprosy in a patient who has numerous hypopigmented lesions with poorly defined borders.

usually one of exclusion in the setting of a contact investigation. Tissue biopsies show diagnostic evidence of leprosy but do not meet sufficient criteria for classification. Up to 50–75% of these lesions will heal spontaneously, and the rest will progress to another form of leprosy.

B. The **WHO classification** can be used when histologic evaluation and confirmatory diagnosis is unavailable, a common scenario in the field. This simplified scheme is based on the number of skin lesions:

1. Paucibacillary (1–5 patches)
2. Multibacillary (>5 patches)

### CLINICAL MANIFESTATIONS

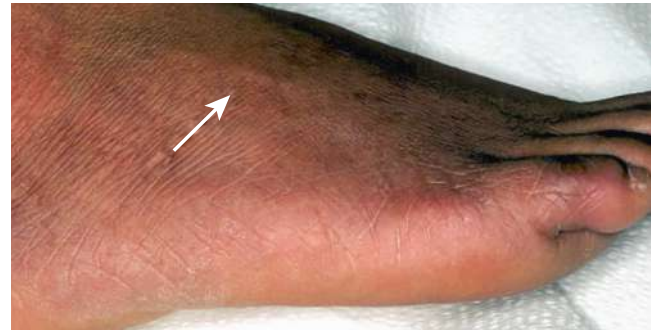
The host immune response determines the clinical spectrum of leprosy. Skin and serologic studies suggest that up to 90% of infected people develop immunity after exposure, without manifesting clinical disease. In genetically susceptible individuals with sufficient exposure to become infected, the cellular host's immunologic response to infection and unique tropism for peripheral nerves determine the wide spectrum of clinical (and histologic) manifestations. Regardless of the disease subtype, HD affects the skin and peripheral nerves. Leprosy lesions usually do not itch or hurt. Polymorphisms in vitamin D and its receptor have been proposed to play a role in the manifestations of leprosy.

#### Skin Involvement

The most common skin lesions are **macules** or **plaques** with unclear outer limits, with or without neurologic symptoms. Diffuse infiltrative lesions and subcutaneous nodules are less common. Initial lesions are insidious hypopigmented macules, although they may appear erythematous on pale skin. Lesions may involve any area of the body, are more pronounced in cooler areas (e.g., earlobes, nose), and occur less frequently in the scalp, axillae, or perineum. Approximately 70% of skin lesions have reduced sensation; the degree of hypoesthesia depends on the location and size of the lesion and the degree of Th1 immune response. Examination of the skin should ideally be performed in natural sunlight and include testing for hypoesthesia to light touch, pinprick, temperature, and anhidrosis. Studies in endemic areas in children <15 years old have shown a predominance of **paucibacillary** forms, with a predominance of single lesions.

#### Nerve Involvement

Peripheral nerves are most frequently affected early in the disease and should be palpated for thickness and tenderness (Fig. 262.3), as well as evaluated for both motor and sensory function, particularly temperature and light touch. The posterior tibial nerve (medial malleolus) is the most common nerve affected, followed by the



**Fig. 262.3** Thickened, superficial peroneal nerve of leprosy.

ulnar (elbow), median (wrist), lateral popliteal (fibular neck), and facial nerves. The skin lesions overlying a nerve trunk distribution predict the involvement of nerves in the vicinity. There is a pure **neuritic** form of leprosy, usually occurring in India and Nepal, in which patients present with asymmetric neuropathy but lack skin lesions.

#### Other Organ Involvement

Ocular involvement leading to vision loss results from both direct bacillary invasion of the eye and optic nerve damage. **Lagophthalmos** occurs when there is destruction of the facial nerve (cranial nerve VII), and trigeminal nerve (cranial nerve V) destruction causes anesthesia of the cornea and conjunctiva, leading to abrasions. Facial skin lesions are associated with a 10-fold higher risk of facial nerve damage. Systemic involvement of other organs is seen mainly in patients with lepromatous leprosy, where a high bacillary burden leads to infiltration of the nasal mucosa, bones, and testes. Renal involvement and amyloidosis are rare findings.

#### Immunologic Reactions

**Leprosy reactions** are acute clinical exacerbations reflecting disturbances of the immunologic balance to *M. leprae* infection and occurring in 30–50% of all leprosy patients. These sudden changes occur in patients with borderline and lepromatous leprosy, typically during the initial years after infection (sometimes as the initial presentation), but can occur before, during, or after completion of treatment. There are two main types of leprosy reactions, which require immediate treatment to prevent long-term complications. In children <15 years old, leprosy reactions range from 1% to 30% and are mainly type 1 reactions.

**Type 1 reactions** (also known as **reversal reactions**) occur in one third of patients with borderline disease. These reactions are characterized by acute edema and increased erythema, warmth, and painful inflammation of preexisting cutaneous plaques or nodules, with acute swelling and tenderness of peripheral nerves that can quickly progress to cause nerve abscesses and necrosis. There may be a peripheral lymphocytosis and an increased cytokine response, but systemic symptoms are uncommon and appear to be associated with an increase in Th1-mediated reactivity to mycobacterial antigens. Increased serum concentrations of CXCL10 have been found in type 1 reactions. Rapid and sustained reversal of the inflammatory process using corticosteroids is essential to prevent continued nerve damage.

**Type 2 reactions**, or **erythema nodosum leprosum (ENL)**, occur in borderline lepromatous and lepromatous forms, as these patients have the highest levels of *M. leprae* antigens and antibodies, most often in the first 2 years after starting therapy. ENL is distinguished from reversal reactions by the development of new painful, erythematous subcutaneous nodules with an accompanying systemic inflammatory response. ENL is accompanied by high circulating concentrations of TNF- $\alpha$ . Patients develop high fever and signs

of systemic toxicity, and in severe cases, ENL can be life threatening, presenting with features similar to septic shock. Deposition of extravascular immune complexes leads to neutrophil infiltration and activation of complement in the skin and other organs. Tender, erythematous dermal papules or nodules (resembling erythema nodosum) occur in clusters, typically on extensor surfaces of the lower extremities and face. Immune complex deposition also contributes to migrating polyarthralgias, painful swelling of lymph nodes and spleen, iridocyclitis, vasculitis, orchitis, and, rarely, nephritis. Patients may present with a single acute episode, a relapsing form comprising multiple acute episodes, or a chronic continuous form. Management of type 2 reactions is usually more complicated because of recurrence and systemic involvement.

**Lucio phenomenon (erythema necroticans)** is an uncommon but potentially fatal reaction distinct from type 1 or 2 reactions and occurs in patients with untreated lepromatous leprosy and in patients whose ancestry is from Mexico. It is a necrotizing vasculitis caused by *M. leprae* directly invading the endothelium. Clinically, patients develop violaceous or hemorrhagic plaques, followed by ulcerations in the absence of systemic complaints. Secondary bacterial infections are common.

## DIAGNOSIS

The diagnosis of HD requires high clinical suspicion and should be considered in any patient with a **hypoesthetic or anesthetic skin lesion that does not respond to standard treatment**, especially if there is a history of travel or residence in an endemic region or a history of contact with leprosy patients or armadillos. There are no reliable tests to diagnose subclinical leprosy. Full-thickness skin biopsy and polymerase chain reaction (PCR) are the main laboratory tests to aid in the diagnosis. Patients are considered to have HD if they have **one or more of the three cardinal signs**: loss of sensation in a localized skin lesion (pale or erythematous), thickened peripheral nerve with loss of sensation and/or weakness of muscles innervated by that nerve, or the presence of AFB on biopsy. The positive predictive value for the diagnosis of leprosy in patients meeting all three criteria is 98%.

To confirm the diagnosis and determine the extent of nerve involvement and the type of infiltrate, a full-thickness skin biopsy from the most active lesion should be performed. *M. leprae* is best identified in tissue using the *Fite stain*. Lesions from patients with the lepromatous form reveal numerous AFB in clumps (globi), whereas patients with the tuberculoid form rarely have mycobacteria identified, but the diagnosis can be made by demonstration of well-formed noncaseating granulomas and nerve involvement. The presence of **neural inflammation** differentiates leprosy from other granulomatous disorders. Mycobacterial culture of lesions should be performed to exclude *M.*

*tuberculosis* and nontuberculous cutaneous infections. If no resources are available, slit-skin (skin smear) biopsies represent an alternative. Slit-skin smears have high specificity but low sensitivity; only 30% of adults and 10–30% of children <15 years old are smear positive (usually patients with the lepromatous form). The bacterial index can range from 0 (no bacilli in 100 oil-immersion fields), as generally seen in paucibacillary disease, to 6+ (>1,000 bacilli/field), as can be seen in multibacillary disease.

Diagnostic and histopathologic consultation in the United States is available through the **National Hansen's Disease Program (NHDP)**; <http://www.hrsa.gov/hansens> or 800-642-2477). Specimens (formalin or paraffin embedded) can be sent to the NHDP for pathologic analysis free of charge. A PCR test for *M. leprae* is not readily available in clinical practice but may be performed at the NHDP. In nonendemic areas, PCR may be useful for diagnosis when AFB are discernible in tissue but clinical and histopathologic features are not typical. *M. leprae* DNA is detectable by PCR in 95% of lepromatous disease and 55% of tuberculoid lepra. PCR has also allowed detection of the organism in nasal secretions from asymptomatic people. Molecular testing for mutations causing drug resistance is also available through the NHDP and is usually used in the setting of relapse.

Antibodies to *M. leprae* are present in 90% of patients with untreated lepromatous disease, 40–50% of patients with paucibacillary disease, and 1–5% of healthy controls. However, serologic testing is insensitive and is not used for diagnosis.

## TREATMENT

The primary goal of treatment is early antimicrobial therapy to prevent permanent neuropathy. Leprosy is curable. Effective treatment requires multidrug therapy (MDT) with **dapsone, clofazimine, and rifampin**. Combination therapy is employed to prevent antimicrobial resistance. In the United States, clinical providers considering a diagnosis and treatment of a patient with HD should obtain **consultation from the NHDP**. The recommended combination MDT can be obtained free of charge from the NHDP (Table 262.1) and in other countries through the WHO (Table 262.2). Compared with the WHO, the NHDP advocates for a longer duration of treatment and daily rather than monthly administration of rifampin because shorter antimicrobial regimens have been associated with a greater risk of relapse. The recommended duration by the WHO for tuberculoid disease is 6 months and for lepromatous disease is 12 months. Since 2018, the WHO has advocated for a three-drug regimen for all leprosy forms; however, NHDP guidelines recommend two drugs (dapsone and rifampin) for the treatment of paucibacillary disease.

Before starting combination MDT, patients should be tested for glucose-6-phosphate dehydrogenase deficiency, have a baseline

**Table 262.1** NHDP-Recommended Multidrug Therapy Regimens for Hansen Disease in the United States

TYPE OF LEPROSY	PATIENT POPULATION	ANTIMICROBIAL THERAPY	DURATION OF THERAPY
Multibacillary (LL, BL, BB)	Adult	Dapsone 100mg/day and rifampin* 600mg/day and clofazimine 50mg/day	24mo
	Pediatric†	Dapsone 1mg/kg/day and rifampin 10-20mg/kg/day and clofazimine 1mg/kg/day‡	
Paucibacillary (TT, BT)	Adult	Dapsone 100mg/day and rifampin 600mg/day	12mo
	Pediatric†	Dapsone 1mg/kg/day and rifampin 10-20mg/kg/day	

\*Rifampin is taken monthly if the patient is on prednisone.

†Daily pediatric mg/kg dose should not exceed the adult daily maximum.

‡Clofazimine is only available through NHDP Investigational New Drug (IND) program; minimum formulation is 50 mg, and capsules should not be cut. Alternative dosing includes clofazimine 2 mg/kg every other day.

NHDP, National Hansen's Disease Program; BB, borderline; BL, borderline lepromatous; BT, borderline tuberculoid; LL, lepromatous; TT, tuberculoid.

NHDP multidrug therapy is daily and of longer duration than WHO-recommended regimen. All drugs are administered orally. For immunologically compromised or elderly patients, these protocols may be modified. Consultation with the NHDP is advised.



**Table 262.2** WHO-Recommended Multidrug Therapy (MDT) Regimens for Hansen Disease

TYPE OF LEPROSY	PATIENT POPULATION	ANTIMICROBIAL THERAPY	DURATION OF THERAPY
Multibacillary (LL, BL, BB)	Adult	Rifampicin 600 mg once monthly and dapsones 100 mg/day and clofazimine 300 mg once monthly and 50 mg/day	12 mo
	Pediatric*	Rifampicin 450 mg once monthly and dapsones 50 mg/day and clofazimine 150 mg once monthly and 50 mg every other day	
Paucibacillary (TT, BT)	Adult	Rifampicin 600 mg once monthly and dapsones 100 mg/day and clofazimine 300 mg once monthly and 50 mg/day	6 mo
	Pediatric*	Rifampicin 450 mg once monthly and dapsones 50 mg/day and clofazimine 150 mg once monthly and 50 mg every other day	

\*In children <10 yr old, or <than 40 kg, MDT dosages should be in mg/kg, not to exceed the adult daily maximum: rifampicin 10 mg/kg once monthly, dapsones 2 mg/kg/day, and clofazimine 100 mg once a month, 50 mg twice weekly.

WHO, World Health Organization; BB, borderline; BL, borderline lepromatous; BT, borderline tuberculoid; LL, lepromatous; TT, tuberculoid.

complete blood cell count and liver function testing, and be evaluated for evidence of active tuberculosis, in which monotherapy with rifampin should be avoided. Response to therapy is seen clinically as flattening or disappearance of skin lesions and improvement in nerve function, usually within 1-2 months after initiating MDT. Complete resolution or improvement may take 6-12 months, depending on the severity of infection. Most skin lesions heal without scarring. Identification of biomarkers for the optimal identification and management of leprosy continue to be under study. CXCL10 (IP-10) has been identified as a potential marker to help monitor treatment efficacy in patients with multibacillary disease, as higher levels of CXCL-10 are important for the control of bacillary load.

Alternative agents to treat HD include minocycline, clarithromycin, and some fluoroquinolones (levofloxacin, ofloxacin, moxifloxacin). Given limited data, these alternative antimicrobials are used in selected cases of intolerance to the routine combination MDT regimen or for documented resistance. It is important to note that some patients who have been adequately treated for HD may later show evidence of chronic reversal reactions and late neuropathies, but these are bacillus negative and thus should not be considered relapses. Neuritis must be treated promptly to minimize nerve injury and disability. Treatment with corticosteroids appears to improve nerve function in two thirds of patients.

Bone marrow suppression and hepatotoxicity have been reported and should be monitored every 3 months during therapy. A screening urinalysis should be performed annually. Other reactions, such as methemoglobinemia and hypersensitivity reactions to dapsones, are rare. An ophthalmologic evaluation should routinely be performed in all patients with HD because ocular complications can occur. Given the proclivity for testicular invasion in multibacillary leprosy with resultant testicular dysfunction and infertility, males should be screened for elevated follicle-stimulating hormone or luteinizing hormone concentrations and decreased testosterone levels.

After completion of MDT, annual follow-up for  $\geq 5$  years for paucibacillary and  $\geq 10$  years for multibacillary disease is warranted. Relapse of the disease after completion of MDT is rare (0.01–1.4%) and must be distinguished from the more common leprosy immunologic reactions. Patients who have a bacillary index of  $\geq 4$  pre-MDT or  $\geq 3$  at the completion of MDT have the highest risk of relapse (approximately 20%). When relapse occurs, it is usually within 5-10 years of MDT completion and a result of reactivation of drug-susceptible mycobacteria. Thus patients who are expected to relapse are generally treated with the same MDT regimen. Resistance to all three drugs has been documented,

although it rarely occurs with combination therapy. There is no role for routine baseline resistance testing, but the NHDP can provide it if needed.

### Leprosy Reactions

Immunologic reactions can occur before, during, and years after treatment and should be treated aggressively to prevent peripheral nerve damage. In general, antimycobacterial drugs should be continued. Fatigue, malaise, or fever can be present, and the inflammation associated with these reactions can cause severe nerve injury. Prompt therapy with corticosteroids with or without other antiinflammatory agents, adequate analgesia, and physical support are essential for patients with active neuritis to prevent nerve damage. **If corticosteroids are indicated for a prolonged time, the frequency of rifampicin administration should be decreased from daily to monthly administration** (to avoid drug interactions). In 2020, to aid with the management of leprosy reactions, the WHO published the technical guide: *Leprosy/Hansen Disease: Management of Reactions and Prevention of Disabilities*.

For severe **type 1 reactions, prednisone is recommended**, 1 mg/kg/day orally (40-60 mg) with a slow taper (decreasing by 5 mg every 2-4 weeks after evidence of improvement over 3-6 months) in addition to standard MDT. If there is evidence of peripheral nerve deterioration, higher doses and longer tapers may be needed. Nerve function improves after corticosteroid treatment in 30–80% of patients who did not have preexisting neuritis. In patients not responding to corticosteroids, cyclosporine may be used as a second-line agent.

For severe **type 2 reactions, prednisone is routinely used** at 1 mg/kg/day for 12 weeks. However, given the recurrence and chronicity of ENL, **corticosteroid-sparing agents should be considered** to avoid complications associated with their prolonged use. **Thalidomide** (100-400 mg/daily for 48-72 hours, tapering over 2 weeks to 100 mg/daily) is effective in treating these types of reactions. Given the teratogenicity of thalidomide (contraindicated for children <12 years old and women of childbearing age), the drug is only available through a restrictive distribution program approved by the U.S. Food and Drug Administration (FDA). **Clofazimine** (300 mg/day for several months, tapering to <100 mg/day, within a year) alone or in combination with corticosteroids, has also been useful in managing patients with chronic ENL and is generally used until all signs of the reaction have abated. Other immunosuppressive drugs have been used to treat type 2 reactions with inconsistent results, including cyclosporine, mycophenolate, and methotrexate. **Lucio phenomenon is managed similarly to ENL** and treatment of underlying infections.



## LONG-TERM COMPLICATIONS

Leprosy is a leading cause of permanent physical disability among communicable diseases worldwide. The major chronic complications and deformities of leprosy are caused by **nerve injury**. Nerve impairment may be purely sensory, motor, or autonomic or may be a combination. The prognosis for arresting progression of tissue and nerve damage is good if therapy is started early, but recovery of lost sensory and motor function is variable and frequently incomplete. Nerve function impairment can occur before diagnosis, during MDT, or after MDT and can develop without overt signs of skin or nerve inflammation (silent neuropathy). Patients at highest risk of nerve impairment are those with multibacillary leprosy and preexisting nerve damage. These patients should undergo regular monthly surveillance during therapy and for at least 2 years from the time of diagnosis. In children, deformities can occur in 3–10% of cases and mainly in those with nerve enlargement. Other factors contributing to risk of deformities include increasing age in children, delay in accessing medical care, multiple skin lesions, multibacillary disease, smear positivity, multiple nerve involvement, and leprosy reaction at presentation.

## PREVENTION

In addition to treating active leprosy cases, control measures for HD include the management of **contacts** of index patients. In endemic countries, close monitoring of household contacts of HD patients, particularly HD patients with multibacillary disease, is warranted to ensure that early treatment can be implemented if evidence of early HD develops. These household contacts should be examined at baseline and then yearly for 5 years. In nonendemic areas, disease presenting in the contacts of patients with HD is rare. A single dose of bacille Calmette-Guérin (BCG) vaccine has variable protective efficacy against leprosy, ranging from 10% to 80%; an additional dose results in increased protection. Any suspected or newly diagnosed case of leprosy in the United States should be reported to local and state public health departments, the Centers for Disease Control and Prevention (CDC), and NHDP. There are no leprosy vaccines available or recommended for use in the United States. In the hospital setting, **standard precautions** should be implemented. Hand hygiene is recommended for all people in contact with a patient with lepromatous leprosy. The use of chemoprophylaxis with a single dose of rifampin (SDR) within endemic areas is recommended by the WHO, but not the NHDP, for adults and children  $\geq 2$  years in contact with leprosy patients. Because leprosy is a highly stigmatized disease, caution must be exercised when implementing SDR in contacts, particularly for those outside the patient's family.

Visit Elsevier eBooks+ at [eBooks.Health.Elsevier.com](http://eBooks.Health.Elsevier.com) for Bibliography.

## Chapter 263

# Nontuberculous Mycobacteria

Ericka V. Hayes

Nontuberculous mycobacteria (NTM), also referred to as **atypical mycobacteria** and **mycobacteria other than tuberculosis** (MOTT), are all members of the genus *Mycobacterium* and include species other than *Mycobacterium tuberculosis* complex and *Mycobacterium leprae*. The NTM constitute a highly diverse group of bacteria that differ from *M. tuberculosis* complex bacteria in their pathogenicity, interhuman transmissibility, nutritional requirements, ability to produce pigments,

enzymatic activity, and drug susceptibility. In contrast to the *M. tuberculosis* complex, NTM are acquired from environmental sources and not by person-to-person spread, although the latter is under debate, especially in patients with cystic fibrosis (CF). Their omnipresence in the environment means that the clinical relevance of NTM isolation from clinical specimens is sometimes unclear; a positive culture might reflect occasional presence or contamination rather than true NTM disease. NTM are associated with pediatric lymphadenitis, otomastoiditis, serious lung infections, and, rarely, disseminated disease. Treatment is long-term and cumbersome and often requires adjunctive surgical intervention. Comprehensive guidelines on diagnosis and treatment are provided by the American Thoracic Society (ATS) and British Thoracic Society (BTS).

## ETIOLOGY

NTM are ubiquitous in the environment all over the world, existing as saprophytes in soil and water (including municipal water supplies, tap water, hot tubs, and shower heads), environmental niches that are the supposed sources of human infections. With the introduction of molecular identification tools such as 16S recombinant DNA gene sequencing, the number of identified NTM species has grown to more than 150; the *clinical relevance* (i.e., percentage of isolates that are causative agents of true NTM disease, rather than occasional contaminants) differs significantly by species.

*Mycobacterium avium* complex (MAC; i.e., *M. avium*, *Mycobacterium intracellulare*, and several closely related but rarer species) and *Mycobacterium kansasii* are most often isolated from clinical samples, yet the isolation frequency of these species differs significantly by geographic area. MAC bacteria have been frequently isolated from natural and synthetic environments, and cases of MAC disease have been successfully linked to home exposure to shower and tap water. Although the designation *M. avium* suggests that human infections are acquired from birds (Latin *avium*), molecular typing has established that *M. avium* strains that cause pediatric lymphadenitis and adult pulmonary disease represent the *M. avium* hominis suis subgrouping, mainly found in humans and pigs and not in birds.

Some NTM have well-defined ecologic niches that help explain infection patterns. The natural reservoir for *Mycobacterium marinum* is fish and other cold-blooded animals, and the **fish tank granuloma**, a localized skin infection caused by *M. marinum*, follows skin injury in an aquatic environment. *Mycobacterium fortuitum* complex bacteria and *Mycobacterium chelonae* are ubiquitous in water and have caused clusters of nosocomial surgical wound and venous catheter-related infections. *Mycobacterium ulcerans* is associated with severe, chronic skin infections (**Buruli ulcer disease**) and is endemic mainly in West Africa and Australia, although other foci exist. Its incidence is highest in children <15 years old. *M. ulcerans* had been detected in environmental samples by polymerase chain reaction (PCR) and has been recovered by culture from a water strider (an insect of the *Gerris* genus) from Benin.

## EPIDEMIOLOGY

Humans are exposed to NTM on a daily basis. In rural U.S. counties, where *M. avium* is common in swamps, the prevalence of asymptomatic infections with *M. avium* complex, as measured by skin test sensitization, approaches 70% by adulthood. Still, the incidence and prevalence of the various NTM disease types remain largely unknown, especially for pediatric NTM disease. In Australian children, the overall incidence of NTM infection is 0.84 per 100,000, with lymphadenitis accounting for two thirds of cases. The incidence of pediatric NTM disease in the Netherlands is estimated at 0.77 infections per 100,000 children per year, with lymphadenitis making up 92% of all infections.

In comparison, estimations of the prevalence of NTM from respiratory samples in adults are 5–15 per 100,000 persons per year, with important differences between countries or regions. Because pulmonary NTM disease progresses slowly, over years rather than months, and usually takes several years to cure, the prevalence of pulmonary NTM disease is much higher than incidence rates would suggest.

The paradigm that NTM disease is a rare entity limited to resource-rich countries is changing. In recent studies in African countries with a high prevalence of HIV infection, it has been found that NTM might play a much larger role as a cause of tuberculosis-like disease of children and adults than previously assumed and thus confuse the diagnosis of tuberculosis.

Although it is generally believed that NTM infections are contracted from environmental sources, whole genome sequence analysis of *Mycobacterium abscessus* strains of patients in a CF clinic in the United Kingdom supports the possibility of nosocomial horizontal transmission among CF patients.

## PATHOGENESIS

The histologic appearances of lesions caused by *M. tuberculosis* and NTM are often indistinguishable. The classic pathologic lesion consists of caseating granulomas. Compared with *M. tuberculosis* infections, NTM infections are more likely to result in **granulomas that are non-caseating**, poorly defined (nonpalisading), irregular or serpiginous, or even absent, with only chronic inflammatory changes observed. The histology likely reflects the immune status of the patient.

In patients with AIDS and disseminated NTM infection, the inflammatory reaction is usually scant, and tissues are filled with large

numbers of histiocytes packed with acid-fast bacilli (AFB). These disseminated NTM infections typically occur only after the number of CD4 T lymphocytes has fallen below 50/μL in children ≥6 years, below 75/μL in children 2 to <6 years, below 500/μL in children 1 to <2 years, and below 750/μL in children <1 year, suggesting that specific T-cell products or activities are required for immunity to mycobacteria.

The pivotal roles of interferon (IFN)-γ, interleukin (IL)-12, and tumor necrosis factor (TNF)-α in disease pathogenesis are demonstrated by the high incidence of mostly disseminated NTM disease in children with IFN-γ and IL-12 pathway deficiencies and in persons treated with agents that neutralize TNF-α.

Observed differences in pathogenicity, clinical relevance, and spectrum of clinical disease associated with the various NTM species emphasize the importance of bacterial factors in the pathogenesis of NTM disease, although exact virulence factors remain largely unknown.

## CLINICAL MANIFESTATIONS

**Lymphadenitis** of the superior anterior cervical or submandibular lymph nodes is the most common manifestation of NTM infection in children (Table 263.1). Preauricular, posterior cervical, axillary, and inguinal nodes are involved occasionally. Lymphadenitis is most

**Table 263.1** Major Clinical Syndromes Associated with Nontuberculous Mycobacterial Infection

SYNDROME	MOST COMMON CAUSES	LESS FREQUENT CAUSES*
Chronic nodular disease (adults with bronchiectasis; cystic fibrosis)	MAC ( <i>M. intracellulare</i> , <i>M. avium</i> ), <i>M. kansasii</i> , <i>M. abscessus</i>	<i>M. xenopi</i> , <i>M. malmoense</i> , <i>M. szulgai</i> , <i>M. smegmatis</i> , <i>M. celatum</i> , <i>M. simiae</i> , <i>M. goodii</i> , <i>M. asiaticum</i> , <i>M. heckeshornense</i> , <i>M. branderi</i> , <i>M. lentiflavum</i> , <i>M. triplex</i> , <i>M. fortuitum</i> , <i>M. arupense</i> , <i>M. abscessus</i> subsp. <i>bolletii</i> , <i>M. phocaicum</i> , <i>M. aubagnense</i> , <i>M. florentinum</i> , <i>M. abscessus</i> subsp. <i>massiliense</i> , <i>M. nebraskense</i> , <i>M. saskatchewanense</i> , <i>M. seoulense</i> , <i>M. senuense</i> , <i>M. paraseoulense</i> , <i>M. europaeum</i> , <i>M. sherrisii</i> , <i>M. kyorinense</i> , <i>M. noviomagense</i> , <i>M. mantenii</i> , <i>M. shinjukuense</i> , <i>M. koreense</i> , <i>M. heraklionense</i> , <i>M. parascrofulaceum</i> , <i>M. arosiense</i>
Cervical or other lymphadenitis (especially children)	MAC	<i>M. scrofulaceum</i> , <i>M. malmoense</i> (northern Europe), <i>M. abscessus</i> , <i>M. fortuitum</i> , <i>M. lentiflavum</i> , <i>M. tusciae</i> , <i>M. palustre</i> , <i>M. interjectum</i> , <i>M. elephantis</i> , <i>M. heidelbergense</i> , <i>M. parmense</i> , <i>M. bohemicum</i> , <i>M. haemophilum</i> , <i>M. europaeum</i> , <i>M. florentinum</i> , <i>M. triplex</i> , <i>M. asiaticum</i> , <i>M. kansasii</i> , <i>M. heckeshornense</i>
Skin and soft tissue disease	<i>M. fortuitum</i> group, <i>M. chelonae</i> , <i>M. abscessus</i> , <i>M. marinum</i> , <i>M. ulcerans</i> (Australia, tropical countries only)	<i>M. kansasii</i> , <i>M. haemophilum</i> , <i>M. porcinum</i> , <i>M. smegmatis</i> , <i>M. genavense</i> , <i>M. lacus</i> , <i>M. novocastrense</i> , <i>M. houstonense</i> , <i>M. goodii</i> , <i>M. immunogenum</i> , <i>M. mageritense</i> , <i>M. abscessus</i> subsp. <i>massiliense</i> , <i>M. arupense</i> , <i>M. monacense</i> , <i>M. bohemicum</i> , <i>M. branderi</i> , <i>M. shigaense</i> , <i>M. szulgai</i> , <i>M. asiaticum</i> , <i>M. xenopi</i> , <i>M. kumamotoense</i> , <i>M. setense</i> , <i>M. montefiorensis</i> (eels), <i>M. pseudoshottsii</i> (fish), <i>M. shottsii</i> (fish)
Skeletal (bone, joint, tendon) infection	<i>M. marinum</i> , MAC, <i>M. kansasii</i> , <i>M. fortuitum</i> group, <i>M. abscessus</i> , <i>M. chelonae</i>	<i>M. haemophilum</i> , <i>M. scrofulaceum</i> , <i>M. heckeshornense</i> , <i>M. smegmatis</i> , <i>M. terrae/chromogenicum</i> complex, <i>M. wolinskyi</i> , <i>M. goodii</i> , <i>M. arupense</i> , <i>M. xenopi</i> , <i>M. triplex</i> , <i>M. lacus</i> , <i>M. arosiense</i>
Disseminated infection		<i>M. genavense</i> , <i>M. haemophilum</i> , <i>M. xenopi</i>
HIV-seropositive host	<i>M. avium</i> , <i>M. kansasii</i>	<i>M. marinum</i> , <i>M. simiae</i> , <i>M. intracellulare</i> , <i>M. scrofulaceum</i> , <i>M. fortuitum</i> , <i>M. conspicuum</i> , <i>M. celatum</i> , <i>M. lentiflavum</i> , <i>M. triplex</i> , <i>M. colombiense</i> , <i>M. sherrisii</i> , <i>M. heckeshornense</i>
HIV-seronegative host	<i>M. abscessus</i> , <i>M. chelonae</i>	<i>M. marinum</i> , <i>M. kansasii</i> , <i>M. haemophilum</i> , <i>M. chimaera</i> , <i>M. conspicuum</i> , <i>M. shottsii</i> (fish), <i>M. pseudoshottsii</i> (fish)
Catheter-related infections	<i>M. fortuitum</i> , <i>M. abscessus</i> , <i>M. chelonae</i>	<i>M. mucogenicum</i> , <i>M. immunogenum</i> , <i>M. mageritense</i> , <i>M. septicum</i> , <i>M. porcinum</i> , <i>M. bacteremicum</i> , <i>M. brumae</i>
Hypersensitivity pneumonitis (metal workers; hot tub users)	<i>M. immunogenum</i> , <i>M. avium</i>	

\*The available information is sparse for selected pathogens such as *M. xenopi*, *M. malmoense*, *M. szulgai*, *M. celatum*, and *M. asiaticum* and the newly described species. HIV, Human immunodeficiency virus; MAC, *Mycobacterium avium* complex.

From Brown-Elliott BA, Wallace RJ Jr. Infections caused by nontuberculous mycobacteria other than *Mycobacterium avium* complex. In Bennett JF, Dolin R, Blaser MJ, eds. *Mandell, Douglas, and Bennett's Principles and Practice of Infectious Diseases*, 8th ed. Philadelphia: Elsevier; 2015: Table 254-1.



**Fig. 263.1** Enlarging cervical lymph node infected with *Mycobacterium avium* complex infection. The node is firm, painless, freely movable, and not erythematous.



**Fig. 263.2** Suppurating cervical lymph node infected with *Mycobacterium avium* complex.

common in children 1-5 years of age and has been related to soil exposure (e.g., playing in sandboxes) and teething, although exact predisposing conditions have not been identified. Given the constant environmental exposure to NTM, the occurrence of these infections might also reflect an atypical immune response of a subset of the infected children during or after their first contact with NTM. However, in healthy children with isolated NTM lymphadenitis, immunodeficiency is quite rare.

Affected children usually lack constitutional symptoms and present with a unilateral, subacute, and slowly enlarging lymph node or group of closely approximated nodes >1.5 cm in diameter that are firm, painless, freely movable, and not erythematous (Fig. 263.1). The involved nodes occasionally resolve without progression, but most undergo rapid suppuration after several weeks (Fig. 263.2). The center of the node becomes fluctuant, and the overlying skin thins and becomes erythematous and often even violaceous. Eventually, the nodes rupture and can form cutaneous sinus tracts that can drain persistently, reminiscent of scrofula from tuberculosis (Fig. 263.3).

In the United States and Western Europe, MAC accounts for approximately 80% of NTM lymphadenitis in children. *M. kansasii* accounts for most other cases of lymphadenitis in the United States. *M. malmoense* and *M. haemophilum* have also been described as causative agents of lymphadenitis. *M. malmoense* is most common in Northwestern Europe. For *M. haemophilum*, underestimation of its importance is likely because the bacteria require specific culture conditions (hemin-enriched media, low incubation temperatures). On the basis of PCR analysis of lymph node samples from lymphadenitis cases in The Netherlands, *M. haemophilum* is the second most common cause of this infection, after MAC. One study suggests that children with MAC



**Fig. 263.3** Ruptured cervical lymph node infected with *Mycobacterium avium* complex, which resembles the classic scrofula of tuberculosis.

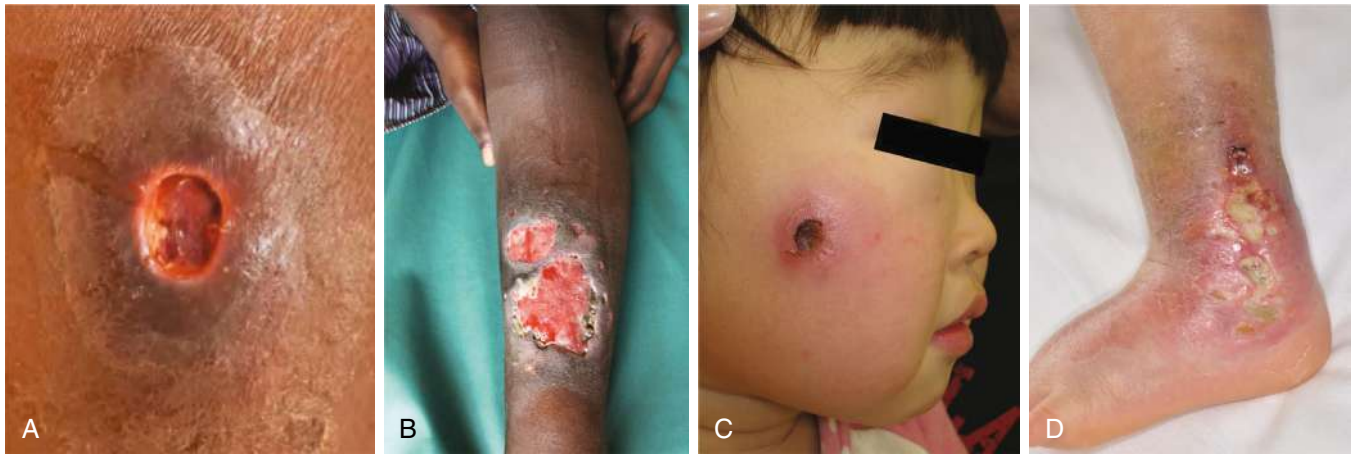
lymphadenitis are significantly younger than those infected by *M. haemophilum*, possibly related to age-specific environmental exposures. *Mycobacterium lentiflavum* is also an emerging NTM associated with lymphadenitis.

**Cutaneous disease** caused by NTM is rare in children (see Table 263.1). Infection usually follows percutaneous inoculation with fresh or salt water contaminated by *M. marinum*. Within 2-6 weeks after exposure, an erythematous papule develops at the site of minor abrasions on the elbows, knees, or feet (**swimming pool granuloma**) and on the hands and fingers of fish tank owners, mostly inflicted during tank cleaning (**fish tank granuloma**). These lesions are usually nontender and enlarge over 3-5 weeks to form violaceous plaques. Nodules or pustules can develop and occasionally will ulcerate, resulting in a serosanguineous discharge. The lesions sometimes resemble sporotrichosis, with satellite lesions near the site of entry, extending along the superficial lymphatics. Lymphadenopathy is usually absent. Although most infections remain localized to the skin, penetrating *M. marinum* infections can result in tenosynovitis, bursitis, osteomyelitis, or arthritis.

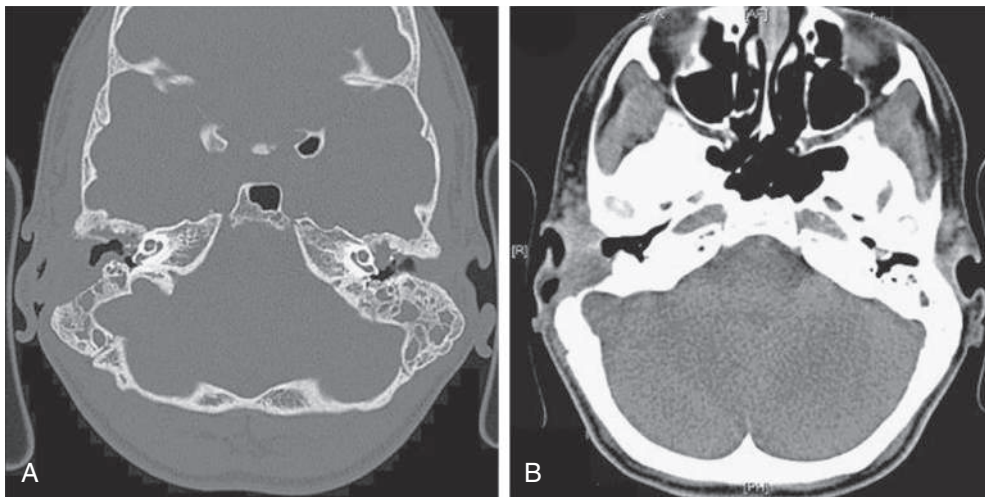
*M. ulcerans* infection is the third most common mycobacterial infection in immunocompetent patients, after *M. tuberculosis* and *M. leprae* infection, and causes cutaneous disease in children living in tropical regions of Africa, South America, Asia, and parts of Australia. In some communities in West Africa, up to 16% of people have been affected. Children <15 years old are particularly affected in rural tropical countries, accounting for 48% of infected individuals in Africa. Infection follows percutaneous inoculation from minor trauma, such as pricks and cuts from plants or insect bites. After an incubation period of approximately 3 months, lesions appear as an erythematous nodule, usually on the legs or arms. The lesion undergoes central necrosis and ulceration. The lesion, often called a **Buruli ulcer** after the region in Uganda where a large case series was reported, has a characteristic undermined edge, expands over several weeks, and can result in extensive, deep soft tissue destruction or bone involvement (Fig. 263.4). Lesions are typically painless, and constitutional symptoms are unusual. Lesions might heal slowly over 6-9 months or might continue to spread, leading to deformities, contractures, and disability. Depending on the location of the ulcer, these can be significantly disfiguring.

Skin and soft tissue infections caused by **rapidly growing mycobacteria**, such as *M. fortuitum*, *M. chelonae*, or *M. abscessus*, are rare in children and usually follow percutaneous inoculation from puncture or surgical wounds, minor abrasions, or tattooing. There has been a large outbreak of *M. fortuitum* furunculosis related to nail salon footbaths. Clinical disease usually arises after a 4- to 6-week incubation period and manifests as localized cellulitis, painful nodules, or a draining abscess. *M. haemophilum* can cause painful subcutaneous nodules, which often ulcerate and suppurate in immunocompromised patients, particularly after kidney transplantation.





**Fig. 263.4** Buruli ulcer lesions in patients from West Africa (A and B) and Japan (C and D). (A, B from Röltgen K, Pluschke G. Buruli ulcer: history and disease burden. In: Pluschke G, Röltgen K, eds. Buruli Ulcer. Cham: Springer; 2019; C, D courtesy Dr Mikio Ohtsuka, Fukushima Medical University.)



**Fig. 263.5** CT images of the middle ear of 6-yr-old child infected with *Mycobacterium abscessus*, demonstrating extensive bone destruction in the right mastoid and associated right-sided mucosal swelling. A, Bone tissue window setting. B, Soft tissue window setting.

NTM are an uncommon cause of **catheter-associated infections** but are becoming increasingly recognized in this respect. Infections caused by *M. fortuitum*, *M. chelonae*, or *M. abscessus* can manifest as bacteremia or localized catheter tunnel infections.

**Otomastoiditis**, or chronic otitis media, is a rare extrapulmonary NTM disease type that specifically affects children with tympanostomy tubes and a history of topical antibiotic or steroid use. *M. abscessus* is the most common causative agent, followed by MAC (see Table 263.1). Patients present with painless, chronic otorrhea resistant to antibiotic therapy. CT can reveal destruction of the mastoid bone with mucosal swelling (Fig. 263.5).

Delayed or unsuccessful treatment can result in permanent hearing loss. In unusual circumstances, NTM cause other bone and joint infections that are indistinguishable from those produced by *M. tuberculosis* or other bacterial agents. Such infections usually result from operative incision or accidental puncture wounds. *M. fortuitum* infections from puncture wounds of the foot resemble infections caused by *Pseudomonas aeruginosa* and *Staphylococcus aureus*.

**Pulmonary infections** are the most common form of NTM illness in adults but are rare in children. MAC bacteria, the most commonly identified organisms (see Table 263.1), are capable of causing acute pneumonitis, chronic cough, or wheezing associated with paratracheal or peribronchial lymphadenitis and airway compression in normal children. Associated constitutional symptoms such as fever, anorexia, and weight loss occur in 60% of these children. Chest radiographic findings are similar to those for primary tuberculosis, with unilateral infiltrates and hilar lymphadenopathy (Fig. 263.6). Pleural effusion is



**Fig. 263.6** Chest radiograph of 2-yr-old child infected with *Mycobacterium avium* complex, demonstrating a left upper lobe infiltrate and left hilar lymphadenopathy.



uncommon. Rare cases of progression to endobronchial granulation tissue have been reported.

Pulmonary infections usually occur in adults with underlying chronic lung disease. The onset is insidious and consists of cough and fatigue, progressing to weight loss, night sweats, low-grade fever, and generalized malaise in severe cases. Thin-walled cavities with minimal surrounding parenchymal infiltrates are characteristic, but radiographic findings can resemble those of tuberculosis. A separate disease manifestation occurs typically in postmenopausal women and is radiologically characterized by bronchiectasis and nodular lesions, often affecting the middle lobe and lingula (Lady Windemere's syndrome).

**Chronic pulmonary infections** specifically affect children with CF and are generally caused by *M. abscessus* or MAC. *M. abscessus* primarily affects children, and MAC is most common among adults. The percentage of CF patients with at least one sputum culture positive for NTM is 6–8.1% overall and increases with age; in CF patients <12 years old, a prevalence of 3.9% has been reported. The strong representation of *M. abscessus* in these patients is remarkable, because this bacterium is an uncommon isolate in other categories of patients. There are indications that NTM infections in CF patients further accelerate the decline in lung function; antimycobacterial therapy can result in weight gain and improved lung function in affected patients.

**Disseminated disease** is usually associated with MAC infection and occurs in immunocompromised children. The first category of patients with disseminated disease includes persons with mutations in genes coding for the interferon- $\gamma$  receptor (IFNGR) or the IL-12 receptor or for IL-12 production. Patients with complete **IFNGR deficiency** have severe, difficult-to-treat disease. Those with partial IFNGR deficiency or IL-12 pathway mutations have milder disease that can respond to IFN- $\gamma$  and antimycobacterial therapy. **Multifocal osteomyelitis** is particularly prevalent in persons with the IFNGR1 818del4 mutation. Recurrences, even years after a course of treatment, and multiple infections are well documented. The second category of patients affected by disseminated disease is patients with **AIDS**. Disseminated NTM disease in patients with AIDS usually appears when CD4 cell counts are <50/ $\mu$ L for children  $\geq 6$  years, <75/ $\mu$ L in children 2 to <6 years, <500/ $\mu$ L in children 1 to <2 years, and <750/ $\mu$ L in children <1 year. The most recent estimate of the incidence of disseminated NTM disease is 0.14–0.2 episodes per 100 person-years, a 10-fold decrease from its incidence before combination antiretroviral therapy (cART) was available.

Colonization of the respiratory or gastrointestinal (GI) tract probably precedes disseminated MAC infections, but screening studies of respiratory secretions or stool samples are not useful to predict dissemination. Continuous high-grade bacteremia is common, and multiple organs are infected, typically including the lymph nodes, liver, spleen, bone marrow, and GI tract. The thyroid, pancreas, adrenal gland, kidney, muscle, and brain can also be involved. The most common signs and symptoms of disseminated MAC infections in patients with AIDS are fever, night sweats, chills, anorexia, marked weight loss, wasting, weakness, generalized lymphadenopathy, and hepatosplenomegaly. Jaundice, elevated alkaline phosphatase or lactate dehydrogenase levels, anemia, and neutropenia can occur. Imaging studies usually demonstrate massive lymphadenopathy of hilar, mediastinal, mesenteric, or retroperitoneal nodes. Successful treatment of disseminated infection in children with AIDS requires immune reconstitution and cART in addition to specific NTM therapy. The survival in children with AIDS has improved considerably with the availability of cART.

Disseminated disease in children without any apparent immunodeficiency is exceedingly rare.

## DIAGNOSIS

For infections of lymph nodes, skin, bone, and soft tissues, isolation of the causative NTM bacteria by *Mycobacterium* culture, preferably with histologic confirmation of granulomatous inflammation, normally suffices for diagnosis. The differential diagnosis of NTM lymphadenitis includes acute bacterial lymphadenitis, tuberculosis, cat scratch disease (*Bartonella henselae* infection), mononucleosis, toxoplasmosis, brucellosis, tularemia, and malignancies, especially lymphomas.

**Table 263.2**

American Thoracic Society Clinical and Microbiologic Criteria for Diagnosis of Nontuberculous Mycobacteria (NTM) Pulmonary Disease

CLINICAL*	PULMONARY OR SYSTEMIC SYMPTOMS
Radiologic*	Nodular or cavitary opacities on chest radiograph or a high-resolution computed tomography (HRCT) scan that shows bronchiectasis with multiple small nodules
AND	Appropriate exclusion of other diagnoses
Microbiologic	<ol style="list-style-type: none"> <li>1. Positive culture results from at least two separate expectorated sputum samples. If the results are nondiagnostic, consider repeat sputum AFB smears and cultures.</li> </ol> <p>or</p> <ol style="list-style-type: none"> <li>2. Positive culture results from at least one bronchial wash or lavage.</li> </ol> <p>or</p> <ol style="list-style-type: none"> <li>3. Transbronchial or other lung biopsy with mycobacterial histologic features (granulomatous inflammation or AFB) and positive culture for NTM or biopsy showing mycobacterial histologic features (granulomatous inflammation or AFB) and one or more sputum or bronchial washings that are culture-positive for NTM.</li> </ol>

\*Note: Both clinical and radiologic criteria are required.

AFB, Acid-fast bacilli.

From Daley CL, Iaccarino JM, Lange C, et al. Treatment of nontuberculous mycobacterial pulmonary disease: an official ATS/ERS/ESCMID/IDSA Clinical Practice Guideline [published correction appears in Clin Infect Dis. 2020 Dec 31;71(11):3023]. *Clin Infect Dis*. 2020;71(4):e1–e36.

Differentiation between NTM and *M. tuberculosis* may be difficult, but children with NTM lymphadenitis usually have a Mantoux tuberculin skin test reaction of <15 mm induration, unilateral anterior cervical node involvement, a normal chest radiograph, and no history of exposure to tuberculosis. Definitive diagnosis requires excision of the involved nodes for culture and histology. Fine-needle aspiration for PCR and culture can enable earlier diagnosis, before excisional biopsy.

The diagnosis of pulmonary NTM infection in children is difficult because many species of NTM, including MAC, are omnipresent in our environment and can contaminate clinical samples or be present but not causative of disease. As a result, isolation of these bacteria from nonsterile specimens (respiratory and digestive tract) does not necessarily reflect true disease. To determine the clinical relevance of isolation of NTM, the ATS/BTS diagnostic criteria are an important support (Table 263.2). These criteria take into consideration clinical features and radiologic, pathologic, and microbiologic findings. Their hallmark is the need for multiple positive cultures yielding the same NTM species to make a definitive diagnosis of pulmonary NTM disease, though a single culture from bronchoalveolar lavage (BAL)/bronchial lavage is acceptable in patients who meet clinical and radiologic criteria. In children, definitive diagnosis often requires invasive procedures such as bronchoscopy and pulmonary or endobronchial biopsy; in CF patients, more aggressive sample pretreatment in the clinical microbiology laboratory is necessary to prevent overgrowth by other species, especially *Pseudomonas*. The chance of NTM isolation being clinically relevant differs significantly by species; some species are more likely causative agents of true pulmonary disease (*M. avium*, *M. kansasii*, *M. abscessus*, *M. malmoense*), whereas others are more likely contaminants (*M. goodii*, *M. fortuitum*, *M. chelonae*).

Blood cultures are 90–95% sensitive in AIDS patients with disseminated infection. MAC may be detected within 7–10 days of inoculation in almost all patients by automated blood culture systems. In adults, some studies have shown that liver biopsy cultures and stains are more sensitive than blood culture or bone marrow biopsy workup. Commercially available DNA probes differentiate NTM from *M.*

*tuberculosis*. If DNA probes cannot identify the causative mycobacteria, DNA sequencing of bacterial housekeeping genes can yield a clue to the identity of these NTM. Identification of histiocytes containing numerous AFB from bone marrow and other biopsy tissues provides a rapid presumptive diagnosis of disseminated mycobacterial infection.

## TREATMENT

Therapy for NTM infections is long-term and cumbersome; expert consultation is advised. Therapy involves medical, surgical, or often combined treatment (see Chapter 260, Table 260.3). Isolation of the infecting strain followed by drug-susceptibility testing is ideal, because it provides a baseline for drug susceptibility. Important discrepancies exist between in vitro drug susceptibility and in vivo response to treatment, explained in part by synergism, mainly among first-line antituberculosis drugs. In vitro, **slow growers** (*M. kansasii*, *M. marinum*, *M. xenopi*, *M. ulcerans*, *M. malmoense*) are usually susceptible to the first-line antituberculosis drugs **rifampin** and **ethambutol**; MAC bacteria are often resistant to these drugs alone but susceptible to the combination and have variable susceptibility to other antibiotics, most importantly the macrolides. **Rapid growers** (*M. fortuitum*, *M. chelonae*, *M. abscessus*) are highly resistant to antituberculosis drugs and often have inducible macrolide-resistance mechanisms. Susceptibility to macrolides, aminoglycosides, carbapenems, tetracyclines, and glycolylcyclines are most relevant for therapy guidance. In all NTM infections, multi-drug therapy (MDT) is essential to avoid development of resistance.

**The preferred treatment of NTM lymphadenitis is complete surgical excision.** Clinical trials revealed that surgery is more effective than antibiotic treatment (see Table 260.3). Nodes should be removed while still firm and encapsulated. Excision is more difficult if extensive caseation with extension to surrounding tissue has occurred, and complications of facial nerve damage or relapse of infection are more likely in such cases. Incomplete surgical excision is not advised, because chronic drainage can develop. If there are concerns or risk factors for possible *M. tuberculosis* infection, therapy with isoniazid, rifampin, ethambutol, and pyrazinamide should be administered until cultures confirm the cause to be NTM (see Chapter 261). If surgery of NTM lymphadenitis cannot be performed, or removal of infected tissue is incomplete, or recurrence or chronic drainage develops, a 3-month trial of antibiotic therapy should be considered. **Clarithromycin or azithromycin combined with rifampin or ethambutol are the most common therapy regimens reported for MAC lymphadenitis** (see Table 260.3). Suppuration may still occur on appropriate antibiotic therapy. In immunocompetent patients, **an observational approach** to NTM lymphadenitis can be chosen without antibiotic therapy, although resolution will take up to 12 months.

Posttraumatic cutaneous NTM lesions in immunocompetent patients usually heal spontaneously after incision and drainage without other therapy. *M. marinum* is susceptible to rifampin, amikacin, ethambutol, sulfonamides, trimethoprim-sulfamethoxazole, and tetracycline. Therapy with a combination of these drugs, particularly clarithromycin and ethambutol, may be given until 1 month after the lesion has disappeared. Corticosteroid injections should not be used. Superficial infections with *M. fortuitum* or *M. chelonae* usually resolve after surgical incision and open drainage, but deep-seated or catheter-related infections require removal of infected central lines and therapy with parenteral amikacin plus cefoxitin, ciprofloxacin, or clarithromycin.

Some localized forms of *M. ulcerans* skin disease (Buruli ulcer) can heal spontaneously; for most forms, excisional surgery with primary closure or skin grafting is recommended. **The combination of rifampin (10 mg/kg once daily) and clarithromycin (7.5 mg/kg twice daily) for 8 weeks results in excellent outcomes and is now the recommended treatment for early limited Buruli ulcer.** Another agent that shows great promise is telacebec (also known as Q203), a novel first-in-class antituberculosis drug targeting cellular energy production through inhibition of the mycobacterial cytochrome bc<sub>1</sub> complex; animal studies have demonstrated significant potency against *M. ulcerans*, possibly allowing for shorter courses of treatment. In January 2021, the U.S. Food and Drug Administration granted orphan drug designation (ODD) to telacebec for Buruli ulcer treatment. **Physiotherapy** after surgery is essential to prevent contractures and functional disabilities.

For patients who meet diagnostic criteria for pulmonary NTM infections (see Table 263.2), treatment rather than observation is recommended, particularly with persistently positive sputum smears and/or cavitary lung disease. Although treatment offers possibility of cure, there can be significant adverse effects of treatment and low cure rates for some forms of infection. Patients who require treatment for NTM pulmonary disease should have isolates sent for susceptibility testing, with the caveat that this testing is helpful for NTM for antibiotics where there is a well-documented correlation between in vitro activity and microbiologic response to therapy. Drugs for which this correlation exist include macrolides (azithromycin, clarithromycin) and amikacin for MAC and *M. abscessus* and rifampin for *M. kansasii*. **For macrolide-susceptible MAC pulmonary disease, treatment with three drugs for at least 12 months after culture conversion is recommended, generally azithromycin, rifampin, and ethambutol.** For macrolide-resistant isolates, parenteral amikacin is often used, as MAC isolates are usually susceptible in vitro to this agent.

Macrolides are a mainstay in the treatment of *M. abscessus* pulmonary disease. However, macrolide resistance can develop via chromosomal mutation or through induction of the erm(41) gene. **For *M. abscessus* disease caused by strains without inducible or chromosomal macrolide resistance, a macrolide-containing treatment regimen is recommended, typically with at least three active drugs. If macrolide resistance (chromosomal or inducible) is present, at least four active drugs are recommended.** Treatment regimens for *M. abscessus* are complex, usually with oral plus parental drugs. Regimens typically include two to three oral agents, which may include azithromycin, clofazimine, or linezolid, and at least one parenteral agent, with options including amikacin, imipenem, and tigecycline. In CF patients, inhaled agents may also have a role. Choice of treatment regimens and duration of therapy should be guided by expert consultation. For select patients, surgical resection of severely diseased lung in addition to medical therapy may be indicated.

For *M. kansasii* pulmonary disease, susceptibility-based treatment for rifampin is recommended over empirical therapy. The recommended treatment regimen for rifampin-susceptible *M. kansasii* infections is rifampin, ethambutol, and either isoniazid or a macrolide for at least 12 months. Fluoroquinolones also have good activity against *M. kansasii* but are reserved for rifampin-resistant *M. kansasii* infection treatment and for patients who have intolerance to one of the first-line antibiotics.

Patients with disseminated MAC and IL-12 pathway defects or IFNGR deficiency should be treated for at least 12 months with clarithromycin or azithromycin combined with rifampin or rifabutin and ethambutol. In vitro susceptibility testing for macrolides is important to guide therapy. Once the clinical illness has resolved, lifelong daily prophylaxis with azithromycin or clarithromycin is advisable to prevent recurrent disease. The use of IFN adjunctive therapy is determined by the specific genetic defect.

In children with AIDS, prophylaxis with azithromycin or clarithromycin is indicated to prevent infection with MAC. Although few pediatric studies exist, the U.S. Public Health Service recommends either **azithromycin** (20 mg/kg once weekly PO, maximum 1,200 mg/dose or 5 mg/kg once daily PO, maximum 250 mg/dose in patients intolerant of the larger dose) or **clarithromycin** (7.5 mg/kg/dose twice daily PO; maximum 500 mg/dose) for HIV-infected children with significant immune deficiency, as defined by the CD4 count (children ≥6 years old, CD4 count <50 cells/μL; 2 to <6 years old, <75/μL; 1 to <2 years old, <500/μL; <1 year old, <750/μL). Rifabutin may also be used. Primary prophylaxis may be safely discontinued in children >2 years old receiving stable highly active antiretroviral therapy (HAART) for >6 months and experiencing sustained (>3 months) CD4 cell recovery well above the age-specific target for initiation of prophylaxis: >100 cells/μL for children ≥6 years old and >200/μL for children 2-5 years old. For children <2 years old, no specific recommendations for discontinuing MAC prophylaxis exist.

Visit Elsevier eBooks+ at [eBooks.Health.Elsevier.com](http://eBooks.Health.Elsevier.com) for Bibliography.

## Section 8

## Spirochetal Infections

## Chapter 264

Syphilis (*Treponema pallidum*)

Alice I. Sato and H. Dele Davies

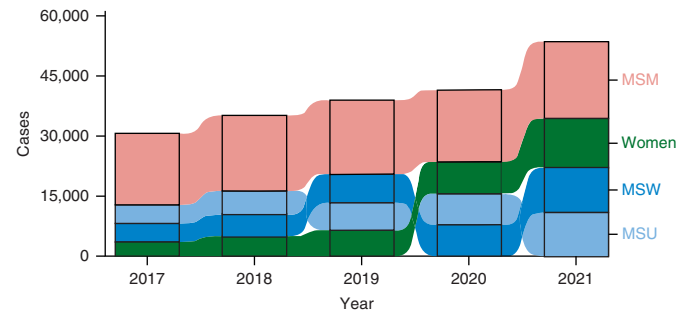
Syphilis is a chronic systemic sexually or vertically (mother to child) transmitted infection that can be easily treated if detected early but manifests with protean clinical symptoms and significant morbidity if left unchecked. (Please note that the terms *mother* and *maternal* are used to designate the birthing parent throughout this chapter and are not intended to exclude other birthing parents.)

## ETIOLOGY

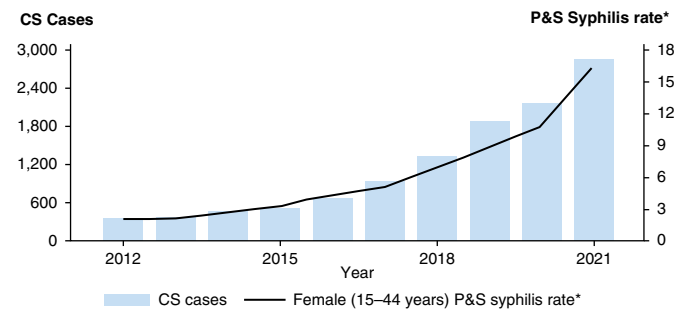
Syphilis is caused by *Treponema pallidum*, a delicate, tightly spiraled, motile spirochete with finely tapered ends belonging to the family Spirochaetaceae. The pathogenic members of this genus include *T. pallidum* subspecies *pallidum* (venereal syphilis), *T. pallidum* subspecies *pertenue* (yaws), *T. pallidum* subspecies *endemicum* (bejel or endemic syphilis), and *T. pallidum* subspecies *carateum* (pinta). Because these microorganisms stain poorly and are below the detection limits of conventional light microscopy, detection in clinical specimens requires dark-field, phase-contrast microscopy or direct immunofluorescent or silver staining. *T. pallidum* has only recently been successfully grown in vitro via co-culture with mammalian tissue culture cells, and a method has now been described for inoculation of fresh and frozen needle aspirates from primary experimental syphilis lesions onto culture plates but remains to be developed for clinical use. Use of nucleic acid amplification testing by polymerase chain reaction (PCR) may have a role in diagnosis, particularly in seronegative patients or those with discrepant serology results.

## EPIDEMIOLOGY

**Acquired syphilis** is transmitted almost exclusively by sexual contact, including vaginal, anal, and oral exposure. Less common modes of transmission include transfusion of contaminated blood or direct contact with infected tissues. Syphilis in men who have sex with men (MSM) may be acquired in the absence of visible lesions. DNA-based *T. pallidum* testing has identified organisms in oral rinse or swab samples and in anal canal swabs, urine, semen, and peripheral blood; the risk is highest in secondary and early latent syphilis. The incubation period for acquired primary syphilis is about 3 weeks (range 10–90 days). After an epidemic resurgence of primary and secondary syphilis in the United States that peaked in 1989, the annual rate declined 90% to the lowest-ever rate by 2000. The total number of cases of primary and secondary syphilis has subsequently rebounded since 2000 (Fig. 264.1). MSM have been disproportionately impacted: ~46% of cases in 2021. Rates of primary and secondary syphilis in women remain lower than in men yet still have increased 55% during 2021. Cases of congenital syphilis reached an historic low in 2005 but have subsequently increased annually since 2013, reflecting the rates among women. In 2021, the US national congenital syphilis rate was 77.9 cases per 100,000 live births, representing a 30.5% increase from 2020 and a 219.3% increase from 2017 (Fig. 264.2); syphilitic still births also increased over this period. The increase occurs across every region and all races and ethnicities, but marked disparities exist,



**Fig 264.1** Primary and secondary syphilis – Reported cases by sex and sex of sex partners 2017–2021. Note: Over the 5-yr period, 0.2% of cases were missing sex and were not included. MSM, Gay, bisexual, and other men who have sex with men; MSU, Men with unknown sex of sex partners; MSW, men who have sex with women only. (From Centers for Disease Control and Prevention. Sexually transmitted disease surveillance. National overview of STDs, 2021. <https://www.cdc.gov/std/statistics/2021/overview.htm>)



**Fig. 264.2** Congenital syphilis — Reported cases by year of birth and rates of reported cases of primary and secondary syphilis among women age 15–44 years, United States, 2012–2021. \*Per 100,000. CS, Congenital syphilis; P&S syphilis, Primary and secondary syphilis. (From Centers for Disease Control and Prevention. Sexually transmitted disease surveillance. National overview of STDs, 2021. <https://www.cdc.gov/std/statistics/2021/overview.htm>)

with minority groups, gay and bisexual men, and youth most affected. The COVID-19 pandemic disrupted screening programs and access to care, and increased cases are expected.

**Congenital syphilis** results from transplacental transmission of spirochetes or occasionally by intrapartum contact with infectious lesions or possibly involved mucosa without obvious lesions. Women with primary and secondary syphilis and spirochetemia are more likely to transmit infection to the fetus than are women with latent infection. Transmission can occur at any stage of pregnancy, resulting in early fetal loss, preterm or low birthweight infants, stillbirths, neonatal deaths, or infants born with congenital disease. The incidence of congenital infection in offspring of untreated or inadequately treated infected women remains highest during the first 4 years after acquisition of primary infection, secondary infection, and early latent disease. Maternal (parental) factors associated with congenital syphilis include limited access to healthcare, late or no prenatal care, drug use, multiple sex partners, unprotected sexual contact, incarceration, work in the sex trade, and inadequate treatment of syphilis during pregnancy. Congenital syphilis may be seen in the context of untreated, inadequately treated, or undocumented treatment before or during pregnancy. In addition, the mother may have been treated appropriately but did not have an adequate serologic response to therapy and the infant was inadequately evaluated, or the infant had documented congenital syphilis. Confirmed cases of both acquired and congenital syphilis must be reported to the local health department.

## CLINICAL MANIFESTATIONS AND LABORATORY FINDINGS

Many persons infected with syphilis are *asymptomatic for years*, or do not recognize the early signs of disease, or do not seek or have access



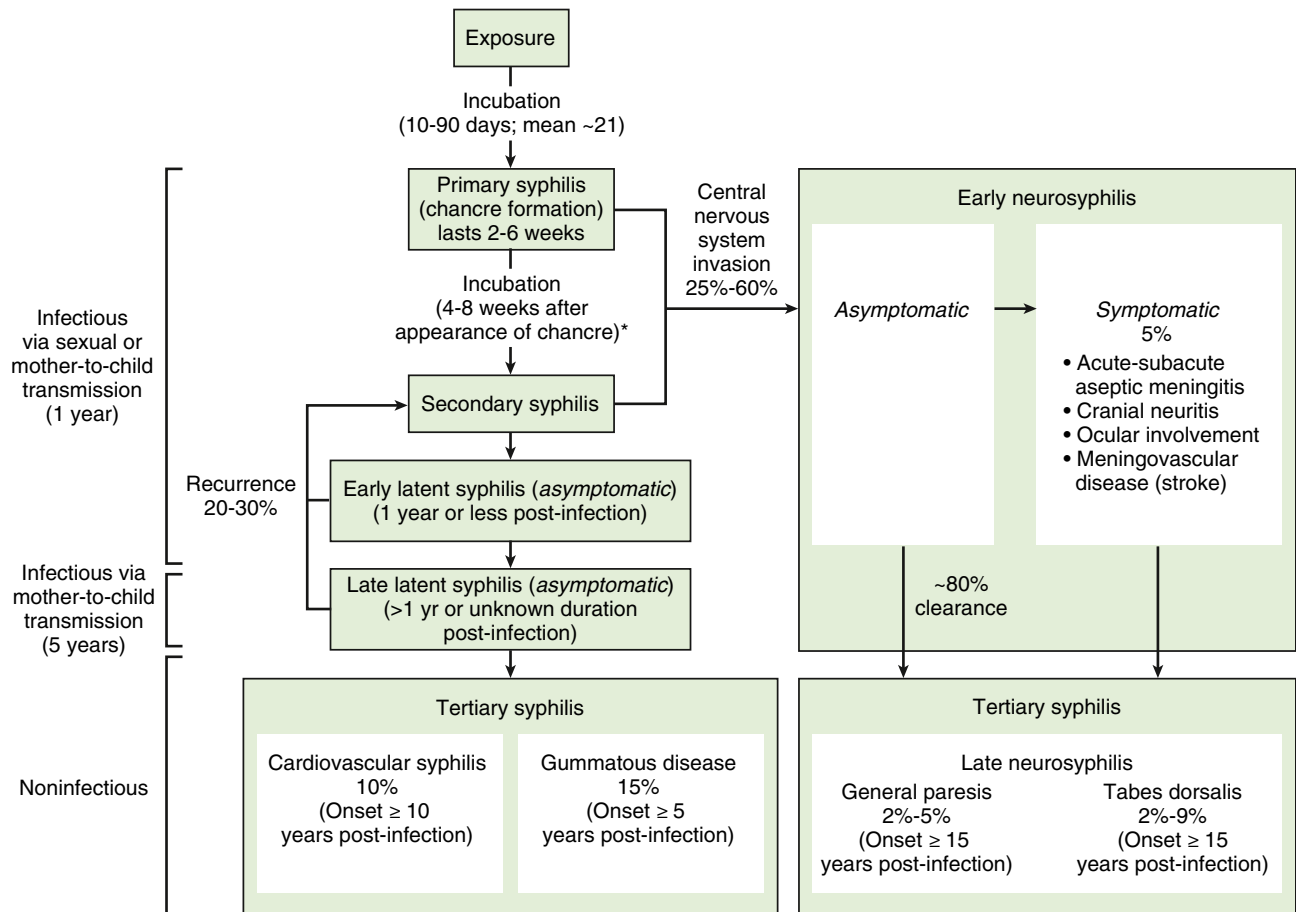
to treatment. The Centers for Disease Control and Prevention (CDC) recommends testing all pregnant persons and selective testing of adolescents, based on lesions or risk factors (those with other sexually transmitted diseases including HIV, MSM, incarcerated individuals, or persons who exchange sex for money or drugs). CDC/MMWR sexually transmitted infection (STI) guidelines should be consulted to ensure that all appropriate screening is performed. All 50 states and the District of Columbia explicitly allow minors to consent for STI services, though as of 2022, 18 states allow (but do not require) physicians to notify parents of STI services provided to a minor (<https://www.cdc.gov/hiv/policies/law/states/minors.html>). Periods of active clinical disease alternate with periods of latency (Fig. 264.3). **Primary syphilis** is characterized by a chancre and regional lymphadenitis. A **painless papule** (which may be overlooked) appears at the site of entry (usually the genitalia) 2-6 weeks after inoculation and develops into a clean, painless but highly contagious ulcer with raised borders (**chancre**) containing abundant *T. pallidum*. Extragenital chancres can occur at other sites of primary entry and pose a diagnostic challenge. Oral lesions can be mistaken for aphthous ulcers or herpes. Lesions on the nipple can be confused with cellulitis or eczema. Adjacent lymph nodes are generally enlarged and nontender. The chancre heals spontaneously within 4-6 weeks, leaving a thin scar.

Untreated patients develop manifestations of **secondary syphilis** related to spirochetemia 2-10 weeks after the chancre heals. Manifestations of secondary syphilis include a generalized nonpruritic maculopapular rash, notably involving the palms and soles (Fig. 264.4). Pustular lesions can also develop. **Condylomata lata**, gray-white to erythematous wartlike plaques, can occur in moist areas around the anus, scrotum, or vagina, and white plaques (**mucous patches**) may

be found in mucous membranes. Secondary syphilis should be considered in the differential diagnosis of virtually any rash of unknown etiology. A **flulike illness** with low-grade fever, headache, malaise, anorexia, weight loss, sore throat, myalgias, arthralgias, and generalized lymphadenopathy is often present. Renal, hepatic, or ocular manifestations may be present. Meningitis occurs in about 30% of patients with untreated syphilis, occurring at any stage but most commonly in



**Fig. 264.4** Secondary syphilis. Ham-colored palmar macules on an adolescent with secondary syphilis. (From Weston WL, Lane AT, Morelli J. *Color Textbook of Pediatric Dermatology*, 3rd ed. St. Louis: Mosby; 2002.)



**Fig. 264.3** Natural course of untreated syphilis. As of January 2018, the Centers for Disease Control and Prevention renamed early and late latent syphilis *early syphilis, nonprimary, nonsecondary* and *syphilis, unknown duration or late*, respectively. \*HIV infection may modify the progression of syphilis; the chancre may coexist with the secondary syphilis stage, suggesting a more rapid progression to the secondary stage. (Modified from Radolf JD, Tramont EC, Salazar JC. *Syphilis [Treponema pallidum]*. In: Bennett JE, Dolin R, Blaser MJ, eds. *Mandell, Douglas, and Bennett's Principles and Practice of Infectious Diseases*, 9th ed. Philadelphia: Elsevier; 2020: Fig. 237.5, p. 2874.)



secondary syphilis (see Fig. 264.3). It is characterized by cerebrospinal fluid (CSF) pleocytosis and elevated protein level. Patients with meningitis might not show neurologic symptoms. Even without treatment, secondary infection becomes **latent** within 1-2 months after onset of rash. Relapses with secondary manifestations can occur during the first year of latency (the **early latent period**). **Late syphilis** follows and may be either asymptomatic (**late latent**) or symptomatic (**tertiary**). Tertiary disease follows in about one-third of untreated cases and is marked by neurologic, cardiovascular, and **gummatous lesions** (non-suppurative granulomas of the skin, bone, and liver resulting from the host cytotoxic T-cell response). In the preantibiotic era, neurologic manifestations of tertiary syphilis (**tabes dorsalis** and **pareisis**) were common. The clinical course of syphilis and its tissue manifestations reflect the immunopathobiology of the host humoral and delayed-type hypersensitivity responses. A robust timeline of progression through the overlapping stages occurs in immunocompromised HIV patients

### Congenital Infection

Untreated syphilis during pregnancy results in a vertical transmission rate approaching 100%, with profound effects on pregnancy outcome,



**Fig. 264.5** Osteochondritis and periostitis in a newborn with congenital syphilis.

reflecting obliterating endarteritis. Fetal or perinatal death occurs in 40% of affected infants. Premature delivery can also occur. Neonates can also be infected at delivery by contact with an active genital lesion. Most infected infants are asymptomatic at birth, including up to 40% with CSF seeding, and are identified only by routine prenatal screening. In the absence of treatment, symptoms develop within weeks or months. Among infants symptomatic at birth or in the first few months of life, manifestations have traditionally been divided into early and late stages. All stages of congenital syphilis are characterized by a vasculitis, with progression to necrosis and fibrosis. The **early signs** appear during the first 2 years of life, and the **late signs** appear gradually during the first 2 decades. Early manifestations vary and involve multiple organ systems, resulting from transplacental spirochetemia, and are analogous to the secondary stage of acquired syphilis. Hepatosplenomegaly, jaundice, and elevated liver enzymes are common. Histologically, liver involvement includes bile stasis, fibrosis, and extramedullary hematopoiesis. Lymphadenopathy tends to be diffuse and resolve spontaneously, although shotty nodes can persist.

Coombs-negative hemolytic anemia is characteristic. Thrombocytopenia is often associated with platelet trapping in an enlarged spleen. Characteristic **osteochondritis** and **periostitis** (Fig. 264.5) and a mucocutaneous rash (Fig. 264.6A and B) manifesting with erythematous maculopapular or vesiculobullous lesions followed by desquamation involving the hands and feet (see Fig. 264.6C) are common. Mucous patches, persistent rhinitis (**snuffles**), and condylomatous lesions (Fig. 264.7) are highly characteristic features of mucous membrane involvement containing abundant spirochetes. Blood and moist, open lesions from infants with congenital syphilis and children with acquired primary or secondary syphilis are infectious until 24 hours of appropriate treatment.

Bone involvement is common. Roentgenographic abnormalities include **Wimberger lines** (demineralization of the medial proximal tibial metaphysis); multiple sites of osteochondritis at the wrists, elbows, ankles, and knees; and periostitis of the long bones and, rarely, the skull. The osteochondritis is painful, often resulting in irritability and refusal to move the involved extremity (**pseudoparalysis of Parrot**).

Congenital neurosyphilis is often asymptomatic in the neonatal period, although CSF abnormalities can occur even in asymptomatic infants. Failure to thrive, chorioretinitis, nephritis, and nephrotic syndrome can also be seen. Manifestations of renal involvement include hypertension, hematuria, proteinuria, hypoproteinemia, hypercholesterolemia, and hypocomplementemia, probably related to glomerular deposition of circulating immune complexes. Less common clinical manifestations of early congenital syphilis include gastroenteritis, peritonitis, pancreatitis, pneumonia, eye involvement (glaucoma and chorioretinitis), nonimmune hydrops, and testicular masses.

Late manifestations (children >2 years of age) are rarely seen in developed countries. These result primarily from chronic granulomatous inflammation of bone, teeth, and the central nervous system and are summarized in Table 264.1. Skeletal changes are caused by persistent or recurrent periostitis and associated thickening of the involved



**Fig. 264.6** A and B, Papulosquamous plaques in two infants with syphilis. C, Desquamation on the palm of a newborn's hand. (A and B from Eichenfeld LF, Frieden IJ, Esterly NB, eds. *Textbook of Neonatal Dermatology*. Philadelphia: WB Saunders, 2001: p. 196; courtesy Dr. Patricia Treadwell.)



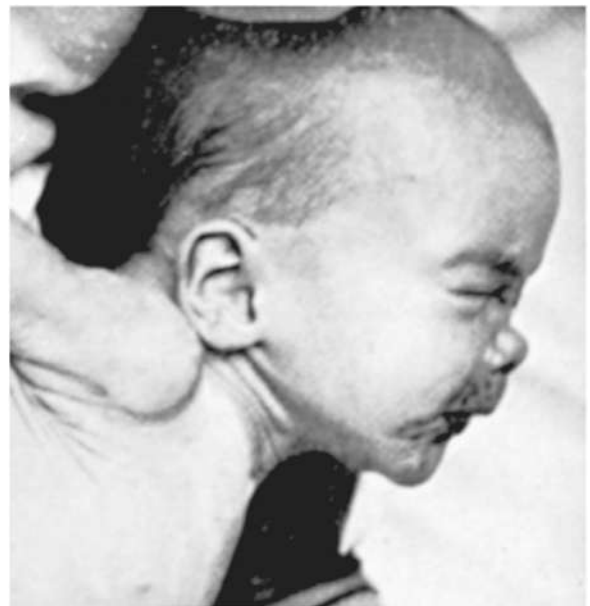
**Fig. 264.7** Perianal condylomata lata. (From Karthikeyan K, Thappa DM. Early congenital syphilis in the new millennium. *Pediatr Dermatol.* 2002;19:275–276.)



**Fig. 264.8** Hutchinson teeth as a late manifestation of congenital syphilis.

<b>Table 264.1</b> Late Manifestations of Congenital Syphilis	
<b>SYMPTOM/SIGN</b>	<b>DESCRIPTION/COMMENTS</b>
Olympian brow	Bony prominence of the forehead caused by persistent or recurrent periostitis
Clavicular or Higoumenakis sign	Unilateral or bilateral thickening of the sternoclavicular third of the clavicle
Saber shins	Anterior bowing of the midportion of the tibia
Scaphoid scapula	Convexity along the medial border of the scapula
Hutchinson teeth	Peg-shaped upper central incisors; they erupt during sixth yr of life with abnormal enamel, resulting in a notch along the biting surface
Mulberry molars	Abnormal first lower (6yr) molars characterized by small biting surface and excessive number of cusps
Saddle nose*	Depression of the nasal root, a result of syphilitic rhinitis destroying adjacent bone and cartilage
Rhagades	Linear scars that extend in a spokelike pattern from previous mucocutaneous fissures of the mouth, anus, and genitalia
Juvenile paresis	Latent meningovascular infection; it is rare and typically occurs during adolescence with behavioral changes, focal seizures, or loss of intellectual function
Juvenile tabes	Rare spinal cord involvement and cardiovascular involvement with aortitis
Hutchinson triad	Hutchinson teeth, interstitial keratitis, and eighth cranial nerve deafness
Clutton joint	Unilateral or bilateral painless joint swelling (usually involving the knees) from synovitis with sterile synovial fluid; spontaneous remission usually occurs after several weeks
Interstitial keratitis	Manifests with intense photophobia and lacrimation, followed within weeks or months by corneal opacification and complete blindness
Eighth cranial nerve deafness	May be unilateral or bilateral, appears at any age, manifests initially as vertigo and high-tone hearing loss, and progresses to permanent deafness

\*A perforated nasal septum may be an associated abnormality.



**Fig. 264.9** Saddle nose in a newborn with congenital syphilis.

bone. Dental abnormalities, such as **Hutchinson teeth** (Fig. 264.8), are common. Defects in enamel formation lead to repeated caries and eventual tooth destruction. **Saddle nose** (Fig. 264.9) is a depression of the nasal root and may be associated with a perforated nasal septum.

Other late manifestations of congenital syphilis can manifest as hypersensitivity phenomena. These include unilateral or bilateral interstitial keratitis and the **Clutton joint** (see Table 264.1). Other common ocular manifestations include choroiditis, retinitis, vascular occlusion, and optic atrophy. Soft tissue gummas (identical to those of acquired disease) and paroxysmal cold hemoglobinuria are rare hypersensitivity phenomena.

## DIAGNOSIS

Fundamental limitations of the currently available tests for syphilis are vexing, but results must always be interpreted in the context of patient history and physical examination. Physicians should remain aware of their local prevalence rates and treat presumptively when syphilis is suspected by clinical and epidemiologic data. The diagnosis of primary syphilis is confirmed when *T. pallidum* is demonstrated by dark-field microscopy or direct fluorescent antibody testing on specimens from skin lesions, placenta, or umbilical cord. Nucleic acid–based amplification assays, such as PCR, are also used in some specialized laboratories but are not commercially available. Despite the absence of a true

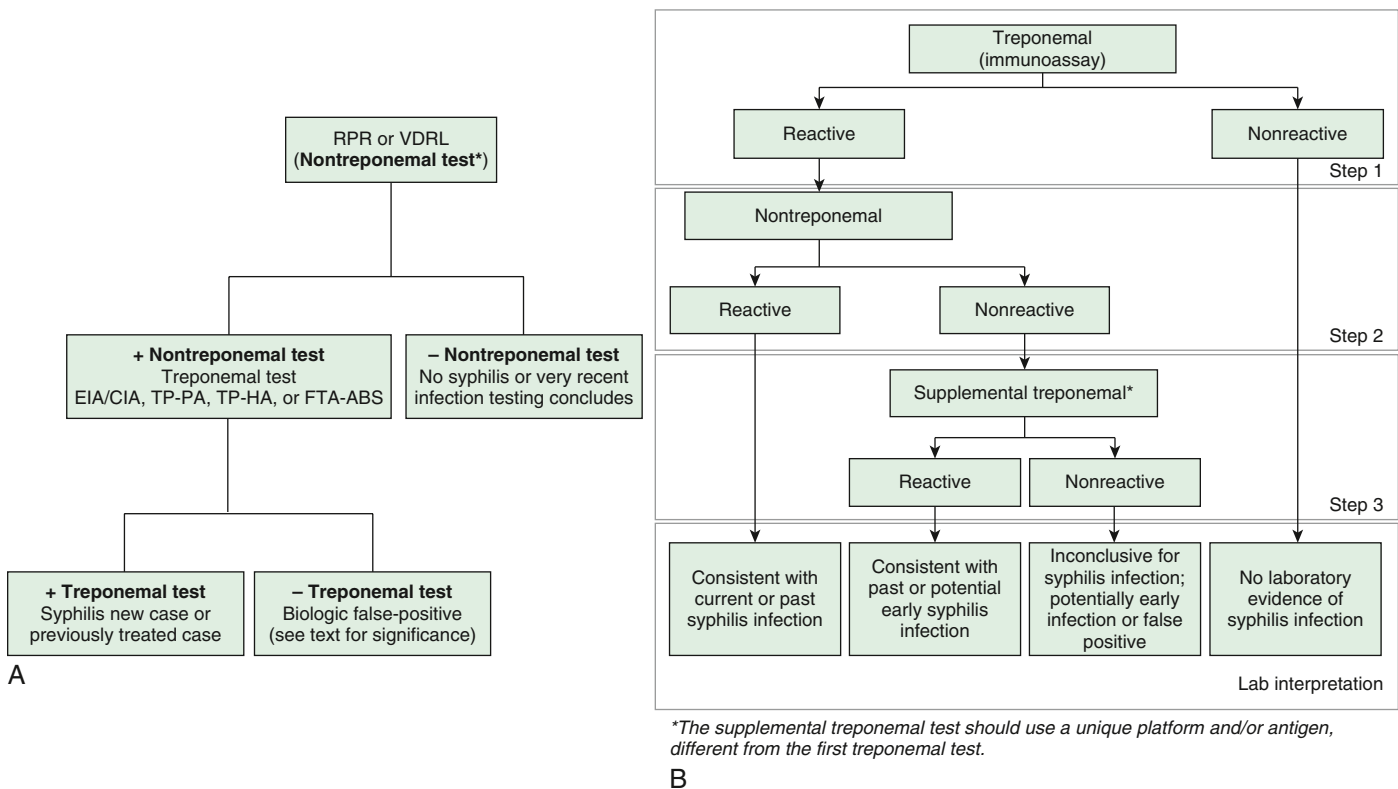
gold-standard serologic assay, serologic testing for syphilis remains the principal means for diagnosis and traditionally involves a two-step screening process with a nontreponemal test followed by a confirmatory treponemal test (Fig. 264.10A). Both test types are required for serologic-based diagnosis. False-negative tests may occur in early syphilis, and high-risk individuals may need repeat testing in 2-4 weeks if clinically indicated.

The **Venereal Disease Research Laboratory (VDRL)** and **rapid plasma reagin (RPR)** tests are sensitive **nontreponemal tests** that detect antibodies against phospholipid antigens on the treponeme surface that cross react with cardiolipin-lecithin-cholesterol antigens of damaged host cells. The quantitative results of these tests are helpful both in screening and in monitoring therapy. Titers increase with active disease, including treatment failure or reinfection, and decline with adequate treatment (Fig. 264.11). Nontreponemal tests usually become nonreactive within 1 year of adequate therapy for primary syphilis and within 2 years of adequate treatment for secondary disease. Fifteen to twenty percent of patients become **serofast** (nontreponemal titers persisting at low levels for long periods). In congenital infection, nontreponemal tests become nonreactive within a few months after adequate treatment. Certain conditions such as infectious mononucleosis and other viral infections, autoimmune diseases, and pregnancy can give false-positive VDRL results. False-positive results are less common with the use of purified cardiolipin-lecithin-cholesterol antigen. All pregnant women should be screened early in pregnancy and at delivery. All positive maternal (parental) serologic tests for syphilis, regardless of titer, necessitate thorough investigation. Antibody excess can give a false-negative reading unless the serum is diluted (**prozone effect**) as the formation of the antigen-antibody lattice needed to visualize a positive flocculation test is disrupted. False-negative results can also occur in early primary syphilis, in latent syphilis of long duration, and in late congenital syphilis.

**Treponemal tests** traditionally are used to confirm diagnosis and measure specific *T. pallidum* antibodies (immunoglobulin [Ig] G, IgM, and IgA), which appear earlier than nontreponemal antibodies. Treponemal tests include the *T. pallidum* particle agglutination test (TP-PA, which is the preferred treponemal test) and the fluorescent treponemal antibody absorption test (FTA-ABS). Treponemal antibody titers become positive soon after initial infection and usually remain positive for life, even with adequate therapy (see Fig. 264.11). These antibody titers do not correlate with disease activity. Traditionally they are useful for diagnosis of a first episode of syphilis and for distinguishing false-positive results of nontreponemal antibody tests but cannot accurately identify length of time of infection, response to therapy, or reinfection.

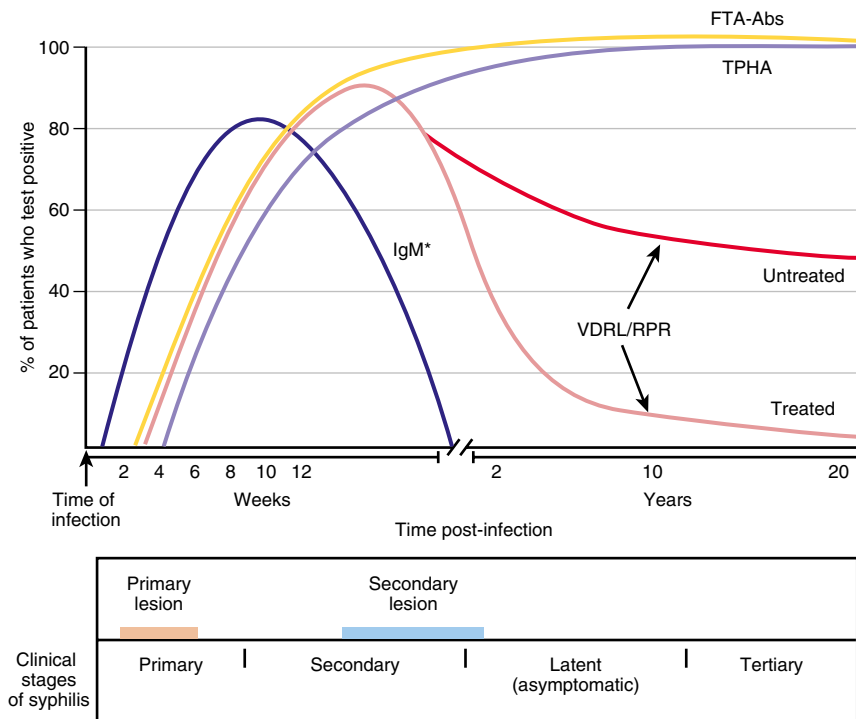
There is limited cross reactivity of treponemal antibody tests with other spirochetes, including the causative organisms of Lyme disease (*Borrelia burgdorferi*), yaws, endemic syphilis, and pinta. Only venereal syphilis and Lyme disease are found in the United States. Nontreponemal tests (VDRL, RPR) are uniformly nonreactive in Lyme disease.

Various enzyme-linked, chemiluminescence, and multiplex flow immunoassays to detect treponemal IgG and IgM have been developed. These assays have increased sensitivity and are amenable to automation and high-volume use. Rapid point-of-care tests are available to allow quality screening programs in resource-limited settings where the World Health Organization otherwise relies on syndromic management of STIs and patients are treated for all likely causes of their constellation of signs and symptoms. In the United States, use of immunoassays has confounded screening because it switches the traditional algorithm: the treponemal-specific testing is done before the nontreponemal testing. Because the former remain positive for life, clinical and epidemiologic data are required to provide guidelines to distinguish cured disease, early syphilis, untreated late latent disease, and true false-positive tests. Benefits of **reverse screening** are



**Fig. 264.10** A, Traditional laboratory testing algorithm for syphilis. B, Suggested alternative testing algorithm. EIA/CIA, Enzyme immunoassay/chemiluminescence immunoassay; FTA-ABS, fluorescent treponemal antibody absorption; RPR, rapid plasma reagin; TP-HA, *Treponema pallidum* hemagglutination; TP-PA, *Treponema pallidum* particle agglutination; VDRL, Venereal Disease Research Laboratory. \*If nontreponemal test is positive qualitatively, a titer is then quantitated. (A based on data from Workowski KA, Berman S; Centers for Disease Control and Prevention. Sexually transmitted diseases treatment guidelines, 2010. *MMWR Recomm Rep* 2010;59[RR-12]:1–110. pp. 26–29.)





\*IgM by ELISA or FTA-ABS 195 or immunoblot.

**Fig. 264.11** Common patterns of serologic reactivity in syphilis patients. FTA-Abs, fluorescent treponemal antibody absorption (test); RPR, rapid plasma reagin (test); TPHA, *Treponema pallidum* hemagglutination assay; VDRL, Venereal Disease Research Laboratory (test). IgM by immunoassay. (From Peeling R, Ye H. Diagnostic tools for preventing and managing maternal and congenital syphilis: an overview. *Bull World Health Organ.* 2004;82[6]:439–446.)

increased detection of transmissible early syphilis and of late latent disease to afford monitoring for tertiary disease. Although the CDC and American Academy of Pediatrics (AAP) Red Book continue to recommend the traditional screen (“conventional diagnostic approach”; see Fig. 264.10A), they have provided guidelines for interpretation of the reverse screening algorithm (see Fig. 264.10B). Reverse screening may yield false-positive results, particularly in low-prevalence populations where testing results should be interpreted with caution, as false-positive testing in children may have serious adverse consequences. If reverse testing yields a positive treponemal result but a negative nontreponemal result, a second treponemal test targeting a different treponemal antigen is needed for confirmation. Interpretation of nontreponemal and treponemal serologic tests in the newborn can be confounded by maternal IgG antibodies transferred to the fetus. Passively acquired antibody is suggested by a neonatal titer at least fourfold (i.e., a two-tube dilution) less than the maternal (parental) titer. This conclusion can be verified by a gradual decline in antibody in the infant, usually becoming undetectable by 3–6 months of age. Conversely, an infant nontreponemal titer fourfold higher than the mother’s at the time of delivery or a persistent or rising nontreponemal titer in the infant suggests congenital infection.

Neurologic involvement can occur at any stage of syphilis. The diagnosis of neurosyphilis remains difficult but is often established by demonstrating pleocytosis and increased protein in the CSF and a positive CSF VDRL test along with neurologic symptoms. The CSF VDRL test is specific but relatively insensitive (22–69%) for neurosyphilis. CSF PCR and IgM immunoblot tests are being studied but not currently recommended for use in making the diagnosis of neurosyphilis.

Dark-field or direct fluorescent antibody microscopy of scrapings from primary lesions or congenital or secondary lesions can reveal *T. pallidum*, often before serology becomes positive, but these modalities are usually not available in clinical practice. Since 2015 different methods of PCR, including routine PCR, nested PCR, reverse-transcriptase PCR, and quantitative PCR targeting different DNA gene sequences, have been used by many laboratories as methods to detect *T. pallidum* in primary disease. However, there are currently

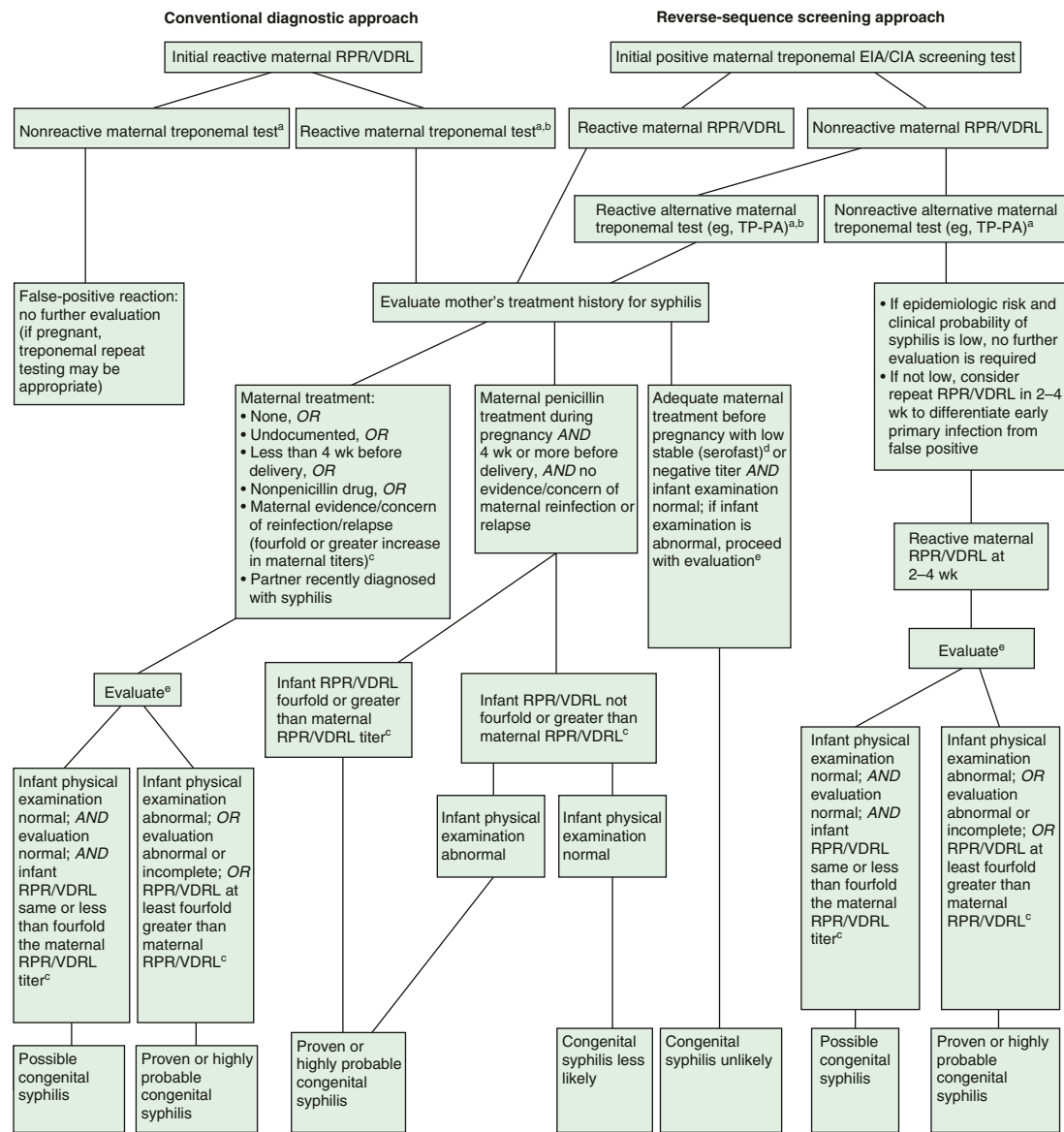
no commercially available test kits, and each test must be validated for use in each laboratory. Furthermore, these tests are not useful for asymptomatic patients, and interpretation may be complicated by the fact that they amplify both dead and living organisms. Placental examination by gross and microscopic techniques can be useful in the diagnosis of congenital syphilis. The disproportionately large placentas are characterized histologically by focal proliferative villitis, endovascular and perivascular arteritis, and focal or diffuse immaturity of placental villi.

### Congenital Syphilis

A diagnosis of congenital syphilis requires a thorough review of maternal (parental) history of syphilis treatment preconception and the testing, treatment, and dynamics of response during the current pregnancy. Regardless of maternal (parental) treatment and the presence/absence of symptoms in the infant, proactive evaluation and treatment of exposed neonates is critical (Fig. 264.12 and Table 264.2). Symptomatic infants should be thoroughly evaluated and treated. Figure 264.12 and Table 264.3 describe the guidelines for evaluating and managing asymptomatic infants who are considered at risk for congenital syphilis because the maternal (parental) nontreponemal and treponemal serology is positive. Internationally adopted, refugee, and immigrant children should also be screened, regardless of history or report of treatment. Diagnostic testing risk-stratifies infants to probability of congenital infection: proven or highly probable congenital syphilis, possible congenital syphilis, congenital syphilis less likely, or congenital syphilis unlikely.

A diagnosis of neurosyphilis in the newborn with syphilitic infection is confounded by poor sensitivity of the CSF VDRL test in this age-group and lack of CSF abnormalities. A positive CSF VDRL test in a newborn warrants treatment for neurosyphilis, even though it might reflect passive transfer of antibodies from serum to CSF. It is now accepted that all infants with a presumptive diagnosis of congenital syphilis should be treated with regimens effective for neurosyphilis because central nervous system involvement cannot be reliably excluded. A diagnosis of syphilis beyond early infancy should lead to consideration of possible child abuse.





**Fig. 264.12** Algorithm for the diagnostic approach of infants born to mothers (birthing parents) with reactive serologic tests for syphilis. <sup>a</sup>*Treponema pallidum* particle agglutination (TP-PA) (which is the preferred treponemal test) or fluorescent treponemal antibody absorption (FTA-ABS). <sup>b</sup>Test for human immunodeficiency virus (HIV) antibody. Infants of HIV-infected mothers do not require different evaluation or treatment for syphilis. <sup>c</sup>A fourfold change in titer is the same as a change of two dilutions. For example, a titer of 1:64 is fourfold greater than a titer of 1:16, and a titer of 1:4 is fourfold lower than a titer of 1:16. When comparing titers, the same type of nontreponemal test should be used (e.g., if the initial test was an RPR, the follow-up test should also be an RPR). <sup>d</sup>Stable VDRL titers 1:2 or less or RPR 1:4 or less beyond 1 year after successful treatment are considered low serofast. <sup>e</sup>Complete blood cell (CBC) and platelet count; cerebrospinal fluid (CSF) examination for cell count, protein, and quantitative VDRL; other tests as clinically indicated (e.g., chest radiographs, long-bone radiographs, eye examination, liver function tests, neuroimaging, and auditory brainstem response). For neonates, pathologic examination of the placenta or umbilical cord with specific fluorescent antitreponemal antibody staining, if possible. RPR, Rapid plasma regain; VDRL, Venereal Disease Research Laboratory. (From American Academy of Pediatrics. *Syphilis*. In Kimberlin DW, Barnett ED, Lynfield R, Sawyer MH, eds. *Red Book: 2021–2024 Report of the Committee on Infectious Diseases*, 32nd ed. Itasca, IL: American Academy of Pediatrics; 2021: Fig. 3.15, p. 734.)

For infants with proven or highly probable disease or abnormal physical findings, complete evaluation, including serologic tests (RPR or VDRL), complete blood count with differential and platelet count, liver function tests, long-bone radiographs, ophthalmology examination, auditory brainstem response, and other tests as indicated, should be performed. If possible, pathologic examination of the placenta and/or umbilical cord with specific fluorescent antitreponemal antibody staining is recommended by the AAP. For infants with a positive VDRL or RPR test result and normal physical examination whose mothers were inadequately treated, further evaluation is not necessary if 10 days of parenteral therapy are administered.

## TREATMENT

The goals of early detection and treatment include treatment of current infection and prevention of both late-stage disease and sexual or vertical transmission. *T. pallidum* remains extremely sensitive to penicillin, with no evidence of emerging penicillin resistance, and thus penicillin remains the treatment drug of choice (additional information available in Table 264.4 and at <http://www.cdc.gov/std/treatment> for patients over 1 month old). Parenteral penicillin G is the only documented effective treatment for congenital syphilis, syphilis during pregnancy, and neurosyphilis and is recommended for treatment of syphilis in persons with HIV. Aqueous crystalline penicillin G is preferred over

**Table 264.2** Clues that Suggest a Diagnosis of Congenital Syphilis

EPIDEMIOLOGIC BACKGROUND	CLINICAL FINDINGS
Untreated early syphilis in the mother	Osteochondritis, periostitis
Untreated latent syphilis in the mother	Snuffles, hemorrhagic or mucopurulent rhinitis
An untreated mother who has contact with a known patient with syphilis during pregnancy	Condylomata lata
Mother treated less than 30 days before delivery	Bullous lesions, palmar or plantar rash
Mother treated for syphilis during pregnancy with a drug other than penicillin	Mucous patches
Mother treated for syphilis during pregnancy without follow-up to demonstrate fourfold decrease in titer	Hepatomegaly, splenomegaly
Mother co-infected with HIV	Jaundice, hepatitis
	Nonimmune hydrops fetalis
	Generalized lymphadenopathy
	Central nervous system signs; elevated cell count or protein in cerebrospinal fluid
	Hemolytic anemia, diffuse intravascular coagulation, thrombocytopenia
	Pneumonitis
	Nephrotic syndrome
	Placental villitis or vasculitis (unexplained enlarged placenta)
	Intrauterine growth restriction

Arranged in decreasing order of confidence of diagnosis.

Modified from Remington JS, Klein JO, Wilson CB, et al., eds. *Infectious Diseases of the Fetus and Newborn Infant*, 6th ed. Philadelphia: WB Saunders; 2006:556.

procaine penicillin, because it better achieves and sustains the minimum concentration of 0.018 µg/mL (0.03 units/mL) needed for 7-10 days to achieve the prolonged treponemicidal levels required for the long dividing time of *T. pallidum*.

In 2023, due to manufacturing limitations and increased demand, the United States entered a period of penicillin G shortage, requiring prioritization of pregnant persons to receive this antibiotic, as no other medication is proven to prevent vertical transmission. Penicillin G is often preferred for IM injection in treatment of other syphilis infections as an approach to ensure adherence to therapy, and thus the shortage may lead to increased transmission.

For proven or highly probable congenital syphilis, procaine penicillin G (50,000 U/kg IM daily × 10 days) should only be used if access to IV penicillin G is limited (such as in a low-resource setting) or if IV access cannot be obtained. For infants with possible congenital syphilis, aqueous penicillin G (50,000 U/kg IV every 12 hours when 1 wk or younger, then every 8 hours for infants older than 1 wk, for a total of 10 days of therapy) is preferred, though procaine penicillin G (50,000 U/kg IM daily × 10 days) may be given. Benzathine penicillin G (50,000 U/kg IM) as a single dose can be considered but only if all components of the evaluation are normal and follow-up is certain. Infants in whom congenital syphilis is less likely may be treated with benzathine penicillin G (50,000 U/kg IM) as a single dose. If no treatment is given, infants must be closely followed until the nontreponemal test becomes nonreactive. If any portion of the assessment for congenital syphilis is abnormal or not obtained, or the CSF studies are uninterpretable, or outpatient follow-up cannot be assured, treatment with procaine penicillin G is preferred. Patients with persistent or increasing titers require repeat evaluation and treatment with a 10-day course of parenteral penicillin G, even if previously treated.

Although nonpenicillin regimens are available to the penicillin-allergic patient, desensitization followed by standard penicillin therapy is the most reliable strategy. Success of treatment also depends on the integrity of the host immune response. A transient acute systemic febrile reaction called the **Jarisch-Herxheimer reaction** (caused by massive release of endotoxin-like antigens during bacterial lysis) occurs in 15–20% of patients with acquired or congenital syphilis treated with penicillin. It is not an indication for discontinuing penicillin therapy.

**Table 264.3** Confirmed Proven or Highly Probable Congenital Syphilis**DIAGNOSIS AND TREATMENT**

Any neonate with:

- An abnormal physical examination that is consistent with congenital syphilis;
- A serum quantitative nontreponemal serologic titer that is fourfold (or greater) higher than the mother's titer at delivery (e.g., maternal titer = 1:2, neonatal titer ≥1:8 or maternal titer = 1:8, neonatal titer ≥1:32); or
- A positive dark-field test or PCR of placenta, cord, lesions, or body fluids or a positive silver stain of the placenta or cord.

**Recommended evaluation:**

- CSF analysis for VDRL, cell count, and protein
- Complete blood count (CBC) and differential and platelet count
- Long-bone radiographs
- Other tests as clinically indicated (e.g., chest radiograph, liver function tests, neuroimaging, ophthalmologic examination, and auditory brainstem response)

**Recommended regimens, confirmed or highly probable congenital syphilis:**

Aqueous crystalline penicillin G 100,000-150,000 units/kg body weight/day, administered as 50,000 units/kg body weight/dose by IV every 12 hr during the first 7 days of life and every 8 hr thereafter for a total of 10 days\*

**OR**

Procaine penicillin G 50,000 units/kg body weight/dose IM in a single daily dose for 10 days

If >1 day of therapy is missed, the entire course should be restarted. Data are insufficient regarding use of other antimicrobial agents (e.g., ampicillin). When possible, a full 10-day course of penicillin is preferred, even if ampicillin was initially provided for possible sepsis. Using agents other than penicillin requires close serologic follow-up for assessing therapy adequacy.

\*Preferred therapy per the 2021-2024 AAP Red Book

From Centers for Disease Control and Prevention. Congenital syphilis. Sexually Transmitted Diseases and Treatment Guidelines, 2021. Scenario 1. <https://www.cdc.gov/std/treatment-guidelines/congenital-syphilis.htm>.

Use of other agents for congenital syphilis should only be done in consultation with a pediatric infectious diseases specialist and requires close clinical and serologic follow-up.

**Acquired Syphilis**

Primary, secondary, and early latent disease is treated with a single dose of benzathine penicillin G (50,000 units/kg IM, maximum 2.4 million units, in a single dose). Persons with late latent or tertiary disease require three doses at 1-week intervals. Nonpregnant penicillin-allergic patients without neurosyphilis may be treated with either doxycycline (4.4 mg/kg divided in 2 doses, max 200 mg per day, orally twice a day for 14 days) or tetracycline (25-50 mg/kg divided in 4 doses, max 2 g per day, orally for 14 days, for age ≥8 years). Emerging *azalide* and *macrolide resistance* has been documented throughout the United States (a 23S ribosomal NA [rRNA] point mutation at position 2058) and, more recently, worldwide (a 23S rRNA point mutation at position 2059), compromising the effective use of these antibiotics. Careful serologic follow-up is always necessary. Documentation of serologic cure is an essential part of syphilis treatment. Less than a fourfold decline in titer reflects treatment failure.

The CDC recommends that all persons with syphilis be tested for HIV and other STIs. Patients diagnosed with syphilis with a negative HIV test should undergo repeat testing 3 months later. Diagnosis of syphilis in high-risk individuals, particularly men or transgender women who have sex with men, is associated with increased risk of

**Table 264.4** Recommended Treatment for Syphilis in People Older Than 1 Mo

STATUS	CHILDREN	ADULTS
Congenital syphilis in patients >1 mo old; OR children >2 mo with late and previously untreated congenital syphilis	Aqueous crystalline penicillin G 200,000-300,000 U/kg/day IV administered as 50,000 U/kg, every 4-6 hr for 10 days*	
Primary, secondary, and early latent syphilis†	Penicillin G benzathine‡ 50,000 U/kg IM, up to the adult dose of 2.4 million U in a single dose <i>If allergic to penicillin and not pregnant,</i> Doxycycline 4.4 mg/kg divided in 2 doses, max 200 mg per day, orally twice a day for 14 days (for ages ≥8 yr) OR Tetracycline 25-50 mg/kg divided in 4 doses, max 2 g per day, orally for 14 days (for ages ≥8 yr)	Penicillin G benzathine 2.4 million U IM in a single dose OR <i>If allergic to penicillin and not pregnant,</i> doxycycline 100 mg orally twice a day for 14 days OR Tetracycline 500 mg orally 4 times/day for 14 days
Late latent syphilis§	Penicillin G benzathine 50,000 U/kg IM, up to the adult dose of 2.4 million U, administered as 3 single doses at 1-wk intervals (total 150,000 U/kg, up to the adult dose of 7.2 million U) <i>If allergic to penicillin and not pregnant,</i> Doxycycline 4.4 mg/kg divided in 2 doses, max 200 mg per day, orally twice a day for 4 weeks (for ages ≥8 yr) OR Tetracycline 25-50 mg/kg divided in 4 doses, max 2 g per day, orally for 4 weeks (for ages ≥8 yr)	Penicillin G benzathine 7.2 million U total, administered as 3 doses of 2.4 million U IM, each at 1-wk intervals; pregnant women who have delays in any dose of therapy beyond 9 days between doses should repeat the full course of therapy OR <i>If allergic to penicillin and not pregnant,</i> Doxycycline 100 mg orally twice a day for 4 wk OR Tetracycline 500 mg orally, 4 times/day for 4 wk
Tertiary	—	Penicillin G benzathine 7.2 million U total, administered as 3 doses of 2.4 million U IM at 1-wk intervals <i>If allergic to penicillin and not pregnant, consult an infectious diseases expert</i>
Neurosyphilis <sup>¶</sup>	Aqueous crystalline penicillin G 200,000-300,000 U/kg/day IV every 4-6 hr for 10-14 days, in doses not to exceed the adult dose	Aqueous crystalline penicillin G 18-24 million U per day, administered as 3-4 million U IV every 4 hr for 10-14 days <sup>¶¶</sup> OR Penicillin G procaine‡ 2.4 million U IM once daily PLUS probenecid 500 mg orally 4 times/day, both for 10-14 days <sup>¶¶</sup>

\*If the patient has no clinical manifestations of disease, the cerebrospinal fluid (CSF) examination is normal, and the CSF Venereal Disease Research Laboratory (VDRL) test result is negative, some experts would treat with up to 3 weekly doses of penicillin G benzathine 50,000 U/kg IM. Some experts also suggest giving these patients a single dose of penicillin G benzathine 50,000 U/kg IM after the 10-day course of intravenous aqueous penicillin.

†Early latent syphilis is defined as being acquired within the preceding year.

‡Penicillin G benzathine and penicillin G procaine are approved for intramuscular administration only.

§Late latent syphilis is defined as syphilis beyond 1 year's duration.

¶Patients who are allergic to penicillin should be desensitized.

¶¶Some experts administer penicillin G benzathine 2.4 million U IM once per week for up to 3 weeks after completion of these neurosyphilis treatment regimens.

IV, Intravenously; IM, intramuscularly.

From American Academy of Pediatrics. Syphilis. In: Kimberlin DW, Barnett ED, Lynfield R, Sawyer MH, eds. *Red Book: 2021–2024 Report of the Committee on Infectious Diseases*, 32nd ed. Itasca, IL: American Academy of Pediatrics; 2021: Table 3.67, pp. 741–742.

subsequent HIV acquisition, and preexposure prophylaxis (PrEP) should be considered. Patients co-infected with HIV are at increased risk for neurologic complications and higher rates of treatment failure. CDC guidelines recommend the same treatment of primary and secondary syphilis as for patients who are not infected with HIV, but some experts recommend three weekly doses of benzathine penicillin G. HIV-infected patients with late latent syphilis or latent syphilis of unknown duration should have a CSF evaluation for neurosyphilis before treatment.

Sex partners of infected persons of any stage should be evaluated and treated. Persons exposed for 90 days or less preceding diagnosis in a sex partner should be treated presumptively even if seronegative. Persons exposed for more than 90 days before the diagnosis in a sex partner should be treated if seropositive or if serologic tests are not available.

Follow-up serology should be performed on treated patients to establish adequacy of therapy, and all patients should be tested for other sexually transmitted diseases, including HIV. Children with acquired primary, secondary, or latent syphilis should undergo evaluation for possible sexual assault or abuse.

### Syphilis in Pregnancy

When clinical or serologic findings suggest active infection or when the diagnosis of active syphilis cannot be excluded with certainty, treatment is indicated. The goals of treatment of the pregnant person include eradication of maternal (parental) disease, prevention of parent-to-child transmission, and treatment of fetal infection. Patients should be treated immediately with the penicillin regimen appropriate for the pregnant person's stage of syphilis. Those who have been

adequately treated in the past do not require additional therapy unless quantitative serology suggests evidence of reinfection (**fourfold elevation in titer**).

Penicillin G is the only agent known to be effective for treating fetal infection and for prevention of congenital infection. Pregnant patients who are allergic to penicillin should be desensitized and treated with penicillin. If doses for late latent syphilis are delayed beyond 9 days from the prior dose, the full course of therapy needs to be repeated. Additional therapy may be considered for pregnant persons with primary, secondary, or early latent syphilis or when syphilis is diagnosed during the second half of pregnancy and sonographic evidence of fetal or placental syphilis is noted. In these cases, a second dose of benzathine penicillin G (2.4 million units IM given 1 week after the initial dose) may decrease the risk of vertical transmission. Jarisch-Herxheimer reaction in the second half of pregnancy may induce premature labor or fetal distress, and patients with reactions should seek obstetric attention promptly.

### Congenital Syphilis

Adequate maternal (parental) treatment at least 30 days before delivery is likely to prevent congenital syphilis. All infants born to pregnant persons with syphilis should be followed until nontreponemal serology is negative. The infant should be treated if there is any uncertainty about the adequacy of maternal (parental) treatment. The goal of infant treatment is prevention of organ damage, skeletal deformity, and developmental delay. Any infant at risk of congenital syphilis should be evaluated for HIV.

Congenital syphilis is treated in infants up to 1 month of age with aqueous penicillin G (100,000-150,000 units/kg/24 hr IV divided every 12 hours for the first week of life and every 8 hours thereafter) or procaine penicillin G (50,000 units/kg IM once daily) given for 10 days. Both penicillin regimens are recognized as adequate therapy for congenital syphilis, but higher concentrations of penicillin are achieved in the CSF of infants treated with intravenous aqueous penicillin G than in those treated with intramuscular procaine penicillin. Treated infants should be closely monitored at 2-, 4-, 6-, and 12-month well child care visits and serologic nontreponemal titers repeated every 2-3 months until nonreactive. Titers generally decrease by 3 months of age and become nonreactive by 6 months of age if adequately treated or if antibody was merely transplacentally acquired without infection. Infants diagnosed and treated for congenital syphilis after 1 month of age should be treated with aqueous crystalline penicillin G 200,000-300,000 U/kg/day IV administered as 50,000 U/kg, every 4-6 hr for 10 days (Table 264.4). Nontreponemal titers may resolve more slowly if the patient was treated after 1 month old. Increasing or persistent stable titers 6-12 months after initial treatment suggest possible ongoing infection, and repeat evaluation, including CSF, is indicated. Repeat treatment (penicillin G IV for 10 days) may be indicated. Infants with a negative nontreponemal test born to a person seroreactive at the time of delivery could have incubating congenital infection and so should be retested at 3 months. Infants with initial abnormal CSF studies only require repeat lumbar puncture if they have persistent nontreponemal serologic titers at 6-12 months old. If CSF has a persistent positive VDRL or abnormal indices not attributable to another ongoing illness, retreatment is indicated after 2 years of follow-up. At age 2 previously treated infants should receive a full developmental assessment. In a very low-risk neonate who is asymptomatic and whose mother was treated appropriately, without evidence of relapse or reinfection but with a low and stable VDRL titer (serofast), no evaluation is necessary. Some specialists, however, would treat such an infant with a single dose of benzathine penicillin G 50,000 units/kg IM.

### PREVENTION

Syphilis, including congenital syphilis, is a reportable disease in all 50 states and the District of Columbia. Testing is indicated at any

time for persons with suspicious lesions, a history of recent sexual exposure to a person with syphilis, or diagnosis of another sexually transmitted infection, including HIV infection. Screening for syphilis in asymptomatic, nonpregnant persons at increased risk for infection has received an A recommendation from the US Preventive Services Task Force (USPSTF) as providing significant benefit. Direct-to-consumer test services for STIs (or “home tests”) have become more acceptable following consumer experience with similar testing during the COVID-19 pandemic, and best practices for implementation are an area of intense research. As of late 2023, the US CDC had posted request for comment on proposed guidelines for the use of doxycycline as post-exposure prophylaxis for bacterial STI prevention, including syphilis, to be offered to MSM and transgender women with a history of at least one bacterial STI in the last 12 months; insufficient evidence is currently available to give recommendations for other groups, including children, cisgender women or heterosexual men, transgender men, or other queer and nonbinary individuals. The resurgence of syphilis compels clinicians to remain cognizant of its protean manifestations to avoid missed or late diagnosis. Timely treatment lessens risk of community spread. Despite the genome sequencing of *T. pallidum* in 1998, vaccine development remains elusive, confounded by the treponeme’s ability to evade the immune system.

### Congenital Syphilis

Congenital syphilis is a preventable disease, a sentinel event indicating multiple missed opportunities. Primary prevention is tied to prevention of syphilis in women of childbearing age, and secondary prevention with early diagnosis and prompt treatment of women and their partners. Access to and use of comprehensive prenatal care is key, with careful history taking (including interim sexual partners) at each visit. Routine prenatal screening for syphilis remains the most important factor in identifying infants at risk for developing congenital syphilis. Screening all women at the beginning of prenatal care is an evidence-based standard of care and legally required in all states. In pregnant women without optimal prenatal care, serologic screening for syphilis should be performed at the time pregnancy is diagnosed. Any person who is delivered of a stillborn infant at 20 weeks or fewer of gestation should be tested for syphilis. In communities and populations with a high prevalence of syphilis and in patients at high risk (pregnant persons with a history of incarceration, drug use, or multiple or concurrent partners), testing should be performed at least two additional times: at the beginning of the third trimester (28 weeks) and at delivery. Some states mandate repeat testing at delivery for all pregnant persons, underscoring the importance of preventive screening. Those at high risk for syphilis should be screened even more frequently, either monthly or, pragmatically (in the case of inconsistent prenatal care), at every medical encounter because they can have repeat infections during pregnancy or reinfection late in pregnancy. Follow-up serologic testing of all treated pregnant persons should be done after treatment to document titer decline, relapse, or reinfection.

No newborn should leave the hospital without the mother’s (parent’s) syphilis status having been determined at least once during pregnancy or at delivery. In states conducting newborn screening for syphilis, both the parent’s and infant’s serologic results should be known before discharge. Appropriate follow-up for the treated or exposed infant should be arranged. In addition, all previously uninvestigated infants of an infected mother should be screened. Strong linkages between clinicians and public health practitioners remain essential for comprehensive prevention of acquired and congenital syphilis.

Visit Elsevier eBooks+ at [eBooks.Health.Elsevier.com](https://eBooks.Health.Elsevier.com) for Bibliography.



## Chapter 265

## Nonvenereal Treponemal Infections

Stephen K. Obaro and H. Dele Davies

Nonvenereal treponemal infections—yaws, bejel (endemic syphilis), and pinta—are caused by different subspecies of *Treponema pallidum* and occur in tropical and subtropical areas. The causative agents of nonvenereal treponematoses—*T. pallidum pertenuis*, *T. pallidum* subspecies *endemicum*, and *Treponema carateum*—cannot be distinguished from *T. pallidum* subspecies *pallidum* by morphologic or serologic tests.

In general, nonvenereal treponematoses have prominent cutaneous manifestations and relapsing courses, as in venereal syphilis, but they are not found in urban centers, they are not sexually transmitted, and they are not congenitally acquired. Transmission is primarily through body contact, poor hygiene, crowded conditions, and poor access to healthcare. Children also serve as the primary reservoirs for these organisms, spreading infection via skin-to-skin and skin-to-mucous membrane contact, and possibly via fomites as well.

*Penicillin remains the treatment of choice for syphilis and nonvenereal treponemal infections.*

Visit Elsevier eBooks+ at [eBooks.Health.Elsevier.com](http://eBooks.Health.Elsevier.com) for Bibliography.

265.1 Yaws (*Treponema pertenuis*)

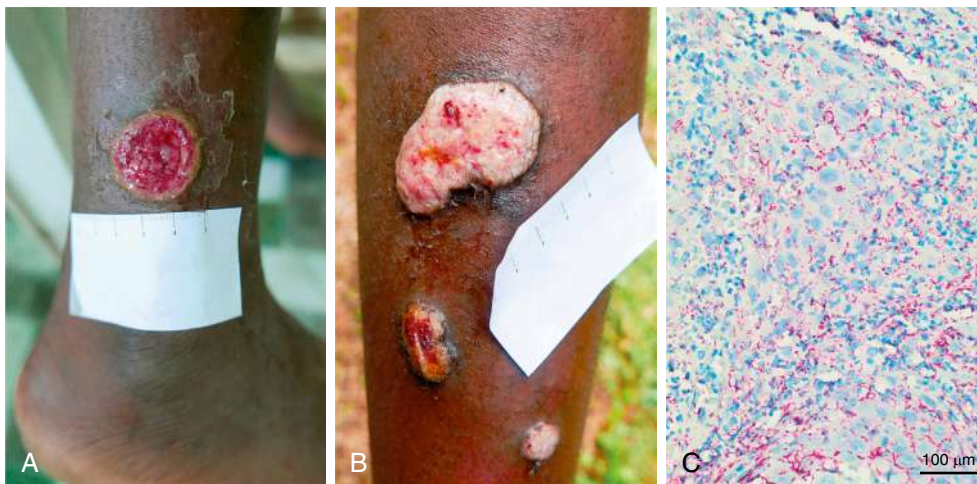
Stephen K. Obaro and H. Dele Davies

Yaws is the most prevalent nonvenereal treponematoses. The causative agent, *Treponema pertenuis*, bears very close genomic resemblance to *T. pallidum* subspecies *pallidum*. The overall sequence

identity between the genomes of *T. pallidum pertenuis* and *T. pallidum* subspecies *pallidum* is 99.8%. Yaws is a contagious, chronic, relapsing infection involving the skin and bony structures caused by the spirochete *T. pertenuis*, which is identical to *T. pallidum* microscopically and serologically. This disease occurs in tropical regions with heavy rainfall and annual temperatures  $\geq 27^{\circ}\text{C}$  ( $80^{\circ}\text{F}$ ). Almost all cases occur in children in tropical and subtropical countries. It is also referred to as “framboesia,” “pian,” “parangi,” and “bouba.” A high percentage of the population is infected in endemic areas.

*T. pertenuis* is transmitted by direct contact from an infected lesion through a skin abrasion or laceration. Transmission is facilitated by overcrowding and poor personal hygiene in the rainforest areas of the world. Yaws predominantly affects children, with approximately 75% of cases being reported in children younger than 15 years of age. This population also constitutes the reservoir for disease transmission. The initial papular lesion, which constitutes **primary yaws**, also described as the **mother yaw**, occurs 2–8 weeks after inoculation. This lesion typically involves the buttocks or lower extremities. The papule develops into a raised, raspberry-like papilloma and is often accompanied by regional lymphadenopathy. The skin pathology is similar to that of venereal syphilis, consisting of epidermal hyperplasia and papillomatosis (Fig. 265.1). Healing of the mother yaw leaves a hypopigmented scar. The **secondary-stage** lesions can erupt anywhere on the body before or after the healing of the mother yaw and may be accompanied by lymphadenopathy, anorexia, and malaise. Multiple cutaneous lesions (daughter yaws, pianomas, or framboesias) appear, spread diffusely, ulcerate, and are covered by exudates containing treponemes. Secondary lesions heal without scarring. Recurrent lesions are common within 5 years after the primary lesion.

The lesions are often associated with bone pain resulting from underlying periostitis or osteomyelitis, especially of the fingers, nose, and tibia. The initial period of clinical activity is followed by a 5- to 10-year period of latency. The appearance of tertiary-stage lesions develops in approximately 10% of infected patients, with onset typically at puberty, with solitary and destructive lesions. These lesions occur as painful papillomas on the hands and feet, gummatous skin ulcerations, or osteitis. Bony destruction and deformity, juxtaarticular nodules, depigmentation, and painful



**Fig. 265.1** Yaws lesions in a patient with treatment failure associated with macrolide-resistant *T. p. pertenuis*. A, Primary lesion (red, moist 2.5-cm ulcer) on the left leg of an 11-yr-old patient with yaws observed at the 30-mo survey. Lesional swab PCR was positive for *T. p. pertenuis* with wild-type 23S rRNA. B, Secondary yaws papillomas (multiple nodules with yellow granular surface) seen at 36-mo survey. These lesions were PCR positive for *T. p. pertenuis* with A2059G mutation in 23S rRNA. C, Photomicrograph of skin biopsy of the larger papilloma lesion in panel B with abundant spirochete organisms stained bright red by the *Treponema pallidum* immunohistochemical stain ( $\times 400$  magnification). *T. p. pertenuis*, *Treponema pallidum* subspecies *pertenuis*. (From Mitja O, Godornes C, Houinei W, et al. Re-emergence of yaws after single mass azithromycin treatment followed by targeted treatment: a longitudinal study. *Lancet*. 2018;391:1599–1606, Fig. 2.)

hyperkeratosis (**dry crab yaws**) of the palms and soles are common. Approximately 10% of patients may progress and develop tertiary-stage lesions after 5 years or more of untreated infection, although this outcome is now rare.

The diagnosis is based on the characteristic clinical manifestations of the disease in an endemic area. Dark-field examination of cutaneous lesions for treponemes and both treponemal and nontreponemal serologic tests for syphilis, which are positive because of cross reactivity, are used to confirm the diagnosis. The nontreponemal agglutination tests, such as the rapid plasma reagin and Venereal Diseases Research Laboratory tests, are positive in untreated cases, and these tests can be used for test of cure, because they revert to negative after treatment. However, the treponemal tests (*T. pallidum* hemagglutination assay, *T. pallidum* particle agglutination assay, and fluorescent treponemal antibody absorption) are more specific and remain positive for life. New immunochromatographic test strips that can be applied for testing both whole blood and serum are simple, cheap, and easy to use and do not require refrigeration. However, they have lower sensitivity compared with the antibody assays and appear to work best in persons with more active disease.

The differential diagnosis includes other conditions with similar cutaneous manifestations such as eczema, psoriasis, excoriated chronic scabies, tungiasis, leishmaniasis, tropical ulcer cutaneous mycoses, and verrucae. Involvement of the bone may mimic dactylitis that is commonly associated with sickle cell disease.

Treatment of yaws consists of a single dose of the long-acting benzathine penicillin G (1.2 million units IM for adults and 0.6 million units for children <10 years) for index patients and all contacts. Patients allergic to penicillin may be treated with erythromycin, doxycycline, or tetracycline at appropriate doses for venereal syphilis (see Chapter 264). One oral dose of azithromycin (30 mg/kg; maximum: 2 g) is as effective as benzathine penicillin. Treatment cures the lesions of active yaws, renders them noninfectious, and prevents relapse. Family members, contacts, and patients with latent infection should receive the same dose as those with active disease. Eradication of yaws from some endemic areas has been accomplished by treating the entire population (mass treatment) with azithromycin, although reemergence has been reported in those who did not receive mass treatment. In 2023, due to manufacturing limitations and increased demand, the United States entered a period of penicillin G shortage, potentially causing treatment to shift to erythromycin, doxycycline, or tetracycline until the shortages are resolved.

Visit Elsevier eBooks+ at [eBooks.Health.Elsevier.com](https://eBooks.Health.Elsevier.com) for Bibliography.

## 265.2 Bejel (Endemic Syphilis; *Treponema pallidum endemicum*)

Stephen K. Obaro and H. Dele Davies

Bejel, or endemic syphilis, affects children in remote rural communities living in poor hygienic conditions. Unlike yaws, bejel can occur in temperate and dry, hot climates. Infection with *T. pallidum* subspecies *endemicum* follows penetration of the spirochete through traumatized skin or mucous membranes. In experimental infections, a primary papule forms at the inoculation site after an incubation period of 3 weeks. A primary lesion is almost never visualized in human infections; however, primary ulcers have been described surrounding the nipples of nursing mothers with infected children.

The clinical manifestations of the **secondary stage** typically occur 3–6 months after inoculation and are confined to the skin and mucous membranes. They consist of highly infectious mucous patches on the oral mucosa and condyloma-like lesions on the moist areas of the body, especially the axilla and anus. These

mucocutaneous lesions resolve spontaneously over a period of several months, but recurrences are common. The secondary stage is followed by a variable latency period before the onset of late or tertiary bejel. The tertiary stage can occur as early as 6 months or as late as several years after resolution of initial symptoms. The lesions in the tertiary stage are identical to those of yaws and include gumma formation in skin, subcutaneous tissue, and bone, resulting in painful destructive ulcerations, swelling, and deformity.

The diagnosis is based on the characteristic clinical manifestations of the disease in an endemic area. Dark-field examination of cutaneous lesions for treponemes and both treponemal and nontreponemal serologic tests for syphilis, which are positive because of cross reactivity, are used to confirm the diagnosis.

Differentiation from venereal syphilis is extremely difficult in an endemic area. Bejel is distinguished by the absence of a primary chancre and lack of involvement of the central nervous system and cardiovascular system during the late stage.

Treatment of early infection consists of a single dose of benzathine penicillin G (1.2 million units IM for adults and 0.6 million units for children <10 years). Late infection is treated with three injections of the same dosage at intervals of 7 days. Patients allergic to penicillin may be treated with erythromycin or tetracycline. Similarly, when penicillin G is unavailable because of manufacturing limitations, treatment with erythromycin or tetracycline is appropriate.

Visit Elsevier eBooks+ at [eBooks.Health.Elsevier.com](https://eBooks.Health.Elsevier.com) for Bibliography.

## 265.3 Pinta (*Treponema carateum*)

Stephen K. Obaro and H. Dele Davies

Pinta is a chronic, nonvenereally transmitted infection caused by *T. pallidum* subsp. *carateum*, a spirochete morphologically and serologically indistinguishable from other human treponemes. This is perhaps the mildest of the nonvenereal treponematoses. The disease is endemic in Mexico, Central America, South America, and parts of the West Indies and largely affects children younger than 15 years of age.

Infection follows direct inoculation of the treponeme through abraded skin. After a variable incubation period of days, the **primary** lesion appears at the inoculation site as a small asymptomatic erythematous papule resembling localized psoriasis or eczema. The regional lymph nodes are often enlarged. Spirochetes can be visualized on dark-field examination of skin scrapings or from biopsy of the involved lymph nodes. After a period of enlargement, the primary lesion disappears. Unlike primary yaws, the lesion does not ulcerate but can expand with central depigmented resolution. **Secondary** lesions follow within 6–8 months and consist of small macules and papules on the face, scalp, and other sun-exposed portions of the body. These pigmented, highly infectious lesions are scaly and nonpruritic and can coalesce to form large plaque-like elevations resembling psoriasis. In the late or **tertiary** stage, atrophic and depigmented lesions develop on the hands, wrists, ankles, feet, face, and scalp. Hyperkeratosis of palms and soles is uncommon.

The diagnosis is based on the characteristic clinical manifestations of the disease in an endemic area. Dark-field examination of cutaneous lesions for treponemes and both treponemal and nontreponemal serologic tests for syphilis, which are positive because of cross reactivity, are used to confirm the diagnosis.

Treatment consists of a single dose of benzathine penicillin G (1.2 million units IM for adults and 0.6 million units for children <10 years). Tetracycline and erythromycin are alternatives for patients allergic to penicillin and during periods when penicillin G is unavailable because of manufacturing limitations. Treatment campaigns and improvement of standards of living are necessary for reduction and elimination of the disease.

## Chapter 266

**Leptospira**

H. Dele Davies and Kari A. Simonsen

Leptospirosis is a common and widespread zoonosis caused by aerobic, motile spirochetes of the genus *Leptospira*.

**ETIOLOGY**

*Leptospira* spp. are thin, helix-shaped members of the phylum Spirochaetes. There are 22 species identified within the genus *Leptospira*, and these are further divided into over 300 serovars. There are at least 10 pathogenic *Leptospira* species, with serovars demonstrating preferential host specificity.

**EPIDEMIOLOGY**

Leptospirosis has a worldwide distribution, but most human cases occur in tropical and subtropical countries with disease burden disproportionately affecting resource-poor populations. Leptospirae survive for days to weeks in warm and damp environmental conditions, including water and moist soil. In the United States, the CDC estimates 100-200 annual cases; Hawaii reports about 50% of U.S. cases, with Pacific Coast and Southern states having a higher incidence than the remainder of the country. Leptospirae infect many species of animals, including rats, mice, and moles; livestock such as cattle, goats, sheep, horses, and pigs; wild mammals like raccoons or opossums; and domestic dogs. Infected animals excrete spirochetes in their urine for prolonged periods. Globally, most human cases result from exposure to water or soil contaminated with rat urine; however, the major animal reservoir in the United States is the dog. Groups at high risk for leptospirosis include persons exposed occupationally or recreationally to contaminated soil, water, or infected animals. High-risk occupations include agricultural workers, veterinarians, abattoir workers, meat inspectors, rodent control workers, laboratory workers, sewer workers, and military personnel. Cases are more frequent in the

late summer and fall and often after heavy rainfalls. Exposure to contaminated floodwaters is also a documented source of infection. Transmission via animal bites and directly from person to person has been rarely reported.

**PATHOLOGY AND PATHOGENESIS**

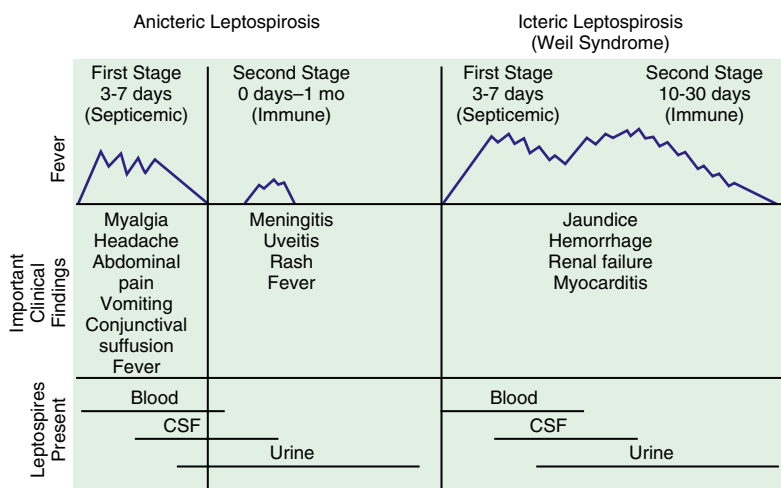
Leptospirae enter human hosts through mucous membranes (primarily the eyes, nose, and mouth), transdermally through abraded skin, or by ingestion of contaminated water. After penetration, they circulate in the bloodstream, causing endothelial damage of small blood vessels with secondary ischemic damage to end organs.

**CLINICAL MANIFESTATIONS**

The spectrum of human leptospirosis ranges from asymptomatic infection to severe disease (5–10% of infections) with multiorgan dysfunction and death. The onset is usually abrupt, and the illness may follow a monophasic or the classically described biphasic course (Fig. 266.1). The incubation period ranges from 2 to 30 days, after which there is an **initial** or **septicemic phase** lasting 2-7 days, during which leptospirae can be isolated from the blood, cerebrospinal fluid (CSF), and other tissues. This phase may be followed by a brief period of well-being before onset of a second symptomatic **immune** or **leptospiruric phase**. This phase is associated with the appearance of circulating IgM antibody, disappearance of organisms from the blood and CSF, and appearance of signs and symptoms associated with localization of leptospirae in the tissues. Despite the presence of circulating antibody, leptospirae can persist in the kidney, urine, and aqueous humor. The immune phase can last for several weeks. Symptomatic infection may be anicteric or icteric.

**Anicteric Leptospirosis**

The **septicemic phase** of anicteric leptospirosis has an abrupt onset with flulike signs of fever, shaking chills, lethargy, severe headache, malaise, nausea, vomiting, and severe debilitating myalgia most prominent in the lower extremities, lumbosacral spine, and abdomen. Bradycardia and hypotension can occur, but circulatory collapse is uncommon. Conjunctival suffusion with photophobia and orbital pain (in the absence of chemosis and purulent exudate),



**Fig. 266.1** Stages of anicteric and icteric leptospirosis. Correlation between clinical findings and presence of leptospirae in body fluids. CSF, Cerebrospinal fluid. (From Feigin RD, Anderson DC. *Human leptospirosis*. CRC Crit Rev Clin Lab Sci. 1975;5:413-467. Copyright CRC Press, Inc., Boca Raton, FL.)



generalized lymphadenopathy, and hepatosplenomegaly may also be present. A transient (<24 hours) erythematous maculopapular, urticarial, petechial, purpuric, or desquamating rash occurs in 10% of cases. Rarer manifestations include pharyngitis, pneumonitis, arthritis, carditis, cholecystitis, and orchitis. The **second** or **immune phase** can follow a brief asymptomatic interlude and is characterized by recurrence of fever and aseptic meningitis. Although 80% of infected children have abnormal CSF profiles, only 50% have clinical meningeal manifestations. CSF abnormalities include a modest elevation in pressure, pleocytosis with early polymorphonuclear leukocytosis followed by mononuclear predominance rarely exceeding 500 cells/mm<sup>3</sup>, normal or slightly elevated protein levels, and normal glucose values. Encephalitis, cranial and peripheral neuropathies, papilledema, and paralysis are uncommon. A self-limited unilateral or bilateral uveitis can occur during this phase, rarely resulting in permanent visual impairment. Central nervous system symptoms usually resolve spontaneously within 1 week, with almost no mortality.

### Icteric Leptospirosis (Weil Syndrome)

Weil syndrome is a severe form of leptospirosis seen more commonly in adults (>30 years) than in children. The initial manifestations are similar to those described for anicteric leptospirosis. However, the immune phase is characterized by jaundice, acute renal dysfunction, thrombocytopenia, and, in fulminant cases, pulmonary hemorrhage and cardiovascular collapse. Hepatic involvement leads to right upper quadrant pain, hepatomegaly, direct and indirect hyperbilirubinemia, and modestly elevated serum levels of hepatic enzymes. Liver function usually returns to normal after recovery. Patients have abnormal findings on urinalysis (hematuria, proteinuria, and casts), and azotemia is common, often associated with oliguria or anuria. Acute kidney failure occurs in 16–40% of cases. Abnormal electrocardiograms are present in 90% of cases, but congestive heart failure is uncommon. Transient thrombocytopenia occurs in >50% of cases. Rarely, hemorrhagic manifestations occur, including epistaxis, hemoptysis, and pulmonary, gastrointestinal, and adrenal hemorrhage. Patients with pulmonary hemorrhage syndrome may have >50% mortality rate, although the overall mortality rate for severe disease is lower, about 5–15%.

### DIAGNOSIS

Leptospirosis should be considered in the differential diagnosis of acute flulike febrile illnesses with a history of direct contact with animals or with soil or water contaminated with animal urine. The disease may be difficult to distinguish clinically from dengue or malaria in endemic areas.

The diagnosis is most often confirmed by serologic testing and less often confirmed by isolation of the infecting organism from clinical specimens. The gold-standard diagnostic method is the microscopic agglutination test, a serogroup-specific assay using live antigen suspension of leptospiral serovars and dark-field microscopy for agglutination. A fourfold or greater increase in titer in paired sera confirms the diagnosis. Agglutinins usually appear by the 12th day of illness and reach a maximum titer by the third week. Low titers can persist for years. Approximately 10% of infected persons do not have detectable agglutinins, presumably

because available antisera do not identify all *Leptospira* serotypes. Additionally, enzyme-linked immunosorbent assay (ELISA) methods, latex agglutination, and immunochromatography are commercially available, and DNA PCR diagnostics have been developed. Phase-contrast and dark-field microscopy are insensitive for spirochete detection, but organisms may be identified using Warthin-Starry silver stain or fluorescent antibody staining of tissue or body fluids. Unlike other pathogenic spirochetes, leptospires can be recovered from the blood or CSF during the first 10 days of illness and from urine after the second week by repeated culture of small inoculum (i.e., one drop of blood or CSF in 5 mL of medium) on commercially available selective media. However, the inoculum in clinical specimens is small, and growth can take up to 16 weeks.

### TREATMENT

*Leptospira* spp. demonstrate in vitro susceptibility to penicillin and tetracyclines, but in vivo effectiveness of these antibiotics in treating human leptospirosis is unclear because of the naturally high spontaneous recovery rates. Some studies suggest that initiation of treatment before the seventh day shortens the clinical course and decreases the severity of the infection; thus treatment with penicillin G, ceftriaxone, or doxycycline (in children ≥8 years of age) should be instituted early when the diagnosis is suspected. There is evidence that a short (<2 weeks) course of doxycycline may be safely used in children >2 years of age. Parenteral penicillin G (6–8 million U/m<sup>2</sup>/day divided every 4 hours IV for 7 days) is recommended, with doxycycline 2 mg/kg/day divided in two doses with a maximum of 100 mg twice daily as an alternative for patients allergic to penicillin. Ceftriaxone, and azithromycin have been evaluated in clinical trials and have demonstrated equivalent effectiveness with doxycycline. These antibiotics can be used as alternatives in patients for whom doxycycline is contraindicated. In mild illness, oral doxycycline, amoxicillin, and ampicillin have been used successfully. In severe illness, supportive care with specific attention given to cardiopulmonary status, renal function, coagulopathy, and fluid and electrolyte balance is warranted.

### PREVENTION

Prevention of human leptospirosis infection is facilitated through rodent control measures and avoidance of contaminated water and soil. Immunization of livestock and domestic dogs is recommended as a means of reducing animal reservoirs. Human vaccine development has been challenging because of the diversity of *Leptospira* serovars and their variable geographic distribution. Protective clothing (i.e., boots, gloves, and goggles) should be worn by persons at risk for occupational exposure. In hospital settings, in addition to standard precautions, contact precautions are recommended for potential exposures to infected urine. Leptospirosis was successfully prevented in American soldiers stationed in the tropics by administering prophylactic doxycycline (200 mg PO once a week). This approach may be similarly effective for travelers to highly endemic areas for short periods; however, there are no specific pediatric data to support any prophylaxis regimen.

Visit Elsevier eBooks+ at [eBooks.Health.Elsevier.com](http://eBooks.Health.Elsevier.com) for Bibliography.



## Chapter 267

Relapsing Fever (*Borrelia*)

Stephen K. Obaro and H. Dele Davies

Relapsing fever is characterized by recurring fevers and flulike symptoms such as headaches, myalgia, arthralgia, and rigors.

**ETIOLOGY**

Relapsing fever is an arthropod (lice or tick)-transmitted infection caused by spirochetes of the genus *Borrelia*.

**Louse-borne (epidemic) relapsing fever** is caused by *Borrelia recurrentis* and is transmitted from person to person by *Pediculus humanus*, the human body louse. Human infection occurs as a result of crushing lice during scratching, facilitating entry of infected hemolymph through abraded or normal skin or mucous membranes.

**Tick-borne (endemic) relapsing fever** is caused by several species of *Borrelia* and is transmitted to humans by *Ornithodoros* ticks. *Borrelia hermsii* and *Borrelia turicatae* are the common species in the western United States, whereas *Borrelia dugesii* is the major cause of disease in Mexico and Central America. Human infection occurs when saliva, coxal fluid, or excrement is released by the tick during feeding, thereby permitting spirochetes to penetrate the skin and mucous membranes.

*Borrelia miyamotoi* has been identified in the Japanese *Ixodes persulcatus* tick and in the *Ixodes dammini* tick, the agent that transmits Lyme disease in the northeastern United States. This *Borrelia* species causes a Lyme disease–like illness rather than relapsing fever.

**EPIDEMIOLOGY**

Louse-borne relapsing fever tends to occur in epidemics associated with war, poverty, famine, and poor personal hygiene, often in association with typhus. This form of relapsing fever is no longer seen in the United States but is endemic in parts of East Africa. Using 16S ribosomal RNA (rRNA) polymerase chain reaction assays for molecular detection, up to 20.5% of all unexplained fever in the Horn of Africa, including northwestern Morocco where the population traditionally lives in mud huts, is caused by tick-borne relapsing fever, making this the most common cause of bacterial infections.

*Ornithodoros* ticks, which transmit endemic relapsing fever and are distributed worldwide, including in the western United States, prefer warm, humid environments and high altitudes and are found in rodent burrows, caves, and other nesting sites (Fig. 267.1). Rodents (e.g., squirrels and chipmunks) are the principal reservoirs. Infected ticks gain access to human dwellings on the rodent host. Human contact is often unnoticed because these soft ticks have a painless bite and detach immediately after a short blood meal.

**PATHOLOGY AND PATHOGENESIS**

Relapsing fever is cyclical because the *Borrelia* organisms undergo antigenic (phase) variation. Multiple variants evolve simultaneously during the first relapse, with one type becoming predominant. Spirochetes isolated during the primary febrile episode differ antigenically from those recovered during a subsequent relapse. During febrile episodes, spirochetes enter the bloodstream, induce the development of specific immunoglobulin M and G antibodies, and undergo agglutination, immobilization, lysis, and phagocytosis. During remission, *Borrelia* spirochetes may remain in the bloodstream, but spirochetemia is insufficient to produce symptoms. The number of relapses in untreated patients depends on the number of antigenic variants of the infecting strain.

**CLINICAL MANIFESTATIONS**

Relapsing fever is characterized by febrile episodes lasting 2–9 days, separated by afebrile intervals of 2–7 days. Louse-borne disease has an incubation period of 2–14 days, longer periods of pyrexia, fewer relapses, and longer remission periods than tick-borne disease. The

incubation period of tick-borne disease is usually 7 days (range: 2–9 days). Each form of relapsing fever is characterized by sudden onset of high fever, lethargy, headache, photophobia, nausea, vomiting, myalgia, and arthralgia. Additional symptoms may appear later and include abdominal pain, a productive cough, mild respiratory distress, and bleeding manifestations, including epistaxis, hemoptysis, hematuria, and hematemesis. During the end of the primary febrile episode, a diffuse, erythematous, macular, or petechial rash lasting up to 2 days may develop over the trunk and shoulders. There may also be lymphadenopathy, pneumonia, and splenomegaly. Hepatic tenderness associated with hepatomegaly is a common sign, with jaundice in half of affected children. Central nervous system manifestations include lethargy, stupor, meningismus, convulsions, peripheral neuritis, focal neurologic deficits, and cranial nerve paralysis and may be the principal feature of late relapses in tick-borne disease. Severe manifestations include myocarditis, hepatic failure, and disseminated intravascular coagulopathy.

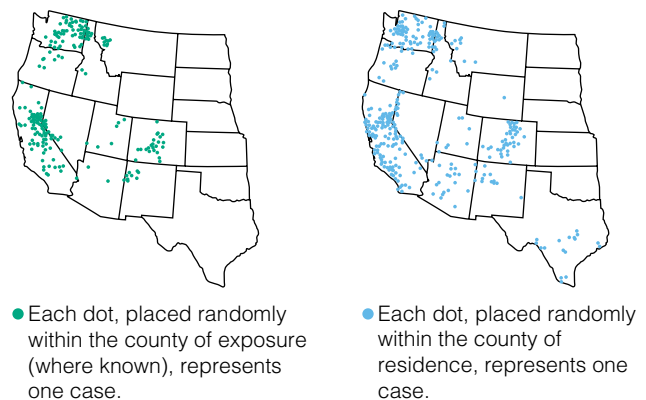
The initial symptomatic period characteristically ends with a crisis in 2–9 days, marked by abrupt diaphoresis, hypothermia, hypotension, bradycardia, profound muscle weakness, and prostration. In untreated patients, the first relapse occurs within 1 week, followed by usually 3 but up to 10 relapses, with symptoms during each relapse becoming milder and shorter as the afebrile remission period lengthens.

**DIAGNOSIS**

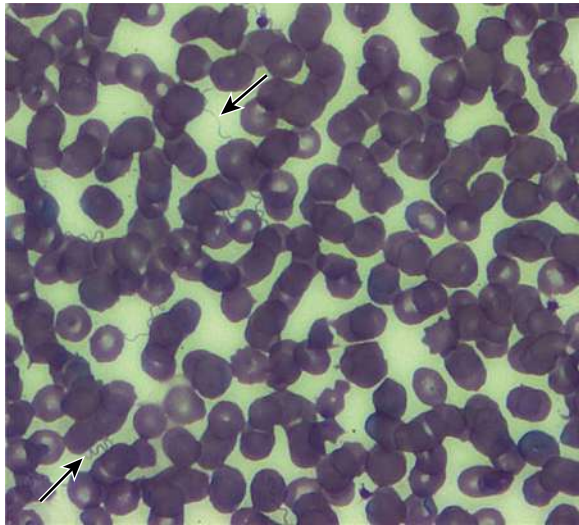
Diagnosis depends on demonstration of spirochetes by dark-field microscopy or in thin or thick blood smears stained with Giemsa or Wright stain and by blood culture (Fig. 267.2). During afebrile remissions, spirochetes are not found in the blood. Serologic tests have not been standardized, are generally not available, and produce cross reactions with other spirochetes, including *Borrelia burgdorferi*, the agent of Lyme disease. Central nervous system involvement may be associated with lymphocytic pleocytosis. Molecular methods, including nested polymerase chain reaction or 16S rRNA polymerase chain reaction assays, have been used for detection of tick-borne and louse-borne recurrent fever and have been found to have improved sensitivity and specificity compared with blood smears. However, these assays are not yet routinely available for commercial use.

**TREATMENT**

Oral or parenteral tetracycline or doxycycline is the drug of choice for louse-borne and tick-borne relapsing fever. For children older than 8 years of age and young adults, tetracycline 500 mg PO every 6 hours or doxycycline 100 mg PO every 12 hours for 10 days is effective. Single-dose treatment with tetracycline (500 mg PO) or



**Fig. 267.1** Cases of tickborne relapsing fever—United States, 1990–2011. During the years 1990–2011, 483 cases of tickborne relapsing fever were reported in the western United States, with infections being transmitted most frequently in California, Washington, and Colorado. (From Centers for Disease Control and Prevention [CDC]. Tick-borne relapsing fever: distribution. Available at: <http://www.cdc.gov/relapsing-fever/distribution>)



**Fig. 267.2** Stained thin smear of a newborn's peripheral blood showing the presence of numerous spirochetes (indicated by arrows) at  $\times 63$  magnification—Colorado, 2011. (From Centers for Disease Control and Prevention [CDC]. Tickborne relapsing fever in a mother and newborn child—Colorado, 2011. *MMWR Morb Mortal Wkly Rep.* 2012;61:174–176.)

erythromycin is efficacious in adults, but experience in children is limited. In children younger than 8 years of age, erythromycin (50 mg/kg/day divided every 6 hours PO) for a total of 10 days is recommended, although there is evidence that doxycycline given for durations of less than 2 weeks is safe in children  $>2$  years of age. Penicillin and chloramphenicol are also effective. Central nervous system involvement is usually responsive to intravenous ceftriaxone or penicillin.

Resolution of each febrile episode either by natural crisis or as a result of antimicrobial treatment is often accompanied by the Jarisch-Herxheimer reaction, which is caused by massive antigen release. Corticosteroid or antipyretic pretreatment does not prevent this reaction.

### PROGNOSIS

With adequate therapy, the mortality rate for relapsing fever is  $<5\%$ . A majority of patients recover from their illness with or without treatment after the appearance of anti-*Borrelia* antibodies, which agglutinate, kill, or opsonize the spirochete. However, pregnant women and their neonates are at increased risk for tick-borne recurrent fever-associated complications, including adult respiratory distress syndrome, Jarisch-Herxheimer reaction, and precipitous or premature delivery. Neonates have up to a 33% case fatality rate. The risk of Jarisch-Herxheimer reaction appears to be much higher in louse-borne relapsing fever (LBRF) (55.8%) compared to TBRF (19.3%). However, they have similar overall case fatality rates, TBRF (6.5%) and LBRF (4–10.2%).

### PREVENTION

No vaccine is available. Disease control requires avoidance or elimination of the arthropod vectors. In epidemics of louse-borne disease, good personal hygiene and delousing of persons, dwellings, and clothing with commercially available insecticides can prevent dissemination. The risk for tick-borne disease can be minimized in endemic areas by maintaining rodent-free dwellings. Giving prophylactic doxycycline for 4 days after a tick bite may prevent tick-borne relapsing fever caused by *Borrelia persica*.

Visit Elsevier eBooks+ at [eBooks.Health.Elsevier.com](http://eBooks.Health.Elsevier.com) for Bibliography.

## Chapter 268

# Lyme Disease (*Borrelia burgdorferi*)

Sanjeev K. Swami

Lyme disease is the most common vector-borne disease in the United States and is an important public health problem.

### ETIOLOGY

Lyme disease is a zoonotic infection caused by the transmission of the spirochete *Borrelia burgdorferi* sensu lato (broad sense) to humans via the bite of an infected tick of the *Ixodes* genus. In North America, *B. burgdorferi* sensu stricto (strict sense) causes almost all cases; another species in the upper Midwestern United States, *Borrelia mayonii* (belonging to the group *B. burgdorferi* sensu lato), also causes Lyme disease, but the illness is slightly different, with more diffuse rashes and gastrointestinal symptoms. In Europe, the species *Borrelia afzelii* and *Borrelia garinii* also cause disease. The three major outer-surface proteins, called *OspA*, *OspB*, and *OspC* (which are highly charged basic proteins of molecular weights of about 31, 34, and 23 kDa, respectively), and the 41-kDa flagellar protein are important targets for the immune response. Differences in the molecular structure of the different species are associated with differences in the clinical manifestations of Lyme borreliosis in Europe and the United States. These differences include the higher incidence of radiculoneuritis in Europe.

### TRANSMISSION

In the eastern and midwestern United States, the vector for Lyme disease is *Ixodes scapularis*, the black-legged tick that is commonly known as the deer tick. It is responsible for most cases in the United States. The vector on the Pacific Coast is *Ixodes pacificus*, the western black-legged tick. *Ixodes* ticks have a 2-year, three-stage life cycle. The larvae hatch in the early summer and are usually uninfected with *B. burgdorferi*. The tick can become infected at any stage of its life cycle by feeding on a host, usually a small mammal such as the white-footed mouse (*Peromyscus leucopus*), which is a natural reservoir for *B. burgdorferi*. The larvae overwinter and emerge the following spring in the nymphal stage, which is the stage of the tick most likely to transmit the infection. The nymphs molt to adults in the fall, and then adults spend the second winter attached to white-tailed deer (*Odocoileus virginianus*). The females lay their eggs the following spring before they die, and the 2-year life cycle begins again.

Several factors are associated with increased risk for transmission of *B. burgdorferi* from ticks to humans. The proportion of infected ticks varies by geographic area and by the stage of the tick's life cycle. In endemic areas in the northeastern and midwestern United States, 15–25% of nymphal ticks and 35–50% of adult ticks are infected with *B. burgdorferi*. By contrast, *I. pacificus* often feeds on lizards, which are not a competent reservoir for *B. burgdorferi*, reducing the chance that these ticks will be infected. The risk for transmission of *B. burgdorferi* from infected *Ixodes* ticks is related to the duration of feeding. Experiments in animals show that infected nymphal ticks must feed for 36–48 hours and infected adults must feed for 48–72 hours before the risk for transmission of *B. burgdorferi* becomes substantial. If the tick is recognized and removed promptly, transmission of *B. burgdorferi* will not occur. *Most patients with Lyme disease do not remember the tick bite that transmitted the infection.*

The habitat of tick species that carry *B. burgdorferi* may be geographically expanding in the United States because of climate change. *I. scapularis* also transmits other microorganisms, namely *Anaplasma*





**Table 268.1** Clinical Stages of Lyme Disease

DISEASE STAGE	TIMING AFTER TICK BITE	TYPICAL CLINICAL MANIFESTATIONS
Early localized	3-30 days	Erythema migrans (single), variable constitutional symptoms (headache, fever, myalgia, arthralgia, fatigue)
Disseminated	3-12 wk	Erythema migrans (single or multiple), worse constitutional symptoms, cranial neuritis, meningitis, carditis, ocular disease
Disseminated	>2 mo	Arthritis



**Fig. 268.2** Skin manifestations of Lyme borreliosis. A, Erythema migrans on the upper leg, showing central clearing. B, Erythema migrans of the arm showing “bull’s-eye” appearance. (A from Stanek G, Strle F. Lyme borreliosis. *Lancet*. 2003;362:1639–1647.)

in the center of the rash. Occasionally the rash is itchy or painful, although usually it is asymptomatic. The lesion can occur anywhere on the body, but the most common locations are the axilla, periumbilical area, thigh, and groin. It is not unusual for the rash to occur on the neck, face, or hairline, especially in young children. Without treatment, the rash gradually expands (hence the name *migrans*) to an average diameter of 15 cm and typically remains present for 1–2 weeks. Erythema migrans may be associated with systemic features, including fever, myalgias, arthralgias, headache, or malaise; gastrointestinal symptoms are rare. Co-infection with *B. microti* or *A. phagocytophilum* during early infection with *B. burgdorferi* is associated with more severe systemic symptoms. **Co-infections** should be suspected with unusual features of Lyme disease, poor response to appropriate antibiotics, prolonged fever, or laboratory abnormalities that include anemia, leukopenia, thrombocytopenia, or elevated liver enzymes.

### Disseminated Disease

In the United States, approximately 20% of patients with acute *B. burgdorferi* infection develop secondary (multiple) erythema migrans lesions, a common manifestation of disseminated Lyme disease,



**Fig. 268.3** Multiple erythema migrans in early disseminated Lyme disease.

caused by hematogenous spread of the organisms to multiple skin sites (Fig. 268.3). The secondary lesions, which can develop several days or weeks after the first lesion, are usually smaller than the primary lesion and are often accompanied by more severe constitutional symptoms. The lesions may not have the classic appearance of erythema migrans; they may lack central clearing, appear oval in shape, or have irregular borders. The most common neurologic manifestations are **peripheral facial nerve palsy** and **meningitis**. Peripheral (or cranial) nerves other than the facial nerve may be affected, and patients can present with multiple concurrent nerve palsies. Lyme meningitis usually has an indolent onset with days to weeks of symptoms (longer than viral meningitis) that can include headache, neck pain and stiffness, and fatigue. Fever is variably present. Patients can present with both peripheral nerve palsy *and* meningitis, but typically they have either central nervous system or peripheral nervous system disease.

The clinical findings of papilledema, cranial neuropathy (especially cranial nerve VII), and erythema migrans, which are present individually or together in up to 90% of cases, help differentiate Lyme meningitis from viral meningitis, in which these findings are rarely present. The aseptic meningitis caused by Lyme disease can be accompanied by significant elevations of intracranial pressure, which can sometimes last weeks or even months. All the cranial nerves except the olfactory have been reported to be involved with Lyme disease, but the most common are VI and especially VII. In endemic areas, Lyme disease is the leading cause of peripheral facial nerve palsy. It is often the initial or the only manifestation of Lyme disease and is sometimes bilateral. The facial paralysis usually lasts 2–8 weeks and resolves completely in most cases. Radiculoneuritis and other peripheral neuropathies can occur but are more common in Europe.

Cardiac involvement occurs in 5–15% of disseminated Lyme disease (overall <1% of Lyme infections) and usually takes the form of **heart block**, which can be first, second, or third degree, and the rhythm can fluctuate rapidly. Rarely, myocardial dysfunction (myocarditis) can occur. Patients presenting with suspected or proven disseminated Lyme disease should have a careful cardiac examination, and electrocardiography should be strongly considered, especially if patients report chest pain, palpitations, or presyncopal symptoms. Lyme carditis is a treatable condition and is the only manifestation of Lyme disease that has been fatal.

Papilledema and uveitis are most common ocular conditions associated with Lyme disease; optic neuritis has also been reported.

**Arthritis** is the most common manifestation of disseminated Lyme disease and begins weeks to months (possibly years) after the initial infection. Lyme arthritis is classically a monoarticular, nonmigratory arthritis affecting the large joints. The knee is the



most commonly infected joint followed by the hip. Lyme arthritis can occasionally be oligoarticular or migratory. The hallmark of Lyme arthritis is joint swelling, which is a result of synovial effusion and sometimes synovial hypertrophy. The swollen joint may be only mildly symptomatic, or less often, it may be painful and tender, although patients usually do not experience the severe pain and systemic toxicity that are common with pyogenic arthritis. Micromotion tenderness is rare with Lyme arthritis. If untreated, the arthritis can last several weeks, resolve, and then be followed by recurrent attacks in the same or other joints.

Other manifestations of Lyme disease involving the central nervous system, sometimes termed *late neuroborreliosis*, are rarely reported in children. In adults, chronic encephalitis and polyneuritis have been attributed to Lyme disease. The term *Lyme encephalopathy* has been used to describe chronic encephalitis (demonstrable by objective measures), but other literature has also used this term in reference to memory loss and other cognitive sequelae after Lyme disease has been treated. At times, the vague and mistaken term *chronic Lyme disease* has been used to describe symptomatology in persons who might have never had well-documented infection with *B. burgdorferi* at all, have serologic evidence of prior infection but current symptoms not consistent with Lyme disease, or have persistent symptoms after having received appropriate antibiotic therapy. Prolonged treatment does not treat the chronic neuropsychiatric symptoms and at times has harmed the patient.

Some patients experience prolonged symptoms after treatment of early or disseminated Lyme disease; these symptoms frequently include fatigue, headaches, myalgias, arthralgias, and difficulty thinking. This phenomenon is termed **posttreatment Lyme disease syndrome**. The etiology for this process is unclear, but prolonged antibiotic treatment has not been shown to hasten recovery and has been associated with harm. Most patients have symptom resolution by 6 months without antibiotic therapy.

### Congenital Lyme Disease

In endemic areas, infection can occur during pregnancy, and although congenital infection appears to be a rare event, there is no recognized congenital infection syndrome associated with Lyme disease. *B. burgdorferi* has been identified from several abortuses and from a few live-born children with congenital anomalies; however, the tissues in which the spirochete has been identified usually have not shown histologic evidence of inflammation. Severe skin and cardiac manifestations have been described in a few cases, but studies conducted in endemic areas have indicated that there is no difference in the prevalence of congenital malformations among the offspring of women with serum antibodies against *B. burgdorferi* and the offspring of those without such antibodies.

### LABORATORY FINDINGS

Standard laboratory tests rarely are helpful in diagnosing Lyme disease because any associated laboratory abnormalities usually are nonspecific. The peripheral white blood cell count may be either normal or elevated. The erythrocyte sedimentation rate (ESR) may be mildly elevated. Liver transaminases are occasionally mildly elevated. In Lyme arthritis, the white blood cell count in joint fluid can range from 25,000 to 100,000/mL, often with a preponderance of polymorphonuclear cells. A lower ESR ( $\leq 40$ ) and C-reactive protein and a peripheral blood absolute neutrophil count of less than 10,000 may help to differentiate Lyme from septic arthritis. When meningitis is present, there usually is a low-grade pleocytosis with a lymphocytic and monocytic predominance. The cerebrospinal fluid (CSF) protein level may be elevated, but the glucose concentration usually is normal. Gram stain and routine bacterial cultures are negative. Imaging of the central nervous system (e.g., magnetic resonance imaging and single-photon emission computed tomography) occasionally reveals abnormalities, but there is no definitive pattern in Lyme disease. The main role of imaging is to exclude other diagnoses.

### DIAGNOSIS

*In the appropriate epidemiologic setting (endemic area, season), typical erythema migrans is pathognomonic.* Occasionally, the diagnosis of erythema migrans may be difficult because the rash initially can be confused with nummular eczema, tinea corporis, granuloma annulare, an insect bite reaction, southern tick-associated rash illness, or cellulitis. The relatively rapid expansion of erythema migrans helps distinguish it from these other skin lesions. The other clinical manifestations of Lyme disease are less specific and may be confused with other conditions; the monoarticular or oligoarticular arthritis sometimes is confused with a septic joint or other causes of arthritis in children, such as juvenile idiopathic arthritis or rheumatic fever; the facial nerve palsy caused by Lyme disease is clinically indistinguishable from Bell palsy, although bilateral involvement is much more common with Lyme disease; Lyme meningitis generally occurs in the warmer months, the same period that enteroviral meningitis is prevalent. Therefore for all disease manifestations other than erythema migrans, it is recommended to have laboratory confirmation of infection with *B. burgdorferi*.

Although *B. burgdorferi* has been isolated from the blood, skin, CSF, myocardium, and synovium of patients with Lyme disease, the organism is difficult to isolate in culture (cultivation is largely relegated to research laboratories). Infection is usually identified by the detection of antibody in serum. Although some laboratories offer polymerase chain reaction as a diagnostic test for Lyme disease, its sensitivity is poor because of the low concentrations of bacteria in many sites, especially CSF. Other antigen-based tests, including a test for *B. burgdorferi* antigens in urine, are unreliable. Clinicians should be aware that some laboratories use alternative diagnostic tests and/or alternative interpretive criteria that are not evidence based, leading to a false diagnosis of Lyme disease. The CDC and the Food and Drug Administration recommend against using these tests.

### Serology

After the transmission of *B. burgdorferi* from a tick bite, specific immunoglobulin (Ig) M antibodies appear first, usually within 2 weeks, peak at 6-8 weeks, and subsequently decline. Sometimes a prolonged or recurrent elevation of IgM antibodies occurs despite effective antimicrobial treatment. Elevated IgM levels after 6-8 weeks are often false positives. Specific IgG antibodies usually appear between 2 and 6 weeks, peak after 4-6 months, and can remain elevated for years, particularly in patients with arthritis. The antibody response to *B. burgdorferi* may be blunted in patients with early Lyme disease who are treated promptly with an effective antimicrobial agent. *Serodiagnosis during the first 4 weeks of infection is not sensitive and may need to be repeated.*

Historically, the most common method used to detect IgG and IgM antibodies has been the enzyme-linked immunosorbent assay (ELISA). *This method is sensitive but not optimally specific.* The ELISA sometimes produces false-positive results because of antibodies that cross react with other spirochetal infections (e.g., *B. miyamotoi*, syphilis, leptospirosis, or relapsing fever), or certain viral infections (e.g., Epstein-Barr virus), or that occur in certain autoimmune diseases (e.g., systemic lupus erythematosus). The positive predictive value of the ELISA result depends primarily on the plausibility that the patient has Lyme disease based on the clinical and epidemiologic history and the physical examination (**the pretest probability**). For patients who have been in endemic areas with opportunities for *Ixodes* tick exposure and who have typical clinical manifestations of Lyme disease, the pretest probability is high, and positive ELISA results are usually true positives. For patients who are from nonendemic areas and/or who have little risk for *Ixodes* tick exposures and/or have nonspecific symptoms (low pretest probability), rates of false-positive results are high. Infection with *B. miyamotoi* may cause false-positive ELISA tests for Lyme disease. This syndrome of relapsing fever, headache, and myalgia

but no rash with neutropenia or thrombocytopenia is uncommon in Lyme disease.

**Western immunoblotting** is well-standardized, and there are accepted criteria for interpretation. Five of 10 IgG bands and 2 of 3 IgM bands are considered reactive. The Western blot is not as sensitive as ELISA, especially in early infection, but is highly specific. Any positive or equivocal ELISA can be confirmed with Western blotting. The CDC recommends using IgM and IgG Western blot confirmation when symptoms have been present  $\leq 30$  days and IgG only when symptoms have been present longer than 30 days.

Two-tier testing is the recommended laboratory evaluation of most cases of Lyme disease and is associated with a high degree of sensitivity and specificity when used appropriately. Two-tier assays using serial ELISAs have been developed that have similar or better sensitivity and specificity when compared with ELISA followed by Western blot. The serial ELISA methodology can have improved turn-around time and has two quantitative tests rather than a quantitative test followed by a test that requires interpretation. Stand-alone ELISAs have also been developed that have similar sensitivity and specificity when compared with two-tier testing.

Clinicians should be aware that Lyme disease might not be the cause of a patient's symptoms despite the presence of antibodies to *B. burgdorferi*. The test result may be falsely positive (as described for ELISA), or the patient might have been infected previously. Antibodies to *B. burgdorferi* that develop with infection can persist for many years despite adequate treatment and clinical cure of the disease. In addition, because some people who become infected with *B. burgdorferi* are asymptomatic, the background rate of seropositivity among patients who have never had clinically apparent Lyme disease may be substantial in endemic areas. Finally, because antibodies against *B. burgdorferi* persist after successful treatment, there is no reason to obtain follow-up serologic tests.

## TREATMENT

Table 268.2 provides treatment recommendations. Most patients can be treated with oral antibiotics. Young children are generally treated with amoxicillin. Doxycycline has the advantages of good central nervous system penetration and activity against *A. phagocytophilum*, which may be transmitted at the same time as *B. burgdorferi* in certain geographic areas. Historically, children  $< 8$  years were not treated with doxycycline because of the risk of staining of the permanent teeth. Data from the CDC have shown that this is not a concern for treatment courses  $< 2$  weeks. Doxycycline oral solution is still challenging to find, so most younger children are prescribed amoxicillin. There are no data that show a difference in efficacy between amoxicillin and doxycycline for the treatment of Lyme disease. Patients who are treated with doxycycline should be alerted to the risk for developing photosensitivity in sun-exposed areas while taking the medication; thus long sleeves, long pants, and a hat are recommended for activities in direct sunlight. The only oral cephalosporin proved to be effective for the treatment of Lyme disease is cefuroxime axetil, which is an alternative for persons who cannot take doxycycline or who are allergic to penicillin. There is no reported resistance of *B. burgdorferi* to these antibiotics. Macrolide antibiotics, including azithromycin, appear to have limited activity and are only recommended for patients allergic to all of the other active medications.

Parenteral therapy is usually recommended for patients with higher degrees of heart block or central nervous system involvement, although oral therapy for meningitis is also considered acceptable for ambulatory patients. Patients with arthritis that fails to resolve after an initial course of oral therapy can be retreated with an oral regimen or can receive intravenous antibiotic therapy. Ceftriaxone is favored because of its excellent anti-*Borrelia* activity, tolerability, and once-daily dosing regimen, which can usually be done on an outpatient basis.

**Table 268.2** Recommended Treatment of Lyme Disease

DRUG	PEDIATRIC DOSING
Amoxicillin	50 mg/kg/day in 3 divided doses (max: 1,500 mg/day)
Doxycycline	4.4 mg/kg/day in 2 divided doses (max: 200 mg/day) (see text regarding doxycycline use in children)
Cefuroxime axetil	30 mg/kg/day in 2 divided doses (max: 1,000 mg/day)
Ceftriaxone (IV)*,†	50-75 mg/kg/day once daily (max: 2,000 mg/day)
Azithromycin‡	10 mg/kg/day once daily $\times 7$ days
RECOMMENDED THERAPY BASED ON CLINICAL MANIFESTATION	
Erythema migrans	Doxycycline $\times 10$ days Amoxicillin $\times 14$ days Cefuroxime $\times 14$ days
Meningitis, radiculopathy	Doxycycline $\times 14-21$ days or Ceftriaxone $\times 14$ days (14-21 for hospitalized patients)
Cranial nerve palsy§	Doxycycline $\times 14-21$ days
Cardiac disease	Oral regimen or ceftriaxone 14-21 days (see text for specifics)
Arthritis	Oral regimen 28 days
Persistent or recurrent arthritis after initial treatment	Oral regimen $\times 28$ days or Ceftriaxone 14-28 days
Borrelial lymphocytoma	Doxycycline, amoxicillin, cefuroxime 14 days

\*Penicillin G is an alternative parenteral agent but requires more frequent dosing.

†Doses of 100 mg/kg/day should be used for meningitis.

‡For those unable to take amoxicillin or doxycycline.

§Treatment is to prevent late disease, not to treat the cranial palsy; avoid corticosteroids.

Peripheral facial nerve palsy can be treated using an oral antibiotic. Experts are divided on whether every patient with Lyme-associated facial palsy needs a CSF analysis, but clinicians should consider lumbar puncture for patients with significant headache, neck pain or stiffness, or papilledema.

Patients with symptomatic cardiac disease, second- or third-degree heart block, or significantly prolonged PR interval should be hospitalized and monitored closely. These patients should receive a parenteral antibiotic for their initial treatment. Patients with first-degree heart block can be treated with an oral antibiotic, and patients with high degrees of heart block can be transitioned to oral treatment as their heart block resolves.

Some patients develop a Jarisch-Herxheimer reaction soon after treatment is initiated; this results from lysis of the *Borrelia*. The manifestations of this reaction are low-grade fever and achiness. These symptoms resolve spontaneously within 24-48 hours, and administration of nonsteroidal antiinflammatory drugs often is beneficial. Nonsteroidal antiinflammatory drugs also may be useful in treating symptoms of early Lyme disease and of Lyme arthritis. *Co-infections with other pathogens transmitted by Ixodes ticks should be treated according to standard recommendations.*

There is no clear evidence that posttreatment Lyme disease syndrome is related to persistence of the organism. Studies in adults have

**Table 268.3** Personal Prevention Measures

BEFORE VENTURING OUTSIDE	DURING AND/OR AFTER EXPOSURE TO TICK HABITAT <sup>†</sup>
Personal prevention measures*	Conduct a thorough tick check of extremities, torso, and areas where ticks may be visually obscured (e.g., axilla, nape of neck, hairline, in and around ears, umbilicus, groin, popliteal fossa)
Avoid risky habitats	Bathe or shower within 2 hr
Wear light-colored clothing	Dry clothes on high heat for at least 10 min; if not possible, wash clothes in hot water
Wear long sleeves and pants	
Tuck pants into socks or footwear	
Wear permethrin-treated clothing	
Use an EPA-approved repellent or insecticide as per manufacturer's instructions	<i>If an attached tick is detected</i> Remove properly and clean bite area
DEET	<a href="https://www.cdc.gov/lyme/removal/index.html">https://www.cdc.gov/lyme/removal/index.html</a>
Picaridin	Tip: Store tick (e.g., in sealed container/plastic bag, wrapped in clear tape, or taped to a piece of paper). Label with date and likely geographic location of exposure.
IR3535	See clinician and show tick if concerned that it is an <i>Ixodes</i> spp. and has fed at least 36 hr.
Oil of lemon eucalyptus (OLE)	Monitor health for symptoms of Lyme disease and other tick-borne diseases
p-Methane-3,8-diol (PMD)	
2-undecanone	
Permethrin (for application to clothing and gear only)	

\*Tip: Have handy a fine-tipped tweezers, tick storage container, and hand sanitizer.

<sup>†</sup>Continue to conduct a tick check whenever possible to detect and remove feeding ticks as soon as possible.

DEET, N,N-Diethyl-meta-toluamide; EPA, Environmental Protection Agency. From Lantos PM, Rumbaugh J, Bockenstedt LK, et al. Clinical Practice Guidelines by the Infectious Diseases Society of America (IDSA), American Academy of Neurology (AAN), and American College of Rheumatology (ACR): 2020 Guidelines for the Prevention, Diagnosis and Treatment of Lyme Disease. *Clin Infect Dis.* 2021;72(1):e1–e48, Table 5, p. e13.

not shown benefit with prolonged or repeated treatment with oral or parenteral antibiotics.

## PROGNOSIS

There is a widespread misconception that Lyme disease is difficult to cure and that chronic symptoms and clinical recurrences are common. The most likely reason for apparent treatment failure is an incorrect diagnosis of Lyme disease.

The prognosis for children treated for Lyme disease is excellent. Children treated for erythema migrans rarely develop symptoms of late Lyme disease. The long-term prognosis for patients who are treated beginning in the later stages of Lyme disease also is excellent. Although chronic and recurrent arthritis may occur, especially among patients

**Table 268.4** Management of a Suspected *Ixodes* Tick Bite in the United States

DO	DO NOT
1. Remove tick with clean fine-tipped tweezers (or other comparable device).	1. Do not use other nonmechanical methods for tick removal.
2. Identify tick. Send to a laboratory, refer to an online resource.	2. Do not test tick for pathogens (e.g., send for PCR).
3. Determine if tick meets high-risk criteria. <ol style="list-style-type: none"> <li>Identified as <i>Ixodes</i> vector species</li> <li>Bite occurred in a highly endemic area</li> <li>Attached for <math>\geq 36</math> hr</li> </ol>	3. Do not initiate prophylaxis in any other scenario.
Consider initiating prophylaxis if a, b, and c are met AND it is within 72 hr of tick removal. See dosing in the footnote*.	

\*Doxycycline is given as a single oral dose, 200 mg for adults and 4.4 mg/kg (up to a maximum dose of 200 mg) for children.

PCR, Polymerase chain reaction.

From Lantos PM, Rumbaugh J, Bockenstedt LK, et al. Clinical Practice Guidelines by the Infectious Diseases Society of America (IDSA), American Academy of Neurology (AAN), and American College of Rheumatology (ACR): 2020 Guidelines for the Prevention, Diagnosis and Treatment of Lyme Disease. *Clin Infect Dis.* 2021;72(1):e1–e48, Table 6, p. e13.

with certain human leukocyte antigen allotypes (an autoimmune process), most children who are treated for Lyme arthritis are cured and have no sequelae. Although there are rare reports of adults who have developed late neuroborreliosis, usually among persons with Lyme disease in whom treatment was delayed for months or years, similar cases in children are rare.

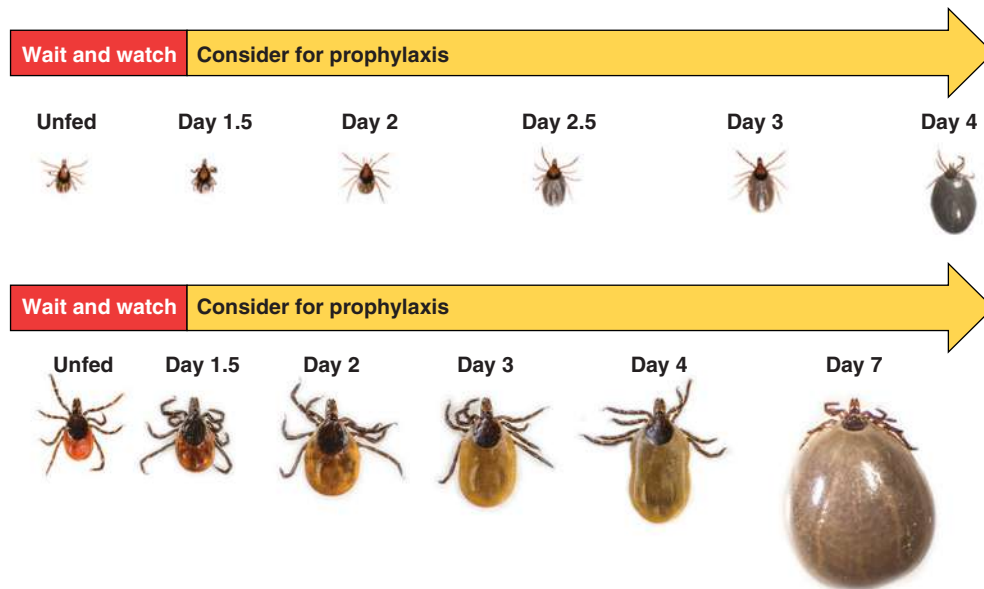
## PREVENTION

The best way to avoid Lyme disease is to avoid tick-infested areas (Table 268.3). Children should be examined for deer ticks after known or potential exposure (although many people are not able to identify the species or the stage of the tick). If a tick attachment is noted, the tick should be grasped at the mouthparts with a forceps or tweezers; if these are not available, the tick should be covered with a tissue (Table 268.4). The recommended method of tick removal is to pull directly outward without twisting; infection is usually preventable if the tick is removed before 36 hours of attachment; at this time the ticks are flat and nonengorged (Fig. 268.4).

The overall risk for acquiring Lyme disease after a tick bite is low (1–3%) in most endemic areas. If the tick is engorged and present for >72 hours (a high-risk tick bite), the risk of infection may increase to 25% in hyperendemic areas. Patients and families should be advised to watch the area for development of erythema migrans and to seek medical attention if the rash or constitutional symptoms occur. If infection develops, early treatment of the infection is highly effective. Prophylaxis after a high-risk tick bite with a single dose of oral doxycycline in adults (200 mg) or 4.4 mg/kg in children is effective in reducing the risk of Lyme disease. The routine testing of ticks that have been removed from humans for evidence of *B. burgdorferi* is not recommended because the value of a positive test result for predicting infection in the human host is unknown.

Personal protective measures that may be effective in reducing the chance of tick bites include wearing protective clothing (long pants tucked into socks, long-sleeved shirts) when entering tick-infested areas, checking for and promptly removing ticks, and using tick repellents such as N,N-diethyl-3-methylbenzamide (DEET) (see Table 268.3). This chemical can safely be used on pants, socks, and shoes; care must be used with heavy or repeated application on skin,





**Fig. 268.4** Relative sizes of engorging nymphal and adult female *Ixodes scapularis* (black-legged = deer tick) as a function of time spent feeding (= attachment time). Transmission of *Borrelia burgdorferi* requires 36–48 hr of feeding, and therefore antibiotic prophylaxis is recommended only if the tick has been attached for at least 36 hr, or 1.5 days. By itself, duration of feeding is insufficient for recommending antibiotic prophylaxis. (Top) Nymphs (Feeding time: Unfed = 0 hr; Day 1.5 = 36 hr; Day 2 = 48 hr; Day 2.5 = 60 hr; Day 3 = 72 hr; Day 4 = 96 hr). (Bottom) Adult females over the same period. Unfed nymph and adult female are the sizes of poppy and sesame seeds, respectively. Not actual size. (Courtesy of URI TickEncounter Resource Center, TickEncounter.org; From Lantos PM, Rumbaugh J, Bockenstedt LK, et al. *Clinical Practice Guidelines by the Infectious Diseases Society of America [IDSA], American Academy of Neurology [AAN], and American College of Rheumatology [ACR]: 2020 Guidelines for the Prevention, Diagnosis and Treatment of Lyme Disease. Clin Infect Dis. 2021;72[1]:e1–e48, Fig. 6.*)

particularly in infants, because of the risk of systemic absorption and toxicity. Permethrin treatment of clothing is also an effective prevention strategy.

Visit Elsevier eBooks+ at [eBooks.Health.Elsevier.com](https://www.elsevier.com/ebooksplus) for Bibliography.

## Section 9

# Mycoplasmal Infections

### Chapter 269

## *Mycoplasma pneumoniae*

Asuncion Mejias and Octavio Ramilo

Among the few *Mycoplasma* species isolated from the human respiratory tract, *Mycoplasma pneumoniae* remains the most common species causing respiratory infections in school-age children and young adults and is associated with a variety of clinical manifestations.

### THE ORGANISM

Mycoplasmas are the smallest self-replicating prokaryotes known to cause disease in humans. Their size of 150–250 nm is more on the order of viruses than bacteria. *M. pneumoniae* is a fastidious double-stranded DNA bacterium that is distinguished by a small genome (~800,000 base pairs) and a long doubling time, which makes culturing it a slow

process (5–20 days) compared to other bacteria. *M. pneumoniae* isolates can be classified in two major genetic groups (subtypes 1 and 2) based on the P1 adhesion protein. Distinguishing these two subtypes is important for epidemiologic purposes. Like other mycoplasmas, *M. pneumoniae* is distinguished by the complete absence of a cell wall, resulting in (1) their dependence on host cells for obtaining essential nutrients, (2) their intrinsic resistance to  $\beta$ -lactam agents, and (3) their pleomorphic shape and lack of visibility on Gram staining.

### EPIDEMIOLOGY

*M. pneumoniae* infections occur worldwide and throughout the year. This organism is a frequent cause of community-acquired pneumonia (CAP) in children >5 years of age and adults, accounting for ~20% of all CAP in middle school and high school children and up to 50% of CAP in college students and military recruits. The proportion of cases increases according to age, as recently shown in a large population-based study of CAP conducted in the United States (3% in <5 years, 17% in 5–9 years, and 24% in 10–17 years).

In contrast to the acute, short-lived epidemics associated with some respiratory viruses, *M. pneumoniae* infection occurs endemically worldwide. Epidemic outbreaks of variable intensity occur every few years and are likely related to the alternative circulation of the two *M. pneumoniae* subtypes. Transmission occurs through the respiratory route by large droplet spread during close contact with a symptomatic person. Community outbreaks have been described in closed settings (colleges, boarding schools, military bases) and can spread largely through school contacts. Attack rates within families are high, with transmission rates of 40–80% for household adult and children contacts, respectively. In contrast to many other respiratory infections, the incubation period is 2–3 weeks; hence, the course of infection in a specific population (family) may last several weeks.

The occurrence of mycoplasma illnesses is related, in part, to age and preexposure immunity. Overt illness is less common before 3 years of age but can occur. Children younger than 5 years of age appear to have milder illnesses associated with upper respiratory tract involvement, vomiting, and diarrhea. Immunity after infection is not long-lasting, as evidenced by the frequency of reinfections over time. Other pathogens



are frequently co-detected in children with *M. pneumoniae*, especially in those younger than 2 years of age, where viral co-infections have been identified in up to 30% of cases. *Asymptomatic carriage* after infection can last up to 4 months despite antibiotic therapy and may contribute to prolonged outbreaks. Children are often the reservoir from whom mycoplasma spreads. In the clinical setting, there are no available tools yet to differentiate carriage vs infection.

## PATHOGENESIS

The pathogenicity of *M. pneumoniae* is dependent on its extracellular attachment and the initiation of the host cell immune response. The mechanisms by which *M. pneumoniae* causes disease include (1) direct bacterial invasion that initiates in the cells of the ciliated respiratory epithelium, the target cells of *M. pneumoniae* infection; (2) toxin mediated through the production of the adenosine diphosphate-ribosylating and vacuolating toxin termed *community-acquired respiratory distress syndrome* (CARDS), an exotoxin that may damage the respiratory tract and has been associated with more severe or even fatal disease; and (3) indirect immune-mediated effects, by altering antigens in the cell surface and inducing the production of autoantibodies.

The organism is an elongated snakelike structure with a one-end organelle, which mediates the attachment to sialic acid receptors in the cilia through a complex set of adhesion transmembrane proteins (P1, P30, proteins B and C, P116, and HMW1-3). Virulent organisms attach to ciliated respiratory epithelial cell surfaces located in the bronchi, bronchioles, alveoli, and possibly upper respiratory tract and burrow down between cells, resulting in ciliostasis and eventual sloughing of the cells. This bacterium is capable of forming biofilms, with strain-specific phenotypic differences, which hinder antibiotic penetration and recognition by the immune system.

Once *M. pneumoniae* reaches the lower respiratory tract, it promotes the polyclonal activation of B lymphocytes and CD4<sup>+</sup> T cells and amplifies the immune response with the production of various proinflammatory and antiinflammatory cytokines and chemokines, such as tumor necrosis factor- $\alpha$ , interleukin (IL)-8, IL-1 $\beta$ , IL-6, and IL-10.

Although it is well documented that specific cell-mediated immunity and antibody titers against *M. pneumoniae* increase with age (and therefore probably follow repeated infections), the immune mechanisms that protect against or clear the infection are not well defined. In humans, nasal IgA antibodies correlated with protection after experimental challenge. A distinct aspect of *M. pneumoniae* is its ability to induce the production of cold agglutinins (IgM antibodies) directed against the I antigen on the erythrocyte's surface. Even though antibody responses do not confer complete protection against reinfections, the importance of a robust humoral response is apparent, because patients with congenital antibody deficiencies, such as those with hypogammaglobulinemia, can develop severe and prolonged disease and have a higher risk of extrapulmonary manifestations. In children with sickle cell disease or sickle-related hemoglobinopathies, *M. pneumoniae* is a common infectious trigger of acute chest syndrome. These children and also children with Down syndrome can develop severe *Mycoplasma pneumoniae*. On the other hand, *M. pneumoniae* does not seem to be a common infectious agent in patients with AIDS.

*M. pneumoniae* has been detected by polymerase chain reaction (PCR) in many nonrespiratory sites, including blood, pleural fluid, cerebrospinal fluid (CSF), and synovial fluid. The mechanisms of extrapulmonary disease associated with *M. pneumoniae* are unclear and appear to be different according to the duration of symptoms at the time of presentation: direct invasion vs immune-mediated.

## CLINICAL MANIFESTATIONS

*M. pneumoniae* is a frequent cause of upper and lower respiratory tract infections in children and adolescents. The clinical manifestations of *M. pneumoniae* can be divided into respiratory (more common) and extrapulmonary (less common).

### Respiratory Tract Disease

Tracheobronchitis and atypical pneumonia are the most commonly recognized clinical syndromes associated with *M. pneumoniae*. This agent is

responsible for up to 20% of all cases of CAP. The clinical manifestations of *M. pneumoniae* pneumonia evolve according to the stage of the disease. The onset is usually characterized by gradual development of headache, malaise, fever, and sore throat, followed by progression of lower respiratory symptoms, including hoarseness and nonproductive cough. The gradual onset in children with atypical pneumonia is in contrast to the sudden onset of lobar pneumonia. Coryza and gastrointestinal manifestations are unusual and suggest a viral etiology, if present. Approximately 10% of children will develop a cutaneous maculopapular rash. Although the clinical course in untreated patients is variable, cough, the clinical hallmark of *M. pneumoniae* infection, usually worsens during the first week of illness. Symptoms generally resolve within 2 weeks, although cough can last up to 4 weeks and may be accompanied by wheezing.

Chest examination may be unrevealing, even in patients with severe cough. There may be no auscultative or percussive findings or only minimum dry rales. Clinical findings are often less severe than suggested by the chest radiograph, explaining why the term "walking pneumonia" is often used to describe CAP caused by *M. pneumoniae*. Radiographic findings are variable and nonspecific, not allowing differentiation from viral or bacterial pathogens. Bilateral diffuse infiltrates, lobar pneumonia, or hilar lymphadenopathy can occur in up to 30% of patients. Although unusual, large pleural effusions associated with lobar infiltrates and necrotizing pneumonia have been described in patients with immunodeficiency, Down syndrome, chronic cardiopulmonary disease, and sickle cell disease. The white blood cell and differential counts are usually normal, whereas the erythrocyte sedimentation rate and C-reactive protein are often elevated. Appropriate antibiotics shorten the duration of illness but do not reliably eradicate the organism from the respiratory tract.

**Other respiratory illnesses** occasionally caused by *M. pneumoniae* include undifferentiated upper respiratory tract infections; intractable, nonproductive cough; pharyngitis (usually without marked cervical lymphadenopathy); sinusitis; croup; and bronchiolitis. *M. pneumoniae* is a common trigger of wheezing in asthmatic children and can cause chronic colonization in the airways, resulting in lung dysfunction in adolescent and adult asthmatic patients. Otitis media and bullous myringitis, which also occur with other viral and bacterial infections, have been described but are rare, and their absence should not exclude the diagnosis of *M. pneumoniae*.

### Extrapulmonary Disease

Despite the reportedly rare isolation of *M. pneumoniae* from nonrespiratory sites, the improved sensitivity of PCR for *M. pneumoniae* DNA detection has led to increasing identification of this bacterium in nonrespiratory sites, particularly the central nervous system (CNS). Patients with or without respiratory symptoms can have involvement of the skin, CNS, blood, heart, gastrointestinal tract, and joints. Extrapulmonary manifestations have been documented in 11–26% of children with *M. pneumoniae* infection and include:

1. **CNS disease:** Occurs in 0.1% of all patients with *M. pneumoniae* infection and in 7% of those requiring hospitalization. Manifestations include encephalitis, acute disseminated encephalomyelitis (ADEM), transverse myelitis, cerebellar ataxia, aseptic meningitis, Guillain-Barré syndrome, Bell palsy, and peripheral neuropathy. CNS disease manifestations occur 3–23 days (mean: 10 days) after onset of respiratory illness but may not be preceded by any signs of respiratory infection in up to 20% of cases. Studies in children suggest that there are two pathogenic mechanisms for *M. pneumoniae*-associated neurologic disease: the first pattern is characterized by almost absent or no prodromal respiratory symptoms (<7 days) and nonreactive IgM responses. On the other hand, the second pattern is characterized by the presence of respiratory symptoms (most commonly cough) for  $\geq 7$  days and reactive IgM in acute serum. In the first group *M. pneumoniae* is usually identified in CSF by PCR but not in the respiratory tract, whereas in children presenting with  $\geq 7$  days of respiratory symptoms, the opposite is true. These studies suggest that encephalitis occurring more than 7 days after onset of prodromal symptoms is more likely to be caused by an autoimmune response to *M. pneumoniae*, whereas its occurrence early in the course of the disease may be associated with direct bacterial invasion of the CNS. Involvement of the brainstem can result in severe

dystonia and movement disorders. The CSF may be normal or have mild mononuclear pleocytosis and/or increased CSF protein concentrations with normal glucose. Diagnosis is confirmed with positive CSF PCR, positive PCR from a throat swab, or demonstration of seroconversion. Findings on MRI include focal ischemic changes, ventriculomegaly, diffuse edema, or multifocal white matter inflammatory lesions consistent with postinfectious ADEM. Long-term sequelae have been reported in 23–64% of cases.

2. **Mucocutaneous disease:** Up to 25% of children with *M. pneumoniae* infections can have associated skin and mucosal exanthems, most notably maculopapular rashes, urticaria, and *Mycoplasma*-induced rash and mucositis syndrome (MIRM) or Stevens-Johnson syndrome (SJS). Gianotti-Crosti syndrome and erythema nodosum are also associated with *M. pneumoniae* infections. Approximately 10% of children with *M. pneumoniae* CAP will exhibit a maculopapular rash. *Mycoplasma*-induced rash and mucositis usually develop 3–21 days after initial respiratory symptoms, last less than 14 days, and are rarely associated with severe complications (Figs. 269.1 and 269.2). *M. pneumoniae* may also produce an isolated oral mucositis in absence of a rash.
3. **Hematologic abnormalities:** Include mild degrees of hemolysis with a positive Coombs test and minor reticulocytosis 2–3 weeks after the onset of illness. Severe hemolysis is associated with high titers of cold hemagglutinins ( $\geq 1:512$ ) and occurs rarely. Thrombocytopenia, aplastic anemia, hemophagocytic syndrome, and coagulation defects occur occasionally.



**Fig. 269.1** Lip changes found in *Mycoplasma pneumoniae*-associated mucositis.



**Fig. 269.2** Classic skin lesions found in *Mycoplasma pneumoniae*-associated rash.

4. **Musculoskeletal:** Arthritis appears to be less common in children than in adults, but monoarthritis, polyarthritis, and migratory arthritis have been described. Rhabdomyolysis has also been documented, often associated with other organ system manifestations.
5. **Other conditions,** such as mild hepatitis, gastroenteritis, pancreatitis, acute glomerulonephritis, iritis or uveitis, and cardiac complications (pericarditis, myocarditis, and rheumatic fever-like syndrome, most commonly seen in adults) are also described. Fatal *M. pneumoniae* infections are rare.

## DIAGNOSIS

No specific clinical, epidemiologic, or laboratory parameters allow for a definite diagnosis of *M. pneumoniae* infection. Nevertheless, pneumonia in school-age children and young adults with a gradual onset and cough as prominent findings suggests *M. pneumoniae* infection. The best method for diagnosis is a combination of PCR from respiratory samples and serology (acute and convalescent), as *M. pneumoniae* colonizes the airway and has been identified in 17–25% of asymptomatic children.

**Cultures** on special media (SP4 agar media) of the throat or sputum might demonstrate the classic *M. pneumoniae* “mulberry” colonies, but growth generally requires incubation for more than 2–3 weeks. The fastidious nutritional requirements of *Mycoplasma* make cultures slow and impractical, and few laboratories maintain the capability of culturing *M. pneumoniae*.

**Serologic tests** (immunofluorescence tests, enzyme-linked immune assays [EIAs]) to detect serum immunoglobulin (Ig) M, IgA, and IgG antibodies against *M. pneumoniae* are commercially available. IgM antibodies have a high rate of false-positive and false-negative results. In most cases, IgM antibodies are not detected within the first week after symptom onset or in children with recurrent infections and may be positive for up to 6–12 months after infection, or even years, and thus may not indicate acute infection. A fourfold or greater increase in IgG antibody titers against *M. pneumoniae* between acute and convalescent sera obtained 2–4 weeks apart is diagnostic. Complement fixation assays are less sensitive and specific than EIA or immunofluorescent assays.

**Cold hemagglutinins** (cold-reacting antibodies [IgM] against red blood cells) can be detected in approximately 50% of patients with *M. pneumoniae* pneumonia. These antibodies are nonspecific, especially at titers  $< 1:64$ , as modest increases in cold hemagglutinins can be observed in other viral infections. Cold agglutinin antibodies should not be used for the diagnosis of *M. pneumoniae* infections if other methods are available.

**Nucleic acid amplification test (NAATs)** for *M. pneumoniae* have replaced other diagnostic tests. PCR of a nasopharyngeal or throat swab (the combination of both increases sensitivity) for *M. pneumoniae* genomic DNA carries a sensitivity and a specificity of 80% to  $> 97\%$ . Different primers have been used to identify gene sequences of the P1 cytoadhesion protein or the ribosomal (r) 16S RNA. PCR allows a more rapid diagnosis in acutely ill patients and can be positive earlier in the course of infection than serologic tests. Identification of *M. pneumoniae* by PCR (or culture) from a patient with compatible clinical manifestations suggests causation.

The diagnosis of extrapulmonary disease associated with *M. pneumoniae* is challenging. Although *M. pneumoniae* has been identified by PCR in the CSF of children with encephalitis, there are currently no reliable tests for the diagnosis of CNS or other nonrespiratory sites associated with *M. pneumoniae*. Because the extrapulmonary manifestations of *M. pneumoniae* may have an immunologic base, measuring acute and convalescent IgM and IgG antibody levels is advisable.

## TREATMENT

*M. pneumoniae* illness is usually mild, and most cases of pneumonia can be managed without the need for hospitalization. Because mycoplasmas lack a cell wall, they are inherently resistant to  $\beta$ -lactam agents that act by inhibiting the cell wall synthesis. In addition, drugs from other classes, such as trimethoprim, rifampin, or linezolid, are inactive against *M. pneumoniae*. Studies regarding the effectiveness of antimicrobial therapy for *M. pneumoniae* infections in children are contradictory. Nevertheless, empiric treatment is often initiated in hospitalized children with CAP or severe extrapulmonary manifestations based on clinical suspicion because of the difficulty of a definitive diagnosis.

## Antimicrobial Therapy

*M. pneumoniae* is typically sensitive to macrolides (erythromycin, clarithromycin, azithromycin), tetracyclines, and quinolones in vitro. Treatment of *Mycoplasma* does not assure eradication. Data from observational studies showed that macrolide treatment of children with *M. pneumoniae* CAP shortened the course of illness. Treatment may be more effective when started within 3–4 days of illness onset. Although macrolides do not have bactericidal activity, they are preferred in children younger than 8 years of age. Two multicenter studies of pediatric CAP demonstrated comparable clinical and bacteriologic success rates between erythromycin and clarithromycin or azithromycin. However, the newer macrolides were better tolerated. The recommended treatment is **clarithromycin (15 mg/kg/day divided into two doses PO for 10 days; maximum daily dose 1 g) or azithromycin (10 mg/kg PO once on day 1 [maximum dose 500 mg] and 5 mg/kg once daily [maximum dose 250 mg] PO on days 2–5)**. Doxycycline (2–4 mg/kg/day PO twice a day for 7 days, maximum daily dose 200 mg) in children of all ages and fluoroquinolones such as levofloxacin (10 mg/kg per dose twice a day in children <5 years; 10 mg/kg/day once a day in children ≥5 years—maximum daily dose 750 mg—for 7–10 days) are effective but have higher minimum inhibitory concentrations (MICs) compared with macrolides and currently are not recommended as a first-line therapy in children.

**Macrolide-resistant** *M. pneumoniae* infections should be suspected in patients with severe infections not responding to macrolide therapy within the first 48 hours of treatment, especially if they have a history of exposure to macrolides. Macrolide-resistant *M. pneumoniae* strains have been reported in Asia (70–90% in Japan and China), Europe (with great variability from country to country: 0% in the Netherlands vs 26% in Italy), and Israel. In the United States and Canada, the rates of resistance have varied from 2.8% to 13% of cases. The clinical significance of macrolide-resistant infections has not been completely elucidated. However, if macrolide-resistant *M. pneumoniae* is suspected, switching to a nonmacrolide antimicrobial regimen such as doxycycline or levofloxacin might be prudent.

## Adjunctive Therapy

There is no evidence that treatment of upper respiratory tract or non-respiratory tract disease with antimicrobial agents alters the course of illness. However, patients with severe manifestations of extrapulmonary disease may benefit from antimicrobial treatment because direct involvement of the bacterium cannot be excluded. Oftentimes antibiotics are administered in combination with immunomodulatory therapy. In this regard, corticosteroids with or without intravenous immunoglobulin are the most commonly used agents for managing severe *M. pneumoniae* extrapulmonary manifestations, particularly for patients with CNS involvement or rash and mucositis. Although definitive data are lacking, case studies suggest the associated clinical benefit of steroids in the management of severe lung disease, SJS, and hemolytic anemia.

## PREVENTION

Trials with inactivated and live attenuated vaccines for *M. pneumoniae* have been conducted with disappointing results. In hospitalized patients, standard and droplet precautions are recommended for the duration of symptoms. It is important to emphasize that *Mycoplasma* infection remains contagious as long as cough persists and despite successful antibiotic therapy. Prophylaxis with tetracyclines or azithromycin substantially reduces the secondary attack rates in institutional outbreaks and family close contacts. Antimicrobial prophylaxis is not recommended routinely; however, it can be considered in patients at high risk for severe disease, such as children with sickle cell disease.

Visit Elsevier eBooks+ at [eBooks.Health.Elsevier.com](http://eBooks.Health.Elsevier.com) for Bibliography.

## Chapter 270

# Genital Mycoplasmas (*Mycoplasma hominis*, *Mycoplasma genitalium*, and *Ureaplasma* *urealyticum*)

María I. Sánchez Códez and  
Asuncion Mejias

## ETIOLOGY

*Mycoplasma* species are small pleomorphic bacteria that typically lack a cell wall and are bound by a cell membrane. Many of the biologic properties of mycoplasmas are in fact the result of the absence of a rigid cell wall, including resistance to  $\beta$ -lactam antibiotics. These ubiquitous organisms are difficult to cultivate using routine media and belong to the family Mycoplasmataceae in the class Mollicutes and represent the smallest self-replicating organisms known to date. The entire genome of many of the *Mycoplasma* species is among the smallest of the prokaryotic genomes. The family Mycoplasmataceae is composed of two genera responsible for human infection: *Mycoplasma* and *Ureaplasma*. Of those, *Mycoplasma hominis*, *Mycoplasma genitalium*, and *Ureaplasma* spp., which include *Ureaplasma urealyticum* (biovar 2) and *Ureaplasma parvum* (biovar 1), are considered human urogenital pathogens and are reviewed in this chapter. The main feature that distinguishes *Ureaplasma* spp. from *Mycoplasma* spp. is the ability of the former to hydrolyze urea for energy production.

Genital mycoplasmas are often associated with sexually transmitted infections such as cervicitis and nongonococcal urethritis (NGU) or with puerperal infections such as endometritis. *M. hominis* and *Ureaplasma* spp. commonly colonize the female genital tract and can cause chorioamnionitis, colonization of neonates, and perinatal infections. The role of *M. genitalium* in pregnant women has not been well defined.

## EPIDEMIOLOGY

Genital mycoplasmas are part of the normal flora and are commonly present in the genitourinary (GU) tract of postpubertal women and men and the upper respiratory tract. The prevalence of genital colonization with these bacteria has been directly associated with low socioeconomic status, hormonal changes, and ethnicity and increases proportionally according to sexual activity, being highest among individuals with multiple sexual partners. Female colonization is greatest in the vagina (and less in the endocervix, urethra, and endometrium), with rates varying from 40% to 80% for *Ureaplasma* spp. and 21–50% for *M. hominis* among sexually active asymptomatic women. *Ureaplasma* is isolated less often from urine than from the cervix, but *M. hominis* is present in the urine and in the cervix with approximately the same frequency. Male colonization is less common and occurs primarily in the urethra. Among prepubertal children and sexually inactive adults, colonization rates are <10%. *M. genitalium* is implicated in approximately 15–20% of NGU cases in men and in 10–30% of women with cervicitis and also plays a role in pelvic inflammatory disease in women. Studies using polymerase chain reaction (PCR) show that colonization of the female lower urogenital tract with *M. genitalium* is less common than with *M. hominis* or *Ureaplasma* spp.



**TRANSMISSION**

Genital mycoplasmas are transmitted by sexual contact or by vertical transmission from mother to infant. As with other perinatal infections, vertical transmission can occur through ascending intrauterine infection or hematogenous spread from placental infection but most often occurs through a colonized birth canal at the time of delivery. Transmission rates among neonates born to women colonized with *Ureaplasma* spp. range from 18% to 88%. Neonatal colonization rates are higher among infants who weigh <1,000 g, infants who are born in the presence of chorioamnionitis, and infants born to mothers who are heavily colonized and of lower socioeconomic status. Neonatal colonization is transient and decreases proportionally with age. Organisms may be recovered from the newborn's throat, vagina, rectum, and, occasionally, conjunctiva and respiratory tract.

**PATHOGENESIS**

Genital mycoplasmas can cause chronic inflammation of the GU tract and amniotic membranes. These bacteria usually live in a state of adherence to the respiratory or urogenital tract but can disseminate to other organs when there is a disruption of the mucosa or a weakened or immature immune system, such as in premature infants. *Ureaplasma* spp. can infect the amniotic sac early in gestation without rupturing the amniotic membranes, resulting in a clinically silent, chronic chorioamnionitis characterized by an intense inflammatory response. In addition, mycoplasmas and *Ureaplasma* spp. hydrolyze arginine or urea into ammonium for energy production. Ammonium causes an increase in the genital pH that leads to bacterial dysbiosis with a reduction in *Lactobacillus* and overgrowth of other genital bacteria that can promote preterm labor, premature rupture of membranes, and chorioamnionitis.

Attachment to fetal human tracheal epithelium can cause ciliary disarray, clumping, and loss of epithelial cells. In vitro studies show that *Ureaplasma* spp. stimulates macrophage production of interleukin (IL)-6 and tumor necrosis factor- $\alpha$ . In addition, high concentrations of proinflammatory cytokines possibly associated with development of bronchopulmonary dysplasia (BPD) of prematurity, such as monocyte chemoattractant protein-1 and IL-8, have been found in tracheal secretions from very low birthweight infants colonized with *Ureaplasma* spp. Immunity appears to require serotype-specific antibody. Thus lack of maternal antibodies might account for a higher disease risk in premature newborns.

**CLINICAL MANIFESTATIONS**

The main syndromes associated with *Ureaplasma* spp., *M. genitalium*, and *M. hominis* are displayed in Table 270.1.

**Intrauterine and Neonatal Infections  
Chorioamnionitis and Early Onset Infections**

Genital mycoplasmas are associated with a variety of fetal and neonatal infections. *Ureaplasma* spp. have been associated with clinically inapparent chorioamnionitis, resulting in spontaneous abortion, increased fetal death, or premature delivery, although the causative role remains uncertain. Studies have shown that women with *Ureaplasma* spp. detected by PCR in amniotic fluid in the first or second trimester of gestation have an increased risk of preterm labor and delivery. In addition, *Ureaplasma* spp. are the microorganism most commonly identified by PCR in women with premature rupture of membranes, and data suggest that *U. parvum* plays a bigger role than *U. urealyticum* in prematurity.

**Table 270.1** Clinical Syndromes and Antibiotic Therapy for *Ureaplasmas* and *Mycoplasmas* Infection

	<b>UREAPLASMA SPP.</b>	<b>M. HOMINIS</b>	<b>M. GENITALIUM</b>
<b>INTRAUTERINE AND NEONATAL INFECTIONS</b>			
Chorioamnionitis	++	++	–
Preterm delivery	++	+	++
Postpartum fever	++	+++	UK
BPD	+++	+	UK
CNS infections	+	+	UK
NEC	+	UK	UK
<b>GENITOURINARY INFECTIONS</b>			
NGU (acute/chronic)	+++*	–	+++
Cervicitis	–	–	+++
PID	+	++	+++
<b>NON-NEONATAL/NONGENITOURINARY INFECTIONS</b>			
CNS disease <sup>†</sup>	+	++	–
Bacteremia	+	++	–
Surgical wound infections	++	++	–
Arthritis	+	++	–
<b>TREATMENT</b>			
Macrolides	++	–	++
Quinolones <sup>‡</sup>	+	++	+
Clindamycin	–	++	+
Tetracyclines (doxycycline)	++	+	+

\*Only *Ureaplasma urealyticum* (not *parvum*).

<sup>†</sup>CNS disease include meningitis, hydrocephalus, brain abscess, subdural empyema, intraventricular hemorrhage, and nonfunctioning CNS shunts.

<sup>‡</sup>The most commonly used quinolones are ciprofloxacin, levofloxacin, and moxifloxacin.

BPD, Bronchopulmonary dysplasia; CNS, central nervous system; NEC, necrotizing enterocolitis; NGU, nongonococcal urethritis; PID, pelvic inflammatory disease; UK, unknown.



*Ureaplasma* spp. can also be recovered from tracheal, blood, cerebrospinal fluid (CSF), or lung biopsy specimens in up to 50% of sick infants younger than 34 weeks of gestation. In a study of 351 mother/infant dyads, isolation of *Ureaplasma* spp. or *M. hominis* from cord blood was documented in 23% of infants born between 23 and 32 weeks of gestation and correlated with the development of systemic inflammatory response syndrome.

### Bronchopulmonary Dysplasia

The role of these organisms in causing severe respiratory insufficiency, the need for mechanical ventilation, the development of BPD, or death remains controversial. Nevertheless, meta-analyses of published studies have identified respiratory colonization with *Ureaplasma* spp. as an independent risk factor for the development of BPD. However, trials using erythromycin or azithromycin therapy in high-risk preterm infants with tracheobronchial colonization of *Ureaplasma* spp. have failed to show any difference in the development of BPD in treated vs. nontreated infants. Similarly, treatment with azithromycin in pregnant women colonized with *Ureaplasma* spp. did not show a reduction in the risk of BPD in neonates. To date there is not enough evidence to support the use of antibiotic therapy in preterm infants at risk for or with confirmed *Ureaplasma* spp. infection to prevent the development of BPD.

### Central Nervous System Infections

*M. hominis* and *Ureaplasma* spp. have been isolated from the CSF of premature infants and, less commonly, full-term infants. These bacteria may represent true pathogens and may be associated with CNS disease based on the host susceptibility/gestational age and bacteria pathogenicity. However, the clinical significance of recovering *M. hominis* and *Ureaplasma* spp. from the CSF is uncertain, as most infants have no overt signs of CNS disease, CSF pleocytosis is not consistent, and spontaneous clearance of mycoplasmas has been documented without specific therapy.

*Ureaplasma* spp. have been associated with the development of subdural empyema and meningitis associated with intraventricular hemorrhage (IVH) and hydrocephalus. Limited data suggest that meningitis caused by *M. hominis* can also be associated with IVH, hydrocephalus, and brain abscess, particularly in low birthweight or preterm neonates and in infants with neural tube defects. In a review of 29 reported neonatal cases with *M. hominis* meningitis, 8 (28%) neonates died and 8 (28%) developed neurologic sequelae. The age of onset of meningitis ranges from 1 to 196 days of life, and organisms can persist in the CSF without therapy for days to weeks. Pachymeningitis may be evident on MRI.

**Other:** *M. hominis* and *Ureaplasma* spp. have also been associated with neonatal conjunctivitis, abscesses (mainly at the scalp electrode site and associated with *M. hominis*), pneumonia, bacteremia, and necrotizing enterocolitis (NEC).

### Genitourinary Infections

In sexually active adolescents and adults, genital mycoplasmas are associated with sexually transmitted diseases and are rarely associated with focal infections outside the genital tract. *U. urealyticum* (not *U. parvum*) and *M. genitalium* are recognized etiologic agents of NGU, mainly in men, and represent the second most common cause of urethritis after *Chlamydia trachomatis*. *M. genitalium* has been identified in 30% of patients with persistent or recurrent NGU, because this bacterium is relatively resistant to the antibiotics recommended for the treatment of NGU. Rare complications of NGU include epididymitis and prostatitis. Salpingitis, cervicitis, pelvic inflammatory disease, and endometritis have been described in women associated with *M. genitalium* and, to a lesser extent, with *M. hominis*.

### Nongenital Infections

*Ureaplasma* spp. and *M. hominis* infections are rarely described outside the neonatal period. These infections have been reported

in both immunocompetent and immunocompromised children, including patients with hypogammaglobulinemia, lymphoma, or solid organ transplant recipients, who appear to be at higher risk of infection.

Cases of *Ureaplasma* spp. pneumonia, osteomyelitis, arthritis, meningitis, mediastinitis, bacteremia, infection of aortic grafts, and surgical site infections have been reported. Recent data suggest that *Ureaplasma* spp. is associated with posttransplant hyperammonemia syndrome, a rare but potentially fatal complication.

*M. hominis* is most commonly reported in systemic infections and has been associated with CNS disease (including meningitis, brain abscesses, subdural empyema, and nonfunctioning shunts), surgical wound infections, arthritis (associated in up to 50% of cases with prior manipulation of the GU tract), prosthetic and naïve endocarditis, osteomyelitis, and pneumonia. There are reports of life-threatening mediastinitis, sternal wound infections, pleuritis, peritonitis, and pericarditis, with high mortality rates in patients after organ transplantation. These infections should be suspected in culture-negative systemic or local infections, when samples have been properly collected and before initiation of antibiotic therapy.

### DIAGNOSIS

All Mollicutes lack a cell wall and are therefore not visible on Gram stain. *M. hominis* and *Ureaplasma* spp. can grow in cell-free media and require sterols for growth, producing characteristic colonies on agar. Colonies of *M. hominis* are 200–300 µm in diameter with a fried-egg appearance, whereas colonies of *Ureaplasma* spp. are smaller (16–60 µm in diameter). *M. genitalium* is a fastidious organism and can be isolated with difficulty in cell culture systems, requiring up to 8 weeks to be detected. Most clinical microbiology laboratories do not routinely test for these pathogens, and nucleic acid–based tests are the preferred method for diagnosis. PCR-based assays have greater sensitivity than culture (90% vs 40%, respectively) and provide a more practical method for detection. Serologic assays for genital mycoplasmas have limited value in the clinical setting and are not commercially available for diagnostic purposes. In addition, serologic studies for *Ureaplasma* spp. are not useful because of the high prevalence of colonization in healthy children and adults.

### Genital Tract Infection

Confirmation of genital tract infection is challenging because of the high colonization rates in the vagina and urethra. NGU is typically defined as new-onset urethral discharge or dysuria with Gram stain of urethral discharge showing ≥5 polymorphonuclear leukocytes per oil-immersion field in the absence of gram-negative diplococci (i.e., *Neisseria gonorrhoeae*). The lack of cell wall prevents the identification of these bacteria by routine Gram stain. Detection of *Ureaplasma* spp. or *M. hominis* by PCR is available for a variety of specimens, including urine and swabs of the cervix, urethra, and vagina. *M. genitalium* is often identified by nucleic acid amplification tests (NAATs) of first-void urine specimens in men and vaginal swabs in women.

### Neonates

*Ureaplasma* spp. and *M. hominis* have been isolated from urine, blood, CSF, tracheal aspirates, pleural fluid, abscesses, and lung tissue. Premature neonates who are clinically ill with pneumonitis, focal abscesses, or CNS disease (particularly progressive hydrocephalus with or without pleocytosis) for whom bacterial cultures are negative or in whom there is no improvement with standard antibiotic therapy warrant further workup to rule out genital mycoplasmas. Isolation of *Ureaplasma* spp. and *M. hominis* requires special media using urea for the former and arginine for the latter, and clinical specimens must be cultured immediately or frozen at –70°C (–94°F) to prevent loss of organisms. *M. hominis* can also be detected sometimes using routine laboratory media such as blood agar or chocolate agar. When inoculated into broth containing arginine (for *M. hominis*) or urea (for *Ureaplasma* spp.), growth is indicated by an alkaline pH. Identification of

*Ureaplasma* spp. on agar requires 1-3 days of growth and visualization with the dissecting microscope, whereas *M. hominis* is apparent to the eye but can require 2-7 days to grow. PCR-based assays are available and will shed light on the causality of these pathogens when sterile sites are tested (e.g., CSF, joint fluid).

### TREATMENT

These organisms lack a cell wall, and thus  **$\beta$ -lactam agents or glycopeptides are not effective**. These bacteria are also resistant to sulfonamides and trimethoprim because they do not synthesize folic acid. Rifamycins do not have activity against Mollicutes (see Table 270.1).

Unlike other mycoplasmas and ureaplasmas, *M. hominis* is resistant to macrolides but generally susceptible to clindamycin and quinolones. Most *Ureaplasma* spp. are susceptible to macrolides and advanced-generation quinolones, such as levofloxacin or moxifloxacin, but are intrinsically resistant to aminoglycosides and often resistant to ciprofloxacin and clindamycin. Susceptibility to tetracyclines is variable for both organisms, with increasing resistance being reported. *M. genitalium* is typically susceptible to macrolides and moxifloxacin, with variable resistance to tetracyclines and clindamycin.

### Adolescents and Adults

Recommended treatment for NGU should include antibiotics with activity against *C. trachomatis* with either doxycycline (100 mg PO twice daily for 7 days) or azithromycin (1 g PO as a single dose). If adherence to a multiday regimen is not a concern, azithromycin administered over a 5-day course (500 mg on day 1 followed by 250 mg daily for 4 days) is an alternative and may limit the development of resistance. Recurrent NGU after completion of treatment suggests the presence of doxycycline or azithromycin-resistant *M. genitalium*. If the initial empiric regimen did not include macrolides, retreatment with an azithromycin-based regimen may be indicated. Azithromycin is also preferred in children younger than 8 years and in those with allergy to tetracyclines. On the other hand, if patients received azithromycin initially, retreatment with moxifloxacin may be most effective. Before the introduction of azithromycin, up to 60% of patients with *M. genitalium* NGU developed recurrent or chronic urethritis despite 1-2 weeks of treatment with doxycycline.

Sexual partners should also be treated to avoid recurrent disease in the index case. Nongenital mycoplasmal infections may require surgical drainage and prolonged antibiotic therapy.

### Neonates

Treatment of these infections in neonates is challenging, and **no optimal treatment has been established**. Doxycycline and quinolones are generally avoided at this age because of their associated toxicities. In addition, attributing causality may be difficult. In general, therapy for neonates with genital mycoplasma infections is indicated if infections are associated with pure growth of the organism or if the organism is detected by PCR from a normally sterile site in conjunction with compatible disease manifestations to assure the treatment of an infectious process rather than merely colonization.

Treatment is usually based on predictable antimicrobial sensitivities because susceptibility testing is not readily available for individual isolates (see Table 270.1). The treatment of BPD with **azithromycin** for the treatment of *Ureaplasma* spp. remains controversial. For infants with symptomatic central nervous system (CNS) infection, cures have been described with chloramphenicol, doxycycline, and quinolones, as they have better penetration into the CSF than macrolides. The long-term consequences of asymptomatic CNS infection associated with genital mycoplasmas, especially in the absence of pleocytosis, are unknown. Because mycoplasmas can spontaneously clear from the CSF, therapy should involve minimal risks.

Visit Elsevier eBooks+ at eBooks.Health.Elsevier.com for Bibliography.

## Section 10

# Chlamydial Infections

## Chapter 271

# *Chlamydia pneumoniae*

Stephan A. Kohlhoff and  
Margaret R. Hammerschlag

*Chlamydia pneumoniae* is a common cause of lower respiratory tract diseases, including pneumonia in children and bronchitis and pneumonia in adults. This organism was briefly known as *Chlamydophila pneumoniae*, and that name is still used as an alternative designation in some sources.

### ETIOLOGY

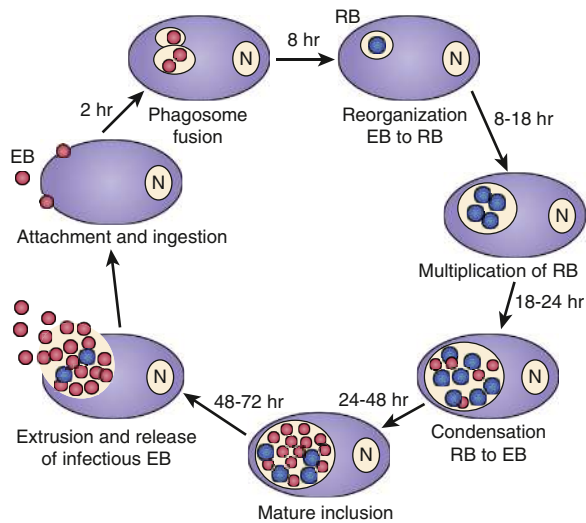
Chlamydiae are obligate intracellular pathogens that have established a unique niche in host cells. Chlamydiae cause a variety of diseases in animal species at virtually all phylogenetic levels. The most significant human pathogens are *C. pneumoniae* and *C. trachomatis* (see Chapter 272). *C. psittaci* is the cause of psittacosis, an important zoonosis (see Chapter 273). There are now nine recognized chlamydial species.

Chlamydiae have a gram-negative envelope without detectable peptidoglycan, although recent genomic analysis has revealed that both *C. pneumoniae* and *C. trachomatis* encode proteins forming a nearly complete pathway for synthesis of peptidoglycan, including penicillin-binding proteins. Chlamydiae also share a group-specific lipopolysaccharide antigen and use host adenosine triphosphate for the synthesis of chlamydial proteins. Although chlamydiae are auxotrophic for three of four nucleoside triphosphates, they encode functional glucose-catabolizing enzymes that can be used to generate adenosine triphosphate. As with peptidoglycan synthesis, for some reason, these genes are turned off. All chlamydiae also encode an abundant surface-exposed protein called the *major outer membrane protein*. The major outer membrane protein is the major determinant of the serologic classification of *C. trachomatis* and *C. psittaci* isolates.

### EPIDEMIOLOGY

*C. pneumoniae* is primarily a human respiratory pathogen. The organism has also been isolated from nonhuman species, including horses, koalas, reptiles, and amphibians, where it also causes respiratory infection, although the role that these infections might play in transmission to humans is unknown. *C. pneumoniae* appears to affect individuals of all ages. The proportion of community-acquired pneumonias associated with *C. pneumoniae* infection is 2-19%, varying with geographic location, the age-group examined, and the diagnostic methods used. Several studies of the role of *C. pneumoniae* in lower respiratory tract infection in pediatric populations have found evidence of infection in 0-18% of patients based on serology or culture for diagnosis. In one study, almost 20% of the children with *C. pneumoniae* infection were co-infected with *Mycoplasma pneumoniae*. *C. pneumoniae* may also be responsible for 10-20% of episodes of acute chest syndrome in children with sickle cell disease, up to 10% of asthma exacerbations, 10% of episodes of bronchitis, and 5-10% of episodes of pharyngitis in children. Asymptomatic infection appears to be common based on epidemiologic studies.

Transmission probably occurs from person to person through respiratory droplets. Spread of the infection appears to be enhanced by close proximity, as is evident from localized outbreaks in enclosed populations, such as military recruits and in nursing homes.



**Fig. 271.1** Life cycle of chlamydiae in epithelial cells. EB, Elementary body; RB, reticulate body. (From Hammerschlag MR. Infections due to *Chlamydia trachomatis* and *Chlamydia pneumoniae* in children and adolescents. *Pediatr Rev.* 2004;25:43–50.)

## **PATHOGENESIS**

Chlamydiae are characterized by a unique developmental cycle (Fig. 271.1) with morphologically distinct infectious and reproductive forms: the elementary body (EB) and reticulate body (RB). After infection, the infectious EBs, which are 200–400 nm in diameter, attach to the host cell by a process of electrostatic binding and are taken into the cell by endocytosis that does not depend on the microtubule system. Within the host cell, the EB remains within a membrane-lined phagosome. The phagosome does not fuse with the host cell lysosome. The inclusion membrane is devoid of host cell markers, but lipid markers traffic to the inclusion, which suggests a functional interaction with the Golgi apparatus. The EBs then differentiate into RBs that undergo binary fission. After approximately 36 hours, the RBs differentiate into EBs. At approximately 48 hours, release can occur by cytolysis or by a process of exocytosis or extrusion of the whole inclusion, leaving the host cell intact. Chlamydiae can also enter a persistent state after treatment with certain cytokines such as interferon- $\gamma$ , treatment with antibiotics, or restriction of certain nutrients. While chlamydiae are in the persistent state, metabolic activity is reduced. The ability to cause prolonged, often subclinical, infection is one of the major characteristics of chlamydiae.

## **CLINICAL MANIFESTATIONS**

Infections caused by *C. pneumoniae* cannot be readily differentiated from those caused by other respiratory pathogens, especially *M. pneumoniae*. The pneumonia usually occurs as a classic atypical (or non-bacterial) pneumonia characterized by mild to moderate constitutional symptoms, including fever, malaise, headache, cough, and often pharyngitis. Severe pneumonia with pleural effusions and empyema has been described. Milder respiratory infections have been described, manifesting as a pertussis-like illness.

*C. pneumoniae* can serve as an infectious trigger for asthma, can cause pulmonary exacerbations in patients with cystic fibrosis, and can produce acute chest syndrome in patients with sickle cell anemia. *C. pneumoniae* has been isolated from middle ear aspirates of children with acute otitis media, most of the time as co-infection with other bacteria. Asymptomatic respiratory infection has been documented in 2–5% of adults and children and can persist for 1 year or longer.

## **DIAGNOSIS**

It is not possible to differentiate *C. pneumoniae* from other causes of atypical pneumonia on the basis of clinical findings. Auscultation reveals the presence of rales and often wheezing. The chest radiograph

often appears worse than the patient's clinical status would indicate and can show mild, diffuse involvement or lobar infiltrates with small pleural effusions. The complete blood count may be elevated with a left shift but is usually unremarkable.

Specific diagnosis of *C. pneumoniae* infection has been based on isolation of the organism in tissue culture. *C. pneumoniae* grows best in cycloheximide-treated HEp-2 and HL cells. The optimum site for culture is the posterior nasopharynx; the specimen is collected with wire-shafted swabs in the same manner as that used for *C. trachomatis*. The organism can be isolated from sputum, throat cultures, bronchoalveolar lavage fluid, and pleural fluid, but few laboratories perform such cultures because of technical difficulties. There are two U.S. Food and Drug Administration (FDA)-cleared multiplexed nucleic acid amplification testing assays available for detection of respiratory viruses; pneumonia pathogens; and *C. pneumoniae*, *M. pneumoniae*, and *Bordetella pertussis* on upper respiratory samples. These systems combine nucleic acid extraction, amplification, detection, and data analysis.

Serologic diagnosis can be accomplished using the microimmunofluorescence (MIF) or the complement fixation tests. The complement fixation test is genus specific and is also used for diagnosis of lymphogranuloma venereum (see Chapter 272.4) and psittacosis (see Chapter 273). Its sensitivity in hospitalized patients with *C. pneumoniae* infection and children is variable. The Centers for Disease Control and Prevention (CDC) has proposed modifications in the serologic criteria for diagnosis. Although the MIF test was considered to be the only currently acceptable serologic test, the criteria were made significantly more stringent. Acute infection, using the MIF test, was defined by a fourfold increase in immunoglobulin (Ig) G titer or an IgM titer of  $\geq 16$ ; use of a single elevated IgG titer was discouraged. An IgG titer of  $\geq 16$  was thought to indicate past exposure, but neither elevated IgA titers nor any other serologic marker was thought to be a valid indicator of persistent or chronic infection. Because diagnosis would require paired sera, this would be a retrospective diagnosis. The CDC did not recommend the use of any enzyme-linked immune assay for detection of antibody to *C. pneumoniae* because of concern about the inconsistent correlation of these results with culture results. Studies of *C. pneumoniae* infection in children with pneumonia and asthma show that more than 50% of children with culture-documented infection have no detectable serum anti-*C. pneumoniae* antibody. Because of the availability of FDA-cleared nucleic acid test technology, diagnosis of acute infection should not be made using serology.

## **TREATMENT**

The optimum dose and duration of antimicrobial therapy for *C. pneumoniae* infections remain uncertain. Most treatment studies have used only serology for diagnosis, and thus microbiologic efficacy cannot be assessed. Prolonged therapy for 2 weeks or longer is required for some patients, because recrudescence symptoms and persistent positive cultures have been described after 2 weeks of erythromycin and 30 days of tetracycline or doxycycline.

Tetracyclines, macrolides (erythromycin, azithromycin, and clarithromycin), and quinolones show in vitro activity. Like *C. psittaci*, *C. pneumoniae* is resistant to sulfonamides. The results of treatment studies have shown that erythromycin (40 mg/kg/day PO divided twice a day for 10 days), clarithromycin (15 mg/kg/day PO divided twice a day for 10 days), and azithromycin (10 mg/kg PO on day 1 and then 5 mg/kg/day PO on days 2–5) are effective for eradication of *C. pneumoniae* from the nasopharynx of children with pneumonia in approximately 80% of cases. Resistance to these commonly used drug classes has not been conclusively demonstrated. Persistent symptoms may, however, reflect persistent infection caused by the latent nature of the organism or another etiology and should prompt a thorough reevaluation.

## **PROGNOSIS**

Clinical response to antibiotic therapy varies. Coughing often persists for several weeks even after therapy.

Visit Elsevier eBooks+ at eBooks.Health.Elsevier.com for Bibliography.



## Chapter 272

***Chlamydia trachomatis***

Margaret R. Hammerschlag

*Chlamydia trachomatis* is subdivided into two biovars, namely, lymphogranuloma venereum (LGV) and trachoma, which is the agent of human oculogenital diseases other than LGV. Although the strains of both biovars have almost complete DNA homology, they differ in growth characteristics and virulence in tissue culture and animals. In developed countries, *C. trachomatis* is the most prevalent sexually transmitted disease, causing urethritis in men, cervicitis and salpingitis in women, and conjunctivitis and pneumonia in infants.

**272.1 Trachoma**

Margaret R. Hammerschlag

Trachoma is the most important preventable cause of blindness in the world. It is caused primarily by the A, B, Ba, and C serotypes of *C. trachomatis*. It is endemic in the Middle East and Southeast Asia and among Navajo Indians in the southwestern United States. In areas that are endemic for trachoma, genital chlamydial infection is caused by the serotypes responsible for oculogenital disease: D, E, F, G, H, I, J, and K. The disease is spread from eye to eye. Flies are a common vector.

Trachoma begins as a **follicular conjunctivitis**, usually in early childhood. The follicles heal, leading to conjunctival scarring that can result in an entropion, with the eyelid turning inward so that the lashes abrade the cornea. It is the corneal ulceration secondary to the constant trauma that leads to scarring and blindness. Bacterial superinfection can also contribute to scarring. Blindness occurs years after the active disease.

Trachoma can be diagnosed clinically. The World Health Organization suggests that at least two of four criteria must be present for a diagnosis of trachoma: lymphoid follicles on the upper tarsal conjunctivae, typical conjunctival scarring, vascular pannus, and limbal follicles. The diagnosis is confirmed by culture or staining tests for *C. trachomatis* performed during the active stage of disease. Serologic tests are not helpful clinically because of the long duration of the disease and the high seroprevalence in endemic populations.

Poverty and lack of sanitation are important factors in the spread of trachoma. As socioeconomic conditions improve, the incidence of the disease decreases substantially. Endemic trachoma is managed by mass drug administration (MDA) with azithromycin in affected communities. Endemic communities should receive MDA until clinical signs of active disease in children 1-9 years of age falls below 5%. MDA with a single dose of azithromycin to all the residents of a village dramatically reduces the prevalence and intensity of infection. This effect continues for 2 years after treatment, probably by interrupting the transmission of ocular *C. trachomatis* infection.

Visit Elsevier eBooks+ at [eBooks.Health.Elsevier.com](http://eBooks.Health.Elsevier.com) for Bibliography.

**272.2 Genital Tract Infections**

Margaret R. Hammerschlag

**EPIDEMIOLOGY**

There are an estimated 3 million new cases of chlamydial sexually transmitted infections each year in the United States. *C. trachomatis*

is a major cause of epididymitis and is the cause of 23–55% of all cases of nongonococcal urethritis. As many as 50% of men with gonorrhea may be co-infected with *C. trachomatis*. The prevalence of chlamydial cervicitis among sexually active women is 2–35%. Rates of infection among girls 15-19 years of age exceed 20% in many urban populations and can be as high as 15% in suburban populations.

Children who have been sexually abused can acquire anogenital *C. trachomatis* infection, which is usually asymptomatic. However, because perinatally acquired rectal and vaginal *C. trachomatis* infections can persist for 3 years or longer, the detection of *C. trachomatis* in the vagina or rectum of a young child is not absolute evidence of sexual abuse.

**CLINICAL MANIFESTATIONS**

The trachoma biovar of *C. trachomatis* causes a spectrum of disease in sexually active adolescents and adults. Up to 75% of women with *C. trachomatis* have no symptoms of infection. *C. trachomatis* can cause urethritis (acute urethral syndrome), epididymitis, cervicitis, salpingitis, proctitis, and pelvic inflammatory disease. The symptoms of chlamydial genital tract infections are less acute than those of gonorrhea, consisting of a discharge that is usually mucoid rather than purulent. Asymptomatic urethral infection is common in sexually active men. Autoinoculation from the genital tract to the eyes can lead to concomitant inclusion conjunctivitis.

**DIAGNOSIS**

Diagnosis of genital chlamydial infection is now accomplished by nucleic acid amplification tests (NAATs). These tests have high sensitivity, detecting 10–20% more cases than culture, while retaining high specificity. Six FDA-approved NAATs are commercially available for detecting *C. trachomatis*, including polymerase chain reaction (PCR; Amplicor Chlamydia test, Roche Molecular Diagnostics, Nutley, NJ), strand displacement amplification (ProbeTec, BD Diagnostic Systems, Sparks, MD), transcription-mediated amplification (Amp CT, Hologic, San Diego, CA), and GeneXpert CT/NG assay (Cepheid, Sunnyvale, CA). PCR and strand displacement amplification are DNA amplification tests that use primers that target gene sequences on the cryptogenic *C. trachomatis* plasmid that is present at approximately 10 copies in each infected cell. Transcription-mediated amplification is a ribosomal RNA amplification assay. GeneXpert is an on-demand, qualitative, real-time PCR. All these assays are also available as co-amplification tests for simultaneously detecting *C. trachomatis* and *Neisseria gonorrhoeae*.

The available commercial NAATs are FDA-approved for cervical and vaginal swabs from adolescent girls and women, urethral swabs from adolescent boys and men, and urine, pharyngeal, and rectal swabs from adolescents and adults. Use of urine avoids the necessity for a clinical pelvic examination and can greatly facilitate screening in certain populations, especially adolescents, although several studies have now demonstrated that endocervical specimens and vaginal swabs are superior to urine for NAAT. Self-collected vaginal specimens appear to be as reliable as specimens obtained by a healthcare professional.

Data on the use of NAATs for vaginal specimens or urine from children are very limited and are insufficient to allow making a recommendation for their use. NAATs can be used, but confirmatory testing must be done. Because of the low prevalence of infection in this population, the positive predictive values of a positive test can be less than 30%. Confirmatory testing should consist of testing the original sample with a second FDA-approved NAAT that targets a different gene sequence from the initial test or repeating the testing **before** treatment. Use of non-FDA-cleared assays is strongly discouraged.

The etiology of most cases of nonchlamydial nongonococcal urethritis is unknown, although *Ureaplasma urealyticum* and possibly *Mycoplasma genitalium* are implicated in up to one third of cases (see Chapter 270). Proctocolitis may develop in individuals who have a rectal infection with an LGV strain (see Chapter 272.4).



## TREATMENT

The first-line treatment regimen now recommended by the CDC for uncomplicated *C. trachomatis* genital and rectal infection in adult and adolescent men and nonpregnant women is doxycycline (100 mg PO twice a day for 7 days). Recent studies have documented that doxycycline is significantly more effective than single-dose azithromycin. Alternative regimens are azithromycin (1 g orally in a single dose) or levofloxacin (500 mg PO once daily for 7 days). Doxycycline and quinolones are contraindicated in pregnant women, and quinolones are contraindicated in persons younger than 18 years. For pregnant women, the recommended treatment regimen is azithromycin (1 g PO as a single dose) or amoxicillin (500 mg PO 3 times a day for 7 days).

**Empirical treatment** without microbiologic diagnosis is recommended only for patients at high risk for infection who are unlikely to return for follow-up evaluation, including adolescents with multiple sex partners. These patients should be treated empirically for both *C. trachomatis* and *N. gonorrhoeae*.

**Sex partners** of patients with nongonococcal urethritis should be treated if they have had sexual contact with the patient during the 60 days preceding the onset of symptoms. The most recent sexual partner should be treated even if the last sexual contact was more than 60 days from onset of symptoms.

## COMPLICATIONS

Complications of genital chlamydial infections in women include perihepatitis (Fitz-Hugh–Curtis syndrome) and salpingitis. Of women with untreated chlamydial infection who develop pelvic inflammatory disease, up to 40% will have significant sequelae; approximately 17% will suffer from chronic pelvic pain, approximately 17% will become infertile, and approximately 9% will have an ectopic (tubal) pregnancy. Adolescent girls may be at higher risk for developing complications, especially salpingitis, than older women. Salpingitis in adolescent girls is also more likely to lead to tubal scarring, subsequent obstruction with secondary infertility, and increased risk for ectopic pregnancy. Approximately 50% of neonates born to pregnant women with untreated chlamydial infection will acquire *C. trachomatis* infection (see [Chapter 272.3](#)). Women with *C. trachomatis* infection have a threefold to fivefold increased risk for acquiring HIV infection.

## PREVENTION

Timely treatment of sex partners is essential for decreasing the risk for reinfection. Sex partners should be evaluated and treated if they had sexual contact during the 60 days preceding onset of symptoms in the patient. The most recent sex partner should be treated even if the last sexual contact was >60 days. Patients and their sex partners should abstain from sexual intercourse until 7 days after a single-dose regimen or after completion of a 7-day regimen.

Annual routine screening for *C. trachomatis* is recommended for all sexually active female adolescents, for all women 20–25 years of age, and for older women with risk factors such as new or multiple partners or inconsistent use of barrier contraceptives. Sexual risk assessment might indicate more frequent screening of some women.

Visit Elsevier eBooks+ at [eBooks.Health.Elsevier.com](http://eBooks.Health.Elsevier.com) for Bibliography.

## 272.3 Conjunctivitis and Pneumonia in Newborns

Margaret R. Hammerschlag

### EPIDEMIOLOGY

Chlamydial genital infection is reported in 5–30% of pregnant women, with a risk for vertical transmission at parturition to newborn infants of approximately 50%. The infant may become infected

at one or more sites, including the conjunctivae, nasopharynx, rectum, and vagina. Transmission is rare after cesarean section with intact membranes. The introduction of systematic prenatal screening for *C. trachomatis* infection and treatment of pregnant women has resulted in a dramatic decrease in the incidence of neonatal chlamydial infection in the United States. However, in countries where prenatal screening is not done, such as the Netherlands, *C. trachomatis* remains an important cause of neonatal infection, accounting for >60% of neonatal conjunctivitis.

### Inclusion Conjunctivitis

Approximately 30–50% of infants born to mothers with active, untreated chlamydial infection develop clinical conjunctivitis. Symptoms usually develop 5–14 days after delivery, or earlier in infants born after prolonged rupture of membranes. The presentation is extremely variable and ranges from mild conjunctival injection with scant mucoid discharge to severe conjunctivitis with copious purulent discharge, chemosis, and pseudomembrane formation. The conjunctiva may be very friable and may bleed when stroked with a swab. Chlamydial conjunctivitis must be differentiated from gonococcal ophthalmia, which is sight-threatening. At least 50% of infants with chlamydial conjunctivitis also have nasopharyngeal infection.

### Pneumonia

Pneumonia caused by *C. trachomatis* can develop in 10–20% of infants born to women with active, untreated chlamydial infection. Only approximately 25% of infants with nasopharyngeal chlamydial infection develop pneumonia. *C. trachomatis* pneumonia of infancy has a characteristic presentation. Onset usually occurs between 1 and 3 months of age and is often insidious, with persistent cough, tachypnea, and absence of fever. Auscultation reveals rales; wheezing is occasionally present but is uncommon. The absence of fever and wheezing generally helps to distinguish *C. trachomatis* pneumonia from respiratory syncytial virus pneumonia. A distinctive laboratory finding is the presence of peripheral eosinophilia (>400 cells/ $\mu$ L). The most consistent finding on chest radiograph is hyperinflation accompanied by minimal interstitial or alveolar infiltrates.

### Infections at Other Sites

Infants born to mothers with *C. trachomatis* can develop infection in the rectum or vagina. Although infection in these sites appears to be totally asymptomatic, it can cause confusion if it is identified later. Perinatally acquired rectal, vaginal, and nasopharyngeal infections can persist for 3 years or longer.

### DIAGNOSIS

Definitive diagnosis is achieved by isolation of *C. trachomatis* in cultures of specimens obtained from the conjunctiva or nasopharynx. Data on the use of NAATs for diagnosis of *C. trachomatis* in children are limited but suggest that PCR may be equivalent to culture for detecting *C. trachomatis* in the conjunctiva of infants with conjunctivitis. However, NAATs are not currently FDA-cleared for use with conjunctival or nasopharyngeal specimens from infants. Laboratories can do internal validation delineated in the CDC 2014 *C. trachomatis* and *N. gonorrhoeae* laboratory guidelines.

### TREATMENT

The recommended treatment regimens for *C. trachomatis* conjunctivitis or pneumonia in infants are erythromycin (base or ethylsuccinate, 50 mg/kg/day divided 4 times a day PO for 14 days) or azithromycin suspension (20 mg/kg/day once daily PO for 3 days). The rationale for using oral therapy for conjunctivitis is that 50% or more of these infants have concomitant nasopharyngeal infection or disease at other sites, and studies demonstrate that topical therapy with sulfonamide drops and erythromycin ointment is not effective. The failure rate with oral erythromycin remains 10–20%, and some infants require a second

course of treatment. Mothers (and their sexual contacts) of infants with *C. trachomatis* infections should be empirically treated for genital infection. An association between treatment with oral erythromycin or oral azithromycin and infantile hypertrophic pyloric stenosis has been reported in infants younger than 6 weeks of age.

## PREVENTION

Neonatal gonococcal prophylaxis with topical erythromycin ointment does not prevent chlamydial ophthalmia or nasopharyngeal colonization with *C. trachomatis* or chlamydial pneumonia. *The most effective method of controlling perinatal chlamydial infection is screening and treatment of pregnant women.* In 2015, the Canadian Pediatric Society recommended that neonatal ocular prophylaxis be discontinued and that prenatal screening for chlamydia be enhanced. The program was implemented in 2016. In the United States, implementation of prenatal screening and treatment of pregnant women has resulted in a dramatic decrease in perinatal chlamydial infections. For treatment of *C. trachomatis* infection in pregnant women, the CDC currently recommends either azithromycin (1 g PO as a single dose) or amoxicillin (500 mg PO 3 times a day for 7 days) as first-line regimens. Erythromycin base (250 mg PO 4 times a day for 14 days) and erythromycin ethylsuccinate (800 mg 4 times a day for 7 days, or 400 mg PO 4 times a day for 14 days) are listed as alternative regimens. Reasons for failure of maternal treatment to prevent infantile chlamydial infection include poor compliance and reinfection from an untreated sexual partner.

Visit Elsevier eBooks+ at [eBooks.Health.Elsevier.com](http://eBooks.Health.Elsevier.com) for Bibliography.

## 272.4 Lymphogranuloma Venereum

Margaret R. Hammerschlag

LGV is a systemic sexually transmitted disease caused by the L<sub>1</sub>, L<sub>2</sub>, and L<sub>3</sub> serotypes of the LGV biovar of *C. trachomatis*. Unlike strains of the trachoma biovar, LGV strains have a predilection for lymphoid tissue. Fewer than 1,000 cases are reported in adults in the United States annually. There has been a resurgence of LGV infections among men who have sex with men in Europe and the United States. Many of the men were HIV infected and used illicit drugs, specifically methamphetamines. The only pediatric case that has been reported since the emergence of the new clusters of HIV-associated cases in 2003 was a 16-year-old boy who presented with LGV proctocolitis after having receptive unprotected anal intercourse with a 30-year-old man he met on the Internet. This history was obtained after the boy was found to be HIV-positive. The diagnosis of LGV, particularly when it presents with proctocolitis, relies on a high index of suspicion that would lead to emphasizing certain aspects of the history and ordering the pertinent diagnostic tests. Many pediatricians and pediatric gastroenterologists might not be familiar with the entity and might not entertain it as a diagnostic consideration in pediatric patients. The diagnosis can be further suggested by *C. trachomatis* testing; commonly by NAATs or culturing the organism if culture is available. Currently available NAATs will not differentiate LGV from other *C. trachomatis* serovars. NAATs for *C. trachomatis* are also not FDA-cleared for testing rectal specimens, but laboratories can do an internal validation as recommended in the CDC 2014 *C. trachomatis* and *N. gonorrhoeae* laboratory guidelines. NAATs have been found in several clinical studies to perform well with rectal specimens. Typing of the *C. trachomatis* specimen can be done by sequencing from the NAAT specimen by many state laboratories. Trying to ascertain the *C. trachomatis* serovar for confirmation of LGV has therapeutic implications, as LGV needs to be treated with a 3-week course of doxycycline; a single-dose of azithromycin will not eradicate the infection.

## CLINICAL MANIFESTATIONS

The **first stage** of LGV is characterized by the appearance of the primary lesion, a painless, usually transient papule on the genitals. The **second stage** is characterized by usually unilateral femoral or inguinal lymphadenitis with enlarging, painful buboes. The nodes may break down and drain, especially in men. In women, the vulvar lymph drains to the retroperitoneal nodes. Fever, myalgia, and headache are common. The **third stage** is a genitoanorectal syndrome with rectovaginal fistulas, rectal strictures, and urethral destruction. Among men who have sex with men, rectal infection with LGV can produce a severe, acute proctocolitis, which can be confused with inflammatory bowel disease or malignancy.

## DIAGNOSIS

LGV can be diagnosed by serologic testing or by culture of *C. trachomatis* or molecular testing for *C. trachomatis* from a specimen aspirated from a bubo. Most patients with LGV have complement-fixing antibody titers of >1:16. Chancroid and herpes simplex virus can be distinguished clinically from LGV by the concurrent presence of painful genital ulcers. Syphilis can be differentiated by serologic tests. However, co-infections can occur.

## TREATMENT

Doxycycline (100 mg PO bid for 21 days) is the recommended treatment. Alternative regimens are azithromycin (1 g PO once weekly for 3 weeks) or erythromycin base (500 mg PO 4 times a day for 21 days). As the azithromycin regimen has not been validated, it is recommended that a test of cure with a *C. trachomatis* NAAT 4 weeks after completion of therapy be performed. Sex partners of patients with LGV should be treated if they have had sexual contact with the patient during the 30 days preceding the onset of symptoms.

Visit Elsevier eBooks+ at [eBooks.Health.Elsevier.com](http://eBooks.Health.Elsevier.com) for Bibliography.

## Chapter 273

# Psittacosis (*Chlamydia psittaci*)

Stephan A. Kohlhoff and  
Margaret R. Hammerschlag

*Chlamydia psittaci*, the agent of psittacosis (also known as **parrot fever** and **ornithosis**), is primarily an animal pathogen and rarely causes human disease. In birds, *C. psittaci* infection is known as *avian chlamydiosis*.

## ETIOLOGY

*C. psittaci* affects both psittacine birds (e.g., parrots, parakeets, macaws) and nonpsittacine birds (ducks, turkeys); the known host range includes 130 avian species. The life cycle of *C. psittaci* is the same as for *C. pneumoniae* (see Chapter 271). Strains of *C. psittaci* have been analyzed by patterns of pathogenicity, inclusion morphology in tissue culture, DNA restriction endonuclease analysis, and monoclonal antibodies, which indicate that there are seven avian serovars. The organism has also been found in nonavian domestic animals,

including cattle, sheep, pigs, goats, and cats. Nonavian *C. psittaci* has rarely caused disease in humans. Two of the avian serovars, psittacine and turkey, are of major importance in the avian population of the United States. Each is associated with important host preferences and disease characteristics. There are four other *Chlamydia* species that have birds as their primary hosts: *C. avium* (pigeons, parrots), *C. gallinacea* (chickens, turkeys, ducks), *C. ibidis* (ibis), and *C. buteonis* (hawks, buzzards). *C. gallinacea* may have the potential to cause outbreaks in poultry plants.

## EPIDEMIOLOGY

On average, 11 cases of psittacosis per year in the United States were reported from 2000 to 2017. However, experts believe the disease is potentially underreported and underdiagnosed. In 2018, a multistate psittacosis outbreak among poultry plant workers had 13 laboratory-confirmed cases. The majority of cases were associated with exposure to birds, including 70% after exposure to caged pet birds, which were usually psittacine birds, including cockatiels, parakeets, parrots, and macaws. Chlamydiosis among caged nonpsittacine birds occurs most often in pigeons, doves, and mynah birds. Persons at highest risk for acquiring psittacosis include workers in poultry plants, bird fanciers, owners of pet birds, and pet shop employees. Reported cases most likely underestimate the number of actual infections owing to a lack of awareness and readily available diagnostic tests.

Inhalation of aerosols from feces, fecal dust, and nasal secretions of animals infected with *C. psittaci* is the primary route of infection. Source birds are either asymptomatic or have anorexia, ruffled feathers, lethargy, and watery green droppings. Psittacosis is uncommon in children, in part because children may be less likely to have close contact with infected birds. One high-risk activity is cleaning the cage.

## CLINICAL MANIFESTATIONS

Infection with *C. psittaci* in humans ranges from clinically inapparent to severe disease, including pneumonia and multiorgan involvement. The mean incubation period is 15 days after exposure, with a range of 5–21 days. Onset of disease is usually abrupt, with fever, cough, headache, myalgia, and malaise. The fever is high and is often associated with rigors and sweats. The headache can be so severe that meningitis is considered. The cough is usually nonproductive. Gastrointestinal symptoms are occasionally reported. Crackles may be heard on auscultation. Chest radiographs are usually abnormal and are characterized by the presence of variable infiltrates, sometimes accompanied by pleural effusions. The white blood cell count is usually normal but is sometimes mildly elevated. Elevated levels of aspartate aminotransferase, alkaline phosphatase, and bilirubin are common. Nonpulmonary complications include pericarditis, endocarditis, and myocarditis. Mortality occurs in 5% of cases.

## DIAGNOSIS

Psittacosis can be difficult to diagnose because of the varying clinical presentations. A history of exposure to birds or association with an active case can be important clues, but as many as 20% of patients with psittacosis have no known contact. Person-to-person spread has been suggested but not proved. Other infections that cause pneumonia with high fever, unusually severe headache, and myalgia include routine bacterial and viral respiratory infections as well as *Coxiella burnetii* infection (Q fever), *Mycoplasma pneumoniae* infection, *C. pneumoniae* infection, tularemia, tuberculosis, fungal infections, and Legionnaires' disease.

A patient is considered to have a confirmed case of psittacosis if clinical illness is compatible with psittacosis and the case is laboratory confirmed by identification of *C. psittaci* by polymerase chain reaction (PCR) from respiratory specimens (e.g., sputum, pleural fluid, or lung tissue), blood, or stool. Serologic methods are most available, but these tests have poor specificity and require testing of paired specimens collected weeks apart, delaying or preventing confirmation of the clinical diagnosis in a timely fashion. A patient is considered to have a probable case of psittacosis if the clinical illness is compatible with psittacosis and there is an epidemiologic exposure. Lower respiratory tract samples are the specimen of choice, although 5 of 13 (38%) of the patients in the 2018 multistate outbreak also had *C. psittaci* DNA detected in their stool specimens.

Although *C. psittaci* will grow in the same culture systems used for isolation of *C. trachomatis* and *C. pneumoniae*, very few laboratories culture for *C. psittaci*, mainly because of the potential biohazard. Real-time PCR assays can distinguish *C. psittaci* from other chlamydial species and identify different *C. psittaci* genotypes. Currently real-time PCR for *C. psittaci* is only available at the CDC.

## TREATMENT

Recommended treatment regimens for psittacosis are doxycycline (100 mg PO twice daily) or tetracycline (500 mg PO 4 times a day) for at least 10–14 days after the fever abates. The initial treatment of severely ill patients is doxycycline hyclate (4.4 mg/kg/day divided every 12 hours IV; maximum: 100 mg/dose). Erythromycin (500 mg PO 4 times a day) and azithromycin (10 mg/kg PO on day 1, not to exceed 500 mg, followed by 5 mg/kg PO on days 2–5, not to exceed 250 mg) are alternative agents if tetracyclines are contraindicated (e.g., children <8 years of age and pregnant women) but may be less effective. Remission is usually evident within 48–72 hours. Reinfection and clinical disease can develop within 2 months of treatment, indicating that initial infection does not appear to be followed by long-term immunity.

## PROGNOSIS

The mortality rate of psittacosis is 15–20% with no treatment but is <1% with appropriate treatment. Severe illness leading to respiratory failure and fetal death has been reported among pregnant women.

## PREVENTION

Several control measures are recommended to prevent transmission of *C. psittaci* from birds. Bird fanciers should be cognizant of the potential risk. *C. psittaci* is susceptible to heat and to most disinfectants and detergents but is resistant to acid and alkali. Accurate records of all bird-related transactions aid in identifying sources of infected birds and potentially exposed persons. Newly acquired birds, including birds that have been to shows, exhibitions, fairs, or other events, should be isolated for 30–45 days or tested or treated prophylactically before adding them to a group of birds. Care should be taken to prevent transfer of fecal material, feathers, food, or other materials between birdcages. Birds with signs of avian chlamydiosis (e.g., ocular or nasal discharge, watery green droppings, or low body weight) should be isolated and should not be sold or purchased. Their handlers should wear protective clothing and a disposable surgical cap and use a respirator with an N95 or higher efficiency rating (not a surgical mask) when handling them or cleaning their cages. Infected birds should be isolated until fully treated, which is generally 45 days.

Visit Elsevier eBooks+ at [eBooks.Elsevier.com](https://eBooks.Elsevier.com) for Bibliography.



## Section 11

## Rickettsial Infections

## Chapter 274

## Spotted Fever Group Rickettsioses

Megan E. Reller and J. Stephen Dumler

*Rickettsia* species were classically divided into *spotted fever* and *typhus* groups based on serologic reactions and the presence or absence of the outer membrane protein A gene (*ompA*). Sequencing of over 150 complete genomes has refined distinctions. However, there is controversy regarding phylogeny, and some data suggest that diversity and pathogenicity are the result of gene loss and lateral gene transfer from other prokaryotes or even eukaryotes, which further obscures accurate taxonomic classification. One proposal is to divide existing species into spotted fever and *transitional* groups based on genetic relatedness; both include pathogenic species and species not now known to cause human disease (Table 274.1). Although increasingly more is understood about the molecular basis by which these bacteria cause human illness, an alternative classification system based on pathogenetic mechanisms has not been defined.

The list of pathogens and potential pathogens in the spotted fever group has expanded dramatically in recent years. Unfortunately, the most common diagnostic approach uses a serologic method that cannot distinguish among related species; thus the CDC classifies serologically defined cases as “spotted fever rickettsiosis” to reflect this uncertainty. Among the etiologic agents of spotted fever rickettsiosis are the tick-borne agents *Rickettsia rickettsii*, the cause of Rocky Mountain or Brazilian spotted fever (RMSF); *R. conorii*, the cause of Mediterranean spotted fever (MSF) or boutonneuse fever; *R. sibirica*, the cause of North Asian tick typhus; *R. japonica*, the cause of Oriental or Japanese spotted fever; *R. honei*, the cause of Flinders Island spotted fever or Thai tick typhus; *R. africae*, the cause of African tick bite fever; *R. akari*, the cause of mite-transmitted rickettsialpox; *R. felis*, the cause of cat flea-transmitted typhus; and *R. australis*, the cause of tick-transmitted Queensland tick typhus. The recognition that *R. parkeri* and “*R. philipii*” (*Rickettsia* 364D) both cause mild spotted fever in North America and the association of high seroprevalence for spotted fever group *Rickettsia* infections in humans where *Amblyomma* ticks frequently contain *R. amblyommatis* suggest that the full range of agents that can cause spotted fever is still to be discerned.

Infections with other members of the spotted fever and transitional groups are clinically similar to MSF, with fever, maculopapular rash, and eschar at the site of the tick bite. Israeli spotted fever (*R. conorii* infection) is generally associated with a more severe course in children, including death. African tick bite fever is relatively mild, can include a vesicular rash, and often manifests with multiple eschars. New potentially pathogenic rickettsial species have been identified, including *R. slovaca*, the cause of tick-borne lymphadenopathy or *Dermacentor*-borne necrosis and lymphadenopathy. *R. aeschlimannii*, *R. heilongjiangensis*, *R. helvetica*, *R. massiliae*, and *R. raoultii* are all reported to cause mild to moderate illnesses in humans, although few cases have been described. Fortunately, the vast majority of infections respond well to doxycycline treatment if instituted early in illness; however, this is a significant challenge.

Visit Elsevier eBooks+ at [eBooks.Health.Elsevier.com](http://eBooks.Health.Elsevier.com) for Bibliography.

274.1 Rocky Mountain Spotted Fever (*Rickettsia rickettsii*)

Megan E. Reller and J. Stephen Dumler

RMSF is the most severe rickettsial disease in the United States and Western Hemisphere. Although spotted fever rickettsiosis is the most common vector-borne disease in the United States after Lyme disease, the proportion of these cases caused by *R. rickettsii* is not known. Although considered uncommon, RMSF is believed to be greatly underdiagnosed and underreported. RMSF should be considered in the differential diagnosis of fever, headache, and rash in the summer months, especially after tick exposure. Because fulminant disease and death are associated with delays in treatment, patients in whom the illness is clinically suspected should be treated promptly.

## ETIOLOGY

RMSF results from systemic infection of endothelial cells by the obligate intracellular bacterium *R. rickettsii*.

## EPIDEMIOLOGY

The term **Rocky Mountain spotted fever** is historical, because the agent was discovered in the Bitterroot Range of the Rocky Mountains of Montana. Few cases are reported from this region. Cases have been reported throughout the continental United States (except Vermont and Maine), southwestern Canada, Mexico, Central America, and South America, but not from outside of the Western Hemisphere. In 2010, the CDC reporting criteria for RMSF changed to **spotted fever group rickettsiosis**, because serology often does not distinguish *R. rickettsii* from infection by other spotted fever group *Rickettsia*. Additionally, cases detected by enzyme immunoassay were classified as probable. Thus in 2012, 2,802 confirmed and probable cases of spotted fever rickettsiosis were reported in *Morbidity and Mortality Weekly Reports* Summary of Notifiable Diseases. Unlike in prior years, most cases were reported from the west southcentral states, especially from Arkansas, Oklahoma, and Missouri; high numbers of cases were also reported from North Carolina, Tennessee, Virginia, New Jersey, Georgia, Alabama, and Arizona (Fig. 274.1). The incidence of RMSF cycles over 25- to 35-year intervals, but spotted fever rickettsioses have steadily increased since 1998 over which time approximately 14% occur in individuals younger than 19 years. Habitats favored by ticks, including wooded areas or coastal grassland and salt marshes, and, in the southwestern United States and Mexico, shaded areas where dogs congregate and acquire infected ticks are those that place children at increased risk for infection. Foci of intense risk for infection are found both in rural and urban areas, most recently in Mexico and South America. Clustering of cases within families likely reflects shared environmental exposures. In the United States, 90% of cases occur between April and September, months in which humans spend the most time outdoors. The highest age-specific incidence of RMSF among children is seen in those older than 10 years of age, with males outnumbering females; however, the highest case fatality rate for RMSF is observed in those less than 10 years of age.

## TRANSMISSION

Ticks are the natural hosts, reservoirs, and vectors of *R. rickettsii* and maintain the infection in nature by transovarial transmission (passage of the organism from infected ticks to their progeny). Ticks harboring rickettsiae are substantially less fecund than uninfected ticks; thus horizontal transmission (acquisition of rickettsiae by taking a blood meal from transiently rickettsemic hosts such as small mammals or dogs) contributes to maintenance of rickettsial infections in ticks. Uninfected ticks that simultaneously feed (co-feed) with infected transmitting ticks easily become infected, even if feeding on an immune host, and are also likely to be major contributors to natural transmission and maintenance. Ticks transmit the infectious agent to mammalian hosts (including humans) via infected saliva during feeding. The pathogen *R. rickettsii* in ticks becomes virulent after exposure to blood or increased temperature; thus the longer the tick is attached, the greater the risk of transmission. The principal tick



**Table 274.1** Summary of Rickettsial Diseases of Humans, Including *Rickettsia*, *Orientia*, *Ehrlichia*, *Anaplasma*, *Neorickettsia*, and *Coxiella*

GROUP OR DISEASE AGENT		ARTHROPOD VECTOR, TRANSMISSION HOSTS		GEOGRAPHIC DISTRIBUTION	PRESENTING CLINICAL FEATURES*	COMMON LAB ABNORMALITIES	DIAGNOSTIC TESTS	TREATMENT†
<b>SPOTTED FEVER GROUP</b>								
Rocky Mountain spotted fever	<i>Rickettsia rickettsii</i>	Tick bite: <i>Dermacentor</i> species (wood tick, dog tick) <i>Rhipicephalus sanguineus</i> (brown dog tick)	Dogs Rodents	Western hemisphere	Fever, headache, rash,* emesis, diarrhea, myalgias	AST, ALT ↓Na (mild) ↓Platelets ±Leukopenia Left shift	Early: IH, DFA, PCR After first wk: IFA	<b>Doxycycline</b> Tetracycline Chloramphenicol
Mediterranean spotted fever (boutonneuse fever)	<i>Rickettsia conorii</i>	Tick bite: <i>R. sanguineus</i> (brown dog tick)	Dogs Rodents	Africa, Mediterranean, India, Middle East	Painless eschar (tache noir) with regional lymphadenopathy, fever, headache, rash,* myalgias	AST, ALT ↓Na (mild) ↓Platelets ±Leukopenia Left shift	Early: IH, DFA, PCR After first wk: IFA	<b>Doxycycline</b> Tetracycline Chloramphenicol Azithromycin Clarithromycin Fluoroquinolones
African tick-bite fever	<i>Rickettsia africae</i>	Tick bite	Cattle Goats?	Sub-Saharan Africa, Caribbean	Fever, single or multiple eschars, regional lymphadenopathy, rash* (can be vesicular)	AST, ALT ↓Platelets	Early: IH, DFA After 1st wk: IFA	<b>Doxycycline</b>
Tickborne lymphadenopathy (TIBOLA); Dermacentor-borne necrosis and lymphadenopathy (DEBONEL)	<i>Rickettsia slovaca</i> , <i>Rickettsia raoultii</i> , <i>Rickettsia sibirica mongolotimonae</i>	Tick bite: <i>Dermacentor</i>	?	Europe	Eschar (scalp), painful lymphadenopathy	?	PCR	<b>Doxycycline</b>
<i>Rickettsia</i> spp., 364D genotype	" <i>Rickettsia philippii</i> "	<i>Dermacentor occidentalis</i> (Pacific coast tick)		California	Eschar, fever, headache, lymphadenopathy, malaise	Unremarkable	PCR	Doxycycline
Flea-borne spotted fever	<i>Rickettsia felis</i>	Flea bite	Opossums Cats Dogs	Western hemisphere, Europe	Fever, rash,* headache	?	Early: PCR After first wk: IFA	Doxycycline
<b>TRANSITIONAL GROUP</b>								
Rickettsialpox	<i>Rickettsia akari</i>	Mite bite	Mice	North America, Russia, Ukraine, Adriatic, Korea, South Africa	Painless eschar, ulcer or papule; tender regional lymphadenopathy, fever, headache, rash* (can be vesicular)	↓WBC	Early: IH, DFA After first wk: IFA	<b>Doxycycline</b> Chloramphenicol
Queensland tick typhus	<i>Rickettsia australis</i>	<i>Ixodes holocyclus</i> , <i>I. tasmani</i>	Bandicoots and Rodents	Australia, Tasmania	Fever, eschar, headache, myalgia, lymphadenopathy	↓WBC, ↓platelets	Early: PCR on eschar or eschar swab; After first wk: IFA	<b>Doxycycline</b>
<b>TYPHUS GROUP</b>								
Murine typhus	<i>Rickettsia typhi</i>	Flea feces	Rats Opossums	Worldwide	Fever, headache, rash,* myalgias, emesis, lymphadenopathy, hepatosplenomegaly	AST, ALT ↓Na (mild) ↓WBC ↓ Platelets	Early: DFA, PCR After first wk: IFA	<b>Doxycycline</b> Chloramphenicol

**Table 274.1** Summary of Rickettsial Diseases of Humans, Including *Rickettsia*, *Orientia*, *Ehrlichia*, *Anaplasma*, *Neorickettsia*, and *Coxiella*—cont'd

GROUP OR DISEASE AGENT	ARTHROPOD VECTOR, TRANSMISSION HOSTS	GEOGRAPHIC DISTRIBUTION	PRESENTING CLINICAL FEATURES*	COMMON LAB ABNORMALITIES	DIAGNOSTIC TESTS	TREATMENT†		
Epidemic (louse-borne) typhus (recrudescence form: Brill-Zinsser disease)	<i>Rickettsia prowazekii</i>	Louse feces	Humans	South America, Central America, Mexico, Africa, Asia, Eastern Europe	Fever, headache, abdominal pain, rash,* CNS involvement	AST, ALT ↓Platelets	Early: none After first wk: IgG/ IgM, IFA	<b>Doxycycline</b> Tetracycline Chloramphenicol
Flying squirrel (sylvatic) typhus	<i>Rickettsia prowazekii</i>	Louse feces? Flea feces or bite?	Flying squirrels	Eastern United States	Same as above (often milder)	AST, ALT ↓Platelets	Early: none After first wk: IFA	<b>Doxycycline</b> Tetracycline Chloramphenicol
<b>SCRUB TYPHUS</b> Scrub typhus	<i>Orientia tsutsugamushi</i> , <i>Orientia chuto</i> "Orientia chiloensis"	Chigger bite: <i>Leptotrombidium</i> spp.	Rodents?	South Asia, Japan, Indonesia, Korea, China, Russia, Australia, Africa, Middle East, Chile	Fever, rash,* headache, painless eschar, hepatosplenomegaly, gastrointestinal symptoms	↓Platelets AST, ALT	Early: none After first wk: IFA	<b>Doxycycline</b> Tetracycline Chloramphenicol <b>Rifampicin</b> Azithromycin
<b>EHRlichiosis AND ANAPLASMOSIS</b> Human monocytic ehrlichiosis	<i>Ehrlichia chaffeensis</i>	Tick bite: <i>Amblyomma americanum</i> (lone star tick)	Deer Dogs	United States, Mexico	Fever, headache, malaise, myalgias, rash*‡, hepatosplenomegaly,‡ swollen hands/feet‡	AST, ALT ↓WBC ↓Platelets ↓Na (mild)	Early: PCR After first wk: IFA	<b>Doxycycline</b> Tetracycline
Human granulocytic anaplasmosis	<i>Anaplasma phagocytophilum</i>	Tick bite: <i>Ixodes</i> species <i>Haemaphysalis longicornis</i>	Rodents Deer Ruminants	United States, Europe, Asia	Fever, headache, malaise, myalgias	AST, ALT ↓WBC, ↓ANC ↓Platelets	Early: PCR, blood smear After first wk: IFA	<b>Doxycycline</b> Tetracycline Rifampin
Ewingii ehrlichiosis	<i>Ehrlichia ewingii</i>	Tick bite: <i>Amblyomma americanum</i> (lone star tick)	Dogs Deer	United States (south-central, southeast)	Fever, headache, malaise, myalgias	AST, ALT, ↓WBC ↓Platelets	Early: PCR serology not available	<b>Doxycycline</b> Tetracycline
<i>Ehrlichia muris eauclairensis</i> infection	<i>Ehrlichia muris</i> ssp. <i>eauclairensis</i>	<i>Ixodes scapularis</i>	?	Minnesota, Wisconsin	Fever, headache, malaise, myalgias	AST, ALT ↓WBC, ↓Platelets	Early: PCR specific serology not available	<b>Doxycycline</b>
Neoehrlichiosis	<i>Neoehrlichia mikurensis</i>	<i>Ixodes ricinus</i>	Small mammals?	Europe, Asia	Fever, headache, myalgias, thrombosis	Neutrophilia, anemia, elevated CRP, AST, ALT	PCR	<b>Doxycycline</b>
Sennetsu neorickettsiosis	<i>Neorickettsia sennetsu</i>	Ingestion of fish helminth?, ingestion of fermented fish	Fish, trematodes	Japan, Malaysia, Laos	Fever, "mononucleosis" symptoms, postauricular and posterior cervical lymphadenopathy	Atypical lymphocytosis	Early: none After first wk: IFA	<b>Doxycycline</b> Tetracycline

Continued

**Table 274.1** Summary of Rickettsial Diseases of Humans, Including *Rickettsia*, *Orientia*, *Ehrlichia*, *Anaplasma*, *Neorickettsia*, and *Coxiella*—cont'd

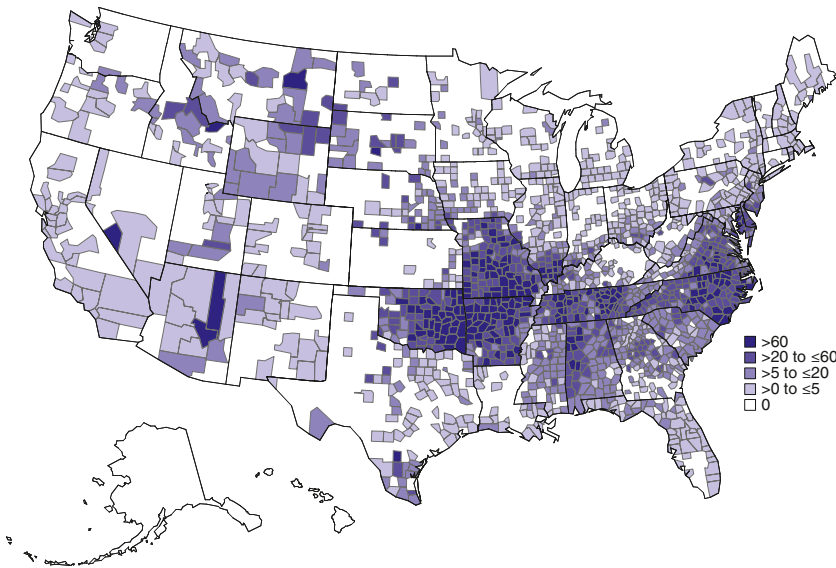
GROUP OR DISEASE AGENT		ARTHROPOD VECTOR, TRANSMISSION HOSTS		GEOGRAPHIC DISTRIBUTION	PRESENTING CLINICAL FEATURES*	COMMON LAB ABNORMALITIES	DIAGNOSTIC TESTS	TREATMENT <sup>†</sup>
<b>Q FEVER</b>								
Q Fever: acute (for chronic, see text)	<i>Coxiella burnetii</i>	Inhalation of infected aerosols: contact with parturient animals, abattoir, cheese and milk, ?ticks	Cattle Sheep Goats Cats Rabbits	Worldwide	Fever, headache, arthralgias, myalgias, gastrointestinal symptoms, cough, pneumonia, rash (children)	AST, ALT WBC ↓ Platelets Interstitial infiltrate	Early: PCR After first wk: IFA	<b>Doxycycline</b> Tetracycline Fluoroquinolones Trimethoprim-sulfamethoxazole

\*Rash is infrequently present at initial presentation but appears during the first wk of illness.

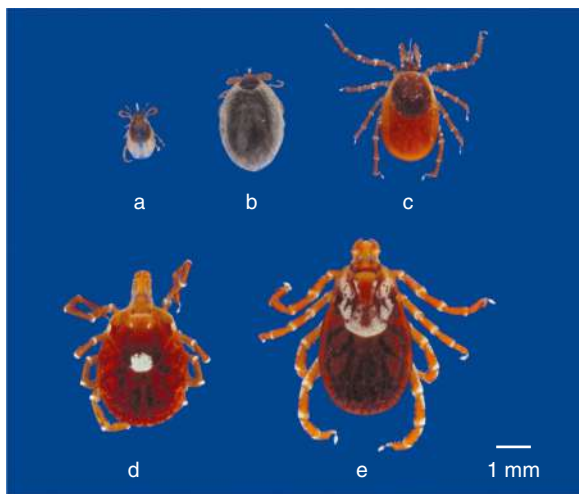
<sup>†</sup>Preferred treatment is in **bold**.

<sup>‡</sup>Often present in children but not adults.

ALT, Alanine aminotransferase; ANC, absolute neutrophil count; AST, aspartate aminotransferase; CNS, central nervous system; DFA, direct fluorescent antibody; IFA, indirect fluorescent antibody; IgG, immunoglobulin G; IgM, immunoglobulin M; IH, immunohistochemistry; PCR, polymerase chain reaction; WBC, white blood cell count.



**Fig. 274.1** Reported incidence rate\* of spotted fever rickettsiosis,† by county—United States, 2000–2013. \*As reported through national surveillance, per 1,000,000 persons per year. Cases are reported by county of residence, which is not always where the infection was acquired. †Includes Rocky Mountain spotted fever (RMSF) and other spotted fever group rickettsioses. In 2010, the name of the reporting category changed from RMSF to spotted fever rickettsiosis. (From Biggs HM, Behravesh CB, Bradley KK, et al. *Diagnosis and management of tickborne rickettsial diseases: Rocky Mountain spotted fever and other spotted fever group rickettsioses, ehrlichioses, and anaplasmosis—United States*. MMWR Recomm Rep. 2016;65:1–44. Fig. 1.)

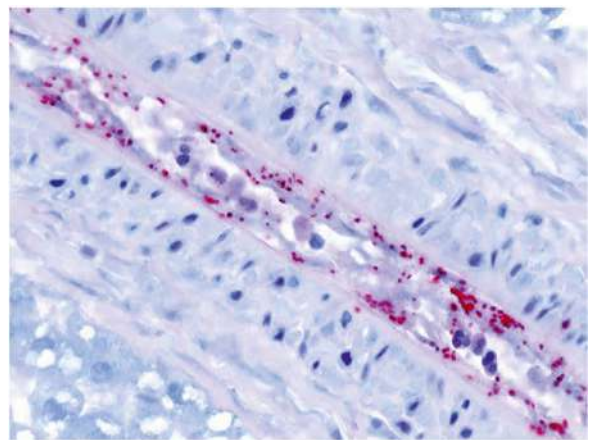


**Fig. 274.2** Tick vectors of agents of human rickettsial diseases. An unengaged nymph (a), engorged nymph (b), and adult female (c) of *Ixodes scapularis* (deer tick), the vector of *Anaplasma phagocytophilum* and *Ehrlichia muris*-like agent (EMLA), the causes of human granulocytic anaplasmosis and EMLA ehrlichiosis, respectively. An adult female (d) of *Amblyomma americanum* (lone star tick), the vector of *Ehrlichia chaffeensis* and *Ehrlichia ewingii*, the causes of human monocytic ehrlichiosis and ewingii ehrlichiosis, respectively. An adult female (e) of *Dermacentor variabilis* (American dog tick), the vector of *Rickettsia rickettsii*, the cause of Rocky Mountain spotted fever.

hosts of *R. rickettsii* are *Dermacentor variabilis* (the American dog tick) in the eastern United States and Canada, *Dermacentor andersoni* (the wood tick) in the western United States and Canada, *Rhipicephalus sanguineus* (the common brown dog tick) in the southwestern United States and in Mexico, and several *Amblyomma* spp. in Central and South America (Fig. 274.2).

Dogs can serve as reservoir hosts for *R. rickettsii*, can develop RMSF themselves, and can bring infected ticks into contact with humans. Serologic studies suggest that many patients with RMSF likely acquired the illness from ticks carried by the family dog.

Humans can also become infected when trying to remove an attached tick, because *R. rickettsii*-containing tick fluids or feces can be rubbed into the open wound at the bite site or into the conjunctivae by contaminated fingers. Inhalation of aerosolized rickettsiae has caused severe infections and deaths in laboratory workers, highlighting another mechanism of infection.



**Fig. 274.3** Immunohistochemical stain demonstrating *Rickettsia* (red) in infection of blood vessel endothelial cells. (From Biggs HM, Behravesh CB, Bradley KK, et al. *Diagnosis and management of tickborne rickettsial diseases: Rocky Mountain spotted fever and other spotted fever group rickettsioses, ehrlichioses, and anaplasmosis—United States*. MMWR Recomm Rep. 2016;65:1–44, Fig. 20.)

## PATHOLOGY AND PATHOGENESIS

Systemic infection is most obvious on the skin (rash), but nearly all organs and tissues are affected. After inoculation of tick saliva into the dermis, rickettsial outer surface proteins bind to the vascular endothelial cell surface proteins, which signals focal cytoskeletal changes and endocytosis. Thereafter, rickettsia phospholipase-mediated dissolution of the endosomal membranes allows escape into the cytosol. Members of the spotted fever group actively nucleate actin polymerization on one pole to achieve directional movement, allowing some to propel into neighboring cells despite minimal initial host cell damage. The rickettsiae proliferate and injure host cells by oxidative membrane alterations, protease activation, or continued phospholipase activity. It is likely that some aspects of intracellular infection are mediated by rickettsial protein effectors delivered into the host cell by bacterial secretion systems.

The histologic correlate of the initial macular or maculopapular rash is perivascular infiltration of lymphoid and histiocytic cells with edema but without significant endothelial damage. Proliferation of rickettsiae within the cytoplasm of infected endothelial cells leads to endothelial injury and **lymphohistiocytic or leukocytoclastic vasculitis** of small venules and capillaries, which allows extravasation of intravascular erythrocytes into the dermis and manifests as a petechial rash (Fig. 274.3). This process is systemic and ultimately results in widespread microvascular leakage,



tissue hypoperfusion, and possibly septic shock or end-organ ischemic injury. Infrequently, inflammation leads to nonocclusive thrombi. Very rarely, small and large vessels become completely obliterated by thrombi, leading to tissue infarction or hemorrhagic necrosis. Interstitial pneumonitis and vascular leakage in the lungs can lead to noncardiogenic pulmonary edema, and meningoencephalitis can cause significant cerebral edema and herniation.

The presence of the infectious agent initiates an inflammatory cascade, including release of cytokines and chemokines such as tumor necrosis factor, interleukin-1 $\beta$ , interferon- $\gamma$ , and regulated upon activation, normal T-cell expressed and secreted (RANTES). Infection of endothelial cells by *R. rickettsii* induces surface E-selectin expression and procoagulant activity followed by chemokine recruitment of lymphocytes, macrophages, and, occasionally, neutrophils. Local inflammatory and immune responses are suspected to contribute to the vascular injury; however, the benefits of effective innate immunity are greater. Blockade of tumor necrosis factor and interferon- $\gamma$  in animal models diminishes survival and increases morbidity; reactive oxygen intermediates, nitric oxide expression, and sequestration of tryptophan from rickettsiae are mechanisms by which rickettsiae are killed within cells. Direct contact of infected endothelial cells with perforin-producing CD8 T lymphocytes and interferon- $\gamma$ -producing natural killer cells, accompanied by rickettsia antibody, helps control the infection. The timing and balance between rickettsia-mediated increases in vascular permeability and the benefits of induction of innate and adaptive immunity are likely the major determinants of severity and outcome.

### CLINICAL MANIFESTATIONS

The incubation period of RMSF in children varies from 2 to 14 days (median: 7 days). In 49% of cases, patients or their parents report a history of removing an attached tick, although the site of the tick bite is usually inapparent. Epidemiologic clues include living in or visiting an endemic area, playing or hiking in the woods, typical season, similar illness in family members, and close contact with a dog. In patients presenting for care, the illness is initially nonspecific, and most patients are not diagnosed during their first visit with a health-care practitioner. Manifestations often (>50%) include fever, rash (frequently involving the palms or soles), nausea and vomiting, and headache and, less often (<50%), myalgias, abdominal pain, diarrhea, conjunctival injection, altered mental status, lymphadenopathy, and peripheral edema. Pain and tenderness of calf muscles are particularly common in children.

The typical **clinical triad of fever, headache, and rash** is observed in 58% of pediatric patients overall, and rash involving the soles and palms first appearing after day 3 is associated with significantly higher risk of death. Fever and headache persist if the illness is untreated. Fever can exceed 40°C (104°F) and can remain persistently elevated or can fluctuate dramatically. Headache is severe, unremitting, and unresponsive to analgesics.

Rash usually appears after only 1-2 days of illness, and an estimated 3–5% of children never develop a rash that is recognized. Initially, discrete, pale, rose-red blanching macules or maculopapules appear; characteristically, this initial rash is observed on the extremities, including the wrists, ankles, or lower legs (Fig. 274.4). In 65% of patients, the initial rash spreads rapidly to involve the entire body, including the soles and palms. The rash can become petechial or even hemorrhagic, sometimes with palpable purpura.

In severe disease, the petechiae can enlarge into ecchymoses, which can become necrotic (Fig. 274.5). Severe vascular obstruction secondary to the rickettsial vasculitis and thrombosis is uncommon but can result in gangrene of the digits, earlobes, scrotum, nose, or an entire limb.

**Central nervous system** infection usually manifests as changes in mental status (33%) or as photophobia (18%), seizure (17%), or meningismus (16%). Patients can also manifest ataxia, coma, or auditory deficits. Cerebrospinal fluid parameters are usually normal, but one third have pleocytosis (<10–300 cells/ $\mu$ L), either mononuclear or, less often, neutrophil-dominated. Some (20%) have elevated protein (<200 mg/dL) in the cerebrospinal fluid; hypoglycorrachia is rare.



**Fig. 274.4** Maculopapular rash with central petechiae associated with Rocky Mountain spotted fever. (From Biggs HM, Behravesh CB, Bradley KK, et al. *Diagnosis and management of tickborne rickettsial diseases: Rocky Mountain spotted fever and other spotted fever group rickettsioses, ehrlichioses, and anaplasmosis—United States*. *MMWR Recomm Rep*. 2016;65:1–44, Fig. 21.)



**Fig. 274.5** Late-stage petechial purpuric rash involving the sole of the foot in a patient with Rocky Mountain spotted fever. (From Biggs HM, Behravesh CB, Bradley KK, et al. *Diagnosis and management of tickborne rickettsial diseases: Rocky Mountain spotted fever and other spotted fever group rickettsioses, ehrlichioses, and anaplasmosis—United States*. *MMWR Recomm Rep*. 2016;65:1–44, Fig. 22.)

Neuroimaging studies often reveal only subtle abnormalities. However, with advanced disease and neurologic signs, a unique but nonspecific “starry sky” appearance may be observed on brain MRI that reflects the same systemic vasculitis observed with skin lesions.

### Other

Pulmonary disease occurs more often in adults than in children. However, 33% of children examined have a chest radiograph interpreted as an infiltrate or pneumonia. The clinical presentation in these cases can manifest as rales, infiltrates, and noncardiogenic pulmonary edema. Other findings can include conjunctival suffusion, periorbital edema, dorsal hand and foot edema, and hepatosplenomegaly. Severe disease can include myocarditis, acute renal failure, and vascular collapse.

Persons with glucose-6-phosphate dehydrogenase deficiency are at increased risk for fulminant RMSF, defined as death from *R. rickettsii* infection within 5 days. The clinical course of fulminant RMSF is characterized by profound coagulopathy and extensive thrombosis leading to kidney, liver, and respiratory failure. Features associated with increased risk of death include altered mental status, admission to an intensive care unit, need for inotropic support, coma, and need for rapidly administered intravenous fluid.

Occasionally, clinical signs and symptoms suggest a localized process such as appendicitis or cholecystitis. Thorough evaluation usually reveals evidence of a systemic process, and unnecessary surgical interventions are avoided.

### LABORATORY FINDINGS

Laboratory abnormalities are common but nonspecific. Thrombocytopenia occurs in 60%, and the total white blood cell count is most often normal, with leukocytosis in 24% and leukopenia in 9%. Other characteristic abnormalities include a left-shifted leukocyte differential, anemia (33%), hyponatremia (<135 mEq/mL in 52%), and elevated serum aminotransferase levels (50%).

### DIAGNOSIS

Delays in diagnosis and treatment are associated with severe disease and death. Because no reliable diagnostic test is readily available to confirm RMSF during illness, which lasts from 10 days to not more than 3 weeks, the decision to treat must be based on compatible epidemiologic, clinical, and laboratory features. RMSF should be considered in patients presenting spring through fall with an acute febrile illness accompanied by headache and myalgia (particularly if they report exposure to ticks or contact with a dog or have been in forested or tick-infested rural areas). A history of tick exposure, a rash (especially if on the palms or soles), a normal or low leukocyte count with a marked left shift, a relatively low or decreasing platelet count, and a low serum sodium concentration are all clues that can support a diagnosis of RMSF. In patients without a rash or in dark-skinned patients in whom a rash can be difficult to appreciate, the diagnosis can be exceptionally elusive and delayed. One half of pediatric deaths occur within 9 days of onset of symptoms. Thus treatment should not be withheld pending definitive laboratory results for a patient with clinically suspected illness. Further, prompt response to early treatment is diagnostically helpful.

If a rash is present, a vasculotropic rickettsial infection can be diagnosed as early as day 1 or 2 of illness with biopsy of a petechial lesion and immunohistochemical or immunofluorescent demonstration of a specific rickettsial antigen in the endothelium. Although highly specific, the sensitivity of this method is probably 70% at most. Furthermore, it can be adversely influenced by prior antimicrobial therapy, suboptimal selection of skin lesions for biopsy, and examination of insufficient tissue because of the focal nature of the infection. Tissue or blood can also be evaluated for *R. rickettsii* nucleic acids by polymerase chain reaction (PCR) at the CDC and selected public health or reference laboratories; PCR on blood is less sensitive than PCR on tissue and of similar sensitivity to tissue immunohistochemistry, probably because the level of rickettsemia is generally very low (<6 rickettsiae/mL). Because eschars are rare with RMSF, scab scrapings or skin swabs are not useful specimens for the detection of rickettsemia by PCR.

Definitive diagnosis is most often accomplished by serology, which is retrospective, because a rise in titer is not seen until after the first week of illness. The gold standard for the diagnosis of RMSF is a fourfold increase in immunoglobulin G antibody titer by indirect fluorescent antibody assay between paired acute and convalescent (at 2-4 weeks) sera, including in the case of seroconversion. A single IgG titer is neither sensitive (patients can die before seroconversion) nor specific (an elevated titer can represent prior infection). IgM is nonspecific and does not confirm acute infection. With current serologic methods, RMSF cannot be reliably distinguished from other spotted fever group rickettsiae infections, some of which are not known to be pathogenic. Therefore confirming acute spotted fever group rickettsia infection requires a compatible clinical illness. Cross reactions of spotted fever group rickettsiae with typhus group rickettsiae also occur, but titers may be lower for the typhus group. Cross reactions are not seen with *Ehrlichia* or *Anaplasma* infections. Currently, enzyme-linked immunosorbent assay (ELISA) serologic methods can only provide “probable” rather than confirmed evidence of infection. Weil-Felix antibody testing should not be performed because it lacks both sensitivity and specificity. RMSF and other spotted fever group rickettsioses are reportable diseases in the

United States; however, few reported cases include paired IgG serology, PCR with sequencing, and epidemiologic and clinical metadata. Therefore little is known about the breadth, pathogenicity, and epidemiology of different spotted fever group rickettsiae in the United States or across the globe. Chronic infections by spotted fever group rickettsiae are not documented, such that positive serologic tests after 1 month or more do not reflect ongoing spotted fever group rickettsia infection.

### DIFFERENTIAL DIAGNOSIS

Other rickettsial infections are easily confused with RMSF, especially all forms of human ehrlichiosis and murine typhus and novel spotted fever group rickettsioses that result from *R. parkeri* or “*R. philipii*” str. 364D infections. RMSF can also mimic a variety of other diseases, such as meningococcemia and enterovirus infections. Negative blood cultures can exclude meningococcemia. PCR can differentiate enterovirus from *R. rickettsii* in patients with aseptic meningitis and cerebrospinal fluid pleocytosis. Other diseases in the differential diagnosis are typhoid fever, secondary syphilis, Lyme disease, leptospirosis, rat-bite fever, scarlet fever, toxic shock syndrome, rheumatic fever, rubella, parvovirus infection, Kawasaki disease, idiopathic thrombocytopenic purpura, thrombotic thrombocytopenic purpura, Henoch-Schönlein purpura, hemolytic uremic syndrome, aseptic meningitis, acute gastrointestinal illness, acute abdomen, hepatitis, infectious mononucleosis, hemophagocytic and macrophage activation syndromes, dengue fever, and drug reactions.

### TREATMENT

The time-proven effective therapies for RMSF are tetracyclines and chloramphenicol. The treatment of choice for suspected RMSF in patients of all ages, including children under 8 years of age, is doxycycline (4 mg/kg/day divided every 12 hours PO or IV; maximum: 200 mg/day). Tetracycline (25-50 mg/kg/day divided every 6 hours PO; maximum: 2 g/day) is an alternative. Chloramphenicol (50-100 mg/kg/day divided every 6 hours IV; maximum: 4 g/day) should be reserved for patients with doxycycline allergy and for pregnant women because chloramphenicol is an independent risk factor for increased mortality vs tetracyclines. If used, chloramphenicol should be monitored to maintain serum concentrations of 10-30 µg/mL. Chloramphenicol is preferred for pregnant women because of potential adverse effects of doxycycline on fetal teeth and bone and maternal liver function. RMSF is a life-threatening illness for which prompt therapy is imperative, and multiple recent studies demonstrate a negligible risk for tooth discoloration in children younger than 8 years of age with the use of doxycycline. Chloramphenicol is rarely associated with aplastic anemia and is no longer available as an oral preparation in the United States. An additional benefit of doxycycline over chloramphenicol is its effectiveness against potential concomitant *Ehrlichia* or *Anaplasma* infection. Sulfonamides should not be used because they are associated with greater morbidity and mortality with all rickettsial infections. Other antibiotics, including penicillins, cephalosporins, and aminoglycosides, are not effective. The use of alternative antimicrobial agents, such as fluoroquinolones and the macrolides (azithromycin and clarithromycin), has not been evaluated.

Therapy should be continued for a minimum of 5-7 days and until the patient has been afebrile for at least 3 days. Treated patients usually defervesce within 48 hours, so the duration of therapy is usually <10 days. Spotted fever group rickettsia infection resolves within several weeks if treated appropriately; thus patients with remitting clinical manifestations after 1 month do not benefit from continued or additional treatment.

### SUPPORTIVE CARE

Most infections resolve rapidly with appropriate antimicrobial therapy and do not require hospitalization or other supportive care. Among those hospitalized, 36% require intensive care. Particular attention to hemodynamic status is mandatory in severely ill children because iatrogenic pulmonary or cerebral edema could be easily precipitated owing to diffuse microvascular injury of the lungs, meninges, and

brain. Judicious use of corticosteroids for meningoencephalitis has been advocated by some, but no controlled trials have been conducted.

## COMPLICATIONS

Complications of RMSF include noncardiogenic pulmonary edema from pulmonary microvascular leakage, cerebral edema from meningoencephalitis, and multiorgan damage (hepatitis, pancreatitis, cholecystitis, epidermal necrosis, and gangrene) mediated by rickettsial vasculitis and/or the accumulated effects of hypoperfusion and ischemia (acute renal failure). Long-term neurologic sequelae can occur in any child with RMSF but are more likely to occur in those hospitalized for  $\geq 2$  weeks. Examples of neurologic sequelae include speech or swallowing disorders; global encephalopathy; cerebellar, vestibular, and motor dysfunction; hearing loss; and cortical blindness. Learning disabilities and behavioral problems are the most common neurologic sequelae among children who have survived severe disease.

## PROGNOSIS

Delays in diagnosis and therapy are significant factors associated with severe illness or death. Before the advent of effective antimicrobial therapy for RMSF, the case fatality rate was 10% for children and 30% for adults. The overall case fatality rate decreased to a historic low (0.3–0.4%) from 2003 to 2012; however, many experts attribute this decrease to detection and reporting of other less virulent emerging forms of spotted fever group rickettsioses that cannot be readily differentiated from RMSF using current serologic tests. The overall case fatality rate of children 0–9 years of age was 1.4%, but rates as high as 8.5% and 11.8% were documented in Texas (1986–1996) and in Arizona (1999–2007), respectively, and rates as high as 30–40% are now reported from outbreaks in Mexico, Brazil, and other parts of South America. Diagnosis based on serology alone underestimates the true mortality of RMSF, because death occurs at a median of 7 days (before developing a serologic response). Deaths occur despite the availability of effective therapeutic agents, indicating the need for clinical vigilance and a low threshold for early empiric therapy. Even with administration of appropriate antimicrobials, delayed therapy can lead to irreversible vascular or end-organ damage and long-term sequelae or death. Early therapy in uncomplicated cases usually leads to rapid defervescence within 1–3 days and recovery within 7–10 days. A slower response may be seen if therapy is delayed. In those who survive despite no treatment, fever subsides in 2–3 weeks.

## PREVENTION

No vaccines are available. Prevention of RMSF is best accomplished by preventing or treating tick infestation in dogs, avoiding areas where ticks reside, using insect repellents containing N,N-diethyl-3-methylbenzamide (DEET) or new alternatives (<https://www.epa.gov/insect-repellents/find-repellent-right-you>), wearing protective clothing, and carefully inspecting children after play in areas where they are potentially exposed to ticks. Recovery from infection yields lifelong immunity.

Prompt and complete removal of attached ticks helps reduce the risk for transmission because rickettsiae in the ticks need to be reactivated to become virulent, and this requires at least several hours to days of exposure to body heat or blood. Contrary to popular belief, the application of petroleum jelly, 70% isopropyl alcohol, fingernail polish, or a hot match are not effective in removing ticks. A tick can be safely removed by grasping the mouth parts with a pair of forceps at the site of attachment to the skin and applying gentle and steady pressure to achieve retraction without twisting, thereby removing the entire tick and its mouth parts. The site of attachment should then be disinfected. Ticks should not be squeezed or crushed, because their fluids may be infectious. The removed tick should be soaked in alcohol or flushed down the toilet, and hands should be washed to avoid accidental inoculation into conjunctivae, mucous membranes, or breaks in skin. Typically, prophylactic antimicrobial therapy is not recommended because tetracyclines and chloramphenicol are only rickettsiastatic; however, the evidence to support this position is meager.

Visit Elsevier eBooks+ at [eBooks.Health.Elsevier.com](http://eBooks.Health.Elsevier.com) for Bibliography.

## 274.2 Mediterranean Spotted Fever or Boutonnoise Fever (*Rickettsia conorii*)

Megan E. Reller and J. Stephen Dumler

MSF, or boutonnoise fever, is caused by *R. conorii*; it is also called by other names, such as *Kenya tick typhus*, *Indian tick typhus*, *Israeli spotted fever*, and *Astrakhan fever*. It is a moderately severe vasculotropic rickettsiosis in adults but comparatively milder in children, with more frequent lymphadenopathy; often, MSF is initially associated with an eschar at the site of the tick bite. Minor differences in clinical presentation could be associated with genetic diversity of this species.

## ETIOLOGY

MSF is caused by systemic endothelial cell infection by the obligate intracellular bacterium *R. conorii*. Similar species are distributed globally, such as *R. sibirica*, *R. heilongjiangensis*, and *R. mongolotimonae* in Russia, China, Mongolia, and Pakistan; *R. australis* and *R. honei* in Australia; *R. japonica* in Japan; *R. africae* in South Africa; and *R. parkeri* and “*R. philippii*” str. 364D in the Americas (see [Table 274.1](#)). Analysis of antigens and related DNA sequences show that all are closely related within a broad genetic clade that includes spotted fever group *Rickettsia* species such as *R. rickettsii*, the cause of RMSF.

## EPIDEMIOLOGY

*R. conorii* is distributed over a large geographic region, including India, Pakistan, Russia, Ukraine, Georgia, Israel, Morocco, southern Europe, Ethiopia, Kenya, and South Africa. Reported cases of MSF in southern Europe have steadily increased since 1980, and the seroprevalence is 11–26% in some areas. The peak in reported cases occurs during July and August in the Mediterranean basin; in other regions it occurs during warm months when ticks are active.

## TRANSMISSION

Transmission occurs after the bite of the brown dog tick, *R. sanguineus*, or for other *Rickettsia* spp. tick genera such as *Dermacentor*, *Haemaphysalis*, *Amblyomma*, *Hyalomma*, and *Ixodes*. Clustering of human cases of boutonnoise fever, infected ticks, and infected dogs implicates the household dog as a potential vehicle for transmission.

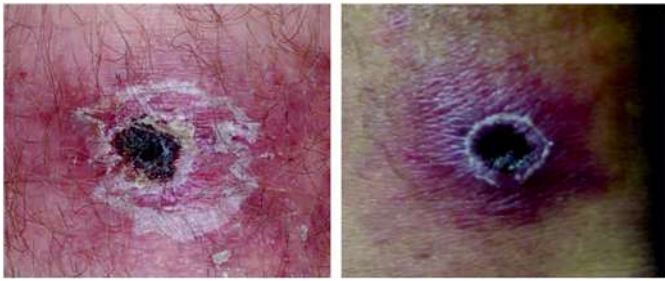
## PATHOLOGY AND PATHOGENESIS

The underlying pathology seen with MSF is nearly identical to that of RMSF, except that eschars are often present at the site of a tick bite where inoculation of rickettsiae occurs. The histopathology of the resultant lesion includes necrosis of dermal and epidermal tissues with a superficial crust; a dermis densely infiltrated by lymphocytes, histiocytes, and scattered neutrophils; and damaged capillaries and venules in the dermis. Immunohistochemical stains and nucleic acid amplification tests confirm that the lesions contain rickettsia-infected endothelial cells and potentially other cells such as macrophages. The necrosis results from both direct rickettsia-mediated vasculitis and resultant extensive local inflammation. Thus rickettsiae have ready access to lymphatics and venous blood and disseminate to cause systemic disease.

## CLINICAL MANIFESTATIONS AND LABORATORY FINDINGS

Typical findings in children include fever (37–100%), a maculopapular rash that appears 3–5 days after onset of fever (94–100%), hepatosplenomegaly (20–83%), myalgias and arthralgias (10–42%), headache (8–63%), nausea, vomiting, or diarrhea (5–28%), and lymphadenopathy (52–54%). In 60–90% of patients, a **painless eschar, or tache noire**, appears at the site of the tick bite, often on the scalp, with accompanying regional lymphadenopathy (50–60%) ([Fig. 274.6](#)). The infection can be severe, mimicking RMSF, although morbidity and fatalities in children





**Fig. 274.6** Various appearances of eschars associated with *Rickettsia parkeri* rickettsiosis. (From Biggs HM, Behravesh CB, Bradley KK, et al. *Diagnosis and management of tickborne rickettsial diseases: Rocky Mountain spotted fever and other spotted fever group rickettsioses, ehrlichioses, and anaplasmosis—United States. MMWR Recomm Rep. 2016;65:1–44, Fig. 24.*)

are less frequent than in adults. Findings can include seizures, purpuric skin lesions, meningitis and neurologic deficits, respiratory and/or acute renal failure, and severe thrombocytopenia. Even though the case fatality rate can be as high as 10% in adults and severe infections occur in approximately 9% of children, pediatric deaths are rare. As with RMSF, a particularly severe form occurs in patients with glucose-6-phosphate dehydrogenase deficiency and in patients with underlying conditions such as alcoholic liver disease or diabetes mellitus.

### DIAGNOSIS

Laboratory diagnosis of MSF and related spotted fever group rickettsioses is the same as that for RMSF. Cases can be confirmed by immunohistologic or immunofluorescent demonstration of or amplification of nucleic acids from rickettsiae in eschar crust or skin biopsies, or demonstration of seroconversion, or accompanied by a fourfold rise in serum antibody titer to spotted fever group rickettsiae between acute and convalescent sera. Antibodies to spotted fever group antigens cross react, so RMSF or other spotted fever group rickettsiosis in the United States or MSF in Europe, Africa, and Asia cannot be distinguished by these methods. When eschars are present, biopsy of the eschar with submission of tissue or a swab of the base for PCR provides considerably higher sensitivity than PCR on blood and is advocated, if available. In vitro cultivation via centrifugation-assisted shell vial tissue culture is rarely used for clinical diagnosis. Treatment should not be withheld while waiting for diagnostic test results.

### DIFFERENTIAL DIAGNOSIS

The differential diagnosis includes conditions also associated with single eschars, such as anthrax, bacterial ecthyma, brown recluse spider bite, rat-bite fever (caused by *Spirillum minus*), and other rickettsioses (such as rickettsialpox, African tick-bite fever, *R. parkeri* or “*R. philipii*” str. 364D rickettsiosis, and scrub typhus). The spotted fever group rickettsia *R. africae* causes African tick-bite fever, a milder illness than MSF that is often associated with multiple eschars and occasionally a vesicular rash. African tick-bite fever can be contracted in North Africa, where MSF also occurs, and is a common infection of travelers to sub-Saharan Africa who encounter bush or high grasslands on safari. *R. parkeri* and “*R. philipii*” str. 364D rickettsiosis are emerging infections in North and South America and in the U.S. western states, respectively. Both often present with an eschar and milder clinical manifestations similar to those observed with African tick-bite fever.

### TREATMENT AND SUPPORTIVE CARE

In adults, MSF is effectively treated with tetracycline, doxycycline, chloramphenicol, ciprofloxacin, ofloxacin, levofloxacin, azithromycin, or clarithromycin. For children, the treatment of choice is doxycycline (4 mg/kg/day divided every 12 hours PO or IV; maximum: 200 mg/day). Tetracycline and chloramphenicol are alternatives, as for RMSF. Azithromycin (10 mg/kg/day once daily PO for 3 days) and clarithromycin (15 mg/kg/day divided twice daily PO for 7 days) are also used.

Specific fluoroquinolone regimens effective for children have not been established, although recent reports suggest that the use of fluoroquinolones is associated with increased disease severity as compared with doxycycline. Intensive care may be required.

### COMPLICATIONS

The complications of MSF are similar to those of RMSF. Overall, the case fatality rate is less than 2%, but fatalities are rare in children. Particularly severe infections have been noted in patients with underlying medical conditions, including glucose-6-phosphate dehydrogenase deficiency and diabetes mellitus.

### PREVENTION

MSF is transmitted by tick bites, and prevention is the same as recommended for RMSF. No vaccine is currently available.

Visit Elsevier eBooks+ at [eBooks.Health.Elsevier.com](http://eBooks.Health.Elsevier.com) for Bibliography.

## 274.3 Rickettsialpox (*Rickettsia akari*) and Flea-Borne Spotted Fever

Megan E. Reller and J. Stephen Dumler

Rickettsialpox is caused by *R. akari*, a transitional-group *Rickettsia* species that is transmitted by the mouse mite, *Allodermanyssus sanguineus*. The mouse host for this mite is widely distributed in cities in the United States, Europe, and Asia. Seroepidemiologic studies suggest a high prevalence of this infection in urban settings. The disease is uncommon and is usually mild. Unlike the situation with most forms of rickettsiosis, the macrophage is an important target cell for *R. akari*.

Rickettsialpox is best known because of its association with a varicelliform rash. In fact, this rash is a modified form of an antecedent typical macular or maculopapular rash like those seen in other vasculotropic rickettsioses and is occasionally seen with other rickettsioses such as African tick-bite fever. Clinical descriptions in children are infrequent. At presentation, most patients have fever, headache, and chills. In up to 90% of cases, there is a painless papular, ulcerative lesion, or eschar at the initial site of inoculation, which can be associated with tender regional lymphadenopathy. In some patients, the maculopapular rash becomes vesicular, involving the trunk, head, and extremities. The infection generally resolves spontaneously and does not require therapy. However, a short course of doxycycline hastens resolution and is sometimes used in patients older than 8 years of age and in young children with relatively severe illness. Complications and fatalities are rare; however, clear examples of severe disease in children like that observed with RMSF are described.

Flea-borne spotted fever, caused by *Rickettsia felis*, is often considered within the typhus group because of flea transmission; however, phylogenetic studies place it close to the *Rickettsia* genus spotted fever or within the “transitional” group. Similarly, a related cat flea-associated agent, *R. asembonensis*, was isolated from cat fleas; it and other related rickettsiae in fleas have been identified in environmental samples over broad geographic regions but are not known to cause human disease. Since the discovery of *R. felis* in a febrile patient from Texas by use of molecular amplification methods, and its subsequent isolation from infected cat fleas, molecular and cross reactive serologic tests have purported to identify human infections globally, some at high rates of prevalence. Clinical isolates have yet to be made from infected humans, and many patients identified by molecular methods lack serologic responses or even clinical signs. Its identification within mosquitoes and in conjunction with malaria further confound its role as a human pathogen. Until many of the discrepant findings observed with *R. felis* are resolved, its role as an important infectious agent in humans remains to be resolved.

Visit Elsevier eBooks+ at [eBooks.Health.Elsevier.com](http://eBooks.Health.Elsevier.com) for Bibliography.



## Chapter 275

# Scrub Typhus (*Orientia tsutsugamushi*)

Megan E. Reller and J. Stephen Dumler

Scrub typhus is an important cause of acute febrile illness in South and East Asia and the Pacific and could be emerging in the Middle East, Africa, and South America. The causative agent is distinct from, but related to, *Rickettsia* species. The infection is transmitted via chigger (larval mite) bites and involves many antigenically diverse strains of *Orientia tsutsugamushi* or emerging *Orientia* spp. such as “*O. chuto*” and “*O. chiloensis*,” hampering vaccine development.

## ETIOLOGY

The causative agent of scrub typhus, or tsutsugamushi fever, is *O. tsutsugamushi*, which is distinct from other spotted fever and typhus group rickettsiae (see Table 274.1 in Chapter 274). *O. tsutsugamushi* lacks both lipopolysaccharide and peptidoglycan in its cell wall. Like other vasculotropic rickettsiae, *O. tsutsugamushi* infects endothelial cells and causes vasculitis, the predominant clinicopathologic feature of the disease. However, the organism also infects macrophages and cardiac myocytes. A new *Candidatus* species, “*Orientia chuto*,” was isolated from a patient in the Middle East, and definitive evidence of infection based on serology and/or PCR amplification of *O. tsutsugamushi* genes from acute-phase blood suggests a wider range for scrub typhus and related infections. Similarly, a scrub typhus–like illness in southern Chile has been attributed to infection by a new species, “*Orientia chiloensis*.”

## EPIDEMIOLOGY

At least 1 million infections occur each year, and it is estimated that more than 1 billion people are at risk. Scrub typhus is recognized mostly in Asia, including areas delimited by Korea, Pakistan, and northern Australia. Outside these tropical and subtropical regions, the disease occurs in Japan, the Primorsky of far eastern Russia, Tajikistan, Nepal, and nontropical China, including Tibet. Cases imported to the United States and other parts of the world are reported. Endemic scrub typhus has historically been confined to Asia and Oceania and the tsutsugamushi triangle; however, *Orientia* may be distributed more broadly, with confirmed cases in South America and possible cases in Africa. Most infections in children are acquired in rural areas. In Thailand and Sri Lanka, scrub typhus is the cause of 1–8% of acute fevers of unknown origin. Infections are most common during rainy months, usually June through November. Reported cases in boys are higher than in girls.

## TRANSMISSION

*O. tsutsugamushi* is transmitted via the bite of the larval stage (chigger) of a trombiculid mite (*Leptotrombidium* in Asia, *Herpetacarus* in Chile, and *Microtrombicula* in Africa), which serves as both vector and reservoir. Vertical transovarial transmission (passage of the organism from infected mites to their progeny) is the major mechanism for maintenance in nature. Because only the larval stage takes blood meals, a role for horizontal transmission from infected rodent hosts to uninfected mites has not been proved, but transmission among co-feeding larval mites is a possibility. Multiple serotypes of *O. tsutsugamushi* are recognized, and some share antigenic cross reactivity; however, they do not stimulate protective cross-immunity.

## PATHOLOGY AND PATHOGENESIS

The pathogenesis of scrub typhus is uncertain. The process may be stimulated by widespread infection of vascular endothelial cells, which

corresponds to the distribution of disseminated vasculitic and perivascular inflammatory lesions observed in histopathologic examinations. In autopsy series, the major result of the vascular injury appears to be hemorrhage. However, data support the concept that vascular injury initiated by the infection is sustained by immune-mediated inflammation that together cause significant vascular leakage. The net result is significant vascular compromise and ensuing end-organ injury, most often manifested in the brain and lungs, as with other vasculotropic rickettsioses.

## CLINICAL MANIFESTATIONS AND LABORATORY FINDINGS

Scrub typhus can be mild or severe in children and can affect almost every organ system. Most patients present with fever for 9–11 days (range: 1–30 days) before seeking medical care. Regional or generalized lymphadenopathy is reported in 23–93%, hepatomegaly in about two thirds, and splenomegaly in about one third of children with scrub typhus. Gastrointestinal symptoms, including abdominal pain, vomiting, and diarrhea, occur in up to 40% of children at presentation. A **single painless eschar** with an erythematous rim at the site of the chigger bite is seen in 7–68% of cases, and a maculopapular rash is present in less than half; both can be absent. Hemophagocytic lymphohistiocytosis has been described. Leukocyte and platelet counts are most commonly within normal ranges, although thrombocytopenia occurs in one quarter to one third of children, and leukocytosis is observed in approximately 40% of children. Clinical manifestations often respond dramatically to appropriate treatment. Adverse outcomes in fetuses and newborn infants of infected mothers have been described, resulting from vertical transmission.

## DIAGNOSIS AND DIFFERENTIAL DIAGNOSIS

Owing to the potential for severe complications, diagnosis and decision to initiate treatment should be based on clinical suspicion. The reference diagnostic standard for acute scrub typhus remains demonstration of a fourfold rise in IgG antibody titer by indirect fluorescent antibody testing of acute-phase and convalescent-phase (obtained at 2- to 4-week follow-up) sera. The IgG indirect fluorescent antibody assay is >90% sensitive with 11 days or more of fever but does not distinguish acute from past infection in those residing in endemic regions. A positive acute-phase IgM is also not definitive evidence of acute scrub typhus. Although the rickettsiae can be cultivated using tissue culture methods, polymerase chain reaction tests are not highly sensitive, and these diagnostic methods are not widely available. The differential diagnosis includes fever of unknown origin, enteric fever, typhoid fever, dengue hemorrhagic fever, other rickettsioses, tularemia, anthrax, dengue, leptospirosis, malaria, and infectious mononucleosis.

## TREATMENT AND SUPPORTIVE CARE

The recommended treatment regimen for scrub typhus is doxycycline (4 mg/kg/day PO or IV divided every 12 hours; maximum: 200 mg/day). Alternative regimens include tetracycline (25–50 mg/kg/day PO divided every 6 hours; maximum: 2 g/day) or chloramphenicol (50–100 mg/kg/day divided every 6 hours IV; maximum: 4 g/24 hr). If used, chloramphenicol should be monitored to maintain serum concentrations of 10–30 µg/mL. Alternatives now supported by data from randomized trials include azithromycin (10 mg/kg PO on day 1, then 5 mg/kg PO; maximum: 500 mg/day) or clarithromycin (15–30 mg/kg/day PO divided every 12 hours; maximum: 1 g/day). Therapy should be continued for a minimum of 5 days and until the patient has been afebrile for at least 3 days to avoid relapse. However, a single dose of oral doxycycline was reported effective for all 38 children treated with this regimen in a large series from Thailand. Most children respond rapidly to doxycycline or chloramphenicol within 1–2 days (range: 1–5 days). Strains of *O. tsutsugamushi* with modestly higher doxycycline minimal inhibitory concentrations are reported in some regions of Thailand. Clinical trials showed that azithromycin could be as effective and that rifampicin is superior to doxycycline in such cases and could have a role as an alternative therapy, especially for pregnant women. The use of ciprofloxacin in pregnant women resulted in an adverse outcome in

five of five pregnancies among Indian women. Intensive care may be required for hemodynamic management of severely affected patients.

## COMPLICATIONS

Serious complications include pneumonitis in 20–35% and meningoencephalitis in approximately 10–25% of children. Acute renal failure, myocarditis, and septic shock occur less often. Cerebrospinal fluid examination shows a mild mononuclear pleocytosis with normal glucose levels. Chest radiographs reveal transient perihilar or peribronchial interstitial infiltrates in most children who are examined. The reported case fatality rate varies widely; among 883 patients <20 years of age in 18 published studies, the case fatality rate was 11%; the median for the studies was 1.6–1.8% and ranged as high as 33%. In a contemporary systematic review and meta-analysis of Indian children, the case fatality rate was 1.1%.

## PREVENTION

Prevention is based on avoidance of the chiggers that transmit *O. tsutsugamushi*. Protective clothing is the next most useful mode of prevention. Infection provides immunity to reinfection by homologous but not heterologous strains; however, because natural strains are highly heterogeneous, infection does not always provide complete protection against reinfection. No vaccines are currently available.

Visit Elsevier eBooks+ at [eBooks.Health.Elsevier.com](http://eBooks.Health.Elsevier.com) for Bibliography.

## Chapter 276

# Typhus Group Rickettsioses

Megan E. Reller and J. Stephen Dumler

Members of the typhus group of rickettsiae (see Table 274.1 in Chapter 274) include *Rickettsia typhi*, the cause of murine typhus, and *Rickettsia prowazekii*, the cause of louse-borne or epidemic typhus. *R. typhi* is transmitted to humans by fleas, and *R. prowazekii* is transmitted in the feces of body lice. Louse-borne or epidemic typhus is widely considered to be the most virulent of the rickettsial diseases, with a high case fatality rate even with treatment. Murine typhus is moderately severe and likely underreported worldwide; global warming and increased precipitation may increase cases and spread. The genomes of both *R. typhi* and *R. prowazekii* are similar.

Visit Elsevier eBooks+ at [eBooks.Health.Elsevier.com](http://eBooks.Health.Elsevier.com) for Bibliography.

## 276.1 Murine (Endemic or Flea-Borne) Typhus (*Rickettsia typhi*)

Megan E. Reller and J. Stephen Dumler

### ETIOLOGY

Murine typhus is caused by *R. typhi*, a rickettsia transmitted from infected fleas to rats, other rodents, or opossums and back to fleas. Transovarial transmission (passage of the organism from infected fleas to their progeny) in fleas is inefficient. Transmission depends on infection from the flea to uninfected mammals that then sustain transient rickettsemia and serve as sources of the bacterium for uninfected fleas that bite during the period of rickettsemia.

### EPIDEMIOLOGY

Murine typhus has a worldwide distribution and occurs especially in warm coastal ports, where it is primarily maintained in a cycle involving rat fleas (*Xenopsylla cheopis*) and rats (*Rattus* species). Peak incidence occurs when rat populations are highest during spring, summer, and fall. Sentinel surveillance studies suggest that travel-acquired murine typhus occurs most often in those visiting Southeast Asia and Africa. In the United States, murine typhus was prevalent before eradication efforts using DDT in the 1940s and is now re-emerging. The disease is recognized most often in south Texas and Southern California. However, seroprevalence studies among children indicate that murine typhus is acquired across the southeast and southcentral United States, thus expanding the endemic areas in which pediatricians must be alert for this infection. In the coastal areas of south Texas and in Southern California, the disease is seen in all months, but predominantly from January through July, and is associated with a *sylvatic cycle* involving opossums and cat fleas (*Ctenocephalides felis*). The marked increase in reported cases in the past decade likely relates to increased recognition, improved surveillance, and ecologic factors.

### TRANSMISSION

*R. typhi* normally cycles between rodents or midsize animals such as opossums and their fleas. Human acquisition of murine typhus occurs when rickettsiae-infected flea feces contaminate flea bite wounds. Direct inoculation via flea bite is possible, but inefficient.

### PATHOLOGY AND PATHOGENESIS

*R. typhi* is a vasculotropic rickettsia that causes disease in a manner similar to *Rickettsia rickettsii* (see Chapter 274.1). *R. typhi* organisms in flea feces deposited on the skin as part of the flea feeding reflex are inoculated into the pruritic flea bite wound. After an interval for local proliferation, the rickettsiae spread systemically via lymphatics to the blood, after which they infect the endothelium in many tissues. As with spotted fever group rickettsiae, typhus group rickettsiae infect endothelial cells, but unlike the spotted fever group rickettsiae, they polymerize intracellular actin poorly, have limited intracellular mobility, and probably cause cellular injury by either enzymatic membrane or mechanical lysis after accumulating in large numbers within the endothelial cell cytoplasm. Intracellular infection leads to endothelial cell damage, recruitment of inflammatory cells, and vasculitis. The inflammatory cell infiltrates bring in a number of effector cells, including macrophages that produce proinflammatory cytokines, and CD4, CD8, and natural killer lymphocytes, which can produce immune cytokines such as interferon- $\gamma$  or participate in cell-mediated cytotoxic responses. Intracellular rickettsial proliferation of typhus group rickettsiae is inhibited by cytokine-mediated mechanisms and nitric oxide-dependent and -independent mechanisms.

Pathologic findings include systemic vasculitis in response to rickettsiae within endothelial cells. This vasculitis manifests as interstitial pneumonitis, meningoencephalitis, interstitial nephritis, myocarditis, and mild hepatitis with periportal lymphohistiocytic infiltrates. As vasculitis and inflammatory damage accumulate, multiorgan damage can ensue.

### CLINICAL MANIFESTATIONS

In children, murine typhus is generally a self-limited infection, but can be severe, similar to other vasculotropic rickettsioses. The incubation period varies from 1 to 2 weeks. The initial presentation is often nonspecific and mimics typhoid fever; fever of undetermined origin is the most common presentation. Pediatric patients with murine typhus exhibit symptoms classically attributed to other vasculotropic rickettsioses, such as rash (48–80%), myalgias (29–57%), vomiting (29–45%), cough (15–40%), headache (19–77%), and diarrhea or abdominal pain (10–40%). A petechial rash is observed in <15% of children, and the usual appearance is that of macules or maculopapules distributed on the trunk and extremities. The rash can involve both the soles and palms. Among common clinical features, only abdominal pain, diarrhea, and sore throat are more common in children than in adults, underscoring

the mild nature of most cases in children. Murine typhus-associated hemophagocytic lymphohistiocytosis (HLH) is described. Although neurologic involvement is a common finding in adults with murine typhus, photophobia, confusion, stupor, coma, seizures, meningismus, and ataxia are seen in <20% of hospitalized children and <6% of infected children treated as outpatients. Poor neonatal outcomes are reported with infection during pregnancy; however, frequency and clinical spectrum are not well documented.

### LABORATORY FINDINGS

Although nonspecific, laboratory findings are less severe than in adults. Helpful findings include mild leukopenia (28–40%) with a moderate left shift, mild to marked thrombocytopenia (30–60%), hyponatremia (20–66%), hypoalbuminemia (30–87%), and elevated aspartate aminotransferase (82%) and alanine aminotransferase (38%). Elevations in serum urea nitrogen are usually a result of prerenal mechanisms.

### DIAGNOSIS AND DIFFERENTIAL DIAGNOSIS

Delays in diagnosis and therapy are associated with increased morbidity and mortality; thus diagnosis must be based on clinical suspicion. Occasionally, patients present with findings suggesting pharyngitis, bronchitis, hepatitis, gastroenteritis, or sepsis; thus the differential diagnosis may be extensive. Murine typhus can also mimic SARS-CoV-2-associated multisystem inflammatory syndrome in children (MIS-C).

Confirmation of the diagnosis is usually accomplished by comparing acute- and convalescent-phase antibody titers obtained with the indirect fluorescent antibody assay (IFA) to demonstrate a fourfold rise in titer. Current objective studies of the diagnostic yield of *R. typhi* nucleic acid amplification from acute-phase whole blood show disappointingly low sensitivity, and rickettsial culture is not readily available. Thus paired (acute and convalescent) serology to demonstrate a fourfold rise in immunoglobulin (Ig) G antibody titer by IFA remains the standard for confirming acute infection. Use of IgM serologic tests is discouraged for diagnosis of rickettsial infections because of both limited sensitivity and specificity.

### TREATMENT

A meta-analysis of murine typhus in children reviewed treatment in 261 children, including 54 who received no antimicrobial therapy. Although 15% had complications, there were no deaths. The standard therapy for murine typhus in children was similar to that for adults and focused on use of tetracyclines or chloramphenicol. Quinolones have been used in children, and limited clinical studies show that ciprofloxacin is as effective as doxycycline and chloramphenicol to treat murine typhus; however, treatment failures are reported. In vitro experiments suggest that minimal inhibitory concentrations of azithromycin and clarithromycin for *R. typhi* should be easily achieved. However, in adult patients, a prospective randomized clinical trial showed that either a 3- or 7-day course of doxycycline was superior to 3 days of azithromycin for fever clearance.

Therefore the time-honored recommended treatment for murine typhus remains doxycycline (4 mg/kg/day divided every 12 hours PO or IV; maximum: 200 mg/day). Alternative regimens include tetracycline (25–50 mg/kg/day divided every 6 hours PO; maximum: 2 g/day) or chloramphenicol (50–100 mg/kg/day divided every 6 hours IV; maximum: 4 g/day). Therapy should be for a minimum of 3 days and continued until the patient has been afebrile for at least 3 days.

### SUPPORTIVE CARE

Although disease is usually mild, 15% of children have complications and 2–7% require intensive care for management of meningoencephalitis, a disseminated intravascular coagulation-like condition, or other conditions. As for other rickettsial infections with significant systemic vascular injury, careful hemodynamic management is mandatory to avoid pulmonary or cerebral edema.

### COMPLICATIONS

Complications of murine typhus in pediatric patients are uncommon; however, relapse, stupor, facial edema, dehydration, splenic rupture, and meningoencephalitis are reported. Predominance of abdominal pain has led to surgical exploration to exclude a perforated viscus.

### PREVENTION

Control of murine typhus was dependent on elimination of the flea reservoir and control of flea hosts, and this approach remains important. However, with the recognition of cat fleas as potentially significant reservoirs and vectors, the presence of these flea vectors and their mammalian hosts in suburban areas where close human exposures occur poses increasingly difficult control problems. It is not known with certainty if infection confers protective immunity; reinfection appears to be rare.

Visit Elsevier eBooks+ at [eBooks.Health.Elsevier.com](https://eBooks.Health.Elsevier.com) for Bibliography.

## 276.2 Epidemic (Louse-Borne) Typhus (*Rickettsia prowazekii*)

Megan E. Reller and J. Stephen Dumler

### ETIOLOGY

Humans are considered the principal reservoir of *R. prowazekii*, the causative agent of epidemic or louse-borne typhus and its recrudescence form, Brill-Zinsser disease. Another reservoir exists in flying squirrels, their ectoparasites, and potentially ticks in a sylvatic cycle with small rodents. *R. prowazekii* is the most pathogenic member of the genus *Rickettsia* and multiplies to very large intracellular quantities before rupture of infected endothelial cells.

### EPIDEMIOLOGY

The infection is characteristically seen in winter or spring and especially during times of poor hygienic practices associated with crowding, war, famine, extreme poverty, and civil strife. As observed in a recent outbreak among youths at a rehabilitation center in Rwanda, infections in children under these conditions can lead to severe adverse outcomes. *R. prowazekii* has also been associated with sporadic cases of a mild, typhus-like illness in the United States; such cases are associated with exposure to flying squirrels harboring infected lice or fleas. *R. prowazekii* organisms isolated from these squirrels appear to be genetically similar to isolates obtained during typical outbreaks.

Most cases of louse-borne typhus in the developed world are sporadic, but outbreaks have been identified in Africa (Ethiopia, Nigeria, Rwanda, and Burundi), Mexico, Central America, South America, Eastern Europe, Afghanistan, Russia, northern India, and China within the past 25 years. After the Burundi Civil War in 1993, 35,000–100,000 cases of epidemic typhus were diagnosed in displaced refugees, resulting in an estimated 6,000 deaths.

### TRANSMISSION

Human body lice (*Pediculus humanus*) become infected by feeding on persons who have rickettsiae circulating in their blood owing to endothelial cell infection. The ingested rickettsiae infect the midgut epithelial cells of the lice and are passed into the feces, which, in turn, are introduced into a susceptible human host through abrasions or perforations in the skin, through the conjunctivae, or rarely, through inhalation as fomites in clothing, bedding, or furniture.

### CLINICAL MANIFESTATIONS

Louse-borne typhus can be mild or severe in children. The incubation period is usually <14 days. The typical clinical manifestations include fever, severe headache, abdominal tenderness, and rash in most patients, as well as chills (82%), myalgias (70%), arthralgias (70%), anorexia (48%), nonproductive cough (38%), dizziness (35%),



photophobia (33%), nausea (32%), abdominal pain (30%), tinnitus (23%), constipation (23%), meningismus (17%), visual disturbances (15%), vomiting (10%), and diarrhea (7%). However, investigation of recent African outbreaks has shown a lower incidence of rash (25%) and a high incidence of delirium (81%) and cough associated with pneumonitis (70%). The rash is initially pink or erythematous and blanches. In one third of patients, red, nonblanching macules and petechiae appear predominantly on the trunk. Infections identified during the preantibiotic era typically produced a variety of central nervous system findings, including delirium (48%), coma (6%), and seizures (1%). Estimates of case fatality rates range between 3.5% and 20% in outbreaks.

**Brill-Zinsser disease** is a form of typhus that becomes recrudescent months to years after the primary infection, thus rarely affecting children. When bacteremic with rickettsiae, these infected patients can transmit the agent to lice, potentially providing the initial event that triggers an outbreak if hygienic conditions permit.

## TREATMENT

Recommended treatment regimens for louse-borne or sylvatic typhus are identical to those used for murine typhus. The treatment of choice is doxycycline (4 mg/kg/day divided every 12 hours PO or IV; maximum: 200 mg/day). Alternative treatments include tetracycline (25–50 mg/kg/day divided every 6 hours PO; maximum: 2 g/day) or chloramphenicol (50–100 mg/kg/day divided every 6 hours IV; maximum: 4 g/day). Therapy should be continued for a minimum of 5 days and until the patient is afebrile for at least 3 days. Evidence exists that doxycycline as a single 200-mg oral dose (4.4 mg/kg if <45 kg) is also efficacious.

## PREVENTION

Immediate destruction of vectors with an insecticide is important in the control of an epidemic. Lice live in clothing rather than on the skin; thus searches for ectoparasites should include examination of clothing. For epidemic typhus, antibiotic therapy and delousing measures interrupt transmission, reduce the prevalence of infection in the human reservoir, and diminish the impact of an outbreak. Dust containing excreta from infected lice is stable and capable of transmitting typhus, and care must be taken to prevent its inhalation. Infection confers solid protective immunity. However, recrudescence can occur years later with Brill-Zinsser disease, implying that immunity is not complete.

Visit Elsevier eBooks+ at eBooks.Health.Elsevier.com for Bibliography.

## Chapter 277

# Ehrlichiosis and Anaplasmosis

Megan E. Reller and J. Stephen Dumler

## ETIOLOGY

**Ehrlichiosis** in humans was first described in 1987, when clusters of bacteria confined within cytoplasmic vacuoles of circulating leukocytes (morulae), particularly **mononuclear** leukocytes, were detected in the peripheral blood of a patient with suspected Rocky Mountain spotted fever (RMSF). The etiologic agent, *Ehrlichia chaffeensis*, was cultivated from blood of an infected patient in 1990 and identified as the predominant cause of human ehrlichiosis. Investigations showed that infection by *E. chaffeensis* is transmitted by *Amblyomma americanum* ticks and occurs more often than RMSF in some geographic areas. By 1994, other cases in which morulae were found only in

**neutrophils** and lacked serologic evidence for *E. chaffeensis* infection led to the recognition of the species classified as *Anaplasma phagocytophilum*, which encompasses several previously described veterinary pathogens on at least two different continents and causes **anaplasmosis**.

Since these discoveries, additional species in the Anaplasmataceae family were identified as human pathogens, including (1) *Ehrlichia ewingii* in 1996, a veterinary pathogen of canine neutrophils transmitted by *A. americanum* ticks; (2) the *Ixodes scapularis*-transmitted *Ehrlichia muris* subsp. *euclairensis* in 2009, only present so far in patients from Minnesota and Wisconsin in the United States; (3) infections by *Candidatus Neoehrlichia mikurensis*, presumably *Ixodes* spp. or *Haemaphysalis concinna* tick-transmitted, recognized in 2010 as a cause of sepsis-like infections of immune-compromised patients in Europe, and later as a cause of mild febrile illness in healthy individuals in China; (4) Panola Mountain *Ehrlichia*, a bacterium rarely associated with infections in humans but present in *A. americanum* ticks in the United States and with genetic features of the ruminant pathogen *Ehrlichia ruminantium*; (5) *Ehrlichia canis*, the established canine pathogen that has infected humans in Venezuela and possibly Costa Rica; and (6) *Anaplasma capra*, the cause of mild fever after *Ixodes persulcatus* tick bites, so far only identified in China. The latter five have not yet been established as causes of infection in children.

Although the infections caused by these various genera have been called ehrlichiosis, further study has identified substantial differences in biology and diagnostic approaches such that the CDC now generally separates these into ehrlichiosis, anaplasmosis, or undetermined ehrlichiosis/anaplasmosis. **Human monocytic ehrlichiosis (HME)**, or simply ehrlichiosis, describes disease characterized by infection of predominantly monocytes and is caused by *E. chaffeensis*; **human granulocytic anaplasmosis (HGA)**, now “anaplasmosis,” describes disease related to infection of circulating neutrophils by *Anaplasma phagocytophilum*; and **ewingii ehrlichiosis** is caused by infection of granulocytes by *E. ewingii* (see Table 274.1 in Chapter 274).

All of these organisms are tick-transmitted and are small, obligate intracellular bacteria with gram-negative-type cell walls. *Neorickettsia sennetsu* is another related bacterium that is rarely recognized as a cause of human disease and is not transmitted by ticks. *E. chaffeensis* alters host signaling and transcription once inside the cell. It survives in an endosome that enters a receptor recycling pathway to avoid phagosome-lysosome fusion and growth into a **morula**, an intravacuolar aggregate of bacteria. *A. phagocytophilum* survives in a unique vacuole that becomes decorated by microbial proteins that prevent normal endosomal trafficking and lysosome fusion. Little is known about the vacuoles in which *E. ewingii* and *E. muris* subsp. *euclairensis* grow. These bacteria are pathogens of phagocytic cells in mammals, and characteristically each species has a specific host cell affinity: *E. chaffeensis* infects mononuclear phagocytes, and *A. phagocytophilum* and *E. ewingii* infect neutrophils. Infection leads to direct modifications in function, in part the result of changes in intracellular signal transduction or modulation of transcription of the host cell that diminishes host defenses toward the bacterium. Yet host immune and inflammatory reactions are still activated and in part account for many of the clinical manifestations in ehrlichiosis, such as overlaps with macrophage activation syndrome or hemophagocytic lymphohistiocytosis.

## EPIDEMIOLOGY

Infections with *E. chaffeensis* occur across the southeastern, south central, and Mid-Atlantic States of the United States in a distribution that parallels that of RMSF; cases have also been reported in northern California. Reported cases of ehrlichiosis have more than doubled since adoption of the current surveillance case definition in 2008. Suspected cases with appropriate serologic and occasionally molecular evidence have been reported in Europe, Africa, South America, and the Far East, including China and Korea. Human infections with *E. ewingii* have only been identified in the United States in



photophobia (33%), nausea (32%), abdominal pain (30%), tinnitus (23%), constipation (23%), meningismus (17%), visual disturbances (15%), vomiting (10%), and diarrhea (7%). However, investigation of recent African outbreaks has shown a lower incidence of rash (25%) and a high incidence of delirium (81%) and cough associated with pneumonitis (70%). The rash is initially pink or erythematous and blanches. In one third of patients, red, nonblanching macules and petechiae appear predominantly on the trunk. Infections identified during the preantibiotic era typically produced a variety of central nervous system findings, including delirium (48%), coma (6%), and seizures (1%). Estimates of case fatality rates range between 3.5% and 20% in outbreaks.

**Brill-Zinsser disease** is a form of typhus that becomes recrudescent months to years after the primary infection, thus rarely affecting children. When bacteremic with rickettsiae, these infected patients can transmit the agent to lice, potentially providing the initial event that triggers an outbreak if hygienic conditions permit.

## TREATMENT

Recommended treatment regimens for louse-borne or sylvatic typhus are identical to those used for murine typhus. The treatment of choice is doxycycline (4 mg/kg/day divided every 12 hours PO or IV; maximum: 200 mg/day). Alternative treatments include tetracycline (25–50 mg/kg/day divided every 6 hours PO; maximum: 2 g/day) or chloramphenicol (50–100 mg/kg/day divided every 6 hours IV; maximum: 4 g/day). Therapy should be continued for a minimum of 5 days and until the patient is afebrile for at least 3 days. Evidence exists that doxycycline as a single 200-mg oral dose (4.4 mg/kg if <45 kg) is also efficacious.

## PREVENTION

Immediate destruction of vectors with an insecticide is important in the control of an epidemic. Lice live in clothing rather than on the skin; thus searches for ectoparasites should include examination of clothing. For epidemic typhus, antibiotic therapy and delousing measures interrupt transmission, reduce the prevalence of infection in the human reservoir, and diminish the impact of an outbreak. Dust containing excreta from infected lice is stable and capable of transmitting typhus, and care must be taken to prevent its inhalation. Infection confers solid protective immunity. However, recrudescence can occur years later with Brill-Zinsser disease, implying that immunity is not complete.

Visit Elsevier eBooks+ at eBooks.Health.Elsevier.com for Bibliography.

## Chapter 277

# Ehrlichiosis and Anaplasmosis

Megan E. Reller and J. Stephen Dumler

## ETIOLOGY

**Ehrlichiosis** in humans was first described in 1987, when clusters of bacteria confined within cytoplasmic vacuoles of circulating leukocytes (morulae), particularly **mononuclear** leukocytes, were detected in the peripheral blood of a patient with suspected Rocky Mountain spotted fever (RMSF). The etiologic agent, *Ehrlichia chaffeensis*, was cultivated from blood of an infected patient in 1990 and identified as the predominant cause of human ehrlichiosis. Investigations showed that infection by *E. chaffeensis* is transmitted by *Amblyomma americanum* ticks and occurs more often than RMSF in some geographic areas. By 1994, other cases in which morulae were found only in

**neutrophils** and lacked serologic evidence for *E. chaffeensis* infection led to the recognition of the species classified as *Anaplasma phagocytophilum*, which encompasses several previously described veterinary pathogens on at least two different continents and causes **anaplasmosis**.

Since these discoveries, additional species in the Anaplasmataceae family were identified as human pathogens, including (1) *Ehrlichia ewingii* in 1996, a veterinary pathogen of canine neutrophils transmitted by *A. americanum* ticks; (2) the *Ixodes scapularis*-transmitted *Ehrlichia muris* subsp. *euclairensis* in 2009, only present so far in patients from Minnesota and Wisconsin in the United States; (3) infections by *Candidatus Neoehrlichia mikurensis*, presumably *Ixodes* spp. or *Haemaphysalis concinna* tick-transmitted, recognized in 2010 as a cause of sepsis-like infections of immune-compromised patients in Europe, and later as a cause of mild febrile illness in healthy individuals in China; (4) Panola Mountain *Ehrlichia*, a bacterium rarely associated with infections in humans but present in *A. americanum* ticks in the United States and with genetic features of the ruminant pathogen *Ehrlichia ruminantium*; (5) *Ehrlichia canis*, the established canine pathogen that has infected humans in Venezuela and possibly Costa Rica; and (6) *Anaplasma capra*, the cause of mild fever after *Ixodes persulcatus* tick bites, so far only identified in China. The latter five have not yet been established as causes of infection in children.

Although the infections caused by these various genera have been called ehrlichiosis, further study has identified substantial differences in biology and diagnostic approaches such that the CDC now generally separates these into ehrlichiosis, anaplasmosis, or undetermined ehrlichiosis/anaplasmosis. **Human monocytic ehrlichiosis (HME)**, or simply ehrlichiosis, describes disease characterized by infection of predominantly monocytes and is caused by *E. chaffeensis*; **human granulocytic anaplasmosis (HGA)**, now “anaplasmosis,” describes disease related to infection of circulating neutrophils by *Anaplasma phagocytophilum*; and **ewingii ehrlichiosis** is caused by infection of granulocytes by *E. ewingii* (see Table 274.1 in Chapter 274).

All of these organisms are tick-transmitted and are small, obligate intracellular bacteria with gram-negative-type cell walls. *Neorickettsia sennetsu* is another related bacterium that is rarely recognized as a cause of human disease and is not transmitted by ticks. *E. chaffeensis* alters host signaling and transcription once inside the cell. It survives in an endosome that enters a receptor recycling pathway to avoid phagosome-lysosome fusion and growth into a **morula**, an intravacuolar aggregate of bacteria. *A. phagocytophilum* survives in a unique vacuole that becomes decorated by microbial proteins that prevent normal endosomal trafficking and lysosome fusion. Little is known about the vacuoles in which *E. ewingii* and *E. muris* subsp. *euclairensis* grow. These bacteria are pathogens of phagocytic cells in mammals, and characteristically each species has a specific host cell affinity: *E. chaffeensis* infects mononuclear phagocytes, and *A. phagocytophilum* and *E. ewingii* infect neutrophils. Infection leads to direct modifications in function, in part the result of changes in intracellular signal transduction or modulation of transcription of the host cell that diminishes host defenses toward the bacterium. Yet host immune and inflammatory reactions are still activated and in part account for many of the clinical manifestations in ehrlichiosis, such as overlaps with macrophage activation syndrome or hemophagocytic lymphohistiocytosis.

## EPIDEMIOLOGY

Infections with *E. chaffeensis* occur across the southeastern, south central, and Mid-Atlantic States of the United States in a distribution that parallels that of RMSF; cases have also been reported in northern California. Reported cases of ehrlichiosis have more than doubled since adoption of the current surveillance case definition in 2008. Suspected cases with appropriate serologic and occasionally molecular evidence have been reported in Europe, Africa, South America, and the Far East, including China and Korea. Human infections with *E. ewingii* have only been identified in the United States in

areas where *E. chaffeensis* also exists, perhaps owing to the shared tick vector. Canine infections are documented in both sub-Saharan Africa and South America.

Although the median age of patients with ehrlichiosis and anaplasmosis is generally older (>51 years), many infected children have been identified, and for ehrlichiosis, the case fatality rate is 4% in those <5 years of age. Perinatal transmission of ehrlichiosis and anaplasmosis has been documented in case reports. Little is known about the epidemiology of *E. ewingii* infections; although infections in children occur, they are recognized at a rate 100-fold less than for *E. chaffeensis*. All infections are strongly associated with tick exposure and tick bites and are identified predominantly during May through September. Although both nymphal and adult ticks can transmit infection, nymphs are more likely to transmit disease because they are most active during the summer.

## TRANSMISSION

The predominant tick species that harbors *E. chaffeensis* and *E. ewingii* is *A. americanum*, the lone star tick (see Fig. 274.2d in Chapter 274). The tick vectors of *A. phagocytophilum* are *Ixodes* spp., including *I. scapularis* (black-legged or deer tick) in the eastern United States (see Fig. 274.1 in Chapter 274), *Ixodes pacificus* (western black-legged tick) in the western United States, *Ixodes ricinus* (sheep tick) in Europe, *Ixodes persulcatus* in Eurasia, and *Haemaphysalis* spp. in China. The *Ixodes* spp. ticks also transmit *Borrelia burgdorferi*, *Borrelia miyamotoi*, *Borrelia mayonii*, *Babesia microti*, and tick-borne encephalitis-associated flaviviruses in Europe and Powassan viruses and *E. muris* subsp. *eaucalirensis* in North America. Co-infections with these agents and *A. phagocytophilum* are documented in children and adults.

*Ehrlichia* and *Anaplasma* species are maintained in nature predominantly by horizontal transmission (tick to mammal to tick) because the organisms are not transmitted to the progeny of infected adult female ticks (transovarial transmission). The major reservoir for *E. chaffeensis* is the white-tailed deer (*Odocoileus virginianus*), which is found abundantly in many parts of the United States. A reservoir for *A. phagocytophilum* in the eastern United States appears to be the white-footed mouse, *Peromyscus leucopus*. Deer or domestic ruminants can sustain persistent asymptomatic infections, but the genetic variants in these reservoirs might not be infectious for humans. Efficient transmission requires persistent infections of mammals. Although *E. chaffeensis* and *A. phagocytophilum* can cause persistent infections in animals, clear evidence of chronic infections in humans is exceedingly rare. Transmission of *Ehrlichia* can occur within hours of tick attachment, in contrast to the 1-2 days of attachment required for transmission of *B. burgdorferi* to occur. Transmission of *A. phagocytophilum* is via the bite of the small nymphal stage of *Ixodes* spp., including *I. scapularis* (see Fig. 274.2a in Chapter 274), and is effective only after 36 hours of attachment on laboratory mice.

## PATHOLOGY AND PATHOGENESIS

Although ehrlichiosis and anaplasmosis often clinically mimic RMSF or typhus, vasculitis is rare. Pathologic findings include mild, diffuse perivascular lymphohistiocytic infiltrates; Kupffer cell hyperplasia and mild lobular hepatitis with infrequent apoptotic hepatocytes and, less frequently, centrilobular necrosis, cholestasis, and steatosis; infiltrates of mononuclear phagocytes in the spleen, lymph nodes, and bone marrow with occasional hemophagocytosis; granulomas of the liver and bone marrow in patients with *E. chaffeensis* infections; and hyperplasia of one or more bone marrow hematopoietic lineages.

The exact pathogenetic mechanisms are poorly understood, but histopathologic examinations suggest diffuse macrophage activation and poorly regulated host immune and inflammatory reactions. This activation results in moderate to profound leukopenia and thrombocytopenia despite a hypercellular bone marrow, and deaths often are related to hemorrhage or secondary opportunistic infections. Hepatic and other organ-specific injury occurs by a mechanism that appears to be triggered by the bacterium but is more closely related to induction of innate and adaptive immune effectors that are dysregulated in severely

affected patients. Meningoencephalitis with a mononuclear cell pleocytosis in the cerebrospinal fluid (CSF) occurs with ehrlichiosis but is rare with anaplasmosis.

## CLINICAL MANIFESTATIONS

The clinical manifestations of ehrlichiosis, anaplasmosis, and ewingii ehrlichiosis are similar. Many well-characterized infections of ehrlichiosis and anaplasmosis of variable severity have been reported in children, including deaths. Whereas anaplasmosis is more common in children, ehrlichiosis appears to be more severe. Children with ehrlichiosis are often ill for 4-12 days, shorter than in adults. Abdominal pain may occur disproportionately in children vs adults with anaplasmosis. In a series of children with ehrlichiosis, most required hospitalization and many (25%) required intensive care; these statistics might represent preferential reporting of severe cases. However, review of case reports and electronic surveillance of anaplasmosis to the CDC identified that 42% of patients 5-9 years of age required hospitalization, and the case fatality rate is 4% among children <5 years of age. Population-based studies document that seroconversion often occurs in children who are well or who have only a mild illness. Many fewer pediatric cases of *E. ewingii* infection are reported, so the clinical manifestations related to this infection are less well characterized. The incubation period (time from last tick bite or exposure) appears to range from 2 days to 3 weeks. Nearly 25% of patients do not report a tick bite.

Clinically, ehrlichiosis and anaplasmosis are undifferentiated febrile illnesses. In ehrlichiosis, fever (~100%), headache (77%), and myalgia (77%) are most common, but many patients also report abdominal pain, nausea, and vomiting. Altered mental status accompanied by other signs of central nervous system involvement is present in 36%. Rash is a common feature (~60%) in children. The rash is usually macular or maculopapular, but petechial lesions can occur. The triad of fever, headache, and rash is observed in ~50%. Photophobia, conjunctivitis, pharyngitis, and arthralgias can occur but are less consistently present. Lymphadenopathy, hepatomegaly, and splenomegaly are detected in nearly 50% of children with ehrlichiosis. Edema of the face, hands, and feet occurs more commonly in children than in adults, but arthritis is uncommon.

Similar but less severe manifestations occur with anaplasmosis in children, including fever (93%), headache (73%), myalgia (73%), and rigors (60%). Nausea, vomiting, abdominal pain, and anorexia occur in 30% or less of patients. Cough is present in 20%. Rash is infrequent in anaplasmosis and most often is erythema migrans that results from concurrent Lyme disease.

Meningoencephalitis with a lymphocyte-predominant CSF pleocytosis is an uncommon but potentially severe complication of ehrlichiosis that appears to be rare with anaplasmosis. CSF protein may be elevated, and glucose may be mildly depressed in adults with ehrlichiosis meningoencephalitis, but CSF protein and glucose in affected children are typically normal. In one series, 19% of adult patients with central nervous system symptoms and abnormal CSF died despite normal CTs of the brain.

Chronic or persistent disease with low or absent fever is very unlikely to be any form of ehrlichiosis.

## LABORATORY FINDINGS

Characteristically, most children with ehrlichiosis and anaplasmosis present with leukopenia (57-80%) and thrombocytopenia (38-93%); cytopenias reach a nadir several days into the illness. Lymphopenia is common in both ehrlichiosis and anaplasmosis. Leukocytosis can also occur, but usually after the first week of illness or with effective antimicrobial treatment. Adults with pancytopenia often have a cellular or reactive bone marrow examination, and in nearly 75% of bone marrow specimens from adults with ehrlichiosis, granulomas and granulomatous inflammation are present; this finding is not a feature of adults with anaplasmosis. Mild to markedly elevated serum hepatic transaminase levels are frequent in both ehrlichiosis (85-92%) and anaplasmosis (40-50%). Hyponatremia (<135 mEq/L) is present in most cases. A clinical picture similar to disseminated intravascular coagulopathy has also been reported.

## DIAGNOSIS

Any delays in diagnosis or treatment are major contributors to increased morbidity or mortality in adults, where those not started on doxycycline at hospital admission are much more likely to require intensive care and undergo a significantly longer course of illness and hospitalization. Tick bites are not always reported; thus treatment must begin as early as possible based on epidemiologic (geographic) and clinical suspicion. Because both ehrlichiosis and anaplasmosis can be fatal, therapy should not be withheld while waiting for the results of confirmatory testing. In fact, prompt response to therapy supports the diagnosis.

Although several reports document pediatric patients with *E. chaffeensis* infection diagnosed based on typical *Ehrlichia morulae* in peripheral blood leukocytes (Fig. 277.1A), this finding is too infrequent to be considered a useful diagnostic approach. In contrast, anaplasmosis in adults presents with a small but significant percentage (1–40%) of circulating neutrophils (see Fig. 277.1B) containing typical morulae in 20–60% of patients.

*E. chaffeensis* and *A. phagocytophilum* infections are currently most frequently established by specific polymerase chain reaction assays used during the acute phase of illness when antibodies are often not detected. Both infections can be confirmed by demonstrating a fourfold change in immunoglobulin G titer by indirect immunofluorescence assay between paired sera. Serologic tests during the acute phase of infection are often negative; consequently, confirmation of acute infection requires demonstration of a fourfold rise in IgG titer in paired samples. A single specific titer of  $\geq 128$  is suggestive, but the use of IgM testing is discouraged owing to a lack of specificity. Identification of morulae in monocytes or macrophages for *E. chaffeensis* or in neutrophils or eosinophils for *A. phagocytophilum* by microscopy is suggestive. Demonstration of specific antigen in a tissue sample by immunohistochemistry and isolation of the organism in cell culture are not timely and are used infrequently. *E. ewingii* infection can only be confirmed by polymerase chain reaction because it has not been cultured and serologic antigens are not available. *E. ewingii* antibodies cross react with *E. chaffeensis* in routine serologic tests. Up to 15% of patients with anaplasmosis have serologic cross reactions with *E. chaffeensis*; thus serodiagnosis depends on testing with both *E. chaffeensis* and *A. phagocytophilum* antigens and demonstrating a fourfold or higher difference between titers.

## DIFFERENTIAL DIAGNOSIS

Because of the nonspecific presentation, ehrlichiosis mimics other arthropod-borne infections such as RMSF, tularemia, babesiosis, Lyme disease, murine typhus, relapsing fever, and Colorado tick fever. Other potential diagnoses often considered include otitis media, streptococcal pharyngitis, infectious mononucleosis, Kawasaki disease, endocarditis, respiratory or gastrointestinal viral syndromes, hepatitis, leptospirosis,

Q fever, collagen-vascular diseases, hemophagocytic syndromes, and leukemia. If rash and disseminated intravascular coagulopathy predominate, meningococcemia, bacterial sepsis, and toxic shock syndrome should also be suspected. Meningoencephalitis might suggest aseptic meningitis caused by enterovirus or herpes simplex virus, bacterial meningitis, or RMSF. Severe respiratory disease may be confused with bacterial, viral, and fungal causes of pneumonia. Mounting evidence suggests that ehrlichiosis and anaplasmosis may be precipitating factors for hemophagocytic lymphohistiocytosis.

## TREATMENT

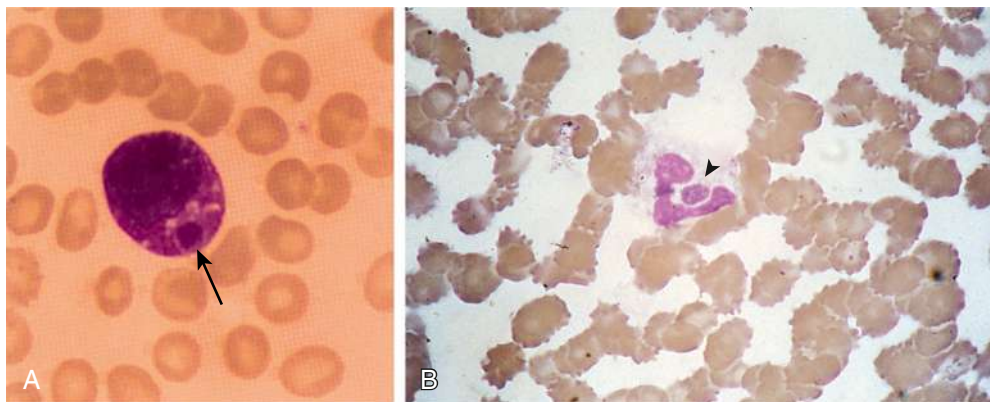
Both ehrlichiosis and anaplasmosis are effectively treated with tetracyclines, especially doxycycline, and the majority of patients improve within 48 hours. In vitro tests document that both *E. chaffeensis* and *A. phagocytophilum* have minimal inhibitory concentrations to chloramphenicol above blood levels that can be safely achieved. Therefore a short course of doxycycline is the recommended regimen. Doxycycline is used safely in children younger than 8 years of age because tooth discoloration is dose dependent and the need for multiple courses is unlikely; experience has demonstrated that adverse consequences of doxycycline use in children <8 years of age are extremely rare, in particular if courses are relatively short. Few data exist to recommend alternative therapies; however, both *E. chaffeensis* and *A. phagocytophilum* are susceptible in vitro to rifampin, which has been used successfully to treat anaplasmosis in pregnant women and children.

The recommended regimen for patients of all ages with severe or complicated ehrlichiosis and anaplasmosis is doxycycline (for those who weigh <45 kg, 4 mg/kg/day PO or IV divided every 12 hours; maximum 200 mg/day). An alternative regimen is tetracycline (25–50 mg/kg/day divided every 6 hours PO; maximum 2 g/day). For children who weigh more than 45 kg, the adult dose, 100 mg twice daily by oral or intravenous route, can be used. Therapy should be continued for  $\geq 5$  days and until the patient has been afebrile for  $\geq 2$ –4 days.

Other broad-spectrum antibiotics, including penicillins, cephalosporins, aminoglycosides, and macrolides, are not effective. In vitro studies suggest that fluoroquinolones are active against *A. phagocytophilum*, although at least one patient relapsed when levofloxacin was discontinued. *E. chaffeensis* is naturally resistant to fluoroquinolones owing to a single nucleotide change in *gyrA*, which suggests that *A. phagocytophilum* could also become resistant to fluoroquinolones rapidly.

## COMPLICATIONS AND PROGNOSIS

Fatal ehrlichiosis has been reported in occasional pediatric patients, where the findings included pulmonary involvement and respiratory failure in patients with or without immune compromise. The pattern of severe pulmonary involvement culminating in diffuse alveolar damage and acute respiratory distress syndrome and secondary nosocomial



**Fig. 277.1** Morulae in peripheral blood leukocytes in patients with human monocytic ehrlichiosis and human granulocytic anaplasmosis. A, A morula (arrow) containing *Ehrlichia chaffeensis* in a monocyte. B, A morula (arrowhead) containing *Anaplasma phagocytophilum* in a neutrophil. Wright stains, original magnifications  $\times 1,200$ . *E. chaffeensis* and *A. phagocytophilum* have similar morphologies but are serologically and genetically distinct.



or opportunistic infections is now well-documented with ehrlichiosis and anaplasmosis in adults. Of greater concern is the frequency with which secondary hemophagocytic lymphohistiocytosis is diagnosed with ehrlichiosis and anaplasmosis in children. Children and adults who are immunocompromised (e.g., HIV infection, high-dose corticosteroid therapy, cancer chemotherapy, immunosuppression for organ transplantation) are at high risk for fulminant *E. chaffeensis* infection, for *E. ewingii* infection, and for severe anaplasmosis.

## PREVENTION

Ehrlichiosis, anaplasmosis, and ewingii ehrlichiosis are tick-borne diseases, and any activity that increases exposure to ticks increases risk. Avoiding tick-infested areas, wearing appropriate light-colored clothing, spraying tick repellents on clothing, carefully inspecting for ticks after exposure, and promptly removing any attached ticks diminish the risk. The interval between tick attachment and transmission of the agents may be as short as 4 hours; thus attached ticks should be removed promptly. A role of prophylactic therapy for ehrlichiosis and anaplasmosis after tick bites has not been investigated. It is not known if infection confers protective immunity; however, reinfection appears to be rare.

Visit Elsevier eBooks+ at [eBooks.Health.Elsevier.com](http://eBooks.Health.Elsevier.com) for Bibliography.

## Chapter 278

# Q Fever (*Coxiella burnetii*)

Megan E. Reller and J. Stephen Dumler

Q fever (for query fever, the name given after an outbreak of febrile illness in an abattoir in Queensland, Australia) is rarely reported in children but is probably underdiagnosed. Symptomatic patients can have acute or chronic disease.

## ETIOLOGY

Although previously classified within the order Rickettsiales, *Coxiella burnetii* (the causative agent of Q fever) is genetically distinct from the genera *Rickettsia*, *Orientia*, *Ehrlichia*, and *Anaplasma*. Hence, based on small genome analysis, it best aligns with the order Legionellales, family Coxiellaceae. *C. burnetii* is highly infectious for both humans and animals; even a single organism can cause infection. The agent has been nationally notifiable since 1999 and is listed as a Category B agent of bioterrorism by the Centers for Disease Control and Prevention (CDC). Unlike *Rickettsia*, the organism can enter a sporogenic differentiation cycle, which renders it highly resistant to chemical and physical treatments.

*C. burnetii* resides intracellularly within macrophages. In vitro, the organism undergoes a lipopolysaccharide phase variation similar to that described for smooth and rough strains of Enterobacteriaceae. Unlike *Ehrlichia*, *Anaplasma*, and *Chlamydia*, *C. burnetii* survives and proliferates within acidified phagosomes to form aggregates of >100 bacteria.

## EPIDEMIOLOGY

The disease is reported worldwide, except in New Zealand. Although seroepidemiologic studies suggest that infection occurs just as often in children as in adults, children less often present with clinical disease than adults. During the large outbreak of Q fever in the Netherlands in 2007–2009, only 3.5% of those diagnosed with Q fever were age 19 years or younger. Infections are recognized more often in men than in

women. Historically, reported cases in boys and girls have been equal, although a recent study reported male predominance. Approximately 60% of infections are asymptomatic, and only 5% of symptomatic patients require hospitalization. Seroprevalence surveys show that 6–70% of children in endemic European and African communities have evidence of past infection. In France, the overall incidence of Q fever is estimated to be 50 cases per 100,000 persons. A similar estimate is not available for Africa, where cases are likely misdiagnosed as malaria. The seroprevalence of Q fever in the United States is estimated to be 3.1%. Reported cases of Q fever in the United States have been received from every state, but 35% are reported from four states (California, Texas, Colorado, and Illinois). In the United States, reported Q fever cases increased by greater than ninefold from 17 cases in 2000 to 167 cases in 2008, reflecting an increase in incidence, increased reporting after September 11, 2001, improved diagnostic tools, or a combination of factors. Cases decreased significantly in 2008–2013 relative to 2007 but returned to previous high levels in 2014 (173 cases, including 147 acute and 39 chronic). Beginning in 2008, reported cases in the United States have been classified as acute or chronic. Between 2002 and 2014, more than 50% of recognized cases in the United States required hospitalization. Reported cases in Asia and Australia have also increased. Most infections in children are identified during the lamb birthing season in Europe (January through June), after farm visits, or after exposure to placentas of dogs, cats, and rabbits. The largest (~4,000 human cases) community outbreak ever described occurred in the Netherlands in 2007–2012 and was associated with intensive farming of dairy goats and dairy sheep. In 2011, the first multistate outbreak of Q fever in humans was linked to interstate sale of infected goats; an outbreak of unknown source was also reported. From 2000 to 2010, 60% of cases reported to the CDC occurred in individuals without reported exposure to livestock. More than 20% of cases of clinically recognized acute or chronic Q fever occur in immunosuppressed hosts or in persons with prosthetic valves or damaged native valves or vessels. These findings highlight the need for considering Q fever in those with clinically compatible illness, especially but not exclusively in those with likely exposures and in vulnerable hosts. Epidemiologic investigations and control efforts require a One Health approach, with consideration of the interactions between humans, animals, environment, and public health.

## TRANSMISSION

In contrast to other rickettsial infections, humans usually acquire *C. burnetii* by inhaling infectious aerosols (e.g., contaminated barnyard dust) or ingesting (and likely aspirating) contaminated foods. Ticks are rarely implicated. Cattle, sheep, and goats are the primary reservoirs, but infection in other livestock and domestic pets is also described. Organisms are excreted in milk, urine, and feces of infected animals, but especially in amniotic fluids and the placenta. An increase in incidence is associated with the seasonal mistral winds in France that coincide with lamb birthing season and with consumption of cheese among children in Greece. In Nova Scotia and Maine, exposure to newborn animals, especially kittens, has been associated with small outbreaks of Q fever in families. Exposure to domestic ruminants is the major risk in Europe and Australia, although many urban dwellers in France also acquire Q fever without such an exposure. Person-to-person transmission is possible but rare. Clinical Q fever during pregnancy can result from primary infection or reactivation of latent infection and is associated with miscarriage, intrauterine growth retardation, and premature births. Obstetricians and other related healthcare workers are at risk for acquiring infection because of the quantity of *C. burnetii* sequestered in the placenta. Sexual transmission and cases attributable to blood transfusion or bone marrow transplantation are also reported. Transmission after *live cell therapy* (injected live animal cells) has also been reported.

## PATHOLOGY AND PATHOGENESIS

The pathology of Q fever depends on the mode of transmission, route of dissemination, specific tissues involved, and course of the infection. When acquired via inhalation, a mild interstitial lymphocytic pneumonitis and macrophage- and organism-rich intraalveolar exudates are



often seen. When the liver is involved, a mild to moderate lymphocytic lobular hepatitis can be seen. Inflammatory pseudotumors can develop in the pulmonary parenchyma or other tissues. Classic fibrin-ring (“doughnut”) granulomas, generally associated with acute, self-limited infections, are occasionally identified in liver, bone marrow, meninges, and other organs. Typically, infected tissues are also infiltrated by lymphocytes and histiocytes.

Recovery from symptomatic or asymptomatic acute infection can result in persistent subclinical infection, possibly maintained by dysregulated cytokine responses. The persistence of *C. burnetii* in tissue macrophages at sites of preexisting tissue damage elicits low-grade chronic inflammation and, depending on the site of involvement, can result in irreversible cardiac valve damage, persistent vascular injury, or osteomyelitis. Endocarditis of native or prosthetic valves is characterized by infiltrates of macrophages and lymphocytes in necrotic fibrinous valvular vegetations and an absence of granulomas.

### CLINICAL MANIFESTATIONS AND COMPLICATIONS

Children are less likely to develop symptoms compared with adults. Only approximately 40–50% of people infected with *C. burnetii* develop symptoms. Historically, two forms of symptomatic disease have been thought to occur. **Acute Q fever**, now better characterized as **primary Q fever**, is more common and usually manifests as self-limited undifferentiated fever or an influenza-like illness with interstitial pneumonitis. Persistent localized infection with *C. burnetii* can cause what has historically been referred to as **chronic Q fever**. In adults, persistent localized infection usually involves the cardiovascular system—native heart valves, especially those with preexisting valvulopathy, prosthetic valves, or other endovascular prostheses. Q fever osteomyelitis is less common but proportionally more common as a manifestation of infection in children. Less common persistent localized *C. burnetii* infections include lymphadenitis, genital infection, and pericarditis.

#### Primary (Acute) Q Fever

Acute Q fever develops approximately 3 weeks (range: 14–39 days) after exposure to the causative agent. The severity of illness in children ranges from subclinical infection to a systemic illness of sudden onset characterized by high fever, severe frontal headache, nonproductive cough, chest pain, vomiting, diarrhea, abdominal pain, arthralgias, and myalgias. Approximately 40% of children with acute Q fever present with fever, 25% with pneumonia or an influenza-like illness, >10% with meningoenzephalitis, and >10% with myocarditis. Other manifestations include pericarditis, hepatitis, hemophagocytic lymphohistiocytosis, rhabdomyolysis, and a hemolytic uremic–like syndrome. Rash, ranging from maculopapular to purpuric lesions, is an unusual finding in adults with Q fever but is observed in approximately 50% of pediatric patients. Rigors and night sweats are common in adults with Q fever and occur less often in children. Prominent clinical findings that can create diagnostic confusion include fatigue, vomiting, abdominal pain, and meningismus. Hepatomegaly and splenomegaly may be detected in some patients.

Routine laboratory investigations in pediatric acute Q fever are usually normal but can reveal mild leukocytosis and thrombocytopenia. Up to 85% of children have modestly elevated serum hepatic transaminase levels that usually normalize within 10 days. Hyperbilirubinemia is uncommon in the absence of complications. C-reactive protein may not be elevated in pediatric Q fever. Chest radiographs are abnormal in nearly 30% of all patients; in children, the most common findings include single or multiple bilateral infiltrates with reticular markings in the lower lobes.

Primary Q fever in children is usually a self-limited illness, with fever persisting for only 7–10 days compared with 2–3 weeks in adults. However, severe manifestations of acute illness, such as myocarditis requiring cardiac transplantation, meningoenzephalitis, pericarditis, hemophagocytosis, thrombosis with antiphospholipid antibody syndrome, and a relapsing febrile illness lasting for several months, have been reported.

### Persistent Localized Q Fever Infection

The risk for developing persistent localized Q fever infection, historically called *chronic Q fever*, is strongly correlated with advancing age and underlying conditions such as cardiac valve damage or immunosuppression; persistent localized Q fever infection is rarely diagnosed in children. A review identified only five cases of Q fever endocarditis and six cases of osteomyelitis among children, none of whom had known predisposing immune deficiencies. Four of the five cases of endocarditis occurred in children with underlying congenital heart abnormalities and involved the aortic, pulmonary, and tricuspid valves. Four of the six children with Q fever osteomyelitis had a prior diagnosis or clinical course consistent with idiopathic chronic recurrent multifocal osteomyelitis. A long interval before diagnosis and lack of high fever are common in pediatric cases of persistent localized Q fever infection—historically chronic Q fever.

Although Q fever endocarditis often results in death (23–65% of cases) in adults, mortality has not been reported for children. Endocarditis associated with persistent or chronic Q fever can occur months to years after acute infection and can occur in the absence of recognized acute Q fever and in the absence of clinically recognized valvulopathy. Chronic hepatitis has also been reported.

### LABORATORY FINDINGS

Laboratory features in children with chronic Q fever are poorly documented; adult patients often have an erythrocyte sedimentation rate of >20 mm/hr (80% of cases), hypergammaglobulinemia (54%), and hyperfibrinogenemia (67%). In children, the presence of rheumatoid factor in >50% of cases and circulating immune complexes in nearly 90% suggest an autoimmune process. The presence of antiplatelet antibodies, anti-smooth muscle antibodies, antimitochondrial antibodies, circulating anticoagulants, positive direct Coombs tests, and antiphospholipid antibodies also suggest this possibility.

### DIAGNOSIS AND DIFFERENTIAL DIAGNOSIS

Although uncommonly diagnosed, Q fever in children most often mimics other childhood respiratory infections. It should be considered in children who have an influenza-like illness, lower or upper respiratory tract infection, fever of unknown origin, myocarditis, meningoenzephalitis, culture-negative endocarditis, or recurrent osteomyelitis and who live in rural areas or who are in close contact with domestic livestock, cats, or animal products.

The diagnosis of primary (acute) Q fever is most easily and commonly confirmed by testing acute and convalescent sera (3–6 weeks apart), which show a fourfold increase in indirect fluorescent immunoglobulin G antibody titers to phase II *C. burnetii* antigens. The phase II antibody response to *C. burnetii* appears first and is higher than the phase I antibody response. Phase II immunoglobulin G antibodies can remain elevated for months to years, regardless of initial symptoms or lack thereof. In contrast, persistent localized (chronic) Q fever is characterized by a phase I immunoglobulin G antibody titer greater than 800 that is sustained for 6 months or more, such as occurs with Q fever endocarditis in patients with valvular heart disease. Cross-reactions with antibodies to *Legionella* and *Bartonella* can occur.

Although culture has been considered the gold standard, sensitivity (compared with a composite standard including serology and polymerase chain reaction [PCR]) is low. *C. burnetii* has been cultivated in tissue culture cells, which can become positive within 48 hours, but isolation and antimicrobial susceptibility testing of *C. burnetii* should be attempted only in specialized biohazard facilities. Testing by PCR can be performed on blood, serum, and tissue samples and is available only in some public health, reference, or research laboratories. PCR has been helpful in patients with equivocal titers, as occurs with early infection. PCR usually remains positive for 7–10 days after acute infection. Sensitivity has been improved by real-time methods and the use

of repeated sequences as targets. Immunohistochemical staining has also been used but is not readily available. PCR should be performed either before or shortly after initiation of treatment. PCR can also confirm a serologic diagnosis of endocarditis in untreated patients. Genotyping has aided epidemiologic investigations to confirm the source of infection. The differential diagnosis depends on the clinical presentation. In patients with respiratory disease, *Mycoplasma pneumoniae*, *Chlamydia pneumoniae*, legionellosis, psittacosis, and Epstein-Barr virus infection should be considered. In patients with granulomatous hepatitis, tuberculous and nontuberculous mycobacterial infections, salmonellosis, visceral leishmaniasis, toxoplasmosis, Hodgkin disease, monocytic ehrlichiosis, brucellosis, cat scratch disease (*Bartonella henselae*), or autoimmune disorders such as sarcoidosis should be considered. **Culture-negative endocarditis** suggests infection with *Brucella*, *Bartonella*, HACEK organisms (*Haemophilus*, *Aggregatibacter*, *Cardiobacterium hominis*, *Eikenella corrodens*, *Kingella*), partially treated bacterial endocarditis, nonbacterial endocarditis, or potentially noninfectious inflammatory conditions, including chronic recurrent multifocal osteomyelitis and antiphospholipid syndrome.

### TREATMENT

Selection of an appropriate antimicrobial regimen for children is difficult owing to the lack of rigorous studies, the limited therapeutic window for drugs that are known to be efficacious, and the potential length of therapy required to preclude relapse.

Most pediatric patients with Q fever have a self-limited illness that is identified only on retrospective serologic evaluation. However, to prevent potential complications, treatment should be considered for patients who present with suspected acute Q fever within 3 days of onset of symptoms, because therapy started more than 3 days after the onset of illness has little effect on the course of acute Q fever. Early treatment is effective in shortening illness duration and severity. Doxycycline (100 mg orally 2 times/day for children 8 years or older or 4 mg/kg/day orally divided 2 times/day for children younger than 8 years, maximum: 200 mg/day, for 14 days) is the drug of choice. Doxycycline may cause permanent tooth discoloration for children younger than 8 years if used repeatedly but is generally safe when used for short courses. Children younger than 8 years with mild illness, pregnant adolescents, and patients allergic to doxycycline can be treated with trimethoprim-sulfamethoxazole.

For persistent focal Q fever, especially endocarditis and mostly in adults, therapy for 18-36 months is mandatory, because treatment is more difficult and relapses can occur despite appropriate therapy. The current recommended regimen for Q fever endocarditis is a combination of doxycycline and hydroxychloroquine for 18 months or longer. For patients with heart failure, valve replacement could be necessary.

### PREVENTION

Recognition of the disease in livestock or other domestic animals should alert communities to the risk for human infection by aerosol exposures within 15 km. Milk from infected herds must be pasteurized at temperatures sufficient to destroy *C. burnetii*. *C. burnetii* is resistant to significant environmental conditions but can be inactivated with a solution of 1% Lysol, 1% formaldehyde, or 5% hydrogen peroxide. Special isolation measures are not required because person-to-person transmission is rare, except when others are exposed to the placenta of an infected patient. A vaccine is available and provides protection against Q fever for at least 5 years in abattoir workers; however, it is not licensed in the United States. Prospective studies of vaccination in children at high risk are needed. Clusters of cases resulting from intense natural exposures, such as in slaughterhouses or on farms, are well documented. Clusters of cases that occur in the absence of such an exposure should be investigated as potential sentinel events for bioterrorism.

Visit Elsevier eBooks+ at eBooks.Health.Elsevier.com for Bibliography.

## Section 12

# Fungal Infections

### Chapter 279

## Principles of Antifungal Therapy

William J. Steinbach

Invasive fungal infections are a major cause of morbidity and mortality in the growing number of immunocompromised children. The antifungal armamentarium has markedly increased in recent years (Tables 279.1 and 279.2).

### POLYENES

#### Amphotericin B

The prototype of the oldest antifungal class, the polyene macrolides, is amphotericin B deoxycholate. Amphotericin B was once the preferred treatment for most invasive fungal infections and the standard of comparison for all newer antifungal agents. Amphotericin B is so named because it is amphoteric, forming soluble salts in both acidic and basic environments. However, because of its insolubility in water, amphotericin B for clinical use is actually amphotericin B mixed with the detergent deoxycholate. Amphotericin B binds to ergosterol, the major sterol found in fungal cytoplasmic membranes, and acts by creating transmembrane channels. The fungicidal activity is the result of a damaged barrier and subsequent cell death through leakage of essential nutrients from the fungal cell.

Amphotericin B is released from its carrier and distributes efficiently with lipoproteins and is then taken up preferentially by organs of the reticuloendothelial system. After an initial 24- to 48-hour distributional half-life, there is very slow release and a subsequent terminal elimination half-life of up to 15 days. In addition to conventional amphotericin B deoxycholate, two fundamentally different lipid-associated formulations are currently available that offer the advantage of an increased daily dosage of the parent drug, better delivery to the primary reticuloendothelial organs (lungs, liver, spleen), and reduced toxicity. Amphotericin B lipid complex (ABLC) is a tightly packed ribbon-like structure of a bilayered membrane, and liposomal amphotericin B (L-amphotericin B) consists of small uniformly sized vesicles of a lipid bilayer of amphotericin B. Lipid formulations of amphotericin B generally have a slower onset of action, presumably owing to the required disassociation of free amphotericin B from the lipid vehicle. The ability to safely administer higher daily doses of the parent drugs improves their efficacy, comparing favorably with amphotericin B deoxycholate but with less toxicity. Lipid formulations have the added benefit of increased tissue concentrations compared with conventional amphotericin B, specifically in the liver, lungs, and spleen. Tolerance to amphotericin B deoxycholate is limited by its acute and chronic toxicities. In addition to interacting with fungal ergosterol, the drug also interacts with cholesterol in human cell membranes, likely accounting for its toxicity. Up to 80% of patients receiving amphotericin B develop either infusion-related toxicity or nephrotoxicity, especially with concomitant therapy with nephrotoxic drugs such as aminoglycosides, vancomycin, cyclosporine, or tacrolimus. Renal function usually returns to normal after cessation of amphotericin B, although permanent renal impairment can occur after larger doses. Amphotericin B nephrotoxicity is generally less severe in infants and children than in adults, likely because of the more rapid clearance of the drug in children. Lipid formulations appear to stabilize

**Table 279.1** Suggested Dosing of Antifungal Agents in Children and Neonates

DRUG	FORMULATIONS	SUGGESTED PEDIATRIC DOSAGE	COMMENTS
Amphotericin B deoxycholate	IV	1 mg/kg/day	Generally less toxicity in children than adults; do not start with smaller test doses
Lipid amphotericin B formulations	IV	5 mg/kg/day	Generally, all lipid formulations are dosed the same; there is no clear indication of one formulation over another for clinical efficacy
Fluconazole	IV, PO	12 mg/kg/day	Loading dose (25 mg/kg) is recommended in neonates based on pharmacokinetic simulations and likely suggested in children, but insufficiently studied
Itraconazole	PO	2.5 mg/kg/dose bid	Divide dosage twice daily in children; follow trough levels
Voriconazole	IV, PO	8 mg/kg/dose bid IV maintenance; 9 mg/kg/dose bid oral maintenance	Linear pharmacokinetics in children requires higher dosing than in adults; 9 mg/kg/dose bid IV loading, followed by maintenance dosing; follow trough levels carefully
Posaconazole	IV, PO	At least 18 mg/kg/day divided tid for oral suspension; IV and new powder for oral suspension 6 mg/kg/day once daily (given bid as a loading dose on first day)	Dosage unclear in children at present In adults, max dosage for oral suspension is 800 mg/day, and optimally divide this into 2 or 3 doses; follow trough levels; adult dosing for IV and extended-release tablet is 300 mg twice on first day, then 300 mg once daily
Isavuconazole	PO, IV	10 mg/kg (q8h on days 1 and 2 and then once daily thereafter)	Adult dosing for IV and tablet is 200 mg 3 times on first day, then 200 mg once daily
Micafungin	IV	2-10 mg/kg/day	Highest dosages in neonates (10 mg/kg/day) and lower dosages in children; >8yr of age, use adult dosage
Anidulafungin	IV	1.5 mg/kg/day	Loading dose of 3 mg/kg/day
Caspofungin	IV	50 mg/m <sup>2</sup> /day; neonates 25 mg/m <sup>2</sup> /day	Load with 70 mg/m <sup>2</sup> /day, then 50 mg/m <sup>2</sup> /day as maintenance dosage

amphotericin B in a self-associated state so that it is not available to interact with the cholesterol of human cellular membranes.

A clinical trial comparing L-amphotericin B at doses of 3 mg/kg/day versus 10 mg/kg/day found no efficacy benefit for the higher dose and only greater toxicity. Therefore it is generally not recommended to use any lipid amphotericin B preparations at very high dosages (>5 mg/kg/day), although some experts report using higher dosing in very difficult infections where a lipid amphotericin B formulation is the first-line therapy (e.g., mucormycosis).

## PYRIMIDINE ANALOGS

### 5-Fluorocytosine

5-Fluorocytosine (5-FC) is a fluorinated analog of cytosine and has antifungal activity resulting from the rapid conversion into 5-fluorouracil (5-FU) within susceptible fungal cells. Clinical and microbiologic antifungal resistance develops quickly to 5-FC monotherapy, so clinicians have reserved it for combination approaches. Fungistatic 5-FC is thought to enhance the antifungal activity of amphotericin B, especially in anatomic sites where amphotericin B penetration is often sub-optimal, such as cerebrospinal fluid (CSF). 5-FC penetrates well into most body sites because it is small, highly water-soluble, and not bound by serum proteins to any great extent. One explanation for the synergy detected with the combination of amphotericin B plus 5-FC is that the membrane-permeabilizing effects of low concentrations of amphotericin B facilitate penetration of 5-FC to the cell interior. 5-FC is only available as an oral formulation in the United States, and the dosage is 150 mg/kg/day in four divided doses.

5-FC can exacerbate myelosuppression in patients with neutropenia, and toxic levels can develop when used in combination with amphotericin B, owing to nephrotoxicity of the amphotericin B and decreased

renal clearance of 5-FC. Routine serum 5-FC level monitoring is warranted in high-risk patients, and levels should be obtained after 3-5 days of therapy, with a goal to achieve a 2-hour postdose peak <100 µg/mL (and ideally 30-80 µg/mL). Levels >100 µg/mL are associated with bone marrow aplasia. Toxicities can include azotemia, renal tubular acidosis, leukopenia, thrombocytopenia, and others and appear in approximately 50% of patients in the first 2 weeks of therapy.

Nearly all clinical studies involving 5-FC for cryptococcal meningitis are combination antifungal protocols with amphotericin B. The use of 5-FC for *Candida* meningitis in premature neonates is discouraged. A study evaluating risk factors and mortality rates of neonatal candidiasis among extremely premature infants showed that infants with *Candida* meningitis who received amphotericin B in combination with 5-FC had a prolonged time to sterilization of the CSF compared with infants receiving amphotericin B monotherapy.

## AZOLES

The azole antifungals inhibit the fungal cytochrome P450<sub>14DM</sub> (also known as *lanosterol 14α-demethylase*), which catalyzes a late step in fungal cell membrane ergosterol biosynthesis. Of the older first-generation, itraconazole has activity against *Aspergillus*, but fluconazole is ineffective against *Aspergillus* and other molds. Second-generation triazoles (voriconazole, posaconazole, and isavuconazole) have an expanded antifungal spectrum of activity, including activity against molds, and generally greater in vitro antifungal activity.

### Fluconazole

Fluconazole is fungistatic, and this activity is not influenced by concentration once the maximal fungistatic concentration is surpassed (concentration independent), in contrast to the concentration-dependent

**Table 279.2** Suggested Antifungals for Specific, More Common Fungal Pathogens

FUNGAL SPECIES	AMP	FLU	ITR	VOR	POS	ISA	FLUC	CMA
<i>Aspergillus calidoustus</i>	++	–	–	–	–	–	–	++
<i>Aspergillus fumigatus</i>	+	–	±	++	+	++	–	+
<i>Aspergillus terreus</i>	–	–	+	++	+	++	–	+
<i>Blastomyces dermatitidis</i>	++	+	++	+	+	+	–	–
<i>Candida albicans</i>	+	++	+	+	+	+	+	++
<i>Candida glabrata</i>	+	–	±	±	±	±	+	±
<i>Candida krusei</i>	+	–	–	+	+	+	+	++
<i>Candida lusitanae</i>	–	++	+	+	+	+	+	+
<i>Candida parapsilosis</i>	++	++	+	+	+	+	+	±
<i>Coccidioides immitis</i>	++	+	++	+	++	+	–	–
<i>Cryptococcus</i> spp.	++	+	+	+	+	+	++	–
<i>Fusarium</i> spp.	±	–	–	++	+	+	–	–
<i>Histoplasma capsulatum</i>	++	+	++	+	+	+	–	–
<i>Mucor</i> spp.	++	–	±	–	+	+	–	–
<i>Scedosporium apiospermum</i>	–	–	±	+	+	+	–	±
<i>Scedosporium prolificans</i>	–	–	±	±	±	±	–	±

AMP, amphotericin B formulations; FLU, fluconazole; ITR, itraconazole; VOR, voriconazole; POS, posaconazole; ISA, isavuconazole; FLUC, flucytosine; CMA, caspofungin, micafungin, or anidulafungin.

++, preferred therapy(ies); +, usually active; ±, variably active; –, usually not active.

fungicidal activity of amphotericin B. Fluconazole is available as either an oral or intravenous form, and oral administration has a bioavailability of approximately 90% relative to intravenous administration. Fluconazole passes into tissues and fluids quite rapidly, probably because of its relatively low lipophilicity and limited degree of binding to plasma proteins. Concentrations of fluconazole are 10- to 20-fold higher in the urine than in blood, making it an ideal agent for treating fungal urinary tract infections. Concentrations in the CSF and vitreous humor of the eye are approximately 80% of those found simultaneously in blood.

Simple conversion of the corresponding adult dosage of fluconazole on a weight basis is inappropriate for pediatric patients. Fluconazole clearance is generally more rapid in children than in adults, with a mean plasma half-life of approximately 20 hours in children and approximately 30 hours in adult patients. Therefore to achieve comparable exposure in pediatric patients, the daily fluconazole dosage needs to be essentially doubled. Correct pediatric fluconazole dosages should be proportionately higher than adult dosages, generally 12 mg/kg/day. In neonates, the volume of distribution is significantly greater and more variable than in infants and children, and doubling the dosage for neonatal patients is necessary to achieve comparable plasma concentrations. The increased volume of distribution is thought to be the result of the larger amount of body water found in the total body volume of neonates. A pharmacokinetic study in premature infants suggests that maintenance fluconazole dosages of 12 mg/kg/day are necessary to achieve exposures similar to those in older children and adults. In addition, a loading dose of 25 mg/kg in neonates has achieved steady-state concentrations sooner. Although a fluconazole loading dose has

been studied in adult and neonatal patients, this approach has never been formally studied in children, yet makes clinical sense. Side effects of fluconazole are uncommon but generally include gastrointestinal upset (vomiting, diarrhea, nausea) and skin rash.

Fluconazole plays an important role in the treatment of invasive candidiasis. Consensus guidelines suggest that use of the fungistatic fluconazole for invasive candidiasis is acceptable as step-down therapy after a good clinical response to initial therapy with an echinocandin. Other clinical scenarios for fluconazole include patients who are not critically ill and who are considered unlikely to have a fluconazole-resistant *Candida* species. Although most isolates of *Candida albicans* remain susceptible to fluconazole, for certain *Candida* species, fluconazole is not an ideal agent: *C. krusei* is generally resistant, and *C. glabrata* is often resistant. There is no confirmed role for combination antifungal therapy with fluconazole and another antifungal against invasive candidiasis.

Prophylaxis with fluconazole to prevent neonatal candidiasis remains a controversial topic. In the first prospective, randomized double-blind trial of 100 infants with birthweights <1,000 g, infants who received fluconazole for 6 weeks had a decrease in fungal colonization and a decrease in the development of invasive fungal infection (0% vs 20%) compared with placebo. Other studies have yielded similarly encouraging results and have demonstrated that use of fluconazole prophylaxis for 4-6 weeks in high-risk infants does not increase the incidence of fungal colonization and infections caused by natively fluconazole-resistant *Candida* species. A more recent large trial studied fluconazole prophylaxis in extremely low birthweight infants in nurseries with a lower incidence of candidiasis and found that fluconazole



prophylaxis led to a decreased incidence of candidiasis but had no effect on mortality. The universal implementation of such a strategy across nurseries is discouraged, because the rate of *Candida* infections varies greatly among centers. Consensus guidelines now recommend fluconazole prophylaxis only in centers with high rates (>10%) of neonatal candidiasis.

### Itraconazole

Compared to fluconazole, itraconazole has the benefit of antifungal activity against *Aspergillus* species but comes with several practical constraints, such as erratic oral absorption in high-risk patients and significant drug interactions. These pharmacokinetic concerns have been addressed with a better-absorbed oral solution to replace the unpredictable capsules used earlier. Itraconazole has a high volume of distribution and accumulates in tissues, and tissue-bound levels are probably more clinically relevant to infection treatment than serum levels. Dissolution and absorption of itraconazole are affected by gastric pH. Patients with achlorhydria or taking H<sub>2</sub>-receptor antagonists might demonstrate impaired absorption, and co-administration of the capsule with acidic beverages such as colas or cranberry juice can enhance absorption. Administration with food significantly increases the absorption of the capsule formulation, but the oral suspension with a cyclodextrin base is better absorbed on an empty stomach.

Side effects are relatively few and include nausea and vomiting (10%), elevated transaminases (5%), and peripheral edema. There have been reports in adults of development of cardiomyopathy. Because of important drug interactions, prior or concurrent use of rifampin, phenytoin, carbamazepine, and phenobarbital should be avoided.

Itraconazole has its largest role in treating less serious infections with endemic mycoses (histoplasmosis, coccidioidomycosis, and blastomycosis). The plethora of drug interactions make itraconazole a concern in complex patients receiving other medications. As with most azole antifungals, monitoring itraconazole serum levels is a key principle in management (generally itraconazole trough levels should be 1–2 µg/mL; trough levels >5 µg/mL may be associated with increased toxicity). Concentrations should be checked after 5 days of therapy to ensure adequate drug exposure. When measured by high-pressure liquid chromatography, both itraconazole and its bioactive hydroxyitraconazole metabolite are reported, the sum of which should be considered in assessing drug levels.

### Voriconazole

Voriconazole is a second-generation triazole and a synthetic derivative of fluconazole. Voriconazole generally has the spectrum of activity of itraconazole and the high bioavailability of fluconazole. Importantly, it is fungicidal against *Aspergillus* and fungistatic against *Candida*. It is extensively metabolized by the liver and has approximately 90% oral bioavailability in adults but appears to be closer to 50–60% bioavailability in children. The cytochrome P450 2C19 (CYP2C19) enzyme appears to play a major role in the metabolism of voriconazole, and polymorphisms in CYP2C19 are associated with slow voriconazole metabolism. As many as 20% of non-Indian Asians have low CYP2C19 activity and develop voriconazole levels as much as fourfold higher than those in homozygous subjects, leading to potentially increased toxicity.

Voriconazole is available as an oral tablet, an oral suspension, and an intravenous solution. In adults, voriconazole exhibits nonlinear pharmacokinetics, has a variable half-life of approximately 6 hours with large interpatient variation in blood levels, and achieves good CSF penetration. In contrast to the situation in adults, elimination of voriconazole is linear in children. A multicenter safety, population pharmacokinetic study of intravenous voriconazole dosages in immunocompromised pediatric patients showed that body weight was more influential than age in accounting for the observed variability in voriconazole pharmacokinetics, and voriconazole needs to be dosed higher in pediatric patients than in adult patients. Adult patients load with 6 mg/kg/dose and then transition to a maintenance dosage of 4 mg/kg/dose, but children should begin and continue with 9 mg/kg/dose intravenously (see Table 279.1) and continue maintenance dosing at 8 mg/kg/

dose. This need for an increased dosage in treating children is crucial to understand and is mandated by the fundamentally different pharmacokinetics of this drug in pediatric patients. Obtaining voriconazole serum levels (to achieve ≥2 µg/mL) is critical for therapeutic success. Oral voriconazole is best absorbed on an empty stomach. Generally a trough level greater than the minimum inhibitory concentration (MIC) of the infecting organism is preferred, and very high voriconazole levels have been associated with toxicity (generally >6 µg/mL). However, many studies have shown an inconsistent relationship between dosing and levels, highlighting the need for close monitoring after the initial dosing scheme and then dose adjustment as needed in the individual patient. Trough levels should be monitored approximately 5 days after initiation of therapy and repeated the following week to confirm the patient remains in the therapeutic range or repeated 4 days after change of dose. The main side effects of voriconazole include reversible dosage-dependent visual disturbances (increased brightness, blurred vision) in as many as one third of treated patients, elevated hepatic transaminases with increasing dosages, and occasional skin reactions likely caused by photosensitization. In some rare long-term (mean of 3 years of therapy) cases, this voriconazole phototoxicity has developed into cutaneous squamous cell carcinoma. Discontinuing voriconazole is recommended in patients experiencing chronic phototoxicity.

The largest prospective clinical trial of voriconazole as primary therapy for invasive aspergillosis compared initial randomized therapy with voriconazole versus amphotericin B and demonstrated improved response and survival with voriconazole over amphotericin B. **Voriconazole is guideline-recommended as the preferred primary therapy against invasive aspergillosis.** Voriconazole also has a role in treating candidiasis, but its fungistatic nature makes it often less than ideal for treating critically ill or neutropenic patients where the fungicidal echinocandin antifungals are preferred.

### Posaconazole

Posaconazole is a second-generation triazole that is a derivative of itraconazole and is currently available as an oral suspension, an intravenous formulation, and a delayed-release tablet. The antimicrobial spectrum of posaconazole is similar to that of voriconazole; however, the former is active against mucormycosis, and voriconazole is not active against these particular mold infections.

Effective absorption of the less desirable oral suspension strongly requires taking the medication with food, ideally a high-fat meal; taking posaconazole on an empty stomach will result in approximately one fourth of the absorption as in the fed state, emphasizing the importance of diet to increase serum levels of oral suspension posaconazole (the opposite of voriconazole). Posaconazole exposure is maximized with acidic beverages, administration in divided doses, and the absence of proton pump inhibitors. The tablet formulation has much better absorption because of its delayed release in the small intestine, but absorption will still be slightly increased with food. If the patient can take the large-sized tablets, the delayed-release tablet is the preferred form because of the ability to easily obtain higher and more consistent drug levels. Importantly, the delayed-release tablet cannot be broken for use due to its chemical coating. As a result of the low pH (<5) of IV posaconazole, a central venous catheter is required for administration. The IV formulation contains only slightly lower amounts of the cyclodextrin vehicle than voriconazole, so similar theoretical renal accumulation concerns exist. Posaconazole causes transient hepatic reactions, including mild to moderate elevations in liver transaminases, alkaline phosphatase, and total bilirubin.

In adult patients, dosages of the oral suspension at >800 mg/day do not result in increased serum levels, and division of daily dosing into three or four doses/day results in greater serum levels than a once- or twice-daily dosing scheme when using the oral suspension. The pediatric oral suspension dose recommended by some experts for treating invasive disease is estimated to be at least 18 mg/kg/day divided 3 times daily, but even that dose did not achieve target levels when studied. A study with a new pediatric formulation for suspension, essentially the tablet form that is able to be suspended, showed a dose of 6 mg/

kg (given twice a day as a loading dose on the first day and then once daily) achieved target exposures necessary for antifungal prophylaxis, with a safety profile similar to adult patients. A subsequent study suggested that posaconazole dosing for the delayed-release tablets and IV formulation requires greater daily doses for children <13 years old. Pediatric dosing with the current IV or extended-release tablet dosing is not yet fully defined, but adolescents can likely follow the adult dosing schemes. Similar to itraconazole and voriconazole, posaconazole should be monitored with trough levels (to achieve  $\geq 1$   $\mu\text{g/mL}$  for treatment and  $\geq 0.07$   $\mu\text{g/mL}$  for prophylaxis).

In an international randomized, single-blinded study of posaconazole versus fluconazole or itraconazole in neutropenic patients undergoing chemotherapy for acute myelogenous leukemia or myelodysplastic syndromes, posaconazole was superior in preventing invasive fungal infections. Another multisite international randomized, double-blinded study in patients with allogeneic hematopoietic stem cell transplantation and graft versus host disease showed that posaconazole was not inferior to fluconazole in the prevention of invasive fungal infections. **Posaconazole is approved for prophylaxis against invasive fungal infections but has shown great efficacy in clinical experience with recalcitrant mold infections.**

In patients with chronic granulomatous disease (CGD) and proven invasive fungal infection refractory to standard therapy, posaconazole was proved to be well tolerated and quite effective and is the preferred agent against invasive aspergillosis in this patient population.

### Isavuconazole

Isavuconazole is a triazole that was FDA approved in 2015 for treatment of invasive aspergillosis and invasive mucormycosis with oral (capsules only) and IV formulations. Isavuconazole has an antifungal spectrum similar to that of voriconazole and some activity against *Zygomycetes* such as mucormycosis (yet potentially not as potent against *Zygomycetes* as posaconazole). A phase 3 clinical trial in adult patients demonstrated noninferiority versus voriconazole against invasive aspergillosis and other mold infections, whereas another study showed good clinical activity against mucormycosis. Isavuconazole is dispensed as the prodrug isavuconazonium sulfate. Dosing in adult patients is loading with isavuconazole 200 mg (equivalent to 372-mg isavuconazonium sulfate) every 8 hours for 2 days (6 doses), followed by 200 mg once daily for maintenance dosing. The half-life is long (>5 days), there is 98% bioavailability in adults, and there is no reported food effect with oral isavuconazole. Unlike voriconazole, the IV formulation does not contain the vehicle cyclodextrin, possibly making it more attractive in patients with renal failure. Early experience suggests a much lower rate of photosensitivity and skin disorders as well as visual disturbances compared with voriconazole. A recently completed pediatric pharmacokinetic study reported that a dose of 10 mg/kg (q8h on days 1 and 2 and once daily thereafter) resulted in similar exposures and safety as seen in adults.

## ECHINOCANDINS

The echinocandins are a class of antifungals that interfere with cell wall biosynthesis by noncompetitive inhibition of 1,3- $\beta$ -D-glucan synthase, an enzyme present in fungi but absent in mammalian cells. 1,3- $\beta$ -glucan is an essential cell wall polysaccharide and provides structural integrity for the fungal cell wall. Echinocandins are generally fungicidal in vitro against *Candida* species, although not as rapidly as amphotericin B, and are fungistatic against *Aspergillus*. As a class, these agents are not metabolized through the CYP enzyme system, lessening some of the drug interactions and side effects seen with the azole class. The echinocandins appear to have a prolonged and dosage-dependent fungicidal antifungal effect on *C. albicans* compared with the fungistatic fluconazole. Three compounds in this class (caspofungin, micafungin, and anidulafungin) are FDA approved for use, but there are others (rezafungin) in late-stage clinical trials. Owing to the large size of the molecules, the current echinocandins are only available in an intravenous formulation. Because 1,3- $\beta$ -glucan is a selective target present only in fungal cell walls and not in mammalian cells, drug-related toxicity is

minimal, with no apparent myelotoxicity or nephrotoxicity with the agents. **The echinocandins are the preferred primary therapy for invasive candidiasis.**

### Caspofungin

Caspofungin is administered to adults as a 70-mg loading dose followed by a daily maintenance 50-mg dosage. Caspofungin has been evaluated at double the recommended dosage (100 mg/day in adults) with no adverse effects, and it is unclear if higher dosage of this relatively safe agent results in greater clinical efficacy. At present there is no known maximum tolerated dosage and no toxicity-determined maximum length of therapy for caspofungin.

Pharmacokinetics are slightly different in children, with caspofungin levels lower in smaller children and with a reduced half-life. A study evaluated the pharmacokinetics of caspofungin in children with neutropenia and showed that in patients receiving 50 mg/m<sup>2</sup>/day (maximum, 70 mg/day), the levels were similar to those in adults receiving 50 mg/day and were consistent across age ranges. In this study, weight-based dosing (1 mg/kg/day) was suboptimal when compared with body surface area regimens, so caspofungin should be appropriately dosed in children as a loading dose of 70 mg/m<sup>2</sup>/day, followed by daily maintenance dosing of 50 mg/m<sup>2</sup>/day.

Echinocandins like caspofungin are guideline-recommended initial therapy for invasive candidiasis but should be used against invasive aspergillosis only in the setting of potential combination therapy or for resistant or refractory disease. In a multicenter trial of patients with invasive candidiasis, 73% of patients who received caspofungin had a favorable response at the end of therapy compared with 62% in the amphotericin B group. Importantly, caspofungin treatment performed equally well to amphotericin B treatment for all the major *Candida* species. Earlier studies suggested that some infections with *C. parapsilosis* do not potentially clear as effectively with an echinocandin, but the echinocandins are still preferred empiric therapy against invasive candidiasis. Caspofungin was also evaluated against L-amphotericin B in the empirical treatment of patients with persistent fever and neutropenia and was not inferior to liposomal amphotericin B. A study in children with acute myeloid leukemia demonstrated that caspofungin prophylaxis resulted in a significantly lower incidence of invasive fungal disease compared with fluconazole prophylaxis. A study comparing caspofungin with triazole prophylaxis in pediatric allogeneic hematopoietic stem cell transplant recipients found no difference in the agents.

Caspofungin in newborns (25 mg/m<sup>2</sup>/day) has been used for refractory cases of disseminated candidiasis. Neonates with invasive candidiasis are at high risk for central nervous system involvement; it is not known if the dosages of caspofungin studied provide sufficient exposure to penetrate the central nervous system at levels necessary to cure infection. Therefore caspofungin is not recommended as standard monotherapy in neonatal candidiasis.

### Micafungin

The pharmacokinetics of micafungin have been evaluated in children and young infants. An inverse relation between age and clearance was observed, where mean systemic clearance was significantly greater and mean half-life was significantly shorter in patients 2-8 years of age compared to patients 9-17 years of age. Therefore dosing of micafungin in children is age-related and needs to be higher in children <8 years old. Doses in children are generally 2 mg/kg/day, with higher doses needed for neonates, infants, and younger patients, and with a dose of 10 mg/kg/day for preterm neonates. Several pharmacokinetic studies in term and preterm infants have shown that micafungin has a shorter half-life and a more rapid rate of clearance in infants compared with published data in older children and adults. Adult micafungin dosing (100 or 150 mg once daily) is to be used in patients who weigh more than 40 kg. Unlike the other echinocandins, a loading dose is not required for micafungin.

Clinical trials, including those of micafungin used for treatment of invasive candidiasis, as well as prophylaxis studies in patients after

stem cell transplantation, have demonstrated fewer adverse events compared with liposomal amphotericin B and fluconazole. The most common adverse events experienced by these patients are related to the gastrointestinal tract (nausea, diarrhea). Hypersensitivity reactions associated with micafungin have been reported, and liver enzymes are elevated in 5% of patients receiving this agent. Hyperbilirubinemia, renal impairment, and hemolytic anemia related to micafungin use have also been identified in postmarketing surveillance of the drug.

Micafungin at dosages of 100 and 150 mg daily was also noninferior to caspofungin in an international, randomized, double-blinded study of adults with candidemia or invasive candidiasis and was found to be superior to fluconazole in the prevention of invasive fungal infections in a randomized study of adults undergoing hematopoietic stem cell transplantation.

Of the three drugs within the echinocandin class, micafungin has been the one most extensively studied in children. A pediatric sub-study as part of a double-blind, randomized, multinational trial comparing micafungin (2 mg/kg/day) with liposomal amphotericin B (3 mg/kg/day) as first-line treatment for invasive candidiasis showed similar success for micafungin and liposomal amphotericin B. In general, micafungin was better tolerated than liposomal amphotericin B, as evidenced by fewer adverse events leading to discontinuation of therapy.

### Anidulafungin

Anidulafungin has the longest half-life of all the echinocandins (approximately 18 hours). In a study of 25 neutropenic children receiving anidulafungin as empirical therapy, four patients in the group receiving 0.75 mg/kg/day experienced adverse events such as facial erythema and rash, elevation in serum blood urea nitrogen, and fever and hypotension. In a pharmacokinetic study in neonates and young infants, anidulafungin exposures comparable to adults were achieved with doses of 1.5 mg/kg/day (3 mg/kg loading dose). One infant in this cohort supported by extracorporeal membrane oxygenation achieved the lowest exposure, which suggests that dose adjustments are required in this population. The adult dose for invasive candidiasis is a loading dose of 200 mg on the first day, followed by 100 mg daily. An open-label study of invasive candidiasis in children showed similar efficacy and minimal toxicity, comparable to the other echinocandins. An additional study showed similar and acceptable pharmacokinetics in patients 1 month to 2 years of age.

### Ibrexafungerp

Ibrexafungerp was approved in 2021 for adults with vulvovaginal candidiasis after two phase 3 studies (VANISH203 and VANISH 306). This is the first new class of antifungals (also called “fungers”). Similar to the echinocandins, ibrexafungerp noncompetitively inhibits  $\beta$ -1,3-glucan synthase and is also fungicidal against *Candida* spp. and *Aspergillus* spp. The binding site on the glucan synthase enzyme is not the same as the echinocandins. Resistance or reduced susceptibility to the echinocandins is largely through two hot-spot pathogenic variants in the *FKS1* gene, whereas many resistance mutations to ibrexafungerp are caused by the *FKS2* gene, and ibrexafungerp does have activity against some echinocandin-resistant isolates. Ibrexafungerp is the first orally available glucan synthase inhibitor and has a long half-life, suggesting once-daily dosing for clinical use. Similar to the echinocandins, initial studies show limited to no distribution to the central nervous system and variable distribution to the eye. In a phase 2 study, ibrexafungerp as step-down therapy after initial echinocandin therapy for invasive candidiasis was well-tolerated and achieved a favorable global response similar to the standard of care. There is an ongoing co-administration study with voriconazole in pulmonary invasive aspergillosis (SCYNERGIA) and an ongoing recurrent vulvovaginal candidiasis study (CANDLE), yet no completed pediatric studies.

Visit Elsevier eBooks+ at eBooks.Health.Elsevier.com for Bibliography.

## Chapter 280

# Candida

Jessica E. Ericson and Daniel K. Benjamin Jr.

Candidiasis encompasses many clinical syndromes that may be caused by several species of *Candida*. Invasive candidiasis (*Candida* infections of the blood and other sterile body fluids) is a leading cause of infection-related mortality in hospitalized immunocompromised patients.

*C. albicans* accounts for most human infections, but *C. parapsilosis*, *C. tropicalis*, *C. krusei*, *C. lusitanae*, *C. glabrata*, and several other species are commonly isolated from hospitalized children. Species identification and susceptibility testing are important owing to increasing frequency of fluconazole resistance and increasing prevalence of non-*albicans* *Candida* species. *C. auris* is an emerging multiresistant invasive pathogen that has a global presence and affects immunocompromised patients; nosocomial spread has been reported.

Treatment of invasive *Candida* infections is complicated by the emergence of non-*albicans* strains. Amphotericin B deoxycholate is inactive against approximately 20% of strains of *C. lusitanae*. Fluconazole is useful for many *Candida* infections but is inactive against all strains of *C. krusei* and 5–25% of strains of *C. glabrata*. Most *Candida* are susceptible to echinocandins, but resistance is occasionally seen, most often among *C. krusei* and *C. glabrata*. **Susceptibility testing of these clinical isolates is recommended.**

## 280.1 Neonatal Infections

Jessica E. Ericson and Daniel K. Benjamin Jr.

*Candida* is a common cause of oral mucous membrane infections (**thrush**) and perineal skin infections (***Candida* diaper dermatitis**) in young infants. Rare presentations include **congenital cutaneous candidiasis**, caused by an ascending infection into the uterus during gestation, and **invasive fungal dermatitis**, a postnatal skin infection resulting in positive blood cultures. Invasive candidiasis is a common infectious complication in the neonatal intensive care unit (NICU) because of improved survival of extremely preterm infants.

### EPIDEMIOLOGY

*Candida* species are a common cause of bloodstream infection in premature infants. The incidence varies greatly by individual NICU. Among centers in the National Institutes of Health–sponsored Neonatal Research Network, the cumulative incidence of candidiasis among infants <1,000 g birthweight ranges from 2% to 28%. Colonization is associated with a significantly increased risk of future invasive *Candida* infection. Up to 10% of full-term infants are colonized as the result of vertical transmission from the mother at birth, with slightly higher rates of colonization in premature infants. Colonization rates increase to >50% among infants admitted to the NICU by 1 month of age. Histamine-2 blockers, corticosteroids, and broad-spectrum antibiotics facilitate *Candida* colonization and overgrowth.

Significant risk factors for neonatal invasive candidiasis include prematurity, low birthweight, exposure to broad-spectrum antibiotics, abdominal surgery, endotracheal intubation, and presence of a central venous catheter.

### PATHOGENESIS

Immunologic immaturity along with an underdeveloped layer of skin, need for invasive measures (endotracheal tubes, central venous catheters), and exposure to broad-spectrum antibiotics places pre-term infants at great risk for invasive candidiasis. Premature infants are also at high risk for spontaneous intestinal perforations and



necrotizing enterocolitis. Both conditions require abdominal surgery, prolonged exposure to broad-spectrum antibiotics, and total parenteral nutrition administration requiring placement of central venous catheters. Each of these factors increases the risk of invasive candidiasis by decreasing the physiologic barriers that protect against invasive infection.

### CLINICAL MANIFESTATIONS

The manifestations of neonatal candidiasis vary in severity from oral thrush and *Candida* diaper dermatitis (see [Chapter 280.2](#)) to invasive candidiasis that can manifest with overwhelming sepsis (see [Chapter 280.3](#)). Signs of invasive candidiasis among premature infants are often nonspecific and include temperature instability, lethargy, apnea, hypotension, respiratory distress, abdominal distention, and thrombocytopenia.

Central nervous system involvement is common and is most accurately described as meningoencephalitis. *Candida* infections involving the central nervous system often result in abscesses, leading to unremarkable cerebrospinal fluid parameters (white blood cell count, glucose, protein) even though central nervous system infection is present. Endophthalmitis is an uncommon complication affecting <5% of infants with invasive candidiasis, but candidemia is associated with an increased risk of severe retinopathy of prematurity. Renal involvement commonly complicates neonatal invasive candidiasis. Renal involvement may be limited to candiduria or can manifest with diffuse infiltration of *Candida* throughout the renal parenchyma or the presence of *Candida* and debris within the collecting system. Because of the poor sensitivity of blood cultures for *Candida*, candiduria should be considered a surrogate marker of candidemia in premature infants. Other affected organs include the heart, bones, joints, liver, and spleen.

### DIAGNOSIS

Mucocutaneous infections are most often diagnosed by direct clinical exam. Scrapings of skin lesions may be examined with a microscope after Gram staining or suspension in KOH. Definitive diagnosis of invasive disease requires histologic demonstration of the fungus in tissue specimens or recovery of the fungus from normally sterile body fluids. Hematologic parameters are sensitive but not specific. Thrombocytopenia occurs in more than 80% of premature infants with invasive candidiasis, but also occurs in 75% of premature infants with gram-negative bacterial sepsis and nearly 50% of infants with gram-positive bacterial sepsis. Blood cultures have very low sensitivity for invasive candidiasis. In a study of autopsy-proven candidiasis in adult patients, the sensitivity of multiple blood cultures for detecting single-organ disease was 28%. Blood culture volumes in infants are often only 0.5–1 mL, making the sensitivity in this population almost certainly lower. Blood culture volume should be maximized as much as possible to increase sensitivity.

Further assessment of infants in the presence of documented candidemia should include ultrasound or computerized tomography of the head to evaluate for abscesses; ultrasound of the liver, kidney, and spleen; cardiac echocardiography; ophthalmologic exam; lumbar puncture; and urine culture. These tests are necessary to determine if more than one body system is infected, which is commonly the case.

### PROPHYLAXIS

NICUs with a high incidence of invasive candidiasis should consider prophylaxis with fluconazole in infants <1,000 g birthweight as a cost-effective method of reducing invasive candidiasis. Twice-weekly fluconazole at 3 or 6 mg/kg/dose decreases rates of both colonization with *Candida* species and invasive fungal infections. Use of this dosing strategy has not been shown to increase the frequency of infections caused by fluconazole-resistant strains, but use of an alternative antifungal class for cases of breakthrough infection is suggested.

### TREATMENT

In the absence of systemic manifestations, **topical antifungal therapy is the treatment of choice for congenital cutaneous candidiasis in**

**full-term infants.** Congenital cutaneous candidiasis in preterm infants can progress to systemic disease, and therefore systemic therapy is warranted in these patients.

Every attempt should be made to **remove or replace central venous catheters** once the diagnosis of candidemia is confirmed. Delayed removal has been consistently associated with increased mortality and morbidity, including poor neurodevelopmental outcomes.

Although no well-powered randomized controlled trials exist to guide the length and type of therapy, **21 days of systemic antifungal therapy from the last positive *Candida* culture is recommended in infants.** Antifungal therapy should be targeted based on susceptibility testing. Amphotericin B deoxycholate has been the mainstay of therapy for systemic candidiasis and is active against both yeast and mycelial forms. Nephrotoxicity, hypokalemia, and hypomagnesemia are common, but amphotericin B deoxycholate is better tolerated in infants than in adult patients. *C. lusitanae*, an uncommon pathogen in infants, is often resistant to amphotericin B deoxycholate. Liposomal amphotericin is associated with worse outcomes in infants and should be used only when urinary tract involvement can reliably be excluded. Fluconazole is often used instead of amphotericin B deoxycholate for treatment of invasive neonatal *Candida* infections because of its effectiveness and low incidence of side effects. It is particularly useful for urinary tract infections, obtaining high concentrations in the urine. A loading dose should be given to obtain therapeutic serum concentrations in a timely manner. Fluconazole is inactive against all strains of *C. krusei* and some isolates of *C. glabrata*. Additionally, in centers where fluconazole prophylaxis is used, another agent, such as amphotericin B deoxycholate, should be used for treatment. The echinocandins have excellent activity against most *Candida* species and have been used successfully in patients with resistant organisms or in whom other therapies have failed. Two trials comparing an echinocandin with amphotericin B deoxycholate were stopped early because of low recruitment but found similar efficacy for the two treatments among the included patients. Several studies have described the pharmacokinetics of antifungals in infants ([Table 280.1](#)).

### PROGNOSIS

Mortality after invasive candidiasis in premature infants has been consistently reported to be around 20% in large studies but can be as high as 50% in infants <1,500 g birthweight. Candidiasis is also associated with poor neurodevelopmental outcomes, chronic lung disease, and severe retinopathy of prematurity.

Visit Elsevier eBooks+ at [eBooks.Health.Elsevier.com](http://eBooks.Health.Elsevier.com) for Bibliography.

## 280.2 Infections in Immunocompetent Children and Adolescents

Jessica E. Ericson and Daniel K. Benjamin Jr.

### ORAL CANDIDIASIS

**Oral thrush** is a superficial mucous membrane infection that affects approximately 2–5% of normal neonates. *C. albicans* is the most commonly isolated species. Oral thrush can develop as early as 7–10 days of age. The use of antibiotics, especially in the first year of life, can lead to recurrent or persistent thrush. It is characterized by pearly white, curdlike material visible on the tongue, palate, and buccal mucosa. Oral thrush may be asymptomatic or can cause pain, fussiness, and decreased feeding, leading to inadequate nutritional intake and dehydration. It is uncommon after 1 year of age but can occur in older children treated with antibiotics. Persistent or recurrent thrush with no obvious predisposing reason, such as recent antibiotic treatment, warrants investigation of an underlying immunodeficiency, especially vertically transmitted HIV infection or a primary congenital immune defect.

Treatment of mild cases might not be necessary. When treatment is warranted, the most commonly prescribed antifungal agent is topical



**Table 280.1** Dosing of Antifungal Agents Studied in Infants\* with Reported Pharmacokinetic (PK) Parameters

DRUG	PK STUDIED IN INFANTS	SUGGESTED DOSE
Amphotericin B deoxycholate	Yes (multiple)	1 mg/kg/day
Amphotericin B lipid complex	Yes (single)	5 mg/kg/day
Liposomal amphotericin B	Yes (single)	5 mg/kg/day
Amphotericin B colloidal dispersion	No	5 mg/kg/day
Fluconazole <sup>†</sup>	Yes (best studied with ~250 infant contributing PK samples)	12 mg/kg/day
Voriconazole	No – drug concentrations reported for a single infant with neonatal candidiasis	
Posaconazole	No – drug concentrations reported for a single infant with cutaneous rhizopus infection	
Micafungin <sup>‡</sup>	Yes (multiple)	10 mg/kg/day
Caspofungin <sup>§</sup>	Yes (single)	50 mg/m <sup>2</sup> /day
Anidulafungin <sup>‡</sup>	Yes (single)	1.5 mg/kg/day

\*Voriconazole and posaconazole dosing have not been investigated in the nursery. Doses are those suggested by experts.

<sup>†</sup>A loading dose of 25 mg/kg of fluconazole is necessary to achieve therapeutic serum and cerebrospinal fluid concentrations in the early days of therapy.

<sup>‡</sup>Micafungin has been studied in infants <120 days of life at this dosage.

<sup>§</sup>Caspofungin and anidulafungin should generally be avoided because dosing sufficient to penetrate brain tissue has not been studied.

nystatin. For recalcitrant or recurrent infections, a single dose of fluconazole may be useful. In breastfed infants, simultaneous treatment of infant and mother with topical nystatin or oral fluconazole may be indicated.

### DIAPER DERMATITIS

Diaper dermatitis is the most common infection caused by *Candida* (see Chapter 707) and is characterized by a confluent erythematous rash with satellite pustules. *Candida* diaper dermatitis often complicates other noninfectious diaper dermatitides and often occurs after a course of oral antibiotics.

A common practice is to presumptively treat any diaper rash that has been present for longer than 3 days with topical antifungal therapy such as nystatin, clotrimazole, or miconazole. If significant inflammation is present, the addition of hydrocortisone 1% may be useful for the first 1-2 days, but topical corticosteroids should be used cautiously in infants because the relatively potent topical corticosteroid can lead to adverse effects. Frequent diaper changes and short periods without diapers are important adjunctive treatments.

### UNGUAL AND PERIUNGUAL INFECTIONS

Paronychia and onychomycosis may be caused by *Candida*, although *Trichophyton* and *Epidermophyton* are more common causes. *Candida* onychomycosis differs from tinea infections by its propensity to involve the fingernails and not the toenails and by the associated paronychia. *Candida* paronychia often responds to treatment consisting of keeping the hands dry and using a topical antifungal agent. Psoriasis and immune dysfunction, including HIV and primary immunodeficiencies, predispose to *Candida* unguinal infections. Unguinal infections often require systemic antifungal therapy. **Once-weekly fluconazole for 4-12 months is an effective treatment strategy with fairly low toxicity.**

### VULVOVAGINITIS

**Vulvovaginitis** is a common *Candida* infection of pubertal and postpubertal female patients. Predisposing factors include pregnancy, use of oral contraceptives, and use of oral antibiotics. Prepubertal children with *Candida* vulvovaginitis usually have a predisposing factor such as

diabetes mellitus or prolonged antibiotic treatment. Clinical manifestations can include pain or itching, dysuria, vulvar or vaginal erythema, and an opaque white or cheesy exudate. More than 80% of cases are caused by *C. albicans*.

***Candida* vulvovaginitis can be effectively treated with either vaginal creams or troches of nystatin, clotrimazole, or miconazole. Oral therapy with a single dose of fluconazole is also effective.**

Visit Elsevier eBooks+ at [eBooks.Health.Elsevier.com](http://eBooks.Health.Elsevier.com) for Bibliography.

## 280.3 Infections in Immunocompromised Children and Adolescents

Jessica E. Ericson and Daniel K. Benjamin Jr.

### ETIOLOGY

*Candida albicans* is the most common cause of invasive candidiasis among immunocompromised pediatric patients and is associated with higher rates of mortality and end-organ involvement than are non-*albicans* species.

### CLINICAL MANIFESTATIONS

#### HIV-Infected Children

Oral thrush and diaper dermatitis are the most common *Candida* infections in HIV-infected children. Besides oral thrush, three other types of oral *Candida* infections can occur in HIV-infected children: atrophic candidiasis, which manifests as a fiery erythema of the mucosa or loss of papillae of the tongue; chronic hyperplastic candidiasis, which presents with oral symmetric white plaques; and angular cheilitis, in which there is erythema and fissuring of the angles of the mouth. Topical antifungal therapy may be effective, but **systemic treatment with fluconazole or itraconazole is usually necessary.** Symptoms of dysphagia or poor oral intake can indicate progression to *Candida* esophagitis, requiring systemic antifungal therapy. In HIV patients, esophagitis can also be caused by cytomegalovirus, herpes simplex virus, reflux, or lymphoma; *Candida* is the most common cause, and *Candida* esophagitis can occur in the absence of thrush.

*Candida* dermatitis and onychomycosis are more common in HIV-infected children. These infections are generally more severe than they are in immunocompetent children and can require systemic antifungal therapy.

### Cancer and Transplant Patients

Fungal infections, especially *Candida* and *Aspergillus* infections, are a significant problem in oncology patients with chemotherapy-associated neutropenia (see Chapter 223). Greater than 5 days of fever during a neutropenic episode is associated with presence of an invasive fungal infection. Accordingly, empirical antifungal therapy should be started if fever and neutropenia persist for 5 or more days. **An echinocandin should be used until sensitivity testing results are available.** High-risk oncology patients warrant prophylaxis against invasive *Candida* infection. Both fluconazole and echinocandins are used for this indication, typically at lower doses than those used for treatment. If an echinocandin is used for prophylaxis, liposomal amphotericin B should be used if empirical treatment becomes warranted.

Bone marrow transplant recipients have a much higher risk of fungal infections because of the dramatically prolonged duration of neutropenia. Voriconazole prophylaxis decreases the incidence of candidemia in bone marrow transplant recipients with the additional benefit over fluconazole of mold prophylaxis. The use of granulocyte colony-stimulating factor reduces the duration of neutropenia after chemotherapy and is associated with decreased risk for candidemia. When *Candida* infection occurs in this population, the lung, spleen, kidney, and liver are involved in more than 50% of cases.

Solid organ transplant recipients are also at increased risk for superficial and invasive *Candida* infections. Studies in liver transplant recipients demonstrate the utility of antifungal prophylaxis with amphotericin B deoxycholate, fluconazole, voriconazole, or caspofungin in high-risk patients (those with prolonged surgical time, comorbidities, recent antibiotic exposure, or bile leak).

### Catheter-Associated Infections

Central venous catheter infections occur most often in oncology patients but can affect any patient with a central catheter. Neutropenia, use of broad-spectrum antibiotics, and parenteral alimentation are associated with increased risk for *Candida* central catheter infection. Treatment typically requires removing or replacing the catheter followed by a 2- to 3-week course of systemic antifungal therapy. **Removal of the central catheter in place at the time of a positive blood culture and use of a peripheral IV or enteral support for at least 48 hours before obtaining central access is advocated.** Removal of the original catheter followed by immediate replacement with a new central catheter in a different anatomic location is acceptable if an interval without central access is not feasible. Delays in catheter removal are associated with increased risks of metastatic complications and death.

### DIAGNOSIS

The diagnosis is often presumptive in neutropenic patients with prolonged fever because positive blood cultures for *Candida* occur only in a minority of patients who are later found to have disseminated infection. If isolated, *Candida* grows readily on routine blood culture media, with  $\geq 90\%$  of positive cultures identified within 72 hours. CT scan may demonstrate findings consistent with invasive fungal infection but also is limited by nonspecific findings and false negatives. The role of screening by CT scan has not been well defined. In high-risk patients, serial serum assays for (1,3)- $\beta$ -D-glucan, a polysaccharide component of the fungal cell wall, may contribute to the diagnosis of invasive *Candida* infection. However, this test is not

**Table 280.2** Dosing of Antifungal Agents in Children Older Than 1 Year of Age for Treatment of Invasive Disease

DRUG	SUGGESTED DOSE
Amphotericin B deoxycholate	1 mg/kg/day
Amphotericin B lipid complex	5 mg/kg/day
Liposomal amphotericin B	5 mg/kg/day
Amphotericin B colloidal dispersion	5 mg/kg/day
Fluconazole <sup>†</sup>	12 mg/kg/day
Voriconazole <sup>*‡</sup>	8 mg/kg every 12 hr
Micafungin	2-4 mg/kg/day
Caspofungin	50 mg/m <sup>2</sup> /day
Anidulafungin	1.5 mg/kg/day

\*Use adult dosages in children older than 12 yr of age for voriconazole and older than 8 yr of age for micafungin.

<sup>†</sup>Loading doses should be used for fluconazole (25 mg/kg), voriconazole (9 mg/kg q 12 × 24 hr), caspofungin (70 mg/m<sup>2</sup>), and anidulafungin (3 mg/kg).

<sup>‡</sup>Dosing should be adjusted based on the results of therapeutic drug monitoring.

sensitive or specific enough to be used without a careful assessment of the limitations of the assay.

### TREATMENT

**Echinocandins are favored as empirical therapy for moderately or severely ill children and for those with neutropenia;** fluconazole is acceptable for those who are infected with a susceptible organism and are less critically ill; amphotericin B products are also acceptable. Definitive antifungal selection should be made based on susceptibility testing results. Fluconazole is not effective against *C. krusei* and some isolates of *C. glabrata*. *C. parapsilosis* has occasional resistance to the echinocandins, but the overall rate is still low. Amphotericin B deoxycholate is inactive against approximately 20% of the strains of *C. lusitanae*, and therefore susceptibility testing should be performed for all strains (Table 280.2). *C. auris*, a species first identified in 2009 that has caused nosocomial infections worldwide, is resistant to most antifungals. An echinocandin should be used until sensitivity results are available.

### PRIMARY IMMUNE DEFECTS

**Chronic mucocutaneous candidiasis** involves *Candida* infections of the oral cavity, esophagus, and/or genital mucosa, as well as involvement of skin and nails, that is recurrent or persistent and difficult to treat. There is a broad spectrum of genetic immune defects associated with chronic mucocutaneous candidiasis mostly related to severe T-cell defects or disorders of interleukin-17 production. Genes or disorders associated with chronic mucocutaneous candidiasis include severe combined immunodeficiency syndrome, NEMO or IKKG deficiency, DOCK8 deficiency, STAT3 deficiency (autosomal dominant hyperimmunoglobulin E syndrome), autoimmune polyendocrinopathy type 1, CARD9 deficiency, *STAT1* gain-of-function mutations, and *IL17RA* mutations.

Primary immunodeficiencies associated with an increased risk of invasive *Candida* infections include severe congenital neutropenia, CARD9 deficiency, chronic granulomatous disease, and leukocyte adhesion deficiency type 1.

Visit Elsevier eBooks+ at [eBooks.Health.Elsevier.com](http://eBooks.Health.Elsevier.com) for Bibliography.

## Chapter 281

***Cryptococcus neoformans*  
and *Cryptococcus gattii***

David L. Goldman

**ETIOLOGY**

More than 30 cryptococcal species have been described; however, 2 species (*Cryptococcus neoformans* and *Cryptococcus gattii*) cause the vast majority of disease in children and adults. Both *C. neoformans* and *C. gattii* are encapsulated, facultative intracellular yeasts that are recognized for their tendency to cause central nervous system (CNS) infection, especially in immunocompromised patients. Although there is significant overlap in the disease caused by these pathogens, there are key differences in epidemiology and clinical presentation, which will be reviewed here. Cryptococcal disease may rarely be caused by other species (e.g., *C. laurentii* and *C. albidus*), especially in immunocompromised individuals (including neonates). These latter species will not be covered in this chapter.

**EPIDEMIOLOGY**

Cryptococcosis is primarily acquired from exposure to contaminated environments. *C. neoformans* is distributed in temperate climates predominantly in soil contaminated with droppings from certain avian species, including pigeons, canaries, and cockatoos. It may also be found on rotting wood, fruits, and vegetables and may be carried by cockroaches. Transmission from pet birds to their owners and via solid organ transplantation of infected organs are uncommon, but have also been described.

Disease secondary to *C. neoformans* occurs primarily in immunocompromised individuals and especially in those with defects in cellular immunity, though apparently normal individuals can also be affected. A large increase in the incidence of cryptococcosis was noted in association with the AIDS epidemic, with disease generally occurring with severe immunosuppression ( $CD4^+$  T cells  $<100/\mu\text{L}$ ). However, since the development of effective antiretroviral therapies (ART), the incidence of AIDS-associated cryptococcosis has decreased dramatically, except in resource-limited areas of the world such as sub-Saharan Africa, where ART is not readily available.

Other risk factors for cryptococcal infection include immunosuppression associated with organ transplantation, diabetes mellitus, renal failure, cirrhosis, corticosteroids, rheumatologic conditions, chemotherapeutics, and immune-modulating monoclonal antibodies (e.g., etanercept, infliximab, and alemtuzumab). In patients who have undergone organ transplantation, cryptococcosis is the third most common fungal infection after candidiasis and aspergillosis. Children with certain primary immunodeficiency diseases may also be at increased risk for cryptococcosis, including those with hyper-IgM syndrome, severe combined immunodeficiency, idiopathic  $CD4^+$  lymphopenia, autoantibodies to granulocyte-macrophage colony-stimulating factor or interferon- $\gamma$ ,  $CD40$  ligand deficiency, and monoMAC syndrome (monocytopenia, B and natural killer cell lymphopenia).

*C. gattii* was initially recognized for its tendency to cause disease in tropical regions, especially among the native peoples of Australasia, where the organism can be found in association with eucalyptus trees. In these regions, affected individuals are typically immunocompetent. *C. gattii* disease has also been observed outside these tropical regions. An outbreak of *C. gattii* disease involving British Columbia and extending into the Pacific Northwest region of the

United States was first recognized in 1999. Affected individuals were typically adults, with disease occurring in both immunocompetent and immunocompromised individuals. However, comorbid conditions were often present, including chronic lung and heart disease. A disproportionate fraction of patients (relative to those infected with *C. neoformans*) presented with pulmonary disease. An incubation period ranging from 2 to 12 months is typical. Thus in the appropriate clinical context, cryptococcosis should be considered in the differential diagnosis of residents of the Pacific Northwest and returning travelers.

Overall, cryptococcosis (both caused by *C. neoformans* and *C. gattii*) is significantly less common in children than in adults. The basis for this discrepancy is poorly understood but could be related to differences in exposure or immune response. Serologic studies suggest that subclinical infection is common among children living in urban areas after age 2 years. Reactivation of latent infection is thought to be an important mechanism of cryptococcal pathogenesis. It is reasonable to postulate that children do not have enough exposures to establish latent infection. During the early AIDS epidemic, the incidence of cryptococcosis in the United States was reported to be on the order of 10% in adults and 1% in children. The largest series of pediatric cryptococcosis comes from South Africa and describes 361 cases, accounting for 2% of the cryptococcosis cases over a 2-year period.

**PATHOGENESIS**

Like many fungi, *C. neoformans* and *C. gattii* survive as saprophytes in the environment. Their virulence characteristics appear to have evolved as an adaptive response to environmental stressors and predators, such as amoeba. Several key factors have been identified, including the ability to grow at 37°C, encapsulation, and melanin production. These same traits allow the organisms to successfully replicate within the host cell. The polysaccharide capsule, which is readily recognized by India ink staining of cerebrospinal fluid (CSF), is an essential virulence factor. Disease secondary to acapsular strains is exceedingly rare. The capsular material exhibits a variety of biologic activities that are important in the pathogenesis of disease, including interference with opsonization, inhibition of chemotaxis, and enhancement of nonprotective type 2 helper T cells (TH2) inflammation. Capsular material is shed by the organism into body tissues and fluids during infection and has been implicated in the development of increased intracranial pressure (ICP), a hallmark of cryptococcal meningoencephalitis. Detection of shed capsular antigen in the serum and CSF is key to the diagnosis of cryptococcal disease. The organism also has the ability to undergo phenotypic variation in response to environmental changes through a variety of mechanisms and can form large giant cells (on the order 20 times its normal size), which are resistant to phagocytosis. Other recognized virulence factors include a secreted urease, which may promote intraphagolysosomal survival.

In most cases, infection is believed to be acquired by inhalation of desiccated forms of the organism, which upon deposition within the lungs are engulfed by alveolar macrophages. An additional portal of entry is the transplantation of infected organs. Furthermore, direct inoculation can lead to cutaneous or ophthalmic infection. After entry into the respiratory tract, infection can be latent and later progress (i.e., reactivate) in the context of immunodeficiency, in a manner similar to tuberculosis. Alternatively, infection can immediately progress and disseminate to produce symptomatic disease. Cell-mediated immunity that leads to macrophage activation is the most important host defense and is associated with granulomatous inflammation, which effectively contains infection. The precise mechanism of entry of this yeast into the CNS is not known, though several mechanisms have been hypothesized, including transit via infected macrophages (Trojan horse model), direct uptake by endothelial cells, and entry between the tight junctions of endothelial cells.



## CLINICAL MANIFESTATIONS

The manifestations of cryptococcal infection reflect the route of inoculation, the infecting strain, and the immune status of the host. Sites of infection include the lung, CNS, blood, skin, bone, eyes, and lymph nodes.

### Meningitis/Meningoencephalitis

CNS disease is the most commonly recognized manifestation of cryptococcosis. The disease is characteristically subacute or chronic (evolving over weeks to months). Although the term *meningitis* is commonly used to describe CNS involvement, some degree of encephalitis is also typically present, with occasional patients developing intracerebral masses, known as *cryptococcomas*. Importantly, meningeal signs and fever (typical of other forms of meningitis) may be lacking. In a review of pediatric cryptococcosis from Colombia, the most common symptoms were headache (78%), fever (69%), nausea and vomiting (66%), confusion (50%), and meningismus (38%). Other symptoms include decreased level of consciousness, changes in personality, ataxia, hearing deficits, and visual deficits. Increased intracranial pressure is thought to occur as a result of impaired absorption of CSF and has been reported to occur in more than 50% of adults with cryptococcal meningitis.

Despite antifungal therapy, the mortality rate for cryptococcosis remains high, ranging from 15–40%. Most deaths occur within several weeks of diagnosis. Factors associated with a poor prognosis reflect a high fungal burden and poor host response, including altered mentation, high CSF fungal burden, low CSF white blood cell (WBC) number (<10 cells/mm<sup>3</sup>), and failure to rapidly sterilize the CSF. Increased ICP is a key factor in the morbidity and mortality of cryptococcal meningitis and is especially problematic for patients with *C. gattii* disease. Appropriate management of increased ICP is therefore essential to the appropriate management of cryptococcal meningitis (see later). Postinfectious sequelae are common and include hydrocephalus, decreased visual acuity, deafness, cranial nerve palsies, seizures, and ataxia.

### Pneumonia

Cryptococcosis is acquired via inhalation, and pneumonia is the most commonly recognized form of disease after meningitis. As with meningitis, pneumonia occurs in both immunocompetent and immunocompromised individuals. Pulmonary disease can present in isolation or in the context of disseminated disease/meningitis, which is typical among immunocompromised individuals. Among adults with AIDS-associated cryptococcal pneumonia, over 90% had concomitant CNS infection. Thus clinicians should have a high suspicion for cryptococcal meningitis/disseminated disease in patients with cryptococcal pneumonia, especially among immunocompromised individuals, and should pursue a workup to exclude dissemination.

Cryptococcal pneumonia is often asymptomatic and may be detected because of radiographs performed for other reasons. In this regard, asymptomatic pulmonary nodules secondary to *C. neoformans* can be found in children with sarcomas, who are being evaluated for metastatic disease. Among symptomatic patients, a wide array of symptoms has been reported, including fever, cough, pleuritic chest pain, and constitutional symptoms like weight loss. Severe disease may result in respiratory failure. Chest radiographic findings are variable and may demonstrate a poorly localized bronchopneumonia, nodules, masses, or lobar consolidations. Pulmonary cavities and pleural effusions are rare. Immunocompromised patients with disseminated disease can have alveolar and interstitial infiltrates that mimic the pattern of disease seen in some patients with *Pneumocystis* pneumonia.

### Cutaneous Infection

Cutaneous disease occurs most commonly in the context of disseminated cryptococcosis but rarely can result from local inoculation. The

appearance of cutaneous cryptococcosis is both nondistinct and variable and includes papules, ulcers, subcutaneous nodules, and rarely, cellulitis. The lesions are typically subacute, evolving over weeks to months. Early lesions are often erythematous, are variably indurated and tender, and may be single or multiple. Lesions often become ulcerated with central necrosis and raised borders. Cutaneous cryptococcosis in immunocompromised patients can also resemble *Mollicutes contagiosum*. Given the variable and nondistinct nature of this disease, a high suspicion of disease, especially in the appropriate clinical context (e.g., immunocompromised host), is needed to make the diagnosis.

### Skeletal Infection

Skeletal infection occurs in approximately 5% of patients with disseminated infection but rarely in HIV-infected patients. Interestingly, chronic infection of the tibia was the first recognized manifestation of cryptococcal disease and was described in 1894. Like other forms of cryptococcosis, the onset of symptoms is insidious and chronic. Bone involvement is typified by soft tissue swelling and tenderness, and arthritis is characterized by effusion, erythema, and pain on motion. Skeletal disease is unifocal in approximately 75% of cases. The vertebrae are the most common site of infection, followed by the tibia, ileum, rib, femur, and humerus. Concomitant bone and joint disease can result from contiguous spread.

### Sepsis Syndrome

Sepsis syndrome is a rare manifestation of cryptococcosis and occurs almost exclusively among HIV-infected patients. Fever is followed by respiratory distress and multiorgan system disease that is often fatal.

### Immune Reconstitution Inflammatory Syndrome

Cryptococcal-associated immune reconstitution inflammatory syndrome (C-IRIS) occurs in the setting of AIDS and in solid organ transplantation. Improvement of immune function resulting from the administration of ART in AIDS patients (or the reduction of immunosuppression in transplant recipients) is thought to enhance and dysregulate inflammation, leading to an exacerbation of symptoms. This situation is similar to IRIS seen with other opportunistic pathogens. More commonly, C-IRIS presents as a worsening of symptoms in someone with a known diagnosis of cryptococcosis, often within 1–2 months of initiation of ART. Occasionally, C-IRIS, which presents as a meningitis or lymphadenitis, occurs in individuals who were never known to have cryptococcosis (unmasking-IRIS). IRIS is particularly problematic in CNS cryptococcosis and may result in worsening of increased ICP. Although cases of C-IRIS have been described in children, the incidence is not well defined.

## DIAGNOSIS

The approach to the diagnosis of cryptococcosis depends on the organ system involved. Recovery of the fungus by culture or demonstration of the fungus in histologic sections of infected tissue or body fluids by India ink staining is definitive. Cryptococci readily grow on standard fungal and bacterial culture media. Colonies can be seen within 48–72 hours when grown aerobically at standard temperatures. The CSF profile in patients with cryptococcal meningitis typically reveals a mild lymphocytosis and elevated protein, but findings can also be normal.

Detection of cryptococcal polysaccharide in the CSF, which can be done by several different methods, is key to the diagnosis of CNS infection. One of the earliest detection tests to be developed is the latex agglutination test, which can detect cryptococcal antigen in serum and CSF. Titers of  $\geq 1:4$  in bodily fluid strongly suggest infection, and titers of  $>1:1,024$  reflect high burden of yeast, poor host immune response, and greater likelihood of therapeutic failure. Serial monitoring of cryptococcal antigen levels is not useful in guiding



therapy, as the polysaccharide antigen is actively shed into the tissue and may persist for prolonged periods. Patients with localized pneumonia typically do not have elevated serum antigen levels (though occasionally low levels of antigen, <1:4, may be detected). Higher serum antigen levels in patients with pulmonary disease are indicative of dissemination outside the lungs. A point-of-care, lateral flow assay for polysaccharide detection has been developed and has comparable sensitivity to the latex-agglutination assay, with the advantage of being less labor intensive. This assay provides a qualitative positive/negative result, but can also be performed to provide a semiquantitative result. False negatives for both latex agglutination and lateral flow assays may occur in the context of antigen excess, so samples are typically run both undiluted and diluted. False-positive results can occur with other fungal infections, including infection with *Trichosporon* spp. and, rarely, by disinfectants. A commercially available ELISA also allows for the detection of cryptococcal polysaccharide in body fluids. Several PCR-based film arrays have also been developed for the diagnosis of cryptococcosis. These assays allow for the detection of *C. neoformans* DNA in the CSF as part of a panel of meningitis/encephalitis-associated pathogens. Nonetheless, both false positives and false negatives (especially in the context of low-burden disease) have been well documented.

## TREATMENT

The choice of treatment for cryptococcosis depends on the sites of involvement and the host immune status. These regimens have not been rigorously studied in children and generally represent extrapolations from studies done in adults. Guidelines for the treatment of pediatric cryptococcosis have been developed by the Infectious Diseases Society of America (IDSA) and the World Health Organization (WHO).

### Pulmonary Disease

The immunocompetent patient with asymptomatic or mild disease limited to the lungs should be treated with oral fluconazole (pediatric dose 6–12 mg/kg/day and adult dose 400 mg/day) for 6–12 months to prevent dissemination and progression of disease. Alternative treatments include itraconazole in solution form (pediatric dose 5–10 mg/kg/day divided every 12 hours and adult dose 400 mg/day), voriconazole, and posaconazole. Fluconazole therapy can also be used for immunocompromised individuals with isolated mild to moderate pulmonary disease in the absence of dissemination or CNS disease. Longer maintenance therapy with fluconazole to prevent recurrence should be considered in this cohort, especially among AIDS patients if the CD4<sup>+</sup> T cells remain less than 100/μL. Adjunctive surgical management of pulmonary lesions that are not responsive to surgical management should be considered. Patients with diffuse pulmonary disease or those with severe symptoms (e.g., acute respiratory distress syndrome) should be treated in the same manner as those with meningitis.

### Disseminated Disease and Meningitis

For more severe forms of disease, including meningitis and any form of disseminated disease, an initial induction regimen to promote rapid decline in fungal burden is indicated. According to Infectious Diseases Society of America (IDSA) guidelines, induction therapy should consist of amphotericin B (1 mg/kg/day) plus flucytosine (100–150 mg/kg/day divided every 6 hours, assuming normal kidney function) for a minimum of 2 weeks, keeping serum flucytosine concentrations between 40 and 60 μg/mL. Lipid amphotericin B has replaced standard amphotericin B for the treatment of severe cryptococcosis in adults, primarily based on its lower toxicity profile. Strong consideration should be given to the use of lipid complex amphotericin B (3–6 mg/kg/day) in all affected pediatric patients, especially those with underlying kidney disease or at risk for kidney

disease. Alternative induction therapies as outlined by the WHO guidelines include (1) 1 week of amphotericin B in combination with flucytosine, followed by 1 week of high-dose fluconazole with amphotericin B; and (2) 2 weeks of amphotericin B in combination with high-dose fluconazole. Repeat lumbar puncture is generally recommended at the end of induction therapy to document sterilization of CSF. Longer periods of induction (4–6 weeks) should be considered in the following scenarios: (1) immunocompetent patients with cryptococcal meningitis, (2) meningitis secondary to *C. gattii*, (3) failure to sterilize CSF, and (4) neurologic complications (including cryptococcomas). After induction, consolidation therapy with oral fluconazole (pediatric dose 10–12 mg/kg/day, adult dose 400–800 mg/day) should be given for 8 weeks. In patients with ongoing immunosuppression, maintenance fluconazole should be used to prevent recurrence. In organ transplant recipients, current recommendations are for 6–12 months of maintenance therapy with fluconazole (pediatric dose 6 mg/kg/day, adult dose 200–400 mg/day). In patients with AIDS, prolonged maintenance therapy should be given. Studies in adults suggest that maintenance therapy can be discontinued once the patient has achieved immune reconstitution (as indicated by CD4<sup>+</sup> T cells >100/μL and an undetectable or very low HIV RNA level that is sustained for greater than 3 months). A minimum of 12 months of antifungal therapy is indicated. Use of adjuvant interferon gamma for patients with refractory cryptococcal meningitis has been described in adults, but not in pediatric patients.

**Increased ICP.** Increased ICP contributes greatly to the morbidity and mortality of cryptococcal meningitis, and aggressive management of this phenomenon is indicated. Current guidelines indicate that in patients with increased ICP (>25 cm H<sub>2</sub>O), CSF should be removed to establish a pressure ≤20 cm H<sub>2</sub>O or by 50% if ICP is extremely high. Serial lumbar punctures may be needed to ensure normalization of ICP, and ventriculoperitoneal shunts can be considered for patients with persistently elevated increased ICP. Corticosteroids, mannitol, and acetazolamide are generally not indicated in the treatment of increased ICP, though anecdotal reports describe use in association with cryptococcoma (in patients with *C. gattii* infection) and C-IRIS.

**C-IRIS.** To prevent the development of C-IRIS, most experts recommend delaying the institution of ART for 4–6 weeks after the initiation of antifungal therapy. Recurrence of disease and emergence of antifungal resistance should be excluded in the context of a diagnosis of C-IRIS. Treatment strategies have not been well studied but generally consist of antifungal therapy along with antiinflammatory agents (e.g., NSAIDs and corticosteroids). Reduction of increased ICP through therapeutic lumbar puncture may be necessary.

## PREVENTION

Persons at high risk for cryptococcosis should be advised to avoid exposures to bird droppings. Effective ART for persons with HIV infection significantly reduces the risk of cryptococcal disease. For adolescent patients with AIDS, regular cryptococcal antigen testing with subsequent diagnostic evaluation and therapy should be considered for individuals with CD4<sup>+</sup> lymphocyte counts <100/μL. Cryptococcal antigen screening should also be done before the initiation of antiretroviral therapy in patients newly diagnosed with HIV infection. In the absence of ability to perform regular screening, fluconazole prophylaxis for all patients with CD4<sup>+</sup> lymphocyte counts <100/μL can be considered. However, in children for whom the incidence of cryptococcosis is relatively low, screening and prophylaxis are generally not needed.

Visit Elsevier eBooks+ at [eBooks.Health.Elsevier.com](http://eBooks.Health.Elsevier.com) for Bibliography.

## Chapter 282

**Malassezia**

Ashley M. Maranich

Members of the genus *Malassezia* are lipophilic yeasts that are a significant component of the skin microbiome. They have a predilection for the sebum-rich areas of the skin and are considered normal skin flora. Colonization is established just after birth and rises before puberty, with distribution (both in species and number) related to numerous factors, including age, body site, and geographic location.

The history of *Malassezia* nomenclature is complex and can be confusing. Yeast forms may appear oval or round, resulting in early designations of both *Pityrosporum ovale* and *Pityrosporum orbiculare*. Additionally, newer technologies, such as matrix-assisted laser desorption/ionization time of flight mass spectrometry (MALDI-TOF MS), are allowing for an improved classification system. The genus *Malassezia* has recently been assigned its own class, Malasseziomycetes, with 18 currently recognized species. Disease is facilitated by transformation of the yeast form to a hyphal form, with clusters of thick-walled blastospores with the hyphae producing the characteristic **spaghetti-and-meatballs** appearance of *Malassezia* spp. under light microscopy.

*Malassezia* can cause a number of dermatologic conditions, more commonly in tropical environments, to include **tinea versicolor** (also **pityriasis versicolor**) (Fig. 282.1; see Chapter 707), neonatal acne, seborrheic dermatitis, dandruff, *Malassezia* folliculitis, and onychomycosis and are linked with atopic dermatitis and psoriasis. *M. sympodialis*, *M. globosa*, and *M. furfur* are the major causes of tinea versicolor. *Malassezia* spp. may be isolated from sebum-rich skin areas of asymptomatic persons, emphasizing that demonstration of the fungus does not equate with infection.



**Fig. 282.1** A young adult with tinea versicolor. Notice the characteristic hypopigmented scaling macules. (Courtesy Ashley M. Maranich, MD.)

Invasive infections, namely catheter-associated **fungemia**, can occur, with premature infants and immunocompromised individuals (especially those with malignancies) the most high-risk populations. *M. furfur* is the species most commonly causing fungemia, with *M. pachydermatis* implicated in neonatal intensive care unit outbreaks. The use of lipid emulsions containing medium-chain triglycerides inhibits the growth of *Malassezia* spp. and can prevent infection. Symptoms of catheter-associated fungemia are indistinguishable from other causes of catheter-associated infections but should be suspected in patients, especially neonates, receiving intravenous lipid infusions. Compared with other causes of fungal sepsis, it is unusual for catheter-related *Malassezia* fungemia to be associated with secondary focal infection.

*Malassezia* species do not grow readily on standard fungal media, and successful culture requires overlaying the agar with olive oil. Recovery of *Malassezia* from blood culture is optimized by supplementing the medium with olive oil or palmitic acid and allowing for prolonged incubation for at least 2 weeks.

Topical treatment of skin-related conditions is considered first-line to minimize the risk of side effects. **The traditional primary therapy for tinea versicolor is daily use of topical selenium sulfide 2.5% applied to affected areas for 10 minutes for a week. Additional regimens for skin disorders include topical azole creams, ketoconazole 2% shampoo applied daily for 3 days, and terbinafine 1% cream applied 1-2 times daily for 1-2 weeks. Malassezia-associated skin diseases limited to the head and neck can be managed with either 1% ciclopirox, ketoconazole, or zinc pyrithione shampoos.** Regardless of the agent chosen, recovery time can be prolonged, with repigmentation not occurring for several months. **Continued application of topical treatment on a weekly or monthly basis is frequently recommended to prevent relapse.** Recurrence is common and usually responds well to the original treatment regimen.

Oral therapy for tinea versicolor with fluconazole or itraconazole is easier to administer (especially with large areas of skin involved) but is more expensive, has higher side effect risks, and may be less effective than topical therapy. **Various dosing regimens have been used with success, including fluconazole 300 mg weekly for 2-4 weeks, fluconazole as a single 400-mg dose, and itraconazole 200 mg daily for 5-7 days or 100 mg daily for 2 weeks.** Recent studies have examined alternative therapies, with early data suggesting that essential oils might be a possible option for long-term therapy of *Malassezia* skin infections, with additional studies needed.

Treatment of *Malassezia* fungemia is complicated by the lack of standardized susceptibility testing references. **Recent consensus recommendations name liposomal amphotericin B as first-line treatment for systemic *Malassezia* infections, with amphotericin B deoxycholate as an alternative.** Additionally, the involved catheter should be removed and any lipid infusion should be discontinued. Itraconazole, posaconazole, or voriconazole may be alternative agents, but fluconazole should be avoided, given that many patients with *Malassezia* bloodstream infections in existing clinical series were receiving fluconazole prophylaxis at the time of developing the infection.

Visit Elsevier eBooks+ at [eBooks.Health.Elsevier.com](https://eBooks.Health.Elsevier.com) for Bibliography.

## Chapter 283

**Aspergillus**

William J. Steinbach

The genus *Aspergillus* contains approximately 250 species, but most human disease is caused by *Aspergillus fumigatus*, *A. flavus*, *A. niger*, *A. terreus*, and *A. nidulans*. Invasive disease is most commonly caused by *A. fumigatus*. Most cases of *Aspergillus* disease (**aspergillosis**) are caused by inhalation of airborne spores (conidia) that subsequently germinate into fungal hyphae and invade host tissue. When inhaled by an immunocompetent person, conidia are rarely deleterious, presumably because they are efficiently cleared by phagocytic cells. Macrophage- and neutrophil-mediated host defenses are required for resistance to invasive disease.

*Aspergillus* is a relatively unusual pathogen in that it can create very different disease states depending on the host characteristics, including allergic (hypersensitivity), saprophytic (noninvasive), chronic, or invasive disease. Immunodeficient hosts are at risk for invasive disease, whereas immunocompetent atopic hosts tend to develop allergic disease. Disease manifestations include primary allergic reactions; colonization of the lungs or sinuses; localized infection of the lung or skin; chronic infection of the lung; invasive pulmonary disease; or widely disseminated disease of the lungs, brain, skin, eye, bone, heart, and other organs. Clinically, these syndromes often manifest with mild, nonspecific, and late-onset symptoms, particularly in the immunosuppressed host, complicating accurate diagnosis and timely treatment.

### 283.1 Allergic Disease (Hypersensitivity Syndromes)

William J. Steinbach

#### ASTHMA

Attacks of atopic asthma can be triggered by inhalation of *Aspergillus* conidia, producing allergic responses and subsequent bronchospasm. Exposure to fungi, especially *Aspergillus*, needs to be considered as a trigger in a patient with an asthma flare, especially in those patients with severe or recalcitrant asthma.

#### ALLERGIC BRONCHOPULMONARY ASPERGILLOSIS

Allergic bronchopulmonary aspergillosis (ABPA) is a hypersensitivity disease resulting from immunologic sensitization to *Aspergillus* antigens. It is primarily seen in patients with asthma or cystic fibrosis. Inhalation of conidia produces noninvasive colonization of the bronchial airways, resulting in persistent inflammation and development of hypersensitivity inflammatory responses. Disease manifestations are the result of abnormal immunologic responses to *A. fumigatus* antigens and include wheezing, pulmonary infiltrates, bronchiectasis, and even fibrosis.

There are eight primary diagnostic criteria for ABPA: episodic bronchial obstruction, peripheral eosinophilia, immediate cutaneous reactivity to *Aspergillus* antigens, precipitating IgE antibodies to *Aspergillus* antigen, elevated total IgE, serum precipitin (specific IgG) antibodies to *A. fumigatus*, pulmonary infiltrates, and central bronchiectasis. Secondary diagnostic criteria include repeated detection of *Aspergillus* from sputum by identification of morphologically consistent fungal elements or direct culture and coughing of brown plugs or specks. Radiologically, bronchial wall thickening, pulmonary infiltrates, and central bronchiectasis can be seen.

Treatment depends on relieving inflammation via an extended course of systemic corticosteroids. Addition of oral antifungal agents, such as itraconazole or voriconazole, is used to decrease the fungal burden and diminish the inciting stimulus for inflammation. Because disease activity

is correlated with serum IgE levels, these levels are used as one marker to define duration of therapy. An area of research interest is the utility of anti-IgE antibody therapy in the management of ABPA.

#### ALLERGIC ASPERGILLUS SINUSITIS

Allergic *Aspergillus* sinusitis is thought to be similar in etiology to ABPA. It has been primarily described in young adult patients with asthma and may or may not be seen in combination with ABPA. Patients often present with symptoms of chronic sinusitis or recurrent acute sinusitis, such as congestion, headaches, and rhinitis, and are found to have nasal polyps and opacification of multiple sinuses on imaging. Laboratory findings can include elevated IgE levels, precipitating antibodies to *Aspergillus* antigen, and immediate cutaneous reactivity to *Aspergillus* antigens. Sinus tissue specimens might contain eosinophils, Charcot-Leyden crystals, and fungal elements consistent with *Aspergillus* species. **Surgical drainage is an important aspect of treatment, often accompanied by courses of either systemic or inhaled steroids. Use of an antifungal agent may also be considered.**

Visit Elsevier eBooks+ at [eBooks.Health.Elsevier.com](http://eBooks.Health.Elsevier.com) for Bibliography.

### 283.2 Saprophytic (Noninvasive) Syndromes

William J. Steinbach

#### PULMONARY ASPERGILLOMA

Aspergillomas are masses of fungal hyphae, cellular debris, and inflammatory cells that proliferate without vascular invasion, generally in the setting of preexisting cavitory lesions or ectatic bronchi. These cavitory lesions can occur as a result of infections such as tuberculosis, histoplasmosis, or resolved abscesses or secondary to congenital or acquired defects such as pulmonary cysts or bullous emphysema. Patients may be asymptomatic, with diagnosis made through imaging for other reasons, or may present with hemoptysis, cough, or fever. On imaging, initially there may be thickening of the walls of a cavity, and later on there is a solid round mass separated from the cavity wall as the fungal ball develops. Detection of *Aspergillus* antibody in the serum suggests this diagnosis. Treatment is indicated for control of complications, such as hemoptysis. **Surgical resection is the definitive treatment but has been associated with significant risks. Systemic antifungal treatment with azole-class agents is indicated in certain patients.**

#### CHRONIC PULMONARY ASPERGILLOSIS

Chronic aspergillosis can occur in patients with normal immune systems or mild degrees of immunosuppression, including intermittent corticosteroids. Three major categories, each with overlapping clinical features, have been proposed to describe different manifestations of chronic aspergillosis. The first is chronic **cavitory pulmonary aspergillosis** (CCPA), which is similar to aspergilloma, except that multiple cavities form and expand with occupying fungal balls. The second is **chronic fibrosing pulmonary aspergillosis**, where the multiple individual lesions progress to significant pulmonary fibrosis. The final is **subacute invasive aspergillosis** (IA), which was previously called *chronic necrotizing pulmonary aspergillosis*, a slowly progressive process found in patients with mild to moderate immune impairment.

Treatment based on consensus guidelines can sometimes involve surgical resection, although long-term antifungal therapy is often indicated. Management of semi-IA is similar to that of invasive pulmonary aspergillosis; however, the disease is more indolent, and thus there is a greater emphasis on oral therapy. Direct instillation of antifungals into the lesion cavity has been employed with some success.

#### OTOMYCOSIS

*Aspergillus* can colonize the external auditory canal, with possible extension to the middle ear and mastoid air spaces if the tympanic membrane is disrupted by concurrent bacterial infection. Symptoms include pain, itching, decreased unilateral hearing, or otorrhea.



Otomycosis is more often seen in patients with impaired mucosal immunity, such as patients with hypogammaglobulinemia, diabetes mellitus, chronic eczema, or HIV and those using chronic steroids. **Treatments have not been well studied, but topical treatment with acetic or boric acid instillations or oral azoles such as voriconazole, itraconazole, and posaconazole have been described.**

Visit Elsevier eBooks+ at [eBooks.Health.Elsevier.com](http://eBooks.Health.Elsevier.com) for Bibliography.

### 283.3 Invasive Disease

William J. Steinbach

IA is primarily a disease of immunocompromised hosts, and common risk factors in adults include cancer or chemotherapy-induced neutropenia, particularly if severe and/or prolonged; hematopoietic stem cell transplantation, especially during the initial preengraftment phase or if complicated by graft-versus-host disease; neutrophil or macrophage dysfunction, as occurs in severe combined immunodeficiency (SCID) or chronic granulomatous disease (CGD); prolonged high-dose steroid use; solid organ transplantation; and rarely, HIV. The most common site of primary infection is the lung, but primary invasive infection is also seen in the sinuses and skin and rarely elsewhere. Secondary infection can be seen after hematogenous spread, often to the skin, central nervous system (CNS), eye, bone, and heart.

#### INVASIVE PULMONARY ASPERGILLOSIS

Invasive pulmonary aspergillosis is the most common form of aspergillosis and plays a significant role in morbidity and mortality in the patient populations mentioned at increased risk for IA. Presenting symptoms can include fever despite initiation of empirical broad-spectrum antibacterial therapy, cough, chest pain, hemoptysis, and pulmonary infiltrates. Patients on high-dose steroids are less likely to present with fever. Symptoms in these immunocompromised patients can be very vague, and thus maintaining a high index of suspicion when confronted with a high-risk patient is essential.

#### Diagnosis

Imaging can be helpful, although no finding is pathognomonic for invasive pulmonary aspergillosis. Characteristically, multiple ill-defined nodules can be seen, though lobar or diffuse consolidation is not uncommon, and normal chest x-rays do not rule out disease. Classic radiologic signs on CT during neutropenia include the **halo sign**, when angioinvasion produces a hemorrhagic nodule surrounded by ischemia (Fig. 283.1). Early on there is a rim of ground-glass



**Fig. 283.1** Angioinvasive aspergillosis. CT section at the level of the lower trachea shows a consolidation with an eccentric cavitation and air crescent sign (arrows). This finding in this neutropenic patient is highly diagnostic of angioinvasive aspergillosis. (From Franquet T. *Nonneoplastic parenchymal lung disease*. In: Haaga JR, Boll DT, eds. *CT and MRI of the Whole Body*, 6th ed. Philadelphia: Elsevier; 2017: Fig. 36.14.)

opacification surrounding a nodule. Over time, these lesions evolve into cavitary lesions or lesions with an **air crescent sign** when the lung necroses around the fungal mass, often seen during recovery from neutropenia. Unfortunately, these findings are not specific to invasive pulmonary aspergillosis and can also be seen in other pulmonary fungal infections, and in pulmonary hemorrhage and organizing pneumonia. In addition, several reviews of imaging results of pediatric aspergillosis cases suggest that cavitation and air crescent formation are less common among these patients than among adult patients. On MRI, the typical finding for pulmonary disease is the **target sign**, a nodule with a lower central signal compared with the rim-enhancing periphery.

Conclusive diagnosis requires culture of *Aspergillus* from a normally sterile site and histologic identification of tissue invasion by fungal hyphae consistent with *Aspergillus* morphology. In addition, depending on the specimen type, a positive result from culture can represent colonization rather than infection; however, all positive cultures should be interpreted conservatively in high-risk patients. Serology can be useful in the diagnosis of allergic *Aspergillus* syndromes and in aspergilloma but is low yield for invasive disease, likely because of deficient immune responses in the high-risk immunocompromised population. Bronchoalveolar lavage (BAL) can be useful, but negative culture results cannot be used to rule out disease, owing to inadequate sensitivity. Proven disease requires histologic confirmation or microbiologic recovery of the organism, whereas probable disease diagnosis includes radiographic findings coupled with molecular biologic assays such as galactomannan antigen detection either in the serum or from the BAL. This galactomannan assay has been shown to be the most sensitive in detecting disease in cancer patients or hematopoietic stem cell transplant recipients, with less utility in solid organ transplant recipients. Earlier reports of increased false-positive reactions in children versus adults have been refuted, and the galactomannan assay is effective in diagnosing IA in children. This test does possess high rates of false negativity in patients with congenital immunodeficiency (e.g., CGD) and invasive *Aspergillus* infections. The beta-glucan assay is a nonspecific molecular fungal assay that detects the major component of the fungal cell wall. Unlike the galactomannan assay, which is specific for *Aspergillus*, the beta-glucan assay will not discriminate which fungal organism is infecting the patient. Polymerase chain reaction (PCR)-based assays are in development for the diagnosis of aspergillosis but are still being optimized.

#### Treatment

Successful treatment of IA hinges on the ability to reconstitute normal immune function and use of effective antifungal agents until immune recovery can be achieved. Therefore lowering overall immunosuppression, specifically via cessation of corticosteroid use, is vital to improve the ultimate outcome. **Multiple published guidelines recommend that primary therapy for all forms of IA is voriconazole**, based on several studies showing both improved response rates and improved survival in patients receiving voriconazole when compared with amphotericin B. Guideline-recommended alternative therapies include liposomal amphotericin B, isavuconazole, and other lipid formulations of amphotericin B. European guidelines recommend isavuconazole and voriconazole for treatment of pulmonary disease with a similar strength of recommendation, mentioning fewer adverse effects with isavuconazole than with voriconazole and use of liposomal amphotericin B as an alternative. Posaconazole is another triazole antifungal that is approved for antifungal prophylaxis and may be considered an alternative agent for first-line treatment of IA.

The echinocandin class of antifungals may also play a role in treatment of IA, but to date, these agents are generally employed as second-line medications, particularly for salvage therapy. Combination antifungal therapy has revealed disparate results. The U.S. guidelines state that combination primary antifungal therapy with voriconazole plus an echinocandin may be considered in select patients with documented IA; however, this is not a recommendation. Importantly, primary therapy with an echinocandin is not recommended, but an echinocandin can be used in the settings in which azole or polyene antifungals are contraindicated. Unfortunately, even with newer



antifungals, complete or partial response rates for treatment of IA are only approximately 50%. To augment antifungal therapies, patients have been treated with growth factors to increase neutrophil counts, granulocyte transfusions, interferon- $\gamma$ , and surgery. Treatment of IA should be continued for a minimum of 6-12 weeks; however, many experts feel that treatment should continue until complete clinical and radiographic resolution of disease.

### Special Populations

Patients with CGD represent a pediatric population at particular risk for pulmonary aspergillosis. Invasive pulmonary aspergillosis can be the first serious infection identified in these patients, and the lifetime risk of developing pulmonary aspergillosis is estimated to be 33%. Unlike classical IA in cancer patients, the onset of symptoms is often gradual, with slow development of fever, fatigue, pneumonia, and elevated sedimentation rate. The neutrophils of patients with CGD surround the collections of fungal elements but cannot kill them, thereby permitting local invasion with extension of disease to the pleura, ribs, and vertebrae, though angioinvasion is not seen. Imaging in these patients is much less likely to reveal the halo sign, infarcts, or cavitory lesions and instead generally shows areas of tissue destruction caused by the ongoing inflammatory processes.

### CUTANEOUS ASPERGILLOSIS

Cutaneous aspergillosis can occur as a primary disease or as a consequence of hematogenous dissemination or spread from underlying structures. Primary cutaneous disease classically occurs at sites of skin disruption, such as intravenous access device locations, adhesive dressings, or sites of injury or surgery. Premature infants are at particular risk, given their immature skin and need for multiple access devices. Cutaneous disease in transplant recipients tends to reflect hematogenous distribution from a primary site of infection, often the lungs. Lesions are erythematous, indurated papules that progress to painful, ulcerated, necrotic lesions. Treatment depends on the combination of surgical debridement and antifungal therapy, with systemic voriconazole recommended as primary therapy.

### INVASIVE SINONASAL DISEASE

Invasive *Aspergillus* sinusitis represents a difficult diagnosis because the clinical presentation tends to be highly variable. Patients can present with congestion, rhinorrhea, epistaxis, headache, facial pain or swelling, orbital swelling, fever, or abnormal appearance of the nasal turbinates. Because noninvasive imaging can be normal, diagnosis rests on direct visualization via endoscopy and biopsy. Sinus mucosa may be pale, discolored, granulating, or necrotic, depending on the stage and extent of disease. The infection can invade adjacent structures, including the eye and brain. This syndrome is difficult to distinguish clinically from other types of invasive fungal disease of the sinuses such as mucormycosis, rendering obtaining specimens for culture and histology extremely important. If the diagnosis is confirmed, treatment should be with voriconazole similar to invasive pulmonary disease. Because voriconazole is not active against mucormycosis, amphotericin B formulations should be considered in invasive fungal sinusitis pending definitive identification.

### CENTRAL NERVOUS SYSTEM

The primary site of *Aspergillus* infection tends to be the lungs, but as the hyphae invade into the vasculature, fungal elements can dislodge and travel through the bloodstream, permitting establishment of secondary infection sites. One of the sites commonly involved in disseminated disease is the CNS. Cerebral aspergillosis can also arise secondary to local extension of sinus disease. The presentation of cerebral aspergillosis is highly variable but can include changes in mental status, seizures, paralysis, coma, and ophthalmoplegia. As the hyphae invade the CNS vasculature, hemorrhagic infarcts develop that convert to abscesses. Biopsy is required for definitive diagnosis, but patients are often too ill to tolerate surgery. Imaging can be helpful for diagnosis, and MRI is preferred. In general, the prognosis for CNS aspergillosis is extremely poor, likely owing to the late onset at presentation. Reversal of immunosuppression

is extremely important, when possible. Surgical resection of lesions may be useful. Voriconazole is the best therapy, usually at high doses.

### EYE

Fungal endophthalmitis and keratitis may be seen in patients with disseminated *Aspergillus* infection. Pain, photophobia, and decreased visual acuity may be present, though many patients are asymptomatic. Emergent ophthalmologic evaluation is important when these entities are suspected. Endophthalmitis is treated with intravitreal injection of either amphotericin B or voriconazole along with surgical intervention and systemic antifungal therapy with voriconazole. Keratitis requires topical and systemic antifungal therapy.

### BONE

*Aspergillus* osteomyelitis can occur, most commonly in the vertebrae. Rib involvement occurs as a result of extension of disease in patients with CGD and is most often caused by *A. nidulans*. Treatment depends on the combination of surgical debridement and systemic antifungals. Arthritis can develop after hematogenous dissemination or local extension, and treatment depends on joint drainage combined with antifungal therapy. Voriconazole is the preferred first-line therapy.

### HEART

Cardiac infection can occur as a result of surgical contamination, secondary to disseminated infection, or after direct extension from a contiguous focus of infection and includes endocarditis, myocarditis, and pericarditis. Treatment requires surgical intervention in the case of endocarditis and pericarditis, along with systemic antifungals, sometimes lifelong because of the possibility of recurrent infection.

Visit Elsevier eBooks+ at [eBooks.Health.Elsevier.com](http://eBooks.Health.Elsevier.com) for Bibliography.

## Chapter 284

# Histoplasmosis (*Histoplasma capsulatum*)

Matthew C. Washam and  
Lara A. Danziger-Isakov

### ETIOLOGY

Histoplasmosis is caused by *Histoplasma capsulatum*, a dimorphic fungus found in the environment as a saprobe in the mycelial (mold) form and in tissues in the parasitic form as yeast.

### EPIDEMIOLOGY

Two varieties of *Histoplasma* cause human histoplasmosis. The most common variety, *H. capsulatum* var. *capsulatum*, is found in soil as the saprotrophic form throughout the midwestern United States, primarily along the Ohio and Mississippi rivers. In parts of Kentucky and Tennessee, almost 90% of the population older than 20 years of age have positive skin test results for histoplasmin. Sporadic cases have also been reported in nonendemic states in patients without a travel history. Worldwide, *H. capsulatum* var. *capsulatum* is endemic to parts of Central and South America, the Caribbean, China, India, Southeast Asia, and the Mediterranean. The less common variety, *H. capsulatum* var. *duboisii*, is endemic to certain areas of western and central sub-Saharan Africa.

*H. capsulatum* thrives in soil rich in nitrates such as areas that are heavily contaminated with bird or bat droppings or decayed wood. Fungal spores are often carried on the wings of birds. Focal outbreaks of histoplasmosis have been reported after aerosolization of microconidia

resulting from construction in areas previously occupied by starling roosts or chicken coops or by chopping decayed wood or burning bamboo exposed to a blackbird roost. Unlike birds, bats are actively infected with *Histoplasma*. Focal outbreaks of histoplasmosis have also been reported after intense exposure to bat guano in caves and along bridges frequented by bats. Horizontal person-to-person transmission does not occur, although transplacental transmission of *H. capsulatum* has been reported in immunocompromised mothers.

### PATHOGENESIS

Inhalation of microconidia (fungal spores) is the initial stage of human infection. The conidia reach the alveoli, germinate, and proliferate as yeast. Alternatively, spores can remain as mold with the potential for activation. Most infections are asymptomatic or self-limited. When disseminated disease occurs, any organ system can be involved. The initial infection is a bronchopneumonia. As the initial pulmonary lesion ages, giant cells form, followed by formation of caseating or noncaseating granulomas and central necrosis. Granulomas contain viable yeast, and disease can relapse. At the time of spore germination, yeast cells are phagocytosed by alveolar macrophages, where they replicate and gain access to the reticuloendothelial system via the pulmonary lymphatic system and hilar lymph nodes. Dissemination with splenic involvement typically follows the primary pulmonary infection. In normal hosts, specific cell-mediated immunity follows in approximately 2 weeks, enabling sensitized T cells to activate macrophages and kill the organism. The initial pulmonary lesion resolves within 2-4 months but may undergo calcification resembling the Ghon complex of tuberculosis. Alternatively, buckshot calcifications involving the lung and spleen may be seen. Unlike tuberculosis, reinfection with *H. capsulatum* may occur and can lead to exaggerated host responses in some cases.

Children with immune deficiencies, specifically deficiencies involving cell-mediated immunity, are at increased risk for disseminated histoplasmosis. Primary immunodeficiencies involving pathogenic genetic variants in the interleukin (IL)-12/interferon (IFN)- $\gamma$  pathway have been reported in children with disseminated histoplasmosis, including IL-12R $\beta$ 1 deficiency and IFN- $\gamma$  R1 deficiency. Other primary immunodeficiencies identified in children with disseminated disease include *STAT1* gain-of-function pathogenic genetic variants, idiopathic CD4 lymphopenia, AR-DOCK8 deficiency, AD-GATA2 deficiency, and X-linked CD40L deficiency. Children with certain secondary immunodeficiencies (cancer patients, solid organ transplant recipients, children with HIV infection, and children receiving immunomodulatory therapy with tumor necrosis factor [TNF]- $\alpha$  inhibitors) are also at increased risk for disseminated disease.

### CLINICAL MANIFESTATIONS

Exposure to *Histoplasma* is common in endemic areas, although most infections are subclinical. Less than 1% of those infected display the following clinical manifestations:

**Acute pulmonary histoplasmosis** follows initial or recurrent respiratory exposure to microconidia. Symptomatic disease occurs more often in young children; in older patients, symptoms follow exposure to large inocula in closed spaces (e.g., chicken coops or caves) or prolonged exposure (e.g., camping on contaminated soil, chopping decayed wood). The median incubation time is 14 days. The prodrome is not specific and usually consists of flulike symptoms, including headache, fever, chest pain, cough, and myalgias. Hepatosplenomegaly occurs more often in infants and young children. Symptomatic infections may be associated with significant respiratory distress and hypoxia and can require intubation, mechanical ventilation, and steroid therapy. Acute pulmonary disease can also manifest with a prolonged illness (10 days to 3 weeks) consisting of weight loss, dyspnea, high fever, asthenia, and fatigue. Children with symptomatic disease typically have a patchy bronchopneumonia; hilar lymphadenopathy is variably present (Fig. 284.1). In young children, the pneumonia can coalesce. Focal or buckshot calcifications are convalescent findings in patients after acute pulmonary infection.



Fig. 284.1 Radiograph of a 5-yr-old child with acute pulmonary histoplasmosis showing right perihilar lymphadenopathy.

**Complications of pulmonary histoplasmosis** occur secondary to exaggerated host responses to fungal antigens within the lung parenchyma or hilar lymph nodes. **Histoplasmosis** are of parenchymal origin and are usually asymptomatic. These fibroma-like lesions are often concentrically calcified and single. Rarely, these lesions produce broncholithiasis associated with “stone spitting,” wheezing, and hemoptysis. In endemic regions, these lesions can mimic parenchymal tumors and are occasionally diagnosed at lung biopsy. **Mediastinal granulomas** form when reactive hilar lymph nodes coalesce and mat together. Although these lesions are usually asymptomatic, huge granulomas can compress the mediastinal structures, producing symptoms of esophageal, bronchial, or vena caval obstruction. Local extension and necrosis can produce pericarditis or pleural effusions. **Mediastinal fibrosis** is a rare complication of mediastinal granulomas and represents an uncontrolled fibrotic reaction arising from the hilar nodes. Structures within the mediastinum become encased within a fibrotic mass, producing obstructive symptomatology. Superior vena cava syndrome, pulmonary venous obstruction with a mitral stenosis-like syndrome, and pulmonary artery obstruction with congestive heart failure have been described. Dysphagia accompanies esophageal entrapment, and a syndrome of cough, wheeze, hemoptysis, and dyspnea accompanies bronchial obstruction. Rarely, children develop a sarcoid-like disease with arthritis or arthralgia, erythema nodosum, keratoconjunctivitis, iridocyclitis, and pericarditis. **Pericarditis**, with effusions both pericardial and pleural, is a self-limited benign condition that develops as a result of an inflammatory reaction to adjacent mediastinal disease. The effusions are exudative, and the organism is rarely culturable from fluid. **Progressive disseminated histoplasmosis** can occur in infants and in children with deficient cell-mediated immunity. Disseminated disease may occur either during the initial acute infection in children with primary or secondary immunodeficiencies affecting T-cell function (see “Pathogenesis”), in infants, or as a reactivation of a latent focus of infection within the reticuloendothelial system in children who acquire an immunosuppressive condition years after primary infection. Disseminated histoplasmosis in an HIV-infected patient is an AIDS-defining illness. Fever is the most common finding and can persist for weeks to months before the condition is diagnosed. The majority of patients have hepatosplenomegaly, lymphadenopathy, and interstitial pulmonary disease. Extrapulmonary infection is a characteristic of disseminated disease and can include destructive bony lesions, Addison

disease, meningitis, multifocal chorioretinitis, and endocarditis. Some patients develop mucous membrane ulcerations and skin findings such as nodules, ulcers, or molluscum-like papules. A sepsis-like syndrome has been identified in a small number of HIV-infected patients with disseminated histoplasmosis and is characterized by the rapid onset of shock, multiorgan failure, and coagulopathy. Reactive hemophagocytic syndrome has been described in immunocompromised patients with severe disseminated histoplasmosis. Many children with disseminated disease experience transient hyperglobulinemia. Elevated acute-phase reactants and hypercalcemia are typically seen but are nonspecific. Anemia, thrombocytopenia, and pancytopenia are variably present; elevated liver function tests and high serum concentrations of angiotensin-converting enzyme may be observed. Chest radiographs are normal in more than half of children with disseminated disease.

**Chronic pulmonary histoplasmosis** is an opportunistic infection in adult patients with centrilobular emphysema. **Chronic progressive disseminated histoplasmosis** is a slowly progressive infection caused by *Histoplasma* that occurs in older adults without obvious immunosuppression that is uniformly fatal if untreated. These entities are rare in children.

## DIAGNOSIS

Optimal diagnosis of suspected histoplasmosis depends on the clinical presentation and underlying immune status of the patient. Using serum and urine antigen tests along with serum antibody tests via complement fixation and immunodiffusion yields a diagnostic sensitivity >90% for acute pulmonary and disseminated forms of histoplasmosis. Diagnostic testing options include the following:

Antigen detection is the most widely available diagnostic study for patients with suspected pulmonary histoplasmosis or progressive disseminated histoplasmosis. Current laboratory methodology uses enzyme immunoassay (EIA) to detect *H. capsulatum* polysaccharide antigen in urine, blood, bronchoalveolar lavage fluid, and cerebrospinal fluid. In patients at risk for disseminated disease, antigen can be demonstrated in the urine, blood, or bronchoalveolar lavage fluid in more than 90% of cases. Antigenuria has been shown to correlate with severity of disseminated histoplasmosis. Serum, urine, and bronchoalveolar lavage fluid from patients with acute or chronic pulmonary infections are variably antigen positive. In one study, antigenuria was present in 83% of patients with acute pulmonary disease and 30% of patients with subacute pulmonary disease. False-positive results on urinary antigen testing can occur in patients with *Blastomyces dermatitidis*, *Coccidioides immitis*, *Coccidioides posadasii*, *Paracoccidioides brasiliensis*, and *Penicillium marneffeii*. Testing both urine and serum samples for histoplasma antigen increases the sensitivity compared with testing only the urine or serum alone. Sequential measurement of serum antigen levels in patients with disseminated disease is useful for monitoring response to therapy; persistent low-level antigenuria may occur in some patients who have completed therapy and have no evidence of active infection.

Antibody tests continue to be useful for the diagnosis of acute pulmonary histoplasmosis, its complications, and chronic pulmonary disease. Serum antibody to yeast and mycelium-associated antigens is classically measured by complement fixation. Although titers of >1:8 are found in more than 80% of patients with histoplasmosis, titers of  $\geq 1:32$  are most significant for the diagnosis of recent infection. Complement-fixation antibody titers are often not significant early in the infection and do not become positive until 4-6 weeks after exposure. A fourfold increase in either yeast or mycelial-phase titers or a single titer of  $\geq 1:32$  is presumptive evidence of active infection. Complement-fixation titers may be falsely positive in patients with other systemic mycoses such as *B. dermatitidis* and *C. immitis* and may be falsely negative in immunocompromised patients. Antibody detection by immunodiffusion is less sensitive but more specific than complement fixation and is used to confirm questionably positive complement-fixation titers. An EIA-based method that has improved sensitivity and specificity compared with other serologic methods has been developed. The highest sensitivity for antibody testing can be achieved by combining methodologies.

Culture sensitivity of tissue or body fluid samples is generally highest for children with progressive disseminated histoplasmosis or acute

pulmonary histoplasmosis caused by a large inoculum of organisms. *Histoplasma* typically grows within 6 weeks on Sabouraud agar at 25°C (77°F). Identification of tuberculate macroconidia allows for only a presumptive diagnosis, because *Sepedonium* species form similar structures. A confirmatory test using a chemiluminescent DNA probe for *H. capsulatum* is necessary to establish a definitive identification. The yeast can be recovered from blood or bone marrow in >90% of patients with progressive disseminated histoplasmosis. Sputum cultures are rarely obtained and are variably positive in normal hosts with acute pulmonary histoplasmosis; cultures of bronchoalveolar lavage fluid appear to have a slightly higher yield than sputum cultures. Blood cultures are sterile in patients with acute pulmonary histoplasmosis, and cultures from any source are typically sterile in patients with the sarcoid form of the disease.

Histologic examination can identify yeast forms in tissue from patients with complicated forms of acute pulmonary disease (histoplasmosis and mediastinal granuloma). Tissue should be stained with methenamine silver or periodic acid-Schiff stains, and yeast can be found within or outside of macrophages. In children with disseminated disease, organisms can be identified from bone marrow, liver, and mucocutaneous lesions. In those who are severely ill, Wright stain of peripheral blood can demonstrate fungal elements within leukocytes. Examination of fibrotic tissue from children with mediastinal fibrosis usually demonstrates no organisms.

Real-time polymerase chain reaction has been used on formalin-fixed, paraffin-embedded biopsy tissue and has an analytical sensitivity of at least 6 pg/ $\mu$ L from tissue-extracted DNA and a clinical sensitivity and specificity of 88.9% and 100%, respectively. Although not widely available, molecular methods may ultimately provide a more timely and accurate diagnosis.

Skin testing is useful only for epidemiologic studies, as cutaneous reactivity is lifelong and intradermal injection can elicit an immune response in otherwise seronegative persons. Reagents are no longer commercially available.

## TREATMENT

**Acute pulmonary histoplasmosis** does not require antifungal therapy for asymptomatic or mildly symptomatic children. Oral itraconazole (4-10 mg/kg/day in two divided doses, not to exceed 400 mg daily) for 6-12 weeks should be considered in patients with acute pulmonary infections who fail to improve clinically within 1 month. Although it appears to be less effective, fluconazole may be considered as an alternative therapy in children intolerant to itraconazole. Clinical experience in treating histoplasmosis with the newer azoles (voriconazole and posaconazole) is increasing, with posaconazole having increased in vitro activity. *Patients with pulmonary histoplasmosis who become hypoxemic or require ventilatory support* should receive amphotericin B deoxycholate (0.7-1.0 mg/kg/day) or amphotericin B lipid complex (3-5 mg/kg/day) until improved, and adjunctive corticosteroids (intravenous methylprednisolone at a dose of 0.5-1 mg/kg/day) can be considered for 1-2 weeks; continued therapy with oral itraconazole for a minimum of 12 wk is also recommended. The lipid preparations of amphotericin are not preferentially recommended in children with pulmonary histoplasmosis, as the classic preparation is generally well tolerated in this patient population. Patients with severe obstructive symptoms caused by granulomatous mediastinal disease may be treated sequentially with amphotericin B followed by itraconazole for 6-12 months, and inclusion of adjunctive corticosteroids should be considered for the first 1-2 weeks. Patients with milder mediastinal disease may be treated with oral itraconazole alone. Some experts recommend that surgery be reserved for patients who fail to improve after 1 month of intensive amphotericin B therapy. Sarcoid-like disease with or without pericarditis may be treated with nonsteroidal antiinflammatory agents for 2-12 weeks.

**Progressive disseminated histoplasmosis** usually requires amphotericin B deoxycholate (1.0 mg/kg/day for 4-6 weeks) or amphotericin B lipid complex (3-5 mg/kg/day). Alternatively, amphotericin B may be given for 2-4 weeks followed by oral itraconazole (4-10 mg/kg/day in two divided doses) as maintenance therapy for 12 months,



depending on *Histoplasma* antigen status. Longer therapy may be needed in patients with severe disease, immunosuppression, or primary immunodeficiency syndromes. It is recommended to monitor blood levels of itraconazole during treatment, aiming for a concentration of  $\geq 1$   $\mu\text{g/mL}$  but  $< 10$   $\mu\text{g/mL}$  to avoid potential drug toxicity. It is also recommended to monitor urine antigen levels during therapy and for 12 months after therapy has ended to ensure cure. Relapses in immunocompromised patients with progressive disseminated histoplasmosis are relatively common. Lifelong suppressive therapy with daily itraconazole (5 mg/kg/day up to adult dose of 200 mg/day) may be required if immunosuppression cannot be reversed. For severely immunocompromised HIV-infected children living in endemic regions, itraconazole (2–5 mg/kg every 12–24 hours) may be used prophylactically. Care must be taken to avoid interactions between antifungal azoles and protease inhibitors.

Visit Elsevier eBooks+ at [eBooks.Health.Elsevier.com](http://eBooks.Health.Elsevier.com) for Bibliography.

## Chapter 285

# Blastomycosis

Gregory M. Gauthier and Bruce S. Klein

### ETIOLOGY

The etiologic agents of blastomycosis belong to a species complex and include *Blastomyces dermatitidis*, *B. gilchristii*, *B. helicus*, *B. emzantsi*, *B. percursorus*, *B. parvus*, and *B. silverae*. The latter two species (*B. parvus*, *B. silverae*) rarely cause human infection. All *Blastomyces* species exhibit thermal dimorphism in which they grow as mold and produce spores in the soil at environmental temperature (22–25°C [71.6–77°F]) and as pathogenic yeast at core human body temperature (37°C [98.6°F]). Once in tissue, *Blastomyces* infection results in pyogranulomatous inflammation, which is characterized by neutrophil infiltration and granuloma formation. *Blastomyces* yeast can be differentiated from other fungi by the presence of a broad-based budding pattern between dividing yeast cells, which occurs in all *Blastomyces* species.

### EPIDEMIOLOGY

*Blastomyces* species cause disease in immunocompetent and immunocompromised children. Approximately 2–13% of blastomycosis cases occur in the pediatric population (average age: 9.1–12.9 years; range: 19 days to 18 years). Blastomycosis of newborns and infants is rare. In North America, the traditional geographic range of blastomycosis cases is restricted to the Midwest, southcentral, and southeastern United States and parts of Canada bordering the Great Lakes and Saint Lawrence River Valley. In these geographic regions, several areas are hyperendemic for blastomycosis (e.g., Marathon and Vilas counties, Wisconsin; central and southcentral Mississippi; Kenora, Ontario). Outside of North America, autochthonous infections have been reported from Africa (~100 cases), India (<12 cases), and Israel. *B. dermatitidis* is not endemic to Central America, South America, Europe, Asia, or Australia.

In North America, *B. dermatitidis* and *B. gilchristii* grow in an ecological niche characterized by forested, sandy soils with an acidic pH that have decaying vegetation and are near water. *B. dermatitidis* is located throughout the traditional geographic range, whereas *B. gilchristii* is restricted to Minnesota, Wisconsin, Canada, and areas along the St. Lawrence River. *B. helicus* is located in the western United States (California, Montana, Idaho, Colorado, Nebraska, Texas) and Canada (Saskatchewan, Alberta); however, its environmental niche remains

to be determined. In Africa, there are multiple species of *Blastomyces*, including *B. dermatitidis*, *B. gilchristii*, *B. percursorus*, and *B. emzantsi*. Knowledge about the ecological niche and geographic distribution of *Blastomyces* species in Africa is limited. *B. percursorus* has been reported from Israel.

Most *Blastomyces* infections are sporadic, but at least 20 outbreaks have been reported, and most of these outbreaks have included pediatric patients. Outbreaks have been associated with construction or outdoor activities (camping, hiking, fishing, rafting on a river, using a community compost pile); however, some outbreaks have no identifiable risk factors other than geography. Although blastomycosis is often thought to be an infection that primarily affects persons residing in or visiting rural areas, outbreaks and sporadic cases of blastomycosis are well reported in urban areas. Blastomycosis outbreak investigations in Wisconsin suggested that persons of Hmong ethnicity are at increased risk for the disease, which may be the result of polymorphisms in the interleukin-6 (IL-6) gene. These polymorphisms result in reduced IL-6 cytokine production and CD4<sup>+</sup> T lymphocytes that produce IL-17, which in turn, impairs activation of neutrophils and macrophages against *Blastomyces*. Although persons of Hmong ethnicity are at increased risk for blastomycosis, they do not appear to be at risk for disseminated infection. Increased incidence of blastomycosis has also been reported in indigenous persons living in the United States and Canada.

The severity of infection is influenced by the size of the inhaled inoculum and the integrity of the patient's immune system. Solid organ transplant recipients are at risk for severe pulmonary blastomycosis, including acute respiratory distress syndrome (ARDS); however, they are not at higher risk for disseminated infection. Although blastomycosis is uncommon in persons immunosuppressed with AIDS, there is an increased risk for dissemination to the central nervous system (CNS). Persons receiving tumor necrosis factor- $\alpha$  inhibitors are at risk for blastomycosis, but rates of dissemination or severe disease are not well defined.

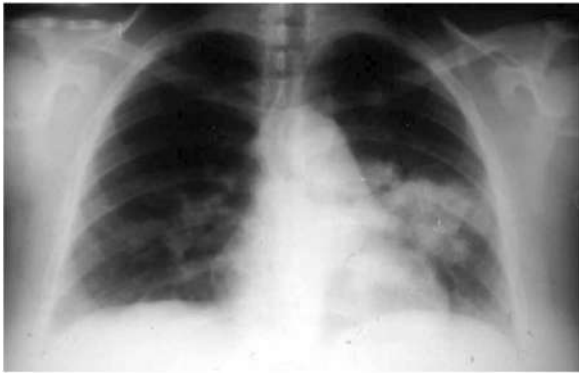
### PATHOGENESIS

The ability of mycelial fragments and spores to convert to yeast in the lung is a crucial event in the pathogenesis of infection with *Blastomyces* and other dimorphic fungi. This temperature-dependent morphologic shift, which is known as the *phase transition*, enables *Blastomyces* to evade the host immune system and establish infection. In the yeast form, the essential virulence factor BAD1 (*Blastomyces adhesin-1*; formerly WI-1) is secreted into the extracellular milieu and binds back to chitin on the fungal cell wall. BAD1 is a multifunctional protein that promotes binding of yeast to alveolar macrophages (via CR3 and CD14 receptors) and lung tissue (via heparan sulfate), blocks the deposition of complement on the yeast surface, binds calcium, suppresses the host's ability to produce cytokines (tumor necrosis factor- $\alpha$ , IL-17, interferon-gamma), and inhibits activation of CD4<sup>+</sup> T lymphocytes. Deletion of *BAD1* abolishes virulence of *Blastomyces* yeast in a murine model of pulmonary infection.

The phase transition between mold and yeast forms is a complex event that involves alteration in cell wall composition, metabolism, intracellular signaling, and gene expression. The morphologic shift to yeast is regulated in part by a histidine kinase known as DRK1 (*dimorphism regulating kinase-1*). This sensor kinase controls not only the conversion of mold to yeast but also spore production, cell wall composition, and *BAD1* expression; the loss of *DRK1* gene expression through gene disruption renders *B. dermatitidis* avirulent in a murine model of pulmonary blastomycosis. The function of DRK1 is conserved in other thermally dimorphic fungi, including *Histoplasma capsulatum* and *Talaromyces marneffeii* (formerly *Penicillium marneffeii*).

The phase transition is reversible, and after a drop in temperature from 37°C (98.6°F) to 22°C (71.6°F), yeast convert to sporulating mold. Growth as mold promotes survival in the soil, allows for sexual reproduction to enhance genetic diversity, and facilitates transmission to new hosts (via spores and mycelial fragments). The transition from





**Fig. 285.1** Left lung infection in a patient with symptoms resembling acute bacterial pneumonia. Organisms of *Blastomyces* in the sputum seen with potassium hydroxide preparation, and subsequent culture confirmed the diagnosis. (From Bradsher RW Jr. *Blastomycoses*. In: Bennett JE, Blaser MJ, Dolin R, et al, eds. *Mandell, Douglas, and Bennett's Principles and Practice of Infectious Diseases, 8th ed*, Philadelphia: Saunders; 2015: Fig. 266-5.)

yeast to mold is influenced by *SREB* (siderophore biosynthesis repressor in *Blastomyces*) and *N*-acetylglucosamine transporters (NGT1, NGT2). Deletion of *SREB*, which encodes a GATA transcription factor, results in the failure of *B. dermatitidis* yeast to complete the conversion to mold at 22°C. *N*-Acetylglucosamine, which polymerizes to form chitin, accelerates the transition to hyphae via NGT1 and NGT2 transporters.

Innate and adaptive immune systems are required to effectively control infection; humoral immunity is dispensable. Macrophages and neutrophils are capable of ingesting and killing *Blastomyces* conidia. In contrast, yeast are poorly killed by nonactivated macrophages, are resistant to reactive oxygen species, and suppress nitric oxide production. Adaptive immunity is mediated by T lymphocytes (Th1 and Th17), which activate macrophages and neutrophils to facilitate clearance of infection. After infection, cell-mediated immunity against *Blastomyces* can last for at least 2 years.

## CLINICAL MANIFESTATIONS

The clinical manifestations of blastomycosis are diverse and include subclinical infection, symptomatic pneumonia, and disseminated disease. Clinical disease develops 3 weeks to 3 months after inhalation of spores or mycelial fragments. Asymptomatic or subclinical infections are estimated to occur in 50% of patients.

The most common clinical manifestation of blastomycosis is **pneumonia**, which can range from acute to chronic. Acute symptoms resemble community-acquired pneumonia and include fever, dyspnea, cough, chest pain, and malaise (Fig. 285.1). Respiratory failure, including ARDS, can occur in patients with an overwhelming burden of infection. The most common chest imaging pattern is air space consolidation with or without air bronchograms. Any lobe of the lung can be involved, and multiple lobe involvement is not uncommon. Other radiographic features include masslike consolidation, nodules with cavity formation, reticulonodular pattern, and miliary disease. Hilar adenopathy and pleural effusions occur in approximately 20% of cases. Because the clinical and radiographic features often mimic bacterial pneumonia, patients can be mistakenly treated with antibiotics, resulting in disease progression, which can result in disseminated disease or respiratory failure, including ARDS. Patients with subacute or chronic pneumonia experience fevers, chills, night sweats, cough, weight loss, hemoptysis, dyspnea, and chest pain. Mass lesions and cavitary disease on chest roentgenography can mimic malignancy and tuberculosis, respectively.

**Extrapulmonary blastomycosis** most often affects the skin or bone but can involve almost any organ. The incidence of **extrapulmonary blastomycosis** in children ranges from 38% to 50%, similar

to rates in adult patients (15–48%). *B. dermatitidis* is more likely to cause disseminated infection, whereas *B. gilchristii* is more likely to remain localized to the lungs. The skin is the most common site for extrapulmonary blastomycosis, which is usually the result of hematogenous dissemination. Direct inoculation of *B. dermatitidis* into the skin from trauma or a laboratory accident can result in primary cutaneous blastomycosis. Skin manifestations include plaques, papules, ulcers, nodules, and verrucous lesions. *Erythema nodosum* is rare in blastomycosis. Dissemination of *B. dermatitidis* to the bone results in lytic destruction, pain, soft tissue swelling, sinus tract formation, and ulceration. The ribs, skull, spine, and long bones are most commonly affected. Patients with osteomyelitis often have pulmonary or cutaneous involvement. Vertebral osteomyelitis can be complicated by paraspinal abscess, psoas abscess, and vertebral body collapse. Extension of long bone osteomyelitis can result in pathologic fracture or septic arthritis. Genitourinary blastomycosis occurs in just under 10% of adults but is rare in children.

**CNS blastomycosis** (brain abscess, meningitis) occurs in <10% of immunocompetent patients but in up to 40% of persons with AIDS. The majority of patients with CNS blastomycosis have clinically apparent infection at non-CNS sites (e.g., lung, skin, mass lesion). Symptoms of CNS infection include headache, altered mental status, memory loss, seizure, cranial nerve deficits, and focal neurologic deficits. Complications include hydrocephalus, cerebral herniation, infarction, panhypopituitarism, residual weakness, and poor functioning in school. Lumbar puncture demonstrates leukocytosis with a neutrophil or lymphocyte predominance, elevated protein, and low glucose. Growth of *Blastomyces* in culture from cerebrospinal fluid occurs in less than 50% of affected patients.

Blastomycosis can complicate pregnancy, and clinical information is limited to case reports. Disseminated infection involving the lungs, skin, and bone is common. Spread of infection to the placenta has been documented by histopathology; however, the frequency of placental blastomycosis remains unknown. Transmission of *Blastomyces* to the fetus is uncommon and is postulated to occur through transplacental transmission or aspiration of infected vaginal secretions. Although clinical data are limited, blastomycosis during pregnancy does not appear to increase the risk for congenital malformations.

## DIAGNOSIS

The diagnosis of blastomycosis requires a high index of suspicion because the clinical and radiographic manifestations can mimic other diseases, including community-acquired pneumonia, tuberculosis, and malignancy. The misdiagnosis of blastomycosis, most often as community-acquired pneumonia, results in a delay of therapy and progression of disease, including dissemination and respiratory failure. In addition, absence of exposure to traditional environmental risk factors for blastomycosis can lead to a delay in diagnosis. Blastomycosis should be included in the differential diagnosis for patients with pneumonia who (1) live in or visit areas in which this pathogen is endemic, (2) fail to respond to a treatment course of antibiotics, or (3) have concomitant skin lesions or osteomyelitis. A detailed medical history regarding exposure risks (e.g., canoeing, rafting, hiking, fishing, playing in outdoor forts, beaver dam exploration, home remodeling, nearby road or building construction, woodpile for a wood burning stove, and use of a community compost pile) should be obtained. In addition, the health of family pets such as dogs should be ascertained, as canine disease may be a harbinger of human infection. Studies from Wisconsin and Minnesota have demonstrated that 7.7–10% of persons with blastomycosis have a dog with concomitant or prior blastomycosis. The incidence of canine blastomycosis is 10-fold higher than human blastomycosis, and canine infection suggests a common source of environmental *Blastomyces* exposure.

Growth of *Blastomyces* in culture from sputum, skin, bone, or other clinical specimens provides a definitive diagnosis. Sputum specimens should be stained with 10% potassium hydroxide or calcofluor white. Histopathology shows neutrophilic infiltration with noncaseating

granulomas (pyogranulomas). *Blastomyces* yeast in tissue samples can be visualized using Gomori methenamine silver or periodic acid–Schiff stains. Yeasts are 4–29 µm in size, have a double refractile cell wall, and are characterized by broad-based budding between mother and daughter cells.

Nonculture diagnostic techniques should be used in conjunction with fungal smears and cultures to facilitate the diagnosis of blastomycosis. The development of a *Blastomyces* antigen test has supplanted insensitive serologic methods such as complement fixation and immunodiffusion. Urine, serum, cerebrospinal fluid, and bronchoalveolar fluid specimens can be collected for the *Blastomyces* antigen test. Sensitivity of the urine antigen test ranges from 85% to 93% and is influenced by the burden of infection. The antigen test has similar sensitivity for *B. dermatitidis* and *B. gilchristii*, but ability to detect other species is poorly characterized. The antigen test can cross react with other dimorphic fungi, including *Histoplasma capsulatum*, *Paracoccidioides brasiliensis*, and *Penicillium marneffeii*, decreasing the specificity to 76.9–79%. An antibody test against the BAD1 protein has been developed and has a sensitivity of 87.8% and a specificity of 94–99%; however, this test is not yet commercially available. Combination antigen and BAD1 antibody testing can increase diagnostic sensitivity to 97.6%.

## TREATMENT

Antifungal therapy is influenced by the severity of the infection, involvement of the CNS, the integrity of the host's immune system, and pregnancy. All persons diagnosed with blastomycosis should receive antifungal therapy. **Newborns** with blastomycosis should be treated with amphotericin B deoxycholate 1 mg/kg/day. **Children with mild to moderately severe infection** can be treated with itraconazole 10 mg/kg/day (maximum: 400 mg/day) for 6–12 months. **Children with severe disease, immunodeficiency, or immunosuppression** should be treated with amphotericin B deoxycholate 0.7–1.0 mg/kg/day or lipid amphotericin B 3–5 mg/kg/day until there is clinical improvement, generally 7–14 days, and then itraconazole 10 mg/kg/day (maximum: 400 mg/day) for a total of 12 months. **Central nervous system blastomycosis** requires therapy with lipid amphotericin B 5 mg/kg/day for 4–6 weeks, followed by itraconazole, fluconazole, or voriconazole for ≥12 months.

All pediatric patients of childbearing age should undergo pregnancy testing before initiation of azole antifungals. Itraconazole can increase the risk for spontaneous abortion, and fluconazole can cause craniofacial defects resembling Antley-Bixler syndrome. Voriconazole and posaconazole cause skeletal abnormalities in animal models. Treatment of blastomycosis in **pregnant patients** consists of lipid amphotericin B 3–5 mg/kg/day for 6–8 weeks.

For patients receiving itraconazole, the oral antifungal of choice, therapeutic drug monitoring should be performed 14 days into therapy (goal total itraconazole level 1–5 µg/mL), and liver function tests should be monitored periodically. Because of the long half-life of itraconazole, serum drug levels can be obtained at any time of the day, irrespective of when the drug was administered. Total itraconazole level is determined by adding itraconazole and hydroxyitraconazole concentrations; hydroxyitraconazole is a metabolite that possesses antifungal activity. Voriconazole, posaconazole, and isavuconazonium sulfate have activity against *B. dermatitidis*. Clinical experience with these drugs is growing, and treatment outcomes are promising. Therapeutic drug monitoring is recommended for voriconazole and posaconazole (goal trough levels 1–5 µg/mL) and can be considered with isavuconazonium sulfate. The echinocandins (caspofungin, micafungin, and anidulafungin) should not be used to treat blastomycosis. Serial measurement of urine antigen levels to assess response to therapy can be a helpful adjunct in monitoring response to antifungal therapy.

Visit Elsevier eBooks+ at [eBooks.Health.Elsevier.com](http://eBooks.Health.Elsevier.com) for Bibliography.

## Chapter 286

# Coccidioidomycosis (*Coccidioides* Species)

Felicia A. Scaggs Huang and  
Rebecca C. Brady

## ETIOLOGY

**Coccidioidomycosis** (valley fever, San Joaquin fever, desert rheumatism, coccidioidal granuloma) is caused by *Coccidioides* spp., a soil-dwelling dimorphic fungus. *Coccidioides* spp. grow in the environment as spore-bearing (arthroconidia-bearing) mycelial forms. In their parasitic form, they appear as unique, endospore-bearing spherules in infected tissue. The two recognized species, *C. immitis* and *C. posadasii*, cause clinically indistinguishable illnesses.

## EPIDEMIOLOGY

*Coccidioides* spp. inhabit soil in arid regions. *C. immitis* is primarily found in California's San Joaquin Valley. *C. posadasii* is endemic to southern regions of Arizona, Utah, Nevada, New Mexico, western Texas, and regions of Mexico and Central and South America. The risk of infection among long-term residents in endemic regions is 3% per year.

Population migrations into endemic areas and increasing numbers of immunosuppressed persons have caused coccidioidomycosis to become an important health problem. From 2000 to 2012 in California, 4,582 cases, 1,301 hospitalizations, and 11 deaths associated with coccidioidomycosis were reported in children, who accounted for 9.2% of total cases. From 2015 to 2016, the rate of coccidioidomycosis cases among California children increased from 2.1 per 100,000 to 5.2 per 100,000. Case and hospitalization rates were highest in males and those 12–17 years. Another recent California study showed that 55% of children were hospitalized, with a median length of stay of 44 days.

Infection results from inhalation of aerosolized spores. Incidence increases during windy, dry periods that follow rainy seasons. Seismic events, archaeological excavations, and other activities that disturb contaminated sites have caused outbreaks. Person-to-person transmission does not occur. Rarely, infections result from spores that contaminate fomites or grow beneath casts or wound dressings of infected patients. Infection has also resulted from transplantation of organs from infected donors and from mother to fetus. Visitors to endemic areas can acquire infections, and diagnosis may be delayed when they are evaluated in nonendemic areas. Spores are highly virulent, and *Coccidioides* spp. are potential agents of bioterrorism (see [Chapter 763](#)).

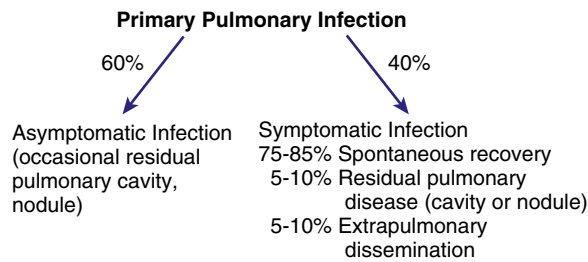
## PATHOGENESIS

Inhaled spores reach terminal bronchioles, where they transform into septated spherules that resist phagocytosis and within which many endospores develop. Released endospores transform into new spherules, and the process results in an acute focus of infection. Endospores can also disseminate lymphohematogenously. Eventually, a granulomatous reaction predominates. Both recovery and protection upon reexposure depend on effective cellular immunity.

Children with congenital primary immunodeficiency disorders may be at increased risk for infection; these disorders include interleukin-12Rβ1 deficiency, interferon-γR1 deficiency, and *STAT1* gain-of-function mutations.

## CLINICAL MANIFESTATIONS

The clinical spectrum ([Fig. 286.1](#)) encompasses pulmonary and extrapulmonary disease. Pulmonary infection occurs in 95% of cases and can be divided into primary, complicated, and residual



**Fig. 286.1** Natural history of coccidioidomycosis.

infections. Approximately 60% of infections are asymptomatic. Symptoms in children are often milder than those in adults. The incidence of extrapulmonary dissemination in children approaches that of adults.

### Primary Coccidioidomycosis

The incubation period is 1-4 weeks, with an average of 10-16 days. Early symptoms include malaise, chills, fever, and night sweats. Chest discomfort occurs in 50–70% of patients and varies from mild tightness to severe pain. Headache and/or backache are sometimes reported. Evasive, generalized, fine macular, erythematous or urticarial eruptions may be seen within the first few days of infection. Erythema nodosum can occur (more often in females) and is sometimes accompanied by erythema multiforme, usually 3-21 days after the onset of symptoms. The clinical constellation of erythema nodosum, fever, chest pain, and arthralgias (especially knees and ankles) is called *desert rheumatism* and *valley fever*. Profound fatigue can occur and lasts weeks to months. Of note, extrapulmonary manifestations of a primary pulmonary infection do not necessarily represent disseminated disease. In hospitalized children, pulmonary symptoms are most common. The chest examination is often normal even if radiographic findings are present. Dullness to percussion, friction rub, or fine rales may be present. Pleural effusions can occur and can become large enough to compromise respiratory status. Hilar and mediastinal lymphadenopathy are common (Fig. 286.2).

### Complicated Pulmonary Infection

Complicated infections include severe and persistent pneumonia, progressive primary coccidioidomycosis, progressive fibrocavitary disease, transient cavities that develop in areas of pulmonary consolidation, and empyema that follows rupture of a cavity into the pleural space. Some cavities persist, are thin walled and peripheral, and cause no symptoms; occasionally there is mild hemoptysis, and rarely there is serious hemorrhage. Rarely, acute respiratory insufficiency occurs after intense exposure; this condition is associated with high mortality rates.

### Residual Pulmonary Coccidioidomycosis

Residual pulmonary coccidioidomycosis includes fibrosis and persisting pulmonary nodules. Nodules are present in 5–7% of infections and sometimes require differentiation from malignancy in adults.

### Disseminated (Extrapulmonary) Infection

Clinically apparent dissemination occurs in 0.5% of patients. Its incidence is increased in infants; men; pregnant women who become infected during the second and third trimesters; persons of Filipino, African, and Latin American ancestry; and persons from other Asian backgrounds. Primary or acquired disorders of cellular immunity (Table 286.1) markedly increase the risk of dissemination. A convenience sample of 108 children in California reported that diagnosis occurred a median of 57 days after symptom onset in those with disseminated infection (compared to 16 days in those with acute or pulmonary coccidioidomycosis).

Symptoms usually occur within 6 months of primary infection. Prolonged fever, toxicity, skin lesions, subcutaneous and/or osseous cold abscesses, and laryngeal lesions can herald the onset. Skin



**Fig. 286.2** Chest radiograph of a 19-yr-old male with acute primary coccidioidomycosis. There is prominent hilar lymphadenopathy and mediastinal widening.

**Table 286.1** Risk Factors for Poor Outcome in Patients with Active Coccidioidomycosis

#### PRIMARY INFECTIONS

Severe, prolonged ( $\geq 6$  wk), or progressive infection

#### RISK FACTORS FOR EXTRAPULMONARY DISSEMINATION

Primary or acquired cellular immune dysfunction (including patients receiving tumor necrosis factor inhibitors or high-dose glucocorticoids)

Neonates, infants, the elderly

Male sex (adult)

Filipino, African, Native American, or Latin American ethnicity

Late-stage pregnancy and early postpartum period

Standardized complement fixation antibody titer  $>1:16$  or increasing titer with persisting symptoms

Blood group B

Human leukocyte antigen class II allele-DRB1\*1301

Diabetes mellitus

lesions have a predilection for the nasolabial area and appear initially as papules, which evolve to form pustules, plaques, abscesses, and verrucous plaques. Biopsy of these lesions demonstrates spherules. **Basilar meningitis** is the most common manifestation and may be accompanied by ventriculitis, ependymitis, cerebral vasculitis, abscess, and syringomyelia. Headache, vomiting, meningismus, and cranial nerve dysfunction are often present. Untreated meningitis is almost invariably fatal. Hydrocephalus is the most common complication in surviving patients. Bone infections account for 20–50% of extrapulmonary manifestations, are often multifocal, and can affect adjacent structures. Miliary dissemination and peritonitis can mimic tuberculosis.



## DIAGNOSIS

Nonspecific tests have limited usefulness. Most routine laboratory evaluations are unremarkable. Complete blood count might show an elevated eosinophil count; marked eosinophilia can accompany dissemination. As a result, a high index of suspicion is required to direct an appropriate workup, especially in patients who have visited or reside in an endemic area.

## Culture, Histopathologic Findings, and Antigen Detection

Any isolation of *Coccidioides* spp. from a patient specimen is considered definitive evidence of infection because the fungus is not part of the normal human microbiome. However, although diagnostic, culture is positive in only 8.3% of respiratory tract specimens and in 3.2% of all other sites. It may take several days for a specimen to grow. *Coccidioides* spp. is isolated from clinical specimens as the spore-bearing mold form, and thus the laboratory should be informed and use special precautions when the diagnosis is suspected. Inappropriate biocontainment procedures can lead to infection of exposed laboratory staff. The observation of endospore-bearing spherules in histopathologic specimens using potassium hydroxide (KOH) preparations, calcofluor white, or hematoxylin and eosin (H&E) stains is diagnostic. Periodic acid Schiff- or Gomori-methenamine silver stains also may be used to demonstrate the fungus.

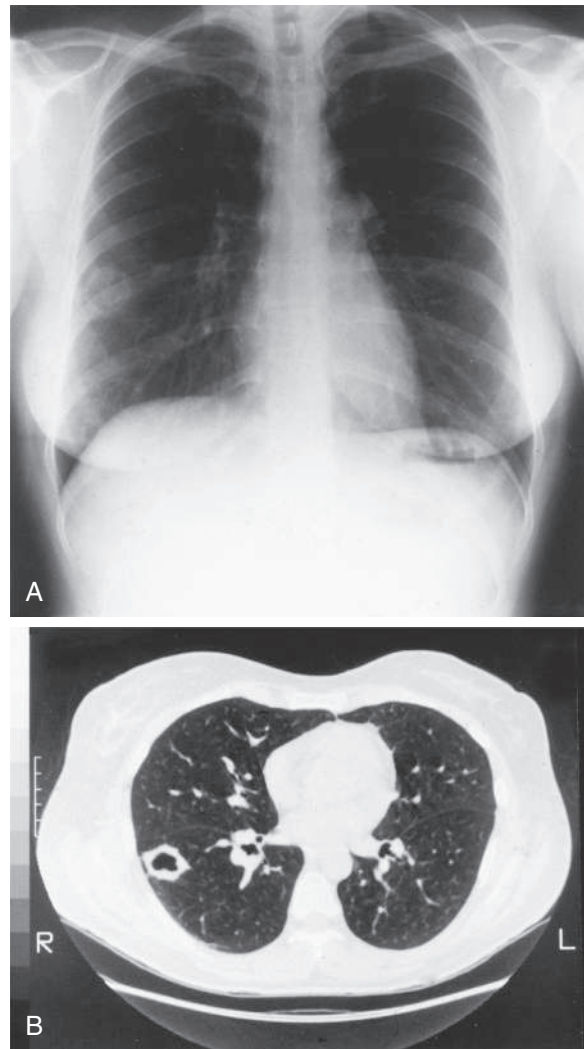
A quantitative enzyme immunoassay (EIA) (MiraVista Diagnostics, Indianapolis, IN) that detects coccidioidal galactomannan in urine, serum, plasma, cerebrospinal fluid (CSF), or bronchoalveolar lavage fluid has excellent specificity and is positive in 70% of patients with severe infections. Although the EIA can cross react with other endemic mycoses, interpretation is often straightforward because there is negligible geographic overlap with areas endemic for other mycoses. In addition, a real-time polymerase chain reaction (PCR) assay has been developed to directly detect the fungus in tissue samples. The specificity is high, but sensitivity is not greater than that of routine cultures. Presently, *Coccidioides* spp. PCR is available through reference laboratories.

CSF analysis should be performed in patients with suspected dissemination. Findings in meningitis are similar to those seen with tuberculous meningitis (see Chapter 261). Eosinophilic pleocytosis may be present. Fungal stains and culture are usually negative. Volumes of 10 mL in adults have improved the yield of culture.

## Serology

Serologic tests provide valuable diagnostic information but may be falsely negative early in self-limited infections and in immunocompromised patients. Three major methods are used, including EIA, complement fixation (CF), and immunodiffusion. EIA and CF tests are best done in experienced reference laboratories because false-positive results may be reported.

Immunoglobulin (Ig) M-specific antibody becomes measurable in 50% of infected patients 1 week after onset and in 90% of infected patients by 3 weeks. EIA is sensitive and can detect IgM and IgG antibody. It is less specific than other methods; confirmation with immunodiffusion or CF may be needed. IgG antibodies measured by CF appear between the second and third week but can take several months; follow-up testing is needed if tests are negative and clinical suspicion persists. In the presence of CF titers of 1:2 or 1:4, a positive immunodiffusion test can help corroborate significance because it is less sensitive but more specific than EIA. IgG-specific antibody can persist for months, with titers elevated in proportion to the severity of illness. CF titers >1:16 are suggestive of dissemination. Direct comparison of the results of CF (IgG) antibody tests measured by different methodologies should be interpreted with caution. IgG antibody titers used to monitor disease activity should be tested concurrently with serum samples taken earlier in the illness using the same methodology.



**Fig. 286.3** A, Chest radiograph revealing a chronic cavitary lesion in the right lung of a female with coccidioidomycosis. B, CT showing the same cavity in the right lung.

*C. immitis* antibody is present in CSF in 95% of patients with meningitis and is usually diagnostic. Rarely, “spillover” in patients without meningitis but with high IgG titers in serum can be present in CSF. Isolation of *Coccidioides* spp. from CSF culture of patients with meningitis is uncommon, although culture of large volumes of CSF may improve sensitivity.

## Imaging Procedures

During primary infection, chest radiography may be normal or demonstrate consolidation, single or multiple circumscribed lesions, or soft pulmonary densities. Pulmonary infiltrates in the upper lobes are more common in coccidioidal infection than in classic bacterial pneumonia. Hilar and subcarinal lymphadenopathy is often present (see Fig. 286.2). Cavities tend to be thin walled (Fig. 286.3). Pleural effusions vary in size. The presence of miliary or reticulonodular lesions is prognostically unfavorable. Isolated or multiple osseous lesions are usually lytic and affect cancellous bone. Lesions can affect adjacent structures, and vertebral lesions can affect the spinal cord.

## TREATMENT

Based on the few rigorous clinical trials performed in adults and the opinions of experts in the management of coccidioidomycosis, consensus treatment guidelines have been developed (Table 286.2).



**Table 286.2** Indications for Treatment of Coccidioidomycosis in Adults

INDICATION	TREATMENT
Acute pneumonia, mild	Observe without antifungal treatment at 1- to 3-mo intervals for 2yr; some experts recommend antifungal treatment
Weight loss >10%; night sweats >3wk; infiltrates at least half of one lung or parts of both lungs; prominent or persistent hilar lymphadenopathy; complement fixation titers >1:16; inability to work, symptoms >2mo	Treat with an azole daily for 3-6 mo, with follow-up at 1- to 3-mo intervals for 2yr
Uncomplicated acute pneumonia, special circumstances: immunosuppression, late pregnancy, Filipino or African ancestry, age >55yr, other chronic diseases (diabetes, cardiopulmonary disease), symptoms >2mo	Treat with an azole daily for 3-6 mo, with follow-up at 1- to 3-mo intervals for 2yr Treat with amphotericin B if in late pregnancy
Diffuse pneumonia: reticulonodular or miliary infiltrates suggest underlying immunodeficiency and possible fungemia	Treat initially with amphotericin B if significant hypoxia or rapid deterioration, followed by an azole for ≥1 yr In mild cases, an azole for ≥1 yr
Chronic pneumonia	Treat with an azole for ≥1 yr
Disseminated disease, nonmeningeal	Treat with an azole for ≥1 yr except in severe or rapidly worsening cases, for which amphotericin B is recommended
Disseminated disease, meningeal	Treat with fluconazole (some add intrathecal amphotericin B) and treat indefinitely

Consultation with experts in an area of endemicity should be considered when formulating a management plan. Many patients with mild primary coccidioidomycosis do not require antifungal therapy. However, those at risk of severe or complicated disease should receive treatment.

Treatment is recommended for HIV-infected patients with active coccidioidomycosis and CD4 counts <250/μL. After successful treatment, antifungals may be stopped if the CD4 count exceeds 250/μL. Treatment should be continued if the CD4 count remains less than 250/μL and should be given indefinitely in all HIV-infected patients with coccidioidal meningitis. Patients with other forms of chronic immunosuppression (e.g., solid organ transplant recipients) may also require lifelong therapy.

First-line agents include oral and intravenous preparations of **fluconazole** (6-12 mg/kg; max 400-1200 mg/day) and itraconazole (2-5 mg/kg PO twice daily; max 400 mg/day). Fluconazole is often the first-line therapy because it has high bioavailability and few side effects. Serum concentrations of itraconazole should be monitored.

**Amphotericin B** is preferred for initial treatment of severe infections. Amphotericin B deoxycholate is less costly than lipid formulations and is often well tolerated in children. Once a daily dose of amphotericin B deoxycholate of 0.5-1.5 mg/kg/day is achieved, the frequency of administration can be reduced to 3 times weekly. The recommended total dosage ranges from 15-45 mg/kg and is determined by the clinical response. Lipid formulations of amphotericin are

recommended for patients with impaired renal function, for patients receiving other nephrotoxic agents, or if amphotericin B deoxycholate is not tolerated. Some experts prefer liposomal amphotericin to treat central nervous system infections because it achieves higher levels in brain parenchyma. Amphotericin B preparations do not cross the blood-brain barrier to effectively treat *Coccidioides* spp., but they can mask the signs of meningitis. Infections during pregnancy should be treated with amphotericin B, because the azoles are potentially teratogenic. Isavuconazole, voriconazole, and posaconazole have been used successfully as salvage therapy.

### Primary Pulmonary Infection

Primary pulmonary coccidioidomycosis resolves in 95% of patients without risk factors for dissemination; antifungal therapy does not lessen the frequency of dissemination or pulmonary residua. When it is elected to defer antifungal therapy, visits are recommended at 1- to 3-month intervals for 2 years and as needed.

Patients with significant or prolonged symptoms are more likely to incur benefit from antifungal agents, but there are no established criteria upon which to base the decision. Table 286.2 summarizes commonly used indicators in adults. A treatment trial in adults with primary respiratory infections examined outcomes of antifungal therapy prescribed on the basis of severity and compared them with an untreated group with less severe symptoms; complications occurred only in patients in the treatment group and only in those in whom treatment was stopped. If treatment is elected, a 3- to 6-month course of fluconazole (12 mg/kg/day) or itraconazole (10 mg/kg/day) is recommended.

### Diffuse Pneumonia

Diffuse reticulonodular densities or miliary infiltrates, sometimes accompanied by severe illness, can occur in dissemination or after exposure to a large fungal inoculum. In this setting, amphotericin B is recommended for initial treatment, followed thereafter by extended treatment with high-dose fluconazole (see Table 286.2).

### Disseminated (Extrapulmonary) Infection

For nonmeningeal infection (see Table 286.2), oral fluconazole and itraconazole are effective for treating disseminated coccidioidomycosis that is not extensive, is not progressing rapidly, and has not affected the central nervous system. Some experts recommend higher doses for adults than were used in clinical trials. A subgroup analysis showed a tendency for improved response of skeletal infections that were treated with itraconazole. Amphotericin B deoxycholate is used as an alternative, especially if there is rapid worsening and lesions are in critical locations. Voriconazole has been used successfully as salvage therapy. The optimal duration of therapy with the azoles has not been clearly defined. Late relapses have occurred after lengthy treatment and favorable clinical response.

### Meningitis

Therapy with oral or IV fluconazole is currently preferred for coccidioidal meningitis. In adults, a dosage of 400-1,200 mg/day is recommended. For children, the dose is 12 mg/kg/day. Some experts use intrathecal, intraventricular, or intracisternally administered amphotericin B in addition to an azole, believing that the clinical response may be faster. Patients who respond to the azole should continue treatment indefinitely. Hydrocephalus is common and not necessarily a marker of treatment failure. In the event of treatment failure with azoles, intrathecal amphotericin B deoxycholate is indicated, with or without the azole. Cerebral vasculitis can occur and may predispose to cerebral ischemia, infarction, or hemorrhage. The efficacy of high-dose steroids is unresolved. Salvage therapy with isavuconazole or voriconazole has been effective.

### Surgical Management

If a pulmonary cavity is located peripherally or there is recurrent bleeding or pleural extension, excision may be needed. Infrequently, bronchopleural fistula or recurrent cavitation occurs as a surgical

complication; rarely, dissemination can result. Perioperative intravenous amphotericin B may be considered. Drainage of cold abscesses, synovectomy, and curettage or excision of osseous lesions are sometimes needed. Surgical consultation is appropriate if vertebral involvement is identified to evaluate for spinal cord involvement. Local and systemic administration of amphotericin B can be used to treat coccidioidal articular disease.

### Monitoring

Patients should be followed closely because late relapses can occur despite treatment, especially in those who are immunosuppressed or have severe manifestations. Testing for CF antibodies should be obtained every 12 weeks during treatment. Most titers decline as the patient improves and ultimately become undetectable. However, titers may remain positive in recovered patients. Progressive or disseminated disease should be considered when titers are persistently elevated (>1:32). These individuals may need thorough physical examinations and imaging studies. After completion of therapy, patients should be evaluated yearly for at least 2 years because some patients relapse (28% of adults who completed 12 months of fluconazole, 18% for itraconazole).

### Refractory Disease

In patients who do not improve clinically on appropriate therapy, develop new symptoms, or have persistently elevated CF titers, investigations are indicated for complicated and disseminated disease. Evaluations should assess for joint effusions, skin lesions, and neurologic dysfunction. Consultation with a physician experienced in the management of coccidioidal infections should be considered.

### PREVENTION

Prevention relies on education about ways to reduce exposure. Physicians practicing in nonendemic regions should incorporate careful travel histories when evaluating patients with symptoms compatible with coccidioidomycosis.

Visit Elsevier eBooks+ at [eBooks.Health.Elsevier.com](http://eBooks.Health.Elsevier.com) for Bibliography.

## Chapter 287

# Paracoccidioides brasiliensis

Andrew P. Steenhoff

### ETIOLOGY

Paracoccidioidomycosis (South American or Brazilian blastomycosis, Lutz-Splendore-Almeida disease) is the most common systemic mycosis in Latin America. It is a fungal infection that is endemic in South America, with cases also reported in Mexico and Central America. Brazil accounts for more than 80% of all reported cases. The etiologic agent, *Paracoccidioides brasiliensis*, is a thermally dimorphic fungus found in the environment in the mycelial (mold) form and in tissues as yeast.

### EPIDEMIOLOGY

*P. brasiliensis* is a soil-inhabiting microorganism and is ecologically unique to Central and South America. Endemic outbreaks occur mainly in the tropical rainforests of Brazil, with cases scattered in Argentina, Colombia, and Venezuela. There is an increased incidence

in areas with moderately high altitude, with high humidity and rainfall, and where coffee and tobacco are grown. Armadillos appear to be a natural reservoir for *P. brasiliensis*. The most common route of infection is by inhalation of conidia. The disease is not usually thought to be contagious, and person-to-person transmission has not been confirmed. Paracoccidioidomycosis is more common among boys after puberty because of the role of estrogen in preventing the transition of conidia to the yeast form. Children account for <10% of the total number of cases.

### PATHOGENESIS

Invasion of *P. brasiliensis* into the human body is based on a myriad of fungal components and strategies to bypass host defense mechanisms. With the emergence of CRISPR technology and full access to diverse databanks (such as genomes, transcriptomes, proteomes, metabolomes, lipidomes), investigators are poised to better understand the virulence processes of *P. brasiliensis*, hopefully allowing translation into benefits for patients.

The entry route into the body is via the respiratory tract, and the lungs are the site of primary infection, although not all patients have respiratory symptoms. Once the conidia or hyphal fragments reach the alveoli, yeast transformation takes place. The infection then spreads to the mucous membranes of the nose, mouth, and gastrointestinal tract. Cell-mediated immunity, mainly through lymphocytes and the production of Th-1 cytokines, is crucial to containing the infection. Tumor necrosis factor- $\alpha$  and interferon- $\gamma$  activated macrophages are responsible for intracellular killing of *P. brasiliensis*. If the initial immune response is not successful, the response may shift toward a Th-2 pattern, which is unable to contain the infection, resulting in clinical progression. The yeast can disseminate by the lymphohematogenous route to skin, lymph nodes, and other organs and remain dormant in lymph nodes, producing a latent infection with reactivation occurring later in life. There are cases of patients who developed disease 30 or more years after leaving an endemic region.

Histopathologically, the yeastlike cells are round, with the parent cell being quite large and surrounded by small buds, giving it the appearance of a ship's wheel. A mixed suppurative and granulomatous inflammatory reaction with areas of necrosis is seen in pulmonary infections. In chronic infections, fibrosis and calcification may be seen. Mucocutaneous infections are typified by ulceration and pseudoepitheliomatous hyperplasia.

### CLINICAL MANIFESTATIONS

There are two clinical forms of disease. The **acute** form (juvenile paracoccidioidomycosis) is rare, occurs almost exclusively in children and persons with impaired immunity, and targets the reticulo-endothelial system. Pulmonary symptoms may be absent, although chest radiographs often show patchy, confluent, or nodular densities. Patients typically present acutely with fever, malaise, wasting, lymphadenopathy, and abdominal enlargement from intraabdominal lymphadenopathy. Hepatomegaly and splenomegaly are nearly constant. Localized bony lesions have been reported in children and can progress to systemic disease. Multifocal osteomyelitis, arthritis, and pericardial effusions can also occur. Nonspecific laboratory findings include anemia, eosinophilia, and hypergammaglobulinemia. Acute paracoccidioidomycosis has a 25% mortality rate. Hepatic involvement associated with jaundice and hypoalbuminemia may confer a worse prognosis.

Adults develop a **chronic** progressive illness that manifests initially with flulike symptoms, fever, and weight loss (adult paracoccidioidomycosis). Pulmonary infection develops with dyspnea, cough, chest pain, and hemoptysis. Findings on physical examination are scant, although chest radiographs can show infiltrates that are disproportionate with mild clinical findings. Mucositis involving the mouth and its structures as well as the nose can manifest as localized pain, change in voice, or dysphagia. Lesions can extend beyond the oral cavity onto the skin. Generalized lymphadenopathy, hepatosplenomegaly, and

adrenal involvement (seen in 15–50% of cases) can lead to Addison disease. Meningoencephalitis and central nervous system granulomas can occur as presenting or secondary symptoms. Adults with extensive exposure to soil, such as farmers, are most likely to develop the chronic form of the disease.

## DIAGNOSIS

Demonstration of the fungus by direct wet mount (potassium hydroxide) preparation of sputum, exudate, or pus supports the diagnosis in many cases. Histopathologic examination of biopsy specimens using special fungal staining techniques is also diagnostic. Immunohistochemistry using monoclonal antibodies to specific glycoproteins can also be done on tissue sections. Culture of the fungus on Sabouraud dextrose or yeast extract agar confirms the diagnosis. Antibodies to *P. brasiliensis* can be demonstrated in most patients. Serial antibody titers and lymphocyte proliferative responses to fungal antigens are useful for monitoring the response to therapy. The 43-kDa glycoprotein (gp43) is present in sera of more than 90% of patients with paracoccidioidomycosis by immunodiffusion (the most commonly used diagnostic test) and in 100% of patients by immunoblotting. A latex particle agglutination test using pooled crude fungal exoantigens is being developed for the detection of anti-*P. brasiliensis* antibodies and has shown 92% agreement with the immunodiffusion test. Newer diagnostic methods that might prove to be very useful in the future include polymerase chain reaction, detection of gp43, and capture enzyme-linked immunosorbent assay to detect specific immunoglobulin E in patient sera. Skin testing with paracoccidioidin is not reliable, because 30–50% of patients with active disease are nonreactive initially, and a positive test indicates previous exposure but not necessarily active disease.

## TREATMENT

**Itraconazole (5–10 mg/kg/day with a maximum dose of 200 mg/day) orally for 6 months is the treatment of choice** for paracoccidioidomycosis. **Fluconazole has also been used**, but high doses ( $\geq 600$  mg/day) and longer treatment periods are required. A small number of patients have been treated with other azoles, including **voriconazole, posaconazole, and isavuconazole**. These drugs are potential substitutes for itraconazole but are more costly and can have interactions with other drugs. **Terbinafine** is an allylamine that has potent in vitro activity against *P. brasiliensis* and has been used for successful treatment of paracoccidioidomycosis. **Amphotericin B** is recommended for disseminated disease and if other therapies fail. Therapy with sulfonamide compounds, including sulfadiazine, TMP-SMX (trimethoprim 8–10 mg/kg/day to maximum of 160 mg, sulfamethoxazole 40–50 mg/kg/day to maximum of 800 mg), and dapsone, have been used historically and are generally less expensive than the newer azoles and allylamines. The primary disadvantage is that the treatment course is very long, lasting months to years, depending on the agent selected. Relapse can occur after any form of therapy, including with amphotericin B. In selected patients with intense inflammation in sites such as the central nervous system or with lung lesions causing respiratory insufficiency, there is some evidence that use of prednisone for 1–2 weeks concomitantly with antifungal therapy reduces inflammation more effectively and may be of benefit. Occasionally children develop paradoxical clinical worsening during treatment, including new lymph node enlargement, fistula formation, fever, and weight loss. In this circumstance, steroids are also recommended.

Two therapies currently under investigation include the use of **curcumin**, an antioxidant found in the Indian spice turmeric, and the calcineurin inhibitor **cyclosporine**. Curcumin was found to have more antifungal activity than fluconazole against *P. brasiliensis* when studied in vitro using human buccal epithelial cells. Cyclosporine blocks the thermodimorphism of *P. brasiliensis*. Animal models demonstrate that fungal whole cells, purified antigens, peptides, and DNA vaccines have great potential toward the development of a vaccine for use in humans.

Visit Elsevier eBooks+ at [eBooks.Health.Elsevier.com](http://eBooks.Health.Elsevier.com) for Bibliography.

## Chapter 288

# Sporotrichosis (*Sporothrix schenckii*)

Andrew P. Steenhoff

## ETIOLOGY

Sporotrichosis is a rare fungal infection that occurs worldwide, both sporadically and in outbreaks, and is caused by *Sporothrix schenckii*, which exhibits temperature dimorphism, existing as a mold at environmental temperatures (25–30°C [77–86°F]) and as a yeast in vivo (37°C [98.6°F]). *S. schenckii* comprises a group of cryptic, phylogenetically related species, including *S. brasiliensis*, *S. chilensis*, *S. globosa*, *S. luriei*, *S. mexicana*, and *S. pallida*. *S. brasiliensis* is the most virulent species.

## EPIDEMIOLOGY

*S. schenckii* is found throughout the world, but most cases of sporotrichosis are reported from South America, Central America, and Asia, including Japan, India, and China. In the United States, the majority of cases have occurred in the Midwest, particularly in areas along the Mississippi and Missouri rivers. The fungus is found in decaying vegetation and has been isolated most commonly from sphagnum moss, rosebushes, barberry, straw, and some types of hay. Sporotrichosis can occur as an occupational disease among farmers, gardeners, veterinarians, and laboratory workers. Transmission from bites and scratches of animals, most commonly cats and armadillos, has occurred. Reports of human-to-human transmission are rare. Sporotrichosis has rarely been reported in infants. The mechanism of transmission in children may be zoonotic but usually is unclear. In one endemic area of Peru, the incidence of infection is greater in children than in adults; risk factors for infection in these children are playing in crop fields, living in houses with dirt floors, and owning a cat.

## PATHOGENESIS

Disease in humans usually follows cutaneous inoculation of the fungus into a minor wound. Pulmonary infection can result from the inhalation of large numbers of spores. Disseminated infection is unusual but can occur in immunocompromised patients after ingestion or inhalation of spores. The cellular immune response to *S. schenckii* infection is both neutrophilic and monocytic. Histologically, the coexistence of noncaseating granulomas and microabscess formation is characteristic. T-cell-mediated immunity appears to be important in limiting infection, and antibody does not protect against infection. As a result of the paucity of organisms, it is usually difficult to demonstrate the fungi in biopsy specimens.

## CLINICAL MANIFESTATIONS

Cutaneous sporotrichosis is the most common form of disease in all age-groups. Cutaneous disease may either be lymphocutaneous or fixed cutaneous, the former being much more common (Fig. 288.1). Lymphocutaneous sporotrichosis accounts for more than 75% of reported cases in children and occurs after traumatic subcutaneous inoculation. After a variable and often prolonged incubation period (1–12 weeks), an isolated, painless erythematous papule develops at the inoculation site. The initial lesion is usually on an extremity in adults but is often on the face in children. The original papule enlarges and ulcerates. Although the infection might remain limited to the inoculation site (fixed cutaneous form), satellite lesions follow lymphangitic spread and appear as multiple tender subcutaneous nodules tracking along the lymphatic channels that drain the lesion. These secondary nodules are subcutaneous granulomas that adhere to the overlying skin and subsequently ulcerate. Sporotrichosis does not heal spontaneously, and these ulcerative lesions can persist for years if untreated. Systemic signs and symptoms are uncommon.





**Fig. 288.1** Sporotrichosis. Erythematous papules and nodules on the plantar surface with early lymphangitic (sporotrichoid) spread. (From Paller AS, Mancini AJ. *Hurwitz Clinical Pediatric Dermatology, 5th ed.* Philadelphia: Elsevier; 2016: Fig. 17.48.)

Extracutaneous sporotrichosis is rare in children, and most cases are reported in adults with underlying medical conditions, including AIDS and other immunosuppressing diseases. The most common form of extracutaneous sporotrichosis involves infection of the bones and joints. Pulmonary sporotrichosis usually manifests as a chronic pneumonitis similar to the presentation of pulmonary tuberculosis. Erythema nodosum is an immunoreactive manifestation.

## DIAGNOSIS

Cutaneous and lymphocutaneous sporotrichosis must be differentiated from other causes of nodular lymphangitis, including atypical mycobacterial infection, nocardiosis, leishmaniasis, tularemia, melioidosis, cutaneous anthrax, and other systemic mycoses, including coccidioidomycosis. Definitive diagnosis requires isolation of the fungus from the site of infection by culture. Special histologic staining such as periodic acid–Schiff and methenamine silver is required to identify yeast forms in tissues, which are typically oval or cigar-shaped. In spite of special staining techniques, diagnostic yield from biopsy specimens is low because of the small number of organisms present in the tissues. In cases of disseminated disease, demonstration of serum antibody against *S. schenckii*-related antigens can be diagnostically useful. Serologic testing is not commercially available but is offered by specialized laboratories, including the Centers for Disease Control and Prevention in the United States.

## TREATMENT

Although comparative trials and extensive experience in children are not available, **itraconazole is the recommended treatment of choice for infections outside the central nervous system.** The recommended dosage for children is 5–10 mg/kg/day orally, with an initial maximum dose of 200 mg daily, which may be increased up to 400 mg daily if there is no initial response. Alternatively, **younger children with cutaneous disease only may be treated with a saturated solution of potassium iodide** (1 drop, 3 times daily by mouth, increasing as tolerated to a maximum of 1 drop/kg of body weight or 40–50 drops, 3 times daily, whichever is lowest). Adverse reactions, usually in the form of nausea and vomiting, should be managed with temporary cessation of therapy and reinstitution at a lower dosage. Therapy is continued 2–4 weeks after cutaneous lesions have resolved, which usually takes at least 6–12 weeks. **Terbinafine has been used successfully to treat cutaneous sporotrichosis but is reported to have lower cure rates and higher relapse rates than itraconazole.** Further clinical efficacy data are needed to routinely recommend its use. **Amphotericin B is the treatment of choice for pulmonary infections, disseminated infections, central nervous system disease, and infections in immunocompromised persons.** Oral **fluconazole** 12 mg/kg daily (maximum dose, 400–800 mg daily) can be used if other agents are not tolerated. **Posaconazole** shows promise, but further data are needed.

Therapy with azoles or a saturated solution of potassium iodide should not be used in pregnant women. **Amphotericin B can be used safely for cases of pulmonary or disseminated disease in pregnancy.** Pregnant patients with cutaneous disease can be treated with local hyperthermia or can have therapy delayed until the pregnancy is completed. Hyperthermia involves heating the affected area to 42–45°C (107.6–113°F) using water baths or heating pads and works by inhibiting growth of the fungus. Dissemination to the fetus does not occur, and the disease is not worsened by pregnancy. **Surgical debridement has a role in the treatment of some cases of sporotrichosis, particularly in osteoarticular disease.**

Visit Elsevier eBooks+ at [eBooks.Health.Elsevier.com](http://eBooks.Health.Elsevier.com) for Bibliography.

## Chapter 289

# Mucormycosis

Rachel L. Wattier and William J. Steinbach

## ETIOLOGY

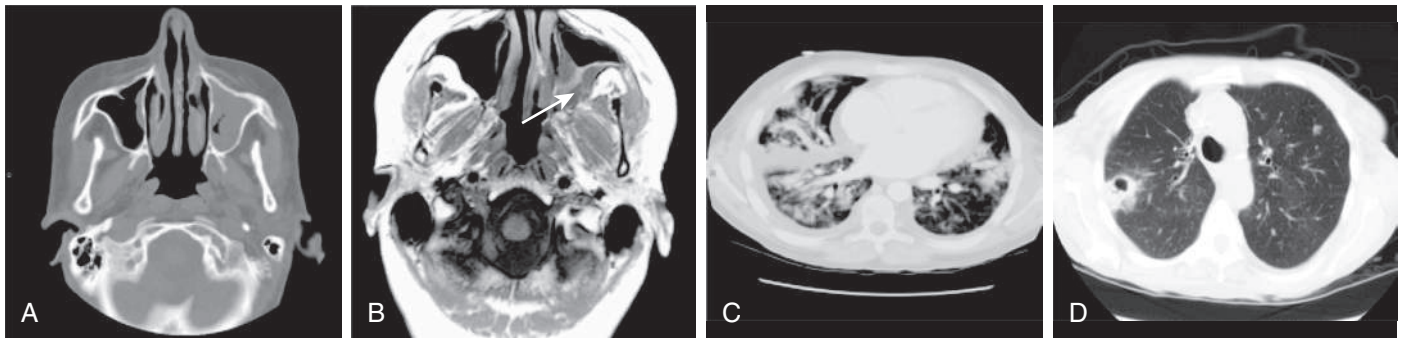
Mucormycosis refers to opportunistic invasive fungal infections caused by fungi of the order Mucorales. These organisms are found commonly in soil and decaying organic matter and are distributed worldwide. Mucormycosis was previously called *zygomycosis*, but this terminology has been abandoned because of reclassification of organisms using molecular phylogenetic analysis. The most common disease-causing genera of Mucorales are *Rhizopus*, *Mucor*, and *Lichtheimia* (formerly *Absidia*). Infections caused by organisms of the genera *Rhizomucor*, *Cunninghamella*, *Saksena*, *Apophysomyces*, and others are less common. Mucormycosis in humans is characterized by a rapidly evolving course, tissue necrosis, and blood vessel invasion.

## EPIDEMIOLOGY

Mucormycosis is primarily a disease of persons with underlying conditions that impair host immunity, though it can sometimes manifest with cutaneous and soft tissue infections at sites of trauma in immunocompetent hosts. Predisposing factors include poorly controlled diabetes, especially if complicated by ketoacidosis, and profound immunocompromise resulting from therapy for hematologic malignancies (especially with prolonged neutropenia), stem cell or organ transplantation, and/or high-dose corticosteroid therapy. Other risk factors include iron overload and prematurity. Mucormycosis may develop as a breakthrough infection in patients receiving voriconazole antifungal prophylaxis; voriconazole lacks activity against the Mucorales. Therefore breakthrough infections or non-response to voriconazole should prompt increased consideration of mucormycosis.

Mucormycosis is the second most common invasive mold infection in immunocompromised hosts after aspergillosis, and its incidence is increasing because of an increase in the number and improved survival of immunocompromised persons at risk. A contemporary review of reported pediatric cases from 2008 to 2017 found a 32% case fatality rate across all included cases. Mortality rates vary depending on disease manifestations of mucormycosis and underlying patient conditions, with worse outcomes observed in patients with more extensive disease manifestations and those with irreversible predisposing risk factors. However, observational studies suggest that pediatric patients with mucormycosis generally have more favorable outcomes compared to adults and that outcomes may be improving over time with contemporary therapeutic approaches.





**Fig. 289.1** Radiographic findings in mucormycosis. A, CT scan shows left maxillary sinus air-fluid level, similar to bacterial sinusitis. B, Magnetic resonance image reveals T2 signal hyperintensity in the left pterygoid musculature (arrow) in conjunction with a left maxillary sinus air-fluid level. C, Multiple heterogeneous nodular and consolidative lesions with a large pulmonary vessel infarct and modest pleural effusions are shown in a patient with cancer and pulmonary mucormycosis. D, Contrast-enhanced CT scan demonstrates a cavity within a dense infiltrate in a patient with acute myelogenous leukemia and pulmonary mucormycosis. (Courtesy Dr. Edith Marom, University of Texas, MD Anderson Cancer Center, Houston, Texas.)

## PATHOGENESIS

Spores can be inhaled from the environment into the upper and/or lower airways, inoculated at sites of cutaneous trauma, or, less commonly, ingested. If, because of impaired immune response, spores are not cleared by macrophages and neutrophils, they germinate into hyphae, resulting in local invasion and tissue destruction. Mucormycosis is characterized by extensive angioinvasion, resulting in thrombosis, infarction, and tissue necrosis, which can limit the delivery of antifungal agents and leukocytes to the site of infection and contribute to dissemination of the infection to other organs.

Many of the Mucorales can scavenge iron, an element essential for cell growth, from the host. The iron chelator deferoxamine paradoxically increases iron availability and uptake by members of the Mucorales. Acidosis diminishes the phagocytic and chemotactic ability of neutrophils while increasing the availability of unbound iron, likely explaining the susceptibility to mucormycosis among individuals with uncontrolled acidosis.

## CLINICAL MANIFESTATIONS

Mucormycosis can occur as any of several clinical syndromes, including rhinocerebral, pulmonary, cutaneous or subcutaneous, gastrointestinal, or disseminated disease. The initial symptoms and signs of each may be subtle and not easily distinguishable from other infections, so it is important to have a high index of suspicion for the disease in patients at risk.

**Rhinocerebral mucormycosis** is the most common form and can involve the palate, sinuses, orbit, and/or adjacent structures with potential progression to the brain. Initial symptoms are similar to sinusitis and include headache, retroorbital pain, fever, and nasal discharge. Infection can evolve rapidly or be slowly progressive. Orbital involvement manifests as periorbital edema, proptosis, ptosis, and/or ophthalmoplegia. The nasal discharge may be dark and bloody; involved tissues become red, then violaceous, and then black as vessel thrombosis and tissue necrosis occur. Extension beyond the nasal cavity into the mouth is common and may be apparent as palatal lesion(s). Destructive paranasal sinusitis with bone involvement and possible intracranial extension can be demonstrated by computed tomography (CT) or magnetic resonance imaging (MRI) (Fig. 289.1). Rhinocerebral mucormycosis can be complicated by cavernous sinus thrombosis or thrombosis of the internal carotid artery. Intracranial extension can occur directly from the nasal cavity and sinuses, usually to the frontal or frontotemporal lobes, or hematogenously, commonly involving the occipital lobe or brainstem.

**Pulmonary mucormycosis** usually occurs in profoundly neutropenic patients and presents similarly to other pulmonary invasive mold infections. Manifestations can include fever, tachypnea, productive cough, pleuritic chest pain, and hemoptysis; however, initial symptoms may be minimal. A wide range of pulmonary radiographic findings, including pulmonary nodules, consolidation, cavitory lesion(s), and lung infarct(s), are recognized (see Fig. 289.1). Although the radiographic findings overlap with other pulmonary invasive fungal



**Fig. 289.2** Cutaneous presentation of mucormycosis. Chronic, non-healing ulcer with necrosis after traumatic inoculation. (From Kontoyianis DP, Lewis RE. *Agents of mucormycosis and entomophthoromycosis*. In Bennett JF, Dolin R, Blaser MJ (eds). *Mandell, Douglas, and Bennett's Principles and Practice of Infectious Diseases*, 8th ed. Philadelphia: Elsevier, 2015. Fig. 260-6A; Courtesy Drs. Gerald Bodey and Saud Ahmed, University of Texas, MD Anderson Cancer Center, Houston, TX.)

infections, the presence of multiple nodules ( $\geq 10$ ), pleural effusion(s), or the **reverse halo sign**, a focal area of ground-glass opacity surrounded by a ring of consolidation, is more suggestive of mucormycosis.

**Cutaneous and soft tissue mucormycosis** can be primary, resulting from direct inoculation at sites of trauma, including burns, surgical sites, or vascular access sites, or secondary, resulting from hematogenous dissemination to the skin from another primary site. Primary cutaneous lesions manifest initially as painful erythematous papules that ulcerate, leaving a black necrotic center. In contrast, secondary cutaneous lesions from hematogenous seeding tend to be nodular, with minimal destruction of the epidermis. Either may be invasive locally, progressing through multiple tissue layers, including muscle, fascia, and bone (Fig. 289.2), with accompanying tissue necrosis.

**Gastrointestinal mucormycosis** is the least common form of disease except in preterm neonates, in whom it is the most commonly reported form of mucormycosis. Manifestations include abdominal pain, nausea, vomiting, gastrointestinal bleeding, obstruction, and perforation. Any part of the gastrointestinal tract can be involved, with the stomach followed by colon and ileum being the most commonly

affected. The clinical presentation in neonates mimics necrotizing enterocolitis, sometimes with a palpable abdominal mass. Recognition of gastrointestinal mucormycosis is challenging given its rarity and overlap in presentation with other gastrointestinal diseases. It is associated with particularly high mortality and commonly not diagnosed until postmortem examination.

**Disseminated mucormycosis** can develop from any site of primary disease but is more commonly associated with initial pulmonary disease. It carries the highest mortality rates seen with mucormycosis, especially among immunocompromised persons. The clinical presentation varies based on the involved sites. Dissemination of mucormycosis to the brain is of particular concern and alters management and prognosis, so many experts recommend brain imaging routinely, even in the absence of neurologic symptoms.

## DIAGNOSIS

All forms of mucormycosis are considered medically emergent, and some (e.g., rhinocerebral) are also surgical emergencies. Diagnostic evaluation and initiation of treatment should be pursued simultaneously with a coordinated multidisciplinary approach. The diagnosis depends on early recognition of compatible clinical findings in a patient with predisposing risk factors. Once mucormycosis is suspected, cross-sectional imaging should be performed to define the site(s) of disease as indicated based on the clinical presentation, and tissue from the site of disease should be obtained for diagnostic evaluation, along with initial surgical debridement for rhinocerebral or cutaneous mucormycosis. The diagnosis relies on direct morphologic identification of mycotic elements from culture or tissue biopsy specimens. Mucorales appear as broad (5–25  $\mu\text{m}$  in diameter), infrequently septate (denoted as aseptate or pauci-septate on pathology), thin-walled hyphae, branching irregularly at right angles when stained with Gomori methenamine silver (GMS) or hematoxylin and eosin. Organisms may be challenging to identify reliably by morphology from tissue specimens; immunohistochemistry or molecular diagnostic tests can provide more reliable identification to the species level.

Mucorales can be cultured on standard laboratory media; however, cultures from nontissue specimens, such as bronchoalveolar lavage fluid, have poor sensitivity. Mucorales hyphae can also be easily disrupted, decreasing the yield of cultures. Submitting fresh tissue with careful handling to avoid disruption (e.g., grinding) can improve yield. When an organism is visualized by histopathology but not recovered in culture, molecular methods may improve detection. Though Mucorales can be culture contaminants, isolation in a susceptible host should prompt consideration of clinical disease. Noninvasive fungal biomarkers, such as galactomannan and 1,3- $\beta$ -D-glucan, do not detect the causative agents of mucormycosis. Though molecular tests are available to detect Mucorales and other fungal pathogens directly from blood samples, these have not yet been sufficiently validated to replace tissue-based diagnosis.

## TREATMENT

Though mucormycosis can be aggressive and difficult to treat, with high mortality rates, more favorable outcomes can be achieved via early recognition and prompt institution of medical therapy combined with extensive surgical debridement of devitalized tissue to the extent possible. It is essential to reverse predisposing factors, such as neutropenia, hyperglycemia, and/or acidosis, and to withdraw immunosuppression or deferoxamine therapy, if applicable.

Given the rarity of mucormycosis, there are few clinical trials to guide optimal therapy. Based on clinical experience, observational data, and small clinical trials, the European Confederation of Medical Microbiology and the Mycoses Study Group published “global guidelines” for mucormycosis in 2019. **Lipid formulations of amphotericin B, with preference for liposomal amphotericin B, are strongly recommended as first-line therapy for all forms of mucormycosis in all age-groups.** It is recommended to initiate therapy with the full dose of liposomal amphotericin B of at least 5 mg/kg/day, with consideration up to 10 mg/kg/day, and 10 mg/kg/day is recommended for treatment of central nervous system infection. Other antifungals with activity

against the Mucorales include isavuconazole (administered as the pro-drug isavuconazonium sulfate) and posaconazole; however, there is less experience with these antifungals for initial or “primary therapy” of mucormycosis, and their activity can vary based on causative species and specific antifungal susceptibility patterns. Guidelines moderately recommend primary therapy with IV formulations of either posaconazole or isavuconazole in patients with significant preexisting renal impairment, because of potential nephrotoxicity with amphotericin B formulations. However, some experts prefer liposomal amphotericin B for patients with severe or progressive mucormycosis even in the setting of renal impairment.

There is increasing pharmacokinetic and safety data supporting the use of isavuconazole and posaconazole in pediatric patients, though posaconazole pharmacokinetics vary by formulation, and the immediate-release oral suspension does not reliably achieve optimal target concentrations. Therefore IV or delayed-release formulations of posaconazole are preferred. **Isavuconazole or posaconazole is recommended for specific roles in the treatment of mucormycosis, the most established role being for “salvage therapy” in patients who either do not respond adequately to initial amphotericin B-based therapy or who develop intolerance precluding continuation of amphotericin B-based therapy.** In the case of inadequate response, many experts recommend combination therapy, including liposomal amphotericin B with either isavuconazole or posaconazole, so that the “backbone” therapy with liposomal amphotericin B can also be continued. Given the rapidly progressive course and severe outcomes associated with mucormycosis, primary combination therapy (a regimen with multiple antifungal agents from the beginning) is also frequently used in practice. However, there is currently insufficient evidence to determine whether initial combination therapy is beneficial over monotherapy with liposomal amphotericin B. The results of animal model studies and observational clinical studies have varied, and some of the better-quality observational studies have not shown a clear benefit. **Combination therapy with liposomal amphotericin B and isavuconazole or posaconazole is therefore marginally recommended in the global mucormycosis guidelines.** Some clinicians have given combination therapy with an echinocandin antifungal (e.g., caspofungin) added to amphotericin B-based therapy based on animal model data and limited clinical studies showing potential benefit with this combination. However, this combination has been less preferred recently, partly because echinocandins lack intrinsic activity against the Mucorales and because increasing data favor isavuconazole or posaconazole for salvage therapy.

Given the complex considerations when selecting and monitoring antifungal therapy for mucormycosis, and also considering surgical approaches, which are well-established for rhinocerebral and cutaneous mucormycosis and favored when possible for localized pulmonary mucormycosis, a multidisciplinary approach with expert guidance is necessary. Patients with mucormycosis should be monitored with frequent repeat imaging to evaluate their response to therapy, and multiple surgical procedures are often necessary to achieve stabilization of disease.

The duration of antifungal therapy is individualized but is usually continued until all clinical and radiographic findings have resolved and the patient shows reconstitution or significant improvement of their immune response. Patients with a good response to initial IV antifungal therapy may be converted to maintenance therapy with enteral isavuconazole or posaconazole.

Various adjunctive therapies have been reported for mucormycosis; the most commonly used are treatments such as hematopoietic growth factors to reverse neutropenia as a predisposing factor. Hyperbaric oxygen has been used anecdotally as an adjunctive therapy but is not well established and not routinely recommended. Iron chelation with deferasirox has been tried as salvage therapy in refractory mucormycosis but is currently not recommended because of adverse outcomes in a small clinical trial. The overall emphasis of disease management should remain on optimizing the antifungal and surgical therapies and reversing any modifiable predisposing conditions.



## Chapter 290

*Pneumocystis jirovecii*

Francis Gigliotti and Terry W. Wright

*Pneumocystis jirovecii* pneumonia (interstitial plasma cell pneumonitis) in an immunocompromised person is a life-threatening infection. Primary infection in the immunocompetent individual is usually subclinical and goes unrecognized. The disease most likely results from new or repeat acquisition of the organism rather than reactivation of latent organisms. Even in the most severe cases, with rare exceptions, the pathogen remains localized to the lungs.

**ETIOLOGY**

The genus *Pneumocystis* contains a group of common extracellular fungal pathogens, which are found worldwide and exist exclusively in the lungs of mammalian hosts as **obligate biotrophs**. The initial taxonomic placement of *Pneumocystis* was ambiguous. However, comparative genomics definitively positioned *Pneumocystis* among the ascomycetous fungi, despite sharing certain morphologic features and drug susceptibility profiles with protozoa. Detailed information on the basic biology and life cycle of *Pneumocystis* is incomplete because of the inability to grow these organisms in culture. However, phenotypic and genotypic analyses show that the *Pneumocystis* organisms infecting each individual mammalian host are unique and restricted to that host. Current knowledge suggests that a distinct *Pneumocystis* evolved in each host species and ultimately adapted to its specific host in a manner that prevented transmission and replication in heterologous host species.

The clear biological distinction of *Pneumocystis* from different mammalian hosts led to the **division of *Pneumocystis* into multiple species** that are named according to the host from which they are derived. Current convention uses the name *P. jirovecii* to refer to the *Pneumocystis* species infecting humans, whereas those infecting rats and mice are designated *P. carinii* and *P. murina*, respectively. Clinicians should be aware that the term *P. carinii* was originally used for all *Pneumocystis* regardless of host species of origin and may sometimes refer to human-derived *Pneumocystis* in older medical literature.

**EPIDEMIOLOGY**

*P. jirovecii* is found worldwide, but a natural habitat outside of the human host has not been identified. Serologic surveys show that most humans are exposed to *P. jirovecii* before 4 years of age, and polymerase chain reaction (PCR) analyses has confirmed the prevalence of *P. jirovecii* in both children and adults. Full genome sequencing of three *Pneumocystis* species, including *P. jirovecii*, revealed that ***Pneumocystis* has lost critical genes required for autonomous survival and growth**. Thus currently available evidence suggests that *P. jirovecii* only lives in the lungs of humans and that it persists in the human population through repeat subclinical or mild infection of immunocompetent adults and children. Gene loss helps to explain the inability to either culture *Pneumocystis* or identify a natural reservoir outside the host. The universal prevalence of *P. jirovecii* in the human population likely explains why *P. jirovecii* is a common opportunistic infection in immunocompromised people not receiving prophylaxis.

The mode of *Pneumocystis* transmission to humans is undefined, but animal-to-animal airborne transmission has been clearly demonstrated. Animal-to-human transmission is unlikely because of the stringent host-species restriction of *Pneumocystis* species. Person-to-person transmission is likely but has not been directly proven. However, the appearance of geographically clustered *Pneumocystis* cases caused by genetically similar *P. jirovecii* strains supports the occurrence of community spread among immunocompromised patients. In addition, *P. jirovecii* has been detected in air samples collected in close proximity to patients with *Pneumocystis* pneumonia. **Thus it seems likely that *P. jirovecii* is passed from human to human through an airborne route.**

Most humans are infected with *P. jirovecii* during early childhood. In the immunocompetent child, these infections are usually asymptomatic or mild and indistinguishable from other common childhood respiratory infections. Pneumonia caused by *P. jirovecii* occurs almost exclusively in severely immunocompromised hosts, including those with congenital or acquired immunodeficiency disorders, malignancies, or transplanted organs. Patients with primary immunodeficiency diseases at risk for infection include severe combined immunodeficiency disease, X-linked CD40 ligand deficiency, major histocompatibility complex class II deficiency, nuclear factor kappa B essential modulator (NEMO) deficiency, dedicator of cytokinesis 8 (DOCK8) deficiency, Wiskott-Aldrich syndrome, and caspase recruitment domain 11 (CARD11) deficiency. *P. jirovecii* can be found in the lungs of infants who have died with the diagnosis of sudden infant death syndrome (SIDS). However, further study concluded that *P. jirovecii* is likely not the cause of SIDS but instead that there is overlap in the timing of the primary *P. jirovecii* infection and the onset of SIDS. Recent studies have described pathologic changes in the lungs of infants during primary infection and have suggested a possible association of *P. jirovecii* with respiratory distress syndrome in preterm infants.

Without chemoprophylaxis, approximately 40% of infants and children with AIDS, 70% of adults with AIDS, 12% of children with leukemia, and 10% of patients with organ transplants develop *P. jirovecii* pneumonia. Epidemics that occurred among debilitated infants in Europe during and after World War II are attributed to malnutrition. Currently, **the use of novel immunosuppressive agents for the treatment of inflammatory syndromes, autoimmune disease, and malignancy has expanded the at-risk population**. For example, the addition of anti-tumor necrosis factor (TNF) therapy to the management of patients with inflammatory bowel disease or rheumatoid arthritis has resulted in a demonstrable increase in *P. jirovecii* pneumonia in these patient populations. The use of rituximab or ibrutinib in patients with hematologic malignancies also increases the risk of *Pneumocystis* pneumonia.

**PATHOGENESIS**

Two forms of *P. jirovecii* are found in the alveolar spaces: the cyst form (or ascus), which are 5–8  $\mu\text{m}$  in diameter and contain up to eight pleomorphic intracystic bodies (sporozoites or ascospores); and trophic forms (or trophozoites), which are 2–5  $\mu\text{m}$  cells derived from excysted sporozoites. The names sporozoite and trophozoite were based on the morphologic similarities to protozoa. However, the inclusion of *Pneumocystis* among the fungi led to the adoption of names such as ascus and ascospore, which are derived from fungal terminology. The cyst form accounts for 5–10% of the *Pneumocystis* in the lung. The cyst has a thick wall composed of  $\beta$ -glucan, which is thought to be a major driver of pulmonary inflammation during *Pneumocystis* pneumonia. *P. jirovecii* trophic forms typically constitute approximately 90% of the *Pneumocystis* in the lungs and have the ability to suppress inflammation induced by the cyst form. Trophic forms attach firmly to the type 1 pneumocytes lining the alveoli, possibly by adhesive bridging proteins such as fibronectin or mannose-dependent ligands. The consequences of this interaction are unclear, but it may provide signals or nutrients to *Pneumocystis* to stimulate growth. As the infection progresses, this interaction may contribute to the characteristic alveolar damage.

Control of *P. jirovecii* infection in immunocompetent people requires functional cell-mediated immunity, and patients with AIDS show an increased incidence of *Pneumocystis* pneumonia as CD4<sup>+</sup> T-lymphocyte counts decrease. Before widespread prophylaxis of AIDS patients, life-threatening *Pneumocystis* pneumonia occurred in a high percentage of these patients when CD4<sup>+</sup> T cell counts dropped below 200 cells/mm<sup>3</sup>. **CD4<sup>+</sup> T cell counts provide a useful indicator in both older children and adults of the need for prophylaxis against *Pneumocystis* pneumonia.** Although normally functioning CD4<sup>+</sup> T cells are central to controlling *P. jirovecii* infection, the final effector pathway for destruction of *P. jirovecii* is poorly understood but likely requires macrophages. CD4<sup>+</sup> T cells may activate macrophages for phagocytosis and clearance of *Pneumocystis* through local cytokine secretion, and also provide help for the production of specific antibody.

Anti-*Pneumocystis* antibody has the potential to facilitate fungal clearance through opsonization, complement activation, or interfering with *Pneumocystis* binding to lung epithelial cells.

Clinical investigation as well as work in animal models has revealed that the host's immune response to *Pneumocystis* infection is a major contributor to the pathogenesis of *Pneumocystis* pneumonia. Human studies found that the severity of disease correlates with the degree of lung inflammation but not with fungal burden. Furthermore, patients with profound AIDS-related immunosuppression present with higher *P. jirovecii* burdens but better lung function than non-AIDS patients with *Pneumocystis* pneumonia and with greater retained immune function. A classic AIDS-related presentation of *Pneumocystis* pneumonia can be modeled in CD4<sup>+</sup> T cell-depleted rodents and simian immune virus-infected nonhuman primates. In the absence of CD4<sup>+</sup> T cells a progressive accumulation of CD8<sup>+</sup> T cells occurs in a likely attempt to fight the infection. These cells do not provide effective host defense against *Pneumocystis*, but instead directly contribute to *Pneumocystis* pneumonia-related immunopathogenesis and lung injury. Similar to humans with *Pneumocystis* pneumonia, polymorphonuclear leukocytes (PMNs) also accumulate in the lungs of animals as *Pneumocystis* pneumonia progresses. These phagocytes do not contribute meaningfully to either *Pneumocystis* eradication or immunopathogenesis. However, as is the case in human patients, there is a strong correlation between the number of PMNs in the lung and the severity of disease.

In the complete absence of an adaptive immune response, as can be modeled in severe combined immunodeficient (SCID) mice, *Pneumocystis* infection produces little alteration in lung histology or function until late in the course of the disease. However, if congenic lymphocytes are transferred to *Pneumocystis*-infected SCID mice, an acute CD4<sup>+</sup> T cell-dependent immune response is mounted against the *Pneumocystis*. There is rapid onset of pulmonary inflammation, surfactant dysfunction, severe respiratory impairment, and significant hypoxia, mimicking the characteristic changes of *Pneumocystis* pneumonia in humans. The functional CD4<sup>+</sup> T cells generate an effective immune response against the existing infection, but also cause inflammation and lung injury. CD8<sup>+</sup> T cells are typically ineffective in the eradication of *Pneumocystis* but may modulate the CD4<sup>+</sup> T cell response to lessen the immune-mediated damage. **The functional interactions of T cell subsets in patients with differing and often fluctuating immune status are likely responsible for the variations in presentation and outcome of *Pneumocystis* pneumonia.**

## **PATHOLOGY**

The histopathologic features of *P. jirovecii* pneumonia are of two types. The first type is infantile interstitial plasma cell pneumonitis, which was observed in epidemic outbreaks in debilitated infants 3-6 months of age. Extensive infiltration with thickening of the alveolar septum occurs, and plasma cells are prominent. The second type is a diffuse desquamative alveolar pneumonitis found in immunocompromised children and adults. The alveoli contain large numbers of *P. jirovecii* in a foamy exudate with alveolar macrophages active in the phagocytosis of organisms. The alveolar septum is not infiltrated to the extent it is in the infantile type, and plasma cells are usually absent.

## **CLINICAL MANIFESTATIONS**

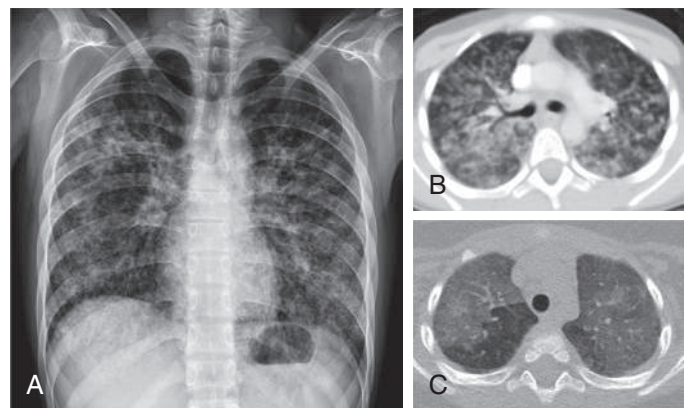
There are at least three distinct clinical presentations of *P. jirovecii* pneumonia. In patients with profound congenital immunodeficiency or in AIDS patients with very few CD4<sup>+</sup> T cells, the onset of hypoxia and symptoms is subtle and often without fever, with tachypnea progressing to nasal flaring; intercostal, suprasternal, and infrasternal retractions; and cyanosis in severe cases. In children and adults with immunodeficiency resulting from immunosuppressive medications, the onset of hypoxia and symptoms is often more abrupt, with fever, tachypnea, dyspnea, and cough, progressing to severe respiratory compromise. This type accounts for the majority of cases, although the severity of clinical expression can vary. *Rales are usually not detected on physical examination.* The third pattern of *Pneumocystis* pneumonia is reported in severely immunocompromised patients who appear to be responding to therapy but then have an acute and seemingly

paradoxical deterioration thought to be associated with the restoration of immune function. This condition is referred to as *immune reconstitution inflammatory syndrome* and is most commonly seen in patients with newly diagnosed AIDS who present with *P. jirovecii* pneumonia and who have a rapid response to antiretroviral therapy that is instituted at the same time as anti-*Pneumocystis* therapy. It can also occur in stem cell transplant recipients who engraft while infected with *P. jirovecii*.

## **LABORATORY FINDINGS AND DIAGNOSIS**

The chest radiograph reveals bilateral diffuse interstitial or alveolar ground glass infiltrates (Fig. 290.1). The earliest densities are perihilar, and progression proceeds peripherally, sparing the apical areas until last. The arterial oxygen tension (Pao<sub>2</sub>) is invariably decreased. The major role of the laboratory in establishing a diagnosis of *P. jirovecii* pneumonia is to identify organisms in lung specimens by a variety of methods. **Definitive diagnosis requires visualization of *P. jirovecii* in the lung in the presence of clinical signs and symptoms of the infection.** Organisms can be detected in specimens collected by bronchoalveolar lavage (BAL), tracheal aspirate, transbronchial lung biopsy, bronchial brushings, percutaneous transthoracic needle aspiration, and open lung biopsy. Hypertonic saline-induced sputum samples are helpful if *P. jirovecii* is found, but the absence of the organisms in induced sputum does not exclude the infection and BAL should be performed. Open lung biopsy is the most reliable method, although BAL is more practical in most cases. Estimates of the diagnostic yield of the various specimens are 20–40% for induced sputum, 50–60% for tracheal aspirate, 75–95% for BAL, 75–85% for transbronchial biopsy, and 90–100% for open lung biopsy.

Once obtained, the specimens are typically stained with one of four commonly used stains: Grocott-Gomori silver stain and toluidine blue stain for the cyst form, polychrome stains such as Giemsa stain for the trophic forms and ascospores, and the fluorescein-labeled monoclonal antibody stains for both trophic forms and cysts. **Many clinical laboratories have adopted polymerase chain reaction analysis of respiratory specimens for the diagnosis of *Pneumocystis* pneumonia.** Serum lactate dehydrogenase (LDH) levels are often elevated during *Pneumocystis* pneumonia, and although elevated LDH is not a specific or definitive diagnosis, high levels should raise suspicion.



**Fig. 290.1** *Pneumocystis jirovecii* infection in a 17-yr-old male with acute lymphoblastic leukemia and immunodeficiency, who presented with dyspnea, fever, nonproductive cough, and decreased white blood cell counts. **A**, Radiograph shows diffuse bilateral interstitial opacity throughout the lungs. **B**, Contrast-enhanced computed tomography confirms the bilateral patchy and ground-glass opacities in both lungs. The diagnosis was confirmed by a positive polymerase chain reaction test from bronchial lavage fluid. **C**, CT in a different patient demonstrates a typical “crazy paving” pattern in both upper lobes. (From Westra SJ, Yikilmaz A, Lee EY. Pulmonary infection. In: Coley BD, ed. *Caffey's Pediatric Diagnostic Imaging*, 13th ed. Philadelphia: Elsevier; 2019: Fig. 54.30.)



## TREATMENT

The recommended therapy for *P. jirovecii* pneumonia is trimethoprim-sulfamethoxazole (TMP-SMX) (15–20 mg TMP and 75–100 mg SMX/kg/day in four divided doses) administered intravenously or orally if there is mild disease and no malabsorption or diarrhea. The duration of treatment is 3 weeks for patients with AIDS and 2 weeks for other patients. Unfortunately, adverse reactions often occur with TMP-SMX, especially rash and neutropenia in patients with AIDS. For patients who cannot tolerate or who fail to respond to TMP-SMX after 5–7 days, pentamidine isethionate (4 mg/kg/day as a single dose IV) may be used. Adverse reactions are frequent and include renal and hepatic dysfunction, hyperglycemia or hypoglycemia, rash, and thrombocytopenia. Atovaquone (750 mg twice daily with food, for patients >13 years of age) is an alternative treatment that has been used primarily in adults with mild to moderate disease. Limited experience is available for younger children. Pharmacokinetic studies of atovaquone show that a dose of 30 mg/kg/day PO in two divided doses for children 0–3 months of age and older than 2 years of age is adequate and safe; a dose of 45 mg/kg/day PO in two divided doses is needed for children between 4 months and 2 years of age. Other effective therapies include trimetrexate glucuronate or combinations of trimethoprim plus dapsone or clindamycin plus primaquine. The combination of caspofungin and TMP-SMX is also being assessed as a treatment for *Pneumocystis* pneumonia and may help control inflammation in some patients.

Some studies in adults suggest that administration of **corticosteroids as adjunctive therapy to suppress the inflammatory response** increases the chances for survival in moderate and severe cases of *P. jirovecii* pneumonia. The recommended regimen of corticosteroids for adolescents older than 13 years of age and for adults is oral prednisone, 80 mg/day PO in two divided doses on days 1–5, 40 mg/day PO once daily on days 6–10, and 20 mg/day PO once daily on days 11–21. A reasonable regimen for children is oral prednisone, 2 mg/kg/day for the first 7–10 days, followed by a tapering regimen for the next 10–14 days.

## SUPPORTIVE CARE

Basic supportive care is dictated by the condition of the patient, with careful attention to maintain appropriate hydration and oxygenation. Only 5–10% of patients with AIDS require mechanical ventilation compared with 50–60% of patients without AIDS, consistent with the hypothesis that the patient's ability to mount an immune/inflammatory response correlates with severity and outcome of *Pneumocystis* pneumonia. There are anecdotal reports of giving surfactant to children with severe *P. jirovecii* pneumonia, although the use of surfactant to treat adult-type respiratory distress syndrome is controversial.

## COMPLICATIONS

Most complications occur as adverse events associated with the treatment drugs or as a consequence of mechanical ventilation. The most severe pulmonary complication of *P. jirovecii* pneumonia is adult-type respiratory distress syndrome. Rarely, *P. jirovecii* infection affects extrapulmonary sites (e.g., retina, spleen, and bone marrow), but such infections are usually not symptomatic and also respond to treatment.

## PROGNOSIS

Without treatment, *P. jirovecii* pneumonitis is fatal in almost all immunocompromised hosts within 3–4 weeks of onset. The mortality rate varies with patient population and is related to inflammatory response rather than organism burden. Patients with AIDS have a mortality rate of 5–10%, and patients with other diseases such as malignancies have mortality rates as high as 20–25%. Patients who require mechanical ventilation have mortality rates of 60–90%. Patients remain at risk for *P. jirovecii* pneumonia as long as they are immunocompromised. Continuous prophylaxis should be initiated or reinstated at the end of therapy for patients with AIDS (see Chapter 322).

## PREVENTION

Patients at high risk for *P. jirovecii* pneumonia should be placed on chemoprophylaxis. Prophylaxis in infants born to HIV-infected

mothers and for HIV-infected infants and children is based on age and CD4 cell counts (see Chapter 322). Because CD4 counts fluctuate rapidly during the first year of life, infants born to HIV-infected mothers should be placed on prophylaxis during the first year of life until HIV infection is ruled out. Patients with severe combined immunodeficiency disease, patients receiving intensive immunosuppressive therapy for cancer or other diseases, and organ transplant recipients are also candidates for prophylaxis. **TMP-SMX (5 mg/kg TMP and 25 mg SMX/kg PO once daily or divided into two doses daily) is the drug of choice and may be given for 3 consecutive days each week or, alternatively, each day.** Alternatives for prophylaxis include **dapsone** (2 mg/kg/day PO, maximum: 100 mg/dose; or 4 mg/kg PO once weekly, maximum: 200 mg/dose), **atovaquone** (30 mg/kg/day PO for infants 1–3 months and ≥24 months of age; 45 mg/kg/day for infants and toddlers 4–23 months of age), and **aerosolized pentamidine** (300 mg/mo by Respigard II nebulizer), but all of these agents are inferior to TMP-SMX. Finally, limited clinical experience suggests that pentamidine can be given intravenously once monthly to prevent *P. jirovecii* pneumonia. Prophylaxis must be continued as long as the patient remains immunocompromised. Some patients with AIDS who reconstitute adequate immunity during highly active antiretroviral therapy may have prophylaxis withdrawn. Recent animal studies suggest that vaccines may be effective at preventing *Pneumocystis* pneumonia in immunocompromised hosts, but to date none have been tested in humans.

Visit Elsevier eBooks+ at [eBooks.Health.Elsevier.com](http://eBooks.Health.Elsevier.com) for Bibliography.

## Chapter 291

# Other Pathogenic Fungi

William J. Steinbach

Less common fungi that were once innocent or only contaminants are now emerging as lethal pathogens in a world of increasingly immunocompromised patients. Although there are reports of countless previously considered nonpathogenic fungi infecting severely immunocompromised patients, this chapter focuses on the most common and relevant miscellaneous fungi causing disease.

## PHAEOPHYCOMYCOSIS: CLADOPHIALOPHORA BANTIANA, BIPOLARIS SPP., AND OTHERS

Phaeohyphomycosis is a heterogeneous group of fungal species commonly found in the soil and characterized by dematiaceous (darkly pigmented brown or black) hyphal forms in tissue. This staining can help distinguish between *Aspergillus* infections, and hyphae often appear more fragmented than seen with *Aspergillus* infections. The characteristic color of the hyphae is related to the presence of melanin in the fungal cell wall, which likely plays a role in fungal pathogenesis. *Phaeo* comes from Greek, meaning “dark,” and has been commonly used to describe infections with these fungi as phaeohyphomycosis. It has been suggested that the term *dematiaceous* is not appropriate given its etymologic derivation from the Greek *deme*, meaning “bundle,” although it has become fairly entrenched in medical mycologic literature. The term *melanized* is also used, given its specific meaning.

Phaeohyphomycosis has been attributed to more than 150 species of fungi. Among the most prevalent causes of human infection are *Alternaria alternata*, *Acrophialophora fusispora*, *Aureobasidium pullulans*, *Bipolaris* spp., *Curvularia* spp., *Chaetomium* spp., *Cladophialophora*

*bantiana*, *Exserohilum*, *Fonsecaea*, *Hortaea werneckii*, *Neoscytalidium dimidiatum*, *Verruconis gallopava* (previously *Ochroconis gallopava*), *Phaeoacremonium*, *Phoma*, *Pyrenochaeta*, *Rhinocladiella*, *Veronaea botryosa*, *Wangiella dermatitidis* (previously *Exophiala dermatitidis*), and *Phialophora* spp.

In the multicenter CDC-funded epidemiologic TRANSNET study, 26 cases of phaeohyphomycosis were identified in hematopoietic stem cell transplant (HSCT) recipients analyzed, representing 2.6% of all reported invasive fungal disease in the HSCT cohort. The median time from transplant to diagnosis was 100 days, and 92% of cases were seen in allogeneic HSCT recipients. The mortality rate was 42% at 90 days after diagnosis. There was a higher incidence of phaeohyphomycosis noted from transplant centers in the southern United States versus other regions of the country. Phaeohyphomycosis also represented 2.5% of the overall number of invasive fungal disease in solid organ transplant (SOT) recipients in the TRANSNET study. The median time from transplant to diagnosis was much longer at 18 months, and 53% of cases were specifically diagnosed in lung transplant recipients. There was a 10% mortality rate at 90 days after diagnosis. Overall, cutaneous disease was more common in SOT recipients, whereas pulmonary disease was more common in hematopoietic stem cell transplant recipients. In this series, bloodstream and central nervous system (CNS) infections were seen only in hematopoietic stem cell transplant recipients.

Historically, organisms causing phaeohyphomycosis have been largely associated with cutaneous and subcutaneous infections occurring mostly in immunocompetent persons in tropical and subtropical regions. However, they have emerged with increasing frequency as causes of invasive disease in immunocompromised persons worldwide. Infections can manifest as a range of clinical entities, including localized cutaneous infection and subcutaneous nodules, mycetomas (localized infections involving the cutaneous and subcutaneous tissue, fascia, and bone, often of the lower extremities, and characterized by mycotic granules), chromoblastomycosis (sclerotic bodies in tissues usually seen in tropical regions), keratitis, pulmonary infections, localized deep infections, cerebral abscesses, disseminated infection, allergic fungal sinusitis, and allergic bronchopulmonary mycosis.

*C. bantiana* is the etiology for the majority of CNS phaeohyphomycosis, including patients that may have no apparent immunosuppression. CNS disease commonly presents with a headache and a focal neurologic deficit, frequently a hemiparesis, or seizures. The most common CNS manifestation is a solitary brain abscess. Though the pathophysiology is not well understood, these are thought to originate via hematogenous dissemination from occult pulmonary or cutaneous foci.

Diagnosis of phaeohyphomycosis relies on pathologic examination of cultures and biopsies, often with expert gross and microscopic examination required. There are no serologic or antigen tests to detect these fungi in blood or tissue, and PCR is in its infancy for this group of organisms. Almost all allergic disease and eosinophilia is caused by either *Bipolaris* spp. or *Curvularia* spp.

### Treatment

Treatment recommendations for the rare molds causing phaeohyphomycosis are unfortunately primarily based on in vitro susceptibility data, case reports, and expert opinion. Recommendations can be found in European and Australian guidelines and the American Transplant Society Infectious Diseases Community of Practice Guidelines. European antifungal treatment guidelines highlight the sparse data on preferred therapy, including in vitro data, limited animal model studies, and expert opinion. **There are no clearly defined standard therapies, but the guideline panel generally recommended voriconazole, posaconazole, or itraconazole, because those agents demonstrate the most consistent in vitro antifungal activity against this group of fungi. Specifically, voriconazole is likely the best for CNS infections because of its excellent CNS penetration. For invasive infections, surgery is crucial to the overall treatment.** For phaeohyphomycosis, there is substantial variability in susceptibility both between and within

species of a given genus, making correct species identification and susceptibility testing especially critical in guiding therapy for these infections. Combination therapy is suggested in some circumstances for disseminated or CNS infection and for organisms for which no single agent has predictably favorable activity.

Therapy for CNS infections with *C. bantiana* is often unsuccessful despite susceptibility of this organism to several antifungal agents, and it is unclear whether antifungal therapy alters outcome, because survival without complete abscess resection is exceedingly rare. Some experts recommend combination therapy, particularly for cases in which the abscess cannot be completely resected. Surgery is particularly important for brain abscesses secondary to *C. bantiana* infection; regardless of host immune status and antifungal therapy, survival is extremely poor if the abscess is not completely resected. If an invasive mold infection is associated with an intravenous catheter or a peritoneal dialysis catheter, removal of the catheter is recommended.

Including only culture-positive cases of CNS phaeohyphomycosis, the survival rate for this infection is only 35%. A series of 30 cases revealed those patients with single, encapsulated CNS lesions did much better than those with multifocal disease. However, no patient who did not undergo surgery survived. Whether patients underwent neurosurgery alone or with antifungal therapy, the most important factor for cure was resectability of the lesion; antifungal therapy itself was not associated with improved survival.

### HYALOPHYPHOMYCOSIS: FUSARIUM AND SCEDOSPORIUM SPP. AND OTHERS

In contrast to phaeohyphomycosis, hyalohyphomycosis refers to infections caused by hyaline (colorless, nonpigmented, nonmelanized) septate fungal hyphae. The major hyalohyphomycotic pathogens are *Fusarium* spp., *Scedosporium* spp., *Paecilomyces* spp., *Trichoderma* spp., *Acremonium* spp., *Scopulariopsis* spp., and *Purpureocillium* spp. These species are often misidentified as *Aspergillus* spp., but they can be differentiated by their conidia and phialide morphologies. This section focuses on *Fusarium* and *Scedosporium* spp., which are usually the third and fourth most common invasive mold diseases in immunocompromised hosts, after invasive aspergillosis and mucormycosis.

The majority of human cases of fusariosis are caused by members of the *Fusarium solani*, *Fusarium oxysporum*, and *Fusarium fujikuroi* spp. complexes, with the *F. solani* spp. complex demonstrating greater pathogenicity. Nomenclature of organisms causing scedosporiosis can be confusing and has undergone recent changes. The genus name *Pseudallescheria* applies to the sexual state (teleomorph) whereas *Scedosporium* applies to the asexual state (anamorph) of these organisms. *Scedosporium apiospermum* was once thought to be the anamorph of *Pseudallescheria boydii*, but these organisms are now known to be distinct species. The *S. apiospermum* spp. complex encompasses *S. apiospermum*, *Scedosporium boydii*, *Scedosporium aurantiacum*, *Scedosporium dehoogii*, and *Scedosporium minutispora*. The organism formerly known as *Scedosporium prolificans* is now renamed *Lomentospora prolificans* and is phylogenetically distinct from the *Scedosporium* spp.

In addition to the usual airborne and cutaneous inoculation routes of acquisition common to other invasive molds, *Fusarium* can be transmitted via contaminated water sources (e.g., shower heads) and can cause infection associated with intravenous catheters. Both *Fusarium* and *Scedosporium/Lomentospora* spp. can cause infection in immunocompetent hosts, primarily localized infections such as keratitis or onychomycosis. In immunocompromised patients, *Fusarium* can disseminate from initially localized infections such as onychomycosis or intertrigo. The major predisposing factors for invasive disease are profound and prolonged neutropenia and severe cell-mediated immunodeficiency.

Among HSCT recipients in the TRANSNET study, fusariosis accounted for 3% of invasive fungal disease. Identified risk factors for fusariosis in HSCT recipients include history of cytomegalovirus infection, receipt of an umbilical cord blood transplant (compared with other stem cell sources), receipt of antithymocyte globulin, and

hyperglycemia. Risk factors specific to development of fusariosis beyond day 40 after transplant include graft-versus-host disease and prior invasive mold disease. Scedosporiosis is less common among HSCT recipients compared with fusariosis, with only 16 cases identified in the TRANSNET study compared with 31 cases of fusariosis and 77 cases of mucormycosis. Among 1208 invasive fungal infections in the TRANSNET study of SOT recipients, there were 6 cases of fusariosis and 11 cases of scedosporiosis, compared with 28 cases of mucormycosis. In a literature review of *L. prolificans* cases, SOT recipients constituted 8.6% of cases. Scedosporiosis is most common among lung transplant recipients, in whom colonization of the airways can occur pretransplantation (particularly in patients with cystic fibrosis), or posttransplantation, and may progress to invasive infection. Among patients undergoing therapy for cancer, fusariosis primarily occurs in those with hematologic malignancy, especially acute myelogenous leukemia. In a single center study of 44 cases, the most commonly identified risk factors for fusariosis in patients with hematologic malignancy were active leukemia, prolonged and profound neutropenia, and high-dose corticosteroid exposure.

### Clinical Presentations

The most common sites of invasive fusariosis in immunocompromised persons are the skin (60–80% of cases), lungs (50–80% of cases), and sinuses (20–30% of cases). *Fusarium* can develop yeastlike adventitious sporulation within infected tissue, which facilitates dissemination, seen in 70% of cases. Unlike other molds that infrequently cause detectable fungemia and are difficult to recover in standard blood culture media, blood cultures are positive for *Fusarium* in 40–50% of cases.

Radiographic series comparing findings of pulmonary fusariosis to those of invasive aspergillosis and mucormycosis note that the halo sign (a nodule surrounded by ground glass opacity) is frequently absent in cases of fusariosis. Cutaneous lesions of invasive fusariosis are distinctive, consisting of painful, circular macules or papules, usually with central necrosis and surrounding erythema. Appearance of cutaneous lesions in invasive fusariosis is usually secondary to hematogenous dissemination to the skin, rather than direct inoculation into the skin.

Invasive disease caused by *S. apiospermum* spp. complex most frequently involves the skin, lungs, and CNS. CNS disease develops in the context of hematogenous dissemination and can manifest as brain abscess(es) or meningoencephalitis. Other manifestations include sinusitis and endogenous endophthalmitis. Skin lesions of *S. apiospermum* spp. complex can manifest as nodules, erythematous or violaceous papules, or bullae, which may develop necrosis. They are usually secondary to hematogenous dissemination rather than primary cutaneous lesions from direct inoculation of the skin. Lymphangitic or sporotrichoid spreading patterns have been described. Blood cultures are positive in approximately 30% of cases of invasive infection with *S. apiospermum* spp. complex. Similar manifestations are seen in invasive *L. prolificans* infections, but the propensity to disseminate is higher and positive blood cultures are reported in over 50% of cases. Hematogenous dissemination of *L. prolificans* to the CNS is common.

### Diagnosis

Diagnosis of fusariosis or scedosporiosis requires isolation and identification of the causative organism from the affected site(s). The causative organisms have thin septate hyphae with acute angle branching; they are not morphologically distinguishable from *Aspergillus* when examined in tissue. Culture is necessary for definitive identification of these organisms, though distinguishing between *Fusarium* spp. complexes may be difficult using conventional methods. Organisms causing fusariosis and scedosporiosis can be detected in conventional blood cultures; however, they may be initially reported out as “yeast” because of the appearance of conidia produced by adventitious sporulation.

The *Aspergillus* serum galactomannan assay is positive in approximately half of patients with invasive fusariosis and detection of serum

galactomannan above threshold has been shown to precede diagnosis of invasive fusariosis in a high prevalence setting.

### Treatment

Treatment recommendations for fusariosis and scedosporiosis are provided in European Society of Clinical Microbiology and Infectious Diseases (ESCMID) and European Confederation of Medical Mycology (ECMM) joint guidelines, and in Australian consensus guidelines. The optimal therapy is unknown; recommendations are primarily based on case reports, clinical experience, and in vitro data, given a lack of clinical trials for these rare diseases. **The ESCMID/ECMM guidelines recommend voriconazole or a lipid-based amphotericin B formulation for treatment of fusariosis, with preference for voriconazole.** Australian guidelines do not state a preference for either agent on the basis of inadequate data. Voriconazole treatment has been associated with higher treatment responses and improved survival, though these should be interpreted with caution because of potential confounding by earlier diagnosis or other interventions.

Because in vitro susceptibility of *Fusarium* isolates to both voriconazole and amphotericin B varies widely, some experts routinely use combination therapy with voriconazole and lipid-based amphotericin B to ensure that at least one agent is active. Some reports describe successful combination therapy with terbinafine and either liposomal amphotericin B or voriconazole, and in vitro data show synergy between terbinafine and voriconazole. Isavuconazole has been studied in few adult cases; based on in vitro susceptibilities it appears to be less active than voriconazole. *Fusarium* spp. are resistant to the echinocandins and to itraconazole.

The activity of antifungal agents against members of the *S. apiospermum* spp. complex is variable, and there are species-based differences in susceptibility pattern. Amphotericin B–based therapy is not recommended due to in vitro resistance and poor clinical responses. Voriconazole is the most active agent and the recommended first-line therapy. In a large observational study, the response rate to voriconazole therapy for *S. apiospermum* infections was 66%. The echinocandins, itraconazole, and posaconazole have variable activity. Isavuconazole is active in vitro but so far has been studied in only a handful of adults with scedosporiosis, limiting conclusions about its utility.

*L. prolificans* is highly resistant to all antifungal agents currently available. Successful treatment of infections caused by this organism depends on reversal of predisposing conditions and aggressive surgical debridement. Voriconazole is the antifungal with best demonstrated activity, but minimum inhibitory concentrations tend to be high and clinical responses to voriconazole therapy are suboptimal. Combination therapy is typically used, including voriconazole and other agents; successful outcomes have been reported with voriconazole or posaconazole and terbinafine or voriconazole with an echinocandin. Australian guidelines recommend the combination of voriconazole with terbinafine. However, terbinafine is highly protein-bound with distribution primarily to skin and adipose tissue, leading some experts to doubt its utility in treating systemic fungal infections. There have been reports of combination therapy including miltefosine, which is typically used in the treatment of leishmaniasis but demonstrates some in vitro antifungal activity against *L. prolificans*. It is important to recognize that publication bias likely has an impact on reporting of outcomes and no particular antifungal regimen has convincing evidence to support efficacy against *L. prolificans*.

Surgical debridement of infected and necrotic tissue is recommended to facilitate cure, particularly in *L. prolificans* infection, for which surgery and immune reconstitution are the primary effective therapies. Removal of intravenous catheters is recommended for catheter-associated fusariosis.

Visit Elsevier eBooks+ at [eBooks.Health.Elsevier.com](http://eBooks.Health.Elsevier.com) for Bibliography.



## Section 13

## Viral Infections

## Chapter 292

## Principles of Antiviral Therapy

Mark R. Schleiss

Antiviral chemotherapy typically requires a delicate balance between targeting critical steps in viral replication without interfering with host cellular function. Because viruses require cellular functions to complete replication, many antiviral agents exert significant host cellular toxicity, a limitation that has hindered antiviral drug development. In spite of this limitation, a number of agents are licensed for use against viruses, particularly herpesviruses, respiratory viruses, and hepatitis viruses (Table 292.1).

In making the decision to commence antiviral drugs, it is important for the clinician to obtain appropriate diagnostic specimens, which can help clarify the antiviral of choice. The choice of a specific antiviral is based on the recommended agent of choice for a particular clinical condition, pharmacokinetics, toxicities, cost, and the potential for development of resistance (Table 292.2). Intercurrent conditions in the patient, such as renal insufficiency, should also be considered. Clinicians must monitor antiviral therapy closely for adverse events or toxicities, both anticipated and unanticipated.

In vitro sensitivity testing of virus isolates to antiviral compounds usually involves a complex tissue culture system. The potency of an antiviral is determined by the **50% inhibitory dose (ID<sub>50</sub>)**, which is the antiviral concentration required to inhibit the growth in cell culture of a standardized viral inoculum by 50%. Because of the complexity of these assays, the results vary widely, and the actual relationship between antiviral sensitivity testing and antiviral therapy outcomes is sometimes unclear. Because these assays are often not readily available and take considerable time to complete, **genotypic analysis** for antiviral susceptibility is increasingly being offered. Such assays may be useful for patients on long-term antiviral therapy.

Clinical context is essential in making decisions about antiviral treatment, along with knowledge of a patient's immune status. For example, antiviral treatment is rarely if ever indicated in an immunocompetent child shedding cytomegalovirus (CMV) but may be lifesaving when administered to an immunocompromised solid organ transplant (SOT) or hematopoietic stem cell transplant (HSCT) patient. Antivirals can be used with a variety of clinical goals in mind. Antivirals can be used for **treatment** of active end-organ disease, as **prophylaxis** to prevent viral infection or disease, or as **preemptive therapy** aimed at reducing risk of progression to disease (i.e., a positive signal indicating viral replication but in the absence of clinical evidence of end-organ disease). In preemptive therapy, a patient will usually have a positive signal for polymerase chain reaction–based identification of viral nucleic acids in a clinical sample (blood or body fluid) but have no symptoms. However, SOT and HSCT patients are at high risk of developing disease in this setting (particularly due to CMV infection), a scenario that warrants preemptive treatment with an antiviral agent. In contrast, prophylaxis is administered to seropositive patients who are at risk to reactivate latent viral infection but do not yet have evidence of active viral replication or shedding.

A fundamental concept important in the understanding of the mechanism of action of most antivirals is that viruses must use host cell components to replicate. Thus mechanisms of action for antiviral compounds must be selective to virus-specific functions whenever possible, and antiviral agents may have significant toxicities to the host if these compounds impact cellular physiology. Some of the more commonly targeted sites of action for antiviral agents include viral entry, absorption, penetration, and uncoating (amantadine, rimantadine); transcription or replication of the viral genome (acyclovir, valacyclovir, cidofovir, famciclovir, letermovir, maribavir, penciclovir, foscarnet, ganciclovir, valganciclovir, ribavirin, trifluridine); viral protein synthesis (interferons [IFNs]) or protein modification (protease inhibitors); and viral assembly, release, or deaggregation (baloxavir, oseltamivir, peramivir, zanamivir, IFNs).

An understudied and underappreciated issue in antiviral therapy is emergence of resistance, particularly in the setting of high viral load, high intrinsic viral mutation rate, and prolonged or repeated courses of antiviral therapy. Resistant viruses are more likely to develop or be selected for in immunocompromised patients because these patients are more likely to have multiple or long-term exposures to an antiviral agent.

## ANTIVIRALS USED FOR HERPESVIRUSES

The herpesviruses are important pediatric pathogens, particularly in newborns and immunocompromised children. Most of the licensed antivirals are nucleoside analogs that inhibit viral DNA polymerase, inducing premature chain termination during viral DNA synthesis in infected cells.

## Acyclovir

Acyclovir is a safe and effective therapy for herpes simplex virus (HSV) infections. The favorable safety profile of acyclovir derives from its requirement for activation to its active form via phosphorylation by a viral enzyme, thymidine kinase (TK). Thus acyclovir can be activated only in cells already infected with HSV that express the viral TK enzyme, a strategy that maximizes selectivity and reduces the potential for cellular toxicity in uninfected cells. Acyclovir is most active against HSV and is also active against varicella-zoster virus (VZV); therapy is indicated for infections with these viruses in a variety of clinical settings. Activity of acyclovir against CMV is less pronounced, and activity against Epstein-Barr virus is minimal, both in vitro and clinically. Therefore, under most circumstances, acyclovir should not be used to treat CMV or Epstein-Barr virus infections.

The biggest impact of acyclovir in clinical practice is in the treatment of primary and recurrent genital HSV infections. Oral nucleoside therapy plays an important role in the management of acute primary genital herpes, treatment of episodic symptomatic reactivations, and prophylaxis against reactivation. Acyclovir is also indicated in the management of suspected or proven HSV encephalitis in patients of all ages and for treatment of neonatal HSV infection, with or without central nervous system (CNS) involvement. With respect to neonatal HSV infection, the routine empirical use of acyclovir against presumptive or possible HSV infection in infants admitted with fever and no focus in the first 4 weeks of life is controversial. Acyclovir should be used routinely in infants born to women with risk factors for primary genital herpes or infants presenting with any combination of vesicular lesions, seizures, meningoencephalitis, hepatitis, pneumonia, or disseminated intravascular coagulation. Some experts advocate the initiation of acyclovir in all febrile neonates. Other experts have argued that a selective approach based on the history and physical examination is more appropriate when making decisions about the use of acyclovir in febrile infants. Given the safety of the drug, prudence would dictate the use of acyclovir in such patients if HSV infection cannot be excluded.

Acyclovir is indicated for the treatment of primary HSV gingivostomatitis and for primary genital HSV infection. Long-term suppressive therapy for genital HSV and for recurrent oropharyngeal infections (herpes labialis) is also effective. Acyclovir is also recommended for



**Table 292.1** Currently Licensed Antiviral Drugs

ANTIVIRAL	TRADE NAME	MECHANISM OF ACTION/COMMENTS
Acyclovir	Zovirax	Inhibits viral DNA polymerase
Adefovir	Hepsera	Nucleotide reverse transcriptase inhibitor
Amantadine*	Symmetrel	Blocks M2 protein ion channel
Baloxavir	Xofluza	Inhibits polymerase acidic endonuclease, blocking viral replication
BMS-791325	Beclabuvir	Inhibitor of HCV NS5B Evaluated in combination with asunaprevir and daclatasvir; active against HCV genotype 1
Boceprevir†	Victrelis	Inhibitor of HCV NS3 serine protease Active against HCV genotype 1
Cidofovir	Vistide	Inhibits viral DNA polymerase
Daclatasvir	Daklinza	Inhibitor of HCV NS5A Used in varying combinations with sofosbuvir, ribavirin, and interferon
Dasabuvir	Exviera	Inhibitor of HCV NS5B Used together with the combination medication ombitasvir/paritaprevir/ritonavir (Viekira Pak) Activity limited to HCV genotype 1
Elbasvir	(Zepatier)	Inhibitor of HCV NS5A Used in combination with the NS3/4A protease inhibitor grazoprevir under the trade name Zepatier, either with or without ribavirin
Entecavir	Baraclude	Nucleoside reverse transcriptase inhibitor Active against HBV
Famciclovir†	Generic	Inhibits viral DNA polymerase
Fomivirsen‡	Vitravene	Phosphorothioate oligonucleotide inhibits viral replication via antisense mechanism
Foscarnet	Foscavir	Inhibits viral DNA polymerase and reverse transcriptase at pyrophosphate-binding site
Ganciclovir	Cytovene	Inhibits viral DNA polymerase
Grazoprevir	Zepatier	Inhibitor of HCV NS3-4A serine protease Used in combination with elbasvir under the trade name Zepatier, either with or without ribavirin
Idoxuridine Ophthalmic†	Herplex	Inhibits viral DNA polymerase
Interferon- $\alpha$	Intron-A (interferon- $\alpha$ 2b) Roferon-A (interferon- $\alpha$ 2a) Infergen (interferon alfacon-1)	Produces multiple effector proteins that exert antiviral effects; also directly interacts with immune system components
Interferon- $\alpha$ 2b plus ribavirin	Rebetron	Not established
Lamivudine (3TC)	Epivir	Inhibits viral DNA polymerase and reverse transcriptase; active against HBV With dolutegravir, Dovato; with tenofovir, Delstrigo; with zidovudine, Combivir; with abacavir and dolutegravir, Triumeq.
Ledipasvir	(with Sofosbuvir: Harvoni)	Inhibitor of HCV NS5A
Letermovir	Prevymis	Prophylaxis against CMV following HSCT
Maribavir	Livtencity	Treatment of refractory CMV disease when treated with conventional antiviral therapy
Molnupiravir	Lagevrio	Treatment of SARS-CoV-2 Induces viral RNA mutations during replication
Nirmatrelvir/ritonavir	Paxlovid	Treatment of SARS-CoV-2 Protease inhibitor
Ombitasvir	(Viekira Pak)	Inhibitor of HCV NS5A Used in combination with paritaprevir, ritonavir and dasabuvir in Viekira Pak Active against HCV genotype 1

Continued

<b>Table 292.1</b> Currently Licensed Antiviral Drugs—cont'd		
<b>ANTIVIRAL</b>	<b>TRADE NAME</b>	<b>MECHANISM OF ACTION/COMMENTS</b>
Oseltamivir	Tamiflu	Neuraminidase inhibitor; interference with deaggregation and release of viral progeny
Paritaprevir	(Viekira Pak) (Technivie <sup>†</sup> /Viekirax)	Inhibitor of HCV NS3-4A serine protease Used in combination with ombitasvir, ritonavir and dasabuvir (Viekira Pak), or in combination with ombitasvir and ritonavir (Technivie <sup>†</sup> /Viekirax)
Pegylated interferon	PEG-Intron ( $\alpha$ 2b), Pegasys ( $\alpha$ 2a)	Same as interferon
Penciclovir (topical)	Denavir	Inhibits viral DNA polymerase
Peramivir	Rapivab	Neuraminidase inhibitor
Remdesivir	Veklury	Treatment of SARS-CoV-2 Inhibits viral RNA polymerase
Ribavirin	Virazole, Rebetol, Copegus	Interference with viral messenger RNA
Rimantadine*	Flumadine	Blocks M2 protein ion channel
Simeprevir <sup>†</sup>	Olysio	Inhibitor of HCV NS3-4A serine protease Active against genotype 1 $\pm$ genotype 4 Used in combinations with sofosbuvir or ribavirin and pegylated interferon-alfa <sup>†</sup>
Sofosbuvir	(Harvoni)	Inhibitor of HCV NS5B Used in combination with ledipasvir (Harvoni) Approved in children >6 years of age and >17 kg
Telaprevir <sup>†</sup>	Incivek Incivo VX-950	Inhibitor of HCV NS3-4A serine protease Active against HCV genotype 1 No longer available in United States
Telbivudine <sup>†</sup>	Tyzeka	Interferes with HBV DNA replication No longer available in United States
Tenofovir	Viread Vemlidy	Nucleoside reverse transcriptase inhibitor Active against HBV
Trifluridine	Viroptic	Inhibits viral DNA polymerase
Valacyclovir	Valtrex	Same as acyclovir
Valganciclovir	Valcyte	Same as ganciclovir
Velpatasvir	(Epclusa, Sofosvel, Velpanat)	Inhibitor of HCV NS5A Used in combination with sofosbuvir (Epclusa, Sofosvel, Velpanat) Active against all 6 HCV genotypes
Vidarabine	Ara-A	Inhibits viral DNA polymerase (and to lesser extent, cellular DNA polymerase)
Zanamivir	Relenza	Neuraminidase inhibitor; interference with deaggregation and release of viral progeny
<b>FDA-APPROVED COMBINATION THERAPIES WITH INTERFERONS</b>		
Interferon- $\alpha$ 2b + ribavirin	Rebeton (Intron-A plus Rebetol <sup>†</sup> [ribavirin])	Discontinuation of Rebetol announced by FDA in 2019
Interferon- $\alpha$ 2a + ribavirin	Roferon-A <sup>†</sup> + ribavirin	Discontinuation of Roferon announced by manufacturer in 2020
Pegylated interferon- $\alpha$ 2b + ribavirin (3yr and older)	PEG-Intron PegIntron Sylatron ViraferonPeg PEG-Intron/Rebetol (with ribavirin)	Indicated for chronic hepatitis C
Pegylated interferon- $\alpha$ 2a $\pm$ ribavirin (5yr and older)	Pegasys + Copegus	Approved for the treatment of chronic hepatitis C (in combination with ribavirin) and treatment of chronic hepatitis B (can be used alone) Has been used in the treatment of mycosis fungoides (a T-cell lymphoma)

\*No longer recommended by Centers for Disease Control and Prevention for treatment of influenza.

<sup>†</sup>No longer marketed in United States.

<sup>‡</sup>No longer available.

<b>Table 292.2 Antiviral Therapies for Non-HIV Clinical Conditions*</b>			
<b>*VIRUS</b>	<b>CLINICAL SYNDROME</b>	<b>ANTIVIRAL AGENT OF CHOICE</b>	<b>ALTERNATIVE ANTIVIRAL AGENTS</b>
Influenza A and B	Treatment	Oseltamivir (>2wk old)	Zanamivir (>7 yr old) Peramivir (>2 yr old) Baloxavir (>12 yr old)
	Prophylaxis	Oseltamivir (>3mo old)	Zanamivir (>5yr old)
Respiratory syncytial virus	Bronchiolitis or pneumonia in high-risk host	Ribavirin aerosol	
COVID-19	Pneumonia MIS-C†	Remdesivir	Nirmatrelvir-ritonavir Molnupiravir
Adenovirus	In immunocompromised patients: Pneumonia Viremia Nephritis Hemorrhagic cystitis	Cidofovir	
CMV	Congenital CMV infection (symptomatic disease)	Valganciclovir (long-term oral valganciclovir may improve developmental and hearing outcomes)	Ganciclovir
	Retinitis in AIDS patients	Valganciclovir	Ganciclovir Cidofovir Foscarnet Ganciclovir ocular insert
	Pneumonitis, colitis; esophagitis in immunocompromised patients	Ganciclovir (IV)	Foscarnet Cidofovir Valganciclovir Maribavir
	Prophylaxis for HSCT or SOT	Acyclovir (high-dose; oral)	Valganciclovir Letermovir
HSV	Neonatal herpes	Acyclovir (IV)	
	Suppressive therapy following neonatal herpes	Acyclovir (PO)	
	HSV encephalitis	Acyclovir (IV)	
	HSV gingivostomatitis	Acyclovir (PO)	Acyclovir (IV) Valacyclovir (PO)
	First episode genital infection	Acyclovir (PO)	Valacyclovir
			Acyclovir (IV) (severe disease)
	Recurrent genital herpes	Acyclovir (PO)	Valacyclovir
	Suppression of genital herpes	Acyclovir (PO)	Valacyclovir
	Cutaneous HSV (whitlow, herpes gladiatorum)	Acyclovir (PO)	Penciclovir (topical)
	Eczema herpeticum	Acyclovir (PO)	Acyclovir (IV) (severe disease)
	Mucocutaneous infection in immunocompromised host (mild)	Acyclovir (IV)	Acyclovir (PO) (if outpatient therapy acceptable)
	Mucocutaneous infection in immunocompromised host (moderate to severe)	Acyclovir (IV)	
	HSV prophylaxis in bone marrow transplant recipients	Acyclovir (IV)	Valacyclovir
Acyclovir-resistant HSV	Foscarnet	Cidofovir	
Keratitis or keratoconjunctivitis	Trifluridine	Vidarabine	

Continued

**Table 292.2** Antiviral Therapies for Non-HIV Clinical Conditions\*—cont'd

*VIRUS	CLINICAL SYNDROME	ANTIVIRAL AGENT OF CHOICE	ALTERNATIVE ANTIVIRAL AGENTS
Varicella-zoster virus	Chickenpox, healthy child	Supportive care	Acyclovir (PO)
	Chickenpox, immunocompromised child	Acyclovir (IV)	
	Zoster (not ophthalmic branch of trigeminal nerve), healthy child	Supportive care	Acyclovir (PO)
	Zoster (ophthalmic branch of trigeminal nerve), healthy child	Acyclovir (IV)	
	Zoster, immunocompromised child	Acyclovir (IV)	Valacyclovir

\*For antiviral agents for hepatitis B and hepatitis C, see Table 292.1.

†For MIS-C, adjunctive therapies also include steroids, immunomodulatory therapy; see Chapter 449.1. CMV, Cytomegalovirus; HSV, herpes simplex virus.

less commonly encountered HSV infections, including herpetic whitlow, eczema herpeticum, and herpes gladiatorum. In addition, acyclovir is commonly used for prophylaxis against HSV reactivation in SOT and HSCT patients. Severe end-organ HSV disease, including disseminated infection, is occasionally encountered in immunocompromised or pregnant patients, representing another clinical scenario in which acyclovir therapy is warranted.

Acyclovir modifies the course of primary VZV infection, although the effect is modest. Acyclovir or another nucleoside analog should always be used in localized or disseminated VZV infections in immunocompromised patients. Primary VZV infection in pregnancy is another setting in which acyclovir is indicated; this is a high-risk scenario and can be associated with a substantial risk of maternal mortality, particularly if pneumonia is present.

Acyclovir is available in topical (5% ointment), parenteral, and oral formulations, including an oral suspension formulation for pediatric use. Topical therapy has little role in pediatric practice and should be avoided in favor of alternative modes of delivery, particularly in infants with vesicular lesions compatible with herpetic infection, where topical therapy should never be used. The bioavailability of oral formulations is modest, with only 15–30% of the oral dose being absorbed. There is widespread tissue distribution after systemic administration, and high concentrations of drug are achieved in the kidneys, lungs, liver, myocardium, and skin vesicles. Cerebrospinal fluid concentrations are approximately 50% of plasma concentrations. Acyclovir crosses the placenta, and breast milk concentrations are approximately 3 times plasma concentrations, although there are no data on efficacy of in utero therapy or impact of acyclovir therapy on nursing infants. Acyclovir therapy in a nursing mother is not a contraindication to breastfeeding. The main route of elimination is renal, and dosage adjustments are necessary for renal insufficiency. Hemodialysis also eliminates acyclovir.

Acyclovir has an exceptional safety profile. Toxicity is observed typically only in exceptional circumstances: for example, if administered by rapid infusion to a dehydrated patient or a patient with underlying renal insufficiency, acyclovir can crystallize in renal tubules and produce a reversible obstructive uropathy. High doses of acyclovir are associated with neurotoxicity, and prolonged use can cause neutropenia. The favorable safety profile of acyclovir is underscored by recent studies of its safe use during pregnancy, and suppressive therapy in pregnant women with histories of recurrent genital HSV infection, typically with valacyclovir (see later), has become standard of care among many obstetricians. One uncommon but important complication of long-term use of acyclovir is the selection for acyclovir-resistant HSV strains, which usually occurs from pathogenic variants in the HSV *TK* gene. Resistance is rarely observed in pediatric practice but should be considered in any patient who has been on long-term antiviral therapy and who has an HSV or VZV infection that fails to clinically respond to acyclovir therapy.

### Valacyclovir

Valacyclovir is the L-valyl ester of acyclovir and is rapidly converted to acyclovir after oral administration. This agent has a safety and activity profile similar to that of acyclovir but has a bioavailability of >50%, 3–5-fold greater than that of acyclovir. Plasma concentrations approach those observed with intravenous acyclovir. Valacyclovir is available only for oral administration. A suspension formulation is not commercially available, but an oral suspension (25 mg/mL or 50 mg/mL) may be prepared extemporaneously from 500-mg caplets for use in pediatric patients for whom a solid dosage form is not appropriate. Suppressing therapy with valacyclovir is commonly prescribed in the second and third trimesters of pregnancy in women who have a clinical history of recurrent genital herpes. *It is important to be aware that perinatal transmission of HSV can occur, leading to symptomatic disease in spite of maternal antenatal antiviral prophylaxis.* In such settings, the possibility of emergence of acyclovir-resistant virus should be considered.

### Penciclovir and Famciclovir

Penciclovir is an acyclic nucleoside analog that, like acyclovir, inhibits the viral DNA polymerase after phosphorylation to its active form. Compared with acyclovir, penciclovir has a substantially longer intracellular half-life, which in theory can confer superior antiviral activity at the intracellular level; however, there is no evidence that this effect confers clinical superiority. Penciclovir is licensed only as a topical formulation (1% penciclovir cream), and this formulation is indicated for therapy of cutaneous HSV infections. Topical therapy for primary or recurrent herpes labialis or cutaneous HSV infection is an appropriate use of penciclovir in children older than 2 years of age.

Famciclovir is the prodrug formulation (diacetyl ester) of penciclovir. After oral administration, famciclovir is deacetylated to the parent drug, penciclovir. The efficacy of famciclovir for HSV and VZV infections appeared equivalent to that of acyclovir, although the pharmacokinetic profile was more favorable. As of 2016, the drug has been discontinued.

### Ganciclovir and Valganciclovir

Ganciclovir is a nucleoside analog with structural similarity to that of acyclovir. Like acyclovir, ganciclovir must be phosphorylated for antiviral activity, which is targeted against the viral polymerase. The gene responsible for ganciclovir phosphorylation is not *TK* but rather the virally encoded UL97 phosphotransferase gene. Antiviral resistance in CMV can be observed with prolonged use of nucleoside antivirals, and resistance should be considered in patients on long-term therapy who appear to fail to respond clinically and virologically. Ganciclovir is broadly active against many herpesviruses, including HSV and VZV, but is most valuable for its activity against CMV. Ganciclovir was



the first antiviral agent licensed specifically to treat and prevent CMV infection. It is indicated for prophylaxis against and therapy of CMV infections in high-risk patients, including HIV-infected patients and SOT or HSCT recipients. Of particular importance is the use of ganciclovir in the management of CMV retinitis, a sight-threatening complication of HIV infection. Ganciclovir is also of benefit for newborns with symptomatic congenital CMV infection and may be of value in partially ameliorating the sensorineural hearing loss and developmental disabilities that are common complications of congenital CMV infection.

Ganciclovir is supplied in parenteral and oral (as the prodrug, valganciclovir) formulations. Ganciclovir ocular implants are also available for the management of CMV retinitis. The bioavailability of oral ganciclovir is poor, <10%, and therefore oral ganciclovir therapy has been supplanted by the oral prodrug valganciclovir, which is well absorbed from the gastrointestinal tract and quickly converted to ganciclovir by intestinal or hepatic metabolism. Bioavailability of ganciclovir (from valganciclovir) is approximately 60% from tablet and solution formulations. Significant concentrations are found in the aqueous humor, subretinal fluid, cerebrospinal fluid, and brain tissue (enough to inhibit susceptible strains of CMV). Subretinal concentrations are comparable with plasma concentrations, but intravitreal concentrations are lower. Drug concentrations in the CNS range from 24% to 70% of plasma concentrations. The main route of elimination is renal, and dosage adjustments are necessary for renal insufficiency. Dose reduction is proportional to the creatinine clearance. Hemodialysis efficiently eliminates ganciclovir, so administration of additional doses after dialysis is necessary.

Ganciclovir has several important toxicities. Reversible myelosuppression is the most important toxicity and commonly requires either discontinuation of therapy or the intercurrent administration of granulocyte colony-stimulating factor. There are also the theoretical risks of carcinogenicity and gonadal toxicity; although these effects have been observed in some animal models, they have never been observed in patients. The decision to administer ganciclovir to a pediatric patient is complex and should be made in consultation with a pediatric infectious disease specialist.

### Foscarnet

Foscarnet has a unique profile, insofar as it is not a nucleoside analog but rather a pyrophosphate analog. The drug has broad activity against most herpesviruses. Like the nucleoside analogs, foscarnet inhibits viral DNA polymerase. On the other hand, foscarnet does not require phosphorylation to exert its antiviral activity, thus differing from the nucleoside analogs. It binds to a different site on the viral DNA polymerase to exert its antiviral effect and therefore retains activity against strains of HSV and CMV that are resistant to nucleoside analogs. Its clinical utility is as a second-line agent for management of CMV infections in high-risk patients who cannot tolerate ganciclovir and as an alternative for patients with persistent or refractory HSV, CMV, or VZV disease with suspected or documented antiviral drug resistance.

Foscarnet is available only as a parenteral formulation and is a toxic agent that must be administered cautiously. Nephrotoxicity is common, and reversible renal insufficiency is often observed, as evidenced by an increase in serum creatinine. Abnormalities in calcium and phosphorus homeostasis are common, and electrolytes and renal function must be monitored carefully during treatment.

### Cidofovir

Cidofovir is an acyclic nucleotide analog that requires phosphorylation to its active form, cidofovir diphosphate, to exert its antiviral effect. Analogous to penciclovir, it has an extended intracellular half-life that contributes to its prolonged antiviral activity. Cidofovir is active against HSV, VZV, and CMV. In contrast to most of the other agents with activity against herpesviruses, cidofovir also exhibits broad-spectrum activity against other DNA viruses, most notably the poxviruses. Cidofovir has activity against the BK virus, a polyomavirus, and therapy may be

warranted in some settings of BK reactivation after HSCT and SOT. Cidofovir is useful in the management of adenovirus infections in the immunocompromised host. Cidofovir is also useful in the management of CMV disease caused by strains with documented ganciclovir resistance.

Cidofovir is administered intravenously and is cleared renally by tubular secretion. Extensive prehydration and co-administration of probenecid are recommended. Nephrotoxicity is commonly encountered, even with appropriate prehydration; cidofovir must be co-administered with care with other nephrotoxic medications. Other potential toxicities include reproductive toxicity and carcinogenesis.

### Trifluridine

Trifluridine is a pyrimidine nucleoside analog with activity against HSV, CMV, and adenovirus. It is formulated as a 1% ophthalmic solution and approved for topical use in the treatment of HSV keratitis and keratoconjunctivitis. Trifluridine is the treatment of choice for HSV keratitis, a disease that should always be managed in consultation with an ophthalmologist.

### Vidarabine

Vidarabine is a nucleoside analog that has activity against HSV. It was the first parenteral antiviral agent for HSV infection, although it is no longer available for intravenous administration. A topical preparation remains available to treat HSV keratitis and is considered a second-line agent for this indication.

### Fomivirsen

Fomivirsen is an anti-CMV compound that was used as a second-line agent for CMV retinitis by direct injection into the vitreous space. It is an antisense 21-mer DNA oligonucleotide that binds directly to complementary messenger RNA. This agent is of interest because it was the first antisense antiviral agent approved by the U.S. Food and Drug Administration (FDA). The drug is no longer marketed.

### Letermovir

Letermovir is a highly orally bioavailable agent with a novel mechanism of antiviral action, functioning through interference with the viral terminase complex. This agent demonstrates substantial promise as an alternative to more toxic antivirals in patients at high risk for CMV disease, particularly in the transplantation setting. It is licensed for prophylaxis for CMV infection and disease in adult CMV-seropositive recipients of allogeneic HSCT.

### Maribavir

Maribavir is a licensed orally bioavailable agent that targets the CMV gene product UL97, in the process blocking viral replication. The drug is indicated to treat patients >12 years of age who weigh >35 kg and have evidence of posttransplant CMV infection and/or disease that does not respond to other antiviral agents.

## ANTIVIRALS USED FOR RESPIRATORY VIRAL INFECTIONS

Antiviral therapies are available for many respiratory pathogens, including respiratory syncytial virus (RSV), influenza A, and influenza B. Antiviral therapy for respiratory viral infections is of particular value for infants, children with chronic lung disease, and immunocompromised children.

### Ribavirin

Ribavirin is a guanosine analog that has broad-spectrum activity against a variety of viruses, particularly RNA viruses. Its precise mechanism of action is incompletely understood but is probably related to interference with viral messenger RNA processing and translation. Ribavirin is available in oral, parenteral, and aerosolized formulations. Although intravenous ribavirin is highly effective in

the management of Lassa fever and other hemorrhagic fevers, this formulation is not licensed for use in the United States. The only licensed formulations in the United States are an aqueous formulation for aerosol administration (indicated for RSV infection) and an oral formulation that is combined with IFN- $\alpha$  for the treatment of hepatitis C. (For more information about antivirals for hepatitis, see [Chapter 406](#).) Administration of ribavirin by aerosol should be considered for serious RSV lower respiratory tract disease in immunocompromised children, young infants with serious RSV-associated illness, and high-risk infants and children (children with chronic lung disease or cyanotic congenital heart disease). In vitro testing and uncontrolled clinical studies also suggest efficacy of aerosolized ribavirin for parainfluenza, influenza, and measles infections.

Ribavirin is generally nontoxic, particularly when administered by aerosol. Oral ribavirin is used in combination with other agents for therapy of hepatitis C (discussed later). There is no role for the use of oral ribavirin in the treatment of community-acquired viral respiratory tract infections. Ribavirin and its metabolites concentrate in red blood cells and can persist for several weeks and, in rare instances, may be associated with anemia. Conjunctivitis and bronchospasm have been reported after exposure to aerosolized drug. Care must be taken when using aerosolized ribavirin in children undergoing mechanical ventilation to avoid precipitation of particles in ventilator tubing; the drug is not formally approved for use in the mechanically ventilated patient, although there is published experience with this approach, which can be considered for mechanically ventilated patients, particularly in a “high-dose, short-duration” regimen (6 g/100 mL water given for a period of 2 hours 3 times a day). Concerns regarding potential teratogenicity from animal studies have not been borne out in clinical practice, although care should be taken to prevent inadvertent exposure to aerosolized drug in pregnant health-care providers.

### Amantadine and Rimantadine

Amantadine and rimantadine are tricyclic amines (adamantanes) that share structural similarity. Both were indicated for prophylaxis and therapy of influenza A. The mechanism of action of the tricyclic amines against influenza A virus was unclear, but they appeared to exert their antiviral effect at the level of uncoating of the virus. Both agents are extremely well absorbed after oral administration and are eliminated via the kidneys (90% of the dose is unchanged), necessitating dosage adjustments for renal insufficiency. The toxicities of the tricyclic amines are modest and include CNS adverse effects such as anxiety, difficulty concentrating, and lightheadedness and gastrointestinal adverse effects such as nausea and loss of appetite.

Although these agents are still manufactured and available, the Centers for Disease Control and Prevention (CDC) no longer recommends the use of the adamantane agents in treatment or prophylaxis against influenza, because of the emergence of widespread resistance.

### Oseltamivir, Peramivir, Zanamivir (Neuraminidase Inhibitors)

These agents are active against both influenza A and B, although the importance of this broader spectrum of antiinfluenza activity in disease control is modest because influenza B infection is typically a much milder illness. Emerging strains of influenza, including H5N1 and the 2009 to 2010 pandemic strain, H1N1 (swine flu), are susceptible to oseltamivir and zanamivir but resistant to amantadine. Therefore these agents have emerged as the antivirals of choice for influenza infection. These agents have no appreciable activity against other respiratory viruses. The mechanism of antiviral activity of oseltamivir, zanamivir, and peramivir is via inhibition of the influenza neuraminidase. Unfortunately, oseltamivir resistance may occur as a result of a mutation in 2009 H1N1 viruses, resulting in treatment failure.

Zanamivir has poor oral bioavailability and is licensed only for inhalational administration. With inhaled administration, >75% of the dose

is deposited in the oropharynx and much of it is swallowed. The actual amount distributed to the airways and lungs depends on factors such as the patient's inspiratory flow. Approximately 13% of the dose appears to be distributed to the airways and lungs, with approximately 10% of the inhaled dose distributed systemically. Local respiratory mucosal drug concentrations greatly exceed the drug concentration needed to inhibit influenza A and B viruses. Elimination is via the kidneys, and no dosage adjustment is necessary with renal insufficiency, because the amount systemically absorbed is low.

Oseltamivir is administered as an esterified prodrug that has high oral bioavailability. It is eliminated by tubular secretion, and dosage adjustment is required for patients with renal insufficiency. Gastrointestinal adverse effects, including nausea and vomiting, are occasionally observed. The drug is indicated for both treatment and prophylaxis. The usual adult dosage for treatment of influenza is 75 mg twice daily for 5 days. Treatment should be initiated within 2 days of the appearance of symptoms. Recommended treatment dosages for children vary by age and weight. The recommended dose for children younger than 1 year of age is 3 mg/kg/dose twice a day. For children older than 1 year of age, doses are 30 mg twice a day for children weighing  $\leq 15$  kg, 45 mg twice a day for children weighing 15–23 kg, 60 mg twice a day for those weighing 23–40 kg, and 75 mg twice a day for children weighing  $\geq 40$  kg. Dosages for chemoprophylaxis are the same for each weight group in children older than 1 year, but the drug should be administered only once daily rather than twice daily. Oseltamivir is FDA approved for therapy of influenza A and B treatment in children 2 weeks of age and older, whereas zanamivir is recommended for treatment of children 7 years of age and older. Current treatment and dosage recommendations for treatment of influenza in children and for chemoprophylaxis are available at <https://www.cdc.gov/flu/highrisk/children-antiviral.htm>. Oseltamivir has been described to produce neuropsychiatric (narcolepsy) and psychologic (suicidal events) side effects in some patient populations; the drug should be discontinued if behavioral or psychiatric side effects are observed. In late 2014 the FDA approved the neuraminidase inhibitor peramivir for treatment of influenza in pediatrics. It is available as a single-dose, intravenous option. The drug is currently approved for use in children >2 years. The dose is 12 mg/kg dose, up to 600 mg maximum, by intravenous infusion for a minimum of 15 minutes in children from 2 to 12 years. Children 13 and older should receive the adult dose (600 mg IV in a single, one-time dose).

### Baloxavir

Baloxavir is dosed as baloxavir marboxil, a prodrug that is converted by hydrolysis to baloxavir, the active agent. It is active against influenza A and B. Baloxavir inhibits the endonuclease activity of the influenza polymerase acidic (PA) protein, in the process inhibiting virus replication. It is administered as a single dose of 40 mg in individuals 40–80 kg, and 80 mg in those >80 kg.

Oral baloxavir marboxil (Xofluza) is approved by the FDA for treatment of acute uncomplicated influenza within 2 days of illness onset in people  $\geq 12$  years. The safety and efficacy of baloxavir for the treatment of influenza have been established in pediatric patients  $\geq 12$  years and older weighing at least 40 kg. Safety and efficacy in patients <12 years or weighing less than 40 kg have not been established. Baloxavir efficacy is based on clinical trials in outpatients 12 to 64 years of age; people with underlying medical conditions and adults >65 years were not included in the initial published clinical trials. There are no available data for baloxavir treatment of hospitalized patients with influenza.

### ANTIVIRALS USED FOR COVID-19

The advent of the COVID-19 pandemic has necessitated the urgent development of antivirals active against the SARS-CoV-2 virus. **Remdesivir** is an adenosine analog that was originally developed as a therapeutic option for Ebola virus. It is metabolized to its active metabolite, remdesivir triphosphate, which is a structural analog of adenosine triphosphate and results in delayed chain termination during viral replication. It reduces early-stage COVID-19 mortality and the need for mechanical

ventilation among hospitalized COVID-19 patients. The dose for pediatric patients less than 12 years of age and weighing at least 3 kg (and <40 kg) is a single loading dose of 5 mg/kg on day 1 followed by 2.5 mg/kg once daily for up to 5 days; for hospitalized patients requiring invasive mechanical ventilation and/or ECMO, up to 10 days total therapy can be administered. **Paxlovid** (also variably referred to as ritonavir-boosted nirmatrelvir) is a therapeutic combination consisting of two compounds: nirmatrelvir, an oral inhibitor of SARS-CoV-2 protease, and ritonavir, an inhibitor of the HIV-1 protease. Ritonavir is also a potent inhibitor of cytochrome P-450 (CYP) 3A; thus its inclusion results in higher levels of PF-07321332. In patients with SARS-CoV-2 infection who were treated with Paxlovid within 3 days of symptom onset, hospitalization and mortality rates were statistically significantly lower compared with placebo. The FDA Emergency Use Authorization (EUA) includes treatment of children over 12 years of age with a body weight of >40 kg, with a suggested dose of 300 mg nirmatrelvir (two 150-mg tablets) with 100 mg ritonavir (one 100-mg tablet), with all three tablets taken together, twice daily, by oral administration, for 5 days. **Molnupiravir** (Lagevrio) was originally developed as an influenza antiviral agent. It is a prodrug of a synthetic nucleoside hydroxycytidine derivative. Its antiviral effect is mediated by the introduction of copying errors during the SARS-CoV-2 RNA replication cycle. The reported efficacy against hospitalization or death in an adult study of mild or moderate COVID-19 disease was approximately 30%. The drug is not authorized for patients <18 years of age because of concerns that it may affect cartilage and bone growth.

### ANTIVIRALS USED FOR HEPATITIS

Seven antiviral agents have been approved by the FDA for treatment of adults with chronic hepatitis B in the United States. These agents are categorized as either IFN- $\alpha$ 2b and peginterferon- $\alpha$ 2a or nucleoside or nucleotide analogs (lamivudine, adefovir, entecavir, tenofovir, telbivudine). Lamivudine is currently considered the first-line therapy in adult patients, but experience in children is limited. In 2012 tenofovir was FDA approved for children with chronic hepatitis B age  $\geq$ 12 years weighing >35 kg. Entecavir was approved in the United States for use in children 2 years and older with chronic HBV and evidence of active viral replication and disease activity and, with IFN- $\alpha$ , is emerging as a first-line antiviral regimen for children with hepatitis B who are candidates for antiviral therapy.

Adefovir demonstrates a favorable safety profile and is less likely to select for resistance than lamivudine, but virologic response was limited to adolescent patients and was lower than that of lamivudine. Most experts recommend watchful waiting of children with chronic hepatitis B infection, because current therapies are only modestly effective at best and evidence of long-term benefit is scant. Young children are often thought to be immune tolerant of hepatitis B infection (i.e., they have viral DNA present in serum but normal transaminase levels and no evidence of active hepatitis). These children should have transaminases and viral load monitored but are not typically considered to be candidates for antiviral therapy.

Various formulations of IFNs and ribavirin have been approved by the FDA to treat adults and children with chronic hepatitis C (see Tables 292.1 and 292.2). The impact of hepatitis C genotype had formerly been a major issue in treatment response. Previous studies using ribavirin and pegylated IFNs demonstrated significant genotype-dependent differences in responsiveness to antiviral therapy; patients with genotype 1 had the lowest levels of sustained virologic response, and patients with genotype 2 or 3 had the highest response. The development of novel and highly effective antivirals for HCV has revolutionized the care of hepatitis C patients. Novel drugs include ledipasvir, sofosbuvir, daclatasvir, elbasvir, beclabuvir, grazoprevir, paritaprevir, ombitasvir, velpatasvir, and dasabuvir. Ledipasvir, ombitasvir, daclatasvir, elbasvir, and velpatasvir inhibit the virally encoded phosphoprotein NS5A, which is involved in viral replication, assembly, and secretion, whereas sofosbuvir is metabolized to

a uridine triphosphate mimic, which functions as an RNA chain terminator when incorporated into the nascent RNA by the NS5B polymerase enzyme. Dasabuvir and beclabuvir are also NS5B inhibitors. Paritaprevir and grazoprevir inhibit the nonstructural protein 3 (NS3/4) serine protease, a viral nonstructural protein that is the 70-kDa cleavage product of the hepatitis C virus polyprotein.

Sofosbuvir in a fixed-dose combination was originally licensed for treatment of hepatitis C in adults. It is highly effective (>90%) for hepatitis C genotypes 1 through 6. In 2020, it was licensed for treatment in children ages 6 years and older and weighing at least 17 kilograms for any of the six HCV genotypes in patients without cirrhosis or with mild cirrhosis. Epclusa in combination with ribavirin is indicated for the treatment of pediatric patients 6 years and older or weighing at least 17 kilograms with severe cirrhosis.

### ANTIVIRAL IMMUNE GLOBULINS

Immune globulins are useful adjuncts in the management of viral disease. However, they are most valuable when administered as prophylaxis against infection and disease in high-risk patients; their value as therapeutic agents in the setting of established infection is less clear. **Varicella-zoster immune globulin (human)** is valuable for prophylaxis against VZV in high-risk children, particularly newborns and immunocompromised children (see Chapter 300). **CMV immune globulin** is warranted for children at high risk for CMV disease, particularly SOT and HSCT patients, and can play a role in preventing injury to the infected fetus when administered to the pregnant patient (see Chapter 302). **Palivizumab**, a monoclonal antibody with anti-RSV activity, is effective for preventing severe RSV lower respiratory tract disease in high-risk premature infants and has replaced **RSV immune globulin** (see Chapter 307). **Hepatitis B immune globulin** is indicated in infants born to hepatitis B surface antigen-positive mothers (see Chapter 406). A variety of monoclonal antibodies had received FDA EUA clearance for prophylaxis and/or therapy of SARS-CoV-2 infection, including **bamlanivimab** (LY-CoV555; administered alone or in combination with **etesevimab**), the combination of **casirivimab** and **imdevimab** (REGEN-COV), and the combination of **tixagevimab** (AZD8895) and **cilgavimab** (AZD1061), also known as Evusheld. As of late 2023, these products are no longer available due to their lack of effectiveness against emerging circulating variants of the SARS-CoV-2 virus. The US Centers for Disease Control and Prevention's (CDC) Advisory Committee on Immunization Practices has also recently recommended the routine use of **nirsevimab**, a monoclonal antibody targeting the prefusion conformation of the RSV F protein, for the prevention of RSV lower respiratory tract disease (see Chapter 307). Treatment is recommended for newborns and infants younger than 8 months of age during, or entering, their first RSV season, as well as for children up to 24 months of age at increased risk of developing RSV disease entering their second RSV season. A single dose of 50 mg administered intramuscularly is recommended for infants <5 kg, and 100 mg is recommended for infants  $\geq$ 5 kg. Nirsevimab should not be given to children  $\geq$ 8 months and older who are not at increased risk of severe RSV disease. For the 2023-24 respiratory virus season, and in light of shortage and distribution issues with nirsevimab, the CDC has recommended (<https://emergency.cdc.gov/han/2023/han00499.asp>) assigning the highest priority for nirsevimab 100 mg doses for infants at the highest risk for severe RSV disease: young infants (age <6 months and >5 kg) and infants with underlying conditions that place them at highest risk for severe RSV disease. The CDC also recommended that providers not use nirsevimab in palivizumab-eligible children ages 8–19 months for the 2023–24 RSV season; instead, they should receive palivizumab per American Academy of Pediatrics (AAP) recommendations (<https://publications.aap.org/pediatrics/article/152/1/e2023061803/192153/Palivizumab-Prophylaxis-in-Infants-and-Young?autologincheck=redirected>).

Visit Elsevier eBooks+ at [eBooks.Elsevier.com](https://eBooks.Elsevier.com) for Bibliography.



## Chapter 293

## Measles

Hayley A. Gans

Measles is highly contagious, but endemic transmission has been interrupted in the United States as a result of widespread vaccination; imported cases have resulted in epidemics in the United States in unimmunized or partially immunized individuals. In some areas of the world, measles remains a major cause of morbidity and mortality in children (Fig. 293.1).

### ETIOLOGY

Measles virus is a negative sense single-stranded, lipid-enveloped RNA virus in the family Paramyxoviridae and genus *Morbillivirus*. Other members of the genus *Morbillivirus* affect a variety of mammals, such as rinderpest virus in cattle and distemper virus in dogs, but humans are the only host of measles virus. Of the six major structural proteins of measles virus, the two most important in terms of induction of immunity are the hemagglutinin (H) protein and the fusion (F) protein. The neutralizing antibodies are directed against the H protein, and antibodies to the F protein limit proliferation of the virus during infection. Small variations in genetic composition have also been identified that result in no effect on protective immunity but provide molecular markers that can distinguish between viral types. Related genotypes have been grouped by clades, and the World Health Organization (WHO) recognizes 8 clades, A-H, and 23 genotypes. These markers have been useful in the evaluation of endemic and epidemic spread of measles.

### EPIDEMIOLOGY

The measles vaccine has changed the epidemiology of measles dramatically. Once worldwide in distribution, endemic transmission of measles has been interrupted in many countries where there is widespread vaccine coverage. Historically, measles caused universal infection in childhood in the United States, with 90% of children acquiring the infection before 15 years of age. Morbidity and mortality associated with measles decreased before the introduction of the vaccine as a result of improvements in healthcare and nutrition. However, the incidence declined dramatically following the introduction of the measles vaccine in 1963. The attack rate fell from 313 cases per 100,000 population in 1956–1960 to 1.3 cases per 100,000 in 1982–1988.

A nationwide indigenous measles outbreak occurred in the United States in 1989–1991, resulting in more than 55,000 cases, 11,000 hospitalizations, and 123 deaths, demonstrating that the infection had not yet been controlled. This resurgence was attributed to vaccine failure in a small number of school-age children, low coverage of preschool-age children, and more rapid waning of maternal antibodies in infants born to mothers who had never experienced wild-type measles infection. Implementation of the two-dose vaccine policy and more intensive immunization strategies resulted in interruption of endemic transmission, and in 2000 measles was declared eliminated from the United States.

Measles continues to be imported into the United States; therefore continued maintenance of >90% immunity through vaccination is necessary to prevent widespread outbreaks from occurring (see Fig. 293.1).

Since elimination in 2000, there have been several measles epidemics, with the two largest occurring in 2014 with 667 cases and in 2019 with 1,282 cases. In 2014 there were 23 outbreaks reported, compared with a median of 4 outbreaks reported annually during 2001–2010. The majority of cases were associated with importations from other countries (returning tourists, adoptees, refugees), particularly from the Philippines, with prior year epidemics associated with epidemics in the WHO European Region. Measles cases were largely restricted to unvaccinated individuals. The epidemic in 2019 resulted in the highest

number of cases since 1992, with 89% of cases in unvaccinated or unknown vaccination status, and 10% of cases requiring hospitalization. There were 22 outbreaks in 17 states (7 were multistate outbreaks), and 85% of cases were in close-knit, isolated communities where standard control measures that generally quickly contain outbreaks were difficult to implement.

Population levels of measles immunity of ~95% are required to interrupt the endemic spread of measles. In the United States this can be achieved through the current two-dose immunization strategies when coverage rates are high (>90% one-dose coverage at 12–15 months and >95% two-dose coverage in school-age children). Although measles-mumps-rubella coverage remains high (~95% for 2011–2020), pockets of lower coverage rates exist because of reluctance of parents to vaccinate their children. This variability in vaccination has contributed to outbreaks among children in recent years.

### TRANSMISSION

The portal of entry of measles virus is through the respiratory tract or conjunctivae following contact with large droplets or small-droplet aerosols in which the virus is suspended. Individuals are infectious from 3 days before to up to 4–6 days after the onset of rash. Approximately 90% of exposed susceptible individuals experience measles. Face-to-face contact is not necessary, because viable virus may be suspended in air for as long as 2 hours after the source case leaves a room. Secondary cases from spread of aerosolized virus have been reported in airplanes, physicians' offices, and hospitals.

### PATHOLOGY

Measles infection causes necrosis of the respiratory tract epithelium and an accompanying lymphocytic infiltrate. Measles produces a small-vessel vasculitis on the skin and on the oral mucous membranes. Histology of the rash and exanthem reveals intracellular edema and dyskeratosis associated with formation of epidermal syncytial giant cells with up to 26 nuclei. Viral particles have been identified within these giant cells. In lymphoreticular tissue, lymphoid hyperplasia is prominent. Fusion of infected cells results in multinucleated giant cells, the **Warthin-Finkeldey giant cells** that are pathognomonic for measles, with up to 100 nuclei and intracytoplasmic and intranuclear inclusions.

### PATHOGENESIS

Measles infection consists of four phases: incubation period, prodromal illness, exanthematous phase, and recovery. During incubation, measles virus migrates to regional lymph nodes. A primary viremia ensues that disseminates the virus to the reticuloendothelial system. A secondary viremia spreads virus to body surfaces. The prodromal illness begins after the secondary viremia and is associated with epithelial necrosis and giant cell formation in body tissues. Cells are killed by cell-to-cell plasma membrane fusion associated with viral replication that occurs in many body tissues, including cells of the central nervous system. Virus shedding begins in the prodromal phase. With onset of the rash, antibody production begins, and viral replication and symptoms begin to subside. Measles virus also infects CD4<sup>+</sup> T cells, resulting in suppression of the Th1 immune response and a multitude of other immunosuppressive effects.

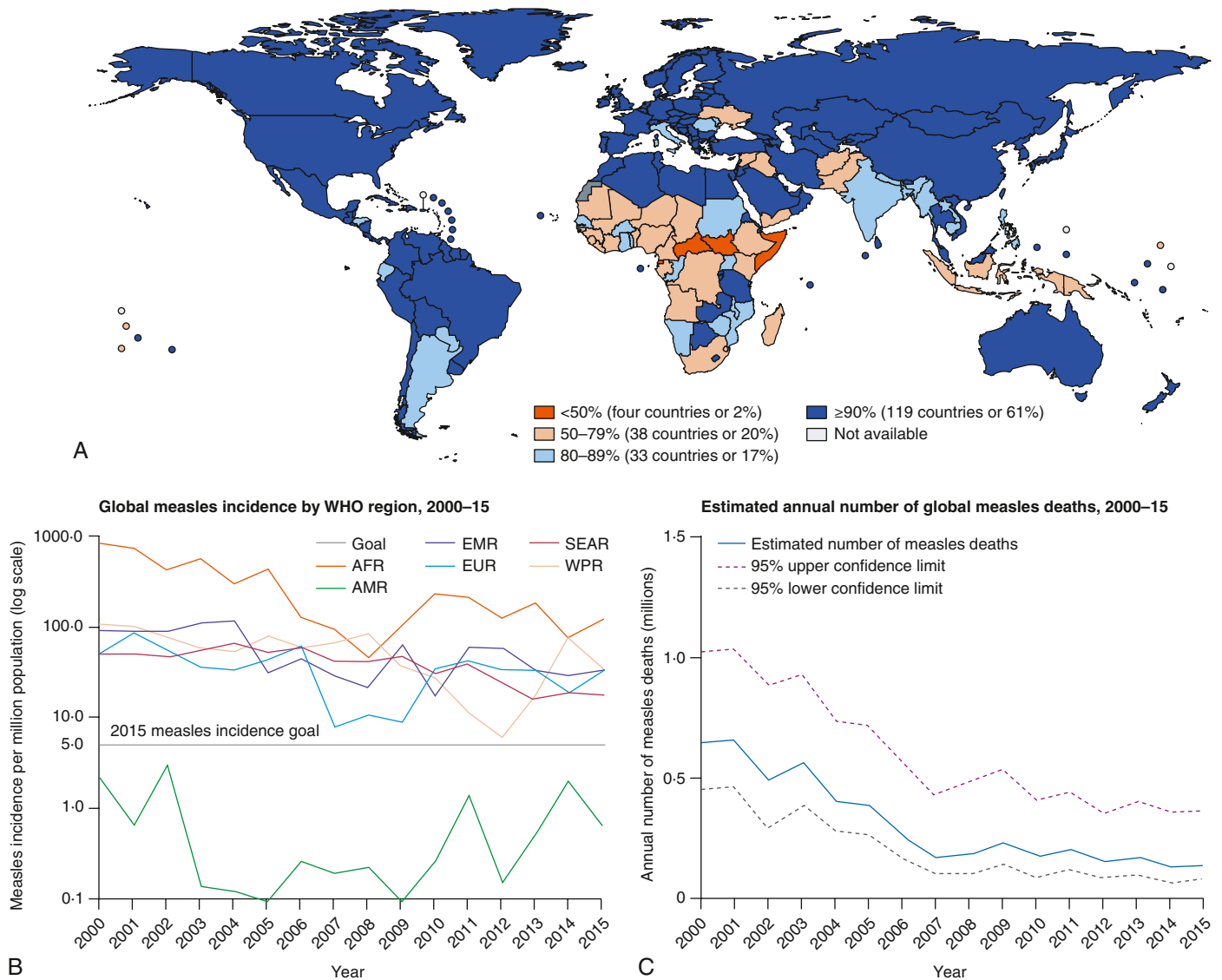
Measles virus attaches to specific cell receptors to infect host cells. Studies in primates show that the initial targets for measles virus are alveolar macrophages, dendritic cells, and lymphocytes. The cell receptor in these cells appears to be the signaling lymphocyte-activating molecule CD150. Subsequently, respiratory epithelial cells become infected by attachment to the PVRL4 receptor (Nectin4), which is expressed on cells in the trachea, oral mucosa, nasopharynx, and lungs.

### CLINICAL MANIFESTATIONS

Measles is a serious infection characterized by high fever, an enanthem, cough, coryza, conjunctivitis, and a prominent exanthem (Fig. 293.2). After an incubation period of 8–12 days, the prodromal phase begins with a mild fever followed by the onset of conjunctivitis with photophobia, coryza, a prominent cough, and increasing fever. **Koplik spots**



## MCV1 coverage in infants, 2015



**Fig. 293.1** Progress toward achieving global measles milestones for measles vaccine coverage (A), measles incidence (B), and measles mortality (C). **A**, Milestone 1: increase routine coverage with the first dose of measles-containing vaccine (MCV1) for children age 1 yr to  $\geq 90\%$  nationally and  $\geq 80\%$  in every district. Progress: The number of countries with  $\geq 90\%$  MCV1 coverage increased from 84 (44%) in 2000 to 119 (61%) in 2015. Among countries with  $\geq 90\%$  MCV1 coverage nationally, the percentage with  $\geq 80\%$  coverage in every district was only 39% of 119 countries in 2015. **B**, Milestone 2: reduce global measles incidence to  $< 5$  cases/1 million population. Progress: reported global annual measles incidence decreased 75% from 2000 to 2015, but only the Region of the Americas achieved the milestone of  $< 5$  cases/1 million population. **C**, Milestone 3: reduce global measles mortality by 95% from the 2000 estimate. Progress: the number of estimated global annual measles deaths decreased 79% from 2000 to 2015. AFR, African Region; AMR, Region of the Americas; EMR, Eastern Mediterranean Region; EUR, European Region; SEAR, South-East Asia Region; WPR, Western Pacific Region. (From Moss WJ. Measles. *Lancet*. 2017;390:2490–2502. Fig. 2; with data from Patel MK, Gacic-Dobo M, Strebel PM, et al. Progress toward regional measles elimination—worldwide, 2000–2015. *MMWR Morb Mortal Wkly Rep*. 2016;65:1228–1233.)

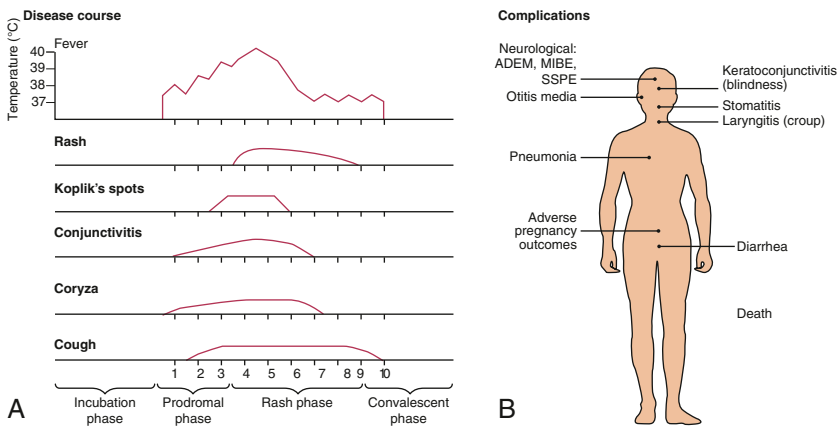
represent the enanthem and are the pathognomonic sign of measles, appearing 1–4 days before the onset of the rash (Fig. 293.3). They first appear as discrete red lesions with bluish-white spots in the center on the inner aspects of the cheeks at the level of the premolars. They may spread to involve the lips, hard palate, and gingiva. They also may occur in conjunctival folds and in the vaginal mucosa. Koplik spots have been reported in 50–70% of measles cases but probably occur in the great majority.

Symptoms increase in intensity for 2–4 days until the first day of the rash. The rash begins on the forehead (around the hairline), behind the ears, and on the upper neck as a red maculopapular eruption. It then spreads downward to the torso and extremities, reaching the palms and soles in up to 50% of cases. The exanthem frequently becomes confluent on the face and upper trunk (Fig. 293.4).

With the onset of the rash, symptoms begin to subside. The rash fades over about 7 days in the same progression as it evolved, often leaving a fine desquamation of skin in its wake. Of the major symptoms of measles, the cough lasts the longest, often up to 10 days. In more severe cases, generalized lymphadenopathy may be present, with cervical and occipital lymph nodes especially prominent.

### MODIFIED MEASLES INFECTION

In individuals with passively acquired antibody, such as infants and recipients of blood products, a subclinical form of measles may occur. The rash may be indistinct, brief, or, rarely, entirely absent. Similarly, some individuals who have been vaccinated may have a rash but few other symptoms after exposure to measles. Persons with modified measles are not considered highly contagious.



**Fig. 293.2** Measles disease course (A) and complications (B). ADEM, Acute demyelinating encephalomyelitis; MIBE, measles inclusion body encephalitis; SSPE, subacute sclerosing panencephalitis. (Modified from Moss WJ. Measles. *Lancet*. 2017;390:2490–2502. Fig. 4.)



**Fig. 293.3** Koplik spots on the buccal mucosa during the third day of rash. (From Centers for Disease Control and Prevention [CDC]. Public health image library, image 4500. <https://phil.cdc.gov/Details.aspx?id=4500>.)

### LABORATORY FINDINGS

The diagnosis of measles is almost always based on clinical and epidemiologic findings. Laboratory findings in the acute phase include reduction in the total white blood cell count, with lymphocytes decreased more than neutrophils. However, absolute neutropenia has been known to occur. In measles not complicated by bacterial infection, the erythrocyte sedimentation rate and C-reactive protein level are usually normal.

### DIAGNOSIS

Isolation of measles from blood, urine, or respiratory secretions can be accomplished by culture at the CDC or local or state laboratories. Molecular detection by polymerase chain reaction (PCR) can be performed on specimens from nasopharyngeal aspirates, throat swabs, or urine. Serologic confirmation is most conveniently made by identification of immunoglobulin (Ig) M antibody in serum. IgM antibody appears 1–2 days after the onset of the rash and remains detectable for about 1 month. If a serum specimen is collected <72 hours after onset of rash and is negative for measles antibody, a second specimen should be obtained. Serologic confirmation may also be made by demonstration of a fourfold rise in IgG antibodies in acute and convalescent specimens collected 2–4 weeks apart. Collection of both a throat swab specimen for PCR and a serum specimen for IgM detection is recommended from all patients with clinical features compatible with measles. In addition, samples should be sent to local state public health laboratories or the CDC for genotyping.

### DIFFERENTIAL DIAGNOSIS

Typical measles is unlikely to be confused with other illnesses, especially if Koplik spots are observed. Measles in the later stages or



**Fig. 293.4** A child with measles displaying the characteristic red blotchy pattern on his face and body. (From Kremer JR, Muller CP. Measles in Europe—there is room for improvement. *Lancet*. 2009;373:356–358.)

modified or atypical infections may be confused with a number of other exanthematous immune-mediated illnesses and infections, including rubella, adenovirus infection, enterovirus infection, and Epstein-Barr virus infection. Exanthem subitum (in infants) and erythema infectiosum (in older children) may also be confused with measles. *Mycoplasma pneumoniae* and group A *Streptococcus* may also produce rashes similar to that of measles. Kawasaki syndrome can cause many of the same findings as measles but lacks discrete intraoral lesions (Koplik spots) and a severe prodromal cough and typically leads to elevations of neutrophils and acute-phase reactants. In addition, the characteristic thrombocytosis of Kawasaki syndrome is absent in measles (see Chapter 208). Drug eruptions may occasionally be mistaken for measles.

**TABLE 293.1** Complications by Age for Reported Measles Cases, United States, 1987–2000

COMPLICATION	OVERALL (67,032 CASES WITH AGE INFORMATION)	NO. (%) OF PERSONS WITH COMPLICATION BY AGE GROUP				
		<5 YR (N = 28,730)	5-9 YR (N = 6,492)	10-19 YR (N = 18,580)	20-29 YR (N = 9,161)	<30 YR (N = 4,069)
Any	19,480 (29.1)	11,883 (41.4)	1,173 (18.1)	2,369 (12.8)	2,656 (29.0)	1,399 (34.4)
Death	177 (0.3)	97 (0.3)	9 (0.1)	18 (0.1)	26 (0.3)	27 (0.7)
Diarrhea	5,482 (8.2)	3,294 (11.5)	408 (6.3)	627 (3.4)	767 (8.4)	386 (9.5)
Encephalitis	97 (0.1)	43 (0.2)	9 (0.1)	13 (0.1)	21 (0.2)	11 (0.3)
Hospitalization	12,876 (19.2)	7,470 (26.0)	612 (9.4)	1,612 (8.7)	2,075 (22.7)	1,107 (27.2)
Otitis media	4,879 (7.3)	4,009 (14.0)	305 (4.7)	338 (1.8)	157 (1.7)	70 (1.7)
Pneumonia	3,959 (5.9)	2,480 (8.6)	183 (2.8)	363 (2.0)	554 (6.1)	379 (9.3)

From Perry RT, Halsey NA. The clinical significance of measles: a review. *Clin Infect Dis*. 2004;189(Suppl. 1):S4–S16.

## COMPLICATIONS

Complications of measles are largely attributable to the pathogenic effects of the virus on the respiratory tract and immune system (Table 293.1, see Fig. 293.2). Several factors make complications more likely. Morbidity and mortality from measles are greatest in individuals younger than 5 years of age (especially <1 year of age) and older than 20 years of age. In resource poor countries, higher case fatality rates have been associated with crowding, possibly attributable to larger inoculum doses after household exposure. Severe malnutrition in children results in a suboptimal immune response and higher morbidity and mortality with measles infection. Low serum retinol levels in children with measles are associated with higher measles morbidity and mortality in developing countries and in the United States. Measles infection lowers serum retinol concentrations, so subclinical cases of hyporetinolemia may be made symptomatic during measles. Measles infection in immunocompromised persons is associated with increased morbidity and mortality. Among patients with malignancy in whom measles develops, pneumonitis occurs in 58% and encephalitis occurs in 20%.

Pneumonia is the most common cause of death in measles. It may manifest as **giant cell pneumonia** caused directly by the viral infection or as superimposed bacterial infection. The most common bacterial pathogens are *Streptococcus pneumoniae*, *Haemophilus influenzae*, and *Staphylococcus aureus*. Following severe measles pneumonia, the final common pathway to a fatal outcome is often the development of bronchiolitis obliterans.

Croup, tracheitis, and bronchiolitis are common complications in infants and toddlers with measles. The clinical severity of these complications frequently requires intubation and ventilatory support until the infection resolves.

Acute otitis media is the most common complication of measles and was of particularly high incidence during the epidemic of the late 1980s and early 1990s because of the relatively young age of affected children. Sinusitis and mastoiditis also occur as complications. Viral and/or bacterial tracheitis is seen and can be life-threatening. Retropharyngeal abscess has also been reported.

Measles infection is known to suppress skin test responsiveness to purified tuberculin antigen. There may be a higher rate of activation of pulmonary tuberculosis in populations of individuals infected with *Mycobacterium tuberculosis* who are then exposed to measles.

Diarrhea and vomiting are common symptoms associated with acute measles, and diffuse giant cell formation is found in the epithelium in the gastrointestinal tract. Dehydration is a common consequence, especially in young infants and children. Appendicitis or abdominal pain may occur from obstruction of the appendiceal lumen by lymphoid hyperplasia.

Febrile seizures occur in <3% of children with measles. Encephalitis following measles is a long-associated complication, often with

an unfavorable outcome. Rates of 1-3 in 1,000 cases of measles have been reported, with greater numbers occurring in adolescents and adults than in preschool- or school-age children. Encephalitis is a postinfectious, immunologically mediated process and is not the result of a direct effect by the virus. Clinical onset begins during the exanthem and manifests as seizures (56%), lethargy (46%), coma (28%), and irritability (26%). Findings in cerebrospinal fluid include lymphocytic pleocytosis in 85% of cases and elevated protein concentrations. Approximately 15% of patients with measles encephalitis die. Another 20–40% of patients suffer long-term sequelae, including cognitive impairment, motor disabilities, and deafness.

Measles encephalitis in immunocompromised patients results from direct damage to the brain by the virus. Subacute measles encephalitis manifests 1-10 months after measles in immunocompromised patients, particularly those with AIDS, lymphoreticular malignancies, and immunosuppressive therapy. Signs and symptoms include seizures, myoclonus, stupor, and coma. In addition to intracellular inclusions, abundant viral nucleocapsids and viral antigen are seen in brain tissue. Progressive disease and death almost always occur. A severe form of encephalitis called measles inclusion-body encephalitis (MIBE) is being increasingly recognized in immunocompromised hosts, typically occurring within a year of infection or vaccination and almost universally resulting in death. Although the pathophysiology is incompletely understood, the measles viruses implicated in MIBE are usually replication-defective, with their genomes possessing numerous mutations. Diagnosis is confirmed by detection of virus via immunohistochemistry of brain tissue.

A severe form of measles rarely seen nowadays is **hemorrhagic measles** or **black measles**. It manifested as a hemorrhagic skin eruption and was often fatal. Keratitis, appearing as multiple punctate epithelial foci, resolved with recovery from the infection.

Myocarditis is a rare complication of measles. Miscellaneous bacterial infections have been reported, including bacteremia, cellulitis, and toxic shock syndrome. Measles during pregnancy is associated with high rates of maternal morbidity, fetal wastage, and stillbirths, with congenital malformations in 3% of liveborn infants.

## Subacute Sclerosing Panencephalitis

Subacute sclerosing panencephalitis (SSPE) is a chronic complication of measles with a delayed onset and an outcome that is nearly always fatal. It appears to result from a persistent infection with an altered measles virus that is harbored intracellularly in the central nervous system for several years. After 7-10 years the virus apparently regains virulence and attacks the cells in the central nervous system that offered the virus protection. This “slow virus infection” results in inflammation and cell death, leading to an inexorable neurodegenerative process.



SSPE is a rare disease and generally follows the prevalence of measles in a population. The incidence in the United States in 1960 was 0.61 cases per million persons younger than age 20 years. By 1980 the rate had fallen to 0.06 cases per million. Between 1956 and 1982 a total of 634 cases of SSPE had been reported to the national SSPE registry. After 1982 ~5 cases/year were reported annually in the United States, and only 2-3 cases/year were reported in the early 1990s. However, between 1995 and 2000, reported cases in the United States increased and 13 cases were reported in 2000. Of the 13 cases, 9 occurred in foreign-born individuals. This "resurgence" may be the result of an increased incidence of measles between 1989 and 1991. Although the age of onset ranges from <1 year to <30 years, the illness is primarily one of children and adolescents. Measles at an early age favors the development of SSPE: 50% of patients with SSPE have had primary measles before 2 years of age, and 75% have had measles before 4 years of age. Males are affected twice as often as females, and there appear to be more cases reported from rural than urban populations. Recent observations from the registry indicate a higher prevalence among children of Hispanic origin.

The pathogenesis of SSPE remains enigmatic. Factors that seem to be involved include defective measles virus and interaction with a defective or immature immune system. The virus isolated from brain tissue of patients with SSPE is missing one of the six structural proteins, the matrix or M protein. This protein is responsible for assembly, orientation, and alignment of the virus in preparation for budding during viral replication. Immature virus may be able to reside, and possibly propagate, within neuronal cells for long periods. The fact that most patients with SSPE were exposed at a young age suggests that immune immaturity is involved in pathogenesis.

Clinical manifestations of SSPE begin insidiously 7-13 years after primary measles infection. Subtle changes in behavior or school performance appear, including irritability, reduced attention span, and temper outbursts. This initial phase (**stage I**) may at times be missed because of brevity or mildness of the symptoms. Fever, headache, and other signs of encephalitis are absent. The hallmark of the **second stage** is massive myoclonus, which coincides with extension of the inflammatory process site to deeper structures in the brain, including the basal ganglia. Involuntary movements and repetitive myoclonic jerks begin in single muscle groups but give way to massive spasms and jerks involving both axial and appendicular muscles. Consciousness is maintained. In the **third stage**, involuntary movements disappear and are replaced by choreoathetosis, immobility, dystonia, and lead pipe rigidity that result from destruction of deeper centers in the basal ganglia. The sensorium deteriorates into dementia, stupor, and then coma. The **fourth stage** is characterized by loss of critical centers that support breathing, heart rate, and blood pressure. Death soon ensues. Progression through the clinical stages may follow courses characterized as acute, subacute, or chronic progressive.

The diagnosis of SSPE can be established through documentation of a compatible clinical course and at least one of the following supporting findings: (1) measles antibody detected in cerebrospinal fluid, (2) characteristic electroencephalographic findings, and (3) typical histologic findings in and/or isolation of virus or viral antigen from brain tissue obtained by biopsy or postmortem examination.

Cerebrospinal fluid analysis reveals normal cells but elevated IgG and IgM antibody titers in dilutions >1:8. Electroencephalographic patterns are normal in stage I, but in the myoclonic phase, suppression-burst episodes are seen that are characteristic of, but not pathognomonic for, SSPE. Brain biopsy is no longer routinely indicated for diagnosis of SSPE.

Management of SSPE is primarily supportive and similar to care provided to patients with other neurodegenerative diseases. Clinical trials using isoprinosine with or without interferon suggest significant benefit (30-34% remission rate) compared with patients without treatment (5-10% with spontaneous remissions).

It is recognized that carbamazepine is of significant benefit in the control of myoclonic jerks in the early stages of the illness.

Virtually all patients eventually succumb to SSPE. Most die within 1-3 years of onset from infection or loss of autonomic control mechanisms. Prevention of SSPE depends on prevention of primary measles infection through vaccination. SSPE has been described in patients who have no history of measles infection and exposure only to the vaccine virus. However, wild-type virus, not vaccine virus, has been found in brain tissue of at least some of these patients, suggesting that they had subclinical measles previously.

## TREATMENT

Management of measles is supportive because there is no specific antiviral therapy approved for treatment of measles. Maintenance of hydration, oxygenation, and comfort are goals of therapy. Antipyretics for comfort and fever control are useful. For patients with respiratory tract involvement, airway humidification and supplemental oxygen may be of benefit. Respiratory failure from croup or pneumonia may require ventilatory support. Oral rehydration is effective in most cases, but severe dehydration may require intravenous therapy. Prophylactic antimicrobial therapy to prevent bacterial infection is not indicated.

Measles infection in immunocompromised patients is highly lethal. Ribavirin is active in vitro against measles virus. Anecdotal reports of ribavirin therapy with or without intravenous gamma globulin suggest some benefit in individual patients. Although no controlled trials have been performed, many experts favor use of ribavirin for treatment of measles pneumonia in patients <12 months, patients ≥12 months with pneumonia requiring ventilatory support, and patients with severe immunosuppression. Ribavirin dosing is 15-20 mg/kg/day orally in two divided doses. The optimal duration of therapy is not known; a duration of 5-7 days may be reasonable, guided by the patient's clinical status (respiratory symptoms and chest radiograph findings). Several investigational treatments have been used in individuals with SSPE with the goal of stabilization and delay of progression, including Isoprinosine (inosine pranobex) and interferon- $\alpha$  and interferon- $\beta$ .

## Vitamin A

Vitamin A deficiency in children in resource poor countries has long been known to be associated with increased mortality from a variety of infectious diseases, including measles. In the United States, studies in the early 1990s documented that 22-72% of children with measles had low retinol levels. In addition, one study demonstrated an inverse correlation between the level of retinol and severity of illness. Several randomized controlled trials of vitamin A therapy in the developing world have demonstrated reduced morbidity and mortality from measles. Use of vitamin A for treatment of measles in developed countries has not been evaluated in a large clinical trial, but a small study showed no effect on morbidity. Given the potential for benefit, the WHO and the CDC recommend that vitamin A be administered to all children with acute measles, even in countries where measles is not usually severe. Vitamin A should be administered once daily for 2 days at doses of 200,000 IU for children 12 months of age or older; 100,000 IU for infants 6-11 months of age; and 50,000 IU for infants younger than 6 months of age. In children with signs and symptoms of vitamin A deficiency, a third age-appropriate dose is recommended 2-4 weeks after the second dose.

## PROGNOSIS

In the early 20th century, deaths from measles in the United States varied between 2,000 and 10,000 per year, or about 10 deaths per 1,000 cases of measles. With improvements in healthcare and antimicrobial therapy, better nutrition, and decreased crowding, the death-to-case ratio fell to 1 per 1,000 cases. Between 1982 and 2002, the CDC estimated that there were 259 deaths caused by measles in the United States, with a death-to-case ratio of 2.5-2.8 per 1,000 cases of measles. Pneumonia and encephalitis were complications in most of the fatal cases, and immunodeficiency conditions were identified in 14-16% of deaths. In 2011, of the 222 cases reported in the United States, 70



(32%) were hospitalized, including 17 (24%) with diarrhea, 15 (21%) with dehydration, and 12 (17%) with pneumonia. No cases of encephalitis or deaths were reported. In 2019, 10% of cases were hospitalized, 5% had pneumonia, and one (0.1%) had encephalitis, but no deaths were reported.

## PREVENTION

Patients shed measles virus from 7 days after exposure to 4-6 days after the onset of rash. Exposure of susceptible individuals to those with measles should be avoided during this period. In hospitals, standard and airborne precautions should be observed for this period. Immunocompromised individuals with measles will shed virus for the duration of the illness, so isolation should be maintained throughout the disease.

## Vaccine

Vaccination against measles is the most effective and safe prevention strategy. Measles vaccine in the United States is available as a combined vaccine with measles-mumps-rubella vaccine (Table 293.2). After the measles resurgence of 1989–1991, a second dose of measles vaccine was added to the schedule. The current recommendations include a first dose at 12-15 months of age and a second dose at 4-6 years of age. However, the second dose can be given any time after

30 days following the first dose, and the current schedule is a convenience schedule. Seroconversion is slightly lower in children who receive the first dose before or at 12 months of age (87% at 9 months, 95% at 12 months, and 98% at 15 months) because of persisting maternal antibody; however, this is an evolving situation, with children currently as young as 6 months unprotected from maternal antibodies and susceptible to measles infection. For children who have not received two doses by 11-12 years of age, a second dose should be provided. Infants who receive a dose before 12 months of age should be given two additional doses, one at 12-15 months and another at 4-6 years of age. Children who are traveling should be offered either primary measles immunization even as young as 6 months or a second dose even if <4 years.

Adverse events from the measles-mumps-rubella vaccine include fever (usually 6-12 days after vaccination), rash in approximately 5% of vaccinated persons, and, rarely, transient thrombocytopenia. Children prone to febrile seizures may experience an event following vaccination, so the risks and benefits of vaccination should be discussed with parents. Encephalopathy and autism have not been shown to be causally associated with the measles-mumps-rubella vaccine or vaccine constituents.

A review of the effect of measles vaccination on the epidemiology of SSPE has demonstrated that measles vaccination protects against SSPE

**TABLE 293.2** Recommendations for Measles Immunization

CATEGORY	RECOMMENDATIONS	CATEGORY	RECOMMENDATIONS
Unimmunized, no history of measles (12-15 mo of age)	MMR or MMRV vaccine is recommended at 12-15 mo of age; a second dose is recommended at least 28 days after the first dose (or 90 days for MMRV) and usually is administered at 4 through 6 yr of age	History of receipt of inactivated measles vaccine or unknown type of vaccine, 1963–1967	Dose not considered valid; immunize (2 doses)
Children 6-11 mo of age in epidemic situations or before international travel	Immunize with MMR vaccine, but this dose is not considered valid, and 2 valid doses administered on or after the first birthday are required. The first valid dose should be administered at 12-15 mo of age; the second valid dose is recommended at least 28 days later and usually is administered at 4 through 6 yr of age. MMRV should not be administered to children <12 mo of age.	Further attenuated or unknown vaccine administered with immunoglobulin	Dose not considered valid; immunize (2 doses)
		Allergy to eggs	Immunize; no reactions likely
Students in kindergarten, elementary, middle, and high school who have received 1 dose of measles vaccine at 12 mo of age or older	Administer the second dose	Neomycin allergy, nonanaphylactic	Immunize; no reactions likely
		Severe hypersensitivity (anaphylaxis) to neomycin or gelatin	Avoid immunization
Students in college and other postsecondary institutions who have received 1 dose of measles vaccine at 12 mo of age or older	Administer the second dose	Tuberculosis	Immunize; if patient has untreated tuberculosis disease, start antituberculosis therapy before immunizing
		Measles exposure	Immunize or give immunoglobulin, depending on circumstances
History of immunization before the first birthday	Dose not considered valid; immunize (2 doses)	HIV infected	Immunize (2 doses) unless severely immunocompromised; administration of immunoglobulin if exposed to measles is based on degree of immunosuppression and measles vaccine history
		Personal or family history of seizures	Immunize; advise parents of slightly increased risk of seizures
		Immunoglobulin or blood recipient	Immunize at the appropriate interval

MMR, Measles-mumps-rubella vaccine; MMRV, measles-mumps-rubella-varicella vaccine. From American Academy of Pediatrics. Measles. In Kimberlin DW, Brady MT, Jackson MA, Long SS, eds. *Red Book 2018 Report of the Committee on Infectious Diseases*, 31st ed. Itasca, IL: American Academy of Pediatrics, 2018: Table 3.39, p. 543.

**TABLE 293.3** Suggested Intervals Between Immunoglobulin Administration and Measles Immunization\*

INDICATION FOR IMMUNOGLOBULIN	ROUTE	DOSE		
		UNITS (U) OR MILLILITERS (ML)	MG IgG/KG	INTERVAL (MO) <sup>†</sup>
Tetanus (as tetanus Ig)	IM	250 U	10	3
Hepatitis A prophylaxis (as Ig):				
Contact prophylaxis	IM	0.02 mL/kg	3.3	3
International travel	IM	0.06 mL/kg	10	3
Hepatitis B prophylaxis (as hepatitis B Ig)	IM	0.06 mL/kg	10	3
Rabies prophylaxis (as rabies Ig)	IM	20 IU/kg	22	4
Varicella prophylaxis (as VariZIG)	IM	125 U/10 kg (maximum 625 U)	20-40	5
Measles prophylaxis (as Ig):				
Standard	IM	0.50 mL/kg	80	6
Immunocompromised host	IV		400 mg/kg	8
Respiratory syncytial virus prophylaxis (palivizumab monoclonal antibody) <sup>‡</sup>	IM	—	15 mg/kg (monoclonal)	None
Cytomegalovirus immune globulin	IV	3 mL/kg	150	6
Blood transfusion:				
Washed RBCs	IV	10 mL/kg	Negligible	0
RBCs, adenine-saline added	IV	10 mL/kg	10	3
Packed RBCs	IV	10 mL/kg	20-60	6
Whole blood	IV	10 mL/kg	80-100	6
Plasma or platelet products	IV	10 mL/kg	160	7
Replacement (or therapy) of immune deficiencies (as IVIG)	IV	—	300-400	8
ITP (as IVIG)	IV	—	400	8
ITP	IV	—	1,000	10
ITP or Kawasaki disease	IV	—	1,600-2,000	11

\*Immunization in the form of measles-mumps-rubella (MMR), measles-mumps-rubella-varicella (MMRV), or monovalent measles vaccine.

<sup>†</sup>These intervals should provide sufficient time for decreases in passive antibodies in all children to allow for an adequate response to measles vaccine. Physicians should not assume that children are fully protected against measles during these intervals. Additional doses of Ig or measles vaccine may be indicated after exposure to measles.

<sup>‡</sup>Monoclonal antibodies, such as palivizumab, do not interfere with the immune response to vaccines.

Ig, Immunoglobulin; IgG, immunoglobulin G; ITP, immune (formerly termed "idiopathic") thrombocytopenic purpura; IVIG, intravenous Ig; RBCs, red blood cells.

From American Academy of Pediatrics. *Red Book: 2015 Report of the Committee on Infectious Diseases*, 30th ed. Elk Grove Village, IL: American Academy of Pediatrics; 2015: Table 1.10, p. 39.

and does not accelerate the course of SSPE or trigger the disease in those already infected with wild measles virus.

Passively administered immune globulin may inhibit the immune response to live measles vaccine, and administration should be delayed for variable amounts of time based on the dose of Ig (Table 293.3).

Live vaccines should not be administered to pregnant women or to immunodeficient or immunosuppressed patients. However, patients with HIV who are not severely immunocompromised should be immunized. Because measles virus may suppress the cutaneous response to tuberculosis antigen, skin testing for tuberculosis should be performed before or at the same time as administration of the vaccine. Individuals infected with *M. tuberculosis* should be receiving appropriate treatment at the time of administration of measles vaccine.

### Postexposure Prophylaxis

Susceptible individuals exposed to measles may be protected from infection either by vaccine administration or with Ig. The vaccine is effective in prevention or modification of measles if given within 72 hours of exposure. Ig may be given up to 6 days after exposure to prevent or modify infection. Immunocompetent children should receive 0.5 mL/kg (maximum dose in both cases is 15 mL/kg) intramuscularly. For severely immunocompromised children and pregnant woman without evidence of measles immunity, immunoglobulin intravenously (IGIV) is the recommended Ig at 400 mg/kg. Ig is indicated for susceptible household contacts of patients with measles, especially infants <6 months of age, pregnant women, and immunocompromised persons.

Visit Elsevier eBooks+ at [eBooks.Health.Elsevier.com](http://eBooks.Health.Elsevier.com) for Bibliography.

## Chapter 294

## Rubella

Hayley A. Gans

Rubella (**German measles** or **3-day measles**) is a mild, often exanthematous disease of childhood that is typically more severe and associated with more complications in adults. Its major clinical significance is transplacental infection and fetal damage as part of the **congenital rubella syndrome (CRS)**.

## ETIOLOGY

Rubella virus is a member of the family *Togaviridae* and is the only species of the genus *Rubivirus*. It is a positive-sense single-stranded RNA virus with a lipid envelope and three structural proteins, including a nucleocapsid protein (C) that is associated with the nucleus and two glycoproteins, E1 and E2, that are associated with the envelope, carry the main epitopes, and therefore are the major antigenic sites of the virus. The virus is sensitive to heat, ultraviolet light, and extremes of pH but is relatively stable at cold temperatures. Humans are the only known reservoir.

## EPIDEMIOLOGY

Rubella is found worldwide and circulates predominantly in late winter and early spring. In the United States, in the prevaccine era, rubella appeared to occur in major epidemics every 6–9 years, with smaller peaks interspersed every 3–4 years, and was most common in preschool-age and school-age children. During the rubella epidemic of 1964–1965 there were an estimated 12.5 million cases of rubella associated with 2,000 cases of encephalitis, more than 13,000 abortions or perinatal deaths, and 20,000 cases of CRS. After introduction of the rubella vaccine in 1969 in the United States, the incidence of rubella fell 78% and CRS cases fell 69% by 1976 (Fig. 294.1). Further decline in rubella and CRS cases occurred when certain at-risk populations were added to those for whom rubella immunization is indicated, including adolescents and college students. After years of decline, a resurgence of rubella and CRS cases occurred during 1989–1991 in association with the epidemic of measles during that period (see Fig. 294.1). Subsequently, a two-dose recommendation for rubella vaccine was implemented and resulted in a decrease in incidence of rubella from 0.45 per

100,000 population in 1990 to 0.1 per 100,000 population in 1999 and a corresponding decrease of CRS, with an average of six infants with CRS reported annually from 1992 to 2004. Mothers of these infants tended to be young, Hispanic, or foreign born. The number of reported cases of rubella continued to decline through the 1990s and the first decade of this century.

The endemic spread of rubella was declared eliminated in the United States in 2004 and eliminated in the Americas in 2015. However, cases of rubella continue to be imported into the United States from countries where it remains endemic. Accelerated global vaccine efforts have resulted in declines of rubella cases worldwide from 94,277 in 2012 to 10,194 in 2020. Rubella elimination has been verified in 93 (48%) of 194 countries, with 70% of infants globally receiving a rubella vaccine in 2020. From 2004 to 2016 there were 101 cases of rubella and 11 cases of CRS reported in the United States, all of which were imported cases of unknown source. Three of the CRS cases were acquired in Africa. This information highlights the need for continued maintenance of high levels of immunity in the United States.

## PATHOLOGY

Little information is available on the pathologic findings in rubella occurring postnatally. The few reported studies of biopsy or autopsy material from cases of rubella revealed only nonspecific findings of lymphoreticular inflammation and mononuclear perivascular and meningeal infiltration. The pathologic findings for CRS are often severe and may involve nearly every organ system (Table 294.1).

## PATHOGENESIS

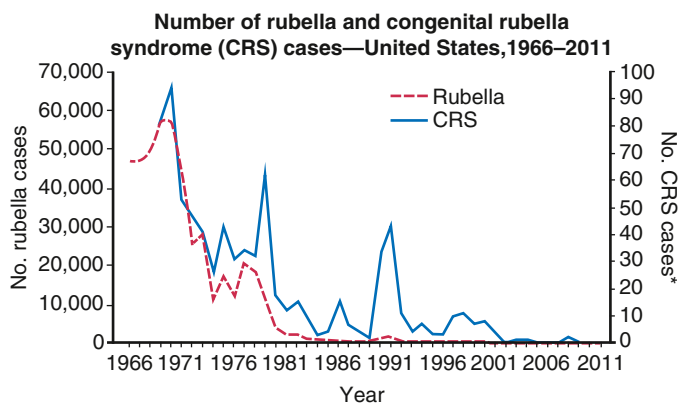
The viral mechanisms for cell injury and death in postnatal or congenital rubella are not well delineated. The main mechanisms of transmission is respiratory for postnatal infection and transplacental in CRS. The incubation period following respiratory exposure averages 14 days, with a range from 12 to 23 days. After infection, the virus replicates in the respiratory epithelium and then spreads to regional lymph nodes (Fig. 294.2). Viremia ensues and is most intense from 10 to 17 days after infection. Viral shedding from the nasopharynx begins approximately 10 days after infection and may be detected up to 2 weeks after onset of the rash. The period of highest communicability is from 5 days before to 6 days after the appearance of the rash.

Congenital infection occurs during maternal viremia. After infecting the placenta, the virus spreads through the vascular system of the developing fetus and may infect any fetal organ. The most important risk factor for severe congenital defects is the stage of gestation at the time of infection. Maternal infection during the first 8 weeks of gestation results in the most severe and widespread defects. The risk for congenital defects has been estimated at 90% for maternal infection before 11 weeks of gestation, 33% at 11–12 weeks, 11% at 13–14 weeks, and 24% at 15–16 weeks. Defects occurring after 16 weeks of gestation are uncommon, even if fetal infection occurs.

Causes of cellular and tissue damage in the infected fetus may include tissue necrosis due to vascular insufficiency, reduced cellular multiplication time, chromosomal breaks, and production of a protein inhibitor causing mitotic arrests in certain cell types. The most distinctive feature of congenital rubella is chronicity. Once the fetus is infected early in gestation, the virus persists in fetal tissue until well beyond delivery. Persistence suggests the possibility of ongoing tissue damage and reactivation, most notably in the brain.

## CLINICAL MANIFESTATIONS

**Postnatal infection** with rubella is typically a mild disease not easily discernible from other viral infections, especially in children. After an incubation period of 12–23 days, a prodrome consisting of low-grade fever, sore throat, red eyes with or without eye pain, headache, malaise, anorexia, and lymphadenopathy begins. Suboccipital, postauricular, and anterior cervical lymph nodes are most prominent. In children, the first manifestation of rubella is usually the rash, which is variable and not distinctive, often more prominent with heat. It begins on the face and neck as small, irregular pink macules that coalesce, and it spreads centrifugally to involve the torso and extremities, where



\*By year of birth.

**Fig. 294.1** Number of rubella and congenital rubella syndrome cases—United States, 1966–2011. Rubella and CRS data provided were reported voluntarily to Centers for Disease Control and Prevention from state health departments. (From McLean HQ, Fiebelkorn AP, Temte JL, et al. *Prevention of measles, rubella, congenital rubella syndrome, and mumps*, 2013. *MMWR Recomm Rep*. 2013;62[RR-04]:1–34.)

it tends to occur as discrete macules (Fig. 294.3). About the time of onset of the rash, examination of the oropharynx may reveal tiny, rose-colored lesions (**Forchheimer spots**) or petechial hemorrhages on the soft palate. The rash fades from the face as it extends to the rest of the body so that the whole body may not be involved at any one time. The duration of the rash is generally 3 days, and it usually resolves without desquamation. Subclinical infections are common, and 25–40% of children may not have a rash. Teenagers and adults tend to be more

symptomatic and have systemic manifestations, with up to 70% of females demonstrating arthralgias and arthritis.

**LABORATORY FINDINGS**

Leukopenia, neutropenia, and mild thrombocytopenia have been described during postnatal rubella.

**DIAGNOSES**

A specific diagnosis of rubella is important for epidemiologic reasons, for diagnosis of infection in pregnant women, and for confirmation of the diagnosis of congenital rubella. The most common diagnostic test is rubella immunoglobulin (Ig) M enzyme immunosorbent assay, which is typically present ~4 days after the appearance of the rash. As with any serologic test, the positive predictive value of testing decreases in populations with low prevalence of disease and in immunized individuals. Tests should be performed in the context of a supportive history of exposure or consistent clinical findings. The relative sensitivity and specificity of commercial kits used in most laboratories range from 96–99% and 86–97%, respectively. A caveat for testing of congenitally infected infants early in infancy is that false-negative results may occur owing to competing IgG antibodies circulating in these patients. In

TABLE 294.1 Pathologic Findings in Congenital Rubella Syndrome	
SYSTEM	PATHOLOGIC FINDINGS
Cardiovascular	Patent ductus arteriosus Pulmonary artery stenosis Ventriculoseptal defect Myocarditis
Central nervous system	Chronic meningitis Parenchymal necrosis Vasculitis with calcification
Eye	Microphthalmia Cataract Iridocyclitis Ciliary body necrosis Glaucoma Retinopathy
Ear	Cochlear hemorrhage Endothelial necrosis
Lung	Chronic mononuclear interstitial pneumonitis
Liver	Hepatic giant cell transformation Fibrosis Lobular disarray Bile stasis
Kidney	Interstitial nephritis
Adrenal gland	Cortical cytomegaly
Bone	Malformed osteoid Poor mineralization of osteoid Thinning cartilage
Spleen, lymph node	Extramedullary hematopoiesis
Thymus	Histiocytic reaction Absence of germinal centers
Skin	Erythropoiesis in dermis



Fig. 294.3 Rash of rubella.

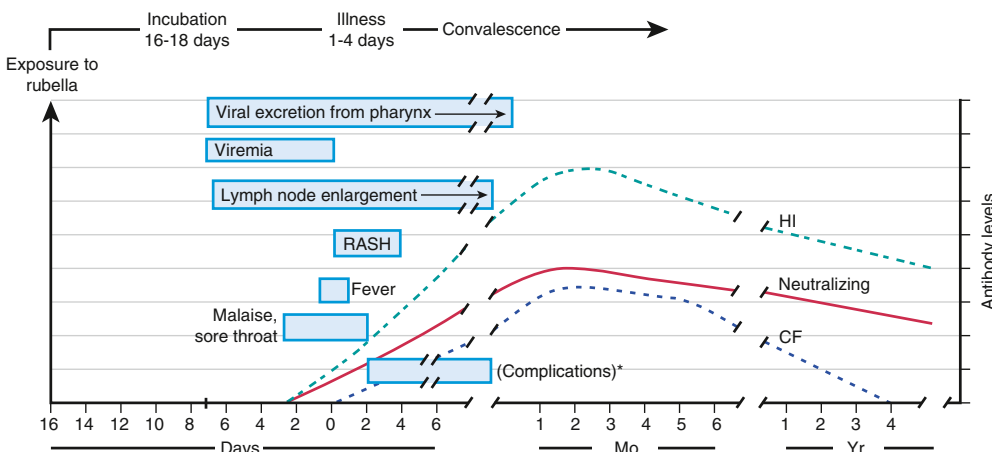


Fig. 294.2 Pathophysiological events in postnatally acquired rubella virus infection. \*Possible complications include arthralgia and/or arthritis, thrombocytopenic purpura, and encephalitis. CF, Complement fixation titer; HI, hemagglutination-inhibition titer. (From Lamprecht CL. Rubella virus. In: Beshe RB, ed. Textbook of Human Virology, 2nd ed. Littleton, MA: PSG Publishing; 1990:685.)



such patients, an IgM capture assay, reverse transcriptase polymerase chain reaction (PCR) test, or viral culture should be performed for confirmation. Virus can be detected by PCR in nasal, throat, urine, blood, and cerebrospinal fluid (CSF) specimens up to 10 days after rash onset (with highest yield within 3 days). Viral isolation by culture or PCR of nasopharyngeal secretions, urine in the newborn (as close to birth as possible), or cord blood or placenta can be used to diagnose congenital infection. PCR testing of amniotic fluid during pregnancy is also an appropriate approach to diagnose congenital infection. If CRS is confirmed, infants should be screened for viral shedding monthly after the age of 3 months until two consecutive negative tests are obtained. Viral shedding may be detected for up to 1 year.

## DIFFERENTIAL DIAGNOSES

Rubella may manifest as distinctive features suggesting the diagnosis. It is frequently confused with other infections because it is uncommon, is similar to other viral exanthematous diseases, and demonstrates variability in the presence of typical findings. In severe cases, it may resemble measles. The absence of Koplik spots, a severe prodrome, and a shorter course, allow for differentiation from measles. Other diseases frequently confused with rubella include infections caused by adenoviruses, parvovirus B19 (erythema infectiosum), Epstein-Barr virus, enteroviruses, roseola, and *Mycoplasma pneumoniae*.

## COMPLICATIONS

Complications following postnatal infection with rubella are infrequent and generally not life threatening.

Postinfectious **thrombocytopenia** occurs in approximately 1 in 3,000 cases of rubella and occurs more frequently among children and in girls. It manifests about 2 weeks after the onset of the rash as petechiae, epistaxis, gastrointestinal bleeding, and hematuria and is usually self-limited.

**Arthritis** following rubella occurs more commonly among adults, especially women. It begins within 1 week of onset of the exanthem and classically involves the small joints of the hands. It is self-limited and resolves within weeks without sequelae. There are anecdotal reports and some serologic evidence linking rubella with rheumatoid arthritis, but a true causal association remains speculative.

**Encephalitis** is the most serious complication of postnatal rubella. It occurs in two forms: a postinfectious syndrome following acute rubella and a rare progressive panencephalitis manifesting as a neurodegenerative disorder years after rubella.

Postinfectious encephalitis is uncommon, occurring in 1 in 5,000 cases of rubella. It appears within 7 days after onset of the rash, consisting of headache, seizures, confusion, coma, focal neurologic signs, and ataxia. Fever may recrudescence with the onset of neurologic symptoms. CSF may be normal or have a mild mononuclear pleocytosis and/or elevated protein concentration. Virus is rarely, if ever, isolated from CSF or brain, suggesting a noninfectious pathogenesis. Most patients recover completely, but mortality rates of 20% and long-term neurologic sequelae have been reported.

**Progressive rubella panencephalitis (PRP)** is an extremely rare complication of either acquired rubella or CRS. It has an onset and course similar to those of the subacute sclerosing panencephalitis associated with measles (see Chapter 293). However, unlike in the postinfectious form of rubella encephalitis, rubella virus may be isolated from brain tissue of the patient with PRP, suggesting an infectious pathogenesis, albeit a slow one. The clinical findings and course are indistinguishable from those of subacute sclerosing panencephalitis and transmissible spongiform encephalopathies (see Chapter 324). Death occurs 2–5 years after onset.

Other neurologic syndromes rarely reported with rubella include Guillain-Barré syndrome and peripheral neuritis. Myocarditis is a rare complication.

## Congenital Rubella Syndrome

In 1941 an ophthalmologist first described a syndrome of cataracts and congenital heart disease that he correctly associated with rubella

**TABLE 294.2** Clinical Manifestations of Congenital Rubella Syndrome in 376 Children After Maternal Rubella\*

MANIFESTATION	RATE (%)
Deafness	67
Ocular	71
Cataracts	29
Retinopathy	39
Heart disease†	48
Patent ductus arteriosus	78
Right pulmonary artery stenosis	70
Left pulmonary artery stenosis	56
Valvular pulmonic stenosis	40
Low birthweight	60
Psychomotor delay	45
Neonatal purpura	23
Death	35

\*Other findings: hepatitis, linear streaking of bone, hazy cornea, congenital glaucoma, delayed growth.

†Findings in 87 patients with congenital rubella syndrome and heart disease who underwent cardiac angiography.

From Cooper LZ, Ziring PR, Ockerse AB, et al. Rubella: clinical manifestations and management. *Am J Dis Child.* 1969;118:18–29.

infections in the mothers during early pregnancy (Table 294.2). Shortly after the first description, hearing loss was recognized as a common finding often associated with microcephaly. In 1964 to 1965 a pandemic of rubella occurred, with 20,000 cases reported in the United States, leading to more than 11,000 spontaneous or therapeutic abortions and 2,100 neonatal deaths. From this experience emerged the expanded definition of CRS that includes numerous other transient or permanent abnormalities.

Nerve deafness is the single most common finding among infants with CRS. Most infants have some degree of intrauterine growth restriction. Retinal findings described as **salt-and-pepper retinopathy** are the most common ocular abnormality but have little early effect on vision. Unilateral or bilateral cataracts are the most serious eye finding, occurring in about a third of infants (Fig. 294.4). Cardiac abnormalities occur in half of the children infected during the first 8 weeks of gestation. Patent ductus arteriosus is the most frequently reported cardiac defect, followed by lesions of the pulmonary arteries and valvular disease. Interstitial pneumonitis leading to death in some cases has been reported. Neurologic abnormalities are common and may progress following birth. Meningoencephalitis is present in 10–20% of infants with CRS and may persist for up to 12 months. Longitudinal follow-up through 9–12 years of infants without initial retardation revealed progressive development of additional sensory, motor, and behavioral abnormalities, including hearing loss and autism. PRP has also been recognized rarely after CRS. Subsequent postnatal growth retardation and ultimate short stature have been reported in a minority of cases. Rare reports of immunologic deficiency syndromes have also been described.

A variety of late-onset manifestations of CRS have been recognized. In addition to PRP, they include diabetes mellitus (20%), thyroid dysfunction (5%), and glaucoma and visual abnormalities associated with the retinopathy, which had previously been considered benign.

## TREATMENT

There is no specific treatment available for either acquired rubella or CRS.



**Fig. 294.4** Bilateral cataracts in infant with congenital rubella syndrome.

### SUPPORTIVE CARE

Postnatal rubella is generally a mild illness that requires no care beyond antipyretics and analgesics. Intravenous immunoglobulin or corticosteroids can be considered for severe, nonremitting thrombocytopenia.

Management of children with CRS is more complex and requires pediatric, cardiac, audiologic, ophthalmologic, and neurologic evaluation and follow-up because many manifestations may not be readily apparent initially or may worsen with time. Hearing screening is of special importance because early intervention may improve outcomes in children with hearing problems caused by CRS.

### PROGNOSIS

Postnatal infection with rubella has an excellent prognosis. Long-term outcomes of CRS are less favorable and somewhat variable. In an Australian cohort evaluated 50 years after infection, many had chronic conditions but most were married and had made good social adjustments. A cohort from New York from the mid-1960s epidemic had less-favorable outcomes, with 30% leading normal lives, 30% in dependent situations but functional, and 30% requiring institutionalization and continuous care.

**Reinfection** with wild virus occurs postnatally in both individuals who were previously infected with wild-virus rubella and vaccinated individuals. Reinfection is defined serologically as a significant increase in IgG antibody level and/or an IgM response in an individual who has a documented preexisting rubella-specific IgG above an accepted cutoff. Reinfection may result in an anamnestic IgG response, an IgM and IgG response, or clinical rubella. There are 29 reports in the literature of CRS following maternal reinfection. Reinfection with serious adverse outcomes to adults or children is rare and of unknown significance.

### PREVENTION

Patients with postnatal infection should be isolated from susceptible individuals for 7 days after onset of the rash. Standard plus droplet precautions are recommended for hospitalized patients. Children with CRS may excrete the virus in respiratory secretions up to 1 year of age, so contact precautions should be maintained for them until 1 year of age, unless repeated cultures of urine and pharyngeal secretions are negative. Similar precautions apply to patients with CRS with regard to attendance in school and out-of-home childcare.

Exposure of susceptible pregnant women poses a potential risk to the fetus. For pregnant women exposed to rubella, a blood specimen should be obtained as soon as possible for rubella IgG-specific

antibody testing; a frozen aliquot also should be saved for later testing. If the rubella antibody test result is positive, the mother is likely immune. If the rubella antibody test is negative, a second specimen should be obtained 2-3 weeks later and tested concurrently with the saved specimen. If both of these samples test negative, a third specimen should be obtained 6 weeks after exposure and tested concurrently with the saved specimen. If both the second and third specimens test negative, infection has not occurred. A negative first specimen and a positive test result in either the second or third specimen indicate that seroconversion has occurred in the mother, suggesting recent infection. Counseling should be provided about the risks and benefits of termination of pregnancy. The routine use of immunoglobulin for susceptible pregnant women exposed to rubella is not recommended and is considered only if termination of pregnancy is not an option because of maternal preferences. In such circumstances, immunoglobulin 0.55 mL/kg intramuscularly may be given with the understanding that prophylaxis may reduce the risk for clinically apparent infection but does not guarantee prevention of fetal infection.

### VACCINATION

Rubella vaccine in the United States consists of the attenuated Wistar RA 27/3 strain that is usually administered in combination with measles and mumps (MMR) or also with varicella (MMRV) in a two-dose regimen at 12-15 months and 4-6 years of age. It theoretically may be effective as postexposure prophylaxis if administered within 3 days of exposure. Vaccine should not be administered to severely immunocompromised patients. Patients with HIV infection who are not severely immunocompromised may benefit from vaccination. Fever is not a contraindication, but if a more serious illness is suspected, immunization should be delayed. Immunoglobulin preparations may inhibit the serologic response to the vaccine (see [Chapter 215](#)). Vaccine should not be administered during pregnancy. If pregnancy occurs within 28 days of immunization, the patient should be counseled on the theoretical risks to the fetus. Studies of more than 200 women who had been inadvertently immunized with rubella vaccine during pregnancy showed that none of their offspring developed CRS. Therefore interruption of pregnancy is probably not warranted.

Following a single dose of rubella RA 27/3 vaccine, 95% of persons 12 months of age and older develop serologic immunity, and after two doses 99% have detectable antibody. Rubella RA 27/3 vaccine is highly protective, because 97% of those vaccinated are protected from clinical disease after one dose. Detectable antibodies remain for 15 years in most individuals vaccinated after one dose, and 91-100% had antibodies after 12-15 years after two doses. Although antibody levels may wane, especially after one dose of vaccine, increased susceptibility to rubella disease does not occur.

Adverse reactions to rubella vaccination are uncommon in children. MMR administration is associated with fever in 5-15% of vaccinees and with rash in approximately 5% of vaccinees. Arthralgia and arthritis are more common after rubella vaccination in adults. Approximately 25% of postpubertal women experience arthralgia, and 10% of postpubertal women experience arthritis. Peripheral neuropathies and transient thrombocytopenia may also occur.

As part of the worldwide effort to eliminate endemic rubella virus transmission and occurrence of CRS, maintaining high population immunity through vaccination coverage and high-quality integrated measles-rubella surveillance have been emphasized as being vital to its success.

Visit Elsevier eBooks+ at [eBooks.Health.Elsevier.com](http://eBooks.Health.Elsevier.com) for a Bibliography.

## Chapter 295

## Mumps

Hayley A. Gans

Mumps is an acute self-limited infection that was once commonplace but is now uncommon in countries with widespread use of vaccination. It is characterized by fever, bilateral or unilateral parotid swelling and tenderness, and the frequent occurrence of meningoencephalitis and orchitis. Although infrequent in countries with extensive vaccination programs, mumps remains endemic in the rest of the world, warranting continued vaccine protection. Nonetheless, outbreaks of mumps have been reported in highly vaccinated populations in the United States, particularly among students.

## ETIOLOGY

Mumps virus is in the family Paramyxoviridae and the genus *Rubulavirus*. It is a negative-sense single-stranded nonsegmented RNA virus encapsulated in a lipoprotein envelope possessing seven structural proteins. Surface glycoproteins called HN (hemagglutinin-neuraminidase) and F (fusion) mediate absorption of the virus to host cells and penetration of the virus into cells, respectively. Both proteins stimulate production of protective antibodies. Mumps virus exists as a single serotype with up to 12 known genotypes, and humans are the only natural host.

## EPIDEMIOLOGY

In the prevaccine era, mumps occurred primarily in young children between the ages of 5 and 9 years and in epidemics about every 4 years. Mumps infection occurred more often in the winter and spring months. In 1968, just after the introduction of the mumps vaccine, 185,691 cases were reported in the United States. Following the recommendation for routine use of mumps vaccine in 1977, the incidence of mumps fell dramatically in young children (Fig. 295.1) and shifted instead to older children, adolescents, and young adults. Outbreaks continued to occur *even in highly vaccinated* populations as a result of primary vaccine failure with one dose of vaccine and because of undervaccination of susceptible persons. After implementation of the two-dose recommendation for the measles-mumps-rubella (MMR) vaccine for measles control in 1989, the number of mumps cases declined further. During 2001–2003, fewer than 300 mumps cases were reported each year. In 2006 the largest mumps epidemic in the past 20

years occurred in the United States. A total of 6,584 cases occurred, 85% of them in 8 midwestern states. Twenty-nine percent of the cases occurred in patients 18–24 years old, most of whom were attending college. An analysis of 4,039 patients with mumps seen in the first 7 months of the epidemic indicated that 63% had received more than two doses of the MMR vaccine. Subsequently, several outbreaks of mumps have been documented in highly vaccinated populations in the United States, several in school settings including universities and in Guam. This phenomenon is reported globally as well. The majority of cases in vaccinated persons represent close contact thought to provide intense exposure that may overcome vaccine immunity and perhaps genotype mismatch between circulating mumps genotypes and those in the vaccine. Through 2020, mumps outbreaks have continued to occur, with a peak in 2016 with 6,366 cases, which dropped to 154 in 2021.

Mumps is spread from person to person by respiratory droplets. Virus appears in the saliva from up to 7 days before to as long as 7 days after onset of parotid swelling. The period of maximum infectiousness is 1–2 days before to 5 days after onset of parotid swelling. Viral shedding before onset of symptoms and in asymptomatic infected individuals impairs efforts to contain the infection in susceptible populations. The risk of spreading the virus increases the longer and the closer the contact a person has with someone who has mumps. The U.S. Centers for Disease Control and Prevention, the American Academy of Pediatrics, and the Health Infection Control Practices Advisory Committee recommend an isolation period of 5 days after onset of parotitis for patients with mumps in both community and healthcare settings.

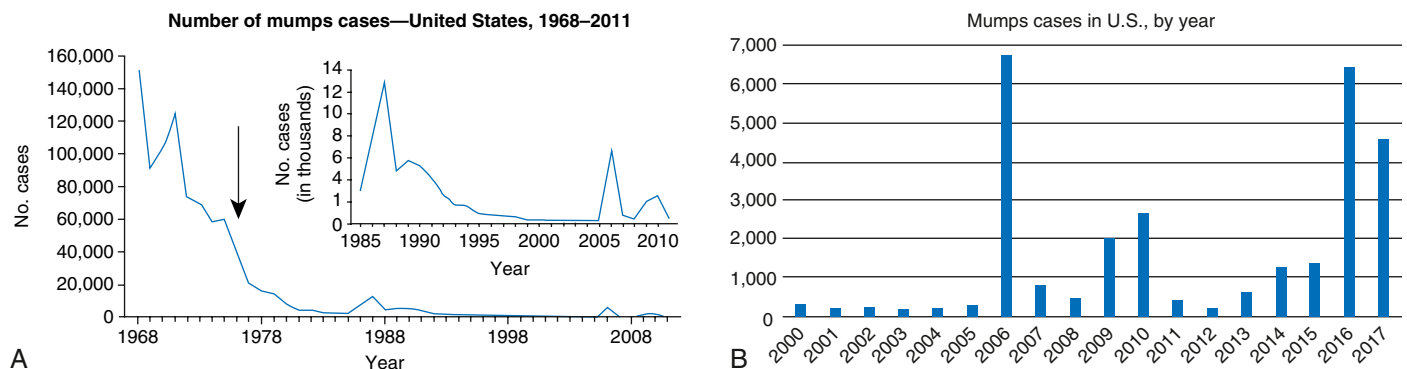
## PATHOLOGY AND PATHOGENESIS

Mumps virus targets the salivary glands, central nervous system (CNS), pancreas, testes, and, to a lesser extent, thyroid, ovaries, heart, kidneys, liver, and joint synovia.

After infection, initial viral replication occurs in the epithelium of the upper respiratory tract. Infection spreads to the adjacent lymph nodes by the lymphatic drainage, and viremia ensues, spreading the virus to targeted tissues, including the meninges, salivary glands, pancreas, testes, and ovaries. Mumps virus causes necrosis of infected cells and is associated with a lymphocytic inflammatory infiltrate. Salivary gland ducts are lined with necrotic epithelium, and the interstitium is infiltrated with lymphocytes. Swelling of tissue within the testes may result in focal ischemic infarcts. The cerebrospinal fluid (CSF) frequently contains a mononuclear pleocytosis, even in individuals without clinical signs of meningitis.

## CLINICAL MANIFESTATIONS

The incubation period for mumps ranges from 12–25 days but is usually 16–18 days. Mumps virus infection may result in clinical presentation



**Fig. 295.1** A, Mumps cases in the United States from 1968, right after the live mumps vaccine was introduced in 1967, to 2011. There was a steady decline following introduction of the vaccine and recommendation for routine vaccination in 1977 (arrow). Note national increases in activity in 1986–1987, 2006. Mumps data provided were reported voluntarily to the Centers for Disease Control and Prevention (CDC) from state health departments. B, Mumps cases in the United States from 2000–2017 showing the increased activity in 2006, 2009, 2010, and 2014–2017. Mumps data provided were reported voluntarily to CDC from state health departments. (A, From McLean HQ, Fiebelkorn AP, Temte JL, et al. *Prevention of measles, rubella, congenital rubella syndrome and mumps*. *MMWR Recomm Rep*. 2013;62[RR-04]:1–34; B, From *Morbidity and Mortality Weekly Report (MMWR): Notifiable Diseases and Mortality Tables*. <https://www.cdc.gov/mumps/outbreaks.html>)



ranging from asymptomatic (in the prevaccine era 15–24% of infections were asymptomatic; accurate estimates in the postvaccination era are difficult to measure) or nonspecific symptoms to the typical illness associated with parotitis with or without complications involving several body systems. The typical patient presents with a prodrome lasting 1–2 days consisting of fever, headache, vomiting, malaise, and myalgias. Parotitis follows and may be unilateral initially but becomes bilateral in approximately 70% of cases (Fig. 295.2). The parotid gland is tender, and parotitis may be preceded or accompanied by ear pain on the ipsilateral side. Ingestion of sour or acidic foods or liquids may enhance pain in the parotid area. As swelling progresses, the angle of the jaw is obscured, and the ear lobe may be lifted upward and outward (see Figs. 295.2 and 295.3). The opening of the Stensen duct may be red and edematous. The parotid swelling peaks in approximately 3 days and then gradually subsides over 7 days. Fever and the other systemic symptoms resolve in 3–5 days. A morbilliform rash is rarely seen. Submandibular salivary glands may also be involved or may be enlarged without parotid swelling. Edema over the sternum as a result of lymphatic obstruction may also occur. Symptoms in immunized individuals are the same but tend to be less severe, and parotitis may be absent.

## DIAGNOSIS

When mumps was highly prevalent, the diagnosis could be made on the basis of a history of exposure to mumps infection, an appropriate incubation period, and development of typical clinical findings. Confirmation of the presence of parotitis could be made with demonstration of an elevated serum amylase value. Leukopenia with a relative lymphocytosis was a common finding. Currently, in highly immunized populations patients with parotitis lasting longer than 2 days and of unknown cause, a specific diagnosis of mumps should be confirmed or ruled out by virologic or serologic examination. This step may be accomplished by isolation of the virus in cell culture, detection of viral antigen by direct immunofluorescence, or identification of nucleic acid by reverse transcriptase polymerase chain reaction (PCR). Virus can be isolated from upper respiratory tract secretions (buccal and oropharyngeal mucosa), CSF, or urine during the acute illness; however, PCR from the oropharyngeal secretions becomes negative quickly, especially in immunized individuals, and thus should be run within 3 days of parotid swelling. Serologic testing is usually a more convenient and available mode of diagnosis. A significant increase in serum mumps immunoglobulin G (IgG) antibody between acute and convalescent serum specimens as detected by complement fixation, neutralization hemagglutination, or enzyme immunoassay tests establishes the diagnosis. Mumps IgG antibodies may cross react with antibodies to parainfluenza virus in serologic testing. More commonly, an enzyme immunoassay for mumps IgM antibody is used to identify recent infection. All serologic tests are

difficult to interpret in immunized individuals, and negative test results do not rule out mumps infection. Skin testing for mumps is neither sensitive nor specific and should not be used.

## DIFFERENTIAL DIAGNOSIS

Parotid swelling may be caused by many other infectious and noninfectious conditions, especially in sporadic cases. Viruses that cause parotitis include parainfluenza 1 and parainfluenza 3 viruses, influenza A virus, cytomegalovirus, Epstein-Barr virus, enteroviruses, lymphocytic choriomeningitis virus, and HIV. Purulent parotitis, usually caused by *Staphylococcus aureus*, is unilateral, is extremely tender, is associated with an elevated white blood cell count, and may involve purulent drainage from the Stensen duct. Submandibular or anterior cervical adenitis from a variety of pathogens may also be confused with parotitis. Other noninfectious causes of parotid swelling include obstruction of the Stensen duct, collagen vascular diseases such as Sjögren syndrome, systemic lupus erythematosus, immunologic diseases, tumor, and drugs.

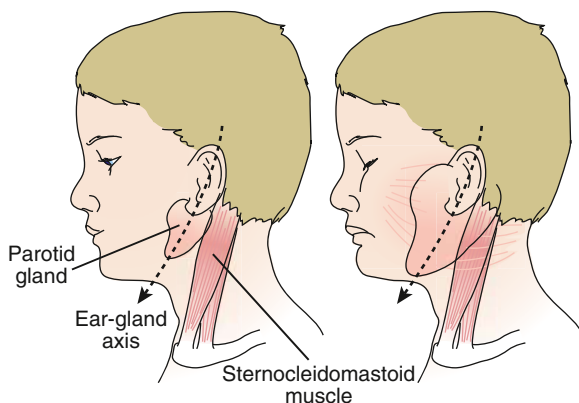
## COMPLICATIONS

The most common complications of mumps are meningitis, with or without encephalitis, and gonadal (orchitis, oophoritis) involvement. Uncommon complications include conjunctivitis, optic neuritis, pneumonia, nephritis, pancreatitis, mastitis, and thrombocytopenia. Complications can occur in the absence of parotitis, especially in immunized individuals, and overall complication rates in immunized individuals are lower than in unimmunized and are shifted toward the adult populations.

Maternal infection with mumps during the first trimester of pregnancy results in increased fetal wastage. No fetal malformations have been associated with intrauterine mumps infection. However, perinatal mumps disease has been reported in infants born to mothers who acquired mumps late in gestation.

## Meningitis and Meningoencephalitis

Mumps virus is neurotropic and is thought to enter the CNS via the choroid plexus and infect the choroidal epithelium and ependymal cells, both of which can be found in CSF along with mononuclear leukocytes. In the prevaccine era mumps represented one of the most common causes of aseptic meningitis and hearing loss among children. Symptomatic CNS involvement occurs in 10–30% of infected individuals, but CSF pleocytosis has been found in 40–60% of patients with mumps parotitis. The meningoencephalitis may occur before, along with, or following the parotitis. It most commonly manifests 5 days after the parotitis. Clinical findings vary with age. Infants and young children have fever, malaise, and lethargy, whereas older children, adolescents, and adults complain of headache and demonstrate



**Fig. 295.2** Schematic of a parotid gland infected with mumps (right) compared with a normal gland (left). An imaginary line bisecting the long axis of the ear divides the parotid gland into two equal parts. These anatomic relationships are not altered in the enlarged gland. An enlarged cervical lymph node is usually posterior to the imaginary line. (From *Mumps [epidemic parotitis]*. In Krugman S, Ward R, Katz SL, eds. *Infectious Diseases in Children*, 6th ed. St. Louis: Mosby; 1977:182.)



**Fig. 295.3** A child with mumps showing parotid swelling. (From the Centers for Disease Control and Prevention. Public Health Image Library [PHIL], Image 4491. <https://phil.cdc.gov/Details.aspx?pid=4491>.)



meningeal signs. In a series of children with mumps and meningeal involvement, findings were fever in 94%, vomiting in 84%, headache in 47%, parotitis in 47%, neck stiffness in 71%, lethargy in 69%, and seizures in 18%. In typical cases, symptoms resolve in 7–10 days. CSF in mumps meningitis has a white blood cell pleocytosis of 200–600  $\mu\text{L}$  with a predominance of lymphocytes. The CSF glucose content is normal in most patients, but a moderate hypoglycorrhachia (glucose content 20–40 mg/dL) may be seen in 10–20% of patients. The CSF protein content is normal or mildly elevated.

Less-common CNS complications of mumps include transverse myelitis, acute disseminated encephalomyelitis (ADEM), aqueductal stenosis, and facial palsy. Sensorineural hearing loss is rare and has been estimated to occur in 0.5–5.0 in 100,000 cases of mumps. The hearing loss can be transient. There is some evidence that hearing loss is more likely in patients with meningoencephalitis.

### Orchitis and Oophoritis

In adolescent and adult males, orchitis is second only to parotitis as a common finding in mumps. Involvement in prepubescent boys is extremely rare, but after puberty, orchitis occurs in 30–40% of males. It begins within days following onset of parotitis in most cases and is associated with moderate to high fever, chills, and exquisite pain and swelling of the testes. In 30% or less of cases, the orchitis is bilateral. Atrophy of the testes may occur, but sterility is rare even with bilateral involvement.

Oophoritis is uncommon in postpubertal females but may cause severe pain and may be confused with appendicitis when located on the right side.

### Pancreatitis

Pancreatitis may occur in mumps with or without parotid involvement. Severe disease is rare, but fever, epigastric pain, and vomiting are suggestive. Epidemiologic studies have suggested that mumps may be associated with the subsequent development of diabetes mellitus, but a causal link has not been established.

### Cardiac Involvement

Myocarditis has been reported in mumps, and molecular studies have identified mumps virus in heart tissue taken from patients with endocardial fibroelastosis.

### Arthritis

Arthralgia, monoarthritis, and migratory polyarthritis have been reported in mumps. Arthritis is seen with or without parotitis and usually occurs within 3 weeks of onset of parotid swelling. It is generally mild and self-limited.

### Thyroiditis

Thyroiditis is rare following mumps. It has not been reported without parotitis and may occur weeks after the acute infection. Most cases resolve, but some become relapsing and result in hypothyroidism.

## TREATMENT

No specific antiviral therapy is available for mumps. Management should be aimed at reducing the pain associated with meningitis or orchitis and maintaining adequate hydration. Antipyretics may be given for fever.

## PROGNOSIS

The outcome of mumps is nearly always excellent, even when the disease is complicated by encephalitis, although fatal cases from CNS involvement or myocarditis have been reported. No mumps deaths have occurred in the recent outbreaks in the United States.

## PREVENTION

Immunization with the live mumps vaccine is the primary mode of prevention used in the United States. It is given as part of the MMR two-dose vaccine schedule, at 12–15 months of age for the first dose and 4–6 years of age for the second dose. If not given at 4–6 years, the second dose should be given before children enter puberty. In those traveling, two doses are recommended in individuals older than 12 months administered at least 28 days apart. Antibody develops in 94%

(range: 89–97%) after one dose. Antibody levels achieved after vaccination are lower than after natural infection.

The median vaccine effectiveness of mumps vaccine after one dose of vaccine is 78% (range: 49–92%) and after two doses is 88% (range: 66–95%). Duration of effectiveness is  $\geq 10$  years after one dose and  $\geq 15$  years after two doses.

During outbreaks, a *third MMR dose* administered to the at-risk population was associated with improved outbreak control with significantly fewer cases in those receiving the third dose compared with those not receiving it. Despite these results, modeling supports the current two-dose schedule without a routine third booster dose because the current regimen significantly controls size of outbreaks, severity of disease, and number of hospitalizations, whereas the third dose appears to be a possible strategy during an outbreak.

As a live-virus vaccine, MMR should not be administered to pregnant women or to severely immunodeficient or immunosuppressed individuals. HIV-infected patients who are not severely immunocompromised may receive the vaccine, because the risk for severe infection with mumps outweighs the risk for serious reaction to the vaccine. Individuals with anaphylactoid reactions to egg or neomycin may be at risk for immediate-type hypersensitivity reactions to the vaccine. Persons with other types of reactions to egg or reactions to other components of the vaccine are not restricted from receiving the vaccine.

In 2006, in response to the multistate outbreak in the United States, evidence of immunity to mumps through vaccination was redefined. Acceptable presumptive evidence of immunity to mumps now consists of one of the following: (1) documentation of adequate vaccination at age 12 months or older, (2) laboratory evidence of immunity, (3) birth before 1957, and (4) documentation of physician-diagnosed mumps. Evidence of immunity through documentation of adequate vaccination is defined as one dose of a live mumps virus vaccine for preschool-age children and adults not at high risk and two doses for school-age children (i.e., grades K–12) and for adults at high risk (e.g., healthcare workers, international travelers, and students at post-high school educational institutions).

All persons who work in healthcare facilities should be immune to mumps. Adequate mumps vaccination for healthcare workers born during or after 1957 consists of two doses of a live mumps virus vaccine. Healthcare workers with no history of mumps vaccination and no other evidence of immunity should receive two doses, with  $>28$  days between doses. Healthcare workers who have received only one dose previously should receive a second dose. Because birth before 1957 is only presumptive evidence of immunity, healthcare facilities should consider recommending one dose of a live mumps virus vaccine for unvaccinated workers born before 1957 who do not have a history of physician-diagnosed mumps or laboratory evidence of mumps immunity. During an outbreak, healthcare facilities should strongly consider recommending two doses of a live mumps virus vaccine to unvaccinated workers born before 1957 who do not have evidence of mumps immunity.

**Adverse reactions** to mumps virus vaccine are rare. Parotitis and orchitis have been reported rarely. There is inadequate information to make a causal relationship to other reactions, such as febrile seizures, deafness, rash, purpura, encephalitis, and meningitis with the strain of mumps vaccine virus used for immunization in the United States. Higher rates of aseptic meningitis following vaccination for mumps are associated with vaccine strains used elsewhere in the world, including the Leningrad 3 and Urabe Am 9 strains. Transient suppression of reactivity to tuberculin skin testing has been reported after mumps vaccination.

In 2005 the quadrivalent measles, mumps, rubella, and varicella (MMRV) vaccine was made available. However, in 2010, studies showed a greater risk of febrile seizures in children 12–23 months of age 5–12 days after administration of the vaccine. No increased risk of seizures was seen in children receiving the first dose of the MMRV at older than 48 months of age. As a result, the American Academy of Pediatrics currently recommends either the MMR vaccine and separate varicella vaccine or the MMRV vaccine in children 12–47 months of age. After 48 months of age, the MMRV is generally preferred.

Visit Elsevier eBooks+ at [eBooks.Health.Elsevier.com](http://eBooks.Health.Elsevier.com) for Bibliography.

## Chapter 296

## Polioviruses

Eric A.F. Simões

**ETIOLOGY**

The polioviruses are nonenveloped, positive-stranded RNA viruses belonging to the Picornaviridae family, in the genus *Enterovirus*, species enterovirus C and consist of three antigenically distinct serotypes (types 1, 2, and 3). Polioviruses spread from the intestinal tract to the central nervous system (CNS), where they cause aseptic meningitis and poliomyelitis, or polio. The polioviruses are extremely hardy and can retain infectivity for several days at room temperature.

**EPIDEMIOLOGY**

The most devastating result of poliovirus infection is paralysis, although 90–95% of infections are inapparent. Despite the absence of symptoms, clinically inapparent infections induce protective immunity. Clinically apparent but nonparalytic illness occurs in approximately 5% of all infections, with paralytic polio occurring in approximately 1 in 1,000 infections among infants to approximately 1 in 100 infections among adolescents. In industrialized countries before universal vaccination, epidemics of paralytic poliomyelitis occurred primarily in adolescents. Conversely, in developing countries with poor sanitation, infection early in life results in infantile paralysis. Improved sanitation explains the virtual eradication of polio from the United States in the early 1960s, when only approximately 65% of the population was immunized with the Salk vaccine, which contributed to the disappearance of circulating wild-type poliovirus in the United States and Europe.

**TRANSMISSION**

Humans are the only known reservoir for the polioviruses, which are spread by the fecal-oral route. Poliovirus has been isolated from feces for longer than 2 weeks before paralysis to several weeks after the onset of symptoms.

**PATHOGENESIS**

Polioviruses infect cells by adsorbing to the genetically determined **poliovirus receptor (CD155)**. The virus penetrates the cell, is uncoated, and releases viral RNA. The RNA is translated to produce proteins responsible for replication of the RNA, shutoff of host cell protein synthesis, and synthesis of structural elements that compose the capsid. Mature virus particles are produced in 6–8 hours and are released into the environment by disruption of the cell.

In the contact host, wild-type and vaccine strains of polioviruses gain host entry via the gastrointestinal tract. Recent studies in non-human primates demonstrate that the primary sites of replication are in the CD155<sup>+</sup> epithelial cells lining the mucosa of the tonsil follicle and small intestine, as well as in the macrophages/dendritic cells in the tonsil follicle and Peyer patches. Regional lymph nodes are infected, and primary viremia occurs after 2–3 days. The virus seeds multiple sites, including the reticuloendothelial system, brown fat deposits, and skeletal muscle. Wild-type poliovirus probably accesses the CNS along peripheral nerves. Vaccine strains of polioviruses do not replicate in the CNS, a feature that accounts for the safety of the live-attenuated vaccine. Occasional **revertants** (by nucleotide substitution) of these vaccine strains develop a neurovirulent phenotype and cause **vaccine-associated paralytic poliomyelitis (VAPP)**. Reversion occurs in the small intestine and probably accesses the CNS via the peripheral nerves. Poliovirus has almost never been cultured from the cerebrospinal fluid (CSF) of patients with paralytic disease, and patients with aseptic meningitis caused by poliovirus never have paralytic disease. With the first appearance of non-CNS symptoms, a secondary viremia

probably occurs as a result of enormous viral replication in the reticuloendothelial system.

The exact mechanism of entry into the CNS is not known. However, once entry is gained, the virus may traverse neural pathways, and multiple sites within the CNS are often affected. The effect on motor and autonomic neurons is most striking and correlates with the clinical manifestations. Perineuronal inflammation, a mixed inflammatory reaction with both polymorphonuclear leukocytes and lymphocytes, is associated with extensive neuronal destruction. Petechial hemorrhages and considerable inflammatory edema also occur in areas of poliovirus infection. The poliovirus primarily infects motor neuron cells in the spinal cord (**the anterior horn cells**) and the medulla oblongata (the cranial nerve nuclei). Because of the overlap in muscle innervation by two to three adjacent segments of the spinal cord, clinical signs of weakness in the limbs develop when more than 50% of motor neurons are destroyed. In the medulla, less-extensive lesions cause paralysis, and involvement of the reticular formation that contains the vital centers controlling respiration and circulation may have a catastrophic outcome. Involvement of the intermediate and dorsal areas of the horn and the dorsal root ganglia in the spinal cord results in hyperesthesia and myalgias that are typical of acute poliomyelitis. Other neurons affected are the nuclei in the roof and vermis of the cerebellum, the substantia nigra, and, occasionally, the red nucleus in the pons; there may be variable involvement of thalamic, hypothalamic, and pallidal nuclei and the motor cortex.

Apart from the histopathology of the CNS, inflammatory changes occur generally in the reticuloendothelial system. Inflammatory edema and sparse lymphocytic infiltration are prominently associated with hyperplastic lymphocytic follicles.

Infants acquire immunity transplacentally from their mothers. Transplacental immunity disappears at a variable rate during the first 4–6 months of life. Active immunity after natural infection is probably lifelong but protects against the infecting serotype only; infections with other serotypes are possible. Poliovirus-neutralizing antibodies develop within several days after exposure as a result of replication of the virus in the tonsils and in the intestinal tract and deep lymphatic tissues. This early production of circulating immunoglobulin (Ig) G antibodies protects against CNS invasion. Local (mucosal) immunity, conferred mainly by secretory IgA, is an important defense against subsequent reinfection of the gastrointestinal tract.

**CLINICAL MANIFESTATIONS**

The incubation period of poliovirus from contact to initial clinical symptoms is usually considered to be 8–12 days, with a range of 5–35 days. Poliovirus infections with wild-type virus may follow one of several courses: **inapparent infection**, which occurs in 90–95% of cases and causes no disease and no sequelae; abortive poliomyelitis; nonparalytic poliomyelitis; or paralytic poliomyelitis. Paralysis, if it occurs, appears 3–8 days after the initial symptoms. The clinical manifestations of paralytic polio caused by wild or vaccine strains are comparable, although the incidence of abortive and nonparalytic paralysis with vaccine-associated poliomyelitis is unknown.

**Abortive Poliomyelitis**

In approximately 5% of patients, a nonspecific influenza-like syndrome occurs 1–2 weeks after infection, which is termed *abortive poliomyelitis*. Fever, malaise, anorexia, and headache are prominent features, and there may be sore throat and abdominal or muscular pain. Vomiting occurs irregularly. The illness is short lived, lasting up to 2–3 days. The physical examination may be normal or may reveal nonspecific pharyngitis, abdominal or muscular tenderness, and weakness. Recovery is complete, and no neurologic signs or sequelae develop.

**Nonparalytic Poliomyelitis**

In approximately 1% of patients infected with wild-type poliovirus, signs of abortive poliomyelitis are present, as are more intense headache, nausea, and vomiting, as well as soreness and stiffness of the posterior muscles of the neck, trunk, and limbs. Fleeting paralysis of the bladder and constipation are frequent. Approximately two thirds

of these children have a short symptom-free interlude between the first phase (**minor illness**) and the second phase (CNS disease or **major illness**). Nuchal rigidity and spinal rigidity are the basis for the diagnosis of nonparalytic poliomyelitis during the second phase.

Physical examination reveals nuchal-spinal signs and changes in superficial and deep reflexes. Gentle forward flexion of the occiput and neck elicits nuchal rigidity. The examiner can demonstrate head drop by placing the hands under the patient's shoulders and raising the patient's trunk. Although normally the head follows the plane of the trunk, in poliomyelitis it often falls backward limply, but this response is not attributable to true paresis of the neck flexors. In struggling infants, it may be difficult to distinguish voluntary resistance from clinically important true nuchal rigidity. The examiner may place the infant's shoulders flush with the edge of the table, support the weight of the occiput in the hand, and then flex the head anteriorly. True nuchal rigidity persists during this maneuver. When open, the anterior fontanel may be tense or bulging.

In the early stages the reflexes are normally active and remain so unless paralysis supervenes. Changes in reflexes, either increased or decreased, may precede weakness by 12-24 hours. The superficial reflexes, the cremasteric and abdominal reflexes, and the reflexes of the spinal and gluteal muscles are usually the first to diminish. The spinal and gluteal reflexes may disappear before the abdominal and cremasteric reflexes. Changes in the deep tendon reflexes generally occur 8-24 hours after the superficial reflexes are depressed and indicate impending paresis of the extremities. Tendon reflexes are absent with paralysis. Sensory defects do not occur in poliomyelitis.

### Paralytic Poliomyelitis

Paralytic poliomyelitis develops in approximately 0.1% of persons infected with poliovirus, causing 3 clinically recognizable syndromes that represent a continuum of infection differentiated only by the portions of the CNS most severely affected. These are (1) spinal paralytic poliomyelitis, (2) bulbar poliomyelitis, and (3) polioencephalitis.

**Spinal paralytic poliomyelitis** may occur as the second phase of a biphasic illness, the first phase of which corresponds to abortive poliomyelitis. The patient then appears to recover and feels better for 2-5 days, after which severe headache and fever occur with exacerbation of the previous systemic symptoms. Severe muscle pain is present, and sensory and motor phenomena (e.g., paresthesia, hyperesthesia, fasciculations, and spasms) may develop. On physical examination the distribution of paralysis is characteristically spotty. Single muscles, multiple muscles, or groups of muscles may be involved in any pattern. Within 1-2 days, *asymmetric flaccid paralysis or paresis occurs*. Involvement of one leg is most common, followed by involvement of one arm. The proximal areas of the extremities tend to be involved to a greater extent than the distal areas. To detect mild muscular weakness, it is often necessary to apply gentle resistance in opposition to the muscle group being tested. Examination at this point may reveal nuchal stiffness or rigidity, muscle tenderness, initially hyperactive deep tendon reflexes (for a short period) followed by absence or diminution of reflexes, and paresis or flaccid paralysis. In the spinal form, there is weakness of some of the muscles of the neck, abdomen, trunk, diaphragm, thorax, or extremities. *Sensation is intact; sensory disturbances, if present, suggest a disease other than poliomyelitis.*

The paralytic phase of poliomyelitis is extremely variable; some patients progress during observation from paresis to paralysis, whereas others recover, either slowly or rapidly. The extent of paresis or paralysis is directly related to the extent of neuronal involvement; paralysis occurs if >50% of the neurons supplying the muscles are destroyed. The extent of involvement is usually obvious within 2-3 days; only rarely does progression occur beyond this interval. Bowel and bladder dysfunction ranging from transient incontinence to paralysis with constipation and urinary retention often accompany paralysis of the lower limbs.

The onset and course of paralysis are variable in developing countries. The biphasic course is rare; typically the disease manifests in a single phase in which prodromal symptoms and paralysis occur in a continuous fashion. In developing countries, where a history of

intramuscular injections precedes paralytic poliomyelitis in approximately 50-60% of patients, patients may present initially with fever and paralysis (**provocation paralysis**). The degree and duration of muscle pain are also variable, ranging from a few days usually to a week. Occasionally, spasm and increased muscle tone with a transient increase in deep tendon reflexes occur in some patients, whereas in most patients, flaccid paralysis occurs abruptly. Once the temperature returns to normal, progression of paralytic manifestations stops. Little recovery from paralysis is noted in the first days or weeks, but, if it is to occur, it is usually evident within 6 months. The return of strength and reflexes is slow and may continue to improve for as long as 18 months after the acute disease. Lack of improvement from paralysis within the first several weeks or months after onset is usually evidence of permanent paralysis. Atrophy of the limb, failure of growth, and deformity are common and are especially evident in the growing child.

**Bulbar poliomyelitis** may occur as a clinical entity without apparent involvement of the spinal cord. Infection is a continuum, and designation of the disease as bulbar implies only dominance of the clinical manifestations by dysfunctions of the cranial nerves and medullary centers. The clinical findings seen with bulbar poliomyelitis with respiratory difficulty (other than paralysis of extraocular, facial, and masticatory muscles) include (1) nasal twang to the voice or cry caused by palatal and pharyngeal weakness (hard-consonant words such as cookie and candy bring this feature out best); (2) inability to swallow smoothly, resulting in accumulation of saliva in the pharynx, indicating partial immobility (holding the larynx lightly and asking the patient to swallow will confirm such immobility); (3) accumulated pharyngeal secretions, which may cause irregular respirations that appear interrupted and abnormal even to the point of falsely simulating intercostal or diaphragmatic weakness; (4) absence of effective coughing, shown by constant fatiguing efforts to clear the throat; (5) nasal regurgitation of saliva and fluids as a result of palatal paralysis, with inability to separate the oropharynx from the nasopharynx during swallowing; (6) deviation of the palate, uvula, or tongue; (7) involvement of vital centers in the medulla, which manifest as irregularities in rate, depth, and rhythm of respiration and as cardiovascular alterations, including blood pressure changes (especially increased blood pressure), alternate flushing and mottling of the skin, and cardiac arrhythmias; and as rapid changes in body temperature; (8) paralysis of one or both vocal cords, causing hoarseness, aphonia, and, ultimately, asphyxia unless the problem is recognized on laryngoscopy and managed by immediate tracheostomy; and (9) the **rope sign**, an acute angulation between the chin and larynx caused by weakness of the hyoid muscles (the hyoid bone is pulled posteriorly, narrowing the hypopharyngeal inlet).

Uncommonly, bulbar disease may culminate in an ascending paralysis (Landry type), in which there is progression cephalad from initial involvement of the lower extremities. Hypertension and other autonomic disturbances are common in bulbar involvement and may persist for a week or more or may be transient. Occasionally, hypertension is followed by hypotension and shock and is associated with irregular or failed respiratory effort, delirium, or coma. This kind of bulbar disease may be rapidly fatal.

The course of bulbar disease is variable; some patients die as a result of extensive, severe involvement of the various centers in the medulla; others recover partially but require ongoing respiratory support, and others recover completely. Cranial nerve involvement is seldom permanent. Atrophy of muscles may be evident, patients immobilized for long periods may experience pneumonia, and renal stones may form as a result of hypercalcemia and hypercalciuria secondary to bone resorption.

**Polioencephalitis** is a rare form of the disease in which higher centers of the brain are severely involved. Seizures, coma, and spastic paralysis with increased reflexes may be observed. Irritability, disorientation, drowsiness, and coarse tremors are often present with peripheral or cranial nerve paralysis that coexists or ensues. Hypoxia and hypercapnia caused by inadequate ventilation due to respiratory insufficiency may produce disorientation without true encephalitis. The manifestations are common to encephalitis of any cause and can be



attributed to polioviruses only with specific viral diagnosis or if accompanied by flaccid paralysis.

**Paralytic poliomyelitis with ventilatory insufficiency** results from several components acting together to produce ventilatory insufficiency resulting in hypoxia and hypercapnia. It may have profound effects on many other systems. Because respiratory insufficiency may develop rapidly, close continued clinical evaluation is essential. Despite weakness of the respiratory muscles, the patient may respond with so much respiratory effort associated with anxiety and fear that overventilation may occur at the outset, resulting in respiratory alkalosis. Such effort is fatiguing and contributes to respiratory failure.

There are certain characteristic patterns of disease. Pure spinal poliomyelitis with respiratory insufficiency involves tightness, weakness, or paralysis of the respiratory muscles (chiefly the diaphragm and intercostals) without discernible clinical involvement of the cranial nerves or vital centers that control respiration, circulation, and body temperature. The cervical and thoracic spinal cord segments are chiefly affected. Pure bulbar poliomyelitis involves paralysis of the motor cranial nerve nuclei with or without involvement of the vital centers. Involvement of the 9th, 10th, and 12th cranial nerves results in paralysis of the pharynx, tongue, and larynx with consequent airway obstruction. Bulbos-pinal poliomyelitis with respiratory insufficiency affects the respiratory muscles and results in coexisting bulbar paralysis.

The clinical findings associated with involvement of the respiratory muscles include (1) anxious expression; (2) inability to speak without frequent pauses, resulting in short, jerky, breathless sentences; (3) increased respiratory rate; (4) movement of the alae nasi and of the accessory muscles of respiration; (5) inability to cough or sniff with full depth; (6) paradoxical abdominal movements caused by diaphragmatic immobility caused by spasm or weakness of one or both leaves; and (7) relative immobility of the intercostal spaces, which may be segmental, unilateral, or bilateral. When the arms are weak, and especially when deltoid paralysis occurs, there may be impending respiratory paralysis because the phrenic nerve nuclei are in adjacent areas of the spinal cord. Observation of the patient's capacity for thoracic breathing while the abdominal muscles are splinted manually indicates minor degrees of paresis. Light manual splinting of the thoracic cage helps to assess the effectiveness of diaphragmatic movement.

## DIAGNOSIS

Poliomyelitis should be considered in any unimmunized or incompletely immunized child with paralytic disease. Although this guideline is most applicable in poliomyelitis endemic countries (Afghanistan, and Pakistan in 2023), the spread of polio in 2013 from endemic countries to many nonendemic countries (Niger, Chad, Cameroon, Ethiopia, Kenya, Somalia, and Syria) and the isolation of wild poliovirus type 1 in Israel in 2014 and circulating type 1 vaccine-associated paralytic polio in Ukraine in 2015 suggest that the diagnosis of polio should be entertained in all countries. VAPP should be considered in any child with paralytic disease occurring 7-14 days after receiving the orally administered polio vaccine (OPV). VAPP can occur at later times after administration and should be considered in any child with paralytic disease in countries or regions where wild-type poliovirus has been eradicated and the OPV has been administered to the child or a contact. The combination of fever, headache, neck and back pain, asymmetric flaccid paralysis without sensory loss, and pleocytosis does not regularly occur in any other illness.

The World Health Organization (WHO) recommends that the laboratory diagnosis of poliomyelitis be confirmed by isolation and identification of poliovirus in the stool, with specific identification of wild-type and vaccine-type strains. In suspected cases of acute flaccid paralysis, two stool specimens should be collected 24-48 hours apart as soon as possible after the diagnosis of poliomyelitis is suspected. Poliovirus concentrations are high in the stool in the first week after the onset of paralysis, which is the optimal time for collection of stool specimens. Polioviruses may be isolated from 80-90% of specimens from acutely ill patients, whereas <20% of specimens from such patients may yield virus at 3-4 weeks after onset of paralysis. Because most children with spinal or bulbospinal poliomyelitis have constipation, rectal

straws may be used to obtain specimens; ideally a minimum of 8-10 g of stool should be collected. In laboratories that can isolate poliovirus, isolates should be sent to either the U.S. Centers for Disease Control and Prevention (CDC) or to one of the WHO-certified poliomyelitis laboratories where DNA sequence analysis can be performed to distinguish between wild poliovirus and neurovirulent, revertant OPV strains. With the current WHO plan for global eradication of poliomyelitis, most regions of the world (the Americas, Europe, and Australia) have been certified wild-poliovirus free; in these areas, poliomyelitis is most often caused by vaccine strains. Hence it is critical to differentiate between wild-type and revertant vaccine-type strains.

The CSF is often normal during the minor illness and typically contains a pleocytosis with 20-300 cells/ $\mu$ L with CNS involvement. The cells in the CSF may be polymorphonuclear early during the course of the disease but shift to mononuclear cells soon afterward. By the second week of major illness, the CSF cell count falls to near-normal values. In contrast, the CSF protein content is normal or only slightly elevated at the outset of CNS disease but usually rises to 50-100 mg/dL by the second week of illness. In polioencephalitis, the CSF may remain normal or show minor changes. Serologic testing demonstrates seroconversion or a fourfold or greater increase in antibody titers from the acute phase of illness to 3-6 weeks later.

## DIFFERENTIAL DIAGNOSIS

Poliomyelitis should be considered in the differential diagnosis of any case of paralysis and is only one of many causes of acute flaccid paralysis (AFP) in children and adults. There are numerous other causes of acute flaccid paralysis (Table 296.1). As evidence of this point, in 2022 of the 57,983 cases of AFP reported to WHO, there were 30 cases of WPV1, 173 of cVDPV1, and 648 cases of cVDPV2. In most conditions, the clinical features are sufficient to differentiate between these various causes, but in some cases nerve conduction studies and electromyograms, in addition to muscle biopsies, may be required.

The possibility of polio should be considered in any case of acute flaccid paralysis, even in countries where polio has been eradicated. The diagnoses most often confused with polio are VAPP, West Nile virus infection, and infections caused by other enteroviruses (including EV-A71 and EV-D68), as well as Guillain-Barré syndrome, transverse myelitis, and traumatic paralysis. In **Guillain-Barré syndrome**, which is the most difficult to distinguish from poliomyelitis, the paralysis is characteristically symmetric, and sensory changes and pyramidal tract signs are common, contrasting with poliomyelitis. Fever, headache, and meningeal signs are less notable, and the CSF has few cells but an elevated protein content. **Transverse myelitis** progresses rapidly over hours to days, causing an acute symmetric paralysis of the lower limbs with concomitant anesthesia and diminished sensory perception. Autonomic signs of hypothermia in the affected limbs are common, and there is bladder dysfunction. The CSF is usually normal. **Traumatic neuritis** occurs from a few hours to a few days after the traumatic event, is asymmetric, is acute, and affects only one limb. Muscle tone and deep tendon reflexes are reduced or absent in the affected limb with pain in the gluteus. The CSF is normal.

Conditions causing pseudoparalysis do not present with nuchal-spinal rigidity or pleocytosis. These causes include unrecognized trauma, transient (toxic) synovitis, acute osteomyelitis, acute rheumatic fever, scurvy, and congenital syphilis (pseudoparalysis of Parrot).

## TREATMENT

There is no specific antiviral treatment for poliomyelitis. However, pocapavir (a capsid inhibitor) and V-7404 (an enterovirus 3C protease inhibitor) are being developed potentially for use in combination for treatment of poliovirus and other enteroviral infections. The management is supportive and aimed at limiting progression of disease, preventing ensuing skeletal deformities, and preparing the child and family for the prolonged treatment required and for permanent disability if this seems likely. Patients with the nonparalytic and mildly paralytic forms of poliomyelitis may be treated at home. All intramuscular injections and surgical procedures are contraindicated during the



**Table 296.1** Differential Diagnosis of Acute Flaccid Paralysis

SITE, CONDITION, FACTOR, OR AGENT	CLINICAL FINDINGS	ONSET OF PARALYSIS	PROGRESSION OF PARALYSIS	SENSORY SIGNS AND SYMPTOMS	REDUCTION OR ABSENCE OF DEEP TENDON REFLEXES	RESIDUAL PARALYSIS	PLEOCYTOSIS
<b>ANTERIOR HORN CELLS OF SPINAL CORD</b>							
Poliomyelitis (wild and vaccine-associated paralytic poliomyelitis)	Paralysis	Incubation period 7-14 days (range: 4-35 days)	24-48 hr to onset of full paralysis; proximal → distal, asymmetric	No	Yes	Yes	Aseptic meningitis (moderate polymorphonuclear leukocytes at 2-3 days)
Nonpolio enteroviruses (including EV-A71, EV D68)	Hand-foot-and-mouth disease, aseptic meningitis, acute hemorrhagic conjunctivitis, possibly idiopathic epidemic flaccid paralysis	As in poliomyelitis	As in poliomyelitis	No	Yes	Yes	As in poliomyelitis
West Nile virus	Meningitis encephalitis	As in poliomyelitis	As in poliomyelitis	No	Yes	Yes	Yes
<b>OTHER NEUROTROPIC VIRUSES</b>							
Rabies virus		Mo to yr	Acute, symmetric, ascending	Yes	Yes	No	±
Varicella-zoster virus	Exanthematous vesicular eruptions	Incubation period 10-21 days	Acute, symmetric, ascending	Yes	±	±	Yes
Japanese encephalitis virus		Incubation period 5-15 days	Acute, proximal, asymmetric	±	±	±	Yes
<b>GUILLAIN-BARRÉ SYNDROME</b>							
Acute inflammatory polyradiculoneuropathy	Preceding infection, bilateral facial weakness	Hr to 10 days	Acute, symmetric, ascending (days to 4 wk)	Yes	Yes	±	No
Acute motor axonal neuropathy	Fulminant, widespread paralysis, bilateral facial weakness, tongue involvement	Hr to 10 days	1-6 days	No	Yes	±	No

Continued

**Table 296.1** Differential Diagnosis of Acute Flaccid Paralysis—cont'd

SITE, CONDITION, FACTOR, OR AGENT	CLINICAL FINDINGS	ONSET OF PARALYSIS	PROGRESSION OF PARALYSIS	SENSORY SIGNS AND SYMPTOMS	REDUCTION OR ABSENCE OF DEEP TENDON REFLEXES	RESIDUAL PARALYSIS	PLEOCYTOSIS
<b>ACUTE TRAUMATIC SCIATIC NEURITIS</b>							
Intramuscular gluteal injection	Acute, asymmetric	Hr to 4 days	Complete, affected limb	Yes	Yes	±	No
Acute transverse myelitis	Preceding <i>Mycoplasma pneumoniae</i> , <i>Schistosoma</i> , other parasitic or viral infection	Acute, symmetric hypotonia of lower limbs	Hr to days	Yes	Yes, early	Yes	Yes
Epidural abscess	Headache, back pain, local spinal tenderness, meningismus	Complete		Yes	Yes	±	Yes
Spinal cord compression; trauma		Complete	Hr to days	Yes	Yes	±	±
<b>NEUROPATHIES</b>							
Exotoxin of <i>Corynebacterium diphtheriae</i>	In severe cases, palatal paralysis, blurred vision	Incubation period 1-8 wk (paralysis 8-12 wk after onset of illness)		Yes	Yes		±
Toxin of <i>Clostridium botulinum</i>	Abdominal pain, diplopia, loss of accommodation, mydriasis	Incubation period 18-36 hr	Rapid, descending, symmetric	±	No		No
Tick bite paralysis	Ocular symptoms	Latency period 5-10 days	Acute, symmetric, ascending	No	Yes		No
<b>DISEASES OF THE NEUROMUSCULAR JUNCTION</b>							
Myasthenia gravis	Weakness, fatigability, diplopia, ptosis, dysarthria		Multifocal	No	No	No	No
<b>DISORDERS OF MUSCLE</b>							
Polymyositis	Neoplasm, autoimmune disease	Subacute, proximal → distal	Wk to mo	No	Yes		No
Viral myositis		Pseudoparalysis	Hr to days	No	No		No
<b>METABOLIC DISORDERS</b>							
Hypokalemic periodic paralysis		Proximal limb, respiratory muscles	Sudden postprandial	No	Yes	±	No
<b>INTENSIVE CARE UNIT WEAKNESS</b>							
Critical illness polyneuropathy	Flaccid limbs and respiratory weakness	Acute, following systemic inflammatory response syndrome/sepsis	Hr to days	±	Yes	±	No

Modified from Marx A, Glass JD, Sutter RW. Differential diagnosis of acute flaccid paralysis and its role in poliomyelitis surveillance. *Epidemiol Rev.* 2000;22:298-316.

acute phase of the illness, especially in the first week of illness, because they might result in progression of disease.

### Abortive Poliomyelitis

Supportive treatment with analgesics, sedatives, an appetizing diet, and bed rest until the child's temperature is normal for several days is usually sufficient. Avoidance of exertion for the ensuing 2 weeks is desirable, and careful neurologic and musculoskeletal examinations should be performed 2 months later to detect any minor involvement.

### Nonparalytic Poliomyelitis

Treatment for the nonparalytic form is similar to that for the abortive form; in particular, relief is indicated for the discomfort of muscle tightness and spasm of the neck, trunk, and extremities. Analgesics are more effective when they are combined with the application of hot packs for 15-30 minutes every 2-4 hours. Hot tub baths are sometimes useful. A firm bed is desirable and can be improvised at home by placing table leaves or a sheet of plywood beneath the mattress. A foot-board or splint should be used to keep the feet at a right angle to the legs. Because muscular discomfort and spasm may continue for some weeks, even in the nonparalytic form, hot packs and gentle physical therapy may be necessary. Patients with nonparalytic poliomyelitis should also be carefully examined 2 months after apparent recovery to detect minor residual effects that might cause postural problems in later years.

### Paralytic Poliomyelitis

Most patients with the paralytic form of poliomyelitis require hospitalization with complete physical rest in a calm atmosphere for the first 2-3 weeks. **Suitable body alignment** is necessary for comfort and to avoid excessive skeletal deformity. A neutral position with the feet at right angles to the legs, the knees slightly flexed, and the hips and spine straight is achieved by use of boards, sandbags, and, occasionally, light splint shells. The position should be changed every 3-6 hours. **Active and passive movements** are indicated as soon as the pain has disappeared. Moist hot packs may relieve muscle pain and spasm. Opiates and sedatives are permissible only if no impairment of ventilation is present or impending. Constipation is common, and fecal impaction should be prevented. When bladder paralysis occurs, a parasympathetic stimulant such as bethanechol may induce voiding in 15-30 minutes; some patients show no response to this agent, and others respond with nausea, vomiting, and palpitations. Bladder paresis rarely lasts more than a few days. If bethanechol fails, manual compression of the bladder and the psychological effect of running water should be tried. If catheterization must be performed, care must be taken to prevent urinary tract infections. An appealing diet and a relatively high fluid intake should be started at once unless the patient is vomiting. Additional salt should be provided if the environmental temperature is high or if the application of hot packs induces sweating. Anorexia is common initially. Adequate dietary and fluid intake can be maintained by placement of a central venous catheter. An orthopedist and a physiatrist should see patients as early in the course of the illness as possible and should assume responsibility for their care before fixed deformities develop.

The management of pure bulbar poliomyelitis consists of maintaining the airway and avoiding all risk of inhalation of saliva, food, and vomitus. Gravity drainage of accumulated secretions is favored by using the head-low (foot of bed elevated 20-25 degrees) prone position with the face to one side. Patients with weakness of the muscles of respiration or swallowing should be nursed in a lateral or semiprone position. Aspirators with rigid or semirigid tips are preferred for direct oral and pharyngeal aspiration, and soft, flexible catheters may be used for nasopharyngeal aspiration. Fluid and electrolyte equilibrium is best maintained by intravenous infusion because tube or oral feeding in the first few days may incite vomiting. In addition to close observation for respiratory insufficiency, the blood pressure should be measured at least twice daily because hypertension is not uncommon and occasionally leads to hypertensive encephalopathy. Patients with pure bulbar poliomyelitis may require tracheostomy because of vocal cord paralysis or constriction of the hypopharynx; most patients who recover have

little residual impairment, although some exhibit mild dysphagia and occasional vocal fatigue with slurring of speech.

Impaired ventilation must be recognized early; mounting anxiety, restlessness, and fatigue are early indications for preemptive intervention. Tracheostomy is indicated for some patients with pure bulbar poliomyelitis, spinal respiratory muscle paralysis, or bulbospinal paralysis because such patients are generally unable to cough, sometimes for many months. Mechanical respirators are often needed.

### COMPLICATIONS

Paralytic poliomyelitis may be associated with numerous complications. Acute gastric dilation may occur abruptly during the acute or convalescent stage, causing further respiratory embarrassment; immediate gastric aspiration and external application of ice bags are indicated. Melena severe enough to require transfusion may result from single or multiple superficial intestinal erosions; perforation is rare. Mild hypertension for days or weeks is common in the acute stage and probably related to lesions of the vasoregulatory centers in the medulla and especially to underventilation. In the later stages, because of immobilization, hypertension may occur along with hypercalcemia, nephrocalcinosis, and vascular lesions. Dimness of vision, headache, and a lightheaded feeling associated with hypertension should be regarded as premonitory of a frank convulsion. Cardiac irregularities are uncommon, but electrocardiographic abnormalities suggesting myocarditis occur with some frequency. Acute pulmonary edema occurs occasionally, particularly in patients with arterial hypertension. Hypercalcemia occurs because of skeletal decalcification that begins soon after immobilization and results in hypercalciuria, which in turn predisposes the patient to urinary calculi, especially when urinary stasis and infection are present. High fluid intake is the only effective prophylactic measure.

### PROGNOSIS

The outcome of inapparent, abortive poliomyelitis and aseptic meningitis syndromes is uniformly good, with death being exceedingly rare and with no long-term sequelae. The outcome of paralytic disease is determined primarily by degree and severity of CNS involvement. In severe bulbar poliomyelitis, the mortality rate may be as high as 60%, whereas in less-severe bulbar involvement and/or spinal poliomyelitis, the mortality rate varies from 5-10%, death generally occurring from causes other than the poliovirus infection.

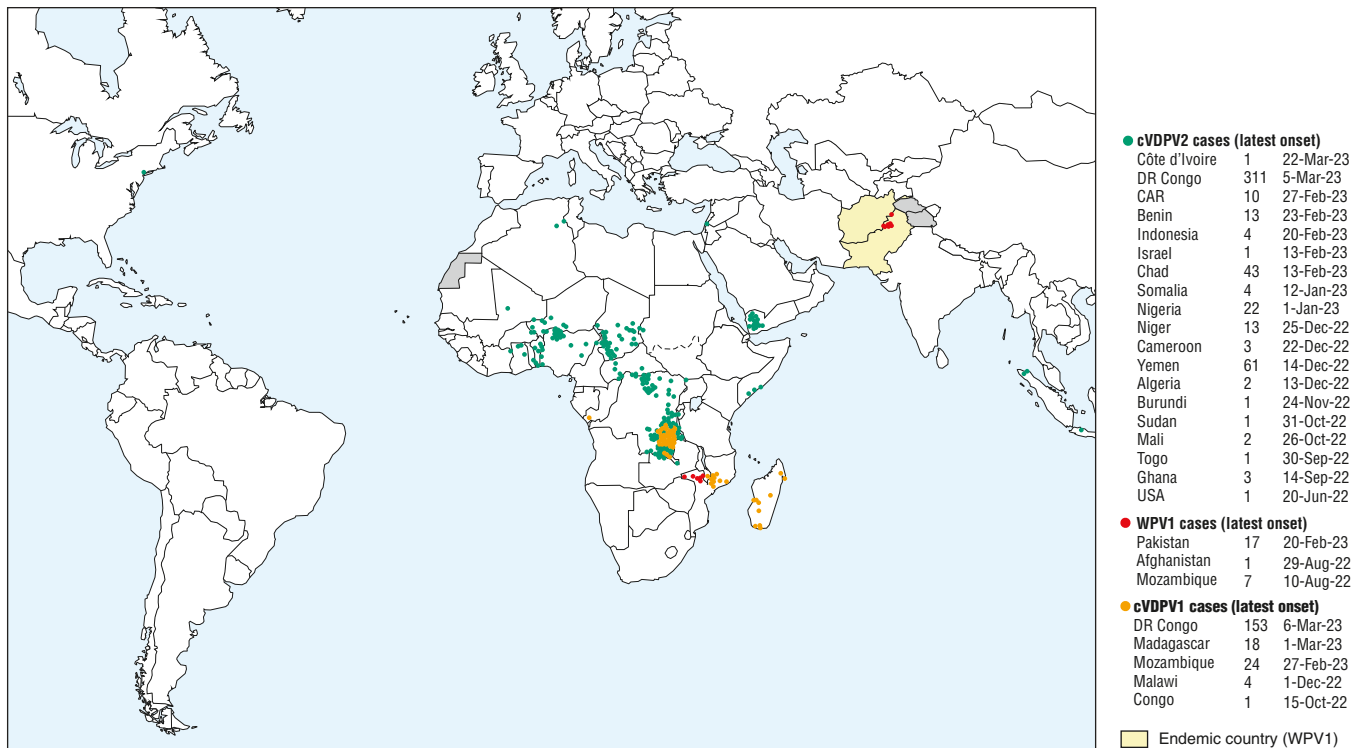
Maximum paralysis usually occurs 2-3 days after the onset of the paralytic phase of the illness, with stabilization followed by gradual return of muscle function. The recovery phase usually lasts about 6 months, beyond which persisting paralysis is permanent. In general, paralysis is more likely to develop in male children and female adults. Mortality and the degree of disability are greater after the age of puberty. Pregnancy is associated with an increased risk for paralytic disease. Tonsillectomy and intramuscular injections may enhance the risk for acquisition of bulbar and localized disease, respectively. Increased physical activity, exercise, and fatigue during the early phase of illness have been cited as factors leading to a higher risk for paralytic disease. Finally, it has been clearly demonstrated that type 1 poliovirus has the greatest propensity for natural poliomyelitis and type 3 poliovirus has a predilection for producing VAPP.

### Postpolio Syndrome

After an interval of 30-40 years, as many as 30-40% of persons who survived paralytic poliomyelitis in childhood may experience muscle pain and exacerbation of existing weakness or development of new weakness or paralysis. This entity, referred to as postpolio syndrome, has been reported only in persons who were infected in the era of wild-type poliovirus circulation. Risk factors for postpolio syndrome include increasing length of time since acute poliovirus infection, presence of permanent residual impairment after recovery from acute illness, and female sex.

### PREVENTION

Vaccination is the only effective method of preventing poliomyelitis. Hygienic measures help to limit the spread of the infection among



**Fig. 296.1** Global WPV1 and cVDPV cases, previous 12 months. Excludes viruses detected from environmental surveillance. Onset of paralysis: 3 May 2022 to 2 May 2023; data in WHO HQ as of 2 May 2023. (Courtesy Global Polio Eradication Initiative. <https://polioeradication.org/polio-today/polio-now/>. Accessed Jan 26, 2022.)

young children, but immunization is necessary to control transmission among all age groups. Both the inactivated polio vaccine (IPV), which is currently produced using better methods than those for the original vaccine and is sometimes referred to as enhanced IPV, and the live-attenuated OPV have established efficacy in preventing poliovirus infection and paralytic poliomyelitis. Both vaccines induce production of antibodies against the three strains of poliovirus. IPV elicits higher serum IgG antibody titers, but the OPV also induces significantly greater mucosal IgA immunity in the oropharynx and gastrointestinal tract, which limits replication of the wild poliovirus at these sites. Transmission of wild poliovirus by fecal spread is limited in OPV recipients. The immunogenicity of IPV is not affected by the presence of maternal antibodies, and IPV has no adverse effects. Live vaccine may undergo reversion to neurovirulence as it multiplies in the human intestinal tract and may cause VAPP in vaccinees or in their contacts. The overall risk for recipients varies from 1 case per 750,000 immunized infants in the United States to 1 in 143,000 immunized infants in India. The risk for paralysis in the B-cell-immunodeficient recipient may be as much as 6,800 times that in normal persons. HIV infection has not been found to result in long-term excretion of virus. *As of January 2000, the IPV-only schedule is recommended for routine polio vaccination in the United States.* All children should receive four doses of IPV, at 2 months, 4 months, 6-18 months, and 4-6 years of age. Five combination vaccines (DTaP-HepB-IPV-Pediarix; DTaP-IPV/Hib—Pentacel; DTaP-IPV-Hib-HepB—Vaxelis, and DTaP-IPV—Kinrix and Quadracel) and a single antigen IPV (IPOL; distributed in 10 dose vials) are approved in the United States with different schedules and ages for use. Given the rapid spread of cVPDV (Fig. 296.1) in many countries of the world, the reader is advised to refer to CDC or WHO websites to determine the necessity for accelerated vaccination of children going to identified countries. IPV can be given at a minimum of 6, 10, or 14 weeks of age with a booster at 6 months.

In 1988 the World Health Assembly resolved to eradicate poliomyelitis globally by 2000, and remarkable progress had been made toward reaching this target. To achieve this goal, the WHO used four basic

strategies: routine immunization, National Immunization Days, acute flaccid paralysis surveillance, and mop-up immunization. This strategy has resulted in a >99% decline in poliomyelitis cases; in early 2002, there were only 10 countries in the world endemic for poliomyelitis. In 2012 there were the fewest cases of poliomyelitis ever and the virus was endemic in only three countries (Afghanistan, Pakistan, and Nigeria). The last case of WPV 3 infection occurred in Nigeria in November 2012, leading to certification of global WPV3 eradication. The last case of wild poliovirus type 2 infection occurred in India in October 1999. Polioviruses remain endemic in Pakistan and Afghanistan. The rejection of poliovirus vaccine initiatives and campaign quality in security-compromised areas in parts of these countries are still the main factors interfering with efforts to eradicate polio.

In May 2013 the WHO assembly recommended the development of a *Polio Eradication and Endgame Strategic Plan*. This plan included the replacement of trivalent OPV (tOPV) with bivalent OPV (bOPV) containing only Sabin types 1 and 3 in all countries by 2016 and the introduction of initially one dose of IPV followed by the replacement of bOPV with IPV in all countries of the world by 2019. As long as the OPV is being used, there is the potential that vaccine-derived poliovirus (VDPV) will acquire the neurovirulent phenotype and transmission characteristics of the wild-type polioviruses. VDPV emerges from the OPV because of continuous replication in immunodeficient persons (iVDPV) or by circulation in populations with low vaccine coverage (cVDPVs). The risk was highest with the type 2 strain. Since the world switched from the use of tOPV to bOPV, tOPV is no longer used globally in any routine or supplemental immunization activities.

Recommendations for international travelers to certain countries were made by the WHO and endorsed by the CDC. Continuing spread due to poor herd immunity and now international spread pose a significant threat to the eradication effort. The committee recommended that for countries with WPV1, cVDPV1, or cVDPV2 with potential risk of international spread, all residents and long-term visitors (i.e., >4 weeks) of all ages receive a dose of bOPV or IPV between 4 weeks and 12 months before travel to these countries. Such travelers should



be provided with an International Certificate of Vaccination of Prophylaxis to record their polio vaccination and service proof of vaccination. These countries have been advised to restrict at the point of departure the international travel of any resident lacking documentation of full vaccination, whether by air, sea, or land. For countries infected with cVDPV2 with potential risk of international spread (see Fig. 296.1 and WHO website), visitors should be encouraged to follow these recommendations (not mandated).

The WHO has mandated that infants in all countries still using bOPV should receive a dose of IPV, to offer protection against polio virus type 2. These efforts have been stymied because of the global inability to produce IPV in a large enough volume to cover all the 128 million babies born annually in the world. This problem was a crisis during the global synchronized introduction of bOPV, when several countries (e.g., India) had to use two fractional doses of IPV (1/5 dose) administered intradermally. To enhance scale-up of IPV production in countries such as India, Brazil, and China, IPV using Sabin strains of poliovirus (sIPV) were developed in Japan and China. These mitigate the stringent requirements for wild-type poliovirus culture that are normally required for IPV production. Other strategies include developing adjuvants for IPV (approved by the Danish Medicines Agency in 2019) and other novel *E. coli*-based adjuvants that could potentially lower the antigen quantities needed for each dose.

Given the ongoing spread of cVDPVs, alternative stable novel Sabin vaccine strains that do not revert to neurovirulence (nOPVs) were developed for all three strains (Bio Farma, Indonesia) and have been shown to be immunogenic, stable, and safe.

In countries where bOPV is included in routine immunization, it is best if it follows at least one dose of IPV or two doses of fractional intradermal IPV.

Visit Elsevier eBooks+ at [eBooks.Health.Elsevier.com](http://eBooks.Health.Elsevier.com) for Bibliography.

## Chapter 297

# Nonpolio Enteroviruses

Kevin B. Messacar and Mark J. Abzug

The genus *Enterovirus* contains a large number of viruses spread via the gastrointestinal and respiratory routes that produce a broad range of illnesses in patients of all ages. Many of the manifestations predominantly affect infants and young children.

### ETIOLOGY

Enteroviruses are nonenveloped, single-stranded, positive-sense viruses in the Picornaviridae (small RNA virus) family, which also includes the rhinoviruses, hepatitis A virus, and parechoviruses. The original human enterovirus subgroups—polioviruses (see Chapter 296), coxsackieviruses, and echoviruses—were differentiated by their replication patterns in tissue culture and animals (Table 297.1). Enteroviruses have been reclassified on the basis of genetic similarity into four species, human enteroviruses A-D. Specific enterovirus types are distinguished by antigenic and genetic sequence differences, with enteroviruses discovered after 1970 classified by species and number (e.g., enterovirus D68 and A71). Although more than 100 types have been described, 10-15 account for the majority of disease. No disease is uniquely associated with any specific serotype, although certain manifestations are associated with specific serotypes. *The closely related human parechoviruses can cause clinical presentations similar to those associated with enteroviruses.*

**Table 297.1** Classification of Human Enteroviruses

Family	Picornaviridae
Genus	<i>Enterovirus</i>
Subgroups*	Poliovirus serotypes 1-3 Coxsackie A virus serotypes 1-22, 24 (23 reclassified as echovirus 9) Coxsackie B virus serotypes 1-6 Echovirus serotypes 1-9, 11-27, 29-33 (echoviruses 10 and 28 reclassified as nonenteroviruses; echovirus 34 reclassified as a variant of coxsackie A virus 24; echoviruses 22 and 23 reclassified within the genus <i>Parechovirus</i> ) Numbered enterovirus serotypes (enterovirus 72 reclassified as hepatitis A virus)

\*The human enteroviruses have been alternatively classified on the basis of nucleotide and amino acid sequences into four species (human enteroviruses A-D).

### Epidemiology

Enterovirus infections are common, with a worldwide distribution. In temperate climates, annual epidemic peaks occur in summer/fall, although some transmission occurs year-round. Enteroviruses are responsible for 33–65% of acute febrile illnesses and 55–65% of hospitalizations for suspected sepsis in infants during the summer and fall in the United States. In tropical and semitropical areas, enteroviruses typically circulate year-round. In general, only a few serotypes circulate simultaneously. Infections by different serotypes can occur within the same season. Factors associated with increased incidence and/or severity include young age, male sex, exposure to children, poor hygiene, overcrowding, and low socioeconomic status. More than 25% of symptomatic infections occur in children younger than 1 year of age. Breastfeeding reduces the risk for infection, likely via enterovirus-specific antibodies.

Humans are the only known natural reservoir for human enteroviruses. Virus is primarily spread person to person, by the fecal-oral and respiratory routes, although types causing acute hemorrhagic conjunctivitis may be spread via airborne transmission. Virus can be transmitted vertically prenatally or in the peripartum period or possibly via breastfeeding. Enteroviruses can survive on environmental surfaces, permitting transmission via fomites. Enteroviruses also can frequently be isolated from water sources, sewage, and wet soil. Although contamination of drinking water, swimming pools and ponds, and hospital water reservoirs may occasionally be responsible for transmission, such contamination is often considered the result rather than the cause of human infection. Transmission is common within families (≥50% risk of spread to nonimmune household contacts), daycare centers, playgrounds, summer camps, orphanages, and hospital nurseries; severe secondary infections may occur in nursery outbreaks. Transmission risk is increased by diaper changing and decreased by handwashing. Tickborne transmission has been suggested by some authors but is not a predominant route of transmission.

Large enterovirus outbreaks have included meningitis epidemics (echoviruses 4, 6, 9, 13, and 30 commonly); epidemics of hand-foot-and-mouth disease with severe central nervous system (CNS) and/or cardiopulmonary disease caused by enterovirus A71 in Asia and Australia; outbreaks of atypical, severe hand-foot-and-mouth disease caused by coxsackievirus A6 in the United States and United Kingdom; outbreaks of human enterovirus D68 respiratory illness associated with acute flaccid myelitis in the Americas, Europe, and Asia; outbreaks of acute hemorrhagic conjunctivitis caused by enterovirus D70, coxsackievirus A24, and coxsackievirus A24 variant in tropical and temperate regions; and community outbreaks of uveitis. Reverse transcription polymerase chain reaction (RT-PCR) and genomic sequencing help identify outbreaks and demonstrate commonality of outbreak strains, differences among epidemic strains and older prototype strains, changes in circulating viral subgroups over time, cocirculation of multiple genetic lineages, co-infections with different enterovirus serotypes, and associations between specific genogroups and/or

be provided with an International Certificate of Vaccination of Prophylaxis to record their polio vaccination and service proof of vaccination. These countries have been advised to restrict at the point of departure the international travel of any resident lacking documentation of full vaccination, whether by air, sea, or land. For countries infected with cVDPV2 with potential risk of international spread (see Fig. 296.1 and WHO website), visitors should be encouraged to follow these recommendations (not mandated).

The WHO has mandated that infants in all countries still using bOPV should receive a dose of IPV, to offer protection against polio virus type 2. These efforts have been stymied because of the global inability to produce IPV in a large enough volume to cover all the 128 million babies born annually in the world. This problem was a crisis during the global synchronized introduction of bOPV, when several countries (e.g., India) had to use two fractional doses of IPV (1/5 dose) administered intradermally. To enhance scale-up of IPV production in countries such as India, Brazil, and China, IPV using Sabin strains of poliovirus (sIPV) were developed in Japan and China. These mitigate the stringent requirements for wild-type poliovirus culture that are normally required for IPV production. Other strategies include developing adjuvants for IPV (approved by the Danish Medicines Agency in 2019) and other novel *E. coli*-based adjuvants that could potentially lower the antigen quantities needed for each dose.

Given the ongoing spread of cVDPVs, alternative stable novel Sabin vaccine strains that do not revert to neurovirulence (nOPVs) were developed for all three strains (Bio Farma, Indonesia) and have been shown to be immunogenic, stable, and safe.

In countries where bOPV is included in routine immunization, it is best if it follows at least one dose of IPV or two doses of fractional intradermal IPV.

Visit Elsevier eBooks+ at [eBooks.Health.Elsevier.com](https://www.elsevier.com/ebooks) for Bibliography.

## Chapter 297

# Nonpolio Enteroviruses

Kevin B. Messacar and Mark J. Abzug

The genus *Enterovirus* contains a large number of viruses spread via the gastrointestinal and respiratory routes that produce a broad range of illnesses in patients of all ages. Many of the manifestations predominantly affect infants and young children.

### ETIOLOGY

Enteroviruses are nonenveloped, single-stranded, positive-sense viruses in the Picornaviridae (small RNA virus) family, which also includes the rhinoviruses, hepatitis A virus, and parechoviruses. The original human enterovirus subgroups—polioviruses (see Chapter 296), coxsackieviruses, and echoviruses—were differentiated by their replication patterns in tissue culture and animals (Table 297.1). Enteroviruses have been reclassified on the basis of genetic similarity into four species, human enteroviruses A-D. Specific enterovirus types are distinguished by antigenic and genetic sequence differences, with enteroviruses discovered after 1970 classified by species and number (e.g., enterovirus D68 and A71). Although more than 100 types have been described, 10-15 account for the majority of disease. No disease is uniquely associated with any specific serotype, although certain manifestations are associated with specific serotypes. *The closely related human parechoviruses can cause clinical presentations similar to those associated with enteroviruses.*

**Table 297.1** Classification of Human Enteroviruses

Family	Picornaviridae
Genus	<i>Enterovirus</i>
Subgroups*	Poliovirus serotypes 1-3 Coxsackie A virus serotypes 1-22, 24 (23 reclassified as echovirus 9) Coxsackie B virus serotypes 1-6 Echovirus serotypes 1-9, 11-27, 29-33 (echoviruses 10 and 28 reclassified as nonenteroviruses; echovirus 34 reclassified as a variant of coxsackie A virus 24; echoviruses 22 and 23 reclassified within the genus <i>Parechovirus</i> ) Numbered enterovirus serotypes (enterovirus 72 reclassified as hepatitis A virus)

\*The human enteroviruses have been alternatively classified on the basis of nucleotide and amino acid sequences into four species (human enteroviruses A-D).

### Epidemiology

Enterovirus infections are common, with a worldwide distribution. In temperate climates, annual epidemic peaks occur in summer/fall, although some transmission occurs year-round. Enteroviruses are responsible for 33–65% of acute febrile illnesses and 55–65% of hospitalizations for suspected sepsis in infants during the summer and fall in the United States. In tropical and semitropical areas, enteroviruses typically circulate year-round. In general, only a few serotypes circulate simultaneously. Infections by different serotypes can occur within the same season. Factors associated with increased incidence and/or severity include young age, male sex, exposure to children, poor hygiene, overcrowding, and low socioeconomic status. More than 25% of symptomatic infections occur in children younger than 1 year of age. Breastfeeding reduces the risk for infection, likely via enterovirus-specific antibodies.

Humans are the only known natural reservoir for human enteroviruses. Virus is primarily spread person to person, by the fecal-oral and respiratory routes, although types causing acute hemorrhagic conjunctivitis may be spread via airborne transmission. Virus can be transmitted vertically prenatally or in the peripartum period or possibly via breastfeeding. Enteroviruses can survive on environmental surfaces, permitting transmission via fomites. Enteroviruses also can frequently be isolated from water sources, sewage, and wet soil. Although contamination of drinking water, swimming pools and ponds, and hospital water reservoirs may occasionally be responsible for transmission, such contamination is often considered the result rather than the cause of human infection. Transmission is common within families (≥50% risk of spread to nonimmune household contacts), daycare centers, playgrounds, summer camps, orphanages, and hospital nurseries; severe secondary infections may occur in nursery outbreaks. Transmission risk is increased by diaper changing and decreased by handwashing. Tickborne transmission has been suggested by some authors but is not a predominant route of transmission.

Large enterovirus outbreaks have included meningitis epidemics (echoviruses 4, 6, 9, 13, and 30 commonly); epidemics of hand-foot-and-mouth disease with severe central nervous system (CNS) and/or cardiopulmonary disease caused by enterovirus A71 in Asia and Australia; outbreaks of atypical, severe hand-foot-and-mouth disease caused by coxsackievirus A6 in the United States and United Kingdom; outbreaks of human enterovirus D68 respiratory illness associated with acute flaccid myelitis in the Americas, Europe, and Asia; outbreaks of acute hemorrhagic conjunctivitis caused by enterovirus D70, coxsackievirus A24, and coxsackievirus A24 variant in tropical and temperate regions; and community outbreaks of uveitis. Reverse transcription polymerase chain reaction (RT-PCR) and genomic sequencing help identify outbreaks and demonstrate commonality of outbreak strains, differences among epidemic strains and older prototype strains, changes in circulating viral subgroups over time, cocirculation of multiple genetic lineages, co-infections with different enterovirus serotypes, and associations between specific subgroups and/or

genetic substitutions and epidemiologic and clinical characteristics. Genetic analyses have demonstrated recombination and genetic drift that lead to evolutionary changes in genomic sequence and antigenicity and extensive genetic diversity. For example, emergence of new sub-genotypes and genetic lineages of enterovirus A71 may contribute to sequential outbreaks and increases in circulation.

The incubation period is typically 3-6 days, except for a 1-3 day incubation period for acute hemorrhagic conjunctivitis. Symptomatic and asymptomatic infected children typically shed cultivable virus from the respiratory tract for <1-3 weeks. In contrast, fecal shedding of cultivable virus continues for as long as 7-11 weeks for acid stable strains (e.g., poliovirus, enterovirus A71). Enterovirus RNA can be shed from mucosal sites for comparable and possibly longer periods.

## PATHOGENESIS

Cell surface macromolecules, including poliovirus receptor, integrin very-late-activation antigen (VLA)-2, decay-accelerating factor/complement regulatory protein (DAF/CD55), intercellular adhesion molecule-1 (ICAM-1), ICAM-5, and coxsackievirus-adenovirus receptor, serve as viral receptors. In addition, respiratory epithelial cell sialic acids serve as receptors for enterovirus D68, enterovirus D70, and coxsackievirus A24 variants, and human scavenger receptor class B2 (SCARB2), human P-selectin glycoprotein ligand-1, and DC-SIGN are receptors for enterovirus A71. After virus attaches to a cell surface receptor, a conformational change in surface capsid proteins expels a hydrophobic pocket factor, facilitating penetration and uncoating with release of viral RNA in the cytoplasm. Translation of the positive-sense RNA produces a polyprotein that undergoes cleavage by proteases encoded in the polyprotein. Several proteins resulting from cleavage of the polyprotein guide synthesis of negative-sense RNA that serves as a template for replication of new positive-sense RNA. The genome is approximately 7,500 nucleotides long and includes a highly conserved 5' noncoding region important for replication efficiency and a highly conserved 3' polyA region; these regions flank a continuous region encoding viral proteins. The 5' end is covalently linked to a small viral protein (VPg) necessary for initiation of RNA synthesis. There is significant variation within genomic regions encoding the structural proteins, leading to variability in antigenicity. Replication is followed by further cleavage of proteins and assembly into 30-nm icosahedral virions. Of the four structural proteins (VP1-VP4) in the capsid, VP1 is the most important determinant of serotype specificity. Additional regulatory proteins such as an RNA-dependent RNA polymerase and proteases are also present in the virion. Approximately  $10^4$ - $10^5$  virions are released from an infected cell by lysis within 5-10 hours of infection.

Following oral or respiratory acquisition, initial replication for most enteroviruses occurs in the pharynx and intestine, possibly within mucosal M cells. The acid stability of most enteroviruses favors survival in the gastrointestinal tract. Two or more enteroviruses may invade and replicate in the gastrointestinal tract simultaneously, but interference due to replication of one type often hinders growth of the heterologous type. Initial replication of most enteroviruses in the pharynx and intestine is followed within days by multiplication in lymphoid tissue, such as tonsils, Peyer patches, and regional lymph nodes. A primary, transient viremia (**minor viremia**) results in spread to distant parts of the reticuloendothelial system, including the liver, spleen, bone marrow, and distant lymph nodes. Host immune responses may limit replication and progression beyond the reticuloendothelial system, resulting in subclinical infection. Clinical infection occurs if replication proceeds in the reticuloendothelial system and virus spreads via a secondary, sustained viremia (**major viremia**) to target organs such as the CNS, heart, and skin. *Tropism to target organs is determined in part by the infecting serotype.* Some enteroviruses, such as enterovirus D68, can be acid-labile and bind sialic acid receptors on respiratory epithelial cells in the upper and lower respiratory tract and primarily produce respiratory illness. Cytokine responses may contribute to development of respiratory disease by these viruses. Enterovirus D68 RNA has also been transiently detected by PCR in the blood of young children with enterovirus D68 pneumonia when drawn soon after illness onset.

Enteroviruses can damage a wide variety of organs and systems, including the CNS, heart, liver, lungs, pancreas, kidneys, muscle, and skin. Damage is mediated by necrosis and the inflammatory response. **CNS infections** are often associated with pleocytosis in the cerebrospinal fluid (CSF), composed of macrophages and activated T lymphocytes, and a mixed meningeal inflammatory response. Parenchymal involvement may affect the cerebral white and gray matter, cerebellum, basal ganglia, brainstem, and spinal cord with perivascular and parenchymal mixed or lymphocytic inflammation, gliosis, cellular degeneration, and neuronophagocytosis. **Encephalitis** during enterovirus A71 epidemics has been characterized by severe involvement of the brainstem, spinal cord gray matter, hypothalamus, and subthalamic and dentate nuclei, and can be complicated by pulmonary edema, pulmonary hemorrhage, and/or interstitial pneumonitis, presumed secondary to brainstem damage; sympathetic hyperactivity; myoclonus; ataxia; autonomic dysfunction; and CNS and systemic inflammatory responses (including cytokine and chemokine overexpression). Immunologic cross-reactivity with brain tissue has been postulated as one mechanism responsible for neurologic damage and sequelae following enterovirus A71 infection.

Enterovirus **myocarditis** is characterized by perivascular and interstitial mixed inflammatory infiltrates and myocyte damage, possibly mediated by viral cytolytic (e.g., cleavage of dystrophin or serum response factor) and innate and adaptive immune-mediated mechanisms. Chronic inflammation may persist after viral clearance.

The potential for enteroviruses to cause persistent infection is controversial. Persistent infection in dilated cardiomyopathy and in myocardial infarction has been suggested, but enterovirus RNA sequences and/or antigens have been demonstrated in cardiac tissues in some, but not other, series. Infections with enteroviruses such as coxsackievirus B4, during gestation or subsequently, have been implicated as a trigger for development of  $\beta$ -cell autoantibodies and/or type 1 diabetes in genetically susceptible hosts. Persistent infection in the pancreas, intestine, or peripheral blood mononuclear cells, with downstream immunomodulatory effects, has been suggested, but data are inconsistent. Similarly, persistent infection has been implicated in a variety of conditions, including amyotrophic lateral sclerosis, Sjögren syndrome, chronic fatigue syndrome, and gastrointestinal tumors. Early enterovirus infection was associated with reduced risk of developing lymphocytic and myeloid leukemia in a large retrospective Taiwanese cohort study.

Severe **neonatal infections** can produce hepatic necrosis, hemorrhage, inflammation, endotheliitis, and venoocclusive disease; myocardial mixed inflammatory infiltrates, edema, and necrosis; meningeal and brain inflammation, hemorrhage, gliosis, necrosis, and white matter damage; inflammation, hemorrhage, thrombosis, and necrosis in the lungs, pancreas, and adrenal glands; and disseminated intravascular coagulation. In utero infections are characterized by placentitis and infection of multiple fetal organs such as heart, lung, and brain.

Development of type-specific neutralizing antibodies appears to be the most important immune defense, mediating prevention against and recovery from infection. Immunoglobulin (Ig) M antibodies, followed by long-lasting IgA and IgG antibodies, and secretory IgA, mediating mucosal immunity, are produced. Although local reinfection of the gastrointestinal tract can occur, replication is usually limited and not associated with disease. In vitro and animal experiments suggest that heterotypic antibody may enhance disease caused by a different serotype. Evidence also suggests that subneutralizing concentrations of serotype-specific antibody may lead to antibody-dependent enhancement of enterovirus A71 infection. Innate and cellular defenses (macrophages and cytotoxic T lymphocytes) may play important roles in recovery from infection. Altered cellular responses to enterovirus A71, including T lymphocyte and natural killer cell depletion, have been associated with severe meningoencephalitis and pulmonary edema.

*Hypogammaglobulinemia and agammaglobulinemia predispose to severe, often chronic enterovirus infections.* Similarly, perinatally infected neonates lacking maternal type-specific antibody to the infecting virus are at risk for severe disease. Enterovirus A71 disease increases after 6 months of age, when maternal serotype-specific antibody levels have





**Fig. 297.1** A, Oval blisters of the palms in a child with hand-foot-and-mouth disease (coxsackievirus A16 infection). B, Oval blisters on the feet of a child with hand-foot-and-mouth disease. C, Erosion of the tongue in a child with hand-foot-and-mouth disease. (From Weston WL, Lane AT, Morelli JG. *Color Textbook of Pediatric Dermatology*, 3rd ed. St. Louis: Mosby; 2002:109.)

declined. Other risk factors for significant illness include young age, immune suppression (posttransplantation and lymphoid malignancy), and, according to animal models and/or epidemiologic observations, exercise, cold exposure, malnutrition, and pregnancy. Specific human leukocyte antigen genes, immune response gene (e.g., interleukin-10 and interferon- $\gamma$ ) polymorphisms, and low vitamin A levels have been linked to enterovirus A71 susceptibility and severe disease.

### CLINICAL MANIFESTATIONS

Manifestations are protean, ranging from asymptomatic infection to undifferentiated febrile or respiratory illnesses, often in association with exanthems and/or enanthems, to, less frequently, severe diseases such as meningoencephalitis, myocarditis, and neonatal sepsis. A majority of individuals are asymptomatic or have very mild illness, yet may serve as important sources for spread of infection. Symptomatic disease is generally more common in young children.

### Nonspecific Febrile Illness

Nonspecific febrile illnesses are the most common symptomatic manifestations, especially in infants and young children. These are difficult to differentiate clinically from serious infections such as urinary tract infection, bacteremia, and bacterial meningitis, often necessitating hospitalization with diagnostic testing and presumptive antibiotic therapy for suspected bacterial infection in young infants.

Illness usually begins abruptly with fever of 38.5–40°C (101.3–104°F), malaise, and irritability. Associated symptoms may include lethargy, anorexia, diarrhea, nausea, vomiting, abdominal discomfort, rash, sore throat, and respiratory symptoms. Older children may have headaches and myalgias. Findings are generally nonspecific and may include mild conjunctivitis, pharyngeal injection, and cervical lymphadenopathy. Meningitis may be present, but specific clinical features such as meningeal findings or bulging anterior fontanelle distinguishing those with meningitis are often lacking in infants. Fever lasts a mean of 3 days and occasionally is biphasic. Duration of illness is usually 4–7 days but can range from 1 day to >1 week. White blood cell (WBC) count, inflammatory biomarkers (e.g., C-reactive protein, erythrocyte sedimentation rate), and results of routine laboratory tests are generally normal, although transient neutropenia can be seen. Concomitant enterovirus and bacterial infection is rare but has been observed in a small number of infants, most commonly with urinary tract infections.

Enterovirus illnesses may be associated with a wide variety of skin manifestations, including macular, maculopapular, urticarial, vesicular, and petechial eruptions. Rare cases of idiopathic thrombocytopenic purpura have been reported. Enteroviruses have also been implicated in cases of pityriasis rosea. In general, the frequency of cutaneous manifestations is inversely related to age. Serotypes commonly associated with rashes are echoviruses 9, 11, 16, and 25; coxsackie A viruses 2, 4, 6, 9, and 16; coxsackie B viruses 3–5; and enterovirus A71. Virus can occasionally be recovered from vesicular skin lesions.

### Hand-Foot-and-Mouth Disease

Hand-foot-and-mouth disease, one of the more distinctive rash syndromes, is most frequently caused by coxsackievirus A16, sometimes in large outbreaks, and can also be caused by enterovirus A71; coxsackie A viruses 5, 6, 7, 9, and 10; coxsackie B viruses 2 and 5; and some echoviruses. It is usually a mild illness, with or without low-grade fever. When the mouth is involved, the oropharynx is inflamed and often contains scattered, painful vesicles on the tongue, buccal mucosa, posterior pharynx, palate, gingiva, and/or lips (Fig. 297.1). These lesions may ulcerate, leaving 4–8 mm shallow lesions with surrounding erythema. Maculopapular, vesicular, and/or pustular lesions may occur on the hands and fingers, feet, and buttocks and groin (see Figs. 297.1 and 297.2). Skin lesions occur more commonly on the hands than feet and are more common on dorsal surfaces, but frequently also affect palms and soles. Hand and foot lesions are usually tender, 3–7-mm vesicles that resolve in about 1 week. Buttock lesions do not usually progress to vesiculation. Disseminated vesicular rashes described as **eczema coxsackium** may complicate preexisting eczema. Coxsackievirus A6, in particular, is responsible for relatively severe, atypical hand-foot-and-mouth disease (and herpangina) affecting adults and children that is characterized by fever, generalized rash (face, proximal extremities, and trunk, in addition to hands, feet, and buttocks), pain, dehydration, and desquamation of palms and soles (see Fig. 297.2). **Onychomadesis** (nail shedding) has been observed following coxsackievirus A6 and other coxsackievirus infections. Hand-foot-and-mouth disease caused by enterovirus A71 can be associated with neurologic and cardiopulmonary involvement, especially in young children (see “Neurologic Manifestations,” later). Hand-foot-and-mouth disease caused by coxsackievirus A16 also can occasionally be associated with complications such as encephalitis, acute flaccid paralysis, myocarditis, pericarditis, and shock.

### Herpangina

Herpangina is characterized by sudden onset of fever, sore throat, dysphagia, and painful lesions in the posterior pharynx. Temperatures range from normal to 41°C (105.8°F); fever tends to be higher in younger patients. Headache and backache may occur in older children, and vomiting and abdominal pain occur in 25% of cases. Characteristic lesions, present on the anterior tonsillar pillars, soft palate, uvula, tonsils, posterior pharyngeal wall, and, occasionally, the posterior buccal surfaces, are discrete 1–2-mm vesicles and ulcers that enlarge over 2–3 days to 3–4 mm and are surrounded by erythematous rings that vary in size up to 10 mm. The number of lesions can range from 1 to >15 but is most commonly around 5. The remainder of the pharynx appears normal or minimally erythematous. Most cases are mild and have no complications. However, dehydration as a result of decreased oral intake may occur with more severe illness; meningitis can also sometimes occur. Fever generally lasts 1–4 days, and resolution of symptoms occurs in 3–7 days. A variety of enteroviruses cause herpangina, including enterovirus A71, but coxsackie A viruses are implicated most often.





**Fig. 297.2** Atypical hand-foot-and-mouth disease. Vesiculobullous rash on the right buttock and posterior thigh. (From Waldman A, Thomas L, Thacker S, et al. Vesiculobullous eruption as an atypical hand, foot, and mouth presentation. *J Pediatr*. 2016;179:273. Fig. B.)

### Respiratory Manifestations

Symptoms such as sore throat and coryza frequently accompany and sometimes dominate enterovirus illnesses. Other respiratory findings may include wheezing, exacerbation of asthma, apnea, pneumonia, otitis media, bronchiolitis, croup, parotitis, and pharyngotonsillitis, which may occasionally be exudative. Lower respiratory tract infection may be significant in immunocompromised patients. Clusters and outbreaks of cases of severe respiratory disease, including pneumonia and wheezing (both in children with a history of asthma and those unaffected by asthma), have been increasingly recognized in association with multiple lineages of enterovirus D68.

**Pleurodynia (Bornholm disease)**, caused most frequently by coxsackie B viruses 3, 5, 1, and 2 and echoviruses 1 and 6, is an epidemic or sporadic illness characterized by paroxysmal thoracic pain, as a result of myositis involving chest and abdominal wall muscles and, possibly, pleural inflammation. In epidemics, which occur every 10-20 years, children and adults are affected, but most cases occur in persons younger than age 30 years. Malaise, myalgias, and headache are followed by sudden onset of fever and spasmodic, pleuritic pain in the chest or upper abdomen aggravated by coughing, sneezing, deep breathing, or other movement. During spasms, which last from a few minutes to several hours, pain may be severe, and respirations are usually rapid, shallow, and grunting, suggesting pneumonia or pleural inflammation. A pleural friction rub is noted during pain episodes in <10% of patients. Chest radiographs are generally normal but can demonstrate pulmonary infiltrates or pleural effusions. Pain localized to the abdomen may suggest colic, intestinal obstruction, appendicitis, or peritonitis. Pain usually subsides within 3-6 days but may persist for up to weeks. Symptoms may occur in a biphasic or, rarely, recurrent pattern, with less prominent fever during recurrences. Pleurodynia may be associated with meningitis, orchitis, myocarditis, or pericarditis.

Life-threatening noncardiogenic pulmonary edema, hemorrhage, and/or interstitial pneumonitis may occur in patients with enterovirus A71 brainstem encephalitis.

### Ocular Manifestations

Epidemics of **acute hemorrhagic conjunctivitis**, primarily caused by enterovirus D70 and coxsackievirus A24/A24 variant, are explosive

and marked by high contagiousness, with spread mainly via eye-hand-fomite-eye transmission. School-age children, teenagers, and adults 20-50 years of age have the highest attack rates. Sudden onset of severe eye pain is associated with photophobia, blurred vision, lacrimation, conjunctival erythema and congestion, lid edema, preauricular lymphadenopathy, and, in some cases, subconjunctival hemorrhages and superficial punctate keratitis. Subconjunctival hemorrhage is the hallmark of enterovirus D70 cases (>70%) but is more rare with coxsackievirus infections. Eye discharge is initially serous but becomes mucopurulent with secondary bacterial infection. Systemic symptoms, including fever and headache, occur in up to 20% of cases; manifestations suggestive of pharyngoconjunctival fever occasionally occur. Recovery is usually complete within 1-2 weeks. Polyradiculoneuropathy or acute flaccid paralysis following enterovirus D70 infection occurs occasionally. Other enteroviruses have occasionally been implicated as causes of keratoconjunctivitis.

Epidemic and sporadic uveitis in infants caused by subtypes of enteroviruses 11 and 19 can be associated with severe complications, including destruction of the iris, cataracts, and glaucoma. Enteroviruses have been implicated in cases of chorioretinitis, uveoretinitis, optic neuritis, and unilateral acute idiopathic maculopathy.

### Myocarditis and Pericarditis

Enteroviruses account for approximately 25-35% of cases of myocarditis and pericarditis of proven etiology (see [Chapters 488 and 489](#)). Coxsackie B viruses are most commonly implicated, although coxsackie A viruses and echoviruses also may be causative. Adolescents and young adults (especially physically active males) are disproportionately affected. Myopericarditis may be the dominant feature, or it may be one manifestation of disseminated disease, as in neonates. Disease ranges from relatively mild to severe. Upper respiratory tract symptoms frequently precede fatigue, dyspnea, chest pain, congestive heart failure, and dysrhythmias. Presentations may mimic myocardial infarction; sudden death may also occur (including apparent sudden infant death syndrome). A pericardial friction rub indicates pericardial involvement. Chest radiography often demonstrates cardiac enlargement, and echocardiography may confirm ventricular dilation, reduced contractility, and/or pericardial effusion. Electrocardiography frequently reveals ST segment, T wave, and/or rhythm abnormalities, and serum myocardial enzyme concentrations are often elevated. The acute mortality of enterovirus myocarditis is 0-4%. Recovery is complete without residual disability in the majority of patients. Occasionally, chronic cardiomyopathy, inflammatory ventricular microaneurysms, or constrictive pericarditis may result. The role of persistent infection in chronic dilated cardiomyopathy is controversial. Enteroviruses have also been implicated in late adverse cardiac events following heart transplantation and in acute cardiac events such as myocardial infarction, endocarditis, and peripartum cardiomyopathy. Cardiopulmonary dysfunction observed in enterovirus A71 epidemics most commonly occurs without evidence of myocarditis and may be of neurogenic origin; however, true myocarditis has also been described.

### Gastrointestinal and Genitourinary Manifestations

Gastrointestinal symptoms such as emesis (especially with meningitis), diarrhea (rarely severe), and abdominal pain are frequent but generally not dominant. Diarrhea, hematochezia, pneumatosis intestinalis, and necrotizing enterocolitis have occurred in premature infants during nursery outbreaks. Enterovirus infection has been implicated in acute and chronic gastritis, intussusception, chronic intestinal inflammation in hypogammaglobulinemic patients, sporadic hepatitis in normal children, severe hepatitis in neonates, and pancreatitis, which may result in transient exocrine pancreatic insufficiency.

Coxsackie B viruses are second only to mumps as causes of orchitis, most commonly presenting in adolescents. The illness is frequently biphasic; fever and pleurodynia or meningitis are followed approximately 2 weeks later by orchitis, often with epididymitis. Enteroviruses have also been implicated in cases of nephritis and IgA nephropathy.

## Neurologic Manifestations

Enteroviruses are the most common cause of viral **meningitis** in mumps-immunized populations, accounting for up to 90% or more of cases in which a cause is identified. Meningitis is particularly common in infants, especially in those younger than 3 months of age, often during community epidemics. Frequently implicated serotypes include coxsackie B viruses 2-5; echoviruses 4, 6, 7, 9, 11, 13, 16, and 30; and enteroviruses D70 and A71. Most cases in infants and young children are mild and lack specific meningeal signs, whereas nuchal rigidity is apparent in more than half of children older than 1-2 years of age. Fever is present in 50–100% and may be accompanied by irritability, malaise, headache, photophobia, nausea, emesis, anorexia, lethargy, hypotonia, rash, cough, rhinorrhea, pharyngitis, diarrhea, and/or myalgia. Some cases are biphasic, with fever and nonspecific symptoms lasting a few days and followed by return of fever with meningeal signs several days later. Fever usually resolves in 3-5 days, and other symptoms in infants and young children usually resolve within 1 week. In adults, symptoms tend to be more severe and of longer duration. CSF findings include pleocytosis (generally <500 but occasionally as high as 1,000-8,000 WBCs/ $\mu$ L; often predominantly polymorphonuclear cells in the first 48 hours before becoming mostly mononuclear); normal or slightly low glucose content (10% <40 mg/dL); and normal or mildly increased protein content (generally <100 mg/dL). *CSF parameters are normal in up to half of young infants despite detection of enterovirus in CSF and may also be normal in older children early after illness onset.* Acute complications occur in approximately 10% of young children, including simple and complex seizures, obtundation, increased intracranial pressure, syndrome of inappropriate antidiuretic hormone secretion, ventriculitis, transient cerebral arteriopathy, and coma. The long-term prognosis for most children, even in those with acute complications, is good.

Enteroviruses are also responsible for  $\geq 10$ –20% of cases of **encephalitis** with an identified cause. Frequently implicated serotypes include echoviruses 3, 4, 6, 9, and 11; coxsackie B viruses 2, 4, and 5; coxsackie A virus 9; and enterovirus A71. After initial nonspecific symptoms, there is progression to encephalopathy characterized by confusion, weakness, lethargy, and/or irritability. Symptoms are most commonly generalized, although focal findings, including focal motor seizures, hemichorea, acute cerebellar ataxia, aphasia, extrapyramidal symptoms, and/or focal imaging abnormalities, may occur. Meningeal signs and CSF indices similar to those of enteroviral meningitis are commonly present, leading to characterization of most cases as **meningoencephalitis**. Severity ranges from mild alteration in mental status to coma and decerebrate status. Long-term sequelae, including epilepsy, weakness, cranial nerve palsy, spasticity, psychomotor retardation, and hearing loss, or death may follow severe disease. Persistent or recurrent cases have been observed rarely.

Neurologic manifestations have been prominent in epidemics in Asia and Australia of enterovirus A71, and, to a lesser extent, coxsackievirus A16 disease. Many affected children have had hand-foot-and-mouth disease, some have had herpangina, and others have had no mucocutaneous manifestations. Neurologic syndromes in a fraction of children have included meningitis, meningoencephalomyelitis, **acute flaccid paralysis**, Guillain-Barré syndrome, transverse myelitis, acute disseminated encephalomyelitis, cerebellar ataxia, opsoclonus-myoclonus syndrome, benign intracranial hypertension, and **brainstem encephalitis (rhombencephalitis)** involving the midbrain, pons, and medulla). Enterovirus A71 rhombencephalitis is characterized by altered consciousness, myoclonus, vomiting, ataxia, nystagmus, tremor, cranial nerve abnormalities, autonomic dysfunction, and MRI demonstrating lesions in the brainstem, thalamus, and cerebellum. Although the disease has been mild and reversible in some children, others have had rapid progression to noncardiogenic (presumed neurogenic) pulmonary edema and hemorrhage, cardiopulmonary failure, shock, and coma. High mortality rates have been reported in children younger than 5 years of age, especially in those younger than 1 year of age. Deficits such as central hypoventilation, bulbar dysfunction, neurodevelopmental delay, cerebellar defects, attention deficit/hyperactivity-related symptoms, persistent

limb weakness, and muscle atrophy have been observed among survivors, especially those who experienced cardiopulmonary failure or acute flaccid paralysis during their acute illness. Although the most severe cases have been associated with enterovirus A71, similar clinical pictures have been produced by other enterovirus serotypes (e.g., coxsackieviruses A16 and B5, echovirus 7).

Patients with **antibody or combined immunodeficiencies** (including human immunodeficiency virus infection, acute lymphocytic leukemia, and transplantation) and patients receiving anti-CD20 antibody therapy are at risk for acute or, more commonly, **chronic enterovirus meningoencephalitis**. The latter is characterized by persistent CSF abnormalities, viral detection in CSF or brain tissue for years, and recurrent encephalitis and/or progressive neurologic deterioration, including insidious intellectual or personality deterioration, altered mental status, seizures, motor weakness, and increased intracranial pressure. Although disease may wax and wane, deficits generally become progressive and ultimately are frequently fatal or lead to long-term sequelae. A **dermatomyositis-like syndrome**, hepatitis, arthritis, myocarditis, or disseminated infection may also occur. Chronic enterovirus meningoencephalitis has become less common with prophylactic high-dose intravenous immunoglobulin replacement in agammaglobulinemic patients.

A variety of nonpoliovirus enteroviruses, including enteroviruses D68, D70, A71, coxsackie A viruses 7 and 24, coxsackie B viruses, and several echoviruses, have been associated with acute flaccid paralysis with motor weakness as a result of spinal cord anterior horn cell involvement. **Acute flaccid myelitis** is used to designate the clinical syndrome of acute flaccid limb weakness with longitudinal MRI abnormalities in the spinal cord gray matter. Neurologic abnormalities are commonly preceded by a febrile respiratory or gastrointestinal prodromal illness around 1 week before onset. Limb involvement tends to be asymmetric and varies from one to all four limbs, with severity ranging from mild weakness to complete paralysis. Cranial nerve dysfunction, including bulbar paralysis, and respiratory failure requiring ventilator support, similar to poliovirus poliomyelitis, have been described in acute flaccid myelitis cases associated with enterovirus D68 and enterovirus A71. Sensory involvement, encephalopathy, seizures, and supratentorial imaging changes are uncommon with enterovirus D68 infection. Functional improvements may be seen over time, but muscle atrophy with limb weakness and some degree of disability persist in the vast majority of cases. A proportion of children with acute flaccid myelitis will have a need for long-term tracheostomy, ventilation, and enteral feeding tubes as a result of persistent bulbar or respiratory paralysis, and scoliosis requiring spinal fusion, limb deformity requiring orthotics and assistive devices, and low bone density predisposing to fractures are common. Nerve transfer surgical procedures that involve splitting and moving functioning nerves to completely denervated muscles have been used to improve functional outcomes in select cases.

Other neurologic syndromes include cerebellar ataxia; transverse myelitis; Guillain-Barré syndrome (including Miller Fisher variant) and axonal polyneuropathy; acute disseminated encephalomyelitis; peripheral neuritis; optic neuritis; sudden hearing loss, tinnitus, and inner ear disorders such as vestibular neuritis; and other cranial neuropathies.

## Myositis and Arthritis

Although myalgia is common, direct evidence of muscle involvement, including rhabdomyolysis, muscle swelling, focal myositis, and polymyositis, has uncommonly been reported. A dermatomyositis-like syndrome and arthritis can be seen in enterovirus-infected patients with hypogammaglobulinemia. Enteroviruses are a rare cause of arthritis in normal hosts.

## Neonatal Infections

Neonatal infections are relatively common, with a disease incidence comparable to or greater than that of symptomatic neonatal herpes simplex virus, cytomegalovirus, and group B streptococcus infections. Infection frequently is caused by coxsackie B viruses 2-5 and

echoviruses 6, 9, 11, and 19, although many serotypes have been implicated, including coxsackie B virus 1 and echovirus 30 in more recent years. Enteroviruses may be acquired vertically before, during, or after delivery, including possibly via breast milk; horizontally from family members; or by sporadic or epidemic transmission in nurseries. In utero infection can lead to fetal demise, nonimmune hydrops fetalis, or neonatal illness. Additionally, maternal and intrauterine infections have been speculatively linked to congenital anomalies; prematurity, low birthweight, and intrauterine growth restriction; neurodevelopmental sequelae; unexplained neonatal illness and death; and increased risk of type 1 diabetes and schizophrenia.

The majority of neonatal infections are asymptomatic, and symptomatic presentations range from benign febrile illness to severe multisystem disease. Most affected newborns are full term and previously well. Maternal history often reveals a recent viral illness preceding or immediately following delivery, which may include fever and abdominal pain. Neonatal symptoms may occur as early as day 1 of life, with onset of severe disease generally within the first 2 weeks of life. Frequent findings include fever or hypothermia, irritability, lethargy, anorexia, rash (usually maculopapular, occasionally petechial or papulovesicular), jaundice, respiratory symptoms, apnea, hepatomegaly, abdominal distention, emesis, diarrhea, and decreased perfusion. Most patients have benign courses, with resolution of fever in an average of 3 days and of other symptoms in about 1 week. A biphasic course may occur occasionally. A minority have severe disease dominated by any combination of sepsis, meningoencephalitis, myocarditis, hepatitis, coagulopathy, and/or pneumonitis. Meningoencephalitis may be manifested by focal or complex seizures, bulging fontanelle, nuchal rigidity, and/or reduced level of consciousness. Myocarditis, most often associated with coxsackie B virus infection, may be suggested by tachycardia, dyspnea, cyanosis, and cardiomegaly. Hepatitis and pneumonitis are most often associated with echovirus infection, although they may also occur with coxsackie B viruses. Gastrointestinal manifestations may be prominent in premature neonates. Laboratory and radiographic evaluation may reveal leukocytosis, thrombocytopenia, CSF pleocytosis, CNS white matter damage, elevations of serum transaminases and bilirubin, coagulopathy, pulmonary infiltrates, and electrocardiographic changes.

Complications of severe neonatal disease include CNS necrosis and generalized or focal neurologic compromise; arrhythmias, congestive heart failure, myocardial infarction, and pericarditis; hepatic necrosis and failure; coagulopathy with intracranial or other bleeding; adrenal necrosis and hemorrhage; and rapidly progressive pneumonitis and pulmonary hypertension. Myositis, arthritis, necrotizing enterocolitis, inappropriate antidiuretic hormone secretion, hemophagocytic lymphohistiocytosis-like presentation, bone marrow failure, and sudden death are rare events. Mortality with severe disease is significant and is most often associated with hepatitis and bleeding complications, myocarditis, and/or pneumonitis.

Survivors of severe neonatal disease may have gradual resolution of hepatic and cardiac dysfunction, although persistent hepatic dysfunction and residual cardiac impairment, chronic calcific myocarditis, and ventricular aneurysm may occur. Meningoencephalitis may be associated with speech and language impairment; cognitive deficits; spasticity, hypotonicity, or weakness; seizure disorders; microcephaly or hydrocephaly; and ocular abnormalities. However, many survivors appear to have no long-term sequelae. Risk factors for severe disease include illness onset in the first few days of life; maternal illness just before or after delivery; prematurity; male sex; infection by echovirus 11 or a coxsackie B virus; positive serum viral culture; absence of neutralizing antibody to the infecting virus; and evidence of severe hepatitis, myocarditis, and/or multisystem disease.

### Transplant Recipients and Patients with Malignancies

Enterovirus infections in stem cell and solid organ transplant recipients may be severe and/or prolonged, causing progressive pneumonia, severe diarrhea, pericarditis, heart failure, meningoencephalitis, and disseminated disease. Enterovirus-associated hemophagocytic lymphohistiocytosis, meningitis, encephalitis, acute flaccid myelitis, and

myocarditis have been reported in children with malignancies and patients treated with anti-CD20 monoclonal antibody. Infections in these groups are associated with high fatality rates.

### DIAGNOSIS

Clues to enterovirus infection include characteristic findings such as hand-foot-and-mouth disease or herpangina lesions, consistent seasonality, known community outbreak, and exposure to enterovirus-compatible disease. Acute flaccid myelitis due to enterovirus should be considered in the differential diagnosis of any child presenting with acute-onset limb weakness, particularly in the summer to fall during enterovirus outbreaks and when following a febrile illness. In the neonate, history of maternal fever, malaise, and/or abdominal pain near delivery during enterovirus season is suggestive.

Traditionally, enterovirus infection has been confirmed with viral culture using a combination of cell lines. Sensitivity of culture ranges from 50% to 75% and can be increased by sampling of multiple sites (e.g., CSF plus oropharynx and rectum in children with meningitis). In neonates, yields of 30–70% are achieved when blood, urine, CSF, and mucosal swabs are cultured. A major limitation is the inability of most coxsackie A viruses to grow in culture. Yield may also be limited by neutralizing antibody in patient specimens, improper specimen handling, or insensitivity of the cell lines used. Culture is relatively slow, with 3–8 days usually required to detect growth. Although cultivation of an enterovirus from any site can generally be considered evidence of recent infection, isolation from the rectum or stool can reflect more remote shedding. Similarly, recovery from a mucosal site may suggest an association with an illness, whereas recovery from a normally sterile site (e.g., CSF, blood, or tissue) is more conclusive evidence of causation. Serotype identification by type-specific antibody staining or neutralization of a viral isolate is generally required only for investigation of an outbreak or an unusual disease manifestation, for surveillance, or to distinguish nonpoliovirus enteroviruses from vaccine or wild-type polioviruses.

Direct testing for nucleic acid has replaced culture because of increased sensitivity and more rapid turnaround. RT-PCR detection of highly conserved areas of the enterovirus genome can detect the majority of enteroviruses in CSF; serum; urine; conjunctival, nasopharyngeal, oropharyngeal, tracheal, rectal, and stool specimens; dried blood spots; and tissues such as myocardium, liver, and brain. However, the closely related parechoviruses are not detected by most enterovirus RT-PCR primers. Sensitivity and specificity of RT-PCR are high, with results available in as short as 1 hour. Real-time, quantitative PCR assays and nested PCR assays with enhanced sensitivity have been developed, as have enterovirus-containing multiplex PCR assays, nucleic acid sequence-based amplification assays, reverse transcription loop-mediated isothermal amplification, culture-enhanced PCR assays, and PCR-based microarray assays. PCR testing of CSF from children with meningitis and from hypogammaglobulinemic patients with chronic meningoencephalitis is frequently positive despite negative cultures. Routine PCR testing of CSF in infants and young children with suspected meningitis during enterovirus season decreases the number of diagnostic tests, duration of hospital stay, antibiotic use, and overall costs. Enterovirus RNA may not be detected in CSF by the time of clinical presentation with neurologic syndromes associated with certain enteroviruses (e.g., enterovirus A71 and D68), but shedding may still be detectable in nonsterile sites (stool/rectal for enterovirus A71; respiratory for enterovirus D68). PCR testing of tracheal aspirates of children with myocarditis has good concordance with testing of myocardial specimens. In ill neonates and young infants, PCR testing of serum and urine has higher yields than culture. Viral load in blood of neonates is correlated with disease severity; viral nucleic acid may persist in blood of severely ill newborns for up to 2 months.

Sequence analysis of amplified nucleic acid can be used for serotype identification and phylogenetic analysis and to establish a transmission link among cases. Serotype-specific (e.g., enterovirus A71, enterovirus D68, and coxsackievirus A16) PCR assays have been developed. For enterovirus A71, the yield of specimens other than CSF and blood (oropharyngeal, nasopharyngeal, rectal, vesicle swabs, and CNS tissue) is greater than the yield of CSF and blood, which are infrequently



positive. Enterovirus D68 is more readily detected in respiratory specimens (i.e., nasal wash or nasopharyngeal swab) compared to stool/rectal or CSF specimens. Routine collection and testing of respiratory and stool/rectal specimens, in addition to CSF, is warranted in neurologic presentations potentially associated with these viruses. Of note, commercially available multiplex respiratory PCR assays generally are unable to distinguish enteroviruses (including enterovirus D68) from rhinoviruses. Antigen detection assays that target specific serotypes such as enterovirus A71 with monoclonal antibodies have also been developed.

Enterovirus infections can be detected serologically by a rise in serum or CSF of neutralizing, complement fixation, enzyme-linked immunosorbent assay, or other type-specific antibody or by detection of serotype-specific IgM antibody. However, serologic testing requires presumptive knowledge of the infecting serotype or an assay with sufficiently broad cross-reactivity. Sensitivity and specificity may be limiting, and cross-reactivity among serotypes may occur. Except for epidemiologic studies or cases characteristic of specific serotypes (e.g., enterovirus A71 or enterovirus D68), serology is generally less useful than culture or nucleic acid detection. Enterovirus antibodies have been detected in CSF of children with acute flaccid myelitis when viral RNA was not detectable.

## DIFFERENTIAL DIAGNOSIS

The differential diagnosis of enterovirus infections varies with the clinical presentation (Table 297.2).

**Human parechoviruses**, members of the Picornaviridae family, produce many manifestations similar to the nonpolio enteroviruses. They are small RNA viruses that were originally classified as echoviruses. Nineteen parechoviruses have been identified that infect humans; serotypes 1 and 3 are the most common causes of symptomatic infection. Parechovirus epidemics occur in the same season

as enterovirus infections, with a biennial pattern of circulation noted in Europe. Outbreaks have been described in the nursery setting. In young infants, parechoviruses can cause a sepsis-like illness similar to enterovirus illness and are a common, underrecognized cause of viral meningoencephalitis. More frequently than with enteroviruses, infants with parechovirus CNS infection often have no CSF pleocytosis. There is also a higher incidence of white matter MRI abnormalities and long-term neurodevelopmental deficits with parechovirus encephalitis compared with enterovirus encephalitis. Rarely, parechoviruses have been identified in cases of hepatitis or myocarditis. Infections in older children are often unrecognized or cause acute, benign febrile, respiratory, or gastrointestinal illnesses with few specific findings.

Infants suspected of having an enterovirus infection should also be considered as possibly having a parechovirus infection, because the two may be indistinguishable. A distinctive rash involving the extremities with palm and sole erythema or peripheral leukopenia in the setting of high fever during the summer-fall season are clinical findings that should also prompt consideration of parechovirus infection. The diagnosis of parechovirus infection is confirmed by human parechovirus-specific PCR on CSF, blood, stool, and oropharyngeal or nasopharyngeal specimens.

## TREATMENT

In the absence of a proven antiviral agent for enterovirus infections, supportive care is the mainstay of treatment. Newborns and young infants with nonspecific febrile illnesses and children with meningitis frequently require diagnostic evaluation and hospitalization for presumptive treatment of bacterial and herpes simplex virus infection. Neonates with severe disease and infants and children with concerning disease manifestations (e.g., myocarditis, enterovirus A71 neurologic and cardiopulmonary disease, enterovirus D68 respiratory failure, and acute flaccid myelitis) may require intensive cardiorespiratory support.

**Table 297.2** Differential Diagnosis of Nonpolio Enterovirus Infections

CLINICAL MANIFESTATION	BACTERIAL PATHOGENS	VIRAL PATHOGENS	NONINFECTIOUS
Nonspecific febrile illness	<i>Streptococcus pneumoniae</i> , <i>Haemophilus influenzae</i> type b, <i>Neisseria meningitidis</i>	Influenza viruses, human herpesviruses 6 and 7, human parechoviruses	Rheumatologic disorders, oncologic diseases, drug reaction
Exanthems/enanthems	Group A <i>Streptococcus</i> , <i>Staphylococcus aureus</i> , <i>N.</i> <i>meningitidis</i> , <i>T. pallidum</i> , <i>M.</i> <i>pneumoniae</i>	Herpes simplex virus, adenoviruses, varicella-zoster virus, Epstein-Barr virus, measles virus, rubella virus, human herpesviruses 6 and 7, human parechoviruses	Drug reaction, Stevens Johnson syndrome, toxic epidermal necrolysis, Kawasaki syndrome, vasculitis
Respiratory illness/ conjunctivitis	<i>S. pneumoniae</i> , <i>H. influenzae</i> (nontypeable and type b), <i>N.</i> <i>meningitidis</i> , <i>Mycoplasma</i> <i>pneumoniae</i> , <i>Chlamydia</i> <i>pneumoniae</i>	Adenoviruses, influenza viruses, respiratory syncytial virus, parainfluenza viruses, rhinoviruses, human metapneumovirus, coronaviruses	Asthma exacerbation, rheumatologic uveitis, Kawasaki syndrome
Myocarditis/pericarditis	<i>S. aureus</i> , <i>H. influenzae</i> type b, <i>M.</i> <i>pneumoniae</i>	Adenoviruses, influenza virus, parvovirus, cytomegalovirus	Drugs, Kawasaki syndrome, rheumatic fever
Meningitis/encephalitis	<i>S. pneumoniae</i> , <i>H. influenzae</i> type b, <i>N. meningitidis</i> , <i>Mycobacterium tuberculosis</i> , <i>Borrelia burgdorferi</i> , <i>M.</i> <i>pneumoniae</i> , <i>Bartonella</i> <i>henselae</i> , <i>Listeria monocytogenes</i>	Herpes simplex virus, West Nile virus, influenza viruses, adenoviruses, Epstein-Barr virus, mumps virus, lymphocytic choriomeningitis virus, arboviruses, human parechoviruses	Drugs, intravenous immunoglobulin, Kawasaki syndrome, autoimmune encephalitis (e.g., anti-NMDA receptor), acute disseminated encephalomyelitis (ADEM), demyelinating disorders
Acute flaccid myelitis	<i>C. botulinum</i>	Poliovirus, West Nile virus, Japanese encephalitis virus, rabies virus, adenovirus	Spinal cord infarction, antemyelin oligodendrocyte glycoprotein (MOG) myelitis, neuromyelitis optica (NMO), Guillain-Barré syndrome, ADEM, transverse myelitis, lupus, tick paralysis
Neonatal infections	Group B <i>Streptococcus</i> , gram-negative enteric bacilli, <i>L. monocytogenes</i> , <i>Enterococcus</i>	Herpes simplex virus, adenoviruses, cytomegalovirus, rubella virus, human parechoviruses	Neonatal lupus, Aicardi-Goutières syndrome



Milrinone has been suggested as a useful agent in severe enterovirus A71 cardiopulmonary disease. Liver and cardiac transplantation have been performed for neonates with progressive end-organ failure.

Immunoglobulin has been used to treat enterovirus infections based on the importance of the humoral immune response to enterovirus infection and the observation that absence of neutralizing antibody is a risk factor for symptomatic infection. Immunoglobulin products contain neutralizing antibodies to many commonly circulating serotypes, although titers vary with serotype and among products and lots. Anecdotal and retrospective, uncontrolled use of intravenous immunoglobulin or infusion of maternal convalescent plasma to treat newborns with severe disease has been associated with varying outcomes. The one randomized controlled trial was too small to demonstrate significant clinical benefits, although neonates who received immunoglobulin containing high neutralizing titers to their own isolates had shorter periods of viremia and viruria. Immunoglobulin has been administered intravenously and intraventricularly to treat hypogammaglobulinemia in patients with chronic enterovirus meningoencephalitis and intravenously in transplant and oncology patients with severe infections, with variable success. Intravenous immunoglobulin and corticosteroids have been used for patients with neurologic disease caused by enterovirus A71, enterovirus D68, and other enteroviruses. Modulation of cytokine profiles after administration of intravenous immunoglobulin for enterovirus A71-associated brainstem encephalitis has been demonstrated. High-titer enterovirus A71 immunoglobulin appeared promising in animal models, and clinical trials in regions with epidemic enterovirus A71 disease are ongoing. Anti-enterovirus A71 and D68 monoclonal antibodies have also been generated and evaluated in vitro and in animal models. A retrospective study suggested that treatment of presumed viral myocarditis with immunoglobulin was associated with improved outcome; however, virologic diagnoses were not made. Evaluation of corticosteroids and cyclosporine and other immunosuppressive therapy for myocarditis has been inconclusive. Successful treatment of enterovirus myocarditis with interferon- $\alpha$  has been reported anecdotally, and interferon- $\beta$  treatment was associated with viral clearance, improved cardiac function, and survival in chronic cardiomyopathy associated with persistence of enterovirus (or adenovirus) genome. Activity of interferon- $\alpha$  against enterovirus A71 has been demonstrated with in vitro and animal models, but potency varies with interferon- $\alpha$  type.

Antiviral agents that act at various steps in the enterovirus life cycle—attachment, penetration, uncoating, translation, polyprotein processing, protease activity, replication, and assembly—are being evaluated. Candidates include pharmacologically active chemical compounds, small interfering RNAs and DNA-like antisense agents, purine nucleoside analogs, synthetic peptides, enzyme inhibitors of signal transduction pathways, interferon-inducers, and herbal compounds. Pleconaril, an inhibitor of attachment and uncoating, was associated with benefit in some controlled studies of enterovirus meningitis and picornavirus upper respiratory tract infections, and uncontrolled experience suggested possible benefits in high-risk infections. A randomized controlled trial of pleconaril in neonates with severe hepatitis, coagulopathy, and/or myocarditis suggested possible virologic and clinical benefits of treatment. Pocopavir, an agent with a similar mechanism of action that is in development for treatment of poliovirus infections, has been used in a small number of cases of severe neonatal enterovirus sepsis. Vapendavir is another attachment inhibitor that is in clinical trials for rhinovirus infections and has in vitro activity against enteroviruses (including enterovirus A71) but has not entered clinical trials for enterovirus infections. Pleconaril, pocopavir, and vapendavir are not currently available for clinical use.

Design and evaluation of candidate agents active against enterovirus A71 and enterovirus D68 are high priorities. Challenges for therapies of enterovirus A71 include limited cross-genotypic activity of candidate compounds and high viral mutagenicity that favors emergence of resistance. Lactoferrin and ribavirin have demonstrated activity with in vitro and/or animal models. The investigational agents rupintrivir and V-7404, which inhibit the 3C-protease conserved among many enteroviruses and essential for infectivity, have broad activity in vitro, including against both enterovirus A71 and enterovirus D68. DAS181 is an investigational, inhaled drug with sialidase activity that

has in vitro activity against recently circulating strains of enterovirus D68. The antidepressant fluoxetine interacts with the enterovirus 2C protein and has in vitro activity against group B and D enteroviruses; it has been used anecdotally for chronic enterovirus encephalitis associated with agammaglobulinemia and enterovirus D68-associated acute flaccid myelitis. A retrospective study did not demonstrate a signal of efficacy in the latter condition.

## COMPLICATIONS AND PROGNOSIS

The prognosis in the majority of enterovirus infections is excellent. Morbidity and mortality are associated primarily with myocarditis, neurologic disease, severe neonatal infections, and infections in immunocompromised hosts.

## Prevention

The first line of defense is prevention of transmission through good hygiene, such as handwashing, avoidance of sharing utensils and drinking containers and other potential fomites, disinfection of contaminated surfaces, and avoiding community settings where exposures are likely to occur. The paucity of enterovirus circulation and associated hand-foot-mouth disease and respiratory and neurologic disease in 2020 during the COVID-19 pandemic provides indirect evidence of the efficacy of nonpharmaceutical interventions targeted to decrease SARS-CoV-2 spread (masking, distancing, school mitigation strategies) against enteroviruses. Chlorination of drinking water and swimming pools also may be an important preventative strategy. Contact precautions should be used for all patients with enterovirus infections in the hospital setting; droplet precautions should also be included for patients with respiratory syndromes and, possibly, enterovirus A71 and D68 infection. Infection control techniques such as cohorting have proven effective in limiting nursery outbreaks. Prophylactic administration of immunoglobulin or convalescent plasma has been used in nursery epidemics; simultaneous use of infection control interventions makes it difficult to determine efficacy.

Pregnant women near term should avoid contact with individuals ill with possible enterovirus infections. If a pregnant woman experiences a suggestive illness, it is advisable not to proceed with emergency delivery unless there is concern for fetal compromise or obstetric emergencies cannot be excluded. Rather, it may be advantageous to extend pregnancy, allowing the fetus to passively acquire protective antibodies. A strategy of prophylactically administering immunoglobulin (or maternal convalescent plasma) to neonates born to mothers with enterovirus infections is untested.

Maintenance antibody replacement with high-dose intravenous immunoglobulin for patients with hypogammaglobulinemia has reduced the incidence of chronic enterovirus meningoencephalitis, although breakthrough infections occur. Inactivated vaccines to prevent enterovirus A71 infections, given to children 6–35 months of age, have been demonstrated to be safe and effective (>90% against enterovirus A71 hand-foot-and-mouth disease and >80% against enterovirus A71 serious disease) in phase 3 clinical trials. Three inactivated enterovirus A71 vaccines have been licensed and approved for prevention of severe hand-foot-and-mouth disease in China and are being studied in other Asian countries. Other vaccine strategies for enterovirus A71, including VP1 capsid protein-based subunit, DNA, and vector vaccines; combined peptide vaccines; live-attenuated vaccines; virus-like particles; breast milk enriched with VP1 capsid protein or lactoferrin; and interferon- $\gamma$ -expressing recombinant viral vectors, are also under investigation. Circulation of multiple enterovirus A71 types, antigenic drift, viral recombination, and potential immunologic cross-reactivity with brain tissue may pose challenges to development of enterovirus A71 vaccines. Vaccine candidates against EV-D68, including virus-like particle vaccines and inactivated whole virus vaccines, are in development, but have not progressed beyond animal studies. Most enterovirus vaccines do not provide cross-protection against other serotypes; however, the potential to create multivalent enterovirus vaccines targeting several common strains with severe manifestations is under investigation.

## Chapter 298

## Parvoviruses

William C. Koch

The parvoviruses are small, single-stranded DNA viruses. They are common infectious agents of a wide variety of animal species, including mammals, birds, and insects. Parvoviruses as a group include a number of important animal pathogens. There are five different types of parvoviruses known to infect humans: the dependoviruses, also called adeno-associated viruses (AAVs), parvovirus B19 (B19V), human bocaviruses (HBoVs), parvovirus 4 (PARV4), and human bufavirus (HBuV). B19V and HBoV are the only two parvoviruses proven to be pathogenic in humans. B19V is the most well studied and clinically important of the human parvoviruses and the cause of **erythema infectiosum** or **fifth disease**. *Human bocavirus* is an emerging human pathogen.

## ETIOLOGY

The five human parvoviruses are distinct enough from each other to represent five different genera within the Parvoviridae family. B19V is a member of the genus *Erythroparvovirus*, is composed of an icosahedral protein capsid without an envelope, and contains a single-stranded DNA genome of approximately 5.5 kb. It is relatively heat and solvent resistant. It is antigenically distinct from other mammalian parvoviruses and has only one known serotype, with three distinct genotypes described. The relatively short genome in parvoviruses does not encode a DNA polymerase, so all parvoviruses require either host cell factors present in late S phase or co-infection with another virus to replicate their DNA. B19V can be propagated effectively in vitro only in CD36<sup>+</sup> erythroid progenitor cells derived from human bone marrow, umbilical cord blood, or peripheral blood.

**HBoV** is a member of the genus *Bocaparvovirus*. HBoV was first isolated from nasopharyngeal specimens from children with respiratory tract infection in 2005. It was identified using random polymerase chain reaction (PCR) amplification and sequencing methods specifically designed to detect previously unknown viral sequences. Analysis of the gene sequences showed similarities to both bovine and canine parvoviruses, and thus the virus was named human bocavirus. Later, three other HBoVs were identified in stool samples and designated as HBoV types 2, 3, and 4, with the initial respiratory isolate called HBoV1. The HBoV capsid structure and genome size are similar to those of B19V, but the genomic organization and replication are different (though not fully characterized to date). HBoVs cannot be propagated in conventional cell culture but have been grown in a pseudostratified human airway epithelial cell culture system.

The **AAVs** are members of the genus *Dependoparvovirus* and were the first parvoviruses to be found in humans. They were originally identified as contaminants in laboratory preparations of adenovirus, resulting in the designation “adeno-associated viruses.” They were later isolated directly from human tissue samples, and now several AAV serotypes are known to commonly infect humans. AAVs have a unique life cycle that can take one of two paths: (1) a lytic infection with replication of viral DNA and production of new virus, or (2) viral integration into the host cell DNA. In the presence of a “helper” virus, usually an adenovirus or a herpesvirus, AAV can replicate its DNA, produce capsids, and release new virions by cell lysis. In the absence of a helper virus infection, the AAV genome becomes integrated into the host cell DNA. This feature has drawn interest in AAVs as potential vectors for gene therapy. Although human infection with AAVs is common, there is only one possible disease association (idiopathic hepatitis) (see [Chapter 406](#)).

PARV4 was initially identified in 2005 from the blood of an adult patient with acute viral syndrome, who was also an intravenous drug user co-infected with hepatitis C. Subsequently, this virus has been found

in blood donors and donated plasma pools in many different countries. It appears to be present in approximately 3% of blood donors in the United States and 4% of plasma pools. There is currently no known disease association or clinical symptomatology associated with infection. Likewise, BuV is a parvovirus that was first identified in 2012 in the feces from children <5 years of age with acute diarrhea but has an unclear role as a pathogen. PARV4 has been assigned to the genus *Tetraparvovirus*, and BuV is a member of the genus *Protoparvovirus*. The full epidemiology and clinical relevance of these viruses await further study.

## EPIDEMIOLOGY

## Parvovirus B19

Infections with B19V are common and occur worldwide. Clinically apparent infections, such as the rash illness of erythema infectiosum and transient aplastic crisis, are most prevalent in school-age children (70% of cases occur in patients between 5 and 15 years of age). Seasonal peaks occur in the late winter and spring, with sporadic infections throughout the year. Seroprevalence increases with age, with 40–60% of adults having evidence of prior infection.

Transmission of B19V is by the respiratory route, presumably via large-droplet spread from nasopharyngeal viral shedding. The transmission rate is 15–30% among susceptible household contacts, and mothers are more commonly infected than fathers. In outbreaks of erythema infectiosum in elementary schools, the secondary attack rates range from 10–60%. Nosocomial outbreaks also occur, with secondary attack rates of 30% among susceptible healthcare workers.

Although respiratory spread is the primary mode of transmission, B19V is also transmissible in blood and blood products, as documented among children with hemophilia receiving pooled-donor clotting factor. Given the resistance of the virus to solvents, fomite transmission could be important in childcare centers and other group settings, but this mode of transmission has not been definitively established.

## Human Bocaviruses

The majority of published studies have used molecular methods to detect HBoV DNA in respiratory secretions, fecal samples, blood, and other tissues. HBoV DNA (HBoV1) can be found commonly in respiratory secretions from children hospitalized with acute lower respiratory tract infections (LRTIs). It is more prevalent in children younger than 2 years of age and seems to be associated with wheezing respiratory illness. However, it can be isolated from respiratory secretions from asymptomatic children and can often be found as a co-infection with other common respiratory pathogens of children this age, including respiratory syncytial virus, human metapneumovirus, and rhinoviruses. This has caused some confusion as to the pathogenic role of HBoV in acute LRTI, including whether it can persist in secretions long after a subclinical infection or requires a helper virus. A limited number of seroepidemiologic studies have been performed, and these suggest that infection is common in children younger than 5 years of age. The most recent studies provide evidence that the virus is in fact pathogenic, especially in children younger than 2 years with wheezing and LRTI, because HBoV1 is more likely to be the only virus isolated in these patients and more likely to have an acute antibody response when coupled with specific antibody testing. When quantitative PCR is used, the virus is found to be much higher in titer in these symptomatic cases.

HBoV DNA (HBoV2, HBoV3, and HBoV4) has also been found in fecal samples in studies from various countries, but its role as a cause of viral gastroenteritis is still undetermined.

## PATHOGENESIS

## Parvovirus B19

The primary target of B19V infection is the erythroid cell line, specifically erythroid precursors near the pronormoblast stage. Viral infection produces cell lysis, leading to a progressive depletion of erythroid precursors and a transient arrest of erythropoiesis. The virus has no apparent effect on the myeloid cell line. The tropism for erythroid cells is related to the erythrocyte P blood group antigen, which is the primary cell receptor for the virus and is also found on endothelial cells, placental cells, and fetal myocardial cells. Thrombocytopenia and

neutropenia are often observed clinically, but the pathogenesis of these abnormalities is not completely understood.

Experimental infection of normal volunteers with B19V revealed a biphasic illness. From 7-11 days after inoculation, subjects had viremia and nasopharyngeal viral shedding with fever, malaise, and rhinorrhea. Reticulocyte counts dropped to undetectable levels but resulted in only a mild, clinically insignificant fall in serum hemoglobin. With the appearance of specific antibodies, symptoms resolved and serum hemoglobin returned to normal. Several subjects experienced a rash associated with arthralgia 17-18 days after inoculation. Some manifestations of B19 infection, such as transient aplastic crisis, appear to be a direct result of viral infection, whereas others, including the exanthem and arthritis, appear to be *postinfectious phenomena* related to the immune response. Skin biopsy of patients with erythema infectiosum reveals edema in the epidermis and a perivascular mononuclear infiltrate compatible with an immune-mediated process.

Individuals with **chronic hemolytic anemia** and increased red blood cell (RBC) turnover are very sensitive to minor perturbations in erythropoiesis. Infection with B19V leads to a transient arrest in RBC production and a precipitous fall in serum hemoglobin, often requiring transfusion. The reticulocyte count drops to undetectable levels, reflecting the lysis of infected erythroid precursors. Humoral immunity is crucial in controlling infection. Specific immunoglobulin (Ig) M appears within 1-2 days of infection and is followed by anti-B19 IgG, which leads to control of the infection, restoration of reticulocytosis, and a rise in serum hemoglobin.

Individuals with **impaired humoral immunity** are at increased risk for more serious or persistent infection with B19V, which usually manifests as chronic RBC aplasia, although neutropenia, thrombocytopenia, and marrow failure are also described. Children undergoing chemotherapy for leukemia or other forms of cancer, transplant recipients, and patients with congenital or acquired immunodeficiency states (including AIDS) are at risk for chronic B19V infections.

Infections in the **fetus** and **neonate** are somewhat analogous to infections in immunocompromised persons. B19V is associated with nonimmune fetal hydrops and stillbirth in women experiencing a primary infection but does not appear to be teratogenic. Like most mammalian parvoviruses, B19V can cross the placenta and cause fetal infection during primary maternal infection. Parvovirus cytopathic effects are seen primarily in erythroblasts of the bone marrow and sites of extramedullary hematopoiesis in the liver and spleen. Fetal infection can presumably occur as early as 6 weeks of gestation, when erythroblasts are first found in the fetal liver; after the fourth month of gestation, hematopoiesis switches to the bone marrow. In some cases, fetal infection leads to profound fetal anemia and subsequent high-output cardiac failure (see [Chapter 138](#)). **Fetal hydrops** ensues and is often associated with fetal death. There may also be a direct effect of the virus on myocardial tissue that contributes to the cardiac failure. However, most infections during pregnancy result in normal deliveries at term. Some of the asymptomatic infants from these deliveries have been reported to have chronic postnatal infection with B19V that is of unknown significance.

### Human Bocaviruses

Mechanisms of HBoV replication and pathogenesis are poorly characterized to date. Growth of HBoV1 in tissue culture is difficult, though the virus has been cultured in primary respiratory epithelial cells as noted above. The primary site of viral replication appears to be the respiratory tract, because the virus has been detected most frequently and in highest copy numbers here. HBoV1 has also been found occasionally in the serum, suggesting the potential for systemic spread. HBoV1 has also been detected in stool, but copy numbers are very low. In contrast, HBoV types 2-4 are found predominantly in the stool, but host cell types are not known.

## CLINICAL MANIFESTATIONS

### Parvovirus B19

Many infections are clinically inapparent ([Table 298.1](#)). Infected children characteristically demonstrate the rash illness of erythema

**TABLE 298.1** Clinical Associations with Parvovirus B19 Infection

Asymptomatic infection
Exanthematous disorders
Erythema infectiosum (fifth disease)
Papular-purpuric gloves-and-socks syndrome
Asymmetric periflexural exanthem
"Bathing trunk" exanthem
Petechial exanthems
Other disorders
Arthritis
Transient aplastic crises
Chronic anemia
Refractory anemia after solid organ or stem cell transplantation
Hemophagocytic lymphohistiocytosis
Myelodysplastic syndrome
Fetal hydrops
Vasculitis
Neurologic disease, including arterial ischemic stroke, encephalopathy, encephalitis
Rheumatologic disease
Liver failure
Myocarditis

From Paller AS, Mancini AJ. *Hurwitz Clinical Pediatric Dermatology*, 6th ed. Philadelphia: Elsevier; 2022: Box 16.2, p. 452.



**Fig. 298.1** Erythema infectiosum. Erythema of the bilateral cheeks, which has been likened to a "slapped-cheek" appearance. (From Paller AS, Mancini AJ. *Hurwitz Clinical Pediatric Dermatology*, 3rd ed. Philadelphia: WB Saunders; 2006:431.)

infectiosum. Adults, especially women, frequently experience acute polyarthropathy with or without a rash.

### Erythema Infectiosum (Fifth Disease)

The most common manifestation of B19V is erythema infectiosum, also known as *fifth disease*, which is a benign, self-limited exanthematous illness of childhood.

The incubation period for erythema infectiosum is 4-28 days (average: 16-17 days). The prodromal phase is mild and consists of low-grade fever in 15-30% of cases, headache, and symptoms of mild upper respiratory tract infection. The hallmark of erythema infectiosum is the characteristic rash, which occurs in three stages that are not always distinguishable. The initial stage is an erythematous facial flushing, often described as a **slapped-cheek appearance** ([Fig. 298.1](#)). The rash spreads rapidly or concurrently to the trunk and proximal extremities as a diffuse macular erythema in the second stage. Central clearing of macular lesions occurs promptly, giving the rash a **lacy, reticulated appearance** ([Fig. 298.2](#)). The rash tends to be more prominent on extensor surfaces, sparing the palms and soles. Affected children are afebrile and do not appear ill. Some have petechiae. Older children and adults often complain of mild pruritus. The rash resolves spontaneously without desquamation but tends to wax and wane over 1-3 weeks. It can recur with exposure to sunlight, heat, exercise, and stress.





**Fig. 298.2** Erythema infectiosum. Reticulate erythema on the upper arm of a patient with erythema infectiosum. (From Paller AS, Mancini AJ. *Hurwitz Clinical Pediatric Dermatology*, 3rd ed. Philadelphia: WB Saunders; 2006:431.)

Lymphadenopathy and atypical papular, purpuric and vesicular rashes are also described.

### Arthropathy

Arthritis and arthralgia may occur in isolation or with other symptoms. Joint symptoms are much more common among adults and older adolescents with B19V infection. Females are affected more frequently than males. In one large outbreak of fifth disease, 60% of adults and 80% of adult women reported joint symptoms. Joint symptoms range from diffuse polyarthralgia with morning stiffness to frank arthritis. The joints most often affected are the hands, wrists, knees, and ankles, but practically any joint may be affected. The joint symptoms are self-limited and, in the majority of patients, resolve within 2-4 weeks. Some patients may have a prolonged course of many months, suggesting rheumatoid arthritis. Transient rheumatoid factor positivity is reported in some of these patients but with no joint destruction.

### Transient Aplastic Crisis

The transient arrest of erythropoiesis and absolute reticulocytopenia induced by B19V infection leads to a sudden fall in serum hemoglobin in individuals with chronic hemolytic conditions. This B19V-induced RBC aplasia or transient aplastic crisis occurs in patients with all types of chronic hemolysis and/or rapid RBC turnover, including sickle cell disease, thalassemia, hereditary spherocytosis, and pyruvate kinase deficiency, among others. In contrast to children with erythema infectiosum only, patients with aplastic crisis are ill at presentation with fever, malaise, and lethargy and have signs and symptoms of profound anemia, including pallor, tachycardia, and tachypnea. Rash is rarely present. The incubation period for transient aplastic crisis is shorter than that for erythema infectiosum because the crisis occurs coincident with the viremia. Children with sickle cell hemoglobinopathies may also have a concurrent vasoocclusive pain crisis, further confusing the clinical presentation.

### Immunocompromised Persons

Individuals with impaired humoral immunity are at risk for chronic B19V infection. Chronic anemia is the most common manifestation, sometimes accompanied by neutropenia, thrombocytopenia, or complete marrow suppression. Chronic infections occur in persons receiving cancer chemotherapy or immunosuppressive therapy for transplantation and persons with congenital immunodeficiencies, AIDS, and functional defects in IgG production who are thereby unable to generate neutralizing antibodies.

### Fetal Infection

Primary maternal infection is associated with nonimmune fetal hydrops and intrauterine fetal demise, with the risk for fetal loss when



**Fig. 298.3** Papular-purpuric gloves-and-socks syndrome. Petechial purpura of the palms in a patient with parvovirus B19 infection. (From Paller AS, Mancini AJ. *Hurwitz Clinical Pediatric Dermatology*, 6th ed. Philadelphia: Elsevier; 2022: Fig. 16.18, p. 453.)

infection occurs in pregnancy estimated at 2–5%. The mechanism of fetal disease appears to be a viral-induced RBC aplasia at a time when the fetal erythroid fraction is rapidly expanding, leading to profound anemia, high-output cardiac failure, and fetal hydrops. Viral DNA has been detected in infected abortuses. The second trimester seems to be the most sensitive period, but fetal losses are reported at every stage of gestation. If maternal B19V infection is suspected, fetal ultrasonography and measurement of the peak systolic flow velocity of the middle cerebral artery are sensitive, noninvasive procedures to diagnose fetal anemia and hydrops. Most infants infected in utero are born normal at term, including some who have had ultrasonographic evidence of hydrops. A small subset of infants infected in utero may acquire a chronic or persistent postnatal infection with B19V that is of unknown significance. Congenital anemia associated with intrauterine B19V infection has been reported in a few cases, sometimes following intrauterine hydrops. This process may mimic other forms of congenital hypoplastic anemia (e.g., Diamond-Blackfan syndrome). Fetal infection with B19V has been associated with bone lesions but has not been associated with other birth defects. B19V is only one of many causes of hydrops fetalis (see [Chapter 140](#)).

### Myocarditis

B19V infection has been associated with myocarditis in fetuses, infants, children, and a limited number of adults. Diagnosis has often been based on serologic findings suggestive of a concurrent B19V infection, but in many cases B19V DNA has been demonstrated in cardiac tissue. B19-related myocarditis is plausible because fetal myocardial cells are known to express P antigen, the cell receptor for the virus. In the few cases in which histology is reported, a predominantly lymphocytic infiltrate is described. Outcomes have varied from complete recovery to chronic cardiomyopathy to fatal cardiac arrest. Although B19-associated myocarditis seems to be a rare occurrence, there appears to be enough evidence to consider B19V as a potential cause of lymphocytic myocarditis, especially in infants and immunocompromised persons.

### Other Cutaneous Manifestations

A variety of atypical skin eruptions have been reported with B19V infection. Most of these are petechial or purpuric, often with evidence of vasculitis on biopsy. Among these rashes, the **papular-purpuric gloves-and-socks syndrome (PPGSS)** is well established in the dermatologic literature as distinctly associated with B19V infection ([Figs. 298.3 and 298.4](#)). PPGSS is characterized by fever, pruritus, and painful edema and erythema localized to the distal extremities in a distinct gloves-and-socks distribution, followed by acral petechiae and oral lesions. The syndrome is self-limited and resolves within a few weeks. Although PPGSS was initially described in young adults, a number of reports of the disease in



children have since been published. In those cases linked to B19V infection, the eruption is accompanied by serologic evidence of acute infection. Generalized petechial rash has also been reported.

### Human Bocaviruses

Many studies have reported an association between respiratory tract infection and HBoV1 infection as detected by PCR of respiratory secretions, primarily nasopharyngeal secretions. Clinical manifestations in these studies have ranged from mild upper respiratory symptoms to pneumonia. However, the role of HBoV1 as a pathogen has been challenged by the detection of the virus in asymptomatic children and by the frequent detection of other respiratory viruses in the same samples. Nonetheless, studies that have included some combination of quantitative PCR, serum PCR, and serology have been more convincing about HBoV1 as a human pathogen. The use of a quantitative PCR method also seems to differentiate between HBoV1 infection (and wheezing) and prolonged viral shedding, because patients with higher viral titers were more likely to be symptomatic, to be viremic, and to have HBoV1 isolated without other viruses.

HBoV type 2 DNA has been found in the stool of 3–25% of children with gastroenteritis, but often with another enteric virus. DNA



**Fig. 298.4** Papular-purpuric gloves-and-socks syndrome. Erythema and petechiae of the plantar feet were accompanied by pruritus and sore throat in this young girl with parvovirus B19 infection. (From Paller AS, Mancini AJ. *Hurwitz Clinical Pediatric Dermatology*, 6th ed. Philadelphia: Elsevier; 2022: Fig. 16.19, p. 454.)

of HBoV types 2, 3, and 4 has also been found in the stool of healthy, asymptomatic individuals. At present, there are few data linking HBoV2, HBoV3, or HBoV4 to gastroenteritis or any clinical illness. Further studies are required to determine if any of the HBoVs are associated with some cases of childhood gastroenteritis.

### DIAGNOSIS

#### Parvovirus B19 Infection

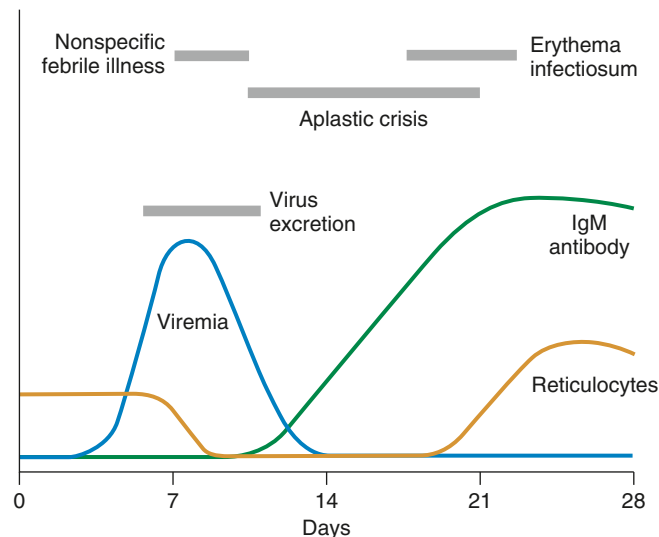
The diagnosis of erythema infectiosum is usually based on clinical presentation of the typical rash and rarely requires virologic confirmation. Similarly, the diagnosis of a typical transient aplastic crisis in a child with sickle cell disease is generally made on clinical grounds without specific virologic testing.

Serologic tests for the diagnosis of B19V infection are available. B19-specific IgM develops within 2–3 days after infection and persists up to 6 months (Fig. 298.5). Anti-B19 IgG serves as a marker of current or past infection. Seroconversion of anti-B19 IgG antibodies in paired sera can also be used to confirm recent infection.

Serologic diagnosis is unreliable in immunocompromised persons; diagnosis in these patients requires methods to detect viral DNA. Because the virus cannot be isolated by standard cell culture, methods to detect viral particles or viral DNA, such as PCR are necessary to establish the diagnosis. Viral DNA may be detectable for ~1 month after infection in immunocompetent patients but longer in immune compromised patients. Some reports suggest that prolonged detection of viral DNA (months) may represent DNA but not the complete virus. Prenatal diagnosis of B19V-induced fetal hydrops can be accomplished by detection of viral DNA in fetal blood or amniotic fluid by these methods.

#### Human Bocavirus Infections

HBoV1 infections cannot be differentiated from other viral respiratory infections on clinical grounds. HBoV DNA can be readily detected by PCR methods and is now included in several commercially available multiplex respiratory virus PCR assays. Quantitative PCR is useful to differentiate acute infection from persistent viral shedding, because higher viral copy numbers ( $>10^4$  HBoV1 genomes/mL) correlate with acute illness, but this test is not widely available. Likewise, serologic methods to detect specific IgM and IgG antibodies have been developed, but these too are not routinely available and there are problems with cross-reactivity among antibodies to the various HBoV types. The most reliable method to diagnose HBoV1 infection would include detection of viral DNA in serum by PCR and in respiratory tract samples by quantitative PCR, with concurrent detection of IgM or a diagnostic IgG response in paired samples.



**Fig. 298.5** Selected virologic, immunologic, hematologic, and clinical events in parvovirus B19 virus infection. (From Schulte DJ. *Human parvovirus B19*. In Kaplan SL, Harrison GJ, Steinbach WJ, Cherry JD, Hotez PJ, eds. *Feigin and Cherry's Textbook of Pediatric Infectious Diseases*, 8th ed. Philadelphia: Elsevier, 2019. Fig 152.1.)

## DIFFERENTIAL DIAGNOSIS

### Parvovirus B19

The rash of erythema infectiosum must be differentiated from roseola, rubella, measles, enteroviral infections, and drug reactions. Rash and arthritis in older children should prompt consideration of juvenile idiopathic arthritis, systemic lupus erythematosus, serum sickness, and other connective tissue disorders.

### Human Bocavirus

Respiratory illness and wheezing caused by HBoV1 cannot be differentiated clinically from other common viral respiratory infections, especially respiratory syncytial virus, human metapneumovirus, rhinoviruses, enterovirus D68, and parainfluenza viruses. HBoV1 infection in young children seems to most closely resemble that of respiratory syncytial virus and human metapneumovirus, because the clinical symptoms and age ranges will overlap.

## TREATMENT

### Parvovirus B19

There is no specific antiviral therapy approved for B19V infection. The acyclic nucleoside phosphonates cidofovir and brincidofovir have been shown to inhibit B19V replication *in vitro*, but no clinical studies have been performed and thus antiviral therapy cannot be recommended. Commercial lots of intravenous immunoglobulin (IVIG) have been used with some success to treat B19V-related episodes of anemia and bone marrow failure in immunocompromised children. Specific antibody may facilitate clearance of the virus but is not always necessary, because cessation of cytotoxic chemotherapy with subsequent restoration of immune function often suffices. In patients whose immune function is not likely to recover, such as patients with AIDS, administration of IVIG may give only a temporary remission, and periodic reinfusions may be required. In patients with AIDS, clearance of B19V infection has been reported after initiation of highly active antiretroviral therapy (HAART) without the use of IVIG.

No controlled studies have been published regarding dosing of IVIG for B19V-induced RBC aplasia. Multiple case reports and limited clinical series have reported successful treatment of severe anemia secondary to chronic B19V infection using several different IVIG dosing regimens. Initial reports recommended a starting dose of 400 mg/kg/day for up to 5 days. Other reports have used higher doses ranging from 1-2 g/kg split into one to three infusions. The dose and duration of IVIG may be adjusted based on the response to therapy. The optimal schedule of IVIG treatment is not known.

B19V-infected fetuses with anemia and hydrops have been managed successfully with intrauterine RBC transfusions, but this procedure has significant attendant risks. Once fetal hydrops is diagnosed, regardless of the suspected cause, the mother should be referred to a fetal therapy center for further evaluation because of the high risk for serious complications (see [Chapter 140](#)).

### Human Bocavirus

There is no specific antiviral therapy available. Appropriate supportive treatment for viral LRTI and pneumonia is recommended, as directed by clinical severity. For children with wheezing illness specifically caused by HBoV1 infection, there are no data examining their response to bronchodilator therapy.

## COMPLICATIONS

### Parvovirus B19

Erythema infectiosum is often accompanied by arthralgias or arthritis in adolescents and adults that may persist after resolution of the rash (see [Table 298.1](#)). B19V may rarely cause thrombocytopenic purpura. Neurologic conditions, including aseptic meningitis, encephalitis, and peripheral neuropathy, have been reported in both immunocompromised and healthy individuals in association with B19V infection. The incidence of stroke may be increased in children with sickle cell disease

following B19V-induced transient aplastic crisis. B19V is also a cause of infection-associated hemophagocytic lymphohistiocytosis, usually in immunocompromised persons.

### Human Bocavirus

There are no studies reporting on complications of HBoV1 infection. Complications of wheezing and viral pneumonia would be possible, including hypoxemia and secondary bacterial infection, among others.

## PREVENTION

### Parvovirus B19

Children with erythema infectiosum are not likely to be infectious at presentation because the rash and arthropathy represent immune-mediated, postinfectious phenomena. Isolation and exclusion from school or childcare are unnecessary and ineffective after diagnosis.

Children with B19V-induced RBC aplasia, including the transient aplastic crisis, are infectious upon presentation and demonstrate a more intense viremia. Most of these children require transfusions and supportive care until their hematologic status stabilizes. They should be isolated in the hospital to prevent spread to susceptible patients and staff. Isolation should continue for at least 1 week and until fever has resolved. Pregnant caregivers should not be assigned to these patients. Exclusion of pregnant women from workplaces where children with erythema infectiosum may be present (e.g., primary and secondary schools) is not recommended as a general policy because it is unlikely to reduce their risk. There are no data to support the use of IVIG for postexposure prophylaxis in pregnant caregivers or immunocompromised children. No vaccine is currently available, though this is a topic of ongoing research.

### Human Bocavirus

There are no studies that have addressed the prevention of transmission of this infection. In the hospital setting, standard precautions should be observed to limit spread of the virus. Because HBoV1 causes respiratory infection and can be detected in respiratory secretions sometimes in very high titer, measures to limit contact with respiratory secretions should be considered, including contact and droplet isolation for severely symptomatic young children. No vaccine is available, and no other preventive measures have been reported.

Visit Elsevier eBooks+ at [eBooks.Elsevier.com](http://eBooks.Elsevier.com) for Bibliography.

## Chapter 299

# Herpes Simplex Virus

Lawrence R. Stanberry and Philip Zachariah

The two closely related herpes simplex viruses (HSVs), HSV type 1 (HSV-1) and HSV type 2 (HSV-2), cause a variety of illnesses, depending on the anatomic site where the infection is initiated, the immune state of the host, and whether the symptoms reflect primary or recurrent infection. Common infections involve the skin, eye, oral cavity, and genital tract. Infections tend to be mild and self-limiting, except in the immunocompromised patient and newborn infants, in whom they may be severe and life-threatening.

**Primary infection** occurs in individuals who have not been infected previously with either HSV-1 or HSV-2. Because these individuals are HSV seronegative and have no preexisting immunity to HSV, primary infections can be severe. **Nonprimary first infection** occurs in individuals previously infected with one type of HSV (e.g., HSV-1) who

have become infected for the first time with the other type of HSV (HSV-2). Because immunity to one HSV type provides some cross-protection against disease caused by the other HSV type, nonprimary first infections tend to be less severe than true primary infections. During primary and nonprimary initial infections, HSV establishes latent infection in regional sensory ganglion neurons. Virus is maintained in this latent state for the life of the host but periodically can reactivate and cause **recurrent infection**. Symptomatic recurrent infections tend to be less severe and of shorter duration than first infections. Asymptomatic recurrent infections are extremely common and cause no physical distress, although patients with these infections are contagious and can transmit the virus to susceptible individuals. Reinfection with a new strain of either HSV-1 or HSV-2 at a previously infected anatomic site (e.g., the genital tract) can occur but is relatively uncommon, suggesting that host immunity, perhaps site-specific local immunity, resulting from the initial infection affords protection against exogenous reinfection.

## ETIOLOGY

HSVs contain a double-stranded DNA genome of approximately 152 kb that encodes at least 84 proteins. The DNA is contained within an icosahedral capsid, which is surrounded by an outer envelope composed of a lipid bilayer containing at least 12 viral glycoproteins. These glycoproteins are the major targets for humoral immunity, whereas other nonstructural proteins are important targets for cellular immunity. Two encoded proteins, viral DNA polymerase and thymidine kinase, are targets for antiviral drugs. HSV-1 and HSV-2 have a similar genetic composition with extensive DNA and protein homology. One important difference in the two viruses is their glycoprotein G proteins, which have been exploited to develop a new generation of commercially available, accurate, type-specific serologic tests that can be used to discriminate whether a patient has been infected with HSV-1 or HSV-2 or both.

## EPIDEMIOLOGY

HSV infections are ubiquitous, and there are no seasonal variations in risk for infection. The only natural host is humans, and the mode of transmission is direct contact between mucocutaneous surfaces. There are no documented incidental transmissions from inanimate objects such as toilet seats.

All infected individuals harbor latent infection and experience recurrent infections, which may be symptomatic or may go unrecognized and thus are periodically contagious. This information helps explain the widespread prevalence of HSV.

HSV-1 and HSV-2 are equally capable of causing initial infection at any anatomic site but differ in their capacity to cause recurrent infections. HSV-1 has a greater propensity to cause recurrent oral infections, whereas HSV-2 has a greater proclivity to cause recurrent genital infections. For this reason, HSV-1 infection typically results from contact with contaminated oral secretions, whereas HSV-2 infection most commonly results from anogenital contact.

HSV seroprevalence rates are highest in developing countries and among lower socioeconomic groups, although high rates of HSV-1 and HSV-2 infections are found in developed nations and among persons of the highest socioeconomic strata. Incident HSV-1 infections are more common during childhood and adolescence but are also found throughout later life. Data on HSV-1 and HSV-2 antibody prevalence from the National Health and Nutrition Examination Survey (NHANES) among persons age 14–49 years showed the prevalence of HSV-1 and HSV-2 to be 47.8% and 11.9%, respectively. Prevalence of both HSV-1 and HSV-2 increased linearly with age and was higher among females than males.

Modifiable factors that predict HSV-2 seropositivity include less education, poverty, cocaine use, and a greater lifetime number of sexual partners. Studies show that only approximately 10–20% of HSV-2-seropositive subjects report a history of genital herpes, emphasizing the asymptomatic nature of most HSV infections.

A 3-year longitudinal study of Midwestern adolescent females 12–15 years of age found that 44% were seropositive for HSV-1 and 7% for HSV-2 at enrollment. At the end of the study, 49% were seropositive for HSV-1 and 14% for HSV-2. The attack rates, based on the number of cases per 100 person-years, were 3.2 for HSV-1 infection among all females and 4.4 for HSV-2 infection among females who reported being sexually experienced. Findings of this study indicate that sexually active young women have a high attack rate for genital herpes and suggest that genital herpes should be considered in the differential diagnosis of any young woman who reports recurrent genitourinary complaints. In this study, participants with preexisting HSV-1 antibodies had a significantly lower attack rate for HSV-2 infection, and those who became infected were less likely to have symptomatic disease than females who were HSV seronegative when they entered the study. Prior HSV-1 infection appears to afford adolescent females some protection against becoming infected with HSV-2; in adolescent females infected with HSV-2, the preexisting HSV-1 immunity appears to protect against development of symptomatic genital herpes.

**Neonatal herpes** is an uncommon but potentially fatal infection of the fetus or more likely the newborn. It is not a reportable disease in most states, and therefore there are no solid epidemiologic data regarding its frequency in the general population. The overall U.S. incidence of neonatal HSV was estimated to be 9.6 per 100,000 births in 2006, which is higher than reported for the reportable perinatally acquired sexually transmitted infections such as congenital syphilis and gonococcal ophthalmia neonatorum. More than 90% of the cases are the result of maternal-child transmission. The risk for transmission is greatest during a primary or nonprimary first infection (30–50%) and much lower when the exposure is during a recurrent infection (<2%). HSV viral suppression therapy in mothers does not consistently eliminate the possibility of neonatal infection. Infants born to mothers dually infected with HIV and HSV-2 are also at higher risk for acquiring HIV than infants born to HIV-positive mothers who are not HSV-2 infected. It is estimated that approximately 25% of pregnant women are HSV-2 infected and that approximately 2% of pregnant women acquire HSV-2 infection during pregnancy.

HSV is a leading cause of sporadic, fatal encephalitis in children and adults. In the United States the annual hospitalization rate for HSV encephalitis has been calculated to be  $10.3 \pm 2.2$  cases/million in neonates,  $2.4 \pm 0.3$  cases/million in children, and  $6.4 \pm 0.4$  cases/million in adults.

## PATHOGENESIS

In the immunocompetent host the pathogenesis of HSV infection involves viral replication in skin and mucous membranes followed by replication and spread in neural tissue. Viral infection typically begins at a cutaneous portal of entry such as the oral cavity, genital mucosa, ocular conjunctiva, or breaks in keratinized epithelia. The virus enters the cell through attachment and fusion, a multistep process mediated by interaction of viral envelope glycoproteins (e.g., gB and gH-gL) with host surface receptors (e.g., Nectin-1). Virus replicates locally, resulting in the death of the cell, and sometimes produces clinically apparent inflammatory responses that facilitate the development of characteristic herpetic vesicles and ulcers. Virus also enters nerve endings and spreads beyond the portal of entry to sensory ganglia by intraneuronal transport. Virus replicates in some sensory neurons, and the progeny virions are sent via intraneuronal transport mechanisms back to the periphery, where they are released from nerve endings and replicate further in skin or mucosal surfaces. It is virus moving through this neural arc that is primarily responsible for the development of characteristic herpetic lesions, although most HSV infections do not reach a threshold necessary to cause clinically recognizable disease. Although many sensory neurons become productively infected during the initial infection, some infected neurons do not initially support viral replication. It is in these neurons that the virus establishes a latent infection, a condition in which the viral genome persists within the neuronal nucleus in a largely metabolically inactive state. Intermittently throughout the



life of the host, undefined changes can occur in latently infected neurons that trigger the virus to begin to replicate. This replication occurs despite the host's having established a variety of humoral and cellular immune responses that successfully controlled the initial infection. With reactivation of the latent neuron, progeny virions are produced and transported within nerve fibers back to cutaneous sites somewhere in the vicinity of the initial infection, where further replication occurs and causes recurrent infections. Recurrent infections may be symptomatic (with typical or atypical herpetic lesions) or asymptomatic. In either case, virus is shed at the site where cutaneous replication occurs and can be transmitted to susceptible individuals who come in contact with the site or with contaminated secretions. Latency and reactivation are the mechanisms by which the virus is successfully maintained in the human population.

Viremia, or hematogenous spread of the virus, does not appear to play an important role in HSV infections in the immunocompetent host but can occur in neonates, individuals with eczema, and severely malnourished children. It is also seen in patients with depressed or defective cell-mediated immunity, as occurs with HIV infection, malignancy, or immunosuppressive therapies. Viremia can result in dissemination of the virus to visceral organs, including the liver and adrenals. Hematogenous dissemination of virus to the central nervous system appears to only occur in neonates.

The pathogenesis of HSV infection in newborns is complicated by their relative immunologic immaturity. The source of virus in neonatal infections is typically but not exclusively the mother. Transmission generally occurs during delivery, although it is well documented to rarely occur with cesarean delivery with intact fetal membranes. The most common portals of entry are the conjunctiva, mucosal epithelium of the nose and mouth, and breaks or abrasions in the skin that occur with scalp electrode use or forceps delivery. With prompt antiviral therapy, virus replication may be restricted to the site of inoculation (the skin, eye, or mouth). However, virus may also extend from the nose to the respiratory tract to cause pneumonia, move via intraneuronal transport to the central nervous system to cause encephalitis, or spread by hematogenous dissemination to visceral organs and the brain. Factors that may influence neonatal HSV infection include the virus type, portal of entry, inoculum of virus to which the infant is exposed, gestational age of the infant, and presence of maternally derived antibodies specific to the virus causing infection. Latent infection is established during neonatal infection, and survivors may experience recurrent cutaneous and neural infections. Persistent central nervous system infection may affect the neurodevelopment of the infant.

## CLINICAL MANIFESTATIONS

The hallmarks of common HSV infections are skin vesicles and shallow ulcers. Classic infections manifest as small, 2- to 4-mm vesicles that may be surrounded by an erythematous base. These may persist for a few days before evolving into shallow, minimally erythematous ulcers. The vesicular phase tends to persist longer when keratinized epithelia is involved and is generally brief and sometimes just fleeting when moist mucous membranes are the site of infection. Because HSV infections are common, and their natural history is influenced by many factors, including portal of entry, immune status of the host, and whether it is an initial or recurrent infection, the typical manifestations are seldom classic. Most infections are asymptomatic or unrecognized, and nonclassic presentations, such as small skin fissures and small erythematous nonvesicular lesions, are common.

### Acute Oropharyngeal Infections

**Herpes gingivostomatitis** most often affects children 6 months to 5 years of age but is seen across the age spectrum. It is an extremely painful condition with sudden onset, pain in the mouth, drooling, refusal to eat or drink, and fever of up to 40.0–40.6°C (104–105.1°F). The gums become markedly swollen, and vesicles may develop throughout the oral cavity, including the gums, lips, tongue, palate, tonsils, pharynx,



**Fig. 299.1** Clustered perioral vesicles and erosions in an infant with primary herpetic gingivostomatitis. (From Schachner LA, Hansen RC, eds. *Pediatric Dermatology*, 3rd ed. Philadelphia: Mosby; 1988:1078.)

and perioral skin (Fig. 299.1). The vesicles may be more extensively distributed than typically seen with enteroviral herpangina. During the initial phase of the illness there may be tonsillar exudates suggestive of bacterial pharyngitis. The vesicles are generally present only a few days before progressing to form shallow indurated ulcers that may be covered with a yellow-gray membrane. Tender submandibular, submaxillary, and cervical lymphadenopathy is common. The breath may be foul as a result of overgrowth of anaerobic oral bacteria. Untreated, the illness resolves in 7–14 days, although the lymphadenopathy may persist for several weeks.

In older children, adolescents, and college students, the initial HSV oral infection may manifest as pharyngitis and tonsillitis rather than gingivostomatitis. The vesicular phase is often over by the time the patient presents to a healthcare provider, and signs and symptoms may be indistinguishable from those of streptococcal pharyngitis, consisting of fever, malaise, headache, sore throat, and white plaques on the tonsils. The course of illness is typically longer than for untreated streptococcal pharyngitis.

### Herpes Labialis

**Fever blisters (cold sores)** are the most common manifestation of recurrent HSV-1 infections. The most common site of herpes labialis is the vermilion border of the lip, although lesions sometimes occur on the nose, chin, cheek, or oral mucosa. Older patients report experiencing burning, tingling, itching, or pain 3–6 hours (rarely as long as 24–48 hours) before the development of the herpes lesion. The lesion generally begins as a small grouping of erythematous papules that progress over a few hours to create a small, thin-walled vesicle. The vesicles may form shallow ulcers or become pustular. The short-lived ulcer dries and develops a crusted scab. Complete healing without scarring occurs with reepithelialization of the ulcerated skin, usually within 6–10 days. Some patients experience local lymphadenopathy but no constitutional symptoms.

### Cutaneous Infections

In the healthy child or adolescent, cutaneous HSV infections are generally the result of skin trauma with macroabrasions or microabrasions and exposure to infectious secretions. This situation most often occurs in play or contact sports such as wrestling (**herpes gladiatorum**) and rugby (**scrum pox**). An initial cutaneous infection establishes a latent infection that can subsequently result in recurrent infections at or near the site of the initial infection. Pain, burning, itching, or tingling often precedes the herpetic eruption by a few hours to a few days. Like herpes labialis, lesions begin as grouped, erythematous papules that progress to vesicles, pustules, ulcers, and crusts and then heal without scarring in 6–10 days. Although herpes labialis typically results in a single lesion, a cutaneous HSV infection results in multiple discrete lesions





**Fig. 299.2** Herpes simplex infection of finger (whitlow). (From Schachner LA, Hansen RC, eds. *Pediatric Dermatology*, 3rd ed. Philadelphia: Mosby; 1988:1079.)

and involves a larger surface area. Regional lymphadenopathy may occur, but systemic symptoms are uncommon. Recurrences are sometimes associated with local edema and lymphangitis or local neuralgia.

**Herpes whitlow** is a term generally applied to HSV infection of fingers or toes, although strictly speaking it refers to HSV infection of the paronychia. Among children, this condition is most commonly seen in infants and toddlers who suck the thumb or fingers and who are experiencing either a symptomatic or a subclinical oral HSV-1 infection (Fig. 299.2). An HSV-2 herpes whitlow occasionally develops in an adolescent as a result of exposure to infectious genital secretions. The onset of the infection is heralded by itching, pain, and erythema 2-7 days after exposure. The cuticle becomes erythematous and tender and may appear to contain pus, although if it is incised, little fluid is present. Incising the lesion is discouraged, because this maneuver typically prolongs recovery and increases the risk for secondary bacterial infection. Lesions and associated pain typically persist for about 10 days, followed by rapid improvement and complete recovery in 18-20 days. Regional lymphadenopathy is common, and lymphangitis and neuralgia may occur. Unlike other recurrent herpes infections, recurrent herpetic whitlows are often as painful as the primary infection but are generally shorter in duration.

Cutaneous HSV infections can be severe or life-threatening in patients with disorders of the skin such as eczema (eczema herpeticum), pemphigus, burns, and Darier disease and following laser skin resurfacing. The lesions are frequently ulcerative and nonspecific in appearance, although typical vesicles may be seen in adjacent normal skin (Fig. 299.3). If untreated, these lesions can progress to disseminated infection and death. Recurrent infections are common but generally less severe than the initial infection.

### Genital Herpes

Genital HSV infection is common in sexually experienced adolescents and young adults, but up to 90% of infected individuals are *unaware* they are infected. Infection may result from genital-genital transmission (usually HSV-2) or oral-genital transmission (usually HSV-1). Symptomatic and asymptomatic individuals periodically shed virus from anogenital sites and hence can transmit the infection to sexual partners or, in the case of pregnant women, to their newborns. Classic primary genital herpes may be preceded by a short period of local burning and tenderness before vesicles develop on genital mucosal surfaces or keratinized skin and sometimes around the anus or on the buttocks and thighs. Vesicles on mucosal surfaces are short lived and rupture to produce shallow, tender ulcers covered with a yellowish gray exudate and surrounded by an erythematous border. Vesicles on keratinized epithelium persist for a few days before progressing to the pustular stage and then crusting.

Patients may experience urethritis and dysuria severe enough to cause urinary retention and bilateral, tender inguinal and pelvic lymphadenopathy. Women may experience a watery vaginal discharge,



**Fig. 299.3** Widespread cutaneous herpes infection in a child with underlying eczema (eczema herpeticum).

and men may have a clear mucoid urethral discharge. Significant local pain and systemic symptoms such as fever, headache, and myalgia are common. Aseptic meningitis develops in an estimated 15% of cases. The course of classic primary genital herpes from onset to complete healing is 2-3 weeks.

Most patients with symptomatic primary genital herpes experience at least one recurrent infection in the following year. Recurrent genital herpes is usually less severe and of shorter duration than the primary infection. Some patients experience a sensory prodrome with pain, burning, and tingling at the site where vesicles subsequently develop. Asymptomatic recurrent anogenital HSV infections are common, and all HSV-2-seropositive individuals appear to periodically shed virus from anogenital sites. *Most sexual transmissions and maternal-neonatal transmissions of virus result from asymptomatic shedding episodes.*

Genital infections caused by HSV-1 and HSV-2 are indistinguishable, but HSV-1 causes significantly fewer subsequent episodes of recurrent infection; hence, knowing which virus is causing the infection has important prognostic value. Genital HSV infection increases the risk for acquiring HIV infection.

Rarely, genital HSV infections are identified in young children and preadolescents. Although genital disease in children should raise concerns about possible sexual abuse, there are documented cases of autoinoculation, in which a child has inadvertently transmitted virus from contaminated oral secretions to his or her own genitalia.

### Ocular Infections

HSV ocular infections may involve the conjunctiva, cornea, or retina and may be primary or recurrent. Conjunctivitis or keratoconjunctivitis is usually unilateral and is often associated with blepharitis and tender preauricular lymphadenopathy. The conjunctiva appears edematous but there is rarely purulent discharge. Vesicular lesions may be seen on the lid margins and periorbital skin. Patients typically

have fever. Untreated infection generally resolves in 2-3 weeks. Obvious corneal involvement is rare, but when it occurs it can produce ulcers that are described as appearing dendritic or geographic. Extension to the stroma is uncommon although more likely to occur in patients inadvertently treated with corticosteroids. When it occurs, it may be associated with corneal edema, scarring, and corneal perforation. Recurrent infections tend to involve the underlying stroma and can cause progressive corneal scarring and injury that can lead to blindness.

Retinal infections are rare and are more likely among infants with neonatal herpes and immunocompromised persons with disseminated HSV infections.

### Central Nervous System Infections

HSV encephalitis is the leading cause of sporadic, nonepidemic encephalitis in children and adults in the United States. It is an acute necrotizing infection generally involving the frontal and/or temporal cortex and the limbic system and, beyond the neonatal period, is almost always caused by HSV-1. The infection may manifest as nonspecific findings, including fever, headache, nuchal rigidity, nausea, vomiting, generalized seizures, and alteration of consciousness. Injury to the frontal or temporal cortex or limbic system may produce findings more indicative of HSV encephalitis, including anosmia, memory loss, peculiar behavior, expressive aphasia and other changes in speech, hallucinations, and focal seizures. The untreated infection progresses to coma and death in 75% of cases. Examination of the cerebrospinal fluid (CSF) typically shows a moderate number of mononuclear cells and polymorphonuclear leukocytes, a mildly elevated protein concentration, a normal or slightly decreased glucose concentration, and often a moderate number of erythrocytes. HSV has also been associated with autoimmune (NMDA receptor) encephalitis (see Chapter 638.4). Genetic factors that increase the susceptibility to HSV encephalitis include pathogenic variants in toll-like receptor-3 (*TLR3*)-dependent interferon immunity, *DBR1*, *RNA5SP141*, *TRAF3*, and other genes involved in *TLR3* sensing or downstream signaling.

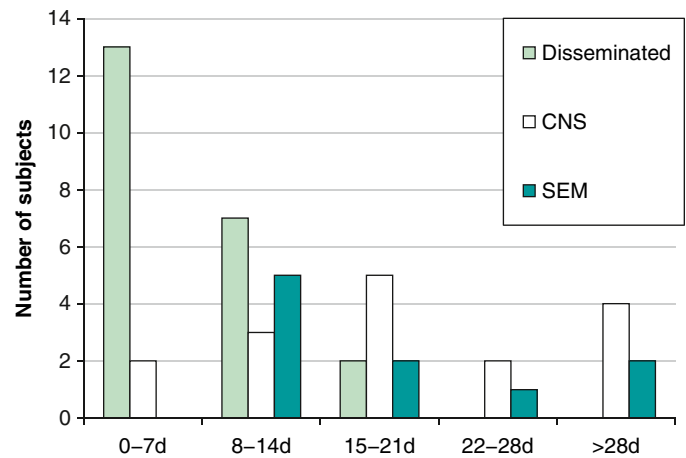
HSV is also a cause of aseptic meningitis and is the most common cause of recurrent aseptic meningitis (**Mollaret meningitis**).

### Infections in Immunocompromised Persons

Severe, life-threatening HSV infections can occur in patients with compromised immune functions, including neonates, the severely malnourished, those with primary or secondary immunodeficiency diseases (including AIDS), and those receiving some immunosuppressive regimens, particularly for cancer and organ transplantation. Mucocutaneous infections, including mucositis and esophagitis, are most common, although their presentations may be atypical and can result in lesions that slowly enlarge, ulcerate, become necrotic, and extend to deeper tissues. Other HSV infections include tracheobronchitis, pneumonitis, and anogenital infections. Disseminated infection can result in a sepsis-like presentation, with liver and adrenal involvement, disseminated intravascular coagulopathy, and shock.

### Perinatal Infections

HSV infection may be acquired in utero, during the birth process, or during the neonatal period. Intrauterine (prenatal) and postpartum (cutaneous lesions in caretakers) infections are well described but occur infrequently. Postpartum transmission may be from the mother or another adult with a nongenital (typically HSV-1) infection such as herpes labialis. Most cases of neonatal herpes result from maternal infection and transmission, usually during passage through an infected birth canal of a mother with asymptomatic genital herpes. Transmission is well documented in infants delivered by cesarean section. *Fewer than 30% of mothers of an infant with neonatal herpes have a history of genital herpes.* The risk for infection is higher in infants born to mothers with primary genital infection (>30%) than with recurrent genital infection (<2%). Use of scalp electrodes may also increase risk. There



**Fig. 299.4** Herpes simplex virus (HSV). Age at presentation by HSV disease type. SEM, skin, eye, mouth. (From Curfman AL, Glissmeyer EW, Ahmad FA, et al. Initial presentation of neonatal herpes simplex virus infection. *J Pediatr.* 2016;172:121-126, p. 124.)

also have been rare cases of neonatal herpes associated with Jewish ritual circumcisions, but only with ritual oral contact with the circumcision site.

Neonatal HSV infection is thought to never be asymptomatic. Its clinical presentation reflects timing of infection, portal of entry, and extent of spread. Infants with the rare onset of **intrauterine infection** typically have skin vesicles or scarring; eye findings, including chorioretinitis and keratoconjunctivitis; and microcephaly or hydranencephaly that are present at delivery.

Few infants survive without therapy, and those who do generally have severe sequelae. Infants infected during delivery or the postpartum period present with one of the following three patterns of disease: (1) disease localized to the skin, eyes, or mouth; (2) encephalitis with or without skin, eye, and mouth disease; and (3) disseminated infection involving multiple organs, including the brain, lungs, liver, heart, adrenals, and skin (Fig. 299.4). Most present in the first 28 days of life. Approximately 20% present between 5 and 9 weeks of age.

Infants with **skin, eye, and mouth disease** generally present at 5-11 days of life and typically demonstrate a few clustered small vesicles, particularly on the presenting part or at sites of trauma such as sites of scalp electrode placement. If untreated, skin, eye, and mouth disease in infants may progress to encephalitis or disseminated disease.

Infants with encephalitis typically present at 8-17 days of life with clinical findings suggestive of bacterial meningitis, including irritability, lethargy, poor feeding, poor tone, and seizures. Fever or hypothermia may occur but is not universal; skin vesicles occur in only approximately 60% of cases (Fig. 299.5). If untreated, 50% of infants with HSV encephalitis die and most survivors have severe neurologic sequelae.

Infants with disseminated HSV infections generally become ill at 5-11 days of life. Their clinical picture is similar to that of infants with bacterial sepsis, consisting of hyperthermia or hypothermia, irritability, poor feeding, and vomiting. They may also exhibit respiratory distress, cyanosis, apneic spells, jaundice, purpuric rash, and evidence of central nervous system infection; seizures are common. Skin vesicles are seen in approximately 75% of cases. If untreated, the infection causes shock and disseminated intravascular coagulation; approximately 90% of these infants die, and most survivors have severe neurologic sequelae.

Infants with neonatal herpes whose mothers received antih herpes antiviral drugs in the weeks before delivery may present later than their untreated counterparts; whether the natural history of the infection in these infants is different is an unanswered question.



**Fig. 299.5** Vesicular-pustular lesions on the face of a neonate with herpes simplex virus infection. (From Kohl S. Neonatal herpes simplex virus infection. *Clin Perinatol.* 1997;24:129–150.)

## DIAGNOSIS

The clinical diagnosis of HSV infections, particularly life-threatening infections and genital herpes, should be confirmed by laboratory test, preferably isolation of virus or detection of viral DNA by polymerase chain reaction (PCR). Histologic findings or imaging studies may support the diagnosis but should not substitute for virus-specific tests. HSV immunoglobulin M tests are notoriously unreliable, and the demonstration of a fourfold or greater rise in HSV-specific immunoglobulin G titers between acute and convalescent serum samples is useful only in retrospect.

The highest yield for virus cultures comes from rupturing a suspected herpetic vesicle and vigorously rubbing the base of the lesion to collect fluid and cells. Culturing dried, crusted lesions is generally of low yield. Although not as sensitive as viral culture, direct detection of HSV antigens in clinical specimens can be done rapidly and has very good specificity. The use of DNA amplification methods such as PCR for detection of HSV DNA is highly sensitive and specific and in some instances can be performed rapidly. It is the test of choice in examining CSF in cases of suspected HSV encephalitis.

**Evaluation of the neonate** with suspected HSV infection should include cultures and/or PCR of suspicious lesions as well as nasopharynx, mouth, conjunctivae, rectum, umbilicus, and scalp electrode site (if applicable), and PCR of *both* CSF and blood. In neonates testing for elevation of liver enzymes may provide indirect evidence of HSV dissemination to visceral organs. Efforts to develop clinical scoring systems for invasive HSV in infants have identified younger age, prematurity, seizure at home, ill appearance, abnormal triage temperature (fever or hypothermia), vesicular rash, thrombocytopenia, and CSF fluid pleocytosis as predictors.

Culture or antigen detection should be used in evaluating lesions associated with suspected acute genital herpes. HSV-2 type-specific antibody tests are useful for evaluating sexually experienced adolescents or young adults who have a history of unexplained recurrent nonspecific urogenital signs and symptoms, but these tests are less useful for general screening in populations in which HSV-2 infections are of low prevalence.

Because most HSV diagnostic tests take at least a few days to complete, treatment should not be withheld but rather initiated promptly so as to ensure the maximum therapeutic benefit.

## LABORATORY FINDINGS

Most self-limited HSV infections cause few changes in routine laboratory parameters. Mucocutaneous infections may cause a moderate polymorphonuclear leukocytosis. In HSV meningoencephalitis there can be an increase in mononuclear cells and protein in CSF, the glucose content may be normal or reduced, and red blood cells may be present. The electroencephalogram and MRI of the brain may show temporal lobe abnormalities in HSV encephalitis beyond the neonatal period. Encephalitis in the neonatal period tends to be more global and not limited to the temporal lobe (Fig. 299.6). Disseminated infection may cause elevated liver enzymes, thrombocytopenia, and abnormal coagulation.

## TREATMENT AND PREVENTION

See Chapter 292 for more information about principles of antiviral therapy.

Three antiviral drugs are available in the United States for the management of HSV infections, namely acyclovir, valacyclovir, and famciclovir. All three are available in oral form, but only acyclovir is available in a suspension form. Acyclovir has the poorest bioavailability and hence requires more frequent dosing. Valacyclovir, a prodrug of acyclovir, and famciclovir, a prodrug of penciclovir, both have very good oral bioavailability and are dosed once or twice daily. Acyclovir and penciclovir are also available in a topical form, but these preparations provide limited or no benefit to patients with recurrent mucocutaneous HSV infections. Only acyclovir has an intravenous formulation. Early initiation of therapy results in the maximal therapeutic benefit. All three drugs have exceptional safety profiles and are safe to use in pediatric patients. *Doses should be modified in patients with renal impairment.*

Resistance to acyclovir and penciclovir is rare in immunocompetent persons but does occur in immunocompromised persons and is usually mediated by mutations within the thymidine kinase and DNA polymerase genes. Virus isolates from immunocompromised persons whose HSV infection is not responding or is worsening with acyclovir therapy should be tested for drug sensitivities. Foscarnet and cidofovir have been used in the treatment of HSV infections caused by acyclovir-resistant mutants.

Topical trifluridine and topical ganciclovir are used in the treatment of herpes keratitis.

Patients with genital herpes also require counseling to address psychosocial issues, including possible stigma, and to help them understand the natural history and management of this chronic infection.

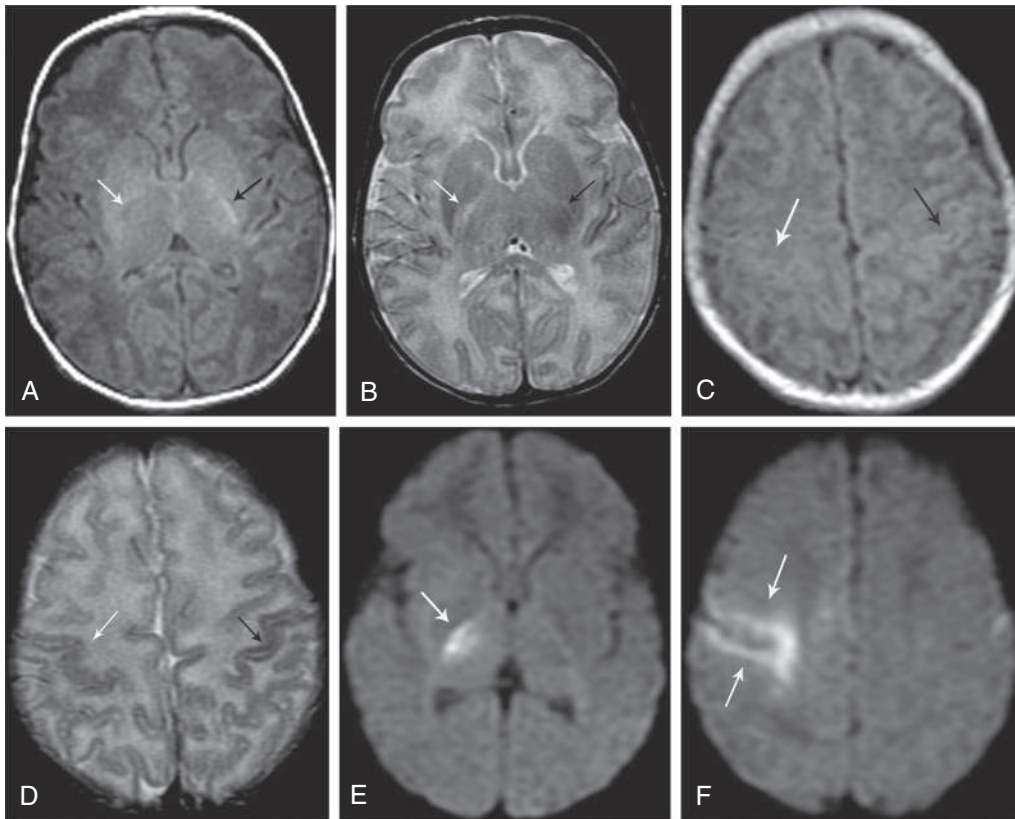
## Acute Mucocutaneous Infections

For gingivostomatitis, limited evidence suggests that oral acyclovir (15 mg/kg/dose 5 times a day PO for 7 days; maximum: 1 g/day) started within 72 hours of onset reduces the severity and duration of the illness. Pain associated with swallowing may limit oral intake of infants and children, putting them at risk for dehydration. Intake should be encouraged through the use of cold beverages, ice cream, and yogurt.

For **herpes labialis**, oral treatment is superior to topical antiviral therapy. For treatment of a recurrence in adolescents, oral valacyclovir (2,000 mg bid PO for 1 day), acyclovir (400 mg 5 times daily PO for 5 days), or famciclovir (1,500 mg once daily PO for 1 day) shortens the duration of the episode. Long-term daily use of oral acyclovir (400 mg bid PO) or valacyclovir (500 mg once daily PO) has been used to prevent recurrences in individuals with frequent or severe recurrences.

Anecdotal reports suggest that treatment of adolescents with **herpes gladiatorum** with valacyclovir (500 mg bid PO for 7–10 days) at the





**Fig. 299.6** Involvement of corticospinal tract and thalamus in a 2-wk old infant. **A**, Axial T1-weighted MRI demonstrating subtle loss of T1 hyperintensity corresponding to myelination in the posterior limb of the right internal capsule (white arrow). T1 hyperintensity in the left posterior limb of the internal capsule is maintained (black arrow). **B**, T2 weighted image showing findings similar to those seen on T1-weighted imaging. **C**, Axial T1- and (D) T2-weighted images through the vertex demonstrating subtle indistinct margins of the cortex around the right central sulcus (white arrow) compared to the normal appearance on the left side (black arrow). **E** and **F**, Diffusion-weighted images with more extensive diffusion restriction in the posterior limb of the right internal capsule and lateral thalamus (arrows), and in the right precentral and postcentral gyrus (arrows). (From Bajaj M, Mody S, Natarajan G. Clinical and neuroimaging findings in neonatal herpes simplex virus infection. *J Pediatr*. 2014;165:404-407. Fig. 1.)

first signs of the outbreak can shorten the course of the recurrence with accompanying guidance on the importance of good hydration. For patients with a history of recurrent herpes gladiatorum, chronic daily prophylaxis with valacyclovir (500-1,000 mg/day) has been reported to prevent recurrences.

There are no clinical trials assessing the benefit of antiviral treatment for **herpetic whitlow**. High-dose oral acyclovir (1,600-2,000 mg/day divided in two or three doses PO for 7-21 days) started at the first signs of illness has been reported to abort some recurrences and reduce the duration of others in adults.

Children with mild cases of **eczema herpeticum** can be treated with oral acyclovir (10-20 mg/kg three times daily) or valacyclovir (20 mg/kg per day in three divided doses) for 7-21 days. However, serious infections should be treated with intravenous acyclovir. Oral-facial HSV infections can reactivate after cosmetic facial laser resurfacing, causing extensive disease and scarring. Treatment of adults beginning the day before the procedure with either valacyclovir (500 mg twice daily PO for 10-14 days) or famciclovir (250-500 mg bid PO for 10 days) has been reported to be effective in preventing the infections. HSV infections in **burn patients** can be severe or life-threatening and have been treated with intravenous acyclovir (10-20 mg/kg/day divided every 8 hours).

Antiviral drugs are not effective in the treatment of HSV-associated **erythema multiforme**, but their daily use as for herpes labialis prophylaxis prevents *reoccurrences* of erythema multiforme.

### Genital Herpes

Pediatric patients, usually adolescents or young adults, with suspected first-episode genital herpes should be treated with antiviral therapy. Treatment of the initial infection reduces the severity and duration of the illness but has no effect on the frequency of subsequent recurrent infections. Treatment options for adolescents include acyclovir (400 mg

tid PO for 7-10 days), famciclovir (250 mg tid PO for 7-10 days), or valacyclovir (1,000 mg bid PO for 7-10 days). The twice-daily valacyclovir option avoids treatment during school hours. For smaller children, acyclovir suspension can be used at a dose of 10-20 mg/kg/dose 4 times daily, not to exceed the adult dose. The first episode of genital herpes can be extremely painful, and use of analgesics is generally indicated. Intravenous acyclovir is indicated for those with severe or complicated primary infections that may require hospitalization. All patients with genital herpes should be offered counseling to help them deal with psychosocial issues and understand the chronic nature of the illness.

There are three strategic options regarding the management of recurrent infections. The choice should be guided by several factors, including the frequency and severity of the recurrent infections, the psychologic impact of the illness on the patient, and concerns regarding transmission to a susceptible sexual partner. Option 1 is no therapy; option 2 is episodic therapy; and option 3 is long-term suppressive therapy. For **episodic therapy**, treatment should be initiated at the first signs of an outbreak. Recommended choices for episodic therapy in adolescents include famciclovir (1,000 mg bid PO for 1 day), acyclovir (800 mg tid PO for 2 days), or valacyclovir (500 mg bid PO for 3 days.) Long-term suppressive therapy offers the advantage that it prevents most outbreaks, improves patient quality of life in terms of the psychosocial impact of genital herpes, and, with daily valacyclovir therapy, also reduces (but does not eliminate) the risk for sexual transmission to a susceptible sexual partner. Options for **long-term suppressive therapy** are acyclovir (400 mg bid PO), famciclovir (250 mg bid PO), and valacyclovir (500 or 1,000 mg qd PO).

### Ocular Infections

HSV ocular infections can result in blindness. Management should involve consultation with an ophthalmologist.



### Central Nervous System Infections

Patients older than neonates who have herpes encephalitis should be promptly treated with intravenous acyclovir (10 mg/kg every 8 hours given as a 1-hour infusion for 21 days). Treatment for increased intracranial pressure, management of seizures, and respiratory compromise may be required.

### Infections in Immunocompromised Persons

Severe mucocutaneous and disseminated HSV infections in immunocompromised patients should be treated with intravenous acyclovir (30 mg/kg per day, in three divided doses for 7-14 days) until there is evidence of resolution of the infection. Oral antiviral therapy with acyclovir, famciclovir, or valacyclovir has been used for treatment of less-severe HSV infections and for suppression of recurrences during periods of significant immunosuppression. Drug resistance does occur occasionally in immunocompromised patients, and in individuals whose HSV infection does not respond to antiviral drug therapy, viral isolates should be tested to determine sensitivity. Acyclovir-resistant viruses are often also resistant to famciclovir but may be sensitive to foscarnet or cidofovir.

### Perinatal Infections

All infants with proven or suspected neonatal HSV infection should be treated immediately with high-dose intravenous acyclovir (60 mg/kg/day divided every 8 hours). Treatment may be discontinued in infants shown by laboratory testing not to be infected. Infants with HSV disease limited to skin, eyes, and mouth should be treated for 14 days, whereas those with disseminated or central nervous system disease should receive a minimum of 21 days of therapy. Patients receiving high-dose therapy should be monitored for neutropenia.

**Suppressive oral acyclovir therapy** for 6 months after completion of the intravenous therapy has been shown to improve the neurodevelopment of infants with central nervous system infection and to prevent cutaneous recurrences in infants regardless of disease pattern. Infants surviving neonatal HSV disease of any classification should receive 300 mg/m<sup>2</sup> per dose 3 times daily for 6 months. The absolute neutrophil count should be measured at weeks 2 and 4 after initiation of treatment and then monthly.

### PROGNOSIS

Most HSV infections are self-limiting, last from a few days (for recurrent infections) to 2-3 weeks (for primary infections) and heal without scarring. Recurrent oral-facial herpes in a patient who has undergone dermabrasion or laser resurfacing can be severe and lead to scarring. Because genital herpes is a sexually transmitted infection, it can be stigmatizing, and its psychologic consequences may be much greater than its physiologic effects. Some HSV infections can be severe and may have grave consequences without prompt antiviral therapy. Life-threatening conditions include neonatal herpes, herpes encephalitis, and HSV infections in immunocompromised patients, burn patients, and severely malnourished infants and children. Recurrent ocular herpes can lead to corneal scarring and blindness.

### PREVENTION

Transmission of infection occurs through exposure to virus either as the result of skin-to-skin contact or from contact with contaminated secretions. Good handwashing and, when appropriate, the use of gloves provide healthcare workers with excellent protection against HSV infection in the workplace. Healthcare workers with active oral-facial herpes or herpetic whitlow should take precautions,

particularly when caring for high-risk patients such as newborns, immunocompromised individuals, and patients with chronic skin conditions. Patients and parents should be advised about good hygienic practices, including handwashing and avoiding contact with lesions and secretions, during active herpes outbreaks. Schools and daycare centers should clean shared toys and athletic equipment such as wrestling mats at least daily after use. Athletes with active herpes infections who participate in contact sports such as wrestling and rugby should be excluded from practice or games until the lesions are completely healed. Genital herpes can be prevented by avoiding genital-genital and oral-genital contact. The risk for acquiring genital herpes can be reduced but not eliminated through the correct and consistent use of condoms. Male circumcision is associated with a reduced risk of acquiring genital HSV infection. The risk for transmitting genital HSV-2 infection to a susceptible sexual partner can be reduced but not eliminated by the daily use of oral valacyclovir by the infected partner.

For **pregnant women with active genital herpes** at the time of delivery, the risk for mother-to-child transmission can be reduced but not eliminated by delivering the baby via a cesarean section. The risk for recurrent genital herpes, and therefore the need for cesarean delivery, can be reduced but not eliminated in pregnant women with a history of genital herpes by the daily use of oral acyclovir, valacyclovir, or famciclovir during the last 4 weeks of gestation, which is recommended by the American College of Obstetrics and Gynecology. There are documented cases of neonatal herpes occurring in infants delivered by cesarean section, as well as in infants born to mothers who have been appropriately treated with antiherpes antiviral drugs for the last month of gestation. Therefore a history of cesarean delivery or antiviral treatment at term does not rule out consideration of neonatal herpes.

Asymptomatic infants delivered vaginally to women with *first-episode* genital herpes are at *very high risk* for acquiring HSV infection. The nasopharynx, mouth, conjunctivae, rectum, umbilicus, and scalp electrode site (if applicable) should be cultured (with PCR surface testing if available) at approximately 24 hours after birth for all infants born to mothers with primary genital herpes. Some also recommend HSV-PCR on blood and CSF. Some authorities recommend that these infants receive anticipatory acyclovir therapy for at least 10 days, and others treat such infants if signs develop or if there is evidence of HSV infection. Infants delivered to women with a history of *recurrent genital herpes* are at low risk for development of neonatal herpes. In this setting, while surface cultures and PCRs are done, empirical acyclovir is not started. Parents should be educated about the signs and symptoms of neonatal HSV infection and should be instructed to seek care without delay at the first suggestion of infection. When the situation is in doubt, infants should be evaluated and tested with surface culture (and PCR) for neonatal herpes as well as with PCR on blood *and* CSF; intravenous acyclovir is begun until culture and PCR results are negative or until another explanation can be found for the signs and symptoms.

Recurrent genital HSV infections can be prevented by the daily use of oral acyclovir, valacyclovir, or famciclovir, and these drugs have been used to prevent recurrences of oral-facial (labialis) and cutaneous (gladiatorum) herpes. Oral and intravenous acyclovir also have been used to prevent recurrent HSV infections in immunocompromised patients. Use of sun blockers is reported to be effective in preventing recurrent oral-facial herpes in patients with a history of sun-induced recurrent disease.

Visit Elsevier eBooks+ at [eBooks.Health.Elsevier.com](http://eBooks.Health.Elsevier.com) for Bibliography.

## Chapter 300

## Varicella-Zoster Virus\*

Shivang S. Shah, Mona Marin,  
Philip S. LaRussa, and Anne A. Gershon

Varicella-zoster virus (VZV) causes primary, latent, and reactivation infections. The primary infection manifests as varicella (chickenpox) and results in establishment of a lifelong latent infection of sensory ganglionic neurons. Reactivation of the latent infection causes herpes zoster (shingles). Although often a mild illness of childhood, varicella can cause substantial morbidity and mortality in otherwise healthy children. Morbidity and mortality are higher in immunocompetent infants, adolescents, and adults, as well as in immunocompromised persons. Varicella predisposes to severe group A streptococcus and staphylococcus infections. Primary clinical disease can be prevented by immunization with live-attenuated varicella vaccine. A clinically modified disease can occur among vaccinated persons (breakthrough varicella), usually with milder presentation. Varicella and herpes zoster can be treated with antiviral drugs. Vaccines are also available to prevent herpes zoster in older adults.

### ETIOLOGY

VZV is a neurotropic human herpesvirus with similarities to herpes simplex virus. VZV enveloped viruses contain double-stranded DNA genomes that encode 71 proteins, including proteins that are targets of cellular and humoral immunity.

### EPIDEMIOLOGY

Before the introduction of the varicella vaccine in 1995, varicella was an almost universal communicable infection of childhood in the United States. Annual varicella epidemics occurred in winter and spring, and there were about 4 million cases of varicella, 11,000-13,500 hospitalizations, and 100-150 deaths every year in the United States. Most children were infected by 10 years of age, with fewer than 5% of adults remaining susceptible. This pattern of infection at younger ages remains characteristic in all countries in temperate climates. By contrast, in tropical areas, children acquire varicella at older ages and a higher proportion of young adults remain susceptible, leading to a higher proportion of cases occurring among adults. Varicella is a more serious disease in young infants, adults, and immunocompromised persons, in whom there are higher rates of complications and deaths than in healthy children. Primary varicella is highly transmissible. Within households, transmission of VZV to susceptible individuals occurs at a rate of 65-86%; more casual contact, such as occurs in a school classroom, is associated with lower attack rates among susceptible children. Persons with varicella may be contagious 24-48 hours before the rash is evident and until vesicles are crusted, usually 4-7 days after onset of rash, consistent with evidence that VZV is spread by aerosolization of virus in cutaneous lesions; spread from oropharyngeal secretions may occur but to a much lesser extent. Susceptible persons may also acquire varicella after close, direct contact with adults or children who have herpes zoster, again via aerosolization of virus in skin lesions.

Since implementation of the varicella vaccination program in 1995, there have been substantial declines in varicella morbidity and mortality in the United States. By 2006, before implementation of the two-dose program, one-dose vaccination coverage had reached 90% and varicella incidence had declined 90% since 1995 in sites where active surveillance was being conducted; varicella-related hospitalizations had declined 84% from prevaccine years. Varicella-related deaths decreased by 88%

from 1990-1994 to 2005-2007; in persons younger than 20 years of age there was a 97% decline in deaths. Declines in morbidity and mortality were seen in all age groups, including infants younger than 12 months of age who were not eligible for vaccination, indicating protection from exposure by indirect vaccination effects. The continued occurrence of breakthrough infections and of outbreaks in settings with high one-dose varicella vaccine coverage, together with the evidence that one dose is only 82% effective against all varicella, prompted adoption in 2007 of a routine two-dose childhood varicella vaccination program with catch-up vaccination of all individuals without evidence of immunity. Further declines in morbidity and mortality occurred during the two-dose program so that by 2019, declines reached more than 97% for incidence and 90% for hospitalizations and deaths. The greatest decline occurred in persons younger than 20 years of age, born during the varicella vaccination program, with 99%, 97%, and >99% reduction in incidence, hospitalizations, and deaths, respectively. Additionally, the two-dose program led to a reduction in the number, size, and duration of varicella outbreaks. Although the age-specific incidence has declined in all age groups, the median age at infection has increased, with cases occurring predominantly in children in ages 7-10 years rather than in the preschool years. This change in varicella epidemiology highlights the importance of offering vaccine to every susceptible child, adolescent, and adult.

**Herpes zoster** is caused by the reactivation of latent VZV. It is not common in childhood and shows no seasonal variation in incidence. Zoster is not caused by exposure to a patient with varicella; in fact, exposures to varicella boost the cell-mediated immune response to VZV in individuals with prior infection, decreasing the likelihood of reactivation of latent virus. The lifetime risk for herpes zoster for individuals with a history of varicella is at least 30%, with 75% of cases occurring after 45 years of age. Herpes zoster is unusual in healthy children younger than 10 years of age, with the exception of those infected with VZV in utero or in the first year of life, who have an increased risk for development of zoster in the first few years of life. Herpes zoster in otherwise healthy children tends to be milder than herpes zoster in adults, is less frequently associated with acute pain, and is generally not associated with postherpetic neuralgia. In children receiving immunosuppressive therapy for malignancy or other diseases and in those who have HIV infection, herpes zoster occurs more frequently, occasionally multiple times, and may be severe. The attenuated VZV in the varicella vaccine can establish latent infection and reactivate as herpes zoster. However, the risk for development of subsequent herpes zoster is much lower after vaccination than after natural VZV infection among both healthy and immunocompromised children. Although the Oka vaccine type VZV is attenuated, in children the severity of zoster caused by the Oka strain seems to be similar to or slightly milder than that caused by the natural or wild-type VZV. Vaccinated children who do develop zoster may have disease resulting from either vaccine or wild-type VZV, due to breakthrough varicella or subclinical infection of some vaccinees with wild-type VZV occurring at some point after immunization.

### PATHOGENESIS

Primary infection (varicella) results from inoculation of the virus onto the mucosa of the upper respiratory tract and tonsillar lymphoid tissue. During the early part of the 10- to 21-day incubation period, virus replicates in the local lymphoid tissue and spreads to T lymphocytes, causing a viremia that delivers the virus to skin where innate immunity controls VZV replication for several days. After innate immunity is overcome in skin, widespread cutaneous lesions develop as the incubation period ends. Adaptive host immune responses, especially cellular immunity, limit viral replication and lead to recovery from infection. In the immunocompromised child, the failure of adaptive immunity, especially cellular immune responses, results in continued viral replication that may lead to prolonged and/or disseminated infection with resultant complications of infection in the lungs, liver, brain, and other organs.

Latent infection develops during the incubation period or the disease itself. VZV is transported in a retrograde manner through sensory axons to the dorsal root ganglia in the spinal cord and to cranial nerve ganglia. Latency may also develop from viremia, infecting spinal and cranial nerve ganglia as well as autonomic ganglia that do not project to

\* The findings and conclusions in this report are those of the authors and do not necessarily represent the official position of the Centers for Disease Control and Prevention, U.S. Department of Health and Human Services.

the skin, including the enteric nervous system of the intestine. Latency of VZV occurs only in ganglionic neurons. Subsequent **reactivation** of latent VZV causes **herpes zoster**, usually manifested by a vesicular rash that is unilateral and dermatomal in distribution. Reactivation of VZV may also occur without a rash; examples are unilateral dermatomal pain without rash (**zoster sine herpette**), aseptic meningitis, and gastrointestinal illness (enteric zoster). During herpes zoster, necrotic changes may be produced in the neurons and surrounding satellite cells in associated ganglia. The skin lesions of varicella and herpes zoster have identical histopathology, and infectious VZV is present in both. Varicella elicits humoral and cell-mediated immunity that is highly protective against symptomatic reinfection. Suppression of cell-mediated immunity to VZV correlates with an increased risk for VZV reactivation as herpes zoster.

## CLINICAL MANIFESTATIONS

Varicella is an acute febrile rash illness that was common in children in the United States before the universal childhood vaccination program. It has variable severity but is usually self-limited. It may be associated with severe complications, including bacterial superinfection, especially with staphylococci and group A streptococci, pneumonia, encephalitis, bleeding disorders, congenital infection, and life-threatening perinatal infection. Herpes zoster is not common in children and typically causes localized cutaneous symptoms, but may disseminate in immunocompromised patients.

### Varicella in Unvaccinated Individuals

The illness usually begins 14–16 days after exposure, although the incubation period can range from 10–21 days. Subclinical varicella is rare; almost all exposed, susceptible persons experience a rash, albeit so mild in some cases that it may go unnoticed. Prodromal symptoms may be present, particularly in older children and adults. Fever, malaise, anorexia, headache, and occasionally mild abdominal pain may occur 24–48 hours before the rash appears. Temperature elevation is usually 37.8–38.9°C (100–102°F) but may be as high as 41.1°C (106°F); fever and other systemic symptoms usually resolve within 2–4 days after the onset of the rash.

Varicella lesions often appear first on the scalp, face, or trunk. The initial exanthem consists of intensely pruritic erythematous macules that evolve through the papular stage to form clear, fluid-filled vesicles. Clouding and umbilication of the lesions begin in 24–48 hours. While the initial lesions are crusting, new crops form on the trunk and then the extremities; the simultaneous presence of lesions in various stages of evolution is characteristic of varicella (Fig. 300.1). The distribution of the rash is predominantly central or centripetal, with the greatest concentration on the trunk and proximally on the extremities. Ulcerative lesions involving the mucosa of the oropharynx and vagina are also common; many children have vesicular lesions on the eyelids and conjunctivae, but corneal involvement and serious ocular disease are



**Fig. 300.1** A, Varicella lesions in unvaccinated persons display the characteristic “cropping” distribution, or manifest themselves in clusters; the simultaneous presence of lesions in various stages of evolution is characteristic. B, Breakthrough varicella lesions are predominantly maculopapular, and vesicles are less common; the illness is most commonly mild with <50 lesions. (Courtesy Centers for Disease Control and Prevention and Dr. John Noble, Jr.)

rare. The average number of varicella lesions is about 300, but healthy children may have fewer than 10 to more than 1,500 lesions. In cases resulting from secondary household spread and in older children, more lesions usually occur, and new crops of lesions may continue to develop for more than 7 days. The exanthem may be much more extensive in children with skin disorders, such as eczema or recent sunburn. Hypopigmentation or hyperpigmentation of lesion sites persists for days to weeks in some children, but severe scarring is unusual unless the lesions were secondarily infected.

The differential diagnosis of varicella includes vesicular rashes caused by other infectious agents, such as herpes simplex virus, enterovirus, monkey pox (mpox), rickettsial pox, and *Staphylococcus aureus*; drug reactions; disseminated herpes zoster; contact dermatitis; and insect bites (especially for breakthrough varicella). Severe varicella was the most common illness confused with smallpox before the eradication of smallpox.

### Varicelliform Rashes in Vaccinated Individuals

Varicelliform rashes that occur after vaccination could be a result of wild-type VZV, vaccine strain VZV, or other causes (e.g., insect bites, coxsackievirus). During days 0–42 after vaccination, the likelihood of rash from wild-type or vaccine strain VZV varies depending on the stage of a country’s vaccination program. In the early stages of a vaccination program, rash within 1–2 weeks is still most commonly caused by wild-type VZV, reflecting exposure to varicella before vaccination could provide protection. Rash occurring 14–42 days after vaccination is a result of either wild-type or vaccine strains, reflecting exposure and infection before protection from vaccination or an adverse event of vaccination (vaccine-associated rash), respectively. As wild-type varicella continues to decline as a consequence of the vaccination program, wild-type VZV circulation will also decline and rashes in the interval 0–42 days after vaccination will be less commonly caused by wild-type VZV, as is the case in the United States. Spread of vaccine type VZV from a vaccinee with skin lesions has occurred but is rare. The resulting illness in contacts is commonly mild with only a few vesicular lesions. Clinical reversion of the vaccine virus to virulence has not been described.

**Breakthrough varicella** is disease caused by **wild-type** virus in a vaccinated person, occurring after 42 days past vaccination. One dose of varicella vaccine is 98% effective in preventing moderate and severe varicella and is 82% effective in preventing all disease after exposure to wild-type VZV. This means that after close exposure to VZV, as may occur in a household or an outbreak setting in a school or daycare center, about 1 of every 5 children who received one dose of vaccine may experience breakthrough varicella. Exposure to VZV may also result in asymptomatic infection in the previously immunized child. The rash in breakthrough disease is frequently atypical and predominantly maculopapular, and vesicles are seen less commonly. The illness is most commonly mild with fewer than 50 lesions, shorter duration of rash, fewer complications, and little or no fever. However, approximately 25–30% of breakthrough cases in vaccinees who received one dose are not mild, with clinical features more similar to those of wild-type infection. Breakthrough cases are overall **less contagious** than wild-type infections within household settings, but contagiousness varies proportionally with the number of lesions; typical breakthrough cases (<50 lesions) are about one-third as contagious as disease in unvaccinated cases, whereas breakthrough cases with ≥50 lesions are as contagious as wild-type cases. Consequently, children with breakthrough disease should be considered potentially infectious and excluded from school until lesions have crusted or, if there are no vesicles present, until no new lesions are occurring. Transmission has been documented to occur from breakthrough cases in household, childcare, and school settings.

Two doses of varicella vaccine provide better protection than a one-dose schedule. One clinical trial estimated the two-dose vaccine efficacy for preventing all disease at 98%; the estimate is 92% in conditions of everyday clinical practice. Institution of two doses routinely in the United States substantially reduced the school outbreaks that were occurring among children who had received only one dose.



Breakthrough cases have been reported among two-dose vaccinees; however, recipients of two doses of varicella vaccine are less likely to have breakthrough disease than those who received one dose. Additionally, data suggest that breakthrough varicella may be further attenuated among two-dose vaccine recipients.

### Neonatal Varicella

Mortality is particularly high in neonates born to susceptible mothers who contract varicella around the time of delivery. Infants whose mothers demonstrate varicella in the period from 5 days before delivery to 2 days afterward are at high risk for severe varicella. These infants acquire the infection transplacentally as a result of maternal viremia, which may occur up to 48 hours before onset of maternal rash. The infant's rash usually occurs toward the end of the first week to the early part of the second week of life (although it may be as soon as 2 days). Because the mother has not yet developed a significant antibody response, the infant receives a large dose of virus without the moderating effect of maternal anti-VZV antibody. If the mother demonstrates varicella more than 5 days before delivery, she still may pass virus to the soon-to-be-born child, but infection is attenuated because of transmission of maternal VZV-specific antibody across the placenta. This moderating effect of maternal antibody is present if delivery occurs after about 30 weeks of gestation, when maternal immunoglobulin (Ig) G (IgG) is able to cross the placenta in significant amounts. The recommendations for use of human varicella-zoster immunoglobulin (VZIG) differ based on when the infant is exposed to varicella. Newborns whose mothers develop varicella during the period of 5 days before to 2 days after delivery should receive VZIG as soon as possible after birth. Although neonatal varicella may occur in about half of these infants despite administration of VZIG, it is milder than in the absence of VZIG administration. All premature infants born <28 weeks of gestation to a mother with active varicella at delivery (even if the maternal rash has been present for >1 week) should receive VZIG. If VZIG is not available, intravenous immunoglobulin (IVIG) may provide some protection, although varicella-specific antibody titers may vary from lot to lot. Because perinatally acquired varicella may be life threatening, the infant should usually be treated with acyclovir (10–15 mg/kg every 8 hours IV) when lesions develop. Neonatal varicella can also follow a postpartum exposure of an infant delivered to a mother who was susceptible to VZV, although the frequency of complications declines rapidly in the weeks after birth. Recommendations for VZIG administration for these infants are presented in the postexposure prophylaxis section. Neonates with community-acquired varicella who experience severe varicella, especially those who have a complication such as pneumonia, hepatitis, or encephalitis, should also receive treatment with intravenous acyclovir (10 mg/kg every 8 hours). Infants with neonatal varicella who receive prompt antiviral therapy have an excellent prognosis.

### Congenital Varicella Syndrome

In utero transmission of VZV can occur; however, because most adults in temperate climates are immune, pregnancy complicated by varicella is unusual in these settings. When pregnant women do contract varicella early in pregnancy, experts estimate that as many as 25% of the fetuses may become infected. Fortunately, clinically apparent disease in the infant is uncommon: the congenital varicella syndrome occurs in approximately 0.4% of infants born to women who have varicella during pregnancy before 13 weeks of gestation and in approximately 2% of infants born to women with varicella between 13 and 20 weeks of gestation. Rarely, cases of congenital varicella syndrome have been reported in infants of women infected after 20 weeks of pregnancy, the latest occurring at 28 weeks of gestation. Before availability of varicella vaccine in the United States, 44 cases of congenital varicella syndrome were estimated to occur each year. The congenital varicella syndrome is characterized by cicatricial skin scarring in a zoster-like distribution; limb hypoplasia; and abnormalities of the neurologic system (e.g., microcephaly, cortical atrophy, seizures, and intellectual disability), eye (e.g., chorioretinitis, microphthalmia, and cataracts), renal system (e.g., hydronephrosis and hydronephrosis), and autonomic nervous system



**Fig. 300.2** Newborn with congenital varicella syndrome. The infant had severe malformations of both lower extremities and cicatricial scarring over his left abdomen.

(e.g., neurogenic bladder, swallowing dysfunction, and aspiration pneumonia). Low birthweight is common among infants with congenital varicella syndrome. Most of the manifestations can be attributed to virus-induced injury to the nervous system, although there is no obvious explanation why certain regions of the body are preferentially infected during fetal VZV infection. The characteristic cutaneous lesion has been called a cicatrix, a zigzag scarring, in a dermatomal distribution, often associated with atrophy of the affected limb (Fig. 300.2). Many infants with severe manifestations of congenital varicella syndrome (atrophy and scarring of a limb) have significant neurologic deficiencies. Alternatively, there may be neither skin nor limb abnormalities, but the infant may show cataracts or even extensive aplasia of the entire brain.

There are rare case reports of fetal abnormalities after the development of herpes zoster in the mother; whether these cases truly represent the congenital varicella syndrome is unclear. If it does occur, the congenital syndrome acquired as a result of maternal herpes zoster is exceedingly rare. Maternal herpes zoster was associated with typical congenital varicella syndrome in one case, but the mother had disseminated herpes zoster (at 12 weeks of gestation).

The diagnosis of VZV fetopathy is based mainly on the history of gestational varicella combined with the presence of characteristic abnormalities in the newborn infant. Virus cannot be cultured from the affected newborn, but viral DNA may be detected in tissue samples by polymerase chain reaction (PCR). Because many infants with congenital varicella syndrome develop zoster before a year of age, it may be possible to isolate VZV from that rash. Alternatively, use of PCR to identify VZV DNA in vesicular fluid or scabs from zoster lesions in such an infant may be diagnostic. VZV-specific IgM antibody is detectable in the cord blood sample in some infants, although the IgM titer drops quickly in the postpartum period and can be nonspecifically positive. Chorionic villus sampling and fetal blood collection for the detection of viral DNA, virus, or antibody have been used in an attempt to diagnose fetal infection and embryopathy. The usefulness of these tests for patient management and counseling has not been defined. Because these tests may not distinguish between infection and disease, their utility may primarily be that of reassurance when the result is negative. Ultrasound may be useful to try to identify limb atrophy, which is common in congenital varicella syndrome. A persistently positive VZV IgG antibody titer at 12–18 months of age is a reliable indicator of prenatal



infection in the asymptomatic child, as is the development of zoster in the first year of life without evidence of postnatal infection.

VZIG has often been administered to the susceptible mother exposed to varicella to modify maternal disease severity; it is uncertain whether this step modifies infection in the fetus, although some evidence suggests that it may be beneficial for the fetus too. Similarly, acyclovir treatment may be given to the mother with severe varicella. A prospective registry of acyclovir use in the first trimester demonstrated that the occurrence of birth defects approximates that found in the general population. Acyclovir is a class B drug for pregnancy and should be considered when the benefit to the mother outweighs the potential risk to the fetus. The efficacy of acyclovir treatment of the pregnant woman in preventing or modifying the severity of congenital varicella is not known, but its use should be considered to protect the mother from severe disease. Because the damage caused by fetal VZV infection does not progress in the postpartum period, antiviral treatment of infants with congenital VZV syndrome is not indicated.

## COMPLICATIONS

The complications of VZV infection (*varicella* or *zoster*) occur more commonly in immunocompromised patients. In the otherwise healthy child, asymptomatic transient varicella hepatitis is relatively common. Mild thrombocytopenia occurs in 1–2% of children with varicella and may be associated with petechiae. Purpura, hemorrhagic vesicles, hematuria, and gastrointestinal bleeding are rare complications that may have serious consequences. Other complications of varicella, some of them rare, include acute cerebellar ataxia, encephalitis, pneumonia, nephritis, nephrotic syndrome, hemolytic-uremic syndrome, arthritis, myocarditis, pericarditis, pancreatitis, orchitis, and acute retinal necrosis. A reduction in the number and rates of varicella-related complications is seen in vaccinated populations. Reports of serious varicella-related complications in vaccinated persons (breakthrough) are rare (meningitis, pneumonia, acute transverse myelitis, encephalitis [one fatal case in an apparently immunocompetent child], and sepsis). Severe breakthrough varicella can occur among healthy persons, but cases appear to be more common among immunocompromised persons who are usually not recommended to receive varicella vaccine.

Declines in varicella-related hospitalizations and deaths in the United States since implementation of the varicella vaccination program provide supporting evidence that varicella vaccine reduces severe complications from varicella. Approximately 105 deaths (with varicella listed as the underlying cause of death) occurred in the United States annually before the introduction of the varicella vaccine; during 2017–2019 the annual average number of varicella deaths was 18. In both the pre- and postvaccine eras, the majority of deaths (>80%) have been among persons without high-risk preexisting conditions.

## Bacterial Infections

Secondary bacterial infections of the skin, usually caused by group A streptococcus or *S. aureus*, may occur in children with varicella. These range from impetigo to cellulitis, lymphadenitis, and subcutaneous abscesses. An early manifestation of secondary bacterial infection is erythema of the base of a new vesicle. Recrudescence of fever 3–4 days after the initial exanthem may also herald a secondary bacterial infection. Varicella is a well-described risk factor for serious invasive infections caused by group A streptococcus, which can have a fatal outcome. The more invasive infections, such as varicella gangrenosa, bacterial sepsis, pneumonia, arthritis, osteomyelitis, cellulitis, and necrotizing fasciitis, account for much of the morbidity and mortality of varicella in otherwise healthy children. Bacterial toxin-mediated diseases (e.g., toxic shock syndrome) also may complicate varicella. A substantial decline in varicella-related invasive bacterial infections is associated with the use of the varicella vaccine.

## Encephalitis and Cerebellar Ataxia

Encephalitis (1 per 50,000 cases of varicella in unvaccinated children) and acute cerebellar ataxia (1 per 4,000 cases of varicella in unvaccinated children) are well-described neurologic complications

of varicella; morbidity from central nervous system complications is highest among patients younger than 5 years and older than 20 years. Nuchal rigidity, altered consciousness, and seizures characterize meningoencephalitis. Patients with cerebellar ataxia have a gradual onset of gait disturbance, nystagmus, and slurred speech. Neurologic symptoms usually begin 2–6 days after the onset of the rash but may occur during the incubation period or after resolution of the rash. Clinical recovery is typically rapid, occurring within 24–72 hours, and is usually complete. Although severe hemorrhagic encephalitis, analogous to that caused by herpes simplex virus, is very rare in children with varicella, the consequences are similar to those of herpes simplex virus encephalitis. Reye syndrome (hepatic dysfunction with hypoglycemia and encephalopathy) associated with varicella and other viral illnesses such as influenza is rare now that salicylates are no longer used as antipyretics in these situations (see [Chapter 405](#)).

## Pneumonia

Varicella pneumonia (viral, due to VZV) is a severe complication that accounts for most of the increased morbidity and mortality from varicella in adults and other high-risk populations, but viral pneumonia may also complicate varicella in young children. Respiratory symptoms, which may include cough, dyspnea, cyanosis, pleuritic chest pain, and hemoptysis, usually begin within 1–6 days after the onset of the rash. Smoking has been described as a risk factor for severe pneumonia complicating varicella. The frequency of varicella pneumonia may be greater in the parturient.

## Progressive Varicella

Progressive varicella, with visceral organ involvement, coagulopathy, severe hemorrhage, and continued vesicular lesion development after 7 days, is a severe complication of primary VZV infection. Severe abdominal pain, which may reflect involvement of mesenteric lymph nodes or the liver, or the appearance of hemorrhagic vesicles in otherwise healthy adolescents and adults, immunocompromised children, pregnant women, and newborns, may herald severe, and potentially fatal, disease. Although rare in healthy children, the risk for progressive varicella is highest in children with congenital cellular immune deficiency disorders and those with malignancy, particularly if chemotherapy, and especially corticosteroids, had been given during the incubation period and the absolute lymphocyte count is <500 cells/μL. The mortality rate for children who acquired varicella while undergoing treatment for malignancy and who were not treated with antiviral therapy approached 7%; varicella-related deaths usually occurred within 3 days after the diagnosis of varicella pneumonia. Children who acquire varicella after organ transplantation are also at risk for progressive VZV infection. Children undergoing long-term, low-dose systemic or inhaled corticosteroid therapy are not considered to be at higher risk for severe varicella, but progressive varicella does occur in patients receiving high-dose corticosteroids. There are case reports in patients receiving inhaled corticosteroids as well as in asthmatic patients receiving multiple short courses of systemic corticosteroid therapy. Unusual clinical findings of varicella, including lesions that develop a hyperkeratotic appearance and continued new lesion formation for weeks or months, have been described in children with untreated, late-stage HIV infection. Immunization of HIV-infected children who have a CD4<sup>+</sup> T-lymphocyte percent ≥15%, as well as children with leukemia and solid organ tumors who are in remission and whose chemotherapy can be interrupted for 2 weeks around the time of immunization or has been terminated, have reduced frequency of severe disease. Moreover, since the advent of the universal immunization program in the United States, many children who would become immunocompromised later in life because of disease or treatment are protected before the immunosuppression occurs; also, as a result of reductions in varicella incidence, immunocompromised children are less likely to be exposed to varicella.

## Herpes Zoster

Herpes zoster manifests as vesicular lesions clustered within one or, less commonly, two adjacent dermatomes ([Fig. 300.3](#)). In the elderly,



**Fig. 300.3** Herpes zoster involving the lumbar dermatome. (From Mandell GL, Bennett JE, Dolin R, eds. *Principles and Practice of Infectious Diseases*, 6th ed. Philadelphia: Elsevier; 2005:1783.)



**Fig. 300.4** Many groups of blisters occurring over the arm in a child with herpes zoster. (From Weston WL, Lane AT, Morelli J. *Color Textbook of Pediatric Dermatology*, 3rd ed. St. Louis: Mosby; 2002: Fig. 8-28.)

herpes zoster typically begins with burning pain or itching followed by clusters of skin lesions in a dermatomal pattern. Almost half of the elderly with herpes zoster experience complications; the most frequent complication is postherpetic neuralgia, a painful condition that affects the nerves despite resolution of the skin lesions. Approximately 4% of patients suffer a second episode of herpes zoster; three or more episodes are rare. Unlike herpes zoster in adults, zoster in children is infrequently associated with localized pain, hyperesthesia, pruritus, low-grade fever, or complications. In children, the rash is mild, with new lesions appearing for a few days (Fig. 300.4); symptoms of acute neuritis are minimal; and complete resolution usually occurs within 1-2 weeks. Unlike in adults, postherpetic neuralgia is unusual in children. An increased risk for herpes zoster early in childhood has been described in children who acquire infection with VZV in utero or in the first year of life.

Immunocompromised children may have more severe herpes zoster, similar to the situation in adults, including postherpetic neuralgia. Immunocompromised patients may also experience disseminated cutaneous disease that mimics varicella, with or without initial dermatomal rash, as well as visceral dissemination with pneumonia, hepatitis, encephalitis, and disseminated intravascular coagulopathy. Severely immunocompromised children, particularly those with advanced HIV infection, may have unusual, chronic, or relapsing cutaneous disease, retinitis, or central nervous system disease without rash. The finding of a lower risk for herpes zoster among vaccinated children with leukemia than in those who have had varicella suggested that the vaccine

virus reactivates less commonly than wild-type VZV. A study of HIV-infected vaccinated children found no cases of zoster 4.4 years after immunization, which was significantly different from the rate in children who had experienced varicella. Studies to date indicate that the risk for herpes zoster in healthy children who have received one or more doses of vaccine is 78% lower than in children who had wild-type varicella, with two-dose vaccination providing 50% greater protection than one-dose. Many more years of follow-up are needed to determine whether this lower risk is maintained among older persons who are at greatest risk for herpes zoster.

## DIAGNOSIS

Varicella and herpes zoster are usually diagnosed primarily by their clinical appearance. Laboratory evaluation has not been considered necessary for diagnosis or management. However, as varicella disease has declined to low levels, laboratory confirmation has become increasingly necessary. The atypical nature of breakthrough varicella, with a higher proportion of papular rather than vesicular rashes, poses both clinical and laboratory diagnostic challenges.

Rapid laboratory diagnosis of VZV is often important in high-risk patients and can be important for infection control, especially for breakthrough cases that have mild or atypical presentations. Confirmation of VZV infections can be accomplished by many referral hospital laboratories and all state health laboratories. VZV can be identified quickly by either PCR amplification testing (vesicular fluid, crusts) or direct fluorescence assay of cells from cutaneous lesions (vesicular fluid). In the absence of vesicles or scabs, scrapings of maculopapular lesions can be collected for PCR or direct fluorescence assay testing. Infectious virus may be recovered by means of tissue culture methods; such methods require specific expertise, and virus may take days to weeks to grow. Of available tests, PCR is the most sensitive and also allows for differentiation of wild-type and vaccine strains. Direct fluorescence assay is specific and less sensitive than PCR but when available allows for rapid diagnosis. Although multinucleated giant cells can be detected with nonspecific stains (Tzanck smear), they have poor sensitivity and do not differentiate VZV from herpes simplex virus infections. Strain identification (genotyping) can distinguish wild-type VZV from the vaccine strain in a vaccinated child; however, genotyping is available only at specialized reference laboratories. Laboratory tests of lesions cannot be used to distinguish between varicella and disseminated herpes zoster. VZV IgG antibodies can be detected by several methods, and a fourfold or greater rise in IgG antibodies is confirmatory of acute infection (although this requires a 2- to 3-week delay to collect a convalescent specimen). In vaccinated persons, commercially available tests are not sufficiently sensitive to always detect antibodies following immunization, and a fourfold rise in IgG antibodies may not occur. Testing for VZV IgM antibodies is not useful for routine confirmation or ruling out of varicella because commercially available methods are unreliable and the kinetics of the IgM response have not been well defined. IgM is inconsistently detected, even among patients with PCR-confirmed disease. Furthermore, IgM detection does not confirm a primary infection because specific IgM antibodies are transiently produced on each exposure to VZV, whether through primary infection, reinfection, or reactivation from latency, even subclinical. Serologic tests are not useful for the initial diagnosis of herpes zoster, but a significant rise in IgG titer in convalescent titer in the presence of an atypical zoster rash is confirmatory. As with any laboratory test, a negative varicella test should be considered in the context of the clinical presentation. Clinicians should use clinical judgment to decide on the best course of therapy. VZV IgG antibody can be useful to determine the immune status of individuals whose clinical history of varicella is unknown or equivocal. However, caution must be taken in interpreting tests for immunity to VZV, especially in immunocompromised patients after a close exposure to VZV. Due to the possibility of false-positive results, it is preferable to rely on clinical rather than laboratory information, and if in doubt, assume the individual is susceptible to varicella and proceed accordingly.

## TREATMENT

Antiviral treatment with acyclovir or valacyclovir modifies the course of both varicella and herpes zoster. Antiviral drug resistance is rare for VZV but has occurred, primarily in children with HIV infection and other immunocompromising conditions in which frequent relapse of VZV infections has resulted in multiple courses of antiviral therapy. Foscarnet and cidofovir may be useful for the treatment of acyclovir-resistant VZV infections, but consultation of an infectious diseases specialist is recommended.

### Varicella

Given the safety profile of acyclovir and valacyclovir, and their demonstrated efficacy in the treatment of varicella, treatment of all children, adolescents, and adults with varicella is acceptable. Oral therapy with acyclovir (20 mg/kg/dose; maximum: 800 mg/dose) given as four doses/day for 5 days can be used to treat uncomplicated varicella. Therapy is particularly important for individuals at increased risk for moderate to severe varicella: individuals older than 12 years of age; individuals older than 12 months of age with chronic cutaneous or pulmonary disorders; individuals receiving short-term, intermittent, or aerosolized corticosteroid therapy; individuals receiving long-term salicylate therapy; and possibly secondary cases among household contacts. To be most effective, treatment should be initiated as early as possible, preferably within 24 hours of the onset of the exanthem. There is less clinical benefit if treatment is initiated more than 72 hours after onset of the exanthem. Acyclovir therapy does not interfere with the induction of VZV immunity. Acyclovir has been successfully used to treat varicella in pregnant women. Valacyclovir or famciclovir may be given to older children who can swallow tablets. These drugs are highly active against VZV by the same mechanism as acyclovir and are better absorbed by the oral route than acyclovir. Valacyclovir (20 mg/kg/dose; maximum: 1,000 mg/dose, administered 3 times daily for 5 days) is licensed for treatment of varicella in children 2 to <18 years of age, and both valacyclovir and famciclovir are approved for treatment of herpes zoster in adults. Patients receiving these antivirals should be well hydrated, and for prolonged use, renal function and white blood cell counts (especially neutrophils) should be monitored frequently. Common adverse symptoms during valacyclovir treatment are neurologic (headache, agitation, dizziness) and gastrointestinal (nausea, abdominal pain).

Intravenous therapy is indicated for severe disease and for varicella in immunocompromised patients (even if begun more than 72 hours after onset of rash). Any patient who has signs of disseminated VZV, including pneumonia, severe hepatitis, thrombocytopenia, or encephalitis, should receive immediate treatment. Intravenous acyclovir therapy (10 mg/kg or 500 mg/m<sup>2</sup> every 8 hours) initiated within 72 hours of development of initial symptoms decreases the likelihood of progressive varicella and visceral dissemination in high-risk patients. Treatment is continued for 7-10 days or until no new lesions have appeared for 48 hours. Delaying antiviral treatment in high-risk individuals until it is obvious that prolonged new lesion formation is occurring is not recommended because visceral dissemination occurs during the same period.

Acyclovir-resistant VZV has been identified primarily in children infected with HIV. These children may be treated with intravenous foscarnet (120 mg/kg/day divided every 8 hours). The dose should be modified in the presence of renal insufficiency. Resistance to foscarnet has been reported with prolonged use. Cidofovir is also useful in this situation. Because of the increased toxicity profile of foscarnet and cidofovir, these two drugs should be initiated in collaboration with an infectious diseases specialist.

### Herpes Zoster

Antiviral drugs are effective for treatment of herpes zoster. In healthy adults, acyclovir (800 mg 5 times a day PO for 5-7 days), famciclovir (500 mg tid PO for 7 days), and valacyclovir (1,000 mg tid PO for 7 days) reduce the duration of the illness but do not prevent development

of postherpetic neuralgia. In otherwise healthy children, herpes zoster is a less-severe disease, and postherpetic neuralgia usually does not occur. Therefore treatment of uncomplicated herpes zoster in the child with an antiviral agent may not always be necessary, although some experts would treat with oral acyclovir (20 mg/kg/dose; maximum: 800 mg/dose) to shorten the duration of the illness. It is important to start antiviral therapy as soon as possible. Delay beyond 72 hours from onset of rash limits its effectiveness.

In contrast, herpes zoster in immunocompromised children can be severe, and disseminated disease may be life-threatening. Patients at high risk for disseminated disease should receive intravenous acyclovir (500 mg/m<sup>2</sup> or 10 mg/kg every 8 hours). Oral acyclovir, famciclovir, and valacyclovir are options for immunocompromised patients with uncomplicated herpes zoster, who are considered at low risk for visceral dissemination. Neuritis with herpes zoster should be managed with appropriate analgesics.

Use of corticosteroids in the treatment of herpes zoster in children is not recommended.

## PROGNOSIS

Primary varicella in unvaccinated persons has a mortality rate of 2-3 per 100,000 cases, with the lowest case fatality rates among children 1-9 years of age (~1 deaths/100,000 cases). Compared with these age groups, infants have a 4 times greater risk of dying and adults have a 25 times greater risk of dying. The most common complications among people who died from varicella were pneumonia, central nervous system complications, secondary infections, and hemorrhagic conditions. The mortality rate of untreated primary infection was 7% in immunocompromised children in the 1960s. In the era of antiviral therapy and improved supportive care, the prognosis has improved with treatment administered early in the course of illness, but deaths have continued to occur. Herpes zoster among healthy children has an excellent prognosis and is usually self-limited. Severe presentation with complications and sometimes fatalities can occur in immunocompromised children.

## PREVENTION

VZV transmission is difficult to prevent, especially from persons with varicella, because a person with varicella may be contagious for 24-48 hours before the rash is apparent. Herpes zoster is less infectious than varicella; nonetheless, transmission has been reported even in the absence of direct contact with the patient. Infection control practices, including caring for patients with varicella in isolation rooms with filtered air systems, are essential. All healthcare workers should have evidence of varicella immunity (Table 300.1). Unvaccinated healthcare workers without other evidence of immunity who have had a close exposure to VZV should be furloughed for days 8-21 after exposure because they are potentially infectious during this period. Routine testing for VZV antibodies after vaccination is not useful for identifying individuals who are immune to varicella because the tests are insensitive for this purpose.

### Vaccine

Varicella is a vaccine-preventable disease. Varicella vaccine contains live, attenuated VZV (Oka strain) and is indicated for subcutaneous or intramuscular administration. In the United States, varicella vaccine is recommended for routine administration as a two-dose regimen to healthy children at ages 12-15 months and 4-6 years. Administration of the second dose earlier than 4-6 years of age is acceptable, but it must be at least 3 months after the first dose. Catch-up vaccination with the second dose is recommended for children and adolescents who received only one dose. Vaccination with two doses is recommended for all persons without evidence of immunity. The minimum interval between the two doses is 3 months for persons 12 years of age or younger and 4 weeks for older children, adolescents, and adults. Administration of varicella vaccine within 4 weeks of measles-mumps-rubella (MMR) vaccination is associated with a



**Table 300.1** Evidence of Immunity to Varicella

Evidence of immunity to varicella consists of any of the following:

- Documentation of age-appropriate vaccination with a varicella vaccine:
  - Preschool-age children (i.e., age  $\geq 12$  mo): one dose
  - School-age children, adolescents, and adults: two doses\*
- Laboratory evidence of immunity<sup>†</sup> or laboratory confirmation of disease
- Birth in the United States before 1980<sup>‡</sup>
- Diagnosis or verification of a history of varicella disease by a healthcare provider<sup>§</sup>
- Diagnosis or verification of a history of herpes zoster by a healthcare provider

\*For children who received their first dose at younger than age 13 years and for whom the interval between the two doses was 28 or more days, the second dose is considered valid.

<sup>†</sup>Commercial assays can be used to assess disease-induced immunity, but they lack sensitivity to always detect vaccine-induced immunity (i.e., they might yield false-negative results).

<sup>‡</sup>For healthcare personnel, pregnant women, and immunocompromised persons, birth before 1980 should not be considered evidence of immunity.

<sup>§</sup>Verification of history or diagnosis of typical disease can be provided by any healthcare provider (e.g., school or occupational clinic nurse, nurse practitioner, physician assistant, or physician). For persons reporting a history of, or reporting with, atypical or mild cases, assessment by a physician or his/her designee is recommended, and one of the following should be sought: (1) an epidemiologic link to a typical varicella case or to a laboratory-confirmed case or (2) evidence of laboratory confirmation if it was performed at the time of acute disease. When such documentation is lacking, persons should not be considered as having a valid history of disease, because other diseases might mimic mild atypical varicella.

higher risk for breakthrough disease; therefore it is recommended that the varicella and MMR vaccines either be administered simultaneously at different sites or be given at least 4 weeks apart. Varicella vaccine can be administered as a monovalent vaccine (for all healthy persons  $\geq 12$  months of age) or as the quadrivalent measles-mumps-rubella-varicella (MMRV) vaccine (for children age 12 months through 12 years only).

Varicella vaccine is contraindicated for persons who have a history of anaphylactic reaction to any component of the vaccine; pregnant women; persons with cell-mediated immune deficiencies, including those with leukemia, lymphoma, and other malignant neoplasms affecting the bone marrow or lymphatic systems; persons receiving immunosuppressive therapy; and persons who have a family history of congenital or hereditary immunodeficiency in first-degree relatives unless the immune competence of the potential vaccine recipient is demonstrated. Children with isolated humoral immunodeficiencies may receive varicella vaccine. The monovalent varicella vaccine has been studied in clinical trial settings in children with acute lymphocytic leukemia and certain solid tumors who were in remission, but this practice is not recommended except in a research setting. Varicella vaccine can be administered to patients with leukemia, lymphoma, or other malignancies whose disease is in remission, who have restored immunocompetence, and whose chemotherapy has been terminated for at least 3 months.

The vaccine should be considered for HIV-infected children with a CD4<sup>+</sup> T-lymphocyte count  $\geq 200$  cells/mm<sup>3</sup> or percentage  $\geq 15\%$ . These children should receive two doses of the monovalent vaccine, 3 months apart. Specific guidelines for immunizing these children should be reviewed before vaccination. Data indicate that varicella vaccine is highly effective in preventing herpes zoster among children infected with HIV. MMRV should not be administered as a substitute for the component vaccines in HIV-infected children.

A recombinant subunit (non-live) adjuvanted vaccine is available in the United States for use for prevention of herpes zoster and its related complications among individuals 50 years and older and among those 19 years and older who are or will be immunodeficient or immunosuppressed because of disease or therapy. The zoster vaccine is not

indicated for primary prevention of varicella, or for the treatment of zoster or postherpetic neuralgia.

### Vaccine-Associated Adverse Events

Varicella vaccine is safe and well tolerated. The incidence of injection site complaints observed  $\leq 3$  days after vaccination was slightly higher after dose 2 (25%) than after dose 1 (22%). A mild vaccine-associated varicelliform rash was reported in approximately 1–5% of healthy vaccinees, consisting of 6–10 papular-vesicular, erythematous lesions with peak occurrence 8–21 days after vaccination. Serious adverse reactions confirmed to be caused by the vaccine strain are rare and include pneumonia, hepatitis, meningitis, recurrent herpes zoster, severe rash, and seven deaths (all deaths occurred in persons with immunocompromising conditions). Transmission of vaccine virus to susceptible contacts is a very rare event from healthy vaccine recipients (13 instances from 11 immunocompetent varicella vaccine recipients, all in the presence of a rash in the vaccinee, 6 varicella-like and 5 herpes zoster). MMRV vaccine is associated with a greater risk for febrile seizures 5–12 days after the first dose among children 12–23 months of age compared with simultaneous MMR and varicella vaccines (one extra febrile seizure for every 2,500 children vaccinated).

### Postexposure Prophylaxis

Vaccine given to healthy children within 3 and up to 5 days after exposure (as soon as possible is preferred) is effective in preventing or modifying varicella. Varicella vaccine is recommended for postexposure use and for outbreak control. Oral acyclovir administered late in the incubation period may modify subsequent varicella in the healthy child; however, its use in this manner is not recommended until it can be further evaluated.

High-titer anti-VZV immune globulin as postexposure prophylaxis is recommended for immunocompromised children, pregnant women, and newborns exposed to varicella. Since 2012 the product licensed for use in the United States is VariZIG. VariZIG is commercially available from a broad network of specialty distributors in the United States (list available at <https://www.varizig.com>). The recommended dose is 1 vial (125 units) for each 10-kg increment of body weight (maximum: 625 units), except for infants weighing  $\leq 2$  kg who should receive 0.5 vial. VariZIG should be given intramuscularly as soon as possible but may be efficacious up to 10 days after exposure.

Newborns whose mothers have varicella 5 days before to 2 days after delivery should receive VariZIG (0.5 vial for those weighing  $\leq 2$  kg and 1 vial for those weighing  $> 2$  kg). VariZIG is also indicated for pregnant women and immunocompromised persons without evidence of varicella immunity; hospitalized premature infants born at  $< 28$  weeks of gestation (or weight  $< 1,000$  g) who were exposed to varicella, regardless of maternal varicella immunity; and hospitalized premature infants born at  $\geq 28$  weeks of gestation who were exposed to varicella and whose mothers have no evidence of varicella immunity. Patients given VariZIG should be monitored closely and treated with acyclovir if necessary once lesions develop.

Close contact between a susceptible high-risk patient and a patient with herpes zoster is also an indication for VariZIG prophylaxis. Passive antibody administration or treatment does not reduce the risk for herpes zoster or alter the clinical course of varicella or herpes zoster when given after the onset of symptoms.

Although licensed pooled IVIG preparations contain anti-VZV antibodies, the titer varies from lot to lot. In situations in which administration of VariZIG is not possible, IVIG can be administered (400 mg/kg administered once within 10 days of exposure). Immunocompromised patients who have received high-dose IVIG ( $> 400$  mg/kg) for other indications within 3 weeks before VZV exposure can be expected to have serum antibodies to VZV.

Visit Elsevier eBooks+ at [eBooks.Health.Elsevier.com](http://eBooks.Health.Elsevier.com) for Bibliography.



## Chapter 301

## Epstein-Barr Virus

Terri L. Stillwell and Jason B. Weinberg

**Infectious mononucleosis** is the best-known clinical syndrome caused by Epstein-Barr virus (EBV). It is characterized by systemic somatic complaints consisting primarily of fatigue, malaise, fever, sore throat, and generalized lymphadenopathy. Originally described as glandular fever, it derives its name from the mononuclear lymphocytosis with atypical-appearing lymphocytes that accompany the illness.

**ETIOLOGY**

EBV is a double-stranded DNA virus that is a member of the gamma-herpesviruses and causes >90% of cases of infectious mononucleosis. Two distinct types of EBV, type 1 and type 2 (also called type A and type B), have been characterized and have 70–85% sequence homology. EBV-1 is more prevalent worldwide, although EBV-2 is more common in Africa than in the United States and Europe. Both types lead to *persistent, lifelong, latent infection*. Dual infections with both types have been documented among immunocompromised persons. EBV-1 induces in vitro growth transformation of B lymphocytes more efficiently than does EBV-2, but no type-specific disease manifestations or clinical differences have been identified.

As many as 5–10% of infectious mononucleosis-like illnesses are caused by other types of primary infections, particularly cytomegalovirus but also pathogens such as *Toxoplasma gondii*, adenovirus, hepatitis viruses, and HIV. In the majority of EBV-negative cases of infectious mononucleosis, the exact cause remains unknown.

**EPIDEMIOLOGY**

EBV infects more than 95% of the world's population. It is transmitted primarily via oral secretions. Among children, transmission may occur by exchange of saliva from child to child, such as occurs between children in out-of-home childcare. EBV is shed in oral secretions consistently for more than 6 months after acute infection and then intermittently for life. As many as 20–30% of healthy EBV-infected persons shed virus at any particular time. EBV is also found in male and female genital secretions, and some studies suggest the possibility of spread through sexual contact. Nonintimate contact, environmental sources, and fomites do not contribute to transmission of EBV.

Infection with EBV in developing countries and among socioeconomically disadvantaged populations in developed countries usually

occurs during infancy and early childhood. In central Africa, almost all children are infected by 3 years of age. Among more affluent populations in industrialized countries, half of the population is infected by 6–8 years of age, with approximately 30% of infections occurring during adolescence and young adulthood. In the United States, seroprevalence increases with age, from approximately 54% for children 6–8 years to 83% for patients 18–19 years. Seroprevalence at each age is substantially higher for Mexican-Americans and non-Hispanic Blacks than for non-Hispanic Whites. Large differences are seen by family income, with highest seroprevalence in children of families with lowest income.

The epidemiology of the disease manifestations of infectious mononucleosis is related to the age of acquisition of EBV infection. Primary infection with EBV during childhood is usually asymptomatic or mild and indistinguishable from other childhood infections. Primary EBV infection in adolescents and adults manifests in 30–50% of cases as the **classic triad of fatigue, pharyngitis, and generalized lymphadenopathy**, which constitute the major clinical manifestations of infectious mononucleosis. This syndrome may be seen at all ages but is rarely apparent in children younger than 4 years of age, when most EBV infections are asymptomatic, or in adults older than 40 years of age, when most individuals have already been infected by EBV. The true incidence of the syndrome of infectious mononucleosis is unknown but is estimated to occur in 20–70 per 100,000 person-years. In young adults, the incidence increases to approximately 100 per 100,000 person-years. The prevalence of serologic evidence of past EBV infection increases with age; almost all adults in the United States are seropositive.

EBV infection has been implicated in other diseases, including both nonmalignant and malignant disorders such as lymphoproliferative diseases and lymphomas (Table 301.1). In addition, various monogenic immune susceptibility defects predispose to EBV-associated hemophagocytic lymphohistiocytosis, lymphoproliferative disorders, or lymphoma (Fig. 301.1; see also Chapter 174.3).

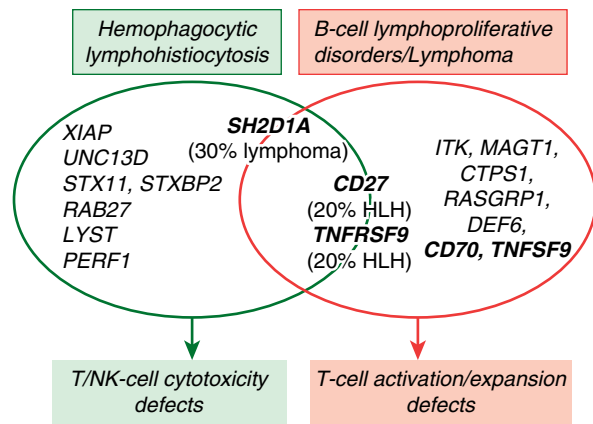
**PATHOGENESIS**

After transmission by saliva to the oral cavity, EBV infects both oral epithelial cells and tonsillar B lymphocytes, although it is unclear which cells are the primary initial targets. Ongoing viral replication leads to viremia and dissemination of infected B lymphocytes into peripheral blood and the lymphoreticular system, including the liver and spleen. Clinical manifestations of infectious mononucleosis, which are due to the host immune response to EBV infection, occur after a 6-week incubation period following acute infection. The atypical lymphocytes that are frequently detected in patients with infectious mononucleosis are primarily CD8 T lymphocytes. Polyclonal CD8 T lymphocyte activation occurs early during the incubation period following infection, whereas expansion of EBV-specific CD8 T lymphocytes is detected closer to the time of symptom onset. Natural killer (NK) cells also

**Table 301.1** Diseases Caused by Epstein-Barr Virus Infection

INFECTED CELL TYPE	NONMALIGNANT DISEASES	MALIGNANT DISEASES
B lymphocytes	<ul style="list-style-type: none"> <li>B-lymphoproliferations (B-LPD)</li> <li>Posttransplant B-LPD</li> <li>Hemophagocytic lymphohistiocytosis (HLH)</li> </ul>	<ul style="list-style-type: none"> <li>Hodgkin lymphoma (HL)</li> <li>Diffuse large B cell lymphoma (DLBCL)</li> <li>Burkitt lymphoma (BL)</li> </ul>
T/NK lymphocytes	<ul style="list-style-type: none"> <li>Systemic T/NK-cell type chronic active EBV (CAEBV)</li> <li>Cutaneous CAEBV               <ul style="list-style-type: none"> <li>Hydroa vacciniforme-like lymphoproliferation (HVL)</li> <li>Severe mosquito bite allergy (SMBA)</li> </ul> </li> <li>HLH</li> </ul>	<ul style="list-style-type: none"> <li>Systemic EBV+ T-cell lymphoma of childhood (STLC)</li> <li>Extranodal NK/T-cell lymphoma (ENKTL)</li> <li>Aggressive NK cell leukemia (ANKL)</li> </ul>
Smooth muscle cells	<ul style="list-style-type: none"> <li>Smooth muscle tumor/leiomyoma (SMT)</li> </ul>	
Epithelial cells	<ul style="list-style-type: none"> <li>Hairy leukoplakia*</li> </ul>	<ul style="list-style-type: none"> <li>Nasopharyngeal carcinoma (NPC)</li> <li>Gastric carcinoma</li> </ul>

\*Hairy leukoplakia is a benign epithelial/mucosal disease caused by uncontrolled lytic infection that occurs in immunocompromised patients. It is characterized by white patches with hairy appearance on the tongue.



**Fig. 301.1** Classification of gene defects predisposing to Epstein-Barr virus (EBV)-driven hemophagocytic lymphohistiocytosis (HLH) or B-cell lymphoproliferative disorders. *Red circle*, Gene defects associated with impaired cell-cytotoxicity causing HLH. *Green circle*, Gene defects associated with impaired T-cell activation/expansion causing B cell lymphoproliferative disorder (B-LPD)/lymphoma. Gene defects with a highly selective predisposition to EBV are in **bold**. In parentheses is the percentage of patients having developed HLH or B lymphoma for defects associated with both HLH and B-LPD/lymphoma. (From Fournier B, Latour S. *Immunity to EBV as revealed by immunodeficiencies*. *Curr Opin Immunol*. 2021;72:107–115. Fig. 1.)

expand in frequency and number following infection, particularly a CD56<sup>dim</sup> CD16<sup>-</sup> NK cell subset that is more effective than other NK cell subsets at recognizing infected cells. The host immune response is effective in rapidly reducing the EBV viral load, although persistent shedding of high levels of virus can be detected in the oropharynx for up to 6 months. Intermittent shedding from the oropharynx occurs for many years following primary infection.

EBV, like the other herpesviruses, establishes lifelong latent infection after the primary infection. Latent virus persists primarily in memory B lymphocytes. The EBV genome persists as an episome in the nucleus of an infected cell and replicates with cell division. Viral integration into the cell genome is not typical. Only a few viral proteins, including the EBV-determined nuclear antigens (EBNAs), are produced during latency. These proteins are important in maintaining the viral episome during the latent state. Reactivation and new viral replication occur at a low rate in populations of latently infected cells and is responsible for intermittent viral shedding in oropharyngeal secretions of infected individuals. *Reactivation is unlikely to be accompanied by distinctive clinical symptoms.*

## CLINICAL MANIFESTATIONS

The incubation period of infectious mononucleosis in adolescents is 30–50 days. In children, it may be shorter. The majority of cases of primary EBV infection in infants and young children are clinically silent. In older patients, the onset of illness is usually insidious and vague. Patients may complain of malaise, fatigue, acute or prolonged (>1 week) fever, headache, sore throat, nausea, abdominal pain, and myalgia. This prodromal period may last 1–2 weeks. The complaints of sore throat and fever gradually increase until patients seek medical care. Splenic enlargement may be rapid enough to cause left upper quadrant abdominal discomfort and tenderness, which may be the presenting complaint.

The **classic physical examination findings** are generalized lymphadenopathy (90% of cases), splenomegaly (50% of cases), and hepatomegaly (10% of cases). Lymphadenopathy occurs most commonly in the anterior and posterior cervical nodes and the submandibular nodes and less commonly in the axillary and inguinal lymph nodes. Epitrochlear lymphadenopathy is particularly suggestive of infectious mononucleosis. Although liver enzymes are usually elevated, symptomatic hepatitis or jaundice is uncommon. Splenomegaly to 2–3 cm below the costal margin is typical (15–65% of cases); massive enlargement is uncommon.



**Fig. 301.2** Tonsillitis with membrane formation in infectious mononucleosis. (Courtesy Alex J. Steigman, MD.)



**Fig. 301.3** Amoxicillin-induced rash in Epstein-Barr virus infection. Morbilliform maculopapular rash on the leg, which appeared shortly after starting amoxicillin. The rash is typical of that seen in the context of Epstein-Barr virus infection in patients treated with amoxicillin or ampicillin. (From Norman SD, Murray IA, Shetty D, et al. *Jaundice, abdominal pain, and fever in a young woman*. *Lancet*. 2017;390:1713–1714. Fig. A.)

The sore throat is often accompanied by moderate to severe pharyngitis with marked tonsillar enlargement, occasionally with exudates (Fig. 301.2). Palatal petechiae at the junction of the hard and soft palate are frequently seen. The pharyngitis is similar to that caused by streptococcal infection. Other clinical findings may include rashes and edema of the eyelids. Rashes are usually maculopapular and have been reported in 3–15% of patients. Patients with infectious mononucleosis who are treated with ampicillin or amoxicillin may experience an **ampicillin rash**, which may also occur with other  $\beta$ -lactam antibiotics (Fig. 301.3). This morbilliform, vasculitic rash is probably immune mediated and resolves without specific treatment. EBV can also be associated with Gianotti-Crosti syndrome, a symmetric rash on the cheeks with multiple erythematous papules, which may coalesce into plaques and persist for 15–50 days. The rash has the appearance of atopic dermatitis and may also appear on the extremities and buttocks.

## DIAGNOSIS

A presumptive diagnosis of infectious mononucleosis may be made by the presence of classic clinical symptoms with atypical lymphocytosis in the peripheral blood. The diagnosis is usually confirmed by serologic testing, either for heterophile antibody or specific EBV antibodies.

## Differential Diagnosis

EBV is the most common cause of infectious mononucleosis. Infectious mononucleosis-like illnesses may also be caused by primary infection with other pathogens, such as cytomegalovirus, *T. gondii*, adenovirus, and HIV. Streptococcal pharyngitis may cause sore throat and cervical lymphadenopathy indistinguishable from that of

infectious mononucleosis, but it is not typically associated with hepatosplenomegaly. Approximately 5% of cases of EBV-associated infectious mononucleosis have throat cultures positive for group A *Streptococcus*, representing pharyngeal streptococcal carriage. Failure of a patient with presumed streptococcal pharyngitis to improve within 48-72 hours should evoke suspicion of infectious mononucleosis. Hematologic malignancies should also be considered in a patient with an infectious mononucleosis-like illness, particularly when lymphadenopathy and hepatosplenomegaly are appreciated and the results of an initial laboratory evaluation are not consistent with an infectious etiology.

### Laboratory Diagnosis

The majority of patients (>90%) have a leukocytosis of 10,000-20,000 cells/ $\mu$ L, of which at least two thirds are lymphocytes; atypical lymphocytes usually account for 20-40% of the total number. The atypical cells are mature T lymphocytes that have been antigenically activated. Compared with regular lymphocytes microscopically, **atypical lymphocytes** are larger overall, with larger, eccentrically placed indented and folded nuclei with a lower nuclear-to-cytoplasm ratio. Although atypical lymphocytosis may be seen with many other infections associated with lymphocytosis, the highest degree of atypical lymphocytes is classically seen with EBV infection. Mild thrombocytopenia to 50,000-200,000 platelets/ $\mu$ L occurs in more than 50% of patients but only rarely is associated with purpura. Mild elevation of hepatic transaminases occurs in approximately 75% of uncomplicated cases, but it is usually asymptomatic and without jaundice.

### Detection of Heterophile Antibodies

**Heterophile antibodies** are cross-reactive immunoglobulin (Ig) M antibodies that agglutinate mammalian erythrocytes but are not EBV-specific. Heterophile antibody tests, such as the **monospot** test, are positive in 90% of cases of EBV-associated infectious mononucleosis in adolescents and adults during the second week of illness, but in only up to 50% of cases in children younger than 4 years of age. Test results can remain positive for up to 12 months. The false-positive rate is low, generally <10%. A positive heterophile antibody test in a patient with classic clinical manifestations of mononucleosis strongly supports that diagnosis. However, because of the nonspecific nature of heterophile antibody testing, EBV-specific antibody testing should be performed when a precise diagnosis is necessary.

### Detection of Epstein-Barr Virus-Specific Antibodies

If the heterophile test result is negative and an EBV infection is suspected, EBV-specific antibody testing is indicated. Measurement of antibodies to EBV proteins, including viral capsid antigen (VCA), Epstein-Barr nuclear antigen (EBNA), and early antigen (EA), are used most frequently (Fig. 301.4 and Table 301.2). The acute phase of infectious mononucleosis is characterized by rapid IgM and IgG antibody responses to VCA in all cases and an IgG response to EA in most cases. The IgM response to VCA is transient but can be detected for at least 4 weeks and occasionally up to 3 months; in rare cases, anti-VCA IgM can persist even longer. The IgG response to VCA usually peaks late in the acute phase, declines slightly over the next several weeks to months, and then persists at a relatively stable level for life.

Anti-EA IgG antibodies are usually detectable for several months but may persist or be detected intermittently at low levels for many years. Antibodies to the diffuse-staining component of EA (EA-D) are found transiently in 80% of patients during the acute phase of infectious mononucleosis. Antibodies to the cytoplasmic-restricted component of EA (EA-R) emerge transiently in the convalescence from infectious mononucleosis. High levels of antibodies to EA-D or EA-R may be found also in immunocompromised patients with persistent EBV infections and active EBV replication.

Anti-EBNA IgG antibodies are the last to develop in infectious mononucleosis and gradually appear 3-4 months after the onset of illness and remain at low levels for life. Absence of anti-EBNA when other antibodies are present implies recent infection, whereas the presence of anti-EBNA implies infection occurring more than 3-4 months previously. The wide range of individual antibody responses and the

various laboratory methods used can occasionally make interpretation of an antibody profile difficult. The detection of IgM antibody to VCA is generally sufficient to confirm the diagnosis of acute EBV infection, although false positive results can still occasionally occur.

### Detection of Viral DNA

EBV DNA can be detected and viral genome copy number quantified in whole blood, peripheral blood mononuclear cells (PBMCs), and plasma using real-time polymerase chain reaction. EBV DNA can be detected in PBMCs and plasma of patients with infectious mononucleosis for a brief period after the onset of symptoms and in PBMCs for an extended period. However, detection of EBV DNA is usually not necessary to diagnose infectious mononucleosis in immunocompetent patients with typical manifestations of disease. In contrast, serial measurements of EBV genome copy number are often used following solid organ or hematopoietic stem cell transplantation as surveillance for posttransplant lymphoproliferative disease (PTLD). Very high or consistently increasing EBV genome copy number suggests an increased risk for PTLD, although definitive diagnosis is typically based on tissue biopsy. The frequency and duration of monitoring EBV genome copy number is determined by the time after transplant and risk factors such as the type of transplant and the degree of immunosuppression. Serial measurement of EBV genome copy number can be useful in monitoring response to therapy for PTLD. Measurement of EBV genome copy number can also be used for screening and to determine prognosis for some EBV-associated malignancies, such as nasopharyngeal carcinoma and Hodgkin lymphoma.

### COMPLICATIONS

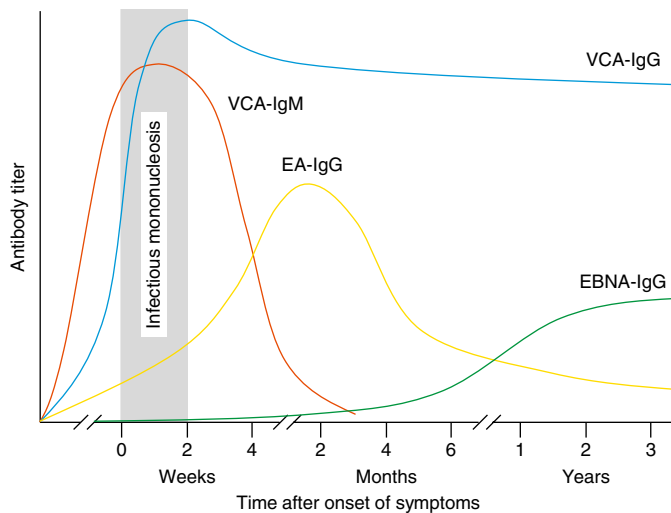
Severe complications are unusual in patients with infectious mononucleosis. Splenic rupture, either spontaneous or following mild trauma, may occur in approximately 0.1% of cases but is rarely fatal. Airway obstruction due to swelling of oropharyngeal lymphoid tissue occurs in <5% of cases. A variety of neurologic conditions have been associated with EBV infectious mononucleosis. Headache is a common symptom, but symptomatic meningitis or encephalitis is uncommon. More severe neurologic manifestations, such as seizures and ataxia, may occur in 1-5% of cases. Perceptual distortions of sizes, shapes, and spatial relationships, known as the **Alice in Wonderland syndrome (metamorphopsia)**, may be a presenting symptom. Some reports suggest an association between infectious mononucleosis and the possible development of multiple sclerosis. Hematologic abnormalities such as mild hemolytic anemia, thrombocytopenia, and neutropenia are relatively common, but aplastic anemia, severe thrombocytopenia, and severe neutropenia are rare. Other rare complications include myocarditis, interstitial pneumonia, pancreatitis, parotitis, and orchitis.

Patients with dysregulated immune responses to primary infection, such as individuals with primary or secondary **hemophagocytic lymphohistiocytosis (HLH)**, can develop severe, life-threatening complications with primary EBV infection (see Fig. 301.1). Patients with other primary immunodeficiencies that result in failure to control EBV infection and/or abnormal inflammatory responses to infection are at risk for severe manifestations of EBV infection, often with fulminant infectious mononucleosis, chronic viremia, dysgammaglobulinemia, and lymphoproliferation. Immunodeficiencies most commonly linked to severe EBV infection tend to be those affecting aspects of NK cell, T lymphocyte, and NKT lymphocyte function. Examples include X-linked lymphoproliferative (XLP) syndrome, which is caused by variants in genes encoding the signaling lymphocytic activation molecule (SLAM)-associated protein (SAP) or X-linked inhibitor of apoptosis (XIAP); X-linked immunodeficiency with magnesium defect, EBV infection, and neoplasia (XMEN), caused by mutations in *MAGT1*, which encodes a magnesium transporter protein; and deficiencies in interleukin-2-inducible T-cell kinase (ITK), CD27, or CD70 (see Fig. 301.1; Chapter 174.3).

### ONCOGENESIS

Infection with EBV, the first human virus to be associated with malignancy, accounts for up to 2% of cancers worldwide (see Table 301.1).





**Fig. 301.4** Kinetics of antibody responses to Epstein-Barr virus (EBV) antigens in infectious mononucleosis. EA, Early antigen; EBNA, EBV-determined nuclear antigens; IgG, immunoglobulin G; IgM, immunoglobulin M; VCA, viral capsid antigen.

CLINICAL STATUS	VCA IgM	VCA IgG	EA IgG	EBNA IgG
Susceptible	–	–	–	–
Acute primary infection	+	+	±	–
Recent primary infection	±	+	±	±
Past infection	–	+	±	+

EA, Early antigen (typically the diffuse staining component, or EA-D); EBNA, EBV-determined nuclear antigens; EBV, Epstein-Barr virus; IgG, immunoglobulin G; IgM, immunoglobulin M; VCA, viral capsid antigen.

Manipulation of infected cells by EBV can lead to transformation and oncogenesis. EBV is associated with lymphoid malignancies, such as Burkitt lymphoma, Hodgkin lymphoma, aggressive NK cell leukemia, T- and NK-cell lymphoproliferative disorder, and epithelial cell malignancies such as nasopharyngeal carcinoma and gastric carcinoma.

**Endemic Burkitt lymphoma** is the most common childhood cancer in equatorial East Africa and Papua New Guinea. These regions are holoendemic for *Plasmodium falciparum* malaria and have a high rate of EBV infection early in life. Constant exposure to malaria is thought to act as a B lymphocyte mitogen that contributes to the polyclonal B-lymphocyte proliferation with EBV infection, impairs T lymphocyte surveillance of EBV-infected B lymphocytes, and increases the risk for developing Burkitt lymphoma. Approximately 98% of cases of endemic Burkitt lymphoma contain the EBV genome compared with only 20% of nonendemic (sporadic) Burkitt lymphoma cases in other areas of the world.

The incidence of **Hodgkin lymphoma** peaks in childhood in developing countries and in young adulthood in developed countries. Infection with EBV increases the risk for Hodgkin lymphoma by a factor of 2-4, with the risk of developing Hodgkin lymphoma peaking at 2.4 years following infectious mononucleosis. EBV is associated with more than half of cases of mixed-cellularity Hodgkin lymphoma and approximately one quarter of cases of the nodular sclerosing subtype, but it is rarely associated with lymphocyte-predominant Hodgkin

lymphoma. Immunohistochemical studies have localized EBV to the Reed-Sternberg cells and their variants, the pathognomonic malignant cells of Hodgkin lymphoma.

Numerous congenital and acquired immunodeficiency syndromes are associated with an increased incidence of EBV-associated B-lymphocyte lymphoma, especially central nervous system lymphoma and leiomyosarcoma (see Fig. 301.1). Congenital immunodeficiencies predisposing to EBV-associated lymphoproliferation include XLP syndrome, common-variable immunodeficiency, ataxia-telangiectasia, Wiskott-Aldrich syndrome, and Chédiak-Higashi syndrome. Individuals with acquired immunodeficiencies resulting from anticancer chemotherapy, immunosuppression after solid organ or hematopoietic cell transplantation, or HIV infection have a significantly increased risk for EBV-associated lymphoproliferation. The lymphomas may be focal or diffuse and are usually histologically polyclonal but may become monoclonal. EBV-associated PTLD can occur following solid organ transplantation and, less commonly, allogeneic hematopoietic cell transplantation. The most important risk factors for PTLD are the degree of T lymphocyte immunosuppression and recipient EBV serostatus.

## TREATMENT

There is no specific treatment for infectious mononucleosis. The mainstays of management are rest, adequate fluid and nutrition intake, and symptomatic treatment to manage fever, throat discomfort, and malaise. Bed rest is necessary only when the patient has debilitating fatigue. As soon as there is definite symptomatic improvement, the patient should be encouraged to resume normal activities. Because blunt abdominal trauma may predispose patients to splenic rupture, it is customary and prudent to advise against participation in contact sports and strenuous athletic activities during the first 2-3 weeks of illness or while splenomegaly is present.

*Antiviral therapy is not recommended.* Although nucleoside analogs such as acyclovir and ganciclovir inhibit viral replication in vitro and decrease the duration of oropharyngeal viral shedding in patients with infectious mononucleosis, they have not been shown to provide consistent clinical benefit for patients with infectious mononucleosis or EBV-associated malignancies. Short courses of corticosteroids may be helpful for selected complications of infectious mononucleosis, such as airway obstruction, but there are insufficient data to support the use of corticosteroids to control typical symptoms in patients with infectious mononucleosis. Adoptive immunotherapy involving the infusion of EBV-specific cytotoxic T lymphocytes has shown some promise in early trials for transplant recipients with PTLD and for other patients with EBV-associated malignancies.

## PROGNOSIS

The prognosis for complete recovery is excellent. The major symptoms typically last 2-4 weeks, followed by gradual recovery within 2 months of symptom onset. Cervical lymphadenopathy and fatigue may resolve more slowly. Prolonged and debilitating fatigue and malaise may wax and wane for several weeks to 6 months and are common complaints even in otherwise unremarkable cases. Occasional persistence of fatigue for a few years after infectious mononucleosis is well recognized. There is no convincing evidence linking EBV infection or EBV reactivation to chronic fatigue syndrome.

## PREVENTION

Vaccination against EBV would be an appealing strategy to prevent acute disease (infectious mononucleosis) and complications such as EBV-associated malignancies. Early clinical trials using strategies targeting the EBV gp350 envelope glycoprotein demonstrated some protection against symptomatic infectious mononucleosis, although vaccination did not prevent EBV infection. No EBV vaccine is currently approved for clinical use.

Visit Elsevier eBooks+ at [eBooks.Elsevier.com](http://eBooks.Elsevier.com) for Bibliography.



## Chapter 302

## Cytomegalovirus

Suresh B. Boppana and William J. Britt

Human cytomegalovirus (CMV) is ubiquitous in the population, with serologic evidence of infection in >50% of adults in the United States and >96% in many populations in South America, Africa, and Asia. Individuals who become infected remain persistently infected for life and shed infectious virus intermittently from mucosal surfaces, thus serving as a source of infectious virus for transmission within populations. Although CMV infection rarely causes symptoms in immunocompetent individuals, it is an important cause of morbidity and sometimes death in immunocompromised hosts. CMV remains a well-recognized cause of disease in the newborn infant following intrauterine infection (congenital CMV) and in allograft recipients undergoing posttransplantation immunosuppression. CMV emerged as the most common opportunistic infection in HIV/AIDS patients before the advent of effective antiretroviral therapy. Invasive CMV infections can also be observed in patients treated with immunosuppressive biologics such as anti-tumor necrosis factor (TNF) antibodies. In each of these clinical settings that share some degree of immunosuppression, the association of disease with CMV infection has been linked to high levels of virus replication and end organ disease, usually associated with virus dissemination. In contrast, there is likely another group of disease states associated with chronic effects of persistent CMV infection that reflects the robust inflammatory response induced by this virus during persistent infection. Such associations have been proposed to include coronary artery disease, transplant vasculopathy and cardiac allograft loss, renal tubular sclerosis and renal allograft loss, exacerbations of inflammatory bowel disease, and possibly even some cancers such as glioblastoma. Whether definitive evidence will eventually directly link CMV to these disease states is uncertain.

### THE VIRUS AND ITS HOST INTERACTIONS

CMV is the largest of the human herpesviruses, with an estimated size of 190 nm. The 230-kb double-stranded DNA genome is about 50% larger than the herpes simplex virus genome and encodes over 200 open reading frames, which conservatively estimated includes >100 unique virion proteins and an unknown number of nonstructural proteins. Viral DNA replication takes place in the nucleus of the infected cell followed by virus assembly in both the nucleus and cytoplasm. The structure of the virus is typical of herpesviruses and includes a complex envelope composed of host cell-derived membrane studded with virion glycoproteins, a less well-structured area between the envelope and the capsid called the tegument layer, and an icosahedral capsid that contains the virion DNA. The tegument layer is highly immunogenic and induces strong adaptive immune responses, including CMV specific CD8<sup>+</sup> cytotoxic T lymphocytes that are thought to play a pivotal role in controlling CMV replication in the infected host. Likewise, the protein components of the viral envelope are also immunogenic and induce antibody responses that have been correlated with virus neutralization, antibody dependent cellular cytotoxicity (ADCC), antibody dependent cellular phagocytosis (ADCP), and other potential protective effector functions. In vivo, CMV appears to replicate in nearly all tissue and cell types, whereas in vitro productive virus replication (production of infectious progeny) occurs in primary fibroblasts and cells derived from epithelial tissue. Human CMV is species specific and productively infects only cells of human origin. Each strain of CMV that is isolated from epidemiologically unrelated individuals is genetically unique, a finding that suggests an extraordinarily large and undefined number of genetically unique viruses exist in the human population. Furthermore, studies using next-generation sequencing technologies have provided evidence that CMV can exist as genetically diverse populations of viruses within an individual. This

finding has argued that during replication, CMV DNA synthesis is error prone, resulting in sequence error rates in its genome that are much higher than previous studies would predict and/or a high likelihood of recombination events between viral genomes if permissive cells are infected with genetically diverse populations of viruses. Thus repeated exposures to CMV over time could result in an individual acquiring a library of CMVs as reinfection of previously infected individuals with new strains of CMV also appears commonplace. These observations have led many investigators to argue that CMV must express an armamentarium of immune evasion functions that allow it to persist even in the presence of robust host immunity. This relationship between host and virus is best illustrated by the finding that over years a persistently infected individual can maintain a stable virus load in sites of persistence, unwavering antiviral antibody responses, and, in some individuals, up to 15% of total peripheral blood CD8<sup>+</sup> cytotoxic T lymphocyte activity can be directed at CMV antigens derived from a diverse number of virus-encoded proteins. These observations have resulted in a central paradigm of CMV biology in which, following infection, a detente is established between virus replication and host innate and adaptive antiviral immunity. Thus CMV can efficiently persist in an infected host for a lifetime while inducing chronic immune activation. This latter characteristic of the biology of CMV infection has supported a linkage between CMV and chronic inflammation, a link that could provide a common mechanism for many of the chronic diseases that have been associated with this ubiquitous virus.

### EPIDEMIOLOGY

CMV infections can be acquired through several settings: (1) community exposure, (2) nosocomial transmission, and (3) intrauterine infection leading to congenital infection.

**Community acquisition** of CMV occurs throughout life and is linked by exposure to CMV shed from mucosal surfaces such as saliva, genital secretions, and urine. Peaks in exposure to infectious virus occur during childhood and in adolescents and young adults, presumably secondary to initiation of sexual activity in the latter age group. In addition, differences in age-specific and overall rates of virus infection in the United States are observed in different racial, ethnic, and socioeconomic groups. Common routes of infection of the very young infant include perinatal exposure to infected genital secretions during birth and ingestion of CMV-containing breast milk. Breastfeeding is the most common route of CMV infection in infancy. Ingestion of breast milk from seropositive women results in a rate of infection of about 60% in infants. Infection is most common during the first several months of breastfeeding, but the risk continues for the duration of breastfeeding. Infants infected through breast milk can shed large amounts of virus in the saliva and urine for prolonged periods measured in months to years, thus serving as a reservoir of virus for transmission to other infants, children, and adults. After this period of intense exposure to CMV during the first year of life, infection in the remainder of childhood and early teenage years depends on specific exposures such as enrollment in group childcare facilities and/or exposure to infected, similarly aged siblings. Up to 50% of young infants and children attending group care facilities can be excreting CMV, a source of virus that can result in infection of children enrolled in the facility and in some cases the adult workers within the facility. Furthermore, infants and children who acquire CMV in a group care setting can then transmit virus to their parents and siblings, thus providing a mechanism for spread of CMV within the community. Throughout childhood and early adulthood, CMV is transmitted by exposure to saliva and urine. However, in adolescence and early adulthood there is a spike in infection presumably associated with sexual exposure. CMV is considered a sexually transmitted infection (STI); data have shown an increased rate of CMV infection in sexually active populations and high rates of virus transmission in CMV-discordant couples.

**Nosocomial infections** with CMV are well described and can be associated with exposure to blood products containing CMV or to an allograft following transplantation of an organ from a CMV-infected donor. Before improvements in blood banking that limited the number of leukocytes in red cell transfusions and that more efficiently identified

CMV infected donors, transmission of CMV by blood transfusion was not uncommon and was closely related to the volume of blood that was transfused. **Transfusion-acquired CMV** infections often resulted in symptomatic illness, with laboratory findings including hepatitis and thrombocytopenia in children and adults. Severe and sometimes fatal infections can develop following exposure to CMV-infected blood products in newborn infants who lack transplacentally transferred antibodies to CMV either as a result of being born to women without seroimmunity to CMV or secondary to extreme prematurity. Similarly, immunocompromised patients who receive CMV-containing blood can also develop severe infection, regardless of their prior exposure to CMV. Methodologies that efficiently deplete contaminating leukocytes and the use of blood products from CMV seronegative donors have greatly decreased the incidence of transfusion-associated CMV infections. CMV transmission through **infected allografts** is well described; infections arising from CMV transferred in an infected allograft are a major cause of morbidity in both the early and late period after transplantation. Severe infections and graft loss following solid organ transplantation (SOT) are more often associated with mismatches between the donor and recipient, such as that following transplantation of an organ from a donor with a history of CMV infection (donor, CMV positive) into a recipient who has not been exposed to CMV (recipient, CMV negative; D+/R– mismatch). However, clinically significant CMV infections can occur even in moderate-risk allograft recipients (D+/R+). In contrast to the risk stratification for CMV infection and disease in SOT recipients, the highest risk of posttransplant CMV infection and disease occurs following reactivation of CMV in hematopoietic stem cell transplant (HSCT) recipients with prior CMV infection (D+/-/R+) presumably because the risk of transmission in the graft is considerably lower than reactivation of persistent infection in the previously infected recipient. Even with effective antiviral therapy to modify CMV infections in the early posttransplant period during intense immunosuppression, CMV infection is linked to long-term graft dysfunction and graft loss and in specific patient groups such as cardiac and lung transplant recipients, can represent a barrier to long-term graft survival.

**Congenital CMV infection** (present at birth) occurs following intrauterine transmission of CMV and infection of the fetus. Rates of congenital infection between 0.4% and 1.0% have been reported in the United States, with perhaps the best estimate being about 0.4% based on a large multicenter study of nearly 100,000 births. Rates as high as 2% in some areas in Asia and Africa have been described. CMV is thought to be transferred to the developing fetus following hematogenous spread of CMV to the placenta, infection of resident cells of the placenta followed by cell-free transfer of virus to the fetal blood system. The rate of transmission to the fetus is about 30% in nonimmune women with primary infection during pregnancy; in utero infections also occur in previously immune women (nonprimary infection), albeit at a reduced rate that has been suggested to be ~1–2%. The rate of transmission of CMV is more frequent following primary maternal infection; the absolute number of congenitally infected infants born to women with nonprimary infections in most populations outnumber those resulting from primary maternal infection by threefold to fourfold. This is particularly true in Africa, South America, and Asia, where maternal seroimmunity to CMV often exceeds 95%. Interestingly, many of these highly CMV seroimmune maternal populations also have the highest prevalence of congenital CMV infections and almost certainly account for overall burden of congenital CMV infections in most regions of the world. In fact, recent estimates based on the prevalence of congenital CMV infections in sub-Saharan Africa, Asia, and South America suggest that 90% of all cases of congenital CMV infections followed nonprimary maternal infections. The source of nonprimary maternal infection remains less well defined. Reinfection by genetically distinct strains of CMV is frequent in previously infected women and viruses acquired by maternal reinfection can be transmitted to the developing fetus. The reinfection rates are ~15–20%, with annualized rates as high as 25%. Thus immunity to CMV is far from protective, although it can modify the risk of transmission to the developing fetus.

In addition to the impact of maternal to fetal transmission, the type of maternal infection (primary versus nonprimary) has also been shown to be a major determinant in the outcome of the intrauterine infection. The existing paradigm is that maternal immunity can modify the severity of the intrauterine infection, thus maternal infections in women with preexisting CMV immunity (nonprimary maternal infections) that result in intrauterine transmission are less likely to result in a severe infection in the fetus. Nonetheless, severe CMV infections may occur in fetuses infected following a nonprimary maternal infection, suggesting that the characteristics of the fetal infection such as timing of infection during gestation could be as important to the outcome of a fetal infection as the maternal immune status during pregnancy. Studies have documented a higher frequency of severe infections in fetuses that were infected in the first and early second trimester of gestation, findings that parallel similar risk stratifications for other intrauterine infections, including those caused by Zika virus, rubella virus, and *Toxoplasma gondii*.

### Mechanisms of Disease Associated with Cytomegalovirus Infections

The mechanism(s) of disease associated with CMV infections remains either undefined or incompletely defined for many of the clinical syndromes that follow CMV infection. Several reasons have contributed to the overall lack of understanding of the pathogenesis of CMV infections and include (1) the asymptomatic nature of infections in almost all immunocompetent individuals; (2) the complexity of the multiple disease processes in immunocompromised hosts that can confound the assignment of specific manifestations of CMV infection; (3) the species-specific tropism of human CMV; and, perhaps most importantly, (4) limitations inherent in observational studies in humans. Although CMV replicates in a limited number of cell types in vitro, CMV inclusions, antigens, and nucleic acids can be demonstrated in almost all organ systems and most cell types in individuals with severe, disseminated infections. Thus CMV does not exhibit strict cellular or organ system tropism in vivo. Hematogenous dissemination has been argued to be associated primarily with cell-associated virus, and significant levels of plasma virus are usually detected only in severely immunocompromised hosts with high levels of total-blood viral loads. Virus and viral DNA can be recovered from neutrophils, monocytes, and endothelial cells present in peripheral blood, thus providing evidence for the significance of cell-associated spread of this virus. High levels of virus replication can result in end-organ disease secondary to direct virus-mediated cellular damage. These manifestations of CMV infections are thought to result from uncontrolled virus replication, dissemination, and virus-induced cytopathology secondary to deficits in innate and adaptive immune responses to CMV. In some cases, clinical disease has also been observed in patients without significant levels of virus replication, a finding suggesting indirect mechanisms of disease such as immunopathologic responses to CMV. Such a mechanism of disease was shown to be operative in patients with immune recovery vitritis, a pathologic T-lymphocyte-mediated response to CMV in HIV/AIDS patients with CMV retinitis that developed after successful active retroviral therapy and reconstitution of their CMV-specific T lymphocyte responses. Likewise, the level of virus replication has not been closely correlated with several chronic diseases thought to be linked to CMV, an observation that is consistent with indirect mechanisms of disease such as immunopathologic responses to a persistent infection.

From early observations in allograft recipients with invasive CMV infections it was apparent that immunosuppressive therapies that resulted in altered T lymphocyte function predisposed these patients to severe infections. Definitive evidence consistent with the critical role of CMV-specific T lymphocyte immunity in protection from disease in these patients was provided by a clinical study in which in vitro expanded, CMV-specific cytotoxic T lymphocytes limited invasive infection in hematopoietic cell transplant recipients. Invasive infections associated with end-organ disease, such as retinitis and colitis in HIV/AIDS patients with very low CD4<sup>+</sup> T-lymphocyte counts, also clearly demonstrated the importance of T lymphocyte response

control of invasive CMV infections, as the risk for these manifestations of CMV infections could be predicted in models that were based on CD4<sup>+</sup> T-lymphocyte counts in these patients. However, a role of anti-CMV antibodies in limiting the early events of CMV infection was also shown in studies in SOT recipients. These early studies demonstrated the transfer of immune globulins containing high titers of anti-CMV antibodies when used in a prophylaxis protocol could provide some degree of protection from CMV infections and end-organ disease. This important finding was consistent with the proposed role of antiviral antibodies in limiting CMV dissemination and disease in animal models of invasive CMV infections. The importance of innate immune responses such as natural killer (NK) cells and  $\gamma\delta$  T lymphocytes in limiting invasive infections have been well documented in animal models. Similarly, NK cells have been associated with both control of CMV reactivation and limiting the severity of CMV end-organ disease in human HCST and SOT recipients. Effector molecules such as interferon- $\gamma$  appear to contribute to the control of local CMV infections in animal models, but evidence of a similar role in humans has not been demonstrated.

Studies in immunocompromised human hosts have shown that the control of acute CMV infection depends on an effective adaptive immune response; however, even a vigorous T lymphocyte response is not sufficient to eliminate CMV from the infected host, because CMV persists for the lifetime of the host either as a low-level chronic infection and/or as a latent infection with limited transcription from multiple regions of its genome. The inability of the host to completely clear CMV remains incompletely understood, but the large array of immune evasion functions encoded by this virus likely contributes to the blunted innate and adaptive immune response. Examples of these functions include (1) inhibition of cell death functions of infected cells, including apoptosis, necroptosis, and pyroptosis, (2) inhibition of interferon-regulated responses, (3) inhibition of NK cell activation, (4) downregulation of class I major histocompatibility complex (MHC) expression and inhibition of class II MHC function, and (5) mechanisms to limit antibody recognition of envelope proteins, including carbohydrate masking of antibody recognition sites and variation in amino acid sequences in virion envelope proteins targeted by antiviral antibodies. Although each of these functions by itself could potentially have only limited effects on virus clearance, the redundancy of these viral immune evasion functions when acting in concert likely provide the virus a sufficient advantage to favor persistence.

## CLINICAL MANIFESTATIONS

The clinical manifestations of CMV infection reflect two parameters of the infection that are often linked: (1) the level of virus replication and (2) the degree of end-organ involvement. The manifestations of CMV infections that have been most well described in clinical studies are those that are present in acutely infected individuals without existing immunity to the virus. Such infections are termed acute or primary infections to distinguish these infections from persistent infections that are established after an acute infection. Similar clinical findings can be observed in patients with significant underlying deficits in innate and adaptive immune responses, regardless if infection follows an acute infection or recurrence/reactivation of persistent infection and reflect loss of immune control of virus replication. In contrast, the clinical manifestations of persistent or chronic CMV infections are frequently overlaid on underlying disease syndromes such as cardiovascular disease, thus confounding the contribution of CMV to the primary disease process and clinical findings in these patients.

### Normal Host

In the overwhelming majority of patients with acute CMV infections, there are no specific symptoms or clinical findings. In patients with symptomatic, acute CMV infection, clinical findings have been most commonly reported to resemble a mononucleosis-like syndrome, with fatigue and occasionally cervical adenopathy. Up to 20% of heterophile

antibody-negative mononucleosis may be attributed to CMV. Laboratory findings can include mild elevation of hepatic transaminases and decreased platelet counts.

### Immunocompromised Host

The clinical presentation of CMV infection in immunocompromised hosts often reflects the magnitude of the immunodeficiency. Profoundly immunocompromised hosts such as HSCT recipients can present with disseminated infection and clinical manifestations of disease in multiple organ systems, including liver, lung, gastrointestinal tract, and, less frequently, the CNS. Organ-threatening and life-threatening disease is not infrequent in these patients. In less immunocompromised patients such as the case of most SOT recipients, CMV infection can present with fever, fatigue, hematologic abnormalities, including leukopenia and thrombocytopenia, and mild hepatocellular dysfunction, a collection of laboratory findings and symptoms described as the CMV syndrome (Table 302.1). In contrast to renal and liver SOT recipients, heart-lung and lung transplant recipients are at high risk for severe manifestations from CMV infection, presumably because the transplanted organ is a site of virus replication, disease, and virus-induced life-threatening organ dysfunction (see Table 302.1). Before the widespread use of antivirals for prophylaxis of allograft recipients, clinical disease usually developed between 30 and 60 days after transplantation. Prolonged antiviral prophylaxis has greatly reduced the frequency of CMV disease in the early posttransplant period in most SOT and HCST recipients; late manifestations of CMV infection often become apparent after discontinuation of antiviral prophylaxis. These late manifestations are most worrisome in HSCT recipients, because they may signal deficits in graft function that in turn predispose these patients to invasive CMV infections. Long-term graft function has been reported to be influenced by CMV infection. This has been most well studied in renal allograft recipients and is thought by many investigators to represent a significant cause of chronic graft dysfunction and eventual loss of the graft. Perhaps the most dramatic impact of CMV infection late in the posttransplant period can be seen in heart transplant recipients, in whom CMV is thought to play a major role in transplant vascular sclerosis, a vasculopathy of the coronary arteries in the allograft leading to loss of the transplanted heart allograft.

### Congenital Infection

Congenital infection with CMV can present with clinically apparent (symptomatic) infection (Table 302.2) in about 10% of infected newborns, whereas 90% of infected infants will have *no clinical manifestations* of infection in the newborn period (asymptomatic infection) and can be identified only by screening newborns for the presence

**Table 302.1** Findings in Cytomegalovirus Infections in Solid Organ Transplant Recipients

CLINICAL FINDINGS	LABORATORY FINDINGS
<b>CMV SYNDROME</b>	
Fever, nonspecific findings, fatigue	Leukopenia, thrombocytopenia, reactive lymphocytosis, hepatitis, CMV DNA in blood
<b>END-ORGAN DISEASE</b>	
Gastrointestinal disease, including esophagitis, colitis, and hepatitis	Detection of CMV DNA in blood; detection of CMV in tissue biopsy; hepatitis, including elevated bilirubin
Lung disease; hypoxemia	Abnormalities in lung imaging CMV in bronchoalveolar lavage fluid
Encephalitis	CSF pleocytosis, elevated CSF protein Abnormalities in CNS imaging
Allograft dysfunction	Evidence of graft rejection



**Table 302.2** Findings in Infants with Symptomatic Congenital Cytomegalovirus Infection

FINDINGS	% OF INFANTS
<b>CLINICAL FINDINGS</b>	
Prematurity (<37 wk)	24
Jaundice (direct bilirubin >2mg/dL)	42
Petechiae	54
Hepatosplenomegaly	19
Purpura	3
Microcephaly	35
IUGR	28
1 clinical finding	41
2 clinical findings	59
<b>LABORATORY FINDINGS</b>	
Elevated ALT (>80IU/mL)	71
Thrombocytopenia (<100,000/k/mm <sup>3</sup> )	43
Direct hyperbilirubinemia (>2mg/dL)	54
Head CT abnormalities	42

Findings in 70 infants with symptomatic congenital CMV infection identified during newborn screening program for infants with congenital CMV infection at the University of Alabama Hospitals over an approximate 20-yr interval.  
 CMV, Cytomegalovirus; IUGR, in utero growth restriction; ALT, alanine aminotransferase.

of CMV in saliva, urine, or, less commonly, blood. **Severe multiorgan disease** is infrequent and occurs in approximately 30% of infants with symptomatic congenital CMV infections. The clinical findings in infants with symptomatic congenital CMV infections can include hepatosplenomegaly, petechial rashes, jaundice, and microcephaly. Intrauterine growth restriction is also a finding of symptomatic congenital CMV infection. Laboratory findings are consistent with the clinical findings and include direct hyperbilirubinemia, elevation of hepatic transaminases, thrombocytopenia, and abnormal findings on cranial ultrasonography/computed tomography/MRI (Fig. 302.1). If cerebrospinal fluid is obtained, there can be evidence of encephalitis, with elevation of mononuclear cell number and, in some cases, elevation of protein. A small number of symptomatically infected infants (<10%) will have chorioretinitis. Because **hearing loss** is the most common long-term sequela associated with congenital CMV infection, the failure of an infant to pass a newborn hearing screening exam should alert caregivers to the possibility of congenital CMV infection. Hearing loss in the older infant and young child should also alert the clinician to the possibility of congenital CMV infection, because about 50% of infants with hearing loss associated with congenital CMV infection will pass an initial hearing screening exam but will exhibit hearing loss in later infancy and early childhood. Importantly, hearing loss can be progressive in infants with congenital CMV infections and late-onset hearing loss and/or progression of hearing loss can only be identified by follow-up testing of hearing in congenitally infected infants (see later). Finally, the diagnosis of congenital CMV infection must be made within the first 2-3 weeks of life, and congenital CMV infection cannot be assumed to be the cause of hearing loss in older infants without evidence of CMV infection in the newborn period.

An organized plan for follow-up is an important component of the clinical management of infants with congenital CMV infection. Because permanent sequelae are limited to disorders of the central nervous system (CNS), long-term follow-up should include appropriate assessment of development and neuromuscular function in infected infants, with referral to specialized care if necessary. This is particularly important for infected infants who present with evidence



**Fig. 302.1** Cytomegalovirus (CMV). One-day-old with congenital CMV infection. Noncontrast CT of the head demonstrates multiple areas of confluent calcifications within the periventricular regions bilaterally (arrows), typical of the expected distribution of calcification secondary to CMV. Note the abnormal sulcal pattern of the right hemisphere, indicating associated polymicrogyria (arrowheads). (From Rothenberg Maddocks AB, Pollok AN. *Infection and inflammation*. In: Coley BD, ed. *Caffey's Pediatric Diagnostic Imaging*, 13th ed. Philadelphia: Elsevier; 2019: Fig. 34.31, p. 342.)

of CNS damage such as microcephaly, seizures, or obvious motor deficits. Overall, about 11% of infected infants will exhibit some degree of hearing loss; hearing loss in some infants will progress during infancy or less frequently, develop later in infancy. Thus comprehensive audiologic testing and follow-up are mandatory in these patients. Other sequelae such as vision loss are infrequent, but vision testing and comprehensive eye examinations should be included in the care plan of infants with congenital CMV infection.

### Perinatal Infection

Perinatal infections can be acquired during birth or following ingestion of CMV-containing breast milk. In almost all cases perinatal infections have not been associated with clinical manifestations of the infection and have not been associated with long-term sequelae that have been described in infants with congenital CMV infections. In rare cases such as is seen in breast milk transmission of CMV to extremely premature infants or infants born to nonimmune women, perinatal infection can result in severe, disseminated infections associated with end-organ disease and death. These more severe infections are thought to develop in infants that lack transplacentally acquired antiviral antibodies, either secondary to extreme prematurity or as the product of a mother lacking anti-CMV antibodies.

### DIAGNOSIS

In the nonimmunocompromised individual, diagnosis of CMV infection has required evidence of a primary or acute infection. Serologic reactivity for CMV is lifelong following primary infection; therefore the presence of immunoglobulin (Ig) G antibody to CMV does not provide evidence of acute infection unless the absence of CMV-specific IgG reactivity in a prior serum specimen can be demonstrated, thus providing evidence of IgG seroconversion. In addition, IgM reactivity for CMV can be detected for prolonged periods after acute infection and cannot be used to reliably estimate the duration of a primary infection. Furthermore, recovery of virus from body fluids such as saliva or urine does not in itself permit diagnosis of



CMV infection, because persistently infected individuals can intermittently shed virus. In contrast, in the immunocompromised host, CMV can frequently be recovered from patients in the absence of evidence of invasive CMV infection. Thus assignment of CMV as a cause of disease in immunocompromised patients must be made carefully, and other potential causes of symptoms and clinical findings in these patients must also be considered. Serologic assays are of limited value in the transplant recipient secondary to the impact of immunosuppression on antibody responses in the allograft recipient. Moreover, IgM antibodies can be produced following a nonprimary infection in these patients. Sequential viral load measurements by nucleic acid amplification testing (NAAT) such as polymerase chain reaction (PCR) in relevant body fluids such as blood and detection of CMV DNA in biopsy tissue can be of great value in establishing CMV as a cause of disease in allograft recipients because increasing viral loads can provide evidence of the lack of host control of CMV replication (Table 302.3). Detection of CMV in urine, saliva, blood, and tissue specimens obtained at biopsy can most reliably be accomplished by NAAT, and because findings can be quantified, treatment responses can be monitored. However, conventional culture of CMV using human dermal fibroblasts often combined with immunofluorescence detection of CMV-encoded immediate early antigens also remains standard in many institutions. Histopathologic studies of tissue specimens that permit detection of CMV-infected cells containing characteristic nuclear inclusions (owl's-eye inclusions) are relatively insensitive but can aid in the diagnosis of an invasive CMV infection. The addition of immunohistochemistry for the detection of CMV-encoded proteins and/or in situ hybridization for the detection of CMV nucleic acids has greatly improved the sensitivity of histologic detection of CMV in tissue and/or biopsy specimens (see Table 302.3).

In practice, in nonimmunocompromised patients the demonstration of CMV-specific IgG seroconversion or the presence of CMV-specific IgM antibodies is considered evidence of a recently acquired CMV infection. However, in the case of pregnant women the timing of a primary infection often requires a more precise estimate of when the infection was acquired because CMV infections before conception

carry significantly less risk to the developing fetus than infections acquired after conception. Furthermore, as noted in previous sections, maternal infections acquired in the first and early second trimester are more frequently associated with severe intrauterine infections and result in more significant long-term sequelae in infants with congenital CMV infections. Because IgM anti-CMV antibody reactivity can persist for months depending on the sensitivity of the particular assay, the use of IgM detection to precisely time the acquisition of CMV is of limited value. However, when combined with IgG avidity assays in which CMV-specific binding antibodies are eluted with increasing concentrations of chaotropic agents such as urea, IgG serology can provide a more accurate estimate of the duration of infection. Thus the IgG avidity assay has been used almost exclusively in the management of CMV infections during pregnancy to aid in identifying primary maternal infections in women who present at the first prenatal visits with CMV-specific IgM antibodies. The presence of CMV-specific IgG antibodies with high avidity argues for an infection that occurred in the distant past, whereas low-avidity CMV-specific IgG antibodies argues for a more proximal timing of infection. The presence of anti-CMV IgG antibodies with intermediate avidity is considered uninterpretable (see Table 302.3).

### Congenital Infections

The diagnosis of congenital CMV infections requires the recovery of replicating virus and/or viral nucleic acids within the first 2-3 weeks of life. Sources of virus and viral nucleic acids include urine, saliva, and blood. Methods of detection include routine virus culture combined with immunofluorescence and NAAT. Although quantification of virus in various specimens can suggest the likelihood of long-term sequelae such as hearing loss for a population of infected newborns, the predictive value for the individual patient remains limited. A considerable amount of effort has been devoted to identifying screening assays that would be suitable for populations of newborn infants. Initial interest centered on dried blood spots, because these samples are routinely collected as a component of newborn screening programs. Unfortunately, studies have indicated that the sensitivity of detection of congenitally infected infants using dried blood spots is too low to be considered

**Table 302.3** Laboratory Detection of Cytomegalovirus Infection

ASSAY	APPLICATION	CHARACTERISTICS OF ASSAY
<b>TISSUE CULTURE</b> Virus isolation	Detection of virus in clinical material	Requires prolonged culture periods; low sensitivity compared with molecular techniques; expensive
<b>HISTOPATHOLOGY</b> Histopathology	Identification of CMV infected cells (owl's eye inclusions)	Routine for most laboratories; low sensitivity is improved with IHC (see below)
Viral antigen detection (immunohistochemistry)	Sensitive and allows detection of CMV-infected cells in variety of specimens	Rapid and can be quantitative
<b>MOLECULAR METHODOLOGIES</b> Nucleic acid amplification (NAAT), including quantitative PCR, transcription-mediated amplification (TMA)	Quantitation of CMV DNA and viral RNA	Rapid, sensitive, and quantitative; can be applied to variety of clinical specimens (blood, saliva, urine, biopsy specimens, etc.)
DNA/RNA in-situ hybridization	Sensitive detection of CMV DNA or RNA transcripts in tissue specimens	Technically more difficult than NAAT, long turnaround times, can identify specific cells infected with CMV
<b>SEROLOGIC TESTING</b> CMV-specific IgM serology	Screening for recent infections	Variability in duration of response and low levels of IgM antibodies decrease sensitivity and specificity
CMV-specific IgG serology	Detection of infection with HCMV, useful for seroprevalence studies	Rapid, specific, and quantitative; gold standard for CMV infection (acute and past)
CMV-specific IgG avidity	Estimate of duration of HCMV infection	Interpretation limited to high and low values of avidity; useful for timing of recent CMV infections in pregnancy; not useful in allograft recipients

useful for screening. In contrast, newborn screening using saliva has proven sensitive and specific and is used for newborn screening in many institutions. The identification of an infected infant by screening of saliva requires confirmation, preferably by assaying urine for the presence of CMV.

## TREATMENT

Treatment of *immunocompromised hosts* with invasive CMV disease limits both the morbidity and the mortality in the patient with disseminated CMV infections with end-organ disease. This has been shown in allograft transplant recipients and patients with HIV/AIDS. Similarly, antiviral prophylaxis can limit the development of clinically important CMV disease in allograft recipients and is the standard of care in most transplant centers, with the remaining centers using *pre-emptive* treatment in which antivirals are given once a predetermined level of CMV viremia is detected during routine monitoring in the posttransplant period. Several agents are licensed for CMV infections, including ganciclovir, foscarnet, and cidofovir; all have appreciable toxicity. Letermovir is another agent that has been licensed for use in adults; it is expected that indications for this agent will extend into pediatrics in the future. The antiviral agent, maribavir, has been licensed to treat refractory CMV infections in adult transplant recipients. In some transplant centers, high-titer CMV immunoglobulins have been included as a component of prophylaxis, most commonly in heart and lung SOT recipients. Early on, when the treatment of CMV infections with antiviral agents was in its infancy, treatment with CMV immunoglobulins was shown to alter the natural history of CMV infection in renal and liver allograft recipients. However, the efficacy of antiviral agents when used as prophylaxis in the immediate posttransplant period has resulted in less frequent use of these biologics.

Treatment of **congenitally infected infants** with ganciclovir has been studied in several clinical trials, and a significant number of infected infants with symptomatic congenital CMV infections have been treated off-label with this agent. In addition, infants with severe perinatal CMV infection following breast milk ingestion with documented end-organ disease have been successfully treated with ganciclovir. Two studies have suggested that 6 weeks of intravenously administered ganciclovir or 6 months of valganciclovir, an oral preparation of ganciclovir, could limit hearing loss and possibly improve developmental outcome of infected infants followed for approximately 2 years. In contrast to the apparent efficacy of valganciclovir treatment in congenitally CMV infected infants in these studies with relatively short-term follow-up, another study reported that valganciclovir failed to provide evidence of efficacy in altering the long-term outcomes of congenitally infected infants when followed over a longer time. Currently, there are no recommendations for the treatment of infants with congenital CMV infection.

## PREVENTION

### Passive Immunoprophylaxis

Passive transfer of anti-CMV antibodies has been used to limit disease but not infection in allograft recipients. A similar approach has also been considered for prevention of intrauterine transmission of CMV; disease based on studies from limited observational data suggests that antiviral antibodies could limit disease following CMV infections in the perinatal period. An uncontrolled trial of human immune globulin provided provocative evidence that passive transfer of anti-CMV antibodies to pregnant women undergoing primary CMV infection could limit intrauterine transmission and disease. A second study using the same immune globulin preparation failed to demonstrate that immune globulins provided protection from intrauterine transmission or disease. Another multicenter trial sponsored by the NIH was terminated secondary to the lack of any efficacy of the treatment. It remains to be determined if passively

transferred anti-CMV antibodies can modulate infection and disease following intrauterine exposure to CMV.

### Active Immunoprophylaxis

Active immunization for the prevention of congenital CMV infection (and in transplant recipients) has been a goal of biomedical research for over 3 decades. A number of different vaccine platforms have been explored, including replicating attenuated CMV vaccines, protein-based vaccines, heterologous virus-vectored CMV vaccines, DNA vaccines, and mRNA-based vaccines. In all cases, some level of immunity has been induced by each of these candidate vaccines. Larger scale trials have been carried out using replication competent, attenuated CMV vaccines and adjuvanted recombinant protein vaccines. Current approaches are directed toward development of an adequately attenuated replicating CMV strain that retains sufficient immunogenicity to induce protective responses. In contrast to programs testing candidate attenuated CMV vaccines, considerable progress has been made in the testing of adjuvanted recombinant viral proteins. An adjuvanted recombinant glycoprotein B, a major protein component of the envelope and target of neutralizing antibodies, has been shown to induce virus neutralizing antibodies and CD4<sup>+</sup> T lymphocyte proliferative responses. Moreover, this vaccine reduced virus acquisition by about 50% in a trial carried out in young women. Closer examination of this particular trial revealed that protection was very short-lived and that the effectiveness of the vaccine was not convincingly demonstrated because of the small numbers of subjects in the trial, despite attaining minimal statistical significance. A follow-up trial in adolescent women using the same vaccine preparation failed to show any statistically significant difference between vaccine and placebo recipients. A major question that will face all vaccine programs is whether existing immunity in seropositive women can be augmented to a level to prevent damaging infection in their offspring. The maternal population with existing immunity to CMV before childbearing age is responsible for the vast majority of congenitally infected infants in almost all regions of the world; thus merely recapitulating naturally acquired adaptive immunity to CMV with a vaccine may not be sufficient to prevent congenital CMV infection and/or limit disease.

### Counseling

Studies of the natural history of CMV have repeatedly demonstrated that transmission requires repeated close, often direct contact with infected material such as secretions from the oral or genitourinary tract. Although limited data suggest that CMV can be transmitted from fomites, infectivity can persist for hours on surfaces such as toys. Limiting exposure to such secretions and attention to hygiene such as handwashing can drastically limit acquisition of CMV. Counseling has been shown to be very effective in the prevention of CMV infection in women of childbearing age. In fact, counseling programs have been shown to be more effective in limiting CMV infection during pregnancy than any vaccine that has been tested to date. Sexual transmission is an important route of infection, because CMV is considered to be an STI. Limiting sexual transmission through education and counseling should be considered in sexually active individuals. The acquisition of CMV by hospital workers and other healthcare providers has been shown to be less than in age-matched individuals in the general public. Importantly, these early studies in healthcare workers were carried out before universal precautions that are in place in most hospitals today. Thus patient education with an emphasis on describing the sources of infectious virus in communities and attention to general hygiene could dramatically reduce community-acquired CMV, particularly in women of childbearing age.

Visit Elsevier eBooks+ at [eBooks.Health.Elsevier.com](http://eBooks.Health.Elsevier.com) for Bibliography.

## Chapter 303

## Roseola (Human Herpesviruses 6 and 7)

Brenda L. Tesini

Human herpesvirus 6 (HHV-6A and HHV-6B) and human herpesvirus 7 (HHV-7) cause ubiquitous infection in infancy and early childhood. HHV-6B is responsible for the majority of cases of **roseola infantum (exanthem subitum or sixth disease)** and is associated with other diseases, including encephalitis, especially in immunocompromised hosts. A small percentage of children with roseola have primary infection with HHV-7.

**ETIOLOGY**

HHV-6A, HHV-6B, and HHV-7 are the sole members of the Roseolovirus genus in the Betaherpesvirinae subfamily of human herpesviruses. Human cytomegalovirus, the only other  $\beta$ -herpesvirus, shares limited sequence homology with HHV-6 and HHV-7. Morphologically all human herpesviruses are composed of an icosahedral nucleocapsid, protein-dense tegument, and lipid envelope. Within the nucleocapsid, HHV-6 and HHV-7 both contain large, linear, double-stranded DNA genomes that encode more than 80 unique proteins.

Initially, two strain groups of HHV-6 were recognized: HHV-6 variant A and HHV-6 variant B. Despite sharing highly conserved genomes with approximately 90% sequence identity, the two variants could be distinguished by restriction fragment length polymorphisms, reactivity with monoclonal antibodies, differential cell tropism, and epidemiology. Because of these differences, the two were reclassified as separate species in the genus Roseolovirus by the International Committee on the Taxonomy of Viruses in 2012. HHV-6A detection is quite rare, and HHV-6B is the overwhelmingly predominant virus found in both immunocompetent and immunocompromised hosts. Previous reports of HHV-6A detection in children in Africa have not been substantiated in a large cohort using a more specific PCR target.

**EPIDEMIOLOGY**

Primary infection with HHV-6B is acquired rapidly by essentially all children after the loss of maternal antibodies in the first few months of infancy, with 95% of children being infected by 2 years of age. The peak age of primary HHV-6B infection is 6–9 months of life, with infections occurring sporadically and without seasonal predilection or contact with other ill individuals. Infection with HHV-7 is also widespread but occurs later in childhood and at a slower rate; only 50% of children have evidence of prior infection with HHV-7 by 3 years of age. Seroprevalence reaches 75% by 6 years of age. In a small study of children with primary HHV-7 infection, the mean age of the patients was 26 months, significantly older than that of children with primary HHV-6 infection.

Preliminary data suggest that the majority of children acquire primary infection with HHV-6 from the saliva or respiratory droplets of asymptomatic adults or older children. However, congenital infection with HHV-6 occurs in 1% of newborns. Two mechanisms of vertical transmission of HHV-6 have been identified: transplacental infection and chromosomal integration. HHV-6 is unique among the human herpesviruses in that it is integrated at the telomere end of human chromosomes at a frequency of 0.2–2.2% of the population and is passed from parent to child via the germline. Chromosomal integration of HHV-7 has been suggested in only a single case report thus far. Chromosomal integration has been identified as the major mechanism by which HHV-6 is vertically transmitted, accounting for 86% of congenital

infections, with one third resulting from HHV-6A, a percentage much higher than in primary infection in the United States. The clinical consequences of chromosomal integration or transplacental infection with HHV-6 have yet to be determined. In one series of infants identified with HHV-6 congenital infection, no evidence of disease was present in the early neonatal period. However, reactivation of chromosomally integrated HHV-6 virus has been demonstrated following hematopoietic stem cell transplantation (HSCT). Primary infection with HHV-7 is presumed to be spread by the saliva of asymptomatic individuals. DNA of both HHV-6 and HHV-7 has been identified in the cervical secretions of pregnant women, suggesting an additional role for sexual or perinatal transmission of these viruses. Breast milk does not appear to play a role in transmission of either HHV-6 or HHV-7.

**PATHOLOGY AND PATHOGENESIS**

Primary HHV-6B infection causes a viremia that can be demonstrated by co-culture of the patient's peripheral blood mononuclear cells with mitogen-stimulated cord blood mononuclear cells. HHV-6 has a recognizable cytopathic effect, consisting of the appearance of large refractile mononucleated or multinucleated cells with intracytoplasmic and/or intranuclear inclusions. Infected cells exhibit a slightly prolonged life span in culture; however, lytic infection predominates. HHV-6 infection also induces apoptosis of T cells. In vitro, HHV-6 can infect a broad range of cell types, including primary T cells, monocytes, natural killer cells, dendritic cells, and astrocytes. HHV-6 has also been documented to infect B-cell, megakaryocytic, endothelial, and epithelial cell lines. Human astrocytes, oligodendrocytes, and microglia have been infected with HHV-6 ex vivo. The broad tropism of HHV-6 is consistent with the recognition that CD46, present on the surface of all nucleated cells, is a cellular receptor for HHV-6, HHV-6A in particular. CD134, a member of the TNFR superfamily, is the main entry receptor for HHV-6B and may explain some of the differences in tissue tropism noted between HHV-6A and HHV-6B. The CD4 molecule has been identified as a receptor for HHV-7. HHV-7 has been demonstrated to reactivate HHV-6 from latency in vitro, but whether this phenomenon occurs in vivo is not clear.

Primary infection with HHV-6 and HHV-7 is followed by **lifelong latency** or persistence of virus at multiple sites. HHV-6 exists in a true state of viral latency in monocytes and macrophages. The detection of replicating HHV-6 in cultures of primary CD34<sup>+</sup> hematopoietic stem cells has also been described, suggesting that cellular differentiation is a trigger of viral reactivation. This observation is clinically significant because HHV-6 may cause either primary or reactivated infection during HSCT. Additionally, HHV-6 and HHV-7 infection may be persistent in salivary glands, and DNA of both HHV-6 and HHV-7 can be routinely detected in the saliva of both adults and children. HHV-7 can also be isolated in tissue culture from saliva, but HHV-6 cannot. HHV-6 DNA has been identified in the cerebrospinal fluid (CSF) of children, both during and subsequent to primary infection, as well as in brain tissue from immunocompetent adults at autopsy, implicating the central nervous system (CNS) as an additional important site of either viral latency or persistence. HHV-7 DNA has also been found in adult brain tissue but at a significantly lower frequency.

**CLINICAL MANIFESTATIONS**

Roseola infantum (**exanthem subitum**, or **sixth disease**) is an acute, self-limited disease of infancy and early childhood. It is characterized by the abrupt onset of high fever, which may be accompanied by fussiness. The fever usually resolves acutely after 72 hours (crisis) but may gradually fade over a day (lysis) coincident with the appearance of a faint pink or rose-colored, nonpruritic, 2- to 3-mm morbilliform rash on the trunk (Fig. 303.1). The rash usually lasts 1–3 days but is often described as evanescent and may be visible only for hours, spreading from the trunk to the face and extremities. Because the rash is variable in appearance, location, and duration, it is not distinctive and may be missed. Associated signs are few but can include mild injection of the pharynx, palpebral conjunctivae, or tympanic membranes and





**Fig. 303.1** Roseola infantum. A, Erythematous, blanching macules and papules in an infant who had high fever for 3 days preceding development of the rash. B, On closer inspection some lesions reveal a subtle peripheral halo of vasoconstriction. (From Paller AS, Mancinini AJ, eds. *Hurwitz Clinical Pediatric Dermatology*, 3rd ed. Philadelphia: Elsevier; 2006: p. 434)

enlarged suboccipital nodes. In Asian countries, ulcers at the uvulo-palatoglossal junction (**Nagayama spots**) are commonly reported in infants with roseola.

High fever (mean: 39.7°C [103.5°F]) is the most consistent finding associated with primary HHV-6B infection. Rash detected either during the illness or following defervescence has been reported in approximately 20% of infected children in the United States. Additional symptoms and signs include irritability, inflamed tympanic membranes, rhinorrhea and congestion, gastrointestinal complaints, and encephalopathy. Symptoms of lower respiratory tract involvement such as cough are identified significantly less frequently in children with primary HHV-6B infection than in children with other febrile illnesses. The mean duration of illness caused by primary HHV-6B infection is 6 days, with 15% of children having fever for 6 or more days. Primary infection with HHV-6B accounts for a significant burden of illness on the healthcare system; one study found that 24% of visits to emergency departments by infants between 6 and 9 months of age were because of primary HHV-6B infection. A population-based study of primary HHV-6B infection confirmed that 93% of infants had symptoms and were more likely to visit a physician than noninfected infants. Fever was less likely to be present with HHV-6B infection in children younger than 6 months of age but was significantly more common in older infants and children.

Much less is known about the clinical manifestations of HHV-7 infection. Primary infection with HHV-7 has been identified in a small number of children with roseola in whom the illness is indistinguishable from that caused by HHV-6B. Secondary cases of roseola caused by infection with HHV-7 have also been reported. Additionally, primary infection with HHV-7 may be asymptomatic or may cause a non-specific febrile illness lasting approximately 3 days.

### LABORATORY FINDINGS

The most characteristic laboratory findings noted in children with primary HHV-6B infection are lower mean numbers of total white blood cells (8,900/μL), lymphocytes (3,400/μL), and neutrophils (4,500/μL) than in febrile children without primary HHV-6B infection. Similar hematologic findings have been reported during primary infection with HHV-7. Thrombocytopenia, elevated serum transaminase values, and atypical lymphocytes have also been noted sporadically in children with primary HHV-6B infection.

Results of CSF analyses reported in patients with encephalitis thought to be caused by HHV-6 have been normal or demonstrated only minimal CSF pleocytosis with mild elevations of protein, especially early in the course of the disease, which may progress with time. Areas of hyperintense signal on T2 weighted and fluid attenuation inversion recovery images of the hippocampus, uncus, and amygdala have been found on MRI, and increased metabolism within the hippocampus has been observed on positron emission tomography scanning.

### DIAGNOSIS

Although roseola is generally a benign self-limited disease, its diagnosis can exclude other, more serious disorders that cause fever and rash. A history of 3 days of high fever in an otherwise nontoxic 10-month-old infant with a blanching maculopapular rash on the trunk suggests a diagnosis of roseola. **A specific diagnosis of HHV-6 is not usually necessary except in situations in which the manifestations of the infection are severe or unusual and might benefit from antiviral therapy.**

**The diagnosis of primary infection with either HHV-6 or HHV-7 is confirmed by demonstrating the presence of actively replicating virus in the patient's blood sample coupled with seroconversion.** Viral culture is the gold standard method to document active viral replication. Unfortunately, culture is expensive, time consuming, and available only in research laboratories. Two other methods used to identify active HHV-6 replication are the detection of viral DNA by PCR on acellular fluids such as plasma or reverse transcriptase PCR on peripheral blood mononuclear cell samples designed to detect viral transcription and protein production. Quantitative PCR for HHV-6 genome copy numbers on various specimens is also frequently reported and is commercially available. However, the role of this methodology is not clear, as a specific value of DNA that can discriminate between patients with viremia and those who are culture negative has not been determined. Complicating the use of molecular assays for the detection of active replication of HHV-6 is the recognition that individuals with chromosomally integrated HHV-6 have persistent HHV-6 DNA in plasma, peripheral blood mononuclear cells, and CSF in the absence of disease and replicating virus.

Serologic methods such as indirect immunofluorescence assays, enzyme-linked immunosorbent assays, neutralization assays, and immunoblot have been described for the measurement of concentrations of antibodies to HHV-6 and HHV-7 in serum or plasma and are commercially available. Although immunoglobulin M antibody is produced early in infection with HHV-6, assays designed to measure this response have not proved useful in the diagnosis of primary or reactivated infection. The absence of immunoglobulin G antibody in an infant older than 6 months of age combined with the presence of replicating virus is strong evidence of primary infection with either HHV-6 or HHV-7. Alternatively, the demonstration of seroconversion between acute and convalescent samples also confirms primary infection but is not clinically useful in the acute care setting. Unfortunately, serologic assays have not been found reliable in the detection of HHV-6 reactivation and cannot be used to differentiate between infection with HHV-6A and infection with HHV-6B. Additionally, limited antibody cross-reactivity has been demonstrated between HHV-6 and HHV-7, complicating the interpretation of serologic assays, especially if low titers are reported.

### Differential Diagnosis

Primary infection with either HHV-6B or HHV-7 usually causes an undifferentiated febrile illness that may be very difficult to distinguish from other common viral infections of childhood. This difficulty also applies to the early stages of roseola, before the development of rash. Once the rash is present, roseola may be confused with other exanthematous diseases of childhood, especially measles and rubella. Children with **rubella** often have a prodrome characterized by mild illness with low-grade fever, sore throat, arthralgia,



and gastrointestinal complaints, unlike those with roseola. On physical examination, suboccipital and posterior auricular lymph nodes are prominent up to 1 week before the rash of rubella is evident and persist during the exanthematous phase. Additionally, the rash of rubella usually begins on the face and spreads to the chest, like that in measles. The associated symptoms of **measles** virus infection include cough, coryza, and conjunctivitis, with high fever coincident with the development of rash, unlike in roseola. Roseola may also be confused with scarlet fever, though the latter is rare in children younger than 2 years of age and causes a characteristic sandpaper-like rash concurrent with fever.

Roseola may be confused with illness caused by **enterovirus infections**, especially in the summer and fall months. Drug hypersensitivity reactions may also be difficult to distinguish from roseola. Antibiotics are frequently prescribed for children with fever from roseola before the appearance of rash. A child who then demonstrates rash after the resolution of fever may erroneously be labeled as being drug allergic.

## COMPLICATIONS

Convulsions are the most common complication of roseola and are recognized in up to one third of patients. Seizures are also the most common complication of children with documented primary HHV-6B infection, occurring in approximately 15%, with a peak age of 12-15 months. Children with primary HHV-6B infection are also reported to have a higher frequency of partial seizures, prolonged seizures, postictal paralysis, and repeated seizures than are children with febrile seizures not associated with HHV-6. In a study limited to children with primary HHV-6B infection and seizures, 30% of patients had prolonged seizures, 29% had focal seizures, and 38% had repeated seizures. A prospective study of children 2-35 months of age with suspected encephalitis or severe febrile illness with convulsions found that 17% had primary infection with either HHV-6 or HHV-7, and status epilepticus was the most common presentation. Among children with febrile status epilepticus (FSE), primary or reactivated infection with HHV-6B or HHV-7 has been identified in approximately one third.

An association between recurrent seizures and reactivated or persistent infection of the CNS by HHV-6 has also been suggested. Studies evaluating brain tissue specimens implicate HHV-6 in as many as 60% of patients with temporal lobe epilepsy (TLE), high viral loads being found in the hippocampus or lateral temporal lobe regions. HHV-6 is postulated to induce neuroinflammation and potential injury via innate and adaptive immune system activation as a result of the broad tissue tropism of the virus. Subsequent neuronal hyperexcitability through the loss of glutamate regulatory control and increased blood-brain barrier permeability have been proposed as possible mechanisms for the development of recurrent seizures based on animal models and clinical data of patients with TLE and HHV-6 DNA detected in CNS specimens. Contrary to these findings, limited clinical data suggest that there may be a decreased risk of recurrent seizures after primary infection with HHV-6 and febrile seizures than of febrile seizures from other causes. Additionally, children with FSE associated with HHV-6B and HHV-7 had similar seizure characteristics and a similar proportion of electroencephalography and MRI hippocampal abnormalities as children with FSE not associated with HHV-6B or HHV-7, suggesting a shared pathogenesis to other etiologies of FSE.

Case reports and small-patient series have described additional complications in children with primary HHV-6B infection, including encephalitis, acute disseminated demyelination, autoimmune encephalitis, acute cerebellitis, hepatitis, and myocarditis. Late-developing long-term sequelae, including developmental disabilities and autistic-like features, are reported rarely in children who have CNS symptoms during primary HHV-6B infection.

Reactivation of HHV-6 has been reported in several different populations with and without disease with the use of various methods of detection. The best documentation of HHV-6 reactivation has been in immunocompromised hosts, especially those patients who have undergone HSCT. Such reactivation occurs in approximately 50% of patients, typically at 2-4 weeks after transplantation, and the risk of reactivation is associated with a lack of donor-derived HHV-6-specific T-cell immunity. Many of the clinical complications seen following HSCT have been associated with HHV-6B reactivation, including fever, rash, delayed engraftment of platelets or monocytes, and graft-versus-host disease, with variable degrees of support in the literature for each. HHV-6 reactivation has been associated with worse overall survival compared with HSCT recipients who did not experience reactivation.

HHV-6B reactivation has also been reported as a cause of encephalitis in both immunocompetent and immunocompromised hosts. A distinct syndrome of **posttransplant acute limbic encephalitis (PALE)** has been described primarily in patients following HSCT, especially cord blood stem cell transplantation; it is characterized by short-term memory dysfunction, confusion, and insomnia, with seizures noted either clinically or on prolonged electroencephalography monitoring. HHV-6B DNA has been identified in the CSF in the majority of these patients, with additional evidence of reactivation by detection of HHV-6B DNA in plasma. HHV-6 proteins were identified in the astrocytes of the hippocampus in one postmortem specimen, consistent with active HHV-6B infection at the time of death. The development of PALE is associated with increased mortality and long-term neurocognitive sequelae.

## TREATMENT

Supportive care is usually all that is needed for infants with roseola. Parents should be advised to maintain hydration and may use antipyretics if the child is especially uncomfortable with the fever. Specific antiviral therapy is not recommended for routine cases of primary HHV-6B or HHV-7 infection. Unusual or severe manifestations of primary or presumed reactivated HHV-6B infection such as encephalitis/PALE, especially in immunocompromised patients, may benefit from treatment. Ganciclovir, foscarnet, and cidofovir all demonstrate inhibitory activity against HHV-6 in vitro, similar to their activity against cytomegalovirus. Case reports suggest that all three drugs, alone or in combination, can decrease HHV-6 viral replication, as evidenced by decreased viral loads in plasma and CSF. However, clinical data regarding efficacy are sparse and contradictory, with no randomized trials to guide use. Additionally, in vitro resistance of HHV-6 to all three drugs has been described. Despite these drawbacks, treatment with ganciclovir or foscarnet as first-line agents has been recommended for a minimum of 3 weeks in patients with PALE. Foscarnet appears to be most likely to have activity against HHV-7 on the basis of in vitro testing, but no clinical data are available.

## PROGNOSIS

Roseola is generally a self-limited illness associated with complete recovery. The majority of children with primary infections with HHV-6B and HHV-7 also recover uneventfully without sequelae. Although seizures are a common complication of primary infection with HHV-6B and HHV-7, the risk of recurrent seizures does not appear to be higher than that associated with other causes of simple febrile seizures.

## PREVENTION

Primary infections with HHV-6 and HHV-7 are widespread throughout the human population with no current means of interrupting transmission.

Visit Elsevier eBooks+ at [eBooks.Health.Elsevier.com](http://eBooks.Health.Elsevier.com) for Bibliography.

## Chapter 304

## Human Herpesvirus 8

Brenda L. Tesini

Human herpesvirus 8 (HHV-8) is an oncogenic virus identified in tissue specimens from patients with Kaposi sarcoma (KS). Because of this association, it is also known as **Kaposi sarcoma-associated herpesvirus**. HHV-8 is the etiologic agent of two additional lymphoproliferative disorders: **primary effusion-based lymphoma (PEL)** and **multicentric Castlemann disease (MCD)**.

**ETIOLOGY**

HHV-8 is a  $\gamma_2$ -human herpesvirus similar to Epstein-Barr virus. The virus contains a large DNA genome encoding 85–95 unique proteins. Infection is followed by both lytic and latent viral states, with different degrees of viral replication associated with distinct disease manifestations.

**EPIDEMIOLOGY**

The prevalence of infection with HHV-8 varies both geographically and by population and roughly matches the epidemiology of KS. HHV-8 infection is endemic in Africa and parts of South America, with infection rates of up to 30–60% by adolescence. Seroprevalence >20% has also been found in regions bordering the Mediterranean. In contrast, infection rates <5% are noted in North America, Central Europe, and Asia. However, within geographic regions, the prevalence of infection varies with risk behaviors, with rates of 30–75% being found among men who have sex with men in North America and Europe. HHV-8 DNA can be detected in saliva, blood, semen, and tissues. Based on large-scale epidemiologic studies and the high prevalence of viral shedding in oral secretions, saliva is believed to be the major mode of transmission. Other less common routes of HHV-8 transmission include blood transfusion, bone marrow transplantation, and solid organ transplantation. Vertical transmission and transmission via breast milk may occur in regions where HHV-8 is highly endemic, but the risk appears low.

**PATHOLOGY AND PATHOGENESIS**

HHV-8 contains multiple genes that affect cell-cycle regulation and the host immune response. Viral proteins interfere with the function of the tumor suppressor molecules, induce the expression of proangiogenesis factors, and lead to upregulation of the rapamycin pathway target, which is instrumental in the control of cell growth and metabolism. HHV-8 also encodes a homolog of human interleukin-6, which can bind and activate cytokine receptors and serve as a host cell autocrine growth factor. Additionally, viral proteins are associated with the constitutive expression of the transcription factor nuclear factor- $\kappa$ B. All of these proteins may be potential targets for therapeutic intervention.

**CLINICAL MANIFESTATIONS**

Although subclinical infection appears to be common, symptomatic primary HHV-8 infection has been described in immunocompetent children. Patients commonly have fever and a maculopapular rash or a mononucleosis-like syndrome, with full recovery the rule. In immunocompromised patients, primary infection has been associated with fever, rash, splenomegaly, pancytopenia, and lymphoid hyperplasia and may be quite severe. Additionally, preliminary data suggest that

transfusion-associated primary infection with HHV-8 is associated with an increased risk of mortality.

Even in regions with high rates of seroprevalence, the development of KS is uncommon. KS has several different clinical forms; each includes multifocal, angiogenic lesions arising from vascular endothelial cells infected with HHV-8. Classic KS is an indolent disorder seen in elderly men with limited involvement of the skin of the lower extremities. Endemic KS is more aggressive, occurring in children and young people, primarily in Africa, and can include visceral involvement as well as widespread cutaneous lesions (patches, plaques, or nodules). Posttransplantation KS and AIDS-related KS are the most severe forms, with disseminated lesions, often in the gastrointestinal tract and lungs, with or without cutaneous findings.

**Primary effusion-based lymphoma** is a rare disease caused by HHV-8 that is seen most commonly in HIV-infected individuals. It consists of lymphomatous invasion of the serosal surfaces of the pleura, pericardium, and peritoneum. Similarly, **multicentric Castlemann disease** is an unusual lymphoproliferative disorder characterized by anemia, thrombocytopenia, generalized lymphadenopathy, and constitutional symptoms and is frequently associated with HHV-8 infection and a high degree of viral replication.

**DIAGNOSIS**

**Serologic assays, including immunofluorescence and enzyme-linked immunosorbent assays, are the primary methods of diagnosing infection with HHV-8.** However, testing has limited sensitivity, specificity, and reproducibility and is primarily a research tool with no universally recognized standard assays. Additionally, the loss of antibodies over time, referred to as *seroreversion*, has been described, further complicating serodiagnosis. Immunohistochemistry and molecular methods are available for the detection of HHV-8 in tissue samples and are used in the diagnosis of KS, PEL, and MCD, alongside their disease-specific clinical manifestations. Nucleic acid testing of blood and other body fluids is also available but has a limited diagnostic role.

**TREATMENT**

Treatment for KS, PEL, and MCD is multifaceted and includes attempts to control malignant proliferations with traditional chemotherapeutic regimens and biologic agents as well as agents aimed at specific cellular pathways targeted by HHV-8 proteins. Combined antiretroviral therapy (ART) is a mainstay of both prevention and therapy for HHV-8-related disease in HIV-infected patients. In HIV-associated KS, treatment with ART alone is often used for the control of mild (i.e., cutaneous) disease, whereas ART plus chemotherapy is used for more severe disease. In transplantation-associated KS, the first line of treatment includes decreasing immunosuppression, often in association with a switch from calcineurin inhibitors to sirolimus (rapamycin) to block the mammalian target of rapamycin pathway. Severe disease frequently requires the use of traditional chemotherapy as well. The role of specific antiherpesvirus antiviral treatment is unclear. Valganciclovir and ganciclovir treatment have been associated with decreased viral replication and rates of development of KS in HIV-infected individuals. However, results of using antivirals in the treatment of established disease have been generally disappointing. The prognosis for PEL tends to be poor despite the use of traditional chemotherapy, whereas rituximab (anti-CD20)-based therapy has been highly successful for MCD treatment. However, relapse and the development of lymphoma after treatment can still occur. Rituximab treatment may also worsen concurrent KS without additional agents.

Visit Elsevier eBooks+ at [eBooks.Health.Elsevier.com](http://eBooks.Health.Elsevier.com) for Bibliography.

## Chapter 305

## Influenza Viruses

Flor M. Munoz

Influenza viral infections cause a broad array of respiratory illnesses that are responsible for significant morbidity and mortality in children during **seasonal epidemics**. Influenza A viruses also have the potential to cause **global pandemics**, which can happen when a **new (novel) influenza A virus** emerges and transmits efficiently from person to person.

## ETIOLOGY

Influenza viruses are large, single-stranded RNA viruses belonging to the family Orthomyxoviridae, which includes three genera (or types): A, B, and C. Influenza A and B viruses are the primary human pathogens causing seasonal epidemics, whereas influenza virus type C is a sporadic cause of predominantly mild upper respiratory tract illness. Influenza A viruses are further divided into subtypes based on two surface proteins that project as spikes from the lipid envelope, the hemagglutinin (HA) and neuraminidase (NA) proteins (Fig. 305.1). Strain variants are identified by antigenic differences in their HA and NA and are designated by the geographic area from which they were originally isolated, isolate number, and year of isolation—for example, influenza

A/Victoria/361/2011(H3N2). The HA and NA antigens from influenza B and C viruses do not receive subtype designations, because there is less variation among influenza B and C antigens. However, influenza B viruses can be further broken down into lineages, with recent examples including the B/Yamagata and B/Victoria lineages.

## EPIDEMIOLOGY

Influenza has generally been thought to be transmitted primarily via respiratory droplets, but transmission through contact with secretions and small-particle aerosols may also occur. The typical incubation period ranges from 1 to 4 days, with an average of 2 days. Healthy adults are generally considered potentially infectious from a day before symptoms develop until 5-7 days after becoming ill. Children with primary influenza infection have higher influenza viral loads and more prolonged viral shedding than adults; therefore children may be able to infect others for a longer time. Influenza outbreaks occur commonly in schools and childcare settings. Healthcare-associated influenza infections can also occur in healthcare settings, and outbreaks in long-term care facilities and hospitals may cause significant morbidity.

In the United States, seasonal influenza viruses can be detected year-round, but circulating viruses are most common during the fall and winter. Transmission through a community is rapid, with the highest incidence of illness occurring within 2-3 weeks of introduction.

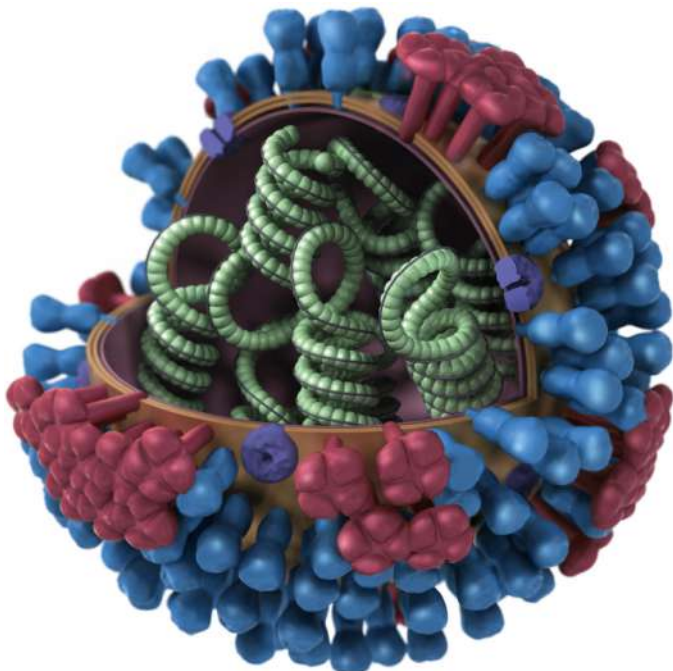
## Antigenic Variation

Influenza A and B viruses contain a genome consisting of 8 single-stranded RNA segments. Minor changes within a subtype continually occur through point mutations during viral replication, particularly in the HA gene, and result in new influenza strains of the same HA type. This phenomenon, termed **antigenic drift**, occurs in both influenza A and B viruses. Variation in antigenic composition of influenza virus surface proteins occurs almost yearly, which confers a selective advantage to a new strain and contributes to annual epidemics. For this reason, the formulation of the influenza vaccine is reviewed each year and updated as needed.

Less frequent but more dramatic major changes in virus subtype can occur, resulting in a new influenza A subtype to which most people have little to no immunity. This process is called **antigenic shift** and can occur through reassortment of viral gene segments when there is simultaneous infection by more than one strain of influenza in a single host, or by direct adaptation of an animal virus to a human host. Antigenic shift occurs in influenza A viruses, which have multiple avian and mammalian hosts acting as reservoirs for diverse strains.

Through the process of **reassortment**, potentially any of 18 HA and 11 NA proteins currently known to reside in influenza A viruses of nonhuman hosts could be introduced into humans, who may have little existing immunologic cross protection to emerging viruses. A global pandemic can result if an influenza A virus with a novel HA or NA enters a nonimmune human population and acquires the capacity for sustained and efficient transmission between people. Four major **global pandemics** have occurred since 1900: in 1918 caused by an influenza A(H1N1) virus, 1957 caused by an influenza A(H2N2) virus, 1968 caused by an influenza A(H3N2) virus, and 2009 caused by an influenza A virus designated A(H1N1)pdm09. The most severe influenza pandemic in recorded history occurred in 1918, when the virus was estimated to have killed at least 50 million people. The 1918 pandemic virus was likely the result of direct adaptation of an avian influenza virus to the human host, rather than from reassortment. The 2009 pandemic virus stemmed from reassortment of genes from swine, avian, and human viruses (Fig. 305.2). This resulted in the emergence of a novel influenza A(H1N1)pdm09 virus that spread quickly from North America across the globe and replaced the previously circulating seasonal H1N1 viruses.

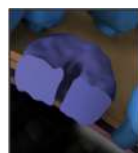
Several novel influenza viruses, all originating in animals, have also caused outbreaks of human infections. Avian influenza A(H5N1), a virulent avian influenza virus that was first identified in 1997, has caused more than 880 documented cases in 19 countries, with a mortality rate over 50%. A novel avian influenza A(H5N6) with a case fatality rate of >40%, emerged in China in 2014, causing infection in at least



Hemagglutinin



Neuraminidase



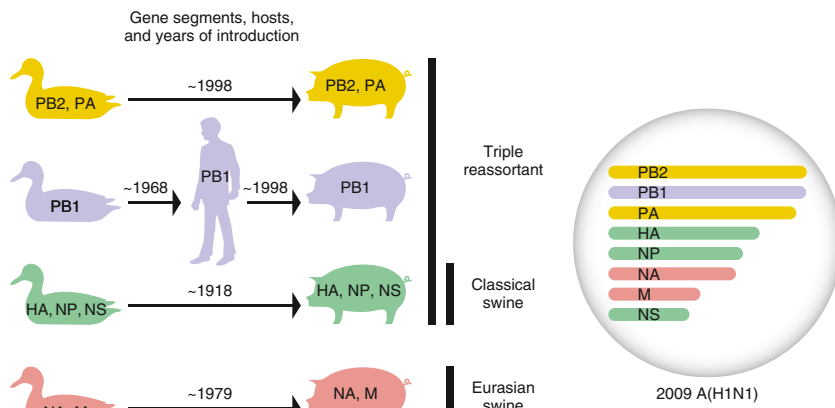
M2 ion channel



RNP

**Fig. 305.1** Graphical representation of influenza virus. The key at bottom identifies the surface protein constituents: the hemagglutinin, neuraminidase, matrix protein 2 (M2) ion channel, and ribonucleoprotein (RNP). (From Centers for Disease Control and Prevention Public Health Image Library, Image ID#11822. <https://phil.cdc.gov/Details.aspx?pid=11822>; courtesy CDC/Douglas Jordan and Dan Higgins, 2009.)





**Fig. 305.2** Host and lineage origins for the gene segments of the 2009 A(H1N1) virus. HA, Hemagglutinin; M, matrix gene; NA, neuraminidase; NP, nucleoprotein; NS, nonstructural gene; PA, polymerase acidic; PB1, polymerase basic 1; PB2, polymerase basic 2. Color of gene segment in circle indicates host. (From Garten RJ, Davis CT, Russell CA, et al. Antigenic and genetic characteristics of swine-origin 2009 A(H1N1) influenza viruses circulating in humans. *Science*. 2009;325[5937]:197–201.)

**Table 305.1** Subtypes of Novel Influenza A Viruses and Clinical Syndromes in Human Infections

	LPAI VIRUSES	HPAI VIRUSES	VARIANT VIRUSES*
Conjunctivitis	H7N2, H7N3, H7N7, H10N7	H7N3, H7N7	H1N1v, H3N2v
Upper respiratory tract illness	H6N1, H7N2, H7N3, H7N9, H9N2, H10N7	H5N1, H5N6, H7N7	H1N1v, H1N2v, H3N2v
Lower respiratory tract disease, pneumonia	H7N2, H7N9, H9N2, H10N8	H5N1, H5N6, H7N7, H7N9	H1N1v, H3N2v
Respiratory failure, acute respiratory distress syndrome	H7N9, H10N8	H5N1, H5N6, H7N7, H7N9	H1N1v, H3N2v
Multiorgan failure	H7N9, H10N8	H5N1, H5N6, H7N7, H7N9	—
Encephalopathy or encephalitis	H7N9	H5N1	—
Fatal outcomes†	H7N9, H9N2, H10N8	H5N1, H5N6, H7N7, H7N9	H1N1v, H3N2v

\*Variant viruses of swine origin.

†High mortality in reported cases: about 40% for LPAI H7N9, about 50% for HPAI H5N1, and about 70% for HPAI H5N6.

HPAI, Highly pathogenic avian influenza; LPAI, low-pathogenic avian influenza.

From Uyeki TM, Katz JM, Jernigan DB. Novel influenza A viruses and pandemic threats. *Lancet*. 2017;389:2172–2174.

60 people. Another avian influenza, A(H7N9) virus, has caused more than 1,500 documented cases and is also highly virulent. This virus first caused an outbreak of human infections in China during the spring of 2013, with annual epidemics in China occurring in subsequent years. During the first four yearly epidemics, infection was fatal in approximately 40% of documented cases.

In addition, novel influenza A variant viruses have caused human infections (Table 305.1). These include H3N2v viruses, which caused 372 confirmed human infections in the United States from 2011 to 2016 and were primarily transmitted through swine contact at agricultural fairs. Influenza viruses that normally circulate in swine are designated variant (“v”) viruses when detected in humans, and H3N2v and other variant viruses, including H1N1v and H1N2v, continue to be detected and sporadically infect humans with prolonged exposure to infected pigs. In contrast to avian influenza A(H5N1), A(H5N6), and A(H7N9) viruses, variant viruses generally cause mild illness and have been primarily detected in children. However, none of these viruses has exhibited sustained, efficient human-to-human transmission.

### Seasonal Influenza

An estimated 11,000–45,000 children younger than 18 years of age are hospitalized annually in the United States as a result of seasonal influenza-associated complications, with approximately 6,000–26,000 hospitalizations in children younger than 5 years of age. Since 2004, the annual number of reported influenza-associated pediatric deaths in the United States has ranged from 37 to 199 during regular influenza seasons (358 were reported to have occurred during the 2009 H1N1 pandemic). Influenza disproportionately affects children with specific chronic conditions, such as underlying pulmonary, cardiac, or neurologic and neuromuscular disorders. Very young children,

especially those younger than 2 years of age, and children with chronic medical conditions are more likely to develop severe influenza-related complications, including viral and bacterial pneumonia, hospitalization, respiratory failure, and death. However, although children with underlying medical conditions are at higher risk of complications, many healthy children are hospitalized with influenza, and nearly half of pediatric influenza-associated deaths are in children that have no known underlying medical condition.

Influenza also causes a substantial burden of disease in outpatient settings. It contributes to an estimated 600,000 to 2,500,000 outpatient medical visits annually in children younger than 5 years of age and has been identified in 10–25% of outpatient visits among all children with respiratory symptoms during influenza season. Influenza may also be underdiagnosed. Many who seek medical care for influenza do not have laboratory testing performed and do not receive a diagnosis of influenza. Every year, three or four influenza virus types or subtypes typically co-circulate, including influenza A(H3N2), influenza A(H1N1), and two types of B viruses. Although one subtype usually predominates in any given season, it is difficult to predict which will be predominant. Thus the influenza vaccine varies annually and contains three or four antigens representing the expected circulating types.

### PATHOGENESIS

Influenza viruses infect the respiratory tract epithelium, primarily the ciliated columnar epithelial cells, by using the HA to attach to sialic acid residues. After viral entry into cells, virus replication occurs usually within 4–6 hours, and new virus particles are assembled and released to infect neighboring cells. With primary infection, virus replication continues for 10–14 days. Influenza virus causes a lytic infection of the respiratory epithelium with loss of ciliary function, decreased mucus



production, and desquamation of the epithelial layer. These changes permit secondary bacterial invasion, either directly through the epithelium or, in the case of the middle ear space, through obstruction of the normal drainage through the eustachian tube.

The exact immune mechanisms involved in termination of primary infection and protection against reinfection are complex. Induction of cytokines that inhibit viral replication, such as interferon and tumor necrosis factor, as well as other host defenses, such as cell-mediated immune responses and local and humoral antibody defenses, all likely play a role. Secretory immunoglobulin A antibodies produced by the respiratory mucosa are thought to be an effective and immediate response generated during influenza infection. Serum antibody levels inhibiting HA activity can usually be detected by the second week after infection. These antibodies are also generated by vaccines, and high HA inhibition antibody titers correlate with protection.

## CLINICAL MANIFESTATIONS

The onset of influenza illness is *often abrupt*, with a predominance of systemic symptoms, including fever, myalgias, chills, headache, malaise, and anorexia. Coryza, pharyngitis, and dry cough are also usually present at the onset of illness but may be less prominent than systemic symptoms. Respiratory manifestations can include isolated upper respiratory tract illness, including croup, or progression to lower tract disease, such as bronchiolitis or pneumonia. More than other respiratory viruses, influenza virus typically causes systemic manifestations such as high temperature, myalgia, malaise, and headache. Less common clinical manifestations can include parotitis and rash.

Abdominal pain, vomiting, and diarrhea may also occur in children; in some studies, diarrhea was reported to be more often associated with influenza A(H1N1)pdm09 compared with influenza A(H3N2) or influenza B viruses. Influenza is a less distinct illness in younger children and infants. The infected young infant or child may be highly febrile and toxic in appearance, prompting a full diagnostic workup. The typical duration of the febrile illness is 2–4 days. Cough may persist for longer periods, and evidence of small airway dysfunction is often found weeks later. Owing to the high transmissibility of influenza, other family members or close contacts of an infected person often experience a similar illness.

## COMPLICATIONS

Otitis media and pneumonia are common complications of influenza in young children. Acute otitis media may be seen in up to 25% of cases of documented influenza. Pneumonia accompanying influenza may be a primary viral process or a secondary bacterial infection (such as with *Staphylococcus aureus*) facilitated through damaged respiratory epithelium. Influenza may cause acute myositis or rhabdomyolysis marked by muscle weakness and pain, particularly in the calf muscles, and myoglobinuria. Other extrapulmonary complications include acute renal failure, myocarditis, and sepsis. Central nervous system complications, such as encephalitis, myelitis, and Guillain-Barré syndrome, can occur and are seen more commonly in children than adults. Although it has essentially disappeared in the United States, Reye syndrome can result with the use of salicylates during influenza infection (see [Chapter 409](#)). Bacterial co-infection may also exacerbate respiratory complications of influenza and lead to sepsis, bacteremia, toxic shock syndrome, and other manifestations.

Influenza is particularly severe in some children, including those with underlying cardiopulmonary disease, including congenital and acquired valvular disease, cardiomyopathy, bronchopulmonary dysplasia, asthma, cystic fibrosis, and neurologic conditions. Pregnant women and adolescent females are also at high risk for severe influenza. Children receiving cancer chemotherapy and children with immunodeficiency also have a higher risk of complications and may shed virus for longer periods than immunocompetent children.

## LABORATORY FINDINGS

The clinical laboratory abnormalities associated with influenza are nonspecific. Chest radiographs may show evidence of atelectasis or infiltrate.

## DIAGNOSIS AND DIFFERENTIAL DIAGNOSIS

The diagnosis of influenza depends on epidemiologic, clinical, and laboratory considerations. In the context of an epidemic, the clinical diagnosis of influenza in a child who has fever, malaise, and respiratory symptoms may be made based on clinical discretion; however, clinical presentation is often indistinguishable from infection with other respiratory viruses, including SARS-CoV-2, respiratory syncytial virus, parainfluenza virus, human metapneumovirus, adenovirus, and even rhinovirus. Confirmation of influenza virus infection by diagnostic testing might be helpful in certain circumstances when other viruses are co-circulating, but it is not required for clinical decisions to prescribe antiviral medications, and prompt suspicion or diagnosis of influenza may allow for early antiviral therapy to be initiated and may reduce inappropriate use of antibiotics.

A number of diagnostic tests may be used for laboratory confirmation of influenza ([Table 305.2](#)). Although rapid influenza diagnostic tests based on antigen detection are often employed because of their ease of use and fast results, they can have suboptimal sensitivity to detect influenza virus infection, particularly for novel influenza viruses. Sensitivities of rapid antigen diagnostic tests are generally 50–70% compared to viral culture or reverse-transcription polymerase chain reaction (RT-PCR). Specificities are higher, approximately 95–100%. Therefore false-negative results occur more often than false-positive results, particularly when the prevalence of influenza is high (i.e., during peak influenza activity in the community). The interpretation of negative results should consider the clinical characteristics and the patient's risk for complications. If there is clinical suspicion for influenza in a patient at high risk for complications ([Table 305.3](#)), early empirical treatment should be given regardless of a negative rapid antigen diagnostic test result, and another type of test may be performed for confirmation. RT-PCR or other rapid molecular assays are now preferred for influenza diagnosis in both outpatients and hospitalized patients.

## TREATMENT

Antiviral medications are an important adjunct to influenza vaccination. Three classes of antiviral drugs are licensed for treatment of influenza in children. The neuraminidase inhibitors (NAIs), oral oseltamivir and inhaled zanamivir, may be used for treatment of children from birth and 7 years, respectively ([Table 305.4](#)). In December 2012, the U.S. Food and Drug Administration (FDA) approved the use of oseltamivir for the treatment of influenza in infants as young as 2 wk of age, and the Centers for Disease Control and Prevention (CDC), the American Academy of Pediatrics, and the Infectious Diseases Society of America recommend its use in infants of any age. A third NAI, peramivir, is given as an intravenous infusion and is approved for treatment in persons 2 years of age and older.

The second class of drugs is represented by a new orally administered influenza antiviral called baloxavir marboxil, which was approved by the FDA in October 2018. Baloxavir is active against both influenza A and B viruses and is a cap-dependent endonuclease inhibitor that interferes with viral RNA transcription and blocks virus replication. It is approved for treatment of acute uncomplicated influenza in people 12 years and older.

The third class of drugs is the adamantanes, including oral amantadine and oral rimantadine, which are effective only against influenza A viruses. Genetic variants have conferred widespread adamantane resistance among circulating influenza A viruses, including seasonal influenza viruses and many H5N1 and H7N9 avian influenza viruses; *therefore this class of antivirals is not currently recommended for use.*

When initiated early in the course of uncomplicated influenza illness, antiviral agents can reduce the duration of symptoms and the likelihood of complications. Among hospitalized patients, observational studies suggest that early treatment reduces disease severity and mortality. Although most data regarding potential benefit are for adults, a few studies support the use of antiviral agents in children. Antiviral treatment within 2 days of illness onset has been reported to reduce illness duration, the risk of otitis media, and the likelihood of hospitalization in children. Clinical benefit is greatest when antiviral

**Table 305.2** Influenza Virus Testing Methods

METHOD	ACCEPTABLE SPECIMENS	TEST TIME	COMMENTS
Rapid influenza diagnostic tests (antigen detection)	Nasopharyngeal (NP) swab, aspirate or wash, nasal swab, aspirate, or wash, throat swab	<15 min	Rapid turnaround; suboptimal sensitivity
Rapid molecular assay (influenza nucleic acid amplification)	NP swab, nasal swab	15-30 min	Rapid turnaround; high sensitivity
Immunofluorescence, direct (DFA) or indirect (IFA) fluorescent antibody staining (antigen detection)	NP swab or wash, bronchial wash, nasal or endotracheal aspirate	1-4 hr	Relatively rapid turnaround; requires laboratory expertise and experience
RT-PCR (singleplex and multiplex; real-time and other RNA-based) and other molecular assays (influenza nucleic acid amplification)	NP swab, throat swab, NP or bronchial wash, nasal or endotracheal aspirate, sputum	Varies by assay (generally 1-8 hr)	Excellent sensitivity, relatively rapid turnaround compared with conventional methods
Rapid cell culture (shell vials, cell mixtures; yields live virus)	NP swab, throat swab, NP or bronchial wash, nasal or endotracheal aspirate, sputum	1-3 day	Culture isolates important for strain information and antiviral resistance monitoring
Viral tissue cell culture (conventional; yields live virus)	NP swab, throat swab, NP or bronchial wash, nasal or endotracheal aspirate, sputum	3-10 day	Not recommended for routine patient diagnosis
Serologic tests (antibody detection)	Paired (appropriately timed) acute and convalescent serum specimens	N/A (not performed during acute infection)	Not recommended for routine patient diagnosis; useful for research studies

N/A, Not applicable; RT-PCR, reverse transcription-polymerase chain reaction.

Modified from Centers for Disease Control and Prevention (CDC): *Influenza virus testing methods*. Available at <https://www.cdc.gov/flu/professionals/diagnosis/table-testing-methods.htm> in Information for Health Professionals (<https://www.cdc.gov/flu/professionals/index.htm>); and from 2018 IDSA Clinical Practice Guidelines.

**Table 305.3** Children and Adolescents Who Are at Higher Risk for Influenza Complications for Whom Antiviral Treatment is Recommended\*

- Children younger than 2 yr of age<sup>†</sup>
- Persons with chronic pulmonary (including asthma), cardiovascular (except hypertension alone), renal, hepatic, hematologic (including sickle cell disease), and metabolic disorders (including diabetes mellitus); or neurologic and neurodevelopmental conditions (including disorders of the brain, spinal cord, peripheral nerve, and muscle such as cerebral palsy, epilepsy [seizure disorders], stroke, intellectual disability, moderate to severe developmental delay, muscular dystrophy, or spinal cord injury)
- Persons with immunosuppression, including that caused by medications or by HIV infection
- Adolescents who are pregnant, or postpartum (within 2 wk after delivery)
- Persons younger than 19 yr of age who are receiving long-term aspirin- or salicylate-containing medications therapy
- Indigenous/Alaska Natives
- Persons who are extremely obese (body mass index  $\geq 40$ )
- Residents of long-term care facilities
- Hospitalized patients at high risk for influenza complications

\*Antiviral treatment is recommended for children at high risk with confirmed or suspected influenza; antivirals are also recommended for children who are hospitalized or have severe or progressive disease.

<sup>†</sup>Although all children younger than 5 yr of age are considered at higher risk for complications from influenza, the highest risk is for those younger than 2 yr of age, with the highest hospitalization and death rates among infants younger than 6 mo of age.

Current for 2021–2022 influenza season.

Adapted from Centers for Disease Control and Prevention (CDC): *Influenza antiviral medications: summary for clinicians*. <https://www.cdc.gov/flu/professionals/antivirals/summary-clinicians.htm>; and from American Academy of Pediatrics Policy Statement: *Recommendations for Prevention and Control of Influenza in Children, 2021–2022*. For current details, consult annually updated recommendations at <https://www.cdc.gov/flu/professionals/index.htm>.

treatment is administered early, especially within 48 hours of influenza illness onset.

The CDC recommends treatment as early as possible for (1) hospitalized patients, (2) patients with severe, complicated, or progressive illness, and (3) patients at high risk for influenza complications (see Table 305.3). Decisions about starting antiviral treatment should not wait for laboratory confirmation of influenza. Although early treatment is desired, treatment more than 48 hours from onset may be beneficial and is recommended for these three categories of patients.

The recommended treatment course for uncomplicated influenza is twice daily oral oseltamivir for 5 days, twice daily inhaled zanamivir for 5 days, or a single dose of intravenous peramivir or oral baloxavir. Currently, for hospitalized patients and patients with severe or complicated illness, treatment with oral or enterically administered oseltamivir is recommended. The optimal duration and dose are uncertain for severe or complicated influenza, and longer courses of treatment (e.g., 10 days of treatment) may be considered.

Clinical judgment considering a patient's disease severity, age, underlying medical conditions, likelihood of influenza, and time since onset of symptoms is important when making antiviral treatment decisions for outpatients at high risk for complications. Antiviral treatment can also be considered for any previously healthy, symptomatic outpatient not at high risk with confirmed or suspected influenza, if treatment can be initiated within 48 hours of illness onset.

Some influenza viruses may become resistant during antiviral treatment, an occurrence that has been reported most often for oseltamivir resistance in influenza A(H1N1) viruses. Following treatment with baloxavir, emergence of viruses with molecular markers associated with reduced susceptibility to baloxavir has been observed in clinical trials. Antiviral resistance and reduced susceptibility can also occasionally occur spontaneously with no known exposure to antiviral drugs. It is important to review annual recommendations and updates published by CDC before prescribing influenza antiviral medications (see <https://www.cdc.gov/flu/professionals/antivirals/index.htm>).

**Table 305.4** Recommended Dosage and Schedule of Influenza Antiviral Medications for Treatment and Chemoprophylaxis in Children for the 2021–2022 Influenza Season: United States

MEDICATION	TREATMENT DOSING*	CHEMOPROPHYLAXIS DOSING*
<b>ORAL OSELTAMIVIR<sup>†</sup></b>		
Adults	75 mg twice daily	75 mg once daily
Children ≥12 mo		
≤15 kg (≤33 lb)	30 mg twice daily	30 mg once daily
>15–23 kg (33–51 lb)	45 mg twice daily	45 mg once daily
>23–40 kg (>51–88 lb)	60 mg twice daily	60 mg once daily
>40 kg (>88 lb)	75 mg twice daily	75 mg once daily
Infants 9–11 mo <sup>‡</sup>	3 mg/kg per dose twice daily	3 mg/kg per dose once daily
Term infants ages 0–8 mo <sup>‡</sup>	3 mg/kg per dose twice daily	3 mg/kg per dose once daily for infants 3–8 mo old; not recommended for infants <3 mo old unless situation judged critical because of limited safety and efficacy data in this age group
Preterm infants	See details in footnote <sup>§</sup>	Not recommended
<b>INHALED ZANAMIVIR<sup>¶</sup></b>		
Adults	10 mg (two 5-mg inhalations) twice daily	10 mg (two 5-mg inhalations) once daily
Children (≥7 yr old for treatment; ≥5 yr old for chemoprophylaxis)	10 mg (two 5-mg inhalations) twice daily	10 mg (two 5-mg inhalations) once daily
<b>INTRAVENOUS PERAMIVIR</b>		
Adults	600 mg intravenous infusion once given over 15–30 min	Not recommended
Children (2–12 yr old)	One 12 mg/kg dose, up to 600 mg maximum, once via intravenous infusion for 15–30 min	Not recommended
Children (13–17 yr old)	One 600 mg dose once via intravenous infusion for 15–30 min	Not recommended
<b>ORAL BALOXAVIR<sup>#</sup></b>		
Adults		
40 to <80 kg	One 40-mg dose	One 40-mg dose
>80 kg	One 80-mg dose	One 80-mg dose
Children		
2–11 yr	Not recommended	Not recommended
12–17 yr, 40 to <80 kg	One 40-mg dose	One 40-mg dose
12–17 yr, >80 kg	One 80-mg dose	One 80-mg dose

\*Antiviral treatment duration for uncomplicated influenza is 5 days for oral oseltamivir or inhaled zanamivir, and a single dose for intravenous peramivir or oral baloxavir.

Recommended postexposure chemoprophylaxis with oseltamivir or zanamivir in a nonoutbreak setting is 7 days after last known exposure.

<sup>†</sup>Osetamivir is administered orally without regard to meals, although administration with meals may improve gastrointestinal tolerability. Osetamivir is available as Tamiflu or as a generic formulation as capsules and as a powder for oral suspension that is reconstituted to provide a final concentration of 6 mg/mL.

<sup>‡</sup>Approved by the FDA for children as young as 2 wk of age. Given preliminary pharmacokinetic data and limited safety data, oseltamivir can be used to treat influenza in both term and preterm infants from birth because benefits of therapy are likely to outweigh possible risks of treatment. CDC and U.S. Food and Drug Administration (FDA)-approved dosing is 3 mg/kg per dose twice daily for children age 9–11 mo; the American Academy of Pediatrics recommends 3.5 mg/kg per dose twice daily. The dose of 3 mg/kg provides oseltamivir exposure in children similar to that achieved by the approved dose of 75 mg orally twice daily for adults, as shown in two studies of oseltamivir pharmacokinetics in children. The AAP has recommended an oseltamivir treatment dose of 3.5 mg/kg orally twice daily for infants 9–11 mo, on the basis of data that indicated that a higher dose of 3.5 mg/kg was needed to achieve the protocol-defined targeted exposure for this cohort as defined in the CASG 114 study. It is unknown whether this higher dose will improve efficacy or prevent the development of antiviral resistance. However, there is no evidence that the 3.5-mg/kg dose is harmful or causes more adverse events to infants in this age group.

<sup>§</sup>Osetamivir dosing for preterm infants. The weight-based dosing recommendation for preterm infants is lower than for term infants. Preterm infants may have lower clearance of oseltamivir because of immature renal function, and doses recommended for term infants may lead to high drug concentrations in this age group. Limited data from the National Institute of Allergy and Infectious Diseases Collaborative Antiviral Study Group provide the basis for dosing preterm infants by using their postmenstrual age (gestational age plus chronological age): 1 mg/kg per dose orally twice daily for those <38 wk postmenstrual age; 1.5 mg/kg per dose orally twice daily for those 38–40 wk postmenstrual age; and 3 mg/kg per dose orally twice daily for those >40 wk postmenstrual age. For extremely preterm infants (<28 wk), please consult a pediatric infectious diseases physician.

<sup>¶</sup>Zanamivir is administered by inhalation by using a proprietary Diskhaler device distributed together with the medication. Zanamivir is a dry powder, not an aerosol, and should not be administered by using nebulizers, ventilators, or other devices typically used for administering medications in aerosolized solutions. Zanamivir is not recommended for people with chronic respiratory diseases, such as asthma or chronic obstructive pulmonary disease, which increase the risk of bronchospasm.

<sup>#</sup>Oral baloxavir marboxil is approved by the FDA for treatment of acute uncomplicated influenza within 2 days of illness onset in people 12 yr and older. The safety and efficacy of baloxavir for the treatment of influenza have been established in pediatric patients 12 yr and older weighing at least 40 kg. Safety and efficacy in patients <12 yr of age or weighing <40 kg have not been established. Baloxavir efficacy is based on clinical trials in outpatients 12 to 64 yr of age; people with underlying medical conditions and adults >65 yr were not included in the initial published clinical trials (Hayden F et al; *Clin Infect Dis* 2018). There are no available data for baloxavir treatment of hospitalized patients with influenza.

Adapted from Centers for Disease Control and Prevention (CDC): *Influenza antiviral medications: summary for clinicians*. <https://www.cdc.gov/flu/professionals/antivirals/summary-clinicians.htm>. For current details, consult annually updated recommendations at <https://www.cdc.gov/flu/professionals/index.htm>; 2018 IDSA Clinical Practice Guidelines; and from Kimberlin DW, Acosta EP, Prichard MN, et al. National Institute of Allergy and Infectious Diseases Collaborative Antiviral Study Group. Oseltamivir pharmacokinetics, dosing, and resistance among children aged <2 yr with influenza. *J Infect Dis*. 2013;207(5):709–720.

## SUPPORTIVE CARE

Adequate fluid intake and rest are important in the management of influenza. Bacterial superinfections are relatively common and should be appropriately treated with antibiotic therapy. Bacterial superinfection should be suspected with recrudescence of fever, prolonged fever, or deterioration in clinical status. With uncomplicated influenza, people should usually start to feel better after the first 48–72 hours of symptoms.

## PROGNOSIS

The prognosis for recovery from uncomplicated influenza is generally excellent, although full return to normal level of activity and freedom from cough may require weeks rather than days. Fatigue may also persist for weeks. However, severe influenza disease can be associated with hospitalizations and death, even among previously healthy children.

## PREVENTION

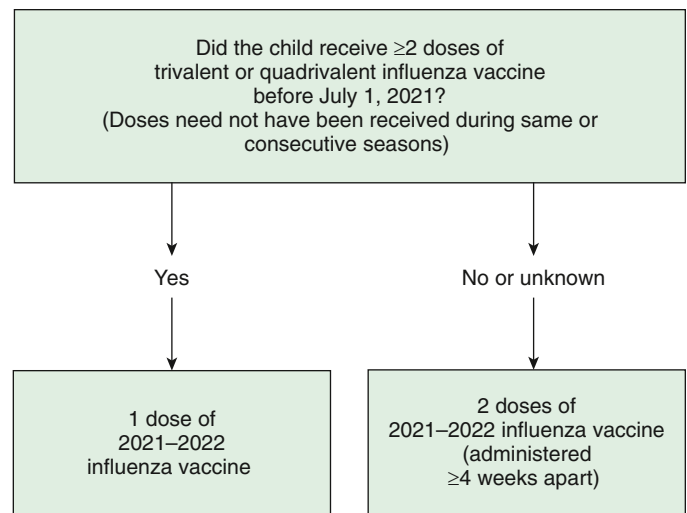
Influenza vaccination is the best means of preventing influenza illness. In studies of children who are fully vaccinated, influenza vaccine is 40–60% effective in reducing the risk of laboratory-confirmed influenza illness. Vaccine effectiveness can vary from year to year and among different age and risk groups. Recommendations for use of the influenza vaccine have broadened as the impact of influenza is appreciated in such groups as pregnant women and young infants. Starting in the 2008–2009 influenza season, the United States Advisory Committee on Immunization Practices (ACIP) recommended that all children from 6 months to 18 years of age be vaccinated against influenza unless they have a specific contraindication to receiving the vaccine. Since the 2010–2011 season, annual flu vaccination is recommended for everyone 6 months and older, with rare exception. In 2012, the Department of Health in the United Kingdom extended their influenza vaccination program to include all children between the ages of 2 and 17 years. To protect infants younger than 6 months who are too young to receive a vaccine, pregnant women, household contacts, and out-of-home caregivers are groups for whom additional vaccination efforts should be made. Chemoprophylaxis with antiviral medications is a secondary means of prevention and is not a substitute for vaccination.

## Vaccines

There are two main categories of seasonal influenza vaccines available for children: inactivated influenza vaccine (IIV) and live-attenuated influenza vaccine (LAIV). Previously referred to as the trivalent inactivated vaccine, IIV is given intramuscularly; it uses killed virus components. The LAIV vaccine uses weakened influenza virus and is administered as an intranasal spray. Neither IIV nor LAIV can cause influenza. Although in 2014–2015 ACIP and CDC recommended the use of the LAIV nasal spray vaccine for healthy children 2 through 8 years of age, this preferential recommendation was removed for the 2015–2016 season, and for the 2016–2017 and 2017–2018 seasons, ACIP and CDC made the interim recommendation that LAIV should not be used. This decision was based on concerns regarding low effectiveness against influenza A(H1N1)pdm09 in the United States noted during the 2013–2014 and 2015–2016 seasons. After review of additional data, LAIV containing an updated influenza A(H1N1)pdm09-like vaccine virus, was again recommended by CDC and ACIP as an option for vaccination for the 2018–2019 season. Since the 2018–2019 season, ACIP and CDC have recommend that LAIV4 may be used.

Special vaccination instructions for children 6 months to 8 years of age should be followed: children in this age group who have not previously received a total of at least two previous doses of trivalent or quadrivalent vaccine require two doses (at least 4 weeks apart) of the current season's influenza vaccine to optimize immune response (Fig. 305.3). Influenza vaccines have an excellent safety profile, with the most common side effects being soreness, redness, tenderness, or swelling from the injection, and nasal congestion after the nasal spray. Seasonal influenza vaccines may be co-administered with other vaccines, including SARS-CoV-2 vaccines.

Seasonal influenza vaccines become available in the late summer and early fall each year. The formulation reflects the strains of influenza viruses that are expected to circulate in the coming influenza season. Beginning in the 2013–2014 season, IIVs were available in both



**Fig. 305.3** Influenza vaccine dosing algorithm for children age 6 months through 8 years—Advisory Committee on Immunization Practices, United States, 2021–2022 influenza season. \*For children age 8 years who require two doses of vaccine, both dosages should be administered even if the child turns age 9 years between receipt of dose 1 and dose 2. (From Grohskopf LA, Alyanak E, Ferdinands JM, et al. Prevention and control of seasonal influenza with vaccines: recommendations of the advisory committee on immunization practices—United States, 2021–22 Influenza Season. *MMWR Recomm Rep.* 2021;70[No. RR-5]:1–28.)

trivalent and quadrivalent formulations. The trivalent vaccine (IIV3) contains two influenza A strains and one influenza B strain; the quadrivalent vaccine (IIV4) contains a second influenza B strain of an antigenically distinct lineage. In addition to IIV and LAIV, a third vaccine category, recombinant HA influenza vaccine, became available in the 2013–2014 season. Since the 2020–2021 influenza season, all influenza vaccines used in the United States are quadrivalent.

Ideally, vaccination should be given before the onset of influenza circulation in the community, so that there is time for antibodies to reach protective levels. Healthcare providers should offer vaccination by the end of October, if possible. The ACIP publishes guidelines for vaccine use each year when the vaccines are formulated and released; these guidelines should be referred to each season. The ACIP guidelines are widely publicized but appear initially in the *Morbidity and Mortality Weekly Report* published by CDC (<https://www.cdc.gov/flu/index.htm>).

## Chemoprophylaxis

Routine use of antiviral medications for chemoprophylaxis is not recommended. Examples for which the use of chemoprophylaxis may be considered to prevent influenza after exposure to an infectious person include (1) unvaccinated persons at high risk of influenza complications, (2) persons for whom vaccine is contraindicated or expected to have low effectiveness, and (3) residents/patients in care facilities during institutional influenza outbreaks. Oral oseltamivir or inhaled zanamivir may be used for chemoprophylaxis of influenza; baloxavir is approved for postexposure prophylaxis in persons 12 years of age and older. Peramivir is not recommended for chemoprophylaxis because of a lack of data, and adamantanes are not currently recommended because of widespread adamantane resistance. Table 305.4 shows the recommendations for dosage and duration of treatment and chemoprophylaxis for the 2021–2022 influenza season, but updated recommendations from the ACIP and CDC should be consulted every season (<https://www.cdc.gov/flu/professionals/antivirals/index.htm>).

In general, postexposure chemoprophylaxis for persons at high risk of influenza complications (see Table 305.3) should be started within 48 hours of exposure to an infectious person and should be continued for 7 days after the last known exposure. An alternative to chemoprophylaxis for some persons after a suspected exposure is close monitoring and early initiation of antiviral treatment if symptoms develop.



For control of influenza outbreaks among high-risk persons living in institutional settings, such as long-term care facilities, antiviral chemoprophylaxis is recommended for all vaccinated and unvaccinated residents and for unvaccinated healthcare providers. In these circumstances, CDC and the Infectious Diseases Society of America recommend antiviral chemoprophylaxis for a minimum of 2 weeks and up to 1 week after the last known case is identified, whichever is longer.

Visit Elsevier eBooks+ at [eBooks.Health.Elsevier.com](https://eBooks.Health.Elsevier.com) for Bibliography.

## Chapter 306

# Parainfluenza Viruses

Fiona P. Havers and Angela J.P. Campbell

Human parainfluenza viruses (HPIVs) are common causes of acute respiratory illness in infants and children and are important causes of lower respiratory tract disease in young children and immunocompromised persons. These viruses cause a spectrum of upper and lower respiratory tract illnesses but are particularly associated with **croup** (laryngotracheitis or laryngotracheobronchitis), **bronchiolitis**, and **pneumonia**.

### ETIOLOGY

HPIVs are members of the **Paramyxoviridae** family. Four HPIVs cause illness in humans, classified as types 1-4, with diverse manifestations of infection. Type 4 is divided into two antigenic subtypes: 4a and 4b. HPIVs have a nonsegmented, single-stranded RNA genome with a lipid-containing envelope derived from budding through the host cell membrane. The major antigenic moieties are the hemagglutinin neuraminidase (HN) and fusion (F) surface glycoproteins.

### EPIDEMIOLOGY

By 5 years of age, most children have experienced primary infection with HPIV types 1, 2, and 3. HPIV-3 infections generally occur earliest, with half of infants infected by age 1 year and over 90% by age 5 years. HPIV-1 and HPIV-2 are more common after infancy, with approximately 75% infected by age 5 years. With increased use of multiplex molecular testing and more frequent addition of HPIV-4 as a panel target, HPIV-4 is more frequently recognized and appears to occur earlier in life than HPIV-1 and -2. In the United States and temperate climates, HPIV-1 has typically been reported to have biennial epidemics in the fall in odd-numbered years, whereas HPIV-2 has biennial outbreaks in the fall of even-numbered years, with peaks that are not as high as HPIV-1 or HPIV-3 (Fig. 306.1). HPIV-3 can be endemic throughout the year but typically peaks yearly in late spring or early summer. In years with less HPIV-1 activity, the HPIV-3 season has been observed to extend longer or to have a second peak in the fall (see Fig. 306.1). The epidemiology of HPIV-4 was historically less well defined, but with an increase in molecular detection, it has been found to have yearly peaks starting in the fall and peaking in winter (see Fig. 306.1).

Similar to what has been observed for other non-SARS-CoV-2 respiratory viruses, during the COVID-19 pandemic in 2020 and early 2021, HPIVs circulated at levels lower than prior years. However, HPIVs began increasing in the United States in spring of 2021 and, for HPIV types 1, 3, and 4, circulation patterns in 2022 and through fall 2023 were similar to pre-pandemic seasons; HPIV-2 continued to circulate at lower levels during that period. National HPIV trends are created from weekly laboratory test result data that are reported on a voluntary basis and are available at the Centers for Disease Control and Prevention (CDC) National Respiratory and Enteric Virus Surveillance System (NREVSS) website (<https://www.cdc.gov/surveillance/nrevss>).

HPIVs are spread primarily from the respiratory tract of an infected person by inhalation of large respiratory droplets or contact with infected nasopharyngeal secretions. HPIVs are notable for causing **outbreaks**

of respiratory illness in hospital wards, clinics, neonatal nurseries, and other institutional settings. The incubation period from exposure to symptom onset may range from 2 to 6 days. Children are likely to excrete virus from the oropharynx for 2-3 weeks, but shedding can be more prolonged, especially in immunocompromised children, and may persist for months. Primary infection does not confer permanent immunity, and reinfections are common throughout life. Reinfections are usually mild and self-limited but can cause serious lower respiratory tract illness, particularly in children with compromised immune systems.

### PATHOGENESIS

HPIVs replicate in the respiratory epithelium. The propensity to cause illness in the upper large airways is presumably related to preferential replication in the larynx, trachea, and bronchi in comparison with other viruses. Some HPIVs induce cell-to-cell fusion. During the budding process, cell membrane integrity is lost, and viruses can induce cell death through the process of apoptosis. In children, the most severe illness generally coincides with the time of maximal viral shedding. However, disease severity is likely related to the host immune response to infection as much as to direct cytopathic effects of the virus. Virus-specific immunoglobulin A antibody levels and serum antibodies to the surface HN and F glycoproteins are able to neutralize HPIV, and both likely contribute to host immunity. Cell-mediated cytotoxicity is also important for controlling and terminating HPIV infection.

### CLINICAL MANIFESTATIONS

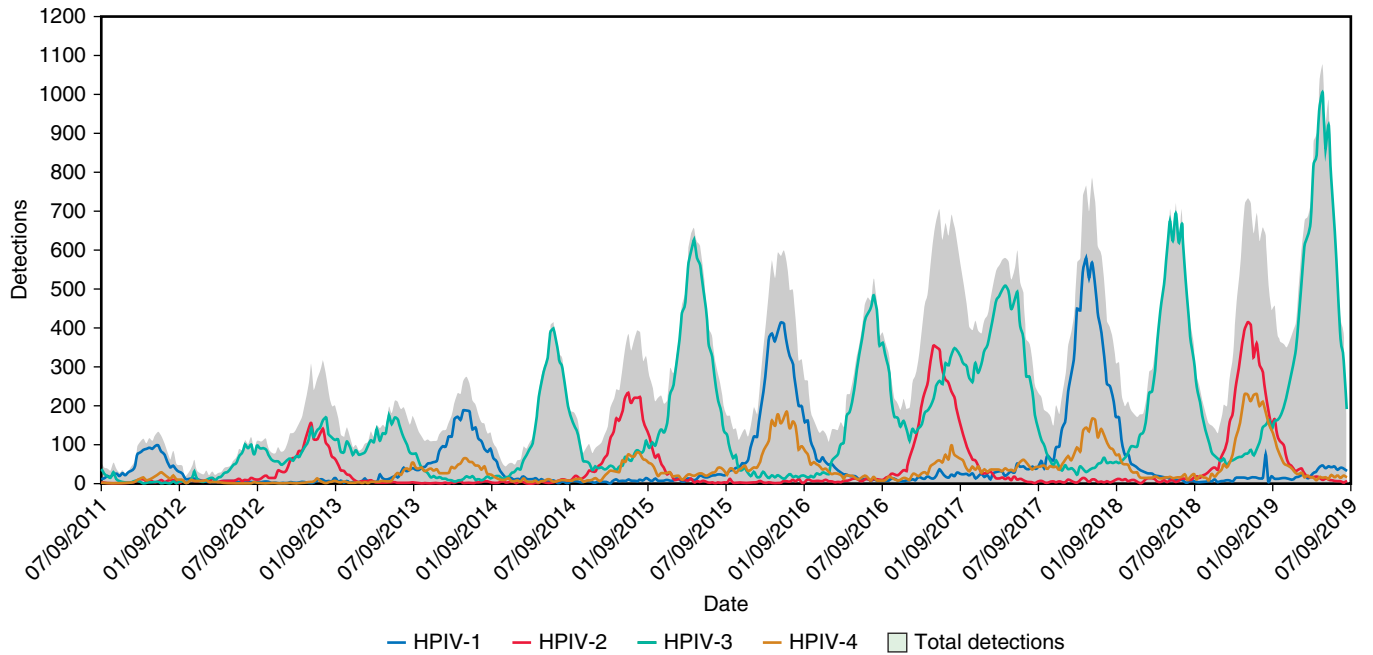
The most common type of illness caused by HPIV infection consists of some combination of low-grade fever, rhinorrhea, cough, pharyngitis, and hoarseness and may be associated with vomiting or diarrhea. Rarely, HPIV infection is associated with parotitis. HPIVs have also been associated with a variety of skin manifestations, including typical maculopapular viral exanthems, erythema multiforme, and papular acrodermatitis, or Gianotti-Crosti syndrome (see Chapter 708). Although often mild, more serious HPIV illness may result in hospitalization, with common discharge diagnoses of bronchiolitis, fever/possible sepsis, and apnea among younger children and croup, pneumonia, and asthma among older children (Fig. 306.2). HPIVs account for 50% of hospitalizations for croup and at least 15% of cases of bronchiolitis and pneumonia. HPIV-1 and HPIV-2 cause more cases of croup, whereas HPIV-3 is more likely to infect the small air passages of the lower respiratory tract and cause pneumonia, bronchiolitis, or bronchitis. HPIV-4 causes a similar range of illness as the other types, and with advancements in molecular diagnosis, there is evidence that HPIV-4 may be comparable to HPIV-3 and frequently associated with acute lower respiratory infection (ALRI).

In fact, any HPIV can cause lower respiratory tract disease, particularly during primary infection or in patients with compromised immune systems. In children and adult patients with hematologic malignancies and undergoing hematopoietic stem cell transplantation, lymphopenia has repeatedly been shown to be an independent risk factor for progression from upper to lower respiratory tract disease. Recently, the first global burden estimates of HPIV-associated and HPIV-attributable ALRI were generated, with approximately 13% of ALRI cases, 4-14% of ALRI hospital admissions, and 4% of childhood ALRI mortality attributable to HPIV.

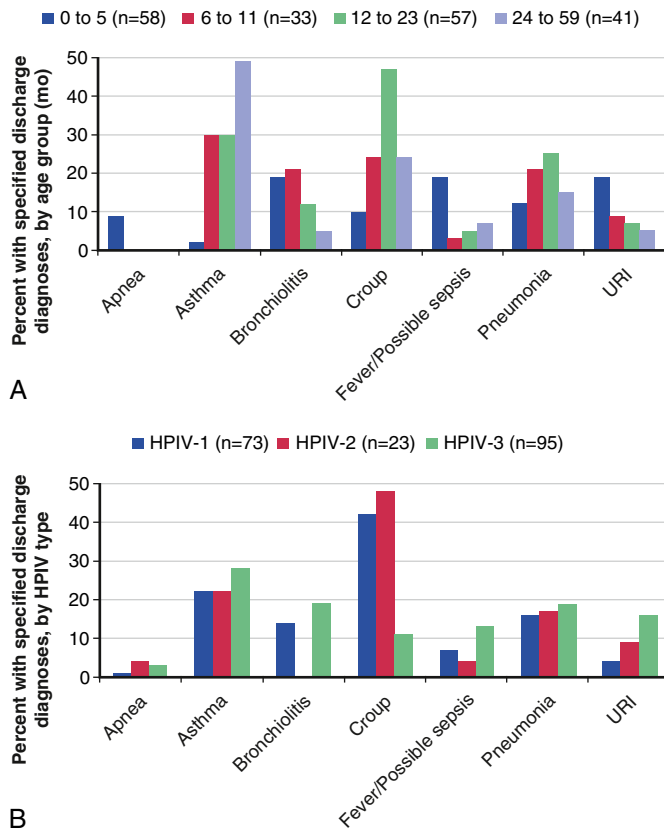
### DIAGNOSIS AND DIFFERENTIAL DIAGNOSIS

The diagnosis of HPIV infection in children is often based solely on clinical and epidemiologic criteria. Croup is a clinical diagnosis and must be distinguished from other diagnoses, including foreign body aspiration, epiglottitis, retropharyngeal abscess, angioedema, and subglottic stenosis or hemangioma. Although the radiographic **“steeple sign,”** consisting of progressive narrowing of the subglottic region of the trachea, is characteristic of croup, differential considerations include acute epiglottitis, thermal injury, angioedema, and bacterial tracheitis. Manifestation of HPIV lower respiratory tract disease may be similar to that of a number of other respiratory viral infections; therefore virus identification should be sought by the most sensitive diagnostic means available for certain severe illnesses, such as pneumonia in immunocompromised children.

Sensitive, specific, and rapid molecular assays such as multiplex polymerase chain reaction assays have become more widely available



**Fig. 306.1** Human parainfluenza virus (HPIV) circulation, National Enteric and Respiratory Virus Surveillance System, United States Census Regions, 2011–2019. (From DeGroot NP, Haynes AK, Taylor C, et al. Human parainfluenza virus circulation, United States, 2011–2019. *J Clin Virol.* 2020;124:104261. Fig. 1.)



**Fig. 306.2** Selected discharge diagnoses of hospitalized children with parainfluenza (HPIV) infection, by age in months (A) and virus type (B). (Data from Weinberg GA, Hall CB, Iwane MK, et al. Parainfluenza virus infection of young children: estimates of the population-based burden of hospitalization. *J Pediatr.* 2009;154:694–699, Table II)

and greatly increase sensitivity of HPIV detection. For immunocompromised patients, these highly sensitive platforms provide the critical ability to make a prompt diagnosis by detecting a wide range of viral pathogens, including HPIVs, thus allowing for early implementation of infection prevention measures and potential treatment. Other laboratory diagnosis methods are available, such as isolation in tissue culture and direct immunofluorescent staining for identification of virus antigens in respiratory secretions, but these have been used less frequently given the increasing availability of molecular assays.

## TREATMENT

There are no specific antiviral medications approved for the treatment of HPIV infections. For croup, the possibility of rapid respiratory compromise should influence the level of care and treatment given (see [Chapter 433](#)). The **severity assessment** of croup generally incorporates a number of clinical features, which include the presence and degree of chest wall retractions, whether stridor is present at rest, and evaluation of the child's mental status (e.g., for agitation, anxiety, lethargy).

Humidified air has not been shown to be significantly effective in reducing symptom severity. **Glucocorticoids** improve symptoms at 2 hours after treatment, lessen the need for other medications, and shorten hospital stays. **In general, because of its safety, efficacy, and cost-effectiveness, a single dose of oral dexamethasone (0.15 to 0.6 mg/kg) is the primary treatment for mild croup in the office or emergency room setting.** Oral prednisolone (1 mg/kg) is an acceptable alternative in this setting, particularly if dexamethasone is not available; however, in a meta-analysis, dexamethasone significantly reduced the rate of return visits and/or (re)admissions.

**For obstructive airway symptoms associated with moderate to severe croup, corticosteroid therapy is recommended: oral dexamethasone (0.6 mg/kg) should be given if oral intake is tolerated. A single dose of intramuscular dexamethasone or budesonide (2 mg [2 mL solution] via nebulizer) may provide an alternative to oral dexamethasone for children with severe respiratory distress or vomiting.** Alternatively, intravenous (IV) dexamethasone can be administered if IV access has been established. **Nebulized epinephrine (either racemic epinephrine 2.25% solution, 0.05 mL/kg/dose [up to maximum of 0.5 mL/dose] diluted to 3 mL with normal**

## Chapter 307

## Respiratory Syncytial Virus

James E. Crowe Jr.

saline, or L-epinephrine using parenteral 1 mg/ml [1:1000] solution, 0.5 mL/kg/dose [up to maximum 5 mL/dose]) is also recommended and may provide temporary symptomatic improvement. Children should be observed for at least 2 hours after receiving epinephrine treatment for return of obstructive symptoms. Repeated treatments may be provided, depending on the duration of symptoms. The dexamethasone dose may be repeated, but this should not be necessary on a routine basis, and there are no guidelines to compare outcomes of single- and multiple-dose treatment schedules. Moderate to severe symptoms that persist for more than a few days should prompt investigation for other causes of airway obstruction. Oxygen should be administered for hypoxia, and supportive care with analgesics and antipyretics is reasonable for fever and discomfort associated with HPIV infections. The indications for antibiotics are limited to well-documented secondary bacterial infections of the middle ear(s) or lower respiratory tract.

Ribavirin has some antiviral activity against HPIVs in vitro and in animal models. Inhaled ribavirin has been given to severely immunocompromised children with HPIV pneumonia; however, the majority of data have not shown improved outcomes, and randomized controlled studies are lacking. Some institutions use intravenous immunoglobulin for HPIV pneumonia in children with hematologic malignancies or who have undergone hematopoietic stem cell transplantation; the impact of this treatment strategy on clinical outcomes is also limited by lack of controlled studies. Use of DAS181, a novel sialidase fusion protein inhibitor, has shown clinical potential in a phase 2 clinical trial when used for treatment of HPIV lower respiratory tract disease among solid organ and hematopoietic stem cell transplant recipients, and a phase 3 trial is ongoing. Other potential strategies for drug development include hemagglutinin-neuraminidase inhibitors, transcription inhibitors, and synthetic small interfering RNAs.

### COMPLICATIONS

Eustachian tube obstruction can lead to secondary bacterial invasion of the middle ear space and acute otitis media in 30–50% of HPIV infections. Similarly, obstruction of the paranasal sinuses can lead to sinusitis. The destruction of cells in the upper airways can lead to secondary bacterial invasion and resultant bacterial tracheitis, and antecedent HPIV infection of lower airways may predispose to bacterial pneumonia. Nonrespiratory complications of HPIV are rare but include aseptic meningitis, encephalitis, acute disseminated encephalomyelitis, rhabdomyolysis, myocarditis, and pericarditis.

### PROGNOSIS

The prognosis for full recovery from HPIV infection in the immunocompetent child is generally excellent, with no long-term pulmonary sequelae. Deaths may rarely occur, particularly in immunocompromised children with lower respiratory tract infection.

### PREVENTION

Vaccine development has focused largely on live-attenuated intranasal HPIV-3 vaccines. Candidates include a recombinant human HPIV-3 virus (rcp45) derived from complementary DNA, as well as a complementary DNA-derived chimeric bovine/human HPIV-3 virus; these candidates are well tolerated and immunogenic in infants and young children. Constructs using chimeric bovine/human HPIV-3 virus in addition to the F or both F and G proteins of respiratory syncytial virus (RSV) have been investigated. A combined messenger RNA (mRNA) vaccine against HPIV-3 and human metapneumovirus has completed phase 1 clinical trials. Live attenuated candidate HPIV-1 and HPIV-2 vaccines have also undergone phase 1 clinical studies ([www.clinicaltrials.gov](http://www.clinicaltrials.gov)). The measure of protection afforded by vaccines will be difficult to assess, because symptomatic reinfection occurs and the frequency of serious infection in the general population is low. Nonetheless, it is clear that prevention of acute respiratory illness caused by HPIVs, particularly lower respiratory tract infections among infants and young children, is a worthwhile goal.

Visit Elsevier eBooks+ at [eBooks.Health.Elsevier.com](http://eBooks.Health.Elsevier.com) for Bibliography.

Respiratory syncytial virus (RSV) is the major cause of bronchiolitis (see Chapter 439) and viral pneumonia in children younger than 1 year of age and is the most important respiratory tract pathogen of early childhood.

### ETIOLOGY

RSV is an enveloped RNA virus with a single-stranded negative-sense genome that replicates entirely in the cytoplasm of infected cells and matures by budding from the apical surface of the cell membrane. Because this virus has a nonsegmented genome, it cannot undergo antigenic shift by reassortment like the influenza viruses do. The virus belongs to the family Pneumoviridae, which comprises large enveloped, negative-sense RNA viruses. This taxon was formerly a subfamily within the Paramyxoviridae but was reclassified in 2016 as a family with two genera, *Orthopneumovirus* (which includes RSV) and *Metapneumovirus* (which includes human metapneumovirus; see Chapter 308). There are two antigenic subgroups of RSV (subgroups A and B), distinguished based primarily on sequence and antigenic variation in one of the two surface proteins, the G glycoprotein that is responsible for attachment to host cells. Sequence analysis of cDNAs of the full G glycoprotein ectodomain region allows clustering of sequence patterns and identification of molecular markers that can be used to assign genotypes, subgenotypes, and lineages. There is no unified classification scheme for genotypes, so reports differ in the number of genotypes in circulation. The observed genotypic variation, which also can alter antigenic properties at the protein level, is caused by point mutations from infidelity of the viral RNA polymerase and may contribute to some degree to the frequency with which RSV reinfects children and adults. However, adult human challenge experiments have shown that the same RSV strain can reinfect in the upper respiratory tract repetitively, suggesting that mucosal immunity in that site is incomplete or short-lived.

RSV replicates in a wide variety of cell line monolayer cultures in the laboratory. In HeLa and HEp-2 cell monolayers, the virus causes cell-to-cell fusion that produces characteristic cytopathology called syncytia (multinucleate enlarged cells), from which the virus derives its name. Identification of syncytia in diagnostic cultures of respiratory secretions is helpful in identifying RSV, but it is not clear whether syncytium formation occurs to any significant degree in the airway epithelium in patients.

### EPIDEMIOLOGY

RSV is distributed worldwide and appears in yearly epidemics. In temperate climates, these epidemics occur each winter over a 4- to 5-month period. During the remainder of the year, infections are sporadic and much less common. In the Northern hemisphere, epidemics usually peak in January, February, or March, but peaks have been recognized as early as December and as late as June. Some areas in the United States, such as Florida, report a moderate incidence year-round. In the Southern hemisphere, outbreaks also occur during the winter months in that hemisphere. RSV outbreaks often overlap with outbreaks of influenza virus or human metapneumovirus but are generally more consistent from year to year and result in more disease overall, especially among infants younger than 6 months of age. In the tropics, the epidemic pattern is less clear. The pattern of widespread annual outbreaks and the high incidence of infection during the first 3-4 months of life are unique among human viruses. The conventional seasonality of RSV outbreaks was altered in 2020–2021 by events associated with the COVID-19 pandemic. Delayed and out-of-season RSV epidemics occurred during the COVID-19 pandemic when reopening activities



occurred after a long period of reduced transmission due to nonpharmaceutical interventions such as masking, distancing, and daycare and school closure reduced transmission.

Transplacentally acquired anti-RSV maternal immunoglobulin G (IgG) serum antibodies, if present in high concentration, appear to provide partial protection for the neonate. The age of peak incidence of severe lower respiratory tract disease and hospitalization is about 6 weeks. Maternal IgGs may account for the lower severity and incidence of RSV infections during the first 4–6 weeks of life, except among infants born prematurely, who receive less maternal immunoglobulin. Breastfeeding provides some protection against severe disease, an effect that may pertain only to female and not male infants. RSV is one of the most contagious viruses that affect humans. Infection is nearly universal among children by their second birthday. Reinfection occurs at a rate of at least 10–20% per epidemic throughout childhood, with a lower frequency among adults. In situations of high exposure, such as daycare centers, attack rates are nearly 100% among previously uninfected infants and 60–80% for second and subsequent infections.

Reinfection may occur as early as a few weeks after recovery but usually takes place during subsequent annual outbreaks. Antigenic variation is not required for reinfection, as shown by the fact that a proportion of adults inoculated repeatedly with the same experimental preparation of wild-type virus could be reinfected multiple times. The immune response of infants is poor in quality, magnitude, and durability. The severity of illness during reinfection in childhood is usually lower than that in first infection and appears to be a function of partial acquired immunity, more robust airway physiology, and increased age.

Asymptomatic RSV infection is unusual in young children. Most infants experience coryza and pharyngitis, often with fever and frequently with otitis media caused by virus in the middle ear or bacterial superinfection following eustachian tube dysfunction. The lower respiratory tract is involved to a varying degree, with bronchiolitis and bronchopneumonia in about a third of children. The hospitalization rate for RSV infection in otherwise healthy infants is typically 0.5–4%, depending on region, sex, socioeconomic status, exposure to cigarette smoke, gestational age, and family history of atopy. The admitting diagnosis is usually bronchiolitis with hypoxia, although this condition is often indistinguishable from RSV pneumonia in infants, and, indeed, the two processes frequently coexist. All RSV diseases of the lower respiratory tract (excluding croup) have their highest incidence at 6 weeks to 7 months of age and decrease in frequency thereafter. The syndrome of bronchiolitis is much less common after the first birthday. The terminology used for the diagnosis of virus-associated wheezing illnesses in toddlers can be confusing, because these illnesses are variably termed *wheezing-associated respiratory infection*, *wheezing bronchiolitis*, *exacerbation of reactive airways disease*, or *asthma attack*. Because many toddlers wheeze during RSV infection but do not go on to have lifelong asthma, it is best to use the diagnostic term *asthma* only later in life. It is still uncertain if RSV-associated wheezing illness in infancy causes asthma in later life. On the whole, prevention of severe RSV illness in high-risk infants using RSV monoclonal antibody prophylaxis does not seem to reduce the incidence of asthma in those populations significantly. Whether a vaccine will have such an effect in the future is still to be determined.

Acute viral pneumonia is a recurring problem throughout childhood, although RSV becomes less prominent as the etiologic agent after the first year. RSV plays a causative role in an estimated 40–75% of cases of hospitalized bronchiolitis, 15–40% of cases of childhood pneumonia, and 6–15% of cases of croup. Bronchiolitis and pneumonia resulting from RSV are more common in males than in females by a ratio of approximately 1.5:1. Other risk factors with a similar impact in the United States include one or more siblings in the home, White race, rural residence, maternal smoking, and maternal education <12 years. The medical factors in infants associated with the highest risk are chronic lung disease of prematurity, congenital heart disease, immunodeficiency, and prematurity. Still, most infants admitted to the hospital because of RSV infection do not have strong, easily identifiable risk factors. Therefore any strategy for prophylaxis focused only on individuals with strong risk factors probably could prevent only approximately

10% of hospitalizations, even if the prophylaxis was 100% effective in treated high-risk individuals.

The incubation period from exposure to first symptoms is approximately 3–5 days. The virus is excreted for variable periods, probably depending on the severity of illness and immunologic status. Most infants with lower respiratory tract illness shed infectious viruses for 1–2 weeks after hospital admission. Excretion for 3 weeks and even longer has been documented. Spread of infection occurs when large infected droplets, either airborne or conveyed on hands or other fomites, are inoculated in the nasopharynx of a susceptible subject. RSV is probably introduced into most families by young schoolchildren experiencing reinfection. Typically, in the space of a few days, 25–50% of older siblings and one or both parents acquire upper respiratory tract infections, but infants become more severely ill with fever, otitis media, or lower respiratory tract disease.

Nosocomial infection during RSV epidemics is an important concern. Virus is usually spread from child to child on the hands of caregivers or other fomites. Adults experiencing reinfection also have been implicated in the spread of the virus. Contact precautions are sufficient to prevent spread when compliance is meticulous, because the virus is not spread by small particle aerosol to an appreciable degree, and a distance of about 6 ft is likely sufficient to avoid aerosol transmission. During the COVID-19 pandemic, widespread social measures, including masking and distancing, appeared to prevent transmission of RSV on a world-wide basis. However, in normal circumstances, adherence to isolation procedures by caregivers often is not complete.

## PATHOGENESIS

Bronchiolitis is caused by obstruction and collapse of the small airways during expiration. Infants are particularly apt to experience small airway obstruction because of the small size of their normal bronchioles; airway resistance is proportional to  $1/\text{radius}^4$ . There has been relatively little pathologic examination of RSV disease in the lower airways of otherwise healthy subjects. Airway narrowing likely is caused by virus-induced necrosis of the bronchiolar epithelium, hypersecretion of mucus, and round-cell infiltration and edema of the surrounding submucosa. These changes result in the formation of mucus plugs obstructing bronchioles, with consequent hyperinflation or collapse of the distal lung tissue. In interstitial pneumonia, the infiltration is more generalized, and epithelial shedding may extend to both the bronchi and the alveoli. In older subjects, smooth muscle hyperreactivity may contribute to airway narrowing, but the airways of young infants typically do not exhibit a high degree of reversible smooth muscle hyperreactivity during RSV infection.

Several facts suggest that elements of the host response may cause inflammation and contribute to tissue damage. The immune response required to eliminate virus-infected cells (mostly containing cytolytic T cells) is a double-edged sword, reducing the cells producing virus but also causing host cell death in the process. Many soluble factors, such as cytokines, chemokines, and leukotrienes, are released in the process, and skewing of the patterns of these responses may predispose some individuals to more severe disease. There is also evidence that genetic factors may predispose to more severe bronchiolitis.

Some studies have identified the presence of both RSV and human metapneumovirus viral RNA in airway secretions in a significant proportion of infants requiring assisted ventilation and intensive care. It may be that co-infection is associated with more severe disease. Positive results of polymerase chain reaction (PCR) analysis must be interpreted carefully because this positivity can remain for prolonged periods after infection, even when infectious virus can no longer be detected.

It is not clear how often superimposed bacterial infection plays a pathogenic role in RSV lower respiratory tract disease. RSV bronchiolitis in infants is probably exclusively a viral disease, although there is evidence that bacterial pneumonia can be triggered by respiratory viral infection, including with RSV. A large clinical study of pneumococcal vaccine showed that childhood vaccination reduced the incidence of viral pneumonia by approximately 30%, suggesting viral-bacterial interactions that we currently do not fully understand.



## CLINICAL MANIFESTATIONS

Typically, the first sign of infection in infants with RSV is rhinorrhea. Cough may appear simultaneously but more often does so after an interval of 1-3 days, at which time there may also be sneezing and a low-grade fever. Soon after the cough develops, the child who experiences bronchiolitis begins to wheeze audibly. If the disease is mild, the symptoms may not progress beyond this stage. Auscultation often reveals diffuse fine inspiratory crackles and expiratory wheezes. Rhinorrhea usually persists throughout the illness, with intermittent fever. Chest radiograph findings at this stage are frequently normal.

If the illness progresses, cough and wheezing worsen and air hunger ensues, with an increased respiratory rate, intercostal and subcostal retractions, hyperexpansion of the chest, restlessness, and peripheral cyanosis. Signs of severe, life-threatening illness are central cyanosis, tachypnea of >70 breaths/min, listlessness, and apneic spells. At this stage, the chest may be significantly hyperexpanded and almost silent to auscultation because of poor air movement.

Chest radiographs of infants hospitalized with RSV bronchiolitis have normal findings in approximately 30% of cases, with the other 70% showing hyperexpansion of the chest, peribronchial thickening, and interstitial infiltrates. Segmental or lobar consolidation is unusual, and pleural effusion is rare.

In some infants, the course of the illness may resemble that of pneumonia, the prodromal rhinorrhea and cough being followed by dyspnea, poor feeding, and listlessness. Although the clinical diagnosis is pneumonia, wheezing is often present intermittently, and the chest radiographs may show air trapping.

Fever is an inconsistent sign in RSV infection. In young infants, particularly those who were born prematurely, periodic breathing and apneic spells have been distressingly frequent signs, even with relatively mild bronchiolitis. Apnea is not necessarily caused by respiratory exhaustion but rather appears to be a consequence of alterations in the central control of breathing.

RSV infections in profoundly immunocompromised hosts or those with chronic lung disease or pulmonary hypertension may be severe at any age of life. The mortality rates associated with RSV pneumonia in the first few weeks after hematopoietic stem cell or solid-organ transplantation in both children and adults are high. RSV infection does not appear to be more severe in HIV-infected patients with reasonable control of HIV disease, although these patients may shed virus in respiratory secretions for prolonged periods.

Secondary (associated) bacterial infections are uncommon in most previously healthy patients with RSV bronchiolitis. However, otitis media may be present because of either RSV or bacterial middle ear infection.

## DIAGNOSIS

Bronchiolitis is a clinical diagnosis. RSV can be suspected with varying degrees of certainty based on the season of the year and the presence of the virus in the community. Other epidemiologic features that may be helpful are the presence of common colds in older household contacts and the age of the child. The other respiratory viruses that attack infants frequently during the first few months of life are human metapneumovirus, influenza viruses, parainfluenza virus type 3, rhinoviruses, enteroviruses, and coronaviruses.

Routine laboratory tests are of minimal diagnostic use in most cases of bronchiolitis or pneumonia caused by RSV. The white blood cell count is normal or elevated, and the differential cell count may be normal with either a neutrophilic or mononuclear predominance. Hypoxemia as measured by pulse oximetry or arterial blood gas analysis is frequent and tends to be more marked than anticipated from the clinical findings. A normal or elevated blood carbon dioxide value in a patient with a markedly elevated respiratory rate is a sign of respiratory failure.

The most important diagnostic concern is to differentiate viral infection from bacterial or chlamydial infection. When bronchiolitis is not accompanied by infiltrates on chest radiographs, there is little likelihood of a bacterial component. In infants 1-4 months of age, interstitial pneumonia may be caused by *Chlamydia trachomatis* (see Chapter 272).

With *C. trachomatis* pneumonia, there may be a history of conjunctivitis, and the illness tends to be of subacute onset. Coughing and inspiratory crackles may be prominent; wheezing is not. Fever is usually absent.

Lobar consolidation without other signs or with pleural effusion should be considered of bacterial etiology until proved otherwise. Other signs suggesting bacterial pneumonia are neutrophilia, neutropenia in the presence of severe disease, ileus or other abdominal signs, high temperature, and circulatory collapse. In such instances, antibiotics should be initiated.

The definitive diagnosis of RSV infection is based on the detection in respiratory secretions of live virus by cell culture. Molecular diagnostic tests are more available, however. The presence of viral RNA (detected by a molecular diagnostic test using reverse transcription PCR) or viral antigens (detected by a rapid diagnostic test, usually a membrane blotting test incorporating antibody detection of viral proteins) is strongly supportive in the right clinical setting. The antigen test is less sensitive than virus culture, whereas reverse transcription PCR analysis is more sensitive than culture. An aspirate of mucus or a nasopharyngeal wash from the child's posterior nasal cavity is the optimal specimen. Nasopharyngeal or throat swabs are less preferable but are acceptable. A tracheal aspirate is unnecessary, but endotracheal tube lavage fluid from patients intubated for mechanical ventilation can be tested. The specimen should be placed on ice, taken directly to the laboratory, and processed immediately for culture, antigen detection, or PCR analysis. RSV is thermolabile, so it degrades over relatively short periods of time unless it is frozen at a low temperature such as  $-80^{\circ}\text{C}$  ( $-112^{\circ}\text{F}$ ) in freezers used in research settings.

## TREATMENT

The treatment of uncomplicated cases of bronchiolitis is symptomatic. Many infants are slightly to moderately dehydrated, and therefore fluids should be carefully administered in amounts somewhat greater than those for maintenance. Often, intravenous or tube feeding is helpful when sucking is difficult because of tachypnea. Humidified oxygen and suctioning usually are indicated for hospitalized infants who are hypoxic. High-flow nasal cannula (HFNC) therapy is used for respiratory distress either before or after admission to an intensive care unit. HFNC is often started based on the subjective assessment of work of breathing; despite HFNC use, it remains uncertain if the outcome of RSV bronchiolitis has been improved with HFNC. Nasal continuous positive airway pressure is used in the intensive care unit for infants who have increased work of breathing, and mechanical ventilation is used for respiratory failure.

There is disagreement among experts regarding the usefulness of aerosolized saline or hypertonic saline, epinephrine, or  $\beta_2$ -agonists in RSV bronchiolitis. Most patients do not receive lasting benefit from prolonged therapy, which is associated with a relatively high frequency of side effects. Corticosteroid therapy is not indicated except in older children with an established diagnosis of asthma, because its use is associated with prolonged virus shedding and is of no proven clinical benefit. The 2014 American Academy of Pediatrics bronchiolitis clinical practice guideline suggests limitations on the use of  $\alpha$ - and  $\beta$ -adrenergic agents and corticosteroids.

In nearly all instances of bronchiolitis, antibiotics are not useful, and their inappropriate use contributes to the development of antibiotic resistance. Interstitial pneumonia in infants 1-4 months old may be caused by *C. trachomatis*, and macrolide therapy may be indicated for that infection if identified by specific testing.

## PROGNOSIS

The mortality rate of hospitalized infants with RSV infection of the lower respiratory tract is very low in the developed world. Almost all deaths occur among young, premature infants or infants with underlying disease of the neuromuscular, pulmonary, cardiovascular, or immunologic system. However, it is estimated that more than 160,000 children worldwide in resource-poor settings die each year from RSV. In addition, thousands of elderly patients die of RSV infection each year in the United States.

There is recurrent wheezing in 30-50% of children who have severe RSV bronchiolitis in infancy, and many older children who are diagnosed with asthma have a history of severe bronchiolitis in infancy. The likelihood of the recurrence of wheezing is increased in the presence

of an allergic diathesis (e.g., eczema, hay fever, or a family history of asthma). With a clinical presentation of bronchiolitis in a patient older than 1 year of age, there is an increasing probability that, although the episode may be virus-induced, the event is likely the first of multiple wheezing attacks that will later be diagnosed as hyperreactive airways disease or asthma. Asthma is difficult to diagnose in the first year of life. It is not fully clear at this time whether early, severe RSV wheezing disease causes some cases of asthma or whether persons destined to have asthma present with symptoms first when provoked by RSV infection during infancy. Results from a long-term follow-up study of infants who received palivizumab prophylaxis suggested that the prevention of severe RSV infection may reduce the incidence of reactive airways disease later in life.

## PREVENTION

### Prevention of Nosocomial Spread

In the hospital, the most important preventive measures are aimed at blocking nosocomial spread. During RSV season, high-risk infants should be separated from all infants with respiratory symptoms. Gowns, gloves, and careful handwashing (contact isolation) should be used for the care of all infants with suspected or established RSV infection. A high level of compliance with contact isolation is essential. Viral laboratory tests are adequate for diagnosis in the setting of acute disease when levels of virus are high, but they are not designed to detect low levels of virus. Therefore, contact precaution isolation should be observed for the duration of hospitalization for most patients admitted for acute disease. Rapid antigen tests should not be used to determine whether a patient still requires isolation, because low concentrations of virus may be present in respiratory secretions that are infectious for humans but below the lower limit of detection for such assays. Ideally, patients with RSV or metapneumovirus infections are housed separately because co-infection with the two viruses may be associated with more severe disease.

### Protection of Infants Against Infection or Severe Disease

Antibodies that neutralize RSV are the principal mechanism of protection against infection or reinfection. Antibodies are induced by natural infection but can also be provided to infants prior to a first infection in several ways. *First*, all mothers pass along their own naturally occurring IgG antibodies across the placenta beginning at about 28–32 weeks' gestation. *Second*, breastfeeding may transfer maternal antibodies (including IgA antibodies) to infant mucosal surfaces, providing benefit in some infants. *Third*, antibodies manufactured as biologic drugs can be administered directly to infants after birth. *Fourth*, maternal immunization with an approved RSV vaccine can increase the level of antibodies in the mother's serum and thus also the level of antibodies transferred across the placenta. The Advisory Committee on Immunization Practices (ACIP) in the United States recommends that either antibody administration to the infant or maternal vaccination during pregnancy should be used to prevent RSV-associated lower respiratory tract illness among all infants, but *both* exogenous antibodies and maternal vaccination are not needed for most infants.

### Passive Immunoprophylaxis

A neutralizing humanized murine monoclonal antibody against RSV given IM once a month (palivizumab) has been approved for protecting high-risk children against serious complications from RSV disease. A next-generation monoclonal antibody (nirsevimab, Beyfortus, Sanofi and AstraZeneca) was subsequently approved for the prevention of lower respiratory tract infection caused by RSV in the European Union, United Kingdom, United States, and Canada. Nirsevimab is an RSV fusion-protein-specific monoclonal antibody with an extended half-life because of engineered changes in the antibody Fc region. Since the antibody is long-acting (with a half-life of about 3 months instead of 3 weeks as for conventional IgG), only a single dose is necessary to protect term, preterm, and high-risk infants for an entire RSV season. In the United States, nirsevimab is indicated for the prevention of RSV lower respiratory tract disease in neonates and infants <8 months born during or entering their first RSV season and in children 8–19 months of age at increased risk for severe RSV disease entering their second RSV season.

Nirsevimab is dispensed in prefill syringes of either 50 or 100 mg; the dose is 50 mg IM for infants < 5 kg, and 100 mg IM for infants < 8 months old and  $\geq$  5 kg. The first dose for infants <8 months of age may be given in the first week of life. For infants 8–19 months of age entering their second RSV season and at increased risk for severe RSV infection, the dose is 200 mg.

Because of a projected shortage of the 100 mg dose, it is recommended that only infants  $\geq$  5kg who are at high risk for severe RSV infection receive the 100 mg dose. High risk patients are defined as:

- Infants < 6 months
- American Indian and Alaska Natives < 8 months
- Infants age 6 to < 8 months with prematurity (< 29 weeks), chronic lung disease of prematurity, hemodynamically significant congenital heart disease, severe immunocompromise, cystic fibrosis, neuromuscular disease, or congenital pulmonary abnormalities that impair the ability to clear secretions

*Palivizumab should be administered only to high risk infants (8–19 months old) and to eligible infants <8 months old if nirsevimab is not available.*

Administration of palivizumab (15 mg/kg intramuscularly once a month) is recommended for protecting high-risk children against serious complications from RSV disease. Palivizumab is administered from the beginning to the end of the RSV season. Palivizumab prophylaxis may be considered for the following infants and children:

- Infants born before 29 wk of gestation in the first year of life
- Infants born before 32 wk of gestation, who have chronic lung disease of prematurity (required > 21% Fio<sub>2</sub> [fraction of inspired oxygen] for  $\geq$  28 days after birth), in the first year of life and in the second RSV season if continued medical support (oxygen, diuretics, steroids) is needed
- Infants younger than 1 yr of age with hemodynamically *significant* cyanotic congenital heart disease or those with moderate to severe pulmonary hypertension and those patients following cardiac transplantation (children < 2 yr of age)
- Children 24 mo of age or younger with profound immunocompromising conditions during RSV season
- Infants in the first year of life who have either congenital abnormalities of the airway or neuromuscular disease that compromises the handling of respiratory secretions

### Vaccine

There are two licensed subunit protein vaccines against RSV for older adults (Abrysvo, Pfizer; Arexvy, GSK) based on a prefusion conformation of the RSV fusion (F) protein (RSVpreF). The bivalent RSVpreF Abrysvo vaccine has subunit proteins for both the type A and type B RSV antigenic subgroups, while the Arexvy vaccine contains only subgroup A antigen combined with an adjuvant. Neither vaccine is approved for use in infants or children, but Abrysvo is used in pregnant mothers 32–36 weeks pregnant during RSV season with the goal to protect infants. The mechanism of protection is that the resulting increased serum level of RSV-neutralizing antibodies in the mother can enhance immunity in neonates following transplacental transfer of those maternal RSV antibodies to the fetus. In efficacy trials, this vaccination reduced the incidence of medically attended RSV lower respiratory tract infections and hospitalization within 90 days after birth. The Abrysvo vaccine is recommended during September through January for most of the United States, since RSV typically peaks in fall and winter. The seasonality of RSV season varies depending on location, and thus state, local, or territorial health departments may recommend different timing for administration in diverse areas. The risk of severe RSV is even greater in infants born at <32 weeks' gestation. When Abrysvo was compared to placebo in clinical trials, infants born to pregnant individuals experienced low birth weight (5.1% Abrysvo compared to 4.4% placebo, a difference that was not statistically significant). The European Medicines Agency chose to approve maternal immunization with Abrysvo between weeks 24 and 36 of gestation, while the US FDA chose to approve the vaccine between weeks 32 and 36 of gestation while awaiting additional safety information from ongoing studies.

Visit Elsevier eBooks+ at [eBooks.Health.Elsevier.com](http://eBooks.Health.Elsevier.com) for Bibliography.

## Chapter 308

## Human Metapneumovirus

James E. Crowe Jr.

**ETIOLOGY**

Human metapneumovirus (HMPV) is a respiratory virus that is one of the most common causes of serious lower respiratory tract illness in children throughout the world.

**ETIOLOGY**

HMPV is an enveloped, single-stranded, nonsegmented, negative-sense RNA genome of the family Pneumoviridae, which comprises large enveloped negative-sense RNA viruses. This taxon was formerly a subfamily within the Paramyxoviridae but was reclassified in 2016 as a family with two genera: *Metapneumovirus* (which includes HMPV) and *Orthopneumovirus* (which includes respiratory syncytial virus [RSV]; see Chapter 307). HMPV and the avian pneumoviruses are highly related and are separated into the separate genus *Metapneumovirus* because the gene order in the nonsegmented genome is slightly altered and because avian pneumoviruses/HMPVs lack the genes for two nonstructural proteins, NS1 and NS2, which are encoded at the 3' end of RSV genomes. These proteins are thought to counteract host type I interferons. The absence of NS1/NS2 in the metapneumoviruses (compared with RSV) may contribute to an overall slightly reduced pathogenicity relative to wild-type RSV strains.

The HMPV genome encodes nine proteins in the order 3'-N-P-M-F-M2-(orf1 and 2)-SH-G-L-5'. The genome also contains noncoding 3' leader, 5' trailer, and intergenic regions, consistent with the organization of most paramyxoviruses, with a viral promoter contained in the 3' end of the genome. The F (fusion), G (glycosylated), and SH (short hydrophobic) proteins are integral membrane proteins on the surfaces of infected cells and virion particles. The F protein is a classic type I integral membrane viral fusion protein that contains two heptad repeats in the extracellular domain that facilitate membrane fusion. There is a predicted protein cleavage site near a hydrophobic fusion peptide that likely is cleaved by an extracellular protease, activating the F protein for fusion. The predicted attachment (G) protein of HMPV exhibits the basic features of a glycosylated type II mucin-like protein. The HMPV G protein differs from the RSV G protein that inhibits innate immune responses in that the HMPV G lacks a cysteine noose structure. The internal proteins of the virus appear similar in function to those of other paramyxoviruses.

**EPIDEMIOLOGY**

HMPV outbreaks occur in annual epidemics during late winter and early spring in temperate climates, often overlapping with the second half of the annual RSV epidemic (Fig. 308.1). Sporadic infections occur year-round. A near-total decline of HMPV infections occurred in the 2020–2021 winter associated with COVID-19 public health measures, followed by a delayed or interseasonal outbreak in 2021. The usual period of viral shedding is likely to be many days or even several weeks after primary infection in infants. The incubation period is approximately 3–5 days. Humans are the only source of the virus; there is no known animal or environmental reservoir. Transmission occurs by close or direct contact with contaminated secretions involving large-particle aerosols, droplets, or contaminated surfaces. Nosocomial infections have been reported, and contact isolation with excellent handwashing for health-care providers is critical in medical settings. This virus also affects the elderly, immunocompromised patients, and patients with reactive airways disease more severely than otherwise healthy individuals.

**PATHOLOGY**

Infection is usually limited to the superficial layer of airway epithelial cells and is associated with a local inflammatory infiltrate consisting of lymphocytes and macrophages. Immunocompromised individuals

have evidence of both acute and organizing injuries during prolonged infection.

**PATHOGENESIS**

Infection occurs via inoculation of the upper respiratory tract. Infection can spread rapidly to the lower respiratory tract, but it is not clear whether the dissemination is mediated by cell-to-cell spread or by aspiration of infected materials from the upper tract. Severe lower respiratory tract illness, especially wheezing, occurs mainly during the first year of life, at a time when the airways are of a very small diameter and thus a high resistance. Maternal serum-neutralizing antibodies that cross the placenta may afford a relative protection against severe disease for several weeks or months after birth. Once infection is established, it is likely that cytotoxic T cells recognize and eliminate virus-infected cells, thus terminating the infection but also causing some cytopathology. The virus appears to have specific mechanisms for inhibiting T-cell responses during acute infection. Individuals with an underlying predisposition for reactive airways disease (including adults) are susceptible to severe wheezing during reinfection later in life, suggesting that HMPV may cause smooth muscle hyperactivity, inflammation, or increased mucus production in such individuals. Infection in otherwise healthy individuals resolves without apparent long-term consequences in most cases. HMPV infection is associated with exacerbations of asthma later in life.

**CLINICAL MANIFESTATIONS**

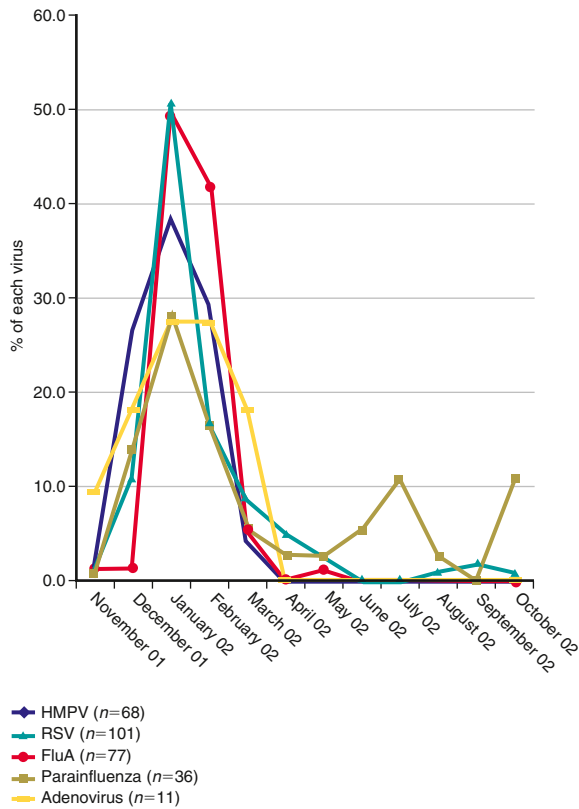
HMPV is associated with the common cold (complicated by otitis media in approximately 30% of cases) and with lower respiratory tract illnesses such as bronchiolitis, pneumonia, croup, and exacerbation of reactive airways disease. The profile of signs and symptoms caused by HMPV is similar to that caused by RSV (Table 308.1). Approximately 5–10% of outpatient lower respiratory tract illnesses in otherwise healthy young children are associated with HMPV infection, which is second in incidence only to RSV. Children with RSV or HMPV infection require supplemental oxygen and medical intensive care at similar frequencies.

About half of the cases of HMPV lower respiratory tract illness in children occur in the first 6 months of life, suggesting that young age is a major risk factor for severe disease. Both young adults and the elderly can have HMPV infection that requires medical care, including hospitalization, but severe disease occurs at much lower frequencies in adults than in young children. Severe disease in pediatric and older subjects is most common in immunocompromised patients or those with complications of preterm birth, congenital heart disease, and neuromuscular disease and can be fatal. A significant number of both adult and pediatric patients with asthma exacerbations have HMPV infection; it is not clear whether the virus causes long-term wheezing. RSV and HMPV co-infections have been reported; co-infections may be more severe than infection with a single virus, resulting in pediatric intensive care unit admissions. It is difficult to define true co-infections because these viral RNA genomes can be detected by a reverse transcriptase polymerase chain reaction (PCR) in respiratory secretions for at least several weeks after illness, even when virus shedding has terminated.

**LABORATORY FINDINGS**

The virus can be visualized only with electron microscopy. The virus grows in primary monkey kidney cells or LLC-MK2 cell-line or Vero cell-line monolayer cultures in reference or research laboratories, but efficient isolation of the virus requires an experienced laboratory technician. Conventional bright-field microscopy of infected cell monolayer cultures often reveals a cytopathic effect only after multiple passages in the cell culture. The characteristics of the cytopathic effect are not sufficiently distinct to allow identification of the virus on this basis alone, even by a trained observer. The most sensitive test for identification of HMPV in clinical samples is reverse transcriptase PCR, usually performed with primers directed to conserved viral genes. Detection by this modality is also available in some multiplex PCR tests for panels of respiratory viruses. Real-time reverse transcriptase PCR tests offer enhanced sensitivity and specificity, including assays designed to detect viruses from the four known genetic lineages. Direct





**Fig. 308.1** Temporal distribution of respiratory viruses among children hospitalized with lower respiratory tract infections from November 2001 through October 2002. Data are displayed as the proportion of each virus detected monthly. FluA, influenza A; HMPV, human metapneumovirus; RSV, respiratory syncytial virus. (From Wolf DG, Greenberg D, Kalkstein D, et al. Comparison of human metapneumovirus, respiratory syncytial virus and influenza A virus lower respiratory tract infections in hospitalized young children. *Pediatr Infect Dis J.* 2006;25:320–324.)

**Table 308.1** Clinical Manifestations of Human Metapneumovirus in Children

<b>COMMON (&gt;50%)</b>
Fever >38°C (100.4°F)
Cough
Rhinitis, coryza
Wheezing
Tachypnea, retractions
Hypoxia (O <sub>2</sub> saturation <94%)
Chest radiograph demonstration of infiltrates or hyperinflation
<b>LESS COMMON</b>
Otitis media
Pharyngitis
Rales
<b>RARE</b>
Conjunctivitis
Hoarseness
Encephalitis
Fatal respiratory failure in immunocompromised children

antigen tests for identification of HMPV antigens in nasopharyngeal secretions are available but are less efficient than nucleic acid–based detection. Some laboratories have success with the use of immunofluorescence staining with monoclonal or polyclonal antibodies to detect HMPV in nasopharyngeal secretions and shell vial cultures or in monolayer cultures in which virus has been cultivated, with reported sensitivities varying from about 65% to 90%. A fourfold rise in serum

antibody titer to HMPV from the acute to convalescent time point can be used in research settings to confirm infection.

## DIAGNOSIS AND DIFFERENTIAL DIAGNOSIS

In temperate areas, the diagnosis should be suspected during the late winter in infants or young children with wheezing or pneumonia and a negative RSV diagnostic test result. The diseases caused by RSV and HMPV cannot be distinguished clinically. Many other common respiratory viruses, such as parainfluenza viruses, influenza viruses, adenoviruses, rhinoviruses, enteroviruses, and coronaviruses, can cause similar disease in young children. Some of these viruses can be identified by PCR genetic testing or conventional cell culture means. Chest radiographs are not very specific, mostly showing parahilar opacities, hyperinflation, atelectasis, and, occasionally, consolidation but not pleural effusion or pneumothorax.

## COMPLICATIONS

Bacterial superinfection of the lower airways is unusual but does occur. The local complication of otitis media is common, likely a result of eustachian tube dysfunction caused by the virus.

## TREATMENT

There is no specific treatment currently for HMPV infection. A single small-molecule drug inhibitor for HMPV is in clinical trials as of early 2022. Management consists of supportive care like that used for RSV (see Chapter 307). The rate of bacterial lung infection or bacteremia associated with HMPV infection is not fully defined but is suspected to be low. Antibiotics are usually not indicated in the treatment of infants hospitalized for HMPV bronchiolitis or pneumonia.

## Supportive Care

Treatment is supportive and includes careful attention to hydration; monitoring of respiratory status by physical examination and measurement of oxygen saturation; the use of supplemental oxygen, high-flow nasal cannula therapy, and nasal continuous positive airway pressure in an intensive care unit for increased work of breathing; and, in the case of respiratory failure, mechanical ventilation.

## PROGNOSIS

Most infants and children recover from acute HMPV infection without apparent long-term consequences. Many experts believe an association exists between severe HMPV infections in infancy and the risk for recurrent wheezing or the development of asthma; however, it is not clear whether the virus causes these conditions or precipitates their first manifestations.

## PREVENTION

The only method of prevention of HMPV infection is reduction of exposure. Contact precautions are recommended for the duration of HMPV-associated illness among hospitalized infants and young children. The near-total absence of HMPV infections during the first year of the COVID-19 pandemic suggests that nonpharmacologic interventions (such as masking and distancing) are effective when compliance is high. Patients known to have HMPV infection should be housed in single rooms or with a cohort of HMPV-infected patients. When feasible, it is wise to care for patients with RSV infection in a separate cohort from HMPV-infected patients to prevent co-infection, which may be associated with more severe disease. Preventive measures include limiting exposure to contagious settings during annual epidemics (such as daycare centers) as much as possible and an emphasis on hand hygiene in all settings, including the home, especially during periods when the contacts of high-risk children have respiratory infections. However, providers should keep in mind that infection is universal in the first several years of life. Therefore reduction of exposure makes the most sense during the first 6 months of life, when infants are at the highest risk for severe disease. Experimental HMPV vaccine candidates using live attenuated viruses or a messenger RNA (mRNA)–encoded HMPV fusion protein gene are under study.

Visit Elsevier eBooks+ at [eBooks.Elsevier.com](https://eBooks.Elsevier.com) for Bibliography.



## Chapter 309

## Adenoviruses

Terri L. Stillwell and Jason B. Weinberg

Human adenoviruses (HAdVs) are a common cause of human disease. Conjunctivitis is a familiar illness associated with the HAdVs, but these viruses also cause upper and lower respiratory disease, pharyngitis, gastroenteritis, and hemorrhagic cystitis. HAdVs can cause severe disease in immunocompromised hosts. Outbreaks of HAdV infection occur in communities and closed populations, notably the military. No currently approved antiviral drugs are highly effective against HAdVs. Vaccines are available for HAdV types 4 and 7 but are used only in military populations.

**ETIOLOGY**

Adenoviruses are nonenveloped viruses with an icosahedral protein capsid. The double-stranded DNA viral genome is contained within the particle complexed with several viral proteins. Antigenic variability in surface proteins of the virion and genomic sequencing define over 100 types, grouped into seven species. HAdV species differ in their tissue tropism and target organs, causing distinct clinical infections (Table 309.1). HAdVs can be shed from the gastrointestinal and respiratory tracts for prolonged periods and can establish persistent infection in mucosal lymphoid tissue.

**EPIDEMIOLOGY**

HAdVs circulate worldwide and cause endemic infections year-round in immunocompetent hosts. Asymptomatic infections are also common. Epidemics of conjunctivitis (often severe), pharyngitis, and respiratory disease can occur, especially in schools, congregate living arrangements, and military settings. Outbreaks of febrile respiratory illness caused by HAdV-4 and HAdV-7 are major sources of morbidity in military barracks, with attack rates ranging from 25% to over 90%. HAdV spread occurs by respiratory and fecal-oral routes. An important factor in HAdV transmission, especially in epidemics, is the ability of the nonenveloped particle to survive on inanimate objects in the environment. Nosocomial outbreaks have been reported.

**PATHOGENESIS**

HAdVs bind to cell surface receptors and trigger internalization by endocytosis. Acidification of the endosome induces conformational changes in the capsid, leading to eventual translocation of the genome to the cell nucleus. Viral messenger RNA transcription and genomic replication occur in the nucleus. Progeny virion particles assemble in the nucleus. Lysis of the cell releases new infectious particles and causes damage to epithelial mucosa, sloughing of cell debris, and inflammation. Host responses to HAdV infection include the recruitment of neutrophils, macrophages, and natural killer cells to the site of infection and the elaboration by those cells of numerous cytokines and chemokines. This host immune response is likely to contribute to the symptoms of HAdV infection, but the strict species specificity of the adenoviruses has hindered detailed studies of HAdV pathogenesis in animal models. Studies using HAdV in Syrian hamsters, which are permissive for HAdV replication, and in a humanized mouse model have provided some insight. Mouse adenoviruses have also been used to study adenovirus pathogenesis using a murine model.

**CLINICAL MANIFESTATIONS**

HAdVs cause a variety of common clinical syndromes in both immunocompetent and immunocompromised hosts. These syndromes are difficult to reliably distinguish from similar illnesses caused by other pathogens, such as respiratory syncytial virus, human metapneumovirus, human rhinovirus, rotavirus, group A *Streptococcus*, and other common viral and bacterial pathogens.

**Acute Respiratory Disease**

Respiratory tract infections are common manifestations of HAdV infections in children and adults. HAdVs cause an estimated 5–10% of all childhood respiratory diseases. Primary infections in infants may manifest as bronchiolitis or pneumonia. HAdV pneumonia may present with features more typical of bacterial disease (lobar infiltrates, high fever, parapneumonic effusions). HAdV-14 has emerged as a significant cause of severe acute respiratory disease in military and civilian populations, in some cases leading to hospitalization and death. Pharyngitis caused by HAdV infection typically includes symptoms of coryza, sore throat, and fever. The virus can be identified in 15–20% of children with isolated pharyngitis, mostly in preschool children and infants.

**Ocular Infections**

The common follicular conjunctivitis caused by HAdV infection is self-limiting and requires no specific treatment. A more severe form called **epidemic keratoconjunctivitis** involves the cornea and conjunctiva. **Pharyngoconjunctival fever** is a distinct syndrome that includes a high temperature, pharyngitis, nonpurulent conjunctivitis, and preauricular and cervical lymphadenopathy.

**Gastrointestinal Infections**

HAdV can be detected in the stools of 5–10% of children with acute diarrhea. Most cases of acute diarrhea are self-limiting, although severe disease can occur. Enteric infection with HAdV is often asymptomatic, and shedding of virus after acute infection can be prolonged, so the causative role in these episodes is frequently uncertain. HAdV infection may also cause mesenteric adenitis.

**Hemorrhagic Cystitis**

**Hemorrhagic cystitis** consists of a sudden onset of hematuria, dysuria, frequency, and urgency with negative urine bacterial culture results. Urinalysis may show sterile pyuria in addition to hematuria. This illness occurs more frequently in young males and typically resolves on its own in 1–2 weeks.

**Other Complications**

Less frequently, HAdVs are associated with myocarditis, hepatitis, or meningoencephalitis in immunocompetent individuals.

**Adenoviruses in Immunocompromised Patients**

Immunocompromised persons, particularly recipients of hematopoietic stem cell transplants (HSCTs) and solid organ transplants, are at high risk for severe and fatal disease caused by HAdV. These patients may experience primary HAdV infection, but reactivation of persistent virus in a transplant recipient or transmission of virus from a donor organ may also occur. Organ failure as a consequence of pneumonia, hepatitis, gastroenteritis, and/or disseminated infection can occur in these immunocompromised patients. HAdV infection in HSCT recipients commonly manifests as pulmonary or disseminated disease and is most likely to occur in the first 100 days after transplantation. Hemorrhagic cystitis caused by HAdV can be severe in HSCT recipients. Infections caused by HAdV in solid organ transplant recipients usually involve the transplanted organ. Immunocompromised children are at greater risk than immunocompromised adults for complicated HAdV infection, presumably because of a lack of preexisting immunity. Additional risk factors include T-cell-depleted grafts, high-level immunosuppression, and the presence of graft-versus-host disease. Some experts advocate a preemptive screening approach to detect and treat HAdV infection early in immunocompromised patients, with the intent to prevent dissemination and severe illness in this vulnerable population, though no highly effective antiviral therapy exists.

**DIAGNOSIS**

HAdV may be suspected as the etiology of an illness on the basis of epidemiologic or clinical features, but neither of these categories is specific enough to firmly establish the diagnosis. The **frequency of asymptomatic shedding of HAdV** makes assigning causality to this pathogen

**Table 309.1** Examples of Human Adenovirus Types and Common Manifestations of Disease

SPECIES	TYPE	COMMON DISEASE ASSOCIATIONS
A	12, 18, 31, 61	Gastroenteritis
B	3, 7, 11, 14, 16, 21, 34, 35, 50, 55, 66	Pharyngitis, pharyngoconjunctival fever, acute respiratory disease, pneumonia, hemorrhagic cystitis
C	1, 2, 5, 6, 57	Pharyngitis
D	8-10, 13, 15, 17, 19, 20, 22-30, 32, 33, 36-39, 42-49, 51, 53, 54, 56, 58-60, 63-67, 69, 70-75	Epidemic keratoconjunctivitis
E	4	Acute respiratory disease
F	40, 41	Gastroenteritis
G	52	Gastroenteritis

difficult. Although most HAdV serotypes grow well in culture, culture-based identification requires several days and thus is not helpful for early identification, and most clinical microbiology laboratories no longer perform viral cultures on a routine basis. Cells from respiratory or ocular specimens can be tested using immunofluorescent staining with antibodies to detect HAdV protein. Commercially available enzyme-linked immunoassays can be used to rapidly detect HAdV in patient specimens, usually in stool. Multiplex molecular assays capable of identifying HAdV, in addition to other pathogens, are increasingly available and useful for rapid diagnosis. Specific diagnosis of HAdV infections are most clinically useful in immunocompromised hosts. In these patients, measurement of the **HAdV genome copy number (viral load)** using quantitative real-time polymerase chain reaction can facilitate diagnosis, and repeated measurements can aid in assessing a patient's response to treatment. Serology is generally useful only in epidemiologic investigations.

### COMPLICATIONS

HAdV pneumonia can lead to respiratory failure requiring mechanical ventilation, especially in immunocompromised patients. Secondary bacterial pneumonia does not appear to be as common after HAdV infection as it is after influenza infection, but data that address this issue are limited. Severe HAdV pneumonia has been linked to chronic lung disease and bronchiolitis obliterans in a minority of cases. Epidemic keratoconjunctivitis is a vision-threatening form of HAdV infection. Nearly any form of HAdV infection can be fatal in an HSCT or solid organ transplant recipient. Refractory severe anemia requiring repeated blood transfusions can develop in HSCT recipients with hemorrhagic cystitis. Mortality rates of up to 60–80% have been reported in transplant recipients with disseminated HAdV or HAdV pneumonia.

### TREATMENT

**Supportive care is the mainstay of treatment for HAdV infections.** Patients with severe HAdV conjunctivitis should be referred for ophthalmologic consultation. The nucleoside analog cidofovir has *in vitro* activity against most HAdV serotypes. Cidofovir is used topically to treat epidemic keratoconjunctivitis, often in conjunction with topical steroids or other immunosuppressive agents to limit the inflammatory component of the disease process. Cidofovir may be used intravenously for HAdV infections in immunocompromised patients. Cidofovir is highly nephrotoxic, but prehydration, concomitant administration of probenecid, and weekly dosing may reduce nephrotoxicity. Clinical studies suggest some benefit from cidofovir, but there are no prospective randomized controlled trials of cidofovir for HAdV infection. In addition, no formal guidelines or recommendations for treatment exist. The cidofovir derivative brincidofovir is better tolerated than cidofovir and has been evaluated as treatment of HAdV disease in immunocompromised patients, but it is not currently available for clinical use. Adoptive immunotherapy involving the infusion of HAdV-specific T cells may also provide some benefit for immunocompromised patients with life-threatening HAdV infections.

### PREVENTION

Environmental and fomite transmission of HAdV occurs readily; therefore simple measures such as handwashing and cleaning are likely to reduce spread. Live-attenuated HAdV-4 and HAdV-7 vaccines were used effectively in the U.S. military from the 1970s until 1999. Cessation of their use led to widespread outbreaks in barracks, and those vaccines were subsequently reintroduced into military use. However, no HAdV-specific vaccines are available for routine use. HAdVs are highly immunogenic and have been used as gene therapy vectors and vaccine vectors for other pathogens, including malaria, HIV, and SARS-CoV-2.

Visit Elsevier eBooks+ at [eBooks.Health.Elsevier.com](http://eBooks.Health.Elsevier.com) for Bibliography.

## Chapter 310

# Rhinoviruses

Katherine M. Richardson and  
Jennifer E. Schuster

Human rhinoviruses (HRVs) are the most frequent cause of the **common cold** in both adults and children. Although HRVs were once thought to cause only the common cold, it is now known that they are also associated with lower respiratory infections in adults and children. Many HRVs do not grow in culture. Recent studies using molecular diagnostic tools such as the polymerase chain reaction (PCR) have revealed that HRVs are leading causes of both mild and serious respiratory illnesses in children.

### ETIOLOGY

HRVs are members of the Picornaviridae family (“pico” = small; “rna” = RNA genome). Traditional methods of virus typing using immune antiserum have identified approximately 100 serotypes, classified into HRVA, HRVB, and, recently, HRVC species based on the genetic sequence similarity. HRVCs can be detected by reverse transcriptase PCR but have been cultured only using highly specialized methods. Virus gene sequence analysis demonstrates that HRVCs are a genetically distinct and diverse species. The increased proportions of HRV reported in recent PCR-based studies are likely the result of detection of these previously unknown HRVC viruses in addition to improved detection of known HRVA and HRVB strains.

## EPIDEMIOLOGY

Rhinoviruses are distributed worldwide. There is no consistent correlation between serotypes and epidemiologic or clinical characteristics. Several studies suggest that HRVCs may be more strongly associated with lower respiratory infection and asthma, and HRVC has been associated with children admitted to intensive care units with asthma exacerbations, bronchiolitis, and pneumonia. However, more studies are needed to determine severity compared with other HRVs. Multiple types circulate in a community simultaneously, and HRV strains may be isolated during consecutive epidemic seasons, suggesting persistence in a community over an extended period. In temperate climates, the incidence of HRV infection peaks in the fall, with another peak in the spring, but HRV infections occur year-round. HRVC appears to circulate with seasonal variation, exchanging dominance with HRVA. HRVs are the major infectious trigger for asthma among young children, and numerous studies have described a sharp increase in asthma attacks in this age-group when school opens in the fall. The peak HRV incidence in the tropics occurs during the rainy season, from June to October.

HRVs are present in high concentrations in nasal secretions and can be detected in the lower airways. HRV particles are nonenveloped and quite hardy, persisting for hours to days in secretions on hands or other surfaces such as telephones, light switches, doorknobs, and stethoscopes. Sneezing and coughing are inefficient methods of transfer. Transmission occurs when infected secretions carried on contaminated fingers are rubbed onto the nasal or conjunctival mucosa. HRVs are present in aerosols produced by talking, coughing, and sneezing. Children are the most important reservoir of these viruses.

## PATHOGENESIS

The majority of HRVs infect respiratory epithelial cells via intercellular adhesion molecule-1, but some HRV strains utilize the low-density lipoprotein receptor. The receptor for HRVC is cadherin-related family member 3 (CDHR3); however, distinct genetic alleles encoding this protein confer different susceptibility to HRVC infection. Infection begins in the nasopharynx and spreads to the nasal mucosa and, in some cases, to bronchial epithelial cells in the lower airways. There is no direct cellular damage from the virus, and it is thought that many of the pathogenic effects are produced by the host immune response. Infected epithelial cells release a number of cytokines and chemokines, which induce an influx of neutrophils to the upper airway. Both innate and adaptive immune mechanisms are important in HRV pathogenesis and clearance. HRV-specific nasal immunoglobulin (Ig) A can be detected on day 3 after infection, followed by the production of serum IgM and IgG after 7-8 days. Neutralizing IgG to HRVs may prevent or limit the severity of illness after reinfection. However, cross protection by antibodies to different HRV serotypes is limited in breadth and duration, allowing recurrent infection. Both allergen exposure and elevated IgE values predispose patients with asthma to more severe respiratory symptoms in response to HRV infection. Abnormalities in the host cellular response to HRV infection that result in impaired apoptosis and increased viral replication may be responsible for the severe and prolonged symptoms in individuals with asthma.

## CLINICAL MANIFESTATIONS

Most HRV infections produce clinical symptoms, but many are asymptomatic. Symptomatic HRV infection induces a much more robust host immune response in the blood than asymptomatic infection. After an incubation period of 1-4 days, typical symptoms of sneezing, nasal congestion, rhinorrhea, and sore throat develop. Cough and hoarseness are present in one third of cases. Fever is less common with HRV than with other common respiratory viruses, including influenza virus, respiratory syncytial virus (RSV), and human metapneumovirus. However, HRV was detected in 35% of febrile infants less than 90 days of age. Symptoms are frequently more severe and last longer in children, with 70% of children compared with 20% of adults still reporting symptoms by day 10. Virus can be shed for as long as 3 weeks. When

HRV is detected >30 days from the initial illness, it is more likely to be a genotypically different strain of HRV. HRVA and HRVC are more commonly associated with symptomatic HRV infection compared with HRVB.

HRVs are the most prevalent agents associated with acute wheezing, otitis media, and hospitalization for respiratory illness in children and are an important cause of severe pneumonia and exacerbation of asthma or chronic obstructive pulmonary disease in adults. HRV-associated hospitalizations are more frequent in young infants than in older children and in children with a history of wheezing or asthma. Children hospitalized with HRV bronchiolitis are more likely to be older and have a history of wheezing than children with bronchiolitis caused by RSV. HRV infection in immunocompromised hosts may be life threatening. Certain strains or species of HRV, namely HRVC, may be more pathogenic than others.

## DIAGNOSIS

Culturing HRVs is labor intensive and of relatively low yield. Sensitive and specific diagnostic methods based on reverse transcriptase PCR are commercially available. However, because commercially available reverse transcriptase PCR tests do not identify the HRV types, it can be difficult to distinguish prolonged shedding from newly acquired infection. An important caveat of HRV detection is the fact that HRV infection can be asymptomatic, and thus the presence of the virus does not prove causality in all cases. Serology is impractical because of the great number of HRV serotypes. A presumptive clinical diagnosis based on symptoms and seasonality is not specific, because many other viruses cause similar clinical illnesses. Rapid detection techniques for HRV might lessen the use of unnecessary antibiotics or procedures.

## COMPLICATIONS

Possible complications of HRV infection include sinusitis, otitis media, asthma exacerbation, bronchiolitis, pneumonia, and, rarely, death. HRV-associated wheezing during infancy is a significant risk factor for the development of childhood asthma. In particular, this association has been noted with HRVA and HRVC, which have been associated with greater risk for recurrence of both wheezing and new infection with HRV. This effect appears to remain until adulthood, but the mechanisms have not been elucidated. One large study determined that genetic variants at the 17q21 locus were associated with asthma in children who had experienced HRV wheezing illnesses during infancy. A prospective study on a preterm cohort showed that a single nucleotide polymorphism on the gene coding for the vitamin D receptor was associated with development of lower respiratory infection with HRV. Further studies are required to determine the likely multiple genetic and environmental factors that contribute to HRV-related asthma.

## TREATMENT

**Supportive care is the mainstay of HRV treatment.** The symptoms of HRV infection are commonly treated with analgesics, decongestants, antihistamines, or antitussives. Data are limited on the effectiveness of such nonprescription cold medications for children. If bacterial superinfections are highly suspected or diagnosed, antibiotics may be appropriate. Antibiotics are not indicated for uncomplicated viral upper respiratory infection. There are no licensed antivirals.

## PREVENTION

Good handwashing remains the mainstay of the prevention of HRV infection and should be reinforced frequently, especially in young children, the predominant "vectors" for disease. Vaccines have not been successfully developed because of the numerous HRV serotypes and limited cross protection between serotypes. However, a polyvalent inactivated vaccine showed promise in a nonhuman primate.

Visit Elsevier eBooks+ at [eBooks.Health.Elsevier.com](http://eBooks.Health.Elsevier.com) for Bibliography.



## Chapter 311

## Coronaviruses

Samuel R. Dominguez and Roberta L. DeBiasi

Coronaviruses are increasingly recognized as important human pathogens. Currently there are seven known coronaviruses that have been found to infect humans. Four coronaviruses are endemic in humans: human coronaviruses (HCoVs) 229E, OC43, NL63, and HKU1. These CoVs cause up to 15% of common colds and have been implicated in more serious diseases, including croup, asthma exacerbations, bronchiolitis, and pneumonia. Evidence also suggests that coronaviruses may cause enteritis and might also be agents of meningitis or encephalitis. The fifth identified HCoV, SARS-associated coronavirus (SARS-CoV), the etiologic agent of severe acute respiratory syndrome (SARS), emerged in 2003 and caused a world-wide pandemic resulting in over 8,000 cases with an estimated case fatality rate of 10% before circulation ceased because of implementation of world-wide public health measures. Similarly, Middle East respiratory syndrome coronavirus (MERS-CoV), the sixth identified HCoV, first emerged in 2012 causing significant respiratory distress with very high mortality rates. MERS-CoV continues to cause local cases and outbreaks likely as a result of continued emergent events from its animal reservoir. Likely because of their high mortality, lower transmissibility, and lack of asymptomatic or presymptomatic spread, neither SARS-CoV nor MERS-CoV became endemic viruses.

In 2019 a seventh human coronavirus, SARS-CoV-2, emerged as the etiologic agent of novel coronavirus disease 2019 (COVID-19), resulting in a multiyear and ongoing global pandemic with multiple waves of circulating variants and disease burden exceeding any prior respiratory virus pandemic, including the 1918 influenza pandemic. The ultimate trajectory of SARS-CoV-2 global circulation is unclear, but it is likely that this virus will evolve to become the fifth endemic human coronavirus. The emergence of three distinct human coronaviruses resulting in world-wide pandemics in the past 2 decades emphasizes the potential for coronaviruses to emerge from animal hosts and become important human pathogens.

**ETIOLOGY**

Coronaviruses are enveloped viruses of medium to large size (80–220 nm) that possess the largest known single-stranded positive-sense RNA genomes. These viruses encode the protein nsp14-ExoN, which is the first known RNA proofreading enzyme and is likely responsible for the evolution of the large and complex coronavirus genome. Coronaviruses derive their name from the characteristic surface projections of the spike protein, giving a corona or crownlike appearance on negative-stain electron microscopy. The human coronaviruses are all part of the order Nidovirales, suborder Cornidovirineae, family Coronaviridae, and subfamily Orthocoronavirinae. The subfamily Orthocoronavirinae is further subdivided into four genera based on genomic phylogenetic relationships. The genus alphacoronavirus includes HCoV-229E and HCoV-NL63. The remaining 5 HCoVs fall within the genus betacoronavirus. HCoV-OC43 and HCoV-HKU1 are in the subgenus Embecovirus, MERS-CoV is in the subgenus Merbecovirus, and SARS-CoV-1 and SARS-CoV-2 are in the subgenus Sarbecovirus (species severe acute respiratory syndrome-related coronavirus). Gammacoronaviruses and deltacoronaviruses presently include exclusively nonhuman pathogens.

Coronaviruses received international attention during the SARS outbreak, which was responsible for more than 800 deaths in 30

countries. SARS-CoV, a novel coronavirus at the time of the epidemic, was found to be the causative agent of SARS. The detection of SARS-like coronaviruses in a live animal market in the Guangdong province in Southern China, along with serologic evidence of exposure in food handlers in the same market, suggest that these markets facilitated the spread of SARS-CoV to humans from an animal reservoir. Subsequent studies identified SARS-like coronaviruses in fecal specimens from asymptomatic Chinese horseshoe bats that are very closely related to SARS-CoV and are capable of infecting human cells. Thus SARS-CoV likely originated in bats and was transmitted to humans via an intermediary animal host such as the palm civet.

Another novel coronavirus, **MERS-CoV**, was first isolated from a man with acute pneumonia and renal failure in Saudi Arabia. As of late 2023, the World Health Organization (WHO) had recorded 2,605 confirmed cases of MERS in 27 countries, with 937 deaths worldwide (~36% mortality rate). MERS-CoV differs from SARS in that it seems to be less communicable, although human-to-human transmission has been documented. MERS-CoV uses dipeptidyl peptidase 4 and carcinoembryonic antigen-like cell-adhesion molecule 5 as its cellular receptor and co-receptor, respectively, whereas SARS-CoV and SARS-CoV-2 use the angiotensin-converting enzyme-2 receptor. With this receptor specificity, MERS-CoV can infect cells from several animal lineages, including human, pig, and bat, suggesting the possibility of movement between multiple species.

**EPIDEMIOLOGY****Endemic Coronaviruses**

Seroprevalence studies have demonstrated that antibodies against endemic coronaviruses 229E and OC43 increase rapidly during early childhood, so that by adulthood 90–100% of persons are seropositive. Although less information is available for HKU1 and NL63, available studies demonstrate similar patterns of seroconversion to these viruses during early childhood. Seroprevalence studies have also suggested that prevalence rates may differ by geographic region. Although some degree of strain-specific protection may be afforded by recent infection, reinfections are common and occur despite the presence of strain-specific antibodies. Attack rates are similar in different age-groups. Although infections occur throughout the year, there is a peak during the winter and early spring for each of these HCoVs. In the United States, outbreaks of OC43 and 229E have occurred in 2- to 3-year alternating cycles. Independent studies of viral etiologies of upper and lower respiratory infections during the same period, but from different countries, have confirmed that all known HCoVs have a worldwide distribution. Studies using both viral culture and polymerase chain reaction (PCR) multiplex assays demonstrate that coronaviruses often appear in coinfections with other respiratory viruses. Volunteer studies demonstrated that OC43 and 229E are transmitted predominantly through the respiratory route. Droplet spread appears to be most important, although aerosol transmission may also occur.

**SARS-CoV**

There have been no identified natural or laboratory-acquired cases of SARS-CoV since 2004, but the mechanisms of introduction, spread, and disease remain important for potential animal-to-human transmission and disease. The primary mode of SARS-CoV transmission occurred through direct or indirect contact of mucous membranes with infectious droplets or fomites. Aerosol transmission was less common, occurring primarily in the setting of endotracheal intubation, bronchoscopy, or treatment with aerosolized medications. Fecal-oral transmission did not appear to be an efficient mode of transmission but may have occurred because of the profuse diarrhea observed in some patients. The seasonality of SARS-CoV remains unknown. SARS-CoV is not highly infectious,



with generally only two to four secondary cases resulting from a single infected adult. During the SARS epidemic, a small number of infected individuals, “superspreaders,” transmitted infection to a much larger number of persons, but the mechanism for this high degree of spread remains unknown. In contrast, persons with mild disease, such as children younger than 12 years of age, rarely transmitted the infection to others. Infectivity correlated with disease stage; transmission occurred almost exclusively during symptomatic disease. During the 2003 outbreak, most individuals with SARS-CoV infection were hospitalized within 3–4 days of symptom onset. Consequently, most subsequent infections occurred within hospitals and involved either healthcare workers or other hospitalized patients.

### MERS-CoV

As of late 2023, the WHO had recorded cases of MERS-CoV in 27 countries, all of which were linked to exposures in the Arabian Peninsula (~80% in Saudi Arabia). Though the route of transmission between animals and humans is not fully understood, MERS-CoV is proposed to have repeatedly entered the human population through contact with respiratory secretions of dromedary camels and possibly with raw camel products (e.g., unpasteurized milk). Antibodies to MERS-CoV are found in dromedaries throughout the Middle East, and strains identical to human MERS-CoV isolates have been found in camels in Egypt, Oman, Qatar, and Saudi Arabia. These strains do not appear to be highly pathogenic or virulent in camels and have likely circulated within dromedaries for >30 years. Despite well-documented zoonotic transmission, most reported cases occur through linked human-to-human transmission in healthcare settings, including outbreaks in Jordan, South Korea, and Saudi Arabia in 2015 and 2016. Risk factors for nosocomial MERS-CoV outbreaks include overcrowded emergency departments, delayed diagnosis or isolation, and poor infection control practices. Transmission most likely occurs through respiratory droplets and is thus a greater risk during aerosol-generating procedures. Outside of healthcare settings, human-to-human transmission has been infrequently documented and is primarily associated with close contact within households.

## CLINICAL MANIFESTATIONS

### Endemic Coronaviruses: Respiratory Manifestations

Even though up to 50% of respiratory tract infections with OC43 and 229E are asymptomatic, coronaviruses are still responsible for up to 15% of common colds and can cause fatal disease. Cold symptoms caused by HCoV are indistinguishable from those caused by rhinoviruses and other respiratory viruses. The average incubation period is 2–4 days, with symptoms typically lasting 4–7 days. Rhinorrhea, cough, sore throat, malaise, and headache are the most common symptoms. Fever occurs in up to 60% of cases. Coronavirus NL63 is a cause of croup in children younger than 3 years of age. Coronavirus infections are linked to episodes of wheezing in asthmatic children, albeit at a lower frequency and severity than observed with rhinovirus and respiratory syncytial virus infections. Lower respiratory tract infections, including bronchiolitis and pneumonia, are also reported in immunocompetent and immunocompromised children and adults. As with respiratory syncytial virus or rhinovirus, coronavirus detection in upper respiratory infections is frequently associated with acute otitis media and can be isolated from middle ear fluid.

### Endemic Coronaviruses: Nonrespiratory Manifestations

There is prior evidence to support a role for coronaviruses in human gastrointestinal disease, particularly in young children. Coronavirus-like particles have been detected by electron microscopy in the stools of infants with nonbacterial gastroenteritis. In

addition, several outbreaks in neonatal intensive care units (ICUs) of gastrointestinal disease characterized by diarrhea, bloody stools, abdominal distention, bilious gastric aspirates, and classic necrotizing enterocolitis have also been associated with the presence of coronavirus-like particles in stools. In older children and adults, coronavirus-like viruses have been observed with similar frequency in symptomatic and asymptomatic individuals, making it difficult to discern if they are pathogenic in the gastrointestinal tract. Additionally, more recent studies using PCR assays of stool from children with gastroenteritis have infrequently found HCoVs. Coronaviruses are well-known causes of neurologic disease in animals, including demyelinating encephalitis, but their role in causing human neurologic disease remains unclear. Several studies have found an association of HCoVs, particularly HCoV-HKU1, with febrile seizures in young children. HCoVs have been detected by culture, *in situ* hybridization, and reverse-transcriptase PCR (RT-PCR) in brain tissue from a few patients with multiple sclerosis. HCoV-OC43 has been detected by RT-PCR in the spinal fluid, nasopharynx, or brain biopsy specimens of two children with acute encephalomyelitis. However, coronavirus RNA has also been recovered from the spinal fluid and brain tissue of adults without neurologic disease.

### Severe Acute Respiratory Syndrome–Associated Coronavirus

During the 2002–2003 global outbreak of SARS, the incubation period for SARS-CoV ranged from 1–14 days, with a median of 4–6 days. SARS-CoV infections in teenagers and adults included a viral replication phase and an immunologic phase. During the viral replication phase, there was a progressive increase in viral load that reached its peak during the second week of illness. The appearance of specific antibodies coincided with peak viral replication. Clinical symptoms were nonspecific, most commonly consisting of fever, cough, malaise, coryza, chills or rigors, headache, and myalgia. Gastrointestinal symptoms, including diarrhea and nausea or vomiting, occurred in up to one third of cases. The clinical deterioration that typified the second and third week of illness was characterized by a decline in the viral load and evidence of tissue injury, likely from cytokine-mediated immunity.

Seroepidemiologic studies suggest that asymptomatic SARS-CoV infections were uncommon. The clinical course of SARS-CoV infection varied with age. Adults were most severely affected, with initial onset of fever, cough, chills, myalgia, malaise, and headache. Following an initial improvement at the end of the first week, fever recurred, and respiratory distress developed, with dyspnea, hypoxemia, and diarrhea. These symptoms progressed in 20% of patients to acute respiratory distress syndrome and respiratory failure. Adolescents manifested increasing severity in direct correlation to increasing age; respiratory distress and hypoxemia were observed in 10–20% of patients, one third of whom required ventilator support. Acute renal failure with histologic acute tubular necrosis was present in 6.9% of patients overall, likely a result of hypoxic kidney damage. Of SARS patients, 28.8% had abnormal urinalysis, with viral genome detectable by quantitative RT-PCR. The case fatality rate from SARS-CoV infection during the 2003 outbreak was 10–17%. No pediatric deaths were reported. The estimated case fatality rate according to age varied from <1% for those younger than 20 years of age to >50% for those older than 65 years of age.

In contrast, children younger than 12 years of age had a relatively mild nonspecific illness, with only a minority experiencing significant lower respiratory tract disease and illness typically lasting less than 5 days. Some young children had no respiratory symptoms. Coryza was more common in children younger than 12 years of age, whereas systemic symptoms were seen more often in teenagers. There were no deaths or cases of acute respiratory distress syndrome in children younger than 12 years of age from SARS-CoV infection.

### Middle East Respiratory Syndrome Coronavirus

The incubation period of MERS-CoV is 2–14 days. The syndrome usually presents with nonspecific clinical features typical of acute febrile respiratory illnesses, including low-grade fever, rhinorrhea, sore throat, and myalgia. In mildly symptomatic cases, radiographic findings are typically normal. Severe disease is characterized by the acute respiratory distress syndrome with multilobular airspace disease, ground-glass opacities, and occasional pleural effusions on radiography. The median time between hospitalization and ICU transfer for critical illness is 2 days. Risk factors for severe disease include age >50 years and comorbidities such as obesity, diabetes, chronic obstructive pulmonary disease (COPD), end-stage renal disease, cancer, and immunosuppression. Specific host genetic risk factors have not been identified. Variation in clinical outcomes does not appear to be explained by viral strain-specific sequence variability. As with SARS, extrapulmonary manifestations are common in severe MERS disease. Gastrointestinal symptoms such as nausea, vomiting, and diarrhea occur in one third of patients, and acute kidney injury has been documented in half of critically ill patients. Encephalitis-like neurologic manifestations have been observed in three cases. Laboratory analyses typically detect leukopenia and lymphopenia, with occasional thrombocytopenia, anemia, and aminotransferase elevations. The case fatality rate remains at 35%, though the true incidence of MERS-CoV infection is likely underestimated by existing data. Most patients have been adults, although children as young as 9 months of age have been infected. It is not known whether children are less susceptible to MERS-CoV or present with a different clinical picture.

### DIAGNOSIS

With the advent of commercially available, syndromic, multiplex PCR respiratory panels, respiratory infections due to the four endemic HCoV are now easily diagnosed and widely available in most clinical settings. These panels have rapid turnaround times, excellent sensitivity and specificity, and most commonly use upper respiratory tract specimens. Virus culture of primary clinical specimens remains a challenge for HCoV HKU1, OC43, 229E, and NL63, even though the epidemic coronaviruses can successfully be grown in culture from respiratory samples. Serodiagnosis with complement fixation, neutralization, hemagglutination inhibition, enzyme immunoassay, and Western blots have been used in the research setting. The diagnosis of SARS-CoV infection can be confirmed by serologic testing, detection of viral RNA using RT-PCR, or isolation of the virus in cell culture. Even though the serology for SARS-CoV has a sensitivity and specificity approaching 100%, antibodies are not detectable until 10 days after the onset of symptoms, and immunoglobulin (Ig) G seroconversion may be delayed for up to 4 weeks. The diagnosis of MERS-CoV should be guided by clinical features and an epidemiologic link. The mainstay for laboratory confirmation of MERS-CoV infection is real-time RT-PCR. The best diagnostic sensitivity is achieved from lower respiratory tract samples collected within the first week of infection, though MERS-CoV RNA can be detected in upper respiratory and blood samples. Alternatively, seroconversion can be documented by screening enzyme-linked immunosorbent assays followed by immunofluorescence microscopy. For all known endemic and emerging HCoV, respiratory specimens (nasopharyngeal swabs or aspirates) are most likely to be positive, but in a setting of a possible novel coronavirus, saliva, serum, or stool may also be positive.

### TREATMENT AND PREVENTION

Several antiviral agents are available for clinical use against coronaviruses targeting the conserved coronavirus protease and polymerase. Ribavirin was extensively used during the 2003 SARS-CoV outbreak but is of questionable benefit given its poor *in vitro* activity against SARS-CoV at clinically relevant concentrations.

Challenges for the development of effective vaccines targeted against OC43, 229E, HKU1, and NL63 include the fact that infections are rarely life-threatening and reinfection is the rule, even in the presence of natural immunity from previous infections. The durability of immunity to SARS-CoV and MERS-CoV is poorly understood. Nevertheless, effective vaccines for SARS-CoV and MERS-CoV are highly desirable but not yet available.

Visit Elsevier eBooks+ at [eBooks.Elsevier.com](https://ebooks.elsevier.com) Bibliography.

## 311.1 COVID-19

Samuel Dominguez and Roberta L. DeBiasi

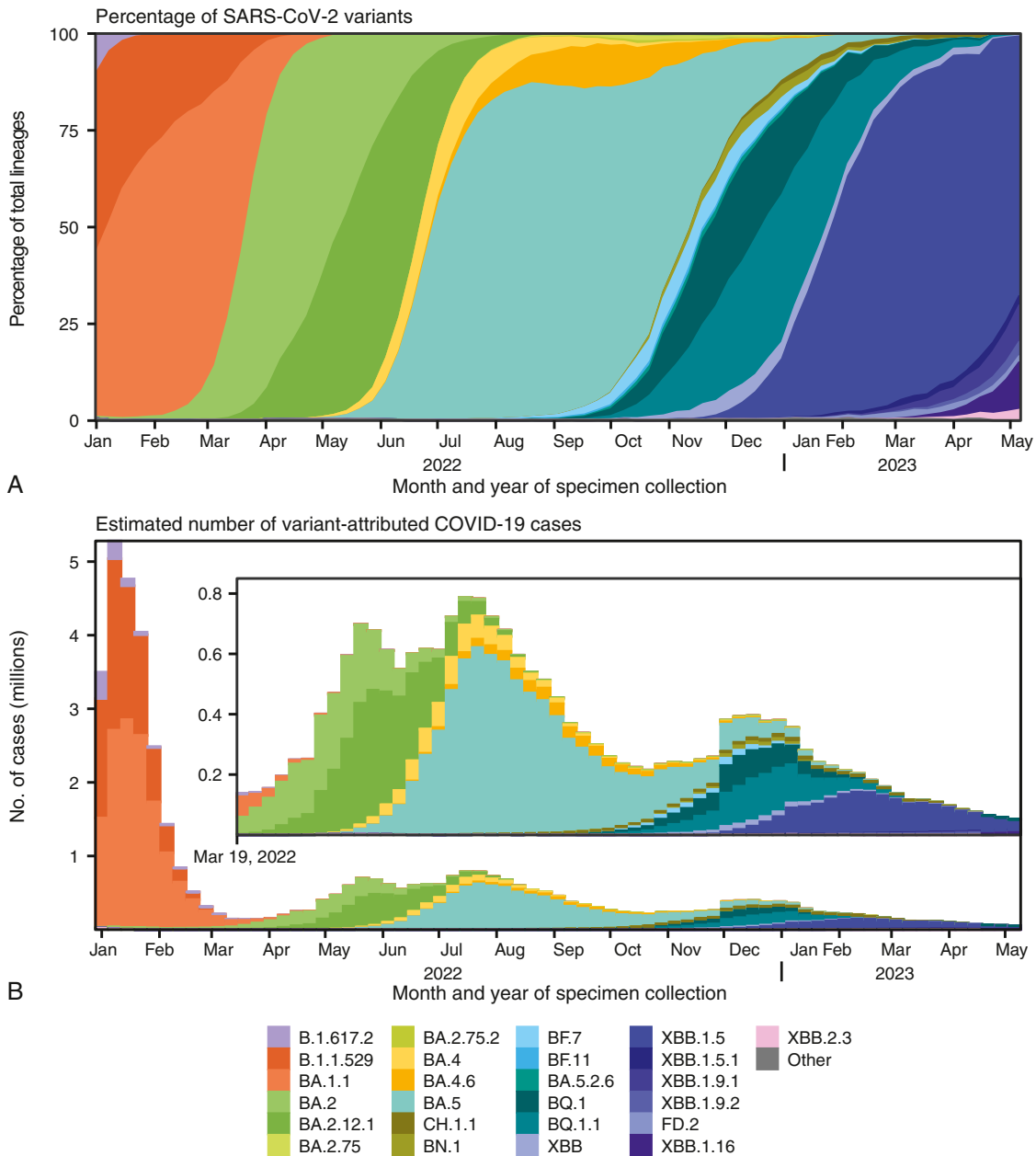
*New variants may evolve: recommendations for treatment and prevention may change. See Centers for Disease Control and Prevention for updates.*

SARS-CoV-2 first emerged in Wuhan China in December 2019 as the etiologic agent of a severe respiratory illness termed COVID-19. Despite measures to contain transmission, SARS-CoV-2 rapidly spread globally, resulting in declaration of a worldwide pandemic by March 2020. As of late 2023, over 770 million cases and nearly 7 million deaths have occurred globally due to SARS-CoV-2. Ongoing transmission has led to the emergence of sequential variants (e.g., Delta, Omicron, BA.2, BA.5, BQ, XBB1.5 variants) with progressively unique gene variants in the receptor binding domain of the spike protein, conferring increased transmissibility compared to the parent strain (Alpha variant). Gene changes in some variants have been associated with reduced susceptibility to monoclonal antibody therapeutics and/or reduced neutralization by convalescent and vaccine-induced antibodies, promoting immune escape and breakthrough infections in previously infected and/or immunized individuals and ongoing community transmission.

### EPIDEMIOLOGY

SARS-CoV-2 transmission occurs from human to human primarily by respiratory droplet, as well as by aerosol transmission, with the highest rates of transmission occurring from 2 days prior to 2–3 days after symptom onset. Transmission is quite common among asymptomatic or presymptomatic infected patients. Close contact (conversation distance) increases the risk; normal conversation as well as coughing, sneezing, singing, or just breathing are mechanisms. Immunocompromised hosts may shed infectious virus for longer periods of time, up to 21 days or more after symptom onset. Spread within households and close communal settings is common; transmission has been confirmed from infants, toddlers, and school-age children (who may have very high viral loads in the anterior nares even with asymptomatic or mild infection) and from adolescents to adult household members as well as from adults to children. A metaanalysis of household secondary transmission has identified household secondary attack rates of nearly 17%, which exceeds that for SARS-CoV (7.5%) and MERS-CoV (4.7%). Secondary attack rates within households are increased from symptomatic compared to asymptomatic index cases, in adults compared to children, in spouses compared to other household members, and in households with three or more contacts. Throughout the pandemic, it has been noted that transmission is increased in unvaccinated compared to vaccinated individuals.

Young children were initially reported to be less likely to be infected or more likely to be asymptomatic with SARS-CoV-2 (alpha, delta strains) than adults and unlikely to develop severe disease. However, despite overall lower rates of hospitalization and death, children are efficiently infected and can develop severe disease (usually older children and adolescents) that results in hospitalization, ICU admission, and occasional death (mortality <0.5%); the majority of young children experience mild to moderate illness.



**Fig. 311.1** National weekly proportion estimates\* of SARS-CoV-2 variants† (A) and estimated number of variant-attributed cases‡ (B) United States, January 2, 2022–May 13, 2023. \*Sequences are reported to CDC through NS3, contract laboratories, public health laboratories, and other U.S. institutions. Variant proportion estimation methods use a complex survey design and statistical weights to account for the probability that a specimen is sequenced. †Lineages reaching a prevalence of 1% with spike protein substitutions of potential therapeutic relevance and separated out on the COVID Data Tracker website. ‡Estimated numbers of COVID-19 cases attributable to variants were calculated by multiplying weekly numbers of reported positive nucleic acid amplification tests from CELR with estimated variant proportions. (From Ma KC, Shirk P, Lambrou AS, et al: Genomic surveillance for SARS-CoV-2 variants: circulation of omicron lineages—United States, January 2022–May 2023. *MMWR* 2023;72:651–656. Fig. 1, p. 653.)

As of spring 2023, over 15 million laboratory-confirmed infections and nearly 40,000 hospitalizations have occurred cumulatively in U.S. children ≤18 years of age, representing ~13% of overall infections and up to 4.5% of hospitalizations in the United States. Young children under 5 years of age have made up a relatively increased proportion of cases and hospitalizations during later stages of the pandemic (late variants) presenting more with upper respiratory infection, croup, or bronchiolitis (Fig. 311.1). Milder illness may be due to less virulent variants or prior immunity from vaccination or infection; morbidity and mortality have remained low compared

to adults, despite the increased transmissibility of more recent variants.

Early in the pandemic, a post-infectious hyperinflammatory complication of SARS-CoV-2 infection termed multisystem inflammatory syndrome of children (MIS-C; also referred to as pediatric inflammatory multisystem syndrome temporally associated with COVID-19, PIMS-TS) was recognized. MIS-C is associated with higher acuity in older children and initially was associated with higher rates of mortality due to hemodynamic instability, myocardial dysfunction, and cardiovascular collapse. With better recognition of this syndrome, key

**Table 311.1** Case Definition for Multisystem Inflammatory Syndrome in Children (MIS-C)

Any illness in a person < 21 years that meets:

- The clinical AND the laboratory criteria (*Confirmed*), OR
- The clinical criteria AND epidemiologic linkage criteria (*Probable*), OR
- The vital records criteria (*Suspect*)

CLINICAL CRITERIA	LABORATORY CRITERIA FOR SARS-COV-2 INFECTION	EPIDEMIOLOGIC LINKAGE CRITERIA	VITAL RECORDS CRITERIA
<p>An illness characterized by <i>all of the following</i>, in the absence of a more likely alternative diagnosis*</p> <ul style="list-style-type: none"> <li>• Subjective or documented fever (temperature <math>\geq 38.0^{\circ}\text{C}</math>)</li> <li>• Clinical severity requiring hospitalization or resulting in death</li> <li>• Evidence of systemic inflammation indicated by C-reactive protein <math>\geq 3.0</math> mg/dL (30 mg/L)</li> <li>• New-onset manifestations in <i>at least</i> two of the following categories:               <ol style="list-style-type: none"> <li>1. <b>Cardiac</b> involvement indicated by:                   <ul style="list-style-type: none"> <li>• Left ventricular ejection fraction <math>&lt; 55\%</math> OR</li> <li>• Coronary artery dilatation, aneurysm, or ectasia, OR</li> <li>• Troponin elevated above laboratory normal range, or indicated as elevated in a clinical note</li> </ul> </li> <li>2. <b>Mucocutaneous</b> involvement indicated by:                   <ul style="list-style-type: none"> <li>• Rash, OR</li> <li>• Inflammation of the oral mucosa (e.g., mucosal erythema or swelling, drying or fissuring of the lips, strawberry tongue), OR</li> <li>• Conjunctivitis or conjunctival injection (redness of the eyes), OR</li> <li>• Extremity findings (e.g., erythema [redness] or edema [swelling] of the hands or feet)</li> </ul> </li> <li>3. <b>Shock</b><sup>§</sup></li> <li>4. <b>Gastrointestinal</b> involvement indicated by:                   <ul style="list-style-type: none"> <li>• Abdominal pain, OR</li> <li>• Vomiting, OR</li> <li>• Diarrhea</li> </ul> </li> <li>5. <b>Hematologic</b> involvement indicated by:                   <ul style="list-style-type: none"> <li>• Platelet count <math>&lt; 150,000</math> cells/<math>\mu\text{L}</math> OR</li> <li>• Absolute lymphocyte count (ALC) <math>&lt; 1,000</math> cells/<math>\mu\text{L}</math></li> </ul> </li> </ol> </li> </ul>	<ul style="list-style-type: none"> <li>• Detection of SARS-CoV-2 RNA in a clinical specimen<sup>†</sup> up to 60 days before or during hospitalization, or in a postmortem specimen using a diagnostic molecular amplification test (e.g., polymerase chain reaction [PCR]), OR</li> <li>• Detection of SARS-CoV-2–specific antigen in a clinical specimen<sup>†</sup> up to 60 days before or during hospitalization, or in a postmortem specimen, OR</li> <li>• Detection of SARS-CoV-2–specific antibodies<sup>‡</sup> in serum, plasma, or whole blood associated with current illness resulting in or during hospitalization</li> </ul>	<p>Close contact<sup>‡</sup> with a confirmed or probable case of COVID-19 disease in the 60 days before hospitalization</p>	<p>A person whose death certificate lists MIS-C or multisystem inflammatory syndrome as an underlying cause of death or a significant condition contributing to death</p>

\*If documented by the clinical treatment team, a final diagnosis of Kawasaki Disease should be considered an alternative diagnosis. These cases should not be reported to national multisystem inflammatory syndrome in children (MIS-C) surveillance.

<sup>†</sup>Positive molecular or antigen results from self-administered testing using over-the-counter test kits meet laboratory criteria.

<sup>‡</sup>Includes a positive serology test regardless of COVID-19 vaccination status. Detection of anti-nucleocapsid antibody is indicative of SARS-CoV-2 infection, and antispikes protein antibody may be induced either by COVID-19 vaccination or by SARS-CoV-2 infection.

<sup>§</sup>Clinician documentation of shock meets this criterion.

<sup>‡</sup>Close contact is generally defined as being within 6 feet for at least 15 min (cumulative over a 24-hr period). However, it depends on the exposure level and setting; for example, in the setting of an aerosol-generating procedure in healthcare settings without proper personal protective equipment (PPE), this may be defined as any duration.

From Centers for Disease Control and Prevention. Information for healthcare providers about multisystem inflammatory syndrome in children (MIS-C). <https://www.cdc.gov/mis/mis-c/hcp/index.html>

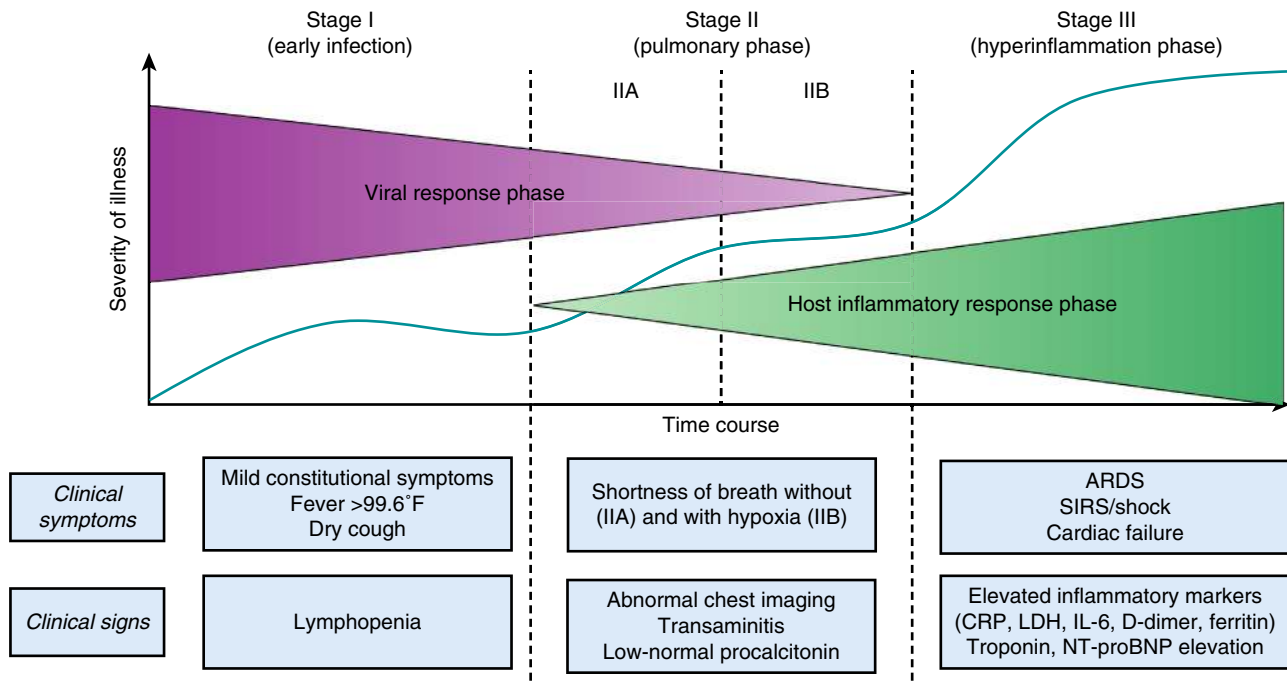
discriminatory diagnostic criteria, and institution of rapid immunomodulatory treatment, outcomes have improved (Table 311.1; Table 208.4 in Chapter 208). As of late 2023, there have been >9500 cases and 79 deaths due to MIS-C in the United States. The incidence of MIS-C has substantially decreased with the appearance of the late pandemic viral variants.

### Pathogenesis of COVID-19

Severe disease in COVID-19 likely results from both direct virologic damage and subsequent immunopathology (Fig. 311.2). Postmortem exams have demonstrated COVID-19 virus in almost all tissues

(lung, blood vessels, brain, gastrointestinal tract, heart, etc.). Substantial viral loads can be detected in the upper and lower respiratory tracts, stool, and blood. Late progression to severe disease appears *independent* of the quantity and timing of viremia; excessive host immune responses likely play an important role in the progression to lower respiratory disease, acute respiratory distress syndrome, and MIS-C (see Fig. 311.2). COVID-19 is associated with massive elaboration of inflammatory cytokines and recruitment of inflammatory cells. The roles for inflammatory cells are controversial, with cytotoxic T cells and macrophages implicated in both immune protection and immunopathology.





**Fig. 311.2** Staging of acute COVID-19 infection. Classification of COVID-19 disease states and potential therapeutic targets. The figure illustrates three escalating phases of COVID-19 disease progression, with associated signs, symptoms. ARDS, Acute respiratory distress syndrome; JAK, Janus kinase; LDH, lactate dehydrogenase; NT-proBNP, N-terminal pro B-type natriuretic peptide; SIRS, systemic inflammatory response syndrome. (Modified from Siddiqi HK, Mehra MR. COVID-19 illness in native and immunosuppressed states: a clinical-therapeutic staging proposal. *J Heart Lung Transpl.* 2020;39[5]:405–407. Fig. 1.)

Table 311.2 Clinical Spectrum of SARS-CoV-2 Infection	
<ul style="list-style-type: none"> <li>• <b>Asymptomatic or presymptomatic infection:</b> Individuals who test positive for SARS-CoV-2 using a virologic test (i.e., a nucleic acid amplification test [NAAT] or an antigen test) but have no symptoms consistent with COVID-19.</li> <li>• <b>Mild illness:</b> Individuals who have any of the various signs and symptoms of COVID-19 (e.g., fever, cough, sore throat, malaise, headache, muscle pain, nausea, vomiting, diarrhea, loss of taste and smell) but do not have shortness of breath, dyspnea, or abnormal chest imaging.</li> <li>• <b>Moderate illness:</b> Individuals who show evidence of lower respiratory disease during clinical assessment or imaging and who have an oxygen saturation measured by pulse oximetry (SpO<sub>2</sub>) ≥94% on room air at sea level.</li> <li>• <b>Severe illness:</b> Individuals who have SpO<sub>2</sub> &lt;94% on room air at sea level, a ratio of arterial partial pressure of oxygen to fraction of inspired oxygen (PaO<sub>2</sub>/F<sub>i</sub>O<sub>2</sub>) &lt;300 mm Hg, a respiratory rate &gt;30 breaths/min, or lung infiltrates &gt;50%.</li> <li>• <b>Critical illness:</b> Individuals who have respiratory failure, septic shock, and/or multiple organ dysfunction.</li> </ul> <p>SpO<sub>2</sub> is a key parameter for defining the listed illness categories. However, pulse oximetry has important limitations. Clinicians who use SpO<sub>2</sub> when assessing a patient must be aware of those limitations and conduct the assessment in the context of that patient's clinical status.</p>	<p><b>Underlying conditions</b> associated with a higher risk of severe COVID-19 include asthma, cancer, cardiovascular disease, chronic kidney disease, chronic liver disease, chronic lung disease, diabetes, advanced or untreated HIV infection, obesity, pregnancy, cigarette smoking, and being a recipient of immunosuppressive therapy or a transplant.</p> <p>The initial evaluation for patients may include chest imaging (e.g., x-ray, ultrasound or computed tomography scan) and an electrocardiogram. Laboratory testing should include a complete blood count with differential and a metabolic profile, including liver and renal function tests. Although inflammatory markers such as C-reactive protein (CRP), D-dimer, and ferritin are not routinely measured as part of standard care, results from such measurements may have prognostic value.</p> <p>In children with COVID-19, radiographic abnormalities are common and, for the most part, should not be the only criteria used to determine the severity of illness. The normal values for respiratory rate also vary with age in children; therefore hypoxemia should be the primary criterion used to define severe COVID-19, especially in younger children. In a small subset of children and young adults, SARS-CoV-2 infection may be followed by the severe inflammatory condition multisystem inflammatory syndrome in children (MIS-C).</p>

From Centers for Disease Control and Prevention. Clinical spectrum of SARS-CoV-2 infection. <https://www.covid19treatmentguidelines.nih.gov/overview/clinical-spectrum>

**CLINICAL MANIFESTATIONS**

In both children and adults, the spectrum of clinical manifestations of SARS-CoV-2 infection ranges from asymptomatic infection to mild, moderate, or severe, life-threatening pulmonary and extra-pulmonary manifestations (Table 311.2). Children are more likely than adults to experience asymptomatic (up to 40%) or mild disease (all variants) but can also experience moderate and severe illness, including need for critical care support (MIS-C or early variants in

older children or adolescents). Mild, moderate, or severe illness can include nonspecific symptoms such as fever, headache, myalgias, and fatigue (Table 311.3). Respiratory manifestations of COVID-19 in children are similar to those in adults and may include mild upper respiratory tract symptoms such as rhinorrhea, congestion, cough, and sore throat and lower respiratory symptoms such as shortness of breath and chest pain. Patients with severe or critical pulmonary and systemic features are at risk for venous thrombosis;

**Table 311.3** Clinical Criteria for COVID-19**In the absence of a more likely diagnosis:**

- At least two of the following symptoms:
  - Fever (measured or subjective)
  - Chills
  - Rigors
  - Myalgia
  - Headache
  - Sore throat
  - Nausea or vomiting
  - Diarrhea
  - Fatigue
  - Congestion or runny nose

OR

- Any one of the following symptoms:
  - Cough
  - Shortness of breath
  - Difficulty breathing
  - New olfactory disorder
  - New taste disorder

OR

- Severe respiratory illness with at least one of the following:
  - Clinical or radiographic evidence of pneumonia
  - Acute respiratory distress syndrome (ARDS)

**LABORATORY CRITERIA (SEE TABLE 311.10)****EPIDEMIOLOGIC LINKAGE**

- One or more of the following exposures in the prior 14 days:
  1. Close contact\* with a confirmed or probable case of COVID-19 disease
  2. Member of a risk cohort as defined by public health authorities during an outbreak

**CASE CLASSIFICATION†****Suspect**

- Meets supportive laboratory evidence‡ with no prior history of being a confirmed or probable case.

**Probable**

- Meets clinical criteria AND epidemiologic linkage with no confirmatory laboratory testing performed for SARS-CoV-2
- Meets presumptive laboratory evidence
- Meets vital records criteria with no confirmatory laboratory evidence for SARS-CoV-2

**Confirmed**

- Meets confirmatory laboratory evidence

**VITAL RECORDS CRITERIA**

- A death certificate that lists COVID-19 disease or SARS-CoV-2 as an underlying cause of death or a significant condition contributing to death.

\*Close contact is generally defined as being within 6 feet for at least 15 min. However, it depends on the exposure level and setting; for example, in the setting of an aerosol-generating procedure in healthcare settings without proper personal protective equipment (PPE), this may be defined as any duration. Data are insufficient to precisely define the duration of exposure that constitutes prolonged exposure and thus a close contact.

†The terms *confirmatory*, *presumptive*, and *supportive* are categorical labels used here to standardize case classifications for public health surveillance. The terms should not be used to interpret the utility or validity of any laboratory test methodology.

‡For suspect cases (positive serology only), jurisdictions may opt to place them in a registry for other epidemiologic analyses or investigate to determine probable or confirmed status.

From Centers for Disease Control and Prevention. Coronavirus disease 2019 (COVID-19): 2020 interim case definition. Approved August 5, 2020. <https://ndc.services.cdc.gov/case-definitions/coronavirus-disease-2019-covid-19/>

prophylactic doses of enoxaparin are recommended. Chest imaging is essential in those with respiratory symptoms (Fig. 311.3). Croup and bronchiolitis presentations have been observed in association with the Omicron and later variants. Anosmia and ageusia have been reported in 10–15% of cases in children as well as

adults. Gastrointestinal symptoms such as abdominal pain (pseudo-appendicitis), diarrhea, and vomiting may be more prominent in pediatric patients (COVID-19 and/or MIS-C) compared to adults (Fig. 311.4). Although children with and without underlying medical conditions may be infected, up to 60% of hospitalized children have one or more underlying medical conditions and up to 80% of children with severe disease requiring critical care support have an underlying condition.

Cutaneous lesions have often been reported in pediatric patients with COVID-19 and pediatric patients with MIS-C (Table 311.4 and Fig. 311.5).

SARS-CoV-2 is a neurotropic virus; 10–20% of pediatric patients with COVID-19 and/or MIS-C have central or peripheral nervous system manifestations during the acute illness. The most common neurologic manifestations include seizures (including status epilepticus), headaches, behavioral changes, myalgias, and encephalopathy (~30% with reversible splenic lesions). Other identifiable syndromes include stroke, acute disseminated encephalomyelitis (ADEM) (~50% are myelin oligodendrocyte glycoprotein [MOG] antibody positive), Guillain-Barré syndrome (also reported with the vaccine), optic neuritis, psychosis, and cerebellar or brainstem lesions.

Neuroimaging findings associated with neurologic complications in children with COVID-19 are shown in Fig. 311.6. Cerebrospinal fluid (CSF) findings include a pleocytosis.

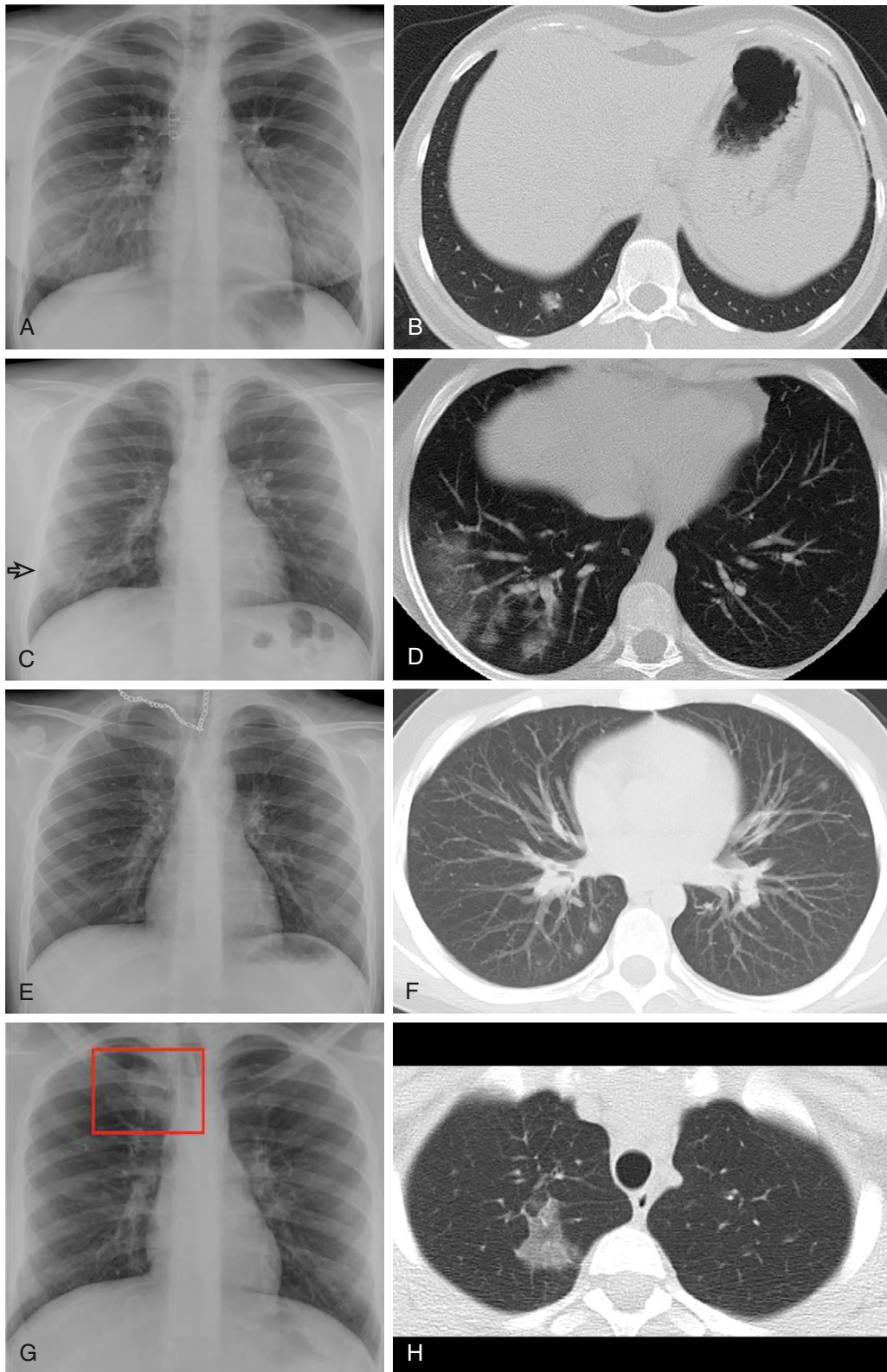
Neonates are often hospitalized because of SARS-CoV-2 infection due to febrile illness with less prominent respiratory complaints, primarily to exclude neonatal bacterial sepsis or neonatal herpes simplex virus (HSV) infection. Although nearly 15% of women presenting in labor during the early phase of the COVID-19 pandemic were found to be SARS-CoV-2 PCR positive (majority are asymptomatic), very few infants born to these women are PCR positive at birth or become infected perinatally. Preterm birth and stillbirth due to effects on the placenta, placental inflammation, and other specific abnormalities have been reported in pregnant women with symptomatic SARS-CoV-2 infection. Congenital abnormalities or intrauterine growth restriction have not been observed in live-born infants with in-utero SARS-CoV-2 exposure; potential long-term neurodevelopmental effects are not yet known.

Over the course of the pandemic, extrapulmonary manifestations and complications of SARS-CoV-2 infection have increasingly been appreciated, including new onset or exacerbation of type 1 and type 2 diabetes, intestinal inflammation (pseudo-appendicitis) and mesenteric lymphadenitis (see Fig. 311.4), and vascular complications such as thrombosis of vessels in the extremities as well as cerebral vasculature. SARS-CoV-2 infection has been associated with sickle cell vasoocclusive crises and acute chest syndrome in patients with sickle cell disease and increased seizures in children with seizure disorders.

**MIS-C**

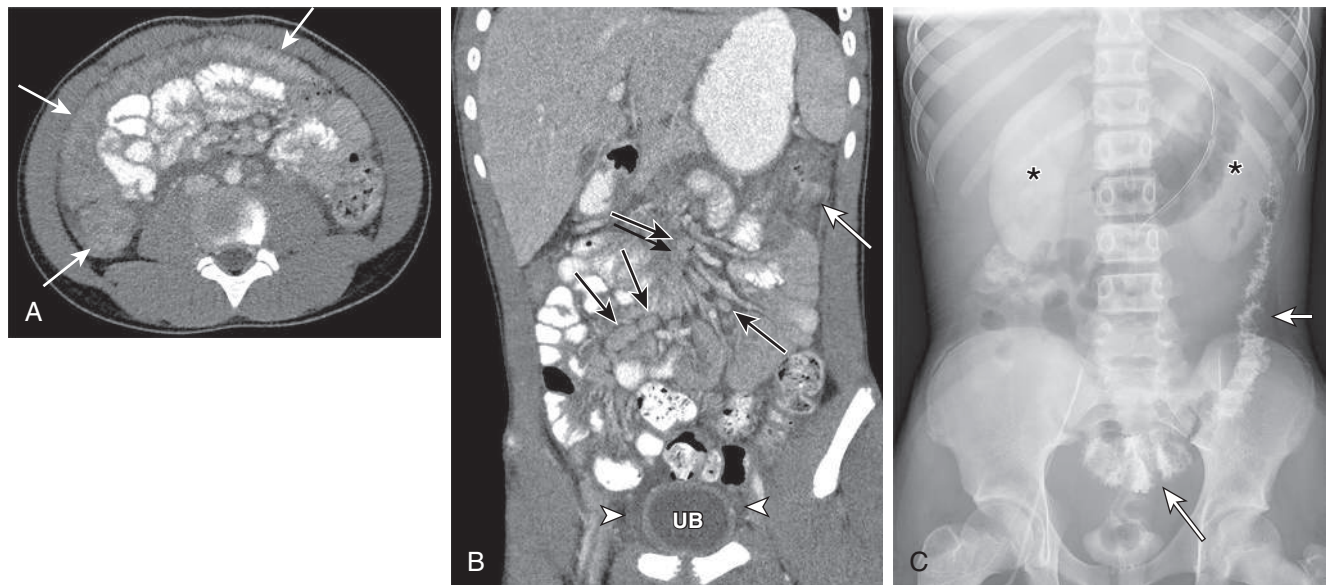
The primary clinical manifestations of MIS-C occur 2–6 weeks after SARS-CoV-2 infection and consist of unremitting fever, involvement of two or more organ systems (cardiac, renal, respiratory, hematologic, gastrointestinal, dermatologic, or neurologic), clinical severity requiring hospitalization, and laboratory evidence of inflammation (see Table 311.1). In addition, there is evidence for recent SARS-CoV-2 infection by RT-PCR, serology, or antigen test; or exposure to a suspected or confirmed COVID-19 case within the 4 weeks before the onset of symptoms.

The median age for children with MIS-C is 8–10 years (range 4–14 years), but MIS-C can affect any age group, including adolescents and rarely infants. A similar syndrome, MIS-A, has been reported in adults (≥21 years). The vast majority of cases of MIS-C have occurred in children with no underlying medical conditions or immunodeficiency. Cardiac manifestations including myocardial dysfunction, coronary artery dilatation, and aneurysm formations (Fig. 311.7), valvular dysfunction, reduced left ventricular ejection fraction, shock, cardiac arrhythmias, and pericardial effusion are present in up to 50% of children at presentation. With institution of rapid



**Fig. 311.3** Chest radiography and chest CT findings of children with COVID-19 in conjunction with symptom and time interval between imaging studies. **A**, Posteroanterior chest radiograph of a 13-yr-old patient who presented with fever for 2 days. Chest radiography and chest CT images were obtained on the same day. Chest radiograph was normal. **B**, Chest CT image in the axial plan revealed a single, peripheral located, ground-glass opacity (GGO) at the posterobasal segment of the right lower lobe. The opacity was obscured with the right liver lobe and diaphragm on chest radiography. **C**, Posteroanterior chest radiograph of a 10-yr-old patient who presented with cough and fever for 2 days. Chest radiography and chest CT images were obtained on the same day. Chest radiograph revealed peripheral GGO (*arrow*) at the basal segments of the right lower lobe. **D**, Axial section chest CT examination revealed bronchovascular distributed GGOs at the periphery of the basal segments of the right lower lobe. **E**, Posteroanterior chest radiograph of a 13-yr-old patient who presented with cough and fever for 2 days. Chest radiography and chest CT images were obtained on the same day. Chest radiograph was interpreted as normal. **F**, Axial chest CT image without contrast demonstrates bilateral, multifocal, peripheral, and perivascular distributed millimetric nodular-shaped GGOs. The opacities were not detected on chest radiography due to the smaller size and lower density. **G**, Posteroanterior chest radiograph of a 16-yr-old patient who presented with cough and fever for 3 days. Chest radiography and chest CT images were obtained on the same day. Chest radiograph demonstrates paramediastinal GGO at the right upper lobe (*red box*). **H**, Axial chest CT image without contrast demonstrates peripherally distributed GGO at the right upper lobe with an interlobular interstitial thickening. (From Bayramoglu Z, Canipek E, Comert RG, et al. *Imaging features of pediatric COVID-19 on chest radiography and chest CT: a retrospective, single-center study. Acad Radiol.* 2021;28:18–27. Fig. 1.)





**Fig. 311.4** A 14-yr-old with multisystem inflammatory syndrome in children (MIS-C). Imaging findings showed bowel wall thickening, acute kidney injury, ascites, and mesenteric adenopathy. **A**, Axial contrast-enhanced CT image shows diffuse mural thickening and mild mucosal hyperenhancement of colon (arrows). **B**, Coronal image from same CT examination as **A** shows mesenteric lymphadenopathy (black arrows) and pelvic ascites (arrowheads). Wall of urinary bladder (UB) is thickened, and thickening of colon (white arrow) is again noted. **C**, Supine anteroposterior abdominal radiograph obtained 15 hours after CT (**A** and **B**) shows retention of IV contrast material in kidneys (asterisks) (termed *delayed nephrogram*) in setting of acute kidney injury. Residual oral contrast material is present in descending colon and sigmoid (arrows) and shows wall thickening and irregularity. (From Blumfield E, Levin TL, Kurian J, et al. Imaging findings in multisystem inflammatory syndrome in children (MIS-C) associated with coronavirus disease (COVID-19). *AJR*. 2021;216:507–518. Fig. 7.)

**Table 311.4** Rashes Reported in COVID-19 Infected Patients

<ul style="list-style-type: none"> <li>• Morbilliform*</li> <li>• Chilblain-like/pernio*</li> <li>• Urticarial</li> <li>• Macular papular erythema*</li> <li>• Vesicular</li> <li>• Acrocyanosis</li> <li>• Acral desquamation</li> <li>• Papulosquamous</li> <li>• Livedo reticularis-like*</li> <li>• Erythema multiforme-like*</li> <li>• Erythroderma</li> <li>• Grover-like</li> <li>• Retiform purpura*</li> <li>• Petechial</li> </ul>	<ul style="list-style-type: none"> <li>• Bullous</li> <li>• Palpable purpura/vasculitis (leukocytoclastic)*</li> <li>• Dengue-like</li> <li>• Pressure injury</li> <li>• Erythema nodosum</li> <li>• Livedo racemose*</li> <li>• Miliaria rubra</li> <li>• Acneiform</li> <li>• Enanthem</li> <li>• Anagen effluvium</li> <li>• Erythema elevatum diutinum</li> <li>• Photo-distributed</li> </ul>
---	--

\*Common.  
Modified from Dinulos JE, Dinulos JG. Cutaneous coronavirus disease 2019 in children: a clinical primer for diagnosis and treatment. *Curr Opin Pediatr*. 2021;33:691–703. Table 1.

immunomodulation, short-term outcomes appear to be favorable, including resolution of coronary abnormalities in the majority of cases. Studies to evaluate the long-term prognosis for cardiac function are in progress, including studies using sensitive measures such as cardiac MRI. Patients with severe cardiac dysfunction must be followed by a pediatric cardiologist and abstain from sports for 3–6 months or until cleared by the cardiologist.

Sub-phenotypes of MIS-C include cases that appear very similar to Kawasaki disease (marked conjunctival injection, adenopathy, and/or prominent rash [Table 208.4 in Chapter 208]) and cases lacking

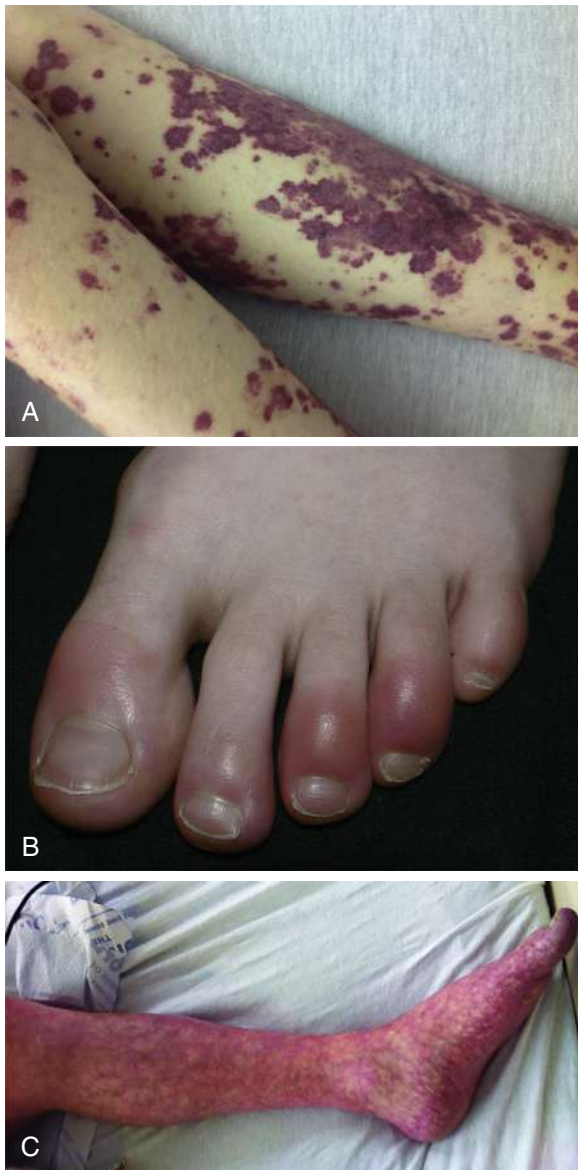
Kawasaki disease features but with prominent abdominal symptoms mimicking an acute abdomen. Analysis of cytokine responses in children with MIS-C has identified elevation of a variety of biomarkers, confirming the hyperinflammatory nature of this illness (Table 311.5). Rapid institution of immunomodulatory therapy has been shown to be lifesaving in the setting of MIS-C and has included intravenous immunoglobulin (IGIV) with methylprednisolone and/or other biologics such as anakinra, tocilizumab, or infliximab (Table 311.6). The incidence of MIS-C has dramatically decreased with the appearance of newer variants.

Infectious complications are uncommon and are noted in Table 311.7. Another complication is rebound (recurrence) of COVID-19 symptoms after an initial episode (Table 311.8).

### Post-Acute Sequelae of SARS-CoV-2 Infection (Long COVID)

An estimated 10–40% of adults and a much lower percentage of children who have recovered from recognized or unrecognized SARS-CoV-2 infection may develop long-standing and in some cases severe symptoms that are not specifically related to their original symptoms (Table 311.9). These may include ill-defined pain syndromes, headaches, abdominal pain, fatigue and postexertional malaise, shortness of breath, chronic cough, palpitations, dizziness/syncope, among others, as well as anxiety, depression, and posttraumatic stress disorder. The pathogenesis of long COVID is not yet known but may include genetic determinants related to immune dysregulation, autonomic instability, or persistent indolent viral effects. Long COVID may occur in individuals with mild symptoms, as well as those with moderate or severe infection. Affected individuals may benefit from multidisciplinary and coordinated evaluation in centers that can coordinate subspecialty evaluations





**Fig. 311.5** Dermatologic manifestations of COVID-19. A, Petechial rash. B, Chilblains of the foot. C, Livedo reticularis of the lower extremity. (A and B from Gottlieb M, Long B. Dermatologic manifestations and complications of COVID-19. *Am J Emerg Med.* 2020;38:1715–1721. Figs. 4 and 5; C from Nantsupawat T, Mankongpaisarnrung C, Soontrapa S, et al. Obscure severe infrarenal aortoiliac stenosis with severe transient lactic acidosis. *J Investig Med High Impact Case Rep.* 2013;1(1):2324709613479940. Fig. 2.)

at a single visit, with focus on the symptoms that are most disruptive to quality of life and function.

## DIAGNOSIS

Numerous diagnostic assays have been developed for the diagnosis of SARS-CoV-2, including laboratory-based and rapid/point-of-care nucleic acid amplification tests, rapid antigen tests, and serologic assays (Table 311.10). Multiple platforms targeting different aspects of the viral spike and nucleocapsid genes or proteins have

been used for direct viral detection. Antibody to the spike protein may develop with either natural infection or vaccination, but presence of nucleocapsid antibody indicates natural infection. Virus may be detected by PCR or antigen-based methods for many days after the onset of symptoms, but immunocompetent individuals are generally not contagious after 10 days and immunocompromised patients are generally not contagious after 21 days, with late viral detection representing nonviable, replication incompetent remnants. Cycle time (Ct) in nonquantitative PCR assays cannot directly correlate with disease or likelihood of disease severity or progression but can be used as a rough estimate of viral load and shedding over time within a single patient, with lower Ct representing high viral loads and high Ct more likely representing shedding of nonviable virus.

Antibodies usually develop within 2 weeks of infection, but there is great variability in antibody responses to natural infection. Some infected individuals mount high antibody responses that are durable over many months, but others may not mount an effective or long-lived response after natural infection, highlighting the importance of vaccination for reliable immunity. Antibody responses have been documented to wane over time in both naturally infected and vaccinated individuals, leading to the recommendation for booster doses of vaccine. Vaccination has continued to be highly effective in prevention of severe disease, hospitalization, and death and in reducing the likelihood of MIS-C.

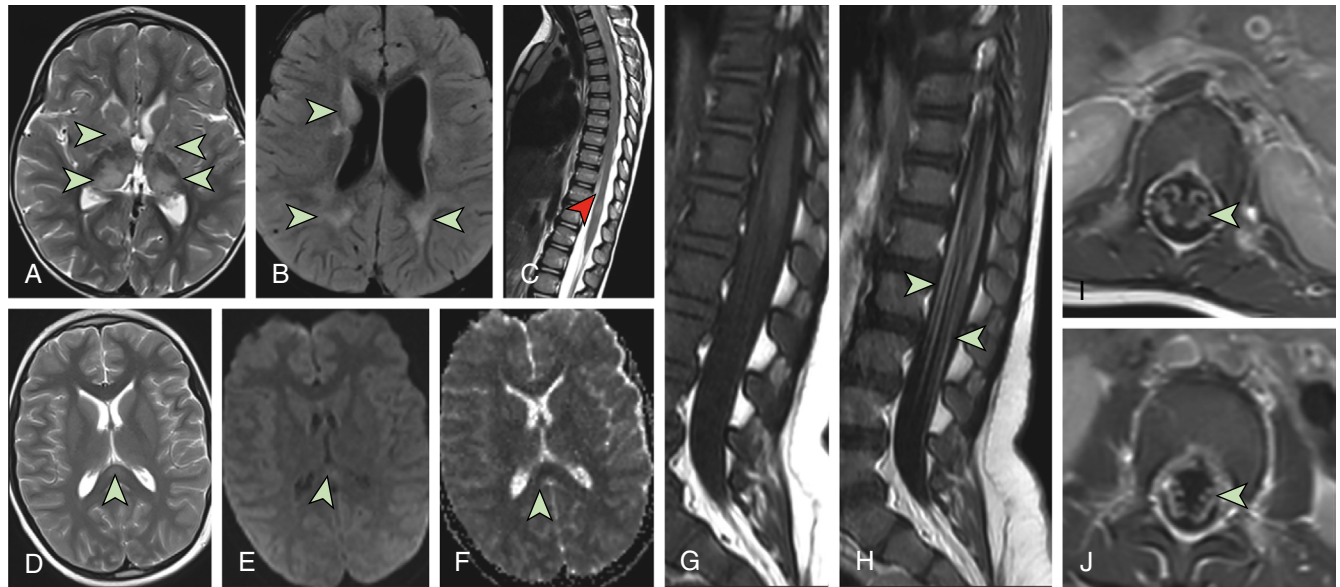
## TREATMENT AND PREVENTION

Therapeutic agents for SARS-CoV-2 include antivirals that inhibit viral replication such as intravenous remdesivir, oral nirmatrelvir/ritonavir combination therapy, and oral molnupiravir. These antivirals reduce morbidity and mortality in hospitalized patients (5–10 day courses of intravenous remdesivir) as well as nonhospitalized high-risk children and adults (oral agents and shorter 3-day courses of intravenous remdesivir). High-risk conditions associated with severe disease include obesity, diabetes, chronic lung disease, neurologic disorders, cardiovascular disease, sickle cell disease, or immunosuppression because of underlying conditions or medications. Systemic corticosteroid therapy (dexamethasone) has been shown to significantly reduce morbidity and mortality in the treatment of hospitalized patients with COVID-19 pulmonary disease. Several monoclonal antibodies were developed and found to be effective during the early phase of the pandemic in preventing progression to severe disease in individuals with high-risk conditions. However, these antibodies have not retained activity against more recent variants of SARS-CoV-2. High-titer immune plasma has demonstrated variable efficacy with the original variant and is not recommended. Other biologics, such as the interleukin-6 inhibitor tocilizumab, have been used in critically ill adults unresponsive to first-line therapies but are used less commonly in children.

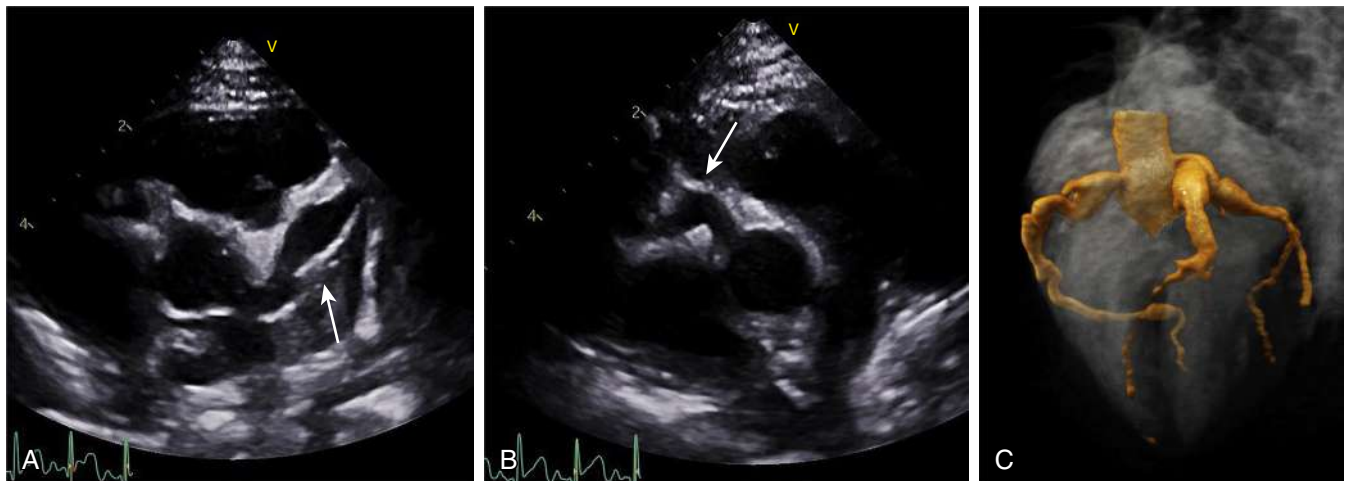
Multiple vaccines have been developed to combat spread of SARS-CoV-2, including novel platforms such as mRNA-based vaccines and adenovirus vector-based vaccines (see Chapter 215). For the majority of these SARS-CoV-2 vaccines, the primary target is the viral spike protein. The FDA had granted EUA approval for SARS-CoV-2 vaccines in the United States in children >6 months of age and adults.

Guidelines in late 2023 regarding isolation and precautions for people with COVID-19 are summarized in Table 311.11. However, guidelines continue to evolve and are available at the Centers for Disease Control and Prevention website (<https://www.cdc.gov/coronavirus/2019-ncov/your-health/isolation.html>).

Visit Elsevier eBooks+ at [eBooks.Health.Elsevier.com](https://eBooks.Health.Elsevier.com) for Bibliography.



**Fig. 311.6** MRI scans showing a range of neurologic complications. A-C, MRI brain and spine scans from 2-yr-old child with acute disseminated encephalomyelitis. Multiple hyperintense foci on axial T2-weighted (A) and T2 FLAIR (B) images involve both cerebral hemispheres, including the basal ganglia, thalami, and subcortical and periventricular white matter (arrowheads). C, Sagittal T2-weighted image of the spine shows a focus of hyperintensity within the cord close to the conus (arrowhead). D-F, MRI brain scans from 11-yr-old child who presented with MIS-C, encephalopathy, and MERS. D, Axial T2-weighted image shows a focus of hyperintensity involving the splenium of the corpus callosum along the midline (arrowhead). The B1000 (E) and the ADC maps (F) from diffusion-weighted imaging show subtle diffusion restriction involving the lesion. G-J, MRI spine scans from a 16-mo-old infant who presented with Guillain-Barré syndrome. Sagittal T1-weighted images before (G) and after contrast (H) show enhancement of the lumbosacral nerve roots (arrowheads). I, J, Axial T1-weighted postcontrast images show bilateral enhancement of the nerve roots. ADC, Apparent diffusion coefficient; FLAIR, fluid-attenuated inversion recovery; MERS, mild encephalopathy with reversible splenial lesion; MIS-C, multisystem inflammatory syndrome in children. (Modified from Ray ST, Abdel-Mannon O, Sa M, et al. Neurological manifestations of SARS-CoV-2 infection in hospitalised children and adolescents in the UK: a prospective national cohort study. *Lancet Child Adolesc.* 2021;5:631–641. Fig. 2.)



**Fig. 311.7** Early cardiac imaging. Echocardiography (day 21) showing a giant (z score +26) left anterior descending artery aneurysm (A) and a large (z score +8.5) right coronary artery aneurysm (B, arrow). C, Three-dimensional reconstruction of coronary architecture. (Modified from Villacis-Nunez DS, Hashemi S, Nelson MC, et al. Giant coronary aneurysms in multisystem inflammatory syndrome in children associated with SARS-CoV-2 infection. *JACC Case Rep.* 2021;3[13]:1499–1508. Fig. 2.)

**Table 311.5** Evaluation of MIS-C**LABORATORY TESTING**

- A C-reactive protein  $\geq 3.0$  mg/dL (30 mg/L) is required for the CSTE/CDC MIS-C surveillance case definition; other laboratory tests may also indicate evidence of inflammation (e.g., erythrocyte sedimentation rate, fibrinogen, procalcitonin, and ferritin).
- Similarly, SARS-CoV-2 laboratory testing is indicated. Although detection of anti-nucleocapsid antibody or anti-spike protein antibody fulfill criteria for the case definition, when feasible SARS-CoV-2 anti-nucleocapsid antibody testing is recommended, particularly in children with a history of COVID-19 vaccination because anti-nucleocapsid antibody is indicative of SARS-CoV-2 infection, whereas antispike protein antibody may be induced either by COVID-19 vaccination or by SARS-CoV-2 infection. Serology testing should be obtained before administering intravenous immunoglobulin or any other exogenous antibody treatments whenever possible.

**IMAGING**

Given the frequent association of MIS-C with cardiac involvement, the following tests are usually performed:

- Echocardiogram
- Electrocardiogram

Other imaging should be directed by patient signs or symptoms but could include:

- Imaging to evaluate for acute appendicitis
- Imaging to evaluate for pharyngeal space infection

**OTHER EVALUATIONS**

It is important to evaluate children with suspected MIS-C for alternative diagnoses, particularly because MIS-C clinical manifestations overlap with those of other etiologies. Testing to evaluate for other potential diagnoses should be directed by patient signs or symptoms. Alternative diagnoses to consider include:

- Acute viral infection (e.g., SARS-CoV-2, influenza, adenovirus)
- Acute viral infection myocarditis (e.g., influenza, enteroviruses)
- Kawasaki disease
- Rickettsial disease (e.g., typhus)

CSTE/CDC, Council of State and Territorial Epidemiologists/Centers for Disease Control and Prevention; MIS-C, multisystem inflammatory syndrome in children.

From Centers for Disease Control and Prevention. Information for healthcare providers about multisystem inflammatory syndrome in children (MIS-C). <https://www.cdc.gov/mis/mis-c/hcp/index.html>

**Table 311.6** Treatment of MIS-C

Initial treatment is tailored according to the patient's presenting signs and symptoms and may include:

- Fluid resuscitation
- Inotropic support
- Respiratory support

Antiinflammatory measures have included the frequent use of intravenous immunoglobulin and steroids. There is some evidence that multisystem inflammatory syndrome in children (MIS-C) with milder manifestations can be treated with steroid monotherapy and that prolonged duration of outpatient steroids should be avoided. The use of other antiinflammatory medications (e.g., anakinra) and the use of anticoagulation treatments have been variable. Aspirin has commonly been used because of concerns for coronary artery involvement, and antibiotics are routinely used to treat potential sepsis while awaiting bacterial cultures. Thrombotic prophylaxis is often used given the hypercoagulable state typically associated with MIS-C.

From Centers for Disease Control and Prevention. Information for healthcare providers about multisystem inflammatory syndrome in children (MIS-C). <https://www.cdc.gov/mis/mis-c/hcp/index.html>

**Table 311.7** Infectious Complications in Patients with COVID-19

- *Co-infections at presentation:* Although most individuals present with only SARS-CoV-2 infection, concomitant viral infections, including influenza and other respiratory viruses, have been reported. Community-acquired bacterial pneumonia also has been reported, but it is uncommon, with a prevalence that ranges from 0% to 6% of people with SARS-CoV-2 infection. Antibacterial therapy is generally not recommended unless additional evidence for bacterial pneumonia is present (e.g., leukocytosis, the presence of a focal infiltrate on imaging).
- *Reactivation of latent infections:* There are case reports of underlying chronic hepatitis B virus and latent tuberculosis infections reactivating in patients with COVID-19 who receive immunomodulators as treatment, although the data are currently limited. Reactivation of herpes simplex virus and varicella zoster virus infections have also been reported. Cases of severe and disseminated strongyloidiasis have been reported in patients with COVID-19 during treatment with tocilizumab and corticosteroids. Many clinicians would initiate empirical treatment (e.g., with the antiparasitic drug ivermectin), with or without serologic testing, in patients who require immunomodulators for the treatment of COVID-19 and have come from areas where *Strongyloides* is endemic (i.e., tropical, subtropical, or warm temperate areas).
- *Nosocomial infections:* Hospitalized patients with COVID-19 may acquire common nosocomial infections, such as hospital-acquired pneumonia (including ventilator-associated pneumonia), line-related bacteremia or fungemia, catheter-associated urinary tract infection, and *Clostridioides difficile*-associated diarrhea. Early diagnosis and treatment of these infections are important for improving outcomes in these patients.
- *Opportunistic fungal infections:* Invasive fungal infections, including aspergillosis and mucormycosis, have been reported in hospitalized patients with COVID-19. Although these infections are relatively rare, they can be fatal, and they may be seen more commonly in patients who are immunocompromised or receiving mechanical ventilation. The majority of mucormycosis cases have been reported in India and are associated with diabetes mellitus or the use of corticosteroids.

From Centers for Disease Control and Prevention. Clinical spectrum of SARS-CoV-2 infection. <https://www.covid19treatmentguidelines.nih.gov/overview/clinical-spectrum>

**Table 311.8** Viral or Symptom Rebound Soon After COVID-19

- Observational studies and results from clinical trials of therapeutic agents have described SARS-CoV-2 viral or COVID-19 symptom rebound in patients who have completed treatment for COVID-19.
- Viral and symptom rebounds have also occurred when anti-SARS-CoV-2 therapies were not used.
- Typically, this phenomenon has not been associated with progression to severe COVID-19.

From Centers for Disease Control and Prevention. Clinical spectrum of SARS-CoV-2 infection. <https://www.covid19treatmentguidelines.nih.gov/overview/clinical-spectrum>



**Table 311.9** Adjusted Hazard Ratios of Selected Potential Post–COVID-19 Symptoms and Conditions Among Children and Adolescents Age 2-17 Years With and Without COVID-19, by Age Group: HealthVerity Medical Claims Database, United States, March 1, 2020–January 31, 2022

OUTCOME	ADJUSTED HAZARD RATIO (95% CI)*		
	2-4 YR	5-11 YR	12-17 YR
<b>SYMPTOM</b>			
Smell and taste disturbances	1.22 (0.70-2.15)	0.94 (0.83-1.07)	1.23 (1.16-1.31) <sup>†</sup>
Circulatory signs and symptoms	1.17 (1.12-1.23) <sup>†</sup>	1.11 (1.08-1.13) <sup>†</sup>	1.04 (1.02-1.06) <sup>†</sup>
Malaise and fatigue	1.13 (1.05-1.22) <sup>†</sup>	1.08 (1.05-1.12) <sup>†</sup>	1.03 (1.01-1.04) <sup>†</sup>
Musculoskeletal pain	1.16 (1.10-1.21) <sup>†</sup>	1.06 (1.04-1.07) <sup>†</sup>	1.00 (0.99-1.01)
Dizziness and syncope	1.08 (0.90-1.29)	1.03 (0.99-1.08)	1.00 (0.98-1.02)
GI and esophageal disorders	1.15 (1.10-1.20) <sup>†</sup>	1.02 (1.00-1.04) <sup>†</sup>	0.97 (0.95-0.99) <sup>†</sup>
Sleeping disorders	0.99 (0.93-1.06)	0.89 (0.86-0.92) <sup>†</sup>	0.91 (0.89-0.94) <sup>†</sup>
Respiratory signs and symptoms	1.07 (1.04-1.10) <sup>†</sup>	0.93 (0.92-0.94) <sup>†</sup>	0.88 (0.87-0.89) <sup>†</sup>
Symptoms of mental conditions	1.03 (0.97-1.10)	0.92 (0.90-0.95) <sup>†</sup>	0.89 (0.86-0.91) <sup>†</sup>
<b>CONDITION</b>			
Acute pulmonary embolism	— <sup>‡</sup>	— <sup>‡</sup>	2.03 (1.61-2.56) <sup>†</sup>
Myocarditis and cardiomyopathy	2.39 (1.57–3.65) <sup>†</sup>	2.84 (2.39-3.37) <sup>†</sup>	1.66 (1.48-1.88) <sup>†</sup>
Venous thromboembolic event	— <sup>‡</sup>	2.69 (1.73-4.19) <sup>†</sup>	1.52 (1.22-1.91) <sup>†</sup>
Acute and unspecified renal failure	1.52 (1.07–2.14) <sup>†</sup>	1.38 (1.16–1.63) <sup>†</sup>	1.27 (1.15–1.40) <sup>†</sup>
Type 1 diabetes	1.01 (0.57-1.78)	1.31 (1.13-1.53) <sup>†</sup>	1.20 (1.09–1.33) <sup>†</sup>
Coagulation and hemorrhagic disorders	1.47 (1.20-1.80) <sup>†</sup>	1.28 (1.15-1.43) <sup>†</sup>	1.10 (1.03–1.19) <sup>†</sup>
Type 2 diabetes	1.24 (0.85-1.81)	1.14 (1.02-1.28) <sup>†</sup>	1.18 (1.11-1.24) <sup>†</sup>
Cardiac dysrhythmias	1.44 (1.22-1.70) <sup>†</sup>	1.23 (1.14-1.32) <sup>†</sup>	1.12 (1.08-1.17) <sup>†</sup>
Cerebrovascular disease	1.66 (0.85-3.23)	1.14 (0.79-1.64)	1.18 (0.93-1.48)
Chronic kidney disease	0.86 (0.54-1.36)	1.04 (0.83-1.31)	1.12 (0.96-1.31)
Asthma	1.12 (1.07-1.18) <sup>†</sup>	1.02 (1.00-1.05) <sup>†</sup>	0.96 (0.94-0.98) <sup>†</sup>
Muscle disorders	0.87 (0.77-0.98) <sup>†</sup>	0.86 (0.82-0.91) <sup>†</sup>	0.96 (0.93-0.99) <sup>†</sup>
Neurologic conditions	0.98 (0.93-1.04)	0.96 (0.93-0.98) <sup>†</sup>	0.91 (0.89-0.93) <sup>†</sup>
Anxiety and fear-related disorders	0.91 (0.83-1.00)	0.86 (0.83-0.88) <sup>†</sup>	0.84 (0.82-0.85) <sup>†</sup>
Mood disorders	0.82 (0.62-1.08)	0.73 (0.69-0.77) <sup>†</sup>	0.80 (0.77-0.83) <sup>†</sup>

\*Each adjusted hazard ratio was obtained from a single Cox proportional hazards model stratified by age group, with the specific symptom or condition as the outcome and the following covariates: presence of COVID-19, age (continuous variable), sex, race, U.S. Census Bureau region, payor type, previous medical complexity, and previous hospitalization. †P-value < 0.05.

<sup>‡</sup>Age-stratified analyses were performed only when there were at least 10 patients with COVID-19 and at least 10 patients without COVID-19 in that age group with the specific symptom or condition.

From Kompaniyets L, Bull-Otterson L, Boehmer TK, et al. Post-COVID-19 symptoms and conditions among children and adolescents—United States, March 1, 2020–January 21, 2022. *Morb Mortal Wkly Rep.* 2022;71(31):993–998. Table 3.

**Table 311.10** Laboratory Evidence for COVID-19 Infection

Laboratory evidence using a method approved or authorized by the U.S. Food and Drug Administration (FDA) or designated authority:

**CONFIRMATORY\* LABORATORY EVIDENCE**

- Detection of SARS-CoV-2 ribonucleic acid (RNA) in a clinical or postmortem specimen using a diagnostic molecular amplification test performed by a Clinical Laboratory Improvement Amendments (CLIA)-certified provider<sup>†</sup> OR
- Detection of SARS-CoV-2 RNA in a clinical or postmortem specimen by genomic sequencing<sup>‡</sup>

**PRESUMPTIVE\* LABORATORY EVIDENCE**

- Detection of SARS-CoV-2–specific antigen in a clinical or postmortem specimen using a diagnostic test performed by a CLIA-certified provider.<sup>†</sup>

**SUPPORTIVE\* LABORATORY EVIDENCE**

- Detection of SARS-CoV-2 specific antigen by immunocytochemistry, OR
- Detection of SARS-CoV-2 RNA or specific antigen using a test performed without CLIA oversight.

\*The terms *confirmatory*, *presumptive*, and *supportive* are categorical labels used here to standardize case classifications for public health surveillance. The terms should not be used to interpret the utility or validity of any laboratory test methodology.

<sup>†</sup>Includes those tests performed under a CLIA certificate of waiver.

<sup>‡</sup>Some genomic sequencing tests that have been authorized for emergency use by the FDA do not require an initial polymerase chain reaction (PCR) result to be generated. Genomic sequencing results may be all the public health agency receives.

Modified from Centers for Disease Control and Prevention. Coronavirus disease 2019 (COVID-19) 2023 Case Definition. <https://ndc.services.cdc.gov/case-definitions/coronavirus-disease-2019-covid-19/>



**Table 311.11** Isolation and Precautions for People with COVID-19**WHEN TO ISOLATE**

- If you test negative: You can end your isolation.
- If you test positive: Follow the full isolation recommendations below.
- When you have COVID-19, isolation is counted in days, as follows.

**If You Had No Symptoms**

- Day 0 is the day you were tested (not the day you received your positive test result).
- Day 1 is the first full day following the day you were tested.
- If you develop symptoms within 10 days of when you were tested, the clock restarts at day 0 on the day of symptom onset.

**If You Had Symptoms**

- Day 0 of isolation is the day of symptom onset, regardless of when you tested positive.
- Day 1 is the first full day after the day your symptoms started.

**Isolation**

- If you test positive for COVID-19, stay home for at least 5 days and isolate from others in your home.
- You are likely most infectious during these first 5 days.
- Wear a high-quality mask if you must be around others at home and in public.
- Do not go places where you are unable to wear a mask. For travel guidance, see CDC's Travel webpage.
- Do not travel.
- Stay home and separate from others as much as possible.
- Use a separate bathroom, if possible.
- Take steps to improve ventilation at home, if possible.
- Do not share personal household items, such as cups, towels, and utensils.
- Monitor your symptoms. If you have an emergency warning sign (like trouble breathing), seek emergency medical care immediately.
- Learn more about what to do if you have COVID-19.

**ENDING ISOLATION**

- End isolation based on how serious your COVID-19 symptoms were.
- Loss of taste and smell may persist for weeks or months after recovery and need not delay the end of isolation.

**If You Had No Symptoms**

- You may end isolation after day 5.

**If You Had Symptoms and Your Symptoms Are Improving**

- You may end isolation after day 5 if you are fever free for 24 hr (without the use of fever-reducing medication).

**Your Symptoms Are Not Improving**

Continue to isolate until:

- You are fever free for 24 hr (without the use of fever-reducing medication).
- Your symptoms are improving.\*

*If You Had Symptoms and Had Moderate illness (you experienced shortness of breath or had difficulty breathing)*

- You need to isolate through day 10.

**Severe Illness (You Were Hospitalized) or Have a Weakened Immune System**

- You need to isolate through day 10.
- Consult your doctor before ending isolation.
- Ending isolation without a viral test may not be an option for you.
- If you are unsure if your symptoms are moderate or severe or if you have a weakened immune system, talk to a healthcare provider for further guidance.

**Regardless of When You End Isolation**

Until at least day 11:

- Avoid being around people who are more likely to get very sick from COVID-19.
- Remember to wear a high-quality mask when indoors around others at home and in public.
- Do not go places where you are unable to wear a mask until you are able to discontinue masking (see below).
- For travel guidance, see CDC's Travel webpage.

**Removing Your Mask**

After you have ended isolation, when you are feeling better (no fever without the use of fever-reducing medications and symptoms improving):

- Wear your mask through day 10.

OR

- If you have access to antigen tests, you should consider using them. With two sequential negative tests 48 hr apart, you may remove your mask sooner than day 10.

**NOTE:** If your antigen test results\* are positive, you may still be infectious. You should continue wearing a mask and wait at least 48 hours before taking another test. Continue taking antigen tests at least 48 hr apart until you have two sequential negative results. This may mean you need to continue wearing a mask and testing beyond day 10.

After you have ended isolation, if your COVID-19 symptoms recur or worsen, restart your isolation at day 0. Talk to a healthcare provider if you have questions about your symptoms or when to end isolation.

\*As noted in the U.S. Food and Drug Administration labeling for authorized over-the-counter antigen tests, negative test results do not rule out SARS-CoV-2 infection and should not be used as the sole basis for treatment or patient management decisions, including infection control decisions.

From Centers for Disease Control and Prevention. Isolation and precautions for people with COVID-19. <https://www.cdc.gov/coronavirus/2019-ncov/your-health/isolation.html>

## Chapter 312

# Rotaviruses, Caliciviruses, and Astroviruses

Dorsey M. Bass

Diarrhea is a leading cause of childhood death in the world, accounting for 5-10 million deaths per year. In early childhood, the single most important cause of severe dehydrating diarrhea is rotavirus infection. Rotavirus and other gastroenteric viruses are not only major causes of pediatric deaths but also lead to significant morbidity. Before rotavirus

vaccines were available, children in the United States were estimated to have a risk of hospitalization for rotavirus diarrhea of 1:43, corresponding to 80,000 hospitalizations annually.

## ETIOLOGY

Rotaviruses, astroviruses, caliciviruses such as the Norwalk agent, and enteric adenoviruses are the medically important pathogens of human viral gastroenteritis (see Chapter 387).

**Rotaviruses** are in the Reoviridae family and cause disease in virtually all mammals and birds. These viruses are wheel-like, triple-shelled icosahedrons containing 11 segments of double-stranded RNA. The diameter of the particles on electron microscopy is approximately 80 nm. Rotaviruses are classified by serogroup (A, B, C, D, E, F, and G) and subgroup (I or II). Rotavirus strains are species specific and do not cause disease in heterologous hosts. Group A includes the common human pathogens and a variety of animal viruses. Group B rotavirus is reported as a cause of severe disease in infants and adults in China

only. Occasional human outbreaks of group C rotavirus are reported. The other serogroups infect only nonhumans.

Subgrouping of rotaviruses is determined by the antigenic structure of the inner capsid protein, VP6. Serotyping of rotaviruses, described for group A only, is determined by classic cross-neutralization testing and depends on the outer capsid glycoproteins, VP7 and VP4. The VP7 serotype is referred to as the *G type* (for glycoprotein). There are 10 *G* serotypes, of which 4 cause most illness and vary in occurrence from year to year and region to region. The VP4 serotype is referred to as the *P type*. There are 11 *P* serotypes. Although both VP4 and VP7 elicit neutralizing immunoglobulin (Ig) G antibodies, the relative role of these systemic antibodies compared with mucosal IgA antibodies and cellular responses in protective immunity remains unclear.

**Caliciviruses**, which constitute the Caliciviridae family, are small, 27- to 35-nm viruses and are the most common cause of gastroenteritis outbreaks in older children and adults. Caliciviruses also cause a rotavirus-like illness in young infants. They are positive-sense, single-stranded RNA viruses with a single structural protein. Human caliciviruses are divided into two genera, the noroviruses and sapoviruses. Caliciviruses have been named for locations of initial outbreaks: Norwalk, Snow Mountain, Montgomery County, Sapporo, and others. Caliciviruses and astroviruses are sometimes referred to as **small, round viruses** on the basis of their appearance on electron microscopy.

**Astroviruses** constitute the Astroviridae family and are important agents of viral gastroenteritis in young children, with a high incidence in both the developing and developed worlds. Astroviruses are positive-sense, single-stranded RNA viruses. They are small particles, approximately 30 nm in diameter, with a characteristic central five- or six-pointed star when viewed on electron microscopy. The capsid consists of three structural proteins. There are eight known human serotypes.

**Enteric adenoviruses** are a common cause of viral gastroenteritis in infants and children. Although many adenovirus serotypes exist and are found in human stool, especially during and after typical upper respiratory tract infections (see Chapter 309), only serotypes 40 and 41 cause gastroenteritis. These strains are very difficult to grow in tissue culture. The virus consists of an 80-nm-diameter icosahedral particle with a relatively complex double-stranded DNA genome.

**Aichi virus** is a picornavirus that is associated with gastroenteritis and was initially described in Asia. Several other viruses that may cause diarrheal disease in animals have been postulated but are not well established as human gastroenteritis viruses. These include coronaviruses, toroviruses, and pestiviruses. The **picobirnaviruses** are an unclassified group of small (30-nm), single-stranded RNA viruses that have been found in 10% of patients with HIV-associated diarrhea.

## EPIDEMIOLOGY

Worldwide, rotavirus is estimated to cause more than 111 million cases of diarrhea annually in children <5 years. Of these, 18 million cases are considered at least moderately severe, with approximately 200,000 deaths per year. Rotavirus caused 3 million cases of diarrhea, 80,000 hospitalizations, and 20-40 deaths annually in the United States before widespread vaccine use.

**Rotavirus** infection is most common in winter months in temperate climates. In the United States, the annual winter peak historically spread from west to east. Unlike the spread of other winter viruses, such as influenza, this wave of increased incidence was not caused by a single prevalent strain or serotype. Since widespread adoption of rotavirus vaccines, this geographic phenomenon has vanished and peaks have decreased. Typically, several serotypes predominate in a given community for one or two seasons, but nearby locations may harbor unrelated strains. Disease tends to be most severe in patients 3-24 months of age, although 25% of the cases of severe disease occur in children older than 2 years of age, with serologic evidence of infection developing in virtually all children by 4-5 years of age. Infants younger than 3 months are relatively protected by transplacental antibody and possibly breastfeeding. Infections in neonates and in adults in close contact with infected children are generally asymptomatic. Some rotavirus strains have stably colonized newborn nurseries for years, infecting virtually all newborns without causing any overt illness.

Rotavirus and the other gastrointestinal viruses spread efficiently by the fecal-oral route, and outbreaks are common in children's hospitals and childcare centers. The virus is shed in stool at a very high

concentration before and for days after the clinical illness. Very few infectious virions are needed to cause disease in a susceptible host.

The epidemiology of **astroviruses** is not as thoroughly studied as that of rotavirus, but these viruses are a common cause of mild to moderate watery winter diarrhea in children and infants and are an uncommon pathogen in adults. Hospital outbreaks are common. **Enteric adenovirus** gastroenteritis occurs year-round, mostly in children younger than 2 years. Nosocomial outbreaks occur but are less common than with rotavirus and astrovirus. **Calicivirus** is best known for causing large, explosive outbreaks among older children and adults, particularly in settings such as schools, cruise ships, and hospitals. Often a single food, such as shellfish or water used in food preparation, is identified as a source. Like astrovirus and rotavirus, caliciviruses are also commonly found in winter infantile gastroenteritis and are now the leading cause of significant pediatric viral diarrhea in communities with high rates of rotavirus vaccination.

## PATHOGENESIS

Viruses that cause human diarrhea selectively infect and destroy villus tip cells in the small intestine. Biopsies of the small intestines show variable degrees of villus blunting and round cell infiltrate in the lamina propria. Pathologic changes may not correlate with the severity of clinical symptoms and usually resolve before the clinical resolution of diarrhea. The gastric mucosa is not affected despite the commonly used term *gastroenteritis*, although delayed gastric emptying has been documented during Norwalk virus infection.

In the small intestine, the upper villus enterocytes are differentiated cells, which have both digestive functions, such as hydrolysis of disaccharides, and absorptive functions, such as the transport of water and electrolytes via glucose and amino acid cotransporters. Crypt enterocytes are undifferentiated cells that lack the brush-border hydrolytic enzymes and are net secretors of water and electrolytes. Selective viral infection of intestinal villus tip cells thus leads to (1) decreased absorption of salt and water and an imbalance in the ratio of intestinal fluid absorption to secretion and (2) diminished disaccharidase activity and malabsorption of complex carbohydrates, particularly lactose. Most evidence supports altered absorption as the more important factor in the genesis of viral diarrhea. It has been proposed that a rotavirus non-structural protein (NSP4) functions as an enterotoxin.

Viremia may occur in severe, primary infections, but symptomatic **extraintestinal infection** is extremely rare in immunocompetent persons. In contrast, immunocompromised patients may occasionally experience central nervous system, hepatic, or renal involvement. The increased vulnerability of infants (compared with older children and adults) to severe morbidity and mortality from gastroenteritis viruses may relate to a number of factors, including decreased intestinal reserve function, lack of specific immunity, and decreased nonspecific host defense mechanisms such as gastric acid and mucus. Viral enteritis greatly enhances intestinal permeability to luminal macromolecules and has been postulated to increase the risk for food allergies and celiac disease.

## CLINICAL MANIFESTATIONS

**Rotavirus infection** typically begins after an incubation period of <48 hours (range: 1-7 days) with mild to moderate fever as well as vomiting, followed by the onset of frequent, watery stools. All three symptoms are present in about 50-60% of cases. Vomiting and fever typically abate during the second day of illness, but diarrhea often continues for 5-7 days. The stool is without gross blood or white blood cells. Dehydration may develop and progress rapidly, particularly in infants. The most severe disease typically occurs among children 4-36 months of age. Malnourished children and children with underlying intestinal disease, such as short-bowel syndrome, are particularly likely to acquire severe rotavirus diarrhea. Rarely, immunodeficient children experience severe and prolonged illness. Rotavirus has rarely been associated with mild encephalopathy that may progress to cerebellitis and with reversible splenic lesions. Although most newborns infected with rotavirus are asymptomatic, some outbreaks of necrotizing enterocolitis have been associated with the appearance of a new rotavirus strain in the affected nurseries.

The clinical course of **astrovirus** infection appears to be similar to that of rotavirus gastroenteritis, with the notable exception that the disease tends to be milder, with less significant dehydration. **Adenovirus enteritis** tends to cause diarrhea of longer duration, often 10-14 days. The **Norwalk virus** has a short (12-hour) incubation period. Vomiting and nausea tend to predominate in an illness associated with the Norwalk virus, and the duration is brief, usually consisting of 1-3 days of symptoms. The clinical and epidemiologic picture of Norwalk virus often closely resembles so-called food poisoning from preformed toxins such as *Staphylococcus aureus* and *Bacillus cereus*.

## DIAGNOSIS

In most cases, a satisfactory diagnosis of acute viral gastroenteritis can be made on the basis of the clinical and epidemiologic features. Many hospitals now offer multiplex PCR stool testing for multiple diarrheal pathogens, including a variety of bacterial and protozoan and all five common viral agents in one test. Enzyme-linked immunosorbent assays, which offer >90% specificity and sensitivity, are available for the detection of group A rotaviruses, caliciviruses, and enteric adenoviruses in stool samples. Research tools include electron microscopy of stools, RNA polymerase chain reaction analysis to identify G and P antigens, and culture. The diagnosis of viral gastroenteritis should always be questioned in patients with persistent or high fever, blood or white blood cells in the stool, or persistent severe or bilious vomiting, especially in the absence of diarrhea.

## LABORATORY FINDINGS

Isotonic dehydration with acidosis is the most common finding in children with severe viral enteritis. The stools are free of blood and leukocytes. Although the white blood cell count may be moderately elevated secondary to stress, the marked left shift seen with invasive bacterial enteritis is absent.

## DIFFERENTIAL DIAGNOSIS

The differential diagnosis includes other infectious causes of enteritis, such as bacteria and protozoa. Occasionally, surgical conditions such as appendicitis, bowel obstruction, and intussusception may initially mimic viral gastroenteritis.

## TREATMENT

Avoiding and treating dehydration are the main goals in the treatment of viral enteritis. A secondary goal is maintenance of the nutritional status of the patient (see [Chapters 74 and 387](#)).

There is no routine role for antiviral drug treatment of viral gastroenteritis. Controlled studies show limited benefits for antidiarrheal drugs, and there is a significant risk for serious side effects with these types of agents. Antibiotics are similarly of no benefit. Antiemetics such as ondansetron may help alleviate vomiting in children older than 2 years. Immunoglobulins have been administered orally to both normal and immunodeficient patients with severe rotavirus and norovirus gastroenteritis, but this treatment is currently considered experimental. Therapy with probiotic organisms such as *Lactobacillus* spp. has been shown to be helpful only in mild cases and not in dehydrating disease.

## Supportive Treatment

Rehydration via the oral route can be accomplished in most patients with mild to moderate dehydration (see [Chapters 74 and 387](#)). Severe dehydration requires immediate intravenous therapy followed by oral rehydration. Modern oral rehydration solutions containing appropriate quantities of sodium and glucose promote the optimum absorption of fluid from the intestine. There is no evidence that a particular carbohydrate source (rice) or the addition of amino acids improves the efficacy of these solutions for children with viral enteritis. Other clear liquids, such as flat soda, fruit juice, and sports drinks, are inappropriate for the rehydration of young children with significant stool loss. Rehydration via the oral (or nasogastric) route should be done over 6-8 hours, and feedings should be initiated immediately thereafter. Providing the rehydration fluid at a slow, steady rate, typically 5 mL/min, reduces vomiting and improves the success of oral therapy. Rehydration solution should be continued as a supplement to make up for

ongoing excessive stool loss. Initial intravenous fluids are required for the infant in shock or the occasional child with intractable vomiting.

After rehydration has been achieved, resumption of a normal diet for age has been shown to result in a more rapid recovery from viral gastroenteritis. Prolonged (>12 hours) administration of exclusive clear liquids or dilute formula is without clinical benefit and actually prolongs the duration of diarrhea. Breastfeeding should be continued even during rehydration. Selected infants may benefit from lactose-free feedings (e.g., soy formula and lactose-free cow's milk) for several days, although this step is not necessary for most children. Hypocaloric diets low in protein and fat such as BRAT (*bananas, rice, cereal, applesauce, and toast*) have not been shown to be superior to a regular diet.

## PROGNOSIS

Most fatalities occur in infants with poor access to medical care and are attributed to dehydration. Children may be infected with rotavirus each year during the first 5 years of life, but each subsequent infection decreases in severity. Primary infection results in a predominantly serotype-specific immune response, whereas reinfection, which is usually with a different serotype, induces a broad immune response with cross-reactive heterotypic antibody. After the initial natural infection, children have limited protection against subsequent asymptomatic infection (38%) and greater protection against mild diarrhea (73%) and moderate to severe diarrhea (87%). After the second natural infection, protection increases against subsequent asymptomatic infection (62%) and mild diarrhea (75%) and is complete (100%) against moderate to severe diarrhea. After the third natural infection, there is even more protection against subsequent asymptomatic infection (74%) and near-complete protection against even mild diarrhea (99%).

## PREVENTION

Good hygiene reduces the transmission of viral gastroenteritis, but even in the most hygienic societies, virtually all children become infected as a result of the efficiency of infection of the gastroenteritis viruses. Good handwashing and isolation procedures can help control nosocomial outbreaks. The role of breastfeeding in prevention or amelioration of rotavirus infection may be slight, given the variable protection observed in a number of studies. Vaccines offer the best hope for control of these ubiquitous infections.

## Vaccines

A trivalent rotavirus vaccine was licensed in the United States in 1998 and was subsequently linked to an increased risk for intussusception, especially during the 3- to 14-day period after the first dose and the 3- to 7-day period after the second dose. The vaccine was withdrawn from the market in 1999. Subsequently, two new live, oral rotavirus vaccines have been approved in the United States after extensive safety and efficacy testing.

A live, oral, pentavalent rotavirus vaccine was approved in 2006 for use in the United States. The vaccine contains five reassortant rotaviruses isolated from human and bovine hosts. Four of the reassortant rotaviruses express one serotype of the outer protein VP7 (G1, G2, G3, or G4), and the fifth expresses the protein P1A (genotype P[8]) from the human rotavirus parent strain. The pentavalent vaccine protects against rotavirus gastroenteritis when administered as a three-dose series at 2, 4, and 6 months of age. The first dose should be administered between 6 and 12 wk of age, with all three doses completed by 32 weeks of age. The vaccine provides substantial protection against rotavirus gastroenteritis, with a primary efficacy of 98% against severe rotavirus gastroenteritis caused by G1-G4 serotypes and 74% efficacy against rotavirus gastroenteritis of any severity through the first rotavirus season after vaccination. It provides a 96% reduction in hospitalizations for rotavirus gastroenteritis through the first 2 years after the third dose. In a study of more than 70,000 infants, the pentavalent vaccine did not increase the risk for intussusception, although other studies suggest a slight increased risk.

Another monovalent rotavirus vaccine was licensed in the United States and also appears to be safe and effective. It is an attenuated monovalent human rotavirus and is administered as two oral doses at 2 and 4 months of age. The vaccine has 85% efficacy against severe gastroenteritis and was found to reduce hospital admissions for all diarrhea by



42%. Despite being monovalent, the vaccine is effective in prevention of all four common serotypes of human rotavirus.

Preliminary surveillance data on the rotavirus incidence from the U.S. Centers for Disease Control and Prevention suggest that rotavirus vaccination greatly reduced the disease burden in the United States during the 2007–2008 rotavirus season and thereafter. Given the incomplete vaccine coverage during this period, the results suggest a degree of “herd immunity” from rotavirus immunization. Studies from several developed countries show greater than 90% protection against severe rotavirus disease. Studies from developing countries show 50–60% protection from severe disease. Vaccine-associated disease has been reported in vaccine recipients who have severe combined immunodeficiency disease (a contraindication). In addition, vaccine-derived virus may undergo reassortment and become more virulent, producing diarrhea in unvaccinated siblings.

Visit Elsevier eBooks+ at [eBooks.Health.Elsevier.com](http://eBooks.Health.Elsevier.com) for Bibliography.

## Chapter 313

# Human Papillomaviruses

Kristen A. Feemster

See also [Chapter 708](#).

Human papillomaviruses (HPVs) cause a variety of proliferative cutaneous and mucosal lesions, including common skin warts, benign and malignant anogenital tract lesions, oral pharyngeal cancers, and life-threatening respiratory papillomas. Most HPV-related infections in children and adolescents are benign (see also [Chapter 708](#)).

### ETIOLOGY

The papillomaviruses are small (55 nm), DNA-containing viruses that are ubiquitous in nature, infecting most mammalian and many non-mammalian animal species. Strains are almost always species specific. Viral DNA is divided into an early region, which encodes proteins associated with viral replication and transcription, and a late region, which encodes capsid proteins necessary for virion assembly. These structural proteins are also the immunodominant antigens leading to type-specific immune responses. More than 100 different types of HPVs have been identified through the comparison of sequence homologies. The different HPV types typically cause disease in specific anatomic sites; more than 30 HPV types have been identified from genital tract specimens.

### EPIDEMIOLOGY

HPV infections of the skin are common, and most individuals are probably infected with one or more HPV types at some time. There are no animal reservoirs for HPV; all transmission is presumably from person to person. There is little evidence to suggest that HPV is transmitted by fomites. Common warts, including palmar and plantar warts, are frequently seen in children and adolescents and typically infect the hands and feet, common areas of frequent minor trauma.

HPV is also the most prevalent viral sexually transmitted infection in the United States. Up to 80% of sexually active women will acquire HPV through sexual transmission; most have their first infection within 3 years of beginning sexual intercourse. Thus HPV disproportionately affects youth, with 75% of new infections occurring in 15- to 24-year-olds. The greatest risk for HPV in sexually active adolescents is exposure to new sexual partners, but HPV can still be acquired even with a history of one partner, underscoring the ease of transmission of this virus through sexual contact. It is estimated that after 11 acts of sexual intercourse, 100% of all HPV types infecting an individual will be transmitted to the other sexual partner. Couple studies show that

there is high concordance in the genital area as well as between the hand and the genital area in the other partner. Whether the DNA detected in HPV on the hand is capable of transmitting infectious particles is unknown. Unlike other sexually transmitted infections, female-to-male transmission appears greater than male-to-female transmission. This may be because males in general have superficial transient infections or deposition. In turn, males do not develop an adequate immune response, so reinfections are quite common. The prevalence of HPV in women decreases with time, suggesting immune protection, whereas in men, the prevalence of HPV remains high across all ages.

As with many other genital pathogens, perinatal transmission to newborns can occur. Transmission from caregiver to child during the early childhood years has also been documented. However, both perinatal and early childhood infections appear transient. It remains unclear whether these HPV DNA detections are simply a deposition of caregiver DNA or a true infection. Detection of HPV DNA in older preadolescent children is rare. HPV DNA detection in non-sexually active adolescents has been reported, but a history of sexual activity in adolescents is not always disclosed and is therefore difficult to confirm. Although caregivers can spread HPV to young children, if lesions are detected in a child older than 3 years of age, the possibility of sexual transmission should be raised.

In adolescents, HPV DNA is most commonly detected without evidence of any lesion. Some of these detections are thought to be the result of partner deposition and hence do not represent a true infection. In older women, detection of HPV DNA is more commonly associated with a lesion. This is because the HPV DNA detected in older women reflects those HPV infections that became established persistent infections. Persistence is now the known necessary prerequisite for the development of significant precancerous lesions and cervical cancer.

Approximately 15–20% of sexually active adolescents have detectable HPV at any given time and have normal cytologic findings. The most common clinically detected lesion in adolescent women is the cervical lesion termed **low-grade squamous intraepithelial lesion (LSIL)** ([Table 313.1](#)). LSILs can be found in 25–30% of adolescents infected with HPV. External genital warts are much less common, occurring in <1% of adolescents; the incidence has decreased since introduction of HPV vaccines, but approximately 10% of individuals will develop genital warts in their lifetime. LSIL is a cytologic and histologic term to reflect the benign changes caused by an active viral infection and is likely present in most, if not all, women with HPV infection. However, the majority of women have very minute or subtle lesions not easily detected by cytology. As with HPV DNA detection, most LSILs regress spontaneously in young women and do not require any intervention or therapy. Less commonly, HPV can induce more severe cellular changes, termed **high-grade squamous intraepithelial lesions (HSILs)** (see [Chapter 590](#)).

Although HSILs are considered precancerous lesions, they rarely progress to invasive cancer. HSILs occur in approximately 0.4–3% of sexually active women, whereas invasive cervical cancer occurs in 8 cases per 100,000 adult women. In the United States, there are approximately 12,000 new cases (~7 cases/100,000) and 4,000 deaths from cervical cancer each year. Worldwide, cervical cancer is the fourth most common cause of cancer deaths among women. HPV is also associated with a range of other anogenital cancers, including an estimated 9,000 cases of anal cancer and 44,000 cases of oropharyngeal cancers in men and women.

Some infants may acquire papillomaviruses during passage through an infected birth canal, leading to recurrent **juvenile laryngeal papillomatosis (JLP)**; also referred to as *respiratory papillomatosis*. Cases also have been reported after cesarean section. The incubation period for emergence of clinically apparent lesions (genital warts or laryngeal papillomas) after perinatally acquired infection is unknown but is estimated to be around 3–6 months (see [Chapter 438.2](#)). It may be that infections can also occur during hygienic care from an infected parent.

Genital warts may represent a sexually transmitted infection even in some very young children. Therefore genital warts appearing in childhood should raise suspicion for possible sexual abuse with HPV



**Table 313.1** Terminology for Reporting Cervical Cytology and Histology

DESCRIPTIVE DIAGNOSIS OF EPITHELIAL CELL ABNORMALITIES	EQUIVALENT TERMINOLOGY
<b>SQUAMOUS CELL</b> Atypical squamous cells of undetermined significance (ASC-US)	Squamous atypia
Atypical squamous cells, cannot exclude HSIL (ASC-H)	
Low-grade squamous intraepithelial lesion (LSIL)	Mild dysplasia, condylomatous atypia, HPV-related changes, koilocytic atypia, cervical intraepithelial neoplasia (CIN) 1
High-grade squamous intraepithelial lesion (HSIL)	Moderate dysplasia, CIN 2, severe dysplasia, CIN 3, carcinoma in situ
<b>GLANDULAR CELL</b> Endometrial cells, cytologically benign, in a postmenopausal woman <i>Atypical</i> Endocervical cells, NOS Endometrial cells, NOS Glandular cells, NOS Endocervical cells, favor neoplastic Glandular cells, favor neoplastic	
<b>ENDOCERVICAL ADENOCARCINOMA IN SITU</b> <i>Adenocarcinoma</i> Endocervical Endometrial Extrauterine NOS	

NOS, Not otherwise specified.

transmission during the abusive contact. A child with genital warts should thus be provided with a complete evaluation for evidence of possible abuse (see [Chapter 17.1](#)), including the presence of other sexually transmitted infections (see [Chapter 163](#)). However, the presence of genital warts in a child does not confirm sexual abuse, because perinatally transmitted genital warts may go undetected until the child is older. Typing for specific genital HPV types in children is not helpful in diagnosis or to confirm sexual abuse status, because the same genital types occur in both perinatal transmission and abuse. In true virginal populations, including children who are not sexually abused, rates of clinical disease are close to zero.

## PATHOGENESIS

Initial HPV infection of the cervix or other anogenital surfaces is thought to begin by viral invasion of the basal cells of the epithelium, a process that is enhanced by disruption of the epithelium caused by trauma or inflammation. It is thought that the virus initially remains relatively dormant because virus is present without any evidence of clinical disease. The life cycle of HPV depends on the differentiation program of keratinocytes. The pattern of HPV transcription varies throughout the epithelial layer and through different stages of disease (LSIL, HSIL, invasive cancer). Understanding of HPV transcription enhances understanding of its ability to behave as an oncovirus. Early region proteins, E6 and E7, function as transactivating factors that regulate cellular transformation. Complex interactions between E6- and E7-transcribed proteins and host proteins result in the perturbation of normal processes that regulate cellular DNA synthesis. The perturbations caused by E6 and E7 are primarily disruption of the anti-oncoprotein p53 and retinoblastoma protein (Rb), respectively, contributing to the development of anogenital cancers. Disruption of these proteins results in continued cell proliferation, even under the circumstances of DNA damage, which leads to basal cell proliferation, chromosomal abnormalities, and aneuploidy, hallmarks of squamous intraepithelial lesion (SIL) development.

Evidence of productive viral infection occurs in benign lesions such as external genital warts and LSILs, with the abundant expression of viral capsid proteins in the superficial keratinocytes. The appearance of the HPV-associated koilocyte is a result of the expression of E4, a structural protein that causes collapse of the cytoskeleton. Low-level expression of E6 and E7 proteins results in cell proliferation seen in the basal cell layer of LSILs. LSILs are a manifestation of active viral replication and protein expression. In HSILs, expression of E6 and E7 predominates throughout the epithelium, with little expression of the structural proteins L1 and L2. This results in the chromosomal abnormalities and aneuploidy characteristic of the higher-grade lesions. The critical events that lead to cancer have not been verified; however, several mechanisms are thought to be critical, including viral integration into the host chromosome and activation of telomerase to lengthen chromosomes and avoid physiologic cell senescence. Over 150 HPV types have been documented and are classified by extent of their DNA homology into 5 genera, with the different types having different life cycle and disease characteristics. The predominant group is  $\alpha$  HPV types, which are associated with cutaneous and mucosal anogenital infections and cancers.  $\beta$ ,  $\gamma$ ,  $\mu$ , and  $\nu$  cause predominantly benign cutaneous lesions but can be difficult to manage in severely immunocompromised individuals. B types are commonly detected on the skin without any apparent lesions but are associated with the development of skin cancers in those with epidermodysplasia verruciformis or other forms of immunodeficiencies. Genital lesions caused by the  $\alpha$  HPV types may be broadly grouped into those with little to no malignant potential (low risk) and those with greater malignant potential (high risk). Low-risk HPV types 6 and 11 are most commonly found in genital warts and are rarely found isolated in malignant lesions. High-risk HPV types are those types that are associated with anogenital cancers, specifically cervical cancer. HPV 16 and 18 are thought to be more oncogenic than other HPV types because they comprise 70% of cervical cancers, whereas each of the other 12 high-risk types (31, 33, 35, 39, 45, 51, 52, 56, 58, 59, 68, and 73) contribute less than 1–9%. HPV 16 appears to be even more important in anal and HPV-associated oropharyngeal cancers, comprising close to 90% of these cancers. HPV 16 is also commonly found in women without lesions or in those with LSILs, making the connection with cancer confusing. Genital warts and SIL are commonly associated with the detection of multiple HPV types, including a combination of low- and high-risk HPV types. Data show that it is likely that a single lesion arises from a single HPV type. Detection of multiple HPV types reflects the presence of cervical and anal coexisting lesions. Almost all (95%) incident low-risk and high-risk HPV DNA detections, with or without detectable SIL, will spontaneously resolve within 1–3 years. Although HPV 16 has a slower rate of regression than some of the other high-risk types, the majority of incident HPV 16 detections also will resolve. Data suggest that clearance of an HPV type results in natural immune protection against reinfection with that same type. Redetections of the same type are not common and when found are often associated with a history of a new sexual partner, suggesting that these are not reactivated infections but are due to new exposures. These redetections rarely result in high-grade disease. Persistent high-risk-type infections are associated with increased risk for development of HSILs and invasive cancer. Progression of HSIL to invasive cancer is still rare, with only 5–15% showing progression. Approximately 50% of HPV 16-associated HSILs and 80% of non-HPV 16 HSILs will spontaneously regress in young women. Genital and common warts in general also resolve without therapy but may take years to do so. Genital warts in only extremely rare conditions can become malignant.

Most infants with recognized genital warts are infected with the low-risk types. In contrast, children with a history of sexual abuse have a clinical picture more like that of adult genital warts, consisting of mixed low- and high-risk types. There are rare reports of HPV-associated genital malignancies occurring in preadolescent children and adolescents. On the other hand, precancerous HSILs do occur in sexually active adolescents. There is a concern that younger age of sexual debut has contributed to the increase in invasive cervical cancers seen in women younger than 50 years of age in the United States, specifically cervical adenocarcinomas. Persistent HPV infections are considered necessary but not sufficient for the development of invasive



**Fig. 313.1** Common warts of the left hand and the chest wall. (From Meneghini CL, Bonifaz E. *An Atlas of Pediatric Dermatology*, Chicago: Year Book; 1986:45.)



**Fig. 313.2** Common warts of the hand in a mother and perianal condylomata acuminata in her son. (From Meneghini CL, Bonifaz E. *An Atlas of Pediatric Dermatology*, Chicago: Year Book; 1986:44.)

cancers. Other risk factors for which there is relatively strong suggestive evidence of association include smoking cigarettes, prolonged oral contraceptive use, greater parity, and *Chlamydia trachomatis* and herpes simplex virus infections.

### CLINICAL MANIFESTATIONS

The clinical findings in HPV infection depend on the site of epithelial infection.

#### Skin Lesions

The typical HPV-induced lesions of the skin are proliferative, papular, and hyperkeratotic. Common warts are raised circinate lesions with a keratinized surface (Fig. 313.1). Plantar and palmar warts are practically flat. Multiple warts are common and may create a mosaic pattern. Flat warts appear as small (1- to 5-mm), flat, flesh-colored papules.

#### Genital Warts

Genital warts may be found throughout the perineum around the anus, vagina, and urethra, as well as in the cervical, intravaginal, and intraanal areas (Fig. 313.2). Intraanal warts occur predominantly in patients who have had receptive anal intercourse, in contrast with perianal warts,

which may occur in men and women without a history of anal sex. Although rare, lesions caused by genital genotypes can also be found on other mucosal surfaces, such as the conjunctivae, tongue, gingivae, and nasal mucosa. They may be single or multiple lesions and are frequently found in multiple anatomic sites, including the cervix. External genital warts can be flat, dome shaped, keratotic, pedunculated, and cauliflower shaped and may occur singly, in clusters, or as plaques. On mucosal epithelium, the lesions are softer. Depending on the size and anatomic location, lesions may be pruritic and painful, may cause burning with urination, may be friable and bleed, or may become superinfected. Adolescents are frequently disturbed by the development of genital lesions. Other rarer lesions caused by HPV of the external genital area include Bowen disease, bowenoid papulosis, squamous cell carcinomas, Buschke-Löwenstein tumors, and vulvar intraepithelial neoplasias.

#### Squamous Intraepithelial Lesions and Cancers

SILs detected with cytology are usually invisible to the naked eye and require the aid of colposcopic magnification and acetic acid. With aid, the lesions appear white and show evidence of neovascularity. SILs can occur on the cervix, vagina, vulva, penis, and intraanus. HPV-associated squamous cell lesions can also be found in the oropharynx. Invasive cancers tend to be more exophytic, with aberrant-appearing vasculature. These lesions are rarely found in non-sexually active individuals.

#### Laryngeal Papillomatosis

The median age at diagnosis of recurrent laryngeal papillomatosis is 3 years. Children present with hoarseness, an altered cry, and sometimes stridor. Rapid growth of respiratory papillomas can occlude the upper airway, causing respiratory compromise. These lesions may recur within weeks of removal, requiring frequent surgery. The lesions do not become malignant unless treated with irradiation.

#### DIAGNOSIS

The diagnosis of external genital warts and common warts may be reliably determined by visual inspection of a lesion by an experienced observer and does not require additional tests for confirmation. A biopsy should be considered if the diagnosis is uncertain, the lesions do not respond to therapy, or the lesions worsen during therapy.

Screening for cervical cancer in young women begins with cytology, which is performed by either Papanicolaou smear or liquid-based cytology and may also include high-risk HPV DNA testing for women age 30-65 years. Screening guidelines were updated in 2018 by the U.S. Preventive Services Task Force (USPSTF) and recommend starting screening at age 21 years. Screening earlier is more likely to result in unnecessary referrals for colposcopy, because most lesions, including both LSILs and HSILs in this age-group, are likely to regress. Guidelines recommend screening with cytology every 3 years through 29 years of age. For women age 30-65 years of age, USPSTF recommends screening every 3 years with cervical cytology alone, or every 5 years with high-risk HPV testing alone or high-risk HPV testing with cytology (co-testing). High-risk HPV testing is not recommended earlier than age 30 years, because HPV infections are extremely common in young women, resulting in a very low positive predictive value in this age-group. These recommendations apply to all persons who have a cervix, regardless of sexual history or HPV vaccination history.

The recommended terminology used for cytologic evaluation is based on the Bethesda system (see Table 313.1). Recent updates to the terminology used for histology uses similar terms. Many clinicians still prefer the World Health Organization terminology using cervical intraepithelial neoplasia (CIN) 1, 2, and 3 (see Table 313.1). Although the purpose of screening is to identify CIN 3+ lesions, the majority of CIN lesions are found in women who were referred for **atypical squamous cells of undetermined significance (ASC-US)** or LSILs on cytology. On the other hand, few CIN 3 or cancers exist in women younger than 24 years of age. Thus, for women 21-24 years of age, ASC-US and LSILs are treated the same.

Consensus guidelines from the American Society of Colposcopy and Cervical Pathology for the management of cervical cancer screening abnormalities were updated in 2019 and used a risk-based (related to

a patient's risk of CIN 3) rather than test-based algorithm. Treatment guidelines are also dichotomized by age group, 21–24 years and 25 years or older. Women age 21–24 years with ASC-US or LSIL should have repeat cytology at 12 months and 24 months after the initial abnormal result. For persistent ASC-US or LSILs at 2 years of follow-up or for HSIL at any point, referral for colposcopy is recommended. If colposcopy results show LSIL, cytology should be repeated in 1 year. If there are two negative cytology results, routine age-based screening can be resumed. If repeat cytology shows HSIL with CIN2+, observation with repeat colposcopy every 6 months should be performed. If HSIL persists for 2 years or if CIN 3+ is identified, treatment with an excisional procedure is recommended. In women 25 years of age and older, HSIL can be treated without histologic confirmation. However, this approach should be avoided in those 21–24 years of age, because HSIL is often misdiagnosed in this group or will resolve spontaneously.

In all women age 21 years and older, high-risk HPV testing is acceptable to assist in ASC-US triage. This recommendation is based on the observations that adult women with ASC-US and a positive HPV test result for high-risk types are more likely to have CIN 2/3 than women with a negative HPV test result. However, in women with ASC-US and a positive HPV test for high-risk types, repeat cytology is recommended for confirmation. In women 21–24 years of age referred for colposcopy and found to have no lesion or biopsy-confirmed LSIL after ASC-US or LSIL cytology, repeat cytology is recommended at 12-month intervals as described previously. In women with biopsy-confirmed LSIL after atypical squamous cells of high grade (ASC-H) or HSIL, observation with cytology and colposcopy is recommended at 6-month intervals for up to 2 years. For persistent ASC-H or HSIL at 2 years or progression at any time, treatment is recommended. These guidelines and updates can be found at <http://www.asccp.org>.

Very sensitive tests for the presence of HPV DNA, RNA, and proteins are becoming generally available, although they are not required for the diagnosis of external genital warts or related conditions. There are no indications for HPV DNA testing in women younger than 21 years of age or children. HPV DNA testing is also not recommended in women 21–29 years of age but is acceptable for ASC-US triage. Diagnosis of JLP is made based on laryngeal examination. There are no routine screening recommendations for noncervical or oropharyngeal lesions.

## DIFFERENTIAL DIAGNOSIS

A number of other conditions should be considered in the differential diagnosis of genital warts, including condyloma latum, seborrheic keratoses, dysplastic and benign nevi, molluscum contagiosum, pearly penile papules, neoplasms, Bowen disease, bowenoid papulosis, Buschke-Löwenstein tumors, and vulvar intraepithelial neoplasias.

Condyloma latum is caused by secondary syphilis and can be diagnosed with darkfield microscopy and standard serologic tests for syphilis. Seborrheic keratoses are common, localized, hyperpigmented lesions that are rarely associated with malignancy. Molluscum contagiosum is caused by a poxvirus, is highly infectious, and is often umbilicated. Pearly penile papules occur at the penile corona and are normal variants that require no treatment.

## TREATMENT

Most common (plantar, palmar, skin) warts eventually resolve spontaneously (see [Chapter 708](#)). Symptomatic lesions should be removed. Removal includes a variety of self-applied therapies, including salicylic acid preparations and provider-applied therapies (cryotherapy, laser therapy, electrocauterization). Genital warts are benign and usually remit, but only over an extended period. It is recommended that genital lesions be treated if the patient or the parent requests therapy. Treatments for genital warts are categorized into self-applied and provider-applied. No one therapy has been shown to be more efficacious than any other. Recommended patient-applied treatment regimens for external genital warts include topical podofilox, imiquimod, and sinecatechins. Podofilox 0.5% solution (using a cotton swab) or gel (using a finger) is applied to visible warts in a cycle of applications twice per day for 3 days followed by 4 days of no therapy, repeated for up to a total of four cycles as needed. The total volume of podofilox used per day should not exceed 0.5 mL, and patients should wash hands before and

after each application. Imiquimod 5% cream is applied at bedtime, 3 times per week, every other day, for up to 16 weeks. Imiquimod 3.75% cream is applied at bedtime every night for up to 8 weeks. For both formulations, the treated area should be washed with mild soap and water 6–10 hours after treatment. Sinecatechins (15% ointment) is a topical product from green tea extract used for external genital wart treatment that is applied 3 times daily until warts have completely resolved but no longer than 16 weeks. A 0.5-cm strand of ointment should be applied to each wart as a thin layer.

Provider-applied therapies include surgical treatments (electrosurgery, tangential scissor or shave excision, curettage, laser surgery), cryotherapy with liquid nitrogen or a cryoprobe and office-based application of bichloroacetic (BCA) or trichloroacetic acid (TCA) 80–90% solution. Surgical treatments require appropriate training and equipment but can be most beneficial for patients with large or extensive warts. Surgical removal or cryotherapy are also recommended for urethral meatus warts, while surgical removal, cryotherapy or BCA / TCA is recommended for vaginal, cervical, and intraanal warts. BCA or TCA treatment should be applied only to warts and can be repeated once per week for 3–6 weeks.

Alternative regimens include podophyllin resin, intralesional interferon, photodynamic therapy, and topical cidofovir, but there are few available data regarding their efficacy. Intralesional interferon is associated with significant adverse effects and is reserved for treatment of recalcitrant cases. Podophyllin resin is no longer recommended because of the availability of other, safer regimens but may be considered for provider-administered treatment if there can be strict adherence to recommendations to prevent complications from systemic absorption.

Many therapies are painful, and children should not undergo painful genital treatments unless adequate pain control is provided. Parents and patients should not be expected to apply painful therapies themselves. None of the patient-applied therapies are approved for use during pregnancy, and podofilox is contraindicated in pregnancy. For any of the nonsurgical treatments, prescription is contraindicated in a patient with any history of hypersensitivity to any product constituents.

If HPV exposure as a result of sexual abuse is suspected or known, the clinician should ensure that the child's safety has been achieved and is maintained.

When indicated, the most common treatments for CIN 2/3 are ablative and excisional treatments, including cryotherapy, laser, and loop electrocauterization excisional procedures. Once confirmed by histology with CIN 1, LSILs can be observed as described previously. The decision to treat a persistent CIN 1 rests between the provider and patient. Risks of treatment, including premature delivery in a future pregnancy, should be discussed before any treatment decision. Treatment in pregnancy is not recommended unless invasive cancer is present.

JLP is commonly treated with surgical removal of lesions, but laser and microdebriders are also used. However, because of the incidence of scar formation after repeat debridement procedures, medical therapies have been increasingly investigated. Adjunctive treatments have included interferon- $\alpha$ , antivirals such as cidofovir administered locally or systemically, photodynamic therapy, antiinflammatory drugs (celecoxib), heat shock protein, human monoclonal antibodies (bevacizumab), and HPV vaccination. However, the effectiveness of adjunctive therapies is not consistent.

## COMPLICATIONS

The presence of HPV lesions in the genital area may be a cause of profound embarrassment to a child or parent. Complications of therapy are uncommon; chronic pain (vulvodynia) or hypoesthesia may occur at the treatment site. Lesions may heal with hypopigmentation or hyperpigmentation and less commonly with depressed or hypertrophic scars. Surgical therapies can lead to infection and scarring. Premature delivery and low birthweight in future pregnancies are complications of excisional therapy for CIN.

It is estimated that 5–15% of untreated CIN 3 lesions will progress to cervical cancer. Most cancer is prevented by early detection and treatment of these lesions. Despite screening, cervical cancer develops rapidly in a few adolescents and young women. The reason for the rapid



development of cancer in these rare cases remains unknown, but host genetic defects are likely underlying causes. JLPs rarely become malignant, unless they have been treated with irradiation. Vulvar condylomas rarely become cancerous. HPV-associated cancers of the vagina, vulva, anus, penis, and oral cavity are much rarer than cervical tumors, and therefore screening for noncervical lesions is not currently recommended. However, anal, vaginal, and vulvar cancers are more common in women with cervical cancer; thus it is recommended to screen women with cervical cancer for other anogenital or oropharyngeal tumors with visual and/or digital inspection

## PROGNOSIS

With all forms of therapy, genital warts commonly recur, and approximately half of children and adolescents require a second or third treatment. Recurrence is also evident in patients with JLP. Patients and parents should be warned of this likelihood. Combination therapy for genital warts (imiquimod and podofilox) does not improve response and may increase complications. Prognosis of cervical disease is better, with 85–90% cure rates after a single treatment with the loop electrosurgical excision procedure. Cryotherapy has a slightly lower cure rate. Recalcitrant disease should prompt an evaluation and is common in immunocompromised individuals, specifically men and women infected with HIV.

## PREVENTION

The only means of preventing all types of HPV infection is to avoid direct contact with lesions. Condoms may reduce the risk for HPV transmission; condoms also prevent other sexually transmitted infections, which are risk factors associated with SIL development. In addition, condoms appear to hasten the regression of LSILs in women. Avoiding smoking cigarettes is important in preventing cervical cancer. Prolonged oral contraceptive use and parity have been shown to be risks for cervical cancer. However, the mechanisms associated with these factors have not been identified, and consequently no change in counseling is recommended.

HPV vaccines show efficacy against type-specific persistence and development of type-specific disease, including the cervix, vagina, vulva, and anus. A quadrivalent HPV vaccine containing types 6, 11, 16, and 18 was licensed in the United States in 2006, and a bivalent HPV vaccine containing types 16 and 18 was licensed in the United States in 2009. A 9-valent vaccine containing types 6, 11, 16, 18, 31, 33, 45, 52, and 58 was approved in 2014. Initial licensure was for vaccination of persons age 9–26 years. In 2018, the FDA expanded licensure to include men and women age 27–45 years based on quadrivalent HPV vaccine clinical trial results in women age 27–45 years and bridging immunogenicity and safety data in women and men. The bivalent vaccine is indicated for the prevention of cervical precancer and cancer in females. The 4- and 9-valent HPV vaccines are indicated for the prevention of anal, cervical, vaginal, and vulvar precancers/cancers, as well as genital warts in females and anal precancer cancer and genital warts in males. The indication for the 9-valent HPV vaccine was expanded to include oropharyngeal and other head and neck cancers in 2021.

The types targeted by the nonavalent vaccine account for up to 85% of cervical cancer cases. The efficacy of these vaccines is mediated by the development of neutralizing antibodies. Prelicensure studies demonstrate 90–100% efficacy in the prevention of persistent HPV infection, CIN 2/3, adenocarcinoma in situ, anogenital warts, and precancerous vaginal and vulvar lesions. Since vaccine introduction, data from Sweden and Australia show a decrease in national rates of genital warts within 4 years of implementing vaccination programs. Data from the United States show significant reductions in the prevalence of the HPV types contained in the quadrivalent vaccine among adolescent and young adult females in the years 2009–2012 (postvaccine) compared with 2003–2006 (prevaccine). Additionally, the HPV vaccine-type prevalence was 2.1% in vaccinated compared with 16.9% in unvaccinated 14- to 24-year-old sexually active females. A systematic review of 20 studies conducted in nine high-income countries showed reductions of at least 68% in the prevalence of HPV 16 and 18 among

13- to 19-year-olds in countries with HPV vaccination rates >50%. Recent data also demonstrate significant reductions in cervical cancer rates and CIN 3 with the highest reductions among women who were vaccinated at age 12–13 years after implementation of a national HPV vaccination program in the United Kingdom. A 29% reduction in cervical cancer annual incidence rates from 2003–2006 to 2011–2014 was observed among females age 15–24 years in the United States. Additionally, an analysis of data from a population-based cancer registry showed a decline in the incidence of squamous cell carcinoma and adenocarcinoma among young women age 15–29 years, with the largest reductions in the 15- to 20-year age group. Available effectiveness data suggest that HPV vaccination confers herd immunity in addition to individual protection.

Vaccination in the United States is recommended routinely for all adolescents at 11–12 years of age and is administered intramuscularly in the deltoid region in a two-dose series at 0 and 6–12 months. A two-dose series was approved and recommended in 2016 for younger adolescents who initiate the HPV vaccine series before age 15 years based on immunogenicity data showing a comparable immune response among younger adolescents who receive a two-dose series compared with older adolescents, who receive a three-dose series. The effectiveness of one dose has also been evaluated in observational and post-hoc analyses from clinical trials.

It is important that vaccination take place in children before they become sexually active, because the rate of HPV acquisition is high shortly after the onset of sexual activity. Vaccine can be given to adolescents as young as 9 years of age, and catch-up vaccination is now recommended in all persons through 26 years of age. Vaccination is also recommended for adults 27–45 years using shared clinical decision making if they have not been previously vaccinated. For any adolescent who receives his or her first HPV vaccine dose at age 15 years or older, a three-dose series at 0, 1–2, and 6 months is recommended. The three-dose series is also recommended for adolescents and young adults 9–26 years of age who have an immunocompromising condition. Individuals who are already infected with one or more vaccine-related HPV types before vaccination are protected from clinical disease caused by the remaining vaccine HPV types. Therefore a history of prior HPV infection is not a contraindication to vaccine receipt. Currently licensed HPV vaccines are not therapeutic. However, there are therapeutic HPV vaccines under development that are primarily designed to generate a cell-mediated immune response to target infected cells.

Post-licensure vaccine safety surveillance has not identified any serious adverse events attributable to HPV vaccine receipt. Three large observational studies and safety monitoring through active and passive surveillance networks among more than 1 million individuals have not identified any association between HPV vaccination and outcomes such as autoimmune disorders, stroke, or venous thrombotic emboli. Vaccination can cause fever in approximately 1 in 60 and discomfort at the injection site in 1 in 30 vaccine recipients. Syncope has also been found to be correlated with vaccine administration in 0.1% of vaccine recipients. Therefore it is advised that adolescents remain seated for 15 minutes after vaccination.

Despite an excellent safety and efficacy profile, HPV vaccine uptake has been slow. Immunization rates have consistently lagged behind rates for the other vaccines included in the adolescent immunization platform. In 2020, 75% of 13- to 17-year-olds had received at least one HPV vaccine dose compared with 89% who received at least one dose of the quadrivalent meningococcal vaccine and 92% who received tetanus-diphtheria-acellular pertussis (Tdap) vaccine. Reasons for the slow uptake include inconsistent provider recommendation, lack of knowledge about HPV, parental belief that vaccination is not necessary for younger adolescents, and misconceptions about vaccine safety, among others. There is a growing body of literature evaluating interventions to improve HPV vaccine uptake. One important strategy is a strong, consistent recommendation in which HPV vaccines are presented in the same way as Tdap and meningococcal vaccines.

Visit Elsevier eBooks+ at [eBooks.Elsevier.com](https://eBooks.Elsevier.com) for Bibliography.



## Chapter 314

## Arboviral Infections

Scott B. Halstead

The arthropod-borne viral infections are caused by a group of mosquito- or tick-transmitted viral pathogens of several taxa and manifest clinically mostly as neurologic infections, influenza-like illnesses, or acute viral exanthems. In temperate countries, arboviruses are transmitted during warmer weather; however, in tropical and subtropical countries, arboviruses may be transmitted year-round either in an urban cycle (human to mosquito to human) or by arthropods that feed on other vertebrate species and then feed on humans.

## ETIOLOGY

The principal arthropod-borne viral infections in North America are West Nile encephalitis (WNE), St. Louis encephalitis (SLE), Powassan (POW) encephalitis, a complex of California encephalitis group viruses, and, less frequently, western equine encephalitis (WEE), eastern equine encephalitis (EEE), and Colorado tick fever (Fig. 314.1). In 2013, chikungunya virus (CHIK) emerged from its original African zoonosis via Asia into the tropical and subtropical Western Hemisphere, exposing indigenes and many visitors who were traveling in the region. A few cases occurred in southern United States. In 2015, Zika virus (ZIKV), a flavivirus also maintained in Africa zoonoses, was introduced into the Americas, again from endemic areas in Asia. Limited transmission occurred within the continental United States. The major source of infection among Americans for each of these viruses has been travel to tropical and subtropical countries. CHIK appears to be endemic now, whereas ZIKV illnesses have decreased dramatically.

Throughout the world outside North America, there are many arboviruses that pose major health problems (Fig. 314.2). In descending order, these are the dengue viruses (DENV; Chapter 315), transmitted in all subtropical and tropical countries; Japanese encephalitis (JE), transmitted in northern, southern, and Southeast Asia; tick-borne encephalitis (TBE), transmitted across Europe and into northern and eastern Asia; yellow fever (YF; Chapter 316), transmitted from zoonotic cycles in Africa and South America; and Venezuelan equine encephalitis (VEE), transmitted in parts of South and Central America.

The etiologic agents belong to different viral taxa: *alphaviruses* of the family *Togaviridae* (CHIK, EEE, VEE, WEE), *flaviviruses* of the family *Flaviviridae* (DENV, JE, POW, SLE, TBE, WNE, YF, ZIKV), the California complex of the family *Bunyaviridae* (California encephalitis), and *Reoviridae* (Colorado tick fever virus). *Alphaviruses* are 69-nm, enveloped, positive-sense RNA viruses. Studies suggest that this group of viruses had a marine origin (specifically the southern ocean) and has subsequently spread to both the Old and New Worlds. VEE circulates in nature in six subtypes. Virus types I and III have multiple antigenic variants. Types IAB and IC have caused epizootics and human epidemics. Flaviviruses are 40- to 50-nm, enveloped, positive-sense RNA viruses that evolved from a common ancestor. They are mosquito-borne (WNE, SLE, JE, YF, DENV, ZIKV) and tick-borne (POW, TBE) agents, globally distributed, and responsible for many important human viral diseases. The California serogroup, 1 of 16 Bunyavirus groups, are 75- to 115-nm enveloped viruses possessing a three-segment, negative-sense RNA genome. Reoviruses are 60- to 80-nm double-stranded RNA viruses.

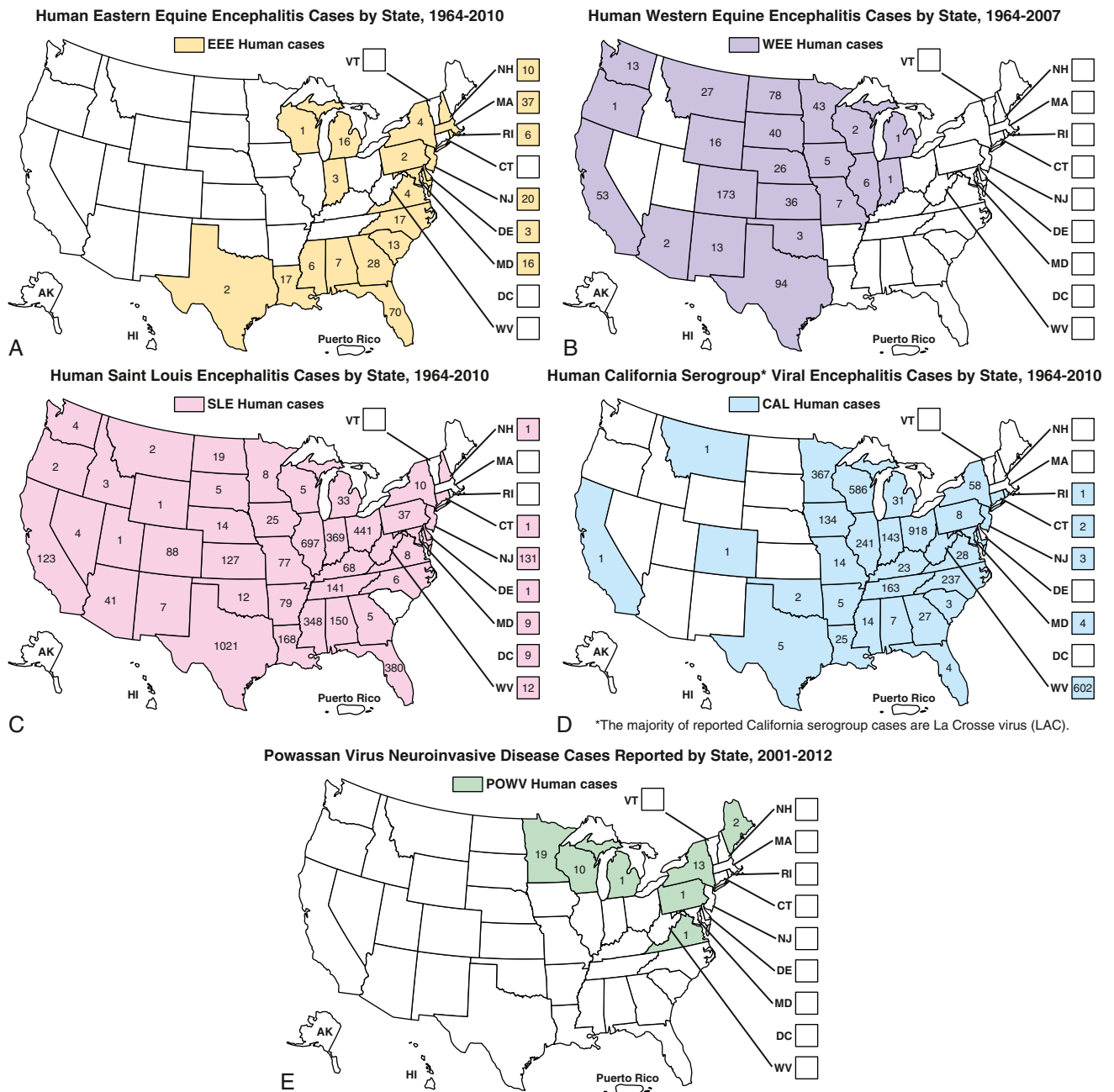
## DIAGNOSIS

For arboviral infections not described separately, the etiologic diagnosis is established by testing either an acute-phase serum to detect the virus, viral antigen, or viral RNA (influenza-like illnesses or viral exanthems) or by recovery of virus from central nervous system (CNS) tissue or cerebrospinal fluid (CSF). More commonly, the diagnosis is established serologically. Serum obtained  $\geq 5$  days after the onset of illness is tested for the presence of virus-specific immunoglobulin (Ig) M antibodies using an enzyme-linked immunosorbent assay IgM capture test, an indirect immunofluorescence test, or a precipitin test. Alternatively, acute and convalescent sera can be tested for a fourfold or greater increase in enzyme-linked immunosorbent assay, hemagglutination inhibition, or neutralizing antibody titers. Commercial serologic diagnostic kits are marketed for DENV, CHIK, JE, TBE, WNE, YF, and ZIKV viral infections. The serum and CSF should be tested for JE or WNE virus-specific IgM. However, IgM may reflect past infection, because it may be present up to 12 months after infection. For suspected flavivirus infections, including ZIKV, it may be possible to establish infection using a serologic test, calling on the specificity of neutralizing antibodies. The most common of these is the plaque or focus-reduction neutralizing antibody test. Reference laboratories offer tests for all of the pathogenic flaviviruses. The diagnosis may also be established by the isolation of virus in cell cultures, by identification of viral RNA, or by detection of viral proteins (e.g., dengue NS1) from blood, brain tissue obtained by brain biopsy, or tissues obtained at autopsy.

## PREVENTION

Several vaccines for JE and TBE are licensed in endemic and non-endemic countries. An experimental vaccine for VEE is available to protect laboratory workers. Travelers who plan to be in rural areas of Asia during the expected period of seasonal transmission should receive JE vaccine. Similarly, travelers who plan to travel, camp, or picnic in rural areas of Europe and East Asia should consult local health authorities concerning the need to be vaccinated against TBE. An inactivated JE vaccine manufactured in Japan by intracerebral injection of young mice once available throughout the world was taken off the market owing to a high incidence of adverse events. In 2008–2009, tissue culture–based JE vaccine (Ixiaro) was licensed in Europe, Australia, and the United States. In the United States, this vaccine, licensed for use in children and adults, distributed by Novartis (Basel), is administered intramuscularly as two doses of 0.5 mL each, 28 days apart. The final dose should be completed at least 1 week before the patient's expected arrival in a JE endemic area. This vaccine contains alum and protamine sulfate and has exhibited only mild adverse events. Chimerivax-JE, marketed by Sanofi Pasteur and licensed in Australia and several Asian countries, is a live-attenuated two-dose vaccine composed of the structural gene of JE inserted into the YF 17D vaccine backbone. A highly efficacious live-attenuated single-dose JE vaccine, SA 14-14-2, developed in China for children is licensed and marketed in Asian countries. This vaccine can be co-administered with live-attenuated measles vaccine without altering the immune responses to either vaccine. In humans, prior DENV infection provides partial protection against clinical JE.

No TBE vaccines are licensed or available in the United States. Two inactivated cell culture–derived TBE vaccines are available in Europe, in adult and pediatric formulations: FSME-IMMUN (Baxter, Austria) and Encepur (Novartis, Germany). The adult formulation of FSME-IMMUN is also licensed in Canada. Two other inactivated TBE vaccines are available in Russia: TBE-Moscow (Chumakov Institute, Russia) and EnceVir (Microgen, Russia). Immunogenicity studies suggest that the European and Russian vaccines should provide cross-protection against all three TBE virus subtypes. For both FSME-IMMUN and Encepur, the primary vaccination series consists of three doses. The specific recommended



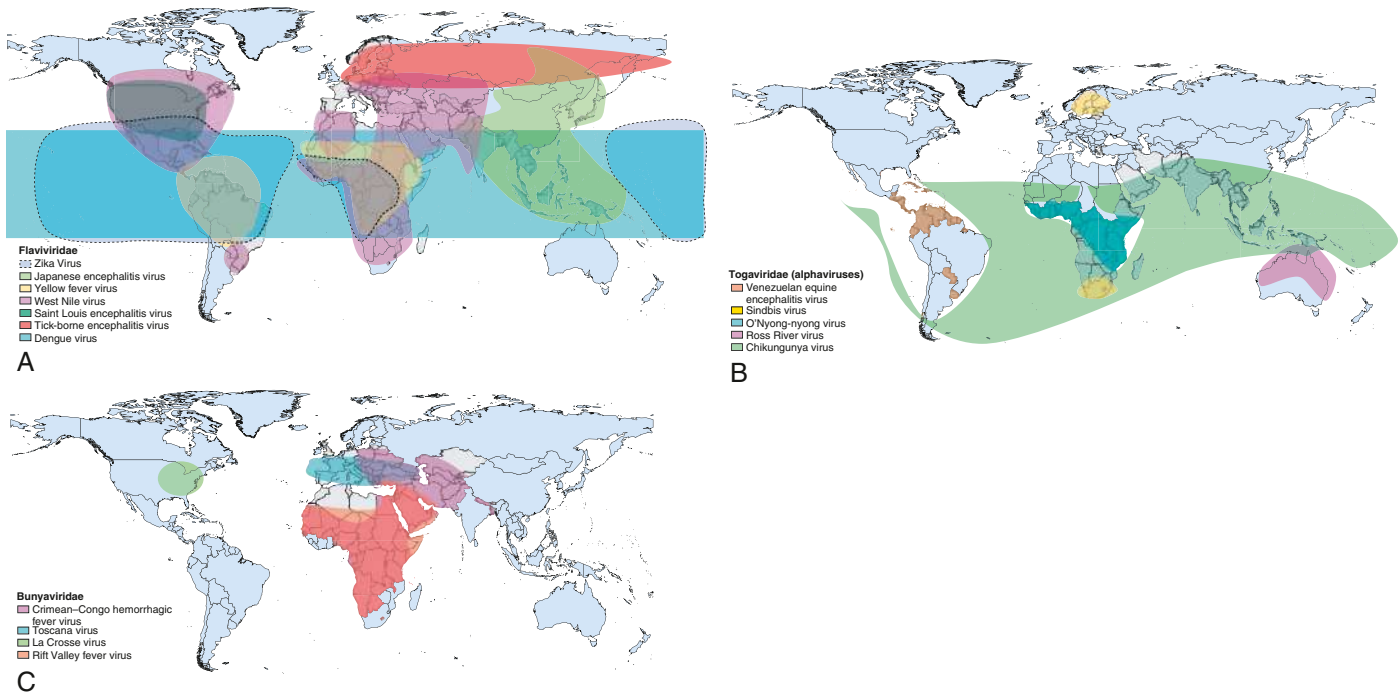
**Fig. 314.1** The distribution and incidence of reported cases of eastern equine encephalitis (A), western equine encephalitis (B), St. Louis encephalitis (C), California serogroup encephalitis (D), and Powassan encephalitis; (E), reported by state to the Centers for Disease Control and Prevention, 1964 to 2010. (From Division of Vector-Borne Diseases, Centers for Disease Control and Prevention. <http://www.cdc.gov/ncidod/dvbid/arbor/arbo-case/htm>)

intervals between doses vary by country and vaccine. Because the routine primary vaccination series requires  $\geq 6$  months for completion, most travelers to TBE-endemic areas will find avoiding tick bites to be more practical than vaccination.

For all viral diseases discussed in this chapter, personal measures should be taken to reduce exposure to mosquito or tick bites, especially for short-term residents in endemic areas. These measures include avoiding evening outdoor exposure, using insect repellents, covering

the body with clothing, and using bed nets or house screening. Commercial pesticides, widely used by rice farmers, may be useful in reducing populations of vector mosquitoes or ticks. Fenthion, fenitrothion, and phenthoate are effectively adulticidal and larvicidal. Insecticides may be applied from portable sprayers or from helicopters or light aircraft.

Visit Elsevier eBooks+ at [eBooks.Health.Elsevier.com](http://eBooks.Health.Elsevier.com) for Bibliography.



**Fig. 314.2** World distribution of major arbovirus infections. (From Charlier C, Beaudoin MC, Couderc T, et al. *Arboviruses and pregnancy: maternal, fetal, and neonatal effects*. *Lancet Child Adolesc*. 2017;1:134–146. Fig. 1.)

### 314.1 Eastern Equine Encephalitis

Scott B. Halstead

In the United States, EEE is a disease with a very low incidence, with a median of eight cases occurring annually in the Atlantic and Gulf states from 1964 to 2007. A severe outbreak in 2019 resulted in 19 fatalities among 38 cases (see Fig. 314.1). Transmission occurs often in focal endemic areas of the coast of Massachusetts, the six southern counties of New Jersey, and northeastern Florida. In North America, the virus is maintained in freshwater swamps in a zoonotic cycle involving the *Culiseta melanura* mosquito and birds. Various other mosquito species obtain viremic meals from birds and transmit the virus to horses and humans. Virus activity varies markedly from year to year in response to still unknown ecologic factors. Most infections in birds are silent, but infections in pheasants are often fatal, and epizootics in these species are used as sentinels for periods of increased viral activity. Cases have been recognized on Caribbean islands. The case:infection ratio is lowest in children (1:8) and somewhat higher in adults (1:29).

EEE virus infections result in fulminant encephalitis with a rapid progression to coma and death in one third of cases. In infants and children, abrupt onset of fever, irritability, and headache are followed by lethargy, confusion, seizures, and coma. High temperature, bulging fontanel, stiff neck, and generalized flaccid or spastic paralysis are observed. There may be a brief prodrome of fever, headache, and dizziness. Unlike most other viral encephalitides, the peripheral white blood cell count usually demonstrates a marked leukocytosis and the CSF may show marked pleocytosis. Pathologic changes are found in the cortical and gray matter, with viral antigens localized to neurons. There is necrosis of neurons, neutrophilic infiltration, and perivascular cuffing by lymphocytes.

The prognosis in EEE is better for patients with a prolonged prodrome; the occurrence of convulsions conveys a poor prognosis. Patient fatality rates are 33–75% and are highest in the elderly. Residual neurologic defects are common, especially in children.

The diagnosis of encephalitis may be aided by CT or MRI and by electroencephalography. Focal seizures or focal findings on CT or MRI or electroencephalography should suggest the possibility of herpes simplex encephalitis, which should be treated with acyclovir (see Chapter 299).

Visit Elsevier eBooks+ at [eBooks.Health.Elsevier.com](https://www.elsevier.com/ebooksplus) for Bibliography.

### 314.2 Western Equine Encephalitis

Scott B. Halstead

WEE infections occur principally in the United States and Canada west of the Mississippi River (see Fig. 314.1). Cases occur mainly in rural areas where water impoundments, irrigated farmland, and naturally flooded land provide breeding sites for the *Culex tarsalis* mosquito. The virus is transmitted in a cycle involving mosquitoes, birds, and other vertebrate hosts. Humans and horses are susceptible to encephalitis. The case:infection ratio varies by age, having been estimated at 1:58 in children younger than 4 years of age and 1:1,150 in adults. Infections are most severe at the extremes of life; one third of cases occur in children younger than 1 year of age. Recurrent human epidemics have been reported from the Yakima Valley in Washington State and the Central Valley of California; the largest outbreak on record resulted in 3,400 cases and occurred in Minnesota, North and South Dakota, Nebraska, and Montana, as well as Alberta, Manitoba, and Saskatchewan, Canada. Epizootics in horses precede human epidemics by several weeks. For the past 20 years, only three cases of WEE have been reported, presumably reflecting successful mosquito abatement.

In WEE, there may be a prodrome with symptoms of an upper respiratory tract infection. The onset is usually sudden with chills, fever, dizziness, drowsiness, increasing headache, malaise, nausea and vomiting,

stiff neck, and disorientation. Infants typically present with the sudden cessation of feeding, fussiness, fever, and protracted vomiting. Convulsions and lethargy develop rapidly. On physical examination, patients are somnolent, exhibit meningeal signs, and have generalized motor weakness and reduced deep tendon reflexes. In infants, a bulging fontanel, spastic paralysis, and generalized convulsions may be observed. On pathologic examination, disseminated small focal abscesses, small focal hemorrhages, and patchy areas of demyelination are distinctive.

Patient fatality rates in WEE are 3–9% and are highest in the elderly. Major neurologic sequelae have been reported in up to 13% of cases and may be as high as 30% in infants. Parkinsonian syndrome has been reported as a residual in adult survivors.

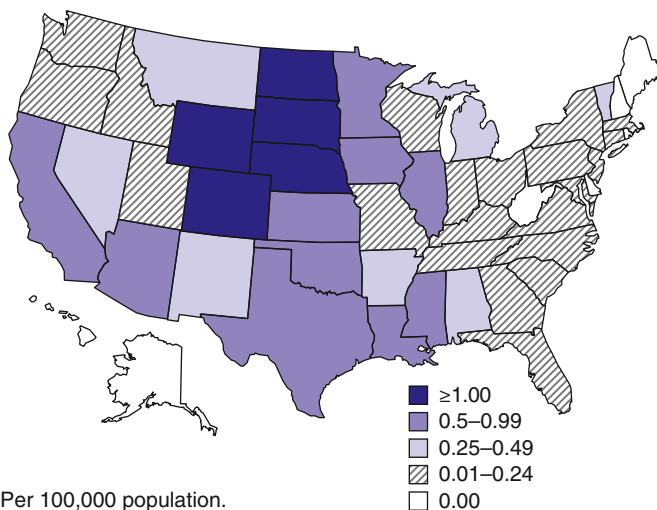
Visit Elsevier eBooks+ at [eBooks.Health.Elsevier.com](https://eBooks.Health.Elsevier.com) for Bibliography.

### 314.3 St. Louis Encephalitis

Scott B. Halstead

Cases of SLE are reported from nearly all states; the highest attack rates occur in the gulf and central states (see Fig. 314.1). Epidemics frequently occur in urban and suburban areas; the largest occurred in 1975 and involved 1,800 persons living in Houston, Chicago, Memphis, and Denver. Cases often cluster in areas where there is ground water or septic systems, which support mosquito breeding. The principal vectors are *Culex pipiens* and *Culex quinquefasciatus* mosquitoes in the central gulf states, *Culex nigripalpus* in Florida, and *Culex tarsalis* in California. SLE virus is maintained in nature in a bird-mosquito cycle. Viral amplification occurs in bird species abundant in residential areas (e.g., sparrows, blue jays, and doves). Virus is transmitted in the late summer and early fall. The case:infection ratio may be as high as 1:300. Age-specific attack rates are lowest in children and highest in individuals older than 60 years. The most recent small outbreaks were in Florida in 1990 and Louisiana in 2001. For the past 15 years, there have been a mean of 18 cases annually.

Clinical manifestations of SLE vary from a mild flulike illness to fatal encephalitis. There may be a prodrome of nonspecific symptoms with subtle changes in coordination or mentation of several days to 1 week in duration. Early signs and symptoms include fever, photophobia, headache, malaise, nausea, vomiting, and neck stiffness. About half of patients exhibit an abrupt onset of weakness, incoordination, disturbed



\*Per 100,000 population.

**Fig. 314.3** Rate (per 100,000 population) of reported cases of West Nile virus neuroinvasive disease, United States, 2016. (From Burakoff A, Lehman J, Fischer M, et al. West Nile virus and other nationally notifiable arboviral diseases, United States, 2016. *MMWR Morb Mortal Wkly Rep.* 2018;67[1]L13–17.)

sensorium, restlessness, confusion, lethargy, and delirium or coma. The peripheral white blood cell count is modestly elevated, with 100–200 white blood cells/ $\mu\text{L}$  found in the CSF. On autopsy, the brain shows scattered foci of neuronal damage and perivascular inflammation.

The principal risk factor for fatal outcome of SLE is advanced age, with patient fatality rates being as high as 80% in early outbreaks. In children, mortality rates are 2–5%. In adults, underlying hypertensive cardiovascular disease has been a risk factor for fatal outcome. Recovery from SLE is usually complete, but the rate of serious neurologic sequelae has been reported to be as high as 10% in children.

Visit Elsevier eBooks+ at [eBooks.Health.Elsevier.com](https://eBooks.Health.Elsevier.com) for Bibliography.

### 314.4 West Nile Encephalitis

Scott B. Halstead

West Nile virus (WNV) was imported into the United States in 1999 and survives in a broad enzootic cycle across the United States and Canada. Every state in the continental United States plus nine provinces in Canada have reported mosquito, bird, mammalian, or human WN virus infection, most frequently during the summer or fall months. Through the end of 2015, a total of 43,937 cases had been reported in the United States, 40–50% of which were neuroinvasive, with 1,911 deaths (Fig. 314.3). In 2020, there were 505 WNV cases, 159 of which were neuroinvasive, resulting in 52 deaths. WNV transmission cycles have come to resemble JE with large epizootics and human cases occurring every 5–10 years. WNV has entered the blood supply through asymptomatic viremic potential blood donors. Since 2003, blood banks screen for WNV RNA. During the major outbreak of 2012, 597 viremic potential blood donors were identified and the donation was rejected. WNV has also been transmitted to humans via the placenta, breast milk, and organ transplantation. Throughout its range, the virus is maintained in nature by transmission between mosquitoes of the *Culex* genus and various species of birds. In the United States, human infections are largely acquired from *C. pipiens*. Horses are the nonavian vertebrates most likely to exhibit disease with WNV infection. During the 2002 transmission season, 14,000 equine cases were reported, with a mortality rate of 30%. Disease occurs predominantly in individuals >50 years of age. WNV has been implicated as the cause of sporadic summertime cases of human encephalitis and meningitis in Israel, India, Pakistan, Romania, Russia, Canada, the United States, and parts of Central and South America. All North and South American WNVs are genetically similar and are related to a virus recovered from a goose in Israel in 1998.

West Nile encephalitis (WNE) may be asymptomatic, but when clinical features appear, they include an abrupt onset of high fever, headache, myalgias, and nonspecific signs of emesis, rash, abdominal pain, or diarrhea. Most infections manifest as a flulike febrile illness, whereas a minority of patients demonstrate meningitis or encephalitis or both. Rarely there may be cardiac dysrhythmias, myocarditis, rhabdomyolysis, optic neuritis, uveitis, retinitis, orchitis, pancreatitis, or hepatitis. WNV disease in the United States has been accompanied by prolonged lymphopenia and an acute asymmetric polio-like paralytic illness with CSF pleocytosis involving the anterior horn cells of the spinal cord. A striking but uncommon feature has been parkinsonism and movement disorders (with tremor and myoclonus). WNV infections have been shown to lead to chronic kidney disease in a small group of patients.

Cases of WNE and deaths due to the disease occur mainly in the elderly, although many serologic surveys show that persons of all ages are infected. In 2015, among a total of 2,175 human cases, 1,455 were neuroinvasive disease with 146 deaths, a 10% mortality rate (see Fig. 314.2). Paralysis may result in permanent weakness.

Visit Elsevier eBooks+ at [eBooks.Health.Elsevier.com](https://eBooks.Health.Elsevier.com) for Bibliography.



### 314.5 Powassan Encephalitis

Scott B. Halstead

POW virus is transmitted by *Ixodes cookei* among small mammals in eastern Canada and the United States; it has been responsible for 39 deaths in the United States since 2008 (see Fig. 314.1). Other ticks may transmit the virus in a wider geographic area, and there is some concern that *Ixodes scapularis* (also called *Ixodes dammini*), a competent vector in the laboratory, may become involved as it becomes more prominent in the United States.

In a limited experience, POW encephalitis has occurred mainly in adults with vocational or recreational exposure and has a high fatality rate.

POW encephalitis has occurred mostly in adults living in enzootic areas with vocational or recreational exposure; it is associated with significant long-term morbidity and has a case fatality rate of 10–15%.

Visit Elsevier eBooks+ at [eBooks.Health.Elsevier.com](http://eBooks.Health.Elsevier.com) for Bibliography.

### 314.6 La Crosse and California Encephalitis

Scott B. Halstead

La Crosse viral infections are endemic in the United States, occurring annually from July to September, principally in the north-central and central states (see Fig. 314.1). Infections occur in peridomestic environments as the result of bites from *Aedes triseriatus* mosquitoes, which often breed in tree holes. The virus is maintained vertically in nature by transovarial transmission and can be spread between mosquitoes by copulation and amplified in mosquito populations by viremic infections in various vertebrate hosts. Amplifying hosts include chipmunks, squirrels, foxes, and woodchucks. A case:infection ratio of 1:22–300 has been surmised. La Crosse encephalitis is principally a disease of children, who may account for up to 75% of cases. A mean of 100 cases has been reported annually for the past 10 years.

The clinical spectrum includes a mild febrile illness, aseptic meningitis, and fatal encephalitis. Children typically present with a prodrome of 2–3 days of fever, headache, malaise, and vomiting. The disease evolves with clouding of the sensorium, lethargy, and, in severe cases, focal or generalized seizures. On physical examination, children are lethargic but not disoriented. Focal neurologic signs, including weakness, aphasia, and focal or generalized seizures, have been reported in

16–25% of cases. CSF shows low to moderate leukocyte counts. On autopsy, the brain shows focal areas of neuronal degeneration, inflammation, and perivascular cuffing.

Recovery from California encephalitis is usually complete. The case fatality rate is approximately 1%.

Visit Elsevier eBooks+ at [eBooks.Health.Elsevier.com](http://eBooks.Health.Elsevier.com) for Bibliography.

### 314.7 Colorado Tick Fever

Scott B. Halstead

Colorado tick fever virus is transmitted by the wood tick *Dermacentor andersoni*, which inhabits high-elevation areas of states extending from the central plains to the Pacific coast. The tick is infected with the virus at the larval stage and remains infected for life. Squirrels and chipmunks serve as primary reservoirs. Human infections typically occur in hikers and campers in indigenous areas during the spring and early summer.

Colorado tick fever begins with the abrupt onset of a flulike illness, including high temperature, malaise, arthralgia and myalgia, vomiting, headache, and decreased sensorium. Rash is uncommon. The symptoms rapidly disappear after 3 days of illness. However, in approximately half of patients, a second identical episode reoccurs 24–72 hours after the first one, producing the typical saddleback temperature curve of Colorado tick fever. Complications, including encephalitis, meningoencephalitis, and a bleeding diathesis, develop in 3–7% of infected persons and may be more common in children younger than 12 years of age.

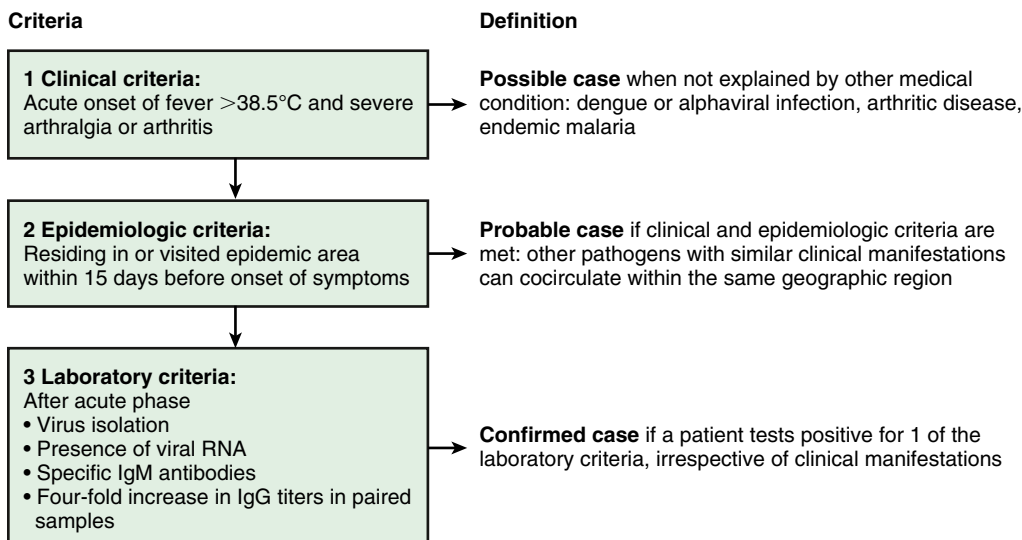
Recovery from Colorado tick fever is usually complete. Three deaths have been reported, all in persons with hemorrhagic signs.

Visit Elsevier eBooks+ at [eBooks.Health.Elsevier.com](http://eBooks.Health.Elsevier.com) for Bibliography.

### 314.8 Chikungunya Fever

Scott B. Halstead

Chikungunya virus is enzootic in several species of African subhuman primates but also is endemic in urban *Aedes aegypti* or *Aedes albopictus* transmission cycles in Africa, Asia, and the Americas. From the 18th century, chikungunya exited Africa eastward, producing Asian pandemics in 1790, 1824, 1872, 1924, 1963, and 2005. In 1827, chikungunya went the other direction via the slave trade, reaching the Western



**Fig. 314.4** Algorithm showing diagnostic criteria for chikungunya virus fever. (From Burt FJ, Rolph MS, Rulli NE, et al. Chikungunya: a re-emerging virus. *Lancet*. 2012;379:662–668. Fig. 6.)

Hemisphere predominantly in the Caribbean. In 2005, proceeding again in an easterly direction, virus appeared on Reunion Island and then traveled to Asia across the Indian Ocean. In 2013, chikungunya virus from this epidemic was introduced into the Americas, where it is now endemic.

Clinical manifestations begin 3-7 days after a mosquito bite; the onset is abrupt, with high fever and often severe joint symptoms (hands, feet, ankles, wrists) that include symmetric bilateral polyarthralgia or arthritis. Infections in children are often asymptomatic, but all ages are vulnerable to classic disease. There may be headache, myalgias, conjunctivitis, weakness, lymphopenia, and a maculopapular rash. Mortality is rare; some individuals develop prolonged joint symptoms (tenosynovitis, arthritis) lasting over a year. The acute episode lasts 7-10 days. The differential diagnosis includes dengue, West Nile, enterovirus diseases, leptospirosis, rickettsial disease, measles, parvovirus disease, rheumatologic diseases, and other alphavirus diseases (e.g., Ross River virus) in endemic areas. [Figure 314.4](#) lists the diagnostic criteria.

The incidence of febrile convulsions is high in infants. The prognosis is generally good, although in large outbreaks in Africa and India, severe disease and deaths have been attributed to chikungunya infections, predominantly in adults.

Visit Elsevier eBooks+ at [eBooks.Health.Elsevier.com](https://www.elsevier.com/health/elsevier.com) for Bibliography.

### 314.9 Venezuelan Equine Encephalitis

Scott B. Halstead

VEE virus was isolated from an epizootic in Venezuelan horses in 1938. Human cases were first identified in 1943. Hundreds of thousands of equine and human cases have occurred over the past 70 years. During 1971, epizootics moved through Central America and Mexico to southern Texas. After 3 decades of quiescence, epizootic disease emerged again in Venezuela and Colombia in 1995. Between December 1992 and January 1993, the Venezuelan state of Trujillo experienced an outbreak of this virus. Overall, 28 cases of the disease were reported, along with 12 deaths. A bigger outbreak occurred in June 1993, resulting in the death of 55 humans and 66 horses. A much larger outbreak in Venezuela and Colombia occurred in 1995. On May 23, 1995, equine encephalitis-like cases were reported in the northwest portion of the country. Eventually, the outbreak spread toward the north, as well as to the south. The outbreak caused about 11,390 febrile cases in humans, as well as 16 deaths. About 500 equine cases were reported with 475 deaths.

The incubation period is 2-5 days, followed by the abrupt onset of fever, chills, headache, sore throat, myalgia, malaise, prostration, photophobia, nausea, vomiting, and diarrhea. In 5-10% of cases, there is a biphasic illness; the second phase is heralded by seizures, projectile vomiting, ataxia, confusion, agitation, and mild disturbances in consciousness. There is cervical lymphadenopathy and conjunctival suffusion. Cases of meningoencephalitis may demonstrate cranial nerve palsy, motor weakness, paralysis, seizures, and coma. Microscopic examination of tissues reveals inflammatory infiltrates in lymph nodes, spleen, lung, liver, and brain. Lymph nodes show cellular depletion, necrosis of germinal centers, and lymphophagocytosis. The liver shows patchy hepatocellular degeneration, the lungs demonstrate a diffuse interstitial pneumonia with intraalveolar hemorrhages, and the brain shows patchy cellular infiltrates. Vertical transmission from mother to fetus has been documented. Ten fetal autopsies performed during an outbreak demonstrated VEE virus in the brains of aborted fetuses. <https://www.ncbi.nlm.nih.gov/books/NBK559332/>. Infants born to mothers with VEE may have neurologic sequelae or fatal cerebral lesions.

There is no specific treatment for VEE. The treatment is intensive supportive care (see [Chapter 82](#)), including control of seizures (see [Chapter 633](#)).

In patients with VEE meningoencephalitis, the fatality rate ranges from 10-25%. Sequelae include nervousness, forgetfulness, recurrent headache, and easy fatigability.

Several veterinary vaccines are available to protect equine animals. VEE virus is highly infectious in laboratory settings, and biosafety level 3 containment should be used. An experimental vaccine is available for use in laboratory workers. Several vaccine constructs are in the pipeline for potential use in humans.

Visit Elsevier eBooks+ at [eBooks.Health.Elsevier.com](https://www.elsevier.com/health/elsevier.com) for Bibliography.

### 314.10 Japanese Encephalitis

Scott B. Halstead

JE is a mosquito-borne viral disease of humans, as well as horses, swine, and other domestic animals. The virus causes human infections and acute disease in a vast area of Asia, from Indochina through the Indian subcontinent, northern Japan, Korea, China, Taiwan, the Philippines, and the Indonesian archipelago. *Culex tritaeniorhynchus summarosus*, a night-biting mosquito that feeds preferentially on large domestic animals and birds but only infrequently on humans, is the principal vector of zoonotic and human JE in northern Asia. A more complex ecology prevails in southern Asia. From Taiwan to India, *C. tritaeniorhynchus* and members of the closely related *Culex vishnui* group are vectors. Before the introduction of JE vaccine, summer outbreaks of JE occurred regularly in Japan, Korea, China, Okinawa, and Taiwan. Over the past decade, there has been a pattern of steadily enlarging recurrent seasonal outbreaks in Vietnam, Thailand, Nepal, and India, with small outbreaks in the Philippines, Indonesia, and the northern tip of Queensland, Australia. Seasonal rains are accompanied by increases in mosquito populations and JE transmission. Pigs serve as an amplifying host.

The annual incidence in endemic areas ranges from 1-10 per 10,000 population. Children younger than 15 years of age are principally affected, with nearly universal exposure by adulthood. The case:infection ratio for JE virus has been variously estimated at 1:25 to 1:1,000. Higher ratios have been estimated for populations indigenous to enzootic areas. JE occurs in travelers visiting Asia; therefore a travel history in the diagnosis of encephalitis is critical.

After a 4- to 14-day incubation period, cases typically progress through the following four stages: prodromal illness (2-3 days), acute stage (3-4 days), subacute stage (7-10 days), and convalescence (4-7 weeks). The onset may be characterized by an abrupt onset of fever, headache, respiratory symptoms, anorexia, nausea, abdominal pain, vomiting, and sensory changes, including psychotic episodes. Grand mal seizures are seen in 10-24% of children with JE; parkinsonian-like nonintention tremor and cogwheel rigidity are seen less frequently. Particularly characteristic are rapidly changing central nervous system signs (e.g., hyperreflexia followed by hyporeflexia or plantar responses that change). The sensory status of the patient may vary from confusion through disorientation and delirium to somnolence, progressing to coma. There is usually a mild pleocytosis (100-1,000 leukocytes/ $\mu$ L) in the cerebrospinal fluid, initially polymorphonuclear but in a few days predominantly lymphocytic. Albuminuria is common. Fatal cases usually progress rapidly to coma, and the patient dies within 10 days.

JE should be suspected in patients reporting exposure to night-biting mosquitoes in endemic areas during the transmission season. The etiologic diagnosis of JE is established by testing acute-phase serum collected early in the illness for the presence of virus-specific IgM antibodies or, alternatively, demonstrating a fourfold or greater increase in IgG antibody titers by testing paired acute and convalescent sera. The virus can also be identified by polymerase chain reaction (PCR).

There is no specific treatment for JE. The treatment is intensive supportive care (see [Chapter 82](#)), including control of seizures (see [Chapter 633](#)).

Patient fatality rates for JE are 24-42% and are highest in children 5-9 years of age and in adults older than 65 years of age. The frequency

of sequelae is 5–70% and is directly related to the age of the patient and severity of disease. Sequelae are most common in patients younger than 10 years at the onset of disease. The more common sequelae are mental deterioration, severe emotional instability, personality changes, motor abnormalities, and speech disturbances.

Visit Elsevier eBooks+ at [eBooks.Health.Elsevier.com](http://eBooks.Health.Elsevier.com) for Bibliography.

### 314.11 Tick-Borne Encephalitis

Scott B. Halstead

TBE refers to neurotropic tick-transmitted flaviviral infections occurring across the Eurasian land mass. In the Far East, the disease is called *Russian spring-summer encephalitis*; the milder, often biphasic form in Europe is simply called TBE. TBE is found in all countries of Europe except Portugal and the Benelux countries. The incidence is particularly high in Austria, Poland, Hungary, Czech Republic, Slovakia, former Yugoslavia, and Russia. The incidence tends to be very focal. Seroprevalence is as high as 50% in farm and forestry workers. The majority of cases occur in adults, but even young children may be infected while playing in the woods or on picnics or camping trips. The seasonal distribution of cases is midsummer in southern Europe, with a longer season in Scandinavia and the Russian Far East. TBE can be excreted in the milk of goats, sheep, or cows. Before World War II, when unpasteurized milk was consumed, milk-borne cases of TBE were common.

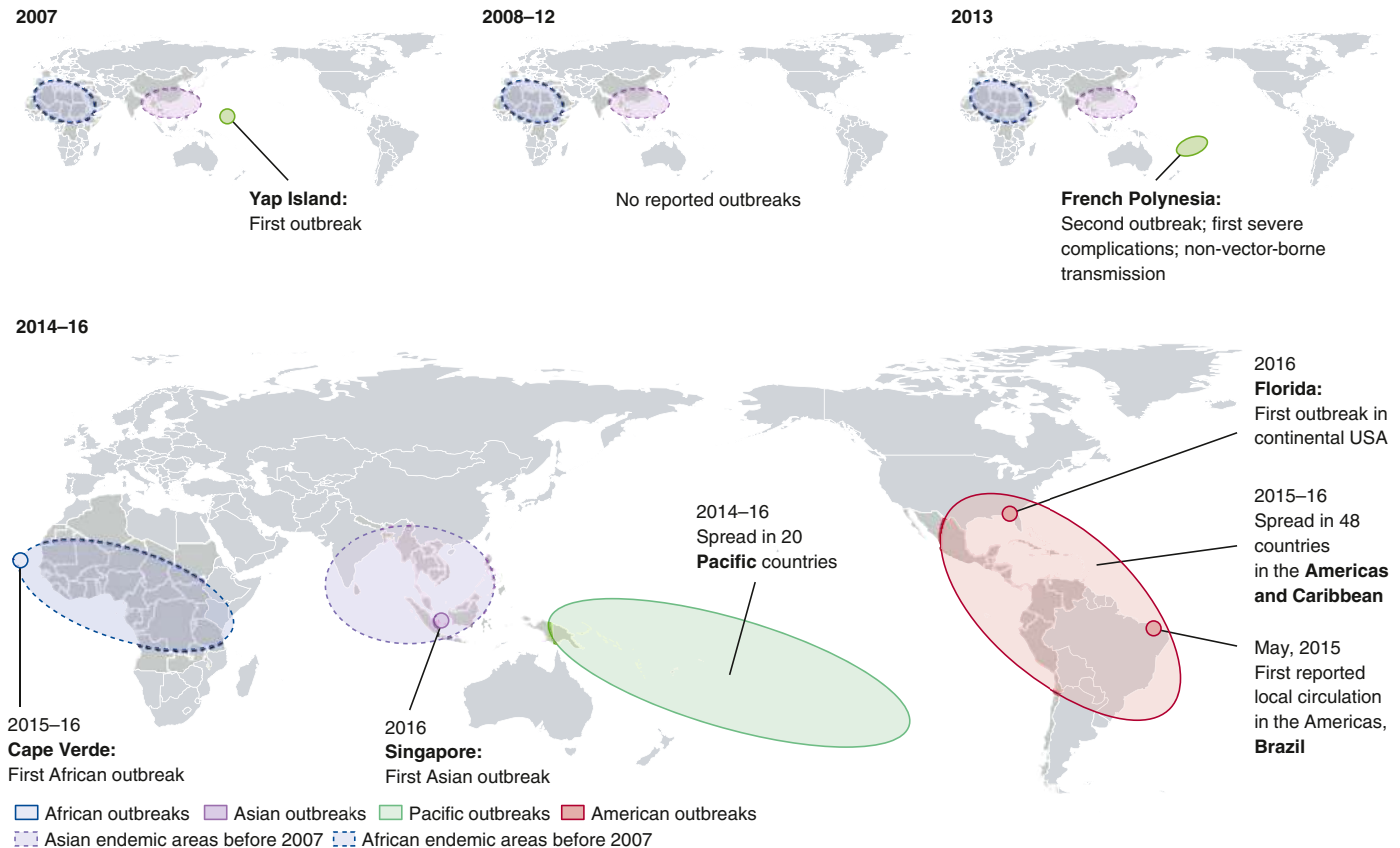
Viruses are transmitted principally by hard ticks, *Ixodes ricinus* in Europe and *Ixodes persulcatus* in the Far East. Viral circulation is maintained by a combination of transmission from ticks to birds, rodents, and larger mammals and transstadial transmission from larval to nymphal and adult stages. In some parts of Europe and Russia, ticks feed actively during the spring and early fall, giving rise to the name *spring-summer encephalitis*.

After an incubation period of 7-14 days, the European form begins as an acute nonspecific febrile illness that is followed in 5–30% of cases by meningoencephalitis. The Far Eastern variety more often results in encephalitis with higher case fatality and sequelae rates. The first phase of illness is characterized by fever, headache, myalgia, malaise, nausea, and vomiting for 2-7 days. Fever disappears but after 2-8 days may return, accompanied by vomiting, photophobia, and signs of meningeal irritation in children and more severe encephalitic signs in adults. This phase rarely lasts more than 1 week.

There is no specific treatment for TBE. The treatment is intensive supportive care (see [Chapter 82](#)), including control of seizures (see [Chapter 633](#)).

The main risk for a fatal outcome is advanced age; the fatality rate in adults is approximately 1%, but sequelae in children are rare. Transient unilateral paralysis of an upper extremity is a common finding in adults. Common sequelae include chronic fatigue, headache, sleep disorders, and emotional disturbances.

Visit Elsevier eBooks+ at [eBooks.Health.Elsevier.com](http://eBooks.Health.Elsevier.com) for Bibliography.



**Fig. 314.5** Zika virus outbreaks from 2007 to 2016. (From Baud D, Gubler DJ, Schaub B, et al. An update on Zika virus infection. *Lancet*. 2017;390:2099–2109. Fig. 2.)



**Table 314.1** Surveillance Case Classification: Children, Neonate to 2 Years of Age, Born to Mothers with Any Evidence of Zika Virus Infection During Pregnancy

#### ZIKA-ASSOCIATED BIRTH DEFECTS

Selected structural anomalies of the brain or eyes present at birth (congenital) and detected from birth to age 2 yr. Microcephaly at birth, with or without low birthweight, was included as a structural anomaly.

- **Selected congenital brain anomalies:** intracranial calcifications; cerebral atrophy; abnormal cortical formation (e.g., polymicrogyria, lissencephaly, pachygyria, schizencephaly, gray matter heterotopia); corpus callosum abnormalities; cerebellar abnormalities; porencephaly; hydranencephaly; ventriculomegaly/hydrocephaly.
- **Selected congenital eye anomalies:** microphthalmia or anophthalmia; coloboma; cataract; intraocular calcifications; chorioretinal anomalies involving the macula (e.g., chorioretinal atrophy and scarring, macular pallor, and gross pigmentary mottling), excluding retinopathy of prematurity; optic nerve atrophy, pallor, and other optic nerve abnormalities.
- **Microcephaly at birth:** birth head circumference <3rd percentile for infant sex and gestational age based on INTERGROWTH-21st online percentile calculator (<http://intergrowth21.ndog.ox.ac.uk/>).

#### NEURODEVELOPMENTAL ABNORMALITIES POSSIBLY ASSOCIATED WITH CONGENITAL ZIKA VIRUS INFECTION

Consequences of neurologic dysfunction detected from birth (congenital) to age 2 yr. Postnatal-onset microcephaly was included as a neurodevelopmental abnormality.

- **Hearing abnormalities:** Hearing loss or deafness documented by testing, most frequently auditory brainstem response (ABR). Includes sensorineural hearing loss, mixed hearing loss, and hearing loss not otherwise specified. Failed newborn hearing screening is not sufficient for diagnosis.
- **Congenital contractures:** Multiple contractures (arthrogryposis) and isolated clubfoot documented at birth. Brain anomalies must be documented for isolated clubfoot but not for arthrogryposis.
- **Seizures:** Documented by electroencephalogram or physician report. Includes epilepsy or seizures not otherwise specified; excludes febrile seizures.
- **Body tone abnormalities:** Hypertonia or hypotonia documented at any age in conjunction with (1) a failed screen or assessment for gross motor function; (2) suspicion or diagnosis of cerebral palsy from age 1–2 yr; or (3) assessment by a physician or other medical professional, such as a physical therapist.
- **Movement abnormalities:** Dyskinesia or dystonia at any age; suspicion or diagnosis of cerebral palsy from age 1–2 yr.
- **Swallowing abnormalities:** Documented by instrumented or noninstrumented evaluation, presence of a gastrostomy tube, or physician report.
- **Possible developmental delay:** Abnormal result from most recent developmental screening (i.e., failed screen for gross motor domain or failed screen for two or more developmental domains at the same time point or age); developmental evaluation; or assessment review by developmental pediatrician. Results from developmental evaluation are considered the gold standard if available.
- **Possible visual impairment:** Includes strabismus (esotropia or exotropia), nystagmus, failure to fix and follow at age <1 yr; diagnosis of visual impairment at age ≥1 yr.
- **Postnatal-onset microcephaly:** Two most recent head circumference measurements reported from follow-up care <3rd percentile for child's sex and age based on World Health Organization child growth standards; downward trajectory of head circumference percentiles with most recent measurement <3rd percentile. Age at measurement was adjusted for gestational age in infants born at <40 wk of gestational age through age 24 mo chronological age.

From Rice ME, Galang RR, Roth NM, et al. Vital signs: Zika-associated birth defects and neurodevelopmental abnormalities possibly associated with congenital Zika virus infection—US territories and freely associated states, 2018. *MMWR Morb Mortal Wkly Rep.* 2018;67(31):858–866.

## 314.12 Zika Virus

Scott B. Halstead

### EPIDEMIOLOGY

ZIKV, a member of the *Flavivirus* genus, is maintained in complex African zoonotic cycles, spilling over from time to time into the *Aedes aegypti*/*A. albopictus* urban transmission cycles, possibly over a period of many years (Fig. 314.5). After the virus was discovered in Africa in 1947, human antibodies were found widely dispersed throughout tropical Asia. However, in all these locations, human ZIKV disease was mild and rare until 2007, when there was an outbreak of a mild febrile exanthem on the Yap Islands in the western Pacific. Soon thereafter an outbreak on Tahiti in 2013–2014 was followed in 4 weeks by a small outbreak of Guillain-Barré syndrome (GBS). In 2015 a massive epidemic in South America was accompanied by focal reports, particularly in Brazil, of ZIKV infections of pregnant women that produced infected and damaged fetuses or newborns. The epidemiology of ZIKV infections is essentially identical to that of the DENV and CHIK. Residents of urban areas, particularly those without adequate sources of piped water, are at highest risk. *A. aegypti*, the principal vector mosquito, is very abundant and widespread throughout South and Central America, Mexico, and the Caribbean region. During the North, Central, and South American pandemic, ZIKV was found to infect the male reproductive tract, be secreted in urine and saliva, and be sexually transmitted. By 2017, the ZIKV epidemic in the American tropics appeared to wane, with few cases reported since then. During 2015–2016, large numbers of imported ZIKV infections, some in pregnant women, were reported in the United States and other temperate-zone developed countries. Small outbreaks of endogenous human ZIKV infections were reported in South Florida during the summer of 2016.

From the pediatric perspective, the most important outcome of human ZIKV infection is termed the *congenital Zika syndrome (CZS)*, which consists of microcephaly, facial disproportion, hypertonia/spasticity, hyperreflexia, irritability, seizures, arthrogryposis, ocular abnormalities, and sensorineural hearing loss (Table 314.1). A comprehensive understanding of the precise antecedents to CZS is not known. It appears that the earlier during pregnancy that ZIKV infections occur, the greater the likelihood of and the more severe is the CZS. Vertical transmission appears to follow viremia with ZIKV, transiting the uterus to infect the placenta and then the fetus. However, factors that affect the occurrence or severity of CZS, such as age, ethnicity, or prior immune status of the mother, are not known. In vitro studies have demonstrated that DENV antibodies can enhance ZIKV infection in vitro, in Fc-receptor-bearing cells. In Nicaraguan children, a prior DENV infection did not enhance Zika disease, and, as yet, there is no evidence that a prior DENV infection alters the chance of ZIKV crossing the placenta or increases the risk of CZS. Maternal–fetal transmission of ZIKV can occur during labor and delivery. There are no reports of ZIKV infection acquired by an infant at the time of delivery leading to microcephaly. There are no data to contraindicate breastfeeding, although the virus has been identified in breast milk. Maternal and newborn laboratory testing is indicated during the first 2 weeks of life if the mother had relevant epidemiologic exposure within 2 weeks of delivery and had clinical manifestations of ZIKV infection (e.g., rash, conjunctivitis, arthralgia, or fever). Infants and children who acquire ZIKV infection postnatally appear to have a mild course, similar to that seen in adults.

### CLINICAL FEATURES

**Congenital Zika syndrome** may be defined in a fetus with diagnostic evidence of ZIKV infection, including (1) severe microcephaly (>3 SD below the mean), partially collapsed skull, overlapping cranial sutures, prominent occipital bone, redundant scalp skin, and neurologic impairment; (2) brain anomalies, including cerebral cortex thinning, abnormal gyral patterns, increased fluid spaces, subcortical calcifications, corpus callosum anomalies, reduced white matter, and cerebellar vermiform hypoplasia; (3) ocular findings, such as macular scarring, focal pigmentary retinal mottling, structural anomalies (microphthalmia,



**Table 314.2** CDC Recommendations for Preconception Counseling and Prevention of Sexual Transmission of Zika Virus Among Persons with Possible Zika Virus Exposure: United States, August 2018

EXPOSURE SCENARIO	RECOMMENDATIONS (UPDATE STATUS)
Only the male partner travels to an area with risk for ZIKV transmission and couple is planning to conceive	The couple should use condoms or abstain from sex for at least 3 mo after the male partner's symptom onset (if symptomatic) or last possible ZIKV exposure (if asymptomatic). <b>(Updated recommendation)</b>
Only the female partner travels to an area with risk for ZIKV transmission and couple is planning to conceive	The couple should use condoms or abstain from sex for at least 2 mo after the female partner's symptom onset (if symptomatic) or last possible ZIKV exposure (if asymptomatic). <b>(No change in recommendation)*</b>
Both partners travel to an area with risk for ZIKV transmission and couple is planning to conceive	The couple should use condoms or abstain from sex for at least 3 mo from the male partner's symptom onset (if symptomatic) or last possible ZIKV exposure (if asymptomatic). <b>(Updated recommendation)</b>
One or both partners have ongoing exposure (i.e., live in or frequently travel to an area with risk for ZIKV transmission) and couple is planning to conceive	The couple should talk with their healthcare provider about their plans for pregnancy, their risk for ZIKV infection, the possible health effects of ZIKV infection on a baby, and ways to protect themselves from ZIKV. If either partner develops symptoms of ZIKV infection or tests positive for ZIKV infection, the couple should follow the suggested time frames listed previously before trying to conceive. <b>(No change in recommendation)*</b>
Men with possible ZIKV exposure whose partner is pregnant	The couple should use condoms or abstain from sex for the duration of the pregnancy. <b>(No change in recommendation)*</b>

\*Petersen EE, Meaney-Delman D, Neblett-Fanfair R, et al. Update: interim guidance for preconception counseling and prevention of sexual transmission of Zika virus for persons with possible Zika virus exposure—United States, September 2016. *MMWR Morb Mortal Wkly Rep.* 2016;65:1077–1081.

From Polen KD, Gilboa SM, Hills S, et al. Update: interim guidance for preconception counseling and prevention of sexual transmission of Zika virus for men with possible Zika virus exposure: United States, August 2018. *MMWR Morb Mortal Wkly Rep.* 2018;67(31):868–870.

coloboma, cataracts, and posterior anomalies), chorioretinal atrophy, or optic nerve hypoplasia/atrophy; (4) congenital contractures, including unilateral or bilateral clubfoot and arthrogryposis multiplex congenita; and (5) neurologic impairment, such as pronounced early hypertonia/spasticity with extrapyramidal symptoms, motor disabilities, cognitive disabilities, hypotonia, irritability/excessive crying, tremors, swallowing dysfunction, vision impairment, hearing impairment, and epilepsy (see [Table 314.1](#)).

Acquired ZIKV infection may present with nonspecific viral syndrome–like features. Nonetheless, patients are at increased risk of myelitis and GBS. In addition, the virus may remain present in the blood and body fluids for months after resolution of clinical symptoms.

## MANAGEMENT

For infants with confirmed ZIKV infection, close follow-up is necessary. The appropriate follow-up evaluation depends on whether the infant has clinical signs and symptoms of congenital ZIKV syndrome. All infants should have close monitoring of growth and development, repeat ophthalmologic examinations, and auditory brainstem response testing (see [Table 314.1](#)).

## LABORATORY DIAGNOSIS

Laboratory testing for ZIKV infection in the neonate includes the following: serum and urine for ZIKV RNA by real-time reverse transcription polymerase chain reaction (rRT-PCR) and serum ZIKV IgM enzyme-linked immunosorbent assay. If the IgM is positive, the plaque reduction neutralization test is used to confirm the specificity of the IgM antibodies against ZIKV and to exclude a false-positive IgM result. If CSF is available, it should be tested for ZIKV RNA (via rRT-PCR), as well as ZIKV IgM. CSF specimens need not be collected for the sole purpose of ZIKV testing but may be reasonable for the evaluation of infants with microcephaly or intracranial calcifications. A definitive

diagnosis of congenital ZIKV infection is confirmed by the presence of ZIKV RNA in samples of serum, urine, or CSF collected within the first 2 days of life; IgM antibodies may be positive or negative. A negative rRT-PCR result with a positive ZIKV IgM test result indicates probable congenital ZIKV infection.

Fetuses or infants born to mothers who test positive for ZIKV infection should be studied sonographically or for clinical evidence of congenital Zika syndrome; a comprehensive evaluation (including ophthalmologic examination, laboratory tests, and specialist consultation) should be performed before hospital discharge.

## PROGNOSIS

The prognosis of newborns with congenital Zika syndrome is unclear. Reported acute mortality rates among live-born infants range from 4–6%. The combination of ZIKV-related microcephaly and severe cerebral abnormalities generally has a poor prognosis, but little is known about the prognosis for congenitally infected infants with less severe or no apparent abnormalities at birth.

## DIFFERENTIAL DIAGNOSIS

The differential diagnosis for congenital ZIKV infection includes other congenital infections and other causes of microcephaly.

## PREVENTION

The prevention of the congenital Zika syndrome includes avoidance of travel to endemic regions, if possible; if travel to endemic regions cannot be avoided, careful contraception (male and female) is essential, especially with the knowledge that ZIKV can persist in semen for months after a primary infection ([Table 314.2](#)).

Visit Elsevier eBooks+ at [eBooks.Health.Elsevier.com](http://eBooks.Health.Elsevier.com) for Bibliography.

## Chapter 315

## Dengue Fever, Dengue Hemorrhagic Fever, and Severe Dengue

Scott B. Halstead

**Dengue fever** is a benign syndrome caused by several arthropod-borne viruses and is characterized by biphasic fever, myalgia or arthralgia, rash, leukopenia, and lymphadenopathy. **Dengue hemorrhagic fever** (Philippine, Thai, or Singapore hemorrhagic fever; hemorrhagic dengue; acute infectious thrombocytopenic purpura) is a severe, often fatal, febrile disease caused by one of four dengue viruses. It is characterized by capillary permeability, abnormalities of hemostasis, and, in severe cases, a protein-losing shock syndrome (**dengue shock syndrome**), which is thought to have an immunopathologic basis.

A revised case definition adopted by the World Health Organization (WHO) in 2009 includes as **severe dengue** those cases accompanied by fluid loss leading to shock, fluid loss with respiratory distress, liver damage evidenced by elevations of ALT or AST to >1000 U/L, severe bleeding, and altered consciousness or significant heart abnormalities.

**ETIOLOGY**

There are at least four distinct antigenic types of dengue virus (dengue 1, 2, 3, and 4), members of the family Flaviviridae. In addition, three other arthropod-borne viruses (arboviruses) cause similar dengue fever syndromes with rash (Table 315.1; see also Chapter 314).

**EPIDEMIOLOGY**

Dengue viruses are transmitted by mosquitoes of the Stegomyia family. *Aedes aegypti*, a daytime biting mosquito, is the principal vector, and all four virus types have been recovered from it. Transmission occurs from viremic humans by bite of the vector mosquito in which virus multiplies during an extrinsic incubation period and then by bite is passed on to a susceptible human in what is called the urban transmission cycle. In most tropical areas, *A. aegypti* is highly urbanized, breeding in water stored for drinking or bathing and in rainwater collected in any container. Dengue viruses have also been recovered from *A. albopictus*, as in the 2001 and 2015 Hawaiian epidemics, whereas outbreaks in the Pacific area have been attributed to several other *Aedes* species. These species breed in water trapped in vegetation. In Southeast Asia and West Africa, dengue virus may be maintained in a cycle

involving canopy-feeding jungle monkeys and *Aedes* spp, which feed on monkeys.

In the 19th and early 20th centuries, epidemics were common in temperate areas of the Americas, Europe, Australia, and Asia. After several decades of virus control in the Americas, dengue fever and dengue-like disease are now endemic in tropical Asia, the South Pacific Islands, northern Australia, tropical Africa, the Arabian Peninsula, the Caribbean, and Central and South America (Fig. 315.1). The wide distribution of *A. aegypti* is frequently attributed to global warming, but this view is mistaken. This mosquito was widely dispersed during the “little ice age” in the 1700s, supporting yellow fever epidemics in New York and continental Europe. Mosquito breeding depends on access to stored fresh water, not temperature. Dengue fever occurs frequently among travelers to endemic areas. Locally acquired disease has been reported in Florida, Arizona, and Texas, and imported cases in the United States occur in travelers to endemic areas. More than 390 million dengue infections occur annually; approximately 96 million have clinical disease.

Dengue outbreaks in urban areas infested with *A. aegypti* may be explosive; in virgin soil epidemics, up to 70–80% of the population may be involved. Most overt disease occurs in older children and adults. Because *A. aegypti* has a limited flight range, spread of an epidemic occurs mainly through viremic human beings and follows the main lines of transportation. Sentinel cases may infect household mosquitoes; a large number of nearly simultaneous secondary infections give the appearance of a contagious disease. Where dengue is highly endemic, indigenous children and susceptible foreigners may be the only persons to acquire overt disease, because adults have become immune.

**Dengue-Like Diseases**

Dengue-like diseases may occur in epidemics. Epidemiologic features depend on the vectors and their geographic distribution (see Chapter 314). Chikungunya virus is enzootic in subhuman primates throughout much of West, Central, and South Africa. Periodic introductions of virus into the urban transmission cycle have led to pandemics, resulting in widespread endemicity in the most populous areas of Asia. In Asia, *A. aegypti* is the principal vector; in Africa, other *Stegomyia* spp. may be important vectors. In Southeast Asia, dengue and chikungunya outbreaks occur concurrently in the urban cycle. Outbreaks of o'nyong-nyong fever usually involve villages or small towns, in contrast to the urban outbreaks of dengue and chikungunya. West Nile virus is enzootic in Africa. Chikungunya is now endemic in urban cycles in tropical countries throughout the world. Intense transmission in Caribbean and Central and South American countries beginning in 2013 results in the emergence of limited chikungunya transmission in the United States.

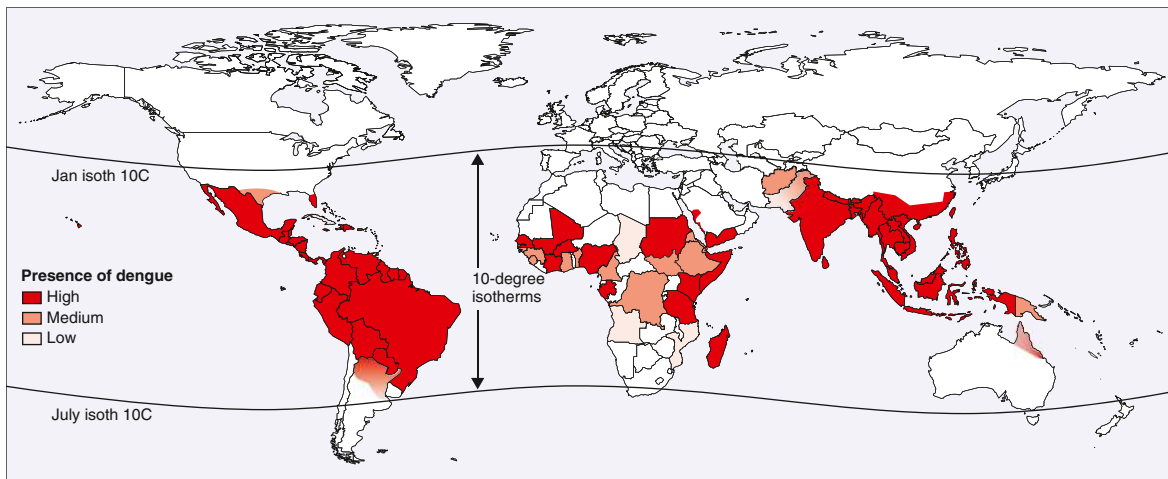
**Dengue Hemorrhagic Fever**

Dengue hemorrhagic fever occurs where multiple types of dengue virus are simultaneously or sequentially transmitted. It is endemic in tropical America, Asia, the Pacific Islands, and parts of Africa, where warm temperatures and the practices of water storage in homes plus outdoor breeding sites result in large, permanent populations of *A. aegypti*. Under these conditions, infections with dengue viruses of all types are common. A first infection, referred to as a primary infection, may be followed by infection with a different dengue virus, referred to as a secondary infection. In areas of high endemicity, secondary infections are frequent.

Secondary dengue infections are relatively mild in the majority of instances, ranging from an inapparent infection through an undifferentiated upper respiratory tract or dengue-like disease, but may also progress to dengue hemorrhagic fever. Nonimmune foreigners, both adults and children, who are exposed to dengue virus during outbreaks of hemorrhagic fever have classic dengue fever or even milder disease. The differences in clinical manifestations of dengue infections between natives and foreigners in Southeast Asia are related to immunologic status. Dengue hemorrhagic fever is unusual in patients with primary dengue infection, with the exception of infants whose mothers

**Table 315.1** Vectors and Geographic Distribution of Dengue-Like Diseases

VIRUS	GEOGRAPHIC GENUS AND DISEASE	VECTOR	DISTRIBUTION
Togavirus	Chikungunya	<i>Aedes aegypti</i> <i>Aedes africanus</i> <i>Aedes albopictus</i>	Africa, India, Southeast Asia, Latin America, United States
Togavirus	O'nyong-nyong	<i>Anopheles funestus</i>	East Africa
Flavivirus	West Nile fever	<i>Culex molestus</i> <i>Culex univittatus</i>	Europe, Africa, Middle East, India



**Fig. 315.1** Global dengue burden, 2014. (From Guzman MG, Harris E. *Dengue*. *Lancet*. 2015;385:453–462. Fig. 1.)

are immune to dengue. Dengue hemorrhagic fever or severe dengue occurs rarely in individuals of African ancestry because of an as yet incompletely described resistance gene. This gene is thought to have originated in populations with long-standing exposure to yellow fever and explains the low incidence of severe dengue throughout much of Africa and among African populations in the American tropics despite high rates of dengue infection.

### **PATHOGENESIS**

The pathogenesis of dengue hemorrhagic fever is incompletely understood, but epidemiologic studies strongly associate this syndrome with second heterotypic infections with dengue types 1–4 or in infants born to mothers who have had two or more lifetime dengue infections. Retrospective studies of sera from human mothers whose infants acquired dengue hemorrhagic fever and prospective studies in children acquiring sequential dengue infections have shown that the circulation of infection-enhancing antibodies at the time of infection is the strongest risk factor for development of severe disease. The absence of dengue neutralizing antibodies in the presence of enhancing antibodies from passive transfer or active production is the best correlate of risk for dengue hemorrhagic fever. Monkeys that are infected sequentially or have received enhancing antibodies experience enhanced viremias. In humans studied early during the course of secondary dengue infections, viremia levels directly predicted disease severity. When dengue virus immune complexes attach to monocyte/macrophage Fc receptors, a signal is sent that suppresses innate immunity, resulting in enhanced viral production. In the Americas, dengue hemorrhagic fever and dengue shock syndrome have been associated with dengue types 1–4 strains of recent Southeast Asian origin. Outbreaks of dengue hemorrhagic fever in all areas of the world are correlated with secondary dengue infections.

Early in the acute stage of secondary dengue infections, there is rapid activation of the complement system. Shortly before or during shock, blood levels of soluble tumor necrosis factor receptor, interferon- $\gamma$ , and interleukin-2 are elevated, C1q, C3, C4, C5–C8, and C3 proactivators are depressed, and C3 catabolic rates are elevated. All of these outcomes are attributed to circulating viral nonstructural protein 1 (NS1), a viral toxin that activates myeloid cells to release cytokines by attaching to toll-like receptor 4. NS1 also contributes to increased vascular permeability by activating complement and, most importantly, interacting with and damaging endothelial cells and interacting with blood clotting factors and platelets. The mechanism of bleeding in dengue hemorrhagic fever is not fully understood, but a mild degree of disseminated intravascular coagulopathy, liver damage, and thrombocytopenia may operate synergistically. NS1-mediated capillary damage allows fluid,

electrolytes, small proteins, and, in some instances, red blood cells to leak into extravascular spaces. This internal redistribution of fluid, together with deficits caused by fasting, thirsting, and vomiting, results in hemoconcentration, hypovolemia, increased cardiac work, tissue hypoxia, metabolic acidosis, and hyponatremia.

Usually no pathologic lesions are found to account for death. In rare instances, death may be a result of gastrointestinal or intracranial hemorrhages. Minimal to moderate hemorrhages are seen in the upper gastrointestinal tract, and petechial hemorrhages are common in the interventricular septum of the heart, on the pericardium, and on the subserosal surfaces of major viscera. Focal hemorrhages are occasionally seen in the lungs, liver, adrenals, and subarachnoid space. The liver is usually enlarged, often with fatty changes. Yellow, watery, and at times blood-tinged effusions are present in serous cavities in approximately 75% of patients at autopsy.

Dengue virus is frequently absent in tissues at the time of death; viral antigens or RNA have been localized to hepatocytes and macrophages in the liver, spleen, lung, and lymphatic tissues.

### **CLINICAL MANIFESTATIONS**

#### **Dengue Fever**

The incubation period is 1–7 days. The clinical manifestations are variable and are influenced by the age of the patient. In infants and young children, the disease may be undifferentiated or characterized by fever for 1–5 days, pharyngeal inflammation, rhinitis, and mild cough. A majority of infected older children and adults experience sudden onset of fever, with temperature rapidly increasing to 39.4–41.1°C (103–106°F), usually accompanied by frontal or retro-orbital pain, particularly when pressure is applied to the eyes. Occasionally, severe back pain precedes the fever (back-break fever). A transient, macular, generalized rash that blanches under pressure may be seen during the first 24–48 hours of fever. The pulse rate may be slow relative to the degree of fever. Myalgia and arthralgia occur soon after the onset of fevers and increase in severity over time. From the second to sixth day of fever, nausea and vomiting are apt to occur, and generalized lymphadenopathy, cutaneous hyperesthesia or hyperalgesia, taste aberrations, and pronounced anorexia may develop.

Approximately 1–2 days after defervescence, a generalized, morbiliform, maculopapular rash appears that spares the palms and soles. It disappears in 1–5 days; desquamation may occur. Rarely there is edema of the palms and soles. About the time this second rash appears, the body temperature, which has previously decreased to normal, may become slightly elevated and demonstrate the characteristic biphasic temperature pattern.

## Dengue Hemorrhagic Fever and Dengue Shock Syndrome

The differentiation between dengue fever and dengue hemorrhagic fever is difficult early in the course of illness. A relatively mild first phase with abrupt onset of fever, malaise, vomiting, headache, anorexia, and cough may be followed after 2-5 days by rapid clinical deterioration and collapse. In this second phase, the patient usually has cold, clammy extremities, a warm trunk, flushed face, diaphoresis, restlessness, irritability, mid-epigastric pain, and decreased urinary output. There may be scattered petechiae on the forehead and extremities; spontaneous ecchymoses may appear, and easy bruising and bleeding at sites of venipuncture are common. A macular or maculopapular rash may appear, and there may be circumoral and peripheral cyanosis. Respirations are rapid and often labored. The pulse is weak, rapid, and thready, and the heart sounds are faint. The liver may enlarge to 4-6 cm below the costal margin and is usually firm and somewhat tender. Approximately 20-30% of cases of dengue hemorrhagic fever are complicated by shock (dengue shock syndrome). Dengue shock can be subtle, arising in patients who are fully alert, and is accompanied by increased peripheral vascular resistance and raised diastolic blood pressure. Shock is not from congestive heart failure but from venous pooling. With increasing cardiovascular compromise, the diastolic pressure rises toward the systolic level and the pulse pressure narrows. Fewer than 10% of patients have gross ecchymosis or gastrointestinal bleeding, usually after a period of uncorrected shock. After a 24- to 36-hour period of crisis, convalescence is fairly rapid in the children who recover. The temperature may return to normal before or during the stage of shock. Bradycardia and ventricular extrasystoles are common during convalescence.

## Dengue with Warning Signs and Severe Dengue

In hyperendemic areas, dengue hemorrhagic fever/dengue shock syndrome (DHF/DSS) is the life-threatening event during a dengue infection that challenges the identifying physician. When the four dengue viruses spread to the American hemisphere and to South Asia, there were millions of primary and secondary dengue infections in individuals of all ages. Dengue disease in these areas presented a wider clinical spectrum resulting in a new diagnostic algorithm and case definitions (see later).

## DIAGNOSIS

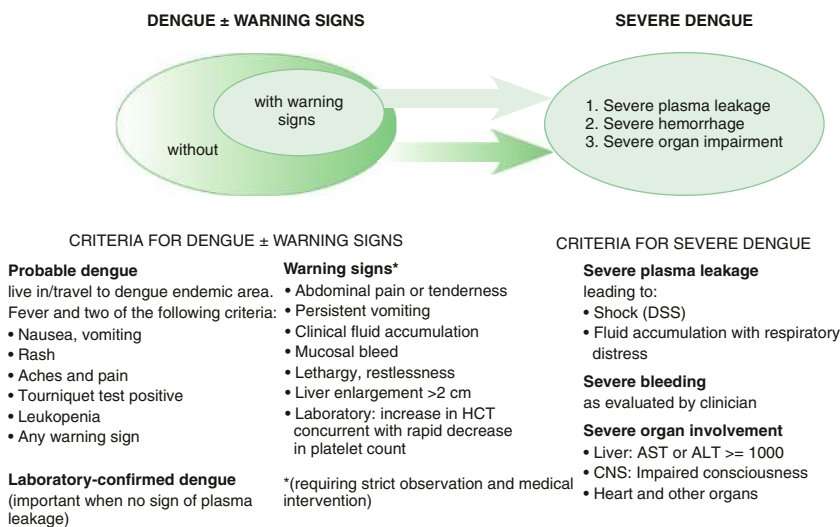
A clinical diagnosis of dengue fever derives from a high index of suspicion and knowledge of the geographic distribution and environmental cycles of causal viruses (for nondengue causes see Chapter 314).

Because clinical findings vary and there are many possible causative agents, the term *dengue-like disease* should be used until a specific diagnosis is established. A case is confirmed by virologic diagnosis, which can be established by serologic tests, by detection of viral proteins or viral RNA, or by the isolation of the virus from blood leukocytes or acute-phase serum. A probable case is a typical acute febrile illness with supportive serology and occurrence at a location where there are confirmed cases.

The WHO criteria for **dengue hemorrhagic fever** are fever (2-7 days in duration or biphasic); minor or major hemorrhagic manifestations, including a positive tourniquet test, thrombocytopenia ( $\leq 100,000/\mu\text{L}$ ), and objective evidence of increased capillary permeability (hematocrit increased by  $\geq 20\%$ ); pleural effusion or ascites (by chest radiography or ultrasonography); or hypoalbuminemia. **Dengue shock syndrome** criteria include those for dengue hemorrhagic fever as well as hypotension, tachycardia, narrow pulse pressure ( $\leq 20$  mm Hg), and signs of poor perfusion (cold extremities).

In 2009, the WHO promulgated guidelines for the diagnosis of probable dengue, dengue with warning signs, and a category called severe dengue (Fig. 315.2). The presence of warning signs in an individual with probable dengue alerts the physician to the possible need for hospitalization. Severe dengue is a mixture of the syndromes that are associated with dengue infection, including classic DHF/DSS, but also rare instances of encephalitis or encephalopathy, liver damage, or myocardial damage. Severe dengue also includes respiratory distress, a harbinger of pulmonary edema caused by overhydration, an all-too-common outcome of inexpert treatment (see "Treatment" and "Complications" sections).

After primary and secondary dengue infections, there is an appearance of anti-dengue (immunoglobulin [Ig] M) antibodies. These disappear after 6-12 weeks, a feature that can be used to date a dengue infection. In secondary dengue infections, most dengue antibody is of the IgG class. Serologic diagnosis depends on a fourfold or greater increase in IgG antibody titer in paired sera by hemagglutination inhibition, complement fixation, enzyme immunoassay, or neutralization test. Carefully standardized IgM and IgG capture enzyme commercial immunoassays are now widely used to identify acute-phase antibodies from patients with primary or secondary dengue infections in single-serum samples. Usually such samples should be collected not earlier than 5 days and not later than 6 weeks after onset. It may not be possible to distinguish the infecting virus by serologic methods alone, particularly when there has been prior infection with another member of the same arbovirus group. Virus can be recovered from acute-phase serum after inoculating tissue culture or living mosquitoes. Viral RNA can be



**Fig. 315.2** Suggested dengue case classification and levels of severity. (From World Health Organization [WHO] and Special Programme for Research and Training in Tropical Diseases [TDR]. *Dengue: guidelines for diagnosis, treatment, prevention and control, 2009*. Fig. 1.4, [http://apps.who.int/iris/bitstream/handle/10665/44188/9789241547871\\_eng.pdf?sequence=1](http://apps.who.int/iris/bitstream/handle/10665/44188/9789241547871_eng.pdf?sequence=1))



detected in blood or tissues by specific complementary RNA probes or amplified first by polymerase chain reaction or by real-time polymerase chain reaction. A viral nonstructural protein, NS1, is released by infected cells into the circulation and can be detected in acute-stage blood samples using monoclonal or polyclonal antibodies. The detection of NS1 is the basis of commercial tests, including rapid lateral flow tests. These tests offer a reliable point-of-care diagnosis of acute dengue infection.

### DIFFERENTIAL DIAGNOSIS

The differential diagnosis of dengue fever includes dengue-like diseases, viral respiratory and influenza-like diseases, including COVID-19, the early stages of malaria, mild yellow fever, scrub typhus, viral hepatitis, and leptospirosis.

Four arboviral diseases have dengue-like courses but without rash: Colorado tick fever, sandfly fever, Rift Valley fever, and Ross River fever (see [Chapter 314](#)). Colorado tick fever occurs sporadically among campers and hunters in the western United States; sandfly fever in the Mediterranean region, the Middle East, southern Russia, and parts of the Indian subcontinent; and Rift Valley fever in North, East, Central, and South Africa. Ross River fever is endemic in much of eastern Australia, with epidemic extension to Fiji. In adults, Ross River fever often produces protracted and crippling arthralgia involving weight-bearing joints.

Because meningococemia, yellow fever (see [Chapter 316](#)), other viral hemorrhagic fevers (see [Chapter 317](#)), many rickettsial diseases, and other severe illnesses caused by a variety of agents may produce a clinical picture similar to that of dengue hemorrhagic fever, the etiologic diagnosis should be made only when epidemiologic or serologic evidence suggests the possibility of a dengue infection.

### LABORATORY FINDINGS

In patients with dengue fever, pancytopenia may develop after the 3–4 days of illness. Neutropenia may persist or reappear during the latter stage of the disease and may continue into convalescence, with white blood cell counts  $<2,000/\mu\text{L}$ . Platelet counts rarely fall below  $100,000/\mu\text{L}$ . Venous clotting, bleeding and prothrombin times, and plasma fibrinogen values are within normal ranges. The tourniquet test result may be positive. Mild acidosis, hemoconcentration, increased transaminase values, and hypoproteinemia may occur during some primary dengue virus infections. The electrocardiogram may show sinus bradycardia, ectopic ventricular foci, flattened T waves, and prolongation of the P–R interval.

In dengue hemorrhagic fever, dengue shock syndrome, and severe dengue, the most common hematologic abnormalities are hemoconcentration with an increase of  $>20\%$  in the hematocrit, thrombocytopenia, a prolonged bleeding time, and a moderately decreased prothrombin time that is seldom  $<40\%$  of control. Fibrinogen levels may be subnormal, and fibrin split-product values are elevated. Other abnormalities include moderate elevations of serum transaminase levels, depressed complement levels, mild metabolic acidosis with hyponatremia, occasional hypochloremia, slight elevation of blood urea nitrogen, and hypoalbuminemia. Chest x-ray reveals pleural effusions (right  $>$  left) in nearly all patients with dengue shock syndrome. Ultrasonography can be used to detect serosal effusions of the thorax or abdomen. Thickening of the gallbladder wall and the presence of perivesicular fluid, ascites, or pleural effusions are characteristic signs of increased vascular permeability.

### TREATMENT

#### Dengue

Treatment of uncomplicated dengue fever is supportive. Bed rest is advised during the febrile period. Antipyretics should be used to keep the body temperature  $<40^\circ\text{C}$  ( $104^\circ\text{F}$ ). Analgesics or mild sedation may be required to control pain. Aspirin is contraindicated and should not be used because of its effects on hemostasis. Fluid and electrolyte replacement is required for deficits caused by sweating, fasting, thirsting, vomiting, and diarrhea.

### Dengue Hemorrhagic Fever and Dengue Shock Syndrome

Shock syndrome is a medical emergency that may occur in any child who lives in or has a recent travel history to a tropical destination. Management begins with diagnostic suspicion and the understanding that shock often accompanies defervescence. Detailed instructions for case management are available at the Centers for Disease Control and Prevention web site: <https://www.cdc.gov/dengue/healthcare-providers/index.html>. Management of dengue hemorrhagic fever and dengue shock syndrome includes immediate evaluation of vital signs and degrees of hemoconcentration, dehydration, and electrolyte imbalance. Close monitoring is essential for at least 48 hours because shock may occur or recur precipitously, usually several days after the onset of fever. Patients who are cyanotic or have labored breathing should be given oxygen. Rapid intravenous replacement of fluids and electrolytes can frequently sustain patients until spontaneous recovery occurs. Normal saline is more effective than the more expensive Ringer lactated saline in treating shock. When the pulse pressure is  $\leq 10$  mm Hg or when elevation of the hematocrit persists after the replacement of fluids, plasma or colloid preparations are indicated. Oral rehydration of children who are being monitored is useful. Prophylactic platelet transfusions have not been shown to reduce the risk of hemorrhaging or improve low platelet counts and may be associated with adverse effects.

Care must be taken to avoid overhydration, which may contribute to cardiac failure. Transfusions of fresh blood may be required to control bleeding but should not be given during hemoconcentration and should be administered only after evaluation of hemoglobin or hematocrit values. Salicylates are contraindicated because of their effect on blood clotting.

Sedation may be required for children who are markedly agitated. Use of vasopressors has not resulted in a significant reduction of mortality rates over that observed with simple supportive therapy. Disseminated intravascular coagulation may require treatment (see [Chapter 532](#)). Corticosteroids do not shorten the duration of disease or improve the prognosis in children receiving careful supportive therapy.

### COMPLICATIONS

Hypervolemia during the fluid reabsorptive phase may be life-threatening and is heralded by a decrease in hematocrit with wide pulse pressure. Diuretics and digitalization may be necessary.

Primary infections with dengue fever and dengue-like diseases are usually self-limited and benign. Fluid and electrolyte losses, hyperpyrexia, and febrile convulsions are the most frequent complications in infants and young children. Epistaxis, petechiae, and purpuric lesions are uncommon but may occur at any stage. Blood from epistaxis that is swallowed, vomited, or passed by rectum may be erroneously interpreted as gastrointestinal bleeding. In adults and possibly in children, underlying conditions may lead to clinically significant bleeding. Convulsions may occur during a high temperature. Infrequently, after the febrile stage, prolonged asthenia, mental depression, bradycardia, and ventricular extrasystoles may occur in children.

In endemic areas, dengue hemorrhagic fever should be suspected in children with a febrile illness suggestive of dengue fever who experience hemoconcentration and thrombocytopenia.

### PROGNOSIS

#### Dengue Fever

The prognosis for dengue fever is good. Care should be taken to avoid the use of drugs that suppress platelet activity.

#### Dengue Hemorrhagic Fever

The prognosis of dengue hemorrhagic fever is adversely affected by a late diagnosis and delayed or improper treatment. Death has occurred in 40–50% of patients with shock, but with adequate intensive care, deaths should occur in  $<1\%$  of cases. Infrequently, there

is residual brain damage as a consequence of prolonged shock or occasionally of intracranial hemorrhage. Many fatalities are caused by overhydration.

## PREVENTION

Dengue vaccines have been under development continuously since the 1970s. One such vaccine, Dengvaxia, developed by Sanofi Pasteur, is a mixture of four chimeras, dengue virus structural genes coupled with nonstructural genes of yellow fever 17D. Dengvaxia completed phase III per protocol analyses on 32,568 children, vaccinated and controls, age 2-16 years. These studies revealed poor protection and sensitization of seronegative vaccinated children to severe breakthrough dengue but moderate protection of children vaccinated when seropositive, who experienced a reduction of hospitalization and severe disease. Based on these data, the vaccine was endorsed by the WHO, United States, and European regulatory agencies for targeted use in individuals 9 years of age and older who have laboratory-based evidence of a prior dengue infection. The vaccine has been licensed for use in 20 countries. Other dengue type 1-4 vaccines are under development. The Takeda dengue 2 chimeric tetravalent vaccine has completed phase III testing with follow-up data for 2 years demonstrating strong protection against dengue 2 infection but modest protection against the other three viruses. A tetravalent dengue vaccine composed of mutagenized dengue 1, 3, and 4 and a chimeric dengue 2 virus developed by the U.S. National Institutes of Allergy and Infectious Diseases and Instituto Butantan in São Paulo, Brazil, is in the fourth year of phase III testing. Phase IIb live dengue virus human challenge data suggest this vaccine will provide solid protective immunity.

Prophylaxis in the absence of vaccine consists of avoiding daytime household-based mosquito bites through the use of insecticides, repellents, body covering with clothing, screening of houses, and destruction of *A. aegypti* breeding sites. If water storage is mandatory, a tight-fitting lid or a thin layer of oil may prevent egg laying or hatching. A larvicide, such as Abate (O,O'-[thiodi-*p*-phenylene] O,O,O,O'-tetramethyl phosphorothioate), available as a 1% sand-granule formation and effective at a concentration of 1 ppm, may be added safely to drinking water. Ultra-low-volume spray equipment effectively dispenses the adulticide malathion from trucks or airplanes for rapid intervention during an epidemic. Mosquito repellents and other personal anti-mosquito measures are effective in preventing mosquito bites in the field, forest, or jungle.

Visit Elsevier eBooks+ at [eBooks.Health.Elsevier.com](http://eBooks.Health.Elsevier.com) for Bibliography.

## Chapter 316

# Yellow Fever

Scott B. Halstead

Yellow fever is an acute infection characterized in its most severe form by fever, jaundice, proteinuria, and hemorrhage. The virus is mosquito-borne and occurs as urban epidemic, endemic, or jungle enzootic forms in South America and Africa. Until 1900, seasonal urban epidemics occurred in cities in temperate areas of Europe and the Americas. Urban and jungle yellow fever continues to be active in West, Central, and East Africa.

## ETIOLOGY

Yellow fever is the prototype of the *Flavivirus* genus of the family Flaviviridae, which are enveloped, single-stranded RNA viruses 35-50 nm in diameter.

Yellow fever circulates zoonotically as five genotypes: type IA in West Central Africa, type IB in South America, type II in West Africa, type III in East Central Africa, and type IV in East Africa. Types IA and IB are capable of urban transmission between human beings by *Aedes aegypti*. Sometime in the 1600s, *A. aegypti*, together with yellow fever virus, were brought to the American tropics through the African slave trade. Subsequently, yellow fever caused enormous coastal and riverine epidemics in the Atlantic and Caribbean basins until the 20th century, when the virus and its urban and sylvan mosquito cycles were identified, mosquito control methods were perfected, and a vaccine was developed. The East and East/Central African genotypes have not fully entered the urban cycle and have not spread to the east coast of Africa or to the countries of Asia.

## EPIDEMIOLOGY

Human and nonhuman primate hosts acquire the yellow fever infection by the bite of infected mosquitoes. After an incubation period of 3-6 days, virus appears in the blood and may serve as a source of infection for other mosquitoes. The virus must replicate in the gut of the mosquito and pass to the salivary gland before the mosquito can transmit the virus. Yellow fever virus is transmitted in an urban cycle—human to *A. aegypti* to human—and a jungle cycle—monkey to jungle mosquitoes to monkey. Classic yellow fever epidemics in the United States, South America, the Caribbean, and parts of Europe were of the urban variety. Since 2000, West Africa has experienced five urban epidemics, including in the capital cities of Abidjan (Cote d'Ivoire), Conakry (Guinea), and Dakar (Senegal). In 2012–2013, large outbreaks of East and East/Central yellow fever occurred across a large, predominantly rural area of war-ravaged Darfur in southwestern Sudan and in adjacent areas of northern Uganda. Beginning in 2015 and continuing to mid-2016, there were sharp outbreaks of yellow fever in and around Rwanda, Angola, and the bordering Democratic Republic of Congo, where there were 7,000 reported cases and 500 deaths. Eleven cases were imported into China by workers in Angola. In South America, all of the approximately 200 cases reported each year are jungle yellow fever. In late 2016 and continuing through 2019, a widespread zoonosis resulted in an estimated 2,237 yellow fever cases in natives and visitors to Brazil. In colonial times, urban yellow fever attack rates in White adults were very high, suggesting that subclinical infections are uncommon in this age-group. Yellow fever may be less severe in children, with subclinical infection:clinical case ratios  $\geq 2:1$ . In areas where outbreaks of urban yellow fever are common, most cases involve children because many adults are immune. Transmission in West Africa is highest during the rainy season, from July to November.

In tropical forests, yellow fever virus is maintained in a transmission cycle involving monkeys and tree hole–breeding mosquitoes (*Haemagogus* in Central and South America; the *Aedes africanus* complex in Africa). In the Americas, most cases involve tourists, campers, those who work in forested areas, and vacationers exposed to infected mosquitoes. In Africa, enzootic virus is prevalent in moist savanna and savanna transition areas, where other tree hole–breeding *Aedes* vectors transmit the virus between monkeys and humans and between humans.

## PATHOGENESIS

Pathologic changes seen in the liver include (1) coagulative necrosis of hepatocytes in the midzone of the liver lobule, with sparing of cells around the portal areas and central veins, (2) eosinophilic degeneration of hepatocytes (**Councilman bodies**), (3) microvacuolar fatty change, and (4) minimal inflammation. The kidneys show acute tubular necrosis. In the heart, myocardial fiber degeneration and fatty infiltration are seen. The brain may show edema and petechial hemorrhages. Direct viral injury to the liver results in impaired ability to perform functions of biosynthesis and detoxification; this is the central pathogenic event of yellow fever. Hemorrhage is postulated to result from decreased synthesis of vitamin K–dependent

clotting factors and, in some cases, disseminated intravascular clotting. The shock that occurs in patients with yellow fever appears similar to the shock associated with dengue shock syndrome and other viral hemorrhagic fevers and results at least in part from viral damage to endothelial cells. Death and severe disease rates are lower in susceptible sub-Saharan African Black people than in other racial groups, suggesting existence of a resistance gene.

Renal dysfunction has been attributed to hemodynamic factors (prerenal failure progressing to acute tubular necrosis).

### CLINICAL MANIFESTATIONS

In Africa, inapparent, abortive, or clinically mild infections are frequent. Some studies suggest that children experience a milder disease than do adults. Abortive infections, characterized by fever and headache, may be unrecognized except during epidemics.

In its classic form, yellow fever begins with a sudden onset of fever, headache, myalgia, lumbosacral pain, anorexia, nausea, and vomiting. Physical findings during the early phase of illness, when virus is present in the blood, include prostration, conjunctival injection, flushing of the face and neck, reddening of the tongue at the tip and edges, and relative bradycardia. After 2-3 days, there may be a brief period of remission, followed in 6-24 hours by the reappearance of fever with vomiting, epigastric pain, jaundice, dehydration, gastrointestinal and other hemorrhages, albuminuria, hypotension, renal failure, delirium, convulsions, and coma. Death may occur after 7-10 days, with a fatality rate in severe cases approaching 50%. Some patients who survive the acute phase of illness later succumb to renal failure or myocardial damage. Laboratory abnormalities include leukopenia; prolonged clotting, prothrombin, and partial thromboplastin times; thrombocytopenia; hyperbilirubinemia; elevated serum transaminase values; albuminuria; and azotemia. Hypoglycemia may be present in severe cases. Electrocardiogram abnormalities such as bradycardia and ST-T changes are described.

### DIAGNOSIS

Yellow fever should be suspected when fever, headache, vomiting, myalgia, and jaundice appear in residents of enzootic areas or in unimmunized visitors who have recently traveled (within 2 weeks before the onset of symptoms) to endemic areas. There are clinical similarities between yellow fever and dengue hemorrhagic fever. In contrast to the gradual onset of acute viral hepatitis resulting from hepatitis A, B, C, D, or E virus, jaundice in yellow fever appears after 3-5 days of high temperature and is often accompanied by severe prostration. Mild yellow fever is dengue-like and cannot be distinguished from a wide variety of other infections. Jaundice and fever may occur in any of several other tropical diseases, including malaria, viral hepatitis, louse-borne relapsing fever, leptospirosis, typhoid fever, rickettsial infections, certain systemic bacterial infections, sickle cell crisis, Rift Valley fever, Crimean-Congo hemorrhagic fever, and other viral hemorrhagic fevers. Outbreaks of yellow fever always include cases with severe gastrointestinal hemorrhage.

The specific diagnosis depends on the detection of the virus or viral antigen in acute-phase blood samples or antibody assays. The immunoglobulin M enzyme immunoassay is particularly useful. Sera obtained during the first 10 days after the onset of symptoms should be kept in an ultra-low-temperature freezer ( $-70^{\circ}\text{C}$  [ $-94^{\circ}\text{F}$ ]) and shipped on dry ice for virus testing. Convalescent-phase samples for antibody tests are managed by conventional means. In handling acute-phase blood specimens, medical personnel must take care to avoid contaminating themselves or others on the evacuation trail (laboratory personnel and others). The postmortem diagnosis is based on virus isolation from liver or blood, identification of Councilman bodies in liver tissue, or detection of antigen or viral genome in liver tissue.

### TREATMENT

It is customary to keep patients with yellow fever in a mosquito-free area, with use of mosquito nets if necessary. Patients are viremic during the febrile phase of the illness. Although there is no specific treatment for yellow fever, medical care is directed at maintaining the physiologic status with the following measures: (1) sponging and acetaminophen to reduce a high temperature, (2) vigorous fluid replacement of losses resulting from fasting, thirsting, vomiting, or plasma leakage, (3) correcting an acid-base imbalance, (4) maintaining nutritional intake to lessen the severity of hypoglycemia, and (5) avoiding drugs that are either metabolized by the liver or toxic to the liver, kidney, or central nervous system.

### COMPLICATIONS

Complications of acute yellow fever include severe hemorrhage, liver failure, and acute renal failure. Bleeding should be managed by transfusion of fresh whole blood or fresh plasma with platelet concentrates if necessary. Renal failure may require peritoneal dialysis or hemodialysis.

### PREVENTION

Yellow fever 17D is a live-attenuated vaccine with a long record of safety and efficacy. It is administered as a single 0.5-mL subcutaneous injection at least 10 days before arrival in a yellow fever-endemic area. YF-VAX, manufactured by Sanofi Pasteur, is licensed for use in the United States. With the exceptions noted later, individuals traveling to endemic areas in South America and Africa should be considered for vaccination, but the length of stay, exact locations to be visited, and environmental or occupational exposure may determine the specific risk and individual need for vaccination. Persons traveling from yellow fever-endemic to yellow fever-receptive countries may be required by national authorities to obtain a yellow fever vaccine (e.g., from South America or Africa to India). Usually, countries that require travelers to obtain a yellow fever immunization do not issue a visa without a valid immunization certificate. Vaccination is valid for 10 years for international travel certification, although immunity lasts at least 40 years and probably for life. Immunoglobulin M antibodies circulate for years after administration of yellow fever vaccine.

Since 1996, there have been a number of reports of *yellow fever vaccine-associated viscerotropic disease* with a higher risk in elderly vaccine recipients and a few cases in persons with previous thymectomies. Yellow fever vaccine should not be administered to persons who have symptomatic immunodeficiency diseases, are taking immunosuppressant drugs, have HIV, or have a history of thymectomy. A recent study has shown that individuals taking maintenance corticosteroids may be successfully vaccinated. Although the vaccine is not known to harm fetuses, its administration during pregnancy is not advised. The vaccine virus may be rarely transmitted through breastfeeding. In very young children, there is a small risk of encephalitis and death after yellow fever 17D vaccination. The 17D vaccine should not be administered to infants younger than 6 months. Residence in or travel to areas of known or anticipated yellow fever activity (e.g., forested areas in the Amazon basin), which puts an individual at high risk, warrants immunization of infants 6-8 months of age. Immunization of children 9 months of age and older is routinely recommended before entry into endemic areas. Immunization of persons older than 60 years of age should be weighed against their risk for sylvatic yellow fever in the American tropics and for urban or sylvatic yellow fever in Africa. Vaccination should be avoided in persons with a history of egg allergy. Alternatively, a skin test can be performed to determine whether a serious allergy exists that would preclude vaccination.

Visit Elsevier eBooks+ at [eBooks.Health.Elsevier.com](http://eBooks.Health.Elsevier.com) for Bibliography.



## Chapter 317

## Ebola and Other Viral Hemorrhagic Fevers

Scott B. Halstead

Viral hemorrhagic fevers are a loosely defined group of clinical syndromes in which hemorrhagic manifestations are either common or especially notable during severe illness. Both the etiologic agents and the clinical features of the syndromes differ, but coagulopathy may be a common pathogenetic feature.

**ETIOLOGY**

Six of the viral hemorrhagic fevers are caused by arthropod-borne viruses (arboviruses) (Table 317.1). Four are caused by togaviruses of the family **Flaviviridae**: Kyasanur Forest disease, Omsk hemorrhagic fever, dengue (see Chapter 315), and yellow fever (see Chapter 316) viruses. Three are caused by viruses of the family **Bunyaviridae**: Congo fever, Hantaan fever, and Rift Valley fever (RVF) viruses. Four are caused by viruses of the family **Arenaviridae**: Junin fever, Machupo fever, Guanarito fever, and Lassa fever. Two are caused by viruses in the family **Filoviridae**: Ebola virus and Marburg virus, enveloped, filamentous RNA viruses that are sometimes branched, unlike any other known virus.

**EPIDEMIOLOGY**

With some exceptions, the viruses causing viral hemorrhagic fevers are transmitted to humans via a nonhuman entity. The specific ecosystem required for viral survival determines the geographic distribution of disease. Although it is commonly thought that all viral hemorrhagic fevers are arthropod borne, seven may be contracted from environmental contamination caused by animals or animal cells or from infected humans (see Table 317.1). Laboratory and hospital infections have occurred with many of these agents. Lassa fever and Argentine

and Bolivian hemorrhagic fevers are reportedly milder in children than in adults.

**Crimean-Congo Hemorrhagic Fever**

Sporadic human infection with Crimean-Congo hemorrhagic fever in Africa provided the original virus isolation. Natural foci are recognized in Bulgaria, western Crimea, and the Rostov-on-Don and Astrakhan regions; disease occurs in Central Asia from Kazakhstan to Pakistan. Index cases were followed by nosocomial transmission in Pakistan and Afghanistan in 1976, in the Arabian Peninsula in 1983, and in South Africa in 1984. In the Russian Federation, the vectors are ticks of the species *Hyalomma marginatum* and *Hyalomma anatolicum*, which, along with hares and birds, may serve as viral reservoirs. Disease occurs from June to September, largely among farmers and dairy workers.

**Kyasanur Forest Disease**

Human cases of Kyasanur Forest disease occur chiefly in adults in an area of Mysore State, India. The main vectors are two Ixodidae ticks, *Haemaphysalis turturis* and *Haemaphysalis spinigera*. Monkeys and forest rodents may be amplifying hosts. Laboratory infections are common.

**Omsk Hemorrhagic Fever**

Omsk hemorrhagic fever occurs throughout south-central Russia and northern Romania. Vectors may include *Dermacentor pictus* and *Dermacentor marginatus*, but direct transmission from moles and muskrats to humans seems well established. Human disease occurs in a spring–summer–autumn pattern, paralleling the activity of the vectors. This infection occurs most frequently in persons with outdoor occupational exposure. Laboratory infections are common.

**Rift Valley Fever**

The virus causing RVF is responsible for epizootics involving sheep, cattle, buffalo, certain antelopes, and rodents in North, Central, East, and South Africa. The virus is transmitted to domestic animals by *Culex theileri* and several *Aedes* species. Mosquitoes may serve as reservoirs by transovarial transmission. An epizootic in Egypt in 1977–1978 was accompanied by thousands of human infections, principally among veterinarians, farmers, and farm laborers. Smaller outbreaks occurred in Senegal in 1987, Madagascar in 1990, and Saudi Arabia and Yemen in 2000–2001. Humans are most often infected during the slaughter or skinning of sick or dead animals. Laboratory infection is common.

**Argentine Hemorrhagic Fever**

Before the introduction of vaccine, hundreds to thousands of cases of Argentine hemorrhagic fever occurred annually from April through July in the maize-producing area northwest of Buenos Aires that reaches to the eastern margin of the Province of Cordoba. Junin virus has been isolated from the rodents *Mus musculus*, *Akodon arenicola*, and *Calomys laucha*. It infects migrant laborers who harvest the maize and who inhabit rodent-contaminated shelters.

**Bolivian Hemorrhagic Fever**

The recognized endemic area of Bolivian hemorrhagic fever consists of the sparsely populated province of Beni in Amazonian Bolivia. Sporadic cases occur in farm families who raise maize, rice, yucca, and beans. In the town of San Joaquin, a disturbance in the domestic rodent ecosystem may have led to an outbreak of household infection caused by Machupo virus transmitted by chronically infected *Calomys callosus*, ordinarily a field rodent. Mortality rates are high in young children.

**Venezuelan Hemorrhagic Fever**

In 1989, an outbreak of hemorrhagic illness occurred in the farming community of Guanarito, Venezuela, 200 miles south of Caracas. Subsequently, in 1990–1991, there were 104 cases reported with 26 deaths caused by Guanarito virus. Cotton rats (*Sigmodon alstoni*) and cane rats (*Zygodontomys brevicauda*) have been implicated as likely reservoirs of Venezuelan hemorrhagic fever.

Table 317.1 Viral Hemorrhagic Fevers

MODE OF TRANSMISSION	DISEASE	VIRUS
Tick-borne	Crimean-Congo hemorrhagic fever (HF)*	Congo
	Kyasanur Forest disease	Kyasanur Forest disease
	Omsk HF	Omsk
Mosquito-borne†	Dengue HF	Dengue (4 types)
	Rift Valley fever	Rift Valley fever
	Yellow fever	Yellow fever
Infected animals or materials to humans	Argentine HF	Junin
	Bolivian HF	Machupo
	Lassa fever*	Lassa
	Marburg disease*	Marburg
	Ebola HF*	Ebola
	HF with renal syndrome	Hantaan

\*Patients may be contagious; nosocomial infections are common.

†Chikungunya virus is associated infrequently with petechiae and epistaxis. Severe hemorrhagic manifestations have been reported in some cases.



### Lassa Fever

Lassa virus has an unusual potential for human-to-human spread, resulting in many small epidemics in Nigeria, Sierra Leone, and Liberia. In 2012, an outbreak of more than 1,000 cases of Lassa fever occurred in east-central Nigeria. Medical workers in Africa and the United States have also contracted the disease. Patients with acute Lassa fever have been transported by international aircraft, necessitating extensive surveillance among passengers and crews. The virus is probably maintained in nature in a species of African peridomestic rodent, *Mastomys natalensis*. Rodent-to-rodent transmission and infection of humans probably operate via mechanisms established for other arenaviruses.

### Marburg Disease

Previously, the world experience of human infections caused by Marburgvirus had been limited to 26 primary and 5 secondary laboratory-based cases in Germany and Yugoslavia in 1967 and to small outbreaks in Zimbabwe in 1975, Kenya in 1980 and 1988, and South Africa in 1983. However, in 1999 a large outbreak occurred in the Republic of Congo, and in 2005 a still larger outbreak occurred in Uige Province, Angola, with 252 cases and 227 deaths. In laboratory and clinical settings, transmission occurs by direct contact with tissues of the African green monkey or with infected human blood or semen. A reservoir in the African fruit bat, *Rousettus aegyptiacus*, has been demonstrated. Fruit bats infected with Marburg virus do not show obvious signs of illness. It appears that the virus is transmitted by close contact with fructivorous bats and by aerosol from bats.

### Ebola Hemorrhagic Fever

Ebola virus was isolated in 1976 from a devastating epidemic involving small villages in northern Zaire and southern Sudan; smaller outbreaks have occurred subsequently. Outbreaks have initially been nosocomial. Attack rates have been highest in children from birth to 1 year of age and in persons from 15–50 years of age. The virus is in the *Filovirus* family and closely related to viruses in the genus Marburg virus. An Ebola virus epidemic occurred in Kikwit, Zaire, in 1995, followed by scattered outbreaks in Uganda and Central and West Africa. The virus has been recovered from chimpanzees, and antibodies have been found in other subhuman primates, which apparently acquire infection from a zoonotic reservoir in bats. The natural reservoir of Ebola is thought to be fruit bats. Reston virus, related to Ebola virus, has been recovered from Philippine monkeys and pigs and has caused subclinical infections in humans working in monkey colonies in the United States.

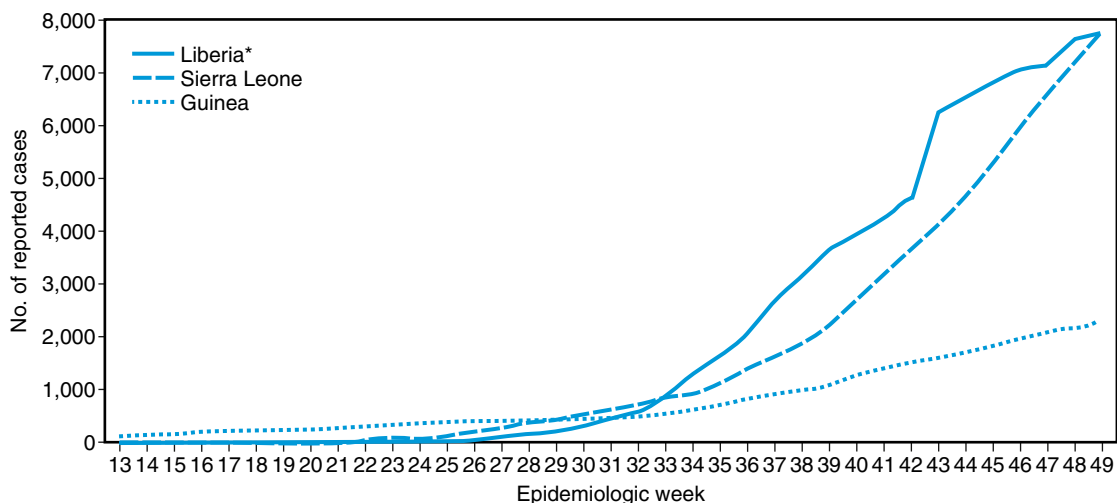
In 2014, West Africa experienced the largest outbreak of Ebola virus disease (EVD) in history and the first transmission in a large urban area (Fig. 317.1). Countries primarily affected were Liberia, Sierra

Leone, and Guinea, with imported cases reported in Nigeria, Mali, and Senegal, as well as Europe and the United States. The outbreak was caused by the Zaire Ebola virus (species of Ebola virus include the Zaire, Sudan, Bundibugyo, Reston, and Tai Forest species), which has a mortality rate of approximately 55–65%. As of 8 May 2016, the World Health Organization (WHO) and respective governments reported a total of 28,616 suspected cases and 11,310 deaths (39.5%), though the WHO thinks that this substantially understates the magnitude of the outbreak. The outbreak had largely subsided by the end of 2015. In 2018–2020, an outbreak occurred in the Democratic Republic of the Congo, affecting more than 500 people (age 8–80 years), with a case fatality of approximately 50% (Fig. 317.2). In 2021 the Ministry of Health (MOH) in the Democratic Republic of the Congo (DRC) announced that a case of EVD had been confirmed in Biena Health Zone, North Kivu Province. Sequencing of samples suggests that this outbreak was linked to the 2018–2020 outbreak, likely caused by a persistent infection in a survivor that led to either a relapse or sexual transmission of the virus.

EVD may occur after exposure to fruit bats or bushmeat but most often occurs through exposure to body fluids of infected individuals (blood, sweat, saliva, vomitus, diarrhea, and less often human milk or semen) (Table 317.2). Persistent infection after recovery from acute EVD has been well documented, with virus particles present in body fluids such as semen for many months in apparently healthy survivors. Patients are infectious once they are symptomatic; the incubation period is 2–21 days (mean: 11 days). The age range in the West African epidemic was broad, but most patients were between 15 and 44 years old.

### Hemorrhagic Fever with Renal Syndrome

The endemic area of hemorrhagic fever with renal syndrome (HFRS), also known as *epidemic hemorrhagic fever* and *Korean hemorrhagic fever*, includes Japan, Korea, far eastern Siberia, north and central China, European and Asian Russia, Scandinavia, Czechoslovakia, Romania, Bulgaria, Yugoslavia, and Greece. Although the incidence and severity of hemorrhagic manifestations and the mortality rates are lower in Europe than in northeastern Asia, the renal lesions are the same. Disease in Scandinavia, *nephropathia epidemica*, is caused by a different although antigenically related virus, Puumala virus, associated with the bank vole, *Clethrionomys glareolus*. Cases occur predominantly in the spring and summer. There appears to be no age factor in susceptibility, but because of occupational hazards, young adult men are most frequently attacked. Rodent plagues and evidence of rodent infestation have accompanied endemic and epidemic occurrences. Hantaan virus has been detected in the lung tissue and excreta



**Fig. 317.1** Cumulative number of Ebola virus disease cases reported—three countries, West Africa, April 13, 2016. Reported from Sierra Leone (14,124 cases) and Liberia (10,678), followed by Guinea (3,814). (Data from the number of cases and deaths in Guinea, Liberia, and Sierra Leone during the 2014–2016 West Africa Ebola Outbreak. <https://www.cdc.gov/vhf/ebola/outbreaks/2014-west-africa/case-counts.html>)

of *Apodemus agrarius coreae*. Antigenically related agents have been detected in laboratory rats and in urban rat populations around the

world, including Prospect Hill virus in the wild rodent *Microtus pennsylvanicus* in North America and *sin nombre* virus in the deer mouse in the southern and southwestern United States; these viruses are causes of hantavirus pulmonary syndrome (see Chapter 319). Rodent-to-rodent and rodent-to-human transmission presumably occurs via the respiratory route.

**CLINICAL MANIFESTATIONS**

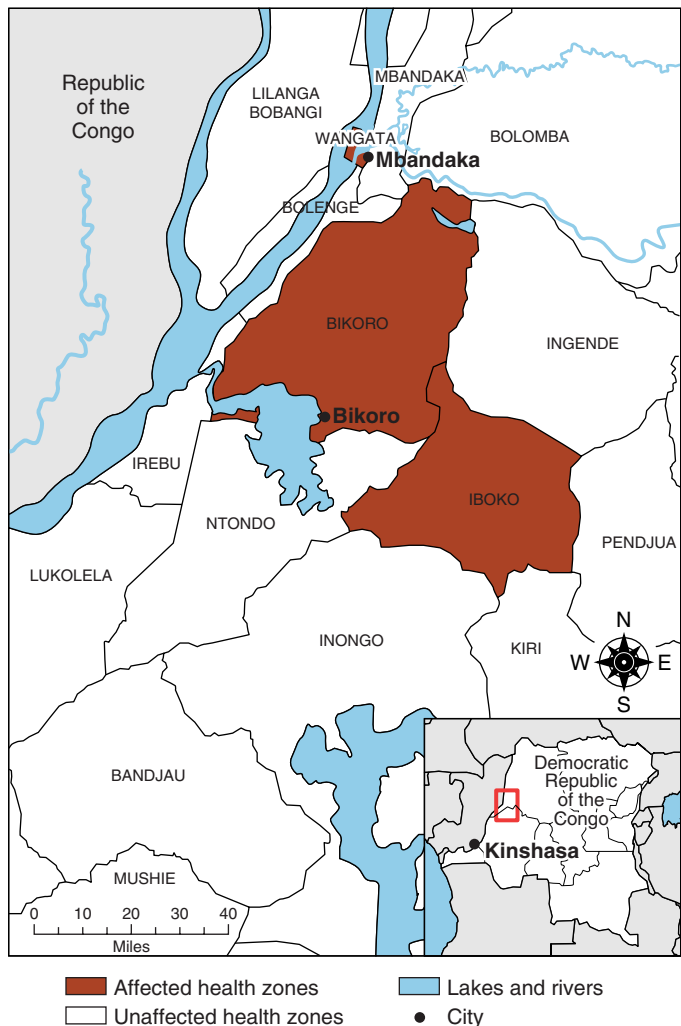
Dengue hemorrhagic fever (see Chapter 315) and yellow fever (see Chapter 316) cause similar syndromes in children in endemic areas.

**Crimean-Congo Hemorrhagic Fever**

The incubation period of 3-12 days is followed by a febrile period of 5-12 days and a prolonged convalescence. Illness begins suddenly with fever, severe headache, myalgia, abdominal pain, anorexia, nausea, and vomiting. After 1-2 days, the fever may subside until the patient experiences an erythematous facial or truncal flush and injected conjunctivae. A second febrile period of 2-6 days then develops, with a hemorrhagic enanthem on the soft palate and a fine petechial rash on the chest and abdomen. Less frequently, there are large areas of purpura and bleeding from the gums, nose, intestines, lungs, or uterus. Hematuria and proteinuria are relatively rare. During the hemorrhagic stage, there is usually tachycardia with diminished heart sounds and occasionally hypotension. The liver is usually enlarged, but there is no icterus. In protracted cases, central nervous system signs include delirium, somnolence, and progressive clouding of the consciousness. Early in the disease, leukopenia with relative lymphocytosis, progressively worsening thrombocytopenia, and gradually increasing anemia occur. In convalescence there may be hearing and memory loss. The mortality rate is 2–50%.

**Kyasanur Forest Disease and Omsk Hemorrhagic Fever**

After an incubation period of 3-8 days, both Kyasanur Forest disease and Omsk hemorrhagic fever begin with the sudden onset of fever and headache. Kyasanur Forest disease is characterized by severe myalgia, prostration, and bronchiolar involvement; it often manifests without hemorrhage but occasionally involves severe gastrointestinal bleeding. In Omsk hemorrhagic fever, there is moderate epistaxis, hematemesis, and a hemorrhagic enanthem but no profuse hemorrhage; bronchopneumonia is common. In both diseases, severe leukopenia and thrombocytopenia, vascular dilation, increased vascular permeability, gastrointestinal hemorrhages, and subserosal and interstitial petechial hemorrhages occur. Kyasanur Forest disease may be complicated by acute degeneration of the renal tubules and focal liver damage. In many patients, recurrent febrile illness may follow an



**Fig. 317.2** Map of Ebola-affected health zones in the Democratic Republic of the Congo (DRC), 2018. (Courtesy the Centers for Disease Control and Prevention, 2018. <https://www.cdc.gov/vhf/ebola/outbreaks/drc/drc-map.html>)

Table 317.2 Clinical Recommendations for Ebola Virus Infection		
RECOMMENDATION	POPULATION	INTERVENTION
1	Patients with suspected, probable, or confirmed Ebola virus disease	Oral rehydration
2	Patients with suspected, probable, or confirmed Ebola virus disease who are unable to drink or who have inadequate oral intake	Parenteral administration of fluids
3	Patients with suspected, probable, or confirmed Ebola virus disease	Systematic monitoring and charting of vital signs and volume status
4	Patients with suspected, probable, or confirmed Ebola virus disease	Serum biochemistry
5	Patients with suspected, probable, or confirmed Ebola virus disease	Staffing ratio
6	Patients with suspected, probable, or confirmed Ebola virus disease	Communication with family and friends
7	Patients with suspected, probable, or confirmed Ebola virus disease who are in pain	Analgesic therapy
8	Patients with suspected, probable, or confirmed Ebola virus disease with high severity of illness	Antibiotics

Modified from Lamontagne F, Fowler RA, Adhikari NK, et al. Evidence-based guidelines for supportive care of patients with Ebola virus disease. *Lancet*. 2018;391:700–708. Table 2.

**Table 317.3** Clinical Stages of Lassa Fever

STAGE	SYMPTOMS
1 (days 1-3)	General weakness and malaise; high fever >39°C (102.2°F), constant with peaks of 40–41°C (104–105.8°F)
2 (days 4-7)	Sore throat (with white exudative patches) very common; headache; back, chest, side, or abdominal pain; conjunctivitis; nausea and vomiting; diarrhea; productive cough; proteinuria; low blood pressure (systolic <100mm Hg); anemia
3 (after 7 days)	Facial edema; convulsions; mucosal bleeding (mouth, nose, eyes); internal bleeding; confusion or disorientation
4 (after 14 days)	Coma and death

From Richmond JK, Baglole DJ. Lassa fever: epidemiology, clinical features, and social consequences. *BMJ*. 2003;327:1271–1275.

afebrile period of 7–15 days. This second phase takes the form of a meningoencephalitis.

### Rift Valley Fever

Most RVF infections have occurred in adults with signs and symptoms resembling those of dengue fever (see [Chapter 315](#)). The onset is acute, with fever, headache, prostration, myalgia, anorexia, nausea, vomiting, conjunctivitis, and lymphadenopathy. The fever lasts 3–6 days and is often biphasic. The convalescence is often prolonged. In the 1977–1978 outbreak, many patients died after showing signs that included purpura, epistaxis, hematemesis, and melena. RVF affects the uvea and posterior chorioretina; macular scarring, vascular occlusion, and optic atrophy occur, resulting in permanent visual loss in a high proportion of patients with mild to severe RVF. At autopsy, extensive eosinophilic degeneration of the parenchymal cells of the liver has been observed.

### Argentine, Venezuelan, and Bolivian Hemorrhagic Fevers and Lassa Fever

The incubation period in Argentine, Venezuelan, and Bolivian hemorrhagic fevers and Lassa fever is commonly 7–14 days; the acute illness lasts for 2–4 weeks. Clinical illnesses range from undifferentiated fever to the characteristic severe illness. **Lassa fever** is most often clinically severe in White persons. The onset is usually gradual, with increasing fever, headache, diffuse myalgia, and anorexia ([Table 317.3](#)). During the first week, signs frequently include a sore throat, dysphagia, cough, oropharyngeal ulcers, nausea, vomiting, diarrhea, and pains in the chest and abdomen. Pleuritic chest pain may persist for 2–3 weeks. In Argentine and Bolivian hemorrhagic fevers and less frequently in Lassa fever, a petechial enanthem appears on the soft palate 3–5 days after onset and at about the same time on the trunk. The tourniquet test may be positive. The clinical course of Venezuelan hemorrhagic fever has not been well described.

In 35–50% of patients, these diseases may become severe, with persistent high temperature, increasing toxicity, swelling of the face or neck, microscopic hematuria, and frank hemorrhages from the stomach, intestines, nose, gums, and uterus. A syndrome of **hypovolemic shock** is accompanied by pleural effusion and renal failure. **Respiratory distress** resulting from airway obstruction, pleural effusion, or congestive heart failure may occur. A total of 10–20% of patients experience late neurologic involvement, characterized by intention tremor of the tongue and associated speech abnormalities. In severe cases, there may be intention tremors of the extremities, seizures, and delirium. The cerebrospinal fluid is normal. In Lassa fever, nerve deafness occurs in early convalescence in 25% of cases. Prolonged convalescence is accompanied by alopecia and, in Argentine and Bolivian

hemorrhagic fevers, by signs of autonomic nervous system lability, such as postural hypotension, spontaneous flushing or blanching of the skin, and intermittent diaphoresis.

**Laboratory studies** reveal marked leukopenia, mild to moderate thrombocytopenia, proteinuria, and, in Argentine hemorrhagic fever, moderate abnormalities in blood clotting, decreased fibrinogen, increased fibrinogen split products, and elevated serum transaminases. There is focal, often extensive eosinophilic necrosis of the liver parenchyma, focal interstitial pneumonitis, focal necrosis of the distal and collecting tubules, and partial replacement of splenic follicles by amorphous eosinophilic material. Usually, bleeding occurs by diapedesis with little inflammatory reaction. The mortality rate is 10–40%.

### Marburg Disease and Ebola Hemorrhagic Fever

After an incubation period of 4–7 days, the illness begins abruptly, with severe frontal headache, malaise, drowsiness, lumbar myalgia, vomiting, nausea, and diarrhea. A **maculopapular** eruption begins 5–7 days later on the trunk and upper arms. It becomes generalized and often hemorrhagic and exfoliates during convalescence. The exanthem is accompanied by a dark red enanthem on the hard palate, conjunctivitis, and scrotal or labial edema. Gastrointestinal hemorrhage occurs as the severity of illness increases. Late in the illness, the patient may become tearfully depressed, with marked hyperalgesia to tactile stimuli. In fatal cases, patients become hypotensive, restless, and confused and lapse into coma. Convalescent patients may experience alopecia and may have paresthesias of the back and trunk. There is a marked leukopenia with necrosis of granulocytes. Dysfunction in bleeding and clotting and thrombocytopenia are universal and correlated with the severity of disease; there are moderate abnormalities in concentrations of clotting proteins and elevations of serum transaminases and amylase. Pregnant women and young children are at high risk of severe disease with a fatal outcome. The mortality rate of Marburg disease is 25–85%, and the mortality rate of Ebola hemorrhagic fever 50–90%. High viral loads in acute-phase blood samples convey a poor prognosis. Viral RNA persists in tissues long after symptoms subside, and the virus has been excreted in semen more than 1 year after recovery.

Manifestations of EVD may come in stages, but most EVD begins with the sudden onset of fever accompanied by fatigue, weakness, myalgias, headache, and sore throat. This is followed by gastrointestinal involvement, including anorexia, nausea, abdominal pain, vomiting, and diarrhea. Hemorrhage (defined by any evidence of bleeding) is seen in more than 50% and is a serious later phase, often accompanied by vascular leakage, multiorgan failure, and death. Those who survive improve on approximately days 6–11 of EVD. One late relapse producing meningoencephalitis has been reported.

### Hemorrhagic Fever with Renal Syndrome

In most cases, HFRS is characterized by fever, petechiae, mild hemorrhagic phenomena, and mild proteinuria, followed by a relatively uneventful recovery. In 20% of recognized cases, the disease may progress through four distinct phases. The febrile phase is ushered in with fever, malaise, and facial and truncal flushing. It lasts 3–8 days and ends with thrombocytopenia, petechiae, and proteinuria. The hypotensive phase of 1–3 days follows defervescence. Loss of fluid from the intravascular compartment may result in marked hemoconcentration. Proteinuria and ecchymoses increase. The oliguric phase, usually 3–5 days in duration, is characterized by a low output of protein-rich urine, increasing nitrogen retention, nausea, vomiting, and dehydration. Confusion, extreme restlessness, and hypertension are common. The diuretic phase, which may last for days or weeks, usually initiates clinical improvement. The kidneys show little concentrating ability, and rapid loss of fluid may result in severe dehydration and shock. Potassium and sodium depletion may be severe. Fatal cases manifest as abundant protein-rich retroperitoneal edema and marked hemorrhagic necrosis of the renal medulla. The mortality rate is 5–10%.



## DIAGNOSIS

The diagnosis of these viral hemorrhagic fevers depends on a high index of suspicion in endemic areas. In nonendemic areas, histories of recent travel, recent laboratory exposure, or exposure to an earlier case should evoke suspicion of a viral hemorrhagic fever.

In all viral hemorrhagic fevers, the viral agent circulates in the blood at least transiently during the early febrile stage. Togaviruses and bunyaviruses can be recovered from acute-phase serum samples by inoculation into a tissue culture or living mosquitoes. Argentine, Bolivian, and Venezuelan hemorrhagic fever viruses can be isolated from acute-phase blood or throat washings by intracerebral inoculation into guinea pigs, infant hamsters, or infant mice. Lassa virus may be isolated from acute-phase blood or throat washings by inoculation into tissue cultures. For Marburg disease and Ebola hemorrhagic fever, acute-phase throat washings, blood, and urine may be inoculated into a tissue culture, guinea pigs, or monkeys. The viruses are readily identified on electron microscopy, with a filamentous structure differentiating them from all other known agents. Specific complement-fixing and immunofluorescent antibodies appear during convalescence. The virus of HFRS is recovered from acute-phase serum or urine by inoculation into a tissue culture. A variety of antibody tests using viral subunits is becoming available. The serologic diagnosis depends on the demonstration of seroconversion or a fourfold or greater increase in immunoglobulin G antibody titer in acute and convalescent serum specimens collected 3–4 weeks apart. Viral RNA may also be detected in blood or tissues with the use of reverse transcriptase polymerase chain reaction analysis.

The diagnosis of EVD is confirmed by enzyme-linked immunosorbent assay immunoglobulin M and polymerase chain reaction (which may need to be repeated if initially negative) testing. Criteria to aid in the diagnosis of EVD include temperature  $>38.6^{\circ}\text{C}$  ( $101.5^{\circ}\text{F}$ ) plus symptoms; contact with an affected patient, the patient's body fluids, or the funeral; residence in or travel to an endemic region; or a history of handling bats, rodents, or primates from an endemic area.

*Handling blood and other biologic specimens is hazardous and must be performed by specially trained personnel.* Blood and autopsy specimens should be placed in tightly sealed metal containers, wrapped in absorbent material inside a sealed plastic bag, and shipped on dry ice to laboratories with biocontainment safety level 4 facilities. Even routine hematologic and biochemical tests should be done with extreme caution.

## Differential Diagnosis

Mild cases of hemorrhagic fever may be confused with almost any self-limited systemic bacterial or viral infection. More severe cases may suggest typhoid fever; epidemic, murine, or scrub typhus; leptospirosis; or a rickettsial spotted fever, for which effective chemotherapeutic agents are available. Many of these disorders may be acquired in geographic or ecologic locations endemic for a viral hemorrhagic fever.

The differential diagnosis of EVD includes malaria, typhoid, Lassa fever, influenza infection, and meningococemia.

## TREATMENT

Ribavirin administered intravenously is effective in reducing mortality rates in Lassa fever and HFRS. Further information and advice about the management, control measures, diagnosis, and collection of biohazardous specimens can be obtained from the Centers for Disease Control and Prevention, National Center for Infectious Diseases, Viral Special Pathogens Branch, Atlanta, Georgia 30333 (470-312-0094).

The therapeutic principle involved in all of these diseases, especially HFRS, is the reversal of dehydration, hemoconcentration, renal failure, and protein, electrolyte, or blood losses (see Table 317.2). The contribution of disseminated intravascular coagulopathy to the

hemorrhagic manifestations is unknown, and the management of hemorrhage should be individualized. Transfusions of fresh blood and platelets are frequently given. Good results have been reported in a few patients after the administration of clotting factor concentrates. The efficacy of corticosteroids,  $\epsilon$ -aminocaproic acid, pressor amines, and  $\alpha$ -adrenergic blocking agents has not been established. Sedatives should be selected with regard to the possibility of kidney or liver damage. The successful management of HFRS may require renal dialysis.

Whole-blood transfusions from Ebola virus-immune donors and administration of Ebola monoclonal antibodies have been shown to be effective in lowering case fatality rates.

Patients suspected of having Lassa fever, Ebola fever, Marburg fever, or Congo-Crimean hemorrhagic fever should be placed in a private room on standard contact and droplet precautions. Caretakers should use barrier precautions to prevent skin or mucous membrane exposure. All persons entering the patient's room should wear gloves, gowns, and face shields. Before exiting the patient's room, caretakers should safely remove and dispose of all protective gear and should clean and disinfect shoes. Protocols require two-person clinical care teams, one observer and one caregiver (see Centers for Disease Control and Prevention [CDC] website: <https://www.cdc.gov/vhf/ebola>).

Treatment of EVD often requires an intensive care unit and management of multiorgan system dysfunction, including correction of hypovolemia, hyponatremia, hypokalemia, hypoalbuminemia, hypocalcemia, and hypoxia, often with renal replacement therapy as well as ventilation support (see Table 317.2). Convalescent serum and monoclonal antibodies have been employed on an experimental basis. Strict isolation and appropriate barrier protection of healthcare workers is mandatory. Several vaccines have been shown to be immunogenic, and one used late in the epidemic was protective. Epidemic control measures, isolation, and quarantine have been used to attempt to decrease the spread of the West African epidemic.

## PREVENTION

A live-attenuated vaccine (Candid-I) for Argentine hemorrhagic fever (Junin virus) is highly efficacious. A form of inactivated mouse brain vaccine is reported to be effective in preventing Omsk hemorrhagic fever. Inactivated RVF vaccines are widely used to protect domestic animals and laboratory workers. HFRS inactivated vaccine is licensed in Korea, and killed and live-attenuated vaccines are widely used in China. A vaccinia-vector glycoprotein vaccine provides protection against Lassa fever in monkeys. Single doses of recombinant vesicular stomatitis virus or adenovirus type 3 vaccines containing surface glycoproteins from Ebola and Marburg viruses have been shown to protect monkeys against Ebola virus and Marburg virus disease. The vesicular stomatitis-vectored Ebola vaccine was shown to be effective in preventing Ebola cases in a ring vaccination trial in Guinea and has been used widely in outbreaks since 2018.

Prevention of mosquito-borne and tick-borne infections includes use of repellents, wearing of tight-fitting clothing that fully covers the extremities, and careful examination of the skin after exposure, with removal of any vectors found. Diseases transmitted from a rodent-infected environment can be prevented through methods of rodent control; elimination of refuse and breeding sites is particularly successful in urban and suburban areas.

Patients should be isolated until they are virus-free or for 3 weeks after illness. Patient urine, sputum, blood, clothing, and bedding should be disinfected. Disposable syringes and needles should be used. Prompt and strict enforcement of barrier nursing may be lifesaving. The mortality rate among medical workers contracting these diseases is 50%. A few entirely asymptomatic Ebola infections result in strong antibody production.

Visit Elsevier eBooks+ at [eBooks.Elsevier.com](http://eBooks.Elsevier.com) for Bibliography.



## Chapter 318

# Lymphocytic Choriomeningitis Virus

Daniel J. Bonthius

Lymphocytic choriomeningitis virus (LCMV) is a prevalent human pathogen and an important cause of meningitis in children and adults. Capable of crossing the placenta and infecting the fetus, LCMV is also an important cause of neurologic birth defects and encephalopathy in the newborn.

## ETIOLOGY

LCMV is a member of the family *Arenaviridae*, which are enveloped, negative-sense, single-stranded RNA viruses. The name of the arenaviruses is derived from *arenosus*, the Latin word for “sandy,” because of the fine granularities observed within the virion on ultra-thin electron microscopic sections.

## EPIDEMIOLOGY

Like all arenaviruses, LCMV uses rodents as its reservoir. The common house mouse, *Mus musculus*, is both the natural host and primary reservoir for the virus, which is transferred vertically from one generation of mice to the next via intrauterine infection. Hamsters and guinea pigs are also potential reservoirs. Although heavily infected with LCMV, rodents that acquire the virus transplacentally often remain asymptomatic because congenital infection provides rodents with immunologic tolerance for the virus. Infected rodents shed the virus in large quantities in nasal secretions, urine, feces, saliva, and milk throughout their lives.

Humans typically acquire LCMV by contacting fomites contaminated with infectious virus or by inhaling aerosolized virus. Most human infections occur during the fall and early winter, when mice move into human habitations. Humans can also acquire the virus via organ transplantation. Congenital LCMV infection occurs when a woman acquires a primary LCMV infection during pregnancy. The virus passes through the placenta to the fetus during maternal viremia. The fetus may also acquire the virus during passage through the birth canal from exposure to infected vaginal secretions. Outside of organ transplantation and vertical transmission during pregnancy, there have been no cases of human-to-human transmission of LCMV.

LCMV is prevalent in the environment, has a great geographic range, and infects large numbers of humans. The virus is found throughout the world's temperate regions and probably occurs wherever the genus *Mus* has been introduced (which is every continent but Antarctica). An epidemiologic study found that 9% of house mice are infected and that substantial clustering occurs, where the prevalence is higher. Serologic studies demonstrate that approximately 5% of adult humans possess antibodies to LCMV, indicating prior exposure and infection.

## PATHOGENESIS

LCMV is not a cytolytic virus. Thus unlike many other nervous system pathogens that directly damage the brain by killing host brain cells, LCMV pathogenesis involves other underlying mechanisms. Furthermore, the pathogenic mechanisms are different in postnatal (acquired) infection compared with prenatal (congenital) infection. A critical difference in the pathogenesis of postnatal versus prenatal infection is that the virus infects brain parenchyma in the case of prenatal infection but is restricted to the meninges and choroid plexus in postnatal cases.

In postnatal infections, LCMV replicates to high titers in the choroid plexus and meninges. Viral antigen within these tissues becomes the target of an acute mononuclear cell infiltration driven by CD8<sup>+</sup> T lymphocytes. The presence of lymphocytes in large numbers within

the meninges and cerebrospinal fluid (CSF) leads to the symptoms of meningitis that mark acquired LCMV infection. As the lymphocytes clear the virus from the meninges and CSF, the density of lymphocytes declines and the symptoms of meningitis resolve. Thus symptoms of acquired (postnatal) LCMV infection are immune mediated and are a result of the presence of large numbers of lymphocytes.

Prenatal infection likewise inflames the tissues surrounding the brain parenchyma, and this inflammation leads to some of the signs of congenital LCMV. In particular, within the ventricular system, congenital LCMV infection often leads to ependymal inflammation, which may block the egress of CSF at the cerebral aqueduct and lead to hydrocephalus. However, unlike postnatal cases, prenatal infection with LCMV includes infection of the substance of the brain rather than just the meninges or ependyma. This infection of brain parenchyma leads to the substantial neuropathologic changes typically accompanying congenital LCMV infection. In particular, LCMV infects the mitotically active neuroblasts, located at periventricular sites. Through an unknown mechanism, the presence of the virus kills these periventricular cells, leading to periventricular calcifications, a radiographic hallmark of this disorder. Within the fetal brain, LCMV infection of neurons and glial cells also disrupts neuronal migration, leading to abnormal gyral patterns, and interferes with neuronal mitosis, leading to microcephaly and cerebellar hypoplasia.

## CLINICAL MANIFESTATIONS

The clinical manifestations of LCMV infection depend on whether the infection occurs prenatally or postnatally. Congenital infection with LCMV is unique, as it involves both the postnatal infection of a pregnant woman and the prenatal infection of a fetus.

### Acquired (Postnatal) Lymphocytic Choriomeningitis Virus Infection

LCMV infection during postnatal life (during childhood or adulthood) typically consists of a brief febrile illness from which the patient fully recovers. The illness classically consists of two clinical phases. In the first phase, the symptoms are those of a nonspecific viral syndrome and include fever, myalgia, malaise, nausea, anorexia, and vomiting. These symptoms usually resolve after several days but are followed by a second phase, consisting of central nervous system disease. The symptoms of this second phase are those of aseptic meningitis, including headache, fever, nuchal rigidity, photophobia, and vomiting. The entire course of the biphasic disease is typically 1-3 weeks.

The clinical spectrum of LCMV infection is broad. One third of postnatal infections are asymptomatic. Other patients develop extraneural disease that extends beyond the usual symptoms and may include orchitis, pneumonitis, myocarditis, parotitis, dermatitis, alopecia, and pharyngitis. In others, the neurologic disease may be considerably more severe than usual and may include transverse myelitis, Guillain-Barré syndrome, hydrocephalus, and encephalitis. Recovery from acquired LCMV infection is usually complete, but fatalities occasionally occur.

LCMV infections acquired via solid organ transplantation always induce severe disease. Several weeks after the transplantation, recipients of infected organs develop fever, leukopenia, and lethargy. After these nonspecific symptoms, the course of the disease rapidly progresses to multiorgan system failure and shock. These cases are almost always fatal.

### Congenital Lymphocytic Choriomeningitis Virus Infection

LCMV infection during pregnancy can kill the fetus and induce spontaneous abortion. Among surviving fetuses, the two clinical hallmarks of congenital LCMV infection are vision impairment and brain dysfunction.

The vision impairment in congenital LCMV infection is a result of **chorioretinitis** and the formation of chorioretinal scars. The scarring is usually bilateral and most commonly located in the periphery of the fundus, but involvement of the macula also occurs.

Although the retinal injuries from congenital LCMV infection are often severe, it is the *brain* effects that cause the greatest disability. Prenatal infection with LCMV commonly induces either macrocephaly or microcephaly. **Macrocephaly** after LCMV infection is almost invariably caused by noncommunicating hydrocephalus, stemming from inflammation within the ventricular system. **Microcephaly** is a result of the virus-induced failure of brain growth. In addition to disturbances of head size, periventricular calcifications are also cardinal features of congenital LCMV infection.

Although hydrocephalus, microencephaly, and periventricular calcifications are by far the most commonly observed abnormalities of the brain in congenital LCMV, other forms of neuropathology, alone or in combination, can also occur. These include periventricular cysts, porencephalic cysts, encephalomalacia, intraparenchymal calcifications, cerebellar hypoplasia, and neuronal migration disturbances.

Infants with congenital LCMV infection typically present during the newborn period with evidence of brain dysfunction. The most common signs are lethargy, seizures, irritability, and jitteriness.

Within the fetus, LCMV has a specific tropism for the brain. Thus unlike many other congenital infections, LCMV usually does not induce systemic manifestations. Birthweight is typically appropriate for gestational age. Skin rashes and thrombocytopenia, which are common in several other prominent congenital infections, are unusual in congenital LCMV infection. Hepatosplenomegaly is only rarely observed, and serum liver enzyme levels are usually normal. Auditory deficits are unusual.

### LABORATORY FINDINGS

In acquired (postnatal) LCMV infection, the hallmark laboratory abnormality occurs during the second (central nervous system) phase of the disease and is CSF pleocytosis. The CSF typically contains hundreds to thousands of white blood cells, almost all of which are lymphocytes. However, CSF eosinophilia may also occur. Mild elevations of CSF protein and hypoglycorrhachia are common.

In congenital LCMV infection, laboratory findings in the newborn depend on whether the infant is still infected or not. If the infant still harbors the infection, then examination of the CSF may reveal a lymphocytic pleocytosis. Unlike many other congenital infections, LCMV does not typically induce elevations in liver enzymes, thrombocytopenia, or anemia. In many cases, the most reliably abnormal test is the head CT scan, which typically reveals a combination of microencephaly, hydrocephalus, and periventricular calcifications (Fig. 318.1).

### DIAGNOSIS AND DIFFERENTIAL DIAGNOSIS

Acute LCMV infections can be diagnosed by isolating the virus from CSF. Polymerase chain reaction has also been used to detect LCMV RNA in patients with active infections. However, by the time of birth, a baby prenatally infected with LCMV may no longer harbor the virus. Thus congenital LCMV infection is more commonly diagnosed by serologic testing. The immunofluorescent antibody test detects both immunoglobulin (Ig) M and IgG and has greater sensitivity than the more widely available complement fixation method. The immunofluorescent antibody test is commercially available, and its specificity and sensitivity make it an acceptable diagnostic tool. A more sensitive test for detecting congenital LCMV infection is the enzyme-linked immunosorbent assay, which measures titers of LCMV IgG and IgM and is performed at the Centers for Disease Control and Prevention.

For acquired (postnatal) LCMV infection, the principal items in the differential diagnosis are the other infectious agents that can induce meningitis. These include bacteria, fungi, viruses, and some other forms of pathogens. The most common viral causes of meningitis are the enteroviruses, including coxsackieviruses and echoviruses, and the arboviruses, including La Crosse encephalitis virus and equine encephalitis virus. Unlike LCMV, which is most common in winter, the enteroviruses and arboviruses are most commonly acquired in summer and early fall.

The principal items in the differential diagnosis of congenital LCMV infection are the other infectious pathogens that can cross the placenta and damage the developing fetus. These infectious agents are linked by the acronym TORCHS and include *Toxoplasma gondii*, rubella virus, cytomegalovirus, herpes simplex virus, and syphilis. Toxoplasmosis,

Zika virus infection, and cytomegalovirus infection are particularly difficult to differentiate from LCMV, because all of these infectious agents can produce microcephaly, intracerebral calcifications, and chorioretinitis. Although clinical clues may aid in distinguishing one congenital infection from another, definitive identification of the causative infectious agent usually requires laboratory data, including cultures and serologic studies.

### COMPLICATIONS

Complications in children with congenital LCMV infection are nonspecific and include the medical problems that commonly arise in scenarios involving ventriculoperitoneal shunts, severe seizure disorders, and static encephalopathy. These complications include shunt failure or infection, aspiration pneumonia, injuries from falls, and joint contractures.

### TREATMENT

**There is no specific treatment for acquired or congenital LCMV infection.** An effective antiviral therapy for LCMV infection has not yet been developed. Ribavirin is active against LCMV and other arenaviruses *in vitro*, but its utility *in vivo* is unproven. Immunosuppressive therapy, if present, should be reduced.

### Supportive Care

Children with hydrocephalus from congenital LCMV infection often require placement of a ventriculoperitoneal shunt during infancy for treatment of hydrocephalus. Seizures often begin during early postnatal life, are often difficult to control, and require administration of multiple antiepileptic medications. The mental retardation induced by congenital LCMV infection is often profound. In most cases, affected children should be referred for educational intervention during early life. The spasticity accompanying congenital LCMV infection is often severe. Although physical therapy can help to maintain the range of motion and minimize painful spasms and contractures, implantation of a baclofen pump is often helpful.

### PROGNOSIS

The great majority of patients with postnatally acquired LCMV infection have a full recovery with no permanent sequelae. Rarely, postnatal infections induce hydrocephalus and require shunting. Rarer yet, postnatal LCMV infection is fatal.

In contrast to the usual benign outcome of postnatal infections, prenatal infections typically lead to severe and permanent disability.



**Fig. 318.1** Head CT scan from a 2-mo-old microcephalic baby with congenital lymphocytic choriomeningitis virus infection. The scan reveals enlargement of the lateral ventricles (LV) and periventricular calcifications (arrows).

In children with congenital LCMV infection, brain function is nearly always impaired and chorioretinitis is invariably present. Mental retardation, cerebral palsy, ataxia, epilepsy, and blindness are common neurologic sequelae. However, children with congenital LCMV infection have diverse outcomes. All children with the combination of microcephaly and periventricular calcifications are profoundly neurologically impaired. Blindness, medically refractory epilepsy, spastic quadriplegia, and mental retardation are typical of this group. However, other children with congenital LCMV infection who do not have the combination of microcephaly and periventricular calcifications often have a more favorable outcome, with less severe motor, mental, and vision impairments. Children with isolated cerebellar hypoplasia may be ataxic but have only mild or moderate mental retardation and vision loss.

## PREVENTION

No vaccine exists to prevent LCMV infection. However, measures can be taken to reduce the risk of infection. Because rodents, especially house mice, are the principal reservoir of LCMV, people can reduce their risk of contracting the virus by minimizing their exposure to the secretions and excretions of mice. This can be accomplished most effectively by eliminating cohabitation with mice. Congenital LCMV infection will not occur unless a woman contracts a primary infection with LCMV during pregnancy. Thus women should be especially careful to avoid contact or cohabitation with mice during pregnancy. Pregnant women should also avoid contact with pet rodents, especially mice and hamsters. These facts should be stressed during prenatal visits.

Acquisition of LCMV from solid organ transplantation represents a substantial risk to organ recipients. Prospective donors with LCMV meningitis or encephalitis pose a clear risk for transmitting a fatal infection to recipients. Healthcare providers, transplantation centers, and organ procurement organizations should be aware of the risks posed by LCMV and should consider LCMV in any potential donor with signs of aseptic meningitis but no identified infectious agent. The risks and benefits of offering and receiving organs from donors with possible LCMV infection should be carefully considered.

Visit Elsevier eBooks+ at [eBooks.Health.Elsevier.com](http://eBooks.Health.Elsevier.com) for Bibliography.

## Chapter 319

# Hantavirus Pulmonary Syndrome

Scott B. Halstead

Hantavirus pulmonary syndrome (HPS) is caused by multiple closely related hantaviruses that have been identified from the western United States, with sporadic cases reported from the eastern United States (Fig. 319.1) and Canada and important foci of disease in several countries in South America. HPS is characterized by a febrile prodrome followed by the rapid onset of noncardiogenic pulmonary edema and hypotension or shock. Sporadic cases in the United States caused by related viruses may manifest with renal involvement. Cases in Argentina and Chile sometimes include severe gastrointestinal hemorrhaging; nosocomial transmission has been documented in this geographic region only.

## ETIOLOGY

Hantaviruses are a genus in the family Bunyaviridae, which are lipid-enveloped viruses with a negative-sense RNA genome composed of three unique segments. Several pathogenic viruses that have been recognized within the genus include Hantaan virus, which causes the

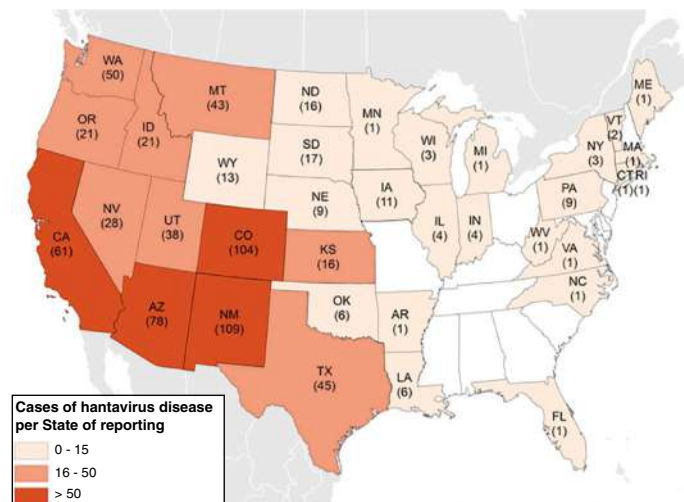
severe disease; hemorrhagic fever with renal syndrome (HFRS), seen primarily in mainland Asia (see Chapter 317); Dobrava virus, the cause of a form of HFRS seen primarily in the Balkans; Puumala virus, which causes a milder disease with a high proportion of subclinical infections prevalent in northern Europe; and Seoul virus, which results in moderate HFRS and is transmitted predominantly in Asia by urban rats or worldwide by laboratory rats. Prospect Hill virus, a hantavirus that is widely disseminated in meadow voles in the United States, is not known to cause human disease. There are an increasing number of case reports of European hantaviruses causing HPS.

HPS is associated with *sin nombre* virus, isolated from deer mice, *Peromyscus maniculatus*, in New Mexico. The multiple HPS-like agents in the Northern Hemisphere isolated to date belong to a single genetic group of hantaviruses and are associated with rodents of the family Muridae, subfamily Sigmodontinae. These rodent species are restricted to the Americas, suggesting that HPS may be a Western Hemisphere disease.

## EPIDEMIOLOGY

Persons acquiring HPS generally have a history of recent outdoor exposure or live in an area with large populations of deer mice. Clusters of cases have occurred among individuals who have cleaned houses that were rodent infested. *P. maniculatus* is one of the most common North American mammals and, where found, is frequently the dominant member of the rodent community. About half of the average of 30+ cases seen annually occurs between the months of May and July. Patients are almost exclusively 12-70 years of age; 60% of patients are 20-39 years of age. Rare cases are reported in children younger than 12 years of age. Two thirds of patients are male, probably reflecting their greater outdoor activities. It is not known whether almost complete absence of disease in young children is a reflection of innate resistance or simply lack of exposure. Evidence of human-to-human transmission has been reported in Argentine outbreaks. As of January 2017, 728 cases of hantavirus disease have been reported in the United States since surveillance began in 1993.

Hantaviruses do not cause apparent illness in their reservoir hosts, which remain asymptotically infected for life. Infected rodents shed virus in saliva, urine, and feces for many weeks, but the duration of shedding and the period of maximum infectivity are unknown. The presence of infectious virus in saliva, the sensitivity of these animals to parenteral inoculation with hantaviruses, and field observations of infected rodents indicate that biting is important for rodent-to-rodent transmission. Aerosols from infective saliva or excreta of rodents are implicated in the transmission of hantaviruses to humans. Persons visiting animal care areas housing infected rodents have been infected



**Fig. 319.1** Total number of confirmed cases of hantavirus pulmonary syndrome, by state reporting, United States, 1993-2016. N = 728 as of January 2017. (From Viral Special Pathogens Branch, Centers for Disease Control and Prevention. <http://www.cdc.gov/hantavirus/surveillance/reporting-state.html>)



after exposure for as little as 5 minutes. It is possible that hantaviruses are spread through contaminated food and breaks in skin or mucous membranes; transmission to humans has occurred by rodent bites. Person-to-person transmission is distinctly uncommon but has been documented in Argentina.

### PATHOGENESIS

HPS is characterized by sudden and catastrophic pulmonary edema, resulting in anoxia and acute heart failure. The virus is detected in pulmonary capillaries, suggesting that pulmonary edema is the consequence of a T-cell attack on virus-infected capillaries. The disease severity is predicted by the level of acute-phase viremia titer. A useful hamster model of HPS is available.

### CLINICAL MANIFESTATIONS

HPS is characterized by a prodrome and a cardiopulmonary phase. The mean duration after the onset of prodromal symptoms to hospitalization is 5.4 days. The mean duration of symptoms to death is 8 days (median: 7 days; range: 2-16 days). The most common **prodromal symptoms** are fever and myalgia (100%); cough or dyspnea (76%); gastrointestinal symptoms, including vomiting, diarrhea, and midabdominal pain (76%); and headache (71%). The **cardiopulmonary phase** is heralded by progressive cough and shortness of breath. The most common initial physical findings are tachypnea (100%), tachycardia (94%), and hypotension (50%). Rapidly progressive acute pulmonary edema, hypoxia, and shock develop in most severely ill patients. Pulmonary vascular permeability is complicated by cardiogenic shock associated with increased vascular resistance. The clinical course of the illness in patients who die is characterized by pulmonary edema accompanied by severe hypotension, frequently terminating in sinus bradycardia, electromechanical dissociation, ventricular tachycardia, or fibrillation. Hypotension may be progressive even with adequate oxygenation. HPS virus is excreted in the urine during the acute illness phase, and survivors may demonstrate evidence of chronic renal damage.

### DIAGNOSIS

The diagnosis of HPS should be considered in a previously healthy patient presenting with a febrile prodrome, acute respiratory distress, and thrombocytopenia who has had outdoor exposure in the spring and summer months. A specific diagnosis of HPS is made by serologic tests that detect hantavirus immunoglobulin M antibodies. The early appearance of immunoglobulin G antibodies signals probable recovery. Hantavirus antigen can be detected in tissue by immunohistochemistry and amplification of hantavirus nucleotide sequences detected by reverse transcriptase polymerase chain reaction. The state health department or the Centers for Disease Control and Prevention should be consulted to assist in the diagnosis, epidemiologic investigations, and outbreak control.

### Laboratory Findings

Laboratory findings include leukocytosis (median: 26,000 cells/ $\mu$ L), an elevated hematocrit resulting from hemoconcentration, thrombocytopenia (median: 64,000 cells/ $\mu$ L), prolonged prothrombin and partial thromboplastin times, elevated serum lactate dehydrogenase concentration, decreased serum protein concentrations, proteinuria, and microscopic hematuria. Patients who die often experience disseminated intravascular coagulopathy, including frank hemorrhage and exceptionally high leukocyte counts.

### DIFFERENTIAL DIAGNOSIS

The differential diagnosis includes adult respiratory distress syndrome, pneumonic plague, psittacosis, severe mycoplasmal pneumonia, influenza, leptospirosis, inhalation anthrax, rickettsial infections, pulmonary tularemia, atypical bacterial and viral pneumonia, legionellosis, meningococcemia, and other sepsis syndromes. The key determinant in the diagnosis of HPS is thrombocytopenia.

### TREATMENT

Management of patients with hantavirus infection requires maintenance of adequate oxygenation and careful monitoring and support

of cardiovascular function. The pathophysiology of HPS somewhat resembles that of dengue shock syndrome (see Chapter 315). Pressor or inotropic agents, such as dobutamine, should be administered in combination with judicious volume replacement to treat symptomatic hypotension or shock while avoiding exacerbation of the pulmonary edema. Intravenous ribavirin, which is lifesaving if given early in the course of HFPS and is effective in preventing death in the hamster model, has not yet been demonstrated to be of value in HPS.

Further information and advice about management, control measures, diagnosis, and collection of biohazardous specimens can be obtained from the Centers for Disease Control and Prevention, National Center for Infectious Diseases, Viral Special Pathogens Branch, Atlanta, Georgia 30333 (470-312-0094).

### PROGNOSIS

In some geographic areas, fatality rates for HPS have been 50%. Severe abnormalities in hematocrit, white blood cell count, lactate dehydrogenase value, and partial thromboplastin time and a high viral load predict death with high specificity and sensitivity. The early appearance of immunoglobulin G antibodies may signal a hopeful prognosis.

### PREVENTION

Avoiding contact with rodents is the only preventive strategy against HPS. Rodent control in and around the home is important. Barrier nursing is advised, and biosafety level 3 facilities and practices are recommended for laboratory handling of blood, body fluids, and tissues from suspect patients or rodents, because the virus may be aerosolized. However, to date, there are no cases of person-to-person transmission of HPS.

Visit Elsevier eBooks+ at [eBooks.Health.Elsevier.com](http://eBooks.Health.Elsevier.com) for Bibliography.

## Chapter 320

# Rabies

Rodney E. Willoughby Jr.

Rabies virus is a bullet-shaped, negative-sense, single-stranded, enveloped RNA virus from the family Rhabdoviridae, genus *Lyssavirus*. There are 17 species of *Lyssavirus*, divided into three antigenic phylogroups. Rabies vaccines and immunoglobulins are active against phylogroup I viruses. The classic rabies virus (phylogroup I, genotype 1) is distributed worldwide and naturally infects a large variety of animals. The other genotypes are more geographically confined, with none found in the Americas. Six *Lyssavirus* genotypes are associated with rabies in humans, although genotype 1 accounts for the great majority of cases. Within genotype 1, different lineages are specific to animal reservoirs, although cross-species transmission can occur. Cosmopolitan dog, vampire bat, and insectivorous bat lineages in the Americas cause overlapping but distinct clinical syndromes and vary in immunogenicity, affecting survival.

### EPIDEMIOLOGY

Rabies is present on all continents except Antarctica. Rabies predominantly afflicts underaged, poor, and geographically isolated populations. Approximately 59,000 cases of human rabies occur in Africa and Asia annually. Rabies virus can infect any mammal or bird, but true animal reservoirs that maintain the presence of rabies virus in the population are limited to terrestrial carnivores and bats. Worldwide, transmission from dogs accounts for >90% of human cases. In Africa and Asia, other animals serve as prominent reservoirs, such as jackals, mongooses, and raccoon dogs. In the United States, raccoons are the most infected wild animal along the eastern seaboard. Three lineages



of skunk rabies are endemic in the Midwest (north and south) and California, gray foxes harbor rabies in Arizona and Texas, red foxes and arctic foxes harbor rabies in Alaska, and mongooses carry rabies in Puerto Rico. Rabies occurs infrequently in livestock. Among American domestic pets, infected cats outnumber infected dogs, probably because cats frequently prowl unsupervised and are not uniformly subject to vaccine laws. Rabies is rare in small mammals, including mice, squirrels, and rabbits; to date, no animal-to-human transmission from these animals has been documented.

*The epidemiology of human rabies in the United States is dominated by cryptogenic bat rabies.* Bats are migratory in the spring and fall; rabid bats are identified in every state of the union except Hawaii. In almost all cases of bat-associated human rabies in the United States, there was no history of a bat bite. Among inhabitants of the Peruvian Amazon region who have exposure to rabies-infected vampire bats, there are some who have rabies virus–neutralizing antibodies. Antibody-positive patients remember bat bites but do not recall symptoms of rabies.

In the United States, 30,000 episodes of rabies postexposure prophylaxis (PEP) occur annually. Between one and three endemic human cases are diagnosed annually, half postmortem. There have been five outbreaks of rabies associated with solid organ and corneal transplantation.

## TRANSMISSION

Rabies virus is found in large quantities in the saliva of infected animals, and transmission occurs almost exclusively through inoculation of the infected saliva through a bite or scratch from a rabid mammal. Approximately 35–50% of people who are bitten by a known rabies-infected animal and receive no PEP contract rabies. The transmission rate is increased if the victim has suffered multiple bites and if the inoculation occurs in highly innervated parts of the body such as the face and the hands. Infection does not occur after exposure of intact skin to infected secretions, but virus may enter the body through intact mucous membranes. Claims that spelunkers may experience rabies after inhaling bat excreta have come under doubt, although inhalational exposure can occur during laboratory accidents.

No case of nosocomial transmission to a healthcare worker has been documented to date, but caregivers of a patient with rabies are advised to use full barrier precautions. The virus is rapidly inactivated in the environment, and contamination of fomites is not a mechanism of spread.

## PATHOGENESIS

After inoculation, rabies virus replicates slowly and at low levels in muscle or skin. This slow initial step likely accounts for the disease's long incubation period. The virus then enters the peripheral motor nerve, using the nicotinic acetylcholine receptor and possibly other receptors for entry. Once in the nerve, the virus travels by fast axonal transport, crossing synapses roughly every 12 hours. Rapid dissemination occurs throughout the brain and spinal cord before symptoms appear. Infection of the dorsal root ganglia is apparently futile but causes characteristic radiculitis. Infection concentrates in the brainstem, accounting for autonomic dysfunction and relative sparing of cognition. Despite severe neurologic dysfunction with rabies, histopathology reveals limited damage, inflammation, or apoptosis. The pathologic hallmark of rabies, the Negri body, is composed of clumped viral nucleocapsids that create cytoplasmic inclusions on routine histology. Negri bodies can be absent in documented rabies virus infection. Rabies may be a metabolic disorder of neurotransmission; tetrahydrobiopterin deficiency in human rabies causes severe deficiencies in dopamine, norepinephrine, and serotonin.

After infection of the central nervous system, the virus travels anterograde through the peripheral nervous system to virtually all innervated organs, further exacerbating dysautonomia. It is through this route that the virus infects the salivary glands. Many victims of rabies die from uncontrolled cardiac dysrhythmia in the first week of objective signs of rabies.

Deficiency of tetrahydrobiopterin, an essential cofactor for neuronal nitric oxide synthase, is predicted to lead to spasm of the basilar arteries. Onset of vasospasm has been confirmed in a few patients within 5–8 days of the first hospitalization, at about the time coma supervenes in the natural history. Metabolites in cerebrospinal fluid (CSF) consistent with ketogenesis are associated with demise. Immune response to rabies is delayed, usually evident 4–14 days after onset of clinical signs. Immune response to rabies varies by lineage; antibody responses in CSF are often inferior to those in serum. Common complications include complete heart block in dog rabies and cerebral edema in bat rabies.

## CLINICAL MANIFESTATIONS

The incubation period for rabies is 1–3 months. In severe wounds to the head, symptoms may occur within 5 days after exposure, and occasionally the incubation period can extend to 8 years. Rabies has two principal clinical forms, but these overlap in practice. **Encephalitic or furious rabies** is extrapolated from carnivores and begins with non-specific symptoms, including fever, sore throat, malaise, headache, nausea and vomiting, and weakness. Symptoms are often accompanied by paresthesia and pruritus at or near the site of the bite. The patient begins to demonstrate symptoms of encephalitis, with agitation, sleep disturbance, or depressed mentation. Characteristically, patients with rabies encephalitis initially have periods of lucidity alternating with periods of profound encephalopathy. Hydrophobia and aerophobia are the cardinal signs of rabies; they are unique to humans and are not universal or specific. Phobic spasms are manifested by agitation and fear created by being offered a drink or fanning of air in the face, which in turn produce choking and aspiration through spasms of the pharynx, neck, and diaphragm. Seizures are rare and should point to an alternative diagnosis; orofacial dyskinesias and myoclonus may be confused with seizures. Severe dysautonomia is common, and cardiac arrests occur in 25% of patients in the first week of hospitalization. The illness is relentlessly progressive. There is a dissociation of brain electrical activity with findings of brainstem coma caused by anterograde denervation. Death almost always occurs within 1–2 days of hospitalization in developing countries and by 18 days of hospitalization with intensive care.

**Paralytic or dumb rabies**, extrapolated from herbivores, is seen much less frequently and is characterized principally by fevers and ascending motor weakness affecting both the limbs and the cranial nerves. Most patients with paralytic rabies also have some element of encephalopathy as the disease progresses subacutely.

Case reports suggest that milder forms of rabies encephalitis may exist, and 45 rabies survivors are known. Rabies should be considered earlier and more frequently than current practice to improve outcomes.

## DIFFERENTIAL DIAGNOSIS

The differential diagnosis of rabies encephalitis includes all forms of severe cerebral infections, tetanus, and some intoxications and envenomations. Rabies can be confused with autoimmune (anti-N-methyl-D-aspartate receptor, NMDAR) encephalitis, other infectious forms of encephalitis, psychiatric illness, drug abuse, and conversion disorders. Paralytic rabies is frequently confused with Guillain-Barré syndrome. The diagnosis of rabies is frequently delayed in Western countries because of the unfamiliarity of the medical staff with the infection. These considerations highlight the need to pursue a history of contact with an animal belonging to one of the known reservoirs for rabies or to establish a travel history to a rabies-endemic region.

## DIAGNOSIS

The Centers for Disease Control and Prevention (CDC) require complementary tests to confirm a clinically suspected case of rabies. The virus can be grown both in cell culture and after animal injection, but these methods are slow. Pan-lyssavirus reverse transcription polymerase chain reaction is 90% sensitive for the diagnosis of rabies when done on skin and iteratively in saliva. Rabies antigen is detected

through immunofluorescence of saliva or biopsies of hairy skin or brain. Corneal impressions are not recommended. Rabies-specific antibody can be detected in serum or CSF samples, but most patients die while seronegative. Antirabies antibodies are present in the sera of patients who have received an incomplete course of the rabies vaccine, precluding a meaningful interpretation in this setting. Recent treatment with intravenous immunoglobulin may result in a false-positive antibody test. Antibody in CSF is rarely detected after vaccination and is considered diagnostic of rabies regardless of immunization status. CSF abnormalities in cell count, glucose, and protein content are minimal and not diagnostic. MRI findings in the brain are late.

## TREATMENT AND PROGNOSIS

Rabies is generally fatal. Conventional critical care yielded 6 survivors from 79 attempts since 1990. Seventeen of 103 patients survived with use of the Milwaukee Protocol (MP) (<http://www.mcw.edu/rabies>); neurologic outcomes are poor in half of patients. Neither rabies immunoglobulin (RIG) nor rabies vaccine provides benefit once symptoms have appeared. Among 10 survivors of rabies after use of rabies vaccine, 7 had poor neurologic outcomes. Among seven vaccine-naïve survivors, two had poor outcomes. Antiviral treatments have not been effective; favipiravir has been administered to eight patients with modest clinical effect. Ribavirin and RIG delay the immune response and should be avoided. In contrast, appearance of the normal antibody response by 7 days is associated with clearance of salivary viral load and survival.

## PREVENTION

Primary prevention of rabies infection includes vaccination of domestic animals and education to avoid wild animals, stray animals, and animals with unusual behavior.

### Immunization and Fertility Control of Animal Reservoirs

The introduction of routine rabies immunization for domestic pets in the United States and Europe during the middle of the 20th century virtually eliminated infection in dogs. Dog rabies has now been almost eliminated from the Americas; residual cases concentrate in the Caribbean and Bolivia. In the 1990s, control efforts in Europe and North America shifted to immunization of wildlife reservoirs of rabies, where rabies was newly emerging. These programs employed bait laced with either an attenuated rabies vaccine or a recombinant rabies surface glycoprotein inserted into vaccinia, distributed by air or hand into areas inhabited by rabid animals. Human contact with vaccine-laden bait has been infrequent. Adverse events after such contact have been rare, but the vaccinia vector poses a threat to the same population at risk for vaccinia itself, namely, pregnant women, immunocompromised patients, and people with atopic dermatitis. Mass culling of endemic reservoirs has never worked; vaccination and fertility control stop outbreaks. Bats are ubiquitous and very important for insect control. Less than 1% of free-flying bats but >8% of downed bats and bats found in dwellings are rabid.

### Postexposure Prophylaxis

Only one case of rabies has been documented in a person in the United States receiving the recommended schedule of PEP since introduction of modern cellular vaccines in the 1970s.

Given the incubation period for rabies, PEP is a medical urgency, not emergency. The relevance of rabies for most pediatricians centers on evaluating whether an animal exposure warrants PEP (Fig. 320.1). The decision to proceed ultimately depends on the local epidemiology of animal rabies as determined by active surveillance programs, information that can be obtained from local and state health departments. In general, bats, raccoons, skunks, coyotes, and foxes should be considered rabid unless proven otherwise through euthanasia and testing of brain tissue, whereas bites from small herbivorous animals (squirrels, hamsters, gerbils, chipmunks, rats, mice, and rabbits) can be discounted. The response to bites from a pet, particularly a dog, cat,

or ferret, depends on local surveillance statistics and on whether the animal is vaccinated and available for observation. Areas free of canine lineage of rabies virus may still have rabid dogs and cats through wild-life transmission.

The approach to nonbite bat exposures is controversial. In response to the observation that most cases of rabies in the United States have been caused by bat variants and that most affected patients had no recollection of a bat bite, the CDC has recommended that **rabies PEP be considered after any physical contact with bats and when a bat is found in the same room as persons who may not be able to accurately report a bite**, assuming that the animal is unavailable for testing. Such people include young children, the mentally disabled, and intoxicated individuals. Other nonbite contacts (e.g., handling a carcass, exposure to an animal playing with a carcass, or coming into contact with blood or excreta from a potentially rabid animal) usually do not require PEP.

In all instances of a legitimate exposure, effort should be made to recover the animal for quarantine and observation or brain examination after euthanasia. Testing obviates the need for PEP more than half the time. In most instances, PEP can be deferred until the results of observation or brain histology are known. In dogs, cats, and ferrets, symptoms of rabies always occur within several days of viral shedding; therefore in these animals a 10-day observation period is sufficient to eliminate the possibility of rabies.

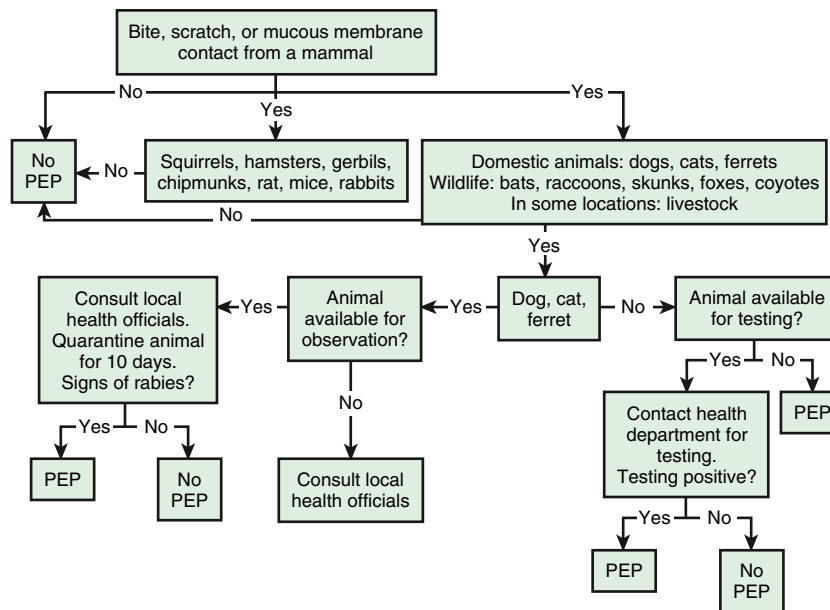
No duration of time between exposure and onset of symptoms should preclude rabies prophylaxis. Rabies PEP is most effective when applied expeditiously. Nevertheless, the series should be initiated in the asymptomatic person as soon as possible, regardless of the length of time since the bite. Rabies vaccine and RIG are contraindicated once symptoms develop.

The first step in rabies PEP is to cleanse the wound thoroughly. Soapy water is sufficient to inactivate an enveloped virus, and its effectiveness is supported by broad experience. Other commonly used disinfectants, such as iodine-containing preparations, are virucidal and should be used in addition to soap when available. Probably the most important aspect of this component is that the wound is cleansed with copious volumes of disinfectant. Primary closure is avoided; wounds may be bacterially infected as well, so cosmetic repair should follow. Antibiotics and tetanus prophylaxis (see Chapter 257) should be applied with the use of usual wound care criteria.

Schedules and indications for administration of rabies vaccine and human-derived rabies immunoglobulin (HRIG) are available at the CDC website (<https://www.cdc.gov/vaccines/hcp/acip-recs/vacc-specific/rabies.html>). These do not harmonize fully with international recommendations by the World Health Organization that seek greater efficiencies in PEP and use of RIG after dog bites.

The second component of rabies PEP consists of passive immunization with RIG. Most failures of PEP are attributed to not using RIG. HRIG, the formulation used in industrialized countries, is administered at a dose of 20 IU/kg. Globally, the World Health Organization recommends that as much of the dose is infused around the wound as possible. In the United States, where bat rabies dominates, the remainder is injected intramuscularly in a limb distant from the one injected with the killed vaccine. Like other immunoglobulin preparations, RIG interferes with the take of live viral vaccines for at least 4 months after administration of the RIG dose. A more concentrated formulation of HRIG is available, which may be more suitable for bites on the face and digits to minimize risk of compartment syndrome after injection. HRIG is not available in many parts of the developing world. Modern preparations of equine RIG are associated with fewer side effects than prior products composed of crude horse serum. Regrettably, for a large segment of the world's population, no passive immunization product is available at all, so preexposure prophylaxis (PreRP) should be considered. Monoclonal antibody products are in clinical trials and may alleviate this deficiency.

The third component of rabies PEP is immunization with inactivated vaccine. In most of the world, cell-based vaccines have replaced previous preparations. Two formulations currently are available in the United States, namely, RabAvert (Chiron Behring Vaccines, Maharashtra, India), a purified chick embryo cell-cultivated vaccine, and Imovax



**Fig. 320.1** Algorithm for evaluating a child for rabies postexposure prophylaxis. This and any other algorithm should be used in concert with local epidemiologic information regarding the incidence of animal rabies in any given location.

Rabies (Aventis Pasteur, Bridgewater, NJ), cultivated in human diploid cell cultures. In both children and adults, both vaccines are administered intramuscularly in a 1-mL volume in the deltoid or anterolateral thigh on days 0, 3, 7, and 14 after presentation. Injection into the gluteal area is associated with a blunted antibody response, so this area should not be used. The rabies vaccines can be safely administered during pregnancy. In most persons the vaccine is well tolerated; most adverse effects are related to booster doses. Pain and erythema at the injection site occur commonly, and local adenopathy, headache, and myalgias occur in 10–20% of patients. Approximately 5% of patients who receive the human diploid cell vaccine experience an immune complex–mediated allergic reaction, including rash, edema, and arthralgias, several days after a booster dose. The World Health Organization has approved schedules using smaller amounts of vaccine, administered intradermally, that are immunogenic and protective, but none is approved for use in the United States. Other cell culture–derived rabies virus vaccines are available in the developing world. A few countries still produce nerve tissue–derived vaccines; these preparations are poorly immunogenic, and cross reactivity with human nervous tissue may occur, producing severe neurologic symptoms even in the absence of rabies infection. Prompt travel to a clinic or country to obtain modern rabies vaccine is advised instead.

### Preexposure Prophylaxis

The killed rabies vaccine can be given to prevent rabies in persons at high risk for exposure to wild-type virus, including laboratory personnel working with rabies virus, veterinarians, and others likely to be exposed to rabid animals as part of their occupation. PreEP should be considered for persons traveling to a rabies-endemic region where there is a credible risk for a bite or scratch from a rabies-infected animal, particularly if there is likely to be a shortage of RIG or cell culture–based vaccine. Rabies vaccine as part of the routine vaccine series is under investigation in some countries. The schedule for PreEP consists of two intramuscular injections on days 0, and 7; other schedules are available globally. PEP in the patient who has received PreEP or a prior three doses of PEP consists of two doses of vaccine (one each on days 0 and 3) and does not require RIG. Immunity from PreEP wanes after several years and requires boosting if the potential for exposure to rabid animals recurs.

Visit Elsevier eBooks+ at [eBooks.Health.Elsevier.com](http://eBooks.Health.Elsevier.com) for Bibliography.

## Chapter 321

# Polyomaviruses

Bijal A. Parikh

Human polyomaviruses (PyV) comprise a unique group of viruses that cause disease in immunocompromised individuals but not in the healthy immune-competent host. The two best-studied human PyV, BK PyV and JC PyV, are acquired relatively early in life and generally cause no clinical disease, despite occasional bouts of asymptomatic viral shedding. PyV-associated sequelae become especially relevant in the setting of **posttransplant renal graft failure** and **hemorrhagic cystitis** in the case of BK PyV and **neurologic disease** for JC PyV reactivation. The number of human PyV has expanded dramatically, with discovery of up to 12 additional viruses. Two PyV, designated KI virus and WU virus, can be detected in respiratory samples from children; however, their disease associations are not as well established outside of a few case reports. Exceptions include **Merkel cell** or **MC PyV** and **trichodysplasia spinulosa-associated** or **TS PyV**, yet their relevance in the pediatric population is limited. Current knowledge regarding BK PyV and JC PyV epidemiology and disease associations with special emphasis on diagnostic and clinical management of pediatric populations is summarized next.

### GENOMIC ORGANIZATION

PyV are nonenveloped, icosahedral virions of 40–45 nm in diameter. The genomes are circular double-stranded DNA composed of approximately 5,000 base pairs. The type member of the parent family, *Polyomaviridae*, is **simian virus 40** (SV40). Translation of proteins occurs from both early and late transcripts, transcribed in opposite directions from the noncoding control region (NCCR). The host range of PyV is very broad, having been isolated from a variety of mammals, birds, and even fish. However, PyV are strictly species specific; thus human PyV only infect humans.

### PyV EPIDEMIOLOGY

Almost 90% of adults have been infected with BK PyV by their third decade; only 20% of children are seropositive for BK PyV by age 3,



climbing to 80% by age 7. Approximately 50–70% of adults are seropositive for JC PyV, and children show even lower seroprevalence rates, with less than 30% positive by age 7. Both BK PyV and JC PyV are primarily respiratory tract infections with subsequent spread to the kidneys and the central nervous system (CNS), respectively. **Tropism** for BK PyV has been demonstrated to be the bladder urothelium and renal tubular cells, where lifelong latency is likely established. In contrast, the primary tropism for JC PyV includes the CNS and lymphoid and renal tissue. MC PyV is found and shed from skin, although little is known about its acquisition.

### BK PyV

BK PyV was first detected in the urine from a renal allograft recipient suffering from ureteral stenosis with the initials “BK.” In the immunocompetent host, BK PyV may never result in any observable clinical disease. However, in the immunocompromised, BK PyV reactivation can lead to serious consequences. Immune suppression can either be iatrogenic after transplantation or constitutional, such as with inherited immune-deficiency syndromes. In renal transplant recipients, interstitial nephritis, renal dysfunction, and ultimately graft failure can develop. In **hematopoietic stem cell transplant (HSCT)** recipients, reactivation can lead to hemorrhagic cystitis. Although the incidence of such symptomatic complications is rare, **BK PyV must be proactively managed through careful monitoring and alteration of immunosuppressive regimens.**

Although the most common complication after pediatric kidney transplantation continues to be graft failure caused by chronic rejection, infections of the transplanted organ can also promote graft dysfunction. Common infectious complications placing pediatric recipients at risk for graft failure include EBV, CMV, BK PyV, and JC PyV. Fortunately, with current monitoring and interventions, the incidence of pediatric transplants that will fail as a result of nephropathy correlating with BK PyV infection is very low.

Nearly two thirds of pediatric renal transplant recipients show evidence of **BK viremia** (virus in the urine), with one fifth showing **viremia** (virus in the blood). **BK virus–associated nephropathy (BKVAN)** can **initially manifest as rising creatinine and is diagnosed definitively through core renal biopsies.** However, because the nephropathy can be focal, a single unaffected core specimen does not exclude disease. In the core biopsy, **BKVAN is characterized by tubular injury with cellular enlargement, epithelial necrosis, erosion of tubular basement membranes, and intranuclear inclusion bodies in epithelial cells.** If untreated, tubular necrosis and sclerosing allograft nephropathy can lead to irreversible renal impairment and rejection. Importantly, reduction of immunosuppression in viremic patients has been highly effective in limiting rejection caused by BKVAN. Rates of BKVAN in the pediatric population have been estimated at around 5%, and approximately 0.5% of renal transplant recipients will lose their graft because of BKVAN.

Laboratory evidence of BK PyV infection is best achieved through a **microscopic urine examination, followed by molecular (polymerase chain reaction [PCR]–based) quantitative analysis of urine and plasma (Table 321.1).** Depending on the method and analyte, a wide range of sensitivity and specificity has been reported. **Detection of “haufen,”** which are viral aggregates that can be detected only by electron microscopy, is nearly 100% sensitive and specific but requires special equipment. An alternative diagnostic approach includes

microscopic examination for the **presence of decoy cells** (urothelial cells containing abundant viral particles) in the urine; however, sensitivity is poor, and thus examination for decoy cells is not the preferred screening method. More commonly, **PCR testing for BK genomic DNA from urine and plasma** is employed. Although highly sensitive for BK PyV, the specificity of single-time-point molecular tests for predicting renal nephropathy is low, as asymptomatic individuals can intermittently shed virus without progression to renal disease. Therefore the presence of **isolated BK viremia is not sufficient to diagnose infection** leading to renal impairment.

Accurate quantification of BK PyV in plasma and urine is essential for standardized care across transplant centers with broadly applied thresholds for intervention. The first WHO international standard for BK PyV was made available to enable interassay comparisons in 2016. In 2020, the first molecular platform to obtain FDA clearance for quantitative BK PyV testing included plasma and urine for monitoring renal transplant recipients based on the use of the WHO standard.

**No single guideline exists for routine monitoring for BKVAN in either pediatric or adult populations,** and thus transplant centers need to design strategies that best fit their local prevalence rates. One proposed guideline suggests **urine screening monthly in the first months after transplant, then every 3 months for 2 years, and then annually in years 3, 4, and 5. If viremia exceeds  $1 \times 10^7$  copies/mL, then biopsy should be performed with a concomitant reduction in immunosuppression.** In addition, plasma levels exceeding  $1 \times 10^4$  copies/mL should also prompt a biopsy and reduction in immunosuppression. Centers may include routine renal biopsies to monitor for overall graft health, and these may also be used to evaluate for BKVAN.

Although **there are no direct antiviral treatments for BK PyV,** the primary clinical parameter shown to have the greatest effect on preventing long-term kidney damage and rejection is **careful adjustment of the dose of immunosuppression.** This adjustment allows the body’s natural immunity, specifically the T-cell compartment, to effectively reduce the viral burden. However, decreasing immunosuppression comes at a risk of graft rejection if not cautiously approached. A growing body of literature is beginning to emerge that reevaluates the anecdotal successes of specific treatments, including **cidofovir (CDV)** and **leflunomide.** These two drugs have shown efficacy in culture conditions, yet clinical utility remains unproven. The antibiotic class of fluoroquinolones has also demonstrated in vitro activity without a subsequent sustained clinical effect. Finally, both intravenous **immunoglobulin (IVIG)** and **cyclosporine A** have shown equally limited effects in clinical trials. In summary, **the current treatment options rely heavily on early and accurate detection of infection followed by an appropriately titered dose reduction in immunosuppressive drugs.**

In pediatric HSCT recipients, a common association between BK PyV shedding and hemorrhagic cystitis (HC) has been clinically observed. HC can occur in one fifth to one third of pediatric patients after HSCT; however, it rarely results in death. Unfortunately, the long-term sequelae of fibrosis and bladder contracture can lead to significant morbidity. After HSCT, either **early-onset (within 1 week) or late-onset (2–8 weeks) HC** may occur, with the timing providing insight into the pathogenic process. Early-onset HC appears to be a result of direct urothelial damage from conditioning agents (cyclophosphamide,

**Table 321.1** Recommendations for Patients with BK PyV–Associated Nephropathy

	SCREENING	DIAGNOSIS	MONITORING
Cytology	Poor sensitivity	Decoy cells, Haufen	Poor sensitivity
Molecular	Routine BK PyV PCR after renal transplant	BK viremia >10,000 copies/mL	Follow until viral loads trend lower
Pathology	Institution specific for the frequency of kidney biopsy	Kidney allograft biopsy with characteristic changes and positive immunohistochemistry (IHC) demonstrating viral antigen	Institution specific for the frequency of kidney biopsy



busulfan, radiation) before transplant, independent of any infectious process, whereas the more commonly observed late-onset HC occurs around the time of engraftment. Although primarily associated with BK PyV, the differential diagnosis for late-onset HC also includes JC PyV, CMV, and adenovirus. **All causes of HC must be carefully considered for effective clinical management.**

Diagnosis of HC requires a triad of findings: cystitis, gross hematuria, and urine BK PyV loads  $>7 \log_{10}$  copies/mL (Table 321.2). Current guidelines do not recommend screening for BK PyV after HSCT, citing a lack of effective prophylactic treatment. However, long-term sequelae of renal impairment greater than 2 years after transplant have been described, and therefore routine monitoring may need to eventually be considered.

The presence of BK PyV in the urine occurs in the majority of HSCT recipients and is therefore neither specific nor predictive of BK PyV-HC. Although not as sensitive, the presence of virus in plasma of  $>3 \log_{10}$  copies/mL is seen in two thirds of recipients with BK PyV-HC, and diminution of viremia correlates strongly with resolution of HC.

For individuals with severe HC, standard treatment includes hyperhydration and diuretics. Bladder irrigation may be necessary to avoid renal damage and clotting. Less severe cases will spontaneously resolve in a few weeks. Unlike with renal transplantation, reduction of immunosuppression carries a large risk for potentially life-threatening graft-versus-host disease (GVHD) and so is not considered to be the initial treatment approach. Additionally, if thrombocytopenia and anemia are present, appropriate transfusions should be initiated to maintain adequate blood counts. The role of CDV in treating or preventing HC in the context of HSCT remains controversial, and thus professional society guidelines currently do not recommend its routine use.

### JC PyV

JC PyV was first detected in the brain of a patient with Hodgkin lymphoma with the initials "JC." JC PyV can be acquired by the respiratory route and through ingestion from contaminated surfaces, food, and water and ultimately establishes latency in the kidneys, brain, and various lymphoid organs. In renal transplant recipients, JC PyV can be shed in the urine but only rarely causes nephropathy. After HSCT, HC from BK PyV is far more likely than from JC PyV. Conversely, only JC PyV infects the oligodendrocytes of the CNS and is responsible for

**progressive multifocal leukoencephalopathy (PML).** PML is a fatal demyelinating disease that results from the lysis of specific glial cells in afflicted immunocompromised individuals. In patients with hematologic malignancy, autoimmune disorders, or HIV infection leading to decreased cellular immunity, JC PyV reactivation can lead to PML. In immunocompetent adults, PML is a feared consequence of monoclonal antibody treatments for multiple sclerosis. However, the literature for JC PyV infection in the pediatric population is sparse, with the majority of studies provided as case reports. As a result, many of the clinical guidelines for screening, diagnosis, and therapy must be extended from the adult literature.

The more common clinical manifestations of PML in children are similar to what has been observed in adults and includes hemiparesis, ataxia, dysarthria, and seizures. Evaluation for PML is primarily through radiologic imaging, with primary findings consistent with characteristic asymmetric white matter lesions. The diagnosis of PML is established through molecular detection of viral DNA in the cerebrospinal fluid (CSF) or viral proteins on a brain biopsy (Table 321.3). Unlike with BK PyV, there are no quantitative thresholds because any amount of virus in the CSF is considered abnormal. Although the sensitivity for detection in pediatric cases is under 60%, the specificity is near 100%; therefore a positive PCR result can be considered diagnostic. Remarkably, the CSF cell counts and protein and glucose levels are typically normal. Cases without molecular evidence may still be termed "possible PML" based on neurologic and radiologic findings.

Treatment for PML is primarily through reversing the underlying cause of immune dysfunction. Adults with advanced HIV infection should be treated with antiretroviral therapy (ART), but the efficacy of ART for resolution of PML in children is not well-documented. It is important for the clinician to be aware of a rare but serious complication after HIV suppression promoting a paradoxical increase in JC PyV-mediated damage. This phenomenon has been termed PML-immune reconstitution inflammatory syndrome and can often be treated with steroids. Unfortunately, the prognosis for PML in children is grim, with most patients succumbing to the disease within 6 months. It remains to be seen if absolute viral load or specific radiologic and clinical findings might be used to better predict outcomes in children.

Visit Elsevier eBooks+ at [eBooks.Health.Elsevier.com](http://eBooks.Health.Elsevier.com) for Bibliography.

**Table 321.2** Recommendations for Patients with BK PyV–Associated Hemorrhagic Cystitis

	SCREENING	DIAGNOSIS	MONITORING
Clinical	Suspect with anemia, thrombocytopenia, dysuria, or urinary obstruction after HSCT	Cystitis/lower abdominal pain	Follow clinical resolution
Cytology	Gross hematuria	Gross hematuria	No recommendations
Molecular	No recommendations	BK viruria $>10,000,000$ copies/mL	

**Table 321.3** Recommendations for Patients with JCV PyV/Progressive Multifocal Leukoencephalopathy

	SCREENING	DIAGNOSIS	MONITORING
Clinical	Suspect in an immunosuppressed patient with subacute neurologic findings		
Imaging	No recommendations	Characteristic MRI findings	No recommendations
Molecular	No recommendations	Positive CSF PCR for JC PyV	
Pathology	No recommendations	Brain biopsy with characteristic lesions and positive IHC demonstrating viral antigen	

## Chapter 322

# Human Immunodeficiency Virus and Acquired Immunodeficiency Syndrome

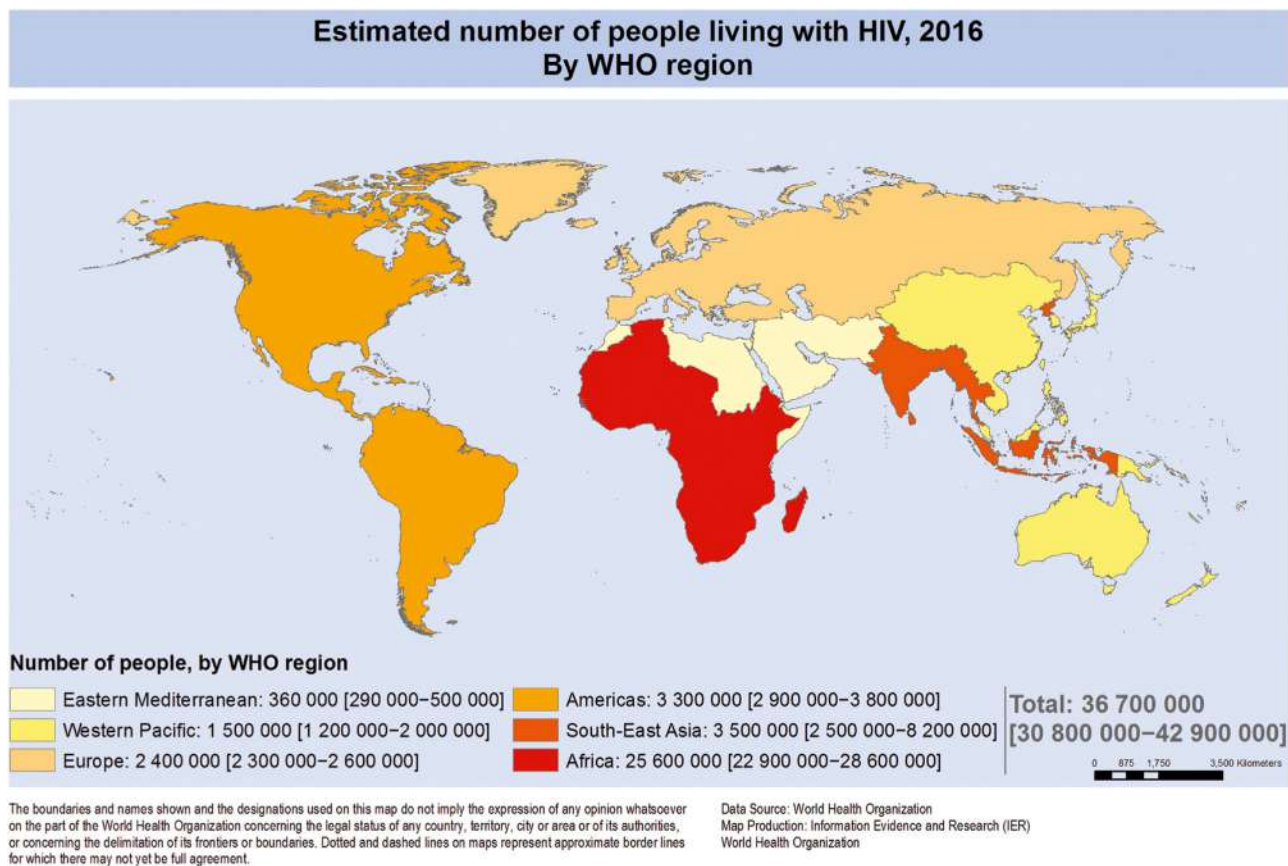
Ericka V. Hayes

Advances in research and major improvements in the treatment and management of HIV infection have brought about a substantial decrease in the incidence of new HIV infections and AIDS in children. Globally, from 2000–2015, there has been an estimated 70% decline in new infections in children age 0–14 years, largely the result of antiretroviral treatment (ART) of HIV-infected pregnant individuals for the prevention of vertical transmission. Of adults and children with HIV infection, 70% live in sub-Saharan Africa, where the disease continues to have a devastating impact (Fig. 322.1). Children experience more rapid disease progression than adults, with up to half of untreated children dying within the first 2 years of life. This rapid progression is correlated with a higher viral burden and faster depletion of infected CD4 lymphocytes in infants and children than in adults. Accurate diagnostic tests and the early initiation of potent drugs to inhibit HIV replication have dramatically increased the ability to prevent progression and control this disease.

## ETIOLOGY

HIV-1 and HIV-2 are members of the Retroviridae family and belong to the *Lentivirus* genus, which includes cytopathic viruses causing diverse diseases in several animal species. The HIV-1 genome contains two copies of single-stranded RNA that is 9.2 kb in size. At both ends of the genome there are identical regions, called long terminal repeats, which contain the regulation and expression genes of HIV. The remainder of the genome includes three major sections: the GAG region, which encodes the viral core proteins (p24 [capsid protein: CA], p17 [matrix protein: MA], p9, and p6, which are derived from the precursor p55); the POL region, which encodes the viral enzymes (i.e., reverse transcriptase [p51], protease [p10], and integrase [p32]); and the ENV region, which encodes the viral envelope proteins (gp120 and gp41, which are derived from the precursor gp160). Other regulatory proteins, such as transactivator of transcription (tat: p14), regulator of viron (rev: p19), negative regulatory factor (nef: p27), viral protein r (vpr: p15), viral infectivity factor (vif: p23), viral protein u (vpu in HIV-1: P16), and viral protein x (vpx in HIV-2: P15), are involved in transactivation, viral messenger RNA expression, viral replication, induction of cell cycle arrest, promotion of nuclear import of viral reverse transcription complexes, downregulation of the CD4 receptors and class I major histocompatibility complex (MHC), proviral DNA synthesis, and virus release and infectivity (Fig. 322.2).

The HIV tropism to the target cell is determined by its envelope glycoprotein (Env). Env consists of two components: the surface, heavily glycosylated subunit, gp120 protein and the associated transmembrane subunit glycoprotein gp41. Both gp120 and gp41 are produced from the precursor protein gp160. The glycoprotein gp41 is very immunogenic and is used to detect HIV-1 antibodies in diagnostic assays; gp120 is a complex molecule that includes the highly variable V3 loop. This region is immunodominant for neutralizing antibodies. The heterogeneity of gp120 presents major obstacles in establishing an



**Fig. 322.1** Estimated number of people living with HIV in 2016 by WHO region. Data from WHO 2017 report. (Courtesy World Health Organization, 2017. Global Health Observatory (GHO) data. [http://www.who.int/gho/hiv/epidemic\\_status/cases\\_all/en/](http://www.who.int/gho/hiv/epidemic_status/cases_all/en/))

effective HIV vaccine. The gp120 glycoprotein also carries the binding site for the CD4 molecule, the most common host cell surface receptor of T lymphocytes. This tropism for CD4<sup>+</sup> T cells is beneficial to the virus because of the resulting reduction in the effectiveness of the host immune system. Other CD4-bearing cells include macrophages and microglial cells. The observations that CD4<sup>-</sup> cells are also infected by HIV and that some CD4<sup>+</sup> T cells are resistant to such infections suggests that other cellular attachment sites are needed for the interaction between HIV and human cells. Several chemokines serve as co-receptors for the envelope glycoproteins, permitting membrane fusion and entry into the cell. Most HIV strains have a specific tropism for one of the chemokines, including the fusion-inducing molecule CXCR-4, which acts as a co-receptor for HIV attachment to lymphocytes, and CCR-5, a β chemokine receptor that facilitates HIV entry into macrophages. Several other chemokine receptors (CCR-3) have also been shown in vitro to serve as virus co-receptors. Other mechanisms of attachment of HIV to cells use nonneutralizing antiviral antibodies and complement receptors. The Fab portion of these antibodies attaches to the virus surface, and the Fc portion binds to cells that express Fc

receptors (macrophages, fibroblasts), thus facilitating virus transfer into the cell. Other cell-surface receptors, such as the mannose-binding protein on macrophages or the DC-specific, C-type lectin (DC-SIGN) on dendritic cells, also bind to the HIV-1 envelope glycoprotein and increase the efficiency of viral infectivity. Cell-to-cell transfer of HIV without formation of fully formed particles is a more rapid mechanism of spreading the infection to new cells than is direct infection by the virus.

After viral attachment, gp120 and the CD4 molecule undergo conformational changes, and gp41 interacts with the fusion receptor on the cell surface (Fig. 322.3). Viral fusion with the cell membrane allows entry of viral RNA into the cell cytoplasm. This process involves accessory viral proteins (nef, vif) and binding of cyclophilin A (a host cellular protein) to the capsid protein (p24). A number of HIV drugs that target the viral fusion/cell entry of the virus have been developed. The p24 protein is involved in virus uncoating, recognition by restriction factors, and nuclear importation and integration of the newly created viral DNA. Viral DNA copies are then transcribed from the virion RNA through viral reverse transcriptase enzyme activity, which builds the first DNA strand from the viral RNA and then destroys the viral RNA and builds a second DNA strand to produce double-stranded circular DNA (see Fig. 322.3). The HIV-1 reverse transcriptase is error prone and lacks error-correcting mechanisms. Thus many mutations arise, creating a wide genetic variation in HIV-1 isolates even within an individual patient. Many of the drugs used to fight HIV infection were designed to block the reverse transcriptase action. The circular DNA is transported into the cell nucleus, using viral accessory proteins such as vpr, where it is integrated (with the help of the virus integrase) into the host chromosomal DNA and referred to as the *provirus* (see Fig. 322.3). Drugs have been developed that block this integration step. The provirus has the advantage of latency, because it can remain dormant for extended periods, making it extremely difficult to eradicate. The infected CD4<sup>+</sup> T cells that survive long enough to revert to resting memory state become the HIV latent reservoir where the virus persists

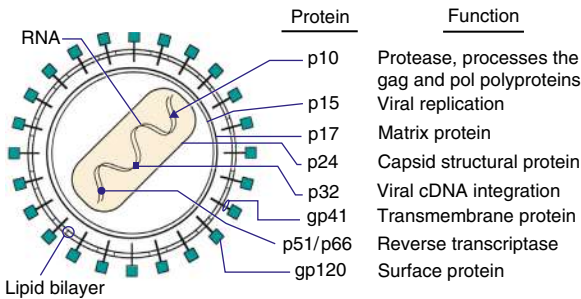


Fig. 322.2 The human immunodeficiency virus and associated proteins and their functions.

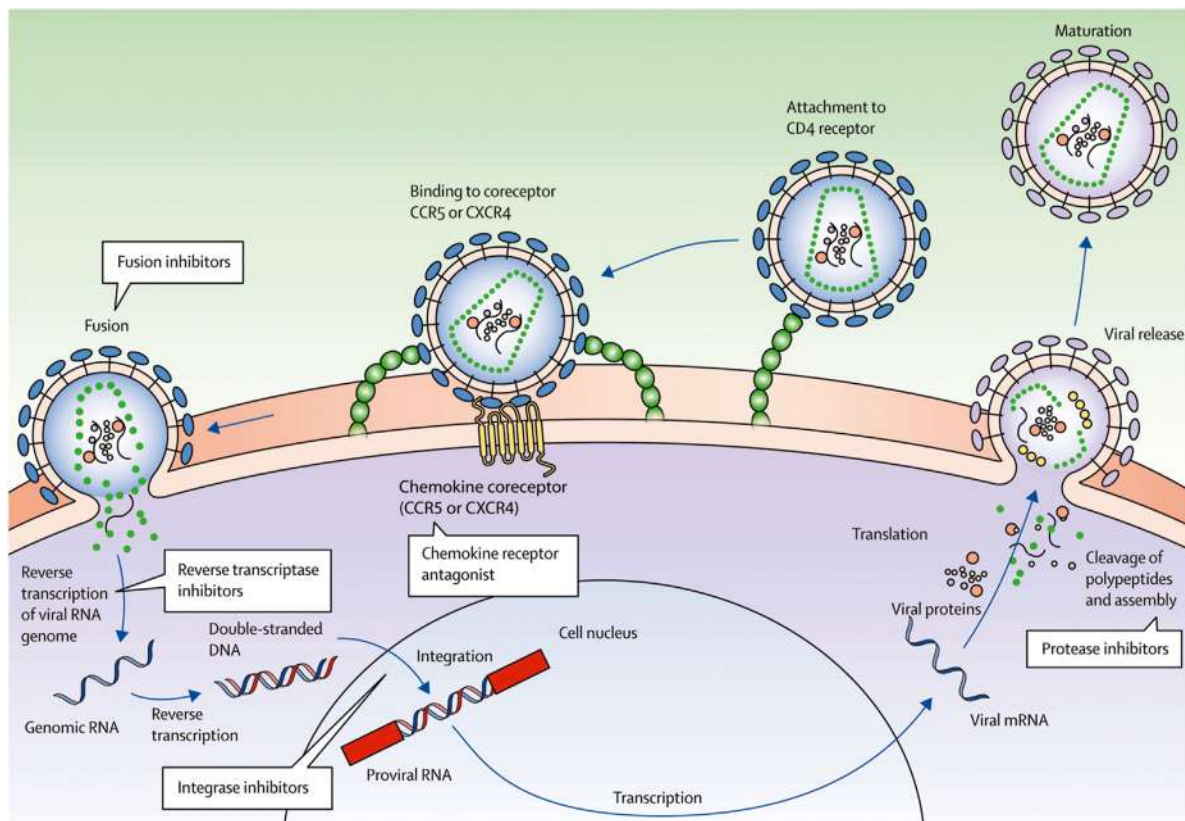


Fig. 322.3 HIV life cycle showing the sites of action and different classes of antiretroviral drugs. (Adapted from Ralston SH, Penman ID, Strachan MWJ, Hobson R, eds. Davidson's Principles and Practice of Medicine, 23rd ed. London: Elsevier, 2018.)



indefinitely even in patients who respond favorably to potent ART. The molecular mechanisms of this latency are complex and involve unique biologic properties of the latent provirus (e.g., absence of *tat*, epigenetic changes inhibiting HIV gene expression) and the nature of the cellular host (e.g., absence of transcription factors such as nuclear factor  $\kappa$ B). Integration usually occurs near active genes, which allow a high level of viral production in response to various external factors such as an increase in inflammatory cytokines (by infection with other pathogens) and cellular activation. Depending on the relative expression of the viral regulatory genes (*tat*, *rev*, *nef*), the proviral DNA may encode production of the viral RNA genome, which, in turn, leads to production of viral proteins necessary for viral assembly.

HIV-1 transcription is followed by translation (see Fig. 322.3). A capsid polyprotein is cleaved to produce the virus-specific protease (p10), among other products. This enzyme is critical for HIV-1 assembly because it cleaves the long polyproteins into the proper functional pieces. Several HIV-1 antiprotease drugs have been developed, targeting the increased sensitivity of the viral protease, which differs from the cellular proteases. The regulatory protein *vif* is active in virus assembly and Gag processing. The RNA genome is then incorporated into the newly formed viral capsid that requires zinc finger domains (p7) and the matrix protein (MA: p17). The matrix protein forms a coat on the inner surface of the viral membrane, which is essential for the budding of the new virus from the host cell's surface. As new virus is formed, it buds through specialized membrane areas, known as lipid rafts, and is released. The virus release is facilitated by the viroporin *vpu*, which induces rapid degradation of newly synthesized CD4 molecules that impede viral budding. In addition, *vpu* counteracts host innate immunity (e.g., hampering natural killer T-cell activity).

Full-length sequencing of the HIV-1 genome demonstrated three different groups (M [main], O [outlier], and N [non-M, non-O]), probably occurring from multiple zoonotic infections from primates in different geographic regions. The same technique identified eight groups of HIV-2 isolates. Group M diversified to nine subtypes (or clades A to D, F to H, J, and K). In each region of the world, certain clades predominate, for example, clade A in Central Africa, clade B in the United States and South America, clade C in South Africa, clade E in Thailand, and clade F in Brazil. Although some subtypes were identified within group O, none was found in any of the HIV-2 groups. Clades are mixed in some patients as a result of HIV recombination, and some crossing between groups (i.e., M and O) has been reported.

HIV-2 has a similar life cycle to HIV-1 and is known to cause infection in several monkey species. Subtypes A and B are the major causes of infection in humans, but rarely cause infection in children. HIV-2 differs from HIV-1 in its accessory genes (e.g., it has no *vpu* gene but contains the *vpx* gene, which is not found in HIV-1). It is most prevalent in western Africa, but increasing numbers of cases are reported from Europe and southern Asia. The diagnosis of HIV-2 infection is more difficult because of major differences in the genetic sequences between HIV-1 and HIV-2. Thus several of the standard confirmatory assays (immunoblot), which are HIV-1 specific, may give indeterminate results with HIV-2 infection. If HIV-2 infection is suspected, a combination screening test that detects antibody to HIV-1 and HIV-2 peptides should be used. In addition, the rapid HIV detection tests have been less reliable in patients suspected to be dually infected with HIV-1 and HIV-2, because of lower antibody concentrations against HIV-2. HIV-2 viral loads also have limited availability. Notably, HIV-2 infection demonstrates a longer asymptomatic stage of infection and slower declines of CD4<sup>+</sup> T-cell counts and is less efficiently transmitted vertically than HIV-1, likely related to lower levels of viremia with HIV-2.

## EPIDEMIOLOGY

In 2022, the World Health Organization (WHO) estimated that 2.6 million children younger than 19 years of age worldwide were living with HIV-1 infection, with 270,000 new infections annually. Nearly 90% of these children 0–9 years of age live in sub-Saharan Africa. From 2010–2022, there has been a 58% reduction in infection in children 0–9 years of age, reflecting steady expansion of services to prevent perinatal

transmission of HIV to infants globally. Over the same period there has been a 46% reduction in new cases 10–19 years of age. Notably, there were still 100,000 deaths worldwide of children <19 years of age with HIV in 2020. As of 2022, an estimated 13.9 million children have been orphaned by AIDS (i.e., having at least one parent die from AIDS).

Globally, the vast majority of HIV infections in early childhood are the result of **vertical transmission**. In the United States, approximately 11,700 children, adolescents, or young adults were reported to be living with perinatally acquired HIV infection in 2014. The number of U.S. children with AIDS diagnosed each year increased from 1984–1992 but then declined by more than 95% to <100 cases annually by 2003, largely from the success of prenatal screening and perinatal **combination antiretroviral treatment (cART)** of HIV-infected pregnant individuals and infants. From 2014–2018, there were 507 infants born with perinatally acquired HIV in the United States and Puerto Rico, declining 54% over that interval, with 65 infants being born infected in 2018. As of 2019, the overall rate of perinatally acquired HIV infection in the United States was 0.8 per 100,000 births. Children of racial and ethnic minority groups are overrepresented, particularly non-Hispanic Blacks, who had a rate of 2.9 per 100,000 births in 2019. Race and ethnicity are not risk factors for HIV infection but more likely reflect other social determinants of health that may be predictive of an increased risk for HIV infection, such as lack of educational and economic opportunities as well as decreased access and barriers to healthcare. As of 2017, Florida, Illinois, Texas, Virginia, California, Tennessee, and Maryland are the states with the highest numbers of perinatally acquired cases of HIV in the United States.

**Adolescents** (13–24 years of age) constitute an important growing population of newly infected individuals; in 2018, 21% of all new HIV infections in the United States occurred in this age-group, with 81% of youth cases occurring in young males who have sex with males (MSM). It is estimated that 50% of HIV-positive youth, the highest rate of any age group, are unaware of their diagnosis. Considering the long latency period between the time of infection and the development of clinical symptoms, reliance on AIDS case definition surveillance data significantly underrepresents the impact of the disease in adolescents. Based on a median incubation period of 8–12 years, it is estimated that 15–20% of all patients with AIDS acquired HIV infection between 13 and 19 years of age.

Risk factors for HIV infection vary by sex in adolescents. Whereas 91–93% of males between the ages of 13 and 24 years with HIV acquire infection through sex with other males, 91–93% of adolescent females with HIV are infected through heterosexual contact. Adolescent racial and ethnic minority populations are overrepresented, especially among females. Another important group are **transgender** individuals. Transgender women in the United States have 49 times the odds of contracting HIV compared to the general population; transgender men have rates that are lower than in transgender women but still significantly higher than the rate in the general population. Transgender individuals unfortunately have many barriers to accessing and receiving appropriate transgender sensitive care and HIV testing and treatment that must be addressed.

## Transmission

Transmission of HIV-1 occurs via sexual contact, parenteral exposure to blood, or vertical transmission from pregnant individual to child via exposure to vaginal secretions during birth or via breast milk. The primary route of infection in the pediatric population (<15 years) is vertical transmission. Rates of vertical transmission of HIV have varied in high- and low-resource countries; the United States and Europe have documented transmission rates in untreated pregnant individuals of 12–30%, whereas transmission rates in Africa and Haiti have been higher (25–52%), likely because of more advanced disease and the presence of co-infections. Perinatal treatment of HIV-infected pregnant persons with antiretroviral drugs has dramatically decreased the transmission rate to <2%.

**Vertical transmission** of HIV can occur before delivery (**intrauterine**), during delivery (**intrapartum**), or after delivery (**postpartum** through **breastfeeding**). Although intrauterine transmission



has been suggested by identification of HIV by culture or polymerase chain reaction (PCR) in fetal tissue as early as 10 weeks, statistical modeling data suggest that the majority of in utero transmissions likely occur in late gestation, when the vascular integrity of the placenta weakens and microtransfusions across the maternal–fetal circulation occur. It is generally accepted that 20–30% of infected newborns are infected in utero, because this percentage of infants has laboratory evidence of infection (positive viral culture or PCR) within the first week of life. Some studies have found that viral detection soon after birth is also correlated with an early onset of symptoms and rapid progression to AIDS, consistent with more long-standing infection during gestation.

A higher percentage of HIV-infected children acquire the virus intrapartum, evidenced by the fact that 70–80% of infected infants do not demonstrate detectable virus until after 1 week of age. The mechanism of transmission appears to be mucosal exposure to infected blood and cervicovaginal secretions in the birth canal, and intrauterine contractions during active labor/delivery may also increase the risk of late microtransfusions. Breastfeeding is the least-common route of vertical transmission in resource-rich nations but is responsible for as much as 40% of perinatal infections in resource-limited countries. The risk of an infant acquiring HIV through breastfeeding is 15–20% over 2 years without parental cART or infant prophylaxis. Both free and cell-associated viruses have been detected in breast milk from HIV-infected individuals. The risk for transmission through breastfeeding for individuals not on suppressive cART is approximately 9–16% in individuals with established infection but is 29–53% in those who acquire HIV postnatally, suggesting that the viremia experienced by the breastfeeding individual during primary infection at least triples the risk for transmission. Where replacement feeding is readily available and safe, it is recommended that the parent substitute infant formula for breast milk if they are known to be HIV infected and not on suppressive cART or are at risk for ongoing sexual or parenteral exposure to HIV. However, the WHO recommends that in resource-limited countries where other diseases (diarrhea, pneumonia, malnutrition) substantially contribute to a high infant mortality rate, the benefit of breastfeeding outweighs the risk for HIV transmission, and HIV-infected persons in developing countries should exclusively breastfeed their infants for at least the first 6 months of life, ideally with parent on suppressive cART. Recently, infant feeding recommendations for breastfeeding (or chestfeeding) persons with HIV in resource-rich settings have evolved as well, given that the risk of transmission via breastfeeding from an individual on suppressive cART is very low (<1%) (see “Prevention” for more discussion).

Several risk factors influence the rate of vertical transmission: pregnant parent viral load at delivery, preterm delivery (<34 weeks' gestation), and low antenatal CD4 count. The most important variable is the level of viremia; the odds of transmission may be increased more than twofold for every  $\log_{10}$  increase in viral load at delivery. Elective cesarean delivery has been shown to decrease transmission by 87% if used in conjunction with zidovudine therapy in the pregnant individual and infant. However, because these data predated the advent of cART (also called **highly active antiretroviral therapy [HAART]**), the additional benefit of cesarean section is negligible if the viral load is <1,000 copies/mL. It should be noted that rarely ( $\leq 0.1\%$ ), transmission may occur with viral loads <50 copies/mL.

**Transfusions of infected blood** or blood products have historically accounted for 3–6% of all pediatric AIDS cases. The period of highest risk was between 1978 and 1985, before the availability of HIV antibody-screened blood products. Whereas the prevalence of HIV infection in individuals with hemophilia treated before 1985 was as high as 70%, heat treatment of factor VIII concentrate and HIV antibody screening of donors has virtually eliminated HIV transmission in this population. Donor screening has dramatically reduced, but not eliminated, the risk for blood transfusion-associated HIV infection: nucleic acid amplification testing of minipools (pools of 16–24 donations) performed on antibody-nonreactive blood donations (to identify donations made during the window period before seroconversion) reduced the residual risk of transfusion-transmitted HIV-1 to approximately 1 in 2 million blood units. However, in many resource-limited countries,

screening of blood is not uniform, and the risk for transmitting HIV infection via transfusion remains in these settings.

Although HIV can be isolated rarely from saliva, it is in very low titers (<1 infectious particle/mL) and saliva has not been implicated as a transmission vehicle. Studies of hundreds of household contacts of HIV-infected individuals have found that the risk for household HIV transmission is essentially nonexistent. Only a few cases have been reported in which urine or feces (possibly devoid of visible blood) have been proposed as a possible vehicle of HIV transmission, though these cases have not been fully verified.

In the pediatric population, sexual transmission is infrequent, but a small number of cases resulting from sexual abuse have been reported. Sexual contact is the major route of transmission in the adolescent population ( $\geq 13$  years), accounting for the vast majority of cases. Infection via shared needles with IV drug use is seen in this population, but much less frequently.

## PATHOGENESIS

HIV infection affects most of the immune system and disrupts its homeostasis (see Fig. 322.3). In most cases, the initial infection is caused by low amounts of a single founder virus. Therefore disease may be prevented by drug prophylaxis or vaccine. When the mucosa serves as the portal of entry for HIV, the first cells to be affected are the dendritic cells. These cells collect and process antigens introduced from the periphery and transport them to the lymphoid tissue. HIV does not infect the dendritic cell but binds to its DC-SIGN surface molecule, allowing the virus to survive until it reaches the lymphatic tissue. In the lymphatic tissue (e.g., lamina propria, lymph nodes), the virus selectively binds to cells expressing CD4 molecules on their surface, primarily helper T lymphocytes (CD4<sup>+</sup> T cells) and cells of the monocyte-macrophage lineage. Other cells bearing CD4, such as microglia, astrocytes, oligodendroglia, and placental tissue containing villous Hofbauer cells, may also be infected by HIV. Additional factors (co-receptors) are necessary for HIV fusion and entry into cells. These factors include the chemokines **CXCR-4** (fusion) and **CCR-5**. Other chemokines (CCR1, CCR3) may be necessary for the fusion of certain HIV strains. Several host genetic determinants affect the susceptibility to HIV infection, the progression of disease, and the response to treatment. These genetic variants vary in different populations. A deletion in the **CCR-5** gene that is protective against HIV infection (CCR-5 $\Delta 32$ ) is relatively common in individuals of European descent but is rare in individuals of African descent. Several other genes that regulate chemokine receptors, ligands, the MHC, and cytokines also influence the outcome of HIV infection. Usually, CD4<sup>+</sup> lymphocytes migrate to the lymphatic tissue in response to viral antigens and then become activated and proliferate, making them highly susceptible to HIV infection. This antigen-driven migration and accumulation of CD4 cells within the lymphoid tissue may contribute to the generalized lymphadenopathy characteristic of acute HIV infection in adults and adolescents. HIV preferentially infects the very cells that respond to it (HIV-specific memory CD4 cells), accounting for the progressive loss of these cells and the subsequent loss of control of HIV replication. The continued destruction of memory CD4<sup>+</sup> cells in the gastrointestinal tract (in the gut-associated lymphoid tissue or GALT) leads to reduced integrity of the gastrointestinal epithelium followed by leakage of bacterial particles into the blood and increased inflammatory response, which cause further CD4<sup>+</sup> cell loss. When HIV replication reaches a threshold (usually within 3–6 weeks from the time of infection), a burst of plasma viremia occurs. This intense viremia causes **acute HIV infection**, formerly known as **acute retroviral syndrome** which can present similar to **influenza or mononucleosis** (fever, rash, pharyngitis, lymphadenopathy, malaise, arthralgia, fatigue, cytopenias, elevated liver enzymes) in 50–70% of infected adolescents and adults; this syndrome is not typically seen in infants. With establishment of a cellular and humoral immune response within 2–4 months, the viral load in the blood declines substantially, and patients enter a phase characterized by a lack of symptoms and a return of CD4 cells to only moderately decreased levels. Typically, adult patients who are not treated eventually progress to achieve a virologic set point (steady state), usually ranging from 10,000–100,000 during this clinical latency.

This is in contrast to untreated infants with vertically acquired HIV who have viral loads that are much higher, resulting in faster CD4 count declines and earlier onset of significant immunodeficiency. HIV rapidly responds to the immune system pressure by developing a genetically complex population (quasi-species) that successfully evades the immune system. In addition, inappropriate use of ART increases the ability of the virus to diverge even further by selecting for mutants with fitness or resistance advantages in the presence of subtherapeutic drug levels. Early HIV-1 replication in children has no apparent clinical manifestations. Whether tested by virus isolation or by PCR for viral nucleic acid sequences, fewer than 40% of HIV-1-infected infants demonstrate evidence of the virus at birth. The viral load increases by 1-4 months, and essentially all perinatally HIV-infected infants have detectable HIV-1 in peripheral blood by 4 months of age, except for those who may acquire infection via ongoing breastfeeding.

In adults, the long period of clinical latency (typically 8-12 years) is not indicative of viral latency. In fact, there is a very high turnover of virus and CD4 lymphocytes (more than a billion cells per day), gradually causing deterioration of the immune system, marked by depletion of CD4 cells. Several mechanisms for the depletion of CD4 cells in adults and children have been proposed, including HIV-mediated single cell killing, formation of multinucleated giant cells of infected and uninfected CD4 cells (syncytia formation), virus-specific immune responses (natural killer cells, antibody-dependent cellular cytotoxicity), superantigen-mediated activation of T cells (rendering them more susceptible to infection with HIV), autoimmunity, and programmed cell death (apoptosis). The viral burden is greater in the lymphoid organs than in the peripheral blood during the asymptomatic period. As the virions and their immune complexes migrate through the lymph nodes, they are trapped in the network of dendritic follicular cells. Because the ability of HIV to replicate in T cells depends on the state of activation of the cells, the immune activation that takes place within the microenvironment of the lymph nodes in HIV disease serves to promote infection of new CD4 cells, as well as subsequent viral replication within these cells. Monocytes and macrophages can be productively infected by HIV yet resist the cytopathic effect of the virus and, with their long lifespan, explain their role as reservoirs of HIV and as effectors of tissue damage in organs such as the brain. In addition, they reside in anatomic viral sanctuaries where current treatment agents are less effective.

The innate immune system responds almost immediately after HIV-1 infection by recognizing the viral nucleic acids, once the virus fuses to the infected cell, by the toll-like receptor 7. This engagement leads to activation of pro-inflammatory cytokines and interferon (IFN- $\alpha$ ), which blocks virus replication and spread. The virus uses its Nef protein to downregulate the expression of MHC and non-MHC ligands to reduce the natural killer (NK) cell-mediated anti-HIV activity. It also modulates NK cell differentiation and maturation, dysregulates cytokine production, and increases apoptosis. Although the mechanism by which the innate system triggers the adaptive immune responses is not yet fully understood, cell-mediated and humoral responses occur early in the infection. CD8 T cells play an important role in containing the infection. These cells produce various ligands (macrophage inflammatory proteins 1 $\alpha$  and 1 $\beta$ , RANTES), which suppress HIV replication by blocking the binding of the virus to the co-receptors (CCR-5). HIV-specific cytotoxic T lymphocytes (CTLs) develop against both the structural (ENV, POL, GAG) and regulatory (tat) viral proteins. The CTLs appear at the end of the acute infection, as viral replication is controlled by killing HIV-infected cells before new viruses are produced and by secreting potent antiviral factors that compete with the virus for its receptors (CCR-5). Neutralizing antibodies appear later in the infection and seem to help in the continued suppression of viral replication during clinical latency. There are at least two possible mechanisms that control the steady-state viral load level during the chronic clinical latency. One mechanism may be the limited availability of activated CD4 cells, which prevent a further increase in the viral load. The other mechanism is the development of an active immune response, which is influenced by the amount of viral antigen and limits viral replication at a steady state. There is no general consensus about which of these two mechanisms is more important. The CD4 cell limitation mechanism accounts for the effect of ART, whereas the

immune response mechanism emphasizes the importance of immune modulation treatment (cytokines, vaccines) to increase the efficiency of immune-mediated control. A group of cytokines that includes tumor necrosis factor- $\alpha$  (TNF- $\alpha$ ), TNF- $\beta$ , interleukin-1 (IL-1), IL-2, IL-3, IL-6, IL-8, IL-12, IL-15, granulocyte-macrophage colony-stimulating factor, and macrophage colony-stimulating factor plays an integral role in upregulating HIV expression from a state of quiescent infection to active viral replication. Other cytokines such as IFN- $\gamma$ , IFN- $\beta$ , and IL-13 exert a suppressive effect on HIV replication. Certain cytokines (IL-4, IL-10, IFN- $\gamma$ , transforming growth factor- $\beta$ ) reduce or enhance viral replication depending on the infected cell type. The interactions among these cytokines influence the concentration of viral particles in the tissues. Plasma concentrations of cytokines need not be elevated for them to exert their effect, because they are produced and act locally in the tissues. The activation of virtually all the cellular components of the immune system (i.e., T and B cells, NK cells, and monocytes) plays a significant role in the pathologic aspects of HIV infection. Further understanding of their interactions during the infection will expand our treatment options. Commonly, HIV isolated during the clinical latency period grows slowly in culture and produces low titers of reverse transcriptase. These isolates from earlier in clinical latency use CCR-5 as their co-receptor. By the late stages of clinical latency, the isolated virus is phenotypically different. It grows rapidly and to high titers in culture and uses CXCR-4 as its co-receptor. The switch from CCR-5 receptor to CXCR-4 receptor increases the capacity of the virus to replicate, to infect a broader range of target cells (CXCR-4 is more widely expressed on resting and activated immune cells), and to kill T cells more rapidly and efficiently. As a result, the clinical latency phase is over and progression toward AIDS is noted. The **progression of disease** is related temporally to the gradual disruption of lymph node architecture and degeneration of the follicular dendritic cell network with loss of its ability to trap HIV particles. The virus is freed to recirculate, producing high levels of viremia and an increased disappearance of CD4 T cells during the later stages of disease.

The clinical course of HIV infection shows substantial heterogeneity. This variation is determined by both viral and host factors. HIV viruses that use co-receptor CXCR-4 in the course of the infection are associated with an accelerated deterioration of the immune system and more rapid progression to AIDS. In addition, several known host genetic determinants (e.g., variants in the human leukocyte antigen region, polymorphisms in the CCR-5 region such as CCR-5 $\Delta$ 32) affect disease course. There are likely additional host and viral factors yet to be identified that contribute to the variable course of HIV infection in individuals, as well. **Three distinct patterns of disease** are described in children. Approximately 15–25% of HIV-infected newborns in high resource settings present with a **rapid progression** course, with onset of AIDS and symptoms during the first few months of life and a median survival time of 6-9 months if untreated. In resource-limited settings, the majority of HIV-infected newborns will have this rapidly progressing disease course. It has been suggested that if intrauterine infection coincides with the period of rapid expansion of CD4 cells in the fetus, the virus could effectively infect the majority of the body's immunocompetent cells. The normal migration of these cells to the marrow, spleen, and thymus would result in efficient systemic delivery of HIV, unchecked by the immature immune system of the fetus. Thus infection would be established before the normal ontogenic development of the immune system, causing more-severe impairment of immunity. Most children in this group have detectable virus in the plasma (median level: 11,000 copies/mL) in the first 48 hours of life. This early evidence of viral presence suggests that the newborn was infected in utero. The viral load rapidly increases, peaking by 2-3 months of age (median: 750,000 copies/mL) and staying high for at least the first 2 years of life.

Sixty percent to 80% of perinatally infected newborns in high-resource settings present with a **slower progression** of disease, with a median survival time of 6 years representing the second pattern of disease. Many patients in this group have a negative PCR result in the first week of life and are therefore considered to be infected intrapartum. In a typical patient, the viral load rapidly increases, peaking by 2-3 months of age (median: 100,000 copies/mL) and then slowly declines

**Table 322.1** HIV Infection Stage\* Based on Age-Specific CD4<sup>+</sup> T-Lymphocyte Count or CD4<sup>+</sup> T-Lymphocyte Percentage of Total Lymphocytes

STAGE	AGE ON DATE OF CD4 <sup>+</sup> T-LYMPHOCYTE TEST					
	<1 Yr		1-5 Yr		≥6 Yr	
	CELLS/μL	%	CELLS/μL	%	CELLS/μL	%
1	≥1,500	≥34	≥1,000	≥30	≥500	≥26
2	750-1,499	26-33	500-999	22-29	200-499	14-25
3	<750	<26	<500	<22	<200	<14

\*Stage is based primarily on the CD4<sup>+</sup> T-lymphocyte count. The CD4<sup>+</sup> T-lymphocyte count takes precedence over the CD4<sup>+</sup> T-lymphocyte percentage, and the percentage is considered only if the count is missing.

From Centers for Disease Control and Prevention. Revised surveillance case definition for HIV infection—United States, 2014. *MMWR Morb Mortal Wkly Rep.* 2014;63(No RR-3):1–10.

over a period of 24 months. The slow decline in viral load is in sharp contrast to the rapid decline after primary infection seen in adults. This observation can be explained only partially by the immaturity of the immune system in newborns and infants.

The third pattern of disease occurs in <5% of perinatally infected children, referred to as **long-term survivors** or **long-term nonprogressors**, who have minimal or no progression of disease with relatively normal CD4 counts and very low viral loads for longer than 8 years. Mechanisms for the delay in disease progression include effective humoral immunity and/or CTL responses, host genetic factors (e.g., human leukocyte antigen profile), and infection with an attenuated (defective-gene) virus. A subgroup of the long-term survivors called elite survivors or elite suppressors has no detectable virus in the blood and may reflect different or greater mechanisms of protection from disease progression. Note that both groups warrant long-term close follow-up because later in their course they may begin to progress with their disease.

HIV-infected children have changes in the immune system that are similar to those in HIV-infected adults. Absolute CD4 cell depletion may be less dramatic because infants normally have a relative lymphocytosis. A value of 750 CD4 cells/μL in children younger than 1 year of age is indicative of severe CD4 depletion and is comparable to <200 CD4 cells/μL in adults. Lymphopenia is relatively rare in perinatally infected children and is usually only seen in older children or those with end-stage disease. Although cutaneous anergy is common during HIV infection, it is also frequent in healthy children younger than 1 year of age, and thus its interpretation is difficult in infected infants. The depletion of CD4 cells also decreases the response to soluble antigens such as in vitro mitogens phytohemagglutinin and concanavalin A.

Polyclonal activation of B cells occurs in most children early in the infection, as evidenced by elevation of immunoglobulins IgA, IgM, IgE, and, particularly, IgG (**hypergammaglobulinemia**), with high levels of anti-HIV-1 antibody. This response may reflect both dysregulation of the T-cell suppression of B-cell antibody synthesis and active CD4 enhancement of the B-lymphocyte humoral response. As a result, the antibody response to routine childhood vaccinations may be abnormal. The B-cell dysregulation precedes the CD4 depletion in many children and may serve as a surrogate marker of HIV infection in symptomatic children in whom specific diagnostic tests (PCR, culture) are not available or are too expensive. Despite the increased levels of immunoglobulins, some children lack specific antibodies or protective antibodies. Hypogammaglobulinemia is very rare (<1%).

**Central nervous system (CNS)** involvement is more common in pediatric patients than in adults. Macrophages and microglia play an important role in HIV neuropathogenesis, and data show that astrocytes may also be involved. Although the specific mechanisms for encephalopathy in children are not yet clear, the developing brain in young infants is affected by at least two mechanisms. The virus itself may directly infect various brain cells or cause indirect damage to the nervous system by the release of cytokines (IL-1α, IL-1β, TNF-α, IL-2) or reactive oxygen damage from HIV-infected lymphocytes or macrophages.

## CLINICAL MANIFESTATIONS

The clinical manifestations of HIV infection vary widely among infants, children, and adolescents. In most infants, physical examination at birth is normal. Initial symptoms may be subtle, such as lymphadenopathy and hepatosplenomegaly, or nonspecific, such as failure to thrive, chronic or recurrent diarrhea, respiratory symptoms, or oral thrush, and may be distinguishable only by their persistence. Whereas systemic and pulmonary findings are common in the United States and Europe, chronic diarrhea, pneumonia, wasting, and severe malnutrition predominate in Africa. Clinical manifestations found more commonly in children than adults with HIV infection include recurrent bacterial infections, chronic parotid swelling, lymphocytic interstitial pneumonitis (LIP), and early onset of progressive neurologic deterioration; note that chronic parotid swelling and LIP are associated with a slower progression of disease.

The Centers for Disease Control and Prevention (CDC) Surveillance Case Definition for HIV infection is based on the age-specific CD4<sup>+</sup> T-lymphocyte count or the CD4<sup>+</sup> T-lymphocyte percentage of total lymphocytes (Table 322.1), except when a stage 3–defining opportunistic illness (Table 322.2) supersedes the CD4 data. Age adjustment of the absolute CD4 count is necessary because counts that are relatively high in normal infants decline steadily until age 6 years, when they reach adult norms. The CD4 count takes precedence over the CD4 T-lymphocyte percentage, and the percentage is considered only if the count is unavailable.

## Infections

Approximately 20% of AIDS-defining illnesses in children are recurrent bacterial infections caused primarily by encapsulated organisms such as *Streptococcus pneumoniae* and *Salmonella* as a result of disturbances in humoral immunity. Other pathogens, including *Staphylococcus*, *Enterococcus*, *Pseudomonas aeruginosa*, and *Haemophilus influenzae*, and other gram-positive and gram-negative organisms may also be seen. The most common serious infections in HIV-infected children are bacteremia, sepsis, and bacterial pneumonia, accounting for more than 50% of infections in these patients. Meningitis, urinary tract infections, deep-seated abscesses, and bone/joint infections occur less frequently. Milder recurrent infections, such as otitis media, sinusitis, and skin and soft tissue infections, are very common and may be chronic with atypical presentations.

**Opportunistic infections** are generally seen in children with severe depression of the CD4 count. In adults, these infections often represent reactivation of a latent infection acquired early in life. In contrast, young children generally have primary infection and often have a more fulminant course of disease reflecting the lack of prior immunity. In addition, infants <1 year of age have a higher incidence of developing stage 3–defining opportunistic infections and mortality rates compared with older children and adults even at higher CD4 counts, reflecting that the CD4 count may overpredict the immune competence in young infants. This principle is best illustrated by ***Pneumocystis jirovecii* pneumonia** (formerly *Pneumocystis carinii*), the most common opportunistic infection in the pediatric population (see Chapter 290). The peak incidence of *Pneumocystis* pneumonia occurs at age 3–6



**Table 322.2** Stage 3—Defining Opportunistic Illnesses in HIV Infection

- Bacterial infections, multiple or recurrent\*
- Candidiasis of bronchi, trachea, or lungs
- Candidiasis of esophagus
- Cervical cancer, invasive†
- Coccidioidomycosis, disseminated or extrapulmonary
- Cryptococcosis, extrapulmonary
- Cryptosporidiosis, chronic intestinal (>1 mo duration)
- Cytomegalovirus disease (other than liver, spleen, or nodes), onset at age >1 mo
- Cytomegalovirus retinitis (with loss of vision)
- Encephalopathy attributed to HIV‡
- Herpes simplex: chronic ulcers (>1 mo duration) or bronchitis, pneumonitis, or esophagitis (onset at age >1 mo)
- Histoplasmosis, disseminated or extrapulmonary
- Isosporiasis, chronic intestinal (>1 mo duration)
- Kaposi sarcoma
- Lymphoma, Burkitt (or equivalent term)
- Lymphoma, immunoblastic (or equivalent term)
- Lymphoma, primary, of brain
- *Mycobacterium avium* complex or *Mycobacterium kansasii*, disseminated or extrapulmonary
- *Mycobacterium tuberculosis* of any site, pulmonary,† disseminated, or extrapulmonary
- *Mycobacterium*, other species or unidentified species, disseminated or extrapulmonary
- *Pneumocystis jiroveci* (previously known as *Pneumocystis carinii*) pneumonia
- Pneumonia, recurrent‡
- Progressive multifocal leukoencephalopathy
- *Salmonella* septicemia, recurrent
- Toxoplasmosis of brain, onset at age >1 mo
- Wasting syndrome attributed to HIV‡

\*Only among children age <6 yr.

†Only among adults, adolescents, and children age ≥6 yr.

‡Suggested diagnostic criteria for these illnesses, which might be particularly important for HIV encephalopathy and HIV wasting syndrome, are described in the following references: Centers for Disease Control and Prevention. 1994 Revised classification system for human immunodeficiency virus infection in children less than 13 years of age. *MMWR Recomm Rep*. 1994;43(No. RR-12); Centers for Disease Control and Prevention. 1993 Revised classification system for HIV infection and expanded surveillance case definition for AIDS among adolescents and adults. *MMWR Recomm Rep*. 1992;41(No. RR-17).

From Centers for Disease Control and Prevention. Revised surveillance case definition for HIV infection—United States, 2014. *MMWR Morb Mortal Wkly Rep*. 2014;63(No. RR-3):1–10.

months in the setting of undiagnosed perinatally acquired HIV infection, with the highest mortality rate in children younger than 1 year of age regardless of CD4 count. Aggressive approaches to treatment have improved the outcome substantially. Although the overall incidence of opportunistic infections has markedly declined since the era of combination ART, opportunistic infections still occur in patients with severe immunodepletion as the result of unchecked viral replication, which often accompanies poor ART adherence.

The classic clinical presentation of *Pneumocystis* pneumonia includes an acute onset of fever, tachypnea, dyspnea, and marked hypoxemia; in some children, more indolent development of hypoxemia may precede other clinical or x-ray manifestations. In some cases, fever may be absent or low grade, particularly in more indolent cases. Chest x-ray findings most commonly consist of interstitial infiltrates or diffuse alveolar disease, which rapidly progresses. Chest x-ray in some cases can have very subtle findings and can mimic the radiologic appearance of viral bronchiolitis. Nodular lesions, streaky or lobar infiltrates, or pleural effusions may occasionally be seen. The diagnosis is established by demonstration of *P. jiroveci* with appropriate staining of induced sputum or bronchoalveolar fluid lavage; rarely, an open lung biopsy is necessary. Bronchoalveolar lavage and open lung biopsy have significantly improved sensitivity (75–95%) for *Pneumocystis* testing than induced sputum (20–40%), such that if an induced sputum is negative,

it does not exclude the diagnosis. PCR testing on respiratory specimens is also available and is more sensitive than microscopy but also has less specificity; it is also not widely available.

The first-line therapy for *Pneumocystis* pneumonia is trimethoprim-sulfamethoxazole (TMP-SMX) (15–20 mg/kg/day of the TMP component divided every 6 hours intravenously) with adjunctive corticosteroids for moderate to severe disease, usually defined as if the PaO<sub>2</sub> is <70 mm Hg while breathing room air. After improvement, therapy with oral TMP-SMX should continue for a total of 21 days while the corticosteroids are weaned. An alternative therapy for *Pneumocystis* pneumonia includes intravenous administration of pentamidine (4 mg/kg/day). Other regimens such as TMP plus dapsone, clindamycin plus primaquine, or atovaquone are used as alternatives in adults but have not been widely used in children to date.

**Nontuberculous mycobacteria (NTM)**, with *Mycobacterium avium-intracellulare* complex (MAC) being most common, may cause disseminated disease in HIV-infected children who are severely immunosuppressed. The incidence of MAC infection in ART-naïve children >6 years with <100 CD4 cells/μL is estimated to be as high as 10%, but effective cART that results in viral suppression makes MAC infections rare. Disseminated MAC infection is characterized by fever, malaise, weight loss, and night sweats; diarrhea, abdominal pain, and, rarely, intestinal perforation or jaundice (a result of biliary tract obstruction by lymphadenopathy) may also be present. Labs may be notable for significant anemia. The diagnosis is made by the isolation of MAC from blood, bone marrow, or tissue; the isolated presence of MAC in the stool does not confirm a diagnosis of disseminated MAC. Treatment can reduce symptoms and prolong life but is at best only capable of suppressing the infection if severe CD4 depletion persists. Therapy should include at least two drugs: clarithromycin or azithromycin and ethambutol. A third drug (rifabutin, rifampin, ciprofloxacin, levofloxacin, or amikacin) may be added to decrease the emergence of drug-resistant isolates. Careful consideration of possible drug interactions with anti-retroviral agents is necessary before initiation of disseminated MAC therapy. Drug susceptibilities should be ascertained, and the treatment regimen should be adjusted accordingly in the event of an inadequate clinical response to therapy. Because of the great potential for toxicity with most of these medications, surveillance for adverse effects should be ongoing. Less commonly, NTM infections, including lymphadenitis, osteomyelitis, tenosynovitis, and pulmonary disease, can also be seen.

Oral candidiasis is the most common **fungal infection** seen in HIV-infected children. Oral nystatin suspension (2–5 mL qid) is often effective. Clotrimazole troches or fluconazole (3–6 mg/kg orally qd) are effective alternatives. Oral thrush progresses to involve the esophagus in as many as 20% of children with severe CD4 depletion, presenting with symptoms such as anorexia, dysphagia, vomiting, and fever. Treatment with oral fluconazole for 7–14 days generally results in rapid improvement in symptoms. Fungemia rarely occurs, usually in the setting of indwelling venous catheters, and up to 50% of cases may be caused by non-*albicans* species. Disseminated histoplasmosis, coccidioidomycosis, and cryptococcosis are rare in pediatric patients but may occur in endemic areas.

**Parasitic infections** such as intestinal cryptosporidiosis and microsporidiosis and rarely isosporiasis or giardiasis are other opportunistic infections that cause significant morbidity. Although these intestinal infections are usually self-limited in healthy hosts, they cause severe chronic diarrhea in HIV-infected children with low CD4 counts, often leading to malnutrition. Nitazoxanide therapy is partially effective at improving cryptosporidia diarrhea, but immune reconstitution with cART is the most important factor for clearance of the infection. Albendazole has been reported to be effective against most microsporidia (excluding *Enterocytozoon bienersi* and *Vittaforma corneae*), and TMP-SMX appears to be effective for isosporiasis. Systemic fumagillin can be used to treat *Enterocytozoon* and *Vittaforma*.

**Viral infections**, especially with the herpesvirus group, pose significant problems for HIV-infected children. HSV causes recurrent gingivostomatitis, which may be complicated by local and distant cutaneous dissemination. Primary varicella-zoster virus infection (chickenpox) may be prolonged and complicated by bacterial superinfections or



visceral dissemination, including pneumonitis. Recurrent, atypical, or chronic episodes of herpes zoster are often debilitating and require prolonged therapy with acyclovir; in rare instances, varicella-zoster virus has developed a resistance to acyclovir, requiring the use of foscarnet. Disseminated cytomegalovirus infection occurs in the setting of severe CD4 depletion (<50 CD4 cells/ $\mu$ L for  $\geq 6$  years) and may involve single or multiple organs. Retinitis, pneumonitis, esophagitis, gastritis with pyloric obstruction, hepatitis, colitis, and encephalitis have been reported, but these complications are rarely seen if cART is given. Ganciclovir and foscarnet are the drugs of choice and are often given together in children with sight-threatening cytomegalovirus retinitis. Intraocular injections of foscarnet or intraocular ganciclovir implants plus oral valganciclovir have also been efficacious in adults and older children with cytomegalovirus retinitis. Measles may occur despite immunization and may present without the typical rash. It often disseminates to the lung or brain with a high mortality rate in these patients. HIV-infected children with low CD4 counts can also develop extensive cutaneous molluscum contagiosum infection. Respiratory viruses such as respiratory syncytial virus and adenovirus may present with prolonged symptoms and persistent viral shedding. In parallel with the increased prevalence of genital tract human papillomavirus infection, cervical intraepithelial neoplasia and anal intraepithelial neoplasia also occur with increased frequency among HIV-1-infected adult females compared with HIV-seronegative females. The relative risk for cervical intraepithelial neoplasia is 5–10 times higher for HIV-1 seropositive females. Multiple modalities are used to treat human papillomavirus (HPV) infection (see [Chapter 313](#)), although none is uniformly effective and the recurrence rate is high among HIV-1-infected persons. Prevention with appropriate vaccinations in patients whose CD4 counts are above threshold is recommended, including mumps-measles-rubella (MMR), varicella vaccine, and HPV vaccine (see “Supportive Care” section).

Appropriate therapy with antiretroviral agents may result in **immune reconstitution inflammatory syndrome (IRIS)**, which is characterized by an increased inflammatory response from the recovered immune system to subclinical opportunistic infections (e.g., *Mycobacterium* infection, herpes simplex virus (HSV) infection, toxoplasmosis, cytomegalovirus (CMV) infection, *Pneumocystis* infection, cryptococcal infection). This condition is more commonly observed in patients with progressive disease and severe CD4<sup>+</sup> T-lymphocyte depletion. Patients with IRIS develop fever and worsening of the clinical manifestations of the opportunistic infection or new manifestations (e.g., enlargement of lymph nodes, pulmonary infiltrates), typically within the first few weeks after initiation of ART. Determining whether the symptoms represent IRIS, worsening of a current infection, a new opportunistic infection, or drug toxicity can be challenging. If the syndrome does represent IRIS, adding nonsteroidal antiinflammatory agents or corticosteroids may alleviate the inflammatory reaction, although the use of corticosteroids is usually reserved for severe cases. The inflammation may take weeks or months to subside. In most cases, continuation of cART while treating the opportunistic infection (with or without antiinflammatory agents) is sufficient. If opportunistic infection is suspected before the initiation of ART, appropriate antimicrobial treatment should be started before starting cART, particularly in the case of cryptococcal meningitis.

### Central Nervous System

The incidence of CNS involvement in perinatally infected children is as high as 50–90% in resource-limited settings but significantly lower in resource-rich settings, with a median onset at 19 months of age. Manifestations may range from subtle developmental delay to progressive encephalopathy with loss or plateau of developmental milestones, cognitive deterioration, impaired brain growth resulting in acquired microcephaly, and symmetric motor dysfunction. **Encephalopathy** may be the initial manifestation of the disease or may present much later when severe immune suppression occurs. With progression, marked apathy, spasticity, hyperreflexia, and gait disturbance may occur, as well as loss of language and oral, fine, and/or gross motor skills. The encephalopathy may progress intermittently, with periods of deterioration followed

by transiently stable plateaus. Older children may exhibit behavioral problems and learning disabilities. Associated abnormalities identified by neuroimaging techniques include cerebral atrophy in up to 85% of children with neurologic symptoms, increased ventricular size, basal ganglia calcifications, and, less frequently, leukomalacia.

Fortunately, since the advent of cART, the incidence rate of encephalopathy has dramatically declined to as low as 0.08% in 2006. However, as HIV-infected children progress through adolescence and young adulthood, other subtle manifestations of CNS disease are evident, such as cognitive deficits, attention problems, and psychiatric disorders. Living with a chronic, often stigmatizing, disease; parental loss; and the requirement for lifelong pristine medication adherence compounds these issues, making it challenging for these youth as they inherit responsibility for managing their disease as adults.

Focal neurologic signs and seizures are unusual and may imply a comorbid pathologic process such as a CNS tumor, opportunistic infection, or stroke. **CNS lymphoma** may present with new-onset focal neurologic findings, headache, seizures, and mental status changes. Characteristic findings on neuroimaging studies include a hyperdense or isodense mass with variable contrast enhancement or a diffusely infiltrating contrast-enhancing mass. **CNS toxoplasmosis** is exceedingly rare in young infants but may occur in vertically HIV-infected adolescents and is typically associated with serum anti-toxoplasma IgG as a marker of infection. Other opportunistic infections of the CNS are rare and include infection with CMV, JC virus (**progressive multifocal leukoencephalopathy**), HSV, *Cryptococcus neoformans*, and *Coccidioides immitis*. Although the true incidence of cerebrovascular disorders (both hemorrhagic and nonhemorrhagic strokes) is unclear, 6–10% of children from large clinical series have been affected.

### Respiratory Tract

Recurrent upper respiratory tract infections such as otitis media and sinusitis are very common. Although the typical pathogens (*S. pneumoniae*, *H. influenzae*, *Moraxella catarrhalis*) are most common, unusual pathogens such as *P. aeruginosa*, yeast, and anaerobes may be present in chronic infections and result in complications such as invasive sinusitis and mastoiditis.

**LIP** is the most common chronic lower respiratory tract abnormality reported to the CDC for HIV-infected children; historically this occurred in approximately 25% of HIV-infected children, although the incidence has declined in the cART era. LIP is a chronic process with nodular lymphoid hyperplasia in the bronchial and bronchiolar epithelium, often leading to progressive alveolar capillary block over months to years. It has a characteristic chronic diffuse reticulonodular pattern on chest radiography rarely accompanied by hilar lymphadenopathy, allowing a presumptive diagnosis to be made radiographically before the onset of symptoms. There is an insidious onset of tachypnea, cough, and mild to moderate hypoxemia with normal auscultatory findings or minimal rales. Progressive disease presents with symptomatic hypoxemia, which usually resolves with oral corticosteroid therapy, accompanied by digital clubbing. Several studies suggest that LIP is a lymphoproliferative response to a primary Epstein-Barr virus infection in the setting of HIV infection. It is also associated with a slower immunologic decline.

Most symptomatic HIV-infected children experience at least one episode of pneumonia during their disease. *S. pneumoniae* is the most common bacterial pathogen, but *P. aeruginosa* and other gram-negative bacterial pneumonias may occur in end-stage disease and may produce acute respiratory failure and death. Rarely, severe recurrent bacterial pneumonia results in bronchiectasis. *Pneumocystis* pneumonia is the most common opportunistic infection, but other pathogens, including CMV, *Aspergillus*, *Histoplasma*, and *Cryptococcus*, can cause pulmonary disease. Infection with common respiratory viruses, including respiratory syncytial virus, parainfluenza, influenza, and adenovirus, may occur simultaneously and have a protracted course and prolonged period of viral shedding from the respiratory tract. Infection with SARS-CoV-2 may also occur, without clear evidence of increased morbidity relative to children without HIV infection.

Pulmonary and extrapulmonary tuberculosis (TB) has been reported with increasing frequency in HIV-infected children in low-resource countries, although it is considerably more common in HIV-infected adults. Because of drug interactions between rifampin and ritonavir-based ART and poor tolerability of the combination of multiple drugs required, treatment of TB/HIV co-infection is particularly challenging in children.

### Cardiovascular System

Cardiac dysfunction, including left ventricular hypertrophy, left ventricular dilation, reduced left ventricular fractional shortening, and/or heart failure occurred in 18–39% of HIV-infected children in the pre-cART era; among those affected, a lower nadir CD4 percentage and a higher viral load were associated with lower cardiac function. However, a more current evaluation of HIV-infected children taking long-term cART found that echocardiographic findings were closer to normal and none had symptomatic heart disease, suggesting that cART has a cardioprotective effect. What is still unclear is whether an increased rate of premature cardiovascular disease that has been seen in adults will be seen in children who have disease- or treatment-related hyperlipidemia, and prospective studies are needed to assess this risk. Because of this risk, regular monitoring of cholesterol and lipids, as well as education regarding a heart-healthy lifestyle and diet, is an important part of pediatric HIV care.

### Gastrointestinal and Hepatobiliary Tract

Oral manifestations of HIV disease include erythematous or pseudo-membranous candidiasis, periodontal disease (e.g., ulcerative gingivitis or periodontitis), salivary gland disease (i.e., swelling, xerostomia), and, rarely, ulcerations or oral hairy leukoplakia. Gastrointestinal tract involvement is common in HIV-infected children. A variety of pathogens can cause gastrointestinal disease, including bacteria (*Salmonella*, *Campylobacter*, *Shigella*, MAC), protozoa (*Giardia*, *Cryptosporidium*, *Iso-spora*, microsporidia), viruses (CMV, HSV, rotavirus), and fungi (*Candida*). MAC and the protozoal infections are most severe and protracted in patients with severe CD4 cell depletion. Infections may be localized or disseminated and affect any part of the gastrointestinal tract from the oropharynx to the rectum. Oral or esophageal ulcerations, either viral in origin or idiopathic, are painful and often interfere with eating. AIDS enteropathy, a syndrome of malabsorption with partial villous atrophy not associated with a specific pathogen, has been postulated to be a result of direct HIV infection of the gut. Disaccharide intolerance is common in HIV-infected children with chronic diarrhea.

The most common symptoms of gastrointestinal disease are chronic or recurrent diarrhea with malabsorption, abdominal pain, dysphagia, and failure to thrive. Prompt recognition of weight loss or poor growth velocity in the absence of diarrhea is critical. Linear growth impairment is often correlated with the level of HIV viremia. Supplemental enteral feedings should be instituted, either by mouth or with nighttime nasogastric tube feedings in cases associated with more severe chronic growth problems; placement of a gastrostomy tube for nutritional supplementation may be necessary in severe cases. The wasting syndrome, defined as a loss of >10% of body weight, is not as common as failure to thrive in pediatric patients, but the resulting malnutrition is associated with a grave prognosis. Chronic liver inflammation evidenced by fluctuating serum levels of transaminases with or without cholestasis is relatively common, often without identification of an etiologic agent. Cryptosporidial cholecystitis is associated with abdominal pain, jaundice, and elevated  $\gamma$ -glutamyltransferase. In some patients, chronic hepatitis caused by CMV, hepatitis B, hepatitis C, or MAC may lead to portal hypertension and liver failure. Several of the antiretroviral drugs or other drugs such as didanosine, protease inhibitors (PIs), nevirapine, and dapsone may also cause reversible elevation of transaminases.

Pancreatitis with increased pancreatic enzymes with or without abdominal pain, vomiting, and fever may be the result of drug therapy (e.g., with pentamidine, didanosine, or stavudine) or, rarely, opportunistic infections such as MAC or CMV.

### Renal Disease

Nephropathy is an unusual presenting symptom of HIV infection, more commonly occurring in older symptomatic children. A direct effect of HIV on renal epithelial cells has been suggested as the cause, but immune complexes, hyperviscosity of the blood (secondary to hyperglobulinemia), and nephrotoxic drugs are other possible factors. A wide range of histologic abnormalities has been reported, including focal glomerulosclerosis, mesangial hyperplasia, segmental necrotizing glomerulonephritis, and minimal change disease. Focal glomerulosclerosis generally progresses to renal failure within 6–12 months, but other histologic abnormalities in children may remain stable without significant renal insufficiency for prolonged periods. **Nephrotic syndrome** is the most common manifestation of pediatric renal disease, with edema, hypoalbuminemia, proteinuria, and azotemia with normal blood pressure. Cases resistant to steroid therapy may benefit from cyclosporine therapy. Polyuria, oliguria, and hematuria have also been observed in some patients.

### Skin Manifestations

Many cutaneous manifestations seen in HIV-infected children are inflammatory or infectious disorders that are not unique to HIV infection. These disorders tend to be more disseminated and respond less consistently to conventional therapy than in the uninfected child. Seborrheic dermatitis or eczema that is severe and unresponsive to treatment may be an early nonspecific sign of HIV infection. Recurrent or chronic episodes of HSV, herpes zoster, molluscum contagiosum, flat warts, anogenital warts, and candidal infections are common and may be difficult to control.

Allergic drug eruptions are also common, in particular related to nonnucleoside reverse transcriptase inhibitors; they generally respond to withdrawal of the drug but also may resolve spontaneously without drug interruption; rarely, progression to Stevens-Johnson syndrome has been reported. Epidermal hyperkeratosis with dry, scaling skin is frequently observed, and sparse hair or hair loss may be seen in the later stages of the disease.

### Hematologic and Malignant Diseases

**Anemia** occurs in 20–70% of HIV-infected children, more commonly in children with AIDS. The anemia may be a result of chronic infection, poor nutrition, autoimmune factors, virus-associated conditions (hemophagocytic syndrome, parvovirus B19 red cell aplasia), or the adverse effect of drugs (zidovudine).

**Leukopenia** occurs in almost 30% of untreated HIV-infected children, and neutropenia often occurs. Multiple drugs used for treatment or prophylaxis for opportunistic infections, such as *Pneumocystis* pneumonia (TMP-SMX), MAC, and CMV (ganciclovir), or antiretroviral drugs (zidovudine) may also cause leukopenia and/or neutropenia. In cases in which therapy cannot be changed, treatment with subcutaneous granulocyte colony-stimulating factor may be necessary.

**Thrombocytopenia** has been reported in 10–20% of patients. The etiology may be immunologic (i.e., circulating immune complexes or antiplatelet antibodies) or, less commonly, from drug toxicity, or idiopathic. cART may also reverse thrombocytopenia in ART-naïve patients. In the event of sustained severe thrombocytopenia (<10,000 platelets/ $\mu$ L), treatment with intravenous immunoglobulin or anti-D immune globulin offers temporary improvement in most patients already taking cART. If ineffective, a course of steroids may be an alternative, but consultation with a hematologist should be sought. Deficiency of clotting factors (factors II, VII, IX) is not rare in children with advanced HIV disease and corrects with vitamin K.

A novel disease of the thymus has been observed in a few HIV-infected children. These patients were found to have characteristic anterior mediastinal multilocular thymic cysts without clinical symptoms. Histologic examination shows focal cystic changes, follicular hyperplasia, and diffuse plasmacytosis and multinucleated giant cells. Treatment with cART may result in resolution, and spontaneous involution occurs in some cases.

Malignant diseases have been reported infrequently in HIV-infected children, representing only 2% of AIDS-defining illnesses. Non-Hodgkin lymphoma (including Burkitt lymphoma), primary CNS lymphoma, and

leiomyosarcoma are the most commonly reported neoplasms among HIV-infected children. Epstein-Barr virus is associated with most lymphomas and with all leiomyosarcomas (see [Chapter 301](#)). Kaposi sarcoma, which is caused by human herpesvirus 8, occurs frequently among HIV-infected adults but is exceedingly uncommon among HIV-infected children in resource-rich settings (see [Chapter 304](#)).

## DIAGNOSIS AND TESTING

All infants born to HIV-infected individuals test antibody-positive at birth because of passive transfer of HIV antibody across the placenta during gestation; therefore antibody should not be used to establish the diagnosis of HIV in an infant. Most uninfected infants without ongoing exposure (i.e., who are not breastfed) lose antibodies against HIV between 6 and 18 months of age and are known as **seroreverters**. Because a small proportion of uninfected infants continue to test HIV antibody-positive for up to 24 months of age, positive IgG antibody tests, including the rapid tests, cannot be used to make a definitive diagnosis of HIV infection in infants younger than 24 months. The presence of IgA or IgM anti-HIV in the infant's circulation can indicate HIV infection, because these immunoglobulin classes do not cross the placenta; however, IgA and IgM anti-HIV assays have been both insensitive and nonspecific and therefore are not valuable for clinical use. In any child older than 24 months of age, demonstration of IgG antibody to HIV by a repeatedly reactive enzyme immunoassay and confirmatory HIV PCR establishes the diagnosis of HIV infection. Certain diseases (e.g., syphilis and autoimmune diseases) may cause false-positive or indeterminate results in antibody testing. In such cases, specific viral diagnostic tests must be done.

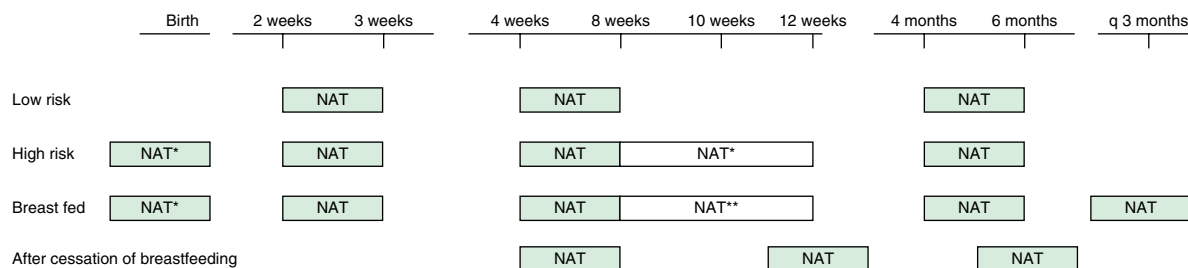
Several rapid HIV tests are currently available with sensitivity and specificity better than those of the standard enzyme immunoassay. Many of these tests require only a single step that allows test results to be reported within less than 30 minutes. Performing rapid HIV testing on individuals during delivery or immediately after birth is crucial for the care of HIV-exposed newborns whose birth parent's HIV status was unknown during pregnancy. A positive rapid test must be confirmed by a second different rapid test (testing different HIV-associated antibodies) or by HIV RNA PCR (viral load). Given the earlier detection of fourth-generation HIV enzyme-linked immunosorbent assay (ELISA) testing (p24 antigen + HIV-1, HIV-2 IgG and IgM antibodies), Western blots are not appropriate to confirm testing because the fourth-generation assays can be positive before the Western blot becomes positive (i.e., in acute infection). In acute infection, patients may have only a positive p24 antigen with negative antibodies on confirmatory testing; these patients should have HIV RNA PCR performed to confirm acute infection (or establish that the p24 antigen result was a false positive test). In infants who are at risk of exposure to HIV-2 infection (e.g., born to an HIV-infected person from West Africa or who has a partner with HIV from West Africa), a rapid test that can detect both HIV-1 and HIV-2 should be used. However, if the HIV testing is negative or the Western blot test reveals an unusual

pattern, further diagnostic tests should be considered. In addition, they should be tested with an HIV-2-specific DNA PCR assay.

Viral diagnostic assays, such as HIV DNA or RNA PCR, are more useful in young infants, allowing a definitive diagnosis in most infected infants by 1-4 months of age. By 4 months of age, HIV PCR testing identifies all infected nonbreastfed infants. Historically, HIV DNA PCR testing was the preferred virologic assay over HIV RNA PCR testing in high-resource settings for young infants because of what was thought to be a modest advantage in detecting intrapartum acquired infection for DNA PCR in the first month of life. An FDA-approved HIV DNA PCR test is no longer commercially available in the United States, but other assays exist; however, the sensitivity and specificity of noncommercial HIV-1 DNA tests (using individual laboratory reagents) may differ from the sensitivity and specificity of the prior FDA-approved commercial test. HIV RNA PCR is recommended for non-subtype B viruses or group O infections, which are not common in the United States. It should be noted that PCR results can be affected by ART in both the birthing parent and the infant, serving as the rationale for the recommendation for testing 2-6 weeks after completing prophylaxis in high-risk newborns ([Fig. 322.4](#)). Almost 40% of infected newborns have positive DNA PCR test results in the first 2 days of life, with >90% testing positive by 2 weeks of age. The commercially available HIV-1 assays are not designed for quantification of HIV-2 RNA and thus should not be used to monitor patients with this infection.

Viral diagnostic testing should be performed within the first 12-24 hours of life for high-risk infants (i.e., those born to individuals without sustained virologic suppression, a late cART start, or a diagnosis with acute or primary HIV during the pregnancy); the tests can identify almost 40% of intrauterine HIV-infected children. Birth testing is optional in low-risk infants. Additional testing should be done at 2-3 weeks of age, 4-8 weeks of age, and 4-6 months of age. For higher-risk infants, additional virologic diagnostic testing should be done at 2 to 6 weeks after cessation of ARV prophylaxis (i.e., at 8-12 weeks of life) (see [Fig. 322.4](#)). Breastfed infants should have PCR testing performed per testing schedule based on their risk through 4 months of age; an additional test should be done between the 4- to 8-week test and the 4- to 6-month test if the gap between tests is more than 3 months. Breastfed infants should then be tested every 3 months while breastfeeding continues and then at 4-6 weeks, 3 months, and 6 months after cessation of breastfeeding regardless of age to identify those who may become infected at the end of lactation by the HIV-infected individual (see [Fig. 322.4](#)).

A positive virologic assay (i.e., detection of HIV by PCR) suggests HIV infection and should be confirmed by a repeat test on a second specimen as soon as possible because false-positive tests can occur. A confirmed diagnosis of HIV infection can be made with two positive virologic test results obtained from different blood samples. HIV infection can be presumptively excluded in nonbreastfed infants with two or more negative virologic tests (one at age  $\geq 14$  days and one at age  $\geq 4$  weeks), one negative virologic test (i.e., negative RNA or DNA) at age  $\geq 8$  weeks done at least 2 weeks after discontinuation of multidrug



**Fig. 322.4** Recommended virologic testing schedules for infants exposed to HIV by perinatal HIV transmission risk and breastfed infants. See [Table 322.7](#) for definitions of low and high risk. \*For higher-risk infants, additional virologic diagnostic testing should be done at birth and 2-6 wk after cessation of ARV prophylaxis (i.e., at 8-10 wk of life). \*\*For breastfed infants, an additional virologic test should be performed between the 1- to 2-mo and 4- to 6-mo time points if the gap between tests is >3 mo. NAT, Nucleic acid test. (Content adapted from *Recommendations for the Use of Antiretroviral Drugs During Pregnancy and Interventions to Reduce Perinatal HIV Transmission in the United States*. <https://clinicalinfo.hiv.gov/sites/default/files/guidelines/documents/perinatal-hiv/guidelines-perinatal.pdf>)



empirical therapy or prophylaxis, or one negative HIV antibody test at age  $\geq 6$  months. Definitive exclusion of HIV infection in nonbreastfed infants is based on two or more negative virologic tests, with one obtained at age  $\geq 1$  month (done 2-6 weeks after the cessation of multidrug empirical therapy or prophylaxis) and one at age  $\geq 4$  months, or two negative HIV antibody tests from separate specimens obtained at age  $\geq 6$  months. Documentation of seroreversion (loss of antibody) at 12-18 month of age is no longer routinely recommended for nonbreastfed infants meeting definitive exclusion criteria who have had no known or suspected postnatal HIV exposure. Infants  $< 18$  months who have postnatal HIV exposure, including new HIV infection of breastfeeding parent, pre-masticated feedings, sexual abuse, contaminated blood product, or percutaneous exposure, should have HIV PCR-based testing to determine infection status. Children  $\geq 18$  months of age with no HIV perinatal exposure history with these postnatal exposures should be tested with HIV antibody/antigen testing. Note that HIV antibody/antigen testing should not be used for diagnosis in the perinatally exposed child until age  $\geq 24$  months. Any child or adolescent suspected of HIV infection should be tested with age-appropriate testing with the caveat that if acute infection is suspected, additional HIV PCR testing may be required to establish the diagnosis.

## TREATMENT

The currently available therapies do not eradicate the virus and cure the patient; instead they suppress the virus for extended periods and change the course of the disease to a chronic process. It is now recommended that all children be started on cART, regardless of viral load, CD4 count, or clinical status at diagnosis. Treatment should be initiated within 7 days of diagnosis, with counseling and support for adherence. Because cART therapy changes as new drugs become available, decisions regarding therapy should be made in consultation with an expert in pediatric HIV infection. The following principles form the basis for cART:

1. Uninterrupted HIV replication causes destruction of the immune system and progression to AIDS.
2. The magnitude of the viral load predicts the rate of disease progression, and the CD4 cell count reflects the risk of opportunistic infections and HIV infection complications.
3. cART, which includes at least three drugs with at least two different mechanisms of action, should be the initial treatment. Potent combination therapy that suppresses HIV replication to an undetectable level restricts the selection of ART-resistant mutants; drug-resistant strains are the major factor limiting successful viral suppression and delay of disease progression.
4. The goal of sustainable suppression of HIV replication is best achieved by the simultaneous initiation of combinations of antiretroviral drugs to which the patient has not been exposed previously and to which the patient's virus does not have cross resistance.
5. Drug-related interactions and toxicities should be minimized as much as possible.
6. Adherence to the complex drug regimens is crucial for a successful outcome.

Very rarely, treatment may need to be deferred on a case-by-case basis based on clinical or psychosocial factors that may affect adherence with the caregivers and child. In these children, virologic, immunologic, and clinical status should be closely monitored at least every 3-4 months.

## Combination Therapy

As of February 2023, 21 individual ART drugs, 22 co-formulated combination tablets, one injectable long-acting combination regimen, as well as two pharmacokinetic boosters were approved by the FDA for use in HIV-infected adults and adolescents. Of the 21 individual drugs, 19 were approved for at least some portion of the pediatric population (0-12 years of age), with many but not all of them available as a liquid, powder, or small tablet/capsule (Table 322.3). ART drugs are categorized by their mechanism of action, such as preventing viral entrance into CD4<sup>+</sup> T cells, inhibiting the HIV reverse-transcriptase or protease enzymes, or inhibiting integration of the virus into the

human DNA (see Fig. 322.3). Within the reverse-transcriptase inhibitors, a further subdivision can be made: **nucleoside (or nucleotide) reverse transcriptase inhibitors (NRTIs)** and **nonnucleoside reverse transcriptase inhibitors (NNRTIs)** (see Fig. 322.3). The NRTIs have a structure similar to that of the building blocks of DNA (e.g., thymidine, cytosine). When incorporated into DNA, they act as chain terminators and block further incorporation of nucleosides, preventing viral DNA synthesis. Among the NRTIs, thymidine analogs (e.g., zidovudine) are found in higher concentrations in activated or dividing cells, producing  $>99\%$  of the HIV virion population, and nonthymidine analogs (e.g., lamivudine and emtricitabine) have more activity in resting cells, which account for  $<1\%$  of the HIV virions but may serve as a reservoir for HIV. Suppression of replication in both populations is important for long-term viral control. NNRTIs (i.e., nevirapine, efavirenz, etravirine, rilpivirine, doravirine) act differently than NRTIs. They attach to the reverse transcriptase and cause a conformational change, reducing the activity of the enzyme (see Fig. 322.3). The PIs are potent agents that act farther along the viral replicative cycle. They bind to the site where the viral long polypeptides are cut into individual, mature, and functional core proteins that produce the infectious virions before they leave the cell (see Fig. 322.3). The virus entry into the cell is a complex process that involves several cellular receptors and fusion. Several drugs have been developed to prevent this process (see Fig. 322.3). The **fusion inhibitor** enfuvirtide (T-20), which binds to viral gp41, causes conformational changes that prevent fusion of the virus with the CD4<sup>+</sup> cell and entry into the cell; with the common use of integrase inhibitors, this medication is now used very rarely. Two entry-inhibiting drugs are now approved for use only in treatment-experienced adult patients with multidrug-resistant HIV infection. Fostemsavir is an **attachment inhibitor** prodrug of temsavir that works by blocking CD4 binding to gp120; ibalizumab is a humanized monoclonal antibody (mAb) that acts as a postattachment inhibitor and prevents the HIV connection to co-receptors CCR-5 or CXCR-4. Maraviroc is an example of a **selective CCR-5 co-receptor antagonist** that blocks the attachment of the virus to this chemokine (an essential process in the viral binding and fusion to the CD4<sup>+</sup> cells). **Integrase inhibitors (INSTIs)** (i.e., raltegravir, dolutegravir, elvitegravir, bictegravir) block the enzyme that catalyzes the incorporation of the viral genome into the host's DNA (see Fig. 322.3).

By targeting different points in the viral life cycle and stages of cell activation and by delivering drug to all tissue sites, maximal viral suppression is achievable. **Combinations of three drugs consisting of a two-NRTI backbone of (1) a guanosine or thymidine analog NRTI (abacavir or zidovudine) or tenofovir and (2) a nonthymidine analog NRTI (lamivudine or emtricitabine) to suppress replication in both active and resting cells added to (3) a ritonavir-boosted PI (lopinavir, atazanavir, or darunavir), an NNRTI (efavirenz, nevirapine, rilpivirine, or etravirine), or an INSTI (raltegravir, dolutegravir, elvitegravir, or bictegravir) can produce prolonged suppression of the virus.** The use of three drugs from three different classes generally should be avoided but may be necessary in children with highly resistant viruses; these regimens should be chosen only by an HIV specialist with expert pharmacist input. For adult patients with established virologic suppression, some combination therapies pare down to just two drugs. Combination treatment increases the rate of toxicities (see Table 322.3), and complex drug-drug interactions occur among many of the antiretroviral drugs, particularly with the pharmacokinetic boosters ritonavir and cobicistat. Many PIs are inducers or inhibitors of the cytochrome P450 system and are therefore likely to have serious interactions with multiple drug classes, including non-sedating antihistamines and psychotropic, vasoconstrictor, antimycobacterial, cardiovascular, anesthetic, analgesic, and gastrointestinal drugs (cisapride). Whenever new medications are added to an ART regimen, especially a PI- or cobicistat-containing regimen, a pharmacist and/or HIV specialist should be consulted to address possible drug interactions. The inhibitory effect of ritonavir (a PI) on the cytochrome P450 system is exploited, and small doses of the drug are added to several other PIs (e.g., lopinavir, atazanavir, darunavir) to slow their metabolism by the P450 system and to



**Table 322.3** Summary of Antiretroviral Therapies Available in 2023

DRUG (TRADE NAMES, FORMULATIONS)	DOSING	SIDE EFFECTS	COMMENTS
<b>NUCLEOSIDE/NUCLEOTIDE REVERSE TRANSCRIPTASE INHIBITORS</b>			
Class adverse effects: Lactic acidosis with hepatic steatosis, particularly for older members of the class			
<b>Abacavir</b> (Ziagen, ABC): tablet: 300 mg; oral solution: 20 mg/mL Epzicom: combination of lamivudine, ABC (300, 600 mg) Triumeq: combination of ABC, lamivudine, dolutegravir (600, 300, 50 mg) Triumeq PD: combination of ABC, lamivudine, dolutegravir (60, 30, 5 mg)	Children: Full term <1 mo: 2 mg/kg/dose bid Full term ≥1 mo to <3 mo: 4 mg/kg/dose bid ≥3 mo to 13 yr: 8 mg/kg/dose bid (max: 300 mg bid) >25 kg: 300 mg bid Children with stable CD4 counts and undetectable viral load >6 mo while taking ABC can transition to 16 mg/kg once daily (max: 600 mg) Children ≥25 kg, adolescents and adults: 300 mg bid or 600 mg qd Epzicom (>25 kg): 1 tablet qd Triumeq: 1 tablet qd Triumeq PD (≥10 kg to <25 kg): Must be dispersed in 20 mL of water, not swallowed whole, cut, or chewed 10 kg to <14 kg: 4 tablets qd 14 kg to <20 kg: 5 tablets qd 20 kg to <25 kg: 6 tablets qd	Common: nausea, vomiting, anorexia, fever, headache, diarrhea, rash Less common: hypersensitivity reactions, which can be fatal Rare: lactic acidosis with hepatic steatosis, pancreatitis, elevated triglycerides, myocardial infarction	Genetic screening for HLAB*5701 must be done before initiation of ABC-containing treatment. If test is positive, avoid ABC. Once-daily dosing is not preferred with liquid formulations. Can be given with or without food Do not restart ABC in patients who had hypersensitivity-like symptoms (e.g., flulike symptoms). Oral solution does not require refrigeration. Abacavir should never be used for postexposure prophylaxis (PEP).
<b>Emtricitabine</b> (Emtriva, FTC): capsule: 200 mg; oral solution: 10 mg/mL Truvada: combination of FTC, tenofovir disoproxil fumarate (TDF) (200, 300 mg) Truvada Low Strength: combinations of FTC/TDF (100, 150 mg); (133, 200 mg); (167, 250 mg) Descovy: combinations of FTC, tenofovir alafenamide (TAF) (200, 25 mg); (120, 15 mg) Atripla: combination of FTC, TDF, efavirenz (EFV) (200, 300, 600 mg) Biktarvy: combinations of FTC, TAF, bictegravir (BIC) (200, 25, 50 mg); (120, 15, 30 mg) Complera: combination of FTC, TDF, rilpivirine (RPV) (200, 300, 25 mg) Odefsey: combination of FTC, TAF, RPV (200, 25, 25 mg) Stribild: combination of FTC, TDF, elvitegravir (EVG), cobicistat (COBI) (200, 300, 150, 150 mg) Genvoya: combination of FTC, TAF, EVG, COBI (200, 10, 150, 150 mg) Symtuza: combination of FTC, TAF, darunavir (DRV), COBI (200, 10, 800, 150 mg)	Infants: 0-<3 mo: 3 mg/kg qd Children ≥3 mo to 17 yr, oral solution: 6 mg/kg (max: 240 mg) qd >33 kg, adolescents and adults: 200 mg capsule or 240 mg solution qd ≥14 to <25 kg: Biktarvy (120, 15, 30 mg), Descovy (120, 15 mg): 1 tablet qd ≥25 kg: Biktarvy (200, 25, 50 mg), Genvoya: 1 tablet qd >25 kg to 35 kg: Descovy (200 mg, 25 mg) but cannot pair with boosted PI or COBI: 1 tablet qd ≥35 kg: Complera, Odefsey, Descovy (200, 25 mg): 1 tablet qd ≥35 kg, SMR* 4 or 5: Stribild: 1 tablet qd ≥40 kg Atripla, Symtuza: 1 tablet qd *SMR = Sexual maturity rating	Common: headache, insomnia, diarrhea, nausea, skin discoloration (hyperpigmentation of palms, soles) Less common: lactic acidosis with hepatic steatosis, neutropenia	Patient should be tested for hepatitis B virus (HBV) before starting because HBV exacerbation can occur when emtricitabine is discontinued. Some combination drugs may have food requirements. Oral solution should be refrigerated if temperature above 25°C (77°F) and for long-term storage. COBI is a pharmacokinetic enhancer (boosting agent) used to optimize drug levels; it is not interchangeable with ritonavir. It can alter renal tubular secretion of Cr, resulting in elevated Cr with normal GFR. Note FTC oral solution is less bioavailable and has a max dose of 240 mg, whereas the max dose for capsules is 200 mg.

**Table 322.3** Summary of Antiretroviral Therapies Available in 2023—cont'd

DRUG (TRADE NAMES, FORMULATIONS)	DOSING	SIDE EFFECTS	COMMENTS
<p><b>Lamivudine</b> (EpiVir, EpiVir HBV, 3TC): tablet: 150 (scored), 300 mg (EpiVir, generic), 100 mg (EpiVir HBV); Solution: 5 mg/mL (EpiVir HBV), 10 mg/mL (EpiVir)</p> <p>Combivir: combination of ZDV, lamivudine (300, 150 mg)</p> <p>Cimduo: combination of 3TC, TDF (300 mg, 300 mg)</p> <p>Delstrigo: combination of 3TC, TDF, doravirine (DOR) (300, 300, 100 mg)</p> <p>Dovato: combination of 3TC, DTG (300, 50 mg)</p> <p>Symfi: combination of 3TC, TDF, EFV (300, 300, 600 mg)</p> <p>Symfi Lo: combination of 3TC, TDF, EFV (300, 300, 400 mg)</p> <p>Temixys: combination of 3TC, TDF (300, 300 mg)</p> <p>Epzicom and Triumeq, Triumeq PD combination (see abacavir)</p>	<p>Neonates (<math>\geq 32</math> wk gestational age through 4 wk of age for term infants): 2 mg/kg/dose bid</p> <p><math>\geq 4</math> wk to <math>&lt; 3</math> mo: 4 mg/kg/dose bid</p> <p><math>\geq 3</math> mo to <math>&lt; 3</math> yr: 5 mg/kg/dose bid (max: 150 mg)</p> <p><math>\geq 3</math> yr: 5 mg/kg/dose bid (max: 150 mg) or 10 mg/kg/dose qd (max: 300 mg)</p> <p>For <math>\geq 14</math> kg with scored tablet (150 mg)</p> <p>14 to <math>&lt; 20</math> kg: 75 mg bid or 150 mg qd (if <math>&gt; 3</math> yr)</p> <p><math>\geq 20</math> to <math>&lt; 25</math> kg: 75 mg qAM and 150 mg qPM or 225 mg qd (if <math>&gt; 3</math> yr)</p> <p><math>\geq 25</math> kg: 150 mg bid or 300 mg qd</p> <p>Children should be switched to once-daily dosing of lamivudine (oral solution or tablets) from twice-daily dosing at <math>\geq 3</math> yr if clinically stable for 36 wk with an undetectable viral load and stable CD4 count</p> <p>Adolescents and adults: Combivir, (<math>\geq 30</math> kg): 1 tablet bid</p> <p>Cimduo (<math>&gt; 35</math> kg): 1 tablet qd</p> <p>Epzicom (<math>\geq 25</math> kg): 1 tablet qd</p> <p>Triumeq (<math>\geq 25</math> kg): 1 tablet qd</p> <p>Triumeq PD: see abacavir</p> <p>Symfi (<math>\geq 40</math> kg), Symfi Lo (<math>\geq 35</math> kg and SMR* 4 or 5): 1 tablet qd on empty stomach</p> <p>Temixys (<math>\geq 35</math> kg): 1 tablet qd</p> <p>Dovato: 1 tablet qd in children who meet minimum body weight as part of a three-drug regimen</p> <p>Child and adolescent <math>\geq 35</math> kg and virologically suppressed: Delstrigo: 1 tablet qd*</p> <p>SMR = Sexual maturity rating</p>	<p>Common: headache, nausea</p> <p>Less common: pancreatitis, peripheral neuropathy, lactic acidosis with hepatic steatosis, lipodystrophy</p>	<p>No food restrictions for lamivudine alone but some restrictions with combination drugs</p> <p>Patient should be tested for hepatitis B virus (HBV) before starting because HBV exacerbation can occur when lamivudine is discontinued. M184V mutation for this drug decreases viral fitness and can be advantageous to maintain including inducing AZT hypersusceptibility.</p>
<p><b>Tenofovir alafenamide</b> (Vemlidy, TAF)</p> <p>Descovy: combinations of TAF, FTC (25, 200 mg); (15, 120 mg)</p> <p>Genvoya: combination of TAF, FTC, EVG, COBI (10, 200, 150, 150 mg)</p> <p>Odefsey: combination of TAF, FTC, RPV (25, 200, 25 mg)</p> <p>Biktarvy: combinations of TAF, FTC, BIC (25, 200, 50 mg); (15, 120, 30 mg)</p> <p>Symtuza: combination of TAF, FTC, DRV, COBI (10, 200, 800, 150 mg)</p>	<p><math>\geq 2</math> yr</p> <p><math>\geq 14</math> kg to <math>&lt; 25</math> kg: Biktarvy (15, 120, 30 mg): 1 tablet qd</p> <p>Descovy (15, 120 mg): 1 tablet qd</p> <p><math>\geq 25</math> kg: Biktarvy (25, 200, 50 mg), Descovy (25, 200 mg), Genvoya: 1 tablet qd</p> <p><math>\geq 25</math> kg but <math>&lt; 35</math> kg: Descovy but cannot pair with boosted PI: 1 tablet qd</p> <p><math>\geq 35</math> kg: Descovy: 1 tablet qd</p> <p><math>\geq 35</math> kg and <math>\geq 12</math> yr: Odefsey: 1 tablet qd</p> <p><math>\geq 40</math> kg (adult dose) Symtuza: 1 tablet qd</p>	<p>Common: headache, diarrhea, nausea, asthenia, increased serum lipids</p>	<p>Newer version of TDF that has less renal and bone toxicity. Baseline serum creatinine still recommended before starting. Screen for HBV before TAF is started, because exacerbation of hepatitis may occur when TAF is discontinued. Concentrates in cells more so than TDF</p>

Continued

**Table 322.3** Summary of Antiretroviral Therapies Available in 2023—cont'd

DRUG (TRADE NAMES, FORMULATIONS)	DOSING	SIDE EFFECTS	COMMENTS
<p><b>Tenofovir disoproxil fumarate</b> (Viread, TDF): tablet: 150, 200, 250, 300 mg; powder: 40 mg/1 g powder                      Truvada: combination of FTC, TDF (200, 300 mg)                      Truvada Low Strength: combinations of FTC/TDF (100, 150 mg); (133, 200 mg); (167, 250 mg)                      Cimduo: combination of 3TC, TDF (300 mg, 300 mg)                      Atripla: combination of FTC, TDF, EFV (200, 300, 600 mg)                      Complera: combination of FTC, TDF, RPV (200, 300, 25 mg)                      Delstrigo: combination of 3TC, TDF, DOR (300, 300, 100 mg)                      Stribild: combination of FTC, TDF, EVG, COBI (200, 300, 150, 150 mg)                      Symfi: combination of 3TC, TDF, EFV (300, 300, 600 mg)                      Symfi Lo: combination of 3TC, TDF, EFV (300, 300, 400 mg)                      Temixys: combination of 3TC, TDF (300, 300 mg)</p>	<p>≥2 yr to &lt;12 yr and ≥10 kg: 8 mg/kg/dose qd                      Weight probands for ≥2 yr and ≥17 kg:                      17 to &lt;22 kg: 150 mg qd                      22 to &lt;28 kg: 200 mg qd                      28 to &lt;35 kg: 250 mg qd                      ≥35 kg: 300 mg qd (max dose)                      Atripla (≥40 kg): 1 tablet qd                      Cimduo (≥35 kg): 1 tablet qd                      Complera (≥35 kg): 1 tablet qd                      Symfi (≥40 kg),                      Symfi Lo ≥ 12 yr (≥35 kg and SMR* 4 or 5): 1 tablet qd on empty stomach                      Stribild (≥35 kg, SMR* 4 or 5): 1 tablet qd                      Temixys (≥35 kg): 1 tablet qd                      Delstrigo: Child and adolescent ≥35 kg and virologically suppressed: 1 tablet qd                      *SMR = Sexual maturity rating</p>	<p>Common: nausea, vomiting, diarrhea, asthenia, flatulence                      Less common: lactic acidosis with hepatic steatosis, hepatomegaly, decreased bone density, renal toxicity (glomerular and proximal tubule dysfunction)</p>	<p>Baseline creatinine, urinalysis for protein and glucose should be obtained before starting.                      Screen for HBV before TDF is given, because exacerbation of hepatitis may occur when TDF is discontinued.                      Cautious use in SMR 1 and 2 patients with regard to bone mineral density.</p>
<p><b>Zidovudine</b> (Retrovir, AZT, ZDV): capsule: 100 mg; tablet: 300 mg; syrup: 10 mg/mL; intravenous injection: 10 mg/mL (all available generic)                      Combivir: combination of ZDV, lamivudine (300, 150 mg)</p>	<p><b>Low Risk Prophylaxis:</b>                      ≥35 wk gestation at birth:                      Birth to age 4 wk: 4 mg/kg/dose PO bid (or 3 mg/kg/dose IV q12h)                      ≥30 to &lt;35 wk gestation at birth:                      Birth to age 2 wk: 2 mg/kg/dose PO bid (or 1.5 mg/kg/dose IV q12h)                      THEN                      Age 2 wk to 6 wk:                      3 mg/kg/dose PO bid (or 2.3 mg/kg/dose IV q12h)                      &lt;30 wk gestation at birth                      Birth to age 4 wk: 2 mg/kg/dose PO bid (or 1.5 mg/kg/dose IV q12h)                      THEN                      Age 4 wk to 6 wk:                      3 mg/kg/dose bid (or 2.3 mg/kg/dose IV q12h)                      (See text and Table 322.7 for recommended duration for low risk prophylaxis.)</p>	<p>Common: bone marrow suppression (e.g., anemia, neutropenia), headache, nausea, vomiting, asthenia                      Less common: liver toxicity, lactic acidosis with hepatic steatosis, myopathy, fat redistribution, myopathy/myositis</p>	<p>No food restrictions                      Drug interactions: should not be given with d4T or doxorubicin.                      Only antiretroviral with an IV formulation.</p>
	<p><b>Presumptive HIV therapy for high-risk exposed infants and treatment:</b>                      ≥35 wk gestation at birth:                      Birth to age 4 wk: 4 mg/kg/dose PO bid THEN                      Age &gt;4 wk: 12 mg/kg/dose PO bid                      ≥30 to &lt;35 wk gestation at birth:                      Birth to age 2 wk: 2 mg/kg/dose PO bid THEN                      Age 2 wk to 6 wk: 3 mg/kg/dose PO bid THEN                      Age &gt;6 wk: 12 mg/kg/dose PO bid                      &lt;30 wk gestation at birth:                      Birth to age 4 wk: 2 mg/kg/dose PO bid THEN                      Age 4 wk to 8 wk: 3 mg/kg/dose PO bid THEN                      Age &gt;8 wk: 12 mg/kg/dose PO bid                      Infants &gt;4 kg, ≥35 wk post conception and ≥4 wk post delivery and children:                      4 kg to &lt;9 kg: 12 mg/kg/dose PO bid                      9 kg to &lt;30 kg: 9 mg/kg/dose PO bid                      &gt;30 kg: 300 mg bid (max dose)                      Alternative body surface area dosing:                      180-240 mg/m<sup>2</sup>/dose PO bid                      Combivir (≥30 kg): 1 tablet bid                      IV dose is 75% of PO dose, same interval</p>		

**Table 322.3** Summary of Antiretroviral Therapies Available in 2023—cont'd

DRUG (TRADE NAMES, FORMULATIONS)	DOSING	SIDE EFFECTS	COMMENTS
<b>NONNUCLEOSIDE REVERSE TRANSCRIPTASE INHIBITORS</b>		Class adverse effects: rash is mild to severe, usually within first 6 wk. Discontinue the drug if severe rash (with blistering, desquamation, muscle involvement, or fever)	
<b>Doravirine</b> (Pifeltro, DOR) Tablet: 100 mg Delstrigo: combination of 3TC, TDF, DOR (300, 300, 100 mg)	Child and adolescent $\geq 35$ kg and virologically suppressed: Doravirine: 1 tablet qd Delstrigo: 1 tablet qd	Common: nausea, abdominal pain, diarrhea, vivid dreams, insomnia	Not approved for use in $<18$ yr Can have multiple drug interactions; metabolized by cytochrome P450 3A. If co-administered with rifabutin, dose DOR bid
<b>Efavirenz</b> (Sustiva, EFV): capsule: 50, 200 mg; tablet: 600 mg Atripla: combination of EFV, FTC, TDF (600, 200, 300 mg) Symfi Lo: combination of 3TC, TDF, EFV (300, 300, 400 mg) Symfi: combination of 3TC, TDF, EFV (300, 300, 600 mg)	Children $<3$ yr: Consult with expert; not recommended for children $<3$ yr Children $\geq 3$ yr: 10 to $<15$ kg: 200 mg qd 15 to $<20$ kg: 250 mg qd 20 to $<25$ kg: 300 mg qd 25 to $<32.5$ kg: 350 mg qd 32.5 to $<40$ kg: 400 mg qd $\geq 40$ kg: 600 mg qd or 367 mg/m <sup>2</sup> body surface area (max: dose 600 mg) Atripla ( $\geq 40$ kg): 1 tablet qd on empty stomach Symfi Lo ( $\leq 35$ kg and SMR* 4 or 5): 1 tablet qd on empty stomach *SMR = Sexual maturity rating For Symfi Lo consider use of therapeutic drug monitoring for pediatric patients $\geq 40$ kg Symfi ( $\geq 40$ kg): 1 tablet qd	Common: transient skin rashes, CNS symptoms (e.g., vivid dreams, impaired concentration, insomnia, depression, hallucinations, depression, suicidal ideation esp. in adolescents and young adults), gynecomastia Less common: increased liver enzymes; potentially teratogenic, QTc prolongation (be careful with other QT-prolonging medications), false positives on some cannabinoid and benzodiazepine tests	Capsules can be opened for mixing in food. Administer at bedtime on empty stomach to minimize CNS side effects. Taking with food, especially fatty meal, can increase absorption and worsen CNS side effects. Drug interactions: Efavirenz induces/inhibits CYP3A4 enzymes. For some individuals with certain CYP450 polymorphisms, Symfi Lo is appropriate (lower EFV dose). Increased clearance of drugs metabolized by this pathway (e.g., antihistamines, sedatives and hypnotics, cisapride, ergot derivatives, warfarin, ethinyl estradiol) and several other ARVs (i.e., protease inhibitors). Drugs that induce CYP3A4 (e.g., phenobarbital, rifampin, rifabutin) decrease efavirenz levels. Clarithromycin levels decrease with EFV, and azithromycin should be considered. Avoid using in individuals with a history of past or active psychiatric issues and use with caution in adolescents and young adults owing to possible affective side effects, including increased suicidality.
<b>Etravirine</b> (ETR, Intelence): tablet: 25, 100, 200 mg	Not approved for $<2$ yr 10 to $<20$ kg: 100 mg bid 20 to $<25$ kg: 125 mg bid 25 to $<30$ kg: 150 mg bid $\geq 30$ kg: 200 mg bid	Common: nausea, rash, diarrhea Less common: hypersensitivity reactions with rash, including Stevens-Johnson syndrome, multiorgan dysfunction including hepatic failure	Always administer with a meal for absorption; taking on empty stomach decreases absorption by 50%. Tablets can be dispersed in water but swallowing is preferred because consumption of dispersed tablets results in lower levels. Inducer of CYP3A4 enzymes and inhibitor of CYP2C9 and CYP2C19, causing multiple interactions that should be checked before initiating ETR. Cobicistat-boosted PIs, nonnucleoside reverse transcriptase inhibitors, bictegravir, and elvitegravir/cobicistat should not be used with ETR. Raltegravir and dolutegravir should only be used with ETR with ritonavir (RTV)-boosted atazanavir, darunavir, or lopinavir.

Continued



**Table 322.3** Summary of Antiretroviral Therapies Available in 2023—cont'd

DRUG (TRADE NAMES, FORMULATIONS)	DOSING	SIDE EFFECTS	COMMENTS
Nevirapine (Viramune, NVP): tablet: 200mg; extended-release (XR) tablet: 100, 400mg; suspension: 10mg/mL	<p><b>Presumptive HIV therapy for high-risk exposed infants and treatment:</b></p> <p>32 to &lt;34 wk gestation at birth: Birth to age 2 wk: 2 mg/kg/dose bid            2 wk to 4 wk: 4 mg/kg/dose bid            4 wk to 6 wk: 6 mg/kg bid            &gt;6 wk with confirmed infection: NVP 200 mg/m<sup>2</sup>/dose bid</p> <p>34 wk to &lt;37 wk gestation at birth:            Birth to 1 wk: 4 mg/kg/dose bid            1 wk to 4 wk: 6 mg/kg/dose bid            &gt;4 wk and confirmed infection: 200 mg/m<sup>2</sup>/dose bid</p> <p>≥37 wk gestation at birth:            Birth to age 4 wk: 6 mg/kg/dose bid            Age &gt;4 wk and confirmed infection: 200 mg/m<sup>2</sup>/dose bid</p> <p>≥1 mo to &lt;8 yr: 200 mg/m<sup>2</sup> once daily for 14 days; then same dose bid (max: 200 mg/dose for immediate-release tablets)            ≥8 yr: 120-150 mg/m<sup>2</sup> once daily for 14 days; then bid (max: 200 mg/dose for immediate-release tablets)</p> <p>Adolescents and adults: 200 mg once daily for 14 days; then 200 mg bid</p> <p>Or            XR 400 mg qd (after 14-day lead in)            Extended-release tablets:            ≥6 yr by BSA:            0.58 m<sup>2</sup> to 0.83 m<sup>2</sup>: 200 mg            0.84 m<sup>2</sup> to 1.16 m<sup>2</sup>: 300 mg            ≥1.17 m<sup>2</sup>: 400 mg</p> <p>Patients already on immediate-release formulation can transition to qd XR dosing without lead-in</p> <p>Note doses are never adjusted down if patient is tolerating.</p> <p>3-dose series for high-risk infants (less commonly used) ≥32 wk gestation at birth: NOTE: DOSES ARE A FLAT DOSE, NOT PER KG</p> <p>Dosing intervals: Within 48 hr of birth, 48 hr after first dose, 96 hr after second dose</p> <p>Birth weight 1.5-2 kg: 8 mg/dose PO            Birth weight &gt;2 kg: 12 mg/dose PO</p>	<p>Common: skin rash (usually in first 6 wk of therapy), headache, fever, nausea, abnormal liver function tests</p> <p>Less common: hepatotoxicity (rarely life-threatening hepatic necrosis), hypersensitivity reactions, Stevens Johnson syndrome (1.4–7.1% of pediatric patients in large series) that can have multiorgan involvement</p>	<p>No food restrictions</p> <p>Drug interactions: induces hepatic CYP450A enzymes (including CYP3A and CYP2B6) activity and decreases protease inhibitor concentrations.</p> <p>Rifampin decreases nevirapine serum levels. Anticonvulsants and psychotropic drugs using same metabolic pathways as NVP should be monitored. Oral contraceptives also may be affected. XR formulation must be swallowed whole.</p> <p>For children ≤2 yr, some experts start with bid dosing without the 14 day lead-in of qd dosing. Lead-in dosing decreases occurrence of rash by allowing induction of cytochrome p450 metabolizing enzymes. If rash develops during initial 14 days of therapy, do not increase dose until rash resolves.</p> <p>If therapy is interrupted for &gt;14 days, restart using lead-in dosing.</p> <p>Nevirapine should never be used for postexposure prophylaxis (PEP).</p>

**Table 322.3** Summary of Antiretroviral Therapies Available in 2023—cont'd

DRUG (TRADE NAMES, FORMULATIONS)	DOSING	SIDE EFFECTS	COMMENTS
<p><b>Rilpivirine</b> (Edurant, RPV): tablet: 25 mg Complera: combination of RPV, FTC, TDF (25, 200, 300 mg) Odefsey: combination of FTC, TAF, RPV (25, 200, 25 mg) Juluca: combination of RPV, Dolutegravir (DTG) (25, 50 mg) Co-packaged formulation (Cabenuva): combinations injectable of RPV, cabotegravir: (900, 600 mg); (600, 400 mg)</p>	<p>≥12yr and ≥35kg: 25 mg PO qd Complera or Odefsey: 1 tablet qd Juluca (&gt;18 yr): 1 tablet qd; only for use in adults with ≥6 mo virologic suppression with no resistance to replace current regimen</p> <p>≥12 years and ≥35 kg with virologic suppression and no history of treatment failure starting on last day of 28 day oral lead in therapy: Cabenuva (900, 600 mg) IM, then Cabenuva (600, 400 mg) IM monthly Alternate every 2 mo dosing also available</p>	<p>Headache, insomnia, rash, depression, mood changes Less common: hepatotoxicity</p>	<p>Given with food only, 500-kcal meal (not just liquid). Do not use with proton pump inhibitors; antacids have to be spaced from dose by 2 hr before or 4 hr after. H<sub>2</sub> antagonists should be administered 12 hr before or 4 hr after RPV.</p> <p>Should not be used if viral load &gt;100,000 copies/μL or drugs that induce CYP3A.</p> <p>Injectables can give local site reaction, soreness. Administration window is ±7 days for injectable regimens. It is critical that injectable regimens are received on schedule, as prolonged subtherapeutic drug levels will lead to emergence of resistance.</p>
<b>PROTEASE INHIBITORS</b>		<p>Class adverse effects: GI side effects, hyperglycemia, hyperlipidemia (except atazanavir and darunavir), lipodystrophy, increased transaminases, increased bleeding disorders in hemophiliacs. Can induce metabolism of ethinyl estradiol; use alternative contraception (other than estrogen-containing oral contraceptives). All of these drugs undergo hepatic metabolism, mostly by CYP3A4, with many drug interactions.</p> <p>Treatment note: always administer with boosting agent (RTV or COBI).</p>	
<p><b>Atazanavir</b> (Reyataz, ATV): powder packet: 50mg/packet; capsule: 150, 200, 300mg (NOTE: capsules and packets are not interchangeable) Evotaz: combination of ATV, COBI (300, 150 mg)</p>	<p>Infants and children ≥3 mo and ≥5 kg: 5 to &lt;15 kg: ATV 200 mg (4 packets) + RTV 80 mg qd 15 to &lt;25 kg: ATV 250 mg (5 packets) + RTV 80 mg qd NOTE: Capsules are not approved for &lt;6 yr or &lt;15 kg Children ≥6 yr and ≥15 kg capsule dosing: 15 to &lt;35 kg: 200 mg + RTV qd 100 mg ≥35 kg: 300 mg + RTV 100 mg qd OR Evotaz: 1 tablet qd</p>	<p>Common: elevation of indirect bilirubin; headache, arthralgia, depression, insomnia, nausea, vomiting, diarrhea, paresthesias Less common: prolongation of PR interval on electrocardiogram (ECG); rash, rarely Stevens-Johnson syndrome, diabetes mellitus, nephrolithiasis</p>	<p>Administer ATV with food to increase absorption and decrease GI side effects. Do not open capsules.</p> <p>Review drug interactions before initiating because ATV inhibits CYP3A4, CYP1A2, CYP2C9, and UGT1A1 enzymes. Use with caution with cardiac conduction disease or liver impairment. TDF, antacids, H<sub>2</sub>-receptor antagonists, and proton-pump inhibitors decrease ATV concentrations. PPIs should be taken 12 hr before boosted ATV and not coadministered.</p> <p>COBI is a pharmacokinetic enhancer (boosting agent) used to optimize drug levels; it is not interchangeable with ritonavir. It can alter renal tubular secretion of Cr, resulting in elevated Cr with normal GFR.</p>

Continued

Table 322.3 Summary of Antiretroviral Therapies Available in 2023—cont'd

DRUG (TRADE NAMES, FORMULATIONS)	DOSING	SIDE EFFECTS	COMMENTS
<p><b>Darunavir</b> (Prezista, DRV): tablets: 75, 150, 600, 800 mg; suspension: 100 mg/mL</p> <p>Prezcobix: combination DRV, COBI (800, 150 mg)</p> <p>Symtuza: combination DRV, TAF, FTC, COBI (800, 10, 200, 150 mg)</p>	<p>&lt;3 yr or &lt;10 kg: Do not use</p> <p>3 yr to &lt;12 yr: 10 to &lt;11 kg: DRV 200 mg + RTV 32 mg bid</p> <p>11 to &lt;12 kg: DRV 220 mg + RTV 32 mg bid</p> <p>12 to &lt;13 kg: DRV 240 mg + RTV 40 mg bid</p> <p>13 to &lt;14 kg: DRV 260 mg + RTV 40 mg bid</p> <p>14 to &lt;15 kg: DRV 280 mg + RTV 48 mg bid</p> <p>15 to &lt;30 kg: DRV 375 mg + RTV 48 mg bid</p> <p>30 to &lt;40 kg: DRV 450 mg + RTV 100 mg bid</p> <p>&gt;12 yr and ≥30 to &lt;40 kg: DRV 450 mg + RTV 100 mg bid</p> <p>≥40 kg: DRV 600 mg + RTV 100 mg bid</p> <p>≥12 yr and ≥40 kg and no DRV mutations: DRV 800 mg + RTV 100 mg qd OR Prezcoibix: 1 tablet qd</p> <p>≥40 kg with DRV mutation(s): DRV 600 mg + RTV 100 mg bid</p> <p>&gt;40 kg with no DRV or TDF/TAF resistance: Symtuza: 1 tablet qd</p>	<p>Common: diarrhea, nausea, vomiting, abdominal pain, fatigue, headache</p> <p>Less common: skin rashes (including Stevens-Johnson syndrome), lipid and liver enzyme elevations and hepatotoxicity, hyperglycemia, fat maldistribution</p>	<p>DRV should always be given with food for absorption and to decrease GI side effects. Contraindicated for concurrent therapy with cisapride, ergot alkaloids, benzodiazepines, pimoziide, or any major CYP3A4 substrates. Use with caution in patients taking strong CYP3A4 inhibitors, or moderate/strong CYP3A4 inducers.</p> <p>Contains sulfa moiety: potential for cross-sensitivity with sulfonamide class</p> <p>DRV should not be administered once daily to individuals &lt;12 yr or &lt;40 kg.</p> <p>COBI is a pharmacokinetic enhancer (boosting agent) used to optimize drug levels; it is not interchangeable with ritonavir. It can alter renal tubular secretion of Cr, resulting in elevated Cr with normal GFR.</p>
<p><b>Lopinavir/Ritonavir</b> (Kaletra, LPV/r): tablet: 100/25 mg, 200/50 mg; solution: 80/20 mg per/mL (contains 42% alcohol, 15% propylene glycol)</p>	<p>&lt;14 days: Not approved</p> <p>14 days to 18 yr: LPV 300 mg/m<sup>2</sup>/dose + RTV 75 mg/m<sup>2</sup>/dose bid</p> <p>In treatment naïve children &gt;1 yr a dose of 230 mg/m<sup>2</sup>/dose bid can be used.</p> <p>&gt;18 yr: LPV 400 mg + RTV 100 mg bid</p> <p>Or</p> <p>800 mg LPV + 200 mg RTV qd</p> <p>&gt;45 kg: If taken with NVP, EFV, fosamprenavir, or nelfinavir: LPV 600 mg + RTV 150 mg bid</p>	<p>Common: diarrhea, headache, nausea and vomiting, lipid elevation, alteration of taste, hyperlipidemia (hypertriglyceridemia)</p> <p>Less common: fat redistribution, hyperglycemia, diabetes mellitus, pancreatitis, hepatitis, PR interval prolongation, QT interval prolongation and torsades de pointes. Life threatening cardiotoxicity risk in neonates.</p>	<p><b>Do not administer before postmenstrual age of 42 wk and postnatal age of 14 days due to potential severe toxicities.</b></p> <p>If patient on concomitant NVP or EFV, dosing must be adjusted and it must be given bid.</p> <p>No food restrictions for tablets but has better GI tolerability when given with or after a meal.</p> <p>Oral solution should be administered with high-fat meal to increase absorption. Pills must be swallowed whole. Poor palatability of oral solution is difficult to mask with flavorings or foods. Once-daily dosing is poorly tolerated in most children, and plasma concentration variability makes qd dosing contraindicated in children and adolescents. Interacts with drugs using CYP3A4, which can cause multiple drug interactions.</p>
<p><b>Ritonavir</b> (Norvir, RTV): capsule: 100 mg; tablet: 100 mg; solution: 80 mg/mL (contains 43% alcohol)</p>	<p>Only use is to enhance other PIs; dose varies (see information for specific PI)</p>	<p>Common: nausea, headache, vomiting, abdominal pain, diarrhea, taste aversion, lipid abnormalities, perioral paresthesias</p> <p>Less common: fat redistribution, hyperglycemia, diabetes mellitus, pancreatitis, hepatitis, PR interval prolongation, allergic reactions</p>	<p>Administration with food enhances bioavailability and reduces gastrointestinal symptoms. RTV solution should not be refrigerated (store at 20–25°C). RTV is potent inhibitor of CYP3A4 and CYP2D6 and inducer of CYP3A4 and CYP1A2 that leads to many drug interactions (e.g., protease inhibitors, antiarrhythmics, antidepressants, cisapride). Use cautiously with inhaled steroids (Cushing syndrome has been reported specifically with coadministration with fluticasone).</p>

**Table 322.3** Summary of Antiretroviral Therapies Available in 2023—cont'd

DRUG (TRADE NAMES, FORMULATIONS)	DOSING	SIDE EFFECTS	COMMENTS
<b>ENTRY AND FUSION INHIBITORS</b>			
<b>Fostemsavir</b> (Rukobia, FTR): Extended-release tablet 600 mg	Safety and efficacy data not established for <18 yr Adults >18 yr: 1 tablet twice daily	QTc prolongation with higher than recommended doses, increased transaminases in Hep B or Hep C co-infection	Reserved for treatment in experienced patients with significant resistance. Tablet must be swallowed whole. Do not co-administer with strong P450 CYP 3A4 inducers. Potential drug interactions.
<b>Ibalizumab</b> (Trogarzo, IBA) IV: single-dose vial 200 mg/1.33 mL	Safety and efficacy data for <18 yr olds not established Adults >18 yr: Loading dose 2000 mg IV, maintenance dose 800 mg q2 wk	Diarrhea, nausea, rash, dizziness, IRIS, possible development of anti-IBA antibodies	Reserved for treatment in experienced patients with significant resistance. Used in combination with optimized cART regimen.
<b>Maraviroc</b> (Selzentry, MVC): oral solution: 20 mg/mL; tablet: 25, 75, 150, 300 mg	Given with potent CYP3A inhibitors (all PIs): 2 to <10 kg: Not recommended 10 to <20 kg: 50 mg bid 20 to <30 kg: 75-80 mg bid 30 to <40 kg: 100 mg bid ≥40 kg: 150 mg bid  Given with noninteracting drugs such as NRTIs, T-20, NVP, RAL, or other drugs not affecting CYP3A: 2 to <4 kg: 30 mg bid 4 to <6 kg: 40 mg bid 6 to <10 kg: 100 mg bid 10 to <14 kg: 150 mg bid 14 to <30 kg: 200 mg bid 30 to <40 kg: 300 mg bid ≥40 kg: 300 mg bid Insufficient data for all children and adolescents for dosing with potent CYP3A inducer, including EFV, ETR Adults: Given with noninteracting medications: 300 mg bid Given with potent CYP3A inhibitors (including all PIs): 150 mg bid Given with potent CYP3A inducers including EFV and ETR 600 mg bid	Common: fever, upper respiratory infection-like symptoms including cough, nausea, vomiting, rash, abdominal pain, musculoskeletal symptoms, dizziness	Testing for CCR-5-tropic virus required; virus must not have mixed tropism (i.e., CCR-5/CXC4) to have efficacy. No food restrictions. MVC is a CYP3A4 and P-glycoprotein (Pgp) substrate, which may cause many drug interactions. Caution should be used when given to patients with hepatic impairment or cardiac disease or receiving CYP3A4 or P-glycoprotein-modulating drugs.
<b>INTEGRASE INHIBITORS (INSTI)</b>		Class side effects: headache, mild GI symptoms, potential significant weight gain for some INSTIs	
<b>Bictegravir (BIC)</b> Only available as Biktarvy: combinations of BIC, TAF, FTC (50, 25, 200 mg); (30, 15, 120 mg)	≥2 y and ≥14 kg to <25 kg: 1 tablet (30, 15, 120 mg) qd ≥25 kg: 1 tablet (50, 25, 200 mg) qd	Diarrhea, nausea, headache,	No food restrictions. Metabolized by UGT1A1 and CYP450 (CYP) 3A. For children unable to swallow tablet whole, tablet can be split and all parts swallowed separately within 10 min. All patients should be screened for HBV before using FTC or TAF. Avoid in severe hepatic impairment.

Continued



**Table 322.3** Summary of Antiretroviral Therapies Available in 2023—cont'd

DRUG (TRADE NAMES, FORMULATIONS)	DOSING	SIDE EFFECTS	COMMENTS
<p><b>Cabotegravir</b> (Vocabria, CAB): Tablet: 30 mg Single-dose vial for IM injection (Apretude): 600 mg (PrEP only) Co-packaged formulation (Cabenuva): combinations injectable of RPV, CAB: (900, 600 mg); (600, 400 mg)</p>	<p><b>PrEP (CAB only)</b> Adolescents and adults <math>\geq 35</math> kg confirmed HIV negative who meet criteria: Optional oral lead-in for 1 mo (dosing below) then on last day oral lead-in, patient receives IM 600 mg CAB monthly for 2 mo then every 2 mo</p> <p><b>For treatment of HIV (CAB/RPV):</b> <math>\geq 12</math> y and <math>\geq 35</math> kg and adults with suppressed viral load and no history of treatment failure: Optional oral lead in with oral RPV and CAB for 1 mo: CAB 30 mg, RPV 25 mg PO qd Monthly administration: Starting on last day of oral lead in IM CAB/RPV (600/900 mg) first month then CAB/RPV (400/600 mg) monthly Every 2 mo administration: Starting on last day of oral lead in IM CAB/RPV (600/900 mg) monthly for 2 mo then CAB/RPV (600/900 mg) every 2 mo.</p>	<p>Injection site reactions, depression, insomnia, headache, rash (can be severe with systemic symptoms), hepatotoxicity, weight gain, CPK elevation, ACTH stimulation test alteration of unclear significance</p>	<p>Close monitoring and strong engagement in care needed for injectable therapies as missing doses with prolonged subtherapeutic levels can lead to emergence of resistance and for PrEP acquisition of resistant HIV infection. There is a <math>\pm 7</math> day dose administration window for the monthly dose. CAB and RPV are injected separately into separate ventrogluteal sites.</p>
<p><b>Dolutegravir</b> (Tivicay, DTG): film-coated tablet: 10, 25, 50 mg Dispersible tablets for oral suspension (Tivicay PD): 5 mg Triumeq: combination of ABC, 3TC, DTG (600, 300, 50 mg) Juluca: combination of RPV, DTG (25, 50 mg) Dovato: combination of DTG, 3TC (50, 300 mg) Triumeq PD: combination of ABC, lamivudine, dolutegravir (60, 30, 5 mg)</p>	<p>Neonates: not approved <math>\geq 4</math> wk, <math>\geq 3</math> kg, dispersible tablets: 3 kg to <math>&lt; 6</math> kg: 5 mg qd 6 kg to <math>&lt; 10</math> kg: 15 mg qd 10 kg to <math>&lt; 14</math> kg: 20 mg qd 14 to <math>&lt; 20</math> kg: 25 mg qd <math>\geq 20</math> kg 30 mg qd</p> <p><math>\geq 14</math> kg film coated tablets: 14 kg to <math>&lt; 20</math> kg: 40 mg qd <math>\geq 20</math> kg: 50 mg qd</p> <p><math>\geq 25</math> kg: Triumeq: 1 tablet qd Juluca: 1 tablet qd; only for use in patients with <math>\geq 6</math> mo virologic suppression with no resistance to replace current regimen. Can be used in adolescents meeting weight requirements for treatment simplification Dovato: 1 tablet qd; can be used in adolescents meeting weight requirements for treatment simplification Triumeq PD (<math>\geq 10</math> kg to <math>&lt; 25</math> kg): Must be dispersed, not swallowed whole, cut or chewed 10 kg to <math>&lt; 14</math> kg: 4 tablets 14 kg to <math>&lt; 20</math> kg: 5 tablets 20 kg to <math>&lt; 25</math> kg: 6 tablets</p>	<p>Insomnia, headache, neuropsychiatric illness Rare: rash, hepatotoxicity, hypersensitivity reactions</p>	<p><b>Film-coated tablets and dispersible tablets are not bioequivalent and are not interchangeable.</b> Film-coated tablets should not be used in <math>&lt; 14</math> kg patients. Juluca and Dovato are not recommended as first-line regimens for children and adolescents but if child meets weight criteria and viral load criteria could be used to reduce pill burden).</p>
<p><b>Elvitegravir</b> (EVG): only found in 2 co-formulated fixed-dose combination (FDC) tablets Stribild: combination of EVG, FTC, TDF, COBI (150, 200, 300, 150 mg) Genvoya: combination of FTC, TAF, EVG, COBI (200, 10, 150, 150 mg)</p>	<p><math>\geq 25</math> kg: Genvoya 1 tablet qd <math>&gt; 35</math> kg and SMR* 4 or 5: Stribild 1 tablet qd *SMR = Sexual Maturity Rating</p>	<p>Nausea, diarrhea, headache, fatigue</p>	<p>Administer with food. EVG is metabolized by CYP3A4 and modestly induces CYP2D6 that can cause multiple drug interactions. Use cautiously with nephrotoxic drugs. Administer 4 hr before or after antacids, multivitamins or supplements that contain iron, calcium, aluminum, or magnesium. COBI is a pharmacokinetic enhancer (boosting agent) used to optimize drug levels; it is not interchangeable with ritonavir. It can alter renal tubular secretion of Cr, resulting in elevated Cr with normal GFR.</p>

**Table 322.3** Summary of Antiretroviral Therapies Available in 2023—cont'd

DRUG (TRADE NAMES, FORMULATIONS)	DOSING	SIDE EFFECTS	COMMENTS
Raltegravir (Isentress, RAL): film-coated tablet: 400 mg; film-coated high dose (HD) tablet: 600 mg; chewable tablet: 25, 100 mg (scored); granules for oral suspension: 100 mg suspended in 10 mL of water for final concentration of 10 mg/mL	<p><b>Presumptive therapy for high-risk exposed neonates and treatment:</b></p> <p>≥37 wk gestation at birth and ≥2 kg (oral suspension):  <i>Birth to age 1 wk:</i> approximately 1.5 mg/kg/dose qd            2 to &lt;3 kg: 4 mg qd            3 to &lt;4 kg: 5 mg qd            4 to &lt;5 kg: 7 mg qd</p> <p>If parent on raltegravir in 2-24 hr before delivery, delay first dose 24-48 hr after birth. Start other ART ASAP.</p> <p><i>Age 1-4 wk:</i> approximately 3 mg/kg/dose bid            2 to &lt;3 kg: 8 mg bid            3 to &lt;4 kg: 10 mg bid            4 to &lt;5 kg: 15 mg bid</p> <p><b>Infant and Pediatrics dosing</b>            Oral suspension:            Children age ≥4 wk and ≥3 kg to &lt;20 kg: approximately 6 mg/kg/dose bid            3 to &lt;4 kg: 25 mg bid            4 to &lt;6 kg: 30 mg bid            6 to &lt;8 kg: 40 mg bid            8 to &lt;10 kg: 60 mg bid            10 to &lt;14 kg: 80 mg bid            14 to &lt;20 kg: 100 mg bid</p> <p>Chewable tablet:            3 kg to &lt;6 kg: 25 mg bid            6 to &lt;10 kg: 50 mg bid            10 to &lt;14 kg: 75 mg bid            14 to &lt;20 kg: 100 mg bid            20 to &lt;28 kg: 150 mg bid            28 to &lt;40 kg: 200 mg bid            ≥40 kg: 300 mg bid</p> <p>Film-coated tablet:            ≥25 kg: 400 mg bid            HD tablet:            ≥40 kg HD tablet: 1200 mg qd for treatment naïve patients or patients virologically suppressed on RAL 400 mg bid</p>	<p>Common: nausea, headache, dizziness, diarrhea, fatigue</p> <p>Less common: itching, creatine phosphokinase elevation, myopathy, rhabdomyolysis, depression, hypersensitivity, insomnia, fever</p> <p>Rare: rash including Stevens-Johnson, TEN, hypersensitivity reaction</p>	<p>Oral suspension, film-coated tablet and chewable tablet are not interchangeable; chewable tablets and suspension have better oral bioavailability than film-coated tablet; hence, higher-dose for film-coated tablets.</p> <p>The chewable tablet can be crushed. Place tablet in small clean cup, add 5 mL (1 tsp) of liquid (water, breast milk, juice) and let stand for 2 min while pill absorbs liquid. Use spoon to crush remaining intact pill. Administer immediately. Add 5 mL of liquid to cup, swirl, and administer that liquid as well to ensure full dose consumed.</p> <p>Film-coated tablets must be swallowed whole.</p> <p>RAL is metabolized by UGT1A1 glucuronidation, and inducers of this system (e.g., rifampin) will reduce RAL levels, whereas inhibitors of this system (e.g., ATV) will increase RAL levels. Do not administer rifampin, ETR, or calcium carbonate with once-daily raltegravir (HD). Aluminum and magnesium containing antacids should not be taken while on RAL. UGT1A1 metabolism is low at birth and increases rapidly over first 4-6 wk of life. No data for preterm infants.</p>

Antiretroviral drugs often have significant drug-drug interactions, with each other and with other classes of medicines, which should be reviewed before initiating any new medication.

The information in this table is not all-inclusive. Updated and additional information on dosages, drug-drug interactions, and toxicities is available and regularly updated on the AIDSinfo website at <https://www.nih.gov/research-training/hiv/aids-info-center>

Modified from the Guidelines for use of antiretroviral agents in pediatric HIV infection. <http://aidsinfo.nih.gov/contentfiles/pediatricguidelines.pdf>.

improve their pharmacokinetic profile. This strategy provides more effective drug levels with less toxicity and less-frequent dosing. Cobicistat provides an alternative to ritonavir as a pharmacokinetic booster but does not have antiviral activity against HIV. Although cobicistat is a potent inhibitor of cytochrome P450 3A, it is a weak inhibitor of CYP2D6 and other CYP isoforms (e.g., CYP1A2), making pharmacologic interactions with many drugs more predictable than for ritonavir, which is also active against these isoforms. Studies with cobicistat show a good tolerability profile and less effect on adipocytes (resulting in lesser accumulations of lipid and a milder response to insulin). The better solubility of cobicistat compared with ritonavir has helped the development of more single-tablet combination regimens with cobicistat. Cobicistat is used for boosting both PIs and INSTIs. However, cobicistat is currently approved only for children ≥25 kg; it is not recommended for use in pregnancy because of a paucity of data and concern for pharmacokinetics.

### Adherence

Adherence to the medication schedules and dosages is fundamental to cART success. Therefore assessment of the likelihood of adherence to treatment is an important factor in initiating therapy and choice of regimen. Numerous studies show that compliance of <90% results in less-successful suppression of the viral load. In addition, several studies document that almost half of the pediatric patients surveyed were nonadherent to their regimen. Poor adherence to prescribed medication regimens results in subtherapeutic drug concentrations and enhances the development of resistant viruses, leading to limited treatment options. Several barriers to adherence are unique to children with HIV infection. Combination antiretroviral regimens in liquid form are often unpalatable and require extreme dedication on the part of the caregiver and child; a reluctance to disclose the child's disease to others reduces social support; there may be a tendency to skip doses if the caregiver is not around or when the child is in school. Adolescents have other issues

that reduce adherence. Denial of the diagnosis, an unstructured lifestyle, feelings of invincibility, desires for “normalcy,” adherence fatigue to life-long medications, affective disorders, and substance use are just a few of the many factors that may interfere with long-term adherence in this growing population. These and other barriers make involving the family in optimizing adherence essential when possible. Intensive education on the relationship of drug adherence to viral suppression, training on drug administration, frequent follow-up visits, peer support, ongoing support including text messaging and other platforms from medical team and case managers, and commitment of the caregiver and the patient are critical for successful antiviral treatment. Multiple methods such as the viral load response, self-reporting of missed doses during the last 3-7 days, and pharmacy/pill counting should be used to assess adherence. Assessing for emergence of resistant virus on sequencing (genotype) can also be a helpful tool in patients not achieving virologic suppression as expected. For older children and adults, long-acting injectable regimens also now exist and have the potential for enormous benefit for adherence, though currently are only FDA approved for individuals with virologic suppression and no history of treatment failure.

### Initiation of Therapy

The decision of when to initiate cART has evolved significantly over the years in both adults and children. When cART was first introduced, medication regimens had significant side effects, leading to decisions to delay therapy until it was thought to be most beneficial, usually after advanced immunologic suppression had developed. The Strategic Timing of Antiretroviral Treatment (START) trial demonstrated a strong benefit in starting therapy earlier in adults, even before CD4 counts fell into an immunosuppressed range; this became more feasible with the development of safer, better-tolerated medications. In adults, it has also been found that receiving suppressive cART eliminates the risk of the sexual transmission of HIV to others. Current adult guidelines recommend the initiation of cART in all adults with HIV. **In line with the adult guidelines, the Panel on Antiretroviral Therapy and Medical Management of Children Living with HIV now also recommends starting treatment for all children with HIV as soon as possible.** For children <1 year of age, the Children with HIV Early Antiretroviral Therapy (CHER) trial has clearly demonstrated the benefit of early immediate ART. Children younger than 1 year of age are at high risk for disease progression, and immunologic and virologic tests to identify those likely to develop rapidly progressive disease are less predictive than in older children. Therefore all HIV-infected infants younger than 1 year of age should be treated with cART as soon as the diagnosis of HIV infection has been confirmed, regardless of their clinical or immunologic status or viral load. Data suggest that HIV-infected infants who are treated before the age of 3 months control their HIV infection better than infants whose cART started later than 3 months of age. Among older children, mortality rates are lower and growth is more normal in children who are started on immediate cART. Initiation of cART therapy should be deferred in children with active cryptococcal meningitis, tuberculosis infection, or disseminated MAC infection in collaboration with an HIV expert.

*The pediatric HIV guidelines are updated twice yearly, and care providers should check for revisions regularly at <https://www.nih.gov/research-training/hiv/aids-info-center>.*

### Dosages

Children are usually treated with higher doses (per kilogram weight) than adults because of reduced absorption or increased drug metabolism. Data on ART drug dosages for neonates, especially premature infants, are often limited. Because of the immaturity of the neonatal liver, there often must be an increase in the dosing interval of drugs primarily cleared through hepatic glucuronidation.

For some medications in older children, ART dosages/selections need to factor in sexual maturity rating (SMR) (formerly known as Tanner staging). Fortunately thanks to evolving pediatric pharmacokinetic data, many simpler regimens are now available to children  $\geq 25$  kg, including once-daily, single-pill (fixed-dose combination) regimens (see [Table 322.3](#) for comprehensive dosing information for current

HIV drugs used in children as of February 2023). Because some ART agents may alter the metabolism of some hormonal contraceptives and decrease their effectiveness, interactions should be considered when choosing contraceptive agents for adolescents. A comprehensive table of interactions of HIV medications with hormonal contraceptives can be found in the perinatal HIV guidelines that are updated twice yearly at <https://www.nih.gov/research-training/hiv/aids-info-center>. Medroxyprogesterone (DMPA) is a reasonable choice for most cART regimens. Alternative long-acting contraception options, such as use of an intrauterine device, should also be considered.

### Changing Antiretroviral Therapy

A change in therapy should be strongly considered when the current regimen is judged ineffective as evidenced by an increase in viral load, deterioration of the CD4 cell count, or clinical progression. Development of toxicity or intolerance to drugs is another reason to consider a change in therapy. When a change is considered, the patient and family should be reassessed for adherence concerns. Because adherence is a major issue in this population, resistance testing (while the patient is taking antiretroviral medications) is important in identifying adherence issues (e.g., detectable virus sensitive to current drug regimen is consistent with a lack of adherence) or the development of resistance (e.g., evidence of resistance mutations to current drug regimen). In both situations, other contributing factors, such as poor absorption, an incorrect dose, or drug-drug interactions, should be carefully reviewed. While considering possible new drug choices, the potential for cross-resistance should be addressed. In starting a new regimen in a patient with virologic failure, the new regimen should include at least two, but preferably three, fully active antiretroviral medications, with assessment of the anticipated activity based on the treatment history and resistance testing (genotype or less commonly phenotype). The goal is to achieve and maintain virologic suppression. If virologic suppression cannot be achieved, the goals of therapy should focus on preserving immunologic function and preventing further disease progression, as well as preventing the emergence of additional drug resistance (which could limit future treatment options).

### Monitoring Antiretroviral Therapy

To ensure proper monitoring, the CD4 cell count, viral load, complete blood count, chemistries, urinalysis, and serum lipids should be obtained before an initiation of or change in cART to have a baseline for comparisons during treatment. At entry into care, genotypic resistance testing should be done as well. Children must be seen within 1-4 weeks after initiation of new cART to reinforce and counsel regarding adherence and to screen for potential side effects. Ideally, telephone or text follow-up by the medical team for adherence and side effects also occurs in the interval between cART start and the follow-up visit. Virologic and immunologic surveillance (using the quantitative HIV RNA PCR and CD4 lymphocyte count), as well as clinical assessment, should be performed regularly while on cART. The initial virologic response (i.e., at least a fivefold [ $0.7 \log_{10}$ ] reduction in viral load) should be achieved within 4-8 weeks of initiating ART. The maximum response to therapy usually occurs within 12-16 weeks but may be later (24 weeks) in very young infants. Thus HIV RNA levels should be measured at 4-8 weeks and 12-24 weeks after therapy initiation. Once an optimal response has occurred, the viral load should then be measured at least every 3-6 months. If the response is unsatisfactory, another viral load should be determined as soon as possible to verify the results before a change in therapy is considered. Virologic failure is defined as a repeated plasma viral load  $\geq 200$  copies/mL after 6 months of therapy. The CD4 cells respond more slowly to successful treatment, particularly in patients with long-standing infection and CD4 suppression. CD4 counts should be monitored every 3-4 months and potentially can be done less frequently in adolescents and adults with documented virologic suppression. Potential toxicity should be monitored closely for the first  $\sim 8$  weeks (including complete blood count, serum chemistries), and if no clinical or laboratory toxicity is documented, follow-up visits are recommended every 1-2 months for children <18 months to allow increases in medication doses in

association with weight gain) and every 3-4 months for older children and adolescents. Monitoring for potential toxicity should be tailored to the patient's medication regimen. Toxicities include but are not limited to hematologic complications (e.g., zidovudine); hypersensitivity rash (e.g., efavirenz); lipodystrophy (e.g., redistribution of body fat seen with NRTIs and PIs, which can take several years to emerge); hyperlipidemia (elevation of cholesterol and triglyceride concentrations); hyperglycemia and insulin resistance (e.g., PIs); mitochondrial toxicity leading to severe lactic acidosis; electrocardiogram abnormalities (e.g., atazanavir, lopinavir); abnormal bone mineral metabolism (e.g., tenofovir disoproxil fumarate but not tenofovir alafenamide); and hepatic toxicity, including severe hepatomegaly with steatosis. After a patient is on a stable regimen, labs outside of CD4 count and viral load can be done every 6-12 months. An important part of every visit is ongoing adherence counseling given the need for excellent adherence to cART to avoid the emergence of resistance. *Detailed current guidelines for monitoring HIV-infected children during therapy can be found at <https://www.nih.gov/research-training/hiv/aids-info-center>.*

### Resistance to Antiretroviral Therapy

Young children usually are at greater risk than adults for developing resistance because they have higher viral loads and fewer ART options than adults (reflecting the fact that only some agents are available in a liquid formulation and have pharmacokinetic dosing data for children). The high mutation rate of HIV (mainly as a result of the absence of error-correcting mechanisms in the reverse-transcriptase enzyme) results in the generation of viruses with multiple mutations every day in the absence of cART. Failure to reduce the viral load to <50 copies/mL on cART because of nonadherence resulting in subtherapeutic drug levels increases the risk for developing resistance by selecting those mutant viruses with a competitive advantage (i.e., drug resistance mutations). Even effectively treated patients do not completely suppress all viral replication, and persistence of HIV transcription and evolution of envelope sequences continues in the latent cellular reservoirs, though data show that this evolution does not appear to affect the emergence of resistance to cART in virologically suppressed patients. Accumulation of resistance mutations, particularly in nonadherent patients, progressively diminishes the potency of the cART and challenges the physician to find new regimens. For some drugs (e.g., nevirapine, lamivudine), a single mutation is associated with resistance, whereas for other drugs (e.g., zidovudine, lopinavir, darunavir, etravirine, etc.), several mutations are needed before significant resistance develops. Testing for drug resistance, especially when devising a new regimen, is standard of care. Two types of tests are available; genotype is most commonly used, but the phenotype may be helpful in select patients with complex viral resistance as a result of exposure to multiple cART regimens.

The **phenotype** measures the virus susceptibility in various concentrations of the drug. This allows calculation of the drug concentration that will inhibit the viral replication by 50% ( $IC_{50}$ ). The ratio of the  $IC_{50}$  and a reference virus  $IC_{50}$  is reported as the fold resistance change. Note that this test is usually combined with a genotype when used but is largely reserved for patients with extremely complex mutations. The **genotype** predicts the virus susceptibility from mutations identified in the HIV genome isolated from the patient and is the more commonly used test. Several online sites (e.g., <http://hivdb.stanford.edu>) can assist in interpreting the test's results. Several studies show that the treatment success is higher in patients whose cART was guided by genotype or phenotype testing.

Neither method may detect drug resistance if the amount of the resistant virus is <10% of the circulating population or if it is present only in the latent reservoir. Note that if a patient has not been taking cART for several weeks, the absence of selective drug pressure will make the dominant population of circulating viruses revert to the wild type, and resistance mutations can be missed.

It is recommended to test for drug resistance before initiating therapy and before changing treatment because of virologic failure. When changing therapy, the resistance test results should be considered in the

context of previous resistance tests results, if done, and drugs used in previous regimens.

### Supportive Care

Even before cART drugs were available, a significant impact on the quality of life and survival of HIV-infected children was achieved when supportive care was given. A multidisciplinary team approach is desirable for successful management. After the initiation or change of cART, more frequent visits or contacts with the patient/caregivers for support and education will help in their acceptance and adjustment to the new regimen and will contribute to a better adherence. Close attention should be paid to the nutritional status, which is often delicately balanced and may require aggressive supplementation, especially in children with advanced disease. Painful oropharyngeal lesions and dental caries may interfere with eating, and thus routine dental evaluations and careful attention to oral hygiene are important. Paradoxically, an increasing number of adolescents with perinatally acquired or behavioral risk-acquired disease are obese. Some teens experience cART-related central lipoaccumulation (usually related to older agents), but others have poor dietary habits and inactivity as the cause of their obesity, just as others do who are obese in epidemic numbers in the United States. Their development should be evaluated regularly, with the provision of necessary physical, occupational, and/or speech therapy. Recognition of pain in the young child may be difficult, and effective nonpharmacologic and pharmacologic protocols for pain management should be instituted when indicated.

All HIV-exposed and HIV-infected children should receive standard pediatric immunizations (Table 322.4). Live oral polio vaccine should not be given because of poor immunologic response in HIV-infected children and concern for live vaccination in potentially immunocompromised children. The risk and benefits of rotavirus vaccination should be considered in HIV-exposed infants. Because <1% of these infants in resource-rich settings will develop HIV infection, the vaccine should be given in infants with negative testing at 2-3 weeks and 6-8 weeks of age. In other situations, the considerable attenuation of the vaccine's strains should be considered, and unless the infant has clinical symptoms of AIDS or a CD4 count <750, vaccination is likely appropriate; consultation with an HIV expert is recommended. Other live bacterial vaccines (e.g., bacillus Calmette-Guérin) should be avoided because of the high incidence of bacillus Calmette-Guérin-related disease in HIV-infected infants. Varicella and measles-mumps-rubella vaccines are recommended for children who are not severely immunosuppressed (i.e., CD4 cell percentage  $\geq 15\%$ , absolute CD4 count >500 cells/ $\mu\text{L}$  for ages 1-5 years), but these vaccines should not be given to severely immunocompromised children (i.e., CD4 cell percentage <15%, absolute CD4 count <500 cells/ $\mu\text{L}$  for age 1-5 year). Of note, prior immunizations do not always provide protection, as evidenced by outbreaks of measles and pertussis in immunized HIV-infected children. The durability of vaccine-induced titers is often short, especially if vaccines are administered when the child's CD4 cell count is low, and reimmunization when the CD4 count has increased may be indicated. It is recommended that children with HIV receive quadrivalent meningococcal conjugate vaccine at a younger age than the routine schedule. Adolescent vaccines are also important, including the Tdap booster and HPV vaccine. The current recommended annotated vaccine schedule for HIV-infected children is found here (updated annually): <https://www.cdc.gov/vaccines/schedules/hcp/imz/child-adolescent.html>.

Prophylactic regimens are integral for the care of HIV-infected children. All infants 4-6 weeks to 1 year of age who are proved to be HIV-infected should receive prophylaxis to prevent *P. jiroveci* pneumonia regardless of the CD4 count or percentage (Tables 322.5 and 322.6). Infants exposed to HIV-infected individuals should receive the same prophylaxis until they are proved to be noninfected; however, prophylaxis does not have to be initiated if there is strong presumptive evidence of noninfection (i.e., nonbreastfed infant with two negative HIV PCR tests at >14 days and 4 weeks of age, respectively). When the HIV-infected child is >1 year of age, prophylaxis should be given according to the CD4 lymphocyte count (see Table 322.5). The best prophylactic regimen is 150 mg/ $\text{m}^2$ /day of TMP and 750 mg/



**Table 322.4** Routine Childhood Immunization Schedule for HIV-Infected Children

VACCINE	BIRTH	1 MO	2 MO	4 MO	6 MO	12-15 MO	2 YR	4-6 YR	11-12 YR
Hepatitis B	HepB		HepB			HepB			
Measles, mumps, and rubella* Varicella vaccines*						MMR* Varicella* If CD4 >500		MMR* Varicella* If CD4 >200	
Influenza†					Annual				
COVID-19‡					Regular schedule‡				
Pneumococcal conjugate vaccine§			PCV	PCV	PCV	PCV			
Pneumococcal polysaccharide vaccine							PPSV23		
<i>Haemophilus influenzae</i> B vaccine			Hib	Hib	Hib	Hib			
Diphtheria, tetanus and pertussis			DTaP	DTaP	DTaP	DTaP		DTaP	Tdap
Inactivated polio vaccine			IPV	IPV		IPV		IPV	
Hepatitis A vaccine						HepA	HepA		
Meningococcal conjugate vaccine							MCV4¶ (2-shot series)		
HPV vaccine									HPV** (3-shot series)
Rotavirus vaccine			RV†† (2- to 3-shot series)						
Dengue†††									Dengue†† (3-shot series) If CD4 >200

Note some combination vaccines may allow for fewer doses to be administered (such as for combination vaccines containing DTaP and Hib; followed recommended schedule of product) \*MMR vaccine and varicella vaccine should only be administered to children age 1-5 yr with absolute CD4 count >500 sustained for 6 mo and children >5 yr with CD4 count >200 sustained for 6 mo (or CD4% >15% if absolute count unavailable). MMRV is contraindicated in HIV-infected children. For immune-reconstituted children can consider giving second MMR and varicella vaccines 1-3 mo after first dose as long as criteria are met.

†Inactivated influenza vaccine should be used in ages ≥6 mo.

‡COVID-19 vaccination is recommended for HIV-infected children and should be given per the pediatric recommendations, including boosters starting at 6 mo of age.

§PCV15 or PCV20 can be used.

||PPSV23 is given and boosted at 5 years; If PCV20 is given, PPSV23 optional. PPSV23 must be given 8 weeks after PCV given.

¶MCV4 (quadrivalent conjugate vaccine) should be administered starting 24 mo with 2-dose series 8 wk apart. Must be given at least 4 wk after completion of PCV13 series. Booster recommended at 5 years. Meningococcal B conjugate vaccine also should be considered.

\*\*HPV vaccine should be given in a 3-shot series at 0, 1-2 mo, 6 mo (minimum intervals 4 wk from dose 1 to 2, 12 wk from dose 2 to 3 with minimum of 5 mo between doses 1 and 3). HIV patients require 3 shots regardless of age series is started.

††Rotavirus vaccine has not been well studied in infants with HIV infection. It should be given to low-risk exposed infants. For infected infants, use caution particularly in those with significant immunosuppression. If given, series must be started before 15 wk of age and completed by 8 mo of age.

†††Dengue vaccination is recommended for children 9-16 yr living in endemic areas of dengue who have laboratory confirmed dengue at 0, 6 mo, 12 mo. It should not be given if CD4 <200. It is not recommended for children traveling to dengue-endemic areas.

Current vaccine schedule with recommendations for immunocompromised populations can be found here (updated annually): <https://www.cdc.gov/vaccines/schedules/downloads/child/0-18yrs-child-combined-schedule.pdf>.

m<sup>2</sup>/day of SMX (maximum: 320/1,600 mg) given as 1-2 daily doses 3 days (consecutively or every other day) per week or daily if preferred for ease of adherence. For severe adverse reactions to TMP-SMX, alternative therapies include dapsone, atovaquone, and aerosolized pentamidine.

Prophylaxis against MAC should be offered to HIV-infected children with advanced immunosuppression (i.e., CD4 lymphocyte count <750 cells/μL in children <1 year of age, <500 cells/μL in children 1-2 year of age, <75 cells/μL in children 2-5 years of age, and <50 cells/μL in children >6 years of age) (see Table 322.6). The drugs of choice are azithromycin (20 mg/kg [maximum: 1,200 mg] once a week orally or 5 mg/kg [maximum: 250 mg] once daily orally) or clarithromycin (7.5

mg/kg twice daily orally). In rare situations, rifabutin 300 mg daily can be an alternative for children >6 years of age, though efficacy data in children is very limited.

Based on data for adults, primary prophylaxis against most opportunistic infections may be discontinued if patients have experienced sustained (>6 months' duration) immune reconstitution with cART, even if they had previous opportunistic infections such as *Pneumocystis pneumonia* or disseminated MAC. HIV-infected children are at higher risk for TB and thus should have tuberculin skin testing (5 tuberculin units purified protein derivation [PPD]) or IFN-γ release assay (IGRA) testing for TB annually; an induration of ≥5 mm should be considered positive for the PPD. IGRA is preferred in children with history of BCG

<b>Table 322.5</b> Recommendations for <i>Pneumocystis jiroveci</i> Pneumonia Prophylaxis and CD4 Monitoring for HIV-Exposed Infants and HIV-Infected Children, by Age and HIV Infection Status		
<b>AGE/HIV INFECTION STATUS</b>	<b>PJP PROPHYLAXIS</b>	<b>CD4 MONITORING</b>
Birth to 4-6wk, HIV-exposed	No prophylaxis	None
HIV infection reasonably excluded*	No prophylaxis	None
<1 yr, HIV-infected or HIV-indeterminate	Prophylaxis regardless of CD4 count or percentage	According to local practice for initiation or follow-up of cART
1-5yr, HIV-infected	Prophylaxis if CD4 <500 cells/μL or <15%†	According to local practice for initiation or follow-up of cART
>6yr, HIV-infected	Prophylaxis if CD4 <200 cells/μL or <15%†,‡	According to local practice for initiation or follow-up of cART

The National Perinatal HIV Hotline (1-888-448-8765) provides consultation on all aspects of perinatal HIV care.

\*See text.

†More frequent monitoring (e.g., monthly) is recommended for children whose CD4 counts or percentages are approaching the threshold at which prophylaxis is recommended.

‡Prophylaxis should be considered on a case-by-case basis for children who might otherwise be at risk for PJP, such as children with rapidly declining CD4 counts or percentages or children with category C conditions. Children who have had PJP should receive PJP prophylaxis until their CD4 count is ≥200 cells/mm<sup>3</sup> for patients age ≥6 yr, CD4 percentage is ≥15% or CD4 count is ≥500 cells/mm<sup>3</sup> for patients age 1 to <6 yr for >3 consecutive mo after receiving cART for ≥6 mo.

cART, Combined antiretroviral therapy; PJP, *Pneumocystis jiroveci* pneumonia.

<b>Table 322.6</b> Prophylaxis to Prevent First Episode of Opportunistic Infections Among HIV-Exposed and HIV-Infected Infants and Children, United States*			
<b>PATHOGEN</b>	<b>INDICATION</b>	<b>PREVENTIVE REGIMEN</b>	
		<b>FIRST CHOICE</b>	<b>ALTERNATIVE</b>
<b>STRONGLY RECOMMENDED AS STANDARD OF CARE</b>			
<i>Pneumocystis pneumonia</i> †	HIV-infected or HIV-indeterminate infants age 1-12 mo; HIV-infected children age 1-5yr with CD4 count of <500 cells/μL or CD4 percentage of <15%; HIV-infected children age 6-12yr with CD4 count of <200 cells/μL or CD4 percentage of <15%; >13yr with CD4 count <200 or <15%	<b>TMP-SMX</b> , 150/750 mg/m <sup>2</sup> body surface area per day or 5-10 mg/kg/day (TMP)/25-50 mg/kg/day (SMX) (max: 320/1,600 mg) orally qd or bid 3 times weekly on consecutive days Or qd or bid orally 3 times weekly on alternate days	<b>Dapsone</b> : age ≥ 1 mo: 2 mg/kg (max: 100 mg) orally qd; or 4 mg/kg (max: 200 mg) orally once a week <b>Atovaquone</b> : age 1-3 mo and >24 mo-12 yr: 30 mg/kg orally qd with food Age 4-24 mo: 45 mg/kg orally qd with food; ≥13 yr 1,500 mg orally qd with food <b>Aerosolized pentamidine</b> : age ≥5 yr: 300 mg once a month by Respirgard II (Marquest, Englewood, CO) nebulizer
Malaria	Living or traveling to area in which malaria is endemic	Same for HIV-infected and HIV-uninfected children. Refer to <a href="http://www.cdc.gov/malaria/">http://www.cdc.gov/malaria/</a> for the most recent recommendations. <b>Mefloquine</b> , 5 mg/kg orally 1 time weekly (max: 250 mg) <b>Atovaquone/proguanil</b> (Malarone) qd 11-20 kg: 62.5 mg/25 mg (1 pediatric tablet) 21-30 kg: 2 pediatric tablets 31-40 kg: 3 pediatric tablets >40 kg: 1 adult tablet (250 mg/100 mg)	<b>Doxycycline</b> , 2.2 mg/kg body weight (maximum 100 mg) orally qd for children >8yr <b>Chloroquine</b> , 5 mg/kg base (equal 7.5 mg/kg chloroquine phosphate) orally up to 300 mg weekly (only for regions where the parasite is sensitive)

Continued

**Table 322.6** Prophylaxis to Prevent First Episode of Opportunistic Infections Among HIV-Exposed and HIV-Infected Infants and Children, United States\*—cont'd

PATHOGEN	INDICATION	PREVENTIVE REGIMEN	
		FIRST CHOICE	ALTERNATIVE
<i>Mycobacterium tuberculosis</i>			
Isoniazid-sensitive	TST reaction $\geq 5$ mm Or Prior positive TST result without treatment Or Positive interferon- $\gamma$ release assay (IGRA) result Or Close contact with any person who has contagious TB. TB disease must be excluded before start of prophylaxis	Age $\geq 12$ yr: 12 doses of weekly isoniazid (15 mg/kg rounded up to the nearest 50 or 100 mg; max 900 mg) and rifapentine: 10–14.0 kg: 300 mg 14.1–25.0 kg: 450 mg 25.1–32.0 kg: 600 mg 32.1–49.9 kg: 750 mg $\geq 50.0$ kg: max 900 mg  12 weekly doses of isoniazid (25 mg/kg for children age 2–12 yr) and rifapentine: 10–14.0 kg: 300 mg 14.1–25.0 kg: 450 mg 25.1–32.0 kg: 600 mg 32.1–49.9 kg: 750 mg $\geq 50.0$ kg: max 900 mg Or 20–30 mg/kg body weight (max: 900 mg) orally 2 times weekly for 9 mo; DOT highly recommended	Rifampin, 15–20 mg/kg body weight (max: 600 mg) orally daily for 4 mo Isoniazid 10–15 mg/kg (max 300 mg) daily and rifampin 10–20 mg/kg (max 300 mg/day) for 3 mo Isoniazid 10–15 mg/kg body weight (max 300 mg) daily for 6–9 mo
Isoniazid-resistant	Same as previous pathogen; increased probability of exposure to isoniazid-resistant TB	Rifampin, 10–20 mg/kg body weight (max: 600 mg) orally daily for 4 mo	Consult TB expert
Multidrug-resistant (isoniazid and rifampin)	Same as previous pathogen; increased probability of exposure to multidrug-resistant TB	Choice of drugs requires consultation with public health authorities and depends on susceptibility of isolate from source patient	
<i>Mycobacterium avium</i> complex <sup>†</sup>	For children age $\geq 6$ yr with CD4 count of $< 50$ cells/ $\mu$ L; age 2 to $< 6$ yr with CD4 count of $< 75$ cells/ $\mu$ L; age 1 to $< 2$ yr with CD4 count of $< 500$ cells/ $\mu$ L; age $< 1$ yr with CD4 count of $< 750$ cells/ $\mu$ L	Clarithromycin, 7.5 mg/kg (max: 500 mg) orally bid Or Azithromycin, 20 mg/kg (max: 1,200 mg) orally once a week	Azithromycin, 5 mg/kg body weight (max: 250 mg) orally qd Or Children age $\geq 5$ yr Rifabutin, 300 mg orally qd
Varicella-zoster virus <sup>§</sup>	Exposure to varicella or shingles with no history of varicella Or Zoster or seronegative status for VZV Or Lack of evidence for age-appropriate vaccination	Varicella-zoster immunoglobulin (VariZIG), 125 IU/10 kg (max: 625 IU) IM, administered ideally within 96 hr after exposure; potential benefit up to 10 days after exposure	If VariZIG is not available and $< 96$ hr from exposure, acyclovir 20 mg/kg (max: 800 mg) 4 times a day for 7 days starting 7–10 days postexposure Or IVIg, 400 mg/kg, administered once
Vaccine-preventable pathogens	Standard recommendations for HIV-exposed and HIV-infected children	Routine vaccinations (see <a href="#">Table 322.4</a> )	
<b>USUALLY RECOMMENDED</b>			
<i>Toxoplasma gondii</i> <sup>¶</sup>	Seropositive IgG to <i>Toxoplasma</i> and severe immunosuppression: age $< 6$ yr with CD4 percentage $< 15\%$ ; age $\geq 6$ yr with CD4 count $< 100$ cells/ $\mu$ L	TMP-SMX, 150/750 mg/m <sup>2</sup> orally qd or divided bid	Dapsone, age $\geq 1$ mo: 2 mg/kg or 15 mg/m <sup>2</sup> (max: 25 mg) orally qd Plus Pyrimethamine, 1 mg/kg (max: 25 mg) orally qd Plus Leucovorin, 5 mg orally every 3 days Or Atovaquone per PJP dosing
Invasive bacterial infections	Hypogammaglobulinemia (i.e., IgG $< 400$ mg/dL)	IVIg 400 mg/kg body weight every 2–4 wk	

**Table 322.6** Prophylaxis to Prevent First Episode of Opportunistic Infections Among HIV-Exposed and HIV-Infected Infants and Children, United States\*—cont'd

PATHOGEN	INDICATION	PREVENTIVE REGIMEN	
		FIRST CHOICE	ALTERNATIVE
Cytomegalovirus	CMV antibody positivity and severe immunosuppression (CD4 count <50 cells/ $\mu$ L for >6yr; CD4 percentage <5% for $\leq$ 6yr)	Valganciclovir, 900 mg orally qd with food for older children who can receive adult dosing For children age 4 mo to 16 yr, valganciclovir oral solution 50 mg/mL at dose in milligrams = $7 \times \text{BSA} \times \text{CrCl}$ (up to maximum CrCl of 150 mL/min/1.73 m <sup>2</sup> ) orally qd with food (maximum dose 900 mg/day)	N/A

\*Information in these guidelines might not represent FDA approval or FDA-approved labeling for products or indications. Specifically, the terms *safe* and *effective* might not be synonymous with the FDA-defined legal standards for product approval.

<sup>†</sup>Daily trimethoprim-sulfamethoxazole (TMP-SMX) reduces the frequency of certain bacterial infections. Compared with weekly dapsone, daily dapsone is associated with a lower incidence of PCP but higher hematologic toxicity and mortality rates. Patients receiving therapy for toxoplasmosis with sulfadiazine-pyrimethamine are protected against PCP and do not need TMP-SMX. TMP-SMX, dapsone-pyrimethamine, and possibly atovaquone (with or without pyrimethamine), protect against toxoplasmosis; however, data have not been prospectively collected.

<sup>‡</sup>Substantial drug interactions can occur between rifamycins (i.e., rifampin and rifabutin) and protease inhibitors and nonnucleoside reverse transcriptase inhibitors. A specialist should be consulted.

<sup>§</sup>Children routinely being administered intravenous immunoglobulin (IVIG) should receive VarizIG if the last dose of IVIG was administered more than 21 days before exposure.

<sup>¶</sup>Protection against toxoplasmosis is provided by the preferred anti-*Pneumocystis* regimens and likely by atovaquone.

CMV, Cytomegalovirus; FDA, U.S. Food and Drug Administration; HIV, human immunodeficiency virus; IgG, immunoglobulin G; IM, intramuscularly; IVIG, intravenous immunoglobulin; PCP, *Pneumocystis pneumonia*; TB, tuberculosis; TMP-SMX, trimethoprim-sulfamethoxazole; TST, tuberculin skin test; VZV, varicella-zoster virus.

From Panel on Opportunistic Infections in Children with and Exposed to HIV. Guidelines for the Prevention and Treatment of Opportunistic Infections in Children with and Exposed to HIV. Department of Health and Human Services. Available at <https://clinicalinfo.hiv.gov/en/guidelines/pediatric-opportunistic-infection>. Table 1: Primary Prophylaxis. Accessed 11/5/23.

vaccination. If the child is living in close contact with a person with TB, the child should be tested more frequently. Of note, the sensitivity of PPD and IGRA are reduced in severely immunocompromised patients. The Guidelines for Prevention and Treatment of Opportunistic Infections Among HIV-Exposed and HIV-Infected Children (<https://www.nih.gov/research-training/hiv/aids-info-center>) should be consulted for these and other opportunistic infections that may occur in these populations. To reduce the incidence of opportunistic infections, parents should be counseled about (1) the importance of good handwashing; (2) avoiding raw or undercooked food (*Salmonella*); (3) avoiding drinking or swimming in lake or river water or being in contact with young farm animals (*Cryptosporidium*); and (4) the risk of playing with or having certain pets (*Toxoplasma* and *Bartonella* from cats, *Salmonella* from reptiles).

## PROGNOSIS

The improved understanding of the pathogenesis of HIV infection in children and the availability of more effective antiretroviral drugs has changed the prognosis considerably for children with HIV infection. The earlier cART is started, the better the prognosis. In settings with ready access to early diagnosis and ART, progression of the disease to AIDS has significantly diminished. Since the advent of cART in the mid-1990s, mortality rates in perinatally infected children have declined more than 90% and most children in high-income settings survive to adolescence and adulthood. Even with only partial reduction of the viral load, children may have significant immunologic and clinical benefits. In general, the best prognostic indicators are the sustained suppression of the plasma viral load and the restoration of a normal CD4<sup>+</sup> lymphocyte count. If determinations of the viral load and CD4 lymphocytes are available, the results can be used to evaluate prognosis. It is unusual to see rapid progression in an infant with a viral load <100,000 copies/mL. In contrast, a high viral load (>100,000 copies/mL) over time is associated with a greater risk for disease progression and death. CD4 count is also another prognostic indicator with mortality rate significantly higher in profoundly immunosuppressed individuals. To define the prognosis more accurately, the use of changes in both markers (CD4 lymphocyte percentage and plasma viral load) is recommended.

Even in resource-limited settings where cART and molecular diagnostic tests are less available, the use of cART has had a substantial

benefit on the survival of HIV-infected children and has reduced the likelihood of mortality by >75%. Children with opportunistic infections (e.g., *Pneumocystis pneumonia*, MAC), encephalopathy and regressing developmental milestones, or wasting syndrome, which are all AIDS-defining conditions, have the worst prognosis, with 75% dying before 3 years of age. A higher risk of death was documented in children who did not receive TMP-SMX preventive therapy. Persistent fever and/or oral thrush, serious bacterial infections (meningitis, pneumonia, sepsis), hepatitis, persistent anemia (<8 g/dL), and/or thrombocytopenia (<100,000/ $\mu$ L) also suggest a poor outcome, with >30% of such children dying before 3 years of age. In contrast, lymphadenopathy, splenomegaly, hepatomegaly, lymphoid interstitial pneumonitis, and parotitis are associated with a slower progression of disease and a better prognosis. With sustained virologic suppression and maintained immunologic function, life expectancy is quite good. Unfortunately, access to cART for children in resource-limited settings lags greatly behind access for adults even today. For adults and adolescents acquiring HIV, effective cART can restore life expectancy to near normal.

## PREVENTION

### Parental Treatment and Infant Prophylaxis

Use of ART for interruption of perinatal transmission has been one of the greatest achievements of HIV research. cART is documented to decrease the rate of perinatal HIV-1 transmission to <2%, and to <1% if the person with HIV has a viral RNA level <1,000 copies/mL at delivery. **Therefore it is recommended that all pregnant individuals be tested for HIV, and if they are positive, be treated with a cART regimen, irrespective of the viral load or CD4 count during pregnancy. All infants born to HIV-infected individuals should receive zidovudine prophylaxis; duration is determined by risk status, with 2-4 weeks for low-risk infants and 6 weeks for high-risk infants (Table 322.7).** Additional antiretroviral drugs should be added to zidovudine if the risk of acquiring HIV by the newborn is high. High-risk scenarios include infants born to individuals who received neither antepartum nor intrapartum antiretroviral drugs or only intrapartum antiretroviral drugs, who do not achieve a suppressed viral load near delivery despite cART (defined as at least two consecutive tests with HIV RNA <50 copies/mL obtained at least 4 weeks apart), who have acute or primary HIV infection during the pregnancy, who have unknown HIV status who test positive at delivery or postpartum, or infants who have a positive



**Table 322.7** Intrapartum and Neonatal Management for HIV Exposed Infants by Risk Category

RISK OF PERINATAL HIV TRANSMISSION	DEFINITION	INTRAPARTUM AND NEONATAL ART MANAGEMENT
Low risk (3 defined groups)	Infants $\geq 37$ weeks gestation who are born to a person with HIV who meets <b>ALL</b> of the following criteria: <ul style="list-style-type: none"> <li>• Is currently receiving and has received at least 10 consecutive weeks of ART during pregnancy</li> <li>• Has achieved and maintained or maintained viral suppression<sup>†</sup> for the remainder of the pregnancy</li> <li>• Has a viral load <math>&lt; 50</math> copies/mL at or after 36 wk</li> <li>• Did not have acute HIV infection during pregnancy</li> <li>• Has reported good ART adherence, and adherence concerns have not been identified</li> </ul>	No IV AZT* required in labor Vaginal delivery Prophylaxis with zidovudine $\times$ 2 wk
	Infants born to a person with HIV who do not meet the criteria above but who have a HIV RNA $< 50$ copies/mL at or after 36 wk gestation	No IV AZT* required in labor Vaginal delivery ZDV for 4-6 wk
	Premature infants ( $< 37$ wk gestation) who are not at high risk of perinatal acquisition of HIV	No IV AZT* required in labor Vaginal delivery ZDV for 4-6 wk
High risk	Infants who are born to a person with HIV who meet <b>ANY</b> of the following criteria: <ul style="list-style-type: none"> <li>• Did not receive cART antepartum or received only intrapartum therapy</li> <li>• Did not achieve viral suppression* within 4 wk before delivery</li> <li>• Had acute or primary HIV infection during the pregnancy or breastfeeding (in the case of the latter, breastfeeding should be immediately discontinued [see text])</li> </ul>	Parent should get IV AZT in labor if viral load $> 1000$ or unknown C-section if viral load $> 1000$ or unknown Presumptive HIV therapy regimen $\times$ 6 wk with either <ul style="list-style-type: none"> <li>• Zidovudine, lamivudine, and nevirapine*</li> <li>• Zidovudine, lamivudine and raltegravir* for up to 6 wk</li> </ul> Alternate regimen: <ul style="list-style-type: none"> <li>• Zidovudine <math>\times</math> 6 wk + 3-dose nevirapine protocol</li> </ul> In all cases, duration of zidovudine should be for 6 wk if other 2 medications are discontinued before that time point.
Presumed newborn HIV exposure	Infants born to a person with HIV who: <ul style="list-style-type: none"> <li>• Have unconfirmed HIV status with at least one positive HIV test in labor or during delivery/postpartum period</li> <li>• Have a newborn with positive HIV antibody test at delivery</li> </ul>	Same as for high risk If supplemental testing confirms person giving birth does not have HIV, infant ARV drugs should be discontinued immediately.

\*Due to resistance of HIV-2 to NNRTIs, raltegravir regimen should be considered for high-risk infants born to individuals with HIV-2.

<sup>†</sup>See Table 322.3 for dosing.

Adapted from Recommendations for the Use of Antiretroviral Drugs During Pregnancy and Interventions to Reduce Perinatal HIV transmission in the United States. <http://aidsinfo.nih.gov/contentfiles/vguidelines/PerinatalGL.pdf>.

HIV antibody test on screening after delivery. In these scenarios, three regimen options can be considered: (1) a presumptive HIV therapy regimen of zidovudine, lamivudine, and nevirapine at treatment doses; (2) a presumptive HIV therapy regimen of zidovudine, lamivudine, and raltegravir at treatment doses; or (3) zidovudine plus the addition of three doses of nevirapine (at birth, 48 hours, and 144 hours of life) (see Table 322.7). Note that treatment doses of raltegravir for neonates are different than for older children, with an escalating dose over the 6 weeks of therapy because of evolving liver metabolism in neonates. For infants at high risk, options 1 and 2 are now preferred, though option 3 has excellent data supporting it for select patient scenarios. Enthusiasm and support for treatment regimens (particularly option 1) have been driven by a case of an apparent functional cure in an infant in 2013 who went 2 years without cART with virologic suppression before rebound of the infection occurred (the Mississippi baby), as well as a large cohort of high-risk, exposed infants in Canada. For neonates, experience is greatest with zidovudine, which can cause transient anemia or neutropenia in exposed infants. There is also a strong pool of data supporting the safety of lamivudine in neonates, including neonates born as early as 32 weeks' gestational age (GA). For the remaining drugs for treatment of infants at high risk, data are most robust for nevirapine, with dosing recommendations down to 32 weeks' GA. Data for raltegravir are more limited, supporting use only in newborns 37 weeks' GA and up. *In infants at high risk, consultation with an experienced HIV*

*specialist is highly recommended. The National Perinatal HIV Hotline (1-888-448-8765) provides 24/7 support from experienced HIV specialists to help in managing high-risk infants. Guidelines and current recommended doses for prophylaxis in newborns are updated at least yearly and can be accessed at <https://www.nih.gov/research-training/hiv/aids-info-center>. A complete blood count, differential leukocyte count, and platelet count should be performed at 4-8 weeks of age to monitor zidovudine toxicity. If the child is found to be HIV infected, baseline laboratory assessment (e.g., CD4 count, HIV RNA, complete blood count, chemistries, lipids, and genotype) should be obtained and cART should be started as soon as possible. Cesarean section as a prevention strategy was examined in a multinational meta-analysis, which showed that the combination of elective C-section and parental zidovudine treatment reduced transmission by 87%. However, these data were obtained before the advent of cART, and the additional benefit of elective C-section to the cART-treated individual whose viral load is  $< 1,000$  copies/mL is negligible. Thus elective C-section at 38 weeks of gestation should be considered only for pregnant individuals whose viral load is  $> 1,000$  copies/mL in late gestation, to further reduce the risk of vertical transmission.*

Because perinatal transmission can be reduced dramatically by treating pregnant individuals, prenatal testing and identification of HIV-1 infection as early as possible is extremely important. The benefit of therapy both for the individual's health and to prevent transmission

to the infant cannot be overemphasized. The recommended universal prenatal HIV counseling and testing for all pregnant individuals has reduced the number of new infections dramatically in many areas of the United States and Europe. For those not tested during pregnancy, the use of rapid HIV antibody testing during labor or shortly after the infant's birth is a way to provide perinatal prophylaxis to an additional group of at-risk infants. Perinatal recommendations also now endorse the testing of pregnant individuals' partners to identify partners with HIV who may transmit HIV infection to them, leading to acute HIV infection, which carries an extremely high risk of vertical transmission both intrapartum and postpartum if the individual is breastfeeding and seroconverts.

### Feeding of the HIV-Exposed Infant: Breastfeeding Recommendations and Prophylaxis

It is universally recommended that all pregnant individuals receive a cART regimen appropriate for their own health, which should be continued for the remainder of their lives. This approach improves parental survival, lowers the transmission risk to sexual partners, promotes simplified universal treatment regimens, and reduces transmission during breastfeeding and future pregnancies.

Breastfeeding has been recommended for infants born to individuals with HIV in resource-limited settings by the WHO and other authorities for nearly 2 decades. This recommendation was based on strong evidence that early weaning is not safe in resource-limited settings because of the high risk of death from malnutrition and diarrhea in formula-fed infants without a consistent source of clean water and formula. Furthermore, exclusive breastfeeding (no additional solids or fluids other than water) resulted in less transmission than mixed feeding. Guidelines evolved to recommend that HIV-infected persons living in resource-limited settings should breastfeed their infants until at least 12 months of age, with exclusive breastfeeding for the first 6 months, and cART should continue to be provided to the breastfeeding parent. **Data from multiple large studies of this practice in low- and middle-income countries have shown suppressive parental cART is extremely effective in preventing transmission of HIV via breastfeeding to <1%. Additionally, there have been a series of smaller case series in resource-rich settings with individuals on suppressive cART breastfeeding with no transmission documented. However, it is important to stress that the rate of transmission even for fully suppressed HIV-infected breastfeeding individuals is not zero.** Because of this data, in January 2023, the guidelines in the U.S. for recommended infant feeding have significantly changed for feeding of the HIV-exposed infant. These recommendations were made for several reasons:

- Recognition of the very low risk of transmission from virologically suppressed individuals.
- Recognition of the benefits of breastfeeding to both the infant (improved immune status, lower risk of developing asthma, obesity, type 1 diabetes, severe lower respiratory disease, otitis media, sudden infant death syndrome, gastrointestinal infections, and necrotizing enterocolitis) and breastfeeding parent (decreased risk of hypertension; type 2 diabetes; breast, endometrial, and ovarian cancers; bonding with infant; decreased monetary costs of feeding).
- Recognition that pregnant individuals living with HIV in the United States are disproportionately Black, a group that has significantly higher prevalence of many of these negative health outcomes as well and that prohibiting breastfeeding in this group denies them potential benefit.
- Recognition of important cultural pressures that may affect the desire to breastfeed and fear that by not breastfeeding, HIV status may be inadvertently disclosed to family and friends.
- Recognition that some individuals living with HIV in the past who were prohibited from breastfeeding did so surreptitiously without support that could have decreased risk to infant.

It is now recommended that expectant individuals with HIV should receive evidence-based, patient-centered counseling regarding infant feeding starting early, ideally before conception or in early pregnancy. The provider should engage in open-minded shared decision making in discussing the decision to breastfeed or formula feed the infant throughout the pregnancy. Key points of counseling should include:

- Achieving and maintaining viral suppression through ART during pregnancy and postpartum decreases breastfeeding transmission risk to less than 1%, but not zero.
- Replacement feeding with properly prepared formula or pasteurized donor human milk from a milk bank eliminates the risk of postnatal HIV transmission to the infant. This is the recommended feeding choice for individuals living with HIV who do not have suppressed viral load through the third trimester and at delivery given the significantly increased risk of HIV transmission to the infant.
- Individuals with HIV who are on cART with a sustained undetectable viral load and who choose to breastfeed will be supported in this decision.
- Individuals with HIV who choose to formula feed should also be supported in their decision, and potential barriers should be addressed.

It is important to stress that engaging Child Protective Services or similar agencies is not an appropriate response to infant feeding choices of an individual living with HIV. This puts an important therapeutic relationship at risk for both the individual and the infant, can result in harm to families, and can further exacerbate the stigma and discrimination that individuals living with HIV face.

The risk of HIV transmission via breastmilk for individuals on suppressive cART (<50) is <1%. There are ways to make risk of transmission as low as possible in this scenario, including providing excellent parental support such as addressing resource needs, mental health, and helping promote cART adherence. The postpartum period is a time of high risk for developing nonadherence to cART because of the stress of child-raising, lack of sleep, potential postpartum depression (PPD) and other factors. Individuals living with HIV who give birth have significantly higher rates of PPD that is associated with significant rise in cART nonadherence, so early screening and treatment of PPD is critical. Support of a lactation specialist is also important to help establish and maintain good milk supply so that mixed feeding can be minimized and to promote good breast health and avoidance of milk stasis, bleeding nipples, and mastitis. In the pre cART era, mixed feeding (i.e., introduction of breast milk plus other liquid or solid foods, including formula) was associated with increased risk of transmission of HIV, particularly in the first 2 months of life; no data are available in this area (including just formula supplementation) in the context of cART and virologic suppression. Because of this historical data, the goal is exclusive breastfeeding for 6 months to minimize risk.

It is recommended that individuals with HIV who are breastfeeding/chestfeeding have HIV RNA testing every 1-2 months to monitor virologic suppression closely. For the breastfed infant, the initial testing schedule is dictated by risk of infant at birth. Additionally, the breastfed infant should receive testing at 1-2 months and 4-6 months to avoid an interval of >3 months between tests, and every 3 months after the 4- to 6-month test for as long as breastfeeding continues. It is recommended to avoid rapid weaning, with a goal of weaning over 2-4 weeks because of pre-cART data associating rapid weaning with increased risk of HIV transmission to the infant. Infants should be tested 4-6 weeks, 3 months, and 6 months after weaning is complete (see Fig. 322.4).

Several studies demonstrate the efficacy of ART prophylaxis of the breastfed infant in preventing transmission of HIV during breastfeeding in the era before cART being recommended for all pregnant individuals and in some studies in which pregnant individuals received cART but did not have viral load routinely monitored. Successful regimens have included daily single-dose nevirapine (NVP), lamivudine (3TC), lopinavir/ritonavir (LPV/r), and a combined NVP + ADV regimen. For infants at low risk, it is not clear whether additional prophylaxis during breastfeeding after the initial prophylaxis of 2-6 weeks adds additional benefit; that said, some experts choose to provide prophylaxis for infants at low risk. In the scenario in which an individual with HIV who is not virologically suppressed elects to breastfeed after counseling despite recommendations not to do so because of increased risk, it is recommended that the infant receive 6 weeks of three-drug presumptive HIV therapy (high risk), and then daily NVP throughout

**Table 322.8** Infant Antiretroviral Prophylaxis for Newborns of Individuals Who Breastfeed

NEWBORNS AT LOW RISK OF HIV ACQUISITION DURING BREASTFEEDING*	
RECOMMENDED REGIMEN	DURATION
ZDV	2 wk
EXTENDED POSTNATAL PROPHYLAXIS FOR NEWBORNS AT HIGH RISK OF HIV TRANSMISSION DURING BREASTFEEDING*	
RECOMMENDED REGIMEN	DURATION
ZDV	4-6 wk*
NVP†	SIMPLIFIED AGE-BASED DOSING FOR NEWBORNS ≥32 WK GESTATION RECEIVING EXTENDED NVP PROPHYLAXIS DURING BREASTFEEDING‡
AGE	VOLUME NVP MG/ML ORAL SYRUP DAILY
6 wk to 6 mo	2 mL
6 mo to 9 mo	3 mL
9 mo to 1-4 wk post weaning	4 mL

\*This extended neonatal prophylaxis regimen is optional for low-risk infants, though recommended by some experts. For high-risk breastfed infants (parent not virologically suppressed), 6 wk of ZDV (plus additional agents as recommended in Table 322.7) followed by extended neonatal NVP prophylaxis is recommended.

†For breastfeeding parents with viral resistance to NVP, alternative regimens for infant prophylaxis after completion of the 4-6 wk of presumptive HIV therapy include daily 3TC or LPV/r; see Table 322.3 Antiretroviral Drug Dosing Recommendations for Newborns for dosing information.

‡Extended NVP prophylaxis during breastfeeding recommendations are adapted from the Consolidated Guidelines on HIV Prevention, Testing, Treatment, Service Delivery and Monitoring: Recommendations for a Public Health Approach. If prescribed, these simplified doses should start following confirmation of a negative infant NAT test and completion of a presumptive HIV therapy regimen in infants at high risk of HIV acquisition. For infants at low risk of transmission, these doses can be given from birth. World Health Organization. Consolidated guidelines on HIV prevention, testing, treatment, service delivery and monitoring: recommendations for a public health approach. Geneva: World Health Organization, 2021. Table A1.7. Available at <https://www.who.int/publications/i/item/9789240031593>. (Accessed 5 Nov 2023)

breastfeeding and for 1-4 weeks after weaning to further mitigate risk of HIV transmission (Table 322.8).

HIV-negative breastfeeding individuals with a sexual partner with HIV should also be monitored closely for developing HIV infection, because acute infection during breastfeeding carries a high risk of transmission to the infant (29-53%). It is recommended that these individuals consider preexposure prevention (PrEP) (see later) and practice barrier protection consistently to decrease risk of acute HIV infection during the breastfeeding period and educated on the signs and symptoms of acute HIV infection. They should also be tested every 1-2 months for seroconversion; if they become positive, breastfeeding should cease, and the infant should be placed on a high-risk three-drug presumptive HIV therapy regimen for 28 days and tested per the high-risk schedule with start point at time of cessation of breastfeeding.

Risk of transmission of HIV goes up considerably if virologic suppression in the breastfeeding parent is compromised. Therefore frequent HIV RNA (viral load) monitoring is recommended so that if there is virologic rebound, risk can be mitigated. In the scenario that viral load becomes detectable in the breastfeeding parent, it is recommended that the parent stop breastfeeding the infant immediately; milk can be pumped and discarded to maintain supply. The individual should be provided counseling regarding adherence, support, and resources, and discussion of whether to cease breastfeeding altogether or continue given the risk of HIV transmission to the infant

should occur. Other scenarios that would require either modifying or stopping breastfeeding (in some cases temporarily) include cracked or bleeding nipples and mastitis. In these conditions, breastfeeding can continue on the unaffected side, and milk from the affected side should be pumped and discarded until the breast is fully healed and recovered. Again, having an experienced lactation consultant involved in the care of these individuals is critical. *Clinicians are strongly encouraged to consult the national Perinatal HIV/AIDS hotline (1-888-448-8765) with questions about infant feeding by individuals with HIV; the hotline provides 24/7 support from experienced HIV specialists to help in managing infants at high risk. U.S. guidelines for prevention of vertical transmission are regularly updated at <https://www.nih.gov/research-training/hiv/aids-info-center/> and the international guidelines are regularly updated at the WHO website ([https://www.who.int/health-topics/hiv-aids#tab=tab\\_1](https://www.who.int/health-topics/hiv-aids#tab=tab_1)).*

### Prevention of Sexual Transmission: Preexposure Prophylaxis and Postexposure Prevention

Prevention of sexual transmission involves avoiding the exchange of bodily fluids. In sexually active adolescents, barrier protection (male and female condoms) should be an integral part of programs to reduce sexually transmitted diseases, including HIV-1. Unprotected sex with older partners, multiple partners, transactional sex, and the use of recreational drugs can be associated with acquisition of HIV-1 infection in adolescents and young adults. Educational efforts about avoidance of risk factors and safer sex practices are essential for older school-age children and adolescents and should begin well before the onset of sexual activity. In addition, promising research for sexually active adults may translate to increased prevention for adolescents. Three African trials demonstrated that male circumcision was associated with a 50-60% reduction in the risk of HIV acquisition in young men. For females, use of a 1% vaginal gel formulation of tenofovir during intercourse was found to reduce HIV acquisition by nearly 40% in one study, though subsequent trials have had variable efficacy; other topical microbicides are being investigated. An increasingly important tool for HIV prevention is PrEP using once-daily dosing of co-formulated tenofovir and emtricitabine, approved for adolescents and adults weighing at least 35 kg (77 lb). The efficacy of PrEP in preventing sexual acquisition of HIV in MSM, heterosexual couples, and individuals in noncommitted relationships ranges from 70-92%. A depo injectable PrEP option (cabotegravir) dosed every 8 weeks is now approved for adults and adolescents ≥12 years weighing at least 35 kg (77 lb). Large randomized multinational clinical trials of HIV serodiscordant adults have demonstrated that effective cART therapy in the HIV-infected partner essentially eliminates secondary sexual transmission to an uninfected sexual partner, creating the catchphrase “U = U” or “undetectable = untransmittable.” The data from these trials can likely be extrapolated for youth with long-standing virologic suppression.

**Postexposure prevention (PEP)** is another important tool in HIV prevention and has been used in healthcare workers after needlesticks and body substance exposures. It can also be effective after a single high-risk event (including unprotected sexual activity, high-risk sexual assault, and intravenous drug use/needle sharing). PEP should be given as soon as possible after the high-risk exposure, ideally within 24 hours and at the latest within 72 hours of the exposure to have efficacy. Efficacy is higher the sooner it is given. Baseline testing should be performed at the time PEP is started, but initial doses should not be delayed for laboratory test results. Baseline testing includes HIV antigen/antibody testing (fourth-generation HIV ELISA), hepatitis B and C testing (because most high-risk exposures have risk of transmission of these as well), serum creatinine, and alanine aminotransferase (ALT). If a patient is hepatitis B immune (including having completed a full hepatitis B vaccine series), hepatitis B testing does not need to be performed. For sexual exposures, gonorrhea, chlamydia, and syphilis, testing should be done. After completion of a PEP course, follow-up testing should be done at 4-6 weeks and 3 months after exposure. If hepatitis C was transmitted, HIV testing should be repeated at 6 months as well, because HIV seroconversion can be delayed in patients with co-infection with hepatitis C. PEP regimens are three-drug treatment regimens for 28 days. For



individuals  $\geq 12$  years old, generally the preferred regimen consists of tenofovir DF + emtricitabine with either dolutegravir or raltegravir (note that dolutegravir allows for a once-daily regimen). For individuals 2 years old to  $< 12$  years old, the preferred regimen is tenofovir DF + emtricitabine + raltegravir. For those  $< 2$  years old the preferred regimen is zidovudine + lamivudine + raltegravir. In the rare cases in which the source patient is known to have HIV infection and is in care, selection can be guided by the source patient's genotype and/or treatment history. Abacavir and nevirapine are both contraindicated for use in PEP.

## SUMMARY

The course and prognosis of HIV infection has improved dramatically as a consequence of cART for all ages, particularly with newer agents with fewer side effects. With good adherence, patients can achieve prolonged virologic suppression and immune function can be preserved or reconstituted. However, lifelong adherence and side effects of medications are important challenges to recognize that can prevent patients from achieving good outcomes. Globally, great strides have been made in preventing vertical transmission and increasing access to cART for children and adults, which is important for maintaining health as well as driving down sexual and vertical transmission with virologic suppression. However, there is still much work to be done to ensure the end of the global HIV epidemic, including continued advancement of our understanding of the immunology of HIV latency and reservoirs, HIV vaccines, and continued increases in access to cART worldwide, particularly in children.

Visit Elsevier Ebooks+ at [eBooks.Health.Elsevier.com](http://eBooks.Health.Elsevier.com) for Bibliography.

## Chapter 323

# Human T-Cell Leukemia Viruses (1 and 2)

Paul Spearman and Lee Ratner

## ETIOLOGY

Human T-cell leukemia viruses 1 (HTLV-1) and 2 (HTLV-2) are members of the *Deltaretrovirus* genus of the Retroviridae family, which are single-stranded RNA viruses that encode reverse transcriptase, an RNA-dependent DNA polymerase that transcribes the single-stranded viral RNA into a double-stranded DNA copy. HTLV-1 was the first human retrovirus discovered, isolated in 1979 from a cutaneous T-cell lymphoma. The closely related virus HTLV-2 was subsequently identified in 1981. HTLV-1 is associated with adult T-cell leukemia/lymphoma (ATL) and HTLV-1-associated myelopathy/tropical spastic paraparesis (HAM/TSP), whereas HTLV-2 is less pathogenic and rarely is associated with neurologic diseases.

HTLV-1 and -2 share a genome homology of approximately 65%. The genome contains *gag*, *pr*, *pol*, and *env* genes and several nonstructural genes. The nonstructural proteins include the Tax and Rex regulatory proteins, the novel proteins essential for virus spread (p30, p12, and p13), and the antisense-encoded HTLV-1 basic leucine zipper factor, HBZ. HTLV-1 and -2 infect cells via the ubiquitous glucose transporter type or via neuropilin-1, both of which serve as virus receptors. HTLV-1 and -2 can infect a variety of cells, with HTLV-1 most often found in CD4<sup>+</sup> T cells and HTLV-2 showing preference for CD8<sup>+</sup> T cells. After viral entry, reverse transcription produces a double-stranded DNA copy of the RNA genome that is transported into the nucleus and integrated into chromosomal DNA (the provirus), evading the typical mechanisms of immune surveillance and facilitating lifelong infection.

## EPIDEMIOLOGY AND MODES OF TRANSMISSION

HTLV-1 has infected 15–20 million persons globally. It is endemic in southwestern Japan (where  $> 10\%$  of adults are seropositive); areas of the Caribbean, including Jamaica and Trinidad (up to 6%); and in parts of sub-Saharan Africa (up to 5%). Lower seroprevalence rates are found in South America (up to 2%) and Taiwan (0.1–1%). There is microclustering with marked variability within geographic regions.

The seroprevalence of HTLV-1 and HTLV-2 in the general population in the United States is 0.01–0.03% for each virus, with higher rates with increasing age. The prevalence of HTLV-1 infection is highest in babies born in endemic areas or in persons who have had sexual contact with persons from endemic areas. The prevalence of HTLV-2 infection is highest in intravenous drug users, with a seroprevalence of 8.8–17.6% in this population.

HTLV-1 and -2 are transmitted as cell-associated viruses from mother to child and **transmission** through genital secretions, contaminated blood products, and intravenous drug use. Mother-to-child transmission during the intrauterine period or peripartum period is estimated to occur in less than 5% of cases but increases to approximately 20% with breastfeeding. Higher maternal HTLV-1 proviral load and prolonged breastfeeding are associated with greater risk of mother-to-child transmission. In Japan, approximately 20–25% of children born to HTLV-1-infected mothers became infected before recommendations that seropositive mothers should avoid breastfeeding, with a marked reduction to 2.5% transmission after restriction of breastfeeding. HTLV-2 may also be transmitted via breastfeeding, but it has a slightly lower reported transmission rate via breast milk of approximately 14%.

## DIAGNOSIS

HTLV-1 and HTLV-2 infections are diagnosed by screening using a second-generation enzyme immunoassay with confirmation by immunoblot, indirect immunofluorescence, or line immunoassays. Polymerase chain reaction can also be used to distinguish HTLV-1 from HTLV-2 infection.

## CLINICAL MANIFESTATIONS

The lifetime risk of disease associated with HTLV-1 infection is estimated at 5–10% and is highest after vertical transmission. HTLV-1 is associated with ATL and several nonmalignant conditions, including the neurodegenerative disorder HAM, also known as tropical spastic paraparesis (TSP) and sometimes termed HAM/TSP. The geographic epidemiologic characteristics of ATL and HAM are similar. **HTLV-1-associated arthropathy** mimics rheumatoid arthritis, including a positive rheumatoid factor. Treatment is with antiinflammatory agents. **HTLV-1-associated uveitis** may be unilateral or bilateral, is more common among women, and resolves spontaneously, although it often recurs within 1–3 years. Topical corticosteroids hasten recovery. **HTLV-1-associated infective dermatitis** is a chronic and recurrent eczematous disease occurring during childhood and adolescence that predisposes to staphylococcal infection. HTLV-1 infection predisposes to disseminated and recurrent *Strongyloides stercoralis* infection, increased risk of developing tuberculosis disease after latent infection, and severe scabies.

## ADULT T-CELL LEUKEMIA/LYMPHOMA

The age distribution of ATL peaks at approximately 50 years, underscoring the long latent period of HTLV-1 infection. HTLV-1-infected persons remain at risk for ATL even if they move to an area of low HTLV-1 prevalence, with a lifetime risk for ATL of 2–4%. Most cases of ATL are associated with monoclonal integration of HTLV-1 provirus into the cellular genome of CD4<sup>+</sup> T lymphocytes, resulting in unchecked proliferation of CD4 T cells. There is a spectrum of disease that is categorized into different forms: acute, lymphomatous, chronic, primary cutaneous smoldering, and primary cutaneous tumoral. The acute form of ATL comprises 55–75% of all cases. Smoldering subclinical lymphoproliferation may spontaneously resolve in approximately



half of cases or progress to chronic leukemia or lymphomatous, or even acute ATL. **Chronic, low-grade, HTLV-1-associated lymphoproliferation (pre-ATL)** may persist for years with abnormal lymphocytes with or without peripheral lymphadenopathy before progressing to the acute form. Acute ATL is characterized by hypercalcemia, lytic bone lesions, lymphadenopathy that spares the mediastinum, hepatomegaly, splenomegaly, cutaneous lymphomas, and opportunistic infections. Leukemia may develop with circulating polylobulated malignant lymphocytes, called **flower cells**, possessing mature T-cell markers. Antiviral therapy with zidovudine and interferon- $\alpha$  is the standard therapy for leukemic-type ATL in the United States and Europe. In lymphoma-type ATL, **response rates may be improved using the anti-CCR4 monoclonal antibody mogamulizumab with chemotherapy**. Allogeneic hematopoietic stem cell transplantation is sometimes employed.

### HUMAN T-CELL LYMPHOTROPIC VIRUS-1-ASSOCIATED MYELOPATHY

HAM is more common in women than in men and has a relatively short incubation period of 1-4 years after HTLV-1 infection, compared with 40-60 years for ATL. HAM occurs in up to 4% of persons with HTLV-1 infection, usually developing during middle age. It is characterized by infiltration of mononuclear cells into the gray and white matter of the thoracic spinal cord, leading to severe white matter degeneration and fibrosis. HTLV-1 is found near but not directly within the lesions, suggesting that reactive inflammation is a major mechanism of disease. The cerebrospinal fluid typically shows a mildly elevated protein and a modest monocytic pleocytosis, along with anti-HTLV-1 antibodies. Neuroimaging studies are normal or show periventricular lesions in the white matter. Clinical manifestations include gradual onset of slowly progressive, symmetric neurologic degeneration of the corticospinal tracts and, to a lesser extent, the sensory system that leads to lower-extremity spasticity or weakness, lower back pain, and hyperreflexia of the lower extremities with an extensor plantar response. The bladder and intestines may become dysfunctional, and men may become impotent. Some patients develop dysesthesias of the lower extremities with diminished sensation to vibration and pain. Upper-extremity function and sensation, cranial nerves, and cognitive function are usually preserved. **Treatment regimens have included corticosteroids, danazol, interferon, plasmapheresis, high-dose vitamin C, and antivirals, all with minimal effects.** Recent studies examined the effects of mogamulizumab (anti-CCR4 antibody) on HAM, but results are not yet conclusive.

### HUMAN T-CELL LYMPHOTROPIC VIRUS-2

HTLV-2 was originally identified in patients with hairy cell leukemia, although most patients with hairy cell leukemia are seronegative for HTLV-2 infection. HTLV-2 has been rarely isolated from patients with leukemias or with myelopathies resembling HAM, and there is limited evidence of disease specifically associated with HTLV-2 infection.

### PREVENTION

Routine antibody testing of all blood products for HTLV-1 and -2 is performed in many developed countries and is effective in preventing blood transfusion-associated infections. Unfortunately, this testing is not always available in low- and middle-income countries with higher endemicity. Prenatal screening and avoidance of breastfeeding by HTLV-1-infected mothers is an effective means of reducing mother-to-child transmission of HTLV-1. Safe sexual practices to avoid sexually transmitted infections, such as condom use and avoiding multiple sexual partners, may reduce transmission of both HTLV-1 and HTLV-2. No vaccine is available.

Visit Elsevier eBooks+ at [eBooks.Health.Elsevier.com](http://eBooks.Health.Elsevier.com) for Bibliography.

## Chapter 324

# Transmissible Spongiform Encephalopathies

David M. Asher and Brian S. Appleby

The transmissible spongiform encephalopathies (TSEs, **prion diseases**) are slow infections of the human nervous system, consisting of at least four diseases of humans (Table 324.1): kuru; **Creutzfeldt-Jakob disease (CJD)** with its variants—sporadic CJD (sCJD), familial CJD (fCJD—some authorities prefer “genetic” CJD), iatrogenic CJD (iCJD), and new-variant or **variant CJD (vCJD)**; Gerstmann-Sträussler-Scheinker syndrome (GSS); and fatal familial insomnia (FFI), or the even more rare sporadic fatal insomnia syndrome. sCJD can also be further subdivided based on clinical features—e.g., Heidenhain variant in which early onset of occipital blindness is prominent—or differences in characteristics of abnormal prion protein—e.g., variably protease-sensitive prionopathy (VPSPr). TSEs also affect animals. The most common and best-known TSEs of animals are scrapie in sheep, bovine spongiform encephalopathy (BSE or mad cow disease) in cattle, and a chronic wasting disease (CWD) of deer, elk, reindeer, and moose found in parts of the United States, Canada and, more recently, in Norway, Sweden, and Finland. A TSE of camels has recently been described in North Africa, and others might be anticipated. So far, of all the TSEs of animals, only BSE has proven zoonotic (i.e., transmissible to humans).

All TSEs have similar clinical manifestations and histopathology, and all are “slow” infections with very long asymptomatic incubation periods (often years), durations of several months or more, and overt disease affecting only the nervous system. TSEs are relentlessly progressive after illness begins and invariably fatal. The most striking neuropathologic change that occurs in each TSE, to a greater or lesser extent, is vacuolation, sometimes leading to spongy degeneration of the cerebral cortical gray matter.

### ETIOLOGY

The TSEs are transmissible to susceptible animals by inoculation of suspensions of brain and some other tissues from affected subjects. Although the infectious agents replicate in a few cell cultures, they do not achieve the high titers of infectivity found in brain tissues or cause recognizable cytopathic effects in cultures. Most studies of TSE agents, before discovery of the prion proteins, used *in vivo* bioassays, relying on the transmission of typical neurologic disease to animals as evidence that the agent was present. Inoculation of susceptible recipient animals with small amounts of infectious TSE agents results, months or years later, in the accumulation in tissues of large amounts of agent having the same physical and biologic properties as the original agent. The TSE agents display a spectrum of extreme resistance to inactivation by a variety of chemical and physical treatments that is unknown among conventional pathogens. This characteristic, as well as their partial resistance to protein-disrupting treatments and their consistent association with abnormal isoforms of the normal host-encoded “prion” protein (PrP), stimulated the hypothesis that the TSE agents are probably subviral in size, composed of protein, and devoid of nucleic acid.

The term **prion** (for proteinaceous infectious agent), coined by S. B. Prusiner, is now widely used for such agents. The prion hypothesis proposes that the molecular mechanism by which the pathogen-specific information of TSE agents is propagated involves a self-replicating change in the folding of host-encoded PrP associated with a transition

**Table 324.1** Clinical and Epidemiologic Features of Human Transmissible Spongiform Encephalopathies (Prion Diseases)

DISEASE	CLINICAL FEATURES	SOURCE OF INFECTION	GEOGRAPHIC DISTRIBUTION AND PREVALENCE	USEFUL ANCILLARY TESTS	DURATION OF ILLNESS
sCJD	Dementia, myoclonus, ataxia	Unknown	Worldwide; ~1-2/1 million/yr; 85–95% of all CJD cases in the United States	EEG-PSWCs; CSF 14-3-3; RT-QuIC, MRI/DWI	1-24 mo (mean: 4-6 mo)
fCJD	Dementia, myoclonus, ataxia	Genetic association ( <i>PRNP</i> pathogenic variants)	Worldwide; geographic clusters; >100 known families; 5–15% of CJD cases	Gene testing; EEG-PSWC; CSF 14-3-3, RT-QuIC, MRI/DWI	Mean ~15 mo
iCJD	Incoordination, dementia (late)	Cadaveric dural grafts, human pituitary hormones, corneal transplantation, neurosurgical instruments, EEG depth electrodes	~1% of CJD cases in toto (cadaveric dural grafts); human pituitary hormones, >100 cases; corneal transplantation, three cases; neurosurgical instruments, six cases, including two from cortical depth electrodes; RBC transfusions, four cases of vCJD infection, three clinical, one preclinical (United Kingdom); human plasma-derived factor VIII, one preclinical case of vCJD (United Kingdom)	EEG-PSCW, CSF 14-3-3, RT-QuIC, MRI/DWI	18 mo - >30yr
vCJD	Mood and behavioral abnormalities, paresthesias, dementia	Linked to BSE in cattle, transfusion plasma products	>230 clinical cases (see iatrogenic vCJD): none living, May 2017	Tonsil biopsy may show PrP <sup>TSE</sup> MRI/FLAIR	8-36 mo (mean 14 mo)
Kuru	Incoordination, ataxia, tremors, dementia (late)	Linked to cannibalism	Fore tribe of Papua New Guinea (~2,600 known cases)	EEG-no PSWCs; CSF 14-3-3 often negative; MRI (?)	3-24 mo
GSS	Incoordination, chronic progressive ataxia, corticospinal tract signs, dementia (late), myoclonus (rare)	90% genetic ( <i>PRNP</i> pathogenic variants)	Worldwide; >50 families; ~1-10/100 million/yr	<i>PRNP</i> gene sequencing	2-12 yr (mean ~ 57 mo)
FFI	Disrupted sleep, intractable insomnia; autonomic hyperactivation; myoclonus, ataxia; corticospinal tract signs; dementia	<i>PRNP</i> gene pathogenic variant (D 178L); very rare sporadic cases	~27 families in Europe, United Kingdom, United States, Finland, Australia, China, Japan	<i>PRNP</i> testing; EEG-PSWCs only rarely positive; MRI-no DWI abnormalities; CSF 14-3-3 positive in ~50%	8 mo to 6 yr (mean: <i>PRNP</i> 129 MM 12 ± 4 mo 129 MV 21 ± 15 mo)

BSE, Bovine spongiform encephalopathy; CSF, cerebrospinal fluid; CJD, Creutzfeldt-Jakob disease; DWI, diffusion-weighted image; fCJD, familial Creutzfeldt-Jakob disease; FFI, fatal familial insomnia; FLAIR, fluid attenuation inversion recovery MRI; GSS, Gerstmann-Sträussler-Scheinker syndrome; iCJD, iatrogenic Creutzfeldt-Jakob disease; *PRNP*, prion protein-encoding gene; PrP<sup>TSE</sup>, abnormal prion protein; PSWCs, periodic sharp wave complexes; RBC, red blood cell; RT-QuIC, real-time quaking-induced conversion; sCJD, sporadic Creutzfeldt-Jakob disease; vCJD, variant Creutzfeldt-Jakob disease.

NOTE: PRNP 129 MM, homozygous, encoding the amino acid methionine at both codons 129 of the prion protein-encoding (*PRNP*) gene on chromosome 20; 129 MV, heterozygous at PRNP codon 129, encoding methionine on one chromosome 20 and valine on the other.

Modified from Mandell GL, Bennett JE, Dolin R, eds. *Principles and Practice of Infectious Diseases*. 6th ed. Philadelphia: Elsevier; 2005: p. 2222; Love S, Louis DN, Ellison DW, eds. *Greenfield's Neuropathology*. 8th ed. London: Hodder Arnold; 2008: p. 1239.

from an  $\alpha$ -helix-rich structure in the native protease-sensitive conformation (“cellular” PrP or PrP<sup>C</sup>) to a  $\beta$ -sheet-rich structure in the protease-resistant conformation associated with infectivity. The existence of a second host-encoded protein—termed *protein X*—that participates in the transformation was once postulated to explain certain otherwise puzzling findings but was never identified.

The prion hypothesis is still not universally accepted; it relies on the postulated existence of a genome-like coding mechanism based on differences in protein folding that have not yet been satisfactorily elucidated at a molecular level. In addition, it has yet to account convincingly for the many biologic strains of TSE agent that have been observed, although strain-specific differences in glycosylation patterns

of abnormal PrP have been proposed as providing a plausible molecular basis for the coding. It fails to explain why pure PrP uncontaminated with nucleic acid from an infected host has not consistently transmitted a typical spongiform encephalopathy associated with a serially self-propagating agent. Also troubling is the fact that abnormal PrP and infectivity were not consistently associated in several experimental models and human illnesses. Particularly problematic is the finding that some illnesses associated with pathogenic variants in the *PRNP* gene and accompanied by abnormal PrP failed to transmit infection to animals. If the TSE agents ultimately prove to consist of protein and only protein, with no obligatory nucleic acid component, then proponents of the prion hypothesis will have been prescient. If the agents are ultimately found to contain small nucleic acid genomes, then they might better be considered atypical viruses, for which the term *virino* was once suggested. Until the actual molecular structure of the infectious TSE pathogens and the presence or absence of a nucleic acid genome are rigorously established, it seems acceptable to continue calling them TSE agents (a term that remains popular among some European authorities). Most U.S. authorities now prefer the term *prion* (sometimes referring to the infectious agents of TSEs and sometimes to abnormal PrP, even when not transmissible).

The earliest evidence that abnormal proteins are associated with the TSE was morphologic: scrapie-associated fibrils (SAFs) were found by negative-stain electron microscopy in detergent-treated extracts of brain tissues from patients and animals with TSEs but not in brain tissues of unaffected persons. SAFs resemble but are distinguishable from the amyloid fibrils that accumulate in the brains of patients with Alzheimer disease. Antigenically related protease-resistant PrPs (PrP-res) proved to be components of SAFs and to be present in the amyloid plaques found in the brains of patients and animals with TSEs. The abnormal forms of PrP have been variously designated PrP<sup>Sc</sup> (scrapie-type PrP), PrP-res, PrP<sup>TSE</sup> (TSE-associated PrP), or PrP<sup>D</sup> (also PrP<sup>Dis</sup>, for “disease-associated” PrP) by different authorities.

It remains unclear whether abnormal PrP constitutes the complete infectious particle of spongiform encephalopathies, is a component of those particles, or is a pathologic host protein not usually separated from the actual infectious entity by current techniques. The demonstration that PrP is encoded by a normal host gene seemed to favor the last possibility. (A possible model for mammalian prions was provided by several studies. The model suggested that agent-specific pathogenic information can be transmitted and replicated by different conformations of fungal proteins having the same primary amino acid sequence without participation of any agent-specific nucleic acids, although those transmissions required microinjections and misfolded proteins were apparently not naturally transmitted to recipient fungi as infectious elements.)

Whatever its relationship to the actual infectious TSE particles, PrP clearly plays a central role in susceptibility to infection, because the normal PrP must be expressed in mice and cattle to infect them. Furthermore, inherited normal variations (genetic polymorphisms) in PrP genotype are associated with increased susceptibility to vCJD and, to a lesser extent, to sCJD and with occurrence of two familial TSEs (fCJD and GSS). PrPs are glycoproteins that have the physical properties of amyloid proteins when misfolded and aggregated into protease-resistant PrP<sup>TSE</sup>. The PrPs of different species of animals are very similar in their amino acid sequences and antigenicity but are not identical in structure. The primary structure of PrP is encoded by the host and is not altered by the source of the infectious agent provoking its formation. The function of the normal ubiquitous protease-sensitive PrP precursor (designated either PrP<sup>C</sup> or PrP-sen, for protease-sensitive PrP, by different authorities) in normal cells is unknown; it binds copper and may play some role in normal synaptic transmission but is not required to sustain life or for relatively normal cerebral function in mice and cattle. As noted, animals must express PrP to develop overt TSE as well as to support replication of the TSE

agents. The degree of homology between amino acid sequences of PrPs in different animal species may correlate with a “species barrier” that affects susceptibility of animals of one species to infection with a TSE agent adapted to grow in another species, although the degree of sequence homology does not always predict susceptibility to the same TSE agent.

Attempts to find particles resembling those of known viruses or virus-like agents in brain tissues of humans or animals with spongiform encephalopathies have been unsuccessful. Peculiar tubulovesicular structures reminiscent of some viruses have been seen repeatedly in thin sections of TSE-infected brain tissues and cultured cells but not in normal brain cells; it has never been established that those structures are associated with infectivity.

## EPIDEMIOLOGY

Kuru once affected many children of both sexes  $\geq 4$  years of age, adolescents, and young adults (mainly women) living only in a limited area of Papua New Guinea. The complete disappearance of kuru among people born after 1957 suggests that the practice of ritual cannibalism (thought to have ended that year) was probably the only mechanism by which the infection spread in Papua New Guinea. The probable incubation periods of some cases of kuru have exceeded 50 years. Kuru has not been diagnosed since 2005.

sCJD is the most common human spongiform encephalopathy. Most countries with surveillance for CJD have identified between one and two cases of sCJD per million total population per year (0.25–2 cases per million population, not age-adjusted). That figure is somewhat misleading in that the Centers for Disease Control and Prevention (CDC) has estimated the lifetime risk of sCJD in the United States to be as many as 1 in 6,000 persons, taking into account the number of recognized iCJD cases attributed to use of cadaveric pituitary hormones, typical advanced age of CJD cases at onset, and probable incubation periods of decades. sCJD was formerly thought to occur only in older adults; however, sCJD and sporadic fatal insomnia have also affected a few young people (to date, seven cases reported in adolescents, one in a 14-year-old girl). vCJD, however, has a peculiar predilection for younger people. Of 174 cases of vCJD reported through 2010 in the United Kingdom, all except 23 were in people younger than 40 years of age and 22 were younger than 20 years of age; the youngest age at onset was 12 years.

Proponents of the prion hypothesis are convinced that PrP can spontaneously misfold, becoming self-replicating and causing sCJD; skeptics favor the hypothesis of infection with some ubiquitous TSE agent that, fortunately, has a very low attack rate except in persons with certain pathogenic variants in the *PRNP* gene or possibly non-*PRNP* genetic risk factors. Neither possible etiology has been proven. fCJD, the second most common human TSE, accounts for only 10% or 15% of total cases of CJD. fCJD occurs in a foci of considerably higher incidence in Israel (among Libyan Jews), in isolated villages of Slovakia, and in other limited areas.

sCJD has not been convincingly linked to any prior exposure to other cases and the source of infection remains unknown. Person-to-person spread has been confirmed only for iatrogenic cases. Spouses and household contacts of patients are not at increased risk of acquiring CJD, although two instances of conjugal CJD have been reported. However, medical personnel exposed to brains of patients with CJD may be at some increased risk; at least 20 healthcare workers have been recognized with the disease. In 2019 a young laboratory worker in France died after a 2-year illness confirmed at autopsy to be vCJD; her infection was plausibly attributed to an accidental penetrating wound 7.5 years before onset by a forceps contaminated with brain tissue from a mouse experimentally infected with BSE agent.

The striking resemblance of CJD to scrapie prompted a concern that infected sheep tissues might be a source of spongiform encephalopathy in humans. No reliable epidemiologic evidence suggests that exposure to potentially scrapie-contaminated animals, meat, meat

products, or experimental preparations of the scrapie agent have transmitted a TSE to humans. The potential of the CWD agent to infect human beings has also not been demonstrated but remains under investigation by the CDC and Canadian authorities. Consumption of contaminated venison from animals infected with the CWD agent has not been implicated as a risk factor for human TSE by epidemiologic studies. However, a Canadian study reported that CWD had been experimentally transmitted to monkeys fed venison from overtly healthy infected deer, prompting a health advisory from Canadian authorities (<https://www.thetyee.ca/Documents/2017/06/24/Risk-Advisory-Opinion-CWD-2017.pdf>).

The same thing is not true for vCJD, which is clearly a zoonosis acquired by humans after dietary exposure to the BSE agent. The outbreak of BSE among cattle (possibly infected by eating scrapie agent-contaminated meat-and-bone meal and later bovine-contaminated meal added to feed) was first recognized in the United Kingdom in 1986 and later reported in cattle of 27 other countries, including Canada and the United States. More than 190,000 cases of BSE have been reported to the World Organization for Animal Health (OIE), almost 97% of those from the United Kingdom. Cases of BSE progressively declined in the United Kingdom after 1992 and somewhat later in other countries; in 2016 only two cases worldwide were reported to the OIE (from France and Spain) and none from the United Kingdom. A single case of BSE was recognized in the United States in 2018. Rare sporadic cases of BSE in old cows, associated with an “atypical” PrP<sup>TSE</sup> having somewhat different electrophoretic properties from those of the PrP<sup>TSE</sup> in younger cattle with “classic” cases of BSE during the epidemic, stimulated the hypothesis that atypical BSE was caused by spontaneous generation of a PrP<sup>TSE</sup> rather than by a feed-borne infection; that hypothesis, however intriguing and appealing to some agricultural authorities, remains unconfirmed though little investigated.

The finding of a new TSE in ungulate and feline animals in British zoos and later in domestic cats first raised a fear that the BSE agent might have acquired a range of susceptible hosts broader than that of scrapie, posing a potential danger for humans. A broadening of the host range of BSE agent remains the most plausible explanation for the later appearance of human vCJD, first described in adolescents in Britain in 1996 and, as of August 2021, eventually affecting at least 178 people potentially exposed to a BSE agent in the United Kingdom (not counting a disturbing number of people with evidence of possible asymptomatic or “preclinical” vCJD infection) and more than 50 in 11 other countries (total 231 cases worldwide): 28 in France, 5 in Spain, 4 in Ireland, 3 in the Netherlands, 3 in Italy, 2 in Portugal, and single cases in Japan and Saudi Arabia. vCJD has also occurred in former residents in the United Kingdom (for more than 6 months) later living in Ireland (two cases), France (one case), Canada (one case), Taiwan (one case), and the United States (two cases). Two cases of vCJD, one in the United States and one in Canada, have been reported in former long-time residents of the Kingdom of Saudi Arabia, a country that has not recognized BSE but might have imported infected cattle or contaminated halal beef products from Britain. A third case of vCJD was previously confirmed in a Saudi citizen residing in the Kingdom of Saudi Arabia. The most recent case of vCJD diagnosed in the United States occurred in an immigrant deemed by the CDC to have been infected during years spent in Kuwait or, less likely, Russia.

No case of vCJD has been confirmed in anyone born in the United Kingdom after 1989. However, examination by immunohistochemistry of resected appendices in the United Kingdom for evidence of subclinical vCJD infection suggested that about 1 in 2,000 tissues tested had detectable accumulations of PrP<sup>TSE</sup> in lymphoid follicles. It remains controversial whether those accumulations result from subclinical vCJD or other TSE (<https://app.box.com/s/hhhhg857fjpu2bnxhv6e/1/2936396377/91796156506/1>); none of the PrP<sup>TSE</sup>-positive subjects to date has been reported with overt TSE.

Iatrogenic transmissions of CJD (iCJD) have been recognized for more than 30 years (Table 324.2). Such accidental medical transmissions of CJD have been attributed to use of contaminated neurosurgical instruments (no case reported since 1980), cortical electrodes contaminated during epilepsy surgery, injections of human cadaveric pituitary growth hormone and gonadotropin (neither currently marketed in the United States), transplantation of human dura mater allografts formerly used as a surgical patching material (especially in Japan), and, rarely, contaminated corneal transplants. Pharmaceuticals and tissue grafts derived from or contaminated with human neural tissues, particularly if obtained from unselected donors and large pools of donors, pose special risks.

Studies of animals experimentally infected with TSE agents first suggested that blood and blood components from humans with preclinical CJD infections might pose a risk of transmitting disease to recipients. Since the 1980s such blood components have been withdrawn as a precaution in the United States when a donor was later found to have CJD and blood products were still in-date. A surveillance program in the United Kingdom reported vCJD in three recipients of nonleukoreduced red blood cells from donors later diagnosed with vCJD; there was autopsy evidence of a preclinical vCJD infection in a fourth red cell recipient who died of another disease. (vCJD has not occurred in anyone exclusively transfused with leukoreduced red blood cells from a donor who later developed vCJD.) A study initiated more than 20 years ago by the American Red Cross and CDC found no recipient of blood components obtained from donors later diagnosed with sCJD (and from one donor with fCJD) had ever developed a TSE.

Evidence of a preclinical vCJD infection was found at autopsy in a British patient with hemophilia A treated with a human plasma-derived coagulation factor VIII to which at least one vCJD-infected donor contributed; the coagulation factor involved was never licensed or marketed in the United States. Authorities in the United Kingdom described two recipients of plasma-derived coagulation factors (both having history of transfusion with blood components as well) who later developed sCJD, concluding that the finding, while of concern, might be coincidental.

## PATHOGENESIS AND PATHOLOGY

The probable portal of entry for the TSE agent in kuru is thought to have been either through the gastrointestinal tract or lesions in the mouth or integument incidentally exposed to the agent during cannibalism. Patients with vCJD (and animals with BSE and BSE-related TSEs) are thought to have been similarly infected with the BSE agent by consuming contaminated beef products. Except after direct introduction into the nervous system, the first site of replication of TSE agents appears to be in tissues of the reticuloendothelial system. TSE agents have been detected in low titers in blood of experimentally infected animals (mice, hamsters, cervids, sheep, and monkeys) and in the blood of persons with vCJD; infectivity was mainly associated with nucleated cells, although plasma contained a substantial portion of total infectivity in blood. Mice must have circulating lymphoid cells to be infected by peripheral routes. Limited evidence suggests that TSE agents can also spread to the central nervous system (CNS) by ascending peripheral nerves.

In kuru, it seems probable that the only portal of exit of the agent from the body, at least in quantities sufficient to infect others, was through infected tissues exposed during cannibalism. In iatrogenically transmitted CJD, the brains and eyes of patients with sCJD have been the probable sources of contamination. Experimental transmission of the agent to animals from kidney, liver, lung, lymph node, and spleen sampled at autopsies of patients with sCJD showed that those tissues as well as cerebrospinal fluid (CSF) sometimes contained the CJD agent; none of those sources has been implicated in accidental transmissions of CJD to humans. At no time during the course of any TSE have antibodies or cell-mediated immunity



**Table 324.2** Iatrogenic Transmission of Creutzfeldt-Jakob Disease by Products of Human Origin

PRODUCT	PATIENTS (NO.)	INCUBATION TIME	
		MEAN	RANGE
Cornea	3	17 mo	16-18 mo
Dura mater allograft	>100	7.4 yr	1.3-16 yr
Pituitary extracts			
Growth hormone	>100*	12 yr	5-38.5 yr
Gonadotropin	4	13 yr	12-16 yr
Red blood cells	4	? 6 yr	6.3-8.5 yr†
Plasma-derived coagulation factor VIII	1	? >11 yr‡	

\*There have been 28 cases reported among approximately 8,000 recipients of human cadaveric growth hormone in the United States; the remaining cases have been reported in other countries.

†The second transfusion-transmitted case of vCJD (Peden AH, Head MW, Ritchie DL, et al. Preclinical vCJD after blood transfusion in a PRNP codon 129 heterozygous patient. *Lancet*. 2004;364:527-529) died of unrelated causes about 5 years after transfusion but was found to have accumulations of abnormal PrP in spleen and cervical lymph node, a finding unique to vCJD and interpreted as probable preclinical infection.

‡The diagnosis of vCJD infection attributed to treatment with human plasma-derived coagulation factor VIII (UK Health Protection Agency vCJD abnormal prion protein found in a patient with haemophilia at post mortem. Press release 17 February 2009. [http://webarchive.nationalarchives.gov.uk/20140714084352/http://www.hpa.org.uk/webw/HPAweb&HPAwebStandard/HPAweb\\_C-/1234859690542?p=1231252394302](http://webarchive.nationalarchives.gov.uk/20140714084352/http://www.hpa.org.uk/webw/HPAweb&HPAwebStandard/HPAweb_C-/1234859690542?p=1231252394302)) was also supported by immunohistochemical testing for abnormal PrP in the spleen of a person who died of other causes. Both patients with "preclinical" infections are thought to have died during the asymptomatic incubation period of vCJD.

to the infectious agents been convincingly demonstrated in either patients or animals. However, mice must be immunologically competent to be infected with the scrapie agent by peripheral routes of inoculation.

Typical changes in TSE include vacuolation and loss of neurons with hypertrophy and proliferation of glial cells, most pronounced in the cerebral cortex in patients with CJD and in the cerebellum in those with kuru. The lesions are usually most severe in or even confined to gray matter, at least early in the disease. Loss of myelin appears to be secondary to degeneration of neurons. There generally is no inflammation, but a marked increase in the number and size of astrocytes is usual. Spongiform changes are not a striking autopsy finding in patients with FFI, and neuronal degeneration and gliosis are largely restricted to thalamic nuclei.

Amyloid plaques are found in the brains of all patients with GSS and in at least 70% of those with kuru. These plaques are less common in patients with CJD. Amyloid plaques are most common in the cerebellum but occur elsewhere in the brain as well. In brains of patients with vCJD, plaques surrounded by halos of vacuoles (described as flower-like or "florid" plaques) have been a consistent finding. TSE amyloid plaques react with antiserum prepared against PrP. Even in the absence of plaques, extracellular PrP<sup>TSE</sup> can be detected in the brain parenchyma by immunostaining, Western blotting, and enzyme-linked immunosorbent assay (ELISA).

## CLINICAL MANIFESTATIONS

Kuru was a progressive degenerative disease of the cerebellum and brainstem with less obvious involvement of the cerebral cortex. The first sign of kuru was usually cerebellar ataxia followed by progressive

incoordination. Coarse, shivering tremors were characteristic. Variable abnormalities in cranial nerve function appeared, frequently with impairment in conjugate gaze and swallowing. Patients died of inanition and pneumonia or of burns from cooking fires, usually within 1 year after onset. Although changes in mentation were common, there was no frank dementia or progression to coma, as seen in CJD. There were also no signs of acute encephalitis such as fever, headaches, and convulsions.

Patients with sCJD initially have either sensory disturbances (most often visual) or confusion and inappropriate behavior, progressing over weeks or months to frank dementia, akinetic mutism, and ultimately coma. Some patients have cerebellar ataxia early in disease, and most patients experience myoclonic jerking movements. Mean survival of patients with sCJD has been 4-6 months from the earliest signs of illness, although approximately 10% live for 2 years. vCJD (Table 324.3) differs from the more common sCJD: patients with vCJD are much younger at onset (as young as 12 years) and more often present with complaints of dysesthesia and subtle behavioral changes, often mistaken for psychiatric illness. Severe mental deterioration occurs later in the course of vCJD. Patients with vCJD have survived substantially longer than those with sCJD. (Attempts have been made to subclassify cases of CJD based on electrophoretic differences in PrP<sup>TSE</sup> and variation in its sensitivity to digestion with the proteolytic enzyme proteinase [PK]; the different variants are said to have somewhat different clinical features, including duration of illness, though all are ultimately fatal.)

GSS is a familial disease somewhat resembling CJD but with more prominent cerebellar ataxia or parkinsonian syndrome and amyloid plaques. Dementia may appear only late in the course of GSS, and the average duration of illness is longer than that of typical sCJD (~5 years). Progressively severe insomnia and dysautonomia as well as ataxia, myoclonus, and other signs resembling those of CJD and GSS characterize FFI and sporadic fatal insomnia. GSS has not been diagnosed in children or adolescents. A case of sporadic fatal insomnia has been described in a young adolescent.

## DIAGNOSIS

Diagnosis of spongiform encephalopathies is most often determined on clinical grounds after excluding other diseases. The presence of the 14-3-3 protein (see the section "Laboratory Findings") in CSF may aid in distinguishing between CJD and Alzheimer disease, which is not a consideration in children. Elevations of 14-3-3 protein levels in CSF are not specific to TSEs and are common in viral encephalitis and other conditions causing rapid necrosis of brain tissue. A research-use PrP peptide amplification test (real-time quaking-induced conversion [RT-QuIC]) appears to be sensitive and specific for antemortem diagnosis of sCJD when applied to CSF or nasal brushings but may be less sensitive in younger patients compared with older individuals with TSEs. Brain MRI has proven clinically useful (see later). Brain biopsy may be diagnostic for all forms of CJD but can be recommended only if a potentially treatable disease remains to be excluded or some other reason compels an antemortem diagnosis and may result in a false negative result depending on tissue quality, type, and TSE. Definitive diagnosis usually requires microscopic examination of brain tissue obtained at autopsy. The demonstration of PrP<sup>TSE</sup> in brain extracts augments histopathologic diagnosis. Accumulation of the abnormal PrP in lymphoid tissues, even before the onset of neurologic signs, is typical of vCJD. Tonsil biopsy may avoid the need for brain biopsy when antemortem histologic diagnosis of vCJD is indicated. To date no blood-based test has been validated for antemortem testing of either humans or animals, though one cumbersome PrP<sup>TSE</sup> research-use test (protein misfolding cyclic amplification [PMCA]) shows promise. Transmission of disease to susceptible animals by inoculation of brain suspension, while sensitive, specific, and reliable, must be reserved for cases of special research interest. Diagnosis usually rests on recognizing the typical constellation of clinical findings, course of illness, and

**Table 324.3** Clinical and Histopathologic Features of Patients with Variant and Typical Sporadic Creutzfeldt-Jakob Disease

FEATURE	VARIANT CJD (FIRST 10 PATIENTS)	SPORADIC CJD (185 PATIENTS)
Years of age at death* (range)	29 (19-74)	65
Duration of illness, mo (range)	12 (8-23)	4-6
Presenting signs	Abnormal behavior, dysesthesia	Dementia, ataxia
Later signs	Dementia, ataxia, myoclonus	Ataxia, myoclonus
Periodic complexes on EEG	Rare	Most
PRNP 129 Met/Met	All tested (except one transfusion-transmitted case, one plasma-derivative transmitted case; one possible clinical case in United Kingdom where no tissue was available to confirm)	83%
Histopathologic changes	Vacuolation, neuronal loss, astrocytosis, plaques (100%)	Vacuolation, neuronal loss, astrocytosis, plaques (≤15%)
Florid PrP plaques <sup>†</sup>	100%	0
PrP <sup>TSE</sup> glycosylation pattern	BSE-like <sup>‡</sup>	Not BSE-like

\*Median age and duration for variant CJD; averages for typical sporadic CJD.

<sup>†</sup>Dense plaques with a pale periphery of surrounding vacuolated cells.

<sup>‡</sup>Characterized by an excess of high molecular mass band (diglycosylated) and 19-kDa nonglycosylated band glycoform of PrP-res (Collinge J, Sidle KC, Meads J, et al. Molecular analysis of prion strain variation and the aetiology of "new variant" CJD. *Nature*. 1996;383:685-690).

BSE, Bovine spongiform encephalopathy; CJD, Creutzfeldt-Jakob disease; Met, codon 129 of one *PRNP* gene encoding for methionine; *PRNP*, prion protein-encoding gene; PrP, prion protein.

Modified from Will RG, Ironside JW, Zeidler M, et al. A new variant of Creutzfeldt-Jakob disease in the UK. *Lancet*. 1996;347:921-925.

testing (CSF examination, MRI, EEG), confirmed by histopathology and detection of PrP<sup>TSE</sup> in brain tissues at autopsy (or, less often, by tonsil or brain biopsy).

### LABORATORY FINDINGS

Virtually all patients with typical sporadic, iatrogenic, and familial forms of CJD have abnormal EEGs as the disease progresses; the background becomes slow and irregular with diminished amplitude. A variety of paroxysmal discharges such as slow waves, sharp waves, and spike-and-wave complexes may also appear, and these may be unilateral or focal or bilaterally synchronous. Paroxysmal discharges may be precipitated by loud noise. Many patients have typical periodic suppression-burst complexes of high-voltage slow activity on EEG at some time during the illness. Patients with vCJD have only generalized slowing, without periodic bursts of high-voltage discharges on EEG. CT or MRI may show cortical atrophy and large ventricles late in the course of CJD. Most cases of sCJD and many cases of familial TSE demonstrate hyperintensity in cortex or basal ganglia diffusion by weighted imaging (DWI). Many patients with vCJD have an increase in density of the pulvinar on fluid attenuated inversion recovery (FLAIR) MRI sequences. Reliable interpretation of the images is best left to experienced radiologists.

There may be modest elevation of CSF protein content in patients with TSE. Unusual protein spots were observed in CSF specimens from sCJD patients separated by two-dimensional gel electrophoresis and silver staining; the spots were later identified as 14-3-3 proteins, normal proteins not related to PrP that are abundant in neurons but not ordinarily detected in CSF. However, 14-3-3 protein, as noted previously, has also been detected in CSF specimens from some patients with acute viral encephalitis and recent cerebral infarctions, and is not specific to CJD. Finding the 14-3-3 protein in CSF is neither sensitive nor specific but can help confirm the diagnosis of sCJD, especially when accompanied by increases in other cellular proteins. Tests for 14-3-3 in CSF are often negative in patients with vCJD.

### TREATMENT

No treatment has proven effective for any TSE, and it seems unlikely that treatment can reverse the severe brain damage found in late disease. Studies of cell cultures and rodents experimentally infected with TSE agents suggested that treatments with chlorpromazine, quinacrine, and tetracyclines might be of benefit, especially during the incubation period; however, results of clinical trials based on those studies have been discouraging. Infusions with pentosan polysulfate directly into the cerebral ventricles may have delayed the progression of vCJD in at least one patient but did not reverse earlier brain damage. On the basis of experimental studies in animals, several prophylactic postexposure treatment regimens have been suggested, but none has been validated or widely accepted. Results of some preliminary studies suggested that treatments with antisense oligonucleotides or other molecular genetic therapies might impair translation of the prion protein gene, potentially ameliorating the degenerative process of TSE if initiated before CNS damage has appeared; such early treatment would have to be directed to otherwise healthy persons bearing a pathogenic variant known to occur in familial TSE, because those destined to develop the more common sCJD cannot be identified before brain damage appears. Appropriate compassionate supportive care should be provided to all CJD patients as for those with other progressive fatal neurologic diseases.

### GENETIC COUNSELING

TSEs occur in some families in a pattern consistent with an autosomal dominant mode of inheritance. In patients with a family history of CJD, the clinical and histopathologic findings are similar to those seen in sporadic cases. In the United States, only approximately 10% of cases of CJD are familial. GSS and FFI are always familial. In some affected families, approximately 50% of siblings and children of a patient with a familial TSE eventually acquire the disease; in other families, the "penetrance" of illness is lower.

The gene encoding PrP is closely linked if not identical to that controlling the incubation periods of scrapie in sheep and both scrapie and CJD in mice. The same gene in humans is designated the *PRNP*

gene, located on the short arm of chromosome 20. It has an open reading frame of about 759 nucleotides (253 codons), in which more than 20 different point pathogenic variants and a variety of inserted sequences encoding extra tandem-repeated octapeptides have been linked to the occurrence of spongiform encephalopathy in families, a disease expressed in a pattern consistent with autosomal dominance of variable penetrance. The E200K point pathogenic variant has been the most common worldwide.

The same nucleotide substitution at codon 178 of the *PRNP* gene (D178N) associated with CJD in some families has also been found in all patients with FFI but associated with linkage to a different polymorphic amino acid at codon 129 of the *PRNP* gene on the same chromosome (fCJD with 129V and FFI with 129M). Homozygosity for valine (V) and especially for methionine (M) at codon 129 seems to increase susceptibility to both iCJD and sCJD. All but three patients with vCJD to be genotyped have been homozygous for methionine at codon 129 of the *PRNP* gene. A few probable preclinical vCJD infections and two clinically typical cases of vCJD (one confirmed and another not completely evaluated) occurred in persons with the 129 MV heterozygous genotype. It is of interest that when the *PRNP* genes from appendices containing accumulations of what appears to be PrP<sup>TSE</sup> in the United Kingdom were sequenced, a surprising number were homozygous for 129V—the genotype of only approximately 10% of British subjects—and never found in a case of overt vCJD. The significance of this finding is not clear. Authorities in the United Kingdom adopted the precautionary assumption that some persons with PrP<sup>TSE</sup> in lymphoid tissues may have latent infections; as time goes by without detecting any overt cases of vCJD in those persons, that assumption becomes less likely. Whether the blood or tissues of such persons are infectious remains unknown.

Although the interpretation of these findings in regard to the prion hypothesis remains controversial, persons from families with CJD or GSS who have the associated pathogenic variants in the *PRNP* gene clearly have a high probability of eventually developing TSE. Bearers of TSE-associated pathogenic variants have successfully employed preimplantation genetic diagnosis and in vitro selection of embryos to avoid passing the mutant gene to offspring. The significance of pathogenic variants in the *PRNP* genes of individuals from families with no history of spongiform encephalopathy is not known. It seems wise to avoid alarming those from unaffected families who have miscellaneous pathogenic variants in the *PRNP* gene, because the implications are not yet clear. In the United States, persons are currently deferred from donating blood if a blood relative has been diagnosed with a familial TSE unless the donor (the relative or implicated parent) has no TSE-related mutation.

## PROGNOSIS

The prognosis of all spongiform encephalopathies is uniformly poor. Approximately 10% of patients may survive for longer than 2 years but the quality of life is poor.

## FAMILY SUPPORT

The CJD Foundation (<http://www.cjdfoundation.org>), organized and maintained by family members and friends of patients with CJD and related disorders, working closely with the CDC ([www.cdc.gov/prions/index.html](http://www.cdc.gov/prions/index.html)) and with the National Prion Disease Pathology Surveillance Center, Case Western Reserve University, Cleveland, Ohio (<http://www.cjdsurveillance.com>), is a support and educational group and a useful source of information regarding available resources for those dealing with the diseases.

## PREVENTION

Exposure to the BSE agent in meat products clearly poses a special danger, which is now greatly reduced. Authorities in Canada, the United

States, and other countries responded by implementing progressively more stringent agricultural and public health measures during the past 25 years, with prohibition of most bovine-derived materials from feeds for ruminants probably the most effective measure. Three cases of BSE in native cattle were recognized in the United States from 2004 through 2012; a case was also found in a Canadian cow imported into the United States in 2003. Canada found 20 native cattle with BSE between 2003 and 2015 (and imported a case from the United Kingdom in 1993). In spite of encouraging epidemiologic studies that failed to implicate exposure to scrapie or CWD agents in human TSEs, it seems prudent to avoid exposing children to meat and other products likely to be contaminated with any TSE agent.

The safety of human blood, blood components, and plasma derivatives in the United States and Canada is protected by deferring, as a precaution, some donors with histories suggesting an increased risk of exposure to TSE agents: persons treated with human cadaveric pituitary hormones or dura mater allografts (neither currently marketed in the United States) and donors who voluntarily disclose history of familial TSE (fCJD, GSS, FFI) unless sequencing shows that the TSE-affected relative or the donor has no TSE-related mutation in either *PRNP* gene (<https://www.fda.gov/vaccines-blood-biologics/guidancecompliance-regulatory-information-biologics/biologicsguidances>).

In principle, it would be better to identify the very few blood and tissue donors actually infected with a TSE rather than deferring all those at increased risk of exposure, because most of them are unlikely to have been infected. Antemortem screening tests that might eventually identify donors with preclinical TSE infections are currently under development though not clinically validated. It seems unlikely that any test would be adopted to screen blood donors without simultaneously implementing a highly specific validated confirmatory test to avoid the serious adverse implications resulting from the inevitable false-positive screening results. In any case, the current risk of transfusion-transmitted TSE in the United States appears to be extremely low. Postmortem testing of brain tissue from cadaveric tissue donors would be feasible and more justifiable in view of the surprisingly high lifetime risk of sCJD; tissue transplantation-associated TSE has not been recognized since donors with history of dementia and other neurologic disease have been excluded.

Standard universal precautions should be used to handle all human tissues, blood, and body fluids. Materials and surfaces contaminated with tissues and CSF from patients suspected of having CJD must be treated with great care, paying special attention to preventing injuries with needles and other sharp instruments. Whenever possible, discard contaminated instruments as “medical-pathological waste” by careful packaging and incineration. Contaminated tissues and biologic products probably cannot be completely freed of infectivity without destroying their structural integrity and biologic activity; therefore the medical and family histories of individual tissue donors should be carefully reviewed to exclude a diagnosis of TSE or other neurologic disease. Histopathologic examination of brain tissues of cadaveric donors and rapid testing for abnormal PrP might eventually be performed where feasible (no rapid diagnostic test is currently marketed for use with human tissues, though commercial animal TSE tests detect PrP<sup>TSE</sup> in human CJD brains) to provide some additional assurance of safety. Although no method of sterilization can be relied on to remove all infectivity from contaminated surfaces, exposures to moist heat, sodium hydroxide, chlorine bleach, concentrated formic acid, acidified detergent, and guanidine salts markedly reduced infectivity in experimental studies.

Visit Elsevier eBooks+ at [eBooks.Health.Elsevier.com](http://eBooks.Health.Elsevier.com) for Bibliography.



## Section 14

## Antiparasitic Therapy

## Chapter 325

## Principles of Antiparasitic Therapy

Beth K. Thielen

Parasites are divided into three main groups taxonomically: **protozoans**, which are unicellular, and **helminths** and **ectoparasites**, which are multicellular. Chemotherapeutic agents appropriate for one group may not be appropriate for the others, and not all drugs are readily available (Table 325.1). Some drugs are not available in the United States, and some are available only from the manufacturer, specialized compounding pharmacies, or the Centers for Disease Control and Prevention (CDC). Information on the availability of drugs and expert guidance in management can be obtained by contacting the CDC Parasitic Diseases Branch (1-404-718-4745; e-mail [parasites@cdc.gov](mailto:parasites@cdc.gov) (M-F, 8 AM-4 PM, Eastern time). For assistance in the management of malaria, healthcare providers should call the CDC Malaria Hotline: 1-770-488-7788 or 1-855-856-4713 toll-free, e-mail [malaria@cdc.gov](mailto:malaria@cdc.gov) (M-F, 9 AM-5 PM, Eastern time). For all emergency consultations after hours, clinicians can contact the CDC Emergency Operations Center at 1-770-488-7100 and request to speak with a CDC Malaria Branch clinician or on-call parasitic diseases physician. Some antiparasitic drugs are not licensed for use in the United States but can be obtained as investigational new drugs (INDs) from the CDC; providers should call the CDC Drug Service, Division of Scientific Resources and Division of Global Migration and Quarantine, at 1-404-639-3670.

## SELECTED ANTIPARASITIC DRUGS FOR PROTOZOANS

## Nitazoxanide (Alinia)

Nitazoxanide is a nitrothiazole benzamide, initially developed as a veterinary anthelmintic. Nitazoxanide inhibits pyruvate: ferredoxin oxidoreductase, which is an enzyme necessary for anaerobic energy metabolism. In humans, nitazoxanide is effective against many **protozoans** and **helminths**. Nitazoxanide is approved for the treatment of diarrhea caused by *Cryptosporidium parvum* and *Giardia intestinalis* in patients  $\geq 1$  year of age.

Nitazoxanide is available as a tablet (500 mg) and an oral suspension (100 mg/5 mL), which has a pink color and strawberry flavor. The bioavailability of the suspension is  $\sim 70\%$  compared with the tablet. The drug is well absorbed from the gastrointestinal tract but should be taken with food due to approximately twofold higher absorption. One third is excreted in urine, and two thirds is excreted in feces as the active metabolite, tizoxanide. Although in vitro metabolism studies have not demonstrated cytochrome P450 enzyme effects, no pharmacokinetic studies have been performed in patients with compromised renal or hepatic function. In addition, limited studies have been performed in pregnant or lactating women; nevertheless, CDC Guidelines for the Prevention and Treatment of Opportunistic Infections in Adults and Adolescents with HIV recommend nitazoxanide for the treatment of severe cryptosporidiosis after the first trimester. Tizoxanide is known to be excreted in breast milk, but decisions to breastfeed during therapy can be individualized. Common adverse effects include abdominal pain, diarrhea, nausea, and urine discoloration. Rare side effects include anorexia, flatulence, increased appetite, fever, pruritus,

and dizziness. Intriguingly, nitazoxanide has in vitro activity against multiple other pathogens, including influenza virus, rotavirus, hepatitis C virus, and SARS-CoV-2, although the clinical use of the agent against these viruses remains investigational.

## Tinidazole (Tindamax)

Tinidazole is a synthetic nitroimidazole with a chemical structure similar to metronidazole. It is approved by the Food and Drug Administration (FDA) for patients 3 years of age and older and for treatment of trichomoniasis, giardiasis, and amebiasis. In the treatment of giardiasis, it has the advantages of very few side effects and only requiring a single dose. It is available as a tablet, which can be crushed and administered with food. Its mechanism of action against *Trichomonas* may be secondary to the generation of free nitro radicals by the **protozoan**. The mechanism of action against *Giardia lamblia* and *Entamoeba histolytica* is unknown. Like metronidazole, it can cause a disulfiram-like reaction if combined with alcohol. After oral administration, tinidazole is rapidly and completely absorbed and is distributed into almost all tissues and body fluids; it can cross the blood-brain barrier and placental barrier. It is excreted via urine and feces. Hemodialysis increases clearance of the drug. No studies have been performed for patients undergoing peritoneal dialysis or for patients with compromised hepatic function. Tinidazole is known to cross the placenta and enter fetal circulation; the safety in pregnancy has not been well evaluated, and alternative agents are preferred. It can also be detected in breast milk, and breastfeeding should be interrupted during treatment and for 3 days after treatment.

## Atovaquone/Proguanil (Malarone)

Atovaquone is a hydroxynaphthoquinone and has been used in the past predominantly against *Pneumocystis pneumonia* in AIDS patients. Its mechanism of action is via disruption of the mitochondrial membrane potential through interaction with cytochrome b. However, atovaquone can also effectively inhibit liver stages of all *Plasmodium* species, and in 2000 the FDA approved atovaquone/proguanil for the prevention and treatment of acute, uncomplicated *Plasmodium falciparum* malaria in adults and children  $\geq 11$  kg. Atovaquone alone and in combination with proguanil is the only drug to completely inhibit the liver stage, providing the advantage of only needing to use the drug for 7 days after departing a malaria-endemic area (compared with several weeks).

Proguanil inhibits the parasite dihydrofolate reductase enzyme by the active form, cycloguanil. When used alone, it has poor efficacy for prophylaxis, but when administered with atovaquone, it acts in synergy on the cytochrome b enzyme in *Plasmodium* mitochondria, though the exact mechanism of synergy is unknown.

Two double-blind, randomized clinical trials assessing malaria prophylaxis demonstrated that atovaquone/proguanil was at least comparable to (and perhaps better than) chloroquine plus proguanil, and that atovaquone/proguanil was comparable to mefloquine. Atovaquone/proguanil was better tolerated than chloroquine plus proguanil and mefloquine. Atovaquone/proguanil treatment of acute uncomplicated *P. falciparum* infection has demonstrated higher or comparable cure rates when compared with other *P. falciparum* treatment drugs. Compared with other antimalarial therapies, atovaquone/proguanil has the highest cost. There are limited data on use during pregnancy, and pharmacokinetics may be altered during pregnancy so alternative regimens are preferred for malaria in pregnancy if available.

## ARTEMISININ DERIVATIVES (ARTEMETHER, ARTESUNATE) AND COMBINATION THERAPIES (ARTEMETHER/LUMEFANTRINE OR COARTEM)

Artemisinin is a sesquiterpene lactone isolated from the weed *Artemisia annua*. It was developed in China, where it is known as qinghaosu. Artemisinin and its derivatives act very rapidly against *Plasmodium vivax* as well as chloroquine-sensitive and chloroquine-resistant *P. falciparum*. Artemisinins are also rapidly eliminated. Resistance to artemisinins has been documented in Cambodia, Laos, Myanmar, Thailand, and Vietnam. Coartem is the first artemisinin-containing



**Table 325.1** Drugs for Parasitic Infections

Parasitic infections are found throughout the world. With increasing travel, immigration, use of immunosuppressive drugs, and the spread of HIV, physicians anywhere may see infections caused by previously unfamiliar parasites. This table lists first-choice and alternative drugs for most parasitic infections.

INFECTION	DRUG	ADULT DOSAGE	PEDIATRIC DOSAGE
<b>ACANTHAMOEBA KERATITIS</b>			
Drug of choice:	See footnote <sup>1</sup>		
<b>AMEBIASIS (ENTAMOEBA HISTOLYTICA)</b>			
Asymptomatic			
Drug of choice:	Iodoquinol (Yodoxin) <sup>2</sup>	650 mg PO tid × 20 days	30-40 mg/kg/day (max 1950 mg) in 3 doses PO × 20 days
or	Paromomycin	25-35 mg/kg/day PO in 3 doses × 5-10 days	25-35 mg/kg/day PO in 3 doses × 5-10 days
Alternative:	Diloxanide furoate <sup>3</sup>	500 mg tid PO × 10 days	20 mg/kg/day PO in 3 doses × 10 days
<b>Mild to moderate intestinal disease</b>			
Drug of choice:	Metronidazole	500-750 mg tid PO × 7-10 days	35-50 mg/kg/day PO in 3 doses × 7-10 days
or	Tinidazole <sup>4</sup>	2 g PO once daily × 3 days	50 mg/kg/day PO (max 2 g) in 1 dose × 3 days
Either followed by:	Iodoquinol <sup>2</sup>	650 mg PO tid × 20 days	30-40 mg/kg/day PO in 3 doses × 20 days (max 2 g)
or	Paromomycin	25-35 mg/kg/day PO in 3 doses × 7 days	25-35 mg/kg/day PO in 3 doses × 5-10 days
Alternative:	Nitazoxanide <sup>5</sup>	500 mg bid × 3 days	1-3 yr: 100 mg bid × 3 days 4-11 yr: 200 mg bid × 3 days ≥12 yr: use adult dosing
<b>Severe intestinal and extraintestinal disease</b>			
Drug of choice:	Metronidazole	750 mg PO tid × 7-10 days	35-50 mg/kg/day PO in 3 doses × 7-10 days
or	Tinidazole <sup>4</sup>	2 g PO once daily × 5 days	50 mg/kg/day PO (max 2 g) × 5 days
Either followed by:	Iodoquinol <sup>2</sup>	650 mg PO tid × 20 days	30-40 mg/kg/day PO in 3 doses × 20 days (max 2 g)
or	Paromomycin	25-35 mg/kg/day PO in 3 doses × 5-10 days	25-35 mg/kg/day PO in 3 doses × 7 days
<b>Amebic meningoencephalitis, primary and granulomatous</b>			
<b>NAEGLERIA FOWLERI</b>			
Drug of choice:	Amphotericin B deoxycholate <sup>6,7</sup>	1.5 mg/kg/day IV in 2 divided doses × 3 days, then 1 mg/kg daily IV × 11 days	1.5 mg/kg/day IV in 2 divided doses × 3 days, then 1 mg/kg daily IV × 11 days
	plus Amphotericin B deoxycholate <sup>6,7</sup>	1.5 mg/kg intrathecally daily × 2 days, then 1 mg/kg intrathecally every other day × 8 days	1.5 mg/kg intrathecally daily × 2 days, then 1 mg/kg intrathecally every other day × 8 days
	plus Rifampin <sup>7</sup>	10 mg/kg (max 600 mg) IV or PO daily × 28 days	10 mg/kg (max 600 mg) IV or PO daily × 28 days
	plus Fluconazole <sup>7</sup>	10 mg/kg (max 600 mg) IV or PO daily × 28 days	10 mg/kg (max 600 mg) IV or PO daily × 28 days
	plus Azithromycin <sup>7</sup>	500 mg IV or PO daily × 28 days	10 mg/kg (max 500 mg) IV or PO daily × 28 days

<sup>1</sup>For treatment of keratitis caused by *Acanthamoeba*, 0.02% topical polyhexamethylene biguanide (PHMB) and 0.02% chlorhexidine have been successfully used individually and in combination in a large number of patients (Tabin G, et al. *Cornea*. 2001;20:757; Wysesbeek YS, et al. *Cornea*. 2000;19:464). The expected treatment course is 6-12 mo. PHMB is no longer available from Leiter's Park Avenue Pharmacy but is available from the O'Brien Pharmacy (1-800-627-4360; distributes in many states) and the Greenpark Pharmacy (1-713-432-9855; Texas only). Combinations with either 0.1% propamide isethionate (Brolene) or hexamidine (Desomedine) have been used (Seal DV. *Eye*. 2003;17:893) successfully, but these are not available in the United States. Neomycin is not recommended due to high levels of resistance (*Acanthamoeba* keratitis: Treatment guidelines from *The Medical Letter*, 143, 8/1/2013). In addition, the combination of chlorhexidine, natamycin (pimaricin), and debridement also has been successful (Kitagawa K, et al. *Jpn J Ophthalmol*. 2003;47:161).

<sup>2</sup>The drug is not available commercially but can be compounded by Expert Compounding Pharmacy, 6744 Balboa Blvd, Lake Balboa, CA 91406 (1-800-247-9767 or 1-818-988-7979 or [info@expertpharmacy.org](mailto:info@expertpharmacy.org)).

<sup>3</sup>This drug is not available commercially in the United States.

<sup>4</sup>A nitroimidazole similar to metronidazole, tinidazole was approved by the FDA in 2004 and appears to be as effective and better tolerated than metronidazole. It should be taken with food to minimize GI adverse effects. For children and patients unable to take tablets, a pharmacist may crush the tablets and mix them with cherry syrup (HUMCO, and others). The syrup suspension is good for 7 days at room temperature and must be shaken before use. Ornidazole, a similar drug, is also used outside the United States.

<sup>5</sup>Nitazoxanide is FDA approved as a pediatric oral suspension for treatment of *Cryptosporidium* in immunocompetent children ≥1 yr of age. It has also been used in some small studies for *Balantidium coli* infection. It may also be effective for mild to moderate amebiasis (Diaz E, et al. *Am J Trop Med Hyg*. 2003;68:384; Rossignol JF, et al. *Trans R Soc Trop Med Hyg*. 2007;101:1025) and as an alternative therapy for microsporidiosis (published dosing for microsporidiosis: Bicart-See A, et al. *Antimicrob Agents Chemother*. 2000;44:167), 2020 CDC Guidelines for the Prevention and Treatment of Opportunistic Infections in Adults and Adolescents with HIV). Nitazoxanide is available in 500 mg tablets and an oral suspension; it should be taken with food.

<sup>6</sup>*Naegleria* infection has been treated successfully with IV and intrathecal use of both amphotericin B and miconazole plus rifampin and with amphotericin B, rifampin, and ornidazole (Seidel J, et al. *N Engl J Med*. 1982;306:346; Jain R, et al. *Neurol India*. 2002;50:470). Other reports of successful therapy are less well documented.

<sup>7</sup>An approved drug, but usage is considered off-label for this condition by the FDA.

**Table 325.1** Drugs for Parasitic Infections—cont'd

INFECTION	DRUG	ADULT DOSAGE	PEDIATRIC DOSAGE
	<i>plus</i> Miltefosine <sup>6-8</sup>	50 mg PO tid × 28 days	<45 kg: 50 mg bid (max 2.5 mg/kg) × 28 days ≥45 kg: use adult dosing
	<i>plus</i> dexamethasone	0.6 mg/kg/day IV in 4 divided doses × 4 days	0.6 mg/kg/day IV in 4 divided doses × 4 days
<b>ACANTHAMOEBA</b>			
Drug of choice:	See footnote <sup>7,8</sup>		
<b>BALAMUTHIA MANDRILLARIS</b>			
Drug of choice:	See footnote <sup>7,9,10</sup>		
<b>SAPPINIA DIPLOIDEA</b>			
Drug of choice:	See footnote <sup>11</sup>		
<b>ANCYLOSTOMA CANINUM (EOSINOPHILIC ENTEROCOLITIS)</b>			
Drug of choice:	Albendazole <sup>7</sup>	400 mg PO once	<10 kg/2 yr <sup>12</sup> ≥2 yr: see adult dosing
or	Mebendazole	100 mg PO bid × 3 days	100 mg PO bid × 3 days <sup>13</sup>
or	Pyrantel pamoate (OTC) <sup>7</sup>	11 mg/kg PO (max 1 g) × 3 days	11 mg/kg PO (max 1 g) × 3 days
or	Endoscopic removal		
<b>ANCYLOSTOMA DUODENALE, (see Hookworm infection)</b>			
<b>ANGIOSTRONGYLIASIS (ANGIOSTRONGYLUS CANTONENSIS, ANGIOSTRONGYLUS COSTARICENSIS)</b>			
Drug of choice:	See footnote <sup>14</sup>		
<b>ANISAKIASIS (ANISAKIS SPP.)</b>			
Treatment of choice:	Surgical or endoscopic removal		
Alternative:	Albendazole <sup>7,15</sup>	400 mg PO bid × 6-21 days	<10 kg/2 yr <sup>12</sup> ≥2 yr: see adult dosing
<b>ASCARIASIS (ASCARIS LUMBRICOIDES, ROUNDWORM)</b>			
Drug of choice:	Albendazole <sup>7</sup>	400 mg PO once	<10 kg/2 yr: see adult dosing <sup>12</sup> ≥2 yr: see adult dosing
or	Mebendazole	100 mg PO bid × 3 days or 500 mg PO once	100 mg PO bid × 3 days or 500 mg PO once <sup>13</sup>
or	Ivermectin <sup>7</sup>	150-200 µg/kg PO once	<15 kg: not indicated ≥15 kg: see adult dosing

<sup>8</sup>If you have a patient with suspected free-living amoeba infection, please contact the CDC Emergency Operations Center at 1-800-CDC-INFO to consult with a CDC expert regarding the use of this drug. Miltefosine has been reported to successfully treat primary amebic meningoencephalitis due to *Naegleria fowleri*, although controlled trials have not been conducted (Linam WM, et al. *Pediatrics*. 2015;135:e744).

<sup>9</sup>Strains of *Acanthamoeba* isolated from fatal granulomatous amebic encephalitis are usually susceptible in vitro to pentamidine, ketoconazole, flucytosine, and (less so) amphotericin B. Chronic *Acanthamoeba* meningitis has been successfully treated in two children with a combination of oral trimethoprim-sulfamethoxazole, rifampin, and ketoconazole (Singhal T, et al. *Pediatr Infect Dis*. 2001;J 20:623), and in an AIDS patient with fluconazole, sulfadiazine, and pyrimethamine combined with surgical resection of the CNS lesion (Seijo Martinez M, et al. *J Clin Microbiol*. 2000;38:3892). Disseminated cutaneous infection in an immunocompromised patient has been treated successfully with IV pentamidine isethionate, topical chlorhexidine, and 2% ketoconazole cream, followed by oral itraconazole (Slater CA, et al. *N Engl J Med*. 1994;331:85).

<sup>10</sup>A free-living leptomyxid amoeba that causes subacute to fatal granulomatous CNS disease. Several cases of *Balamuthia* encephalitis have been successfully treated with flucytosine, pentamidine, fluconazole, and sulfadiazine plus either azithromycin or clarithromycin (phenothiazines were also used) combined with surgical resection of the CNS lesion (Deetz TR, et al. *Clin Infect Dis*. 2003;37:1304; Jung S, et al. *Arch Pathol Lab Med*. 2004;128:466). Case reports and in vitro data suggest miltefosine may have some antiamebic activity (Aichelburg AC, et al. *Emerg Infect Dis*. 2008;14:1743; Martinez DY, et al. *Clin Infect Dis*. 2010;51:e7; Schuster FL, et al. *J Eukaryot Microbiol*. 2006;53:121). Miltefosine (Impavido) is now commercially available. Contact the Centers for Disease Control/Agency for Toxic Substances Disease Registry at 1-770-488-7100 or 1-800-232-4636 (main number) for guidance on treatment.

<sup>11</sup>A free-living amoeba not previously known to be pathogenic to humans. It has been successfully treated with azithromycin, IV pentamidine, itraconazole, and flucytosine combined with surgical resection of the CNS lesion (Gelman BB, et al. *J Neuropathol Exp Neurol*. 2003;62:990).

<sup>12</sup>Limited data in children <2 yr but has been used successfully for treatment of cutaneous larva migrans in children as young as 8 mo at a dose of 200 mg daily × 3 days (Black MD, et al. *Australas J Dermatol*. 2010;51:281). The WHO also recommends albendazole in children <2 yr for treatment of taeniasis, strongyloidiasis, filariasis, hookworms, roundworms, pinworms, and threadworms.

<sup>13</sup>Limited safety data in children <2 yr of age.

<sup>14</sup>Most patients have a self-limited course and recover completely. Analgesics, corticosteroids, and careful removal of CSF at frequent intervals can relieve symptoms from increased intracranial pressure (Lo Re V III, Gluckman SJ. *Am J Med*. 2003;114:217). No anthelmintic drug is proven to be effective, and some patients have worsened with therapy (Slom TJ, et al. *N Engl J Med*. 2002;346:668). Mebendazole or albendazole and a corticosteroid appeared to shorten the course of infection (Sawanyawisuth K, et al. *Trans R Soc Trop Med Hyg*. 2008;102:990; Chotmongkol V, et al. *Am J Trop Med Hyg*. 2009;81:443).

<sup>15</sup>(Repiso Ortega A, et al. *Gastroenterol Hepatol*. 2003;26:341.) Successful treatment of a patient with anisakiasis with albendazole has been reported (Moore DA, et al. *Lancet*. 2002;360:54).

Continued

**Table 325.1** Drugs for Parasitic Infections—cont'd

INFECTION	DRUG	ADULT DOSAGE	PEDIATRIC DOSAGE
<b>BABESIOSIS (BABESIA MICROTI)</b>			
Drugs of choice: <sup>16</sup>	Atovaquone <sup>7</sup> plus azithromycin <sup>7</sup>	750 mg PO bid × 7-10 days 500-1,000 mg once, then 250 mg daily × 7-10 days. Higher doses (600-1,000 mg) and/or prolonged therapy (6 wk or longer) may be required for immunocompromised patients	20 mg/kg (max 750 mg) PO bid × 7-10 days 10 mg/kg PO on day 1 (max 500 mg/dose), then 5 mg/kg/day (max 250 mg/dose) PO days 2-10
or	Clindamycin <sup>7</sup> plus quinine <sup>7</sup>	300-600 mg IV qid or 600 mg tid PO × 7-10 days 542 mg base (650 mg salt) tid PO × 7-10 days	20-40 mg/kg/day IV or PO in 3 or 4 doses × 7-10 days (max 600 mg/dose) 6 mg base/kg (8 mg salt/kg) (max 542 mg base or 650 mg salt/ dose), PO tid × 7-10 days
<b>Balamuthia mandrillaris, see Amebic meningoencephalitis, primary</b>			
<b>BALANTIDIASIS (BALANTIDIUM COLI)</b>			
Drug of choice:	Tetracycline <sup>7,17</sup>	500 mg PO qid × 10 days	<8 yr: not indicated ≥8 yr: 10 mg/kg (max 500 mg) PO qid × 10 days
Alternatives:	Metronidazole <sup>7</sup>	750 mg PO tid × 5 days	35-50 mg/kg/day PO in 3 divided doses × 5 days
or	Iodoquinol <sup>2,7</sup>	650 mg PO tid × 20 days	30-40 mg/kg/day (max 2 g) PO in 3 divided doses × 20 days
or	Nitazoxanide <sup>5,7</sup>	500 mg PO bid × 3 days	1-3 yr: 100 mg PO bid × 3 days 4-11 yr: 200 mg PO bid × 3 days ≥12 yr: see adult dosing
<b>BAYLISASCARIASIS (BAYLISASCARIS PROCYONIS)</b>			
Drug of choice:	Albendazole <sup>7,18</sup>	400 mg PO bid × 10-20 days	<10 kg/2 yr: 25-50 mg/kg/day PO in 1-2 divided doses × 10-20 days <sup>12</sup> ≥2 yr: 25-50 mg/kg/day PO in 1-2 divided doses × 10-20 days
<b>BLASTOCYSTIS HOMINIS INFECTION</b>			
Drug of choice:	See footnote <sup>19</sup>		
<b>CAPILLARIASIS (CAPILLARIA PHILIPPINENSIS)</b>			
Drug of choice:	Mebendazole <sup>7</sup>	200 mg PO bid × 20 days	200 mg PO bid × 20 days <sup>13</sup>
Alternative:	Albendazole <sup>7</sup>	400 mg PO daily × 10 days	<10 kg/2 yr <sup>12</sup> ≥15 kg/2 yr: see adult dosing
<b>CHAGAS DISEASE, SEE TRYPANOSOMIASIS</b>			
<b>CLONORCHIS SINENSIS, SEE FLUKE INFECTION</b>			
<b>CRYPTOSPORIDIOSIS (CRYPTOSPORIDIUM PARVUM)</b>			
<b>Immunocompetent</b>			
Drug of choice:	Nitazoxanide <sup>5</sup>	500 mg PO bid × 3 days	1-3 yr: 100 mg PO bid × 3 days 4-11 yr: 200 mg PO bid × 3 days ≥12 yr: see adult dosing

<sup>16</sup>Exchange transfusion has been used in severely ill patients and those with high (>10%) parasitemia (Hatcher JC, et al. *Clin Infect Dis*. 2001;32:1117). Clindamycin and quinine is the preferred therapy for severely ill patients. In patients who were not severely ill, combination therapy with atovaquone and azithromycin was as effective as clindamycin and quinine and may have been better tolerated (Krause PJ, et al. *N Engl J Med*. 2000;343:1454). Highly immunosuppressed patients should be treated for a minimum of 6 wk and at least 2 wk past the last positive smear (Krause PJ, et al. *Clin Infect Dis*. 2008;46:370). High doses of azithromycin (600-1,000 mg) have been used in combination with atovaquone for the treatment of immunocompromised patients (Weiss LM, et al. *N Engl J Med*. 2001;344:773). Resistance to atovaquone plus azithromycin has been reported in immunocompromised patients treated with a single subcurative course of this regimen (Wormser GP, et al. *Clin Infect Dis*. 2010;50:381). Most asymptomatic patients do not require treatment unless parasitemia persists >3 mo (Wormser GP, et al. *Clin Infect Dis*. 2006;43:1089).

<sup>17</sup>Use of tetracyclines has historically been contraindicated in pregnancy and in children younger than 8 yr. The American Academy of Pediatrics now recommends that doxycycline can be administered for short durations (i.e., 21 days or less) without regard to the patient's age (Kimberlin DW, et al. *Red Book: 2021-2024 Report of the Committee on Infectious Diseases*. 32<sup>nd</sup> ed. Elk Grove Village, IL: American Academy of Pediatrics; 2021. p 866).

<sup>18</sup>No drugs have been consistently demonstrated to be effective. The combination of albendazole 37 mg/kg/day PO and high-dose steroids has been used successfully (Peters JM, et al. *Pediatrics*. 2012;129:e806; Haider S. *Emerg Infect Dis*. 2012;18:347). Albendazole 25 mg/kg/day PO × 20 days started as soon as possible (up to 3 days after possible infection) might prevent clinical disease and is recommended for children with known exposure, as in the setting of ingestion of raccoon stool or contaminated soil (Murray WJ, et al. *Clin Infect Dis*. 2004;39:1484). Mebendazole, levamisole, or ivermectin could be tried if albendazole is not available. Ocular baylisascariasis has been treated successfully using laser photocoagulation therapy to destroy the intraretinal larvae.

<sup>19</sup>Clinical significance of these organisms is controversial; metronidazole 750 mg tid × 10 days, iodoquinol 650 mg tid × 20 days, or trimethoprim-sulfamethoxazole 1 DS tablet bid × 7 days has been reported to be effective (Stenzel DJ, et al. *Clin Microbiol Rev*. 1996;9:563; Ok UZ, et al. *Am J Gastroenterol*. 1999;94:3245). Metronidazole resistance may be common (Haresh K, et al. *Trop Med Int Health*. 1999;4:274). Nitazoxanide has been effective in children (Diaz E, et al. *Am J Trop Med Hyg*. 2003;68:384).

**Table 325.1** Drugs for Parasitic Infections—cont'd

INFECTION	DRUG	ADULT DOSAGE	PEDIATRIC DOSAGE
<i>HIV infected</i>			
Drug of choice:	See footnote <sup>20</sup>		
<b>CUTANEOUS LARVA MIGRANS (ANCYLOSTOMA BRAZILIENSE, ANCYLOSTOMA CANINUM, DOG AND CAT HOOKWORM, CREEPING ERUPTION)</b>			
Drug of choice:	Albendazole <sup>7,21</sup>	400 mg PO daily × 3-7 days	<10 kg/2 yr: 200 mg PO daily × 3 days <sup>12</sup> ≥2 yr: see adult dosing
or	Ivermectin <sup>7</sup>	200 µg/kg PO daily × 1-2 days	<15 kg: not indicated ≥15 kg: see adult dosing
Alternative:	Thiabendazole	Apply topically tid × 7 days	Apply topically tid × 7 days
<b>CYCLOSPORIASIS (CYCLOSPORA CAYETANENSIS)</b>			
Drug of choice:	Trimethoprim-sulfamethoxazole (TMP-SMX) <sup>7,22</sup>	TMP 160 mg/SMX 800 mg (1 DS tab) PO bid × 7-10 days	4-5 mg/kg TMP component (max 160 mg) PO bid × 7-10 days
<b>CYSTICERCOSIS, SEE TAPEWORM INFECTION</b>			
<b>CYSTOISOSPORIASIS (CYSTOISOSPORA BELLI, FORMERLY KNOWN AS ISOSPORA BELLI)</b>			
Drug of choice:	TMP-SMX <sup>7</sup>	TMP 160 mg/SMX 800 mg (1 DS tab) PO bid × 10 days	4-5 mg/kg TMP component (max 160 mg) PO bid × 10 days
Alternative:	Pyrimethamine plus leucovorin	50-75 mg PO divided bid × 10 days 10-25 mg PO daily × 10 days	— —
or	Ciprofloxacin <sup>7</sup>	500 mg PO bid × 7-10 days	—
<b><i>Dientamoeba fragilis</i> infection<sup>23</sup></b>			
	Paromomycin <sup>7</sup>	25-35 mg/kg/day PO in 3 doses × 7 days	25-35 mg/kg/day PO in 3 divided doses × 7 days
or	Iodoquinol <sup>2</sup>	650 mg PO tid × 20 days	30-40 mg/kg/day PO (max 2 g) in 3 divided doses × 20 days
or	Metronidazole <sup>7</sup>	500-750 mg tid × 10 days	35-50 mg/kg/day in 3 divided doses × 10 days
<b>DIPHYLLOBOTHRIUM LATUM, SEE TAPEWORM INFECTION</b>			
<b>DRACUNCULUS MEDINENSIS (GUINEA WORM) INFECTION</b>			
Treatment of choice:	Slow mechanical extraction of worm <sup>24</sup>		
<b>ECHINOCOCCUS, SEE TAPEWORM INFECTION</b>			
<b>ENTAMOEBIA HISTOLYTICA, SEE AMEBIASIS</b>			
<b>ENTEROBIUS VERMICULARIS (PINWORM) INFECTION<sup>25</sup></b>			
Drug of choice:	Albendazole <sup>7</sup>	400 mg PO once; repeat in 2 wk	<10 kg/2 yr: 200 mg PO once; repeat in 2 wk <sup>12</sup> ≥2 yr: see adult dosing
or	Mebendazole	100 mg PO once; repeat in 3 wk	100 mg PO once; repeat in 3 wk <sup>13</sup>
or	Pyrantel pamoate (OTC)	11 mg/kg base PO once (max 1 g); repeat in 2 wk	11 mg/kg base PO once (max 1 g); repeat in 2 wk

<sup>20</sup>Nitazoxanide has not consistently been shown to be superior to placebo in HIV-infected patients (Amadi B, et al. *Lancet*. 2002;360:1375). For HIV-infected patients, potent antiretroviral therapy (ART) is the mainstay of treatment. Nitazoxanide 500-1,000 mg for 14 days, paromomycin 500 mg 4 times daily × 14-21 days, or a combination of paromomycin and azithromycin may be tried to decrease diarrhea and recalcitrant malabsorption of antimicrobial drugs, which can occur with chronic cryptosporidiosis (Pantenburg B, et al. *Expert Rev Anti Infect Ther*. 2009;7:385).

<sup>21</sup>Albanese G, et al. *Int J Dermatol*. 2001;40:67.

<sup>22</sup>HIV-infected patients may need a higher dosage and long-term maintenance (Kansouzidou A, et al. *J Trav Med*. 2004;11:61).

<sup>23</sup>Norberg A, et al. *Clin Microbiol Infect*. 2003;9:65.

<sup>24</sup>Treatment of choice is slow extraction of worm combined with wound care (*MMWR Morbid Mortal Wkly Rep*. 2011;60:1450). Instructions for this can be found at <https://www.cdc.gov/parasites/guineaworm/treatment.html>. Ten days of treatment with metronidazole 250 mg tid in adults and 25 mg/kg/day in 3 doses in children is not curative, but it decreases inflammation and facilitates removal of the worm. Mebendazole 400-800 mg/day × 6 days has been reported to kill the worm directly.

<sup>25</sup>Because all family members are usually infected, treatment of the entire household is recommended.

*Continued*



**Table 325.1** Drugs for Parasitic Infections—cont'd

INFECTION	DRUG	ADULT DOSAGE	PEDIATRIC DOSAGE
<b>FASCIOLA HEPATICA, SEE FLUKE INFECTION</b>			
<b>FILARIASIS<sup>26</sup></b>			
<i>Lymphatic filariasis (Wuchereria bancrofti, Brugia malayi, Brugia timori)</i>			
Drug of choice: <sup>27</sup>	Diethylcarbamazine <sup>28,29</sup>	6 mg/kg once or 6 mg/kg PO in 3 divided doses × 12 days <sup>30</sup>	<18 mo: no indication ≥18 mo: see adult dosing
<b>LOA LOA</b>			
<b>&lt;8,000 microfilaria/mL<sup>29</sup></b>			
Drug of choice:	Diethylcarbamazine <sup>28,29</sup>	9 mg/kg PO in 3 doses × 14 days <sup>30</sup>	<18 mo: no indication ≥18 mo: see adult dosing
Alternatives:	Albendazole <sup>28</sup>	200 mg PO bid × 21 days	<10 kg/2 yr <sup>12</sup> ≥2 yr: see adult dosing
<b>8,000 microfilaria/mL<sup>29,31</sup></b>			
Treatment of choice:	Apheresis		
or	Albendazole <sup>28</sup>	200 mg PO bid × 21 days	<10 kg/2 yr <sup>12</sup> ≥2 yr: see adult dosing
Either followed by:	Diethylcarbamazine <sup>28,29</sup>	8-10 mg/kg PO in 3 doses × 21 days <sup>30</sup>	<18 mo: no indication ≥18 mo: see adult dosing
<b>MANSONELLA OZZARDI</b>			
Drug of choice:	See footnote <sup>32</sup>		
<b>MANSONELLA PERSTANS</b>			
Drug of choice:	Doxycycline <sup>7,17,33</sup>	100 mg bid PO × 6 wk	4 mg/kg/day in 2 doses PO × 6 wk
<b>MANSONELLA STREPTOCERCA<sup>34</sup></b>			
Drug of choice:	Diethylcarbamazine <sup>28</sup>	6 mg/kg/day PO × 14 days	6 mg/kg/day PO × 14 days
or	Ivermectin <sup>7</sup>	150 µg/kg PO once	<15 kg: not indicated ≥15 kg: see adult dosing
<b>TROPICAL PULMONARY EOSINOPHILIA (TPE)<sup>35</sup></b>			
Drug of choice:	Diethylcarbamazine <sup>28</sup>	6 mg/kg once or 6 mg/kg PO in 3 divided doses × 14-21 days <sup>27</sup>	<18 mo: no indication ≥18 mo: see adult dosing

<sup>26</sup>Antihistamines or corticosteroids may be required to decrease allergic reactions due to disintegration of microfilariae from treatment of filarial infections, especially those caused by *Loa loa*. Endosymbiotic *Wolbachia* bacteria may have a role in filarial development and host response and may represent a new target for therapy. Treatment with doxycycline 100 or 200 mg/day × 4-6 wk in lymphatic filariasis and onchocerciasis has resulted in substantial loss of *Wolbachia* with subsequent blocking of microfilariae production and absence of microfilaria when followed for 24 mo after treatment (Hoerauf A, et al. *Med Microbiol Immunol*. 2003;192:211; Hoerauf A, et al. *BMJ*. 2003;326:207).

<sup>27</sup>Most symptoms caused by adult worm. Single-dose combination of albendazole (400 mg) with either ivermectin (200 µg/kg) or diethylcarbamazine (6 mg/kg) is effective for reduction or suppression of *Wuchereria bancrofti* microfilaria but does not kill the adult forms (Addiss D, et al. *Cochrane Database Syst Rev*. 2004;(1):CD003753).

<sup>28</sup>This drug is not FDA approved and not commercially available but is available under IND application through the CDC Drug Service (CDC Drug Service, Division of Scientific Resources, telephone at 1-404-639-3670).

<sup>29</sup>Diethylcarbamazine is contraindicated in patients co-infected with *Onchocerca volvulus* due to risk of a life-threatening Mazzotti reaction and in patients with *Loa loa* infection and microfilaria levels ≥8,000 mm<sup>3</sup> due to risk of encephalopathy and renal failure. Some experts use a cutoff of ≥2,500 mm<sup>3</sup>.

<sup>30</sup>For patients with microfilaria in the blood, *Medical Letter* consultants would start with a lower dosage and scale up: day 1, 50 mg; day 2, 50 mg tid; day 3, 100 mg tid; day 4-14, 6 mg/kg in 3 doses (for *Loa loa*, day 4-14, 9 mg/kg in 3 doses). Multidose regimens have been shown to provide more rapid reduction in microfilaria than single-dose diethylcarbamazine, but microfilaria levels are similar 6-12 mo after treatment (Andrade LD, et al. *Trans R Soc Trop Med Hyg*. 1995;89:319; Simonsen PE, et al. *Am J Trop Med Hyg*. 1995;53:267). A single dose of 6 mg/kg is used in endemic areas for mass treatment (Figueredo-Silva J, et al. *Trans R Soc Trop Med Hyg*. 1996;90:192; Noroes J, et al. *Trans R Soc Trop Med Hyg*. 1997;91:78).

<sup>31</sup>In heavy infections with *Loa loa*, rapid killing of microfilariae can provoke encephalopathy. Apheresis has been reported to be effective in lowering microfilarial counts in patients heavily infected with *Loa loa* (Ottesen EA. *Infect Dis Clin North Am*. 1993;7:619). Albendazole or ivermectin has also been used to reduce microfilaremia; albendazole is preferred because of its slower onset of action and lower risk for encephalopathy (Klion AD, et al. *J Infect Dis*. 1993;168:202; Kombila M, et al. *Am J Trop Med Hyg*. 1998;58:458). Albendazole may be useful for treatment of loiasis when diethylcarbamazine is ineffective or cannot be used, but repeated courses may be necessary (Klion AD, et al. *Clin Infect Dis*. 1999;29:680). Diethylcarbamazine, 300 mg once a week, has been recommended for prevention of loiasis (Nutman TB, et al. *N Engl J Med*. 1988;319:752).

<sup>32</sup>Diethylcarbamazine has no effect. Ivermectin 200 µg/kg once has been effective.

<sup>33</sup>Doxycycline is preferred for strains that carry *Wolbachia* bacteria. Combination therapy with diethylcarbamazine and mebendazole and monotherapy with mebendazole have been used successfully in strains that do not carry *Wolbachia*. Evidence is limited, and optimal therapy is uncertain. Ivermectin and albendazole appear to be ineffective.

<sup>34</sup>Diethylcarbamazine is potentially curative because of activity against both adult worms and microfilariae. Ivermectin is only active against microfilariae. (*The Medical Letter: Drugs for parasitic infections*, vol 11, 2013.)

<sup>35</sup>Relapse occurs and can be treated with diethylcarbamazine.

**Table 325.1** Drugs for Parasitic Infections—cont'd

INFECTION	DRUG	ADULT DOSAGE	PEDIATRIC DOSAGE
<b>ONCHOCERCA VOLVULUS (RIVER BLINDNESS)</b>			
Drug of choice:	Ivermectin <sup>36</sup>	150 µg/kg PO once, repeated every 6-12 mo until asymptomatic	<15 kg: not indicated ≥15 kg: see adult dosing
<b>FLUKE, HERMAPHRODITIC, INFECTION</b>			
<i>Clonorchis sinensis</i> (Chinese liver fluke)			
Drug of choice:	Praziquantel	25 mg/kg PO tid × 2 day	25 mg/kg PO tid × 2 day <sup>37</sup>
or	Albendazole <sup>7</sup>	10 mg/kg PO × 7 days	<10 kg/2 yr <sup>12</sup> ≥2 yr: see adult dosing
<i>Fasciola hepatica</i> (sheep liver fluke)			
Drug of choice:	Triclabendazole <sup>7,38,39</sup>	10 mg/kg PO once or twice	10 mg/kg PO once or twice
Alternative:	Nitazoxanide <sup>7</sup>	500 mg PO bid × 7 days	1-3 yr: 100 mg PO bid 4-11 yr: 200 mg PO bid ≥2 yr: see adult dosing
or	Bithionol <sup>3,7</sup>	30-50 mg/kg PO on alternate days × 10-15 doses	30-50 mg/kg PO on alternate days × 10-15 doses
<i>Fasciolopsis buski</i> , <i>Heterophyes heterophyes</i> , <i>Metagonimus yokogawai</i> (intestinal flukes)			
Drug of choice:	Praziquantel <sup>7</sup>	25 mg/kg PO tid × 1 day	25 mg/kg PO tid × 1 day <sup>37</sup>
<i>Metorchis conjunctus</i> (North American liver fluke) <sup>40</sup>			
Drug of choice:	Praziquantel <sup>7</sup>	25 mg/kg PO tid × 1 day	25 mg/kg PO tid × 1 day <sup>37</sup>
<i>Nanophyetus salmincola</i>			
Drug of choice:	Praziquantel <sup>7</sup>	20 mg/kg PO tid × 1 day	20 mg/kg PO tid × 1 day <sup>37</sup>
<i>Opisthorchis viverrini</i> (Southeast Asian liver fluke), <i>Opisthorchis felineus</i> (cat liver fluke)			
Drug of choice:	Praziquantel	25 mg/kg PO tid × 2 days	25 mg/kg PO tid × 2 days <sup>37</sup>
or	Albendazole <sup>7</sup>	10 mg/kg PO × 7 days	<10 kg/2 yr <sup>12</sup> ≥2 yr: see adult dosing
<i>Paragonimus westermani</i> (lung fluke)			
Drug of choice:	Praziquantel <sup>7</sup>	25 mg/kg PO tid × 2 days	25 mg/kg PO tid × 2 days <sup>37</sup>
or	Triclabendazole <sup>7,41</sup>	10 mg/kg PO bid × 1 day or 5 mg/kg daily × 3 days	10 mg/kg PO bid × 1 day or 5 mg/kg daily × 3 days
or	Bithionol <sup>3,7</sup>	30-50 mg/kg PO on alternate days × 10-15 doses	30-50 mg/kg PO on alternate days × 10-15 doses
<b>GIARDIASIS (GIARDIA INTESTINALIS, ALSO KNOWN AS GIARDIA DUODENALIS OR GIARDIA LAMBLIA)</b>			
Drugs of choice:	Metronidazole <sup>7</sup>	250 mg PO tid × 5 days	5 mg/kg (max 250 mg) PO tid × 5 days
or	Nitazoxanide <sup>5</sup>	500 mg PO bid × 3 days	1-3 yr: 100 mg PO every 12 hr × 3 days 4-11 yr: 200 mg PO every 12 hr × 3 days ≥12 yr: see adult dosing

<sup>36</sup>Annual treatment with ivermectin, 150 µg/kg, can prevent blindness from ocular onchocerciasis (Mabey D, et al. *Ophthalmology*. 1996;103:1001). Ivermectin kills only the microfilaria but not the adult worms; emerging evidence suggests doxycycline is effective in killing adult worms and sterilizing females. The recommended regimen from the CDC is doxycycline 100-200 mg PO daily for 6 wk begun 1 wk after a dose of ivermectin is given to reduce the microfilaria burden. Diethylcarbamazine and suramin were formerly used for treatment of this disease but should no longer be used because of the availability of less toxic therapies.

<sup>37</sup>Limited safety data in children <4 yr of age but has been used in mass prevention campaigns with no reported adverse effects.

<sup>38</sup>Unlike infections with other flukes, *Fasciola hepatica* infections do not respond to praziquantel. Triclabendazole may be safe and effective, but data are limited (Graham CS, et al. *Clin Infect Dis*. 2001;33:1). In the United States, the drug is not approved by the FDA and is not yet commercially available. However, it is available to physicians licensed in the United States through the CDC Drug Service, under a special protocol, which requires that both the CDC and FDA agree that the drug is indicated for treatment of a particular patient. Providers should contact the CDC Drug Service, Division of Scientific Resources, at 1-404-639-3670. It is available from Victoria Pharmacy, Zurich, Switzerland ([www.pharmaworld.com](http://www.pharmaworld.com)). The drug should be given with food for better absorption. A single study has found that nitazoxanide has limited efficacy for treating fascioliasis in adults and children (Favennec L, et al. *Aliment Pharmacol Ther*. 2003;17:265).

<sup>39</sup>Richter J, et al. *Curr Treat Options Infect Dis*. 2002;4:313.

<sup>40</sup>MacLean JD, et al. *Lancet*. 1996;347:154.

<sup>41</sup>Triclabendazole may be effective in a dosage of 5 mg/kg once a day × 3 days or 10 mg/kg bid × 1 day (Calvopiña M, et al. *Trans R Soc Trop Med Hyg*. 1998;92:566). In the United States, it is not approved by the FDA and is not yet commercially available. However, it is available to physicians licensed in the United States through the CDC Drug Service, under a special protocol, which requires both the CDC and FDA to agree that the drug is indicated for treatment of a particular patient. Providers should contact the CDC Drug Service, Division of Scientific Resources, at 1-404-639-3670. The drug is available from Victoria Pharmacy, Zurich, Switzerland; Phone, 41 43 344 60 60; FAX, 41 43 344 60 69; <http://www.pharmaworld.com>; e-mail, [info@pharmaworld.com](mailto:info@pharmaworld.com).

**Table 325.1** Drugs for Parasitic Infections—cont'd

INFECTION	DRUG	ADULT DOSAGE	PEDIATRIC DOSAGE
<b>GIARDIASIS (GIARDIA INTESTINALIS, ALSO KNOWN AS GIARDIA DUODENALIS OR GIARDIA LAMBLIA)</b>			
Drugs of choice:	Metronidazole <sup>7</sup>	250 mg PO tid × 5 days	5 mg/kg (max 250 mg) PO tid × 5 days
or	Tinidazole <sup>4</sup>	2 g PO once	50 mg/kg PO once (max 2 g)
Alternatives <sup>42</sup>	Paromomycin <sup>7,43</sup>	25-35 mg/kg/day PO in 3 doses × 7 days	25-35 mg/kg/day PO in 3 doses × 7 days
or	Furazolidone <sup>3</sup>	100 mg PO qid × 7-10 days	6 mg/kg/day PO in 4 doses × 7-10 days
or	Quinacrine <sup>2</sup>	100 mg PO tid × 5 days	2 mg/kg tid PO × 5 days (max 300 mg/day)
<b>GNATHOSTOMIASIS (GNATHOSTOMA SPINIGERUM)</b>			
Treatment of choice: <sup>44</sup>	Albendazole <sup>7</sup>	400 mg PO bid × 21 days	<10 kg/2 yr <sup>12</sup> ≥2 yr: see adult dosing
or	Ivermectin <sup>7</sup>	200 µg/kg/day PO × 2 days	<15 kg: not indicated ≥15 kg: see adult dosing
±	Surgical removal		
<b>GONGYLOMIASIS (GONGYLOMOMA SP.)<sup>45</sup></b>			
Treatment of choice:	Surgical removal		
or	Albendazole <sup>7</sup>	400 mg PO daily × 3 days	10 mg/kg/day PO × 3 days
<b>HOOKWORM INFECTION (ANCYLOSTOMA DUODENALE, NECATOR AMERICANUS)</b>			
Drug of choice:	Albendazole <sup>7</sup>	400 mg PO once	<10 kg/2 yr <sup>12</sup> ≥2 yr: see adult dosing
or	Mebendazole	100 mg PO bid × 3 days or 500 mg once	100 mg PO bid × 3 days or 500 mg once <sup>13</sup>
or	Pyrantel pamoate (OTC) <sup>7</sup>	11 mg/kg (max 1 g) PO × 3 days	11 mg/kg (max 1 g) PO × 3 days
<b>HYDATID CYST, SEE TAPEWORM INFECTION</b>			
<b>HYMENOLEPIS NANA, SEE TAPEWORM INFECTION</b>			
<b>LEISHMANIA INFECTION<sup>46</sup></b>			
Visceral <sup>47</sup>			
Drugs of choice:	Liposomal amphotericin B (AmBisome) <sup>48,49</sup>	3 mg/kg/day IV on days 1-5, 14, and 21 (total dose 21 mg/kg)	3 mg/kg/day IV on days 1-5, 14, and 21 (total dose 21 mg/kg)
or	Miltefosine <sup>50</sup>	30-44 kg: 50 mg PO bid × 28 days 45 kg: 50 mg PO tid × 28 days	<12 yr: 2.5mg/kg daily × 28 days <sup>7</sup> ≥12 yr: see adult dosing
or	Sodium stibogluconate (Pentostam) <sup>28,51</sup>	20 mg Sb/kg/day IV or IM × 28 days	20 mg Sb/kg/day IV or IM × 28 days
or	Amphotericin B deoxycholate <sup>7</sup>	1 mg/kg IV daily or every 2 days for 15-20 doses	1 mg/kg IV daily or every 2 days for 15-20 doses

<sup>42</sup>Albendazole 400 mg daily × 5 days alone or in combination with metronidazole may also be effective (Hall A, et al. *Trans R Soc Trop Med Hyg.* 1993;87:84; Dutta AK, et al. *Indian J Pediatr.* 1994;61:689; Cacopardo B, et al. *Clin Ter.* 1995;146:761). Combination treatment with standard doses of metronidazole and quinacrine given for 3 wk has been effective for a small number of refractory infections (Nash TE, et al. *Clin Infect Dis.* 2001;33:22). In one study, nitazoxanide was used successfully in high doses to treat a case of *Giardia* infection resistant to metronidazole and albendazole (Abboud P, et al. *Clin Infect Dis.* 2001;32:1792).

<sup>43</sup>Not absorbed; may be useful for treatment of giardiasis in pregnancy.

<sup>44</sup>de Gorgolas M, et al. *J Travel Med.* 2003;10:358. All patients should be treated with a medication regardless of whether surgery is attempted.

<sup>45</sup>Eberhard ML, et al. *Am J Trop Med Hyg.* 1999;61:51; Wilson ME, et al. *Clin Infect Dis.* 2001;32:1378.

<sup>46</sup>Consultation with physicians experienced in management of this disease is recommended. To maximize effectiveness and minimize toxicity, the choice of drug, dosage, and duration of therapy should be individualized based on the region of disease acquisition, likely infecting species, number, significance and location of lesions, and host factors such as immune status (Murray HW. *Lancet.* 2005;366:1561; Aronson N, et al. *Clin Infect Dis.* 2016;63:e202). Some of the listed drugs and regimens are effective only against certain *Leishmania* species/strains and only in certain areas of the world (Sundar S, et al. *Expert Opin Pharmacother.* 2013;14:53).

<sup>47</sup>Visceral infection is most commonly caused by the Old World species *Leishmania donovani* (kala-azar) and *Leishmania infantum* and the New World species *Leishmania chagasi*. Treatment duration may vary based on symptoms, host immune status, species, and area of the world in which the infection was acquired. Liposomal amphotericin B is the treatment of choice in the IDSA leishmaniasis guidelines (Aronson N, et al. *Clin Infect Dis.* 2016;63:e202).

<sup>48</sup>Three lipid formulations of amphotericin B have been used for treatment of visceral leishmaniasis. Largely based on clinical trials in patients infected with *Leishmania infantum*, the FDA approved liposomal amphotericin B (AmBisome) for treatment of visceral leishmaniasis (Meyerhoff A. *Clin Infect Dis.* 1999;28:42). Amphotericin B lipid complex (Abelcet) and amphotericin B cholesteryl sulfate (Amphotec) have also been used with good results but are considered investigational for this condition by the FDA.

<sup>49</sup>The FDA-approved dosage regimen for immunocompromised patients (e.g., HIV infected) is 4 mg/kg/day on days 1-5 and 4 mg/kg/day on days 10, 17, 24, 31, and 38. The relapse rate is high; maintenance therapy may be indicated, but there is no consensus as to dosage or duration. (Russo R, et al. *J Infect.* 1996;32:133).

<sup>50</sup>For treatment of kala-azar in adults in India, oral miltefosine 100 mg/day (~205 mg/kg/day) for 3-4 wk was 97% effective after 6 mo (Jha TK, et al. *N Engl J Med.* 1999;341:1795; Sangraula H, et al. *J Assoc Physicians India.* 2003;51:686). GI adverse effects are common, and the drug is contraindicated in pregnancy. The dose of miltefosine in an open-label trial in children in India was 2.5 mg/kg/day × 28 days (Bhattacharya SK, et al. *Clin Infect Dis.* 2004;38:217). Miltefosine (Impavido) has been approved by the FDA for treatment of leishmaniasis due to *Leishmania donovani*; cutaneous leishmaniasis due to *L. braziliensis*, *Leishmania guyanensis*, and *Leishmania panamensis*, and mucosal leishmaniasis due to *L. braziliensis* since 2014 and is now commercially available.

<sup>51</sup>May be repeated or continued; a longer duration may be needed for some patients (Herwaldt BL. *Lancet.* 1999;354:1191).

**Table 325.1** Drugs for Parasitic Infections—cont'd

INFECTION	DRUG	ADULT DOSAGE	PEDIATRIC DOSAGE
Alternative:	Meglumine antimonate <sup>3,51</sup>	20 mg pentavalent antimony/kg/day IV or IM × 28 days	20 mg pentavalent antimony/kg/day IV or IM × 28 days
or	Pentamidine <sup>7</sup>	4 mg/kg IV or IM daily or every 2 days for 15-30 doses	4 mg/kg IV or IM daily or every 2 days for 15-30 doses
<b>Cutaneous<sup>52,53</sup></b>			
Drugs of choice:	Sodium stibogluconate <sup>28,51</sup>	20 mg Sb/kg/day IV or IM × 20 days	20 mg Sb/kg/day IV or IM × 20 days
or	Liposomal amphotericin B (AmBisome) <sup>7</sup>	3 mg/kg/day IV on days 1-5 and 10 or 1-7 (total dose 18-21 mg/kg)	3 mg/kg/day IV on days 1-5 and 10 or 1-7 (total dose 18-21 mg/kg)
or	Amphotericin B deoxycholate <sup>7</sup>	0.5-1 mg/kg IV daily or every 2 days (total dose 15-30 mg/kg)	0.5-1 mg/kg IV daily or every 2 days (total dose 15-30 mg/kg)
or	Miltefosine <sup>50</sup>	30-44 kg: 50 mg PO bid × 28 days ≥ 45 kg: 50 mg PO tid × 28 days	<12 yr: 2.5mg/kg daily × 28 days <sup>7</sup> ≥12 yr: see adult dosing
Alternatives:	Meglumine antimonate <sup>3,51</sup>	20 mg pentavalent antimony/kg/day IV or IM × 20 days	20 mg pentavalent antimony/kg/day IV or IM × 20 days
or	Pentamidine <sup>7,54</sup>	3-4 mg/kg IV or IM every 2 days × 3-4 doses	2-3 mg/kg IV or IM daily or every 2 days × 4-7 doses
or	Paromomycin <sup>7,55</sup>	Topically 2×/day × 10-20 days	Topically 2×/day × 10-20 days
or	Ketoconazole <sup>7</sup>	600 mg daily × 28 days	
or	Fluconazole <sup>7</sup>	200 mg daily × 6 wk	
or	Local therapy including cryotherapy, thermotherapy, intralesional Sb <sup>V</sup> , topical paromomycin, photodynamic or laser therapy		
<b>Mucosal<sup>56</sup></b>			
Drugs of choice:	Sodium stibogluconate <sup>28,51</sup>	20 mg Sb/kg/day IV or IM × 28 days	20 mg Sb/kg/day IV or IM × 28 days
or	Liposomal amphotericin B (AmBisome) <sup>7</sup>	3 mg/kg/day IV × 10 days or 4 mg/kg days 1-5, 10, 17, 24, 31, and 38 (total dose 20-60 mg/kg)	2-4 mg/kg/day IV × 10 days or 4 mg/kg days 1-5, 10, 17, 24, 31, and 38 (total dose 20-60 mg/kg)
or	Amphotericin B deoxycholate <sup>7</sup>	0.5-1 mg/kg IV daily or every 2 days (total dose 20-45 mg/kg)	0.5-1 mg/kg IV daily or every 2 days (total dose 20-45 mg/kg)
or	Miltefosine <sup>50</sup>	30-44 kg: 50 mg PO bid × 28 days 45 kg: 50 mg PO tid × 28 days	<12 yr: 2.5 mg/kg daily × 28 days <sup>7</sup> ≥12 yr: see adult dosing
Alternative:	Meglumine antimonate <sup>3,51</sup>	20 mg pentavalent antimony/kg/day IV or IM × 28 days	20 mg pentavalent antimony/kg/day IV or IM × 28 days
<b>LICE (HEAD AND BODY) INFESTATION (<i>PEDICULUS HUMANUS CAPITIS</i>, <i>PEDICULUS HUMANUS HUMANUS</i>)</b>			
Drugs of choice:	0.5% Malathion (Ovide) <sup>57</sup>	Topically 2×, 1 wk apart	Topically 2×, 1 wk apart, approved for 6 yr
or	1% Permethrin (Nix) (OTC) <sup>57</sup>	Topically 2×, 1 wk apart	Topically 2×, 1 wk apart, approved for 2 mo
or	Pyrethrins with piperonyl butoxide (A-200, Proto, R&C, Rid, Triple X) (OTC) <sup>58</sup>	Topically 2×, 1 wk apart	Topically 2×, 1 wk, approved for ≥2 yr

<sup>52</sup>Cutaneous infection is most commonly caused by the Old World species *Leishmania major* and *Leishmania tropica* and the New World species *Leishmania mexicana*, *Leishmania (Viannia) braziliensis*, and others. Treatment duration may vary based on symptoms, host immune status, species, and area of the world where infection was acquired.

<sup>53</sup>In a placebo-controlled trial in patients 12 yr old and older, oral miltefosine was effective for the treatment of cutaneous leishmaniasis caused by *Leishmania (Viannia) panamensis* in Colombia but not *Leishmania (Viannia) braziliensis* in Guatemala at a dosage of about 2.5 mg/kg/day for 28 days. "Motion sickness," nausea, headache, and increased creatinine were the most frequent adverse effects (Soto J, et al. *Clin Infect Dis*. 2004;38:1266). For treatment of *Leishmania major* cutaneous lesions, a study in Saudi Arabia found that oral fluconazole, 200 mg once/day × 6 wk, appeared to speed healing (Alrajhi AA, et al. *N Engl J Med*. 2002;346:891).

<sup>54</sup>At this dosage, pentamidine has been effective against leishmaniasis in Colombia, where the likely organism was *Leishmania (Viannia) panamensis* (Soto-Mancipe J, et al. *Clin Infect Dis*. 1993;16:417; Soto J, et al. *Am J Trop Med Hyg*. 1994;50:107); its effect against other species is not well established. Updated based on *Leishmania* practice guidelines (Aronson N, et al. *Clin Infect Dis*. 2016;63:e202).

<sup>55</sup>Topical paromomycin should be used only in geographic regions where cutaneous leishmaniasis species have low potential for mucosal spread. A formulation of 15% paromomycin/12% methylbenzethonium chloride (Leshcutan) in soft white paraffin for topical use has been reported to be partially effective in some patients against cutaneous leishmaniasis due to *Leishmania major* in Israel and against *Leishmania mexicana* and *Leishmania (Viannia) braziliensis* in Guatemala, where mucosal spread is very rare (Arana BA, et al. *Am J Trop Med Hyg*. 2001;65:466). Methylbenzethonium is irritating to the skin; lesions may worsen before they improve.

<sup>56</sup>Mucosal infection is most commonly due to the New World species *Leishmania (Viannia) braziliensis*, *Leishmania (Viannia) panamensis*, or *Leishmania (Viannia) guyanensis*. Treatment duration may vary based on symptoms, host immune status, species, and area of the world where infection was acquired.

<sup>57</sup>Yoon KS, et al. *Arch Dermatol*. 2003;139:994.

Continued



**Table 325.1** Drugs for Parasitic Infections—cont'd

INFECTION	DRUG	ADULT DOSAGE	PEDIATRIC DOSAGE
or	0.5% Ivermectin lotion (Sklice)	Topically, once	Topically once, approved for ≥6 mo
or	0.9% Spinosad suspension (Natroba)	Topically once, second dose in 1 wk if live adult lice seen	Topically once, second dose in 1 wk if live adult lice seen, approved for ≥6 mo
or	Ivermectin <sup>7,59</sup>	200-400 µg/kg PO 2×, 1 wk apart	<15 kg: not indicated 15 kg: see adult dosing
or	5% Benzyl alcohol lotion (Ulesfia)	Topically 2×, 1 wk apart	Topically 2×, 1 wk apart
<b>LICE (PUBIC) INFESTATION (<i>PHTHIRUS PUBIS</i>)<sup>60</sup></b>			
Drugs of choice:	1% Permethrin (Nix) (OTC) <sup>57</sup>	Topically 2×, 1 wk apart	Topically 2×, 1 wk apart, approved for ≥2 mo
or	Pyrethrins with piperonyl butoxide (A-200, Proto, R&C, Rid, Triple X) (OTC) <sup>53</sup>	Topically 2×, 1 wk apart	Topically 2×, 1 wk apart, approved for ≥2 yr
or	0.5% Malathion (Ovide) <sup>57</sup>	Topically 2×, 1 wk apart	Topically 2×, 1 wk apart, approved for ≥6 yr
or	0.5% Ivermectin lotion (Sklice)	Topically, once	Topically once, approved for ≥6 mo
or	Ivermectin <sup>7,59</sup>	200-400 µg/kg PO 2×, 1 wk apart	<15 kg: not indicated ≥15 kg: see adult dosing
<b>LOA LOA, SEE FILARIASIS</b>			
<b>MALARIA (<i>PLASMODIUM FALCIPARUM</i>, <i>PLASMODIUM OVALE</i>, <i>PLASMODIUM VIVAX</i>, AND <i>PLASMODIUM MALARIAE</i>) – TREATMENT</b>			
<b>Uncomplicated infection due to <i>P. falciparum</i> or species not identified acquired in areas of chloroquine resistance or unknown resistance<sup>61</sup></b>			
Drugs of choice: <sup>62</sup>	Atovaquone/proguanil (Malarone) Adult tabs: 50 mg atovaquone/100 mg proguanil Pediatric tabs 62.5 mg atovaquone/25 mg proguanil) <sup>63</sup>	4 adult tabs PO once daily or 2 adult tabs PO bid × 3 days <sup>64</sup>	<5 kg: not indicated 5-8 kg: 2 pediatric tabs PO daily × 3 days 9-10 kg: 3 pediatric tabs PO daily × 3 days 11-20 kg: 1 adult tab PO daily × 3 days 21-30 kg: 2 adult tabs PO daily × 3 days 31-40 kg: 3 adult tabs PO daily × 3 days >40 kg: 4 adult tabs PO daily × 3 days
or	Coartem (artemether/lumefantrine) Fixed dose of 20 mg artemether and 120 mg lumefantrine per tablet	4 tablets per dose. A 3-day treatment schedule with a total of 6 oral doses is recommended for both adult and pediatric patients based on weight. These 6 doses should be administered over 3 days at 0, 8, 24, 36, 48, and 60 hr	5 to <15 kg: 1 tablet PO per dose 15 to <25 kg: 2 tablets PO per dose 25 to <35 kg: 3 tablets per dose ≥35 kg: 4 tablets PO per dose

<sup>58</sup>A second application is recommended 1 wk later to kill hatching progeny. Lice are increasingly demonstrating resistance to pyrethrins and permethrin (Meinking TL, et al. *Arch Dermatol.* 2002;138:220). Ivermectin lotion 0.5% was approved by the FDA in 2012 for treatment of head lice in persons 6 mo of age and older. It is not ovicidal, but it appears to prevent nymphs from surviving. It is effective in most patients when given as a single application on dry hair without nit combing ([www.cdc.gov/parasites/lice/head/treatment.html](http://www.cdc.gov/parasites/lice/head/treatment.html)).

<sup>59</sup>Ivermectin is effective against adult lice but has no effect on nits (Jones KN, et al. *Clin Infect Dis.* 2003;36:1355).

<sup>60</sup>For infestation of eyelashes with *Phthirus pubis* lice, use petrolatum; Trimethoprim-sulfamethoxazole (TMP-SMX) has also been used (Meinking TL. *Curr Probl Dermatol.* 1996;24:157). For pubic lice, treat with 5% permethrin or ivermectin as for scabies. TMP-SMX has also been effective, together with permethrin for head lice (Hipolito RB, et al. *Pediatrics.* 2001;107:E30).

<sup>61</sup>Chloroquine-resistant *Plasmodium falciparum* occurs in all malarious areas except Central America west of the Panama Canal Zone, Mexico, Haiti, the Dominican Republic, and most of the Middle East (chloroquine resistance has been reported in Yemen, Oman, Saudi Arabia, and Iran). For treatment of multidrug-resistant *P. falciparum* in Southeast Asia, especially Thailand, where resistance to mefloquine is frequent, atovaquone/proguanil, artesunate plus mefloquine, or artemether plus mefloquine may be used (Luxemburger C, et al. *Trans R Soc Trop Med Hyg.* 1994;88:213; Karbwang J, et al. *Trans R Soc Trop Med Hyg.* 1995;89:296).

<sup>62</sup>Uncomplicated or mild malaria may be treated with oral drugs.

<sup>63</sup>To enhance absorption and reduce nausea and vomiting, it should be taken with food or a milky drink. Safety in pregnancy is unknown, and use is generally not recommended. In a few small studies, outcomes were normal in women treated with the combination in the second and third trimesters (Paternak B, et al. *Arch Intern Med.* 2011;171:259; Boggild AK, et al. *Am J Trop Med Hyg.* 2007;76:208). The drug should not be given to patients with severe renal impairment (creatinine clearance <30 mL/min). There have been isolated case reports of resistance in *Plasmodium falciparum* in Africa, but *Medical Letter* consultants do not believe there is a high risk for acquisition of Malarone-resistant disease (Schwartz E, et al. *Clin Infect Dis.* 2003;37:450; Farnert A, et al. *BMJ.* 2003;326:628; Kuhn S, et al. *Am J Trop Med Hyg.* 2005;72:407; Happi C, et al. *Malar J.* 2006;5:82).

**Table 325.1** Drugs for Parasitic Infections—cont'd

INFECTION	DRUG	ADULT DOSAGE	PEDIATRIC DOSAGE
or	Quinine sulfate	542 mg base (650 mg salt) PO tid × 3-7 days <sup>64</sup>	8.3 mg base/kg (10 mg salt/kg) PO tid × 3-7 days <sup>65</sup>
	plus doxycycline <sup>7,17</sup>	100 mg PO bid × 7 days	4 mg/kg/day PO in 2 doses × 7 days
	or plus tetracycline <sup>7,17</sup>	250 mg PO qid × 7 days	6.25 mg/kg PO qid × 7 days
	or plus clindamycin <sup>7,66</sup>	20 mg/kg/day PO in 3 divided doses × 7 days <sup>67</sup>	20 mg/kg/day PO in 3 doses × 7 days
Alternative:	Mefloquine <sup>68,69</sup>	750 mg PO followed 12 hr later by 500 mg	15 mg/kg PO followed 12 hr later by 10 mg/kg
<b>Uncomplicated infection due to <i>P. falciparum</i> or species not identified acquired in areas of chloroquine sensitivity or uncomplicated <i>P. malariae</i> or <i>P. knowlesi</i></b>			
Drug of choice:	Chloroquine phosphate (Aralen)	600 mg base (1,000 mg salt) PO, then 300 mg base (500 mg salt) PO at 6, 24, and 48 hr	10 mg base/kg (16.7 mg salt/kg) PO, then 5 mg base/kg (8.3 mg salt/kg) PO at 6, 24, and 48 hr
or	Hydroxychloroquine (Plaquenil) <sup>70</sup>	620 mg base (800 mg salt) PO, then 310 mg base (400 mg salt) PO at 6, 24, and 48 hr	10 mg base/kg (12.9 mg salt/kg) PO, then 5.5 mg base/kg (6.5 mg salt/kg) PO at 6, 24, and 48 hr
or	Artemether-lumefantrine (Coartem) <sup>10</sup> (1 tab: 20 mg artemether / 120 mg lumefantrine)	Adults: 4 tabs PO per dose Three-day course: day 1: initial dose and second dose 8 hr later; days 2 and 3: 1 dose bid	5 to <15 kg: 1 tab PO per dose 15 to <25 kg: 2 tabs PO per dose 25 to <35 kg: 3 tabs PO per dose ≥35 kg: 4 tabs PO per dose Three-day course: day 1: initial dose and second dose 8 hr later; days 2 and 3: 1 dose bid
<b>Uncomplicated infection with <i>P. vivax</i> acquired in areas of chloroquine resistance<sup>71</sup></b>			
Drugs of choice:	Atovaquone/proguanil (Malarone) Adult tabs: 50 mg atovaquone/100 mg proguanil Pediatric tabs 62.5 mg atovaquone/25 mg proguanil <sup>63</sup>	4 adult tabs PO once daily × 3 days	<5 kg: not indicated 5-8 kg: 2 pediatric tabs PO daily × 3 days 9-10 kg: 3 pediatric tabs PO daily × 3 days 11-20 kg: 1 adult tab PO daily × 3 days 21-30 kg: 2 adult tabs PO daily × 3 days 31-40 kg: 3 adult tabs PO daily × 3 days >40 kg: 4 adult tabs PO daily × 3 days
	plus primaquine <sup>72</sup>	30 mg base PO daily × 14 days	0.5 mg/kg/day PO × 14 days
or	Quinine sulfate	542 mg base (650 mg salt) PO tid × 3-7 days <sup>64</sup>	8.3 mg base/kg (10 mg salt/kg) PO tid × 3-7 days <sup>58</sup>
	plus doxycycline <sup>7,17</sup>	100 mg PO bid × 7 days	4 mg/kg/day PO in 2 doses × 7 days
	or plus tetracycline <sup>7,17</sup>	250 mg PO qid × 7 days	6.25 mg/kg PO qid × 7 days
	or plus clindamycin <sup>7,66</sup>	20 mg/kg/day PO in 3 divided doses × 7 days <sup>67</sup>	20 mg/kg/day PO in 3 doses × 7 days
	plus primaquine <sup>72</sup>	30 mg base PO daily × 14 days	0.5 mg/kg/day PO × 14 days

<sup>64</sup>Although approved for once-daily dosing, *Medical Letter* consultants usually divide the dose into 2 doses to decrease nausea and vomiting.<sup>65</sup>In Southeast Asia, relative resistance to quinine has increased and treatment should be continued for 7 days.<sup>66</sup>For use in pregnancy.<sup>67</sup>Lell B, et al. *Antimicrob Agents Chemother.* 2002;46:2315.<sup>68</sup>At this dosage, adverse effects, including nausea, vomiting, diarrhea, dizziness, a disturbed sense of balance, toxic psychosis, and seizures can occur. Mefloquine should not be used for treatment of malaria in pregnancy unless there is no other treatment option, because of an increased risk for stillbirth (Nosten F, et al. *Clin Infect Dis.* 1999;28:808). It should be avoided for treatment of malaria in persons with active depression or with a history of psychosis or seizures and should be used with caution in persons with psychiatric illness. Mefloquine can be given to patients taking  $\beta$ -blockers if they do not have an underlying arrhythmia; it should not be used in patients with conduction abnormalities. Mefloquine should not be given together with quinine, quinidine, or halofantrine, and caution is required in using quinine, quinidine, or halofantrine to treat patients with malaria who have taken mefloquine for prophylaxis. Resistance to mefloquine has been reported in some areas, such as the Thailand-Myanmar and Thailand-Cambodia borders and in the Amazon basin, where 25 mg/kg should be used. In the United States, a 250 mg tablet of mefloquine contains 228 mg mefloquine base. Outside the United States, each 275 mg tablet contains 250 mg base.<sup>69</sup>*Plasmodium falciparum* with resistance to mefloquine is a significant problem in the malarious areas of Thailand and in areas of Myanmar and Cambodia that border on Thailand. It has also been reported on the borders between Myanmar and China, Laos and Myanmar, and in Southern Vietnam. In the United States, a 250 mg tablet of mefloquine contains 228 mg mefloquine base. Outside the United States, each 275 mg tablet contains 250 mg base.<sup>70</sup>If chloroquine phosphate is not available, hydroxychloroquine sulfate is as effective; 400 mg of hydroxychloroquine sulfate is equivalent to 500 mg of chloroquine phosphate.<sup>71</sup>*Plasmodium vivax* with decreased susceptibility to chloroquine is a significant problem in Papua New Guinea and Indonesia. There are also a few reports of resistance from Myanmar, India, the Solomon Islands, Vanuatu, Guyana, Brazil, Colombia, and Peru.<sup>72</sup>Primaquine phosphate can cause hemolytic anemia, especially in patients whose red cells are deficient in glucose-6-phosphate dehydrogenase (G6PD). This deficiency is most common in African, Asian, and Mediterranean peoples. Patients should be screened for G6PD deficiency before treatment. Primaquine should not be used during pregnancy. For those with intermediate G6PD deficiency, weekly primaquine may be used (45 mg/wk) for 8 wk with close monitoring for hemolysis. Those with G6PD deficiency may be given chloroquine 300 mg (base) PO weekly for 1 yr for acute infection to prevent relapses.

Continued

Table 325.1 Drugs for Parasitic Infections—cont'd

INFECTION	DRUG	ADULT DOSAGE	PEDIATRIC DOSAGE
or	Artemether-lumefantrine (1 tab: 20 mg artemether/120 mg lumefantrine) Weight-based treatment schedule for both adult and pediatric patients. Patients take initial dose, followed by a second dose 8 hr later, then 1 dose twice a day for the next 2 days (total of 6 oral doses over 3 days)		5 kg to <15 kg: 1 tablet per dose 15 kg to <25 kg: 2 tablets per dose 25 kg to <35 kg: 3 tablets per dose ≥35 kg: 4 tablets per dose Not recommended for people taking mefloquine prophylaxis or for children weighing <5 kg, or people breastfeeding infants weighing <5 kg
or	Mefloquine <sup>68</sup> plus primaquine <sup>72</sup>	750 mg PO followed 12 hr later by 500 mg PO 30 mg base PO daily × 14 days	15 mg/kg PO followed 12 hr later by 10 mg/kg PO 0.5 mg/kg/day PO × 14 days
<b>Uncomplicated infection with <i>P. ovale</i> and <i>P. vivax</i> acquired in areas without chloroquine resistance<sup>71</sup></b>			
Drug of choice:	Chloroquine phosphate (Aralen) plus primaquine <sup>72</sup>	600 mg base (1,000 mg salt) PO, then 300 mg base (500 mg salt) PO at 6, 24, and 48 hr 30 mg base PO daily × 14 days	10 mg base/kg (16.7 mg salt/kg) PO, then 5 mg base/kg (8.3 mg salt/kg) PO at 6, 24, and 48 hr 0.5 mg/kg/day PO × 14 days
or	Hydroxychloroquine (Plaquenil) <sup>70</sup> plus primaquine <sup>72</sup>	620 mg base PO, then 310 mg base PO at 6, 24, and 48 hr 30 mg base PO daily × 14 days	10 mg/kg base PO, then 5 mg/kg base PO at 6, 24, and 48 hr 0.5 mg/kg/day PO × 14 days
or	Tafenoquine (Krintafel) <sup>73</sup>	300 mg PO × 1 dose	>16 yr: see adult dosing
<b>Severe malaria due to all <i>Plasmodium</i> spp.</b>			
Drugs of choice: <sup>74</sup>	Artesunate <sup>28,75</sup> Followed by: • Artemether/lumefantrine (preferred), or • Atovaquone-proguanil, or • Quinine plus doxycycline or clindamycin, or • Mefloquine (only if no other options available)	2.4 mg/kg/dose IV × 3 days, at 0, 12, and 24 hr Dosing as above	2.4 mg/kg/dose IV × 3 days, at 0, 12, and 24 hr Dosing as above
Alternative:	Coartem (Artemether/lumefantrine) Fixed dose of 20 mg artemether and 120 mg lumefantrine per tablet (preferred)	4 tablets per dose. A 3-day treatment schedule with a total of 6 oral doses is recommended for both adult and pediatric patients based on weight. These 6 doses should be administered over 3 days at 0, 8, 24, 36, 48, and 60 hr	5 to <15 kg: 1 tablet PO per dose 15 to <25 kg: 2 tablets PO per dose 25 to <35 kg: 3 tablets per dose ≥35 kg: 4 tablets PO per dose
or	Atovaquone/proguanil (Malarone) Adult tabs: 50 mg atovaquone/100 mg proguanil Pediatric tabs 62.5 mg atovaquone/25 mg proguanil <sup>63</sup>	4 adult tabs PO once daily × 3 days	<5 kg: not indicated 5-8 kg: 2 pediatric tabs PO daily × 3 days 9-10 kg: 3 pediatric tabs PO daily × 3 days 11-20 kg: 1 adult tab PO daily × 3 days 21-30 kg: 2 adult tabs PO daily × 3 days 31-40 kg: 3 adult tabs PO daily × 3 days >40 kg: 4 adult tabs PO daily × 3 days

<sup>73</sup>Tafenoquine received regulatory approval in the United States in 2018 for prophylaxis of malaria and radical cure of *Plasmodium vivax*. Tafenoquine is associated with hemolytic anemia in those with glucose-6-phosphate dehydrogenase (G6PD) deficiency. Prior to use, quantitative G6PD testing is needed to confirm normal activity.

<sup>74</sup>Exchange transfusion has been helpful for some patients with high-density (>10%) parasitemia, altered mental status, pulmonary edema, or renal complications (Miller KD, et al. *N Engl J Med.* 1989;321:65).

<sup>75</sup>Artesunate is considered first-line therapy for severe malaria. If not available within 24 hours, contact CDC's Malaria Hotline. To avoid the development of resistance, adults treated with artesunate must also receive oral treatment doses of either atovaquone/proguanil, doxycycline, clindamycin, or mefloquine; children should take either atovaquone/proguanil, clindamycin, or mefloquine (Nosten F, et al. *Lancet.* 2000;356:297; van Vugt M. *Clin Infect Dis.* 2002;35:1498; Smithuis F, et al. *Trans R Soc Trop Med Hyg.* 2004;98:182). If artesunate is given IV, oral medication should be started when the patient is able to tolerate it (SEAQUAMAT group. *Lancet.* 2005;366:717; Duffy PE, et al. *Lancet.* 2005;366:1908). If oral therapy is not tolerated, consider administration via nasogastric (NG) tube or after an antiemetic. If parasitemia >1%, continue IV artesunate at the same dose daily up to 6 more days until parasite density ≤1%. When parasite density ≤1%, give complete follow-up on oral regimen as listed earlier. Reduced susceptibility to artesunate characterized by slow parasitic clearance has been reported in Cambodia (Rogers WO, et al. *Malar J.* 2009;8:10; Dundorp AM, et al. *N Engl J Med.* 2009;361:455).

**Table 325.1** Drugs for Parasitic Infections—cont'd

INFECTION	DRUG	ADULT DOSAGE	PEDIATRIC DOSAGE
or	Quinine sulfate	648 mg salt PO tid × 3-7 days <sup>64</sup>	10 mg salt/kg PO tid × 3-7 days <sup>58</sup>
	plus doxycycline <sup>7,17</sup>	100 mg PO bid × 7 days	4 mg/kg/day PO in 2 doses × 7 days
	or plus tetracycline <sup>7,17</sup>	250 mg PO qid × 7 days	6.25 mg/kg PO qid × 7 days
	or plus clindamycin <sup>7,66</sup>	20 mg/kg/day PO in 3 divided doses × 7 days <sup>67</sup>	20 mg/kg/day PO in 3 doses × 7 days
or	Artemether-lumefantrine (1 tab: 20 mg artemether/120 mg lumefantrine) Weight-based treatment schedule for both adult and pediatric patients. Patients take initial dose, followed by a second dose 8 hr later, then 1 dose twice a day for the next 2 days (total of 6 oral doses over 3 days)		5 kg to <15 kg: 1 tablet per dose 15 kg to <25 kg: 2 tablets per dose 25 kg to <35 kg: 3 tablets per dose ≥35 kg: 4 tablets per dose Not recommended for people taking mefloquine prophylaxis or for children weighing <5 kg, or people breastfeeding infants weighing <5 kg
or	Mefloquine <sup>68</sup>	750 mg PO followed 12 hr later by 500 mg PO	15 mg/kg PO followed 12 hr later by 10 mg/kg PO
<b>Prevention of relapses: <i>P. vivax</i> and <i>P. ovale</i> only</b>			
Drug of choice:	Primaquine phosphate <sup>72</sup>	30 mg base/day PO × 14 days	0.6 mg base/kg/day PO × 14 days
or	Tafenoquine (Krintafel) <sup>73</sup>	300 mg PO × 1 dose	>16 yr: see adult dosing
<b>MALARIA – PREVENTION<sup>76</sup></b>			
<b>Chloroquine-sensitive areas<sup>61</sup></b>			
Drug of choice	Chloroquine phosphate <sup>77-79</sup>	500 mg salt (300 mg base), PO once/wk beginning 1-2 wk before travel to malarious area and 4 wk after leaving	5 mg/kg base once/wk, up to adult dose of 300 mg base beginning 1-2 wk before travel to malarious area and 4 wk after leaving
or	Hydroxychloroquine (Plaquenil) <sup>70</sup>	400 mg (310 mg base) PO once/wk beginning 1-2 wk before travel to malarious area and 4 wk after leaving	5 mg/kg base once/wk, up to adult dose of 310 mg base beginning 1-2 wk before travel to malarious area and 4 wk after leaving
<b>Chloroquine-resistant areas<sup>61</sup></b>			
Drug of choice:	Atovaquone/proguanil <sup>63,78,80</sup>	1 adult tab PO per day beginning 1-2 days before travel to malarious area and 7 days after leaving	11-20 kg: 1 pediatric tab PO/day 21-30 kg: 2 pediatric tabs PO/day 31-40 kg: 3 pediatric tabs PO/day >40 kg: 1 adult tab PO/day
or	Mefloquine <sup>48,78,79,81</sup>	1 adult tab PO per day beginning 1-2 wk before travel to malarious area and 4 wk after leaving	<9 kg: 5 mg/kg salt once/wk 9-19 kg: 1/4 tab once/wk 19-30 kg: 1/2 tab once/wk 31-45 kg: 3/4 tab once/wk >45 kg: 1 tab once/wk

<sup>76</sup>No drug regimen guarantees protection against malaria. If fever develops within a year (particularly within the first 2 mo) after travel to malarious areas, travelers should be advised to seek medical attention. Insect repellents, insecticide-impregnated bed nets, and proper clothing are important adjuncts for malaria prophylaxis (*Med Lett.* 2003;45:41). Malaria in pregnancy is particularly serious for both the pregnant individual and the fetus; therefore, prophylaxis is indicated if exposure cannot be avoided.

<sup>77</sup>In pregnancy, chloroquine prophylaxis has been used extensively and safely.

<sup>78</sup>For prevention of attack after departure from areas where *Plasmodium vivax* and *Plasmodium ovale* are endemic, which includes almost all areas where malaria is found (except Haiti), some experts prescribe in addition primaquine phosphate 30 mg base/day or, for children, 0.6 mg base/kg/day during the last 2 wk of prophylaxis. Others prefer to avoid the toxicity of primaquine and rely on surveillance to detect cases when they occur, particularly when exposure was limited or doubtful. See also footnote<sup>71</sup>.

<sup>79</sup>Beginning 1-2 wk before travel and continuing weekly for the duration of stay and for 4 wk after leaving malarious zone. Most adverse events occur within three doses. Some *Medical Letter* consultants favor starting mefloquine 3 wk before travel and monitoring the patient for adverse events; this allows time to change to an alternative regimen if mefloquine is not tolerated. Mefloquine should not be taken on an empty stomach; it should be taken with at least 8 oz of water. For pediatric doses less than 1/2 tablet, it is advisable to have a pharmacist crush the tablet, estimate doses by weighing, and package them in gelatin capsules. There are no data for use in children weighing <5 kg, but based on dosages in other weight groups, a dose of 5 mg/kg can be used.

<sup>80</sup>Beginning 1-2 days before travel and continuing for the duration of stay and for 1 wk after leaving malarious zone. In one study of malaria prophylaxis, atovaquone/proguanil was better tolerated than mefloquine in nonimmune travelers (Overbosch D, et al. *Clin Infect Dis.* 2001;33:1015). The protective efficacy of Malarone against *Plasmodium vivax* is variable, ranging from 84% in Indonesian New Guinea (Ling J, et al. *Clin Infect Dis.* 2002;35:825) to 100% in Colombia (Soto J, et al. *Am J Trop Med Hyg.* 2006;75:430). Some *Medical Letter* consultants prefer alternate drugs if traveling to areas where *P. vivax* predominates.

<sup>81</sup>Mefloquine has not been approved for use during pregnancy. However, it has been reported to be safe for prophylactic use during the second or third trimester of pregnancy and possibly during early pregnancy, as well. Mefloquine is not recommended for patients with cardiac conduction abnormalities, and patients with a history of depression, seizures, psychosis, or psychiatric disorders should avoid mefloquine prophylaxis. Resistance to mefloquine has been reported in some areas, such as the Thailand-Myanmar and Thailand-Cambodia borders; in these areas, atovaquone/proguanil or doxycycline should be used for prophylaxis.

Continued



**Table 325.1** Drugs for Parasitic Infections—cont'd

INFECTION	DRUG	ADULT DOSAGE	PEDIATRIC DOSAGE
or	Doxycycline <sup>7,82</sup>	100 mg PO daily	≥8 yr: 2 mg/kg/day, up to 100 mg/day
or	Tafenoquine (Arakoda)	200 mg once daily for 3 days before travel to a malarious area, then 200 mg weekly while in the malarious area, then 200 mg as a single dose, 7 days after leaving malarious area	No dosing data for children
Alternatives for areas with primarily <i>P. vivax</i> :	Primaquine <sup>7,83</sup>	30 mg base PO daily beginning 1-2 days before travel to malarious area and 7-14 days after leaving	0.5 mg/kg base (max 30 mg) daily beginning 1-2 days before travel to malarious area and 7-14 days after leaving
<b>MALARIA – PRESUMPTIVE SELF-TREATMENT<sup>84</sup></b>			
Drugs of choice:	Atovaquone/proguanil (Malarone) Adult tabs: 50 mg atovaquone/100 mg proguanil Pediatric tabs 62.5 mg atovaquone/25 mg proguanil <sup>63</sup>	4 adult tabs PO once daily × 3 days	<5 kg: not indicated 5-8 kg: 2 pediatric tabs PO daily × 3 days 9-10 kg: 3 pediatric tabs PO daily × 3 days 11-20 kg: 1 adult tab PO daily × 3 days 21-30 kg: 2 adult tabs PO daily × 3 days 31-40 kg: 3 adult tabs PO daily × 3 days >40 kg: 4 adult tabs PO daily × 3 days
or	Quinine sulfate <sup>64</sup> plus doxycycline <sup>7,17</sup>	648 mg salt PO tid × 3-7 days 100 mg PO bid × 7 days	10 mg salt/kg PO tid × 3-7 days 4 mg/kg/day PO in 2 divided doses × 7 days
or	Mefloquine <sup>68,69</sup>	750 mg PO followed 12 hr later by 500 mg	15 mg/kg PO followed 12 hr later by 10 mg/kg
<b>MICROSPORIDIOSIS</b>			
<i>Ocular (Encephalitozoon hellem, Encephalitozoon cuniculi, Vittaforma corneae [Nosema corneum])</i>			
Drug of choice:	Albendazole <sup>7,85</sup> plus fumagillin <sup>86</sup>	400 mg PO bid Topical Fumidil B (fumagillin bicyclohexylammonium) in saline (to achieve concentration of 70 mg/mL of fumagillin) 2 drops per eye every 2 hr for 4 days, then 2 drops qid	<10 kg/2 yr: 15 mg/kg/day in 2 doses <sup>12</sup> ≥2 yr: see adult dosing
<i>Intestinal (Enterocytozoon bieneusi, Encephalitozoon [Septata] intestinalis)</i>			
<b><i>E. bieneusi</i><sup>87</sup></b>			
Drug of choice:	Fumagillin	60 mg/day PO × 14 days in 3 divided doses	
Alternatives:	Nitazoxanide <sup>5,7</sup>	1000 mg PO bid × 3 days	
<b><i>E. intestinalis</i></b>			
Drug of choice	Albendazole <sup>7,85</sup>	400 mg PO bid × 21 days	<10 kg/2 yr 15 mg/kg/day in 2 doses: <sup>12</sup> ≥2 yr: see adult dosing
<b><i>Disseminated (E. hellem, E. cuniculi, E. intestinalis, Pleistophora sp., Trachipleistophora sp., and Brachiola vesicularum)</i></b>			
Drug of choice <sup>88</sup>	Albendazole <sup>7,85</sup>	400 mg PO bid	<10 kg/2 yr <sup>12</sup> ≥2 yr: see adult dosing

<sup>82</sup>Beginning 1-2 days before travel and continuing for the duration of stay and for 4 wk after leaving. Use of tetracyclines is contraindicated in pregnancy and in children younger than 8 yr old. Doxycycline can cause GI disturbances, vaginal moniliasis, and photosensitivity reactions.

<sup>83</sup>Studies have shown that daily primaquine beginning 1 day before departure and continued until 3-7 days after leaving the malarious area provides effective prophylaxis against chloroquine-resistant *Plasmodium falciparum* (Baird JK, et al. *Clin Infect Dis*. 2003;37:1659). Some studies have shown less efficacy against *Plasmodium vivax*. Nausea and abdominal pain can be diminished by taking with food.

<sup>84</sup>A traveler can be given a course of atovaquone/proguanil, mefloquine, or quinine plus doxycycline for presumptive self-treatment of febrile illness. The drug given for self-treatment should be different from that used for prophylaxis. This approach should be used only in very rare circumstances when a traveler cannot promptly get to medical care.

<sup>85</sup>For HIV-infected patients, continue until resolution of ocular symptoms and until CD4 count >200 cells/μL for >6 mo after initiation of antiretroviral therapy.

<sup>86</sup>Ocular lesions caused by *Encephalitozoon hellem* in HIV-infected patients have responded to fumagillin eyedrops prepared from Fumidil-B (bicyclohexyl ammonium fumagillin) used to control a microsporidial disease of honey bees (Diesenhouse MC. *Am J Ophthalmol*. 1993;115:293), available from Leiter's Park Avenue Pharmacy (San Jose, CA; 1-800-292-6773; [www.leitertx.com](http://www.leitertx.com)). For lesions caused by *Vittaforma corneae*, topical therapy is generally not effective and keratoplasty may be required (Davis RM, et al. *Ophthalmology*. 1990;97:953).

<sup>87</sup>Oral fumagillin (Sanofi Recherche, Gentilly, France) has been effective in treating *Enterocytozoon. bieneusi* (Molina J-M, et al. *N Engl J Med*. 2002;346:1963), but it has been associated with thrombocytopenia. HAART may lead to microbiologic and clinical response in HIV-infected patients with microsporidial diarrhea (Benson CA, et al. *MMWR Recomm Rep*. 2004;53[RR-15]:1). Octreotide (Sandostat) has provided symptomatic relief in some patients with large-volume diarrhea.

<sup>88</sup>Molina J-M, et al. *J Infect Dis*. 1995;171:245. There is no established treatment for *Pleistophora*. For disseminated disease caused by *Trachipleistophora* or *Brachiola*, itraconazole 400 mg PO once/day plus albendazole may also be tried (Coyle CM, et al. *N Engl J Med*. 2004;351:42).

**Table 325.1** Drugs for Parasitic Infections—cont'd

INFECTION	DRUG	ADULT DOSAGE	PEDIATRIC DOSAGE
MITES, SEE SCABIES			
<i>MONILIFORMIS MONILIFORMIS</i> INFECTION			
Drug of choice:	Pyrantel pamoate (OTC) <sup>7</sup>	11 mg/kg PO once, repeat twice, 2 wk apart	11 mg/kg PO once, repeat twice, 2 wk apart
<i>NAEGLERIA SPECIES</i> , SEE AMEBIC MENINGOENCEPHALITIS, PRIMARY			
<i>NECATOR AMERICANUS</i> , SEE HOOKWORM INFECTION			
<i>OESOPHAGOSTOMUM BIFURCUM</i>			
Drug of choice:	See footnote <sup>89</sup>		
<i>ONCHOCERCA VOLVULUS</i> , SEE FILARIASIS			
<i>OPISTHORCHIS VIVERRINI</i> , SEE FLUKE INFECTION			
<i>PARAGONIMUS WESTERMANI</i> , SEE FLUKE INFECTION			
<i>PEDICULUS CAPITIS</i> , <i>PEDICULUS HUMANUS</i> , <i>PHTHIRUS PUBIS</i> , SEE LICE			
<i>PINWORM</i> , SEE ENTEROBIUS			
<i>PNEUMOCYSTIS JIROVECI</i> (FORMERLY <i>PNEUMOCYSTIS CARINII</i> ) PNEUMONIA (PCP) <sup>90</sup>			
<i>Moderate to severe disease</i>			
Drug of choice:	TMP-SMX	15-20 mg/kg/day TMP component IV in 3-4 divided doses × 21 days (change to PO after clinical improvement)	15-20 mg/kg/day TMP component IV in 3-4 divided doses × 21 days (change to PO after clinical improvement)
Alternatives:	Pentamidine	3-4 mg IV daily × 21 days	3-4 mg IV daily × 21 days
or	Primaquine	30 mg base PO daily × 21 days	0.3 mg/kg base PO (max 30 mg) daily × 21 days
	plus clindamycin <sup>7</sup>	600-900 mg IV tid or qid × 21 days, or 300-450 mg PO tid or qid × 21 days (change to PO after clinical improvement)	15-25 mg/kg IV tid or qid × 21 days, or 10 mg/kg PO tid or qid (max 300-450 mg/dose) × 21 days (change to PO after clinical improvement)
<i>Mild to moderate disease</i>			
Drug of choice:	TMP-SMX	320 mg/1600 mg (2 DS tablets) PO tid × 21 days	TMP 15-20 mg/kg/day PO in 3 or 4 doses × 21 days
Alternative:	Dapsone	100 mg PO daily × 21 days	2 mg/kg/day (max 100 mg) PO × 21 days
	plus trimethoprim	15 mg/kg/day PO in 3 doses	15 mg/kg/day PO in 3 doses
or	primaquine	30 mg base PO daily × 21 days	0.3 mg/kg base PO daily (max 30 mg) × 21 days
	plus clindamycin	300-450 mg PO tid or qid × 21 days	10 mg/kg PO tid or qid (max 300-450 mg/dose) × 21 days
or	atovaquone	750 mg PO bid × 21 days	1-3 mo: 30 mg/kg/day PO in 2 doses × 21 days
<i>Primary and secondary prophylaxis</i> <sup>91</sup>			
Drug of choice:	TMP-SMX	1 tab (single strength or greater) PO daily or 1 DS tab PO 3 days/wk	TMP 150 mg/m <sup>2</sup> in 1-2 doses daily or on 3 consecutive days/wk
Alternatives: <sup>91</sup>	Dapsone <sup>7</sup>	50 mg PO bid, or 100 mg PO daily	2 mg/kg/day (max 100 mg) PO or 4 mg/kg (max 200 mg) PO each wk
or	Dapsone <sup>7</sup>	50 mg PO daily or 200 mg PO each wk	
	plus pyrimethamine <sup>92</sup>	50 mg PO or 75 mg PO each wk	
or	Pentamidine aerosol	300 mg inhaled monthly via Respigard II nebulizer	≥5 yr: 300 mg inhaled monthly via Respigard II nebulizer
or	Atovaquone <sup>7</sup>	1,500 mg/day PO in 1 or 2 doses	1-3 mo: 30 mg/kg/day PO 4-24 mo: 45 mg/kg/day PO in 2 doses × 21 days >24 mo: 30 mg/kg/day PO in 2 doses × 21 days

<sup>89</sup>Albendazole or pyrantel pamoate may be effective (Ziem JB, et al. *Ann Trop Med Parasitol*. 2004;98:385).<sup>90</sup>*Pneumocystis* has been reclassified as a fungus. In severe disease with room air Po<sub>2</sub> ≤70 mm Hg or A-a O<sub>2</sub> gradient ≥35 mm Hg, prednisone should also be used (Gagnon S, et al. *N Engl J Med*. 1990;323:1444; Caumes E, et al. *Clin Infect Dis*. 1994;18:319).<sup>91</sup>Primary/secondary prophylaxis in patients with HIV can be discontinued after the CD4 count increases to >200 × 10<sup>6</sup>/L for longer than 3 mo.<sup>92</sup>Plus leucovorin 25 mg with each dose of pyrimethamine.

Continued

**Table 325.1** Drugs for Parasitic Infections—cont'd

INFECTION	DRUG	ADULT DOSAGE	PEDIATRIC DOSAGE
ROUNDWORM, SEE ASCARIASIS			
SAPPINIA DIPLOIDEA, SEE AMEBIC MENINGOENCEPHALITIS, PRIMARY			
SCABIES ( <i>SARCOPTES SCABIEI</i> )			
Drug of choice:	5% Permethrin <sup>93</sup>	Topically, 2× at least 1 wk apart	Topically 2×, 1 wk apart, approved for ≥ 2 mo
Alternatives: <sup>93</sup>	Ivermectin <sup>7,93,94</sup>	200 µg/kg PO × 2 at least 1 wk apart	<15 kg: not indicated ≥15 kg: see adult dosing
	10% Crothamiton	Topically overnight on days 1, 2, 3, and 8	Topically overnight on days 1, 2, 3, and 8
SCHISTOSOMIASIS (BILHARZIASIS)			
<i>Schistosoma haematobium</i> or <i>Schistosoma intercalatum</i>			
Drug of choice:	Praziquantel	40 mg/kg/day PO in 1 or 2 doses × 1 day	40 mg/kg/day PO in 1 or 2 doses × 1 day <sup>37</sup>
<i>Schistosoma japonicum</i> or <i>Schistosoma mekongi</i>			
Drug of choice:	Praziquantel	60 mg/kg/day PO in 2 or 3 doses × 1 day	60 mg/kg/day PO in 3 doses × 1 day <sup>37</sup>
<i>Schistosoma mansoni</i>			
Drug of choice:	Praziquantel	40 mg/kg/day PO in 1 or 2 doses × 1 day	40 mg/kg/day PO in 1 or 2 doses × 1 day <sup>37</sup>
Alternative:	Oxamniquine <sup>95,96</sup>	15 mg/kg PO once	20 mg/kg/day PO in 2 doses × 1 day
Sleeping sickness, see Trypanosomiasis			
Strongyloidiasis ( <i>Strongyloides stercoralis</i> )			
Drug of choice: <sup>97</sup>	Ivermectin	200 µg/kg/day PO × 2 days	<15 kg: not indicated ≥15 kg: see adult dosing
Alternative:	Albendazole <sup>7,98</sup>	400 mg PO bid × 7 days	<10 kg/2 yr <sup>12</sup> ≥2 yr: see adult dosing
TAPEWORM INFECTION			
<i>Adult (intestinal stage)</i>			
<i>Diphyllobothrium latum</i> (fish), <i>Taenia saginata</i> (beef), <i>Taenia solium</i> (pork), <i>Dipylidium caninum</i> (dog)			
Drug of choice:	Praziquantel <sup>7</sup>	5-10 mg/kg PO once	5-10 mg/kg PO once <sup>37</sup>
Alternative:	Niclosamide	2 g PO once	50 mg/kg PO once
<i>Hymenolepis nana</i> (dwarf tapeworm)			
Drug of choice:	Praziquantel <sup>7</sup>	25 mg/kg PO once	25 mg/kg PO once <sup>37</sup>
Alternative:	Niclosamide <sup>99</sup>	2 g PO daily × 7 days	11-34 kg: 1 g PO on day 1 then 500 mg/day PO × 6 days >34 kg: 1.5 g PO on day 1 then 1 g/day PO × 6 days
<i>Larval (tissue stage)</i>			
<i>Echinococcus granulosus</i> (hydatid disease cystic echinococcosis)			
Drug of choice: <sup>100</sup>	Albendazole <sup>7</sup>	400 mg PO bid × 1-6 mo	<10 kg/2 yr: 10-15 mg/kg/day (max 800 mg/day) PO, in 2 doses <sup>12</sup> ≥2 yr: 15 mg/kg/day PO (max 400 mg) × 1-6 mo

<sup>93</sup>In some cases, treatment may need to be repeated in 10-14 days (Currie BJ, et al. *N Engl J Med*. 2010;362:717). A second ivermectin dose taken 2 wk later increased the cure rate to 95%, which is equivalent to that of 5% permethrin (Usha V, et al. *J Am Acad Dermatol*. 2000;42:236). Ivermectin, either alone or in combination with a topical scabicide, is the drug of choice for crusted scabies in immunocompromised patients (del Giudice P. *Curr Opin Infect Dis*. 2004;15:123).

<sup>94</sup>Ivermectin, either alone or in combination with a topical scabicide, is the drug of choice for crusted scabies in immunocompromised patients (del Giudice P. *Curr Opin Infect Dis*. 2004;15:123). The safety of oral ivermectin in pregnancy and young children has not been well studied. Ivermectin is included on the KIDS list (Meyers RS, et al. *J Pediatr Pharmacol Ther*. 2020;25:175) due to concerns about encephalopathy, but more recent studies suggest that it may be used safely (Levy M, et al. *Br J Dermatol*. 2020;182:1003).

<sup>95</sup>Oxamniquine has been effective in some areas in which praziquantel is less effective (Stelma FF, et al. *J Infect Dis*. 1997;176:304). Oxamniquine is contraindicated in pregnancy.

<sup>96</sup>In East Africa, the dose should be increased to 30 mg/kg, and in Egypt and South Africa to 30 mg/kg/day × 2 days. Some experts recommend 40-60 mg/kg over 2-3 days in all of Africa (Shekhar KC. *Drugs*. 1991;42:379).

<sup>97</sup>In immunocompromised patients or disseminated disease, it may be necessary to prolong or repeat therapy or to use other agents. Veterinary parenteral and enema formulations of ivermectin have been used in severely ill patients unable to take oral medications (Chiodini PL, et al. *Lancet*. 2000;355:43; Orem J, et al. *Clin Infect Dis*. 2003;37:152; Tarr PE. *Am J Trop Med Hyg*. 2003;68:453).

<sup>98</sup>Albendazole must be taken with food; a fatty meal increases oral bioavailability.

<sup>99</sup>Niclosamide must be thoroughly chewed or crushed and swallowed with a small amount of water. Nitazoxanide may be an alternative (Juan JO, et al. *Trans R Soc Trop Med Hyg*. 2002;96:193; Chero JC, et al. *Trans R Soc Trop Med Hyg*. 2007;101:203; Diaz E, et al. *Am J Trop Med Hyg*. 2003;68:384).

<sup>100</sup>Optimal treatment depends on multiple factors, including size, location, and number of cysts and presence of complications. In some patients, medical therapy alone is preferred, but some patients may benefit from surgical resection or percutaneous drainage of cysts. Praziquantel is useful preoperatively or in case of spillage of cyst contents during surgery. Puncture aspiration-injection-reaspiration (PAIR) with ultrasound guidance plus albendazole therapy has been effective for management of hepatic hydatid cyst disease (Smego RA Jr, et al. *Clin Infect Dis*. 2003;37:1073).

**Table 325.1** Drugs for Parasitic Infections—cont'd

INFECTION	DRUG	ADULT DOSAGE	PEDIATRIC DOSAGE
<i>Echinococcus multilocularis</i> (alveolar echinococcosis)			
Treatment of choice: See footnote <sup>101</sup>			
<b>Neurocysticercosis</b>			
<i>Taenia solium</i> (pork)			
1-2 viable parenchymal cysticerci <sup>115</sup>			
Treatment of choice: <sup>102,115</sup>	Albendazole	400 mg bid PO × 8-30 days; can be repeated as necessary	<10 kg/2 yr: 15 mg/kg/day PO in 2 doses (max dose 1200 mg/day) for 10-14 days with food
			≥2 yr: 15 mg/kg/day PO in 2 doses (max 1200 mg/day) for 10-14 days with food
>2 viable parenchymal cysticerci <sup>115</sup>			
	Albendazole plus praziquantel	—	15 mg/kg/day for 10-14 days 50 mg/kg/day for 10-14 days
<i>Single enhancing lesions (SELs) from cysticercosis</i> <sup>115</sup>			
	Albendazole	—	15 mg/kg/day bid with meals for 1–2 weeks
<i>Single enhancing lesions (SELs) from cysticercosis</i> <sup>115</sup>			
	Albendazole	—	15 mg/kg/day bid with meals for 1–2 weeks
<i>Calcified parenchymal lesions</i> <sup>115</sup>			
			Symptomatic therapy alone
			<i>plus steroids</i>
or	Surgical removal		

<sup>101</sup>Surgical excision is the only reliable means of cure. Reports have suggested that in nonresectable cases, the use of albendazole or mebendazole can stabilize and sometimes cure infection (Craig P. *Curr Opin Infect Dis.* 2003;16:437). Medical treatment is prolonged up to 2 yr or more.

<sup>102</sup>Initial therapy for patients with inflamed parenchymal cysticercosis should focus on symptomatic treatment with antiseizure medication. Treatment of parenchymal cysticerci with albendazole or praziquantel is controversial (Maguire JH. *N Engl J Med.* 2004;350:215). Patients with live parenchymal cysts who have seizures should be treated with albendazole together with steroids (6 mg dexamethasone or 40-60 mg prednisone daily) and an antiseizure medication (Garcia HH, et al. *N Engl J Med.* 2004;350:249). Some recent studies have shown improved outcomes with combination albendazole and praziquantel (Garcia HH, et al. *Lancet Infect Dis.* 2014;14:687). Patients with subarachnoid cysts or giant cysts in the fissures should be treated for at least 30 days (Proaño JV, et al. *N Engl J Med.* 2001;345:879). Surgical intervention or CSF diversion is indicated for obstructive hydrocephalus; prednisone 40 mg/day may be given with surgery. Arachnoiditis, vasculitis, or cerebral edema is treated with prednisone 60 mg/day or dexamethasone 4-6 mg/day together with albendazole or praziquantel (White AC Jr. *Annu Rev Med.* 2000;51:187). Any cysticercocidal drug may cause irreparable damage when used to treat ocular or spinal cysts, even when corticosteroids are used. An ophthalmic exam should always precede treatment to rule out intraocular cysts.

<sup>115</sup>For patients with 1-2 viable parenchymal cysticerci, albendazole monotherapy for 10-14 days compared to either no antiparasitic therapy (strong, high) or combination antiparasitic therapy (weak, moderate). We recommend albendazole (15 mg/kg/day) combined with praziquantel (50 mg/kg/day) for 10-14 days rather than albendazole monotherapy for patients with >2 viable parenchymal cysticerci (strong, moderate). We suggest retreatment with antiparasitic therapy for parenchymal cystic lesions persisting for 6 months after the end of the initial course of therapy (weak, low). We suggest albendazole therapy rather than no antiparasitic therapy for all patients with SELs (weak, moderate). Remarks: albendazole (15 mg/kg/day in twice-daily doses up for 1-2 weeks) should be given with meals. We recommend symptomatic therapy alone instead of antiparasitic drugs in patients with calcified parenchymal lesions (strong, moderate). (Infectious Diseases Society of America [IDSA] and the American Society of Tropical Medicine and Hygiene [ASTMH]. Diagnosis and treatment of neurocysticercosis: 2017 Clinical Practice Guidelines by the CID. Published 2/22/2018. *Clin Infect Dis* 2018;66(8):e49-e75.)

Continued



**Table 325.1** Drugs for Parasitic Infections—cont'd

INFECTION	DRUG	ADULT DOSAGE	PEDIATRIC DOSAGE
TOXOCARIASIS, SEE VISCERAL LARVA MIGRANS			
TOXOPLASMOSIS ( <i>TOXOPLASMA GONDII</i> ) <sup>103</sup> (ACQUIRED OR OCULAR INFECTION)			
Drugs of choice: <sup>104,105</sup>	Pyrimethamine <sup>106</sup>	Dosage is adjusted for weight, but 50 mg PO bid on days 1 and 2, then 50 mg qd is maximum. Duration depends on clinical response, treating at least 1-2 wk beyond complete resolution and end of any immune compromise or immaturity. Please see <a href="#">Chapter 336</a>	1 mg/kg (max 50 mg) bid × 2 days, then 1 mg/kg qd (max 50 mg). Duration depends on clinical response, treating at least 1-2 wk beyond complete resolution and end of any immune compromise or immaturity. Please see <a href="#">Chapter 336</a> <sup>107</sup> Calcium leucovorin is always given with pyrimethamine and in the week after discontinuing Please see formulation and instructions for infants in <a href="#">Chapter 336</a> In the United States pyrimethamine serum levels can be measured at NMS Laboratories in Philadelphia Pyrimethamine cannot be given in the first trimester of pregnancy
	plus sulfadiazine	1.5 g PO bid is a standard dose for a 100-lb person, maximum 2 g PO bid. Duration depends on clinical response, treating at least 1-2 wk beyond complete resolution and end of any immune compromise or immaturity. Please see <a href="#">Chapter 336</a> .	1.5 g PO bid is a standard dose for a 100-lb person, maximum 2 g PO bid. Duration depends on clinical response, treating at least 1-2 wk beyond complete resolution and end of any immune compromise or immaturity. Please see <a href="#">Chapter 336</a> This is used with pyrimethamine for synergy
Alternative for sulfadiazine or for suppression/prophylaxis	Trimethoprim-sulfamethoxazole (TMP-SMX)	1 double-strength tablet daily. <i>Alternative dosing:</i> one double-strength tablet 3 times weekly. <i>Adult alternative regimen:</i> Trimethoprim-sulfamethoxazole (TMP-SMX) – 5 mg/kg trimethoprim and 25 mg/kg sulfamethoxazole given PO or IV bid Clindamycin (600 mg IV or PO 4 times daily) plus oral pyrimethamine (200 mg loading dose followed by 50 mg daily among patients <60 kg or 75 mg daily among patients ≥60 kg) plus oral leucovorin (10 to 25 mg daily).	TMP-SMX 150/750 mg/m <sup>2</sup> body surface area once daily PO
TRICHINELLOSIS ( <i>TRICHINELLA SPIRALIS</i> )			
Drugs of choice:	Steroids for severe symptoms	Prednisone 30-60 mg PO daily × 10-15 days	
	plus Albendazole <sup>7</sup>	400 mg PO bid × 8-14 days	<10 kg/2 yr <sup>12</sup> ≥2 yr: see adult dosing
Alternative:	Mebendazole <sup>7</sup>	200-400 mg PO tid × 3 days, then 400-500 mg PO tid × 10 days	200-400 mg PO tid × 3 days, then 400-500 mg PO tid × 10 days <sup>13</sup>
TRICHOMONIASIS ( <i>TRICHOMONAS VAGINALIS</i> )			
Drug of choice: <sup>108</sup>	Metronidazole	2 g PO once or 500 mg PO bid × 7 days	15 mg/kg/day PO in 3 doses × 7 days
or	Tinidazole <sup>4</sup>	2 g PO once	50 mg/kg PO once (max 2 g)
TRICHOSTRONGYLUS INFECTION			
Drug of choice:	Pyrantel pamoate <sup>7</sup>	11 mg/kg base PO once (max 1 g)	11 mg/kg PO once (max 1 g)
Alternative:	Mebendazole <sup>7</sup>	100 mg PO bid × 3 days	100 mg PO bid × 3 days <sup>13</sup>
	Albendazole <sup>7</sup>	400 mg PO once	<10 kg/2 yr <sup>12</sup> ≥2 yr: 15 mg/kg/day PO (max 800 mg) × 1-6 mo

<sup>103</sup>In ocular toxoplasmosis with macular involvement, corticosteroids are recommended in addition to antiparasitic therapy for an antiinflammatory effect.<sup>104</sup>To treat CNS toxoplasmosis in HIV-infected patients, some clinicians have used pyrimethamine 50-100 mg/day (after a loading dose of 200 mg) with sulfadiazine and, when sulfonamide sensitivity developed, have given clindamycin 1.8-2.4 g/day in divided doses instead of the sulfonamide. Atovaquone plus pyrimethamine appears to be an effective alternative in sulfonamide-intolerant patients (Chirgwin K, et al. *Clin Infect Dis*. 2002;34:1243). Treatment is followed by chronic suppression with lower-dosage regimens of the same drugs. For primary prophylaxis in HIV patients with <100 × 10<sup>6</sup>/L CD4 cells, either trimethoprim-sulfamethoxazole, pyrimethamine with dapsone, or atovaquone with or without pyrimethamine can be used. Primary or secondary prophylaxis may be discontinued when the CD4 count increases to >200 × 10<sup>6</sup>/L for more than 3 mo (Benson CA, et al. *MMWR Recomm Rep*. 2004;53[RR-15]:1).<sup>105</sup>Women who develop toxoplasmosis during the first trimester of pregnancy can be treated with spiramycin (3-4 g/day). After the first trimester, if there is no documented transmission to the fetus, spiramycin can be continued until term. If transmission has occurred in utero, therapy with pyrimethamine and sulfadiazine should be started (Montoya JG, et al. *Lancet*. 2004;363:1965). Pyrimethamine is a potential teratogen and should be used only after the first trimester.<sup>106</sup>Plus leucovorin 10-25 mg with each dose of pyrimethamine.<sup>107</sup>Congenitally infected newborns should be treated with pyrimethamine every 2 or 3 days and a sulfonamide daily for about 1 yr (Remington JS, et al., eds. *Infectious Disease of the Fetus and Newborn Infant*. 5th ed. Philadelphia: WB Saunders; 2001: p. 290).<sup>108</sup>Sexual partners should be treated simultaneously. Metronidazole-resistant strains have been reported and can be treated with higher doses of metronidazole (2-4 g/day × 7-14 days) or with tinidazole (Hager WD. *Sex Transm Dis*. 2004;31:343).

**Table 325.1** Drugs for Parasitic Infections—cont'd

INFECTION	DRUG	ADULT DOSAGE	PEDIATRIC DOSAGE
<b>TRICHURIASIS (TRICHURIS TRICHIURA, WHIPWORM)</b>			
Drug of choice:	Mebendazole	100 mg PO bid × 3 days	100 mg PO bid × 3 days <sup>13</sup>
Alternative:	Albendazole <sup>7</sup>	400 mg PO × 3 days	<10 kg/2 yr <sup>12</sup> ≥2 yr: see adult dosing
or	Ivermectin <sup>7</sup>	200 µg/kg PO daily × 3 days	<15 kg: not indicated ≥15 kg: see adult dosing
<b>TRYPANOSOMIASIS<sup>109</sup></b>			
<i>Trypanosoma cruzi</i> (American trypanosomiasis, Chagas disease)			
Drug of choice:	Benznidazole <sup>28</sup>	5-7 mg/kg/day PO in 2 divided doses × 60 days	≤12 yr: 5-7.5 mg/kg/day PO in 2 divided doses × 60 days >12 yr: see adult dosing
Alternative:	Nifurtimox <sup>28,110</sup>	8-10 mg/kg/day PO in 3-4 doses × 90 days	≤10 yr: 15-20 mg/kg/day PO in 3-4 doses × 90 days 11-16 yr: 12.5-15 mg/kg/day in 3-4 doses × 90 days >16 yr: see adult dosing
<i>Trypanosoma brucei gambiense</i> (West African trypanosomiasis, sleeping sickness)			
Hemolympathic stage			
Drug of choice <sup>111</sup>	Pentamidine isethionate <sup>7</sup>	4 mg/kg/day IM × 7-10 days	4 mg/kg/day IM or IV × 7-10 days
Alternative:	Suramin <sup>28</sup>	100 mg (test dose) IV, then 1 g IV on days 1, 3, 7, 14, and 21	2 mg/kg (test dose) IV, then 20 mg/kg IV on days 1, 3, 7, 14, and 21
Late disease with CNS involvement			
Drug of choice:	Eflornithine <sup>28,112</sup>	100 mg/kg IV qid × 14 days	100 mg/kg IV qid × 14 days
Alternative:	Melarsoprol <sup>28,113</sup>	2-3.6 mg/kg (max 200 mg) daily IV (progressively increased during series) × 3 days After 7 days, 3.6 mg/kg daily × 3 days After 7 days, give a third series of 3.6 mg/kg daily × 3 days.	2-3.6 mg/kg (max 200 mg) daily IV (progressively increased during series) × 3 days After 7 days, 3.6 mg/kg daily × 3 days After 7 days, give a third series of 3.6 mg/kg daily × 3 days
<i>Trypanosoma brucei rhodesiense</i> (East African trypanosomiasis, sleeping sickness)			
Hemolympathic stage			
Drug of choice:	Suramin <sup>28</sup>	100 mg (test dose) IV, then 1 g IV on days 1, 3, 7, 14, and 21	2 mg/kg (test dose), then 20 mg/kg IV on days 1, 3, 7, 14, and 21
Late disease with CNS involvement			

<sup>109</sup>Barrett MP, et al. *Lancet*. 2003;362:1469.<sup>110</sup>The addition of  $\gamma$ -interferon to nifurtimox for 20 days in experimental animals and in a limited number of patients appears to shorten the acute phase of Chagas disease (McCabe RE, et al. *J Infect Dis*. 1991;163:912).<sup>111</sup>For treatment of *Trypanosoma brucei gambiense*, pentamidine and suramin have equal efficacy but pentamidine is better tolerated.<sup>112</sup>Eflornithine is highly effective in *Trypanosoma brucei gambiense* but not against *Trypanosoma brucei rhodesiense* infections. It is available in limited supply only from the WHO and the CDC. Eflornithine dose may be reduced to 400 mg/kg IV in 2 doses for 7 days when used in conjunction with nifurtimox at a dose of 5 mg/kg PO tid × 10 days (Priotto G, et al. *Lancet*. 2009;374:56).<sup>113</sup>In frail patients, begin with as little as 18 mg and increase the dose progressively. Pretreatment with suramin has been advocated for debilitated patients. Corticosteroids have been used to prevent arsenical encephalopathy (Pépin J, et al. *Trans R Soc Trop Med Hyg*. 1995;89:92). Up to 20% of patients with *Trypanosoma brucei gambiense* fail to respond to melarsoprol (Barrett MP. *Lancet*. 1999;353:1113). Consultation with experts at the CDC is recommended.

Continued

**Table 325.1** Drugs for Parasitic Infections—cont'd

INFECTION	DRUG	ADULT DOSAGE	PEDIATRIC DOSAGE
Drug of choice:	Melarsopro <sup>128,112</sup>	2-3.6 mg/kg (max 200 mg) daily IV (progressively increased during series) × 3 days After 7 days, 3.6 mg/kg daily × 3 days After 7 days, give a third series of 3.6 mg/kg daily × 3 days	2-3.6 mg/kg (max 200 mg) daily IV (progressively increased during series) × 3 days After 7 days, 3.6 mg/kg daily × 3 days After 7 days, give a third series of 3.6 mg/kg daily × 3 days
VISCERAL LARVA MIGRANS (TOXOCARIASIS) <sup>114</sup>			
Drugs of choice:	Albendazole <sup>7</sup>	400 mg PO bid × 5 days	<10 kg/2 yr <sup>12</sup> ≥2 yr: see adult dosing
or	Mebendazole <sup>7</sup>	100-200 mg PO bid × 5 days	100-200 mg PO bid × 5 days <sup>13</sup>
WHIPWORM, SEE TRICHURIASIS			
WUCHERERIA BANCROFTI, SEE FILARIASIS			

<sup>114</sup>Optimum duration of therapy is not known; some consultants would treat for 20 days. For severe symptoms or eye involvement, corticosteroids can be used in addition. bid, Twice a day; CDC, Centers for Disease Control and Prevention; CNS, central nervous system; CSF, cerebrospinal fluid; DEC, diethylcarbamazine; DS, double strength; FDA, U.S. Food and Drug Administration; GI, gastrointestinal; HAART, highly active antiretroviral therapy; IDSA, Infectious Disease Society of America; IM, intramuscularly; IND, investigational new drugs; IV, intravenously; OTC, over the counter; PO, by mouth; qd, once a day; qid, four times a day; tid, three times a day; WHO, World Health Organization.

Adapted from Drugs for parasitic infection. *Med Lett.* 2013;11(Suppl):e1–e23. Available at <http://www.medicalletter.org>

drug approved for use by the FDA for patients ≥5 kg. It is a fixed-dose combination of two novel antimalarials, artemether (20 mg) and lumefantrine (120 mg). It is a highly effective 3-day malaria treatment, with cure rates of >96%, even in areas of multidrug resistance. It can be used to treat chloroquine-resistant uncomplicated malaria during the second and third trimesters of pregnancy and as an alternative agent in the first trimester. Artesunate was approved by the FDA for intravenous (IV) treatment for severe malaria in 2020.

## SELECTED ANTIPARASITIC DRUGS FOR HELMINTHS AND ECTOPARASITES

### Albendazole (Albenza)

Albendazole is a benzimidazole carbamate structurally related to mebendazole and has similar anthelmintic activity. Its absorption from the gastrointestinal tract is poor but improved with a concomitant high-fat meal. Albendazole sulfoxide, the principal metabolite with anthelmintic activity, has a plasma half-life of 8.5 hours. It is widely distributed in the body, including the bile and cerebrospinal fluid. It is eliminated in bile. Albendazole is FDA approved for treatment of two cestode (tapeworm) infections: neurocysticercosis and hydatid diseases (*Echinococcus granulosus*). It is used off-label for numerous other **helminth** infections, including cutaneous larva migrans (*Ancylostoma caninum* and *Ancylostoma braziliense*), ascariasis (*Ascaris lumbricoides*), liver flukes (*Clonorchis sinensis* and *Opisthorchis viverrini*), pinworm (*Enterobius vermicularis*), lymphatic filariasis (*Wuchereria bancrofti*, *Brugia malayi*, *Brugia timori*), gnathostomiasis (*Gnathostoma* spp.), hookworms (*Ancylostoma duodenale* and *Necator americanus*), microsporidiosis, trichinellosis (*Trichinella spiralis*), and visceral larva migrans (*Toxocara canis* and *Toxocara cati*). Albendazole is generally well tolerated. Common adverse effects include headache, nausea, vomiting, and abdominal pain. Serious adverse effects include elevated liver enzymes and leukopenia, which have occurred in a few patients with treatment of hydatid disease. Rare adverse effects include acute renal failure, pancytopenia, granulocytopenia, and thrombocytopenia. Despite the fact that albendazole and other antiparasitic drugs, including mebendazole, praziquantel, and pyrimethamine, have been in use for decades, the number of manufacturers is small and costs have risen in recent years. Data are limited in pregnancy, and treatment during

pregnancy generally deferred if possible. Albendazole is excreted in breast milk but is generally considered compatible with breastfeeding by the WHO.

### Ivermectin (Stromectol, Mectizan)

Ivermectin is a semisynthetic derivative of one of the avermectins, which is a group of macrocyclic lactones produced by *Streptomyces avermitilis*. After oral administration, ivermectin has peak plasma concentrations after approximately 4 hours and a plasma elimination half-life of approximately 12 hours. It is excreted as metabolites over a 2-week period via feces. It is FDA approved for treatment of two nematode (roundworm) infections: onchocerciasis (*Onchocerca volvulus*) and strongyloidiasis (*Strongyloides stercoralis*). It may have some effect in treating a broad range of other **helminths** and **ectoparasites**, including cutaneous larva migrans (*Ancylostoma braziliense*), ascariasis (*Ascaris lumbricoides*), loiasis, pinworm (*Enterobius vermicularis*), whipworm (*Trichuris trichiura*), gnathostomiasis (*Gnathostoma spinigerum*), *Mansonella* infections, lice (*Pediculus humanus* and *Phthirus pubis*), mites (*Demodex* spp.), and scabies (*Sarcoptes scabiei*). Combination therapies of ivermectin with albendazole or diethylcarbamazine are being used to treat lymphatic filariasis. Combination therapy with albendazole and the off-label use of veterinary injectable formulations have been used to treat complicated *Strongyloides* infections, including disseminated disease and hyperinfection syndrome. Though there has been significant public interest in ivermectin as a treatment for SARS-CoV-2, clinical studies have not shown efficacy. Common adverse events include dizziness, headache, pruritus, and gastrointestinal effects. Serious adverse events include encephalopathy due to pathogenic variants in the *ABCB1* transporter and **Mazzotti reactions** in patients with onchocerciasis, including arthralgia, synovitis, enlarged lymph nodes, rash, and fever secondary to microfilaria death. A topical formulation is available for treatment of head lice, which are increasingly becoming very resistant to over-the-counter medications such as permethrins. Data are limited in pregnancy, and other agents are preferred if available for a given condition. Ivermectin is excreted in breast milk, and decisions to use this medication while breastfeeding should consider the risks and benefits of therapy based on the specific indication.

**Praziquantel (Biltricide)**

Praziquantel achieves its antiparasitic activity via the pyrazino isoquinoline ring system and was originally synthesized as a potential tranquilizer. After oral administration, praziquantel is rapidly absorbed, with peak levels in 1-2 hours and a plasma half-life of about 1-3 hours. Elimination via the urine and feces is >80% complete after 24 hours. Praziquantel is metabolized in the liver by the microsomal cytochrome P450 (especially 2B1 and 3A). Bioavailability of praziquantel is increased with concomitant administration of agents that inhibit cytochrome P450. Praziquantel is FDA approved for treatment of several species of trematodes (flatworms) including the Chinese liver fluke (*Clonorchis sinensis*), Southeast Asian liver fluke (*Opisthorchis viverrini*), and schistosomiasis (*Schistosoma* spp.). It is used off-label for treatment of additional trematode pathogens, including the North American liver fluke (*Metorchis conjunctus*), *Nanophyetus salmincola*, intestinal flukes (*Fasciolopsis buski*, *Heterophyes heterophyes*, *Metagonimus yokogawai*), and lung flukes (*Paragonimus westermani*, *Paragonimus kellicotti*). It is also used off-label for multiple cestode (tapeworm) infections. Adverse effects can be seen in 30–60% of patients, although most are mild and disappear within 24 hours. Common adverse effects include headache, abdominal pain, dizziness, and malaise. Serious but rare adverse effects include arrhythmias, heart block, and convulsions.

## Section 15

**Protozoan Diseases**

## Chapter 326

**Primary Amebic Meningoencephalitis**

Matthew D. Eberly

*Naegleria*, *Acanthamoeba*, *Balamuthia*, and *Sappinia* are small, free-living amoebae that cause human amebic meningoencephalitis, which has two distinct clinical presentations. The more common is an acute, fulminant, and usually fatal **primary amebic meningoencephalitis** caused by *Naegleria fowleri* that occurs in previously healthy children and young adults. **Granulomatous amebic meningoencephalitis**, which is caused by *Acanthamoeba*, *Balamuthia*, and *Sappinia*, is a more indolent infection that typically occurs in immunocompromised hosts and may also present with a disseminated form of the disease.

**ETIOLOGY**

*Naegleria* is an ameboflagellate that can exist as cyst, trophozoite, and transient flagellate forms. Temperature and environmental nutrient and ion concentrations are the major factors that determine the stage of the amoeba. Trophozoites are the only stages that are invasive, although cysts are potentially infective because they can convert to the vegetative form very quickly under the proper environmental stimuli. Although there are over 40 species of *Naegleria*, only *Naegleria fowleri* has been shown to be pathogenic for humans.

*Acanthamoeba* exists in cyst and motile trophozoite forms; only the trophozoite form is invasive. Cases of *Acanthamoeba keratitis* usually follow incidents of trivial corneal trauma followed by flushing

with contaminated tap water. Infections can also occur among contact lens wearers who come into contact with contaminated water during swimming or use contact lenses cleaned or stored in contaminated tap water. Granulomatous amebic encephalitis from *Acanthamoeba* occurs worldwide and is associated with an immunocompromising condition such as HIV infection, diabetes mellitus, chronic liver disease, renal failure, immunosuppressive therapy, or radiation therapy.

*Balamuthia mandrillaris* has been implicated as an etiology of granulomatous amebic encephalitis. Although the clinical presentation is similar to infection with *Acanthamoeba*, most patients are not immunocompromised.

Other free-living amoebae can also cause infection, as illustrated by a case report of *Sappinia pedata* granulomatous encephalitis.

**EPIDEMIOLOGY**

The free-living amoebae have a worldwide distribution. *Naegleria* species have been isolated from a variety of freshwater sources, including ponds and lakes, domestic water supplies, hot springs and spas, thermal discharge of power plants, groundwater, and, occasionally, from the nasal passages of healthy children. *Acanthamoeba* species have been isolated from soil, mushrooms, vegetables, brackish water, and seawater, as well as most of the freshwater sources for *Naegleria*. It can also be found in tap water because chlorination does not kill *Acanthamoeba*. *Balamuthia* is present in soil and may be transmitted by inhalation or contamination of preexisting skin lesions.

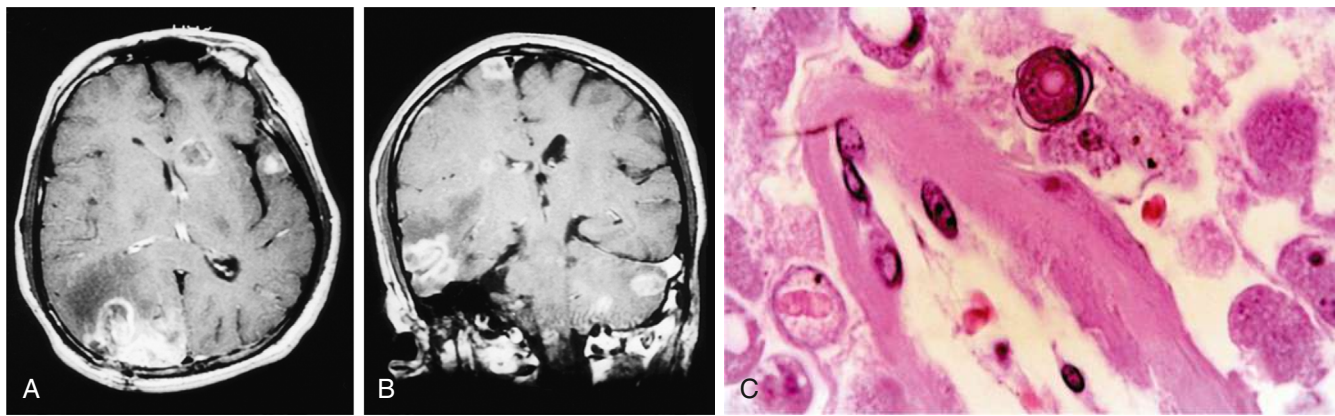
*Naegleria* meningoencephalitis has been reported from every continent except Antarctica. Most of the cases occur during the summer months in previously healthy individuals who have a history of swimming in or contact with freshwater lakes and rivers before their illness. Between 1962 and 2022, 157 cases of primary amebic meningoencephalitis (PAM) were reported in the United States. Most of the reports have come from the southern and southwestern states, particularly Florida and Texas, but infections have occurred in Kansas, Indiana, and Minnesota. Of note, cases have been linked to sinus irrigation with neti pots containing contaminated tap water; exposure to a lawn water slide, which derived its tap water from a treated public drinking water system; a chlorinated recreational splash pad; a swimming pool supplied by an overland water pipe; and rafting on an artificial whitewater river.

**PATHOGENESIS**

The free-living amoebae enter the nasal cavity by inhalation or aspiration of dust or water contaminated with trophozoites or cysts. *Naegleria* gains access to the central nervous system through the olfactory epithelium and migrates via the olfactory nerve to the olfactory bulbs located in the subarachnoid space and bathed by the cerebrospinal fluid (CSF). This space is richly vascularized and is the route of spread to other areas of the central nervous system. Grossly, there is widespread cerebral edema and hyperemia of the meninges. The olfactory bulbs are necrotic, hemorrhagic, and surrounded by a purulent exudate. Microscopically, the gray matter is the most severely affected, with severe involvement in all cases. Fibrinopurulent exudate may be found throughout the cerebral hemispheres, brainstem, cerebellum, and upper portions of the spinal cord. Pockets of trophozoites may be seen in necrotic neural tissue, usually in the perivascular spaces of arteries and arterioles.

The route of invasion and penetration in cases of granulomatous amebic meningoencephalitis caused by *Acanthamoeba* and *Balamuthia* may be by direct spread through olfactory epithelium or hematogenous spread from a primary focus in the skin or lungs. Pathologic examination reveals granulomatous encephalitis, with multinucleated giant cells mainly in the posterior fossa structures, basal ganglia, bases of the cerebral hemispheres, and cerebellum. Both trophozoites and cysts may be found in the central nervous system lesions, primarily located in the perivascular spaces and invading blood vessel walls. The olfactory bulbs and spinal cord are usually spared. The single case of *Sappinia* encephalitis followed a sinus infection, and evaluation revealed a solitary 2 cm temporal lobe mass with mild ring enhancement.





**Fig. 326.1** A and B, MRIs of the brain of a patient with *Balamuthia mandrillaris* granulomatous amebic encephalitis. Multiple enhancing lesions are seen in the right hemisphere, left cerebellum, midbrain, and brainstem. C, Photomicrograph of the brain lesion from the same patient showing perivascular amebic trophozoites. A round amebic cyst with a characteristic double wall is seen in the top center (hematoxylin and eosin, original magnification  $\times 100$ ). (From Deol I, Robledo L, Meza A, et al. Encephalitis due to a free-living amoeba [*Balamuthia mandrillaris*]: case report with literature review. *Surg Neurol.* 2000;53:611–616.)

### CLINICAL MANIFESTATIONS

The incubation period of *Naegleria* infection may be as short as 2 days or as long as 15 days. Symptoms have an acute onset and progress rapidly. Infection is characterized by a sudden onset of severe headache, fever, pharyngitis, nasal congestion or discharge, and nausea and vomiting, followed by altered mental status, nuchal rigidity, photophobia, confusion, somnolence, seizures, and ultimately coma. Most cases end in death within 3–10 days after onset of symptoms.

**Granulomatous amebic meningoencephalitis** may occur weeks to months after the initial infection. The presenting signs and symptoms are often those of single or multiple central nervous system space-occupying lesions and include hemiparesis, ataxia, personality changes, seizures, and drowsiness. Altered mental status is often a prominent symptom. Headache and fever occur only sporadically, but stiff neck is seen in a majority of cases. Cranial nerve palsies, especially of cranial nerves III and VI, may be present. There is also one report of acute hydrocephalus and fever with *Balamuthia*. Granulomatous amebic meningoencephalitis is usually fatal after 4–6 weeks of illness. Results of neuroimaging studies of the brain usually demonstrate multiple low-density lesions resembling infarcts or enhancing lesions of granulomas (Fig. 326.1).

### DIAGNOSIS

The CSF in *Naegleria* infection may mimic that of herpes simplex encephalitis early in the disease and that of acute bacterial meningitis later in the disease, with a neutrophilic pleocytosis, elevated protein level, and hypoglycorrhachia. Motile amebae may be visualized on a wet mount of freshly drawn CSF using Wright or Giemsa stains, but they are often mistaken for lymphocytes or macrophages. Because *Naegleria* are the only amebae that differentiate into the flagellate state in a hypotonic environment, placing a drop of fresh CSF in 1 mL of distilled water and watching for the development of swimming flagellates after 1–2 hours can confirm the diagnosis of *Naegleria*. *Naegleria* can also be grown on a non-nutrient agar plate coated with *Escherichia coli*, on which they feed. Polymerase chain reaction (PCR) and immunofluorescence assays for *Naegleria* performed on CSF and biopsy material are available through the U.S. Centers for Disease Control and Prevention (CDC).

The diagnosis of granulomatous amebic meningoencephalitis relies on the isolation or histologic identification of *Acanthamoeba* trophozoites or cysts from brain tissue specimens. The CSF findings of granulomatous meningoencephalitis reveal lymphocytic pleocytosis, moderately elevated protein, and low glucose concentrations. However, motile trophozoites of *Acanthamoeba* are more difficult to isolate than *Naegleria*, and the CSF is typically sterile. *Acanthamoeba* may be cultured from the same agar used for growing *Naegleria*, but *Balamuthia* must be grown on mammalian cell cultures. Pediatric cases of *Balamuthia* meningoencephalitis have

been diagnosed antemortem by brain biopsy as well as postmortem. PCR and immunofluorescence assays can be used on specimens to identify *Acanthamoeba* and *Balamuthia* species, and are also available from the CDC.

### TREATMENT

*Naegleria* infection is nearly always fatal, but early recognition and treatment are crucial to survival. Until 2013, there had been only two known survivors in North America, with treatment regimens of amphotericin B, either alone or in combination with other agents such as rifampin, chloramphenicol, fluconazole, ketoconazole, and dexamethasone. In 2013, however, the CDC made available the anti-leishmanial drug **miltefosine** for the treatment of primary amebic meningoencephalitis. That summer, two children who contracted *Naegleria* both survived; both patients received oral miltefosine as part of their treatment, and one underwent external ventricular drain placement and therapeutic hypothermia. Miltefosine is now commercially available in the United States ([www.impavido.com](http://www.impavido.com)). **The recommended drug treatment for primary amebic meningoencephalitis by the CDC includes intravenous and intrathecal amphotericin B, oral miltefosine, along with azithromycin, fluconazole, rifampin, and dexamethasone.** Early identification, early initiation of combination therapy, and aggressive management of increased intracranial pressure remain key elements for a successful outcome. For suspected cases, clinicians should contact the CDC Emergency Operations Center at (770) 488-7100 for assistance.

The optimal therapy for granulomatous amebic meningoencephalitis is uncertain. However, miltefosine has likewise been used to successfully treat patients with *Balamuthia* and disseminated *Acanthamoeba* infections. Strains of *Acanthamoeba* isolated from fatal cases are usually susceptible in vitro to pentamidine, ketoconazole, and flucytosine and less so to amphotericin B. One patient was successfully treated with sulfadiazine and fluconazole, and another was successfully treated with intravenous pentamidine followed by oral itraconazole. *Acanthamoeba* keratitis responds to long courses of topical propamidine–polymyxin B sulfate or topical polyhexamethylene biguanide or chlorhexidine gluconate, and antifungal azoles plus topical steroids. Limited success has been demonstrated in *Balamuthia* infection with systemic azole therapy combined with flucytosine. More recently, the combination of flucytosine, pentamidine, fluconazole, sulfadiazine, azithromycin, and phenothiazines resulted in the survival of two patients with *Balamuthia* meningoencephalitis, although both were left with mild neuromotor and cognitive impairment. Corticosteroids before initiating effective therapy appear to have a detrimental effect, contributing to rapid progression of disease.

Visit Elsevier eBooks+ at [eBooks.Health.Elsevier.com](http://eBooks.Health.Elsevier.com) for Bibliography.

## Chapter 327

## Amebiasis

Edsel Maurice T. Salvana and  
Robert A. Salata

*Entamoeba* species infect or colonize up to 10% of the world's population, with a disproportionate burden of illness in resource-limited settings. In most infected individuals, *Entamoeba histolytica* or a related species infects the lumen of the gastrointestinal tract and causes few symptoms or sequelae. Although *E. histolytica* is the only confirmed invasive species, other *Entamoeba* species have been implicated in human disease. Molecular epidemiology is helping detail the role that these diverse protozoans play in human health. Invasive *E. histolytica* infection can lead to **amebic colitis**, **amebic liver abscess**, and, less commonly, abscesses in other extraintestinal sites.

## ETIOLOGY

Four morphologically identical but genetically distinct species of *Entamoeba* are known to infect humans. *Entamoeba histolytica*, the main pathogenic species, causes a spectrum of disease and can become invasive in 4–10% of infected patients. *Entamoeba dispar*, the most prevalent species, does not cause symptomatic disease. *Entamoeba moshkovskii*, can cause diarrhea in infants and children, and asymptomatic infection with *E. moshkovskii* may be as common as *E. dispar* infection in some communities. Patients previously described as asymptomatic carriers of *E. histolytica* based on microscopy findings were likely harboring *E. dispar* or *E. moshkovskii*. A fourth species, *E. bangladeshi*, was discovered in Bangladesh in 2012 and has recently been found in South Africa. The potential for *E. bangladeshi* to cause human disease remains unclear. Four other species of nonpathogenic *Entamoeba* are known to colonize the human gastrointestinal tract: *Entamoeba coli*, *E. hartmanni*, *E. gingivalis*, and *E. polecki*. A fifth species, *E. nuttalli*, typically infects nonhuman primates such as macaques, but a case of asymptomatic infection has been described in a zookeeper.

Infection is usually acquired through the ingestion of parasite cysts, which measure 10–18  $\mu\text{m}$  in diameter and contain four nuclei. Cysts are resistant to harsh environmental conditions, including chlorine concentrations commonly used in water purification, but can be killed by heating them to 55°C (131°F). Cysts are resistant to gastric acidity and digestive enzymes and germinate in the small intestine to form trophozoites. These large, actively motile organisms colonize the lumen of the large intestine and may invade the mucosal lining. Some eventually transform to cysts and are passed out in the stool to infect other hosts anew.

## EPIDEMIOLOGY

The prevalence of infection with *E. histolytica* varies greatly by region and socioeconomic status. Early prevalence studies did not distinguish between *E. histolytica* and *E. dispar*, but more recent estimates show that infection with *E. histolytica* causes 100 million cases of symptomatic disease and 2,000 to 17,000 deaths annually. Molecular studies have put the global prevalence of *E. histolytica* at 3.55%, ranging from 1.72% to 21.58% in different regions of the world.

Prospective studies have shown that 4–10% of individuals infected with *E. histolytica* develop amebic colitis and that <1% of infected individuals develop disseminated disease, including amebic liver abscess. These numbers vary by region; for example, in South Africa and Vietnam, liver abscesses form a disproportionately large number of the cases of invasive disease due to *E. histolytica*. Amebic liver abscesses occur equally in male and female children but are generally rare in childhood. Peak abscess formation occurs in individuals between 30–60 years old and is 10–12 times more prevalent in adult males than females.

Amebiasis causes its largest burden of disease in Africa, Southeast Asia, and the Eastern Mediterranean. In the United States, amebiasis

is seen most frequently in travelers to and immigrants from developing countries. Residents of mental health institutions and men who have sex with men are at increased risk for invasive amebiasis. Food or drink contaminated with *Entamoeba* cysts and oral-anogenital sex are the most common means of infection. Untreated water and night soil (human feces used as fertilizer) are important sources of infection in resource-limited settings. Food handlers shedding amebic cysts play a role in spreading infection.

## PATHOGENESIS

Trophozoites are responsible for tissue invasion and destruction. *E. histolytica* secretes many proteases, the best described of which is amebic cysteine protease 5 (EhCP5). EhCP5 cleaves MUC2 mucin, degrading the intestinal mucus layer and exposing colonic epithelial cells. MUC2 is also involved in regulating antimicrobial peptide production by Paneth cells during *E. histolytica* infection. Amebae then attach using a galactose and *N*-acetyl-D-galactosamine-specific lectin. This lectin also provides resistance to complement-mediated lysis, and its intermediate subunit has been found to have hemagglutinating, hemolytic, and cytolytic activity.

Once attached to the colonic mucosa, trophozoites penetrate the epithelial layer, destroying host cells by cytolysis and induction of apoptosis. Cytolysis is mediated by trophozoite release of amebapores (pore-forming proteins), phospholipases, and hemolysins. Once host cells are partially digested by amebic proteases, the degraded material is internalized through phagocytosis. Trophocytosis is another mechanism that amebae use to kill host cells. This involves ingesting pieces of living cells, inducing intracellular calcium elevation leading to apoptosis.

Early invasive amebiasis produces significant inflammation, owing in part to parasite-mediated activation of nuclear factor- $\kappa\text{B}$ . Once *E. histolytica* trophozoites invade the intestinal mucosa, the organisms multiply and spread laterally underneath the intestinal epithelium to produce the characteristic *flask-shaped ulcers*. Amebae produce similar lytic lesions if they reach the liver. These lesions are commonly called *abscesses*, although they contain no granulocytes. Well-established ulcers and amebic liver abscesses demonstrate little local inflammatory response.

Immunity to infection is associated with a mucosal secretory IgA response against the galactose/*N*-acetyl-D-galactosamine lectin.

Macrophages are among the earliest responders, mediating phagocytosis and secreting cytokines to recruit other inflammatory cells. Eosinophilia is common in parasitic infections and may play a role in IgA regulation. Neutrophils are generally protective and exert amebicidal activity by phagocytosis, degranulation, and formation of neutrophil extracellular traps (NETs). The disparity between the extent of tissue destruction by amebae and the absence of a local host inflammatory response in the presence of systemic humoral and cell-mediated responses may reflect both parasite-mediated apoptosis and the ability of the trophozoite to kill not only epithelial cells but also neutrophils, monocytes, and macrophages.

The *E. histolytica* genome is functionally tetraploid, and there is evidence of lateral gene transfer from bacteria. The amebapore-A (*Ap-A*) gene, along with other important genes, can be epigenetically silenced using plasmids with specifically engineered sequences or short hairpin RNAs. Transcriptional profiling using proteomics and microarrays has identified multiple virulence factors, including cysteine proteases, which modulate lysosome and phagosome function, as well as excretory-secretory proteins. Many calcium-binding proteins are encoded and are involved in motility, adhesion, cytolysis, and phagocytosis. Some of these proteins bind directly to actin to modulate pseudopod formation and phagocytosis. The bacterial microbiome has also been shown to influence *E. histolytica* pathogenicity by affecting lectin expression, with increased *Prevotella copri* populations associated with higher rates of diarrhea in infected children. Enteropathogenic *Escherichia coli* have been linked to increased *E. histolytica* virulence through upregulation of amebic proteolytic activity. Enteric bacteria improve survival of these anaerobic amebae during times of oxidative stress. Decreased bacterial diversity has been linked to an increase in symptomatic amebic infections in children.



## CLINICAL MANIFESTATIONS

Clinical presentations range from asymptomatic cyst passage to amebic colitis, amebic dysentery, ameboma, and extraintestinal disease. Up to 10% of infected persons develop invasive disease within a year, and asymptomatic carriers should be treated. Severe disease is more common in young children, pregnant women, malnourished individuals, and persons taking corticosteroids. Invasive disease is more common in men. Extraintestinal disease usually involves the liver, but less common extraintestinal manifestations include amebic brain abscess, pleuropulmonary disease, skin ulcers, and genitourinary lesions.

### Amebic Colitis

Amebic colitis may occur within 2 weeks of infection or may be delayed for months. The onset is usually gradual, with colicky abdominal pain and frequent bowel movements (6-8/day). Diarrhea is frequently associated with tenesmus. Almost all stool is heme-positive, but most patients do not present with grossly bloody stools. Generalized constitutional symptoms and signs are characteristically absent, with fever documented in only one third of patients. Amebic colitis affects all age groups but is strikingly common in children 1-5 years of age. Severe amebic colitis in infants and young children tends to be rapidly progressive, with more frequent extraintestinal involvement and high mortality rates, particularly in tropical countries. Amebic dysentery can result in dehydration and electrolyte disturbances.

### Amebic Liver Abscess

Amebic liver abscess, a serious manifestation of disseminated infection, is uncommon in children. Although diffuse liver enlargement has been associated with intestinal amebiasis, liver abscesses occur in <1% of infected individuals and may appear in patients with no clear history of intestinal disease. Amebic liver abscess may occur months to years after exposure, so obtaining a careful travel history is critical. In children, fever is the hallmark of amebic liver abscess and is frequently associated with abdominal pain, abdominal distention, and enlargement and tenderness of the liver. Changes at the base of the right lung may also occur, including elevation of the diaphragm and atelectasis or effusion.

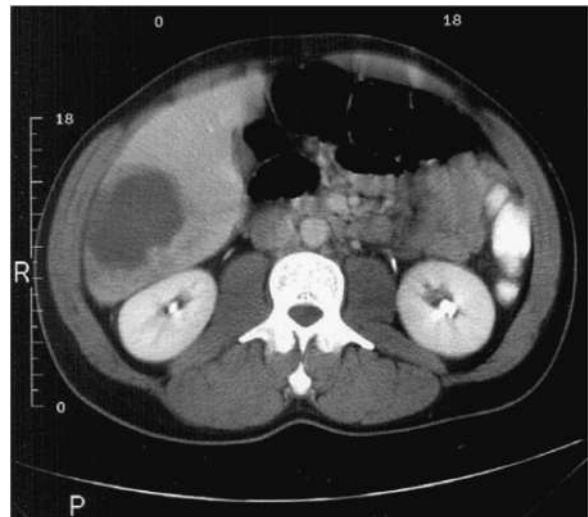
## LABORATORY FINDINGS

Laboratory examination findings are often unremarkable in uncomplicated amebic colitis. Laboratory findings in amebic liver abscess are a slight leukocytosis, moderate anemia, high erythrocyte sedimentation rate, and elevations of hepatic enzyme (particularly alkaline phosphatase) levels. Stool examination for amebae is negative in more than half of patients with documented amebic liver abscess. Ultrasonography, CT, or MRI can localize and delineate the size of the abscess cavity (Fig. 327.1). The most common finding is a single abscess in the right hepatic lobe.

## DIAGNOSIS AND DIFFERENTIAL DIAGNOSIS

A diagnosis of amebic colitis is made in the presence of compatible symptoms with detection of *E. histolytica* either by stool antigen testing or PCR. This approach has a greater than 95% sensitivity and specificity, and when it is coupled with a positive serology test, it is the most accurate means of diagnosis in developed countries. Several approved stool antigen kits are commercially available in the United States, but most cannot distinguish between *E. histolytica* and *E. dispar*. Microscopic examination of stool samples has a sensitivity of 60%. Sensitivity can be increased to 85–95% by examining three stools. Microscopy cannot differentiate between *E. histolytica*, *E. dispar*, *E. moshkovskii*, and *E. bangladeshi* unless phagocytosed erythrocytes (specific for *E. histolytica*) are seen. Endoscopy and biopsies of suspicious areas should be performed when stool sample results are negative and suspicion remains high. Various serum antibody tests are available. Serologic results are positive in 70–80% of patients with invasive disease (colitis or liver abscess) at presentation and in >90% of patients after 7 days. Indirect hemagglutination is the most sensitive serologic test and yields a positive result even years after invasive infection. Therefore many uninfected adults and children in highly endemic areas demonstrate antibodies to *E. histolytica*.

Conventional and real-time multiplex PCR performed on stool is the most sensitive and preferred method for distinguishing *E. histolytica* from nonpathogenic *E. dispar*, *E. moshkovskii*, and *E. bangladeshi*.



**Fig. 327.1** Abdominal CT scan of a patient with an amebic liver abscess. (From Miller Q, Kenney JM, Cotlar AM. Amebic abscess of the liver presenting as acute cholecystitis. *Curr Surg.* 2000;57:476–479. Fig. 1.)

Different multiplex formats have also been developed, including enteric pathogen panels with varying sensitivities and specificities. Tetraplex assays that can distinguish between all four morphologically identical isolates have also been developed. Isothermal nucleic acid methods using recombinase and loop-mediated amplification (LAMP) in point-of-care diagnostics are promising and will greatly facilitate treatment, especially in developing countries. A small study using quantitative PCR detected *E. histolytica* DNA in the serum of patients with amebic liver abscess with a sensitivity of 89.5% and a specificity of 100%.

The **differential diagnosis** for amebic colitis includes colitis due to bacterial, mycobacterial, and viral pathogens, as well as noninfectious causes such as inflammatory bowel disease. Pyogenic liver abscess due to bacterial infection, hepatoma, and echinococcal cysts are in the differential diagnosis for amebic liver abscess. However, echinococcal cysts are rarely associated with systemic symptoms such as fever, unless there is cyst rupture or leakage.

## COMPLICATIONS

Complications of amebic colitis include acute necrotizing colitis, ameboma, toxic megacolon, extraintestinal extension, and local perforation and peritonitis. Less commonly, a chronic form of amebic colitis develops, often recurring over several years. Amebomas are nodular foci of proliferative inflammation that sometimes develop in the wall of the colon. Amebiasis should be excluded before initiating corticosteroid treatment for inflammatory bowel disease because steroid treatment of *E. histolytica* is associated with high mortality rates.

An amebic liver abscess may rupture into the peritoneum, pleural cavity, skin, and pericardium. Cases of amebic abscesses in extrahepatic sites, including the lung and brain, have been reported.

## TREATMENT

Invasive amebiasis is treated with a nitroimidazole such as **metronidazole** or **tinidazole** and then a luminal amebicide (Table 327.1). Tinidazole may have better clinical efficacy than metronidazole, with shorter and simpler dosing, and is better tolerated. Adverse effects include nausea, abdominal discomfort, and a metallic taste that disappears after completion of therapy. Therapy with a nitroimidazole should be followed by treatment with a luminal agent, such as paromomycin (which is preferred) or iodoquinol. Diloxanide furoate can also be used in children >2 years of age but is no longer available in the United States. Paromomycin should not be given concurrently with metronidazole or tinidazole because diarrhea is a common side effect of paromomycin and may confuse the clinical picture. Asymptomatic intestinal infection with *E. histolytica* should be treated, preferably with paromomycin or alternatively with either iodoquinol or diloxanide furoate. For fulminant cases of amebic colitis, some experts suggest adding dehydroemetine (1 mg/kg/

**Table 327.1** Drug Treatment for Amebiasis

MEDICATION	ADULT DOSAGE (ORAL)	PEDIATRIC DOSAGE (ORAL)*
<b>INVASIVE DISEASE</b>		
Metronidazole	Colitis or liver abscess: 500mg tid for 7-10 days	Colitis or liver abscess: 35-50mg/kg/day in 3 divided doses for 7-10 days
Or		
Tinidazole	Colitis: 2g once daily for 3 days Liver abscess: 2g once daily for 3-5 days	Colitis: 50mg/kg/day once daily for 3 days Liver abscess: 50mg/kg/day once daily for 3-5 days
Followed by:		
Paromomycin (preferred)	500mg tid for 7 days	25-35mg/kg/day in 3 divided doses for 7 days
Or		
Diloxanide furoate†	500mg tid for 10 days	20mg/kg/day in 3 divided doses for 7 days
Or		
Iodoquinol	650mg tid for 20 days	30-40mg/kg/day in 3 divided doses for 20 days
<b>ASYMPTOMATIC INTESTINAL COLONIZATION</b>		
Paromomycin (preferred)	As for invasive disease	As for invasive disease
Or		
Diloxanide furoate†		
Or		
Iodoquinol		

\*All pediatric dosages are up to a maximum of the adult dose.

†Not available in the United States.

day subcutaneously or intramuscularly, never intravenously), available only through the Centers for Disease Control and Prevention (CDC). Patients should be hospitalized for monitoring if dehydroemetine is administered. Dehydroemetine should be discontinued if tachycardia, T-wave depression, arrhythmia, or proteinuria develops. Nitazoxanide has been shown to be amebicidal in several clinical trials, but more studies are needed to define optimal dosing and duration of treatment.

Broad-spectrum antibiotic therapy may be indicated in fulminant colitis to cover possible spillage of intestinal bacteria into the peritoneum and translocation into the bloodstream. Intestinal perforation and toxic megacolon are indications for surgery. In amebic liver abscess, image-guided aspiration of large lesions or left lobe abscesses may be necessary if rupture is imminent or if the patient shows a poor clinical response 4-6 days after administration of amebicidal drugs. A Cochrane meta-analysis comparing metronidazole and metronidazole plus aspiration in uncomplicated amebic liver abscess showed that there is insufficient evidence to make any recommendation for or against this approach. Chloroquine, which concentrates in the liver, may also be a useful adjunct to nitroimidazoles in the treatment of amebic liver abscess or in cases of treatment failure or intolerance. To confirm cure, stool examination should be repeated every 2 weeks after completion of therapy until clear.

## PROGNOSIS

Most infections evolve to either an asymptomatic carrier state or eradication. Extraintestinal infection carries about a 5% mortality rate.

## PREVENTION

Control of amebiasis can be achieved by exercising proper sanitation and hygiene. Regular examination of food handlers and thorough

investigation of diarrheal episodes may help identify the source of infection. No prophylactic drug or vaccine is available.

Immunization with different *E. histolytica* antigens has shown promising protective responses in animal models. Amebic surface protein LecA, galactose/*N*-acetyl-D-galactosamine lectin, serine-rich *E. histolytica* protein (SREHP), heparan sulfate binding proteins, and other antigens have elicited protective immune responses, especially in combination with different adjuvants. Acquired immune response can be protective as evidenced by anti-lectin IgA in stool among Bangladeshi children.

Visit Elsevier eBooks+ at [eBooks.Health.Elsevier.com](http://eBooks.Health.Elsevier.com) for Bibliography.

## Chapter 328

# Giardiasis and Balantidiasis

## 328.1 *Giardia duodenalis*

Chandy C. John

*Giardia duodenalis* is a flagellated protozoan that infects the duodenum and jejunum. Infection results in clinical manifestations that range from asymptomatic colonization to acute or chronic diarrhea and malabsorption. Infection is more prevalent in children than in adults. *Giardia* is endemic in areas of the world with poor levels of sanitation. It is also an important cause of morbidity in developed countries, where it is associated with urban childcare centers, residential institutions for the developmentally delayed, and waterborne and foodborne outbreaks. *Giardia* is a particularly significant pathogen in children with malnutrition and certain immunodeficiencies (IgA deficiency, common variable immunodeficiency, X-linked hypogammaglobulinemia).

## ETIOLOGY

The life cycle of *G. duodenalis* (also known as *Giardia lamblia* or *Giardia intestinalis*) is composed of two stages: trophozoites and cysts. *Giardia* infects humans after ingestion of as few as 10-100 cysts, which measure 8-10 µm in diameter. Each ingested cyst produces two trophozoites in the duodenum. After excystation, trophozoites colonize the lumen of the duodenum and proximal jejunum, where they attach to the brush border of the intestinal epithelial cells and multiply by binary fission. The body of the trophozoite is teardrop shaped, measuring 10-20 µm in length and 5-15 µm in width. *Giardia* trophozoites contain two oval nuclei anteriorly, a large ventral disk, a curved median body posteriorly, and four pairs of flagella. As detached trophozoites pass down the intestinal tract, they encyst to form oval cysts that contain four nuclei. Cysts are passed in stools of infected individuals and may remain viable in water for as long as 2 months. Their viability often is not affected by the usual concentrations of chlorine used to purify water for drinking.

*Giardia* strains that infect humans are diverse biologically, as shown by differences in antigens, restriction endonuclease patterns, DNA fingerprinting, isoenzyme patterns, and pulsed-field gel electrophoresis. Studies suggest that different *Giardia* genotypes may cause unique clinical manifestations, but these findings appear to vary according to the geographic region tested.

## EPIDEMIOLOGY

*Giardia* occurs worldwide and is the most common intestinal parasite identified in public health laboratories in the United States, where it is estimated that up to 2 million cases of giardiasis occur annually. *Giardia* infection usually occurs sporadically, but *Giardia* is a frequently identified etiologic agent of outbreaks associated with drinking water. The age-specific prevalence of giardiasis is high during childhood and begins to decline after adolescence. The asymptomatic carrier rate of *G.*



*lamblia* in the United States is as high as 20–30% in children younger than 36 months of age attending childcare centers. Asymptomatic carriage may persist for several months.

Risk of acquiring and transmitting *Giardia* is increased in children and employees in childcare centers, individuals who drink contaminated water, international travelers, men who have sex with men, immunodeficient individuals, and individuals exposed to farm animals. Children visiting friends and relatives are at increased risk for *Giardia* infections during international travel. The major reservoir and vehicle for spread of *Giardia* appears to be water contaminated with *Giardia* cysts, but foodborne transmission also occurs. The seasonal peak in age-specific case reports coincides with the summer recreational water season and may be a result of the extensive use of communal swimming venues by young children, the low infectious dose, and the extended periods of cyst shedding that can occur. In addition, *Giardia* cysts are relatively resistant to chlorination and to ultraviolet light irradiation. Boiling is effective for inactivating cysts.

Person-to-person spread also occurs, particularly in areas of low hygiene standards, frequent fecal-oral contact, and crowding. Individual susceptibility, lack of toilet training, crowding, and fecal contamination of the environment all predispose to transmission of enteropathogens, including *Giardia*, in childcare centers. Childcare centers play an important role in transmission of urban giardiasis, with secondary attack rates in families as high as 17–30%. Children in childcare centers may pass cysts for several months. Campers who drink untreated stream or river water, particularly in the western United States, and residents of institutions for the developmentally delayed are also at increased risk for infection.

Humoral immunodeficiencies, including common variable immunodeficiency and X-linked agammaglobulinemia, predispose humans to chronic symptomatic *Giardia* infection, suggesting the importance of humoral immunity in controlling giardiasis. Selective immunoglobulin A deficiency is also associated with *Giardia* infection. Although many individuals with AIDS have relatively mild *Giardia* infections, *Giardia* infection refractory to treatment may occur in a subset of individuals with AIDS. Human milk contains glycoconjugates and secretory immunoglobulin A antibodies that may provide protection to nursing infants against *Giardia*.

## CLINICAL MANIFESTATIONS

The incubation period of *Giardia* infection usually is 1–2 weeks but may be longer. A broad spectrum of clinical manifestations occurs, depending on the interaction between *G. lamblia* and the host. Children who are exposed to *G. lamblia* may experience asymptomatic excretion of the organism, acute infectious diarrhea, or chronic diarrhea with persistent gastrointestinal tract signs and symptoms, including failure to thrive and abdominal pain or cramping. *Giardia* was the cause of 15% of nondysenteric diarrheal illnesses in children examined in U.S. outpatient clinics in one study. Most infections in children and adults are asymptomatic. There is usually no extraintestinal spread, but occasionally trophozoites may migrate into bile or pancreatic ducts.

Symptomatic infections occur more frequently in children than in adults. Most symptomatic patients usually have a limited period of acute diarrheal disease with or without low-grade fever, nausea, and anorexia; in a small proportion of patients, an intermittent or more protracted course characterized by diarrhea, abdominal distention and cramps, bloating, malaise, flatulence, nausea, anorexia, and weight loss develops (Table 328.1). Stools initially may be profuse and watery and later become greasy and foul smelling and may float. Stools do not contain blood, mucus, or fecal leukocytes. Varying degrees of malabsorption may occur. Abnormal stool patterns may alternate with periods of constipation and normal bowel movements. Malabsorption of sugars, fats, and fat-soluble vitamins is well documented and may be responsible for substantial weight loss. *Giardia* has been associated with iron deficiency in internationally adopted children. Extraintestinal manifestations of *Giardia* appear to be more common in adults than children and include arthritis and, in one report after an outbreak, chronic fatigue syndrome. Giardiasis in children has been associated with growth stunting, and repeated *Giardia* infections correlate with a decrease in cognitive function in children in endemic areas.

**Table 328.1** Clinical Signs and Symptoms of Giardiasis

SYMPTOM	FREQUENCY (%)
Diarrhea	64–100
Malaise, weakness	72–97
Abdominal distention	42–97
Flatulence	35–97
Abdominal cramps	44–81
Nausea	14–79
Foul-smelling, greasy stools	15–79
Anorexia	41–73
Weight loss	53–73
Vomiting	14–35
Fever	0–28
Constipation	0–27

## DIAGNOSIS

Giardiasis should be considered in children who have acute nondysenteric diarrhea, persistent diarrhea, intermittent diarrhea and constipation, malabsorption, chronic crampy abdominal pain and bloating, failure to thrive, or weight loss. It should be particularly high in the differential diagnosis of children in childcare centers, children in contact with an index case, children with a history of recent travel to an endemic area, and children with humoral immunodeficiencies. Testing for giardiasis should be standard for internationally adopted children from *Giardia*-endemic areas, and screening for iron deficiency should be considered in internationally adopted children with giardiasis.

Stool enzyme immunoassay (EIA) or direct fluorescent antibody tests for *Giardia* antigens are the tests of choice for giardiasis. EIA is less reader dependent and more sensitive for detection of *Giardia* than microscopy. Some studies report that a single stool is sufficiently sensitive for detection of *Giardia* by EIA, whereas others suggest that sensitivity is increased with testing of two samples. A diagnosis of giardiasis was traditionally established by microscopy documentation of trophozoites or cysts in stool specimens, but three stool specimens are required to achieve a sensitivity of >90% using this approach. In patients in whom other parasitic intestinal infections are in the differential diagnosis, microscopy examination of stool allows evaluation for these infections in addition to *Giardia*.

Polymerase chain reaction and gene probe–based detection systems specific for *Giardia* have been used in environmental monitoring and clinical testing. Multiplex polymerase chain reaction testing for multiple parasitic pathogens is a viable option for testing.

In patients with chronic symptoms in whom giardiasis is suspected but in whom testing of stool specimens for *Giardia* yields a negative result, aspiration or biopsy of the duodenum or upper jejunum should be considered. In a fresh specimen, trophozoites usually can be visualized by direct wet mount. An alternate method of directly obtaining duodenal fluid is the commercially available Entero-Test (Hedeco Corp, Mountain View, CA), but this method is less sensitive than aspiration or biopsy. The biopsy can be used to make touch preparations and tissue sections for identification of *Giardia* and other enteric pathogens and also to visualize changes in histology. Biopsy of the small intestine should be considered in patients with characteristic clinical symptoms, negative stool and duodenal fluid specimen findings, and one or more of the following: abnormal radiographic findings (such as edema and segmentation in the small intestine); an abnormal lactose tolerance test result; an absent secretory immunoglobulin A level; hypogammaglobulinemia; or achlorhydria. Duodenal biopsy may show findings consistent with chronic inflammation, including eosinophilic infiltration of the lamina propria.

Radiographic contrast studies of the small intestine may show non-specific findings such as irregular thickening of the mucosal folds. Blood cell counts usually are normal. Giardiasis is not tissue invasive and is not associated with peripheral blood eosinophilia.

## TREATMENT

Children with acute diarrhea in whom *Giardia* organisms are identified should receive therapy. In addition, children who manifest failure to thrive or exhibit malabsorption or gastrointestinal tract symptoms such as chronic diarrhea should be treated.

Asymptomatic excretors generally are not treated, except in specific instances such as outbreak control, prevention of household transmission by toddlers to pregnant women and patients with hypogammaglobulinemia or cystic fibrosis, and situations requiring oral antibiotic treatment where *Giardia* may produce malabsorption of the antibiotic.

The FDA has approved tinidazole and nitazoxanide for the treatment of *Giardia* in the United States. Both medications have been used to treat *Giardia* in thousands of patients in other countries and have excellent safety and efficacy records against *Giardia* (Table 328.2). Tinidazole has the advantage of single-dose treatment and very high efficacy (>90%), while nitazoxanide has the advantage of a suspension form, high efficacy (80–90%), and very few adverse effects. Metronidazole, although never approved by the FDA for treatment of *Giardia*, is also highly effective (80–90% cure rate), and the generic form is considerably less expensive than tinidazole or nitazoxanide. For children  $\geq 3$  year of age, tinidazole is the preferred treatment, with nitazoxanide as alternative, while for children 1–2 years, nitazoxanide is the preferred treatment, since tinidazole is approved only for children  $\geq 3$  years of age. Metronidazole is the drug of choice for children <12 months and an alternative to tinidazole and nitazoxanide for children  $\geq 12$  months. Recent reports on travelers to South Asia document resistance rates as high as 30% to metronidazole, so nitazoxanide or tinidazole may be preferred for children who have traveled to or are from this area. Frequent adverse effects are seen with metronidazole therapy, and it requires 3-times-a-day dosing for 5–7 days. Suspension forms of tinidazole and metronidazole must be compounded by a pharmacy; neither drug is sold in suspension form.

Second-line alternatives for the treatment of patients with giardiasis include albendazole, paromomycin, and quinacrine (see Table 328.2). Albendazole may be of similar efficacy to metronidazole. Albendazole has few adverse effects and is effective against many helminths, making it useful for treatment when multiple intestinal parasites are identified or suspected. Paromomycin is a nonabsorbable aminoglycoside and is less effective than other agents but is recommended for treatment of pregnant women with giardiasis because of the potential teratogenic effects of other agents. Quinacrine is effective and inexpensive but is not available commercially and must be obtained from compounding pharmacies (see Table 328.2). Quinacrine can also rarely have serious side effects,

including hallucinations and psychosis. Refractory cases of giardiasis have been successfully treated with a number of regimens, including nitazoxanide, prolonged courses of tinidazole, or combination therapy, most commonly a 3-week course of metronidazole and quinacrine.

## PROGNOSIS

Symptoms recur in some patients in whom reinfection cannot be documented and in whom an immune deficiency such as an immunoglobulin abnormality is not present, despite use of appropriate therapy. Several studies have demonstrated that variability in antimicrobial susceptibility exists among strains of *Giardia*, and in some instances resistant strains have been demonstrated. Combined therapy may be useful for infection that persists after single-drug therapy, assuming reinfection has not occurred and the medication was taken as prescribed.

## PREVENTION

Infected persons and persons at risk should practice strict handwashing after any contact with feces. This point is especially important for caregivers of diapered infants in childcare centers, where diarrhea is common and *Giardia* organism carriage rates are high.

Methods to purify public water supplies adequately include chlorination, sedimentation, and filtration. Inactivation of *Giardia* cysts by chlorine requires the coordination of multiple variables such as chlorine concentration, water pH, turbidity, temperature, and contact time. These variables cannot be appropriately controlled in all municipalities and are difficult to control in swimming pools. Individuals, especially children in diapers, should avoid swimming if they have diarrhea. Individuals should also avoid swallowing recreational water and drinking untreated water from shallow wells, lakes, springs, ponds, streams, and rivers.

Travelers to endemic areas are advised to avoid uncooked foods that might have been grown, washed, or prepared with water that was potentially contaminated. Purification of drinking water can be achieved by a filter with a pore size of <1  $\mu\text{m}$  or that has been rated by the National Sanitation Foundation for cyst removal, or by brisk boiling of water for at least 1 minute. Treatment of water with chlorine or iodine is less effective but may be used as an alternate method when boiling or filtration is not possible.

Visit Elsevier eBooks+ at [eBooks.Health.Elsevier.com](http://eBooks.Health.Elsevier.com) for Bibliography.

## 328.2 Balantidiasis

Chandy C. John

MEDICATION	ADULT DOSAGE (ORAL)	PEDIATRIC DOSAGE (ORAL)*
<b>RECOMMENDED</b>		
Tinidazole	2g once	>3yr: 50mg/kg once
Nitazoxanide	500 mg bid for 3 days	1-3yr: 100 mg (5 mL) bid for 3 days 4-11 yr: 200 mg (10 mL) bid for 3 days >12yr: 500 mg bid for 3 days
Metronidazole	250 mg tid for 5-7 days	15 mg/kg/day in 3 divided doses for 5-7 days
<b>ALTERNATIVE</b>		
Albendazole	400 mg once a day for 5 days	>6yr: 400 mg once a day for 5 days
Paromomycin	500 mg tid for 5-10 days	Not recommended
Quinacrine <sup>†</sup>	100 mg tid for 5-7 days	6 mg/kg/day in 3 divided doses for 5 days

\*All pediatric dosages are up to a maximum of the adult dose.

<sup>†</sup>Not commercially available. Can be compounded by Medical Center Pharmacy in New Haven, CT (203-688-8970) or Panorama Compounding Pharmacy in Van Nuys, CA (818-988-7979).

*Balantidium coli* is a ciliated protozoan and is the largest protozoan that parasitizes humans. Both trophozoites and cysts may be identified in feces. Disease caused by this organism is uncommon in the United States and generally is reported where there is a close association of humans with pigs, which are the natural hosts of *B. coli*. Because the organism infects the large intestine, symptoms are consistent with large bowel disease, similar to those associated with amebiasis and trichuriasis, and include nausea, vomiting, lower abdominal pain, tenesmus, and bloody diarrhea. Symptoms associated with chronic infection include abdominal cramps, watery diarrhea with mucus, occasionally bloody diarrhea, and colonic ulcers similar to those associated with *Entamoeba histolytica*. Extraintestinal spread of *B. coli* is rare and usually occurs only in immunocompromised patients. Most infections are asymptomatic.

Diagnosis using direct saline mounts is established by identification of trophozoites (50–100  $\mu\text{m}$  long) or spherical or oval cysts (50–70  $\mu\text{m}$  in diameter) in stool specimens. Trophozoites usually are more numerous than cysts.

The recommended treatment regimen is metronidazole (25–50 mg/kg/day divided tid PO; maximum: 750 mg/dose) for 5 days, or tetracycline (40 mg/kg/day divided qid PO; maximum: 500 mg/dose) for 10 days for persons older than 8 years of age. An alternative is iodoquinol (40 mg/kg/day divided tid PO; maximum: 650 mg/dose) for 20 days.

Prevention of contamination of the environment by pig feces is the most important means for control.

Visit Elsevier eBooks+ at [eBooks.Health.Elsevier.com](http://eBooks.Health.Elsevier.com) for Bibliography.

## Chapter 329

# Cryptosporidium, Cystoisospora, Cyclospora, and Microsporidia

Sarah M. Heston and Patricia M. Flynn

The spore-forming intestinal protozoa *Cryptosporidium*, *Cystoisospora* (formerly *Isospora*), and *Cyclospora* are important intestinal pathogens in both immunocompetent and immunocompromised hosts. *Cryptosporidium*, *Cystoisospora*, and *Cyclospora* are coccidian parasites that predominantly infect the epithelial cells lining the digestive tract, and all are transmitted by the fecal-oral route. Microsporidia were formerly considered spore-forming protozoa but have been reclassified as fungi. Microsporidia are ubiquitous, obligate intracellular organisms that infect many other organ systems in addition to the gastrointestinal tract and cause a broader spectrum of disease.

## CRYPTOSPORIDIUM

*Cryptosporidium* is recognized as a leading protozoal cause of diarrhea in children worldwide and is a **common cause of outbreaks in child-care centers**; it is also a significant pathogen in immunocompromised patients.

### Etiology

*Cryptosporidium hominis* and *Cryptosporidium parvum* cause most cases of cryptosporidiosis in humans. Disease is initiated by ingestion of infectious oocysts that were excreted in the feces of infected humans and animals. The oocysts are immediately infectious to other hosts or can reinfect the same host. The ingested oocysts release sporozoites that attach to and invade the intestinal epithelial cells.

### Epidemiology

Cryptosporidiosis is associated with diarrheal illness worldwide and is more prevalent in developing countries and among children younger than 2 years of age. It has been implicated as an etiologic agent of persistent diarrhea in the developing world and as a cause of significant morbidity and mortality from malnutrition, including permanent effects on growth. Risk factors for infection include animal contact, diarrhea in a household member, open defecation/lack of toilet facilities, and poor drinking water quality.

Transmission of *Cryptosporidium* to humans can occur by close association with infected animals, via person-to-person transmission, or from environmentally contaminated water and food. Although zoonotic transmission, especially from cows, occurs in persons in close association with animals, person-to-person transmission is probably responsible for cryptosporidiosis outbreaks within hospitals and child-care centers, where transmission rates as high as 67% have been reported. Recommendations to prevent outbreaks in child-care centers include exclusion of children with diarrhea from attending, strict handwashing, elimination of water play or swimming activities, use of protective clothes or diapers capable of retaining liquid diarrhea, and separation of diapering and food-handling areas and responsibilities.

Outbreaks of cryptosporidial infection are associated with contaminated community water supplies and recreational waters, including lakes and chlorinated swimming pools. Wastewater in the form of raw sewage and runoff from dairies and grazing lands can contaminate

both drinking and recreational water sources. It is estimated that *Cryptosporidium* oocysts are present in 65–97% of the surface water in the United States. The organism's small size (4–6 µm in diameter), resistance to chlorination, and ability to survive for long periods outside a host create problems in public water supplies.

### Clinical Manifestations

The **incubation period is 2–10 days** (average, 7 days) after infection. *Cryptosporidium* infection is associated with **profuse, watery, non-bloody diarrhea** that can be accompanied by diffuse crampy abdominal pain, nausea, vomiting, and anorexia. Although less common in adults, vomiting occurs in more than 80% of children with cryptosporidiosis. Nonspecific symptoms such as myalgia, weakness, and headache also may occur. Fever occurs in 30–50% of cases. Malabsorption, lactose intolerance, dehydration, weight loss, and malnutrition often occur in severe cases. The clinical spectrum and disease severity have been linked with both the infecting species and host human leukocyte antigen class I and class II alleles.

In **immunocompetent persons, the disease is usually self-limiting**, typically 5–10 days, although diarrhea may persist for several weeks and oocyst shedding may persist for many weeks after symptoms resolve. Chronic diarrhea is common in young infants and individuals with immunodeficiency, such as congenital hypogammaglobulinemia or HIV infection. Symptoms and oocyst shedding can continue indefinitely and may lead to severe malnutrition, wasting, anorexia, and even death.

Cryptosporidiosis in immunocompromised hosts is often associated with biliary tract disease, characterized by fever, right upper quadrant pain, nausea, vomiting, and diarrhea. It also is associated with pancreatitis. Respiratory tract disease is rare.

### Diagnosis

Infection can be diagnosed by microscopy using modified acid-fast stain or polymerase chain reaction (PCR), but immunodetection of antigens on the surface of the organism in stool samples using monoclonal antibody-based assays is the current diagnostic method of choice because of the high sensitivity and specificity. Multiplex molecular test panels for gastrointestinal pathogens that include *Cryptosporidium* are available and are a standard test.

In stool, oocysts appear as small, spherical bodies (2–6 µm) and stain red with modified acid-fast staining. Because *Cryptosporidium* does not invade below the epithelial layer of the mucosa, fecal leukocytes are not found in stool specimens. Oocyst shedding in feces can be intermittent, and several fecal specimens (at least three for an immunocompetent host) should be collected for microscopic examination. Serologic diagnosis is not helpful in acute cryptosporidiosis.

In tissue sections, *Cryptosporidium* organisms can be found along the microvillus region of the epithelia that line the gastrointestinal tract. The highest concentration usually is detected in the jejunum. Histologic section results reveal villus atrophy and blunting, epithelial flattening, and inflammation of the lamina propria.

### Treatment

Often the diarrheal illness attributable to cryptosporidiosis is self-limited in *immunocompetent* patients and requires no specific antimicrobial therapy. Treatment should focus on supportive care, including rehydration orally or, if fluid losses are severe, intravenously. A 3-day course of nitazoxanide (100 mg bid PO for 3 days for children 1–3 years of age; 200 mg bid PO for children 4–11 years of age; 500 mg bid PO for children ≥12 years of age) is approved for treatment of diarrhea caused by *Cryptosporidium*. A recent meta-analysis revealed a favorable clinical response to treatment with nitazoxanide compared with placebo, although the parasitologic response was no different than the response to placebo. Clinical studies have not definitively demonstrated that nitazoxanide is superior to placebo in trials of HIV-infected (with low CD4 counts) or immunocompromised patients. However, given the severity of the infection in these populations, nitazoxanide treatment



is usually initiated. Immune function should be optimized in immunocompromised patients, with combination antiretroviral therapy in patients living with HIV and decreased immunosuppression in transplant recipients, if possible. Other agents that have been suggested for treatment in clinical reports or small studies include orally administered human serum immunoglobulin or bovine colostrum, paromomycin, spiramycin, azithromycin, and roxithromycin or a combination of antibiotics. Clofazimine was recently investigated as a potential therapy among adults living with HIV; however, it failed to show efficacy based on clinical and parasitologic outcomes. Prevention measures include adequate hand hygiene, avoiding untreated ice or water, especially in areas with poor sanitation, and exclusion of children with diarrhea from public pools.

### CYSTOISOSPORA

Like *Cryptosporidium*, *Cystoisospora belli* is implicated as a cause of diarrhea in institutional outbreaks and in travelers and has also been linked with **contaminated water and food**. *Cystoisospora* appears to be more common in tropical and subtropical climates and in developing areas, including South America, Africa, and Southeast Asia. *Cystoisospora* has not been associated with animal contact. It is also an infrequent cause of diarrhea in patients with AIDS in the United States but may infect up to 15% of AIDS patients in Haiti.

The life cycle and pathogenesis of infection with *Cystoisospora* species are similar to those of *Cryptosporidium* organisms except that oocysts excreted in the stool are not immediately infectious and must undergo further maturation at temperatures below 37°C (98.6°F). Thus **direct person-to-person transmission is unlikely**. The **incubation period averages approximately one week**. The most common clinical manifestation is **watery, nonbloody diarrhea**. Symptoms of infection are indistinguishable from those of cryptosporidiosis, although fever may be a more common finding. Eosinophilia may be present in up to 50% of cases, contrasting with other enteric protozoan infections. The diagnosis is established by detecting the oval, 22- to 33- $\mu$ m long by 10- to 19- $\mu$ m wide oocysts by using modified acid-fast staining of the stool. Fecal leukocytes are not detected. Oocysts are shed in low numbers, underscoring the need for repeated stool examinations. The presence of oocysts in the gastrointestinal tract is almost always associated with clinical symptoms. The histologic appearance of the gastrointestinal epithelium reveals blunting and atrophy of the villi, acute and chronic inflammation, and crypt hyperplasia.

Cystoisosporiasis responds promptly to treatment with oral **trimethoprim-sulfamethoxazole** (TMP-SMX: 5 mg TMP and 25 mg SMX/kg/dose [maximum: 160 mg TMP and 800 mg SMX/dose] bid for 10 days). In patients with AIDS, relapses are common and often necessitate higher doses of TMP/SMX and/or maintenance therapy. Combination antiretroviral therapy associated with immune recovery may also result in improved symptoms. **Ciprofloxacin** or a regimen of **pyrimethamine** alone or with **folinic acid** is effective in patients intolerant of sulfonamide drugs. In endemic areas, *Cystoisospora* can be avoided by ensuring water used for drinking, food preparation, and washing fresh produce has been filtered or boiled.

### CYCLOSPORA

*Cyclospora cayetanensis* is a coccidian parasite similar to but larger than *Cryptosporidium*. The organism infects both immunocompromised and immunocompetent individuals and is more common in children younger than 18 months of age. The pathogenesis and pathologic findings of cyclosporiasis are similar to those of cystoisosporiasis. Asymptomatic carriage of the organism has been found, but travelers who harbor the organism almost always have diarrhea. Most cases of cyclosporiasis in the United States are domestically acquired. Outbreaks of cyclosporiasis are linked with **contaminated food and water** and occur most frequently during spring and summer months. Implicated foods include raspberries, lettuce, snow peas, basil, cilantro, and other fresh food items. After fecal excretion, the oocysts must sporulate

outside the host to become infectious. This finding explains the lack of person-to-person transmission.

The clinical manifestations of cyclosporiasis are similar to those of cryptosporidiosis and cystoisosporiasis and follow an **incubation period of approximately 7 days**. Moderate *Cyclospora* illness is characterized by a median of 6 stools/day with a median duration of 10 days (range: 3-25 days). The duration of diarrhea in immunocompetent persons is characteristically longer in cyclosporiasis than in the other intestinal protozoan illnesses. Associated symptoms frequently include anorexia; fatigue; abdominal bloating or gas; abdominal cramps or pain; nausea; muscle, joint, or body aches; low-grade fever; chills; headache; and weight loss. Vomiting may occur. Bloody stools are uncommon. Biliary disease has been reported. Intestinal pathology includes inflammation with villus blunting.

The diagnosis is established by identification of oocysts in the stool or molecular diagnostic testing. Oocysts are wrinkled spheres, measure 8-10  $\mu$ m in diameter, and resemble large *Cryptosporidium* organisms. The organisms can be seen by using modified acid-fast, auramine-phenol, or modified trichrome staining, but stain less consistently than *Cryptosporidium*. They can also be detected with phenosafranin stain and by autofluorescence using strong green or intense blue under ultraviolet epifluorescence. Multiple stool samples enhance identification of the pathogen. Fecal leukocytes are not present. Commercially available multiplex molecular test panels for gastrointestinal pathogens that include *Cyclospora* are now available and may become the new standard. The sensitivity of molecular testing and the inclusion of *Cyclospora* on multiplex molecular testing may be partly responsible for the increased number of reported cases in the United States in recent years.

The treatment of choice for cyclosporiasis is **TMP-SMX** (5 mg TMP and 25 mg SMX/kg/dose bid [maximum 160 mg TMP and 800 mg SMX/dose] for 10 days.) **Ciprofloxacin** or **nitazoxanide** is effective in patients intolerant of sulfonamide drugs.

### MICROSPORIDIA

Microsporidia are ubiquitous and infect most animal groups, including humans. They are classified as fungi, and multiple species of the phylum Microsporidia have been linked with human disease in both immunocompetent and immunocompromised hosts. The species most commonly associated with gastrointestinal disease are *Enterocytozoon bieneusi* and *Encephalitozoon intestinalis*. The global prevalence of microsporidial infections among children is 7.5%, although prevalence is likely higher among pediatric patients living with HIV, oncology patients, and transplant recipients.

Although still not definitive, the source of human infections is likely zoonotic. Like *Cryptosporidium*, there is concern for waterborne transmission through occupational and recreational contact with contaminated water sources. There is also the potential for foodborne outbreaks; the organisms have been identified on vegetables as a consequence of contaminated irrigation water. Vector-borne transmission is hypothesized because one species, *Brachiola algerae*, typically infects mosquitoes. Finally, transplacental transmission has been reported in animals but not in humans. Once infected, intracellular division produces new spores that can spread to nearby cells, disseminate to other host tissues, or be passed into the environment via feces. Spores also have been detected in urine and respiratory epithelium, suggesting that some body fluids may also be infectious. Once in the environment, microsporidial spores remain infectious for up to 4 months.

Initially, microsporidial intestinal infection had been almost exclusively reported in patients with AIDS, but there are increasing reports of microsporidial infections in transplant recipients, including donor-derived infections in solid organ transplant recipients. There is increasing evidence that immunocompetent individuals are also commonly infected. Microsporidia-associated **diarrhea is intermittent, watery, copious, and nonbloody**. Abdominal cramping and weight loss may be present; fever is unusual. Stromal keratitis and encephalitis may



also be associated with microsporidia infections. Disseminated disease involving most organs, including liver, heart, kidney, bladder, biliary tract, lung, bone, skeletal muscle, central nervous system, skin, and sinuses, has been reported.

Microsporidia stain with modified trichrome, hematoxylin-eosin, Giemsa, Gram, periodic acid-Schiff, and acid-fast stains but are often overlooked because of their small size (1–5  $\mu\text{m}$ ) and the absence of associated inflammation in surrounding tissues. Electron microscopy remains the reference method of detection. An immunofluorescence assay is available. The Centers for Disease Control and Prevention (CDC) offer a molecular identification of *Enterocytozoon bieneusi*, *Encephalitozoon intestinalis*, *Encephalitozoon hellem*, and *Encephalitozoon cuniculi* using species-specific PCR assays.

There is no proven therapy for microsporidial intestinal infections. **Albendazole** (adult dose 400 mg bid PO for 3 weeks; for children, 7.5 mg/kg body weight [maximum 400 mg/dose] bid PO) is usually effective against *E. intestinalis* infection but is ineffective against infection caused by some microsporidial species. Fumagillin (adult dose 20 mg tid PO for 2 weeks) was effective in a small controlled study of adults with *E. bieneusi* infection, and topical therapy with this agent was also demonstrated to be effective in HIV-infected adults with keratoconjunctivitis. Fumagillin is not currently available in the United States. Supportive care with hydration, correction of electrolyte imbalances, and nutrition should be used in gastrointestinal infection when clinically indicated. Improvement in underlying HIV infection with combination antiretroviral therapy also improves microsporidiosis symptoms.

Visit Elsevier eBooks+ at [eBooks.Elsevier.com](https://www.elsevier.com/ebooks) for Bibliography.

## Chapter 330

# Trichomoniasis (*Trichomonas vaginalis*)

Edsel Maurice T. Salvana and  
Robert A. Salata

Trichomoniasis is caused by the protozoan *Trichomonas vaginalis*. It is the second most common sexually transmitted infection worldwide. Vulvovaginitis is the symptomatic disease form, but *T. vaginalis* has been implicated in pelvic inflammatory disease, pregnancy loss, chronic prostatitis, and an increased risk of HIV transmission.

### EPIDEMIOLOGY

Over 156 million new cases of trichomoniasis occur annually around the world. Most men and up to 30% of women are asymptomatic. Although the disease is easily treated, sequelae of untreated infection remain a significant cause of morbidity because of high reinfection rates from untreated partners, underrecognition of asymptomatic cases, and insensitive diagnostics.

Trichomoniasis is the most common parasitic infection in the United States, with a prevalence of 2.6 million cases and 6.9 million incident infections per year. Among the factors associated with a higher prevalence of infection are female sex, belonging to underrepresented minorities, poverty, lower educational attainment, younger age at first sex, multiple sexual partners, and a recent *Chlamydia* infection. Vaginal trichomoniasis is rare until menarche, and its presence in a younger child should raise the possibility of **sexual abuse**.

Trichomoniasis may be transmitted to neonates during passage through an infected birth canal. Infection in this setting is usually self-limited, but rare cases of neonatal vaginitis and respiratory infection have been reported.

### PATHOGENESIS

*T. vaginalis* is an anaerobic, flagellated protozoan parasite. Infected vaginal secretions contain  $10^1$  to  $10^5$  or more protozoa/mL. *T. vaginalis* is pear shaped and exhibits characteristic twitching motility in wet mount (Fig. 330.1). Reproduction is by binary fission. It exists only as vegetative cells; cyst forms have not been described. *T. vaginalis* has hydrogenosomes, which are organelles that produce energy in anaerobic environments and have hydrogen as a waste product. Hydrogenosomes are derived from mitochondria, suggesting that *T. vaginalis* may have had an aerobic ancestor.

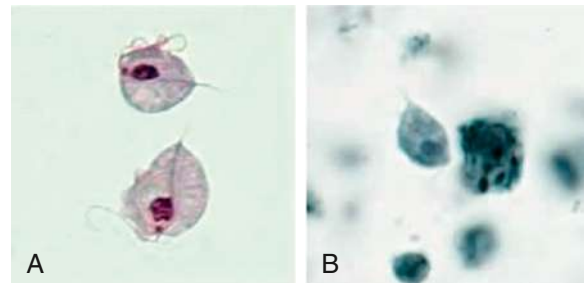
Many types of adhesion molecules allow attachment of *T. vaginalis* to host cells. Tv lipoglycan is a surface glycoconjugate that binds human galectin-1 and galectin-3 and plays a major role in adhesion, pathogenicity, and immune modulation. In addition, hundreds of putative membrane proteins, BspA proteins, and tetraspanins are involved in cellular attachment. Adhesion is a prerequisite for cytolysis and, once attached, the parasite secretes hydrolases, proteases, and cytotoxic molecules that destroy or impair the integrity of host cells.

*Trichomonas* is highly dependent on iron for its growth and metabolism. Cysteine proteinase mRNAs have been shown to interact with other parasite proteins for posttranscriptional regulation in the absence of iron-regulatory proteins. The *T. vaginalis* genome is very large at 160 Mbps, with multiple repetitive sequences and transposable elements making up over 60,000 genes and with apparently nonfunctional but transcribed pseudogenes.

Macrophage migration and cytokine production have been shown to be downregulated by the parasite in successful infection. Parasite-specific antibodies and lymphocyte priming occur in response to infection, but durable protective immunity does not occur, possibly also owing to degradation of antibodies by parasitic cysteine proteases. *Trichomonas* infection has been linked to dysregulation of the vagina microbiota and is frequently associated with concomitant bacterial vaginosis. *Trichomonas* can host *Mycoplasma genitalium* as a symbiont, and the presence of both microorganisms can significantly increase the risk of bacterial vaginosis, pelvic inflammatory disease, and adverse pregnancy outcomes.

### CLINICAL MANIFESTATIONS

The incubation period in females is 5–28 days. Symptoms may begin or worsen with menses. Most infected women eventually develop symptoms, although up to one third remain asymptomatic. Common signs and symptoms include a copious malodorous gray, frothy vaginal discharge, vulvovaginal irritation, dysuria, and dyspareunia. Physical examination may reveal a frothy discharge with vaginal erythema and



**Fig. 330.1** *Trichomonas vaginalis* trophozoites stained with Giemsa (A) and iron hematoxylin (B). (From the Centers for Disease Control and Prevention: Laboratory identification of parasites of public health concern. *Trichomoniasis* [website]. <https://www.cdc.gov/dpdx/trichomoniasis/index.html>)

cervical hemorrhages (strawberry cervix). The discharge usually has a pH of >4.5. Abdominal discomfort is unusual and should prompt evaluation for pelvic inflammatory disease (see Chapter 163).

Most infections in males are asymptomatic. Symptomatic males usually have dysuria and scant urethral discharge. Trichomonads occasionally cause epididymitis, prostatic involvement, and superficial penile ulceration. Infection is often self-limited, spontaneously resolving in about one third of men. *Trichomonas* has been implicated as a cause of recurrent or relapsing urethritis and can be isolated in 3–20% of men with nongonococcal urethritis. Treatment failures with standard therapy for gonorrhea and *Chlamydia* are frequently treated with antitrichomonal therapy.

## DIAGNOSIS

Trichomonads may be recognized in vaginal secretions by wet mount microscopy, which has a sensitivity of 51–65% in vaginal specimens and a lower sensitivity in specimens from men. Although *Trichomonas* is sometimes seen on Pap smears and urine microscopy, these methods are not considered reliable tests for disease. Culture of the organism used to be the gold standard for detection, but this is increasingly being replaced by nucleic acid amplification tests, which are more sensitive. The APTIMA TV (Hologic/Gen-Probe, Inc., Marlborough, MA) assay and the BD Probe Tec TV Q<sup>x</sup> Amplified DNA Assay (Becton Dickinson, Franklin Lakes, NJ) are U.S. Food and Drug Administration (FDA) cleared commercial NAATs for testing of samples from women. Xpert TV (Cepheid Inc., Sunnyvale, CA) is a cartridge-based near-point-of-care nucleic acid test that is FDA-cleared for men and women, with a sensitivity of 95% for self-collected vaginal swabs and up to 100% for symptomatic endocervical swabs. Three point-of-care kits for rapid testing, Affirm VP III (BD Diagnostic Systems, Sparks, MD), OSOM *Trichomonas* Rapid Test (Sekisui Diagnostics, Lexington, MA), and Solana *Trichomonas* Assay (Quidel, San Diego, CA) are FDA cleared for women and can yield results in 45 minutes or less. Patients with *T. vaginalis* should be screened for other sexually transmitted infections.

## COMPLICATIONS

Untreated trichomoniasis has been associated with pelvic inflammatory disease, premature delivery, low birthweight, endometritis, salpingitis, and vaginal cuff cellulitis. The association between trichomoniasis and infertility is relatively weak, but there is some evidence that coinfection with other sexually transmitted infections increases the overall risk of pelvic inflammatory disease. *T. vaginalis* infection increases the risk of acquisition and transmission of HIV. In HIV-infected individuals, trichomoniasis is associated with higher viral loads in cervical secretions and semen, as well as higher levels of infected lymphocytes in urogenital fluids.

## TREATMENT

In the United States, metronidazole and tinidazole are used; in other countries, secnidazole, azanidazole, and ornidazole are also used. Both **metronidazole** (single-dose regimen of 2 g orally as a single dose for adolescents and adults; alternative regimen, 500 mg orally bid for 7 days) and **tinidazole** (single 2 g dose orally in adolescents and adults) are used as first-line treatments. For children infected before adolescence, the recommended regimen is metronidazole 15 mg/kg/day divided in three doses orally for 7 days; tinidazole is not approved for dosing in younger children. For HIV-infected patients, the 7-day course of metronidazole is superior to and recommended over the single-dose regimen. Sexual partners should be treated simultaneously to prevent reinfection. Recent studies have shown that single-dose metronidazole is less effective than a multidose regimen in women. A small number of patients with severe nitroimidazole hypersensitivity have been treated with intravaginal suppositories of boric acid, nitazoxanide, and paromomycin with varying degrees of success. Desensitization to metronidazole with a validated protocol under an allergy specialist is recommended if possible.

Treatment failures have been reported with metronidazole and tinidazole. Metronidazole resistance in *Trichomonas* is estimated to be 4.3–9.6%, and tinidazole resistance is about 1%. Second-line treatment

is a 7-day course of metronidazole 500 mg twice daily. If this approach fails, either metronidazole or tinidazole at 2 g daily for 7 days is recommended. Further treatment failure should be referred to an infectious diseases specialist. Susceptibility testing is available from the Centers for Disease Control and Prevention (CDC). Higher dose tinidazole (2–3 g for 14 days) in combination with intravaginal tinidazole or paromomycin have been used in nitroimidazole-resistant infections. Metronidazole has not been shown to be teratogenic but is currently classified as a category C drug. Treatment of trichomoniasis in pregnancy should always be considered, especially in symptomatic patients, and may decrease the risk of perinatal transmission.

## PREVENTION

Prevention of *T. vaginalis* infection is best accomplished by treatment of all sexual partners of an infected person, and by programs aimed at prevention of all sexually transmitted infections (see Chapter 163). No vaccine is available, and drug prophylaxis is not recommended. A recent randomized controlled trial showed that *T. vaginalis* infection with concurrent bacterial vaginosis responded better to metronidazole treatment when intravaginal probiotics were co-administered, consistent with findings that altered vaginal microflora plays a significant role in *T. vaginalis* pathogenesis.

Visit Elsevier eBooks+ at [eBooks.Health.Elsevier.com](http://eBooks.Health.Elsevier.com) for Bibliography.

## Chapter 331

# Leishmaniasis (*Leishmania*)

Peter C. Melby

The leishmaniasis are a diverse group of diseases caused by intracellular protozoan parasites of the genus *Leishmania*, which are transmitted by phlebotomine sand flies. Multiple species of *Leishmania* are known to cause human disease involving the skin and mucosal surfaces and the visceral reticuloendothelial organs (Table 331.1). Cutaneous disease is usually localized and mild but may cause cosmetic disfigurement. Rarely, cutaneous infection can disseminate or involve the skin diffusely. Mucosal and visceral forms of leishmaniasis are associated with significant morbidity and mortality.

## ETIOLOGY

*Leishmania* organisms are members of the Trypanosomatidae family and include two subgenera, *Leishmania* (*Leishmania*) and *Leishmania* (*Viannia*). The parasite is dimorphic, existing as a flagellate promastigote in the insect vector and as an aflagellate amastigote that resides and replicates within mononuclear phagocytes of the vertebrate host. Within the **sand fly** vector, the promastigote changes from a noninfective procyclic form to an infective metacyclic stage (Fig. 331.1). Amplification of the number of metacyclic promastigotes in the infected sand fly occurs following a second blood meal. Fundamental to metacyclogenesis are changes that take place in the terminal polysaccharides of the surface **lipophosphoglycan**, which allow forward migration of the infective parasites to be inoculated in the host skin during a blood meal. Metacyclic lipophosphoglycan also plays an important role in the entry and survival of *Leishmania* in the vertebrate host cells. Once within the macrophage, the promastigote transforms to an amastigote and resides and replicates within a phagolysosome. The parasite is resistant to the acidic, hostile environment of the macrophage and eventually ruptures the cell and goes on to infect other macrophages. Infected macrophages have a diminished capacity to initiate and respond to an inflammatory response, thus providing a safe haven for the intracellular parasite.

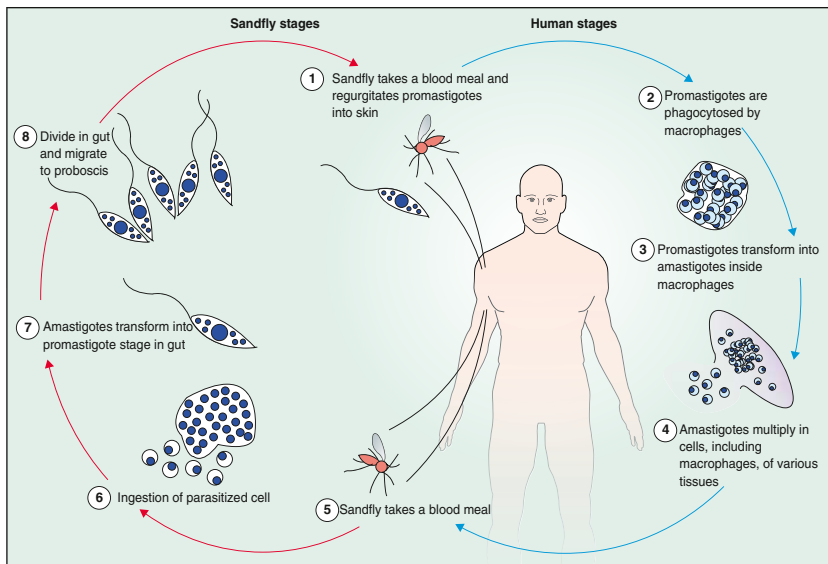
**Table 331.1** Clinical and Epidemiologic Characteristics of Main *Leishmania* Species

	SUBGENUS	CLINICAL FORM	MAIN CLINICAL FEATURES	NATURAL PROGRESSION	RISK GROUPS	MAIN RESERVOIR	HIGH-BURDEN COUNTRIES OR REGIONS	ESTIMATED ANNUAL WORLDWIDE INCIDENCE
<i>Leishmania donovani</i> *	<i>Leishmania</i>	VL, PKDL	Persistent fever, splenomegaly, weight loss, and anemia in VL; multiple painless macular, papular, or nodular lesions in PKDL	VL is fatal within 2yr; PKDL lesions self-heal in up to 85% of cases in Africa but rarely in Asia	Predominantly adolescents and young adults for VL; young children in Sudan and no clearly established risk factors for PKDL	Humans	India, Bangladesh, Ethiopia, Sudan, and South Sudan	50,000-90,000 VL cases; unknown number of PKDL cases
<i>Leishmania tropica</i> *	<i>Leishmania</i>	CL, LR, rarely VL	Ulcerating dry lesions, painless, and frequently multiple	CL lesions often self-heal within 1 yr	No well-defined risk groups	Humans, but zoonotic foci exist	Eastern Mediterranean, Middle East, northeastern and southern Africa	200,000-400,000 CL
<i>Leishmania aethiopica</i> *	<i>Leishmania</i>	CL, DCL, DsCL, oronasal CL	Localized cutaneous nodular lesions; occasionally oronasal; rarely ulcerates	Self-healing, except for DCL, within 2-5yr	Limited evidence; adolescents	Hyraxes	Ethiopia, Kenya	20,000-40,000 CL
<i>Leishmania major</i> *	<i>Leishmania</i>	CL	Rapid necrosis, multiple wet sores, severe inflammation	Self-healing in >50% of cases within 2-8 mo; multiple lesions slow to heal, and severe scarring	No well-defined risk groups	Rodents	Iran, Saudi Arabia, North Africa, Middle East, Central Asia, West Africa	230,000-430,000 CL
<i>Leishmania infantum</i> *	<i>Leishmania</i>	VL, CL	Persistent fever and splenomegaly in VL; typically single nodules and minimal inflammation in CL	VL is fatal within 2yr; CL lesions self-heal within 1 yr and confers individual immunity	Children <5yr old and immunocompromised adults for VL; older children and young adults for CL	Dogs, hares, humans	China, Southern Europe, Brazil, and South America for VL and CL; Central America for CL	6,200-12,000 cases of Old World VL and 4,500-6,800 cases of New World VL; unknown number of CL cases
<i>Leishmania mexicana</i> †	<i>Leishmania</i>	CL, DCL, DsCL	Ulcerating lesions, single or multiple	Often self-healing in 3-4 mo	No well-defined risk groups	Rodents, marsupials	South America	Limited number of cases, included in the 187, 200-300,000 total cases of New World CL‡
<i>Leishmania amazonensis</i> †	<i>Leishmania</i>	CL, DCL, DsCL	Ulcerating lesions, single or multiple	Not well described	No well-defined risk groups	Possums, rodents	South America	Limited number of cases, included in the 187, 200-300,000 total cases of New World CL‡
<i>Leishmania braziliensis</i> †	<i>Viannia</i>	CL, MCL, DCL, LR	Ulcerating lesions can progress to mucocutaneous form; local lymph nodes are palpable before and early on in the onset of the lesions	Might self-heal in 6 mo; 2.5% of cases progress to MCL	No well-defined risk groups	Dogs, humans, rodents, horses	South America	Majority of the 187, 200-300,000 total cases of New World CL‡
<i>Leishmania guyanensis</i> †	<i>Viannia</i>	CL, DsCL, MCL	Ulcerating lesions, single or multiple that can progress to mucocutaneous form; palpable lymph nodes	Might self-heal within 6 mo	No well-defined risk groups	Possums, sloths, anteaters	South America	Limited number of cases, included in the 187, 200-300,000 total cases of New World CL‡

\*Old World leishmaniasis.

†New World leishmaniasis.

‡Estimates are of all New World leishmaniases, with *Leishmania braziliensis* comprising the vast majority of these cases.CL, Cutaneous leishmaniasis; DCL, diffuse cutaneous leishmaniasis; DsCL, disseminated cutaneous leishmaniasis; LR, leishmaniasis recidivans; MCL, mucocutaneous leishmaniasis; PKDL, post-kala-azar dermal leishmaniasis; VL, visceral leishmaniasis. Adapted from Burza S, Croft SL, Boelaert ML. Leishmaniasis. *Lancet*. 2018;392:951-966. Table 1.



**Fig. 331.1** *Leishmania* life cycle. (From Reithinger R, Dujardin JC, Louzir H, et al. *Cutaneous leishmaniasis*. *Lancet Infect Dis*. 2007;7:581–596. Fig. 5.)

## EPIDEMIOLOGY

The leishmaniasis are estimated to affect 10–20 million people in endemic tropical and subtropical regions on all continents except Australia and Antarctica (Fig. 331.2). The different forms of the disease are distinct in their causes, epidemiologic characteristics, transmission, and geographic distribution. The leishmaniasis may occur sporadically throughout an endemic region or may occur in epidemic waves. With only rare exceptions, the *Leishmania* organisms that primarily cause cutaneous disease do not cause visceral disease.

**Localized cutaneous leishmaniasis (LCL)** in the Old World is caused by *L. (Leishmania) major* and *L. (L.) tropica* in North Africa, the Middle East, Central Asia, and the Indian subcontinent. *L. (L.) aethiopicus* is a cause of LCL and **diffuse cutaneous leishmaniasis (DCL)** in Kenya and Ethiopia. In the New World, *L. (L.) mexicana* causes LCL in a region stretching from Texas through Central America. *L. (L.) amazonensis*, *L. (L.) pifanoi*, *L. (L.) garnhami*, and *L. (L.) venezuelensis* cause LCL in South America, the Amazon basin, and northward. These parasites can also cause DCL. Members of the *Viannia* subgenus (*L. [Viannia] braziliensis*, *L. [V.] panamensis*, *L. [V.] guyanensis*, and *L. [V.] peruviana*) cause LCL and **mucosal leishmaniasis (ML)** from the northern highlands of Argentina northward to Central America. Some species, particularly *L. (V.) braziliensis*, rarely cause **disseminated leishmaniasis (DL)**. **Visceral leishmaniasis (VL)** in the Old World is caused by *L. (L.) donovani* in Kenya, Sudan, India, Pakistan, and China and by *L. (L.) infantum* in the Mediterranean basin, Middle East, and central Asia. *L. tropica* also has been recognized as an uncommon cause of visceral disease in the Middle East and India. VL in the New World is caused by *L. (L.) infantum* (formerly also called *L. chagasi*), which is distributed from Mexico (rare) through Central and South America. *L. infantum* can also cause LCL in the absence of visceral disease in this same geographic distribution.

The maintenance of *Leishmania* in most endemic areas is through a **zoonotic** transmission cycle. In general, the dermatotropic strains in both the Old and the New World are maintained in rodent reservoirs, and the domestic dog is the usual reservoir for *L. infantum*. The transmission between reservoir and sand fly is highly adapted to the specific ecologic characteristics of the endemic region. Human infections occur when activities bring them in contact with the zoonotic cycle. **Anthropogenic** transmission, in which humans are the presumed reservoir for vector-borne transmission, occurs with *L. tropica* in some urban areas of the Middle East and Central Asia, and with *L. donovani* in India and Sudan. Congenital transmission of *L. donovani* or *L. infantum* has been reported.

There is a resurgence of leishmaniasis in long-standing endemic areas as well as in new foci. Tens of thousands of cases of LCL occurred in outbreaks in Syria and Kabul, Afghanistan; severe epidemics with

>100,000 deaths from VL have occurred in India and Sudan. VL is most prevalent among the poorest of the poor, with substandard housing contributing to the vector-borne transmission and undernutrition leading to increased host susceptibility. The emergence of the leishmaniasis in new areas is the result of (1) movement of a susceptible population into existing endemic areas, usually because of agricultural or industrial development or timber harvesting; (2) increase in vector and/or reservoir populations as a result of agriculture development projects and/or climate change; (3) increase in anthroponotic transmission resulting from rapid urbanization in some foci; and (4) increase in sand fly density resulting from a reduction in vector control programs.

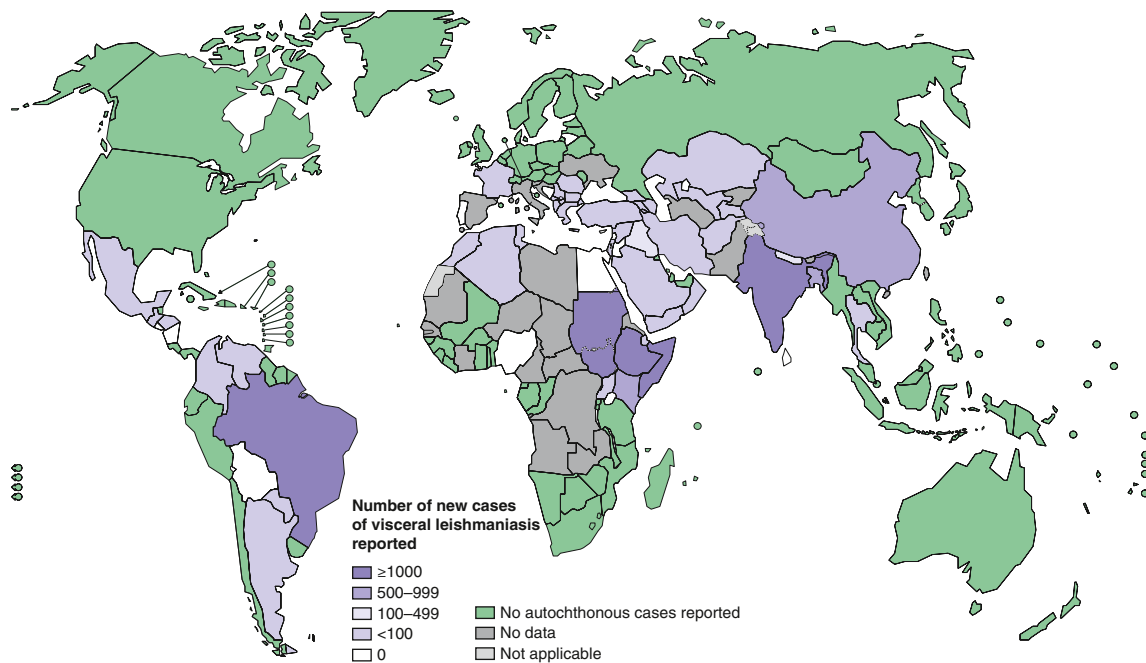
## PATHOLOGY

Histopathologic analysis of the skin lesions of LCL and DL show intense chronic granulomatous inflammation involving the epidermis and dermis with relatively few amastigotes. Occasionally, neutrophils and even microabscesses can be seen. The lesions of DCL are characterized by dense infiltration with vacuolated macrophages containing abundant amastigotes. ML is characterized by an intense granulomatous reaction with prominent tissue necrosis, which may include adjacent cartilage or bone. In VL there is prominent reticuloendothelial cell hyperplasia in the liver, spleen, bone marrow, and lymph nodes. Amastigotes are abundant in the histiocytes and Kupffer cells. Late in the course of disease, splenic infarcts are common, centrilobular necrosis and fatty infiltration of the liver occur, the normal marrow elements are replaced by parasitized histiocytes, and erythrophagocytosis is present.

## PATHOGENESIS

Cellular immune mechanisms determine resistance or susceptibility to infection with *Leishmania*. Resistance is mediated by interleukin (IL)-12–driven generation of a T helper 1 (Th1) cell response, with interferon (IFN)- $\gamma$  inducing classic macrophage (M1) activation and parasite killing. Susceptibility is associated with expansion of IL-4–producing Th2 cells and/or the production of IL-10 and transforming growth factor (TGF)- $\beta$ , which are inhibitors of macrophage-mediated parasite killing, and the generation of regulatory T cells and arginase-producing (M2) macrophages. An exuberant innate inflammatory response involving inflammasome activation and IL-1 $\beta$  production in lesions is associated with greater local pathology and delayed healing. Patients with ML exhibit a hyperresponsive cellular immune reaction that contributes to the prominent tissue destruction seen in this form of the disease. Patients with DCL or active VL demonstrate reduced or altered *Leishmania*-specific cellular immune responses, with prominent generation of IL-10, but these responses recover after successful therapy.





**Fig. 331.2** Status of endemicity of visceral leishmaniasis worldwide in 2016. (From World Health Organization. *Recognizing Neglected Tropical Diseases Through Changes on the Skin: A Training Guide for Front-Line Health Workers*. Geneva: WHO; 2018.)

Within endemic areas, people who have had a subclinical infection can be identified by a positive delayed-type hypersensitivity skin response to leishmanial antigens (**Montenegro skin test**) or by antigen-induced production of IFN- $\gamma$  in a whole blood assay. Subclinical infection occurs considerably more frequently than does active cutaneous or visceral disease. **Host** factors (genetic background, concomitant disease, nutritional status), **parasite** factors (virulence, size of the inoculum), and possibly **vector**-specific factors (vector genotype, immunomodulatory salivary constituents) influence the expression as either subclinical infection or active disease. Within endemic areas, the prevalence of skin test positivity increases with age, and the incidence of clinical disease decreases with age, indicating that immunity is acquired in the population over time. Individuals with prior active disease or subclinical infection are usually immune to a subsequent clinical infection; however, latent infection can lead to active disease if the patient is immunosuppressed.

## CLINICAL MANIFESTATIONS

The different forms of the disease are distinct in their causes, epidemiologic features, transmission, and geographic distribution.

### Localized Cutaneous Leishmaniasis

LCL (**Oriental sore**) can affect individuals of any age, but children are the primary victims in many endemic regions. It may present as one or a few papular, nodular, plaque-like, or ulcerative lesions that are usually located on exposed skin, such as the face and extremities (Fig. 331.3). Rarely, >100 lesions have been recorded. The lesions typically begin as a small papule at the site of the sand fly bite, which enlarges to 1-3 cm in diameter and may ulcerate over the course of several weeks to months. The shallow ulcer is usually nontender and surrounded by a sharp, indurated, erythematous margin. There is no drainage unless a bacterial superinfection develops. Lesions caused by *L. major* and *L. mexicana* usually heal spontaneously after 3-6 months, leaving a depressed scar. Lesions on the ear pinna caused by *L. mexicana*, called **chiclero ulcer** because they were common in chicle harvesters in Mexico and Central America, often follow a chronic, destructive course. In general, lesions caused by *L. (Viannia)* species tend to be larger and more chronic. Regional lymphadenopathy and palpable subcutaneous nodules or lymphatic cords, the so-called sporotrichoid appearance,

are also more common when the patient is infected with organisms of the *Viannia* subgenus. If lesions do not become secondarily infected, there are usually no complications aside from the residual cutaneous scar.

### Diffuse Cutaneous Leishmaniasis

DCL is a rare form of leishmaniasis caused by organisms of the *L. mexicana* complex in the New World and *L. aethiopica* in the Old World. DCL manifests as large, non-ulcerating macules, papules, nodules, or plaques that often involve large areas of skin and may resemble lepromatous leprosy. The face and extremities are most often involved. Dissemination from the initial lesion usually takes place over several years. These patients are anergic to the Montenegro skin test, and it is thought that an immunologic defect underlies this severe form of cutaneous leishmaniasis.

### Disseminated Leishmaniasis

In rare cases, parasites can spread (likely by the hematogenous route) in an immunocompetent host from a primary lesion to cause DL. This is defined as >10 lesions (usually in the hundreds) involving at least two noncontiguous areas of the skin. DL has been most often attributed to *L. (V.) braziliensis*. The lesions are typically inflammatory papules or ulcers, in contrast to the nodular and plaque-like lesions of DCL, and about one-third of patients have mucosal involvement.

### Mucosal Leishmaniasis

ML (**espundia**) is an uncommon but serious manifestation of leishmanial infection resulting from hematogenous spread of parasites to the nasal or oropharyngeal mucosa from a cutaneous infection. It is usually caused by parasites in the *L. (Viannia)* complex. Approximately half of the patients with mucosal lesions have had active cutaneous lesions within the preceding 2 years, but ML may not develop until many years after resolution of the primary lesion. ML occurs in <5% of individuals who have, or have had, LCL caused by *L. (V.) braziliensis*. Patients with ML typically have nasal mucosal involvement and present with nasal congestion, discharge, and recurrent epistaxis. Oropharyngeal and laryngeal involvement is less common but associated with severe morbidity. Marked soft tissue, cartilage, and even bone destruction occurs late in the course of disease and may lead to visible

deformity of the nose or mouth, nasal septal perforation, and tracheal narrowing with airway obstruction.

### Visceral Leishmaniasis

VL (**kala-azar**) typically affects children <5 years old in the New World and Mediterranean region (*L. infantum*) and older children and young adults in Africa and Asia (*L. donovani*). After inoculation of the organism into the skin by the sand fly, the child may have a completely asymptomatic infection or an oligosymptomatic illness that either resolves spontaneously or evolves into active kala-azar. Children with **asymptomatic** infection are transiently seropositive but show no clinical evidence of disease. Children who are **oligosymptomatic** have mild constitutional symptoms (malaise, intermittent diarrhea, poor activity tolerance) and intermittent fever; most will have a mildly enlarged liver. In most of these children the illness will resolve without therapy, but in approximately 25% it will evolve to active kala-azar within 2–8 months. Extreme incubation periods of several years have rarely been described. During the first few weeks to months of disease evolution, the fever is intermittent, there is weakness and loss of energy, and the spleen begins to enlarge. The classic clinical features of high fever, marked splenomegaly, hepatomegaly, and severe cachexia typically develop 3–6 months after the onset of the illness, but a rapid clinical course over 1 month has been noted in up to 20% of patients in some series (Fig. 331.4). At the terminal stages of kala-azar, the hepatosplenomegaly is massive, there is gross wasting, the pancytopenia is profound, and jaundice, edema, and ascites may be present. Anemia may be severe enough to precipitate heart failure. Bleeding episodes, especially epistaxis, are frequent. The late stage of the illness is often complicated by secondary bacterial infections, which frequently are a cause of death. A younger age at the time of infection, HIV coinfection, and underlying malnutrition are risk factors for the development, rapid evolution, and severe disease of active VL. Death occurs in >90% of patients without specific antileishmanial treatment and in 4–10% of treated patients. VL is a known cause of **hemophagocytic lymphohistiocytosis** in endemic areas.

VL is an opportunistic infection associated with **HIV infection**. Most cases have occurred in southern Europe and Brazil, often as a result of needle sharing associated with illicit drug use, with the potential for many more cases as the endemic regions for HIV and VL converge. Leishmaniasis may also result from reactivation of a long-standing subclinical infection. Frequently there is an atypical clinical presentation of VL in HIV-infected individuals with prominent

involvement of the gastrointestinal tract and absence of the typical hepatosplenomegaly.

A small percentage of patients previously treated for VL develop diffuse skin lesions, a condition known as **post-kala-azar dermal leishmaniasis**. These lesions may appear during or shortly after therapy (Africa) or up to several years later (India). The lesions of post-kala-azar dermal leishmaniasis are hypopigmented, erythematous, or nodular and usually involve the face and torso. They may persist for several months or for many years.

### LABORATORY FINDINGS

Patients with cutaneous leishmaniasis or ML generally do not have abnormal laboratory results unless the lesions are secondarily infected with bacteria. Laboratory findings associated with classic kala-azar include anemia (hemoglobin, 5–8 mg/dL), thrombocytopenia, leukopenia (2,000–3,000 cells/ $\mu$ L), elevated hepatic transaminase levels, and hyperglobulinemia (>5 g/dL) that is mostly immunoglobulin G.

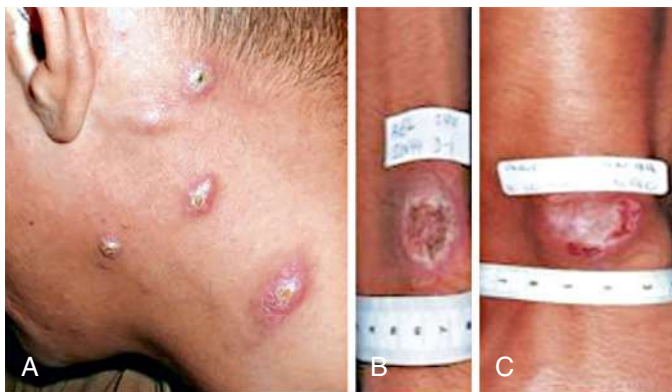
### DIFFERENTIAL DIAGNOSIS

Diseases that should be considered in the differential diagnosis of LCL include sporotrichosis, blastomycosis, chromomycosis, lobomycosis, cutaneous tuberculosis, atypical mycobacterial infection, leprosy, ecthyma, syphilis, yaws, and neoplasms. Infections such as syphilis, tertiary yaws, histoplasmosis, and paracoccidioidomycosis, as well as sarcoidosis, granulomatosis with polyangiitis, midline granuloma, and carcinoma, may have clinical features similar to those of ML. VL should be strongly suspected in the patient with prolonged fever, weakness, cachexia, marked splenomegaly, hepatomegaly, cytopenias, and hypergammaglobulinemia who has had potential exposure in an endemic area. The clinical picture may also be consistent with that of malaria, typhoid fever, miliary tuberculosis, schistosomiasis, brucellosis, amebic liver abscess, infectious mononucleosis, lymphoma, and leukemia.

### DIAGNOSIS

The development of one or several slowly progressive, nontender, nodular, or ulcerative lesions in a patient who had potential exposure in an endemic area should raise suspicion of LCL.

Serologic tests for diagnosis of cutaneous or mucosal disease generally have low sensitivity and specificity and offer little for diagnosis. Serologic testing by enzyme immunoassay, indirect fluorescence assay, or direct agglutination is very useful in VL because of the very high level of antileishmanial antibodies. An immunochromatographic strip test using a recombinant antigen (K39) has a diagnostic sensitivity and specificity for VL of 80–90% and 95%, respectively. Serodiagnostic tests have positive findings in only about half the patients co-infected with HIV.



**Fig. 331.3** Cutaneous disease. A, Old World infection (*Leishmania major*) acquired in Iraq; note five papular and nodular lesions on neck. B, New World infection (*Leishmania panamensis*) in Colombia; purely ulcerative lesion is characteristic of New World disease. C, Healed infection in patient shown in B 70 days after 20 days of meglumine antimonate treatment; note paper-thin scar tissue over flat reepithelialized skin. (A, Courtesy P. Weina; B, Courtesy J. Soto. A–C, Modified from Murray HW, Berman JD, Davies CR, et al. *Advances in leishmaniasis*. *Lancet*. 2005;366:1561–1577.)



**Fig. 331.4** Visceral leishmaniasis (*Leishmania donovani*) in Bihar State, India. A, Hepatosplenomegaly and wasting in a young man. B, Children with burn marks over enlarged spleen or liver evidence of a local shaman's unsuccessful remedy. (A, Courtesy D. Sacks; B, Courtesy R. Kenney; A and B, Adapted from Murray HW, Berman JD, Davies CR, et al. *Advances in leishmaniasis*. *Lancet*. 2005;366:1561–1577.)

Definitive diagnosis of leishmaniasis is established by the demonstration of amastigotes in tissue specimens or isolation of the organism by culture. **Amastigotes** can be identified in Giemsa-stained tissue sections, aspirates, or impression smears in about half the cases of LCL but only rarely in the lesions of ML. **Culture** of a tissue biopsy or aspirate, best performed by using Novy-MacNeal-Nicolle biphasic blood agar medium, yields a positive finding in only approximately 65% of cases of cutaneous leishmaniasis. Identification of parasites in impression smears, histopathologic sections, or culture medium is more readily accomplished in DCL than in LCL. In patients with VL, smears or cultures of material from splenic, bone marrow, or lymph node aspirations are usually diagnostic. In experienced hands, **splenic aspiration** has a higher diagnostic sensitivity, but it is rarely performed in the United States because of the risk for bleeding complications. A positive culture result allows speciation of the parasite, usually by isoenzyme analysis by a reference laboratory, which may have therapeutic and prognostic significance.

## TREATMENT

Specific antileishmanial therapy should be individualized for each patient. It is not routinely indicated for immunocompetent persons having uncomplicated simple LCL (single or few lesions, lesion diameter <1 cm, no mucosal involvement) caused by strains that have a high rate of spontaneous resolution and self-healing (*L. major*, *L. mexicana*). Lesions that are extensive, severely inflamed, or located where a scar would result in disability (near a joint) or cosmetic disfigurement (face or ear), that involve the lymphatics, or that do not begin healing within 3-4 months should be treated. Cutaneous lesions suspected or known to be caused by members of the *Viannia* subgenus (New World) should be treated because of the low rate of spontaneous healing and the potential risk for development of mucosal or disseminated disease. Similarly, patients with lesions caused by *L. tropica* (Old World), which are typically chronic and nonhealing, should be treated. All patients with VL or ML should receive therapy.

The pentavalent **antimony compounds** (sodium stibogluconate [Pentostam, GlaxoSmithKline, Uxbridge, UK] and **meglumine antimoniate** [Glucantime, Aventis, Strasbourg, France]) have been the mainstay of antileishmanial chemotherapy for >40 years. These drugs have similar efficacies, toxicities, and treatment regimens. Currently, for **sodium stibogluconate** (available in the United States from the Centers for Disease Control and Prevention, Atlanta, GA), the recommended regimen is 20 mg/kg/day intravenously (IV) or intramuscularly (IM) for 20 days (for LCL and DCL) or 28 days (for ML and VL). Repeated courses of therapy may be necessary in patients with severe cutaneous lesions, ML, DCL, DL, or VL. An initial clinical response to therapy usually occurs in the first week of therapy, but complete clinical healing (reepithelialization and scarring for LCL and ML, and regression of splenomegaly and normalization of cytopenias for VL) is usually not evident for weeks to a few months after completion of therapy. Cure rates with this regimen of 90–100% for LCL, 50–70% for ML, and 80–100% for VL were common in the 1990s, but treatment failures, especially in children, have become common in parts of India, East Africa, and Latin America.

Relapses are common in patients who do not have an effective antileishmanial cellular immune response (DCL or HIV co-infection). Adverse effects of antimony therapy are dose and duration dependent and include fatigue, arthralgias, and myalgias (50%), abdominal discomfort (30%), elevated hepatic transaminase level (30–80%), elevated amylase and lipase levels (almost 100%), mild hematologic changes (slightly decreased leukocyte count, hemoglobin level, and platelet count) (10–30%), and nonspecific T-wave changes on electrocardiography (30%). Sudden death from cardiac toxicity has rarely been reported with use of very high doses of pentavalent antimony.

**Amphotericin B desoxycholate** and **liposomal amphotericin B** are very useful in the treatment of VL, ML, or DL, and in some regions

have replaced antimony as first-line therapy, especially in HIV-infected patients. However, the prohibitively high cost of these drugs precludes their use in many resource-poor regions of the world. Amphotericin B desoxycholate at doses of 0.5-1.0 mg/kg every day or every other day for 14-20 doses achieved a cure rate for VL of close to 100%, but renal toxicity associated with amphotericin B was common. **Liposomal amphotericin B** (AmBisome, Gilead Sciences, Foster City, CA) is especially attractive for treatment of leishmaniasis because the drug is concentrated in the reticuloendothelial system and is less nephrotoxic. It is approved by the U.S. Food and Drug Administration (FDA) for treatment of VL at a recommended dose for *immunocompetent patients* of 3 mg/kg on days 1-5, 14, and 21 (total dose 21 mg/kg) and should be considered for first-line therapy in the United States. It is highly effective, with a 90–100% cure rate for VL in immunocompetent children, including those who were refractory to antimony therapy. Therapy for *immunocompromised patients* should be prolonged (recommended total dose 40 mg/kg). A single high dose of liposomal amphotericin B (10 mg/kg) was found to be effective in India (approximately 95% efficacy) but was less effective in East Africa (58% efficacy).

Parenteral treatment of VL with the aminoglycoside **paromomycin** (aminosidine) has efficacy (95%) similar to that of amphotericin B in India. A dose-sparing regimen of the combination of sodium stibogluconate and paromomycin is effective and used in East Africa. **Miltefosine**, a membrane-activating alkyl phospholipid, has been approved as the first oral treatment for VL and has a cure rate of 80–90% in Indian patients with VL when administered orally at 50-100 mg/day (or 2.5 mg/kg for children <12 years old) for 28 days. Miltefosine is indicated for cutaneous infection caused by *L. braziliensis*, *L. guyanensis*, and *L. panamensis*; ML caused by *L. braziliensis*; and VL caused by *L. donovani*. Gastrointestinal adverse effects were frequent but did not require discontinuation of the drug. An increased rate of relapse (up to 20%) has been seen in children treated with miltefosine. Dose-sparing combination regimens are being actively investigated for treatment of VL. Treatment of LCL with oral drugs has had only modest success. Ketoconazole has been effective in treating adults with LCL caused by *L. major*, *L. mexicana*, and *L. panamensis*, but not *L. tropica* or *L. braziliensis*. Fluconazole in high doses (up to 8 mg/kg/day) for 4-8 weeks was demonstrated to be effective in treating LCL in studies in both the Old and New World; however, the experience in young children is limited. Miltefosine, 2.5 mg/kg/day orally for 20-28 days, was effective in 70–90% of patients with LCL in the Americas. Local therapy, including heat, cryotherapy, and topical 15% paromomycin ointment has been effective treatment for LCL in selected areas in both the Old and the New World. Enhanced drug development efforts and clinical trials of new drugs are clearly needed, especially in children.

## PREVENTION

Personal protective measures should include avoidance of exposure to the nocturnal sand flies and, when necessary, the use of insect repellent and permethrin-impregnated mosquito netting. Where peridomestic transmission is present, community-based residual insecticide spraying has had some success in reducing the prevalence of leishmaniasis, but long-term effects are difficult to maintain. Control or elimination of infected reservoir hosts (e.g., seropositive domestic dogs) has had limited success. Where anthroponotic transmission is thought to occur, as in south Asia, early recognition, diagnosis, and treatment of cases and vector control measures are essential for progress toward elimination. Several vaccines have been demonstrated to have efficacy in experimental models, and vaccination of humans or domestic dogs may have a role in the control of the leishmaniasis in the future.

Visit Elsevier eBooks+ at [eBooks.Health.Elsevier.com](http://eBooks.Health.Elsevier.com) for Bibliography.



## Chapter 332

# African Trypanosomiasis (Sleeping Sickness; *Trypanosoma brucei* Complex)

Edsel Maurice T. Salvana and  
Robert A. Salata

Sixty-five million people in 36 countries are at risk for infection with *Trypanosoma brucei* complex, the causative agent of sleeping sickness. Also known as **human African trypanosomiasis (HAT)**, this disease is restricted to sub-Saharan Africa, the range of the tsetse fly vector. It is a disease of extreme poverty, with the highest disease burden observed in remote rural areas. HAT comes in two geographically and clinically distinct forms. *Trypanosoma brucei gambiense* causes a chronic infection and affects people who live in western and central Africa (**West African sleeping sickness, Gambian trypanosomiasis**). *Trypanosoma brucei rhodesiense* is a zoonosis that presents as an acute illness lasting several weeks and usually occurs in residents or travelers from eastern and southern Africa (**East African sleeping sickness, Rhodesian trypanosomiasis**).

## ETIOLOGY

HAT is a vector-borne disease caused by parasitic, extracellular, flagellated kinetoplastid protozoans of two subspecies of *T. brucei*. It is transmitted to humans through the bite of *Glossina*, commonly known as the **tsetse fly**.

Humans usually contract East African HAT when they venture from towns to rural areas to visit woodlands or livestock, highlighting the importance of zoonotic reservoirs in this disease. West African HAT is contracted closer to settlements and only requires a small vector population, making it difficult to eradicate. Animal reservoirs occur, but the main source of infection remains chronically infected human hosts.

## LIFE CYCLE

*T. brucei* undergoes several stages of development in the insect and mammalian host. On ingestion with a blood meal, nonproliferative **short stumpy (SS)** forms of the parasite transform into procyclic forms in the insect's midgut. These procyclic forms proliferate and undergo further development into epimastigotes, which then become infective metacyclic forms that migrate to the insect's salivary glands. The life cycle within the tsetse fly takes 15-35 days. On inoculation into the mammalian host, the metacyclic stage transforms into proliferative **long slender (LS)** forms in the bloodstream and the lymphatics, eventually penetrating the central nervous system (CNS). LS forms appear in waves in the peripheral blood, with each wave followed by a febrile crisis and heralding the formation of a new antigenic variant. Once a critical density of LS forms is reached, a quorum-sensing mechanism causes most of these to transform into nonproliferative SS forms that are ingested by *Glossina* and start the cycle anew. Quorum sensing controls peak parasitemia to ensure that the host survives infection long enough for the parasite to complete its life cycle.

Direct transmission to humans has been reported, either vertically to infants or mechanically through contact with tsetse flies with viable LS forms on their mouthparts from a recent blood meal from an infected host.

## EPIDEMIOLOGY

HAT occurs mainly in sub-Saharan Africa between latitudes 14 degrees north and 29 degrees south, where the annual rainfall creates optimal climatic conditions for *Glossina*. In 2009, new HAT cases annually fell below 10,000 as a result of intensive control efforts. In 2018, new cases fell to 977, the lowest level in 80 years since the start of systematic data collection. In the last 10 years, 70% of cases were reported from the Democratic Republic of Congo. Gambian trypanosomiasis is targeted for sustainable elimination as a public health problem by 2030.

*T. brucei rhodesiense* infection is restricted to the eastern third of the endemic area in tropical Africa, stretching from Ethiopia to the northern boundaries of South Africa. *T. brucei gambiense*, which accounts for 95% of HAT cases, occurs mainly in the western half of the continent's endemic region. Rhodesian HAT, which has an acute and often fatal course, greatly reduces chances of transmission to tsetse flies. The ability of *T. brucei rhodesiense* to multiply rapidly in the bloodstream and infect other species of mammals helps maintain its life cycle. HAT is infrequently reported in non-endemic countries, usually in returning travelers or migrants.

## PATHOGENESIS

At the site of the *Glossina* bite, tsetse fly salivary antigens, peptides, and proteins promote an immune-tolerant microenvironment that facilitates parasite invasion. Injected metacyclic parasites transform into LS forms, which rapidly divide by binary fission. The parasites, along with the attendant inflammation, cellular debris, and metabolic products, may give rise to a hard, painful, red nodule known as a **trypanosomal chancre** within 5-15 days postinoculation. Parasites directionally migrate from the skin to the lymphatics via an unknown mechanism and pass into the draining lymph node and onward into the main lymphatic ducts. Dissemination into the blood and lymphatic systems follows, with subsequent localization to the CNS. Histopathologic findings in the brain are consistent with meningoencephalitis. The appearance of **morula** cells of Mott (large, strawberry-like cells, supposedly derived from plasma cells) is a characteristic finding in chronic disease.

Mechanisms underlying virulence in HAT are still incompletely understood but seem to be mediated by a complex interplay of trypanosomal, human, and *Glossina* factors. *T. brucei gambiense* utilizes at least three mechanisms to evade lysis by human sera. These include reduced binding to trypanolytic factor 1 (TLF1) via reduced expression and mutation of a haptoglobin-hemoglobin receptor; expression of a specific glycoprotein TgsGP, which reduces trypanosomal membrane fluidity; and a cysteine protease-mediated reduction of sensitivity to apolipoprotein L-1 (APOL1). *T. brucei rhodesiense*, on the other hand, expresses a protein known as serum resistance-associated protein (SRA), which counteracts trypanolytic APOL1 in human serum. APOL1 and the hemoglobin binding protein haptoglobin-related protein (HPR) are major components of two high-density lipoprotein complexes called TLF1 and TLF2, which protect humans against non-human trypanosomes. Trypanosomes also secrete a host of biologically active molecules that can dampen immune responses.

Antigenic variation of **variant surface glycoprotein (VSG)** on the trypanosome surface has long been recognized as a major factor in evading acquired immunity during infection. This antigenic diversity is generated by a tightly controlled system of DNA double-stranded breaks with associated homologous recombination. VSG also inhibits complement activation and antibody-mediated aggregation, facilitating establishment and maintenance of infection. Soluble VSG is hypersecreted, especially at the peak of parasitemia, and may serve as a decoy for antibodies and complement factor, diverting immune responses away from trypanosomes.

## CLINICAL MANIFESTATIONS

Clinical presentations vary not only because of the two subspecies of organisms but also because of differences in host response in the



indigenous population of endemic areas and in newcomers or visitors. Visitors usually suffer more from the acute symptoms, but if untreated, death usually follows for natives and visitors alike. Symptoms usually occur within 2-3 weeks of infection. The clinical syndromes of HAT are trypanosomal chancre, hemolymphatic stage, and meningoencephalitic stage.

### Trypanosomal Chancre

The site of the tsetse fly bite may be the first presenting feature. A nodule or chancre (3-4 cm) develops in 2-3 days and becomes a painful, hard, red nodule surrounded by an area of erythema and swelling within 1 week. Nodules are typically seen on the lower limbs and sometimes also on the head. They subside spontaneously in about 2 weeks, leaving no permanent scar.

### Hemolymphatic Stage (Stage 1)

The most common presenting features of acute HAT occur at the time of invasion of the bloodstream by the parasites, 2-3 weeks after infection. Patients usually present with irregular episodes of fever, each lasting up to 7 days, accompanied by headache, sweating, and generalized lymphadenopathy. Attacks may be separated by symptom-free intervals of days or even weeks. Painless, nonmatted **lymphadenopathy**, most often of the posterior cervical and supraclavicular nodes, is one of the most constant signs, particularly in the Gambian form. A common feature of trypanosomiasis is the presence of blotchy, irregular, nonpruritic, erythematous **macules**, which may appear any time after the first febrile episode, usually within 6-8 weeks. The majority of macules have a normal central area, giving the rash a circinate outline. This **rash** is seen mainly on the trunk and is evanescent, fading in one place only to appear at another site. Examination of the blood during this stage may show anemia, leukopenia with relative monocytosis, and elevated levels of immunoglobulin M (IgM). Cardiac manifestations of HAT have also been reported but are generally limited to nonspecific ST-T wave electrocardiographic abnormalities. Histopathologic characterization shows a lymphomonohistiocytic infiltrate in the interstitium, with no penetration of the myocardial cells, unlike that for American trypanosomiasis (see [Chapter 333](#)). The perimyocarditis is usually self-limited and does not typically progress to congestive heart failure.

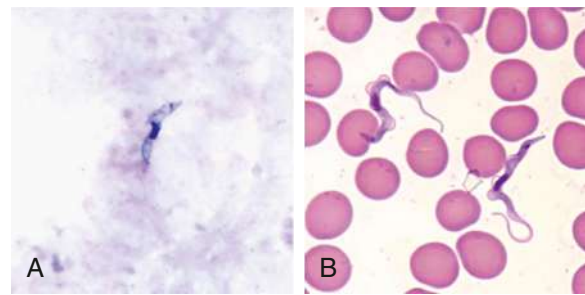
### Meningoencephalitic Stage (Stage 2)

Neurologic symptoms and signs are nonspecific, including irritability, insomnia, and irrational and inexplicable anxieties with frequent changes in mood and personality. Neurologic symptoms may precede invasion of the CNS by the organisms. In untreated *T. brucei rhodesiense* infections, CNS invasion occurs within 3-6 weeks and is associated with recurrent bouts of headache, fever, weakness, and signs of acute toxemia. Death occurs in 6-9 months as a result of secondary infection or cardiac failure.

In Gambian HAT, cerebral symptoms appear within 2 years after the acute symptoms. An increase in drowsiness during the day and insomnia at night reflect the continuous progression of infection and may be accompanied by anemia, leukopenia, and muscle wasting. The chronic, diffuse meningoencephalitis without localizing symptoms is the form referred to as **sleeping sickness**. Drowsiness and an uncontrollable urge to sleep are the major features of this stage and become almost continuous in the terminal stages. Tremor or rigidity with stiff and ataxic gait suggest involvement of the basal ganglia. Psychotic changes occur in one third of untreated patients. Although most untreated disease is fatal, in rare cases, individuals remain asymptomatic, clear parasitemia, and become seronegative.

### DIAGNOSIS

Definitive diagnosis can be established during the early stages by examination of a fresh, thick blood smear, which permits visualization of the



**Fig. 332.1** *Trypanosoma brucei* sp. trypomastigotes in thick blood smear stained with Giemsa (A) and thin blood smear stained with Wright-Giemsa (B). (From Centers for Disease Control and Prevention: *Laboratory identification of parasites of public health concern. Trypanosomiasis, African* [website], 2018. <https://www.cdc.gov/dpdx/trypanosomiasisafrican/index.html>)

motile active forms ([Fig. 332.1](#)). HAT can also be detected from blood using a variety of sensitive techniques, such as quantitative buffy coat smears and mini anion exchange resins. Dried, Giemsa-stained smears should be examined for the detailed morphologic features of the organisms. If a thick blood or buffy coat smear is negative, concentration techniques may help. Aspiration of an enlarged lymph node can also be used to obtain material for parasitologic examination. If positive, cerebrospinal fluid (CSF) should also be examined for the organisms. The presence of trypanosomes, or  $\geq 5$  white blood cells (WBCs)/ $\mu\text{L}$ , or both, is indicative of stage 2 disease. If trypanosomes are absent in the CSF, some authorities use a count of 10-20 WBCs/ $\mu\text{L}$  as a cutoff for diagnosing late-stage disease.

The card agglutination trypanosomiasis test (CATT) is of value for epidemiologic purposes and for screening for *T. brucei gambiense*. Lateral flow formats of CATT have enabled point-of-care testing. Because CATT detects antibodies against particular VSG molecules, it cannot distinguish present from past infection.

Polymerase chain reaction-based tests have been shown to be highly sensitive and specific, but these tests require laboratory facilities. Field-based loop-mediated isothermal amplification tests have been developed and validated. Other areas of active research for diagnostics include new biomarkers, cytokine profiles, proteomics, and polysomnography, which are being used not only to identify disease but to differentiate disease stages.

### TREATMENT

The choice of chemotherapeutic agents for treatment depends on the stage of the infection and the causative organisms.

#### Stage 1 Treatment

Hematogenous forms of both Rhodesian and Gambian HAT have been traditionally treated with either suramin or pentamidine. **Suramin** is a polysulfonated symmetric naphthalene derivative given as a 10% solution for intravenous (IV) administration. A **test dose** (10 mg for children; 100-200 mg for adults) is initially administered to detect rare idiosyncratic reactions of shock and collapse. The dose for subsequent IV injections is 20 mg/kg (maximum 1 g) administered on days 1, 3, 7, 14, and 21. Suramin is nephrotoxic; thus a urinalysis should be performed before each dose. Marked proteinuria, blood, or casts is a contraindication to continuation of suramin. Resistance is rare but has been reported.

**Pentamidine isethionate** (4 mg/kg/day intramuscularly [IM] daily or on alternate days for 7-10 days) concentrates to high levels in trypanosomes and is highly trypanocidal. It is better tolerated than suramin but carries significant risk of hypoglycemia, nephrotoxicity, hypotension, leukopenia, and liver enzyme elevation. Because of its

potency, long half-life, and toxicity, short-course treatment is desirable and is being investigated.

**Fexinidazole** has recently been approved for oral treatment of stage 1 and 2 Gambian HAT in 6 years of age and older and weighing at least 20 kg. Dosing is weight based over 10 days. For 35 kg and above, a loading dose of 1,800 mg for 4 days followed by a maintenance dose of 1,200 mg over 6 days is recommended. For 20 kg to <35 kg, the loading dose is 1,200 mg over 4 days and 600 mg maintenance over 6 days. Common side effects include gastrointestinal upset, asthenia, headache, tremors, and dizziness. Some patients may develop neutropenia.

### Stage 2 Treatment

Combination **eflornithine and nifurtimox** (NECT) is the current treatment of choice for *T. brucei gambiense* CNS infection. Eflornithine is given at 400 mg/kg/day IV divided every 12 hours for 7 days, along with nifurtimox, 15 mg/kg/day orally divided every 8 hour for 10 days. If nifurtimox is unavailable, eflornithine monotherapy can be given at 400 mg/kg/day IV divided every 6 hours for 14 days. Adverse reactions to these regimens include fever, hypertension, and seizures, with NECT having less frequent events.

**Fexinidazole** is a safe and effective, all oral alternative to NECT for stage 2 Gambian HAT. However, it is associated with lower efficacy in severe disease (86.9% with fexinidazole vs 98.7% for NECT). Dosing and duration are the same as for stage 1 disease.

**Melarsoprol** is an arsenical compound and is the only effective treatment for late *T. brucei rhodesiense* disease. Treatment of children is initiated at 0.36 mg/kg IV once daily, with gradually escalating doses every 1-5 days to 3.6 mg/kg once daily; treatment is usually 10 doses (18-25 mg/kg total dose). Treatment of adults is with melarsoprol 2-3.6 mg/kg IV once daily for 3 days; and after 1 week, 3.6 mg/kg once daily for 3 days, which is repeated after 10-21 days. An alternative regimen is 2.2 mg/kg once daily for 10 days. Guidelines recommend 18-25 mg/kg total over 1 month. Reactions such as fever, abdominal pain, and chest pain are rare but may occur during or shortly after administration. Serious toxic effects include encephalopathy and exfoliative dermatitis.

Following on the success of fexinidazole, other candidate oral drugs for HAT are being studied. This includes acoziborole, which is currently in clinical trials as a single-dose oral treatment for stage 2 HAT.

### PREVENTION

A vaccine or consistently effective prophylactic therapy is not available and is particularly challenging because of the antigenic variation caused by VSGs. Virus-like particles are being explored as an adjuvant to hurdle the complexities of the immunologic response. A single injection of pentamidine (3-4 mg/kg IM) provides protection against Gambian trypanosomiasis for at least 6 months, but the effectiveness against the Rhodesian form is uncertain.

Vector control programs against *Glossina* have been essential in controlling disease, coupled with the use of screens, traps, insecticides, and sanitary measures. Neutral-colored clothing may reduce tsetse fly bites. Control of infection in animal reservoirs with mass administration of trypanocidal drugs in cattle has met with some success.

The full genome of *T. brucei* with about 9,000 genes has been sequenced. Approximately 10% of these genes encode VSGs. CRISPR-Cas9-based gene editing has helped identify genes relevant to the disease and its possible prevention, as well as the design of new anti-trypanosomal drugs, including those that target specific metabolic pathways.

Visit Elsevier eBooks+ at [eBooks.Elsevier.com](https://www.elsevier.com/ebooks) for Bibliography.

## Chapter 333

# American Trypanosomiasis (Chagas Disease; *Trypanosoma cruzi*)

Edsel Maurice T. Salvana and  
Robert A. Salata

American trypanosomiasis or Chagas disease is caused by the protozoan *Trypanosoma cruzi*. Its natural vectors are the reduviid insects, specifically **triatomines**, variably known as wild bedbugs, assassin bugs, or kissing bugs. It can also be transmitted orally from contaminated food, vertically from mother to child, and through blood transfusion or organ transplantation. Signs and symptoms of acute Chagas disease are usually nonspecific, whereas chronic disease may manifest as cardiomyopathy or severe gastrointestinal (GI) dilation and dysfunction.

### ETIOLOGY

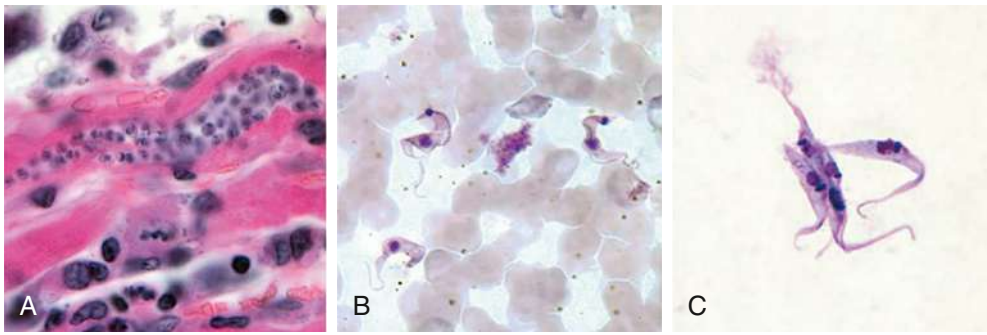
American trypanosomiasis is caused by *T. cruzi*, a parasitic, flagellated kinetoplastid protozoan. The main vectors for *T. cruzi* are insects of the family Reduviidae, subfamily Triatominae, which includes *Triatoma infestans*, *Rhodnius prolixus*, and *Panstrongylus megistus*.

### LIFE CYCLE

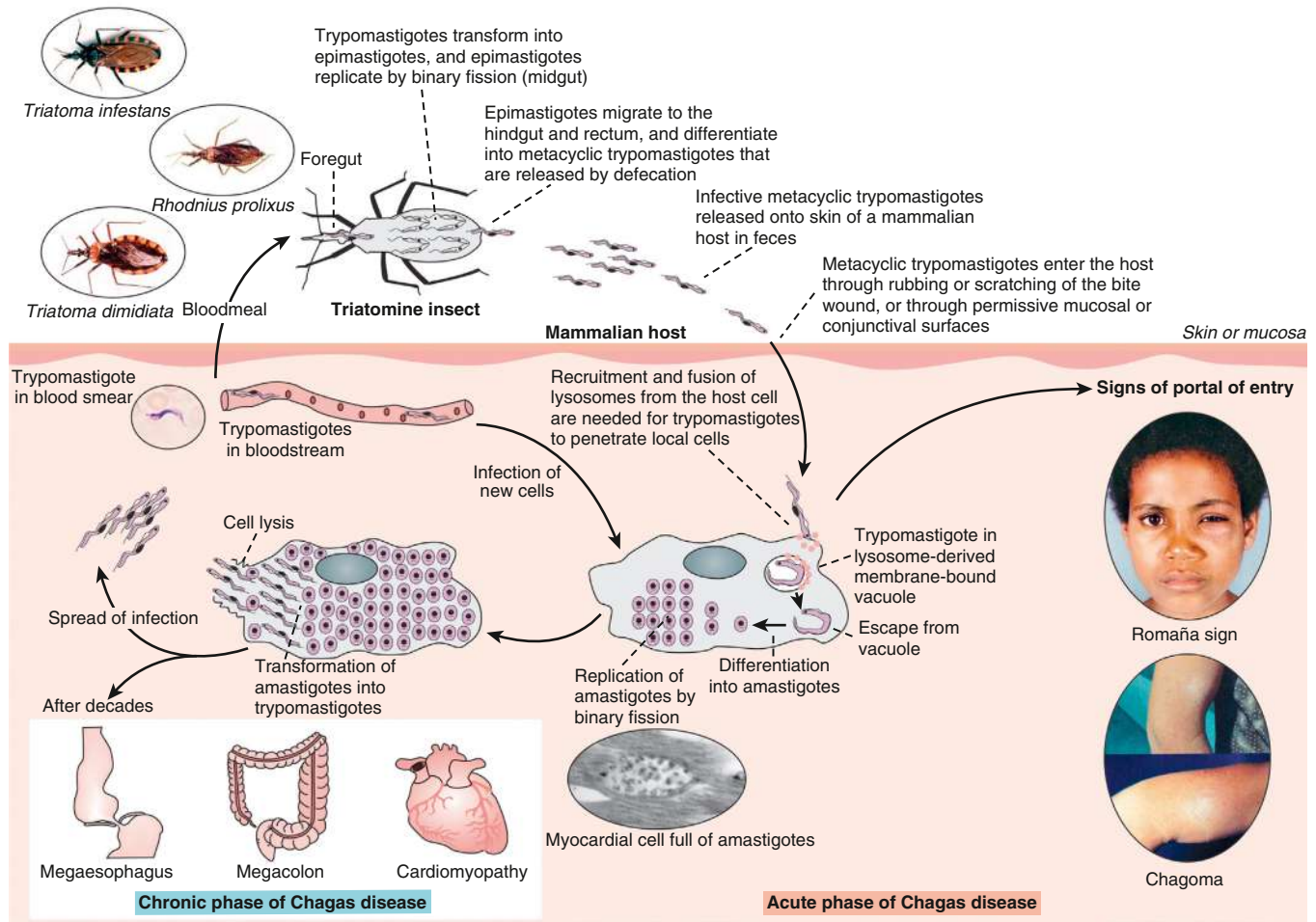
*T. cruzi* has three recognizable morphogenetic phases: amastigotes, trypomastigotes, and epimastigotes (Figs. 333.1 and 333.2). **Amastigotes** are intracellular forms found in mammalian tissues that are spherical and have a short flagellum but form clusters of oval shapes (pseudocysts) within infected tissues. **Trypomastigotes** are spindle-shaped, extracellular, nondividing forms that are found in blood and are responsible for both transmission of infection to the insect vector and cell-to-cell spread of infection. **Epimastigotes** are found in the midgut of the vector insect and multiply in the midgut and rectum of arthropods, differentiating into metacyclic forms. **Metacyclic trypomastigotes** are the infectious form for humans and are released onto the skin of a human when the insect defecates close to the site of a bite, entering through the damaged skin or mucous membranes. Once in the host, these multiply intracellularly as amastigotes, which then differentiate into bloodstream trypomastigotes and are released into the circulation when the host cell ruptures. Blood-borne trypomastigotes circulate until they enter another host cell or are taken up by the bite of another insect, completing the life cycle. There is some variability in these stages. Reverse transitions can occur; epimastigote-like forms have been found in the mammalian hosts, and trypomastigotes have been observed to replicate. Amastigotes can also quickly transform into quiescent forms upon drug exposure and can maintain persistent infection despite treatment.

### EPIDEMIOLOGY

Natural transmission of Chagas disease occurs in North and South America, most frequently in continental Latin America. The disease may arise elsewhere because of migration and transmission through contaminated blood. World Health Organization (WHO) and Pan-American Health Organization-led efforts in large-scale vector control, blood donor screening to prevent transmission through transfusion and case finding, and treatment of chronically infected



**Fig. 333.1** Stages of *Trypanosoma cruzi*. A, Amastigote. B, Trypomastigote. C, Epimastigotes. (From Centers for Disease Control and Prevention. Laboratory identification of parasites of public health concern. Trypanosomiasis, American [website], 2018. <https://www.cdc.gov/dpdx/trypanosomiasis-american/index.html>)



**Fig. 333.2** Vector-borne transmission and life cycle of *Trypanosoma cruzi*. (From Rassi A Jr, Rassi A, Marin-Neto JA. Chagas disease. Lancet. 2010;375:1388–1400. Fig. 1.)

mothers and newborn infants have effectively halted transmission in a number of areas of South America. The number of cases has dropped from a peak of 24 million in 1984 to a current estimate of 6–7 million. Incident cases are estimated at 30,000 infections per year, including 8,000 newborns from vertical transmission. Chagas disease causes 10,000–12,000 deaths annually. This is likely an underestimate as long-term complications of Chagas disease as a cause of death may not be properly attributed to undiagnosed, chronically infected persons.

Infection is divided into two main phases: acute and chronic (Table 333.1). **Acute infection** can manifest as fever, lymphadenopathy, organomegaly, myocarditis, and meningoencephalitis but is otherwise

asymptomatic in up to 95% of infected individuals. **Chronic infection** in 60–70% of patients is *indeterminate*, meaning the patient is asymptomatic but has a positive antibody titer. Approximately 30% of infected persons proceed to chronic determinate or symptomatic *T. cruzi* infection.

The *T. cruzi* genome has been fully sequenced and contains 12,000 genes, the most widely expanded among trypanosomatids, and may reflect its ability to invade virtually any nucleated cell type within reach. Significant variability is present, along with extensive epigenetic modification of surface proteins, which may contribute to immune evasion. Seven genetic lineages, known as *discrete typing units* (DTUs) are recognized. These are referred to as TcI through TcVI, and Tcbat for



**Table 333.1** Clinical Features and Diagnosis of Chagas Disease

	GEOGRAPHIC DISTRIBUTION	CLINICAL SIGNS/SYMPTOMS	DIAGNOSIS
<b>ACUTE FORMS*</b>			
Vectorial	Endemic countries	<ul style="list-style-type: none"> <li>• Incubation period: 1-2wk</li> <li>• Signs of portal of entry: indurated cutaneous lesion (chagoma) or palpebral edema (Romaña sign)</li> <li>• Most cases are mild disease (95–99%) and unrecognized</li> <li>• Persistent fever, fatigue, lymphadenopathy, hepatomegaly, splenomegaly, morbilliform rash, edema</li> <li>• In rare cases, myocarditis or meningoencephalitis</li> <li>• Anemia, lymphocytosis, elevated AST/ALT concentrations</li> <li>• Risk of mortality: 0.2–0.5%</li> </ul>	<ul style="list-style-type: none"> <li>• Direct parasitologic methods: patent parasitemia up to 90 days</li> <li>• Microscopic examination of fresh blood, Giemsa-stained thin and thick blood films, or buffy coat</li> <li>• Concentration methods: microhematocrit and Strout method PCR techniques</li> <li>• Serology is not useful</li> </ul>
Congenital	Endemic and nonendemic countries	<ul style="list-style-type: none"> <li>• Incubation period: birth to several weeks</li> <li>• Most are asymptomatic or have mild disease</li> <li>• Prematurity, low birthweight, abortion, neonatal death</li> <li>• Fever, jaundice, edema, hepatomegaly, splenomegaly, respiratory distress syndrome, myocarditis, meningoencephalitis</li> <li>• Anemia and thrombocytopenia</li> <li>• Risk of mortality: &lt;2%</li> </ul>	<ul style="list-style-type: none"> <li>• Direct parasitologic methods</li> <li>• Concentration methods: microhematocrit, Strout method</li> <li>• Direct microscopy also useful</li> <li>• PCR: most sensitive technique</li> <li>• Serology: after 9 mo or later</li> </ul>
Oral	Restricted areas of endemic countries (Amazon basin) and local outbreaks	<ul style="list-style-type: none"> <li>• Incubation period: 3-22 days</li> <li>• Fever, vomiting, periocular edema, dyspnea, fever, myalgia, prostration, cough, splenomegaly, hepatomegaly, chest pain, abdominal pain, digestive hemorrhage</li> <li>• Risk of mortality: 1–35%</li> </ul>	Same as for vectorial
Transfusion and transplant	Endemic and nonendemic countries	<ul style="list-style-type: none"> <li>• Incubation period: 8-160 days; persistent fever</li> <li>• Clinical characteristics similar to those of vectorial cases (excluding portal of entry signs)</li> <li>• Risk of mortality is variable and depends on the severity of baseline disease</li> </ul>	<ul style="list-style-type: none"> <li>• Same as for vectorial</li> <li>• PCR techniques usually yield positive results days to weeks before trypomastigotes are detectable in blood</li> <li>• Tissue samples are needed in some circumstances</li> </ul>
Reactivation in HIV-infected patients	Endemic and nonendemic countries	<ul style="list-style-type: none"> <li>• Behaves as other opportunistic infections</li> <li>• Reactivation with &lt;200 CD4 cells/μL (mostly with &lt;100)</li> <li>• Affects CNS (75–90%) as single or multiple space-occupying lesions or as severe necrohemorrhagic meningoencephalitis</li> <li>• Cardiac involvement (10–55%): myocarditis, pericardial effusion or worsening of previous cardiomyopathy</li> <li>• Risk of mortality: 20%</li> </ul>	<ul style="list-style-type: none"> <li>• Direct parasitologic methods, as in vectorial cases</li> <li>• Parasite can be found in CSF, other body fluids, and tissue samples</li> <li>• PCR: not useful for diagnosis of reactivation</li> <li>• Serology: indicative of chronic infection and helpful in cases of suspected disease</li> </ul>
Reactivation in other immunosuppressed patients	Endemic and nonendemic countries	<ul style="list-style-type: none"> <li>• Reactivation after transplantation or in patients with hematologic malignancies</li> <li>• Clinical characteristics similar to those of patients who undergo transfusion and those with panniculitis and other skin disorders</li> <li>• Risk of mortality is variable and depends on severity of baseline disease and prompt diagnosis</li> </ul>	<ul style="list-style-type: none"> <li>• Direct parasitologic methods, as in vectorial cases</li> <li>• Parasite can be found in tissue samples</li> <li>• PCR: increasing parasite load detected with real-time PCR in serial specimens could be indicative of a high risk of reactivation</li> </ul>
<b>CHRONIC FORMS</b>			
Indeterminate	Endemic and nonendemic countries	<ul style="list-style-type: none"> <li>• Asymptomatic</li> <li>• Normal chest radiograph and 12-lead ECG</li> </ul>	<ul style="list-style-type: none"> <li>• Serology: detection of IgG</li> <li>• PCR: low sensitivity</li> </ul>



**Table 333.1** Clinical Features and Diagnosis of Chagas Disease—cont'd

GEOGRAPHIC DISTRIBUTION		CLINICAL SIGNS/SYMPTOMS	DIAGNOSIS
Cardiac and gastrointestinal	Endemic and nonendemic countries	<ul style="list-style-type: none"> <li>Cardiac manifestations: fatigue, syncope, palpitations, dizziness, stroke; late manifestations: chest pain (atypical), dyspnea, edema, left ventricular dysfunction, congestive heart failure; alterations in 12-lead ECG, echocardiography, or other heart function tests</li> <li>Gastrointestinal: dysphagia, regurgitation, severe constipation (dilated esophagus or colon); alterations in esophageal manometry, barium swallow, or barium enema</li> </ul>	<ul style="list-style-type: none"> <li>Serology: detection of IgG</li> <li>PCR: low sensitivity</li> </ul>

\*Including reactivation in immunosuppressed patients.

ALT, Alanine transaminase; AST, aspartate transaminase; CNS, central nervous system; CSF, cerebrospinal fluid; PCR, polymerase chain reaction. From Pérez-Molina J, Molina I. Chagas disease. *Lancet*. 2018;391:82–92. Table 2.

the seventh DTU. DTUs may differ in geographic distribution and predominant vector and hosts and may also vary in disease manifestations and response to treatment. A recent meta-analysis showed that TcI, the most widespread DTU, may be less susceptible to benznidazole.

*T. cruzi* infection is primarily a zoonosis, and humans are incidental hosts. *T. cruzi* has a large sylvan reservoir and has been isolated from numerous animal species. The presence of reservoirs and vectors of *T. cruzi* and the socioeconomic and educational levels of the population are the most important risk factors for vector-borne transmission to humans. Insect vectors are found in rural, wooded areas and acquire infection through ingestion of blood from humans or animals with circulating trypomastigotes.

Housing conditions are very important in the transmission chain. Incidence and prevalence of infection depend on the adaptation of the triatomines to human dwellings, as well as the vector capacity of the species. Animal reservoirs of reduviid bugs include dogs, cats, rats, opossum, guinea pigs, monkeys, bats, and raccoons. Humans often become infected when land in enzootic areas is developed for agricultural or commercial purposes. An estimated 240,000 to 350,000 immigrants from endemic countries living in the United States are likely infected with *T. cruzi*. Seventy-six cases of **autochthonous** transmission in the United States have also been reported from 2000 to 2018; more than half of the cases were described in Texas.

The risk of congenital Chagas disease transmission is 1–5%. Heavy parasite loads are associated with higher risk of vertical transmission. Transplacental infection is associated with premature birth, fetal wastage, hepatomegaly, and anemia. Infected infants are mostly asymptomatic at birth, although 10–40% may have signs suggestive of congenital infection. Untreated infected infants are at risk for developing Chagas cardiomyopathy later in life.

Disease transmission can occur through blood transfusions in endemic areas from asymptomatic blood donors. The risk for transmission through a single blood transfusion from a chagasic donor is 13–23%. Blood screening for Chagas disease in the United States has detected 2,462 confirmed cases between 2007 and 2019 ([www.aabb.org](http://www.aabb.org)).

Percutaneous injection from laboratory accidents is a documented mode of transmission. Oral transmission through **contaminated food** can occur. Although transmission from breastfeeding is uncommon, women with acute infections should not nurse until they have been treated.

## PATHOGENESIS

### Acute Disease

At the site of entry or puncture site, neutrophils, lymphocytes, macrophages, and monocytes infiltrate. *T. cruzi* organisms are engulfed by

macrophages and are sequestered in membrane-bound vacuoles. Trypanosomes lyse the phagosomal membrane, escape into the cytoplasm, and replicate. A local tissue reaction, the **chagoma**, develops and the process extends to a local lymph node (see [Fig. 333.2](#)). Blood forms appear, and the process disseminates. A multitude of innate response mechanisms are deployed at the beginning of infection but are largely ineffective for controlling invasion. However, this initial response is essential for setting up the more potent subsequent adaptive response. Peak parasite numbers are seen after 2–3 weeks and drop quickly when the adaptive immune response comes into play. This response, while efficient at clearing up to 95% of the parasites, is not sterilizing and parasites can persist in more susceptible tissues such as muscle and ganglion cells.

### Chronic Disease

The pathophysiology of chronic Chagas disease involves several mechanisms and most significantly affects two main target organs: the heart and the GI tract. Development of pathology in these organs is linked to parasite tropism and persistence in susceptible tissue types against the background of an otherwise effective *T. cruzi*-specific systemic immune response.

In the case of cardiac pathology, parasite-dependent myocardial damage plays some role because of invasion of myocardial cells. The extent of injury seems to be less severe compared to acute disease, and its actual proportional contribution to overall tissue destruction is unclear. Additional damage comes from chronic immune-mediated myocardial injury as a result of delayed type IV hypersensitivity to parasite persistence in myocardial cells. This causes mononuclear myocarditis and myocytolysis, leading to fibrosis and contributing to the development of cardiomyopathy. Dysautonomia due to direct damage to ganglion cells and antineuronal autoimmune reactions leads to the development of cardiomyopathy as an effect of excess catecholamine stimulation. This phenomenon in turn increases myocardial irritability resulting in a higher risk of malignant arrhythmias and sudden cardiac death. Microvascular disturbances also further exacerbate cardiac damage from intimal proliferation and fibrosis due to parasite-induced perivascular inflammation and cell necrosis.

In patients with GI tract involvement, myenteric plexus destruction leads to pathologic organ dilation. There is a diminution in the Auerbach and the Meissner plexus, as well as preganglionic lesions and a reduction in the number of dorsal motor nuclear cells of the vagus nerve. Loss of ganglia in the esophagus results in abnormal dilation.

Antibodies involved in resistance to *T. cruzi* invasion are related to the phase of infection. IgG antibodies to several major surface antigens mediate immunophagocytosis of *T. cruzi* by macrophages. Activation

of autoreactive T- and B-cell clones (with B-cell clones resulting in the production of autoantibodies) is a well-described phenomenon during *T. cruzi* infection. However, the contribution of this activation to pathology seems to be dependent on persistence of infection. Conditions that depress cell-mediated immunity increase the severity of *T. cruzi* infection. There is evidence that host genetic factors play a significant role in progression and severity of chronic disease.

## CLINICAL MANIFESTATIONS

**Acute Chagas disease** in children is usually asymptomatic or is associated with mild febrile illness characterized by malaise, facial edema, and lymphadenopathy (see Table 333.1). Infants often demonstrate local signs of inflammation at the site of parasite entry, which is then referred to as a **chagoma**. Approximately 50% of children come to medical attention with the **Romaña sign** (unilateral, painless eye swelling), conjunctivitis, and preauricular lymphadenitis. Patients complain of fatigue and headache. Fever can persist for 4-5 weeks. More severe systemic presentations can occur in children <2 years old and may include lymphadenopathy, hepatosplenomegaly, and meningoencephalitis. A cutaneous morbilliform eruption can accompany the acute syndrome. Anemia, lymphocytosis, hepatitis, and thrombocytopenia have also been described.

The heart, central nervous system (CNS), peripheral nerve ganglia, and reticuloendothelial system are often heavily parasitized. The heart is the primary target organ. The intense parasitism can result in acute inflammation and in four-chamber cardiac dilation.

**Intrauterine infection** in pregnant women can cause spontaneous abortion or premature birth. In children with congenital infection, severe anemia, hepatosplenomegaly, jaundice, and seizures can mimic congenital cytomegalovirus infection, toxoplasmosis, and erythroblastosis fetalis. *T. cruzi* can be visualized in the cerebrospinal fluid in cases of meningoencephalitis. Children usually undergo spontaneous remission in 8-12 weeks and enter the indeterminate chronic phase with lifelong low-grade parasitemia and development of antibodies to many *T. cruzi* cell surface antigens. In acute disease, mortality is 5-10%, with deaths caused by acute myocarditis, with resultant heart failure, or meningoencephalitis. Acute Chagas disease should be differentiated from malaria, schistosomiasis, visceral leishmaniasis, brucellosis, typhoid fever, and infectious mononucleosis.

Autonomic dysfunction and peripheral neuropathy can occur. CNS involvement in Chagas disease is uncommon. If granulomatous encephalitis occurs during acute infection, it is usually fatal.

**Chronic Chagas disease** may be asymptomatic or symptomatic. The most common presentation of chronic *T. cruzi* infection is **cardiomyopathy**, manifested by congestive heart failure, arrhythmia, and thromboembolic events. ECG abnormalities include partial or complete atrioventricular block and right bundle branch block. Left bundle branch block is unusual. Myocardial infarction has been reported and may be secondary to left apical aneurysm embolization or necrotizing arteriolitis of the microvasculature. Left ventricular apical aneurysms are pathognomonic of chronic chagasic cardiomyopathy.

GI manifestations of chronic Chagas disease occur in 8-10% of patients. Characteristically, this involvement presents clinically as megaesophagus and megacolon. Sigmoid dilation, volvulus, and fecalomas are often found in **megacolon**. **Megaesophagus** presents as dysphagia, odynophagia, and cough. The esophagus can reach up to 26 times its normal weight and hold up to 2 L of excess fluid. Esophageal body abnormalities occur independently of lower esophageal dysfunction. Megaesophagus can lead to esophagitis and cancer of the esophagus. Aspiration pneumonia and pulmonary tuberculosis are also more common in patients with megaesophagus.

## Immunocompromised Persons

*T. cruzi* infections in immunocompromised persons may be caused by **transmission** from an asymptomatic donor of blood products or

**reactivation** of prior infection. Organ donation to allograft recipients can result in a devastating form of the illness. Cardiac transplantation for Chagas cardiomyopathy has resulted in reactivation, despite prophylaxis and postoperative treatment with benznidazole. HIV infection also leads to reactivation in about 20% of cases; cerebral lesions are more common in these patients and can mimic *Toxoplasma* encephalitis. Myocarditis is also frequently observed, and secondary prophylaxis may be of benefit in some HIV-co-infected patients. In immunocompromised patients at risk for reactivation, serologic testing and close monitoring are necessary.

## DIAGNOSIS

A careful history with attention to geographic origin and travel is important. A peripheral blood smear or a Giemsa-stained smear during the acute phase of illness may show motile trypanosomes, which is diagnostic for Chagas disease (see Fig. 333.1). These are only seen in the first 6-12 weeks of illness. Buffy coat smears may improve yield.

Most persons seek medical attention during the chronic phase of the disease, when parasites are not found in the bloodstream and clinical symptoms are not diagnostic. Serologic testing is used for diagnosis, most commonly enzyme-linked immunosorbent assay (ELISA), indirect hemagglutination, and indirect fluorescent antibody testing. No single serology test is sufficiently reliable to make the diagnosis, so repeat or parallel testing using a different method or antigen is required to confirm the result of an initial positive serologic test, and in the case of discordant results, a third test may be employed. Two tests, the Ortho *T. cruzi* ELISA Test System and the Abbott Prism Chagas Assay, are approved by the U.S. Food and Drug Administration (FDA) for screening of blood donors but not for clinical samples. For clinical samples in suspected Chagas cases in the United States, contact the Centers for Disease Control and Prevention (CDC) for further guidance. Confirmatory tests include the radiologic immunoprecipitation assay (Chagas RIPA, currently for research or limited clinical testing only) and Western blot assays based on trypomastigote excreted-secreted antigens (TESA-WB). The Abbott Enzyme Strip Assay Chagas (ESA-Chagas) using recombinant *T. cruzi* antigens is the only FDA-approved confirmatory test in the United States.

Nonimmunologic methods of diagnosis are available. Mouse inoculation and **xenodiagnosis** (allowing uninfected reduviid bugs to feed on a patient's blood and examining the intestinal contents of those bugs 30 days after the meal) are cumbersome and not routinely performed. Parasites can be cultured in Novy-MacNeal-Nicolle (NNN) media. Polymerase chain reaction (PCR) tests of nuclear and kinetoplast DNA sequences have been developed and can be highly sensitive in acute disease but are less reliable in chronic disease. PCR has been used as an early indicator of treatment failure in therapeutic clinical trials, and to detect reactivation in chronically infected patients at risk because of immunosuppression. PCR is not sufficiently sensitive for blood screening. Moreover, there is significant variability among methods and parasite strains. Diagnosis of congenital transmission in newborns cannot be made at birth with serology because of the presence of maternal antibodies in the first 6 months of life. Microscopic examination, parasite culture, or PCR can be used. However, a serologic test at 6-12 months is recommended to exclude infection definitively.

## TREATMENT

Biochemical differences between the metabolism of American trypanosomes and that of mammalian hosts have been exploited for chemotherapy. Trypanosomes are very sensitive to oxidative radicals and do not possess catalase or glutathione reductase/glutathione peroxidase, which are key enzymes in scavenging free radicals. All trypanosomes also have an unusual, reduced nicotinamide adenine dinucleotide phosphate (NADPH)-dependent disulfide reductase. Drugs that stimulate hydrogen peroxide (H<sub>2</sub>O<sub>2</sub>) generation or prevent its utilization are potential trypanosomicidal agents. Other biochemical pathways

that have been targeted include ergosterol synthesis using azole compounds and the hypoxanthine-guanine phosphoribosyltransferase pathway using allopurinol.

Drug treatment for *T. cruzi* infection is currently limited to nifurtimox and benznidazole. Both are effective against trypomastigotes and amastigotes and have been used to eradicate parasites in the acute stages of infection. Treatment responses vary according to the phase of Chagas disease, duration of treatment, dose, age of the patient, and geographic origin of the patient. For acute disease, the average cure rate is about 60–80%. Cure of chronic disease is difficult to assess due to the different definitions of cure, whether with a negative serology or quantitative PCR. Other drugs that have been tried include posaconazole, ravuconazole, and fexinidazole but have not been as successful as traditional treatment.

**Benznidazole**, a nitroimidazole derivative, is the most effective treatment for Chagas disease. Benznidazole's primary mechanism of action involves covalent binding with trypanosomal protein thiols and low molecular weight thiols, resulting in depletion of these molecules and disruption of the parasite metabolism. The recommended treatment regimen for children 2–12 years old is 5–8 mg/kg/day orally (PO), which can be divided twice daily (bid) for 60 days. For those >12 years old, 5–7 mg/kg/day for 60 days is recommended. The tablets can be administered as a slurry for children who have difficulty swallowing. A recent meta-analysis suggests a 30-day regimen may be noninferior to a 60-day regimen. Cure rates for chronic disease as assessed by PCR is 66–91% at the end of treatment, but this drops to 82% at 1 year, 55% at 2 years, and 47% at 5 years. This drug is associated with significant toxicity, including rash, photosensitivity, peripheral neuritis, granulocytopenia, and thrombocytopenia.

**Nifurtimox** generates highly toxic oxygen metabolites through the action of nitroreductases, which produce unstable nitroanion radicals, which in turn react with oxygen to produce peroxide and superoxide free radicals. The FDA recently approved nifurtimox for the treatment of Chagas disease in pediatric patients from birth to <18 years of age and weighing at least 2.5 kg. The recommended total daily dose in pediatric patients is 10–20 mg/kg/day orally divided into three doses for 60 days for children <40 kg, and 8–10 mg/kg/day orally divided into three doses for children >40 kg. Nifurtimox has been associated with weakness, anorexia, GI disturbances, toxic hepatitis, tremors, seizures, and hemolysis in patients with glucose-6-phosphate dehydrogenase deficiency.

With the adoption by WHO of control and elimination strategies for Chagas disease, both acute and chronic disease should be treated. Serologic conversion is seen as an appropriate treatment response for chronic disease, although some patients who achieve this still eventually develop symptoms. One study reported cure rates as high as 97% for chronic disease in patients <16 years old and supports early and aggressive case findings and treatment. Infants suspected of congenitally acquired Chagas disease should be properly evaluated and treated immediately upon confirmation of the diagnosis. Women who give birth to infants with congenital Chagas disease should be offered treatment to prevent congenital transmission in subsequent pregnancies. Continuing efforts for elimination will necessitate development of more accurate diagnostics and more effective drugs, particularly for chronic disease.

Treatment of congestive heart failure is generally in line with recommendations for management of dilated cardiomyopathy from other causes.  $\beta$ -Adrenergic blockers have been validated in the management of these patients. Digitalis toxicity occurs frequently in patients with Chagas cardiomyopathy. Pacemakers may be necessary in cases of severe heart block. Although cardiac transplantation has been used successfully in chagasic patients, it is reserved for those with the most severe disease manifestations. Plasmapheresis to remove antibodies with adrenergic activity has been proposed for refractory patients; this approach has worked in patients with dilated cardiomyopathy from other causes, but its application to Chagas disease is unproved.

A light, balanced diet is recommended for **megaesophagus**. Surgery or dilation of the lower esophageal sphincter treats megaesophagus; pneumatic dilation is the superior mode of therapy. Nitrates and nifedipine have been used to reduce lower esophageal sphincter pressure in patients with megaesophagus. Treatment of **megacolon** is surgical and symptomatic.

In accidental infection when parasitic penetration is certain, treatment should be immediately initiated and continued for 10–15 days. Blood is usually collected and serologic samples tested for seroconversion at 15, 30, and 60 days.

## PREVENTION

Massive coordinated vector control programs under the auspices of WHO and the Pan-American Health Organization and the institution of widespread blood donor screening and targeted surveillance of chronically infected mothers and infants at risk have effectively eliminated or at least drastically reduced transmission in most endemic countries. Chagas disease remains linked to poverty; thus improvement of living conditions is likewise essential to successful control and eradication. Education of residents in endemic areas, use of bed nets, use of insecticides, and destruction of adobe houses that harbor reduviid bugs are effective methods to control the bug population. Synthetic pyrethroid insecticides help keep houses free of vectors for up to 2 years and have low toxicity for humans. Paints incorporating insecticides have also been used.

Because immigrants can carry this disease to nonendemic areas, serologic testing should be performed in blood and organ donors from endemic areas. Potential seropositive donors can be identified by determining whether they have been or have spent extensive time in an endemic area. Questionnaire-based screening of potentially infected blood and organ donors from areas endemic for infection can reduce the risk for transmission. Seropositivity should be considered a contraindication to organ donation, particularly for heart transplantation.

Prophylactic and therapeutic vaccine development is being pursued but is hampered by the ability of the parasite to evade immune mechanisms and persist in different body compartments. Nucleic acid-based techniques and viral vectors are being explored, along with novel adjuvants and strategies for addressing significant genetic variability among the DTUs.

Visit Elsevier eBooks+ at [eBooks.Health.Elsevier.com](http://eBooks.Health.Elsevier.com) for Bibliography.

## Chapter 334

# Malaria (*Plasmodium*)

Chandy C. John and Robert O. Opoka

Malaria is a vector-borne disease caused by intraerythrocytic protozoa of the genus *Plasmodium* and transmitted by an infective female *Anopheles* mosquito. Malaria is an acute illness characterized by paroxysms of fever, chills, sweats, fatigue, anemia, and splenomegaly. It has played a major role in human history, causing harm to more people than perhaps any other infectious disease. Although substantial progress has been made in combating malaria in endemic areas, with a 22% reduction in malaria incidence since 2010, malaria remains one of the leading causes of morbidity and mortality worldwide, with an estimated 229 million cases and 409,000 deaths in 2019. Malarial deaths in areas of high malaria transmission occur primarily in children <5 years of age, but in areas of low transmission, a large percentage of



deaths may occur in older children and adults. Although malaria is not endemic in the United States, 1,500–2,000 imported cases are seen in the United States each year. Physicians practicing in non-endemic areas should consider the diagnosis of malaria in any febrile child who has returned from a malaria-endemic area within the previous year, because delay in diagnosis and treatment can result in severe illness or death.

### ETIOLOGY

Malaria is caused by intracellular *Plasmodium* protozoa transmitted to humans by female *Anopheles* mosquitoes. Before 2004, only four species of *Plasmodium* were known to cause malaria in humans: *P. falciparum*, *P. malariae*, *P. ovale*, and *P. vivax*. In 2004, *P. knowlesi* (a primate malaria species) was also shown to cause human malaria, and cases of *P. knowlesi* infection have been documented in Malaysia, Indonesia, Singapore, and the Philippines. Malaria also can be transmitted through blood transfusion and use of contaminated needles and transplacentally from a pregnant woman to her fetus. The risk for blood transmission is low in the United States, but may occur through transfusion of whole blood, packed red blood cells (RBCs), platelets, and leukocytes and through organ transplantation.

### EPIDEMIOLOGY

Malaria is a major worldwide problem, occurring in 87 countries that comprise approximately half the world's population (Fig. 334.1). Worldwide malaria cases decreased from an estimated 238 million cases in 2010 to 229 million cases of in 2019. The principal areas of transmission are Africa, Asia, and South America. *P. falciparum* and *P. malariae* are found in most malarious areas. *P. falciparum* is the predominant species in Africa, Haiti, and New Guinea. *P. vivax* predominates in Bangladesh, Central America, India, Pakistan, and Sri Lanka. *P. vivax* and *P. falciparum* predominate in Southeast Asia, South America, and Oceania. *P. ovale* is the least common species and is transmitted primarily in Africa. Transmission of malaria has been eliminated in most of North America (including the United States), Europe, and most of the Caribbean, as well as Australia, Chile, Israel, Japan, Lebanon, and Taiwan. In 2021, the World Health Organization (WHO) certified that China had eliminated malaria, a landmark achievement for this area of >1 billion people.

*P. falciparum* is the parasite most commonly associated with severe illness and death, typically among young children. *P. falciparum* is the predominant species in Africa, Haiti, and New Guinea. Over 99% of cases in Africa are caused by *P. falciparum*, and 94% of all malaria deaths occur in Africa. Previously malarial deaths were predominantly

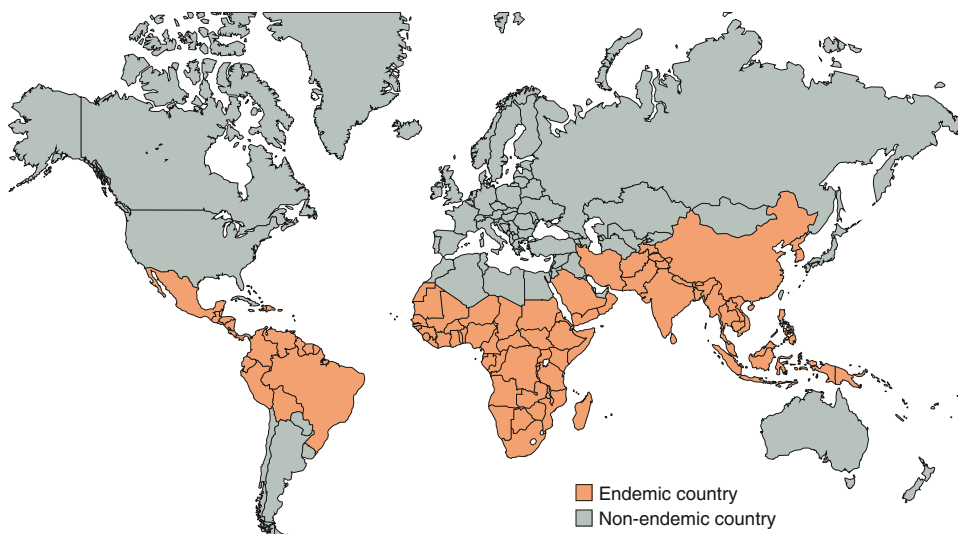
in children under 5 years of age but over the years more older children are being affected, with the percentage of total malaria deaths among children age under 5 years dropping from 84% in 2000 to 67% in 2019. *P. vivax*, contributes to about 3.3% of global malaria. *P. vivax* is responsible for 75% of malaria cases in central America and 50% of cases in Southeast Asia (World Malaria Report 2019).

Most cases of malaria in the United States occur among previously infected visitors to the United States from endemic areas and among U.S. citizens who travel to endemic areas without appropriate chemoprophylaxis. Due to the increase in global travel, the number of imported malaria cases has been increasing over the last 40 years, with 2,161 cases reported in 2017. Most cases were acquired in Africa (87%), with Asia (8%), South America (1.9%), and Central America (1.5%) contributing most remaining cases. Among all cases, *P. falciparum* accounted for the majority of infections (1,523; 70.5%), followed by *P. vivax* (216; 10.0%), *P. ovale* (119; 5.5%), and *P. malariae* (55; 2.6%). Among all reported cases of malaria in 2017, a total of 312 (14.4%) were classified as severe malaria, and 6 of these 312 persons (1.9%) died. Cases peak during the summer travel months. Children comprised 18% of all malaria cases in the United States in 2017, and 39% of pediatric cases occurred in U.S. resident children, 70% of whom were visiting friends or relatives. Severe malaria was more slightly common in children (18.4%) than adults (13.6%).

Local transmission of malaria can rarely occur in the United States, as demonstrated in 2003, when eight cases were diagnosed among non-travelers in Palm Beach, Florida, and as demonstrated again in 2023 in Florida, Texas, and Maryland. These cases may result from transmission from untreated and often asymptomatic infected individuals from malaria-endemic countries who travel to the United States and infect local mosquitoes or from infected mosquitoes from malaria-endemic areas that are transported to the United States on airplanes. Transfusion-transmitted malaria can also occur in the United States.

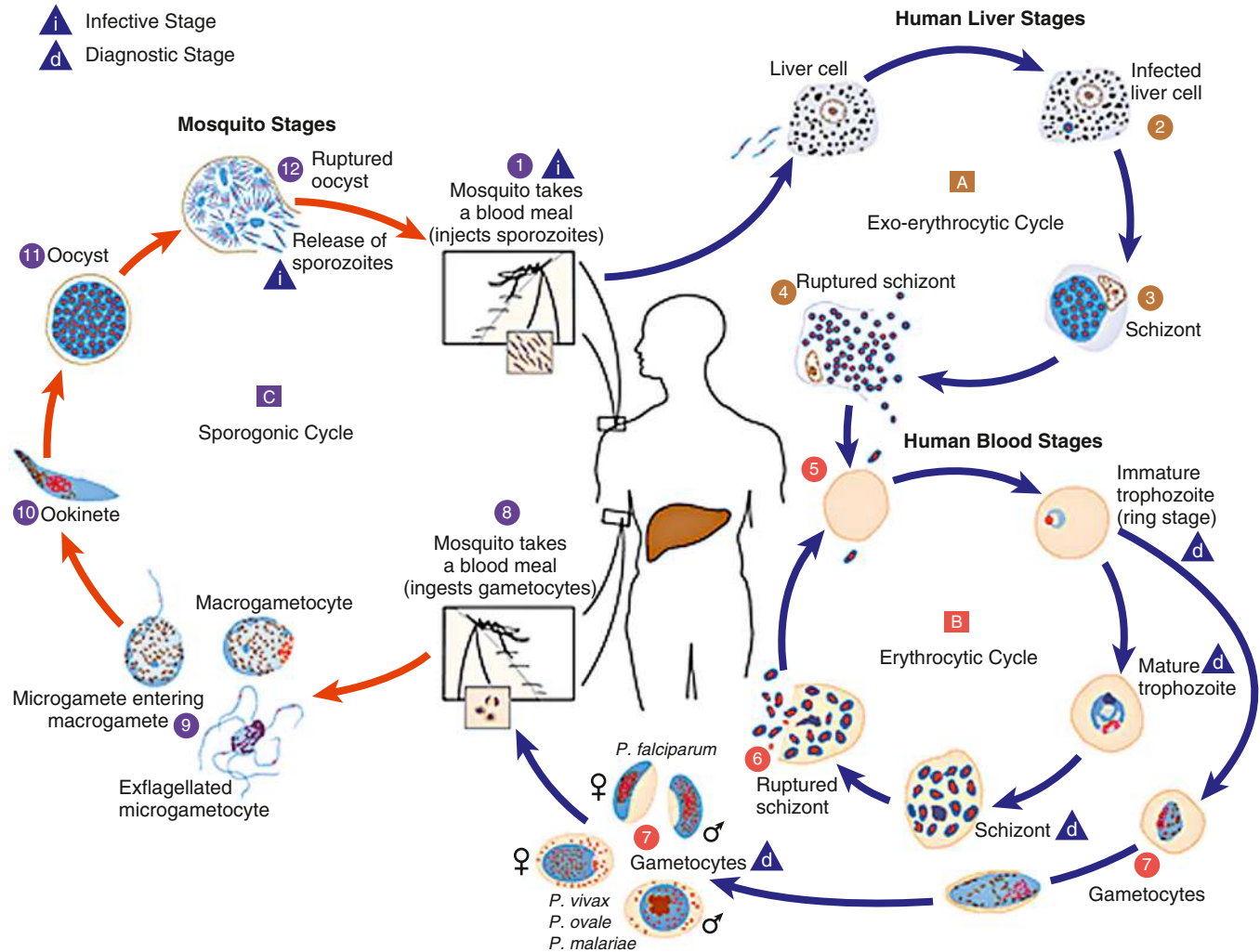
### PATHOGENESIS

*Plasmodium* species exist in a variety of forms and have a complex life cycle that enables them to survive in different cellular environments in the human host (asexual phase) and the mosquito (sexual phase) (Fig. 334.2). A marked amplification of *Plasmodium*, from approximately  $10^2$  to as many as  $10^{14}$  organisms, occurs during a two-step process in humans, with the first phase in hepatic cells (pre-erythrocytic phase) and the second phase in the RBCs (erythrocytic phase). The **pre-erythrocytic phase** begins with inoculation of sporozoites into the bloodstream by a female *Anopheles* mosquito. Within minutes the



**Fig. 334.1** Spatial distribution of malaria in the Eastern and Western hemispheres. In this map, countries with areas endemic for malaria are shaded completely even if transmission occurs only in a small part of the country. For more specific within-country malaria transmission information, see the Yellow Fever & Malaria Information, by Country section in the Centers for Disease Control and Prevention (CDC) link in this caption. (From Tan RK, Arguin PM. Malaria. In Centers for Disease Control and Prevention. CDC Yellow Book 2020: Health Information for International Travel. New York: Oxford University Press; 2017. Maps 4.8 and 9 <https://wwwnc.cdc.gov/travel/yellowbook/2020/travel-related-infectious-diseases/malaria#5217>)





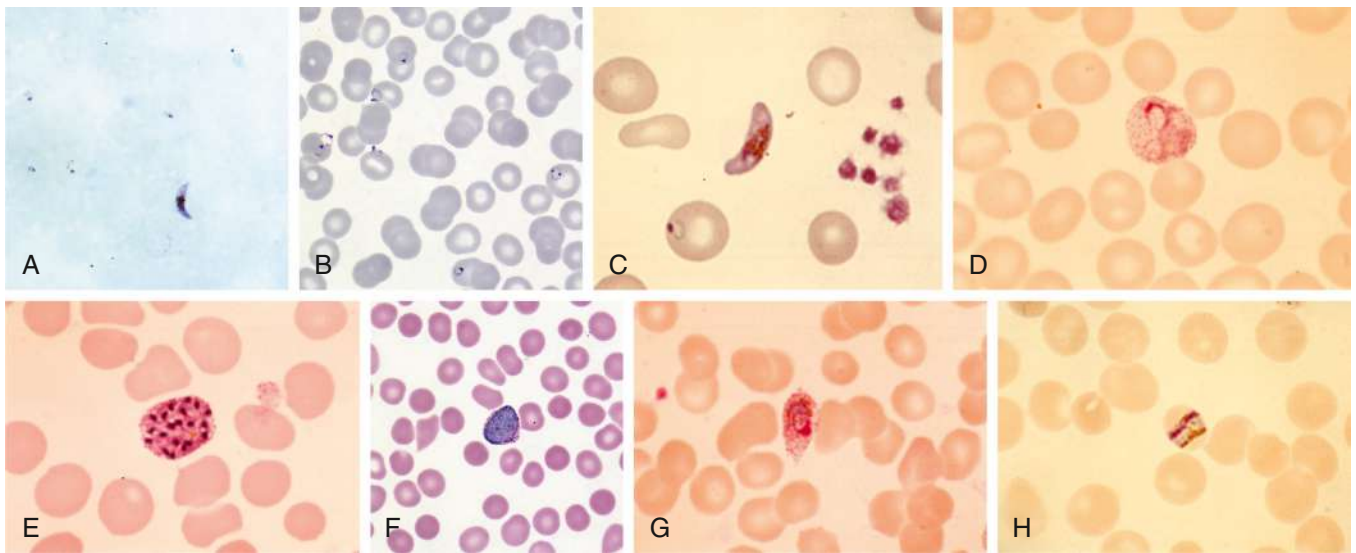
**Fig. 334.2** Life cycle of *Plasmodium* spp. (From Centers for Disease Control and Prevention. Laboratory diagnosis of malaria: *Plasmodium* spp. <https://www.cdc.gov/dpdx/malaria/index.html>)

sporozoites enter the hepatocytes of the liver, where they develop and multiply asexually as a **schizont**. After 1-2 weeks, the hepatocytes rupture and release thousands of merozoites into the circulation. The tissue schizonts of *P. falciparum*, *P. malariae*, and apparently *P. knowlesi* rupture once and do not persist in the liver. There are two types of tissue schizonts for *P. ovale* and *P. vivax*. The primary type ruptures in 6-9 days, and the secondary type remains dormant in the liver cell for weeks, months, or as long as 5 years before releasing merozoites and causing relapse of infection. The **erythrocytic phase** of *Plasmodium* asexual development begins when the merozoites from the liver penetrate erythrocytes. Once inside the erythrocyte, the parasite transforms into the **ring form**, which then enlarges to become a **trophozoite**. These latter two forms can be identified with Giemsa stain on blood smear, the primary means of confirming the diagnosis of malaria (Fig. 334.3). The trophozoite multiplies asexually to produce a number of small erythrocytic **merozoites** that are released into the bloodstream when the erythrocyte membrane ruptures, which is associated with fever. Over time, some of the merozoites develop into male and female gametocytes that complete the *Plasmodium* life cycle when they are ingested during a blood meal by the female anopheline mosquito. The male and female gametocytes fuse to form a **zygote** in the stomach cavity of the mosquito. After a series of further transformations, sporozoites enter the salivary gland

of the mosquito and are inoculated into a new host with the next blood meal.

Pathophysiology and pathogenesis in malaria differ according to species. Infection with all species leads to **fever**, caused by the host immune response when erythrocytes rupture and release merozoites into the circulation, and **anemia**, caused by hemolysis and bone marrow suppression. Severe malaria is more common in *P. falciparum* because of several processes, including higher-density parasitemia, which may lead to excessive production of proinflammatory cytokines; cytoadherence of *P. falciparum*-infected erythrocytes to the vascular endothelium; and polyclonal activation, resulting in both hypergammaglobulinemia and the formation of immune complexes. **Cytoadherence** of infected erythrocytes to vascular endothelium can lead to obstruction of blood flow and capillary damage, with resultant vascular leakage of blood, protein, and fluid and tissue anoxia. Parasite anaerobic metabolism may also lead to hypoglycemia and metabolic acidosis. The cumulative effects of these pathologic processes may lead to cerebral, cardiac, pulmonary, renal, and hepatic failure.

Immunity after *Plasmodium* sp. infection is incomplete, preventing severe disease but still allowing future infection. In some cases, parasites circulate in small numbers for a long time but are prevented from rapidly multiplying and causing severe illness. Repeated episodes



**Fig. 334.3** Giemsa-stained thick (A) and thin (B-H) smears used for the diagnosis of malaria and the speciation of *Plasmodium* parasites. A, Multiple signet-ring *Plasmodium falciparum* trophozoites that are visualized outside erythrocytes. B, A multiply infected erythrocyte containing signet-ring *P. falciparum* trophozoites, including an accolade form positioned up against the inner surface of the erythrocyte membrane. C, Banana-shaped gametocyte unique to *P. falciparum*. D, Amoeboid trophozoite characteristic of *P. vivax*. Both *P. vivax*- and *P. ovale*-infected erythrocytes exhibit Schüffner dots and tend to be enlarged compared with uninfected erythrocytes. E, *P. vivax* schizont. Mature *P. falciparum* parasites, by contrast, are rarely seen on blood smears because they sequester in the systemic microvasculature. F, *P. vivax* spherical gametocyte. G, *P. ovale* trophozoite. Note Schüffner dots and ovoid shapes of the infected erythrocyte. H, Characteristic band-form trophozoite of *P. malariae*, containing intracellular pigment hemozoin. (A, B, and F, from Centers for Disease Control and Prevention. DPDx: Laboratory identification of parasites of public health concern. <https://www.cdc.gov/dpdx/malaria/index.html>; C, D, E, G, and H, courtesy David Wyler, Newton Centre, MA.)

of infection occur because the parasite has developed a number of immune-evasive strategies, such as intracellular replication, vascular cytoadherence that prevents infected erythrocytes from circulating through the spleen, rapid antigenic variation, and alteration of the host immune system resulting in partial immune suppression. The human host response to *Plasmodium* infection includes natural immune mechanisms that prevent infection by other *Plasmodium* spp., such as those of birds or rodents, as well as several alterations in erythrocyte physiology that prevent or modify malarial infection. Erythrocytes containing **hemoglobin S** (sickle erythrocytes) resist malaria parasite growth, erythrocytes lacking Duffy blood group antigen are relatively resistant to *P. vivax*, and erythrocytes containing **hemoglobin F** (fetal hemoglobin) and ovalocytes are resistant to *P. falciparum*. In hyperendemic areas, newborns rarely become ill with malaria, in part because of passive maternal antibody and high levels of fetal hemoglobin. Children 3 months to 2-5 years of age have little specific immunity to malaria species and therefore suffer yearly attacks of debilitating and potentially fatal disease. Immunity is subsequently acquired, and severe cases of malaria become less common. Severe disease may occur during pregnancy, particularly first pregnancies or after extended residence outside the endemic region. Both T-cell and antibody responses are important in development of biologic and clinical immunity to *Plasmodium* spp.

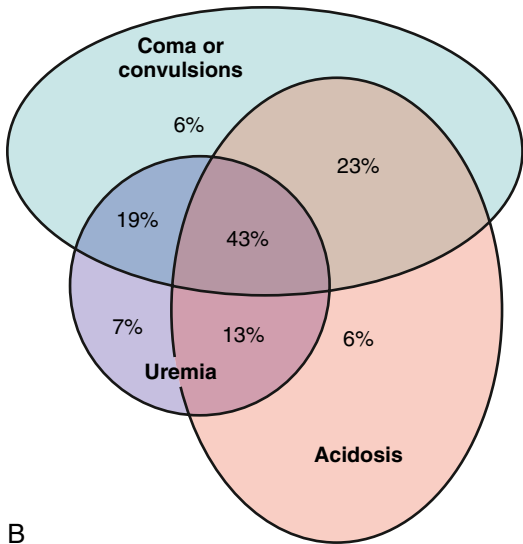
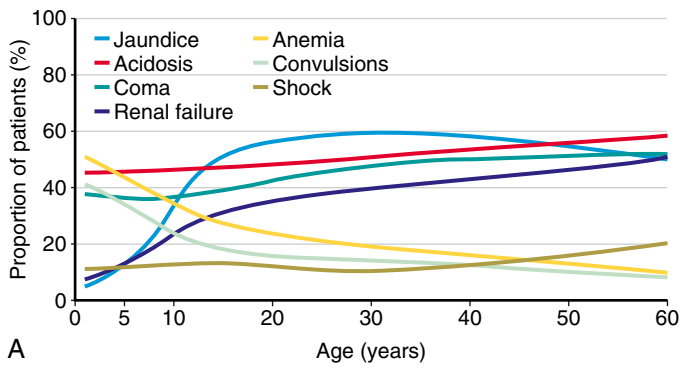
### CLINICAL MANIFESTATIONS

Children and adults are asymptomatic during the initial phase of infection, the incubation period of malaria infection. The usual incubation periods are 9-14 days for *P. falciparum*, 12-17 days for *P. vivax*, 16-18 days for *P. ovale*, and 18-40 days for *P. malariae*. The incubation period can be as long as 6-12 months for *P. vivax* and can also be prolonged for patients with partial immunity or incomplete chemoprophylaxis. A prodrome lasting 2-3 days is noted in some patients before parasites are detected in the blood. Prodromal symptoms include headache, fatigue, anorexia, myalgia, slight fever, and pain in the chest, abdomen, and joints.

Children with malaria often lack the typical paroxysms seen in adults (high fever, followed by shaking chills and then diaphoresis) and may have nonspecific symptoms, including fever (may be low grade but is often  $>40^{\circ}\text{C}$  [ $104^{\circ}\text{F}$ ]), headache, drowsiness, anorexia, nausea, vomiting, and diarrhea. Although the rupture of schizonts that occurs every 48 hours with *P. vivax* and *P. ovale* and every 72 hours with *P. malariae* can result in a classic pattern of fevers every other day (*P. vivax* and *P. ovale*) or every third day (*P. malariae*), periodicity is less apparent with *P. falciparum* and mixed infections and may not be apparent early on in infection, when parasite broods have not yet synchronized. Patients with primary infection, such as travelers from non-endemic regions, also may have irregular symptomatic episodes for 2-3 days before regular paroxysms begin, so most travelers presenting with malaria lack a classic malaria fever pattern. Distinctive physical signs may include fever, pallor as a consequence of anemia, and splenomegaly or hepatomegaly. Typical laboratory findings include anemia, thrombocytopenia, and a normal or raised leukocyte count.

*P. falciparum* is the most severe form of malaria and is associated with higher-density parasitemia and a number of complications (Fig. 334.4). The most common serious complication is severe **anemia**, which also is associated with other malaria species. Serious complications that appear unique to *P. falciparum* include cerebral malaria, respiratory distress from metabolic acidosis, acute renal failure, hypotension, and bleeding diatheses (Table 334.1) (see “Severe Malaria”).

The diagnosis of *P. falciparum* malaria in a nonimmune individual constitutes a medical emergency. Severe complications and death can occur if appropriate therapy is not instituted promptly. In contrast to malaria caused by *P. ovale*, *P. vivax*, and *P. malariae*, which usually result in parasitemias of  $<2\%$ , malaria caused by *P. falciparum* can be associated with parasitemia levels as high as 60%. The differences in parasitemia reflect that *P. falciparum* infects both immature and mature erythrocytes, whereas *P. ovale* and *P. vivax* primarily infect immature erythrocytes and *P. malariae* infects only mature erythrocytes. Like *P.*



**Fig. 334.4** Manifestations of severe falciparum malaria by age (A) and mortality in children associated with central nervous system involvement, acidosis, and uremia (B). Data from 3,228 prospectively studied African children with severe falciparum malaria. Uremia here is defined as a blood urea nitrogen >7.14 mmol/L. Surface areas denote the relative prevalence of the different severity signs, which frequently coexist. The percentages denote the observed mortality associated with the presenting signs. (From White NJ, Pukrittayakamee S, Hien TT, et al. *Malaria*. *Lancet*. 2014;383:723–735.)

*falciparum*, *P. knowlesi* has a 24-hour replication cycle and can also lead to very high density parasitemia.

*P. vivax* malaria has long been considered less severe than *P. falciparum* malaria, but recent reports suggest that in some areas it is as frequent a cause of severe disease and death as *P. falciparum*. Severe disease and death from *P. vivax* are usually caused by severe anemia and sometimes splenic rupture. *P. ovale* malaria is the least common type of malaria. It is similar to *P. vivax* malaria and usually is found in conjunction with *P. falciparum* malaria. Case reports of worsening *P. ovale* disease with respiratory symptoms and pulmonary infiltrates and/or effusions after antimalarial treatment have been reported, but all resolved with completion of treatment. *P. malariae* is the mildest and most chronic of all malaria infections. **Nephrotic syndrome** is a rare complication of *P. malariae* infection that is not observed with any other human malaria species. Nephrotic syndrome associated with *P. malariae* infection is poorly responsive to corticosteroids. Low-level, undetected *P. malariae* infection may be present for years and is sometimes unmasked by immunosuppression or physiologic stress such as splenectomy or corticosteroid treatment. *P. knowlesi* malaria is most often uncomplicated but can lead to severe malaria and death if high-density parasitemia is present.

**Table 334.1** World Health Organization Criteria for Severe Malaria, 2021

SEVERE MALARIA CRITERION	DEFINITION
Impaired consciousness	Glasgow Coma Scale score <11 in adults or Blantyre coma score <3 in children
Prostration	Generalized weakness so that a person is unable to sit, stand, or walk without assistance
Multiple convulsions	More than two episodes of convulsions within 24 hr
Acidosis	A base deficit of >8 mEq/L, a plasma bicarbonate level of <15 mmol/L, or venous plasma lactate ≥5 mmol/L. Severe acidosis manifests clinically as respiratory distress (rapid, deep, labored breathing)
Hypoglycemia	Blood or plasma glucose <40 mg/dL (<2.2 mmol/L)
Severe malarial anemia	Hemoglobin concentration ≤5 g/dL or hematocrit ≤15% in children <12 years of age (<7 g/dL and <20%, respectively, in those ≥12 years) with parasite count >10,000/μL
Renal impairment (acute kidney injury)	Plasma or serum creatinine >3 mg/dL (265 μmol/L) or blood urea >20 mmol/L
Jaundice	Plasma or serum bilirubin >50 μmol/L (3 mg/dL) with a parasite count >100,000/μL (approximately 2%).
Pulmonary edema	Radiographically confirmed or oxygen saturation <92% on room air with respiratory rate >30/min, often with chest indrawing and crepitation on auscultation
Significant bleeding	Includes recurrent or prolonged bleeding from the nose, gums, or venipuncture sites; hematemesis, or melena
Shock	Compensated shock is defined as capillary refill ≥3 sec or temperature gradient on leg (mid to proximal limb) but no hypotension. Decompensated shock is defined as systolic blood pressure <70 mm Hg in children or <80 mm Hg in adults, with evidence of impaired perfusion (cool peripheries or prolonged capillary refill)
Hyperparasitemia	<i>P. falciparum</i> parasitemia >10% (>500,000/μL)

The definition of severe *P. vivax* or *P. ovale* malaria is the same as that of severe falciparum malaria except that there are no parasite density thresholds. The definition of severe malaria due to *P. knowlesi* differs from that of severe falciparum malaria; the threshold parasite density is >100,000/μL (alone) or >20,000/μL in patients with jaundice.

**Recrudescence** after a primary attack may occur from the survival of erythrocyte forms in the bloodstream. Long-term relapse is caused by release of merozoites from a pre-erythrocytic source in the liver, which occurs with *P. vivax* and *P. ovale*, or from persistence within the erythrocyte, which occurs with *P. malariae* and rarely with *P. falciparum*. A history of typical symptoms in a person >4 weeks after return from an endemic area is therefore more likely to be *P. vivax*, *P. ovale*, or *P. malariae* infection than *P. falciparum* infection. In the most recent survey of malaria in the United States (2013) by the CDC, among individuals in whom a malaria species was identified, 61% of cases were caused by *P. falciparum*, 14% by *P. vivax*, 2% by *P. malariae*, 4% by *P. ovale*, and 2% by mixed-species infection; 94% of *P. falciparum* infections were diagnosed within 30 days of arrival in the United States,



and 99% within 90 days of arrival. In contrast, 54% of *P. vivax* cases occurred >30 days after arrival in the United States.

**Congenital malaria** is acquired from the mother prenatally or perinatally but is rarely reported in the United States. Congenital malaria usually occurs in the offspring of a nonimmune mother with *P. vivax* or *P. malariae* infection, although it can be observed with any of the human malaria species. The first sign or symptom typically occurs between 10 and 30 days of age (range: 14 hours to several months of age). Signs and symptoms include fever, restlessness, drowsiness, pallor, jaundice, poor feeding, vomiting, diarrhea, cyanosis, and hepatosplenomegaly. **Malaria in pregnancy** is a major health problem in malaria-endemic countries, can be severe, and is associated with adverse outcomes in the fetus or neonate, including intrauterine growth restriction and low birthweight, even in the absence of transmission from mother to child.

### Severe Malaria

WHO has identified 12 complications of *P. falciparum* malaria that define severe malaria (see Table 334.1 and Fig. 334.4). The most common complications in children are severe anemia, impaired consciousness (including cerebral malaria), respiratory distress (a result of metabolic acidosis), acute kidney injury, multiple seizures, prostration, and jaundice. A more complete discussion of severe malaria is provided in the treatment section (see “Treatment of Severe Malaria”), where treatment for these complications is also described.

### DIAGNOSIS

Any child who presents with fever or unexplained systemic illness and has traveled or resided in a malaria-endemic area within the previous year should be evaluated for malaria. Malaria should be considered regardless of the use of chemoprophylaxis. Important criteria that suggest *P. falciparum* malaria include symptoms occurring <1 month after return from an endemic area, >2% parasitemia, ring forms with double-chromatin dots, and erythrocytes infected with greater than one parasite.

The diagnosis of malaria is established by identification of organisms on Giemsa-stained smears of peripheral blood (see Fig. 334.3) or by rapid immunochromatographic assay (rapid diagnostic test). Giemsa stain is superior to Wright stain or Leishman stain. Both thick and thin blood smears should be examined. The concentration of erythrocytes on a **thick smear** is 20–40 times that on a thin smear and is used to quickly scan large numbers of erythrocytes. The **thin smear** allows for positive identification of the malaria species and determination of the percentage of infected erythrocytes and is useful in following the response to therapy. Identification of the species is best made by an experienced microscopist and checked against color plates of the various *Plasmodium* spp. (see Fig. 334.3). Morphologically, it is impossible to distinguish *P. knowlesi* from *P. malariae*, so polymerase chain reaction (PCR) detection by a reference laboratory or the CDC is required. Although *P. falciparum* is most likely to be identified from blood just after a febrile paroxysm, most children with malaria will have a positive blood smear regardless of the time the smear is obtained. Most guidelines recommend at least three negative blood smears to rule out malaria in children in whom malaria is strongly suspected, because low-level parasitemia could potentially go undetected early in the illness. However, few data are available on the utility of repeated blood smears for malaria detection, and most case reports and series document a positive initial smear.

The BinaxNOW Malaria test is approved by the U.S. Food and Drug Administration (FDA) for rapid diagnosis of malaria. This immunochromatographic test for *P. falciparum* histidine-rich protein (HRP2) and aldolase is approved for testing for *P. falciparum* and *P. vivax*. **Aldolase** is present in all five of the malaria species that infect humans; thus a positive result for *P. vivax* could be because of *P. ovale* or *P. malariae* infection. Sensitivity and specificity for *P. falciparum* (94–99% and 94–99%, respectively) and *P. vivax* (87–93% and 99%, respectively) are good, but sensitivity for *P. ovale* and *P. malariae* is lower. Sensitivity for *P. falciparum* decreases at lower levels of parasitemia, so microscopy is still advised in areas where expert microscopy is available. The test is simple to perform and can be done in the field

or laboratory in 10 minutes. PCR is more sensitive than microscopy but is technically more complex. It is available in some reference laboratories and can be useful for confirmation and for diagnosis of multiple species of malaria. The time delay in availability of results typically precludes its use for acute diagnosis of malaria, but it is useful to send where available, as it can confirm the diagnosis, allow for detection of multiple infections, and detect malaria not detected by standard microscopy because of low levels of parasitemia (particularly nonfalciparum malaria). PCR detection may detect asymptomatic parasitemia in children with very low level parasitemia (e.g., internationally adopted children from malaria-endemic areas), with greater sensitivity than microscopy, and may be the preferred method of detection in these children, who, because they are asymptomatic, do not require immediate treatment.

### Differential Diagnosis

The differential diagnosis of malaria is broad. In a child traveler returning to or arriving in the United States from an endemic area, diseases that may mimic malaria include viral infections such as influenza and hepatitis, sepsis, pneumonia, meningitis, encephalitis, endocarditis, gastroenteritis, pyelonephritis, babesiosis, brucellosis, leptospirosis, tuberculosis, relapsing fever, typhoid fever, yellow fever, viral hemorrhagic fevers, amebic liver abscess, neoplasm, and collagen vascular disease. There is also considerable clinical overlap between features of malaria (uncomplicated or severe) and other common bacterial and viral infections. Malaria in child travelers returning to or arriving in the United States is typically the sole reason for the clinical symptoms the child presents with, but the relatively nonspecific presentation may require a larger workup and empiric treatment for other conditions while awaiting testing results.

### TREATMENT

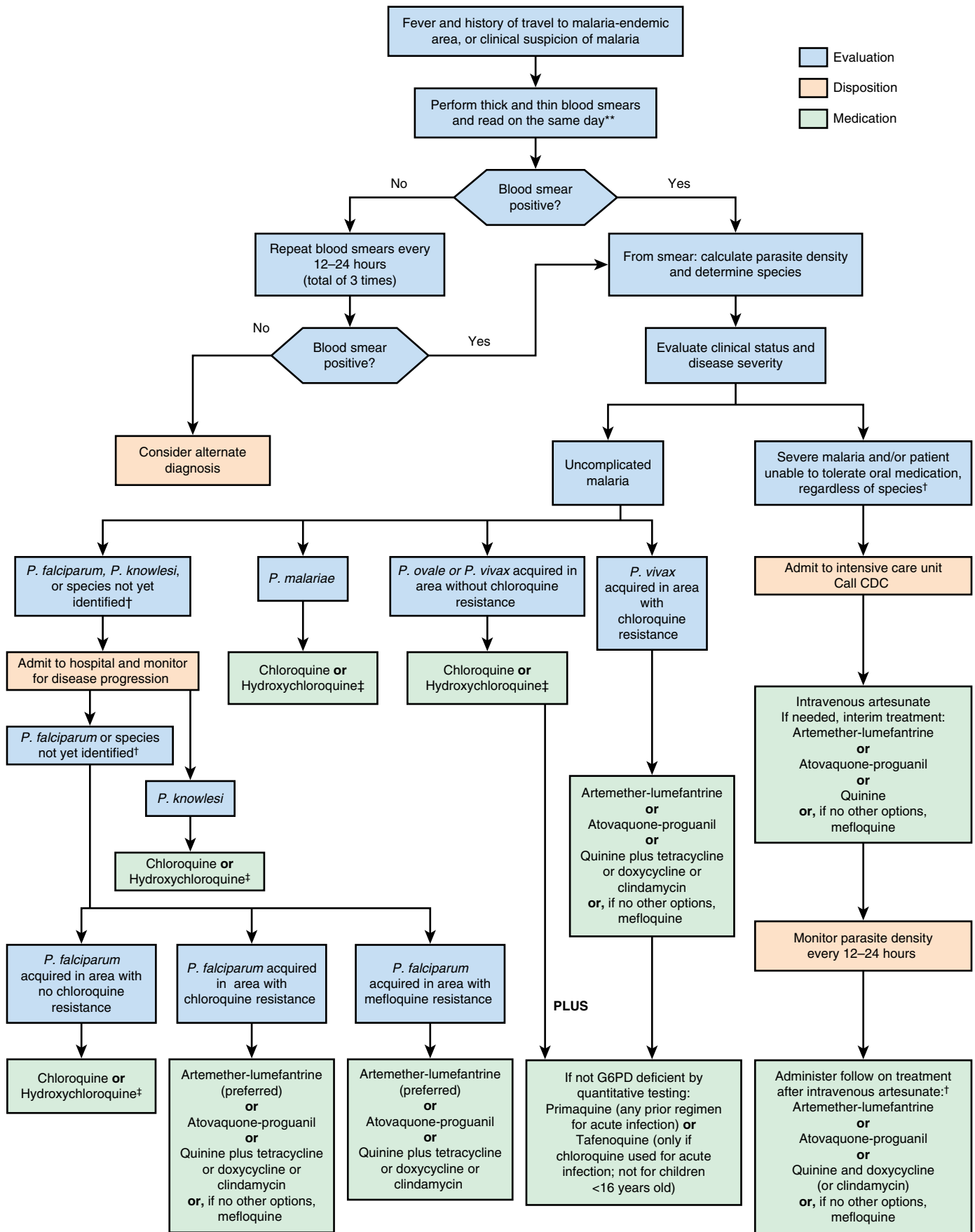
Physicians caring for patients with malaria or traveling to endemic areas need to be aware of current information regarding malaria because resistance to antimalarial drugs has complicated therapy and prophylaxis. The CDC website provides excellent guidance on diagnosis and treatment of malaria in individuals in the United States ([https://www.cdc.gov/malaria/diagnosis\\_treatment/diagnosis.html](https://www.cdc.gov/malaria/diagnosis_treatment/diagnosis.html)). Specific pages provide general guidelines ([https://www.cdc.gov/malaria/diagnosis\\_treatment/clinicians1.html](https://www.cdc.gov/malaria/diagnosis_treatment/clinicians1.html)), a treatment algorithm ([https://www.cdc.gov/malaria/resources/pdf/Malaria\\_Management\\_Algorithm.pdf](https://www.cdc.gov/malaria/resources/pdf/Malaria_Management_Algorithm.pdf), Fig. 334.5), a treatment table for all forms of uncomplicated and severe malaria ([https://www.cdc.gov/malaria/resources/pdf/Malaria\\_Treatment\\_Table.pdf](https://www.cdc.gov/malaria/resources/pdf/Malaria_Treatment_Table.pdf), Tables 334.2–334.6), and specific guidance on obtaining artesunate, which is now available commercially in the United States as an FDA-approved drug ([https://www.cdc.gov/malaria/diagnosis\\_treatment/artesunate.html](https://www.cdc.gov/malaria/diagnosis_treatment/artesunate.html)) and must be ordered emergently by hospitals that do not have it in stock. Severe malaria care requires infectious diseases consultation. In cases where treatment is unclear or complex, calling the CDC Malaria Hotline is strongly recommended. CDC expert malaria guidance is available to physicians 24 hours a day (844-856-4713, from 9 AM to 5 PM Eastern Time Monday–Friday, and 770-488-7100 at all other times and on holidays; request to speak to the CDC Malaria Branch Expert).

### General Principles

Treatment for malaria should be based on laboratory confirmation of the diagnosis. “Presumptive treatment,” i.e., without laboratory confirmation, may be required in children with severe disease in a setting where prompt laboratory diagnosis is not available. Once the diagnosis of malaria has been made, appropriate antimalarial treatment should be initiated immediately. Treatment is influenced by multiple factors, including infecting *Plasmodium* species; clinical status of the patient; expected drug susceptibility of the infecting parasite as determined by the geographic area where the infection was acquired; and previous use of antimalarials, including those taken for malaria chemoprophylaxis.

Fever without an obvious cause in any patient who has left a *P. falciparum*-endemic area within 30 days and is nonimmune should be





**Fig. 334.5** Algorithm for approach to patient with malaria in the United States. Treatment for special populations (children and pregnant women) can be found in the Centers for Disease Control and Prevention (CDC) Treatment Guidelines and Treatment Table at [https://www.cdc.gov/malaria/resources/pdf/Malaria\\_Treatment\\_Table.pdf](https://www.cdc.gov/malaria/resources/pdf/Malaria_Treatment_Table.pdf). \*\*If rapid diagnostic test performed, smear should also be performed with results available as soon as possible. †If species later identified as *P. vivax* or *P. ovale*, add primaquine if not glucose-6-phosphate (G6PD) deficient by quantitative testing. Tafenoquine can only be used if chloroquine or hydroxychloroquine used for acute infection. ‡Drug options for chloroquine-resistant *P. falciparum* may be used. (From Centers for Disease Control and Prevention. <http://www.cdc.gov/malaria/resources/pdf/algorithm.pdf>)

considered a medical emergency. Thick and thin blood smears should be obtained immediately, and all children with symptoms of severe disease should be hospitalized. If negative, blood films should be repeated every 12 hours until three smears are documented as negative. If the patient is severely ill, antimalarial therapy should be initiated immediately. Outpatient therapy generally is not given to nonimmune children but may be considered in immune or semi-immune children who have low-level parasitemia (<1%), no evidence of complications defined by WHO, no vomiting, and a lack of toxic appearance; who are able to contact the physician or emergency department at any time; and in whom follow-up within 24 hours is ensured.

## TREATMENT OF UNCOMPLICATED MALARIA

### *P. falciparum* or Species Not Identified: Acquired in Areas with Chloroquine Resistance

Treatment regimens for children with uncomplicated malaria in the United States are summarized in Tables 334.2-334.5. For *P. falciparum* infections acquired in areas with chloroquine resistance, four treatment options are available. These include artemether-lumefantrine (Coartem), which is the preferred option if readily available, and atovaquone-proguanil (Malarone). These are fixed-dose combination therapies that can be used for pediatric patients >5 kg. Quinine sulfate plus doxycycline, tetracycline, or clindamycin is the next treatment option. For the quinine sulfate combination options, quinine sulfate plus either doxycycline or tetracycline is generally preferred to quinine sulfate plus clindamycin because there are more data on the efficacy of quinine plus doxycycline or tetracycline. Quinine should be given for 3 days, except for infections acquired in Southeast Asia where 7 days of treatment is required. The fourth option, mefloquine, is associated with rare but potentially severe neuropsychiatric reactions when used at treatment dose, and it is recommended only if the other options cannot be used.

For infections attributed to “species not identified” in areas with chloroquine resistance that are subsequently diagnosed as being due to *P. vivax* or *P. ovale*, additional treatment with primaquine or tafenoquine should be administered, as described in the section on *P. vivax* and *P. ovale* treatment.

### *P. falciparum* or Species Not Identified: Acquired in Areas Without Chloroquine Resistance

For *P. falciparum* infections acquired in areas without chloroquine-resistant strains, which include Central America west of the Panama Canal, Haiti, and the Dominican Republic, patients can be treated with oral chloroquine. Alternatively, hydroxychloroquine may be used at recommended doses. In addition, any of the regimens listed for the treatment of chloroquine-resistant malaria may be used for the treatment of chloroquine-sensitive *P. falciparum* malaria. Prompt initiation of an effective regimen is vitally important as delay of initiation of treatment may increase the risk of progression to severe disease in patients with *P. falciparum* infection. If infections initially attributed to “species not identified” are subsequently diagnosed as being due to *P. vivax* or *P. ovale*, additional treatment with primaquine or tafenoquine should be administered, as outlined in the sections on *P. vivax* and *P. ovale*.

### *P. vivax* and *P. ovale*

Chloroquine (or hydroxychloroquine) remains an effective choice for *P. vivax* and *P. ovale* infections except for *P. vivax* infections acquired in Papua New Guinea or Indonesia, as there is high prevalence of chloroquine-resistant *P. vivax* in these countries. Rare cases of chloroquine-resistant *P. vivax* have also been documented in Burma (Myanmar), India, and Central and South America. Persons acquiring *P. vivax* infections from regions other than Papua New Guinea or Indonesia should initially be treated with chloroquine. If chloroquine is not available, or if the infection was acquired in an area with a high frequency of chloroquine resistance (Indonesia or Papua New Guinea), artemether-lumefantrine, atovaquone-proguanil, quinine sulfate plus doxycycline or tetracycline or clindamycin, or mefloquine should be used (mefloquine should be used only if the other drugs are not available or contraindicated). If chloroquine is given and the patient

has an inadequate response including persistence or worsening of clinical symptoms or no decrease in parasite density, treatment should be changed to one of the regimens recommended for chloroquine-resistant *P. vivax* infections.

In addition to requiring the acute phase treatment of blood-stage parasites, *P. vivax* and *P. ovale* infections can relapse due to hypnozoites, which are dormant forms that remain in the liver. To eradicate the hypnozoites, patients should be treated with either tafenoquine (Krintafel) or primaquine phosphate. If primaquine phosphate is used, the CDC recommends a dose of 30 mg (base) by mouth daily for 14 days for adults, and a dose of 0.5 mg/kg (base) by mouth, to a maximum of 30 mg (base) daily for children.

### *P. malariae* and *P. knowlesi*

There has been no widespread evidence of chloroquine resistance in *P. malariae* and *P. knowlesi* species; therefore chloroquine (or hydroxychloroquine) may still be used for both of these species. In addition, any of the regimens listed previously for the treatment of chloroquine-resistant *P. falciparum* may be used for the treatment of *P. malariae* and *P. knowlesi* infections. Due to the risk of complications among patients with *P. knowlesi*, clinicians should consider hospitalization to monitor clinical response and check parasite density every 12-24 hours until clinical presentation improves and a decrease in parasite density becomes apparent.

## TREATMENT OF SEVERE MALARIA

### General Principles

Death due to severe malaria can occur within hours of presentation, so prompt assessment and initiation of effective antimalarial therapy is essential. Equally important is the concurrent administration of supportive therapy to manage life-threatening complications of the disease. Supportive measures such as oxygen therapy, blood transfusion, rehydration, control of convulsions, correction of metabolic derangements like hypoglycemia, and institution of antibiotics in children with features of sepsis should be instituted as indicated by clinical findings. Children with severe malaria should be managed in an intensive care unit (ICU).

The risk of death due to severe malaria is greatest in the first 24 hours after clinical presentation. Independent predictors for fatality among African children with severe malaria include acidosis, impaired consciousness, elevated blood urea nitrogen, and acute kidney injury. Early diagnosis and prompt initiation of antimalarial medication and appropriate supportive care can reduce mortality.

Drug treatment guidelines in this chapter are based on treatment for children in the United States (Table 334.6). Children in other areas have other drugs and treatments available, and local or WHO guidelines for malaria treatment are available at <https://www.who.int/publications/i/item/guidelines-for-malaria>.

### Intravenous Antimalarial Therapy for Severe Malaria

Treatment of severe malaria involves initial treatment with intravenous (IV) artesunate, followed by a full dose of effective artemisinin combination therapy (ACT). In the United States, the only FDA-approved treatment for severe malaria is IV artesunate. Quinidine, which was previously approved for treatment of severe malaria, ceased to be manufactured in 2019. Artesunate dosing need not be adjusted for hepatic or renal failure, nor for concomitant or previous therapy with other medications. Artesunate is well tolerated with few side effects. Adverse effects include nausea, vomiting, anorexia, and dizziness, although these may be due to malaria rather than drug toxicity. In nonimmune patients, delayed onset of anemia has been noted in some cases, so patients treated with IV artesunate should be monitored for delayed hemolytic anemia, and repeat hemoglobin testing at 7, 14, and 30 days should be considered.

In the United States, IV artesunate was approved by the FDA through the CDC as part of an expanded-use investigational new drug (IND) protocol in May 2020. As of June 2021, the drug can be obtained through major drug distributors. Healthcare providers treating patients meeting the following criteria and who are unable to obtain

**Table 334.2** Treatment of Uncomplicated Malaria: *Plasmodium falciparum* or Unknown Species<sup>1-3</sup> (If Later Diagnosed as *P. vivax* or *P. ovale*, See Table 334.3 for Antirelapse Treatment)

DRUG SUSCEPTIBILITY (BASED ON WHERE ACQUIRED)	RECOMMENDED ADULT REGIMENS	RECOMMENDED PEDIATRIC REGIMENS <sup>4</sup>
Chloroquine resistant or unknown resistance (All malaria-endemic regions except those in Central America west of Panama Canal, Haiti, and Dominican Republic)	<p><b>A. Artemether-lumefantrine (Coartem)<sup>5</sup></b> (1 tab: 20 mg artemether and 120 mg lumefantrine) Adults: 4 tabs PO per dose Three-day course: Day 1: Initial dose and second dose 8 hr later Days 2 and 3: 1 dose bid</p> <p><b>B. Atovaquone-proguanil (Malarone)<sup>6</sup></b> (Adult tab: 250 mg atovaquone and 100 mg proguanil) 4 adult tabs PO qd × 3 days</p> <p><b>C. Quinine sulfate<sup>7</sup> plus doxycycline,<sup>8</sup> tetracycline,<sup>8</sup> or clindamycin<sup>9</sup></b> Quinine sulfate: 542 mg base (650 mg salt) PO tid × 3 or 7 days<sup>7</sup> Doxycycline: 100 mg PO bid × 7 days Tetracycline: 250 mg PO qid × 7 days Clindamycin: 20 mg/kg/day PO divided tid × 7 days</p> <p><b>D. Mefloquine<sup>10</sup></b> Dose 1: 684 mg base (750 mg salt) PO Dose 2 at 6-12 hr: 456 mg base (500 mg salt) PO</p>	<p><b>A. Artemether-lumefantrine (Coartem)<sup>5</sup></b> (1 tab: 20 mg artemether and 120 mg lumefantrine) 5 to &lt;15 kg: 1 tab PO per dose 15 to &lt;25 kg: 2 tabs PO per dose 25 to &lt;35 kg: 3 tabs PO per dose ≥35 kg: 4 tabs PO per dose Three-day course: Day 1: Initial dose and second dose 8 hr later Days 2 and 3: 1 dose bid</p> <p><b>B. Atovaquone-proguanil (Malarone)<sup>6</sup></b> (Adult tab: 250 mg atovaquone and 100 mg proguanil; Peds tab: 62.5 mg atovaquone and 25 mg proguanil) 5 to &lt;8 kg: 2 peds tabs PO qd × 3 days 8 to &lt;10 kg: 3 peds tabs PO qd × 3 days 10 to &lt;20 kg: 1 adult tab PO qd × 3 days 20 to &lt;30 kg: 2 adult tabs PO qd × 3 days 30 to &lt;40 kg: 3 adult tabs PO qd × 3 days ≥40 kg: 4 adult tabs PO qd × 3 days</p> <p><b>C. Quinine sulfate<sup>7</sup> plus doxycycline,<sup>8</sup> tetracycline,<sup>8</sup> or clindamycin<sup>9</sup></b> Quinine sulfate: 8.3 mg base/kg (10 mg salt/kg) PO tid × 3 or 7 days<sup>7</sup> Doxycycline: 2.2 mg/kg PO bid × 7 days Tetracycline: 25 mg/kg/day PO divided qid × 7 days Clindamycin: 20 mg /kg/day PO divided tid × 7 days</p> <p><b>D. Mefloquine<sup>10</sup></b> Dose 1: 13.7 mg base/kg (15 mg salt/kg) PO Dose 2 at 6-12 hr: 9.1 mg base/kg (10 mg salt/kg) PO</p>
Chloroquine sensitive <sup>11</sup> (Central America west of Panama Canal, Haiti, and Dominican Republic)	<p><b>Chloroquine phosphate (Aralen and generics)</b> Dose 1: 600 mg base (1,000 mg salt) PO Doses 2-4 (3 additional doses) at 6, 24, and 48 hr: 300 mg base (500 mg salt) PO per dose OR <b>Hydroxychloroquine (Plaquenil and generics)</b> Dose 1: 620 mg base (800 mg salt) PO Doses 2-4 (3 additional doses) at 6, 24, and 48 hr: 310 mg base (400 mg salt) PO per dose</p>	<p><b>Chloroquine phosphate (Aralen and generics)</b> Dose 1: 10 mg base/kg (16.7 mg salt/kg) PO Doses 2-4 (3 additional doses) at 6, 24, and 48 hr: 5 mg base/kg (8.3 mg salt/kg) PO per dose OR <b>Hydroxychloroquine (Plaquenil and generics)</b> Dose 1: 10 mg base/kg (12.9 mg salt/kg) PO Doses 2-4 (3 additional doses) at 6, 24, and 48 hr: 5 mg base/kg (6.5 mg salt/kg) PO per dose</p>

<sup>1</sup>qd, once a day; bid, twice a day; tid, three times a day; qid, four times a day; PO, by mouth; tab(s), tablet(s).

<sup>2</sup>If an antimalarial is taken for chemoprophylaxis, a different drug should be used for treatment.

<sup>3</sup>Option A preferred, Options B and C adequate alternatives and should be used if more readily available than Option A. Option D should be used only if other options not available.

<sup>4</sup>Not to exceed adult dose.

<sup>5</sup>Artemether-lumefantrine can be used in second and third trimesters of pregnancy and, if no other options available, in first trimester as well. Not for infants <5 kg or women breastfeeding infants <5 kg.

<sup>6</sup>Atovaquone-proguanil not recommended during pregnancy, in infants <5 kg, or in women breastfeeding infants <5 kg. May be considered if other treatment options not available or not tolerated, and benefits outweigh risks.

<sup>7</sup>Quinine to be given for 3 days, except for infections acquired in Southeast Asia, where 7 days of treatment are required. Quinine available in the United States has 324 mg (salt) per capsule, therefore two capsules for adult dosing. Pediatric dosing may need compounding pharmacy.

<sup>8</sup>Doxycycline or tetracycline combined with quinine preferred due to more efficacy data, but not recommended during pregnancy or in children <8 yr old unless no other options and benefits outweigh risks.

<sup>9</sup>Clindamycin with quinine preferred option for pregnant women and children <8 yr old.

<sup>10</sup>Mefloquine not recommended for infections acquired in Southeast Asia due to drug resistance. Not recommended if other options available or in patients with neuropsychiatric history.

<sup>11</sup>Regimens used to treat chloroquine-resistant *P. falciparum* infections may be used if chloroquine and hydroxychloroquine not available.

From Centers for Disease Control and Prevention. Malaria Treatment Tables. [https://www.cdc.gov/malaria/resources/pdf/Malaria\\_Treatment\\_Table.pdf](https://www.cdc.gov/malaria/resources/pdf/Malaria_Treatment_Table.pdf)

commercially available artesunate within 24 hours should call the CDC Malaria Hotline to obtain IV artesunate.

If artesunate is not immediately available, oral antimalarials can be given while waiting to obtain IV artesunate. Choices include artemether-lumefantrine (preferred), atovaquone-proguanil, quinine sulfate, and mefloquine (Table 334.2).

## FOLLOW-UP ORAL ANTIMALARIAL THERAPY FOR SEVERE MALARIA

Parenteral artesunate should be given for three doses over 24 hours at 0, 12, and 24 hours. If parasite density is <1% at 20 hours and the patient can take oral medication, treatment should be completed with an effective oral medication, such as artemether-lumefantrine (preferred),

**Table 334.3** Treatment of Uncomplicated Malaria: *P. vivax* or *P. ovale*<sup>1,2</sup>

DRUG SUSCEPTIBILITY (BASED ON WHERE ACQUIRED)	RECOMMENDED ADULT REGIMENS (BOTH ACUTE AND ANTIRELAPSE TREATMENTS RECOMMENDED)	RECOMMENDED PEDIATRIC REGIMENS <sup>3</sup> (BOTH ACUTE AND ANTIRELAPSE TREATMENTS RECOMMENDED)
Chloroquine sensitive (All malaria-endemic regions except Papua New Guinea and Indonesia)	<p><b>Acute treatment<sup>4</sup>:</b>  <b>Chloroquine phosphate (Aralen and generics)</b>            Dose 1: 600 mg base (1,000 mg salt) PO            Doses 2-4 (3 additional doses) at 6, 24, and 48 hr:            300 mg base (500 mg salt) PO per dose            OR  <b>Hydroxychloroquine (Plaquenil and generics)</b>            Dose 1: 620 mg base (800 mg salt) PO            Doses 2-4 (3 additional doses) at 6, 24, and 48 hr:            310 mg base (400 mg salt) PO per dose  <b>AND</b>  <b>Antirelapse treatment<sup>5</sup>:</b>  <b>Primaquine phosphate<sup>6-8</sup></b>            30 mg base PO qd × 14 days            OR  <b>Tafenoquine (Krintafel)<sup>6,7,9</sup></b>            300 mg PO × 1 dose</p>	<p><b>Acute treatment<sup>4</sup>:</b>  <b>Chloroquine phosphate (Aralen and generics)</b>            Dose 1: 10 mg base/kg (16.7 mg salt/kg) PO            Doses 2-4 (3 additional doses) at 6, 24, and 48 hr: 5 mg            base/kg (8.3 mg salt/kg) PO per dose            OR  <b>Hydroxychloroquine (Plaquenil and generics)</b>            Dose 1: 10 mg base/kg (12.9 mg salt/kg) PO            Doses 2-4 (3 additional doses) at 6, 24, and 48 hr: 5 mg            base/kg (6.5 mg salt/kg) PO per dose  <b>AND</b>  <b>Antirelapse treatment<sup>5</sup>:</b>  <b>Primaquine phosphate<sup>6-8</sup></b>            0.5 mg base/kg PO qd × 14 days            OR  <b>Tafenoquine (Krintafel)<sup>6,7,9</sup></b>            300 mg PO × 1 dose, only for patients ≥16 yr old</p>
Chloroquine resistant (Papua New Guinea and Indonesia)	<p><b>Acute treatment:</b>  <b>A. Artemether-lumefantrine (Coartem)<sup>10</sup></b>            (1 tab: 20 mg artemether and 120 mg            lumefantrine)            Adults: 4 tabs PO per dose            Three-day course:            Day 1: Initial dose and second dose 8 hr later            Days 2 and 3: 1 dose bid  <b>B. Atovaquone-proguanil (Malarone)<sup>11</sup></b>            (Adult tab: 250 mg atovaquone and 100 mg            proguanil)            4 adult tabs PO qd × 3 days  <b>C. Quinine sulfate<sup>12</sup> plus doxycycline,<sup>13</sup>            tetracycline,<sup>13</sup> or clindamycin<sup>14</sup></b>            Quinine sulfate: 542 mg base (650 mg salt) PO tid            × 3 days            Doxycycline: 100 mg PO bid × 7 days            Tetracycline: 250 mg PO qid × 7 days            Clindamycin: 20 mg/kg/day PO divided tid × 7            days  <b>D. Mefloquine<sup>15</sup></b>            Dose 1: 684 mg base (750 mg salt) PO            Dose 2 at 6-12 hr: 456 mg base (500 mg salt) PO  <b>AND</b>  <b>Antirelapse treatment<sup>16</sup>:</b>  <b>Primaquine phosphate<sup>17,18,19</sup></b>            30 mg base PO qd × 14 days</p>	<p><b>Acute treatment:</b>  <b>A. Artemether-lumefantrine (Coartem)<sup>10</sup></b>            (1 tab: 20 mg artemether and 120 mg lumefantrine)            5 to &lt;15 kg: 1 tab PO per dose            15 to &lt;25 kg: 2 tabs PO per dose            25 to &lt;35 kg: 3 tabs PO per dose            ≥35 kg: 4 tabs PO per dose            Three-day course:            Day 1: Initial dose and second dose 8 hr later            Days 2 and 3: 1 dose bid  <b>B. Atovaquone-proguanil (Malarone)<sup>11</sup></b>            (Adult tab: 250 mg atovaquone and 100 mg proguanil;            peds tab: 62.5 mg atovaquone and 25 mg proguanil)            5 to &lt;8 kg: 2 peds tabs PO qd × 3 days            8 to &lt;10 kg: 3 peds tabs PO qd × 3 days            10 to &lt;20 kg: 1 adult tab PO qd × 3 days            20 to &lt;30 kg: 2 adult tabs PO qd × 3 days            30 to &lt;40 kg: 3 adult tabs PO qd × 3 days            ≥40 kg: 4 adult tabs PO qd × 3 days  <b>C. Quinine sulfate<sup>12</sup> plus doxycycline,<sup>13</sup> tetracycline,<sup>13</sup>            or clindamycin<sup>14</sup></b>            Quinine sulfate: 8.3 mg base/kg (10 mg salt/kg) PO tid            × 3 days            Doxycycline: 2.2 mg/kg PO q12h × 7 days            Tetracycline: 25 mg/kg/day PO divided qid × 7 days            Clindamycin: 20 mg/kg/day PO divided tid × 7 days  <b>D. Mefloquine<sup>10</sup></b>            Dose 1: 13.7 mg base/kg (15 mg salt/kg) PO            Dose 2 at 6-12 hr: 9.1 mg base/kg (10 mg salt/kg) PO  <b>AND</b>  <b>Antirelapse treatment<sup>16</sup>:</b>  <b>Primaquine phosphate<sup>17-19</sup></b>            0.5 mg base/kg PO qd × 14 days</p>

<sup>1</sup>qd, once a day; bid, twice a day; tid, three times a day; qid, four times a day; PO, by mouth; tab(s), tablet(s).

<sup>2</sup>If an antimalarial is taken for chemoprophylaxis, a different drug should be used for treatment.

<sup>3</sup>Not to exceed adult dose.

<sup>4</sup>Regimens used to treat chloroquine-resistant *P. vivax* infections may be used if chloroquine and hydroxychloroquine not available.

<sup>5</sup>Either option for antirelapse treatment recommended if chloroquine or hydroxychloroquine used for acute treatment. If regimens other than either chloroquine or hydroxychloroquine are used for acute treatment, primaquine is the only option for antirelapse treatment.

<sup>6</sup>Primaquine and tafenoquine associated with hemolytic anemia in those with glucose-6-phosphate dehydrogenase (G6PD) deficiency. Before use, quantitative G6PD testing needed to confirm normal activity. For those with intermediate G6PD deficiency, weekly primaquine may be used (45 mg/wk) for 8 wk with close monitoring for hemolysis. Those with G6PD deficiency may be given chloroquine 300 mg (base) PO weekly for 1 yr from acute infection to prevent relapses.

<sup>7</sup>Primaquine and tafenoquine must not be used during pregnancy; pregnant patients with *P. vivax* and *P. ovale* infections should receive chloroquine 300 mg (base) PO weekly after acute treatment for the remainder of pregnancy. After delivery, patients with normal G6PD activity can be given primaquine or tafenoquine depending on breastfeeding, or continue with chloroquine prophylaxis for a total of 1 yr from acute infection. Primaquine can be used during breastfeeding if infant found to also have normal G6PD activity; tafenoquine not recommended during breastfeeding.

<sup>8</sup>Dose of primaquine in patients ≥70 kg should be adjusted to a total dose of 6 mg/kg, divided into doses of 30 mg per day.

<sup>9</sup>Tafenoquine can only be used if chloroquine or hydroxychloroquine administered for acute treatment due to limited data on efficacy when used in combination with other regimens.

<sup>10</sup>Artemether-lumefantrine can be used in second and third trimesters of pregnancy and, if no other options available, in first trimester as well. Not for infants <5 kg or women breastfeeding infants <5 kg.

<sup>11</sup>Atovaquone-proguanil not recommended during pregnancy, in infants <5 kg, or in women breastfeeding infants <5 kg. May be considered if other treatment options not available or not tolerated, and benefits outweigh risks.

<sup>12</sup>Quinine available in the United States has 324 mg (salt) per capsule, therefore, two capsules for adult dosing. Pediatric dosing may need compounding pharmacy.



**Table 334.3** Treatment of Uncomplicated Malaria: *P. vivax* or *P. ovale*<sup>1,2</sup>—cont'd

<sup>13</sup>Doxycycline or tetracycline combined with quinine preferred due to more efficacy data, but not recommended during pregnancy or in children <8 yr old unless no other options and benefits outweigh risks.

<sup>14</sup>Clindamycin with quinine preferred option for pregnant women and children <8 yr old.

<sup>15</sup>Use only if no other options available. Not for use in patients with neuropsychiatric history.

<sup>16</sup>Primaquine is the only option if regimens other than either chloroquine or hydroxychloroquine are used for treatment of acute infection.

<sup>17</sup>Primaquine associated with hemolytic anemia in those with glucose-6-phosphate dehydrogenase (G6PD) deficiency. Before use, quantitative G6PD testing needed to confirm normal activity. For those with intermediate G6PD deficiency, weekly primaquine may be considered (45 mg/wk) for 8 wk with close monitoring for hemolysis. Those with G6PD deficiency may be given chloroquine 300 mg (base) PO weekly for 1 yr from acute infection to prevent relapses.

<sup>18</sup>Primaquine must not be used during pregnancy; pregnant patients with *P. vivax* and *P. ovale* infections should receive chloroquine 300 mg (base) PO weekly after acute treatment for the remainder of pregnancy. After delivery, patients with normal G6PD activity can be given primaquine depending on breastfeeding or continue with chloroquine prophylaxis for a total of 1 yr from acute infection. Primaquine can be used during breastfeeding if infant found to also have normal G6PD activity.

<sup>19</sup>Dose of primaquine in patients ≥70 kg should be adjusted to a total dose of 6 mg/kg, divided into doses of 30 mg/day.

From Centers for Disease Control and Prevention. Malaria Treatment Tables. [https://www.cdc.gov/malaria/resources/pdf/Malaria\\_Treatment\\_Table.pdf](https://www.cdc.gov/malaria/resources/pdf/Malaria_Treatment_Table.pdf)

**Table 334.4** Treatment of Uncomplicated Malaria: *P. malariae* or *P. knowlesi*<sup>1,2</sup>

DRUG SUSCEPTIBILITY (BASED ON WHERE ACQUIRED)	RECOMMENDED ADULT REGIMENS	RECOMMENDED PEDIATRIC REGIMENS <sup>3</sup>
Chloroquine sensitive (All malaria-endemic regions, no known resistance)	<p><b>A. Chloroquine phosphate (Aralen and generics)</b> Dose 1: 600 mg base (1,000 mg salt) PO Doses 2-4 (3 additional doses) at 6, 24, and 48 hr: 300 mg base (500 mg salt) PO per dose OR <b>Hydroxychloroquine (Plaquenil and generics)</b> Dose 1: 620 mg base (800 mg salt) PO Doses 2-4 (3 additional doses) at 6, 24, and 48 hr: 310 mg base (400 mg salt) PO per dose</p> <p><b>B. Artemether-lumefantrine (Coartem)<sup>4</sup></b> (1 tab: 20 mg artemether and 120 mg lumefantrine) Adults: 4 tabs PO per dose Three-day course: Day 1: Initial dose and second dose 8 hr later Days 2 and 3: 1 dose bid</p> <p><b>C. Atovaquone-proguanil (Malarone)<sup>5</sup></b> (Adult tab: 250 mg atovaquone and 100 mg proguanil) 4 adult tabs PO qd × 3 days</p> <p><b>D. Quinine sulfate<sup>6</sup> plus doxycycline,<sup>7</sup> tetracycline,<sup>7</sup> or clindamycin<sup>8</sup></b> Quinine sulfate: 542 mg base (648 mg salt) PO tid × 3 days Doxycycline: 100 mg PO bid × 7 days Tetracycline: 250 mg PO qid × 7 days Clindamycin: 20 mg/kg/day PO divided tid × 7 days</p> <p><b>E. Mefloquine<sup>9</sup></b> Dose 1: 684 mg base (750 mg salt) PO Dose 2 at 6-12 hr: 456 mg base (500 mg salt) PO</p>	<p><b>A. Chloroquine phosphate (Aralen and generics)</b> Dose 1: 10 mg base/kg (16.7 mg salt/kg) PO Doses 2-4 (3 additional doses) at 6, 24, and 48 hr: 5 mg base/kg (8.3 mg salt/kg) PO per dose OR <b>Hydroxychloroquine (Plaquenil and generics)</b> Dose 1: 10 mg base/kg (12.9 mg salt/kg) PO Doses 2-4 (3 additional doses) at 6, 24, and 48 hr: 5 mg base/kg (6.5 mg salt/kg) PO per dose</p> <p><b>B. Artemether-lumefantrine (Coartem)<sup>4</sup></b> (1 tab: 20 mg artemether and 120 mg lumefantrine) 5 to &lt;15 kg: 1 tab PO per dose 15 to &lt;25 kg: 2 tabs PO per dose 25 to &lt;35 kg: 3 tabs PO per dose ≥35 kg: 4 tabs PO per dose Three-day course: Day 1: Initial dose and second dose 8 hr later Days 2 and 3: 1 dose bid</p> <p><b>C. Atovaquone-proguanil (Malarone)<sup>5</sup></b> (Adult tab: 250 mg atovaquone and 100 mg proguanil; peds tab: 62.5 mg atovaquone and 25 mg proguanil) 5 to &lt;8 kg: 2 peds tabs PO qd × 3 days 8 to &lt;10 kg: 3 peds tabs PO qd × 3 days 10 to &lt;20 kg: 1 adult tab PO qd × 3 days 20 to &lt;30 kg: 2 adult tabs PO qd × 3 days 30 to &lt;40 kg: 3 adult tabs PO qd × 3 days ≥40 kg: 4 adult tabs PO qd × 3 days</p> <p><b>D. Quinine sulfate<sup>6</sup> plus doxycycline,<sup>7</sup> tetracycline,<sup>7</sup> or clindamycin<sup>8</sup></b> Quinine sulfate: 8.3 mg base/kg (10 mg salt/kg) PO tid × 3 days Doxycycline: 2.2 mg/kg PO bid × 7 days Tetracycline: 25 mg/kg/day PO divided qid × 7 days Clindamycin: 20 mg/kg/day PO divided tid × 7 days</p> <p><b>E. Mefloquine<sup>9</sup></b> Dose 1: 13.7 mg base/kg (15 mg salt/kg) PO Dose 2 at 6-12 hr: 9.1 mg base/kg (10 mg salt/kg) PO</p>

<sup>1</sup>qd, once a day; bid, twice a day; tid, three times a day; qid, four times a day; PO, by mouth; tab(s), tablet(s).

<sup>2</sup>If an antimalarial is taken for chemoprophylaxis, a different drug should be used for treatment.

<sup>3</sup>Not to exceed adult dose.

<sup>4</sup>Artemether-lumefantrine can be used in second and third trimesters of pregnancy and, if no other options available, in first trimester as well. Not for infants <5 kg or women breastfeeding infants <5 kg.

<sup>5</sup>Atovaquone-proguanil not recommended during pregnancy, in infants <5 kg, or in women breastfeeding infants <5 kg. May be considered if other treatment options not available or not tolerated, and benefits outweigh risks.

<sup>6</sup>Quinine available in the United States has 324 mg (salt) per capsule, therefore, two capsules for adult dosing. Pediatric dosing may need compounding pharmacy.

<sup>7</sup>Doxycycline or tetracycline combined with quinine preferred due to more efficacy data, but not recommended during pregnancy or in children <8 yr old unless no other options and benefits outweigh risks.

<sup>8</sup>Clindamycin with quinine preferred option for pregnant women and children <8 yr old.

<sup>9</sup>Use only if no other options available. Not for use in patients with neuropsychiatric history.

From Centers for Disease Control and Prevention. Malaria Treatment Tables. [https://www.cdc.gov/malaria/resources/pdf/Malaria\\_Treatment\\_Table.pdf](https://www.cdc.gov/malaria/resources/pdf/Malaria_Treatment_Table.pdf)

**Table 334.5** Treatment of Uncomplicated Malaria in Pregnant Women<sup>1,2</sup>

SPECIES AND DRUG SUSCEPTIBILITY (BASED ON WHERE ACQUIRED)	RECOMMENDED ADULT REGIMENS
<b>Chloroquine resistant<sup>3</sup></b> <i>P. falciparum</i> (All malaria-endemic regions except Central America west of Panama Canal, Haiti, and Dominican Republic) <i>P. vivax</i> or <i>P. ovale</i> (Papua New Guinea and Indonesia)	Preferred for second and third trimesters: <b>Artemether-lumefantrine (Coartem)<sup>4</sup></b> (1 tab: 20 mg artemether and 120 mg lumefantrine) Adults: 4 tabs PO per dose Three-day course: Day 1: Initial dose and second dose 8 hr later Days 2 and 3: 1 dose bid <b>All trimesters: Quinine sulfate plus clindamycin</b> Quinine sulfate: 542 mg base (650 mg salt) PO tid × 3 or 7 days <sup>5</sup> Clindamycin: 20 mg/kg/day PO divided tid × 7 days <b>If no other options, all trimesters: Mefloquine</b> Dose 1: 684 mg base (750 mg salt) PO Dose 2 at 6-12 hr: 456 mg base (500 mg salt) PO <b>AND if <i>P. vivax</i> or <i>P. ovale</i>:</b> <b>Chloroquine</b> 500 mg salt (300 mg base) weekly until delivery, then consider antirelapse treatment (Table 334.3 for options and dosing) Antirelapse treatment with either primaquine or tafenoquine contraindicated during pregnancy
<b>Chloroquine sensitive</b> <i>P. falciparum</i> (Central America west of Panama Canal, Haiti, and Dominican Republic) <i>P. vivax</i> or <i>P. ovale</i> (All malaria-endemic regions except Papua New Guinea and Indonesia) <i>P. malariae</i> or <i>P. knowlesi</i>	<b>Chloroquine phosphate (Aralen and generics)</b> Dose 1: 600 mg base (1,000 mg salt) PO Doses 2-4 (3 additional doses) at 6, 24, and 48 hr: 300 mg base (500 mg salt) PO per dose OR <b>Hydroxychloroquine (Plaquenil and generics)</b> Dose 1: 620 mg base (800 mg salt) PO Doses 2-4 (3 additional doses) at 6, 24, and 48 hr: 310 mg base (400 mg salt) PO per dose <b>Options above for chloroquine-resistant malaria parasites</b> <b>AND if <i>P. vivax</i> or <i>P. ovale</i>:</b> <b>Chloroquine</b> 500 mg salt (300 mg base) weekly until delivery, then consider antirelapse treatment (Table 334.3 for options and dosing) Antirelapse treatment with either primaquine or tafenoquine contraindicated during pregnancy

<sup>1</sup>bid, twice a day; tid, three times a day; PO, by mouth; tab(s), tablet(s).<sup>2</sup>If an antimalarial is taken for chemoprophylaxis, a different drug should be used for treatment.<sup>3</sup>Atovaquone-proguanil not listed due to insufficient data on its safety during pregnancy but may be considered if other treatment options not available or not tolerated, and benefits outweigh risks.<sup>4</sup>Artemether-lumefantrine may be considered during first trimester if other treatment options not available or not tolerated, and benefits outweigh risks.<sup>5</sup>Quinine to be given for 3 days for *P. falciparum* and *P. vivax* infections, except for *P. falciparum* infections acquired in Southeast Asia where 7 days of treatment is required.From Centers for Disease Control and Prevention. Malaria Treatment Tables. [https://www.cdc.gov/malaria/resources/pdf/Malaria\\_Treatment\\_Table.pdf](https://www.cdc.gov/malaria/resources/pdf/Malaria_Treatment_Table.pdf)

atovaquone-proguanil, quinine sulfate, or mefloquine (mefloquine only if the other options are not available) (Table 334.6). If parasitemia is >1%, continue IV artesunate daily up to 6 more days until the parasite density is <1%. After this, the oral regimen can be completed (Table 334.6).

### Supportive Care for Severe Malaria

It is the malaria-associated complications that might kill the patient, so intensive nursing care, preferably in an ICU where possible, is required. Clinical observations should be made as frequently as possible and should include monitoring of vital signs, coma score, and urine output. Blood glucose should be monitored every 4 hours, if possible, particularly in unconscious patients.

**Severe malarial anemia (SMA)** is defined as the presence of *P. falciparum* parasitemia in an individual with a hemoglobin of <5 g/dL. In endemic areas, WHO includes a parasitemia cutoff of >10,000 parasites per microliter for this definition. SMA is the most common severe complication of malaria in children and is the leading cause of anemia leading to hospital admission in African children. The etiology of SMA is complex, involving increased destruction and removal of infected and uninfected RBCs and reduced RBC production due to bone marrow dyserythropoiesis. Timely blood transfusion is critical, and mortality in this condition is low with timely transfusion. However, SMA is not benign; it contributes to significant long-term morbidity, including impaired neurocognitive function, repeated hospitalizations, and postdischarge mortality.

**Cerebral malaria** is defined as the presence of coma in a child with *P. falciparum* parasitemia and an absence of other reasons for coma. Children with altered mental status who are not in a coma fall into the larger category of *impaired consciousness*. Cerebral malaria is most common in children in areas of midlevel transmission and in adolescents or adults in areas of very low transmission. It is less frequently seen in areas of very high transmission. Cerebral malaria often develops after the patient has been ill for several days but may develop precipitously. Cerebral malaria has a fatality rate of 15–40% and is associated with long-term cognitive impairment in children. Repeated seizures are frequent in children with cerebral malaria. Hypoglycemia is common, but children with true cerebral malaria fail to arouse from coma even after receiving a dextrose infusion that normalizes their glucose level. Physical findings may include high fever, seizures, muscular twitching, rhythmic movement of the head or extremities, contracted or unequal pupils, retinal hemorrhages, hemiplegia, absent or exaggerated deep tendon reflexes, and a positive Babinski sign. Lumbar puncture reveals increased pressure and mildly increased cerebrospinal fluid protein, typically with no cerebrospinal fluid (CSF) pleocytosis, and a normal CSF glucose. Studies suggest that fundoscopic findings of **malaria retinopathy** (retinal hemorrhages, peripheral whitening, macular whitening, vessel changes) are relatively specific for cerebral malaria, so children with cerebral malaria who do not have malaria retinopathy should be carefully assessed for other causes of coma. However, they should still be treated for cerebral malaria because a growing body of evidence suggests that even in these children, *P. falciparum* is a contributor to their comatose state. Beyond antimalarial medications, treatment of cerebral malaria is largely supportive and includes evaluation and treatment of seizures and hypoglycemia. A study using MRI to assess children with cerebral malaria documented that cerebral edema with increased intracranial pressure is the leading cause of death in children with cerebral malaria, and treatment with mannitol and corticosteroids has not improved outcomes in these children.

**Respiratory distress syndrome (RDS)** is best characterized by signs of acute respiratory distress and deep acidotic breathing. The acidosis is partly due to impaired tissue perfusion secondary to RBC sequestration and reduced oxygen-carrying capacity. RDS is a poor prognostic indicator in severe malaria and in children it appears to be caused by **metabolic acidosis** rather than intrinsic pulmonary disease. The kidney is important in acid metabolism and excretion and is believed to contribute to the acidosis seen in severe malaria. To date, no successful interventions for treatment of metabolic acidosis in children with severe malaria have been described, and primary therapy of malaria appears to be the most effective way to address acidosis.

**Table 334.6** Treatment of Severe Malaria<sup>1-5</sup>

SPECIES AND DRUG SUSCEPTIBILITY (BASED ON WHERE ACQUIRED)	RECOMMENDED ADULT REGIMEN	RECOMMENDED PEDIATRIC REGIMEN
All species, drug susceptibility not relevant for acute treatment of severe malaria If <i>P. vivax</i> or <i>P. ovale</i> infections, in addition to acute treatment listed here, antirelapse treatment needed (Table 334.3)	<p><b>IV artesunate:</b> Commercially available. If not in stock or available within 24 hr, contact CDC Malaria Hotline: (770) 488-7100 or (855) 856-4713 (toll free) Mon–Fri, 9 am–5 pm EST; (770) 488-7100 after hours, weekends, and holidays. 1 dose = 2.4 mg/kg IV doses (3 in total) at 0, 12, and 24 hr <b>PLUS reassessment and follow-on the following treatment</b></p> <p>If IV artesunate not readily available, give oral antimalarials while obtaining IV artesunate. When IV artesunate arrives, discontinue oral antimalarial and initiate IV treatment. Interim treatment options (Table 334.2 for dosing):</p> <ul style="list-style-type: none"> <li>• Artemether-lumefantrine (Coartem) (preferred), or</li> <li>• Atovaquone-proguanil (Malarone), or</li> <li>• Quinine sulfate, or</li> <li>• Mefloquine (only if no other options available)</li> </ul> <p>If oral therapy not tolerated, consider administration via nasogastric (NG) tube or after an antiemetic</p> <p><b>Reassessment and follow-on treatment:</b>  <b>Reassess parasite density at least 4 hr after the third dose</b>  <b>Parasite density ≤1% and patient able to tolerate oral medications:</b> Give a complete follow-on oral regimen. Options include (Table 334.2 for dosing):</p> <ul style="list-style-type: none"> <li>• Artemether-lumefantrine (Coartem) (preferred), or</li> <li>• Atovaquone-proguanil (Malarone), or</li> <li>• Quinine plus doxycycline or, in children &lt;8 yr old and pregnant women, clindamycin, or</li> <li>• Mefloquine (only if no other options available)</li> </ul> <p><b>Parasite density &gt;1%:</b> Continue IV artesunate, same dose, qd up to 6 more dys until parasite density ≤1%. When parasite density ≤1%, give complete follow-on oral regimen as listed previously (Table 334.2 for dosing)</p> <p><b>Parasite density ≤1% but patient unable to take oral medication:</b> Continue IV artesunate, same dose, qd up to 6 more days until patient able to take oral therapy</p>	

<sup>1</sup>qd, once a day; IV, intravenous.

<sup>2</sup>If an antimalarial is taken for chemoprophylaxis, a different drug should be used for treatment.

<sup>3</sup>Laboratory-confirmed or suspected malaria cases with ≥1 clinical criteria for severe disease (impaired consciousness/convulsions/coma, severe anemia [hemoglobin <7 mg/dL], acute kidney injury, acute respiratory distress syndrome, circulatory shock, disseminated intravascular coagulation, acidosis, jaundice [plus at least one other sign]); and/or parasite density ≥5%. Information on how to estimate parasite density available at [www.cdc.gov/dpdx](http://www.cdc.gov/dpdx).

<sup>4</sup>Parasite density should be repeated every 12–24 hr until negative.

<sup>5</sup>Exchange transfusion no longer recommended based on a systematic review of the literature and analysis of US malaria surveillance data showing no added benefit.

From Centers for Disease Control and Prevention. Malaria Treatment Tables. [https://www.cdc.gov/malaria/resources/pdf/Malaria\\_Treatment\\_Table.pdf](https://www.cdc.gov/malaria/resources/pdf/Malaria_Treatment_Table.pdf)

**Seizures** are a common complication of severe malaria, occurring in up to 70% of children with severe malaria; subclinical seizures occur in 15–20% of cases. Most of the seizures are associated with cerebral malaria, but it is important to evaluate for other common causes of seizure such as hypoglycemia and fever and to treat accordingly. Benzodiazepines are first-line therapy for seizures. Diazepam (0.4 mg/kg) can be administered IV or per rectum; lorazepam (0.1 mg/kg) can be administered IV or intrasubcutaneously. These doses can be repeated once if seizures do not cease within 5 minutes of the initial dose. Benzodiazepines should not be combined due to risk of respiratory depression. For persistent seizures, phenobarbital or phenytoin are the standard medications used. Phenobarbital is given at dose of 15–20 mg/kg, slow IV push) while phenytoin is given at a dose of 18 mg/kg diluted in 100 mL normal saline, infused over 20 minutes. Phenytoin may be preferred for seizure treatment, particularly in hospitals or clinics where ventilatory support is not available. However, no comparative trials of the two drugs have been performed. Routine seizure prophylaxis should not be given in children with rapid resolution of seizures during their hospital course. There are currently no drugs recommended for seizure prophylaxis in children with severe malaria. Phenobarbital prophylaxis decreased seizure activity but increased mortality in one major study of children with severe malaria, probably because the respiratory depression associated with phenobarbital may have been exacerbated by benzodiazepine therapy.

**Hypoglycemia** is a complication of malaria that is more common in children, pregnant women, and patients receiving quinine therapy. Patients may have a decreased level of consciousness that can be confused with cerebral malaria. Any child with impaired consciousness and malaria should have a glucose level checked, and if glucometers are not immediately available, an empirical bolus of dextrose should be given. Hypoglycemia is associated with increased mortality and neurologic sequelae.

**Shock** is a rare complication that manifests as hypotension, hypothermia, rapid weak pulse, shallow breathing, pallor, and vascular

collapse. It is most likely caused by bacterial superinfection, because up to 15% of children in endemic areas with severe malaria may have concurrent bacteremia. Death may occur within hours. Any child with severe malaria and hypotension or hypoperfusion should have a blood culture obtained and should be treated empirically for bacterial sepsis.

**Acute kidney injury (AKI)** is increasingly being recognized as an important complication of severe malaria and an independent predictor of mortality, occurring in >40% of children with severe malaria in one study of Ugandan children. The WHO 2023 definition of renal impairment in children with severe malaria (creatinine of ≥3.0 mg/dL) uses almost certainly too high a creatinine cutoff value, as severe AKI associated with increased mortality has been seen in children with much lower creatinine levels. Ongoing work seeks to use Kidney Disease: Improving Global Outcomes (KDIGO) criteria to establish better creatinine values to define AKI and renal impairment in children with severe malaria. Although data suggest AKI is related to reduced kidney perfusion, additional studies are needed to evaluate the spectrum of AKI over hospitalization to define the etiology and pathophysiology of AKI in pediatric severe malaria. In adults, use of acetaminophen has been associated with decreased AKI, and studies are investigating this possibility in children. Other urinary tract complications in children include **blackwater fever (or dark urine syndrome)**, which has reemerged as a clinical problem in some areas of Africa. The syndrome is thought to be associated in part with increased use of artemisinin derivatives and is associated with increased risk of readmission or death.

**Prostration** is defined as the inability to sit, stand, or eat without support, in the absence of impaired consciousness. Prostration has also been associated with increased mortality in some studies, but the pathophysiology of this process is not well understood.

In children, **abnormal bleeding** and **pulmonary edema** are uncommon, though the latter may sometimes be seen after treatment in *P. vivax* or *P. ovale* malaria.

### Long-Term Complications of Malaria

**Neurocognitive impairment and behavioral and mental health problems** occur in children after episodes of cerebral malaria and severe malarial anemia. **Epilepsy** also occurs in a subset of children after severe malaria. The mechanisms leading to brain injury and subsequent neurocognitive complications due to severe malaria are still being investigated. Clinical predictors of neurocognitive impairment in children with cerebral malaria include duration of coma, number of seizures, acute kidney injury, and severe malarial anemia. CSF cytokines and metabolites like tumor necrosis factor (TNF)- $\alpha$  and kynurenic acid, as well as plasma and CSF levels of tau, a marker of neuronal injury, are elevated acutely in children with cerebral malaria who subsequently develop cognitive impairment. Additional studies are needed to delineate the mechanisms leading to neurocognitive complications in severe malaria, particularly in children without overt clinical signs suggestive of brain injury. Interventions to rehabilitate children with cognitive impairment have provided only short-term improvement in specific areas of function, and further studies in this area are needed.

**Hyperreactive malarial splenomegaly (HMS)** is a chronic complication of *P. falciparum* malaria in which massive splenomegaly persists after treatment of acute infection. Major criteria include splenomegaly (>10 cm), IgM >2 SD above local mean, high levels of antibodies to a blood-stage *P. falciparum* antigen, and a clinical response to an antimalarial drug. HMS occurs exclusively in children in endemic areas with repeated exposure to malaria and is thought to be caused by an impaired immune response to *P. falciparum* antigens. Prolonged antimalarial prophylaxis (for at least 1 year, typically with chloroquine, quinine, or mefloquine) is required to treat this syndrome if the child remains in a malaria-endemic area. Spleen size gradually regresses on antimalarial prophylaxis but often increases again if prophylaxis is stopped.

### PREVENTION

Malaria prevention consists of reducing exposure to infected mosquitoes and chemoprophylaxis. The most accurate and current information on areas in the world where malaria risk and drug resistance exist

can be obtained by contacting local and state health departments or the CDC or consulting *Health Information for International Travel*, which is published by the U.S. Public Health Service.

Travelers to endemic areas should remain in well-screened areas from dusk to dawn, when the risk for transmission is highest. They should sleep under permethrin-treated mosquito netting and spray insecticides indoors at sundown. During the day, travelers should wear clothing that covers the arms and legs, with trousers tucked into shoes or boots. Mosquito repellent should be applied to thin clothing and exposed areas of the skin, with applications repeated as noted on the repellent instructions, and at least every 4 hours. A child should not be taken outside from dusk to dawn, but if at risk for exposure, a solution with 25–35% *N,N*-diethyltoluamide (DEET) (not >40%) should be applied to exposed areas, except for the eyes, mouth, or hands. Hands are excluded because they are often placed in the mouth. DEET should then be washed off as soon as the child comes back inside. The American Academy of Pediatrics recommends that DEET solutions be avoided in children <2 months old. Adverse reactions to DEET include rashes, toxic encephalopathy, and seizures, but these reactions occur almost exclusively with inappropriate application of high concentrations of DEET. **Picaridin** is an alternative and sometimes better tolerated repellent. Even with these precautions, a child should be taken to a physician immediately if the child develops illness when traveling to a malarious area.

Chemoprophylaxis is necessary for all visitors to and residents of the tropics who have not lived there since infancy, including children of all ages (Tables 334.7 and 334.8). Healthcare providers should consult the latest information on resistance patterns before prescribing prophylaxis for their patients. Chloroquine is given in the few remaining areas of the world free of chloroquine-resistant malaria strains. In areas where chloroquine-resistant *P. falciparum* exists, atovaquone-proguanil, mefloquine, or doxycycline may be given as chemoprophylaxis. **Atovaquone-proguanil** is generally recommended for shorter trips (up to 2 weeks) because it must be taken daily. Pediatric tablets are available and are generally well tolerated, although the taste is

**Table 334.7** Drugs Used in the Prophylaxis of Malaria

DRUG	USAGE	ADULT DOSE	PEDIATRIC DOSE	COMMENTS
Atovaquone-proguanil	Prophylaxis in all areas	Adult tablets contain 250 mg atovaquone and 100 mg proguanil hydrochloride. 1 adult tablet orally, daily	Pediatric tablets contain 62.5 mg atovaquone and 25 mg proguanil hydrochloride. 5–8 kg: ½ pediatric tablet daily >8–10 kg: ¾ pediatric tablet daily >10–20 kg: 1 pediatric tablet daily >20–30 kg: 2 pediatric tablets daily >30–40 kg: 3 pediatric tablets daily >40 kg: 1 adult tablet daily	Begin 1–2 days before travel to malarious areas. Take daily at the same time each day while in the malarious area and for 7 days after leaving such areas. Contraindicated in people with severe renal impairment (creatinine clearance <30 mL/min). Atovaquone-proguanil should be taken with food or a milky drink. Not recommended for prophylaxis for children weighing <5 kg, pregnant women, and women breastfeeding infants weighing <5 kg. Partial tablet doses may need to be prepared by a pharmacist and dispensed in individual capsules
Chloroquine	Prophylaxis only in areas with chloroquine-sensitive malaria	300 mg base (500 mg salt) orally, once/wk	5 mg/kg base (8.3 mg/kg salt) orally, once/wk, up to maximum adult dose of 300 mg base	Begin 1–2 wk before travel to malarious areas. Take weekly on the same day of the week while in the malarious area and for 4 wk after leaving such areas. May exacerbate psoriasis
Doxycycline	Prophylaxis in all areas	100 mg orally, daily	≥8 yr of age: 2.2 mg/kg up to adult dose of 100 mg/day	Begin 1–2 days before travel to malarious areas. Take daily at the same time each day while in the malarious area and for 4 wk after leaving such areas. Contraindicated in children <8 yr of age and pregnant women

Continued



**Table 334.7** Drugs Used in the Prophylaxis of Malaria—cont'd

DRUG	USAGE	ADULT DOSE	PEDIATRIC DOSE	COMMENTS
Hydroxychloroquine	An alternative to chloroquine for prophylaxis only in areas with chloroquine-sensitive malaria	310 mg base (400 mg salt) orally, once/wk	5 mg/kg base (6.5 mg/kg salt) orally, once/wk, up to a maximum adult dose of 310 mg base	Begin 1-2 wk before travel to malarious areas. Take weekly on the same day of the week while in the malarious area and for 4 wk after leaving such areas
Mefloquine	Prophylaxis in areas with mefloquine-sensitive malaria	228 mg base (250 mg salt) orally, once/wk	≤9 kg: 4.6 mg/kg base (5 mg/kg salt) orally, once/wk >9-19 kg: ¼ tablet once/wk >19-30 kg: ½ tablet once/wk >30-45 kg: ¾ tablet once/wk >45 kg: 1 tablet once/wk	Begin ≥2 wk before travel to malarious areas. Take weekly on the same day of the week while in the malarious area and for 4 wk after leaving such areas. Contraindicated in people allergic to mefloquine or related compounds (quinine, quinidine) and in people with active depression, a recent history of depression, generalized anxiety disorder, psychosis, schizophrenia, other major psychiatric disorders, or seizures. Use with caution in people with psychiatric disturbances or a previous history of depression. Not recommended for people with cardiac conduction abnormalities
Primaquine <sup>1</sup>	Prophylaxis for short-duration travel to areas with principally <i>P. vivax</i>	30 mg base (52.6 mg salt) orally, daily	0.5 mg/kg base (0.8 mg/kg salt) up to adult dose orally, daily	Begin 1-2 days before travel to malarious areas. Take daily at the same time each day while in the malarious area and for 7 days after leaving such areas
	Presumptive antirelapse therapy (PART or terminal prophylaxis) to decrease the risk for relapses of <i>P. vivax</i> and <i>P. ovale</i>	30 mg base (52.6 mg salt) orally, daily	0.5 mg/kg base (0.8 mg/kg salt) up to adult dose orally, daily	PART indicated for people with prolonged exposure to <i>P. vivax</i> , <i>P. ovale</i> , or both: daily for 14 days after departure from the malarious area Contraindicated in people with G6PD deficiency. Also contraindicated during pregnancy and lactation, unless the infant being breastfed has a documented normal G6PD level
Tafenoquine <sup>1</sup>	Prophylaxis in all areas	200 mg orally	Not indicated in children <16 yr old	Begin taking daily for 3 days before travel to malarious areas. Then, take weekly while at the malarious area, and for 1 wk after leaving the malarious area
	Presumptive antirelapse therapy (PART or terminal prophylaxis) to decrease the risk for relapses of <i>P. vivax</i> and <i>P. ovale</i>	300 mg orally once	300 mg orally once for children ≥16 yr old	PART indicated for people who had prolonged exposure to <i>P. vivax</i> , <i>P. ovale</i> , or both: Administered as a single dose Contraindicated in people with G6PD deficiency. Also contraindicated during pregnancy and lactation unless the infant being breastfed has a documented normal G6PD level

<sup>1</sup>All people who take primaquine or tafenoquine should have a documented normal G6PD level before starting the medication.

PART, presumptive antirelapse therapy; G6PD, glucose-6-phosphate dehydrogenase.

From Tan KR, Arguin PM: Malaria. In Centers for Disease Control and Prevention. CDC Yellow Book 2020: Health Information for International Travel. New York: Oxford University Press; 2017. Table 4.10. <https://wwwnc.cdc.gov/travel/yellowbook/2020/travel-related-infectious-diseases/malaria#5217>

**Table 334.8** Considerations When Choosing a Drug for Malaria Prophylaxis

DRUG	REASONS TO CONSIDER USE OF THIS DRUG	REASONS TO CONSIDER AVOIDING USE OF THIS DRUG
Atovaquone-proguanil	<ul style="list-style-type: none"> <li>• Good for last-minute travelers because the drug is started 1-2 days before travel</li> <li>• Some people prefer to take a daily medicine</li> <li>• Good choice for shorter trips because the traveler takes the medicine for only 7 days after traveling rather than 4 wk.</li> <li>• Well tolerated; side effects uncommon</li> <li>• Pediatric tablets are available and may be more convenient</li> </ul>	<ul style="list-style-type: none"> <li>• Cannot be used by women who are pregnant or breastfeeding a child that weighs &lt;5 kg</li> <li>• Cannot be taken by people with severe renal impairment</li> <li>• Tends to be more expensive than some of the other options (especially for long trips)</li> <li>• Some people (including children) would rather not take a medicine every day</li> </ul>
Chloroquine	<ul style="list-style-type: none"> <li>• Some people would rather take medicine weekly</li> <li>• Good choice for long trips because it is taken only weekly</li> <li>• Some people are already taking hydroxychloroquine chronically for rheumatologic conditions; in those instances, they may not have to take an additional medicine</li> <li>• Can be used in all trimesters of pregnancy</li> </ul>	<ul style="list-style-type: none"> <li>• Cannot be used in areas with chloroquine or mefloquine resistance</li> <li>• May exacerbate psoriasis</li> <li>• Some people would rather not take a weekly medication</li> <li>• For short trips, some people would rather not take medication for 4 wk after travel</li> <li>• Not a good choice for last-minute travelers, because drug needs to be started 1-2 wk before travel</li> </ul>
Doxycycline	<ul style="list-style-type: none"> <li>• Some people prefer to take a daily medicine</li> <li>• Good for last-minute travelers because the drug is started 1-2 days before travel</li> <li>• Tends to be the least expensive antimalarial</li> <li>• People who are already taking doxycycline chronically to prevent acne do not have to take an additional medicine</li> <li>• Doxycycline also can prevent some additional infections (such as rickettsial infections and leptospirosis), so it may be preferred by people planning to hike, camp, and swim in fresh water</li> </ul>	<ul style="list-style-type: none"> <li>• Cannot be used by pregnant women and children age &lt;8 yr</li> <li>• Some people would rather not take a medicine every day</li> <li>• For short trips, some people would rather not take medication for 4 wk after travel</li> <li>• Women prone to getting vaginal yeast infections when taking antibiotics may prefer taking a different medicine</li> <li>• People may want to avoid the increased risk of sun sensitivity</li> <li>• Some people are concerned about the potential of getting an upset stomach from doxycycline</li> </ul>
Mefloquine	<ul style="list-style-type: none"> <li>• Some people would rather take medicine weekly</li> <li>• Good choice for long trips because it is taken only weekly</li> <li>• Can be used in all trimesters of pregnancy</li> </ul>	<ul style="list-style-type: none"> <li>• Cannot be used in areas with mefloquine resistance</li> <li>• Cannot be used in patients with certain psychiatric conditions</li> <li>• Cannot be used in patients with a seizure disorder</li> <li>• Not recommended for people with cardiac conduction abnormalities</li> <li>• Not a good choice for last-minute travelers because drug needs to be started <math>\geq 2</math> wk before travel</li> <li>• Some people would rather not take a weekly medication</li> <li>• For short trips, some people would rather not take medication for 4 wk after travel</li> </ul>
Primaquine	<ul style="list-style-type: none"> <li>• It is the most effective medicine for preventing <i>P. vivax</i>, so it is a good choice for travel to places with &gt;90% <i>P. vivax</i></li> <li>• Good choice for shorter trips because you only have to take the medicine for 7 days after traveling rather than 4 wk</li> <li>• Good for last-minute travelers because the drug is started 1-2 days before travel</li> <li>• Some people prefer to take a daily medicine</li> </ul>	<ul style="list-style-type: none"> <li>• Cannot be used in patients with G6PD deficiency</li> <li>• Cannot be used in patients who have not been tested for G6PD deficiency</li> <li>• There are costs and delays associated with getting a G6PD test; however, it only has to be done once. Once a normal G6PD level is verified and documented, the test does not have to be repeated the next time primaquine is considered</li> <li>• Cannot be used by pregnant women</li> <li>• Cannot be used by women who are breastfeeding, unless the infant has also been tested for G6PD deficiency</li> <li>• Some people (including children) would rather not take a medicine every day</li> <li>• Some people are concerned about the potential of getting an upset stomach from primaquine</li> </ul>
Tafenoquine	<ul style="list-style-type: none"> <li>• One of the most effective drugs for prevention of <i>P. vivax</i> malaria but also prevents <i>P. falciparum</i></li> <li>• Good choice for shorter trips because the traveler takes the medicine once, 1 wk after traveling rather than 4 wk</li> <li>• Good for last-minute travelers because the drug is started 3 days before travel</li> </ul>	<ul style="list-style-type: none"> <li>• Cannot be used in people with G6PD deficiency</li> <li>• Cannot be used in patients who have not been tested for G6PD deficiency</li> <li>• There are costs and delays associated with getting a G6PD test; however, it only has to be done once. Once a normal G6PD level is verified and documented, the test does not have to be repeated the next time tafenoquine or primaquine is considered</li> <li>• Cannot be used by children</li> <li>• Cannot be used by pregnant women</li> <li>• Cannot be used by women who are breastfeeding</li> <li>• Not recommended in those with psychotic disorders</li> </ul>

From Tan KR, Arguin PM: Malaria. In Centers for Disease Control and Prevention. CDC Yellow Book 2020: Health Information for International Travel. New York: Oxford University Press; 2017. Table 4.9. <https://wwwnc.cdc.gov/travel/yellowbook/2020/travel-related-infectious-diseases/malaria#5217>

sometimes unpleasant to very young children. For longer trips, **mefloquine** is preferred, because it is given only once a week. Mefloquine does not have a pediatric formulation and has an unpleasant taste that usually requires that the cut tablet be disguised in another food, such as chocolate syrup. Mefloquine should not be given to children if they have a known hypersensitivity to mefloquine, are receiving cardiotropic drugs, have a history of convulsive or certain psychiatric disorders, or travel to an area where mefloquine resistance exists (the borders of Thailand with Myanmar and Cambodia, western provinces of Cambodia, and eastern states of Myanmar). Atovaquone-proguanil is started 1–2 days before travel, and mefloquine is started 2 weeks before travel. It is important that these doses are given, both to allow therapeutic levels of the drugs to be achieved and to be sure that the drugs are tolerated. **Doxycycline** is an alternative for children >8 years old. It must be given daily and should be given with food. Side effects of doxycycline include photosensitivity and vaginal yeast infections. **Primaquine** is a daily prophylaxis option for children who cannot tolerate any of the other options, but it should be provided in consultation with a travel medicine specialist if needed, and all children should be checked for glucose-6-phosphate dehydrogenase (G6PD) deficiency before prescribing this medication, because it is contraindicated in children with G6PD deficiency. Provision of medication can be considered in individuals who refuse to take prophylaxis or will be in very remote areas without accessible medical care. Provision of medication for self-treatment of malaria should be done in consultation with a travel medicine specialist, and the medication provided should be different than that used for prophylaxis.

A number of other efforts are currently underway to prevent malaria in malaria-endemic countries. Some have been highly successful, leading to a significant decrease in malaria incidence in many countries in Africa, Asia, and South America in the past decade. These interventions include the use of **insecticide-treated bed nets** (which have decreased all-cause mortality in children <5 years old in several highly malaria-endemic areas by approximately 20%), indoor residual spraying with long-lasting insecticides, and the use of **artemisinin-combination therapy** for first-line malaria treatment.

**Intermittent prevention treatment** is successfully used in many African countries for seasonal chemoprevention treatment in areas with seasonal malaria transmission. **Sulfadoxine-pyrimethamine** given to infants at the second and third doses of the diphtheria, tetanus toxoid, and pertussis vaccine is safe and relatively effective. Intermittent prevention treatment has also been given to pregnant women; three doses of sulfadoxine-pyrimethamine have resulted in a reduction of low birthweight infants. Treatment of African children in malaria-endemic areas who have severe anemia with **dihydroartemisinin-piperazine** reduces their risk of readmission and death, and this intervention is under consideration for standard treatment of severe anemia in children in several African countries.

The first malaria vaccine to have any degree of efficacy is the **RTS,S vaccine**, which is based on the circumsporozoite protein of *P. falciparum*. The RTS,S vaccine was approved by WHO in 2021 for use in children <2 years of age in malaria-endemic regions, in combination with other malaria prevention strategies. WHO approval was based on the results of phase IV studies showing a 30% reduction in severe malaria in children who received the four-dose vaccine series. WHO also approved the R21/Matrix-M vaccine in 2023 for use in children <2 years of age in malaria-endemic regions. Numerous other vaccines are also in current clinical trials. There is currently no vaccine with sufficient efficacy to be considered for prevention of malaria in travelers. A trial of monoclonal antibodies showed short-term efficacy in prevention of malaria, and this intervention could potentially be useful in malaria prevention in travelers and the military if efficacy is reproduced in larger studies. Trials of monoclonal antibodies for prevention of seasonal malaria in African children are also ongoing. If monoclonal antibodies can be produced at low cost, they may have a role in prevention in areas of seasonal malaria transmission.

Visit Elsevier eBooks+ at [eBooks.Elsevier.com](https://ebooks.elsevier.com) for Bibliography.

## Chapter 335

# Babesiosis (*Babesia*)

Peter J. Krause

Babesiosis is a malaria-like disease caused by intraerythrocytic protozoa that are transmitted by hard body (**ixodid**) ticks. The clinical manifestations of babesiosis range from subclinical illness to fulminant disease resulting in death.

### ETIOLOGY

More than 100 species of *Babesia* infect a wide variety of wild and domestic animals throughout the world. Only a few of these species have been reported to infect humans, including *Babesia crassa*-like agent, *Babesia divergens*, *Babesia duncani*, *Babesia microti*, *Babesia motosi*, and *Babesia venatorum*.

### EPIDEMIOLOGY

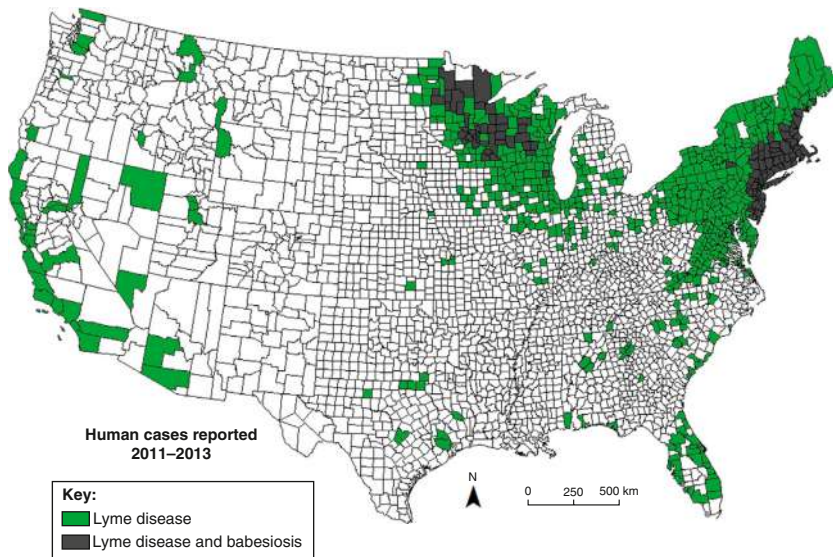
*Babesia* organisms are transmitted to humans from vertebrate reservoir hosts by the *Ixodes ricinus* family of ticks. *B. microti* is the most common cause of babesiosis in humans. The primary reservoir for *B. microti* in the United States is the white-footed mouse, *Peromyscus leucopus*, and the primary vector is *Ixodes scapularis*, the black-legged tick. *I. scapularis* ticks also transmit the causative agents of **Lyme disease**, human granulocytic anaplasmosis, *Borrelia mayonii*, *Borrelia miyamotoi* infection, *Ehrlichia muris euclairensis*, and Powassan virus encephalitis and may simultaneously transmit two or more microorganisms. White-tailed deer (*Odocoileus virginianus*) serve as the host on which adult ticks most abundantly feed but are incompetent reservoirs of *B. microti*. Babesiosis may be transmitted through blood transfusion, and *B. microti* has been one of the most frequently reported transfusion-transmitted microbial agents in the United States. Rarely, babesiosis is acquired by transplacental transmission or organ transplantation.

In the United States, human *B. microti* infection is endemic in the Northeast and Upper Midwest with more than 2,000 reported cases a year, although the actual number of cases is probably much greater (Fig. 335.1). Most cases occur in June, July, and August. *B. duncani* infects humans along the Pacific coast and is reported sporadically, with less than 50 cases having been described to date. *B. divergens*-like infections have been described in Arkansas, Kentucky, Missouri, and Washington State. In Europe, human babesiosis caused by *B. divergens*, *B. microti*, and *B. venatorum* occurs sporadically. In Asia, *B. venatorum* and *Babesia crassa*-like agent are endemic in northeastern China. Cases of *B. microti* infection are endemic in southwestern China and also have been described in Taiwan and Japan. Infection due to *Babesia motosi* has been reported in Korea. Human babesiosis also has been documented in Africa, Australia, Canada, Cuba, Egypt, India, Mexico, South America, and Turkey.

In certain sites and in certain years of high transmission, babesiosis constitutes a significant public health burden. On Nantucket Island, case rates as high as 280 per 100,000 population have been recorded, placing the community burden of disease in a category with gonorrhea as “moderately common.” Comparable incidence rates have been described elsewhere on the southern New England coast.

### PATHOGENESIS

The pathogenesis of human babesiosis is not well understood. Lysis of infected erythrocytes with resultant anemia and the excessive production of proinflammatory cytokines such as tumor necrosis factor and interleukin-1 may account for most of the clinical manifestations and complications of the disease. Cytoadherence of *Babesia*-infected red blood cells to vascular epithelium with subsequent vascular obstruction and tissue anoxia might also cause complications. The spleen has an important role in clearing parasitemia, as do T and B cells, macrophages, polymorphonuclear leukocytes, cytokines, antibody, and complement.



**Fig. 335.1** Human babesiosis emerging in areas endemic for Lyme disease. This U.S. map is based on data obtained from the Centers for Disease Control and Prevention that recorded the names of counties that reported cases of Lyme disease and/or babesiosis from 2011 to 2013. Counties with  $\geq 3$  cases of Lyme disease but  $< 3$  cases of babesiosis are depicted in green. Counties with  $\geq 3$  cases of Lyme disease and  $\geq 3$  cases of babesiosis are depicted in gray. No county reported  $\geq 3$  cases of babesiosis but  $< 3$  cases of Lyme disease. (Adapted from Diuk-Wasser M, Vannier E, Krause PJ. Coinfection by *Ixodes* tick-borne pathogens: ecological, epidemiological, and clinical consequences. *Trends Parasitol.* 2016;32:30–42.)

## CLINICAL MANIFESTATIONS

The clinical severity of babesiosis ranges from subclinical infection to fulminant disease and death. In clinically apparent cases, symptoms of babesiosis begin after an incubation period of 1–9 weeks from the beginning of tick feeding or 1 week to 6 months after transfusion. Typical symptoms in moderate to severe infection include intermittent fever to as high as 40°C (104°F) accompanied by any combination of chills, sweats, headache, and myalgias. Less common are arthralgias, sore throat, abdominal pain, nausea, vomiting, emotional lability, hyperesthesia, conjunctival injection, photophobia, weight loss, and nonproductive cough. The findings on physical examination generally are minimal, often consisting only of fever. Splenomegaly, hepatomegaly, or both are noted occasionally, but rash is seldom reported. Abnormal laboratory findings include moderately severe hemolytic anemia, elevated reticulocyte count, thrombocytopenia, proteinuria, and elevated bilirubin, BUN, and creatinine levels. The leukocyte count is normal to slightly decreased, often with neutropenia. Complications include respiratory failure, disseminated intravascular coagulation, congestive heart failure, renal failure, liver failure, coma, and death. Babesiosis symptoms usually last for 1–2 weeks, although prolonged recovery of over 1 year may occur in highly immunocompromised hosts who experience relapsing infection despite multiple courses of antibabesial therapy. Such patients include those with cancer and asplenia, those receiving immunosuppressive therapy, and those with HIV/AIDS. In one study, more than 20% of these patients died, while the remainder were cured after an average of 3 months (range: 1–24 months) of antibabesial therapy.

**Risk factors for severe disease** include aging, neonatal prematurity, anatomic or functional asplenia, malignancy, HIV/AIDS, immunosuppressive drugs, acquisition of infection through blood transfusion, or organ transplantation. Concurrent babesiosis and Lyme disease has been reported in 3–11% of patients experiencing Lyme disease, depending on location in the United States. Such co-infection results in more severe Lyme disease illness. Moderate to severe babesiosis may occur in children, but infection generally is less severe than in adults. About half of infected children are asymptomatic or experience minimal symptoms. Neonates may develop severe illness and usually are infected from blood transfusion.

## DIAGNOSIS

Diagnosis of *B. microti* infection in human hosts is confirmed by microscopic demonstration of the organism using Giemsa-stained thin blood films. Parasitemia may be exceedingly low, especially early in the course of illness. Thick blood smears may be examined, but the organisms may be mistaken for stain precipitate or iron inclusion bodies. Polymerase chain reaction (PCR) is a sensitive and specific test for detection of *Babesia* DNA and can be used in addition to or instead of blood smear

to confirm the diagnosis. Serologic testing can be useful in supporting the diagnosis of *Babesia* infection. The indirect immunofluorescence serologic assay for both IgG and IgM antibodies is sensitive and specific, although it may reflect past infection rather than acute disease. The diagnosis of babesiosis is most reliably made in patients who have lived or traveled in an area where babesiosis is endemic, who experience viral infection-like symptoms, and who have identifiable parasites on blood smear or amplifiable *Babesia* DNA in blood. The diagnosis of active babesial infection based on seropositivity alone is suspect.

## TREATMENT

The combination of **clindamycin** (7–10 mg/kg given intravenously [IV] or orally [PO] every 6–8 hr, up to maximum of 600 mg/dose) and **quinine sulfate** (8 mg/kg PO every 8 hr, up to maximum of 650 mg/dose) for 7–10 days was the first effective therapeutic combination for the treatment of babesiosis; however, adverse reactions associated with this regimen are common, especially tinnitus and abdominal distress. The combination of **atovaquone** (20 mg/kg PO every 12 hr, up to maximum of 750 mg/dose) and **azithromycin** (10 mg/kg/day PO once on day 1, up to maximum of 500 mg/dose, and 5 mg/kg once daily thereafter, up to maximum of 250 mg/dose) for 7–10 days is as effective as clindamycin and quinine but has far fewer adverse effects. Atovaquone with azithromycin has been used successfully to treat babesiosis in infants and should be used initially in all children experiencing babesiosis. Clindamycin with quinine is an alternative choice. Treatment failure with atovaquone-azithromycin and clindamycin-quinine may occur in highly immunocompromised hosts. Consultation with an infectious diseases expert is recommended in these cases. Exchange blood transfusion can decrease parasitemia rapidly and remove toxic by-products of infection. Partial or complete exchange transfusion is recommended for children with high-grade parasitemia ( $> 10\%$ ), severe anemia (hemoglobin  $< 10$  g/dL), or severe pulmonary, renal, or hepatic compromise.

## PROGNOSIS

Moderate to severe disease is frequently observed in some highly endemic areas but mostly in adults. The babesiosis case fatality rate was estimated at 5% in a retrospective study of 136 New York cases but may be as high as 21% in immunocompromised hosts and those who acquire babesiosis through blood transfusion. Clearance of infection is sometimes delayed, with low-level asymptomatic parasitemia persisting for as long as 26 months after symptoms have resolved, or with relapsing symptomatic disease in immunocompromised hosts.

## PREVENTION

Prevention of babesiosis can be accomplished by avoiding areas where ticks, deer, and mice are known to thrive. Use of clothing that covers the



lower part of the body and that is sprayed or impregnated with diethyltoluamide (DEET), dimethyl phthalate, or permethrin (Permanone) is recommended for those who travel in the foliage of endemic areas. DEET can be applied directly to the skin. A search for ticks should be carried out and the ticks removed using tweezers. Prospective blood donors with a history of babesiosis are excluded from giving blood to prevent transfusion-related cases.

Visit Elsevier eBooks+ at [eBooks.Health.Elsevier.com](http://eBooks.Health.Elsevier.com) for Bibliography.

## Chapter 336

# Toxoplasmosis (*Toxoplasma gondii*)

Rima McLeod and Kenneth M. Boyer

*Toxoplasma gondii*, an obligate, intracellular, apicomplexan protozoan, is acquired perorally, transplacentally, or rarely parenterally in laboratory accidents, transfusions, or from a transplanted organ. In immunologically normal children, acute acquired infection most often is asymptomatic or unrecognized but may cause lymphadenopathy or affect almost any organ. Once acquired, latent encysted organisms persist in the host throughout life. In immunocompromised persons, initial acquisition or recrudescence of latent organisms can cause signs or symptoms related to the central nervous system (CNS) or result in systemic disease, as in bone marrow transplant recipients. If untreated, congenital infection causes disease that manifests either perinatally or later in life, most frequently chorioretinitis and CNS lesions. Other manifestations include intrauterine growth restriction, prematurity, cognitive and motor deficits, fever, lymphadenopathy, rash, hearing loss, pneumonitis, hepatitis, thrombocytopenia, and cerebrospinal fluid (CSF) inflammatory changes. Unrecognized congenital toxoplasmosis in infants with HIV infection may be fulminant.

## ETIOLOGY

*T. gondii* is a coccidian protozoan that multiplies only in living cells. It is descended from an ancient, free-living, single-celled extracellular parasite called *Colpodella*, which shares some ultrastructural features with *T. gondii* (Fig. 336.1A). Tachyzoites are the pathogenic form of the parasite in active infections and are oval or crescent-like, measuring 2–4 × 4–7 μm (see Fig. 336.1B). Tissue cysts are 10–100 μm in diameter, may contain thousands of latent parasites called bradyzoites (see Fig. 336.1C), and will remain in tissues, especially the CNS and skeletal and heart muscle, for the life of the host. *Toxoplasma* can multiply in all tissues of mammals and birds. There is also a dormant “stressed persister” form of the parasite that arrests and does not progress through the G1 phase of the cell cycle, unable to pass a checkpoint into the tachyzoite replicative phase of the cell cycle. In recent years critical transcription factors that can distinguish *Toxoplasma* bradyzoites from tachyzoites and merozoites have been identified.

Oocysts are another form of the parasite and are formed in the cat intestine (see Fig. 336.1D). Newly infected, nonimmune cats and other Felidae species are the definitive hosts of *T. gondii* and represent the location where genetic exchange occurs during a sexual cycle. *Toxoplasma* organisms are transmitted to cats when the cat ingests infected meat containing encysted bradyzoites or ingests oocysts containing sporozoites excreted by other recently infected cats. The parasites then multiply through schizogonic merozoite and other gametogonic cycles in the distal ileal epithelium of the cat intestine. Intestinal delta-6-desaturase activity and linoleic acid determine the host range of oocyst formation in cats. Genes in the parasite that promote fusion of the female and male gamete to form a zygote and are critical for conception have been identified. Oocysts containing two

sporocysts are excreted, and under the proper temperature and moisture conditions each sporocyst matures into four sporozoites. For approximately 2 weeks the cat excretes 10<sup>5</sup>–10<sup>7</sup> oocysts daily, which may retain their viability for >1 year in a suitable environment. Oocysts sporulate 1–5 days after excretion and are then infectious. They are killed by drying or boiling but are resistant to bleach. Oocysts have been isolated from soil and sand frequented by cats, and outbreaks associated with contaminated food and water have been reported. Oocysts and tissue cysts are sources of animal and human infections (see Fig. 336.1D).

There are genetically distinct types of *T. gondii* that differ in virulence for mice, form different numbers of cysts in the brain of outbred mice, and cause different clinical manifestations for humans. In the United States, there are four predominant clonal lineages called types I, II, III, and IV (haplogroup XII) in addition to atypical, recombinant types. There is one predominant clonal type (type II) in France, Austria, and Poland, and nonarchetypal parasites are prevalent in Brazil, Guyana, French Guiana, and Central America. Hypervirulent parasites containing a single stranded RNA virus appear to cause epidemics of disease in Guiana and Victoria Canada.

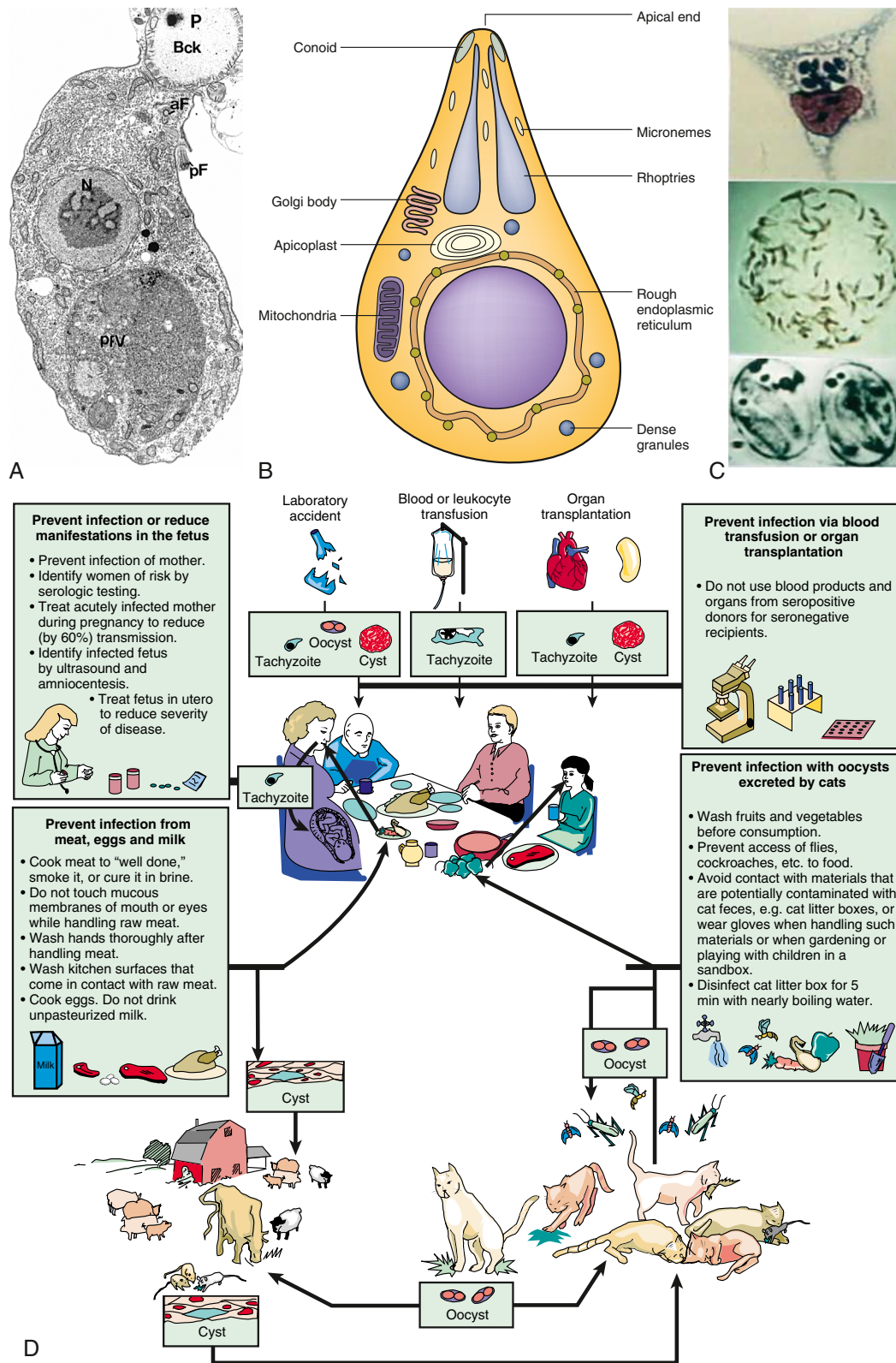
## EPIDEMIOLOGY

*Toxoplasma* infection is ubiquitous in animals and is one of the most common latent infections of humans throughout the world, infecting and persisting in approximately 2 billion people. Prevalence varies considerably among people and animals in different geographic areas. In different areas of the world, approximately 3–35% of pork, 7–60% of lamb, and 0–9% of beef contain *T. gondii* organisms. Significant antibody titers are detected in 50–80% of residents of some localities, such as France, Brazil, and Central America, and in <5% of populations in other areas. The current overall prevalence estimate in the United States is 10%, but prevalence varies among different demographic groups and in different geographic locations. For example, in a study of pregnant women in an Amish community in Lancaster County, Pennsylvania, prevalence was 50%. There appears to be a higher prevalence of infection in some warmer, more humid climates. Non-type II parasites are more common in mothers of congenitally infected infants in warm, moist southern climates, in rural areas, in those with lower socioeconomic status and with Hispanic ethnicity in the United States. Non-type II parasites are more often associated with prematurity and severe congenital infection in the United States.

Human infection in older children and adults is usually acquired orally by eating undercooked or raw meat that contains cysts or food or other material contaminated with oocysts from acutely infected cats. Fruits and vegetables that have not been properly washed may carry oocysts, consistent with the high overall prevalence of *Toxoplasma* oocysts in the soil and water in many regions of the globe. Freezing meat to –20°C (–4°F) or heating meat to 66°C (150.8°F) renders the tissue cysts noninfectious. Outbreaks of acute acquired infection have occurred in families, at social gatherings, and in restaurants where people have consumed the same infected food or water. It was previously thought that *T. gondii* could not be transmitted from person to person except for transplacental infection from mother to fetus and, rarely, by organ transplantation or transfusion. However, there is now increasing evidence of the ability of both humans and animals to pass *T. gondii* from male to female via sperm.

Seronegative transplant recipients who receive an organ, bone marrow, or stem cells from seropositive donors have experienced life-threatening illness requiring immediate therapy. Seropositive recipients who receive an infected donor organ may have increased serologic titers without recognized, associated disease. Laboratory accidents have resulted in infections, including fatalities.

Transmission to the fetus usually follows acquisition of primary infection by an immunologically normal pregnant woman during gestation. Congenital transmission from mothers infected before pregnancy is extremely rare except for immunocompromised women who are chronically infected. The estimated incidence of congenital infection in the United States ranges from 1 in 1,000 to 1 in 8,000 live births. An estimated 15 million people are living with congenital toxoplasmosis worldwide. The incidence of infection among pregnant women depends on the general risk for infection in the specific locale and the proportion of the population that has not been infected previously.



**Fig. 336.1** The parasite: *Toxoplasma* ancient ancestor, ultrastructure, and life cycle stages affecting humans. **A**, *Colpodella vorax*, an ancient progenitor to the apicomplexans. **B**, Ultrastructure of *T. gondii* tachyzoite. **C**, Light micrographs of, top to bottom, tachyzoite, bradyzoite, and sporozoite stages of *T. gondii*. **D**, Life cycle of *Toxoplasma gondii* and prevention of toxoplasmosis by interruption of transmission to humans. N, nucleus; PBck, prey being ingested; aF, anterior flagellum; pF, posterior flagellum; pFV, posterior food vacuole. (**A** from Brugerolle G. *Colpodella vorax*: Ultrastructure, predation, life-cycle, mitosis, and phylogenetic relationships. *Eur J Protistol.* 2002;38[2]:113–125; **B** from Wheeler K. *Characterization of Toxoplasma gondii dense granule protein 1: Genetic, functional, and mechanistic analyses* (Undergraduate Honors thesis), Kelsey Wheeler; **C**, bottom panel, from Dubey JP, Miller N, Frenkel JK. *The Toxoplasma gondii oocyst from cat feces.* *J Exp Med.* 1970;132[4]:636–662.)

## PATHOGENESIS

*T. gondii* is acquired by children and adults from ingesting food that contains cysts or that is contaminated with oocysts from acutely infected cats. Oocysts also may be transported to food by flies and cockroaches and may be carried to people on the fur of dogs. When the organism is ingested, bradyzoites are released from cysts or sporozoites are produced from oocysts. The organisms enter gastrointestinal (GI) cells, where they multiply, rupture cells, infect contiguous cells, enter the lymphatics and blood, and disseminate lymphohematogenously throughout the body. **Tachyzoites** proliferate, producing necrotic foci surrounded by a cellular reaction. With development of a normal immune response that is both humoral and cell mediated, tachyzoites disappear from tissues. In immunocompromised individuals and also in some apparently immunocompetent people, acute infection progresses and may cause pneumonitis, myocarditis, or encephalitis, sometimes resulting in lethal disease.

Alterations of T-lymphocyte populations during acute *T. gondii* infection are common and include lymphocytosis, increased CD8<sup>+</sup> T-cell count, and decreased CD4<sup>+</sup>/CD8<sup>+</sup> ratio. Characteristic histopathologic changes in lymph nodes during acute infection include (1) reactive follicular hyperplasia with irregular clusters of epithelioid histiocytes that encroach on and blur margins of germinal centers, and (2) focal distention of sinuses with monocytoïd cells. Depletion of CD4<sup>+</sup> T cells in patients with AIDS predisposes to severe manifestations of toxoplasmosis.

Cysts form as early as 7 days after infection and remain in the host for life. During latent infection they produce little or no inflammatory response but can cause recrudescence disease in immunocompromised persons. **Recrudescence chorioretinitis** can occur in children and adults with postnatally acquired infection and in older children and adults with congenitally acquired infection. Host and parasite genetics influence outcomes.

When a mother acquires infection during gestation, organisms may disseminate hematogenously to the placenta. Infection may be

transmitted to the fetus transplacentally or to the infant during vaginal delivery. Of untreated maternal infections acquired in the first trimester, approximately 17% of fetuses are infected, usually with severe disease. Of untreated maternal infection acquired in the third trimester, approximately 65% of fetuses are infected, usually with disease that is milder and sometimes inapparent at birth (Fig. 336.2). These different rates of transmission and outcomes are most likely related to placental blood flow, virulence, inoculum of *T. gondii*, and immunologic capacity of the mother and fetus to limit parasitemia.

Examination of the placenta of infected newborns may reveal chronic inflammation and cysts. Tachyzoites can be seen with Wright or Giemsa stains but are best demonstrated with the immunoperoxidase technique. Tissue cysts stain well with periodic acid–Schiff and silver stains as well as with the immunoperoxidase technique. Gross or microscopic areas of necrosis may be present in many tissues, especially the CNS, choroid and retina, heart, lungs, skeletal muscle, liver, and spleen. Areas of calcification occur in the brain.

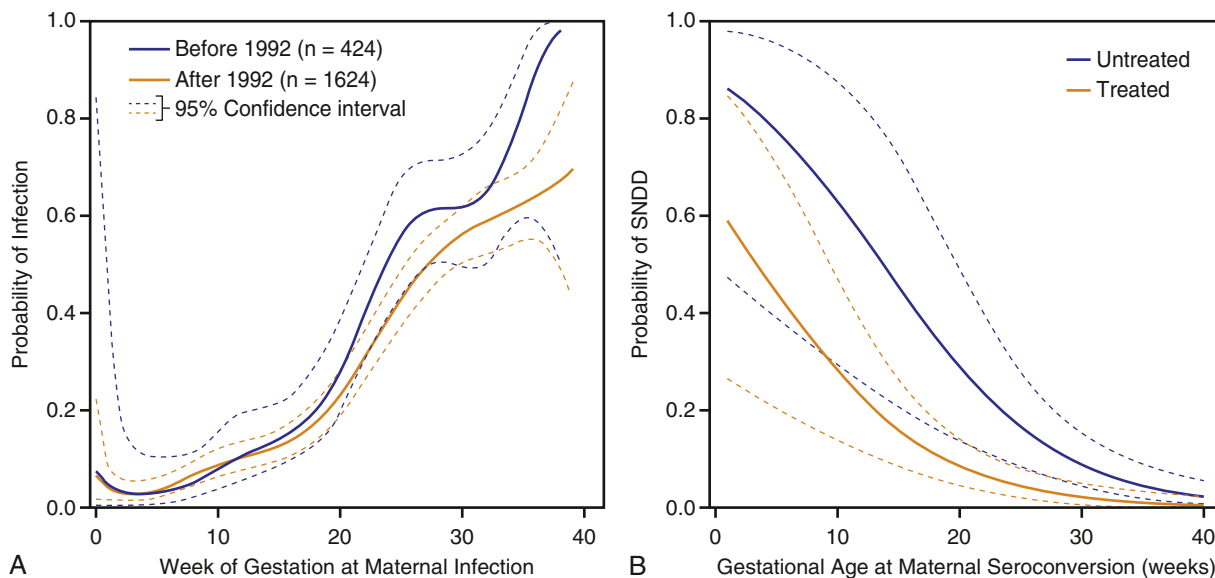
Almost all congenitally infected individuals who are not treated develop signs or symptoms of infection by adolescence. Some severely affected infants with congenital infection appear to have *Toxoplasma* antigen-specific cell-mediated hyporesponsiveness, which may be important in the pathogenesis of disease.

## CLINICAL MANIFESTATIONS

Manifestations of primary infection with *T. gondii* are highly variable and are influenced primarily by host immunocompetence. Clinical features range from no signs or symptoms to severe disease. Reactivation of previously asymptomatic congenital toxoplasmosis usually manifests as ocular toxoplasmosis.

### Acquired Toxoplasmosis

Immunocompetent children who acquire infection postnatally generally do not have clinically recognizable symptoms. When clinical



**Fig. 336.2** Probability and severity of congenital toxoplasmosis and relationship to gestational age at the time of maternal infection before ( $n = 451$ ) and after ( $n = 1624$ ) mid-1992, Lyon cohort (1987–2008). **A**, Risk of severe neurologic disease or death (SNDD) in children with congenital toxoplasmosis (CT) according to antepartum treatment. Probability of SNDD according to imputed gestational age at seroconversion and 95% Bayesian credible limits. *Gold lines* denote treated pregnancies; *purple lines* denote untreated pregnancies. (SNDD is a composite outcome comprising a pediatric report at any age of microcephaly; insertion of an intraventricular shunt; an abnormal or suspicious neurodevelopmental examination that resulted in referral to a specialist; seizures during infancy or at an older age that required anticonvulsant therapy; severe bilateral visual impairment [visual acuity of Snellen  $\leq 6/60$  in both eyes assessed after 3 yr]; cerebral palsy; or death from any cause before age 2 years, including termination of pregnancy [consistency of SNDD findings was checked through multiple assessments].) Severe neurologic sequelae were assessed at a median of 4 years' follow-up, death was assessed by age 2 yr, and severe bilateral visual impairment was included in the composite outcome of severe neurologic sequelae. (*A* from Wallon M, Peyron F, Cornu C, et al. *Congenital toxoplasmosis infection: monthly prenatal screening decreases transmission rate and improves clinical outcome at age 3 years*. *Clin Infect Dis*. 2013;56:1229; *B* from Cortina-Borja M, Tan HK, Wallon M, et al. *Prenatal treatment of serious neurologic sequelae of congenital toxoplasmosis: an observational prospective cohort study*. *PLoS Med*. 2010;7:e1000351.)



manifestations are apparent, they may include almost any combination of fever, stiff neck, myalgia, arthralgia, maculopapular rash that spares the palms and soles, localized or generalized lymphadenopathy, hepatomegaly, hepatitis, reactive lymphocytosis, meningitis, brain abscess, encephalitis, confusion, malaise, pneumonia, polymyositis, pericarditis, pericardial effusion, and myocarditis. **Chorioretinitis** occurs in approximately 1% of U.S. cases and in 20% of cases in epidemics in Brazil at 2 years after infection. Approximately 10% of mothers of congenitally infected infants have eye lesions on dilated indirect ophthalmoscopic examinations. Postnatally acquired chorioretinal lesions cannot be distinguished from congenitally acquired lesions based on appearance. In some areas of Brazil, 80% of the population is infected, with 50% of infected individuals >50 years old and 20% of infected individuals having retinal involvement. Symptoms and signs of active ocular infection may be present for a few weeks only or may persist for many months.

The most common manifestation of acute acquired toxoplasmosis is enlargement of one or a few cervical lymph nodes. Cases of *Toxoplasma lymphadenopathy* can resemble infectious mononucleosis, lymphoma, or other lymphadenopathies (see Chapter 539). Pectoral, mediastinal, mesenteric, and retroperitoneal lymph nodes may be involved. Involvement of intraabdominal lymph nodes may be associated with fever, mimicking appendicitis. Nodes may be tender but do not suppurate. Lymphadenopathy may wax and wane for as long as 1-2 years. However, almost all patients with lymphadenopathy recover spontaneously without antimicrobial therapy. Significant organ involvement in immunologically normal persons is uncommon, although some individuals have significant morbidity, including rare cases of encephalitis, brain abscesses, hepatitis, myocarditis, pericarditis, and polymyositis. In persons acquiring *T. gondii* in Guyana near the Maroni River and along Amazon tributaries, a severe form of life-threatening, multi-visceral involvement with fever has occurred. The causative parasites in these cases are genetically different from the parasites in others.

### Ocular Toxoplasmosis

In the United States and Western Europe, *T. gondii* is estimated to cause 35% of cases of **chorioretinitis** (Fig. 336.3). In Brazil, *T. gondii* retinal lesions are common. Clinical manifestations include blurred vision, visual floaters, photophobia, epiphora, and, with macular involvement, loss of central vision. Ocular findings of **congenital toxoplasmosis** also include strabismus, microphthalmia, microcornea, cataracts, anisometropia, nystagmus, glaucoma, optic neuritis, and optic atrophy. Episodic recurrences are common, but precipitating factors have not been defined. Recurrent, active disease usually occurs at school-entry age and during adolescence. Anecdotally, stress or trauma seems to precipitate symptoms. Recurrences are most common closest to the time of acquisition of infection, and treatment leads to resolution of activity. PD-L1 may contribute to susceptibility to recurrent active retinal disease.

### Immunocompromised Persons

Host factors play a prominent role in susceptibility to disease due to *T. gondii* and in the outcome of toxoplasmosis. Disseminated *T. gondii* infection among older children who are **immunocompromised** by AIDS, malignancy, cytotoxic therapy, corticosteroids, or immunosuppressive drugs given for organ transplantation involves the CNS in 50% of cases and may also involve the heart, lungs, and GI tract. Stem cell transplant recipients present a special problem, because active infection is difficult to diagnose serologically. After transplantation, *T. gondii*-specific antibody levels may remain the same, increase, or decrease, and can even become undetectable. Toxoplasmosis in transplantation patients results from reactivation of latent organisms or transplantation from a seropositive donor to a seronegative recipient; thus knowledge of the serologic status of the donor and recipient is essential. Prompt diagnosis is of utmost importance, as active infection is often fulminant and rapidly fatal without treatment.

Congenital *T. gondii* infection in infants with HIV infection is rare in the United States but can be a severe and fulminant disease with substantial CNS involvement. Alternatively, it may be more indolent in presentation, with focal neurologic deficits or systemic manifestations such as

pneumonitis occurring with progressive CD4 depletion in infants who are not receiving highly active antiretroviral therapy (HAART).

Up to 50% of persons with *T. gondii* antibodies and HIV infection who are not on antiretroviral treatment eventually experience **toxoplasmic encephalitis**, which is fatal if not treated. HAART and trimethoprim-sulfamethoxazole (TMP-SMX) prophylaxis to prevent *Pneumocystis jirovecii* have reduced the incidence of toxoplasmosis in patients with HIV infection, but toxoplasmic encephalitis remains a presenting manifestation in some adult patients with AIDS. Typical findings include fever, headache, altered mental status, psychosis, cognitive impairment, seizures, and focal neurologic defects such as hemiparesis, aphasia, ataxia, visual field loss, cranial nerve palsies, dysmetria, and movement disorders. In adult patients with AIDS, toxoplasmic retinal lesions are often large with diffuse necrosis and contain many organisms but little inflammatory cellular infiltrate. Diagnosis of presumptive toxoplasmic encephalitis based on neuroradiologic studies in patients with AIDS necessitates a prompt therapeutic trial of medications effective against *T. gondii*. Clear clinical improvement within 7-14 days and improvement of neuroradiologic findings within 3 weeks make the presumptive diagnosis almost certain.

### Congenital Toxoplasmosis

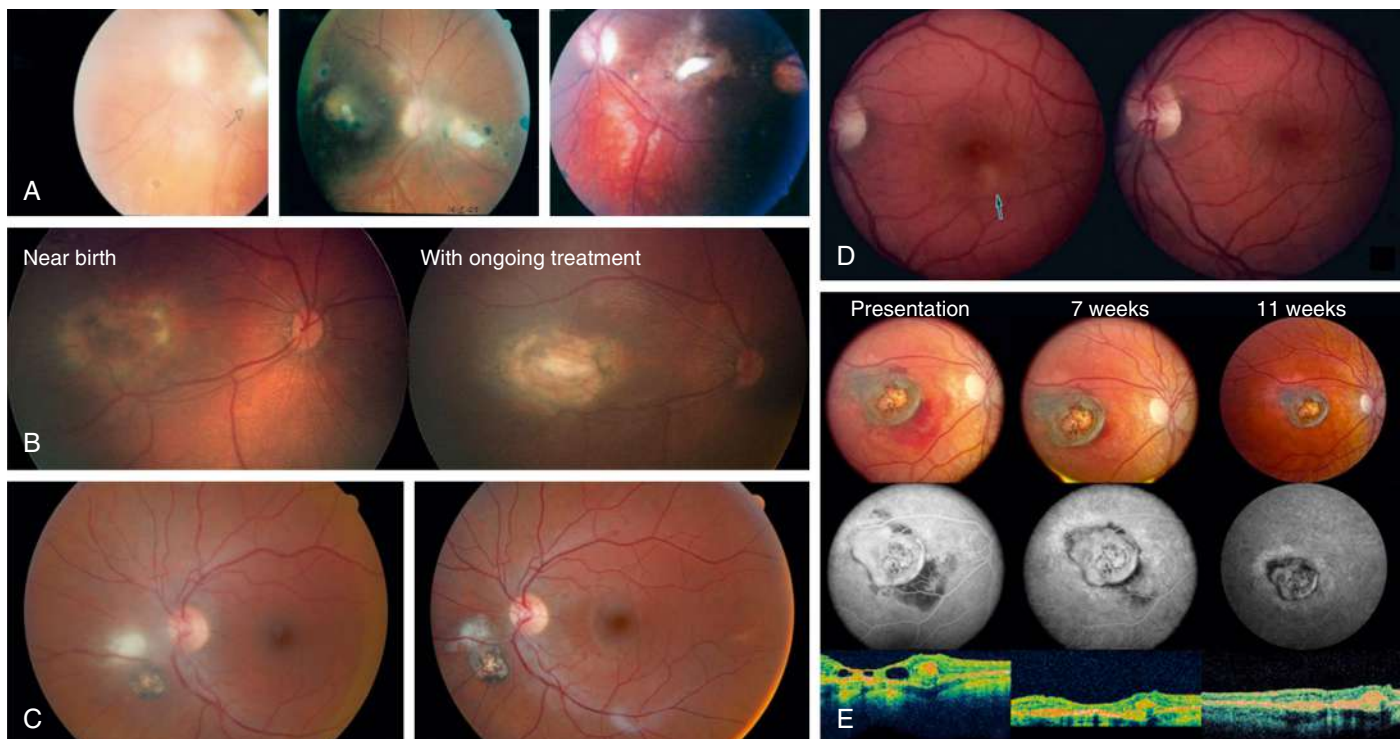
Congenital toxoplasmosis usually occurs when a woman acquires primary infection while pregnant. Most often, maternal infection is asymptomatic or without specific symptoms or signs. As with other adults with acute toxoplasmosis, lymphadenopathy is the most commonly identified physical finding.

In monozygotic twins the clinical pattern of involvement is most often similar, whereas in dizygotic twins the manifestations often differ, including cases of congenital infection in only one twin. The major histocompatibility complex class II gene DQ3 appears to be more common than DQ1 among HIV-infected persons seropositive for *T. gondii* who develop toxoplasmic encephalitis, as well as in children with congenital toxoplasmosis who develop hydrocephalus. These findings suggest that the presence of HLA-DQ3 is a risk factor for severity of toxoplasmosis. Other allelic variants of genes, including *COL2A*, *ABC4R*, *P2X7R*, *NALP1*, *ALOX12*, *TLR9*, *TIRAP*, *MAL*, and *ERAAIP*, are also associated with increased susceptibility.

Congenital infection may present as a mild or severe neonatal disease (Table 336.1). It may also present with sequelae or relapse of a previously undiagnosed and untreated infection later in infancy or even later in life (see Table 336.1). There is a wide variety of manifestations of congenital infection, ranging from hydrops fetalis and perinatal death to small size for gestational age, prematurity, peripheral or central retinal scars, persistent jaundice, mild thrombocytopenia, CSF pleocytosis, and the characteristic triad of chorioretinitis, hydrocephalus, and cerebral calcifications (Figs. 336.4 and 336.5). More than 50% of congenitally infected infants are considered normal in the perinatal period, but almost all such children will develop ocular involvement later in life if they are not treated during infancy. Neurologic signs such as convulsions, setting-sun sign with downward gaze, and increased head circumference due to ventricular dilatation or hydrocephalus caused by relatively mild involvement with inflammation or marked destruction of tissue obstructing the aqueduct of Sylvius or foramen of Monroe or inflammation resulting in stiff ventricles may be associated with substantial cerebral damage. If affected infants are treated promptly with antimicrobial therapy and placement of a ventriculoperitoneal shunt, signs and symptoms may resolve and development may be normal, making evidence of hydrocephalus a medical emergency. Early signs of potential congenital toxoplasmosis, such as ventricular dilatation or hydrocephalus, should be treated as a pediatric emergency. Outcomes are better with prompt placement of a ventriculoperitoneal shunt when indicated than when shunt placement is delayed. Head circumference crossing percentiles and obviously dilated ventricles with increased intracranial pressure require shunt placement, and ventricular dilatation without obvious increased pressure can also benefit from shunt placement.

The spectrum and frequency of neonatal manifestations of 210 newborns with congenital *Toxoplasma* infection identified by a serologic screening program of pregnant women in France were described in 1984. In this study, 10% had severe congenital toxoplasmosis with CNS involvement, eye lesions, and general systemic manifestations; 34% had mild





**Fig. 336.3** Toxoplasmic chorioretinitis. A, Retinal photographs of a child with severe vitreitis that is less intense than the classic “headlight in fog” appearance (left). Resolving vitreitis caused by underlying active lesion (middle). Resolved healed lesion without vitreitis (right). B, Retina photographs for a newborn infant with active vitreitis (left, “near birth”) with clearing of vitreitis and marked, but not complete, resolution of activity of the lesion 3 wk later (right, “with ongoing treatment”). C, Retinal photographs of a child showing an active lesion at presentation (left), and scarred lesion (right). D, Retinal photographs showing an active retinal lesion before treatment (left) and a completely resolved normal appearing retina within 1 mo of initiating treatment (right). E, Active choroidal neovascular membranes in a child. Fundus photographs (top row), fluorescein angiogram (middle row), and ocular coherence tomography (bottom row) of a child at presentation (first column), 7 wk after first ranibizumab (Lucentis, antibody to vascular endothelial growth factor [VEGF]) injection (second column), and 11 wk after first ranibizumab injection (third column). (A–D, Adapted from Delair E, Laskany P, Noble AG, et al. *Clinical manifestations of ocular toxoplasmosis. Ocul Immunol Inflamm.* 2011;19:91–102; E, Adapted from Benvenuto JD, Jager RD, Noble AG, et al. *Toxoplasmosis-associated neovascular lesions treated successfully with ranibizumab and antiparasitic therapy. Arch Ophthalmol.* 2008;126:1152–1156.)

involvement with normal clinical examination results other than retinal scars on dilated indirect exams or isolated intracranial calcifications in brain CT scans; and 55% had no detectable manifestations. These numbers represent an *underestimation* of the incidence of severe congenital infection for several reasons: the most severe cases, including most who died, were not referred; therapeutic abortion sometimes was performed when acute acquired infection of the mother was diagnosed early during pregnancy; in utero **spiramycin** therapy prevented or diminished the severity of infection; and only 13 of 210 congenitally infected newborns had brain CT, and only 77% of these 210 infants had a CSF examination. Routine newborn examinations often yield normal findings for congenitally infected infants, but more careful evaluations may reveal significant abnormalities. A 2012 analysis of the **National Collaborative Chicago-Based Congenital Toxoplasmosis Study** (NCCCTS, 1981–2009) data found that 72% of children at or near birth had chorioretinal scars, 70% had CNS calcifications, 12% had microcephaly, 37% had hydrocephalus, 41% had thrombocytopenia, 39% had hepatomegaly, 32% had splenomegaly, and 41% were born prematurely. In a study of 28 infants in New England identified by a universal state-mandated serologic screening program for *T. gondii*-specific immunoglobulin (Ig) M, 26 (93%) had normal findings on routine newborn examination, but 14 (50%) had significant abnormalities detected with more careful evaluation. The abnormalities included retinal scars (seven infants), active chorioretinitis (three infants), and CNS abnormalities (eight infants). In Fiocruz, Belo Horizonte, Brazil, infection is common, affecting 1 in 600 live births. Half of these infected infants have active chorioretinitis at birth.

There is also a wide spectrum of symptoms of untreated congenital toxoplasmosis that presents later in the first year of life. These children may have IQ scores of <70, convulsions, and severely impaired vision. When the infection is acquired in utero and the fetus is treated by drug therapy

of the pregnant woman with pyrimethamine, sulfadiazine, and leucovorin, ocular and neurologic sequelae in the infant may be prevented.

### SYSTEMIC SIGNS

From 25–50% of infants with clinically apparent disease at birth are born prematurely. Parasite clonal types other than type II are more often associated with prematurity and more severe disease. Intrauterine growth restriction, low Apgar scores, and temperature instability are common. Other manifestations may include lymphadenopathy, hepatosplenomegaly, myocarditis, pneumonitis, nephrotic syndrome, vomiting, diarrhea, and feeding problems. Bands of metaphyseal lucency and irregularity of the line of provisional calcification at the epiphyseal plate may occur without periosteal reaction in the ribs, femurs, and vertebrae. Congenital toxoplasmosis may be confused with erythroblastosis fetalis resulting from isosensitization, although the Coombs test result is usually negative with congenital *T. gondii* infection.

Prematurity, growth restriction, signs suggesting sepsis, thrombocytopenia, and abnormal CSF cells, protein, and glucose in the perinatal period should suggest congenital toxoplasmosis.

### Skin

Cutaneous manifestations among newborn infants with congenital toxoplasmosis include rashes and jaundice and/or petechiae secondary to thrombocytopenia, but ecchymoses and large hemorrhages secondary to thrombocytopenia also occur. Rashes may be fine punctate, diffuse maculopapular, lenticular, deep blue-red, sharply defined macular, or diffuse blue and papular. Macular rashes involving the entire body including the palms and soles, exfoliative dermatitis, and cutaneous calcifications have been described. **Jaundice** with hepatic involvement and/or hemolysis, cyanosis due to interstitial pneumonitis from congenital infection, and edema

**Table 336.1** Signs and Symptoms Occurring Before Diagnosis or During the Course of Untreated Acute Congenital Toxoplasmosis in 152 Infants (A) and in 101 of These Same Children After They Had Been Followed  $\geq 4$  Years (B)

SIGNS AND SYMPTOMS	FREQUENCY OF OCCURRENCE IN PATIENTS WITH	
	"NEUROLOGIC" DISEASE*	"GENERALIZED" DISEASE†
<b>A. Infants</b>	<b>108 Patients (%)</b>	<b>44 Patients (%)</b>
Chorioretinitis	102 (94)	29 (66)
Abnormal cerebrospinal fluid	59 (55)	37 (84)
Anemia	55 (51)	34 (77)
Convulsions	54 (50)	8 (18)
Intracranial calcification	54 (50)	2 (4)
Jaundice	31 (29)	35 (80)
Hydrocephalus	30 (28)	0 (0)
Fever	27 (25)	34 (77)
Splenomegaly	23 (21)	40 (90)
Lymphadenopathy	18 (17)	30 (68)
Hepatomegaly	18 (17)	34 (77)
Vomiting	17 (16)	21 (48)
Microcephaly	14 (13)	0 (0)
Diarrhea	7 (6)	11 (25)
Cataracts	5 (5)	0 (0)
Eosinophilia	6 (4)	8 (18)
Abnormal bleeding	3 (3)	8 (18)
Hypothermia	2 (2)	9 (20)
Glaucoma	2 (2)	0 (0)
Optic atrophy	2 (2)	0 (0)
Microphthalmia	2 (2)	0 (0)
Rash	1 (1)	11 (25)
Pneumonitis	0 (0)	18 (41)
<b>B. Children <math>\geq 4</math> Yr Old</b>	<b>70 Patients (%)</b>	<b>31 Patients (%)</b>
Intellectual impairment	62 (89)	25 (81)
Convulsions	58 (83)	24 (77)
Spasticity and palsies	53 (76)	18 (58)
Severely impaired vision	48 (69)	13 (42)
Hydrocephalus or microcephaly	31 (44)	2 (6)
Deafness	12 (17)	3 (10)
Normal	6 (9)	5 (16)

\*Patients with otherwise undiagnosed central nervous system disease in the first year of life.

†Patients with otherwise undiagnosed nonneurologic diseases during the first 2 mo of life.

Adapted from Eichenwald H. A study of congenital toxoplasmosis. In: Slim JC, ed. *Human Toxoplasmosis*. Copenhagen: Munksgaard; 1960: pp 41–49. Study performed in 1947. The most severely involved institutionalized patients were not included in the later study of 101 children.

secondary to myocarditis or nephrotic syndrome may be present. Jaundice and conjugated hyperbilirubinemia may persist for months.

### Endocrine Abnormalities

Endocrine abnormalities may occur secondary to hypothalamic or pituitary involvement or end-organ involvement but are not common. Occasionally reported endocrine manifestations include myxedema, persistent hypernatremia with vasopressin-sensitive diabetes insipidus, sexual precocity, and partial anterior hypopituitarism.

### Central Nervous System

Neurologic manifestations of congenital toxoplasmosis vary from massive acute encephalopathy to subtle neurologic syndromes. Toxoplasmosis should be considered as a potential cause of any undiagnosed neurologic disease in children  $<1$  year old, especially if retinal lesions are present.

**Hydrocephalus** may be the sole neurologic manifestation of congenital toxoplasmosis and almost always requires shunt placement (see Fig. 336.5). Hydrocephalus may present prenatally and progress during the perinatal period or, much less often, may present later in life. Patterns of seizures

are protean and have included focal motor seizures, petit and grand mal seizures, muscular twitching, opisthotonos, and hypsarrhythmia. Spinal or bulbar involvement may be manifested by paralysis of the extremities, difficulty swallowing, and respiratory distress. **Microcephaly** usually reflects severe brain damage, but some children with microcephaly caused by congenital toxoplasmosis who have been treated promptly have normal or even superior cognitive function. Seizures, focal motor defects, and

intellectual impairment may become apparent after the newborn period, even when infection is subclinical at birth.

### Other Neurologic Disease

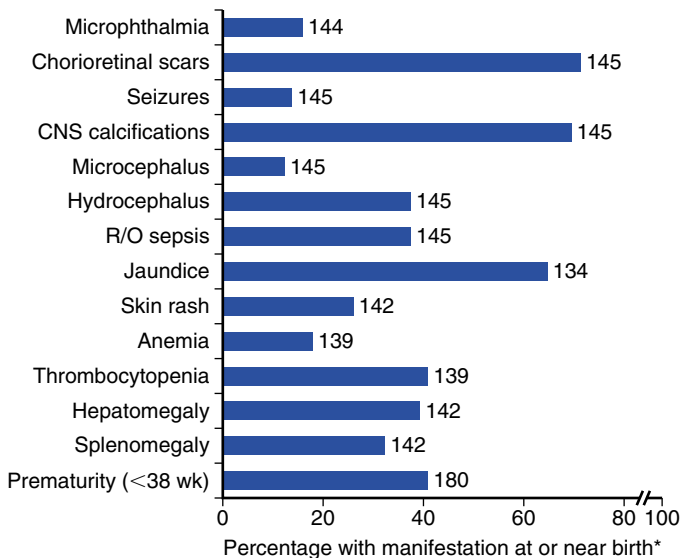
*T. gondii* infection is a cause of epilepsy and other neurologic disorders that improve with medical treatment. Ketogenic diet has led to resolution of seizures refractory to other treatments due to *T. gondii*. Symptomatic spinal cord lesions may be evident as T2-weighted abnormalities and can also resolve with medical treatment.

Symptomatic spinal cord lesions may be evident as T2 weighted abnormalities on MRI and can resolve with medical treatment.

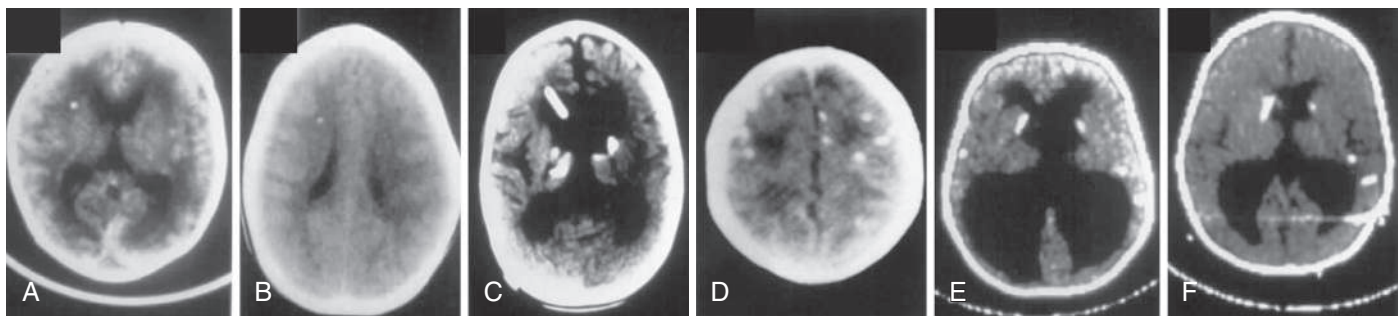
CSF abnormalities occur in at least 50% of infants with congenital toxoplasmosis. A CSF protein level >1 g/dL is characteristic of severe CNS toxoplasmosis and is usually accompanied by hydrocephalus. Local production of *T. gondii*-specific IgG and IgM antibodies may be demonstrated. CT of the brain is useful to detect calcifications, determine ventricular size, and demonstrate porencephalic cystic structures (see Fig. 336.5). MRI is used to assess ventricular size and configuration and can detect T2-weighted abnormalities associated with active disease. **Calcifications** occur throughout the brain, but there is a propensity for development of calcifications in the caudate nucleus and basal ganglia, choroid plexus, and subependyma. MRI and contrast-enhanced CT brain scans are useful for detecting active inflammatory lesions. Rapid MRI or ultrasonography may be useful for following ventricular size. Medical treatment in utero and in the first year of life results in improved neurologic outcomes and oftentimes diminution or disappearance of calcifications.

### Eyes

Almost all untreated congenitally infected infants develop **chorio-retinal lesions** by adulthood and may have severe visual impairment. *T. gondii* causes a **focal necrotizing retinitis** in congenitally infected individuals (see Fig. 336.3). Retinal detachment may occur. Any part of the retina may be involved, either unilaterally or bilaterally, including the maculae. The optic nerve may be involved, and toxoplasmic lesions that involve projections of the visual pathways in the brain or the visual cortex also may lead to visual impairment. In association with severe retinal lesions and vitritis, secondary anterior uveitis may develop and occasionally lead to erythema of the external eye.



**Fig. 336.4** Congenital toxoplasmosis: manifestations at presentation. National Collaborative Chicago-Based Congenital Toxoplasmosis Study (NCCCTS, 1981–2009). \*Infants diagnosed with congenital toxoplasmosis in the newborn period and referred to the NCCCTS during the first year of life. Numbers adjacent to histogram bars represent number of infants with this manifestation and are based on information in birth records. Sample size dependent on available birth records/diagnoses at birth. R/O, Rule out; CNS, central nervous system. (Adapted from McLeod R, Boyer KM, Lee D, et al. Prematurity and severity are associated with *Toxoplasma gondii* alleles [NCCCTS, 1981–2009]. *Clin Infect Dis*. 2012;54:1595–1605.)



**Fig. 336.5** Head CT scans of infants with congenital toxoplasmosis. A, CT scan at birth that shows areas of hypolucency, mildly dilated ventricles, and small calcifications. B, CT scan of the same child at 1 yr of age (after antimicrobial therapy for 1 yr). This scan is normal, with the exception of two small calcifications. This child's Mental Development Index (MDI) at 1 yr old was 140 by the Bayley Scale of Infant Development. C, CT scan from a 1-yr-old infant who was normal at birth. His meningoencephalitis became symptomatic in the first few weeks of life but was not diagnosed correctly and remained untreated during his first 3 mo of life. At 3 mo old, development of hydrocephalus and bilateral macular chorioretinitis led to the diagnosis of congenital toxoplasmosis, and antimicrobial therapy was initiated. This scan shows significant residual atrophy and calcifications. This child had substantial motor dysfunction, development delays, and visual impairment. D, CT scan obtained during the first month of life of a microcephalic child. Note the numerous calcifications. This child's IQ scores using the Stanford-Binet Intelligence Scale for children when she was 3 yr old and Wechsler Preschool and Primary Scale Intelligence when she was 5 yr old were 100 and 102, respectively. She received antimicrobial therapy during her first year of life. E, CT scan with hydrocephalus caused by aqueductal obstruction, before placement of a ventricular shunt. F, Scan from the same patient as the scan in E, after shunt placement. This child's IQ scores using the Stanford-Binet Intelligence Scale for children were approximately 100 when she was 3 yr old and 6 yr old. (A–F adapted from McAuley J, Boyer K, Patel D, et al. Early and longitudinal evaluations of treated infants and children and untreated historical patients with congenital toxoplasmosis: the Chicago Collaborative Treatment Trial. *Clin Infect Dis*. 1994;18:38–72.)



Other ocular findings include cells and protein in the anterior chamber, large keratic precipitates, posterior synechiae, nodules on the iris, and neovascular formation on the surface of the iris, sometimes with increased intraocular pressure and glaucoma. Rarely, the extraocular musculature may also be involved directly. Other manifestations include strabismus, nystagmus, visual impairment, and microphthalmia. Enucleation has been required for a blind, phthisic, painful eye. The **differential diagnosis** of ocular toxoplasmosis includes congenital coloboma and inflammatory lesions caused by cytomegalovirus (CMV), lymphocytic choriomeningitis virus, *Bartonella henselae*, *Toxocara canis*, *Treponema pallidum*, *Mycobacterium tuberculosis*, varicella-zoster virus, Zika virus, or vasculitis. Ocular toxoplasmosis may be a recurrent and progressive disease that requires multiple courses of therapy. Limited data suggest that occurrence of lesions in the early years of life may be prevented by instituting **antimicrobial treatment** with pyrimethamine and sulfadiazine during the first year of life. Initiation of treatment of the infected fetus in utero followed by treatment in the first year of life further reduces the incidence and the severity of retinal disease.

### Ears

Both mild and severe sensorineural hearing loss may occur. It is not known whether this hearing loss is a static or progressive disorder. Treatment in the first year of life is associated with decreased frequency of hearing loss.

## DIAGNOSIS

Diagnosis of acute *T. gondii* infection can be established by a number of methods (Table 336.2): isolation of *T. gondii* from blood or body fluids; identification of tachyzoites in sections or preparations of tissues and body fluids, amniotic fluid, or placenta; identification of cysts in the placenta or tissues of a fetus or newborn; and characteristic lymph node histologic features. Serologic tests are very useful for diagnosis. Polymerase chain reaction (PCR) is useful to identify *T. gondii* DNA in CSF and amniotic fluid and has been reported to be useful with infant peripheral blood and urine to establish the diagnosis definitively and in immunocompromised patients for diagnosis and monitoring treatment.

### Isolation or Identification of *T. gondii*

Organisms can be isolated by inoculation of body fluids, leukocytes, or tissue specimens into mice or tissue culture cells. Body fluids should be processed and inoculated immediately, but *T. gondii* has been isolated from tissues and blood that have been stored overnight or even for 4-5 days at 4°C (39.2°F). Freezing or treatment of specimens with formalin kills *T. gondii*. From 6-10 days after inoculation into mice, or earlier if mice die, peritoneal fluids should be examined for tachyzoites. If inoculated mice survive for 6 weeks and seroconvert, definitive diagnosis is made by visualization of *Toxoplasma* cysts in mouse brain. If cysts are not seen, **subinoculation** of mouse tissue into other mice is performed. Treatment of subinoculated mice with corticosteroids appears to enhance ability to isolate the parasite.

Microscopic examination of tissue culture cells inoculated with *T. gondii* shows necrotic, heavily infected cells with numerous extracellular tachyzoites. Isolation of *T. gondii* from blood or body fluids reflects acute infection. Except in the fetus or neonate, it is usually not possible to distinguish acute from past infection by isolation of *T. gondii* from tissues (e.g., skeletal muscle, lung, brain, eye) obtained by biopsy or at autopsy.

Diagnosis of acute infection can be established by visualization of tachyzoites in biopsy tissue sections, bone marrow aspirates, or body fluids (e.g., CSF, amniotic fluid). Immunofluorescent antibody and immunoperoxidase staining techniques may be necessary, because it is often difficult to distinguish the tachyzoite using ordinary stains. Tissue cysts are diagnostic of infection but do not differentiate between acute and chronic infection, although the presence of many cysts suggests recent acute infection. Cysts in the placenta or tissues of the newborn infant establish the diagnosis of congenital infection.

Characteristic histologic features strongly suggest the diagnosis of toxoplasmic lymphadenitis.

### Serologic Testing

Serologic tests are useful in establishing the diagnosis of congenital or acutely acquired *T. gondii* infection. Each laboratory that reports serologic test results must have established values for their tests that diagnose infection in specific clinical settings, provide interpretation of their results, and ensure appropriate quality control before therapy is based on serologic test results. Serologic test results used as the basis for therapy should ideally be confirmed in a reference laboratory.

The **Sabin-Feldman dye test** is sensitive and specific. This test measures primarily IgG antibodies. Results should be expressed in international units (IU/mL), based on international standard reference sera available from the World Health Organization (WHO).

The **IgG indirect fluorescent antibody (IgG-IFA) test** measures the same antibodies as the Sabin-Feldman dye test, and the titers tend to be parallel. These antibodies usually appear 1-2 weeks after infection, reach high titers ( $\geq 1:1,000$ ) after 6-8 weeks, and then decline over months to years. Low titers (1:4 to 1:64) usually persist for life. Antibody titer does not correlate with severity of illness.

An **agglutination test** (bioMérieux, Lyon, France) available commercially in Europe uses formalin-preserved whole parasites to detect IgG antibodies. This test is accurate, simple to perform, and inexpensive.

The **IgM-IFA test** is useful for the diagnosis of acute acquired infection with *T. gondii* in the older child because IgM antibodies appear earlier, often by 3-5 days after infection, and diminish more quickly than IgG antibodies. In most instances, IgM antibodies rise rapidly (1:50 to  $\geq 1:1,000$ ) and then fall to low levels (1:10 or 1:20) or disappear after weeks or months. However, some patients continue to have positive IgM levels with low titers for several years. The IgM-IFA test detects *Toxoplasma*-specific IgM in only approximately 25% of congenitally infected infants at birth. IgM antibodies may not be present in sera of immunocompromised patients with acute toxoplasmosis or in patients with reactivation of ocular toxoplasmosis. The IgM-IFA test may yield false-positive results as a result of rheumatoid factor (RF).

The **double-sandwich IgM enzyme-linked immunosorbent assay (IgM-ELISA)** is also useful for detection of *Toxoplasma* IgM antibodies. In the older child, serum IgM-ELISA *Toxoplasma* antibodies of  $>2$  (a value of one reference laboratory; each laboratory must establish its own value for positive results) indicates that *Toxoplasma* infection most likely has been acquired recently. The IgM-ELISA identifies approximately 50-75% of infants with congenital infection. IgM-ELISA avoids both the false-positive results from RF and the false-negative results from high levels of passively transferred maternal IgG antibody in fetal serum, as may occur with the IgM-IFA test. Results obtained with commercial kits must be interpreted with caution, because false-positive reactions can occur. Care must also be taken to determine whether kits have been standardized for diagnosis of infection in specific clinical settings, such as in the newborn infant. The **IgA-ELISA** also is a sensitive test for detection of maternal and congenital infection, and results may be positive when those of the IgM-ELISA are not.

The **immunosorbent agglutination assay (ISAGA)** combines trapping of a patient's IgM to a solid surface and use of formalin-fixed organisms or antigen-coated latex particles. It is read as an agglutination test. There are no false-positive results from RF or antinuclear antibodies (ANAs). **IgM-ISAGA** is more sensitive and may detect specific IgM antibodies before and for longer periods than IgM-ELISA.

At present, IgM-ISAGA and IgA-ELISA are the most useful tests for diagnosis of congenital infection in the newborn but are not positive in all infected infants. The IgE-ELISA and IgE-ISAGA are also sometimes useful in establishing the diagnosis of congenital toxoplasmosis or acute acquired *T. gondii* infection. The presence of IgM antibodies in the older child or adult can never be used alone to diagnose acute acquired infection. The lateral immunochromatographic test (ICT) can identify IgG and/or IgM in serum or whole blood from fingerstick precisely and rapidly. Western blot II is highly accurate for identifying *T. gondii*-specific IgG and for IgM.



**Table 336.2** Generalizations Concerning Clinical Presentations, *Toxoplasma*-Specific Diagnostic Tests, and Treatment

CLINICAL SETTING AND MANIFESTATION	SAMPLE SOURCE	TOXOPLASMA-SPECIFIC DIAGNOSTIC TESTS								TREATMENT				
		G	M	A	E	AV	AC/HS	PCR KARIUS	SUBINOCULATION	SP	PSL*	CO	LU	NONE
<b>PRENATAL</b>														
Acute infection in pregnant woman ≤15wk amenorrhea in gestation and no clinical evidence of fetal infection	Mother	+	+	+	+	L	Acute	AF (17-18wk)	NS		+	+	†No P first trimester	
Acute infection in pregnant woman ≤15 wk amenorrhea in gestation and signs of fetal infection	Mother	+	+	+	+	L	Acute	AF (may not be necessary)	NS			+	†No P first trimester	
Acute infection in pregnant woman at >18wk gestation	Mother	+	+	+	+	L	Acute	AF	NS		+			
Congenital infection in infant	Infant	+	+	+	+	L	Acute	Placenta/buffy coat	Placenta/buffy coat		+		‡	
<b>POSTNATAL</b>														
Acute, symptomatic	Child	+	+	+	+	L	Acute	NS	NS		+			+
Acute, self-limited symptoms	Child	+	+	+	+	L	Acute	§		Body fluids/buffy coat	+			
Chronic, asymptomatic	Child	+	-	-	-	H	Chronic	NS	NS					
Chronic, severely symptomatic	Child	+	+	+	+	L	Acute	§		Body fluids/buffy coat	+			
Immune compromised¶	Child	+/-	+/-	+/-	+/-	+/-	+/-	§		Body fluids/buffy coat				
Laboratory accident#	Child	+/-	+/-	+/-	+/-	+/-	+/-	NS	NS		+			
<b>Eye Disease</b>														
Quiescent scar**	Child	+	+/-	+/-	+/-	+/-	+/-	NS	NS					+
Active chorioretinitis**	Child	+	+/-	+/-	+/-	+/-	+/-	NS	NS		+			
Active CNVM**	Child	+	+/-	+/-	+/-	+/-	+/-	NS	NS		+		††	

\*Pyrimethamine and leucovorin should be adjusted for granulocytopenia; complete blood counts, including platelets, should be monitored each Monday and Thursday. If there is sulfonamide allergy, alternative medicines include azithromycin (first choice), clarithromycin, or clindamycin in place of sulfadiazine.

†Do not use pyrimethamine in the first 14 weeks of gestation.

‡Occasionally, corticosteroids (prednisone) have been used when CSF protein is ≥1 g/dL or when active chorioretinitis threatens vision and should be continued until signs of inflammation or active chorioretinitis that threatens vision have subsided; then dosage can be tapered and the steroids discontinued.

§Utility of PCR depends on clinical setting. For example, the following may be useful to establish the diagnosis: PCR of body fluids such as amniotic fluid or CSF; cells from bronchoalveolar lavage from a patient with pneumonia; or tissue such as placenta where the presence of parasites or parasite DNA would support a diagnosis of infection.

¶In some cases, in immunocompromised persons, there is no detectable serologic response to *T. gondii*. However, if clinical presentation is indicative of infection in the absence of positive serologic results, CSF, buffy coat of peripheral blood, histopathology of tissue samples, or body fluids tested with PCR or subinoculation may be useful. If PCR demonstrates the presence of *T. gondii* DNA in the sample, it is useful for diagnosis. However, the sensitivity of PCR has been variable in this setting. In some circumstances, presumptive treatment may be warranted.

#Whether a person should be treated for a laboratory accident depends on the nature of the accident, the serology of the person before the accident, and other factors. When there is risk of infection, prompt treatment is given, considering the possible genetic manipulation of the laboratory strain.

\*\*Serologic results depend on whether infection is acute (recently acquired) or chronic. When testing serum from persons with ocular toxoplasmosis, *T. gondii*-specific IgG may be demonstrable only in an undiluted serum sample.

††Corticosteroids (prednisone) are used if inflammation or edema caused by infection threatens vision and should be continued until signs of inflammation or active chorioretinitis that threatens vision have subsided; then dosage can be tapered and the steroids discontinued.

+, Positive; -, negative; +/-, equivocal; A, *T. gondii*-specific IgA; AC/HS, differential agglutination test where A represents acetone fixed parasites and H represents formalin fixed antigen; AF, amniotic fluid; Av, *T. gondii*-specific IgG avidity; CNVM, choroidal neovascular membrane; Co, corticosteroids (prednisone); CSF, cerebrospinal fluid; E, *T. gondii*-specific IgE; G, *T. gondii*-specific IgG; L, leucovorin; Lu, Lucentis (antibody to vascular endothelial growth factor); M, *T. gondii*-specific IgM; NS, not standard to obtain; P, pyrimethamine; PCR, polymerase chain reaction; PSL, pyrimethamine (P), sulfadiazine (S), leucovorin (L) (folinic acid); Sp, spiramycin.

Adapted from Remington JS, McLeod R, et al. Toxoplasmosis. In: Remington JS, Klein JO, eds. *Infectious Diseases of the Fetus and Newborn Infant*. 6th ed. Philadelphia: Saunders; 2006.

The **differential agglutination test (HS/AC)** compares antibody titers obtained with formalin-fixed tachyzoites (**HS antigen**) with titers obtained using acetone-fixed tachyzoites (**AC antigen**) to differentiate recent and remote infections in adults and older children. This method may be particularly useful in differentiating remote infection in pregnant women, because levels of IgM and IgA antibodies detectable by ELISA or ISAGA may remain elevated for months to years in adults and older children.

The **avidity test** can be helpful to establish time of acquisition of infection. A high-avidity test result indicates that infection began >12-16 weeks earlier, which is especially useful in determining time of acquisition of infection in the first or final 16 weeks of gestation. A low-avidity test result may be present for many months or even years and does not definitively identify recent acquisition of infection.

A relatively higher level of *Toxoplasma* antibody in the aqueous humor or in CSF demonstrates local production of antibody during active ocular or CNS toxoplasmosis. This comparison yields a coefficient [C], which is calculated as follows:

$$C = \frac{\text{Antibody titer in body fluid}}{\text{Antibody titer in serum}} \times \frac{\text{Concentration of IgG in serum}}{\text{Concentration of IgG in body fluid}}$$

Significant coefficients [C] are >8 for ocular infection, >4 for congenital CNS infection, and >1 for CNS infection in patients with AIDS. If the serum dye test titer is >300 IU/mL, it is not possible to demonstrate significant local antibody production using this formula with either the dye test or the IgM-IFA test titer. IgM antibody may be detectable in CSF.

Comparative **Western immunoblot** tests of sera from a mother and infant may detect congenital infection. Infection is suspected when the mother's serum and her infant's serum contain antibodies that react with different *Toxoplasma* antigens.

The **enzyme-linked immunofiltration assay** using micropore membranes permits simultaneous study of antibody specificity by immunoprecipitation and characterization of antibody isotypes by immunofiltration with enzyme-labeled antibodies. This method is able to detect 85% of cases of congenital infection in the first few days of life.

Serologic tests in development include multiplex antibody tests for IgG-, IgM-, and IgA-specific antibodies and point-of-care tests designed to provide accurate and rapid identification of recent infection or seroconversion in pregnant women. The ICT point-of-care IgG-IgM test (LDBIO Diagnostic, Lyon, France) has shown very high diagnostic sensitivity and specificity and has been CE marked for use in Europe.

### Nucleic Acid Detection

PCR on amniotic fluid is used to detect a repetitive *T. gondii* gene such as the 529 bp multi-copy gene or the 20 copy B1 gene and is the method of choice for establishing the diagnosis of congenital *Toxoplasma* infection in the fetus. Sensitivity and specificity of PCR on amniotic fluid obtained between 17 and 21 weeks of gestation are approximately 95% for diagnosing congenital infection. PCR of peripheral white blood cells, CSF, and urine has been used to detect congenital infection at birth or postnatally. PCR of vitreous or aqueous fluids has been used to diagnose ocular toxoplasmosis. Karius test also detects nucleic acid. Abnormalities in MRI studies of brain and spinal cord may demonstrate activity of infection and are indicative (see Fig. 336.4). Both patient and parasite genetics contribute to severity and manifestations of illness (see Figs. 336.3 to 336.5).

### Other Tests

**Lymphocyte blastogenesis** to *T. gondii* antigens has been used to diagnose congenital toxoplasmosis when the diagnosis is uncertain and other test results are negative. However, a negative result does not exclude the diagnosis, as immune tolerance sometimes interferes with response of neonatal peripheral blood lymphocytes to *T. gondii* antigens. Novel biomarkers such as microRNAs and certain proteins may indicate active infection.

### Acquired Toxoplasmosis

Recent infection is diagnosed by seroconversion from a negative to a positive IgG antibody titer (in the absence of transfusion), a two-tube increase in *Toxoplasma*-specific IgG titer when serial sera are obtained

3 weeks apart and tested in parallel, or the detection of *Toxoplasma*-specific IgM antibody in conjunction with other tests, but never alone.

### Ocular Toxoplasmosis

IgG antibody titers of 1:4 to 1:64 are typical in older children with active *Toxoplasma* chorioretinitis. The presence of antibodies measurable only when serum is tested undiluted is also helpful in establishing the diagnosis. The diagnosis of ocular infection is likely with characteristic retinal lesions and positive serologic tests. PCR of aqueous or vitreous fluid has been used to diagnose ocular toxoplasmosis but is performed infrequently because of the risks associated with obtaining intraocular fluid and because the diagnosis can be made based on clinical appearance and history.

### Immunocompromised Persons

*Toxoplasma* IgG antibody titers may be low and *Toxoplasma* IgM is often absent in immunocompromised stem cell transplant recipients but not in kidney or heart transplant recipients with toxoplasmosis. Demonstration of *Toxoplasma* DNA by PCR in serum, blood, and CSF may identify disseminated *Toxoplasma* infection in immunocompromised persons. Resolution of CNS lesions during a therapeutic trial of pyrimethamine and sulfadiazine has been useful to diagnose toxoplasmic encephalitis in patients with AIDS. Brain biopsy has been used to establish the diagnosis if there is no response to a therapeutic trial and to exclude other possible diagnoses such as CNS lymphoma.

### Congenital Toxoplasmosis

Fetal ultrasound examination performed every 2 weeks during gestation beginning at diagnosis of acute acquired infection in a pregnant woman and PCR analysis of amniotic fluid are used for prenatal diagnosis. Examination of the placenta at delivery by histology and by PCR may facilitate diagnosis of congenital infection but is not sufficiently sensitive or specific for routine diagnosis.

Newborns suspected of having congenital toxoplasmosis should be evaluated by general, ophthalmologic, and neurologic examinations; head CT scan; and ideally all of the following tests: an attempt to detect *T. gondii* in the placenta and the infant's leukocytes from peripheral blood buffy coat; measurement of serum *Toxoplasma*-specific IgG, IgM, IgA, and IgE antibodies and the levels of total serum IgM and IgG; lumbar puncture, including analysis of CSF for cells, glucose, protein, *Toxoplasma*-specific IgG and IgM antibodies, and level of total IgG; and testing of CSF for *T. gondii* by PCR and inoculation into mice. Presence of *Toxoplasma*-specific IgM in CSF that is not contaminated with blood or confirmation of local antibody production of *Toxoplasma*-specific IgG antibody in CSF establishes the diagnosis of congenital *Toxoplasma* infection.

Serologic tests are also useful in establishing a diagnosis of congenital toxoplasmosis. Either persistent or rising titers in the Sabin-Feldman dye test or the IgG-IFA test or a positive IgM-ELISA or IgM-ISAGA result is diagnostic of congenital toxoplasmosis. The half-life of IgM is approximately 2 days, so presence of detectable IgM antibodies in the infant's serum decreases relatively quickly, usually within 1 week. Passively transferred maternal IgG antibodies may require many months to a year to disappear from the infant's serum, depending on the magnitude of the original titer. The half-life of passively transferred maternal IgG is approximately 30 days, so the titer diminishes by half each 30 days. Synthesis of *Toxoplasma* antibody is usually demonstrable by the third month of life if the infant is untreated, although the rate of IgG synthesis varies considerably in infants <1 year old. If the infant is treated, synthesis may be delayed for as long as the ninth month of life and occasionally does not occur at all. When an infant begins to synthesize IgG antibody, infection may be documented serologically even without demonstration of IgM antibodies by an increase in the ratio of specific serum IgG antibody titer to the total IgG. In contrast, the ratio of specific serum IgG to the total IgG will decrease if the specific IgG antibody has been passively transferred from the mother.

Many manifestations of congenital toxoplasmosis are similar to findings that occur in other perinatal infections, especially congenital CMV infection. Because neither cerebral calcification nor chorioretinitis is pathognomonic, a negative urine culture or PCR for CMV soon after birth is a useful adjunctive test. The clinical picture in the newborn infant may also be compatible with sepsis, aseptic meningitis, syphilis,

or hemolytic disease. Some children <5 years old with chorioretinitis have postnatally acquired *T. gondii* infection.

## TREATMENT

Currently available treatments are effective against the active tachyzoite form of the parasite. No commercially available medicines to date eliminate the latent encysted form of the parasite, although promising preclinical data suggest that such treatments will be possible in the future. Table 336.1 summarizes treatments in each clinical category.

A number of therapeutic agents, including pyrimethamine, sulfonamides, and macrolides, have been used to treat toxoplasmosis in its various clinical manifestations. In general, they have activity that is limited to the pathogenic tachyzoite stage of the parasite's life cycle. No clinically available antimicrobial agent has yet been found capable of eliminating the encysted bradyzoite stage. Thus, active disease may be effectively treated, but not ultimately cured, by current therapies. In a person with normal cell-mediated immunity, a single course of therapy may be sufficient. In immune-compromised patients and congenital infection, recurrences may be a long-term management problem. Curative therapies remain an area of continuing active research, with several promising candidates. Table 336.2 summarizes treatment according to clinical category of disease.

**Pyrimethamine** and **sulfadiazine** act synergistically against *Toxoplasma*, and combination therapy is **considered the treatment of choice** and is indicated for all clinical presentations of toxoplasmosis that require treatment, except for acute *Toxoplasma* infection acquired during the first trimester of pregnancy (see Table 336.2). Pyrimethamine is contraindicated during the first trimester of pregnancy because of teratogenic effects. Pyrimethamine and sulfadiazine are used in Austria and Germany and now sometimes in France and the United States for treatment of newly seropositive mothers after 15 weeks of gestation.

In contrast to mammals, *Toxoplasma* cannot take up folic acid, a precursor for folate synthesis. Thus folic acid protects the human bone marrow from toxicity due to pyrimethamine, which inhibits the enzyme dihydrofolate reductase (DHFR), blocking synthesis of folic acid. By correcting an enzymatic pathway accessible in human cells but not in *Toxoplasma*, leucovorin (folic acid) renders pyrimethamine/sulfadiazine a safer and more selective antiparasitic combination. Leucovorin is always given in conjunction with pyrimethamine and in the week after discontinuing pyrimethamine because of pyrimethamine's long half-life.

Pyrimethamine levels can be measured to make certain that they are in a therapeutic, nontoxic range of less than approximately 2.3 mg/dL and more than approximately 0.5 mg/dL for pyrimethamine when older children are treated for retinal disease or in other circumstances when medicines may be continued for longer times and reach high levels. Therapeutic endpoint is until resolution of the active retinal lesion and then at least 1 month beyond that, with no immune compromise, immune deficiency, or immune immaturity (for infants).

For treatment of those with primary, acute acquired toxoplasma in gestation to prevent or treat infection in the fetus, pyrimethamine is contraindicated during the first trimester of pregnancy. Pyrimethamine sulfadiazine is used in Austria and Germany, and now sometimes in France and the United States for treatment of those newly seropositive mothers after 15 weeks amenorrhea during gestation.

Spiramycin is used to attempt to prevent vertical transmission of infection to the fetus of acutely infected pregnant women in the first trimester. A recent meta-analysis adds to the evidence of significant reduction in mother-to-child transmission rates following spiramycin treatment of diagnosed gestational *T. gondii* infection. In 2018, Mandelbrot et al. reported results of a randomized controlled trial that compared treatment with pyrimethamine sulfadiazine promptly following seroconversion after 15 weeks rather than using spiramycin until 17 weeks' gestation with pyrimethamine sulfadiazine initiated only for PCR-positive amniotic fluid. Hypersensitivity for the mother is a greater risk in the group that receives pyrimethamine sulfadiazine earlier and may make diagnosis more difficult by obscuring evidence of infection in the fetus and infant. There was a very small increase in

the number of infants with severe findings in the group that received pyrimethamine sulfadiazine initiated at the later time.

The merits of this gestational treatment approach have been examined in cost-benefit analyses examining both the United States and Austria, and the first direct cost-benefit comparison of prenatal and neonatal in the context of France (not yet published) all indicate better outcomes for affected infants and the healthcare system if treatment is started in utero, rapidly following seroconversion. *Toxoplasma* cannot take up folic acid, a precursor for folate synthesis, whereas mammalian cells can take up folic acid. Thus, folic acid protects the human bone marrow from toxicity due to pyrimethamine. Use of pyrimethamine is contraindicated in the first trimester of pregnancy; it inhibits the enzyme dihydrofolate reductases and thus synthesis of folic acid.

**Spiramycin** is a macrolide antibiotic that is active against *Toxoplasma* in the placenta but does not reach sufficient levels in other tissues to treat a fetus or to be used postnatally. Hence, it has been used successfully to prevent congenital toxoplasmosis in pregnant women who have documented seroconversion in the first trimester when pyrimethamine is contraindicated.

**Azithromycin** is a macrolide that is used in severe or recurrent disease when sulfonamide allergy precludes the use of sulfadiazine. Azithromycin has been used to suppress infection and prevent recurrences of retinochoroiditis.

TMP-SMX is less active than pyrimethamine/sulfadiazine, with a suboptimal ratio of the DHFR and para-amino benzoic acid synthase inhibitors and with a shorter half-life of trimethoprim relative to pyrimethamine. Treatment failures have occurred with TMP-SMX, underscoring the importance of treating with pyrimethamine and sulfadiazine if at all possible. Clindamycin and atovaquone have also been used as second line agents but not as single antimicrobial agents.

**Reversible neutropenia** is the most common adverse effect in pyrimethamine-treated infants and typically responds to temporary holding of doses. All patients treated with pyrimethamine should have leukocyte counts twice weekly. Medicines may be held temporarily. G-CSF treatment is rarely needed. Improper preparation of medicine, not making it fresh each week, is a cause of increased difficulties with neutropenia. Seizures may occur with overdose of pyrimethamine. Potential toxic effects of sulfonamides include crystalluria, hematuria, and rash. Profound neutropenia is a risk with sulfonamide overdose, which has occurred when pharmacies make large quantities of the suspension and there is settling of the medication with the starch binder. The protocol for preparation for infants should be followed carefully, with fresh medicine prepared weekly and the bottle shaken well. Hypersensitivity reactions occur, especially in patients with AIDS. For older children and adults, eight glasses of a nonacidic beverage should be consumed each day while taking the medicine. Hypersensitivity reactions occur, especially frequently in patients with AIDS. As mentioned above, folic acid, as calcium leucovorin, should always be administered concomitantly and for 1 week after treatment with pyrimethamine is discontinued to prevent bone marrow suppression.

## Acquired Toxoplasmosis

Patients with acquired toxoplasmosis and lymphadenopathy usually do not need specific treatment unless they have severe and persistent symptoms or evidence of damage to vital organs (see Table 336.2). If such signs and symptoms occur, treatment with pyrimethamine, sulfadiazine, and leucovorin should be initiated. Patients who appear to be immunocompetent but have severe and persistent symptoms or damage to vital organs (e.g., chorioretinitis, myocarditis) need specific therapy until these specific symptoms resolve, followed by therapy for an additional 2 weeks. Therapy often is administered for at least 4-6 weeks, though the optimal duration of therapy has not been defined. A loading dose of pyrimethamine for older children is 2 mg/kg/day divided twice daily (maximum 50 mg bid), given for the first 1-2 days of treatment. The maintenance dose begins on the third day and is 1 mg/kg/day (maximum 50 mg/day). Sulfadiazine is administered at 100 mg/kg/day bid (maximum 4 g/day). Leucovorin is administered orally at 5-20 mg 3 times weekly (or 10 mg daily depending on the leukocyte count).



### Ocular Toxoplasmosis

Patients with active ocular toxoplasmosis are treated with pyrimethamine, sulfadiazine, and leucovorin (see Table 336.2). They are treated while disease is active and then for at least several weeks after the lesion has developed a quiescent appearance (i.e., sharp borders, pigmentation at margins of the lesion, and resolution of associated inflammatory cells in the vitreous), which usually occurs in 2-4 weeks when treatment is initiated promptly. Within 7-10 days, the borders of the retinal lesions sharpen, and visual acuity usually returns to the level before development of the acute lesion. Systemic corticosteroids have been administered concomitantly with antimicrobial treatment when lesions involve the macula, optic nerve head, or papillomacular bundle. Corticosteroids must never be given alone but may be initiated after loading doses of pyrimethamine and sulfadiazine have been administered (2 days). With recurrences, new lesions often appear contiguous to old ones. Very rarely, vitrectomy and removal of the lens are needed to restore visual acuity. Active choroidal neovascular membranes as a result of toxoplasmic chorioretinitis have been treated successfully in children with intravitreal injection of antibody to vascular endothelial growth factor in addition to oral anti-*Toxoplasma* medicines. Suppressive treatment has prevented frequent recurrences of vision-threatening lesions.

### Immunocompromised Persons

Serologic evidence of acute infection in an immunocompromised patient, regardless of whether signs and symptoms of infection are present or tachyzoites are demonstrated in tissue, is indication for therapy similar to that described for immunocompetent persons with symptoms of organ injury (see Table 336.2). It is important to establish the diagnosis as rapidly as possible and institute treatment early. In immunocompromised patients other than those with AIDS, therapy should be continued for at least 4-6 weeks beyond complete resolution of all signs and symptoms of active disease and resolution of immune compromise. Careful follow-up of these patients is imperative because relapse may occur, requiring prompt reinstitution of therapy. Relapse was once common in AIDS patients without antiretroviral treatment, and suppressive therapy with pyrimethamine and sulfadiazine, or TMP-SMX, was continued for life. Now it is possible to discontinue maintenance therapy when the CD4 count remains at >200 cells/ $\mu$ L for 4 months and all lesions have resolved. Therapy usually induces a beneficial response clinically but does not eradicate cysts. Treatment of *T. gondii*-seropositive patients with AIDS should be continued as long as CD4 counts remain at <200/ $\mu$ L. Prophylactic TMP-SMX therapy for *P. jirovecii* pneumonia significantly reduces the incidence of toxoplasmosis in AIDS patients.

### Congenital Toxoplasmosis

All fetuses and newborns infected with *T. gondii* should be treated regardless of whether they have clinical manifestations of infection, because treatment may be effective in interrupting acute disease that damages vital organs (see Table 336.2). The fetus is treated by treating the pregnant woman with pyrimethamine, sulfadiazine, and leucovorin after the first trimester. Infants should be treated for 1 year with pyrimethamine (2 mg/kg/day orally [PO] bid for 2 days, then 1 mg/kg/day for 2-6 months, and then 1 mg/kg given on Monday, Wednesday, and Friday), sulfadiazine (100 mg/kg/day PO bid), and leucovorin (5-10 mg PO given on Monday, Wednesday, and Friday, or more often depending on neutrophil count). The relative efficacy in reducing sequelae of infection and the safety of treatment with 2 months vs 6 months of the higher dosage of pyrimethamine are being compared in the U.S. National Collaborative Study. (Updated information about this study and these regimens is available from Dr. Rima McLeod, 773-834-4131.) Pyrimethamine and sulfadiazine are available only in tablet form but can be prepared as suspensions. **Prednisone** (1 mg/kg/day PO bid) has been used in addition when active chorioretinitis involves the macula or otherwise threatens vision or when the CSF protein is >1,000 mg/dL at birth, but the efficacy of this adjunctive therapy is not established. Prednisone is continued only for as long as the active inflammatory

process in the posterior pole of the eye is vision-threatening or the CSF protein is >1,000 mg/dL and is then tapered rapidly if the duration of treatment has been brief.

### Pregnant Women with *Toxoplasma gondii* Infection

The immunologically normal pregnant woman who acquires *T. gondii* >6 months before conception does not need treatment to prevent congenital infection of her fetus. Although data are not available to allow for a definitive time interval, if infection occurs during or shortly before the pregnancy, it is reasonable to evaluate the fetus by PCR on amniotic fluid and ultrasonography and to treat to prevent congenital infection in the fetus (see Table 336.2).

Treatment of a pregnant woman who acquires infection at any time during pregnancy reduces the chance of congenital infection in her infant. If the mother develops acute toxoplasmosis during the first trimester of pregnancy, **spiramycin** (1 g PO every 8 hours without food) or sulfadiazine is recommended for prevention of fetal infection. Spiramycin is available in the United States on an "emergency use" request by a physician through the FDA Division of Anti-Infective Drugs (301-796-1400) after the diagnosis of acute infection is confirmed in a reference laboratory (Palo Alto Medical Facility Toxoplasma Serology Lab, 650-853-4828). With this approval, the physician can then contact the spiramycin manufacturer, Sanofi Pasteur (1-800-822-2463), to obtain spiramycin for the patient. Adverse reactions to spiramycin are infrequent and include paresthesia, rash, nausea, vomiting, and diarrhea.

For treatment of the pregnant woman whose fetus has a confirmed or probable infection in the second or third trimester, the combination of pyrimethamine, sulfadiazine, and leucovorin is recommended. Following a loading dose of pyrimethamine (50 mg bid) for 2 days, then pyrimethamine is administered at 50 mg once daily beginning on the third day. Sulfadiazine (1.5-2.0 g PO bid) and leucovorin (10 mg PO once daily) are initiated on the first day of treatment with pyrimethamine and continued for the full course of treatment. Delay in maternal treatment during gestation results in greater brain and eye disease in the infant. Diagnostic amniocentesis should be performed at >17-18 weeks of gestation in pregnancies when there is high suspicion of fetal infection. After 24 weeks of gestation, incidence of transmission is relatively high, and all pregnant women who are infected acutely after that time are treated with pyrimethamine, sulfadiazine, and leucovorin to treat the fetus.

The approach in France to congenital toxoplasmosis includes systematic serologic screening of all pregnant women beginning at  $\leq$ 11 weeks of gestational age. For women who are seronegative, testing is performed again each month during gestation, at birth, and 1 month after birth. Mothers with acute infection early in gestation and without evidence of involvement of the fetus are treated with spiramycin to prevent transmission and sulfadiazine and pyrimethamine to treat possible fetal infection. Ultrasonography and amniocentesis for PCR at approximately week 17-18 of gestation are used for fetal diagnosis and have 97% sensitivity and 100% specificity. Confidence intervals for sensitivity are larger early and late in gestation. Fetal infection is treated with pyrimethamine, sulfadiazine, and leucovorin after 14 weeks of gestation, and termination of pregnancy is very rare at present. Prompt initiation of treatment with pyrimethamine, sulfadiazine, and leucovorin during pregnancy usually results in an excellent outcome, with normal development of children in most cases. Only 19% of infants have findings of congenital infection, including intracranial calcifications (13%) and chorioretinal scars (6%), although the prevalence of chorioretinal scars is 39% at follow-up later in childhood. Several studies have demonstrated improved outcomes with shorter times between diagnosis and initiation of treatment. In Germany, for seroconverting women who are between 15 and 17 weeks' gestation and before amniocentesis, administration of pyrimethamine, sulfadiazine, and leucovorin results in good outcomes for infants but is sometimes associated with sulfadiazine hypersensitivity in mothers.

Chronically infected pregnant women who are immunocompromised have transmitted *T. gondii* to their fetuses. Such women should be treated with spiramycin throughout gestation. The optimal



management for prevention of congenital toxoplasmosis in the fetus of a pregnant woman with HIV infection, a CD4 count <200 cells/ $\mu$ L, and inactive *T. gondii* infection is unknown. Fortunately, this situation now is rarely encountered in the United States. If the pregnancy is not terminated, some experts suggest that the mother should be treated with spiramycin or sulfadiazine alone during the first 14 weeks of gestation and thereafter with pyrimethamine, sulfadiazine, and leucovorin until term. There are no universally accepted guidelines at present.

In a study of adult patients with AIDS and toxoplasmic encephalitis, pyrimethamine (75 mg PO once daily) combined with high dosages of intravenous clindamycin (1,200 mg every 6 hr) appeared equal in efficacy to pyrimethamine and sulfadiazine in the treatment of toxoplasmic encephalitis. Other experimental agents include the macrolides clarithromycin and azithromycin.

### Future Treatments

Many potential future treatments are currently being studied, including tetrahydroquinolones and another cytochrome b/c inhibitor as a prodrug, calcium kinase inhibitors, DHFR inhibitors, and nanoparticle technology. Research is ongoing regarding the molecular targets of a toxoplasmosis vaccine that could be administered to mothers, children, or the general population. One group has developed an effective, porous, nanoparticle-based, intranasally administered vaccine against latent and congenital toxoplasmosis that protects nonhuman primates.

### PROGNOSIS

Early institution of specific treatment for congenitally infected infants usually rapidly controls the active manifestations of toxoplasmosis, including active chorioretinitis, meningitis, encephalitis, hepatitis, splenomegaly, and thrombocytopenia. Rarely, hydrocephalus resulting from aqueductal obstruction may develop or become worse during therapy. Treatment appears to reduce the incidence of diminished cognitive and abnormal motor function. Chorioretinitis often recurs in untreated patients and sometimes recurs in treated patients. Treated children with extensive involvement at birth may function normally later in life or have mild to severe impairment of vision, hearing, cognitive function, and other neurologic functions. Delays in diagnosis and therapy, perinatal hypoglycemia, hypoxia, hypotension, repeated shunt infections, and severe visual impairment are associated with a poorer prognosis. The prognosis is not necessarily poor for infected babies. Currently available treatments do not eradicate encysted parasites.

Studies in France have demonstrated that outcome of treated fetal toxoplasmosis, even when infection is acquired early in gestation, is usually favorable if no hydrocephalus is detected on ultrasound and treatment with pyrimethamine, sulfadiazine, or leucovorin is initiated promptly. The **Systematic Review on Congenital Toxoplasmosis** (SYROCOT) study in Europe indicated that neurologic outcome is improved with shorter times between diagnosis and initiation of treatment of fetal toxoplasmosis. Work in Lyon, France, has indicated a low incidence of recurrent eye disease in children with congenital toxoplasmosis who had been treated in utero and in their first year of life. The NCCCTS (1981–2004) in the United States found that neurologic, developmental, audiologic, and ophthalmologic outcomes are considerably better for most children who were treated in the first year of life with pyrimethamine, sulfadiazine, and leucovorin compared with children who had not been treated or were treated for only 1 month in earlier decades described in the literature.

### PREVENTION

Counseling pregnant women about the methods of preventing transmission of *T. gondii* (see Fig. 336.1) during pregnancy can reduce acquisition of infection during gestation. Women who do not have specific antibody to *T. gondii* before pregnancy should only eat well-cooked meat during pregnancy and should avoid contact with materials contaminated with oocysts excreted by cats, when possible. Cats that are kept indoors, maintained on prepared food, and not fed fresh, uncooked meat should not contact encysted *T. gondii* or shed oocysts. Serologic screening, ultrasound monitoring, and treatment of pregnant

women during gestation can also reduce the incidence and manifestations of congenital toxoplasmosis.

Point-of-care testing to facilitate gestational screening, recent developments in medicines for treatment of active and chronic infections, and progress toward vaccines to prevent infections in humans and oocyst shedding by cats are all recent advances with promise to prevent or improve outcomes for *Toxoplasma gondii* infections. There is a point-of-care test that has been CE marked for use in Europe and is currently moving toward completion of feasibility studies in the United States with consideration of FDA clearance, potentially marking the beginning of more widespread testing for optimal obstetrical care to prevent congenital toxoplasmosis and for public health initiatives to identify prevalence of toxoplasmosis in specific high-risk areas of the globe.

### ACKNOWLEDGMENT

We gratefully acknowledge the participant families, physicians, and other personnel of the National Collaborative Congenital Toxoplasmosis Study (NCCTS), and colleagues, for helping to create the understanding and knowledge in this chapter; and the Cornwell Mann, Rodriguez, and Morel families. Taking out Toxo (TOT), TRI, and NIH, NIAID/DMID ROI AI27530 and ROI AI071319-01 for support. We also thank Andrew Grose for his assistance in preparing this chapter.

Visit Elsevier eBooks+ at eBooks.Health.Elsevier.com for Bibliography.

## Section 16

# Helminthic Diseases

## Chapter 337

# Ascariasis (*Ascaris lumbricoides*)

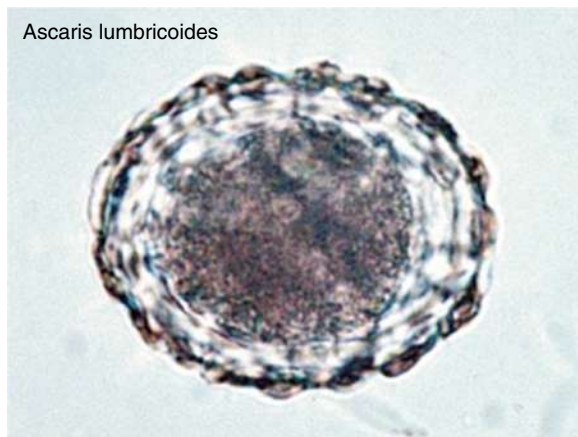
Katherine R. Dobbs and Arlene E. Dent

### ETIOLOGY

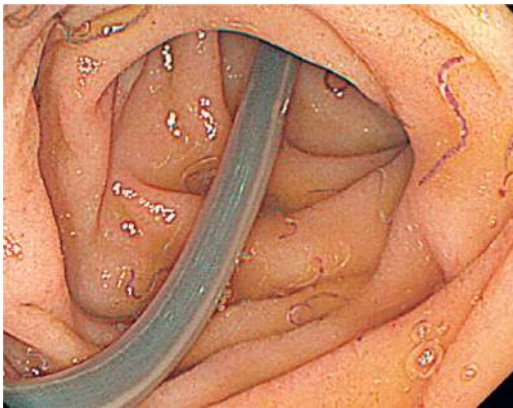
Ascariasis is caused by the nematode, or **roundworm**, *Ascaris lumbricoides*. Adult worms of *A. lumbricoides* inhabit the lumen of the small intestine. The reproductive potential of *Ascaris* is prodigious; a gravid female worm produces 200,000 eggs per day. The fertile ova are oval in shape with a thick, mamillated covering measuring 45–70  $\mu$ m in length and 35–50  $\mu$ m in breadth (Fig. 337.1). After passage in the feces, the eggs embryonate and become infective in 5–10 days under favorable environmental conditions. Adult worms can live for 12–18 months (Fig. 337.2).

### EPIDEMIOLOGY

Ascariasis occurs globally and is the most prevalent human **helminthiasis** in the world. It is most common in tropical areas (South America, Africa, Asia) where environmental conditions are optimal for maturation of ova in the soil. Approximately 1 billion persons are estimated to be infected. Although the number of cases in the United States is not known precisely, the highest prevalence is thought to be in high-poverty areas of the South and Appalachia. Pig farming is also associated with *Ascaris* species. Key factors linked with a higher prevalence of infection include poor socioeconomic conditions, use of human feces as fertilizer, and geophagia. Even though infection can occur at any age, the highest rate is in preschool or early school-age children. Transmission is primarily hand to mouth but may also involve ingestion of



**Fig. 337.1** Soil-transmitted helminth eggs (*Ascaris lumbricoides*). (From Bethony J, Brooker S, Albonico M, et al. Soil-transmitted helminth infections: ascariasis, trichuriasis, and hookworm. *Lancet*. 2006;367:1521–1532.)



**Fig. 337.2** Endoscopic image of intestinal *Ascaris lumbricoides* and hookworm co-infection. The ascaris worm is large in relation to the lumen and multiple blood-filled hookworms. (Courtesy Dr. Kunimitsu Inoue, Nakamura Hospital, Oita, Japan.)

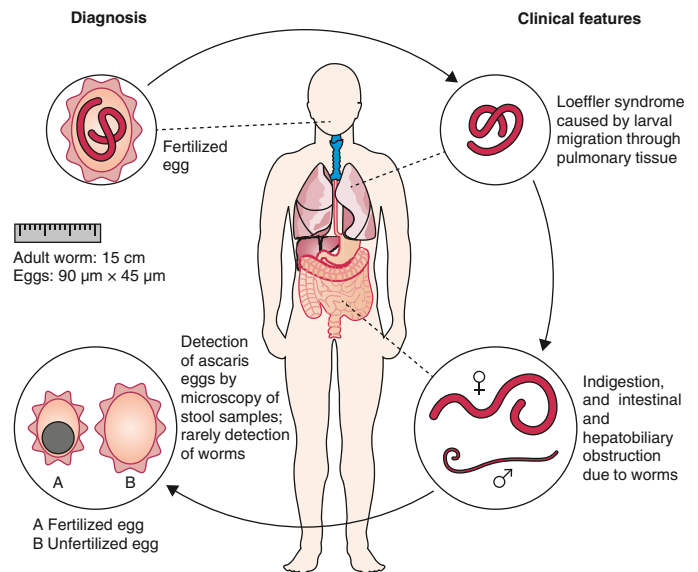
contaminated raw fruits and vegetables. Transmission is enhanced by the high output of eggs by fecund female worms and resistance of ova to the outside environment. *Ascaris* eggs can remain viable at 5–10°C (41–50°F) for as long as 2 years.

### PATHOGENESIS

*Ascaris* ova hatch in the small intestine after ingestion by the human host. Larvae are released, penetrate the intestinal wall, and migrate to the lungs by way of the venous circulation. The parasites then cause **pulmonary ascariasis** as they enter into the alveoli and migrate through the bronchi and trachea (Fig. 337.3). They are subsequently swallowed and return to the intestines, where they mature into adult worms. Female *Ascaris* begin depositing eggs in 8–10 weeks.

### CLINICAL MANIFESTATIONS

The clinical presentation depends on the intensity of infection and the organs involved. Most individuals have low to moderate worm burdens and have no symptoms or signs. The most common clinical problems are from **pulmonary disease** and **obstruction of the intestinal or biliary tract**. Larvae migrating through these tissues may cause allergic symptoms, fever, urticaria, and granulomatous disease. The pulmonary manifestations resemble Loeffler syndrome and include transient respiratory symptoms such as cough and dyspnea, pulmonary infiltrates, and blood eosinophilia. Larvae may be observed in the sputum. Vague abdominal complaints have been attributed to the presence of adult worms in the



**Fig. 337.3** Transmission of *Ascaris lumbricoides*: diagnosis and clinical features. (From Jourdan PM, Lamberton PHL, Fenwick A, Addiss DG. Soil-transmitted helminth infections. *Lancet*. 2018;391:252–262. Fig 2A.)

small intestine, although the precise contribution of the parasite to these symptoms is difficult to ascertain. A more serious complication occurs when a large mass of worms leads to acute bowel obstruction. Children with heavy infections may present with vomiting, abdominal distention, and cramps. In some cases, worms may be passed in the vomitus or stools. *Ascaris* worms occasionally migrate into the biliary and pancreatic ducts, where they cause cholecystitis or pancreatitis. Worm migration through the intestinal wall can lead to peritonitis. Dead worms can serve as a nidus for stone formation. Studies show that chronic infection with *A. lumbricoides* (often coincident with other helminth infections) impairs growth, physical fitness, and cognitive development.

### DIAGNOSIS

Microscopic examination of fecal smears can be used for diagnosis because of the high number of eggs excreted by adult female worms (see Fig. 337.1). A high index of suspicion in the appropriate clinical context is needed to diagnose pulmonary ascariasis or obstruction of the gastrointestinal tract. Ultrasound examination of the abdomen is capable of visualizing intraluminal adult worms.

### TREATMENT

Although several chemotherapeutic agents are effective against ascariasis, none has documented utility during the pulmonary phase of infection. Treatment options for gastrointestinal ascariasis include **albendazole** (400 mg orally once, for all ages), **mebendazole** (100 mg orally twice daily for 3 days or 500 mg once, for all ages), **pyrantel pamoate** (11 mg/kg orally once; maximum dose: 1g), or **ivermectin** (200 µg/kg orally once). **Nitazoxanide** (100 mg orally twice per day for 3 days for children 1–3 years old; 200 mg twice per day for 3 days for children 4–11 years; 500 mg twice per day for 3 days for adolescents and adults) produces cure rates comparable to single-dose albendazole. **Piperazine citrate** (75 mg/kg/day for 2 days; maximum dose: 3.5 g/day), which causes neuromuscular paralysis of the parasite and rapid expulsion of the worms, is a good treatment for intestinal or biliary obstruction but has been withdrawn from the market in many regions due to toxicity and good alternatives. Surgery may be required for cases with severe obstruction. Drug resistance has not been reported, but repeated treatment for ascariasis may be necessary because reinfection is common.

### PREVENTION

Although ascariasis is the most prevalent worm infection in the world, little attention has been given to its control (Table 337.1). **Anthelmintic**

**Table 337.1** Clinical and Public Health Control of Soil-Transmitted Helminthiasis

	CLINICAL DIAGNOSIS AND MANAGEMENT	PUBLIC HEALTH CONTROL
Diagnosis	Individual	Community level (e.g., in select schools)
Diagnostic criteria	Parasitologic	Residence in an area with soil-transmitted helminthiasis prevalence >20%
Treatment approach	Single dose or multiple dose	Single-dose periodic mass treatment
Threshold for treatment	Travel history, symptoms and signs, positive laboratory test	Estimated prevalence of infection in target population
Treatment objective	Parasitologic cure	Decreased worm burden; reduction in transmission
Ancillary treatment	Based on clinical signs and symptoms	Typically, only if included in mass treatment (e.g., vitamin A supplementation)
Follow-up	Parasitologic test of cure; improvement in associated health conditions	Not usually done
Health education (sanitation/hygiene)	Recommended	Recommended

From Jourdan PM, Lamberton PHL, Fenwick A, Addiss DG. Soil-transmitted helminth infections. *Lancet*. 2018;391:252–262. Table 1.

**chemotherapy programs** can be implemented in one of three ways: (1) offering universal treatment to all individuals in an area of high endemicity; (2) offering treatment targeted to groups with high frequency of infection, such as children attending primary school; or (3) offering individual treatment based on intensity of current or past infection. Improving education about and practices of sanitary conditions and sewage facilities, discontinuing the practice of using human feces as fertilizer, and education are the most effective long-term preventive measures.

Visit Elsevier eBooks+ at [eBooks.Health.Elsevier.com](http://eBooks.Health.Elsevier.com) for Bibliography.

## Chapter 338

# Hookworms (*Necator americanus* and *Ancylostoma* spp.)

Peter J. Hotez

### ETIOLOGY

Two major genera of hookworms, which are nematodes, or roundworms, infect humans. *Necator americanus*, the only representative of its genus, is a major **anthropophilic** hookworm and is the most common cause of human hookworm infection. Hookworms of the genus *Ancylostoma* include the anthropophilic hookworm *Ancylostoma duodenale*, which also causes classic hookworm infection, and the less common **zoonotic** species *Ancylostoma ceylanicum* (restricted mostly to Southeast Asia). Human zoonotic infection with the dog hookworm *Ancylostoma caninum* is associated with an eosinophilic enteritis syndrome. The larval stage of *Ancylostoma braziliense*, whose definitive hosts include dogs and cats, is the principal cause of cutaneous larva migrans.

The infective larval stages of the anthropophilic hookworms live in a developmentally arrested state in warm, moist soil. Larvae infect humans either by penetrating through the skin (*N. americanus* and *A. duodenale*) or when they are ingested (*A. duodenale*). Larvae entering the human host by skin penetration undergo **extraintestinal migration** through the venous circulation and lungs before they are swallowed, whereas orally ingested larvae may undergo extraintestinal migration

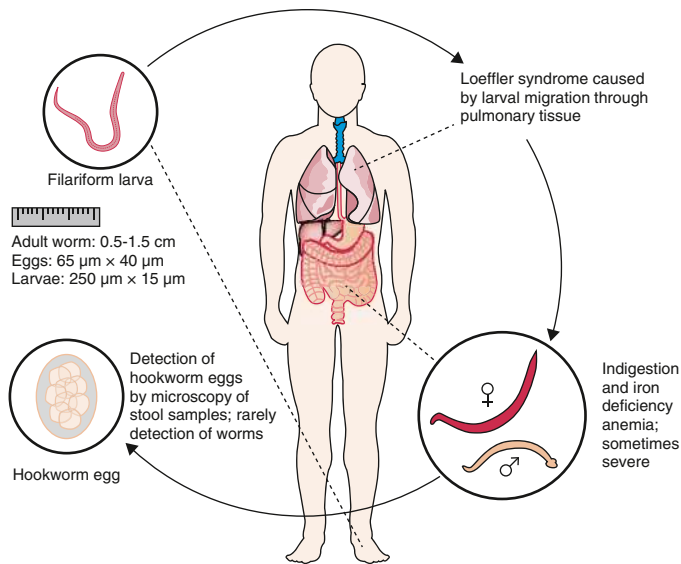
or remain in the gastrointestinal (GI) tract (Figs. 338.1 and 338.2). Larvae returning to the small intestine undergo two molts to become adult, sexually mature, male and female worms ranging in length from 5–13 mm. The buccal capsule of the adult hookworm is armed with cutting plates (*N. americanus*) or teeth (*A. duodenale*) to facilitate attachment to the mucosa and submucosa of the small intestine. Hookworms can remain in the intestine for 1–5 years, where they mate and produce eggs. Although up to 2 months is required for the larval stages of hookworms to undergo extraintestinal migration and develop into mature adults, *A. duodenale* larvae may remain developmentally arrested for many months before resuming development in the intestine. Mature *A. duodenale* female worms produce about 30,000 eggs per day; daily egg production by *N. americanus* is <10,000/day (Fig. 338.3). The eggs are thin shelled and ovoid, measuring approximately 40–60 μm. Eggs that are deposited on soil with adequate moisture and shade develop into first-stage larvae and hatch. Over the ensuing several days and under appropriate conditions, the larvae molt twice to the **infective** stage. Infective larvae are developmentally arrested and nonfeeding. They migrate vertically in the soil until they either infect a new host or exhaust their lipid metabolic reserves and die.

### EPIDEMIOLOGY

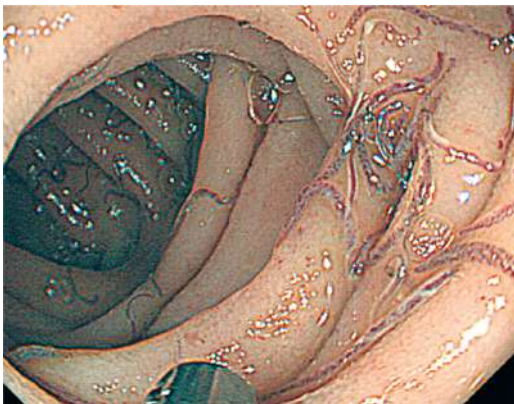
Hookworm infection is one of the most prevalent infectious diseases of humans. The Global Burden of Disease Study 2015 reported that approximately 428 million people are infected with hookworms, with further estimates indicating that hookworm infection globally results in 4.1 million disability-adjusted life-years, possibly leading all **neglected tropical diseases** in years lost through disability. In the case of hookworm infection, all the years lost through disability are attributed to anemia from intestinal blood loss. There is also a massive socioeconomic impact from hookworm infection, with estimates that hookworm can cause up to \$139 billion in losses from diminished productivity.

Because of the requirement for adequate soil moisture, shade, and warmth, hookworm infection is usually confined to rural areas, especially where human feces are used for fertilizer or where sanitation is inadequate. Hookworm is an infection associated with *economic underdevelopment and poverty* throughout the tropics and subtropics. Sub-Saharan Africa, East Asia, and tropical regions of the Americas have the highest prevalence of hookworm infection. High rates of infection are often associated with cultivation of certain agricultural products, such as tea in India; sweet potato, corn, cotton, and mulberry trees in China; coffee in Central and South America; and rubber in Africa. It is not uncommon to find dual *N. americanus* and *A. duodenale* infections. *N. americanus* predominates in Central and South America as well as in southern China and Southeast Asia, whereas *A. duodenale* predominates in North Africa, in northern India, in China north of the Yangtze River,





**Fig. 338.1** Transmission of hookworm (*Ancylostoma duodenale* and *Necator americanus*): diagnosis and clinical features. (From Jourdan PM, Lambertson PHL, Fenwick A, Addiss DG. Soil-transmitted helminth infections. *Lancet*. 2018;391:252–262. Fig 2C.)



**Fig. 338.2** Endoscopic images of intestinal hookworm infection. (Courtesy Dr. Kunimitsu Inoue, Nakamura Hospital, Oita, Japan.)



**Fig. 338.3** Soil-transmitted hookworm helminth eggs. (From Bethony J, Brooker S, Albonico M, et al. Soil-transmitted helminth infections: ascariasis, trichuriasis, and hookworm. *Lancet*. 2006;367:1521–1532.)

and among aboriginal people in Australia. The ability of *A. duodenale* to withstand somewhat harsher environmental and climatic conditions may reflect its ability to undergo arrested development in human tissues. *A. ceylanicum* infection occurs in India and Southeast Asia.

**Eosinophilic enteritis** caused by *A. caninum* was first described in Queensland, Australia, with two reported cases in the United States. Because of its global distribution in dogs, it was initially anticipated that human *A. caninum* infections would be identified in many locales, but this has not been found.

## PATHOGENESIS

The major morbidity of human hookworm infection is a direct result of **intestinal blood loss**. Adult hookworms adhere tenaciously to the mucosa and submucosa of the proximal small intestine by using their cutting plates or teeth and a muscular esophagus that creates negative pressure in their buccal capsules. At the attachment site, host inflammation is downregulated by the release of antiinflammatory polypeptides by the hookworm. Rupture of capillaries in the lamina propria is followed by blood extravasation, with some of the blood ingested directly by the hookworm. After ingestion, the blood is anticoagulated, the red blood cells are lysed, and the hemoglobin is released and digested. Each adult *A. duodenale* hookworm causes loss of an estimated 0.2 mL of blood/day; blood loss is less for *N. americanus*. Individuals with light infections have minimal blood loss and thus may have hookworm infection but not hookworm disease. There is a direct correlation between the number of adult hookworms in the gut and the volume of fecal blood loss. Hookworm disease results only when individuals with moderate and heavy infections experience sufficient blood loss to develop iron deficiency and anemia. Hypoalbuminemia and consequent edema and anasarca from the loss of intravascular oncotic pressure can also occur. These features depend heavily on the dietary reserves of the host.

## CLINICAL MANIFESTATIONS

Chronically infected children with moderate and heavy hookworm infections suffer from intestinal blood loss that results in **iron deficiency** and can lead to anemia as well as protein malnutrition. Prolonged iron deficiency associated with hookworms in childhood can lead to physical growth retardation and cognitive and intellectual deficits.

Anthropophilic hookworm larvae elicit dermatitis sometimes referred to as **ground itch** when they penetrate human skin. The vesiculation and edema of ground itch are exacerbated by repeated infection. Infection with a zoonotic hookworm, especially *A. braziliense*, can result in lateral migration of the larvae to cause the characteristic cutaneous tracts of **cutaneous larva migrans** (see Chapter 338.1). Cough subsequently occurs in *A. duodenale* and *N. americanus* hookworm infection when larvae migrate through the lungs to cause laryngotracheobronchitis, usually about 1 week after exposure. Pharyngitis also can occur. The onset of eosinophilia coincides with the entry of hookworm larvae into the GI tract. Upper abdominal pain can occur during this period, but it eventually subsides.

Chronic intestinal hookworm infection is not typically associated with specific GI complaints, although pain, anorexia, and diarrhea have been attributed to the presence of hookworms. The major clinical manifestations are related to intestinal blood loss. Heavily infected children exhibit all the signs and symptoms of **iron-deficiency anemia** and **protein malnutrition**. In some cases, children with chronic hookworm disease acquire a yellow-green pallor known as **chlorosis**.

An infantile form of **ancylostomiasis** resulting from heavy *A. duodenale* infection has been described. Affected infants experience diarrhea, melena, failure to thrive, and profound anemia. Infantile ancylostomiasis has significant mortality.

**Eosinophilic enteritis** caused by *A. caninum* is associated with colicky abdominal pain that begins in the epigastrium and radiates outward and is usually exacerbated by food. Extreme cases may mimic acute appendicitis.

## DIAGNOSIS

Children with hookworm release eggs that can be detected by direct fecal examination (see Fig. 338.3). Quantitative methods are available



to determine whether a child has a heavy **worm burden** that can cause hookworm disease. The eggs of *N. americanus* and *A. duodenale* are morphologically indistinguishable. Species identification typically requires egg hatching and differentiation of third-stage infective larvae; methods using polymerase chain reaction (PCR) have been developed but are not generally used in clinical practice.

In contrast, eggs are generally not present in the feces of patients with eosinophilic enteritis caused by *A. caninum*. Eosinophilic enteritis is often diagnosed by demonstrating ileal and colonic ulcerations by colonoscopy in the presence of significant blood eosinophilia. An adult canine hookworm may occasionally be recovered during colonoscopic biopsy. Patients with this syndrome develop IgG and IgE serologic responses.

## TREATMENT

The goal of **deworming** is removal of the adult hookworms with an **anthelmintic** drug. The **benzimidazole** anthelmintics, mebendazole and albendazole, are effective at eliminating hookworms from the intestine, although multiple doses are sometimes required. **Albendazole** (400 mg orally [PO] once, for all ages) often results in cure, although *N. americanus* adult hookworms are sometimes more refractory and require additional doses. **Mebendazole** (100 mg PO twice daily [bid] for 3 days, for all ages) is also effective. In many developing countries, mebendazole is administered as a single dose of 500 mg; however, the cure rates with this regimen can be as low as 10% or less. According to the World Health Organization (WHO), children should be encouraged to chew tablets of albendazole or mebendazole, because forcing very young children to swallow large tablets may cause choking or asphyxiation. Mebendazole is recommended for *A. caninum*-associated eosinophilic enteritis, although recurrences are common. Because the benzimidazoles have been reported to be embryotoxic and teratogenic in laboratory animals, their safety during pregnancy and in young children is a potential concern, and the risks vs benefits must be carefully considered. WHO currently supports the use of benzimidazoles in infected children  $\geq 1$  year old but at a reduced dose (200 mg for albendazole) in the youngest age-group (1-2 years old). The most up to date guidelines for treating these populations are available from the US Centers for Disease Control and Prevention [https://www.cdc.gov/parasites/hookworm/health\\_professionals/index.html#tx](https://www.cdc.gov/parasites/hookworm/health_professionals/index.html#tx). In some countries, **pyrantel pamoate** (11 mg/kg PO once daily for 3 days; maximum dose: 1 g) is available in liquid form and is an effective alternative to the benzimidazoles. A newer drug known as **tribendimidine** is still under clinical development and may be available in the future. Replacement therapy with oral iron is not usually required to correct hookworm-associated iron deficiency in children.

## PREVENTION

In 2001, the World Health Assembly urged its member states to implement programs of periodic deworming so as to control the morbidity of hookworm and other soil-transmitted helminth infections (see Table 337.1 in Chapter 337). Although anthelmintic drugs are effective at eliminating hookworms from the intestine, the high rates of drug failure from single-dose mebendazole or albendazole and post-treatment reinfection among children suggest that mass drug administration alone is not effective for controlling hookworm in highly endemic areas. Moreover, data suggest that the efficacy of mebendazole decreases with frequent, periodic use, leading to concerns about the possible emergence of **anthelmintic drug resistance**. To reduce the reliance exclusively on anthelmintic drugs, a recombinant human hookworm vaccine has been developed and is undergoing clinical testing. Economic development and associated improvements in sanitation, health education, and avoidance of human feces as fertilizer remain critical for reducing hookworm transmission and endemicity.

Visit Elsevier eBooks+ at [eBooks.Elsevier.com](https://www.elsevier.com/health/elsevier.com) for Bibliography.

## 338.1 Cutaneous Larva Migrans

Peter J. Hotez

### ETIOLOGY

Cutaneous larva migrans (**creeping eruption**) is caused by the larvae of several nematodes, primarily hookworms, which are not usually



**Fig. 338.4** Creeping eruption of cutaneous larva migrans. (From Kortling GW. *Hautkrankheiten bei Kindern und Jugendlichen*. Stuttgart, Germany: FK Schattauer Verlag, 1969.)

parasitic for humans. *A. braziliense*, a hookworm of dogs and cats, is the most common cause, but other animal hookworms may also produce the disease.

### EPIDEMIOLOGY

Cutaneous larva migrans is usually caused by *A. braziliense*, which is endemic to the southeastern United States and Puerto Rico. Travelers account for a significant percentage of the cases. Recently, autochthonous cases have been reported from Europe.

### CLINICAL MANIFESTATIONS

After penetrating the skin, larvae localize at the epidermal-dermal junction and migrate in this plane, moving at a rate of 1-2 cm/day. The response to the parasite is characterized by raised, erythematous, serpiginous tracks, which occasionally form bullae (Fig. 338.4). These lesions may be single or numerous and are usually localized to an extremity, although any area of the body may be affected. As the organism migrates, new areas of involvement may appear every few days. Intense localized pruritus, without any systemic symptoms, may be associated with the lesions. Bacterial superinfection can occur.

### DIAGNOSIS

Cutaneous larva migrans is diagnosed by clinical examination of the skin. Patients are often able to recall the exact time and location of exposure because the larvae produce intense itching at the site of penetration. Eosinophilia may occur but is uncommon.

### TREATMENT

If left untreated, the larvae die, and the syndrome resolves within a few weeks to several months. Treatment with **ivermectin** (200  $\mu$ g/kg PO in a single dose for children over 15 kg; considered drug of choice by some investigators), **albendazole** (400 mg PO daily for 3 days, for children over the age of 2 years), or topical **thiabendazole** hastens resolution, if symptoms warrant treatment. The U.S. Food and Drug Administration has not approved these drugs for cutaneous larva migrans. The safety of ivermectin in young children (weighing <15 kg) and pregnant women remains to be established. Albendazole should be taken with a fatty meal. The latest guidelines from the US Centers for Disease Control and Prevention can be found at [https://www.cdc.gov/parasites/zoonotichookworm/health\\_professionals/index.html#tx](https://www.cdc.gov/parasites/zoonotichookworm/health_professionals/index.html#tx).

Visit Elsevier eBooks+ at [eBooks.Elsevier.com](https://www.elsevier.com/health/elsevier.com) for Bibliography.

## Chapter 339

Trichuriasis (*Trichuris trichiura*)

Katherine R. Dobbs and Arlene E. Dent

## ETIOLOGY

Trichuriasis is caused by the **whipworm**, *Trichuris trichiura*, a nematode, or roundworm, that inhabits the cecum and ascending colon. The principal hosts of *T. trichiura* are humans, who acquire infection by ingesting embryonated, barrel-shaped eggs (Fig. 339.1). The larvae escape from the shell in the upper small intestine and penetrate the intestinal villi. The worms slowly move toward the cecum, where the anterior three-quarters whiplike portion remains within the superficial mucosa and the short posterior end is free in the lumen (Fig. 339.2). In 1-3 months, the adult female worm begins producing 5,000-20,000 eggs per day. After excretion in the feces, embryonic development occurs in 2-4 weeks with optimal temperature and soil conditions. The adult worm life span is approximately 2 years.

## EPIDEMIOLOGY

Trichuriasis occurs throughout the world and is especially common in poor rural communities with inadequate sanitary facilities and soil contaminated with human or animal feces. Trichuriasis is one of the most prevalent human helminthiases, with an estimated 1 billion infected individuals worldwide. In many parts of the world, where protein-energy malnutrition and anemia are common, the prevalence of *T. trichiura* infection can be as high as 95%. Although trichuriasis occurs in the rural southeastern United States, its prevalence has not been reported. The highest rate of infection occurs among children 5-15 years old. Infection develops after ingesting embryonated ova by direct contamination of hands, food (raw fruits and vegetables fertilized with human feces), or drink (Fig. 339.3). Transmission can also occur indirectly through flies or other insects.

## CLINICAL MANIFESTATIONS

Most persons harbor low worm burdens and do not have symptoms. Some individuals may have a history of right lower quadrant or vague periumbilical pain. Adult *Trichuris* ingest approximately 0.005 mL of blood per worm per day. Children, who are most likely to be heavily infected, frequently suffer from disease. Clinical manifestations

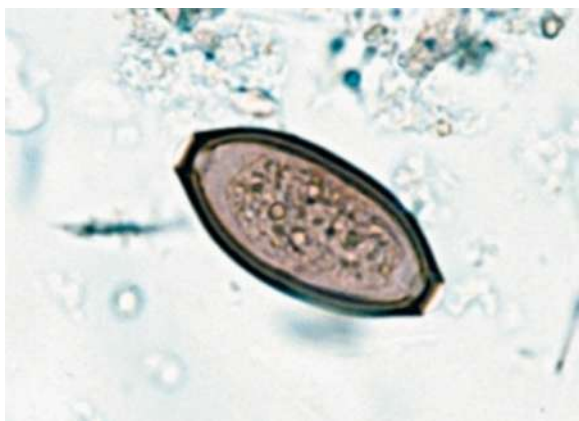


Fig. 339.1 *Trichuris trichiura*. Soil-transmitted helminth eggs. (From Bethony J, Brooker S, Albonico M, et al. Soil-transmitted helminth infections: ascariasis, trichuriasis, and hookworm. *Lancet*. 2006;367:1521-1532.)



Fig. 339.2 *Trichuris trichiura* infection. (Courtesy Dr. Kunimitsu Inoue, Nakamura Hospital, Oita, Japan.)

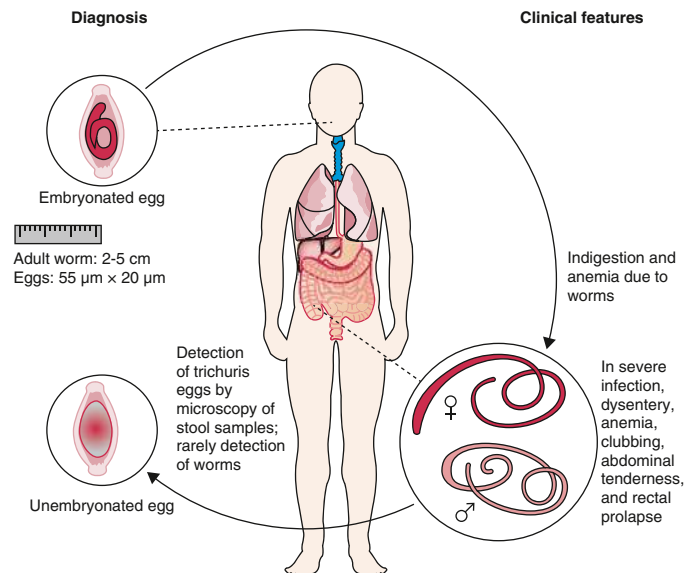


Fig. 339.3 Transmission of *Trichuris trichiura*: diagnosis and clinical features. (From Jourdan PM, Lamberton PHL, Fenwick A, Addiss DG. Soil-transmitted helminth infections. *Lancet*. 2018;391:252-262. Fig 2B.)

include chronic dysentery, rectal prolapse, anemia, poor growth, as well as developmental and cognitive deficits. There is no significant eosinophilia, even though a portion of the worm is embedded in the mucosa of the large bowel.

## DIAGNOSIS

Because egg output is so high, fecal smears frequently reveal the characteristic barrel-shaped ova of *T. trichiura*.

## TREATMENT

**Albendazole** (400 mg orally for 3 days, for all ages) is the drug of choice and is safe and effective, in part because it is poorly absorbed from the gastrointestinal tract. It reduces egg output by 90-99% and has cure rates of 70-90%, although reinfection and resumption of egg production by live worms that presumably survive after treatment may occur. Alternatives include **mebendazole** (100 mg orally twice daily for 3 days) and **ivermectin** (600  $\mu\text{g}/\text{kg}$  orally for 3 days). Single-day treatment with albendazole, nitazoxanide, or albendazole plus nitazoxanide leads to cure rates that are low and short-lived. Combination treatment with **oxantel pamoate** (20 mg/kg) plus 400 mg albendazole on consecutive days may have the highest cure rate.

## PREVENTION

Disease can be prevented by personal hygiene, improved sanitary conditions, and eliminating the use of human feces as fertilizer (see Table 337.1 in Chapter 337).

Visit Elsevier eBooks+ at [eBooks.Elsevier.com](http://eBooks.Elsevier.com) for Bibliography.



## Chapter 340

Enterobiasis (*Enterobius vermicularis*)

Katherine R. Dobbs and Arlene E. Dent

## ETIOLOGY

The cause of enterobiasis, or **pinworm** infection, is *Enterobius vermicularis*, which is a small (1 cm in length), white, threadlike nematode, or roundworm that typically inhabits the cecum, appendix, and adjacent areas of the ileum and ascending colon. Gravid females migrate at night to the perianal and perineal regions, where they deposit up to 15,000 eggs. Ova are convex on one side and flattened on the other and have diameters of approximately  $30 \times 60 \mu\text{m}$ . Eggs embryonate within 6 hours and remain viable for 20 days. Human infection occurs by the fecal-oral route typically by ingestion of embryonated eggs that are carried on fingernails, clothing, bedding, or house dust. After ingestion, the larvae mature to form adult worms in 36-53 days.

## EPIDEMIOLOGY

Enterobiasis infection occurs in individuals of all ages and socioeconomic levels. It is prevalent in regions with temperate climates and is the most common helminth infection in the United States. It infects 30% of children worldwide, and humans are the only known host. Infection occurs primarily in institutional or family settings that include children. The prevalence of pinworm infection is highest in children 5-14 years of age. It is common in areas where children live, play, and sleep close together, thus facilitating egg transmission. Because the life span of the adult worm is short, chronic parasitism is likely caused by repeated cycles of reinfection. **Autoinoculation** can occur in individuals who habitually put their fingers in their mouth.

## PATHOGENESIS

*Enterobius* infection may cause symptoms by mechanical stimulation and irritation, allergic reactions, and migration of the worms to anatomic sites where they become pathogenic. *Enterobius* infection has been associated with concomitant *Dientamoeba fragilis* infection, which causes diarrhea.

## CLINICAL MANIFESTATIONS

Pinworm infection is innocuous and rarely causes serious medical problems. The most common complaints include itching and restless sleep secondary to nocturnal perianal or **perineal pruritus**. The precise cause and incidence of pruritus are unknown but may be related to the intensity of infection, psychologic profile of the infected individual and the family, or allergic reactions to the parasite. Eosinophilia is not observed in most cases, because tissue invasion does not occur. Aberrant migration to ectopic sites occasionally may lead to appendicitis, chronic salpingitis, pelvic inflammatory disease, peritonitis, hepatitis, and ulcerative lesions in the large or small bowel.

## DIAGNOSIS

A history of nocturnal **perianal pruritus** in children strongly suggests enterobiasis. Definitive diagnosis is established by identification of parasite eggs or worms. Microscopic examination of adhesive cellophane tape pressed against the perianal region early in the morning frequently demonstrates eggs (Fig. 340.1). Repeated examinations increase the chance of detecting ova; one examination detects 50% of infections, three examinations 90%, and five examinations 99%. Worms seen in the perianal region should be removed and preserved in 75% ethyl alcohol until microscopic examination can be performed. Digital rectal examination may also be used to obtain samples for a wet mount. Routine stool samples rarely demonstrate *Enterobius* ova.



Fig. 340.1 Eggs of *Enterobius vermicularis*. (From Guerrant RL, Walker DH, Weller PF, et al. *Tropical Infectious Diseases*. Philadelphia: Churchill Livingstone, 2006. p. 1248.)

## TREATMENT

Anthelmintic drugs should be administered to infected individuals and their family members. **Albendazole** (400 mg orally with a repeat dose 2 week later for all age-groups) is the treatment of choice and results in cure rates exceeding 90%. Alternatives include **mebendazole** (100 mg orally with a repeat dose 2 weeks later) and **pyrantel pamoate** (11 mg/kg base orally 3 times a day up to a maximum of 1 g; repeat at 2 weeks). Morning bathing removes a large portion of eggs. Frequent changing of underclothes, bedclothes, and bedsheets decreases environmental egg contamination and may decrease the risk for autoinfection.

## PREVENTION

Household contacts can be treated at the same time as the infected individual. Repeated treatments every 3-4 months may be required in circumstances with repeated exposure, such as with institutionalized children. Good hand hygiene is the most effective method of prevention.

Visit Elsevier eBooks+ at [eBooks.Health.Elsevier.com](http://eBooks.Health.Elsevier.com) for Bibliography.

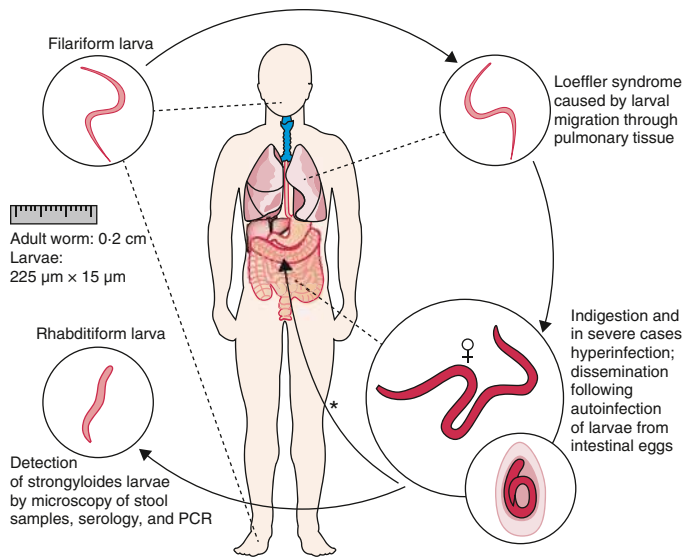
## Chapter 341

Strongyloidiasis (*Strongyloides stercoralis*)

Katherine R. Dobbs and Arlene E. Dent

## ETIOLOGY

Strongyloidiasis is caused by the nematode, or roundworm, *Strongyloides stercoralis*. Only adult female worms inhabit the small intestine. The nematode reproduces in the human host by parthenogenesis and releases eggs containing mature larvae into the intestinal lumen. **Rhabditiform** larvae immediately emerge from the ova and are passed in feces, where they can be visualized by stool examination. Rhabditiform larvae either differentiate into free-living adult male and female worms or metamorphose into the infectious **filariform** larvae. Sexual reproduction occurs only in the free-living stage. Humans are usually infected through skin contact with soil contaminated with infectious larvae (Fig. 341.1). Larvae penetrate the skin, enter the venous circulation, and then pass to the lungs, break into alveolar spaces, and migrate up the bronchial tree. They are then swallowed and pass through the stomach, and adult female worms develop in the small intestine. Egg deposition begins approximately 28 days after initial infection.



**Fig. 341.1** Transmission of *Strongyloides stercoralis*: diagnosis and clinical features. (From Jourdan PM, Lambertson PHL, Fenwick A, et al. Soil-transmitted helminth infections. *Lancet*. 2018;391:252–262. Fig 2D.)

The **hyperinfection syndrome** occurs when large numbers of larvae transform into infective organisms during their passage in feces and then reinfect (**autoinfect**) the host by way of the lower gastrointestinal (GI) tract or perianal region. This cycle may be accelerated in immunocompromised persons, particularly those with depressed T-cell function.

## EPIDEMIOLOGY

*S. stercoralis* infection is prevalent in tropical and subtropical regions of the world and is endemic in several areas of Europe, the southern United States, and Puerto Rico. Transmission requires appropriate environmental conditions, particularly warm, moist soil. Poor sanitation and crowded living conditions are conducive to high levels of transmission. Dogs and cats can act as reservoirs. The highest prevalence of infection in the United States occurs in impoverished areas and among socially marginalized groups, such as immigrants, refugees, and indigenous or ethnic minority groups. Infection may be especially common among residents of mental institutions, veterans who were prisoners of war in areas of high endemicity, and refugees and immigrants. Because of internal autoinfection, individuals may remain infected for decades. Infection may be transmitted by organ transplantation. Individuals with hematologic malignancies, autoimmune diseases, malnutrition, and drug-induced immunosuppression (especially corticosteroids) are at high risk for the hyperinfection syndrome. Patients with AIDS may experience a rapid course of disseminated strongyloidiasis with a fatal outcome.

## PATHOGENESIS

The initial host immune response to infection is production of immunoglobulin E and eosinophilia in blood and tissues, which presumably prevents dissemination and hyperinfection in the immunocompetent host. Adult female worms in otherwise healthy and asymptomatic individuals may persist in the GI tract for years. If infected persons become immunocompromised, the reduction in cellular and humoral immunity may lead to an abrupt and dramatic increase in parasite load with systemic dissemination.

## CLINICAL MANIFESTATIONS

Approximately 30% of infected individuals are asymptomatic. The remaining patients have symptoms that correlate with the three stages of infection: invasion of the skin, migration of larvae through the lungs, and parasitism of the small intestine by adult worms. **Larva currens** is the manifestation of an allergic reaction to filariform larvae

that migrate through the skin, where they leave pruritic, tortuous, urticarial tracks. The lesions may recur and are typically found over the lower abdominal wall, buttocks, or thighs, resulting from larval migration from defecated stool. Pulmonary disease secondary to larval migration through the lung rarely occurs and may resemble **Loeffler syndrome** (cough, wheezing, shortness of breath, transient pulmonary infiltrates accompanied by eosinophilia). GI strongyloidiasis is characterized by indigestion, crampy abdominal pain, vomiting, diarrhea, steatorrhea, protein-losing enteropathy, protein-caloric malnutrition, and weight loss. Edema of the duodenum with irregular mucosal folds, ulcerations, and strictures can be seen radiographically. Infection may be chronic in nature and is associated with **eosinophilia**.

Strongyloidiasis is potentially lethal because of the ability of the parasite to replicate within the host and cause overwhelming hyperinfection in immunocompromised persons. The **hyperinfection syndrome** is characterized by an exaggeration of the clinical features that develop in symptomatic immunocompetent individuals. The onset is usually sudden, with generalized abdominal pain, distention, and fever. Multiple organs can be affected as massive numbers of larvae disseminate throughout the body and introduce bowel flora. The latter may result in bacteremia and septicemia. Cutaneous manifestations may include petechiae and purpura. Cough, wheezing, and hemoptysis are indicative of pulmonary involvement. Whereas eosinophilia is a prominent feature of strongyloidiasis in immunocompetent persons, this sign may be absent in immunocompromised persons. Because of the low incidence of strongyloidiasis in industrialized countries, it is often misdiagnosed, resulting in a significant delay in treatment.

## DIAGNOSIS

Intestinal strongyloidiasis is diagnosed by examining feces or duodenal fluid for the characteristic larvae (Fig. 341.2). Several stool samples should be examined by direct smear, the Koga agar plate method, or the Baermann test. Alternatively, duodenal fluid can be sampled by the **enteric string test** (Entero-Test) or aspiration via endoscopy. In children with the hyperinfection syndrome, larvae may be found in sputum, gastric aspirates, and rarely in small intestinal biopsy specimens. An enzyme-linked immunosorbent assay for IgG antibody to *Strongyloides* may be more sensitive than parasitologic methods for diagnosing intestinal infection in the immunocompetent host. The utility of the assay in diagnosing infection in immunocompromised patients with the hyperinfection syndrome has not been determined. Eosinophilia is common.

## TREATMENT

Treatment is directed at eradication of infection. **Ivermectin** (200 μg/kg/day once daily orally for 2 days) is the drug of choice for uncomplicated strongyloidiasis. Alternatively, **albendazole** (400 mg orally twice daily for 7 days) may be used. Patients with the hyperinfection syndrome should be treated with ivermectin for 7–14 days and may require repeated courses. Reducing the dose of immunosuppressive therapy and treatment of concomitant bacterial infections are essential in the management of the **hyperinfection syndrome**. Close follow-up with repeated stool examination is necessary to ensure complete elimination of the parasite. *Strongyloides* antibodies decrease within 6 months after successful treatment.

## PREVENTION

Sanitary practices designed to prevent soil and person-to-person transmission are the most effective control measures (see Table 337.1). Wearing **shoes** is a main preventive strategy. Reducing transmission in institutional settings can be achieved by decreasing fecal contamination of the environment, such as by the use of clean bedding. Because infection is uncommon in most settings, case detection and treatment are advisable. Individuals who will be given prolonged high-dose corticosteroids, immunosuppressive drugs before organ transplantation, or cancer chemotherapy should have a screening examination for *S. stercoralis*. If infected, they should be treated before immunosuppression is initiated.





Fig. 341.2 Larvae of intestinal strongyloidiasis.

Visit Elsevier eBooks+ at [eBooks.Health.Elsevier.com](http://eBooks.Health.Elsevier.com) for Bibliography.

## Chapter 342

# Lymphatic Filariasis (*Brugia malayi*, *Brugia timori*, and *Wuchereria bancrofti*)

Katherine R. Dobbs and Arlene E. Dent

### ETIOLOGY

The filarial worms *Brugia malayi* (Malayan filariasis), *Brugia timori*, and *Wuchereria bancrofti* (bancroftian filariasis) are threadlike nematodes that cause similar infections. Infective larvae are introduced into humans during blood feeding by the mosquito vector. Over 4–6 months, the larval forms develop into sexually mature adult worms. Once an adequate number of male and female worms accumulate in the afferent lymphatic vessels, adult female worms release large numbers of microfilariae that circulate in the bloodstream. The life cycle of the parasite is completed when mosquitoes ingest microfilariae in a blood meal, which molt to form infective larvae over 10–14 days. Adult worms have a 5–7-year life span.

### EPIDEMIOLOGY

More than 120 million people living in tropical Africa, Asia, and Latin America are infected; approximately 10–20% of these individuals have clinically significant morbidity attributable to filariasis. *W. bancrofti* is transmitted in Africa, Asia, and Latin America and accounts for 90% of lymphatic filariasis. *B. malayi* is restricted to the South Pacific and Southeast Asia, and *B. timori* is restricted to several islands of Indonesia. Travelers from nonendemic areas of the world who spend brief periods in endemic areas are rarely infected. Global programs have targeted elimination in >80% of endemic countries by 2030.

### CLINICAL MANIFESTATIONS

The clinical manifestations of *B. malayi*, *B. timori*, and *W. bancrofti* infection are similar; manifestations of acute infection include

transient, recurrent lymphadenitis and lymphangitis. The early signs and symptoms include episodic fever, lymphangitis of an extremity, lymphadenitis (especially the inguinal and axillary areas), headaches, and myalgias that last a few days to several weeks. These symptoms are caused by an acute inflammatory response triggered by death of adult worms. Initial damage to lymphatic vessels may remain subclinical for years. The syndrome is most frequently observed in persons 10–20 years old. Manifestations of chronic lymphatic filariasis occur mostly in adults  $\geq 30$  years old and result from anatomic and functional obstruction to lymph flow. This obstruction results in lymphedema of the legs, arms, breasts, and/or genitalia. Male genital involvement, such as hydrocele, is very common in *W. bancrofti* infection, but uncommon in *Brugia* spp. infection. Chronic lymphedema predisposes affected extremities to bacterial superinfections, sclerosis, and verrucous skin changes, resulting in elephantiasis, which may involve one or more limbs, the breasts, or genitalia. It is uncommon for children to have overt signs of chronic filariasis.

### Tropical Pulmonary Eosinophilia

The presence of microfilariae in the body has no apparent pathologic consequences except in persons with tropical pulmonary eosinophilia, a syndrome of filarial etiology in which microfilariae are found in the lungs and lymph nodes but not the bloodstream. It occurs only in individuals who have lived for years in endemic areas. Men 20–30 years old are most likely to be affected, although the syndrome occasionally occurs in children. The presentation includes paroxysmal nocturnal cough with dyspnea, fever, weight loss, and fatigue. Rales and rhonchi are found on auscultation of the chest. The x-ray findings may occasionally be normal, but increased bronchovascular markings, discrete opacities in the middle and basal regions of the lung, or diffuse miliary lesions are usually present (Fig. 342.1). Recurrent episodes may result in interstitial fibrosis and chronic respiratory insufficiency in untreated individuals. Hepatosplenomegaly and generalized lymphadenopathy are often seen in children. The diagnosis is suggested by residence in a filarial endemic area, eosinophilia ( $>2,000/\mu\text{L}$ ), compatible clinical symptoms, increased serum IgE ( $>1,000 \text{ IU/mL}$ ), and high titers of antimicrofilarial antibodies in the absence of microfilaremia. Although microfilariae may be found in sections of lung or lymph node, biopsy of these tissues is unwarranted in most situations. The clinical response to diethylcarbamazine (2 mg/kg/dose orally 3 times daily for 12–21 days) is the final criterion for diagnosis; the majority of patients improve with this therapy. If symptoms recur, a second anthelmintic course should be administered. Patients with chronic symptoms are less likely to show improvement than those who have been ill for a short time.

### DIAGNOSIS

Demonstration of microfilariae in the blood is the primary means for confirming the diagnosis of lymphatic filariasis. Because microfilaremia is nocturnal in most cases, blood samples should be obtained between 10 PM and 2 AM. Anticoagulated blood is passed through a Nuclepore filter that is stained and examined microscopically for microfilariae. Adult worms or microfilariae can be identified in tissue specimens obtained at biopsy. Infection with *W. bancrofti* in the absence of bloodborne microfilariae may be diagnosed by detection of parasite antigen in the serum. Adult worms in lymphatic vessels can be visualized by ultrasonography.

### TREATMENT

The use of antifilarial drugs in the management of acute lymphadenitis and lymphangitis is controversial. No controlled studies demonstrate that administration of drugs such as diethylcarbamazine modifies the course of acute lymphangitis. Diethylcarbamazine may be given to asymptomatic microfilaremic persons to lower the intensity of parasitemia. The drug also kills a proportion of the adult worms. Because treatment-associated complications such as pruritus, fever, generalized body pain, hypotension, and even death may occur, especially with high microfilarial levels, the dose of diethylcarbamazine should be increased gradually (children: 1 mg/kg orally as a single dose on day 1,



**Fig. 342.1** Chest radiograph of tropical pulmonary eosinophilia. Reticulonodular opacities are scattered throughout both lungs. (From Mandell GL, Bennett JE, Dolin R, eds. *Principles and Practice of Infectious Diseases*, 6th ed. Philadelphia: Elsevier, 2006. p. 3274.)

1 mg/kg 3 times daily on day 2, 1-2 mg/kg 3 times daily on day 3, and 2 mg/kg 3 times daily on days 4-14; *adults*: 50 mg orally on day 1, 50 mg 3 times daily on day 2, 100 mg 3 times daily on day 3, and 2 mg/kg 3 times daily on days 4-14). For patients with no microfilaria in the blood, the full dose (2 mg/kg/day orally divided 3 times daily) can be given beginning on day 1. Repeat doses may be necessary to further reduce the microfilaremia and kill lymph-dwelling adult parasites. *W. bancrofti* is more sensitive than *B. malayi* to diethylcarbamazine.

Global programs to control and ultimately eradicate lymphatic filariasis from endemic populations outside of sub-Saharan Africa currently recommend triple drug treatment with one or two annual doses of **diethylcarbamazine** (6 mg/kg orally once), **albendazole** (400 mg orally once), and **ivermectin** (150 µg/kg orally once) (mass drug administration). In co-endemic areas of filariasis and **onchocerciasis**, mass drug applications with single-dose ivermectin and albendazole are used because of severe adverse reactions with diethylcarbamazine in onchocerciasis-infected individuals.

Visit Elsevier eBooks+ at [eBooks.Health.Elsevier.com](http://eBooks.Health.Elsevier.com) for Bibliography.

## Chapter 343

# Other Tissue Nematodes

Katherine R. Dobbs and Arlene E. Dent

### ONCHOCERCIASIS (*ONCHOCERCA VOLVULUS*)

Infection with *Onchocerca volvulus* leads to onchocerciasis or **river blindness**. Onchocerciasis occurs primarily in West Africa but also in Central and East Africa and is the world's second leading infectious cause of blindness. There have been scattered foci in South America and Yemen. *O. volvulus* larvae are transmitted to humans by the bite of *Simulium* black flies that breed in fast-flowing streams. The larvae penetrate the skin and migrate through the connective tissue and eventually develop into adult worms that can be found tangled in fibrous tissue. Adult worms can live in the human body for up to 14 years. Female worms produce large numbers of microfilariae that migrate through the skin, connective tissue, and eye. Most infected individuals

are asymptomatic. In heavily infected individuals, clinical manifestations are a result of localized host inflammatory reactions to dead or dying microfilariae and subcutaneous adult worms surrounded by a palpable fibrous capsule. Cutaneous and ocular reactions to microfilariae produce pruritic dermatitis, punctate keratitis, corneal pannus formation, and chorioretinitis. Adult worms in subcutaneous nodules are not painful and tend to occur over bony prominences of the hip. The **diagnosis** can be established by obtaining snips of skin covering the scapulae, iliac crests, buttocks, or calves. The snips are immersed in saline for several hours and examined microscopically for microfilariae that have emerged into the fluid. The diagnosis can also be established by demonstrating microfilariae in the cornea or anterior chamber on slit-lamp examination or finding adult worms on a nodule biopsy specimen. Ophthalmology consultation should be obtained before treatment of eye lesions.

A single dose of **ivermectin** (150 µg/kg orally) is the drug of choice and clears *O. volvulus* microfilariae from the skin for several months but has no effect on the adult worm. Treatment with ivermectin should be repeated every 6-12 months until the patient is asymptomatic or has no evidence of eye infection. Adverse effects of ivermectin therapy include fever, urticaria, and pruritus, which are more frequent in individuals not born in endemic areas who acquired the infection after periods of intense exposure, such as Peace Corps volunteers. Patients with concurrent high-density microfilaremia from loiasis may develop potentially fatal encephalopathy with ivermectin therapy. Treatment with ivermectin should be withheld until *Loa loa* microfilaremia can be reduced. **Moxidectin** is a promising new agent. Personal protection includes avoiding areas where biting flies are numerous, wearing protective clothing, and using insect repellent. Programs of mass treatment with ivermectin have been implemented in Africa and South America in an effort to reduce the prevalence of onchocerciasis.

The World Health Organization (WHO) set goals for onchocerciasis elimination by 2025 using mass drug administration with ivermectin. Elimination can be declared only after 3 years of posttreatment surveillance without microfilaria detection in skin biopsies.

**Nodding syndrome**, a form of epilepsy in African children living in focal areas of Uganda and South Sudan, was epidemiologically associated with onchocerciasis, but an etiologic link was not established. Recently, researchers identified neurotoxic autoantibodies that cross-react with *O. volvulus* proteins, which were found more frequently in people with nodding syndrome than in those in the same village without the syndrome. Nodding syndrome may be an autoimmune epileptic disorder triggered by *O. volvulus* infection.

### LOIASIS (*LOA LOA*)

Loiasis is caused by infection with the tissue nematode *Loa loa*. The parasite is transmitted to humans by diurnally biting flies (*Chrysops*) that live in the rain forests of West and Central Africa. Migration of adult worms through skin, subcutaneous tissue, and subconjunctival area can lead to transient episodes of pruritus, erythema, and localized edema known as **Calabar swellings**, which are nonerythematous areas of subcutaneous edema 10-20 cm in diameter typically found around joints such as the wrist or the knee (Fig. 343.1). They resolve over several days to weeks and may recur at the same or different sites. Lifelong residents of *L. loa*-endemic regions may have microfilaremia and eosinophilia but are often asymptomatic. In contrast, travelers to endemic regions may have a hyperreactive response to *L. loa* infection characterized by frequent recurrences of swelling, high level eosinophilia, debilitation, and serious complications such as glomerulonephritis and encephalitis. **Diagnosis** is usually established on clinical grounds, often assisted by the infected individual reporting a worm being seen crossing the conjunctivae. Microfilariae may be detected in blood smears collected between 10 AM and 2 PM. Adult worms should be surgically excised when possible.

**Diethylcarbamazine** is the treatment of choice for loiasis, as there is evidence that it kills both microfilariae and adult worms and results in a sustained decrease in microfilarial intensity after treatment. Because treatment-associated complications such as pruritus, fever, generalized body pain, hypertension, and even death may occur, especially





**Fig. 343.1** Calabar swelling of the right hand. (From Guerrant RL, Walker DH, Weller PF, et al. *Tropical Infectious Diseases*. Philadelphia: Churchill Livingstone, 2006: p. 1165.)

with high microfilaria levels, the dose of diethylcarbamazine should be increased gradually in such cases (*children*: 1 mg/kg orally on day 1, 1 mg/kg three times daily on day 2, 1-2 mg/kg three times daily on day 3, 3 mg/kg three times daily on days 4-21; *adults*: 50 mg orally on day 1, 50 mg three times daily on day 2, 100 mg three times daily on day 3, 3 mg/kg three times daily on days 4-21). Full doses can be instituted on day 1 in persons without microfilaremia (3 mg/kg orally times daily for 21 days). A 3-week course of **albendazole** can also be used to slowly reduce *L. loa* microfilarial levels as a result of embryotoxic effects on the adult worms. Antihistamines or corticosteroids may be used to limit allergic reactions secondary to killing of microfilariae. Personal protective measures include avoiding areas where biting flies are present, wearing protective clothing, and using insect repellents. Diethylcarbamazine (300 mg orally once weekly) prevents infection in travelers who spend prolonged periods in endemic areas. *L. loa* do not harbor *Wolbachia* endosymbionts, and therefore doxycycline has no effect on infection.

### INFECTION WITH ANIMAL FILARIAE

The most commonly recognized zoonotic filarial infections are caused by members of the genus *Dirofilaria*. The worms are introduced into humans by the bites of mosquitoes containing third-stage larvae. The most common filarial zoonosis in the United States is *Dirofilaria tenuis*, a parasite of raccoons. In Europe, Africa, and Southeast Asia, infections are usually caused by the dog parasite *Dirofilaria repens*. The **dog heartworm**, *Dirofilaria immitis*, is the second most frequently encountered filarial zoonosis worldwide. Other genera, including *Dipetalonema*-like worms, *Onchocerca*, and *Brugia*, are rare causes of zoonotic filarial infections.

Animal filariae do not undergo normal development in the human host. The clinical manifestations and pathologic findings correspond to the anatomic site of infection and can be categorized into four major groups: subcutaneous, lung, eye, and lymphatic. Pathologic examination of affected tissue reveals a localized foreign body reaction around a dead or dying parasite. The lesion consists of granulomas with eosinophils, neutrophils, and tissue necrosis. *D. tenuis* does not leave the subcutaneous tissues, whereas *Brugia beaveri* eventually localizes to superficial lymph nodes. Infections may be present for up to several months. *D. immitis* larvae migrate for several months in subcutaneous tissues and most frequently result in a well-circumscribed, coinlike lesion in a single lobe of the lung. The chest radiograph typically reveals a solitary pulmonary nodule 1-3 cm in diameter. Definitive **diagnosis** and cure depend on surgical excision and identification of the nematode within the surrounding granulomatous response. *D. tenuis* and *B. beaveri* infections present as painful, rubbery, 1-5 cm nodules in the skin of the trunk, of the extremities, and around the orbit. Patients often report having been engaged in activities predisposing to exposure

to infected mosquitoes, such as working or hunting in swampy areas. Management is by **surgical excision**.

### ANGIOSTRONGYLUS CANTONENSIS

*Angiostrongylus cantonensis*, the **rat lungworm**, is the most common cause of **eosinophilic meningitis** worldwide. Rats are the definitive host. Human infection follows ingestion of third-stage larvae in raw or undercooked intermediate hosts such as snails and slugs, or transport hosts such as freshwater prawns, frogs, and fish. Most cases are sporadic, but clusters have been reported, including clusters related to consumption of lettuce contaminated with intermediate or transport hosts. Even though most infections have been described in Southeast Asia, the South Pacific, and Taiwan, shipboard travel of infected rats has spread the parasite to Madagascar, Africa, the Caribbean, and most recently Australia and North America. Larvae penetrate the vasculature of the intestinal tract and migrate to the meninges, where they usually die but induce eosinophilic aseptic meningitis. Patients present 2-35 days after ingestion of larvae with severe headache, neck pain or nuchal rigidity, hyperesthesias and paresthesias (often migrating), fatigue, fever, rash, pruritus, nausea, and vomiting. Neurologic involvement varies from asymptomatic to paresthesias, severe pain, weakness, and focal neurologic findings such as cranial nerve palsies. Symptoms can last for several weeks to months, especially headache. Coma and death from hydrocephalus occur rarely in heavy infections. Peripheral blood eosinophilia is not always present on initial examination but peaks about 5 weeks after exposure, often when symptoms are improving. Cerebrospinal fluid (CSF) analysis reveals pleocytosis with >10% eosinophils in more than half of patients, with mildly elevated protein, a normal glucose level, and an elevated opening pressure. Head CT or MRI is usually unremarkable. The **diagnosis** is established clinically with supporting travel and diet history. A sensitive and specific enzyme-linked immunosorbent assay (ELISA) is available on a limited basis from the Centers for Disease Control and Prevention (CDC) for testing CSF or serum.

**Treatment** is primarily supportive because the majority of infections are mild, and most patients recover within 2 months without neurologic sequelae. Analgesics should be given for headache. Careful, repeated lumbar punctures should be performed to relieve hydrocephalus. Anthelmintic drugs have not been shown to influence the outcome and may exacerbate neurologic symptoms. The use of corticosteroids may shorten the duration of persistent and severe headaches. There is a higher incidence of permanent neurologic sequelae and mortality among children than among adults. Infection can be avoided by not eating raw or undercooked crabs, prawns, or snails.

### ANGIOSTRONGYLUS COSTARICENSIS

*Angiostrongylus costaricensis* is a nematode that infects several species of rodents and causes abdominal **angiostrongyliasis**, which has been described predominantly in Latin America and the Caribbean. The mode of transmission to humans, who are accidental hosts, is unknown. It is speculated that infectious larvae from a molluscan intermediate host, such as the slug *Vaginulus plebeius*, contaminate water or vegetation that is inadvertently consumed (chopped up in salads or on vegetation contaminated with the slug's mucous secretions). Although this slug is not indigenous to the continental United States, it has been found on imported flowers and produce. The incubation period for abdominal angiostrongyliasis is unknown, but limited data suggest that it ranges from 2 weeks to several months after ingestion of larvae. Third-stage larvae migrate from the gastrointestinal tract to the mesenteric arteries, where they mature into adults. These eggs degenerate and elicit an eosinophilic granulomatous reaction. The clinical findings of abdominal angiostrongyliasis mimic **appendicitis**, although the former is typically more indolent. Children can have fever, right lower quadrant pain, a tumor-like mass, abdominal rigidity, and a painful rectal examination. Most patients have leukocytosis with eosinophilia. Radiologic examination may show bowel wall edema, spasticity, or filling defects in the ileocecal region and the ascending colon. Examination of stool for ova and parasites is not useful for *A. costaricensis* but is useful for evaluating the presence of other intestinal parasites. An

ELISA is available for **diagnosis** on a limited basis from the CDC, but the test has a low specificity and is known to cross react with *Toxocara*, *Strongyloides*, and *Paragonimus*.

Many patients undergo laparotomy for suspected appendicitis and are found to have a mass in the terminal ileum to the ascending colon. *No specific treatment is known for abdominal angiostrongyliasis*. Even though the use of anthelmintic therapy has not been studied systematically, thiabendazole or diethylcarbamazine has been suggested. The prognosis is generally good. Most cases are self-limited, although surgery may be required in some patients. Cornerstones of **prevention** include avoidance of slugs and not ingesting raw food and water that may be contaminated with imperceptible slugs or slime from slugs. Rat control is also important in preventing the spread of infection.

### DRACUNCULIASIS (*DRACUNCULUS MEDINENSIS*)

Dracunculiasis is caused by the guinea worm, *Dracunculus medinensis*. WHO has targeted dracunculiasis for eradication in 2030. Eradication efforts have been hampered by conflicts as well as increasing rates of infections in animals such as dogs. As of 2021, transmission of the infection was occurring in Chad, Ethiopia, Mali, South Sudan, Angola, and Cameroon. Humans become infected by drinking contaminated stagnant water that contains immature forms of the parasite in the gut of tiny crustaceans (copepods or water fleas). Larvae are released in the stomach, penetrate the mucosa, mature, and mate. Approximately 1 year later, the adult female worm (1–2 mm in diameter and up to 1 m long) migrates and partially emerges through the human host skin, usually of the legs. Thousands of immature larvae are released when the affected body part is immersed in the water. The cycle is completed when larval forms are ingested by the crustaceans. Infected humans have no symptoms until the worm reaches the subcutaneous tissue, causing a **stinging papule** that may be accompanied by urticaria, nausea, vomiting, diarrhea, and dyspnea. The lesion vesiculates, ruptures, and forms a painful ulcer in which a portion of the worm is visible. **Diagnosis** is established clinically. Larvae can be identified by microscopic examination of the discharge fluid.

**Metronidazole** (25 mg/kg/day orally divided into three doses for 10 days; maximum dose: 750 mg) decreases local inflammation. Although the drug does not kill the worm, it facilitates its removal. The worm must be physically removed by rolling the slowly emerging 1 m-long parasite onto a thin stick over a week. Topical corticosteroids shorten the time to complete healing, while topical antibiotics decrease the risk of secondary bacterial infection. Dracunculiasis can be prevented by boiling or chlorinating drinking water or passing the water through a cloth sieve before consumption. Eradication is dependent on behavior modification and education.

### GNATHOSTOMA SPINIGERUM

*Gnathostoma spinigerum* is a dog and cat nematode endemic to Southeast Asia, Japan, China, Bangladesh, and India, but it has been sporadically reported in numerous countries worldwide. Infection is acquired by ingesting intermediate hosts containing larvae of the parasite, such as raw or undercooked freshwater fish, chickens, pigs, snails, or frogs. Penetration of the skin by larval forms and prenatal transmission has also been described. Nonspecific signs and symptoms such as generalized malaise, fever, urticaria, anorexia, nausea, vomiting, diarrhea, and epigastric pain develop 24–48 hours after ingestion of *G. spinigerum*. Ingested larvae penetrate the gastric wall and migrate through soft tissue for up to 10 years. Moderate to severe eosinophilia can develop. Cutaneous **gnathostomiasis** manifests as intermittent episodes of localized, migratory nonpitting edema associated with pain, pruritus, or erythema. Central nervous system involvement in gnathostomiasis is suggested by focal neurologic findings, initially neuralgia followed within a few days by paralysis or changes in mental status. Multiple cranial nerves may be involved, and CSF may be xanthochromic but typically shows an eosinophilic pleocytosis. **Diagnosis** of gnathostomiasis is based on clinical presentation and epidemiologic background. Brain and spinal cord lesions may be seen on CT or MRI. Serologic testing varies in sensitivity and specificity and is available through the CDC.

There is no well-documented effective chemotherapy, although **albendazole** (400 mg orally twice daily for 21 days) as first-line therapy or **ivermectin** (200 µg/kg for 2 days) as an alternative is recommended without or with surgical removal. Multiple courses may be needed. Corticosteroids have been used to relieve focal neurologic deficits. **Surgical resection** of the *Gnathostoma* is the major mode of therapy and the treatment of choice. Blind surgical resection of subcutaneous areas of diffuse swelling is not recommended because the worm can rarely be located. **Prevention** through the avoidance of ingestion of poorly cooked or raw fish, poultry, or pork should be emphasized for individuals living in or visiting endemic areas.

Visit Elsevier eBooks+ at [eBooks.Elsevier.com](https://eBooks.Elsevier.com) for Bibliography.

## Chapter 344

# Toxocariasis (Visceral and Ocular Larva Migrans)

Katherine R. Dobbs and Arlene E. Dent

Most cases of human toxocariasis are caused by the **dog roundworm**, *Toxocara canis*. Adult female *T. canis* worms live in the intestinal tracts of young puppies and their lactating mothers. Large numbers of eggs are passed in the feces of dogs and embryonate under optimal soil conditions. *Toxocara* eggs can survive relatively harsh environmental conditions and are resistant to freezing and extremes of moisture and pH. Humans ingest embryonated eggs contaminating soil, hands, or fomites. The larvae hatch and penetrate the intestinal wall and travel via the circulation to the liver, lung, and other tissues. Humans do not excrete *T. canis* eggs because the larvae are unable to complete their maturation to adult worms in the intestine. The **cat roundworm**, *Toxocara cati*, is responsible for far fewer cases of **visceral larva migrans (VLM)** than *T. canis*. Ingestion of infective larvae of the raccoon ascarid *Baylisascaris procyonis* rarely leads to VLM but can cause **neural larva migrans**, resulting in fatal eosinophilic meningitis. Ingestion of larvae from the opossum ascarid *Lagochilascaris minor* leads to VLM rarely.

### EPIDEMIOLOGY

Human *T. canis* infections have been reported in almost all parts of the world, primarily in temperate and tropical areas where dogs are popular household pets. Young children are at highest risk because of their unsanitary play habits and tendency to place fingers in the mouth. Other behavioral risk factors include **pica**, contact with puppy litters, and institutionalization. In North America, the highest prevalence of infection is in the southeastern United States and Puerto Rico, particularly among socially disadvantaged Black and Hispanic children. In the United States, serosurveys show that 3–3.9% of children are infected. Assuming an unrestrained and untreated dog population, toxocariasis is prevalent in settings where other **geohelminth infections**, such as ascariasis, trichuriasis, and hookworm infections, are common.

### PATHOGENESIS

*T. canis* larvae secrete large amounts of immunogenic glycosylated proteins. These antigens induce immune responses that lead to eosinophilia and polyclonal and antigen-specific immunoglobulin E production. The characteristic histopathologic lesions are granulomas containing eosinophils, multinucleated giant cells (histiocytes), and collagen. Granulomas are typically found in the liver but may also



**Table 344.1** Clinical Syndromes of Human Toxocariasis

SYNDROME	CLINICAL FINDINGS	AVERAGE AGE	INFECTIOUS DOSE	INCUBATION PERIOD	LABORATORY FINDINGS	ELISA
Visceral larva migrans	Fevers, hepatomegaly, asthma	5yr	Moderate to high	Weeks to months	Eosinophilia, leukocytosis, elevated IgE	High (≥1:16)
Ocular larva migrans	Visual disturbances, retinal granulomas, endophthalmitis, peripheral granulomas	12yr	Low	Months to years	Usually none	Low
Covert toxocariasis	Abdominal pain, gastrointestinal symptoms, weakness, hepatomegaly, pruritus, rash	School-age to adult	Low to moderate	Weeks to years	± Eosinophilia ± Elevated IgE	Low to moderate

ELISA, Enzyme-linked immunosorbent assay; IgE, immunoglobulin E; ±, with or without.

Adapted from Glickman LT, Schantz PM. Epidemiology and pathogenesis of zoonotic toxocariasis. *Epidemiol Rev.* 1981;3:230–250.

occur in the lungs, central nervous system (CNS), and ocular tissues. Clinical manifestations reflect the intensity and chronicity of infection, anatomic localization of larvae, and host granulomatous responses.

### CLINICAL MANIFESTATIONS

Three major clinical syndromes are associated with human toxocariasis: VLM, **ocular larva migrans (OLM)**, and **covert toxocariasis** (Table 344.1). The classic presentation of VLM includes eosinophilia, fever, and hepatomegaly and occurs most often in toddlers with a history of pica and exposure to puppies. The findings include fever, cough, wheezing, bronchopneumonia, anemia, hepatomegaly, leukocytosis, eosinophilia, and positive *Toxocara* serology. Cutaneous manifestations such as pruritus, eczema, and urticaria can be present. OLM tends to occur in older children without signs or symptoms of VLM. Presenting symptoms include unilateral visual loss, eye pain, white pupil, or strabismus that develops over weeks. Granulomas occur on the posterior pole of the retina and may be mistaken for retinoblastoma. Serologic testing for *Toxocara* has allowed the identification of individuals with less obvious or covert symptoms of infection. These children may have nonspecific complaints that do not constitute a recognizable syndrome. Common findings include hepatomegaly, abdominal pain, cough, sleep disturbance, failure to thrive, and headache with elevated *Toxocara* antibody titers. Eosinophilia may be present in 50–75% of cases. The prevalence of positive *Toxocara* serology in the general population supports that most children with *T. canis* infection are asymptomatic and will not develop overt clinical sequelae over time. A correlation between positive *Toxocara* serology and allergic asthma has also been described.

### DIAGNOSIS

A presumptive diagnosis of toxocariasis can be established in a young child with **eosinophilia** (>20%), leukocytosis, hepatomegaly, fevers, wheezing, and a history of geophagia and exposure to puppies or unrestrained dogs. Supportive laboratory findings include hypergammaglobulinemia and elevated isohemagglutinin titers to A and B blood group antigens. Most patients with VLM have an absolute eosinophil count >500/μL. Eosinophilia is less common in patients with OLM. Biopsy confirms the diagnosis. When biopsies cannot be obtained, an enzyme-linked immunosorbent assay using excretory-secretory proteins harvested from *T. canis* larvae maintained in vitro is the standard serologic test used to confirm toxocariasis. A titer

of 1:32 is associated with a sensitivity of approximately 78% and a specificity of approximately 92%. The sensitivity for OLM is significantly less. The diagnosis of OLM can be established in patients with typical clinical findings of a retinal or peripheral pole granuloma or endophthalmitis with elevated antibody titers. Vitreous and aqueous humor fluid anti-*Toxocara* titers are usually greater than serum titers. The diagnosis of covert toxocariasis should be considered in individuals with chronic weakness, abdominal pain, or allergic signs with eosinophilia and increased IgE. In temperate regions of the world, nonparasitic causes of eosinophilia that should be considered in the differential diagnosis include allergies, drug hypersensitivity, lymphoma, vasculitis, and idiopathic hypereosinophilic syndrome (see Chapter 169).

### TREATMENT

Most patients do not require treatment because signs and symptoms are mild and subside over weeks to months. Several anthelmintic drugs have been used for symptomatic cases, often with adjunctive corticosteroids to limit inflammatory responses that presumably result from release of *Toxocara* antigens by dying parasites. **Albendazole** (400 mg orally twice daily for 5 days for all ages) has demonstrated efficacy in both children and adults. **Mebendazole** (100–200 mg PO twice daily for 5 days for all ages) is also useful. Anthelmintic treatment of CNS and ocular disease should be extended (3–4 weeks). Even with no clinical trials on OLM therapy, a course of oral corticosteroids such as **prednisone** (1 mg/kg/day PO for 2–4 weeks) has been recommended to suppress local inflammation while treatment with anthelmintic agents is initiated.

### PREVENTION

Transmission can be minimized by public health measures that prevent dog feces from contaminating the environment. These include keeping dogs on leashes and excluding pets from playgrounds and sandboxes that toddlers use. Children should be discouraged from putting dirty fingers in their mouth and eating dirt. Vinyl covering of sandboxes reduces the viability of *T. canis* eggs. Widespread veterinary use of broad-spectrum anthelmintics effective against *Toxocara* may lead to a decline in parasite transmission to humans.

Visit Elsevier eBooks+ at [eBooks.Elsevier.com](http://eBooks.Elsevier.com) for Bibliography.

## Chapter 345

**Trichinellosis (*Trichinella spiralis*)**

Katherine R. Dobbs and Arlene E. Dent

**ETIOLOGY**

Human trichinellosis (also called **trichinosis**) is caused by consumption of meat containing encysted larvae of *Trichinella spiralis*, a tissue-dwelling nematode with a worldwide distribution. After ingestion of raw or inadequately cooked meat from pigs (or other commercial meat sources such as horses) containing viable *Trichinella* larvae, the organisms are released from the cyst by acid-pepsin digestion of the cyst walls in the stomach and then pass into the small intestine. The larvae invade the small intestine columnar epithelium at the villi base and develop into adult worms. The adult female worm produces about 500 larvae over 2 weeks and is then expelled in the feces. The larvae enter the bloodstream and seed striated muscle by burrowing into individual muscle fibers. Over a period of 3 weeks, they coil as they increase about 10 times in length and become capable of infecting a new host if ingested. The larvae eventually become encysted and can remain viable for years. **Sylvatic** *Trichinella* spp. (*T. britovi*, *T. nativa*, *T. pseudospiralis*, and *T. murrelli*) are present in traditional native foods, such as walrus meat, and **game meat** may also cause disease similar to that caused by *T. spiralis*.

**EPIDEMIOLOGY**

Despite public health efforts to control trichinellosis by eliminating the practice of feeding garbage to domestic swine, epidemics and isolated cases of *Trichinella* spp. infection continue to be a health problem in many areas of the world. It is most common in Asia, Latin America, and Central Europe. Swine fed with garbage may become infected when given uncooked trichinous scraps, usually pig meat, or when the carcasses of infected wild animals such as rats are eaten. Prevalence rates of *T. spiralis* in domestic swine range from 0.001% in the United States to  $\geq 25\%$  in China. The resurgence of this disease can be attributed to translocations of animal populations, human travel, and export of food as well as ingestion of sylvatic *Trichinella* through game meat. In the United States from 2008 to 2012, wild game meat (especially bear or wild boar meat) was the most common source of infection. Most outbreaks occur from the consumption of *T. spiralis*-infected pork (or horse meat in areas of the world where horse is eaten) obtained from a single source.

**PATHOGENESIS**

During the first 2-3 weeks after infection, pathologic reactions to infection are limited to the gastrointestinal (GI) tract and include a mild, partial villous atrophy with an inflammatory infiltrate of neutrophils, eosinophils, lymphocytes, and macrophages in the mucosa and submucosa. Larvae are released by female worms and disseminate over the next several weeks. Skeletal muscle fibers show the most striking changes with edema and basophilic degeneration. The muscle fiber may contain the typical coiled worm, the cyst wall derived from the host cell, and the surrounding lymphocytic and eosinophilic infiltrate.

**CLINICAL MANIFESTATIONS**

The development of symptoms depends on the number of viable larvae ingested. Most infections are asymptomatic or mild, and children often show milder symptoms than adults who consumed the same amount of infected meat. Watery diarrhea is the most common symptom corresponding to maturation of the adult worms in the GI tract, which occurs during the first 1-2 weeks after ingestion. Patients may also complain of abdominal discomfort and vomiting. Fulminant **enteritis** may develop in individuals with extremely high worm burdens. The classic symptoms of facial and periorbital edema, fever, weakness, malaise, and myalgia peak approximately 2-3 weeks after the infected meat is ingested, as the larvae migrate and then encyst in the muscle. Headache, cough, dyspnea, dysphagia, subconjunctival and splinter hemorrhages, and a macular or petechial rash may occur. Patients with high-intensity infection may die from myocarditis, encephalitis, or pneumonia. In symptomatic patients, **eosinophilia** is common and may be dramatic.

**DIAGNOSIS**

The Centers for Disease Control and Prevention (CDC) diagnostic criteria for trichinellosis require positive serology or muscle biopsy for *Trichinella* with one or more compatible clinical symptoms (eosinophilia, fever, myalgia, facial or periorbital edema). To declare a discrete outbreak, at least one person must have positive serology or muscle biopsy. Antibodies to *Trichinella* are detectable approximately 3 weeks after infection. Severe muscle involvement results in elevated serum creatine phosphokinase and lactic dehydrogenase levels. Muscle biopsy is not usually necessary, but if needed, a sample should be obtained from a tender swollen muscle. A history of eating undercooked meat supports the diagnosis. The cysts may calcify and may be visible on radiograph.

**TREATMENT**

Recommended treatment of trichinellosis diagnosed at the GI phase is **albendazole** (400 mg orally twice daily for 8-14 days for all ages) to eradicate the adult worms if a patient has ingested contaminated meat within the previous 1 week. An alternative regimen is mebendazole (200-400 mg PO 3 times daily for 3 days followed by 400-500 mg 3 times daily for 10 days). There is no consensus for treatment of muscle-stage trichinellosis. Corticosteroids may be used, although evidence for efficacy is anecdotal.

**PREVENTION**

*Trichinella* larvae can be killed by cooking meat ( $\geq 55^{\circ}\text{C}$  [ $131^{\circ}\text{F}$ ]) until there is no trace of pink fluid or flesh, or by storage in a freezer ( $-15^{\circ}\text{C}$  [ $5^{\circ}\text{F}$ ]) for  $\geq 3$  wk. Freezing to kill larvae should only be applied to pork meat, because larvae in horse, wild boar, or game meat can remain viable even after 4 weeks of freezing. Smoking, salting, and drying meat are unreliable methods of killing *Trichinella*. Strict adherence to public health measures, including garbage feeding regulations, stringent rodent control, prevention of exposure of pigs and other livestock to animal carcasses, constructing barriers between livestock, wild animals, and domestic pets, and proper handling of wild animal carcasses by hunters, can reduce infection with *Trichinella*. Current meat inspection for trichinellosis is by direct digestion and visualization of encysted larvae in meat samples. Serologic testing does not have a role in meat inspection.

Visit Elsevier eBooks+ at [eBooks.Health.Elsevier.com](http://eBooks.Health.Elsevier.com) for Bibliography.

## Chapter 346

Schistosomiasis  
(*Schistosoma*)Amaya L. Bustinduy, Sophie Pach, and  
Katja Doerholt

The term **schistosomiasis** (also known as **bilharzia**) encompasses the acute and chronic inflammatory disorders caused by human infection with *Schistosoma* spp. parasites. Disease is related to both the systemic and the focal effects of schistosome infection and its consequent host immune responses triggered by parasite eggs deposited in the tissues. For the affected individuals, this frequently manifests as disabling chronic morbidity.

**ETIOLOGY**

*Schistosoma* organisms are trematodes, or **flukes**, that parasitize the bloodstream. Five schistosome species are known to infect humans: *Schistosoma haematobium*, *S. mansoni*, *S. japonicum*, *S. intercalatum*, and *S. mekongi*. Humans are infected through contact with water contaminated with *cercariae*, the free-living infective stage of the parasite. These motile, forked-tail organisms emerge from infected snails and are capable of penetrating intact human skin. As they reach maturity, adult worms migrate to specific anatomic sites characteristic of each schistosome species: *S. haematobium* adults are found in the perivesical and periureteral venous plexus, *S. mansoni* in the inferior mesenteric veins, and *S. japonicum* in the superior mesenteric veins. The less common *S. intercalatum* and *S. mekongi* are usually found in the mesenteric vessels. Adult schistosome worms (1-2 cm long) are clearly adapted for an intravascular existence. The female accompanies the male in a groove formed by the lateral edges of its body. On fertilization, female worms begin oviposition in the small venous tributaries. The eggs of the three main schistosome species have characteristic morphologic features: *S. haematobium* has a terminal spine, *S. mansoni* has a lateral spine, and *S. japonicum* has a smaller size with a short, curved spine (Fig. 346.1). Parasite eggs provoke a significant granulomatous inflammatory response that allows them to ulcerate through host tissues to reach the lumen of the urinary tract or the intestines. They are carried to the outside environment in urine or feces (depending on the species), where they will hatch if deposited in freshwater. Motile miracidia emerge, infect specific freshwater snail intermediate hosts, and divide asexually. After 4-12 weeks, the infective cercariae are released by the snails into the contaminated water.

**EPIDEMIOLOGY**

Schistosomiasis affects more than 300 million people worldwide with more than 700 million people at risk, primarily children and young adults. There are 1.8 million disability-adjusted life-years (DALYs) attributed to schistosomiasis, making it the second most disabling parasitic disease after malaria. Prevalence is increasing in many areas as population density increases and new irrigation projects provide broader habitats for the intermediate **snail** hosts. Humans are the main definitive hosts for the five clinically important species of schistosomes, although *S. japonicum* is also a zoonosis, infecting animals such as dogs, rats, pigs, and cattle. *S. haematobium* is prevalent in Africa and the Middle East with cases reported in the Mediterranean (Corsica in France); *S. mansoni* is prevalent in Africa, the Middle East, the Caribbean, and South America; and *S. japonicum* is prevalent in China, the Philippines, and Indonesia, with some sporadic foci in parts of Southeast Asia. The other two species are less prevalent. *S. intercalatum* is found in West and Central Africa, and *S. mekongi* is found only along the upper Mekong River in Asia.

Transmission depends on water contamination by human excreta (urine and stool), the presence of specific intermediate snail hosts, and the patterns of water contact and social habits of the population (Fig. 346.2). The distribution of infection in endemic areas shows that prevalence increases with age, to a peak at 10-20 years old. Exposure to infected water starts early in life for children living in endemic areas. Passive water contact by infants (accompanying mothers in their daily household activities) evolves to more active water contact as preschool and school-age children pursue recreational activities such as swimming and wading.

Measuring intensity of infection (by quantitative egg count in urine or feces) demonstrates that the heaviest worm loads are found in school-age and adolescent children. Even though schistosomiasis is most prevalent and most severe in older children and young adults, who are at maximal risk for suffering from its acute and chronic sequelae, preschool children can also exhibit significant disease manifestations.

**PATHOGENESIS**

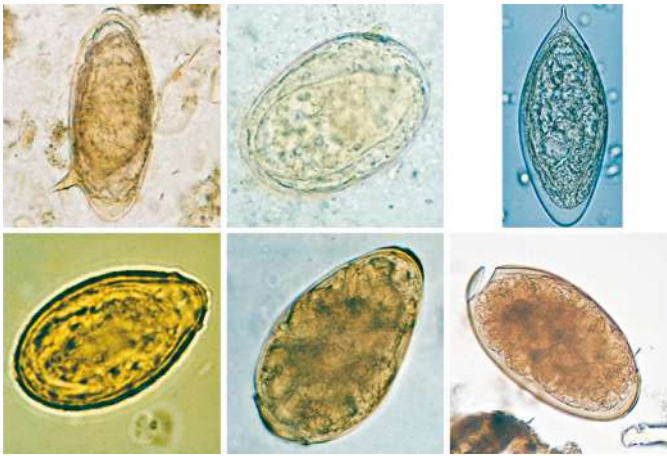
Both early and late manifestations of schistosomiasis are immunologically mediated. *Acute* schistosomiasis, known as **snail fever** or **Katayama syndrome**, is a febrile illness that represents an immune complex disease associated with early infection and oviposition 4-8 weeks after cercarial skin penetration. The major pathology of infection occurs later, with *chronic* schistosomiasis, in which retention of eggs in the host tissues is associated with chronic granulomatous injury. Eggs may be trapped at sites of deposition (urinary bladder, ureters, cervix, intestine) or may be carried by the bloodstream to ectopic sites, most frequently the liver and less often the lungs and central nervous system (CNS). The host response to these eggs involves local as well as systemic manifestations. The cell-mediated immune response leads to granulomas composed of lymphocytes, macrophages, and eosinophils that surround the entrapped eggs and add significantly to the degree of tissue destruction. Granuloma formation in the bladder wall and at the ureterovesical junction results in the major disease manifestations of *S. haematobium* infection: hematuria, dysuria, and obstructive uropathy. Granulomata in the genital tissues also contributes to reproductive organ obstruction and local inflammation. Intestinal as well as hepatic granulomas underlie the pathologic sequelae of the other schistosome infections: ulcerations and fibrosis of intestinal wall, hepatosplenomegaly, and portal hypertension caused by presinusoidal obstruction of blood flow. In terms of systemic disease, antischistosome inflammation increases circulating levels of proinflammatory cytokines such as tumor necrosis factor- $\alpha$  and interleukin-6, associated with elevated levels of C-reactive protein. These responses are associated with hepcidin-mediated inhibition of iron uptake and use, leading to anemia of chronic inflammation. Schistosomiasis-related undernutrition and decreased cognition may be the result of similar pathways of chronic inflammation. Acquired partial protective immunity against schistosomiasis has been demonstrated in some animal species and may occur in humans.

**CLINICAL MANIFESTATIONS**

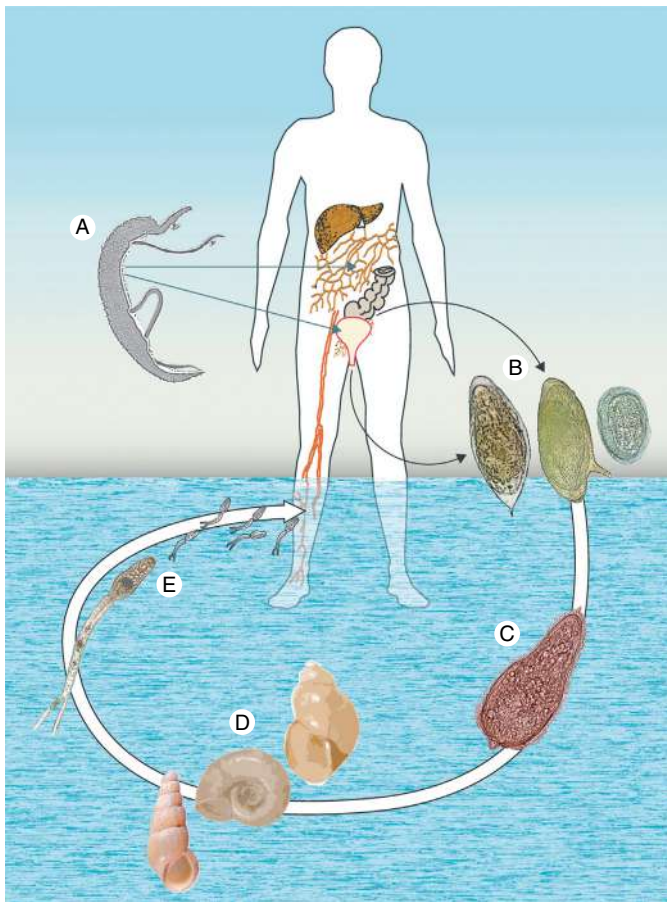
Two main chronic clinical syndromes arise from *Schistosoma* spp. infection: **urogenital schistosomiasis** caused by *S. haematobium* and **intestinal schistosomiasis** caused by *S. mansoni* or *S. japonicum*. Most chronically infected individuals experience mild symptoms and may not seek medical attention; the more severe symptoms of schistosomiasis occur mainly in those who are heavily infected or who have been infected over longer periods. In addition to organ-specific morbidities, infected patients frequently demonstrate anemia (often complicated by malaria in endemic regions), chronic pain, diarrhea, exercise intolerance, and chronic undernutrition manifesting as growth stunting. Cercarial penetration of human skin may result in a pruritic papular rash known as **schistosomal dermatitis** or **swimmer's itch**. Skin manifestations are more pronounced in previously exposed individuals and are characterized by edema and intense cellular infiltrates in the dermis and epidermis.

**Acute schistosomiasis** (Katayama syndrome) may occur 4-8 weeks after exposure and is most commonly seen in *S. japonicum* endemic





**Fig. 346.1** Eggs of common human trematodes. Clockwise from upper left: *Schistosoma mansoni*, *S. japonicum*, *S. haematobium*, *Clonorchis sinensis*, *Paragonimus westermani*, and *Fasciola hepatica* (note the partially open operculum). (From Centers for Disease Control and Prevention. DPDx: laboratory identification of parasites of public health concern. <http://www.cdc.gov/dpdx/az.html>)



**Fig. 346.2** Life cycle of *Schistosoma mansoni*, *S. haematobium*, and *S. japonicum*. A, Paired adult worms (larger male enfolding slender female). B, Eggs (left to right, *S. haematobium*, *S. mansoni*, *S. japonicum*). C, Ciliated miracidium. D, Intermediate host snails (left to right, *Oncomelania*, *Biomphalaria*, *Bulinus*). E, Cercariae. (From Colley DG, Bustinduy AL, Secor WE, King CH. Human schistosomiasis. *Lancet*. 2014;383:2253–2264. Fig 1.)

areas, though it can occur with all species. This is a serum sickness–like syndrome manifested by the acute onset of fever, cough, chills, sweating, abdominal pain, lymphadenopathy, hepatosplenomegaly,

and eosinophilia. Acute schistosomiasis typically presents in first-time visitors to endemic areas who experience primary infection at an older age.

**Chronic schistosomiasis** occurs after granuloma formation in the organs where eggs have entrapped. In urogenital schistosomiasis, caused by *S. haematobium*, symptomatic children usually complain of frequency, dysuria, and macro- and micro-hematuria. Urine examination shows erythrocytes, parasite eggs, and occasional eosinophiluria. In endemic areas, moderate to severe pathologic lesions have been demonstrated in the urinary tract of >20% of infected children. The extent of disease correlates with the intensity of infection, but significant morbidity can occur even in lightly infected children, including children under 5 years of age. The advanced stages of urogenital schistosomiasis are associated with chronic renal failure, secondary infections, and squamous cell carcinoma of the bladder.

An important complication of *S. haematobium* infection to consider, particularly in adolescent females, is **female genital schistosomiasis (FGS)**. Eggs migrate from the vesical plexus to lodge in the female genital tract, where they induce a granulomatous inflammatory response that can manifest as contact bleeding, pain after sex, ectopic pregnancies, and infertility. Symptoms start before sexual debut and get later confused with those of sexually transmitted infections. There is a threefold to fourfold greater risk of HIV transmission. Pathognomonic lesions can be visualized in the cervix by colposcopy. **Male genital schistosomiasis (MGS)** can present in adolescent males with hematospermia, pain, erectile dysfunction, and infertility and is likely to contribute to increased male-to-female HIV transmission.

Children with **chronic intestinal schistosomiasis** due to *S. mansoni*, *S. japonicum*, and, less commonly, *S. intercalatum* or *S. mekongi* can present with intestinal symptoms; colicky abdominal pain and bloody diarrhea are the most common. However, the intestinal phase may remain subclinical, and the late syndrome of hepatosplenomegaly, portal hypertension, ascites, and hematemesis may then be the first clinical presentation in later years. Liver disease is caused by granuloma formation and subsequent **periportal fibrosis**; no appreciable liver cell injury occurs, and hepatic function may be preserved for a long time. Schistosome eggs can escape into the lungs, causing **pulmonary hypertension** and cor pulmonale. *S. japonicum* worms may migrate to the brain vasculature and produce localized lesions that cause seizures. **Transverse myelitis**, spinal compression, and other CNS involvement (meningoencephalitis) are rare but well-known complications in children or young adults with either acute or chronic *S. haematobium* or *S. mansoni* infection.

Although end-organ scarring is pathognomonic, affected children may also have persistent long-term systemic effects of infection, including poor growth, anemia, decreased aerobic capacity, and cognitive impairment and poor school performance.

## DIAGNOSIS

**Parasitologic diagnosis** entails finding schistosome eggs in the excreta of infected individuals; quantitative methods should be used to provide an indication of the burden of infection. For the diagnosis of *S. haematobium* infection, a volume of 10 mL of urine should be collected around midday, the time of maximal egg excretion, and filtered for microscopic examination. Stool examination by the Kato-Katz thick smear procedure and detection of parasite antigen in patient serum or urine are the methods of choice for diagnosis and quantification of other schistosome infections (*S. mansoni* and *S. japonicum*). More sensitive **antigenic diagnosis** includes the unique schistosome antigens in urine or plasma: *circulating anodic antigen* (CAA), which is not yet commercially available, and *circulating cathodic antigen* (CCA) from stool for the detection only of *S. mansoni* and *S. japonicum*.

**Morbidity diagnosis** can be ascertained by abdominal ultrasonography; in urogenital schistosomiasis, by the detection of **bladder polyps** and derived renal complications, and in intestinal schistosomiasis, by the detection of **periportal fibrosis** in the liver. **Colposcopy** and **semen** analysis are useful in adolescent children suspected of having FGS and MGS.



## TREATMENT

Treatment of children with schistosomiasis should be based on an appreciation of the intensity of infection and the extent of disease. The World Health Organization (WHO)–recommended treatment for schistosomiasis is **praziquantel**. For infection due to *S. mansoni*, *S. haematobium*, or *S. intercalatum*, the dose of praziquantel is 40 mg/kg/day PO divided into two doses for 1 day. For infection due to *S. japonicum* or *S. mekongi*, the dose of praziquantel is 60 mg/kg/day PO divided into three doses for 1 day. A second treatment 4–6 weeks after the first course is advised by some experts, allowing for maturation of immature forms not cleared initially. Praziquantel is well tolerated but can give side effects that correlate with intensity of infection, including abdominal pain and cramps, sweating, and somnolence. Pregnant and lactating women with schistosomiasis can safely be treated with praziquantel at usual doses starting at the second trimester of pregnancy.

## PREVENTION

Transmission in endemic areas may be decreased by reducing the parasite load in the human population. WHO recommends praziquantel to be given as a single dose to school-age children through mass drug administration programs once or twice a year depending on parasite endemicity levels. Recently, preschool children 2 years and older have also been included in control strategies. When added to national drug-based control programs, other measures such as improved sanitation, antiparasitic treatment given at well child visits, focal application of molluscicides, and animal vaccination may prove useful in breaking the cycle of transmission. Ultimately, control of schistosomiasis is closely linked to economic and social development.

Visit Elsevier eBooks+ at [eBooks.Elsevier.com](http://eBooks.Elsevier.com) for Bibliography.

## Chapter 347

# Flukes (Liver, Lung, and Intestinal)

Amaya L. Bustinduy, Sophie Pach, and Katja Doerholt

Several different **trematodes**, or flukes, can parasitize humans and cause disease. Flukes are endemic worldwide but are more prevalent in the less developed parts of the world. They include *Schistosoma*, or the blood flukes (see Chapter 346), as well as fluke species that cause infection in the human biliary tree, lung tissue, and intestinal tract. These latter trematodes are characterized by complex life cycles (Fig. 347.1). Sexual reproduction of adult worms in the definitive host produces eggs that are passed in the stool. Larvae, called **miracidia**, develop in freshwater. These, in turn, infect certain species of mollusks (aquatic snails or clams), in which asexual multiplication by parasite larvae produces cercariae. Cercariae then seek a second intermediate host, such as an insect, crustacean, or fish, or attach to vegetation to produce infectious **metacercariae**. Humans acquire liver, lung, and intestinal fluke infections by eating uncooked, lightly cooked, pickled, or smoked foods containing these infectious parasite cysts. The “alternation of generations” requires that flukes parasitize more than one host (often three) to complete their life cycle. Because parasitic flukes are dependent on these nonhuman species for transmission, the distribution of human fluke infection closely matches the ecologic range of the flukes’ intermediate hosts. As a group, these parasites are commonly referred to as **food-borne trematodes**.

## LIVER FLUKES

### Fascioliasis (*Fasciola hepatica*)

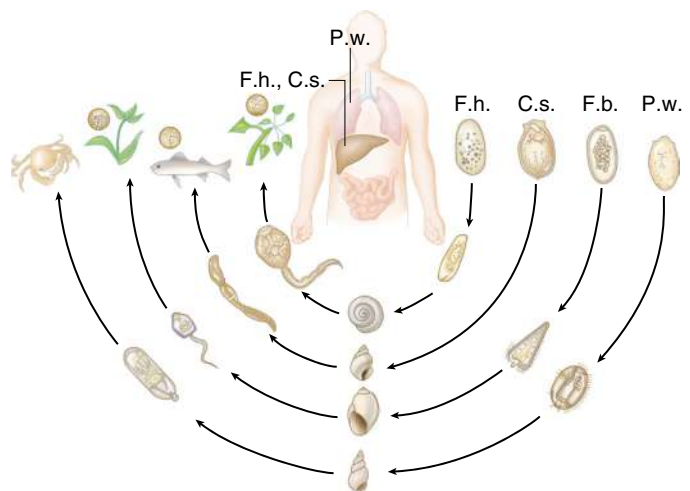
*Fasciola hepatica*, the sheep liver fluke, infects cattle, other ungulates, and occasionally humans. This infection affects approximately 17 million people worldwide and has been reported in many different parts of the world, particularly South America, Europe, Africa, China, Australia, and Cuba. Although *F. hepatica* is enzootic in North America, reported cases are extremely rare. Humans are infected by ingestion of metacercariae attached to vegetation, especially wild watercress, lettuce, and alfalfa. In the duodenum, the parasites excyst and penetrate the intestinal wall, liver capsule, and parenchyma. They wander for a few weeks before entering the bile ducts, where they mature. Adult *F. hepatica* (1–2.5 cm) commence oviposition approximately 12 weeks after infection; the eggs are large (75–140 μm) and operculated. They pass to the intestines with bile and exit the body in the feces (see Fig. 347.1). On reaching freshwater, the eggs mature and hatch into miracidia, which infect specific snail intermediate hosts to multiply into many cercariae. These then emerge from infected snails and encyst on aquatic grasses and plants.

**Clinical manifestations** usually occur either during the liver migratory phase of the parasites or after their arrival at their final habitat in upper bile ducts. Fever, right upper quadrant pain, and hepatosplenomegaly characterize the first phase of illness. Peripheral blood eosinophilia is usually marked. As the worms enter bile ducts, most of the acute symptoms subside. On rare occasions, patients may have obstructive jaundice or biliary cirrhosis, with signs of cholestasis, ascending cholangitis, cholelithiasis and jaundice and increased liver enzymes, direct bilirubin, and  $\gamma$ -glutamyl transpeptidase. *F. hepatica* infection is diagnosed by identifying the characteristic eggs in fecal smears or duodenal aspirates. **Diagnosis** can be suggested by positive serology and imaging that reveals acute, hypodense liver lesions that change over time. Presentation can be dramatic in children, with features including generalized edema, hepatic cirrhosis with esophageal varices, and in severe cases, death from generalized organ failure.

The recommended **treatment** of fascioliasis is triclabendazole (10 mg/kg orally [PO] once or twice) or bithionol (30–50 mg/kg PO once daily on alternate days for a total of 10–15 doses). In the United States, bithionol is not generally available, but it may be available from compounding pharmacies.

### Clonorchiasis (*Clonorchis sinensis*)

Infection of bile passages with *Clonorchis sinensis*, the Chinese or oriental liver fluke, is endemic in China, South Korea, northern Vietnam,



**Fig. 347.1** Life cycle of parasitic liver, lung, and intestinal flukes. C.s., *Clonorchis sinensis*; F.b., *Fasciolopsis buski*; F.h., *Fasciola hepatica*; P.w., *Paragonimus westermani*. (Adapted from Mandell GL, Bennett JE, Dolin R, eds. *Principles and Practice of Infectious Diseases*, 7th ed. Philadelphia: Elsevier, 2010: Fig 289-2.)

and parts of Russia and Japan, affecting more than 15 million people. Humans acquire infection by ingestion of raw or inadequately cooked **freshwater fish** carrying the encysted metacercariae of the parasite under their scales or skin. Metacercariae excyst in the duodenum and pass through the ampulla of Vater to the common bile duct and bile capillaries, where they mature into hermaphroditic adult worms (3–15 mm). *C. sinensis* worms deposit small operculated eggs (14–30 µm), which are discharged through the bile duct to the intestine and feces (see Fig. 347.1). The eggs mature and hatch outside the body, releasing motile miracidia into local freshwater streams, rivers, or ponds. If these are taken up by the appropriate snails, they develop into cercariae, which are, in turn, released from the snail to encyst under the skin or scales of freshwater fish.

**Clinical manifestations** are minimal in most individuals with *C. sinensis* infection, particularly those with few organisms. Among heavily infected individuals, who tend to be older (>30 years), localized obstruction of a bile duct results from repeated local trauma and inflammation. In these patients, **cholangitis and cholangiohepatitis** may lead to liver enlargement and jaundice. In Hong Kong, Korea, and other parts of Asia, **cholangiocarcinoma** is associated with chronic *C. sinensis* infection.

**Diagnosis** of clonorchiasis is made by examination of feces or duodenal aspirates for the parasite eggs and serology. Radiologic imaging (CT scan) can detect fibrosis in the biliary tract and cholangiocarcinoma. The recommended **treatment** of clonorchiasis is praziquantel (75 mg/kg/day PO divided 3 times daily [tid] for 2 days). An alternative, used in adults, is albendazole (10 mg/kg once daily PO for 7 days). Tribendimidine (400 mg PO for 3 days) has been used in China with good cure rates.

### Opisthorchiasis (*Opisthorchis* spp.)

Infections with species of *Opisthorchis* are clinically similar to those caused by *C. sinensis*. *Opisthorchis felineus* and *Opisthorchis viverrini* are liver flukes of cats and dogs that infect humans through ingestion of metacercariae in freshwater fish. Infection with *O. felineus* is endemic in Eastern Europe and Southeast Asia, and *O. viverrini* is found mainly in Thailand, affecting an estimated 10 million people. Most individuals are minimally symptomatic; liver enlargement, relapsing cholangitis, and jaundice may occur in heavily infected individuals. *O. viverrini* is a known carcinogen, much like *Clonorchis* spp. responsible for **cholangiocarcinoma**. Diagnosis is based on recovering eggs from stools or duodenal aspirates and serology. The recommended **treatment** of opisthorchiasis is praziquantel (75 mg/kg/day PO tid for 2 days).

## LUNG FLUKES

### Paragonimiasis (*Paragonimus* spp.)

Human infection by the lung fluke *Paragonimus westermani*, and less frequently other species of *Paragonimus*, occurs throughout the Far East, in localized areas of West Africa, and in several parts of Central and South America, affecting approximately 20 million people. The highest incidence of paragonimiasis occurs in older children and adolescents 11–15 years of age. Although *P. westermani* is found in many carnivores, human cases are relatively rare and seem to be associated with specific dietary habits, such as eating raw **freshwater crayfish or crabs**. These crustaceans contain the infective metacercariae in their tissues. After ingestion, the metacercariae excyst in the duodenum, penetrate the intestinal wall, and migrate to their final habitat in the lungs. Adult worms (5–10 mm) encapsulate within the lung parenchyma and deposit brown operculated eggs (60–100 µm) that pass into the bronchioles and are expectorated by coughing (see Fig. 347.1). Ova can be detected in the sputum of infected individuals or in their feces. If eggs reach freshwater, they hatch and undergo asexual multiplication in specific snails. The cercariae encyst in the muscles and viscera of crayfish and freshwater crabs.

### Clinical Manifestations

Most individuals infected with *P. westermani* harbor low or moderate worm loads and are minimally symptomatic. The clinical manifestations include cough, production of rust-colored sputum, and

**hemoptysis** (*mimicking tuberculosis*), which is the principal manifestation and occurs in 98% of symptomatic children. In addition, children with paragonimiasis have pleural effusions, hepatomegaly, and subcutaneous nodules. For the **diagnosis**, there are no characteristic physical findings, but laboratory examination usually demonstrates marked **eosinophilia**. Chest radiographs often reveal small, **patchy infiltrates** or radiolucencies in the middle lung fields; however, radiographs may appear normal in one fifth of infected individuals. In rare circumstances, lung abscess, pleural or pericardial effusion, or bronchiectasis may develop. Extrapulmonary localization of *P. westermani* in the brain, peritoneum, intestines, or pericardium may rarely occur. **Cerebral paragonimiasis** occurs primarily in heavily infected individuals living in highly endemic areas of the Far East. The clinical presentation resembles jacksonian epilepsy or the symptoms of cerebral tumors. Definitive diagnosis of paragonimiasis is established by identification of eggs in fecal or sputum smears and serology. The recommended **treatment** of paragonimiasis is praziquantel (75 mg/kg/day PO tid for 2 days). Triclabendazole can also be used (10 mg/kg PO daily for 1–2 days).

## INTESTINAL FLUKES

Several wild and domestic animal intestinal flukes, including *Fasciolopsis buski*, *Nanophyetus salmincola*, and *Heterophyes heterophyes*, may accidentally infect humans who eat uncooked or undercooked fish or water plants. For example, *F. buski* is endemic in the Far East, where humans who ingest metacercariae encysted on aquatic plants become infected. These develop into large flukes (1–5 cm) that inhabit the duodenum and jejunum. Mature worms produce operculated eggs that pass with feces; the organism completes its life cycle through specific snail intermediate hosts. Individuals with *F. buski* infection are usually asymptomatic; heavily infected patients complain of **abdominal pain and diarrhea** and show signs of malabsorption. **Diagnosis** of fasciolopsiasis and other intestinal fluke infections is established by fecal examination and identification of the eggs (see Fig. 347.1). As for other fluke infections, praziquantel (75 mg/kg/day PO tid for 2 days) is the drug of choice.

Visit Elsevier eBooks+ at [eBooks.Health.Elsevier.com](http://eBooks.Health.Elsevier.com) for Bibliography.

## Chapter 348

# Adult Tapeworm Infections

Philip R. Fischer and A. Clinton White Jr.

Tapeworms are adult forms of **cestodes**, multicellular helminth parasites, that live in human intestines and cause non–life-threatening illness. Invasive larval forms of cestodes are associated with cysts that lead to severe human disease such as neurocysticercosis (*Taenia solium*; see Chapter 349) and echinococcosis (mostly *Echinococcus granulosus* and *E. multilocularis*; Chapter 350). The adult worms themselves are flat and multisegmented, varying in length from 8 mm to 10 meters (m). **Table 348.1** summarizes the key features of tapeworms that affect children.

## ETIOLOGY

The **beef tapeworm** (*Taenia saginata*), the **pork tapeworm** (*T. solium*), and the Asian tapeworm (*Taenia asiatica*) are long worms (4–10 m) named for their intermediate hosts (*T. saginata*, *T. solium*) or geographic distribution (*T. asiatica*; larval host is the pig). The adult worms are found only in the human intestine. As with the adult stage of all

**Table 348.1** Key Features of Common Tapeworms in Children

PARASITE SPECIES	GEOGRAPHY	SOURCE	SYMPTOMS	TREATMENT
<i>Taenia saginata</i>	Asia, Africa, Latin America	Cysts in beef	Abdominal discomfort, motile proglottid migration, passing segments	Praziquantel or niclosamide, possibly nitazoxanide
<i>Taenia solium</i>	Asia, Africa, Latin America	Cysticerci in pork	Minimal, proglottids in stool	Praziquantel or niclosamide
<i>Taenia asiatica</i>	Asia	Pigs	Minimal	Praziquantel or niclosamide
<i>Dibothriocephalus latus</i>	Europe, North America	Plerocercoid cysts in freshwater fish	Usually minimal; with prolonged or heavy infection with <i>D. latus</i> , vitamin B <sub>12</sub> deficiency	Praziquantel or niclosamide
<i>Dibothriocephalus nihonkaiense</i>	Northeast Asia, North Pacific coast of North America	Plerocercoid cysts in saltwater fish	Usually minimal; passing proglottids	Praziquantel or niclosamide
<i>Adenocephalus pacificus</i>	Pacific Coast of South America	Infected fish	Usually none or mild	Praziquantel or niclosamide
<i>Hymenolepis</i>	Worldwide, often northern areas	Infected humans, rodents	Mild abdominal discomfort	Praziquantel, niclosamide, or nitazoxanide
<i>Dipylidium caninum</i>	Worldwide	Domestic dogs and cats	Proglottids in stool, anal pruritus confused with pinworm	Praziquantel or niclosamide

tapeworms, their body is a series of hundreds or thousands of flattened segments (**proglottids**) with an anterior attachment organ (**scolex**) that anchors the parasite to the bowel wall. New segments arise from the distal aspect of the scolex with progressively more mature segments attached distally. The gravid terminal segments contain 50,000-100,000 eggs, and the eggs or even detached intact proglottids pass out of the child through the anus (with or separate from defecation). These tapeworms differ most significantly in that the intermediate stage of the pork tapeworm (**cysticercus**) can also infect humans and cause significant morbidity (see [Chapter 349](#)), whereas the larval stage of *T. saginata* does not cause human disease. *T. asiatica* is similar to and often confused with the beef tapeworm.

## EPIDEMIOLOGY

The pork and beef tapeworms are distributed worldwide, with the highest risk for infection in Latin America, Africa, India, Southeast Asia, and China, where the relevant intermediate host is raised domestically. The prevalence in adults may not reflect the prevalence in young children, because cultural practices may dictate how well meat is cooked and how much is served to children.

## PATHOGENESIS

When children ingest raw or undercooked meat containing larval cysts, gastric acid and bile facilitate release of immature scolices that attach to the lumen of the small intestine. The parasite grows, adding new segments at the base of the scolex. The terminal segments mature and after 2-3 months produce eggs that are released in stool. The surface of proglottids serves as an absorptive organ to “steal” nutritional elements from the child’s small bowel for use by the parasite. There is sometimes a transient eosinophilia before the parasite matures enough to release eggs.

## CLINICAL MANIFESTATIONS

Nonspecific abdominal symptoms have been reported with beef and pork tapeworm infections, but the most bothersome symptom is the psychologic distress caused by seeing proglottids in the stool or undergarments. The released segments of the worms are motile (especially

those of *T. saginata*) and sometimes lead to anal pruritus. The adult beef and pork tapeworms are only rarely associated with other symptoms.

## DIAGNOSIS

Identification of the infecting tapeworm species facilitates understanding of risk for invasive disease. Carriers of adult pork tapeworms are at increased risk for transmitting eggs with the pathogenic intermediate stage (cysticercus) to themselves or others, whereas children infected with the beef tapeworm or *T. asiatica* are a risk only to livestock. Because proglottids are generally passed intact, visual examination for gravid proglottids in the stool is a sensitive test; these segments may be used to identify species. Eggs, by contrast, are often absent from stool and cannot distinguish between *T. saginata* and *T. solium* ([Fig. 348.1](#)). If the parasite is completely expelled, the scolex of each species is diagnostic. The scolex of *T. saginata* has only a set of four anteriorly oriented suckers, whereas *T. solium* is armed with a double row of hooks in addition to suckers. The proglottids of *T. saginata* have >20 branches from a central uterine structure, and the proglottids of *T. solium* have ≤10 branches. Expelled proglottid segments are usually approximately 0.5 × 1-2 × 0.1 cm in size. Molecular methods can distinguish *T. saginata* from *T. asiatica*. Antigen detection tests are increasingly available.

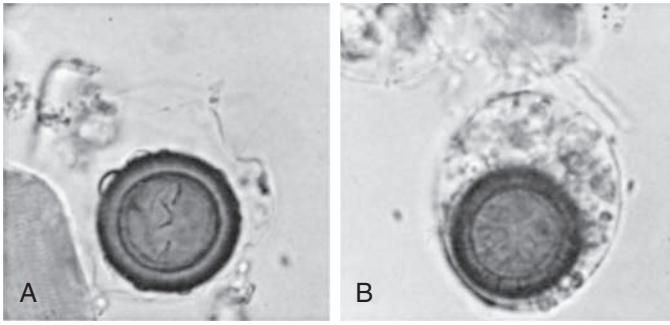
## DIFFERENTIAL DIAGNOSIS

Anal pruritus may mimic symptoms of pinworm (*Enterobius vermicularis*) infection. Broad tapeworms such as *Dibothriocephalus latus* (formerly *Diphyllobothrium latum*) and *Ascaris lumbricoides* (a long round worm) may be mistaken for *T. saginata* or *T. solium* in stools.

## TREATMENT

Infections with all adult tapeworms respond to praziquantel (25 mg/kg orally [PO] once). When available, an alternative treatment for taeniasis is niclosamide (50 mg/kg PO once for children; 2 g PO once for adults). Nitazoxanide is sometimes effective as well. The parasite is usually expelled on the day of administration. Treatment with electrolyte–polyethylene glycol bowel preparations can increase the yield of passage of scolices.





**Fig. 348.1** Eggs of *Taenia saginata* recovered from feces (original magnification  $\times 400$ ). A and B, The eggs are generally bile-stained, dark, and prismatic. There is occasionally some surrounding cellular material from the proglottid in which the egg develops, which is more evident in B than in A. The larva within the egg shows three pairs of hooklets (A), which may occasionally be observed in motion.

### PREVENTION

Prolonged freezing or thorough cooking of beef and pork kills the larval cystic forms of the parasite. Appropriate human sanitation can interrupt transmission by preventing infection in livestock. Mass treatment does not lead to lasting reductions in prevalence.

### DIPHYLLOBOTHRIASIS (*DIBOTHRIOCEPHALUS* SPP.)

#### Etiology

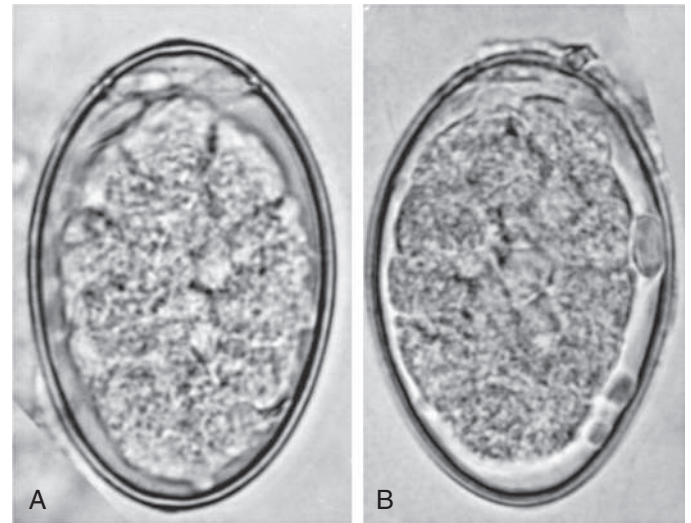
The **broad tapeworms** of the order Diphyllbothriidea are the longest human tapeworms, reaching  $>10$  m in length, and have an anatomic organization similar to that of other adult cestodes. An elongated scolex, equipped with slits (**bothria**) along each side but no suckers or hooks, is followed by thousands of segments looped in the small bowel. Gravid terminal proglottids detach periodically but tend to disintegrate before expulsion, thus releasing eggs rather than intact worm segments in the feces. In contrast to taeniids, the life cycle of Diphyllbothriid spp. requires two intermediate hosts. Small, freshwater crustaceans (copepods) take up the larvae that hatch from parasite eggs. The parasite passes up the food chain as small fish eat the copepods and are, in turn, eaten by larger fish. In this way, the juvenile parasite becomes concentrated in pike, walleye, perch, burbot, and salmon. Consumption of raw or undercooked fish leads to human infection with adult fish tapeworms. Recent molecular studies have led to marked revision in the taxonomy with regional differences in the predominant species (*Dibothriocephalus latus* in Europe, North America; *Dibothriocephalus nihonkaiense* in Japan, Northeast Asia, and the northern Pacific coast of North America, and *Adenocephalus pacificus* in coastal South America).

#### Epidemiology

The fish tapeworms are most prevalent in the temperate climates of Europe, North America, and northeastern Asia and along the Pacific coast of South America and in Africa. In North America the prevalence is highest in Alaska, Canada, and northern areas of the continental United States. The tapeworm is found in fish from those areas that are then taken to market. Persons who prepare raw fish for home or commercial use or who sample fish before cooking are particularly at risk for infection.

#### Pathogenesis

The adult worm of *Dibothriocephalus latus* (found in northern Europe) has high-affinity receptors and efficiently scavenges vitamin B<sub>12</sub> for its own use in the constant production of large numbers of segments and as many as 1 million eggs per day. As a result, diphyllbothriasis causes **megaloblastic anemia** in 2–9% of infections. Interestingly, other Diphyllbothriid spp. do not out-compete the host for vitamin B<sub>12</sub>. Children with other causes of vitamin B<sub>12</sub> or folate deficiency, such as chronic infectious diarrhea, celiac disease,



**Fig. 348.2** Eggs of *Dibothriocephalus latus* as seen in feces (original magnification  $\times 400$ ). A and B, The caplike operculum is at the upper end of the eggs here.

or congenital malabsorption, are more likely to develop symptomatic infection.

#### Clinical Manifestations

Infection is largely asymptomatic. Segments may be noted in stool. Those who develop vitamin B<sub>12</sub> or folate deficiency present with megaloblastic anemia with leukopenia, thrombocytopenia, glossitis, and/or signs of spinal cord posterior column dysfunction (loss of vibratory sense, proprioception, and coordination).

#### Diagnosis

Parasitologic examination of the stool is useful because eggs are abundant in the feces and have morphology distinct from that of all other tapeworms. The eggs are ovoid and have an **operculum**, which is a cap structure at one end that opens to release the embryo (Fig. 348.2). The worm itself has a distinct scolex and proglottid morphology; however, these are not likely to be passed spontaneously.

#### Differential Diagnosis

A segment or a whole section of the worm might be confused with *Taenia* or *Ascaris* after it is passed. Pernicious anemia, bone marrow toxicity, and dietary restriction may contribute to or mimic the nutritional deficiencies associated with diphyllbothriasis.

#### Treatment

As with all adult tapeworms, *D. latus* infections respond to praziquantel (5–10 mg/kg PO once). Niclosamide (50 mg/kg PO in a single dose) is also effective.

#### Prevention

The intermediate stage is easily killed by brief cooking or prolonged freezing of fish before ingestion. Because humans are the major reservoir for adult worms, health education is one of the most important tools for preventing transmission, together with improved human sanitation.

### HYMENOLEPIASIS (*HYMENOLEPIS*)

Infection with *Hymenolepis nana*, the **dwarf tapeworm**, is very common in developing countries. Most cases are asymptomatic. However, heavy infection has been associated with diarrhea, weight loss, fever, anemia, and eosinophilia. The intermediate stage of *Hymenolepis diminuta* develops in various hosts (e.g., rodents, ticks, fleas), but the entire life cycle of *H. nana* is completed in humans. Therefore hyperinfection with thousands of small adult worms in a single child may occur. A similar infection may occur less often with *H. diminuta*. Eggs



but not segments may be found in the stool. *H. nana* infection responds to praziquantel (25 mg/kg PO once). Nitazoxanide is effective in about three fourths of children (100 mg PO twice daily [bid] for 3 days for children 1-3 years old, 200 mg bid for 3 days for children 4-11 years old, and 500 mg bid for 3 days for older children).

### DIPYLIDIASIS (*DIPYLIDIUM CANINUM*)

*Dipylidium caninum* is a common tapeworm of domestic dogs and cats. Human infection is relatively rare. Direct transmission between pets and humans does not occur; human infection requires ingestion of the parasite's intermediate host, the dog or cat flea. Infants and small children are particularly susceptible because of their level of hygiene, generally more intimate contact with pets, and activities in areas where fleas can be encountered. Thus children are most at risk of inadvertent ingestion of fleas infected with the larvae. The most common symptom is passage of proglottids in stool. The proglottids are similar in size and shape to white rice grains. Anal pruritus, vague abdominal pain, and diarrhea have at times been associated with dipylidiasis, which is thus sometimes confused with pinworm (*E. vermicularis*). Dipylidiasis responds to treatment with praziquantel (5-10 mg/kg PO once) and niclosamide (50 mg/kg PO as a single dose). **Deworming** of pets and **flea control** are the best preventive measures.

Visit Elsevier eBooks+ at [eBooks.Health.Elsevier.com](http://eBooks.Health.Elsevier.com) for Bibliography.

## Chapter 349

# Cysticercosis

A. Clinton White Jr., Miguel M. Cabada,  
and Philip R. Fischer

*Taenia solium*, also known as the **pork tapeworm**, causes two different infections in children. In its normal life cycle, children can acquire the tapeworm form by ingestion of undercooked pork containing the larval cysts (see [Chapter 348](#)). In the intestines, the cyst converts into the tapeworm form. Children are also susceptible to infection by the eggs shed by tapeworm carriers. After the eggs are ingested, the larvae are released from the eggs, invade through the intestines, and migrate through the bloodstream to the muscles (and other organs), where they form tissue cysts (0.2-2.0 cm fluid-filled bladders containing a single invaginated **scolex**). Infection with the cystic form is termed **cysticercosis**, and involvement of the central nervous system (CNS) is termed **neurocysticercosis**. The tapeworm form only develops after ingestion of undercooked pork. Ingestion of pork is not necessary to develop cysticercosis, but individuals harboring an adult worm may infect themselves with the eggs by the fecal-oral route.

### EPIDEMIOLOGY

The pork tapeworm is widely distributed wherever pigs are raised and have contact with human fecal material. Intense transmission occurs in Central and South America, southern and Southeast Asia, and much of sub-Saharan Africa. In these areas, approximately 30% of cases of seizures may be a result of cysticercosis. Most cases of cysticercosis in the United States are imported; however, local transmission has been documented.

### PATHOGENESIS

Living, intact cystic stages usually suppress the host immune and inflammatory responses. Intact cysts can be associated with disease when they obstruct the flow of cerebrospinal fluid. Most cysts

remain asymptomatic for a few years. Symptoms typically develop as the cysticerci begin to degenerate, associated with a host inflammatory response. The natural history of cysts is eventually to resolve by complete resorption or calcification, but this process may take years. Cysticerci can also present as subcutaneous nodules, ocular infection, or spinal lesions with myelopathy or radiculopathy.

### CLINICAL MANIFESTATIONS

**Seizures** and headache are the presenting findings in the vast majority of children with neurocysticercosis. Less common manifestations include hydrocephalus, diffuse cerebral edema, or focal neurologic findings. It is important to classify neurocysticercosis as parenchymal, intraventricular, subarachnoid, spinal, or ocular on the basis of anatomic location, clinical presentation, and radiologic appearance because the prognosis and management vary with location.

**Parenchymal** neurocysticercosis typically presents with seizures. The seizures are usually focal, but often generalize. Children may present with a single seizure or recurrent epilepsy. Mild neurocognitive defects have been documented from cysticerci alone but are more commonly associated with poorly controlled seizures. A fulminant encephalitis-like presentation may rarely occur after a massive initial infection associated with cerebral edema. **Intraventricular** neurocysticercosis (up to 20% of cases) is associated with obstructive hydrocephalus and acute, subacute, or intermittent signs of increased intracranial pressure, usually without localizing signs. **Subarachnoid** neurocysticercosis is rare in children. It can be associated with basilar arachnoiditis that can present with signs of meningeal irritation, communicating hydrocephalus, cerebral infarction, or **spinal** disease with radiculitis or transverse myelitis. Cysticerci in the tissues may present with focal findings from mass effect. **Ocular** neurocysticercosis causes decreased visual acuity because of cysticerci in the retina or vitreous, retinal detachment, or iridocyclitis.

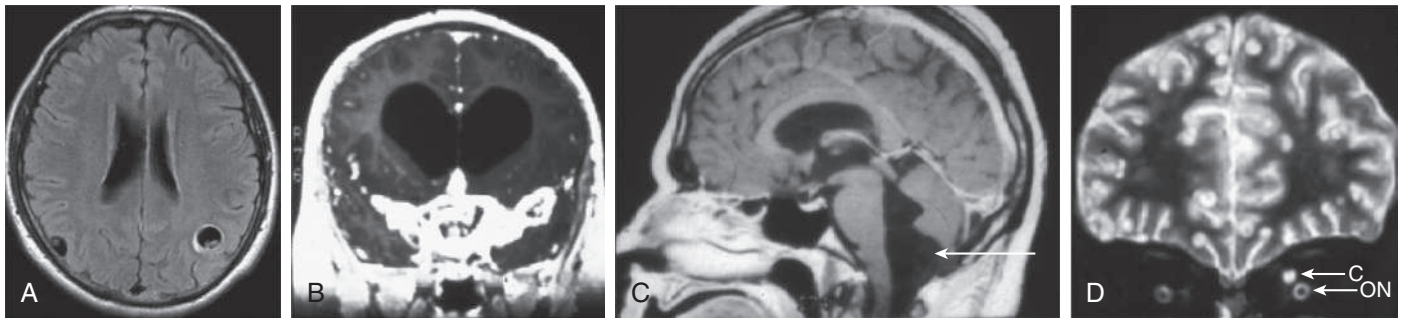
### DIAGNOSIS

Neurocysticercosis should be suspected in a child with onset of seizures or hydrocephalus and who also has a history of residence in an endemic area and/or a care provider from an endemic area. The most useful diagnostic study for parenchymal disease is MRI of the head. MRI provides the most information about cyst location, cyst viability, and associated inflammation. The scolex can appear as a 1-2 mm nodule attached to the cyst wall, and, when identified, is diagnostic for cysticercosis ([Fig. 349.1A](#)). The MRI also better detects basilar arachnoiditis ([Fig. 349.1B](#)), intraventricular cysts ([Fig. 349.1C](#)), and cysts in the spinal cord. CT is best for identifying calcifications. A solitary parenchymal cyst, with or without contrast enhancement, or CNS calcifications are the most common findings in children ([Fig. 349.2](#)). Plain films may reveal calcifications in muscle or brain consistent with cysticercosis. In children from endemic regions, the presentation with a single enhancing lesion that is round and <2 cm in diameter, absence of symptoms or signs of other diseases (e.g., no fever or lymph nodes), no focal findings, and no evidence of increased intracranial pressure is highly specific for neurocysticercosis.

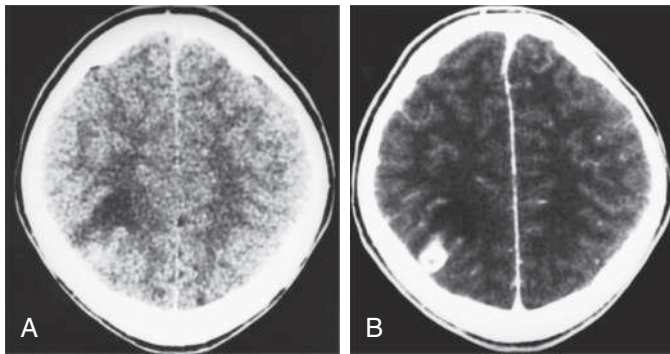
Serologic diagnosis using the enzyme-linked immunotransfer blot is available commercially in the United States and through the Centers for Disease Control and Prevention (CDC). Serum antibody testing is highly specific but is frequently negative in children with single lesions or just calcifications. Antigen-detection assays and polymerase chain reaction assays show promise for diagnosis of ventricular and subarachnoid disease and are available from the Laboratory for Parasitic Diseases, National Institutes of Health (NIH). They are not commercially available in the United States.

### Differential Diagnosis

Neurocysticercosis is often confused clinically with other seizure disorders. Clinical suspicion is based on travel history, a history of contact with an individual who might carry an adult tapeworm, or suggestive



**Fig. 349.1** Neurocysticercosis. A, T1-weighted MRI demonstrating two parenchymal cysts with scoleces. B, T1-weighted MRI of cysticercal basilar arachnoiditis. C, T1-weighted MRI showing a cyst below the fourth ventricle (arrow). D, T2-weighted MRI showing a cysticercus (C) above the optic nerve (ON).



**Fig. 349.2** Neurocysticercosis. CT image of a solitary lesion with (A) and without (B) contrast, showing contrast enhancement. (Courtesy Dr. Wendy G. Mitchell and Dr. Marvin D. Nelson, Children's Hospital, Los Angeles.)

imaging studies. The imaging appearance can be confused with brain abscess, granulomas (including tuberculomas, fungal infections, Langerehans histiocytosis, and toxoplasmosis), and tumors.

## TREATMENT

The initial management of cysticercosis should focus on symptomatic therapy for seizures and/or hydrocephalus. Seizures can usually be controlled using standard antiepileptic drugs. If the lesions resolve, antiepileptic drugs can often be tapered and stopped. Frequent seizures or the development of calcified lesions are risk factors for recurrent seizures and indications for prolonged or lifelong antiepileptic therapy.

The natural history of **parenchymal** lesions is to resolve spontaneously, with or without antiparasitic drugs, but this process is often prolonged (months to years). Solitary parenchymal cysts resolve slightly more rapidly with antiparasitic therapy. Antiparasitic drugs also decrease the frequency of recurrent seizures. Other forms of the disease are less common in children. In adults with cystic lesions, randomized controlled trials suggested an overall 50% decrease in recurrence of generalized seizures with albendazole treatment. The benefit to children was significantly less, perhaps because most of these infections were with only one to two cysts. Corticosteroids likely also decrease seizure frequency.

The most commonly used antiparasitic is **albendazole** (15 mg/kg/day orally [PO] divided twice daily [bid]). It should be taken with a fatty meal to improve absorption. The most common duration of therapy is 7 days for single parenchymal lesions. However, longer duration (months), higher doses (up to 30 mg/kg/day), or combination therapy with praziquantel is often required for multiple lesions or subarachnoid disease. For example, in adults with more than two cysticerci, trials note improved resolution with combination therapy

with corticosteroids, albendazole, and praziquantel (50 mg/kg/day PO divided three times daily for 14 days). **Praziquantel** (50-100 mg/kg/day for 28 days) may be used as an alternative to albendazole. First-pass metabolism is common with corticosteroids or antiepileptic drugs. **Cimetidine** can be used in conjunction with praziquantel to blunt the first-pass metabolism. A worsening of symptoms can follow the use of either drug based on the host's inflammatory response to the dying parasite. Patients should be medicated with prednisone (1-2 mg/kg/day) or oral dexamethasone (0.15 mg/kg/day) beginning before the first dose of antiparasitic drugs and continuing for at least 2 weeks.

Most patients with hydrocephalus require neurosurgical interventions. Some cases require emergent placement of a ventriculostomy, but most can be managed by cystectomy alone. For obstructive hydrocephalus caused by ventricular cysticercosis, many patients can be cured by minimally invasive surgery. **Neuroendoscopy** is the preferred approach to cysticerci in the lateral or third ventricle. Cysticerci in the fourth ventricle can be removed by a suboccipital craniotomy. There are also reports of endoscopic removal of fourth ventricular cysticerci using flexible neuroendoscopy. Adherent cysticerci that cannot be removed can be treated by placement of a ventriculoperitoneal shunt (VPS). However, there is a high rate of shunt failure, which can be minimized somewhat by treatment with antiparasitic drugs plus corticosteroids.

**Subarachnoid** disease has a poor prognosis. The prognosis is much improved by aggressive therapy, including antiparasitic drugs, anti-inflammatory treatment, and neurosurgical procedures for hydrocephalus (e.g., VPS placement). However, the duration of antiparasitic and anti-inflammatory therapy often needs to be prolonged. **Methotrexate** and/or tumor necrosis factor inhibitors can be used as a steroid-sparing agent in patients requiring prolonged anti-inflammatory therapy. **Ocular** cysticercosis is usually treated surgically, although there are reports of cure using medical therapy alone.

## PREVENTION

In areas with evolved public health systems, cysticercosis can largely be eliminated by meat inspection, condemnation of infected meat, thorough cooking of pork, and improved sanitation. This approach has not worked in countries where most meat is butchered informally. Mass chemotherapy for tapeworm carriers, mass treatment of pigs, and improved personal hygiene have decreased or eliminated transmission in some areas. Screening family members and those preparing food for index cases for cysticercosis has a very low yield, in part because of the poor sensitivity of current tests. Those who have noted passing material consistent with taeniasis should be treated with praziquantel regardless of the results of stool studies. Veterinary vaccines for several cestode infections have a high degree of efficacy and have a potential role in decreasing parasite transmission.

Visit Elsevier eBooks+ at [eBooks.Health.Elsevier.com](http://eBooks.Health.Elsevier.com) for Bibliography.

## Chapter 350

# Echinococcosis (*Echinococcus granulosus sensu lato* and *Echinococcus multilocularis*)

Miguel M. Cabada, Philip R. Fischer, and  
A. Clinton White Jr.

## ETIOLOGY

Echinococcosis (**hydatid disease** or **hydatidosis**) is a widespread, serious human cestode infection (Fig. 350.1). Two major *Echinococcus* groups of species are responsible for distinct clinical presentations. *Echinococcus granulosus sensu lato* causes **cystic echinococcosis**, and *Echinococcus multilocularis* causes **alveolar echinococcosis**. The adult parasites are small (2–7 mm) tapeworms with only two to six segments that inhabit the intestines of canines such as dogs, wolves, dingoes, jackals, coyotes, and foxes. Canines are infected by ingesting contaminated viscera from ungulates (*E. granulosus sensu lato*) or mice (*E. multilocularis*). These carnivores pass the eggs in their stool, which contaminate the soil, pasture, and water, as well as their own fur. Domestic animals, such as sheep, goats, cattle, and camels, ingest *E. granulosus* complex eggs while grazing. Some species of *E. granulosus sensu lato* have a **sylvatic** cycle involving wild cervids such as moose, elk, and deer. For *E. multilocularis*, the main intermediate hosts are small rodents. Humans are infected by consuming eggs by direct contact with infected canines or from ova in the environment. In Europe, contamination of gardens by fox excrement is a major risk factor for transmission. The larvae hatch, penetrate the gut, and are carried by the vascular or lymphatic systems to the liver, lungs, and less frequently, bones, kidney, brain, or heart in *E. granulosus* infection. *E. multilocularis* larvae infect the liver almost exclusively.

*Echinococcus granulosus sensu lato* comprises several recognized species, including *E. granulosus sensu stricto*, *E. equinus*, *E. ortleppi*, and *E. canadensis*. The species within *E. granulosus sensu lato* show significant variation not only in genetics but also in ecology. While *E. granulosus sensu stricto* is mainly found in domesticated ovines and dogs around the world, *E. canadensis* is found in a sylvatic wolf/moose cycle in North America and Siberia and has been identified in bovines and swine in South America.

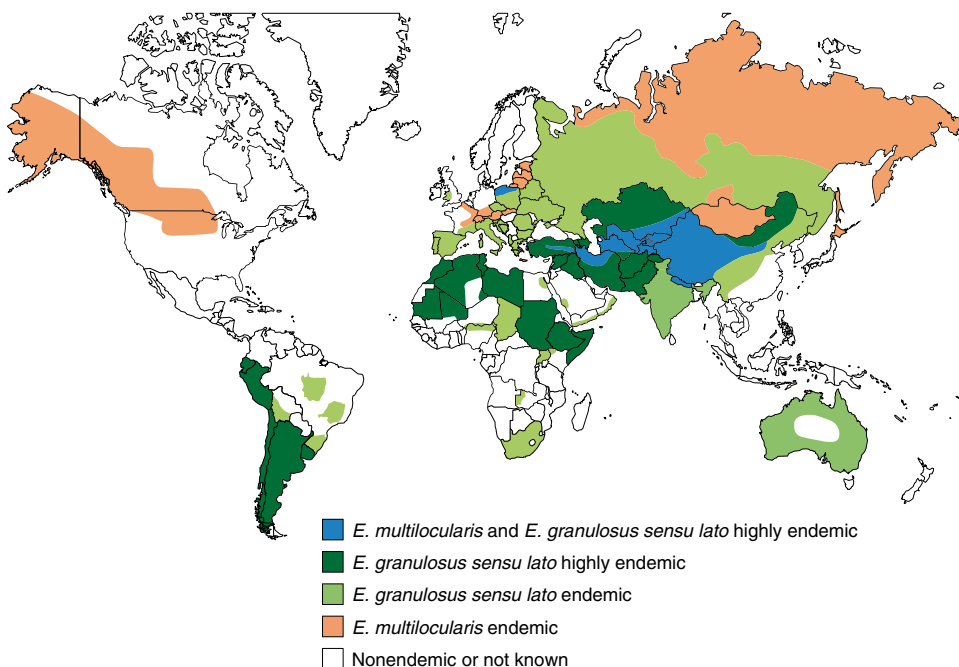
## EPIDEMIOLOGY

There is potential for transmission of *E. granulosus* to humans wherever dogs are allowed to ingest the entrails of herd animals. Disease is highly endemic in the Middle East and Central Asia. Cysts have been detected in up to 10% of the human population in northern Kenya and western China. In South America, the disease is prevalent in sheep-herding areas of the Andes, the beef-herding areas of the Brazilian/Argentine Pampas, and Uruguay. Among developed countries, the disease is recognized in Italy, Greece, Portugal, Spain, and Australia and is reemergent in dogs in Great Britain. In North America, transmission occurs rarely through a sylvatic cycle in the Arctic regions and in sheep-raising areas of the western United States.

Transmission of *E. multilocularis* occurs primarily in Western China, Central Europe, Siberia, and Turkey. Transmission is now rare in western Canada and the Arctic regions of North America. Ingestion of infected rodents by dogs or foxes facilitates transmission to children. Separate species, *E. vogeli* and *E. oligarthrus*, have mainly a sylvatic cycle involving canines and felines causing polycystic disease in northern South America.

## PATHOGENESIS

*E. granulosus sensu lato* parasites are often acquired in childhood, and cysts require many years to become large enough to be detected or cause symptoms. In children the lung is a common site of infection, whereas in adults up to 70% of cysts develop in the liver. Cysts can also develop in bone, the genitourinary system, spleen, subcutaneous tissues, and brain. The host surrounds the primary cyst with a tough, fibrous capsule. Inside this capsule, the parasite produces a thick lamellar layer with the consistency of a soft-boiled egg white. Inside the lamellar layer is the thin germinal layer of cells responsible for production of 1000s of protoscoleces that remain attached to the wall or float free in the cyst fluid (Video 350.1). Smaller internal daughter cysts may develop within the primary cyst capsule. The fluid in a healthy cyst is clear, colorless, and watery. Rupture of the cyst, which can occur



**Fig. 350.1** Global distribution of cystic echinococcosis and alveolar echinococcosis. (From Wen H, Vuitton L, Tuxun T, et al. Echinococcosis: advances in the 21st century. *Clin Microbiol Rev.* 2019;32[2]:e00075–18. Fig 3.)



spontaneously, with trauma, or during surgery, can be associated with immediate hypersensitivity reactions, including anaphylaxis. Protoscolexes released into the tissues can also develop into new cysts.

*E. multilocularis* almost always involves the liver. The lesions grow very slowly and rarely present in children. The secondary reproductive units bud externally and are not confined within a single, well-defined structure. Thus the lesions are invasive and often confused with a malignancy. Furthermore, the cyst tissues are poorly demarcated from those of the host, making surgical removal difficult. The secondary cysts are also capable of distant metastatic spread. The growing cyst mass eventually replaces a significant portion of the liver and compromises adjacent tissues and structures.

### CLINICAL MANIFESTATIONS

In the liver, cysts may remain asymptomatic, may regress spontaneously, or may produce nonspecific symptoms. Symptomatic cysts can cause increased abdominal girth, hepatomegaly, a palpable mass, vomiting, or abdominal pain. In the lung, cysts produce chest pain, chronic cough, or hemoptysis. Expecterated fluid from ruptured lung cysts is often described as “salty.” Mass effects can be noted in the brain and bone. Serious complications result from compression of adjacent structures or spillage of cyst contents. Type I hypersensitivity reactions, including **anaphylaxis**, can occur with spontaneous spillage or with cyst rupture from trauma or during surgery. Fluid from ruptured lung cysts can cause hypersensitivity pneumonitis. Spillage of fluid from a viable cyst can cause catastrophic long-term complications. Each protoscolex can form a new cyst and fill up the abdominal cavity or other spaces, including the pleura, biliary tree, and pelvis. Jaundice from cystic hydatid disease is rare.

Alveolar hydatid disease is sometimes diagnosed incidentally, but often the proliferating mass compromises the biliary system and/or hepatic tissue, causing progressive obstructive jaundice and hepatic failure. Symptoms also occur from expansion of extrahepatic foci.

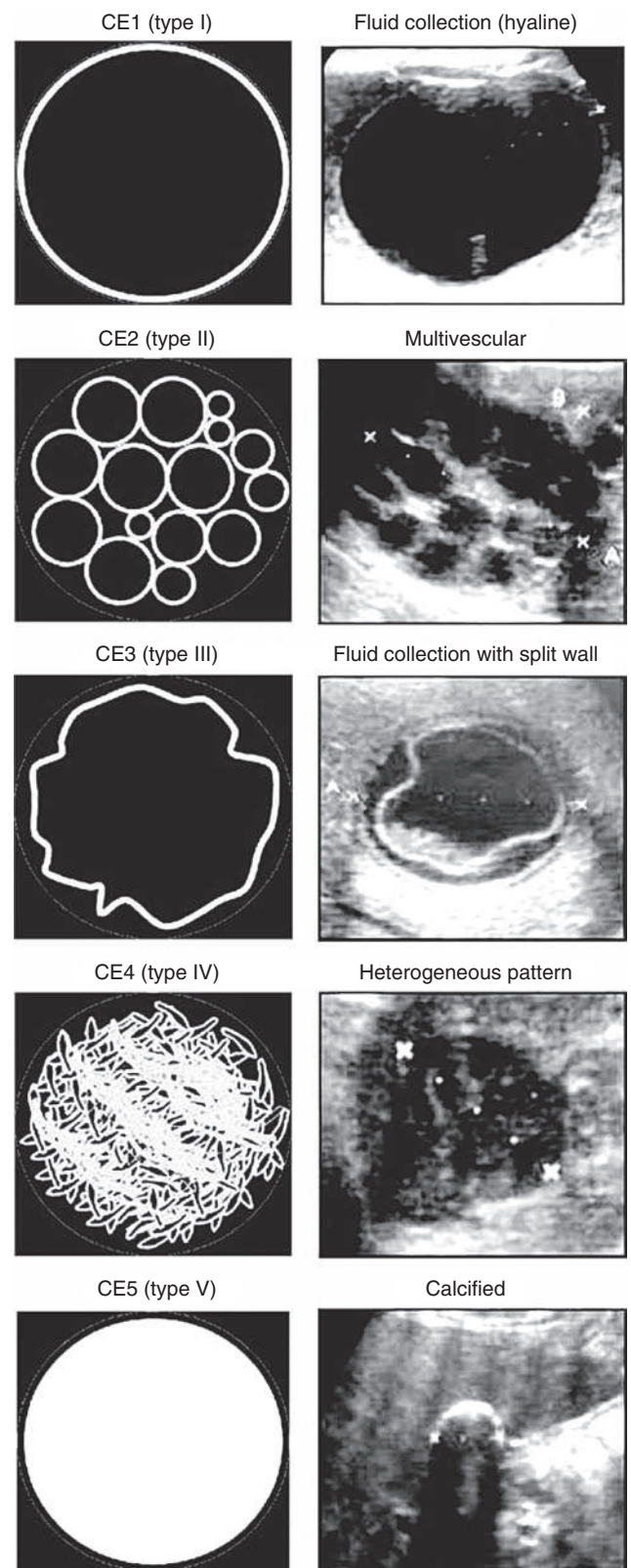
### DIAGNOSIS

Ultrasonography is the most valuable tool for both the diagnosis and treatment of cystic echinococcosis of the liver. The World Health Organization (WHO) standardized ultrasound criteria for classification of liver cystic echinococcosis have been shown to be reliable with excellent inter/intraobserver reliability. Ultrasonography staging has a direct use in defining optimal therapy with cystic echinococcosis types 1 and type 2 (CE1 and CE2) cysts considered fully active, CE3a and CE3b transitional, and CE4 and CE5 inactive (Fig. 350.2). Chest radiographs frequently reveal characteristic rounded masses in lung cystic echinococcosis (Fig. 350.3). Alveolar disease resembles a diffuse solid tumor. CT findings are similar to those of ultrasonography and may at times be useful in distinguishing alveolar from cystic echinococcosis in geographic regions where both occur (Fig. 350.4). CT or MRI is also important in planning a surgical intervention.

Serologic studies are used to confirm the diagnosis of cystic echinococcosis, although some children with active cystic echinococcosis do not have detectable levels of specific antibody. Cross-reaction with other helminths is possible when using crude hydatid fluid antigens for the serology. The sensitivity and specificity of serologic assays to diagnose cystic echinococcosis vary significantly by location of the cyst, stage, and treatment status. The enzyme-linked immunosorbent assay performs better than Western blot and indirect hemagglutination with the highest sensitivity for CE2, CE3, and CE1 cysts (64–99%) compared to CE4 and CE5 (51–91%). The sensitivity is higher for hepatic or bone disease, but the false-negative rate may be >50% with pulmonary or central nervous system (CNS) infection.

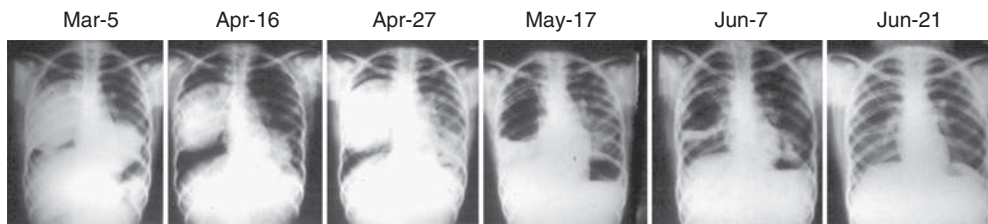
### Differential Diagnosis

Benign hepatic cysts are common but can be distinguished from cystic echinococcosis by the absence of a distinct three-layer wall, internal membranes, and hydatid sand. The density of bacterial hepatic abscesses is distinct from the watery cystic fluid characteristic of *E. granulosus* infection, but *Echinococcus* cysts may also be complicated

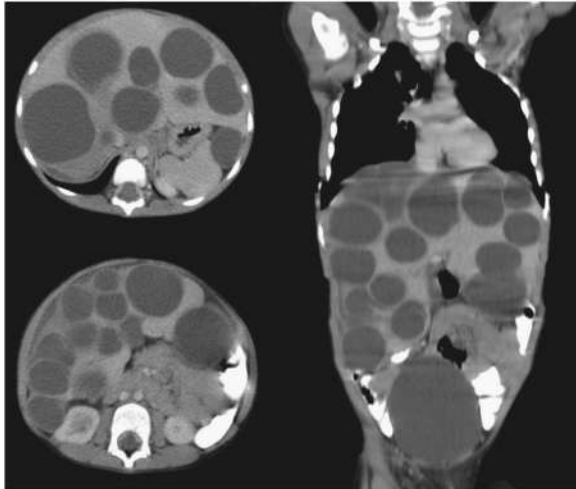


**Fig. 350.2** Ultrasound classification of cystic echinococcosis (CE) cysts. The WHO informal working group on echinococcosis classification differs from that of Gharbi and colleagues by the addition of a “cystic lesion” (CL) stage (undifferentiated) (*not shown*) and by reversing the order of CE types 2 and 3. CE3 transitional cysts may be differentiated into CE3a (with detached endocyst) and CE3b (predominantly solid with daughter vesicles). CE1 and CE3a are early-stage cysts and CE4 and CE5 late-stage cysts. (From McManus DP, Gray DJ, Zhang W, Yang Y. Diagnosis, treatment, and management of echinococcosis. *BMJ*. 2012;344:e3866. Fig 4.)





**Fig. 350.3** Serial chest radiographs of bilateral hydatid cysts. After 2 months of albendazole therapy, sudden rupture of the right cyst was associated with massive aspiration and acute respiratory distress.



**Fig. 350.4** Liver cystic echinococcosis (hydatid disease). Abdominal CT revealed hepatomegaly and multiple (>20) liver cysts. (From Ben-Shimol S, Zelcer I. Liver hydatid cysts. *J Pediatr.* 2013;163:1792.)

by secondary bacterial infection. Alveolar echinococcosis is often confused with hepatoma or metastatic tumor.

## TREATMENT

Management of cystic echinococcosis should be individualized and guided by disease stage and location. Approaches range from surgical resection for disease that tends to respond poorly to drugs and complicated cysts to watchful waiting for cysts that have already degenerated. For CE1 or CE3a cysts (see Fig. 350.2) that are <5 cm in diameter, **albendazole** chemotherapy alone (15 mg/kg/day orally divided twice daily for 1-6 months; maximum 800 mg/day) may result in a high rate of cure. Adverse effects include occasional alopecia, mild gastrointestinal disturbance, and elevated transaminases on prolonged use. Because of leukopenia, the U.S. Food and Drug Administration (FDA) recommends that blood counts be monitored at the beginning and every 2 weeks during the first 3 months of therapy and monthly afterward. Medical treatment with albendazole may also be used for cysts that are not suitable for interventions such as **PAIR** (percutaneous, aspiration, instillation, and reaspiration) or surgery, but response rates are low.

For larger CE1 and CE3a lesions, ultrasound- or CT-guided PAIR is the preferred therapy. Compared with surgical treatment alone, PAIR plus albendazole results in similar cyst disappearance with fewer adverse events and fewer days in the hospital. Spillage with PAIR is uncommon, but prophylactic albendazole therapy is routinely administered at least 1 week before PAIR and 1 month afterward. PAIR is contraindicated in pregnancy and for bile-stained cysts, which may indicate the presence of a biliary fistula. The scolical agents instilled during PAIR may increase risk for biliary complications in these patients. Surgery with albendazole

treatment is the recommended approach for CE2 and CE3b cysts of the liver. In experienced centers, cysts with thick internal septation (CE2) can be managed using a trocar to break up the membranes and external drainage. CE4 and CE5 cysts do not require immediate interventions and are followed ultrasonographically for signs of reactivation.

Surgery is the treatment of choice for complicated **cysts**, including ruptured cysts, cysts communicating with the biliary tract, large pulmonary cysts, or cysts of the CNS or bones. Small thoracic cysts may resolve with albendazole, but most cysts require operative removal.

For conventional surgery, the inner cyst wall (only laminar and germinal layers are of parasite origin) can be easily peeled from the fibrous layer, although some studies suggest that removal of the whole capsule has a better outcome in terms of recurrent disease. Considerable care must be taken to avoid spillage of cyst contents, and surgical drapes should be soaked in hypertonic saline because cyst fluid contains viable protoscolices, each capable of producing secondary cysts. An additional risk is anaphylaxis because of spilled cyst fluid, making it useful to employ a surgeon experienced in this surgery. For hepatic cysts, patients should begin therapy with albendazole (ideally in combination with praziquantel) for several days to weeks preoperatively. Antiparasitic drugs should be continued for 4-12 weeks postoperatively.

**Alveolar hydatidosis** frequently requires radical surgery, including partial hepatectomy, lobectomy, or liver transplantation. Medical therapy with albendazole should be continued for at least 2 years after presumably curative surgery. In patients who are not operative candidates or whose lesions are not amenable to surgical cure, albendazole long-term suppressive therapy should be used to slow the progression, but the infection generally recurs if albendazole is stopped.

## PROGNOSIS

Factors predictive of success with chemotherapy are age of the cyst (<2 years), low internal complexity of the cyst, and small size. The site of the cyst is not important, although cysts in bone respond poorly. For alveolar echinococcosis, if surgical removal is unsuccessful, the average mortality is 92% by 10 years after diagnosis.

## PREVENTION

Important measures to interrupt transmission include thorough **hand-washing**, avoiding contact with dogs in endemic areas, and boiling or filtering water when camping. Strict procedures for proper disposal of refuse from slaughterhouses must be instituted and followed so that dogs and wild carnivores do not have access to entrails. Other useful measures are control or treatment of the feral dog population and regular praziquantel treatment of pets and working dogs in endemic areas. Vaccines have been developed to prevent infection in grazing animals but are not widely used.

Visit Elsevier eBooks+ at [eBooks.Health.Elsevier.com](http://eBooks.Health.Elsevier.com) for Bibliography.